

## Durham E-Theses

---

### *Studies on some unsaturated organonitrogen metal systems*

El Erian

#### How to cite:

---

Erian, El (1983) Studies on some unsaturated organonitrogen metal systems. Doctoral thesis, Durham University.

#### Use policy

---

The full-text may be used and/or reproduced, and given to third parties in any format or medium, without prior permission or charge, for personal research or study, educational, or not-for-profit purposes provided that:

- a full bibliographic reference is made to the original source
- a <https://etheses.durham.ac.uk/id/eprint/7200/> is made to the metadata record in Durham E-Theses
- the full-text is not changed in any way

The full-text must not be sold in any format or medium without the formal permission of the copyright holders.

Please consult the [full Durham E-Theses policy](#) for further details.

STUDIES ON SOME UNSATURATED  
ORGANONITROGEN METAL SYSTEMS

by

M.A.I. EL ERIAN, B.Sc.  
(Graduate Society)

The copyright of this thesis rests with the author.  
No quotation from it should be published without  
his prior written consent and information derived  
from it should be acknowledged.

A thesis submitted in accordance with  
the regulations for the Degree of Doctor  
of Philosophy in the University of Durham

Department of Chemistry

February 1983.

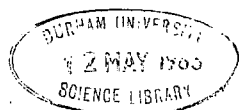

To My Parents

## ACKNOWLEDGEMENTS

I would like to thank Dr. K. Wade under whose supervision this work was carried out, for his valuable guidance, helpful encouragement and critical reading of the final draft of this thesis. I also wish to thank Drs. J.E. Edwards and P.G. Huggett for many constructive discussions and suggestions.

I would like to thank the members of staff of the Department of Chemistry, University of Durham for both the useful discussions and also for allowing me to use the facilities of the Chemistry Department. My special thanks to Miss Catherine Cross for checking the language and the grammar in this thesis.

Further, I would like to express my gratitude to Mrs. Margaret Chipchase for her unerring expertise in the typing and correcting of this thesis.

I am indebted to the British Council for the financial support of my tuition fees under the terms of the Fee Support Scheme for Postgraduate Students from developing countries. I am also grateful to my parents for moral and financial support especially during my visits to Egypt. My appreciation is also extended to the Egyptian Student Society in the U.K. and also to all my friends who encouraged and supported me financially during the last four months.

THESIS ABSTRACT

This thesis describes studies on the coordination chemistry and reactions with metal halides of some unsaturated organonitrogen compounds. The systems studied included various ketimines,  $R^1R^2C = NH$ , and derivatives thereof,  $R^1R^2C = NH$ ,  $MX_n$  or  $R^1R^2C = NMX_{n-1}$  containing antimony or tin atoms attached to the imino-nitrogen atoms. Aspects of the coordination chemistry of acrylonitrile  $CH_2 : CHC : N$  and its methyl derivatives,  $CH_2 : CMeC : N$  and  $MeCH : CHC : N$  have also been studied as well as their reactions with ether/ $SnCl_2/HCl$  systems.

The main feature studied in the imine work was the tendency of compounds  $(4-XC_6H_4)_2C = NSbCl_n$  ( $X = H$  or  $Me$ ,  $n = 2$  or  $4$ ) to undergo cyclometallation reaction forming a new type of antimony ring compound;

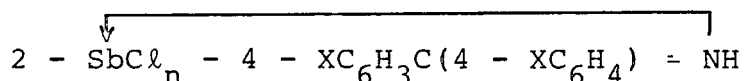

Related cyclometallation reactions are surveyed in chapter 1.

During attempts to prepare other diarylketimino antimony tetrachlorides such as *o*-tolyl,  $\text{ph}C = NSbCl_4$ ;

*m*-tolyl,  $\text{ph}C = NSbCl_4$  and  $(4 - FC_6H_4)_2C = NSbCl_4$ , no analogous

cyclometallated products were obtained. Instead two

different products were isolated:  $\text{Aryl}_2\text{CNH}_2^{\oplus}\text{SbCl}_4^{\ominus}$  and

$\text{Aryl}_2\text{CNH}_2^{\oplus}\text{SbCl}_6^{\ominus}$ . Attempts to prepare *t*-butyl derivatives

of general formula  $\text{Ar, Bu}^tC = NSbCl_4$  ( $\text{Ar} = \textit{o}$ -tolyl, *p*-tolyl; *m*-tolyl) afforded aryl nitrile,  $HCl$  and  $SbCl_3$ , probably by

elimination of  $Me_2C = CH_2$ . Chloroform solutions of diphenyl-

ketimine and antimony penta- or tri-chloride deposited

$\text{ph}_2\text{CNH}_2^{\oplus}\text{SbCl}_6^{\ominus}$  or  $(\text{ph}_2\text{CNH}_2^{\oplus})_2\text{SbCl}_5^{2\ominus}$  respectively.

In the nitrile work, using ether/SnCl<sub>2</sub>/HCl systems which contain R<sub>2</sub>OH<sup>+</sup> · SnCl<sub>3</sub><sup>⊖</sup> and (R<sub>2</sub>O<sup>+</sup>H)<sub>2</sub> · SnCl<sub>4</sub><sup>2⊖</sup>, addition to the C = C bond of the acrylonitrile yielded Cl<sub>3</sub>Sn·CH<sub>2</sub>·CH<sub>2</sub>·CN. Methacrylonitrile and crotononitrile gave more complicated reactions with ether/SnCl<sub>2</sub>/HCl systems, apparently undergoing dimerization to form amidinium cations containing C = N - CR = NH<sub>2</sub><sup>+</sup> units.

Finally, several complexes were isolated from reactions between acrylonitrile or its methyl derivatives and the metal chlorides TiCl<sub>4</sub>, SnCl<sub>4</sub>, SbCl<sub>5</sub>, BCl<sub>3</sub>, CoCl<sub>2</sub>, ZnCl<sub>2</sub>, TiBr<sub>4</sub>, TaCl<sub>5</sub>, NiCl<sub>2</sub>/2SbCl<sub>5</sub> and NiCl<sub>2</sub>/2ZnCl<sub>2</sub>. Spectroscopic and conductivity studies of these complexes were carried out, and used to deduce their probable structures.

## CONTENTS

Page No.

ACKNOWLEDGEMENTS

THESIS ABSTRACT

### CHAPTER ONE

#### A Survey of Cyclometallation Reactions

1.1	Introduction	1
1.2	Definition and Scope of This Survey	2
1.3	Organic Residues Known to Undergo Cyclometallation Reactions	4
1.4	Metals Known To Be Capable of Cyclometallation Reactions	8
1.5	Mechanism of Cyclometallation Reactions	11
1.6	Reactions of Cyclometallated Complexes	33
1.6.1	Reactivity of Carbon-Metal Bond	33
1.6.2	Reactivity of the Halogen-Metal Bond	37
1.6.3	Reactivity of the Nitrogen-Metal Dative Bond	41
1.6.4	Reactivity of the Hydrogen-Metal Bond	41
1.7	Summary	43

### CHAPTER TWO

#### Orthometallation Reactions of Ketimino- Antimony Chlorides

2.1	Introduction	44
2.2	Discussion	45
2.2.1	Reactions yielding Orthometallated Compounds	46
2.2.1.1	Investigation of the Preparative Route	46
2.2.1.2	Spectroscopic Data	71

A	Mass Spectra	71
B	Infrared Spectra	74
C	Proton Magnetic Resonance Spectra	76
2.2.2	Reactions Yielding Non-ortho-metallated Compounds	79
2.2.2.1	Preparative Routes	79
2.2.2.2	Spectroscopic Data	86
A	Mass Spectra	86
B	Infra-red Spectra	88
C	Proton Magnetic Resonance Spectra	91
D	Carbon-13 Magnetic Resonance Spectra	93
2.2.3	The Reaction of t-Butyl, Aryl-Ketiminolithium with Antimony Pentachloride	95
2.2.4	The reaction of N-Chloro dip-tolylketimine with Antimony Trichloride	98
2.3	Conclusion	100
2.4	Experimental Work	102
2.4.1	Reaction of Diphenylketiminolithium with Antimony Pentachloride (Mole Ratio 1:1, Solvent Diethyl Ether/Toluene, Temperature 90°)	102
2.4.2	Reaction of Diphenylketiminolithium with Antimony Pentachloride (1:1 in Toluene/Chloroform at 15°)	103
2.4.3	Reaction of Diphenylketiminotrimethylsilane with Antimony Pentachloride (1:1 in Toluene at 18°)	104
2.4.4	Reaction of Diphenylketiminolithium with Antimony Pentachloride (5:1 in Toluene at 100°).	105
2.4.5	Reaction of Di-p-tolylketiminolithium with Antimony Pentachloride (1:1 in Diethyl Ether/Toluene at 90°).	106

- 2.4.6 Reaction of Di-p-tolylketiminolithium with Antimony Pentachloride (1:1 in Toluene/Chloroform at 18°). 107
- 2.4.7 Reaction of Di-p-tolylketiminotrimethylsilane with Antimony Pentachloride (1:1 in Toluene at 80°). 108
- 2.4.8 Reaction of Di-p-fluorophenylketimino-lithium with Antimony Pentachloride (1:1 in Toluene/Chloroform at 18°). 109
- 2.4.9 Reaction of m-Tolylphenylketiminolithium with Antimony Pentachloride (1:1 in Toluene/Chloroform at 18°). 110
- 2.4.10 Reaction of o-Tolylphenylketiminolithium with Antimony Pentachloride (1:1 in Toluene/Chloroform at 18°). 111
- 2.4.11 Reaction of o-Tolylphenylketimino-trimethylsilane with Antimony Pentachloride (1:1 in Toluene at 16°). 112
- 2.4.12 Reaction of Mesityl, phenylketimino-lithium with Antimony Pentachloride (1:1 in Diethyl Ether at 15°). 112
- 2.4.13 Reaction of Mesityl, phenylketimino-lithium with Antimony Pentachloride (1:1 in Toluene/Chloroform at 15°). 113
- 2.4.14 Reaction of t-Butyl, p-tolylketimino lithium with Antimony Pentachloride (1:1 in Et<sub>2</sub>O at 18°). 114
- 2.4.15 Reaction of t-Butyl, o-tolylketimino-lithium with Antimony Pentachloride (1:1 in Et<sub>2</sub>O/Toluene at 90°). 115
- 2.4.16 Reaction of Diphenylketiminolithium with Antimony Trichloride (1:1 in Et<sub>2</sub>O/Toluene at 110°). 116
- 2.4.17 Reaction of Diphenylketiminolithium with Antimony Trichloride (3:1 in Et<sub>2</sub>O/Toluene at 90-110°). 117
- 2.4.18 Attempted Reaction of N-chlorodip-tolylketimine with Antimony Trichloride (1:1, no solvent at 18°). 117

- 2.4.19 Attempted Reaction of N-Chloro di-  
p-tolylketimine with Antimony  
Trichloride (1:1 in Chloroform/  
Toluene at 80-90°). 119
- 2.4.20 Reaction of Diphenylketimino-  
lithium with Tin Tetrachloride  
(1:1 in Et<sub>2</sub>O/Chloroform at 20°). 120

## CHAPTER THREE

Reaction of Diphenylmethylenamine with Antimony  
Chlorides

- 3.1 Introduction 121
- 3.1.1 Reaction of Ammonia and Amines  
with Metal or Metalloid Halides 122
- 3.1.2 Reaction of Diphenylmethylenamine  
with Boron Halides 126
- 3.1.3 The chemistry of Antimony Penta- and  
tri-Halides towards the Organo-  
nitrogen compounds 128
- 3.2 Experimental 130
- 3.2.1 Reaction of Diphenylmethylenamine,  
ph<sub>2</sub>CNH with Antimony Pentachloride,  
SbCl<sub>5</sub> (1:1 ratio in toluene at 120°). 130
- 3.2.2 Reaction of Diphenylmethylenamine,  
ph<sub>2</sub>CNH with Antimony Pentachloride,  
SbCl<sub>5</sub> (1:1 ratio in chloroform). 132
- 3.2.3 Reaction of Diphenylmethylenamine,  
ph<sub>2</sub>CNH with Antimony Pentachloride,  
SbCl<sub>5</sub> (1:1 ratio in CCl<sub>4</sub>/toluene). 133
- 3.2.4 Reaction of Diphenylmethylenamine  
Hydrochloride, ph<sub>2</sub>CNH<sub>2</sub>Cl<sup>-</sup> with  
Antimony Pentachloride, SbCl<sub>5</sub> (1:1  
ratio in chloroform). 134
- 3.2.5 Reaction of Diphenylmethylenamine,  
ph<sub>2</sub>CNH with Antimony Trichloride,  
SbCl<sub>3</sub> (1:1 ratio in chloroform). 135
- 3.2.6 Reaction of Diphenylmethylenamine,  
ph<sub>2</sub>CNH with Antimony Trichloride,  
SbCl<sub>3</sub> (2:1 ratio in chloroform). 136
- 3.2.7 Reaction of Diphenylmethylenamine  
Hydrochloride, ph<sub>2</sub>CNH<sub>2</sub>Cl<sup>-</sup> with  
Antimony Trichloride, SbCl<sub>3</sub> (1:1  
ratio in chloroform). 136

3.3	Results and Discussion	137
3.3.1	Reactions of Diphenylmethyleamine with Antimony Pentachloride	137
3.3.2	Reactions of Diphenylmethyleamine with Antimony trichloride	142
3.4	Conclusion	145

## CHAPTER FOUR

## The Reaction of Tin Dichloride and Hydrogen Chloride with some Methyl Derivatives of Acrylonitrile

4.1	Introduction	147
4.2	The Reactivity of Nitriles towards protic Acids	148
4.3	Experimental	153
4.3.1	Reaction of Acrylonitrile with Hydrogen Chloride and Tin Dichloride	153
4.3.2	Reaction of Methacrylonitrile with Hydrogen Chloride and Tin Dichloride ( $\text{SnCl}_2/\text{HCl}$ System prepared in $\text{Et}_2\text{O}$ ).	155
4.3.3	Reaction of Methacrylonitrile with Hydrogen Chloride and Tin Dichloride ( $\text{SnCl}_2/\text{HCl}$ system prepared in petroleum Ether - $\text{Et}_2\text{O}$ ).	158
4.3.4	Reaction of cis-/trans-crotononitrile with Hydrogen Chloride and Tin Dichloride ( $\text{SnCl}_2/\text{HCl}$ system prepared in $\text{Et}_2\text{O}$ ).	160
4.3.5	Reaction of cis-/trans-crotononitrile with Hydrogen Chloride and Tin Dichloride ( $\text{SnCl}_2/\text{HCl}$ system prepared in petroleum Ether - $\text{Et}_2\text{O}$ ).	163
4.4	Discussion	164
4.4.1	The Reaction of Tin Dichloride with Hydrogen Chloride	164
4.4.2	The Reaction of Chlorostannate (II) with Acrylonitrile	166

4.4.3	The Reaction of Chlorostannate (II) with Methacrylonitrile	168
4.4.4	The Reaction of Chlorostannate (II) with cis-/trans-Crotononitrile	176
4.5	Mechanistic Aspects	179
4.6	Conclusion	184

## CHAPTER FIVE

Syntheses and Properties of some metal Halide complexes of Acrylonitrile, Methacrylonitrile and Crotononitrile.

5.1	Introduction	185
5.1.1	Adducts Bonded through the Nitrile Nitrogen	186
5.1.2	Adducts Bonded through the C = C Double Bond.	193
5.1.3	Adducts Bonded through both of the Nitrogen and the (C = C) Double Bond	199
5.2	Experimental	203
5.3	Results and Discussion	209
5.3.1	Infrared Spectra	210
5.3.2	Proton Magnetic Resonance Spectra	220
5.3.3	Electrical Conductivity Measurements	225
5.3.4	The Stability of Adducts	229
5.3.5	Raman and Far infrared Spectra	235
5.4	Conclusion	238

	Page No.
APPENDIX 1	
Mössbauer and Electrical Conductivity Data of Some Ortho-and non-ortho- metallated Antimony Compounds	A.1
APPENDIX 2	
Infrared Spectra	A.7
APPENDIX 3	
Nuclear Magnetic Resonance Spectra	A.9
APPENDIX 4	
Far Infrared and Raman Spectra	A.11
APPENDIX 5	
Electrical Conductivity Measurements Graphs	A.12
APPENDIX 6	
General Experimental Details	A.13
APPENDIX 7	
Research Colloquia, Seminars and Lectures	A.17
REFERENCES OF CHAPTER ONE	R.1
REFERENCES - TABLE 1.2	R.4
REFERENCES OF CHAPTER TWO	R.13
REFERENCES OF CHAPTER THREE	R.15
REFERENCES OF CHAPTER FOUR	R.17
REFERENCES OF CHAPTER FIVE	R.19
REFERENCES OF APPENDIX 1	R.22



CHAPTER ONE

A SURVEY OF CYCLOMETALLATION REACTIONS

1.1 INTRODUCTION

This thesis describes studies on the coordination chemistry, and reactions with metal halides, of some unsaturated organo-nitrogen compounds. The systems studied included various ketimines,  $R^1R^2C = NH$ , and derivatives thereof,  $R^1R^2C = NHMX_n$  or  $R^1R^2C = NMX_{n-1}$ , containing metal or metalloid atoms M attached to the imino-nitrogen atoms. Aspects of the coordination chemistry of acrylonitrile,  $CH_2 = CHC \equiv N$ , and its methyl derivatives,  $MeCH = CHC \equiv N$  and  $CH_2 = C Me C \equiv N$ , have also been studied.

The main feature studied in the imine work was the tendency of the arylketimino residue,  $aryl.CR = N$ , when attached to metals like tin or antimony, to undergo cyclometallation reactions, e.g.

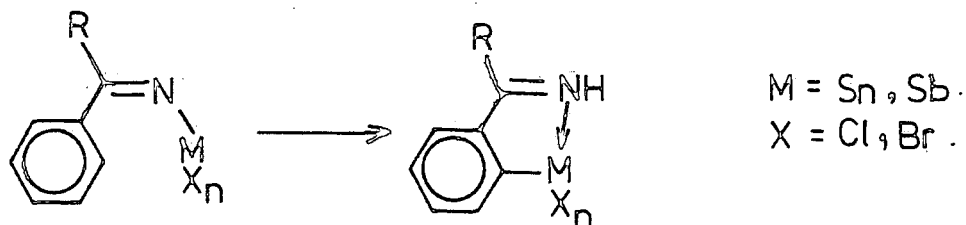

Reactions of this type, in which a metal atom becomes attached to the aryl residue of one of its ligands, have acquired some importance in organometallic and coordination chemistry, particularly where the metal involved is a transition metal. Examples involving main group metals or metalloids are much rarer. It accordingly seemed appropriate to introduce this work by a survey of cyclometallation reactions in order to set the present tin and antimony work in context.

Short surveys of relevant acrylonitrile coordination chemistry follow in later chapters by way of introduction to the acrylonitrile work.

### 1.2 DEFINITION AND SCOPE OF THIS SURVEY

The term 'cyclometallation' is usually applied to reactions of metal complexes in which organic ligands undergo intramolecular metallation to form chelate rings. Such reactions may be represented generally as follows:

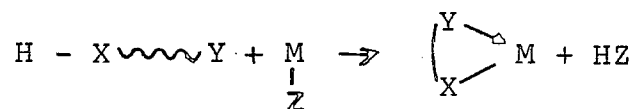

where X is the atom metallated,

M is the metal concerned,

Y is the donor atom (N,P,As,Sb,O,S)

through which the organic ligand is initially attached to M, and Z is the leaving group, which may be a halogen atom or alkyl or aryl group.

Clearly, reactions of metal ions with chelating ligands  $\text{HX} \sim \text{Y}$  which are protic acids, e.g. acetylacetonone (in its enol form  $\text{HO} - \text{C}(\text{Me}) = \text{CHC}(\text{Me}) = \text{O}$ ), ethanolamine  $\text{HOCH}_2\text{CH}_2\text{NH}_2$ , or

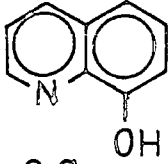
8 - hydroxyquinoline,  are examples of cyclometallation reactions, e.g.

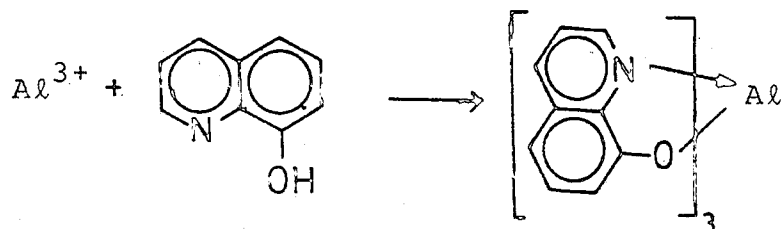

Ref. 5b

However, since such reactions normally proceed directly to the chelated derivatives they tend not to be treated as cyclometallations. Indeed, the term 'cyclometallation' is normally reserved for systems in which the formation of the chelate ring is quite distinct from the initial coordination reaction, and moreover is generally restricted to systems in which it is a carbon atom that is metallated. It is in this sense that the term is used here.

The cyclometallation reactions studied in the present work all entailed metallation of an aryl residue attached to the azomethine grouping  $>C = N -$ , e.g.

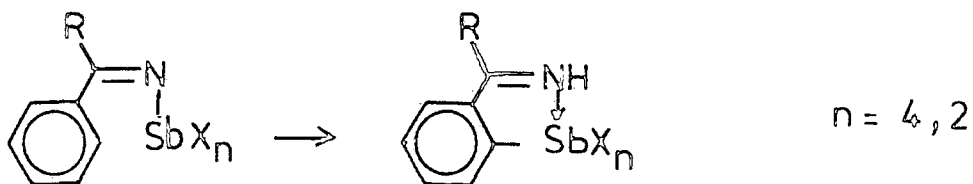

Such reactions, which involve metallation of an aryl group in the ortho position with respect to the group providing a link to the metal atom, are generally referred to as 'orthometallation reactions', and these form an important category of cyclometallation reactions. It is worth noting that, in the example cited, the new metal-carbon bond is formed without simultaneous loss of HX - cyclometallation reactions can occur without loss of a 'leaving group' if the metal atom concerned starts by being coordinatively unsaturated.

The present survey indicates the range of metals that are known to undergo cyclometallation reactions, and the types of organic ligand known to be susceptible to cyclometallation. An attempt is made to identify the structural and electronic factors that facilitate such reactions.

Useful reviews that discuss the subject of cyclometallation reactions are to be found in references (1-4).

### 1.3 ORGANIC RESIDUES KNOWN TO UNDERGO CYCLOMETALLATION REACTIONS

To undergo the cyclometallation reaction, the organic compound should have a donor atom and a (C-H) bond. The donor atom may be nitrogen, oxygen, phosphorus, sulphur, halogen, or the carbon atoms of phenyl, or even alkenyl groups. If the organic compound has a nitrogen donor, then the metal will attack the CH carbon atom whether this carbon atom is saturated as in aliphatic systems or unsaturated as in aromatic, olefinic, benzylic and heterocyclic systems. Examples of such cyclometallated compounds containing a nitrogen donor are given in table (1.1).

The readiness of systems to undergo cyclometallation reactions depends on the nature of both the donor atom and the C-H bond. The donor atom needs to coordinate strongly to the metal in order to hold the organic residue in a suitable position for cyclometallation. The presence of a bulky group on the donor atom, provided that it does not seriously weaken the coordinate link, may encourage the organic ligand to cyclometallate by preventing rotation about the coordinate link. The reactions of primary, secondary and tertiary benzylamines  $\text{PhCH}_2\text{NH}_x\text{Me}_{2-x}$  ( $x = 2, 1$  or  $0$ ) with platinum (II) or palladium (II) chlorides illustrate this. The bulky ligand  $\text{PhCH}_2\text{NMe}_2$  suffers cyclometallation, whereas the others form products containing no metal-carbon  $\sigma$ -bond. <sup>5a</sup>

TABLE (1.1)

EXAMPLES OF NITROGEN DONOR-CYCLOMETALLATED SYSTEMS

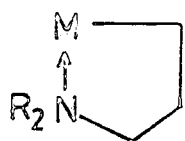

Alkylamines

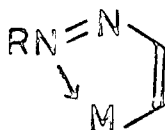

2-(Methylazo)  
Propenes

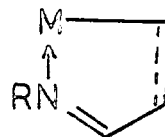

Imines

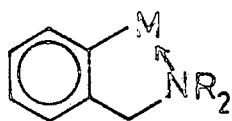

Benzylamines

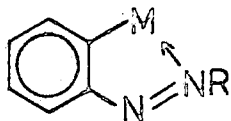

Azobenzenes

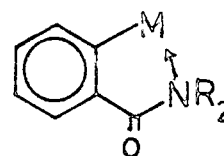

Benzoylamines

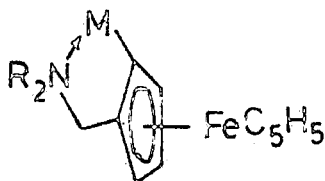

Amino Ferro-  
cenes

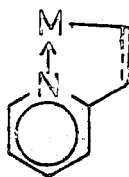

Heteroaromatic  
Compounds

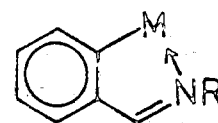

Benzylidene-  
amines

The susceptibility of a particular C-H bond to metallation will depend on both steric and electronic factors. Sterically, the number of atoms separating that bond from the donor atom will determine its proximity to the metal. The C-H bonds of carbon atoms in a  $\gamma$  position with respect to the donor atom are particularly susceptible to attack, since cyclometallation of such bonds affords the favoured 5-membered ring:-

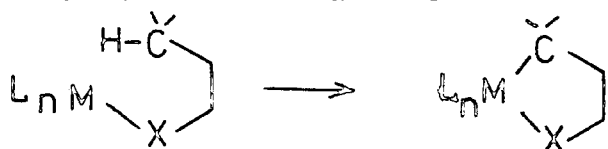

Cyclometallation of  $\beta$ - or  $\delta$ -C-H bonds will be less likely to occur, because the products of these reactions will be 4- or 6-membered rings respectively.

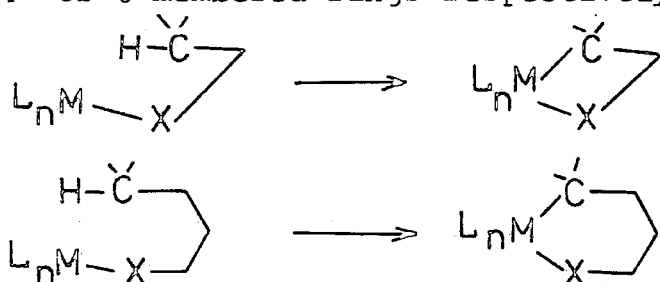

The reason for this is that the five-membered rings of organometallic intramolecular-coordination compounds can generally be formed sterically free from strain due to bond lengths, and the bond angles of each atom since the metal generally forms four-(square planar), five-(trigonal bipyramidal) and six-(octahedral) coordination structures, also the bond angle made by the two bonds containing the metal in the centre of two atoms is closer to  $90^\circ$  than to  $109^\circ 28'$  ( $Sp^3$ ) or to  $120^\circ$  ( $Sp^2$ ).

The effect of chelate ring size is illustrated by using different ligands such as  $PhNMe_2$ ,  $PhCH_2NMe_2$ ,  $Ph(CH_2)_2NMe_2$ , and  $Ph(CH_2)_3NMe_2$ , in a cyclopalladation reaction which would generate 4, 5, 6, or 7-membered rings respectively

by substitution of an ortho-hydrogen of the phenyl group. However, only the compound with a five-membered ring is obtained<sup>5a</sup> - the other ligands do not undergo cyclometallation.

In rare cases, a cyclometallated compound containing a six membered ring can be formed. For example, N-aryl-amidines or amides can be palladated producing a compound containing a six-membered ring<sup>9</sup> (see figure 1.1):

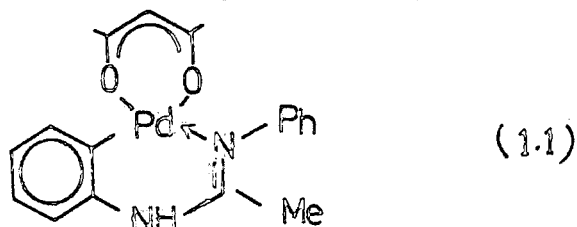

Electronically, the nature of the C-H bond will also be important. For example, Schiff's bases coordinated to Rh(I) or Ir(I) undergo cyclometallation with a facility that decreases in the sequence  $C-H_{\text{aromatic}} > C-H_{\text{olefinic}} > C-H_{\text{aliphatic}}$ <sup>6,7</sup>. In orthometallation reactions, the susceptibility of the ring to metallation varies markedly with the ring substituents, which ideally need to be electron-releasing to facilitate cyclometallation since the coordinatively unsaturated metal atom functions as an electrophile. For example,

*para* methylazobenzene,  $MeC_6H_4N=NPh$ , suffers metallation

(of the tolyl ring) more readily than its *para*

chloro counterpart  $ClC_6H_4N=NPh$ , in which the

chlorinated ring can be metallated only with difficulty,

using Pd<sup>(II)</sup> 8.

1.4 METALS KNOWN TO BE CAPABLE OF CYCLOMETALLATION REACTIONS

The cyclometallation reaction depends on the type of the metal used and also on the group attached to this metal as well as the nature of the organic residue.

To illustrate the effect of metal type we can consider the reactions of the complex  $[\text{RhCl}(\text{C}_8\text{H}_{14})_2]_2$  and its related Ir(I) complex with a N-donor ligands in the presence of  $\text{PPh}_3$  as represented in equation (1.1), in which the Ir(I) metal undergoes the cyclometallation reaction, whilst the other metal, Rh(I) does not<sup>6</sup>.

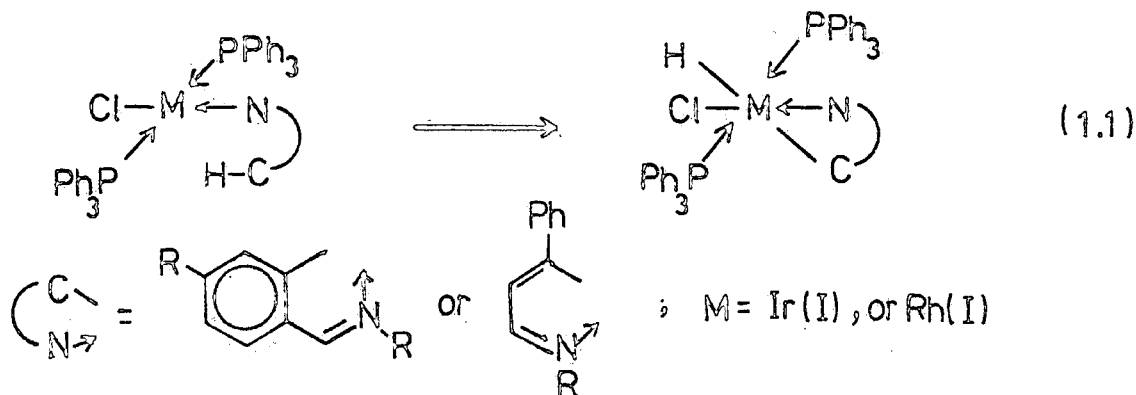

The influence of metal basicity on the cleavage of (C-H) bonds by Rh(I) and Ir(I) in the metal-imine compounds has been studied by Vrieze and Co-workers<sup>6</sup> using the symmetry rules for chemical reactions presented by Pearson. Pearson's concept suggests that the chemical reaction will take place if compatible symmetry of the highest energy ( $E_o$ ) occupied MO (HOMO) and a low energy ( $E_k$ ) unoccupied MO (LUMO) leads to positive total overlap and thus to the possibility of HOMO-LUMO electron transfer. This electron transfer will occur more readily as  $|E_o - E_k|$  becomes smaller. On application of Pearson's concept of the cyclometallation reaction through which the cyclometallated product is formed by (C-H) bond breaking and (M-H) and (M-C) bond formation, then

the HOMO in the nonmetallated compound may be a metal d orbital (if M is considered as a nucleophile) and the LUMO should be the  $\sigma^*$  (CH) orbital, since it is the only unoccupied orbital possessing the possibility of a sterically favoured overlap with the HOMO. The next step of Pearson's concept is the overlap between HOMO/LUMO orbitals. There are two possible overlaps concerning the metal d orbital as shown in figure (1.2 - a,b).

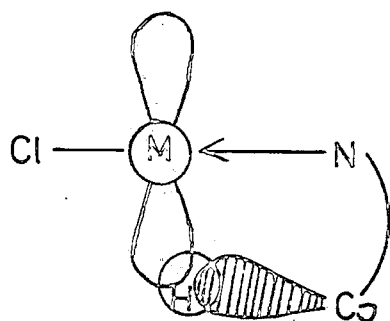

(a) Overlap between the metal  $d_{z^2}$  and (C-H) bonds.

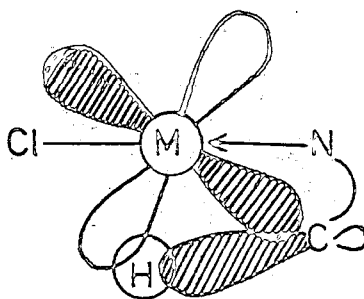

(b) Overlap between the metal  $d_{xz}$  and (C-H) bond.

Fig. 1.2 Possible HOMO/LUMO overlaps between the metal and (C-H) bond in the cyclometallated reactions.

The most favourable overlap is overlap (a), as strongly indicated by the crystal structural<sup>10,11</sup> data, where the  $\hat{NMC}$  bond angle is closer to  $90^\circ$  rather than to  $45^\circ$ .

The last step of Pearson's concept, is to recognize whether the metal can cyclometallate with the organic ligand or not from the  $|E_o - E_k|$  value. For example, on going from Ir(I) to Rh(I) and on changing from very basic to much less basic coligand, the  $d_{z^2}$  ( $d_{xz}$ ) level will move to lower energy, i.e.  $|E_o - E_k|$  becomes larger for the (C-H) bond, leading to a lower reactivity towards the (C-H) bond. This may explain the absence of  $\hat{C}$  cyclometallation of Rh(I) illustrated

in equation (1.1) in comparison with Ir(I) complexes. A further lowering of the metal d levels in energy, for example, going from Rh(I) to Pd(II), the HOMO-LUMO electron transfer from the metal d orbital to the  $\sigma^*$  (C-H) bond (i.e. nucleophilic behaviour) will change over to electrophilic behaviour, where the electron transfer will occur from the  $\sigma$  (C-H) bonding orbital (HOMO) to the metal orbital (LUMO) of appropriate symmetry. The corresponding  $|E_o - E_k|$  value is expected to be apparently lower than that for the metal  $d \rightarrow \sigma^*$  transition.

There is a lack of knowledge of the position of  $\sigma^*$  (CH) energy levels ( $E_o$ ) for different kinds of CH bonds, i.e. aromatic, olefinic, or an aliphatic CH bond. It is therefore, difficult to explain the difference in reactivity of Rh(I) and Ir(I) towards the different kinds of (C-H) bonds.

#### Influence of other ligands on metal.

The group(s) attached to the metal has some influence on the cyclometallated system and on the cyclometallation reaction. The more electronegative group(s), the stronger the intramolecular coordination bond that can be obtained, as indicated from X-ray crystallographic studies. Also, the higher the thermodynamic stability of the group leaving the metal upon cyclometallation, the easier that metallation can occur. For example the relative ease of metallation of azobenzene by  $MnR(CO)_5$  has been qualitatively established as  $R = PhCH_2 > Et > Me > CH_2 C_6 Me_5^{12}$ . This is explained on the basis of the higher thermodynamic stability of toluene relative to the others. Examples of cyclometallated compounds containing nitrogen donor atoms are represented in table (1.2) which divides the

literature on the basis of metal studied and its position in the periodic table.

### 1.5 MECHANISM OF CYCLOMETALLATION REACTIONS

The mechanism of cyclometallation reactions has been discussed by Parshall<sup>4</sup>. He suggested that the reaction path involves firstly, the coordination of the nitrogen lone pair to the metal to form a  $\sigma$ -N metal complex, secondly further coordination from the  $\pi$ -electrons of the ligand unsaturated hydrocarbon into this metal if the metal is electron-deficient or from the metal into the  $\pi$ -system if the metal is electron rich. The final step is the formation of the cyclometallated product by cleavage of the (C-H) bond and formation of the (M-C) bond. The way that the metal-carbon bond is formed, is still uncertain, since the cyclometallation reaction may proceed via different mechanisms, depending on the metal and the substrate, or more probably to the balance of steric and electronic factors.

However, Parshall has proposed three possible different mechanisms to explain the cyclometallation process. The cyclometallation may occur by way of an electrophilic substitution of the metal on the carbon, nucleophilic attack of the metal on the aromatic (olefinic) system, or an oxidative addition of (C-H) bond on the metal followed by a reductive elimination.

The cyclopalladation of azobenzene is an example of a reaction which occurs by way of an electrophilic substitution mechanism. The pathway of this reaction is illustrated in scheme (1.1).

TABLE 1.2

EXAMPLES OF CYCLOMETALLATED COMPOUNDS CLASSIFIED ACCORDING TO THE MAIN AND TRANSITION GROUP ELEMENTS OF THE PERIODIC TABLE

Cyclometallated Compound

Ref.

Cyclometallated Compound

Ref.

Group IA :

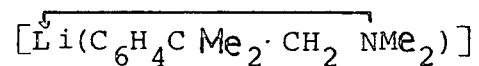

1

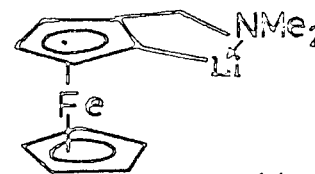

3,7

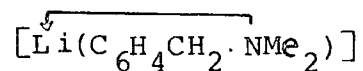

2

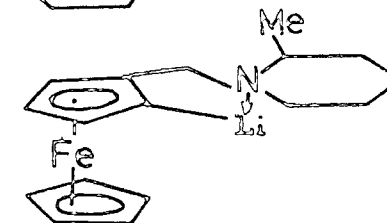

8,9

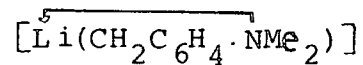

3

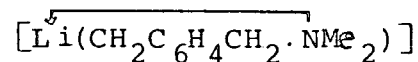

3

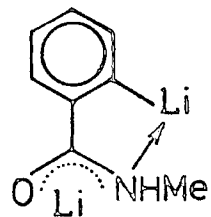

4

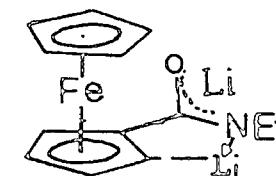

10

Group IIA:

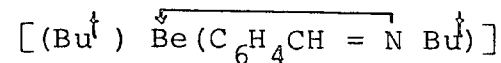

11

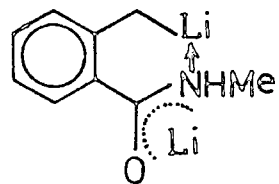

5

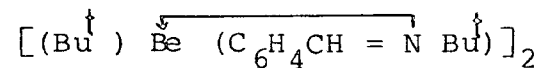

11

Cyclometallated Compound

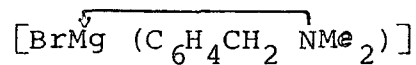
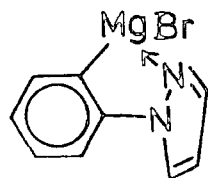

Group IIA:

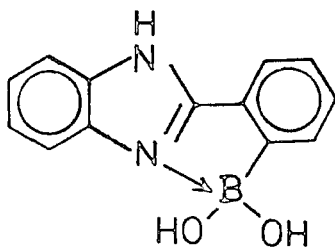
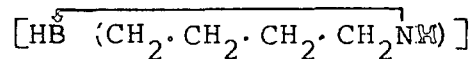
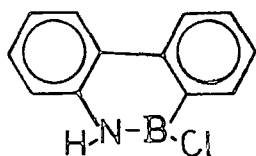
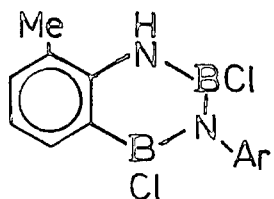
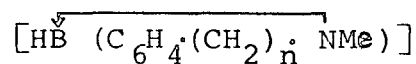

Ref.

Cyclometallated Compound

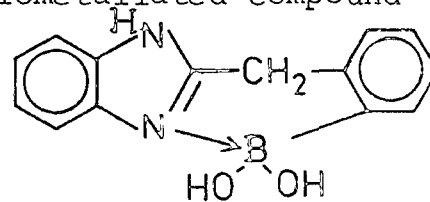

12

Ref

18

13

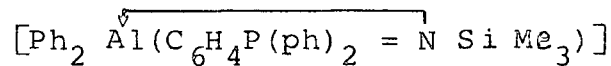

19

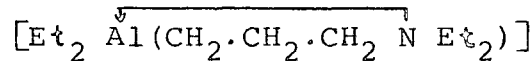

20

14

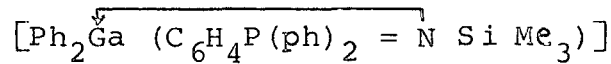

19

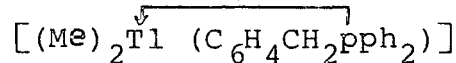

21

15

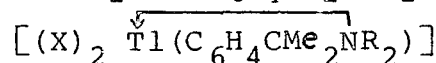

22

Group IVA:

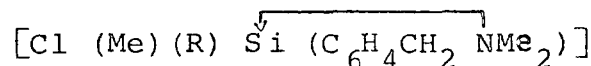

23

16

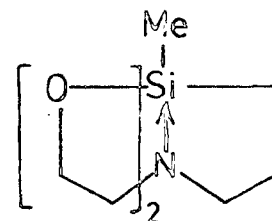

24

17

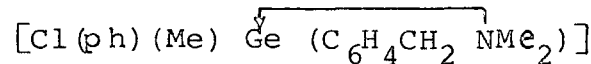

23

18

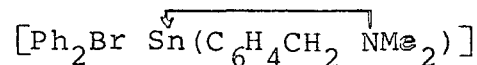

25

Cyclometallated Compound

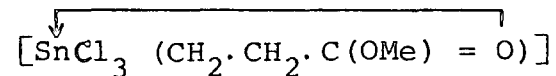
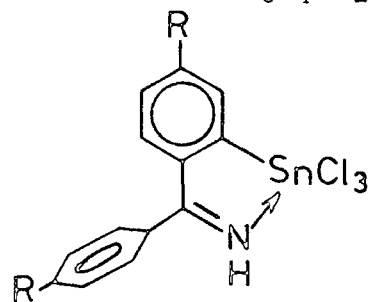
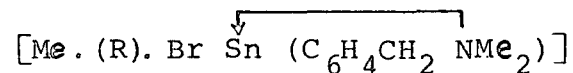
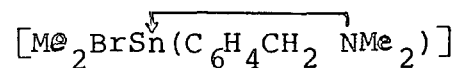

Group IB:

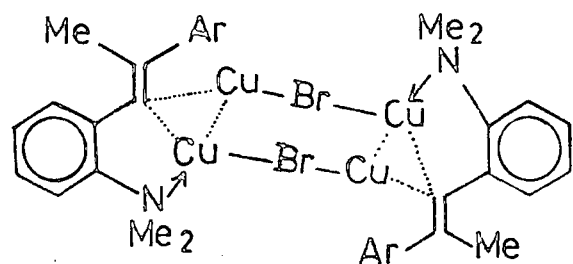
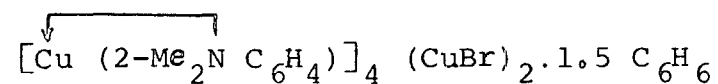
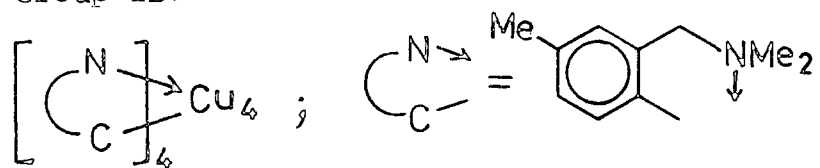

Ref.

Cyclometallated Compound

Ref

26

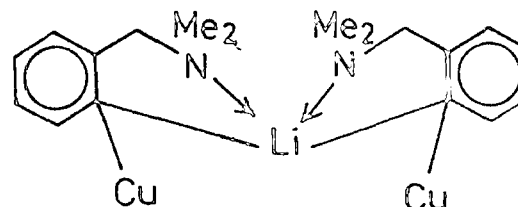

27

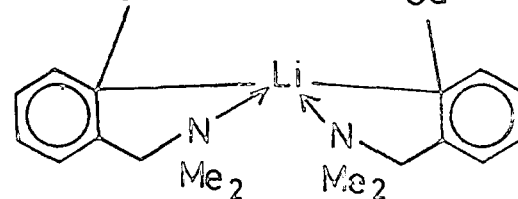

33

28

Group IIB:

29

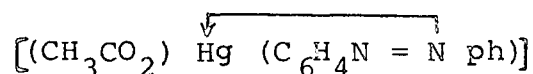

34, 35, 36

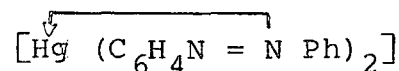

37

30

Group IIIB:

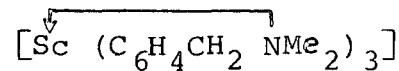

38, 39

Group IVB:

31

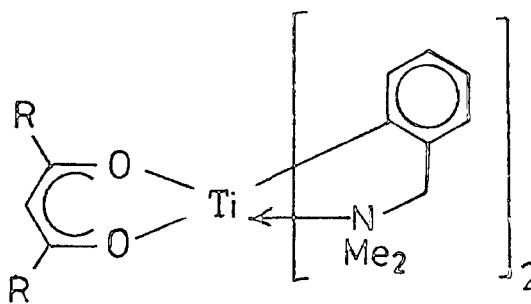

40

32

Cyclometallated Compound

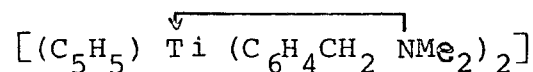
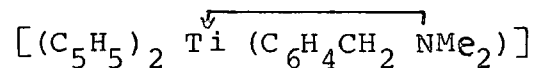
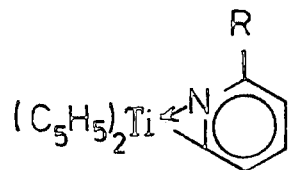
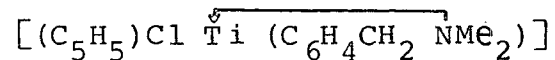

Group VB :

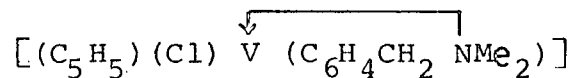

Group VIB:

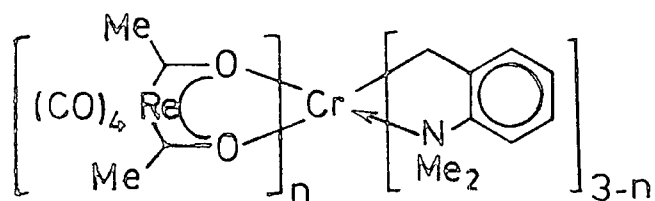
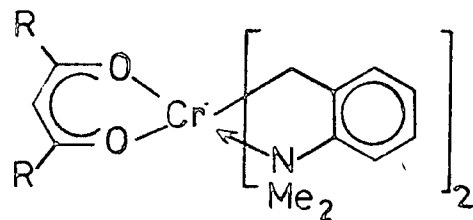

Ref.

Cyclometallated Compound

Re

41

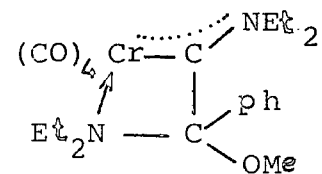

45

42

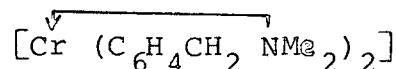

38, 39

38, 39

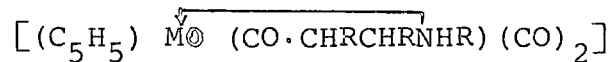

46

38, 39

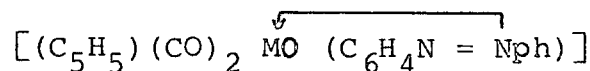

47

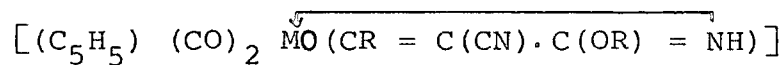

48

41

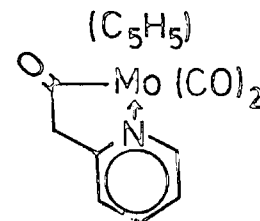

49

43

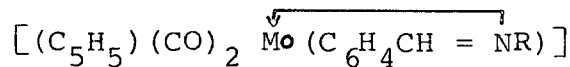

50

44

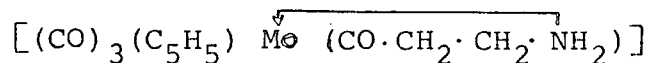

46

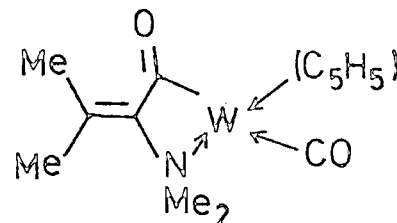

51, 52

Cyclometallated Compound

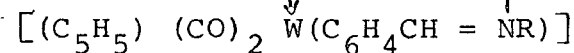
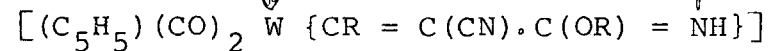
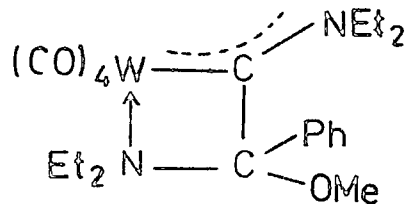

Group VII B :

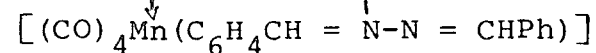
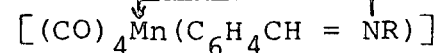
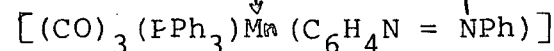
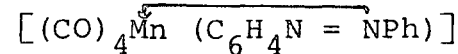
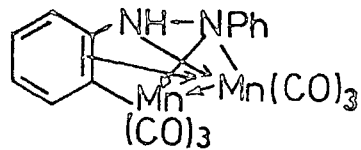
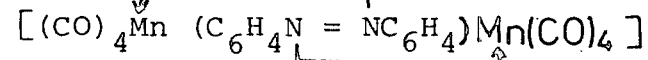

Ref.

Cyclometallated Compound

Ref.

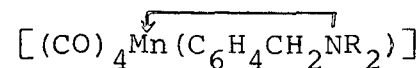

55

45

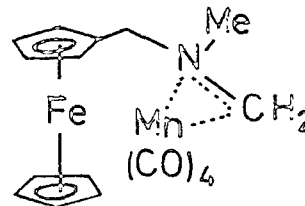

56

48

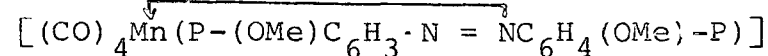

55

50

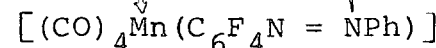

57

53

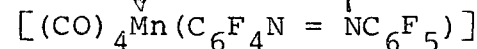

57

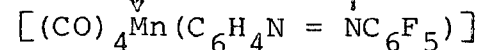

57

53

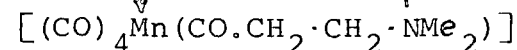

49, 58

47

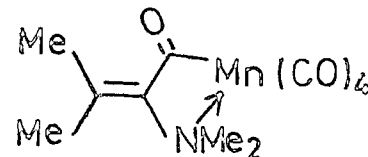

51, 52

47

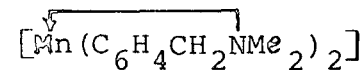

38, 39

55

Cyclometallated Compound

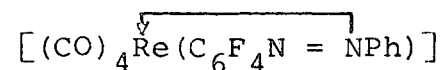
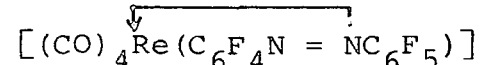
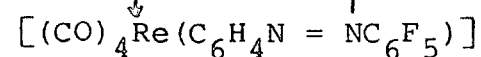
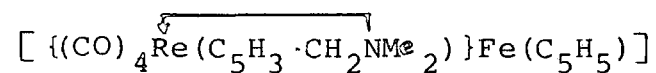
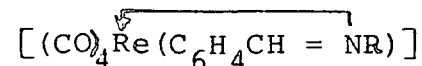
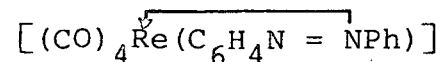
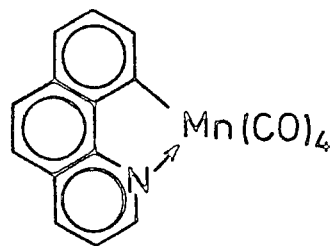
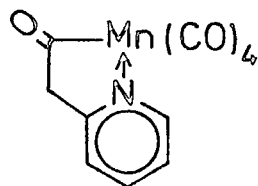

Ref.

49

59

47

54

56

57

57

57

Cyclometallated Compound

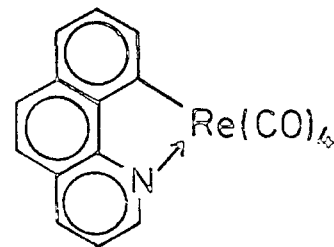

Group VIII B :

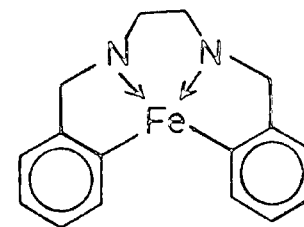
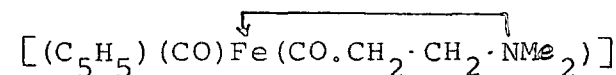
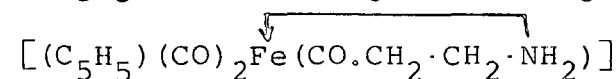
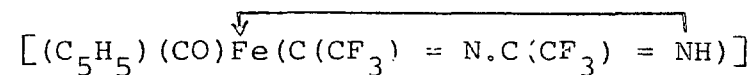
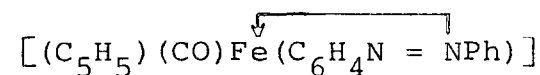
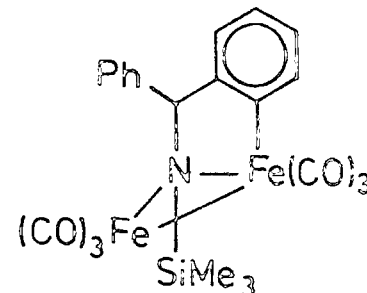

Ref.

59

60, 61, 62, 63

47

64

46

49, 58

65

Cyclometallated Compound

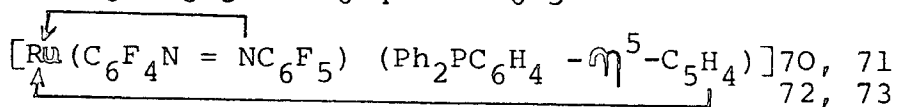
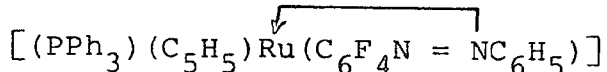
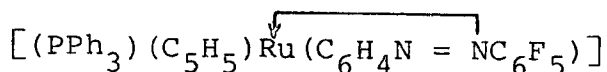
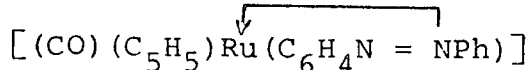
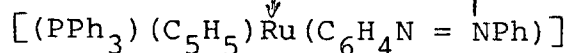
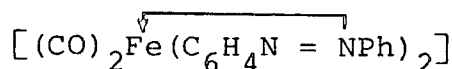
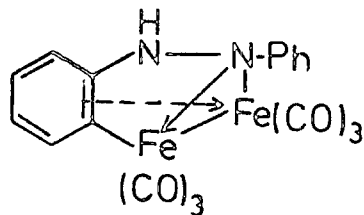
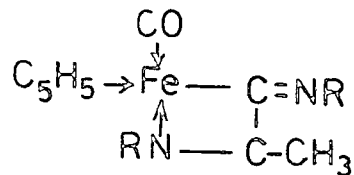
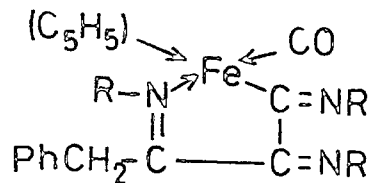

Ref.

66

67

61, 68

61, 68

69, 70

47

70

70

70, 71  
72, 73

Cyclometallated Compound

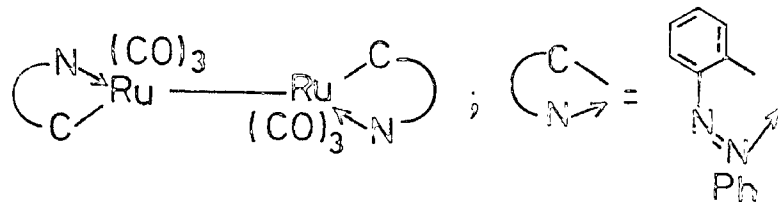
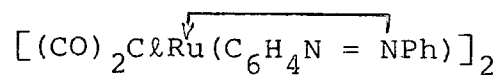
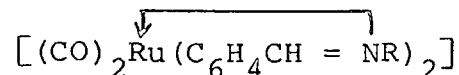

Ref.

74

75, 76

77

59

78

74

59

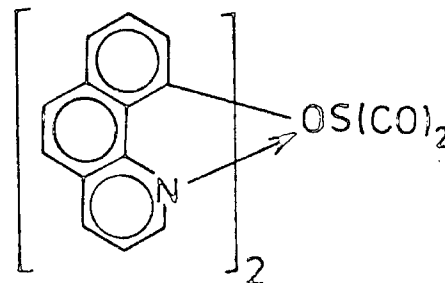
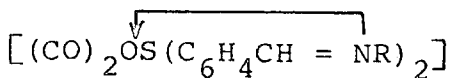
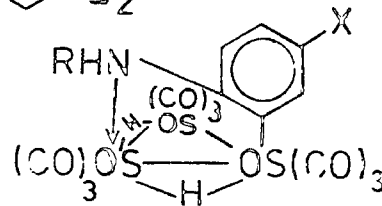
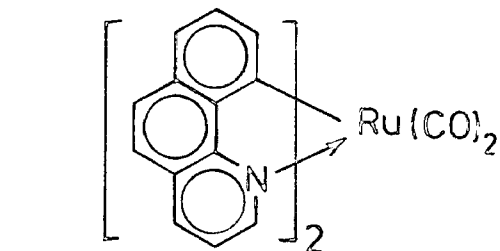

Cyclometallated compound

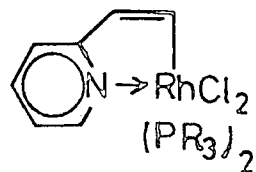
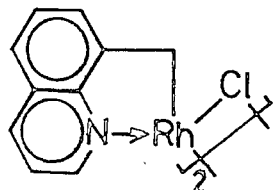
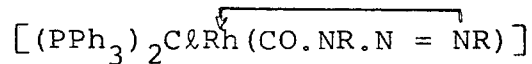
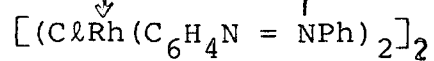
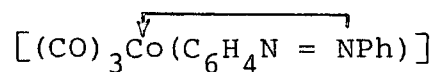
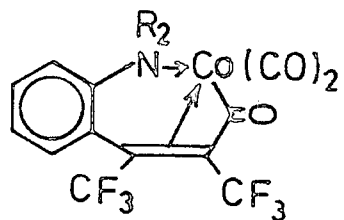
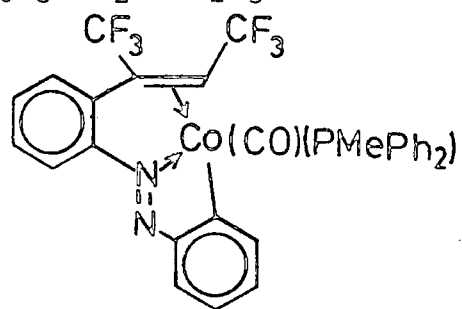
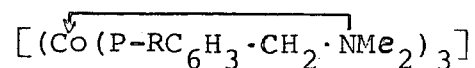

Ref.

79

80

81

82

83

85

86, 87

Cyclometallated compound

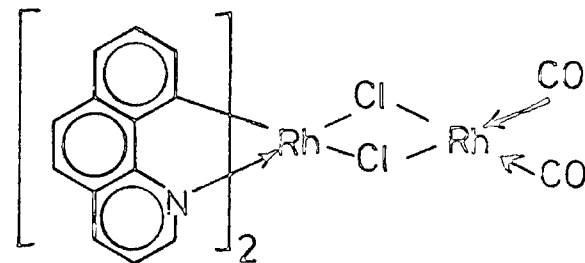
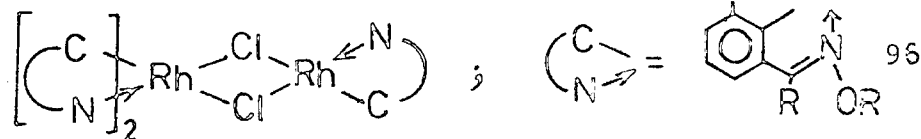
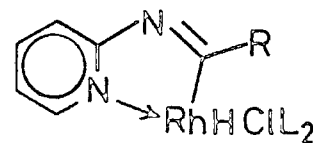
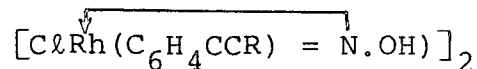
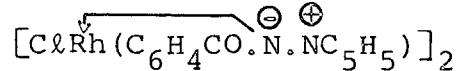
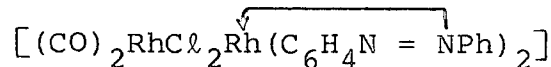
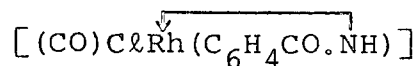
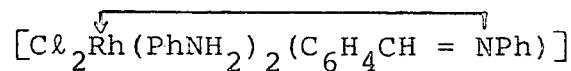
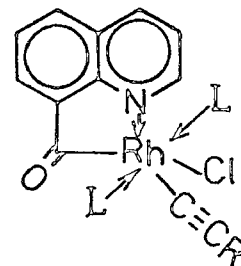

Ref

88, 89

90

91

92

93

94

95

96

59

Cyclometallated compound

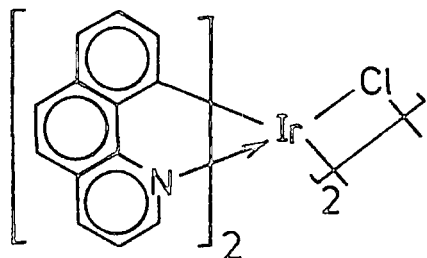
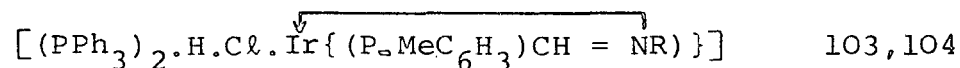
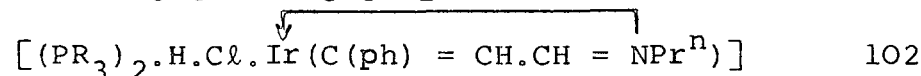
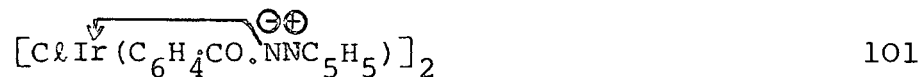
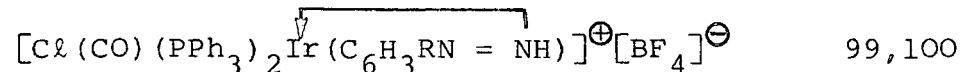
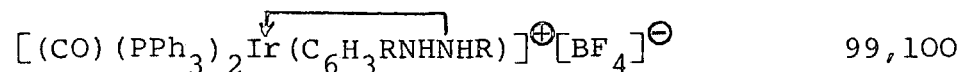
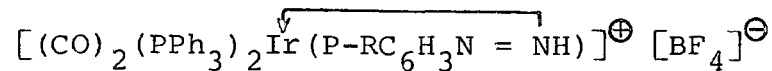

105

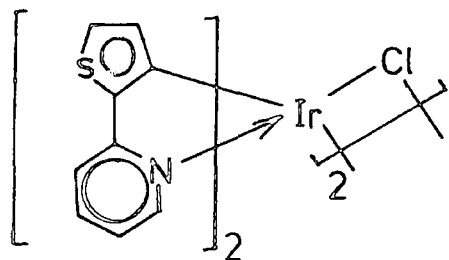

106

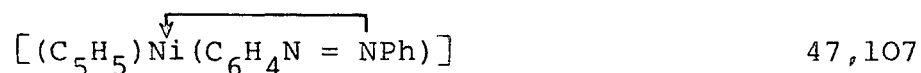

47,107

Ref.

97,98

99,100

99,100

101

102

103,104

Cyclometallated Compound

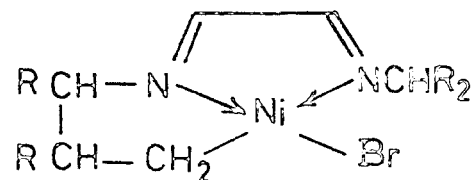

Ref.

108

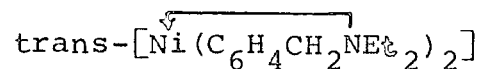

109

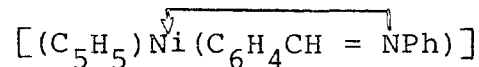

110

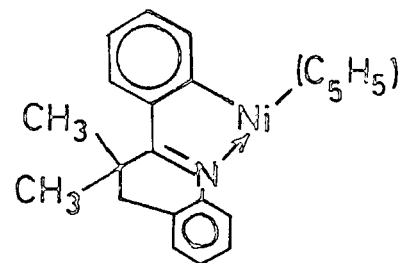

110

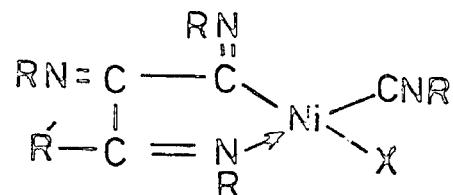

111,112

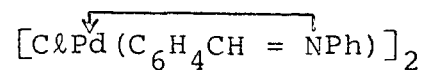

113,114

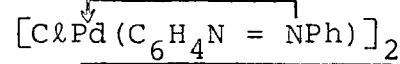

107,115

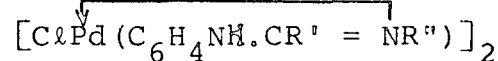

116

Cyclometallated compound

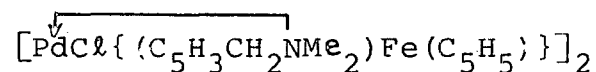
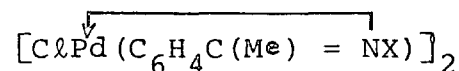
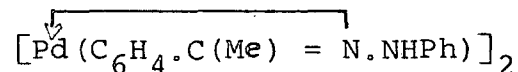
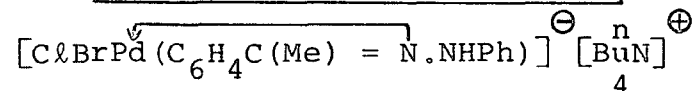
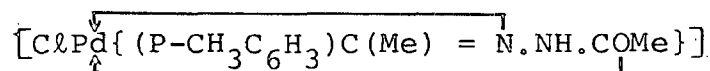
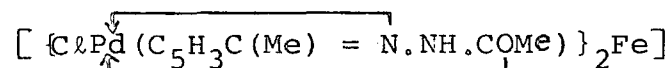
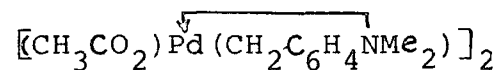
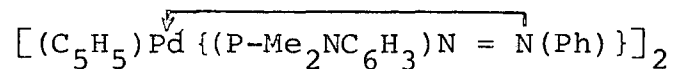
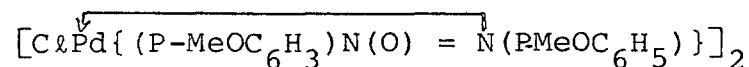
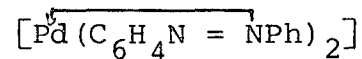
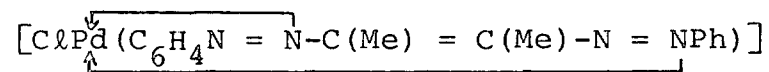

Ref.

117

118

55

55

119

120

121

122

123

124

125

Cyclometallated compound

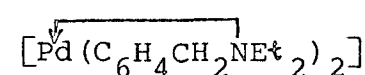
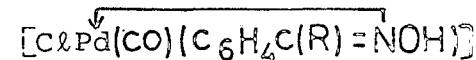
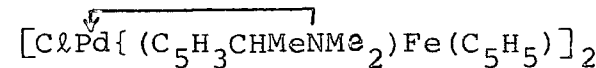
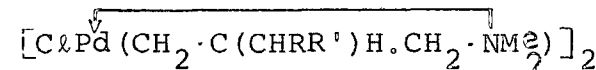
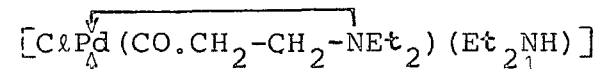
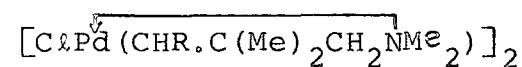
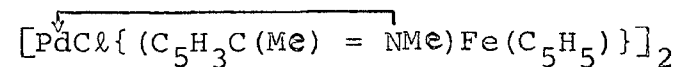
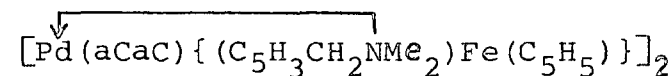

Ref.

125

126

127

128

129, 130

131

132

133

134

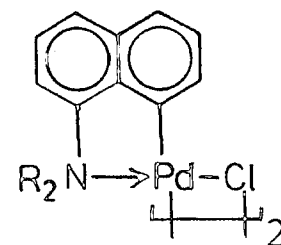

Cyclometallated compound

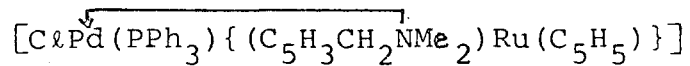
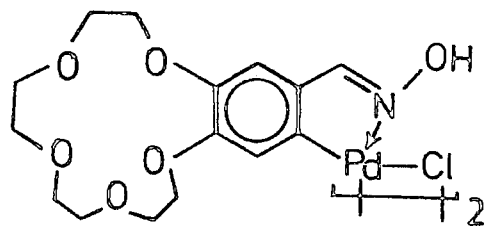
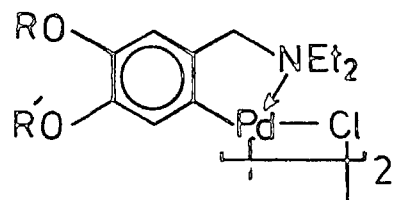
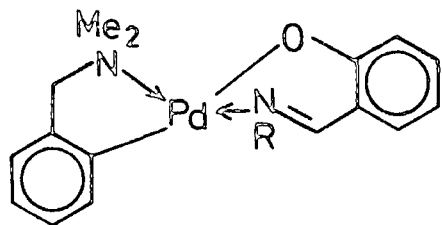
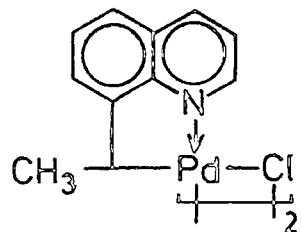

Ref.

135,136

137

138

139

140

Cyclometallated compound

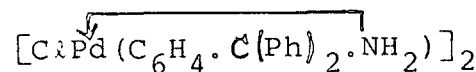
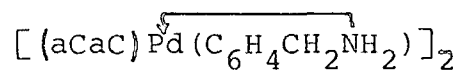
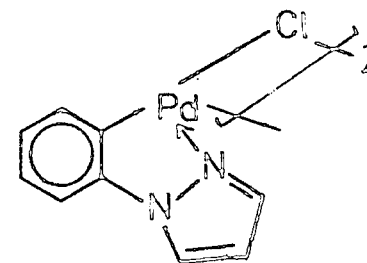
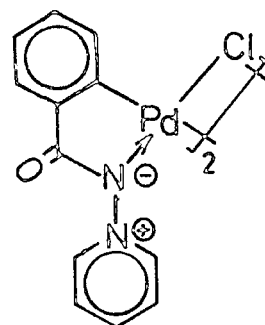
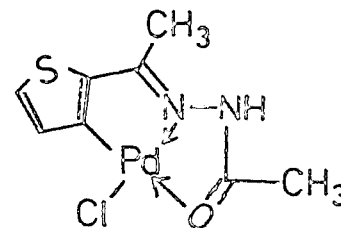
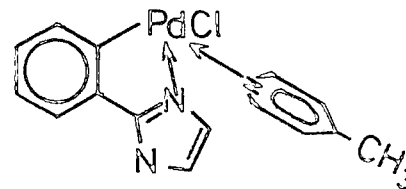

Ref.

141

142

141,142

143

144

145

Cyclometallated compound

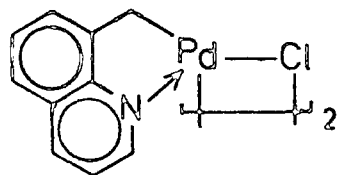

136, 146

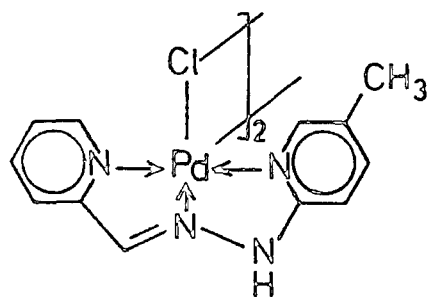

147

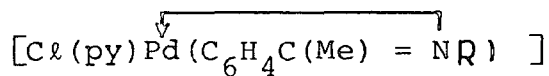

148

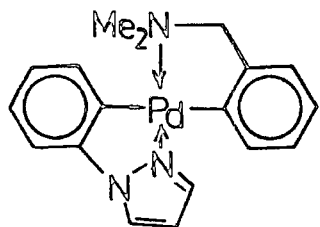

143

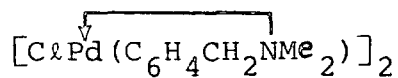

149, 150

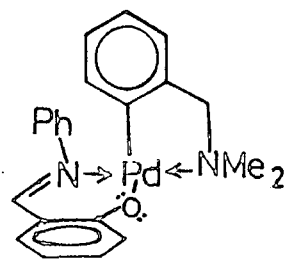

151

Cyclometallated compound

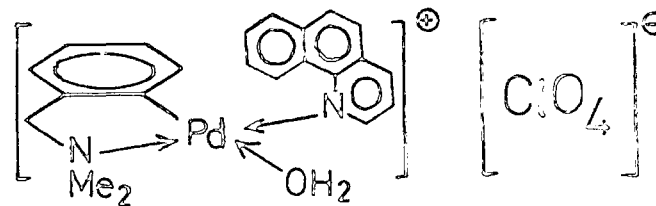

152

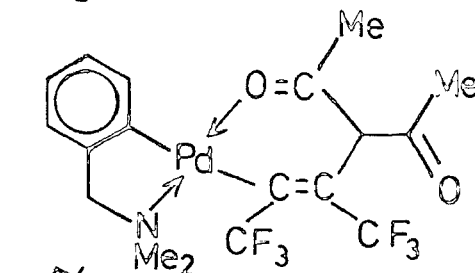

153

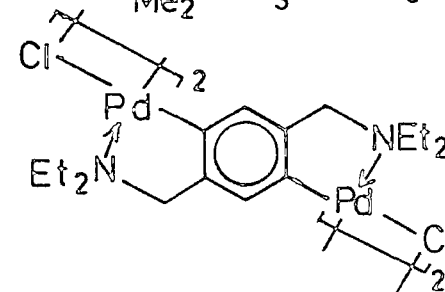

143, 154

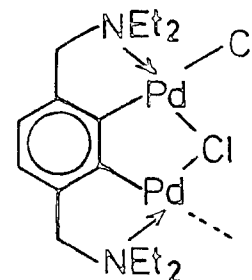

143, 154

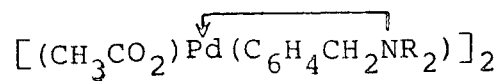

155

Cyclometallated compound

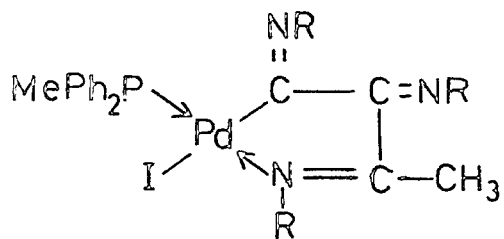
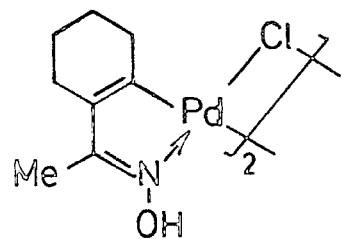
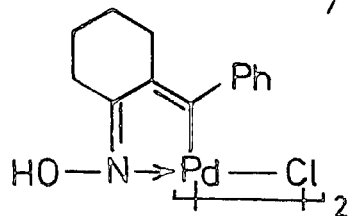
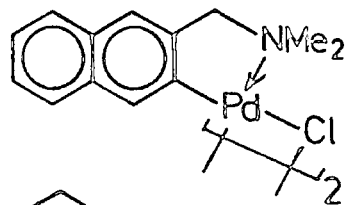
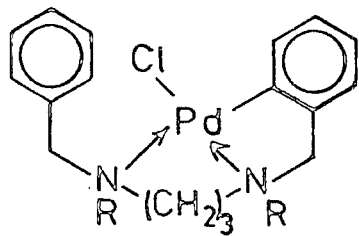

Ref.

156

157

158

158

159

Cyclometallated compound

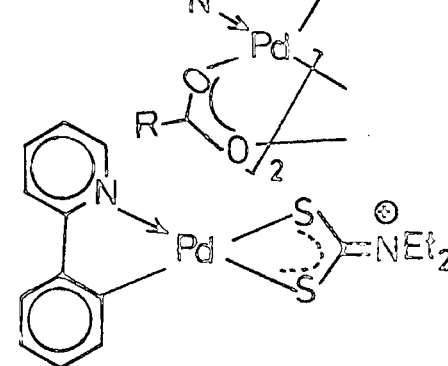
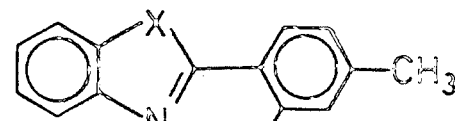
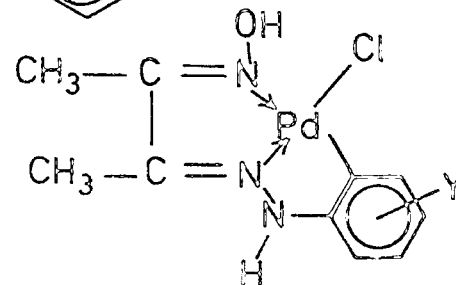
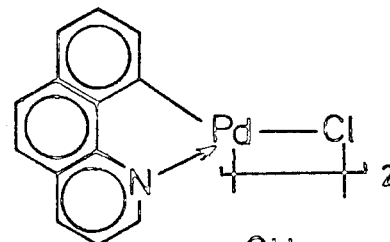
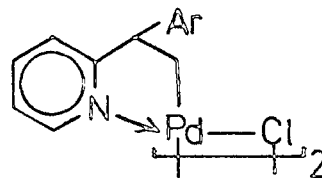

Ref.

160

99, 161

162

163

164

X=O,S

Cyclometallated compound

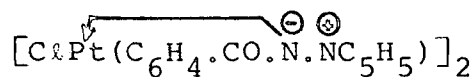
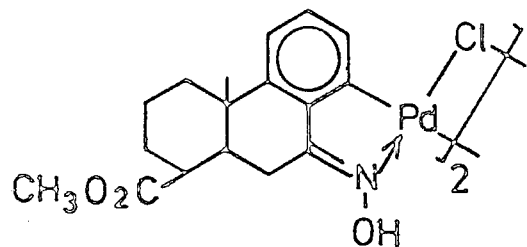
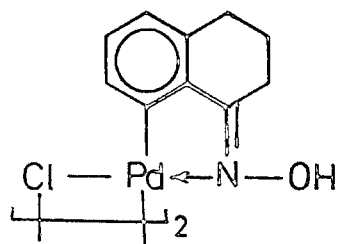

93, 101, 142

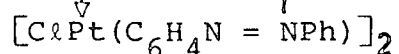

82

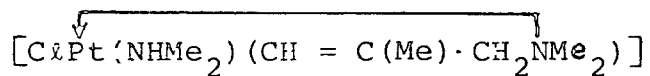

166

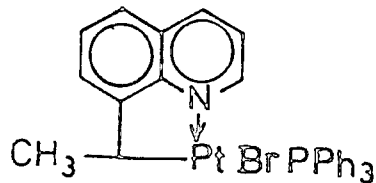

167

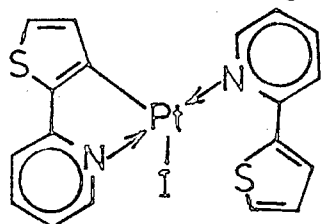

168

Cyclometallated compound

Ref.

165

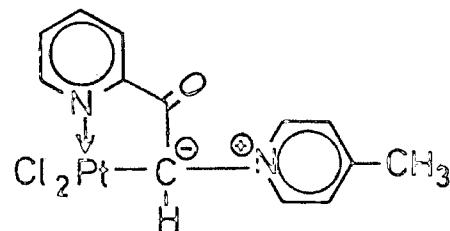

169

165

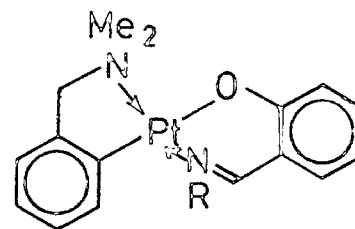

170

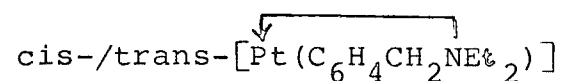

133, 171

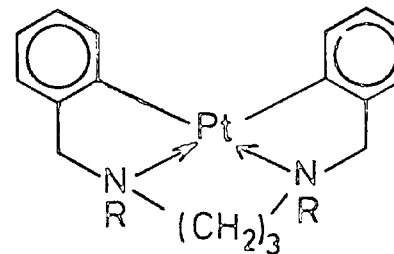

172

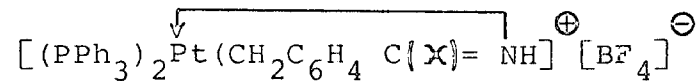

173, 174

Cyclometallated compound

Ref.

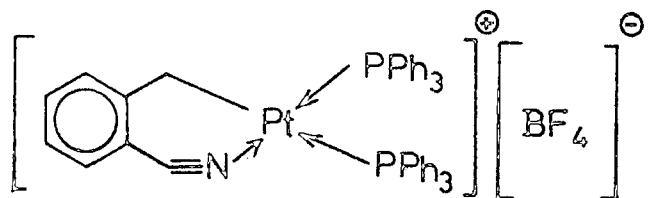

173

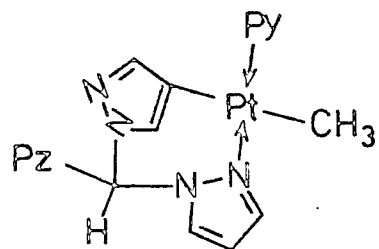

175

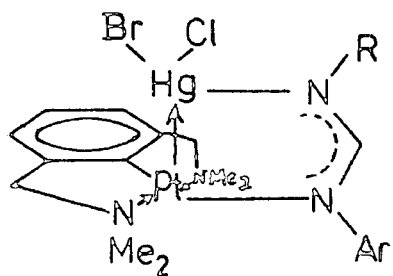

176

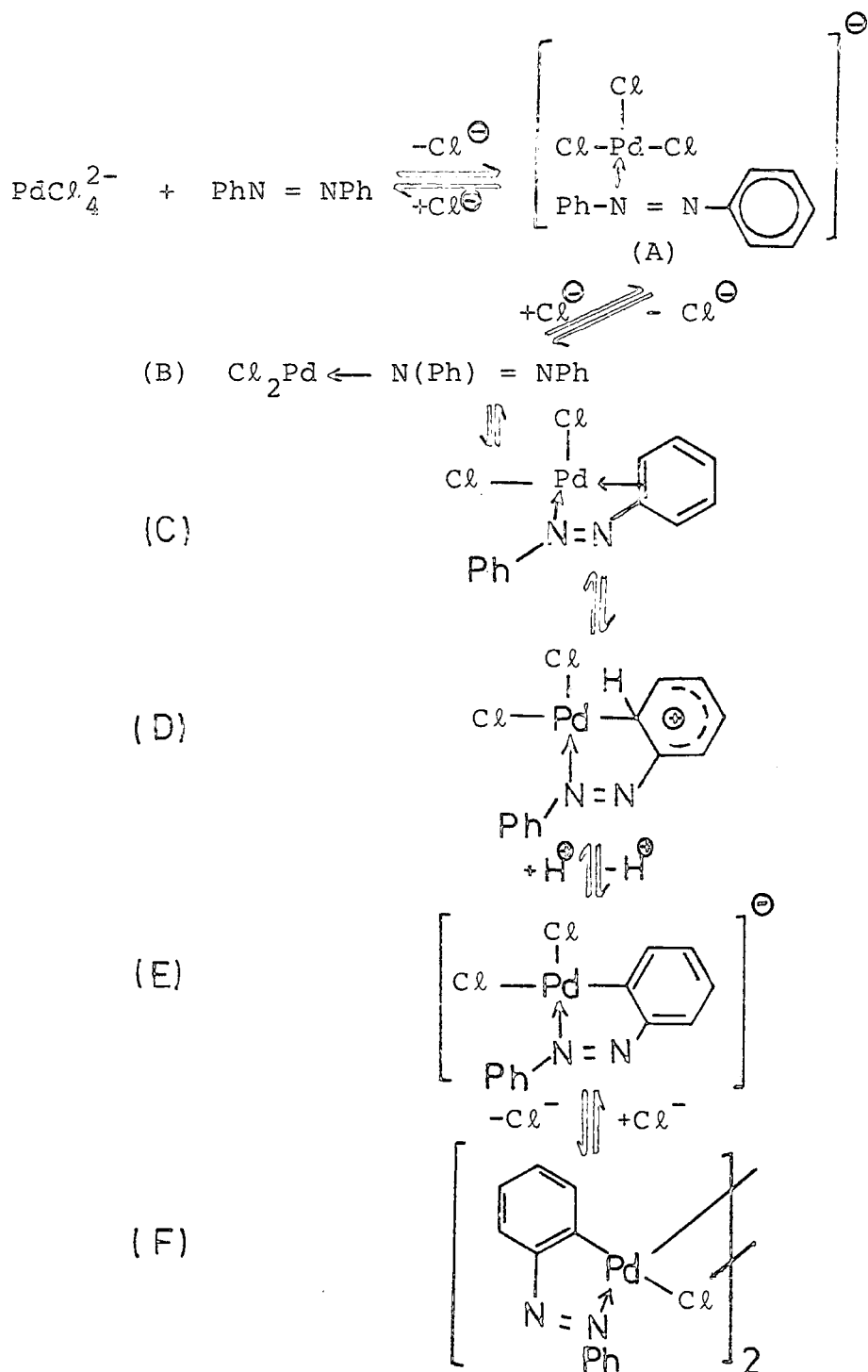

Scheme (1.1) Proposed pathway of the reaction between azobenzene and palladium tetrachloride anion.

The reaction of Scheme (1.1) proceeds with evolution of hydrogen chloride and may be accelerated by the addition of a base to the medium.

In contrast, the reaction of certain electron-rich metals, such as  $\text{MnCH}_3(\text{CO})_5$  with substituted azobenzene is consistent with the nucleophilic mechanism<sup>13</sup>.

The cyclometallation of ruthenium triphenyl phosphite is believed to occur via an oxidation-reduction mechanism<sup>4</sup> as represented in Scheme (1.2).

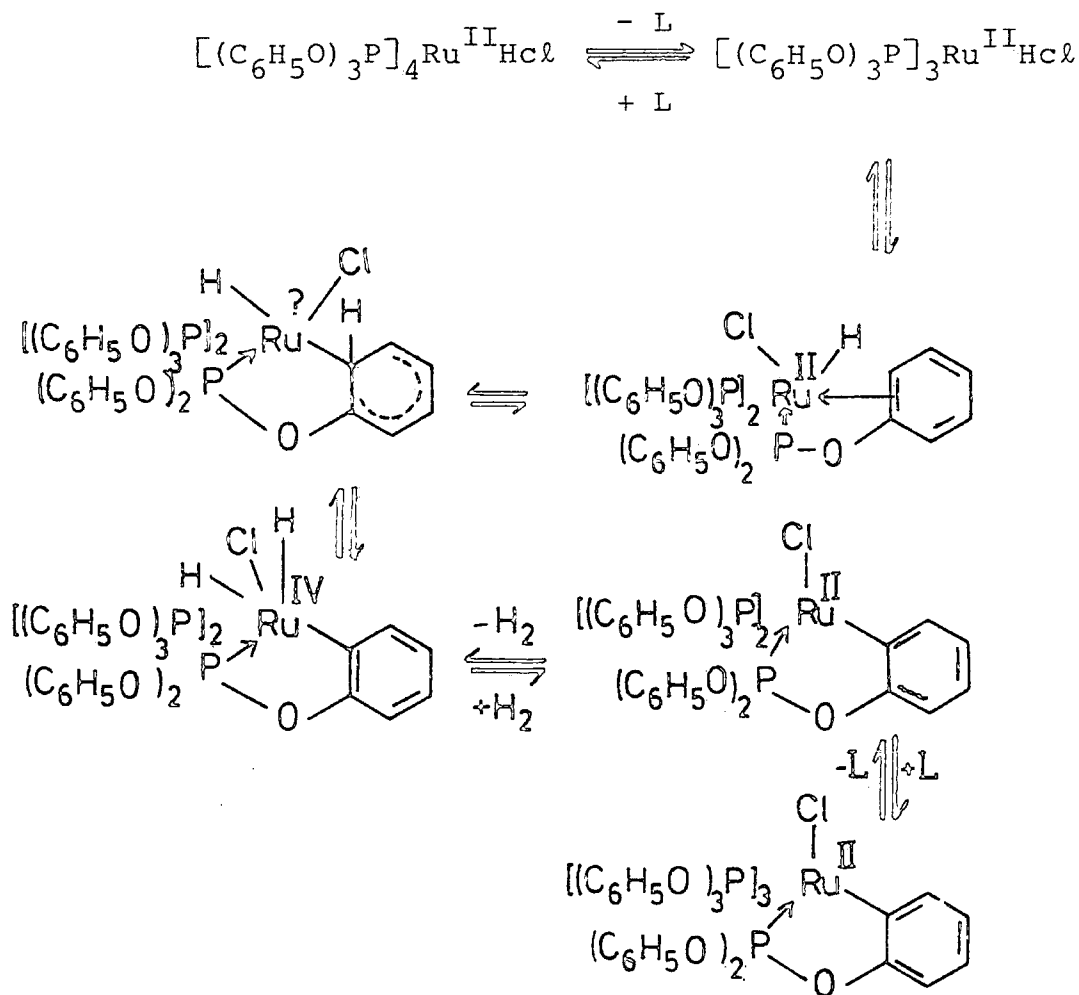

Scheme (1.2) Suggested cyclometallation pathway of

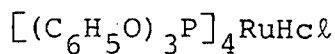

In Scheme (1.2), the metal atom inserts into the sterically favoured ortho-carbon hydrogen bond. The oxidative metal hydride adduct would be expected to be unstable and elimination of hydrogen occurs. This hydrogen elimination is facilitated if a good leaving group e.g. methyl is present in which case methane is formed. On the other hand, the formation of the metal hydride has been confirmed by observation of a  $\nu(\text{M-H})$  stretching frequency band in IR spectra. The mechanism in which  $\text{Ru}^{\text{II}}$  changes into  $\text{Ru}^{\text{IV}}$  still is unknown but the very small deuterium isotope effect noted in the substitution of o-deuteriotriphenylphosphine suggests a three-center intermediate such as

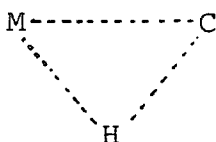

X-ray structural analysis has been used to elucidate the structures of the cyclometallated product and its possible intermediates. In figure (1.3a,b,c), three different structures for the products isolated from the reaction of azobenzene with palladium halides, are given.

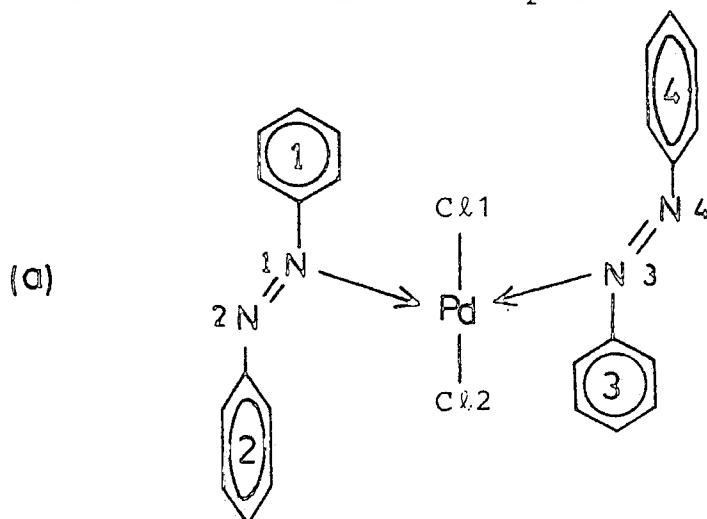

(b)

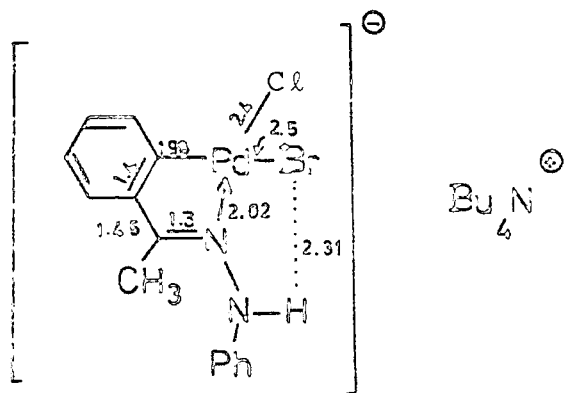

(c)

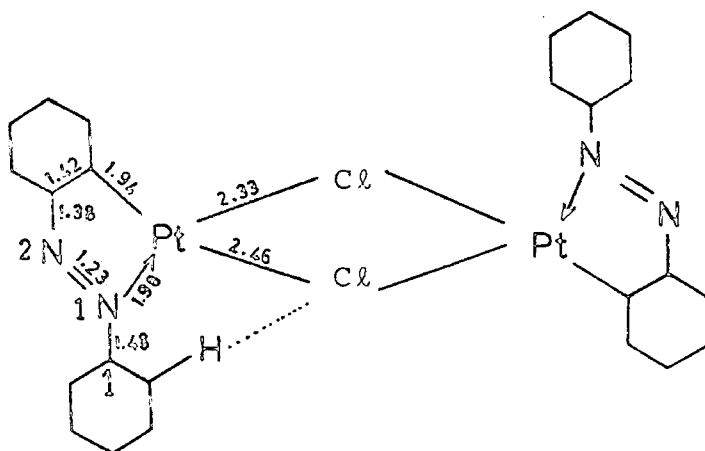

Figure (1.3) X-ray structures of:

- (a)  $(\text{PhN} = \text{NPh})_2\text{PdCl}_2$
- (b)  $[\text{o-PdClBr}(\text{C}_6\text{H}_4\text{C}(\text{CH}_3) = \text{NNHPh})] \text{Bu}_4\text{N}^\ominus$
- (c)  $[\text{Cl}, \text{o-Pd}(\text{C}_6\text{H}_4\text{N} = \text{NPh})]_2$

The main feature in the structure of dichloro-bis-azobenzene palladium(II)<sup>16</sup> shown in figure (1.3-a) is the nonbonding intramolecular contacts of the palladium atom to both the ortho-hydrogens and ortho-carbons of each phenyl. The shorter contacts (2.61, 2.60 Å) involve the hydrogens on phenyl rings 1 and 3 while the longer ones (2.89, 2.88 Å) are to rings 2 and 4. The Pd .....C distances associated with these two types of Pd .....H contact are 2.97 and 3.21 Å. They support Parshall's suggestion that a σ-N metal complex

is the first step in the cyclometallation reaction.

In addition to these nonbonding intramolecular interactions, the phenyl ortho-hydrogen atoms are observed to be in contact with the chlorine atom (Cl2), where the PdCl2...H distance is 2.59<sup>o</sup>A which is shorter than the sum of the hydrogen and chlorine Van der Waals' radii of 3.0<sup>o</sup>A. As a result of H .....Cl2 contacts, three changes are observed in the molecular structure. Firstly, the (Pd-Cl2) distance (2.299<sup>o</sup>A) in which the Cl2 atom is involved in Cl.....H interactions becomes longer than (Pd-Cl1) distance (2.285<sup>o</sup>A). This lengthening of the (Pd-Cl2) distance is believed to allow the elimination of a single chloride ion from the metal complex as shown in the reaction of intermediate (A) to form intermediates (B) - (F) in Scheme (1.1). Secondly, phenyl groups 1 and 3 twist out of the PdCl<sub>2</sub>N<sub>2</sub> plane by 22.9<sup>o</sup>. Finally, the square planar structure about the palladium distorts slightly from ideality as indicated by the (ClPdN) bond angle of 88<sup>o</sup>.

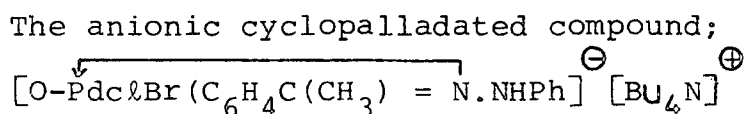

the structure of which is illustrated in figure (1.3-b)<sup>15</sup>, is quite similar to intermediate (E) in Scheme (1.1). In this structure, the palladium atom is directly coordinated to five atoms: Cl, Br, C(1), N(1), and one hydrogen of the [Bu<sub>4</sub>N]<sup>⊕</sup> cation forming a square prism. The atoms Pd, Cl, Br, C(1) and N(1) all lie roughly in one plane.

The last molecular structure (C) in figure (1.3)<sup>16</sup> shows two square planar coordinated palladium atoms bridged

by a pair of chloride ligands. Coordination about each platinum atom consists of two  $\sigma$ -bonds to a 2-phenylazophenyl ligand, one to the ortho carbon atom of a phenyl ring and the other to the distant azo nitrogen atom to form a five-membered chelate ring, coplanar with the phenyl metallated ring. Another important feature in that structure comes from the close contact between the o-hydrogen of the free phenyl and the chloride which will be expected to be  $\approx 1.77^{\circ}\text{A}$ , if the free ring is coplanar with the molecular plane. However, the actual H(6) ...Cl contact distance is observed to be  $2.7^{\circ}\text{A}$ . Closer contact is avoided in two ways: firstly, the free phenyl ring is moved away from the chloride such that the Pt -  $\hat{\text{N}}(2)$ -C(1) angle is  $126^{\circ}$  and the  $\text{N}(2)$ - $\hat{\text{Pt}}$ -Cl angle opens to  $104.3^{\circ}$ . Secondly, the free phenyl ring is twisted by  $39^{\circ}$  about the C(1)-N(2) bond with respect to the plane of the remainder of the complex - see figure (1.4). It is believed

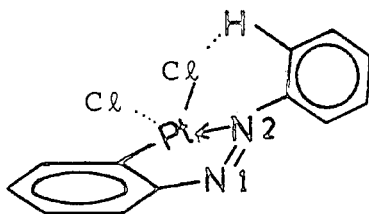

Figure (1.4) Structure of half of the dimeric molecule  $[\text{Cl}\hat{\text{P}}\text{t}(\text{C}_6\text{H}_4\text{N}=\text{NPh})]_2$  to illustrate the twist of the free phenyl ring ( $39^{\circ}$ ).

that the twist angle of the free phenyl ring will be expected to increase in solution in comparison with the solid state,

probably because of the interaction of phenyl hydrogens with solvent molecules.

On the basis of structural data, it is observed that the  $\sigma$  bond between platinum and an aromatic carbon atom causes a significant trans effect, since the (Pt-Cl) bond trans to the metallated carbon is longer than that trans to N(2). The lengthening of the trans (Pt-Cl) distance by 0.134<sup>o</sup>A may explain why this dimer is very reactive towards the phosphine ligands which can break the (Pt-Cl) bridged bonds.

### 1.6 REACTIONS OF CYCLOMETALLATED COMPLEXES

In the cyclometallated systems, the metal atom may possess a carbon-metal, halogen-metal, nitrogen-metal, or hydrogen-metal bond. These types of metal bonds have interesting reactivities towards the other reagents.

In the next section the reactivity of such metal bonds will be discussed as follows:

#### 1.6.1 Reactivity of Carbon-Metal Bond

Generally, the carbon-metal bond in the cyclometallated system is remarkably strong, however this bond can be cleaved by the way of:

- Insertion : by using carbon monoxide and/or acetylene derivatives,<sup>17-20</sup>, vinyl ketones<sup>21</sup>, or molecular oxygen<sup>22</sup>, (see equations 1.2 - 1.5).

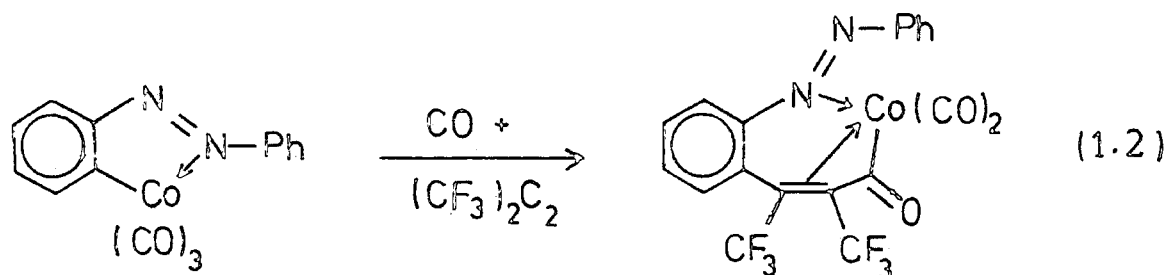

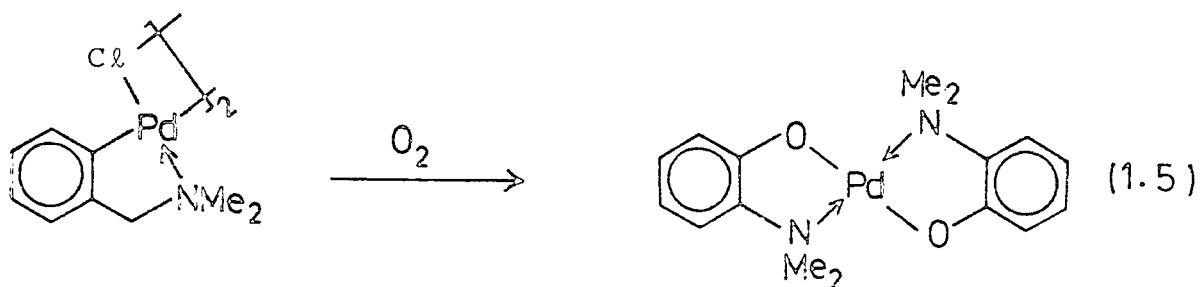
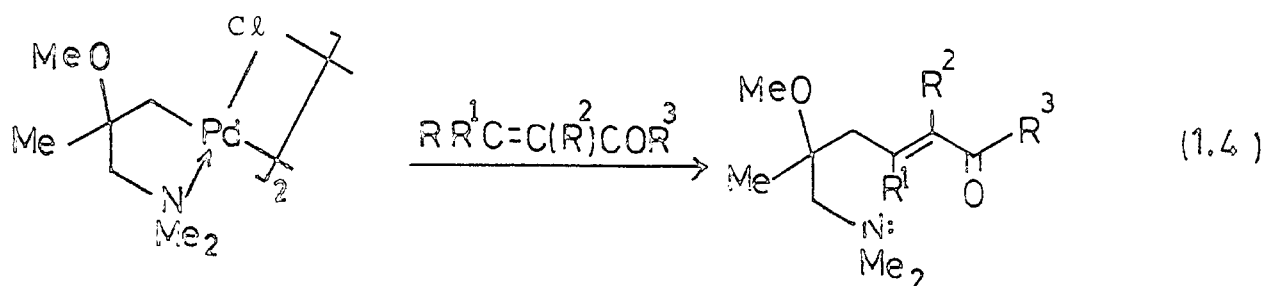
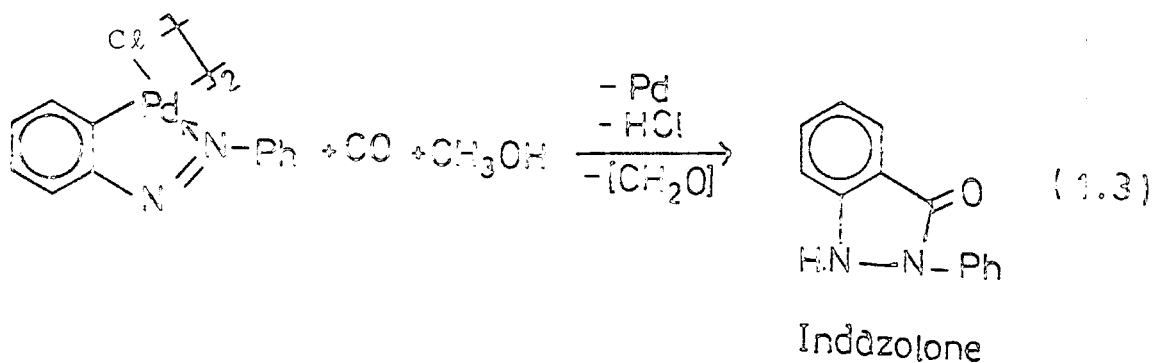

- Reduction: by using lithium aluminium deuteride<sup>23,24</sup>  
 or molecular hydrogen gas<sup>25,26</sup>  
 (see equations 1.6 and 1.7)

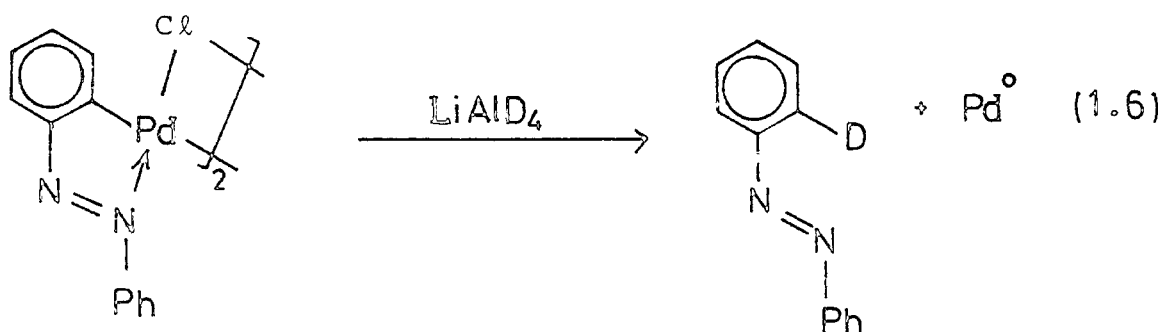

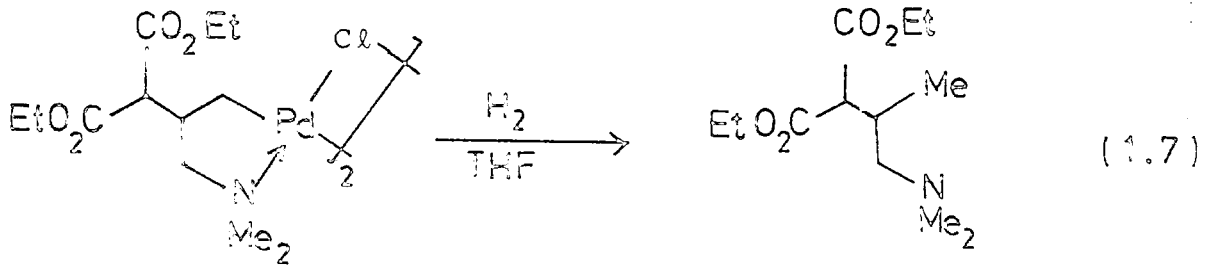

- Halogenations : by chlorination or bromination<sup>27</sup>  
 - see equation (1.8)

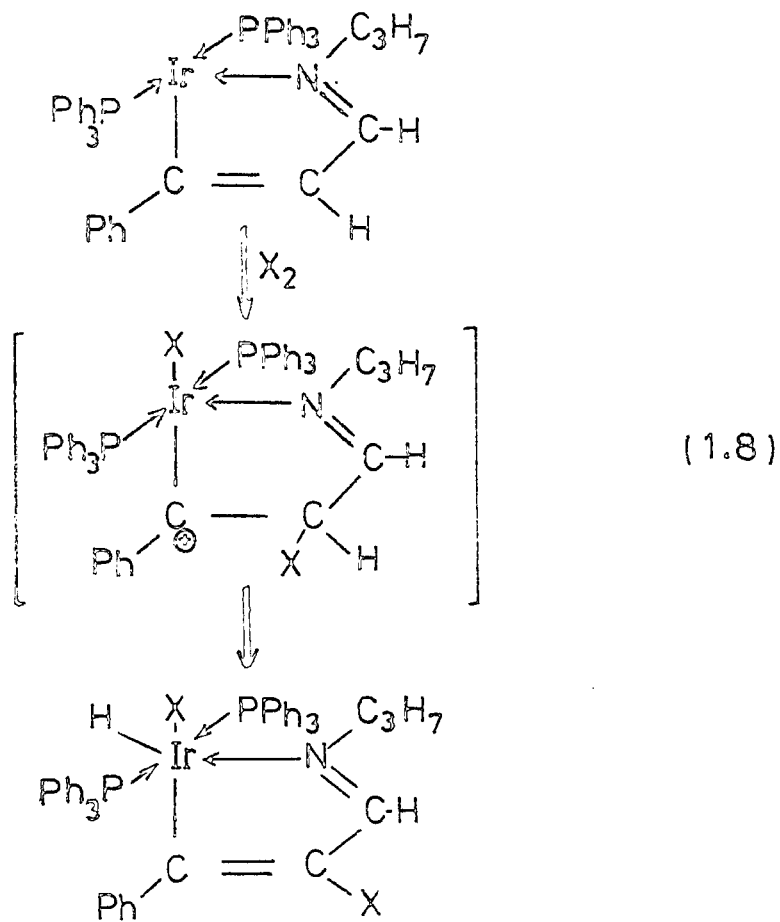

- Other reagents : such as n-butyl lithium,<sup>28</sup> substituted vinyl compound,<sup>21</sup> and metal- $\beta$ -diketonate ligands<sup>29</sup> (see equations 1.9 - 1.11).

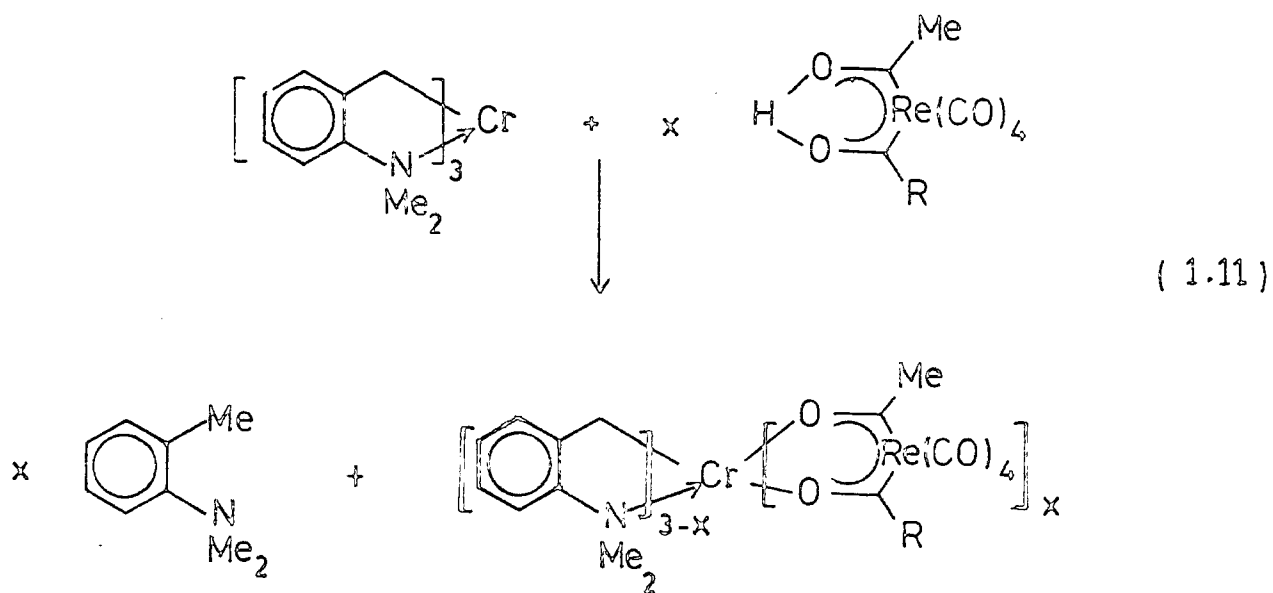
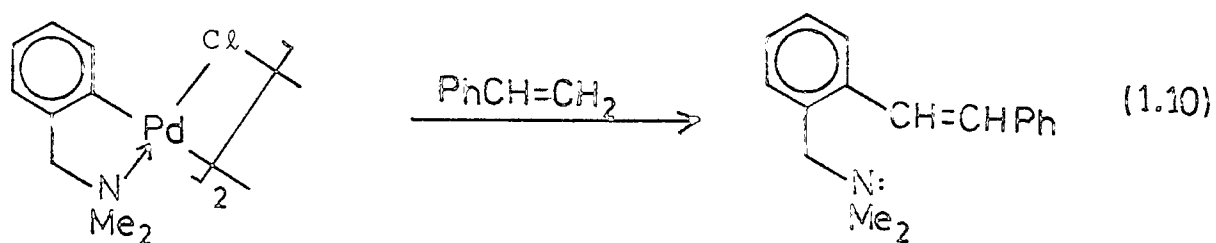
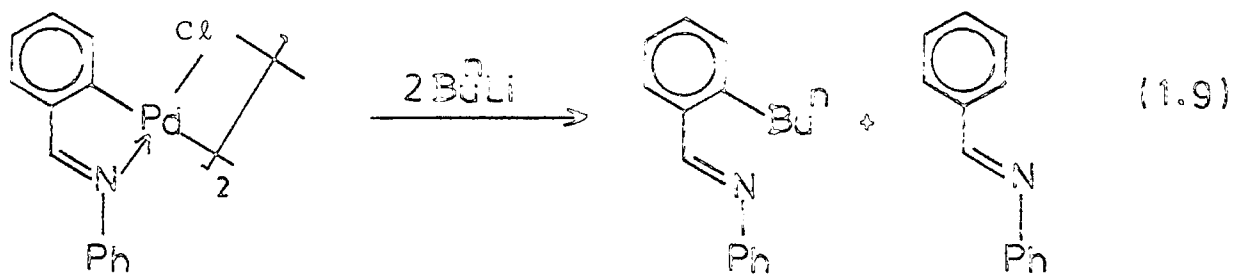

R = Me, Pr<sup>i</sup>, PhCH<sub>2</sub>  
 x = 1 or 2

### 1.6.2 Reactivity of the Halogen-Metal Bond

The halogen-metal bond is generally the most reactive linkage in the cyclometallated compound. The (M-Cl) bond may exist as a bridged or non-bridged bond. The halogen-metal bridges can be broken by using neutral or anionic ligands.<sup>30-39</sup> Some examples of such reactions are illustrated in equations 1.12-1.17

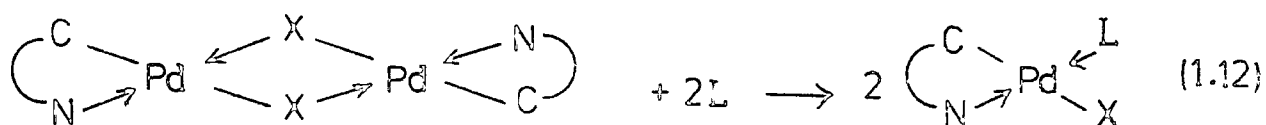

L = CO, Pyridine, Phosphine, trialkyl or triaryl phosphines, amine, pyrazole.

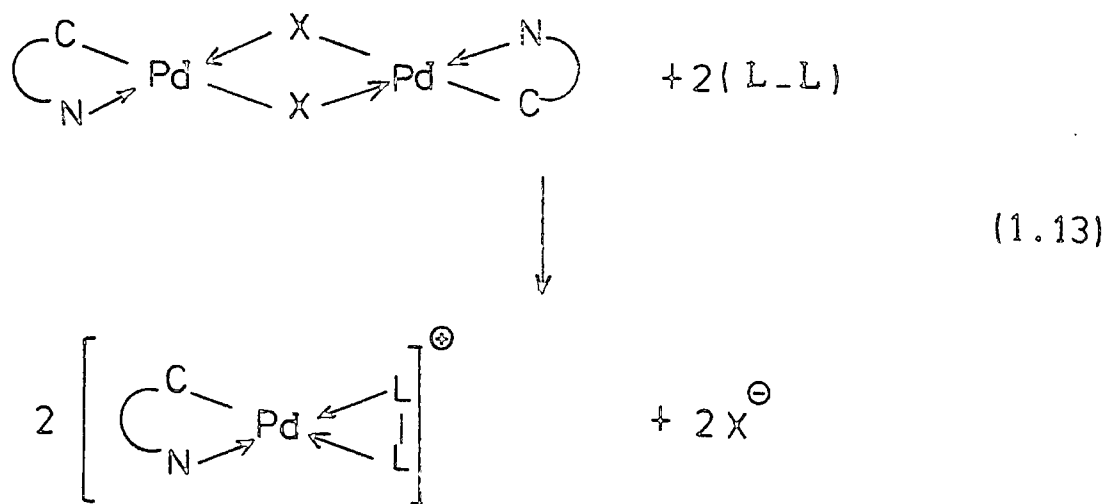

(L-L) = ethylene diamine

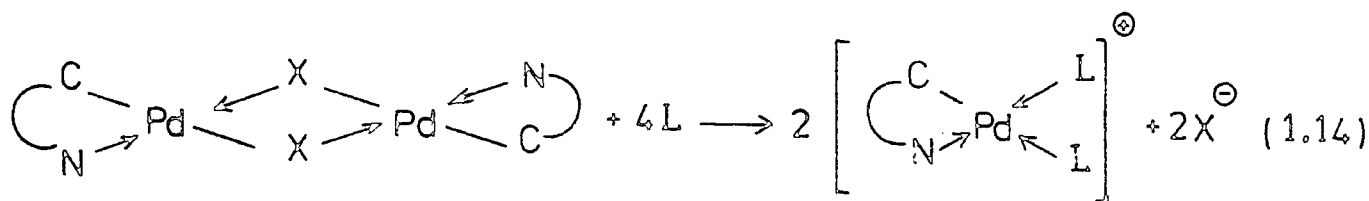

L = Pyridine

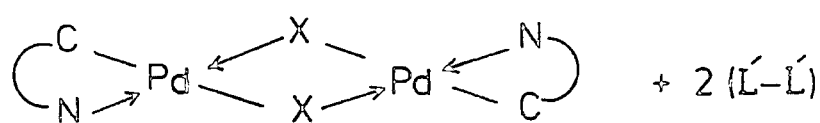
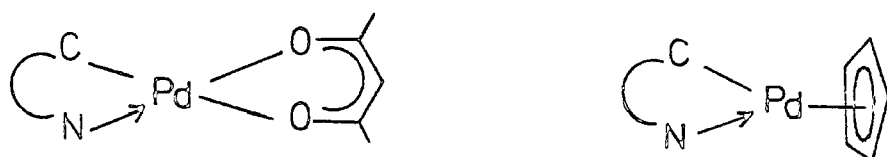
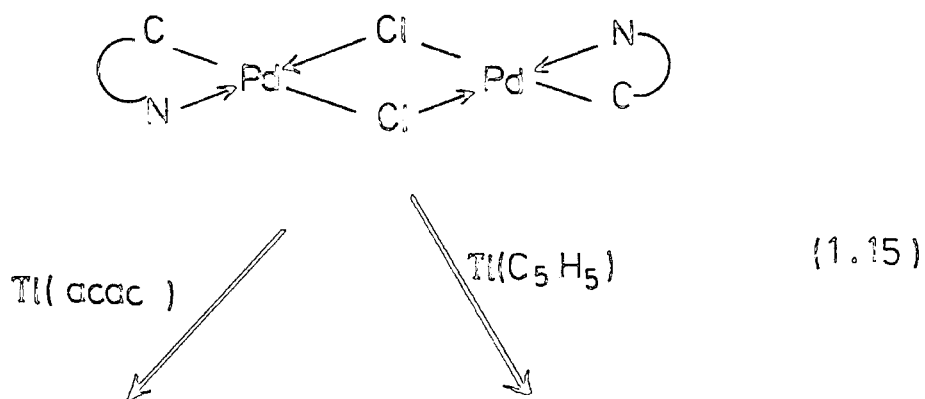

(1.16)

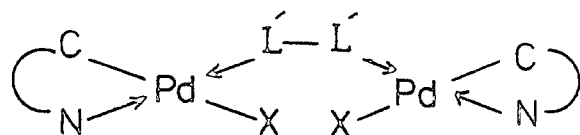

(L'-L') = Diphenyl Phosphino Ethane

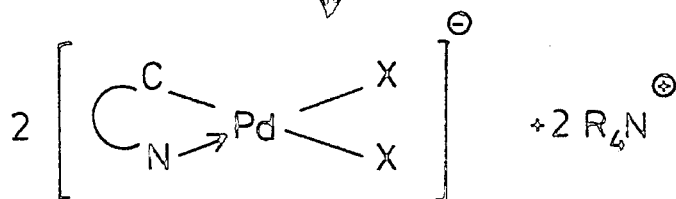
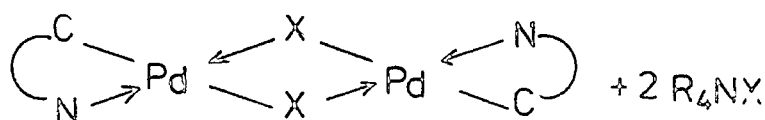

(1.17)

Reagents such as sodium borohydride<sup>40</sup> or a sodium metal carbonyl complex<sup>41,42</sup> can be used to break the non-bridged halogen-metal bond, eventually forming a metal-hydrogen or metal-metal bond. - see equations 1.18-1.20.

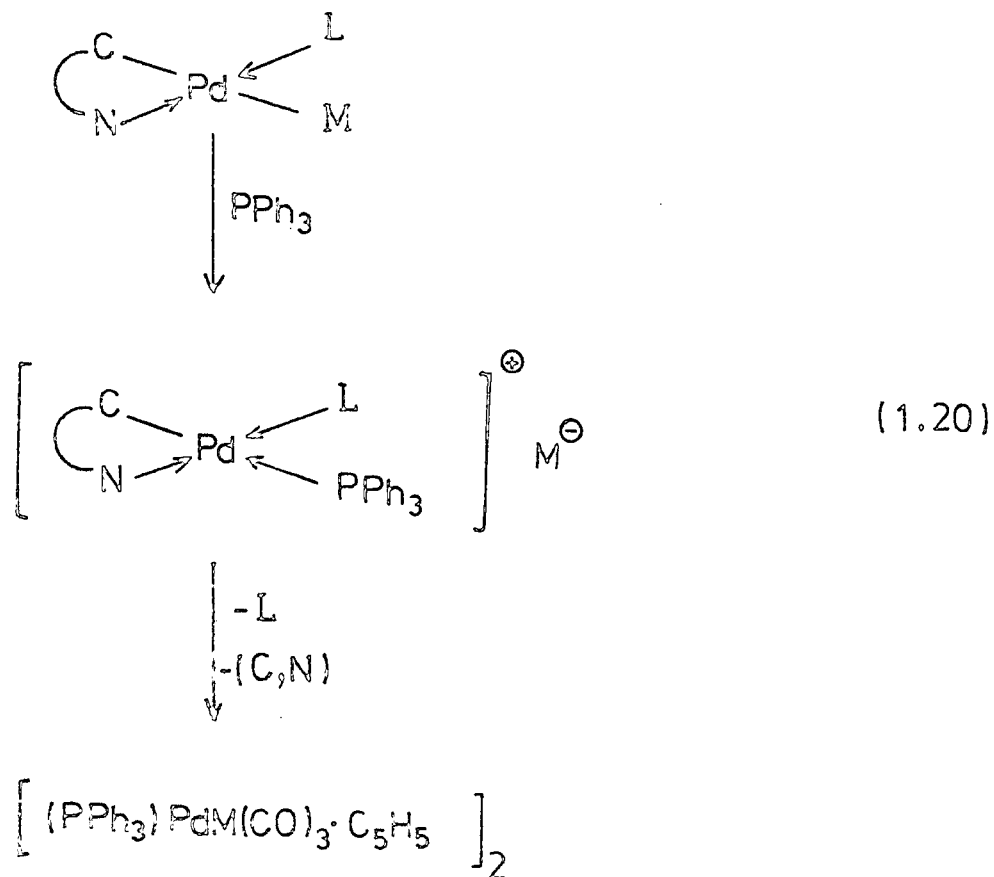
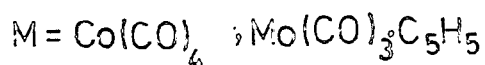
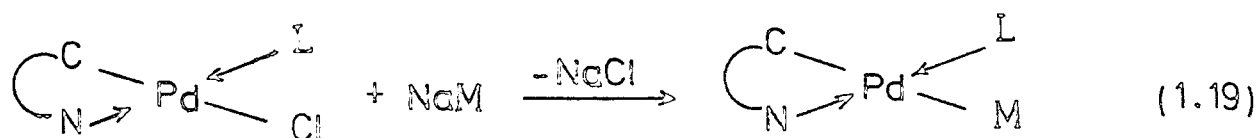
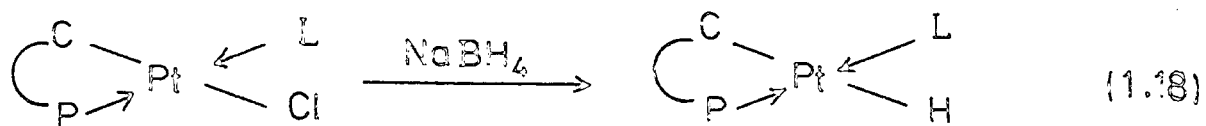

Both bridged and non-bridged halogen-metal bonds in some cyclometallated compounds can be cleaved by using only a single reagent such as NaSPh, sodium o-aminobenzenethiolate potassium or thallium tris (pyrazolyl) borate, or  $\text{Et}_3\text{N}(\text{S}_2\text{CN R}_2)^{43,44,36}$  as shown in equations 1.21 and 1.22

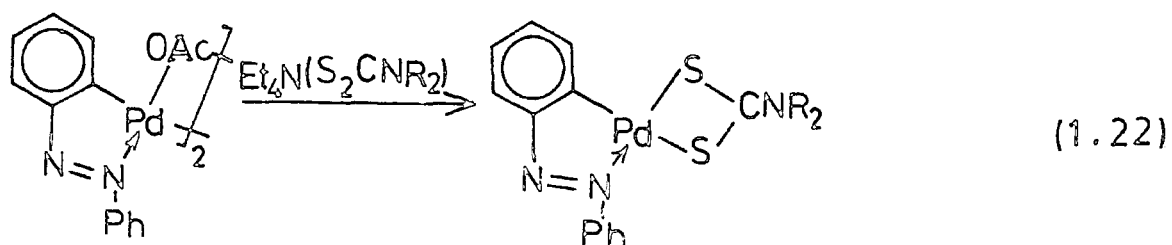
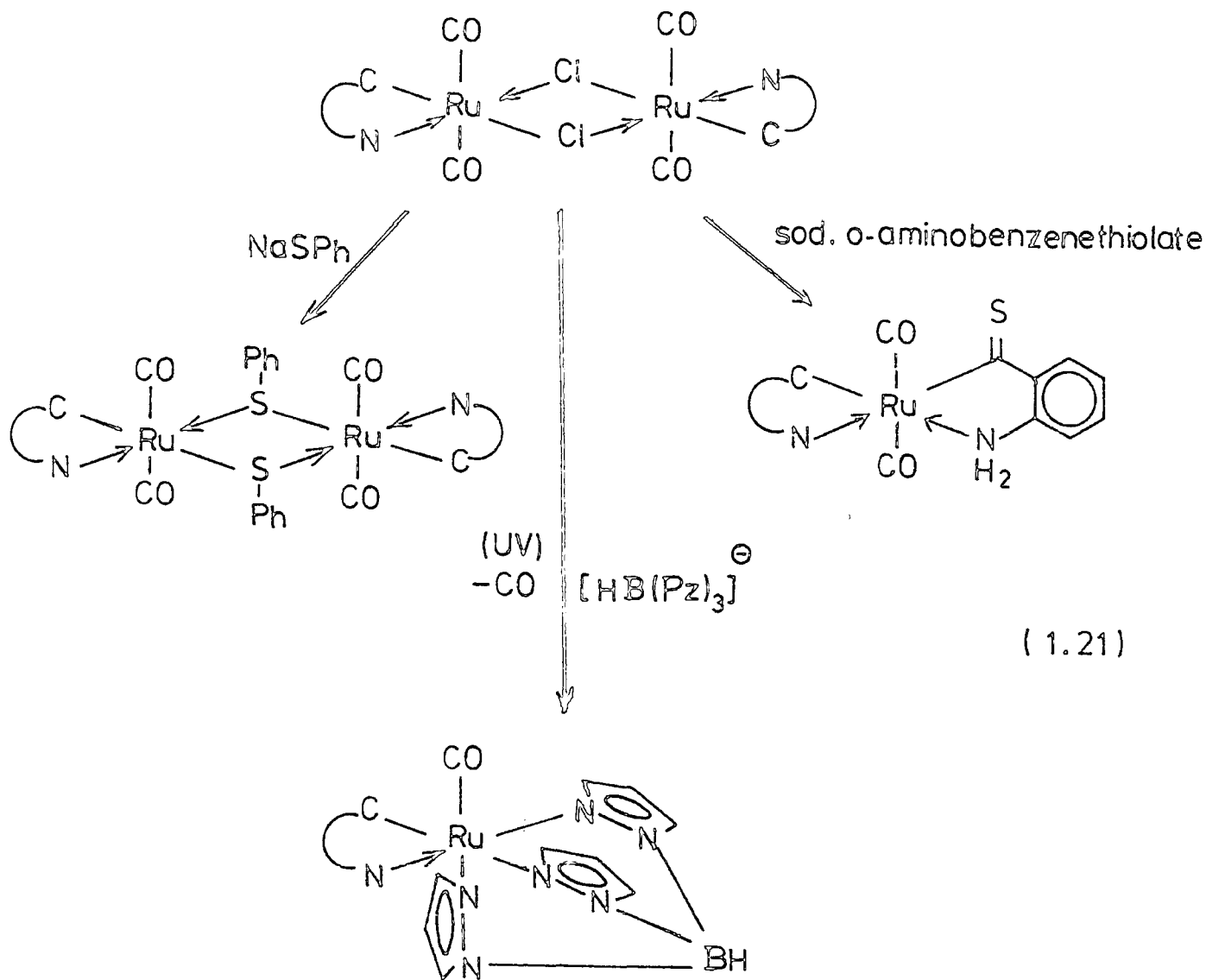

### 1.6.3 Reactivity of the Nitrogen-Metal Dative Bond

Opening of the cyclometallated ring at the nitrogen-metal link can be accomplished using a powerful ligand such as phosphine, phosphorous trifluoride, or carbon monoxide <sup>32, 34, 38, 45-48</sup> see equations 1.23 and 1.24.

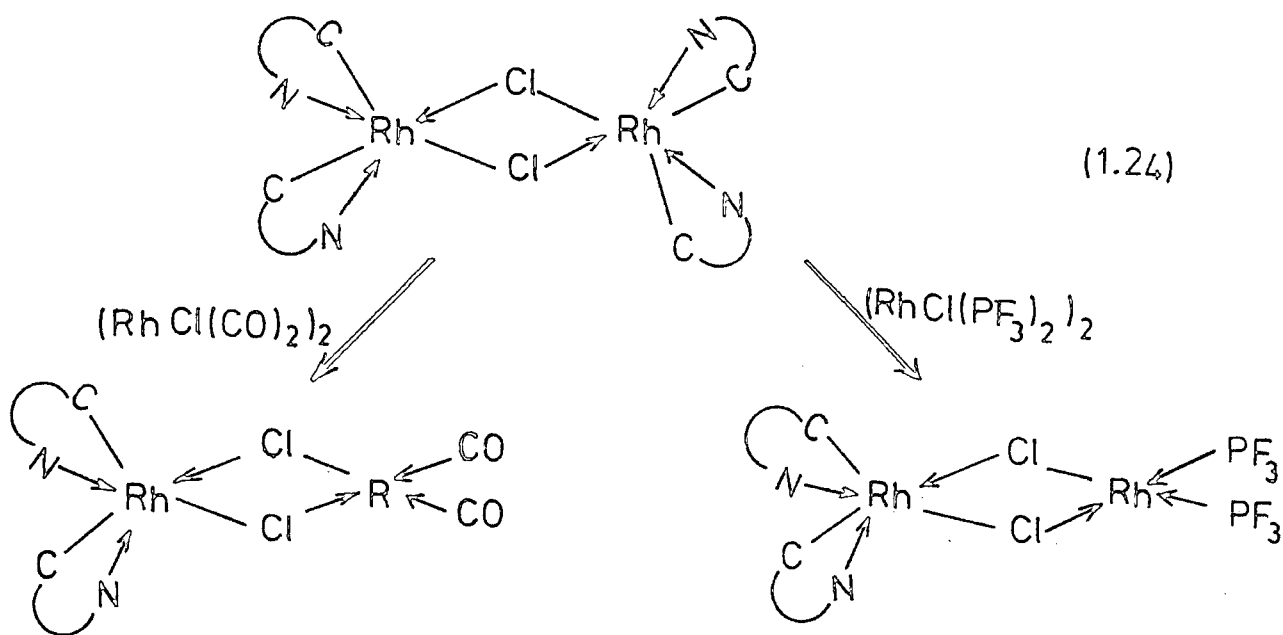
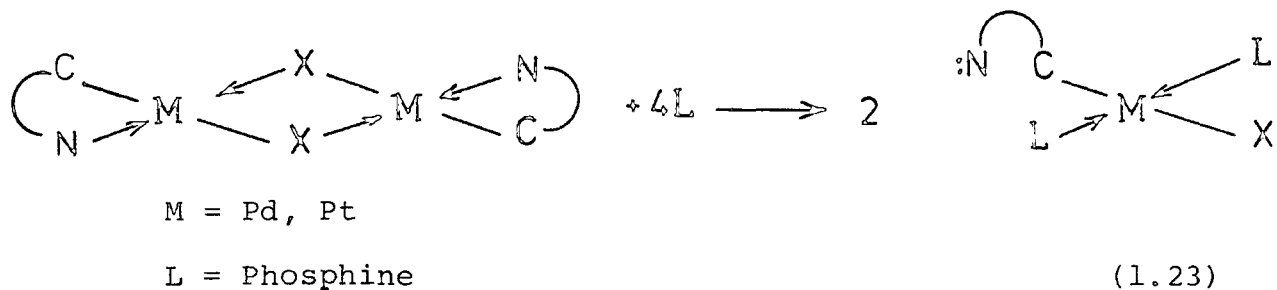

### 1.6.4 Reactivity of the Hydrogen-Metal Bond

In certain cyclometallated compounds, the hydrogen-metal bond may be reactive towards ethylene, generating a metal alkyl that undergoes reductive elimination. Equation (1.25) illustrates an example of this reaction.



## 1.7 SUMMARY

The presence of a chemical system containing a (C - H) bond and a nitrogen donor atom coordinated to a metal (M) may lead to the formation of a cyclometallated product via the breaking of a (C - H) bond and the formation of a (C - M) bond. Such systems will prefer to carry out the cyclometallation process when all their main elements (i.e. (C - H), N, M) lie in one plane and also when both the (C - H) group and the metal lie on one side. Any disturbance in that coplanarity of atoms, for example by steric hindrance between the metal and the hydrocarbon group or by attraction between the (C - H) hydrogen and the electronegative group attached to the metal, will inhibit the cyclometallation reaction.

The ability of the metal to attack the (C - H) bond can be considered as another important factor in the cyclometallation reaction. This attack depends on: (i) nature (coordination, oxidation state) of metal atom, (ii) the electronic effect of the substituent attached to the metal, to the hydrocarbon group or to the donor atom, (iii) the position of the (C - H) bond relative to the donor atom.

CHAPTER TWO

ORTHOMETALLATION REACTIONS OF KETIMINOANTIMONY  
CHLORIDES

2.1 INTRODUCTION

Early work<sup>1</sup> on the preparation of diarylketimino tin (IV) trichlorides  $\text{Ar}_2\text{C}=\text{NSnCl}_3$  has revealed that these compounds have a strong tendency to undergo orthometallation, giving rise to 5-membered heterocycles containing penta-coordinate tin (IV). The diarylketimino tin (IV) trichlorides, which are isolable as ether adducts have been prepared through the reaction of the imino-lithium derivatives with tin tetrachloride as indicated in the reaction sequence:-

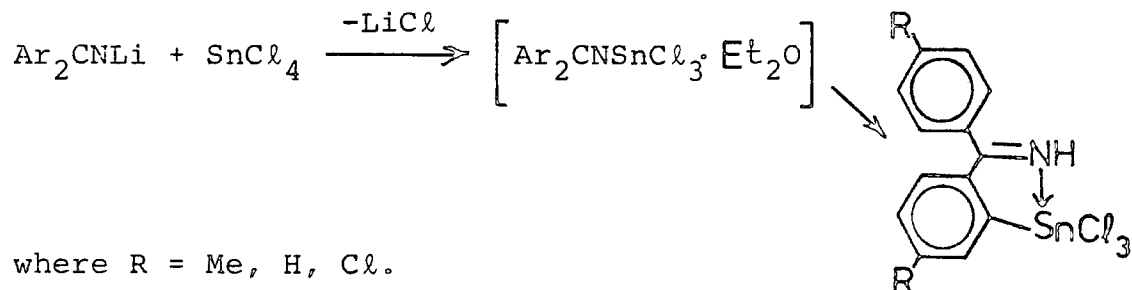

The structure of the resulting compound (R = Me) has been established by X-ray crystallographic studies. It is based on trigonal bipyramidal coordination about tin with the orthometallated chelate ring bridging between the axial (Nitrogen) and equatorial (Aromatic ring) positions. The tin atom readily expands its coordination number to six by adduct formation with THF. The orthometallated tin compounds have been characterised by various spectroscopic methods. In their mass spectra, they show a clear parent peak which indicates the stability of the molecular ion. The IR spectra of these compounds shows the  $\nu(\text{N-H})$  absorption in the region  $3275 - 3335 \text{ cm}^{-1}$ , accompanied with a shift of

$\nu(\text{C}=\text{N})$  to lower energy relative to the parent imine by about  $40 \text{ cm}^{-1}$ . In the region  $900 - 675 \text{ cm}^{-1}$ , the orthometallated diphenylketimino derivatives have a new band at  $730 \text{ cm}^{-1}$  which may be assigned to  $\delta(\text{C}-\text{H})$  for the metallated ring. The proton magnetic resonance spectrum shows a clear (N-H) resonance, quite sharp consistent with a strongly coordinated nitrogen lone pair with an associated low rate of imine proton exchange. The spectra also show a low field absorption for the proton adjacent to the metallation site, which is separated from the other aromatic absorptions. Using the Mössbauer spectroscopic technique, the isomer shifts and the quadrupole splittings of the orthometallated compounds confirm the 5-coordinate structure around the tetravalent tin atom<sup>1</sup>. The mechanism of these orthometallation reactions, the first such reactions to be reported in organotin chemistry, has been suggested as involving electrophilic attack on the aromatic ring by the coordinatively unsaturated  $\text{SnCl}_3$  group.

This chapter describes a novel orthometallation process for another main group element, antimony by the reaction of different ketimino derivatives with antimony chlorides.

## 2.2 DISCUSSION

New orthometallated compounds could be isolated from the reactions of antimony penta- or trichloride with diarylketimino lithium or its derivatives. Their formulae are shown in Figure (2.2).

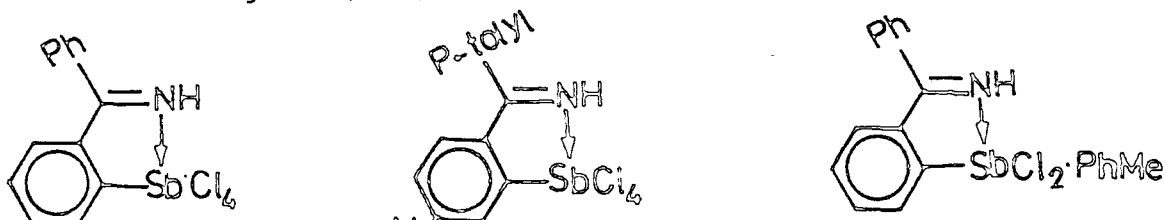

Fig. 2.2

In these reactions, the orthometallated compounds were not the only products obtained, but another two different products have been also isolated from these reactions; namely  $R_2CNH_2^{\oplus}SbCl_4^{\ominus}$  and  $R_2CNH_2^{\oplus}SbCl_6^{\ominus}$ . The conditions under which the reaction does involve orthometallation have been explored by studying the effect of temperature and solvent used. Generally, the precipitation of non-orthometallated compounds such as  $R_2CNH_2^{\oplus}SbCl_4^{\ominus}$  or  $R_2CNH_2^{\oplus}SbCl_6^{\ominus}$  always leads to subsequent difficulty in isolating the desired orthometallated compound. Moreover, the orthometallated products could not be obtained in a high yield. All reactions which are described in the experimental work will be discussed under the following headings:

- (2.2.1) Reactions yielding orthometallated compounds.
- (2.2.2) Reactions yielding non-orthometallated compounds.
- (2.2.3) Reactions of t-butylarylmethyleneamino lithium with antimony pentachloride.
- (2.2.4) Reactions of di-p-tolylmethyleneamino-N-chloride with antimony trichloride.

#### 2.2.1 Reactions yielding orthometallated compounds

##### 2.2.1.1 Investigation of the preparative route:

As shown from the experimental part, there are three new orthometallated compounds of antimony chlorides which could only be prepared in a low yield: (see reactions 2.4.1, 2.4.5 and 2.4.16). They are identified as o-tetrachlorostibino diphenylketimine, o-tetrachlorostibino di-p-tolylketimine, and possibly o-dichlorostibino diphenylketimine monotoluene:

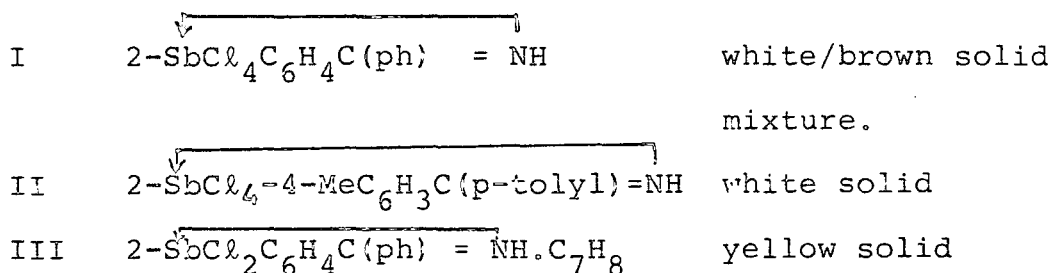

Compounds I and II are very stable towards air and moisture. In contrast, compound III is very sensitive on exposing to air, after which the yellow solid changes to white and a very broad band appears in the IR spectrum at  $3400\text{ cm}^{-1}$  which indicates that this product absorbs water on exposure to air. A sample of Compound I was exposed to air and sunlight for 18 months, but no change has been observed in the sample (via IR spectrum). Compound I is very stable towards heating. An attempt to sublime this product onto a cold finger by heating under vacuum was not successful, but instead, a yellow solid was condensed leaving the ortho-metallated compound. The yellow sublimate was identified as  $\text{Ph}_2\text{CNH}_2^{\oplus}\text{SbCl}_4^{\ominus}$ , considered to be a by-product formed during the orthometallation reaction.

All orthometallated compounds are slightly soluble in aromatic hydrocarbons and they are rapidly deposited from the solution while it is hot. An attempt to grow a single crystal of Compound II for X-ray diffraction studies was unsuccessful.

Compound I was prepared by addition of a (1:1) mole ratio of antimony pentachloride to diphenylketimino lithium;  $\text{Ph}_2\text{CNLi}$  in diethyl ether/n-hexane solution after which the mixture was pumped under vacuum to dryness, then the residue was extracted in toluene and produced a red-brown solution over a viscous dark-brown oil (after separation of

LiCl). The orthometallated solid has been isolated from the oil layer in a low yield. The same reaction was repeated several times under the same conditions but it was observed that the orthometallated compound cannot be isolated in a good yield and instead, a high yield of the  $\text{Ph}_2\text{C}=\text{NH}_2^{\oplus}\text{SbCl}_4^{\ominus}$  salt mainly was obtained.

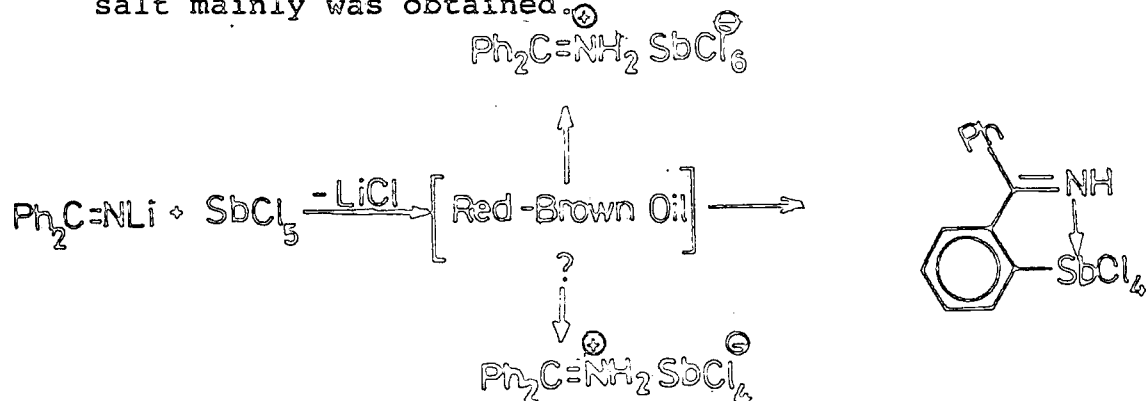

The need to find more information about the nature of the red-brown oil, which can be assumed to be an intermediate for the orthometallation process, has been considered. In one of the repeated reactions, the red-brown oil was pumped off to remove most of the toluene solvent. The mass spectrum of this oil showed no indication for the orthometallated compound.  $\text{O}-\text{SbCl}_4\text{C}_6\text{H}_4\text{C}(\text{ph})=\text{NH}$  ( $m/e = 441$ ). The main fragmentation routes of the red-brown oil are the loss of  $[\text{HSbCl}_4]$  from the hypothesized unstable molecular ion to give a peak at  $m/e = 179$  (46%); i.e.  $(\text{ph}_2\text{CN}-\text{H})^{\oplus}$ . The IR spectrum of the oil showed three bands at 3260, 1590 and  $1542 \text{ cm}^{-1}$  similar to those bands observed in the orthometallated compound and which are believed to be assigned probably to  $\nu(\text{N}-\text{H})$ ,  $\nu(\text{C}=\text{N})$ , and  $\nu(\text{C}=\text{C})$  respectively. Another significant strong bands were observed at 1860 and  $1826 \text{ cm}^{-1}$ . The appearance of such bands at this region may indicate the formation of stibonium imine and/or ylid; or the formation of (Sb-H) bond. The latter is highly unlikely, while the former is fairly possible.

There is a little work which has been reported with these two stibonium derivatives.<sup>2,3</sup> Some examples are given below:

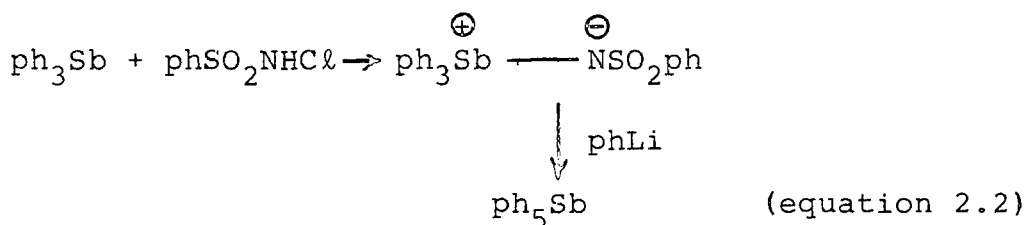
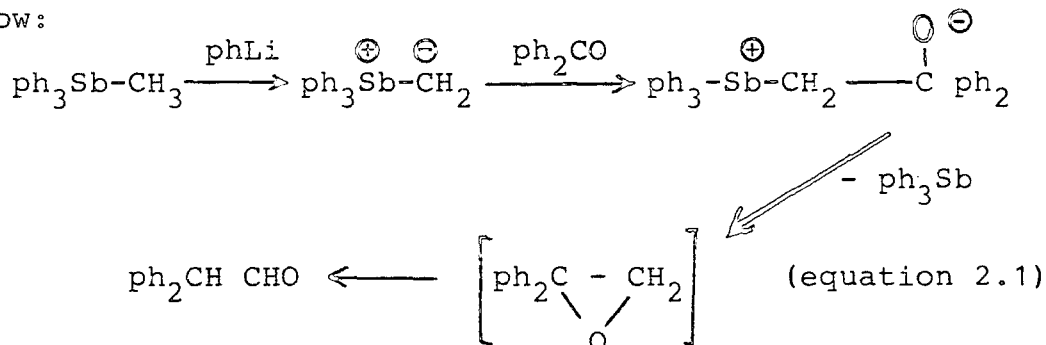

It has been observed that the stibonium ylids appear to afford oxiranes with carbonyl compounds, while the imines afford unsaturated products.<sup>6</sup>

The red brown oil which may have the two possible expected formulae  $(\text{ph}_2\text{CNSbCl}_4)_n$  or  $(\text{O}-\text{SbCl}_4\text{C}_6\text{H}_4\text{C}(\text{ph})=\text{NH})_n$  might exist as stibonium imine or ylid as a result of the dissociation, polarization, or ionization of  $(\text{SbCl}_4)$  group into  $(\overset{\oplus}{\text{SbCl}_3})\overset{\ominus}{\text{Cl}}$ . Such a chlorine transfer had been inferred from radiochlorine exchange investigations. For example the solid  $\text{SbCl}_4\text{OC}_2\text{H}_5$  has been deduced to have the structure  $\overset{\oplus}{\text{SbCl}_4}\overset{\ominus}{\text{SbCl}_4}(\text{OR})_2$  or at least behaved as if it had this, because on adding  $\text{SbCl}_4\text{OEt}$  to an acetonitrile solution of radioactive chlorine of  $\overset{\oplus}{\text{N}}(\text{C}_2\text{H}_5)_4\overset{\ominus}{\text{Cl}}$  inactive  $\overset{\ominus}{\text{SbCl}_4}(\text{OR})_2$  active  $\text{SbCl}_6^\ominus$  have been isolated. The exchange of  $\text{Cl}^\ominus$  ligands does not take place with the anions, but they interact with  $\overset{\oplus}{\text{SbCl}_4}$  as follows:<sup>5</sup>



These assumptions are summarised in scheme (2.1). The IR spectra of those possible intermediates A; B; and C are expected to show a band due to  $\nu(\text{C} = \text{N} \rightleftharpoons \text{SbCl}_4)$ ,  $\nu(\text{C} = \text{N} = \text{SbCl}_3)$  or  $\nu(\text{C}^{\ominus} - \text{SbCl}_3^{\oplus})$  frequency in the region  $1900 - 1700 \text{ cm}^{-1}$ . The intermediate (A) or (B) is more favoured than intermediate (C). The reason for that can be interpreted from the comparison between the stibonium imine (A or B) and

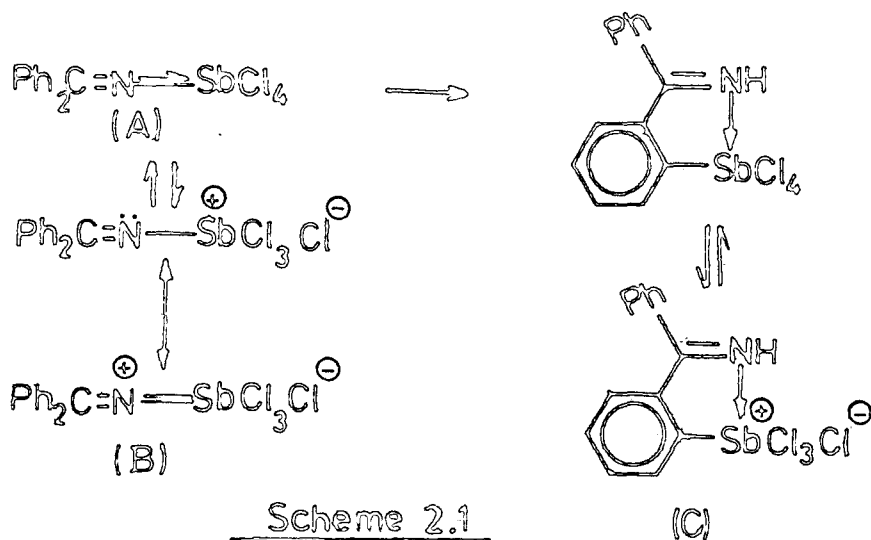

some metal-disubstituted methyleneamino derivatives such as  $\text{R}_2\text{CNBph}_2$ <sup>6</sup>,  $[(\text{R}_2\text{CN})_2\text{Be}]_n$ <sup>7</sup>, and  $[\text{ph}_2\text{CN} : \text{Cph}_2]^{\oplus}\text{SbCl}_6^{\ominus}$ <sup>8</sup>; where R = ph, p-tolyl, n = 2, 3 or  $\infty$ . Each of these comparative samples has been reported to absorb in the IR spectrum at  $1900 - 1700 \text{ cm}^{-1}$  region as a result of the  $\nu_{\text{C}=\text{N}=\text{M}}$  frequency. See table (2.2). From table (2.2) it is noticed that the decreasing frequency of  $\nu_{\text{C}=\text{N}=\text{M}}$  in the sequence M = C > B > Be is due to the decreasing N  $\rightleftharpoons$  M bond order in the same sequences. According to that sequence; if  $\text{ph}_2\text{C} = \text{N} = \text{SbCl}_3^{\oplus}$  or  $\text{ph}_2\text{C} = \text{N} \rightleftharpoons \text{SbCl}_4$  is assumed, then the (C = N  $\rightleftharpoons$  Sb) bond might absorb in IR spectrum near  $1845 \text{ cm}^{-1}$ . Theoretically, the N  $\rightleftharpoons$  Sb bond is believed to reflect the overlap between

Table (2.2)

Infrared spectroscopic data for some disubstituted methyleneamino derivatives.

Compound	$\nu_{\text{C=N}} \text{ cm}^{-1}$	$\nu_{\text{C=N=M}} \text{ cm}^{-1}$
$\text{ph}_2\text{CNB ph}_2$	-	1786
$(\text{C}_6\text{H}_4)_2\text{C=N B ph}_2$	-	1766
$(\text{P-MeC}_6\text{H}_4)_2\text{C=N Bph}_2$	-	1792
$(\text{P-ClX}_6\text{H}_4)_2\text{C=N B ph}_2$	-	1775
$[(\text{p-tolyl}_2\text{CN})_2\text{Be}]_3$	1626	1731
$[(\text{p-tolyl C}(\text{Bu})=\text{N})_2\text{Be}]_2$	1637	1739
$[\text{ph}_2\text{C=N=Cph}_2]^\oplus$	-	1845

the filled 2p-orbitals of the nitrogen and the vacant 5d-orbital of the antimony whether or not the chloride ion is dissociated from  $\text{SbCl}_4$  group. The red-brown oil is not soluble in aliphatic hydrocarbon solvents or even in carbon tetrachloride, and is slightly soluble in aromatic hydrocarbons, but very soluble in chloroform, diethyl ether, tetrahydrofuran and dimethylsulphoxide.. On the other hand, both the acidic and the alkaline hydrolysis of the red brown oil yielded a white solid, its IR spectrum was similar to that of the authentic sample of benzophenone;  $\text{ph}_2\text{CO}$ .

The red-brown oil is sensitive to heat and decomposes at high temperature. Under dry nitrogen gas, no products were collected at  $140^\circ\text{C}$ , but at the same temperature under vacuum, three products were collected by condensation: a colourless oil, a white solid condensate and a yellow oil product. After the thermolysis a black solid residue was obtained. The most interesting product of these, is the colourless oil of which the IR spectrum gave no  $\nu(\text{N-H})$

band. The spectrum showed also three bands at 1660, 1600, and 1575  $\text{cm}^{-1}$  which are probably assigned with  $\nu(\text{C} = \text{N})$  and  $\nu(\text{C} = \text{C})$  bands obtained for  $(\text{Ph}_2\text{CN})_2\text{SiCl}_2$ . That indicates the possibility for the formation of  $(\text{Ph}_2\text{CN})_2\text{SbCl}_3$ , if the  $\text{Ph}_2\text{CNSbCl}_4$  formula is assumed; due to the disproportionation of  $\text{Ph}_2\text{CNSbCl}_4$  into  $(\text{Ph}_2\text{CN})_2\text{SbCl}_3$  and  $\text{SbCl}_5$  (see Scheme 2.2).

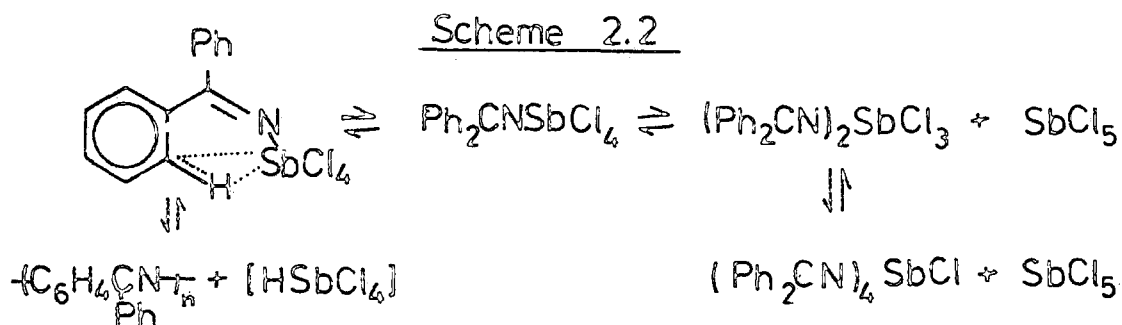

The IR spectra of the other thermolysis products showed a few weak bands in the 4000 - 250  $\text{cm}^{-1}$  region and they are probably polymeric products. However, it seems that the red-brown oil decomposes at higher temperature due to the disproportionation or reduction elimination as shown in the above scheme. Unfortunately, no further studies have been done for these thermal decomposition products since the products were obtained in low yield. In the reaction of antimony pentachloride with imino-lithium the initial stage of the reaction was carried out and repeated using different solvents including diethyl ether, toluene, tetrahydrofuran, N-hexane and carbon tetrachloride. One attempt has been done to react the yellow solid of the imino-lithium with  $\text{SbCl}_5$  at low temperature ( $-196^\circ\text{C}$ ) without using any solvent. In this solid state reaction, the yellow mixture changed at room temperature into an orange-red solid, and then a dark red solid. This solid exploded at  $60^\circ\text{C}$  at the attempt to examine the final products of this

reaction failed.

However, the reaction can be carried out safely under mild conditions using a suitable solvent such as diethyl ether which was usually used for the orthometallation of antimony chlorides in this work, and of the tin tetrachloride.

The reaction of the diphenylketimino lithium with  $\text{SbCl}_5$   $\text{Et}_2\text{O}$  yielded after stirring overnight a yellow solution over a buff viscous residue. A sample of the yellow solution was pumped off under vacuum to dryness, leaving a mixture of a yellow powder and a yellow oil which changed overnight to a dark brown residue. Both the intermediates could be observed spectroscopically as an ether complex. The IR spectrum of the ethereal residue gave an indication of the presence of an orthometallated product, since one band was observed at  $3270 \text{ cm}^{-1}$  assigned probably with  $\nu(\text{N-H})$  and the  $\nu(\text{C=N})$  and  $\nu(\text{C=C})$  bands were shifted to lower frequencies ( $1590, 1550 \text{ cm}^{-1}$  respectively). The asymmetric (C-O-C) stretching vibration of coordinated diethyl ether also was observed at  $1075 \text{ cm}^{-1}$  (free  $\text{Et}_2\text{O}$  absorbs at  $1129 \text{ cm}^{-1}$ ; contact liquid film). These characteristic bands suggest a formula for the ethereal residue intermediate as  $(\text{Et}_2\text{O} \cdot \text{SbCl}_4 \text{C}_6\text{H}_4\text{C}(\text{ph}) = \text{NH})$ .

Although  $\nu(\text{N-H})$ , and coordinated  $\nu_{\text{as}}(\text{C-O-C})$  bands were observed for the buff coloured residue but there were four bands in the ( $1700\text{-}1500 \text{ cm}^{-1}$ ) region ( $1665, 1610, 1588$  and  $1570 \text{ cm}^{-1}$ ) which were different from that spectrum of the residue dissolved in the ether solution. These bands were the same as those observed in the spectrum of  $(\text{ph}_2\text{CN})_2\text{M}^{\text{IV}}\text{Cl}_2$ : M = Sn, Si, Ge which suggests that this

buff residue probably contains a product resulting from the disproportionation of  $(\text{Ph}_2\text{CNSbCl}_4 \cdot \text{Et}_2\text{O})$  or  $(\text{Et}_2\text{O} \cdot \text{o-SbCl}_4\text{C}_6\text{H}_4\text{C}(\text{Ph}) = \text{NH})$ . For the disproportionation of any possible intermediates see scheme (2.4); route A is favoured rather than route B and is known to occur easily with antimony pentavalent halide which has a high content of chlorine atoms.

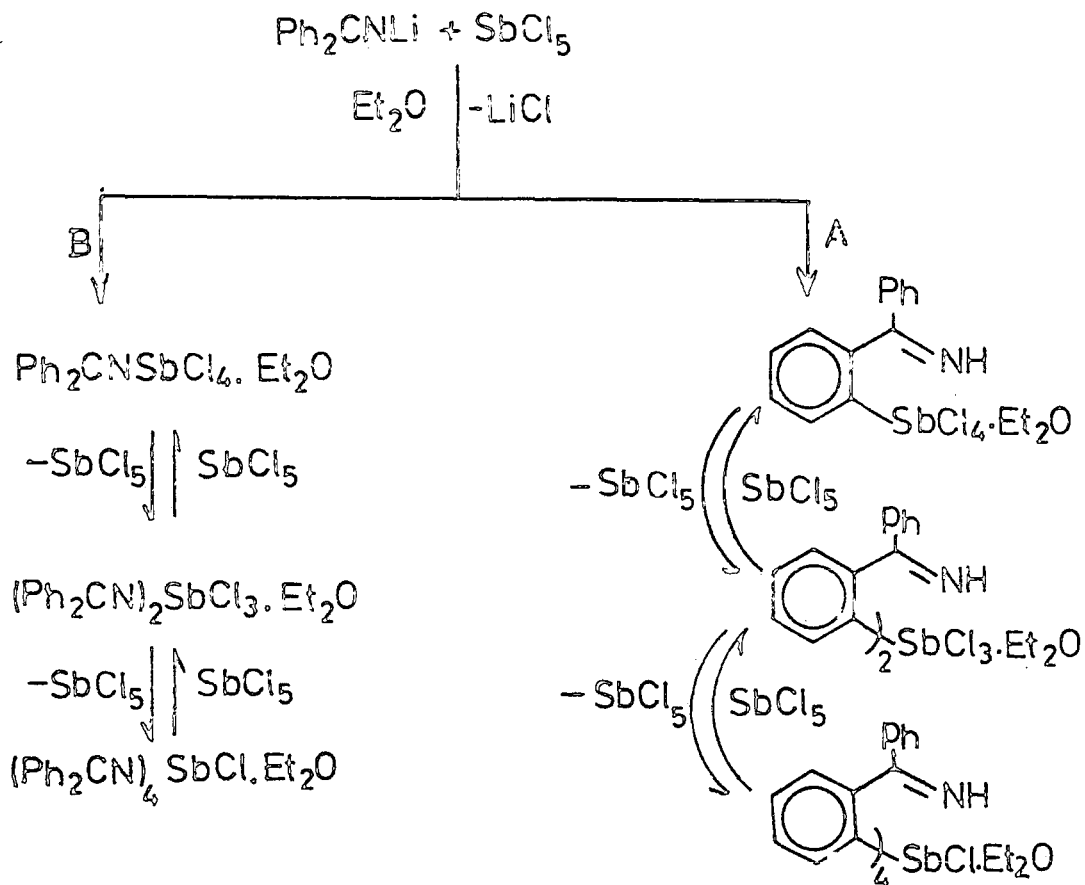

No attempt has been made to isolate  $\text{SbCl}_5$  from the ethereal solution; however, in the preparation of the orthometallated ketimino-tin trichloride, the  $\text{SnCl}_4$  could be isolated from the ethereal solution as an (1:1) adduct of N, N, N', N'-tetramethylene-diamine with  $\text{SnCl}_4$ ;  $\text{TMED} \cdot \text{SnCl}_4$ . Since the yellow powder that resulted from the reaction of diphenyl-

ketimine with n-butyllithium has been confirmed spectroscopically and analytically to have the formula  $(Ph_2CNLi \cdot nEt_2O)_m$ , the reaction of the imino-lithium with antimony pentachloride has been repeated using the yellow powder, as an attempt to eliminate any traces of by-products or unreacted molecules which might complicate the orthometallation reaction. For example, these might include the formation of the HCl molecules due to the reaction of the unreacted  $Ph_2CNH$  or its orthometallated lithium derivative with  $SbCl_5$ , the decomposition of the eliminated  $(HSbCl_4)$  species during the orthometallation, or its elimination from the orthometallated compound, see scheme (2.5).

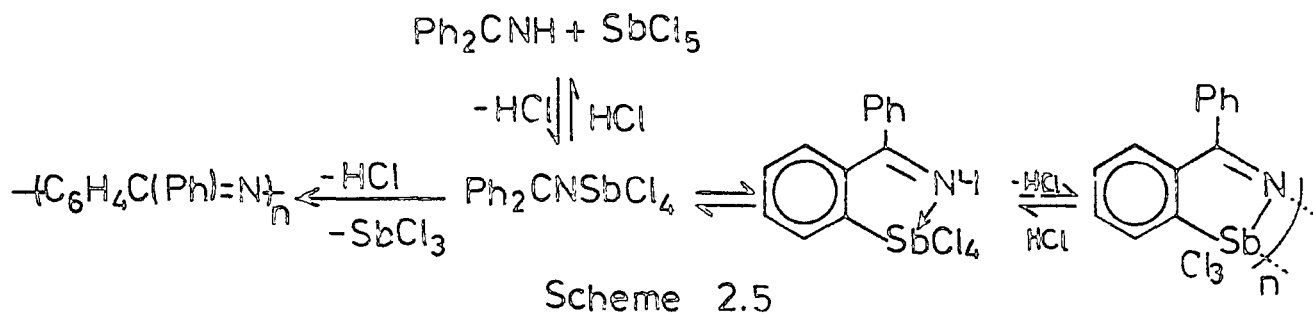

On the other hand, the hydrogen chloride gas is known to attack the corresponding orthometallated compound of tin trichloride and form an ionic salt of the type  $(Ph_2CNH_2)^+ (SnCl_6)^{2-}$  - see reaction (2.3a).

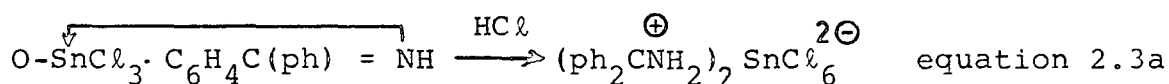

Accordingly, the yellow solid of imino-lithium was dissolved in  $Et_2O$  to form a clear red solution. The solution was cooled to  $-196^\circ C$  and  $SbCl_5$  added in (1:1) molar ratio. The red colour of the solution changed to yellow with precipitation of a white cloudy mass. The final product

was a golden yellow solution with a white precipitate. On stirring overnight in ether, the white precipitate changed to a brown oily residue under the yellow solution. The whole mixture was pumped to remove all the solvent. The IR spectrum for the yellow residue (which changed to dark brown colour) showed  $\nu(\text{N-H})$  band at  $3220\text{ cm}^{-1}$  and two bands at  $1590$  and  $1540\text{ cm}^{-1}$ , probably assigned with  $\nu(\text{C=N})$  and  $\nu(\text{C=C})$  respectively. Once again a broad band was observed at  $1860\text{ cm}^{-1}$  which has been observed before in IR spectrum of red-brown oil (see page 48) and which has been suggested as possibly assigned to  $\nu(\text{C=N=M})$ . Also, a very broad band was observed at  $1050\text{ cm}^{-1}$  assigned with  $\nu_{\text{as}}(\text{C-O-C})$  of coordinated diethyl ether which acts as a coordinated agent and which can block the orthometallation process if a formula  $(\text{ph}_2\text{CNSbCl}_4 \cdot \text{Et}_2\text{O})_n$  is assumed. The concentration of diethyl ether is an important factor since this  $\text{Et}_2\text{O}$  can facilitate the dissociation of the products, or ionize the (1:1) adduct of  $(\text{ph}_2\text{CNSbCl}_4 \cdot \text{Et}_2\text{O})_n$ . If the orthometallation is assumed to occur in  $\text{Et}_2\text{O}$  solution competition is expected between the oxygen of  $\text{Et}_2\text{O}$  and the nitrogen of the stibino-imine for coordination to the metal atom, see equation (2.3.b). Also, in diethyl ether solution it is expected that the orthometallated compound

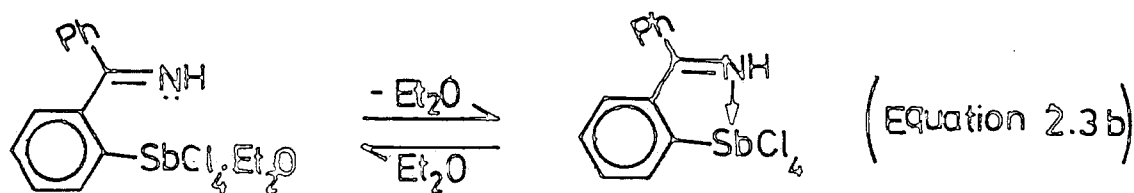

undergoes ionization or decomposition into O-chloro diphenylketimine and antimony trichloride. The

latter decomposition process is suggested in view of the known reaction of  $\text{SbCl}_5$  with aromatic hydrocarbons, e.g. toluene with antimony pentachloride which afforded O-/P-/M-isomers of chloro toluene, antimony trichloride and hydrogen chloride instead of derivatives such as tetra-chlorostibino toluene,<sup>10</sup> see equation (2.4).

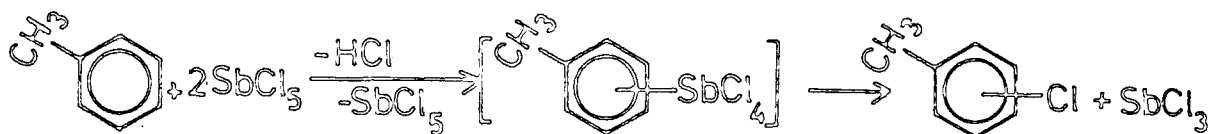

Equation 2.4

Another possibility, it arises from the instability of phenylantimony tetrachloride,  $\text{phSbCl}_4$  which slowly decomposes at room temperature from the pentavalent into trivalent oxidation state<sup>11</sup> as shown in equation (2.5).

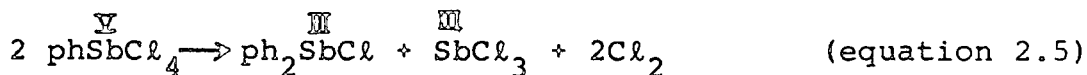

Here, if the latter possibility is assumed, species such as  $\text{O-SbCl}(\text{C}_6\text{H}_4\text{C}(\text{ph})=\text{NH})_2$  and  $\text{SbCl}_3$  and chlorine could be obtained:

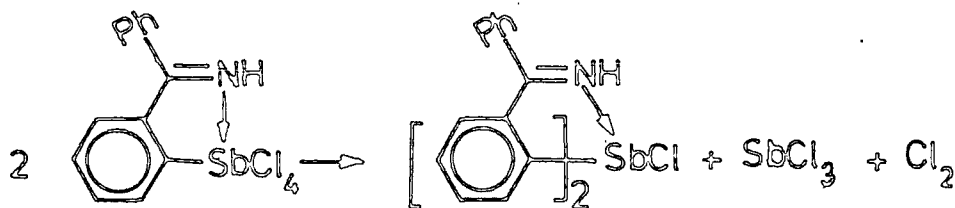

The tetrachloroantimony derivatives,  $\text{RSbCl}_4$ <sup>12</sup> where R =  $\text{C}_6\text{H}_5$  or  $\text{P-CH}_3\text{C}_6\text{H}_4$  have been synthesized from primary dichlorostibines,  $\text{RSbCl}_2$ , and from their complexes with arenediazonium chloride,  $[\text{RN}_2][\text{RSbCl}_3]^\ominus$ , from stibonic acids, and directly from antimony trichloride as summarised below.

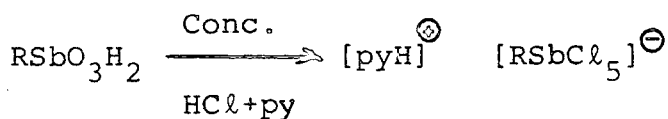
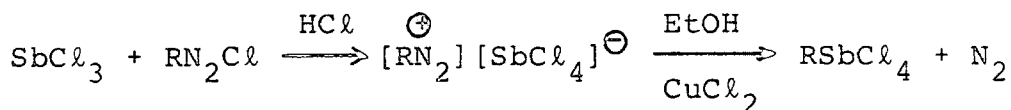
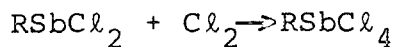

The aryltetrachloro antimony (v) compounds have been found to react with water, hydrogen chloride, lithium aluminium hydride,  $[\text{PhN}_2]_2 \text{ZnCl}_4$ , and Na gluconate as shown below:

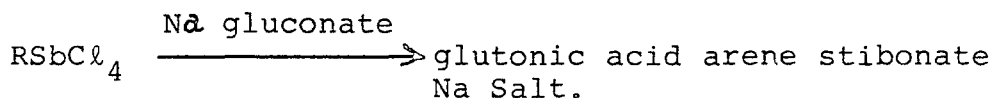
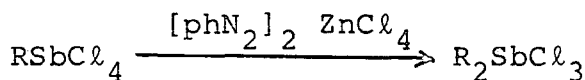
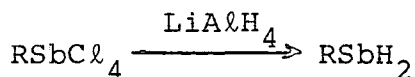
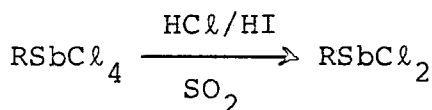
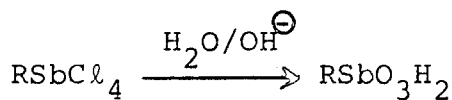

The most important feature of these tetrachloro derivatives is their ability to form complex salts with amines or diazonium salts, e.g.  $[\text{pyH}]^+ \text{Cl}^- + \text{RSbCl}_4 \rightarrow [\text{pyH}]^+ [\text{RSbCl}_5]^-$ . The diethyl ether can block the formation of the ortho-metallated compound, either by trapping  $\text{SbCl}_5$  molecules which will hinder its reaction with the imino-lithium, or by trapping the antimony tetrachloro - derivative. The (1:1) antimony pentachloride diethyl ether;  $\text{SbCl}_5, \text{Et}_2\text{O}$  complex is known to dissociate or decompose on careful heating giving ethyl chloride similar to those observations

of decomposition of the (1:1) Et<sub>2</sub>O complex with NbCl<sub>5</sub> and TaCl<sub>5</sub><sup>13</sup>. The (Et<sub>2</sub>O.SbCl<sub>5</sub>) complex is stable at room temperature, sensitive to moisture and can be attacked by hydrogen chloride gas to form [Et<sub>2</sub>OH]<sup>+</sup>SbCl<sub>6</sub><sup>-</sup>. This is suggested by UV and molecular magnetic rotation comparison studies with ether complexes of BF<sub>3</sub>, AlCl<sub>3</sub>, ZnCl<sub>2</sub>, TiCl<sub>4</sub>, and FeCl<sub>3</sub>, however the electrical conductivity measurements have shown that these complexes have ionic character which suggests a formula (Et<sub>2</sub>OSbCl<sub>4</sub>)<sup>+</sup>Cl<sup>-</sup><sup>14</sup> or [2 Et<sub>2</sub>O → SbCl<sub>4</sub>]<sup>+</sup> [SbCl<sub>6</sub>]<sup>-</sup><sup>15,16</sup>:

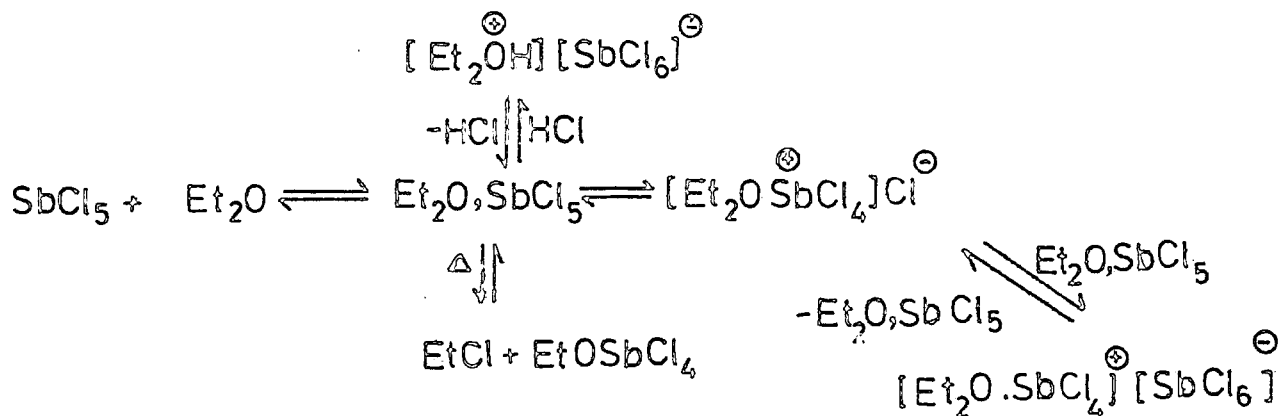

Scheme ( 2.7 )

On the other hand, the possibility of n-butyl lithium to attack Et<sub>2</sub>O in the synthesis of ph<sub>2</sub>CNLi the imino-lithium derivative is not possible since the reaction of BuLi<sup>n</sup> with Et<sub>2</sub>O is much slower than that reaction with ph<sub>2</sub>CNH, however, in the reaction of Et<sub>2</sub>O/BuLi, the following reaction<sup>17</sup> is only observed:

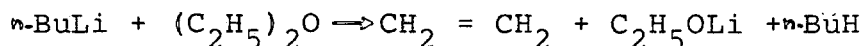

in a separate experiment, antimony pentachloride was dissolved in excess of diethyl ether as an attempt to isolate and characterize the (SbCl<sub>5</sub>Et<sub>2</sub>O) complex. A crystalline solid deposited, but this could not be isolated

in a good yield since it was very soluble in the ether. Both solution and the crystalline solid changed very quickly to a dark brown colour. However, the IR spectrum for the product could be obtained which showed bands at 1010, 1080, 1290, 1260, 1140, 1180, 900 and 730  $\text{cm}^{-1}$ . No band was observed at 4000-3000  $\text{cm}^{-1}$ , suggesting no  $\nu(\text{O-H})$  band in the adduct is formed. Because of the possibility that  $\text{Et}_2\text{O}$  may have an effect on the lack of formation of the orthometallated compound, an attempt was carried out to eliminate all coordinated  $\text{Et}_2\text{O}$  by heating the pumped  $\text{R}_2\text{CNLi/SbCl}_5$  reaction residue under vacuum, where  $\text{R} = \text{ph}, \text{p-tolyl}, \text{P-FC}_6\text{H}_4$ . This attempt was only successful with the thermodynamically stable  $\text{Pt}_2\text{CNSbCl}_4$  which yielded the orthometallated compound (II) after the extraction by toluene. The reaction of diphenyl ketimino-lithium with antimony pentachloride in (1:1) molar ratio using  $\text{Et}_2\text{O}$  as a solvent was repeated as an attempt to isolate any product from the ethereal solution. After the reaction occurred, the yellow ethereal solution was separated by filtration from the buff precipitate - on standing at room temperature for three days, the ethereal solution afforded a dark red-brown oil from which a brown solid deposited. The IR spectrum of this solid suggests the formation of an orthometallated compound different to compound (I), since the spectrum showed  $\nu(\text{N-H})$  at 3240  $\text{cm}^{-1}$  and two  $\nu(\text{C=N})/\nu(\text{C=C})$  bands at 1585 and 1548  $\text{cm}^{-1}$  the analytical data of the solid is in agreement with the  $(\text{ph}_2\text{CNSbCl}_4)_n$  formula. Both IR and analytical data are described below:

$\nu_{\max} \text{ cm}^{-1}$  (Nujol mull) : 3240 (w), 1585 (w/m), 1570 (vw),  
1548 (w/m), 1330 (vw), 1310 (vw), 1295 (vw), 1188 (vw, sh),  
1165 (w), 827 (vw), 800 (w), 789 (w), 775 (w/m), 745 (w),  
715 (w/m), 705 (m), 694 (m/s), 665 (vw), 650 (vw).

Found : C 34.8, H 3.0, N 2.3, Sb 24.6, Cl 29.6%

$(\text{C}_{13}\text{H}_{10}\text{NSbCl}_4)_n$  requires : C 35.1, H 2.3, N 3.1,  
Sb 27.4, Cl 32.0%.

The shift of the  $\nu(\text{N-H})$  band to a lower frequency by  $\sim 20 \text{ cm}^{-1}$  and the difference in the bands in the  $1300 - 1100 \text{ cm}^{-1}$  and  $800 - 600 \text{ cm}^{-1}$  regions, in comparison with the spectrum of compound (I) suggests the possibility of the existence of  $(\text{ph}_2\text{CNSbCl}_4)_n$  in different orthometallated structures. Such as :

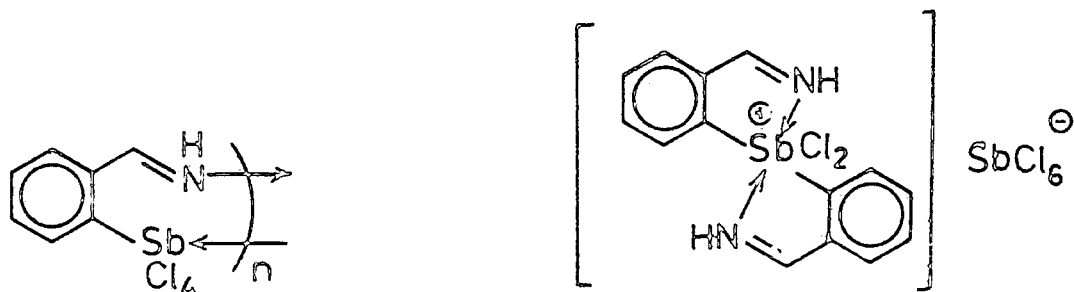

Returning to the reaction of the imino-lithium yellow solid with antimony pentachloride it yielded a dark brown residue. The latter residue was extracted in toluene at below  $120^\circ\text{C}$  forming dark red solution. On continuous heating at  $120^\circ\text{C}$  for half an hour, the colour of the solution changed to brown and separated into two phases : a dark brown oil under a light brown solution. The IR spectrum of the oil showed no bands in the region  $1900 - 1800 \text{ cm}^{-1}$  region, but instead two bands at  $3260$  and  $3335 \text{ cm}^{-1}$  assigned as  $\nu(\text{N-H})$  and three bands at  $1660$ ,  $1590$ , and  $1560 \text{ cm}^{-1}$  probably assigned as  $\nu(\text{C=N})$  and  $\nu(\text{C=C})$  similar to those observed in

$(\text{ph}_2\text{CN})_2 \text{MCl}_2$ ; M = Si, Sn, Ge. This suggests the sensitivity of the orthometallated intermediate towards heat which may lead to the dissociation of the tetrachloroantimony-imine derivative as mentioned before in scheme (2.4), and which hindered the formation of desired orthometallated compound  $\text{O}-\text{SbCl}_4\text{C}_6\text{H}_4\text{C}(\text{ph}) = \text{NH}$ .

The reaction of the imino-lithium with antimony pentachloride was repeated using only n-hexane as a solvent. The reaction gave a high yield of a dark brown residue which seemed to not be soluble in hexane. The solvent was pumped off and the brown viscous residue was investigated by the IR spectrum. Surprisingly, the spectrum was similar to that of solid  $\text{ph}_2\text{CNH}_2^{\oplus} \text{SbCl}_6^{\ominus}$ . The spectrum has been compared with the sample obtained from the reaction of  $\text{ph}_2\text{CNH}_2^{\oplus} \text{Cl}^{\ominus}$  with  $\text{SbCl}_5$  which deposited as a crystalline solid from  $\text{CHCl}_3$  solution. There was some difference in the bands absorbed in the region of  $800 - 700 \text{ cm}^{-1}$ , but the  $\nu(\text{N-H})$ ,  $\nu(\text{C=N})$  and  $\nu(\text{C=C})$  bands were similar except that the  $\nu(\text{C=N})$  at  $1660 \text{ cm}^{-1}$  was less intense (relative to  $\nu(\text{C=C})$  band) than that of the authentic sample of  $\text{ph}_2\text{CNH}_2^{\oplus} \text{SbCl}_6^{\ominus}$ . The IR data of this residue are given below:  $\nu_{\text{max}} \text{ cm}^{-1}$  :  
 3390(w), 3330(w), 3260(w), 1660(m), 1591(vs), 1560(m),  
 1300(w), 1188(w), 1163(w/m), 1075(vw), 1028(vw), 1000(w),  
 978(vw), 940(vw), 845(vw), 790(w/m), 777(w/m), 765(w/m),  
 740(w), 727(m), 700(vs,sh), 605(w), 568(w), 440(sh).

This observation suggests that the residue contains the ionized salt  $\text{ph}_2\text{CNH}_2^{\oplus} \text{SbCl}_6^{\ominus}$  or contains a component such as  $\text{C} = \text{NH}_2^{\oplus} \text{SbCl}_6^{\ominus}$  due to dissociation of  $\text{O}-\text{SbCl}_4\text{C}_6\text{H}_4\text{C}(\text{ph}) = \text{NH}$  compound - see Scheme (2.8).

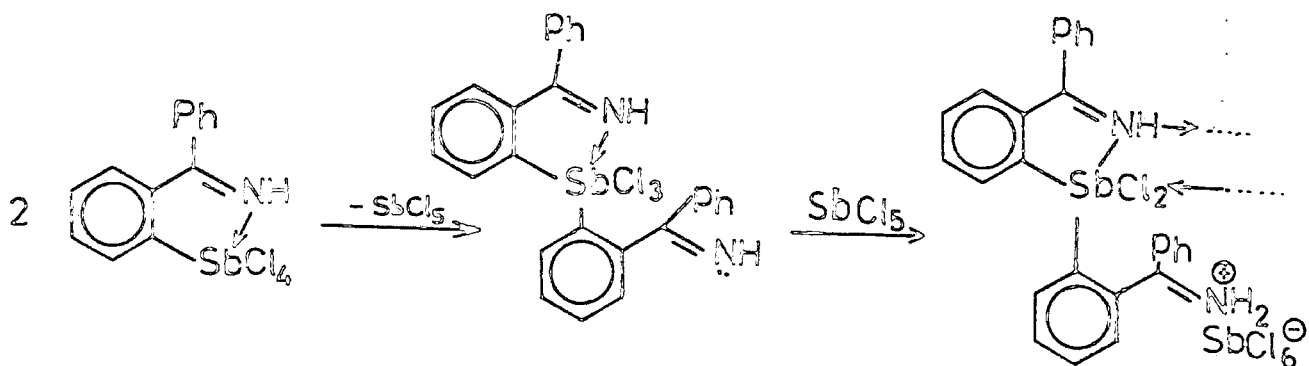

Scheme 2.8

The extraction of this residue in THF at 90°C for 1 hour produced a grey precipitate (mainly LiCl) and a dark brown solution. No solid deposited from this solution, on standing at room temperature for several days, after which the THF was pumped off until a dark black residue was obtained. The IR spectrum of that residue showed the  $\nu$  (C-O-C) bands of coordinated THF at 1045 and 890  $\text{cm}^{-1}$  [the  $\nu$  (C-O-C) THF bands absorbs at 1075 and 910  $\text{cm}^{-1}$ ; contact film]. Other significant bands were also observed such as  $\nu$  (C=N) and  $\nu$  (C=C) at 1633 and 1595  $\text{cm}^{-1}$ , and an ill-defined  $\nu$  (N-H) band. These characteristic bands were quite similar to that of the product obtained from the reaction of SbCl<sub>3</sub> with ph<sub>2</sub>CNH - see chapter 3, which may suggest that the  $>\text{C} = \text{NH}_2^{\oplus} \text{Sb}^{\vee} \text{Cl}_6^{\ominus}$  species, if it is assumed, decomposed on refluxing with THF into  $(>\text{C} = \text{NH}_2^{\oplus})_2 (\text{Sb}^{\text{III}} \text{Cl}_5)^{2\ominus}$ . The IR spectrum data of the extracted THF residue are given below:  $\nu_{\text{max}} \text{cm}^{-1}$  (contact film): 3200 (sh), 1633 (s), 1595 (vs, sh), 1298 (w), 1250 (vw), 1190 (w, sh), 1170 (m/s, sh), 1125 (vw), 1045 (vs), 1000 (w), 980 (vs), 890 (vs, sh), 798 (m/s), 780 (m/s), 730 (m/s), 705 (vs), 610 (w/m, sh), 570 (w/m).

Carbon tetrachloride was used as solvent in a repeated reaction between the imino-lithium and SbCl<sub>5</sub>. The initial

reaction was carried out in n-hexane, after which the solvent was pumped off and then  $\text{CCl}_4$  was added to the dark brown/black residue. On extraction and filtration, a black solid was separated from a dark brown solution. The IR spectrum of the black solid was similar to that extracted residue in THF solution (except the characteristic bands of THF). IR spectrum data of the black solid are given below:

$\nu_{\text{max}} \text{ cm}^{-1}$  (KBr disc) : 3230 (sh), 1640 (m, br), 1593 (m, sh), 1300 (w), 1188 (vw, sh), 1163 (w, sh), 1025 (vw), 999 (vw), 860 (w), 840 (vw), 792 (m), 760 (w/m), 725 (m), 700 (s), 606 (vw), 565 (w), 446 (vw), 320 (w/m).

It seems from the extraction of the  $(\text{ph}_2\text{CNLi/SbCl}_5)$  reaction residue in THF or  $\text{CCl}_4$  that at higher temperatures the hypothesized ketimino-antimony tetrachloride can be reduced from the pentavalent into the trivalent oxidation. The highly exothermic reaction of the imino lithium with antimony pentachloride and the reductance of antimony from the pentavalent into the trivalent oxidation state (confirmed by Mössbauer spectroscopic studies - see Appendix I), may suggest another possibility for the reason of the lack of formation of the orthometallated compound. Both antimony pentachloride and its tetrachloro derivative are known to be sensitive towards heat and may decompose easily at high temperatures or even at room temperature to produce the chlorine gas and the antimony trivalent derivatives - see Equations (2.5) and (2.6).



If the elimination of chlorine is assumed from the ketimino-antimony tetrachloride derivative, then the passing of chlorine gas through the orthometallated reaction inter-

mediate solution may lead to the formation of orthometallated compound. An experiment has been carried out to study the effect of passing chlorine gas through the dark brown toluene solution resulting from the reaction of imino-lithium with  $\text{SbCl}_5$ . A poor yellow precipitate was obtained, its IR spectrum may suggest the formation of an ortho-metallated compound since a sharp weak band for  $\nu(\text{N-H})$  was observed at  $3230 \text{ cm}^{-1}$  and the two bands  $\nu(\text{C=N})$ ,  $\nu(\text{C=C})$  of the parent ketimine were shifted to lower frequencies into positions at 1584 and 1535 respectively. Several bands were also observed in the region  $800 - 700 \text{ cm}^{-1}$  which were quite similar to those observed in IR spectrum of compound (I) ;  $2-\overline{\text{SbCl}_4}\text{C}_6\text{H}_4\text{C}(\text{ph}) = \text{NH}$ .

Unfortunately, the structure of this product could not be determined because of the lack of analytical, mass spectrum and  $^1\text{H-N.M.R.}$  data. The addition of iodine, instead of chlorine judging by the IR spectrum deposited a similar product. The IR data of this yellow product are given below:

$\nu_{\text{max}} \text{ cm}^{-1}$  (Nujol Mull) : 3230(w), 1584(w/m,sh), 1535(m,br), 1182(vw), 1157(vw), 1075(vw), 1010(w), 900(w,br), 785(w), 772(m), 762(m), 742(w), 720(vw,sh), 712(w), 690(w/m), 649(vw), 580(vw), 340(vs). On considering the  $\nu(\text{N-H})$ ,  $\nu(\text{C=N})$ , and  $\nu(\text{C=C})$  bands of the previous spectrum, it seems that the chlorine experiment product is similar to compound (III); i.e.  $2-\overline{\text{SbCl}_2}\text{C}_6\text{H}_4\text{C}(\text{ph}) = \text{NH}$  which suggests the possibility of elimination reduction of chlorine from the antimony tetrachloro derivative as pictured in Scheme (2.9).

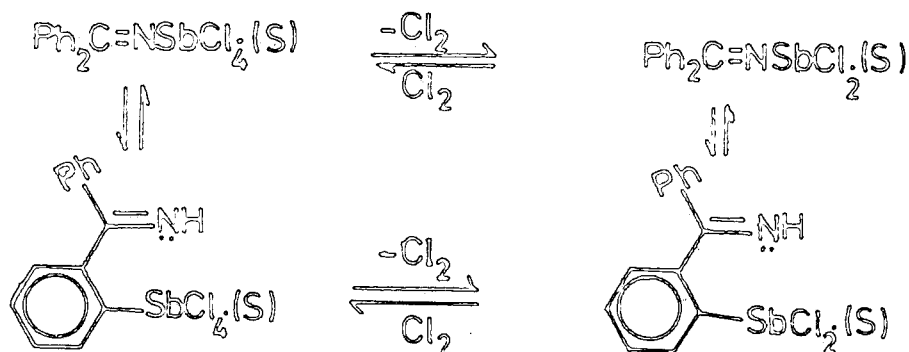

Scheme 2.9

According to the assumption which mentioned before that the antimony tetrachloride ketimine derivative may dissociate in the solution to give  $\text{SbCl}_5$  and  $\text{R}_2\text{SbCl}_3$ ; where  $\text{R} = \text{ph}_2\text{CN}$  and/or  $\text{O}-\text{C}_6\text{H}_4\text{C}(\text{ph}) = \text{NH}$ , the reduction of diphenyl ketimino lithium with  $\text{SbCl}_5$  was repeated, in (2:1) mole ratio. The dark red ethereal solution of imino-lithium faded to yellow and on stirring for 1 hour, the final product was a yellow solution over a yellowish white precipitate. The ethereal solution deposited after one day a yellow oil of which a sample was syringed off and transferred into another flask. This oil was air-sensitive and its IR spectrum showed a band at  $3260 \text{ cm}^{-1}$  assigned to  $\nu(\text{N-H})$  and three bands in the  $\nu(\text{C=N})/\nu(\text{C=C})$  region at 1608, 1588, and  $1565 \text{ cm}^{-1}$  were observed. The IR spectrum data for this oil are given below:

$\nu_{\text{max}} \text{ cm}^{-1}$  (Contact Film) : 3260(w), 3060(w/m), 3030(w), 2960(s), 2930(s), 2870(s), 1608(vs), 1588(vs), 1565(vs), 1488(s), 1445(vs), 1380(s), 1320(s,sh), 1272(s), 1180(w,sh), 1160(w), 1072(w,sh), 1030(w/m), 1000(w), 956(w), 940(w), 910(w), 850(w), 780(vs,sh), 740(m), 700(vs), 655(s), 615(vw), 440(w).

Apart from the yellow oil product, the whole initial mixture was refluxed in toluene at approximately 100°C after pumping off the solvent. Upon filtration a creamy precipitate was obtained and a red-brown solution, which deposited a very poor yield of solid which was similar to the authentic sample of  $\text{Ph}_2\text{CNH}_2^+\text{SbCl}_4^-$  (identified by comparison of IR spectra). No more solid deposited from the toluene solution, but on passing dry chlorine gas, the solution deposited two different products : A brownish-yellow and a bright yellow solid. The IR spectrum for the first product suggests the structure of  $\text{Ph}_2\text{CNH}_2^+\text{SbCl}_6^-$ , however the spectrum of the other product was similar to that spectrum of the yellow solid precipitated from toluene solution of the reaction  $\text{Ph}_2\text{CNLi}/\text{SbCl}_5$ , on addition  $\text{I}_2$  or  $\text{Cl}_2$  - see Page (65). As an attempt to explain the  $\text{Ph}_2\text{CNLi}/\text{SbCl}_5$  (2:1 Mole ratio) reaction, the appearance of  $\nu(\text{N-H})$  in the spectrum of the yellow oil and the three bands at  $\nu(\text{C=N})/\nu(\text{C=C})$  region suggests that an orthometallation process has occurred for the expected  $(\text{Ph}_2\text{CN})_2\text{SbCl}_3$  species which may dissociate in an  $\text{Et}_2\text{O}$  solution into the  $\text{SbCl}_5$  and ketimino-antimony chloride derivatives. This assumption is illustrated below as follows:

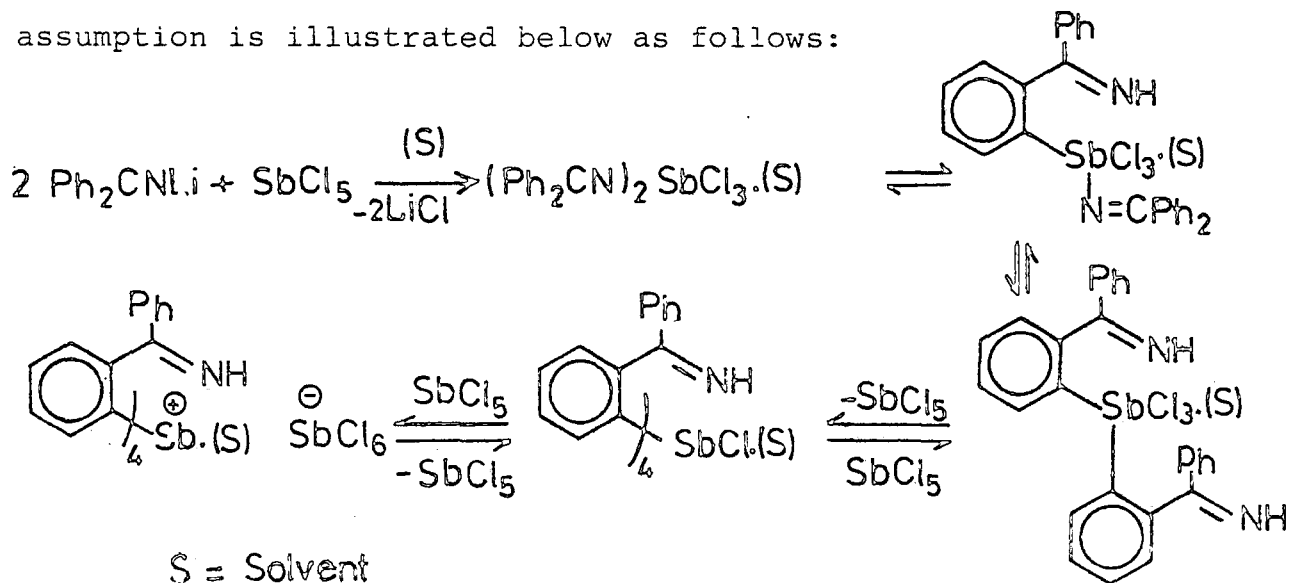

The most valuable point is that both the reactions of  $\text{Ph}_2\text{CNLi/SbCl}_5$  (1:1) or  $\text{Ph}_2\text{CNLi/SbCl}_5$  (2:1) with chlorine gas yielded a similar product. The appearance of the  $\nu(\text{N-H})$  band in this product and also two bands for  $\nu(\text{C=N})$  and  $\nu(\text{C=C})$  which are shifted to lower frequencies supports the existence of an identical intermediate; probably  $(\text{S}) \cdot \text{SbCl}_3(\text{O-C}_6\text{H}_4\text{C}(\text{ph}) = \text{NH})_2$  in the solution. If chlorine gas reacts with this hypothesized intermediate, it is possible to obtain an orthometallated product such as

$[\text{O-SbCl}_3(\text{O-C}_6\text{H}_4\text{C}(\text{ph}) = \text{NH}) (\text{C}_6\text{H}_4\text{C}(\text{ph}) = \text{NH})]^\oplus [\text{SbCl}_6]^\ominus$  which may be suggested as a structure for the yellow product. The reaction of that intermediate with chlorine gas is given below:

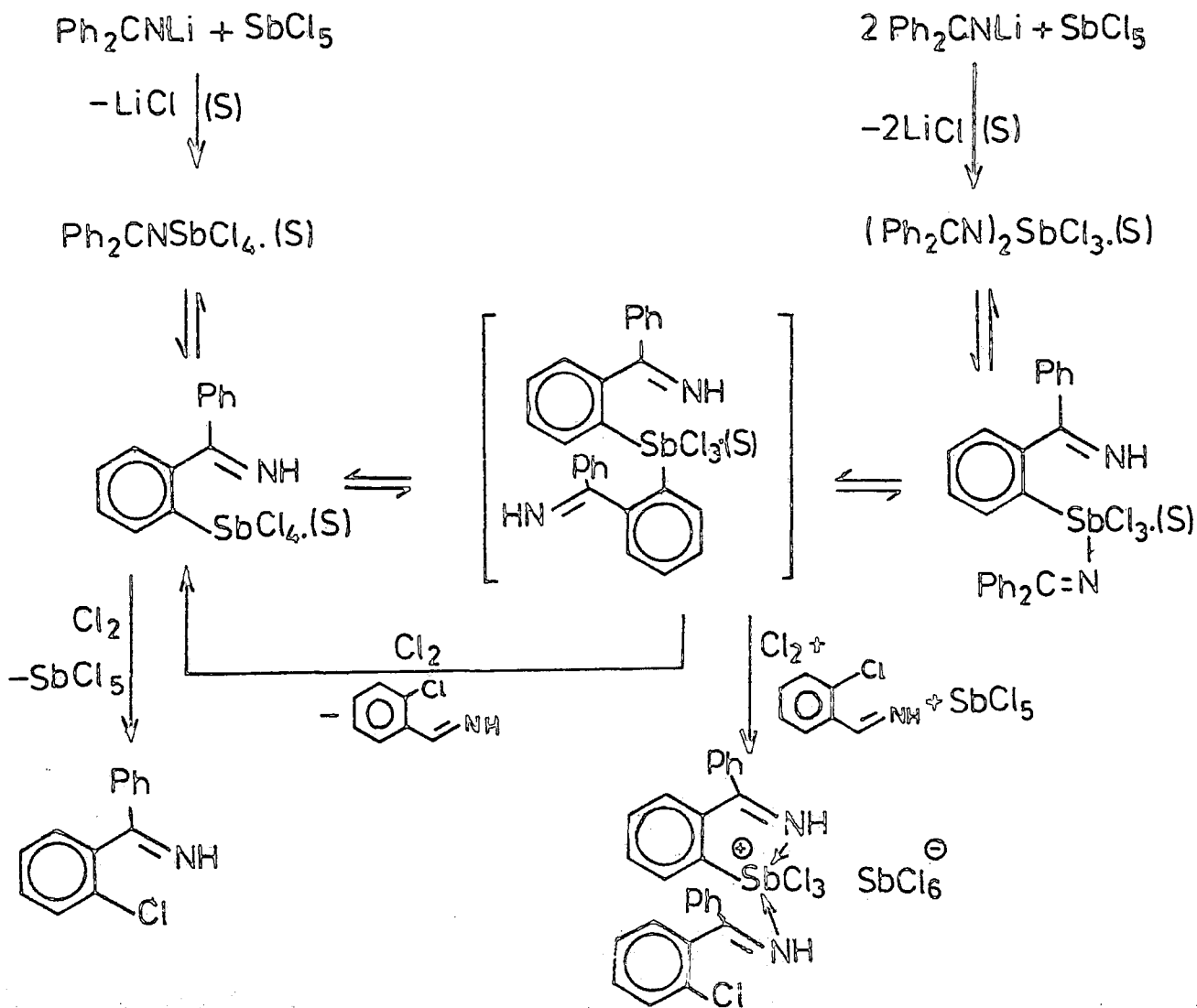

It was interesting to investigate the reaction of benzonitrile with antimony pentachloride in benzene solution, since it is known that  $\text{SbCl}_5$  reacts with benzene to produce chlorobenzene and it was suggested  $\text{phSbCl}_4$  was an intermediate of this reaction, which may undergo an addition reaction across the nitrile group to produce  $\text{ph}_2\text{CNSbCl}_4$ . However, there is another possibility expected from this reaction, in the formation of an  $\sigma$ -N complex;  $(\text{phCN}, \text{SbCl}_5)$  which may deposit from the benzene solution. The latter expectation was observed when the reaction was carried out between  $\text{phCN}$  and  $\text{SbCl}_5$  in benzene solution. A high yield of yellow solid was obtained and identified by the IR spectrum to be the adduct  $\text{phCN} \cdot \text{SbCl}_5$ , since the spectrum showed the  $\nu(\text{C}\equiv\text{N})$  band shifted to higher frequency from 2230 and 2260  $\text{cm}^{-1}$  whilst  $\nu(\text{C}=\text{C})$  shifted to a lower frequency from 1600 to 1590  $\text{cm}^{-1}$ . Two months later the IR spectrum was re-recorded for that product which was completely different from the first spectrum. The  $\nu(\text{C}\equiv\text{N})$  frequency band nearly disappeared leaving a very weak band at 2240  $\text{cm}^{-1}$ , three strong bands appeared in the  $\nu(\text{N}-\text{H})$  region at 3370, 3300 and 3220  $\text{cm}^{-1}$ , and two bands at 1649 and 1594  $\text{cm}^{-1}$ , assigned with  $\nu(\text{C}=\text{N})$  and  $\nu(\text{C}=\text{C})$ . The IR spectra data for both are given below:

IR spectrum for the first product:  $\nu_{\text{max}} \text{cm}^{-1}$  (Nujol Mull),  
2260 (vs), 1590 (s), 1290 (w), 1198 (vw), 1175 (w/m), 1165 (w),  
1022 (w), 996 (vw), 933 (vw), 760 (vs, sh), 700 (vw), 680 (s),  
552 (vs), 495 (s), 365 (vs, br).

IR spectrum for the second product :  $\nu_{\text{max}} \text{cm}^{-1}$  (Nujol Mull),  
3370 (w), 3300 (w), 3220 (w/m), 2240 (vw), 1649 (vs), 1549 (m),

1510(m), 1288(w/m), 1200(vw,sh), 1169(vw), 1100(vw), 932(w), 865(m), 773(m), 768(w), 760(w), 750(w/m), 719(s,sh), 700(m/s), 675(m/s,sh), 550(w), 520(w), 340(vs).

It cannot explain that the solid state changes without consideration of the orthometallation process. Generally, the first step of the orthometallation process is the formation of a  $\sigma$ -N complex after which the metal center attacks the phenyl ring at the ortho-position due to the formation of a  $\pi$ -complex with the elimination of HCl. This type of attack can occur by an electrophilic, nucleophilic, or oxidation-reduction mechanism the exact nature of which has not been defined yet. The same route can be assumed for the change of the  $\text{PhCN} \cdot \text{SbCl}_5$  complex into another different product of which the structure unfortunately cannot be determined because of the lack of analytical and spectroscopic data. However, this reaction is interesting and it is recommended to reinvestigate it again, to study the structure of the  $\text{PhCN} \cdot \text{SbCl}_5$  complex and the effect of temperature or visible light. A possible mechanism is suggested as follows:

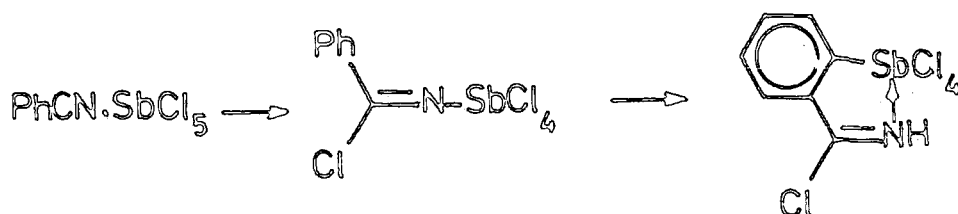

Attempts have been carried out to obtain orthometallated compounds from the reaction of  $\text{R}^1\text{R}^2\text{CNLi}$  with  $\text{SbCl}_5$ ; where  $(\text{R}^1, \text{R}^2) = (\text{o-tolyl}, \text{ph}), (\text{m-tolyl}, \text{ph}), (\text{PF}_2\text{C}_6\text{H}_4)_2$ ; using the same method which is normally used for preparation of orthometallated compounds, but they have not been successful and the only solid products which could be isolated, were

identified as non-orthometallated compounds, having the formulae  $R^1R^2CNH_2^{\oplus}SbCl_4^{\ominus}$  or  $R^1R^2CNH_2^{\oplus}SbCl_6^{\ominus}$ . Compound (III);  $2-\overset{\downarrow}{SbCl_2}C_6H_4C(ph) = NH.C_6H_5CH_3$  was prepared by the method used for compound (I);  $2-\overset{\downarrow}{SbCl_4}C_6H_4C(ph) = NH$ ; which afforded a yellow product; its analytical data are consistent with the above formulae. Toluene of crystallisation has also been found in the case of some related tin compounds. The formation by  $SbCl_3$  of a compound  $SbCl_3 \cdot \frac{1}{2} C_6H_5CH_3$  suggests that weak interaction between the metal atoms and toluene may be involved.

#### 2.2.1.2 Spectroscopic Data:

##### (A) Mass Spectra

The mass spectra of the orthometallated diaryl ketimino antimony chlorides were recorded (except compound I). The results obtained are listed in Table (2.5-a,b). The mass spectrum of compound (II) does not show the parent peak; at  $m/e=469$ ; or even the loss of p-tolyl or methyl group from the expected molecule  $2-\overset{\downarrow}{SbCl_4}-4-MeC_6H_3C(4-MeC_6H_4) = NH$ ; instead loss of hydrogen chloride (100%) and chlorine (14%) is observed. The absence of an intense peak for the ion  $[M-HCl]^+$ ;  $M/e=433$  in the mass spectrum suggests the unstability of this fragment inside the mass spectrometer. However, the most favourable route for the dissociative ionization of the orthometallated compound is the loss of chlorine atoms which leads to the formation of  $M-Cl$ ,  $M-2Cl$ ,  $M-3Cl$  and  $M-4Cl$  fragments. The relatively high stability of these ions are probably due to extensive delocalisation of the positive charge over the aromatic  $\pi$ -system and the orthometallated ring. The elimination of methyl, P-tolyl,

or hydrogen takes place after the loss of at least one chlorine atom from the molecular parent ion ( $m/e=469$ ). The loss of the organic group,  $4\text{-MeC}_6\text{H}_3\text{C}(4\text{-MeC}_6\text{H}_4) = \text{NH}$ . Due to the cleavage of Sb-C bond is not recorded, however other peaks are observed around  $m/e=208$  which indicate the formation of dip-tolylmethyleamine due to the recombination process between  $4\text{-MeC}_6\text{H}_3\text{C}(4\text{-MeC}_6\text{H}_4)\text{CNH}$  and hydrogen fragments. Due to the possibility of  $(p\text{-tolyl})_2\text{CNH}$  formation, other peaks are observed as those resulted from the fragmentation of the parent ketimine such as  $p\text{-tolyl}$ ,  $\text{CNH}_2$ ,  $p\text{-tolyl}\cdot\text{CNH}$ ,... etc. Recombination processes involving metal-containing fragments or organic-chlorine fragments are found, such as  $(p\text{-tolyl})\text{SbCl}^+$ ,  $(p\text{-tolyl})\text{sb}^+$ ,  $(p\text{-tolyl})\text{SbCl}_2^+$ ,  $(p\text{-tolyl})\text{Cl}$ ,  $(p\text{-tolyl})_2\text{CNCl}$ ...

All possible fragments of the antimony chlorides and/or hydrides such as  $\text{Sb}^+$ ,  $\overset{\ast}{\text{SbCl}}$ ,  $\overset{\ast}{\text{SbCl}}_2$ ,  $\overset{\ast}{\text{SbCl}}_3$ ,  $\overset{\ast}{\text{SbCl}}_4$ ,  $\overset{\ast}{\text{SbCl}}_5$ ,  $\overset{\ast}{\text{HSb}}$ ,  $\overset{\ast}{\text{HSbCl}}$ ,... were observed in the spectrum. The formation of the  $\text{HCl}$  fragment is possibly due to the recombination of hydrogen and chlorine fragments or (for less likely) to the decomposition of antimony chloro hydride fragments. The spectra are complicated by the number of antimony isotopes; antimony has about 20 isotopes (from  $\text{Sb}^{112} \rightarrow \text{Sb}^{133}$ ). The most abundant isotopes are  $\text{Sb}^{121}$  (57.25%) and  $\text{Sb}^{123}$  (42.75%).

In the mass spectrum of compound (III);  $2\text{-SbCl}_2\text{C}_6\text{H}_4\text{-C}(\text{ph}) = \text{NH}\cdot\text{C}_7\text{H}_8$  ; the highest mass is observed at  $m/e=375/377$  (3.12, 2.16%, their ratio is similar to  $\text{Sb}^{121}/\text{Sb}^{123} \sim 1.4$ ) which does exactly fit with the molecular ion

( $M_2 - C_7H_8$ ) - see table 2.5b - bearing in mind that  $^{35}Cl$  and  $^{37}Cl$  are present. The mass spectrum does not show toluene to be present in the actual parent ion;  $C_7H_8 \cdot 2SbCl_2 \cdot C_6H_4C(ph) = NH$  at  $m/e = 463$ , but the toluene in the postulated formulae could be identified from the  $C_7H_8^+$  peak at  $m/e = 92$  (4%) and from the  $(C_7H_7SbCl_2^+)$  peak at  $m/e = 283$  (7%). The dissociative paths of the molecular ion ( $M_2$ ) lead to the loss of chlorine, phenyl,  $SbCl_2$  and  $HCl$  as those observed in the mass spectrum of Compound (II). The appearance of high intensity peak at  $m/e = 177$  (100%) may suggest the elimination of the  $(SbCl_2, 3H)$  fragments from the  $(Me - C_7H_8)$  ion.

Table (2.5)

Mass Spectra of Orthometallated Diarylketimino-antimony Chlorides.

- (a)  $2-SbCl_4 - 4-MeC_6H_3C(p-tolyl) = NH = M_1$ :  $m/e$  (Fragment<sup>+</sup>, Rel. Intensity %): 434 ( $M_1 - Cl$ , 0.7), 399 ( $M_1 - 2Cl$ , 1.6), 364 ( $M_1 - 3Cl$ , 26), 348 ( $M_1 - 3Cl - CH_4$ , 16), 329 ( $M_1 - 4Cl$ , 6), 313 ( $M_1 - 4Cl - CH_4$ , 23), 296 ( $SbCl_5$ , 0.4), 282 ( $p-tolyl SbCl_2$ , 1), 278 ( $M_1 - SbCl_2$ , 2.8), 262 ( $HSbCl_4$ , 0.4), 247 ( $p-tolyl SbCl$ , 0.4), 243 ( $M_1 - SbCl_3$ , 1.4), 242 ( $M_1 - HSbCl_3$ , 0.5), 227 ( $HSbCl_3$ , 3), 210 ( $Pt_2CNH_2$ , 3), 207 ( $M_1 - HSbCl_4$ , 4), 191 ( $SbCl_2$ , 16), 156 ( $SbCl$ , 5), 121 ( $Sb$ , 5), 118 ( $PtCNH$ , 17), 104 ( $PhCNH$ , 5), 91 ( $C_7H_7$ , 36), 77 ( $C_6H_5$ , 7), 36 ( $HCl$ , 100), 35 ( $Cl$ , 14).
- (b)  $2-SbCl_2 - C_6H_4C(ph) = NH$ .  $C_7H_8 = M_2$ :  $m/e$  (Fragment<sup>+</sup>, Rel. I%): 375/377 ( $M_2 - C_7H_8$ , 3), 332 ( $M_2 - C_7H_8 - Cl - 4$ , 1.4), 297 ( $M_2 - C_7H_8 - 2Cl - 4$ , 1.3), 283 ( $C_7H_7SbCl_2^+ + 1$ , 7), 227 ( $HSbCl_3$ , 1.6), 223 ( $M_2 - C_7H_8 - phH$ , 1.4), 207 ( $pt_2CN - 1$ , 0.8), 192 ( $HSbCl_2$ , 1.5)

181 (ph<sub>2</sub>CNH, 0.4), 180 (ph<sub>2</sub>CN or C<sub>6</sub>H<sub>4</sub>C(ph) = NH, 8.5),  
 179 (M<sub>2</sub>-C<sub>7</sub>H<sub>8</sub>-HSbCl<sub>2</sub>, 13.7), 177 (M<sub>2</sub>-C<sub>7</sub>H<sub>8</sub>-SbCl<sub>2</sub>-3, 100),  
 121 (Sb, 6), 104 (phCNH, 2), 92 (C<sub>7</sub>H<sub>8</sub>, 4), 76 (C<sub>6</sub>H<sub>4</sub>, 100),  
 75 (C<sub>6</sub>H<sub>3</sub>, 50), 74 (C<sub>6</sub>H<sub>2</sub>, 25), 36 (HCl, 50).

(B) Infra-red Spectra

The IR spectra of the three orthometallated compounds I-III were recorded at the region 4000-250 cm<sup>-1</sup> using mulls in Nujol between KBr plates. The spectrum of each compound shows some significant bands which may confirm the existence of the orthometallated structure as it has been observed in IR spectrum of  $\overset{\downarrow}{2\text{-SnCl}_3\text{-4-MeC}_6\text{H}_3\text{C(4-MeC}_6\text{H}_4\text{)=NH}}$ . In the region 3500 - 3000 cm<sup>-1</sup> each spectrum shows only one sharp band which is assigned to the  $\nu$ (N-H) frequency, also, each spectrum shows 3-5 bands in the region 1600 - 1500 cm<sup>-1</sup> which are assigned to  $\nu$ (C=X) modes and  $\delta$ (N-H) def.; X=C or N - see Table (2.6). The shift of the azomethine stretching frequency can be observed from the appearance of no band in the region 1700 - 1600 cm<sup>-1</sup> relative to the parent imine.<sup>19</sup> This shift of the  $\nu$ (C=N) frequency to lower energy is a common observation for the orthometallated compounds of transition metals, e.g. the orthometallated N-phenyl-benzalimine derivatives of palladium<sup>20</sup>  $\overset{\downarrow}{\text{O-SnCl}_3\text{C}_6\text{H}_4\text{C(ph)=NH}}$  compound. In these orthometallated compounds, the formation of a planar fused aromatic chelated ring will exert a strain on the bond angle at the nitrogen, with the result that the drainage of electrons towards the SbCl<sub>4</sub> or SbCl<sub>2</sub> groups may predominate and the weakened (C=N) bond absorbs at a lower energy.

Table (2.6)

Absorptions in  $\nu(\text{N-H})$ ,  $\nu(\text{C=C})$  and  $\nu(\text{C=N})$  region for some orthometallated diarylketimino antimony chlorides

Compound	$\nu(\text{N-H}) \text{ cm}^{-1}$	$\nu(\text{C=C}) / \nu(\text{C=N}) \text{ cm}^{-1}$
I	3280	1598, 1577, 1569, 1540
II	3260	1610, 1600, 1580, 1538, 1505
III	3250	1581, 1562, 1545
ph <sub>2</sub> CNH	3250, 3210	1600, 1567
pt <sub>2</sub> CNH	3260	1605, 1590, 1548

A strong absorption at  $\sim 740 \text{ cm}^{-1}$  is observed for the orthometallated diphenylketimine derivatives which does not appear in the spectra of the parent imine. This band may be assigned to  $\delta(\text{C-H})$  out-of-plane bending modes which absorb in the range  $900 - 675 \text{ cm}^{-1}$  upon the orthometallation process, and which does not occur for the orthometallated derivative of di p-tolyketimine, since there is relatively little difference in the spectra of 1,4-disubstituted and 1,2,4-trisubstituted benzenes. As there is no information about the IR spectrum of  $\text{ArSbCl}_4$  to use as a model for comparison with the orthometallated compounds (I) and (II), it is difficult to make an assignment for  $\nu(\text{Sb-Cl})$  or  $\nu(\text{Sb-C})$  stretching frequency on those bands which are observed below  $500 \text{ cm}^{-1}$  but, at least they can be regarded as the characteristic bands for the  $\text{Cl}_4\text{Sb} \begin{matrix} \text{C} \\ \diagup \\ \text{R} \text{---} \text{N} \end{matrix}$  species without specific assignment. The position of the metal-halogen or metal-ligand stretching absorption is known to be dependent on several factors such as the oxidation state of metal, the

mass of the metal and of the ligand, the coordination number of the metal, the basicity of the ligand, the bridging or nonbridging character of the ligand, high ligand field stabilization energy, counter-ion effect, and the stereo-chemistry of the complex.<sup>21</sup> By assuming that all of these factors are identical for compounds (I) and (II) it is expected that the same number of bands with small shift, should be present - see Table (2.7).

Table (2.7)

Suggested characteristic IR bands for  $\text{Cl}_4\text{Sb}(\text{N})\text{C}$  species

Compound	$\nu(\text{Sb-C}), \nu(\text{Sb-Cl}) \text{ cm}^{-1}$ **
I	483, 449, 421, 382 (sh), 367, 340, 315
II	493, 435, 409, 370, 352, 335 (sh), 325

\* $\nu(\text{Sb-Cl})$  and  $\nu(\text{Sb-C})$  absorbs in the region  $500 - 200 \text{ cm}^{-1}$ .

For compound (III), in the same region, there are different bands as a result of the change in the oxidation state of the metal. The spectrum shows only one strong band at  $460 \text{ cm}^{-1}$  and several shoulders at 485, 465, 425, 365, 305, and  $290 \text{ cm}^{-1}$ .

### (C) Proton Magnetic Resonance Spectra

The spectra were recorded on solutions in  $d^6$ -DMSO and the proton chemical shifts of the various antimony compounds (except II) are listed in Table (2.8) and illustrated in Figure (2.4 a,b). Each spectrum shows similar signals to those observed for the corresponding tin-orthometallated compounds. The (N-H) resonance appears in each spectrum as a broad peak (Compound I) or as a very

weak triplet peak (Compound III). It is possible to identify two factors which lead to this broadness and weakness of the (N-H) peak; the first one is the slow or intermediate exchange rate of the proton on the nitrogen atom and the other is the effect of the electrical quadrupole moment of the nitrogen nucleus which induces an efficient spin relaxation and thus an intermediate life time for the spin states of the nitrogen nucleus. Due to the latter factor the proton sees three spin states of the nitrogen nucleus which are changing at a moderate rate and the proton responds by giving a broad peak.<sup>22</sup> The aromatic resonances for both compounds (I) and (III) show remarkable changes in the metallated ring in comparison with the parent imine which shows the phenyl resonance at 7.4 ppm. Generally, they consist of a weak low field singlet, and a strong fairly broad high field singlet which overlies or separates from other singlet weak absorptions. It is considered that the strong singlet corresponds to the aromatic protons of the unmetallated ring, and the low field absorption is produced by deshielding of the aromatic proton which is adjacent to the electrophilic  $\text{SbCl}_4$  group, the remaining signals from the metallated ring underlie the strong absorption or shift to lower or higher field. This is consistent with the assignment made for the tin orthometallated compound  $\text{O-SnCl}_3\text{C}_6\text{H}_4\text{C}(\text{ph}) = \text{NH.C}_7\text{H}_8$  and for its related compound  $2\text{-Me}_2\text{Br SnC}_6\text{H}_4\text{CH}_2\text{NMe}_2$ <sup>23</sup> (figure 2.5 a,b).

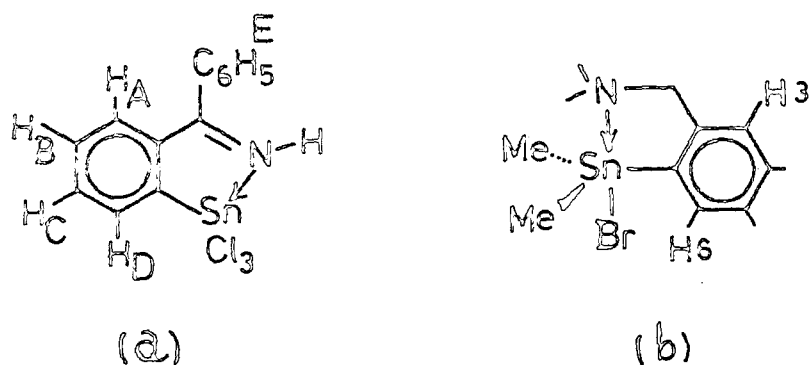
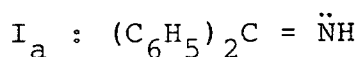
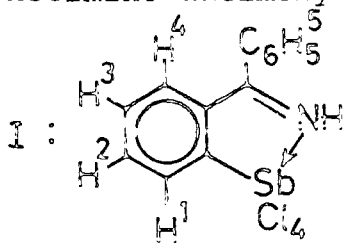

Fig. 2.5

The spectrum of the orthometallated trichlorostannyl-diphenylketimine over the aromatic proton region has been reported to give three complex resonances which were assigned (in order of increasing field)  $H_E$ ,  $H_A$ ,  $H_B$ ,  $H_C$  and  $H_D$ . Similarly, the spectrum of the related compound shown in Figure 2.5(b) has also been assigned with the proton adjacent to the metallation site ( $H_6$ ) giving rise to the aromatic signal at lowest field while the proton ortho to the C-CH<sub>2</sub> bond i.e. ( $H_3$ ) giving rise to the aromatic signal at the highest field. The spectrum of compound (III) shows a methyl proton resonance which supports the existence of coordinated toluene in the orthometallated structure. This coordinated toluene to an orthometallated system has been observed before in the spectrum of the  $O-\overbrace{SnCl_3C_6H_4C(ph)=NH}$  compound.

Table (2.8)

<sup>1</sup>H-NMR Spectra for some ortho-metallated diphenyl ketimino antimony chlorides and diphenyl ketimine



	Solvent	δ ppm					
		N-H	H <sup>1</sup>	H <sup>2</sup>	H <sup>3</sup>	H <sup>4</sup>	H <sup>5</sup>
I	d <sup>6</sup> -DMSO <sup>a</sup>	13.02	9.09	8.41, 8.1	7.48, 6.97	6.62	8.1
I <sub>a</sub>	d <sup>6</sup> -DMSO	10.43		7.43			

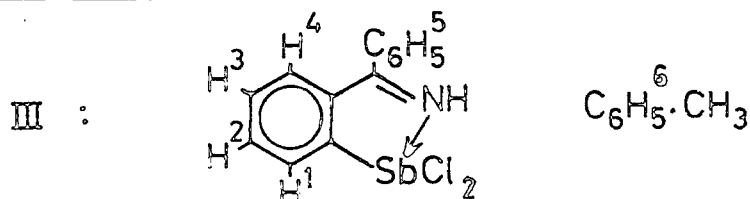

	Solvent	δ ppm							
		N-H	H <sup>1</sup>	H <sup>2</sup>	H <sup>3</sup>	H <sup>4</sup>	H <sup>5</sup>	H <sup>6</sup>	CH <sup>3</sup>
III	d <sup>6</sup> -DMSO <sup>b</sup>	8.6, 8.5, 8.3	7.9	7.63, 7.5				7.16	2.28

a : relative to δ(TMS) = 0 ppm (external reference).

b : relative to δ(TMS) = 0 (internal reference).

### 2.2.2. Reactions yielding non-orthometallated compounds

#### 2.2.2.1 Preparative routes:

As mentioned before in the previous section, the reaction of diarylketimino lithium with antimony pentachloride does not produce only the orthometallated compound as it has been observed in a relative reaction between the imino-lithium and tin-tetrachloride of which the resultant

orthometallated compound has been established by X-ray crystallographic studies but, there are also two different products which could be isolated from the same reaction and under the same conditions of temperature and solvent used. They are postulated as non-orthometallated compounds and probably have the formulae  $\text{Ar}_2\text{CNH}_2^+\text{SbCl}_4^-$  and  $\text{Ar}_2\text{CNH}_2^+\text{SbCl}_6^-$ .

In this section detailed studies have been carried out on these two different products as an attempt to characterize and identify their structures. Consequently, the reaction between diarylketimino lithium (or trimethylsilane) and antimony pentachloride was repeated by using other imine systems differing from that mentioned in the previous section and by changing the conditions of the reaction. In Table (2.10), all products from these attempted reactions and their conditions are listed. The general chemical equation can be described as:

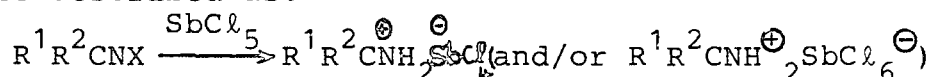

where X = Li, SiMe<sub>3</sub>

$\text{R}^1\text{R}^2$  = ph<sub>2</sub>, (p-tolyl)<sub>2</sub>, (P-FC<sub>6</sub>H<sub>4</sub>)<sub>2</sub>, (O-tolyl,ph), (m-tolyl,ph).

The analytical data for these products (IV-VIII) are in good agreement with their formulae. The products (IV-VII) are found to be stable towards air and moisture, insoluble in all organic solvents (except polar solvents such as dimethylformamide and dimethylsulphoxide), and can be sublimed on a cold finger under vacuum.

Table (2.10)

Non-orthometallated products isolated from the Reactions of  $R^1R^2CNX$  with  $SbCl_5$

No.	product	Reactants of the reaction	Conditions of the reaction
IV	$Ph_2\overset{\oplus}{C}NH_2SbCl_4^{\ominus}$ (white needles)	$ph_2CNLi/SbCl_5$ or $ph_2CNSiMe_3/SbCl_5$	$phCH_3/CHCl_3/R.T.$ $phCH_3/R.T.$
V	$(P\text{-tolyl})_2\overset{\oplus}{C}NH_2SbCl_4^{\ominus}$ (white solid)	$(P\text{-tolyl})_2CNLi/SbCl_5$ $(P\text{-tolyl})_2CNSiMe_3/SbCl_5$	$phCH_3/CHCl_3/R.T.$ $phCH_3/80^\circ C$
VI	$(O\text{-tolyl}), ph\overset{\oplus}{C}NH_2SbCl_4^{\ominus}$ (brown needles)	$(O\text{-tolyl}), phCNLi/SbCl_5$ or $(O\text{-tolyl}), phCNSiMe_3/SbCl_5$	$phCH_3/CHCl_3/R.T.$ $phCH_3/R.T.$
VII	$(m\text{-tolyl}), ph\overset{\oplus}{C}NH_2SbCl_4^{\ominus}$ (buff solid)	$(m\text{-tolyl}), phCNLi/SbCl_5$	$phCH_3/CHCl_3/R.T.$
VIII	$(P\text{-}FC_6H_4)_2\overset{\oplus}{C}NH_2SbCl_4^{\ominus}$ (buff needles)	$(P\text{-}FC_6H_4)_2CNLi/SbCl_5$	$phCH_3/CHCl_3/R.T.$

Because of the difficulty to dissolve these products in a suitable solvent, their molecular weights could not be calculated by using osmometer. The electrical conductivity measurements for compound (IV), show it as ionic product - see Appendix 1. From the Mössbauer spectral data for compounds (IV-VIII Except VI), it has been shown that antimony atom exists in the trivalent oxidation state and that its isomer shift is similar to authentic samples which contain the  $\text{SbCl}_4^-$  anion - see Appendix 1. Other studies such as mass spectra,  $^1\text{HNMR}$ ,  $^{13}\text{CNMR}$ , IR will be discussed later, confirm that these products are actually non-orthometallated or ionic orthometallated compounds. However, the success in isolating salts such as  $\text{ph}_2\text{CNH}_2^+\text{SbCl}_4^-$  and  $\text{ph}_2\text{CNH}_2^+\text{SbCl}_6^-$  from the reaction of  $\text{ph}_2\text{CNH}_2^+\text{Cl}^-$  with  $\text{SbCl}_3$  or  $\text{SbCl}_5$  in chloroform may strongly support the ionic structures of the  $\text{R}^1\text{R}^2\text{CNX/SbCl}_5$  products - (the synthesis of  $\text{ph}_2\text{CNH}_2^+\text{SbCl}_4^-$  and  $\text{ph}_2\text{CNH}_2^+\text{SbCl}_6^-$  salts are mentioned in chapter three). In the reaction pathway on which lithio derivatives  $\text{R}^1\text{R}^2\text{CNLi}$  are used, the reactions were carried out in toluene at their initial stage, after which the solvent was pumped off under vacuum and then  $\text{CHCl}_3$  was added, giving brown solutions which deposited compounds (IV-VIII), and a high yield precipitate. The IR spectrum of this precipitate does not show a simple spectrum as expected for  $\text{LiCl}$  but shows similar bands of those observed in the  $\text{ph}_2\text{CNH}_2^+\text{SbCl}_6^-$  sample. This may indicate that during the formation of the  $\text{R}^1\text{R}^2\text{CNH}_2^+\text{SbCl}_4^-$  product the  $\text{R}^1\text{R}^2\text{CNH}_2^+\text{SbCl}_6^-$  may deposit simultaneously. The other reactions in which silyl compounds  $\text{R}^1\text{R}^2\text{CNSiMe}_3$  are used, were performed in toluene

at room temperature (only for compounds IV and VI) and deposited yellow solids. In the reaction of (p-tolyl)<sub>2</sub>CNSiMe<sub>3</sub> with SbCl<sub>5</sub> the yellow solid did not deposit on stirring at room temperature, but instead two layers were formed : a yellow brown solution (upper) and a red-brown oil (lower). For that reason the mixture was heated at 80°C after which the red-brown oil faded to a yellow-white solid (V). In another experiment, the reaction of O-tolyl phenyl ketimino trimethyl silane with antimony pentachloride was repeated without using any solvent in an attempt to identify the actual products obtained from this reaction. The O-tolyl phenyl ketimino trimethyl silane system was preferably chosen from all ketimine systems since, this system has not produced the tin-orthometallated compound, but a product which is believed to have the formulae (O-tolyl, ph CNSnCl<sub>3</sub>.-n solvent)<sub>m</sub>. The final products of that reaction, after about 30 minutes (started from -196°C until R.T. was reached) were a dark brown viscous liquid under a yellow liquid. The IR spectrum of the latter product is exactly similar to that of an authentic sample of trimethyl chlorosilane Me<sub>3</sub>SiCl, whilst the IR spectrum of the dark brown liquid shows very strong bands at 3340, 3260, 3220 cm<sup>-1</sup> two medium intensity bands at 1870, 1835 cm<sup>-1</sup> and three bands at 1665, 1595, 1550 cm<sup>-1</sup> which are consistent with those bands observed in the dark red-brown oil mentioned in the first section. On heating the dark viscous liquid under vacuum at 80°C, a white solid was sublimed onto a cold finger and was identified as antimony trichloride (SbCl<sub>3</sub>) by its IR spectrum. The remaining residue is a dark brown solid which was not air-

sensitive, very soluble in chloroform and its IR spectrum confirms the existence of the imine system from the appearance of ill-defined  $\nu(\text{N-H})$  band at  $3200 \text{ cm}^{-1}$  and  $\nu(\text{C=N})$  and  $\nu(\text{C=C})$  at  $1640$ ,  $1590$  and  $1540 \text{ cm}^{-1}$ . The isolation of  $\text{Me}_3\text{SiCl}$  and  $\text{SbCl}_3$  from that reaction intermediate suggest the possible pathways as illustrated in Scheme (2.11).

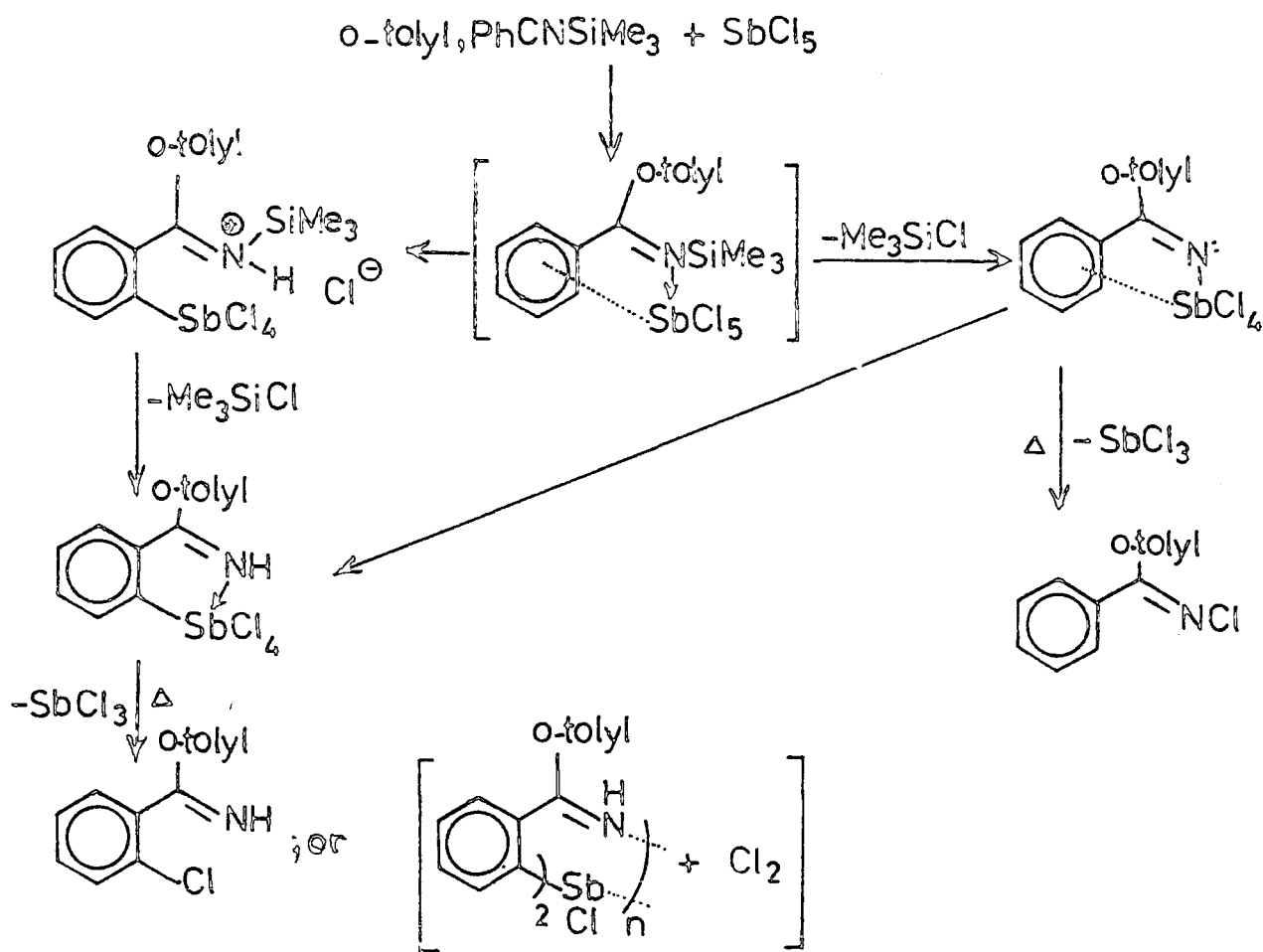

The reason why such ionic compounds :  $\text{R}^1\text{R}^2\text{CNH}_2^{\oplus}\text{SbCl}_4^{\ominus}$  and  $\text{R}^1\text{R}^2\text{CNH}_2^{\oplus}\text{SbCl}_6^{\ominus}$  are separated from the reaction of  $\text{R}^1\text{R}^2\text{CNX}$  with  $\text{SbCl}_5$  - which is expected to afford either the diaryl ketimino antimony tetrachloride or the O-tetra-chlorostibino diaryl ketimine may be explained by assuming

an interaction taking place between the reactive imino-antimony tetrachloride intermediates and the toluene. If such interaction occurs, it will be expected to halogenate the toluene and finally to produce the free ketimine, hydrogen chloride, and antimony trichloride. The last three products are just the starting materials for obtaining the diaryl ketiminium tetrachloro antimonate (III);  $R^1R^2CNH_2^{\oplus}SbCl_4^{\ominus}$ . This assumption is supported by the mass spectrum of the toluene solvent after distillation which implies the presence of chlorotoluene derivatives. The possible pathways for that interaction are illustrated in Scheme (2.12).

Scheme 2.12

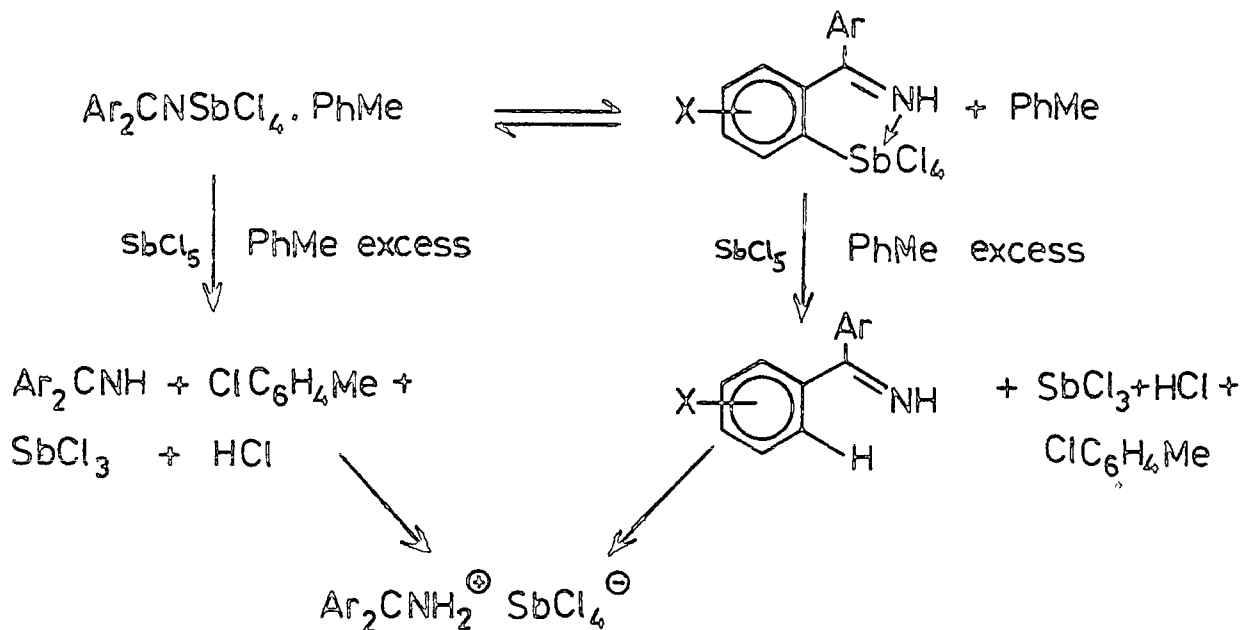

Also it has been taken into account that if a system like  $O-SbCl_4XC_6H_3C(Ar) = NH \cdot C_7H_8$  is assumed to exist, then it can be compared with other systems such as  $phSbCl_4$  or  $p-MeC_6H_4SbCl_4$  which have been characterized to react with the ionic salts to give very stable complex salts. Some

reactions which yield those complex salts<sup>24</sup> are given in the chemical equations (2.7 and 2.8):

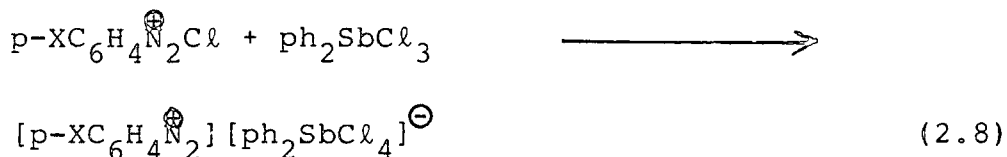
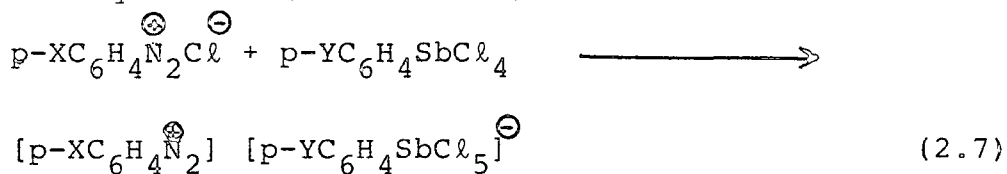

where  $x = \text{C}_2\text{H}_5\text{O}, \text{CH}_3, \text{H}, \text{Br}, \text{NO}_2$

$y = \text{H}, \text{CH}_3, \text{NO}_2$

If the character of the aromatic antimony tetrachloride is considered then it is possible to postulate a series of ionic complexes which can be formed in the antimony ortho-metallation reactions:

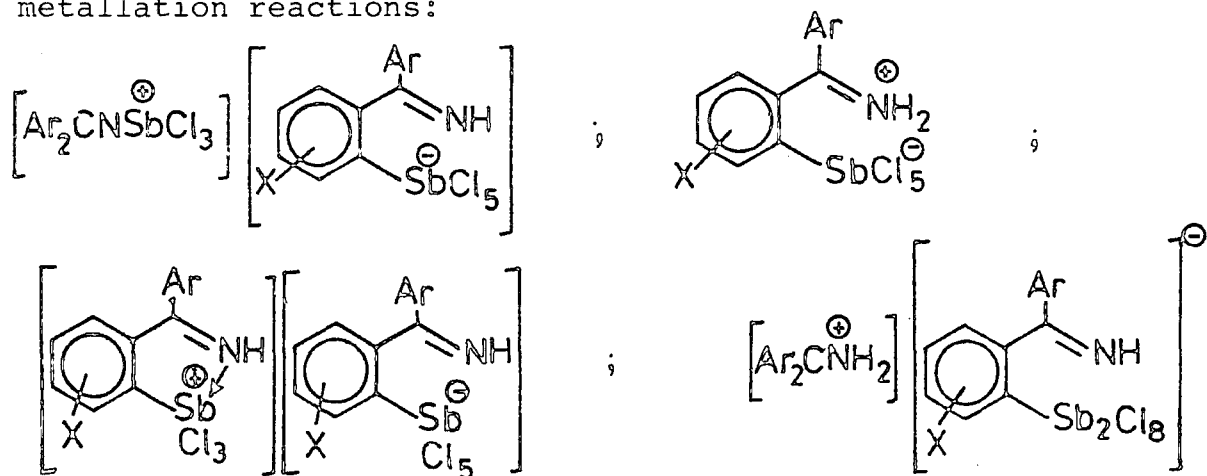

#### 2.2.2.2 Spectroscopic data:

##### (A) Mass Spectra

The mass spectra of all compounds (except V);  $(p\text{-tolyl})_2\text{CNH}_2^\oplus \text{SbCl}_4^\ominus$  were recorded and their results are listed in Table (2.11 - a,b,c,d). There are no peaks arising from fragments of  $\text{R}^1\text{R}^2\text{CNSb}^\oplus$  or any of its chlorides, indicating the absence of any possible orthometallated structure. Most

of the peaks which were observed for these compounds were either due to the organic fragment  $R^1R^2CNH_2^{\oplus}$  or the inorganic fragment  $SbCl_4$ . The organic fragment  $R^1R^2CNH_2^{\oplus}$  itself is unstable and may undergo a further series of decompositions due to electron bombardment or thermal effect to give more stable fragments such as  $R^1R^2CNH^+$ ,  $R^1R^2CN^+$ ,  $R^1CNH^+$ ,  $R^2CNH^+$ ,  $R^1$ ,  $R^2$ . In the compound  $ph_2CNH_2^{\oplus}Cl^{\ominus}$  the mass spectrum does not show an intensive peak at  $m/e = ph_2CNH_2^{\oplus}$ , but in contrast the spectrum shows fragments at  $m/e = 180$  (100%), 179 (56%), 104 (57%), 77 (41%).

Table (2.11)

Mass Spectroscopic Results for  $R_1R_2C:NH_2^{\oplus}SbCl_4^{\ominus}$   
Compounds (IV and VI - VIII).

(a) for  $ph_2CNH_2^{\oplus}SbCl_4^{\ominus}$  (IV)

$m/e$  (Fragment<sup>+</sup>, I<sub>r</sub>%) : 227 ( $SbCl_3+1$ , 13); 191 ( $SbCl_2$ , 39);  
183 ( $ph_2CNH_3$ , 11); 182 ( $ph_2CNH_2$ , 50); 180 ( $ph_2CN$ , 100), 158  
( $SbCl+2$ , 7); 123 (Sb, 7); 121 (Sb, 9); 104 ( $phCNH$ , 73), 77 (ph, 62),  
36 ( $HCl$ , 34); 35 (Cl, 15).

(b) for o-tolyl,  $phCNH_2^{\oplus}SbCl_4^{\ominus}$  (VI)

369 (? , 24); 195 (o-tolyl,  $phCNH$ , 25); 194 (o-tolyl,  $phCN$ , 100);  
193 ( $SbCl_2+2$ , 14), 178 ( $ph_2CN-2H$ , 15); 121 (Sb, 1.3); 116 (o-  
tolyl  $CNH-2$ , 13), 91 (o-tolyl, 10); 77 (ph, 12), 36 ( $HCl$ , 83);  
35 (Cl, 7).

(c) for m-tolyl,  $phCNH_2^{\oplus}SbCl_4^{\ominus}$  (VII)

272 ( $SbCl_4+1$ , 1); 226 ( $SbCl_3$ , 21); 204 ( $MeSbCl_2-2$ , 3);  
197 (m-tolyl,  $phCNH_3$ , 1); 195 (m-tolyl,  $phCNH$ , 49); 194 (m-tolyl,  
 $phCN$ , 99); 192 ( $SbCl_2+1$ , 73); 181 ( $ph_2CNH$ , 31); 180 ( $ph_2CN$ , 79);  
121 (Sb, 4); 118 (m-tolyl  $CNH$ , 27), 104 ( $phCNH$ , 26); 91 (m-tolyl, 100),  
77 (ph, 23), 36 ( $HCl$ , 74).

(d) for  $(p\text{-FC}_6\text{H}_4)_2\text{C} \cong \text{NH}_2^{\oplus}\text{SbCl}_4^{\ominus}$  (VIII)

296 ( $\text{SbCl}_5$  or  $\text{Sb}_2\text{ClF}_4$ , 4); 261 ( $\text{SbCl}_4$ , 1); 241 (? , 3); 226 ( $\text{SbCl}_3$ , 2);  
 217 ( $(p\text{-FC}_6\text{H}_4)_2\text{CNH}$ , 37); 215 ( $(p\text{-FC}_6\text{H}_4)_2\text{CN-H}$ , 87); 121 (Sb, 100),  
 96 ( $p\text{-FC}_6\text{H}_5$ , 15), 95 ( $p\text{-FC}_6\text{H}_4$ , 50); 36 (HCl, 64); 35 (Cl, 23).

The mass spectrum of diphenyl ketiminium chloride, also shows a fragment due to HCl which was the most significant peak for the compounds  $\text{R}^1\text{R}^2\text{CNH}_2^{\oplus}\text{SbCl}_4^{\ominus}$ . The inorganic fragment  $\text{SbCl}_4^+$  could not be observed (except for compounds VII and VIII) and instead a series of peaks were observed with the characteristic relative intensities associated with the presence of one antimony and one, two, or three chlorine atoms. In compound (VI), the mass spectrum shows a single peak at  $m/e = 369$ ; this peak does not contain antimony or chlorine and it is probably a polymeric organic fragment due to some recombination process.

#### (B) Infra-red Spectra

The infra-red spectra of compounds (IV-VIII) were recorded as Nujol Mulls and their most significant bands are illustrated in Table (2.12); together with those of some related compounds.

The spectra strongly resemble those compounds which have been identified as diaryl ketiminium chloride  $\text{Ar}_2\text{-CNH}_2^{\oplus}\text{Cl}^{\ominus}$  for  $\text{Ar}_2 = \text{ph}_2$  or (o-tolyl, ph) which can easily be prepared by passing dry hydrogen chloride gas through an ethereal solution of imine.

The common feature of each spectrum is the appearance of a weak band in the region of  $3200\text{-}3360\text{ cm}^{-1}$  followed by a gradient down to  $3100\text{ cm}^{-1}$  which are possibly due to symmetrical

and asymmetrical stretching vibrations of  $\text{NH}_2$  group. The variation in  $\nu(\text{N-H})$  frequency from one compound to another is believed to reflect the variation of the force constant of the  $\text{C=N}$  bond due to the different carbon-attached substituents i.e.  $\text{H}$ ,  $\text{CH}_3$ ,  $\text{F}$ .

Each spectrum also shows one or two bands in the region  $1685\text{-}1630\text{ cm}^{-1}$  which arise from the stretching vibration of azomethine group;  $\nu(\text{C=N})$ . Actually in the iminium chloride salts,  $\text{Ar}_2\text{CNH}_2^{\oplus} \text{Cl}^{\ominus}$  the  $\nu(\text{C=N})$  stretching frequency is shifted to a higher frequency in comparison with the parent imine (due to the increase of  $\text{p}$ -character of the hybridized nitrogen from the  $\text{SP}^2$  to the  $\text{SP}^3$  state), which appear at about  $1650\text{ cm}^{-1}$  as very strong single band. The appearance of two bands in that region as observed in compounds IV, VI, VII, may be explained by the Fermi resonance effect, where this characteristic strong band for  $\nu(\text{C=N})$  frequency interact with an overtone resulted from a band [ $\delta(\text{C-H})$  out of plane or  $\omega(\text{NH}_2)$ ]; lie in the region  $800 - 850\text{ cm}^{-1}$  and after which the fundamental band at  $\sim 1650\text{ cm}^{-1}$  splits into two less intensity bands, one at about  $1680\text{ cm}^{-1}$  and the other at  $\sim 1630\text{ cm}^{-1}$ . For aromatic system modes, each spectrum shows a very strong band at  $\sim 1595\text{ cm}^{-1}$  assignable to the  $\nu(\text{C=C})$  stretching frequency.

In compounds IV and VI the characteristic bands due to the aromatic  $(\text{C-H})$  bending vibrations out-of-plane  $900\text{-}675\text{ cm}^{-1}$  or in-plane  $1300\text{-}1000\text{ cm}^{-1}$  were quite similar in the number of bands to those bands observed in the parent imines and/or their hydrogen chloride salts. This observation may give an indication that no orthometallation substitution process occurs on the aromatic rings. The IR spectra of compounds

Table (2.12)

Tentative assignments of the most significant bands for diarylketiminium tetrachloro-antimonate (III) derivatives and some of their related compounds.

Compound	$\nu(\text{N-H}) \text{ cm}^{-1}$	$\nu(\text{C=N}) \text{ cm}^{-1}$	$\nu(\text{C=C}) \text{ cm}^{-1}$	Aromatic C-H bending modes <sup>‡</sup> and N-H bending modes <sup>‡</sup> $\text{cm}^{-1}$	$\nu(\text{Sb-Cl}) \text{ cm}^{-1}$
$\text{ph}_2\text{CNH}_2^+\text{SbCl}_4^-$	3360	1638, 1685	1588	858, 825, 797, 775, 725, 703, 695 1297, 1192, 1165, 1120, 1022	320 (sh)
$\text{ph}_2\text{CNH}_2^+\text{Cl}^-$	3300	1655	1598	877, 854, 800, 765, 729, 705 (br), 1285, 1192, 1160, 1145, 1032, 1000	-
$\text{ph}_2\text{CNH}^*$	3250, 3210	1600	1567	890, 850, 789, 760, 720, 695, 1297, 1195, 1178, 1150, 1072, 1030, 1000	-
$(\text{o-tolyl, ph})\text{CNH}_2^+\text{SbCl}_4^-$	3330	1630, 1685	1588	883, 794, 768, 730, 714, 704 (br) 1290, 1195, 1168, 1160, 1127, 1030	-
$(\text{o-tolyl, ph})\text{CNH}_2^+\text{Cl}^-$	3300	1645	1600, 1590	868, 841, 790, 769, 732, 710, 692, 1285, 1209, 1190, 1168, 1160, 1145, 1029	-
$(\text{o-tolyl, ph})\text{CNH}^*$	3260, 3200	1605	1572	893, 802, 782, 760, 730, 695, 1285, 1210, 1190, 1178, 1150, 1110, 1029	-
$(\text{p-tolyl})_2\text{CNH}_2^+\text{SbCl}_4^-$	3200	1630	1604	-	-
$(\text{m-tolyl, ph})\text{CNH}_2^+\text{SbCl}_4^-$	3360	1630, 1680	1594	-	320 (sh)
$(\text{p-FC}_6\text{H}_4)_2\text{CNH}_2^+\text{SbCl}_4^-$	3320	1640	1593	-	320

\* - recorded as contact film.

‡ - aromatic C-H bending modes are out-of-plane and in-plane bending which may include the modes of (N-H) bending:  $\tau(\text{NH}_2)$ ,  $\omega(\text{NH}_2)$ .

IV-VIII does not show any significant bands in the region 350-300  $\text{cm}^{-1}$  as expected for  $\nu(\text{Sb-Cl})$  stretching frequency of the  $[\text{SbCl}_4]^\ominus$  species. However, in some spectra a shoulder band was observed at  $\sim 320 \text{ cm}^{-1}$  which may be assigned as  $\nu(\text{Sb-Cl})$  of  $\text{SbCl}_4^\ominus$  as it has been reported for the  $[\text{C}_5\text{H}_5\text{NH}]^\oplus[\text{SbCl}_4]^\ominus$  and  $[\text{Et}_4\text{N}]^\oplus[\text{SbCl}_4]^\ominus$  complexes of which the  $\nu(\text{Sb-Cl})$  frequency absorb at  $\sim 330 \text{ cm}^{-1}$  further far infra red and Raman spectral studies on these compounds should elucidate this.

### (C) Proton Magnetic Resonance Spectra

The  $^1\text{HNMR}$  spectra were recorded for all compounds (except compound VI), in  $d^6$ -DMSO using tetramethylsilane as external or internal standard. The spectra were simple in comparison with those of orthometallated compounds, particularly in the region of the aromatic protons. Each spectrum shows two or three signals, one for the aromatic protons ( $\sim 8.0$  ppm), and a second very weak broad signal; difficult to determine which is believed to be assigned to the  $(\text{C}=\overset{+}{\text{N}}\text{H}_2)$  protons of the iminium salt ( $\sim 13.0$  ppm), and the third signal is due to the methyl-aromatic substituent protons, only for those compounds V, VII ( $\sim 3.0$  ppm). The  $^1\text{HNMR}$  data for these products (IV-VII) are listed in table (2.13).

To see the effect of protonation on the  $^1\text{HNMR}$  spectrum of the parent imine, e.g.  $\text{ph}_2\text{CNH}$ , the  $^1\text{HNMR}$  spectra were recorded for  $\text{ph}_2\text{CNH}$ ,  $\text{ph}_2\text{CNH}_2^\oplus\text{Cl}^\ominus$  in  $d^6$ -DMSO. Upon protonation, both signals of (N-H) proton and aromatic protons of  $\text{ph}_2\text{CNH}$  were shifted downfield and the signal of  $\text{NH}_2$  protons was broad and weak and difficult to determine - see table (2.13). This broadness and disappearance of  $\text{>C}\overset{+}{\text{N}}\text{H}_2$  peak are familiar characteristics for the protons of the imine salts, which

results from the fast bimolecular rate of exchange of the protons with the medium or by quadrupole relaxation.<sup>27,28</sup>

Another feature of the <sup>1</sup>H NMR spectra of these non-orthometallated products is the absence of a spin-spin splitting for the aromatic protons. In two cases, however, the splitting of aromatic protons were observed (Compounds VII and VIII), but these splittings are believed to occur as a result of coupling with <sup>19</sup>F (as in VIII) - see table (2.13). Also it is possible to consider the possibility of these samples to decompose into Ar<sub>2</sub>CNH and the HSbCl<sub>4</sub> components at room temperature. To eliminate this possibility it recommended to carry out the NMR spectrum at a low temperature.

Table (2.13)

Proton magnetic resonance spectroscopy results for compounds IV-VIII and for some relative compounds.

NO.	Compound	Chemical Shifts ppm*		
		Aromatic protons	CH <sub>3</sub>	NH
IV	ph <sub>2</sub> CNH <sub>2</sub> <sup>+</sup> SbCl <sub>4</sub> <sup>-</sup>	8.05	-	14.5
V	(p-tolyl) <sub>2</sub> CNH <sub>2</sub> <sup>+</sup> SbCl <sub>4</sub> <sup>-</sup>	8.7	3.58	not observed
VII	m-tolyl, phC <sub>2</sub> NH <sub>2</sub> <sup>+</sup> SbCl <sub>4</sub> <sup>-</sup>	7.9, 8.03	2.76	11.1
VIII	(p-FC <sub>6</sub> H <sub>4</sub> ) <sub>2</sub> CNH <sub>2</sub> <sup>+</sup> SbCl <sub>4</sub> <sup>-</sup>	7.6, 7.8, 7.95, 8.1, 8.22, 8.32	-	12.4
	ph <sub>2</sub> CNH	7.43	-	10.43
	ph <sub>2</sub> CNH <sub>2</sub> <sup>+</sup> Cl <sup>-</sup>	7.9	-	not observed

\* The chemical shifts are determined relative to the external TMS except Compound (IV) in which TMS internal is used.

(D) Carbon-13 Magnetic Resonance Spectra

Table (2.14) contains the Carbon-13 chemical shifts for the diphenylketiminium salt of tetrachloro antimonate (Compound IV), its parent imine;  $\text{ph}_2\text{CNH}$  and other relative derivatives. The chemical shifts were measured from the internal  $\text{d}^6$ -DMSO which was used as a solvent and then converted to the TMS scale using the following chemical difference:<sup>29</sup>  $\delta_{\text{TMS}} = \delta_{\text{DMSO}} + 40.5$ .

The chemical shift assignments of the carbon resonances were made tentatively by analogy of the sample to be examined with the relative imine parent and other iminium salts. Also the available  $^{13}\text{C}$ NMR assignments book (Johnson and Jankowski)<sup>30</sup> and Rosenthal-Fendler Review<sup>29</sup> have been applied to assist in the assignments.

The spectrum of the iminium salt,  $\text{ph}_2\text{CNH}_2^{\oplus}\text{SbCl}_4^{\ominus}$  showed three sharp signals in the relative intensity ratio (2:2:1) in the region 130-135 ppm which are believed to be assigned to the non-substituted aromatic carbon resonances in comparison with the diphenyl-ketone;  $\text{ph}_2\text{CO}$  in the latter compound, the o-/m-/p- carbon resonances of the phenyl ring have been assigned to the signals 129.2, 127.6, and 131.6 ppm respectively, if this sequence is applied for sample (IV) then it might be assigned to the signals at 132.38, 129.94, and 136.14 ppm with the o-, m-, p- carbon resonance of the phenyl group respectively.

The  $\delta^{13}\text{C}=\text{N}^+$  resonance was observed at 189.8 ppm as a very weak signal which is normally observed for  $\text{R}_2\text{C} = \text{NR}_2^{\oplus}$  in the region 155-190 ppm<sup>31</sup>. The bridged carbon resonance of the phenyl which may be superimposed on the p-carbon resonance signal could not be observed. The spectrum of the

iminium salt (IV) was recorded again after two days and showed both the bridged carbon and the iminium group more clearly, but a new series of signals were observed in the carbon phenyl resonances. The total number of phenyl resonances was 10 which may seem to be similar to the same number of signals observed for the cyclometallated structure e.g. (aCaC)-  
 $\downarrow$   $\overline{\text{pd-C}_6\text{H}_4\text{N} = \text{Nph}}$  <sup>32</sup>. However, this does not mean the formation of an orthometallated compound since there were no signals observed in the region 145-165 cm<sup>-1</sup> as expected for the metal-carbon resonance. The appearance of the new signals in the iminium salt spectrum may be explained by the thermal decomposition of  $\text{Ph}_2\text{CNH}_2^{\oplus}\text{SbCl}_4^{\ominus}$  upon spinning for a long period which may lead to the formation of new dissociative components which are in equilibrium with the original material, e.g.

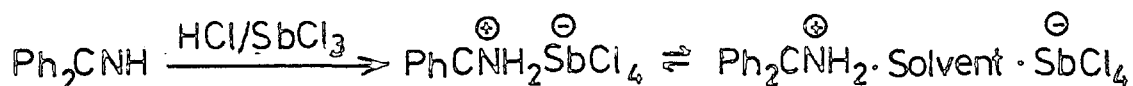

The possibility of the formation of the (C-N) single bond by the way of the addition  $\text{SbCl}_4^{\ominus}$  is eliminated since there is no signal absorbed in the region 50-80 ppm (i.e.  $^{13}\text{C-N}^{\oplus}$ ).

Table (2.14)

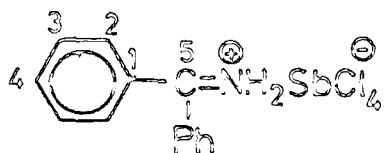

$^{13}\text{C}$  chemical shifts of  $\text{ph}_2\text{CNH}_2\text{SbCl}_4$  and some other relative derivatives

Compound	$\delta\text{C}_2 / \delta\text{C}_3 / \delta\text{C}_4$	$\delta\text{C}_1$	$\delta\text{C}_5 = \text{N}$	$\delta \text{M-C}$	Ref.
$\text{ph}_2\text{CNH}_2^+\text{SbCl}_4^-$	132.38, 129.94, 136.14	not observed	189.83	-	-
$\text{ph}_2\text{CNH}$	127.05, 127.31, 127.96 129.78, 128.74	139.13	175.91	-	-
$\text{ph}_2\text{CO}$	129.2, 127.6, 131.6	137.0	-	-	33
$\text{xyC} = \text{NMe}_2^+$	-	-	155-190	-	31, 34
$(\text{aCaC})-\text{O}-\text{Pd}-\text{C}_6\text{H}_4\text{N}=\text{Nph}$	124.1, 125.6, 128.2 128.6, 130.7, 131.1, 131.4	-	-	151.2, 157.1 163.8	32
$\text{ph}_2\text{C}_6\text{NH}_2^+\text{SbCl}_4^-$ (after 2 days)	129.39, 130.04, 130.43, 131.08, 131.86, 132.38 132.9, 133.55, 136.14	137.84	182.93	-	-

### 2.2.3 The reaction of t-butyl, arylketiminolithium with antimony pentachloride

The reaction of t-butyl, arylketimino lithium with antimony pentachloride, where aryl = p-tolyl, o-tolyl, m-tolyl was attempted. The products (except the product of m-tolyl, t-butyl CNHLi/SbCl<sub>5</sub> reaction) are identified analytically as [2 Bu<sup>t</sup>, p-tolylCNH] · 4HCl · SbCl<sub>3</sub> (IX) and [o-tolylCN] [Bu<sup>t</sup>, o-tolylCNH] · HCl · SbCl<sub>5</sub> (X).

The structure of these products has not been determined, however, they are believed to have an ionic salt structure such as

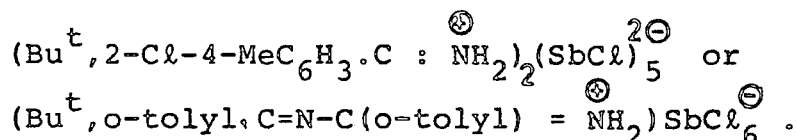

The isolation of ionic salts of the type  $\text{Ar}_2\overset{\oplus}{\text{C}}\text{NH}_2\text{SbCl}_4^\ominus$  or  $\text{Ar}_2\overset{\oplus}{\text{C}}\text{NH}_2\text{SbCl}_6^\ominus$  has been observed, and reported in the previous sections as by-products resulting from the ortho-metallation reactions. In order to investigate the reason for this, the previous reactions were repeated again. The red-brown oil which is usually obtained from such reactions was checked by IR spectroscopy. Surprisingly, a strong band was observed at  $2240\text{ cm}^{-1}$  for the intermediate of (X) which may be assigned as the  $\nu(\text{C}\equiv\text{N})$  stretching frequency. Other significant bands were also observed at 3340, 3190, 1668, 1620, 1600, 1570, and 1540 which are probably assigned with the  $\nu(\text{N-H})$  and  $\nu(\text{C=C})/\nu(\text{C=N})$  stretching frequencies and  $\delta(\text{NH})$  deformations. The appearance of the  $\nu(\text{C}\equiv\text{N})$  band was also observed in the intermediate of the reactions between  $\text{SbCl}_5$  and other ketimino systems such as  $(\text{Bu}^t, m\text{-tolyl})\text{CNLi}$  and  $\text{ph}_2\text{HCNSiMe}_3$ . If a nitrile compound is assumed to be one of the red-brown oil components, then an oxidation process is suggested in which the methyleneamino group  $>\text{C}=\text{N}$  is oxidized into nitrile group;  $\text{C}\equiv\text{N}$ . The possible pathway for these reactions are postulated in Scheme (2.13).

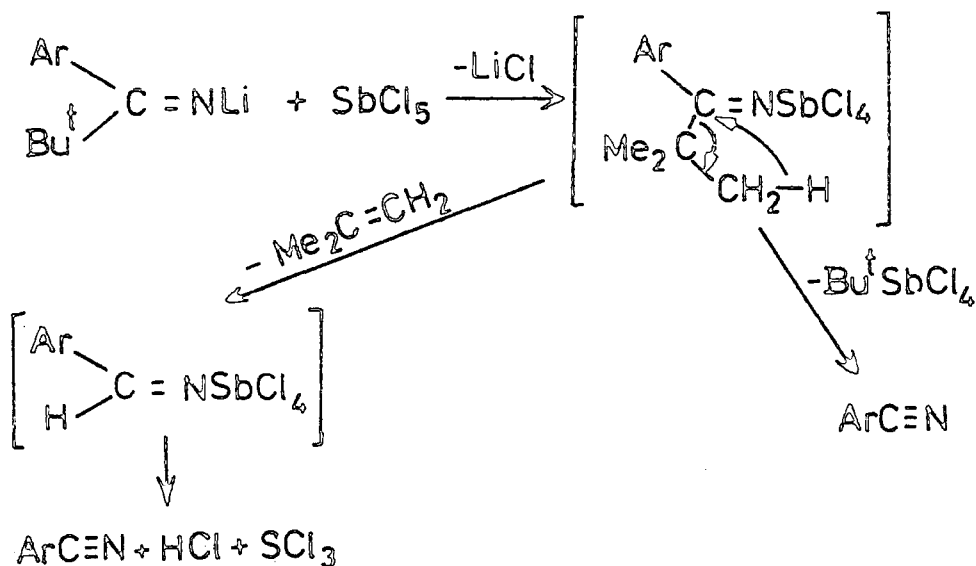

Scheme 2.13

Unfortunately, the IR spectrum of the red-brown oil of compound (IX) has not been recorded. In Table (2.15), the most significant bands of compounds (IX) and (X) such as  $\nu(\text{N-H})$ ,  $\nu(\text{C=C})$ ,  $\nu(\text{C=N})$ ,  $\nu(\text{Sb-Cl})$ , and  $\delta(\text{NH})$  frequencies are listed and compared with the parent imines which was different in the case of (X).

Table (2.15)

Infra-red data of the products resulted from the reaction  $\text{Ar, Bu}^t\text{CNLi/SbCl}_5$

Compound	$\nu(\text{N-H})$ $\text{cm}^{-1}$	$\nu(\text{Sb-Cl})$ $\text{cm}^{-1}$	$\nu(\text{C=C}) / \nu(\text{C=N}) / \delta(\text{N-H})$ $\text{cm}^{-1}$
p-tolyl, $\text{Bu}^t\text{CNH(C)}$	3240. 3210	-	1675 (vw), 1610 (m/s), 1570 (vw), 1510 (w)
IX (n)	3240. 3205	345	1628, 1610, 1594, 1510
o-tolyl, $\text{Bu}^t\text{CNH(C)}$	3240. 3210	-	1615 (s), 1600 (w)
X (n)	3395 3320 3295 3205	340	1700 (w), 1650 (w/m) 1630 (m), 1600 (w), 1520 (w).

(c) : contact liquid film

(n) : nujol mull.

#### 2.2.4 The Reaction of N-chloro di-p-tolyl ketimine with Antimony Trichloride

This reaction was carried out in order to see if any orthometallated product can be prepared and also to study the intermediate of this reaction which might be helpful for the reaction between the imino-lithium and antimony pentachloride. The reaction between the imino chloride and the antimony trichloride was attempted in two different ways, one of them without using any solvent and the other using toluene as a solvent.

In the reaction attempted in the solid state, upon the mixing of the initial reactants in the dry box, a rapid change occurred. This change was exothermic and the white mixture changed into a molten red-brown material. The analytical data of that red-brown material corresponded approximately to the formula  $(pt_2CNC\ell)_3(SbCl_3)_2$ . The IR spectra of that material was recorded as a njuol mull. The spectrum was very similar to the starting compound;  $pt_2CNC\ell$  and there was no  $\nu(N-H)$  stretching band observed or a significant shift for the  $\nu(C=C)/\nu(C=N)$  bands.

In the mass spectrum - see table 2.16 - the dark red-brown substance gives the highest intensity peak at  $m/e = 194$ , which has been assigned before in the previous sections as  $H_3SbCl_2$ . Also the spectrum does not give any indication of the formation of an orthometallated compound or even any fragment corresponding to  $pt_2CNSb^{\oplus}$  or its chlorides. The  $pt_2CNC\ell$  fragment which is normally observed at  $m/e = 243$  and 245 is not observed. The most interesting feature of the mass spectrum is the appearance of several peaks at

m/e = 277, 418 and 488 which are believed to reflect the formation of diantimony chloride fragments such as  $\text{Sb}_2\text{Cl}$ ,  $\text{Sb}_2\text{Cl}_5$  and  $\text{Sb}_2\text{Cl}_7$  fragments.

In another attempt, the same reaction was repeated by extraction of the mixture in toluene solution. No change in the colour was observed and the solution deposited a micro-crystalline solid which apparently has the composition  $(\text{pt}_2\text{CNH} \cdot \text{SbCl}_3 \cdot 2\text{HCl})$ . The reason for suggesting this formula comes from the analytical data, IR and mass spectra. In the IR spectrum, the  $\nu(\text{N-H})$  stretching frequency is observed at  $3330 \text{ cm}^{-1}$  and there is no sign of the appearance of the  $\nu(\text{C=N})$  band as only one band is observed at  $1603 \text{ cm}^{-1}$  which may be assigned to the  $\nu(\text{C=C})$  aromatic frequency. In the region  $1200 - 1000 \text{ cm}^{-1}$  the spectrum is different from the  $(\text{p-tolyl})_2\text{CNCl}$  spectrum, for example, a strong band is observed at  $1020 \text{ cm}^{-1}$  which might be consistent with the  $\nu(\text{C-N})$  frequency -  $\nu(\text{C-N})$  single bond stretching frequency occurs at  $1030-1230 \text{ cm}^{-1}$  for the aliphatic amines.<sup>35</sup> A change is observed also in the region  $900-600 \text{ cm}^{-1}$ , by the appearance of new bands particularly at  $753 \text{ cm}^{-1}$  in comparison with the imino-chloride spectrum, this may be assigned to the  $\nu(\text{C-Cl})$  stretching frequency. The appearance of a band at  $340 \text{ cm}^{-1}$  suggests the existence of the tetrachloro antimonate (III) anion;  $\text{SbCl}_4^\ominus$  for which  $\nu(\text{Sb-Cl})$  would be expected near this frequency.

The mass spectrum of that white solid is nearly similar to that spectrum of the red-brown solid - see table (2.16).

Table (2.16)

Mass spectral data of  $pt_2CNCl/SbCl_3$  Products.

(a) for  $3 pt_2CNCl - 2SbCl_3$  product

m/e (Fragment<sup>+</sup>, I<sub>r</sub>%): 489( $Sb_2Cl_7+2$ , 0.6);  
 277( $Sb_2Cl$ , 0.4); 227( $SbCl_3+1$ , 28); 209( $pt_2CNH$ , 7);  
 194( $SbCl_2+3$  or  $pt, phCN$ , 100); 192( $SbCl_2+1$ , 74); 157( $SbCl+1$ , 7);  
 122( $SbH$ , 12); 120( $ptCNH_3$ , 20); 91( $pt$ , 11), 36( $HCl$ , 56),  
 35( $Cl$ , 17).

(b) for  $pt_2CNH \cdot SbCl_3 - 2HCl$  product: 582(? , 3), 488( $Sb_2Cl_7$   
 $+1$ , 4); 45 (? , 1); 429(? , 15), 359(? , 6); 226( $SbCl_3$ , 19);  
 191( $SbCl_2$ , 70); 193( $SbCl_2+2$ , 100), 156( $SbCl$ , 11), 121( $Sb$ , 18);  
 36( $HCl$ , 28); 35( $Cl$ , 14).

It can be concluded from the reaction of N-chloro di-p-tolyl ketimine with  $SbCl_3$  that the reaction does not yield the orthometallated compound hoped for, probably because of the formation of an anionic product such as  $[2pt_2CNCl \cdot pt_2CN^{\ominus}SbCl_3][SbCl_4]^{\oplus}$  in the case of the solid state reaction or due to the interaction of the reactive intermediate with the solvent which may lead to the formation of hydrogen chloride leading finally to the reduction of the (C=N) double bond into (C-N) and the formation of a compound like  $pt_2C(Cl)NH_3^{\oplus}SbCl_4^{\ominus}$ . The appearance of signals which are believed to arise from the diantimony chlorides may suggest an intermediate with a mainly metal-metal bond which controls the pathway of that reaction.

### 2.3 CONCLUSION

The equimolar reaction of diarylmethyleneamino-lithium with antimony chlorides does not produce only the antimony

orthometallated compounds. Another two different products are isolated and identified as iminium salts of tetra- or hexachloroantimonate. These salts probably result from the interaction of the intermediates with solvents or perhaps due to the thermal decomposition of the intermediates. The most valuable observation of these reactions is the change of the oxidation state of antimony from  $Sb^V$  to  $Sb^{III}$  which indicates that an oxidation-reduction process occurs during the orthometallation reactions. The transference of a group such as the azomethine ( $>C=N-$ ) or chlorine from one Sb atom to another may be responsible for such an oxidation-reduction reaction. In the equimolar reaction of t-butyl, arylketimino lithium with antimony pentachloride, the results show an important behaviour in which the azomethine group; ( $C=N$ ) is oxidized into cyano group; ( $C\equiv N$ ) due to the elimination of  $Me_2C=CH_2$  and  $[HSbCl_4]$ . All types of the reaction between antimony penta- or trichloride and ketimino derivatives, carried out in this work are summarized in the following scheme:

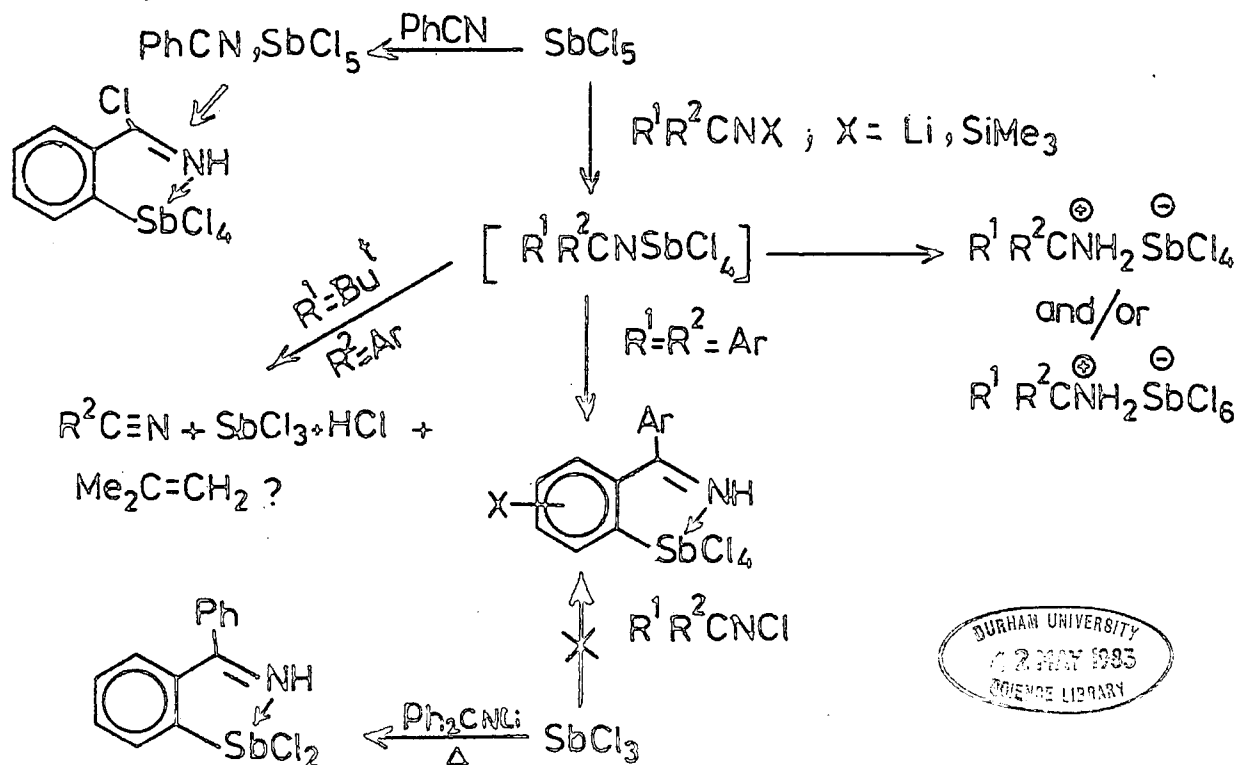

## 2.4 EXPERIMENTAL WORK

All reactions were carried out under an atmosphere of dry nitrogen.

### 2.4.1 Reaction of Diphenylketiminolithium with Antimony Pentachloride (Mole Ratio 1:1, Solvent Diethyl Ether/Toluene, Temperature 90°).

A solution of 22.1 mmol. diphenylketiminolithium in 60 cm<sup>3</sup> dry ether/hexane was cooled to -196°C and 2.8 cm<sup>3</sup> antimony pentachloride were added. The mixture was allowed to warm to room temperature with stirring. The deep red colour of the imino-lithium faded to yellow, and a pale-yellow precipitate formed, which rapidly became sticky and coagulated. The mixture was stirred for twenty hours, with no change in the colour of the mixture. Then all solvent was removed under vacuum. 60 cm<sup>3</sup> dry toluene were then added to the residue, and the dark yellow mixture was heated for one hour at about 90°C.

A deep red oil deposited beneath the red solution. The mixture was filtered while hot, yielding a white solid (LiCl) and the filtrate was separated into two layers; the lower was a deep red oil, and the upper was a red solution. The upper solution was withdrawn by syringe leaving the oil. Both the oil layer and the red solution deposited a bright yellow microcrystalline solid on standing at room temperature for three days. This was identified as ortho-tetra-chlorostibinodiphenylketimine;  $o\text{-Cl}_4\text{SbC}_6\text{H}_4\text{C}(\text{ph}) = \text{NH}$ . Some of the yellow solid was deposited as brown solid. However the analysis and the other spectroscopic analysis showed this brown solid as an orthometallated compound.

\* Analysis:

Found : C 34.5, H 2.7, Cl 33.0,

N 3.0, Sb 26.5%

$C_{13}H_{10}NSbCl_4$  requires:

C 35.2, H 2.3, Cl 32.1, N 3.2, Sb 27.5%.

\*Infrared spectrum:  $\nu_{max} \text{ cm}^{-1}$  (Nujol Mull)

3280(m/s), 3069(m), 3055(m), 3020(m), 3010(m), 1960(vw),

1910(vw), 1845(vw), 1690(vw), 1664(vw), 1615(vw), 1598(m,sh),

1577(w), 1569(m), 1540(m), 1500(vw), 1490(w), 1320(vw),

1310(vw), 1300(w), 1282(vw), 1260(vw), 1218(w), 1158(w),

1124(w), 1000(vw), 885(vw), 848(vw), 824(vw), 789(m), 759(w),

740(w), 722(m), 695(m,sh), 674(w), 650(w,sh), 615(w), 604(m).

2.4.2 Reaction of Diphenylketiminolithium with Antimony Pentachloride (1:1 in Toluene/Chloroform at 15°)

A solution of 16.5 mmoles diphenylketiminolithium in 56 cm<sup>3</sup> dry toluene/hexane was cooled to -196°C, and 2.1 cm<sup>3</sup> antimony pentachloride were added. The mixture was allowed to warm to room temperature with stirring and then stirred overnight. The resulting yellow solution over a white yellow precipitate was then evaporated to dryness under reduced pressure. 30 cm<sup>3</sup> dry chloroform were then added to the residue and the mixture was stirred for ~15 minutes and then filtered yielding a pale yellow solid (bulkier than would be expected for LiCl), and a dark brown solution, which on standing for two days at room temperature deposited a bright white micro-crystalline solid, which was identified as diphenylketiminium,  $(\text{ph}_2\text{C} = \text{NH}_2)^{\oplus} (\text{SbCl}_4)^{\ominus}$ .

\*Analysis

Found: C 35.0, H 3.3, Cl 32.5, N 3.3, Sb 28.0%

$C_{13}H_{12}NSbCl_4$  requires: C 35.0, H 2.7, Cl 31.9, N 3.1,  
Sb 27.3%

\*Infrared spectrum  $\nu_{\max} \text{ cm}^{-1}$  (Nujol Mull)

3360(m), 3100(s), 3086(s), 3060(s), 3030(s), 1988(vw),  
1975(vw), 1910(vw,sh), 1825(vw,sh), 1775(vw), 1685(m),  
1678(m), 1603(m), 1588(w), 1575(m,sh), 1500(w), 1485(w),  
1323(w), 1308(w), 1297(w/m), 1192(w), 1165(m/s), 1120(w),  
1138(vw), 997(vw), 980(vw), 938(vw), 858(vw), 845(w),  
825(m), 797(m,sh), 790(w), 774(m/s), 764(w), 725(m),  
703(s), 695(s), 685(w), 664(m), 614(w), 602(m), 564(m).

2.4.3 Reaction of Diphenylketiminotrimethylsilane with  
Antimony Pentachloride (1:1 in Toluene at 18°).

A solution of 11.85 mmol. diphenylketiminotrimethylsilane in 40 cm<sup>3</sup> dry toluene was cooled to -196°C and 1.5 cm<sup>3</sup> antimonypentachloride were added by syringe. The mixture before reaching room temperature was in two layers; the lower was a dark brown solid and the upper was yellow solution. Evolution of bubbles from the lower layer was observed and the rate of evolution of these bubbles increased with approaching to room temperature. On stirring the mixture for one hour at room temperature, the final product was a light yellow solid below the yellow solution. This mixture was then filtered yielding the yellow powder and a yellow solution. The latter solution deposited, on standing at room temperature for four days, a bright white microcrystalline solid. Its m.p. and i.r. spectrum was identical to that

reported for the crystals of reaction (2.4.2) i.e.  $\text{ph}_2\text{CNH}_2^{\oplus}$   $\text{SbCl}_4^{\ominus}$ . However, the i.r. spectrum for the yellow powder confirmed the existence of another product.

Infrared spectrum for the yellow powder:

$\nu_{\text{max}}$   $\text{cm}^{-1}$  (Nujol Mull).

3289(m), 3260(m), 3060(m), 2720(w), 1815(vw), 1660(w),  
1605(w), 1584(m/s, sh), 1560(m), 1545(m/s), 1485(w), 1300(w),  
1273(w), 1225(w), 1210(vw), 1180(vw), 1165(w), 1072(vw),  
1029(vw), 1000(w), 853(w), 838(w), 789(w), 778(w), 763(w),  
738(w), 728(w), 700(s, sh), 655(w), 642(w), 632(w/m),  
612(w/m), 602(m).

2.4.4. Reaction of Diphenylketiminolithium with Antimony Pentachloride (5:1 in Toluene at 100°).

A solution of 68.4 mmol. diphenylketiminolithium in approximately 100 ml. dry toluene was cooled to  $-196^{\circ}\text{C}$  and 1.75 ml. antimony pentachloride (4.09 g., 13.68 mmol.) were added. The mixture was allowed to warm to room temperature with stirring.

The characteristic red colour of the iminolithium faded to orange and finally to yellow, and at room temperature the reaction mixture consisted of a yellow solution over a yellow-white precipitate. The mixture was stirred at room temperature for 40 minutes, then heated to  $\sim 100^{\circ}\text{C}$  with stirring and filtered whilst hot to produce a white yellow precipitate and a yellow filtrate. On standing at room temperature for 3 days, this filtrate deposited no solid even on cooling. After several weeks standing at room temperature, this solution deposited colourless, long needles which were collected on a filter stick, washed with toluene and dried

under vacuum. They were identified as benzophenone oxime.

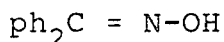

\*Analysis

Found: C 81.3, H 5.3, N 6.6, Sb O, Cl O, Li O%

$\text{C}_{13}\text{H}_{11}\text{NO}$  requires : C 79.2, H 5.6, N 7.1%

\* Infra-red spectrum:  $\nu_{\text{max}} \text{cm}^{-1}$  (Nujol mull).

3090(vw), 3080(vw), 3050(w), 3020(w), 1587(w), 1564(w),  
1320(m/s), 1310(w), 1294(vw), 1270(vw), 1178(w), 1159(vw),  
1075(vw), 1025(w), 999(vw), 982(w), 954(m), 909(w), 775(w/m),  
762(m,sh), 755(w), 749(vw), 723(w), 718(vw), 690(vs),  
665(vw), 652(w/m), 612(vw).

2.4.5 Reaction of Di-p-Tolyketiminolithium with Antimony Pentachloride ( 1:1 in Diethyl Ether/Toluene at 90°C)

The lithiated di-p-tolyketimine (15.7 mmol.) in 60 ml. dry ether/hexane was cooled to  $-196^\circ\text{C}$  and treated with antimony pentachloride (2.08 ml. 15.7 mmol). The solution was allowed to warm up to room temperature during which the very dark red solution changed colour to give a clear solution over a precipitate. All the solvent was removed under vacuum leaving a yellow residue which was heated by a hair drier under vacuum until all the yellow residue melted and turned brown. 45 ml. dry toluene were then added to the brown residue, which readily dissolved in the toluene. The mixture was heated for one hour at about  $90^\circ\text{C}$ , then filtered while hot, yielding a white solid (LiCl) and the filtrate, which separated into two layers as observed in reaction (24.1) On standing at room temperature for three days, the brown filtrate deposited a white solid which was collected on a filter stick, washed with cold toluene and dried under vacuum.

This reaction's product was identified as ortho-tetra-chlorostibinodi-p-tolylketimine.

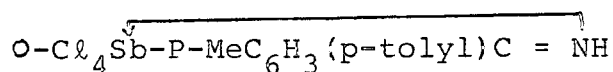

For the purpose of X-ray diffraction analysis, an attempt was made to grow a single crystal of the raw material of the reaction product by recrystallization of the solid in the toluene solution, but it was not successful.

\*Analysis for the recrystallized solid:

Found: C 38.3, H 2.7, N 2.8, Cl 30.0 %

$\text{C}_{15}\text{H}_{14}\text{NSbCl}_4$  requires: C 38.2, H 3.0, N 3.0, Cl 30.1%

\* Infra-red spectrum:  $\nu_{\text{max}} \text{ cm}^{-1}$  (Nujol Mull).

3260(m/s), 1610(w), 1600(m), 1580(w/m), 1538(w/m), 1505(vw,sh), 1560(sh), 1415(vw), 1300(vw), 1290(vw), 1279(vw), 1260(vw), 1230(w), 1210(w,sh), 1190(w), 1170(vw), 1145(w/m,sh), 1020(vw,sh), 930(vw), 855(vw), 839(w), 832(w), 820(vw), 793(vw), 780(w/m), 756(w/m), 720(vw), 670(vw), 612(vw), 640(vw), 630(vw), 493(vw), 435(vw), 409(vw), 352(m/s), 325(vs).

#### 2.4.6 Reaction of Di-P-Tolylketiminolithium with Antimony Pentachloride (1:1 in Toluene/Chloroform at 18°).

A solution of 12.9 mmol. di-p-tolylketiminolithium in  $\sim 50 \text{ cm}^3$  dry toluene/hexane was cooled to  $-196^\circ\text{C}$ , and 1.65 ml. antimony pentachloride were added. The mixture was allowed to warm up to room temperature with stirring. The deep red colour solution of imino-lithium faded to yellow. The mixture was stirred overnight and the colour changed finally to a greenish yellow colour. All solvent was removed under vacuum. The solid was stirred with 40 ml. dry chloroform

for ~15 minutes and filtered to remove lithium chloride. The dark brown filtrate, on concentrating by vacuum and cooling deposited bright pale yellow crystals identified as

di-p-tolyketiminium tetrachloroantimonate (III);

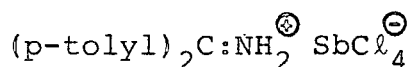

\*Analysis

Found: C 38.0, H 4.2, N 2.7, Sb 26.2, Cl 26.7%

$\text{C}_{15}\text{H}_{16}\text{NSbCl}_4$  requires: C 38.0, H 3.4, N 2.9, Sb 25.7,

Cl 30.0%.

\*Infra-red spectrum:  $\nu_{\text{max}} \text{ cm}^{-1}$  (Nujol Mull).

3200(sh,m), 3020(s,sh), 1630(m,sh), 1604(s/vs,sh), 1189(w),

1162(m), 1138(w), 1134(w), 1115(w), 1018(vw), 830(s,sh),

854(w), 770(w,sh), 738(m,sh), 672(w), 662(w), 632(w),

614(w/m), 549(s).

2.4.7 Reaction of Di-P-Tolyketiminotrimethylsilane with Antimony Pentachloride (1:1 in Toluene at 80°).

A solution of 11.56 mmol. di-p-tolyketiminotrimethylsilane in 40 cm<sup>3</sup> dry toluene was cooled to -196°C, and 1.48 ml. antimony pentachloride was then added. The mixture was allowed to warm up to room temperature, with stirring. The final product was a yellow-brown solution and no solid precipitated as observed with analagous reactions. However, the evolution of bubbles which increased gradually, as the temperature approached room temperature, was observed. The solution was stirred for one hour. On standing, it separated into two layers; a yellow-red solution (the upper layer), and a red-brown oil (the lower layer), and the bubbles still evolved. The two layers were heated with stirring at 40°C and the red-brown oil faded to yellow-white oil. At 80°C, the mixture

was a dark brown-red solution over a white solid. The mixture was then filtered yielding the yellow-white solid, and the dark red-brown filtrate which deposited further crystals.

The i.r. spectrum of these crystals was identical with that spectrum for the product of reaction (2.4.6), i.e.

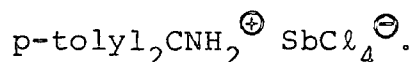

2.4.8 Reaction of Di-P-fluorophenylketiminolithium with Antimony Pentachloride (1:1 in Toluene Chloroform at 18)

A solution of 17.1 mmol. of di-p-fluorophenylketiminolithium in 50 cm<sup>3</sup> dry toluene/hexane was cooled to -196°C and 2.18 cm<sup>3</sup> antimony pentachloride were then added. The mixture was allowed to warm to room temperature with stirring for four hours. On standing the mixture was a yellow-white precipitate below a deep orange-red solution. All solvent was removed under vacuum, 30 cm<sup>3</sup> chloroform were then added to the residue and the mixture was stirred for ~15 minutes and then filtered, yielding the yellow-white precipitate and a dark brown solution. On cooling and standing, bright yellow needles deposited. These were identified as

di-p-fluorophenylketiminium tetrachloroantimonate (III);

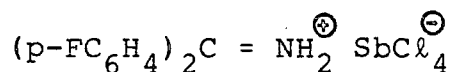

\*Analysis

Found: C 34.8, H 3.3, F 8.0, N 3.0, Sb 24.3, Cl 28.4%

C<sub>13</sub>H<sub>10</sub>F<sub>2</sub>NSbCl<sub>4</sub> requires: C 32.4, H 2.0, F 7.9, N 2.9,

Sb 25.3, Cl 29.5%.

\*Infra-red spectrum:  $\nu_{\text{max}}$  cm<sup>-1</sup> (Nujol Mull).

3320(m), 3190(m,sh), 3070(s), 2720(w/m), 1720(vw), 1625(w, broad), 1593(s), 1510(w), 1500(m), 1246(m/s,sh), 1158(s), 1135(w), 1110(w), 1009(w), 967(vw), 880(w), 851(s,sh), 832(w,sh), 789(w), 749(w), 735(w/m), 720(w), 694(vw), 659(w), 550(s,sh).

2.4.9 Reaction of m-Tolyl, phenylketiminolithium with Antimony Pentachloride (1:1 in Toluene/ Chloroform at 18°).

A solution of 19.97 mmol. m-tolyl, phenylketiminolithium in  $\sim 52 \text{ cm}^3$  dry toluene/hexane was cooled to  $-196^\circ\text{C}$  and  $2.55 \text{ cm}^3$  antimony pentachloride were added. The mixture was allowed to warm up to room temperature with stirring and then stirred overnight at room temperature. The resulting dark brown solution over a white-yellow precipitate was evaporated to dryness.  $30 \text{ cm}^3$  chloroform were then added and stirred for  $\sim 15$  minutes and the mixture was filtered yielding a pale yellow residue and a dark brown solution which on standing at room temperature overnight, deposited a micro-crystalline buff-coloured solid, identified as m-tolyl, phenylketiminium tetrachloroantimonate (III);

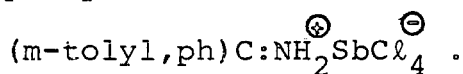

\*Analysis

Found: C 36.4, H 3.6, Cl 30.2, N 3.0, Sb 26.8%

$\text{C}_{14}\text{H}_{14}\text{NSbCl}_4$  requires: C 36.5, H 3.0, Cl 30.9, N 3.0, Sb 26.5%

\* Infra-red spectrum:  $\nu_{\text{max}} \text{ cm}^{-1}$  (Nujol Mull).

3360(w/m,broad), 3108(m), 3035(m), 1680(w), 1630(w), 1594(m), 1300(w), 1266(vw), 1226(vw), 1192(vw), 1178(vw), 1153(w,sh), 1090(vw), 1029(w), 928(vw), 892(vw), 829(w), 807(w), 790(w), 780(w), 728(w/m), 705(m,sh), 668(w), 605(w/m,sh).

2.4.10 Reaction of o-Tolyl, phenylketiminolithium with Antimony Pentachloride (1:1 in Toluene/Chloroform at 18°)

A solution of 15.4 mmoles o-tolyl, phenylmetiminolithium in  $\sim 50 \text{ cm}^3$  dry toluene/hexane was cooled to  $-196^\circ\text{C}$  and  $1.97 \text{ cm}^3$  antimony pentachloride were added. The mixture was allowed to warm to room temperature, with stirring and then stirred overnight. The resulting orange-yellow solution over a yellow white precipitate was then evaporated to dryness.  $30 \text{ cm}^3$  chloroform were then added to the residue and the mixture was stirred for  $\sim 15$  minutes, and then filtered, yielding a pale yellow solid (bulkier than would be expected for  $\text{LiCl}$ ), and a dark brown solution, which on standing for two days at room temperature deposited a small yield of bright brown needle crystals; identified as o-tolyl, phenylketiminium tetrachloroantimonate (III); o-tolyl,  $\text{phC} = \text{NH}_2^{\oplus} \text{SbCl}_4^{\ominus}$

\* Analysis

Found : C 37.6, H 3.7, N 3.4, Sb 26.7, Cl 31.0%

$\text{C}_{14}\text{H}_{14}\text{NSbCl}_4$  requires : C 36.5, H 3.0, N 3.0, Sb 26.5, Cl 30.9%

\* Infra-red spectrum  $\nu_{\text{max}} \text{ cm}^{-1}$  (Nujol Mull).

3330(m,broad), 3104(m), 3095(m), 3065(m), 3010(m), 1685(w), 1630(w,broad), 1599(w), 1588(m), 1195(vw), 1168(w), 1160(w), 1127(vw), 1095(vw), 998(vw), 958(vw), 938(vw), 883(vw), 865(vw), 823(w), 794(w), 768(m), 730(m), 714(w/m), 704(w/m), 666(w), 612(w), 574(w/m), 475(s).

2.4.11 Reaction of o-Tolyl, phenylketimino trimethylsilane with Antimony Pentachloride (1:1 in Toluene at 16°).

A solution of 7.11 mmol. o-tolylphenylmethyleamino-trimethylsilane in 30 cm<sup>3</sup> dry toluene was cooled to -196°C, and 0.91 cm<sup>3</sup> antimonypentachloride were added. The mixture before reaching room temperature formed two layers, the lower layer was a dark brown-red oil, and the upper layer was a light yellow solution. There were some bubbles evolved from the lower layer of which the rate of evolution increased on approaching to room temperature. On stirring, for one hour at room temperature, the mixture was a colourless solution over a yellow solid. The mixture was then filtered yielding a yellow powder and a colourless solution. This latter solution deposited a bright brown microcrystalline solid on standing at room temperature for four days. Its i.r. spectrum was identical to that reported for the product of reaction (2.4.10) i.e. the ketiminium salt o-tolyl(ph)<sup>⊕</sup>CNH<sub>2</sub>SbCl<sub>4</sub><sup>⊖</sup>.

2.4.12 Reaction of Mesityl, phenylketiminotrimethylsilane with Antimony Pentachloride (1:1 in Diethyl Ether at 15°)

A solution of mesityl, phenylketimine (2.25 g., 10.07 mmol.) in 85 cm<sup>3</sup> diethyl ether was cooled to -196°C, and 6.4 ml. n-butyl lithium solution (10.07 mmol. -1.57M n-BuLi in hexane) were added. On warming to room temperature, this gave an orange solution of the iminolithium product. On stirring the solution for 1h., it started to coagulate forming an orange precipitate under a red solution. The mixture was

recooled to  $-196^{\circ}\text{C}$  and  $1.3\text{ cm}^3$  antimony pentachloride was added. When the mixture was warmed to room temperature with stirring, the result was a yellow solution over a yellow precipitate and on continuing the stirring overnight, the yellow precipitate changed to a dark brown oily residue, under the yellow solution. The mixture was then filtered to separate the dark solid ( $\text{LiCl?}$ ) from the solution which was in two layers: a brown oil in the bottom layer and a yellow solution in the upper one. On standing the filtrate for two months, a very low yield of yellow crystals deposited, but due to the low yield and the stickiness of this sample, and the difficulty to handle it, extensive studies on this sample could not be carried out. However, the IR spectrum of this yellow sticky solid showed three bands at 1610, 1590 and  $1563\text{ cm}^{-1}$  which may be attributed to  $\nu(\text{C}=\text{C})$  and  $\nu(\text{C}=\text{N})$ , also it showed a characteristic ether absorption,  $\nu(\text{C}-\text{O}-\text{C})$  at  $\sim 1100\text{ cm}^{-1}$  and no band in the  $\nu(\text{N}-\text{H})$  region, consistent with a polyimino-bridged species of the type  $(\text{R}_2\text{C}=\text{N}-\text{SbCl}_4\text{Et}_2\text{O})_n$ . A sample of the yellow solution (upper layer) was withdrawn by syringe and transferred into another flask and then dry petroleum ether (b.pt- $120^{\circ}\text{C}$ ) was added. The yellow solution started to go turbid and a yellow oil deposited of which the IR spectrum was similar to that of the yellow sticky solid.

2.4.13 Reaction of Mesityl, phenylketiminolithium with Antimony Pentachloride (1:1 in Toluene/Chloroform at  $15^{\circ}$ )

A solution of mesityl, phenylketiminolithium (8.95 mmol.) in  $80\text{ cm}^3$  toluene was cooled to  $-196^{\circ}\text{C}$ , and  $1.15\text{ cm}^3$  antimony pentachloride was added. On allowing the mixture to

warm up to room temperature and on stirring for 1h., the mixture was a dark yellow solution over a dark brown oily layer. The mixture was pumped under vacuum to remove all the solvents and a brown oily residue was obtained. About 30 cm<sup>3</sup> dry chloroform were added to that residue and a brown solution formed which was filtered to isolate the dark white precipitate (LiCl) from the dark brown solution which was in two layers as observed in the other experiments. After being left for 2 months, this filtrate deposited no solid.

2.4.14 Reaction of t-Butyl,p-tolyketiminolithium with Antimony Pentachloride (1:1 in Et<sub>2</sub>O at 18°).

The ketimine was lithiated in the usual way to give a yellow solution of t-butyl-p-tolylmethyleaminolithium (18.83 mmol.) in 60 cm<sup>3</sup> dry diethyl ether/n-hexane solution. The solution was cooled in liquid nitrogen (-196°C) and 2.4 cm<sup>3</sup> of antimony pentachloride were added. On warming the mixture to room temperature, a white condensate was observed in the yellow solution, and on stirring the mixture overnight at room temperature, a yellow solution formed over a buff residue. The whole mixture was filtered to give a white precipitate (LiCl) and a filtrate consisting of two layers; the upper was a yellow ethereal solution and the lower was a brown oily layer. Both layers deposited white needles which were collected on a filter stick, washed with cool diethyl ether and dried. These needles were identified as t-Butyl-2-chloro-4-methylphenylketiminium pentachloroantimonate (III)

$$[2\text{-Cl-4-MeC}_6\text{H}_3\text{C(t-Bu) = NH}_2]^{\oplus} [\text{SbCl}_5]^{2\ominus}$$

\*Analysis

Found : C 40.5, H 6.0, N 4.0, Sb 17.7, Cl 34.9%.

$C_{24}H_{34}N_2SbCl_7$  requires: C 40.0, H 4.7, N 3.9, Sb 16.9, Cl 34.5%

\*Infra-red spectrum :  $\nu_{\max} \text{ cm}^{-1}$  (Nujol Mull).

3240(w), 3205(m), 3040(w), 3060(w), 1628(m), 1610(m),  
1593(m), 1510(vw), 1415(w), 1295(vw), 1276(vw), 1220(vw),  
1200(w), 1188(w/m), 1120(vw), 1040(vw), 1022(vw), 995(vw),  
980(w), 930(vw), 850(w), 820(s,sh), 815(m), 787(vw), 729(w/m),  
705(vw), 655(vw), 590(vw), 558(w/m), 525(vw), 455(w), 345(vs).

2.4.15 Reaction of t-Butyl, o-tolyketiminolithium with Antimony Pentachloride (1:1 in  $Et_2O$ /Toluene at  $90^\circ$ ).

The t-butyl-o-tolyketimine (4.6g., 26.24 mmol.) in diethyl ether (40  $\text{cm}^3$ ) at  $-196^\circ\text{C}$  was treated with 16.7 ml. of n-Butyl lithium, then allowed to warm to room temperature, There were two immiscible layers and on stirring an evolution of bubbles was observed and after  $\frac{1}{2}$  h. the yellow solution started to turbidify forming a white precipitate after stirring for several hours. Once again the mixture was cooled to  $-196^\circ\text{C}$  and 3.4  $\text{cm}^3$  antimony pentachloride were added. On warming to room temperature, a vigorous reaction took place and the white precipitate changed to a dark brown like-tar. Both solution and tar were pumped under vacuum to dryness, leaving a dark brown oily residue. Extraction of this residue in 50  $\text{cm}^3$  dry toluene followed by filtration while hot yielded a precipitate and a dark brown filtrate which deposited a sticky solid of which the i.r. spectrum could not be recorded. For this reason, the solid was re-extracted in the toluene by refluxing for  $\frac{1}{2}$ h., filtered and the filtrate on standing for three days yielded a pale yellow solid. The analytical data

of this product confirmed the presence of C, H, N, Cl, but no Sb could be detected.

Found: C 37.6, H 5.0, N 2.7, Cl 34.7, Sb 0.0%

2.4.16 Reaction of Di Phenylketiminolithium with Antimony Trichloride( 1:1 in Et<sub>2</sub>O/Toluene at 110°).

A solution of 8.3 mmol. diphenylketiminolithium in 40 cm<sup>3</sup> ether/hexane was cooled to -196°C and a solution of antimony trichloride (1.897 g., 8.3 mmol.) in 10 cm<sup>3</sup> diethylether was added. The mixture was allowed to warm to room temperature with stirring. The deep red colour of the imino-lithium faded to yellow-orange. The mixture was pumped under vacuum to remove all solvent, then 30 cm<sup>3</sup> dry toluene were added to the residue. The mixture was refluxed for one hour at 110°C with stirring. On filtration, a dark red solution was isolated from an orange precipitate. On standing the filtrate at room temperature, no crystals deposited, but on cooling this solution deposited a yellow microcrystalline solid, which was collected on a filter stick, washed with cold toluene, and dried under vacuum. This yellow product was tentatively identified as o-dichlorostibinyl (III) diphenylketimine monotoluene;

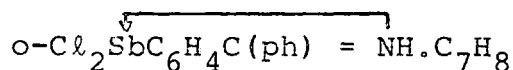

\*Analysis

Found: C 51.0, H 3.5, N 6.2, Sb 25.5, Cl 11.9%.

C<sub>20</sub>H<sub>18</sub>NSbCl<sub>2</sub> requires: C 51.6, H 3.9, N 3.0, Sb 26.2, Cl 15.3%

\* Infra-red spectrum :  $\nu_{\text{max}} \text{ cm}^{-1}$  (Nujol Mull).

3250(w), 1581(s,sh), 1562(s), 1545(vs), 1310(vw), 1292(v),  
1221(w), 1189(vw), 1157(vw), 1122(vw), 1075(vw), 1027(vw),  
1000(vw), 954(w), 940(w), 912(vw), 880(w), 855(vw), 798(m),  
789(w), 775(m), 768(m), 750(w), 740(m), 731(m), 703(vs),  
699(vs), 679(w/m), 658(w), 637(w), 553(w), 521(vw), 485(vw),  
460(w,sh).

2.4.17 Reaction of Di-Phenylketiminolithium with Antimony Trichloride (3:1 in Et<sub>2</sub>O/Toluene at 90-100°).

A solution of 13.13 mmol. diphenylketiminolithium in ~ 30 cm<sup>3</sup> dry diethyl ether/n-hexane was added by syringe to a solution of lg. anhydrous antimony trichloride (4.38 mmol.) in 15 cm<sup>3</sup> dry diethylether at -196°C. The mixture was allowed to warm to room temperature with stirring. The red colour of the imino-lithium changed to orange then to dark yellow. The mixture was then stirred for 3 hours.

The solvent was then removed under vacuum and replaced by 60 cm<sup>3</sup> dry toluene. The mixture was then heated to 90 - 100°C with stirring and filtered while hot yielding a precipitate and a golden yellow solution. The latter was left to stand for three months at -20° but no characterisable product could be obtained.

2.4.18 Attempted Reaction of N-chloro di-p-tolyketimine with Antimony Trichloride (1:1 in Chloroform/Toluene at 80 - 90°).

0.64 g. anhydrous antimony trichloride (2.8 mmol.) was added to 0.68 g. of the N-chloroketimine (2.8 mmol.) inside the glove box at room temperature. The white solid mixture rapidly turned to yellow and then darkened to yield a red-brown viscous liquid which solidified immediately. The

reaction was exothermic. The mixture was taken outside the glove box and then heated under the dry nitrogen gas by hair drier as an attempt to complete this reaction. The solid mixture firstly melted and then on cooling to room temperature solidified, yielding a dark red brown solid. The infra-red and mass spectra of this solid showed no indication for the orthometallated compound formation;  $o\text{-SbCl}_4\text{-4-MeC}_6\text{H}_3\text{C(p-tolyl)=NH}$  and the spectrum was quite similar to that of the starting material  $pt_2\text{CNCl}$ . From the analytical data, this product was identified as containing a 3:2 molar proportion of N-chloro-di-p-tolyketimine with antimony trichloride,  $3pt_2\text{CNCl}\cdot 2\text{SbCl}_3$ .

\*Analysis

Found: C 43.9, H 3.6, N 2.5, Sb 28.6, Cl 31.1%.

$(\text{C}_{15}\text{H}_{14}\text{NCl})_3 \cdot (\text{SbCl}_3)_{2.1}$  requires: C 44.6, H 3.5, N 3.5, Sb 21.1, Cl 27.3%.

\*Infra-red spectrum:  $\nu_{\text{max}} \text{ cm}^{-1}$  (Nujol Mull).

1600(m), 1575(sh), 1550(sh), 1315(w), 1298(w), 1210(vw), 1182(w), 1162(w), 1030(vw), 1016(w), 970(vw), 920(vw), 825(w), 780(vw), 750(vw), 725(w), 655(vw), 630(vw), 570(vw).

This red-brown product was dissolved in  $\sim 7 \text{ cm}^3$  dry toluene, which gave a clear yellow solution after heating with a hair dryer. On standing this solution at room temperature for 2 months or even on cooling, no solid deposited. The solution was then refluxed for one hour at 110 - 120°C, and a red-brown oil deposited. The IR spectrum of that oil was similar to the starting material  $pt_2\text{CNCl}$ . No further investigation has been done for this oil and no solid has deposited from it.

2.4.19 Attempted Reaction of N-Chloro di-p-tolyketimine  
with Antimony Trichloride (1:1 in Chloroform/  
Toluene at 80 - 90°).

A solution of 0.3 g. antimony trichloride (1.31 mmol.) in 5 cm<sup>3</sup> chloroform was cooled to -196°C and a solution of 0.32 g. N-chloro diptolyketimine (1.31 mmol.) in 5 cm<sup>3</sup> dry chloroform, was added to the cooled solution. The mixture was allowed to warm with stirring to produce a colourless solution at room temperature. The solvent was pumped off under vacuum: 20 cm<sup>3</sup> dry toluene was added and the white suspension was heated to 80 - 90°C for half an hour until the white precipitate dissolved completely, yielding a light yellow solution. On standing for 3 hours at room temperature, a bright white microcrystalline solid deposited, which was collected on a filter stick, washed with toluene and dried under vacuum. This solid was identified as containing equimolar proportions of the reagents;  $pt_2CNC\ell.SbCl_3$

\*Analysis

Found: C 37.7, H 3.8, N 2.5, Cl 34.5, Sb 24.3%

$C_{15}H_{14}NCl_4Sb$  requires: C 38.2, H 3.0, N 3.0, Cl 30.1, Sb 25.7%.

\*Infra-red spectrum:  $\nu_{max} cm^{-1}$  (Nujol Mull).

3329(m), 3090(m), 3070(m), 3025(m), 1660(w,br.), 1605(s,sh),  
1515(w), 1189(m), 1162(m), 1088(w), 1018(sh,m), 893(w,sh),  
850(w), 842(w), 832(w), 824(w/m), 774(w), 753(w), 738(w),  
725(w), 705(w), 690(w), 675(w), 663(w), 632(m), 615(m).

2.4.20 Reaction of Diphenylketiminolithium with Tin Tetrachloride (1:1 in Et<sub>2</sub>O Chloroform at 20°).

A solution of 16.55 mmol. diphenylketiminolithium in ~50 cm<sup>3</sup> dry diethylether/hexane was cooled to -196°C and 1.94 cm<sup>3</sup> tin tetrachloride were added. The mixture was allowed to warm to room temperature with stirring. The resulting yellow solution over a white precipitate was then evaporated to dryness. 50 cm<sup>3</sup> dry chloroform were added to the residue and stirred for ten minutes, yielding a golden yellow solution over a white precipitate (LiCl) which was separated from the solution by filtration. On standing the golden filtrate overnight no solid deposited but on cooling a white solid deposited which was collected on a filter stick, washed with the chloroform, and dried under vacuum. From the analytical data and the infrared spectrum, this product (white powder) was found to have the formulae (ph<sub>2</sub>CNH.SnCl<sub>4</sub>)<sub>n</sub>; n = 1, or 2. The IR spectrum showed the characteristic bands of  $\nu(\text{N-H})$ , and  $\nu(\text{C=O})$ ,  $\nu(\text{C=N})$  shifted to lower frequency, relative to the parent ketimine, and a band at 1675 cm<sup>-1</sup> which probably assigned to  $\delta(\overset{\dagger}{\text{NH}}_2)$ .

\*Analysis

Found: C 36.5, H 3.4, N 3.5%.

C<sub>13</sub>H<sub>11</sub>NSnCl<sub>4</sub> requires : C 35.3, H 2.5, N 3.2%.

\*Infra-red spectrum:  $\nu_{\text{max}}$  cm<sup>-1</sup> (Nujol Mull).

3330(w), 3190(s), 3060(vw), 1675(w), 1602(w/m), 1585(m/s,sh), 1565(m/s,sh), 1419(w), 1299(vw), 1254(w/m), 1214(vw), 1188(vw), 1160(w), 1074(vw), 999(w), 930(vw), 910(vw), 877(w), 862(m), 841(vw), 805(vw), 777(s), 760(s,sh), 728(w), 701(s,sh), 665(vw), 649(w), 606(vw), 590(vw), 565(vw), 520(s/m), 488(vw), 462(w), 435(vw).



### 3.1.1 Reaction of Ammonia and Amines with Metal or Metalloid Halides

When a metal halide is mixed with ammonia, two different types of reaction can be observed (depending on the experimental conditions): one involving adduct formation and the other involving ammonolysis. The two types of reaction can be summarized by the general equations (3.2 and 3.3)

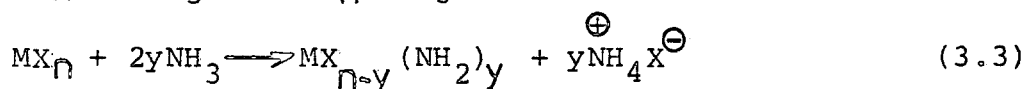
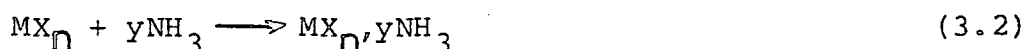

Generally, Ammonolysis of metal halides which can be detected by the formation of ammonium chloride depends on the metal or metalloid and halide involved<sup>1</sup>. For example, boron trichloride, -bromide, and -iodide undergo complete ammonolysis when they react with liquid ammonia<sup>2</sup>, forming the amide which decomposes to the imide-see equation (3.4). On comparison,

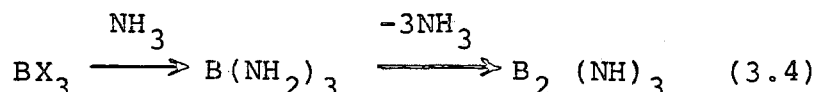

boron trifluoride forms a simple adduct;  $BF_3 \leftarrow NH_3$ , which does not undergo ammonolysis even at 50°<sup>3</sup>. This difference between the fluoride and the other three halides reflects the high metal-fluorine bond strength. In addition, the tetrachlorides of silicon and Germanium are completely ammonolyzed with liquid ammonia at -33.5°<sup>1</sup>, whereas tin tetrachloride is not completely ammonolyzed, even when an excess of liquid ammonia is added: in the final product one tin-chlorine bond remains intact<sup>4</sup>. In equations (3.5, 3.6 and 3.7), the reactions of metal chlorides of Group IVB are summarized.

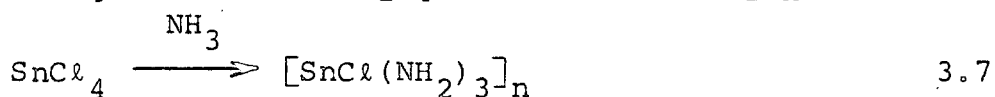
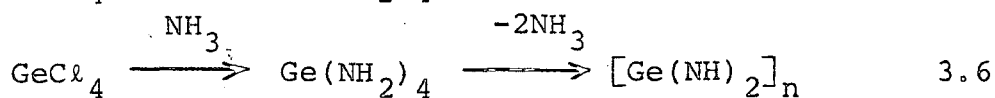

Usually the extent of the ammonolysis increases when the temperature increases. However, this is not the situation for the ammonolysis of tin tetrachloride, where three moles of ammonium chloride can be detected at  $-63^\circ$ , but when the temperature is raised to  $-45^\circ$  or  $-36^\circ$ , only one mole is found. An explanation for this has been suggested by Fowles<sup>1</sup>, who proposed that the higher temperature gives a more concentrated solution of ammonium chloride which is capable of breaking down the polymeric structure of  $\text{SnCl}(\text{NH}_2)_3$ , with the formation of complex anions<sup>4</sup> - see equation (3.8). A polymeric structure for  $\text{SnCl}(\text{NH}_2)_3$  has been suggested since

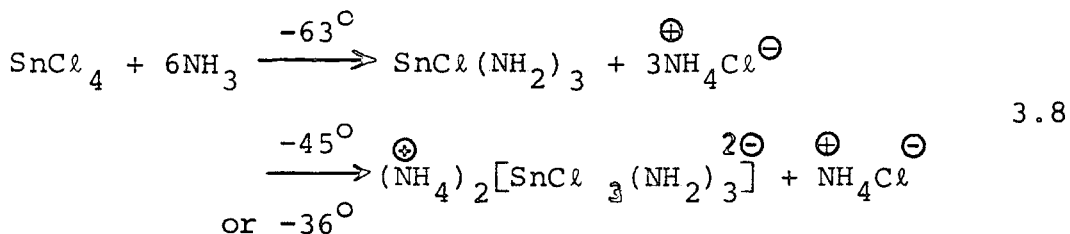

This product was found to be insoluble in ammonia and soluble in ammonium halide/ammonia solutions. The mode of polymerization in  $\text{SnCl}(\text{NH}_2)_3$  is expected to arise through bridging of any one of the types (III) to (VI), or a mixture of these.

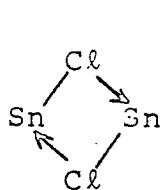

(III)

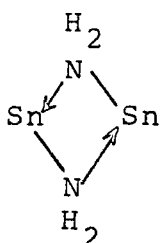

(IV)

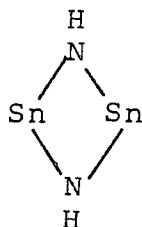

(V)

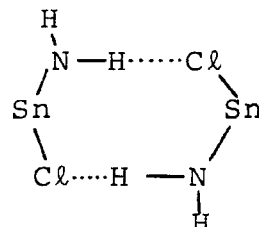

(VI)

By extending the reaction to amines, aliphatic amines react with metal halides to give similar products although there are several important differences. Thus, on going along the series  $\text{NH}_3$ ,  $\text{NH}_2\text{R}$ ,  $\text{NHR}_2$ ,  $\text{NR}_3$  (where the amine gets less ionizing as a solvent) the extent of aminolysis becomes less and adduct formation becomes more important. As an example, tin tetra-chloride forms quite stable adducts  $\text{SnCl}_4 \cdot 2\text{L}$  with  $\text{L} =$  primary, secondary and tertiary aliphatic amines<sup>5</sup>, although aminolysis takes place with excess of primary amine - see equations (3.9, 3.10, and 3.11).

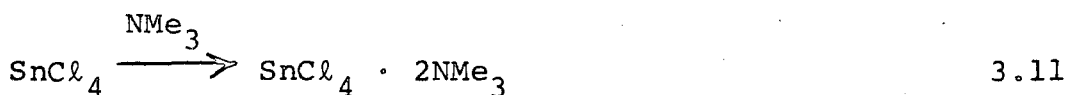
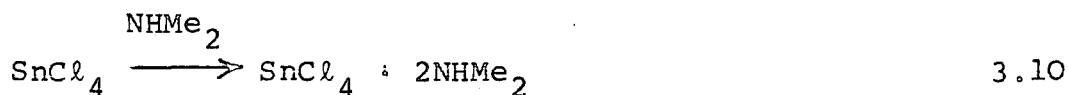
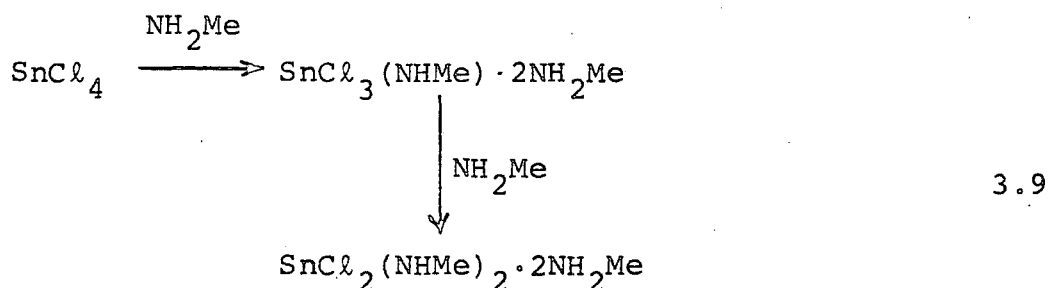

The coordinating power of amines towards metal halides is influenced by electronic and steric properties of the alkyl groups. Firstly, the inductive effect of the alkyl groups is expected to increase the nitrogen donor power, and secondly, the increase in size of the alkyl groups attached to nitrogen may result in steric strain which should weaken the donor-acceptor bond, or reduce the coordination number of the metal. An additional factor that characterizes amine reactions is the tendency for the metal to be reduced to a lower valence

state. This reduction does not occur with ammonia or primary amines but occurs more effectively with secondary and tertiary amines. Some transition metal halides have been observed to suffer such reductions. For example, titanium tetrachloride and-bromide both react initially with trimethylamine to give 1:1 adducts which are monomeric and hence five-coordinate in benzene solution, but reduction to the terv-  
 alent state takes place rapidly (especially with the bromide) and compounds  $TiX_3 \cdot 2NMe_3$  are formed. The oxidation products have not been characterized although it is known that the halogen "lost" by the titanium appears quantitatively as the trimethylammonium salt<sup>6</sup>. It is especially interesting to note the reactions of trimethylamine with both molybdenum pentachloride and tungsten hexachloride in which the 1:1 adducts,  $MoCl_5 \leftarrow NMe_3$ <sup>7</sup> and  $WCl_6 \leftarrow NMe_3$ <sup>8</sup> respectively are formed. Excess of the amine brings about the reduction of Mo and W metal to the quadrivalent state and the formation of the complex salts:  $[Me_3NH]^+ [MoCl_5 - NMe_3]^-$  and  $[Me_3NH]^+ [WCl_6]^-$ . In the  $WCl_6$  reaction, the following reduction mechanism has been suggested<sup>8</sup> on the basis that the hydrogen atom found ultimately attached to nitrogen can only have come from a methyl group :

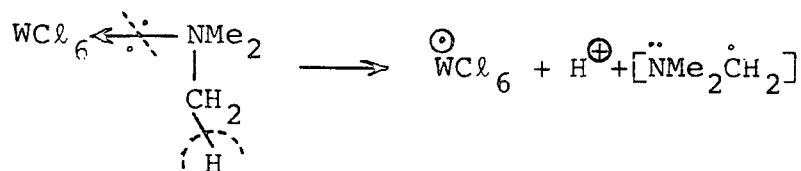

The radical formed could dimerize or react further with solvent or with excess of amine.

Finally, it is interesting to point out the reaction of tellurium tetrachloride with the amino derivative  $R_2NSiMe_3$  ( $R_2 = Et_2$  or  $C_4H_8$ ) in which the expected product  $R_2N^+TeCl_3^-$  was not obtained but instead  $(R_2NH_2)_2TeCl_6^{2-}$  was always obtained - see equations (3.11a and 3.11b). Furthermore, it has been observed that  $Et_2NLi$  will reduce  $Ar_2TeCl_2$  (Ar = ph  $\circ$ P-CH<sub>3</sub>OC<sub>6</sub>H<sub>4</sub>) to  $Ar_2Te$

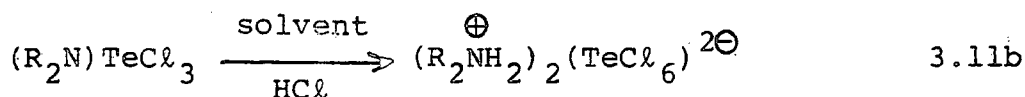
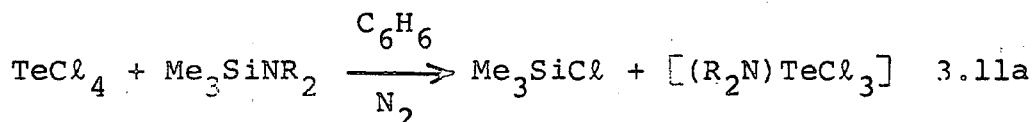

### 3.1.2 Reaction of Diphenylmethylenamine with Boron Halides

These reactions will be discussed in detail, since they are related to the title of this chapter.

As in the reactions of ammonia and amines, diphenylmethylenamine reacts with boron halides to give two different products. Borontrifluoride forms a simple adduct  $ph_2CNH, BF_3$  in which its coordinate link is strong enough to allow vacuum sublimation at 100-120° in comparison with boron trichloride which undergoes complete iminolysis to form the imino-boron derivative,  $(ph_2CN)_3B^{11}$ . The IR spectrum of  $ph_2CNH, BF_3$  adduct showed an increase in the  $\nu(C=N)$  stretching frequency from 1603 (for the free imine) to 1628cm<sup>-1</sup>, an increase that may be attributed to coupling of the C = N and N→B vibrations, although some rehybridization, and increase in the C = N bond order, may also contribute.

In the boron trichloride system, it is believed that diphenylmethylenamine coordinates firstly to boron trichloride, but the adduct formed is not stable even at  $-78^{\circ}$  and readily undergoes iminolysis by elimination of hydrogen chloride. Two imino-boron chloride products;  $(\text{Ph}_2\text{CN})_3\text{B}$  (VII) and  $(\text{Ph}_2\text{CNBCl}_2)_2$  (VIII) can be isolated. The compound  $(\text{Ph}_2\text{CN})_2\text{BCl}$  is difficult to isolate since it disproportionates into (VII) and (VIII). The IR spectra of the isolated imino-boron compounds (III) and (IV) are identical to those of samples prepared previously from the reaction of diphenylmethylenamino trimethylsilane with boron trichloride<sup>1,2</sup> as given in the general equation (3.12).

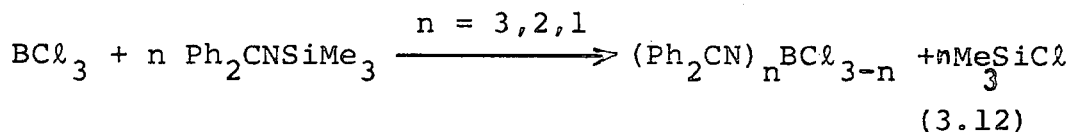

In contrast to the diphenylmethylenamino derivatives of tin trichloride and antimonytetrachloride,  $\text{Ph}_2\text{CNBCl}_2$  does not undergo the orthometallation intramolecular rearrangement but it associates with another molecule to form a dimeric molecule  $(\text{Ph}_2\text{CN-BCl}_2)_2$  with a  $(\text{BN})_2$  ring structure as shown in (IX).

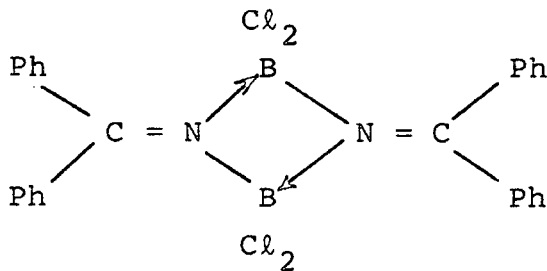

(IX)

### 3.1.3 The Chemistry of Antimony penta- and tri-Halides towards the organonitrogen Compounds

It is important to demonstrate briefly the reactions of antimony penta- and tri-chloride with organonitrogen compounds.

Both  $\text{SbCl}_3$  and  $\text{SbCl}_5$  are capable of forming (1:1) adducts with nitrogen donors, but some antimony trihalides can accept more than one ligand, for example  $\text{SbI}_3$  reacts with alkyl or arylamines to give the (1:3) adducts  $\text{SbI}_3 \cdot 3\text{RNH}_2$ .<sup>13</sup>

Some (1:1) adducts could be isolated such as  $\text{Ph}_2\text{NH}_2 \cdot \text{SbCl}_3$ <sup>14</sup> and  $\text{S}_4\text{N}_4 \cdot \text{SbCl}_5$ <sup>15</sup>. The structures of these adducts have been confirmed by X-ray crystallographic studies as shown in (X) and (XI). The most

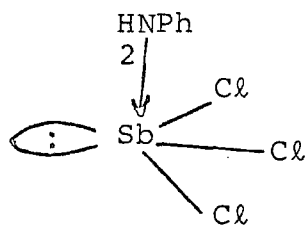

(X)

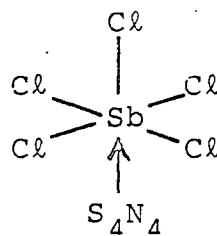

(XI)

important feature of these structures is that the ( $\text{Sb} \leftarrow \text{N}$ ) coordinated link in (X) is longer than that in (XI) which reflects the difference between the covalent radii of Sb(III) and Sb(V).

The antimony-chlorine bond in  $\text{SbCl}_5$  and  $\text{SbCl}_3$  can be cleaved on treatment with an organonitrogen compound, forming compounds with (Sb-N) bonds. For example, triorganosilylazides react with antimony pentachloride in (1:1) mole ratio to form the four-membered cyclostibazane<sup>16</sup> as described in equation (3.13). The structure of this product is supported by

molecular weight determination, infrared and Raman spectra. The antimony-nitrogen heterocyclic ring can be destroyed by triphenylphosphine.

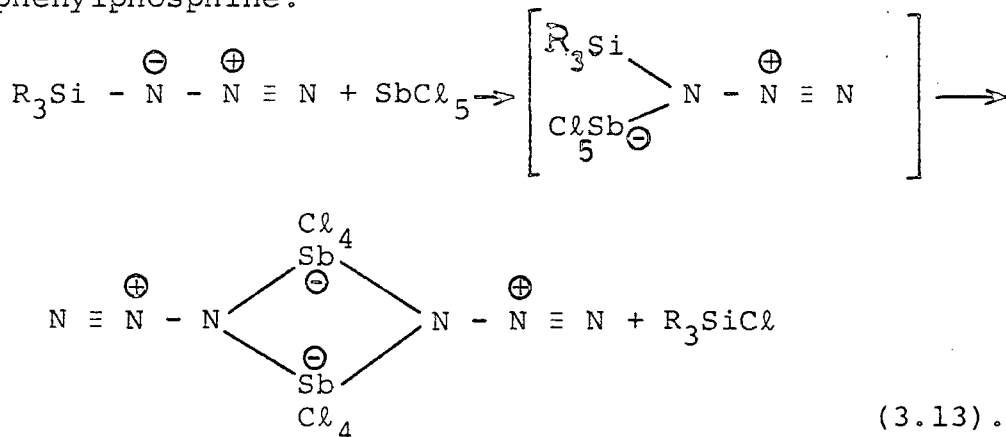

Aminolysis of the trihalides of arsenic, antimony and bismuth can take place by using primary and secondary amines<sup>17</sup>. The aminolysis of SbI<sub>3</sub> is an interesting case. In this reaction as mentioned before, the SbI<sub>3</sub>.3RNH<sub>2</sub> adducts (R = alkyl or aryl) are formed first of all and upon boiling in acetonitrile are converted into a tetrameric products (ISbNR)<sub>4</sub> which may have 8-membered ring or cubane type structures - see equation (3.14).

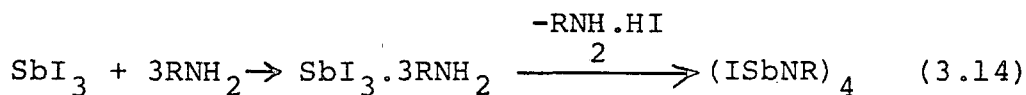

In addition, ammonia interacts with SbI<sub>3</sub> by ammonolysis. The reaction yields (NH<sub>2</sub>)<sub>2</sub>SbI as an intermediate which is transformed to (SbN)<sub>x</sub> in liquid ammonia by losing NH<sub>4</sub><sup>+</sup>I<sup>-</sup><sup>18</sup>.

Temperature-dependent <sup>1</sup>H n.m.r. spectroscopy has been used to study R<sub>2</sub>Sb - NR<sub>2</sub>' type compounds, where R = Bu<sup>t</sup>, Me; R' = SiMe<sub>3</sub>, GeMe<sub>3</sub>, SnMe<sub>3</sub>, Me. The results suggest that the rotation hinderance about the (N - Sb) bond is due to the steric considerations and not pπ-dπ interactions<sup>19</sup>.

Since both antimony penta- and tri-chloride have a high tendency to accept one or more chloride anion, a number of complexes containing  $\text{SbCl}_6^-$ ,  $\text{SbCl}_5^{2-}$ , or  $\text{SbCl}_6^{3-}$  anion can be obtained as ammonium, pyridinium, or iminium salts. In table (3.1), some examples of the different types of antimony halides, as well as their type of study are given. Some mixed-valent antimony halide complexes are also included in the table. These mixed-valence complexes are characterized by their dark colour which may change to a light colour on cooling. It is believed that the charge transfer between the two mixed oxidation states of antimony is responsible for the dark colour.

### 3.2 EXPERIMENTAL

#### 3.2.1 Reaction of Diphenylmethylenamine, $\text{Ph}_2\text{CNH}$ with Antimony Pentachloride, $\text{SbCl}_5$ (1:1 ratio in toluene at $120^\circ\text{C}$ ).

A sample of 2.75 ml of antimony pentachloride (21.5 mmol) was added to a frozen solution of diphenylmethylenamine (3.9g, 21.5mmol) in 50 ml. dry toluene. The mixture was allowed to warm to room temperature with stirring. The final mixture was a red solid suspended in a yellow solution. This was heated for 2 hours at  $120^\circ\text{C}$ , after which it separated into two layers; the upper was a yellow coloured solution, and the lower was a dark red-brown oil which solidified immediately at high temperature. The upper yellow solution was withdrawn by syringe. On standing for two days at room temperature, it deposited yellow needles.

Table (3.1) Some Examples of Organonitrogen Salts with Antimony Halides Anions

<u>Salt</u>	<u>Type of Study</u>	<u>Ref.</u>
$\text{Cl}_2\text{C} = \overset{\oplus}{\text{NH}_2}\text{SbCl}_6^\ominus$	IR	20
$\text{Ph}_2\text{C} = \overset{\oplus}{\text{NMeHSbF}}_6^\ominus$	$^1\text{HNMR}$	21
$(\text{C}_5\text{H}_5\text{NH})\overset{\oplus}{\text{SbCl}}_4^\ominus$	X-Ray	22
$(\text{NH}_4)_2\overset{\oplus}{\text{SbCl}}_5^{2\ominus}$	X-Ray	23
$[\text{Co}(\text{NH}_3)_6]^{3\oplus} [\text{SbCl}_6]^{3\ominus}$	X-Ray	24
$(\text{C}_5\text{H}_5\text{NH})_3^\oplus \cdot (\overset{\text{III}}{\text{Sb}_2\text{Br}_9})^{3\ominus} \cdot (\text{Br})_2^\ominus$	X-Ray	25
$(\text{C}_6\text{H}_7\text{NH})_2^\oplus \cdot (\overset{\text{V}}{\text{SbBr}_6})^\ominus \cdot (\text{Br}_3)^\ominus$	X-Ray	26
$(\text{R}_4\text{N})_3^\oplus (\text{Sb}_2\text{I}_9)^{3\ominus}$	Analysis	27
$(\text{C}_5\text{H}_5\text{NH})_6^\oplus \cdot (\overset{\text{III}}{\text{SbBr}_6})^{3\ominus} \cdot 3(\overset{\text{V}}{\text{SbBr}_6})^\ominus$	X-ray	28

These yellow needles were isolated from the solution by filtration, washed with cold dry toluene and dried. They were identified as the diphenylmethylenamine adduct (1:1) of antimony pentachloride;  $(\text{Ph}_2\text{CNH}, \text{SbCl}_5)$ .

Analysis

Found: C 31.3, H 2.3, N 2.9

Sb 26.7, Cl 35.9%

$\text{C}_{13}\text{H}_{11}\text{NSbCl}_5$  requires: C 32.5, H 2.3, N 2.9

Sb 25.4, Cl 36.9%

Infra-red spectra:  $\nu_{\text{max}} \text{cm}^{-1}$  (Nujol Mull).

3396(w), 3340(w), 3280(m), 3260(Sh), 1660(m), 1595(s),  
1570(w), 1540(vw), 1520(vw), 1300(W,Sh), 1283(vw), 1260(vw),  
1220(w), 1190(vw), 1160(w,Sh), 1125(w), 1030(vw), 1000(vw),  
980(vw), 965(vw), 920(w), 885(vw), 850(vw), 790(s), 780(w),  
760(w), 720(s), 698(s), 650(w), 606(w), 656(vw), 520(vw),  
488(vw), 450(vw), 423(vw), 368(s), 340(vs), 320(vs).

3.2.2 Reaction of Diphenylmethylenamine,  $\text{Ph}_2\text{CNH}$   
with Antimony Pentachloride,  $\text{SbCl}_5$  (1:1 ratio in  
chloroform).

Diphenylmethylenamine (2.7g, 14.89 m mol) was dissolved in 15 ml. dry chloroform which then was cooled to  $-196^\circ\text{C}$  and 1.9 ml antimony pentachloride were added. On allowing the mixture to warm up to room temperature with stirring, the colour changed from yellow to greenish yellow and finally to deep red-brown. On continuing the stirring for 1 h., a dark yellow precipitate was formed below the deep red solution. The mixture was then filtered to produce the yellow powder, and the deep red solution which deposited no crystals on standing overnight. Addition of more chloroform to the solution

deposited yellow crystals immediately which were collected on a filter stick, washed with dry chloroform and dried. These yellow crystals were identified as diphenylmethylen ammonium hexachloroantimonate (v);  $[\text{Ph}_2\text{CNH}_2]^+[\text{SbCl}_6]^-$

Analysis

Found: C 30.3, H 2.5, N 2.2%

$\text{C}_{13}\text{H}_{12}\text{NSbCl}_6$  requires: C 30.2, H 2.3, N 2.7%

Infra-red Spectra :  $\nu_{\text{max}}$   $\text{cm}^{-1}$  (Nujol Mull)

3389 (vs), 3330 (vs), 3255 (vs), 3055 (w), 2000 (vw), 1976 (vw), 1938 (vw), 1913 (vw), 1820 (vw), 1780 (vw), 1732 (vw), 1721 (vw), 1658 (vs), 1603 (w/m), 1591 (vs), 1515 (m/s), 1496 (m), 1483 (w), 1300 (w/m), 1189 (w), 1180 (w), 1165 (s, Sh), 1128 (vw), 1080 (vw, Sh), 1027 (vw), 997 (w), 974 (vw), 940 (vw), 860 (vw), 842 (w, Sh), 796 (w), 779 (vs), 750 (vs), 728 (s), 720 (m), 715 (w), 698 (vs), 670 (m/s, Sh), 600 (m/s), 568 (m), 450 (w), 430 (vw), 400 (w/m), 345 (vs), 328 (Sh).

3.2.3 Reaction of Diphenylmethylenamine,  $\text{Ph}_2\text{CNH}$  with Antimony Pentachloride,  $\text{SbCl}_5$  (1:1 ratio in  $\text{CCl}_4$  (toluene)).

To a cold solution (at  $-196^\circ\text{C}$ ) of diphenylmethylenamine (2.4g, 13.24m mol) in 15 ml. dry carbon tetrachloride, about 1.7 ml antimony pentachloride were added. On allowing the mixture to warm to room temperature with stirring, the reaction was vigorous and exothermic, and the colour changed from yellow to greenish yellow. On stirring for two hours, a greenish yellow solid was formed under the yellow solution. The carbon tetrachloride was pumped off leaving a greenish yellow residue, to which 30 ml. of dry toluene was added and the mixture was stirred overnight which yielded a dark brown solution over a yellow solid. This yellow precipitate was collected on a filter stick, washed, with cold toluene

and dried under vacuum. The resulting yellow powder was identified as diphenylmethyleneammonium hexachloroantimonate (V);  $[\text{Ph}_2\text{CNH}_2]^{\oplus}[\text{SbCl}_6]^{\ominus}$

Analysis

Found: C 31.5, N 2.7, H 2.3, Sb 24.0, Cl 41.2%

$\text{C}_{13}\text{H}_{12}\text{NSbCl}_6$  requires: C 30.2, N 2.7, H 2.3, Sb 23.6, Cl 41.2%

The IR Spectrum was the same as the one observed from the previous reaction 3.2.2.

3.2.4 Reaction of Diphenylmethylenamine Hydrochloride,  $\text{Ph}_2\text{CNH}_2\text{Cl}^{\ominus}$  with Antimony Pentachloride,  $\text{SbCl}_5$  (1:1 ratio in Chloroform).

1.47 ml. antimony pentachloride (11.5 m mol) was added dropwise with stirring to a suspension of diphenylmethylenamine hydrochloride (2.5 g, 115. m mol) in 30 ml dry chloroform at room temperature. A yellow precipitate formed immediately under a very pale yellow solution. The precipitate was filtered off, washed with chloroform, and pumped dry. The resulting yellow powder was identified as diphenylmethylenammonium hexachloroantimonate (V).  $[\text{Ph}_2\text{CNH}_2]^{\oplus}[\text{SbCl}_6]^{\ominus}$

Analysis

Found: C 30.8, H 2.4, N 2.4, Sb 23.4, Cl 41.0%

$\text{C}_{13}\text{H}_{12}\text{NSbCl}_6$  requires: C 30.2, H 2.3, N 2.7, Sb 23.6, Cl 41.2%

The infra-red spectrum showed similar bands to those observed in the IR spectrum of the previous product.

Experiments in which  $\text{Ph}_2\text{CNH}$  and  $\text{SbCl}_5$  were allowed to react in chloroform solution in 1:2 molar ratio, or in diethylether in 2:1 molar ratio yielded further samples of  $\text{Ph}_2\text{CNH}_2\text{SbCl}_6^{\ominus}$  salt.

3.2.5 Reaction of Diphenylmethyleamine, Ph<sub>2</sub>CNH  
with Antimony Trichloride, SbCl<sub>3</sub> (1:1 ratio in  
chloroform).

A solution of 0.84 g anhydrous antimony trichloride (3.68 m mol) in 15 ml. dry chloroform was cooled to -196°C and a solution of diphenylmethyleamine (0.62 ml, 3.68 m mol) in 15 ml. dry chloroform was added. The mixture was allowed to warm with stirring. At room temperature during 30 minutes, the clear yellow solution deposited a yellow micro-crystalline solid. This was isolated by filtration, washed with cold chloroform, and dried under vacuum. The analytical data showed that this product might be the diphenylmethyleammonium salt of the pentachloroantimonate (III) anion;

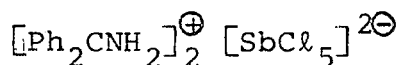

Analysis

Found: C 46.3, H, 4.0, N 4.9, Sb 20.3, Cl 23.7%

C<sub>26</sub>H<sub>24</sub>N<sub>2</sub>SbCl<sub>5</sub> requires: C 47.0, H 2.0, N 4.2, Sb 18.4, Cl 26.7%

IR Spectrum:  $\nu_{\text{max}}$  cm<sup>-1</sup> (Nujol Mull).

3210 (Sh), 1632 (S,br), 1590 (S,Sh), 1300 (w,Sh), 1185 (vw,Sh), 1159 (m,Sh), 1115 (vw,br), 1020 (vw), 996 (vw), 859 (w/m), 840 (w), 793 (m/s), 745 (vw), 725 (m/s), 700 (s), 689 (m), 608 (w), 565 (w), 448 (vw), 432 (vw).

3.2.6 Reaction of Diphenylmethyleamine, Ph<sub>2</sub>CNH with  
Antimony Trichloride, SbCl<sub>3</sub> (2:1 ratio in  
chloroform).

A solution of diphenylmethyleamine (0.94 ml, 5.6 m mol) in 20 ml. dry chloroform was added to a solution of 0.64 g. anhydrous antimony trichloride (2.8 m mol) in 20 ml. dry chloroform at -196°C. The mixture was allowed to warm to

room temperature with stirring after which a clear light yellow solution was obtained. This slowly deposited a yellow microcrystalline solid with an IR spectrum of similar to that of the product of the (1:1) mole ratio reaction between the diphenylmethylenamine and antimony trichloride, which may suggest that this product had the chemical formula:

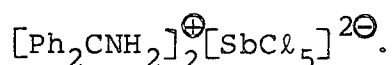

3.2.7 Reaction of Diphenylmethylenamine Hydrochloride,  $\text{Ph}_2\text{CNH}_2\text{Cl}^{\ominus}$  with Antimony Trichloride,  $\text{SbCl}_3$  (1:1 ratio in chloroform).

A solution of 1.06 g. anhydrous antimony trichloride (4.6 m mol.) in 10 ml. dry chloroform was added to a suspension of diphenylmethylenamine hydrochloride (1 g., 4.6 m mol.) in 40 ml. dry chloroform which had been cooled to  $-196^{\circ}\text{C}$ . The mixture was allowed to warm with stirring, then stirred at room temperature overnight. A bright white microcrystalline solid under a pale yellow clear solution was produced. On filtration, the bright white solid was isolated, washed with chloroform and dried under vacuum and identified as diphenylmethylenammonium tetrachloroantimonate (III);  $[\text{Ph}_2\text{CNH}_2]^{\oplus}[\text{SbCl}_4]^{\ominus}$

Analysis

Found: C 36.3, H 3.0, N 3.7, Sb 27.3, Cl 31.0%

$\text{C}_{13}\text{H}_{12}\text{NSbCl}_4$  requires: C 35.0, H 2.7, N 3.1, Sb 27.3, Cl 31.8%

Infra-red Spectrum:  $\nu_{\text{max}}$   $\text{cm}^{-1}$  (Nujol Mull).

3355(vw), 3100(s), 1685(m), 1630(m), 1589(m/s), 1498(vw),  
1295(w), 1190(w), 1182(vw), 1163(m/s), 1120(vw), 1024(vw),  
998(vw), 938(vw), 859(vw), 825(m), 798(m/s), 775(s,Sh),  
728(m), 701(vs), 695(s), 663(w), 602(w), 562(w), 445(w),  
435(w).

The same procedure was used to prepare the diphenylmethyleneammonium pentachloroantimonate (III);  $(\text{Ph}_2\text{CNH}_2^{\oplus})_2\text{SbCl}_5^{2\ominus}$  from  $\text{Ph}_2\text{CNECl}_2^{\oplus\ominus}$  and  $\text{SbCl}_3$  in chloroform in a 2:1 molar ratio.

### 3.3 RESULTS AND DISCUSSION

#### 3.3.1 Reactions of Diphenylmethylenamine with Antimony Pentachloride

When antimony pentachloride was added to a chloroform solution of diphenylmethylenamine in a (1:1) molar ratio, a yellow solid deposited from a dark red-brown solution at room temperature. The IR spectrum of this yellow solid showed the same bands recorded for the diphenylmethylenammonium hexachloroantimonate (V),  $\text{Ph}_2\text{CNH}_2^{\oplus}\text{SbCl}_6^{\ominus}$ , which strongly suggests the same formula for the yellow solid. Moreover, the analytical data, also supports the iminium structure for the yellow product.

The iminium salt,  $\text{Ph}_2\text{CNH}_2^{\oplus}\text{SbCl}_6^{\ominus}$  has been prepared previously from the reaction of diphenylmethylenammonium chloride with antimony pentachloride as described in equation (3.18).

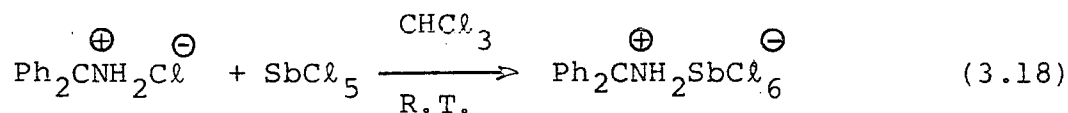

The salt  $\text{Ph}_2\text{CNH}_2^{\oplus}\text{SbCl}_6^{\ominus}$  is very stable towards air and moisture, and insoluble in most organic solvents except highly polar solvents such as dimethylsulphoxide. The salt has a high melting point ( $151^{\circ}$ , sealed tube), at which it decomposes into a dark brown residue. The absence of a dark colour in the iminium salt may suggest the presence of one

valent oxidation state for antimony, i.e.  $\text{Sb}^{\text{V}}$ , whereas the dark brown colour observed in the solution or upon the thermal decomposition of  $\text{Ph}_2\text{CNH}_2^{\oplus}\text{SbCl}_6^{\ominus}$  salt may suggest the existence of two different mixed oxidation states for antimony i.e.  $\text{Sb}^{\text{III}}/\text{Sb}^{\text{V}}$ .

The IR spectra of both samples of  $\text{Ph}_2\text{CNH}_2^{\oplus}\text{SbCl}_6^{\ominus}$  (figure 3.1) showed the  $\nu(\text{C} = \text{N})$  stretching band which occurs at  $\sim 1600 \text{ cm}^{-1}$  in the free imine, to be shifted to a higher energy (at  $\sim 1660 \text{ cm}^{-1}$ ). The same shift was observed for the  $\text{Ph}_2\text{CNH}_2^{\oplus}\text{Cl}^{\ominus}$  salt, but with less absorption intensity and higher half band width. Thus, this indicates the presence of  $\text{>C} = \text{NH}_2^{\oplus}$  group in the isolated salt. The shifted of  $\text{>C} = \text{NH}$  group to a higher frequencies on protonation has been observed and reported for several unsubstituted and substituted methylene-ammonium salts such as  $\text{H}_2\text{C} = \text{NH}_2^{\oplus}\text{SbCl}_6^{\ominus}$ <sup>29</sup>,  $(\text{CH}_3)_2\text{C} = \text{NH}_2^{\oplus}\text{SbCl}_6^{\ominus}$ <sup>30</sup>, and  $\text{Ph}_2\text{CNH}_2^{\oplus}\text{SbF}_6^{\ominus}$ <sup>21</sup>. The NH stretching frequencies were observed at 3585, 3330 and  $3255 \text{ cm}^{-1}$ . Two of them are expected for symmetrical and asymmetrical ( $\text{NH}_2$ ) stretching, but the extra third band may be due to hydrogen bonding. The band observed at  $1602 \text{ cm}^{-1}$  maybe assigned to an  $\delta \text{NH}_2$  deformation. The aromatic bands in the region  $800 - 700 \text{ cm}^{-1}$  did not show any significant changes as compared with the iminium hydrochloride salt. The band observed at  $\sim 1590 \text{ cm}^{-1}$ , which is very close to the corresponding band in  $\text{Ph}_2\text{CNH}_2^{\oplus}\text{Cl}^{\ominus}$  at  $\sim 1600 \text{ cm}^{-1}$ , is assigned to  $\nu(\text{C} = \text{C})$  aromatic. Antimony-chlorine stretching bands were observed at 348 and  $333 \text{ cm}^{-1}$  as expected for  $(\text{SbCl}_6)^{\ominus}$ <sup>31,32</sup>.

The mass spectral data for the yellow product and the assignments are listed in table (3.2). The data are consistent with the salt-like structure  $\text{Ph}_2\text{CNH}_2^{\oplus}\text{SbCl}_6^{\ominus}$ . There are no indications for the formation of an orthometallated product or an imino-antimony chloride fragment. The most characteristic feature of the spectrum is the loss of hydrogen chloride;  $m/e = 36$  (100%), from the salt which arises from the thermal decomposition shown in equation (3.19). The other peaks are less important;

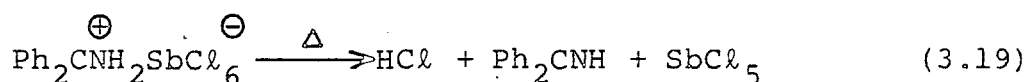

they result from the fragmentation of  $\text{Ph}_2\text{CNH}$  or  $\text{SbCl}_5$  units.

Table ( 3.2) Mass spectral Data for  $\text{Ph}_2\text{CNH}_2^{\oplus}\text{SbCl}_6^{\ominus}$

<u>m/e</u>	<u>Relative Intensity%</u>	<u>Assignment</u>
226	22	$\text{SbCl}_3$
191	53	$\text{SbCl}_2$
181	9	$(\text{C}_6\text{H}_5)_2\text{CNH}$
180	19	$(\text{C}_6\text{H}_5)_2\text{CN}$
121	5	Sb
105	12	$\text{C}_6\text{H}_5\text{CNH}_2$
77	11	$\text{C}_6\text{H}_5$
38	32	$\text{HCl}^{37}$
36	100	$\text{HCl}^{35}$
35	11	Cl

The  $^1\text{H}$  NMR spectrum of the yellow product was recorded in  $d^6$ -DMSO using TMS as external reference - see figure (3.2). The spectrum showed only two signals at the chemical shifts 7.69 and 4.69 ppm. The unit  $\text{C}^{\oplus} = \text{NH}_2$  would be expected to give an absorption at about 11 ppm<sup>30</sup>.

Formation of the iminium salt  $\text{Ph}_2\overset{\oplus}{\text{C}}\text{NH}_2\text{SbCl}_6^\ominus$  from the reaction of  $\text{Ph}_2\text{CNH}$  with  $\text{SbCl}_5$  may be explained on the basis of disproportionation of the probable intermediate  $\text{Ph}_2\text{CNH}, \text{SbCl}_5$ :-

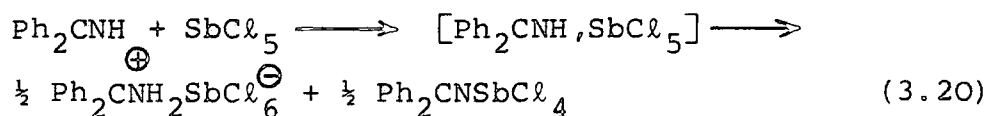

To find out the pathway of this reaction two different imine systems were allowed to interact with antimony pentachloride:  $\text{Ph}_2\text{CNH}$ , and *o*-tolyl,  $\text{PhCNH}$ . The first imine is known to suffer orthometallation, while the second not, as indicated from the  $\text{R}_2\text{CNLi} + \text{SnCl}_4$  reaction. The two reactions were carried out in a (1:1) molar ratio at room temperature without using any solvent to eliminate the protonation of the reaction components by the solvent. Since the two reactions were very vigorous under nitrogen, and since they were then out of control, the reactions were carried out under vacuum.

In the case of the *o*-tolyl,  $\text{PhCNH}/\text{SbCl}_5$  reaction, three products could be isolated:  $\text{HCl}$ ,  $\text{SbCl}_3$  and a high yield of a brown oily residue. The first two products were identified by IR spectra. No attempt has been done to identify the structure of the brown residue, but the production of  $\text{SbCl}_3$  in this reaction may suggest that  $\text{SbCl}_5$  was reduced by the imine to the trivalent oxidation state, as has been observed in the reactions of transition metal halides with the bulky trialkyl or dialkylamines. The mechanism of such redox reactions is still not known and neither the oxidation nor reduction products could be identified. The characteristic features of such redox reactions are: firstly, the high ability to proceed with the more bulky organonitrogen compounds, e.g.  $\text{R}_3\text{N}$ , where there will be a high steric strain

around the metal atom, and secondly, the formation of an organo-nitrogen hydrochloride salt as a by-product. The latter, which can be isolated, is believed to be responsible for the loss of the halide on the reduction of the metal.

In the case of  $\text{Ph}_2\text{CNH}/\text{SbCl}_5$  reaction, it was observed that it follows the same pattern as the *o*-tolyl,  $\text{PhCNH}$  reaction. No orthometallated compound could be obtained from the reaction which is believed to undergo an oxidation-reduction process. The latter process may explain the formation of the  $\text{Ph}_2\text{CNH}_2^+\text{SbCl}_4^-$  salt obtained from the reaction of  $\text{Ph}_2\text{CNLi}$  with  $\text{SbCl}_5$ , as described in chapter two.

By using different solvents the reaction of  $\text{Ph}_2\text{CNH}$  with  $\text{SbCl}_5$  was repeated at room temperature. On extraction of a (1:1) mixture of the two reagents in toluene, two phases were formed: a dark brown residue and a brownish yellow solution. The latter deposited a yellow microcrystalline product in low yield on standing for several days. The analytical data suggest a formula  $\text{Ph}_2\text{CNH},\text{SbCl}_5$  as indicated by the Sb:Cl ratio ( $\sim 1:5$ ) but surprisingly the IR spectrum showed the same spectrum as that of the  $\text{Ph}_2\text{CNH}_2^+\text{SbCl}_6^-$  salt. The main product, a dark brown residue solidified and faded in colour on cooling to room temperature, its IR spectrum shows the same bands observed for the salt  $\text{Ph}_2\text{CNH}_2^+\text{SbCl}_6^-$ . No attempt was made to characterize this product, however the change of its colour from darkness to light is a common observation for the mixed-valence antimony chloride compounds ( $\text{Sb}^{\text{III}}/\text{Sb}^{\text{V}}$ ) in which a charge transfer is believed to occur between the two metals, and which is responsible for the colour and its changes with temperature.

In carbon tetrachloride, the reaction of  $\text{Ph}_2\text{CNH}$  with  $\text{SbCl}_5$  yielded a yellow greenish viscous liquid which was immiscible with the solvent. No solid could be isolated from that reaction, but on treatment of the residue left, after pumping off the  $\text{CCl}_4$  with dry toluene yielded insoluble yellow solid. The analytical data and IR spectrum were similar to the authentic sample,  $\text{Ph}_2\text{CNH}_2^+\text{SbCl}_6^-$ .

### 3.3.2 Reactions of Diphenylmethylenamine with Antimony Tri-chloride

When antimony trichloride was treated with diphenylmethylenamine in (1:1), or (1:2) molar ratios in chloroform solution a yellow product was deposited. The IR spectrum of this product showed the same spectrum recorded for bis-diphenylmethylenammonium pentachloroantimonate (III);  $(\text{Ph}_2\text{CNH}_2^+)_2(\text{SbCl}_5)^{2-}$  which was synthesized from the reaction of the iminium chloride salt and antimony trichloride in a (2:1) molar ratio as described in equation (3.21).

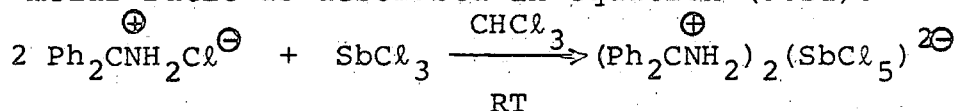

(3.21)

By comparison of the IR spectra and from the analytical data, we can deduce the same structure as that for the yellow product, i.e.  $(\text{Ph}_2\text{CNH}_2^+)_2(\text{SbCl}_5)^{2-}$ . The pentachloroantimonate (III) salt is very stable towards air and moisture and its IR spectrum (see figure 3.3) showed a strong broad band at  $\sim 1630 \text{ cm}^{-1}$ , assignable to  $\nu(\text{C}=\text{NH}_2^+)$  stretching frequency. Table (3.3) gives the frequencies of the  $\nu(\text{C}=\text{NH}_2^+)$  stretching bands for some of the iminium salts isolated in this work are given.

Table (3.3) The  $\nu(\text{C} = \text{NH}_2^{\oplus})$  stretching Frequency for some Iminium Salts

<u>Salt</u>	<u><math>\nu(\text{C} = \text{NH}_2^{\oplus}) \text{ cm}^{-1}</math></u>	<u><math>\Delta\nu(\text{C} = \text{N})^* \text{ cm}^{-1}</math></u>
$(\text{Ph}_2\text{CNH}_2^{\oplus})\text{Cl}^{\ominus}$	1660	60
$(\text{Ph}_2\text{CNH}_2^{\oplus})\text{SbCl}_6^{\ominus}$	1660	60
$(\text{Ph}_2\text{CNH}_2^{\oplus})\text{SbCl}_4^{\ominus}$	1690, 1630	90, 30
$(\text{Ph}_2\text{CNH}_2^{\oplus})_2(\text{SbCl}_5)^{2\ominus}$	1630	30

\*  $\Delta\nu(\text{C} = \text{N}) = \nu(\text{C} = \text{NH}_2^{\oplus}) - \nu(\text{C} = \ddot{\text{N}}\text{H})$  where  
 where  $\nu(\text{C} = \ddot{\text{N}}\text{H}) \sim 1600 \text{ cm}^{-1}$

The above table shows that the  $\nu(\text{C} = \text{NH}_2^{\oplus})$  stretching frequency in  $\text{Ph}_2\text{CNH}_2^{\oplus}\text{Cl}^{\ominus}$  and  $\text{Ph}_2\text{CNH}_2^{\oplus}\text{SbCl}_6^{\ominus}$  salts occurs at  $\sim 1660 \text{ cm}^{-1}$ . This band splits into two bands of equal intensity in the  $\text{Ph}_2\text{CNH}_2^{\oplus}\text{SbCl}_4^{\ominus}$  salt at 1690 and  $1630 \text{ cm}^{-1}$ . This splitting may be explained as a result of coupling between the fundamental  $\nu(\text{C} = \text{N})$  stretching vibration and probably the  $\delta(\text{NH}_2)$  bending vibration which is known as the Fermi resonance effect<sup>33</sup>. In  $(\text{Ph}_2\text{CNH}_2^{\oplus})_2(\text{SbCl}_5)^{2\ominus}$  the methyleneammonium stretching frequency gave only one broad band at  $1630 \text{ cm}^{-1}$ , the broadness of which may be due to the Fermi resonance effect. The reason for the doublet appearance of the  $\nu(\text{C} = \text{NH}_2^{\oplus})$  stretching in  $\text{Ph}_2\text{CNH}_2^{\oplus}\text{SbCl}_4^{\ominus}$  as compared with  $(\text{Ph}_2\text{CNH}_2^{\oplus})_2(\text{SbCl}_5)^{2\ominus}$  may be interpreted from the effect of the negative electrostatic change of the anion attracted to the organic iminium species. As an example to support this the relative intensity of the Fermi resonance doublet bands of  $\nu(\text{C} = \text{O})$  stretching in cyclopentanone have been found to depend on the dielectric constant of the solvent used<sup>33</sup>.

The IR spectrum also showed an ill-defined band at  $3210 \text{ cm}^{-1}$ , assigned to  $\nu(\text{N} - \text{H})$  stretching frequency. The

aromatic vibration modes, such as  $\nu(\text{C} = \text{C})$  stretch, and  $\delta(\text{C} - \text{H})$  out-of-plane deformation were assigned to 1590, and 793, 725, 700  $\text{cm}^{-1}$  respectively which do not differ from the corresponding bands in the other iminium antimony chloride salts except the band at 755  $\text{cm}^{-1}$  which could not be observed in the spectrum.

Mass spectral data for the yellow product;  $(\text{Ph}_2\overset{\oplus}{\text{CNH}}_2)_2\text{SbCl}_5^{2\ominus}$  are listed in table (3.4) with their suggested assignments. The main fragments observed in the spectrum were due to loss of  $\text{HCl}$ ,  $\text{SbCl}_3$  ( $m/e = 226$ , 100%) and  $\text{Ph}_2\text{CN-H}$  ( $m/e = 179$ , 95%); which are expected due to the thermal decomposition of the  $(\text{Ph}_2\overset{\oplus}{\text{CNH}}_2)_2(\text{SbCl}_5)^{2\ominus}$  salt. There was no indication of the presence of any of the stable orthometallated fragments. The weak peaks observed at  $m/e = 333$ , 395, 486, 488 may arise from di-nuclear anionic impurities such as  $\text{Sb}_2\text{Cl}_7^{\ominus}$ .

Table (3.4) Mass Spectral Data for  $(\text{Ph}_2\overset{\oplus}{\text{CNH}}_2)_2(\text{SbCl}_5)^{2\ominus}$

<u>m/e</u>	<u>Relative Intensity %</u>	<u>Assignments</u>
486, 488	1, 1	$\text{Sb}_2\text{Cl}_7$
401	3	?
333, 395	2, 2	?
227	100	$\text{SbCl}_3$
191	75	$\text{SbCl}_2$
179	95	$\text{Ph}_2\text{CN-1}$
177	20	$\text{Ph}_2\text{CN-3}$
121	9	Sb
105	100	$\text{PhCNH}_2$
77	100	Ph
36	100	$\text{HCl}$
35	95	Cl

The proton NMR spectrum of the yellow product was recorded in  $d^6$ -DMSO, using TMS as internal reference. The spectrum (figure 3.4) showed only two signals at 7.66 and 12.6 ppm as expected for the nuclear magnetic resonances of phenyl and  $C = NH_2^+$  protons. The downfield shift of  $C = NH_2^+$  signal as compared with the parent imine ( $\delta = 9.9$ ) may support the  $(Ph_2C = NH_2^+)_2SbCl_5^{2-}$  structure for the yellow product.

From the above results it seems that the iminolysis process is responsible for the formation of such antimony chloride salts which do not dissolve in a chloroform solution. On the other hand, the possibility for the formation of orthometallated compound is unlikely since these  $Ph_2CNH/SbCl_3$  reactions were carried out at RT, whilst the results of the  $Ph_2CNLi/SbCl_3$  reaction showed that the formation of an orthometallated compound occurs at high temperatures - see chapter two.

### 3.4 CONCLUSION

The reaction of diphenylmethylenamine with antimony pentachloride yielded the ionic salt  $Ph_2CNH_2^+SbCl_6^-$ . The formation of such a salt may result from the presence of hydrogen chloride in the reaction medium or from the disproportionation of the  $Ph_2CNH, SbCl_5$  adduct. Since no orthometallated compound or imino-antimony chloride derivatives could be obtained from that reaction, it seems that antimony pentachloride undergoes reduction when it interacts with imines. In the case of the  $Ph_2CNH/SbCl_3$  reaction in (1:1) molar ratio, the isolation of the  $(Ph_2CNH_2^+)_2(SbCl_5)^{2-}$  salt suggests that antimony trichloride interacts with the imine by iminolysis or by an orthometallation process. However,

no products from the latter processes could be isolated.

Finally, the antimony chloride salts:  $\text{Ph}_2\overset{\oplus}{\text{CNH}}_2\text{SbCl}_6^\ominus$ ,  
 $(\text{Ph}_2\overset{\oplus}{\text{CNH}}_2)_2(\text{SbCl}_5)^{2\ominus}$ ,  $\text{Ph}_2\overset{\oplus}{\text{CNH}}_2\text{SbCl}_4^\ominus$  could be prepared  
from the reaction of  $\text{Ph}_2\overset{\oplus}{\text{CNH}}_2\text{Cl}^\ominus$  with  $\text{SbCl}_5$  or  $\text{SbCl}_3$  in  
appropriate molar ratios.

CHAPTER FOUR

THE REACTION OF TIN DICHLORIDE AND HYDROGEN CHLORIDE WITH SOME METHYL DERIVATIVES OF ACRYLONITRILE

4.1 INTRODUCTION

The reaction of hydrogen chloride gas and tin dichloride in diethyl ether has been reported to yield the acids  $\text{Et}_2\text{OH}^+\text{SnCl}_3^-$

and  $(\text{Et}_2\text{OH}^+)_2\text{SnCl}_4^{2-}$ :<sup>(1)</sup>

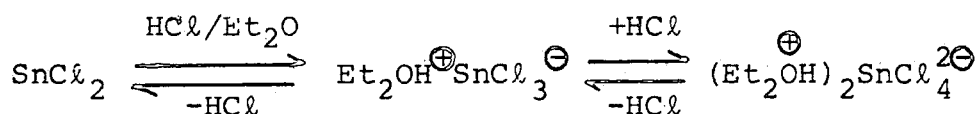

The reactivity of these products towards unsaturated organic compounds such as alkenes and nitriles has proved interesting. In a number of published papers, it has been stated that the chlorostannic (II) acid reacts with  $\alpha$ -alkenes to give the corresponding organotin compounds; equation (4.1).

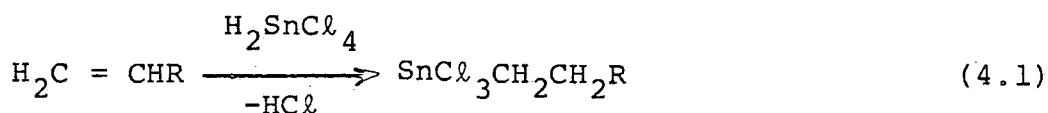

R = alkyl, H,  $\text{CO}_2\text{Me}$ ,  $\text{C} \equiv \text{N}$

Moreover, in a recent study, it has been shown that saturated aliphatic or aromatic nitriles react with chlorostannic (II) acid in diethyl ether to yield the dimeric product I - a,b.

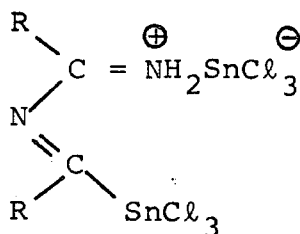

Ia

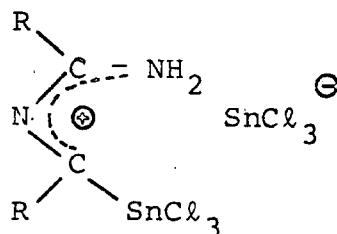

Ib

R = Me, Et, Bu, Ph.

This amidinium-like structure was proposed on the basis of the analytical information which showed that the percentage ratio of the nitrile : Sn (total) : Sn(II) is consistent with the above dimeric structure I, i.e. 2:2:1, and also of the observation of two types of ethyl group in the  $^1\text{H-NMR}$  spectrum of the product (where R = Et); N-(ethyl, trichlorostannylmethylene) propionamidinium trichlorostannate(II).

The aim of this work was to study the effect of replacement of a methyl group in the  $\alpha$ - or  $\beta$ - position of the acrylonitrile when it interacts with the acid  $\text{H}_2\text{SnCl}_4 \cdot 2\text{Et}_2\text{O}$ . Thus, reactions of acrylonitrile, methacrylonitrile and crotononitrile with the  $\text{SnCl}_2/\text{HCl}$  system were carried out. The products obtained were studied analytically and spectroscopically.

Before discussing this work it is helpful to survey the reactivity of nitriles towards protic acids in general.

#### 4.2 THE REACTIVITY OF NITRILES TOWARDS PROTIC ACIDS

In the presence of a protic acid, such as hydrogen halide or sulfuric acid, the nitrile group suffers protonation on the nitrogen atom, forming the nitrilium ion; equation (4. 2).

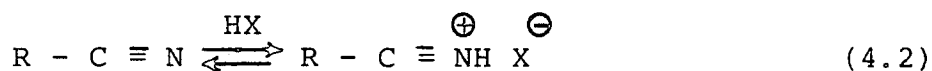

The presence of the nitrilium ion,  $\text{RC} \equiv \overset{\oplus}{\text{N}}$  in the nitrile-hydrogen chloride system, has been claimed on the basis of electrical conductivity measurements.<sup>4,5</sup> Some of these nitrilium salts have been isolated with  $\text{SbCl}_6^\ominus$ ,  $\text{SnCl}_6^{2\ominus}$ ,  $\text{FeCl}_4^\ominus$  and  $\text{BF}_4^\ominus$ <sup>6,7</sup> anions from the reaction of the corresponding nitrile -

Lewis acid complex with hydrogen chloride at low temperature. The linear configuration of the nitrilium ion has been revealed from proton,  $^{13}\text{C}$  and  $^{15}\text{N}$  NMR studies and it has been concluded that only a limited contribution is made by the imino Carbonium ion:

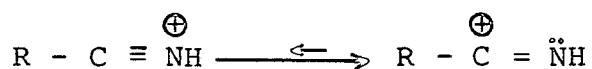

However, protonation of the nitrogen atom will have the effect of making the nitrile carbon atom slightly more positively charged, as electron density is shifted towards the site of protonation. The nitrile carbon atom is therefore made more susceptible to nucleophilic attack.

The nitrilium ions are not thermally stable, for example the nitrilium salt of hexachloroantimonate (V) disproportionates at room temperature to give the iminium salt and the starting complexes:

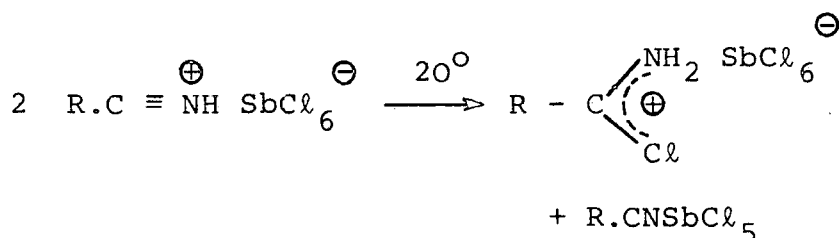

In general, therefore the formation of a nitrilium ion in the reaction of a cyano compound with a protic acid has been recognized as the first step for further reactivity of the cyano group at the carbon centre. The nitrilium species are subjected to nucleophilic attack either by the anion of the protic acid to form the imine or the iminium derivatives, or by the cyano or imidoyl nitrogen leading to the dimerization, or oligomerisation of the nitrile :

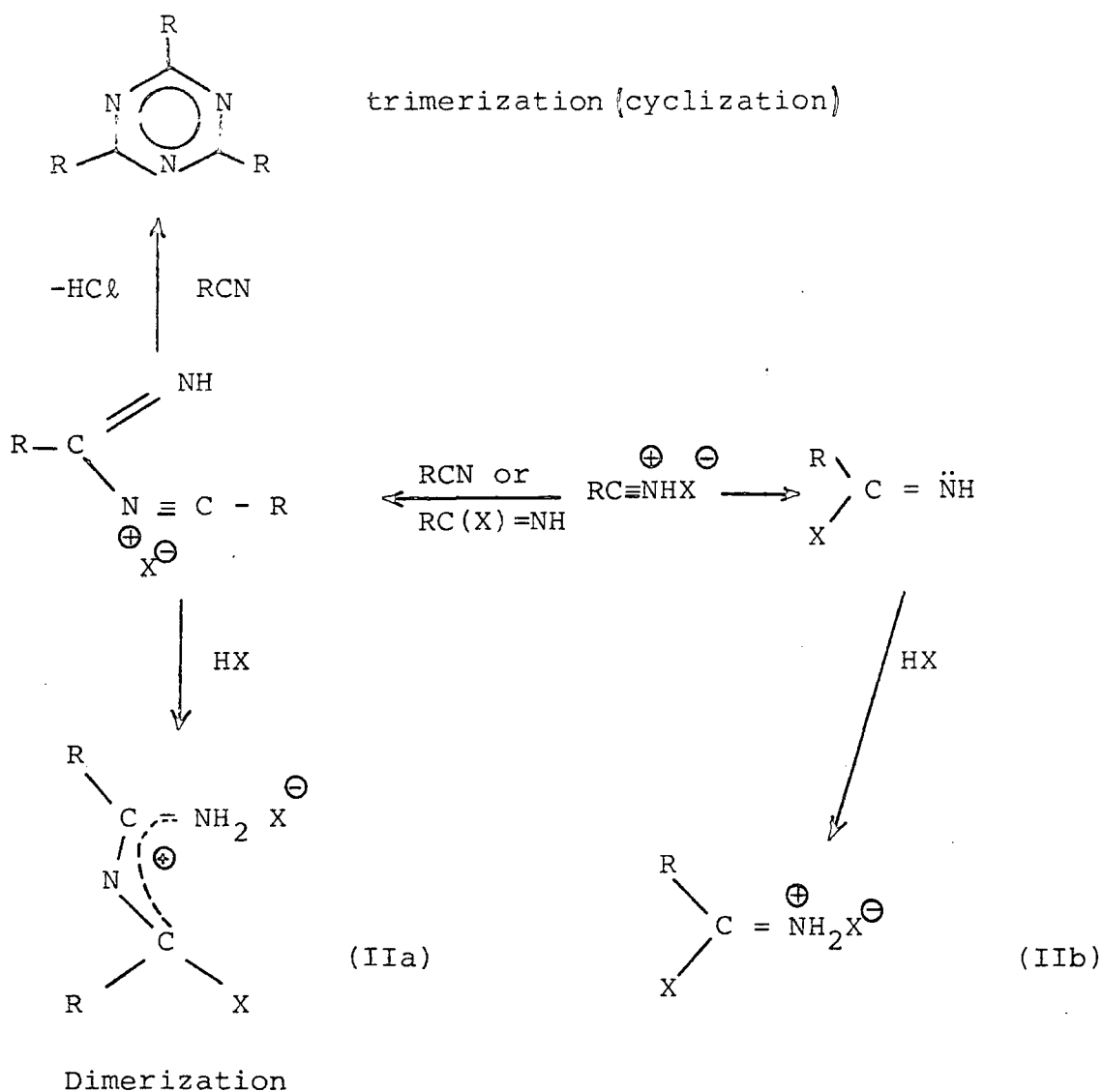

As examples, the reactions of hydrogen halides with aromatic nitriles<sup>8,9</sup> give either the arylhalonium halides (structure IIb) at low temperature, or the amidinium salts (structure IIa)<sup>10</sup> at higher temperatures by the way of dimerization. The aryl amidinium salts at elevated temperatures undergo further reaction to form heterocyclic products, such as 2,4,6-triaryl-S-triazines. Differential thermal analysis showed that a tetrameric product has been involved during the pyrolysis process of the amidinium salt which undergoes the cyclization after losing nitrile.<sup>11</sup>

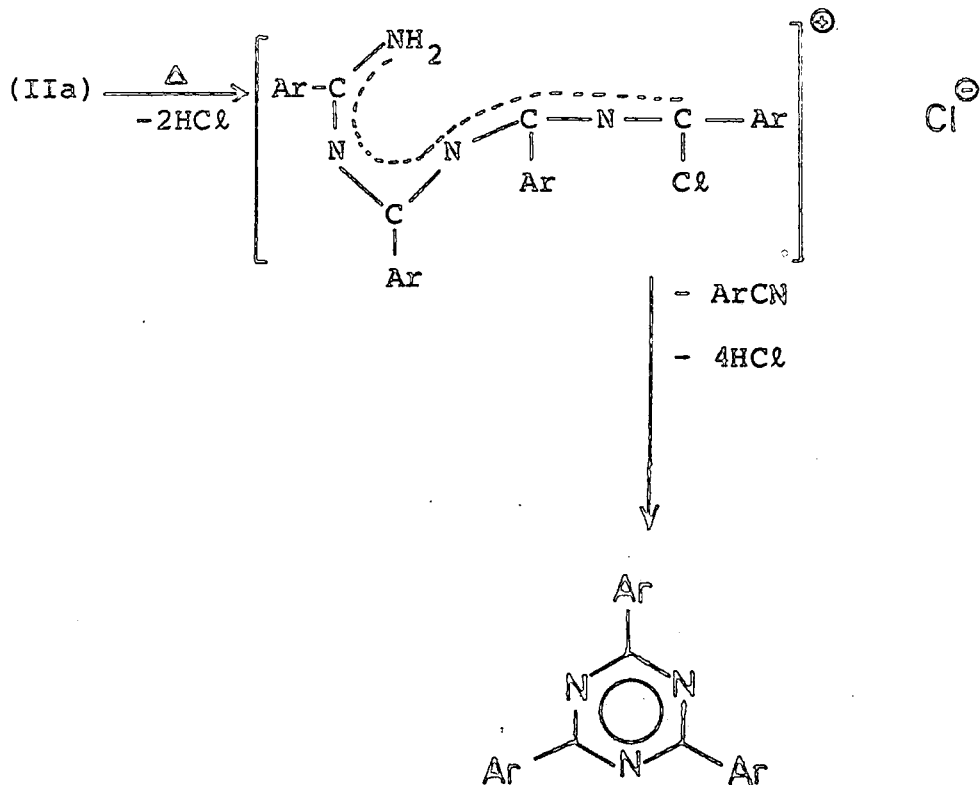

The structure of the iminium salt  $\text{CH}_3\text{CN} \cdot 2\text{HCl}$  has been investigated by X-ray diffraction analysis<sup>17</sup> and structure (IIIa) has been proposed rather than structure (IIIb) on the basis of the normal bond lengths observed for the (single) carbon-chlorine and (double) carbon-nitrogen bonds:

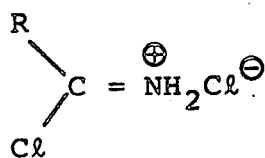

IIIa

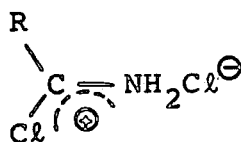

IIIb



The experimental results show that the dimerization of cyano compounds by protic acids to form amidinium salts depends on the reaction temperature, concentration of acids, and the type of cyano compounds and acids involved. For instance, the dissociation constants  $PK_{HX}$  of hydrogen chloride and hydrogen bromide in acetonitrile have been determined to be 8.9 and 5.5, respectively suggesting that hydrogen halides are incompletely ionized and retain their covalent bonding in dilute solution. On the other hand, at low temperature and at high acid concentration nitriles may associate with more than one mole of HCl. Thus low concentrations and low temperatures are not favourable for dimerization reactions. The reactions of nitriles with hydrogen iodide and hydrogen bromide, in contrast to hydrogen chloride, lead to precipitation of the iminium bromides with no inter-molecular dimerization. Furthermore, the melting points of the iminium salts indicate that the iminium iodide and bromide are more stable than the chloride which reflects the order of electron donating ability of halogen atoms. The presence of electron-withdrawing groups bonded to nitriles activates the dimerization reaction of the nitriles.

#### 4.3 EXPERIMENTAL

##### 4.3.1 Reaction of Acrylonitrile with Hydrogen Chloride and Tin Dichloride

Anhydrous hydrogen chloride was passed through a slurry of 33.8 g. of anhydrous tin dichloride (178.27 mmol) in 140 ml. dry diethyl ether at 0°C. After one hour all the tin dichloride had dissolved completely. The hydrogen chloride gas flow was terminated and the solution was allowed

to warm to room temperature. The clear pale yellow solution deposited no pale yellow oil like that observed in an earlier study of this system.<sup>1</sup> However, the solution was stirred for 10 minutes to remove the excess of hydrogen chloride. Once again, the solution was cooled to 0°C and about 70 ml. dry acrylonitrile (1063 mmol) were added. The acrylonitrile was miscible with the ethereal solution which was stirred for one hour at 0°C and then allowed to warm to room temperature. The solution was subsequently stirred overnight. All volatile components were then pumped off under vacuum to leave a mixture of a pale yellow solution over a white precipitate. The solution was distilled in vacuo at 40°C/1 mm Hg. The distillation process afforded a pale yellow solid and about 125 ml. colourless distillate. The latter was identified as 3-chloropropanonitrile,  $\text{Cl}-\text{CH}_2\text{CH}_2\text{CN}$  by comparison of its IR and <sup>1</sup>HNMR spectrum with that of an authentic sample. Overnight, the colourless distillate acquired a pink colour. The yellow solid residue was then extracted with 120 ml. dry toluene for one hour at about 150°C. Most of the solid dissolved in the toluene upon heating, giving a pale yellow solution and a heavy brown oil. On filtration of the hot mixture, the brown precipitate which solidified at room temperature, separated from the pale yellow filtrate. The filtrate deposited pale yellow crystals while the solution was hot, and on standing overnight a high yield of the crystals was obtained, which was isolated by filtration, washed with chilled toluene, dried under vacuum, and identified as 3-cyanoethyl tin trichloride;

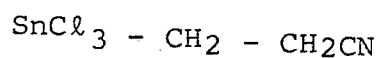

\*

Analysis

Found : C 12.9, H 1.7, N 5.3, Cl 36.0%

$C_3H_4NSnCl_3$  requires : C 12.9, H 1.4, N 5.0, Cl 38.1%

\*

IR Spectrum:  $\nu_{\max}$   $cm^{-1}$  (Nujol Mull).

3420(vw), 3330(vw), 3260(vw), 3190(vw), 2280(vs), 1650(w),  
1560(vw), 1410(m/s), 1320(vw), 1280(sh), 1260(vw), 1245(sh),  
1160(w,sh), 1139(w), 1120(vw), 1100(vw), 1019(w), 970(sh),  
910(w), 890(w), 800(vw), 722(w), 690(w/m), 628(w).

\*

Far IR Spectrum :  $\nu_{\max}$   $cm^{-1}$  (Nujol mull).

387(w/m), 383(m), 375(m), 369(m/s), 365(m), 350(m), 338(w),  
320(m/s), 313(vs), 309(vs,sh), 287(w/m), 277(w/m), 275(w),  
247(vw), 237(vw), 233(vw), 219(vw), 217(vw), 212(vw),  
203(vw), 176(vw), 170(w), 154(w), 150(w), 136(w), 132(w),  
114(vw), 100(vw), 84(vw), 72(m/s).

\*

Raman Spectrum :  $\nu_{\max}$   $cm^{-1}$

2279(vs), 1422(vw), 1165(s), 1412(vw), 1025(w), 920(vw),  
633(s), 616(vw), 580(vw), 472(m), 357(vs), 321(M/s), 290(vw),  
275(vw), 239(w), 162(w/m), 132(m), 96(w), 83(w), 37(s).

4.3.2 Reaction of Methacrylonitrile with Hydrogen Chloride and Tin Dichloride ( $SnCl_2/HCl$  system prepared in  $Et_2O$ ).

Dry hydrogen chloride gas was passed through a slurry of 25.2 g of anhydrous tin dichloride (133 mmol.) in 150 ml. dry diethyl ether for about one hour with stirring at  $0^\circ C$  until all the tin dichloride dissolved completely in the ether solution. The solution was allowed to warm to room

temperature. No pale yellow oil deposited as expected. However, the solution was cooled again to 0°C and about 25 ml. dry methacrylonitrile (19.99 g., 298 mmol.) were added by syringe to the solution with stirring. It was miscible with the solution and after ten minutes, the solution separated into two layers; the lower layer was pale yellow oil and the higher one was a white turbid solution. The mixture was stirred for one hour at 0°C and then stirred at room temperature overnight. The resulting mixture contained three layers : top layer was a colourless ethereal solution; the middle layer was white, a suspension of solid and the lower layer was a pale yellow oil. The whole mixture was pumped (to remove the excess hydrogen chloride, diethyl ether and all other volatile components) under vacuum leaving a pale yellow viscous solution and a white solid. This residue was distilled in vacuo to remove 3-Chloro-2-methylpropanonitrile which was collected as a colourless liquid at 67°/0.1 mm.Hg and identified by IR, <sup>1</sup>HNMR and mass spectrum by comparison with an authentic sample. The remaining white residue after distillation was of a waxy consistency a sticky solid. On extraction of this solid in dry toluene for two hours at 110°C most of the residue did not dissolve in the toluene and the white residue turned to a pale yellow colour. The filtration of the mixture yielded a pale yellow amorphous solid and a filtrate which was in two layers : a poor yield of the pale yellow oil was present under a colourless solution. The pale yellow solid was washed with cold toluene and dried under vacuum. No further purification was done for this product which was difficult to dissolve in

organic solvents (except polar solvents). However, from the analytical data (mentioned below) and the other spectroscopic analytical methods such as IR,  $^1\text{H}$ NMR and Mass spectra, this product was tentatively identified as:

N-(3-Chloro-2-methyl-1-trichlorostannyl propenyl)  
3-chloro-2-methyl propylamidinium trichloro  
stannate (II)

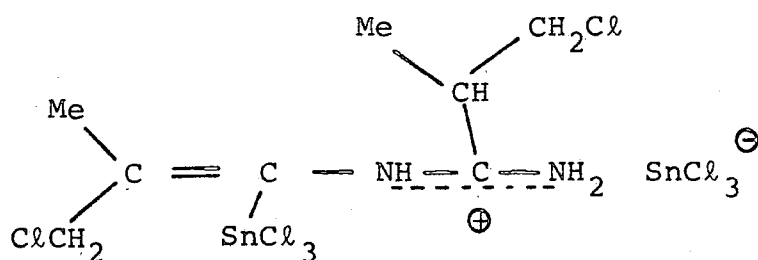

\*Analysis:

Found : C 16.4, H 4.5, N 5.4, Cl 43.5%

$\text{C}_4\text{H}_7\text{N SnCl}_4$  requires : C 14.6, H 2.1, N 4.2, Cl 43.1%

\*Infra-red spectrum :  $\nu_{\text{max}}$   $\text{cm}^{-1}$  (Nujol Mull)

3330(sh), 3200(vs,sh), 1680(vw), 1647(w/m,sh), 1575(vs,br),  
1400(w), 1335(sh), 1300(sh), 1260(vw), 1205(vw), 1160(w/m),  
1090(w), 1058(w/m), 1012(vw), 995(vw), 926(m/s), 853(m),  
799(w), 722(w/m), 570(sh).

The filtrate gave white fumes on exposure to air. The two layers were separated. The colourless toluene solution was transferred by syringe into another empty flask under dry nitrogen gas leaving the pale yellow oil. No solid deposited from the toluene solution on standing overnight, after which dry pyridine (py) was added, and a white precipitate deposited immediately. This white solid was isolated by filtration after

washing with toluene and drying under vacuum, and was identified as an adduct (1:2) tin tetrachloride pyridine;  $\text{SnCl}_4 \cdot 2\text{py}$  from the IR comparison with an authentic sample. On the other hand the pale yellow oil could not be identified. However, the IR spectrum of this oil showed a band at  $2288 \text{ cm}^{-1}$  which could be assigned to  $\nu(\text{C} \equiv \text{N})$  frequency. Other bands were observed in  $\nu(\text{N-H})$  and  $\nu(\text{C=C})/\nu(\text{C=N})$  stretching region. This may suggest that some of the amidinium salt decomposed on heating generating the original nitrile, hydrogen chloride and tin tetrachloride. Further studies are needed to identify the decomposition products.

\*Infra-red spectrum of the pale yellow oil :  $\nu_{\text{max}} \text{ cm}^{-1}$   
(Nujol Mull).

3330(w/m), 3260(w/m), 3200(w/m), 2288(m,sh), 1690(sh),  
1650(vs), 1595(w/m,br.), 1401(vw), 1320(vw), 1302(m),  
1277(vw), 1260(vw), 1200(vw), 1180(vw), 1130(vw), 1113(w),  
1090(vw), 1068(vw), 1042(vw), 1020(vw), 1010(vw), 941(w),  
906(vw), 881(vw), 865(vw), 819(vw), 792(w/m), 742(m), 691(w/m),  
570(vm), 540(vw), 528(vw), 470(vw), 320(vs).

4.3.3 Reaction of Methacrylonitrile with Hydrogen Chloride and Tin Dichloride ( $\text{SnCl}_2/\text{HCl}$  System prepared in petroleum Ether- $\text{Et}_2\text{O}$ ).

Dry hydrogen chloride was passed through a suspension of 3.51 g. of anhydrous tin dichloride (18.5 m mol.) in 50 ml. dry petroleum ether (B.pt =  $120^\circ\text{C}$ ) at  $0^\circ\text{C}$  with stirring for half an hour. The tin dichloride solid did not dissolve in the petroleum ether and then 10 ml. dry diethyl ether were added, and on passing the hydrogen chloride gas again at

0°C, a white suspension was observed in the petroleum ethereal solution and a few oily drops which were immiscible with the solution deposited. Since all the tin dichloride did not dissolve in the solution a further 30 ml. diethyl ether were added and once again the hydrogen chloride gas was passed for 1½h. at 0°C with stirring until all the tin dichloride was dissolved in the solution. On standing, the solution deposited a pale yellow oil which was kept at 0°C since it decomposed easily at room temperature and formed a white solid ( $\text{SnCl}_2$ ). The colourless upper layer solution was syringed off and about 15 ml. dry methacrylonitrile (11.99 g., 179 m mol.) were added, after which a white precipitate deposited immediately and on stirring, the white precipitate started to dissolve into the solution forming a pale yellow solution, then the solution was stirred overnight at room temperature. The resulting solution was warmed gently and pumped under vacuum to remove all volatile components, leaving a pale yellow solution over a white precipitate 20 ml. dry benzene were added to the mixture and refluxed for one hour with stirring. On filtration while hot a white solid was separated from the pale yellow filtrate which deposited a white microcrystalline solid on standing at room temperature for two days. This microcrystalline product was isolated by filtration, washed with cold benzene, dried under vacuum, identified as 3-trichlorostannyl -2-methylpropanonitrile :  $\text{SnCl}_3 \cdot \text{CH}_2 \cdot \text{CHMeCN}$ .

\*Analysis :

Found: C 16.3, H 2.0, N 4.6, Cl 36.3%

$\text{C}_4\text{H}_6\text{NSnCl}_3$  requires : C 16.3, H 2.0, N 4.7, Cl 36.3%

\*Infra-Red Spectrum :  $\nu_{\max}$   $\text{cm}^{-1}$  (Nujol Mull).

3438(s), 3335(s), 3265(m/s), 3195(m/s), 2275(m/s), 1652(s),  
1568(m/s), 1405(m), 1314(w), 1288(w/m), 1268(w,sh), 1200(w),  
1178(w), 1160(w), 1124(w), 1110(w), 1100(w), 1088(w),  
1040(w), 1015(w), 1000(vw,sh), 920(vw), 925(vw,sh), 896(vw,sh),  
810(vw), 790(vw), 762(vw), 745(m), 733(m), 688(w/m), 645(vw),  
587(w), 570(w/m), 552(w,sh), 510(vw), 478(vw), 400(vw,sh),  
382(s), 370(s), 357(vs).

\*Far Infra-red Spectrum :  $\nu_{\max}$   $\text{cm}^{-1}$  (Nujol Mull).

383(vs), 380(vs), 372(vs), 365(s), 356(s), 313(s), 306(s),  
254(vw), 253(vw), 232(vw), 227(vw), 221(vw), 211(vw), 203(vw),  
194(vw), 188(vw), 177(vw), 170(vw), 156(w/m), 150(w/m),  
143(w/m), 132(w), 127(w/m), 107(vw), 101(vw), 95(vw), 88(vw),  
73(m), 65(w), 55(vw).

\*Raman Spectrum :  $\nu_{\max}$   $\text{cm}^{-1}$

2995(m/s), 2975(m/s), 2930(m/s), 2915(m/s), 2875(m),  
2270(s), 1163(s), 656(m), 578(w/m), 512(w), 478(w,sh), 382(m),  
375(m), 357(m), 310(w/m), 213(vw), 205(vw), 200(vw), 145(w/m),  
135(m), 90(w/m), 52(w/m), 40(w/m).

4.3.4 Reaction of Cis-/trans-Crotonitrile with Hydrogen Chloride and Tin Dichloride ( $\text{SnCl}_2/\text{HCl}$  System Prepared in  $\text{Et}_2\text{O}$ ).

Dry hydrogen chloride gas was passed through 200 ml. dry diethyl ether mixed with 49.0 g. anhydrous tin dichloride (258 m mol.) for one hour at  $0^\circ\text{C}$  with stirring until all tin dichloride completely dissolved in the solution. The solution was allowed to warm to room temperature for  $\frac{1}{2}$  hour but no

oil deposited. The solution was then stirred for  $\frac{1}{2}$  hour to remove the excess of the hydrogen chloride gas. The solution was recooled to  $0^{\circ}\text{C}$  and about 70 ml. dry cis-/trans-Crotononitrile (57.67 g., 859 m mol.) were added with stirring for one hour. The ethereal solution was miscible with the crotononitrile. It was then stirred overnight at room temperature after which the solution on standing, separated into two phases; the upper phase was a colourless solution and the lower phase was pale yellow viscous solution. A sample of the upper phase was withdrawn by syringe and transferred into another empty flask under dry nitrogen. It was pumped under vacuum leaving a pale yellow viscous residue. The IR spectrum of this residue was identical to that of an authentic sample of 3-chlorobutanonitrile  $\text{Cl}-\text{CH}(\text{CH}_3)-\text{CH}_2-\text{CN}$ . The extraction of this residue from toluene for  $\frac{1}{2}$  hour at  $120^{\circ}\text{C}$  produced a brown solution from which no solid was deposited.

Another sample was taken from the lower phase for test experiments. This viscous solution, on standing at room temperature for one week produced white needles of which the IR spectrum was identical with that of the white precipitate deposited from the solution after pumping off under vacuum. The IR spectrum showed bands at the region of  $\nu(\text{N-H})$ ,  $\nu(\text{C=C})$ , and  $\nu(\text{C=N})$  bands.

A third sample of the initial solution was transferred into another empty flask, pumped under vacuum to remove all volatile components using a warm water bath thus leaving a pale yellow solution over a white precipitate. The resulting mixture was distilled at  $85^{\circ}\text{C}$  at 0.1 mm. Hg to remove all

3-chlorobutanonitrile. The final residue was a yellow solid. This residue was extracted from the toluene at about 60°C for ½ hour but there was not much solid dissolved in the solution. The solution was filtered leaving a yellow solid on the filter stick and a filtrate which deposited pale yellow oil. The IR spectrum of this oil showed a band for  $\nu(\text{C}\equiv\text{N})$  shifted to higher frequency.

Apart from these test experiments, the whole remaining mixture (two phases) was pumped off under vacuum, distilled under vacuum, as mentioned before, to remove all the 3-chlorobutanonitrile which was identified from the IR spectrum by comparison with an authentic sample, leaving a yellow solid. On continuation of the heating at 0.1 mm.Hg the yellow solid started to melt at 43°C and to change to a dark colour at 50-55°C, then a white solid started to sublime inside the condenser. This solid was heated using a hair drier until it melted and it was collected in an empty distillation flask. From the analytical data and IR spectrum, this solid was identified as an adduct (2:1) of 3-chlorobutanonitrile tin tetrachloride:

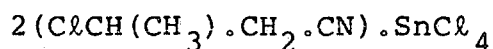

\*Analysis:

Found: C 23.2, H 2.2, N 6.2, Cl 44.5%

$\text{C}_8\text{H}_{12}\text{N}_2\text{SnCl}_6$  requires : C 21.0, H 2.5, N 6.0, Cl 45.5%

\*Infra-Red spectrum of the fungisolid:  $\nu_{\text{max}} \text{ cm}^{-1}$  (fused contact film).

2290(m), 1442(w), 1400(w), 1382(w), 1338(vw), 1273(w),  
1255(w, sh), 1210(vw), 1190(vw), 1109(w), 1078(w), 1010(w/m),

950(vw), 925(w), 885(vw), 850(vw), 710(vw), 655(w), 623(w/m), 605(w/m).

4.3.5 Reaction of cis-/trans-Crotononitrile with Hydrogen Chloride and Tin Dichloride (SnCl<sub>2</sub>/HCl system prepared in petroleum Ether-Et<sub>2</sub>O).

30 ml. dry petroleum ether was added by syringe to 2.18 g. anhydrous tin dichloride (11.5 m mol.), followed by 22 ml. of dry diethyl ether. Dry hydrogen chloride gas was allowed to bubble through the solution for 2½ hours at 0°C with stirring until all the insoluble white solid of tin dichloride had dissolved completely in the solution and the pale yellow oil had been deposited. The petroleum ether/etheral solution was syringed off and then 23 ml. of cis-/trans-Crotononitrile (18.94 g., 282 m mol.) was added at 0°C with stirring, it was miscible in the solution and a pale yellow clear solution was produced. It was stirred overnight at room temperature. All volatile components were pumped off under vacuum leaving a high yield of a white solid which was extracted - without distilling - in 80 ml. dry benzene for one hour at 110°C. Most of the white solid did not dissolve in the hot benzene. On filtration the high yield of the white solid was isolated, washed with benzene and dried under vacuum. The analytical data and the IR spectrum showed that this product had the formula similar to that product obtained from the reaction of methacrylonitrile with SnCl<sub>2</sub>/HCl System (prepared in Et<sub>2</sub>O), i. e. C<sub>4</sub>H<sub>7</sub>NSnCl<sub>4</sub> and therefore the product was tentatively identified as:

N-(3-chloro-1-trichlorostannyl butenyl)



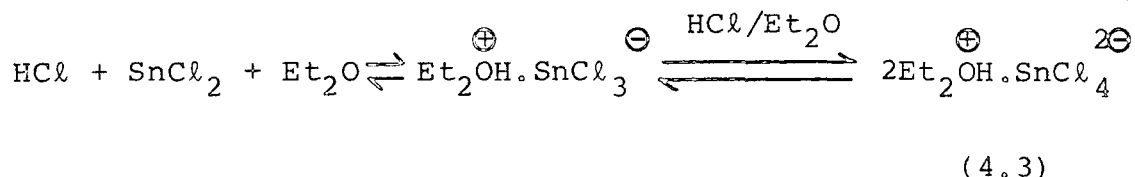

The presence of a strongly ionized proton has been detected from the signal at  $\delta \approx 12$  ppm in the  $^1\text{H}$ -NMR spectrum, which is similar to that observed in the  $\text{Et}_2\text{O}/\text{HCl}$  System ( $\delta \approx 6$  ppm). The tin atom in this reaction is not oxidised from the divalent oxidation state to the tetravalent on the treatment with HCl to give for example the trichlorostannane (IV);  $\text{HSnCl}_3$ . This is confirmed by the IR spectrum of the yellow oil which shows no  $\nu(\text{Sn-H})$  stretching frequency band in the  $1700 - 2200 \text{ cm}^{-1}$  region, and also from its  $^{119}\text{Sn}$  Mössbauer parameters which is consistent with those parameters observed for tin (II)-compounds.<sup>1</sup>

The complexes in the yellow oil are not stable and they tend to dissociate into  $\text{SnCl}_2$  and HCl on addition of more  $\text{Et}_2\text{O}$ , or of inert apolar solvents, and on evaporation of diethyl ether and/or hydrogen chloride. In addition to that, the complexes decompose slowly at room temperature as a result of diethyl ether cleavage, yielding ethanol and ethyl chloride, together with traces of ethyl tin trichloride.

In this work, the reaction of tin dichloride with hydrogen chloride was carried out, firstly, in diethyl ether, but no yellow oily liquid separated out and only a clear colourless solution was obtained. However, on repeating this reaction in a mixture of  $\text{Et}_2\text{O}$  and an inert solvent such as petroleum ether (B.pt =  $120^\circ$ ), the oily liquid could be separated at  $0^\circ\text{C}$  and  $\text{SnCl}_2$  was found to immediately precipitate at room temperature.

4.4.2 The Reaction of Chlorostannate (II) with Acrylonitrile

The reaction of acrylonitrile with the  $\text{SnCl}_2/\text{HCl}$  System (prepared in  $\text{Et}_2\text{O}$ ) yielded a pale yellow solid which is identified analytically and spectroscopically as 2-cyanoethyl trichlorostannane (IV);  $\text{SnCl}_3\text{CH}_2\text{CH}_2\text{CN}$ . This product is very soluble in the demineralized water and its aqueous solution gives no precipitate on treatment with mercury dichloride (equation 4.4), which indicates that the tin atom in this product exists in the +4 oxidation state, rather than +2.

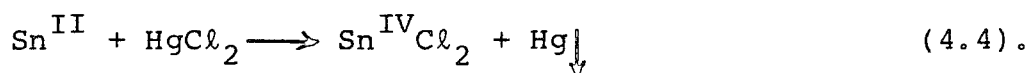

grey or black ppt.

The mass spectral data of this product and their assignments are shown in table (4.1). The spectrum supports strongly the presence of tin-containing organic fragments since the protonated parent ion;  $\text{SnCl}_3\text{CH}_2\text{CH}_2\text{CNH}^{\oplus}$  is observed at  $m/e = 280$ .

Table (4.1) : Mass Spectral data of  $\text{SnCl}_3 \cdot \text{CH}_2 \cdot \text{CH}_2 \cdot \text{CN} = \text{M}$   
 $m/e$  (Fragment<sup>+</sup>, Ir%) : 280(M+1, 0.7), 278 (M-1, 1.2),  
 276(M-2, 0.7), 244 (M-Cl, 2.5), 243(M-HCl, 0.7), 225 ( $\text{SnCl}_3$ , 32),  
 190( $\text{SnCl}_2$ , 10), 155( $\text{SnCl}$ , 34), 120(Sn, 8), 89 ( $\text{HNCCH}_2\text{CH}_2\text{Cl}$ , 17),  
 54( $\text{HNCCH} : \text{CH}_2$ ), 49( $\text{C}_4\text{H}$ , 100), 36( $\text{HCl}$ , 10).

The IR spectrum (Figure (4.1)) showed a very intense absorption at  $2280 \text{ cm}^{-1}$  which is characteristic for  $\nu(\text{C}\equiv\text{N})$  stretching frequency. This nitrile band shifted to lower frequency ( $\sim 2250 \text{ cm}^{-1}$ ), when the trichlorostannane (IV)

product was exposed to air. The characteristic bands of absorbed water, i.e.  $\nu(\text{O-H})$  stretch,  $\delta(\text{HOH})$  bend, were observed at 3600 and 1610  $\text{cm}^{-1}$  respectively. This change in  $\nu(\text{C}\equiv\text{N})$  frequency indicates that  $(\text{C}\equiv\text{N})$  bond is co-ordinating with the tin atom by the nitrogen lone pair. On comparison with the analogous  $\beta$ -Cyanoethyl derivative;  $\text{Cl-CH}_2\text{CH}_2\text{CN}$ ,<sup>21</sup> the IR spectrum showed other bands at 1410, 1323, 1162 and 911  $\text{cm}^{-1}$  which could be assigned to the  $\text{CH}_2$  bending modes, i.e. the scissoring, twisting, wagging and rocking modes. Other weak bands were observed at 1645 and 1540  $\text{cm}^{-1}$  which they are not expected. These two bands will be discussed later, in the next section.

The far IR and Raman spectra (figures 4.2 and 4.3 respectively) of the sample of 2-cyanoethyl tin trichloride were recorded in an attempt to characterize the stereo-chemistry about the tin atom. Each spectrum displayed three bands in the region 500-250  $\text{cm}^{-1}$  at  $\sim 470$ ,  $\sim 363$  and at  $\sim 317$   $\text{cm}^{-1}$  which are expected for the stretching modes of  $\nu(\text{Sn-C})$ ,  $\nu(\text{Sn-Cl})$  and  $\nu(\text{Sn-N})$  respectively. These assignments are proposed using ethyl tin trichloride as a comparative model. In the literature, the latter compound has been reported to give bands at 520 and 370  $\text{cm}^{-1}$  corresponding to  $\nu(\text{Sn-C})$  and  $\nu(\text{Sn-Cl})$  stretching frequencies respectively.<sup>22</sup> On co-ordination of the tin with 2,2'-dipyridyl, both bands of  $\nu(\text{Sn-C})$  and  $\nu(\text{Sn-Cl})$  were shifted to lower frequency with the appearance of a new band at 349  $\text{cm}^{-1}$  corresponding to the  $\nu(\text{Sn-N})$  stretching.<sup>23</sup>

Further evidence for the structure of the trichlorostannane (IV) is provided by  $^1\text{H-NMR}$  spectroscopy - see figure 4.4. The spectrum showed (Table 4.2) two triplets which were similar to the spectrum recorded for  $\text{ClCH}_2\text{CH}_2\text{CN}$ . The upfield triplet is assigned to the  $\alpha$ -methylene group by comparison with  $\text{R}_2\text{SnCl}_2$ <sup>26</sup> and the down field triplet to the  $\beta$ -( $\text{CH}_2$ ) group.

Table (4.2)  $^1\text{H NMR}$  Spectrum of  $\text{NC}\cdot\overset{\alpha}{\text{C}}\text{H}_2\cdot\overset{\beta}{\text{C}}\text{H}_2\cdot\text{SnCl}_3$ \*

Solvent	$\alpha(\text{CH}_2)$	$\beta(\text{CH}_2)$
$\text{CDCl}_3$	2.95t	2.46t
$\text{D}_2\text{O}$	3.40t	2.38t

\*Ref. external TMS ( $\delta = 0$ ), t = triplet.

The  $^{13}\text{C-NMR}$  Spectrum (figure 4.5) was recorded in  $\text{D}_2\text{O}$  using 1,4-dioxane as an internal Reference. The chemical shift obtained, then converted to  $\delta_{\text{TMS}}$  scale by using the relation :  $\delta_{\text{TMS}} = \delta_{1,4\text{Dioxan}} + 66.5$ . The spectrum displayed a signal at  $\delta 121.5$  ppm corresponding to the nitrile group and two other signals at  $\delta 33.2$  and  $\delta 13.2$  ppm corresponding to  $\text{SnCl}_3\text{CH}_2$ - and  $\text{N} \equiv \text{CCH}_2$  carbons respectively.

#### 4.4.3 The Reaction of Chlorostannate (II) with Methacrylonitrile

**[A]** - The reaction of methacrylonitrile with the  $\text{SnCl}_2/\text{HCl}$  system (prepared in  $\text{Et}_2\text{O}$ ) yields a product of the composition  $\text{CH}_2\text{C Me.CN.H}_2\text{SnCl}_4$ . The structure of this new product is believed to be N-(3-chloro-2-methyl-1-trichlorostannyl propenyl) 3-chloro-2-methyl propylamidinium

trichlorostannate (II) - see structure IV.

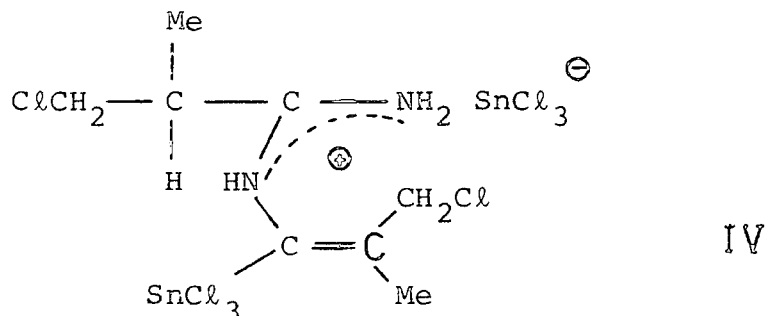

Surprisingly, the analytical data for the C, H and N percentages was consistent with the composition  $\text{CH}_2\text{CMeCN}$ .  $\text{HSnCl}_3$ , but the latter has been rejected on the basis of the higher content found for %Cl. Furthermore, the mass spectrum of the sample gave evidence for the presence of traces of toluene which may explain the higher carbon percentage. The analysis of tin (24%) was not accurate but it is observed to be more than the expected value of total tin (36%).

The product obtained is characterized to be non-air sensitive, very soluble in water, and insoluble in aromatic solvents, particularly, benzene and toluene. In aqueous solutions, this product gives a grey precipitate with  $\text{HgCl}_2$  indicating the presence of Sn(II).

The mass spectral data of the amidinium salt product and their assignments are summarized in table (4.3). The spectrum showed no peak for the parent ion. Except for the peak at  $m/e = 280$ , the highest mass peaks are due to  $\text{SnCl}_4^+$  or  $\text{SnCl}_3^+$  ions. The peak at  $m/e = 280$  is probably due to the formation of a stable heterocyclic fragment such as  $\text{SnCl}_3 - \text{CH} = \text{N} - \text{CH} = \text{NH}$  ion. In practice, it has been observed that trichlorostannyl heterocyclic compounds such as

$\overline{\text{O-SnCl}_3\text{C}_6\text{H}_4\text{Cph} = \text{NH}}$  are stable inside the mass spectrometer. The formation of such fragment, probably as a result of the decomposition of the parent ion, can be considered as evidence supporting the existence of amidinium structure.

Table (4.3). Mass Spectral data for

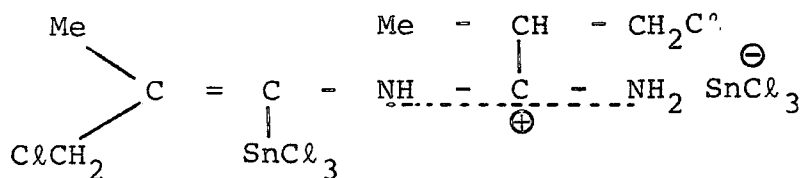

m/e (Fragment<sup>⊕</sup>, I<sub>r</sub>%) = 280 ( $\overline{\text{SnCl}_3\text{CH} = \text{N} - \text{CH} = \text{NH}}$ , 0.3),  
 260 ( $\text{SnCl}_4$ , 1.5), 225 ( $\text{SnCl}_3$ , 5), 155 ( $\text{SnCl}$ , 1.4), 120 ( $\text{Sn}$ , 1.4),  
 102 ( $\text{CH}_2\text{CMeCN} + \text{HCl}$ , 6), 68 ( $\text{CH}_2\text{CMeCNH}$ , 100), 51, 49  
 ( $\text{ClCH}_2$ , 17, 41), 41 ( $\text{C}_3\text{H}_5$ , 23), 36 ( $\text{HCl}$ , 11). 92 ( $\text{C}_7\text{H}_8$ , 46),  
 91 ( $\text{C}_7\text{H}_7$ , 55).

Apart from the peak at 280, it seems that the amidinium salt product obtained from this reaction is not stable on the mass spectrometer probe and it does decompose to give simple fragments such as  $\text{CH}_2\text{CMeCNH}^\oplus$ ,  $\text{ClCH}_2\text{C}(\text{Me}) = \text{C} = \text{NH}^\oplus$ ,  $\text{ClCH}_2^\oplus$ ,  $\text{HCl}$  and the tin chlorides.

The infrared spectrum of the substituted propenyl propylamidinium salt shown in figure (4.6), showed no absorption in the nitrile stretching region, and instead three bands were observed in both the  $\nu(\text{N-H})$  stretching (at 3570, 3320 and 3180  $\text{cm}^{-1}$ ) and in the  $\nu(\text{C=N})/\nu(\text{C=C})$  stretching region (at 1645, 1680 and 1580  $\text{cm}^{-1}$ ). These absorption bands are consistent with the amidinium salt structure which is pictured in structure IV, since it is expected three stretching vibrations arising from  $\text{NH}_2$  and  $\text{NH}$  groups. On



for the methylene protons at the chemical shifts 3.4 and 5.0 in the same ratio. However, the signal of the expected methine proton could not be observed probably because of the overlap with the Me or CH<sub>2</sub> signals. The NH protons were observed at the chemical shifts 7.7 and 8.9 which are expected for amidinium protons  $\text{HN}-\overset{\oplus}{\text{C}}-\text{NH}_2$ . The upfield signal was broad and it is believed to belong to the partially double bond  $\text{C}=\text{NH}_2$  protons, and the low-field signal which was sharp is believed to belong to the highly acidic proton of the partial  $\text{C}=\text{NH}$  double bond. Such a feature of the NMR spectrum has been reported previously for some related compounds of the general formulae <sup>12</sup>  
N-(α-chloroalkenyl) alkylamidinium hydrochloride VI :

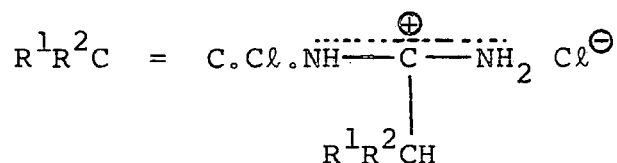

VI

The NMR spectrum was recorded also using D<sub>2</sub>O as a solvent, but the spectrum showed different signals to those observed in the d<sup>6</sup>-DMSO solution which indicates that this sample undergoes hydrolysis with D<sub>2</sub>O. The sensitivity of this amidinium salt towards water can be assumed on the basis of previous studies on the dimeric salt V which reacts with the water to give N-(3-chloro-2-methyl-propionyl)-N-methacryloylamine through partial dehydrochlorination of bis (3-chloro-2-methyl propionyl) amine: <sup>12</sup>



ethereal solution. The mixing of the two reagents was carried out at 0°C and the mixture was stirred for several days. The resulting solution which <sup>was</sup> homogeneous, was pumped on to remove all the volatile materials. The resulting residue was then extracted in benzene without isolation of the expected by-product 3-chloro-2-methyl propanonitrile. A high yield of white solid did not dissolve in the hot benzene. The IR spectrum of the insoluble product showed similar bands to those observed for the isolated product shown in structure IV, i.e. this product has the amidinium salt structure. Another interesting product was isolated from the extracted benzene solution in low yield as a white microcrystalline solid. This product is identified as 3-trichlorostannyl-2-methyl propanonitrile;  $\text{SnCl}_3\text{CH}_2\text{CHMeCN}$ . The analytical data are consistent with the formula  $\text{CH}_2\text{CMeCN} \cdot \text{HSnCl}_3$ . The product is very soluble in water and gives no precipitate with mercuric chloride which implies that this product contains Sn(IV) rather than Sn(II).

The IR spectrum (Figure 4.8) showed a sharp band at  $2275 \text{ cm}^{-1}$  assignable to the expected coordinated cyano stretching group. However, several bands were observed in the  $\nu(\text{N-H})$  stretching region (at  $3438$ ,  $3335$  and  $3265 \text{ cm}^{-1}$ ), and also in the  $\nu(\text{C=N})/\nu(\text{C=C})$  stretching region (at  $1652$  and  $1586 \text{ cm}^{-1}$ ). These bands may be related to some mixed impurities of an amidinium or a chloroiminium salt or even trichlorostannyl imine. Both FIR and Raman spectra (Figures 4.9 and 4.10 respectively) showed in the region  $500 - 200 \text{ cm}^{-1}$  three similar bands to those observed for the 2-cyanoethyl tin trichloride sample at  $478 \text{ cm}^{-1}$  (for  $\nu(\text{Sn-C})$  stretch),

457  $\text{cm}^{-1}$  (for  $\nu(\text{Sn-Cl})$  stretch) and 313  $\text{cm}^{-1}$  (for  $\nu(\text{Sn-N})$  stretch). Once again the impurities showed another band in this region at 375  $\text{cm}^{-1}$  probably corresponding to another Sn-Cl stretching vibration.

The mass spectrum supports the structure of 3-trichlorostannyl-2-methyl propionitrile since it shows the parent ion peaks at  $m/e$  293 and 294. The other fragmentation ions observed in the mass spectrum are given in table (4.4). As in the case of  $\text{SnCl}_3\text{CH}_2\text{CH}_2\text{CN}$ , the loss of chloride ions,  $\text{HCl}$ ,  $\text{Me}$ ,  $\text{HSnCl}_3$  and other fragments was observed. Once again the presence of impurities in the sample may explain the reason for a peak at  $M^{\oplus} + \text{HCl}$  ( $m/e = 329$ ).

Table (4.4) : Mass Spectral Data for  $\text{SnCl}_3\text{CH}_2\text{CHMeCN}(M)$

$m/e(\text{Fragment}^{\oplus}, I_r\%)$
326 ( $M + \text{HCl}, 0.9$ ), 292 ( $M, 2.9$ ),
293 ( $M + 1, 0.8$ ), 294 ( $M + 2, 2.8$ ), 280 ( $\overline{\text{SnCl}_3\text{CH}=\text{N}-\text{CH}=\text{NH}}$ ,
26), 282 ( $\overline{\text{SnCl}_3\text{CH}=\text{N}-\text{CH}=\text{NH}} + 2, 11.2$ ), 284 ( $\overline{\text{SnCl}_3\text{CH}=\text{NCHNH}} + 4,$
5.3), 260 ( $\text{SnCl}_4, 6.7$ ), 258 ( $M-\text{Cl}, 12.7$ ), 257 ( $M-\text{HCl}, 4$ ),
227 ( $\text{SnCl}_3 + 2, 20$ ), 226 ( $\text{SnCl}_3 + 1, 7$ ), 222 ( $M-2\text{Cl}, 28$ ),
190 ( $\text{SnCl}_2, 9$ ), 155 ( $\text{SnCl}$ ), 188 ( $M + 1-3\text{Cl}, 7$ ), 120 ( $\text{Sn}, 17.6$ )
68 ( $M-\text{SnCl}_3, 60$ ), 41 ( $\text{C}_3\text{H}_5, 100$ ), 36 ( $\text{HCl}, 60$ ).

The C-13 NMR spectrum of the sample (figure 4.11) was recorded in 1,4-dioxane which was used as an internal reference. The chemical shifts were then converted to the TMS scale as indicated earlier. The spectrum clearly showed one signal at  $\delta$  124 for the nitrile carbon which was a singlet even without the decoupling. The methylene carbon was observed as a singlet at  $\delta$  43.2 in the same ratio of the

Cyano Signal. The doublet signals observed at  $\delta$ 21.1 and  $\delta$ 34.6 (in 3:1 intensity ratio) probably correspond to the methyl and methine carbons. Using  $^1\text{H NMR}$ , the sample exhibits in  $d^6$ -DMSO three sets of signals at  $\delta$ 8.9 (doublet ; vw), 3.1 (quartet, w), and 1.3 (triplet + doublet, m/s) - see figure (4.12). The first signal is suggested to be for the (N-H) proton of the impurities; the second for the (C-H) proton which is coupled with the methyl protons, and the last one is probably due to  $\text{CH}_3$ ,  $\text{CH}_2$  and CH protons. No signals for the  $d^6$ -DMSO could be observed at  $\delta$ 2.5. To avoid the solvent signals, the spectrum was re-recorded in  $\text{D}_2\text{O}$ . The spectrum (figure 4.13) showed the methyl protons as a doublet at  $\delta$ 1.95 and the (C-H) proton as a quartet at  $\delta$ 3.7. Another set of signals centred at  $\delta$ 2.4 was observed and they probably correspond to the  $\text{CH}_2$  and CH protons.

#### 4.4.4 The Reaction of Chlorostannate (II) with Cis-/trans-Crotononitrile

The reaction of the isomeric mixture of cis-/trans-crotononitrile with the  $\text{SnCl}_2/\text{HCl}$  system prepared either in  $\text{Et}_2\text{O}$  or in a mixture of petroleum ether and diethyl ether forms one product. This product is identified as N-(3-Chloro-1-trichlorostannyl butenyl)-3-chlorobutylamidinium trichlorostannate (II) - see structural formula VII.

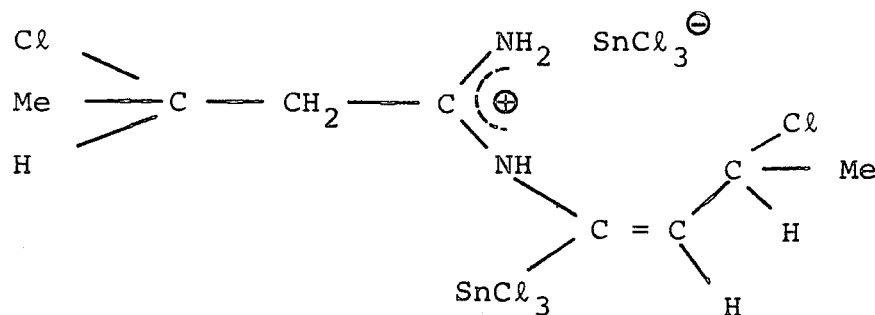

VII

Another product was isolated during the distillation and it is believed to be the  $(\text{ClCHMeCH}_2\text{CN})_2\text{SnCl}_4$  adduct. The latter product was obtained as a white solid which gives white fumes on exposure to air. The IR spectrum showed the stretching band of  $\text{ClCHMeCH}_2\text{CN}$  (at  $2255\text{ cm}^{-1}$ ) shifted to the higher frequencies (at  $2290\text{ cm}^{-1}$ ) as expected for  $\sigma$ -N complexes. Additionally, the IR spectrum showed nearly the same bands observed for the free 3-chlorobutanonitrile which has been previously prepared by passing  $\text{HCl}$  gas through the crotonitrile. The adduct exhibits in the mass spectrum no peak for the organotin fragment, but instead it exhibits simple fragments such as tin chlorides,  $\text{MeCHCHCNH}^+$  and  $\text{ClCHMeCH}_2\text{CNH}^+$  - see the mass spectral data of the adduct in table (4.5).

Table (4.5) : Mass Spectral Data of  $(\text{ClCHMeCH}_2\text{CN})_2/\text{SnCl}_4$

m/e (Fragment<sup>⊕</sup>, I<sub>r</sub>%) : 260 (SnCl<sub>4</sub>, 4.2), 223 (SnCl<sub>3</sub>-1, 29), 226 (SnCl<sub>3</sub> + 1, 5.4), 227 (SnCl<sub>3</sub> + 2, 22), 190 (SnCl<sub>2</sub>, 1.5), 155 (SnCl, 5.3), 120 (Sn, 6.0), 68 (MeCHCHCNH, 6.8), 63 (ClCHMe, 79.8), 65 (ClCHMe + 2, 25.6), 41 (C<sub>3</sub>H<sub>5</sub>, 100), 36 (HCl, 14.4), 35 (Cl, 6.9).

Apart from the by-products, the same product was obtained in  $\text{Et}_2\text{O}$  alone as in the mixed solvent system petroleum ether-diethylether.

In order to support structure VII, the analytical data is consistent with the empirical formula  $(\text{Me-CH}=\text{CHCN} \cdot \text{H}_2\text{SnCl}_4)$ .

The IR Spectrum (figure 4.14) does not show the  $\nu(\text{C} \equiv \text{N})$  stretching band of the starting material, but instead, it shows clearly several bands mainly at 3370, 3330, 3220 and 3180  $\text{cm}^{-1}$  (assignable to  $\nu(\text{N} - \text{H})$  stretching frequencies), and also four bands are observed at 1690, 1632, 1570 and 1515  $\text{cm}^{-1}$  assignable to the  $\nu(\text{C} = \text{N})/\nu(\text{C} = \text{C})$  stretching and  $\text{NH}_2$  bending modes. The mass spectrum of the sample does not show any indication for the presence of the molecular ion  $\text{MeCH} = \text{CHCN} \cdot \text{H}_2\text{SnCl}_4$  or the expected molecular ion shown in structure VII. The spectrum only shows peaks resulting from the tin chloride ions or resulting from the fragmentation of the organic residue; crotononitrile. The mass spectral data are listed in table (4.6).

Table (4.6) : Mass Spectral Data for N-(3-chloro-1-trichlorostannyl butenyl)-3-chloro-butylamidinium trichlorostannate (II).

m/e (Fragment<sup>⊕</sup>, I<sub>r</sub>%) : 268, 270 ( $\text{SnCl}_4$ , 1.4, 2.8) 225 ( $\text{SnCl}_3$ , 6), 190 ( $\text{SnCl}_2$ , 9.4), 155 ( $\text{SnCl}$ , 23), 120 (Sn, 6.1), 78 ( $\text{C}_6\text{H}_6$ , 63), 77 ( $\text{C}_6\text{H}_5$ , 11.7), 68 ( $\text{CH}_3\text{CHCHCNH}$ , 12.4), 69 ( $\text{CH}_3\text{CHCHCNH}_2$ , 15.5), 41 ( $\text{C}_3\text{H}_5$ , 16), 36 ( $\text{HCl}$ , 100), 35 ( $\text{Cl}$ , 23.5).

The <sup>1</sup>H NMR spectrum of the sample was recorded in both  $\text{d}^6$ -DMSO and  $\text{D}_2\text{O}$  (Figure 4.15) using TMS as internal or external reference. The spectra showed three broad signals at the chemical shift 8.0, 7.2 and 6.2 which can be assigned to the NH protons of the amidinium group. These three broad signals have been observed in the NMR spectrum of the dimeric salts of N-( $\alpha$ -chloroalkenyl) alkylamidinium chlorides VI. The spectrum also showed three sets of doublets for the methyl

protons at the chemical shifts 1.6, 1.5 and 1.4 in the ratio 1:2:1. This ratio suggests a coupling between the methyl groups due to the presence of a butenyl group as a mixture of Cis- and trans- almost in equal proportions. the signal observed at  $\delta 4.5$  corresponds to the proton attached to the unsaturated (C = C) double bond. Another signal was observed at  $\delta 2.6$  which is probably due to the methylene protons. The spectrum recorded in  $D_2O$  was different from that in  $d^6$ -DMSO which implies that this product is hydrolyzed by water.

#### 4.5 MECHANISTIC ASPECTS

From the previous discussion sections, one can conclude that the acrylonitrile reacts with the tin dichloride and hydrogen chloride in a different manner to the methyl derivatives of acrylonitrile, i.e. methacrylonitrile and crotononitrile. The former reaction afforded mainly 3-trichlorostannyl propanonitrile, whilst the other reactions afforded mainly a dimeric product linked through the cyano groups as illustrated in the reactions below.

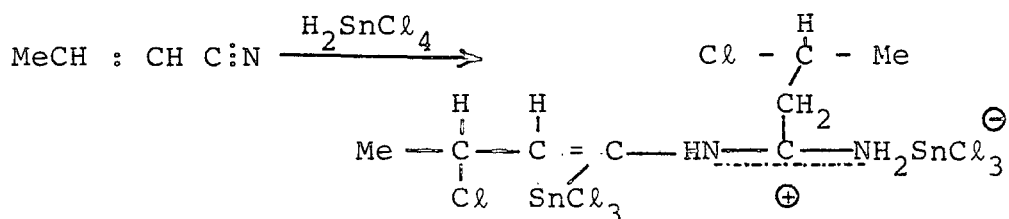
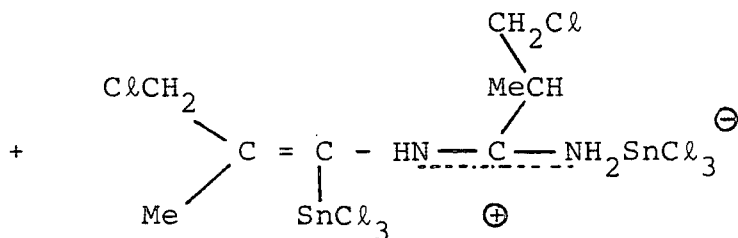
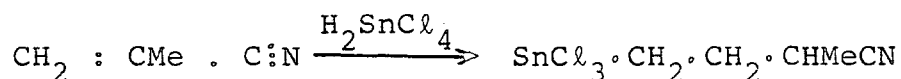
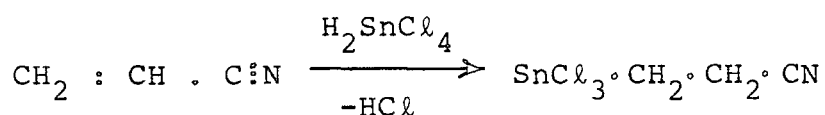

These equations indicate that there are two different ways for the  $\alpha, \beta$ -unsaturated nitriles to react with dihydrogen tetrachlorostannic (II) acid. The reaction may occur at the (C = C) bond to give the cyano trichlorostannyl derivative, or may occur at the (C  $\equiv$  N) bond to give the amidinium salt. The mechanism of these reactions can be proposed in the following steps:

1 - It is strongly believed that the first step of these reactions is the formation of the nitrilium ion since these unsaturated nitriles show a high tendency to coordinate with the Lewis acids as will be demonstrated in the next chapter.

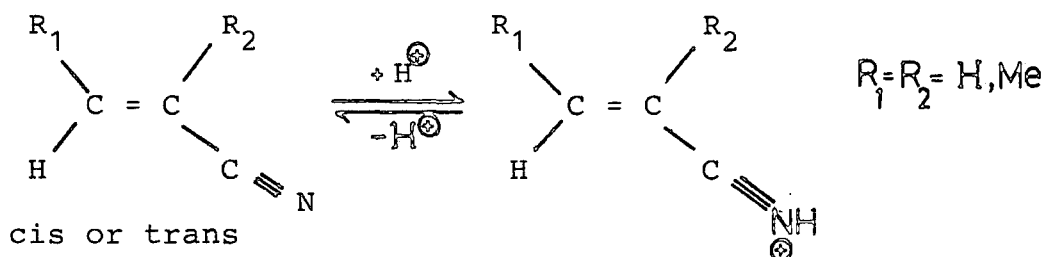

2 - The formation of a positive charge on the nitrogen atom is not favoured because of its higher electronegativity in comparison to the carbon atoms. Consequently, this positive charge tends to delocalize on carbons 2 and 4 through the conjugated unsaturated bonds.

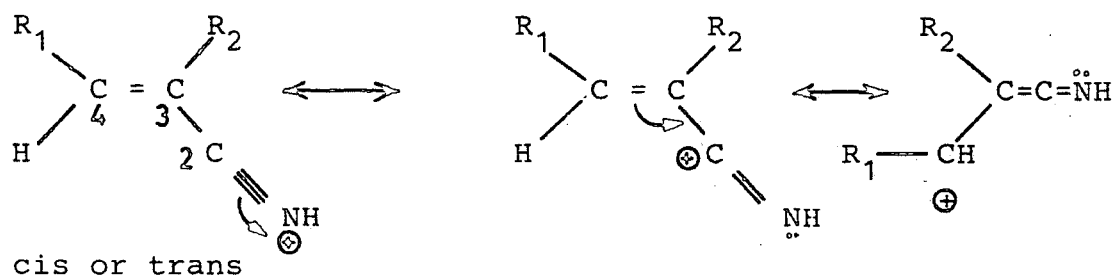

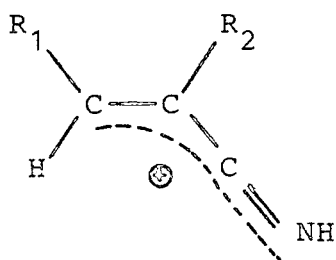

3 - The next step is the addition of the nucleophiles  $\text{SnCl}_3^\ominus$  or  $\text{Cl}^\ominus$  (or probably the anion  $\text{SnCl}_4^{2\ominus}$ ) on the electron-deficient carbon centers. This addition will be expected to occur kinetically on carbon-4 and thermodynamically on Carbon-2, as it has been reported in the reaction of the analogous system, vinyl acetylene with hydrogen chloride <sup>26,27</sup>. The reason for this comes from the energy difference which has been estimated to be 14 KCal/mole, as a result of the presence of the highly destabilized allenic system in comparison with the resonance-stabilized butanoid system. <sup>28,29</sup>

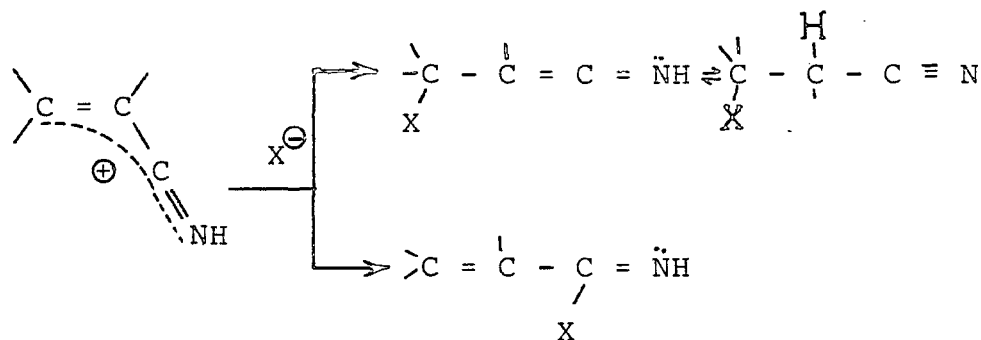

On the basis of the experimental results, it can be concluded that there is competition between the anions  $\text{SnCl}_3^\ominus$  and  $\text{Cl}^\ominus$  on carbon-4. In the acrylonitrile system the carbon-4 cation clearly shows a higher tendency to select  $\text{SnCl}_3^\ominus$  rather than  $\text{Cl}^\ominus$ , whilst in methacrylonitrile and crotononitrile, the same cation prefers to select  $\text{Cl}^\ominus$  rather than  $\text{SnCl}_3^\ominus$ . The reason for this may be explained electronically and/or sterically from the introduction of the methyl group near

the carbonium ion. Thus,

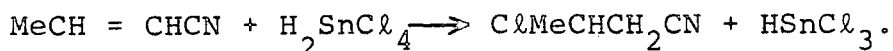
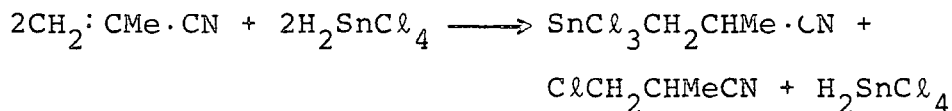

4 - The next step is the interaction of the remaining HCl and/or HSnCl<sub>3</sub> with the cyano group. It seems that the addition of SnCl<sub>3</sub><sup>⊖</sup> is favoured (than Cl<sup>⊖</sup>) on the C ≡ N bond, as no product such as SnCl<sub>3</sub>R<sup>1</sup>CHCHR<sup>2</sup>.C(Cl) =  $\ddot{\text{N}}\text{H}$ , Cl·CR<sup>1</sup>H·CHR<sup>2</sup>-C(Cl) = NH, or their iminium salts were isolated. The only products could be obtained were the amidinium salts which are expected due to the interaction of the nitrolium ion with the 3-chloronitrile derivatives or with the imidoyl tin trichloride or its enamine tautomer.

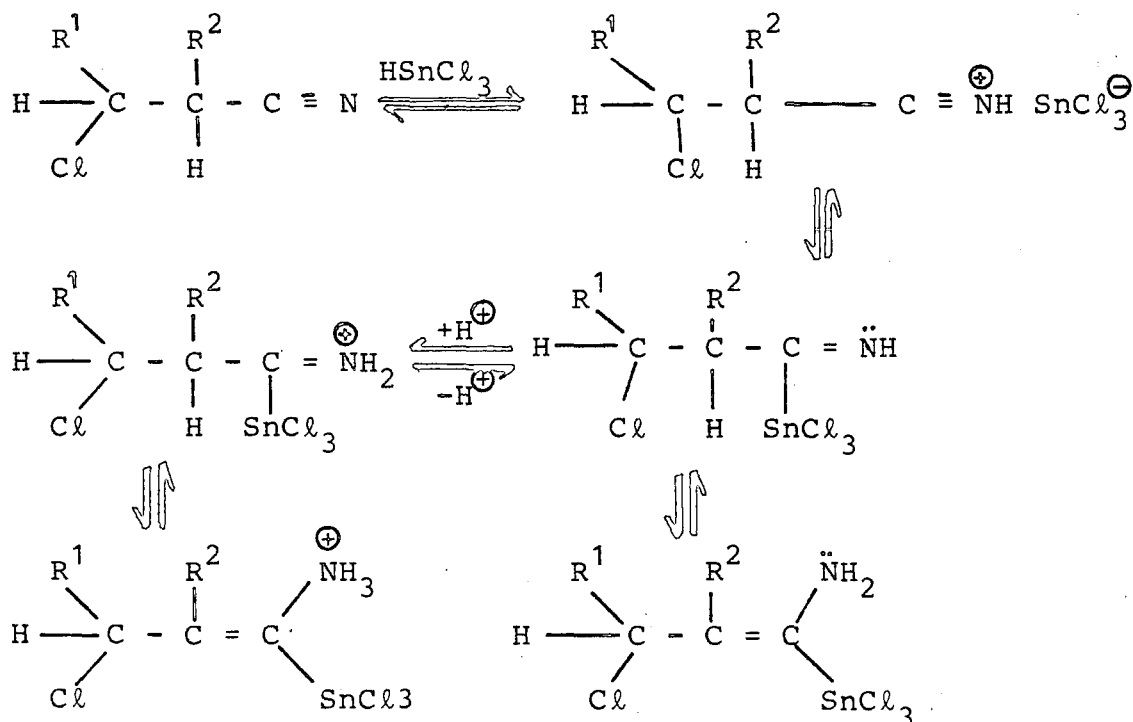

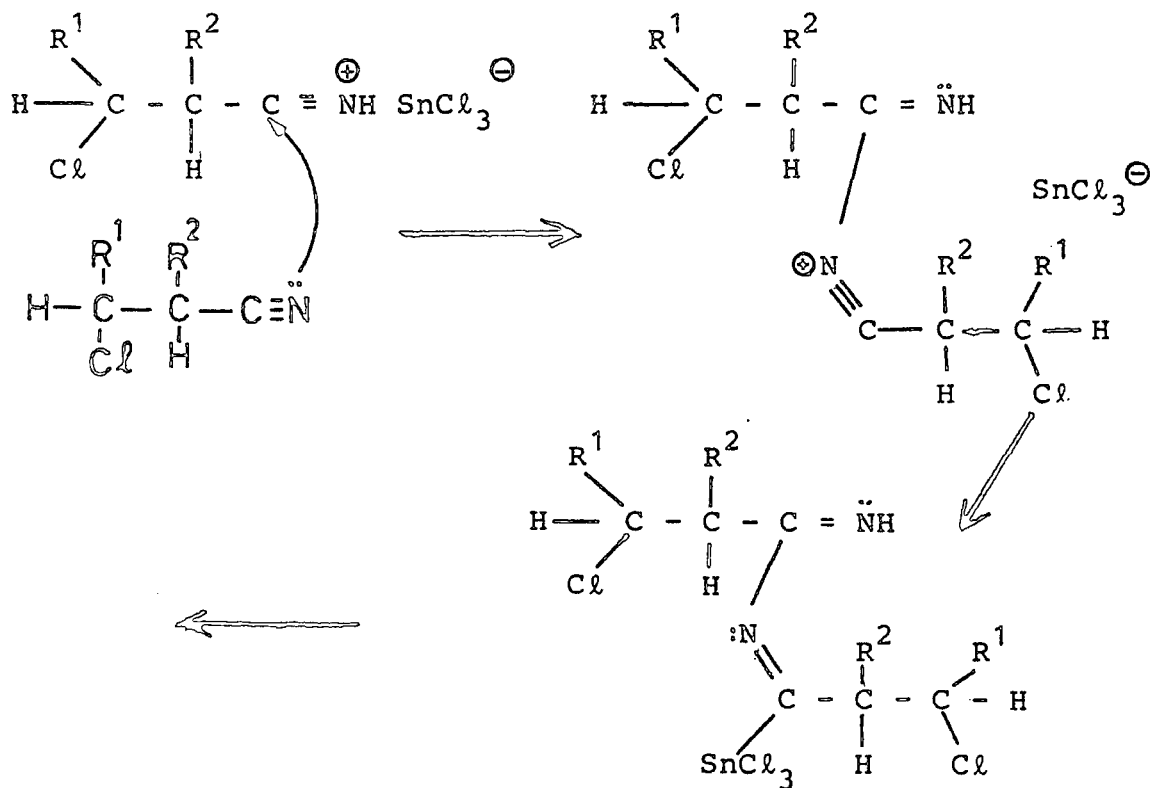
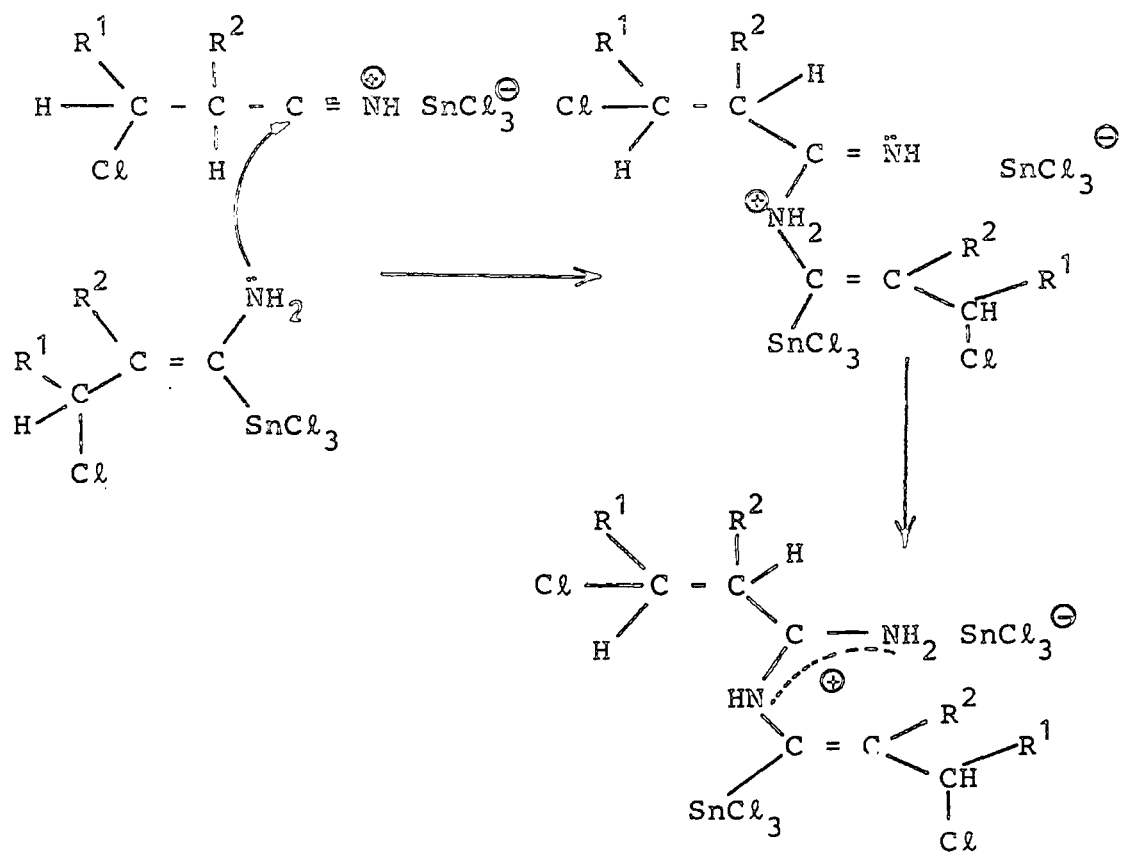

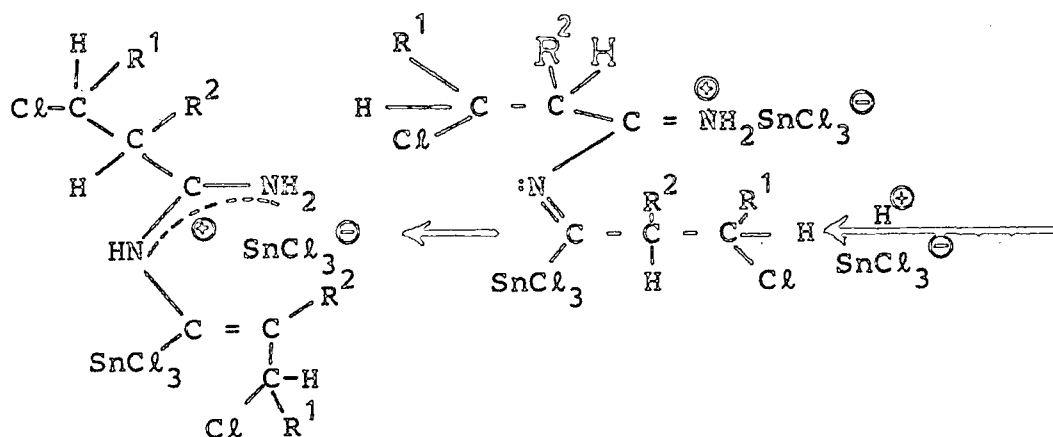

#### 4.6 CONCLUSION

The reaction of acrylonitrile with the SnCl<sub>2</sub>/HCl system shows a different pathway to that of its methyl derivatives; methacrylonitrile and crotononitrile. Clearly the results show that the dihydrogen tetrachlorostannate (II) adds to acrylonitrile at the (C = C) double bond to form the 2-cyanoethyl tin trichloride, whereas the methacrylonitrile and cis-/trans- crotononitrile undergoes a dimerization process (after the saturation of the (C = C) bond by HCl) through the cyano groups to form new amidinium salts of the type N-(3-chloro-1-trichlorostannyl alkenyl) 3-Chloro alkyl amidinium trichlorostannate (II). The replacement of a hydrogen atom in acrylonitrile by a methyl group is suggested to be responsible for the difference.

CHAPTER FIVE

SYNTHESES AND PROPERTIES OF SOME METAL HALIDE  
COMPLEXES OF ACRYLONITRILE, METHACRYLONITRILE  
AND CROTONONITRILE

5.1 INTRODUCTION

In the previous chapter it was concluded that acrylonitrile reacts with the  $\text{SnCl}_2/\text{HCl}$  system in a different way from methacrylonitrile and crotononitrile. This discrepancy has prompted a study of the coordination chemistry of some acrylonitrile derivatives, in particular its methyl derivatives.

In general acrylonitrile derivatives have attracted considerable interest as Lewis bases because they possess two functional groups, the cyano group  $-\text{C} \equiv \text{N}$  and the alkene link  $\text{C} = \text{C}$ , through either or both of which they can coordinate to the metal centre. In several published papers, it has been reported that acrylonitrile itself  $\text{CH}_2:\text{CHCN}$  may coordinate to metal atoms in five different ways.<sup>1,2</sup>

Acrylonitrile may act as a mono dentate ligand either by  $\sigma$ -bonding from the lone pair electrons in the nitrogen atom of the cyano group (I), or by  $\pi$ -bonding from the  $\text{C} = \text{C}$  double bond (II) or from the  $\text{C} \equiv \text{N}$  triple bond (V). On the other hand acrylonitrile may also act as a bidentate ligand using both the nitrile and the olefin groups for coordination with a central metal as shown in (III) and (IV).

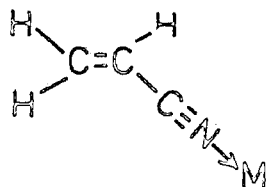

I

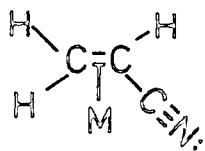

II

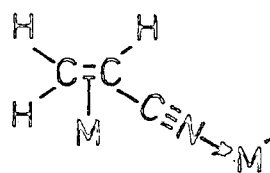

III

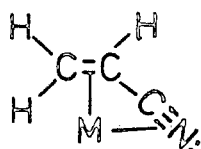

IV

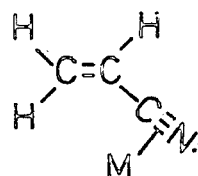

V

However, in practice, only three of these possible types (I - III) have been isolated and identified. These familiar modes of coordination for the acrylonitrile derivative will be briefly surveyed through the next three sub-sections.

Finally, the purpose of this work is to prepare, identify, and study properties of some metal halide complexes with acrylonitrile, methacrylonitrile, and cis-/trans-crotononitrile.

#### 5.1.1 Adducts Bonded through the Nitrile Nitrogen.

In principle the coordination of acrylonitrile derivatives by way of the nitrogen lone pair is generally favoured when the electron density on the central metal acceptor is not very high. Examples of such types of complexes are enormous as has been reported in references 1 and 2. Some of these complexes have been investigated by X-ray crystallographic diffraction. For example, X-ray analysis elucidated the structure (VI) for the  $[\text{Ni}(\text{NCCHCH}_2)_6]^{2\oplus}[\text{Zn}_2\text{Cl}_6]^{2\ominus}$  complex<sup>1</sup> in which acrylonitrile ligands are arranged about the  $\text{Ni}^{2+}$

in an octahedral structure through the lone pair electrons of their nitrile groups.

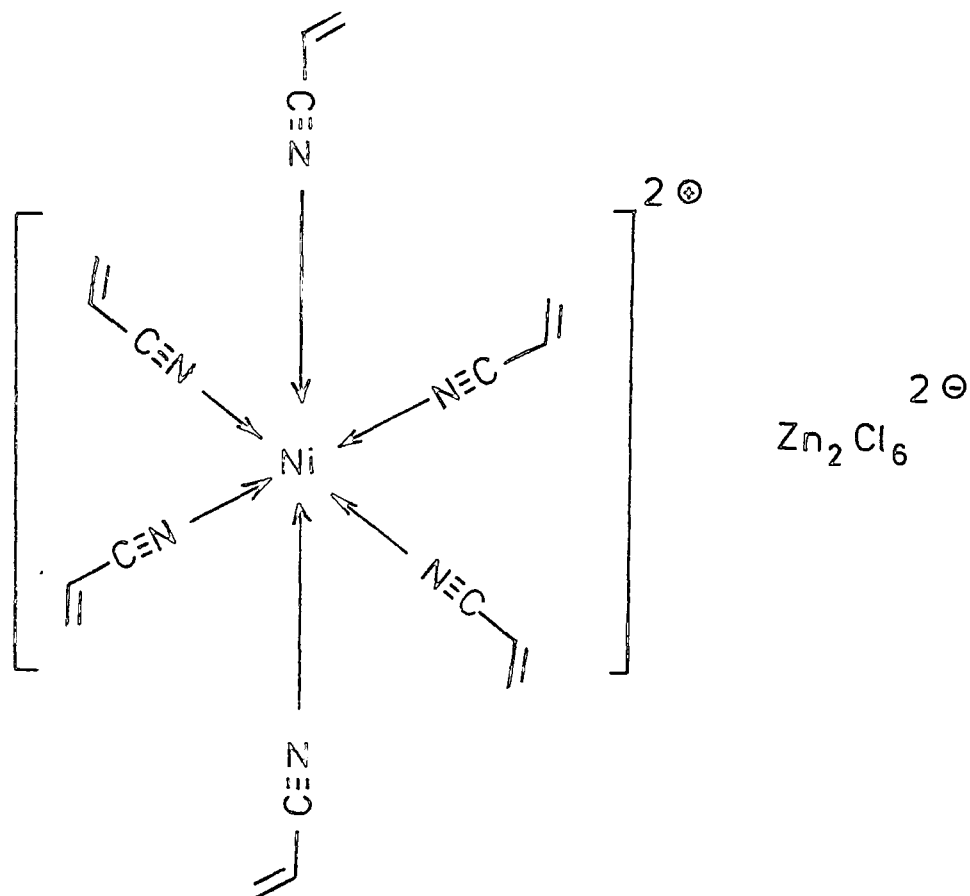

(VI)

The average (C  $\equiv$  N) distance in structure (VI) has been found to be 1.13 pm, shorter than that found in the corresponding free acrylonitrile bond (1.164 pm)<sup>3</sup>. A similar shortening of the C  $\equiv$  N bond on coordination to a Lewis acid has been also reported for the BF<sub>3</sub>,NCMe adduct<sup>4</sup>.

Methacrylonitrile, like acrylonitrile is capable of coordinating to Lewis acids through the nitrogen lone pair.

The crystal structure of  $\text{CuBrNCCMeCH}_2^5$  adduct has been determined as  $\text{Cu}_2\text{Br}_2[\text{CuBr}\cdot 2\text{NCCMeCH}_2]_2$  (structure VII). In this structure the Cu atoms have tetrahedral coordination : Cu(1) with four Br atoms, Cu(2) with two Br and two N atoms; the crystal structure can be described as  $[\text{Cu}_4\text{Br}_4]$  steps, bonded to each other by two Cu-Br bonds, with two methacrylonitrile ligands on each of the external Cu atoms. On comparison of the  $\text{C}\equiv\text{N}$  bond distance of structure (VI) with that of (VII).

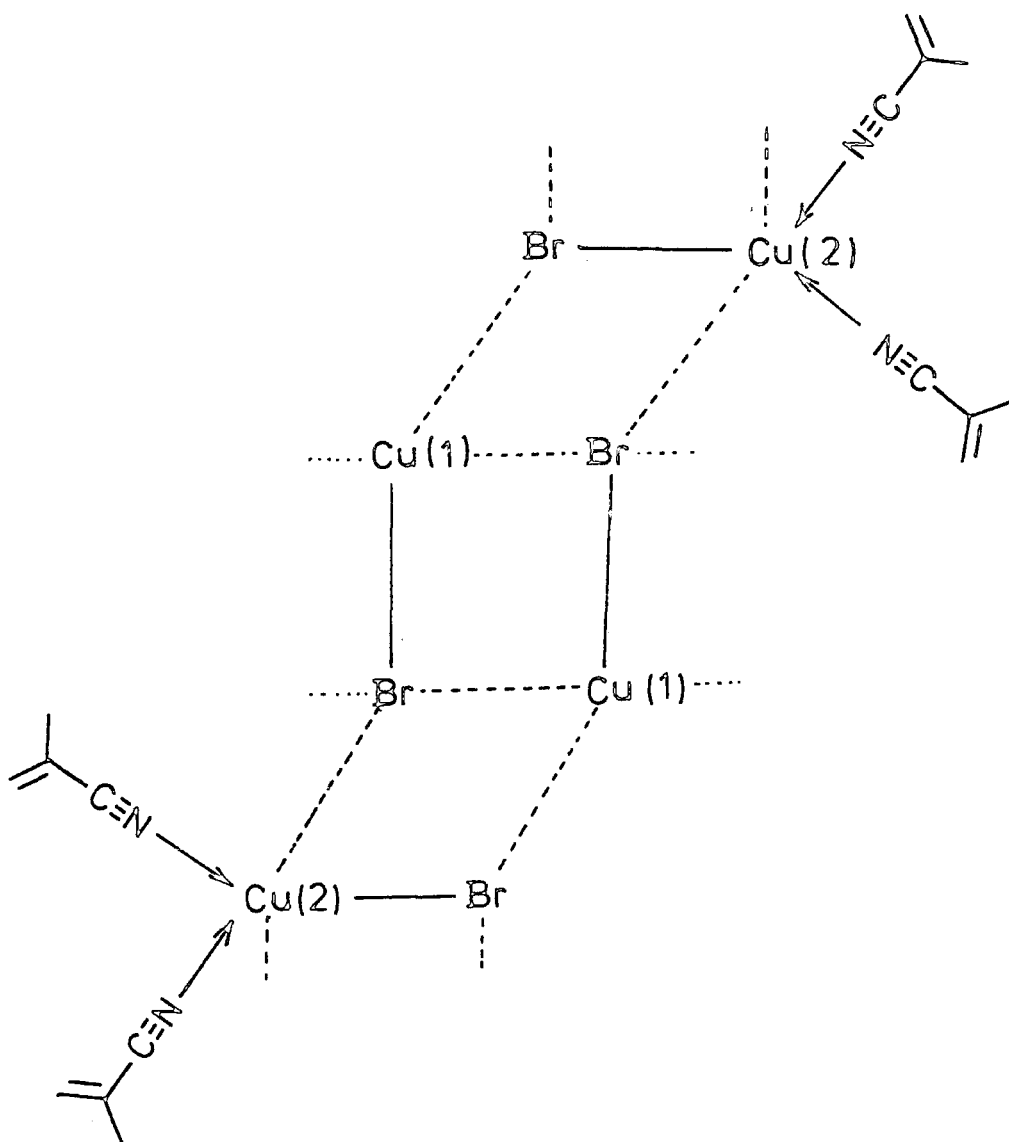

(VII)

it appears that the substitution of a hydrogen in the acrylonitrile by a methyl group does not particularly affect the  $\sigma$ -bonding between the  $\{C \equiv N\}$  group and the metal atom.

The configuration of the methacrylonitrile in structure VII is given in VIII. The most important feature of VIII is the negligible deviation of the  $Cu \leftarrow N \equiv C - C$  chain from linearity. The bond angles for  $\hat{C}u\hat{N}C$  and  $\hat{N}C\hat{C}$  are equal to  $176^\circ$  and  $178^\circ$  respectively.

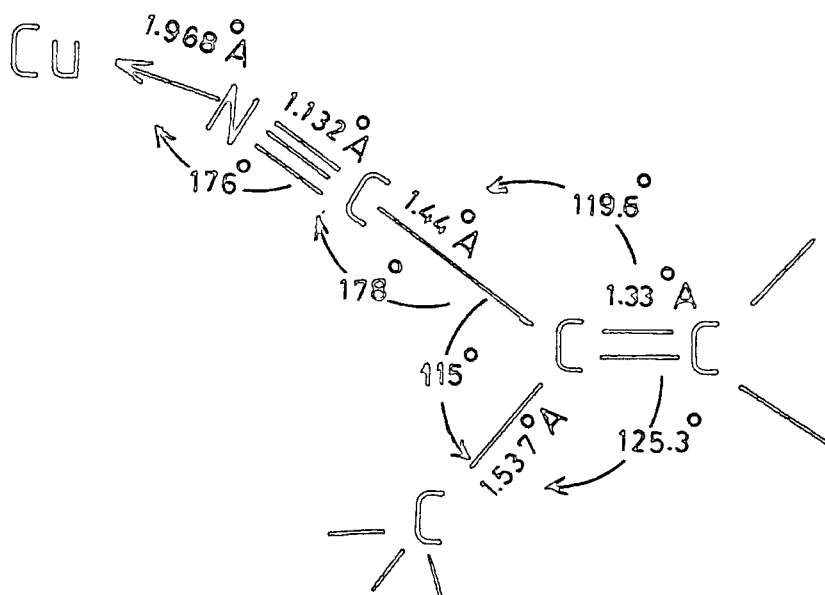

(VIII)

The formation of a  $\sigma$ -N complex between the acrylonitrile derivative and a Lewis acid can be detected from their IR spectra. In general, the IR spectra of such complexes show

characteristic increases in the nitrile stretching frequency;  $\nu(\text{C} \equiv \text{N})$  compared to the free ligand, accompanied by unchanging or a very slight shift to lower frequency of the  $\text{C} = \text{C}$  double bond stretching frequency. For example, the  $\text{C} \equiv \text{N}$  stretching frequencies for  $\text{CH}_2\text{:CHC:N}$  (at  $2230 \text{ cm}^{-1}$ ) and for  $\text{CH}_2\text{:CMeC:N}$  (at  $2235 \text{ cm}^{-1}$ ) were shifted on coordination to  $\text{SnCl}_4$ ,  $\text{TiCl}_4$ , and  $\text{ZnCl}_2$  to higher frequencies by  $25\text{-}50 \text{ cm}^{-1}$ , whilst their  $\nu(\text{C} = \text{C})$  stretching band (at  $\sim 1620 \text{ cm}^{-1}$ ) were shifted to lower frequency by only  $\sim 5 \text{ cm}^{-1}$  <sup>6</sup>.

This increase of  $\nu(\text{C} \equiv \text{N})$  can be attributed to two effects. One is the coupling of the  $(\text{C} \equiv \text{N})$  vibration with that of the new dative  $\text{N} \rightarrow \text{metal}$  bond with which the  $\text{C} \equiv \text{N}$  bond is co-linear, and which will be compressed as the  $(\text{C} \equiv \text{N})$  bond is stretched. The other is the slight strengthening of the  $\text{C} \equiv \text{N}$   $\sigma$ -bonding as the weakly anti-bonding character of the nitrogen lone pair orbital decreases when it becomes the  $\text{N} \rightarrow \text{metal}$  bonding orbital <sup>7-10</sup>.

The shift to higher frequency of the nitrile stretching absorption varies markedly with the Lewis acid  $\text{MX}_n$  involved. In some complexes, the nitrile stretching frequency decreases relative to that of uncoordinated ligand. Significantly, such complexes, which involve soft Lewis acids, are capable of back  $\pi$ -bonding to the nitrile to a sufficient extent to offset the frequency-increasing factors already described. <sup>11</sup> The two possible bonding interactions of a nitrile group with a metal centre are represented in IX and X by analogy with the bonding scheme in metal carbonyls.

SP → nd :

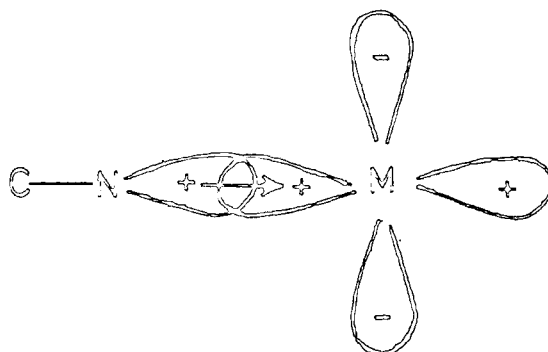

IX

nd : → π\*

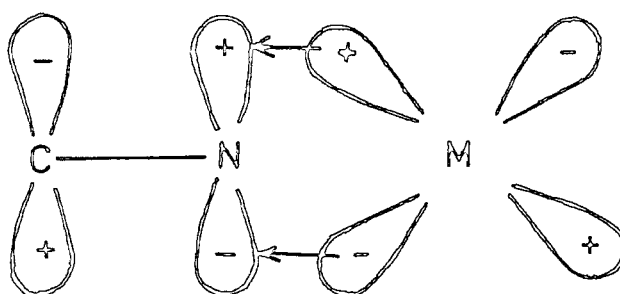

X

As an illustrative example, the decrease in  $\nu(\text{C} \equiv \text{N})$  observed in the  $[\text{Ru}(\text{NH}_3)_5 \cdot \text{NCCHCH}_2]^{2\oplus}$  <sup>12,13</sup> complex cannot exclude the possibility of  $\sigma$ -N-bonding since the n.m.r. spectrum showed the  $\alpha$ -hydrogen of the vinyl group to be deshielded (due to interaction with the cation) whilst the terminal hydrogens appear upfield from the free acrylonitrile. The latter shielding of terminal hydrogens can be explained by strong back donation from d metal orbitals to the  $\pi^*$  orbital of the nitrile as represented in X.

Further characteristic changes from the uncoordinated ligand can be observed in the IR spectrum of the  $\sigma$ -N complexes: firstly, the decrease in the alkene stretching frequency;  $\nu(\text{C} = \text{C})$  due to the reduction in the (C = C) bond order and secondly, the splitting of the out-of-plane hydrogen deformations of the alkene group (i.e.  $\tau(\text{CH}_2)$  twisting and  $\omega(\text{CH}_2)$  wagging vibrations of the methylene group) which cannot

be observed in the uncoordinated ligand. This splitting of  $\delta(\text{CH}_2)$  modes is due to the increase of the inductive effect of the nitrile on coordination giving rise to the following bonding contributions

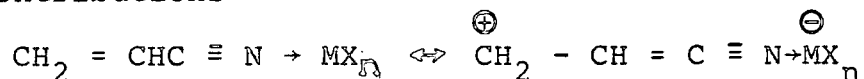

Thus the methylene twist frequency is expected to drop and the wag to increase. For example, the two vibrations of the methylene group in the  $\text{TiCl}_4 \cdot 2\text{NCHCH}_2$  adduct, which coincide in the free ligand, are found split into two bands at  $990 \text{ cm}^{-1}$  ( $\omega(\text{CH}_2)$ ) and at  $958 \text{ cm}^{-1}$  ( $\tau(\text{CH}_2)$ )<sup>14,15</sup>. On the other hand, the amount of splitting can provide a useful direct measure of relative Lewis acidity<sup>16</sup>.

Further information on N-bonded complexes of acrylonitrile derivatives has been obtained from nuclear magnetic resonance studies. For example, chemical shifts for the olefinic protons of  $\text{ZnCl}_2$  adducts<sup>6</sup>;  $\text{ZnCl}_2 \cdot 2\text{NCHCH}_2$  and  $\text{ZnCl}_2 \cdot 2\text{NCCMeCH}_2$  were shifted slightly (as compared with the free ligands) downfield by values of 0.42 ppm, and 0.05 ppm respectively for the  $\alpha$ -hydrogen or for the  $\alpha$ -methyl and by 0.62, 0.35 ppm for the  $\beta$ -hydrogens respectively. A similar shift of the  $\alpha$ -hydrogen resonance on coordination is shown by saturated aliphatic nitriles and is attributed to the electron withdrawing and inductive effect of the Lewis acid. In addition to that nuclear magnetic resonance has been used as a useful technique to decide if the acrylonitrile derivative is coordinating to the metal of  $\text{MX}_n$  through the nitrogen lone pair or through the olefin  $\pi$ -electrons, particularly if the IR spectrum shows a lower shift in the  $\nu(\text{C} \equiv \text{N})$  as reported

above for  $[\text{Ru}(\text{NH}_3)_5\text{NCCHCH}_2]^{2\oplus}$ .

Some metal halides suffer ionization on coordination with the acrylonitrile derivative through the nitrogen lone pair. For example aluminium trichloride is known to undergo solvolysis in acrylonitrile.  $^1\text{H}$  and  $^{27}\text{Al}$  n.m.r. spectroscopic studies have indicated the presence of such ions as  $[\text{Al}(\text{NCCHCH}_2)_6]^{3\oplus}$  and  $[\text{AlCl}_4]^\ominus$  <sup>17a</sup>. The possible complexity of such systems has been revealed by a careful study of the  $\text{AlCl}_3$ -acetonitrile <sup>17b</sup> system by  $^1\text{H}$ ,  $^{27}\text{Al}$  n.m.r., infrared, Raman spectroscopy, and X-ray crystallography which indicated that many solution species were involved and that the adduct  $\text{AlCl}_3 \cdot 3\text{NCMe}$  isolated from solution, instead of having a covalent mer-octahedral structure as might have been expected, actually has the structure

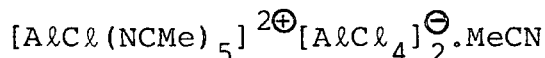

#### 5.1.2 Adducts Bonded through the C = C Double Bond

As an unsaturated ligand, the acrylonitrile derivative may use its olefinic bond to coordinate with a metal centre to form an olefin-metal  $\pi$ -complex. Such types of complex have been widely studied and comprehensively reviewed in reference 2.

Most olefin-metal  $\pi$ -complexes are formed by transition metals of groups VI, VII, VIII and I, where their valence shells contain electron rich d-orbitals ( $d^5$ - $d^{10}$ ). This is because the alkene complex stability depends not only on the capacity of the ligand to release electronic charge to the metal atom from its  $\pi$ -bonding MO as illustrated in (XI) but also on its capacity to withdraw electronic charge from the d-orbitals of the metal into its  $\pi^*$  antibonding MO as pictured in (XII).

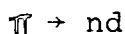
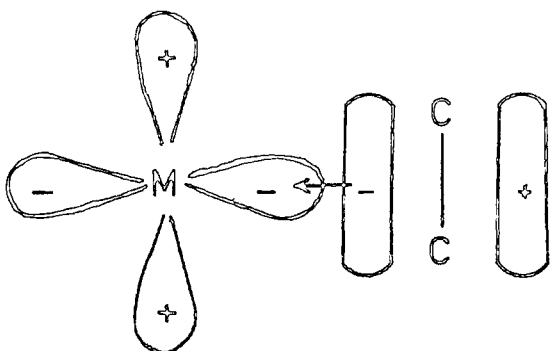

(XI)

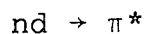
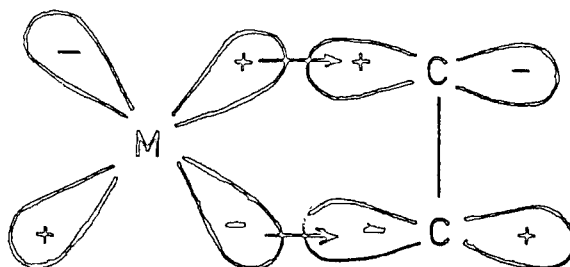

(XII)

In other words the stability of the alkene-metal  $\pi$ -complex depends on the balance between the basic and  $\pi$ -acidic properties of the alkene function. It appears that the latter property,  $\pi$ -acid, is a very important factor for the stability of metal  $\pi$ -complexes as indicated by the very few known complexes of the metals with fewer d-electrons, i.e. main group IIIB - VB metals.

The olefin-metal bond strength depends on two factors. Firstly, the nature of the metal atom which in turn depends on both the energy levels of the metal d-orbitals, and on its oxidation state which influences the d-electron density. Thus the closer the metal d-orbital energy level is to the  $\pi^*$  antibonding level of the alkene group, the greater the  $\pi$ -acid character in the coordinated olefin-metal bond. For example, stable mono-olefin complexes have been obtained from simple metal halides of rhodium ( $d^7$ ),<sup>18</sup> whilst the presence of a strong acceptor ligand such as carbon monoxide, the cyclopentadienyl ring, or tertiary phosphines are required to

confer additional stability on all  $\pi$ -mono olefin complexes of the metals of the chromium<sup>19</sup>, manganese<sup>20</sup> and iron triads<sup>21</sup> ( $d^4-d^6$ ). In addition, the ligand attached to the metal has some influence on the stability of the alkene complex. For example, in acrylonitrile  $\pi$ -complexes  $\text{ArCr}(\text{CO})_2 \cdot \text{CH}_2 = \text{CHCN}$ , where Ar = hexamethylbenzene, mesitylene, or benzene, the stability decreases as the electron-donating properties of the aromatic ring Ar decrease in the order  $\text{Ar} = \text{C}_6\text{Me}_6 > \text{C}_6\text{H}_3\text{Me}_3 > \text{C}_6\text{H}_6$ <sup>22</sup>.

Secondly, the nature of substituents attached directly to the olefinic (C = C) double bond define the energy levels of the olefin. Furthermore, the efficiency of overlap may be affected by the steric influence of substituent groups on the olefin or of other ligands at the metal.

The introduction of a substituent to replace one hydrogen atom in ethylene will enhance or hinder the formation of an alkene metal  $\pi$ -complex. If this substituent has an electron-withdrawing character such as  $\text{C} \equiv \text{N}$ , CO,  $\text{CF}_3$ , F, then this will cause an increase in the electron acceptor character of the alkene. On the other hand, substituents of electron-donating character (Me,  $\text{NR}_2$ , OR) will be expected to increase the donor properties of the olefin. This has been reflected by the equilibrium constants for reaction (5.1) for a variety of olefins<sup>23</sup>.

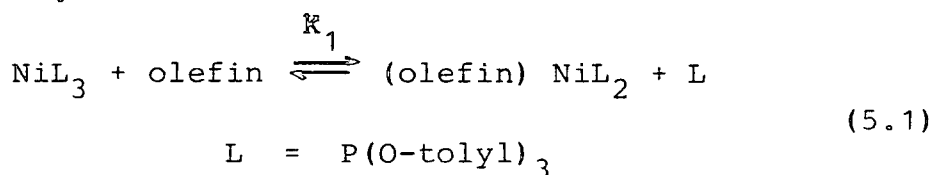

The order of stability for olefin complexes in equation (5.1) is:

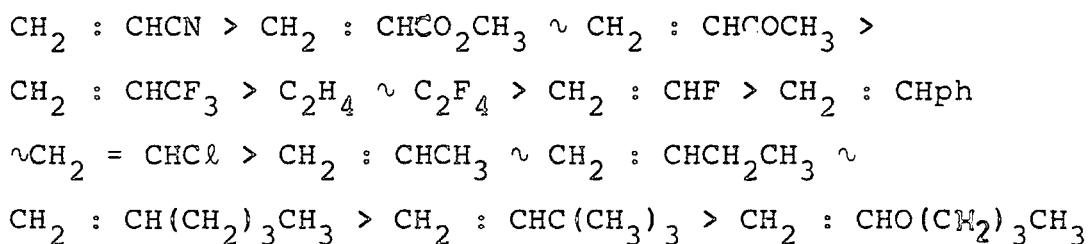

Replacement of a further hydrogen atom of the mono-substituted olefin system will increase the  $\pi$ -acid or the  $\pi$ -base properties of the alkene link if the two substituents are similar, otherwise the effect of one substituent will be offset or reduced by the other one if they are dissimilar. Thus the stability of metal  $\pi$ -complexes of trans-NCCH = CHCN is much higher than that of complexes with trans-phCH = CHph, trans-FCH = CHF and  $(\text{CH}_3)_3\text{CCH} = \text{CHC}(\text{CH}_3)_3$  as indicated from the kinetic studies<sup>23</sup>. On the other hand, complexes of the bis(acrylonitrile) nickel type could not be prepared from  $\alpha$ -methacrylonitrile or from crotononitrile<sup>24</sup>. In contrast to acrylonitrile, no metal  $\pi$ -complex could be isolated from the reaction of CuBr with  $\alpha$ -methacrylonitrile.<sup>25,26,5</sup>

With cyclic alkenes, the stability of the metal  $\pi$ -complex has been found to depend on the strain energies of the rings. For example, norbornene has a much higher strain energy than cyclo-hexene ( $\sim 10$  times), consequently the norbornene in contrast to cyclohexene forms a more stable complex with  $\text{Ni}^0$ <sup>23</sup> and  $\text{Ag}^{\oplus}$ <sup>27</sup> as evidenced by spectrophotometric measurements of equilibrium constants for olefin  $\pi$ -complex formation.

The introduction of third and fourth substituents into the olefin affects the donor-acceptor properties of the olefinic double bond, but one difference is that the ligand may behave as an oxidizing or reducing agent for the metal

atom. As an example, the high electron affinity of tetracyanoethylene  $(\text{CN})_2\text{C} = \text{C}(\text{CN})_2$  can lead to oxidation of the  $\text{Cu}^{\oplus 28}$  and  $\text{Cr}^{\circ 29}$  to  $\text{Cu}^{2\oplus}$  and  $\text{Cr}^{\oplus}$  on its reaction with  $\text{CuCl}$  or  $\text{Cr}(\text{C}_6\text{H}_6)_2$ . In the case of  $[\text{Cr}(\text{C}_6\text{H}_6)_2]^{\oplus}[(\text{CN})_2\text{C} = \text{C}(\text{CN})_2]^{\ominus}$  the characteristic absorptions of both ions  $\text{Cr}(\text{C}_6\text{H}_6)_2^{\oplus}$  and  $[(\text{CN})_2\text{C} = \text{C}(\text{CN})_2]^{\ominus}$  could be identified from IR, UV and ESR spectra. In contrast, the tetrakis (dimethylamino) ethylene;  $((\text{CH}_3)_2\text{N})_2\text{C} = \text{C}(\text{N}(\text{CH}_3)_2)_2$  which is known to be a good  $\pi$ -base, does not form metal  $\pi$ -complexes, but instead it forms tetrakisdimethylamino ethylene salts of metal carbonylate anions such as the following <sup>30</sup>

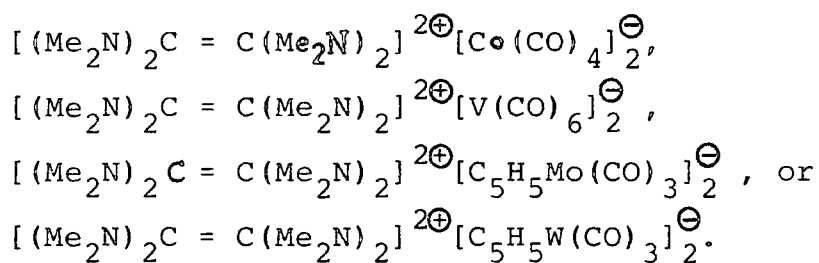

The coordination of a metal atom to the acrylonitrile alkene function can be detected by investigation of  $\nu(\text{C} = \text{C})$  which decreases relative to that of the free ligand, accompanied by the appearance of  $\nu(\text{C} \equiv \text{N})$  at a slightly lower frequency without change in intensity or fine structure. As an example, the  $\nu(\text{C} = \text{C})$  and  $\nu(\text{C} \equiv \text{N})$  frequencies in  $\text{CuCl} \cdot \text{CH}_2 = \text{CHCN}$  complex decrease by 100 and  $10 \text{ cm}^{-1}$  respectively as compared with those of free acrylonitrile<sup>25</sup>.

The magnitude of the  $\nu(\text{C} = \text{C})$  shift varies markedly with the Lewis acid involved. The nitrile stretching frequency may also decrease slightly because of back  $\pi$ -bonding from the electron rich d-orbital of the metal into the alkenyl  $\pi^*$  orbital. The IR spectrum may also exhibit a shift of the (C - H) out-of-plane vibrations and/or an appearance of a

new band in the CsBr region ( $1100 - 385 \text{ cm}^{-1}$ ) which can be assigned to the asymmetric stretching vibration of the metal olefin bond, as has been observed for  $\text{Ni}(\text{CH}_2 = \text{CHCN})_2$ <sup>31</sup>.

In the proton magnetic resonance spectra, the deshielding of the olefinic protons due to  $\pi$ -coordination can be detected by their shift to higher field as compared with those of the free ligand. Thus the vinyl protons of acrylonitrile have been found to be shifted upfield by  $\sim 4\text{ppm}$  on coordination to the  $\text{C}_6\text{H}_6\text{Cr}(\text{CO})_2$  residue<sup>22</sup>.

X-ray crystallographic analysis has been used to determine the structures of some acrylonitrile  $\pi$ -complexes such as  $\text{Fe}(\text{CO})_4(\text{CH}_2 = \text{CHCN})$ <sup>21</sup>. The structure of this monomeric complex consists of a trigonal bipyramid of ligands around the iron center with the acrylonitrile molecule in the equatorial plane. The  $\text{N} \equiv \text{C} - \overset{\cdot}{\text{C}} = \overset{\cdot}{\text{C}}$  - unit of the coordinated acrylonitrile molecule is bent by  $13.6^\circ$ , probably to increase the orbital overlap between iron d-orbitals and the  $(\text{C} = \text{C})$   $\pi$ -system.

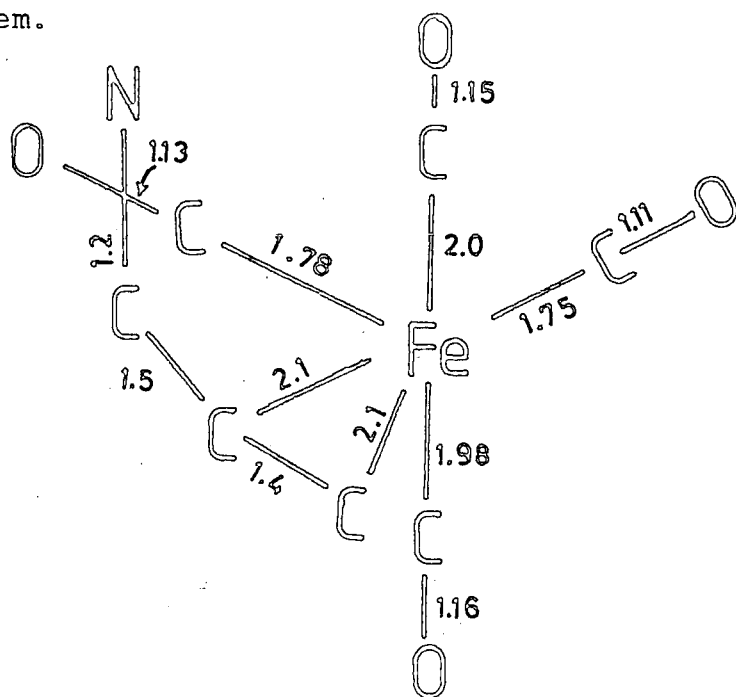

(XIII)

The coordination of the acrylonitrile to the iron metal has led to a significant changes in bond lengths and in bond angles. Thus on coordination of the acrylonitrile, the (C = C) bond length increases from 1.34Å to 1.40Å while the C ≡ N bond length increases from 1.16Å to 1.20Å. The change in the C = C - C bond angle from 122° to 116° can be explained on the basis of a change in hybridization of the central carbon atom.

### 5.1.3 Adducts Bonded through both of the Nitrogen and the (C = C) Double Bond.

The presence of a free cyano group in metal  $\pi$ -complexes of the acrylonitrile derivative introduces a new coordination centre with the result that intramolecular chelation, or alternatively, intermolecular bridge formation becomes possible. In the case of chelation which can be postulated to occur through the (C ≡ N) and the (C = C)  $\pi$ -systems, no example, however of a chelating bidentate acrylonitrile ligand has been ever isolated. A possible reason for this may be seen from consideration of the molecular orbital coefficients of the highest occupied molecular orbital, (HOMO) and the lowest unoccupied molecular, (LUMO) of acrylonitrile<sup>32</sup>:

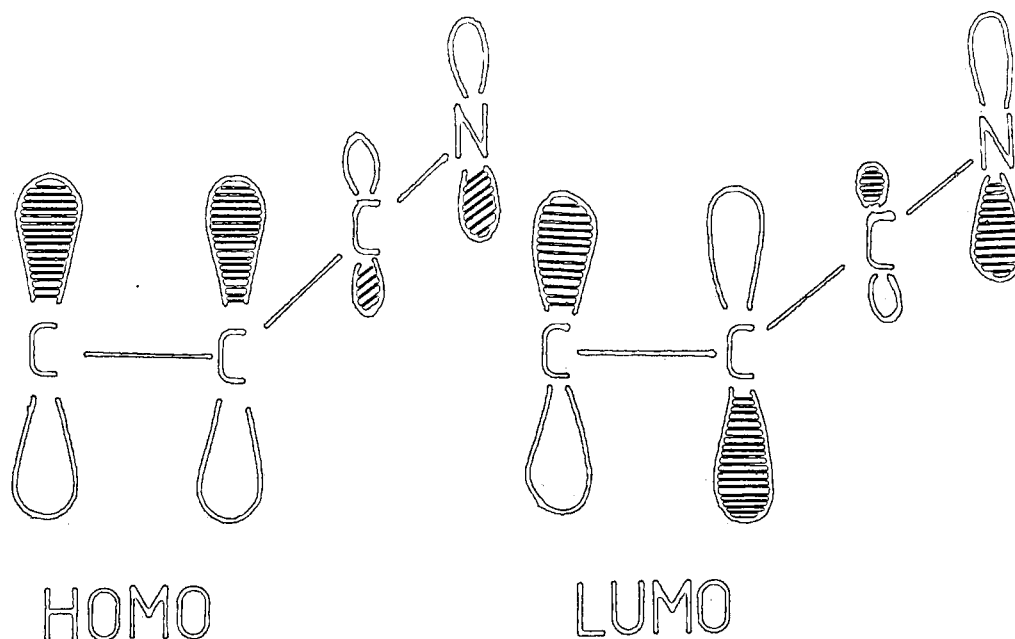

The molecular orbital coefficients are largest on the olefinic carbons in both HOMO and LUMO leading to good overlap at the (C = C) double bond both for donation of electron density from the HOMO to the metal d orbitals and also for back donation from the metal d orbitals to the LUMO. This side on ( $\pi$ ) bonding through the nitrile group is not to be expected.

In the case of bridge formation, the acrylonitrile derivative may coordinate to the metal centers to give a dimeric product with  $\pi$ -olefin- $\sigma$ -nitrile bridging functions. For example, bis (acetonitrile) dicarbonyl di-tributylphosphine molybdenum (0)<sup>33,34</sup> reacts with acrylonitrile to give an unstable N-bonded complex which rapidly loses acetonitrile and dimerizes to form the complex (5.2),

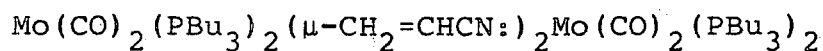

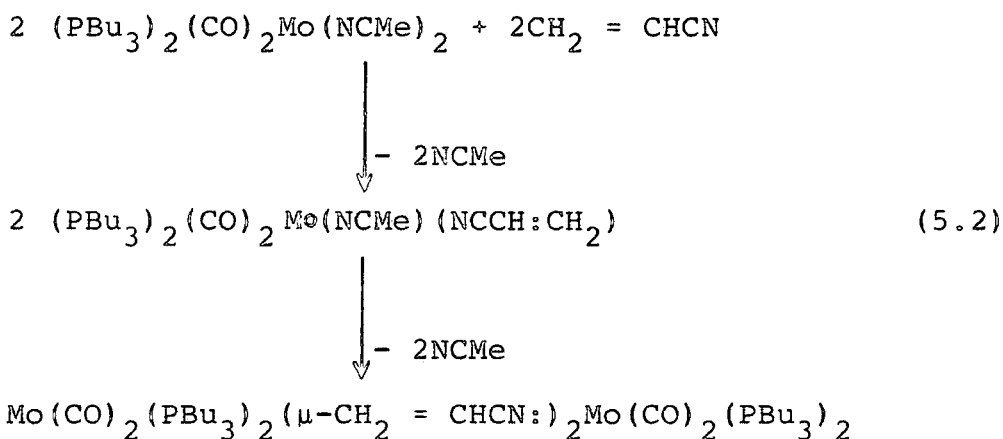

The molecular structure of the above dimeric product has been determined by X-ray diffraction analysis<sup>33</sup> and is illustrated in XIV.

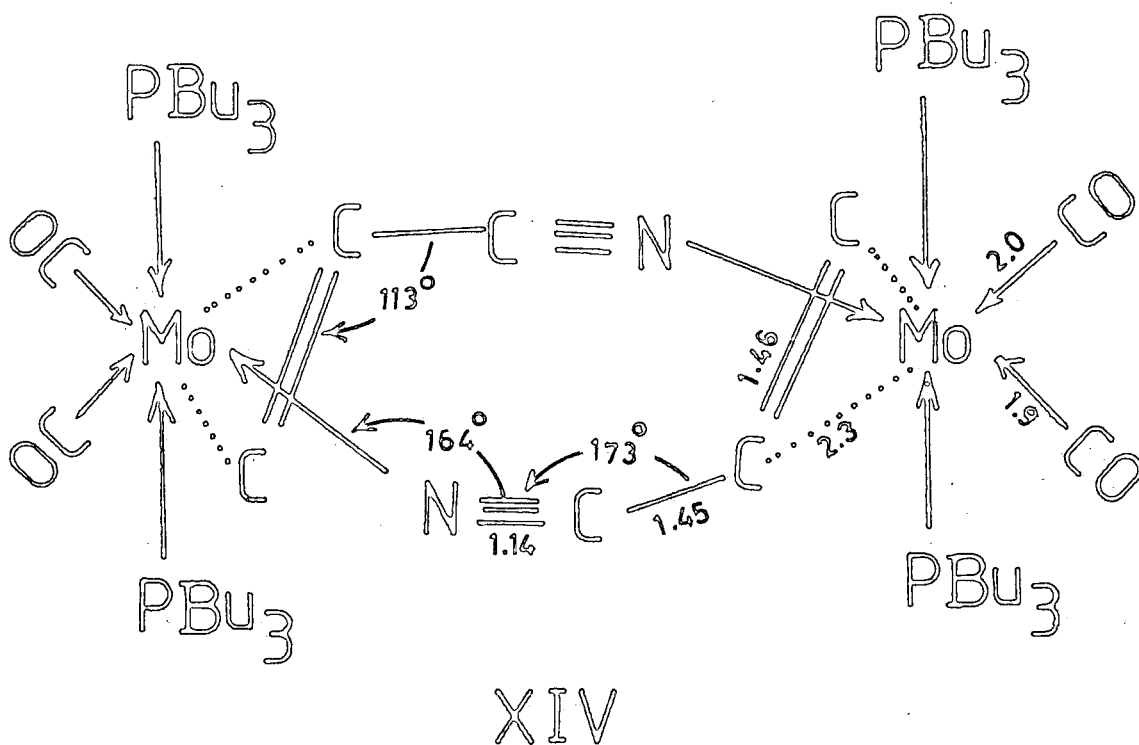

In structure XIV, distances of the N-C-C-C chain are indicative of appreciable electron transfer. The coordinated double bond (1.46°A) is now longer than the other (single) bond in the chain (1.45°A) though the triple bond distance is not altered very much. A similar dimeric structure can be found in bis (μ-acrylonitrile)-bis-(tricarbonyl-iron)<sup>35</sup>.

The most interesting feature in the reaction 5.2 above - if series of acrylonitrile derivatives are concerned - is that the formation of dimers with methacrylonitrile and cinnamic acid nitrile occurs less readily than with acrylonitrile, whilst in the case of crotononitrile no dimerization occurs<sup>34</sup>. This observation may reflect the difficulty for both methacrylonitrile and crotononitrile to coordinate to the metal atom by way of the (C = C) double bond and this may explain why the SnCl<sub>2</sub>/HCl system adds to the alkene bond of acrylonitrile itself whereas it has proved difficult to add HSnCl<sub>3</sub> across the alkene bond of acrylonitrile methyl derivatives. Therefore, it is suggested that the intermediate XV may be formed in the case of acrylonitrile only and that this led to the formation of the SnCl<sub>3</sub>-CH<sub>2</sub>CH<sub>2</sub>CN adduct.

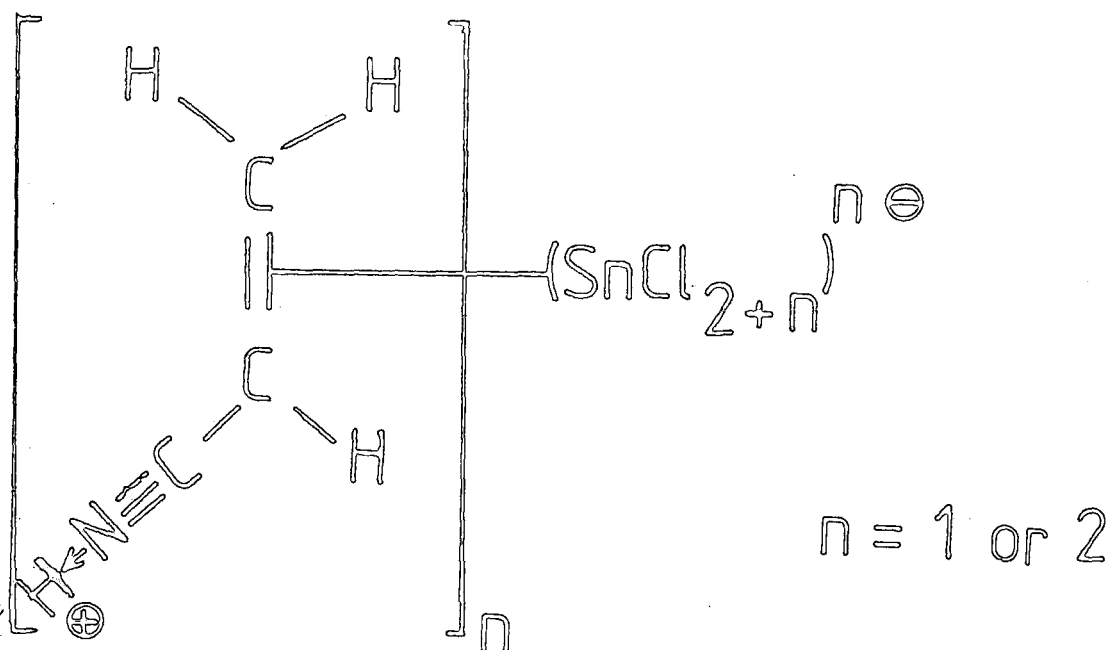

XV

The spectra of some complexes do not provide clear indications of their structures. For example, the proton NMR spectrum indicates that the cyano-olefin ligand in  $[\text{Fe}(\text{CO})_3(\text{CH}_2=\text{CHCN})]_2$  complex is  $\pi$ -bonded, whereas the IR spectrum shows the  $\nu(\text{C} \equiv \text{N})$  frequencies ( $2244$  and  $2218 \text{ cm}^{-1}$ ) are not compatible with free cyano groups<sup>35</sup>.

## 5.2 EXPERIMENTAL

Starting Materials : Tin tetrachloride, titanium tetrachloride, antimony pentachloride and boron trichloride were purified by vacuum distillation. Since the commercial zinc chloride is a very hygroscopic material,  $\text{ZnCl}_2$  was prepared by dissolving Zn metal in diethyl ether saturated with hydrogen chloride, the solution of  $\text{ZnCl}_2$  was filtered to remove unreacted Zn metal and the ether pumped off.

Titanium tetrabromide and tantalum pentachloride were used without purification since their infra-red spectra showed them to be anhydrous.

Cobalt dichloride and nickel dichloride were prepared from hydrated commercial samples by refluxing with thionyl chloride for 24 hours.

Acrylonitrile was purified by refluxing with calcium hydride for 6 hours and then fractionally distilled onto freshly activated 3A molecular sieve. Acrylonitrile was stored in a flask enclosed in a black plastic bag to prevent UV initiated polymerization in the absence of stabilizer.

The purification of methacrylonitrile and cis-/trans-crotononitrile (which have higher boiling points than acrylonitrile) by fractional distillation was not successful. The polymerization of these nitriles on heating could be

observed from the recorded IR spectra of the distillates. For that reason, both methacrylonitrile and cis-/trans-crotononitrile were used without purification and stored over activated 3A molecular sieve.

Manipulations were carried out using a conventional vacuum line, dry nitrogen line, or dry nitrogen-filled glove box.

#### Preparation of Complexes

Since the methods used for the preparation of complexes of the acrylonitrile derivatives are similar, all experiments described below are classified according to the type of metal halide. The term ligand, L is used to denote acrylonitrile, methacrylonitrile, or cis-/trans-crotononitrile. Analytical data are given in table (5.1) below.

$\text{TiCl}_4$ , 2L : about 2.5 ml. of  $\text{TiCl}_4$  was added by syringe to 10 ml. ligand in a cooled flask, the yellow suspension was redissolved by warming with a hair drier until a clear solution obtained. On standing for 15 minutes, the solution deposited yellow crystals which were collected on a filter, washed with cold ligand and dried in a stream of dry nitrogen.

$\text{TiCl}_4$ , L : In (1:1) mole ratio about 5 ml. of titanium tetrachloride was added slowly by syringe to a stirred solution of the ligand in 40 ml. benzene at room temperature. A yellow solid deposited which was redissolved by heating until a clear orange solution was obtained. On standing at room temperature, the solution afforded a yellow microcrystalline solid which was filtered, washed with cold benzene and dried under a stream of nitrogen.

TABLE 5.1 - Analysis for Nitrile-Metal Halide Adducts\*

<u>Compound</u>	<u>%C</u>	<u>%H</u>	<u>%N</u>	<u>Other</u>
TiCl <sub>4</sub> ·2NCCHCH <sub>2</sub>	24.7 (24.3)	2.4 (2.0)	9.5 (9.5)	-
TiCl <sub>4</sub> ·NCCHCH <sub>2</sub>	15.9 (14.8)	1.7 (1.2)	5.5 (5.8)	Cl:54.3 (58.5)
TiBr <sub>4</sub> ·2NCCHCH <sub>2</sub>	15.6 (15.2)	1.4 (1.3)	5.8 (5.9)	-
BCl <sub>3</sub> ·NCCHCH <sub>2</sub>	18.3 (21.2)	1.1 (1.8)	8.2 (8.2)	Cl:54.3 (62.6)
SbCl <sub>5</sub> ·NCCHCH <sub>2</sub>	11.6 (10.2)	1.2 (0.9)	4.4 (4.0)	Cl:48.9 (50.4)
4 TaCl <sub>5</sub> ·5NCCHCH <sub>2</sub>	10.7 (10.6)	1.2 (0.9)	4.8 (4.1)	Cl:34.8 (41.8)
CoCl <sub>2</sub> ·NCCHCH <sub>2</sub>	20.5 (19.7)	2.4 (1.6)	7.7 (7.7)	-
SnCl <sub>4</sub> ·2NCCHCH <sub>2</sub>	19.2 (19.6)	2.1 (1.6)	7.5 (7.6)	Cl:38.8 (38.7)
TiCl <sub>4</sub> ·2NCCMeCH <sub>2</sub>	28.3 (29.6)	3.2 (3.1)	8.1 (8.6)	Cl:41.3 (43.8)
TiCl <sub>4</sub> ·NCCMeCH <sub>2</sub>	19.1 (18.7)	3.1 (2.0)	5.4 (5.5)	Cl:51.2 (55.3)
TiBr <sub>4</sub> ·2NCCMeCH <sub>2</sub>	21.8 (19.1)	2.4 (2.0)	6.5 (5.6)	-
BCl <sub>3</sub> ·NCCMeCH <sub>2</sub>	26.1 (26.1)	2.5 (2.7)	7.7 (7.6)	Cl:57.0 (57.8)
SbCl <sub>5</sub> ·NCCMeCH <sub>2</sub>	12.5 (13.1)	1.7 (1.4)	3.6 (3.8)	Cl:47.4 (48.5)
4 TaCl <sub>5</sub> ·3NCCMeCH <sub>2</sub>	8.8 (8.8)	1.0 (1.0)	2.9 (2.6)	Cl:30.3 (43.4)
SnCl <sub>4</sub> ·2NCCMeCH <sub>2</sub>	24.0 (24.2)	3.6 (2.5)	7.1 (7.1)	Cl:37.0 (35.8)
CoCl <sub>2</sub> ·NCCMeCH <sub>2</sub>	25.2 (24.4)	2.5 (2.5)	7.4 (7.1)	Cl:34.7 (36.1)

<u>Compound</u>	<u>%C</u>	<u>%H</u>	<u>%N</u>	<u>Other</u>
ZnCl <sub>2</sub> .2NCCMeCH <sub>2</sub>	36.1 (35.5)	5.1 (3.7)	9.2 (10.4)	Cl:22.1 (26.3)
Ni(SbCl <sub>6</sub> ) <sub>2</sub> .6NCCMeCH <sub>2</sub>	26.8 (25.5)	3.2 (2.6)	6.5 (7.4)	Cl:34.0 (37.7)
NiZn <sub>2</sub> Cl <sub>6</sub> .6NCCMeCH <sub>2</sub>	32.2 (35.8)	3.9 (3.7)	9.2 (10.4)	Cl:22.7 (26.5) Zn:18.4 (16.3) Ni:3.7 (7.3)
TiCl <sub>4</sub> .2NCCHCHMe	29.2 (29.6)	3.5 (3.1)	3.7 (8.6)	Cl:40.3 (43.8)
TiCl <sub>4</sub> .NCCHCHMe	20.1 (18.7)	2.5 (1.9)	5.6 (5.5)	Cl:52.6 (55.3)
TiBr <sub>4</sub> .2NCCHCHMe	19.3 (19.1)	2.0 (2.0)	5.6 (5.9)	-
BCl <sub>3</sub> .NCCHCHMe	24.8 (26.1)	2.7 (2.7)	7.4 (7.6)	Cl:54.0 (57.8)
SbCl <sub>5</sub> .NCCHCHMe	13.3 (13.1)	1.3 (1.4)	4.1 (3.8)	Cl:45.5 (48.5)
TaCl <sub>5</sub> .NCCHCHMe	10.8 (11.3)	1.3 (1.2)	3.1 (3.3)	Cl:29.7 (41.7), Ta:45.7(42.5)
SnCl <sub>4</sub> .2NCCHCHMe	23.4 (24.2)	3.1 (2.5)	6.2 (7.1)	-
ZnCl <sub>2</sub> .2NCCHCHMe	34.8 (35.5)	4.3 (3.7)	11.6 (10.4)	-
Ni(SbCl <sub>6</sub> ) <sub>2</sub> .6NCCHCHMe	26.2 (25.5)	3.0 (2.6)	8.1 (7.4)	-
NiZn <sub>2</sub> Cl <sub>6</sub> .6NCCHCHMe	39.7 (35.8)	4.9 (3.7)	11.5 (10.4)	Cl: 22.1 (26.5) Zn:14.6 (16.2) Ni:5.7 (7.3)

\* Required in parentheses.

$\text{TiBr}_4$ , 2L : 20 ml. of the ligand was added to about 4g. of titanium tetrabromide in a cooled flask ( $-196^\circ\text{C}$ ). On warming the mixture to room temperature, the yellow solid of  $\text{TiBr}_4$  dissolving easily in the ligand on stirring, yielding a deep red solution. No crystals deposited on standing at room temperature, but on cooling the solution afforded a red microcrystalline solid.

$\text{SnCl}_4$ , 2L : 4 ml. of dry tin tetrachloride was added by syringe to 20 ml. of the ligand in a cooled flask ( $-196^\circ\text{C}$ ). On warming to room temperature an immediate white precipitate formed which redissolved by warming the solution by a hair drier. On standing the clear solution at room temperature, white crystals started to deposit after which the container was shaken very slowly to deposit a microcrystalline solid. These microcrystals were filtered, washed and dried.

$\text{BCl}_3$ , L : 5g. of boron trichloride was condensed under a vacuum in a cooled flask ( $-196^\circ\text{C}$ ) then 30 ml. of dry n-pentane was added after flushing the flask with dry nitrogen gas. The mixture was warmed to room temperature to allow  $\text{BCl}_3$  to dissolve in the pentane. An equivalent molar weight of the ligand was added to the cooled colourless  $\text{BCl}_3$  | n-pentane solution at  $-196^\circ\text{C}$ . On warming to room temperature a white solid precipitated which was filtered, washed with dry n-pentane, and dried under a stream of dry nitrogen.

$\text{SbCl}_5$ , L : 4 ml. of dry antimony pentachloride was added by syringe to 10 ml. of the ligand in a cooled flask ( $-196^\circ\text{C}$ ). On warming to room temperature a very strong exothermic reaction occurred and an immediate white solid precipitated from the solution. This precipitate was redissolved by

warming the solution with a hair drier until a clear yellow solution was obtained. After five minutes, the solution deposited a white crystalline solid which was isolated by filtration, washed with cold ligand and dried. The yellow filtrate on standing for one day at room temperature changed to a dark brown solution.

$\text{TaCl}_5/\text{L}$  : About 5 g. of tantalum pentachloride was refluxed in 25 ml. of the ligand for one hour. On filtration, the undissolved  $\text{TaCl}_5$  was isolated from the clear yellow solution which deposited, on cooling, a white microcrystalline solid. This solid was collected on a filter and dried.

$\text{CoCl}_2, \text{L}$  : About 2 g. of dry cobalt dichloride was refluxed with 20 ml. of the ligand for one hour. The mixture was filtered to remove the excess undissolved  $\text{CoCl}_2$  from the dark blue solution, which deposited (except cis-/trans-crotononitrile solution) a purple amorphous solid on standing at room temperature. This purple solid was separated by filtration, washed with the dry ligand, and dried under a stream of dry nitrogen. An attempt to precipitate a solid from the cis-/trans-crotononitrile solution by evaporation of the solvent and/or cooling the solution was not successful.

$\text{ZnCl}_2, 2 \text{L}$  : About 1 g. of anhydrous zinc dichloride was dissolved in 5 ml. of the ligand (only methacrylonitrile and cis-/trans-crotononitrile) at room temperature yielding a clear colourless solution which on cooling deposited white needles (from the methacrylonitrile solution) and a colourless damp solid (from the crotononitrile solution). These products were collected on a sinter and dried in dry nitrogen.

$\text{NiSb}_2\text{Cl}_{12}$ , 6 L : 5.68 g. of anhydrous nickel dichloride was refluxed with 11.2 ml. of dry antimony pentachloride dissolved in 90 ml. of the ligand (only methacrylonitrile and crotononitrile) for 26 hours with stirring. The excess undissolved  $\text{NiCl}_2$  was removed by filtration yielding a dark brown solution which on cooling deposited brown crystals. These brown crystals on separation and washing with the cold ligand turned to a purple colour.

$\text{NiZn}_2\text{Cl}_6$ , 6 L : 5.39 g. of anhydrous nickel dichloride and 7.43 g. of anhydrous zinc dichloride were ground together in a glove box and refluxed with 100 ml. of the ligand (only the methacrylonitrile and the crotononitrile) for 5 hours, after which the yellow slurry had turned the liquors blue. Excess nickel dichloride was filtered from the hot liquid and on cooling a purple solid and sky blue solid precipitated from cis-/trans-crotononitrile solution and methacrylonitrile solution respectively. These precipitates were filtered, washed, and dried under a stream of dry nitrogen.

### 5.3 RESULTS AND DISCUSSION

About thirty complexes have been prepared from the reactions between acrylonitrile and its methyl derivatives (methacrylonitrile and cis-/trans-crotononitrile) and the metal halides  $\text{TiCl}_4$ ,  $\text{TiBr}_4$ ,  $\text{SnCl}_4$ ,  $\text{BCl}_3$ ,  $\text{SbCl}_5$ ,  $\text{TaCl}_5$ ,  $\text{CoCl}_2$ ,  $\text{ZnCl}_2$ ,  $\text{Ni}(\text{SbCl}_6)_2$  and  $\text{NiZn}_2\text{Cl}_6$ . The analytical data of these complexes are listed in table (5.1). Their stoichiometry has been found either as (1:1) adducts  $\text{L}, \text{MX}_n$  (as in complexes of  $\text{TiCl}_4$ ,  $\text{CoCl}_2$ ,  $\text{BCl}_3$  and  $\text{SbCl}_5$ ), (2:1) adducts  $\text{L}_2\text{MX}_n$  (as in complexes of  $\text{TiCl}_4$ ,  $\text{TiBr}_4$ ,  $\text{SnCl}_4$  and  $\text{ZnCl}_2$ ), or (6:1)

adducts  $L_6MX_n$  (as in complexes of  $Ni(SbCl_6)_2$  and  $NiZn_2Cl_6$ ). No further investigations have been done for  $TaCl_5$  complexes or for  $NiZn_2Cl_6$  complexes with methacrylonitrile (except to record their infrared spectra) since their Analytical data were not as expected for (1:1) or (6:1) adducts respectively. In  $TaCl_5$  complexes, the solids precipitated from the ligand solution after refluxing with  $TaCl_5$  were not consistent with (1:1) adduct as have been observed in  $SbCl_5$  complexes. The reason for that can be attributed to the bridged structure of  $TaCl_5$  molecules which cannot easily stoichiometrically bond to the ligand but may trap or intercalate the ligand molecules. Furthermore, the low content of chlorine in these complexes suggests that  $Ta_2Cl_{10}$  may be reduced by the nitrile to form (1:1) adducts of  $TaCl_4$  as observed in the reaction of some halides of transition metals with nitriles<sup>36</sup>.

In our attempt to characterize these new complexes we studied their IR, <sup>1</sup>H NMR, Raman Spectroscopy, their electrical conductivities and vapor pressure.

### 5.3.1 Infrared Spectra

Infrared spectra of the nujol mulls of these complexes were recorded from 4000 to 250  $cm^{-1}$  using KBr plates. The assignments of the most important characteristic bands for the free acrylonitrile<sup>37</sup>, methacrylonitrile<sup>38</sup> and cis-/trans-crotononitrile<sup>39</sup> and their complexes are given in table (5.2). The later table also includes the absorption shift of the nitrile and the olefin stretching frequencies;  $\Delta\nu(C \equiv N)$  and  $\Delta\nu(C = C)$  which can be defined as the difference in frequency for the functional group before and after coordination. The importance of  $\Delta\nu$  values is to define the change in the

TABLE 5.2

Infrared Spectral Data<sup>†</sup> for Acrylonitrile derivatives and their Complexes

<u>Compound</u>	<u><math>\nu(\text{C}\equiv\text{N})</math></u>	<u><math>\nu(\text{C}=\text{C})</math></u>	<u>Out-of-plane def. of olefinic hydrogens*</u>	<u>Others</u>	<u><math>\Delta\nu(\text{C}\equiv\text{N})</math></u>	<u><math>\Delta\nu(\text{C}=\text{C})</math></u>
$\text{CH}_2=\text{CHC}\equiv\text{N}(\text{L}^\uparrow)$ <sup>f</sup>	2223 m	1608 w	962 vs	1410 vs, 1090 w, 870 w, 685 s	-	-
$\text{BCl}_3 \cdot \text{L}^\uparrow$	2312 vs	1596 s	945 vs 996 vs	1992 vw, 1411 vs, 1100 m, sh	89	-12
$\text{SnCl}_4 \cdot 2\text{L}^\uparrow$	2270 s 2305 w	1605 m	960 ms 990 ms	1974 vw, 1405 s, 1098 w, 893 w, 680 (m)	47	- 3
$\text{SbCl}_5 \cdot \text{L}^\uparrow$	2240 w 2260 w	1600 vw	960 m, sh	1410 wm, 1088 vw, 890 vw, 680 w	37	-8
$\text{TiCl}_4 \cdot 2\text{L}^\uparrow$	2265 vs 2300 w	1600 w	955 s, sh 960 sh 985 s 978 vs	1955 vw, 1970 vw, 1409 s, 1090 (vw), 885 ms, 675 m	42	-8
$\text{TiCl}_4 \cdot \text{L}^\uparrow$	2270 vs 2295 w	1597 vw	953 wm 986 m	1970 vw, 1405 wm, 1090 w, 890 w, 677 vw	47	-11
$\text{TiBr}_4 \cdot 2\text{L}^\uparrow$	2248 s, br 2288 w	1595 w	948 s 972 s	1944 vw, 1400 m, 1080 vw, 885 w, 670 m.	25	-13
$\text{CoCl}_2 \cdot \text{L}^\uparrow$	2260 s 2280 w	1599 wm	952 ms 958 ms 968 m 972 m	1944 vw, 1400 s, 1085 vw, 885 vw, 670 w	37	-9
$\text{TaCl}_5 \cdot \text{L}^\uparrow$	2260 s 2300 m	1593 ms	950 vs 984 vs	1968 vw, 1896 vw, 1404 s, 1088 w, 820 br, 671 s	37	-15

<u>Compound</u>	<u><math>\nu(\text{C}\equiv\text{N})</math></u>	<u><math>\nu(\text{C}=\text{C})</math></u>	<u>Out-of-plane def. of olefinic hydrogens <math>\star</math></u>	<u>Others</u>	<u><math>\Delta\nu(\text{C}\equiv\text{N})</math></u>	<u><math>\Delta\nu(\text{C}=\text{C})</math></u>
$\text{CH}_2=\text{CMeC}\equiv\text{N}(\text{L}^2)^f$	2233 ms	1629 ,	940 vs	1268 m, 752 w, 1048 sh, 1022 w.	-	-
$\text{BCl}_3 \cdot \text{L}^2$	2308 vs	1608 w	840 vs, sh 970 vs 960 vs	1680 vw, 1590 vw, 1260 w, 730 vs, br., sh, 1045 vw, 1015 vw	75	-21
$\text{SnCl}_4 \cdot 2\text{L}^2$	2255 vs, br.	1610 s, sh	925 vs 938 vs 955 vs 965 vs	1932 vw, 1910 vw, 1850 vw, 1260 vs, 768 s, 746 wm, 731 m, 720 wm, 1049 vw, 1020 m	22	-19
$\text{SbCl}_5 \cdot \text{L}^2$	2270 m, br.	1620 w	946 ms 960 ms	1910 vw, 1920 vw, 1265 w, 780 m, 757 w, 725 w, 1046 vw, 1017 w.	37	-9
$\text{TiCl}_4 \cdot 2\text{L}^2$	2265 vs	1613 m	948 vs 955 s 965 s	1907 vw, 1895 vw, 1263 m, 791 vs, 771 vs, 736 vs, sh, 1049 vw, 1019	32	-16
$\text{TiCl}_4 \cdot \text{L}^2$	2255 s	1608 vw	950 sh 957 s, sh	1908 vw, 1916 vw, 1253 vw, 770 m, 732 m, 1045 vw, 1012 vw.	22	-21
$\text{TiBr}_4 \cdot 2\text{L}^2$	2263 m	1613 vw	948 w 960 wm	1925 vw, 1918 vw, 1260 wm, 782 ms, 743 vs, 725 sh, 1043 vw, 1013 w	30	-16
$\text{CoCl}_2 \cdot \text{L}^2$	2275 m	1625 vw	952 w 967 wm	1937 vw, 1923 vw, 1269 w, 775 vw, 725 w, 1019 w	42	-4
$\text{ZnCl}_2 \cdot 2\text{L}^2$	2270 vs	1618 w	929 wm 962 m 973 m	1945 vw, 1264 w, 775 wm, 752 w, 724 w, 1047 vw, 1014 w	37	-11
$\text{TaCl}_5 \cdot \text{L}^2$	2270 vs	1620 vw	823 s 968 s	1930 vw, 1265 w, 775 m, 735 w, 725 w, 1048 vw, 1015 w	37	-9

Compound	$\nu(\text{C}\equiv\text{N})$	$\nu(\text{C}=\text{C})$	Out-of-plane def. of olefinic hydrogens*	Others	$\Delta\nu(\text{C}\equiv\text{N})$	$\Delta\nu(\text{C}=\text{C})$
$\text{NiZn}_2\text{Cl}_6 \cdot 6\text{L}^2$	2275 vs	1623 wm	955 vs, br.	1265 m, 775 w, 724 ms, 1045 vw, 1018 wm	42	-6
$\text{Ni}(\text{SbCl}_6)_2 \cdot 6\text{L}^2$	2270 vs	1620 w	929 ms 955 s, sh 947 vs	1900 vw, 1264 w, 776 w, 738 sh, 1045 vw, 1017 w	37	-9
$\text{MeCH}=\text{CHC}\equiv\text{N}$ (Cis-/trans- mixture) ( $\text{L}^3$ ) <sup>f</sup>	2223 s	1635 m 1627 wm	958 ms 780 vw 727 ms	1227 vw, 1022 vw, 895 vw, 1310 vw	-	-
$\text{BCl}_3 \cdot \text{L}^3$	2300 vs	1620 vs 1610 vs	1008 w, sh 740 vs 942 m	1306 w, 1226 vw	77	-15 -17
$\text{SnCl}_4 \cdot 2\text{L}^3$	2255 m, br.	1628 m 1615 m	969 wm 778 vw 955 m 722 s	1225 vw, 905 w, 1308 vw	32	-7 -12
$\text{SbCl}_5 \cdot \text{L}^3$	2255 vs, br.	1622 s, br.	953 ms 721 vw	1302 w	32	-13 or -5
$\text{TiCl}_4 \cdot 2\text{L}^3$	2250 vs	1621 m 1612 m	968 wm 775 w 949 ms 721 s	1225 vw, 1000 vw, 905 w, 1303 w	27	-14 -15
$\text{TiCl}_4 \cdot \text{L}^3$	2250 vs	1622 s 1608 s	962 ms 795 vs 946 s 718 vs	1218 vw, 1032 ms, 900 m, 1295 w	27	-13 -19
$\text{TiBr}_4 \cdot 2\text{L}^3$	2248 wm	1619 w 1610 w	963 vw 944 w 722 s	900 vw, 1298 vw	25	-16 -17

Compound	$\nu(\text{C}\equiv\text{N})$	$\nu(\text{C}=\text{C})$	Out-of-plane def. of olefinic hydrogens *	Others	$\Delta\nu(\text{C}\equiv\text{N})$	$\Delta\nu(\text{C}=\text{C})$
$\text{ZnCl}_2 \cdot 2\text{L}^3$	2265 s, br.	1630 s, br.	990 m 780 w 955 s 725 w	908 s, 1300 w	42	- 5 or +3
$\text{TaCl}_5 \cdot \text{L}^3$	2260 w	1625 vw 1590 w	948 vw 722 m	1020 vw, 1303 vw	37	-10 -37
$\text{NiZn}_2\text{Cl}_6 \cdot 6\text{L}^3$	2263 vs	1628 vs 1635 sh	962 vs 778 w 962 vs 762 w	1021 w, 907 ms, 1300 w	40	0 + 1
$\text{Ni}(\text{SbCl}_6)_2 \cdot 6\text{L}^3$	2270 s	1632 ms	958 ms 778 vw 725 w	1020 sh, 908 vw, 1305 vw	47	- 3 or +5

\* In the case of acrylonitrile and methacrylonitrile the out-of-plane deformations are referred to twisting and wagging of the methylene group, but in crotononitrile this is referred to symm- and unsymm- of CH : CH group for cis- and trans-isomers.

† IR data are given in  $\text{cm}^{-1}$ .

f the spectrum was recorded as contact film.

force constant of the functional group after coordination; and from which the coordination site of the ligand and the possible geometry of the whole adduct can be determined.

#### Acrylonitrile and Methacrylonitrile Complexes

From the  $\Delta\nu$  values given in table (5.2), all adducts of acrylonitrile and methacrylonitrile show an increase by 22-89  $\text{cm}^{-1}$  for ( $\text{C}\equiv\text{N}$ ) stretching frequency, and a decrease for ( $\text{C}=\text{C}$ ) stretch by 3-21  $\text{cm}^{-1}$ . This observation suggests that the metal halide in these complexes is coordinated either by the nitrogen lone pair only, forming an  $\sigma$ -N complex or by both of the nitrogen lone pair and the alkene  $\pi$ -electrons forming  $\sigma/\pi$  bridging structure. If an  $\sigma$ -coordinate bond is formed by the nitrogen lone pair only, then the force constant of ( $\text{C}\equiv\text{N}$ ) stretch is expected to increase while the ( $\text{C}=\text{C}$ ) stretching frequency is expected to decrease due to the shift of its  $\pi$ -electrons towards the coordinating atom. Consequently, it is expected that the greater the Lewis acidity of the metal, the greater the positive shift value for  $\Delta\nu(\text{C}\equiv\text{N})$  stretch which should be directly proportional to the negative shift of  $\Delta\nu(\text{C}=\text{C})$ , i.e. the order of Lewis acidity for metal halide adducts should be reflected in both  $\Delta\nu(\text{C}\equiv\text{N})$  and  $\Delta\nu(\text{C}=\text{C})$  values.

In an attempt to measure the relative Lewis acidities of the metal halides involved in this work, the amount of splitting of the  $\text{CH}_2$  out-of-plane deformations twisting and wagging [which they are coincide at 962  $\text{cm}^{-1}$  for the free acrylonitrile and at 940  $\text{cm}^{-1}$  for the uncorrdinated methacrylonitrile] has been determined. These amounts of splitting for the acrylonitrile derivative adducts are given in

table (5.3). The  $\tau(\text{CH}_2)$  and  $\omega(\text{CH}_2)$  frequencies are identified from their overtones in the 2000 - 1800  $\text{cm}^{-1}$  region. In acrylonitrile complexes, the size of splitting is ranged from 20 to 51  $\text{cm}^{-1}$  whilst in methacrylonitrile complexes is from 7 to 145  $\text{cm}^{-1}$ . In some cases the splitting found in the methylene group generated more than two bands where each component of the  $\text{CH}_2$  out-of-plane deformation absorption was split into two bands. These were observed in the acrylonitrile complexes of  $\text{TiCl}_4$ ,  $\text{CoCl}_2$  and  $\text{ZnCl}_2$  and in methacrylonitrile complexes of  $\text{BCl}_3$ ,  $\text{SnCl}_4$ ,  $\text{ZnCl}_2$  and  $\text{Ni}(\text{SbCl}_6)_2$ .

According to the data given in table (5.3), one can define the relative Lewis acidity for the metal halides used in this work which was found in the order:

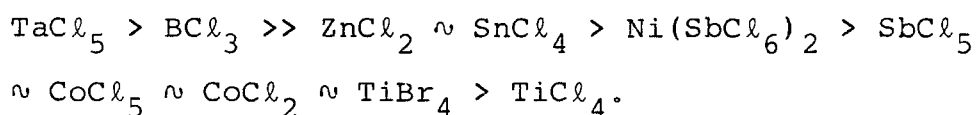

The above order does not agree with the order of  $\Delta\nu(\text{C}\equiv\text{N})$  increase and with  $\Delta\nu(\text{C}=\text{C})$  decrease which may suggest that the nitrogen lone pair of the  $\alpha,\beta$ -unsaturated nitrile is not the only site which coordinates to the metal atom.

In addition to that it seems that the back bonding donation from  $d\pi$  orbitals of the metal into the vacant antibonding  $\pi^*$  orbital of the  $\text{C}\equiv\text{N}$  bond is not an important factor to explain the above order, since the (1:1) complexes of  $\text{BCl}_3$  and  $\text{TiCl}_4$  which do not have d electrons showed a shift in the  $\text{C}\equiv\text{N}$  stretch consistent with the order or the Lewis acidity but however showed a similar shift in the  $\text{C}=\text{C}$  stretching frequency ( $\Delta\nu(\text{C}=\text{C})$  for  $(\text{CH}_2=\text{CHCN})=-12$  and for  $(\text{CH}_2\text{C}(\text{CH}_3)\text{CN})=-21$ ).

TABLE (5.3)

Shifts in the frequencies of characteristic vibrations of Derivative Adducts.

Complex	CH <sub>2</sub> : CHCN	CH <sub>2</sub> : CMeCN	MeCH:CHCN
	$\Delta[\omega(\text{CH}_2) - \tau(\text{CH}_2)]$	$\Delta[\omega(\text{CH}_2) - \tau(\text{CH}_2)]$	$\Delta\nu(\text{CH}:\text{CH})$
BCl <sub>3</sub>	51	130	66
SnCl <sub>4</sub>	30	40	14, 56
SbCl <sub>5</sub>	-	14	-
TiCl <sub>4</sub> (2:1)	30	7	19, 54
TiCl <sub>4</sub> (1:1)	33	7	16, 77
TiBr <sub>4</sub>	24	12	19
CoCl <sub>2</sub>	20	15	-
ZnCl <sub>2</sub>	-	44	35, 55
TaCl <sub>5</sub>	34	145(?)	-
NiZn <sub>2</sub> Cl <sub>6</sub>	-	-	55
Ni(SbCl <sub>6</sub> ) <sub>2</sub>	-	26	53

The decrease of  $3-21 \text{ cm}^{-1}$  in the C=C stretching frequency upon coordination of the ligand to the metal halide studied in this work is not the same magnitude as that observed for olefin metal  $\pi$ -complexes of  $\text{AgBF}_6$ <sup>40</sup> ( $\Delta\nu(\text{C}=\text{C}) \sim 40-70 \text{ cm}^{-1}$ ) and of  $\text{AuCl}$ <sup>41,42</sup> ( $\Delta\nu(\text{C}=\text{C}) = 115-136 \text{ cm}^{-1}$ ). However, this does not imply that the C=C double bond is not a coordination site, particularly for those complexes in which the metal coordination sphere is not complete.

Interestingly, the order of  $\Delta\nu(\text{C}\equiv\text{N})$  for both acrylonitrile and methacrylonitrile complexes was the reverse of the order of  $\Delta\nu(\text{C}=\text{C})$  as shown in table (5.4).

TABLE (5.4)

The order of (C≡N) and (C=C) stretching absorption frequency shifts for Acrylonitrile and Methacrylonitrile adducts

Ligand	$\Delta\nu(\text{C}\equiv\text{N})$	$\Delta\nu(\text{C}=\text{C})$
$\text{CH}_2:\text{CHCN}$	$\text{BCl}_3 > \text{SnCl}_4 \sim$ $\text{TiCl}_4(1:1) > \text{SbCl}_5 >$ $\text{TiCl}_4(2:1) \sim \text{TaCl}_5 \sim$ $\text{CoCl}_2 > \text{TiBr}_4$	$\text{TaCl}_5 > \text{TiBr}_4 >$ $\text{BCl}_3 > \text{TiCl}_4(1:1) > \text{CoCl}_2 >$ $\text{TiCl}_4(2:1) \sim \text{SbCl}_5 >$ $\text{SnCl}_4$
$\text{CH}_2:\text{CMeCN}$	$\text{CoCl}_2 \sim \text{NiZnCl}_6 >$ $\text{ZnCl}_2 \sim \text{TaCl}_5 \sim \text{SbCl}_5$ $\sim \text{NiSb}_2\text{Cl}_{12} > \text{TiCl}_4(2:1)$ $> \text{TiBr}_4 > \text{SnCl}_4 \sim \text{TiCl}_4$ $(1:1)$	$\text{TiCl}_4(1:1) > \text{SnCl}_4$ $> \text{TiCl}_4(2:1) \sim \text{TiBr}_4$ $> \text{ZnCl}_2 \sim \text{TaCl}_5$ $> \text{SbCl}_5 \sim \text{NiSb}_2\text{Cl}_{12}$ $> \text{NiZn}_2\text{Cl}_6 > \text{CoCl}_2$

### Cis-/trans-Crotonitrile Complexes

Since a mixture of cis- and trans- isomers of crotononitrile was used for the syntheses of the crotononitrile complexes, the products are expected to be mixtures of cis-/trans- crotononitrile adducts. The infrared spectrum of the free ligand shows one band at  $2223\text{ cm}^{-1}$  for  $\nu(\text{C}\equiv\text{N})$  stretching frequency and two bands for  $\nu(\text{C}=\text{C})$  stretching at  $1627(\text{cis})$  &  $1635\text{ cm}^{-1}$  for the trans- isomer. On coordination, the  $\nu(\text{C}\equiv\text{N})$  band shifted to higher frequency by  $25-77\text{ cm}^{-1}$  and both bands of  $\nu(\text{C}=\text{C})$  shifted to lower frequency by  $3-37\text{ cm}^{-1}$ , or increased by  $1-5\text{ cm}^{-1}$  or suffered no change at all. Since the values of  $\Delta\nu(\text{C}\equiv\text{N})$  and  $\Delta\nu(\text{C}=\text{C})$  frequencies of crotononitrile complexes are similar to those obtained for methacrylonitrile complexes (see table (5.2)), it can be suggested that crotononitrile complexes have similar structure to the methacrylonitrile complexes and also that the cis-/trans- crotononitrile ligand has a similar basic character to that of methacrylonitrile.

The symmetrical and unsymmetrical out-of-plane olefinic hydrogen atom deformation of crotononitrile isomers have been well characterized by Potts and Nyquist<sup>43</sup>. The cis-crotononitrile absorbs strongly in the infrared spectrum at  $724$  and  $950\text{ cm}^{-1}$  due to HCCH symmetrical and unsymmetrical deformations respectively. In the trans-crotononitrile, the isomer absorbs strongly at  $927\text{ cm}^{-1}$  (assigned to unsymmetrical deformation) and very weakly at  $788\text{ cm}^{-1}$ . The latter symmetrical (HCCH) out-of-plane deformation band is not expected to produce a significant

dipole change<sup>44</sup>.

In practice, the IR spectrum of the cis-/trans-crotononitrile mixture shows the HCCH symmetrical deformation for both isomers at 780 and 727  $\text{cm}^{-1}$ . However, one band has been observed for the unsymmetrical deformation mode which suggests that these two bands coincide in the uncoordinated ligand (see table (5.2)). Upon coordination, the dipole moment of the olefinic bond in the trans-isomer will be expected to increase more than that in the cis-isomer which will lead to a splitting in the unsymmetrical HCCH deformation band into two bands. The amount of that splitting - see table (5.3) - which ranges from 14 to 66  $\text{cm}^{-1}$  can be used to determine the order of relative Lewis acidities which are found in the order:

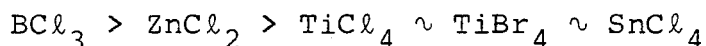

### 5.3.2 Proton Magnetic Resonance Spectra

<sup>1</sup>H NMR spectra have been recorded only for complexes of acrylonitrile derivatives with  $\text{BCl}_3$ ,  $\text{TiCl}_4$ ,  $\text{TiBr}_4$ ,  $\text{SnCl}_4$  and  $\text{SbCl}_5$  in benzene solution using TMS as external standard reference. The changes in the <sup>1</sup>H NMR spectra of free ligands upon coordination to the concerned metal halide are summarized in tables (5.5 - 5.7).

In acrylonitrile complexes each signal of the vinyl protons is shifted upfield by 0.63 - 1.49 ppm after coordination to the metal halide. In methacrylonitrile and cis-/trans-crotononitrile complexes, analogous upfield shifts are observed for both the vinyl and methyl protons by 0.07 - 1.25 and 0.21 - 0.8 ppm respectively.

TABLE (5.5)

<sup>1</sup>HNMR Spectral Data for Acrylonitrile Complexes

PPM	CH <sub>2</sub> :CHCN(L <sup>1</sup> )	TiCl <sub>4</sub> .2L <sup>1</sup>	TiCl <sub>4</sub> .L <sup>1</sup>	TiBr <sub>4</sub> .2L <sup>1</sup>	SnCl <sub>4</sub> .2L <sup>1</sup>	SnCl <sub>4</sub> .L <sup>1*</sup>	BCl <sub>3</sub> .L <sup>1</sup>	SbCl <sub>5</sub> .L <sup>1</sup>
5.0		4.23	4.0	4.06	4.32	4.21	3.98	3.53
5.16		4.42	4.19	4.22	4.52	4.4	4.13	3.73
5.26		4.52	4.3	4.3	4.61	4.5	4.27	3.83
5.46		4.72	4.5	4.5	4.8	4.68	4.47	4.03
δ 5.52		4.98	4.8	4.72	5.1	4.95	4.98	4.51
5.56		5.18	5.0	4.91	5.21	5.1	5.02	4.68
5.7		5.49	5.28	5.02	5.52	5.4	5.20	4.73
5.74		-	-	5.3	-	5.44	5.27	4.97
5.94		-	-	-	-	-	-	-
5.99		-	-	-	-	-	-	-
δ average	5.53	4.79	4.04	4.62	4.9	4.83	4.66	4.25
Δδ average	-	- 0.74	- 1.49	- 0.91	- 0.63	- 0.70	- 0.87	- 1.28

\* Measured for (1:1) molar solution in Bz.

TABLE (5.6)

<sup>1</sup>HNMR Spectral Data for Methacrylonitrile Complexes

PPm	CH <sub>2</sub> :CMeCN(L <sup>2</sup> )	TiCl <sub>4</sub> .2L <sup>2</sup>	TiCl <sub>4</sub> .L <sup>2</sup>	TiBr <sub>4</sub> .2L <sup>2</sup>	SnCl <sub>4</sub> .2L <sup>2</sup>	SnCl <sub>4</sub> .L <sup>2*</sup>	BCl <sub>3</sub> .L <sup>2</sup>	SbCl <sub>5</sub> .L <sup>2</sup>
δ(CH <sub>3</sub> )	1.6	1.1	0.80	1.09	1.23	1.06	0.92	0.82
δ(H) <sub>C</sub>	5.3	4.88	4.52	4.62	5.00	4.83	4.93	4.67
δ(H) <sub>t</sub>	5.4	5.08	4.82	5.16	5.16	4.98	-	4.83
Δδ(CH <sub>3</sub> )	-	-0.5	-0.8	-0.51	-0.37	-0.54	-0.68	-0.78
Δδ(H) <sub>C</sub>	-	-0.42	-0.78	-0.68	-0.3	-0.47	-0.37	-0.63
Δδ(H) <sub>t</sub>	-	-0.32	-0.58	-0.24	-0.24	-0.42	-	-0.57

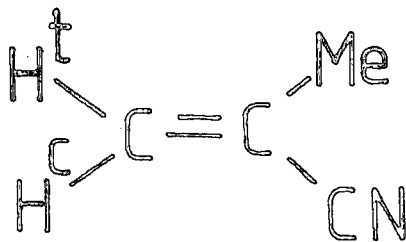
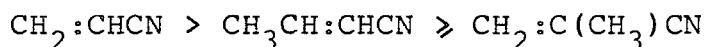

TABLE (5.7)

<sup>1</sup>H NMR Spectral Data for cis-/trans-Crotononitrile Complexes

ppm	MeCH:CHCN(L <sup>3</sup> )	TiCl <sub>4</sub> .2L <sup>3</sup>	TiCl <sub>4</sub> .L <sup>3</sup>	TiBr <sub>4</sub> .2L <sup>3</sup>	SnCl <sub>4</sub> .2L <sup>3</sup>	SnCl <sub>4</sub> .L <sup>3*</sup>	BCl <sub>3</sub> .L <sup>3</sup>	SbCl <sub>5</sub> .L <sup>3</sup>
δ(CH <sub>3</sub> )	1.33	0.88	0.74	0.79	1.1	0.89	0.96	0.55
	1.46	0.98	0.88	0.96	1.2	1.01	1.08	0.68
	1.60	1.29	1.19	1.09	1.42	1.21	1.14	1.13
	1.72	1.40	1.2	1.41	1.55	1.33	1.29	-
δ H <sub>α</sub>	4.6	4.08	3.92	4.25	4.25	4.00	3.83	3.41
	4.71	4.22	4.08	4.37	4.41	4.16	4.1	3.68
	4.9	4.35	4.23	4.52	4.5	4.25	4.28	-
	4.95	4.40	-	-	4.6	4.32	-	-
δ H <sub>β</sub>	5.63	5.43	5.45	5.38	5.62	5.38	5.45	5.01
	5.76	5.49	5.53	5.5	5.73	5.49	5.6	5.15
	5.82	5.55	5.59	5.69	5.87	5.60	5.73	5.31
	5.87	5.60	5.65	5.72	5.9	5.62	5.88	-
	5.93	5.68	5.7	5.8	6.02	5.71	-	5.44
	6.05	5.73	5.75	5.92	-	5.75	-	5.56
	6.20	5.79	5.8	-	-	5.81	-	-
	-	5.82	5.89	-	-	5.89	-	-
	-	5.92	5.92	-	-	5.92	-	-
	-	-	-	-	-	6.00	-	-
Δδ(CH <sub>3</sub> ) avg.	-	- 0.39	- 0.52	- 0.46	- 0.21	- 0.41	- 0.41	- 0.74
Δδ(H) avg.(α)	-	- 0.53	- 0.72	- 0.41	- 0.35	- 0.61	- 0.72	- 1.25
Δδ(H) avg.(β)	-	- 0.23	- 0.20	- 0.23	- 0.07	- 0.18	- 0.23	- 0.60

The shift of the alkene protons for those complexes to the upfield is not as expected for the  $\sigma$ -N nitrile complexes which show an increase in the C $\equiv$ N frequency and a decrease in C=C frequency in the IR spectra. This suggests the presence of an intermolecular interaction between the C=C  $\pi$ -system and the  $\sigma$ -N metal complex probably through dimerization, oligomerization or polymerization process. The order of chemical shifts in the olefinic protons for all these complexes was observed to decrease in the sequence:



which may reflect directly the order of the stability for complexes of acrylonitrile and its methyl derivatives.

On correlating these results with the reaction of acrylonitrile and its methyl derivatives with the  $\text{SnCl}_2/\text{HCl}$  system it seems that all of these  $\alpha,\beta$ -unsaturated nitriles can coordinate with the tin atom via the C=C  $\pi$ -electrons but the kinetic stability of metal  $\pi$ -complexes against nucleophilic attack by, for example,  $\text{Cl}^\ominus$  is less with methacrylonitrile and crotononitrile.

In all complexes of  $\text{TiCl}_4$ , the chemical shifts to the upfield for the 1:1 adducts were slightly higher than that of 2:1 adducts. The same observation occurs with the  $\text{SnCl}_4$  complexes which were prepared in benzene solution in 1:1 and 1:2 molar ratio. This may indicate that the addition of a further mole of the free ligand to the 1:1 adduct breaks down the weak metal/C=C interactions in these adducts. However, a more likely explanation is that the 2:1 adducts on dissolving in the benzene solution undergo dissociation to give (1:1) adducts and free nitriles:

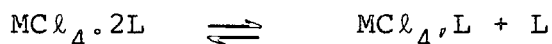

The mixture is expected to display the proton signals at the average of the coordinated and free ligand.

### 5.3.3 Electrical Conductivity Measurements

Electrical conductivities of  $10^{-4}$  -  $10^{-6}$  M solutions of  $TiCl_4$ ,  $SnCl_4$  and  $NiSb_2Cl_{12}$  complexes were determined in dry nitrobenzene at room temperature ( $20 \pm 2^\circ C$ ). The experimental data are represented in table (5.8) as:

The weight of the sample used (Wt.), the assumed molecular weight of the complex (M.Wt.), the volume of the solvent to dissolve the complex (v), the molar concentration ( $C_M$ ), the specific conductance (K) given by conductivity meter and finally the molar conductivity ( $\Lambda_M$ ). The molar conductivity of each solution was calculated from the equation

$$\Lambda_M = \frac{K \times 10^{-6}}{C_M} \text{ Ohm}^{-1} \text{ cm}^2 \cdot \text{Mole}^{-1}$$

The results in table (5.8) show that those complexes of  $TiCl_4$  and  $SnCl_4$  are non-electrolyte in nitrobenzene as compared with 1:1 electrolytes which usually have M values in the range  $20 - 30 \text{ ohm}^{-1} \text{ cm}^2 \cdot \text{mole}^{-1}$  <sup>45</sup>. This rules out the possibility for ionic species such as  $[MCl_2(L_4)]^{2\oplus} MCl_6^{2\ominus}$ . The molar conductivities of  $NiSb_2Cl_{12}$  complexes gave values of  $142 \text{ ohm}^{-1} \text{ cm}^2 \cdot \text{mole}^{-1}$  for methacrylonitrile and  $114 \text{ ohm}^{-1} \text{ cm}^2 \cdot \text{mole}^{-1}$  for cis-/trans-crotononitrile which indicates that these complexes are electrolytes in nitrobenzene.

The molar conductivities for the solutions of  $NiSb_2Cl_{12}$  complexes were plotted against the root of the solution concentration. The results which are given in Table (5.9) gave a good straight line for the plot (figure 5.1) with

TABLE (5.8)

Electrical Conductivity data for  $\text{SnCl}_4$ ,  $\text{TiCl}_4$  and  $\text{NiSb}_2\text{Cl}_{12}$  complexes

Complex	wt. gm	M. wt.	$M \times 10^{-3}$	$v \text{ cm}^3$	$C_M \times 10^{-5}$ mole.cm <sup>-3</sup>	$L \text{ } \mu\text{ohm}^{-1}$	$\Lambda_M \text{ ohm}^{-1} \text{ cm}^2 \cdot \text{mole}^{-1}$
$\text{SnCl}_4 \cdot 2\text{CH}_2\text{CMeCN}$	0.9618	394.68	2.4	47	5.18	40.3	0.8
$\text{SnCl}_4 \cdot 2\text{MeCHCHCN}$	0.6724	394.68	1.7	48	3.55	51.3	1.4
$\text{SnCl}_4 \cdot 2\text{CH}_2\text{CHCN}$	0.8189	366.62	2.2	48	4.65	44.5	1.0
$\text{TiCl}_4 \cdot 2\text{CH}_2\text{CHCN}$	0.3039	295.83	1.0	44	2.33	28.85	1.2
$\text{TiCl}_4 \cdot \text{CH}_2\text{CHCN}$	0.4404	242.77	1.8	45	4.03	54.95	1.4
$\text{TiCl}_4 \cdot 2\text{CH}_2\text{CMeCN}$	0.2567	323.89	0.8	44	1.80	33.5	1.9
$\text{TiCl}_4 \cdot \text{CH}_2\text{CMeCN}$	0.3953	256.8	1.5	46	3.34	49.2	1.5
$\text{TiCl}_4 \cdot 2\text{MeCHCHCN}$	0.3573	323.89	1.1	47	2.35	32.6	1.4
$\text{TiCl}_4 \cdot \text{MeCHCHCN}$	0.2804	256.89	1.1	44	2.48	28.6	1.2
$\text{NiCl}_2 \cdot 2\text{SbCl}_5 \cdot 6\text{CH}_2\text{CMeCN}$	0.20945	1130.2	0.2	48	0.39	549	142
$\text{NiCl}_2 \cdot 2\text{SbCl}_5 \cdot 6\text{MeCHCHCN}$	0.46105	1130.2	0.4	48	0.85	969.5	114

$\Lambda_0$  of  $\sim 200 \text{ ohm}^{-1} \text{cm}^2 \text{mole}^{-1}$ . This value is inconsistent with the typical (2:1) electrolytes measured in nitrobenzene ( $50 - 60 \text{ ohm}^{-1} \text{cm}^2 \text{mole}^{-1}$ ), but however it is close to that of (2:1) electrolytes measured in acetonitrile  $160-200 \text{ ohm}^{-1} \text{cm}^2 \text{mole}^{-1}$  45.

TABLE (5.9)

Conductance Data for  $\text{NiSb}_2\text{Cl}_{12}$  Complexes

(a) for methacrylonitrile compound

$C_M$ mole $\text{cm}^{-3}$	$K$ $\mu \text{ ohm}^{-1}$	$\Lambda_M$ $\text{ohm}^{-1} \text{cm}^2 \text{mole}^{-1}$
0.06088	546.00	147.31
0.05848	511.50	149.56
0.05636	480.00	151.11
0.05538	460.00	149.98
0.05357	443.00	154.36
0.05192	420.00	155.80
0.05041	400.00	157.40
0.04932	387.00	159.09
0.04834	374.00	160.05
0.04741	363.25	161.60
0.04640	349.50	162.33

$$\Lambda_o = 210 \text{ ohm}^{-1} \text{cm}^2 \text{mole}^{-1}$$

(b) for cis-/trans-Crotonitrile compound

0.09033	967.75	118.60
0.08712	924.50	121.80
0.08469	884.75	123.35
0.08246	846.50	124.49
0.08039	810.25	125.37
0.07847	789.50	128.21
0.07501	741.00	131.69
0.07345	707.00	131.04
0.07197	685.00	132.24
0.07104	671.50	133.05

$$\Lambda_o = 198 \text{ ohm}^{-1} \text{cm}^2 \text{mole}^{-1}$$

#### 5.3.4 The Stability of Adducts

The stability of the adducts prepared in this work, to either thermal dissociation or chemical attack were studied to determine the strength of the coordinate bond formed between the metal halide and the acrylonitrile derivative.

These adducts on exposing to air and moisture change either in their colour or in their IR spectra by showing characteristic bands for  $H_2O$  at 3400 and  $1600\text{ cm}^{-1}$  assigned to  $\nu(O-H)$  stretch and  $\delta(HoH)$  deformation. They are soluble in benzene except complexes of  $CoCl_2$ ,  $TaCl_5$ ,  $NiSb_2Cl_{12}$  and  $NiZn_2Cl_6$ , and their IR spectra in the solution do not significantly differ from those spectra recorded for the solid complexes. Antimony pentachloride complexes react with  $SiMe_4$  in benzene solution and deposit a brown oily liquid which is immiscible with the benzene solution.

The vapour pressure for these adducts were measured manometrically by using a cathetometer at room temperature. The results which are summarised in table (5.10) showed that these adducts are volatile solids (with the exception of  $SbCl_5$  and  $TaCl_5$  complexes) and they have vapour pressure in the range 8.91 - 0.04 mm.Hg.

To identify the volatile components, some adducts such as  $TiCl_4$ ,  $SnCl_4$  and  $BCl_3$  complexes were pumped and the resulting volatile products were then collected at U-trap at  $-196^\circ$  or  $0^\circ C$ . The results of the dissociation experiment are summarized in table (5.11).

TABLE (5.10)

Vapour Pressure data for Complexes of Acrylonitrile derivatives in mm.Hg at room temperature.

	<u>CH<sub>2</sub>:CHCN</u>	<u>CH<sub>2</sub>:CMeCN</u>	<u>MeCH:CHCN</u>
TiCl <sub>4</sub> (1:1)	2.52	2.95	3.68
TiCl <sub>4</sub> (2:1)	1.34	3.41	1.15
TiBr <sub>4</sub>	1.04	0.05	0.04
BCl <sub>3</sub>	1.01	0.59	0.52
SnCl <sub>4</sub>	3.12	8.31	0.22
ZnCl <sub>2</sub>	-	8.91	1.00
CoCl <sub>2</sub>	1.43	0.36	-
SbCl <sub>5</sub>	0.00	0.00	0.00
TaCl <sub>5</sub>	0.00	0.00	0.00
NiSb <sub>2</sub> Cl <sub>12</sub>	-	2.88	3.66
NiZn <sub>2</sub> Cl <sub>6</sub>	-	-	2.02

TABLE (5.11)

Experimental Dissociation Results for  $TiCl_4$ ,  $SnCl_4$ ,  $BCl_3$   
Complexes

<u>Complex</u>	<u>Temperature °C of pumped flask</u>	<u>Temperature of U-trap °C</u>	<u>Components Collected* at U-trap</u>
$TiCl_4 \cdot 2NCCHCH_2$	RT	- 196	$CH_2CHCN + TiCl_4 \cdot NCCHCH_2$
$TiCl_4 \cdot 2NCCMeCH_2$	50	- 196	$CH_2CMeCN + TiCl_4 \cdot NCCMeCH_2$
$TiCl_4 \cdot 2NCCHCHMe$	60	- 196	The initial product <sup>+</sup>
$TiCl_4 \cdot NCCHCH_2$	RT	- 196	" "
$TiCl_4 \cdot NCCMeCH_2$	RT	- 196	" "
$TiCl_4 \cdot NCCHCHMe$	RT	-196	" " +
$SnCl_4 \cdot 2NCCHCH_2$	RT	-196, 0	" "
$SnCl_4 \cdot 2NCCMeCH_2$	40	0	" "
$SnCl_4 \cdot 2NCCHCHMe$	60	0	" " +
$BCl_3 \cdot NCCHCH_2$	RT	0	" "
$BCl_3 \cdot NCCMeCH_2$	RT	0	" "
$BCl_3 \cdot NCCHCHMe$	RT; 60	0	" " +

\* The products were identified analytically and by IR Spectra.

+ The products of Crotonitrile complexes were collected in two different phases, one is solid and the other is sticky or viscous liquid.

Only two of these complexes;  $\text{TiCl}_4 \cdot 2\text{NCCHCH}_2$  and  $\text{TiCl}_4 \cdot 2\text{NCCMeCH}_2$  showed tendency to dissociate into the free ligand and the corresponding (1:1) adduct. The temperature required for that dissociation was higher in the case of the methacrylonitrile complex than in the case of the acrylonitrile complex.

### 5.3.5 Raman and Far infrared Spectra

The study of Raman and Far IR spectra will be concentrated only on (2:1) adducts of  $\text{TiCl}_4$  with both methacrylonitrile and cis-/trans-crotononitrile and also on the adduct  $\text{TiBr}_4 \cdot 2\text{NCCMeCH}_2$ . In these complexes two possible configurations based on octahedral coordination are given in figure (5.2) and by assuming the nitrile ligand as a point mass.

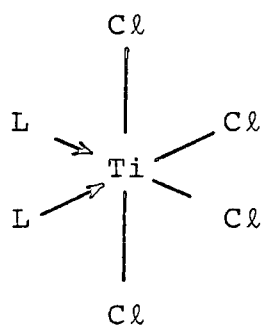

(XVI) Cis

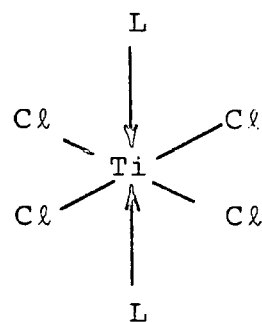

(XVII) trans

Figure (5.2) : Possible structures

for  $\text{TiCl}_4 \cdot 2\text{L}$  Complexes.

In the cis configuration the  $\text{TiCl}_4$  unit has  $C_{2v}$  symmetry while the trans configuration has  $D_{4h}$ . On application of group theory<sup>46</sup> to those two symmetries one can deduce the number of vibrational modes expected for the structures (XVI) and (XVII). These vibrational modes (which are 15 for the cis and 11 for the trans) and their distributions

are given in the equations below:

$$\begin{aligned} \Gamma_{\text{cis}} &= 2A_1 + B_1 + B_2 && \text{Ti-Cl vibrations} \\ &+ A_1 + B_1 && \text{Ti-L vibrations} \\ &+ 3A_1 + 3A_2 + 2B_1 + 2B_2 && \text{Deformations} \end{aligned}$$

$$\begin{aligned} \Gamma_{\text{trans}} &= A_{1g} + B_{1g} + E_u && \text{Ti-Cl vibrations} \\ &+ A_{1g} + A_{2u} && \text{Ti-L vibrations} \\ &+ B_{2g} + E_g + A_{2u} + B_{2u} + 2E_u && \text{Deformations} \end{aligned}$$

The modes which are active in the IR or Raman can be known from the character tables for the point groups  $C_{2v}$  and  $D_{4h}$ . In the cis case 13 IR-active ( $A_1, B_1, B_2$ ) and 15 Raman active vibrations ( $A_1, A_2, B_1, B_2$ ) are expected while in the trans case, only 5 IR active ( $E_u, A_{2u}$ ) and 6 Raman-active vibrations ( $A_{1g}, B_{1g}, B_{2g}, B_{2u}, E_g$ ) are expected.

The main difference between the above two structures is that the trans structure has a centre of symmetry. There will therefore be no coincidence between the IR and Raman spectra for the trans configuration, while there will be 13 coincidences for the cis. Thus the far IR and Raman Spectra (Fig. 5.2 - 5.7) were recorded for the concerned  $TiCl_4$  and  $TiBr_4$  complexes as nujol mulls and in the region  $500 - 50 \text{ cm}^{-1}$ . The spectra are tabulated in table (5.12). The results showed that both the complexes  $TiCl_4 \cdot 2NCCMeCH_2$  and  $TiCl_4 \cdot 2NCCHCHMe$  have a similar structure to the cis configuration as indicated from the similarity in the spectra and from the observed coincidences between IR and Raman.

TABLE (5.12)

FIR and Raman spectra ( $\text{cm}^{-1}$ ) for 1:2 complexes of  $\text{TiCl}_4$  and  $\text{TiBr}_4$ 

$\text{TiCl}_4 \cdot 2\text{NCCMeCH}_2$		$\text{TiCl}_4 \cdot 2\text{NCCHCHMe}$		$\text{TiBr}_4 \cdot 2\text{NCCMeCH}_2$	
FIR	Raman	FIR	Raman	FIR	Raman
415 sh	419 wm	420 sh	417 m	389 ms	296 w
392 s	398 vs	394 s	384 vs	385 ms	197 s
387 s	383 vw	392 s	321 s	381 ms	158 w
382 vs	378 vw	388 s	268 vw	341 ms	107 w
332 m	370 vw	381 vs	242 vw	332 s	67 m
315 ms	333 vw	319 m	225 vw	321 s	
277 w	319 wm	302w sh	208 vw	315 s	
272 w	277 w	295 w	175 w	304 m	
206 wm	272 w	280 wm	180 wm	281 m	
195 wm	210 vw	233 wm	112 m	258 m	
183 m	174 w	260 w	60 s	212 ms	
166 m	155 wm	205 wm	70 m	170 ms	
145 vw	132 wm	187 wm		72 m	
131 vw	90 sh	172 w, sh		50 w	
125 vw	80 sh	166 w			
104 vw	77 sh	160 w			
83 vw	50 m	145 vw			
72 vw	180 vw	139 vw			
		125 vw			
		104 vw			
		83 vw			
		72 m			
		62 vw			

spectra at  $\sim 420$ ,  $320$  and  $270 \text{ cm}^{-1}$ . In contrast, no coincidences could be observed for the  $\text{TiBr}_4$  complex which may suggest the trans configuration for this compound.

#### 5.4 CONCLUSION

From the above discussion one can conclude the following:

- ① - Acrylonitrile and its methyl derivatives coordinate to the metal halide  $\text{MX}_n$  ( $M = \text{Ti}^{\text{IV}}, \text{Sn}^{\text{IV}}, \text{Zn}^{\text{II}}, \text{Co}^{\text{II}}, \text{Ni}^{2+}, \text{Sb}^{\text{V}}, \text{Ta}^{\text{V}}, X = \text{Cl}, \text{Br}$ ) generally from the nitrogen lone pair site to form  $\sigma\text{-N}$  complex. This is confirmed from the shift of  $\nu(\text{C} \equiv \text{N})$  stretching to the higher frequencies and from the lower shift in the  $\nu(\text{C} = \text{C})$  stretching frequency.
- ② - Intermolecular interactions between the  $\sigma\text{-N}$  complex molecules involving the  $(\text{C} = \text{C})$  site may occur in complexes of stoichiometry (1:1). This is inferred from the upfield shift of the olefinic protons in the  $^1\text{H NMR}$  Spectra after coordination.
- ③ -  $\text{TiCl}_4$  and  $\text{SnCl}_4$  adducts are nonelectrolytes in nitrobenzene solution at room temperature while  $\text{NiSb}_2\text{Cl}_{12}$  complexes are electrolytes.
- ④ - In solution, both  $\text{TiCl}_4$  and  $\text{SnCl}_4$  (2:1) adducts dissociate at room temperature into the corresponding (1:1) adduct and the free ligand as indicated by the chemical shifts for the free ligand, (2:1) and (1:1) adducts.
- ⑤ - In the solid state and with the exception of  $\text{SbCl}_5$  and  $\text{TaCl}_5$  all adducts are volatile at room temperature and only the (2:1) adducts of  $\text{TiCl}_4$  with acrylonitrile and methacrylonitrile show a tendency to dissociate in the vapour into the (1:1) adduct and free ligand.

[6] - Raman and Far IR studies for  $\text{TiCl}_4$  (2:1) and  $\text{TiBr}_4$  adducts suggest a cis-octahedral structure for the first and a trans-structure for the second.

APPENDIX 1

Mössbauer and electrical conductivity data of some ortho- and non-orthometallated antimony compounds.

(i) Mössbauer Spectral Data :

The mössbauer spectra of several antimony compounds described in this thesis have been recorded by Dr. R.V. Parish of UMIST, Manchester. The results obtained are listed in table (A1.1).

The orthometallated compound;  $o\text{-SbCl}_4\text{C}_6\text{H}_4\text{C}(\text{ph}) = \text{NH}$  shows a positive isomer shift ( $\delta$ ) within the range expected for antimony (pentavalent) chloride compounds. The ortho-metallated compound also shows a positive quadrupole coupling constant of about  $10\text{mms}^{-1}$  indicating an excess of negative charge on the z axis of a similar magnitude expected for one carbon atom bonded to antimony pentachloride, pentafluoride... etc. So the mössbauer spectrum is consistent with the structure:

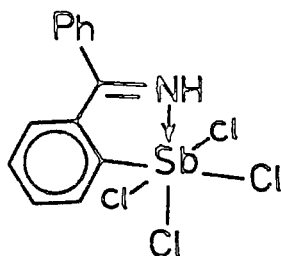

The isomer shift is more positive than its closest analogues  $[\text{phSbCl}_5]^\ominus$ ;  $\delta = 4.06 - 4.47\text{ mms}^{-1}$   $e^2qQ = 11.28 - 12.3\text{ mms}^{-1}$  <sup>(1)</sup>.

However this is expected since the ortho-metallated compound would be neutral, hence a lower electron density than the salts measured by Greenwood <sup>1,2</sup>.

The non-orthometallated compounds which have the general formulae  $R_1R_2CNH_2^{\oplus}SbCl_4^{\ominus}$ ; where  $(R_1R_2) = (ph)_2, (p\text{-tolyl})_2, (P\text{-}FC_6H_4)_2, (m\text{-tolyl}, ph)$ , are characterised by their very large negative isomer shifts indicating that they are all antimony trivalent compounds. The m-tolyl, phenylketiminium compound shows a weak absorption at  $8.4 \text{ mms}^{-1}$ . This indicates some antimony pentavalent oxide type of impurity, e.g. a hydrolysis product of  $SbCl_5$ . The other samples show only one absorption envelope in the antimony trivalent region of the spectrum.

In the iminium compounds.  $ph_2CNH_2^{\oplus}SbCl_4^{\ominus}$  and m-tolyl,  $phCNH_2^{\oplus}SbCl_4^{\ominus}$ , they show similar Mössbauer spectra, typical of a one site antimony in the trivalent oxidation state. The quadrupole coupling constants are all positive as one would expect antimony trivalent compounds to have  $V_{zz}$  axis being in the same direction as the lone pair. The parameters obtained for these two compounds are similar to those previously reported for other  $(SbCl_4^{\ominus})$  salts see table (A1.2). The spectrum for the di-p-tolylketiminium salt, however, at first sight appears to show a large negative quadrupole coupling constant which is very unusual for antimony trivalent compounds, although not known:

$$Na_2SbF_5 \quad e^2qQ = -8.3 \text{ mms}^{-1} \quad \text{Ref. 3}$$

$$Na_2SbF_5 \quad e^2qQ = +15.4 \text{ mms}^{-1} \quad \text{Ref. 4}$$

The reason for the discrepancy between the two reports for  $Na_2SbF_5$  is not known.

However, an attempt to get a good fit for the data obtained for a negative value for  $e^2qQ$  for values of  $\eta$  between 0 and 1 has failed, so the data was fitted to two

sites with positive  $e^2qQ$  which has given a reasonable fit to the data, thus it appears that there could be two unresolved antimony trivalent sites of roughly equal proportions. Site 1 shows similar Mössbauer parameters to those in the other two antimony trivalent compounds, whereas site 2 is quite similar to antimony trichloride, although bearing in mind the variety in structures found in antimony halide chemistry a  $\text{SbCl}_4^\ominus$  structure with two sites is feasible.

In the di-p-Fphenylketiminium salt, it was difficult to obtain a completely satisfactory fit for either a positive or negative quadrupole coupling constant, the peak being almost symmetrical. The best fit was obtained with a large asymmetry parameter, which causes the peak to be more symmetrical. For such a large asymmetry parameter the sign of the quadrupole coupling constant obtained from the spectrum becomes meaningless, since a positive  $e^2qQ$ , and a negative  $e^2qQ$  will both give very similar spectra for large values of the asymmetry parameter. By analogy with the other para-substituted phenyl compound, this one might have two antimony trivalent sites, which could give rise to such a spectrum.

Thus all the compounds of the iminium salts definitely contain  $\text{Sb}^{\text{III}}$  and from the analyses, a formula  $\text{Ar}_2\text{CNH}_2^\oplus\text{SbCl}_4^\ominus$  seems feasible.

TABLE (A1.1)

Mössbauer parameters for some ortho and non-orthometallated compounds of ketimino antimony chlorides.

Compound	Site 1					Site 2			
	$\delta/\text{mms}^{-1}$	$e2qQ/\text{mms}^{-1}$	$\Gamma/\text{mms}^{-1}$	Normalised Chi	$\eta$	$\delta/\text{mms}^{-1}$	$e2qQ/\text{mms}^{-1}$	$\Gamma/\text{mms}^{-1}$	Area ratio Site 1/Site 2
$2\text{-}^{57}\text{SbCl}_4\text{C}_6\text{H}_4\text{C}(\text{ph})=\text{NH}$	+5.29	9.55	2.2	1.15	-				
$\text{ph}_2\text{CNH}_2^{\oplus}\text{SbCl}_4^{\ominus}$	-8.11	+9.6	2.49	0.90	-				
$(\text{p-tolyl})_2\text{CNH}_2^{\oplus}\text{SbCl}_4^{\ominus}$	-7.99	+9.55	2.67	1.26	-	+8.41	-	3.06	6.07
$(\text{p-FC}_6\text{H}_4)_2\text{CNH}_2^{\oplus}\text{SbCl}_4^{\ominus}$	-7.79	+7.8	2.44	1.11	-	-5.3	+12.0	2.23	1.18
$(\text{m-tolyl,ph})_2\text{CNH}_2^{\oplus}\text{SbCl}_4^{\ominus}$	-7.16	+9.5	2.52	1.04	0.99				

Table (A1.2)

Mössbauer parameters for various antimony trivalent chloride complexes

Compound	$\delta/\text{mms}^{-1}$	$e^2qQ/\text{mm}^{-1}$	$\Gamma/\text{mm}^{-1}$	Ref.
$\text{CO}(\text{NH}_3)_5\text{SbCl}_6$	-11.2	-	3.1	5
	-20.2	+6.8	3.7	6
$\text{K}_3\text{SbCl}_6$	- 9.7	-	3.5	5
$\text{Cs}_3\text{SbCl}_6$	- 9.6	-	3.6	5
$(\text{NH}_4)_3\text{SbCl}_6$	- 8.7	-	4.3	5
$(\text{NH}_4)_2\text{SbCl}_5$	- 6.52	+11.2	2.9	7
$\text{Et}_4\text{NSbCl}_4$	- 8.17	+ 8.9		8
	- 7.47	+10.6		3
$\text{pyHSbCl}_4$	- 8.1	+11.3		8
	- 7.98	+ 9.1		3
$\text{SbCl}_3$	- 5.9	13.9		9
$\text{SbCl}_3 \cdot \text{aniline}$	- 6.3	12.0		9
$\text{SbCl}_3 \cdot \text{ph}_2\text{CO}$	- 5.8	14.0		9

(ii) Electrical Conductivity data :

The conductances of six nitromethane solutions each of the orthometallated compound :  $\text{o-SbCl}_4\text{C}_6\text{H}_4\text{C}(\text{ph}) = \text{NH}$  and the ketiminium salt  $\text{ph}_2\text{CNH}_2\text{SbCl}_4$ , concentrations of between  $0.3 \times 10^{-3}$  and  $8 \times 10^{-3}$  mol.  $\text{dm}^{-3}$  were measured in a cell fitted with platinum electrodes, using a "Cambridge Instruments Conductivity bridge". The molar conductivities of the solutions were then plotted against the root of the solution concentration. The results of the orthometallated compound gave molar conductivities of between 12 and 13  $\text{s.cm}^2.\text{mol}^{-1}$  with no significant change with increasing concentrations indicating a non-electrolyte. The results for the iminium salt gave a good straight line for the plot with  $\Lambda_o$  value of  $81.4 \text{ s.cm}^2.\text{mol}^{-1}$  and a slope of  $-279$  ( $\Lambda_m$  at  $10^{-3}$  mol.  $\text{dm}^{-3}$  =  $71.6 \text{ s.cm}^2.\text{mol}^{-1}$ -interpolation). This indicates that this compound is a (1:1) electrolyte.

Results : Cell constant =  $0.2109 \text{ cm}^{-1}$

- for  $\text{o-SbCl}_4\text{C}_6\text{H}_4\text{C}(\text{ph}) = \text{NH}$  Compound (Fig.A1)

Solution No.	CONC $\times 10^2$ mol. $\text{dm}^{-3}$	conductance $\times 10^4$ s	molar conductivities $\text{s.cm}^2.\text{mol}^{-1}$	Conc. <sup>1/2</sup> mol <sup>1/2</sup> $\text{dm}^{-3/2}$
2	0.1271	0.77	12.78	0.0356
3	0.07625	0.45	12.44	0.0276
4	0.2542	1.57	13.02	0.0504
5	0.3813	2.33	12.87	0.0617
6	0.5083	3.13	12.98	0.0713
7	0.6354	3.8	12.61	0.0797

- for  $\text{ph}_2\text{CNH}_2\text{SbCl}_4$  compound (Fig.A2)

1	0.8416	22.35	55.99	0.0917
2	0.505	14.85	62.01	0.0711
3	0.303	9.35	65.07	0.0550
4	0.1818	5.95	69.01	0.0426
5	0.1091	3.75	72.49	0.0330
6	0.0545	1.95	75.39	0.0234

APPENDIX 2

Infrared Spectra

- Fig. 2.1 IR Spectrum for  $2\text{-}\overline{\text{SbCl}_4\text{C}_6\text{H}_4\text{C}(\text{ph}) = \text{NH}}$
- Fig. 2.2 IR Spectrum for  $2\text{-}\overline{\text{SbCl}_4\text{-4-MeC}_6\text{H}_3\text{C}(\text{p-tolyl}) = \text{NH}}$
- Fig. 2.3 IR Spectrum for  $2\text{-}\overline{\text{SbCl}_2\text{-C}_6\text{H}_4\text{C}(\text{ph}) = \text{NH}}$  phMe
- Fig. 2.5 IR Spectrum for  $\text{ph}_2\text{CNH}_2^{\oplus}\text{SbCl}_4^{\ominus}$
- Fig. 2.6 IR Spectrum for  $(\text{p-tolyl})_2\text{CNH}_2^{\oplus}\text{SbCl}_4^{\ominus}$
- Fig. 2.7 IR Spectrum for  $\text{o-tolyl, phCNH}_2^{\oplus}\text{SbCl}_4^{\ominus}$
- Fig. 2.8 IR Spectrum for  $\text{m-tolyl, phCNH}_2^{\oplus}\text{SbCl}_4^{\ominus}$
- Fig. 2.9 IR Spectrum for  $(\text{P-F C}_6\text{H}_4)_2\text{CNH}_2^{\oplus}\text{SbCl}_4^{\ominus}$
- Fig. 2.15 IR Spectrum for  $(\text{Bu}^t, 2\text{-Cl-4-MeC}_6\text{H}_3\text{.CNH}_2)^{\oplus}_2(\text{SbCl}_5)^{2\ominus}$
- Fig. 2.16 IR Spectrum for  $(\text{Bu}^t, \text{o-tolyl C=N-C(o-tolyl) = NH}_2)^{\oplus}\text{SbCl}_6^{\ominus}$
- Fig. 2.17 IR Spectrum for the oil product resulted from the reaction of  $\text{Bu}^t, \text{o-tolyl CNLi}$  with  $\text{SbCl}_5$ .
- Fig. 3.1 IR Spectrum for  $\text{ph}_2\text{CNH}_2^{\oplus}\text{SbCl}_6^{\ominus}$
- Fig. 3.3 IR Spectrum for  $(\text{ph}_2\text{CNH}_2)^{\oplus}_2\text{SbCl}_5^{2\ominus}$
- Fig. 4.1 IR Spectrum for  $\text{SnCl}_3\text{-CH}_2\text{CH}_2\text{CN}$

Fig. 4.6 IR Spectrum for

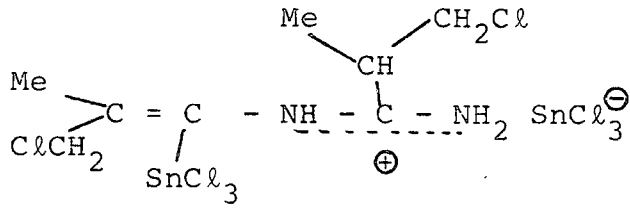

Fig. 4.8 IR Spectrum for

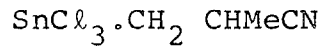
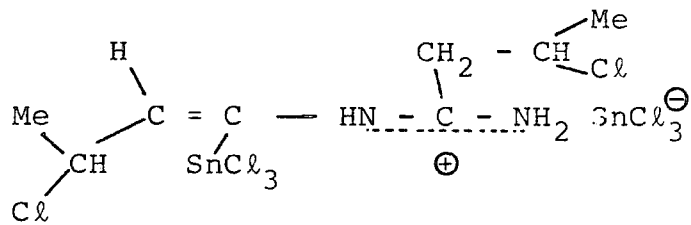
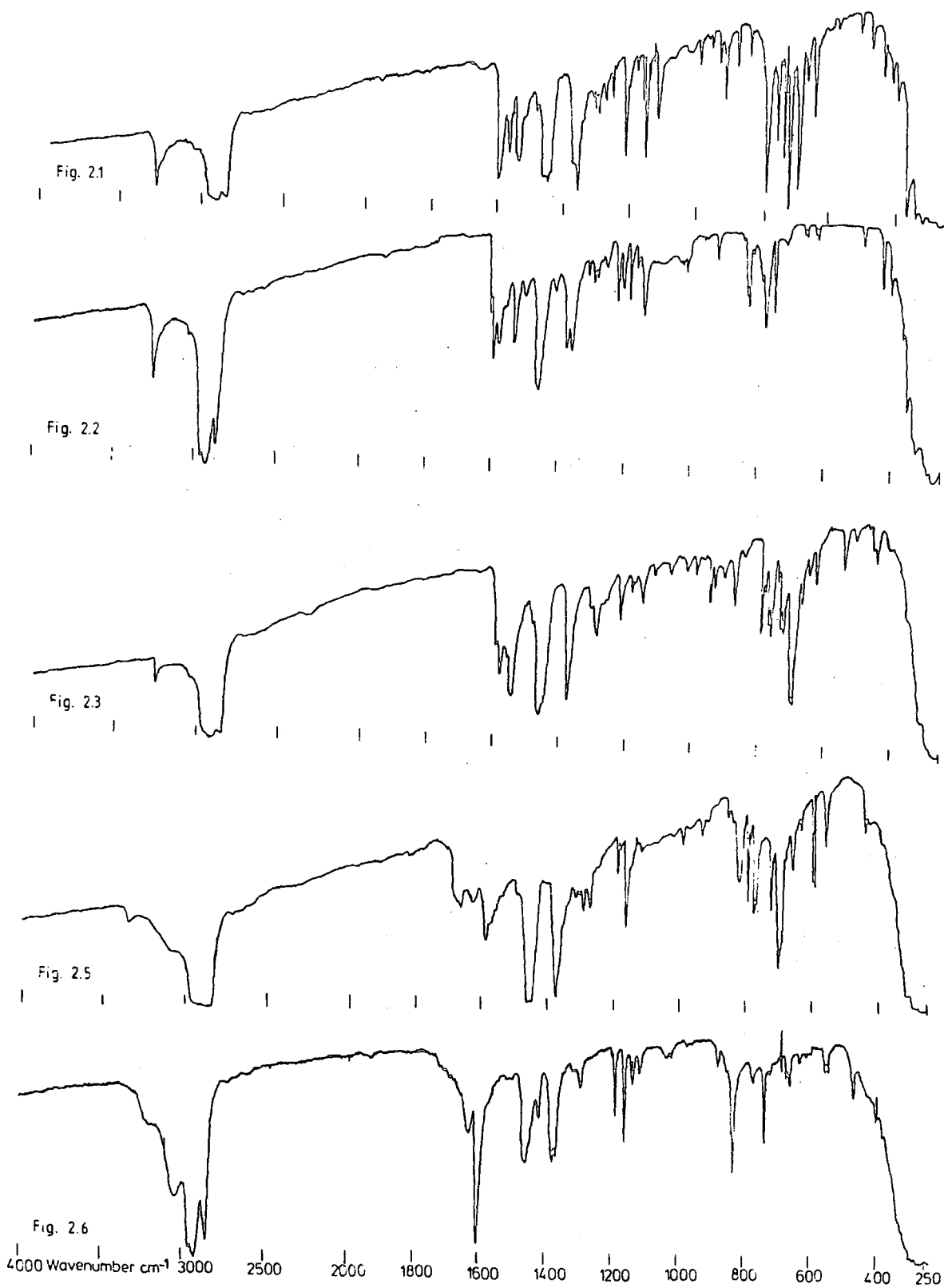
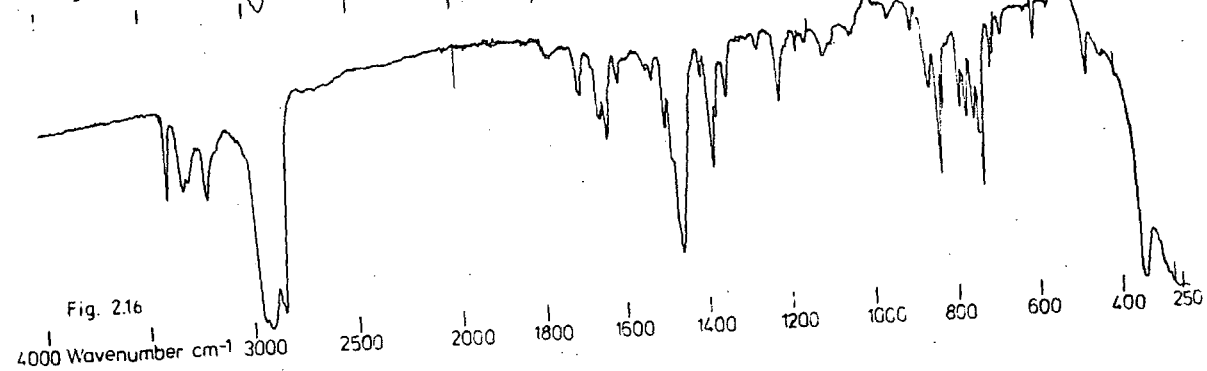
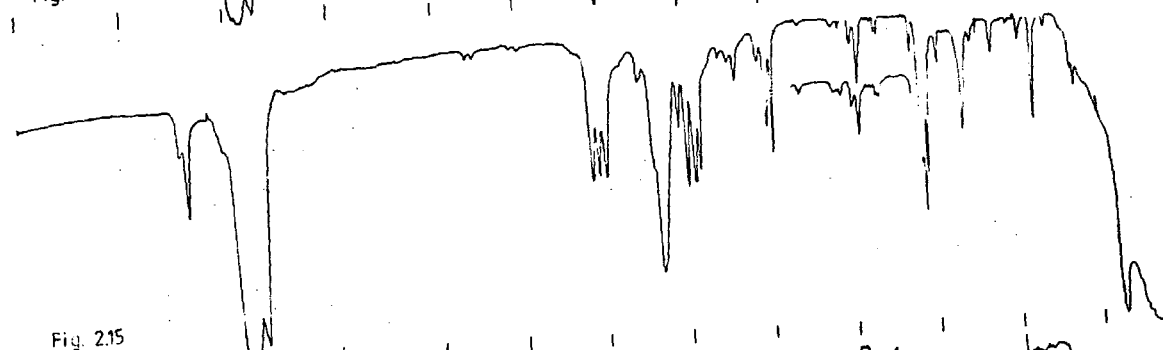
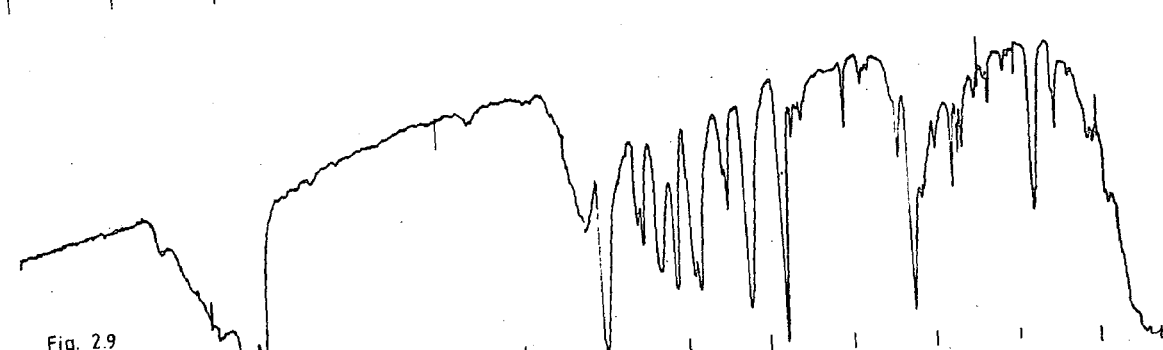
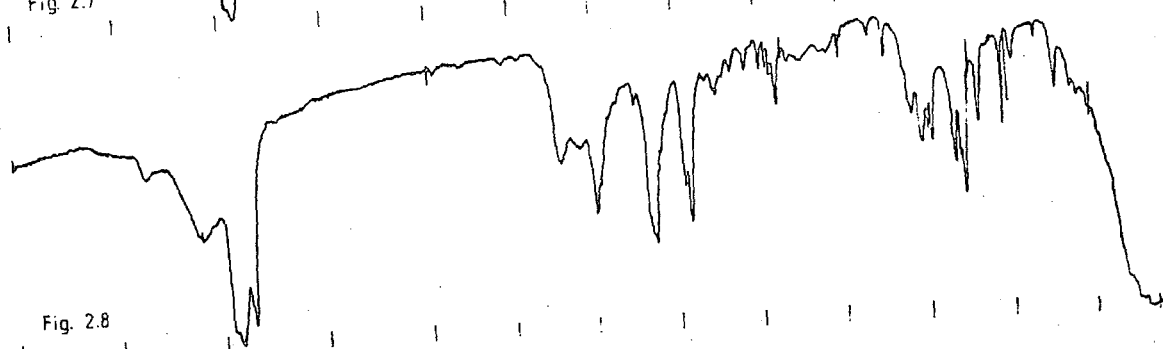
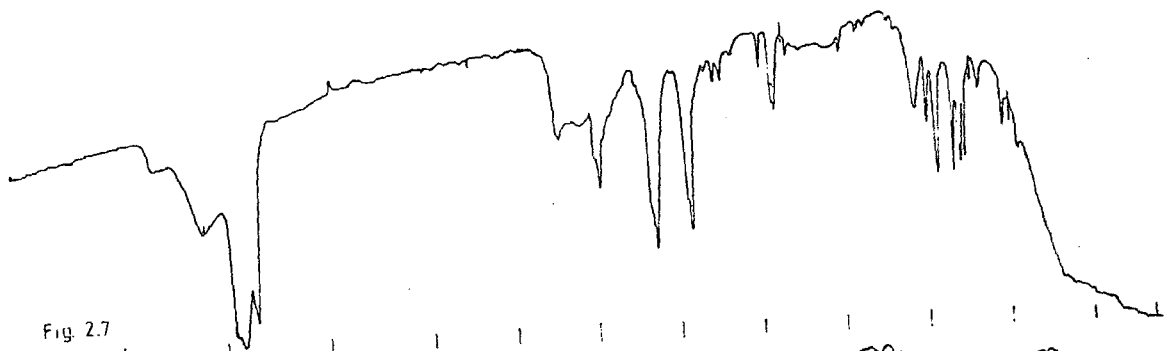

Fig. 4.14 IR Spectrum for







4000 Wavenumber cm<sup>-1</sup> 3000 2500 2000 1800 1500 1400 1200 1000 800 600 400 250

Fig. 2.17

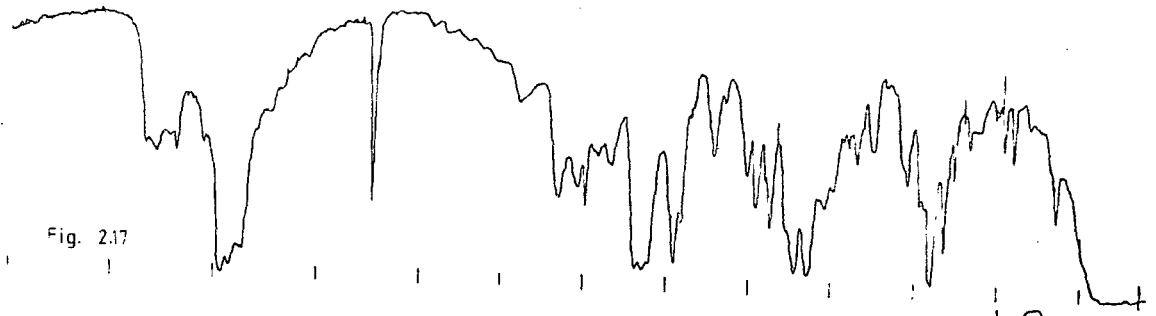

Fig. 3.1

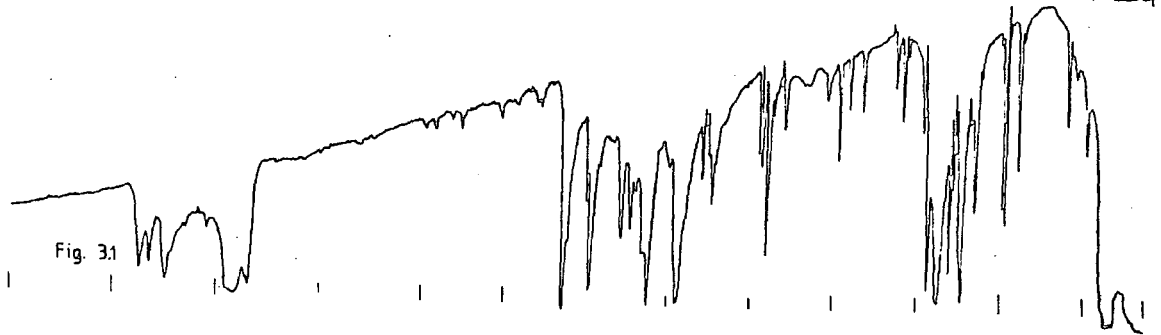

Fig. 3.3

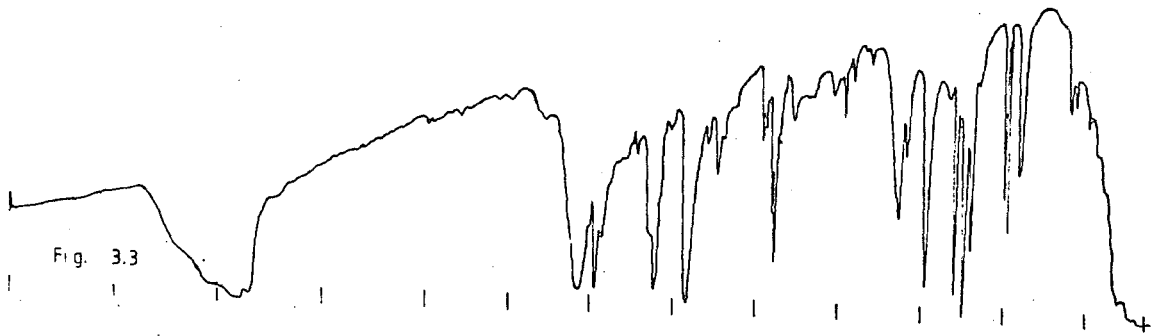

Fig. 4.1

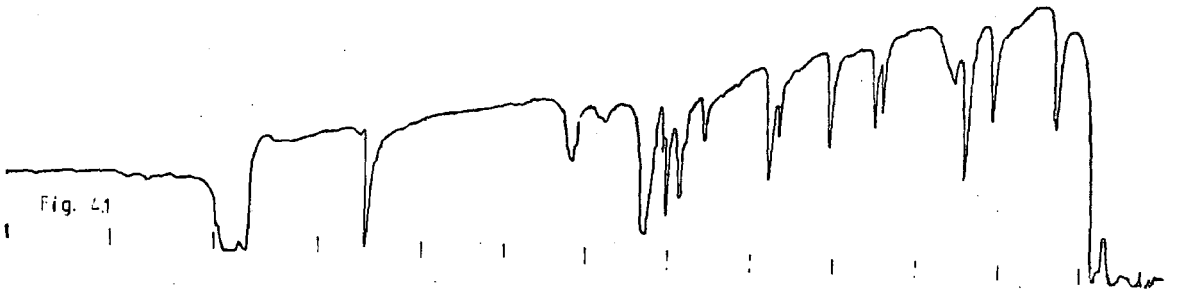
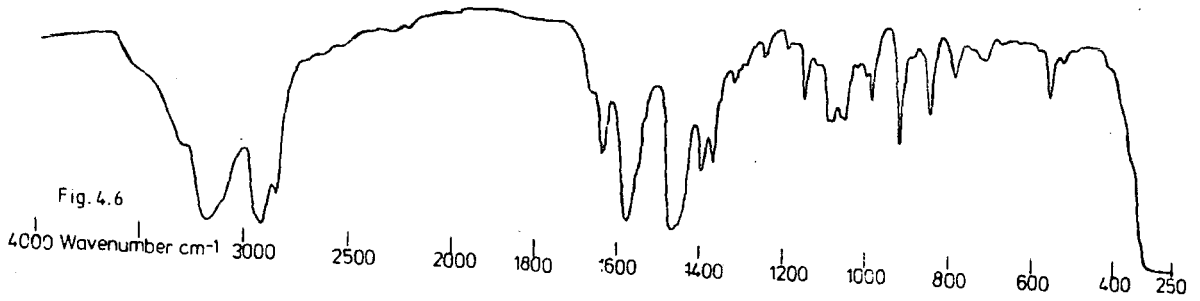

Fig. 4.6



4000 Wavenumber cm<sup>-1</sup> 3000 2500 2000 1800 1600 1400 1200 1000 800 600 400 250

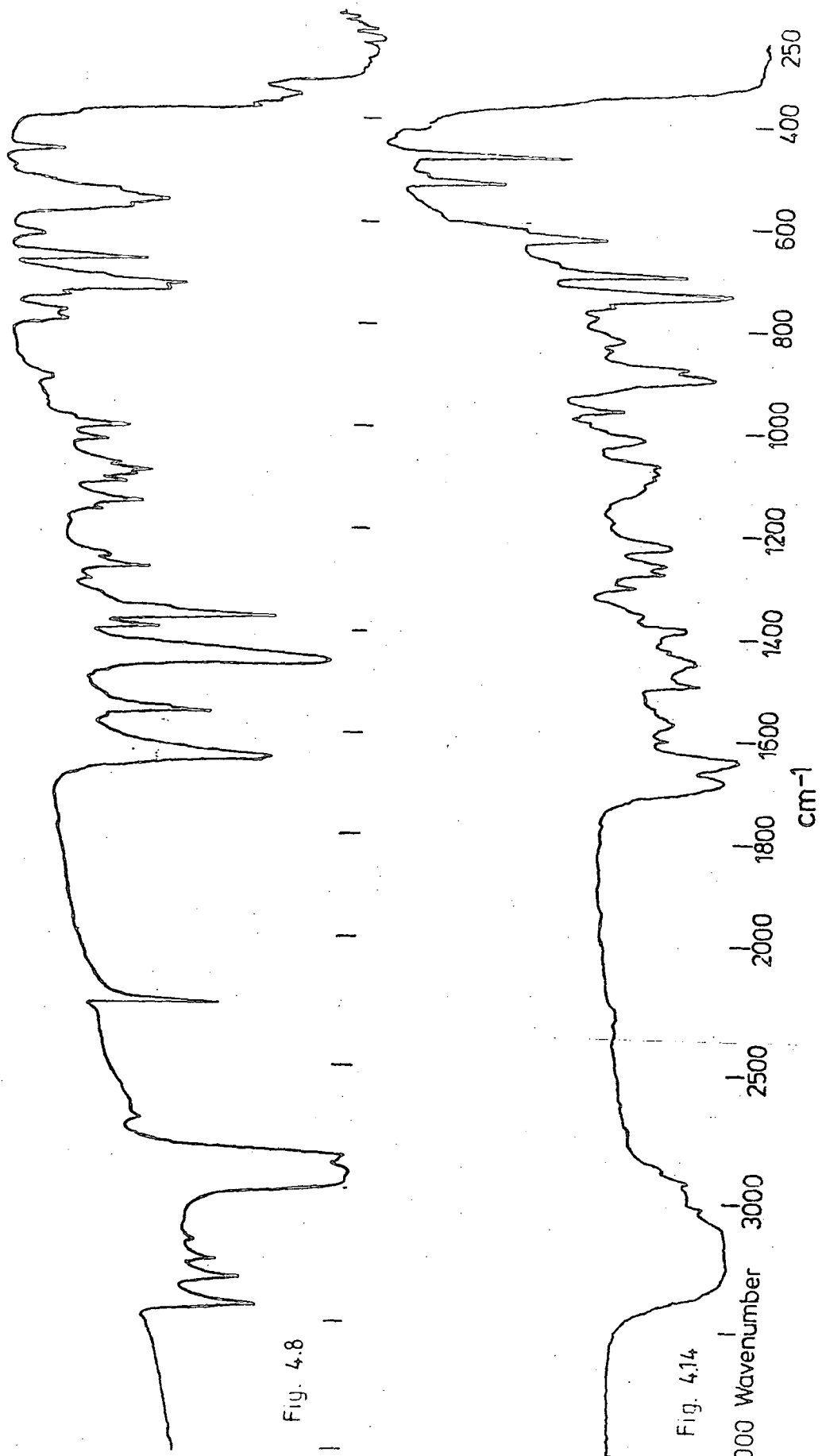

Fig. 4.8

Fig. 4.14

4000 Wavenumber 3000 2500 2000 1800 1500 1400 1200 1000 800 600 250  $\text{cm}^{-1}$

APPENDIX 3

Nuclear Magnetic Resonance Spectra

- Fig. 2.4a  $^1\text{H}$ NMR Spectrum for  $2\text{-SbCl}_4\text{C}_6\text{H}_4\text{C}(\text{ph}) = \text{NH}$
- Fig. 2.4b  $^1\text{H}$ NMR Spectrum for  $2\text{-SbCl}_2\text{C}_6\text{H}_4\text{C}(\text{ph}) = \text{NH}$
- Fig. 2.10  $^1\text{H}$ NMR Spectrum for  $\text{ph}_2\text{CNH}_2^{\oplus} \text{SbCl}_4^{\ominus}$
- Fig. 2.11  $^1\text{H}$ NMR Spectrum for  $(\text{p-tolyl})_2\text{CNH}_2^{\oplus} \text{SbCl}_4^{\ominus}$
- Fig. 2.12  $^1\text{H}$ NMR Spectrum for  $\text{m-tolyl}, \text{phCNH}_2^{\oplus} \text{SbCl}_4^{\ominus}$
- Fig. 2.13  $^1\text{H}$ NMR Spectrum for  $(\text{p-FC}_6\text{H}_4)_2\text{CNH}_2^{\oplus} \text{SbCl}_4^{\ominus}$
- Fig. 2.14  $^{13}\text{C}$  NMR Spectrum for  $\text{ph}_2\text{CNH}_2^{\oplus} \text{SbCl}_4^{\ominus}$
- Fig. 3.2  $^1\text{H}$ NMR Spectrum for  $\text{ph}_2\text{CNH}_2^{\oplus} \text{SbCl}_6^{\ominus}$
- Fig. 3.4  $^1\text{H}$ NMR Spectrum for  $(\text{ph}_2\text{CNH}_2^{\oplus})_2 \text{SbCl}_5^{2\ominus}$
- Fig. 4.4  $^1\text{H}$ NMR Spectrum for
- $\text{SnCl}_3\text{CH}_2\text{CH}_2\text{CN}$
- Fig. 4.5  $^{13}\text{C}$  NMR Spectrum for
- $\text{SnCl}_3\text{CH}_2\text{CH}_2\text{CN}$
- Fig. 4.7  $^1\text{H}$ NMR Spectrum for

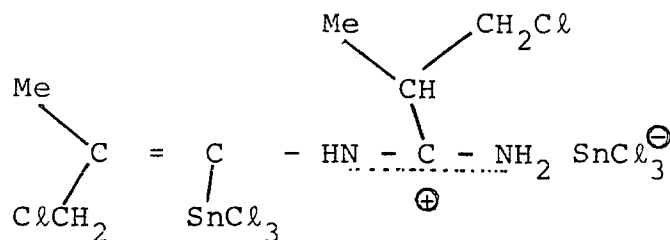

- Fig. 4.11  $^{13}\text{C}$ NMR Spectrum for
- $\text{SnCl}_3\text{CH}_2\text{CHMeCN}$
- Fig. 4.12  $^1\text{H}$ NMR Spectrum for
- $\text{SnCl}_3\text{CH}_2\text{CHMeCN}$
- (in  $d^6$  - DMSO)

Fig. 4.13  $^1\text{H}$ NMR Spectrum for  
 $\text{SnCl}_3\text{CH}_2\text{CHMeCN}$   
(in  $\text{D}_2\text{O}$ )

Fig. 4.15  $^1\text{H}$ NMR Spectrum for

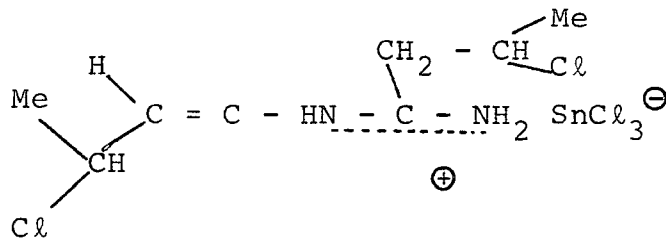

Fig. 2.10

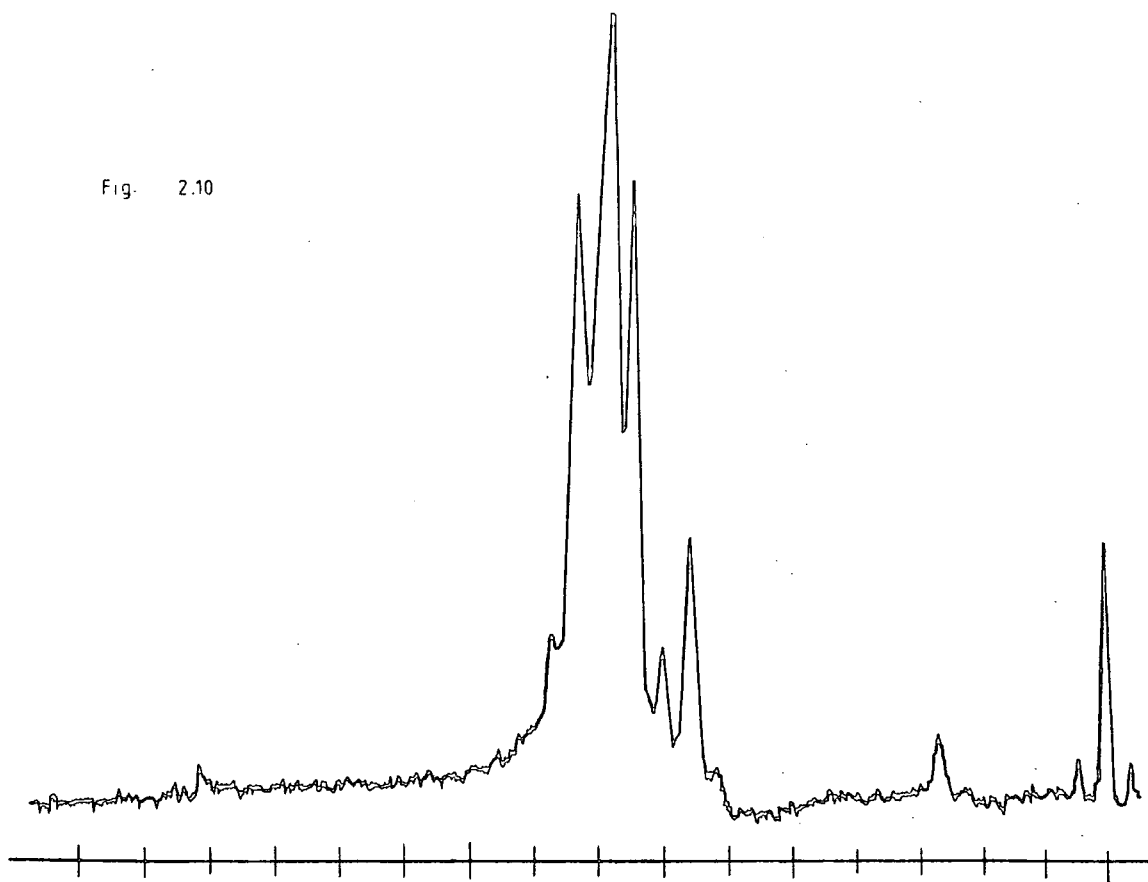

Fig. 2.4 a

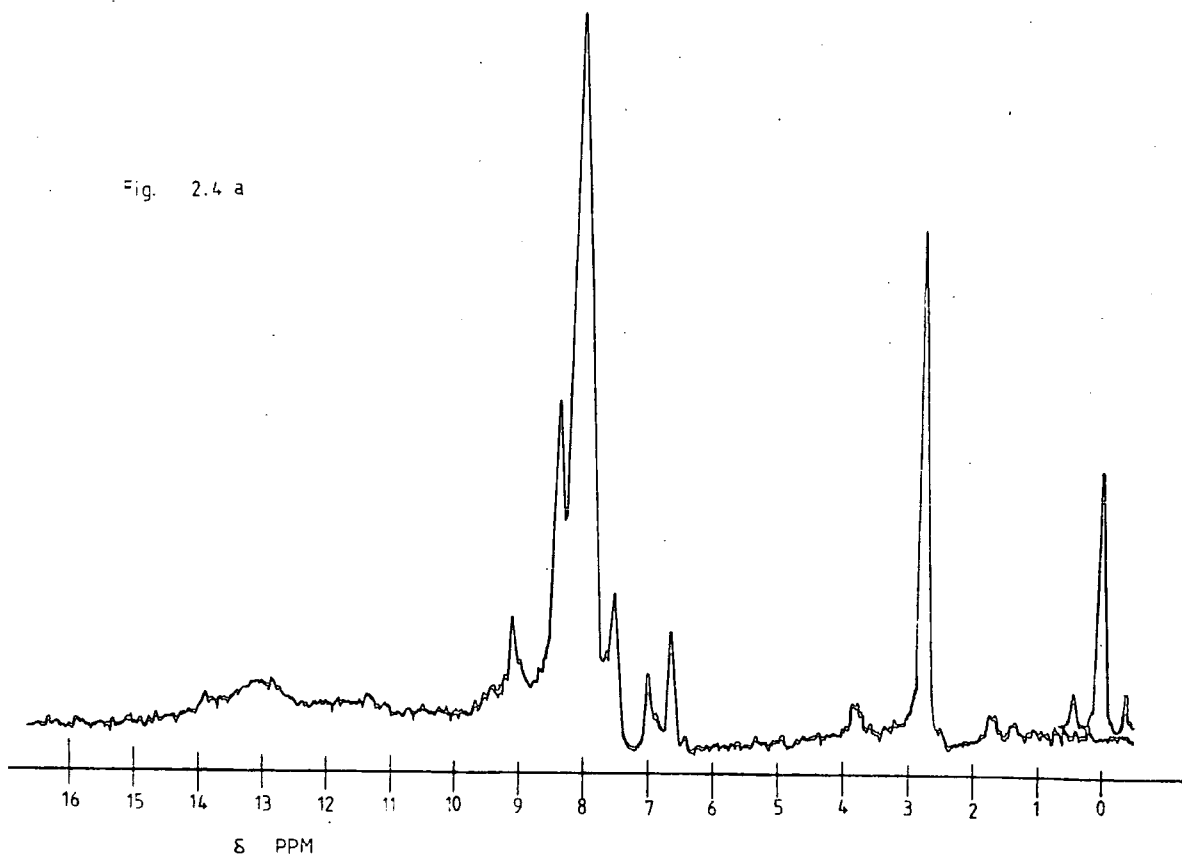

Fig. 2.4 b

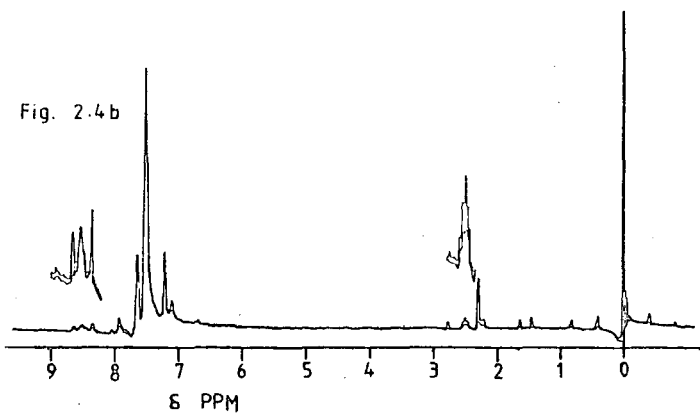

Fig. 2.14

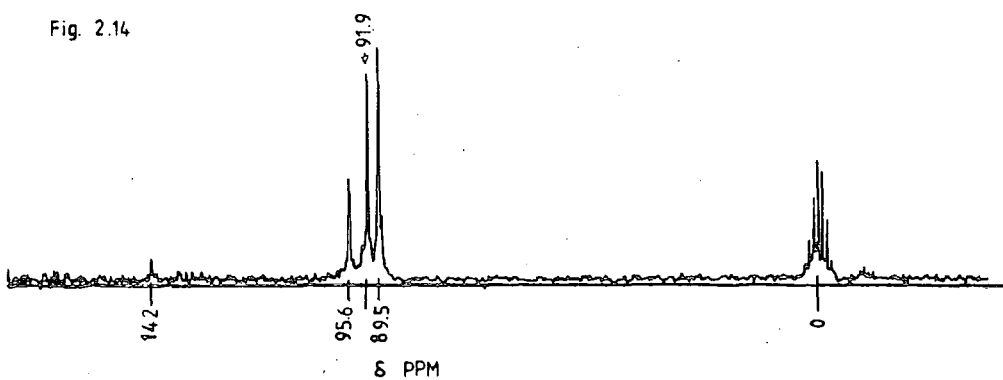

Fig. 4.5

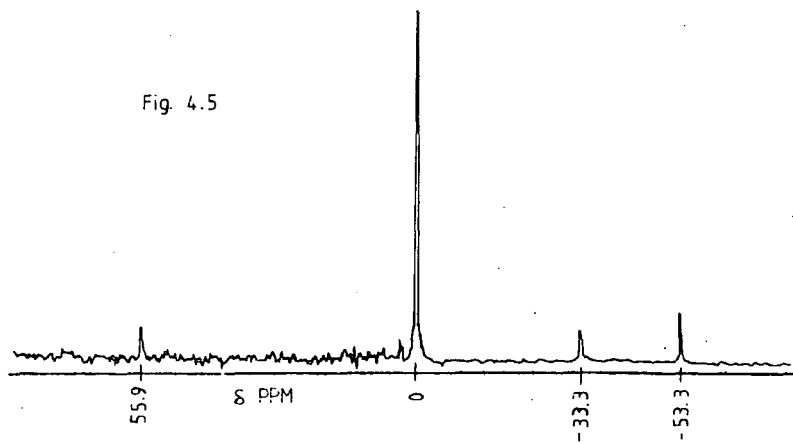

Fig. 4.11

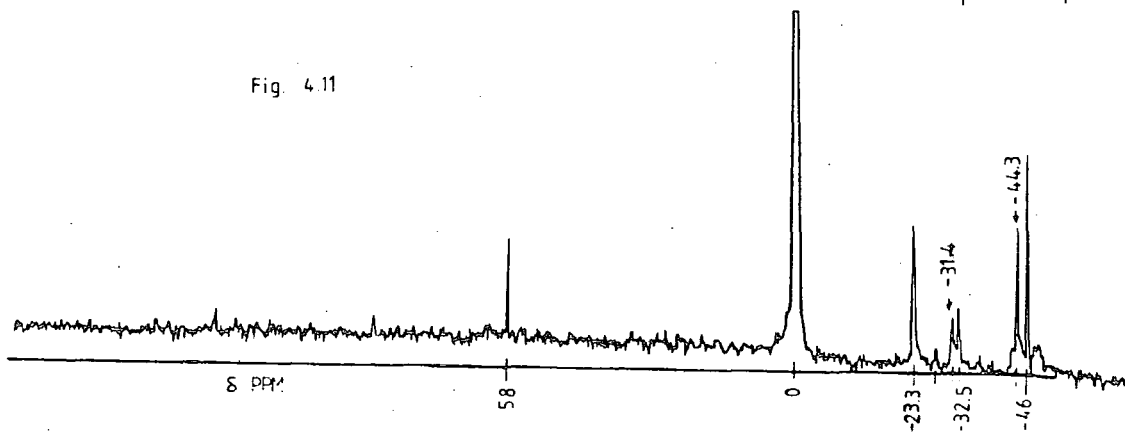

Fig. 2.11

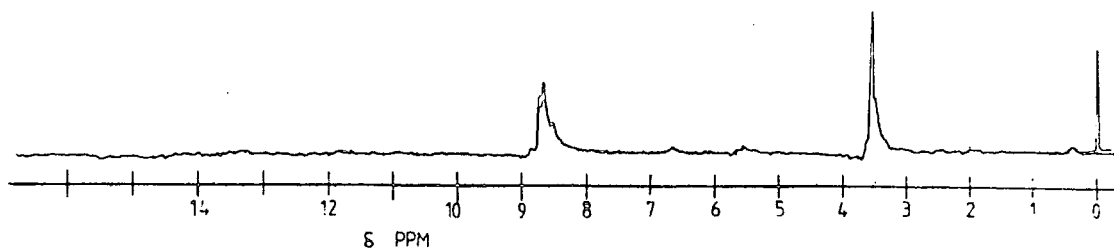

Fig. 2.12

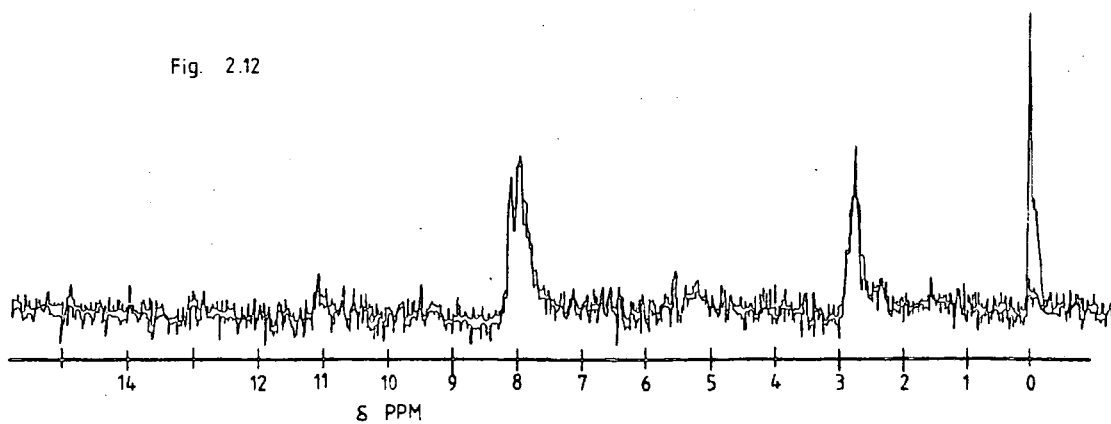

Fig. 2.13

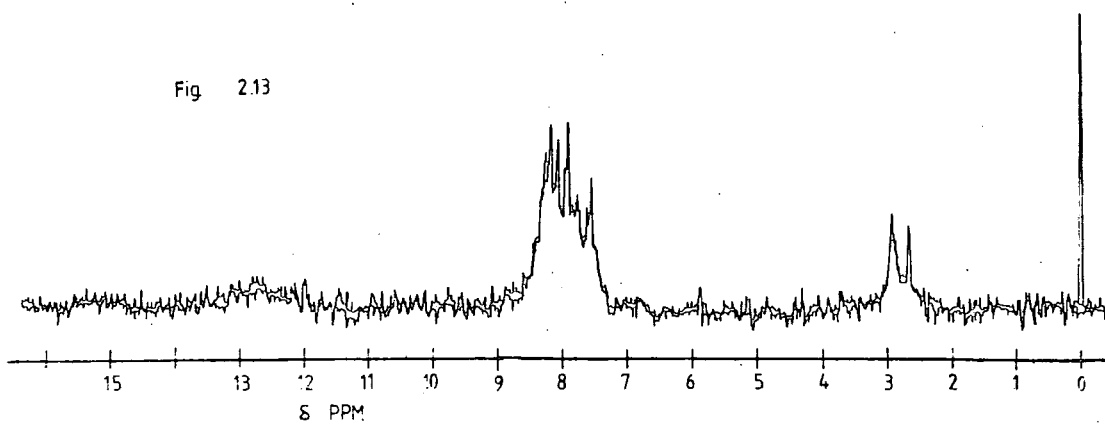

Fig. 3.2

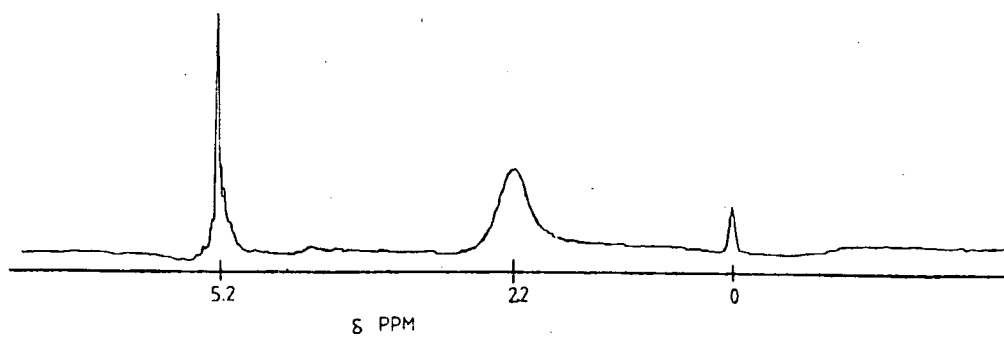

Fig. 4.15

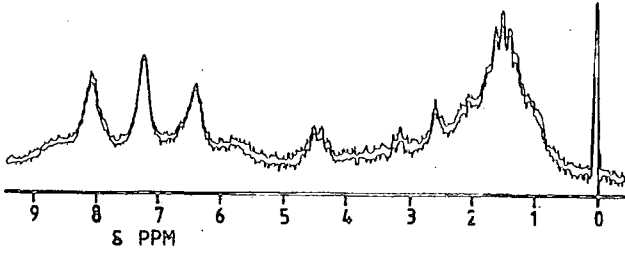

Fig. 6.7

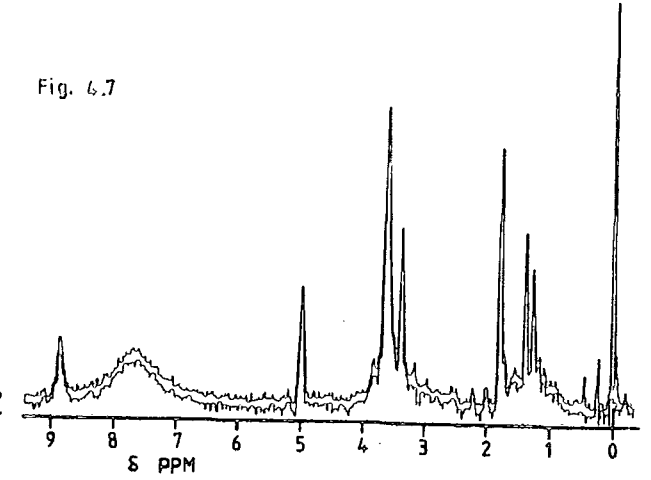

Fig. 4.13

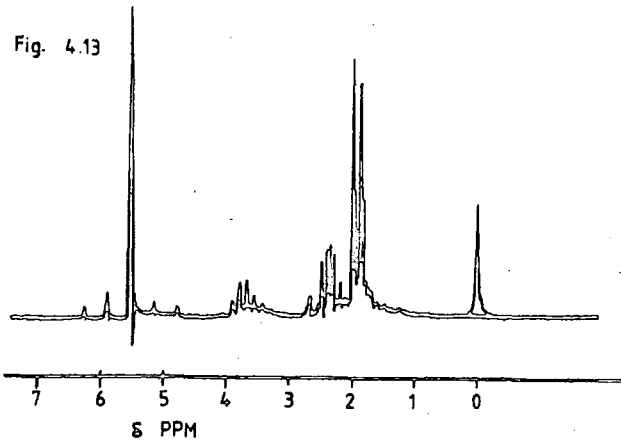

Fig. 4.12

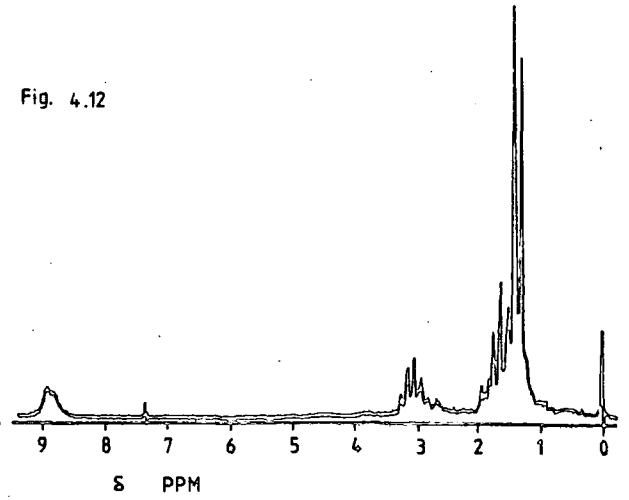

Fig. 3.4

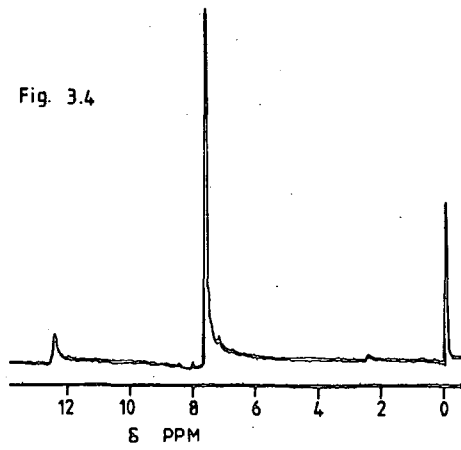
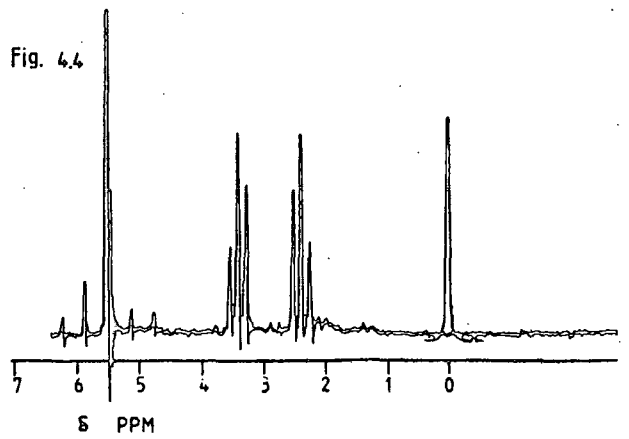

Fig. 4.4



APPENDIX 4

Far Infrared and Raman Spectra

- Fig. 4.2 Far IR Spectrum for  
 $\text{SnCl}_3\text{CH}_2\text{CH}_2\text{CN}$
- Fig. 4.3 Raman Spectrum for  
 $\text{SnCl}_3\text{CH}_2\text{CH}_2\text{CN}$
- Fig. 4.9 Far IR Spectrum for  
 $\text{SnCl}_3\text{CH}_2\text{CHMeCN}$
- Fig. 4.10 Raman Spectrum for  
 $\text{SnCl}_3\text{CH}_2\text{CHMeCN}$
- Fig. 5.2 Far IR Spectrum for  
 $\text{TiCl}_4 \cdot 2\text{NCCMeCH}_2$
- Fig. 5.3 Far IR Spectrum for  
 $\text{TiBr}_4 \cdot 2\text{NCCMeCH}_2$
- Fig. 5.4 Far IR Spectrum for  
 $\text{TiCl}_4 \cdot 2\text{NCCHCHMe}$
- Fig. 5.5 Raman Spectrum for  
 $\text{TiCl}_4 \cdot 2\text{NCCMeCH}_2$
- Fig. 5.6 Raman Spectrum for  
 $\text{TiCl}_4 \cdot 2\text{NCCHCHMe}$
- Fig. 5.7 Raman Spectrum for  
 $\text{TiBr}_4 \cdot 2\text{NCCMeCH}_2$

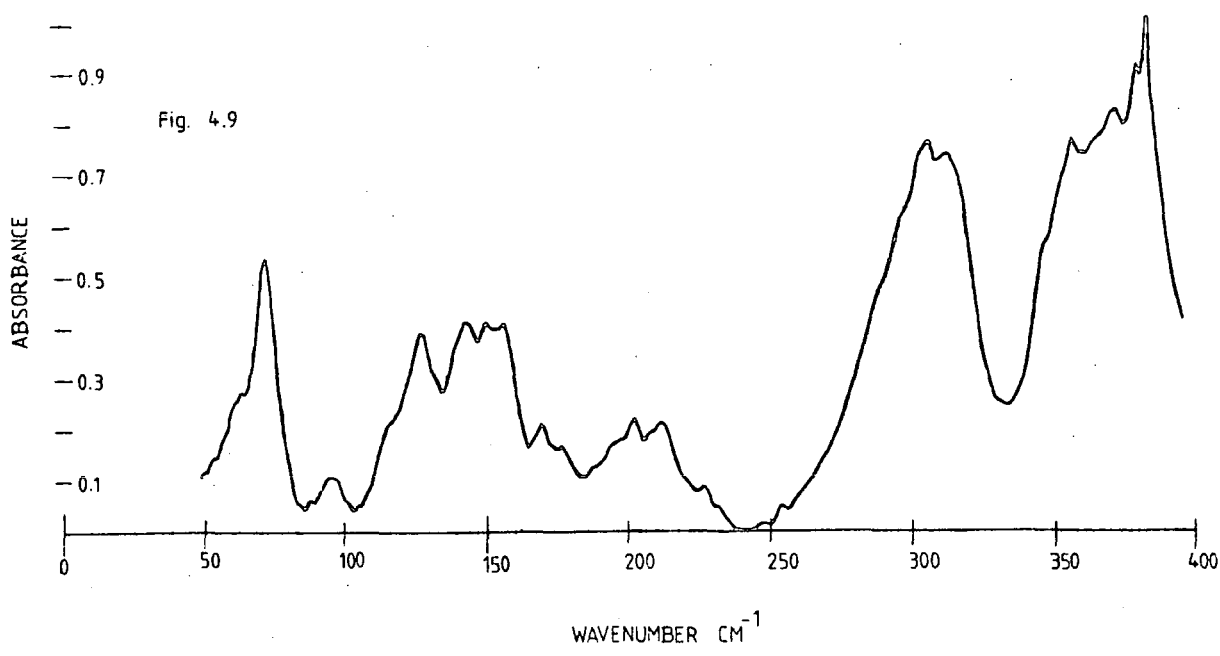
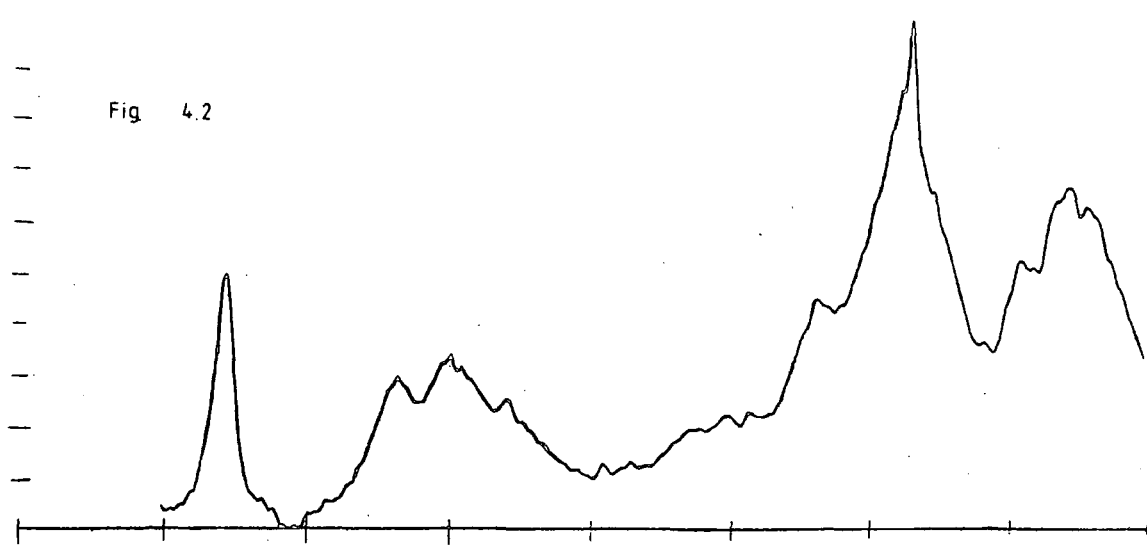

Fig. 4.3

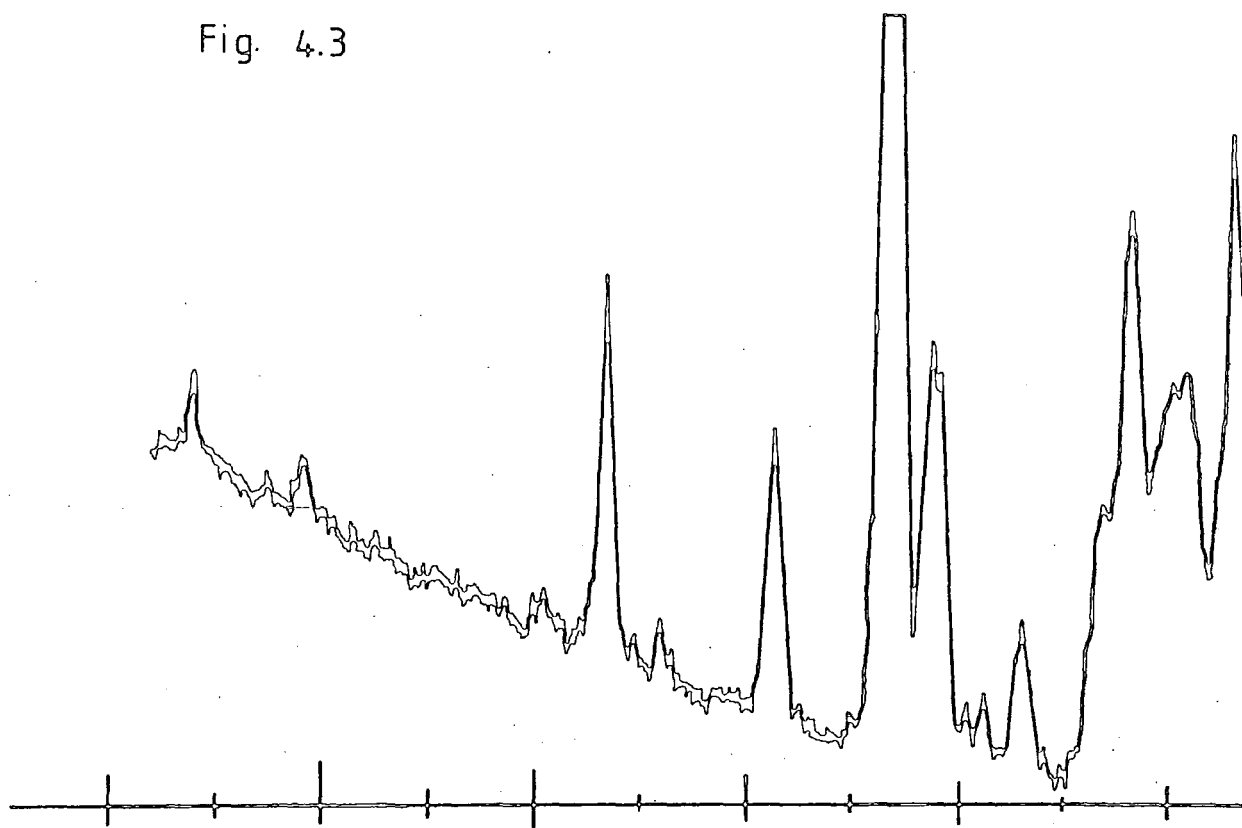
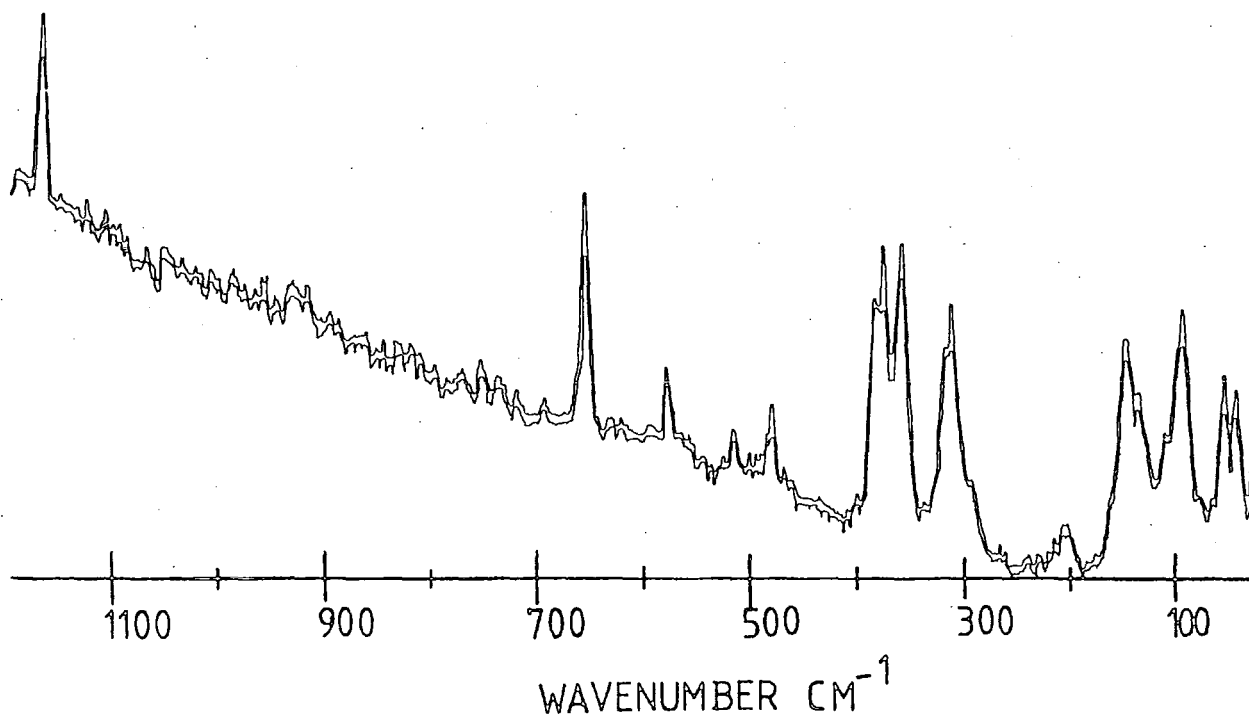

Fig. 4.10



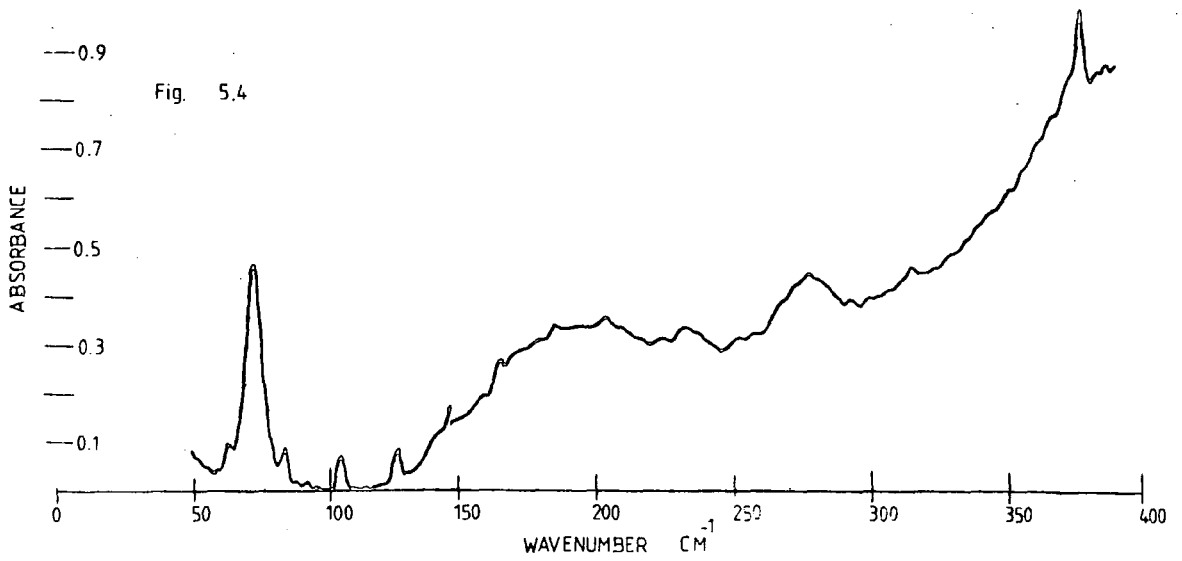
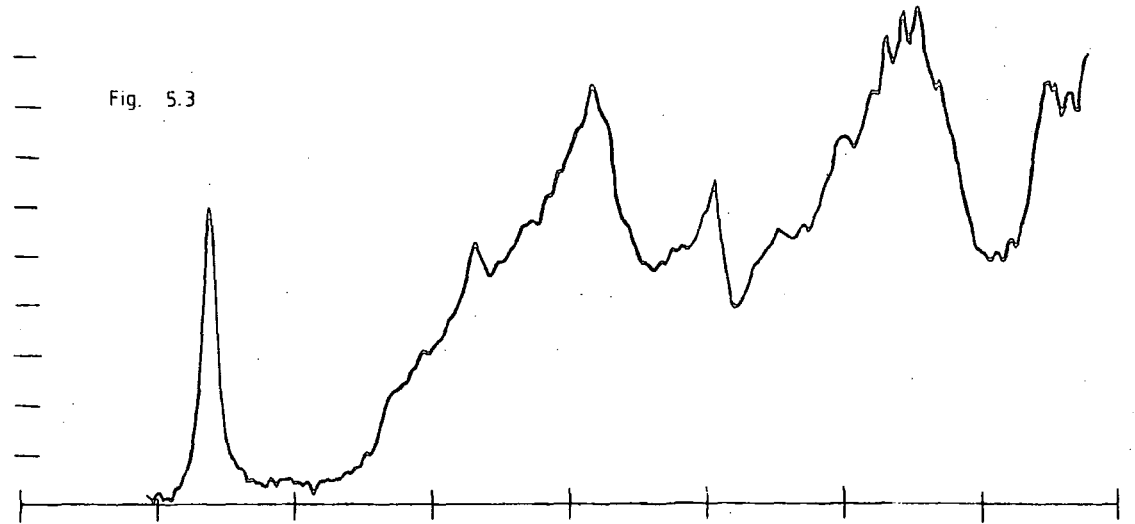
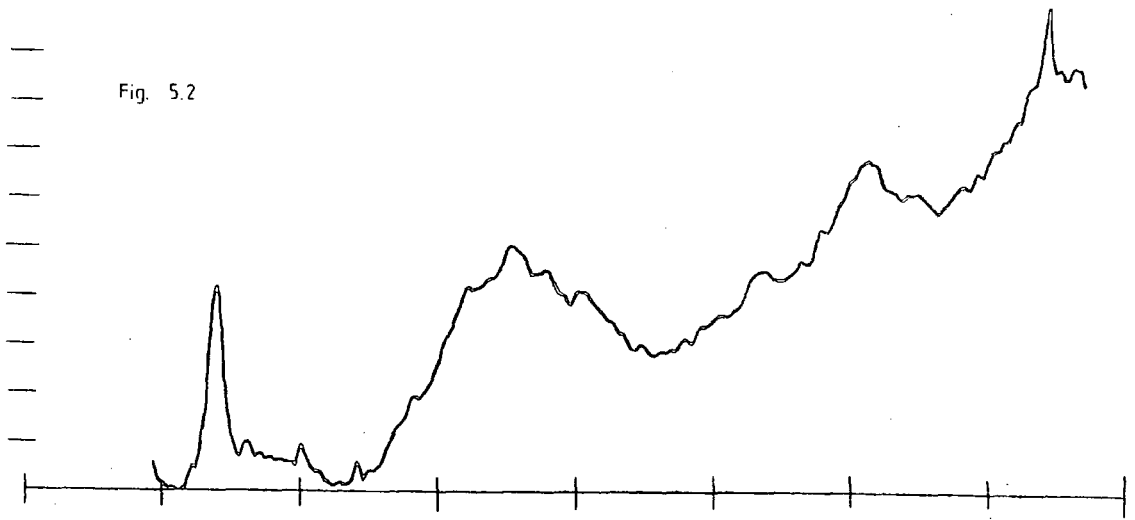

Fig. 5.5

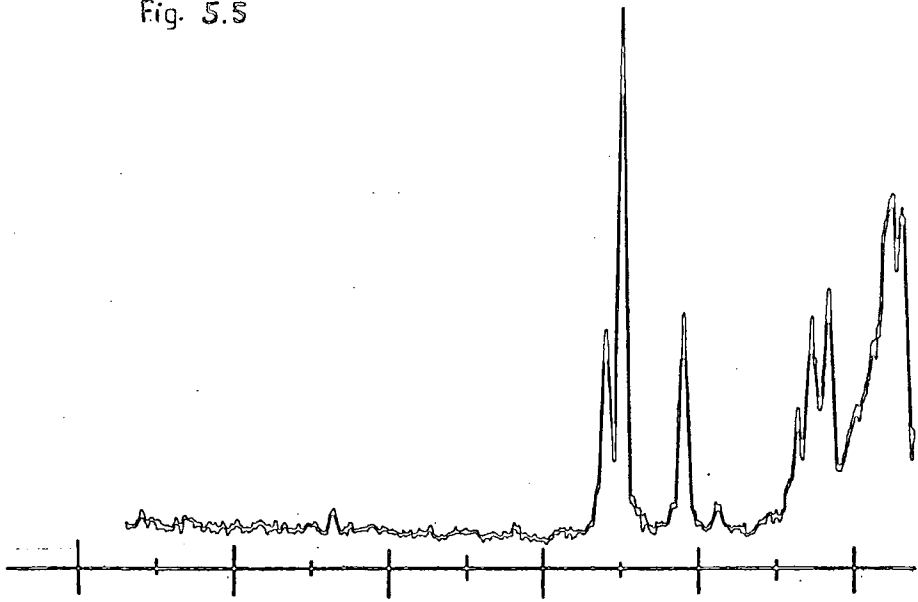

Fig. 5.6

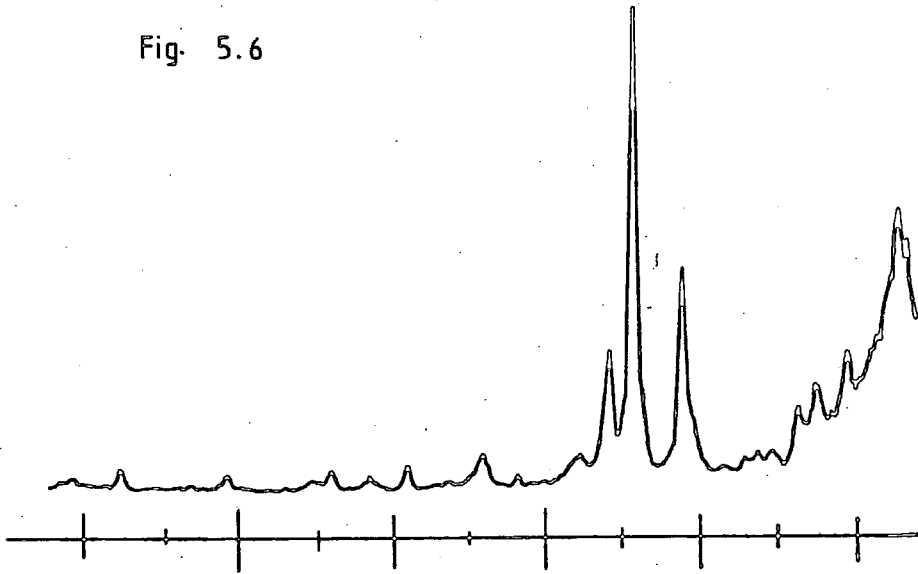
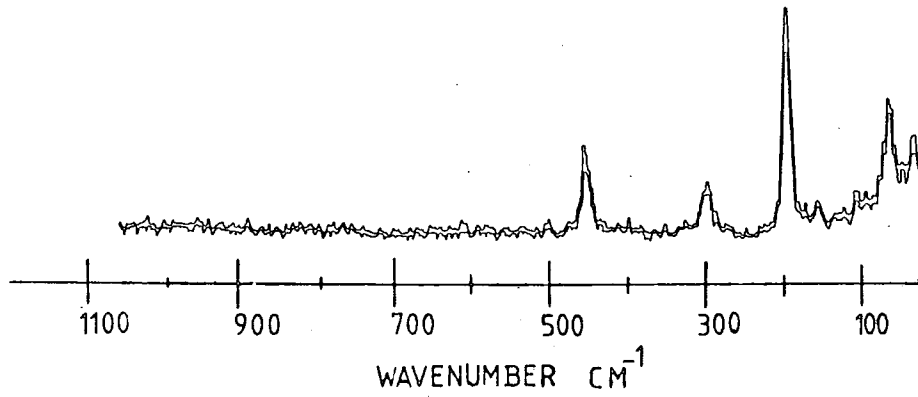

Fig. 5.7



APPENDIX 5

Electrical Conductivity Measurements Graphs

Fig. 5.1 Graph of molar conductance vs. concentration for

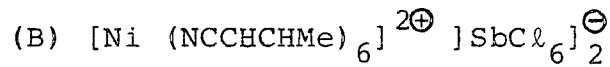
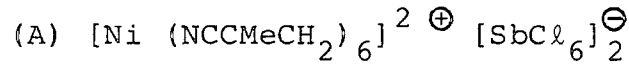

Fig. A1 Graph of molar conductance vs. concentration<sup>1/2</sup>

for

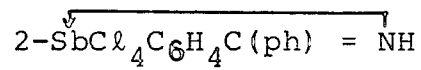
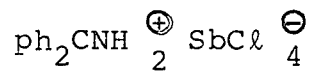
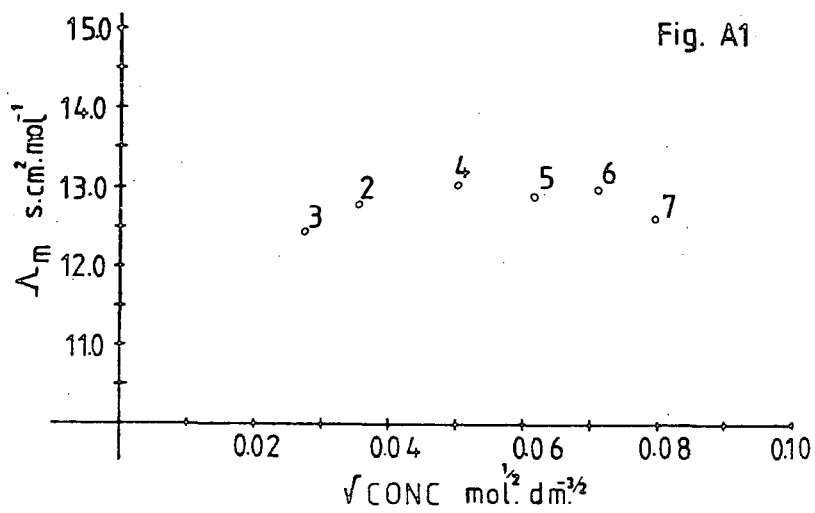
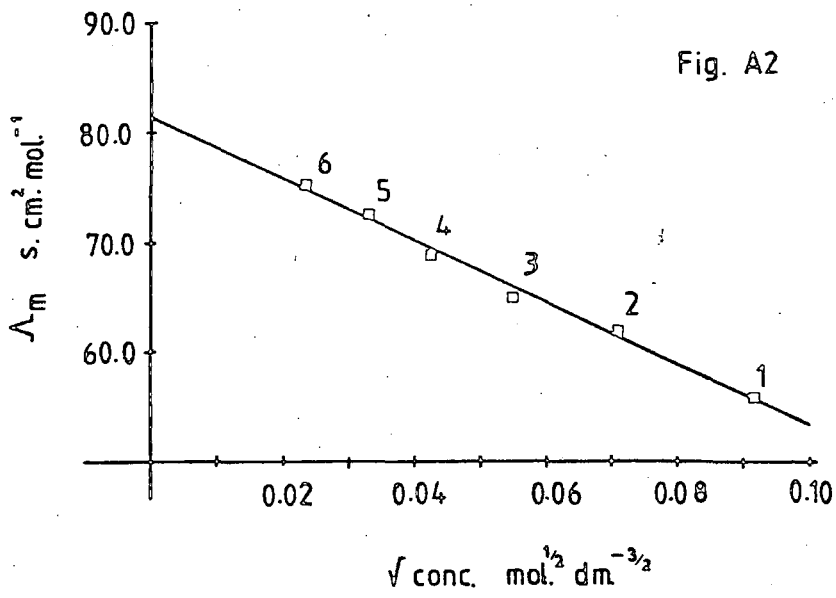
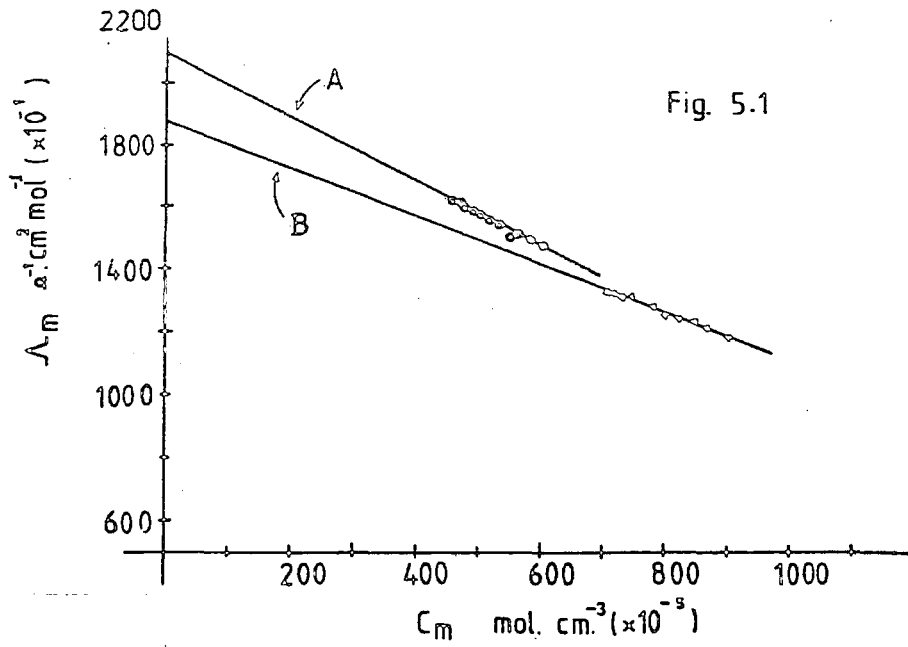

Fig. A2 Graph of molar conductance vs. concentration<sup>1/2</sup>

for





APPENDIX 6

General Experimental Details

Many of the compounds described in this thesis were moisture sensitive. Therefore all operations were carried out under an atmosphere of nitrogen or under vacuum. Liquids and solutions were transferred by syringe against a counter current of nitrogen. Air sensitive solids were handled in a nitrogen filled glove box.

Nitrogen gas

This was supplied as boil off from a tank containing liquid. Traces of oxygen were removed in a heated copper tower at 300 °C and water was removed by a liquid nitrogen trap followed by a tower packed with  $P_2O_5$ . The nitrogen was delivered to a glove box and a multiple outlet system on the bench by glass or nylon tubing to minimize diffusion of oxygen into the system.

The glove box atmosphere was maintained by continuous purge whilst the box was in use and continuous recycling through a KOH tower, a heated copper tower and a  $P_2O_5$  tower to remove acid gases, oxygen and water respectively. All external tubing was of nylon or glass with joints sealed with silicone rubber.

Vacuum System

Evacuation was effected using a rotary oil pump. Access to the system was possible at four points using B14 and S19 sockets. This vacuum system was used for separation, purification of volatile materials by distillation, vapour

pressure measurements, drying of involatile materials and storage of the volatile compounds. The system also was connected to two traps maintained at  $-196^{\circ}$  to collect all volatile compounds.

#### Elemental analysis

Carbon, Hydrogen and Nitrogen were determined using a Perkin-Elmer 240 Elemental Analyser. Samples were sealed into preweighed aluminium capsules in a glove box. Chlorine was determined by oxygen flask combustion followed by potentiometric titration of the chloride ions. Metals were analysed by oxygen flask combustion followed by Atomic Absorption spectrophotometry.

#### Spectroscopic Analysis

Infra-red spectra were recorded on Perkin-Elmer 477 and 577 spectrometers in the range  $4000 - 250 \text{ cm}^{-1}$  and  $4000 - 200 \text{ cm}^{-1}$  respectively. Liquid samples and solid samples as nujol mulls were pressed between KBr, CsI or NaCl plates depending on the region to be studied.

The mass spectra of solid compounds were measured on an AEI MS9 mass spectrometer using electromagnetic scanning, an accelerating voltage of 70 eV and a probe temperature of  $180 - 200^{\circ}\text{C}$ . The spectra of liquids were measured by direct injection into a V.C. Micromass 12B Spectrometer. The spectra were recorded using conventional UV chart recorder or later a V.G. Datasystem 2000 which enabled automatic counting and plotting of the spectra by means of PDP8/3a minicomputer, a Descope visual display unit and a Bryans X-Y plotter.

<sup>1</sup>HNMR spectra were recorded on Varian A60/56D spectrometer operating at 60 MHz and also a fourier transform Bruker HX90E spectrometer operating at 60 MHz. <sup>13</sup>CNMR spectra were recorded using the same Bruker machine operating at 22,6350 MHz. <sup>1</sup>HNMR spectra were also recorded recently on Varian EM-360L NMR spectrometer system.

The specific conductances were measured by using a conductivity cell and PTI-18 digital conductivity meter. The conductivity cell was immersed in a water bath thermostated at 20°C. Because of the sensitivity of the samples for air and moisture, all solutions were prepared in the dry box and measurements were carried out under an atmosphere of dry nitrogen. The conductivity meter was calibrated using a standard normal aqueous solution which was prepared from dissolving research grade KCl in demineralized water.

### Solvents

Diethyl ether, 1,4-dioxan, toluene, benzene and other hydrocarbon solvents were dried with sodium wire. Tetrahydrofuran was dried by refluxing with potassium metal, nitrobenzene and carbon tetrachloride were distilled from P<sub>2</sub>O<sub>5</sub>. Chloroform was dried with anhydrous CaCl<sub>2</sub> and distilled and was protected from direct sunlight. Benzonitrile was purified by distillation from P<sub>2</sub>O<sub>5</sub>.

### Starting Materials

Diphenylketimine was prepared from benzonitrile and phenylmagnesium bromide in diethyl ether. Anhydrous methanol was then added and the resulted inorganic solid was removed by filtration. Diethyl ether was distilled

off and the residual liquid was distilled under vacuum, discarding the first 5 ml. The other ketimine systems were prepared by an exactly analogous method and from the corresponding starting materials. n-BuLi was prepared by the reaction of n-butyl chloride with lithium metal in n-pentane. Ketiminolithium systems were prepared by the action of n-BuLi on Ketimines in diethyl ether. Ketiminium hydro-chloride was prepared by passing dry hydrogen chloride gas into solution of Ketimine in diethyl ether. N-chloro di-p-tolyl ketimine was prepared from the reaction of the Ketiminium hydrochloride with sodium hypochlorite at 0°C.

APPENDIX 7

(a) Lectures and Seminars organised by the Department of Chemistry during the period 1978-1981.

(\* denotes those attended).

15th September 1978

Professor W. Siebert (University of Marburg, West Germany),  
"Boron Heterocycles as Ligands in Transition Metal Chemistry".

\* 22nd September 1978

Professor T. Fehner (University of Notre Dame, U.S.A.).  
"Ferraboranes : Syntheses and Photochemistry".

\* 12th December 1978

Professor C.J.M. Stirling (University of Bangor).  
"'Parting is such sweet sorrow' - the Leaving Group in Organic Reactions".

\* 14th February 1979

Professor B. Dunnell (University of British Columbia),  
"The Application of NMR to the study of Motions in Molecules".

16th February 1979

Dr. J. Tomkinson (Institute of Laue-Langevin, Grenoble).  
"Properties of Adsorbed Species".

14th March 1979

Dr. J.C. Walton (University of St. Andrews),  
"Pentadienyl Radicals".

20th March 1979

Dr. A. Reiser (Kodak Ltd.),  
"Polymer Photography and Mechanism of Cross-line Formation in Solid Polymer Matrices".

25th March 1979

Dr. S. Larsson (University of Uppsala),  
"Some Aspects of Photoionisation Phenomena in Inorganic Systems".

25th April 1979

Dr. C.R. Patrick (University of Birmingham),  
"Chlorofluorocarbons and Stratospheric Ozone : An Appraisal of the Environmental Problem".

1st May 1979

Dr. G. Wyman (European Research Office, US Army),  
"EXcited State Chemistry in Indigoid Dyes".

2nd May 1979

Dr. J.D. Hobson (University of Birmingham),  
"Nitrogen-centred Reactive Intermediates".

\* 8th May 1979.

Professor A. Schmidpeter (Institute of Inorganic Chemistry,  
University of Munich),  
"Five-membered Phosphorus Heterocycles Containing  
Dicoordinate Phosphorus".

9th May 1979.

Dr. A.J. Kirby (University of Cambridge),  
"Structure and Reactivity in Intramolecular and Enzymic  
Catalysis".

9th May 1979

Professor G. Maier (Lahn-Giessen),  
"Tetra-tert-butyltetrahedrane".

10th May 1979

Professor G. Allen, F.R.S., (Science Research Council),  
"Neutron Scattering Studies of Polymers".

16th May 1979.

Dr. J.F. Nixon (University of Sussex),  
"Spectroscopic Studies on Phosphines and their Coordination  
Complexes".

23rd May 1979.

Dr. B. Wakefield (University of Salford),  
"Electron Transfer in Reactions of Metals and Organometallic  
Compounds with Polychloropyridine Derivatives".

\* 13th June 1979

Dr. G. Heath (University of Edinburgh),  
"Putting Electrochemistry into Mothballs - (Redox Processes  
of Metal Porphyrins and Phthalocyanines)".

\* 14th June 1979

Professor I. Ugi (University of Munich),  
"Synthetic Uses of Super Nucleophiles".

\* 20th June 1979

Professor J.D. Corbett (Iowa State University, Ames, Iowa, U.S.A.),

"Zinti Ions : Synthesis and Structure of Homo-polyatomic Anions of the Post-Transition Elements".

27th June 1979

Dr. H. Fuess (University of Frankfurt),

"Study of Electron Distribution in Crystalline Solids by X-ray and Neutron Diffraction".

21st November 1979

Dr. J. Muller (University of Bergen),

"Photochemical Reactions of Ammonia".

28th November 1979

Dr. B. Cox (University of Stirling),

"Macrobicyclic Cryptate Complexes, Dynamics and Selectivity".

5th December 1979

Dr. G.C. Eastmond (University of Liverpool),

"Synthesis and Properties of some Multicomponent Polymers".

12th December 1979

Dr. C.I. Ratcliffe (University of London),

"Rotor Motions in Solids".

19th December 1979

Dr. K.E. Newman (University of Lausanne),

"High Pressure Multinuclear NMR in the Elucidation of the Mechanisms of Fast, Simple Reactions".

\* 20th January 1980

Dr. M.J. Barrow (University of Edinburgh),

"The Structures of some Simple Inorganic Compounds of Silicon and Germanium - Pointers to Structural Trends in Group IV".

\* 6th February 1980

Dr. J.M.E. Quirke (University of Durham),

"Degradation of Chlorophyll-a in Sediments".

23rd April 1980

B. Grievson B.Sc., (University of Durham),

"Halogen Radiopharmaceuticals".

14th May 1980

Dr. R. Hutton (Waters Associates, U.S.A.),  
"Recent Developments in Multi-milligram and Multi-gram  
Scale Preparative High Performance Liquid Chromatography".

\* 21st May 1980

Dr. T.W. Bentley (University of Swansea),  
"Medium and Structural Effects in Solvolytic Reactions".

10th July 1980

Professor P. des Marteau (University of Heidelberg),  
"New Developments in Organonitrogen Fluorine Chemistry".

\* 7th October 1980

Professor T. Felhner (Notre-Dame University, U.S.A.),  
"Metalloboranes - Cages or Coordination Compounds?".

15th October 1980

Dr. R. Adler (University of Bristol),  
"Doing Chemistry Inside Cages - Medium Ring Bicyclic  
Molecules".

12th November 1980

Dr. M. Gerloch (University of Cambridge),  
"Magnetochemistry is about Chemistry".

19th November 1980

Dr. T. Gilchrist (University of Liverpool),  
"Nitroso Olefins as Synthetic Intermediates".

3rd December 1980

Dr. J.A. Connor (University of Manchester),  
"Thermochemistry of Transition Metal Complexes".

18th December 1980

Dr. R. Evans (University of Brisbane, Australia),  
"Some Recent Communications to the Editor of the Australian  
Journal of Failed Chemistry".

18th February 1981

Professor S.F.A. Kettle (University of East Anglia),  
"Variations in the Molecular Dance at the Crystal Ball".

25th February 1981

Dr. K. Bowden (University of Sussex),  
"The Transmission of Polar Effects of Substituents".

4th March 1981

Dr. S. Craddock (University of Edinburgh),  
"Pseudo-Linear Pseudohalides".

11th March 1981

Dr. J.F. Stoddard (I.C.I. Ltd./University of Sheffield),  
"Stereochemical Principles in the Design and Function of  
Synthetic Molecular Receptors".

17th March 1981

Professor W. Jencks (Brandsis University, Massachusetts),  
"When is an Intermediate not an Intermediate?".

\* 18th March 1981

Dr. P.J. Smith (International Tin Research Institute),  
"Organotin Compounds - A Versatile Class of Organometallic  
Compounds".

9th April 1981

Dr. W.H. Meyer (RCA Zurich),  
"Properties of Aligned Polyacetylene".

6th May 1981

Professor M. Szwarc, F.R.S.,  
"Ions and Ion Pairs".

10th June 1981

Dr. J. Rose (I.C.I. Plastics Division),  
"New Engineering Plastics".

17th June 1981

Dr. P. Moreau (University of Montpellier),  
"Recent Results in Perfluoroorganometallic Chemistry".

(b) Conferences attended during the period 1978 - 1981

i. Annual Congress of the Chemical Society and the Royal  
Institute of Chemistry, Durham University, April 1980.

(c) First year induction course (October-November 1978).

A series of one hour presentations on the services available  
in the department.

- i. Departmental organisation.
- ii. Safety matters.
- iii. Electrical appliances.
- iv. Chromatography and microanalysis.
- v. Library facilities.
- vi. Atomic absorption and inorganic analysis.

- vii. Mass spectrometry.
- viii. Nuclear magnetic resonance spectroscopy.
- ix. Glassblowing technique.

REFERENCES OF CHAPTER ONE

1. I. Omae, Chem. Rev., 79, 287, (1979).
2. M.I. Bruce, Angew. Chem. Int. Ed. Engl., 16, 73 (1977).
3. J. Dehand and M. Pfeffer, Coordination Chemistry Reviews, 18, 327 (1976).
4. G.W. Parshall, Accounts Chem. Res., 3, 139 (1970).
- 5a. A.C. Cope and E.F. Friedrich, J. Am. Chem. Soc., 90, 909 (1968).
- 5b. H. Irving, E.J. Butler, and M.F. Ring, J. Chem. Soc., 1489 (1949).
6. J.F. van Baar, K. Vrieze and D.J. Stufkens, J. Organomet. Chem., 97, 461 (1975).
7. J.F. van Baar, K. Vrieze and D.J. Stufkens, J. Organomet. Chem. 85, 249 (1975).
8. H. Takahashi and J. Tsuji, J. Organomet. Chem., 10, 511 (1967).
9. N.D. Cameron and M. Kilner, J. Chem. Soc. Chem. Commun., 687 (1975).
10. F.W.B. Eistein, A.B. Gilchrist, G.W. Rayner-Canham, and D. Sutton, J. Am. Chem. Soc., 94, 645 (1972).
11. F.A. Cotton, T. la Cour, and A.G. Stanislawski, J. Am. Chem. Soc., 96, 754 (1974).
12. R.L. Bennett, M.I. Bruce, and F.G.A. Stone, J. Organomet. Chem., 94, 65 (1975).
13. M.I. Bruce, B.L. Goodall, and F.G.A. Stone, J. Chem. Soc. Chem. Commun., 558 (1973).
14. G.P. Khare, R.G. Little, J.T. Veal, and R.J. Doedens, Inorg. Chem., 14, 2475 (1975).
15. J. Dehand, J. Fischer, M. Pfeffer, A. Mitschler, and M. Zinsius, Inorg. Chem., 15, 2675 (1976).
16. R.C. Elder, R.D. Cruea, and R.F. Morrison, Inorg. Chem., 15, 1623 (1976).
17. M.I. Bruce, B.L. Goodall, A.D. Redhouse, and F.G.A. Stone, J. Chem. Soc. Chem. Commun., 1228 (1972).
18. M.I. Bruce, B.L. Goodall, and F.G.A. Stone, J. Chem. Soc., Dalton Trans., 1651 (1975).
19. See Reference 8.

20. J.M. Thompson and R.F. Heck, *J. Org. Chem.*, 40, 2667 (1975).
21. R.A. Holton, R.A. Kjonaas, *J. Organomet. Chem.*, 133, C5 (1977).
22. D. Ytsma, J.G. Hartsuiker, and J.H. Tenben, *J. Organomet. Chem.*, 74, 239 (1974).
23. A.F.M.J. Voepleog, G. Van Koten, and K. Vrieze, *J. Organomet. Chem.*, 222, 155 (1981).
24. S.L. Kamiyama, T. Kimura, A. Kasahara, T. Izumi, and M. Maemura, *Bull. Chem. Soc. Japan*, 52, 142 (1979).
25. R.A. Holton and R.A. Kjonaas, *J. Am. Chem. Soc.*, 99, 4177 (1977).
26. R.A. Holton and R.A. Kjonaas, *J. Organomet. Chem.*, 142, C15 (1977).
27. J.F. Van Baar, J.M. Klerks, P. Overbosch, D.J. Sufkens, and K. Vrieze, *J. Organomet. Chem.*, 112, 95 (1976).
28. S.I. Murahashi, Y. Tanba, M. Yamamura, and I. Moritani, *Tetrahedron Letters*, 43, 3749 (1974).
29. K.P. Darst, D.T. Hobbs, and C.M. Lukehart, *J. Organomet. Chem.* 179, C9 (1979).
30. S. Trofimenko, *Inorg. Chem.*, 12, 1215 (1973).
31. B.N. Cockburn, D.V. Howe, T. Keating, B.F.G. Johnson and J. Lewis, *J. Chem. Soc., Dalton*, 404 (1973).
32. B. Crociani, T. Boschi, R. Pietropaolo and U. Belluco, *J. Chem. Soc.*, A, 531 (1970).
33. H. Onove, K. Nagakana, and I. Moritani, *J. Organomet. Chem.*, 35, 217 (1972).
34. J. Dehand, M. Pfeffer and M. Zinsius, *Inorg. Chem. Acta*, 13, 229 (1975).
35. P. Braunstein, J. Dehand, and M. Pfeffer, *Inorg. Nucl. Chem. Lett.*, 10, 581 and 521 (1974).
36. M.I. Bruce, M.Z. Iqbal, and F.G.A. Stone, *J. Chem. Soc.*, A, 2820 (1971).
37. R.W. Siekman and D.L. Weaver, *Chem. Commun.*, 1021 (1968).
38. D.L. Weaver, *Inorg. Chem.*, 9, 2250 (1970).
39. A.C. Cope and R.W. Siekman, *J. Am. Chem. Soc.*, 87, 3272 (1965).

40. B.L. Shaw, and M.F. Uttley, J. Chem. Soc., Chem. Commun., 918 (1974).
41. J. Dehand and M. Pfeffer, J. Organomet. Chem., 104, 377 (1976).
42. P. Braunstein, J. Dehand, and M. Pfeffer, J. Organomet. Chem., 76, C35 (1974).
43. M.I. Bruce, M.Z. Iqbal, and F.G.A. Stone, J. Chem. Soc., Chem. Commun., 1325 (1970).
44. M.C. Cornock, R.C. Davis, D. Leaver, and T.A. Stephenson, J. Organomet. Chem., 107, C43 (1976).
45. H. Onove, and I. Moritani, J. Organomet. Chem., 43, 431 (1972).
46. R.J. Cross and N.H. Tennent, J. Chem. Soc., Dalton, 1445 (1974).
47. M.I. Bruce, B.L. Goodall, M.Z. Iqbal, and F.G.A. Stone, J. Chem. Soc., Chem. Commun., 661 (1971).
48. M. Kooti and J.F. Nixon, J. Organomet. Chem., 63, 415 (1973).
49. J.W. Suggs, J. Am. Chem. Soc., 101, 489 (1979).

REFERENCES - TABLE (1.2)

1. R.L. Vauex, F.N. Jones, and C.R. Hauser, *J. Org. Chem.*, 30, 58 (1965).
2. F. Jones, R.L. Vauex, R. Hauser, *J. Org. Chem.*, 28, 3461 (1963).
3. R.E. Ludt, G.P. Crowther, and C.R. Hauser, *J. Org. Chem.*, 35, 1288 (1970).
4. W.H. Puterbaugh and C.R. Hauser, *J. Org. Chem.*, 29, 853 (1964).
5. R.L. Vauex, W.H. Puterbaugh, and C.R. Hauser, *J. Org. Chem.*, 29, 3514 (1964).
6. D.W. Slocum, B.W. Rockett, and C.R. Hauser, *J. Am. Chem. Soc.*, 87, 1241 (1965).
7. M.D. Rausch, G.A. Moser, and C.F. Meade, *J. Organomet. Chem.*, 51, 1, (1973).
8. T. Aratani, T. Gonda, and H. Nozaki, *Tetrahedron Lett.*, 2265 (1969).
9. T. Aratani, T. Gonda, and H. Nozaki, *Tetrahedron*, 26, 5453 (1970).
10. D.W. Slocum and F.E. Stonemark, *J. Org. Chem.*, 38, 1677 (1973).
11. R.A. Anderson and G.E. Coates, *J. Chem. Soc., Dalton*, 1171 (1974).
12. A. Marxer and M. Siegrist, *Helvetica Chimica Acta.*, 57, 1988 (1974).
13. F.N. Jones and C.R. Hauser, *J. Org. Chem.*, 27, 4389 (1962).
14. R. Köster, K. Iwasaki, S. Hattori and Y. Morita, *Annalen*, 720, 23 (1968).
15. H.S. Turner, R.J. Wayne and I.K. Lawrenson, *Chem. Commun.*, 20 (1965).
16. M.J.S. Dewar, V.P. Kubba and R. Pettit, *J. Chem. Soc.*, 3073 (1958).
17. H. Wille and J. Gaubean, *Chem. Ber.*, 105, 2156 (1972).
18. R.L. Letsinger and D.B. Maclean, *J. Am. Chem. Soc.*, 85, 2230 (1963).

19. H. Schmidbaur and W. Wolfsberger, *J. Organomet. Chem.*, 16, 188 (1969).
20. G. Bähr and E. Müller, *Chem. Ber.*, 88, 251, (1955).
21. H.P. Abicht and K. Issleib, *Z. Anorg. Chem.*, 422, 237 (1976).
22. A.F.M.J. Vod. Ploeg, G. Van Koten, and K. Vrieze, *J. Organomet. Chem.*, 222, 155 (1981).
23. G. Royo, *J. Organomet. Chem.*, 205, C1 (1981).
24. L. Párkányi, J. Nagy, and K. Simon, *J. Organomet. Chem.*, 101, 11 (1975).
25. G. Van Koten, J.G. Noltes, *J. Organomet. Chem.*, 118, 183 (1976).
26. G. Van Koten, C.A. Schaap and J.G. Noltes, *J. Organomet. Chem.*, 99, 157 (1975).
27. G. Van Koten and J.G. Noltes, *J. Am. Chem. Soc.*, 98, 5393 (1976),
28. B. Fitzsimmons, D.G. Othen, H.M.M. Shearer, K. Wade and G. Whitehead, *J. Chem. Soc., Chem. Commun.*, 215 (1977)
29. D. Maughan, J.L. Wardell, J.W. Burley, *J. Organomet. Chem.*, 212, 59 (1981).
30. J.M. Guss, R. Mason, I. Sjøtofte, G. Van Koten, and J.G. Noltes, *J. Chem. Soc., Chem. Commun.*, 446 (1972).
31. J.M. Guss, R. Mason, K.M. Thomas, G. Van Koten, and J. G. Nolt es, *J. Organomet. Chem.*, 40, C79 (1972).
32. R.W.M. ten Hoedt, J.G. Noltes, G. Van Koten, and A.L. Spek, *J. Chem. Soc., Dalton*, 1800 (1978).
33. G. Van Koten, and J.G. Noltes, *J. Chem. Soc., Chem. Commun.*, 940 (1972).
34. P.V. Roling, D.D. Kirt, J.L. Dill, S. Hill, and C. Hollstom, *J. Organomet. Chem.*, 116, 39 (1976).
35. P.V. Roling and J.L. Dill, *J. Organomet. Chem.*, 69, C33 (1974).
36. P.V. Roling and R.A. Pickering, *J. Organomet. Chem.*, 122, 289 (1976).
37. V.I. Sokolov, L.L. Troitskaya, and O.A. Reutov, *J. Organomet. Chem.* 93, C11 (1975).
38. L.E. Manzer, *J. Organomet. Chem.*, 135, C6, (1977).
39. L.E. Manzer and L.J. Guggenberger, *J. Organomet. Chem.*, 139, C34 (1977).

40. L.E. Manzer, J. Am. Chem. Soc., 99, 276 (1977).
41. D. Ytsma, J.G. Hartsuiker, and J.H. Tenben, J. Organomet. Chem., 74, 239 (1974).
42. B. Klei and J.H. Teuben, J. Chem. Soc., Chem. Commun., 659 (1978).
43. L.E. Manzer, J. Organomet. Chem., 135, C6 (1977).
44. K.P. Darst, D.T. Hobbs, and C.M. Lukehart, J. Organomet. Chem., 179, C9 (1979).
45. K.H. Dötz and C.G. Kreiter, Chem. Ber., 109, 2026 (1976).
46. W.H. Knoth, Inorg. Chem., 14 1566 (1975).
47. M.I. Bruce, M.Z. Iqbal and F.G. Stone, J. Chem. Soc., A, 3204 (1970).
48. R.B. King and M.S. Saran, Inorg. Chem., 14, 1018 (1975).
49. R.B. King and M.B. Bisnette, Inorg. Chem., 5, 293 (1966).
50. H. Brunner and J. Wachter, J. Organomet. Chem., 107, 307 (1976).
51. R.B. King and K.C. Hodges, J. Am. Chem. Soc., 96, 1263 (1974).
52. R.B. King and K.C. Hodges, J. Am. Chem. Soc., 97, 2702 (1975).
53. R.L. Bennett, M.I. Bruce, B.L. Goodall, and F. Goodall, and F.G.A. Stone, Austral. J. Chem., 27, 2131 (1974).
54. R.L. Bennett, M.I. Bruce, B.L. Goodall, M.Z. Iqbal and F.G.A. Stone, J. Chem. Soc., Dalton, 1787 (1972).
55. R.L. Bennett, M.I. Bruce, and I. Matsuda, Austral. J. Chem., 28, 1265 (1975).
56. S.S. Crawford, G. Firestein and H.D. Kaesz, J. Organomet., 91, C57 (1975).
57. M.I. Bruce, B.L. Goodall, G.L. Sheppard, and F.G.A. Stone, J. Chem. Soc., Dalton, 591 (1975).
58. K.A. Koblyns and A.H. Filbey, J. Am. Chem. Soc., 82, 4204 (1960).
59. M.I. Bruce, B.L. Goodall, and F.G.A. Stone, J. Organomet. Chem., 60, 343 (1973).

60. G. Schmid, J. Pebler, and L. Weber, *J. Organomet. Chem.*, 61, 375 (1973).
61. M.M. Bagga, P.L. Pauson, F.J. Preston, and R.I. Reed, *J. Chem. Soc., Chem. Commun.*, 543 (1965).
62. P.E. Baikie and O.S. Mills, *J. Chem. Soc., Chem. Commun.*, 707 (1966).
63. G. Schmid, J. Pebler, and L. Weber, *J. Organomet. Chem.*, 61, 375 (1973).
64. M. Bottril, R. Goddard, M. Green, P.P. Hughes, M.K. Lloyd, S.H. Taylor and P. Woodward, *J. Chem. Soc., Dalton*, 1150 (1975).
65. F.W. Küpper, *J. Organomet. Chem.*, 13, 219 (1968).
66. Y. Yamamoto and H. Yamazaki, *Inorg. Chem.*, 11, 211 (1972).
67. Y. Yamamoto and H. Yamazaki, *J. Organomet. Chem.*, 90, 329 (1975).
68. M.M. Bagga, W.T. Flannigan, G.R. Knox, and P.L. Pauson, *J. Chem. Soc., C*, 1534 (1969).
69. M.I. Bruce, R.C.F. Gardner, and F.G.A. Stone, *J. Organomet. Chem.*, 40, C39 (1972).
70. M.I. Bruce, R.C.F. Gardner, and F.G.A. Stone, *J. Chem. Soc., Dalton*, 81 (1976).
71. M.I. Bruce, R.C.F. Gardner, B.L. Goodall, F.G.A. Stone, R.J. Doedens, and J.A. Moreland. *J. Chem. Soc., Chem. Commun.*, 185 (1974).
72. J.A. Moreland and R.J. Doedens, *Inorg. Chem.*, 15, 2486 (1976).
73. M.I. Bruce, R.C.F. Gardner, and F.G.A. Stone, *J. Organomet. Chem.*, 40, C39 (1972).
74. C. Choo Yin and A.J. Deeming, *J. Organomet. Chem.*, 133, 123 (1977).
75. M.I. Bruce, M.Z. Iqbal, and F.G.A. Stone, *J. Chem. Soc., Chem. Commun.*, 1325 (1970).
76. M.I. Bruce, M.Z. Iqbal, and F.G.A. Stone, *J. Chem. Soc., A*, 2820 (1971).
77. M.I. Bruce, M.Z. Iqbal, and F.G.A. Stone, *J. Organomet. Chem.*, 31, 275 (1971).
78. C.C. Yin and A.J. Deeming, *J. Chem. Soc., Dalton*, 1013 (1974).

79. A. Cope, and R. Gourley, *J. Organomet. Chem.*, 8, 527 (1967).
80. M.I. Bruce, B.L. Goodall, and F.G.A. Stone, *J. Chem. Soc., Dalton*, 1651 (1975).
81. M.I. Bruce, B.L. Goodall, A.D. Redhouse, and F.G.A. Stone, *J. Chem. Soc., Chem. Commun.*, 1228 (1972).
82. A.C. Cope and R.W. Siekman, *J. Am. Chem. Soc.*, 87, 3272 (1965).
83. M.I. Bruce, M.Z. Iqbal, and F.G.A. Stone, *J. Organomet. Chem.* 40, 393 (1972).
84. P.I. van Vliet, J. Kuypers, and K. Vrieze, *J. Organomet. Chem.*, 122, 99 (1976).
85. M. Nonoyama, *J. Organomet. Chem.*, 74, 115 (1974).
86. R.J. Foot and B.T. Heaton, *J. Chem. Soc., Chem. Commun.*, 838 (1973).
87. R.J. Foot, and B.T. Heaton, *J. Chem. Soc., Dalton*, 295 (1979).
88. J.W. Suggs and S.D. Cox, *J. Organomet. Chem.*, 221, 199 (1981).
89. J.W. Suggs, *J. Am. Chem. Soc.*, 100, 640 (1978).
90. M.I. Bruce, B.L. Goodall, M.Z. Iqbal, and F.G.A. Stone, *Chem. Commun.*, 661 (1971).
91. P.L. Sandrini, R.A. Michelin, and F. Canziani, *J. Organomet. Chem.*, 91, 363 (1975).
92. R.J. Hoare, and O.S. Mills, *J. Chem. Soc., Dalton*, 2141 (1972).
93. S.A. Dias, A.W. Downs and W.R. McWhinnie, *J. Chem. Soc., Dalton*, 162 (1975).
94. H. Onove and I. Moritani, *J. Organomet. Chem.*, 44, 189 (1972).
95. J.W. Suggs, *J. Am. Chem. Soc.*, 101, 489 (1979).
96. H. Onove and I. Moritani, *J. Organomet. Chem.*, 44, 189 (1972).
97. F. Mirzaei, and L. Dahlenburg, *J. Organomet. Chem.*, 173, 325 (1979).
98. F.W.B. Einstein, A.B. Gilchrist, G.W. Rayner-Canham, and D. Sutton, *J. Am. Chem. Soc.*, 94, 645 (1972).
99. N. Farrell, and D. Sutton, *J. Chem. Soc., Dalton*, 2124 (1977).

100. J.A. Carroll, R.E. Cobblestick, F.W.B. Einstein, N. Farrell, D. Sutton, and P. Vogel, *Inorg. Chem.* 16, 2462 (1977).
101. S.A. Dias, A.W. Downs, and W.R. McWhinnie, *J. Chem. Soc., Dalton*, 162 (1975).
102. J.F. van Baar, J.M. Klerks, P. Overbosch, D.J. Stufkens, and K. Vrieze, *J. Organomet. Chem.*, 112, 95 (1976).
103. J.F. van Baar, K. Vrieze, and D.J. Stufkens, *J. Organomet. Chem.* 85, 249 (1975).
104. J.F. van Baar, J.M. Klerks, P. Overbosch, D.J. Stufkens, and K. Vrieze, *J. Organomet. Chem.* 112, 95 (1976).
105. M. Nonoyama, *Bull. Chem. Soc. Jpn.*, 74, 767 (1974).
106. M. Nonoyama, *Bull. Chem. Soc. Jpn.*, 52, 3749 (1979).
107. R.J. Cross and N.H. Tennent, *J. Organomet. Chem.*, 72, 21 (1974).
108. H.T. Dieck, and M. Svaboda, *Chem. Ber.*, 109, 1657 (1976).
109. G. Longoni, P. Fantucci, P. Chini, and F. Canziani, *J. Organomet. Chem.*, 39, 413 (1972).
110. Yu. A. Ustynyuk, V.A. Chertkov, and I.V. Barinov, *J. Organomet. Chem.*, 29, C53 (1971).
111. S. Otsuka, A. Nakamura, and T. Yoshida, *J. Am. Chem. Soc.* 91, 7196 (1969).
112. S. Otsuka, A. Nakamura, and Y. Tatsuo, *J. Am. Chem. Soc.*, 91, 6994 (1969).
113. S.P. Molnar and M. Orchin, *J. Organomet. Chem.*, 16, 196 (1969).
114. H. Onove and I. Moritani, *J. Organomet. Chem.* 43, 431 (1972).
115. R.W. Siekman and D.L. Weaver, *Chem. Commun.* 1021 (1968).
116. M.D. Cameron, and M. Kilner, *J. Chem. Soc., Chem. Commun.*, 687 (1975).
117. L. Maresca, G. Natile, L. Cattalini, and F. Gasparri, *J. Chem. Soc., Dalton*, 1601 (1975).
118. V.I. Sokolov, L.L. Troitskaya, and O.A. Reutov, *J. Organomet. Chem.*, 93, C11 (1975).
119. C. Mutet and M. Pfeffer, *J. Organomet. Chem.*, 171, C34 (1979).
120. M. Sugimoto and M. Nonoyama, *Inorg. Nuclear Chem. Lett.*, 15, 405 (1979).

121. M. Nonoyama and M. Sugimoto, *Inorg. Chim. Acta*, 35, 131 (1979).
122. P. Braunstein, J. Dehand, and M. Pfeffer, *Inorg. Nucl. Chem. Lett.*, 10, 581 (1974).
123. J. Dehand, M. Pfeffer, and M. Zinsius, *Inorg. Chim. Acta*, 13, 229 (1975).
124. J. Dehand, T. Jordanov, and M. Pfeffer, *J. Chem. Soc., Dalton*, 1553 (1976).
125. J.C. Gaunt and B.L. Shaw, *J. Organomet. Chem.*, 102, 511 (1975).
126. M. Nonoyama, *Inorg. Nucl. Chem. Letters*, L2, 709 (1976).
127. E.C. Alyea, S.A. Dias, G. Ferguson, A.J. McAlees, R. McCrindle, and P.J. Roberts, *J. Am. Chem. Soc.*, 99, 4985 (1977).
128. L.S. Hegedus, O.P. Anderson, K. Zetterberg, G. Allen, K. Siirala-Hansen, D.J. Olsen, and A.B. Packard, *Inorg. Chem.*, 16, 1887 (1977).
129. R.A. Holton and R.A. Kjonaas, *J. Am. Chem. Soc.*, 99, 4177 (1977).
130. R.A. Holton and R.A. Kjonaas, *J. Organomet. Chem.*, 142, C15 (1977).
131. V.I. Sokolov, L.L. Troitskaya, and O.A. Reutov, *J. Organomet. Chem.*, 35, 217 (1972).
132. H. Onove, K. Kagakura, and I. Moritani, *J. Organomet. Chem.*, 35, 217 (1972).
133. G. Longoni, P. Fantucci, P. Chini and F. Canziani, *J. Organomet. Chem.*, 39, 413 (1972).
134. V.I. Sikolov, L.L. Troitskaya and T.A. Sorokina, *Izvest. Akad. Nank. S.S.S.R., Ser. khim.* 2612 (1971).
135. V.I. Sokolov, T.A. Sorokina, L.L. Troitskaya, L.I. Solovieva, and O.A. Reutov, *J. Organomet. Chem.*, 36, 389 (1972).
136. I. Rothwell, *J. Organomet. Chem.*, 205, 117 (1981).
137. B.E. Reichert, and B.O. West, *J. Organomet. Chem.*, 54, 391 (1973).
138. R.A. Holton, and R.G. Davis, *J. Am. Chem. Soc.*, 99, 4175 (1977).
139. B.L. Shaw and I. Shepherd, *J. Chem. Soc., Dalton*, 1634, (1979).

140. S.L. Kamiyama, T. Kimura, A. Kasahara, T. Izumi, and M. Maemura, *Bull. Chem. Soc. Japan*, 52, 142 (1979).
141. K. Hiraki, Y. Fuchite, H. Nakaya, and S. Tekakura, *Bull. Chem. Soc. Japan*, 52, 2531 (1979).
142. B. Crociani, T. Boschi, R. Pietropaolo, and U. Belluco, *J. Chem. Soc.*, 531 (1970).
143. S. Trofimenko, *Inorg. Chem.*, 12, 1215 (1973).
144. S. Baba, and S. Kawaguchi, *Inorg. Nuclear Chem. Letters*, 11, 415 (1975).
145. B.N. Cockburn, D.V. Howe, T. Keating, B.F.G. Johnson, and J. Lewis, *J. Chem. Soc., Dalton*, 4C4 (1973).
146. A.J. Deeming, and I.P. Rothwell, *J. Chem. Soc., Dalton*, 1497 (1978).
147. M. Nonoyama, *Inorg. Chim. Acta*, 28, L163 (1978).
148. J. Dehand and M. Pfeffer, *J. Organomet. Chem.*, 104, 377 (1976).
149. B.A. Grigor and A.J. Nielson, *J. Organomet. Chem.*, 129, C17 (1977).
150. A.C. Cope, and E.C. Friedrich, *J. Am. Chem. Soc.*, 90, 909 (1968).
151. S. Baba and S. Kawaguchi, *Inorg. Nucl. Chem. Lett.*, 11, 415 (1975).
152. A.J. Deeming, I.P. Rochwell, M.B. Horsthouse, L. New., *J. Chem. Soc., Dalton*, 1490 (1978).
153. D.R. Russeil, and P.A. Tucker, *J. Chem. Soc., Dalton Trans.*, 1743 (1975).
154. S. Trofimenko, *J. Am. Chem. Soc.*, 93, 1808 (1971).
155. J.M. Thompson, R.F. Heck, *J. Organomet. Chem.*, 40, 2667 (1975).
156. J.M. Duff, and B.L. Shaw, *J. Chem. Soc., Dalton Trans.*, 2219 (1972).
157. M. Julia, M. Duteil, and J.Y. Lallenand, *J. Organomet. Chem.*, 102, 239 (1975).
158. B.A. Grigou and A.J. Nielson, *J. Organomet. Chem.*, 132, 439 (1977).
159. Y. Yamamoto and H. Yamazaki, *Inorg. Chem.*, 13, 438 (1974).

160. A. Kasarhara, T. Izumi, T. Takeda, and H. Imamura, Bull. Chem. Soc. Jpn., 47, 183 (1974).
161. G.E. Hartwell, R.V. Lawrence, and M.J. Smas, J. Chem. Soc., Chem. Commun., 912 (1970).
162. M. Nonoyama, J. Organomet. Chem., 154, 169 (1978).
163. M.R. Churchill, H.J. Wasserman, and G.J. Young, Inorg. Chem., 19, 762 (1980).
164. M.A. Gutierrez, G.R. Newkome and J. Selbin, J. Organomet. Chem., 202, 341 (1980).
165. A.J. Nielson, J. Chem. Soc., Dalton, 205 (1981).
166. J.M. Kliegman and A.C. Cope, J. Organomet. Chem., 16, 309 (1969).
167. V.I. Sokolov, Inorg. Chim. Acta, 18, L9 (1976),
168. T.J. Giordano, and P.G. Rasmussen, Inorg. Chem., 14, 1628 (1975).
169. Gen-Etsu Matsu bayashi, and Y. Kondo, J. Organomet. Chem., 219, 269 (1981).
170. R.E. Reichert and B.O. West, J. Organomet. Chem., 54, 391 (1973).
171. J.D. Ruddick and B.L. Shaw, J. Chem. Soc., A, 2801 (1969).
172. J.M. Duff and B.L. Shaw, J. Chem. Soc., Dalton Trans., 2219 (1972).
173. R. Ros, J. Renaud, and R. Rovlet J. Organomet. Chem., 87, 379 (1975).
174. R. Ros, J. Renaud, and Rovlet, J. Organomet. Chem., 104, 393 (1976).
175. A.J. Canty and N.J. Minchin, J. Organomet. Chem., 226, C14 (1982).
176. A.F.M.J. Van Der Ploeg, G. Van Koten and K. Vrieze, J. Organomet. Chem., 226, 93 (1982).

REFERENCES OF CHAPTER TWO

1. B. Fitzsimmons, D.G. Othen, H.M.M. Shearer, K. Wade, and G. Whitehead, *J.C.S. Chem. Comm.*, 215 (1977).
2. M.C. Henry and G. Wittig, *J. Am. Chem. Soc.*, 82, 563 (1960).
3. G. Wittig and D. Hellwinkel, *Chem. Ber.*, 97, 789 (1964).
4. A.W. Johnson, "Ylid Chemistry", Academic Press, New York, London, (1966), P.284.
5. L. Kolditz and W. Röhusch, *Z. anorg. allg. Chem.*, 315, 213 (1962).
6. J.R. Jennings, I. Pattison, C. Summerford, K. Wade, and B.K. Wyatt, *Chem. Comm.*, 250 (1968).
7. C. Summerford, K. Wade and B.K. Wyatt, *Chem. Comm.*, 61 (1969).
8. B. Samuel and K. Wade, *Chem. Comm.*, 1081 (1968).
9. D.G. Othen, Ph.D. Thesis, Durham 1977.
10. P. Kovacic, and A.K. Sparks, *J.A.C.S.*, 82, 5740 (1960).
11. G.E. Coates, M.L.H. Green and K. Wade, "Organometallic Compounds", vol. one : The main group elements, Methuen and Co. Ltd., London (1965), P.525.
12. M. Dub, "Organometallic Compounds", Vol. III, Springer-Verlag, Berlin- Heidelberg- New York (1968), P.766.
13. A. Cowley, F. Fairbrother, and N. Scott, *J. Chem. Soc.*, 3133 (1958).
14. N.N. Greenwood, R.L. Martin, and H.J. Emeléus, *J. Chem. Soc.*, 3030 (1950).
15. G.A. Olah, "Friedel-Crafts and related reactions", vol. IV, interscience publishers (a division of John Wiley & Sons Inc.), New York-London-Sydney, (1965), P.1.
16. F. Klages, H. Meuresch, and W. Steppich, *Ann. chem. Leibigs.*, 592, 81 (1955).
17. R.L. Burwell, *Chem. Rev.*, 54, 615 (1854).
18. H.J. Emeléus, "Inorganic Chemistry - Series Two", Vol. 2, Butterworths, London, (1975), P.227.
19. A. Perrier-Datin, *Spectrochim. Acta* 25A, 169 (1969).
20. H. Onoue and I. Moritani, *J. Organometal. Chem.*, 16, 196 (1969).

21. J.R. Ferraro, "Low-Frequency Vibrations of inorganic and coordination Compounds", Plenum Press, New York, (1971), P.112, 263.
22. R.M. Silverstein, G.C. Bassler and T.C. Morrill, "Spectrometric identification of Organic Compounds", John Wiley and Sons, Inc., New York, London, (1974), P.177.
23. G. Van Koten, C.A. Schaap and J.G. Noltes, J. Organometal. Chem., 99, 157 (1975).
24. L.A. Kazitsyna, A.V. Kugnetsova, and O.A. Reutov, J. Gen. Chem. USSR, 33, 2186 (1963).
25. G. Ahlijah and M. Goldstein, J. Chem. Soc. (A), 326 (1970).
26. G. Ahlijah and M. Goldstein, Chem. Comm., 1356 (1968).
27. R. Van Der Linde, J.W. Dornseiffen, C.U. Veenland and Th. J. De Boer, Spectrochim. Acta, 25, 375 (1969).
28. G.A. Olah and P. Kreienbühl, J. Am. Chem. Soc., 89, 4756 (1967).
29. S.N. Rosenthal and J.H. Fendler, Adv. Phys. Org. Chem., 13, 279 (1976).
30. L.F. Johnson and W.C. Jankowski, "Carbon-13 NMR Spectra", Wiley-Interscience Publication, New York, (1972).
31. G. Rabiller, J.P. Renov, and G.J. Martin, J.C.S. Perkin II, 536 (1977).
32. A.R. Garber, P.E. Garrow, G.E. Hartwell, M.J. Smas, J.R. Wilkinson and L.J. Todd, J. Organometal. Chem., 86, 219 (1975).
33. G.W. Buchanan, G. Montando and P. Finochiaro, Can. J. Chem. 51, 1053 (1973).
34. H. Böhme and H.G. Viehe, "Iminium Salts in Organic Chemistry" Part 1, Adv. Org. Chem., 9, 76 (1976).
35. K. Nakanishi, "Infrared Absorption Spectroscopy-Practical", Holden-Day, Inc., San Francisco and Nakodo Company Limited, Tokyo (1962), P.38.

REFERENCES OF CHAPTER THREE

1. G.W.A. Fowles, *Progress Inorg. Chem.*, 6, 1 (1964).
2. W.J. McDowell, and C.W. Keenan, *J. Am. Chem. Soc.*, 78, 2069 (1956).
3. W.J. Jenkis, *J. Am. Chem. Soc.*, 78, 5500 (1956).
4. E. Bannister and G.W.A. Fowles, *J. Chem. Soc.*, 751 (1958).
5. E. Bannister and G.W.A. Fowles, *J. Chem. Soc.*, 310 (1959).
6. J.W.A. Fowles, and R.A. Hoodless, *J. Chem. Soc.*, 33 (1963).
7. D.A. Edwards and G.W.A. Fowles, *J. Chem. Soc.*, 24 (1961).
8. B.J. Brisdon, G.W.A. Fowles, and B.P. Osborne, *J. Chem. Soc.*, 1330 (1962).
9. J.M. Miller and R.A.J. K. Chadha, *J. Organomet. Chem.*, 216, 177 (1981).
10. B. Samuel, R. Snaith, C. Summerford, and K. Wade, *J. Chem. Soc.*, A, 2019 (1970).
11. C. Summerford and K. Wade, *J. Chem. Soc.*, A, 1487 (1969).
12. C. Summerford, Ph.D. Thesis, Durham University (1969).
13. D. Haas, *Z. Anorg. Allgem. Chem.*, 332, 287 (1964).
14. R. Hulme and J.C. Scruton, *J. Chem. Soc.*, A, 2448 (1968).
15. V.D. Neubauer and J. Weiss, *Z. Anorg. Allgem. Chem.*, 303, 28 (1960).
16. N. Wiberg, and K.H. Schmidt, *Chem. Ber.*, 100, 741 (1967).
17. L.K. Krannich "Compounds containing As - N bonds", from Benchmark papers *Inorg. Chem.*, Vol. 5, Dowden, Hutchinson and Ross Inc., Stroudsburg and Pennsylvania (1976).
18. H. Remy, and G. Tiedemann, *Chem. Ber.*, 94, 472 (1961).
19. O.J. Scherer and W. Janssen, *Chem. Ber.*, 103, 2784 (1970).
20. E. Allenstein and A. Schmidt, *Chem. Ber.*, 97, 1286 (1964).
21. R. van der Linde, J.W. Dornseiften, J.V. Veenland and Th. de Boer, *Spectrochim. Acta*, 25A, 375 (1969).
22. S.K. Porter and R.A. Jacobson, *J. Chem. Soc.*, A, 1356 (1970).

23. M. Webster and S. Keats, *J. Chem. Soc., A*, 298 (1971).
24. D.R. Schroeder and R.A. Jacobson, *Inorg. Chem.*, 12, 210 (1973).
25. S.K. Porter and R.A. Jacobson, *J. Chem. Soc., A*, 1359 (1970).
26. S.L. Lawton and R.A. Jacobson, *Inorg. Chem.*, 7, 2124 (1968).
27. R.D. Whealy and J.B. Blackstock, *J. Inorg. Nucl. Chem.*, 26, 243 (1964).
28. S.L. Lawton, R.A. Jacobson and R.S. Frye, *Inorg. Chem.*, 10, 701 (1971).
29. J. Goubeau, E. Allenstein, and A. Schmidt, *Chem. Ber.*, 97, 884 (1964).
30. K.E. Elmer, P. Volgandt, G. Heckmann and A. Schmidt, *Spectrochim. Acta*, 35, 473 (1979).
31. I.R. Beattie, *J. Chem. Soc., A*, 712 (1967).
32. Landolt-Bornstein, "Physikalisch-Chemische Tabellen", 2 Teil (1951).
33. R.M. Silverstein, G.C. Bassler, and T.C. Morrill, "Spectrometric identification of organic compounds", John Wiley and Sons, Inc., New York, London, Sydney, Toronto (1974), P.77.
34. P. Day, *Inorg. Chem.*, 2, 452 (1963).

REFERENCES OF CHAPTER FOUR

1. E.J. Bulten and W.G. Van den Hurk, *J. Organomet. Chem.*, 162, 161 (1978).
2. G. Reifenberg, W.J. Considine, *Ger. Offen.*, 1, 963, 569 (1968).
3. P.G. Huggett, Ph.D. Thesis, Durham University, (1979).
4. M.E. Peach and J.C. Waddington, *J. Chem. Soc.*, 600 (1962).
5. G. Jang and S. Danyluk, *J. Am. Chem. Soc.*, 81, 3846, 3850 (1959).
6. F. Klages, R. Ruhnau, and W. Hauser, *Ann. Chem.*, 626 60 (1959).
7. H. Meerwein, P. Laasch, R. Mersch, and J. Spille, *Ber.*, 89, 209 (1956).
8. F. Klages, and W. Grill, *Ann. Chem.*, 594, 21 (1955).
9. Cancelled.
10. S. Yanagida, M. Yokoe, I. Katagiri, M. Ohoka and S. Komori, *Bull. Chem. Soc. Jpn.*, 46, 303 (1973).
11. S. Yanagida, M. Yokoe, I. Katagiri, M. Ohoka, and S. Komori, *Bull. Chem. Soc. Jpn.*, 46, 306 (1973).
12. S. Yanagida, T. Fujita, M. Ohoka, I. Katagiri, and S. Komori, *Bull. Chem. Soc. Jpn.*, 46, 292 (1973).
13. L.E. Hinkel and G.J. Treharne, *J. Chem. Soc.*, 866 (1945).
14. C. Grundmann, G. Weisse, and S. Seide, *Ann. Chem.*, 577, 77 (1952).
15. A.Y. Lazaris, E.N. Zilberman, and O.D. Strizhakov, *J. Gen. Chem. USSR*, 32, 890 (1962).
16. S. Yanagida, M. Ohoka, M. Okahara, and S. Komori, *J. Org. Chem.*, 34, 2972 (1969).
17. S.W. Peterson and J.M. Williams, *J. Am. Chem. Soc.*, 88, 2866 (1966).
18. I.M. Kolthoff, S. Bruckenstein, and M.K. Chantooni, *J. Am. Chem. Soc.*, 83, 3927 (1961).
19. F.E. Murray and W.G. Scheider, *Can. J. Chem.*, 33, 797 (1955).

20. J.W. Mellor, "A Comprehensive Treatise on inorganic and theoretical chemistry", Vol. III, Longmans, Green and Co. Ltd., New York (1927), P.431.
21. P. Klaboe and J. Grundnes, Spectrochim. Acta., 24A, 1905 (1968).
22. D.H. Lohmann, J. Organomet. Chem., 4, 382 (1965).
23. R.J.H. Clark and C.S. Williams, Spectrochim. Acta., 21, 1861 (1965).
24. J.W. Burley, P. Hope, R.E. Hutton, J. Groeneboom, J. Organomet. Chem., 170, 21 (1979).
25. S. Yanagida, M. Okahara and S. Komori, Adv. Org. Chem., 9 (Part 2), 527.
26. W.H. Carothers, G.J. Berchet and A.M. Collins, J. Am. Chem. Soc., 54, 4066, 4071 (1932).
27. P.B.D. de la Mare and R. Bolton, "Electrophilic addition to unsaturated systems", Elsevier Publishing Company, London (1966), P.238.
28. P.B.D. de la Mare, E.D. Hughes and C.K. Ingold, J. Chem. Soc., 17 (1948).
29. C.K. Ingold, "Structure and mechanism in inorganic Chemistry", Bell, London, (1953), P.946.

REFERENCES FOR CHAPTER FIVE

1. M. Herberhold, "Metal  $\pi$ -Complexes", Volume II, Part 1, Elsevier Publishing Company, Amsterdam (1972).
2. S.J. Bryan, P.G. Huggett, K. Wade, J.A. Daniels, and J.R. Jennings, *Coordination Chem. Review*, (1981), under publishing.
3. C.C. Costain, B.P. Stoicheff, *J. Chem. Phys.*, 30, 779 (1959).
4. B. Swanson, D.F. Shriver and J.A. Ibero, *Inorg. Chem.*, 8, 2182 (1969).
5. M. Massaux, G. Ducreux, R. Chevalier, and M.T. Le Bihan, *Acta Cryst.*, B34, 1863 (1978).
6. H. Hirai, S. Okuzawa, T. Ikegami and S. Makishima, *Journal of the faculty of Engineering, Univ. of Tokyo (B)*, 29(1), 115 (1967).
7. B. Swanson and D.F. Shriver, *Inorg. Chem.*, 9, 1406 (1970).
8. D.F. Shriver and B. Swanson, *Inorg. Chem.* 10, 1354 (1971).
9. K.F. Purcell and R.S. Drago, *J. Am. Chem. Soc.*, 88, 919 (1966).
10. K.F. Purcell, *J. Am. Chem. Soc.*, 89, 247, (1967).
11. J.F. Guttenberger and W. Strohmeier, *Chem. Ber.*, 100, 2807 (1967).
12. R.E. Clarke, P.C. Ford, *Inorg. Chem.*, 9, 227 (1970).
13. R.E. Clarke, P.C. Ford, R.D. Foust, *Inorg. Chem.*, 9, 1933 (1970).
14. M.F. Farona, G.R. Tompkin, *Spectrochim. Acta*, 24A, 788 (1968).
15. R.J. Kern, *J. Inorg. Nucl. Chem.*, 25, 5 (1963).
16. W. Kuran, S. Pasykiewicz, Z. Florjanczyk, and E. Lustyk, *Makromol. Chem.*, 177, 2627 (1976).
- 17a. H. Haraguchi and S. Fujiwara, *J. Phys. Chem.*, 73, 3467 (1969).
- 17b. I.R. Beattie, P.J. Jones, J.A.K. Howard, E.L. Smart, C.J. Gilmore and J.W. Aillitt, *J.C.S. Dalton* (1979), 528.

18. R. Cramer, *Inorg. Chem.*, 1, 722 (1962).
19. W. Strohmeier and H. Hellmann, *Chem. Ber.*, 98, 1598 (1965).
20. G. Fiedler, *Z. Physik.Chem. (Frankfurt)*, 37, 79 (1963).
21. A.R. Luxmoore and M.R. Truter, *Acta Cryst.* 15, 1117 (1962).
22. J.F. Guttenberger and W. Strohmeier, *Chem. Ber.*, 100, 2807 (1967).
23. C.A. Tolman, *J. Am. Chem. Soc.*, 96, 2780 (1974).
24. See Reference 1, P.290.
25. G.N. Schrauzer, *Chem. Ber.*, 94, 1891 (1961).
26. M. Massaux, M.T. Le Bihan and R. Chevalier, *Acta. Cryst. (B)* 33, 2084 (1977).
27. M.A. Muhs and F.J. Weiss, *J. Am. Chem. Soc.*, 84, 4697 (1962).
28. G.N.Schrauzer and S. Eichler, *Chem. Ber.*, 95, 260 (1962).
29. J.W. Fitch III and J.J. Lagowski, *Inorg. Chem.*, 4, 864 (1965).
30. R.B. King, *Inorg. Chem.*, 4, 1518 (1965).
31. H.P. Fritz and G.N.Schrauzer, *Chem. Ber.*, 94, 650 (1961).
32. D.A. Brown and G.N. Schrauzer, *Z. Physik. Chem.*, 36, 1-14 (1963).
33. F. Hohmann, H.T. Dieck, C. Krüger and Y.H. Tsay, *J. Organomet. Chem.*, 171, 353 (1979).
34. H.T. Dieck, F. Hohmann, M. Form, T. Mack and I.W. Renk, *J. Less-Common Metals*, 54, 221 (1977).
35. E. Schubert and R.K. Sheline, *Inorg. Chem.*, 5, 1071 (1966).
36. G.W.A. Fowles and K.F. Gadd, *J. Chem. Soc. (A)*, 2232 (1970).
37. F. Halverson, R.F. Stamm and J.J. Whalen, *J. Chem. Phys.*, 16, 808 (1948).
38. J. Bragin, K.L. Kizer and J.R. Durig, *J. Mol. Spec.*, 38, 289 (1971).

39. J.R. Durig, C.K. Tong, C.W. Hawley and J. Bragin, J. Phys. Chem., 75, 44 (1971).
40. H.W. Quinn, J.S. McIntyre and D.J. Peterson, Can. J. Chem., 43, 2896 (1965).
41. R. Hüttel and H. Reinheimer, Chem. Ber., 99, 2778 (1966).
42. R. Hüttel, H. Reinheimer and H. Dietl, Chem. Ber., 99, 462 (1966).
43. W.J. Potts and R.A. Nyquist, Spectrochim. Acta, 15, 679 (1959).
44. N. Suzuki and K. Kozima, J. Mol. Spectrosc. 33, 407 (1970).
45. W.J. Geary, Coord. Chem. Rev., 7, 81 (1971).
46. A. Vincent, "Molecular Symmetry and Group Theory", John Wiley and Sons, London.

REFERENCES OF APPENDIX 1

1. N. Bertazzi, T.C. Gibb and N.N. Greenwood, J.C.S. Dalton, 1153 (1976).
2. N. Bertazzi, F. Di-bianca, T.C. Gibb, N.N. Greenwood, H.A. Meinema and J.G. Moltes, J.C.S. Dalton, 957, (1977).
3. J. Donaldson, J.T. Southern, M.J. Tricker, J.C.S. Dalton, 2637 (1972).
4. J.G. Ballard, T. Birchall, R. Fourcade and G. Mascherpa, J.C.S. Dalton, 2409 (1976).
5. T. Birchall, B. Della Valle, E. Martineau, and T.B. Milne, J.C.S., A, 1855 (1971).
6. B.W. Dale, J.D. Donaldson and M.J. Tricker, J.C.S. Dalton, 893 (1972).
7. T. Birchall and B. Della Valle, Can. J. Chem. 49, 2808 (1971).
8. T. Birchall, J.G. Ballard, J.B. Milne, and W.D. Moffett, Can. J. Chem., 52, 2375 (1974).
9. L.H. Brown, K.A. Taylor, H.K. Chin, and G.G. Long, J. Inorg. Nucl. Chem. 36, 101, (1974).
10. W.J. Geary, Coordination Chemistry Reviews, 7, 81 (1971).
11. R.D. Feltham and R.G. Hayter, J.C.S., 4587 (1964).

