

Durham E-Theses

Industrial development in Qatar: a geographical assessment

Mohammed Ali M. Al-Kubaisi

How to cite:

Al-Kubaisi, Mohammed Ali M. (1984) Industrial development in Qatar: a geographical assessment. Doctoral thesis, Durham University.

Use policy

The full-text may be used and/or reproduced, and given to third parties in any format or medium, without prior permission or charge, for personal research or study, educational, or not-for-profit purposes provided that:

- a full bibliographic reference is made to the original source
- a <https://etheses.durham.ac.uk/id/eprint/7144/> is made to the metadata record in Durham E-Theses
- the full-text is not changed in any way

The full-text must not be sold in any format or medium without the formal permission of the copyright holders.

Please consult the [full Durham E-Theses policy](#) for further details.

INDUSTRIAL DEVELOPMENT IN QATAR

1950 - 1980

A GEOGRAPHICAL ASSESSMENT

by

MOHAMMED ALI M. AL-KUBAISI

(GRADUATE SOCIETY)

The copyright of this thesis rests with the author.
No quotation from it should be published without
his prior written consent and information derived
from it should be acknowledged.

Thesis submitted to the Faculty of Social Science
in the University of Durham for the
Degree of Doctor of Philosophy

May, 1984

Geography Department



-2. NOV. 1984

ABSTRACT

Before oil discovery and exploitation, industry in Qatar took the form of artisanal activities and traditional crafts. Since the 1960's industry has become modernised, complex and diverse in type and scale. This thesis explores the trends in industrial development in Qatar between 1950 and 1980, analyses and evaluates current industrial structure and possible future developments.

The thesis is organised into ten Chapters. The first three describe the parameters, including physical and human resources, within which the process of industrialisation has occurred and may develop. The evaluation of industrial policy, the relevance of standard theories of industrialisation and an examination of the role of government are next considered. Chapters 5 and 6 contain field-work based analyses of the complete inventory of manufacturing industries, public and private, large and small-scale and industrial linkages. This leads to an examination of industrial locations in Qatar. Chapters 8 and 9 are devoted to two themes of fundamental importance, viz. decision-making, investment and management at various levels and secondly, dependency on foreign labour. The judgement arrived at in the Conclusion is that the future for viable and socio-culturally appropriate industries, whether in a national, regional or international context, lies not in the expansion of basic industries but rather in typologically innovative manufacturing processes.

II

ACKNOWLEDGEMENTS

This work would not have been possible without the generous help and encouragement of many individuals, government ministries, departments and centres, other organizations, companies and establishments who provided me with information, source materials, and various types of data. To all of them I owe a great debt and many thanks.

I would like to express my gratitude to my chief supervisor, Professor H. Bowen-Jones, for his enthusiasm and inspiration, his valuable advice and suggestions for improvement, as well as for sustaining his interest throughout this study which enabled me to shape this thesis into its present form. My thanks and gratitude are also extended to my "shadow" or second supervisor, Dr.R.Hudson, for his personal enthusiasm and encouragement. My thanks go to Dr. A.Al-Kobaisi (President Assistance of Qatar University) for reading my work and making useful suggestions. Also I would like to thank the State of Qatar for their financial support.

In Durham, I would like to record my thanks to all of the staff in the Department of Geography who made my stay a pleasant one. I am grateful, too, to Mrs. M. Bell for excellent typing, and to Miss C. Morgan for reading the draft copy of the thesis and making useful corrections. Also my thanks to go all of my colleagues within the University of Durham.

In Qatar, I would like to record my deep gratitude to the Amir's Office who provided me with a letter which helped me to open locked doors. My thanks also go to the staff of Qatar University in general, and of the Geography Department in particular. My deep gratitude and thanks go to all the individuals too numerous to mention, who provided me, in one way or another, with data and information, as well as those who supplied me with special reports and interviews.

III

Finally, I would like to thank the one who I am most indebted to, my wife, Umm Hamad, for her continuous patient encouragement and understanding which established the climate in which to carry on with this study.

To all of these people, and others, I owe a great debt of thanks.

DEDICATED TO:

My Wife

My children

Hamad and Reim

And to My Parents

IV
CONTENTS

	<u>Page</u>
Abstract	I
Acknowledgements	II
Contents	IV
List of Tables	VII
List of Figures	X
List of Charts	XII
List of Appendices	XIII
Abbreviations	XIV
<u>CHAPTER 1 : INTRODUCTION</u>	1
References	9
<u>CHAPTER 2 : PHYSICAL FEATURES AND NATURAL RESOURCES</u>	10 - 22
2.1 Mineral Resources and Geology	10
2.2 Climate	13
2.3 Soil and Ground Water Resources	15
2.4 Marine Resources	17
Conclusion	19
References	21
<u>CHAPTER 3 :) POPULATION AND HUMAN RESOURCES</u>	23 - 63
3.1 General Population Trends	23
3.2 Natural Growth	27
3.3 Migration	30
3.4 Population Structure : Indigenous and Non-Indigenous	38
3.5 Labour Force and Educational Level	41
3.5.1 Labour Force and Economic Activity	41
3.5.2 Education Level of Qataris and Non-Qataris	49
Conclusion	58
References	62

<u>CHAPTER 4 :</u>	<u>INDUSTRIAL DEVELOPMENT IN QATAR - POLICIES AND INSTITUTIONS</u>	64 - 101
4.1	Development of Policy Strategy for Industry ✓	64
4.2	The Linkage of Government Bodies with Political Authority ✓	74
4.3	Ministry of Finance & Petroleum ✓	78
4.4	Ministry of Economy & Commerce ✓	80
4.5	Ministry of Industry & Agriculture	82
4.6	Qatar General Petroleum Corporation (QGPC) .. ✓	84
4.7	Industrial Development Technical Centre (IDTC)	86
4.8	Taxation Laws in Qatar	88
4.9	Industrial Organization	90
4.10	Government Incentives for Industry	94
	References	99
<u>CHAPTER 5 :</u>	<u>EXTRACTIVE INDUSTRY</u>	102 - 139
5.1	Oil Industry ✓	102
5.2	Natural Gas ✓	128
5.3	Other Extractive Industries	134
	References	137
<u>CHAPTER 6 :</u>	<u>THE MANUFACTURING INDUSTRIES - BY TYPE AND SECTOR</u> ...	140 - 224
6.1	Oil Refinery ✓	141
6.2	Cement Factory	149
6.3	Fishing Industry	160
6.4	Flour Mill	165
6.5	Chemical Fertilizer ✓	172
6.6	Iron and Steel Complex	186
6.7	Small-Scale Industries (SSI)	197
6.8	Current Large-Scale Development	210
	Conclusion	216
	References	218

<u>CHAPTER 7</u> :	<u>LOCATION OF MANUFACTURING INDUSTRIES</u>	225 - 255
	7.1 Umm Said Industrial Area	225
	7.2 Industrial Estate of Doha	240
	References	254
<u>CHAPTER 8</u> :	<u>DECISION-MAKING, CAPITAL INVESTMENT AND</u> <u>MANAGEMENT</u>	256 - 276
	8.1 Decision-Making	257
	8.1.1 Process of Industrial Decision-Making in the Public Sector, Ministerial Proj- ects and the Private Sector	258
	8.2 Capital Investment in the Public Sector, Minis- terial Projects and the Private Sector	266
	8.3 Management & Industrial Establishments of Public, Ministerial and Private	270
	References	276
<u>CHAPTER 9</u> :	<u>DEPENDENCE ON FOREIGN LABOUR FORCE IN INDUSTRIAL</u> <u>DEVELOPMENT</u>	277 - 293
	9.1 Factors Which Caused The Dependence ✓	278
	9.2 Occupational Structure of Imported Labour Force ✓	283
	9.3 Occupational Distribution of Qataris and Non-Qataris ✓	287
	9.4 The Impact of the Foreign Labour Force ✓	288
	Concluding Remark	292
	References	293
<u>CHAPTER 10</u> :	<u>CONCLUSION</u>	294 - 322
	References	322
<u>APPENDICES</u>		323 - 343
<u>BIBLIOGRAPHY</u>		344 - 354

VII

LIST OF TABLES

Page

CHAPTER 1

1.1	Actual Government Revenue & Expenditure (1395-1401 H.)	2
-----	--	---

CHAPTER 2

2.1	Generalized Stratigraphy of Qatar	12
2.2	Monthly Average of Maximum and Minimum Temperature and Relative Humidity	14

CHAPTER 3

3.1	Population in the Gulf Emirates	23
3.2	Estimation of Population Growth in Qatar ✓	25
3.3	Population Forecasts of Qatar by Nationality ✓	26
3.4	Total Births Reported in Qatar by Nationality & Sex (1967-80) ✓	28
3.5	Total Deaths in Qatar by Nationality & Sex (1974-81)	29
3.6	Total of New Resident Visas (Issued between 1395-98 H.) . . .	32
3.7	Non-Qatari Population by Nationalities (1970 Census)	33
3.8	The Non-Qatari Population as in 1979	34
3.9	Economically Active Population by Sector and Nationality (1970)	42
3.10	Total Labour Force by Sector (1977 and 1978)	44
3.11	Llewelyn-Davies Weeks, Medium Employment Forecast by Sector (1972-92)	46
3.12	William L. Pereira, Medium Employment Forecast by Sector (1970-95)	46
3.13	Shankland Cox Qatari Population Projection by Age and Sex (1975-2000)	48
3.14	Qatari Potential Labour Force by Age, Sex and Educational Level (1970)	53
3.15	Qatari Manpower by Occupation and Educational Level (1970).	54
3.16	Non-Qatari Potential Labour Force by Age, Sex and Educational Level (1970)	56
3.17	Non-Qatari Manpower by Occupation and Educational Level (1970)	57

CHAPTER 4

4.1	The Members of the Committee of Industrial Development ...	92
4.2	The Members of the Committee of Light Industries Loans ...	93

CHAPTER 5

5.1	Qatar Crude Oil Prices (1953-1982)	108
5.2	Employment of QPC and SCQ by Nationality and Statutes (1975)	109
5.3	Employment Structure of QPPA (1980)	110
5.4	Qatar Crude Oil Production (1949-80)	118
5.5	Crude Oil Production in OAPEC Member Countries (1977-81)..	120
5.6	Production and Reserves of Qatar's Crude Oil	122
5.7	Qatar Crude Oil Exports (1949-80)	124
5.8	Crude Oil Export in OAPEC Member Countries (1977-81)	126
5.9	Crude Oil Exports from Qatar (1968-80)	127
5.10	Production and Consumption of Natural Gas (1969-80)	130

CHAPTER 6

6.1	Topping Plant Production & Oil Products Consumption (1962-67)	142
6.2	Production and Consumption of Oil Products during 1975-80	146
6.3	Profit & Loss Account of NODCO	150
6.4	Price of Imported Oil Product per Gallon	150
6.5	QNCC's Labour Force by Nation	154
6.6	Production & Consumption of Portland & Salt Resistant Cement (1969-80)	157
6.7	Profit & Loss Account of QNCC (1977-80)	160
6.8	Headless Shrimp Production of QNFC (1970-78)	163
6.9	Profit & Loss Account of QNFC (1971-76)	164
6.10	Manpower of QFMC by Nationality and Division (1973-80)....	168
6.11	QFMC's Production & Total Consumption of Flour and Bran in Qatar (1972-80)	169

6.12	Sales Values of Flour & Bran and CIF Values of Imported Products	170
6.13	Production Costs and Sales/Ton	171
6.14	Composition of QAFCO Labour Force by Nationality and Function	178
6.15	QAFCO Production and Sales	182
6.16	Profit & Loss Accounts of QAFCO (1975-79)	183
6.17	QAFCO Ammonia & Urea Prices	185
6.18	Gas Consumption (QAFCO)	185
6.19	QASCO's Manpower as at March 1980	190
6.20	Reinforcing Bars Imported to Qatar by Value	194
6.21	Destination and Quantities of QASCO Sales	195
6.22	Sales Value of QASCO's Bar Products (1978-80)	196
6.23	The Development of Small-Scale Manufacturing Industries during 1950-80	204
6.24	Estimation of SSI Employment in 1980	205
 <u>CHAPTER 7</u>		
7.1	Statement of Government Expenditure in Umm Said	231
7.2	Water Department Budget Estimate 1980	236
7.3	Estimation of Fresh Water Demand in Umm Said (1977-81)	237
7.4	Umm Said Estimated Demand of Electricity (1978-81)	237
7.5	Umm Said Long-term Industrial, Services Employment and Population Estimates	239
7.6	Selected Industrial Registration (1979-Oct.1982)	251
 <u>CHAPTER 8</u>		
8.1	Estimated Financial Source of Major Projects 1978	267
 <u>CHAPTER 9</u>		
9.1	New Residential Visas Issued Between 1396-99 H.(1976-79) by Occupation	285
9.2	Renewed " " "	285
9.3	Distribution of Labour Force by Nationality and Main Economic Sector (1981)	287
 <u>CHAPTER 10</u>		
10.1	Summary Table of the 18 Projects	311
10.2	Main Industrial Area and Development Zones	319

LIST OF FIGURESFollow PageCHAPTER 1

1.1	Employment and G.D.P. by Sectors (1980)	2
1.2	Non-Oil G.D.P. at Current Prices (1975-80)	2

CHAPTER 3

3.1	Qatar Population by Sex/Age Structure (1970)	38
3.2	Qatari Population Pyramid by Sex and Age (1970)	39
3.3	Non-Qatari Population by Sex/Age Structure (1970)	40
3.4	Qatar Population Structure - Male and Female (1981)...	41
3.5	Projection of Labour Force Demand and Qataris over 20 (1970-1995)	49
3.6	Education Ladder in Qatar	50
3.7	Technical and Vocational Training Also Educational Employment	53
3.8	Qatarizations and Vocational Training Programmes	59

CHAPTER 5

5.1	Development of Oil Industry and Concession Areas (1960)	105
5.2	" " " " (1970)	105
5.3	" " " " (1980)	105
5.4	Pipelines in Dukhan (onshore)	114
5.5	Offshore Pipelines	115

CHAPTER 6

6.1	Labour Force by Nationality	178
6.2	QASCO Production of Steel Reinforcing Bars (By month and year)	191
6.3	Sketch Plan of NGL	215
6.4	Inter and Intra-Industrial Linkages	217

<u>CHAPTER 7</u>	<u>Follow Page</u>
7.1 Sea Depth and Approach to Umm Said	226
7.2A Umm Said Existing Conditions	227
7.2B Geomorphology and Layout of Umm Said (1982)	227
7.3 Umm Said Town as in 1982	232
7.4 Action Programme for Roads in Umm Said 1400 H.(1979-80)...	234
7.5 Layout of I.E.D.	244
7.6 Actual Development of I.E.D. as in 1982	249
7.7 Latest Layout of I.E.D.	252
 <u>CHAPTER 8</u>	
8.1 Public Sector, Amir or IDTC Projects	258
8.2 Ministerial Project Development	261
8.3 Private Sector Decision-Making	Page 263

LIST OF CHARTS

<u>CHAPTER 4</u>		<u>Page</u>
4.1	Pre 1972 - Upper Echelons of Government	76
4.2	Post 1972 - Upper Echelons of Government	77
 <u>CHAPTER 8</u>		
8.1	QASCO Organisation Chart Follow Page	271
8.2	Management of Other Public and Ministerial Organization	272
8.3	Management of Private Sector	273

XIII
LIST OF APPENDICES

	<u>Page</u>
1.1 The Questionnaire	323
1.2 Data Classification of The Establishment in Qatar (Survey)	328
4.1 Decree Law No. (10) of year 1974 Concerning the Establish- ment of Qatar General Petroleum Corporation	329
4.2 Law No. (3) of 1973 For Establishing the Industrial Development Technical Centre	332
5.1 Qatar Oil Concession	335
5.2 The Government and Shell Company Agreement	338
10.1 GOIC Agreement	342
10.2 Summary of Author's Translation of GCC Economic Agreement	343

XIV

ABBREVIATIONS

CID	=	Committee of Industrial Development
CIF	=	Cost, Insurance and Freight
CSO	=	Central Statistical Organization
ESD	=	Engineering Services Department
f.o.b.	=	Free on Board
GCC	=	Gulf Co-operative Council
GDP	=	Gross Domestic Product
GOIC	=	Gulf Organization for Industrial Consulting
IDTC	=	Industrial Development Technical Centre
IED	=	Industrial Estate of Doha
I.S.	=	Industrial School
MEDD	=	Middle East Development Division (of MOD)
MEED	=	Middle East Economic Digest
MOD	=	Ministry of Overseas Development
NGL	=	Natural Gas Liquids
NODCO	=	National Oil Distribution Company
OAPEC	=	Organization of Arab Petroleum Exporting Countries
OPEC	=	Organization of Petroleum Exporting Countries
QAFCO	=	Qatar Fertilizer Company
QAPCO	=	Qatar Petrochemical Company
QASCO	=	Qatar Steel Company
QGPC	=	Qatar General Petroleum Corporation
QFMC	=	Qatar Flour Mill Company
QNCC	=	Qatar National Cement Company
QNFC	=	Qatar National Fishing Company
QNOG	=	Qatar National Oil Company

XV

QPC	=	Qatar Petroleum Company
QR	=	Qatari Riyal
SABIC	=	Saudi Arabia Basic Industrial Corporation
SCQ	=	Shell Company (Qatar)
SIDF	=	Saudi Industrial Development Fund
SSI	=	Small-Scale Industry
UAE	=	United Arab Emirates
UK	=	United Kingdom
USA	=	United States of America

CHAPTER 1

INTRODUCTION

BACKGROUND OF THE STATE OF QATAR

Qatar, an independent Arab country, occupies a small peninsula and several very small islands located in the Arabian Gulf mid-way between the head of the Gulf and the Straits of Hormuz. At the neck of the peninsula is Saudi Arabia. Bahrain, United Arab Emirates, Saudi Arabia and Iran are Qatar's seaward neighbours. Qatar's territory has an area of approximately 10,600 sq.km. ⁽¹⁾ and contains a population of about a quarter of a million.

Qatar attained full national sovereignty from Great Britain on 3rd September 1971. On 11th and 16th September 1971 it became a member of both the Arab League and the United Nations respectively. Qatar, before that, was a member of the Organisation of Petroleum Exporting Countries (OPEC) from 1961 and from 1970 a member of the Organisation of Arab Petroleum Exporting Countries (OAPEC).

Oil was discovered in 1939 and the production started in 1949. The oil revenues, as will be seen in the proceeding Chapters, were responsible for transferring Qatar from an almost unknown underdeveloped country to a semi-developed or modern one. Oil production and export, as will be seen in Chapter 5, will continue to be by far the most important sector of Qatar's economy. Figure 1.1 shows that although the oil sector provides only a small share in overall employment it is, and has been, the principal contributor to the national Gross Domestic Product.

If actual government revenue and expenditure are considered the oil sector's contribution becomes even greater. Table 1.1 below shows clearly that the oil revenues during 1395 - 1401 A.H.



(c.a. 1975 - 81 A.D.) were the source of not less than 89 per cent of the total government revenues.

Table 1.1 : Actual Government Revenue & Expenditure (1395 H - 1401 H.)
(In Million QR)

	1395	1396	1397	1398	1399	1400	1401
Total Revenues	7,135	8,927	8,154	8,225	12,090	19,004	19,243
of which oil revenues	6,623	8,020	7,458	7,421	11,220	17,454	17,189
Total Expenditure	4,433	5,809	7,318	6,472	8,273	10,937	14,743
of which capital expenditure on minor and major projects	1,209	2,034	3,022	2,536	2,430	3,260	3,620
Surplus	2,702	3,118	836	1,753	3,817	8,067	4,500

Source : Central Statistical Organization, Annual Statistical Abstract 1981, T.149, p.215.

In non-oil GDP as illustrated in Figure 1.2, all sectors have had a general growth trend but with varying rates. The average growth rate of the manufacturing industrial sector was 24.6 per cent per annum. This rate of growth would have been much greater if the NGL plant had not been destroyed in 1977. The government services sector also rose sharply with an average growth rate of 25.0 per cent per annum.

OBJECTIVES OF THE STUDY

This study, of Qatar's industrial development, has several aims and objectives to achieve:

1. Apart from a relatively few government statistics, there has been no analytical study of what industries there are in Qatar and what their characteristics are. This being the case it was felt

Fig. I.1
Employment and G.D.P. by Sectors (1980)

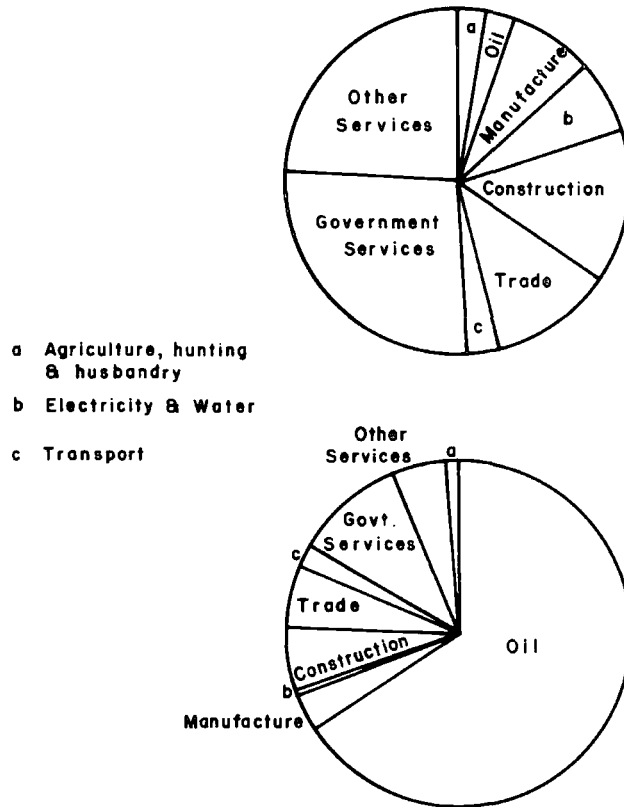
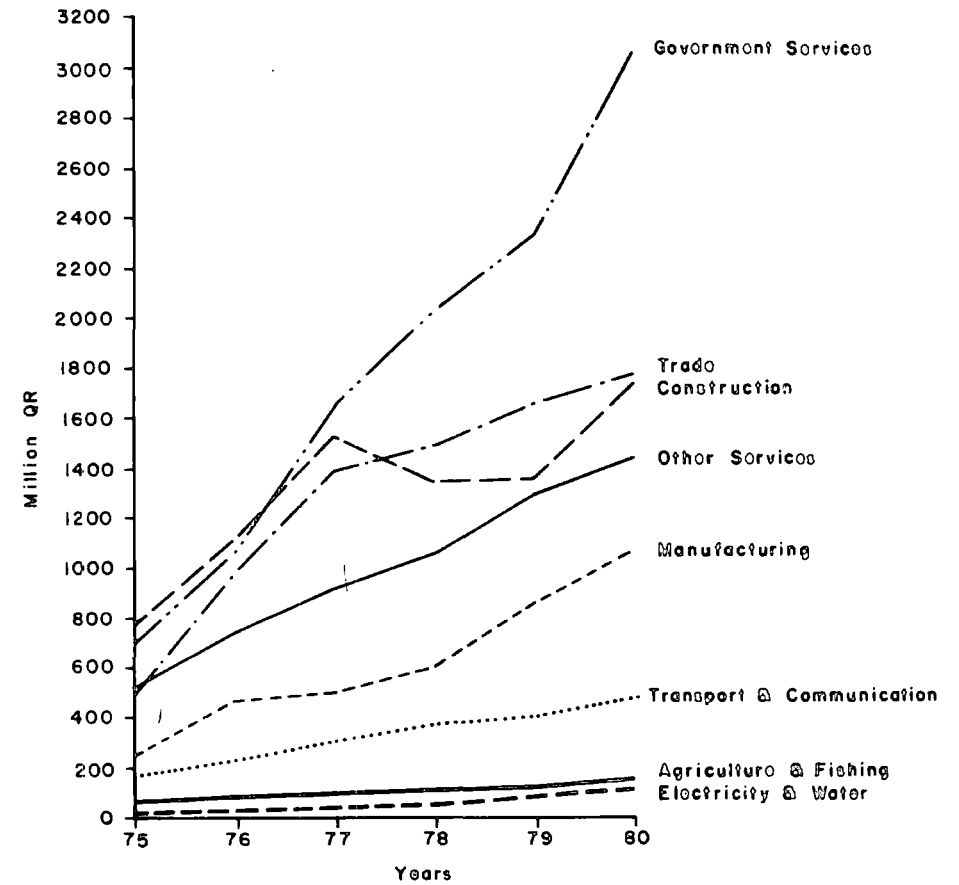

Fig. I.2
Non-Oil G.D.P. at Current Prices (1975-80)



Sources: Compiled by the Author from Central Statistical Organisation, Annual Statistical Abstract 1981, p.213
 T. 147 and Al-Kuwari, Analytical Study of Factors Governing the Size, Structure and Type of Workforce in Qatar, Doha
 1981, Appendices

to be crucial that a first pioneering study should be undertaken. As will be seen, this most important element of Qatar's development programmes does provide a base for further studies on specialised aspects of industrialization in Qatar.

2. To identify and throw light on the manufacturing and extractive industrial sectors and specifically their development trends over the last thirty years (1950-1980).

3. The analysis of each field of industry separately so as to show the structure of manufacturing industries in Qatar.

4. To analyse the process of industrialization and the role of government in its development.

5. To show how the demand on non-indigenous technology has had consequential socio-economic problems, especially that of dependence on a foreign labour force in industrial development.

6. To throw light on the national industrialization policy and strategy which Qatar has been following.

7. To evaluate, in economic terms, the existing industries and their future prospects.

DATA SOURCES

The author paid several visits to Qatar, two for detailed field work while an additional three were spent on data elicitation. The data sources obtained from these visits can be classified as follows:

1. Statistical data and literature

Largely obtained from governmental bodies and agencies; the author also collected various books and reports published by individuals and working groups. These are all generally accessible for

anyone (even though not centrally stored) and are noted in the Bibliography.

2. Primary sources

These sources can be categorized into:

a) Special reports produced for the author of the thesis by various governmental bodies and agencies, as well as joint stock companies.

These reports are mostly confidential and given to the author on condition that no third party is allowed to have direct access to them and that they should be used only for the purpose of this thesis.

b) Feasibility studies and other similar reports.

Although these reports are classified as highly confidential, fortunately the author succeeded in obtaining some of those which are related directly to industrial development in general and specific manufacturing establishments in particular.

c) Interviews.

The author was given special interviews by leading responsible individuals, in both private and public sectors, in which opinions were expressed and information given. These interviews, wherever possible, will be referred to as Personal Communications with the source, but in some cases the author cannot make direct attribution.

3. Field work

Field investigation was of two types:

First : The search in almost every governmental body and agency with special concentration on :

a) Commercial Registry Department of the Ministry of Economy and Commerce. The search in this department enabled the obtaining of a great deal of information about industrial establishments existing

now, or in the past, in Qatar. This information mainly concerned medium and small-scale manufacturing establishments, the specific data being : the name, legal status, location, issued capital by nationality (Qatari, non-Qatari and partnerships of both), date of start-up and other notes concerning the establishments.

b) Statistical Department of the Ministry of the Interior. The author, with the help of this department, was able to obtain the necessary data concerning the non-Qatari population in the country. The information was categorized into occupational groups i.e. labourers, technicians, etc. and, at the same time, classified as holding new or renewed residential visas. Without this information the labour force question would not have been possible to analyse.

The search in the above-mentioned departments and others was conducted only to allow greater depth in the analysis of industries in Qatar and their development.

Lastly, the Questionnaire: It was essential for the study of the private sector to design a questionnaire (see Appendix 1.1) both to obtain data on, and to achieve an understanding of, the various elements of the function of the establishments. The personal carrying out of the field investigation involved enabled the author to extend the information search beyond the topics listed. This survey was essentially a random one because of the small size of some particular groups and because the author had, on some occasions, to use his own judgement in selecting responsible respondents to ensure the accuracy of replies. The situation was confused during fieldwork by other field surveys being carried out by the Industrial Development Technical Centre (IDTC) and the Central Statistical Organisation (CSO). In the judgement of the author it was considered inappropriate to use the

data obtained by questionnaire to complex statistical manipulation but rather to utilise them to clarify and improve the value of other data.

MAJOR RESEARCH DIFFICULTIES

The author faced several research difficulties which can be summarized as follows:

- a) Apart from government statistics, there are few studies carried out on Qatar as a whole and none on the industrial sector of the country.
- b) Even government statistics, in some cases, when published by different bodies do not agree with each other and proved insufficient to meet the requirement of this study. Therefore, most of the tables and figures are compiled after considerable revision by the author.
- c) The author had spent a great deal of time in translating official statements, laws and decrees which concern industry. Although great efforts were made to make the translation convey the specific meaning in English of the Arabic texts of these laws and statements, the original texts remain the ultimate authority.
- d) The language barrier appeared considerable especially with those individuals who did not understand either Arabic or English. These barriers usually exist within some of the small-scale industrial sectors which are owned and run by ethnically non-Arabs, mainly Iranians and Indians. These barriers were in most cases, overcome by inviting a third party to translate.

THE LAY OUT OF THE STUDY

The study is divided into ten Chapters. Chapter 1 contains this brief introduction to the State and the contribution of oil and other sectors to the GDP. Also in this Chapter have been stated the objectives, data sources and other characteristics of this thesis.

Chapter 2 is devoted to an examination of relevant physical features and natural resources. That is to show the availability of industrial raw materials and to explain some influences on industrial trends and to explain why Qatar has felt it necessary to adopt an industrialization strategy. Apart from the availability of capital, the human resources in any country, including Qatar, play a vital role in the development process. This is why Chapter 3 deals with human resources and education levels, as well as the relationship between demand and supply of the labour force in Qatar. In the conclusion of Chapter 3 an attempt is made to design an approach to training which the government could adopt to make maximum use of the available Qatari force which simply cannot supply all of the industrial sector's demand for labour.

Chapter 4, on Industrial Development in Qatar - Policies and Institutions, is devoted to examining the evolution of industrialization strategy, in comparison to some of the existing industrialization theories and models. This leads to the formulation by the author of a suitable model which could be applied to Qatar and/or any of the Arab Gulf States. Chapter 4 goes on to examine government's role and intervention in the industrialization process.

Chapter 5 examines the extractive industries i.e. oil, natural gas and others. This examination is extended to the evaluation of production/reserves of the vital two resources, namely the oil and natural gas.

In Chapter 6 processing and manufacturing industries are discussed separately to show the structure of Qatar's manufacturing industries. The industries examined in this Chapter are : 1) oil refineries; 2) cement factory; 3) fishing industry; 4) flour mill; 5) chemical fertilizers and 6) iron and steel complex. Attention is

also paid to current large scale development as well as to small scale industries. The evaluation of these industries was focussed on the emergence of the industry, the labour force, production and sales or consumption and an economic evaluation of each separate industry.

Umm Said and the Industrial Estate of Doha are the main locations for manufacturing industries in Qatar and Chapter 7 is designed to examine the location of manufacturing industries in these areas. The discussion illuminates government policy toward these two areas, site preparation and the infrastructure provided by the government.

The successful implementation of industrialization policies and the development of each separate industry depend heavily on decision-making, capital investment and management. Chapter 8 focuses on these vital elements in relation to public, Ministry and private sectors.

In Chapter 9 the dependency on the foreign labour force for industrial development will be analysed under four headings:

- a. Factors which cause the dependency
- b. Occupational structure of the imported labour force
- c. Occupational distribution of Qataris and non-Qataris
- d. The impact of the foreign labour force

Chapter 10, the conclusion, contains a summary of the discussions and concluding statements. The Gulf Cooperative Council (GCC) and the Gulf Organisation for Industrial Consulting (GOIC) are also examined in Chapter 10.

References

- (1) IDTC, Qatar Achievements in Industrial Development,
England 1981, p.10.

CHAPTER 2

PHYSICAL FEATURES AND NATURAL RESOURCES

INTRODUCTION

Many trends of industrial development are strongly influenced by the availability of the natural resources. This chapter is devoted to an examination of the physical features and associated natural resources of Qatar.

2.1 MINERAL RESOURCES AND GEOLOGY

The mineral resources of Qatar, exploited and potential, are determined by the geology of the country. The full potential of some of these deposits, particularly in their value as industrial raw materials, has not yet been realised, either as to quantity or possible utility.

Qatar Petroleum Company (QPC) (see Chapter 5, Oil Industry) was very active in the field of geological investigation but because its attention was focussed mainly on hydrocarbons in general and oil specifically, QPC paid little attention to general geological findings. The government in 1970 invited C. Cavalier of the Bureau de Recherches Géologiques et Minières of France, to carry out a full geological survey of Qatar peninsula and its islands.⁽¹⁾ Another comprehensive investigation of Qatar's geology and mineral resources, other than oil, was made available in 1979 by Seltrust Engineering Ltd. of U.K. Seltrust supplied the government with nine volumes of reports.⁽²⁾

For the purposes of this thesis attention will be limited to stratigraphy rather than extended to questions of structure. The peninsula surface is covered by rock which originated from the

Cenozoic era (see Table 2.1). The Cenozoic era contains several formations such as Umm Er Rhaduma, Rus, Dammam, Dam and Hofuf. The relevance of these formations, beside their surface outcrops and their influence on the terrain is that they contain several mineral deposits which have not yet been fully exploited i.e. silt, clay, gypsum etc. (see Chapter 5, pp. 134-136).

The Mesozoic era (200-70 million years old) is the most important element in the geological stratigraphy in Qatar. Within this structure lie the Shuaiba and Uwainat limestones and the Arab Zones Formation, which contain, beside other mineral deposits, the all-important oil and natural gas. The first commercial quantity of crude oil was discovered in 1940, in the Arab Formation of the upper Jurassic, at a depth of 1,733 metres.⁽³⁾ The Khuff formation of Permian age was recognised as an oil and gas producing zone in 1959 by QPC, but because of the large unassociated gas content, the Khuff formation was not utilized until the second half of the 1970's (see Chapter 5 pp. 128-133).

The limestone deposits of the Pleistocene and Middle Eocene era cover the whole of the peninsula but are of relatively small thickness, with the exception of the Umm Salal and Umm Bab areas.⁽⁴⁾ The latter was selected as an industrial site of a cement making factory.

Several geological investigations have proved that iron oxides (hematite and ochre) exist in Qatar's islands i.e. within Halul and Shra'auh. These deposits originated mainly from the Paleozoic era. Due to the high cost involved in the extraction and transportation of such deposits, most reports have recommended that they should be left unexploited for the time being.

Age b.p.	Formation	Sub-formation	Member and Description	Occurrence	Mineral Deposits	
Cenozoic 70 Million years (m.y.)	Recent	Depression muds & Silts (3m), Sabkha(16m) Sand dunes etc.		SURFACE	gravels* sands* silt salts*	
	Miocene and Pliocene 1.2-25 m.y.				Miliolite beds(20m)	Limestones*
		Hofuf			Sandy clay, sandstones gravels (10m)	Gravel* Sand*
		Dam	Upper Dam		Limestones, clays, sand, gypsum(48m)	Gypsum*, clay Celestite, Clay*
			Lower Dam		Limestone, clay (30m)	
	Middle Eocene 47-50 m.y.	Dammam	Upper Dammam		Limestone and Marls (14m) Simsima dolomites & Limestone (45m)	Limestone* Dolomites Phosphatic
			Lower Dammam		Dukhan Alveolina limestones(1m) Midra shales(10m) limestone (1.2m)	Pyrite Attapulgitic Phosphatic
	Lower Eocene 52-62 m.y.	Rus			Chalk(ab.60m)	Part by sub surface Celestite Gypsum
	Pala-eocene	Umm Er Rhaduma				
	Mesozoic 70-200 m.y.	Cretaceous 70 - 135m	Shuaiba Fm, etc.		SUBSURFACE	Petroleum*
Jurassic 135-180mm		Uwainat limestone Arab Zones (3.4) etc.		Petroleum*		
Paleozoic 200-600 m.y.	Permian & carboniferous 225-350mm	Khuff Fm, etc.		Petroleum*		
	Cambrian 350-600 m.y.	Hormuz	Dolomites, sandstones volcanics	Halul & Shra Auh Islands	Hematite, ochre, carbonates, Asbestos, Volcanics	

(3m) = Thickness in metres. * = exploited today or in the past

b.p - m.y. = million years before present

Compiled by Author from: 1. Soliman, S.M. Geology & Min. Activ. in Qatar, Qatar, No. 1974 p.T. 2. FAO, The Water Resources of Qatar and Their Development: Vol.1 Doha 1981 p.3/9.T.3.1 3. Holmes A., Principles of Physical Geology, Nelson G.B. 1965

The fresh water aquifers examined in 2.3 below exist within two main formations; the Rus and Umm Rhaduma.

2.2 CLIMATE

Many writers and experts in the fields of geography and environment have tried to create kinds of linkages between the underdeveloped (or developed) countries and the different elements of climate and environment. Although this is not the place to discuss the different theories, it is well known that climate and weather has played a strong role in directing inhabitants' activities away from physical labour and especially in encouraging the native population towards office work, particularly in the government sector where most, if not all, premises are equipped with cooling systems. Climatic conditions also affect industrial capital goods, in that corrosion becomes serious due to high humidity, temperatures and atmospheric salinity.

Table 2.2 shows the monthly temperature and humidity at Doha International Airport in 1981. The temperature in the winter months (November to March) averages between 18°C - 26°C, while the relative humidity of the same months averages between 55-66 per cent. In the summer months (April to October) the average of temperature and humidity reverse : the temperature rises to an average of 32.8°C and the relative humidity decreases to an average of 52.3 per cent. This phenomenon is present in Qatar due to the configuration of the peninsula and to the prevailing north westerly wind.

The winds are mainly light, with an average of 9.6 knots per hour during 1978.⁽⁵⁾ During December the wind direction is dominantly from the NNE, in February SSE and in the remainder of the year

predominantly NNW.⁽⁶⁾ The average speed and direction of the winds have saved the capital city, Doha, from industrial pollution from the Umm Said area which is to the south of Doha. The configuration of the peninsula has also saved the country from the effects of sand-carrying winds which are dissipated by passing over stretches of sea between Qatar and the rest of the Arabian Peninsula. This contrasts with the situation in Kuwait which is entirely unprotected from such winds.

Table 2.2: Monthly Average of Maximum and Minimum Temperature and Relative Humidity

Month	Temperature (C°)			Relative Humidity (%)		
	Min.Temp.	Max.Temp.	Average	Min.R.H.	Max.R.H.	Mean R.H.
January	11.5	26.7	19.1	32	100	66.0
February	8.8	29.0	18.9	24	100	62.0
March	13.4	35.4	24.4	14	97	55.5
April	14.7	40.1	27.4	12	90	51.0
May	21.3	44.2	32.8	10	93	51.5
June	21.2	45.2	33.2	8	91	49.5
July	27.2	46.0	36.6	8	91	49.5
August	29.0	44.6	36.8	10	91	50.5
September	23.5	42.4	33.0	20	98	59.0
October	21.2	38.9	30.1	15	95	55.0
November	15.9	35.4	25.7	16	99	57.5
December	12.2	30.6	21.4	19	100	59.5
Year's Average	18.3	38.2	28.3	15.7	95.4	55.5

Source : Central Statistical Organization, Annual Statistical Abstract 1981, Doha, 1982 p.9, T.4.

Rainfall, on the other hand, is extremely light and confined to the winter months, with an annual total varying from 10 mm to over 200 mm.⁽⁷⁾ This low rainfall makes it impossible for agriculture other than nomadic pastoralism not to be dependent completely on ground water resources.

2.3 SOIL AND GROUND WATER RESOURCES

Except for the depression areas (Rodha, Pl.Rodat or Riyadh), the soils in Qatar are very poor. In general, the most widespread cultivable soils are very shallow with a thickness of about 10-30 cm.⁽⁸⁾

Soil classification as well as the study of ground water resources was the main mission of the FAO project team in Qatar from 1975-1979. The soils of Qatar can be summarized as follows:⁽⁹⁾

1. Rodha or lowlying soil : covered an area of 27,620 ha. (276.2 sq.km)
 - a. Silty clay loam to clay loam (23,100 ha)
 - b. Sandy loam to sandy clay loam (4,520 ha)
2. Saline sabkha soil : over a total area of 70,124 ha. (701.2 sq. km)
 - a. Gypsiferous depression soil of clay loam texture (6,517 ha)
 - b. Sandy clay loam to sandy loam texture (63,607 ha)
3. Lithosol soil : of an area 1,020,977 ha. (10,210 sq.km)
 - a. Calcareous sandy loam (958,052 ha)
 - b. Rocky hill outcrops (62,925 ha)
4. Sandy soil : covering an area of 36,167 ha.(361.7 sq. km)
 - a. Calcareous coarse sand to loamy coarse sand (4,775 ha)
 - b. White colitic sand of marine origin (31,392 ha)

It is inevitable from the above mentioned soil classification that the only soils suitable for agriculture are those of the first group which represent only 2.4 per cent out of Qatar's total area of 10,600 km². It is now prohibited to remove clay and soil from the better soil areas for use in urban gardens.

The underground fresh water resources, due to the climate and geological structure, are the only natural source of water in Qatar. The main aquifers with potable water lie within the Rus and Umm Er Rhaduma formations.⁽¹⁰⁾ (see also Table 2.1). In 1978/79, the total annual abstraction of the northern province underground water* was 26.7 million m³ from the Rus formation and 25.1 million m³ from Umm Er Rhaduma.⁽¹¹⁾ If the present rate of the fresh ground-water abstraction remains the same the aquifers will be depleted in 20-30 years.⁽¹²⁾

From the point of view of the paucity of agricultural land and of water quality and quantity, the development of the agricultural sector is not favourable. Agricultural development would be costly to finance and simultaneously the crop(s)/hectare production costs would be much higher than in other countries. This, together with the rest of the physical resource situation has left Qatar with very limited opportunities for the diversification of the national economy.

Additionally, the domestic production of agricultural products such as plant or animal fibres, fruit, vegetables, and forestry materials can never be extensive in Qatar. This means that while at the craft level there are some related activities, for example, date palms, the sub-sector of agricultural industries in Qatar cannot be developed on the basis of domestic resources (see Chapter 4).

* Qatar is divided by a "V" shaped structure into two parts; north and south. The salt content of the northern part underground water is between 400-2000 part/million, whilst the southern part is between 3000-6000 part/million. This is mainly due to the geological structure fault, which is present to a great extent in the southern part of the peninsula.

2.4 MARINE RESOURCES

The natural endowments of the peninsula were not favourable to attract the inhabitants to settle inland. Therefore, most of the principal settlement centres were posted on the coastline or nearby. Qatar, as a matter of fact, has an important position because it appears as a "wedge" in the middle of the Arabian Gulf,* which provides a coastline of about 680 km long. (13)

Economically, Qatar and the surrounding Gulf States largely depended on pearl fishing in the past, while fish provided the bulk of food for the Gulf people. More than 85 pearl banks are located within Qatar's territorial waters and these banks appear to be bigger in size and larger in number than those of other Gulf Emirates. (14) Nowadays most of the Gulf peoples, and including the Qataris, have abandoned pearl diving activities, leaving an accumulated and large crop of priceless natural pearls unharvested for more than a third of a century. In addition to the availability of natural pearls, Qatar could easily adopt the Japanese methods of raising the cultured pearls ** which once destroyed Qatar's economy.

The Gulf, apart from the pearl resources, has been supplying the indigenous populations with fresh fish for several hundred centuries. Fishing was one of the principal activities in Qatar, the consumption of fish being estimated at 100 kg. per inhabitant per annum. (15)

J.Moorhead wrote: (16)

"It (the fishing industry) is a very ancient routine and it will probably still be going on long after the last oil tanker has sailed from the Gulf"

* From Qatar to the head of the Gulf lies about 530 km. whilst to the Straits of Hormuz about 560 km.

** The ease of adopting such methods is increased by the fact of water clearness, temperature, salt content, and other factors related to the water of the Gulf.

The fishing field, unfortunately, given all the income provided by oil, has been left as a small residual artisanal industry carried out mainly in the private sector and also by the Qatar National Fishing Company (see Chapter 6 pp.161-162). The potential fisheries resources are quite good, especially if new technologies of fish farming of the more expensive species, i.e. lobster, prawns etc. are adopted. The Regional Fishery Survey and Development Project (RFSDP) of the Gulf, which was hosted by Qatar from 1975 to the end of 1979, carried out an extensive investigation programme on the fisheries in the Arabian Gulf and Gulf of Oman. The general conclusion of their findings was that the Arabian Gulf alone can produce 550,000 tons of fish without affecting their reserves. (17)

As far as manufacturing or industrial processing is concerned, it should be noted that approximately 87.3 per cent of the domestic consumption of fresh fish is supplied by the Qatar National Fishing Co. (QNFC) and small-scale fishing. (18) The potential for fish processing e.g. the making of fish meat or frozen fish for export, appears to be very limited. Nevertheless, there is some possibility of a food processing industry on the basis of fish farming, given the environmental potential.

The sea water and beds are well known for their dissolved and non-dissolved mineral deposits, i.e. salt, phosphate, magnesium, manganese, cobalt, nickel, copper etc. Although operations for extracting such minerals, apart from salt, are difficult and costly, it is essential that the government, while oil revenues are in hand, sets up an evaluation project for the exploitation of such resources. The extraction of inland mineral deposits is analogous to a person living on his capital, whilst the extraction of sea mineral

deposits is like a person living on his income.⁽¹⁹⁾ However, unlike the Red Sea, the structural character of the Gulf suggests that the exploitation of mineral deposits upon the sea bed is again very limited. Thus, whilst Saudi Arabia, through the Saudi-Sudan Red Sea joint committee has already found it worthwhile spending \$58 million on the exploration of sea bed metallic minerals in the Red Sea⁽²⁰⁾ this option is not at the moment available to Qatar.

Conclusion

More investigation of Qatar's mineral resources is still feasible but the author doubts whether any significant deposits, with the exception of oil and gas, will be found within Qatari territory. This may seem pessimistic but the results of all previous investigations support this conclusion.

Climate not only adversely affects the working behaviour of the inhabitants but also stands as a serious barrier toward any significant low cost development of the agricultural sector. High temperatures and humidity place strains on crops and livestock and encourage the proliferation of pests and diseases. Poor soils and low water availability are the final crucial threat to the agricultural development. There is, therefore, great doubt whether Qatar can ever be self-sufficient in food supply or sustain a significant agricultural output. Agricultural raw materials for industry are similarly unpromising.

Qatar, consequently, is left only with an industrialization option to develop and ensure the continued growth of the domestic economy. With a large quantity of unassociated natural gas (see Chapter 5 p. 133) as well as the marine resources which have not been fully exploited, Qatar has a solid base for some

industrialization programmes. The following Chapters will examine the industrial development policies and establishments against this background of a limited range of physical resources. Manpower is perhaps the key resource for industrial and other development, and in Chapter 3 are examined the elements of population and manpower.

CHAPTER 2

References

- (1) See, Cavelier, C., Geological Survey and Mineral Substances Exploration in Qatar, Bureau De Recherches Geologiques et Minieres, Paris, April, 1970.
- (2) Seltrust Engineering Ltd.
 - IDTC Investigation of the Development Potential of Mineral Occurrences in Qatar :
 - Vol.1 Summary & Review of Geology and Mineral Resources of Qatar
 - Vol.2 Interpretation Reports of a Combine Airborne Survey
 - Vol.3 Ground Geophysic
 - Vol.4 Conductivity Report
 - Vol.5 Gypsum, Celestite and Phosphate
 - Vol.6 Industrial Clays, Shales and Sand
 - Vol.7 Building and Ornamental Stone
 - Vol.8 Examination of Potentially Developable Brines
 - Vol.9. Qatar Drill Logs

Qatar, 1979
- (3) QGPC, Sheets of Exploratory Wells 1940-1980, Petroleum Engineering Department, Qatar 1981, p.1.
- (4) QNCC, Special Issue Commemorating the Opening of Qatar Cement Work, Ali Bin Ali Printing Press Qatar (ca 1969), p.7.
- (5) Ministry of Communication & Transport
Annual Climatological Report 1978,
Doha 1979 pp. 4-15.
- (6) Eccleston, B.L., Pike, J.G., Harhash, I. The Water Resources of Qatar and Their Development Ministry of Industry & Agriculture [Water Resources and Agricultural Development Project (FAO Funds-in-Trust)]
Qatar 1981 p. 5/9.
- (7) Ibid. p.5/18.
- (8) Ibid. p.4/1.
- (9) Ibid.
- (10) Ibid, pp.2/5-6 and 2/8.
- (11) Ibid. 2/8.
- (12) Ibid.

- (13) The Arab League, Fishery Production, Vol.7 of Programme of Arab Food Security, The Arab Agricultural Development Organization, Khartoum, August 1980, p.18.
- (14) Al-Duwaik, M.T., Qatar Folk Songs, M.A. thesis submitted to Cairo University, 1973, pp.232-40.
- (15) FAO, Fisheries Travel Report and Aide Memoire, No.130, Department of Fisheries, March 1968, p.15.
- (16) Moorehead, J., In Defiance of the Elements, A personal view of Qatar, Namar Publications, London, 1977, p.146.
- (17) Regional Fishery Survey & Development Project, Final Report, Qatar, 1979, pp.50-52.
- (18) Ministry of Industry and Agriculture, Statistics of Fisheries 1980-81, Fishery Department, Qatar, p.60.
- (19) Cowen, R.C., Frontier of the Sea, Translated by Hilmi, A., Sizil Al-Arab Press, Cairo, (ca 1967) pp.392-93.
- (20) Economic Intelligence Unit, Saudi Arabia : Quarterly Economic Review, No.4, 1984, London.

CHAPTER 3POPULATION AND HUMAN RESOURCES

The size and quality of the active labour force in any country play a vital role in the development of the country's economy in general, and of industry specifically. There is no doubt that the absolute size of, and trends in, population are of key importance in relation not only to the labour force but also to other phenomena, such as the nature and size of the domestic market. These two main factors - trends in the labour force and in the population - have to be viewed side by side with education and vocational training, in the context of this study.

This chapter discusses the population of Qatar in relation to general trends, natural growth, migration, population structure and the labour force and education levels. In Chapter 9 the question of dependence on foreign labour is examined in the context of the preceding analysis of industry.

3.1 General Population Trends

Qatar has long been distinguished by having a very small population even as compared with its neighbours, as shown in Table 3.1.

Table 3.1 Population in the Gulf Emirates

Year	Kuwait	Bahrain	Qatar	U.A.E.*
1905	48,000	100,000	27,000**	86,200
1957	206,473	115,000	50,000	130,000
1970	733,196	216,815	111,113	300,000

* U.A.E. = United Arab Emirates

** 1908

Source : al-Kuwari, A.K., Oil Revenues in the Gulf Emirates, 1978, p.5.

However, to understand the population trends in Qatar, since the State has held only one census in 1970, we are forced to rely on an irregular series of estimations. The first of these was made during the Ottoman occupation between 1872 and 1914, when the population was believed to be some 10,000 people living in 4,000 houses. ⁽¹⁾ Lorimer, in 1908 estimated the population at 27,000 of which 6,000 were foreigners. (see Table 3.2 below). Apparently, until the first half of the 1930's the population figure remained approximately around 27,000. Then, following the decline of the pearl trade, population numbers fell, up to about 1951, despite the fact that oil was discovered in 1939.

During the late 1950's, estimates suggest that the population commenced once more to increase and this has since continued. In 1960 it was estimated at 40,000, whilst in 1969 the population reached about 100,000. This is mainly as a result of the growth of the oil industry and the consequent growth in economic activities, especially in construction, which greatly increased the demand for labourers, technicians ... etc. and which had a considerable effect on in-migration. The population census processed in 1970 showed that the proportion of foreigners then consisted of 59.5 per cent of a total of 111,113. ⁽²⁾ MEED, in 1979 estimated the population at 250,000, of which 60 per cent were foreigners. ⁽³⁾ The consultant firm, William L. Pereira, on the other hand, estimated the population in 1980 at 240,000, with 71.8 per cent foreigners. ⁽⁴⁾ However valid are the estimates, it is clear that foreigners have constituted a majority since the late 1960's, whilst the Qataris became the minority group.

Many studies have suggested that the population of Qatar has recently had an average growth rate of 8 per cent per annum. ⁽⁵⁾ If growth remains at the same rate, ceteris paribus, it has been

Table 3.2 Estimation of Population Growth in Qatar

Year	Total	For- eign	% of F.	Year	Total	For- eign	% of F.
1908	27,000 ^(a)	6,000	22.2	1970	111,133 ^(e)	66,094	59.5
1930	25,000				111,000 ^(b)		59.0
	30,000 ^(b)				120,000 ^(g)	71,600	59.7
1939	28,000 ^(a)	11,000	39.3	1971	111,000 ^(a)		
1940	25,000 ^(a)				130,000 ^(b)		
1945				1972	120,000 ^(f)		
1951	20,000 ^(c)				170,000 ^(b)		
1952	25,000 ^(c)			1973	170,000 ^(a)		
1955	40,000 ^(c)				180,000 ^(b)		
1960	40,000 ^(b)			1975	160,000 ^(a)		
	60,000 ^(c)				180,000 ^(g)		
1965	70,000 ^(c)			1976	180,000 ^(a)		
1967	70,000 ^(c)				202,000 ^(a)		
	80,000 ^(b)				210,000 ^(a)		
1968	80,000 ^(c)			1977	200,000 ^(a)	150,000	75.0
	90,000 ^(b)			1978	230,000 ^(a)		
1969	80,000 ^(a)			1979	250,000 ^(d)	150,000	60.0
	100,000 ^(b)			1980	240,000 ^(g)	172,300	71.8

Sources:

- (a) Lorimer, J.G., Gazetteer of the Gulf, Qatar 1978.
- (b) Buhairi, S. & al-Fara, M. Qatar Geography (n.d), pp.86-92.
- (c) al-Jabir, M.H., Qatar, Human Geography, Cairo, 1977. p.143.
- (d) MEED, Special Report on Qatar, November 1979, p.
- (e) MEDD, The First Population Census of Qatar, 1970, Table 10.
- (f) FAO/UNDP, Report of the FAO/UNDP Programming Mission to Qatar, 1972, p.4.
- (g) William L. Pereira Associates, National Growth Forecasts, May 1977, p.23.

predicted that the total population will reach the figure of 330,000 in 1985 and 600,000 in 1995 (see Table 3.3).

Table 3.3 Population Forecasts of Qatar by Nationality

Year	Qatari	Non-Qatari	Total	Non-Qatari % of Total
1975	57,200	122,800	180,000	68.2
1980	67,700	175,300	243,000	71.1
1985	30,000	250,000	330,000	75.8
1990	94,600	350,400	445,000	78.7
1995	111,900	490,100	602,000	81.4

Source : William L. Pereira Associates, National Growth Forecasts, May, 1977, p.23.

The above table also illustrates very clearly the expected accelerating growth of the proportion of non-Qataris to Qataris in the population. If we accept the linkage between population growth and a policy of development through diversifying economic activity, especially through industrialisation, then the order of magnitude of these changes is probably approximately right. However, more recent changes in oil prices and the fall of oil production due to oil market gluts, and consequent economic reactions by the Qatar government, have shown these assumptions to be rather dubious.

3.2 Natural Growth

3.2.1 Births

Unfortunately, no birth statistics at all were published before 1967, and even after 1967 the statistical data are not sufficiently complete to allow a precise and correct analysis of birth trends. In order to make a reasonable estimation of total births, it is necessary to add, at least 5 per cent to the registered figures.* Table 3.4 below shows the registered and revised statistics. The table illustrates that what had happened to the proportions of Qataris in the total populations also happened in births, i.e. whilst the Qatari population contributed 71 per cent of total births in 1967 this was reversed by 1977 to below 43 per cent out of 5,333. This radical shift would have been much greater if the Qatari Authority had not restricted foreigners from bringing their families with them. There is no doubt, partly due to such immigration restrictions, that the gross birth rate in Qatar had declined from 4 per cent in 1967 to less than 3 per cent in 1978. The data on which this estimate is based are derived from Tables 3.2 and 3.4.

Males, on whom, in accordance to present conditions, economic growth is reliant, formed the highest percentage of recorded births with the exception of 1971, with an average of 51.1 per cent for the whole period,

3.2.2 Deaths

Due to the absence of legislation** governing the registration of cases of death, most of the Ministry of Public Health statistics are believed to have covered only 85 per cent of the total death cases.⁽⁶⁾ It is necessary, therefore, to add at least 15 per cent

* The figures registered are believed to cover only about 95 per cent of total births.

** The legislation of Deaths and Births registration was only introduced in 1982, by Law No (5) of Organizing the Births & Deaths Registration.

Table 3.4 : Total Births Reported in Qatar by Nationality & Sex
(1967-1980)

Year	Qatari	Non Qatari	% of Qatari	Male	Female	% of Male	Reported Births At Home	Total	5% increase for under-registration	Grand Total
1967	(2038)	(836)	70.9	1474*	1400*	51.3	-	2874	144	3018
1968	(2015)	(1177)	63.1	1642*	1560*	51.4	-	3192	160	3352
1969	(2042)	(1396)	59.4	1780*	1658*	51.8	-	3438	172	3610
1970	(2068)	(1543)	57.3	1836*	1775*	50.8	-	3611	181	3792
1971	(2095)	(1826)	53.4	1948*	1973*	49.7	-	3921	196	4117
1972	2108	1912	52.4	2071	1949	51.5	18	4038	202	4240
1973	2228	2121	51.4	2268	2081	52.1	18	4367	218	4585
1974	2092	2268	48.0	2198	2162	50.4	200	4560	228	4788
1975	2141	2518	46.0	2372	2287	50.9	81	4740	237	4977
1976	2180	2731	44.4	2522	2389	51.4	-	4911	246	5157
1977	2261	3052	42.6	2686	2627	50.6	20	5333	267	5600
1978	2813	3164	47.1	3106	2871	52.0	-	5977	299	6276
1979	2752	3305	45.4	3037	3020	50.1	-	6057	303	6360
1980	2853	3897	42.3	3430	3320	50.8	-	6750	338	7088

Sources: Compiled by the Author from

- Ministry of Public Health, Births & Deaths Statistics 1967-1978, Qatar.
- () - Shankland Cox Partnership, Projection of Qatari Population, Qatar 1980
- * - Al-Jabir, M.H., Qatar Human Geography, M.A. Thesis, Cairo University, Cairo, 1977.

to the total to arrive at a reasonable figure. As shown in Table 3.5, the total number of registered deaths varied from one year to another. What appears to be clear is that the male deaths in the whole of the period was much higher than female cases. The mortality rate among Qataris is higher than for non-Qataris, a consequence of differences in age structure, the majority of non-Qatari being young and in the active age group 15 - 59.

Table 3.5 Total Deaths in Qatar by Nationality & Sex (1974-81)

Year	Qatari	Non-Qatari	% of Qatari	Male	Female	% of Male	Total	15% inc- rease for under-est.	Grand Total
1974(a)							688	103	791
1975(a)							600	90	690
1976(a)							609	91	700
1977(a)	303	383	44.2	487	199	71.0	686	103	789
1978(a)	334	303	52.4	426	211	66.9	637	96	733
1979(b)							709	106	815
1980(b)	337	325	50.9	448	214	67.7	662	99	761
1981(b)	334	391	46.1	504	221	69.5	725	109	834

Source: (a) Ministry of Public Health, Births and Deaths Statistics, 1967-1978, p.1.

(b) Central Statistical Organization, Annual Statistical Abstract 1981, July 1982, p.25.

There is no doubt, partly due to the effect of immigration on age-structure as well as the continuing improvement of public health services, that the death rate did decline from 0.5 per cent

in 1967 to a little over 0.3 per cent in 1978. The data on which these estimates are based are found in Tables 3.2 and 3.5.

The natural growth rate, in the light of previous discussion, was about 3.48 per cent in 1967, whilst in 1978 it was 2.52 per cent. The declining natural growth rate can be mainly explained by the effect of the increasing proportion in the population of non-Qataris and the consequent distorting effects, not only on population age structure, but also on sex ratios and marital status; many non-Qataris are young, single males.

Given this rate of natural growth and the low absolute numerical base-level there is no possibility in the foreseeable future that Qatar will be able to sustain the growth of economic demand by using only the citizen labour force. This has forced, and will continue to force, the government to support much, if not all, of its policy of diversification of the economy by the use of expatriate manpower.

3.3 Migration

The migration field can be divided into two broad divisions, internal and external migration. Internal migration, although it has had a severe negative impact on villages and small towns, is very small in size compared to the external flow. At the same time there is no direct linkage of internal migration with the industrialization programme as such. Internal migration, for these reasons is therefore excluded from our discussion which will concentrate on external migration.

3.3.1 External Migration

External migration is one of the State's top-secret subjects and in order to have reliable data concerning external migration one has to obtain special permission from high authority. Even so, the Statistical Section of the Ministry of the Interior would not allow any person to examine all of the statistical records. This, according to official sources, is because it affects the security of the State, has to do with the planning of immigration policy, and, lastly, to avoid publicity-creating anxiety in the local population over the large size of the foreign population. ⁽⁷⁾ Reliance therefore has to be placed on various partial and/or earlier sources.

In the 1970 census, the number of expatriates was recorded as 66,094, that is to say 59.5 per cent out of 111,133. Between 1971 and 1974, 77,230 non-Qataris entered the country, of which only 670 were Arabs. In 1975, the Ministry of Interior, disturbed by this imbalance of expatriates by ethnic origin, instructed the private sector to import its labour requirements from Egypt. ⁽⁸⁾ Thus, in 1975, the number of Arab arrivals had risen to 4,766, to 7,392 in 1976 and 8,514 in 1977. (see Table 3.6). Because of the deteriorating political relations between Qatar and Egypt, the number of immigrant Arabs then declined by 1978, to only 6,684. At the same time the non-Arab element was increasing, partly due to the high turnover of Egyptian workers, ⁽⁹⁾ the total of such newcomers reaching 30,454 in 1978.

It is clear from Table 3.6 that during 1975-78 the non-Qatari population increased rapidly, and since many of the immigrants remained in the country, especially the Asian group, the grand total of this period was 67.6 per cent higher than the 1971-74 period.

Table 3.6 Total of New Resident Visas (Issued between 1395-98H.)

Year	Arabs	Others	% of Arabs	Total
1395	4,766	15,478	23.5	20,244
1396	7,392	26,174	22.0	33,566
1397	8,514*	29,971*	22.1	38,485*
1398	6,684	30,454*	18.0	37,143*

Source: Ministry of the Interior, General Total of issued new resident visas, 1395H - 1398H, Statistic Section, Doha 1979.

* Includes permanent resident visas.

Unfortunately, between 1970 to 1976, the government has not recorded how many of the resident visa holders had finished their contracts and left the country. In 1977, however, the recorded departures numbered 2,885, rising in 1978 to 3,866, of which 1,557 were Arabs. (10)

The non-Qatari immigrants, as shown in Table 3.7, were a mixture of several cultures, a majority being of non-Arab origin. The highest percentage among them, 63.0 per cent of non-Qataris, were derived from Asian countries. The second group was Arab, followed by Europeans and Americans. For individual countries of origin, the Iranians composed the largest element with 31.5 per cent out of the non-Qatari total, this high percentage of Iranians being based on historical and regional trans-Gulf contacts. Pakistanis came second with 25.8 per cent, followed by Jordanians and Palestinians with 14.5 per cent. Gulf State citizens came fourth with 7,556, of which 3,271 were Omanis and 2,042 Saudis.

Table 3.7 Non-Qatari Population by Nationalities (1970 census)

Country	Number	% of their total
<u>Total of Arab Countries</u>	<u>23,208</u>	<u>35.1</u>
Gulf States & Saudi Arabia	7,556	11.4
Jordan & Palestine	9,583	14.5
Other Arab Countries	6,069	9.2
<u>Total of Asian Countries</u>	<u>41,663</u>	<u>63.0</u>
Iran	20,663	31.5
Pakistan	17,076	25.8
Other Asian Countries	3,744	5.7
<u>Total of European and U.S.A.</u>	<u>974</u>	<u>1.5</u>
United Kingdom	756	1.1
U.S.A.	218	0.3
<u>African Countries</u>	<u>245</u>	<u>0.4</u>
<u>Other Countries</u>	<u>4</u>	<u>0.0</u>
Total	66,094	100.0

Source : Computed by the author from MEDD, Qatar Population Census 1970, Table 4.

The immigration authorities, because of the imbalanced structure of the non-Qatari population which the census had shown, evolved a policy which recognised the need for immigrant workers, accepted that there would have to be an increase in the number of Asian origin, but attempted to reduce dependence on immigration from only one or two countries.

In 1979, following the new policy, the composition of the non-Qatari population (excluding GCC citizens), as seen in Table 3.8, shows that the Asian countries contributed almost three quarters of the non-Qatari population. Iranians had moved from first

place in 1970 to third, ranking after Pakistanis and Indians. The total from Arab countries had increased in number, but decreased in proportion from 35.1 per cent in 1970 (see Table 3.7) to only 20.6 per cent of the non-Qatari total. The position of European and Americans had risen from 1.5 per cent in 1970 to 4.2 per cent in 1979. There are no statistics showing how many GCC citizens were in Qatar but 1979 estimates were around 15,000 people.

Table 3.8 The Non-Qatari Population as in 1979

Country	Number	% of their total
<u>Total of Arab Countries *</u>	<u>34,468</u>	<u>20.6</u>
Palestine & Jordan	13,681	8.2
Egypt	12,478	7.5
Other	8,309	5.0
<u>Total of Asian Countries</u>	<u>123,271</u>	<u>73.7</u>
Iran	32,583	19.5
Pakistan	41,498	24.8
India	38,819	23.2
Others	10,371	6.2
<u>Total of European and U.S.A.</u>	<u>7,043</u>	<u>4.2</u>
United Kingdom	4,740	2.8
U.S.A.	326	0.2
Others	1,977	1.2
<u>Other Countries</u>	<u>2,454</u>	<u>1.5</u>
Total	167,236	

* Excluding GCC citizens

Source : Computed by the author from the Ministry of the Interior : Statistics of New and Renewed Visas from 1395-99H. Statistical Section Qatar.

3.3.2 Migration policy

Law No. (3) of 1963 was the first law organizing and controlling the admission of non-Qatari nationals to the country,⁽¹¹⁾ a measure deliberately taken to protect the position of Qataris. Law No. (3) of 1963 and its amendments specified that any expatriate wishing to move to Qatar had to obtain a Qatari sponsor. The Qatari in turn should provide decent employment for the worker(s) under his sponsorship and, once the requirement for the worker(s) ended, the sponsor was responsible for deporting him/them to his/their original country. The government for several reasons, however, did not provide enough powers of implementation for this legislation, and at the same time the law did not provide any restriction on the entry of families accompanying the foreign workers.

The 1970 census opened the government's eyes to the immigration question at a time when there was particular sensitivity over Iranian immigrants. At the same time it appeared that there were 39.1 per cent of economically inactive non-Qataris (or 23.3 per cent out of the total population). The result of the census forced the government to adopt a new policy based on three objectives.

- a) To import more labour to meet internal development demand;
- b) To diversify the labour force of the country of origin, by achieving a balance between main nationalities (Iranians, Pakistanis, Indians and Arabs in general); and
- c) To apply a more restricted policy on the entry of families, although this excluded state employed senior staff, e.g. engineers, experts, doctors, teachers and managerial staff.⁽¹²⁾

This last restriction followed the realisation that a) the families of junior staff and labourers were uneducated, b) the average size of such families was 4-6 which created serious demand problems for public utilities and other facilities, and c) the public expenditure bill for providing the basic requirements for such families was becoming very high. In general, it appeared that expatriate families were consumers rather than producers. (13)

In 1974, and due to the high proportion of non-Arab expatriates, the Qatari Minister of Labour & Social Affairs signed an agreement with his Egyptian counterpart to supply Qatar's requirement for a labour force from Egypt, a step which can be termed the "Arabization of Migration". This policy has failed because of the subsequent Qatar diplomatic boycott of Egypt in 1978. An additional factor was the especially high voluntary turnover of the Egyptian workers which made the private sector reluctant to employ them.

The Minister of the Interior in 1975 set up a committee called Lagnat al-Istigdam, (Committee of Newcomers), consisting of four members representing; 1) the Director of the office of the Minister of the Interior; 2) Director of Immigration & Passport Department, 3) Ministry of Labour & Social Affairs; and 4) the Police Force. The main objective of the committee is to regulate the balance between all- non-Qatari groups in the country by studying the applications for labour by the government, public and private sectors and at the same time to import the right numbers of workers which the country actually requires. (14) The Government, in order to allow the committee to carry out its objectives, instructed all individual persons, government, public or private establishments to submit visa applications to the committee. The committee have the power to 1) instruct the applicants to import their labour requirement

from certain parts of the world; and 2) reject any application.

The granting of valid visas has to be approved by Lagnat al-Istigdam. Although the committee improved balance between different nationalities of origin, as seen in Table 3.8, unfortunately the committee could not control irresponsible individuals and establishments who submitted false applications. Once many applications were approved, the visas ended in the black market where they were easily sold for QR 10,000 for each visa (equivalent to £1,780). In most cases foreign workers who wished to bring in their relatives were the buyers.

In June 1980, the Minister of the Interior suddenly announced that the 1963 edict and its amendments for controlling work and residence permits would be strictly enforced, meaning that the foreign workers in the country had to be employed by their specific sponsors or transfer their sponsorship to their specific new employers, otherwise they had to leave the country.⁽¹⁵⁾ The announcement ended the "visa sale" and forced the sponsors to provide permanent work. The announcement, however, excluded workers in some specific trades which were not likely to be done by Qataris, such as barbers, tailors, ... etc., and the government, according to official sources, is studying the possibility of transferring sponsorship from specific Qatari backers to either the Ministry of Municipal Affairs, or to the Ministry of Labour & Social Affairs. Many expatriates, as a result of this policy, were deported from the country simply because their nominal sponsors could not afford to supply them with work. This policy does not accept the necessity for a pool of casual labour which in 1970 was about 2.1 per cent of the total 43,390.⁽¹⁶⁾

During 1981-82 the Minister of Labour & Social Affairs signed several labour agreements with Somalia, Tunisia, Morocco and Sudan

as part of the Arabization approach. Lagnat al Istiqdam, at the moment, facilitates any application that requires workers from the above-mentioned countries and Egypt.

The migration theme in relation to industrialisation is further developed in Chapter 9.

3.4 Population Structure

Given existing social and traditional customs, a further analysis of the population structure is necessary for the purposes of this study. Because the country has been open to worker immigration we have to deal first with the whole population, and then, in order to understand the actual structural processes relevant here, we have to examine separately the Qatari and non-Qatari element. Unfortunately, the only basic data for general analysis is that of the 1970 census, and that is considered first, followed by a brief consideration of estimates for 1981.

3.4.1 Population Structure of Qatar 1970

Figure 3.1 below shows Qatar's population structure by sex and age groups. Immediately we note that males were the predominant sex in the population, whilst the dominant age groups were 20-29 and 30-39 years. The main reasons behind this unbalanced structure even by 1970 were 1) the pressure of development requirements of manpower; and 2) the preference for economically active male immigrants.

If it was assumed that the age groups under 20 and over 59 were economically inactive (and this is a reasonable assumption for 1970 and later) the pyramid shows that these comprised almost half of the total population. About 91 per cent out of the 15,001 females between 20-59 years of age have to be regarded as effectively economically

Fig. 3-1 Qatar Population by Sex / Age Structure 1970

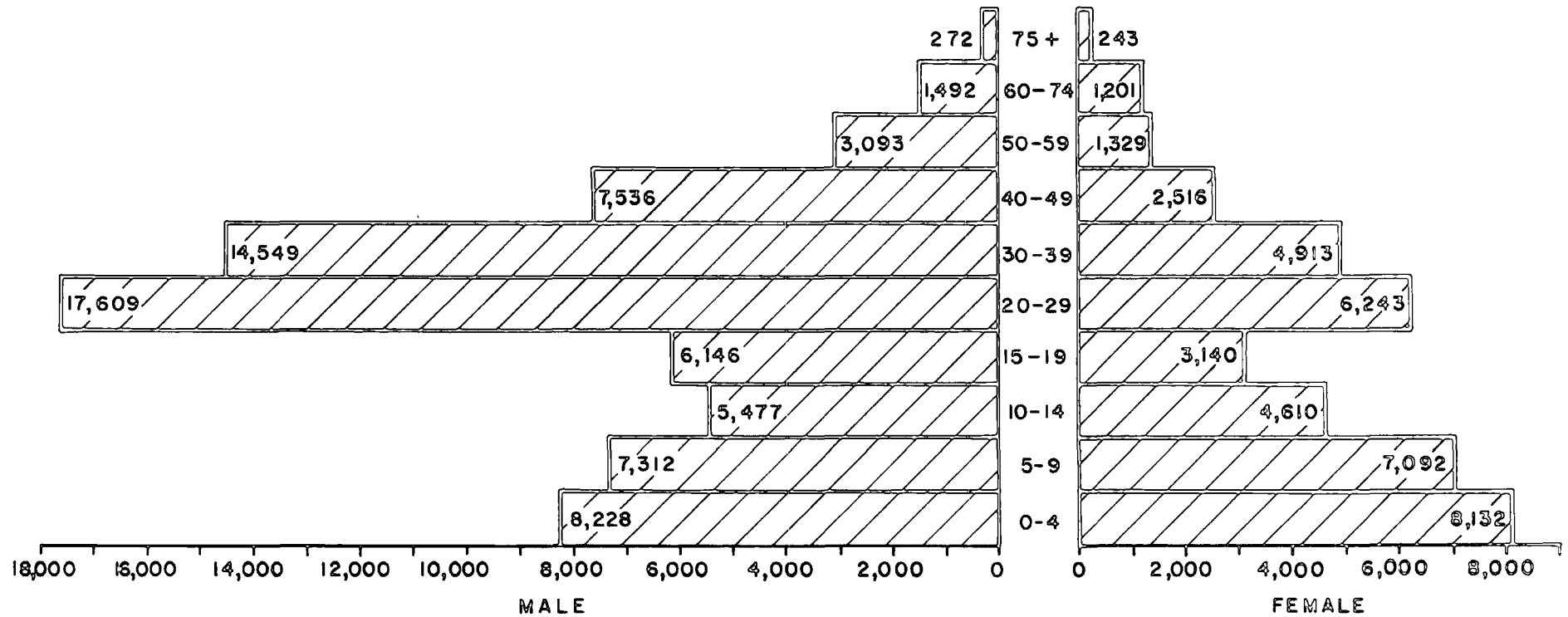

Source : Ministry of Overseas Development, The First Population Census of Qatar, MEDD 1970. T.

inactive (knowing that 96.5 per cent of the female total of 39,419 were recorded as inactive).

The pyramid also shows that the sex ratio of groups under 19 and over 59 was almost balanced, whilst the sex ratio of ages between 20-59 was considerably out of proportion with an average ratio of 285.2 : 100 Males/Females.

Under normal circumstances, the youngest group would be expected to be the largest, but this is only true of the Qatari population in isolation.

3.4.2 Qatari Population Structure

The Qatari population in 1970 was a normal, balanced demographic society with a general sex ratio of 101.3, this in a citizen population of 45,039 people, 40.5 per cent of the total 111,133. The age group under 20 years old was the largest, representing 60.9 per cent of the total Qatari population, so we find that of the total Qatari population 50.9 per cent were juvenile males. The age group between 20-59 years made up 34.1 per cent of the Qatari total (see Fig. 3.2).

If we take the age groups of under 20 and over 59 and add the economically inactive 98.7 per cent of the Qatari female population,⁽¹⁷⁾ we find that in 1970 the economically active proportion of Qatari population was some 18.1 per cent, leaving 81.9 per cent as dependants. The government clearly needed to increase the participation of the female population in economic activities through education, information and advertisements, and encouraging changes in social attitudes.

The population pyramid (Fig. 3.2) shows noticeable bulges in

Fig.3.2 Qatari Population Pyramid by Sex and Age (1970)

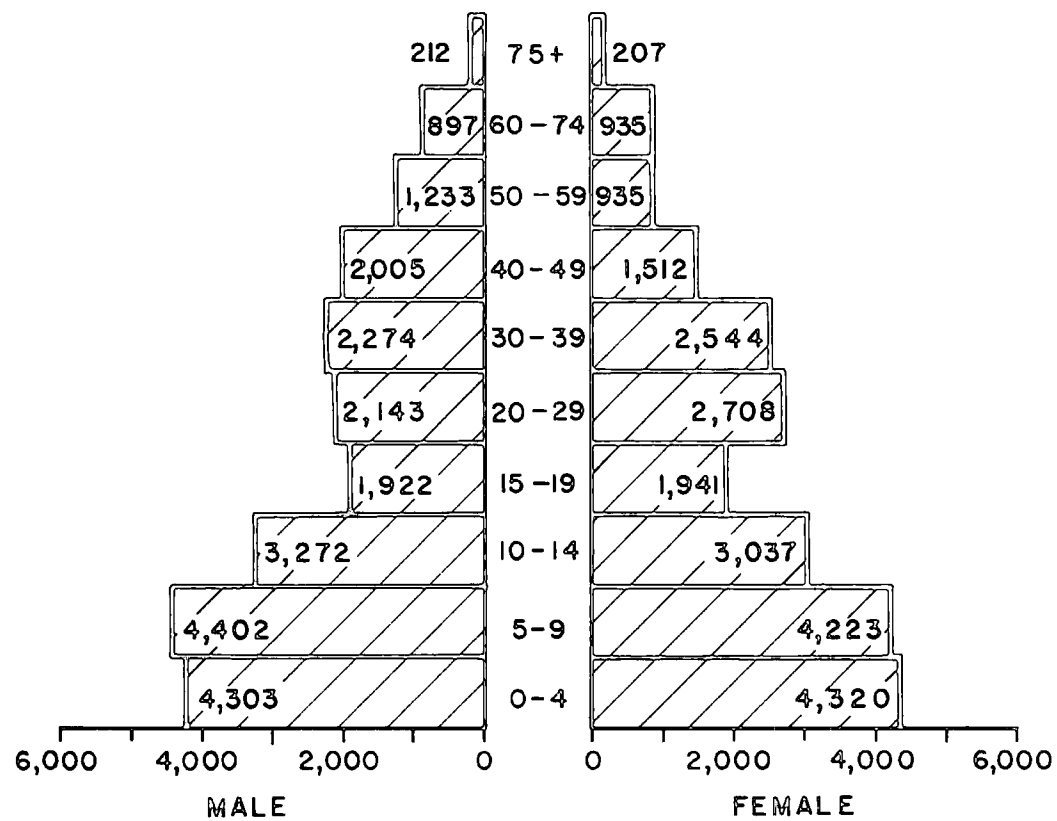

Source : Ministry of Overseas Development, The First Population Census of Qatar, MEDD, 1970 T.

the 0-4, 5-9 and 10-14 age groups, which were masked in Figure 3.1 due to the migration effect. These age groups were the only source of a future Qatari workforce for several decades.

3.4.3 Non-Qatari Population Structure

In 1970, the non-Qatari population numbered 66,094 and according to the population census, the female proportion was 25.8 per cent, giving a general sex ratio of 287.7. It is very clear from Figure 3.3 that the total male population out-numbered the female by almost three to one, whilst males in the age group 20-59 numbered almost five times the females giving an average sex ratio of 481.7.

The figure also shows that the non-Qatari population aged between 20-59 numbered 42,425, 64.2 per cent of the total, whilst the population under 20 and over 59 numbered 23,669, 35.8 per cent. The non-Qatari population was therefore dominantly composed of young adult males for the following reasons:

- (a) Employers naturally chose members of the economically active age group i.e. 20-59.
- (b) Most immigrant workers had to be tough and suitable for hard, manual work (in 1978 about 55.9 per cent of the total of new residential visa holders were labourers)
- (c) Most of the paid work in Qatar, according to the common traditional customs which existed at this time, was confined to males only.

Fig.3-3 Non - Qatari Population by Sex /Age Structure (1970)

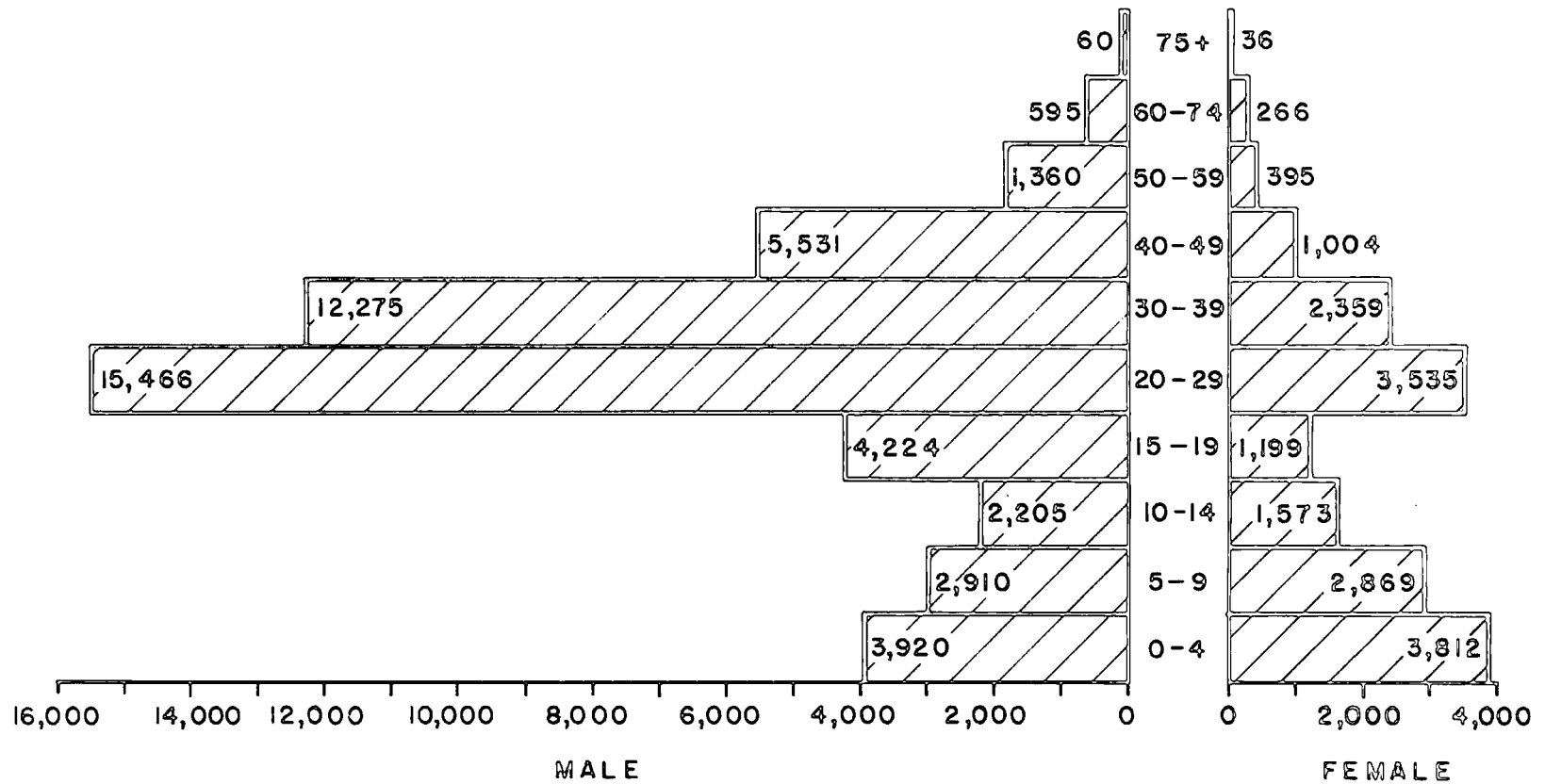

Source : Ministry of Overseas Development, The First Population Census of Qatar, MEDD, 1970 T.

3.4.4 Population Structure 1981

It is recognised that continued reliance on 1970 census analysis is less than satisfactory but no other census-based demographic evidence is available. However, the Central Statistical Office has produced estimates for the age and sex structure of the total population of Qatar in 1981 and these are shown graphically in Figure 3.4. If this is compared with Figure 3.1, and allowance made for the difference between the age-group categories employed in each, what appears as most striking is their similarity. This, together with what other evidence is available, indicates that the demographic situation in Qatar has not changed significantly in terms of structure since 1970.

3.5 Labour Force and Educational Level

Industrial and economic activity depend mainly, beside capital and raw materials, on a labour force. Education, in this sense, can be seen as a means of supplying skilled labour. In this section the argument will be directed to two main subjects : the labour force and economic activity levels, and the educational level of Qataris and non-Qataris.

3.5.1 Labour Force and Economic Activity

Most economic activities, as mentioned earlier, are created by the oil industry as the "propulsive force". Manpower, in this sense, is employed in one or other of the following categories:

- (1) Direct employment in the oil industry and related activities such as exploration, drilling, production, etc.
- (2) Indirect employment by the oil industry in the form of

Fig. 3-4 Qatar Population Structure - Male and Female 1981

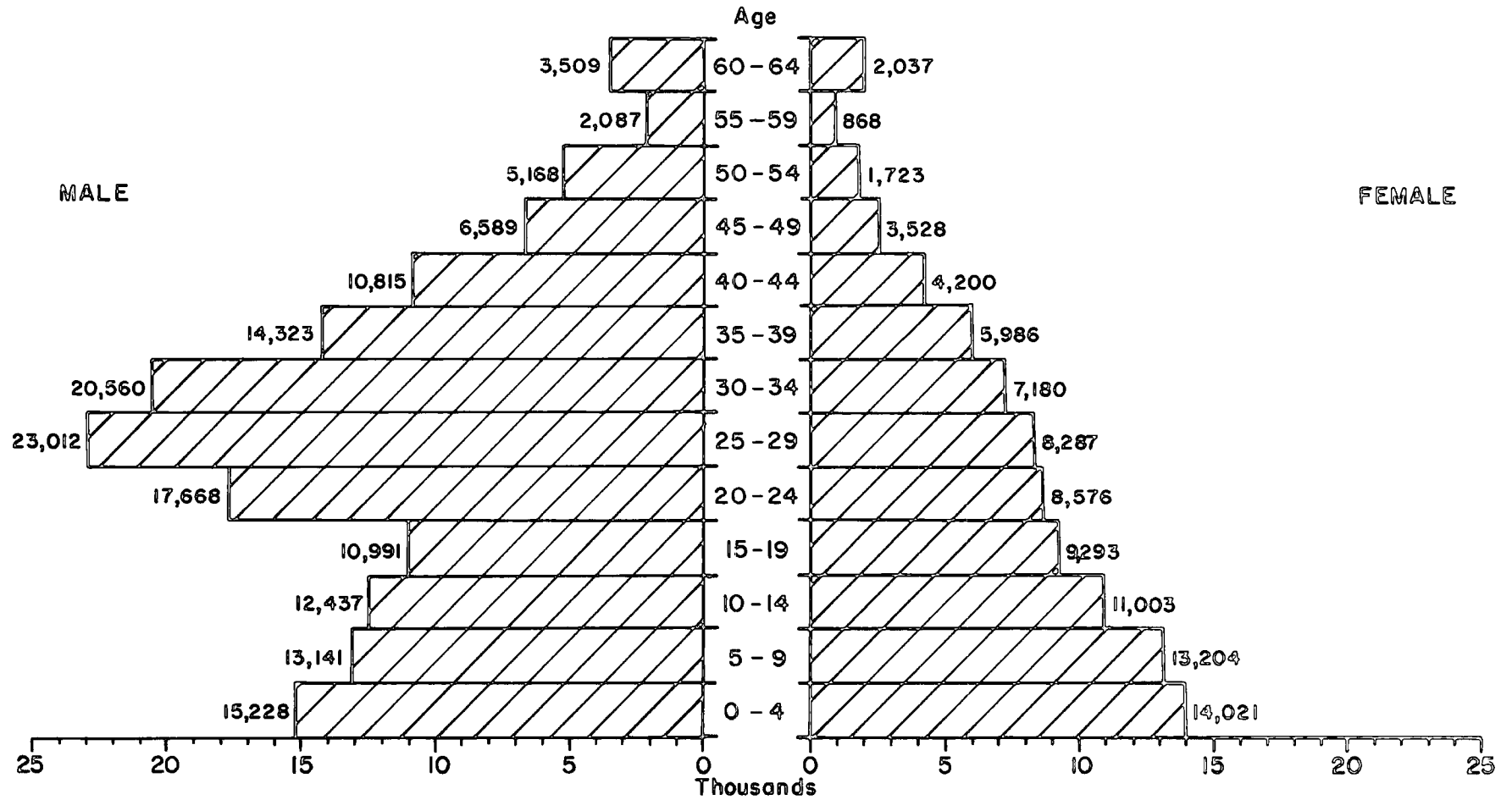

Source: Central Statistical Organization, Annual Statistical Abstract 1981, Qatar 1982

providing the oil industry with its needs such as services, both construction and technical goods, food supplies etc.

- (3) Employment associated with the distribution of oil revenues such as Government programmes of development, including public and private sector industry.

Table 3.9 below, categorising the labour force in Qatar by sectors and nationalities, shows clearly that the non-Qataris out-numbered the Qataris in all the sectors with the exception of direct employment in the oil industry. This exception appears because

"... the oil sector paid them higher salaries than the government sector, and second ... the government had established a kind of arrangement with the oil companies which protected the Qatari labour force from non-Qatari competition."⁽¹⁸⁾

Table 3.9 : Economically Active Population by Sector & Nationality (1970)

Sector	Qataris	Non-Qataris	Total	% of each sector	% of Qataris
Agriculture & Fishing	86	1,984	2,070	4.3	4.2
Manufacturing/Mining/ Quarrying	1,825	3,417	5,242	10.8	34.8
Construction	207	7,578	7,785	16.1	2.7
Oil Industry	1,259	950	2,209	4.6	57.0
Wholesale/Retail Trade	880	7,005	7,885	16.3	11.2
Banking	10	292	302	0.6	3.4
Transport & Communications	655	2,571	3,226	6.7	20.3
Government Services	1,391	4,781	6,172	12.7	22.5
Other Services	1,855	11,644	13,499	27.9	13.7
Total	8,168	40,222	48,390*	100.0	
% of the Total	16.9	83.1	100		

* of which 46,997 males and 1,393 females.

Source : MEDD, 1970 Population Census, Table 16.

The Qataris in other sectors formed in aggregate a proportion of 14.1 per cent. The non-Qataris, who formed 83.1 per cent out of the total labour force, were very much concentrated in services, construction and the wholesale/retail trade.

In the early 1970's, the general policy of diversifying the national income was formulated (see Chapter 4, pp.64-67). This policy required a much greater labour force than existed in 1970, but unfortunately most of the estimates of the labour force growth after that time were far too low. In 1982 H. Al-Khayat stated that Qatar's total population figure in 1979 was 240,000 (that is to say an increase of 116 per cent over the 1970 census figures) while the total labour force figure was 71,117 ⁽¹⁹⁾ (that is to say an increase of only 47 per cent over the 1970 census). This would give a difference in the two rates of growth of 69 per cent which seems unlikely. The most reliable source is the Annual Statistical Abstract of 1981 of the Central Statistical Organization which estimated the population of Qatar to be 244, 534 (an increase of 120 per cent over the 1970 figure) while the employed labour force was estimated to be 111,264 ⁽²⁰⁾ (an increase of 129.9 per cent over the 1970 census). The differences between the estimates of the Statistical Centre and all others are believed to be because the former included the daily workers and all the small-scale purely private sector enterprises whilst the latter estimates excluded these,

The labour force, however, was also estimated by IDTC in 1977 and in 1978 to be around 51,261 and 69,158 respectively. ⁽²¹⁾ This estimation, which is shown in Table 3.10, if corrected for the exclusions, produces somewhat different results. We know that in one year 1977/78 the labour force increased by 34.9 per cent. The largest increase was estimated to be in the services sector, whilst

the largest absolute numbers, both in 1977 and 1978, were concentrated in the government sector and in contracting, which together contained 65.6 and 57.3 per cent of the total labour force in 1977 and 1978 respectively.

Table 3.10 : Total Labour Force* by Sector (1977 and 1978)

Sector	1977	% of each sector	1978	% of each sector	% of increase over 1977 figures
Industrial Companies & Establishments	4,677	9.1	7,441	10.3	59.1
Contracting Companies	15,638	30.5	19,498	28.2	24.7
Petroleum	2,160	4.2	3,126	4.5	44.7
Trading Companies	5,818	11.4	8,797	12.7	51.2
Banks & Insurance Companies	900	1.8	1,091	1.6	21.2
Government Sector	18,006	35.1	20,141	29.1	11.9
Services & others	4,062	7.9	9,064	13.1	123.1
Total	51,261	100	69,158	100	34.9

* Excluding the employment in Agriculture and Fisheries, domestic service, artisans, small establishments, defence & police forces and daily paid labourers.

Source : IDTC, Qatar Achievements in Industrial Development. Qatar 1981. p.27.

As the demand for the labour force is clearly going to increase given Qatar's national development goals, it is necessary at this juncture to throw some light on the expected labour demand up to 1990-1995.

All the estimates and projections which are available have agreed that there will be an increase in the total labour force in Qatar, but all of them predicted different growth rates. Llewelyn-Davies,

the English consultants, for instance, assumed that the labour demand would grow by an average of 2.9 per cent per annum. ⁽²²⁾ William L. Periera, on the other hand, assumed that an average growth of 4.35 per cent per annum would be applicable if the government implemented its diversification policy. ⁽²³⁾ Caution must be used with these predictions because all their assumptions were based on data obtained in the early and mid 1970's. The situation later changed, especially at the end of 1977 when Qatar's trading/construction boom had overloaded the economy, and at the end of 1982 when the real crisis of oil prices developed, which ever since has seriously affected the government's general expenditure policies.

Table 3.11, the Llewelyn-Davies medium employment forecast*, shows that the country over the twenty years 1972-92 would generate at least 43,962 new additional jobs, of which about 76 per cent would be required in the first ten years. The services and government sector would require most of the new jobs, which would result by 1992 in them possessing 79.3 per cent out of a total of 97,338 workers. The primary sector would face a critical period especially in 1992, when employment would be expected to decline by 22.9 per cent from the 1987 figure.

William L. Pereira's team, which did not agree with Llewelyn-Davies' forecast carried out an employment growth forecast by sector, for the twenty-five years 1970-1995 shown in Table 3.12. This forecast stands on a more solid base due to the team's direct link to the Amiri Palace from which all development programmes come; but it did not take into account any possible change in oil prices. Table 3.12 shows that the demand for labour was expected to continue

* It is clear from the Llewelyn-Davies' report that they ignored small-scale industries, and this must be borne in mind in the following analysis.

Table 3.11 : Llewelyn-Davies Weeks, Medium Employment Forecast
by Sector (1972-92)

Sector	1972	%	1977	%	1982	%	1987	%	1992	%
Primary	5,195	9.7	4,988	6.5	5,707	6.6	5,708	6.0	4,400	4.5
Secondary*	478	0.9	1,929	2.5	2,369	2.7	3,010	3.2	3,450	3.6
Tertiary**	39,451	73.9	57,589	75.0	66,436	76.5	74,022	77.9	77,210	79.3
Construction	8,252	15.5	12,278	16.0	12,278	14.2	12,298	12.9	12,278	12.6
Total	53,376	100	76,784	100	86,790	100	95,018	100	97,338	100

* Including proposed Aluminium & Salt plants requirements

** Including government and armed forces.

Source : Compiled by Author from:
Llewelyn-Davies Weeks : Qatar Development Plan, Technical
Paper 3 of Population & Employment Qatar 1972-73, Tables 3 and 4.

Table 3.12 : William L. Pereira, Medium Employment Forecast
by Sector (1970-95)

Sector	1970	%	1975	%	1980	%	1985	%	1990	%	1995	%
Primary	4,300	9	3,800	5	3,400	3	3,400	2	4,000	3	4,400	3
Secondary	5,650	11	8,000	9	13,000	11	17,000	12	19,100	12	22,550	13
Tertiary	26,100	51	38,400	45	48,400	42	58,150	42	67,650	42	73,000	42
Government	6,650	13	14,500	17	20,000	17	24,600	13	28,650	18	31,500	18
Construction	8,500	16	20,500	24	31,300	27	36,250	26	39,775	25	42,000	24
Total Economically Active	51,200	100	85,200	100	116,100	100	139,400	100	159,175	100	173,450	100

Source: William L. Pereira Associates : National Growth Forecasts
Qatar Planning Studies, Qatar 1977, p.26 Table 8.

to increase, reaching a number of 173,450 in 1995, about three and a half times over the 1970 figure. In other words, national activities would create a demand for an additional labour force of about 122,250, of which 53.1 per cent would be required in the first ten years. As a matter of fact, according to the Central Statistical Organization the total employment figure of 1981 had already reached 111,264. William L. Pereira had agreed with Llewelyn-Davies that the dominant sectors (with with different absolute and proportional figures) would be the service sector (including government employment) followed by construction.

At this stage we need to examine the availability of the Qatari labour force, in order to see to what extent the Qatari population could respond to these projections of labour demand. In 1980 Shankland Cox Partnership had carried out projections of the Qatari population from 1970-2000.⁽²⁴⁾ We have intentionally applied highest growth assumption (B), which is slightly higher than the median (A), at the same time assuming that most of the Qataris under 20 years old would remain dependent because of their involvement in education and training (See Fig. 3.6). Table 3.13 shows that in 1975 the Qatari total population was expected to reach 58,969 persons of which only 19,003 were of working age (9,624 of them female). The Qataris are expected to increase at an average of 3.77 per cent per annum, giving a total number of 164,043 Qataris in 2000. All the Qataris of working age would increase by 4.07 per cent per annum reaching the figure of 58,370 in the year 2000 (29,284 of them female). This assumes raising the age of entry to employment to 20 years rather than 15.

To illustrate the width of the gap between labour demand and Qatari labour supply, all the forecasts are displayed on a single

Table 3.13 : Shankland Cox - Qatari Population Projection by Age and Sex

Age Group	1975				1980			
	Male	Female	Total	%	Male	Female	Total	%
0-19	18,839	18,464	37,303	63.3	22,232	22,106	44,338	62.0
20-59	9,379	9,624	19,003	32.2	12,067	12,223	24,291	54.0
60 and Over	1,389	1,274	2,663	4.5	1,554	1,300	2,854	4.0
Total	29,607	29,362	58,969	100	35,853	35,629	71,482	100

Age Group	1985				1990			
	Male	Female	Total	%	Male	Female	Total	%
0-19	26,252	26,314	52,566	60.0	32,232	32,232	64,464	59.5
20-59	15,542	15,754	31,296	35.8	19,491	19,989	39,480	36.5
60 and Over	2,069	1,611	3,680	4.2	2,498	1,883	4,381	4.0
Total	43,863	43,679	87,542	100	54,221	54,104	108,325	100

Age Group	1995				2000			
	Male	Female	Total	%	Male	Female	Total	%
0-19	40,463	40,463	80,926	60.4	49,772	49,772	99,544	60.7
20-59	23,630	23,977	47,607	35.6	29,086	29,284	58,370	35.6
60 and Over	2,832	2,510	5,342	4.0	3,093	3,036	6,129	3.7
Total	66,925	66,950	133,875	100	81,951	82,092	164,043	100

Source : Compiled by the Author from Shankland Cox Partnership, Qatari Population Projection Qatar January 1980, Table 13.

diagram. Figure 3.5 shows that although we have adopted the highest Qatari population growth rate assumption, the gap between demand and supply is still very wide. If present customs remained unchanged ceteris paribus which indicate that work is confined to males rather than females, the gap of labour shortage appears even wider. Figure 3.5, in general, shows that whatever the expected percentage of the increase of the Qatari population, the dependence on foreign labour (Arab or non-Arab) will remain and although the more work is needed to be done on the present pattern of labour deployment, a great number of foreign workers will have to be allowed to enter the country (see Chapter 9).

3.5.2 Education Level of Qataris and Non-Qataris

In 1952 the first primary school for boys was officially opened with 250 boy students educated by six teachers. Prior to that the education was carried out by religious men and women in the form of al-Kuttab. Education, in al-Kuttab was limited to instruction in recitation of the Koran and rudiments of reading and writing. Girls' education did not commence until 1957 when the first primary school for girls was opened, in Doha City, with 451 pupils and 14 female teachers.⁽²⁵⁾ The education of both sexes was carried out from 1957 until 1983 in separate schools and institutions.

In the scholastic year 1979/80 the total number of schools was 142, of which 73 were for boys. The student enrolment for the same year was 37,651 of which 19,367 were boys, while there were 3,204 teachers, of which 1,439 were males.⁽²⁶⁾ Average figures indicate that there was then one teacher for 11-12 pupils and one school for 265 pupils. But these figures are misleading, knowing that the Ministry of Education's annual report had included schools

Fig. 3.5 Projection of Labour Force Demand and Qataris over 20 (1970 - 1995)

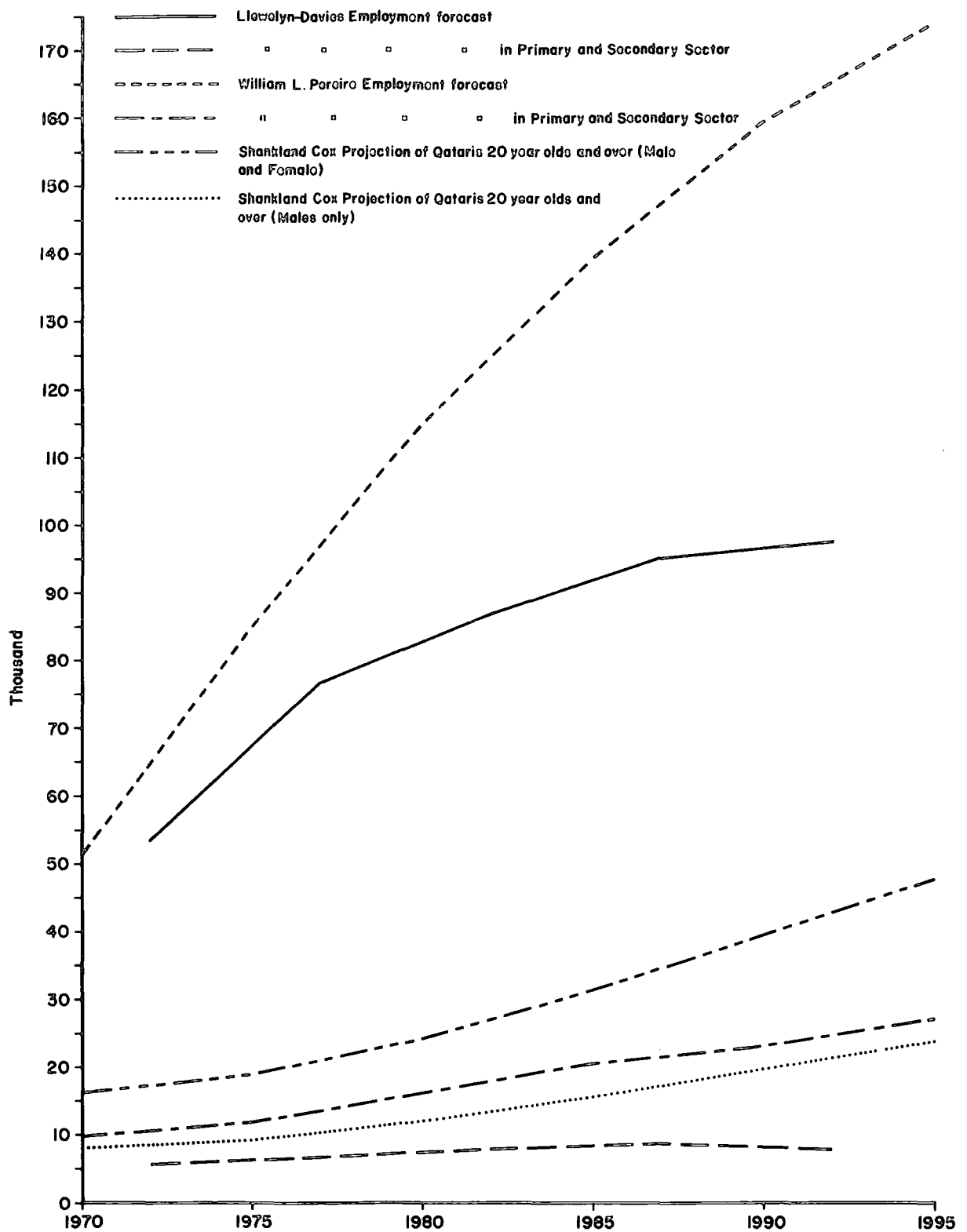

Sources : Llewelyn - Davis, Qatar Development Plan Technical Papers 1972 - 73
 William L. Pereira Associates, National Growth Forecasts, Qatar 1977, p. 23 & 26
 Shankland Cox Partnership, Projections of the Qatari Population 1970 - 2000, Qatar 1980 T.14 P.21

and teachers in villages, and that many village schools comprise a very small number of pupils and therefore have a high teacher : pupil ratio.⁽²⁶⁾ Furthermore there is a noticeable shortage of school buildings in Doha City and many of the existing ones are overcrowded, i.e. 800 pupils or more for a school designed to accommodate 540 pupils.

The ladder of government education is based mainly on three school stages followed by university, abroad or locally. Figure 3.6 shows the education ladder with its main three stages. The first stage is the primary, which children enter at six years old. This stage consists of six different levels. The second stage is the preparatory, where the boys have the choice either to carry on in general education or attend a religious institute, while there is nothing for the girls to choose apart from general education. The second stage takes three years to complete. At the third stage, secondary education, boys can choose from several types of education, i.e. industrial school, commercial school or general level, whilst the girls, if they want to carry on, can only join the secondary general level. The secondary stage takes three years and the pupils at general level and religious institutes have to choose, after the end of the first year, between science or literary streams. After the completion of this last stage the pupils have the right to continue their education, conditional on attaining the required standards, either in Qatar University or overseas universities.

Education in Qatar is still not compulsory and the pupils can leave school at any level they or their parents/ guardians want.

There are, in Qatar, several factors adversely affecting educational progress. The most important of these are:

Fig 3.6

EDUCATION LADDER IN QATAR

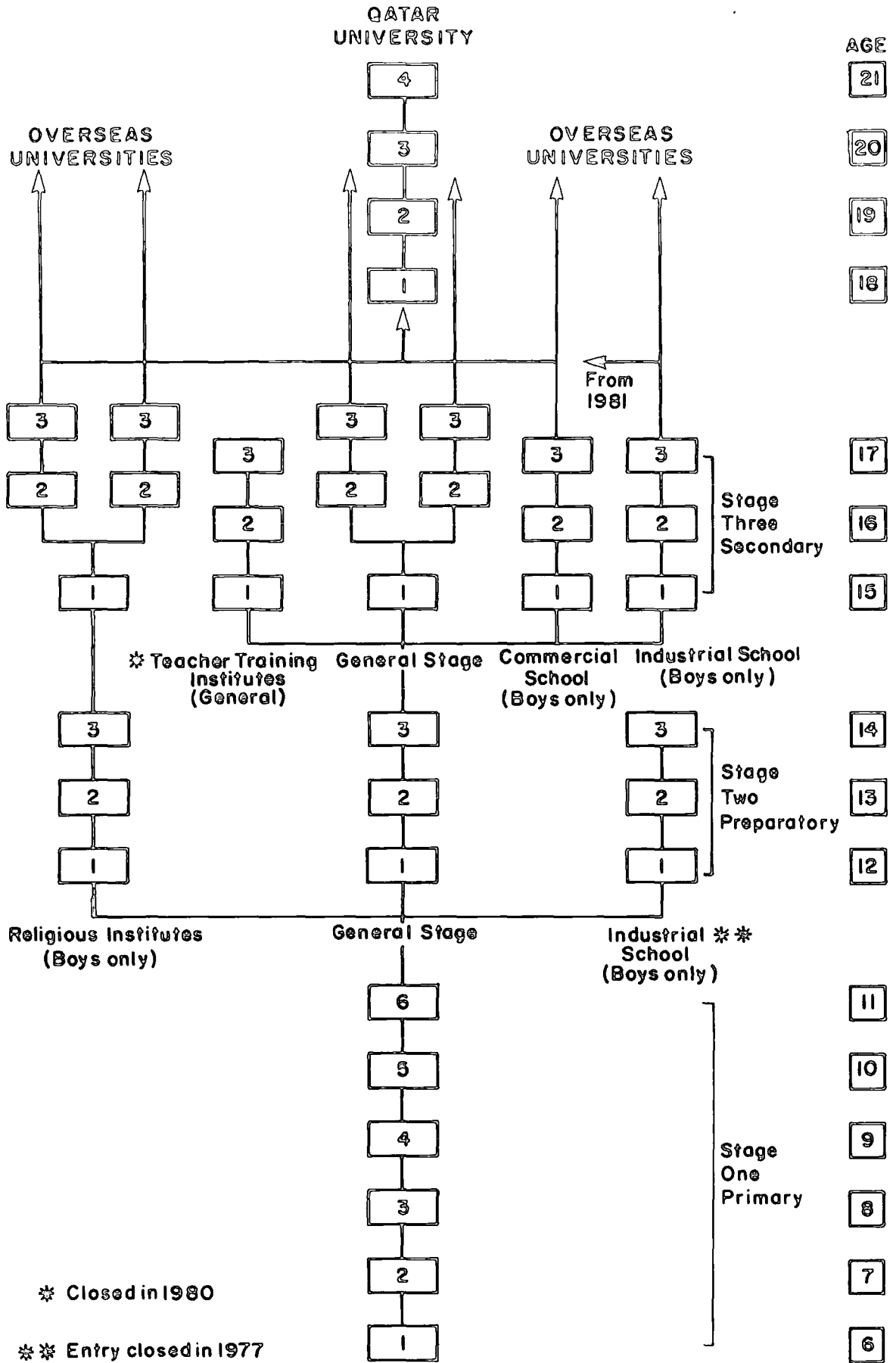

Source : Reversed by the Author from Ministry of Education, Annual Report 1977 / 78

1. Lack of qualified teachers. In 1963/64 for instance, the qualified teachers were only 18 per cent out of 516. In 1968/69 they declined to only 11 per cent out of 666 and in 1978/79 there was 39.5 per cent qualified teachers in the primary stage out of 1,714. At the preparatory and secondary stages the percentage of qualified teachers was 43.8 out of 1,168. (28)
2. Lack of Qatari teachers, especially in preparatory and secondary stages. The Ministry of Education has been filling the gap by importing Arab teachers from abroad. In addition, the participation of Qatari females in education is much higher than that of Qatari males who have many opportunities to work outside the teaching field. (29)
3. Overcrowded classes which have resulted in reducing educational benefit and at the same time decreasing the proper use of school facilities. (30)

After this brief sketch of the education background, we analyse the education level of 1) both of the Qatari potential labour force and the Qatari active labour force; and 2) both of the non-Qatari potential labour force and the non-Qatari active labour force.

3.5.2.1 Education Level of Qataris

According to the 1970 census, the Qatari potential labour force was 19,226 of which 9,649 were female. (31) From Tables 3.14a and 3.14b, showing the potential Qatari labour force by sex and age groups, we can deduce the following:

1. Illiteracy among males over 29 years old was dominant with an average rate of 70.3 per cent of 5,512 persons.

2. Illiteracy among Qatari females was even greater in the age group 20 and over, with an average of 90.1 per cent out of 7,708.
3. Qatari males were better educated than the females, because:
 - a) male education had started earlier;
 - b) in 1970 the total number of male schools was 48 against 39 schools for females; ⁽³²⁾
 - c) parents used to be very hesitant about sending their daughters to al-Kuttab in the first instance, and then on to school;
 - d) there are many obstacles facing females wanting to proceed for further education abroad;
 - e) female education was set up only to meet cultural requirements rather than preparing them to meet the labour shortage; ⁽³³⁾
 - and f) most females, after marriage, would leave school.
4. There is no technical education for females and what in Table 3.14b is referred to as vocational training is confined to that for teachers and nurses.

In spite of the energetic educational policies and considerable expenditure the output of specialized institutions and centres is very low. Figure 3.7 shows the general enrolment of six types of educational bodies. The oldest among them is the Industrial School which was opened in 1957/58 consisting of two stages, preparatory and secondary, with a total enrolment of 15 students. The largest enrolment of the Industrial School was achieved in 1967/68, but from then on the total enrolment declined to somewhere around 50 in 1978/79. The Teacher Training Institutes, Commercial school and Training & Career Centre had faced similar conditions but on different size and time scales. The fastest growing enrolment has been in overseas

Fig 3.7 TECHNICAL AND VOCATIONAL TRAINING ALSO EDUCATIONAL ENROLEMENT

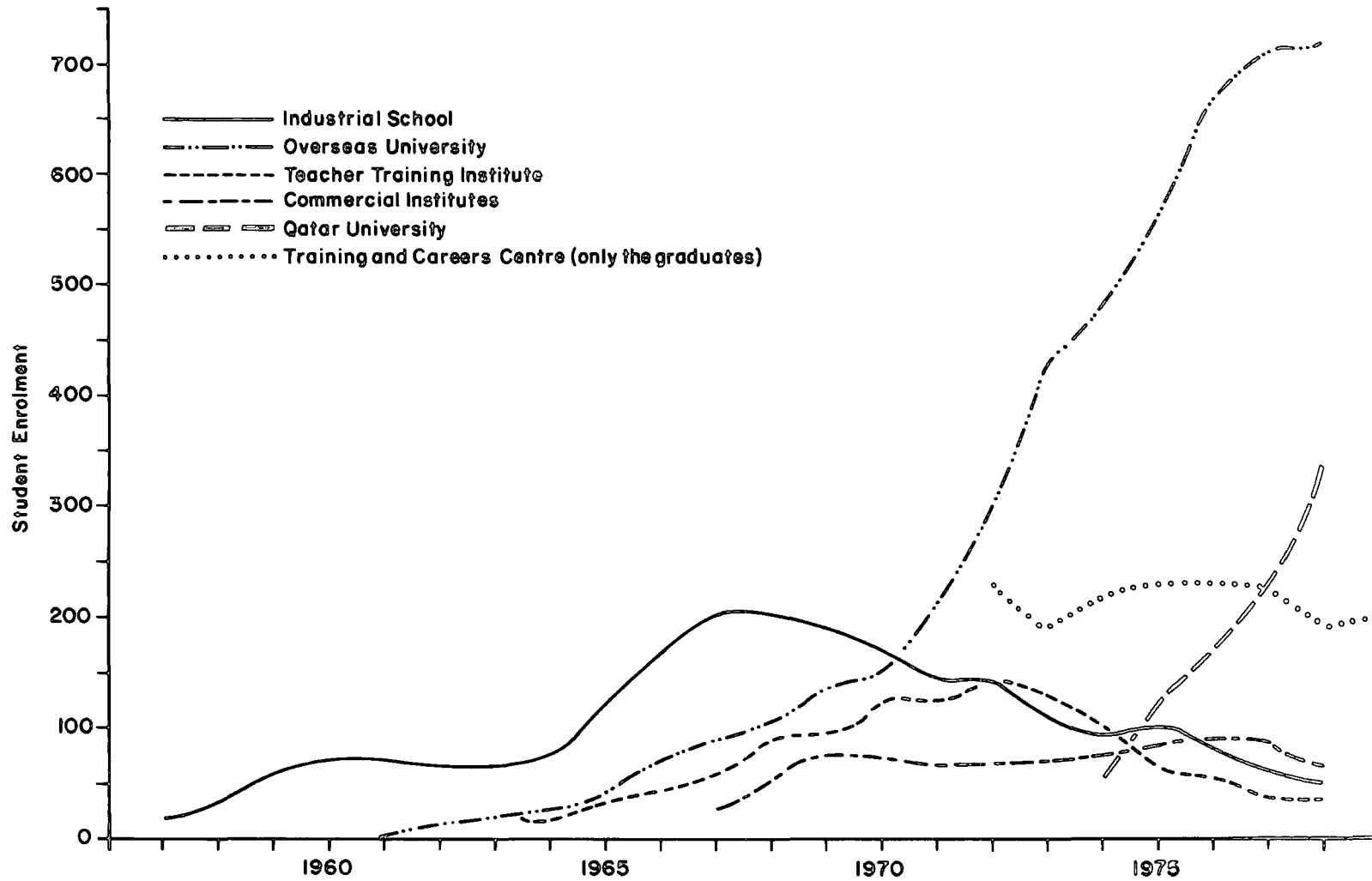

Source : Compiled by the Author from -
 Al - Kabaisi A.J., *The Development of Education in Qatar 1950 - 1977*, Ph.d. Thesis, Durham University, Appendix 2.1
 Training and Careers Centre, *The Centre Graduate since 1972*, Qatar

Table 3.14a : Qatari Potential L-bour Force by Age, Sex and Educational Level (1970 Census)

MALE

Age Group	None	Kuttab	Pri- mary	Sec- ondary	Vocat- ional & Tech.	Univ- ersity	Total	% of none level
15-19	119	10	598	1,038	145	12	1,922	6.2
20-29	588	81	537	600	207	130	2,143	27.4
30-39	1,447	296	331	146	33	21	2,274	63.6
40-49	1,516	362	82	30	13	2	2,005	75.6
50-59	912	285	25	10	1	2	1,233	74.0
Total	4,582	1,032	1,537	1,824	399	167	9,577	47.8
% of level	47.8	10.8	16.4	19.1	4.2	1.7	100	

Table 3.14b

FEMALE

Age Group	None	Kuttab	Pri- mary	Sec- ondary	Vocat- ional & Tech.	Univ- ersity	Total	% of none level
15-19	708	20	723	440	47	3	1,941	36.5
20-29	2,167	103	326	92	9	11	2,708	80.0
30-39	2,400	106	33	13	-	2	2,554	94.0
40-49	1,464	41	6	-	-	1	1,512	96.6
50-59	912	20	2	-	-	-	934	97.6
Total	7,651	290	1,090	545	56	17	9,649	79.3
% of level	79.3	3.0	11.3	5.6	0.6	0.2	100	

Source: Al-Jaber, M.H., Qatar Human Geography, Unpublished M.A.,
Cairo University, Cairo 1977 Appendices.

universities where enrolment in 1961/62 was five students and in 1978/79 the number was 720 students. But following the official opening of Qatar University in 1976/77 the numerical growth rate of overseas students has fallen.

Table 3.15, showing Qatari manpower by occupation and educational level in 1970, indicates that 62.1 per cent of the 8,168 economically active males were illiterate. The table also shows that the illiterate and those only with primary al-Kuttab education comprised 61.3 per cent even of those in Grade I occupations. This high percentage, as well as the general shortage of Qatari labour force led to the creation of "welfare employment", which provided the Qatari males with salaries without the actual need to work, this causing yet more demand for non-Qatari labour.

Table 3.15 : Qatari Manpower by Occupation and Educational Level (1970)

Level of Education	Occupation				Total	% of each to the total	% of total active Popln.	% of Doha City
	I	II	III	IV				
None	212	654	1,830	2,373	5,069	62.1	10.5	52.6
Primary or Kuttab	206	856	559	548	2,169	26.6	4.5	68.0
Secondary	120	415	415	48	657	8.0	1.3	75.2
Technical	92	56	36	9	193	2.4	0.4	72.5
University	52	24	-	4	80	0.9	0.2	92.5
Total	682	2,005	2,499	2,982	8,168	100	16.9	

- I Professional and technical, administrative, executive and managerial workers.
- II Clerical, sales and related workers.
- III Craftsmen, production and related workers.
- IV Farmers, fishermen, transport and service workers and others (including armed forces)

Source: MEDD, Economic Survey of Qatar 1971, p.76, Table 5.1

3.5.2.2. Educational level of non-Qataris

The education of non-Qataris in Qatar is free and there is no restriction over the right of admission against any minorities in the country. The total enrolment, in 1980/81 of non-Qatari pupils was 13,701, that is to say 34.3 per cent out of the total enrolment of 39,944 pupils. (34)

The total non-Qatari potential labour force in 1970, as shown in Tables 3.16a and 3.16b, was 47,848 of which only 8,492 were females, General deductions drawn from these tables are:

- 1) About 67 per cent of the 39,356 males and 53.1 per cent of females, were illiterate. This may be explained by a) most of the males were manual workers brought from Asian Countries, and b) due to the immigration restriction against certain immigrant groups' families (see Migration Policies, pp.35-38).
- 2) Males with secondary education and over made up 15.7 per cent of their total. On the other hand, 30.6 per cent of females had received secondary or further education.
- 3) The overall illiteracy rate in 1970 among non-Qataris was about 65 per cent whilst the Qatari average was 64 per cent.

Employed non-Qataris in 1970 numbered 40,222. (35) Table 3.17 below shows the distribution of these between four major occupation groups. Table 3.17 also shows that the general activity rate among non-Qataris was about 84 per cent out of the potential total. Illiteracy among active non-Qatari workers was higher than the general average of non-Qatari potential labour force. Among non-Qataris in occupational group I numbers tended to increase parallel to rising grades of educational qualification, whilst the general trend in the other groups was the reverse.

Table 3.16a. : Non-Qatari Potential Labour Force by Age, Sex, and Educational Level (1970 Census)

MALE

Age Group	None	Kuttab	Primary	Secondary	Vocational & Tech.	University	Total	% of none level to total group
15-19	2,707	116	722	644	22	13	4,224	64.1
20-29	10,714	447	2,227	1,569	144	365	15,466	69.3
30-39	8,165	522	1,446	1,363	162	617	12,275	66.5
40-49	3,595	295	615	638	106	282	5,531	65.0
50-59	1,312	154	137	139	43	75	1,860	70.5
Total	26,493	1,534	5,147	4,353	477	1,352	39,356	67.3
% of level	67.3	3.9	13.1	11.1	1.2	3.4	100	

Table 3.16b.

FEMALE

Age Group	None	Kuttab	Primary	Secondary	Vocational & Tech.	University	Total	% of none level to total group
15-19	495	27	256	405	7	9	1,199	41.3
20-29	1,567	95	526	1,094	93	160	3,535	44.3
30-39	1,403	58	278	439	67	114	2,359	59.5
40-49	722	29	79	129	14	31	1,004	71.9
50-59	326	11	21	19	8	10	394	82.5
Total	4,513	220	1,160	2,086	189	324	8,492	53.1
% of level	53.1	2.6	13.7	24.6	2.2	3.8	100	

Source : al-Jaber, M.H., Qatar Human Geography, Unpublished M.A. Cairo University Cairo 1977. Appendices.

Table 3.17 . . : Non-Qatari Manpower by Occupation and Education Level (1970)

Educational Level	Occupation				Total	% of each	% of Total Active Popln.
	I	II	III	IV			
None	93	2,662	13,496	11,028	27,279	67.8	56.4
Primary or Kuttab	192	1,535	2,207	2,821	6,755	16.8	13.9
Secondary	896	1,752	949	545	4,142	10.3	8.6
Technical	350	87	100	20	557	1.4	1.1
University	1,107	319	33	30	1,489	3.7	3.1
Total	2,638	6,355	16,785	14,444	40,222	100	83.1

Occupation: I = Professional and Technical, Administrative, Executive and Managerial Workers

II = Clerical, Sales and Related Workers

III = Craftsmen, Production and Related Workers

IV = Farmers, Fishermen, Transport and Service Workers and Others

Source : Compiled by the Author from MEDD, Economic Survey of Qatar, 1971, p.76.

It is clear that by 1981 the labour force and educational level had changed from what it was in 1970, but unfortunately there is no adequate data available. The Central Statistical Organisation has shown that, in 1981, of the employees of the Government, although illiterates comprised 52.9 per cent out of the total of 41,721, the percentage of the Diploma and over qualification holders had reached 9,329.⁽³⁶⁾ That is to say 22.4 per cent out of the total.

Conclusion

There is no doubt that Qatar will continue to depend on a non-Qatari labour force for the foreseeable future and possibly beyond for its development programmes. As more projects, including industrial, are established the more dependence on non-Qataris will follow.

The oil crises of 1982/83 forced the government to reduce oil production and oil prices, thus decreasing the country's income and expenditure. This decrease has forced the government to adopt a tough line in its own direct employment and this will certainly have a "knock-on" effect on the private sector, especially for non-Qataris. This effect could be at least as severe as the slowing down of growth in 1977/78.

Given the very large number of non-Qatari workers, and the unavoidable need for a high proportion of them, the government will have to set up a consistent employment policy to ensure a sufficient supply of labour and to meet other socio-economic requirements. Such a policy, to be acceptable and effective, will have to contain two components, one that offers secured terms of employment, especially for those who have been working for many years in the country. This is to give continuity, particularly important in industry, and secondly a component of Arabization of the labour force i.e. that has been adopted by the Ministry of the Interior in most recent years.

The ultimate policy, which the author recommends, is that of the Qatarization of the labour force in certain selected sectors, i.e. oil, natural gas and basic industries and such a policy, re-examined in the Conclusion could be implemented as follows.

The 1980 manpower has been calculated for all of the major industrial establishments, i.e. QGPC, QAFCO, QAPCO, QFMC, and QNCC. (see also Chapters 5 and 6). The total labour force of the above-mentioned establishments was 6,349 employees, of which 1,393 were Qataris, about 22 per cent of the total. These 1980 figures of employment are taken as the base year from which an assumed 5 per cent increase in employment in these and new activities is then projected. Figure 3.8 illustrates this projection for 1980-1989 together with vocational training programmes for cadres of different types of manpower. The first year as recommended would have three programmes for one to three years, while the fourth would extend for a four year period. This step should be taken to ensure the maintenance of the present Qatari/non-Qatari ratio. The programme should then be carried on four year bases. The enrolment to such a programme should be selected as 64 per cent from preparatory stage leavers and 36 per cent from secondary stage leavers, the preparatory leavers to be trained as technicians and skilled labour force, whilst the secondary leavers to be trained as engineers and highly skilled labour force. The programme for preparatory certificate holders is assumed to run for four years (48 months) as follows -

<u>Period</u>	24 months	6 months	6 months	6 months	6 months
<u>Institution</u>	Industrial school (I.S.)	I.S the Plant (as trainee)	In the Plant (as trainee)	In the Plant (as worker)	Vocational Training
<u>Place</u>	Qatar	Qatar	Qatar	Qatar	Qatar or abroad

Fig 3-8 Qatarizations and Vocational Training Programmes

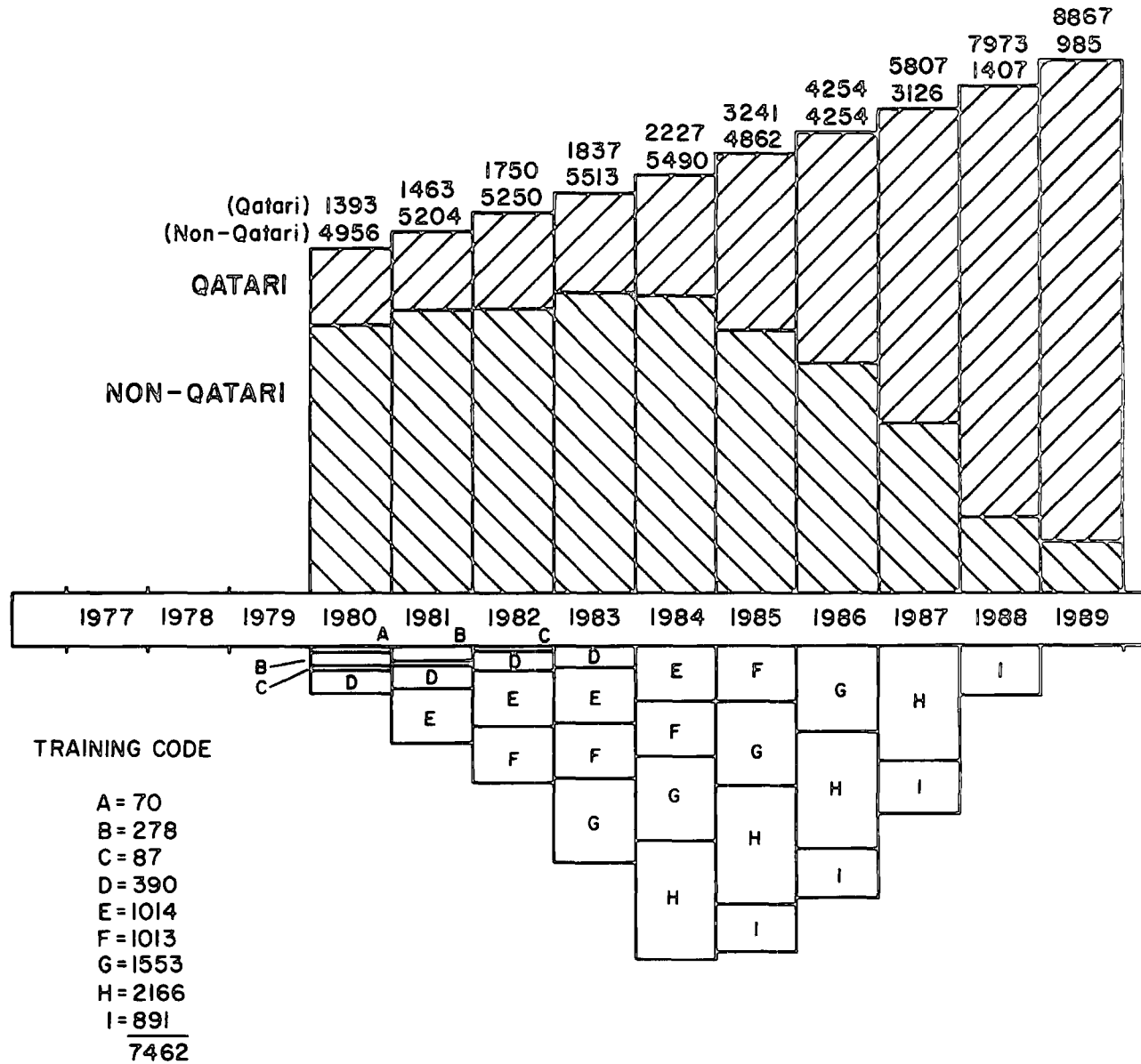

112

The programme for the secondary leavers is assumed to run for four years (48 months) as follows:

<u>Period</u>	6 months	6 months	12 months	24 months
<u>Institution</u>	I.S.	In the plant (as trainee	In the plant (as worker)	Special course
<u>Place</u>	Qatar	Qatar	Qatar	Abroad

By adopting such an extensive programme it is suggested that within 5 years from the base year Qataris could comprise about 50 per cent of the total labour force and within an additional three years the Qataris could make up about 90 per cent; experts and highly qualified engineers of non-Qatari origin would make up the remainder.*

The government, for its part, would have to:

1. Promulgate a law concerning a compulsory form of education, at least until the end of the preparatory stage which will ensure a sufficient enrolment of pupils to feed the training programmes;
2. Improve school standards, especially at elementary and preparatory stages;
3. Improve the standard of the industry School, as well as of the Vocational Training Centre and the Commercial Institute, by adopting up-to-date techniques and methods.
4. Adopt a tough line toward Qatari employees who want to move from the industrial sector to government, or from productive to unproductive work.

* The drop out rate is assumed to be 5 per cent of the total of each programme enrolment, but during the whole period this could be made up from movement into employment from those already in the higher educational pipeline.

5. In spite of the rather disappointing results obtained from specialised schools during the 1970's (see Fig. 3.6), maintain them in their separate identity but radically improve them. One current idea to group them into one body would result in the destruction of all of them.
6. Make proper use of the Ministry of Information facilities to encourage the dissemination of positive attitudes towards education, training and employment.

As we shall see from our analyses of industry in Qatar, this whole question of manpower deployment is absolutely critical to the future as well as significant to the understanding of the present situation.

CHAPTER 3

References

- (1) Al-Jaber, M.H. Qatar Human Geography, Unpublished M.A. Thesis, Cairo University, Cairo 1976/77, p.142, and see
State of Qatar, Some British and Ottoman Documents 1868-1949, Documents of Qatar's History, the Amir's Office, al-Ahliyah Press, Doha, 1979, p.101 and 123.
- (2) Ministry of Overseas Development, The First Population Census of Qatar April/May 1970, Middle East Development Division, British Embassy, Beirut 1970, Table 10.
- (3) MEED, Special Issue : Qatar, November 1979, p.3.
- (4) William L. Periera Associated, National Growth Forecasts, Qatar Planning Studies, Qatar May 1977, p.23, T.4.
- (5) Al-Jaber, M.H. op.cit., pp.142 and 149.
William L. Pereira, op.cit., p.23.
- (6) Al-Jaber, M.H., op.cit., p.144 and
Llewelyn-Davis, The Prospects For Growth : Population and Employment, Technical Paper No.3, Qatar Development Plan, Technical papers 1972-73, Qatar, pp.1-2.
- (7) Personal Communication.
- (8) " "
- (9) " "
- (10) Ministry of The Interior, Cancelled Residential Visa, Statistical Dept. Qatar, 1980.
- (11) Ministry of Justice, Collection of Qatar's Laws 1961-75, Legal Affairs Dept. Qatar, Vol.1, p.119.
- (12) Personal Communication.
- (13) " "
- (14) " "
- (15) " "
- (16) Ministry of Overseas Development, op.cit. T.13.
- (17) Ibid.
- (18) Al-Kobais : A.J., The Development of Education in Qatar 1950-70, Unpublished Ph.D. thesis submitted to Durham University Durham 1979, p.9.

- (19) Al-Khayat, H., Population Stock of the Arabian Gulf States, Qatar University, Qatar 1983, p.258.
- (20) Central Statistical Organization, Annual Statistical Abstract 1984, Doha Modern Press, Qatar, July 1982, p.13, T.6.
- (21) IDTC, Qatar Achievement in Industrial Development, Qatar, 1981, p.27.
- (22) Llewelyn-Davies Weeks, op.cit Tables 1,2, and 3.
- (23) William L. Periera Associates, op.cit., p.23.
- (24) Shankland Cox Partnership, Projection of the Qatari Population 1970-2000, Qatar, January, 1980.
- (25) Ministry of Education, Annual Report 1974/75, Qatar, 1976, p.107.
- (26) Ministry of Education, Annual Report 1980/81, Qatar, p.209.
- (27) Al-Kobaisi, A.J., op.cit., p.224.
- (28) For more information see Ibid, pp.185-192.
- (29) Ibid, pp.176-185.
- (30) Ibid, pp.211-212.
- (31) Ministry of Overseas Development op.cit., T.10.
- (32) Ministry of Education, Annual Report 1974/75 p.107.
- (33) Ministry of Overseas Development, Economic Survey of Qatar 1971 Middle East Development Division, British Embassy Beirut, 1972, p.80.
- (34) Central Statistical Organization, op.cit., p.57, T.38.
- (35) Ministry of Overseas Development, the First Population Census, op.cit. T.13.
- (36) Central Statistical Organization, op.cit. p.44, T.31.

CHAPTER 4

INDUSTRIAL DEVELOPMENT IN QATAR - POLICIES AND INSTITUTIONS

4.1 Development of Policy Strategy for industry

A. The evaluation of a strategy for industrialization : policy and statements

During the 1950's the government, according to QPC reports and statements, was not confident of investing within the country and it preferred to invest oil revenues in securities accounts in the United Kingdom.⁽¹⁾ In addition, the government preferred to leave all industrial projects to oil companies and private exploitation. To emphasize this point, we can note that in 1957 the heir apparent, Sheikh Ahmad, asked QPC to construct an additional oil refinery at the company's cost. This matter had led to serious dispute because of the resistance of QPC to this suggestion.⁽²⁾ (see Oil Refinery in Chapter 6, p. 143). A rare example of the government's interest in local industry occurred in 1957 when, it is believed, that the government invited Le Grand Adesco to study the availability of cement raw material in Qatar.⁽³⁾ Unfortunately neither the report, nor the government response are available but it is known that no action was taken.

At the beginning of Sheikh Ahmad's rule (which started in 1960), two statements relevant to industry emerged. The first was by the Ruler, in which he pointed out:⁽⁴⁾

"I will try my best in industrialization, this is because I am very interested in vocational training, and we should increase the number of industries by educating a large number of Qatar's people"

The second statement was made by the Deputy Ruler (Sheikh Khalifah, the present ruler) in which he declared that: (5)

"Welcome to every Arab producer to Qatar, on condition that he be joined by Qatari capital in investment projects."

In 27 May 1963, after only one month of the 1963 "popular movement", (6) the Ruler issued an "Explanatory statement on the Comprehensive Programme for the Advancement of the Country." This statement is the only one of its kind published in the Official Gazette. The Ruler, in the statement pointed out that (7)

"As the study of natural resources of the country and the discovery of the best way to invest these resources are one of the matters which concern us most in order to lay-down a complete economic plan for development which will stand on a sound scientific base, our government has contracted with Arthur D. Little (An American consultant firm) to carry out the above-mentioned study.

The government will pay full attention in examining these reports when completed, and to take all means to implement the recommendations which prove to be suitable for, and profitable to, the country."

At the end of 1963, Arthur D. Little submitted their report to the government. The report consisted of five main recommendations: (8)

- a) To establish the best basis for the investment of the State's reserve fund
- b) To develop fishery resources
- c) To reclaim lands and to develop the agricultural sector
- d) To exploit natural gas
- e) To utilize mineral deposits, other than oil, in cement manufacture

The government's response to these points was to select the first three recommendations whilst the fourth was left for closer examination and further studies to be carried out by the government. The fifth point was left only for studying its economical viability, including marketing aspects.

The start was delayed for two years and not until 2nd July 1966 did the first industrial establishment emerge. The delay in implementing the plan was caused mainly by the trend in oil revenues which did not rise as expected.⁽⁹⁾ We also note that the government in February 1967 offered 75 per cent of its 60 per cent share in the Qatar National Fishing Company to the Qatari public. But an examination of the government's expenditure during 1966-67 indicates that the real reason behind this action was probably not as the government stated i.e. that this was to encourage the Qataris to invest in public projects,⁽¹⁰⁾ but rather to counteract a decline in revenue at a time when other expenditure was being cut.

The first movement of the government in investing in hydrocarbon industries came in 1968 when it purchased the topping plant from QPC (see Chapter 6, Oil Refinery, p. 143-144).

In 1969 the government, due to the improvement in the proven oil reserves, production and revenues, then adopted a programme based on three general aims : ⁽¹¹⁾

- 1) increase the national income
- 2) diversify the country's income sources
- 3) acquisition of technical skills

It is believed that the government adopted these fundamental approaches to development in accordance with Arthur D. Little's specific recommendations.

The transfer of power in 1972 (see Section 4.2) helped in the acceleration of establishing some elements of an industrialization policy. The acceleration came as a result of the completion of the general infrastructural programme, which was vigorously undertaken between the end of the 1950's and the end of the 1960's. The final

formulation of an industrialization policy in Qatar was achieved in the early 1970's, a policy based on several specific elements :⁽¹²⁾

- 1) Introduction of a petroleum refining industry;
- 2) Application of advanced technology in the production and processing of natural gas;
- 3) Use of sophisticated technical research in any joint venture industry;
- 4) Manufacturing cement from Qatar's own raw materials;
- 5) Utilizing all feasible means to achieve the growth of light industries;
- 6) Encouraging Qatari investment in local joint ventures either with the government or foreign business organizations;
- 7) Exploiting fisheries in Qatar's territorial waters.
- 8) Developing the agricultural sector by adopting up-to-date methods and techniques.

It is clear that the industrialization strategy in Qatar, before evolving to its final form, can be seen as developing in several stages.

B. Industrial development stages in the context of contemporary development theory

Before examining the stages of industrialisation in Qatar, we need at least to examine in outline the theories and models of industrialisation strategies and economic growth which were current at the time Qatar was developing its own national policies. First, we can say that the theory of Stages of Economic Growth as enunciated by W. Rostow was, and is, not applicable to the case of Qatar and the rest of the Gulf Emirates.⁽¹³⁾ This is mainly due to :

- a) the absence of a large peasant agricultural component in the pre-industrial traditional society. Rostow assumed that a developing country possessed a large traditional rural sector with all that that implied.
- b) Rostow in his pre-take off stage assumed that new production functions in agriculture, industry and enterprise would be based on risk investment of savings from several sectors. In Qatar and the Gulf, the only risk investment was provided by foreign oil companies partly through the state's central treasury.
- c) At the take-off stage Rostow assumed that effective investment and choice was mainly carried out by many different types of entrepreneurs. In Qatar, the State early appears as the only major investor.

The only components of Rostow's argument which are relevant in Qatar and the Gulf are those associated with the results of successful growth, i.e. high urbanisation, high income and consumption; these are supported by a broad and high production base in the Rostow's model but in the Emirates are supported only by revenues from exported oil - i.e. a rentier consumerism.

The big push and balanced growth theories are also not applicable in that all of them (Rosenstein-Radon and Nurkse) ⁽¹⁴⁾ also assumed the existence of sizeable multi-sectoral private enterprises responsive to enterprise opportunities through investment. The doctrines of big push and balanced growth are only relevant to Qatar, however, in terms of the considerable resource wealth derived from the sale of hydrocarbon making it possible to invest in other sectors. Imbalanced growth theory, however, implies the possibility

of a choice between sectors to develop, whilst in Qatar and the rest of the Gulf Emirates there is virtually no, or at best only limited, choice due to the disequilibrium in natural resource endowment. But if unbalanced growth is seen from the theoretical viewpoint only, it appears applicable in the Gulf, especially in terms of the growth pole approaches of backward and forward linkages. (15) Even the doctrine of the strategy of import-substitution is far less important than in other developing countries because of the existence of large export oil revenues which provide a large surplus in the balance of payment, while still allowing the consumption of imported goods to increase, e.g. in Qatar from QR 1,610 millions in value in 1975, to QR 5,265 million in value in 1980. (16)

The "Russian" model, which is known as the heavy industrialization strategy, (17) and was adopted by Algeria, appears to fit most closely to the Gulf Emirate situation where analogous autocratic and bureaucratic systems seem to exist and where the bulk of real investment has been carried on by the government in the establishment of heavy industries. But the Gulf area rejects the Marxist communist philosophy as atheistical, with all that that implies, not only in religious matters but also in fundamental socio-economic doctrines and practices. Thus in Qatar we find that Islamic teaching (together with cultural attitudes inherited from a tribal past) produces a situation which can be summarized thus:

- a) The simultaneous alleviation of poverty i.e. social welfare with a preparedness to accept the growth of the wealth of individuals
- b) Absolute respect for private property
- c) Public ownership exists to supplement and complement private ownership and not to replace it.

It appears from a comparative analysis of established development theories and models, some of which are very briefly summarized above, that no single strategy, applied in its entirety, matches exactly with the situation of industrialization strategy in Qatar or in the Gulf Emirates as a whole. All strategies, with the exception of Marxist communism, are compatible with the Islamic system in respect of private ownership and the role of the private sector in saving and investing. However, it is ironic that the skewed balance between investment by the public and private sectors and the methods and fields of investment make it impossible validly to utilise any of the classic models in Qatar. See also the end of Section 4.8, p.90 .

C. An identifiable growth stage model for the Emirates

It is clear from historical evidence that Qatar and the rest of the Gulf Emirates have adopted, unintentionally, an industrialization strategy which can be identified as having four stages. These stages are:

1. Random Stage

Random stage is the stage prior to oil discovery in a period which may extend over the first decade or so after oil discovery. The main economic activity of the inhabitants was pearl fishing which was export-oriented. The leading sheikhs at this stage were essentially tax and customs collectors, for the Ottoman Imperial power up to 1916 and thereafter, to maintain the Ruler and the apparatus of government such as the police force and administration. The only effective risk investment was brought by foreign oil companies, while other investments in a very limited number of fields were carried out by private entrepreneurs. The royalties and duties

which were collected from the oil industry created a need for, and the possibility of developing infrastructural facilities. The revenue for this was concentrated in the hands of the Ruler. In the meantime the Rulers and their developing institutions of government asked several foreign consultants to guide them in possible fields of investment, especially those projects which could utilise the preponderant natural resource, i.e. oil and hydrocarbons. There was no central idea of planning or of policy priorities.

2. Selective and Infrastructural Stage

The selective infrastructural stage, although not separated by a clear boundary line from the previous one, emerged usually after the first decade of oil exploitation. The process of selection by the emerging domestic governmental machinery was carried out in accordance with the foreign consultant's findings and recommendations. The government(s) was strongly influenced towards investment in a limited range of possible heavy industrial projects which private savings could not finance, or where large-scale risk played a vital role. In the meantime the government(s) established for the first time official education systems, health services, roads, i.e. physical and human infrastructure combined with welfare services. Simple arithmetic forced governments to recognize the great length of time required to develop local human resources into highly skilled forms. So these countries (the Gulf Emirates) imported all and more of what was required by the industrial sectors and others. This stage, also lasting about another decade, was essentially a period of broad-front expenditure with no net returns to government investment, and in which the private sector was mainly involved in the rising commercial and importing business.

3. Heavy Industrial and Consumption Stage

The heavy industrial stage, as shown by historical events emerged almost two decades after the oil exploitation. The government(s) in this stage played an effective role in financing and organizing oil, natural gas and other basic industries. The massive expenditure on these projects and other services created a large demand for manpower, building raw materials and other inputs. This led to high aggregate levels of consumption, which as measured by imports was estimated in Qatar in 1980 as QR 21,937,500 per person per annum, or QR 1,828,125 per month.⁽¹⁸⁾ This stage also took approximately a decade. This was a period of upward spiralling expenditure in which growth in each sector encouraged growth elsewhere. Now the private sector began to be involved in industrial activities, investing in the production of construction materials in particular.

4. Forward Linkage Stage

The forward linkage stage emerges after about three decades from the beginning of oil exploitation. The main structural characteristic of this stage is the movement of emphasis away from the governmental creation of heavy industries which are export-oriented to light and medium industries, based on private sector investment, which produce consumer goods as well as construction materials. The high consumption rate which appeared in the previous stage continues at the same level or just above. The private entrepreneurs increasingly play a dominant role in industry, whilst the government more and more assumes an organizing role.

Kuwait entered the fourth stage in the mid-1970's while Qatar entered the last stage at the beginning of the 1980's. The U.A.E., with the exception of Dubai, are in the middle of the third stage.

For Saudi Arabia, although it has resources other than oil, the model is to some extent still applicable and it is believed that it is well advanced in the fourth stage. Bahrain, on the other hand, due to its small oil and gas reserves, has changed the emphasis from growth in manufacturing to become a banking and services centre in the Gulf, a special form of the fourth stage.

A key factor is that Qatar and other Gulf Emirates during all four stages have remained dependent on international markets and suppliers. In the first stage, for instance, the level of earnings of each single year depended mainly on the price of the Gulf pearls in the international markets and when the artificial pearls of Japan were produced, the Gulf pearls retreated in value and collapsed as an industry. In the second, third and fourth stages the government(s) was/were dependent on foreign consultants, trade, labour, technology and capital equipment, etc. in their development programmes, and remain so today. Not only that but the Gulf still relies on international markets for the sale of crude oil and other hydrocarbon exports.

This is not the place to consider the issue of dependence as such but perhaps we can note the following as relevant to the four stages outlined above. The first Random Stage was one which the Gulf Emirates were all to varying degrees politically dependent on external powers, primarily the United Kingdom. Governments which were only slowly evolving from traditional sheikhly systems were also economically dependent on the large and powerful trans-national oil companies for revenues and dependent for advice on foreign consultants. The second Selective and Infrastructural Phase was one in which the economic dependence on oil revenue, still determined by the companies, became even more critical because of rising demands for income to meet soaring expenditure. This was also a period in which, although domestic

government institutions became stronger, the reliance on foreign experts and specialists, as well as general labour grew rapidly and almost uncontrollably. Dependence on foreign markets for crude oil exports and foreign suppliers of virtually all capital and consumer goods, including food, became almost total.

The third Heavy Industry and Consumption Phase shows some changes in the pattern. The governments take control of their oil and, through OPEC and OAPEC, attempt to control the rate of growth of oil production and prices, although still remaining dependent on foreign production companies, who also dominate the marketing of oil. Revenue demands continue to rise as also does the dependence on imported materials and manpower. Further, the new heavy petro-chemical industries themselves are dependent on foreign markets. It is also a period in which importers of oil, gas and feedstock realise their dependence on the Gulf exporters. The fourth stage of Forward Linkages is essentially one of increasingly complex mutual interdependence between the Gulf countries and the industrialised world and also the increasing network of "dependence" linkages between components of the private and public sectors of the domestic economies of the Gulf - especially in industry. The appearance of the GCC extends this into regional areas. The ways in which the question of regional and international linkages have been recently discussed by Arab planners is further considered in the Conclusion.

4.2 The Linkage of Government Bodies with Political Authority

In Qatar, as in many analogous situations, the role of the government in economic decision making, as we shall further consider in Chapter 8, is crucial. As explored later in this and succeeding chapters, government bodies of many types dominate the process of

industrialisation. These bodies are ultimately and directly all responsible to political authority which in Qatar, as in neighbouring states, has evolved from a Sheikhly system to a bureaucratized administration in which the Ruler (or his nominated Deputy) takes final decisions.

As we shall see, although there is considerable continuity throughout the period with which we are concerned, i.e. the oil era, it is useful to make a chronological division - before and after 1972.

The Linkages before 1972

During the late 1940's and the whole of the 1950's English advisers helped the Ruler to develop a bureaucratic administrative system based on three departments, namely Finance, Administrative and Petroleum Affairs Departments. All of these were run and directed by English experts and advisers, and these were the government ministries up to 1962.⁽¹⁹⁾

In 1962 the government issued Law No. (1) of 1962 of Organizing the Supreme Administration of the government. In accordance with Article (1) the Deputy Ruler was invested with the following powers:⁽²⁰⁾

- 1) To prepare a general policy, on the basis of a comprehensive programme, which will guarantee to the State the greatest measure of economic, social, cultural and administrative improvement;
- 2) To propose Laws and decrees organizing the chief principles and basic rules of general government policy;
- 3) To issue regulations, administrative decisions, orders and circulars necessary to put into effect general government policy;

- 4) Higher supervision for running of the government's financial and administrative organisation; and
- 5) The appointment and dismissal of government employees in accordance with the provisions of the law.

In addition to these powers, the Provisional Constitution, which was promulgated on 2nd April 1970, gave the Deputy Ruler the Prime Minister's post. Article (30) of this constitution stated that the Ruler would appoint Ministers in accordance with the Prime Minister's suggestions. In addition, the second clause of Article (38) stated that each minister was individually responsible to the Prime Minister, to carry out his duties and dealing with the subjects with which he is concerned.⁽²¹⁾ Chart 4.1 illustrates the position which had evolved in the period before 1972.

Chart 4.1 Pre 1972 - Upper Echelons of Government

Amir

Deputy Ruler/Prime Minister

Prime Minister/Chairman

Council of Ministers

The linkages after 1972

On 22nd February, 1972 the Deputy Ruler assumed the Amirship from his cousin Sheikh Ahmed bin Ali in a peaceful transfer of power*.

The continuity of direction of the new regime is well established,

* This accession was called "The Correction Movement".

this continuity coming as a result of the authority and responsibility as Deputy Ruler and Prime Minister vested in the present Amir before 1972, which made him, in practice, the strongest figure. Sheikh Khalifa, in the transfer of power, conveyed all powers to himself either directly as the Amir, or indirectly as Prime Minister (see Chart 4.2). These powers are well explained in the Amended Provisional Constitution which was promulgated on 19th April 1972.⁽²²⁾

Chart 4.2

Post 1972 - Upper Echelons of Government

Amir

Prime Minister/Chairman

Council of Ministers

It is clear, therefore, before and after 1972, that Sheikh Khalifa had been, and is still, organizing the general structure of the state's plans and he has also involved himself directly, as will be seen in Chapter 8, with major and minor projects in the state, either economic, social, industry, cultural or administrative.

After outlining how the state runs and controls the matters relevant to this study we can focus our discussion on the key governmental bodies whose jurisdiction involves them in industry and industrial organisation as a whole. We must also bear in mind the characteristics of the linkages outlined in terms of their relevance to development theory as well as practice.

4.3 Ministry of Finance & Petroleum

As mentioned earlier, the bureaucratic organisation of finance and petroleum affairs was started in the 1940's under British control. In accordance with Article (3) of Law No (1) of 1962, Organizing the Supreme Administration of the Government, it was stated, a chief General Department shall be composed of three departments, namely: ⁽²³⁾

1. Department of Finance Affairs
2. Department of Administrative Affairs
3. Department of Petroleum Affairs

The higher supervision of the Petroleum Department was officially handed to the Minister of Finance (the Deputy Ruler) in October 1967. ⁽²⁴⁾ The functions of the petroleum department have changed several times since 1967, and by 1970 the functions of the department, as defined by Law No (5) of 1970, were as follows: ⁽²⁵⁾

- 1) To carry out all the development of the petroleum industry in Qatar, and its progress, organization and the best utilization of oil resources;
- 2) To follow up the activities of exploration, drilling, production, exporting and other technical activities;
- 3) To study the economic bases on which the oil companies in Qatar operate, and to study the technical and economical statements and reports which these companies make, and prepare the necessary reports in this respect;
- 4) To carry out the necessary negotiations with the oil companies operating in Qatar for the best technical and most economical ways which would guarantee the best achievements for the State;

- 5) To prepare studies and statements requested by OPEC, and to express opinions concerning studies and proposals prepared by OPEC.
- 6) To follow up developments and trends relating to the petroleum industry and prepare the requisite studies to show the effects of these developments and trends on the petroleum industry in Qatar.

The Department of Petroleum, during the 1960's existed but at the same time was inactive. This was mainly due to the policy of the oil companies which always made direct contact with the highest level in the State i.e. the Amir and the Deputy Ruler, and not, as specified in the law, through the officials of the petroleum department. This is why in 1970 the Committee for Studying the Ministerial Reports* strongly recommended that any governmental approach to the oil companies, or vice versa should be done through the Department of Petroleum. ⁽²⁶⁾ This recommendation has still not been followed, and the establishment of the Qatar National Oil Company, by Law No (13) of 1972, manacled the department even more, insofar as all important functions and objectives were transferred to QNOC. In addition, later, the government replaced QNOC with an even stronger corporation called the Qatar General Petroleum Corporation (QGPC) (see pp. 84-86). The corporation took full jurisdiction over the oil industry and it usurped the functions of the Petroleum Department in some cases, in following developments and trends relating to the oil industry. ⁽²⁷⁾ The corporation has even become the dominant representative of Qatar in world-wide conferences, i.e. OPEC and OAPEC.

* This Committee was set up in accordance with the Council of Ministers Resolution No (4) of 1970.

The Departments of Finance and Administration have been subdivided into various specialist units, none of which directly controls or affects industrial activities, whilst economic and commercial affairs were transferred to the Ministry of Economy and Commerce.

4.4 Ministry of Economy and Commerce

The first edicts and regulations which directly affect our field of study were as follows:

Article (1)

"An office called the "Commercial Registry" shall be established in the General Department of the Government for the control of companies...."

This is an article included in Law No (11) of 1962 of Establishing a Commercial Registry. ⁽²⁸⁾ In Article (9) of this Law the legislation pointed out that:

"No person, real or juristic, shall be allowed, from the date of promulgating the law, to engage in commerce or to open a commercial or industrial establishment in Qatar without obtaining a licence from the Commercial Registry."

Since 1st October 1962, the companies and establishments should have, but not all of them did, obtained licences to practise business in Qatar. This approach was mainly due to ^{the} essentially commercial characteristics of nominally industrial enterprises which operated in Qatar.

In accordance with Law No (5) of 1970, the Economy Department was included in the Ministry of Finance & Petroleum, whilst the Commerce Department was grouped with Industry and Agriculture. After less than two months Law No (11) of 1970 was issued, as an amendment of the Law No (5), and establishing the new Ministry of Economy and Commerce.

In accordance with Article (4) of Law No (11) of 1970, the functions of the Commerce Department were as follows: (29)

- 1) To lay down the general policy of internal and external trade and to supervise its implementation;
- 2) Conceive methods to facilitate and control the flow of imported and domestic products, industrial, agricultural crops, animal, fishery and others;
- 3) To organise the commercial companies' registration, construction companies' registration and commercial agencies' registration;
- 4) Combat deception in trade;
- 5) To organise and to supervise food supplies and handling.

At the same time Article (4) also defined the Economy Department's function to be as follows:

- 1) To conceive policies and programmes and to prepare projects which support the national economy in a manner which secure the safety and flourishing of the country;
- 2) To direct economic development by scientific planning and cooperation with specialized international organisations to ensure the State's development and progress and to ensure the best living standards of the citizens;
- 3) To prepare studies and monetary statements for Qatar & Dubai's Monetary Council*

The jurisdiction of the Ministry of Economy & Commerce gave the Ministry the power of directing the economy according to the State's

* The QDMC agreement was abolished in 1973.

requirements, but close examination of the Ministry indicates that the most important operational function of the Ministry relevant to this study is the registration section, headed by the Director of the Economic Affairs Department. On the other hand, the most important required function, in the view of the author, which should be established is the integrated direction of economic development. This is in order to create a balance between all industrial fields.

4.5 Ministry of Industry and Agriculture

The Ministry of Industry and Agriculture was created under Article (1) of Law No (5) of 1970 - Delimitation of Ministers Authorities and the Specification of the Ministries and other governmental Institution's Jurisdiction, and its amendment by Law No. (11) of 1970.

The main objectives of the Industrial Department can be stated as follows: (30)

- 1) To lay down the State's general industrialization policy and to supervise the implementation of the policy;
- 2) To utilize the State's natural resources in a manner which will lead to increasing of the production level and decreasing of the production costs.
- 3) To develop the national industries by way of protection, organising and encouragement, with the exception of the petroleum industries;
- 4) To study the application of new projects proposed in connection with the State's requirements for such projects and to carry out all necessary action concerning them;

- 5) To lay down the specifications of industrial production which all the industrial establishments should follow
- 6) To combat deception in industrial products.

According to the above-mentioned objectives, the Ministry was apparently the body most dominant over industries other than oil in Qatar. But, unfortunately, what happened to the Petroleum Department was repeated in the case of the Industry Department and even more so. In 1970 the Committee for studying the Ministries' Reports had recommended that in the primary stage the government should content itself by appointing no more than a Director of Industrial Affairs.⁽³¹⁾ This recommendation remained essentially effective up to 1980. The reasons for this lack of departmental strength lie in a) the establishing of the Industrial Development Technical Centre (IDTC) to carry out planning and supervision, as noted in Section 4.7, and, b) the registration of industrial establishments which was carried out by the Ministry of Economy & Commerce. The release of the Industrial Department from these limitations on full jurisdiction over its stated function came with the promulgation of Law No (11) of 1980 of Industrial Organisation. The effect of this, however, did not last long. This is mainly due to Article (3) of this law where a permanent committee was to be established called the "Committee of Industrial Development". This committee (as considered in Section 4.9) had transferred to its jurisdiction most of the Industrial Department's objectives, leaving the Department to act as little more than a secretariat for the Committee.⁽³²⁾

4.6 Qatar General Petroleum Corporation (QGPC)

Qatar National Oil Company was created by Law No (13) of 1972. The creation of this company came as a result of the participation of the government in QPC's and SCQ's oil concessions. The government, in accordance with the proposal to take over all the country's hydrocarbon resources and related activities, created QGPC by Decree of Law No (10) of 1974. This decree transferred the QNOC's jurisdiction to QGPC.

The main stated function of QGPC was to fully develop the oil industry both within the country and abroad. This included the following:

- a) Exploration and extraction of oil and natural gas;
- b) Production, refining, storing and distribution of oil, oil products and by-products;
- c) Contracting with international firms for marketing abroad.

QGPC, in order to achieve its main functions, has been vested with the following powers:

- 1) Establishing auxiliary companies, independently or jointly;
- 2) Acquisition of, or participation in, existing companies;
- 3) Contracting with other companies or bodies which are involved in similar works, or which may help it in achieving its objectives; the corporation may participate in any manner with such companies or bodies, or may purchase or affiliate with them;
- 4) To carry out all legal matters necessary to perform its operation. (33)

QGPC, although a company rather than strictly a governmental body, is, however, wholly owned by the Government, following the Council

of Ministers' directive, with an initial capitalisation of one thousand million QRs, which has since been increased several times, reaching four billion QRs on 2nd July, 1980.

In accordance with Article (9)(1) of Law No (10) of 1974, the Amir passed Resolution No. (6) of 1974 appointing the QGPC Board of Directors. The Board then comprised seven members,* headed by the Minister of Finance and Petroleum. Three of the members belong to the same ministry, while the other three are the State Adviser (as Vice Chairman), the Director of the Amir's office and the Managing Director of IDTC.⁽³⁴⁾ The Board has the right to undertake all responsibilities for managing the corporation with the exception of the following matters which should be approved by the Council of Ministers:

- a) Obtaining internal or external loans
- b) Establishing auxiliary companies independently or jointly or participation in existing companies.
- c) Practising exploration and drilling of oil and gas operations.⁽³⁵⁾

On 8th February 1975 the Council of Ministers issued Resolution No (1) of 1975, transferring all the remaining rights and assets of foreign oil companies (QPC and SCQ) to QGPC.⁽³⁶⁾ After the final take-over agreement with QPC on 16th September 1976,⁽³⁷⁾ QGPC established Qatar Petroleum Producing Authority - onshore and offshore, to carry out all oil operations, including exploration, drilling, production, processing, developing, transporting and storing, whilst marketing is held by QGPC. (for QGPC and its agreement with the foreign oil companies see Chapter 5, p.106).

* The members of the Board were increased to nine members in 1980. The two additional members are the Deputy Managing Director of QGPC and the Assistant Director of the Office of the Minister of Finance & Petroleum.

It is clear from this brief discussion that QGPC, although under the Chairmanship of the Minister of Finance & Petroleum, took all the oil industrial operations away from the Petroleum Department. At the same time, and in accordance with Article (4) of Law No (10) of 1974, QGPC has the right to set up any kinds of industries in Qatar connected to the oil industry, but this right, as seen above, was limited by the need to obtain the approval of the Council of Ministers. In addition, the corporation should involve IDTC, as seen below, in their preparation for setting up new industries.

4.7 Industrial Development Technical Centre (IDTC)

The Centre is an independent governmental establishment with responsibility directly to the Amir. IDTC was created by Law No (3) of 1973 ⁽³⁸⁾ in order to be the "Think-Tank" of all industrial development plans and to supervise their execution after being ratified. The function of IDTC is best explained by its statutes, which may be summarized as follows (for full details see Appendix 4.2).

- a) Preparing industrialization plans and projects to utilize the State's natural resources in conformity with its revenues and requirements;
- b) To carry out the economic and technical studies of these projects;
- c) To follow up the execution of approved industrial plans and projects;
- d) Participate in planning the availability of Qatari manpower and training;
- e) Co-operate and co-ordinate with other governmental bodies concerned.

The centre was the first specialized body which the government created to deal with industrial development in Qatar and its ultimate fabrication. But the apparent freedom of action of IDTC is restricted by Article (4) of Law No (3) of 1973 in which:⁽³⁹⁾

"The centre shall submit all its reports to the Amir, and the plans and projects submitted will not be considered operative unless they are approved by the Amir."

Even the technical experts at the centre shall be appointed by an Amiri decision.

The centre, however, during its short life has made a number of contributions to industry, such as the formulation and detailed study of proposals for (a) the oil refinery, (b) iron and steel, (c) petrochemicals, (d) expansion of cement plant and lime production, (e) compost fertilizer, (f) automatic slaughterhouse and (g) geological surveys for minerals other than oil and gas, and that is not the full extent of its contributions.⁽⁴⁰⁾

In accordance with Articles(2) and (3) of Law No (3) of 1973 all government ministries and institutions have to involve IDTC in their projects from the first stage to completion, including instructions regarding the supply of capital, pricing the final products and marketing, instructions which must be taken by IDTC and approved by the Amir. Clearly, most of the IDTC functions overlap with, and can conflict with, those of the Industry Department, Petroleum Department, QGPC and the most recent Committee of Industrial Development. But the strength of IDTC is derived from the Amir's power and this is why the centre has survived.

4.8 Taxation Laws in Qatar

Qatar has been familiar with taxation methods since the era of the pearl industry, but the first taxation Law of Qatar is Decree No (1) of 1954 of Qatar Income Tax. This decree was issued, under the instructions of the Political Resident in the Gulf, on 23rd April 1954.⁽⁴¹⁾ This taxation decree was set to levy taxes from the net income of all kinds of activities, either industrial or commercial, which practise business operations on Qatar's territory.

The Director of Income Tax, appointed by the Ruler, was empowered to collect the income tax due and pay it promptly to the Ruler. On 24th September 1955 the Political Resident in the Gulf had issued Decree No (6) of 1955 of Amendment of Qatar Income Tax.⁽⁴²⁾ The tax rate as specified in this amendment was as follows:⁽⁴³⁾

On income more than	But not exceeding	The % shall be
-	70,000	Nil
70,000	250,000	5
250,000	500,000	10
500,000	750,000	15
750,000	1,000,000	20
1,000,000	1,500,000	25
1,500,000	2,000,000	30
2,000,000	3,000,000	35
3,000,000	4,000,000	40
4,000,000	5,000,000	45
5,000,000	-	50

Although Decree No (1) of 1954 and its amendements were issued long ago, the taxation law in practice has been consistently applied

only to foreign banks and oil companies,⁽⁴⁴⁾ whilst Qatari public industries were exempt. This exemption came as a result of implementing Decree - Law No (3) of 1966 of Some Taxation Measurements to Support the National Economy and its Development. ⁽⁴⁵⁾ Article (1) of Decree Law No (3) of 1966 stated that Qatari joint stock companies were exempt both from the existing taxes and whatever might be imposed in the future. Whilst Article (2) with its amendment had made this exemption for five years, this may be extended. But this exemption, as defined by Article (3), should be supported by individual decisions from the Deputy Ruler/Minister of Finance. At no time has there been any specific identification for tax purposes of the Qatari private sector as a whole, and, effectively, the private sector has been virtually ignored by the Income Tax Director.

The other tax applied in Qatar is the Customs Tariff which include: ⁽⁴⁶⁾

1. Payable Tariff*	%
General goods except those prohibited by law	2½
Tobacco, Cigarettes, Cigars etc.	10**
Gramophones & gramophone records	15
Alcoholic beverages, beer, cider and similar	50***

2. Goods exempt from duties

Portland cement, fresh fruits and vegetables, dates, livestock, sugar, rice, animal feed, printed material, gold and silver bullion and coins, undrilled pearls produced in the Arabian Gulf, and personal effects.

* All tariffs are levied on CIF value

** In 1983 the duties were increased to 30%

*** Imported under special permit only

3. Export and Transit goods No duty is Levied

Most, if not all, industrial and commercial establishments in Qatar have been exempted from the 2½ per cent customs duties on everything related to their activities (see 4.10 below). Apart from that there are no other forms of tax applied in Qatar.

Since there is no taxation of activities and since the custom tariffs are generally not applied to Qatari establishments, industrial and commercial, whilst this can be regarded as an act of policy in itself, it does mean that the use by government of taxation and tariffs as instruments to influence the nature of development growth, particularly in industry, is not available to the government. Qatar and its neighbours are strikingly different in this respect to almost all other present-day states.

4.9 Industrial Organizations

The organizing and identification of industries as manufacturing establishments did not attract the attention of the government until very recent years. But the regulation of industries as commercial establishments was, and still is, the main governmental issue. The first attempt in commercially organizing industries was carried out by the promulgation of Law No (11) of 1962 of establishing the Commercial Registry (see Ministry of Economy & Commerce, Section 4.4). However, the government, two decades after establishing the registry, still has no control over the growth and direction of the private sector, either in the field of industry, services or commercial, and still, up to this date, some of the private sector establishments are carrying out industrial and commercial activities without obtaining a licence (see Small Scale Industry and Industrial Estates of Doha, Chapters 6 and 7).

However, the growth in the government's seriousness in organizing the industrial sector as a whole, and private industries specifically, appeared in 1980 with the promulgation of Law No (11) of Industrial Organisation. ⁽⁴⁷⁾ The law consists of 31 articles, of which Article (1) defined the conditions on which the industrial establishment can be recognized. These conditions are that industries should:

- 1) have the main objective of manufacturing, processing or extraction of materials, mixing, collecting, fabrication, packing or cleaning of materials and
- 2) have capital investment not below QR 250,000 and with permanent employees of not less than 10 persons.

Article (2) defined local products as those which utilize as inputs not less than 40 per cent from local sources.

In accordance with Article (3) of Law No (11) of 1980, a permanent committee called the "Committee of Industrial Development" was established. The committee, as specified by the article, consisted of 12 members headed by the Deputy Minister of Industry and Agriculture. (see Table 4.1). The nomination of individual members of the committee was left to be considered by the Council of Ministers.

In Article (5) the legislation stated the following objectives of the committee:

- 1) To study the proposals and systems which aim to organise, protect, encourage and develop the national industries;
- 2) To propose the general policy of benefits, exemptions, facilities and incentives which are granted to industrial projects;
- 3) Any other jurisdiction which the law provides.

Table 4.1 The Members of the Committee of Industrial
Development

1	Deputy Minister of Industry & Agriculture	Chairman
2	Director General of IDTC	Vice-Chairman
3	Representative of the Amir's Office	Member
4	" of Ministry of Industry & Agriculture	"
5	" " Finance & Petroleum	"
6	" " Economy & Commerce	"
7	" " Justice	"
8	" " Electricity & Water	"
9	" " Municipality Affairs	"
10	" " Interior	"
11	" IDTC	"
12	" " Qatar Chamber of Commerce	"

All the Committee's proposals are subject to the approval by the Council of Ministers.

In accordance with Article (20) an industrial establishment which is eligible for loan credit is one in which capital does not exceed QR 20 million. Article (23) limited the loan to 40 per cent of the total capital investment of the industrial establishment, with fixed interest charged of 3 per cent per annum. Article (3) added that the due date of payment of the loan and its interest should be made within seven years, considering the first two years as a tolerance period. Whilst the CID will approve licences, the jurisdiction for granting loans to industrial establishments is held by another committee which was set up according to Article (25). This committee, called the "Committee of Light Industries Loans", consists of five members headed by the representative of the Amir's office (see Table 4.2).

Table 4.2 The Members of the Committee at Light Industries Loans

1	Representative of the Amir's office	Chairman
2	" Ministry of Industry & Agriculture	Member
3	" Ministry of Finance & Petroleum	"
4	" IDTC	"
5	" Qatar Chamber of Commerce	"

The legislation specified in Article (11) that the Minister of Industry and Agriculture, on the recommendation of CID, has the right to cancel the licence of any industrial establishment if one or more of the following conditions are fulfilled:

- 1) If the company's declaration of intent for construction, operation and production, appears frivolous;
- 2) If any of the conditions in the licence have not been met;
- 3) If the industrial establishment intentionally supplied wrong information;
- 4) If it is confirmed that an industrial establishment, which existed at the time of promulgation of this law, did not conform with the law.

Anyone whose licence was cancelled may appeal to the Council of Ministers.

It is clear, from the formulation and representation of Law No (11) of 1980, that the Council of Ministers, which is headed by the Amir, has the upper hand over the performance of these two committees rather than the Minister of Industry and Agriculture. In addition, there is confusion over the jurisdiction of the Industry Department of the Ministry of Industry and Agriculture, IDTC and CID. Furthermore, all the laws and decrees issues are accompanied by an article stating that all previous rules and regulations which are inconsistent shall be abolished, again a source of some confusion.

4.10 Government Incentives for Industry

It is known that every country in the world offers incentives, in one form or another, to local industries, both to public and private sectors. There are several inducements available to attract the entrepreneurs to establish new industries in Qatar, which take direct and indirect forms. The main direct inducements are the following:

1. Lease of land at nominal rent

The land which is leased to industry is the government's own land. The government only supplies the levelled land to the individual project and then the entrepreneurs build their own premises. There are two forms of leasehold, the first not requiring the payment of any sum against the land lease, and normally applied to the public sector industries. Under the second, the occupier is required to pay a nominal amount against the lease, and this is used for the private sector (see Chapter 7 IED). In both cases it is understood that the land will remain in the government's possession.⁽⁴⁸⁾

2. Remission of Taxes and Duties

As mentioned earlier, the only taxes and duties which exist in Qatar are income tax and customs tariffs. The government, by promulgating Law No (3) of 1966 of Some Taxation Measurements to Support the National Economy and its Development, maintained the right to make some taxation exemptions to certain projects of the public sector. QASCO, for instance, under an agreement with the government, would not pay any taxes until the cumulative net profit would equal the initial capital investment in the plant.⁽⁴⁹⁾ The private sector, on the other hand, has not been committed to pay any amount from its net income.

Although the customs duties on equipment, raw materials, and imported services are 2½ per cent of CIF values, the public sector industries have a special arrangement with the Ministry of Finance and Petroleum to receive exemption on the above-mentioned duties. The private sector, in some cases, can obtain the same exemption on equipment, raw materials and imported services. All the exemptions are governed by resolution either from the Amir, the Council of Ministers or the Minister of Finance & Petroleum.

3. Transfer of Foreign Funds

In Qatar there is unrestricted transfer of funds in and out of Qatar. This inducement was set up to attract foreign capital and investment in the country. The attraction of foreign capital, although Qatar has hypothetically enough capital for investment in industry, was seen as a means to transfer modern technology, skill, experience, marketing, administrative and management know-how of the industrial field from industrialized nations to Qatar. The participation of foreigners, in industry and commerce, is, however, governed by Law No (20) of 1963 and its amendments. (50) The legislation in Article (3), stated that

"... Foreigners who are engaged in industry shall be accepted if they have a Qatari partner or partners provided that the capital of the Qataris shall not be less than 51 per cent of the firm's capital." (51)

In Article (2) of Degree-Law No (26) of 1966, the legislation limited the capital of foreigners practising business without a Qatari partner, to be not more than QR 5,000. (52) But, "in the public interest", all or part of Law (20) of 1963 and its amendment can be dispensed with.

4. Foreign Labour

The government, through the Ministry of the Interior, periodically has produced measures to ease the importation of foreign labour needed for industrial establishments. The shortage of the local labour force, as noted in Chapters 3 and 9, made it necessary for the Qatari industrial establishments to import virtually all their requirements of manpower. The government, lately, has given permission to private sector establishments to import their expert and skilled manpower from any part of the world, though of course not from Communist

countries, while semi-skilled and unskilled labour should be from certain Arab countries (mainly from Egypt, Tunisia, Morocco, Somalia and Sudan). The public sector is allowed to import its semi-skilled and unskilled labour from any destination.

Besides these general incentives there are several inducements applied to the public sector as direct incentives whilst the same ones are applied to the private sector as indirect incentives. These are essentially infrastructural facilities, which include the following:

1. Erection of roads from the plant site to the main road network of the country;
2. Provision of gas, electricity and water for industrial establishments at prices close to production cost;
3. Provision of port facilities to service industrial establishments;
4. Development of Qatari human resources through education, technical and administrative training in all fields and at all levels.

There are, in addition to the above-mentioned incentives, several inducements which are confined to the public sector only.

They are:

1. Provision of State's guarantees for foreign loans;
2. In practice, the supply of credit by local banks;
3. Assistance with housing for workers and staff;
4. State participation by not less than 70 per cent in the equity of industrial firms.

The role of the state in providing physical and human infrastructure to support and encourage industrialization was noted. This is

a very complex area because, as in all countries, the separation between the provision of facilities for the social good, such as communication, education, public utilities... etc., grades almost imperceptibly into the provision of those same facilities to give infrastructural support for industry as such. Here all that can be said is that, as noted in Chapter 6 on specific industries in the public sector in particular and in the private sector in the IED there has been a very large outlay by the state specifically to encourage industrial development although it is impossible to quantify this very accurately.

In this chapter we have surveyed the development of the government's policy and institutions relevant to industrialization. We now analyse the main industrial sectors and the structure of operation and it will be shown how these have been governed by the state's policy. In Chapter 8 we return to the key question of decision making covering other elements and utilizing the evidence obtained from the available data.

CHAPTER 4

References

- (1) Qatar Petroleum Company, Memo No. CRQ/TO/3/3846 to the Head Office in London 6/8/1958.
- (2) See *ibid* and
Qatar Petroleum Company, Memo No. CRQ/TO/3/3841 to the Head Office in London 29th July 1958.
- (3) Seltrust Engineering Ltd. Summary & Review of Geological and Mineral Resources of Qatar Vol.1, Qatar 1979, Bibliography.
- (4) Al-Shibani, M.S., The Arabian Emirate of Qatar, Dar al-Thaqafa, Beirut 1962, p.350.
- (5) *Ibid*, p.358.
- (6) For more information on the 'popular movement'
See Al-Kuwari, A.K., Oil Revenues in the Gulf Emirates
Bowker/University of Durham G.B.1978 pp.117-119.
and Al-Kobaisi, A.J., The Development of Education in Qatar 1950-70, Unpublished Ph.D. thesis, Durham University, Durham 1979, p.127.
- (7) Legal Affairs Department, Collection of Qatar's Laws until 1966, p.616.
- (8) Council for Middle East Trade, Report of the British Trade Mission to Kuwait, the Gulf States, Muscat and Oman, Nov. 1964, p.15.
- (9) Al-Kuwair, A.K. *op.cit.*, p.117.
- (10) Ministry of Information, Qatar Into Seventies, Qatar (c.a. 1973), p.99.
- (11) Al-Nahar Magazine, A Struggle for Progress, a special report on Qatar, Beirut, 1969, p.23.
- (12) Ministry of Information, Qatar Yearbook 1980-81, Press and Publication Department, 1982, p.147.
- (13) Karam, A. Economics of Underdevelopment and Development, Markaz al-Inma al-Qaumi/Kuwait University, Beirut, 1980, pp.118-126.
- (14) Meier, G.M. Leading Issues in Economic Development, Oxford University Press, 1976, pp.632-636 and 640-643.
- (15) Hirschman, A.O. The Strategy of Economic Development, Yale University Press, New Haven, 1960, pp.98-119.
- (16) Ministry of Finance & Petroleum, Yearly Bulletin of Imports and Exports for 1980, Customs Department Qatar 1981, p.2.T.2.

- (17) Karam, A., op.cit., pp.206-209.
- (18) Ministry of Finance and Petroleum, op.cit., p.2.
- (19) Al-Kobeisi, A., Two Decades of Public Administration and Development in the State of Qatar, Journal of Gulf and Arabian Peninsula, Kuwait University Vol.VII, No.28, Kuwait, 1981 p.45.
- (20) Ministry of Justice, Collection of Qatar's Laws 1962-1975, Legal Affairs Department, Qatar National Press, Qatar Vol.1,p.344.
- (21) Ibid. p.5.
- (22) See Ibid pp.30-38.
- (23) Ibid. p.345.
- (24) Ibid. p.361.
- (25) Ibid. p.13.
- (26) Committee of Study in the Ministerial Reports, Report submitted by the Committee, Qatar, 1970, p.42.
- (27) Ministry of Justice, op.cit. p.368-371.
- (28) Ibid. p.691.
- (29) Ibid. p.21.
- (30) Ibid. p.15.
- (31) Committee of Studying the Ministerial Reports, op.cit p.146.
- (32) Ibrahim, Z.H., Study on the Mechanism of Granting Industrial licences and Organising the Industrial Files Arab Organisation for Industrial Development/State of Qatar, Baghdad, 1981, p.11.
- (33) Ministry of Justice, op.cit., p.368.
- (34) Ibid. p.372.
- (35) Ibid. p.369.
- (36) Ibid. p.373.
- (37) Ministry of Fiance & Petroleum, Oil Industry in Qatar 1976, Petroleum Department, Martins Press Ltd. England,1977,p.5.
- (38) See Ministry of Justice, op.cit pp.508-509 and IDTC, Qatar : Achievements in Industrial Development,, England, 1981, p.64.
- (39) IDTC op.cit., p.64



- (40) See Ibid, p.7.
- (41) Ministry of Justice, op.cit. pp.1057-1063.
- (42) Ibid, pp.1064-1068.
- (43) Ibid. p.1066.
- (44) IDTC op.cit., p.29.
- (45) Ministry of Justice op.cit., p.1076-1078.
- (46) Ministry of Finance & Petroleum, Yearly Bulletin of Import, Export and Transit from 1979, Customs Department, Dar A-Uloom Est., Qatar 1980, p.1.
- (47) State of Qatar, Law No (11) of 1980, Industrial Organizing, Amiri Palace, Qatar, 1980.
- (48) Personal Communication.
- (49) QASCO, Outline of the Steel Mill Project 1977, p.41.
- (50) Ministry of Justice, op.cit., pp.133-137.
- (51) Ibid. p.135.
- (52) Ibid. p.136.



CHAPTER 5
EXTRACTIVE INDUSTRIES

Introduction

This Chapter discusses the development of extractive industries, especially oil and natural gas. Section 5.1 examines the evolution of the oil extractive industry since the signing of the 1935 Oil Concession Agreement with the Anglo-Persian Oil Company Ltd. The discussion includes the location of oil fields, pipelines, oil storages and terminals. Crude oil production, the evaluation of oil reserves/production rate and export will also be discussed. In Section 5.2, because of several elements concerning the natural gas will have been already outlined in Section 5.1, the discussion is focused on production, consumption and the reserves/production rate of natural gas. Although other extractive industries are minor activities compared to the above-mentioned industries, Section 5.3 highlights these minor extractive industries. The aim here is to identify how the natural endowment has influenced Qatar in devising its strategy of investment in oil and natural gas fields rather than other natural resources.

5.1 Oil Industry

In this section the first concern is with one particular extractive industry which is one way of looking at the oil industry. The oil industry, which originally started as an extractive activity has, in fact, very quickly become much more than merely an extractive industry, and during the period in which the oil industry developed in Qatar there has been an enormous explosion of hydrocarbon processing which we now call "petrochemical". The larger integration is considered later in Chapter 6.

The first indication of oil availability in the Gulf region was made in 1908 in Iran, but Arab countries in the Gulf had no oil discovered in their territories before the 1930's, with the exception of Iraq in 1927. (1)

From the 1920's onwards Frank Holmes, of the Eastern and General Syndicate, tried several times to obtain an oil concession in Qatar from Sheikh Abdulla bin Qasim who tried to follow the example of Ibn Saud of Saudi Arabia, and to disregard the 1916 Treaty with Britain. The British Political Resident blocked this by invoking the 1916 Treaty, especially Articles IV and V. (2)

Article IV : I, Sheikh Abdulla, further undertake that I will not have relations nor correspond with, nor receive the agent of any other Power without the consent of the High British Government, neither will I, without such consent, cede to any other Power or its subjects, land either on lease, sale, transfer, gift, or any other way whatsoever.

Article V : I also declare that, without the consent of the High British Government, I will not grant pearl fishery concessions, or any other monopolies concessions, or cable landing rights to anyone whomsoever.

As a result, on 17 May 1935 Sheikh Abdulla signed an agreement with Charles C. Mylles, who, acting on behalf of the Anglo-Persian Oil Company Ltd. (APOC), obtained a concession covering the entire territory of Qatar in return for 400,000 rupees in cash on signature and 150,000 rupees for each of the following five years, also followed by 300,000 rupees each year to the end of the oil concession agreement. The agreement was for 75 years from the signature date, ending in the year of 2010, with a fixed oil price of 3 rupees per Imperial ton (2240 English pounds av.) which, in turn, equalled 4s.6d. at that time (see Appendix 5.1).

Traces of oil were discovered in 1939 at Dukhan in the extreme west of the country at a depth of 5,685 feet.⁽³⁾ Before any extraction could take place, the company shut down the Dukhan oilfield in 1942 because of World War II. In 1947 the company resumed operations and embarked on an extensive programme preparing for oil production, and the first export shipment took place at Umm Said oil terminal in December 1949. In September 1952, APOC transferred its rights in this concession to Petroleum Development (Qatar) Ltd. In 1955 the company changed its name to Qatar Petroleum Company Ltd. (QPC)*.

Because of irregularities in the 1935 agreement, the government contested the company's claim to include the territorial water in its concession and in 1950 the arbitrators' findings confirmed Qatar's point of view. So, in 1952, a new oil concession agreement was signed between Sheikh Ali bin Abdulla and George O. Higgins giving the rights of offshore oil concession to Shell Overseas Exploration Company Ltd. After two years, the company changed its name to Shell Company - Qatar (SCQ). The offshore concession included all seabed areas beyond the three mile territorial limit which fell under Qatar's jurisdiction (see Appendix 5.2). SCQ carried out extensive operations, but the destruction of the first drilling platform caused a delay of six years. The first offshore oil strike was made in 1960 at the Idd Al-Shargi field.⁽⁴⁾

* This company is an affiliate of the Iraq Petroleum Company (IPC) group and is wholly owned by the following companies:

Royal Dutch/Shell group	23.75%
Companie Francaise des Petroles	23.75%
Near East Development Corp:)	
50% Jersey Standard)	23.75%
50% Mobil Oil)	
Gulbenkian	5.00%
	<hr/>
	100.00%

According to the 1935 and 1952 agreements, Qatar was divided into two parts, one of them covering the whole of inland Qatar under QPC supervision, the other one composed of the entire offshore territories under SCQ supervision (see Fig.5.1). After 1960 the oil companies gradually relinquished areas of their concessions, and by 1970 the QPC concession mainly covered the Dukhan oilfield where the operation centred on an area of 2,000 sq. km. on the western Qatar peninsula. SCQ has released almost half of its concession, retaining only 5,000 sq. km. on the eastern part of Qatar's territorial water (see Fig. 5.2). During the early 1970's, in preparation for taking full control of the oil industry, the Qatar National Oil Company was established to run the Government's share of both companies (see below). Two years later, this company was replaced by Qatar General Petroleum Corporation (QGPC), which was designed to incorporate exploration, production, marketing and processing oil and natural gas and we shall examine the broad activities of QGPC later (also see Chapter 4 pp. 84-86). Here we can note that the Qatar Petroleum Producing Authority (QPPA), as a subsidiary of QGPC, was created after the takeover of the former oil companies to manage the oil and gas operations in Qatar. ⁽⁵⁾ This led to changes in the nature of the concession and to new delimitation of production zones, which by 1979 appeared as shown in Figure 5.3.

Two major changes have been made, apart from those affecting concession areas, since the original oil concession agreements were signed. The first involved the government's share of the net profits of the concessionaires. An increase to 50% came into effect in late 1952. ⁽⁶⁾ In December 1970 a further increase occurred, raising the profit percentage to 55% as the government's 'take'. ⁽⁷⁾ The second major change was that creating government participation in the

Development of Oil Industry and Concession Areas (1960, 70, and 80)

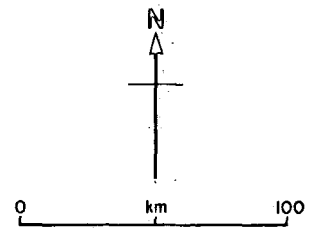
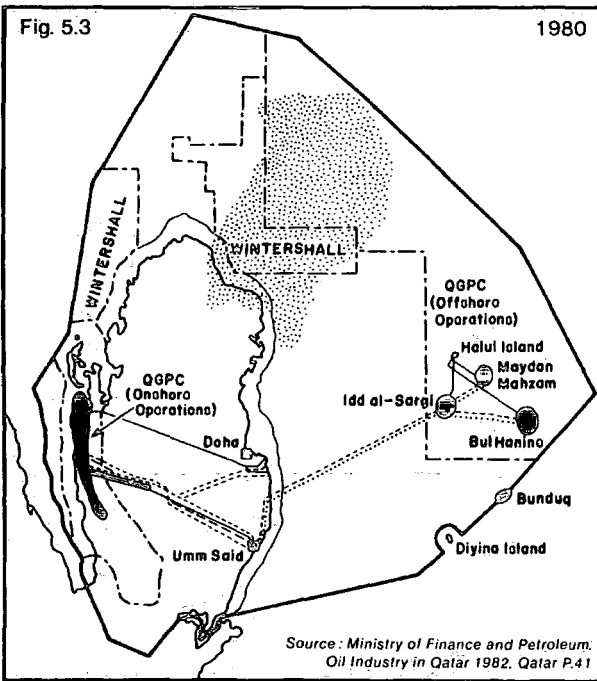
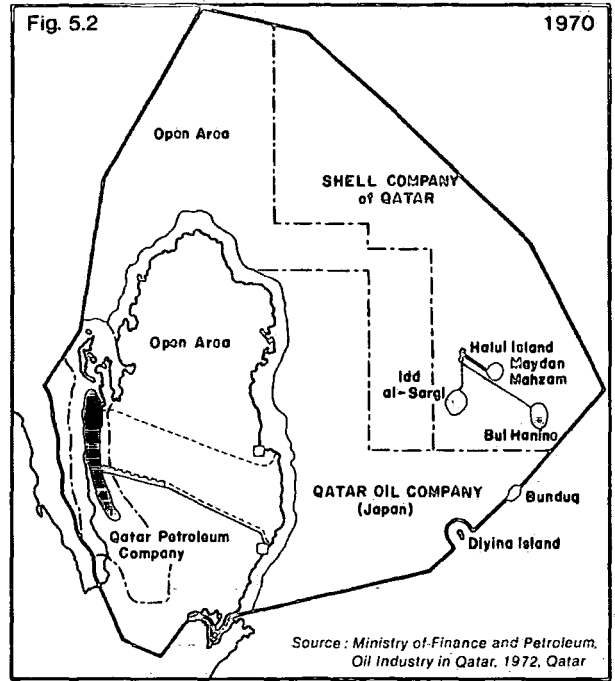
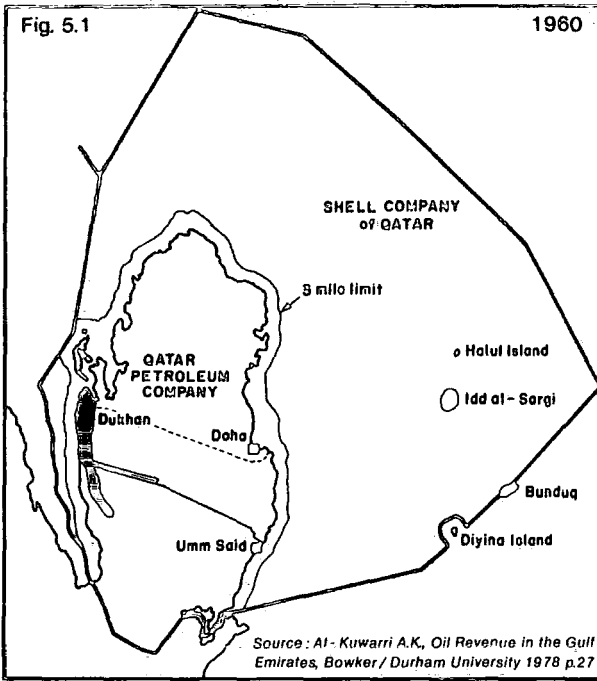

- Oil pipeline
- - - Gas pipeline
- - - NGL pipeline
- Liquid gas pipeline
- Oilfield
- Extent of North Gas Field
- International boundary
- - - Concession boundary

oil industry. The government first acquired, in 1973, a 25 per cent share of asset-owning participation in each concession. In 1974 this was raised to 60 per cent, followed by a final takeover agreement between the government and QPC, signed in late 1976, giving the government 100 per cent ownership. A similar agreement was signed early in 1977 with SCQ. ⁽⁸⁾ Subsequently QGPC signed service agreements with both QPC and SCQ.

In accordance with Article (4) of both agreements, the companies (QPC and SCQ) would establish service companies - one called Dukhan Services Company wholly owned by QPC, while the other called Shell Services Company wholly owned by SCQ. ⁽⁹⁾ QGPC would supply the services companies with a service fee, which at the time of the agreement was 15 cents per barrel of oil produced either from onshore or offshore fields, and give the companies the right of buying 275 thousand barrels per day at the official price until the end of the agreements, which lasted for five years from 1977. The service agreements were changed at the beginning of 1980 to become 20 cents per barrel produced, which would increase to 22 cents from the beginning of 1981, but without the right of buying any of Qatar's crude oil. ⁽¹⁰⁾

QGPC, however, has several subsidiaries, either wholly owned, such as QPPA Onshore and Offshore,* and the National Oil Distribution Company (NODCO); or partly owned, such as Qatar Petrochemical Company (QAPCO), with a Corporation share of 84 per cent, and Qatar Fertilizer Company (QAFCO) in which QGPC has 70 per cent of the ordinary shares and 100 per cent of preference shares. The Corporation also has interests in Arab and foreign joint ventures, whereby QGPC has 18.3 per cent holdings of Arab Ship Building & Repair Yard Co. (ASRY)

* In late 1980, an announcement came from the Amiri Palace declaring the amalgamation of QPPA (Onshore and Offshore) with QGPC.

in Bahrain; 13.6 per cent of Arab Maritime Petroleum Transport Co. (AMPTC) in Kuwait; 10 per cent of Arab Petroleum Investments Corp. (APICORP) in Saudi Arabia; 10 per cent of Arab Petroleum Services Co. (APSC) in Libya; 5 per cent of Arab Petroleum Pipelines Co. (SUMED) in Egypt; and 40 per cent of Compagne Petrochemique du Nord (COPENOR) in France.

All this applies to the domestic scene, and this summary survey of oil in Qatar will be incomplete without an examination of the relationship between Qatar and multilateral oil organizations such as the Organization of Petroleum Exporting Countries (OPEC), and the Organization of Arab Petroleum Exporting Countries (OAPEC). Qatar was the first country to join OPEC after the five founder members ⁽¹¹⁾ (Iran, Iraq, Kuwait, Saudi Arabia and Venezuela). The main object of the organization was to guard against the arbitrary reduction of the oil revenues of its member countries through cuts in oil prices by the international oil companies. For several reasons, Qatar did not gain any increase in posted oil prices until 1971, when OPEC's power became really effective. But the significant increase of posted oil price followed the September 1973 oil conference and the Arab/Israeli War in October 1973 (see Table 5.1).

The most effective part which OPEC played was the introduction of ownership participation agreements between the member countries and the oil companies. This helped Qatar to gain a 100 per cent control and ownership over all phases of oil industry in Qatar. ⁽¹²⁾

Qatar has also been a member of OAPEC since mid-1970, ⁽¹³⁾ and played an active role in the organization and participated in all joint projects which were carried out under the organization's sponsorship, such as AMPTC, ASRY, APICORP and APSC.

Table 5.1 : Qatar Crude Oil Prices* (1953-1982)
(US\$ per barrel)

Date of Change	Onshore	Offshore
15.7.1953	1.830	-
16.7.1953	2.080	-
28.5.1957	2.210	-
13.2.1959	2.030	-
16.8.1960	1.930	-
13.2.1964	-	1.830
15.2.1971	2.280	2.200
1.6.1971	2.387	2.305
20.1.1972	2.590	2.501
1.1.1973	2.705	2.614
1.4.1973	2.862	2.766
1.6.1973	3.025	2.923
1.7.1973	3.084	2.980
1.8.1973	3.200	3.092
1.10.1973	3.143	3.037
16.10.1973	5.835	5.503
1.11.1973	5.899	5.564
1.12.1973	5.737	5.412
1.1.1974	12.414	12.013
1.11.1974	12.014	11.613
1.10.1975	12.740	12.540
1.1.1977	13.190	13.000
1.1.1979	14.030	13.770
15.2.1979	15.050	14.710
1.4.1979	17.040	16.850
17.5.1979	17.840	17.650
1.7.1979	21.420	21.230
1.1.1979	27.420	27.230
December 1979	27.42	27.23
January 1980	29.42	29.23
May 1980	31.42	31.23
July 1980	33.42	33.23
January 1981	37.42	37.23
1st Nov. 1981	35.65	35.50
1st Jan. 1982	35.45	35.30
20 March 1982	34.49	34.30

* Prices until 1.10.1975 are the posted prices and thereafter the official selling prices.

Source : Ministry of Finance & Petroleum, Oil Industry in Qatar 1982, Petroleum Dept., Qatar, 1983, p.48.

The apparently simple fact of the taking over by Qatar of 100% ownership, as stated above, has considerable significance for the development of industrialization in Qatar, as noted in Chapter 4.1.(C). The heavy industrial and consumption stage is approximately coincident with the taking over of total ownership of all oil assets in the early 1970's. It is no accident, therefore, that the last decade or so has seen the evolution of a Qatari industrialization policy during the period in which Qatar not only owns and controls the whole of the oil sector but has now also become responsible for financing it. (see Conclusion).

5.1.1 Manpower in the Oil and Gas Fields

In 1960 the labour force employed by QPC was over 2,500 persons. ⁽¹⁴⁾ In 1972 the labour force of QPC had declined to 875, of which 67.2 per cent were Qataris, while SCQ was employing 598, of which 59.2 per cent were Qataris. ⁽¹⁵⁾

At the end of 1975 the two companies were employing 1,811 persons, of which 969 were Qataris (or about 54 per cent). About 77 per cent of the Qatari total, as seen in Table 5.2, were classified as labourers, whilst only 3.8 per cent of the Qatari total were in the senior staff division (or 12.9 per cent out of the total senior staff).

Table 5.2 Employment of QPC and SCQ by Nationality and Status (1975)

	Senior Staff			Intermediate			Labourers			Total		
	QPC	SCQ	Tot.	QPC	SCQ	Tot.	QPC	SCQ	Tot.	QPC	SCQ	Tot.
Europe & USA	95	123	218	-	-	-	-	-	-	95	123	218
Qataris	19	18	37	122	64	186	370	376	746	511	458	969
Other Arabs	-	23	23	17	98	115	29	17	46	46	138	184
Indian & Pak.	-	9	9	126	63	189	88	14	102	214	86	300
Others	-	-	-	1	-	1	16	123	139	17	123	140
Total	114	173	287	266	225	491	503	530	1,033	883	928	1,811

Source: Compiled by the Author from Ministry of Finance and Petroleum & Oil industry in Qatar 1976

By 1980 the situation of employment in the oil industry had reversed whereas the Qataris declined in percentage from 53.5 in 1975 to only 36.7 per cent out of 2,719 (see Table 5.3). This, as will be noted in Chapter 6, is a common feature of trends in Qatari employment in the industrial field.

Table 5.3 Employment Structure of QPPA* 1980

	Qataris	Non Qataris	Total
Senior Staff	104	426	530
Intermediate Staff	256	608	864
Labourers	639	686	1,325
Total	999	1,720	2,719

* Qatar Petroleum Producing Authority

Source : Al-Kuwari, A.K. The Role of Public Enterprise in Economic Development
Alam al-Ma'rifa, Kuwait, June 1981.

5.1.2 Location of oil fields

In Qatar, at present, there are four oil-producing fields, only one of them onshore and the rest offshore.

(1) Dukhan oil field

The Dukhan oilfield (onshore) lies on the extreme west of the peninsula. The field reaches about 54 km in length and 8 km in width, covering an area of 432 sq. km. It was the first oilfield to be explored in Qatar, being discovered in 1939 by APOC. In 1972 there were 80 wells, of which 58 were oil producing, three abandoned, six used for observation and 13 were water injection wells.⁽¹⁶⁾ By 1979 there were 150 wells, of which 70 were producing, 8 abandoned, 12 for monitoring and controlling the water pressure, 3 water wells

and 57 were injector wells. The 70 oil producing wells were distributed over several zones as follows: ⁽¹⁷⁾ (also see Chapter 2, Table 2.1).

(a) Seventeen of them were located in Arab III limestone, with an average rate of 45,000 barrels per day on an average depth of 6,400 ft. sub sea. The Arab III zone was discovered in 1939 and production started in 1949.

(b) Fifty two were located in Arab IV limestone, the zone which started production in 1950. The total wells have an average production of 185,000 barrels per day at an average depth of 6,500 ft. sub sea.

(c) The third and last zone is Uwainat Limestone which started production in 1960 from an average depth of 7,100 ft. sub sea. This zone has only one oil well, producing oil at a rate of 4,000 barrels per day.

(2) The offshore oilfields

The offshore oilfields are concentrated in the extreme east of Qatar's maritime territory and not far from the marine boundaries between Qatar, Iran and U.A.E. (see Fig. 5.3). There are three oilfields in Qatar's territorial water. These are Idd El-Shargi, Maydan Mahzam and Bul-Hanin.

A. The Idd El-Shargi oilfield was the first discovered, in 1960, where the oil deposits are located within four limestone formations - Arab III, Arab IV, Shuaiba and Uwainat - at depths varying from 4,650 ft. to 8,000 ft. The field covers an area of 68.4 sq. km. In 1972 there were 18 wells, of which 14 were oil producing, at a rate ranging between 250 b/d and 3,000 b/d for each well, and 4 wells abandoned. ⁽¹⁸⁾ There was no development in this oilfield until 1979. ⁽¹⁹⁾

B. The Maydan Mahzam oilfield was discovered in 1963 and started production in 1965. The field covers an area of 29.8 sq. km. The crude oil of this field is produced mainly from three limestone formations - Arab III at a depth of 7,300 ft, Arab IV at a depth of 7,350 ft. and Uwainat at a depth of 3,000 ft. ⁽²⁰⁾ The field has 11 oil-producing wells and 11 dump-flood wells; the production per well varies from 2,500 b/d to 20,000 b/d. ⁽²¹⁾

C. The Bul Hanin oilfield has an area of 41.1 sq. km. The field was discovered by ADMA* in 1965 when the area was claimed to be under Abu Dhabi jurisdiction. ⁽²²⁾ After the settlement of the Qatar/Abu Dhabi offshore boundary in 1969, the field was included in the SCQ concession area. The field had, in 1979, 10 oil-producing wells supported by nine dump-flooders. The production draws from three limestone formations, Arab III, Arab IV and Uwainat, at a rate of 29,000 b/d. ⁽²³⁾

There is another offshore oilfield, Al-Bunduq, on the marine boundary line between Qatar and Abu Dhabi, and covers an area of about 20 sq. km. The field was discovered in 1964 by ADMA and was wholly owned by that company. In 1969, after the settlement of the marine boundary, the two states agreed on the joint exploitation of the field and ADMA was designated as its operator. All royalties, profits and other benefits were to be divided equally between Qatar and Abu Dhabi. In 1970, and after ADMA had released some of its share to a Japanese group, the Bunduq Company Ltd. was formed. In 1979 there were seven producing wells, out of nine, with a production rate in 1976 reaching 30,000 b/d, but then it declined in recessive pressure and production was limited to 10,000 b/d. ⁽²⁴⁾ In 1980 production was halted.

* Abu Dhabi Marine Area Company Ltd.

5.1.3 Location of Pipeline Systems

Before any processing of crude oil can be undertaken, it has to be transported from its field, either to refineries where the oil is treated as raw material or to the oil terminal(s) in order to export crude oil to the international market; such transportation, for many decades, has normally been by pipelines. Pipelines are also needed to gather the crude oil from producing points within the field. In this part we will examine the layout of the pipeline systems which was utilized by both crude oil and natural gas.

Fortunately, the oilfields in Qatar require neither too large an amount of investment in settling pipelines nor very long pipes. This is because, firstly, the majority of the oilfields are in offshore areas where the sea is not deep (about 103 ft. depth) and, secondly, the distance between the west coast, Dukhan field and the east coast, on which lie the oil terminal and industrial activities at Umm Said, is only 82 km, while the distance traversed by pipeline is approximately 78.5 km.

1. Onshore pipelines

Onshore pipelines, as shown in Figures 5.3 and 5.4 are of three categories. First there is the oil pipeline through which crude oil is pumped from Umm Bab to Umm Said through three pipelines, two of them being 14.5 in. diameter, while the third is 16 in. diameter. These three pipelines join together into one pipeline, at a distance of 42.5 km away from the pumping station at Umm Bab, and this 20 in diameter pipeline runs for over 36 km to Umm Said crude oil storage area. Secondly, there is a gas pipeline system distributing associated gas in three main directions to Doha City, Umm Bab

and Umm Said. The oldest of these is the pipeline through Khatiyah (gas separation station) to Doha, where it is used by the government's Water and Electricity Departments. The 10 in pipeline was set up at the beginning of the 1960's, extending about 80 km to Ras Abu Aboud. This pipeline was converted in the early seventies for the carriage of oil to Ras Abu Aboud and Ras Abu Funtas. The second one, which goes to Umm Bab, was set up according to a 1963 agreement between the government and QPC for supplying the Qatar National Cement Company with the associated gas for the Limestone furnace.⁽²⁵⁾ Due to the growing need for associated gas in the Umm Said area as feed stock and for generating power, the third and most important pipeline was introduced into the pipeline network in the early 1970's. Half way between Dukhan and Umm Said, the pipeline forks, one section going to Umm Said and the other towards Doha which also divides into two lines north of Wakra, one for the use of Ras Abu Fontas and the other for Ras Abu Aboud. Thirdly, there is the natural gas liquids pipeline which was set up to maximise the profit from natural and associated gas instead of 'flaring-off'. The government set up two NGL plants at Umm Said. After the separation of associated gas from the oil, the gas is gathered at three stations - Khatiyah, Fahahil and Jaleha - passes through a stripping plant at Fahahil, and is then pumped, via a 12 in pipeline, 88 km. to Umm Said NGL 1. ⁽²⁶⁾ (see Chapter 6, pp.212-216).

2, Offshore Pipelines

Offshore pipelines as shown in Figure 5.5, are of two categories. First there are the oil pipelines, introduced in 1965, connecting the oil-fields of Idd Al-Shagi and Maydan Muhzim to the oil stage installations and terminal at Halul Island. At first, when Idd Al-Shagi was

Fig.5-4 Pipelines in Dukhan (onshore)

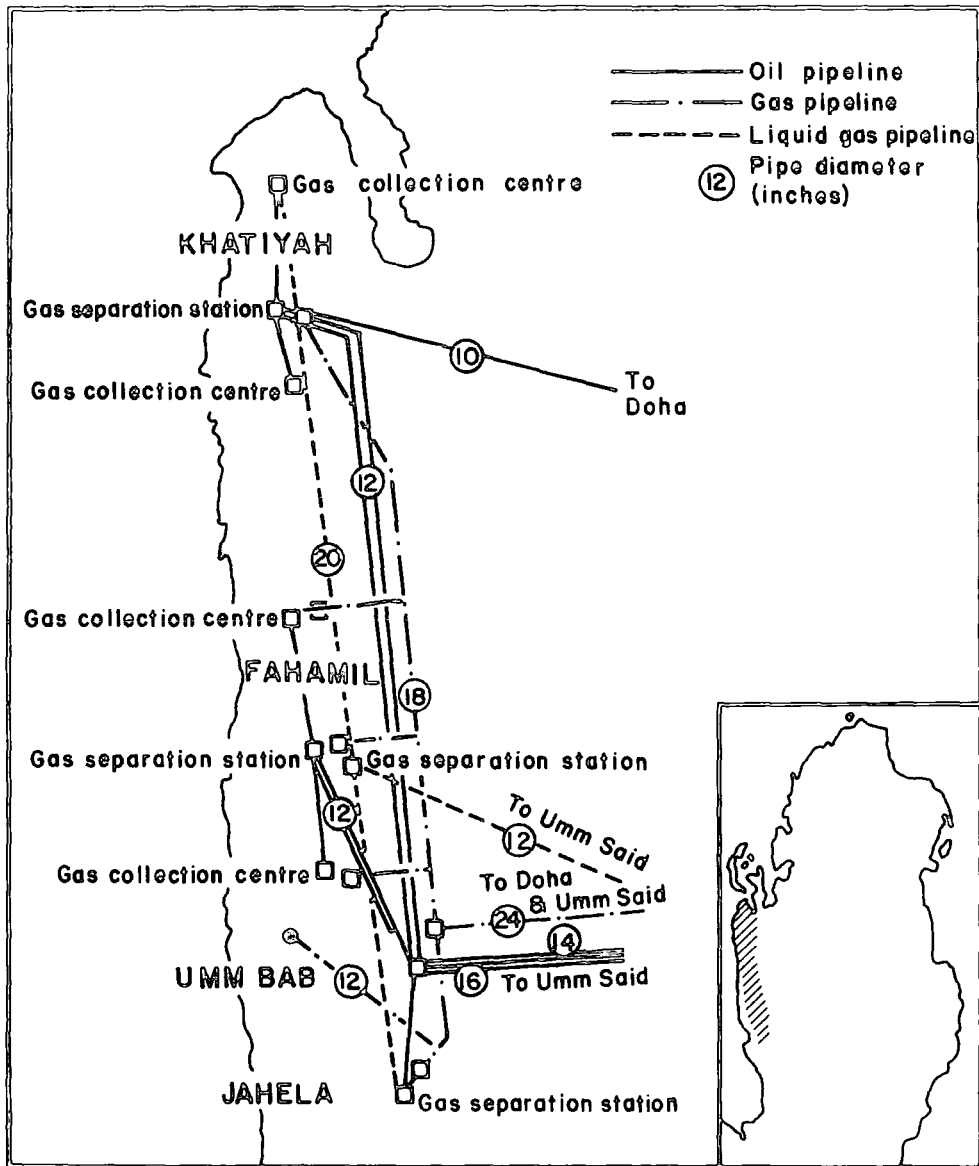

Source : Ministry of Finance and Petroleum Oil Industry in Qatar 1976,
Petroleum Dept. Qatar p.6

discovered, the company (SCQ) used an oil tanker called "Zenatia" as a floating reservoir, but when the second oilfield was discovered, there was a strong need for permanent exporting facilities and the choice was Halul Island. The oil is carried out from Idd Al-Shargi to Halul through a submerged pipeline of 12 in. diameter over about 17.7 km, whilst Maydan Muhzam's oil runs through a 14 in. pipeline covering a distance of about 16.4 km. The oil between Bul Hanin and Halul Island runs over a distance of about 42 km. through a 20 in. pipeline. Secondly, there are the natural gas liquid pipelines. Until very recently all of the natural and associated gas was flared, but in 1978 the QGPC carried out a project which was planned to connect the offshore field with the NGL 2 plant at Umm Said, a project completed in 1980. Two submerged pipelines of 24 in. and 12 in. diameter are used for transferred NGL (gas and liquid) over a distance of 88 km to shore at Wakrah, from which a buried pipeline runs for 28 km to Umm Said. (27)

The onshore and offshore pipelines, as has been noted, involve several pipelines of small diameter which increase the transport costs, although the distances covered are relatively smaller than in other Gulf States. The implications for design of oil pipelines (as with gas gathering systems) of a step by step approach to extraction, industrial supply etc. will be examined later.

5.1.4 Location of oil storages and terminals

Because of the low domestic consumption of oil, export terminals were urgently needed to export the crude oil to the international markets. The location of the onshore oil terminal in Umm Said was greatly influenced by political consideration (see Chapter 7, p.225).

Fig. 5.5 Offshore Pipelines

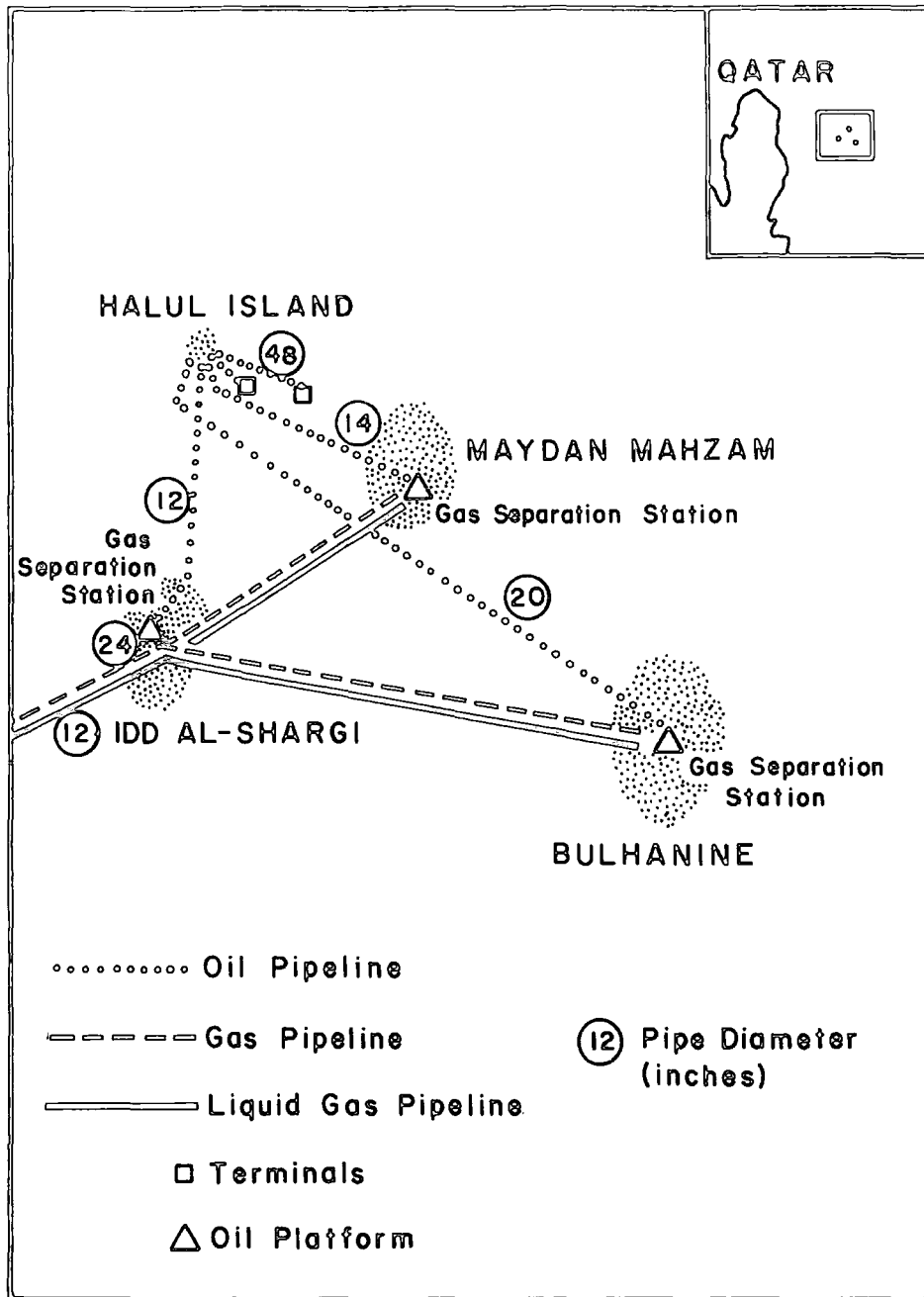

Source: Ministry of Finance and Petroleum, Oil Industry in Qatar 1979, Petroleum Affairs Dept., Qatar

There are sixteen oil storage tanks at Umm Said with a total capacity of 270,430 tons (2.113 million barrels). The oil is pumped from the storage area to four oil measurements at Sealine Area, then to two tanker loading berths through undersea pipelines. The oldest is the Southern Berth which is about one km. from the shore, where the oil is transferred to oil tankers through a 24 in diameter pipeline with a capacity of 3,900 long tons per hour. The second berth, the Northern, was put in use in 1972 with a submerged pipeline of 36 in. diameter and lying 2.7 km. from shore. The total capacity of the Northern Berth is 4,600 long tons per hour. Two oil tankers can be loaded at the same time at a maximum combined rate of 4,900 long tons per hour. In 1980, a total of 81,294,190 barrels were exported from Umm Said oil terminal and loaded onto 167 oil tankers with an average of 486,792 barrels loaded onto each tanker. (28)

While the political aspect played an important role in determining the location of onshore oil terminals, the economic aspect was dominant in locating the offshore oil terminal. The cost-minimising location at Halul Island was partly a function of distance to the earliest oil fields, Idd Al-Shargi and Maydan Mahzam which lay about 17 km. away, partly because deep water surrounded Halul Island and, lastly, because the rock structure of the island reduced expenditure on construction and site preparation compared to neighbouring seabkah or sand coasts.

Before 1965, the oil terminal used by SCQ was an oil tanker located near the Idd Al-Shargi platform. Halul Island, until mid 1962, was considered as part of QPC's concession. The island was included within SCQ's concession in mid 1962. (29) So, in 1963, and after the discovery of Maydan Mahzam, the company chose Halul for the above-mentioned reasons. Work on oil storage and terminal

facilities commenced during 1965. There are nine storage tanks on the island with a total capacity of 4.5 million barrels (589,545 long tons). The crude oil is pumped from the storage area to the oil tankers through two pipelines, one of 30 in. diameter leading to a single point mooring buoy, SBM.I, lying about 2.4 km. to the south east of the island with a capacity of 6,500 long tons per hour, the second a 48 in. diameter pipeline to SBM.II 4.8 km. distant (see Fig. 5.5). In 1980, a total of 89,148,638 barrels were exported through the offshore terminal, loaded onto 121 tankers with an average of 736,766 barrels per shipment.

5.1.5 Crude oil production

As noted earlier, Qatar started oil production in 1949, with the production of over 80,000 long tons. This figure only represented the December production, which explains the sharp rise of the 1950 production, which reached 1,616,598 long tons, i.e. a 1,920 per cent increase. Since then, till the end of 1963, there was a steady yearly increase of onshore oil production with the exception of 1959. Although onshore production during the 1964-80 period fluctuated slightly annually, the period overall shows an average 1.30 per cent increase in oil production per annum. In 1980, onshore production was 10,836,000 long tons (84,664,211 U.S barrels) with a daily average of 29.7 thousand tonnes (see Table 5.4).

Offshore oil production started in 1964 with 1,178,000 long tons from the Idd Al-Shargi field. In 1966, and with the help of the second oilfield (Maydan Mahzam), the production had reached 4,724,000 long tons with a 301 per cent increase from that of 1964. In June 1972 the third field (Bul Hanin) started production and

Table 5.4 : Qatar Crude Oil Production 1949-1980 (in 1,000 Long tons)

Year	Onshore %	% Increase (Decrease)	Offshore**	% Increase (Decrease)	Total	Daily average
1949	80	-	-	-	80	
1950	1,616	+ 1920	-	-	1,616	4.4
1951	2,332	+ 44.3	-	-	2,332	6.4
1952	3,245	+ 39.2	-	-	3,245	8.9
1953	3,998	+ 23.2	-	-	3,998	11.0
1954	4,704	+ 17.7	-	-	4,704	12.9
1955	5,362	+ 14.0	-	-	5,362	14.7
1956	5,784	+ 7.9	-	-	5,784	15.9
1957	6,505	+ 12.5	-	-	6,505	17.8
1958	8,092	+ 24.4	-	-	8,092	22.2
1959	7,867	- 2.8	-	-	7,867	21.6
1960	8,083	+ 2.7	-	-	8,083	22.2
1961	8,249	+ 2.1	-	-	8,249	22.6
1962	8,671	+ 5.1	-	-	8,671	23.8
1963	8,953	+ 3.3	-	-	8,953	24.5
1964	8,802	- 1.7	1,178	-	9,980	27.3
1965	9,014	+ 2.4	1,784	+ 51.4	10,798	29.6
1966	8,915	- 1.1	4,724	+ 164.8	13,639	37.4
1967	9,070	+ 1.7	6,169	+ 30.6	15,239	41.8
1968	9,018	- 0.6	7,009	+ 13.6	16,027	43.9
1969	9,366	+ 3.9	7,390	+ 5.4	16,756	45.9
1970	8,882	- 5.2	8,217	+ 11.2	17,099	46.9
1971	10,386	+ 16.9	9,891	+ 20.3	20,277	55.6
1972	11,368	+ 9.5	11,493	+ 16.2	22,861	62.6
1973	11,730	+ 3.2	15,265	+ 32.8	26,995	74.0
1974	10,430	- 11.1	14,112	- 7.6	24,542	67.2
1975	8,257	- 20.8	12,482	- 11.6	20,739	56.8
1976	11,360	+ 37.6	11,797	- 5.5	23,157	63.4
1977	9,336	- 17.8	11,282	- 4.4	20,618	56.5
1978	11,107	+ 19.0	11,828	+ 4.8	22,935	62.8
1979	10,790	- 2.9	12,847	+ 8.6	23,637	64.8
1980	10,836	+ 0.4	11,539	- 10.2	22,375	61.3
Total	252,208		159,007		411,215	

* Onshore Long ton = 7.813 US barrels

** Offshore Long ton = 7.633 US barrels

Sources: Ministry of Finance and Petroleum, Oil Industry in Qatar 1979
Qatar, 1980, and
QGPC, Production and Export of 1979-80. Qatar 1981.

resulted in production reaching 11.49 million long tons, the first year in which the offshore fields exceeded the onshore production level. From 1973 to 1979 the annual oil production of the offshore field fluctuated slightly, with a general growth rate of -3.97 per cent per annum. In 1980 the production fell 10.2 per cent lower than the 1979 level. The production was then drawn from the three fields as follows:

- a) 761,758 long tons from Idd Al-Shargi
- b) 3,474,480 long tons from Maydan Mahzam
- c) 7,302,734 long tons from Bul-Hanin

At first, the oil production rate of onshore and offshore fields, mainly depended on the decision of the oil companies, but after 1972, the production rate was changed increasingly, according to the State of Qatar's evaluation of international oil prices, the country's revenue needs, as well as the discovery of new fields. For several policy reasons, the Minister of Finance and Petroleum announced in 1976 that the daily rate of oil production would be held around 475,000 barrels per day. ⁽³⁰⁾ From this and Table 5.4 we may realize that the oil production had reached its peak in 1973 and that no new field has been discovered from that date. Henceforth, production would be controlled in order to optimise returns, to limit oil extraction and preserve Qatar's oil reserves (see below).

Table 5.5 shows the daily crude oil production in Qatar compared to other members of the OAPEC countries. During the 1977/79 period, Qatar did not change its relative position which was the seventh amongst the eleven countries. This position has been taken over by Egypt since 1980. The total production of Qatar in 1977 was only 2.2 per cent of the OAPEC total production. In 1981 Qatar's percentage was up to 2.4 per cent of 16,682,000 barrels/day.

Table 5.5 : Crude Oil Production in OAPEC Member Countries(1977-81)
(In thousand barrels/day)

	1977	1978	1979	1980	1981	% of each country in 1981
U.A.E.	1,999	1,829	1,838	1,710	1,502	9.0
Bahrain	58	55	51	48	46	0.3
Tunisia	89	103	117	116	112	0.7
Algeria	1,086	1,287	1,217	1,020	798	4.7
Saudi Arabia	9,200	8,301	9,532	9,900	9,808	58.8
Syria	174	171	167	158	163	1.0
Iraq	2,493	2,629	3,477	2,646	897	5.4
Qatar	445	487	508	472	405	2.4
Kuwait	1,967	2,129	2,445	1,658	1,130	6.8
Libya	2,063	1,983	2,092	1,827	1,218	7.3
Egypt	412	484	497	557	603	3.6
Total	19,986	19,458	21,941	20,112	16,682	100.0

Source : OAPEC, Ninth Annual Statistical Report 1980-81, Economic Department, Kuwait 1983, p.13 T.8.

5.6.1 Evaluation of Reserves/Production Rate

The statistical data on this subject is limited, mainly due to the confidentiality surrounding information on oil reserves; the authorized departments are not eager to divulge this information publicly.

The oil reserves of Qatar were estimated in 1948 to be about 150 million tons, wholly in the Dukhan oilfield.⁽³¹⁾ At the beginning of the seventies, the estimated amount of crude oil reserve was raised to about 651 million tons (4,562 million barrels).⁽³²⁾ After many oil zones had been discovered in Qatar's onshore and offshore areas, the size of the oil reserve rose sharply and in February 1973 reached some 7,000 million barrels, that is to say, about 1,000 million tonnes.⁽³³⁾ There are two kinds of oil reserve estimations; one of them is the estimation of all the crude oil in the field itself, while the other shows the quantities which can be lifted from the field to the surface by using only the methods available at present. In January 1980, there was an estimated 5.4 billion barrels of crude oil which could be brought to the surface, while the total amount of Qatar's oil reserves in the ground is estimated to be about 21 billion barrels.⁽³⁴⁾ This shows that about a quarter of the total reserves could be economically lifted, using normal technology at early 1980 prices. Table 5.6 below shows the production/reserves ratio. If the production rate remains around 475,000 barrels per day ceteris paribus the oil will last for approximately 31 years, or in other words, until the year 2011. During 1979 the exhaustion rate of onshore fields was 3.1 per cent, whilst that of offshore was 3.7 per cent, an average aggregate rate of 3.4 per cent. However, there is a high possibility that Qatar's oil will last longer than 31 years, given

Table 5.6 : Production and Reserves of Qatar's Crude Oil (US barrels)

The reserves in 1.1.1980	5,400,000,000
Production in 1980	172,741,000
Cumulative Production	3,192,444,000
Production Period until 1980	32 years
Average Annual Production (1949-1980)	99,763,875
Average Daily Production	273,326
Fixed Daily Production at a rate of *	475,000
Life Expectancy of the Reserves	31 years (2011)

Source : Compiled by the author from several confidential reports

* See p. 119

certain conditions; a) modern methods of extraction can reduce the cost of lifting the crude, and b) the careful exploitation of the North Dome. The ND, according to official sources, is one of the largest gas fields in the world (see Natural Gas, p. 133) and there are several indications that it also has large crude oil reserves within its structure. (35)

5.1.7 Crude Oil Exporting

Due to the small quantities of oil and oil-products used within Qatar, the country has a large surplus to export, in the form of crude oil, to the international market, which, in turn, provides revenue and capital for its development programmes. Of course, the marketing of crude oil mainly depends on the size of the demand, and the price, as well as its quality. The Dukhan crude is of gravity 41.5° API*, having an average sulphur content of 1.1 per cent by

* API = American Petroleum Institution.

weight, while the offshore holdings yield a crude of lower density than that produced from Dukhan, with 36° API* and an average sulphur content of 1.52 per cent by weight. ⁽³⁶⁾ Qatar's crude oil price trends are shown in Table 5.1 above.

Qatar started the exportation of crude oil at the end of 1949, when about 15.433 long tons of crude were loaded onto an oil tanker called "President Meny" carrying the crude oil to Western Europe. ⁽³⁷⁾ In 1950 the figure of oil exported reached 1,536,420 long tons, with an increase of 9,855 per cent over the previous year. Exporting of crude oil from the Umm Said oil terminal followed an increasing trend until 1963, excluding 1959. In 1964 and in the following years, the export rate became unstable, fluctuating due to the changing demand and the price of Qatar's crude and, of course, the development of offshore fields. The largest quantity ever exported through Umm Said was in 1973. The offshore fields started exporting in 1964 with 1,176 thousand long tons. In 1966 the amount exported increased by 304 per cent over the export rate of 1964. The offshore export level kept increasing from 1966 until 1973 when the largest quantities exported from Halul Island were recorded. Export rates then dropped drastically. Whilst onshore fields took more than 20 years to reach quantities of over 9,500 thousand long tons, the offshore fields took only seven years to reach this level. (see Table 5.7).

However, the export aggregate from both onshore and offshore fields showed an increasing trend over the years, excluding 1959, until the end of 1973. After 1973, the effect of the Arab-Israeli War, changing demand price of crude oil, and governmental policy decisions over production rates, all culminated in a fluctuating but almost static level.

* API = American Petroleum Institution

Table 5.7 : Qatar Crude Oil Exports (1949-1980) (in thousand long tons)

Year	Onshore *	% In-crease (Decrease)	Offshore **	% In-crease (Deacrease)	Total	Daily average
1949	15	-	-	-	15	-
1950	1,536	+10,140	-	-	1,536	4.2
1951	2,246	+ 46.2	-	-	2,246	6.2
1952	3,222	+ 43.5	-	-	3,222	8.8
1953	3,920	+ 21.7	-	-	3,920	10.7
1954	4,546	+ 16.0	-	-	4,546	12.5
1955	5,264	+ 15.8	-	-	5,264	14.4
1956	5,665	+ 7.6	-	-	5,665	15.5
1957	6,488	+ 14.5	-	-	6,488	17.8
1958	8,055	+ 24.2	-	-	8,055	22.1
1959	7,857	- 2.5	-	-	7,857	21.5
1960	7,977	+ 1.5	-	-	7,977	21.9
1961	8,144	+ 2.1	-	-	8,144	22.3
1962	8,615	+ 5.8	-	-	8,615	23.6
1963	8,971	+ 4.1	-	-	8,971	24.6
1964	8,754	- 2.4	1,176	-	9,930	27.2
1965	8,904	+ 1.7	1,716	+ 45.9	10,620	29.1
1966	8,936	+ 0.4	4,755	+177.1	13,691	37.5
1967	8,910	- 0.3	6,148	+ 29.3	15,058	41.3
1968	9,059	+ 1.7	6,971	+ 13.4	16,030	43.9
1969	9,211	+ 1.7	7,437	+ 6.7	16,648	45.6
1970	8,988	- 2.4	8,133	+ 9.4	17,121	46.9
1971	10,303	+ 14.6	9,917	+ 21.9	20,220	55.4
1972	11,358	+ 10.2	11,473	+ 15.7	22,831	62.6
1973	11,675	+ 2.8	15,376	+ 34.0	27,051	74.1
1974	10,325	- 11.6	13,921	- 9.5	24,246	66.4
1975	7,979	- 22.7	12,390	- 11.0	20,369	55.8
1976	11,000	+ 37.9	12,141	- 2.0	23,141	63.4
1977	9,005	- 18.1	10,907	- 10.2	19,912	54.6
1978	10,717	+ 19.0	12,077	+ 10.7	22,794	62.5
1979	10,317	- 3.7	13,195	+ 9.3	23,506	64.4
1980	10,405	+ 0.9	11,084	- 11.5	22,084	60.5
Total	248,361		159,412		407,773	

* Onshore Long ton = 7.813 US barrels

** Offshore Long ton = 7.633 US barrels

Sources: Ministry of Finance and Petroleum, Oil Industry in Qatar 1979, Qatar 1980 and QGPC, Production and Export of 1979-80 Qatar.

Table 5.8 shows the exporting rate in Qatar compared to other members of OAPEC. Qatar, during the whole period held the seventh position amongst OAPEC in the daily exporting rate, with 2.8 per cent of total OAPEC exports in 1981.

The geographical distribution of Qatari exports of crude oil shown in Table 5.9 indicates that the dominant importing region was Western Europe, about 70.3 per cent of the 1968 total, but this percentage dropped in 1972 to 63.3 per cent. The Western European market proportionally decreased every subsequent year, and in 1979 fell to 41.6 per cent, 0.1 per cent less than taken by Asian and Far Eastern countries. In 1980 Western Europe recovered, taking 43.7 per cent of the total, leaving Asian and Far Eastern countries second with 41.2 per cent. Asian and Far Eastern countries had a rapid demand increase from 1968 to 1979, excluding 1975 and 76, but a marked 6.9 per cent decline in 1980. Until the end of 1971 the United Kingdom was the largest single country importing Qatar's crude oil, but in 1972, the Benelux countries came first with 25.4 per cent of the total, with Holland importing almost the whole of this. In 1973, due to the boycott of Holland by the Arab Countries, the Netherlands only imported 3.2 per cent, leaving the first position to the U.K. From 1975 to 1977 the United States of America was the single largest importer but was replaced by Japan between 1978 and 1980. From close examination of Table 5.9 it can be seen that the general pattern of export of crude oil between 1979 and 1980 shows a decline. The main reasons for the decline in the 1980 export rates were:

- 1) competition between Arabian Gulf states;
- 2) fluctuations of supply and demand in the oil international market;

Table 5.8 : Crude Oil Export in OAPEC Member Countries,* 1977-81
(In thousand barrels/day)

	1977	1978	1979	1980	1981	% of each country in 1981
U.A.E.	1,983.6	1,819.2	(*) 1,795.4	(a) 1,690.4	(a) 1,427.4	10.0
Tunisia	24.7	45.6	49.3	54.8	71.2	0.5
Algeria	1,008.2	1,002.7	961.6	717.8	520.6	3.6
Saudi Arabia	8,608.2	7,706.9	8,816.4	9,249.3	9,019.2	63.3
Syria	150.7	153.4	148.0	120.6	104.1	0.7
Iraq	2,301.4	2,383.6	3,274.0	2,465.8	698.6	4.9
Qatar	430.1	487.7	495.9	465.8	391.8	2.8
Kuwait	1,611.0	1,761.6	2,082.2	1,306.9	813.7	5.7
Libya	1,942.5	1,854.8	1,967.1	1,698.6	1,063.0	7.5
Egypt	84.9	101.4	117.8	142.5	137.0	1.0
Total	18,145.3	17,316.9	19,706.8	17,912.5	14,246.6	100.0

* Bahrain does not export crude oil

a Excluding Shargah

Source: Converted to daily rate by the author from OAPEC, Ninth Annual Statistical Report 1980-81 Economic Department, Kuwait, 1983, p.14.T.9.

Table 5.9 :

Crude Oil Exports from Qatar ^(a) (Thousand barrels/day)

Destination	1968	1969	1970	1971	1972	1973	1974	1975	1976	1977	1978	1979	1980	% of 1980
<u>NORTH AMERICA</u>	-	-	-	<u>1.7</u>	<u>3.5</u>	<u>10.9</u>	<u>77.9</u>	<u>88.1</u>	<u>90.8</u>	<u>90.4</u>	<u>42.6</u>	<u>19.4</u>	<u>12.2</u>	<u>2.6</u>
of which														
U.S.A.	-	-	-	1.7	3.5	10.9	77.9	88.1	90.8	90.4	42.6	19.4	12.2	2.6
<u>LATIN AMERICA</u>	<u>5.2</u>	<u>12.3</u>	<u>9.6</u>	<u>10.2</u>	<u>4.8</u>	<u>0.7</u>	-	<u>14.8</u>	-	<u>8.5</u>	<u>25.6</u>	<u>42.7</u>	<u>35.1</u>	<u>7.5</u>
of which														
Brazil	-	-	1.4	10.2	4.8	-	-	-	-	-	2.7	14.7	18.9	4.1
<u>WESTERN EUROPE</u>	<u>238.4</u>	<u>213.8</u>	<u>240.4</u>	<u>294.1</u>	<u>335.7</u>	<u>360.8</u>	<u>291.2</u>	<u>235.0</u>	<u>268.2</u>	<u>171.1</u>	<u>216.8</u>	<u>205.9</u>	<u>203.6</u>	<u>43.7</u>
of which														
France	63.6	46.7	46.0	59.1	45.0	69.9	79.5	32.4	71.7	48.4	89.2	55.6	59.0	12.7
Germany (F.R)	8.8	0.7	-	5.2	5.3	2.2	14.2	20.4	14.9	17.0	4.4	9.5	1.4	0.3
Italy	52.8	55.0	46.4	72.3	57.7	65.8	57.0	42.9	30.7	28.5	31.0	29.8	30.9	6.6
Netherlands	20.6	28.7	31.3	50.3	122.5	144.4	16.3	75.0	84.7	49.9	56.3	69.4	71.8	15.4
Sweden	13.4	8.0	22.2	25.3	15.0	8.0	14.2	1.4	8.3	5.3	2.3	-	1.3	0.3
United Kingdom	64.0	69.2	93.5	76.4	72.9	64.8	97.0	54.8	57.9	22.0	13.8	4.7	10.8	2.3
<u>MIDDLE EAST</u>	-	<u>5.2</u>	<u>1.9</u>	<u>4.3</u>	<u>7.8</u>	<u>9.0</u>	<u>4.9</u>	<u>1.7</u>	<u>5.9</u>	<u>1.1</u>	-	<u>8.5</u>	-	<u>0.0</u>
of which														
Southern Yemen	-	5.2	1.9	4.3	7.8	9.0	4.9	1.7	5.9	1.1	-	8.5	-	0.0
<u>AFRICA</u>	<u>36.5</u>	<u>34.5</u>	<u>49.9</u>	<u>56.5</u>	<u>41.1</u>	<u>89.9</u>	<u>27.3</u>	<u>19.8</u>	<u>20.6</u>	<u>12.6</u>	<u>18.5</u>	<u>6.7</u>	<u>14.5</u>	<u>3.1</u>
<u>ASIA & FAR EAST</u>	<u>38.0</u>	<u>38.9</u>	<u>36.2</u>	<u>36.8</u>	<u>55.8</u>	<u>73.5</u>	<u>99.0</u>	<u>41.9</u>	<u>64.9</u>	<u>108.8</u>	<u>176.5</u>	<u>206.3</u>	<u>192.1</u>	<u>41.2</u>
of which														
Japan	5.0	3.5	3.5	1.5	1.1	3.7	4.7	1.4	4.0	55.4	115.8	141.7	140.3	30.1
Thailand	31.2	35.4	32.7	35.3	44.4	57.6	49.3	27.9	46.3	48.1	46.4	46.0	40.7	8.7
<u>OCEANIA</u>	<u>20.9</u>	<u>48.3</u>	<u>24.8</u>	<u>14.9</u>	<u>17.2</u>	<u>11.5</u>	<u>10.7</u>	<u>4.9</u>	<u>5.2</u>	<u>9.2</u>	-	-	<u>2.7</u>	<u>0.6</u>
of which														
Australia	20.9	48.3	24.8	13.5	11.7	11.5	10.7	4.9	5.2	9.2	-	-	2.7	0.6
<u>UNSPECIFIED (b)</u>	-	-	-	<u>10.1</u>	<u>15.8</u>	<u>14.0</u>	<u>0.2</u>	<u>22.1</u>	<u>31.0</u>	<u>8.6</u>	-	<u>5.4</u>	<u>6.2</u>	<u>1.3</u>
Total	339.0	353.0	362.8	428.6	481.7	570.3	511.2	428.3	486.6	410.3	480.0	494.9	466.4	100

(a) Excluding Al-Bunduq exports. (b) To Gibraltar for wireless order.

Sources : El Malakh, R., Qatar Development of an Oil Economy, Croom-Helm London 1979 p.42.

Ministry of Finance and Petroleum, Yearly Bulletin of Export and Import (1969-80) Qatar.

QGPC, The Monthly Report No.40 of 1980, Qatar.

- 3) large accumulations of oil within the largest consumer countries;
- 4) the decrease of local consumption within importing countries; and
- 5) increased production in non-OPEC countries e.g. the U.K. and Mexico.

All these have had a hand in the decline of the 1980 exporting figures, but the strongest reason of all was government policy on production rates. The relationship between this latter factor and industrialization will be considered later.

5.2 Natural Gas

The term "natural gas" is applied to gas produced at the surface from underground accumulations of widely varying compositions which may or may not be directly associated with accumulations of crude oil.

The emphasis, in this section, will be laid on examining production and consumption, degassing stations, the North Dome (ND), and the evaluation of reserve/production rate.

5.2.1 Production and Consumption

Until recently, Qatar produced large quantities of natural gas, mainly associated with oil, most of which was wasted into the air by "flaring". This was due to:

- 1) the difficulties of storage of natural gas for long periods;
- 2) the absence of any domestic projects dependent upon that resource;
- 3) anxieties arising from natural gas, poisons and explosives.

All these reasons and others led to the wasting of this vital resource. Of course, there are some small quantities used on a small scale in the companies themselves, for instance, for operating gas separation

stations for electricity generation and distillation plants etc. but all these operations only consumed about 10 per cent or less of the total production. Because of the lack of statistical data before 1969, we can only discuss 1969 and the following years.

Table 5.10 below shows production and consumption of natural gas in Qatar in 1969-1980. The gas production of the oilfields in 1969, was 136 billion cu. ft. with a daily average of 373 million cu. ft. The consumption in the same year was only 37 billion cu.ft, that is to say, about 27.2 per cent of the total production, and the remaining quantities were 'flared'. In 1970 production and consumption were down to 131 and 35 billion cu. ft. In 1972 and 1973 production was 181 and 227 billion cu. ft. respectively, while consumption of the same years was 40 and 42.5 billion cu. ft. Production of natural gas fell from 272 billion cu. ft. in 1973 to 158 billion cu. ft. in 1974 and to 146 billion cu. ft. in 1975. The decline in natural gas production was due to a decrease in oil extraction in 1974 and 75 (see Table 5.4). In addition to a decrease in gas production, there was also a decrease in the consumption rate; for instance, consumption for 1974 had fallen to 28.5 b. cu.ft. and to 26.6 b. cu.ft. in 1975. The consumption of previous years was mainly used by the governmental electricity and distillation plants, the cement factory and for use by the oil companies, as well as QAFCO I. Because of the increase in oil production, gas production also increased, and at the same time the opening of the Natural Gas Liquids (NGL) plant helped to increase the consumption proportion, e.g. consumption in 1976 was about 45.7 per cent of the onshore total production, while in 1975 it was 35.7 per cent. In 1978, the production of natural gas increased by 8.1 per cent over the 1977 level, but consumption declined as a result of the discontinuation of the NGL plant in late 1977. In

Table 5.10 : Production & Consumption of Natural Gas 1969-1980

(In billion

Location	1969			1970			1971		
	Prod.	Cons.	% of Con-sum.	Prod.	Cons.	% of Con-sum.	Prod.	Cons.	% of Con-sum.
Onshore	79	25	31.7	75	25	33.3	90	31	34.4
Offshore	57	12	21.1	56	10	17.9	69	4	5.8
Total	136	37	27.2	131	35	26.7	159	35	22.0

Location	1972			1973			1974		
	P.	C.	% of C.	P.	C.	% of C.	P.	C.	% of C.
Onshore	90	35	38.9	111	33	29.7	91	28	30.7
Offshore	91	5	5.5	116	9.5	8.2	67	1.5	2.2
Total	181	40	22.1	227	42.5	18.7	158	29.5	18.0

Location	1975			1976			1977		
	P.	C.	% of C.	P.	C.	% of C.	P.	C.	% of C.
Onshore	70	25	35.7	99.3	45.4	45.7	89.5	54.3	60.7
Offshore	76	1.6	2.1	67.8	1.6	2.3	62.4	1.0	1.6
Total	146	26.6	18.2	167.1	47.0	28.1	151.9	55.3	36.4

Location	1978			1979			1980		
	P.	C.	% of C.	P.	C.	% of C.	P.	C.	% of C.
Onshore	100.7	51.3	50.9	159.1	151.8	95.4	124	110	88.7
Offshore	63.5	0.9	1.4	73.4	2.2	2.0	70.0*	2.0*	2.9
Total	164.2	52.2	31.8	232.5	154.0	66.2	194.0	112.0	57.7

* Reserve Figure

Sources: Computed by the author from
 Ministry of Economy and Commerce, Economic Survey of Qatar (1969-78),
 Qatar
 Ministry of Finance. and Petroleum, Oil Industry in Qatar (Several
 Issues)
 QGPC, The Monthly Report No.40 of 1980 Qatar.

1979 production and consumption of the gas increased by 41.6 and 195 per cent respectively. This may be explained by the setting up of new plants which mainly depended on natural gas such as QAFCO II, expansion of the Cement Factory, the Iron and Steel complex, as well as the increased demand of electricity generating and water desalination plants. In 1980 gas production decreased by 19.6 per cent from the previous years, as a result of the decline of oil production.

Offshore gas consumption, as can be seen in Table 5.10, remained almost the same during the whole period, and the 'flared' gas of the offshore fields remained a very high proportion of the total. In 1979, for instance, the flared gas of the onshore field was 4.6 per cent out of 159.1 billion cu. ft. produced whilst offshore flared gas was 97 per cent out of 73.7 billion cu. ft. This raised the aggregate proportion of flared gas to 33.8 per cent out of 232.5 b. cu.ft.

As may be noticed from the previous assessment, the quantity of natural associated gas produced mainly depends on the production of crude oil, and whenever there was a decline in oil production there was a corresponding decline in natural gas.

Unassociated natural gas was discovered for the first time by QPC in 1959, and because attention was then concentrated upon crude oil, the gas well was closed down. In 1971 SCQ discovered an unassociated gas field at a depth of 2,460 metres. ⁽³⁸⁾ This was the North West Dome* (NWD) gas field, one of the largest natural gas fields in the world. ⁽³⁹⁾ The primary estimation of the field production capacity would be around 2,000 million cu. ft. per day. ⁽⁴⁰⁾ Although the field was discovered in 1971 it has not yet been exploited although a decision in principle to develop it was taken in 1983.

* The name came as a result of the field's location to SCQ's concession. Nowadays this field is called the North Dome.

5.2.2 Gas separation & gathering stations

Natural gas is drawn from six separate gas stations (see Figs. 5.4 and 5.5). There are three stations in the Dukhan oilfield; one is Khadiyah on the northern side of the field; Fahahil located in the middle and, lastly, Jaleha in the western part of the Dukhan field. The crude oil produced from the Dukhan field passes through these stations for the separation of gas and water which accumulate in the crude. The next process is to separate associated natural gas from unassociated gas. Then the transportation of associated to Doha, Umm Bab and Umm Said follows. The gas remaining after these processes is flared.

The other three stations are located offshore on the drilling platforms, and each field has its own station; for instance, the Idd El-Shargi field has a gas separation station with a capacity of 56,000 barrels per day, Maydan Mahzam has a capacity of 180,000 barrels per day, and Bul Hanin 220,000 barrels per day. All these three stations were separating natural gas from the crude oil and using small quantities of gas to operate the oil pumping stations, while the surplus of gas would be flared.

Because of the need to increase the national income from non-oil resources, the government, in 1974, through QGPC, set up onshore field gas collection centres to collect the natural gas from separation stations and pump it to Umm Said. The main gases were propane and butane. To support this the government and QPC set up -

- 1) Pipeline systems connecting the gas separation stations to gas gathering and compression centres;
- 2) Stripping plant at Fahahil;
- 3) New Pipeline systems to transport NGL from Dukhan to Umm Said; and
- 4) NGL plant at Umm Said.

The above operations were successful and the NGL plant started operation early in 1975, but unfortunately there was a mysterious fire which destroyed this plant in 1977. At the end of 1980 the offshore gas gathering centres, located on three different platforms, were put into the operation stream. The natural gas and liquid are, after dehydration, sent via Idd Al-Shargi to Umm Said (See NGL Chapter 6, pp. 212-216).

5.2.3 Evaluation of reserves/production rate

In 1979 production of natural gas amounted to 232.5 billion cu ft. (see Table 5.10) while the reserve of natural gas, associated and non-associated, amounted, in 1979, to approximately 19.3 trillion cu. ft. ⁽⁴¹⁾ which relate only to the onshore field. Because of the absence of offshore oilfield figures for associated natural gas, we can only assume that the same proportional figure as onshore will apply to offshore fields, which gives a total of natural gas reserves of about 38.6 trillion cu. ft. If this is added to the reserves of North Dome, which has a recoverable figure estimated at 150 trillion cu.ft., ⁽⁴²⁾ this will give a total reserve figure of natural gas of 209.6 trillion cu.ft. If the production figure of 232.5 b. cu.ft. and reserves remain the same ceteris paribus, the life expectancy of the reserves will last up to 900 years from 1979 i.e. until the year 2879. There is, however, a belief that the reserves will not last that long, due to expansion in natural gas use in NGL 1 & 2, and others as well as the LNG project which will be set up, according to the latest development, in Umm Said. The ND will be capable, according to present plans, of producing 730 billion cu. ft. per annum, ⁽⁴³⁾ and if we assume that this project will commence production in 1986, the reserves of natural gas will last up to 210 years or to the year 2196.

5.3 Other Extractive Industries

Apart from the exploitation of oil and natural gas, there are very few mineral substances actually extracted in Qatar, and even then on a small scale. Unfortunately, very little attention has been given to these extractive industries and therefore quantitative and qualitative studies are few.

As one might expect from the survey on pp.10-13 and from Table 2.1 all the mineral deposits of Qatar relatively belong to recent sedimentary formations. Several mineral resources which have been extracted for a long time, either for the cement factory or for road/building construction, can be listed thus:

1. Recrystallised limestone and superficial dolomite of the Simsima Member (Upper Dammam formation), with a thickness of 45 metres, are obtained by quarrying and hand-picking. Hand-picking of hard surface boulders is usually carried out near the main road, while quarrying is principally done by the government near Umm El-Afai about 20 km. to the west of Doha City. There are also smaller operations run by private firms. In 1980 private firms owned 18 stone crushing factories, 12 of these totally owned by Qataris. The government and private firms supply most of the building aggregate requirements of nearby Doha.
2. White crystalline limestone of the Upper Dammam is quarried near Umm Bab for use at the cement factory.
3. Green calcareous clay of the Lower Dam formation, with a thickness of 30 metres, is mined at Wadi Huwaila, about 17 km to the south of Umm Bab. All of this goes to the cement factory.
4. Crystalline gypsum of the Upper Dam subformation. Until recently the cement factory imported the gypsum needed for making Portland

cement from Saudi Arabia. According to Claude Cavelier, at the top of An-Nafkah hill (about 85 metres above sea level), are reserves of gypsum estimated at a minimum of 200,000 cu. metres. ⁽⁴⁴⁾ Gypsum is also extracted from the Al-Nikhsh area near the Gulf of Salwa which is about 37 km from the cement factory.

5. Quaternary marine calcareous sand of the Hofuf formation is quarried mostly from al-Mahriga (Balad Ibrahim) east and south east of Doha city, also to the north and south of Wakra and near al-Khor. These sands are required for the building industry and road construction, as well as for infill and trench linings.

There are also other resources that in the past were utilised on a small scale, such as:

1. Salt used to be collected for local consumption. The salt forms at present in Sabkha and in restricted inlets where saline water is evaporated naturally, leaving behind impure salts. The collection of such salt ceased in the early 1970's.

2. White limestone obtained from al-Khor for the use of traditional building. This quarrying of white limestone completely ceased when all construction utilised concrete or concrete blocks.

3. Quaternary pseudo-oolithic limestone of Rus formation, found on the eastern coast and used as rubble in the building industry. The centres of this exploitation were at Jebel Fawairat and Wakra.

4. Recent silts and muds are found in depressions and were usually used in the past for brick making.

Several investigation studies have been carried out in respect of mineral occurrences in Qatar and their development potential. The result of these studies showed that there are several mineral deposits.

that could be developed on a commercial basis and could feasibly be produced economically due to the existence of favourable geographical and energy factors. These are:

1. Salts from which sodium chloride, magnesia, magnesium metal and bromide could be produced.
2. Attapulgitic clays
3. Gypsum
4. Sand
5. Ornamental and building stone

CHAPTER 5

References

- (1) Beaumont, A. Blake G.H., & Wagstaff, J.M., The Middle East, a Geographical Study, Wiley, England 1976, pp.274-83.
- (2) State of Qatar, Some British and Ottoman Documents 1968-1949, Documents of Qatar's History, The Amir's Office, Qatar 1979, p.224 and
Zahlan, R.S., The Creation of Qatar, Croom-Helm, London, 1979, pp.70-78.
- (3) QGPC, Sheets of Exploratory Wells 1940-1980, Petroleum Engineering Dept, 1981, p.1.
- (4) Ministry of Finance & Petroleum Oil Industry in Qatar 1972, Petroleum Department Dar al-Uloom Est., Qatar, 1974, p.24.
- (5) QGPC, Annual Report, 1980, Public Relation Department, Singapore, 1981, p.22.
- (6) Ministry of Finance & Petroleum, Petroleum Concession Agreements and Laws, Petroleum Department, 1973, pp.13 and 173.
- (7) Ibid, pp.147 and 237.
- (8) Ministry of Finance & Petroleum, Oil Industry in Qatar 1977, Petroleum Department, Qatar, 1978, pp.22-23.
- (9) OAPEC, Arab Oil Legislation (1976-77) al-Yaqadhah Press, Kuwait 1979, p.246 and pp.264-269.
- (10) QGPC, Summary of Service Agreements, Qatar, 1980.
- (11) Ministry of Finance & Petroleum, Oil Industry in Qatar 1972, op.cit p.49.
- (12) Ministry of Finance & Petroleum, Oil Industry in Qatar, 1976, Petroleum Department Martins Press, England, 1977. p.25.
- (13) Ibid, p.26.
- (14) Al-Dabagh, M.M. Qatar ... Past and Present, Beirut 1961, p.82.
- (15) Ministry of Finance and Petroleum, Oil Industry in Qatar, 1972 pp.24-25 and 35.
- (16) Ibid, p.18.
- (17) Ministry of Finance & Petroleum, Oil Industry in Qatar, 1979, Petroleum Dept., Dominic Press, Singapore 1980, p.10.
- (18) Ministry of Finance & Petroleum, Oil Industry in Qatar 1972, op.cit., p.25-26.

- (19) Ministry of Finance & Petroleum, Oil Industry in Qatar, 1979
op.cit., p.11.
- (20) Ministry of Finance & Petroleum, Oil Industry in Qatar, 1972,
op.tic. p.14.
- (21) Ibid. pp. 26-27.
- (22) Ibid. pp.27-28.
- (23) Ministry of Finance & Petroleum, Oil Industry in Qatar 1979,
op.cit., p.11.
- (24) Ibid, p.13.
- (25) Ministry of Finance & Petroleum, Oil Concession Agreements and
Laws, op.cit. p.100.
- (26) QGPC Natural Gas Liquids, Public Relation Department
Soman-Wherry Press Ltd., England (c.a. 1981) p.10.
- (27) Ibid. p.12.
- (28) QGPC, Production & Export of Oil from Onshore & Offshore
Fields 1980, Petroleum Engineering Department January
1981 (Typescript).
- (29) Ministry of Finance & Petroleum, Petroleum Concession Agreements
and Laws, op.cit. p.60.
- (30) MEED, Vol. 20:14 2 April 1976, p.23.
- (31) Al-Jaber, M.H., Qatar Human Geography, Unpublished M.A.thesis
Cairo University, Cairo 1976/77, p.60.
- (32) Ibid.
- (33) Ibid.
- (34) QGPC, Oil & Natural Gas Reserves in Qatar, Confidential
Report, Qatar, 1981.
- (35) Personal Communication
- (36) Ministry of Finance & Petroleum Oil Industry in Qatar 1972,
op.cit. p.21 and pp.29-30.
- (37) Ibid. p,16.
- (38) QGPC Sheets of Exploratory Wells 1940-80, op.cit., pp.1-5.
- (39) Ministry of Finance & Petroleum, Oil Industry in Qatar
1977, op.cit., p.31.

- (40) Al Rayyah Newspaper, An Interview with Shaikh Rashid U.Al-Thani, Deputy Managing Director of QGPC No.607 of 2.12.1980, p.2.
- (41) QGPC Oil & Natural Gas Reserves in Qatar op cit.
- (42) Jaidah, A.M., Prospects for Gas Prices and the Development of the Natural Gas Industry in Qatar, in Issues in Development : The Arab Gulf States ed. by Daftari,M.Z., Published by MD Research and Services Ltd.London, 1980,p.156.
- (43) IDTC, Industrial Development in Qatar, Ali bin Ali Press, Qatar, April 1978, p.74.
- (44) Cavelier, C. Geological Survey and Mineral Substances Exploration in Qatar, Bureau De Recherches Geologiques et Minières, Paris, April, 1970, p.85.

CHAPTER 6

The Manufacturing Industries - By Type and Sector

Introduction

The pearling industry, prior to the oil discovery, was the principal source of income for the inhabitants of Qatar. The decline of this industry from the 1930's onward has encouraged the authorities to be very cautious of wealth which will not last for ever, and this has always affected attitudes to oil, the most recent source of wealth. One result has been a more or less consistent wish to diversify the basis for national income. Diversification in Qatar takes many forms, but the main sector is that of manufacturing industries.

In spite of this desire, movement towards industrial development was cautious rather than rapid, and, although many consultant firms were commissioned during the early 1960's to evaluate the feasibility of establishing industries based on gas utilization projects, as well as local minerals, none of these projects saw the light of day during that decade, with the exception of QAFCO (see Section 6.5 and also Chapter 4 and a model of stages of development).

This Chapter examines the evolution of manufacturing industry by sector, in Qatar. In general, the first group of industries which is examined comprises those which are in the public sector and might be loosely described as basic industries. The second group, mainly in the private sector, might be described as covering light industry. The discussion will concentrate, chronologically, through sections 6.1 to 6.6 on the following : Qatar National Oil Distribution Company (NODCO), Qatar National Cement Company (QNCC), Qatar National Fishing Company (QNFC), Qatar Flour Mill Company (QFMC), Qatar Fertilizer Company (QAFCO), and Qatar Steel Company (QASCO). Section 6.7 will examine

other manufacturing industries, including small-scale industries such as building materials, carpentry, metal fabrication and others. Attention is drawn at the end of this Chapter to projects in progress and under study.

6.1 Oil Refinery

According to Articles (1) and (2) of the 1935 Oil Concession Agreement (see Chapter 5.1 and Appendix 5.1) QPC was given the right to establish a refinery plant in Qatar. The relevant negotiations started in 1952 when the ruler insisted on this plant being established though the company tried to convince the government to continue importing oil products from neighbouring countries.⁽¹⁾ In 1953, and following the involvement of the British Political Resident, the company agreed to build a small refinery to supply its own and local needs for petrol, gas oil and kerosene.⁽²⁾ The refinery, which was the smallest of its kind in the world, had a designed input capacity of 24,000 imperial gallons (or 686 barrels) of crude oil per day. The refinery, or as it was then called, the Topping Plant, was situated in the Umm Said area attached to the storage tank farm. The construction of the refinery was started in 1954 and completed in 1955 at a total cost to QPC of £206,000.⁽³⁾

6.1.1 Production and Consumption

Unfortunately, the unavailability of statistical data between the opening of the plant and 1961 forces us to limit analysis to the 1962-1967 period, when the refinery was owned and controlled by QPC.

Table 6.1 : Topping Plant Production & Oil products Consumption
(1962-1967)

(Figure in Barrels*)

Year	Petrol		Kerosene		Gas Oil	
	Production	Consumption	Prod.	Cons.	Prod.	Cons.
1962	36,973	161,247	32,696	53,438	54,227	231,612
1963	23,824	179,486	26,185	59,751	47,120	136,096
1964	14,415	186,390	31,847	64,265	49,530	110,989
1954	6,475	216,268	35,055	63,615	55,609	133,745
1966	3,829	232,152	36,459	59,521	50,420	123,682
1967	2,868	253,917	31,830	59,031	52,020	130,101

* original figures in Imperial gallons

Source : QPC, Topping Plant Products & Purchases from Shell markets.
Finance Dept. 3rd March 1968.

Table 6.1 above shows clearly that in 1962 the total production of the refinery from petrol, kerosene and gas oil met only a little over a quarter of the total domestic consumption in that year. Because of the rapid increase of population in Qatar and of per capita consumption, the demand for oil products rose rapidly. But the refinery could not cope with such an increase due to its limited size. Indeed, the refinery output even included a sharp decline in the most popular product, 70 octane petrol, a decline over 1962-1967 of more than 34 per cent per annum. Kerosene and gas oil production were more stable over the period than petrol production.

The total gross income of QPC's refinery during the 1962-67 period was £886,161 while the imported purchases of oil products for the same period totalled £3,719,554.⁽⁴⁾ This indicates how inadequate was the refinery.

In 1957 the heir apparent, Sheikh Ahmad bin Ali, asked QPC to supply the country's domestic requirement of oil products rather than have Qatar dependent on the Bahrain refinery. The company replied that a new refinery was the only answer, and in response to the request that QPC should construct and finance a new plant, maintained that a new refinery would not be profit making and, therefore, the company would not risk its own capital. QPC also asked why the government, instead of investing in securities in the United Kingdom, should not invest in Qatar.⁽⁵⁾ During several years of negotiation the government and QPC could not reach any solution over this matter. This was because:

- a) The government did not have confidence in investing in Qatar, mainly due to QPC's report of oil reserve evaluation in which they predicted that reserves would last only ten years from the date of the start of production.⁽⁶⁾
- b) QPC had already recorded a net loss of £189,000 in 1957 from the established refinery, although this loss was caused mainly by the operational methods of the old fashioned plant, as well as by the deliberately maintained low selling prices of oil products which equalled in f.s.d. 1s., 9d. and 8d. per gallon for petrol, kerosene and gas oil respectively.⁽⁷⁾

6.1.2 National Oil Distribution Company (NODCO)

In October 1968 the government established NODCO, with government capital and under the control of the Ministry of Finance & Petroleum, with the objective of carrying out oil refining operations and the local distribution of oil products.⁽⁸⁾ The main two reasons for the establishment of NODCO, were a) the increase in the proven oil reserves of the onshore oilfields and in particular the offshore discoveries, and b) the refusal of QPC to construct a new refinery.

QPC's topping plant was purchased by the government at a price of £25,000 in cash, in addition to all equipment and stock belonging to the refinery.⁽⁹⁾ The old refinery, when purchased, was capable of handling an input of 24,000 Imperial gallons (686 barrels) per day with an output of:⁽¹⁰⁾

Standard Petrol (70 octane)	6,000 Im.gal./day
Kerosene	2,400 Im.gal./day
Gas oil	5,000 Im.gal./day

All production was consumed locally with the exception of standard low octane petrol. The balance of oil productions' consumption was met by importing through Shell Markets of the Middle East.⁽¹¹⁾

In January 1972, NODCO signed a construction contract to build a new refinery with a capacity of 6,200 barrels of crude oil per day with the McDermott Qatar Company of America.⁽¹²⁾ However, the construction and installation of the equipment took almost 33 months, and in September 1974⁽¹³⁾ the new refinery, of a total cost around QR 35 million, started its operations, with a designed capacity of 6,200 b/d of crude as input, while the daily output consisted of : 1,097 barrels of regular grade petrol (90 octane); 550 barrels of high octane petrol (97 octane); 580 barrels of jet aircraft fuel; 140 barrels of kerosene; 1,300 barrels of diesel and 121 barrels of LPG.⁽¹⁴⁾ The refinery's input and output have been increased several times and by 1977 the total input of the old and new refineries reached about 11,500 barrels of crude/day.⁽¹⁵⁾

In accordance with Article (6) of Law No.3 of 1972, the government transferred all its rights in NODCO to the Qatar National Petroleum Company (QNPC). By Article (6) of Law No. 10 of 1974 all QNPC's right passed to the Qatar General Petroleum Corporation

(QGPC) (see Chapter 4 pp. 84-86) and accordingly NODCO is now a wholly owned subsidiary of QGPC, with paid-up capital of QR 40 million. (16)

The location of the whole refinery complex at Umm Said resulted from several factors:

1. The old refinery owned by QPC was located in the QPC operational area (see above) and it made sense to locate the second refinery alongside.
2. Umm Said remains the onshore crude oil terminal and storage base, and refinery input could easily be supplied by pipeline from the oil tank farm.
3. Although the Umm Said area is about 40 km away from the largest urbanized area, Doha, which has the main demand for products, in world terms this cost distance is low and the plant's atmospheric and pollution effects are relatively distant from Doha.
4. The availability of land for future expansion.
5. The various support services required for the refinery were available at Umm Said because of the continuing build up of the industrial area with a concentration of public sector heavy industries.

6.1.3 Refinery Production & Consumption (1975-1980)

Table 6.2 shows the production and consumption of oil products in Qatar since the first full operational year of the new refinery. In 1975 Qatar's total consumption of oil products was 1,530 thousand barrels, of which 1,389 thousand barrels were derived from local production; that is to say, 90.8 per cent of the consumption was met locally. In 1976, '77 and '78, the proportion of the refinery's supply of the domestic market was 87.2, 86.6 and 80.5 per cent res-

Table 6.2 :

Production and Consumption of Oil Products During 1975-80

(Thousand barrels)

Year	1975		1976		1977		1978		1979		1980		% of Prod. by product
	Prod.	Cons.	Prod.	Cons.	Prod.	Cons.	Prod.	Cons.	Prod.	Cons.	Prod.	Cons.	
LPG*	22	46	45	64	64	65	72	85	77	98	88	117	5.1
Regular Grade Petrol													
Premium 90R	414	451	526	532	610	602	672	677	885	878	1,005	1,032	55.4
High Octane Petrol													
Super 97R	137	138	146	222	155	308	124	596	36	362	106	395	5.8
Kerosene	36	39	40	38	34	34	38	35	32	34	35	33	1.2
Jet Fuel	250	369	383	560	448	548	455	600	481	549	493	538	17.4
LGO *	550	555	841	856	921	1,020	908	1,027	959	1,035	1,110	1,178	39.1
Total output	1,389	1,550	1,981	2,272	2,232	2,577	2,269	2,818	2,470	2,956	2,837	3,291	100
% of Prod. Increase	-		42.6		12.7		1.7		8.9		14.9		
% of Consumption Increase		-		48.5		13.4		9.4		4.9		11.5	

LPG = Liquefied Petroleum Gas

LGO = Light Gas Oil (Diesel)

Source: National Oil Distribution Company, Annual Production Statistical Report, Qatar.

pectively. This decline was mainly due to the increase of demand by private and public means of transport, as well as other utilities, and was not due to a fall in the refineries' production rate. In order to fill the gap between production and consumption, NODCO became the main importing agency; in 1979 and 1980 NODCO imported 418 and 409 thousand barrels respectively. In addition, SCQ* had imported, in 1979 and 80, 68 and 45 thousand barrels respectively of jet fuel. The total production of the refineries between 1975 to 1980 was 13,178 thousand barrels, of which there were 5,289,000 barrels of LGO (diesel), 4,112,000 barrels of regular grade petrol and 3,777,000 barrels of other products. The total consumption of the oil products for the same period was 15,440,000 barrels, of which there were 5,649,000 barrels of LGO, 4,172,000 barrels of regular grade petrol and 5,623,000 of other products. The refineries in this sense had met 85.3 per cent of the total demand. As seen in Table 6.2 the dominant product of the refineries was diesel, whilst regular grade petrol came second and jet fuel took the third position.

6.1.4 Oil Refinery Project

The first concept of a further refinery project, with an input capacity of 150,000 barrels of crude oil per day, appeared in early 1975. ⁽¹⁷⁾ In February 1976, QGPC signed a contract with OIP Management Services Inc. to carry out a feasibility study for an oil refinery of a capacity of 50,000 barrels of crude, not of 150,000 barrels. ⁽¹⁸⁾ On 11th November 1976, the consultant produced the feasibility study for the project organizer in QGPC. On 12th November 1980, QGPC signed another contract with a French group to carry out the construction and installation of the new refinery. The

* SCQ has a contract with Doha International Airport to supply its requirements of jet fuel. SCQ buys the quantities available from NODCO and then imports the balance.

work on the site, as agreed, will take an approximate period of 33 months. ⁽¹⁹⁾ The new refinery project, according to its design, will consist of eight processing units capable of producing an aggregate of 45,872 barrels per day or 16,743,280 barrels per annum. The product will consist of premium gasoline, super gasoline, LPG, naphtha, jet fuel, kerosene auto diesel, diesel, bunker and asphalt. ⁽²⁰⁾

The location of the QR 134,700 thousand refinery ⁽²¹⁾ will also be in Umm Said, adjacent to the existing refineries.

6.1.5 Economic Evaluation

The old refinery of QPC, as mentioned earlier, was set up on political grounds, and not based on economic viability. It was agreed between the government and QPC that the price charged for the refinery products would be similar to those charged in Kuwait and Bahrain, regardless of the refinery cost of production. ⁽²²⁾ In 1957 losses incurred in meeting domestic consumption were already substantial because of:

- a. The high operational costs of the refinery
- b. The relatively high prices of imported oil products which QPC was obliged to pay, i.e. 31.4 pence for petrol, 24.9 pence for kerosene and 14.0 pence for gas oil per gallon, compared with the low permitted sales price to the state and public (as related earlier, p.143).

QPC estimated a total loss of up to £189 thousand annually. A mixture of economic and political factors can also be seen clearly in the establishing of the second oil refinery, which was set up according to requests from the public and the ruler of Qatar.

The larger capacity of the second refinery, compared to QPC's plant, reduced the operational cost of refining domestic crude. Although

the total cost to NODCO operations included the difference between the cost of imported products and its own production and the sales prices which NODCO was allowed to charge (see Table 6.4), as well as the free-of-charge distribution of oil products through the whole of the peninsula, the company apparently gained a net profit on each operational year. In 1978, for instance, NODCO had total sales of about QR 105 million. Deducting from this the total cost of running the refinery and importing products etc., about QR 75 million, gives a net trading profit of QR 30 million (see Table 6.3). In 1979, although the total sales showed an increase of 26.3 per cent over the previous year, the total costs of the company are recorded as increasing proportionately more than the increase of the total sales. This increase of total costs was mainly due to the sharp rise of imported oil products (see Table 6.3), and subsequently the net profit of 1979 declined from QR 30 million to only about QR 28 million.

Two questions which arise, here and in the context of later sections are, first, how far the reported accounts of NODCO include elements of repayment of, and return to, investment, and, secondly, what are the transfer prices paid for crude by NODCO to the oil producing state owned industries, and also received by NODCO for sales to other agencies. These questions are considered in a wider context in the Conclusion, Chapter 10.

6.2 Cement Factory

The discovery of suitable limestone and other raw materials for cement manufacturing in Qatar came as a result of the Qatar Oil Concession agreement of 1935. The first article of that agreement specifically pointed out that in the case of discovery of any mineral the company must inform the Sheikh, who reserved the right of granting

Table 6.3 : Profit & Loss Account of NODCO (in QR thousand)

Sales & Costs	1978	1979
1. <u>Total Sales</u>	<u>104,999</u>	<u>132,620</u>
2. <u>Total Costs</u>	<u>74,828</u>	<u>104,716</u>
Crude Oil	6,649	8,965
Refineries' Operational Cost	18,166	20,407
Imported Products*	33,244	58,542
Administrative Cost	6,351	8,009
Distribution Cost	7,392	8,793
Others	3,226	-
Net Profit (1 - 2)	30,171	27,904

* See details on Table 6.4 below.

Source : NODCO, General Budget of 31.12.1979, Qatar.

Table 6.4 : Price of Imported Oil Products per Gallon (in QR)

Product	Imported Price	Selling Price	NODCO Subsidies
LPG (a)	1,724.5696	150.00	1,574.5696
Premium (90 R)	5.1983	0.875	4.3233
Super (97 R)	5.4555	1.3949	4.0606
Jet Fuel	5.5161	5.5588	(0.0427)
LGO	5,2155	0.6045 ^(b)	4,6110
		5.000 ^(c)	0.2155

(a) per metric ton

(b) to the Public

(c) to QGPC for Halul Island

Source : NODCO, Price of Imported Oil Products per Gallon, Financial Affairs Department, Qatar.

concessions for the extracting of such minerals discovered by any company or companies (see Appendix 5.1 Article 1).

First thought was given to a cement project in 1957, when P.C. Stevenson of Le Grand Adesco studied raw materials for cement manufacture in Qatar. This study was followed by a survey report carried out by KRUPP in 1963. (23)

In October 1965, the Qatar National Cement Company (QNCC) was formed as a jointly owned share-holding between Qatari private investors and the Government. (24) QNCC's main object was to establish a cement-making factory, as well as marketing the cement in Qatar and abroad. The initial capital was 35 million India Rupees in 1965, distributed over 350,000 shares of 100 rupees per share. The funders of QNCC were the government of Qatar with 105,000 shares, the government of Dubai with 35,000 shares and 18 Qatari businessmen and companies with 1,000 shares each. (25) The remaining 192,000 shares were to be sold in the market, of which only 162,504 shares were purchased. (26)

In 1965, QNCC appointed Henry Pooley(Consulting Engineer - UK) as the overall consultants for the project. Since large quantities of limestone and clay were accessible at several sites, a location choice was possible either at Umm Salal, about 17 km. to the north of Doha, or at Umm Bab, about 75 km. to the west of the capital. The then Deputy Ruler (the present ruler) decided that in order to encourage the development of the western region, the factory should be built at Umm Bab. (27) Work on the site began in 1967, (28) the main cement plant contractor being Franco Tosi of Italy, while Siemens of Italy were awarded the contract to supply and instal electrical equipment. Al-attiyah Trading & Constructing Company of Qatar was appointed as the main contractor of civil engineering works. (29)

In 1968 the government and QNCC signed a special agreement with QPC to supply the factory with natural gas. The three parties agreed that the supply of natural gas would not exceed five million cubic feet per day, the delivery point being at Jaleha gas separation station, to the south of the Dukhan oil field. ⁽³⁰⁾ A local company's engineering department, Kassem Abdullah Sons of Darwish Fakhroo started the erection of equipment and pipe lines. The government agreed to supply the plant with fairly fresh water from the governmental water well field at Rawdat Rashid, about 40 km. to the east of Umm Bab. The main contract for installing water equipment and pipelines was awarded to Tawfeeq Trading & Contracting Company of Qatar. ⁽³¹⁾

The construction and installation of equipment took two years and by April 1969 the factory started the first processing of cement, and the official inauguration of the plant took place in May. ⁽³²⁾ The designed capacity of the factory in 1969 was 100,000 tonnes of Portland cement per annum.

- The establishment of the cement factory was made possible by
- a) The large quantities of limestone at the surface, of quality approved by QPC's geologists, as well as others, and the possibility of quarrying near to the factory;
 - b) The availability of clay near the north edge of Wadi Huwaila at a distance of 20 km. to the south of the factory;
 - c) The availability of energy in the form of natural gas from nearby Dukhan to operate the factory;
 - d) The availability of free water supply from Radhat Rashid.
 - e) Other raw materials such as gypsum and iron oxide were originally planned to be imported no great distance from Saudi Arabia under tender agreements. However, in 1970,

QNCC started quarrying gypsum at a formation less than 40 km. distant and south of Umm Bab in an area called An-Nafkah. The iron oxide is now purchased from QASCO.

In accordance with the Basic Statute of QNCC, the first Board of Directors of the Company chosen in 1965 consisted of nine members, two of them representing the government of Qatar (one of them is the Chairman), one representing the government of Dubai, while the other six were drawn from other founding participants. By 1979 most of the names and statutes of the First Board remained unchanged including the Chairman, with the exception of the Dubai representative who ceased being on the Board of QNCC in 1972. ⁽³³⁾ In March 1980, the Amir passed an Amiri Resolution No. (6) of 1980 indicating the re-formation of the Board of Directors of QNCC. This reduced the members to eight, increasing governmental representation to four and reducing private representatives to only four. ⁽³⁴⁾

6.2.1 Labour Force

Table 6.5 below shows the labour force of QNCC from 1969 to the end of 1981, by nationality and QNCC's divisions. In 1969 the total labour force was 275 employees, of which 148 were Qataris, 53.8 per cent out of the total. Within one year, 1970, the total Qatari figure showed the first indication of decrease, and from that time on became a declining minority. Between 1970 to the end of 1981 the trends in the labour force were as follows

- a. Qatari unskilled labour declined from 49 in 1970 to 2 in 1974, an average decline of 46.1 per cent per annum, whilst the unskilled non-Qataris increased by 9.3 per cent per annum during 1970-81.

- b. Qatari semi-skilled labour declined from 43 to only 8 employees, whilst non-Qataris more than doubled from 60 to 123.
- c. Although the skilled Qataris decreased from 41 to 19 employees this was a slower average trend than that of the semi-skilled. The non-Qatari skilled division, on the other hand, similar to the semi-skilled category increased greatly and at a much higher average rate.

Table 6.5 : QNCC's Labour Force by Nationality & Division (1969-81)

Year	Engineering & Administrative		Skilled		Semi-Skilled		Unskilled		Total		Grand Total	% of Qataris
	Non Qat.	Qat.	N.Q.	Q.	N.Q.	Q.	N.Q.	Q.	N.Q.	Q.		
1969									127	148	275	53.8
1970	7	2	48	41	60	48	33	49	148	140	288	48.6
1971	7	2	45	42	62	44	96	14	210	102	312	32.7
1972	10	2	50	42	70	35	101	10	231	89	320	27.8
1973	10	2	50	42	52	35	37	15	199	94	293	32.1
1974	13	2	92	36	130	8	105	2	340	48	388	12.4
1975	13	2	90	34	129	8	102	2	334	46	380	12.1
1976	16	2	99	30	131	6	100	2	346	40	386	10.4
1977	18	2	157	23	113	10	106	2	394	37	431	8.6
1978	18	2	133	22	121	8	100	2	371	34	405	8.4
1979	19	1	201	16	120	8	106	2	446	27	473	5.7
1980	17	1	220	18	128	8	99	2	464	29	493	5.9
1981	17	1	221	19	123	8	102	2	463	30	493	6.1

Source : Data obtained by the author from Company Records.

A common feature throughout QNCC's labour force during the 1970-1981 period was, then, a decline in the number of Qatari and the increase in non-Qatari employees. The reasons for this trend were

- a. The relatively long distance between the plant and Doha City where most of the Qataris preferred to live and work.
- b. The majority of the QNCC's employees came originally from either India or Pakistan (at the end of 1981 there were 269 Indians, 146 Pakistanis, 30 Qataris and 17 others). (35)

Non-Qatari workers' employment depends on their preparedness to accept the conditions offered and the requirement for them to stay with their sponsors otherwise they have to leave the country.

6.2.2 Production & Consumption

Production at the QNCC plant started officially in May 1969, and in the same month some supplies reached the domestic market. Unfortunately, the cement import figures for 1970 and earlier were not officially recorded, but it is believed that Qatari market consumption was around 70,000 tons a year when the plant began operation. (36)

In 1969 production was 41,140 tonnes of Portland cement only. During seven months of operation the company achieved 41.1 per cent of the total annual capacity and supplied about 50 per cent of the local consumption. (37) In 1970, the first full year of operation of QNCC's factory, production jumped to 80,256 tonnes or about 90.3 per cent of the total capacity. It is worth mentioning here that the factory was designed only to produce Portland cement, but the need for salt resistant cement for construction work on industrial complexes in Umm Said led to plant modifications so as also to produce salt resistant cement. The yearly bulletin of imports for 1970 indicated that there

were no imports of Portland or salt resistant cement during 1970.⁽³⁸⁾ In 1972 production reached 105.8 per cent of design capacity, an increase of 54.8 per cent and a decrease of 59.2 per cent in Portland and salt resistant respectively over 1971. Because of the continued rapid growth in demand, QNCC took over the import operations from 1971 to make up the balance, thus becoming the central supplier and not only a manufacturer.⁽³⁹⁾ In 1974 the government, through the "Supply Department" of the Ministry of Economy and Commerce, took over the cement importation operation. But in 1977, and due to the large demand and short domestic supply of Portland cement, the government lifted the ban on private importation and allowed the private sector to carry out part of the importation of cement but without any government subsidy. In 1980 all of the imported quantities were supplied through the private sector. In 1974, although the production increased, it represented only 55 per cent of the total capacity of 115,000 tonnes per annum. In 1975, however, the company faced serious problems which caused planned production to run behind schedule: (a) the failure of the second furnace, (b) shortage of water supply, and (c) disruption caused by maintenance work on the first furnace and the rebuilding of the heat-resistant bricks. In addition, dislocation was caused by the changing of production from Portland to salt resistant cement.

In 1976, after the starting of the third furnace in September, production of the two products increased to 177,794 tonnes. That is to say, 70.1 per cent of the total design capacity. (see Table 6.6).

In 1975/76, the Amir had established two committees, one for importing cement, the other to supervise the sales and distribution of cement locally. Both of the committees failed in their operations and were abrogated.⁽⁴⁰⁾ During 1977-78 the production of cement was limited by a design failure in the third furnace at a time when the production of

Table 6.6 : Production & Consumption of Portland & Salt Resistant Cement (1969-1980)
(Figures in Tonnes)

Year	Production			% of increase (decrease) in Production	% of Prod. to the capacity	Consumption			% of increase (decrease) in Consumption	% of Prod. to Consumption
	Portland	Salt Resistant	Total			Portland	Salt Resistant	Total		
1969 ^(a)	41,140	-	41,140	-	41.1	-	-	-		
1970	80,256	18,684	98,940	140.5	98.9	80,256	18,684	98,940		
1971	64,336	15,260	79,596	(19.6)	79.6	98,336	15,260	113,596	14.8	70.1
1972	99,585	6,228	105,813	32.9	105.8	136,585	6,228	142,813	25.7	74.1
1973	85,059	14,083	99,142	(6.3)	99.1	142,479	14,083	156,562	9.6	63.3
1974	100,786	17,424	118,210	19.2	66 ^(b)	153,961	17,424	171,385	9.5	69.0
1975	111,858	36,550	148,408	25.6	69	188,978	36,550	225,528	31.6	65.8
1976	147,572	30,222	177,794	19.8	70.1 ^(c)	325,366	61,813	387,179	71.4	46.0
1977	118,448	58,865	177,313	(0.3)	53.7	323,667	120,743	444,410	14.9	39.9
1978	130,399	77,799	208,198	17.4	63.1	354,337	104,799	459,136	3.3	45.3
1979	181,454	68,608	250,062	20.1	75.8	283,447	84,758	368,205	(19.8)	67.9
1980	151,524	58,418	209,942	(16.0)	62.9	297,242	87,116	384,358	4.4	54.6
Grand Total	1,312,417	402,141	1,714,558			2,425,794	567,458	2,993,252		57.3

(a) Production started in May 1969 of 100,000 tonnes per annum capacity

(b) Second furnace started in April of capacity 115,000 tonnes per annum

(c) Third furnace started in September of capacity 115,000 tonnes per annum

() Not available

Source: QNCC, Annual Reports (1969-80) Qatar.

the first and second furnaces was given over mainly to salt-resistant cement for supplying construction work of industrial projects, and by a shortage of raw material crushers for providing inputs to the three furnaces.⁽⁴¹⁾ In 1979 the production reached its peak at 250 thousand tonnes, of which about 69 thousand tonnes was of salt resistant cement. Total local consumption of cement that year was 368,205 tonnes, only 67.9 per cent of which was met locally. In 1980 the total production was 207,712 tonnes, a decline of about 17 per cent over 1979. Total consumption did not increase significantly because of the completion of construction works of several industrial projects in Umm Said, and the slow down in the house building sector.

During the whole period of operations up to the end of 1980, QNCC succeeded in supplying the domestic market with 54.1 per cent of its demand for Portland cement and by 70.9 per cent of salt resistant cement. The achievement could have been much greater if the plant had ever worked at its full capacity, ultimately 330,000 tonnes per annum.

6.2.3 Quick Lime

The other product of QNCC, not included in Table 6.6, is quick lime. In mid 1976 the Amir instructed QNCC to produce quick lime for Qatar Steel Company (QASCO). A joint committee was organized between QASCO and IDTC and by the end of 1976 the committee had appointed Henry Booly as the main consultant, Neweil Danvoud of the U.K. to import, construct, instal and operate the quick lime furnace, and Al-Rabban Contracting & Trading Company of Qatar was awarded the civil engineering contract.⁽⁴²⁾ The total cost of this furnace was estimated to be at a cost of about QR 26 million,⁽⁴³⁾ with a design capacity of 30,000 tons of quick lime. Work was scheduled for completion in November 1977, but for various reasons was not finished until April 1979.

The 1979 production was 13,627 tons rising in 1980 to 18,583 tons, a 36.4 per cent increase over the 1979's figure. In 1981 production was about 21 thousand tons. The main consumer of quick lime is QASCO which utilizes the lime to process steel bars.

In the first instance, when QNCC in the middle seventies was meeting a considerable proportion of Qatar's total demand, the sale price was fixed by the Qatar government. The gap between total demand and domestic supply, as noted earlier, which appeared in 1977 led first to the raising of the sale price for QNCC cement, from QR8 to QR12 (subsequent rises have lifted this to QR14 per 50 kg. bag). Where, however, the private sector has imported cement, in order to make some profit margin, then prices have been generally more than three times as large as prices for locally produced cement. The government, for several purposes, subsidised the difference between the retail price of imported cement and the QNCC supported level. This and other questions of government intervention are considered in more general contexts in the Conclusion.

6.2.4 Economic Evaluation

Table 6.7 below shows the profit and loss account of QNCC during 1977-80. The account shows clearly that although the factory did not reach its full capacity during these years, the company succeeded in achieving a net profit in each individual year. In 1977, for instance, the total sales was QR 40,650.3 thousand; that is to say, about QR 229.3 per one ton. Deduction from that amount of QR 29,004.5 thousand for production, sales, administrative and other costs (QR 163.6 cost per single ton), will give a total trade profit of QR 11,645.8 thousand. Adding QR 664,300 of other income, will give a total net profit of QR 13,310.6 thousand in 1977. In 1978 the total net profit increased

by 94.5 per cent, while 1979's net profit grew a further 51.1 per cent over 1978. In 1980 the total net profit fell by 16.2 per cent out of the 1979 total net profit. This is explained by the decline of total sales figures by QR 7,928.47 thousand from the 1979 total sales; and the increase in various costs by QR 1,194.62 thousand.

Table 6.7 : Profit & Loss Account of QNCC (1977-1980) (In thousand QR)

Sales & Costs	1977	1978	1979	1980
Total Sales	40,650.3	55,747.07	70,670.74	62,742.27*
Production & Sales Costs	27,896.7	31,833.34	34,935.59	35,940.85
Total Profit	12,753.6	23,913.73	35,735.15	26,801.42
Administrative & Other Costs	1,107.8	1,666.74	2,246.55	2,435.37
Total Trade Profit	11,645.8	22,246.99	33,488.60	24,365.55
Other Income **	664.8	1,696.96	2,696.45	5,968.54
Net Profit (Loss)	12,310.6	23,943.96	36,185.05	30,334.09

* Revised

** Other income = interest, differentiation in stocks and others.

Source : QNCC, Annual Reports (31.12.1977-31.12.1980) Qatar.

6.3 Fishing Industry

The fishing industry is potentially an important sector because it is almost the only part of Qatar's industry which is completely unrelated to the oil and natural gas and therefore has prospects for the future. There is a possibility of establishing various industries depending on fish as the primary input, such as fish canning, animal fodder or oil hydrogenation, as well as supplying an important food in the Gulf area.

There are, in Qatar, two types of fishery, one of them the traditional which is not the concern of this study. Mainly because wooden traditional vessels make little demand on modern equipment and manufactures, traditional operations is a catching more than a processing activity, and all caught fish is marketed fresh. The other type of fishing industry, which is the concern of this study, is the processing and quick-freezing of fish. This activity is carried out only by the Qatar National Fishing Company (QNFC).

6.3.1 Qatar National Fishing Company (QNFC)

Arthur D. Little Inc. of U.S. studied Qatar's prospects for fisheries development in 1961/62. The main conclusion of that study was as follows: (44)

"To facilitate the training of local personnel, to ensure outlets to foreign markets and to obtain modern technical and managerial "know-how", the government of Qatar should licence one or more soundly established foreign fishing companies to participate in a fish processing plant in Qatar."

In 1966 the Qatar National Fishing Company was established in terms of Decree No. (9) of 1966, as a joint stock company with a capital of 4 million rupees, distributed in 4 thousand ordinary shares. The government contributed 60 per cent of the total capital while Ross Group International made up the balance. On the signature date, 16th May 1966, the government and Ross paid only 25 per cent of their share, the remainder payable within five years. (45) In January 1967 the appointed Board of Directors of QNFC* signed a fishing concession with the government. The concession, ending in 1982, covers the entire territorial sea water of Qatar. (46) In February 1967, the government by using its right as specified in Article (8) of the QNFC's

* QNFC's Board of Directors consist of seven members, four of them were appointed by the government, while the other three were appointed by Ross Group.

Fundamental Status,⁽⁴⁷⁾ offered the remaining 75 per cent of its shares (18,000 shares) to the Qatari public.

During 1967 and the first months of 1968, the company was engaged in building the plants and related works. At the end of February the company started operation with three Jordanian made steel boats of 35 ft in length, and a quick-freezing plant capable of handling six to seven tons per day.⁽⁴⁸⁾

After nearly thirteen years of operations, the government took over QNFC in 1980. This action came as a result of the drop in the rate of shrimp catching, especially in 1978 and early 1979. In June 1980, the Council of Ministers agreed, in principle, to establish a new fishing company with a governmental capital of QR 10 million.⁽⁴⁹⁾ In September 1980, an Amiri Resolution No. (17) of 1980 was promulgated, appointing the Board of Directors of QNFC.⁽⁵⁰⁾ The new QNFC has three steel boats, one of them, Gazelle, a governmental fishing boat of 110 feet long, bought in 1975 from Holland, the other two inherited from the earlier company. The new QNFC now operates both in shrimp and fish catching. Unfortunately there is no data available concerning the QNFC's employment, except the Economic Survey of Qatar Jan/Feb 1971, carried out by MEDD of M.O.D. when the report classified the work force of QNFC as⁽⁵¹⁾

1. Fishermen on QNFC boats	40
2. Shore based employees of QNFC	59
	<hr/>
Total	99

6.3.2 Production

In 1970, as shown in Table 6.8 below, the production of shrimps was 374 tons, about 1.03 tons per day. Production increased rapidly till the end of 1973, when it reached a 560 ton peak. During 1974

Table 6.8 : Headless Shrimp Production of QNFC (1970-1978) * (in tons)

Year	1970	1971	1972	1973	1974	1975	1976	1977	1978
Total Production	374	391	465	560	422	323	520	572	300
% of increase (Decrease)	-	4.5	18.9	20.9	(24.6)	(23.5)	61	10	(47.6)

* The first statistical data available was in 1970 and the last production year was 1978.

Source : Ministry of Economy & Commerce, An Economic Survey of Qatar (1969-1978), Qatar.

and 75 production declined by 24.6 and 42.3 per cent respectively from the 1973 production, a drop in production rate mainly due to the exhaustion of shrimp reserves in the Gulf area in general and in Qatar's territorial waters specifically. Production, however, increased in 1976 to a second peak of total production of 572 tons. In 1978, once again, production declined to a figure even less than that of 1970 and again mainly as the result of declining stocks. This decline was caused by the increase in industrial projects in Qatar and other Gulf States, which caused pollution and the effect on marine conditions of proliferating water distillation plants. The unscientific catching operations, which did not distinguish between small and large species, had a destructive biological effect, whilst the company, dependent on only one kind of product, was not geared to carefully balanced marine exploitation. The government purchased all the company assets from Ross and the Qatari and company production records only extend to the end of 1978.

The local consumption of QNFC products during 1968 and 1978 was insignificant and virtually all the quantities were exported to U.S.A., Japan and Europe. (52)

6.3.3 Economic Evaluation of QNFC

Table 6.9 shows the profit & loss accounts of QNFC between mid 1970 to the beginning of 1976. The company's operation between mid 70 to mid 71 achieved a total sales value of about QR 2,740 thousand, but the company nevertheless registered a net loss of QR 63,635. In the next financial year the situation improved a little by achieving a total net profit of QR 426,870. The achievement continued in the next financial year which ended in mid 1973. In the financial periods up to 29.2.1976 a net profit was recorded but the annual level declined and the return on capital was low and falling. The company, according to government publications succeeded by the end of February 1978 in gaining a net book profit of QR 1,768,538. (53)

Table 6.9 : Profit & Loss Accounts of QNFC 1971 - 1976 (In QRs)

Sales & Costs	30.6.70 to 30.6.71	To 30.6.72	To 30.6.73	To 28.2.75	To 29.2.76
1. Total sales & Other income	2,739,890	3,675,343	5,008,062	8,621,342	5,010,618
2. Total Costs *	2,749,369	3,194,317	3,786,216	7,678,660	4,964,572
Trade Profit (Losses)	(9,479)	481,026	1,221,845	942,682	46,046
Amortisation of formation and pre- trading expenses	54,156	54,156	36,105	36,105	-
Net Profit (Losses)	(63,635)	426,870	1,185,740	906,577	46,046

* Proposed Directors' attendance fees are not included.

Source : QNFC, Annual Report and Accounts (1971-1976) Qatar.

6.4 Flour Mills

First thought was given to establish a fully mechanized flour mill in Qatar in 1967, following a flour scare which made many Qataris fearful of taking any kind of freshly cooked bread. This situation arose as the result of shipping at least one consignment of flour sacks alongside a highly poisonous pesticide. (54)

At a very early stage some local businessmen contacted their colleagues in Kuwait to find out to what extent Kuwaiti experience in the flour milling field had succeeded.* (55) After two years of close examination the Qatari businessmen were satisfied and on 26th June 1969, nineteen of them signed the foundation document of the Qatar Flour Mill Company (QFMC). On 29th June 1969 the Amir promulgated a Decree of Law No (45) of 1969 permitting the nineteen businessmen to establish a joint stock company with an initial capital of QR 5 million. The main objective of QFMC, as specified in Decree No.(12) of 1969 and the fundamental statutes, is to import flour and wheat grain and pulverise the grain. In addition to that, Article (5) of Decree Law No (12) of 1969 requires the company to hold certain reserves of flour and grain, the reserves to be defined by a resolution from the Minister of Finance. (56)

In 1969 the Deputy Ruler appointed Mr. Ahmad Al-Subaisi to allocate a suitable site for QFMC's plant, the company also appointing its Chairman to help in this mission. After analysing all aspects the government recommended that the location should be in Umm Said, attached to QAFCO. The Chairman was not happy, so a special committee was set up to investigate. It found that because the dominant wind was northerly, and the site selected lay to the north of QAFCO, there

* Kuwait Flour Mill started production in 1967.

was no way that the wheat flour and grain could be polluted by chemical fertilizer. The then Deputy Ruler agreed on the site. (57)

In 1970, the Board of Directors* appointed Gibb-Ewbank of U.K. to design the plant, Darwish Engineering Company of Qatar was awarded the civil engineering contract, the mechanical and electrical installation contract awarded to Power-Gas and George Taylor of the U.K., under the supervision of Thomas Ropension, the equipment importer. (58)

In September 1972 all the construction and installation of the equipment was complete (59) and in November of the same year the plant started operation with a daily capacity of 50 tons. (60) There are, attached to the plant, six silos of a total capacity of 8,000 tons, while the electricity and water supply was met from QAFCO. (61) The imported grain would be transferred to the silos through QAFCO's jetty, all for a cost of just over QR 11.4 million. (62) The government supplied the company with QR 6,962,692 as a loan. (63) In return, a government representative was appointed to the Board of Directors partly to monitor the proper use of the government loan. (64)

After only one full year's operation, the Board of Directors discussed and agreed on a major expansion of the existing plant. This matter was still under study both by the government and the company in mid 1982 because of the difficulties of expanding the plant on the present location surrounded by QAFCO on the south and QAPCO on the north. But during 1977/78 an interim expansion was carried out by the government by which an additional six silos of a total capacity of 8,700 tons were built, the company at the same time installing another production stream, which gave the factory a total operating capacity of 100 tons. (65)

* The Board of Directors consists of nine members and the first Board of Directors was appointed by the founders in 1969.

6.4.1 Manpower

In 1973, as shown in Table 6.10, the company recruitment totalled 52, of which there were two English and six non Qatari Arab senior staff. The Qatari employees formed the single largest nationality group, 48.1 per cent out of the 1973 total. In 1974 the Qatari percentage declined to 39 per cent while the non-Arab nationalities' percentage increased from 28.9 in 1973 to 42.4 per cent in 1974. Since then the number and proportion of Qataris employed by QFMC has been decreasing while other nationalities, especially Egyptian, Indians and Pakistanis increased rapidly.⁽⁶⁶⁾ In 1980 the total labour force of QFMC consisted of 35 Egyptians, three of them senior staff, 30 Indians, one of them senior staff, 12 Pakistanis, one of them senior staff, 8 Palestinians, three of them senior staff, 9 of other nationality and only two intermediate Qatari staff. The reasons behind the decline of Qataris employed in QFMC are believed to be : a) the location of the plant in the Umm Said area and b) the working conditions in industry in general which were regarded by Qataris as relatively unfavourable, given the great rise in governmental demand for Qataris in non-industrial employment. The latter process is also reflected in the falling numbers of Qataris attending technical schools (see Chapters 3 and 9).

Table 6.10 : Manpower of QFMC by Nationality and Division (1973-80)

Year	Senior Staff				Intermediate Staff				Grand Total
	Qat- aris	Arabs	Non- Arabs	Total	Q	A	N-A	T	
1973	-	-	2	2	25	10	15	50	52
1974	-	-	2	2	23	9	25	57	59
1975	-	-	3	3	15	10	30	61	64
1976	-	2	2	4	7	21	37	65	69
1977	-	2	1	3	4	33	32	69	72
1978	-	2	1	3	5	36	33	74	77
1979	-	2	1	3	5	37	40	82	85
1980	-	6	2	8	2	40	46	88	96

Source : QFMC, Statistics of Manpower 1973-80, Qatar 1982.

6.4.2 Production and Consumption

In Table 6.11 we see that following the start of operations in 1972, in 1973 production reached a total output of flour of 10,477 tons. This was a rate of 63.5 of capacity and represented 95.2 per cent out of 11,001 tons consumed domestically in 1973. A distinction in this respect should be made between flour production, which is the principal product of QFMC, and wheat bran which is a by-product of milling. In 1974 production consumption increased by 12.2 and 8.3 per cent respectively, raising QFMC's share of the domestic market supply by 3.5 per cent. In 1976 the company achieved the highest proportion of production to capacity, 94.6 per cent.

During 1977 and 78, due to the installation of additional silos and work on the new production stream installation, the production of flour declined but in 1979 production increased by 42.8 per cent over

Table 6.11 : QFMC's Production & Total Consumption of Flour and Bran in Qatar (1972-80) (in Tons)

Year	Imported Grain	Wheat Flour			% of increase in production	% of production to capacity(1)	Wheat Bran **	Total Flour Consumption	% of Prod- to consumption	Total Bran Consumption	% of Prod. to Consumption
		Ni. 1	No.2	Total							
1972*	7,063	?	?	692	-	25.1	150	9,894	7.0	1,465	10.2
1973	11,175	5,714	4,763	10,477	+1414.0	63.5	2,228	11,001	95.2	4,761	46.8
1974	16,169	6,946	4,808	11,754	+ 12.2	71.2	2,422	11,913	98.7	6,599	36.7
1975	16,070	8,881	4,821	13,702	+ 16.6	83.0	3,327	13,750	99.7	4,095	81.5
1976	17,163	11,140	4,462	15,602	+ 13.9	94.6	3,485	15,745	99.1	5,897	59.1
1977	16,190	12,592	2,985	15,577	- 0.2	94.4	4,242	15,689	99.3	4,788	88.6
1978	23,416	11,614	2,246	13,860	- 11.0	84.0	3,972	16,184	85.6	8,700	46.7
1979 ⁽²⁾	36,786	16,210	3,583	19,793	+ 42.8	60.0	4,981	19,801	99.96	10,585	47.1
1980	25,200	16,755	4,619	21,374	+ 8.0	64.8	5,548	21,508	99.4	31,057	17.7
Grand Total	169,232	89,852	32,287	122,139			30,205	125,591	97.3	76,482	39.5

* Production started in November 1972

(1) Capacity is based on 330 days per annum

(2) Doubling the capacity to 100 ton/day or 33,000 tons/annum

** 28% of flour 1 and 18% of flour 2

Source: QFMC, Production and Total Consumption of Flour and Bran (1972-80) Qatar 1982.

that in 1978, and met all the domestic demand for flour. In 1980 production was 21,374 tons; that is to say 64.8 per cent of the total capacity of the plant.

The cumulative production of flour from 1973-80 (excluding 1972) was 122,139 tons, whilst the consumption was 125,591 tons; that is to say about 97.3 per cent of demand was met locally. The consumption of bran, on the other hand, was 76,482 tons, of which only 30,205 tons was produced locally.

6.4.3 Economic Evaluations

Table 6.12 below shows the sales value of flour and bran either produced locally or imported; Table 6.13 shows the sales and production cost per ton. In 1973 the company succeeded in achieving a trade profit of QR 112.01 per ton produced.

Table 6.12 : Sales Values of Flour & Bran and CIF Values of Imported Products
(in QR ,000)

Year	Wheat Flour (a)			Wheat (a) Bran	Imported (b) Flour	Imported (b) Bran
	No.1	No.2	Total			
1973	4,806	3,584	8,390	676	524	731
1974	6,390	3,943	10,333	969	226	1,642
1975	8,194	3,953	12,147	1,331	141	735
1976	10,249	3,659	13,908	1,394	331	1,973
1977	10,673	2,288	12,961	1,700	438	309
1978	8,362	1,393	9,755	1,589	2,554	2,970
1979	11,671	2,212	13,883	1,992	72	5,492
1980	12,063	2,864	14,927	2,746	414	18,154
Grand Total	72,408	23,896	96,304	12,397	4,700	32,006

Sources: (a) QFMC, Report on Sales Operation 1973-80 Qatar 1981.

(b) Ministry of Finance & Petroleum, Yearly Bulletin for Imports, Exports and Transit (1973-80) Qatar.

Table 6.13 : Production Costs and Sales/ton (in QR)

Costs & Sales	1973	1974	1975	1976	1977	1978	1979	1980
1.Sales Values	713.53	797.24	791.45	801.67	739.71	636.14	641.20	656.45
2.Prod. Costs	601.52	622.90	679.00	734.50	598.25	1,012.06	927.39	1,097.69
(1-2) Profit (Losses) per ton	112.01	174.34	112.45	67.12	141.46	(375.92)	(286.19)	(441.24)

Source : QFMC Special Reports, Qatar, 1981.

In 1974 the total sales value was QR 11,301,696, whilst the production cost was QR 8,330,257. During 1975/76 the company's trade profit decreased by 22.5 and 48.1 per cent respectively from 1974. In 1977 the trade profit was QR 2,804 thousand while the net profit was QR 3,888 thousand. ⁽⁶⁷⁾ From 1978 onward the company faced a real loss in its trade profit figure. In 1978, for instance, QFMC had a trade loss of QR 5,703 thousand, QR 7,090 thousand in 1978, rising in 1980 to QR 11,879 thousand. The losses in trade came as a result of the government's determination to control QFMC's final product pricing. Flour grades 1, 2 and bran sales prices during 1974-76 were QR 0.92, 0.82 and 0.4 per kg. respectively. From 1978 onward the government reduced the flour prices further to QR 0.72 and 0.62 per kg. The government, in this respect, subsidised the company by the difference between the sale prices and production costs. ⁽⁶⁸⁾ In 1978 the government records show that the company made a net profit of QR 2,168 thousand. ⁽⁶⁹⁾ In 1980, and due to governmental backing of QR 16,478, 638, the company made a total net profit of QR 3,921 thousand. ⁽⁷⁰⁾

This last point, which is examined later in the general context of government policy, illustrates one of the features which characterises parts of the industrial economy of Qatar, namely the question of how the viability of industrial enterprises is affected by government financial intervention, in this case in a privately capitalised business.

6.5 Chemical Fertilizer

The discovery of crude oil in 1939 and its exploitation from 1949 not only supplied the country with oil and export revenue, but also with natural gas. The government's first movement towards heavy industries therefore was to establish industries depending mainly on natural gas as a primary input

In the early 1960's, the government was busily engaged in studying several projects, such as chemical fertilizer, petrochemical and others, mainly in order to stop the flaring-off wastage of natural gas.⁽⁷¹⁾ Unfortunately, these projects were "frozen" for several years, due, not to caution in entering the "industrial era", but mainly because oil revenue did not increase as quickly as the government expected. This, of itself, affected the whole economic situation, especially between 1961-1965.⁽⁷²⁾ In early 1967, and thanks to offshore oil field development, the government decided to carry out some of its plans for economic diversification. In December 1967 the Minister of Finance, Sheikh Khalifa al-Thani (the present ruler), instructed Gibb-Ewbank Industrial Consultants of London to carry out a feasibility study concerning an establishment of a Nitrogenous Fertilizer Plant in Qatar, as the first big industrial project. By April 1968 the feasibility study had been prepared and submitted to the government of Qatar.⁽⁷³⁾ The general conclusion of the feasibility study was that

the establishment of a chemical fertilizer plant in Qatar was feasible. This was based mainly on the availability of sufficient quantities of associated natural gas produced at the Dukhan Oil Field, the low material handling costs, and the large and growing world demand for fertilizers, especially within the developing countries.⁽⁷⁴⁾ The Gibb-Ewbank team studied two types of plant:⁽⁷⁵⁾

	Ammonia Capacity	Urea Capacity	Surplus Ammonia	Overall Capital cost
Case A	650	1,000	70	42 million
Case B	900	1,000	320	46 "

In addition, the team also recommended that an international sales organisation with world-wide experience should be set up in order to deal with marketing.

The involvement of foreign companies or bodies in the fertilizer plant project was welcomed by the government, mainly due to:

- 1) The shortage of management know-how in Qatar and the rest of the Gulf;
- 2) The shortage of Qatari skilled labour and supervisors;
- 3) Knowledge of, and the technology in this type of industry was not familiar to the state and its people;
- 4) The absence of international marketing experience in Qatar.

Thus, the first step of establishing the Qatar Fertilizer Company (QAFCO) was made on 29th June 1969 by passing Resolution No. (3) of 1969, permitting the involvement of Norsk Hydro of Norway, Davy Powergas Corp. Ltd. and Hambros Bank, both of U.K., as equity shareholders in QAFCO. On the same day the resolution was supported by an Amiri Decree No. (44) of 1969,

In the first instance, Qatar, from its own revenue, paid for the physical infrastructure, this cost to be discounted over 40 years

and met by a rental charge paid by QAFCO. Secondly, the cost of the plant was met by raising money on the international market, backed by equity share allocation. The equity share capital of QAFCO was QR 56.7 million and divided as follows:

State of Qatar	63%
Norsk Hydro	20%
Davy Powergas Corp.	7%
Hambros Bank	10%
	<hr/>
	100%
	<hr/>

In June 1969, QAFCO signed an agreement with Norsk Hydro, whereby Norsk Hydro undertook to provide staff and supervisors for managing the company, operating the plant and marketing QAFCO's output (ammonia and urea) through their world-wide sales organisation. Gibb-Ewbank was appointed as engineering consultant for the project, while Davy Powergas was awarded the main contract for the plant. Furthermore, Hambros Bank, acting on behalf of six English banks, was appointed to arrange the loan for financing the project.⁽⁷⁶⁾ The government, besides providing and holding 63 per cent of the equity, was to provide infrastructural facilities necessary for the project, such as site preparation, access road, a jetty, conveyors and loading equipment, gas gathering facilities at the Dukhan area, pipeline systems from Dukhan to Umm Said (about 80 km), housing etc.

The plant's location at Umm Said was selected and recommended by the consultant team of Gibb-Ewbank. Their recommendation was based on the following:

- 1) The QPC marine terminal is served by deep water close to the shore, whereas other possible locations lay in shallow water;

- 2) The location at Umm Said is less than 50 km. from Doha City where labour is concentrated.
- 3) Unlimited room for future expansion of the plant.

The then deputy ruler and Minister of Finance supported this recommendation by his agreement.

The work on site started at the end of 1970 and by the end of 1973, all construction and installation of equipment was complete. The factory was designed to work at a daily capacity rate of 900 tonnes of ammonia, two-thirds of which was to be used to give a daily capacity of 1,000 tonnes of urea. In addition, the plant was designed to be self-supporting in many ways, for instance, with two desalination plants with a total capacity of 2,545.5 cubic metres per day, three gas turbine generators with a total capacity of 30 MW, two sea water pumping stations with a total capacity of 625.3 cu. m. per minute, and a nitrogen manufacturing plant with a capacity of 1,000 cu. m. per hour. ⁽⁷⁷⁾ The electricity and desalination plants were also phased in with other general and industry-specific production units to ensure continuity and balance of supply overall.

The direct total investment by the company was around QR 200 million, while government investment on all infrastructure was in the range of QR 60-80 million, ⁽⁷⁸⁾ a total investment of QR 272 million. ⁽⁷⁹⁾

In accordance with Article (4) of Amiri Decree No. (10) of 1974, the government's share in QAFCO reverted to QGPC. The control of the company is vested in a ten member Board of Directors. As the company has developed and expanded, as noted below, the effective representation has become dominated by the State of Qatar through the Chairman and five other directors (four actually appointed) from QGPC and other ministries. Two seats are held by Norsk Hydro and

the others by Davy and Hambros. This reflects changes in equity holding which now gives Qatar 70%, Norsk 25%, Davy 3% and Hambros 2%.

In December 1974, the Board of Directors decided to expand capacity by building a second fertilizer plant of the same capacity as the first. ⁽⁸⁰⁾ The decision was supported fairly quickly and by June 1975 the construction work of QAFCO II started with the co-operation of Norsk Hydro as coordinating engineer, Davy Powergas and Costain Process Engineering & Construction of U.K. as the main mechanical contractors and Chiyoda Chemical Engineering & Construction of Japan as the main engineer. We should note that two Qatari Companies, Howard al-Attiyah and Salmer al-Tadamon now appeared as main civil contractors, Hambros Bank remaining as the financial organiser for the project. ⁽⁸¹⁾ Although the Ammonia II plant is essentially a repeat of the Ammonia I plant, over 200 modifications were implemented in order to improve the performance of the new plant. Urea II on the other hand, is based on a totally different process from Urea I, ^{*(83)} a reminder of the world-wide continuous technological change in industries of this kind and adopted here primarily to extend plant life expectancy. The expansion of plant capacity made it necessary to double the established support and accessory systems, such as nitrogen plant, ammonia storage tank, desalination plant, sea water pumping facilities, gas turbine generators and others. It is worth mentioning here that while the total investment in QAFCO I was QR 272 million, the total investment in QAFCO II was about QR 1,000 million, ⁽⁸⁴⁾ more than three and a half times the investment in the old plant.

Two relevant points may be made in this context. First, the

* Whereas the old urea plant is based on Mitsui Toatsu's Chrystallization process, the new plant is based on Stamicarbon's Stripping process.

very large scale of units of investment which are now required in hydrocarbon processing industries of this kind, and which are very considerable, even for the capital rich Emirates. Secondly, the dependence on imported capital goods exposes an investing country such as Qatar to at least one type of imported inflation, whilst changing the nature of, but not destroying, economic interdependence with other parts of the world.

6.5.1 Manpower

A similar situation of dependence appears when we discuss the question of manpower and the number, but not the position, of Qataris in QAFCO. In this sense we will use QAFCO's manpower divisions (Senior, intermediate staff and daily paid workers) and general total figures.

Figure 6.1, showing manpower by nationalities according to their total number, and Table 6.14, showing QAFCO's three manpower divisions, represent the labour force of QAFCO since the start of operations in 1973. As may be noticed both from Figure 6.1 and Table 6.14, although the Qataris at the end of 1973, constituted one third of total numbers, the majority of them were working as daily paid workers. The highest proportion in the senior staff - the decision makers - comprised the Norwegians. This was as a result of a June 1969 agreement between QAFCO and Norsk Hydro.

Training of nationals for responsible positions in QAFCO, in order to take over the management and operation, is the main aim for the national Qatarisation Committee in general, and for QAFCO in particular. By comparing the total labour force at the end of 1974 with that at the end of 1980, a six year period, we can, however, deduce the following:

Table 6.14 :

Composition of QAFCO Labour Force By Nationalty and Function

End of	Norwegian Sen.* Staff	Regional Senior Staff						Intermediate Staff						Daily Paid						Grand Total
		Qat-ari	Arab	Paki-stan	Ind-ian	Other	Tot.	Q	A	P	In	O	Tot.	Q	A	P	In	O	Tot.	
1973	45	2	3	1	2	2	10	11	61	84	90	-	246	75	23	8	19	19	144	445
1974	47	2	4	1	3	-	10	30	63	108	110	2	313	123	27	9	20	21	200	570
1975	47	2	5	1	3	-	11	67	73	122	156	4	422	101	44	4	25	19	193	673
1976	44	3	9	1	9	-	22	113	71	128	177	6	495	30	23	1	30	21	105	666
1977	47	5	11	1	9	-	26	140	74	148	193	10	565	10	12	2	34	22	80	718
1978	63	6	14	5	17	-	42	146	102	150	309	35	742	5	7	2	32	19	65	912
1979	57	8	19	5	21	-	53	155	108	155	345	40	803	5	4	-	21	16	46	959
1980	56	10	21	5	24	-	60	153	118	151	379	50	851	-	-	-	-	-	-	967

* The full-time Norwegian teachers are not included

Source : QAFCO, Manpower Statistics of 1970-1980, Personnel Dept. Umm Said.

Fig. 6-1 Labour Force by Nationality

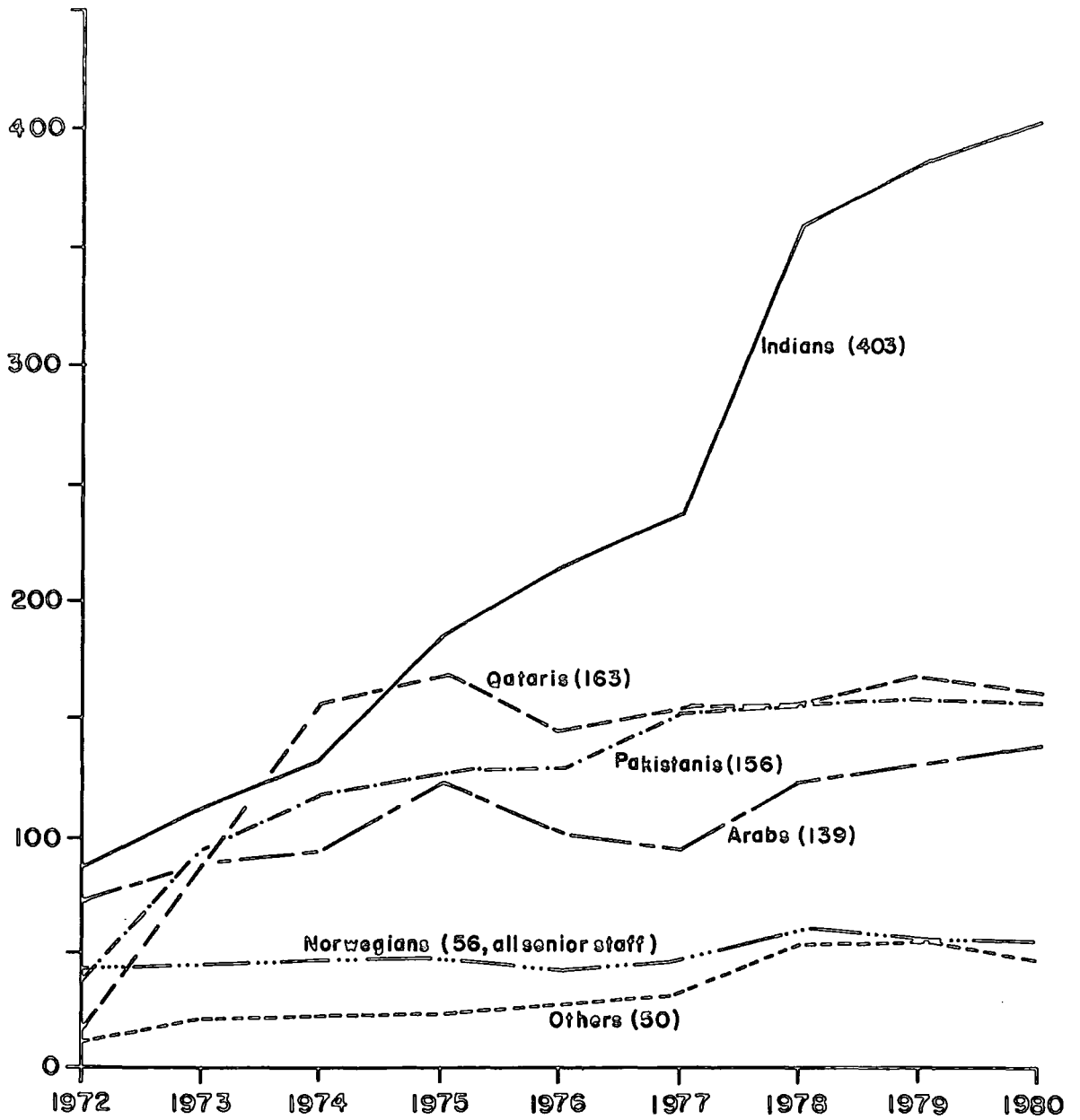

Source: Table 6-14

- 1) There was an increase in Qatari numbers by only 5.2 per cent during the 1974-80 period.
- 2) The percentage of Qataris in the total had declined from 27.2 per cent in 1974 to only 16.9 per cent in 1980.
- 3) The Qatari senior staff had increased from two persons in 1974 to only 10 persons in 1980.
- 4) The number of Indians increased by 203 per cent during 1974-80 with an average growth rate of 16.8 per cent per annum.
- 5) The Norwegian team (all of them senior staff) increased by 19.2 per cent during the 1974-80 period.
- 6) The Qatari intermediate staff increased from 30 persons in 1974 to 153 employees in 1980, but this came mainly as the result of the company's personal policy to transfer all daily paid workers to the status of intermediate staff or monthly paid workers.

In addition QAFCO in 1979 renewed the June 1969 agreement with Norsk Hydro to an additional ten year period. This raises the question to what extent the Qatari labour force has gained from the ten years' cooperation with Norsk Hydro in the chemical fertilizer field.

6.5.2 Production and Marketing

It is noteworthy that Norsk Hydro's Nitrogen Division in Oslo acts as QAFCO's sales department and carried out independent decisions on markets, prices and quantities. (85)

Table 6.15 shows the production, proportion of capacity used and sales operations during 1974-80. In 1974 the production of ammonia was

118,320 tonnes, which represented almost 40 per cent of the ammonia annual capacity. The sales of ammonia, on the other hand, made up almost 60 per cent of the 118,320 tonnes production. This adversely affected the urea production, since that plant was designed to receive two thirds of ammonia output. Therefore, the production of urea was only 71,760 tonnes, or about 22 per cent of the annual capacity. The total sales of urea was 32,003 tonnes.

QAFCO had achieved good f.o.b. prices for its output; for instance, the average ammonia and urea f.o.b. prices were QR 954 and QR 1,362 per tonne respectively. ⁽⁸⁶⁾ The f.o.b. prices of ammonia and urea were much higher than Gibb-Ewbank predicted, and this was the main reason for the expansion of the first plant. In 1975 the improvement in production was noticeable for both ammonia and urea. The ammonia output reached 138,310 tonnes, or 46 per cent of the annual capacity, whilst ammonia sales were only 23 per cent of the total output. This in itself helped the urea production to increase by 133.6 per cent from the previous year, thereby reaching 167,620 tonnes. Another increase successfully achieved was in the urea sales operation where sales had increased four and a half times over the previous year. Unfortunately these increases coincided with a decline in QAFCO f.o.b prices, in which ammonia average prices reduced to QR 443, a decline of 53.6 per cent, while urea prices were down to QR 861, or 36.8 per cent less than 1974. ⁽⁸⁷⁾ In 1977 the company faced a large reduction in its production of both ammonia and urea. The sales accordingly declined. The reduction of 1977 came as a result of:

- a) Local difficulties, such as technical problems in operating the plant, also a complete shutdown of the plant because of natural gas supply shortage;

- b) External reasons such as the continuous decline of export prices due to the surplus in the international market for fertilizers. (QAFCO average f.o.b prices were QR 389 for ammonia and QR 441 for urea), as well as financial burdens. (88)

In 1978 the production increased to more than the 1976 production level, 201,070 tonnes of ammonia and 255,600 tonnes of urea. The sales of ammonia had dropped by 6.8 per cent from 1977, leaving urea sales to score another remarkable increase of 157.4 per cent of the 1977 sales. The increase in the 1978 production and sales was mainly due to the continuous flow of natural gas solving the majority of the technical problems, the increase of the labour force by 27 per cent since 1977, and lastly, the improvement in the international urea f.o.b prices, so that QAFCO's urea average f.o.b price was QR 531 per tonne. (89) In 1980, thanks to the successful operation of QAFCO II the company reached its highest production of ammonia and urea. The production, for instance, of ammonia was 507,709 tonnes. This represents an annual productivity of 525 tonnes per employee. The urea production was 640,678 tonnes, giving an annual productivity of 662 tonnes per person. (The labour force of QAFCO in 1980 was 967 employees including administrative staff). In addition, marketing operations also reached their highest level with 137,501 tonnes of ammonia and 699,156 tonnes of urea. Beside all that, the average QAFCO's f.o.b prices had increased from the previous year by 28.8 per cent for ammonia reaching QR 563 per tonne, and by 24.3 per cent for urea reaching QR 737 per tonne. (90)

The total sales of ammonia during 1974-80 were 478,967 tonnes. About 57 per cent was sold to Asian countries, and another 23.4 per cent out of the total was sold to Western Europe. The total sales of urea during 1974-80 were 1,953,391 tonnes, 96 per cent of total sales sold to Asian countries. (91)

Table 6.15 :

QAFCO Production and Sales

(metric tonnes)

Year	Production ⁽¹⁾						Sales ⁽²⁾	
	Ammonia	% of increase	% of (a) capacity	Urea	% of increase	% to the capacity ^(a)	Ammonia	Urea
1974	118,320	-	39.8	71,760	-	21.7	70,731	32,003
1975	138,310	16.9	46.6	167,620	133.6	50.8	31,731	145,198
1976	163,320	18.1	55.0	206,930	23.5	62.7	58,291	274,540 ^(c)
1977	127,710	21.8	43.0	165,510	20.0	50.2	53,634	115,154
1978	201,070	57.4	67.7	255,600	54.4	77.5	50,003	296,435 ^(c)
1979 ^(b)	369,080	83.6	62.1	496,740	94.3	75.3	77,076	395,905
1980	507,709	37.6	85.5	640,678	29.0	97.1	137,501	699,156 ^(c)
Total	1,625,519			2,004,838			478,967	1,958,391

(a) Annual capacity based on 330 working days per annum

(b) Start of Urea II from April 1979, start of Ammonia II from May 1979

(c) Stock from previous year

Sources: (1) QAFCO, The Monthly Production, 1974-80, Production Department Umm Said

(2) QAFCO, Sales Statistics, 1974-80, Shipping Department Umm Said.

6.5.3 Economic Evaluation

Table 6.16 shows the profit-loss accounts of QAFCO during 1975-79. In 1975 the total sales of QAFCO, after deduction of sales commission, freight and other selling expenses, was QR 123.18 million. By taking away the amount of QR 54.35 million, for operational, administration and related costs, the remaining balance represented a trading profit of QR 68.83 million for 1975. The net profit, after the depreciation of property, plant, equipment and amortisation of pre-production expenses, was QR 32.59 millions. In 1976, although there were increases in ammonia and urea production and marketing, total sales were valued at QR 118.89 million, a 3.5 per cent decline from the 1975 sales figure. This is mainly due

Table 6.16 : Profit & Loss Accounts of QAFCO 1975-79 (in million QR)

	1975	1976	1977	1978	1979
Sales & other income	123.18	118.89	71.98	158.51	225.45
Costs	54.35	98.88	62.08	111.34	141.71
Trade Profit (Losses)	68.83	20.01	9.9	47.17	83.74
Depreciation & other costs	36.24	36.98	41.05	43.55	65.59
Net Profits (Losses)*	32.59	(16.97)	(31.15)	3.62	18.15

* Before appropriations

Source : QAFCO: Profit & Loss Account Reports (1976-79)
Umm Said.

to the sharp decline of ammonia and urea f.o.b prices. In addition, operational costs increased by 81.9 per cent from 1975, reaching QR 98.88 million. The main cause of the cost increase was the higher production level which was reflected in higher consumption of feedstock and other materials. This, in itself, reduced the trade profit to only QR 20.01 million. The company, furthermore, had a total net loss in 1976 of QR 16.97 million.

In 1977, the financial situation of the company became worse, net losses totalling QR 31.15 million. In 1978 the total sales value was QR 158.51 million, of which QR 111.34 million had to be set aside to meet operational and administration costs. The net profit of 1978 was only QR 3.62 million. In 1979 the total sales value was QR 225.45 million, whilst the total costs were QR 141.71 million, of which QR 63.19 million was wages and salaries, QR 12.55 million was management fee, whilst QR 16.33 million was for feedstock. ⁽⁹²⁾ The net profit of 1979 was QR 18.15 million. In 1980, QAFCO had the best year of operation in the company's history, where the total sales reached QR 541 million. After deducting all variable costs, a net profit of QR 134.92 million was achieved. ⁽⁹³⁾

Table 6.17

QAFCO Ammonia & Urea Prices (QR/Tonnes)

Price	1974		1975		1976		1977	
	Amm- onia	Urea	Amm.	Urea	Amm.	Urea	Amm.	Urea
Highest	1,347	1,771	720	1,550	584	575	467	560
Average	954	1,362	443	861	426	386	389	441
Lowest	390	978	330	360	330	336	327	335

Price	1978		1979		1980	
	Amm.	Urea	Amm.	Urea	Amm.	Urea
Highest	420	611	561	683	728	861
Average	338	531	437	597	563	737
Lowest	272	484	388	498	423	596

Source : QAFCO, Sales Statistics, Shipping Dept. Umm Said

Table 6.18

Gas Consumption (QAFCO) (Million SCF)

Year	Gas Consumption*
1974	9,559
1975	11,620
1976	11,926
1977	8,787
1978	12,614
1979	23,584
1980	30,293
Total	108,383

* Gas consumption depends on the plant load and lies in the range
49,000 - 57,000 SCF/tNH₃

Source : QAFCO, Gas Consumption during 1974-80, Production Department, 1980.

6.6 Iron and Steel Complex

The first consideration given to establish a steel complex in Qatar was in the middle of 1972, ⁽⁹⁴⁾ followed by a pre-feasibility study carried out by a team from the Ministry of Finance & Petroleum. The study findings convinced the Amir to go ahead with the steel project, and in April 1973 the Amir ordered IDTC (established at the end of March 1973), to prepare a feasibility study for the steel complex involving the use of natural gas in the direct reduction processing. In June 1973 the feasibility study was completed, IDTC recommending the participation of Tokyo Boeki Ltd. of Japan.

The feasibility study was based on establishing a steel plant with an annual capacity of 147,100 tonnes of steel bars. In addition, IDTC estimated annual sales, in the early years of the operation, domestic and external markets by quantities and sales prices per metric ton as follows: ⁽⁹⁵⁾

	Metric Tons/Annum	Price/M.T.
Qatari Market	45,000	780
Saudi Arabia	20,000	730
Other Countries	82,100	690
	<hr/>	
Total	147,100	

Furthermore, IDTC team assumed that the total manpower required would be 650 with total annual wages and salaries of QR 15.01 million. ⁽⁹⁶⁾ IDTC had added, in the feasibility study that a total investment of QR 210 million was needed. ⁽⁹⁷⁾

In July 1974 the Joint Venture Agreement was concluded and officially signed by Qatar, Kobe Steel and Tokyo Boeki of Japan. On 12 October 1974 a Resolution No. (5) of 1974 was passed permitting the involvement of Kobe Steel and Tokyo Boeki as share holders in

Qatar Steel Company (QASCO) with 30 per cent of QASCO's equity share capital. The Amir supported the Minister of Finance & Petroleum's Resolution by the promulgation of Decree No. (130) of 1974 of Establishing QASCO, with an initial capital of QR 200 million. (Increased to QR 500 million in 1980). The capital is distributed among the three partners as follows: (98)

Shareholder	Number of ordinary shares of QR10,000 each	Nominal Value Million QR	Percentage
State of Qatar	14,000	140	70
Kobe Steel Ltd.	4,000	40	20
Tokyo Boeki Ltd.	2,000	20	10
	—	—	—
Total	20,000	200	100
	—	—	—

In addition, the government has undertaken responsibility for infra-structural requirements such as a public jetty adjacent to the plant site, unloading and loading equipment, additional pipelines supplying natural gas from Dukhan, and the connecting of public water and electricity lines with the plant, plus housing units, access roads etc.

The Board of Directors of QASCO consists of ten members, seven (including the Chairman) to be appointed by the government of Qatar, two by Kobe Steel and one by Tokyo Boeki.

On 3rd November 1974 QASCO had signed four agreements and arrangements. They were as follows: (99)

- a. Management Agreement : this agreement was signed with Kobe Steel Ltd. for an initial period of 8 years which may be extended by mutual agreement. Under this agreement, Kobe Steel had agreed to provide management services to QASCO.
- b. Training Arrangements : whereby Kobe Steel was to provide training for engineers and skilled operatives who will act as a

"core-force" on the production line of QASCO. This arrangement is covered by a "Construction Agreement".

- c. Gas, Power and Water Supply agreement : with the government, where the government undertook to supply and deliver gas, electric power and water to QASCO's plant to meet all its needs. This agreement fixed maximum prices for each item for the first five years of production.
- d. Marketing agreement with Tokyo Boeki : by which Tokyo Boeki undertook to arrange the marketing of the steel products outside Qatar for a period of ten years from the beginning of operations. This agreement may be extended by mutual arrangement.

In addition to the above mentioned agreements, QASCO awarded Kobe Steel a turnkey contract covering the design, engineering, equipment supply and commissioning of the plant, whilst Taisei Corporation of Japan was awarded the contract for building and civil engineering work. (100)

The site for the plant, at Umm Said, had been chosen by the IDTC team and was approved by the Amir. This site covers 650,000 sq. m. while an additional 370,000 sq.m. has been reserved on an adjacent site for possible future expansion.

In March 1975, IDTC marked the beginning of the work on site by reclamation of the land which was allocated to QASCO. In February 1976 the work started on the construction and installation of machinery and equipment. By 15 February 1978 all the work on site was completed, excluding the direct reduction plant. The official inauguration and the start of commercial production was on 26 April 1978, and on 15 August 1978, the direct reduction plant started operation.

The plant has five main units. They are:

- a. Materials reception through a three berth jetty, and three storage yards;
- b. Direct reduction with an annual capacity of 400,000 tons of sponge iron;
- c. Two electric arc furnaces with a total capacity of 415,800 tons/annum;
- d. Two continuous casting machines with total capacity of 1,053,600 tons per annum;
- e. Rolling mill with a rated capacity of 380,000 tons per annum of plain and deformed bars.

There is a strong supposition that there was another feasibility study carried out between June 1973 and July 1974 although no documents are available to support or disprove it. This belief is based on: the fact that the actual constructed size of the plant was not the same as studied by IDTC; and the total capital invested in the project was QR 1,100 million and not QR 210 million, as suggested by ITDC.

QASCO operations are based on imported iron ore pellets and steel scrap. Because of the need of lime for the processing, a committee consisting of members from QASCO and IDTC was established in 1976 to produce quick lime locally. The lime since 1979 has been supplied by QNCC at Umm Bab (see pp. 158-159). By using low priced inputs, from this and other governmentally owned or controlled enterprises, such as natural gas, electricity, water etc. the company can compete with other producers in the international markets.

At the end of 1980, the Board of Directors decided to carry out a pre-feasibility study concerning the expansion of the existing plant. The pre-feasibility study's general conclusions were either to expand the company's output by establishing a new plant with the same capacity

(as was done with QAFCO I and QAFCO II), or to add some 50 per cent to existing capacity, but without a direct reduction plant. No decision has yet been taken.

6.6.1 Manpower

QASCO's manpower data is, unfortunately, very limited because of the extreme reluctance of the Japanese participants to divulge information. We know that in 1978 the total labour force of QASCO numbered 733, of which only 22 were Qataris.⁽¹⁰¹⁾ Table 6.19 shows that the number of Qataris employed by QASCO had risen to 41 by March 1980, an increase of 86.4% over 1978. In March 1980 the Qatari proportion of the total labour force was 3.6% (compared with 3% of a smaller labour force in 1978), but the Qatari proportion of the skilled category was slightly lower at 3.2% out of a total of 819. We also know that the total labour force at the end of 1979 was 1,148⁽¹⁰²⁾ of which 112 were Japanese, these constituting the management team.

Table 6.19 : QASCO's Manpower as at March 1980

	Qatari	Non-Qatari	Total
Administrative	3	211	214
Skilled	26	793	819
Semi-skilled	9	1	10
Unskilled	3	86	89
Total	41	1,091	1,132
Of which:			
Literate	3	-	3
Technical	35	793	828
Secondary	-	148	148
University	3	150	153

Source : Fieldwork questionnaire.

The Japanese management team, by the end of 1980, had declined to a total of 77 ⁽¹⁰³⁾ and by the end of June 1981 had declined even further to 74 employees. ⁽¹⁰⁴⁾ This contrasts markedly with the growth trend in QAFCO's management team (see Section 6.5). The decline in the QASCO team figures may be explained by the Management Agreement with Kobe Steel, whereby the total number in the foreign management team was expected to be 130 at the start-up of the plant and planned to decrease until totally replaced by locally trained employees. ⁽¹⁰⁵⁾ The total number of Qatari employees did increase from 41 in March 1980 to 64 employees at the end of the year. ⁽¹⁰⁶⁾ (see Table 6.19).

6.6.2 Production

Although the work on site was not completed until 15 February 1978, the production of steel bars started at the end of March 1978, with rated annual capacity of 380,000 tonnes of steel bars. Figure 6.2 shows QASCO's monthly production of steel bars. Between March and August 1978 production did not exceed 10,000 metric tons. This was mainly due to the reliance on steel scrap as the main input, and the fact that the installation of the direct reduction plant was continuing during that period. In mid August 1978 the direct reduction plant, using the U.S. developed Midrex process, started operation and managed to work to full daily capacity from the first day. ⁽¹⁰⁷⁾

In 1978 production totalled 113,994 tonnes, a monthly rate of 11,399 tonnes. This figure was less than the planned total of 129,000 tonnes. However, in 1979, QASCO's first full year of production, the output of steel bars was 378,544 tonnes, about 230 per cent of the 1978 level and 18.3 per cent over the planned production figure of 320,000 tonnes. The 1979 production level represented 99.6 per cent of the total capacity of the rolling mill. In 1980 the production of reinforcing bars was 450,340 tonnes, with a monthly average of 37,528 tonnes. The

Fig. 6.2 QASCO Production of Steel Reinforcing Bars (By month and year)

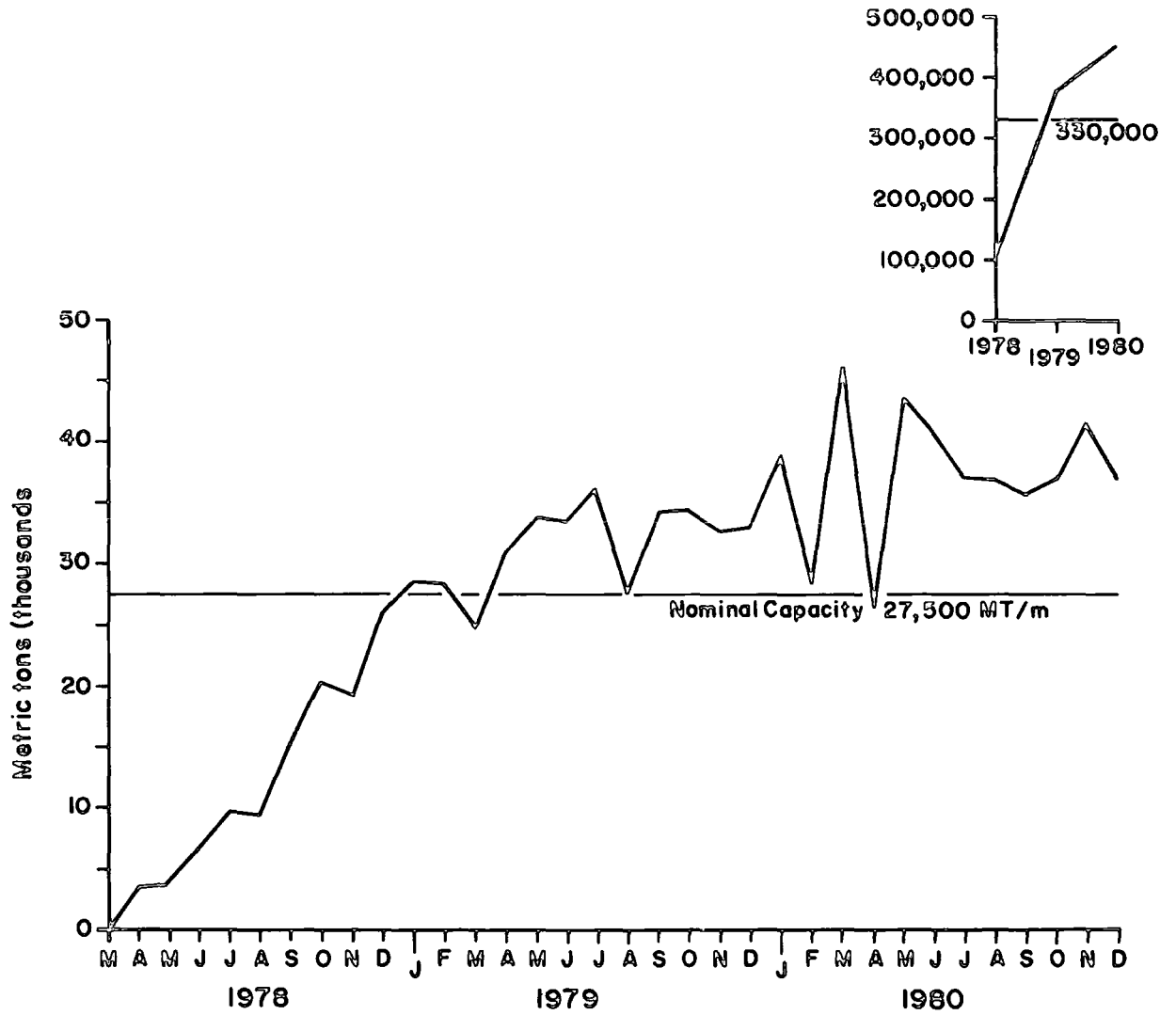

Source : QASCO, Special Report on Production 1977 - 1980, Qatar 1981

highest monthly output figure was achieved in March where the production was 46,107 tonnes and by this figure QASCO had set a world record, ⁽¹⁰⁸⁾ in relation to the nominal monthly capacity of 31,667 tonnes.

The labour force, including administration, at the end of 1980 was 1,184 giving an annual productivity in 1980 of 380.4 tonnes per person, a high rate resulting from the automated systems used by the company.

The 1980 production not only exceeded the planned figure by 45.6 per cent, but exceeded the annual capacity of the plant. This, in itself is open to two possible interpretations. The first is that the Japanese management team ran the plant over normal capacity, disregarding the life expectancy of the complex, in order to maximise early returns from the low fixed prices of the Qatar government's supplies of gas, water and electricity (see p.188). Gas prices were less than 13 per cent of average world prices, ⁽¹⁰⁹⁾ (1982 - QR 0.0229 / cu.m.) whilst electricity at QR 0.04 kw and water at QR 2.2 per cu.m. were also low. ⁽¹¹⁰⁾ This interpretation of exceeding annual capacity is taken seriously by Qataris and expressed thus :

"A local businessman said : By continually seeking to push production beyond the plant's capacity, they are wearing out the equipment prematurely. At this rate we shall have to spend more money to replace burnt-out equipment just for the sake of the record books."⁽¹¹¹⁾

The second realistic possibility is that the actual annual capacity figure of the plant, especially of the rolling mill shop from inception was higher than the published figure.*

* There are several published figures i.e.

- a. al-Mis'hal (The Managing Director of IDTC) stated in 1978 that the designed capacity of QASCO is between 400,000-450,000 M.T. per year.
- b. QASCO pamphlet - 330,000 M.T. per year
- c. QASCO Steel Mill Project - 380,000 M.T. per year.

Unfortunately, there is no answer to this question, the Japanese management believing that the secret of the operations should not "pass through the plant's gates." From a close examination of the description of the steel mill (see page 189) one can deduce from the great capacity of the two continuous casting processes that the rolling mill capacity should be much higher than the stated 380,000 tonnes.

6.6.3 Local Sales & Export Operation

The sales of QASCO's output of reinforcing bars is carried out by two bodies. One of these is QASCO's Sales Department, which undertook to arrange the marketing of the output only inside Qatar, whilst Tokyo Boeki, acting as sales agent of QASCO, undertook external marketing operations.

In 1973, IDTC predicted that by 1977 the local demand for reinforcing bars would reach 45,000 tonnes.⁽¹¹²⁾ In addition, it had been assumed that about 30 per cent of the level of production predicted in the feasibility study - 147,100 tons, would be used locally and the balance would be exported by Tokyo Boeki.⁽¹¹³⁾ According to import statistics for reinforcing bars and from information collected in the field, the annual domestic consumption of bars cannot be expected to exceed 30,000 tonnes without some sudden increased demand, which usually is associated with the construction of major new industrial projects (see Table 6.20) and is not with demand for house construction.

Table 6.21 shows the distribution of QASCO sales during 1978-80. In 1978 QASCO supplied the domestic market with only 457 tonnes, only some 0.5 per cent out of 1978 total sales. In 1978 Saudi Arabia was the dominant market for QASCO's steel, taking 77.8 per cent out of 85,581 tonnes. Second came Kuwait with 12.9 per cent, followed by U.A.E. In 1979, the total sales of QASCO rose to 379,779 tonnes, of which 13.0 per cent was sold locally, 51.8 per cent to Saudi Arabia and

Table 6.20 : Reinforcing Bars Imported to Qatar by Value
(Unit = M.T. Value in 1000 QR)

Year	Quantities	% of increase (Decrease)	CIF Values	Av.Prices/ Tonne in QR
1970	10,588.8	-	8,117	767
1971	15,459.1	46.0	10,481	678
1972	15,665.7	1.3	10,430	666
1973	26,573.4	69.6	22,122	833
1974	53,545.9	101.5	80,879	1,511
1975	26,130.0	(51.2)	30,138	1,153
1976	31,396.2	20.2	39,095	1,245
1977	75,089.2	139.2	84,803	1,129
1978	32,373.2	(56.9)	44,871	1,386
1979	13,701.1	(57.7)	24,536	1,791
1980	7,002.6	(48.9)	11,881	1,697

Construction of QAFCO	during 71-73
" " Flour Mill	" 71-72
" " New Refinery	" 72-74
" " QASCO	" 75-78
" " QAFCO II	" 76-79
" " NGL 2	" 77-80
" " QAPCO	" 77-81
" " NGL1	" 78-81

Source : Ministry of Finance & Petroleum : Yearly Bulletin of Imports and Exports 1970-1980, Customs Dept.

19.7 per cent to Kuwait. The increase in flow to the domestic market in 1979 by steel bars reduced the import figure from 32,373 tonnes in 1978 to only 13,701 tonnes. In 1980 there were several changes which occurred in the domestic and export market levels; for instance, there were decreases in both the quantity and proportion sold at the domestic level and also in other countries such as Saudi Arabia, Kuwait and Oman, whilst the reverse applied to the U.A.E., Bahrain and Iraq. The total sales of 1980, however, increased by 15.9 per cent over 1979 figures.

Between March 1978 and the end of 1980 QASCO succeeded in selling 96.1 per cent of its overall production, with Qatar taking only 9.9 per cent, Saudi Arabia 48.5 per cent, the U.A.E. 18.2 per cent and Kuwait 15.9 per cent of cumulative sales.

Table 6.21 : Destination and Quantities of QASCO sales (in M.T.)

Country	1978	1979	1980	% of 1980	Grand	% of G.Tot.
Qatar	457	49,207	39,653	9.0	89,317	9.9
Saudi Arabia	66,599	196,624	175,841	40.0	439,064	48.5
Kuwait	11,038	74,656	58,167	13.2	143,861	15.9
U.A.E.	7,009	51,852	106,450	24.2	165,511	18.2
Bahrain	478	2,264	6,339	1.4	9,081	1.0
Oman	-	3,409	1,281	0.3	4,690	0.5
Jordan	-	-	527	0.1	527	0.1
Iraq	-	1,767	52,062	11.8	53,829	5.9
Total	85,581	379,779	440,320	100.0	905,680	100.0

Source : QASCO Destinationwise Sales, Qatar 1981.

6.6.4 Sales Value

Table 6.22 below shows the sales value of QASCO's bar products between 1978 and 1980. In 1978 QASCO obtained QR 1,076 per tonne for its exported steel, while the domestic prices were much higher. This fact was due to several factors:

- a) The domestic market was an effective monopoly of QASCO, given by the authority of Law No (2) of 1979 which fixed the customs duty on imported steel bars. ⁽¹¹⁴⁾ This resulted in controlling the local steel prices in favour of QASCO.

b) Open international competition in steel trade outside Qatar had forced the company to lower export steel prices below the international c.i.f. prices and this was made possible by low transfer prices of domestic inputs.

Table 6.22 Sales Value of QASCO's Bar Products (1978-80)
(in 000 QR)

Country	1978		1979		1980	
	Total sales	Price QR/M.T.	Total sales	Price QR/M.T.	Total sales	Price QR/M.T.
Saudi Arabia	72,800	1,093.1	256,221.4	1,303.1	221,994.7	1,262.2
Kuwait	11,600	1,050.9	97,791.1	1,309.9	74,372.7	1,278.6
U.A.E.	7,500	1,070.1	66,434.3	1,281.2	130,935.5	1,230.0
Oman	-	-	4,660.4	1,349.6	1,597.3	1,247.2
Bahrain	500	1,046.0	3,043.4	1,344.5	8,110.0	1,279.4
Jordan					708.6	1,345.1
Iraq	-	-	2,017.1	1,141.4	65,670.3	1,261.4
Total	91,600	1,076.1	430,107.8	1,301.1	503,339.1	1,256.3
Local Sales	600	1,200	64,562.8	1,312.1	54,497.0	1,374.3
G. Total	92,200	1,077.3	494,670.5	1,302.5	557,836.1	1,266.9

Source : Ministry of Finance & Petroleum Yearly Bulletin of Imports & Exports (1978-80) Customs Department, Qatar.

While in 1978 QASCO received QR 92.2 million for total steel bar sales, in 1979 average prices increased by 20.9 per cent over 1978 and this, together with higher sales quantities helped QASCO to achieve total sales value of QR 494.7 million. In 1980, although the average price per tonne was down to QR 1,256.3 the company's sales income reached QR 557.8 million. The only fact which assisted the company was its high productivity.

The profit and loss accounts of QASCO are unknown, but from the government publication, especially of the Ministry of Economy & Commerce, we gather that the company did not make any net profit during 1978-80. Governmental sources have always indicated that QASCO is still in the first stages of its establishment. There have been some recent unofficial statements which cannot be attributed, that since its establishment the company has in fact made a considerable cumulative net loss. The place of QASCO in Qatar's and the region's future industrial scenario is discussed along with that of other industries in the concluding section of this chapter.

6.7 Small-Scale Industries (SSI)

There is no doubt that two fundamental influences on the way in which small-scale industries have developed in Qatar have been, first, the rising revenue from oil exports and, secondly, the structural characteristics of the import trade. The oil revenues, on one hand, provided the cash flow which provided capital for all kinds of industrial development, whilst at the same time these revenues once disbursed into society become the principal factor expanding and changing consumer demand. The importing of finished goods, on the other hand, has had a noticeable effect on limiting the development of some specific types of industry i.e. carpentry.

The general trend of development in SSI in Qatar, in the author's opinion, has included three different and interlocking phases, three phases which can be summarized as follows:

Phase One : Prior to oil discovery

Qatar, at this stage, as with many other analogous countries had traditional crafts rather than what could strictly be called manufacturing industry. These craft activities fell into two main groups. The first

and dominant group was linked with maritime activities i.e. dhow building, the making of fishing nets, sails etc. The second group comprised land-based activities i.e. quarrying, construction of traditional buildings, the making of simple house furniture etc.

The general characteristics of these craft activities can be seen as:

- a) Reliance on manual and physical work.
- b) The use of simple traditional tools in most cases owned by individual workers.
- c) No requirement for financial backing.
- d) More national workers than expatriate.
- e) Production responding to individual domestic demands and requirements.

Phase Two : Following oil exploitation

The discovery and exploitation of oil totally changed the attitudes of the inhabitants toward the sea-related crafts, which had already been weakened by the decay of the pearling industry . The result has been the almost complete abandonment of the majority of traditional crafts. The movement of artisans, mostly self-employed, towards employment by government agencies, became rapid and general. This movement together with the other trends noted in Chapter 3 led to a greater demand for developed urban land while at the same time higher incomes made the effective volume of this demand financially even stronger. The creation of a rich city state led to greater private sector involvement in land purchases, sales and development. The construction industry boomed and created new types of industries, i.e. bricks, tiles, carpentry and metal working. Due to the growing requirement for skilled and semi-skilled labour in the new individual enterprises which made up the

SSI sector and the inability, and/or the reluctance of citizens (given alternative opportunities) to undertake such labouring employment, a large wave of immigrants began pouring into Qatar from many countries, but mainly from Iran. This latter surge, together with the rapid growth of disposable incomes, in turn produced a further escalation in consumption, both in quantity and quality. This in turn helped in the establishment of some consumer goods industries i.e. soft drinks, ice making, dairies etc.

This second phase had some distinguishing characteristics which can be summarized as follows:

- a) The majority of the new activities were industries rather than crafts.
- b) The supplying of building materials to the construction sector became dominant within the new industries.
- c) The growth of imports of luxury commodities.
- d) The dependence on foreign labour both as manual workers and technicians.
- e) The small size of issued capital associated with the new enterprises.

Phase Three : Following independence

In the third phase, although there were many similarities to the second, particularly relating to the types of industrial productions, several significant changes took place. These changes define the characteristics of the third phase as being:

- a) The relatively larger size of individual establishments, both in terms of labour force units, land area required and issued capital.
- b) The appearance of new Qatari investors wishing to introduce new industrial technologies in order to capitalise on more sophisticated demand.

- c) Even more dependence on foreign labour force, than in the second stage.
- d) The change of industrial distribution patterns within Doha City.
- e) The appearance of the Industrial Estate of Doha (IED)(see Chapter 7.2).

In an examination of the small and medium scale industrial sector, which is entirely private enterprise, we have to adopt several different interlocking approaches. The evidence which is available is of four different types:

1. Annual publication of the Ministry of Economy and Commerce.
2. Unpublished statistics for the registration and closing down of establishments.
3. Sample questionnaires.
4. Personal fieldwork data.

However, even before the analysis of these data, we have to clarify several elements:

a) The term "establishment" has been used so far because even though the official data on registration purports to describe industrial enterprises, in fact the distinction between purely or mainly manufacturing businesses and those with large or solely commercial interests is not always clear. For example, during the 1976/80 period there were 202 establishments registered under the carpentry (furniture) heading. Only 73 of these, less than 36.5 per cent, were actually concerned with manufacturing to any extent and Table 6.23 shows the figures corrected as the result of personal fieldwork survey. Even of this reduced number, the majority of industrial enterprises still handle imported furniture and joinery products.

b) It is believed, but this cannot be proved given the nature of commercial and industrial regulations, that many entrepreneurs own major

establishments with several branches or subsidiaries. The issued capital of the major establishments may appear, although to an unknown extent, also as the issued capital of individual branches. Because of the uncertainty, all the registered establishments are treated here as separate units.

c) The question of ownership itself raises some problems in the identification and classification of industries. There are, nominally, legal restrictions on the type and size of enterprise which can be owned by non-citizens. In practice, as the economy has grown and demand become more diverse, and as fieldwork has shown, it has not been possible or even desirable to apply these controls strictly. The maximum capital investment in any business by a non-Qatari is QR 5,000 (as specified by Law No (20) of 1963 and its amendments of Regulation of Non-Qatari Working in Trade and Industry), but field survey shows that many such businesses have much larger fixed capital investment. As a result, the figures for issued capital have to be used with caution.

Major trends in SSI Development

Table 6.23 below shows the development of SSI during 1950-1980. The data are presented as a summary statement of all the evidence available including that from field survey. It can be deduced from the table that:

a) The food industry, during the whole period (1950-1980) was dominant throughout, with a yearly growth of 5.4 per cent in the number of establishments.

b) Although food industrial establishments continued to grow in absolute numbers, their proportional importance fell. For instance, the food industry held 69.6 per cent of total SSI establishments in 1950, but this declined to 64.9, 49.6 and 34.4 per cent in 1956/60, 1966/70 and 1976/80 respectively.

c) There is a clear shift from the company form of enterprise to sole ownership. In 1950, for example, individual entrepreneur owners only made up 28.3 per cent out of the SSI total number. This increased to 52.6 in 1956/60 and after declining to 52.2 in 1966/70 increased again to 51.5 in the period 1976/80.

d) In 1950, Qataris either as individuals or groups owned 32.6 per cent out of the SSI total. This percentage had declined to 16.6 in 1961/65 period. This decline resulted from a reaction to the 1959/60 economic crisis which made Qataris cautious in their involvement with industrial investment. Since then the Qatari percentage has grown rapidly, reaching 41.7 in 1976/80. The Qataris, on the other hand, were the dominant figures, during the whole period, in the field of stone crushing, industrial gases, bricks and tiles and aluminium assembly, while they had lost ground in carpentry from 1961/65 till the end of 1971/75.

e) Although the Qataris, during the whole period, made up less than 50 per cent of the legal owners of establishments, the issued capital of their enterprises made up more than 80 per cent out of SSI total issued capital, again over the whole period. However, this percentage declined i.e. from 99.2 in 1950 to 84.6 per cent in 1976/80 total. This decline came as a result of the increasing proportion of establishments owned by several partners ("Partner" in Table 6.23). These increased by a 6.7 per cent average annual rate. The rate of investment of Qatari capital increased by 5.1 per cent per annum, this in single ownership or partner organized establishments.

f) The general average of issued capital per establishment in all categories was at its highest during the early years, the 1950's, (QR 615,478 per establishment). This has declined ever since, reaching its lowest average of QR 192, 699 in the period 1971/75 and increasing

again in 1976/80 to QR 308,170 per establishment. The Qatari issued capital, in 1950, was QR 1,871,800 per establishment which decreased to QR 625,711 in 1976/80. Partnership investment increased from QR 13,333 in 1950 to QR 223,626 in 1976/80 per establishment. At the same time the average capitalisation per foreign establishment grew from QR 6,964 in 1950 to QR 16,424 in 1951/55. Associated with the economic crisis of 1959/60 and the imposition of Law No.(20) of 1963, during the second half of the 1960's, foreign establishment issued capital average declined to QR 7,017 in 1976/80. The number of such establishments however continued to grow.

g) While the Qatari issued capital during all the periods was much concentrated in the carpentry field with the exception of 1976/80, the partnerships were more concentrated in the field of iron fabrication. The foreign issued capital, on the other hand, was concentrated in the food industries, especially in bakeries.

h) While the total number of establishments were growing by 6 per cent per annum, the issued capital was growing at a much slower rate of 5.3 per cent per annum.

The manufacturing of plastic products, which is not identified in Table 6.23, is the most recent type of private sector industry introduced to the country in 1978. Although the Ministry of Economy & Commerce's annual reports show that in 1980 there were nine establishments in this field, our search in the Ministry files shows that in 1980 there was, in fact, only one Qatari establishment with a total issued capital of QR 2 million. However, whilst this is the only information available relating to the capitalisation of plastic industries, as pointed out in Section 7.2.4 there do exist unregistered factories, some of which are in this field. This new field for industrial ventures is one in which the factual detailed position is by no means clear.

Table 6.23

The Development of Small-Scale Manufacturing Industries during 1950-1980

	Total of Establishments	Legal Status		Ownership of Est.			Issued Capital (in Thousand QR)			
		Co.	Individual owner	Qatari only	Partners	Foreign only	Qatari only	Partners	Foreign only	Total
Stone Crushers	1	-	1	1	-	-	100	-	-	100
Food Industries	32	28	4	2	2	28	17	25	195	237
Carpentry	7	2	5	6	1	-	8,760	15	-	8,775
Industrial Gases	1	1	-	1	-	-	8,500	-	-	8,500
Bricks, tiles	3	1	2	3	-	-	1,200	-	-	1,200
Iron Fabrication	2	1	1	2	-	-	9,500	-	-	9,500
Aluminium Fab.	-	-	-	-	-	-	-	-	-	-
Total	46	33	13	15	3	28	28,077	40	195	28,312
1951-55										
S.C.	1	-	1	1	-	-	100	-	-	100
F.I.	52	46	6	2	4	46	17	34	315.5	336.5
C.	17	5	12	12	2	3	10,600	35	233	10,868
Ind.G.	1	1	-	1	-	-	8,500	-	-	8,500
B.T.	6	3	3	6	-	-	2,350	-	-	2,350
I.F.	6	1	5	2	-	4	9,500	-	322	9,822
Al.F.	-	-	-	-	-	-	-	-	-	-
Total	83	56	27	24	6	53	31,267	69	870.5	32,206.5
1956-60										
S.C.	2	1	1	2	-	-	2,100	-	-	2,100
F.I.	113	95	18	5	10	98	1,150	253.5	717	2,120.5
C.	37	10	27	21	2	14	18,637	35	524.3	19,196.3
Ind.G.	1	1	-	1	-	-	8,500	-	-	8,500.0
B.T.	14	5	9	10	3	1	9,415	150	5	9,570.0
I.F.	7	2	5	2	1	4	9,500	900	322	10,722.0
Al.F.	-	-	-	-	-	-	-	-	-	-
Total	174	114	60	41	16	117	49,302	1,338.5	1,568.3	52,208.8
1961-65										
S.C.	3	2	2	3	-	-	2,140	-	-	2,140.0
F.I.	175	137	38	8	25	142	5,160	634.5	1,894	7,688.5
C.	69	20	49	22	8	39	18,352	594	488.4	19,434.4
Ind.G.	1	1	-	1	-	-	8,500	-	-	8,500.0
B.T.	19	9	10	10	7	2	9,415	320	25	9,760.0
I.F.	17	7	10	3	4	10	9,539	1,253	696	11,508.0
Al.F.	-	-	-	-	-	-	-	-	-	-
Total	284	175	109	47	44	193	53,126	2,801.5	3,103.4	59,030.9
1966-70										
S.C.	4	2	2	2	2	-	140	56.5	-	196.5
F.I.	230	136	94	18	17	195	5,777.5	1,164	2,099.8	9,041.3
C.	116	43	73	32	14	70	24,142	823	561.1	25,526.1
Ind.G.	2	1	1	2	-	-	2,400	-	-	2,400
B.T.	63	33	30	23	18	22	13,670	389.5	177	14,236.5
I.F.	47	12	35	10	5	32	11,371	1,907	294.1	13,572.1
Al.F.	2	2	-	1	1	-	60	900	-	960
Total	464	229	235	88	57	319	57,560.5	5,240	3,132	65,932.5
1971-75										
S.C.	13	10	3	8	5	-	1,745	2,636.5	-	4,381.5
F.I.	257	146	111	25	24	208	8,165.5	2,454	1,174.5	11,794
C.	152	67	85	57	25	70	45,739.4	1,882	572.9	48,194.3
Ind.G.	2	1	1	2	-	-	2,400	-	-	2,400
B.T.	133	68	65	73	34	26	34,623.5	2,222	280.5	37,126
I.F.	89	31	58	28	21	40	14,097.5	4,217	312.1	18,626.6
Al.F.	7	5	2	4	3	-	2,160	1,150	-	3,310
Total	653	328	325	197	112	344	108,930.9	14,561.9	2,340	125,832.4
1976-80										
S.C.	18	12	6	12	6	-	10,295	7,236.5	-	17,531.5
F.I.	304	166	138	61	44	199	32,488.7	5,409	1,144.5	39,042.2
C.	168	68	100	80	34	54	42,854.4	3,806	491.7	47,152.1
Ind.G.	3	1	2	3	-	-	22,400	-	-	22,400
B.T.	177	91	86	103	48	26	58,786.5	5,692	285.5	64,764
I.F.	144	53	91	74	30	40	22,037	12,902	316.6	35,255.6
Al.F.	19	13	6	14	5	-	28,260	2,300	-	30,560
Total	833	404	429	347	167	319	217,121.6	37,345.5	2,238.3	256,705.4

Source: Compiled by the Author from

Ministry of Economy & Commerce : Commercial Registry Files of Existing and Closing Down Establishments. Survey Oct. 1982.

Note : Ownership tabled as "Partnership" involves both Qataris and non-Qataris.

The Labour Force of SSI

Table 6.24 shows the 1980 estimation of labour force employed in SSI by sector. The total employment is estimated by the author to be some 8,640 persons which gives an average of 10.4 persons per establishment. The largest employment group lies within the food industry, whilst the largest average number of employees per establishment is found in the industrial gases plants. The number of Qataris, on the other hand, are very small compared to other nationalities. The Qatari labour force in the SSI is believed to compose around 4.5 per cent of the 1980 total, i.e, a total of 389 persons. This figure in fact represents owner/employers rather than employees.

Table 6.24 : Estimation of SSI Employment in 1980

	Number of Establishments	Estimated total labour force	Estimated average per establishment
Stone Crusher	18	360	20.0
Food Industry	304	2,949	9.7
Carpentry	168	2,050	12.2
Industrial Gases	3	87	29.0
Bricks & Tiles	177	2,053	11.6
Iron fabrication	163	1,141	7.0
Aluminium Assembly			
Total	833	8,640	10.4

Source : Fieldwork

Prospects for SSI

There are, at the moment, several factors affecting the contribution of SSI to the national economy of Qatar. The most important of these are :

a) The size of the domestic market : It is well-known that the size of the domestic market plays a vital role in determining the size of manufacturing operations and their range of activities. Qatar's market, however, is characterised primarily by its small size, and, although there is no restriction whatsoever on exporting and re-exporting, the entrepreneurs prefer to confine themselves to supplying local demand. They have not, until recently, found any attraction in the idea of exporting their establishments' outputs (see also Chapter 10).

b) Inadequate governmental direction : The government, apart from licencing and registering new and wound-up establishments, has no control on the setting up of new industrial establishments, neither in terms of the operation size nor of type. This essentially laissez faire, free economy situation, and the market gap opportunity approach of individual entrepreneurs has led to imbalances between the various industrial fields (see also the conclusion to this chapter).

c) Working under capacity : As a direct result of a) and b) above mentioned, the author found during fieldwork that most, if not all, of SSI establishments were working at a rate of two thirds, and sometimes even one third of their daily or annual capacity. This appeared particularly clear in plants in the newest field, plastic products.

The prospects for each existing field of SSI are evaluated as follows:

a) Stone crushers : The activity of these plants depends mainly on the construction industry which, in turn, mainly depends on government expenditure. In 1980 the import statistics showed that there were some quantities of crushed stone still being imported from abroad, especially from Jordan and Lebanon. These imports include not only materials unavailable in Qatar (see Chapters 2 & 5)

b) Food industry : There is no doubt that the demand for the food industry's products has grown in recent years and will continue to grow in certain categories. Therefore, the number of establishments, especially of bakeries, is expected at first to grow, but at a very slow rate and are later most likely to decline. This is mainly due to the trend, already established, of setting up large establishments (both in terms of size and issued capital), which will put some of the smaller ones out of business. The number and type of dairy and soft drink establishments are expected to remain the same, but they probably will continue to work at less than full capacity. Import statistics do not allow the detailed separate identification of processed foods, but personal observation suggests the following facts and trends. Almost all Qatari households continue to rely on fresh or only partly processed basic food ingredients which are then made up in the house e.g. fresh or frozen meat, vegetables etc. The domestic market for "convenience foods", i.e. frozen made-up meals remains very limited. However, the non-Qatari population, which, as noted in Chapter 3, has a varied ethnic mix, is significant. "Western" expatriates, on the other hand, tend to have a much larger demand for processed foods, whilst Indians, Pakistanis and Iranians (the largest group) tend to have demands similar to the Qataris. Therefore, at the moment, the market attraction for new types of processed food industries is limited and the range and volume of domestically produced agricultural and fish products for local processing is equally limited. There may be a sufficient change in Qatari consumption habits in the future to make innovation possible. Under some circumstances, particularly big cities, i.e. million plus population, as neighbouring Riyadh and Jeddah, such changes are already attracting, not only a fast growing flood of processed food imports,⁽¹¹⁵⁾ but also local investment. The total market demand volume in Qatar, is bound, however, to remain small because of the small population size.

c) Carpentry : The main obstacle to the survival and growth of carpentry and joinery manufactures in the domestic market is the competition of imported ready-made furniture which amounted in 1980 to be QR 161.2 million. Carpentry establishments, in 1980, were working only at less than half of their capacity and they only manufacture to order. But if local carpentry and wood working establishments change their output to suit contemporary general taste and reduce unit costs, only then can they win the local market.

d) Industrial gases : This sector has a great chance to develop and expand in the near future. This expectation is based on the small number (3) and the small size of establishments now involved in this field as well as the reported unsatisfied local demand by the increasing number of various users of gases, i.e. soft drinks plant, hospitals, welding shops, etc.

e) Bricks and tiles : The development prospect for bricks and tiles is in a dilemma. This is mainly due to, firstly, the great early rush to establish brick and tile making plants in response to rapidly rising demand and the high selling prices, which could be obtained. However, there may now be over-capacity of production and the less efficient plants may have to be shut down. Secondly, the growing demand for imported tiles, which in 1972 amounted to 1,761 tons worth QR 1.7 million, increasing in 1978 to 27,225 tons worth QR 37.0 million. This potential market for domestic industries is large even if total demand falls, but here too, home industries have to meet present and future high quality specifications. The decline of building and construction especially during 1978/79 and lately during the 1982/83 oil crisis has totally confused the situation at present and the short-term future is equally unclear.

f) Iron and steel fabrication and turning : In the author's opinion there is little future prospect for growth in iron fabrication and most likely the total number of establishments may decline in the near future. This is mainly because the demand range of fabricated products is restricted. The growing demand for aluminium frames (windows, doors, etc.) is destroying the once important iron fabrications market and the changing from iron water tanks to fibre-glass has had a similar result. Iron and steel turning, on the other hand, has relatively good expectations, mainly due to the demand for machinery repairs by the increased number of SSI with installed machinery and equipment, as well as that in the heavy public sector industries. So far there has not been any development of the standardised production of light structural steel units ready for assembly since the building contractors will only supply a complete building against a specific firm order.

g) Aluminium assembly : It is expected that the assembly of aluminium forms will continue to develop even further, and probably will replace iron fabrication. So far, aluminium forms produced in the Gulf region, e.g. by ALBA in Bahrain, have not been significantly imported.

h) Plastic products. The future of such private sector industries is unforeseeable. This is a field which is rapidly changing. The total number of plants, in 1982, is believed to be more than 15 of which seven were then operational. All but one are designed only to produce plastic bags for the local market and one is known also to produce extruded plastic pipes. There is severe competition from very cheap imported plastic products. At the moment, the relative advantage which hypothetically results from the local production of basic chemical feedstocks does not exist (see Chapter 6 for a consideration of inter-industry linkages). It is not surprising that relatively large production lines are working now at half of their nominal capacity

or less. The future here is partly governed by whether entrepreneurs are prepared to look outside the limited national market for specific products, but mainly on whether the inter-industry linkages, considered in the conclusion to this Chapter, can be fully developed. There is also the problem of competition from other industrialising Gulf countries, a problem considered in the Conclusion to this whole study.

6.8 Current Large Scale Development

There are, additional to the major enterprises already considered, other large scale industrial developments which have either very recently come onstream or are at the planning stage.

6.8.1 Petrochemical Industry

The first pre-feasibility study concerning the establishment of a petrochemical complex in Qatar was carried out in 1962, ⁽¹¹⁶⁾ but the project was completely set aside until the early 1970's. In 1973-74 studies were initiated to investigate the various ways in which to utilize the NGL plant output. ⁽¹¹⁷⁾ On 27.6.1974 the government of Qatar signed an agreement with C.d.F Chimie of France to establish two joint venture petrochemical plants, one of them in France, the other in Qatar. ⁽¹¹⁸⁾ On 2nd September 1974, the Minister of Finance & Petroleum passed Resolution No (3) of 1974, permitting the collaboration of two French companies; C.d.F Chimie and Gazocean, with Qatar Petrochemical Company (QAPCO). On the same day, the Amir signed Decree No (109) of 1974 establishing QAPCO with an initial capital of QR 240 million, divided as follows:

	% of the shares	Value in million QR
State of Qatar	80	192
C.d.F Chimie	15	36
Gazocean	5	12
Total	100%	240

The company was formed for an initial period of 25 years, to be extended by mutual agreement. In November 1974, QAPCO signed four agreements, three with C.d.F Chimie whereby C.d.F Chimie undertook to 1) supervise on site and co-ordinate different contractors, 2) provide a management team for the company and the plant and 3) market overseas Low Density Polyethylene (LDPE) for a period of 10 years. QAPCO's fourth agreement was with Gazocean which undertook to market the ethylene output for a period of 10 years.⁽¹¹⁹⁾ In June 1975 the governmental shares in QAPCO were taken over by QGPC.⁽¹²⁰⁾ In October 1976 Gazocean relinquished its original shareholding and, as a result, the shareholding in QAPCO became 84 per cent by QGPC and 16 per cent by C.d.F Chimie. At the same time the share capital of QAPCO was increased to QR 360 million.⁽¹²¹⁾

In May and June 1977, QAPCO had signed four agreements for the construction of the complex:

- 1) The polyethylene plant contract was awarded to Coppee-Rust of Belgium, valued at QR 450 million. This plant has a capacity of 140,000 tonnes of LDPE per annum.
- 2) Technip of France was awarded the contract to build the ethylene plant of 280,000 tonnes a year capacity. The contract was worth QR 900 million.
- 3) Offsite facilities contract was given to Japan Gasolene Corporation.
- 4) Turbotechnica of Italy was appointed to build the steam and power plant.

Several other contract agreements were signed with different European firms for minor works, such as digging a canal for waste seawater, a small desalination unit, installation of sulphur bulk-loading and a jetty crane.⁽¹²²⁾

The location of QAPCO complex is in Umm Said in an area of 1,050,000 sq.m. between QAFCO and QFMC to the south and QASCO to the north.

The complex, which involved a total investment of QR 2,600 million, started production in December 1980, ⁽¹²³⁾ with a total annual capacity of

280,000 tonnes of pure ethylene

140,000 tonnes of low-density polyethylene (LDPE)

40,000 tonnes of sulphur

5,000 tonnes of propylene

The plant was officially inaugurated in February 1981 and it was estimated that the capital invested should be repaid within seven years.

At the end of 1979 336 persons were employed by QAPCO; ⁽¹²⁴⁾ at the beginning of 1981 the total labour force was 650 persons of which 14.6 per cent were Qataris. ⁽¹²⁵⁾ The division-wise distribution of QAPCO labour force in 1981 was as follows: 65 senior staff (60 French), 125 intermediate employees and 460 workers. ⁽¹²⁶⁾

The total production of QAPCO during the first half of 1981 was 63,277 tonnes of ethylene or 45 per cent of the total capacity, 55,044 tonnes of LDPC, that is to say 78.6 per cent of the plant total capacity and 2,778 tonnes of sulphur, about 11 per cent of the total capacity. ⁽¹²⁷⁾ The company's production rate has not as yet met expectation, mainly due to the shortage of feedstock. This shortage was mainly due to the corrosion of offshore NGL and gas pipelines which considerably reduced the volume and regularity of flow.

6.8.2 Natural Gas Liquids (NGL)

It is useful first to divide the NGL plants into three groups: NGL, NGL 1 and NGL 2.

1) NGL

In March 1971, QPC announced its independent intention to build a factory for the purpose of exporting NGL. In the same year of the announcement, the company carried out the engineering work as well as the site survey, and by the beginning of 1972 the work on site started by site preparation. Shell International was appointed to act on behalf of QPC as the technical consultant.⁽¹²⁸⁾ During 1972 QPC signed several contracts, in respect of erecting the plant, with several international and local companies (none of the companies' names are available). The total cost of QPC's NGL plant was estimated around \$25 million.⁽¹²⁹⁾ (approximately QR 250 million). In early 1975 the plant, which is located in Umm Said, to the north of the oil terminal, started operation⁽¹³⁰⁾ with a designed capacity of 340 MSCFD* of natural gas as feedstock. The output design capacity was:⁽¹³¹⁾

Propane	20,000 b/d
Butane	8,000 b/d
Natural gasoline	4,000 b/d

The actual production of the plant varied between the summer and winter months,⁽¹³²⁾ for instance -

	Summer	Winter
Propane	16,000	14,000 b/d
Butane	9,000	6,000 b/d
Natural gasoline	6,000	3,000 b/d

In 1975 the company, however, exported about 949,843.4 barrels of propane, 675,799.7 barrels of butane and 241,798.1 barrels of natural gasoline.⁽¹³³⁾

The 3rd April, 1977 marked the end of QPC's NGL plant which was destroyed completely by a mysterious fire.⁽¹³⁴⁾

* Million Standard cu.ft./day.

2) NGL 1

Qatar, mainly due to its obligation to other domestic and international markets did not take long to recover from the destruction of NGL. In the second half of 1978, Qatar started to reconstruct NGL 1 on the same site as NGL. Qatar was advised that utilizing the same engineering and basic documents of the old plant would ensure a reduction in overall costs. ⁽¹³⁵⁾ In addition, all the gas collection facilities in Dukhan, as well as the pipelines, were still operational.

The construction of this plant took almost three years, and in 23.2.1981 the Amir officially inaugurated the plant. ⁽¹³⁶⁾ The plant, which involved capital investment of about QR 300 million, had an output design capacity of

Propane	740 tonnes/day
Butane	470 " "
Natural gasoline	310 " "

In addition the plant will produce 24 MSCF_A^{per day} of ethane-rich gas which forms the feedstock for QAPCO, and 140 MSCF of methane-rich gas ⁽¹³⁷⁾ which is consumed as fuel or feedstock in other local industries, particularly QAFCO. (see Fig. 6.3).

3) NGL 2

The major source of gas for industrial and other usage was obtained, until recently, from the onshore oilfield, while all natural gas from offshore fields was 'flared'.

On 4th September, 1974, the government and Shell International (Gas) Ltd, signed the original document of establishing the Qatar Gas Company Ltd. The aim of the company, according to the basic statute was to carry out feasibility studies for developing project(s) in respect of the production of NGL and LNG in Qatar. Article (5) of the Statute limited the share capital to QR 400 million, divided over

40,000 shares. The government contributed 70 per cent of the capital and Shell International made up the balance. (138) On 22nd October 1974 the Amir signed Decree No (133) of 1974, establishing the Qatar Gas Company.

The project, on 1st December, 1976, became the possession of QGPC and Shell remained only to give technical assistance and to act on the account of QGPC as a consultant for the project. (139)

The main object of the NGL 2 plant is to utilize fully offshore associated gas. The work on site was started in January 1977 on a location near to NGL 1, so use can be made of the existing support facilities. The Amir had inaugurated the plant at the same time as NGL 1. NGL 2, which had a total investment of QR 1,400 million, (140) has a design capacity of

Propane	220 tonnes/day
Butane	730 " "
Natural gasoline	73 " "

In addition to the previous output the plant will produce 28 MSCF per day of ethane-rich gas and 110 MSCF per day of methane. (141)

Following the merger of the management of the two plants NGL 1 and NGL 2, the total number of staff reached about 300 persons. (142)

The total production of the two plants in the first half of 1981 was as follows: (143)

	In Tonnes	% of Prod./Capacity
Propane	118,445	38
Butane	78,462	35
Natural gasoline	59,628	31

The main reason for the low production quantities, as with QAPCO, is interruption in the gas-gathering offshore NGL and gas pipeline flows.

On sale operation, NGL 1 - 2 had sold 177,275 tonnes of light

Fig. 6-3 Sketch Plan of NGL

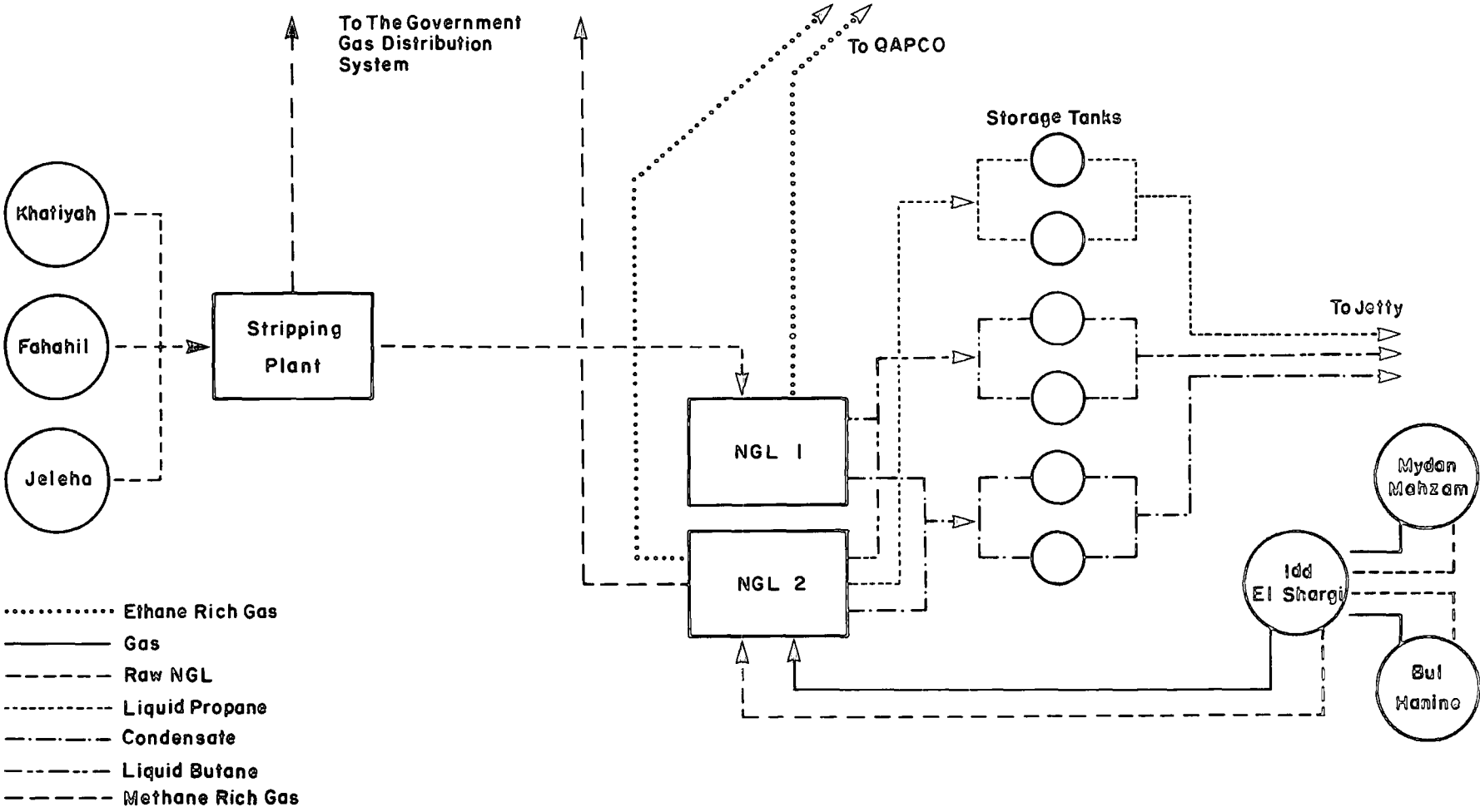

gases* (LPG) (of which 2,070 tonnes were sold locally), and a total of 35,328 tonnes of condensate ** (of which only 135 tonnes were sold locally). (144)

Conclusion

One of the most important aspects of industrialization, whether it be looked at from the point of view of the growth pole concept or that of industrial aggregation, is inter and intra-industry linkages between and within the industrial sector. These linkages can be identified as associated with the basic industries considered in Chapters 5 and 6.

Despite the fact that each one of the public sector industries has been considered here, and indeed were conceived, separately in a unique context, Figure 6.4 illustrates the position of inter-industry linkages as they appear to have been in 1970, as they are now and the way in which they seem to be developing, because here, perhaps, lies one of the keys to the future.

The diagram of linkages has been constructed around the basic heavy industries of the public sector, particularly those associated with hydrocarbons. These industries are the central dynamo of the growth pole model. A review of trends indicates that between the basic industries, there are already established some inter-industry linkages, the basis for them all being associated and, increasingly, unassociated natural gas. The linkages between QASCO and QNCC also include the transfer of lime and iron dioxide. The operation of QAPCO, on the other hand, depends heavily on the performance of NGL 1 and 2.

There are also the linkages between the public sector basic industries and the down-stream private sector, the small - scale industries (see Figure 6.4)

* Consist of propane and butane liquids.

** Natural gasoline.

In some cases there can be identified potential internal linkages, which might develop as the result, for example of the extension of QAPC operations into HDPE and PVC polyester resins which are not yet established but which hypothetically could be established. QASCO, on the other hand, in its present form is strongly tied to the construction industry. This is due to the fact that almost the whole of its present product is reinforcing bars. Future production would still mainly be associated with construction materials but there could be some possible development of different kinds of products (see Figure 6.4).

The future of the two most recent major establishments, QASCO and QAPCO, apart from the internal growth of production linkages and also externally with other industries, is at the moment rather difficult to forecast, since both are heavily export oriented. The way in which other similar industrial ventures, particularly in the QAPCO type field are being developed on a much larger scale in Saudi Arabia raises very considerable problems and this perhaps can only be resolved by regional co-operation. In terms of steel, the growth of steel making capacity in the Gulf is, on the face of it, less threatening, except for the fact that most of the steel making capacity is aimed at the local construction industry, and it is the ups-and-downs of the construction industry which will affect the future of QASCO.

In each of the public sector industries studied, a short statement was made of the financial status, as described by income and expenditure for the most recent years available. In no case ^{can} direct government inputs of capital, either for establishing or expansion of plant, be shown either on the debit side or due for repayment. In all these cases, therefore, one has a situation in which much of the capitalization of the basic industrial organization has been in the nature of expenditure (in addition to infrastructural provisions), expenditure which the government has been prepared in effect to write-off. The profit and loss account is strictly a nominal statement of an excess of income over current expenditure. It is impossible to present any other estimation of the status of the companies.

Fig. 6.4 Inter and Intra- Industrial Linkages

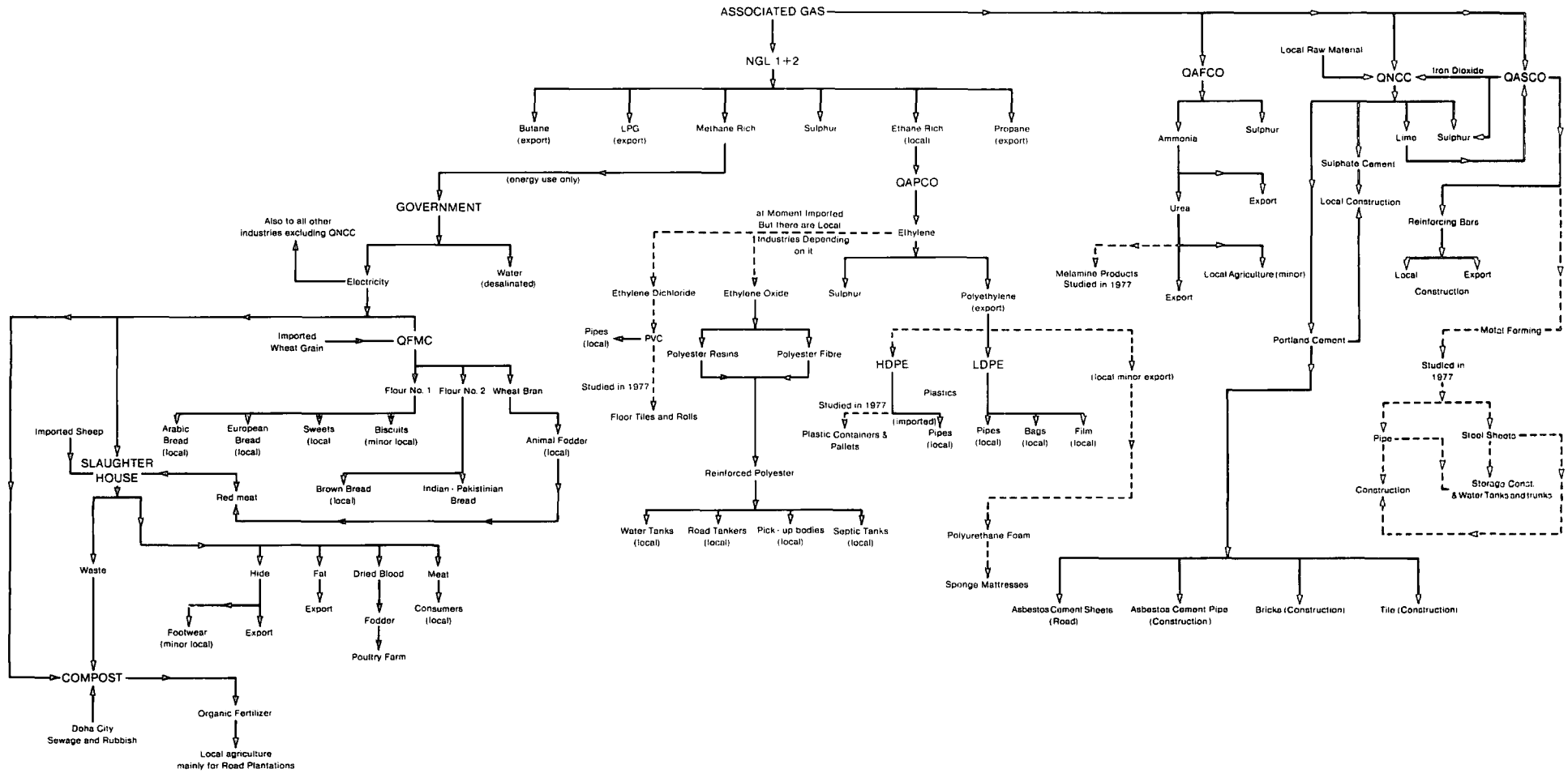

CHAPTER 6

References

- (1) See Petroleum Development (Qatar) Ltd, Memo No.GML 6/3029
2.11.1952; and
Government of Qatar, Letter from the Ruler to the Chairman of
Qatar Petroleum Company in London dated 13.7.1953.
- (2) Petroleum Development (Qatar) Ltd., Minutes of Meetings in
General Manager's Office, Dukhan, Qatar 15.2.1953.
- (3) Qatar Petroleum Company, Topping Plant Operations and Availability
of Products, as Related to the Cost of and Necessity for
Import, Umm Said 18.10.1957.
- (4) Qatar Petroleum Company, Topping Plant Products & Purchased from
Shell Markets Finance Department Qatar 3rd March 1968.
- (5) Qatar Petroleum Company, Memo No CRQ/TO/3/3846 to the Head
Office in London 6/8/1958.
- (6) Abu Naab, I., Qatar : a Story of State Building, Ministry of
Information Qatar (c.a. 1978) p.10.
- (7) Qatar Petroleum Company, Topping Plant Operation, op.cit.
- (8) Ministry of Finance & Petroleum, Oil Industry in Qatar 1972,
Petroleum Affairs Department, Qatar, p.56.
- (9) Ministry of Finance & Petroleum, Petroleum Concession Agreements
& Laws Petroleum Affairs Dept., 1973, Qatar, pp.106-124.
- (10) Ministry of Finance & Petroleum, Oil Industry in Qatar 1972,
op.cit. p.56.
- (11) Ibid.
- (12) Ibid, p.57.
- (13) IDTC, Qatar Achievements in Industry Development, Qatar, 1981, p.34.
- (14) Ministry of Information, Qatar Year book 1976, Press and Publication
Department, Qatar, 1977, p.81.
- (15) IDTC, op.cit., p.34.
- (16) Ministry of Economy & Commerce, Economic Survey of Qatar 1976-77,
Qatar 1978, p.30.
- (17) State of Qatar, Speech of Qatar Representative in a seminar
on the Prospects of Arab Refining Industry organised
by OAPEC, held in Damascus 18-23 October 1975, Kuwait
1976, p.203.

- (18) UOP Management Services Inc, Process Feasibility Study, Revised Cases, Qatar 11 November 1976.
- (19) QGPC, Special Report on the New Refinery Project, Qatar, 1981.
- (20) UOP Management Services Inc, op.cit.
- (21) Ibid.
- (22) Petroleum Development (Qatar) Ltd, Minutes of Meetings, op.cit.,
- (23) Seltrust Engineering Ltd, Investigation of the Development Potential of Mineral Occurrences in Qatar, Vol.1 Summary & Review of Geology & Mineral Resources of Qatar, 1979 (bibliography).
- (24) Ministry of Justice, Collection of Qatar's Laws 1962-75, Legal Affairs Department Vol.2, Qatar 1979, pp.880-882.
- (25) QNCC, Chaplet of Establishment & Basic Statute, Qatar 1965.
- (26) Ministry of Economics & Commerce, Economic Survey of Qatar, Qatar 1979, p.36.
- (27) QNCC, Special Issue Commemorating the Opening of Qatar Cement Work, Qatar 1969, p.7.
- (28) Ministry of Information, Qatar Into Seventies, Qatar (c.a.1973) pp.97-98.
- (29) QNCC, Special Issue op.cit., pp.11-13.
- (30) Ministry of Finance & Petroleum, Petroleum Concession Agreements & Laws, op.cit. p.
- (31) QNCC, Special Issue op.cit., p.9 and pp.14-15.
- (32) QNCC, Fourth Annual Report 31.12.1969, Qatar 1970, p.3.
- (33) See QNCC , The Annual Report (1969-80), Qatar.
- (34) QNCC, Annual Report 1980, Qatar 1981, p.11.
- (35) Personal Communication
- (36) Ministry of Information, Qatar Into Seventies, op.cit. p.98.
- (37) QNCC, Fourth Annual Report, op.cit. p.8.
- (38) Ministry of Finance & Petroleum, Yearly Bulletin of Imports for 1970, Customs Department, Qatar, 1971, pp.1-10.
- (39) QNCC, Annual Report 31.12.1971, Qatar, 1972, p.6.
- (40) QNCC, " " 31.12.1976, Qatar, 1977, p.13.
- (41) QNCC " " 31.12.1977, Qatar, 1978, p.13 and
QNCC " " 31.12.1978, Qatar, 1979, p.12.

- (42) QNCC, Annual Report 31.12.1976, op.cit., pp.9-10.
- (43) IDTC, Industrial Development in Qatar, Qatar 1978, p.58.
- (44) Arthur D. Little Inc. (Incomplete Report), p.112.
- (45) Ministry of Justice, op.cit., p.897.
- (46) Ibid, pp.904-910.
- (47) Ibid, p.898.
- (48) Ministry of Information, Qatar Into Seventies op.cit., p.99, and QNFC, Annual Report and Accounts of 1969, Qatar 1970, p.3.
- (49) The Council of Ministers, Memo on the Meeting No (23) of 1980, Qatar, 19.6.1980.
- (50) State of Qatar, Amiri Resolution No. (17) of 1980, Amiri Palace, Qatar, 7.9.1980.
- (51) Ministry & Overseas Development, Economic Survey of Qatar, 1971, Middle East Development Division, British Embassy, Beirut, p.34.
- (52) Ministry of Economy and Commerce, Economic Survey of Qatar, 1974-75, Qatar, p.13.
- (53) Ministry of Economic & Commerce, Economic Survey of Qatar, 1978, Qatar, p.36.
- (54) Personal Communications with Gazi Al-Salmi, Director of QFMC.
- (55) Ibid.
- (56) Ministry of Justice, op.cit. pp.924-925
- (57) Personal Communication with Gazi Al-Slami.
- (58) QFMC, Special Report on the Company Activities, Qatar 1981.
- (59) Ministry of Information, Qatar into Seventies, op.cit. p.97.
- (60) Ministry of Economy & Commerce, Economic Survey of Qatar 1969-73, Qatar, p.
- (61) Buhairi, S. & Al-Fara, M., Sides of Qatar Geography, Royal Scientific Society Press, Jordan, p.81.
- (62) QFMC, op.cit.
- (63) Abstracted by the Author from QFMC's files.
- (64) Personal Communications.

- (65) Ministry of Information, Qatar Year Book 1980-81, Press and Publications Dept. Singapore, p.160.
- (66) QFMC, Special Report on the Manpower from 1972-80, Qatar 1981
- (67) Ministry of Economy & Commerce, Economic Survey of Qatar 1977, Qatar, p.41.
- (68)* Personal Communications.
- (69) Ministry of Economy & Commerce, Economic Survey of Qatar 1978, op.cit., p.36.
- (70) " " " " 1980. Qatar, p.36.
- (71) Ministry of Education, Qatar Progress, Qatar, 1964, p.37.
- (72) Al-Kuwair, A.K., Oil Revenues in the Gulf Emirates, Bowker/Durham University, G.B. 1978, p.117 and
OPEC, Annual Statistics 1979, p.169, T.112.
- (73) Gibb-Ewbank Industrial Consultant, The Feasibility of Establishing a Nitrogenous Fertilizer Plant, Government of Qatar, Qatar, April 1968, p.1.
- (74) Ibid. p.2.
- (75) Ibid. pp.3-4.
- (76) QAFCO, QAFCO's Pamphlet, Qatar December 1970, p.8.
- (77) Ibid. p.10.
- (78) Ministry of Information, Qatar Into Seventies, op.cit., pp.95-96.
- (79) Ministry of Finance & Petroleum, Oil Industry in Qatar 1976, Petroleum Department, Martins Press, England 1977, p.30.
- (80) IDTC, Industrial Development in Qatar, op.cit., p.52.
- (81) QAFCO, QAFCO's Pamphlet, (c.a. 1980), p.9.
AFCFP, AFCFP Quarterly Journal Vol.1, No.4 Kuwait, December, 1979, p.10.
- (82) Nahawi, Z.S., QAFCO II, Qatar 19.7.1979, p.1.
- (83) QAFCO, An Industry from Flared Gas, Qatar (c.a. 1979), pp.18-20.
- (84) QAFCO, QAFCO's Pamphlet, (c.a. 1980), op.cit p.7.
- (85) QAFCO, An Industry from Flared Gas, op.cit. p.9.
- (86) QAFCO, Sales Statements of 1974 Shipping Department, Umm Said 1975, p.1.

- (87) QAFCO, Sales Statements of 1975 Shipping Department, Umm Said, 1976, p.1.
 - (88) Khalaf, A.H., QAFCO As... A Pillar of the National Economy, Abrajuna, a Quarterly Magazine, No 3 of 1980 QAFCO pp.3-4.
 - (89) QAFCO, Sales Statements of 1978, Shipping Department, Umm Said 1979, p.1.
 - (90) " " 1980, " " Umm Said, 1981, p.1.
 - (91) " " 1974-80, " " Umm Said
 - (92) Whinney Murray & Co., Report of the Auditors of QAFCO as at 31.12.1979. Qatar, 1980.
 - (93) QAFCO, Qatar Fertilizer in Brief 1980, Qatar 1981.
 - (94) Abstracted by the Author from QASCO's files.
 - (95) IDTC, Resume of a Feasibility Study for an Integrated Steel Plant in Qatar, Qatar 1973, p.7.
 - (96) Ibid. p.13.
 - (97) Ibid. p.17.
 - (98) QASCO, Outline of QASCO (c.a. 1978) p.35.
 - (99) QASCO, The Steel Mill Project, Qatar (c.a. 1978) pp.38-39.
 - (100) Ibid. p.36.
 - (101) Data obtained from the questionnaire.
 - (102) QASCO, Department-Wise Manpower List as on 31.12.1979, Personnel Department, 1980.
 - (103) QASCO, Nationality-Wise Statement of the Manpower List as on 31.12.1980, Personnel Dept. 1981.
 - (104) QASCO, Department-Wise Manpower List as on 31.12.1981 Personnel Department, 1982.
- and also see MEED Special Report on Qatar, August, 1981, p.16.
- (105) QASCO, The Steel Mill Project, op.cit. p.38.
 - (106) QASCO, Nationality-Wise Statement of the Manpower List as on 31.12.1980 op.cit.
 - (107) Allam Al-Tijarat Magazine, Arab Steel Industry, Nov. 1979, p.24.
 - (108) MEED, op.cit., p.16.
 - (109) Al-Murgan Magazine, Qatar Forges Ahead, Gulf Hotel, Summer, 1978, p.25.
 - (110) QASCO, Special Report on Vairons Elements of QASCO, Qatar, 1981, p.3.

- (111) MEED op.cit., p.16.
- (112) IDTC, Resume of a Feasibility Study, op.cit., p.6.
- (113) Ibid.
- (114) Ministry of Justice, Official Gazette, No.1 of 1979, Legal Department, Qatar p.9.
- (115) Saudi Economic Review, Vol. XVII, No. 826, 3.8.1983, p.12.
- (116) Ministry of Education op.cit. p.37.
- (117) IDTC, Qatar Achievements in Industrial Development op.cit.p.46.
- (118) IDTC, Industrial Development in Qatar, op.cit., p.64.
- (119) Ministry of Information, Qatar Year Book 1976, op.cit., p.90.
- (120) IDTC, Qatar Achievements in Industrial Development, op.cit., p.47.
- (121) Ibid.
- (122) Gulf Times Newspaper, Special Issue Marking the Visit to Gulf States of Valery Giscard d'Estaing of France, Sunday March 2-8, 1980, p.IV.
- (123) MEED op.cit., p.21.
- (124) QGPC, Annual Report 1980, Public Relation Department Dominic Press, Singapore, 1981, p.31.
- (125) MEED, op.cit., p.21.
- (126) Ministry of Information, Qatar Year Book 1980-81, op.cit., p.132.
- (127) IDTC, Annual Report, 1981, Qatar p.9.
- (128) Ministry of Information, Qatar Year Book, 1976, op.cit., p.82.
- (129) Buhairi, S & al-Fara, M., op cit., p.78; and
Ministry of Finance & Petroleum, Oil Industry in Qatar, 1972, op.cit., p.59.
- (130) IDTC, Plans of Industrial Development, Qatar 1976, p.12.
- (131) Ministry of Finance & Petroleum, Oil Industry in Qatar, 1972, op.cit., p.59.
- (132) Buhairi, S., & al-Fara, M., op.cit., p.79.
- (133) Ministry of Finance & Petroleum, Yearly Bulletin of Imports, Exports & Transit, 1975, Customs Department, Qatar, 1976,p.98.
- (134) QGPC, Annual Report 1980, op.cit., p.29.

- (135) IDTC, Industrial Development in Qatar, op.cit., p.68.
- (136) Arrayah Daily Newspaper, ARticle on the Inauguration of QAPCO and NGL 1 & 2. Qatar, Tuesday 24.2.1981, p.3.
- (137) QGPC, Annual Report 1980, op.cit., p.29.
- (138) Ministry of Justice, Collection of Qatar's Laws, op.cit. pp.995-997.
- (139) IDTC, Industrial Development in Qatar op cit., p.70.
- (140) Ministry of Information, Qatar Year Book 1976, op.cit., p.85.
- (141) QGPC, Annual Report 1980, op.cit., p.29.
- (142) Ministry of Information, Qatar Year Book 1980-81, op.cit., p.133.
- (143) IDTC, Annual Report 1981, op.cit., p.12.
- (144) Ibid. p.13.

CHAPTER 7

LOCATION OF MANUFACTURING INDUSTRIES

In this Chapter the emphasis is entirely on two particular areas which have been deliberately developed by the government as industrial zones. Manufacturing industries in both the private and public sectors, together with some basic utilities, are also found in a few other parts of the peninsula, as well as in the city itself, but these are where the great concentrations lie. Umm Said has now become the great heavy industrial zone, whilst the Industrial Estate of Doha has become the main centre for private sector small-scale industries.

7.1 Umm Said Industrial Area

7.1.1 Introduction and historical background

"... and the Company (APOC later QPC) has the right to choose the port which may be suitable for exporting its substances..."

This phrase is a part of Article (6) of the original oil concession agreement which was signed on 17th May 1935. (see Appendix 5.1). But the power of this article was limited by Article (7) of the same agreement in which:

"... the Company has no right to acquire land occupied by the enterprise of the owners thereof and also houses, places and land which their owners decline to sell or to rent..."

Therefore, having in mind two facts that a) the population at the time was concentrated along the north, north east and east coastlines, as well as in the centre of the peninsula; and b) the coastal waters to the west are very shallow and the seabed is of hard rock, the company was forced to limit its choice of port only to the area south of Wakra village. When the company resumed its operation in 1947, following a war-time shut-down, it settled on the Umm Said area and toward 1949

the work on the oil storage tanks and terminal was complete. Interestingly, the name of Umm Said was neither recorded nor marked on maps before the year 1947.

Umm Said was almost ignored by the government until the end of the 1960's. This was due to several factors:

a) QPC had, as agreed by the government, full control over the Umm Said area. This control was requested by the company to cover the concentration of the oil terminal, storage tanks, topping plant and the company office and employees' residential campus. In addition, the company did not wish any disturbance to the traffic of oil tankers to and from Umm Said.

b) Although the government had it in mind to establish industries based on natural gas, these plans were delayed by the slow growth of oil revenue (see also Chapters 4 and 5).

c) The government's entire attention was directed to the improvement of the capital, Doha, and its facilities.

All these reasons and others contributed to the fact that the area was ignored, and increased the strain on relations between the government and QPC. In 1967, for instance, the government directed Gibb-Ewbank to make a feasibility study for establishing a chemical fertilizer plant in Qatar (see Chapter 6 pp. 172-175). Gibb-Ewbank's team strongly recommended a location at Umm Said, following which the government and the consultant team had discussions with QPC in order to locate the plant in Umm Said. The then QPC indicated in writing the area of the Umm Said marine terminal which they would wish to preserve exclusively for the oil-tankers (see Figure 7.1). Moreover, the company also wished to retain overall traffic control in the channel leading to both the oil terminal and the fertilizer jetty.⁽¹⁾ Umm

Fig. 7.1 Sea Depth and Approach to Umm Said

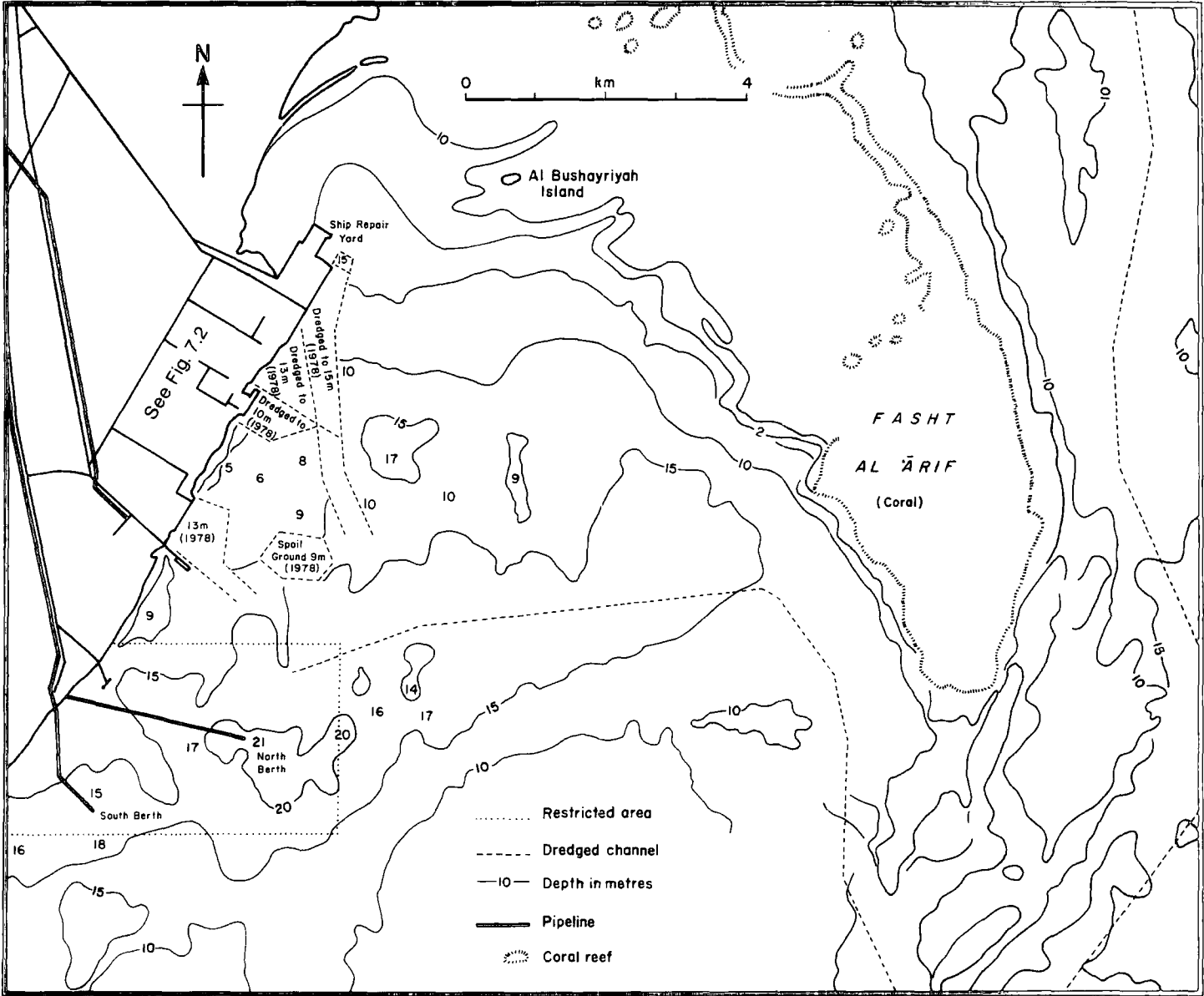

Source: Admiralty Chart No. 3787. Approaches to Musay'id and Al Danshah, Printed Feb. 1983

Said might be said to be an enclave of company territory over which the government appeared not to have full control.

Between 1967 and early 1972 there were several changes which occurred in Qatar as a whole and which affected the control of QPC over the Umm Said area:

- a) The rapid development of the offshore oil fields and their greatly growing contribution to the state revenue.
- b) The purchasing of the topping plant by the government.
- c) The establishment of full independence of the State of Qatar from British control.
- d) The transfer of power from Sheikh Ahmad to Sheikh Khalifa.

All these and other factors brought Umm Said to a more prominent place in government attention. This attention was not accidental but was greatly strengthened by the positive factors of safety and security which the area provided naturally (see below).

7.1.2 Location and Topography

Umm Said, as shown in Figure 7.2, is located on the south east coast of the peninsula, approximately 45 km to the south of Doha City and about 85 km to the south east of Dukhan Town. The area extends over a low promontory of solid ground which is surrounded by sabkha on sides away from the sea. The sabkha zone, 40 km long and 7-10 km wide, is frequently flooded by sea water during the spring, and storm tides produced by easterly winds.⁽²⁾ The area as a whole lies only 0-1.5 m. above sea level.⁽³⁾ (see also Fig. 7.2.B).

There are two areas where the terrain has different characteristics. First there are the sand dunes bordering Umm Said to the south, sizeable features which are not easy to cross by wheeled vehicles.

Fig 7.2 UMM SAID EXISTING CONDITIONS

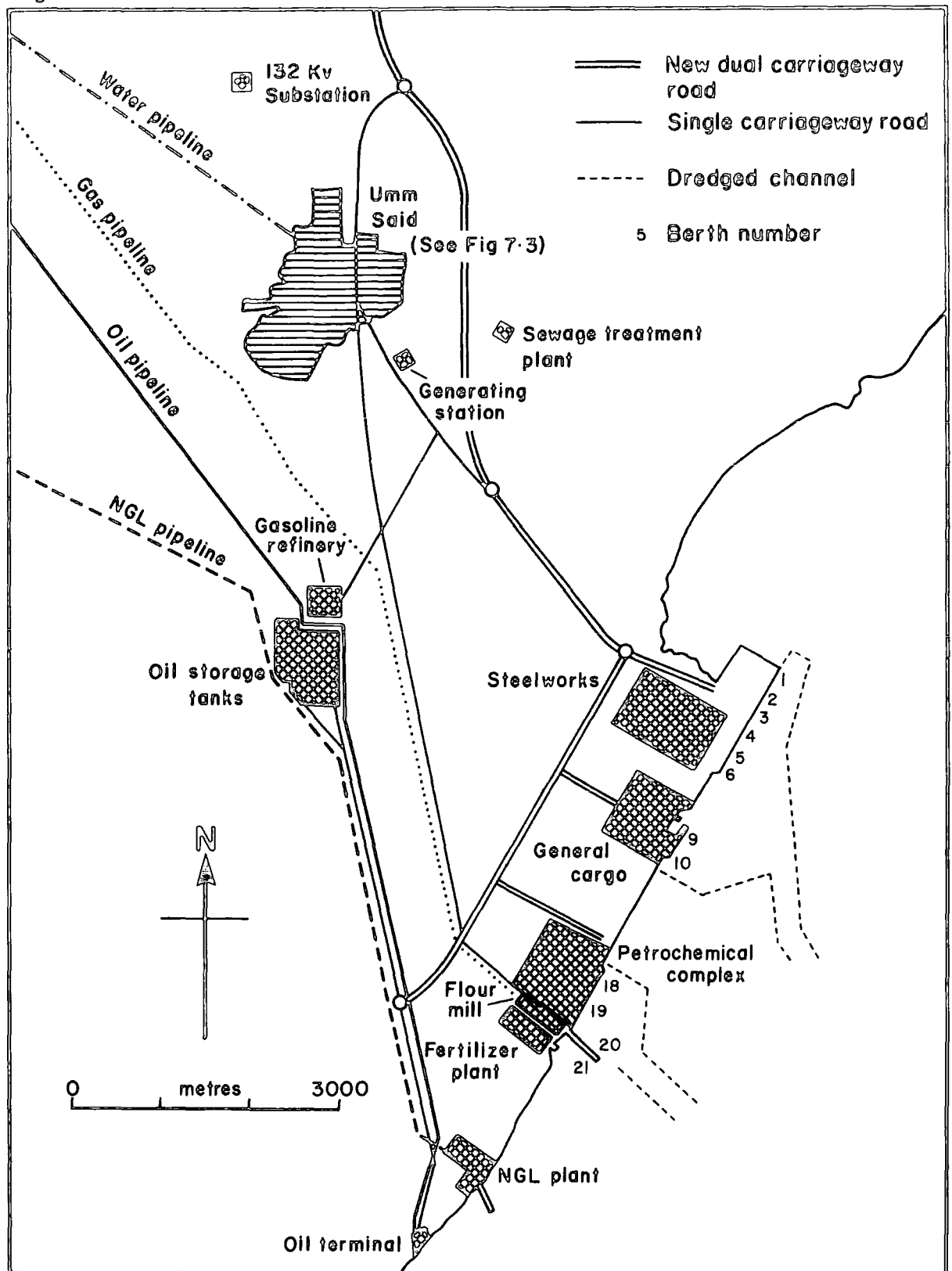
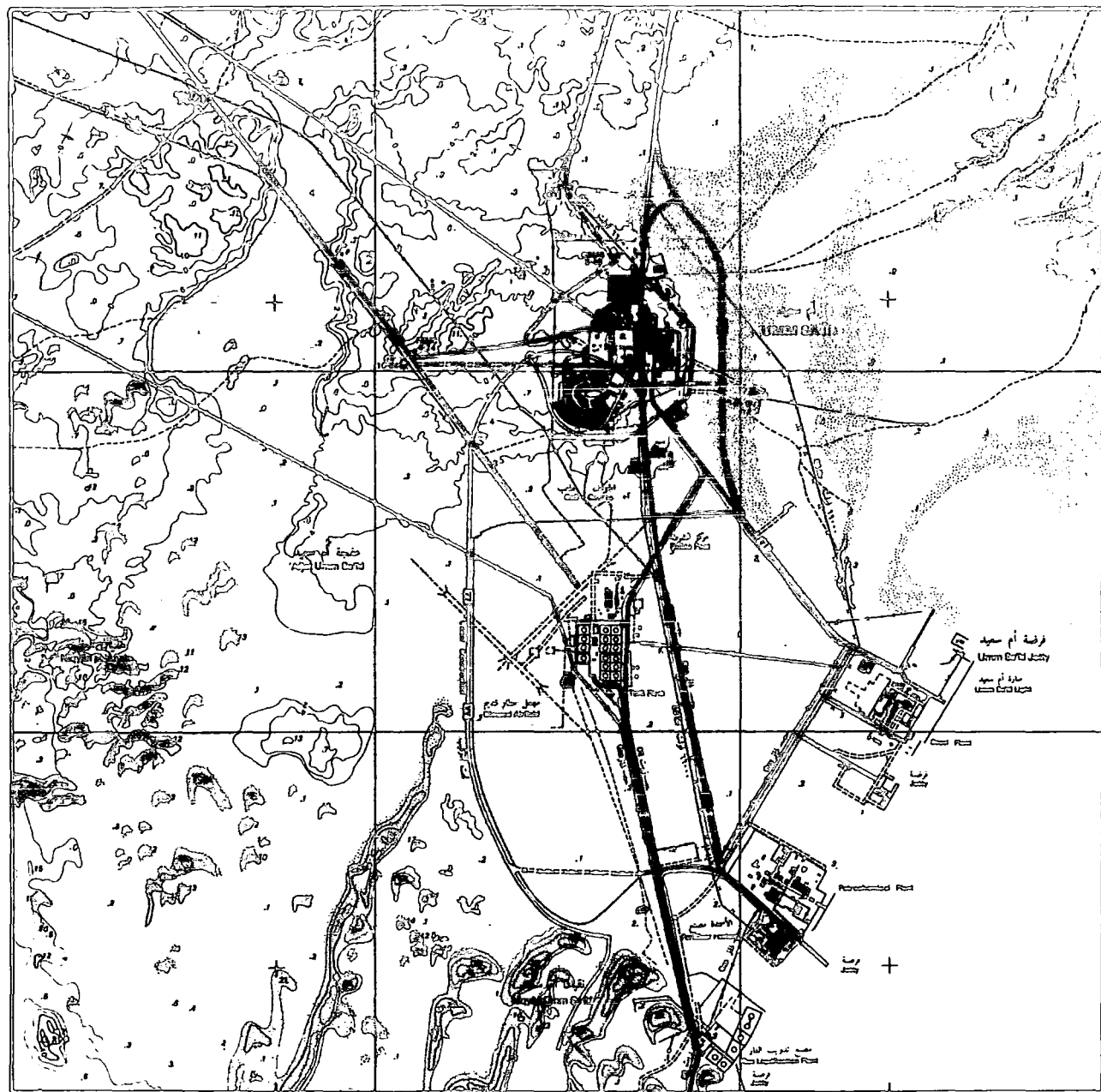

Fig. 7.2B Geomorphology and Layout of Umm Said 1982.



Sabkha
 Sand dunes
 Contour lines
 Electricity cables
 Pipelines

0 km 5

Source : Ministry of Public Works, Qatar's Maps, Sheet No. 200 / 350, Hunting Surveys, London 1982

These dunes, due to the prevailing winds, are not stable, having an annual average movement towards the south of about 8.0 m. ⁽⁴⁾ Secondly, there is a sandy knoll, about 10 km to the north east of the oil terminal, covered by sandy lithosols only 10-20 cm. deep overlying limestone bed rock. The knoll has a maximum height of about 9 m above sea level and its choice for residential development is the reason why Umm Said Town is away from the coastline. Other smaller sandy knolls are found close to the coast. They are of white oolitic sand of marine origin, with a common height of 1-3 m. ⁽⁵⁾ These minor features were critical in determining the detailed layout of installations in the area. (See Fig.7.2.b)

Umm Said, on the offshore side, is relatively well served with deep water close to the shore. The five fathom line (9.14 m) lies less than 2 km to the east of the shore, whilst the 10 fathom line (18.3 m) is only 4 km offshore (see Figure 7.1). The sea-bed near Umm Said consists of materials which have been amenable to navigation channel improvement by dredging : a) quartz and muddy quartz sand extends offshore to the east for some 4 km, followed by b) a mud formation of about 10 km wide, this in turn followed by c) muddy sand formation. To the north of the first two zones lie the Fasht Al-Arif coral reefs, ⁽⁶⁾ which actually protect Umm Said Bay from sea swell driven by the north easterly winds. A natural channel leading to the high seas runs northward through the coral formation.

7.1.3 The effect of climate

Although climatic conditions in Umm Said differ slightly from those of Doha, one can see a great deal of similarity between them. (see Chapter 2 pp.13-15) The weather seriously affects the storage and functional characteristics of production inputs, machinery and its performance. Corrosion of machinery, made worse by high atmospheric

salt content,* produces a significant reduction in its life expectancy. The government, through IDTC, has been forced to set up a cathodic protection programme for the port and other steel erections in Umm Said in order to limit corrosion.⁽⁷⁾ The labour force's dislike of weather conditions at Umm Said is one important reason discouraging citizens from taking employment there.⁽⁸⁾

7.1.4 Government policy

Umm Said, then, was created and set up by QPC, and remained in QPC possession until the early 1970s. The first official positive statement in respect of Umm Said was made by the Amir in 1973 as part of a public presentation of the kind of activities his regime was bringing for the benefit of Qatar.⁽⁹⁾ In 1974 the Amir, in a newspaper interview, said that in the Umm Said area one could see Qatar's future.⁽¹⁰⁾

Unfortunately, no official written statement of general government policy for Umm Said has been made. But from government and other sources we can identify the two main foundations of government policy towards Umm Said. First, there appears the intention to concentrate public or national basic industrial development in one area, which in this case is Umm Said, for reasons of safety and security; secondly, to create a new community in Umm Said to accommodate the labour force required to operate such industrial activities and to relieve the pressure on housing demand from Doha City.

The government, in order to fulfil these two main objectives, employed several governmental bodies to play their separate parts in the Umm Said development, particularly the Ministries of Finance & Petroleum, and Public Works. The area became controlled by one government agency only when IDTC was created. (see Chapter 4, pp.86-87).
The IDTC's main function in Umm Said is as coordinator between the

* This mainly due to the sabkha effect as well as high temperatures which produce a high rate of evaporation of sea and sabkha water.

various ministries for the development requirements of Umm Said, whilst at the same time to keep close contact with, and to monitor, government investment in the area, both in the industrial complex area and in the Umm Said township.

The latest government policy in Umm Said is to approve the establishment by the private sector, in certain areas outside the heavy industrial boundaries, of medium and light industries e.g. a cement clinker grinding mill, and several other types.⁽¹¹⁾

7.1.5 Site preparation and development

The first site prepared for industrial purposes in Umm Said was that of oil storage tanks and the oil terminal pump. The oil storage tanks area (as seen in Figure 7.2) was reclaimed and raised from sabkha, while the oil terminal pump was simply established on a small semi-stable sand dune. Both of these were achieved before 1950 by QPC. During the 1950's and 60's the coastline stayed almost unchanged. The development of Umm Said employees' camps and of offices proceeded especially after 1956 when the head office of QPC was transferred from Dukhan to Umm Said.⁽¹²⁾ From 1970 onward several major changes occurred on the coastline both inshore and offshore.

Whilst the cost of land in Doha City reached extremely high levels during the 1970's, the Umm Said land cost the government nothing, except for site preparation. This was mainly due to the fact that all the land in the Umm Said area is government property whilst that in Doha was, and is, in private ownership. The government therefore was able, relatively cheaply, to carry out extensive preparation of sites for the public sector industries, and to provide low or nil rent incentives, whilst retaining the ownership of the land.

The first site prepared by the Government was for QAFCO in

1970. In 1974 QPC started preparing a new site, to the north of the oil terminal, for the NGL plant (this plant caught fire and was destroyed completely in 1977). The then government decided further to develop the area between the NGL and QPC's Umm Said jetty, and work actually started in March 1975 and lasted till January 1978, development which completely changed Umm Said's coastal line.

The cost of preparation of the specifically industrial area can be seen in Table 7.1, although total expenditure on the whole area is not known.

Table 7.1 Statement of Government Expenditure in Umm Said
(in million QRs)

	Estimated total cost till end of 1398 H	Actual cost till end of 1397 H
Dredged port and site preparation for factories*	275	250
Other construction and port road	55	25
Mechanical equipment	90	30
Umm Said berths	300	285
	720	590

* QAFCO not included

Source : IDTC, Industrial Development in Qatar, 1978. p.105.

The government also proposed to allocate and develop the area to the north of the oil refineries for small scale industries but unfortunately there is no indication of the site preparation costs of this proposal which is still only at a preliminary stage of implementation.

7.1.6 Present development

Existing installations in Umm Said up to the end of 1981 are listed below: (see also Figures 7.2, 7.3).

1. An oil tank farm was established by QPC and expanded later by the government. This farm, at present, has 16 individual tanks with a total capacity of about 275,000 tons.
2. An oil tanker terminal with two submerged berths
3. Oil and gas pipeline networks
4. Two oil refineries (including old QPC's topping plant)
5. Two fertilizer plants
6. Flour mill plant
7. Steel Plant
8. Two natural gas liquefied plants
9. Petrochemical plant
10. An automatic bread-making factory.
11. A sewage treatment plant
12. 2,550 housing units, of which 750 are for families and 1,800 for bachelors
13. Warehouses
14. Water tank
15. A branch of Qatar National Bank
16. Port and port facilities
17. QAFCO's senior staff club
18. QAFCO's kindergarten
19. A few "corner" shops, three supermarkets, an unused tennis court, an open-air cinema and a golf course
20. Government facilities: a) all governmental bodies and agencies have offices in Umm Said
b) Two electricity substations
c) A 66 Kv generator station

(For more details of industrial plants and activities see Chapters 5 and 6)

Fig. 7.3 Umm Said Town as in 1982

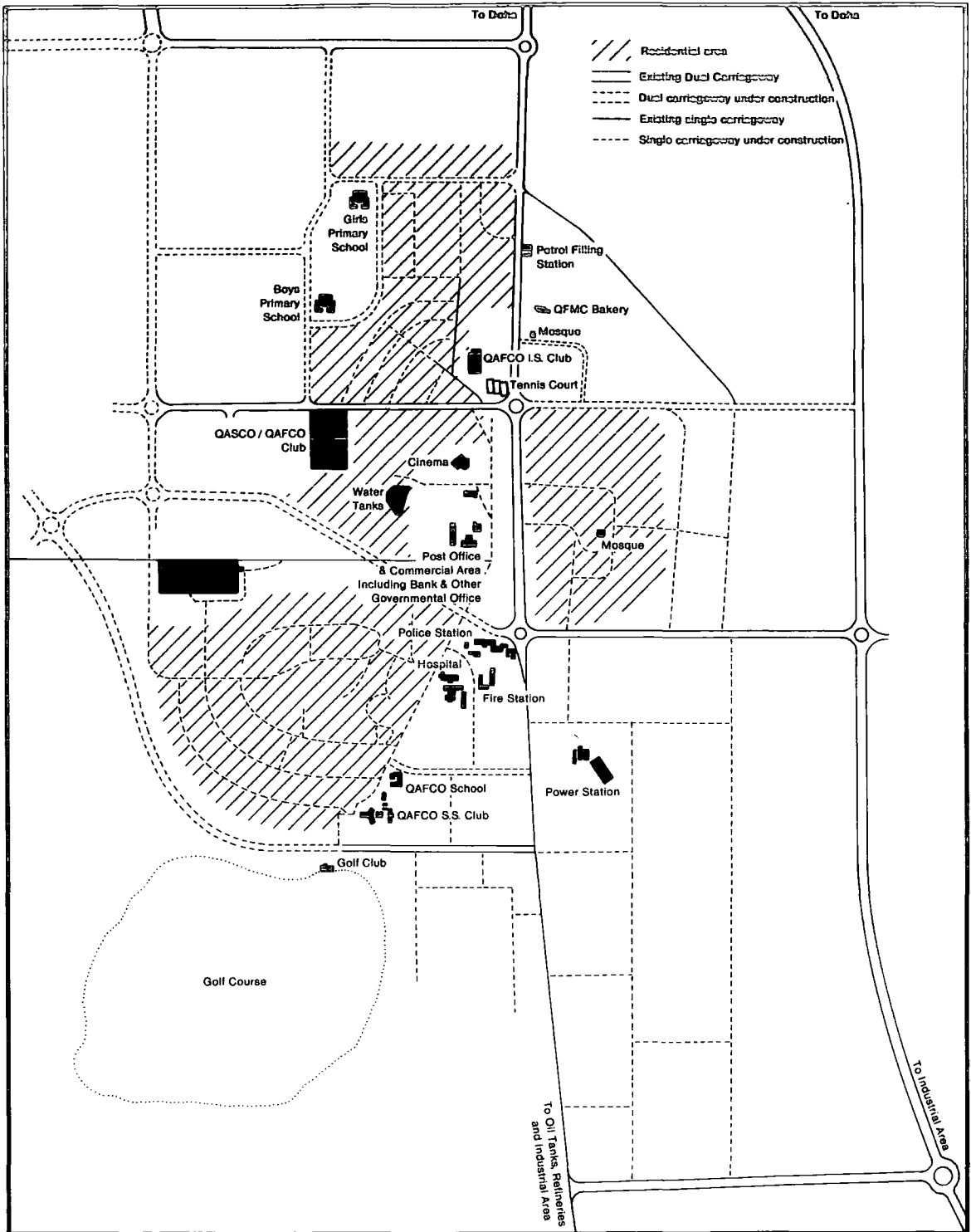

7.1.7 Infrastructural provision

There are three types of infrastructure provided in the Umm Said area. The first of these relates only to the industrial area complex, the second one is related to the township, whilst the third is related to both of these. In this part of the study we examine the development of infrastructure in the Umm Said area as a whole with only passing reference to the three divisions, because industrial development, ultimately, is the justification for all the facilities developed.

1. Transport facilities

Transport facilities in Umm Said now only comprise the seaport and roads. QPC established a small airfield but following the construction of good national road facilities, this airfield went out of commission in the mid 1960's.⁽¹³⁾

a. The seaport. Although the oil terminal was completed in 1949, QPC continued to receive its own imported machinery and equipment from Bahrain through the small west coast port of Zekrit, about 13 km to the north east of Dukhan Town. From 1952 until 1966, Umm Said, besides serving its original purpose as an oil terminal and the company port, became the main port for the Qatar peninsula as a whole.⁽¹⁴⁾ Although there is evidence that coastal modifications were considered from 1971 onward, no real action was carried out until after the Ministers' Council Resolution No (1) of 1975 which announced the 100 per cent take-over by Qatar of the oil Companies' assets.⁽¹⁵⁾ IDTC, through Sir Alexander Gibb & Partners, carried out a massive dredging operation to link the internal sea channel with the outer channel. The dredging operation was to provide sufficient deepwater for large ship manoeuvres and at the same time to reclaim a 650 hectare site for industrial development. The total cost of these operations

was about QR 250 millions.⁽¹⁶⁾ Between 1975 and January 1978 IDTC and several international bodies changed completely the coastal frontage of Umm Said by building and constructing an additional ten berths (see Fig. 7.2 for details).

b. Roads. The first development of roads leading to Umm Said was carried out by QPC purely for company purposes in the late 1940's, and construction consisted entirely of heavy oil surfacing of vehicle tracks. In 1955 the development of hard-top roads became vital due to the planned shifting of the head office of QPC from Dukhan to Umm Said. Between 1955 and 1968 the company carried out no maintenance work on the Doha-Umm Said road or in Umm Said itself. In 1968, due to the poor condition of this road, the government and the company agreed that the government should undertake the responsibility of maintenance of the section between Doha to the southern boundary of Wakrah, while the company should undertake the section from that point to Umm Said, as well as in Umm Said itself.⁽¹⁷⁾

From 1977 onward the government, through IDTC and the Ministry of Public Works, was involved in massive changes in the development of road networks, both in the town itself and the Doha-Umm Said roads via Wakrah. Figure 7.4 illustrates an action programme of the Ministry of Public Works in 1400 H. (1979/80), together with an estimate of the cost. It is worth noting here that the master plan for a road network was prepared and designed by William L. Pereira Associates in 1977.⁽¹⁸⁾

2. Electricity and Water Supplies

The Umm Said area, due to its physical setting, has very poor underground fresh water resources. The area, during the early years, was dependent on the company's fresh water farms at Al-Suna and

Fig 7.4 Action Programme for Roads in Umm Said 1400h (1979 - 80)

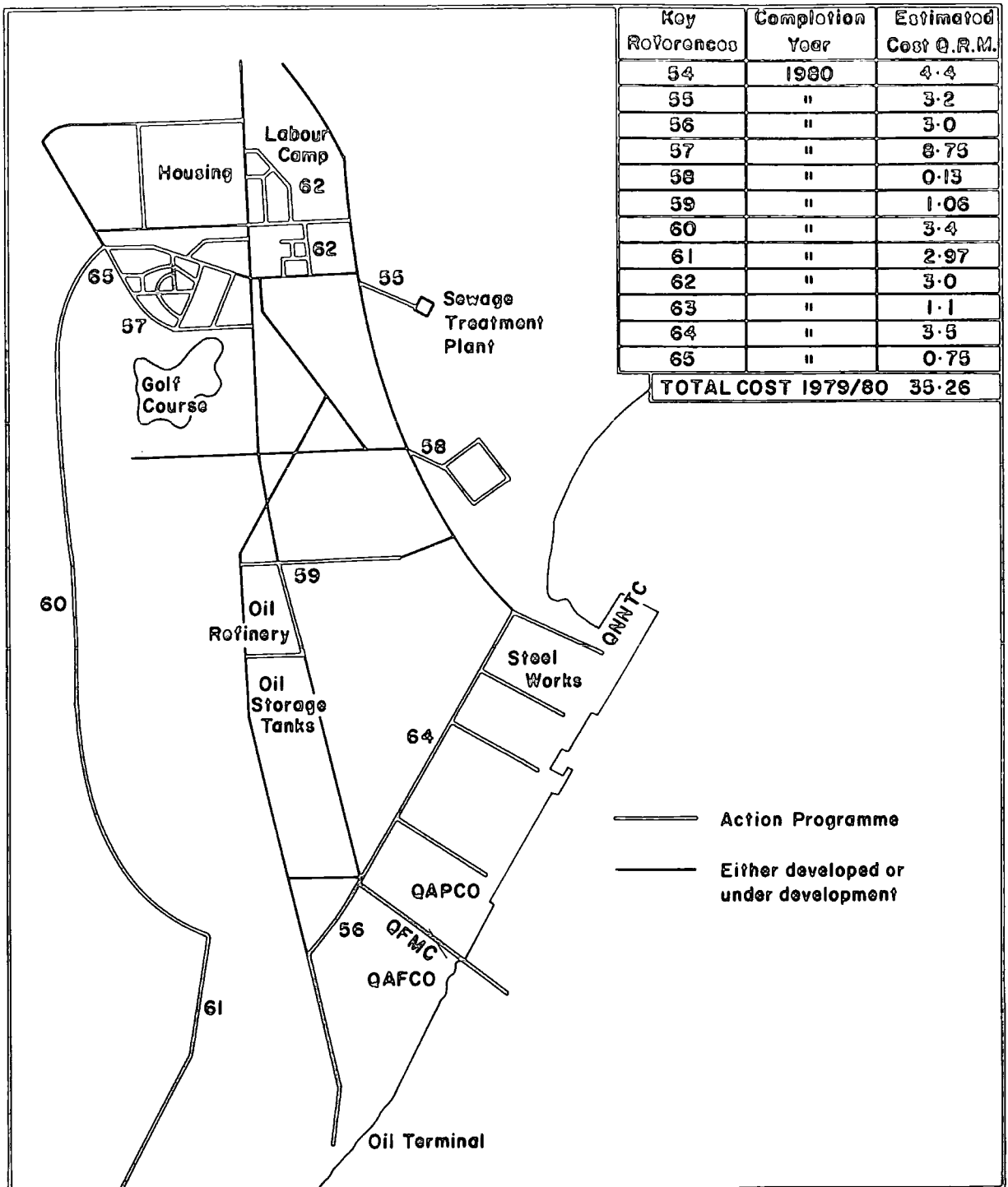

Source: Shankland Cox Partnership, Outline Planning Data, Policy and Procedure Review, Qatar Planning Studies, Qatar 1979, p.157 and Appendix E Table 1

Al-Jumailiah.* The fresh water was transferred from these farms through a pipeline to water tanks in the heart of the town, and then distributed to the city and the jetty. Water consumption until 1953 was very small, not surprisingly, since the resident population was less than 500.⁽¹⁹⁾ Electricity was first provided by a diesel powered plant, but in 1954 the company constructed a distilled water station in Umm Said, located at the jetty with a production capacity of 90,000 gallons of fresh water (409 cu.m.) and 4,510 KWH per day.⁽²⁰⁾ The purpose of this station was to provide fresh water and electricity to the topping plant,** as well as for QPC's other uses. In 1968 the company started to charge the government's topping plant for utilizing the company's water and electricity.⁽²¹⁾ This was probably the main reason for the government's insistence that QAFCO should be self-sufficient, especially in water and electricity supplies.

In 1970 the government connected the Ras Abu Aboud water/power plant with QAFCO via Wakrah, Umm Said Town and the topping plant by 66 KV double circuit overhead line. The fresh water supply was left dependent on QPC's and QAFCO's installations. In 1976 the government, through the Water Department, started to construct a pipeline from the Ras Abu Funtas power/water plant, to both the town and the industrial area of Umm Said.⁽²²⁾ At the same time the government connected Ras Abu Fontas with the Ras Abu Aboud-Umm Said electricity line to ensure the sufficient supply of electricity to the industrial complex and especially to QASCO. Data on the cost of supplying these services are not available for electricity, but are available for water. The estimated

* Al-Suna or Us Suna water well farm is about 75 km to the NNW of Umm Said and 47 km to the NW of Doha, while Al-Jumailiah is about 10 km to the NW of Al-Suna.

** The estimated average Topping Plant consumption was:

- Electricity	: 1,000 K.W.H. per day
- Water	: 1,000 gallons per day

Table 7.3 Estimation of Fresh Water Demand in Umm Said (1977-81)

Fresh Water Utilizers (a)	Years (Cubic Metre/Day)				
	1977	1978	1979	1980	1981
QASCO	909	5,450	5,450	5,450	5,450
QAPCO	1,000	1,000	1,000	1,000	5,000
Umm Said Ports QNNTC Yard	45	91	100	110	110
NGL 1 + NGL 2	227	909	909	909	1,310
NODCO	300	300	300	300	300
Umm Said Town	2,272	3,200	11,360	14,550	13,200
Others	27	350	50	50	100
Total	4,780	16,300	19,169	22,369	30,470

(a) QAPCO is not included due to being self-sufficient.

Sources: Shankland Cox Partnership, Outline Planning Data, Policy and Procedure Review, 1979, p.90.
IDTC, Industrial Development in Qatar, 1978, p.101.

Table 7.4 Umm Said Estimated Demand of Electricity (1978-81)

Electricity Utilizers (a)	Years (Megawatt)			
	1978	1979	1980	1981
QASCO	80	90	110	130
QAPCO	-	-	40	55
Umm Said ports QNNTC's yard	3	3	4	4
NGL 1 & NGL 2	-	10.5	10.5	10.5
NODCO	1.5	1.5	1.5	1.5
Umm Said Town	15	19	22	25
Light Industries	-	5	7	9
Others	0.5	1	2	2
Total	100	130	197	237

(a) QAPCO is not included

Source : IDTC, Industrial Development in Qatar, 1978. p.97.

numbered only 405 ⁽²⁵⁾ (180 offices and 225 residents). In 1981 QNTS tried to catch up with the growing demand in Umm Said, which resulted in the installation of 403 additional lines, thus achieving a total of 808 telephones ⁽²⁶⁾ (259 offices and 549 residents). The companies in Umm Said are also served by an automatic telex service which connects Umm Said via Doha with the international telex net. The total capital cost of QNTS activities in Umm Said, it has been estimated, could reach approximately QR 6,712 million, the reported 1980 expenditure being QR 1,200 million. ⁽²⁷⁾ The author finds the cumulative total unrealistically high.

7.1.8 Population and other facilities

There is strong evidence that the area of Umm Said was not inhabited before oil exploitation began to affect it in 1949. In 1953 the total population of Umm Said was still less than 500, ⁽²⁸⁾ but by 1960 the population had increased, because of the transfer of QPC's head office to Umm Said, to over 2,500. ⁽²⁹⁾ From the mid 1960's the company followed a policy of labour force reduction* which resulted in reducing the population of Umm Said, and by 1970-71 it is clear from personal investigation that the majority of the labour camps and employees' houses were uninhabited. In 1976 and following the development of some of the major industries in Umm Said, the population had grown to somewhere around 2,000. ⁽³⁰⁾

William L. Pereira Associates assumed that the total town population of Umm Said would reach the figure of 21,200 in 1980, ⁽³¹⁾ that is to say a 960 per cent increase from that of 1976 with about 39 per cent out of 21,200 consisting of local employees (see Table 7.5 below). From 1980 to 1995, the WLPA's assumption was based on a 2.27 per cent increase per annum. The slow-down of population growth assumed that there would be

* In 1960 the total manpower of QPC was 3,684 of which 1,790 of which were Qataris. In 1972 the total labour force of the company was 875 of which 588 of them were Qataris.

no further major industrial programme from 1980 onward, but that there would be enough economic activities to ensure the town's continued growth.⁽³²⁾ But in accordance with an IDTC memorandum on employment and the population of Umm Said, the population in 1982 had not reached more than 5,800 of which 4,900 persons were employed by industrial and services enterprises.⁽³³⁾

Table 7.5 Umm Said long term industrial, service employment and population estimates

	1976	1980	1985	1990	1995
Industrial Employment	400	4,900	5,450	6,080	6,770
Services Employment	-	3,350*	3,780	4,200	4,690
Total Town Population	2,000	21,200*	23,600	26,300	29,300

* Based on operating companies' response to WLPA's Survey
Other figures are estimates

Source: William L. Periera Associate,
Umm Said Long term Structure Plan Qatar, 1977,
Tables 1 & 2, pp.15-16.

The government has been confronted with a major challenge to satisfy a large demand for housing, public utilities etc. but, unfortunately, even the government with all its power simply cannot convert yearly plans into actuality. This is mainly due to the absence of government capability to supervise and follow up the plans, and the result has been a delaying of the majority of the development programmes. This is particularly a reflection of the shortage of indigenous trained manpower.

The housing shortage is particularly serious if we consider that the majority of the immigrant expatriate population in Umm Said is composed of single workers. Due to the lack of housing units at Umm Said, the operating companies have moved their personnel accommodation to Wakrah and Doha City. IDTC, in 1976, had forwarded a

memorandum to the High Authority with estimated requirements of housing units in Umm Said. The estimation was 4,440 units, of which 2,020 units were for families and 2,420 units for bachelors.⁽³⁴⁾ In 1982 the total number of housing units available was 2,550, of which 750 units were for families and 1,800 for bachelors.⁽³⁵⁾ Furthermore, in spite of the increase of population and housing, there has been a decrease in health services. For instance, in 1960 QPC's hospital had 40 beds. In 1979 this hospital, which was handed over by QPC to the government, was turned into a health centre with only 29 beds. This is mainly due to the preference of the Ministry of Public Health for centralising health services in Doha City. But because of the Umm Said industrial activities, the area is actually in need of special health care to meet industrial accidents.

Umm Said has now become the zone in which all the basic heavy manufacturing industries have been developed and it seems likely that at least a major part of any North Dome gas development and processing will be also be located in Umm Said. The idea of developing another specialized site in the north of Qatar now seems less likely.

7.2 Industrial Estate of Doha

7.2.1 Introduction and Historical Background

The industrial estate system only became publicly known in the second half of the 1970's, as being under the control and supervision of Doha Municipality, although as noted below, planning started earlier. In the 1950's the location of many private industrial enterprise was decided in most cases by the personal interest and convenience of the entrepreneur concerned, who usually constructed a new establishment on a site very close to his/their residence(s), which also generally coincided with local market demand. This resulted in a scattering of small scale

industrial activities all over the city. In the 1960's commercial and economic, rather than personal reasons, became more effective in influencing the location of manufacturing enterprises. This may be attributed to : a) the accelerated growth of population and income which produced a larger effective market, particularly during the second half of the 1960's, b) the increasing local perception of opportunities and growing commercial and financial sophistication, and c) the growing economic attraction of central city sites for manufacturing, spatially associated with growth of activity in the old markets produced by a) above.

The attitudes in the sixties, therefore, led to more concentration of industries in and surrounding the old market centre. By the early 1970's this process had created an annular zone of commercial and manufacturing activity along concentric streets and roads, together with a "spoke" development along radial roads. This was a more or less spontaneous spatial development of the classical urban model developed by Berry. Because of governmental action to re-develop the city centre, beginning in the early 1970's, many small scale industries began to move from the centre to Fariq al-Najma along one of the radial spokes, especially those concerned with iron working, aluminium fabrication, and carpentry. These activities and other services had spontaneously created in Fariq al-Najma an unplanned market called Souq al-Haraj, or what can be called loosely a spontaneous estate. This was followed by the planned creation of an extra-urban estate, the Industrial Estate of Doha (I.E.D), which here is examined in terms of its planned function as an industrial estate.

The plan

IED is the official name of an area of governmental owned land, developed and subdivided into plots of different size, with provision

for roads and public utilities, for the use of small-scale industry as well as for specific type of manufacturing and services, such as garages and car washing, which cause disturbance and pollution to other life in the city.

UNESOB's publication in 1972 of the report of its Qatar Reconnaissance Mission, was the first report to draw governmental attention to the value of locating small scale industries in one concentrated area. But this report was in some ways already out-dated and in other ways out of phase with government thinking, in that it suggested that such a concentration should be near the population centre and possibly near Doha port, so that its facilities could be utilized for export purposes. (36)

However, the actual location of the present industrial estate on Salwa Road was selected by the High Authority between 1973 and 1974. Documentary evidence for this appears in one of Llewelyn-Davies Weeks reports: (37)

"The changes to the plan (Doha development plan) between 1973 and 1974 have included:

- New industrial site location.

There is no evidence on which date the decision to establish IED was taken, but it is believed that it was made before August 1973.*

The Ministry of Public Works engaged its own Department of Engineering Services in the project, and it is believed that the planning stage and Phase I of land preparation was completed by the end of 1977. Again, there are no detailed records extant.

The industrial estate is located on Salwa Road to the south-west of Doha City and near the junction of Rayan-Salwa Roads. The general height of the area lies between 17.5 to 31.5 m above sea level. (38)

The site has a shallow soil covered with rock fragments, typical

* According to the Municipality's files plot distribution started in August 1973.

lithosols, overlying limestone bed-rock of the Middle Eocene. The engineering geology offers good conditions for construction. Climate and weather conditions on the estate are similar to those of Doha City (see Chapter 2, pp.13-15).

7.2.2 Government Policy

The government's policy, devolved to the policy of the Ministry of Municipal Affairs, was to re-develop Doha City and to create an industrial zone away from the capital to accommodate small and large enterprises which required larger plots for their operations and expansion than could be accommodated in the city, as well as those which produced effluent (solid, liquid or dust) from processing operations which would cause pollution to the city environment.

The first main objective of the policy was therefore to relocate small and large companies and establishments which already existed in Doha on new sites.

The government, in order to achieve this objective, carried out the basic land preparation of the site through the Ministry of Public Works (MPW). At the same time the government promised that water, electricity, sewage and telephone systems would be installed in the area and available at a basic charge approximating to the operational and production costs. The Municipality with MPW also planned the roads within, and leading to, the estate, as well as the serving of the estate by Doha Municipality's public transport.

7.2.3. Land and Site Preparation and Allocation

According to L.-D.W.'s reports and maps, the original area allocated to the estate was 4 sq.km, but more recently published governmental maps show that the area given over for the estate actually occupied 24.5 sq. km.⁽³⁹⁾ (245 hectares). The estate, during the

planning stage and its physical development, was the responsibility of the Engineering Services Department (ESD) of MPW.

The main duty of the ESD was not only to relocate in this area various scattered industry and service activities, but also to group various types of plant within specific parts of the estate.

Figure 7.5, showing the layout of IED, illustrates how the estate was divided into nine blocks:

Block A: an area of 1,206,000 sq.m. divided into 257 varying size plots, all for the use of garages and iron fabrication workshops.

Block B: 1,77,200 sq.m. divided into 223 plots for carpentry workshops.

Block C: 1,141,200 sq.m. divided into 187 plots for concrete product workshop.

Block D: 3,437,000 sq.m. divided into 83 plots for the use of stone crushers.

Block E: 744,950 sq.m. reserve and divided into 103 plots for the use of various types of factories.

Block F: 35 large plots over an area of 816,000 sq.m. for the use of car and heavy machinery agencies, incorporating service and workshop facilities.

Block L: with a total area of 1,986,000 sq.m. was allocated
& K into 32 plots for the use of big firms, apparently for chemical manufacturing processes and warehouses.

Block M: 2,662,000 sq.m. divided into 359 plots for the use of garages, carpentry workshops and big firms.

Fig. 7.5 Layout of I.E.D.

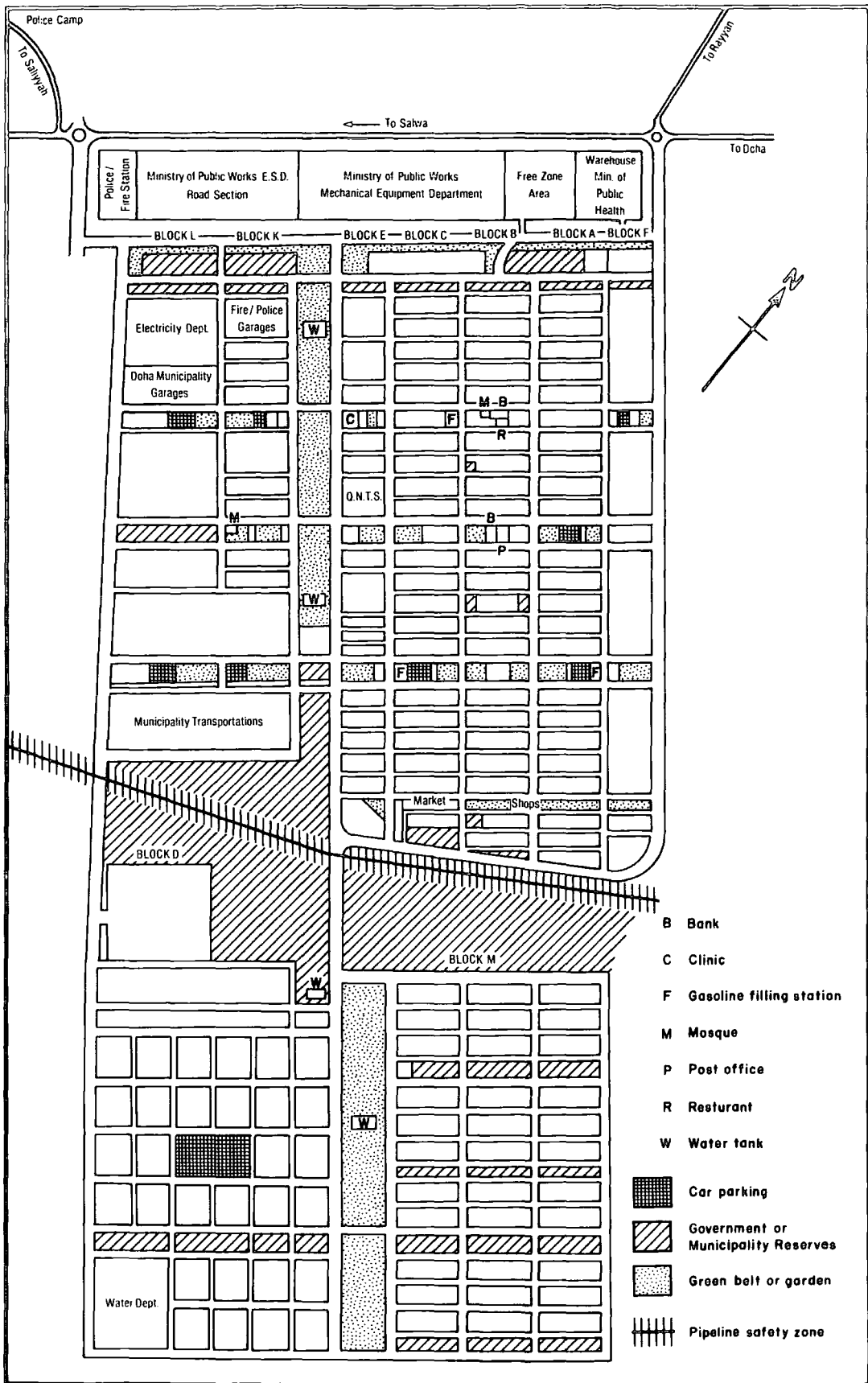

Source: Ministry and Public Works, Salwa Road Industrial Estate, Engineering Services Dept. Qatar 4.6 1979

The plan included a reserve of plots for governmental use, such as the MPW, Doha Municipality, police, fire service, mosque, Electricity and Water Departments, road and open space. A zone in the middle of the estate was set aside as a gas pipeline transmission corridor.

Unfortunately, there is no data available as to the cost of land preparation so far. The cost of road construction, QR 25 million, alone gives some idea of the scale of government expenditure necessary to start the development of IED as an industrial estate.

The Municipality, following land preparation, rents the plots to enterprises and then the lessee of a plot builds his own premises in accordance with the estate building regulations.

The normal procedure for obtaining a plot in IED is that the firm applies for a site to the Director of Doha Municipality who checks the validity of the application. The City Engineer of Doha Municipality is then instructed to allocate a plot to the applicant. The plot is usually granted for five years, extendable for another five to thirty year period, the rent payable in advance. The rental is not designed to recover the cost of the estate development, but rather to establish the fact that occupiers are tenants and not owners of sites. The rates are deliberately low, QR 1 per 60 sq. m. or QR 50 per 3,000 sq.m. are examples quoted. (39)

7.2.4 Implementation

(a) Infrastructure

Mention has been made of the several basic governmental commitments to infrastructural provision necessary for the effective operational development of IED. Here we examine actual implementation between the date when the companies started building their premises to October 1982 (the period covered by the author's fieldwork).

1. Roads: IED is very well connected by first class dual carriageways with both Doha City and Rayyan Town. These roads, however, ^{were} constructed before the establishment of IED. Roads development within the industrial estate can be divided into three phases (see Fig. 7.7)

	<u>Schedules</u>	<u>Estimated Cost (QR m)</u>
Phase I	July 1980 - March 1981	8
Phase II	Jan. 1981 - Sept. 1981	8.5
Phase III	Jan. 1981 - Sept. 1981	8.5

These scheduled phases were concerned only with the main internal roads and not the secondary feeder and access roads which were left as unmade tracks.

2. Electricity: Some of the early arrivals to IED set up their own diesel power generators, but from mid 1980 the government supplied electricity demand from a nearby 66/11 KV sub-station installed at a police camp.

3. Water: In the original plan there were to be provided four fresh water tanks of 0.5 mn.g. each, but none of them has yet been installed. All fresh water demand at the moment is met by road tankers carrying water from Doha City, whilst brackish water for industrial uses is drawn from the underground water table by individual enterprise private wells.

4. Sewerage: There is a comprehensive internal sewage system in the area. The only action by the government was the connection of IED with the Zoo system, but neither of the two pumping stations were operational. (40) Solid industrial wastes are transported by truck to the Doha Municipality tip, near the airport.

5. Telephone System: In 1980 QNTS started the installation of new telephones in the estate, but the unsatisfied demand for telephones and telex is still very high.

The implication of this only partial implementation of infrastructural requirements is examined below.

(b) Type of Industrial Activities

There is a wide range of business enterprises located in IED but in the context of this study, we concentrate only on the manufacturing activities.

The data, obtained from both the Ministry of Economy & Commerce and Ministry of Industry & Agriculture, show that there are five main groups of industrial activities in IED:

1. Food industry

By October 1982 there was only one operational factory, for ice cream, in the estate. Through the Ministry of Industry & Agriculture there had been licensed another six food processing establishments to construct factories in IED, but none had started operation.

2. Chemical Industry

Three companies which exist within the industrial estates can be put in this category. One of them is Hamble Marine and Apartment Paints, one producing detergent liquid and powder, the third processing fibreglass.

The government had authorised eight other factories to be constructed in IED, six of them plastic products factories and two industrial gases producers.

3. Metal Fabrication Industry

There are, according to the official registration, 18 companies of this type which have moved from Doha City to the estate. Three of them are aluminium fabrication establishments, whilst the rest are fabrication plants handling other metals. The actual number of metal fabrication industrial establishments which exist in the estate is believed to be higher than 18.

4. Non-metal Industries

In IED, there are four companies for stone crushing, eight carpentries and 48 make and process bricks, tiles, marble and white stone. This figure is much lower than the observed number because it does not include unregistered firms in IED carrying out the same type of activities.

5. Printing Industry

There is only one printing firm, at this time, in IED called Gulf Publication and Printing Organization.

These total figures are at variance with the claim by Doha Municipality that there is no single plot vacant within IED. The actual number of industrial firms and their type of activities is by no means clear, partly because of the observable presence of unregistered enterprises and partly because of some confusion in the classification of types of non-industrial activities, e.g. warehousing.

7.2.5 The Impact of IED and Conclusion

There is no doubt that IED was well conceived and planned in layout, but this should not blind us to some adverse impact of IED on industrial development. The establishing of IED can be shown to have resulted in the closing down of several industrial firms for a variety of reasons as stated in fieldwork interviews.

1. The expense which the owners would have incurred in transferring their plant from previous sites to the new plots discouraged some entrepreneurs from carrying on with established activities.

2. The expense of developing the new sites (boundary walls, housing units for the employees etc.) were a discouragement to some, noting that some small scale industries applied for, and received, plots larger than strictly required.

3. The distance between IED and the nearest port, Doha, almost 14 km, was regarded as additional transport cost for their raw materials.
4. If the small scale industries are to survive they have to compete with others in close proximity, usually in the same blocks. Some entrepreneurs regarded this as likely to reduce their profits.
5. The close supervision by the owners which was possible at the stage when establishments were deliberately built alongside the owners' residences is not possible in the IED. Given the considerable use of a semi-skilled expatriate labour force, this is often regarded as a disadvantage.
6. Incomplete infrastructural facilities, especially of water, sewerage and road systems, are considered as the main disadvantage, whilst enterprises can obtain these facilities easily at their present locations in the capital.

From field interview and observation it is clear that these perceived disincentives to relocate at IED had the effect of discouraging several individuals from continuing with their usually small scale and very individualist industrial activities.

IED, on the other hand, helped entrepreneurs in adopting and installing up-to-date processing machinery in their plants in IED, which was not possible in the old sites. IED, furthermore, helped new entrepreneurs in finding suitable plots on which to start.

Other conclusions which can be drawn from the study are:

1. Although there are many plots in IED which have not actually been occupied (see Fig.7.6) the Municipality insists that all plots have been distributed. The elucidation of this is found in the way in which lessors behave in reality rather than nominally. Lessors who do not

Fig. 7.6 Actual Development of I.E.D. as in 1982

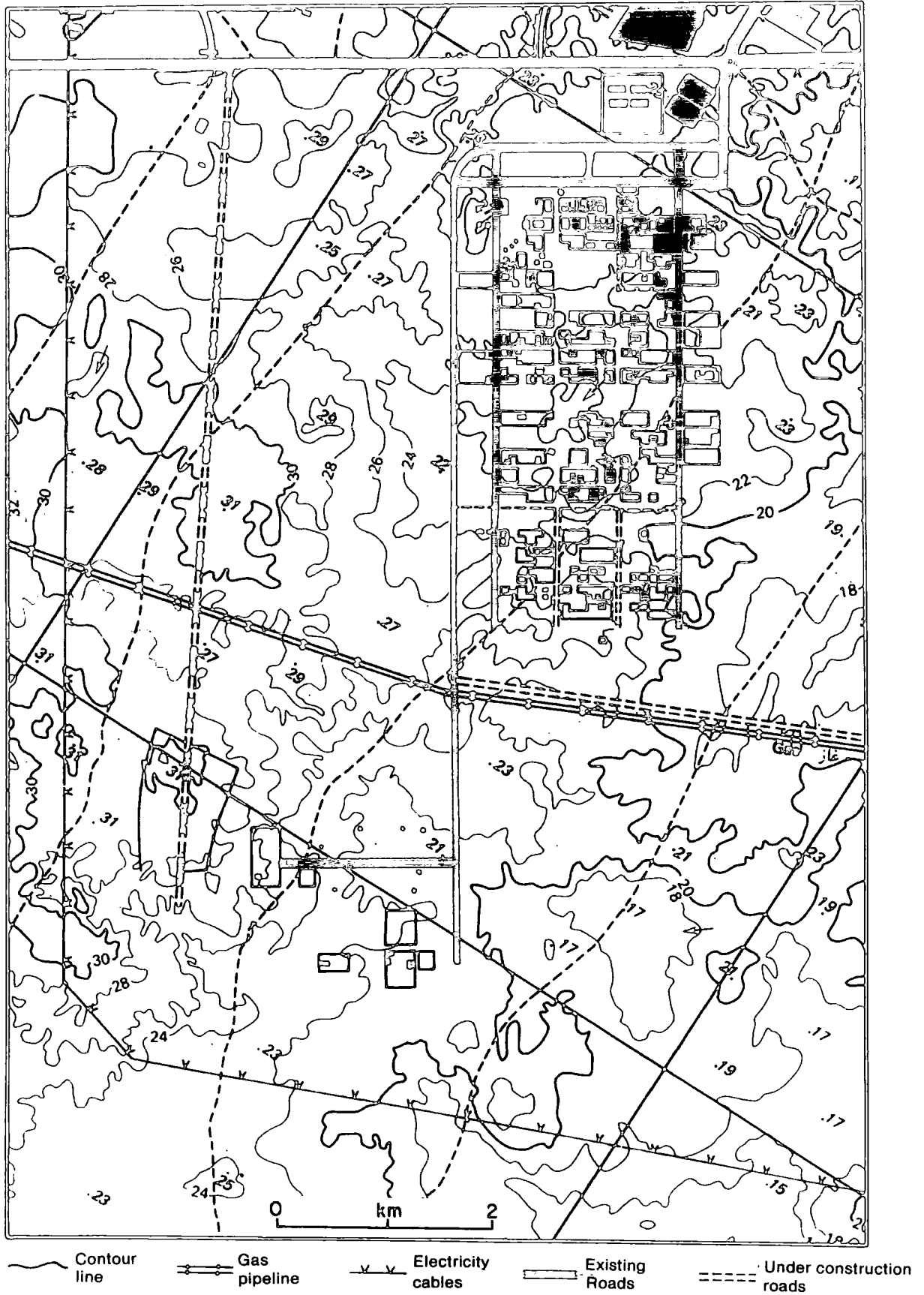

Source : Ministry of Public Works, Qatar's Maps, Sheet No. 200 / 375, Hunting Surveys, London 1982

develop their sites strictly should lose their tenancies, but the very many who wish to seize opportunities for the future but do not wish immediately to set up their factories, tend to construct either only the boundary walls of some minimal structure or merely office units. They then either sub-let the plots to other Qataris or often to expatriate workers, who as non-citizens are unable directly to rent plots from Doha Municipality, often at higher rents than are charged by the Municipality, or merely defer other investment to the future.

These practices can also occur, although illegal and impossible to quantify accurately, because the Municipality, in this respect, does not have sufficiently close supervision and control over IED and the individual firm. The Municipality, in order to achieve this control, should have more direct contact with each lessor than that obtained merely through public notices in local newspapers and magazines. The Municipality risks losing control over the functioning of IED and therefore of the direction of industrial development which can follow paths other than those the government planned. Al-Shuwaikh Industrial Estate in Kuwait is a living example of such loose organisation.⁽⁴¹⁾

2. The Municipality has not got sufficient influence to force industrial firms to move from urban sites to the new estate. This became clear, for example, when the Municipality published in early 1982 a general notice to all the industries and services in the city which were to move to IED, pointing out that if a firm did not move to the new site by the end of April the Municipality would act strongly towards the full implementation of this notice. From personal observation in the following October, six months after the time limit expired, it was clear that the majority of these firms kept running on the same sites in the city and some new firms had joined them on the same location. Because of the lack of firmness there are several

industrial sites still existing within the city, such as at Najma and along the Airport road.

3. There is no co-operation between the Municipality and other governmental bodies. Whilst, for instance, MPW was carrying out road construction in IED, the Municipality finished the distribution of plots to different enterprises. This action delayed the construction operations, and instead of finishing Phase III on schedule (see p. 246) MPW had still not completed its programme a year later. In addition the Ministry of Economy & Commerce between 1979 to 1982 was still granting licences to several new industrial firms, by commercial registration, to enable them to practise their operation in Doha City (see Table 7.6).

Table 7.6 Selected industrial registration 1979 - Oct. 1982

Industrial Activity	in Doha	in IED	Doha suburbs & others	Total
Carpentry	24	5	12	41
Brick, tiles and marble	1	15	3	19
Iron fabrication	18	17	14	49

Source : Compiled by the author from M.E.C. Registration files Oct. 1982.

4. The infrastructure in IED is not yet finished and there is no indication of any strong intention to complete installations:

- a. Fresh water is still delivered by road tankers
- b. Secondary roads within IED are still tracks
- c. There is no effective sewerage system in the area
- d. The Doha Municipality's transport networks have not yet included IED.

5. The living conditions for workers in the area are not really tolerable.

6. Even in the plan, there was no suggestion, in spite of the wide range of activities expected to grow in IED that an establishment or institution for vocational training should be set up in the estate. The value of such central training facilities is clear from British experience, for example, in Newton Aycliffe.

There are additional drawbacks resulting from implementation deficiencies: (see Figure 7.7 compared to Figure 7.5).

- a. There is no single plot reserved for residential use, and in local conditions this raises difficulties with the labour force.
- b. Although the planners had included a site for medical care in the area, the Ministry of Public Health have only included a clinic in plans which are not finalised. The site originally suggested has been allocated to an industrial firm.
- c. There were to be, in the original plans, three bank branches but none of them have yet been constructed.
- d. There was no gasoline filling station operating in 1982.
- e. At the moment there is no car park in the area and traffic congestion is caused by widespread parking on roads. The planned location of a few car parks is clearly not suitable for IED conditions and the whole provision needs completely reviewing otherwise there will be both congestion and under-used car parks.
- f. The original plans appeared with a large area reserved for a green belt. Instead of expanding IED to meet the growing demand, new applicants tend to be allocated plots in the reserved area of the green belt. As with vehicle parking, this defeats the objective of creating an attractive industrial estate with good amenities.

Fig. 7.7 Latest Layout of I.E.D.

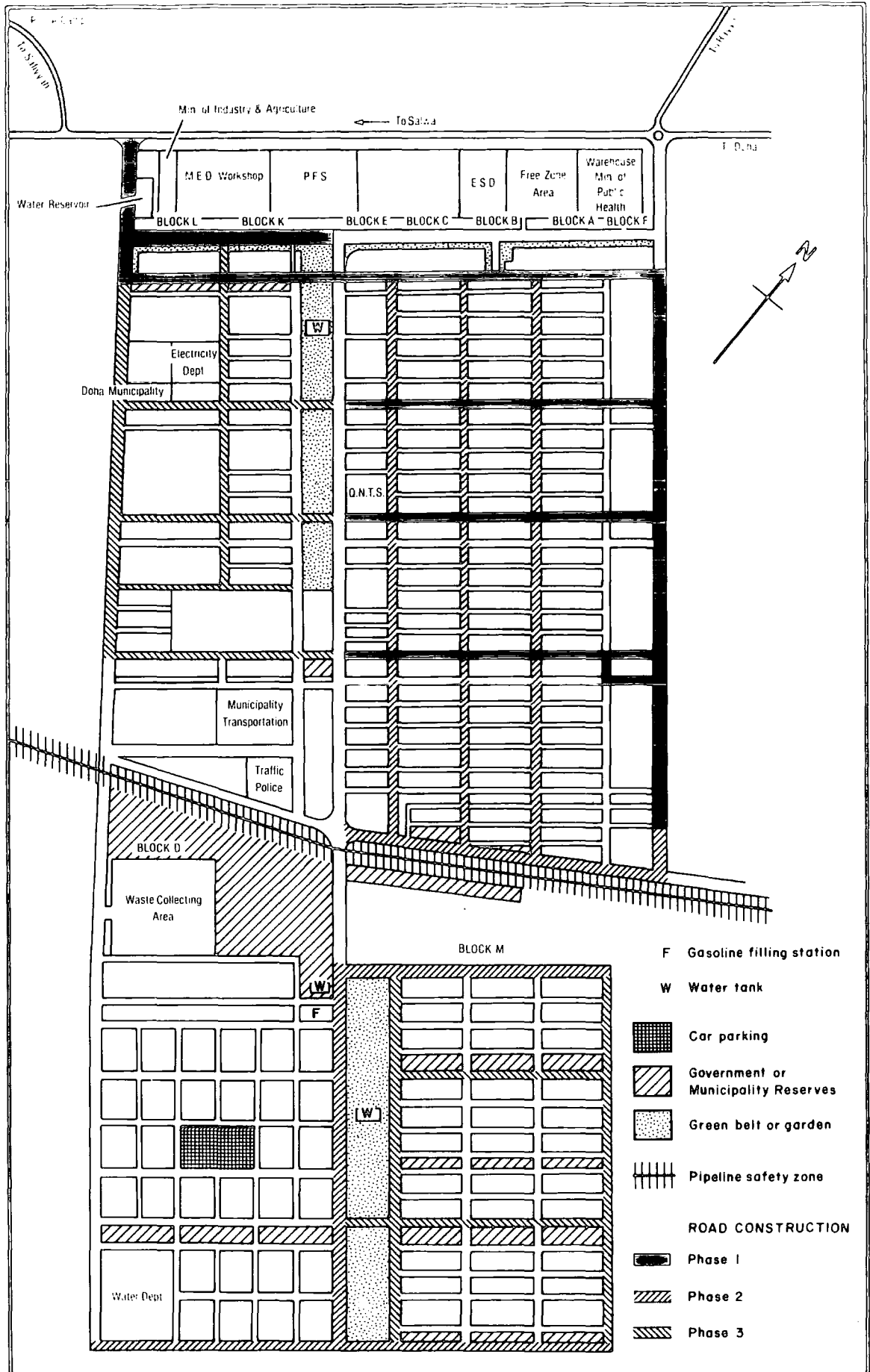

Source : Doha Municipality, Industrial Area, Site Plan, Sheet No. 1, Qatar, 20.12.81

Clearly the Industrial Estate of Doha, while similar in many respects, to planned industrial estates the world over, particularly in the provision of developed sites at low cost for private sector occupation, does also have some special characteristics. As in Saudi Arabia, the purpose seems to have been partly to improve living conditions in the urban centre and partly to provide incentive for private investment in small and light scale industries. There has been here no question of providing new employment opportunities unlike, for example, the Team Valley or in India. As we have seen the first objective of reducing the amount of industrial activity in central Doha City has been almost completely achieved but the incentives for industrial growth have been weakened by the non-completion of any of the necessary facilities on the site.

CHAPTER 7

References

- (1) Gibb-Ewbank Industrial Consultant, The Feasibility of Establishing a Nitrogenous Fertilizer Plant in Qatar, London, April 1968, p.41.
- (2) Shinn, E.A. Sedimentary Accretion along the Leeward, SE Coast of Qatar Peninsula, in The Persian Gulf ed. by Purser, B.H., Berlin, Springer, 1973, pp.199-200.
- (3) Ministry of Public Works, Qatar's Maps, Sheet Nos. 230/350, 355 and 360 Hunting Surveys, London 1980.
- (4) Hunting Surveys, Sand Dune Movement Study South of Umm Said 1963-1976 Technical Report, England June 1977, p.5.
- (5) State of Qatar/UNDP, Reconnaissance Soil Classification Map Qatar, 1976.
- (6) Wagner, C.W., and Togt, C.v.d., Map of the Regional Distribution of the Sediment Types in the Persian Gulf, Enclosure for the Persian Gulf, ed. by Purser, B.H. Berlin, Springer 1973.
- (7) IDTC, Annual Report 1981, Qatar p.
- (8) Personal Communications with Qatari employees in Umm Said.
- (9) Ministry of Information, Speech and Statement by Shaikh Khalifa al-Thani Qatar 1976, p.32.
- (10) Ministry of Information, Newspaper Interviews of Shaikh Khalifa al-Thani, Qatar 1976, p.16.
- (11) IDTC, Report on the Development of Umm Said, Qatar February 1983, p.25.
- (12) Al-Dabagh, M.M., Qatar : Past and Present, Beirut, 1961 p.82.
- (13) IDTC, Report op.cit., p.3.
- (14) Al-Dabagh, M.M., op cit p.82 and
Shankland Cox Partnership, Outline Planning Data, Policy and Procedure Review, Qatar Planning Studies, Qatar, December 1979, p.71.
- (15) Ministry of Justice, Collection of Qatar's Laws 1961-75, Legal Affairs Department Qatar, p.373.
- (16) Sir Alexander Gibb and Partners, Pamphlet of Activities 1980, Readen and IDTC, Qatar Industrial Development, Qatar 1978 p.38.
- (17) Ministry of Finance and Petroleum, Petroleum Concession Agreements and Laws, Petroleum Department, Qatar, 1973 p.126.

- (18) See William L. Pereira Associates, Umm Said : Long Term Structural Plan, Qatar Planning Studies Qatar 1977.
- (19) Ibid p.4.
- (20) Al-Dabagh, M.M., op cit. p.42.
- (21) Ministry of Finance and Petroleum, op cit. p.127 and pp.130-132.
- (22) Ministry of Electricity and Water, Statistical Report 1971-81, Water Department Oryx Publishing Co., Dominic Press, Singapore
and Shankland Cox Partnership, op.cit., Appendix E Table 2.
- (23) IDTC, Qatar Industrial Development, op.cit., p.97.
- (24) Ministry of Communication and Transport, Annual Report 1978, Telecommunication Department, Qatar 1979, p.2.
- (25) Data obtained from Qatar Telephone Directory 1980.
- (26) " " " 1981.
- (27) Shankland Cox Partnership, op cit. Appendix E Table 4.
- (28) William L. Pereira Associates, op.cit p.4.
- (29) Al-Dabagh, M.M., op.cit p.82.
- (30) William L. Pereira Associates, op.cit. p.16.
- (31) Ibid.
- (32) Ibid. p.15.
- (33) IDTC, Report on Population and Housing Units of Umm Said, Qatar 1982, pp.1-5.
- (34) Ibid. p.3.
- (35) Ibid.
- (36) UNESOB, Inter-Disciplinary Reconnaissance Mission Vol.2 Beirut, 1972. p.32.
- (37) Llewelyn-Davies, Report of Progress, Qatar Development Plan, Qatar October 1974, p.8.
- (38) Ministry of Public Works, Qatar's Maps, Sheet No 220/380 Qatar 1979.
- (40) Shankland Cox Partnership, op cit p.34.
- (41) Ibid. p.175.
- (42) Bara, A., Al-Shuwaikh Industrial Estate After Two Decades of Disorder, Al Qabas Newspaper N.4079 Dated 21/9/1983, Kuwait, p.2.

CHAPTER 8

DECISION-MAKING, CAPITAL INVESTMENT AND MANAGEMENT

Industrialisation, ultimately, requires that technical, investment and managerial decisions are taken by some identifiable group of people. In Chapters 2 and 3 we have examined the resource context, both human and physical, in which such decisions have to be taken in Qatar. In Chapter 4, Industrialisation Policies and Institutions, we found that the role of the State is much more than one of general control and regulation but involves State agencies in the decision-making process. Chapters 5 to 7, show this active involvement of government, not only in large public sector industries, but also in the supply, as well as control, of the pre-ponderant source of finance - oil revenue, of land, and as considered specifically in Chapter 9, of labour. The State also is the dominant market for most products of the private sector as well as for the publicly-owned basic industries.

The nature and characteristics of decision-making within, and also externally influencing, industry have, therefore, to be analysed in terms of this situation. The three elements - decision-making, capital investment and management, form one complete combination in any industrial project. Decision-making would be a decision on paper only if there is no financial backing or capital availability. At the same time an establishment without management would act haphazardly. These may seem obvious truisms, but in the case of countries such as Qatar, where industrialisation is recent and rapid and in some ways is a transplant rather than the indigenous product of domestic multi-sectoral growth, they are vital first principles which must consciously be applied.

Many of the existing establishments examined in the previous chapters showed surprisingly similar characteristics in their decision-making, capital investment and management; that is within each group of industries categorised as being public, ministerial or private sector.

This chapter, therefore, deals mainly with decision-making, capital investment and management in each of these three industrial sectors.

8.1 Decision-Making

Unlike Kuwait or U.A.E., Qatar has no planning body. The highest authority for any decision-taking is the Amir himself and the degree to which the Amir's intervention in this respect is a vital factor must continually be remembered (see also Section 4.2).

One very appropriate model with which to start is that of D.W.Taylor, particularly as applied to decision processes in Qatar. Taylor's ideas were grouped in a non-meaningful word called "POSDCORB", which refers to the necessity of "Planning", "Organisation", "Supervision," "Direction", "Coordination", "Reporting", and "Budgeting". These factors are structurally linked, as we shall see in public and ministerial projects, but with varying emphasis. In the private sector, in effect, the situation is different. Discussion in this section will be directed to the process of industrial decision in public, ministerial and private sector projects. The difference between the three industrial divisions will be developed during the argument.

8.1.1 Process of Industrial Decision-making

1) Decision Process in Public Sector

The process of decision-making in public projects is not too complicated due to the existence of a bureaucratic system associated with an autocratic headship.

Figure 8.1 illustrates the decision process of any industrial project from its appearance as an idea up to the production stage. This figure is a synthesis of research observations by the author of what actually happens in the absence of any official code of practice. The information is derived from close examination of the existing industries (as shown in earlier Chapters), personal interviews of some of the leading figures concerned and the relevant legislation (see Chapter 4).

If this schema is applied before 1972, two modifications would have to be made. Firstly, "The Amir" should be changed to "Deputy Ruler" (although the name remains the same). Secondly, "IDTC" should be changed to Ministry of Finance & Petroleum (headed at that time by the Deputy Ruler).

More recently, QGPC replaced the IDTC's position in the decision-process in the field of hydrocarbon industries only. Since the Director General of IDTC is also a member of QGPC's Board of Directors, it still participates in the decision-making process of QGPC.

The figure identifies six different stages in the establishment of an industry: the idea; feasibility study; project management and evaluation; foreign partners and plant design; construction; and operation and production.

Fig 8-1 PUBLIC SECTOR, AMIR OR IDTC PROJECTS

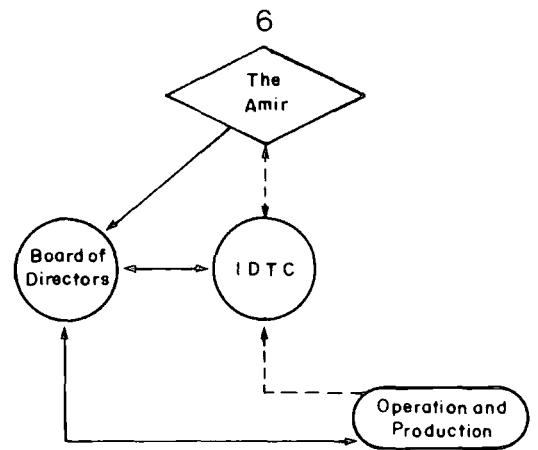
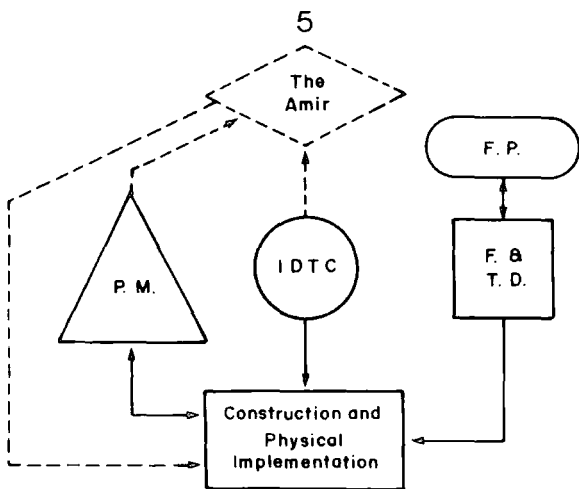
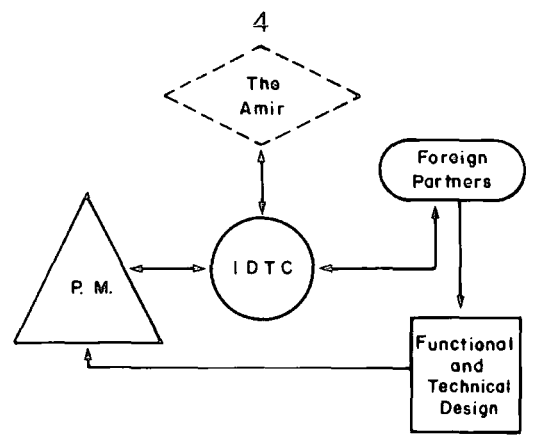
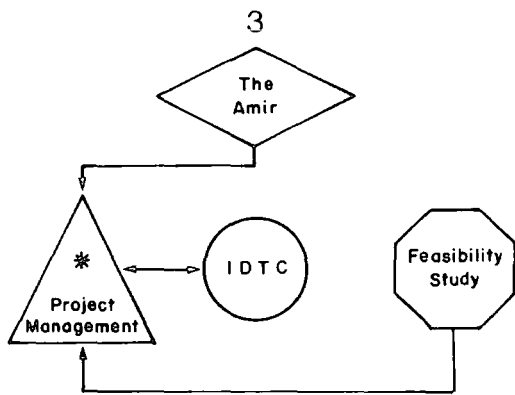
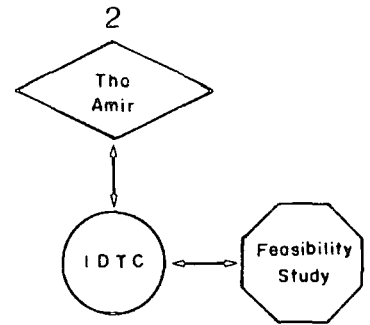
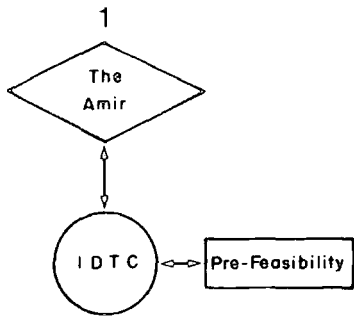

* Project Management or Project Committee

Stage One

At this stage, the Amir and his advisory bodies (IDTC in this case) would consult each other on what kind of industries may be introduced to the country.* The Amir would approve the suitable and more urgently needed concepts. After this approval IDTC will carry out a pre-feasibility study in respect of the project required in its economic aspect (mainly the sales and marketing of the proposed output). This study will be evaluated further by the Amir and his advisers. The Amir will then give his final decision whether the project should be abandoned or be taken on to the second stage.

Stage Two

IDTC, after the position approval of the previous stage, will appoint a foreign consultant (mostly European) to carry out a comprehensive feasibility study. Because of the export-oriented nature of public sector industries (see Chapters 5 and 6) this study concentrates on the evaluation of the world market (production, consumption and trade) in respect of the final output of the project. In addition, the study pays attention to the scale of operations, availability of e.g. feedstock, site location, proposed installation and cost and profitability of the project. If the findings appear favourable and the Amir is satisfied, the project will go to the next stage of the decision process.

Stage Three

In this stage the Amir will choose, based on his own judgement, members of a project management team or committee. The first act of this committee is to evaluate in more detail the feasibility study in general and, specifically, the scale of operation and proposed

* Most of the ideas which often suddenly appear were concentrated on the way in which natural gas (associated or unassociated forms) should be used. The balance of existing industry proved this.

installation. The project management, at this stage is exchanging views on the project with IDTC experts. IDTC in its turn will carry the points arising to the Amir, who usually instructs either IDTC or the project management directly to represent their points of view to the Amir, concerning the viability of the project and its contribution to the state's economy.

This consultation must lead to a clear and objective picture for the Amir who will give positive approval for the project, so that it can move on to the next stage

Stage Four

By this stage most of the project features will have been abundantly studied and its economic values become clearer. The crucial point of the project's life lies in this stage. This is mainly due to the fact that 1) the Amir is in favour of partnership ventures, whereby the foreign partners should provide risk capital through combined Qatari foreign equity; and 2) there is assurance that through foreign partners the management and marketing of the output of the company would be achieved successfully. If the foreign countries or companies are not willing to participate, the project may be delayed.* If the plans to involve foreign partners in the new company work, then the functional and technical design stage of the project will follow. The foreign partners, who will manage the company and market its output, will take the major part in the technical design of the plant.

* Industrial joint ventures represent a large proportion of public sector industries as noted in Chapter 6. The LNG project of North Dome illustrates this pattern in an industrial field regarded as appropriate. The Amir was eager to construct the complex, but at the same time wanted to involve directly foreign participation which would commit foreign contributions of risk capital, provide expertise on the production side and guarantee product outlets. By June 1983 Shell and BP involvement together with assurances from the Japanese market fulfilled these requirements.

Stage Five

An International tender will be announced, at this stage, for construction and equipment installation. The Amir, who usually negotiates the contract terms, has to give his approval before any work commences. If the financial terms are satisfactory to the Amir, the project decision at last becomes irrevocable, the point of no return. The contractor(s), with the collaboration of IDTC, project management and the functional and technical design team will then carry out the construction and physical implementation. At the same time there are progress reports flowing from IDTC and project management to the Amir, as well as site inspections carried out by the Amir himself.

Stage Six

The project is now at the final stages of construction and start-up operation. The Amir will appoint, also based on his own selection, the Qatari members of the Board of Directors of the new company,* who will interpret his ideas and policies in the plant and its performances.

The time required for all of the six stages varies from one project to another, and may take from five years i.e. QASCO, to 19 years, i.e. QAPCO. The reasons which govern the time schedule lie in

- a) the profitability of the project; and b) the response of the Amir.

2) Ministerial Projects

The ministerial projects (see also Chapter 4), although sharing some similarities with the public process, take a different procedural path. Figure 8.2 below represents the author's findings of the characteristics of the decision process carried out in respect of

* The number of the members of the Board of Directors and their subordination depends mainly on the nominal share value.

Fig. 8.2 Ministerial Project Development

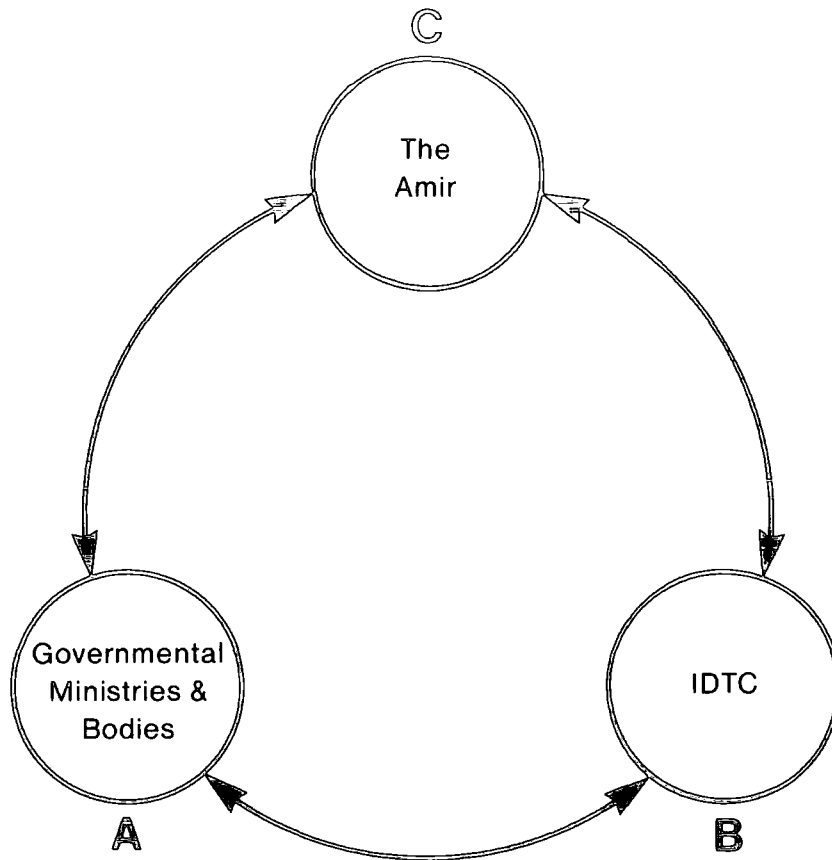

- a = A either direct to C or through B to C
or C and B to A, if approved by C
- b = C to B for study and back for
joint consultation with A, if agreed
- c = A & B to C, if approved
- d = C to B for tender and return to C for
negotiation, if approved
- e = C to B for management control before completion
Payment made by C against A's budget, at completion
- f = B handover to A

ministerial projects.

At the first stage a ministry would inform the Amir (either directly or through the Council of Ministers, or in most cases through IDTC which acts at this point only as postman) of its intentions to establish an industrial plant. The request, after acceptance by the Amir, would be sent back to IDTC for study of the project details and requirement. This study in most cases is carried out jointly with the Ministry concerned. The findings will be forwarded to the Amir. If the Amir accepts, then the project proposals will be sent back to IDTC for international tendering. The Amir, after negotiation of capital investment with the appointed contractors, will then give his final decision concerning this project. If the decision is positive then IDTC, either jointly with the ministry, or separately, will take management control of the project until its completion. At the same time the Amir will make the payment for the project set against the relevant ministry's budget.

At the completion of all the construction and equipment installation the entire project will be handed over to the ministry. IDTC, on the other hand, will keep a linkage with the plant open to receive a monthly report of its performance and to solve any technical problems.

As seen from the previous discussion, the main difference between public and ministerial project decision-taking is that the decision-maker, in the case of the public sector, depends heavily on the studies and evaluations of the project, while the ministerial decision-making is governed not so much by financial income generation as by criteria of social benefit to the population of Qatar. We can, therefore, note that whilst a commercial approach to product marketing is a crucial

element in public projects in the case of ministerial projects such as the slaughter house and compost plant, the question of financial net return on investment is subordinated to perceived need.

3) Private Sector Decision-Making

The decision-making process in the private sector is both very simple and risky at the same time, particularly bearing in mind that the individual entrepreneur often cannot afford to spend capital on studying the project from all sides. Under Law No.11 of 1980, however, (as noted in Section 4.9) applicants for government loans to establish or expand enterprises must submit feasibility studies. The government may make a contribution to the associated costs but this refers only to very large proposals which are rare (see also Chapter 4). The most common procedure followed in the private sector is illustrated in Figure 8.3. The position indicated in this Figure is really based on a fairly simple demand and supply balance, but where the government is seen as the main demand sector along with private demands. The owner(s) of private establishments depend more on quick judgements of market opportunities than careful planning. The whole process of decision-making (and of providing capital) will usually be carried out by a single individual.

Figure 8.3

Private Sector Decision-making

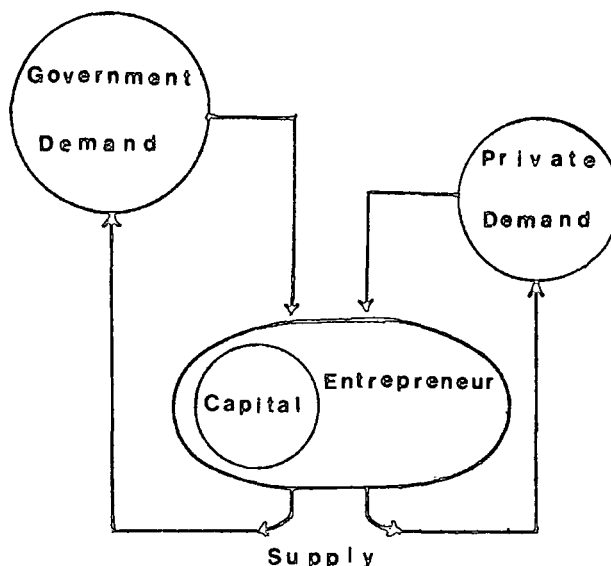

The previous discussion of the decision-making, has pointed out that although many experts (local and foreign consultants) were involved in studying all the project details, the final decision at each stage of public and ministerial industrial activities is highly centralized and confined to the Amir personally. This type of autocratic system with the institutional support available, gives the project, in all respects, a thorough evaluation and in particular an economic one. The Amir, on the other hand, is entitled to reject any project, for any reason at any stage (in practice up to the middle of Stage Five).

The economic aspect controls the nature of industrial decisions as defined in the public sector. At the same time, the Amir has to make sure that no other state in the Gulf would damagingly duplicate or compete with Qatar's industrial output. To emphasise this point deeply, the Aluminium project and QASCO are briefly examined. The first thought of establishing an aluminium smelter was believed to be in the 1960's .⁽¹⁾ Decisions concerning this project developed only to Stage Two, when it was abandoned. The reasons behind the abandonment were:

- a) the feasibility study cast doubt on the advisability of such a project.
- b) Bahrain was already producing aluminium.

The final decision was to co-ordinate, through the Gulf Organization for Industrial Consulting (GOIC), the expansion of Aluminium Bahrain (ALBA) with the cooperation of other Gulf States. QASCO, on the other hand, was seen as an economic project during the whole decision-build-up, since no country in the Gulf had then the desire to establish similar steel production.* Saudi Arabia, in its third five-year plan,

* The output of QASCO was designed to be absorbed in the Gulf market, mainly in Saudi Arabia.

exploded the prospect of Qatar monopolising the Gulf steel round bars market. The Saudi plan is to establish two steel plants with processing methods, capacity and output similar to that of Qatar. Although there is no impact, in the short and medium-run on the performance of QASCO, the risk of competition will be greater in the long run. This is why Qatar invited Saudi Arabia to sign an agreement covering joint steel projects. This agreement was signed on 7th April 1981. (2)

The ministerial projects, on the other hand, (although one can for some purposes include them as public projects) take different processing development paths, despite the fact that they are sharing the dominant role of the Amir. The main reasons for the differences between the relevant decision-making processes lie in the characteristics of the ministerial projects:

- a) The capital value is relatively small compared to the public projects
- b) Their main purpose is to serve the domestic market
- c) They are not based entirely on financial return on investment.

Considering these facts and given the autocratic control of decisions and budgets, the ministerial projects, either industrial or services, in most cases face long delays in their decision-making process.

The private sector decision-making process, in contrast to public and ministerial sectors is very risky. This is mainly because of the unsettled domestic market, as well as the absence of decisions based on close economic evaluations. There is also the fundamental point that the risk here is borne by personal entrepreneurial

finances whilst public and ministerial projects are backed by the treasury of the state.

8.2 Capital Investment

After the taking of any positive decision, either by the Amir in the case of public and ministerial projects, or by an individual entrepreneur, to invest in certain projects, an answer to the question of project financing has to be provided before any procedure is undertaken.

In this review of capital investment in industry, a distinction will be drawn between the three forms of sectoral projects.

1. Capital Investment in Public Sector

The heavy manufacturing industry in the Gulf in general, and Qatar specifically, relies on two factors: a) utilization of natural gas; and b) the availability of financial resources. (3)

The public sector financing plan consists of a combination of equity, finance, government loan, supplier credits, bank loans and others. Table 8.1 below illustrates an estimated financial source for major projects in 1978*. The table points out clearly that the total equity capital raised covered 20.9 per cent of the total, QR 7,890 million. The major financial sources for capital investment were in the form of loans of which large amounts were drawn from European consortiums.

* The actual amounts of capital investment of these projects are higher than those shown in the table. This is mainly due to the strong impact of inflation on investment costs, especially in the case of projects with implementation periods extending over several years. Knowing this we can estimate that the 1978 figures were higher by 39.6 per cent than those of 1977. Moreover, QAFCO I and QAFCO II will illustrate this type of capital investment inflation (see QAFCO p.176).

Table 8.1 : Estimated Financial Sources of Major Projects 1978
(in QR million)

	Equity	Government loans	Supplier Credits	Banking Loans	Others	Total	% of the Total
QASCO	200	275	290	695	-	1,460	18.5
QAFCO I	92	130	158	-	-	380	4.8
QAFCO II	-	140	305	480	25	950	12.0
QAPCO	360	-	950	1,190	-	2,500	31.7
NGL 1	260	-	190	-	450	900	11.4
NGL 2	740	-	760	200	-	1,700	21.6
Total	1,652	545	2,653	2,565	475	7,890	100.0
% of the Sources	20.94	6.91	33.62	32.51	6.02	100.00	

Source : IDTC, Industrial Development in Qatar, Qatar, 1978, p.104.

Governmental loans to the public sector were very small, consisting of 6.9 per cent only out of the total. However, the government provides guarantees for other loan capital. In order to examine the sources of finance more deeply, QASCO is selected as a model. QASCO's 1978 own estimates of its sources of finance differ from those of the IDTC and are as follows: (4)

(In equivalent QR million)

Supplier Credits	347
Qatar Government Loan	275
Euro-Loan (1977)	393
Euro-Loan (1978)	388
Equity	200
Total	1,603
<u>of which:</u>	
Machinery & Equipment	741.5
Erection	112.7
Civil & Building	286.5
Total	1,140.7

In addition to the capital investment in capital goods, the government from its own capital, has to provide infrastructural facilities (for infrastructure see Chapter 7. pp.233-240).

2. Capital Investment in Ministerial Projects

The general features of capital investment in ministerial projects were : 1) relatively small compared to the public sector requirements; 2) all the capital finance is met by the government as well as current expenditure, e.g. the salaries of employees.

Once the Amir has agreed on a ministry's proposal, he has to reserve sufficient funds for the project; these funds are usually distributed over several years and included within the annual budget of the ministry concerned. If the general annual budget of the state, for any reason, had to be changed, the allocation for the project in any particular year could be transferred to a later period. In addition, the Amir himself, as mentioned earlier, carries out the payment for the project and equivalent funds are withheld from the ministry's budget.

3. Capital Investment in Private Sector

There is no industrial bank in Qatar to support the private sector in their struggle for raising sufficient capital for projects, nor has there been any actual flow of government grants or credit to private industry.

The main financial source of private industries, therefore, is the entrepreneur(s)' own capital or the profit of existing establishments. The ordinary banks in Qatar sometimes participate in financing private projects but because of the high (9-10 per cent per annum) interest rate (high, that is, compared to the public sector,

and very high compared with loans available through special credit institutions in Saudi Arabia and other Gulf countries), the complexity of the bank routine and long delays, private approaches are severely discouraged.

As seen from the previous discussion the financial source of capital investment in industry is drawn from two sources : internal and external. Although industrial development can be financed entirely from Qatar's own monetary reserve (domestic and foreign), the main financial source, especially for the public sector, is loans. Loans which are always/^{increasing} in value and linked with varying interests, add more pressures on the companies.

The private sector operation, on the other side, has serious difficulties in financing the project from its own capital because there is no industrial bank in Qatar to support the individual entrepreneur. The government, early in 1981, set up a Committee to supply the private sector with industrial grants, (Chapter 4 pp. 91-93) but unfortunately only a few well known people have succeeded in gaining approval.

The government, in order to maintain good industrial development, should be more positive in encouraging industrial investment of the revenues from oil. This is because :

"what they (Emirates including Qatar) need is not a reserve fund to supplement public revenue in the future, but an investment fund which can invest the major part of oil revenues in long-term national and international investment." (5)

Here one is reminded once more that the industrial development strategy as identified in Chapter 4 is not in fact part of an integrated development plan.

8.3 MANAGEMENT OF INDUSTRIAL ESTABLISHMENTS

The evaluation of the validity of decision-taking in the industrialising process and the efficiency of use of capital investment is very strongly linked with the performance of management.

The management organisation structure in Qatar in general, and in the industrial field specifically, takes the classic pyramidal form, where the shop floor workers form the base of the pyramid.

There are three forms of organisation structure of the industrial establishments in Qatar. They can be divided as follows:

1) Management of Public Joint Ventures

All the feasibility studies carried out by foreign consultants in respect of public projects, recommended strongly that Qatar, in order to achieve maximum benefit from its industrial enterprises, should set up joint venture companies with foreign partnership, who would provide management and marketing know-how. These recommendations were valid knowing that a) there is an absence of modern management practices among Qataris, and b) modern imported technology is involved.

The foreign partners usually tied themselves with the government through long-term agreements. The agreements in all cases covered partnership, engineering design, management, marketing and other elements with varying balances of benefit.

The management agreements with foreign bodies are usually set up for an initial period of 8 years or more with the prospect of being extended by another agreement for similar periods.

The main characteristic of management structure in joint venture public sector and other industrial fields in Qatar is the "Line Organisation", or what is sometimes referred to as "military

organisation". This line organisation tends to proceed to "line and staff organisation" where the general manager appoints officers or managers for all of the development of the company. The officers, usually experts in their field, are followed by section heads, general foremen, foremen and workers.

Chart 8.1 below represents QASCO's organisation structure. This chart, with some modification, can be applied to most of the joint venture public sector companies.

There is, on the top, as Chart 8.1 shows, the Board of Directors. The function of the Board is to decide on major policies of the company. These decisions are referred to the Amir (who is the final authority) for his final approval. The general manager of the company carries out the daily routine works and coordinates all activities of the company with manager/officers. His main function is to implement the policies of the company, as already approved by the Amir and the Board of Directors, and to report to the Board any difficulties facing the smooth working of the company.* He also prepares the draft annual budget containing any suggestions for improvement or future development for the Board to decide.

The main difference between QASCO's organisation chart and other joint venture companies is that QASCO had adapted a network of committees on the line of organisation structure.**

* The general manager of the company is also a member of the Board of Directors.

** The effect of the committees in QASCO is noticeable. The main result of them is to involve their people in working together towards a sound unique solution to the company's problems. The committees have also improved the plant's efficiency. This is very much a Japanese contribution to management structure.

Chart 8.1 QASCO Organization Chart

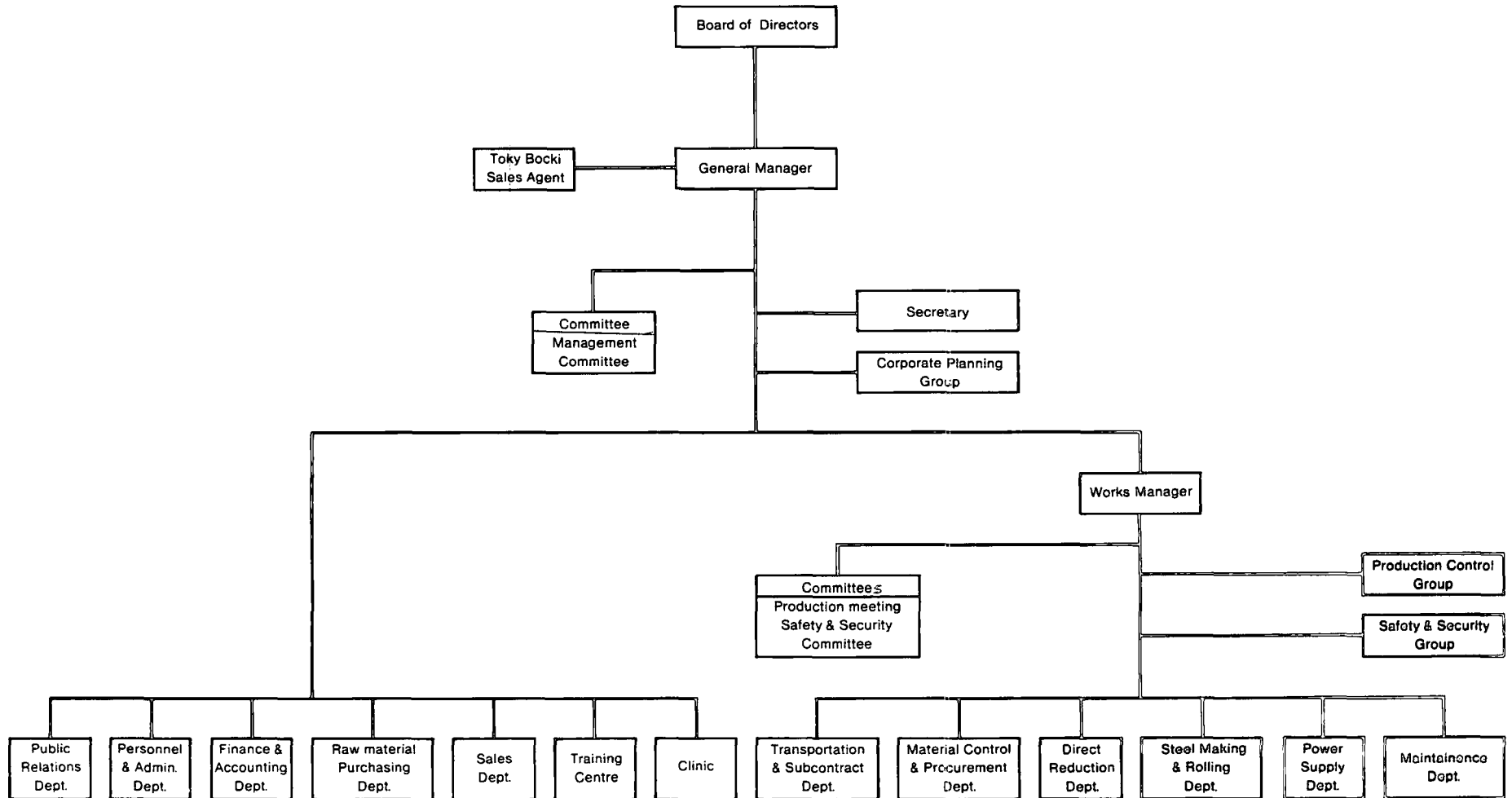

Source : QASCO. QASCO Organisation Chart, Qatar

2) Management of Other Public and Ministerial Organizations

The other public and ministerial establishments which are 100% owned by the government, nearly follow the same path of line and staff organisation. The difference between the joint ventures, on the one hand, and the public and ministerial sector, on the other, lies in the top level of management structure. Whereas the governing body in the first case is the Board of Directors, the latter can be governed by several types of bodies.

Chart 8.2 Management of Other Public and Ministerial Organisations

a. Public

b. Ministerial

QGPC
Board of Directors

Cabinet

QGPC
Managing Director

Minister

Deputy M.D.

Deputy Minister
of
Ministry Director

Head of Refining Gas
processing and Petro-
chemical Dept.

Head of General
Administration

General Manager
of the Company

General Manager
of the Plant

Here, above the plant general manager, comes first the head of Section/Department of a government body or agency, who in turn is responsible to the Deputy/Director of the government body which also operates under the auspices of higher administrative authority. These authorities are supervised by the Council of Ministers or the Board of Directors in the case of QGPC; the QGPC itself is responsible to the Council. All of these combinations lead to the Amir. (see Chart 8.2a and b.)

3) Management of Private Sector

The line organisation is the most common organisational structure followed in the private sector. The structure in most cases consists of two bodies: 1) the manager, who is commonly the entrepreneur(s); and 2) the workers.

The organisation of private establishments, as illustrated in Chart 8.3, falls on the owner/manager who settles all the establishment's requirements. Furthermore, the owner/manager intervenes in all of the establishment's operations i.e. decision-making, sales, production, purchasing, personnel, as well as the finance.

Chart 8.3 Management of Private Sector

Owner (s)

Manager (s)

Section

Section

The centralization forms, as seen in decision-making, also appear when management organisation is discussed. The Amir's hand, in some cases, appears strong and direct in public and ministerial activities while in others the control appears as indirect but is nevertheless present. The entrepreneurs in the private sector, as seen, are involved directly in all aspects of their establishment's activities.

This kind of autocratic system has left the employees entirely dependent on the higher authority of the establishment. This type of dependence is believed to diminish the capability of the employees, whatever their employment status, in developing their administrative skill and freedom of action in respect of the establishment's interests (but see also Chapter 3 conclusion).

Although the straight line organisation structure is very simple and can be applied to all of the industrial organisations, the feed-in, feed-back of information and orders are carried out efficiently only in the case of small -scale industries, whilst in medium and large-scale establishments the flow of information and orders takes a long time, and the ultimate decision maker is so remote from actual operations, rendering him helpless if the information feedback fails or is faulty. This kind of line system isolates rather than improves the co-ordination between the different departments. QASCO, in order to overcome the classic line formational problems, have established different committees on the line. These committees, although taking an advisory form, have created understanding between all of the departments in the company, which has resulted in more co-ordination between them in order to fulfil the company's targets.

Although it is agreed between the government and its foreign

partners that the foreign partners not only undertake the management and marketing but also train local citizens to replace foreign personnel, unfortunately, the existing management has not carried out the planned educational and training programmes for managerial and skilled technicians. The foreign partners, for whatever reason, by ignoring the development of local citizens' abilities and skills, have made the state more dependent on them. It is clear that at least part of the reason - inadequate training - is a desire of at least some foreign partners to maintain this dependence, as a result of the incapability of locals to run large projects. At the same time, the agreements between the foreign partners and the government are made less effective in one way or another as well as the responsibility for, and the supervision of, the Board of Directors of the performance of the companies.

The implications of the way in which decision-making and management structures affecting industry have developed in Qatar are of considerable importance and some of the key points are considered in the whole context in Chapter 10.

CHAPTER 8

References

- (1) UNESOB, Inter-Disciplinary Reconnaissance Mission, Qatar, Vol. 2. July 1972 p.37.
- (2) Arab Press Services Organisation, The OPEC Decision-Makers Survey : Qatar, APS Review Vol. 18 No 2, 13/20 January 1982. Cyprus. p.4.
- (3) Al-Kuwari, A.K., Oil Revenues in the Gulf Emirate, Durham University/Bowker London, 1978 p.34.
- (4) QASCO, The Steel Mill Project, Qatar 1978 p.40.
- (5) Al-Kuwari, A.K.,op cit p.201.

CHAPTER 9

DEPENDENCE ON FOREIGN LABOUR FORCE IN
INDUSTRIAL DEVELOPMENT

Introduction

Arabian Gulf States, despite their oil wealth, have found themselves in an unenviable situation since all of them suffer from a notable shortage of national labour forces and especially of trained labour. This had forced the Gulf States to import most of their labour requirements from outside the region. The ease of this importation operation has made the Gulf States in general, and Qatar specifically, dependent on foreign manpower in all economic sectors i.e. primary, secondary and tertiary.

In this Chapter we come almost full circle back now to consider the question of the place of foreign labour force in industrial development. The population and demographic background were examined in Chapter 3, but it is only after an analysis of the industries and the decision manage-making structure we can now analyse this key factor.

A great deal has been published with regard to immigration of labour in the Gulf area, but most of this has been in the field of the volume of immigration, effects of immigrants on the employment structure, or on the impact on social changes.

This Chapter, therefore, discusses the dependence of the country on a foreign labour force for running the economic dynamo. But, why does the country depend on foreign labour? Which occupational group(s) is/are desirable? Where do the Qataris stand in relation to this massive importation of foreign labour? Is it vital to import

all this large number of foreigners? Moreover, what is the impact of foreign labour on the country and its people? The purpose of this Chapter is to answer these questions.

To begin with, we have to identify the different elements which have helped the appearance of dependence on a foreign labour force in industrial and economic developments.

9.1 Factors Which Caused The Dependence

There are several factors or elements which can be selected and used as evidence for the cause of the dependence on foreign labour force, but the most important of them all are:

1. Oil wealth and the distribution of oil revenues

The slump of the pearl industry in the 1930's severely affected the life of most of the inhabitants of Qatar. Income, on a far greater scale, from oil, during the late 1940's and 1950's suddenly improved immeasurably the life standards of the inhabitants, either directly or indirectly. The government, with the oil wealth which all accrued to it, started to pay more attention to development with particular emphasis on the infrastructure facilities. The government at first started to purchase lands from the original owners. This operation, in itself, rapidly increased the value of land from almost nothing to more or less QR 100 per square foot.* Development carried out by the government, in a country already suffering from the shortage of local manpower, made it difficult not to rely on other countries' human resources. In addition to the development of infrastructure, the government was expanding its own organisational bodies by employing more

* There is no compulsory purchase legislation at present in Qatar, and the acquisition of land for the infrastructure facilities, therefore, can only be carried out by negotiation between the government and the land owners on the price of the land.

manpower. But, unfortunately, this type of distribution of the oil revenues translated the Qatari community into a consumer society rather than a productive one. This, in itself, produced the dangerous idea that "money can buy almost everything" which appeared strongly among the Qataris in general and in the state specifically. This resulted in the large importation of capital goods and, simultaneously, the importation of a foreign labour force to operate them.

2. Qatari's attitude towards manual work

The Qataris' attitude towards manual work can be identified as a cultural and social problem. The main reasons behind this problem are a) the wide range of alternative opportunities that Qataris can take up, especially in the government sector; b) most manual work is in any case characterised by low income; and c) manual work is associated with the menial lowest social classes which most Qataris disdain. These reasons and others have been a compulsive force pushing most of the native population away from manual work. Although not on the same scale as in Kuwait, the flow of money from government through land purchase and compensation during the oil period helped in driving the Qataris even further away from "dirtying their hand" in manual work. Because of all these factors, the demand for foreign manpower, in particular for manual labourers, rose even more sharply (see 9.2 below), not only in fields where no skills were required, but also in areas where literacy and some education is necessary e.g. the industrial shop floor.

3. Lack of educational background and insufficient training

Due to the sudden inflow of wealth and the changing of the population's activities in the country, the Qataris found themselves in urgent need of education. This need in 1952 was recognised by the

establishment of a formal educational system (see Chapter 3 p.49). But after nearly two decades the majority of the Qataris are still illiterate since training and education has not had time to transform the whole population. This together with the Qataris' attitude towards manual work, even of a semi-skilled or skilled nature, has combined in virtually eliminating the governmental objective of developing the Qatari vocational skills. The government, on its side, soon lost its enthusiams for adopting extensive educational and training programmes and has,therefore, tended to replace it with theoretical and "fact-stuffing" programmes,⁽¹⁾ far from the country's requirements (see Fig. 3.7). Furthermore, the extensive development projects carried out in the last decade (1970's), would not have been possible in any case if the government had relied on the educated and highly skilled native population; this tended to reduce the urgency of official action.

4. Marginal participation of women

Women's participation in the economic life of the Gulf in general, and in Qatar specifically, was much more positive in the pre-oil era. Bearing in mind that most, if not all, the active male population were away for most of the year pearling, leaving behind the women, children and inactive males, the women, in order to sustain the life of their own dependants, had to practise one, or several, productive activities, e.g. tailoring, retailing, grazing animals etc. In other words, most of the on-shore activities heavily involved women in a near-subsistence society.

With the appearance of oil wealth, the old values of the "struggle for survival" were completely abolished. In addition, established conservative tendency to segregate women within the

family circle was more easy to achieve, given greater wealth. In addition, development activity led to more foreigners with different cultural backgrounds entering the country and the raising even more of "cultural walls" around Qatari women. Only teaching and nursing activities were permissible and even then only within female circles. If such "walls" were absent, the contribution of women could reduce the huge shortage in the Qatari labour force, hypothetically by almost one-half. In 1981, for instance, the working Qatari women represented only 4.2 per cent out of the 48,000 Qatari native population; 10.7 per cent of the total active Qatari work force of 18,910; and only 1.7 per cent of the total active population of 121,572.

Moreover, new social trends among women have at least temporarily reduced the possibility of their contribution to the national economy. The new trend, which is wrongly known as a "freedom" has made women more dependent on foreign servants in running domestic affairs. Further, women have extended their understanding of freedom to include much of the care for their own babies and the upbringing of their children in which foreign servants and nursemaids now play an important role. This has, however, only partly released women from domestic chores but has not induced them into the active labour force.

5. Government attraction

The dynamic aspect of oil wealth had created formal government bodies which replaced the traditional form of tribal systems of government. The government, in order to fulfil some of its obligations, has acted as a "welfare state" in providing full employment to its native population, identifying and implementing development programmes and setting up public utilities. The government, with huge oil income and expenditure, has expanded its ministerial and departmental

operation which, in turn, has created a large demand for a labour force. At the same time the local population, not unnaturally, assumes it has the right to benefit from the oil revenue flowing into government and in particular has a right to government employment as one means of obtaining such benefit.

The attraction toward government employment, however, came mainly from a) the easiness of government work compared to that of other sectors; b) shorter working hours and only light supervision, whilst the employees of private and public sectors have to work at least eight hours a day; c) the assurance of stability in governmental work; d) most of the governmental posts did not require high qualifications; e) promotion came easily to the governmental employees, and f) other social factors e.g. influence of the bureaucracy, the status associated with government employment, especially for those of top cadres etc. These reasons, and others, had been causing several problems to the private and public sectors in a society already suffering a shortage in its labour force. (2) What we also find is that the employees in the industrial sector eagerly await the chance to transfer themselves from the productive sector to the government services. Moreover, most of the university graduates and the highly skilled members are the most attracted to government offices. This, in itself, has been creating over-employment as well as disguised unemployment in government occupations. The government, instead of dismissing inactive employees from their offices,* import foreign labour to do no more than what other local employees are already

* The government, due to several social factors, could not easily end the employees' contract and once the employees recruited they would continue to work for the government. If the government, on its side, is no more in need of the workings of (a) certain body(ies) the government does not formally abolish the agency but allows that body(ies) to die away itself gradually. This matter is simply due to what is literally translated as the "water of the face" i.e. the loss of face which would be associated with dismissal.

allocated to. The oil crisis of 1982/83 has forced the government to follow a tight employment policy and for the first time it dismissed many expatriates or employees of the government. But if this crisis had not arisen the expectation was that government employment would continue to grow.

We see, therefore, that until very recently these key factors have played a vital role in encouraging the importation of foreign labour to the country, and have resulted in the dependence on foreign labour which appears as one of the major features associated with development.

9.2 Occupational Structure of Imported Labour Force

It is clear that the above factors and the development requirement made it impossible for Qatar to progress without depending on foreign labour. At the same time, these factors have determined the size of foreign labour importation in each of the occupational categories. The occupational categories analysed in this section are selected from the Ministry of the Interior's classifications.

Table 9.1 below shows the new resident visas issued by the Ministry of the Interior between 1396-99 H (1976-79). The new resident visas, in other words, represent the demand on foreign labour in each current year. In 1976 the total demand of new visas was 33,566 of which 61 per cent of the total were labourers. This large proportion of demand for labourers was mainly directed to construction and other manual work. Because of the continuing demand by construction, the labour force in 1977 reached a total of 37,495, of which the labourers had the lion's share of 61.5 per cent. Technicians, although having a smaller proportion of the demand, increased by 42.3 per cent over their 1976 total. At the end of 1977 the domestic

economy was overheated by a trade/construction boom. Immediately the government, in order to reduce the inflation which was caused by this boom, controlled public spending in 1978. (3) This control led to the private sector reducing its activities, especially in the construction activity. Simultaneously, the demand for foreign labour was reduced in 1978 by 3.7 per cent below the 1977 total figure. The categories most hit by this policy were teachers* followed by labourers. But the labourers, on the other hand, still made up more than 55 per cent of the 1978 figure of 36,112. The demand for foreign drivers, engineers and technicians had increased and there was no immediate effect on them from the cut in public spending. The government, in 1979, took a further step in controlling public spending by freezing the government vacancy posts. (4) The government policy for its own recruitment indirectly affected the private sector employment. Thus the total demand for new visas was reduced from 36,112 in 1978 to 28,771 in 1979, a reduction in demand of over 20 per cent. The categories most severely affected by this decline were general labourers followed by farm workers, teachers and engineers, while the demand for technicians and driver groups remained in the growth mode. Total demand during the whole period declined by an average of 5.1 per cent per annum. The labourers had the highest decline of all occupational categories with a fall of 18.0 per cent per annum. The technician, farm worker and driver categories, on the other hand, had an average increase during the period of 14.6, 10.8 and 10.4 per cent per annum respectively. It is obvious that the trend in demands for new resident visas had shifted from importing unskilled manual workers, to a relatively skilled and highly skilled labour force. But, it is believed that, during the next

* The decline in foreign teacher demand was mainly due to graduation from Qatar University and its contribution to education in Qatar.

Table 9.1 New Residential Visas Issued Between 1396-99H (1976-79)
by Occupations

Year	Lab- ourer	% of Growth	Techn- ician	% of Gr.	Ad- min.	% of Gr.	Engin- eer	% of Gr.	Doc- tor	% of Gr.
1396	20,472		4,344		1,211		1,129		47	
1397	23,055	12.6	6,181	42.3	1,057	12.7	1,240	9.8	41	-12.8
1398	20,193	-12.4	6,470	4.7	1,126	6.5	1,604	29.4	48	17.1
1399	11,758	-41.8	6,775	4.7	1,153	2.4	1,425	-11.2	41	14.6
Overall Incr. (Decrease)		(18.0)		14.6		(1.6)		7.7		(4.6)

Year	Tea- cher	% of Gr.	Far- mer	% of Gr.	Dri- ver	% of Gr.	Others	% of Gr.	Grand Total	% of G
1396	268		184		615		5,296		33,566	
1397	392	46.3	329	78.8	478	-22.3	4,722	-10.8	37,495	11.7
1398	239	-39.0	359	9.1	657	37.5	5,416	14.7	36,112	- 3.7
1399	194	-18.8	255	-29.0	841	28.0	6,329	16.9	28,771	-20.3
Overall Incr. (Decrease)		(10.7)		10.8		10.4		5.9		(5.1)

Source: Ministry of Interior : New Residential Visa 1396-99 Doha 1980.

Table 9.2 Renewed Residential Visas Issued Between 1396-99 * (1976-79)
by Occupations

Year	Lab- ourer	% of Gr.	Techn- ician	% of Gr.	Ad- min.	% of Gr.	Engin- eer	% of Gr.	Doc- tor	% of Gr.
1396	40,583		3,785		3,003		456		66	
1397	47,449	16.9	5,043	33.2	3,624	20.7	678	48.7	87	31.8
1398	60,284	27.1	7,149	41.8	6,231	71.9	1,283	89.2	163	87.4
1399	67,910	12.7	7,253	1.5	6,534	4.9	1,425	11.1	141	-13.5
Overall Incr. (Decrease)		16.8		21.0		24.7		34.3		24.2

Year	Tea- cher	% of Gr.	Far- mer	% of Gr.	Dri- ver	% of Gr.	Others	% of Gr.	Grand Total	% of Gr.
1396	524	2.7	1,016		1,797		13,575		64,805	
1397	538		1,555	53.1	2,490	38.6	29,230	115.3	90,694	40.0
1398	1,143	112.5	2,277	46.4	3,007	20.8	38,054	30.2	119,591	31.9
1399	1,186	3.8	1,157	-49.2	3,371	12.1	41,055	7.9	130,032	8.7
Overall Incr. (Decrease)		25.8		4.3		20.3		33.5		22.3

* Revised Figures

Source: Ministry of Interior : Renewed Residential Visa 1396-99 Doha 1980.

few years the manual labour group will continue to take the largest share of the demand. This is mainly due to the continued requirements in the construction field, as well as in small-scale industries and services. (The services are of both the government and private sectors).

Table 9.2 above shows the renewed resident visas issued by the Ministry of the Interior between 1396-99 H (1976-79). The renewed visas can be seen as the accumulated figure of the non-Qataris as a whole (not including the permanent visa holders). The two Tables, 9.1 and 9.2, unfortunately do not give any satisfactory indication of the turnover of the non-Qatari labour force. This is because until 1981 the renewed visa holder could change his original occupation group (see Chapter 3 pp.35-38). In 1976, however, the total renewed visas were 64,805, of which 40,583 were labourers. Technicians came third with only 5.8 per cent out of the 1976 total. In 1977 the labourers' percentage, although continuing to be the dominant group, had declined from 62.6 per cent, in 1976, to 52.3 per cent. In 1978 nearly all of the occupational groups had a large cumulative percentage, varying from 20.8 per cent in the case of the drivers, to 112.5 per cent in the case of teachers, based on 1977 figures. This large accumulation was followed in 1979 by a slow average growth and a sharp decline in some cases i.e. farmworkers and doctors. The general growth of the foreign labour force was sharp in 1977 and 78, and continued to grow in 1979, although on average more slowly than in the previous two years. The increase of the foreign labour force holding renewed visas during the mentioned period was 22.3 per cent per annum. Once again the more skilled labour element was increasing at a higher rate than unskilled workers.

9.3 Occupational Distribution of Qataris and Non-Qataris

Table 9.3 below shows the distribution of the Qatari and non-Qatari (Arab and non-Arab) labour force by the main economic sectors. But, in order to arrive at a full understanding of manpower distribution, one should keep in mind the previous elements of sections 9.1 and 9.2.

Table 9.3 Distribution of labour force by Nationality and Main Economic Section (1981)

Sector	Qataris	% of each sector	Non-Qataris	% of each sector	Total	% of Total (labour force)	% of Non-Qataris in each sector
Agriculture, hunting and husbandry	500	2.6	2,439	2.4	2,939	2.4	83.0
Oil and quarrying	1,114	5.9	2,083	2.0	3,197	2.6	65.2
Manufacturing industry	475	2.5	9,210	9.0	9,685	8.0	95.1
Electricity and water	2,731	14.4	5,777	5.6	8,508	7.0	67.9
Construction	364	1.9	17,053	16.6	17,417	14.3	97.9
Trade	1,035	5.5	13,080	12.7	14,115	11.6	92.7
Transport, store and communication	1,205	6.4	2,751	2.7	3,956	3.3	69.5
Government services	10,835	57.3	25,730	25.1	36,565	30.1	70.4
Other services	651	3.5	24,539	23.9	25,190	20.7	97.4
	18,910	100	102,662	100	121,572	100	84.4

Source: Based on the author's revision of:

Al-Kuwari, A.K., Analysis study of the factors delimiting the size, structure and type of labour force in Qatar. Qatar University 1982. Appendix 1-A.

The total labour force had increased from 48,390 in 1970 (see Chapter 3 Table 3.9) to 121,572 in 1981, an increase of about 151 per cent. The Qataris increased from 8,168 in 1970 to 18,910 in 1981, whilst the non-Qataris increased from 40,222 to 102,662. That is to say, while the Qataris increased by 7.2 per cent per annum the non-Qataris were increasing by 8 per cent per annum. Therefore, the contribution of the Qatari labour force in the economy decreased from 16.9 per cent in 1970, to 15.6 per cent of the total in 1981. The dependence on the foreign labour force appears very strong indeed, knowing the fact that the non-Qataris outnumbered the Qataris in all of the economic sectors, and especially in those requiring manual workers, where their percentage was exceeded by 95 per cent. The Qataris, on the other hand, were concentrating in the purely Governmental sectors, such as government services, electricity and water. This concentration reduced the dependence in these two sectors to almost 70 per cent. The total Qatari labour force in the primary and secondary sectors in 1981 was 5,184, that is to say, 4.3 per cent of the 1981 total labour force. But from close examination the majority of these were actually representing "labour outside the industrial production fields". This is mainly due to the fact that most of the Qataris in industry were in the transport and administrative services.

9.4 The Impact of the Foreign Labour Force

There is, unfortunately, no escape route that the Gulf in general and Qatar in particular can adopt to stop the large importation of foreign labour, except by freezing all the development programmes. The development process, as seen earlier, requires, besides availability of capital, a continuous flow of human resources, something which Qatar cannot manage with its scarce domestic human resources. This,

as seen in Chapter 3, has created a rapidly growing demand on the foreign labour force. But the foreigners brought with them socio-economic and political problems as well as satisfying immediate needs. Some of the identifiable problems are summarily considered here.

1) Qataris and their activities

The spreading of the foreign labour force in Qatar has helped the country to go ahead with its development. The technical and managerial experts and workers brought to the country, hypothetically reduced the gap of technical understanding between Qatar and the industrialized nations. This primarily satisfactory stage has led to laziness of the government bodies in adopting extensive and serious training programmes for the local people. In addition, the effect removed some incentive and motivation in the Qataris and they became content not to practise the work which their foreign analogues were carrying out. Furthermore, this attitude of full dependence on foreign employees has created among Qataris the "absenteeism phenomenon"; absenteeism both from work and their obligations. It is well known that a side effect of dependence on foreign labour is the taking away of the enthusiasm for the acquisition of different types of knowledge and needed skills among most of the Qataris.

The dependence on a foreign labour force has not led to, or helped in, developing the local human resource in skills and qualifications but, on the contrary, it has been accompanied by a strong trend of driving the local manpower away from the fields of production, so it is not surprising that in 1981 about two thirds of the Qatari manpower was concentrated in the government offices. This concentration, together with the absenteeism phenomenon had

been causing over-employment as well as disguised unemployment. The government, on the other hand, instead of disciplining such Qatari employees, had been importing foreign labour to carry out work that Qataris would not fulfil. This, in itself, helped in the spreading of "welfare employment" where citizens and others receive a monthly salary without having to work for it.

2) Public utilities

There is no doubt that there is very heavy dependence on foreign labour in the setting up of the hardware of the public utilities but the foreign labour force is also the main utilizer of the public utilities. The government's tendency in this area towards short term planning methods and the annually increasing pressures of demand on public utilities, have made it necessary almost continuously to increase the output of the public utility units. The electricity maximum demand in 1954, for instance, was 0.6 megawatts (MW). In 1964 demand reached 28.4 MW, while in 1974 it was 116 MW. From 1974 to 1979 the demand increased by 263.8 per cent of that in 1974, reaching a total demand of 442 MW. (5) The causes of such demand growth were the population increase, per capita demand increase and the wide range of economic activities. This kind of increase in the electricity field, can also be seen in the less sophisticated areas of public utilities e.g. water, health, education, telecommunication, road, etc.

3) Housing

Any very rapidly growing country, like Qatar, is likely to find itself with a housing crisis. The increase of oil prices from 1973 onwards put a great pressure on housing supply. This pressure has been mainly created by the increase of the foreign population. Housing construction is carried out by the private sector, which

was not geared to respond to the great and sudden demand. The private sector also controlled the housing market. This control, with the shortage of supply, resulted in a considerable rise in residential unit rents. The private sector, in order to increase their income from the housing rents, started in 1973 to import more labourers, especially from Asian sources in order to construct more housing units. This unlimited importation of Asian workers, and others, in turn created yet more pressure on the available housing units. This great pressure caused a) overcrowding, especially among the Asian bachelor workers, b) even higher rents per housing unit and c) diminution of health standards. (6)

4) Economic

There are positive and negative sides to the foreign workers' impact on the economy and economic activities in Qatar. The residence impact of the foreigners can be seen from the point that the country has been taking a "work-ready" labour force, especially where this was technically well advanced over that of the native work force, and where the country did not require to train the labour. At the same time, and due to the noticeable shortage of quality and quantity of the local manpower, the imported labour force has been able to fill these kinds of shortages. In addition, the large number of foreigners have also helped, either directly or indirectly, in developing and reviving the domestic market.

But, on the other side of the coin, the foreign labour force has also been draining overseas the local capital which is believed to be very high, especially among bachelor workers and those whose families did not accompany them, i.e. a high outward flow of remittances. In addition, the foreign workers have been instrumental

in spreading new consumption patterns which have resulted in obstructing further development of local production especially among small-scale industries.

Concluding remark

It is clear, from the previous discussion, that dependence on foreign labour has appeared very strongly in Qatar. But we should not take this matter as a fact which cannot change or be changed. This is due to the fact that some of the socio-economic values are changing, and once these values change the contribution of the native population to the domestic economy could be great. Some signs of positive changes within the Qatari population e.g. in the attitude to the involvement of women and the attitude to productive work, whilst, negatively, a growing concern over the dependence on foreign labour which has alien cultural values. At the same time, the spread of education and vocational training could enable the citizens of Qatar to be more active in manufacturing industries and they could gradually replace the non-Qataris. Women, moreover, sooner or later, will probably enter the labour market and as a consequence the local labour could comprise at least a high proportion of the total.

The present recruitment methods, which have produced all this disequilibrium in the labour force structure, might have been necessary in the past, given development policy could also be changed. The present situation, arising from the 1982/83 oil price crises, has made governmental and other demands for the labour force more cautious in this approach.

CHAPTER 9

- (1) For more information see:

The Advisory Council, Minutes of the Eighth Meeting of the Council During the Fifth Annual Assembly with Dr.K.Naji, Monday 17.1.1977 pp.2-16 and .

Al-Kobaisi, A.J. The Development of Education in Qatar 1950-77 Unpublished Ph.D. Thesis, Durham University 1979.

- (2) See Al-Kuwair, A.K. The Role of Public Enterprise in Economic Development Alam al Ma'rifa Kuwait June 1981 p.98 and

Abdul Rahman, O., Oil Bureaucratic and Development Difficulties Alam al Ma'rifa Kuwait September 1982, p.121.

- (3) Arab Press Service Organisation, The OPEC Decision-Makers Survey : Qatar,APS Review Vol. No 3 20/27 January 1982 Cyprus p.1.

- (4) Ministry of Finance and Petroleum, Manpower Statistics, Personnel Affairs Department Qatar 1980, p.53.

- (5) Shankland Cox Partnership, Outline Planning Data, Policy and Procedure Review, Qatar Planning Studies Qatar December 1979 p.49, T.7.3.

- (6) Al-Najar, B., Working and Living Conditions of Foreign Labour force in the Arab Gulf Countries, Paper submitted to the conference on 'Foreign manpower in the Arab Gulf Countries held in Kuwait 15-18 January 1983, p.5.

CHAPTER 10

CONCLUSION

A. Summary review of findings

Before essaying an analytical evaluation of industrialisation in Qatar, a summary review of the main factual findings of this study is necessary. First, it is clear the development of manufacturing industry in Qatar has been very strongly influenced by two fundamental factors, the national physical resource endowment (see Chapter 2 and Section 5.3) and the small absolute size of population (see Chapter 3). The exploitation of the only major raw material resource, oil, started in 1949, since when capital has been available for industrial investment and both the economy and society of Qatar have become fundamentally changed. The real involvement of the government in industry came later only after the striking of the offshore oil field in 1960. This involvement, in 1962, took the form of studying different projects for utilizing associated natural gas. Though the resource inventory has subsequently been enlarged by the discovery of very large offshore unassociated natural gas reserves, these as yet have not been exploited.

From one point of view, it might be said that the first third of the thirty year period during which oil has transformed the scene was a period during which industrialization and diversification were not given much attention by government. From another point of view one could state that the whole process of industrialization and of oil revenue based socio-economic change has so far only extended over thirty years i.e. half the current male life expectation. This last point is a reminder of the importance of demographic factors which explicitly and implicitly appear in several contexts throughout the study.

Chapter 4 examines the sequence of government industrial investments in terms of the evaluation of industrialization policy and strategy. The appropriateness of classical development models and theories to the Qatari situation is discussed.

In Chapters 5 and 6 both the extractive and manufacturing industries in the public sector have been analysed in terms of the evaluation of the government policy and the fixed variables of material resources endowment and local manpower availability. Direct government investment in heavy industries took place following studies made in 1962 but the first evidence of implementation of an emerging policy appears in 1965 in the joint venture with Ross in fishing and fish product processing. The next government backed manufacturing industry did not enter production until 1969 i.e. cement production.

The study of the location of manufacturing industries in Chapter 7 highlights the role of the government in its virtually total control of manufacturing industries through decisions on siting and the provision of infrastructure as well as direct investment, and also serves to emphasize the fundamentally different behavioural characteristic of the public and private sectors. This last theme was more fully developed in Chapter 8, which is fundamentally concerned with decision-making as it affects industrialization. In decision making in a State, which is essentially dedicated to the principle of private enterprise, nevertheless, the dominant role of the State comes out very clearly both in the decision-making structure of the public sector and also in the extent to which the government has taken some positive action at least to regulate the private sector.

Even at this level, however, and as appears in all the previous Chapters, the dominant functional variable is that of a shortage of domestic manpower for industry. In Chapter 9 the way in which this factor, directly

and indirectly, profoundly influences everything in the industrial sector was developed.

So, essentially, we have a picture of a state, territorially and demographically small, with a highly skewed material resource base but which in its specific way is very rich. The society of the state has experienced rapidly accelerated change, which, of course, commenced before Qatar started extracting its own oil, and this has effectively influenced attitudes to investment and activity. As a result, qualitative as well as quantitative factors emerge as significantly influencing the process of industrialisation. Qatar, as with its neighbours, has recently committed itself to industrialization, first in national terms and more recently in terms of regional collaboration. The whole process so far has been highly compressed in time. From the study's factual findings some themes of particular significance emerge and, in conclusion, form the basis for an analytical evaluation of the past, present and possible futures of industry in Qatar.

B. Analysis and Evaluation

An important point which needs to be established at the outset of this analysis is that Qatar assumed the power and capability fully to control its national destiny only during the 1970's. Politically, full sovereignty was achieved at the beginning of that decade. As noted in Chapter 5, not until 1977 did Qatar become the sole and complete owner of all the assets of the oil industry, as they existed at that time. It is now the State of Qatar and its government that determine the rate of extraction of both oil and gas and the ways in which they are utilised, the criteria now being those which Qatar determines as suitable for its own development purposes as well as for revenue raising. The balance between the raising of revenue from the export sale of crude oil and semi-processed gas and gas liquid is clearly one vital factor

in determining Qatar's policy toward hydrocarbon exploitation. We must remember, however, that even in the preparation of crude for export and the part processing of gas and natural gas liquids, already an element of manufacturing is involved. The domestic use of hydrocarbons was first thought of as being almost entirely confined to the domestic consumption of a small range of refined products e.g. petrol, gas oil and kerosene. Since then, the situation has become more complex and Qatar now refines not only all the standard products such as those mentioned above, but has adopted refining processes which have become more multi-product and multi-purpose. However, until the unassociated gas resources of the North Dome are exploited, the rate of production of natural gas, now entirely associated, is determined by the rate of crude oil production, which in turn is governed by the export revenue consideration noted above. The significance of this lies in the fact that it is natural gas, rather than oil itself, which is critically important to industry. So far as this matter of national control affects industrialization, Qatar as a State now has total responsibility for balancing the various supplies to meet current demands i.e. for energy, feed stock, electricity and water, and against any future planned development of industry.

During Stages Two and Three of policy evolution, as outlined in Chapter 4, it was government policy towards public sector industrialization which completely dominated supply-side decisions. Qatar has now arrived at what was identified as Stage Four, and as with, for example, the production of industrial gases in the private sector, the role of government has now become one of encouraging or at least reviewing, likely or desired developments in relatively small scale private sector industries as well as those under its direct public sector control. Behind all such decisions lies the second basic fact, following from the

1977 oil asset control, that Qatar is now responsible as a State for financing all operations for exploitation although in processing it may arrange joint venture financing such as QAFCO and QAPCO.

Forward planning, therefore, of any industrial policy can and now must become part of a coherent national economic, as well as development, policy. This includes aspects of meeting desired social aims of consumption as well as determining production patterns.

For sources of finance, Qatar, as already in some joint ventures, has turned and will be turning to the world-finance market in order to meet investment needs. Since now, however, it is a sovereign state which is negotiating for such finance and not a multinational company, Qatar has a different kind of leverage which can be utilized, not only in the procurement of financial backing for investment in the whole hydrocarbon field, but also in creating medium or long term marketing links. Most of the Gulf Emirates and Saudi Arabia have taken the opportunity, presented by their state ownership of major hydrocarbon resources, of entering into agreements which are commercially and financially integrated. This does, however, produce a historically abnormal situation in that the Arab oil producing states rarely negotiate with centrally planned economies such as the Eastern Bloc and mainly deal with non-governmental companies and organizations in countries such as Japan and Western Europe. The essential characteristics of such agreements is their conditionality, i.e. foreign investors are welcome on condition that they also provide markets for Gulf products (see below for further examination of the implied interdependence).

When the oil companies were essentially asset-owning agencies, their needs and wishes in terms of the manpower employed in the industry might very often be negotiated with government, but the companies' technical demands tended to be supreme. As a result the importation of

foreign labour was very considerable. Now that Qatar is in complete control, it might be expected that a manpower and employment policy, which need not be totally dominated by economic and profit-making motives, might have incorporated measures controlling the origins of the work force in the oil sector. However, what the trends in employment seem to indicate is that the technical demands of the oil industry, as it has become a complex of exploration, extraction, processing and export, has not made it possible to reduce dependence on foreign manpower. This question examined in Chapter 9 appears as one which is not easily controlled even in a state-owned oil sector.

The role of government in this context, as noted earlier, is not confined to the ownership but, as in neighbouring countries has been extended into the development of the hydrocarbon industrial sector (or as it is rather inaccurately called, the petrochemical sector). In many statements made, not so much in Qatar as in neighbouring Emirates and also in many theoretical studies, diversification of the economy away from crude-oil export is often seen in terms of movement into the processing of oil and gas. Diversification, if it rests solely or mainly on the processing of oil and gas, rather than on their export as crude or semi-processed commodities is dangerously deceptive as an economic planning objective. On the other hand, movement into hydrocarbon industries is structurally a natural progression for states with large oil and gas resources. The limited range of resource endowment, as noted in Chapter 2, has made it extremely difficult for Qatar and similar states to move into industrial investment in non-hydrocarbon fields. What is important, therefore, perhaps is that for more than intellectual purposes, a clear distinction is made between diversification based on multi-sectoral growth as opposed to diversification which is based on the translation of the

single hydrocarbon resources into other basic forms. Moreover, as considered later in terms of regional and Arab world co-operation and collaboration care must be taken not to exaggerate the capacity of either market complex to absorb the standard range of petrochemical products which Qatar and the other Gulf States are all now producing and whose production will be very rapidly increasing in the near future.

Following what here has been termed Stage Three of industrialisation Qatar, as with neighbouring countries, now has to consider, above all, the market outlets for the products of any further basic hydrocarbon industries. Government policy has now established the basic platform of production, and merely to increase the level of production of the same products e.g. fertilizer, HDPE, etc. is to assume that unlimited markets for these exist. At the same time it has already become clear in statements made by both Saudi Arabia and the United States of America that even the further diversification of petrochemical products for export cannot be assumed to be acceptable automatically in specific world markets as opposed to a hypothetical global market (and see below). It should be noted here that in the case of Qatar the identification of market linkages has been an integral part of the approach both in the discussion of forthcoming North Dome gas exploitation as well as in the involvement in joint ventures with foreign companies who will serve as marketing agencies or market outlets in their own right. This is the reason why the integrated investment and commercial agreements referred to earlier are likely to remain standard practice wherever possible.

The government's role in the public sector industries is thus increasingly becoming important in identifying and capturing external markets, given that, as noted below, the internal national market for a very great range of both public and private sector industries is

limited in volume. The need for an external market drive is obviously very great, and certainly as far as the public sector industries are concerned, the government is now virtually totally responsible. The position as it affects the private sector is less clear and this together with relevant state policy is considered below. Whilst this role of market management is now looming large, the traditional and still basic governmental role is that of deciding on investment, according to various criteria which need not be purely commercial. This necessarily raises the whole question of economic and development planning as a coherent whole.

As far as capital availability for investment is concerned, the government is in a strong position, as are similar states which are able to derive most governmental revenue directly from the major national income source i.e. oil and gas export. However, the balance between investment in manufacturing industries (and other viable production sectors) and expenditure on providing a whole range of goods and services ranging from social and cultural welfare facilities e.g. education, health etc. to basic infrastructure, places further responsibilities on government. We have recognised that much expenditure on infrastructure is, in part, investment for production, in this context in manufacturing. But this is a "grey" area in which the discipline of control requires very considerable skills. For example, it is clear that a full cost-benefit appraisal has not been undertaken for the construction of the road network in Qatar.

Similarly, the supply of electricity and water is not only a matter of providing public utilities but also inputs to manufacturing. When all infrastructural capital costs and a large proportion of recurrent production costs, are met by a government revenue which is not raised by taxation or customer charges, it becomes difficult to distinguish

between wealth creating investment and expenditure for consumption. The place of private sector industries in this context has been indicated in Chapter 6 and is further considered below.

Whilst the situation as so far analysed demonstrates that the government of Qatar has the economic dominance and capability necessary for full economic planning, Qatar has not proceeded to complete planning of the conventional five year plan type. Whilst an over-all strategy has emerged, this remains very much a matter of what is understood to be desirable and acceptable as opposed to a technocratic formulation in firm detail.

Before leaving (at least in general terms) this vital theme of the role of government in industrialisation a further point of clarification is necessary. In this study it is not possible to explore the nature of government in Qatar or its neighbouring countries, but, in fact, the role of government in any economic activity can only be understood by reference to the way in which the form of government present has very strong roots in the cultural and social background of the people. This can mean that whilst, in this thesis, the evidence for government policy has had to be presented in a form which seems highly formalized and institutionalized, it must be appreciated that, while much of the machinery of government is bureaucratic in appearance and often in function, the approach to any planning strategy is more a matter of the evolution of an understanding between a relatively small group of senior Qataris. The place of the Amir, in this case, can become particularly important in deciding on various matters. Moreover, the question of social and cultural acceptability within the Qatari community for particular policies is something which is again a matter of personalized feeling transmitted by personal contact, rather than voting by an electorate. The question of social and cultural acceptability leads the argument from the role of government as such to another key issue, that of industrialisation and manpower.

As noted in Chapters 4, 9 and further below, industrialization as it has proceeded so far has apparently required the very large importation of foreign labour of many different ethnic origins, mostly culturally alien to Qatar. Since this has had many social and cultural as well as economic consequences, this is now a factor which may, therefore, considerably influence government policy. An industrialization strategy now should include the search for industrial ventures which have smaller consequential demands for foreign manpower than those industries already established. Therefore, one has to recognise, before any identification, technical or market orientated, of future industries, is the need for minimising the demand for labour. This is not simply a numerical matter but has to be seen to be qualitative in some specific ways. Since for the foreseeable future, young Qatari males will continue to have a wide range of choice of opportunities, one must take into account the social acceptability of different kinds of employment, even at the managerial and supervisory levels. This is not a static situation but one socio-economic area of investigation could be to try to ensure, as far as possible, that the nominal demands for skilled manpower in any particular project does match what can be measured or predicted in terms of acceptability and attractiveness to future Qatari senior staff work force.

A quite different question of balance often appears in many developing countries. That is the apparent conflict of social interest which can arise from attraction of automated advanced production and control systems where the supply of skilled manpower is limited, even though the potential numerical labour force is large and unemployment is common. This, then, develops into an argument over wealth creating, as opposed to job creating, industries. In Qatar this conflict does not arise since automated systems, even though they may mean technological

import dependence, could, in some cases at least, lead to lower dependence on imported manpower and possibly in time even on imported equipment, whilst at the same time being associated with technological management training of a modern kind. While there is no formal plan in Qatar for education and training, nevertheless, both from what was noted in Chapter 3 and proposed by the author, it has been made clear here the importance of investment by government in what may be called human infrastructure or human resources. The Third Plan of Saudi Arabia specifically makes such provision.

Up to this point a great deal of emphasis has been placed on the role of government, particularly in public sector industries and in manpower policy. The question has also been raised at several points concerning the possible desirability of coherent economic and social strategic planning. The place of private sector industrial activity in all of this, as has been noted, is not clear, because here one is not concerned with direct government investment or with areas such as education, health and communications in which government is now expected to be active. Private sector manufacturing in Qatar appears, in fact to exist in yet another "grey area". In economic terms the government has not provided much direct financial stimulus to private sector industry compared, for example, to Saudi Arabia. Only very recently has there been the provision of interest-free credit for industrial expansion or establishment (as noted in Chapter 4). On the other hand, through low transfer prices, the government has ensured that the private sector can obtain at least some inputs, at or below, their production cost e.g. electricity, water and, in the case of IED, the provision of developed land and at least basic utilities. Qatar would seem to be more or less in step with many other countries, including the industrialized countries, in providing such support.

Far more important, however, is the fact that the government has provided almost guaranteed markets, directly and indirectly, for the products of a large section of the small-scale industrial private sector. First a distinction must be made between consumer goods industries, such as bakeries, where price controls are meant to protect the consumer, rather than the fixed support prices for the producers. Even so, the artificially low prices charged for Flour Mill products, are of assistance to some food industries. In the much larger field of construction materials, however, as long as the government supported large construction projects, there appeared to be an almost unlimited market open to private manufacturers of building materials. In fact, as experienced in 1977/78 and now in 1983/84, when the level of government expenditure on construction projects periodically declines this market appears by no means as safe as some producers had begun to assume.

On the whole, therefore, it could be maintained that small-scale industries in Qatar are risk bearing to a much greater extent than would seem to have been the case if one relied only on the periods of rapid and apparently continuous growth i.e. 1973 to 77 and 79 to 82. As noted in Chapter 6, the response of entrepreneurs venturing into private manufacturing has been a combination of cautiousness and a development of techniques of risk-sharing through the more complex organisation of companies and the frequent involvement of foreign partners, legally and not so legally. Whilst the government can, to a very considerable extent, protect the public sector basic industries from the worst consequences of the small size of the domestic market by negotiating export outlets by exerting governmental leverage (see above) and through large-scale joint ventures, in the case of the private sector things are not so easy. Here the small size of the domestic market also makes reliance on

export necessary in many fields such as plastic goods, but the competition between private sector manufacturing, imports from industrialized countries, the import of re-exports from countries such as the U.A.E, and very likely in the near future from domestic manufacturers in Saudi Arabia, are discouraging much industrial innovation in the private sector. Here again, perhaps, there is a need for a total review of the nature and purpose of governmental assistance and encouragement both in the national sphere and in the regional Gulf sphere. In the private sector perhaps it is even more important, if Qatar is not to be totally government dominated in manufacturing industries, that bodies such as the IDTC should be employed in identifying particular types of manufacturing which could be attractive to private investors in these circumstances, as well as concerning themselves with the public sector. This again requires a more coherent and detailed planning of strategy and techniques.

As far as public industries are concerned, the range of industries in which government investment has been made has been decided by a basic industrial approach modified by the realities of resource endowment. So, in Qatar as in virtually every other developing country, whether energy rich or not, one finds similar early trends, for example, in cement making, flour milling and some kinds of iron or steel making. In Qatar and its neighbours and also in other countries such as Indonesia, the special factor of resource endowment has led to investment in hydro-carbon processing industries. This field, generally, in developing countries, however rich they may be, is beyond the financial and technological scope of private investors. Ministerial projects, as described in Chapter 8, are quasi-industrial, for example, electricity generation and water manufacturing, which import service provision, while part public utility, also have an element of manufacturing processing. The criteria which determine investment here are not economic generally,

but mainly social needs. When we look at SSI i.e. the private sector, this indicates how profit seeking private investors, with dominantly economic motivations, select sectors of viable manufacturing. Until 1980 there was no industrial credit provision in Qatar, and even today very few capital grants or loans are made. So the situation is not obscured by the availability of cheap loan capital. In these circumstances, we find that the type of industries which have developed are much the same in Qatar, in some respects, as in other developing countries i.e. the early boom in building materials and the continued strength of industries supplying construction industries.

What is striking, however, is that one sees in neighbouring Saudi Arabia that through the Saudi Industrial Development Fund (SIDF), established in 1974/75, there has been a massive and accelerating flow of industrial lending.⁽¹⁾ If one excludes the provision of capital to electricity generation and cold stores, which might be regarded as the equivalent of ministerial projects and notes that the basic heavy industries i.e. petrochemicals, are financed separately, the pattern of loan commitment indicates the type of requests for assistance made by potential industrialists in the private sector. If one, therefore, looks at the sectoral break-down of loans made by SIDF to the five identified sectors, one finds that, as in Qatar, the construction activity throughout has remained the dominant area of attraction to industrialists. The accumulative loans up to 1402 shows that 24.2 per cent of loans were made to industries concerned with building products, 25.4 per cent made to cement making, and also much of the engineering products sector is concerned with steel structures for industrial and commercial buildings.⁽²⁾ So, between 50-60 per cent of loan value goes to the same sector.⁽³⁾

Therefore if we examine the small-scale industrial sector as representing the private sector, where the types of industries were dictated by the appreciation of economic opportunities by individuals and groups, then we have some idea of the way in which industrial activity of the conventional kind is developing.

In the public sector one finds analogous conventional development around the basic heavy industries. What then is significant is that in totally different planning or ideological circumstances, as in for example, Algeria, in most developing countries, state investment has generally been made in the same type of basic industries. The private sector in Qatar has responded to market opportunities in ways similar to those found elsewhere where a private sector is tolerated or encouraged. Such conventional developments seem to reflect the effect of forces which are of world-wide significance. The one important difference between the industrial structure of Qatar and the less rich developing countries is that the consumer industries which appear very strongly in the latter, such as footwear, clothing and ceramics, (apart from tiles and bricks) are not represented here. Here one is returned to points which dominate much of the analysis made here, i.e. the small size of the local consumer market and, of course, the free availability of cheap imports together with high disposable incomes. There is, of course, also an absence of a domestic resource base for such goods e.g. leather and textiles.

Within the scope of this thesis it is not possible to develop fully a comparative analysis of general theory concerning why and in what ways forces influence the structural development of manufactures. Nevertheless it can be claimed that this first integrated study of manufacturing in Qatar makes it possible for further research to be made in relevant comparative studies.

A further theme of significance to contemporary and future industry in Qatar emerges from those already examined, that is the pattern which has developed in particular industries of joint ventures between Qatari and foreign interests. As noted in Chapter 6, Qatar, as with many other developing countries has found it necessary and/or worthwhile to enter into joint venture industrial agreements with foreign partners. Without joint ventures very few industrial projects would have been, or are, feasible, but the objectives of the two partners have to be reconciled and made as compatible as possible. The basic objective of the foreign partner, which invariably has been private sector business, is, of course, to maximise its returns over a short or a long period depending on its perception of the future. For Qatar there are other requirements which can not necessarily be stated in a financial balance sheet. The matter is not of course quite as simple as this and joint venture relationships have evolved over time. At the beginning, negotiation between the two partners was strictly unequal, in which the only power held by Qatar was that of being the sovereign state concerned, while the foreign partner had most, if not all, the relevant technology, expertise, and experience in the specific field, management know-how and in most cases access to international markets. Slowly, but at an increasing rate, skills in negotiations, management and appreciation of the consequences of various elements in partnerships have been growing on the Qatari side. In each of the cases mentioned in Chapter 6, it can be noted that terms of agreement increasingly became more favourable to Qatar and lessened the risk carried by the State. On the other hand there is also the question of identifying those foreign partners which are prepared to take a long view of their profitable involvement with enterprises in Qatar and those potential partners that are not solely insistent, directly or indirectly, on becoming the dominant partner i.e. by monopolizing the supply of equipment.

The characteristics of joint venture industrial projects are now and in the future will be of great importance to Qatar. The growing export dependence of public and private sector manufacturing in Qatar, reinforces the importance of the marketing contribution made by the foreign partner. This in turn has strengthened the Qatari drive for foreign partners with such commercial involvement and obligation to market Qatari industrial products as noted earlier. If, as considered later, new industries become more specialised, high value added, and of high technology, the choice of foreign partners becomes even more critical, particularly if there is to be a significant acquirement of skills by Qataris.

As indicated earlier in this Chapter and in Chapter 4, industry in Qatar can be seen to be at a stage (Stage Four) where inter and intra-industrial linkages, within and between the public and private sector, are now developing (see the conclusion to Chapter 6). Of critical importance to this development of linkages are the various studies commissioned during the 1970's from consultants such as Scret, and which were then studied by IDTC, which were specifically concerned with the selection of suitable product areas for domestic industries.⁽⁴⁾ In one final report there was published the identification of 98 potential manufacturing products from which a short list of 18 recommendations was drawn up. In fact, in commissioning these studies, Qatar has recognised the need for selectivity and is now apparently able to select particular industrial projects which would support or promote the national economy. However, an examination of these lists exposes some real problems. First, a comparison of the listed suggestions with those contained in an IBRD study of Kuwait economy as early as 1960⁽⁵⁾ suggests that from the point of view of conventional analysis, very little freedom of manoeuvre is available to Qatar. Table 10.1 shows that apart from items 11 to 13, which are concerned with petrochemical based plastic goods manufactures,

Table 10.1

Summary Table of the 18 Projects

No.	Project Title	Employees Required		Raw mater- ials loc- ally av- ailable	Aver- age Local Sales %	Finance (1000 QR)		Total in- vestment over a 10 year per- iod (1000 QR)	Pay back period (years)
		Total	of which skilled and beyond			Loan	Equity Capital Year		
1	Clay bricks and Products	45	37	Clay + sand	100	30,000	25,088	59,230	10.0
2	Sand-Lime bricks and Products	66	54	Sand + lime	100	20,000	20,372	47,015	9.2
3	Asbestos Cement sheets and Pipes	263	111	Sulph. resist ing cem- ent (39%)	20	55,000	42,012	105,302	5.5
4	Paper tissue conversion	47	31		58	10,000	3,334	16,714	8.0
5	Paints (emulsion)	33	19		80	3,500	2,791	9,306	4.9
6	Detergents(domestic washing powder)	24	14		50	8,000	5,988	14,435	10.0
7	Biscuits	56	20	Flour (23%)	75	10,000	5,912	18,566	7.2
8	Canning(pulses and fish)	93	31		8	10,000	13,440	24,474	- *
9	Packaging of oils and hydroge- ration (GHEE)	74	41	An.Fats 5 to 10%	43	10,000	14,967	27,261	- *
10	Toilet soaps,cosmetics and perfumery	49	26		40	10,000	8,965	19,610	4.3
11	Thermo plastic goods	156	78	LDPE(26%)	15	35,000	35,879	72,593	5.8
12	PVC coverings	26	15		10	8,000	6,949	15,478	8.4
13	Melamine from urea	76	52	Urea	0	65,000	57,570	124,264	9.9
14	Dry cells	139	40		18	15,000	5,493	25,275	- *
15	Automotive batteries	96	37		20	10,000	4,864	18,756	9.6
16	Automotive tyres and tubes	553	399		12	130,000	124,637	271,279	10.0
17	Window type air conditioners	206	90		66	25,000	20,233	47,811	10.0
18	Electrical accessories	40	23		38	5,000	4,893	10,122	- *

- * does not exist.

Source: Compiled by the Author from

IDTC, Development of Light and Medium Industries in Qatar, Final Report, Serete, Qatar 1979, pp.IV 18-19

the two lists are almost identical. Second, the close similarity between the findings of two basically different studies, separated by over eighteen years of time, shows that not only Qatar but also its neighbouring Arab Gulf Emirates are, in fact, severely constrained in what can be done in manufacture, given, as noted earlier in this thesis, the dominant characteristic limitations of their physical and human resources background. Nevertheless however skewed may be the physical and human resource inventories of Qatar and its neighbours it is also true that they are immensely rich in hydrocarbon resources, and these are highly unlikely to lose their world market value even though demand prices may periodically fall. Therefore, a third problem appears, i.e. whether the various conventional studies commissioned for international consultants have been designed to give answers to the right questions. One reason, perhaps why there is the need, in Qatar, for finding non-conventional answers to industrial development questions is that no major international agency or consultant has had sufficient experience in dealing with the unique situation of no more than four states in the world (Qatar, Kuwait, Bahrain and the U.A.E.). For the most part consultant advice is based on either the experience of already industrialized and diversified countries or of other developing countries whose characteristics are totally different to Qatar. An additional reason is that Qatar and its neighbours have themselves experienced very rapid changes in a short time, during most of which time oil revenue upward trends seemed to be permanently set. As a result there was no immediate need to identify anything other than conventional questions concerning directions for growth.

Qatar and the neighbouring Emirates are, in many ways, unique. First, they are all virtually "city states" with a small population and, therefore, have highly urbanized, small potential work forces, and

limited volume domestic markets. Secondly, the only important natural resource which they have is that of hydrocarbon wealth which, as considered earlier in this Chapter, is both a source for revenue through export and a source of energy and raw material sources. Thirdly, Qatar and its neighbours are all in a position where the social consequences of the presence of large non-Arab non-Moslim populations have, in recent years, been recognised as becoming acute. Lastly, Qatar, as with all other Emirates, is necessarily tied into the international economic system and virtually nothing viable can be developed domestically without reference to international markets unless the states are prepared for a few decades to become autarchic. Therefore the question which might very well be asked in Qatar is how to identify industries of a totally different type than those hitherto considered, i.e. non-conventional industries, based on rather different criteria than purely conventional accountancy economics. The aim would be to make a major jump into a new generation of industries with the following essential characteristics:

- a) Requirements for the smallest possible input of labour in absolute numerical terms.
- b) The employment creation must be of jobs which are in terms of social status and social and cultural acceptability attractive to Qatari males.
- c) Jobs for which a small number of Qataris could receive special high level technical and management training, as a deliberate creation of a Qatari elite.
- d) The products have to be identified in terms of reasonable forecasts of future world production demand and this requires long term market identification research of a specialized kind.
- e) Products must be of high value, and the processes in terms of material input requirement, should need little more than energy,

possibly some hydrocarbon products or the small range of other mineral resources available in Qatar, or a small range of specialised imported materials.

So far, discussion has mainly centred on Qatar as a sovereign state, with its own specifically national concepts of industrial development. The general issue of regional and/or Arab economic cooperation is considered later, but in the context of planned selection of future industrial growth in Qatar, the more restricted issue of regional competition is relevant here.

Since 1983 a new measure of urgency has appeared over international industrial collaboration although it has not been reported in any of the published statements yet to come out of the Gulf Cooperation Council. This emergency arises from the rapid coming on stream between 1983-1986 of the enormous petrochemical production built up by SABIC in Saudi Arabia. The implications of this for the industrialized countries have already been reported, ranging from statements such as that of Donald Regan, in October 1983, pointing out that whilst there is no intention in the USA to raise tariff obstacles to the importation of Saudi Arabian petrochemicals, this position would only be maintained as long as imports were not subsidised or unfairly priced by Saudi Arabia. In another statement, in November 1983 the Managing Director of BP Chemicals estimated that by the late 1980's, 5 per cent of the world's ethylene output capacity would be located in Saudi Arabia. The Financial Times of U.K. in 1984 made it clear that the position and the industrial muscle behind the international competitiveness of Saudi Arabia petrochemicals will be a result of the use of very cheap feedstock - about 12 to 15 per cent of the average prices in Europe and America respectively. Additionally, SABIC's production units have as joint venture partners very powerful allies such as Mobil, Mitsubishi, Exxon and Shell.⁽⁶⁾

The financial, organisational and technical muscle behind SABIC is such that it will be very difficult for other newly emerging petrochemical producers to compete, and whatever is done, in terms of collaboration through the GCC, it is now a fact that this production is in being and more will shortly be coming on stream. This addition within some three years of an extra 5 per cent of world ethylene capacity, together with the growing sophistication of the Saudi production system, is something that will have both global consequences and consequences for Saudi Arabia's neighbours.

What is here most relevant to the case of Qatar is that every one of the SABIC units will be exporting, for years at least, some 90 per cent of its production. The strategy for Qatar hitherto has been to make certain of market outlets for its public sector industries before deciding on investment. It would seem that Qatar will not be well advised to go further with mainstream hydrocarbon products. This is, first, because of the danger of market competition with its larger neighbour, and secondly, because in a fight for markets, Qatar could be forced into agreeing to arrangements which were certainly not profitable to Qatar.

So far Qatar has been in a slightly weak position as also have been Saudi Arabia and Kuwait in that present petrochemical industries have been dependent on associated gas, and the availability of this depends on the rate of crude oil extraction. Saudi Arabia would seem likely to continue to be in this position for at least another decade. Qatar, on the other hand, could divorce its gas supplies from the rate of oil production by developing the North Dome offshore gasfield. This perhaps reinforces the point that Qatar, in addition to any regional collaboration, needs urgently to identify some specialised, non-mainstream hydrocarbon based industrial opportunities particularly suited to its present and long-term wealth in unassociated gas.

Already demonstrated is Qatar's particularly vulnerable position in regard to its small domestic population market and indigenous labour force. One has also noted the strength so far of a responsibly managed centralized decision-making system which has been associated with socio-political stability to a greater extent than that found in most neighbouring countries. In Kuwait, for instance, there are clearly major and powerful private economic interests which are not necessarily always in tune with national interest, the U.A.E is still a federal and not a unified state, Saudi Arabia has weaknesses as well as strengths in its great size and diversity.

At the national level, perhaps, the most immediate question for the future is how private sector production is to be diversified viably, noting its export dependence; secondly the evolution of an effective manpower policy linked with the problem of immigration; thirdly, how the machinery of government, as applied to economic management, will continue to evolve.

Over and above all this is the general issue of Qatar's economic relationships with its neighbours in the Gulf and the Arab world and the way in which, in the context of this thesis, there can be an identification of mutual interests in the industrial sector, which are best served by collaboration and co-ordination rather than competition.

Regional and/or Arab cooperation in economic development in general and relating to industry in particular is a subject which on the one hand has been explored by many writers and analysts and on the other hand is of practical concern to Qatar and its neighbours.

A somewhat confused situation has developed because most Arab writers concerned with the theme of industrialization in the Arab world as a whole tend to write from the point of view of non-Gulf nationals and are certainly not the people responsible for actual management

(7)

decisions in the Gulf (see Chapter references). This is not the place to discuss questions on Arab unity or the function and effectiveness of Arab League agencies, but most of the scenarios that come from recent writers on Arab industrialization appeared to adopt the formula of linking the financial and hydro-carbon wealth of the Gulf States with the development needs of other lands such as Egypt and Syria, very nearly a position in which the "have less" are indicating how the "have more" should invest - for non-Gulf purposes. It does, of course, make general economic sense to argue that whilst the Gulf Emirates, acting individually, appear to be in a position of continuing dependence rather than one of increasing dependence, their freedom of manoeuvre would be enlarged if they reduced their individual freedom of action through collaboration and cooperation. However, more detailed examination suggests that regional and/or Arab collaboration are not enough. There are, perhaps, as Besseisu has pointed out, ⁽⁸⁾ several "circles" involved. One is that of the Gulf region, the second is the Gulf with its Arab neighbours, the third being the Gulf, its Arab neighbours and the international economic community. It can be suggested that much relevant Arab writing tends to exaggerate the way in which the first two circles can be isolated from the third, and equally important the willingness of the first circle to have its aspirations limited by the needs of the second. This self-isolating approach is by no means universal and other studies such as that of Besseisu suggest that: ⁽⁹⁾

"... even the Regional circle has severe limitations as illustrated by the limited factor imposed by Regional market on many industrial sub-sectors. All these factors tend to extend the motivation to co-operation outward to the wider international circle."

It is suggested that this present study tends to confirm this view. Countries such as Qatar are exposed to a great range of advice and comments both from within the Arab world and from outside. What is,

perhaps of more immediate significance are the steps which Qatar and its neighbouring countries are taking in establishing formal relationships for the implementation of areas of collaboration, specifically in the industrial sector.

It is significant that these points emerged at an OAPEC sponsored seminar held in Rome in 1981 and attended by most of the OAPEC and South European countries. ⁽¹⁰⁾ If one examines the proceedings of this seminar one is reminded that in any discussion of Qatar's industrialization, one must never forget that Qatar is not a totally isolated unit. In the region discussed, as demonstrated in Table 10.2, it is clear that the component countries do not greatly complement each other in their industrial opportunities but rather are likely to compete. Whatever happens in the region as a whole or in other particular countries affects Qatar's decisions.

The first actual agency created for promoting co-operation was the Gulf Organisation for Industrial Consulting (GOIC), established in February 1976 with its headquarters in Qatar. GOIC, which includes Iraq as well as the Gulf Emirates, Saudi Arabia and Oman, has been most active and carried out under its terms of reference (see Appendix 10.1) the dissemination of published information and studies of industries such as glass fibre and carbon black production. The implementation of recommendations so far has been confined to the expansion of ALBA in Bahrain. This relative slowness appears to arise because all recommendations for the specific siting of new industries raise problems of allocation between states of particular enterprises. For example, as far as Qatar is concerned, none of the listed projects such as the manufacture of carbon black, the glass fibre industry and glass making, were suggested to be located in Qatar.

Table 10.2

Main Industrial Areas and Development Zones

Country	Industrial Areas & Development Zones	Petrochemicals					Gas Processing	Iron & Steel	Aluminium	Cement	Note
		Refining	Ethylene	Ammonia	Urea	Methanol					
Algeria	Arzew	x		x	x	x	x				+ Aromatics Neighbouring the Annaba area (cement, metal industry, etc.) + Light industry
	Skikda	x	x	x			x				
	Algiers	x								x	
(El Hadjar)											
Egypt	Alexandria	x	x		x			x		x	+ Light industry
	Tanta-Talka	x	x		x						
	Cairo-Helwan							x		x	
Libyan AJ	Abu Kammash										Chemical complex Chemical complex + Phosphate Fertilizers Further cement mills in Benghazi, Tripoli, Lebda
	Zuwarah								x		
	Azzawiyah	x								x	
	Misratah Ras Lanuf Marsa El Brega	x x x	x	x	x	x	x x	x			
Bahrain	Awali-Sitra	x		x		x			x	x	
Iraq	Basra	x	x	x	x		x	x		x	
Kuwait	Shuaiba	x	x	x	x		x			x	+ Minor industrial activities
Qatar	Umm Said	x	x	x	x		x	x			+ Cement at Umm Bab
Saudi Arabia	Jubail	x	x		x	x		x			
	Yanbu	x	x				x			x	
Syria	Homs	x		x	x						+ Phosphate Fertilizers
UAE	Ruweis	x		x	x		x				
	Jebel Ali			x	x		x	x	x	x	

Source: ENI Estimates

Note: Describes the situation variously between 1980 & 1982.

Whatever the recommendations made on purely technical and commercial terms, decisions are ultimately only possible as a result of political agreement between the states concerned. This is why the establishment of the Gulf Co-operative Council (GCC) in 1979 and its formulation of an economic agreement^{in 1982} became particularly important. Since its inception, the GCC has become a rapidly evolving organization which constitutionally has political authority, unlike GOIC. In the context of this thesis, the economic agreement (see Appendix 10.2) becomes especially crucial to the future.

In March 1984 the Advisory Council of Qatar gave preliminary approval on behalf of Qatar to the terms of the agreement and this now awaits ratification by the Amir. What now matters, therefore, is how not only policies directly concerned with industrialization but other policies, such as common tariffs and the movement of capital and people and even other, as yet unformulated policies which have been discussed e.g. concerning immigration, are formulated and accepted. There have been Ministerial meetings over agriculture, marine and mineral resources in the GCC area as well as discussions over common currency and other matters which indirectly are of great significance to future industry in Qatar.

On the whole, there should be some general benefit if the GCC confers some socio-economic political stability even more important today than it was 15 years ago, since this can encourage enterprise. But having said that, the situation could also be assessed as one in which Qatar stands to lose rather more than it has to gain in specific fields. This is partly because the small size of its manpower capability and the small size of its domestic market and partly because of the very considerable development in some commercial and industrial fields in other states, e.g. banking in Bahrain, finance in Kuwait and import/export trade

in Dubai. On any detailed evaluation it would seem that further mainstream industrialization in Qatar, even given maximum GCC collaboration, would not be expected to be, in practice, profitable to Qatar in the short and medium term future. It would seem that Qatar is still faced with the classic situation of having to find special market opportunities which have not yet been taken by its neighbours.

So far, as has been shown, the policy of Qatar has been very cautious and selective with regard to the exploration of areas of industry giving the most suitable returns at the most appropriate time. This policy could be even more important in the next decade or so. What one can perhaps assert is that to employ most effectively the most scarce resource, manpower, whether in industry or in other activities, and so to upgrade its indigenous human skills, provides the best long term guarantees for the future of Qatar.

This last general point is also specifically relevant to the industrial sector. In the OAPEC seminar study referred to earlier, and as explicitly stated earlier in this concluding chapter, the need to explore new frontiers of science and technology for innovative fields of industrial development is expressed.⁽¹¹⁾ In this thesis such exploration cannot be taken further but it is clear that Qatar's industrial future needs to be appraised in ways different from those pursued in the past.

CHAPTER 10

References

- (1) See Saudi Industrial Development Fund, Annual Report 1401-02 H. Saudi Arabia.
- (2) Ibid. p.25.
- (3) Ibid. p. 23 and p.34.
- (4) See IDTC, Development of Light and Medium Industries in Qatar, Final Report, Serete, Qatar 1979.
- (5) International Bank for Reconstruction and Development. Economic Development in Kuwait, Translated by Al-Dabagh, S.A., and published by the Arab Bureau, Kuwait (ca 1963), pp.220-228.
- (6) Economic Intelligence Unit, Saudi Arabia, Quarterley Economic Review No 4 1984, London and
Rapoport, C., and Tandy, H., Saudi Arabia Plays an Ace, Financial Times, Thursday 29.3.1984 p.26.
- (7) See Abdalla, I. S., and others, Images of the Arab Future, The United Nations University, Frances Pinter London 1983.
Rashid, A.H., Integration of Arab Economy, Ministry of Information Iraq 1977.
The Institution of Research and Arabian Studies, Studies of Systematic Planning and Integration of Arab Economy, Cairo 1978.
The Arab Economic Unity Council, Industrial Systematic and Its Role in Economic Development, Arab Industrial Systematic Concurrence, Egypt 22-26 June, 1976.
Ghantos, E.T. Arab Industrial integration, a Strategy for Development. Croom-Helm, 1982.
- (8) See Besseisu, F.H., Pragmatic Approach to Arab Gulf States Development Co-operation Conceptual and Practical Basis Unpublished Ph.D, Durham University October 1982.
- (9) Ibid. p.604.
- (10) See ENI/OAPEC, Development Through Co-operation, Seminar Between OAPEC and South European Countries 2 Volumes, Rome November 1981.
- (11) See Ibid Vol.2, p.145-169.

1. Name of the establishment and any subsidiaries.

١- اسم الشركة والفروع

2. Date started operations and date registered as company.

٢- تاريخ افتتاح الحركة وتاريخ التسجيل

A. B.

أ
ب

3. The area which the establishment occupies (sq.m.) and location.

٣- المساحة التي تقوم عليها الشركة وموقعها

4. Since opening, has this establishment been:-

٤- منذ افتتاح الشركة حتى الوقت الحاضر هل

a. Expanded? b. Moved?
c. Remained in same place?

أ- توسمت ب- انتقلت من مكانها
ج- بقيت في نفس المكان

5. If the answer is (a), why?

٥- اذا كان جواب (أ) بالايجاب لماذا؟

6. If the answer is (b),
a. Where were the previous locations?
b. Why did you move?

٦- اذا كان جواب (ب) بالايجاب
أ- اين كان الموقع السابق للشركة
ب- لماذا انتقلت

7. If the answer is (c), why?

٧- اذا كان جواب (ج) بالايجاب لماذا؟

8. Do you want to move your establishment from its present location.

٨- هل تريد نقل شركتك / موسستك من موقعها

a. Yes b. No.

ال الحالي ؟
أ- نعم ب- لا

9. If (Yes), why and where do you want to move?

٩- اذا كان الجواب (نعم) لماذا ؟
لاني اريد ان تنتقل ؟

10. If (No), why?

١٠- اذا كان الجواب بالنفي لماذا ؟

11. Does the owner(s) manage the establishment by himself?

١١- هل صاحب الشركة يدبرها بنفسه

a. Yes b. No.

أ- نعم ب- لا

12. If (No) does one of his family manage the establishment?

١٢- اذا كان الجواب بالنفي فهل احد افراد اصره

a. Yes b. No.

صاحب الشركة يدبرها ؟

أ- نعم ب- لا

13. If (No), is your manager

a. Qatari b. Non-Qatari

١٣- اذا كان الجواب بالنفي هل المدير

أ- قطري ب- غير قطري

14. How many employees did the establishment have when started?

١٤- كم كان عدد الموظفين عند افتتاح الشركة

a. Qatari b. Non-Qatari

أ- قطريين ب- غير قطريين

15. Have you provided any facilities for your employees?

١٥- هل تقدم الشركة اية تسهيلات لموظفيها ؟

a. Yes b. No.

أ- نعم ب- لا

16. If (yes), what are they?

١٦- اذا كان الجواب (نعم) فما هي ؟

17. How many workers are now employed?

١٧- كم هو عدد الموظفين والعمال في الشركة الآن

Q N.Q.

- a. Administrative staff _____
b. Skilled _____
c. Semi-skilled _____
d. Unskilled _____

موظف _____
أ- إداري _____
ب- تامل ماهر _____
ج- نصف ماهر _____
د- غير ماهر _____

18. Which of the following do you pay employees

١٨- ما هي الاشياء التي تدفعها الى الموظفين

In addition to their salaries:

بالإضافة الى رواتبهم:

- A. Social security B. Insurance
C. Retirement and saving fund
D. Medical services E. Rent or
houses. F. Other (please Indicate).

أ- ضمان اجتماعي ب- تأمين
ج- تقاعد وتوفير د- خدمة طبية
هـ- بدل سكن أو سكن و- أخرى
(رجاء التحديد)

19. Can you give a rough estimate of
employees travelling to work?

١٩- هل يمكنك إعطاء تقديرات تقريبية

- a. less than one km. _____
b. 1 - 5 km _____
c. 5 - 20 km _____
d. more than 20 km _____

للصافرة التي يقطنها الموظف/العامل للتقدم
الى العمل
أ- اقل من كيلومتر واحد
ب- من واحد الى خمسة
ج- من خمسة الى عشرين
د- اكثر من عشرين

20. How many of your Qatari employees
have been trained.

٢٠- كم عدد موظفيك القطريين قد ربوا

- a. In Qatar
b. Outside Qatar

أ- في قطر ب- خارج قطر

21. How many of your Non-Qatari employees
have been trained:

٢١- كم عدد موظفيك غير القطريين قد ربوا

- a. In Qatar
b. Outside Qatar

أ- في قطر ب- خارج قطر

22. Which of the following problems have
been encountered to a significant
degree in the labour force:

٢٢- أي من المشاكل الهامة الاتية واجهتها الشركة
/ المؤسسة بالنسبة للموظفين والعمال ؟
أ- عدم وجود نظام صوره
ب- عدم وجود خبرة تشغيل
ج- انتاجية منخفضة من العمال
د- الضباب
هـ- الاجازات
و- مشاكل أخرى

- a. Lack of skilled labour.
b. Lack of operational experience.
c. High turnover of labour.
d. Absenteeism.
e. Holidays and leave
f. Others (please Indicate)

23. Is the building:

٢٣- هل مبنى مجمع الشركة ؟

- a. Personal property?
b. Rented?

أ- ملك خاص
ب- بالاجار

24. If (b), do you rent it from

٢٤- اذا كان جواب (ب) بالا يجاب ؟

- a. the Government.
b. Privately.

أ- من قبل المبنى حكومي
ب- أم ملك خاص

25. How much is the rent?

٢٥- كم هو الاجار في السنة

26. Was the building built specially for
the establishment?

٢٦- هل بنى هذا المبنى خصيصا للشركة/ المؤسسة
أ- نعم
ب- لا

- a. Yes b. No.

27. How many sq.m. were covered when it
started?

٢٧- كم مرقع كانت صالحة للشركة عند الافتتاح ؟

28. How far is this establishment from
Doha City Centre? Roughly.

٢٨- كم تبعد الشركة/ المؤسسة عن مركز مدينة
الدوحة بالتقريب .

29. Has this establishment obtained any
loan from the following sources?

٢٩- هل حصلت الشركة/ المؤسسة على أي قرض من
أ- بنك

- a. Bank b. Government sources.
c. Elsewhere? (please Indicate)

ب- الحكومة

ج- غير ذلك (رجاء التحديد)

30. If the loan was obtained from a bank
please indicate which bank.

٣٠- اذا تم تطلب قرضا من قبل استقرت اموالك
الخاصة ؟

ب- لا

أ- نعم

31. If no loan was obtained did you invest your own money?
a. Yes b. No

٣١ - اذا كان القرض من بنك فاهو اسم هذا البنك

32. What is the main product of the establishment?

٣٢ - ما هو المنتج الرئيسي للشركة/ المؤسسة

33. What other products do you sell?

٣٣ - ما هي السلع الاخرى التي تتماطل فيها الشركة

34. Where do you dispose of your waste materials?

٣٤ - اين تتخلص من نفايات الشركة/ المؤسسة وكيف؟

35. Does the establishment sell the final product through wholesalers?
a. Yes b. No

٣٥ - هل تباع الشركة المنتجات بالجملة
أ - نعم ب - لا

36. If so, where are the wholesalers?

٣٦ - من هم تجار الجملة الذين تتماطل معهم؟

37. If not, how do you market your products?

٣٧ - اذا لم يكن الامر كذلك فكيف تسوق منتجاتك

38. Does your establishment have a deposit account with a bank?

٣٨ - هل للشركة/ المؤسسة حسابات ودائع في البنوك؟
أ - نعم ب - لا

39. In which area do you market the product?

٣٩ - في أي المناطق تسوق انتاج الشركة/ المؤسسة

40. What fuel is used?

- a. Electricity b. Oil
c. coal d. Gas
e. wood f. Others (please indicate)

٤٠ - ما هو الوقود المستخدم في الشركة/ المؤسسة
أ - كهرباء ب - النفط وشتقاته
ج - فحم د - غاز
هـ - خشب و - أخرى
(رجاء التحديد)

41. What is the annual consumption of fuel and energy (in quantity)

٤١ - ما هي كمية الاستهلاك السنوي من الوقود والطاقة؟

42. How do you obtain your fuel and energy?

٤٢ - كيف يتم الحصول على الوقود والطاقة؟

43. What percentage of the raw material which you use in your establishment is from the following sources?

٤٣ - ما هي النسبة المئوية للخامات التي تحصل عليها من المصادر الآتية:
أ - محلي ب - من قطر ج - من الخارج

- a. local derivation,
b. elsewhere in Qatar.
c. abroad.

44. What is the source of the important raw materials?

٤٤ - ما هي مصادر الخامات الهامة التي تستخدمها الشركة/ المؤسسة

45. Can you indicate the sort of raw materials which you use?

٤٥ - هل بإمكانك تحديد نوع الخامات التي تستخدمها الشركة/ المؤسسة

46. Do you use materials manufactured by other factories in Qatar?
a. Yes b. No

٤٦ - هل تستخدم مواد مصنعة في قطر
أ - نعم ب - لا

47. If (Yes), from which factories?

٤٧ - اذا كان الجواب (أ) بالايجاب فمن أي مصنع؟

48. Do you use water?
a. Yes b. No.

٤٨ - هل تستخدم المياه في الشركة/ المؤسسة
أ - نعم ب - لا

49. If (Yes), for what purpose?

٤٩ - اذا كان الجواب (أ) بالايجاب لاي غرض تستخدم

- a. for cleaning. b. for processing as raw material. c. for cooling. d. for drinking or other purposes please indicate

أ - للتنظيف ب - كخامات ج - للتبريد د - للشرب أو أغراض أخرى (حدد)
ج - للتبريد

50. What is the annual consumption of water?

٥٠ - ما هي كمية الاستهلاك السنوي من المياه؟

11. What was the reason(s) for your establishment's location?
 a. Availability of the market?
 b. Labour supply?
 c. Power
 d. City amenities and services.
 e. The cost of land and building
 f. Convenient transport.
 g. Personal choice.
 h. Other (please indicate)

٥١ - ما هي اسباب اختيار هذا الموقع للشركة / للمؤسسة ؟
 أ - توفر السوق ب - توفر العمالة
 ج - الطاقة د - خدمات المدينة وتسهيلات
 هـ - صمر الاراضي وتكلفة البناء
 و - توفر وسائل النقل
 ز - تفضيل شخصي ح - غير ذلك

12. What kind of machinery do you use and the capacity?

No Capacity

- a. Steam Engine
 b. Oil
 c. Electricity
 d. Wind
 e. Solar Energy
 f. Gas
 g. Other

٥٢ - ما هي انواع المكينات التي تستعمل ولما قاتها ؟
 أ - مكائن بخارية ب - مكائن ديزل
 ج - كهربائية د - بقوة الرياح
 هـ - بالطاقة الشمسية
 و - بالغاز
 ز - بطاقة أخرى

13. How do you repair your machine(s)?

٥٣ - كيف يتم اصلاح مكائن الشركة / المؤسسة

14. How do you obtain the spare parts?

- a. From local market?
 b. From abroad?

٥٤ - كيف تحصل على قطع الغيار للمكينات ؟
 أ - من السوق المحلي ب - من الخارج

15. Do you think you would get the same benefits if the factory was established in another area and why?

- a. Yes b. No

٥٥ - هل تعتقد انك ستحصل على نفس الربح اذا كان المصنع انشئ في منطقة اخرى ؟
 أ - نعم ب - لا
 لماذا

16. Do the limited facilities of electricity and water supply affect your establishment site?

٥٦ - هل الوسائل المحدودة للكهرباء والماء تؤثر على موقع الشركة / المؤسسة ؟

57. By what means is the raw material transported to the establishment from abroad?

- a. Road b. Sea c. Air.

٥٧ - ما هي شكل يتنقل المواد الخام للشركة / المؤسسة من الخارج ؟
 أ - بر ب - بحر ج - جسر

58. Does the establishment deal with:

- a. Agriculture b. Machinery
 c. Hotels d. Construction
 e. Transport f. Trade
 g. Import and Export
 h. Food i. Wood and furniture.
 j. Building material
 k. Livestock l. Others (please indicate)

٥٨ - هل نشاط الشركة / المؤسسة يتعلق بأي من الاتي :-
 أ - الزراعة ب - المكينات ج - الفنادق
 د - المقاولات هـ - الختل و - التجارة
 ز - الاستيراد والتصدير ح - المواد الغذائية
 ط - الاخشاب والاثاث ي - مواد البناء
 ك - اللحوم الحيوانية ل - اشياء
 ل - اخرى (رجاء التحديد)

59. At what educational level are the establishment's workers:

- Literate
 Kutab
 Elementary
 Technical
 Preparatory
 Secondary
 University

٥٩ - ما هو المستوى التعليمي لموظفي ومعال الشركة / المؤسسة
 قطري غير قطري

أ - ابي
 ب - كتاب
 ج - ابتدائي
 د - صفائي
 هـ - اعدادي
 و - ثانوي
 ز - جامعي

60. Does the establishment have a special place for workers and where?

٦٠ - هل لدى الشركة / المؤسسة اماكن خاصة لسكن العمال ؟

أ - نعم ب - لا

61. Does the establishment train the workers on its property?

٦١ - هل تقوم الشركة / المؤسسة بتدريب العمال بنفسها ؟

أ - نعم ب - لا

62. Is the establishment an agency for other products from abroad?

٦٢ - هل الشركة / المؤسسة وكالة لمنتجات اخرى من الخارج ؟

أ - نعم ب - لا

63. If (Yes) which products and what role does the agency play?

٦٣ - اذا كان الجواب (أ) فما الاجاب
 هل باسماك تعدد في اي مجال

64. Is the establishment H.Q. and does it have other branches?
a. Qatar b. Abroad.
٦٤ - هل الشركة / المؤسسة المركز الرئيسي ؟
وهل هناك فروع أخرى ؟
أ - في قطر ب - خارج قطر

65. Where are the other branches?
٦٥ - في أي الأماكن تقع هذه الفروع ؟

66. Do you do contract work for:
a. Government b. Any other industry.
٦٦ - هل شماق أعمال مع :
أ - الحكومة ب - لصناعات او مؤسسات
أخرى

67. Why did you invest your money in this particular field?
٦٧ - لماذا استثمرت مالبنا الخاص في هذا المجال
بالأخص

68. Did you make a market survey for the local market before starting?
a. Yes b. No
٦٨ - هل أجريت مسح للسوق المحلي قبل
بدايتك لهذا العمل ؟
أ - نعم ب - لا

69. How did you choose your employees?
٦٩ - كيف تختار موظفيك ؟

70. Is there a test or period of training employees must pass before starting?
a. Yes b. No
٧٠ - هل هناك أي اختبار أو تدريب يجب على
الموظفين اجتيازها قبل البدء بالعمل ؟
أ - نعم ب - لا

71. To what extent does the location affect the price?
٧١ - إلى أي مدى يؤثر الموقع على السعر

72. Are there any problems in marketing your production?
a. Yes b. No
٧٢ - هل هناك مشاكل في تسويق الإنتاج ؟
أ - نعم ب - لا

73. What is your suggestion to solve these problems?
٧٣ - ما هي مقترحاتك لحل هذه المشكلات ؟

74. Who is responsible for transporting the finished products?
a. The factory b. The wholesaler
c. The consumer
٧٤ - من هو المسؤول عن نقل منتجات مؤسستك /
شركتكم ؟
أ - المصنع
ب - تاجر الجملة ج - المستهلك

75. Does the establishment work at full capacity?
a. Yes b. No
٧٥ - هل تستعمل الشركة / المؤسسة بكامل طاقتها
أ - نعم ب - لا

76. If (No), why?
٧٦ - إذا كان الجواب بالنفي لماذا ؟

77. Does the establishment have a shift system?
a. Yes b. No
٧٧ - هل تستعمل الشركة / المؤسسة نظام العمل
التناوب ؟
أ - نعم ب - لا

78. Does the establishment obtain any of the following from the government:
a. Exemption from tax.
b. Exemption from tax duty on raw materials and machinery.
c. Building d. Land
e. Advice in management.
f. Others (Please indicate)
٧٨ - هل الشركة / المؤسسة تحصل من الحكومة على :
أ - إعفاء من الضرائب
ب - إعفاء من الضرائب على المواد الخام والآلات
ج - الجاني
د - أراضي
هـ - إرشاد في الإدارة
و - أشياء أخرى (رجاء التحديد)

79. By what means of transport do the workers travel to work?
a. Public b. Private
c. Establishment d. Other (Please indicate).
٧٩ - بأي وسيلة ينتقل العمال إلى العمل
أ - نقل عام ب - نقل خاص
ج - مؤسسات الشركة / المؤسسة
د - وسائل أخرى (رجاء التحديد)

80. Do you have any arrangements with other companies practicing the same job?
a. Yes b. No
٨٠ - هل هناك تنسيق مع الشركات الأخرى التي
تتداول نفس العمل ؟
أ - نعم ب - لا

81. Does the establishment use a telex in its operations.
٨١ - هل تستعمل التلكس في عملك ؟
أ - نعم ب - لا

82. How many telephone lines does the establishment have?
٨٢ - كم عدد تليفوني تابع للشركة ؟

	The Name of the Establishment
	Legal Status
	Location
	Nationality
	The Issued Capital
	Date of Operation
Qatari	Labour force
Non-Qatari	
	Designed Capacity
	Notes

APPENDIX 4.1

DECREE - LAW NO.10 OF YEAR 1974 CONCERNING THE
ESTABLISHMENT OF THE QATAR GENERAL PETROLEUM CORPORATION

Article (1)

A Public corporation of independent legal personality shall be established to be called "QATAR GENERAL PETROLEUM CORPORATION".

Article (4)

The objectives of this Corporation shall be to engage in all phases of oil industry in Qatar and abroad, including exploration and drilling for oil, natural gas and other hydrocarbon substances, production, refining, transport and storage of the aforementioned substances, and any of their derivatives and by-products, as well as trading in, distribution, sale and export of these substances.

Article (5)

To achieve its objectives, the Corporation may carry out the following:-

1. Establishment of companies either on its own or jointly with others.
2. Acquisition of or participation in existing companies.
3. Contracting with other companies or bodies which practice works similar to its own or which may help achieving its objectives. The Corporation may also participate in any manner with such companies or bodies or may purchase or annex them.
4. To carry out all legal disposition that would be necessary for the Corporation to perform its operations properly.

Article (6)

1. The capital of the Corporation shall be one thousand million Qatar-Riyals which shall be paid fully by the State of Qatar.

The decision of payment shall be issued by the Council of Ministers in accordance with the proposal of the Minister of Finance and Petroleum.

2. As of the effective date of this Law the share of the State in the Companies mentioned hereunder shall revert to this Corporation
 - A. Qatar Petroleum Company Limited.
 - B. The Shell Company of Qatar Limited.

C. The Arab Maritime Petroleum Transport Co. Ltd.

D. Arab Petroleum Pipelines Co. (SUMED).

E. National Oil Distribution Co.

F. Arab Shipbuilding and Repair Yard Co.

4. Subject to the approval of the Council of Ministers, all future petroleum exploitation relating to the objectives of the Corporation whether owned wholly or partly by the State shall be affiliated to the Corporation.

Article (9)

1. The management of the Corporation shall be conducted by a Board of Directors which shall comprise between seven and eleven members including the chairman and his deputy. They shall be appointed by the Amir.

The Board of Directors shall be responsible for conducting the affairs of the Corporation before the Council of Ministers. The Amir may appoint one or more full time managing directors from among the members of the board.

3. The Board of Directors shall exercise all the powers required for the management of the Corporation. Its decisions shall be effective as from the date of their issue. As an exception, the decisions relating to the following matters shall not be considered effective until approved by the Council of Ministers:-

- A Internal or external loans obtained by the Corporation.
- B The establishment of companies by the Corporation on its own or with others or participation in existing companies.
- C Exercising by the Corporation of the operations of search and exploration for oil and natural gas.

Article (10)

The Council of Ministers shall have the right to issue general directives to the Board of Directors regarding the measures to be taken on matters related to public interest.

Article (24)

The auditor shall submit his annual report to the Amir, and a copy thereof to the Board of Directors.

Article (29)

Law No.13 of year 1972 establishing Qatar National Oil Company is hereby repealed.

Khalifa Bin Hamad Al Thani
Amir of The State of Qatar

Issued in Doha Palace
On 14.6.1394 A.H.
Corresponding to 4.7.1974.

APPENDIX 4.2

LAW NO.(3) OF 1973 FOR ESTABLISHING THE
INDUSTRIAL DEVELOPMENT TECHNICAL CENTRE

We, Khalifa bin Hamad, Al Thani, the Amir of the State of Qatar.

After perusing the amended Provisional Basic Ordinance, particularly Articles 23, 34 and 51 thereof, and Law No. (5) of 1970, determining the power of Ministers and specifying the jurisdictions of Ministries and other Government establishments and Laws amending it.

And the Proposed-Law submitted by the Council of Ministers.

And after consulting the Advisory Council.

Have decreed the following Law:

Article (1)

A governmental establishment called 'Industrial Development Technical Centre' shall be established. This establishment shall be directly responsible to the Amir.

Article (2)

The object of establishing this Centre is to lay down industrial development plans for the State and to supervise their execution after being ratified.

Article (3)

To realize the object of its establishment, the Centre shall be concerned in:

- 1) preparing industrialization plans and projects to utilize the State's natural resources in conformity with its revenues and requirements, and to carry out studies of the economic and technical advantages of such projects.
- 2) proposing the extent of the State's participation with the private sector in joint industrial projects.
- 3) participation, with the governmental bodies concerned in planning availability of Qatari manpower, training projects, services and general utilities connected with the technical development of the State.
- 4) preparing statements and technical specifications required for invitation for tenders for industrial projects due to be executed and studying tenders submitted and carrying out negotiations in participation with other governmental parties concerned in preparation

of the relevant contracts necessary for implementation of the said projects.

- 5) following-up the execution of approved industrial plans and projects in co-operation and co-ordination with the government establishments concerned and supervising the handing over of the projects to the parties responsible for their operation.
- 6) preparing detailed and analytical follow-up reports on national industries in which the State participates, stating the extent of success achieved and the obstacles which have been met and putting forward recommendations to overcome them. The Centre should extend technical advice to companies undertaking these industries as well as other national companies belonging to the private sector whenever possible.
- 7) co-ordinating co-operation with foreign bodies, regional and international organizations, and taking part in world conferences relating to industrial development and following-up decisions and agreements concluded in this respect.
- 8) collecting technical, statistical and economic data needed for the preparation and study of industrial development plans and projects in the State.
- 9) following-up economic, scientific and technological activities world-wide in the industrial field.
- 10) studying statements, reports and projects passed on to it by Ministries and other governmental establishments as well as any studies, reports or projects made available in the field of industrial development.
- 11) whatever the Amir decides to refer to the Centre in the way of matters relating to the realization of the objectives for which the Centre is established.

Article (4)

The Centre shall submit all its reports to the Amir, and the plans and projects submitted will not be considered operative unless they are approved by the Amir.

Article (5)

The Centre shall undertake its studies of industrial projects directly through its experts and/or through consultant experts contracted for this purpose as and when required.

Article (6)

The Centre is formed of technical experts, whose appointment shall be by an Amiri decision. The Centre will have a Director selected from among these experts who will administer the Centre in addition to his work as a technical expert.

Article (7)

The Centre shall lay down the rules for the exercise of its functions and an organization plan with the posts required for the discharge of its responsibilities. These rules shall be decreed by the Amir.

Article (8)

The Ministries and other governmental Establishments shall cooperate with the Centre, and will provide it with what they have available and whatever statements, studies, report and statistics relating to industrialization projects and industrial development the Centre may ask for-

Article (9)

Any provision contravening the provisions of this Law shall be considered void.

Article (10)

All parties concerned, each within its own competence, shall execute this Law and it will be published in the Official Gazette and become effective as from the date of its publication.

KHALIFA BIN HAMAD AL THANI
AMIR OF THE STATE OF QATAR

Issued:

19th Safar 1393
24th March 1973

APPENDIX 5.1

QATAR OIL CONCESSION

This Agreement was made on the seventeenth day of May 1935

Article First : The Sheikh grants to the Company ... to explore, to prospect, to drill for and to extract and to ship and to export and the right to refine and sell petroleum and natural gases, ozekerite, asphalt and everything which is extracted therefrom, which shall hereinafter be called "the Substances". If the Company discovers, in the course of its investigation and general activities, any minerals other than the Substances mentioned in the first article, e.g. gold or iron oxide or any other minerals, it shall not be justified to appropriate the same, but must inform the Shaikh of their discovery; and the Shaikh shall have full right to, and absolute control, over those minerals which have been extracted and he shall be free in granting concessions for the extracting of those minerals to any Company or Companies or to dispose of those minerals in any manner he considers to be consistent to his interests

Article Second : ... the Company can operate in any part of the State of Qatar ... but it will not operate on places such as religious lands, cemeteries, lands occupied by religious buildings or by essential enterprise by their owners as may exist on the date of the signature of this Agreement.

The period of this Agreement shall be seventy five years from the date of its signature

Article Third : ... the Company shall employ all customary and proper means and shall carry out the examination by methods agreeable to the modern Scientific knowledge.

Article Fourth : ... the Company shall pay to His Excellency the Shaikh the following payments during the period of this Agreement namely:

- | | |
|--|---|
| (a) On Signature | Four Lakhs of Rupees,
Rs.400,000 |
| (b) At the end of each year of the first five years from the date of Signature | One and a half Lakhs of Rupees. Rs. 150,000 |
| (c) At the end of the sixth year from the date of signature and at the end of every year which follows it until the end of the Concession. | Three Lakhs of Rupees.
Rs. 300,000. |

(d) When the Company wins oil and saves it into Storage it shall pay royalty on the Substances, in accordance with the description of Article First, as follows:-

- | | |
|--|-----------------------------------|
| (1) On all the substances ... except asphalt, ozokerite and natural gas per ton, at the rate of. | Three Rupees.
Rs.3/- |
| (2) On asphalt and ozokerite ... at the rate of. | One Rupee Eight Annas.
Rs. 1/8 |
| (3) On natural gas produced and sold per 1000 cubic feet at the rate of. | Two Annas. As. 2 |

Article Sixth : The Company may construct, maintain and operate roads and telegraph and telephone installations and their lines and wireless stations, railways, refineries and the ordinary ports situated at Doha for importing its materials ... And the Company has the right to choose the port which may be suitable for exporting its substances.

Article Seventh : ... The Company has no right to acquire lands occupied by the enterprise of the owners thereof and also houses, places and lands which their owners decline to sell or to rent; and excepting these, it does not matter to use (other lands) if occasion arose.

Article Eighth : The Company may take any quantity of water which it may require for its operations, free of charge, on the condition that this will not cause any loss or damage to any of the inhabitants.

Article Ninth : The Company can take any earth, mud, gravels, lime, gypsum and stone and other similar substances which it requires for its operations, free of charge.

Article Tenth : ... the Company shall have the right to import ... all equipments and goods required by the Company or by its employees for its operations ... and it shall have the right to export its Substances and their derivatives ... without Customs duty or import duty or export duty or tax or any other duty. ... And the Company and its operations, incomes, profits and properties shall be exempt and free, during the period of this Agreement, from all the present and future Taxes of any kind whatsoever.

Article Fourteenth : The Shaikh has the right to cancel this Agreement in the two cases mentioned below :

- (A) If the Company fails to pay the sums ...
- (B) If the Company is in default

Article Seventeenth : The labourers employed by the Company must be from amongst the Shaikh's own subjects or from amongst those approved by the Shaikh, excepting technical employees and the managers and clerks whom the Company may require and whom it cannot find in the country

(Sgd.) Sheikh Abdullah Bin Qasim Al Thani
Ruler of Qatar

(Sgd.) C.C. Mylles
On behalf of the Anglo-Persian Oil Co.Ltd.

On 14.2.1354 H
Corresponding to 17.5.1935.

APPENDIX 5.2

THE GOVERNMENT AND SHELL COMPANY AGREEMENT

Article 1

"Concession Area" means ... (i) all the seabed and subsoil which fall within the jurisdiction of the Sheikh ... (ii) any and all islands, islets, shoals and bars.

"The Substances" means crude oil, asphalt, ozokerite and natural gas and everything which is extracted therefrom.

Article 2

1. The Sheikh grants to the Company for a period of 75 years from the 6th day of August 1952
 - (a) the sole and exclusive right within the Concession Area to explore for, drill for, develop and produce the Substances, and
 - (b) the right within the Concession Area and elsewhere within the State of Qatar to transport, dispose of and export the Substances.
2. In the exercise of the right specified in clause 1(b) above the Company will have due regard to the prior rights of Petroleum Development (Qatar) Ltd. under the Agreement dated the 17th day of May 1935 corresponding to the 14th day of Safar 1354.

Article 3

On the date of signature of this Agreement the Company will pay to the Sheikh as consideration for the execution of this Agreement the sum of £231,976 sterling.

Article 4

As from the 6th day of August 1952 the Company will pay to the Sheikh an annual rental, at the rate of £75,415 sterling, per annum up to the date of commencement of regular exports of oil, and at the rate of £37,707 sterling per annum thereafter until the termination of this Agreement.

Article 6

1. The Company will pay to the Sheikh royalty as follows:-
 - (a) ... each ton of exported oil ... four shillings and six pence sterling.
 - (b) ... each ton of asphalt or ozokerite ... two shillings and three pence sterling.
 - (c) ... each 1,000 cubic feet of natural gas ... two and one quarter pence sterling.
2. No royalty shall be payable by the Company in respect of the Substances used within the Concession Area or elsewhere within the State of Qatar.

Article 7

1. The Company will pay a taxation commutation of sixpence sterling per ton of the Substances exported ... hereof in consideration of which the Company will be entitled
 - (a) to import free of all import customs and other duties ... whatsoever required by the Company or by its employees for its operations.
 - (b) ... supply and export shall be free of all export customs and other duties.
 - (c) to exemption ... from all taxation.
2. Notwithstanding the provisions of clause 1 (c) of this Article the Company shall not be exempted from liability to Qatar Income Tax in respect of any year or part of a year after the Date of commencement of regular exports of oil.

Article 8

1. The Company undertakes that as from the date of commencement of regular exports of oil the Sheikh shall receive 50 per cent of the oil Profits.

Article 9

1. The Border Value ... of crude oil of 40° A.P.I. ... is eighty-two shillings and three pence sterling per ton.

3. The cost of Exported Oil shall be ascertained by sound and consistent accounting methods as follows:-
 - (a) By determining the total of all costs and expenses of the Company ... Such costs and expenses shall consist of :
 - (i) Operating expenses and overheads,
 - (ii) amortisation of survey exploration and development costs ... at a rate not exceeding 15 per cent per annum until such expenditure is fully written off.

Article 12

The Company shall have, without hindrance, all reasonable rights and facilities within the Concession Area and elsewhere in Qatar for the purposes of its operations under this Agreement including (but not limited to) :-

- (a) The right to build, construct, maintain, operate and use all types of buildings, installations, staff facilities, communication and transport systems and engineering works of every description.
- (b) The right to use free of all payments to the Sheikh earth, stone, sand, gravel, lime, gypsum, clay and similar substances and water that may be available and may be required for its operations provided always that the inhabitants of Qatar shall not thereby be deprived of their usual requirements of these materials, that irrigation is not prejudiced, that no land, habitation or watering place for animals is deprived of a reasonable supply of water and that the water supply of the inhabitants is not endangered.

Article 20

1. The Company will place requests with the Sheikh to provide such labourers as are required but the Company has the right to decide as to the qualifications and suitability of any such labourers for a particular job.

industrial activities all over the city. In the 1960's commercial and economic, rather than personal reasons, became more effective in influencing the location of manufacturing enterprises. This may be attributed to : a) the accelerated growth of population and income which produced a larger effective market, particularly during the second half of the 1960's, b) the increasing local perception of opportunities and growing commercial and financial sophistication, and c) the growing economic attraction of central city sites for manufacturing, spatially associated with growth of activity in the old markets produced by a) above.

The attitudes in the sixties, therefore, led to more concentration of industries in and surrounding the old market centre. By the early 1970's this process had created an annular zone of commercial and manufacturing activity along concentric streets and roads, together with a "spoke" development along radial roads. This was a more or less spontaneous spatial development of the classical urban model developed by Berry. Because of governmental action to re-develop the city centre, beginning in the early 1970's, many small scale industries began to move from the centre to Fariq al-Najma along one of the radial spokes, especially those concerned with iron working, aluminium fabrication, and carpentry. These activities and other services had spontaneously created in Fariq al-Najma an unplanned market called Souq al-Haraj, or what can be called loosely a spontaneous estate. This was followed by the planned creation of an extra-urban estate, the Industrial Estate of Doha (I.E.D), which here is examined in terms of its planned function as an industrial estate.

The plan

IED is the official name of an area of governmental owned land, developed and subdivided into plots of different size, with provision

APPENDIX 10.1

GOIC AGREEMENT

The objectives

The objective of the organization is to achieve industrial co-operation and co-ordination among the member states and, toward that end, the organization shall undertake the following.

1. Collection and publication of information about industrial development projects and policies.
2. Provision of proposals concerning the establishment of common industrial projects among the member states.
3. Provision of recommendation for reconciliation between industrial development projects.
4. Co-ordination and development of technical and economic co-operation among existing or planned industrial companies and establishments.
5. Provision of technical assistance to prepare and evaluate industrial projects.
6. Preparation of statistics and studies concerning industry.

APPENDIX 10.2

SUMMARY OF AUTHOR'S TRANSLATION OF GCC ECONOMIC AGREEMENT

Chapter 1 Trading Exchange (Articles 1 - 7)

Allowing the import and export of national products* free from custom duties, whilst the member countries work towards a fixed uniform customs duties for imported goods from the outside world. The most important purpose of this Chapter is to create joint negotiation power for the member countries against foreign countries in the fields of exports and imports.

Chapter 2. Transfer of Capital and People and Exercising Economic Activity (Articles 8 & 9)

The member countries to agree on

1. Freedom of movement between work and residence for citizens
2. Right of possession, inheritance and trusteeship for citizens
3. Freedom for exercising economic activity
4. Freedom for the movement of capital

Also to encourage the private sector to establish joint venture project(s)

Chapter 3. Development Co-ordination (Articles 10 - 13)

To co-ordinate the development plans, especially of hydrocarbon industries. At the same time to distribute industries among them in accordance to relative advantages and feasibility studies.

Chapter 4. Technical co-operation

To encourage scientific and technological research as well as the setting up of policies for vocational and training programmes to suit the development requirements.

Chapter 5. Transport & communication.

Chapter 6. Capital and financial cooperation

To co-ordinate in unifying investment legislation.

* The national product, as defined in the agreement is of not less than 40% of the added value from local sources, and at least 51% of the establishment assets owned by the citizens of the member countries.

BIBLIOGRAPHY

- Abdalla, I.-S., and others, Images of the Arab Future, The United Nations University, Frances Pinter, London 1983.
- Abdul-Rahman, O., Oil Bureaucratic and the Development Difficulty, Alam al-Ma'rifa, Kuwait, September 1982.
- Abu Naab, I., Qatar : a Story of State Building, Ministry of Information, Qatar 1978.
- AFCFP, AFCFP Quarterly Journal, Vol.1 No. 4 Kuwait December 1979.
- Al-Dabagh, M.M., Qatar : Past and Present, Beirut 1961.
- Al-Duwaik, M.T., Qatar Folk Songs, M.A. thesis Cairo University 1973.
- Al-Jabir, M.H., The Human Geography of Qatar, Unpublished M.A. Cairo University 1977.
- Al-Khayat, H., Population Stock of the Arabian Gulf States, Qatar University Qatar 1983.
- Al-Kobaisi, A.J., The Development of Education in Qatar, 1950-70. Unpublished Ph.D. thesis Durham University 1979.
- Al-Kobeisi, A., Two Decades of Public Administration and Development in the State of Qatar. Journal of the Gulf and Arabian Peninsula Studies, Kuwait University Vol VII No 28, Kuwait 1981.
- Al-Kuwari, A.K., Analysis Study of the Factors Eliminating the Size, Structure and Type of Labour Force in Qatar, Qatar University 1982.
- _____ Oil Revenues in The Gulf Emirates, Durham Univ. Bowker London 1978.
- _____ The Role of Public Enterprises in Economic Development, Alam Al-Ma'rifa, Kuwait, June 1981.
- Allam Al Tijarat Magazine, Arab Steel Industry November 1979.
- Al-Murgan Magazine, Qatar Forces, Gulf Hotel, Qatar Summer 1978.
- Al-Nahar Magazine, A Struggle for Progress, a special Report on Qatar, Beirut 1969.
- Al-Najar, B., Working and Living Conditions of Foreign Labour Force in the Arab Gulf Countries. Paper submitted to the Conference on Foreign Manpower in the Arab Gulf Countries, Kuwait 15-18 January 1983.

- Al-Rayyah Daily Newspaper, 2.12.1980 & 24.2.81.
- Al-Shibani, M.S., The Arabian Emirate of Qatar, Dar al-Thaqafa Beirut 1962.
- Arab Economic Unity Council, Industrial Systematic and its Role in Economic Development, Arab Industrial Systematic Conference, Egypt 22-26, June 1976.
- Arab Press Service Organization, The OPEC Decision-Makers Survey: Qatar, APS Review, Vol 18 No 2, 13/20 January 1982, Cyprus.
- _____ APS Review, Vol 18 No 3, 20/27 January 1982, Cyprus.
- Arthur D. Little Inc., Incomplete Report submitted to the Government of Qatar (c.a. 1963).
- Bara A., Al-Shuwaikh Industrial Estate, after two decades of disorder, Al-Qabas Newspaper No 4079 Kuwait 21/9/1983.
- Beaumont, R., Blake, G.H. and Wagstaff, J.M., The Middle East, a Geographical Study, Wiley, England, 1976.
- Besseisu, F.H., Pragmatic Approach to Arab Gulf States Development Co-operation Conceptual and Practical Basis. Unpublished Ph.D. Durham University October 1982.
- Buhairi, S., and Al-Fara, M., Sides of Qatar Geography Jordan (c.a. 1977).
- Cavelier, C., Geological Survey & Mineral Substances Exploration in Qatar. Bureau De Recherches Géologiques et Minières, Paris.
- Central Statistical Organisation, Annual Statistical Abstract 1981, Doha Modern Press Qatar July 1982.
- Committee of Studying the Ministerial Reports, Report Submitted by the Committee, Qatar 1970.
- Council For Middle East Trade, Report of the British Trade Mission to Kuwait, the Gulf States, Muscat and Oman. London Nov. 1964.
- Cowen, R.C., Frontier of the Sea, Translated by Hilmi, A., Sijil al-Arab Press Cairo (c.a. 1967).
- Doha Municipality, Industrial Area Site Plan Sheet No 1 Qatar 20.12.1981.

- IDTC, Annual Report 1981
Qatar 1982.
- Development of Light and Medium Industries
in the State of Qatar, Final Report,
Serete, Qatar 1979.
- Industrial Development in Qatar
Ali Bin Ali Qatar 1978.
- Plans of Industrial Development
Qatar 1976.
- Resume of a Feasibility Study for an
Integrated Steel Plant in Qatar
Qatar 1973.
- Qatar Achievement in Industrial
Development, Penne Press England 1981.
- Report on Population and Housing Units
of Umm Said, Qatar 1982.
- Report on the Development of Umm Said
Qatar, February 1983.
- Institution of Research and Arabian Studies, Study of Systematic
Planning and Integration of Arab Economy.
Cairo 1978.
- International Bank for Reconstruction and Development, Economic
Development in Kuwait. Translated by
Al-Dabagh, S.A., and Published by the
Arab Bureau, Kuwait (c.a. 1963).
- Jaidah, A.M., Prospects for Gas Prices and the Develop-
ment of the Natural Gas Industry in
Qatar, in Issues in Development : The
Arab Gulf States, ed. by Daftari,
M.Z., Published by MD Research and
Services Ltd. London 1980.
- Karam, A., Economics of Underdevelopment and
Development, Markaz al-In a al-Qaumi/Kuwait
University Beirut 1980.
- Khalaf, A.H., QAFCO As... A Pillar of National Economy,
Abrajuna, QAFCO's Quarterly Magazine
No 3 of 1980.
- Legal Affairs Department, Collection of Qatar's Laws until 1966
Ali bin Ali Printing Press Qatar.
- Llewelyn-Davis, Qatar Development Plan, Technical
Papers 1972-73 Qatar.
- Report of Progress, Qatar Development
Plan Qatar October 1974.

- Lorimer, J.G., Gazetteer of the Gulf, Translated and Printed by the State of Qatar, Qatar 1978.
- MEED, Special Issue : Qatar, November 1979.
- Special Report on Qatar August 1981.
- Meier, G.M., Leading Issues in Economic Development, Oxford University Press 1976.
- Ministry of Communication and Transport Annual Climatological Report 1978 Doha 1979 (Typescript).
- Annual Report 1978 Telecommunication Department Qatar 1979.
- Ministry of Economy and Commerce Economic Survey of Qatar (1969-80) Qatar.
- Ministry of Education, Annual Report 1974/75 Qatar National Press, Qatar 1975.
- Annual Report 1980/81 Qatar 1981.
- Qatar Progress, Ali bin Ali Printing Press Qatar 1964.
- Ministry of Electricity and Water Statistical Report 1971-81, Water Department Qatar 1982.
- Ministry of Finance and Petroleum Manpower Statistics, Personnel Affairs Department Qatar 1980.
- Oil Industry in Qatar 1972, Petroleum Department, Qatar 1974.
- Oil Industry in Qatar 1976, Petroleum Affairs Department England 1977.
- Oil Industry in Qatar 1977, Petroleum Affairs Department, Qatar 1978.
- Oil Industry in Qatar 1979, Petroleum Affairs Department, Singapore 1980.
- Oil Industry in Qatar 1982, Petroleum Affairs Department, Qatar 1983.
- Petroleum Concession Agreements and Laws, Petroleum Affairs Department Qatar 1973.
- Yearly Bulletin of Imports, Exports and Transit (1969-1980) Customs Department, Qatar.

- Ministry of Industry and Agriculture Statistics of Fisheries 1980-81, Fishery Department, Qatar.
- Ministry of Information Newspaper Interviews of Shaikh Khalifa Al-Thani Qatar 1976.
- _____ Qatar into Seventies, Ali bin Ali Printing Press, Qatar 1973.
- _____ Qatar Year Book 1976, Qatar 1977.
- _____ Qatar Year Book 1980-81, Press and Publication Department, Singapore 1982.
- _____ Speech and Statement by Shaikh Khalifa Al-Thani Qatar 1976.
- Ministry of the Interior, Cancelled Residential Visa, Statistical Department Qatar 1980
- _____ General Total of Issued New Resident Visas, 1395-98 H., Statistic Section Doha 1980.
- _____ Statistics of New and Renewed Visas, 1395-99 H. Statistic Section Doha 1980
- Ministry of Justice, Collection of Qatar's Laws 1961-75, 3 Volumes Legal Affairs Department Qatar (c.a. 1978).
- _____ Official Gazette, No. 1 of 1979 Legal Department Qatar.
- Ministry of Overseas Development, Economic Survey of Qatar 1971, Middle East Development Division, British Embassy, Beirut 1972.
- _____ The First Population Census of Qatar, April/May 1970, Middle East Development Division British Embassy, Beirut 1970.
- Ministry of Public Health, Births and Deaths Statistics, 1967-1978, Qatar 1979.
- Ministry of Public Works, Qatar's Maps, Sheet Nos. 230/350, 355 and 360, Hunting Survey London 1980.
- Ministry of Public Works Qatar's Maps, Sheet No 220/380 Qatar 1979.
- Moorehead J., In Defiance of the Elements, A personal view of Qatar, Namara Publications London 1977.

NODCO, Annual Production Statistical Report
1975-80 Qatar 1981.

— General Budget of 31.12.1979.
Qatar 1980.

— Price of Imported Oil Products per Gallon
Financial Affairs Department Qatar.

OAPEC, Arab Oil Legislation 1976-77,
Al-Yaqadhah Press, Kuwait 1979.

— Ninth Annual Statistical Report 1980-81
Economic Department Kuwait 1983.

Petroleum Development (Qatar) Ltd. Memo No. GML.6/3029 Qatar
2.11.1952.

— Minutes of Meetings in General Manager's
Office, Dukhan, 15.2.1953.

QAFCO, An Industry From Flared Gas
Qatar (c.a. 1979).

— Gas Consumption during 1974-80
Production Department Umm Said 1981.

— Manpower Statistics of 1970-80,
Personnel Department Umm Said 1981.

— Profit and Loss Account Reports
(1976-79) Umm Said.

— QAFCO's Pamphlet, Qatar December 1970.

— QAFCO's Pamphlet, Qatar (c.a.1980).

— Qatar Fertilizer in Brief 1980
Qatar 1981.

— The Monthly Production 1974-80
Production Department Umm Said 1981.

— Sales Statements (1974-1980)
Shipping Department Umm Said.

QASCO Department-Wise Manpower List as on
31.12.1981. Personnel Department 1982.

— Department-Wise Manpower List as on
31.12.1979, Personnel Department 1980.

— Destination-Wise Sales, Qatar 1981.

QASCO, Nationality-Wise Statement of the Manpower
as on 31.12.1980. Personnel Department 1981.

— Outline of the Steel Mill Project,
Qatar 1977.

— The Steel Mill Project,
Qatar (c.a. 1978).

— Special Report on Production
1977-80, Qatar 1981.

Qatar National Tel- Qatar Telephone Directory 1980
phone Services Qatar 1980.

— Qatar Telephone Directory 1981
Qatar 1981.

Qatar Petroleum Company, Memo No. CRQ/TO/3841 to the Head Office
in London Dated 29.7.1958.

— Memo No. CRQ/TO/3/3846 to the Head Office
in London Dated 6.8.1958.

— Topping Plant Operations and Availability of
Products, as related to the cost of and
Necessity for Import Umm Said 18.10.1957.

— Topping Plant Products & Purchases from
Shell Markets, Financial Department
Qatar 3.3.1968.

QFMC, Production and Total Consumption of
Flour and Bran 1972-80 Qatar.

— Special Report on the Company Activities
Qatar 1981.

— Special Report on the Manpower from 1972-80
Qatar 1981.

QGPC, Annual Report 1980, Public Relations
Department Qatar 1981.

— Monthly Report No. 40 Qatar December 1980.

— Natural Gas Liquids, Public Relations
Department England 1981.

— Oil and Natural Gas Reserves, Several Reports
Qatar 1981.

— Production and Exports of Oil from Onshore and
Offshore Fields 1980, Petroleum Engineering
Department January 1981.

- QGPC, Sheets of Exploratory Wells 1940-80,
Petroleum Engineering Department
Qatar 1981.
- Special Report on the New Refinery
Project Qatar 1981.
- Summary of Service Agreements
Qatar 1980.
- QNCC, Annual Reports (1969-80)
Qatar.
- Chaplet of Establishment and Basic
Statute, Qatar 1965.
- Special Issue Commemorating the
Opening of Qatar Cement Work, Ali Bin Ali
Press Qatar 1969.
- QNFC, Annual Report and Accounts (1969-1976)
Qatar.
- Rapoport, C., and Tandy, H., Saudi Arabia Plays an Ace
Financial Times, Thursday 29.3.1984.
- Rashid, A.H., Integration of Arab Economy
Ministry of Information, Iraq 1977.
- Regional Fishery Survey and Development Project Final Report
Qatar 1979 (Typescript).
- Saudi Arabia Quarterly Economic Review No.4 1984,
Economist Intelligence Unit London.
- Saudi Economic Survey, Vol XVII No.826 August 3, 1983.
- Saudi Industrial Development Fund, Annual Report 1401-02 H.
Saudi Arabia.
- Seltrust Engineering Ltd Investigation of the Development Potential
IDTC of Mineral Occurrences in Qatar 9 Volumes
Qatar 1979.
- Shankland Cox Projections of the Qatari Population 1970-2000
Partnership Qatar, January 1980.
- Outline Planning Data, Policy and Procedure
Review, Qatar Planning Studies
Qatar December 1979.
- Shinn, E.A. Sedimentary Accretion along the Leeward,
SE Coast of Qatar Peninsula, in The
Persian Gulf ed. by Purser, B.H. Berlin,
Springer 1973.

- Sir Alexander Gibb and Partners, Pamphlet of Activities 1980,
Readon 1981.
- Soliman, S.M., Geology and Mineral Activities in
Qatar, Paper submitted to Second
Arab Mineral Wealth Congress, Saudi
Arabia 2-8 November 1974.
- State of Qatar, Amiri Resolution No. (17) of 1980, Amiri Palace,
Qatar 7.9.1980.
- State of Qatar, Law No (11) of 1980, Industrial Organizing, Amiri
Palace, Qatar 1980.
- State of Qatar, Some British and Ottoman Documents 1863-1949. Documents
of Qatar's History. The Amir's Office,
AL-1.
- State of Qatar, Speech of Qatar Representative, in a seminar on the
Prospects of Arab Refining Industry
organised by OAPEC, Damascus
18-23.10.1975 Kuwait 1976.
- The Advisory Council, Minutes of the Eighth Meeting of the Council
During the Fifth Annual Assembly with
Dr. K.Naji Monday 17.1.1977.
- The Arab League, Fisherby Production, Vol 7 of Programme of Arab Food
Security, The Arab Organization of
Agriculture Development, Khartoum
August 1980.
- The Council of Ministers, Memo on the Meeting No (23) of 1980,
Qatar 19.6.1980.
- Training and Careers Centre, The Centre Graduates since 1972
Qatar.
- UNDP/ State of Qatar, Reconnaissance Soil Classification Map,
Qatar 1976.
- UNESOB, Inter-Disciplinary Reconnaissance
Mission Vol 2 Beirut 1972.
- UOP Management Services Inc., Process Feasibility Study, Revised
Cases, Qatar 11.11.1976.
- Wagner, C.W. and Togt, C.v.d. Map of the Regional Distribution of the
Sediment Types in the Persian Gulf,
Enclosure for the Persian Gulf,
ed. by Purser, B.H., Berlin Springer 1973.
- Whinney Murray & Co., Report of the Auditors of QAFCO as
at 31.12.1979 Qatar 1980.

William L. Pereira Associates,

National Growth Forecasts,
Qatar Planning Studies, Qatar
May 1977.

—

Umm Said : Long Term Structural Plan
Qatar Planning Studies Qatar 1977.

Zahlan, R.S.,

The Creation of Qatar, Croom-Helm
London 1979.

