

Durham E-Theses

*The development of a microcomputer controlled hand
assessment system for quantitative clinical
measurement*

Alan Robert Jones

How to cite:

Jones, Alan Robert (1984) The development of a microcomputer controlled hand assessment system for quantitative clinical measurement. Doctoral thesis, Durham University.

Use policy

The full-text may be used and/or reproduced, and given to third parties in any format or medium, without prior permission or charge, for personal research or study, educational, or not-for-profit purposes provided that:

- a full bibliographic reference is made to the original source
- a <https://etheses.durham.ac.uk/id/eprint/7126/> is made to the metadata record in Durham E-Theses
- the full-text is not changed in any way

The full-text must not be sold in any format or medium without the formal permission of the copyright holders.

Please consult the [full Durham E-Theses policy](#) for further details.

THE DEVELOPMENT OF A
MICROCOMPUTER CONTROLLED HAND
ASSESSMENT SYSTEM FOR QUANTITATIVE
CLINICAL MEASUREMENT

by

Alan Robert Jones B.Sc., M.Sc.

A thesis submitted for the degree of
Doctor of Philosophy
at the University of Durham

The copyright of this thesis rests with the author.
No quotation from it should be published without
his prior written consent and information derived
from it should be acknowledged.

Department of Engineering
Science Laboratories
University of Durham
South Road
Durham
DH1 3LE

June 1984



5 NOV 1984

Recd.
1901/10/1



ABSTRACT

THE DEVELOPMENT OF A MICROCOMPUTER CONTROLLED HAND ASSESSMENT SYSTEM FOR QUANTITATIVE CLINICAL MEASUREMENT

by

Alan Robert Jones B.Sc., M.Sc.

Quantitative hand assessments are necessary in order to not only accurately monitor the disease progress and the effect of therapy, but in the formulation of the therapy and as an aid to a closer understanding of the disease process. Current assessments are very subjective, being based on observations of everyday activities e.g. button fastening or using a knife and fork. Any measurements that are taken, e.g. grip 'strength' using an inflated cuff, are generally inaccurate.

An objective assessment was formulated and constructed using strain-gauged measuring devices that were a blend of functional and strength tasks. The functional tasks included the measurement of the handle grip and lifting forces in pan and kettle lifting and the measurement of torque in key turning and cloth wringing out tasks. Strength measurements included power grip strength, which also gave the individual finger contribution, pulp and lateral pinch and the extension force.

For ease of operation, the measurement devices were all linked via necessary electronic circuitry to a microcomputer. This was used to automatically select the required device, collect the data and calculate, display and store the results. The software provided a user friendly interaction to permit operation by non-technical

staff without the need for excessive training.

A preliminary investigation, which involved measuring patients at regular intervals, indicated the system's capability of monitoring changes in patient performance. Changes were most evident in results pre- and post-injection, pre- and post-operative and in between hands in patients with unilateral disorders.

The system also enables a closer inspection of finger contribution and in the techniques used in pan and kettle lifting.

TO
PUD

CONTENTS

	page
ABSTRACT	
LIST OF FIGURES	8
LIST OF TABLES	16
LIST OF PLATES	18
DECLARATION	19
ACKNOWLEDGEMENTS	20
<u>CHAPTER 1:</u> <u>INTRODUCTION</u>	21
<u>CHAPTER 2:</u> <u>LITERATURE REVIEW</u>	32
2.1. General Background	33
2.2. Functional Assessment Routines	35
2.2.1. 'Strength' measurements	37
2.2.2. Functional assessment	38
2.3. Grip Measurement	42
2.3.1. Dynamic devices	43
2.3.2. Isometric devices	53
2.4. Miscellaneous Assessments	59
2.5. Summary	62
<u>CHAPTER 3:</u> <u>APPARATUS</u>	64
3.1. Measuring Devices	65
3.1.1. Isometric power grip and finger force measurement	65
3.1.2. Pan handle grip force measurement	68
3.1.3. Kettle handle grip force measurement	71
3.1.4. Lifting force measurement	71
3.1.5. Key unit	74
3.1.6. Key unit attachments	76



contents (continued)

	page
3.2. Electronic Circuitry	78
3.3. Computer	83
3.4. Arthrograph	83
3.5. Software	90
3.5.1. Hand assessment	90
3.5.2. Arthrograph	101
<u>CHAPTER 4:</u> <u>MATERIALS AND METHOD</u>	104
4.1. Device Calibration	105
4.2. Healthy Subjects	106
4.3. Patients With Rheumatoid Arthritis	106
4.3.1. The drug trial out-patient clinic	106
4.3.2. The rheumatology out-patient clinic	109
4.3.3. Rheumatology ward	109
4.4. Physiotherapy Out-Patient Hand Clinic	112
4.5. Method	112
<u>CHAPTER 5:</u> <u>RESULTS</u>	125
5.1. Calibration, Accuracy And Precision	126
5.2. Healthy Subject Measurement	126
5.2.1. Subject variability	128
5.2.2. Finger contribution to power grip	129
5.2.3. Pan and kettle lifting and handle grip forces	130
5.2.4. Force-time curves	131
5.2.5. Relationship between the lifting forces and handle grip forces	132
5.3. Initial Measurements On Patients With Rheumatoid Arthritis	133
5.3.1. Finger contribution to power grip	134

contents (continued)

	page
5.3.2. Pan and kettle lifting and handle grip forces	135
5.3.3. Force-time curves	135
5.3.4. Relationship between lifting forces and handle grip forces	137
5.4. Follow Up Measurements On Patients With Rheumatoid Arthritis	138
5.4.1. Drug trial	138
5.4.2. Rheumatology out-patients	145
5.4.3. Rheumatology ward	147
5.5. Physiotherapy Results	151
5.5.1. Initial results	151
5.5.2. Follow-up results	152
<u>CHAPTER 6:</u> <u>DISCUSSION</u>	306
6.1. Calibration	307
6.2. Handling Experience With The System	307
6.3. Initial Results	311
6.4. Follow-Up Results	325
<u>CHAPTER 7:</u> <u>CONCLUSIONS</u>	322
7.1. Suggestions For Further Work	335
<u>APPENDIX 1:</u> <u>MAXIMUM GRIP PRESSURE OF THE HEALTHY HAND</u>	337
A1.1. Introduction	338
A1.2. Results	340
A1.3. Discussion	341
<u>APPENDIX 2:</u> <u>CIRCUIT DIAGRAM</u>	352
<u>APPENDIX 3:</u> <u>D109 INTERFACE CARD</u>	356
A3.1. Description	357

contents (continued)

	page
A3.2. Initialisation	357
<u>APPENDIX 4: FLOWCHART OF CONTROLLING SOFTWARE</u>	361
<u>APPENDIX 5: CONTROLLING SOFTWARE LISTING</u>	366
<u>APPENDIX 6: LISTING OF CALIBRATION SOFTWARE</u>	375
<u>APPENDIX 7: LISTING OF RESULTS EXTRACTION SOFTWARE</u>	379
<u>APPENDIX 8: PRINT-OUT OF PATIENTS' RESULTS</u>	385
<u>APPENDIX 9: RESULTS OF PATIENTS FROM DRUG TRIAL</u>	394
<u>APPENDIX 10: RESULTS OF PATIENTS FROM RHEUMATOLOGY CLINIC</u>	401
<u>APPENDIX 11: RESULTS OF PATIENTS FROM RHEUMATOLOGY WARD</u>	407
<u>APPENDIX 12: RESULTS OF PATIENTS FROM PHYSIOTHERAPY</u>	417
<u>REFERENCES</u>	424

LIST OF FIGURES

<u>FIGURE</u>		page
3.1.	Detail of button and push rod assembly in power grip device	69
3.2.	General detail of the pan handle	69
3.3.	General detail of the kettle handle	72
3.4.	Calculation of pan body tilt and direction of pull	72
3.5.	Arrangement of pinch measuring transducers	77
3.6.	Arrangement of extension force measurement	77
3.7.	Schematic diagram of basic electronic circuitry	79
3.8a	Manual selection of key unit devices	81
3.8b	Automatic selection of key unit devices	81
3.9.	Schematic diagram of the electronic circuitry and logic lines	82
3.10.	Typical arthrograph trace	87
3.11.	A diagram of the arthrograph drive mechanism	89
3.12.	The interface of the arthrograph to the electronic circuitry	91
3.13.	Flowchart showing outline of controlling software	93
3.14.	Print-out of results	100
3.15.	Flowchart showing outline of arthrograph controlling software	102
4.1.	Patient questionnaire	115
5.1.	The calibration factors, accuracy and precision of the transducers	154
5.2.	Scatter diagram of healthy subjects' maximum power grip forces	155
5.3.	Scatter diagram of healthy subjects' maximum pan forces	156
5.4.	Scatter diagram of healthy subjects' maximum kettle forces	157

list of figures (continued)

<u>FIGURE</u>	page
5.5. Scatter diagram of healthy subjects' maximum pulp pinch forces	158
5.6. Scatter diagram of healthy subjects' maximum extension forces	159
5.7. Scatter diagram of healthy subjects' maximum key and tube torques	160
5.8. Scatter diagram of healthy subjects' maximum lateral pinch forces	161
5.9. Mean forces (newtons) obtained from healthy subjects	162
5.10. Techniques used in lifting a pan or kettle	163
5.11. Power grip - subject variability	164
5.12. Pan - subject variability	166
5.13. Kettle - subject variability	168
5.14. Pulp and lateral pinch - subject variability	169
5.15. Key and tube twist and extension - subject variability	171
5.16. A comparison between the subject variability from consecutive and split measurement	172
5.17. Summary table of subject variability	173
5.18. Diagram showing the subject variability of each transducer	174
5.19a Percentage contribution of fingers to power grip in healthy subjects	175
5.19b Comparison between finger contribution to power grip and that using the maximum finger force	175
5.20. Scatter diagram of the finger contribution to power grip in healthy subjects	176
5.21. Histograms of differences between the upper and lower maximum lifting forces in healthy subjects	177
5.22. Scatter diagram and regression analysis: Upper versus lower lifting forces of healthy subjects in left hand pan lifts	178

list of figures (continued)

<u>FIGURE</u>		page
5.23.	As Figure 5.22. except right hand pan lifts	179
5.24.	As Figure 5.22. except left hand kettle lifts	180
5.25.	As Figure 5.22. except right hand kettle lifts	181
5.26.	Histograms of the differences between the maximum handle grip force and the grip force at maximum lift in the pan and kettle lifts of healthy subjects	182
5.27.	Scatter diagram and regression analysis of the handle grip force at maximum lift against the maximum handle grip force: Left hand pan lifts of healthy subjects	183
5.28.	As Figure 5.27. except right hand pan lifts	184
5.29.	As Figure 5.27. except left hand kettle lifts	185
5.30.	As Figure 5.27. except right hand kettle lifts	186
5.31.	Force-time curves of healthy subjects' power grip	187
5.32.	Force-time curves of healthy subjects' pan lift	190
5.33.	Force-time curves of healthy subjects' kettle lift	193
5.34.	Scatter diagram of the mean pan lifting forces against the maximum handle grip forces for left hand lifts of healthy subjects	196
5.35.	Scatter diagram of the mean pan lifting forces against the handle grip forces, at maximum lift, for left hand lifts of healthy subjects	197
5.36.	As Figure 5.34. except right hand lifts	198
5.37.	As Figure 5.35. except right hand lifts	199
5.38.	As Figure 5.34. except left hand kettle lifts	200
5.39.	As Figure 5.35. except left hand kettle lifts	201
5.40.	As Figure 5.34. except right hand kettle lifts	202
5.41.	As Figure 5.35. except right hand kettle lifts	203
5.42.	Regression analysis of the mean lifting forces against the handle gripping forces of healthy subjects	204

list of figures (continued)

<u>FIGURE</u>		page
5.43.	Mean results obtained on each transducer from patients with arthritis	205
5.44.	Scatter diagram of the maximum power grip forces from patients with arthritis	206
5.45.	Scatter diagram of the maximum pan forces from patients with arthritis	207
5.46.	Scatter diagram of the maximum kettle forces from patients with arthritis	208
5.47	Scatter diagrams of the maximum pulp pinch forces from patients with arthritis	209
5.48.	Scatter diagrams of the maximum extension forces from patients with arthritis	210
5.49.	Scatter diagrams of the maximum key and tube torques from patients with arthritis	211
5.50.	Scatter diagram of the maximum lateral pinch forces from patients with arthritis	212
5.51.	Mean results obtained from patients attending the drug trial clinic	213
5.52.	Mean results obtained from patients attending the rheumatology clinic	214
5.53.	Mean results obtained from patients in the rheumatology ward	215
5.54.	Comparison of results from the three clinics using ANOVA and Cochrans C-test	216
5.55a	Contribution of fingers to power grip in patients with arthritis	217
5.55b	Comparison of the finger contribution of patients with arthritis to healthy subjects	218
5.56.	Diagram comparing the finger contributions to power grip of patients with arthritis and healthy subjects	219
5.57.	Histograms of differences between the upper and lower maximum lifting forces of patients with arthritis	220

list of figures (continued)

<u>FIGURE</u>	page
5.58. Scatter diagram and regression analysis of the upper lifting force measurement against the lower force measurement in the left hand pan lift of patients with arthritis	221
5.59. As Figure 5.58. except right hand pan lifts	222
5.60. As Figure 5.58. except left hand kettle lifts	223
5.61. As Figure 5.58. except right hand kettle lifts	224
5.62. Histograms of the differences between the maximum handle grip forces and the grip forces at maximum lift in the pan and kettle lifts of patients with arthritis	225
5.63. Scatter diagram and regression analysis of the handle grip force at maximum lift against the maximum handle grip force: Left hand pan lifts of patients with arthritis	226
5.64. As Figure 5.63. except right hand pan lifts	227
5.65. As Figure 5.63. except left hand kettle lifts	228
5.66. As Figure 5.63. except right hand kettle lifts	229
5.67. Force-time curves of power grip from patients with arthritis	230
5.68. Force-time curves of pan lift from patients with arthritis	235
5.69. Force-time curves of kettle lift from patients with arthritis	240
5.70. A comparison between the two basic force-time curves observed in the pan lift of patients with arthritis	245
5.71. Force-time curves for underarm kettle lift	246
5.72. Scatter diagram of the mean pan lifting forces against the maximum handle grip forces for left hand lifts of patients with arthritis	247
5.73. Scatter diagram of the mean pan lifting forces against the handle grip forces at maximum lift for left hand lifts of patients with arthritis	248
5.74. As Figure 5.72. except right hand lifts	249
5.75. As Figure 5.73. except right hand lifts	250

list of figures (continued)

<u>FIGURE</u>	page
5.76. As Figure 5.72. except left hand kettle lifts	251
5.77. As Figure 5.73. except left hand kettle lifts	252
5.78. As Figure 5.72. except right hand kettle lifts	253
5.79. As Figure 5.73. except right hand kettle lifts	254
5.80. Regression analysis of the mean lifting forces against handle gripping forces of patients with arthritis	255
a) Male and female	
b) Male and female separated	
5.81. Follow-up results of IEJ	257
5.82. Clinical follow-up results of IIJ	258
5.83. Follow-up results of LAO	260
5.84. Clinical follow-up results of LAO	261
5.85. Follow-up results of AHD	263
5.86. Clinical follow-up results of AHD	264
5.87. Follow-up results of DE	266
5.88. Clinical follow-up results of DE	267
5.89. Follow-up results of DS	269
5.90. Clinical follow-up results of DS	270
5.91. Follow-up results of ES	272
5.92. Clinical follow-up results of ES	273
5.93. Force-time curves of left hand power grip of AHD	274
5.94. Force-time curves of right hand power grip of AHD	275
5.95. Force-time curves of AHD pan and kettle lifts showing the peaks obtained	276
5.96. Follow-up results of GEL	278
5.97. Follow-up results of DWW	279
5.98. Follow-up results of JC	280
5.99. Follow-up results of EF	281

list of figures (continued)

<u>FIGURE</u>	page
5.100. Follow-up results of FMB	282
5.101. Follow-up results of GB	283
5.102. Follow-up results of EF	284
5.103. Follow-up results of JW	285
5.104. Follow-up results of RP	286
5.105. Follow-up results of JS	287
5.106. Follow-up results of CWA	288
5.107. Follow-up results of ENC	289
5.108. Follow-up results of GM	290
5.109. Initial results of patients attending the physiotherapy clinic with bilateral hand disorders	291
5.110. Details of the bilateral hand disorders of patients attending the physiotherapy clinic	292
5.111. Initial results of patients attending the physiotherapy clinic with unilateral hand disorders	293
5.112. Details of the unilateral hand disorders of patients attending the physiotherapy clinic	294
5.113. Follow-up results of FS	295
5.114. Follow-up results of FB	296
5.115. Follow-up results of DM	297
5.116. Follow-up results of AGM	298
5.117. Follow-up results of AGR	299
5.118. Follow-up results of JB	300
6.1. An improved arrangement for measuring the full range of lifting forces	312
6.2. The basic force-time curves observed in the pan lift of healthy subjects and patients with arthritis	320
6.3. The basic force-time curve observed in the kettle lift of both healthy subjects and patients with arthritis	323

list of figures (continued)

<u>FIGURE</u>	page
A1.1. Typical pressure-time curves	342
A1.2. Maximum grip pressures of male subjects using the left hand	343
A1.3. Maximum grip pressures of male subjects using the right hand	344
A1.4. Maximum grip pressures of female subjects using the left hand	345
A1.5. Maximum grip pressures of female subjects using the right hand	346
A3.1. Details of the connections to the D109 interface card	360

LIST OF TABLES

<u>TABLE</u>	page
2.1. Summary of functional assessments	36
4.1. Patients attending the drug trial clinic	108
4.2. Patients attending the rheumatology clinic	110
4.3. Patients from the rheumatology ward	111
4.4. Patients from the physiotherapy clinic	113
A1.1. Details of the cuffs used	339
A1.2. Details of the maximum grip pressures obtained from each cuff	347
A1.3. Details of the t-test comparison between cuff diameters	348
A1.4. Details of the t-test and F-test comparison between left and right hands	349
A1.5. Details of the t-test comparison between male and female	350
A3.1. Details of the registers used on the D109	358
A9.1. Results of AHD	395
A9.2. Results of DE	396
A9.3. Results of IEJ	397
A9.4. Results of LAO	398
A9.5. Results of DS	399
A9.6. Results of ES	400
A10.1. Results of JC	402
A10.2. Results of ECF	403
A10.3. Results of GEL	404
A10.4. Results of DWW	405
A10.5. Results of JW	406

list of tables (continued)

<u>TABLE</u>	page
A11.1. Results of CWA	408
A11.2 Results of FMB	409
A11.3. Results of GB	410
A11.4. Results of EMC	411
A11.5. Results of EF	412
A11.6. Results of GM	413
A11.7. Results of RP	414
A11.8. Results of JS	415
A11.9. Results of JW	416
A12.1. Results of FR	418
A12.2. Results of JB	419
A12.3. Results of AGM	420
A12.4. Results of DM	421
A12.5. Results of FS	422
A12.6. Results of AGR	423

LIST OF PLATES

<u>PLATE</u>	page
3.1. Full view of apparatus	66
3.2. Power grip device	67
3.3. Pan and kettle device	70
3.4. Lift measurement	73
3.5. Key unit a) key b) pinch	75
3.6. Top view of arthrograph	84
3.7. Arthrograph finger holder	86
3.8. Patient details display	95
3.9. Device menu display	97
3.10a Graphical display	99
3.10b Numerical display	99
4.1. The pan lift	116
4.2. The pulp pinch	117
4.3. The power grip	119
4.4. The key twist	120
4.5. The tube twist	121
4.6. The lateral pinch	122
4.7. The extension	123

DECLARATION

The work contained in this thesis has not been submitted elsewhere for any other degree or qualification and that unless otherwise referenced it is my own work.

STATEMENT OF COPYRIGHT

The copyright of this thesis rests with the author. No quotation from it should be published without his prior written consent and information derived from it should be acknowledged.

ACKNOWLEDGEMENTS

I would like to register my gratitude and appreciation to all the people from the University of Durham and Middlesbrough Hospitals who have assisted me in this project.

Special thanks go to my academic supervisor, Dr Tony Unsworth, for his continuous help, encouragement and supply of ideas. Also to my clinical supervisor, Dr Ian Haslock, for his help, encouragement and clinical impressions.

My thanks to Mr Ray Mand for manufacturing the devices to such a high standard and to Mr Frank Emery for the carpentry.

Many thanks go to the staff of Middlesbrough Hospitals for allowing me to interrupt their routines and for procuring volunteers for me. These include Mrs Valerie Rhind, Sister Linda Turner and staff, Mrs Liz Sadler and Mrs Anne Richardson and staff, and Mrs Jacqueline Moyes and staff.

Thanks to my employers, STC Components of Great Yarmouth, for use of their photocopying facilities.

Many thanks to Miss Hilary Townshend for making an excellent job of typing the text and to my mother-in-law, Mrs Anne Pendle, for stepping into the breach and doing a super job on the tables.

I would also like to acknowledge the support of the DHSS who funded this work.

Finally, the biggest cuddles go to my wife Sally whose help, support and love have kept me going. She deserves a medal for putting up with me and a 'finishing' thesis for so long.

Once again, thank you all.

CHAPTER 1

INTRODUCTION

INTRODUCTION

The hand is arguably one of the most important features of the human body. It is an interface by which information is transferred from the body to the environment and vice versa. The hand is connected to the trunk of the body via the wrist, elbow and shoulder joints. This articular network ensures that the hand can be placed with great accuracy and stability into any part of a large volume around the body. This enables many diverse functions to be performed including feeding, sensing, using and making tools, grooming, gesture, attack and defence.

The complex structure of the hand and wrist is indicated by the outline drawing, in Figure 1.1., of the hand and wrist in which the bones and joints are detailed. In total there are twenty seven bones, eight of which are found in the wrist. Seven of these are packed together in two rows to form the intercarpal joint. This joint allows a small amount of sliding movement between adjacent bones, but primarily it allows movement between the two rows. This movement plays a large part in the flexion and abduction (radial deviation) of the wrist.

The carpometacarpal joint of the thumb, being a saddle joint, allows flexion, extension, adduction, abduction and rotation of the thumb. It is this range of movement that makes possible thumb opposition, the contact between the pad of the thumb and the pads of the fingers. The carpometacarpal joints of the fingers allow only limited movement.

The metacarpophalangeal joints are almost spherical and allow flexion, extension, adduction, abduction and circumduction of the fingers. The interphalangeal joints are hinge joints only allowing flexion and extension.

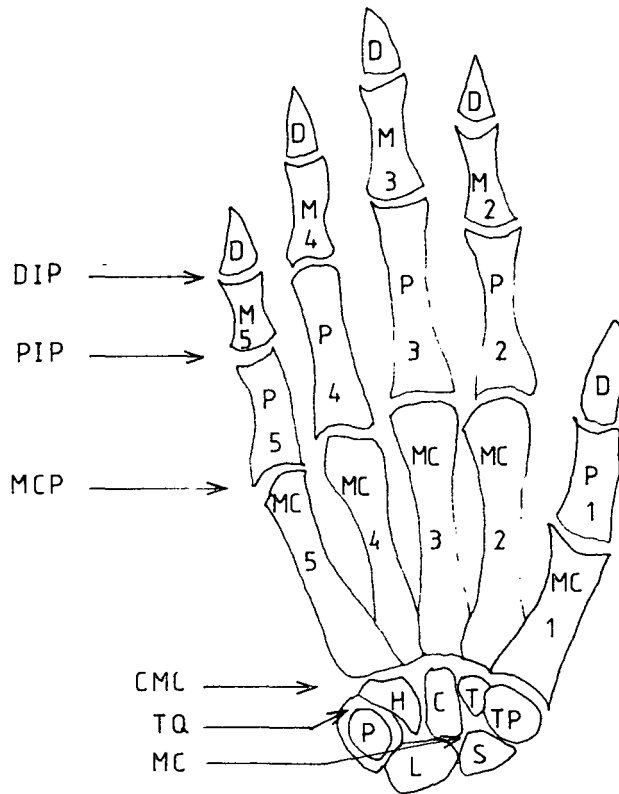

FIGURE 1.1. Skeleton of the hand

KEY:-

FINGERS

1,2,3,4,5-Thumb, Index, Middle, Ring, Little

BONES

- D-Distal Phalanges
- M-Middle Phalanges
- P-Proximal Phalanges
- MC-Metacarpals
- P-Pisiform
- TQ-Triquetrum
- H-Hamate
- C-Capitate
- T-Trapezoid
- TP-Trapezium
- S-Scaphoid
- L-Lunate

} Carpal Bones

JOINTS

- DIP-Distal Interphalangeal
- PIP-Proximal Interphalangeal
- MCP-Metacarpophalangeal
- CMC-Carpometacarpal
- MC-Midcarpal

In order to achieve full control of these articulations, an even more complex arrangement of muscles is required. In total, there are thirty four muscles which are responsible for the movement of the joints in the hand and wrist. Just under half of these, the extrinsic muscles, originate from the forearm. The others, the intrinsic muscles, originate from within the hand and wrist structure.

The combination of bones, joints and muscles gives a very versatile prehensile (gripping) organ. The joints and musculature allow the hand to mould itself to an object and to move objects, using a variety of handling grips. These range from a simple finger pinch to a power grip in which the hand envelopes the object. Napier (1963) classified the prehensile movement of the hands into power grip and precision grip. Power grip is where an object is clamped into the palm of the hand by flexed fingers and the thumb. Precision grip is where an object is held between the pulps of the fingers and thumb in a pinch type posture. Napier also stated that it is the nature of the task to be performed that determines the hand posture and not the shape of the object to be held.

Power grip is a clinical term, power being used as an adjective to indicate the presence of large forces. The scientific definition of power is the rate of doing work, where work is equal to the force applied to an object multiplied by the distance the object is moved in the direction of the force. However, since most hand grips are static, no movement is involved, therefore no work is done and hence there can be no power. Therefore, power grip is a misnomer unless it applies to a dynamic situation. Since it is widely used clinically, we shall continue to use it here, though its clinical definition should not be confused with the scientific one.

The great versatility of the hand can be attributed to the ability of the thumb to oppose the pulps of each finger. The thumb provides the mobility necessary for precise movements while in power movements it provides one jaw of a vice, the fingers providing the other.

Providing such a versatile organ means that there is a large interdependence between different hand parts. For instance, no joint can actively move in isolation. Each movement causes the flexion or extension of other joints thereby forming a chain of articulation. This interdependence is the result of the combination of muscles required to execute a movement. Only the index finger has any independence because it is the only finger to have any independent muscles. Even simple flexion and extension of the fingers involve a combination of muscle activity. Basically, this is the synergistic effect of the flexor and extensor muscles. To flex the finger the extensor must extend as the flexor contracts and vice versa if extension is required.

The complexity and versatility of the hand make it very susceptible to injury, the most minor of which can result in a large reduction in the hands' functional capability. For instance, even a slight scratch is instantly noticeable, and if it happens to be on the touch sensitive parts of the finger pulps, feels like a large cut and makes any grip much more difficult and awkward. This also introduces another aspect of the hand, its unconscious control. Most of the time the hand is used without effort as no conscious thought needs to be applied to achieve its chosen task. For example, how often are objects misplaced because their actual placement cannot be remembered?

Unfortunately, external injuries are not the only source of

problems to the hand. There are several systemic diseases that affect the whole hand. Rheumatoid arthritis is one of these. This is an insidious chronic disease which starts in the peripheral joints as a general weakness with aching and stiffness. This leads to joint inflammation with accompanying pain, redness, warmth and tenderness. The disease spreads to other body joints e.g. the wrists, elbows, hips, knees and ankles. The progress of the disease is not steady, but punctuated with remissions and exacerbations of indefinite periods, over perhaps many years. There are also other systemic manifestations of the disease such as small areas of necrosis on the finger tips, chronic leg ulcers, anaemia, enlargement of lymph nodes etc.

Chronic joint inflammation can lead to destruction of the articular cartilage leaving bare bone. Connective tissue, either fibrous or bony, can then develop between the bare surfaces leading to a solid bridging (ankylosis) and joint immobility. The inflammation also leads to joint instability by weakening the supporting structures (i.e. tendons and ligaments). This can sometimes lead to joint dislocation or subluxation as the muscles change their line of action.

Degenerative joint disease (osteoarthritis) is another disease which can affect hands. It is the destruction of joint cartilage and the formation of bony projections in the joint, causing discomfort, pain and loss of movement. The cause of the disease is not fully understood. Traditionally it was thought to be a mechanical condition affecting the joints subject to most stresses and an inherent aspect of the ageing process. However, recent findings (Huskiison et al. 1979) suggest a metabolic abnormality causing a degradation of the cartilage, with a mineral deposition in the

joint and inflammation.

Treatment of these diseases can only ease the pain and reduce the inflammation. In some instances surgical intervention can help to restore some degree of function. No cure has been found for rheumatoid arthritis and as yet its cause is unknown. Treatment in most cases involves analgesic and anti-inflammatory medication together with physical therapy. Physical therapy involves exercise and splinting to attempt to reduce the effect of joint instability. Education is also part of physical therapy, showing patients how to use their hands defensively. Several daily activities use hand positions or forces that can encourage deformity. The patients are shown other methods of using the hand to do the same task, thus slowing down the rate of deformation. For any treatment to be successful, an accurate assessment of the body or organ being treated is required at regular intervals. If functional changes are observed, the treatment can be modified accordingly. The assessment must be capable of use for all hand injuries and disease. The diseases above are only mentioned because they form the larger proportion of cases. There are still a significant proportion of industrial and all the other types of injuries that require a continual assessment to monitor recovery.

The versatility of the hand makes the classification of an assessment routine difficult. Since the hand is used in so many different ways, with so many orientations, it would be impossible to test every position. Even individual muscles cannot be assessed because a number of muscles are involved in each movement. The purpose of an assessment would be to evaluate the condition of a patient's hand. Primarily, this must be concerned with how that hand is functioning. Therefore, a means of quantifying hand function is

required. The assessment should also be capable of measuring localised dysfunction and to give an indication of the cause of the dysfunction. Another necessary attribute is objectivity. Measurement of any parameter should be performed in such a way that subjective factors are reduced as much as possible, thus minimising inter-observer variation.

Hand function itself is subjective. Every person would describe their hand function differently, depending on their occupation and daily activities. In this respect a hand assessment should be flexible enough to accommodate different activities of daily living (ADL). However, there must be some limit. Purely subjective assessment of ADL's, by observing subjects while they perform the task, would reveal only that the patient had difficulty in performing the task. No accurate measure of the difficulty would be obtained. Careful observation might reveal the cause of any dysfunction, but generally it is only the effect of the dysfunction that is assessed.

To be objective, an assessment task must involve some measurable parameter. This must be measured accurately using a specially designed transducer and must not rely upon observable phenomena. The most obvious parameter is the force applied by the hand, in performing various tasks. Other parameters could be joint stiffness or the range of joint motion. Because of the number of joints, these would provide a lot of data, the consequences of which would not be instantly obvious. They would not give a measure of function, but would measure the disease progress.

Grip 'strength' has regularly been assessed using inflated sphygmomanometer cuffs. However, as discussed later, these only measure a change of pressure and not the applied force. This could be improved and extended to encompass a blend of strength and function

tasks such as pinch force measurement and the measurement of the torque applied to turn a key.

With an objective assessment, if the measurements obtained proved suitable, i.e. they proved sensitive to changes in patient performance, an accurate monitor of the patient's capability would be obtained. An objective assessment would give a greater confidence in the selection of treatment whether medical, surgical or physical. Regular monitoring would ensure a quicker realisation of the disease process and the effect of the treatment given. Depending on the results, the treatment could then be altered to allow a more effective recovery of function. In some cases this would speed up patient recovery making for a quicker return to everyday activities e.g. work.

Based on these criteria an assessment routine was formulated, and measuring devices, that were a blend of functional and strength tasks were built. The functional tasks included were pan and kettle lifting, key turning and wringing out a cloth. Total grip strength, including the strength of the individual fingers, pulp pinch, lateral pinch and extension force were the strength tasks. These were all chosen for their relative simplicity as well as their functional differences. The functional tasks involved three different handling technique using the full hand. In the tasks using the pan and kettle it would be possible to measure the force applied by the hand during the lift and to measure the lifting force itself. The strength tasks could be used to identify isolated dysfunction. For example, finger problems could be highlighted by the power grip, pulp pinch or extension tasks, while the lateral pinch could highlight thumb problems.

All the measurements need to involve maximal effort so that the

full capability of the patient is measured. This is not typical of ADL's, but it would not be practical to suggest that the subject applied a similar effort to that they would apply at home.

Finally, the measuring devices were linked to a microcomputer which displayed all the necessary results. This removed the need for dials and gauges for the observer to read and reduced the time of each task thereby reducing patient fatigue. Using the microcomputer the only variable in operation became the subject, therefore the system was operator independent.

This thesis describes the assessment routine and gives the results of a preliminary investigation into its capability as a monitor of hand function.

CHAPTER 2

LITERATURE REVIEW

LITERATURE REVIEW

The literature could be divided conveniently into four sections:-

- i) General comments on hand assessment
- ii) Functional assessment routines
- iii) Grip measurement
- iv) Miscellaneous hand assessments

2.1. General Background

Dumont (1968) gave a description of the treatment given to a rheumatoid hand when referred to occupational therapy. Grip was tested using an aneroid sphygmomanometer and gripping ability was assessed by how the patient managed with everyday objects e.g. knife and tumbler of liquid. The treatment given depended on the grip test and involved different activities, from cord knotting to weaving, for the patient to carry out.

Ansell (1968) stated the importance of assessing individual joints at regular intervals and to consider the function of the hand, as a whole, in order to see the effect of the disease process. An assessment was described that involved a full clinical examination with measurements of range of joint motion and grip. A ruler was used to measure the former, distance from pulp of finger to palm, and a sphygmomanometer cuff, inflated to 20 mm of mercury, for the latter. The use of photography, cinematography and radiological appraisal were also included. Functional tests, such as picking up objects or unfastening jam jar lids, were also performed, but these were tailored to the needs of the patient. It was required that the assessment be carried out pre-operative, pre-, six and twelve months post-discharge with an annual follow up thereafter.

General guidelines to hand function assessment were given by

Cantrell (1975). The need for an accurate description of the hand, especially in diagnosis and the transfer of information was stressed. This was to enable more accurate comparisons between follow up assessments and so that the patient could see their progress. In addition there should be an accurate method of describing how the hand functions. The point was stressed that it was more important to know what the patient was capable of rather than the physical appearance of the hand and how this differed from the classical medical description. An assessment was described involving clinical examination such as joint movement and grip testing (using an inflated cuff). An occupational functional assessment was also included to see how the patient coped with everyday activities.

Cantrell (1976) also described an assessment which used measurements of pulp pinch force and a functional assessment questionnaire. The questionnaire was based on the patients ability to tackle activities of daily living (ADL). The patients
* subjectively grade themselves on how they find an activity - easy, difficult or impossible to do, while the therapists check for any specific reasons why there should be any difficulty. The pulp pinch results showed a marked difference between weak patients and strong healthy subjects. Analysis of all the results indicated that all patients with arthritis are weak and that this weakness is not just an effect of pain or physical deformity. This led to the conclusion that muscular weakness was a primary part of the disease and a cause of functional disability.

Unsworth (1977) stressed the same points as Cantrell above, but went on to describe specific cases to reinforce the point that functional integrity is preferred to physical integrity. The cases cited showed a patient with a lot of hand deformity, who was

functionally better off than a second patient with no deformity.

Cantrell (1977) reiterated his earlier papers, but added the importance of follow up assessment to monitor the disease progress and to give a better understanding of the underlying process. This led to the points that to be of any value, measurement systems must be more objective to reduce the inter-observer error and to meet the need to demonstrate small changes, in the hand, over a period of time. Cantrell also described the use of wiregrams to record the range of joint movement. These consisted of tracings of metal wire bent to the shape of the flexed or extended finger.

The above papers have only indicated guidelines and the need for carrying out accurate quantitative functional hand assessments at regular intervals so as to monitor small changes. They do not provide a standardised functional assessment routine to be followed for every patient.

2.2. Functional Assessment Routines

These have been described by Carthum et al. (1969), Jebsen et al. (1969), MacBain (1970), Kellor et al. (1971), Clawson et al. (1971), Smith (1973), Peskett (1973 and 1977), Green (1974), Bell et al. (1976) and Walker (1978). Table 2.1. gives a summary of these assessments showing the measurements taken and the activities carried out by the patients. The work by Carthum was a follow up to the earlier work by Clawson but this time using only five of the original tasks and measurements. Each assessment can be divided into two parts, 'strength' measurement and functional assessment. Only Jebsen omitted the former, concentrating on the functional tasks.

AUTHOR =	CARTHUM	CLAWSON	JEBSON	MacBAIN	PESKETT	SMITH	KELLOR	GREEN	BELL	WALKER
TASK										
STRENGTH										
Grip	C	C		C	D	D	D		D	D
Pulp pinch	C	C		C			D	W		D
Lateral pinch	C						D	W		D
Cylindrical grip	W							W		
Finger flexion	D	D								
Spherical grip								W		
Chuck pinch							D			D
Extensor force										D
Hook grip				W						
FUNCTIONAL										
Safety pin	T2			TB	✓	TB				
Button fastening	T2	TB		T2	✓	TB				
Scissors	T2				✓					
Knife and fork	TB	TB		TB	✓					
Shoelace tying	TB			TB		TB				
Writing					✓	T2				
Card turning										
Pick up paper clips				T2						
Spoon				T2						
Stacking checkers				T2						
Pick up empty cans				T2				T2		
Pick up full cans				T2				T2		
Jug pouring				2	✓			T2		
Kettle pouring				2	✓					
Door knob				T2				T2		
Coin pick up				T2	✓	T2			TB	
Moving blocks						T2			2	
Moving nails						T2				
Inserting pegs						T2	T2	T2	T2	T2
Belt buckle						TB				
Zip					✓	TB				
Double knot						TB				
Bow tying						TB				
Pins into cushion					✓			T2	2	
Nut and bolt								T2	T2	
Assemble blocks								T2	TB	
Hand tools									TB	
Door bolt								T2		
Pile plates								T2		
OTHERS										
Pain and tenderness										
Range of motion										
Photographs										

PESKETT also included, pencil pick up, button sewing, match striking, opening an electric plug, taking lid off pan, using a clothes peg, cups and saucers, winding up a watch, screw lid, screwdriver, mixing, wringing, taps, cooker knobs, keys, aids, putting peper into an envelope and picking up marbles.

TABLE 2.1: Summary of functional assessments

KEY: C - cuff; D - dynamometer; W - weights;
T - timed task; B - bilateral task;
2 - both hands used separately

2.2.1. 'Strength' measurements

a) Grip

This was measured in all assessments except Jebsen and Green. Sphygmomanometer cuffs were used by Carthum and Clawson (folded and inflated to 20 mm of mercury) and MacBain (rolled and inflated to 40 mm of mercury).

b) Pulp pinch

Again Carthum, Clawson and MacBain used inflated cuffs to measure this. MacBain used a smaller diameter cuff while Carthum and Clawson used the same cuff but enclosed it between two metal sheets hinged at one end. The patient applying the pulp pinch on the opposite end. A small diameter dowel was used by Green. The patient held this vertically in a pinch grip while the weights hung from the dowel were increased. The pinch force being defined as the maximum sustainable weight. Kellor used a proprietary dynamometer while Walker had two strain gauged cantilevers that were pinched together.

c) Lateral pinch

This was measured by Carthum, Kellor, Green and Walker. All four used the same device as for pulp pinch measurement.

d) Cylindrical grip

Carthum and Green both used the same method of hanging weights from a dowel, held vertically, and gripped until the dowel could not be held against the weight.

e) Others

Carthum and Clawson measured finger flexion force by letting the finger, with the palm supported, press down onto a transducer whose output registered on a dial gauge. Spherical grip was measured by

Green, who hung weights from a sphere held by the patient. MacBain measured hook grip by adding weights to a bucket held with a pronated arm resting on a table. Walker measured chuck pinch using the pinch transducer described above. He also measured finger flexion and extension force using a horizontal strain gauged beam.

2.2.2. Functional assessment

These consisted of several activities designed to test a patient's manipulative ability. In the majority of cases they consisted of timing the patient to see how long they took to accomplish a prescribed task. Green stopped each task after fifteen or thirty seconds and then assessed how much of the task had been completed. A few tasks involved counting or weighing, the results being the number of objects moved in a given time (e.g. Bell, block and pin movement) or the maximum weight at which a task could be sustained (e.g. MacBain, jug and kettle pouring).

* Generally, a mixture of unilateral and bilateral tasks were used with both hands being measured unilaterally. Jebesen used only unilateral tasks while Bell repeated some unilateral tasks, bilaterally. Peskett did not make it clear whether the tasks were performed uni- or bilaterally.

The majority of the assessments were designed for patients with rheumatoid arthritis. However, Jebesen also tested patients with unilateral hemiparesis and C6-7 traumatic quadriplegia, finding that there was a tremendous range in the assessment score from the healthy subject range to 'unable to complete' the task. The healthy subject range was obtained from three hundred subjects.

Bell was specifically concerned with para- and hemiplegia. The results from these patients were compared to a normal value obtained

from fifty healthy subjects. The results were standardised by setting the healthy subject mean result to 100. Eighty patients with paraplegia were measured and their standardised mean results for the assessment ranged from 77 to 96. Forty four patients with right hemiplegia had a range of 60 to 74 while fifty patients with left hemiplegia had an 11 to 60 range. All the patients were right handed and it was not clear why patients with left hemiplegia had a score much lower than the other patients.

Clawson assessed six patients with rheumatoid arthritis over a ten week period using the tests first described by Carthum. Carthum had evaluated the use of a large series of measurements including grip, pinch, range of motion, deformity, pain and ADL's. From this series Clawson extracted five tests that were assessed to be the most reliable and independent of each other, so that they measured different aspects of hand function. The tests were grip, three point pinch, finger flexion power (described above) and two functional tasks, using a knife and fork and the fastening/unfastening of buttons.

Using the five tests, thirty nine healthy subjects were measured to obtain a range of normal values. Using these results a 1 to 20 scaling (poor to good) was given to each task's results. By summing the individual test grades a functional index was obtained. One hundred and six patients with arthritis were also tested. Their results produced a much lower index than the healthy subjects' and that there was a tendency for the index to decrease as the disease progressed.

Sixty four of the patients were followed up to a year and forty two in excess of three years from their initial treatment. After one year, 42% had improved while 23% had deteriorated. After three years

the figures were 40% and 44% respectively. Of twenty five hands that underwent various types of surgery, 64% were shown to have improved and 4% to have a deterioration in the functional index.

MacBain tested a group of healthy subjects to obtain a range of values so that individual test results could be graded as 'normal', 'good', 'fair' or 'poor' for comparison purposes.

Smith and Walker also tested healthy subjects to obtain a base line. Walker also tested six patients with arthritis and showed that they were much weaker in all tests than the healthy subjects.

Carthum, Peskett and Green gave no details of any results obtained. To establish 'norms', Kellor tested between 246 and 274 healthy subjects. He found a linear relationship between age and all the test results for male and female, left and right hand. The strength results all showed a decrease with age while the functional tasks increased.

Most of the above assessments were clearly complex in that they involved lots of tasks for the patient to perform. By subjecting patients to such a battery of tasks, patient fatigue becomes a major problem. This would cause poorer results to be obtained, especially towards the end of an assessment. This would be particularly so in those tasks which aimed to find the maximum sustainable weight that could be held and lifted. These were not very well thought out tasks. Even healthy subjects show muscle fatigue after a short time and their sustainable weight limit would decrease the longer they had to hold the weights. This would be even more so in patients with arthritis.

With so many tasks to assess, a complete assessment took a long time, Smith quoting forty five to sixty minutes. This length of assessment would not only cause fatigue but it would be difficult to

keep up a patient's motivation and it is also an inefficient use of the therapist's time. Only Carthum attempted to reduce tasks to a minimum while Walker used strain gauged dynamometers which only took a short time to measure a force.

The functional tasks also lacked objectivity. Since they only contained timed tasks they could really only indicate whether a patient could accomplish a task slowly or speedily. If the patient were assessed regularly there would be a learning process, causing an apparent improvement unrelated to any improvement caused by the therapy.

The most objective assessments were obviously those that measured a particular hand parameter e.g. the force applied by the hand in gripping and pinching. For this dynamometers were necessary since they actually measure the applied force. Inflated cuffs do not measure a force (or grip strength) since they only measure the ~~pressure~~ change, of the enclosed fluid, caused by the gripping action of the hand. This ~~pressure~~ change depends on the inflated pressure of the cuff, the size of the cuff, the area of contact between the hand and the cuff and the method of gripping. Cuffs were also inaccurate since they were highly susceptible to finger jerking. During a grip any slight finger movement could cause a large increase in pressure. Since only maximum readings were recorded a jerky finger could easily give an excessively high value for the grip test. (Appendix 1.)

Kirkpatrick (1957) in his conclusions of the 'Sub committee for the Study of Grasping Power' of the California Medical Association, also pointed out these inaccuracies of the sphygmomanometer. Kirkpatrick quoted Sanderson (personal communication) in explaining the difference between force and pressure. He used the illustration of standing on one foot, then on a marble and then a nail. Since

pressure equals force divided by area, standing on a nail produces the highest pressures (stresses) with a dramatic effect in this example. Also stated was the need for any grip measuring device to respond to the applied force and not be influenced by any other parameter such as the area of contact.

Robertson et al. (1982) stated that grip measurement using a cuff lacked a standardised method, that even patients with arthritis could exceed the normal maximum value of 300 mm of mercury for a clinical sphygmomanometer. This maximum also ensured the absence of normal values from healthy subjects which would make interpretation difficult.

Therefore, it appeared that none of the above assessments could be used to monitor accurately hand function through the disease process or course of treatment. However, none appeared to be used for this purpose. In the main, the results appeared to be used to form a set of 'norms' for patients to be compared with. Any monitoring that was performed was long term and not concerned with a specific treatment, but rather to evaluate course changes in the disease progress.

As the assessments consisted of a series of functional tasks, they allowed the therapist to carry out a subjective analysis of patient at the same time and to observe where the patient had difficulties. The therapist then decided how best to treat the patient. However, this was mainly subjective and no quantifiable measurements were available to test the treatment given.

2.3. Grip Measurement

Mainly because of its convenience, grip testing has consistently been used as a measure of hand ability. Clinical studies have used

it to assess the rehabilitation of the hand after traumatic injury, operation and in assessments of disease activity. Grip strength has also been used to determine the muscular strength and physical fitness of athletes.

Many instruments have been designed to measure grip strength. They fall into the two general categories of dynamic and isometric. The latter consists of devices using hydraulic or strain gauged systems, while the former included inflated cuffs and elastic deformation devices such as springs and levers.

2.3.1. Dynamic devices

Inflated cuffs have been used consistently, especially clinically, over the past twenty five years. Lansbury (1957 and 1958) used them in a Systemic Index to monitor the disease activity of rheumatoid arthritis. The cuff was double folded and inflated to a pressure of 20 mm of mercury. The rest of the index consisted of measures of morning stiffness duration, the time elapsed since rising before fatigue set in, the number of Aspirin taken per day and erythrocyte sedimentation rate. These results were graded using a set of standard tables, apparently arrived at by clinical experience. The systemic index was then the sum of these grades. Lansbury's evaluation of this index and an articular index, the degree of joint involvement, was based on clinical experience and impression, patients evaluation and comparison with each other.

Wright and Plunkett (1968) and Wright et al. (1969) showed a diurnal variation of grip in patients with rheumatoid arthritis and healthy subjects. A pneumatic dynamometer was used to measure grip. A similar, but opposite variation was also observed in joint stiffness. This was initially measured by counting the number of

knots that the patient could tie in two minutes. Later a specially designed finger arthrograph was used to measure the index finger MCP joint stiffness. The grip variation, which closely followed body temperature, showed up as an early morning (0600 hours) minimum which increased steadily through the morning to an afternoon plateau, only to decline through the night.

Ingpen (1968) also studied joint stiffness and grip in twenty five patients with rheumatoid arthritis. Grip was measured using the same cuff arrangement as Lansbury. The results showed a good correlation between maximum grip and a five point subjective pain self assessment by the patient. Joint stiffness was measured by timing the fall of a weighted finger through a vertical arc of ten degrees about the MCP joint. A diurnal variation, similar to Wright and Plunkett, was observed though a smaller second peak was recorded in the early evening in some patients. A good correlation was also found between the measured stiffness and the patient's self assessment of pain.

Kent (1978) used a horizontal finger arthrograph to evaluate the above finger dropper as a measure of joint stiffness. The arthrograph directly measured joint stiffness by measuring the torque required to rotate the index finger about the MCP joint. No relationship was found between the peak to peak torque, measured 20° either side of the finger resting position, and the fall time measured by the finger dropper. This would, therefore, appear to invalidate the results given by Ingpen, since a finger dropper does not measure joint stiffness.

An assessment of grip testing, using a cuff, was carried out by Lee et al. (1974) using the mean results obtained from between eighteen and twenty one patients with arthritis. The intra-observer

error of 5 to 9 mm of mercury was much lower than the inter-observer error of 17 to 20 mm of mercury. The diurnal variation found was not as pronounced as that reported by Wright and Plunkett. These results confirmed that testing, using a cuff, needed to be carried out by the same person at the same time of day. A double blind study between sodium salicylate and prednisolone therapy, for one week, indicated that over placebo the prednisolone gave a significant improvement while the other therapy did not.

De Choisy (1973) compared the mean results from grip strength measurement, using a cuff inflated to 20 mm of mercury, to those obtained from a torquometer. This was a proprietary device which was held firmly, by the base, in one hand, while the other hand rotated the top half, anti-clockwise, against an internal spring. The maximum rotation was recorded on the device, by a resettable pointer, on an arbitrary scale from 0 to 10. It therefore required wrist and elbow movement together with hand grip. The results, from twenty patients with arthritis, indicated on two separate measurements a significant correlation between both types of device. The correlation coefficients ranged from 0.59 to 0.79. The comparison, using twenty four patients, was performed before and after two types of drug treatment, Benorylate and Ibuprofen. Both types of test indicated a mean improvement after each treatment. A greater correlation was observed in the Benorylate results (0.84) than in the Ibuprofen (0.44).

Brewer et al. (1980) used the same torquometer to do the same comparison but used nearly 200 patients with rheumatoid arthritis. Again, good correlations were obtained between the two device results with coefficients of 0.73 and 0.72 for left and right hand measurement.

Both the above authors stressed the idea that the torquometer was a simple and compact device. Since it required a complex action, grip as well as wrist and elbow movement, it gave a better measure of hand function. The complex action involved being a typical everyday use of the hand, turning door knobs or unscrewing jam jar lids.

*

However, both sets of work were similar in that they only carried out a one to one comparison, using grip strength measurement as an indicator of function. No further work was carried out to assess the reproducibility of the device or its ability to monitor change over a period of time.

The same torquometer was employed by Sheenan et al. (1983) in a more complete study of thirty three patients with rheumatoid arthritis. Again, grip strength was measured using a cuff inflated to 20 mm of mercury. A functional assessment was carried out by Occupational Therapists. This consisted of a three point subjective assessment of ten activities. The points of the assessment were 2, not able to complete the task, 1, to complete it with difficulty and 0, no difficulty. The activities assessed were picking up a pin, lifting a dinner plate, unscrewing and screwing up a nut, unscrewing a jam jar lid, holding a glass, lifting a saucepan of water, cutting out paper with scissors, using a screwdriver, picking up weights and folding up a piece of paper and inserting it into an envelope. Two torque measurements were performed. The first was the bilateral method used above by De Choisy and Brewer. The second, the torquometer was fixed upright on a vertical stand with the patient standing alongside. The height of the stand was adjusted so that the patient could operate the device comfortably with their arm vertically at their side. The results of both torque and the grip measurements were found to have good correlations with the functional assessment.

For a more detailed comparison the functional assessment results were separated into four grips - the tripod (jam jar lid), span (plate pick up), light (pin pick up) and the cylindrical grip (pan lift). Analysis of these results appeared to show that torquometry gave a clearer differentiation between the functional assessments points for the first three grips while in the latter cuff testing appeared better. Overall, the results, together with clinical impression and patient evaluation indicated a complementary use of the torquometer and cuff.

Downie et al. (1978) assessed the accuracy of visual analogue scales (VAS) in grip assessment. A VAS was a line drawn vertically or horizontally with each end labelled with opposite feelings e.g. good and bad. A patient was asked to mark a point somewhere along the line to represent their own subjective assessment of themselves. The grip of ninety three patients with rheumatoid arthritis and seven healthy subjects was first assessed by clinicians in mm of mercury. Using this assessment the patients were split into four functional groups (very weak, weak, normal and strong grip). The patients then assessed their own grip using a VAS labelled with 30 and 300 mm of mercury. These results were also divided into the same functional grouping. Finally, the grip was tested using a folded cuff inflated to 30 mm of mercury. Analysis was carried out using each functional group as defined by the clinicians and patients. The results showed that clinicians were better at gauging the patients' grip in mm of mercury, than the patients using the VAS. This ability was seen as a better delineation of each functional group and a better correlation (0.92) of the clinicians' assessed grip to that measured than the correlation (0.64) between the VAS score and the measured grip. Such a result is not surprising since

it is doubtful whether a patient would know how to classify their grip in mm of mercury. All the patient is aware of is the relative strength of their hand compared to some time previously. A clinician has his experience of seeing patients using a cuff and feeling their physical grip during examination.

Thorngren and Werner (1979) used a vigorimeter, a rubber balloon connected to a manometer, to study 450 male and female subjects that had no history of upper extremity dysfunction. The results showed a fall off of grip with age (21 to 65 years) and a constant dominant to non-dominant hand ratio (1.07 ± 0.11) for both sexes.

Myers et al. (1979 and 1980) added a semiconductor pressure transducer to a cuff inflated to 30 mm of mercury. The transducer output was connected to a chart recorder which recorded the grip as a pressure-time curve. From this was extracted the rates of pressure rise and fall, the work done in compressing the cuff

and the power output (related to the rate of increase in pressure).

Initial results (Myers, 1979) were obtained from nineteen patients with arthritis who were measured at the end of four periods of treatment. These were 'washout' (no anti-inflammatory treatment), two weeks on an anti-inflammatory drug, one week on placebo and finally two weeks on the drug again. The results showed that the maximum grip, work done and power output all increased during the two periods of medication. Over the placebo, the improvement was approximately 48%, 75% and 105% for the maximum grip, the work done and the power output respectively. This led to the conclusion that power and work were more sensitive indicators of change in hand function than maximum grip.

Further work by Myers et al. (1980) compared the mean results

obtained from twenty healthy subjects to those obtained from thirty patients with arthritis (all female). As expected, the patients gave the poorer results, the ratios of the healthy to patient results being 4.2, 0.4, 5.5 and 7.3 for the maximum grip, time to reach 95% of maximum grip, work done and power output respectively. Again, these show that power output appears to register a larger overall difference between the two groups.

The apparatus was further modified (Pearson et al. 1982) to include a microprocessor which gave an immediate digital read-out of five measurements. These were the maximum grip, the rate of pressure rise (the work and power output being derived from these two), the time to reach maximum grip, the grip relaxation during maximum effort (fatigue) and the rate of pressure release. The system was used to assess the diurnal variation of grip and the effect of hot and cold temperature and exercise therapy. Diurnal variation was assessed, using ten healthy subjects, by only measuring the subjects in the morning and afternoon on five consecutive days. The mean results showed that the afternoon measurements of maximum grip were significantly higher than those obtained in the morning. No difference was found between the two times in the other measurements. The daily measurements also indicated no difference for these parameters, though the maximum grip and work results were significantly different on two days for the dominant hand and one day for the non-dominant hand. Cold treatment, an immersion in cold water at 10°C for ten minutes, caused the largest changes in both healthy subjects and patients. In healthy subjects, all measurements were affected in the dominant hand, while only pressure fall rate and time to maximum grip were affected in the non-dominant hand. In the patients only time to maximum grip, for both hands, the pressure rise

rate and fatigue, for non-dominant hands, were affected. Overall, the results were again used to show that power (and possibly work) were more suitable parameters to use in describing hand function. This was because they appeared to be more stable than maximum grip, in that no variation was found between morning, afternoon and consecutive daily measurement.

Another study of healthy subjects was performed by Fernando and Robertson (1982). Again, an inflated cuff was used. This was connected to a 900 mm column for measurement of fifty three healthy subjects. The results gave an overall mean of 400 mm of mercury with a lower quartile of 310 mm, fifth percentile of 210 mm, upper quartile 510 mm and ninety fifth percentile of 630 mm of mercury. Males were found to have a dominant hand mean of 535 mm of mercury and a non-dominant hand mean of 505 mm of mercury. For females, the means were 406 mm and 348 mm of mercury respectively. The dominant hand was found to be 6% higher for males, and 8% higher for females, than the non-dominant hand. These results basically reinforce the wide variation of measurements that are possible, otherwise nothing new was achieved and the work was just a repetition of much previous work.

Diurnal variation of grip strength was noticed in a flurbiprofen study, to determine the optimum dosage schedule, by Kowanko et al. (1982a). Sixteen patients with rheumatoid arthritis tested themselves at home using a cuff inflated to 20 mm of mercury, six times daily (0800 hours to 2300 hours) over a two to three day period. The results were fitted with a best fit sine wave of twenty four hour periodicity to show circadian rhythm. The minimum grip was found at 0600 hours as did Wright and Plunkett.

Subsequent results, Kowanko et al. (1982b), again obtained from

domiciliary self measurement, included a ten point subjective assessment of joint stiffness. These results also showed a diurnal variation (again no overnight measurement) in grip and an opposite one in joint stiffness. The minimum grip and maximum stiffness coincided at 0800 hours.

Diurnal variation was also shown by Harkness et al. (1982). Grip, using a 30 mm of mercury inflated cuff, was tested together with various other rheumatoid disease activity parameters (joint stiffness, pain and eight biochemical analyses of the immune process). Patients were tested five times daily between 0600 hours and 2300 hours. Again, a best fit sine wave analysis was used to provide a significant circadian variation in grip, joint stiffness and three of the biochemical analyses, blood neutrophil count, plasma cortisol concentration and C1q - binding assay. The C1q - binding is a plasma enzyme that controls part of the immune process. The grip minimum and stiffness maximum occurred at approximately 0400 hours and 0300 hours respectively. A substantially different result from that quoted elsewhere.

However, these results (Kowanko and Harkness) cannot be relied on as measures of circadian rhythm. Their results were only obtained between set hours of the day, therefore a diurnal measurement, and then they were extrapolated out of these limits using a best fit sine wave of twenty four hours periodicity to give circadian variation. Further, it would be difficult for patients to observe their maximum grip pressure without causing some effect on their grip. As discussed earlier (paragraph 2.2.2.) inflated cuffs are sensitive to finger jerking and other movements. A patient reading their own gauge would most probably move out of position to 'get a better view', causing a variation in grip.

Cuffs were not the only dynamic devices used to measure grip. They were mainly used in the clinical environment because of their ready availability.

Three different types of dynamic device were used by Bowers (1961) in studying the relationships between grip and several anthropometrical measurements (hand length, middle finger length, proximal phalange length, hand width and the girth of the forearm and wrist). The three devices used were the Stoelting adjustable dynamometer, the Narangansett hand spring dynamometer and the cable tensiometer. No significant correlation was found between any of the parameters and grip. Only the latter two devices produced results that were significantly different.

The contraction and relaxation phases of a maximal grip were studied by Royce (1962) using a dynamic spring loaded ergograph. Exponential equations were produced to describe the phases. Myers et al. (1980), paragraph 2.3.1., modified the equations slightly and used them in the calculations of work done and power output. The results of Royce also showed that a fatigued hand contracted and released slower than a non-fatigue hand.

The optimum span setting for a Stoelting adjustable dynamometer was investigated by Montoyne and Faulkner (1964). Using a healthy population of 138 males and 64 females, it was shown that a slight advantage could be gained by subjects with large or small hands by adjusting the span accordingly. However, no parameter, anthropometric or glove size, was found that could be used as an indicator of the optimum span setting.

Heyward et al. (1975) showed that grip measured using an isometric linear voltage differential transducer gave higher results than using a Stoelting dynamometer. A larger difference being noted

at the higher forces.

2.3.2. Isometric devices

Bechtol (1954) introduced the Jamar dynamometer. This was an adjustable span, hydraulic device for measuring grip strength isometrically. The device was used to measure 217 males and 224 females with no abnormal hand function. The majority of males (132) had their highest grip at the 2 inch span setting. The majority of females (120) had their highest grip at the slightly smaller 1.5 inch span setting. In both populations, the 1.5 and 2 inch span provided most of the highest grips. Also noted from the results was a 5% to 10% major to minor hand difference, a 30% diurnal variation, a less than 10% day to day variation and an age variation. The fifty to sixty five year old age group having a mean grip that was 15% less than the twenty five to forty year old age group.

The Jamar dynamometer was used by Toews (1964) and Schmidt and Toews (1970) to measure the grip strength of steelworkers. Both were primarily interested in showing the relationship between the dominant and non-dominant hands. Knowing this, it was supposed that, in industrial unilateral hand accidents, the amount of lost function in one hand could be assessed from the opposite good hand. Toews studied 231 steelworkers and found that on average the dominant hand was stronger by 5.8%. However, he found such a variation in this figure that it could not be used in any claim for compensation. It was found that 26% of the workers had a stronger non-dominant hand.

Schmidt extended the study to 1128 healthy males and 80 healthy females. Male grip was found to increase with weight and height up to 215 lb (97.5 kg) and 75 in (1.91 m) respectively, followed by a slight reduction. Grip reached a maximum at around thirty years old.

The female results were similar except that maximum grip occurred at about forty years of age. The results of Toews were confirmed with the male dominant hand being stronger by 3.2%, on average, and that 23% of those tested had a stronger non-dominant hand. For the female population the average difference was 8.5% with 20% of those tested having a non-dominant hand equal to or stronger than the dominant hand.

A set of data obtained from fifty healthy males and fifty healthy females was produced by Swanson et al. (1970). Grip strength was measured using the Jamar dynamometer while a small strain gauged disc dynamometer was used to measure pulp, lateral and chuck (three digit) pinch. The results were split into skilled, sedentary and manual occupations. The manual workers in both groups have the stronger grip, chuck and lateral pinch. The grip strength for males and females was highest in the thirty to forty year age group, though the male results were relatively constant in the twenty to fifty year age group. Again, the grip strength of the non-dominant hand was found to be, on average, 5.4% in males and 8.9% in females, weaker than the dominant hand. Also, 29% of the subjects measured had a minor hand grip strength that was equal to or greater than the dominant hand strength.

Isometric devices using strain gauged beams to measure the applied force have been described by Kroemer and Gienapp (1970), Malinen et al. (1979), Pearn and Bullock (1979), An et al. (1980) and Pronk and Neising (1981).

Total grip was measured in the devices described by Malinen, Pearn and Pronk. The first two required the squeezing of U-shaped beams while the third used the deflection of a cantilever.

Pearn tested 221 healthy, five to seventeen year old, children in

a two grip test (right, left, right and left again). No fatigue effect was found and the strongest hand was not necessarily the dominant hand.

Kroemer described a device to measure the thumb force at various orientations to the gripping axis. Thirty healthy male pilots were tested. The thumb force was found to increase as the thumb moved from the straight up ('thumb up') position parallel to the grip axis to flexed position perpendicular to the gripping axis.

Several devices were described by An to measure pinch, lateral deviation force and total grip. A second grip tester was used to measure the forces applied by the individual phalanges of a single finger during a power grip. Using this device four grips were necessary to obtain a full set of data for each hand. A device was also described to measure pinch, abduction (finger spread), adduction (finger close) and opposition forces. Some preliminary results were given of some studies using the devices. These studies included research into hand forces, the assessment of early scleroderma patients and pre- and post-operative measurement of patients with rheumatoid arthritis having replacement of the first carpometacarpel joint. The preliminary results of the phalanges grip force distribution of healthy subjects indicated six different types of grip. These were defined by comparing the magnitudes of the phalanges on a finger. Therefore no definite pattern was observed in the phalanges grip force distribution.

The results of the scleroderma study were given by Askew et al. (1983). Ten patients were assessed before and after, within two hours, of a single therapy session. The therapy consisted of a hot paraffin wax dip, friction massage and active exercise. Hand strength was measured using the devices mentioned above. Also measured was the

joint range of motion, skin compliance and manual dexterity (timed pick and place of objects). Each aspect of the hand (strength, motion, compliance and dexterity) had a functional index assigned. This was calculated from the measurements obtained, which were normalised to results obtained from healthy subjects and weighted, based on clinical judgement. An overall functional index was obtained by averaging all the indices. Analysis was performed on the changes found, in these indices, after the therapy. Overall, the mean changes showed a significant improvement after treatment. Askew also stated that long term assessment was difficult because of the variability of the disease. However, no long term results were presented but it was suggested that since a single therapy session improved the hand, repeated therapy would continue the trend. However, immediately after therapy, as long as there was no fatigue, a patients hand function would be expected to show improvement. They would still be warm and relaxed after the wax and massage. However, it is more important to assess how this improvement persists and to see if regular therapy does continue to improve the hand against the disease progression.

An isometric dynamometer was used by Mundale (1970) to investigate the effects of exercise on total grip strength using ten healthy subjects. The test schedule consisted of pre-exercise grip, ten minutes of exercise, post-exercise grip, four minutes rest period and finally a recovery grip. The exercise period consisted of one, two or three second duration contractions to a pre-determined level of the pre-exercise grip. A one second rest being allowed between each contraction. The results showed that the post-exercise grip was reduced even after exercise in which the contraction was only to 5% of the pre-exercise grip strength. This became highly significant at

the 20%, and above, exercise levels. Post-recovery grip strength was found to be only slightly down on the pre-exercise strength.

Using a similar apparatus, Nwuga (1975) studied the grip endurance of fifteen male and fifteen female healthy physical therapy students. The endurance was defined as the time taken for a continuous maximal grip to relax to 50% of its initial value. The results showed no significant correlation between grip strength and endurance. A positive correlation was found between grip and body weight.

Both Hazleton (1975) and Pryce (1980) studied the effect on grip strength of wrist position. Hazleton measured the forces exerted by the middle and distal phalanges, each phalangeal level being tested simultaneously on all four fingers. Thirty healthy right handed adults were measured in five wrist positions - neutral, volar flexion, dorsi-flexion, fourteen degrees of radial deviation and twenty one degrees of ulnar deviation. The results showed that the maximum and minimum forces exerted by the distal and middle phalanges were obtained in ulnar deviation and volar flexion respectively.

Pryce measured the maximum grip in nine wrist positions from neutral to fifteen and thirty degrees of volar flexion through neutral to fifteen degrees of dorsi-flexion. Very little difference was observed in the various position grip strengths though the higher measurements were obtained, as Hazleton, in the neutral to ulnar deviation and volar flexion positions.

Ohtsuki (1981a and 1981b) studied individual finger strength during unilateral and bilateral power grip exertion. The method used was to fix the forearm horizontally in a plaster cast, with the elbow at ninety degrees and the hand supinated. The cast was to eliminate movement of the forearm, palm and proximal phalanges so that only the

major flexors (digitorum superficialis and profundus) were involved in the gripping process. The four medial phalanges were connected via a leather thong and piano wire to individual strain gauged force transducers. These measured the force exerted when the fingers were flexed. The sum of the finger forces was the total power grip. During bilateral exertion the opposite forearm was similarly constrained, but the grip was measured using only a single transducer. The fingers flexed against a single bar connected to the transducer. Between ten and twelve healthy subjects were tested with their average results showing that the fingers, when flexed alone, exerted a higher force than when flexed together. The maximum force, when flexed together, decreased with the number of fingers being used. All the fingers had a major decrease when flexed with one other finger. Overall, the index and little fingers had the largest proportional decreases of 30% (both hands) when all fingers were flexed. The middle and ring fingers decreased 20 to 25% and 15% for the right and left hands respectively. Ultrasonic scanning was employed to measure the total cross-sectional area of the forearm flexors. This showed that when the areas obtained from individual finger flexion were totalled a better correlation to the flexion force was obtained, than if the areas obtained from multi-finger flexion were used. This indicated that when used on their own, the flexor tendons were used to a greater effect, i.e. produced a greater force, than when used together, thus confirming the force results.

When all the fingers were flexed together, their mean combined force was found to be $77.5 \pm 15.5\%$ and $73.8 \pm 8.5\%$ of the sum of the individual finger forces for the left and right hand results respectively. Also, when flexed together the percentage contribution, in either hand, of each finger to the total grip was

23 to 25% for the index finger, 33% for the middle, 27 to 28% for the ring and 15 to 16% for the little finger.

During bilateral exertion (Ohtsuki 1981b) a lower grip maximum was obtained than in a unilateral exertion. A difference of between 5 and 14% being obtained. This difference, which was also noted in the integrated electromyogram recorded during the grip exertion, was also proportional to the grip force.

Reikeras (1983) used a strain gauged dynamometer to measure grip strength and a piezoresistor dynamometer to measure lateral pinch (key strength). The equipment was used to measure thirty healthy males and thirty healthy females. The results were used to show that there was no significant difference between the mean results of the dominant and non-dominant hands of the subjects.

2.4. Miscellaneous Assessments

Dickson and Nicolle (1972) stated the need for an objective hand assessment. They introduced the idea that assessment at the digital level would be preferred. This was because rheumatoid arthritis can differentially affect the joints of the hand. Integrated hand tests, such as grip, would not reveal digital level involvement or its location.

They described the use of a transducer that measured finger flexion and pulp pinch force. They showed some results which indicated a post-operative improvement in both measurements. A relationship between digital force, both flexor and pinch, and bone density was later put forward by Dickson (1973). Bone density and the finger forces of fifteen healthy and fifteen patients with rheumatoid arthritis were measured. The bone density was measured using X-ray techniques. The results obtained were used to show a correlation

between the pinch force and cross-sectional area of both the metacarpels and proximal phalanx (cross-sectional area having previously been shown to be related to bone density). Dickson concluded that bone density was another parameter that could be measured that would give an indication of the disease progress or hand function.

These two papers were summarised by Dickson and Nicolle (1976) and again showed some results that had post-operative improvement in finger flexor and pinch force. Only operative procedures were investigated and it appeared that no long term post-operative monitoring of the patient was attempted.

Brand (1973) outlined a partial evaluation to be used in treatment monitoring on a day to day basis. It was suggested that range of motion, swelling, temperature of the hand and grip strength should be measured and a series of photographs taken to record the hand shape.

Jacobson and Sperling (1976, 1977 and 1978) and Sperling and Jacobson (1977) presented a series of papers outlining their work on a detailed hand grip classification. They designed a system where subjects were filmed using a mirror reflection method that enabled three projections to be recorded simultaneously. From the film, and using a specifically designed coding system, a very detailed description of the hand was obtained. The coding system described the hand grip used by designating which fingers were being used, their positions, the finger joint positions, the contact surfaces and the orientation of the object being held. The system was used to study healthy hands during a simulated meal and using the Rancho Los Amigos (RLA) hand test apparatus. This was designed to test a patient's ability to handle objects. It consisted of grasping and lifting

various sized objects (cubes and spheres), gripping and sliding a vertical tube on a cylinder, pinching various diameter balls between the thumb and each finger, placing a metal slab on a spike and holding a flat iron by its handle. The simulated eating experiment was used primarily to obtain a detailed knowledge of the various hand grips used in an ADL. The results confirmed the premise that the main factor in determining the grip used was the action to be performed (Napier 1956). When the results of the RLA test were analysed and compared to the simulated meal, they revealed that the intended method of handling the objects were not typical of daily life. Also, when handled spontaneously the objects were handled differently from that intended, and that the test did not include the most frequently used hand grips from daily life. Therefore, the RLA test did not appear applicable as an ADL test and to be of any use in assessing patients, the assessment routine must be based on functional activities. This would appear obvious, but hand assessments do include this type of testing i.e. moving objects. The above results therefore confirm that these assessments are not testing what they intend to test.

The above system is clearly, as the authors state, only a research tool. It would be too cumbersome to have as an everyday clinical tool. The classification system would have to be fully automated first. But it does provide the faculty for the detailed analysis of hand grips for healthy and diseased hands. From the accumulation of this detailed data it may be possible to obtain a deeper understanding of the underlying processes involved in the progression of the disease. Knowing these processes would enable more effective treatment to be given.

Purves et al. (1980) and Purves and Berme (1980) described an

assessment that measured joint range, pulp pinch force and the torque applied to turn a key. Also included were timed activities of filling a container with sand, using a spoon, folding paper and inserting it into an envelope and button and zip fastening. This was used to follow patients with arthritis after joint replacement. The pinch results showed a peak after six weeks followed by a gradual decline. The key torque gradually increased to a plateau. However, the primary interest of the work was a simulated tap and jam jar lid. From this, by using markers attached to the phalanges and orthogonal filming, the applied torque could be measured and the three-dimensional moments about the MCP and PIP joints calculated. The results showed that moments as high as 3.2 Nm could be encountered in a joint. These results are especially important to endoprosthetic designers.

2.5. Summary

This review has shown the effort which has been expended on all aspects of hand assessment. Many studies have been carried out into power grip, using both cuffs and force transducers. However, several of these just repeated previous work with no indication of extending the work. Other studies were carried out to collect basic information and required further study to evaluate whether they contain any detail relevant as an indicator of patient condition.

Even though improved force transducers have been around for a long time, the cuff was still widely used in clinical assessment. Even up to the present, results were still being published on work with them, Fernando and Robertson (1982).

All the hand assessments put forward lack the basic qualities for quantitative measurement, therefore an objective assessment is

still lacking. Latterly, the methods used to test manual dexterity i.e. timed pick and place, have been shown to be measuring untypical hand grips. The results from the assessments have shown very little. The assessments themselves have been used in the wrong way, primarily being used for population studies and finding normal ranges. They have not been used at the individual patient level, which they must be capable of, if they are to be of any use. No important information could be obtained if comparison to a normal population is all that was performed. No effort appears to have been made to close this gap and produce an assessment capable of individual patient monitoring.

2.6. Objectives

Hand assessment equipment for use in the clinical environment should be designed to reduce much of the subjectivity inherent in previously reported methods. It should comprise a blend of basic strength measurements together with some simulated functional tasks. Some basic strength measurements which have been shown to be of use clinically are total grip strength, pulp pinch, lateral pinch and finger extension force. An important feature of the total grip strength should be the simultaneous measurement of individual finger strength to help diagnose causes of finger dysfunction.

After consultation with the occupational therapists pan lift, kettle lift, key twist and cloth wringing out simulations were chosen as typical functional tasks because of their familiarity to patients and rehabilitation staff as well as for their functional differences. The hand is rarely used in isolation, but usually forms part of a combined movement involving interactions of the shoulder, elbow and wrist. Therefore functional assessments, to be realistic, should contain tasks that reflect this interdependence. Lifting a pan not only requires a power grip on the handle but also involvement of the wrist and elbow. The kettle lift however, requires much less gripping of the handle but relies substantially more on shoulder activity. The key twist involves a precision type grip with a simultaneous axial rotation of the wrist while the task to simulate the wringing out of a cloth requires a simultaneous power grip and wrist flexion. In the pan lift and kettle lift there should be simultaneous measurement of the handle grip and lifting forces while in the two twisting tasks the resultant torque needs to be measured.

These functional simulations would be a great improvement on previous assessments because they would be more quantitative. They would rely on the measurement of the applied forces and not on timed tasks as used by Carthum et al.(1969), Jebsen et al.(1969), MacBain(1970), Kellor et al.(1971), Clawson et al.(1971), Smith(1973), Peskett(1973 and 1977), Green(1974), Bell et al.(1976), Walker(1978) and Purves et al.(1980) (A similar key meter was included with timed tasks by Purves). An additional advantage is that the measurements obtained from this system would be recorded during a single trial, therefore substantially reducing the effects of patient fatigue.

A further development would be the linking of the measuring devices to a microcomputer, which would control all the devices and record their output. In this way a significant reduction in the inter-observer variation would be achieved and hence a reduction in the subjective element of the assessment.

For completeness an arthrograph, for measuring the stiffness of the index finger about its metacarpophalangeal joint, was also linked to the microcomputer. However, the results from this form the basis of a separate study and therefore they will not be included here. To help in following the circuit diagrams a brief description of the arthrograph will be given since it was interfaced to the microcomputer and electronic circuitry as part of this work.

As the hand assessment equipment is intended for use in the clinical environment, the software for the computer ought to be written with a 'user friendly' approach, to ensure that occupational therapists, physiotherapists, clinicians and surgeons could use and understand the system without requiring extensive training. To this end instructions would need to be displayed in easy to follow steps with the minimum amount of operator interaction. When operator

action is required a correction message routine should be included to warn of unreasonable responses. The microcomputer would also be used to perform all necessary calculations and to display the results in an easy to understand format.

Initially, healthy subjects would be measured to ensure the robustness and reliability of the equipment in use, the reliability of the software and that the necessary range of measurement is possible. This group would also serve to evaluate the accuracy and reproducibility of the system.

These results would then be compared with the results obtained from patients attending various rheumatology clinics to demonstrate the ability of the system to register large differences between the two populations.

Finally, patients would be monitored over a period of several months, throughout their period of treatment, to demonstrate the capability of the system to register small changes in individual patient performance.

CHAPTER 3

APPARATUS

APPARATUS

The apparatus, shown in Plate 3.1., developed in this work can be divided into three parts:-

- i) the measuring devices
- ii) the electronic circuitry
- iii) the computer

The measuring devices consisted of a series of strain gauged force measuring transducers arranged in several hand measurement devices. These were connected to various electronic circuits, which were used to condition the bridges, amplify their output, routing their signals through selected paths and converting them to digital form. The computer controlled the whole system by switching in the correct circuitry for the measuring device required. It then collected and displayed, on its monitor, the results calculated from the collected data. This data could then either be discarded or stored on magnetic disc.

3.1. Measuring Devices

There were four basic measuring devices used in this work, these were:-

- i) Isometric power grip
- ii) The pan
- iii) The kettle
- iv) The key unit

3.1.1. Isometric power grip and finger force measurement (Plate 3.2.)

This consisted of an aluminium heel plate, shaped to fit comfortably into the palm of the hand, and a key board containing four transducers to measure the applied finger force. Each transducer was a 15 mm x 10 mm x 3 mm mild steel cantilever rigidly clamped into the aluminium body of the key board. Onto each



PLATE 3.1. Full view of apparatus

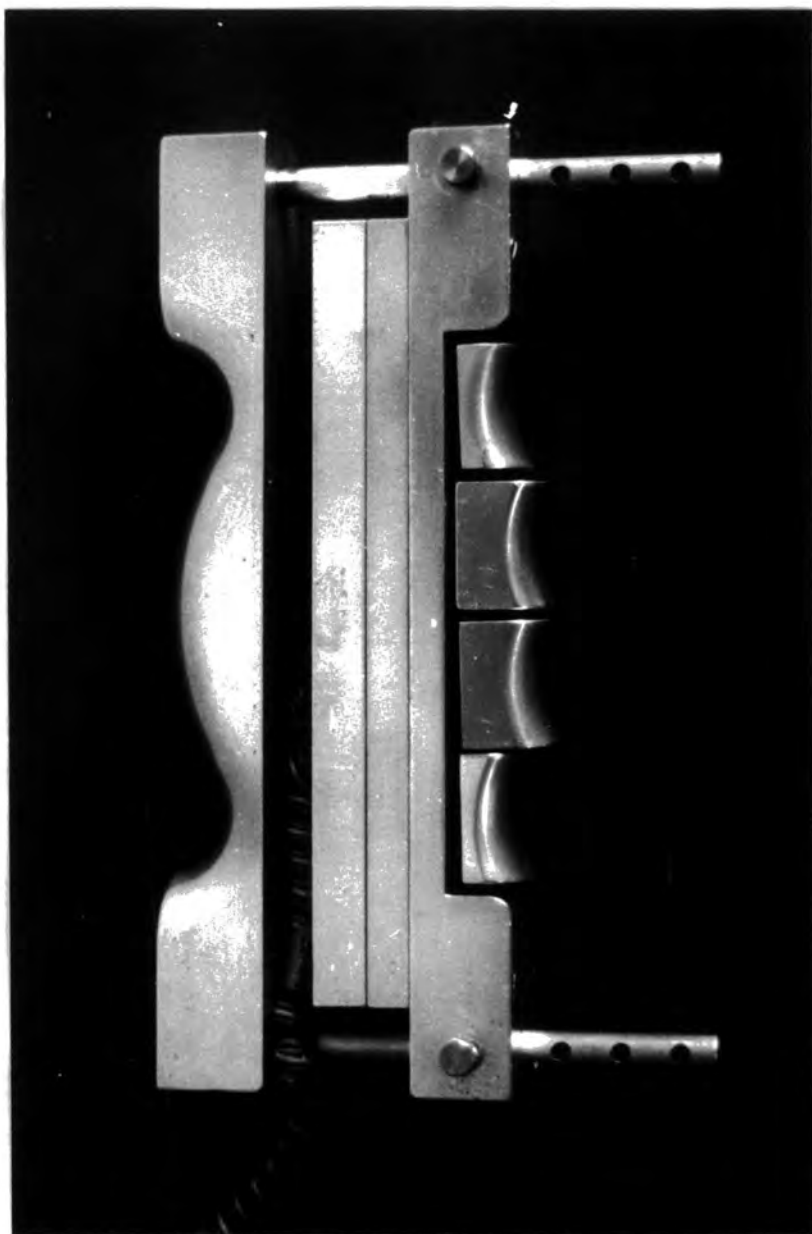

PLATE 3.2. Power grip device

cantilever were secured four strain gauges in a full bridge configuration for maximum sensitivity.

Force, from the fingers, was transferred to the corresponding cantilever via a button and push rod assembly. Each push rod located into a shallow depression on the cantilever to ensure that the force was applied on the same point hence maintaining the same moment axis (Figure 3.1.). Each finger button was contoured in two planes. They were saddle shaped to provide a comfortable contour, with no sharp edges, for the finger to wrap around. The buttons were free to rotate to accommodate some deformity of patients' hands.

The relative position of the heel plate to the key board was adjustable, in 12.5 mm steps. This was achieved by pins which held the key board to two guide bars that were fixed at either end of the heel plate. This enabled the device to be altered from a minimum span of 65 mm to a maximum of 100 mm (as measured across the widest part of the device).

3.1.2. Pan handle grip force measurement (Plate 3.3.)

This consisted of a hollow aluminium body externally shaped as a typical pan handle, fastened to a milk pan body. Inside the handle were two rigidly clamped mild steel cantilevers of size 15 mm x 5 mm x 3 mm. Each cantilever had two strain gauges secured to it; all four being connected in a full bridge to achieve maximum sensitivity.

One side of the handle was free to move in linear bearings sited at each end of the main body. These bearings ensured that any movement of the free side was perpendicular to the cantilevers. Force was transmitted to the cantilevers via two small push rods fastened on the inside of the free handle. Figure 3.2. shows the

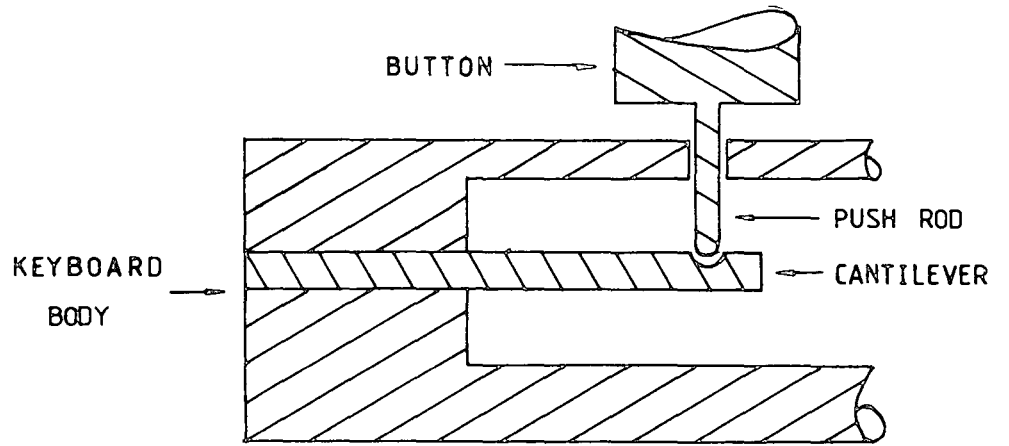

FIGURE 3.1. Detail of button and push rod assembly
in power grip device

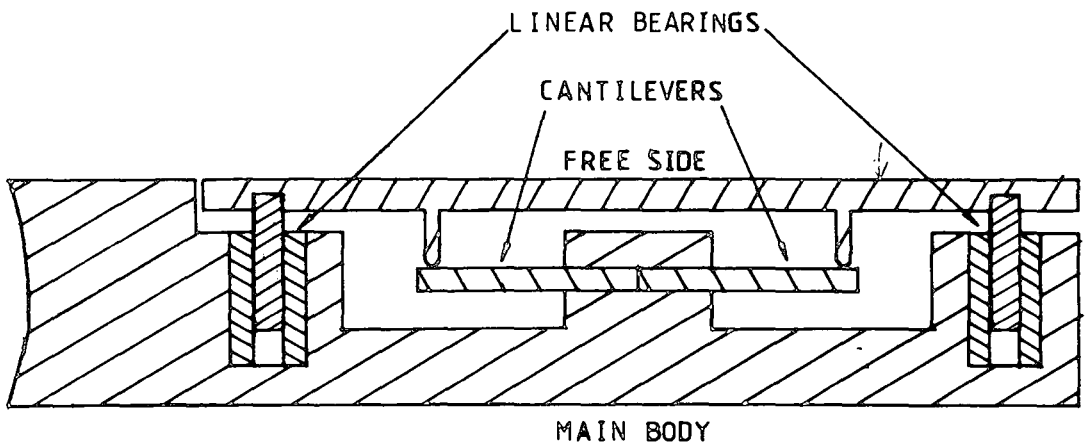

FIGURE 3.2. General detail of the pan handle



PLATE 3.3. Pan and kettle device

general details of the pan handle.

3.1.3. Kettle handle grip force measurement (Plate 3.3.)

The handle consisted again of an aluminium body, shaped as a typical kettle handle. This was fastened to same milk pan body as the pan handle, in order to utilise the same lifting force measurement transducer arrangement (see following section, 3.1.4.). The top face of the handle was free to move, and a push rod on its underside acted against a rigidly fixed mild steel cantilever of size 30 mm x 10 mm x 3 mm. Perpendicular movement of the top face was ensured by constraining it in roller bearings, fastened at either end of the handle (Figure 3.3.).

Four strain gauges were attached, in a full bridge configuration, to the cantilever.

3.1.4. Lifting force measurement (Plate 3.4.)

This consisted of two aluminium cantilevers, 15 mm x 10 mm x 2 mm, one fixed parallel to the pan base and the other fixed parallel to a rigid base. Each transducer was connected by a twin-rate spring in order to limit the lifting movement over a large range of lifting force. For weak patients a low rate spring was necessary in order to provide a small amount of lifting movement. This spring was limited in movement by a cable, which stopped any plastic extension of the spring when used by the stronger patients. A stronger spring then took over limiting the lift movement. A safety chain was also included to protect the transducers, the high rate spring and the electrical connections from extreme movement. Each cantilever was attached with four strain gauges in the usual full bridge configuration for maximum sensitivity.

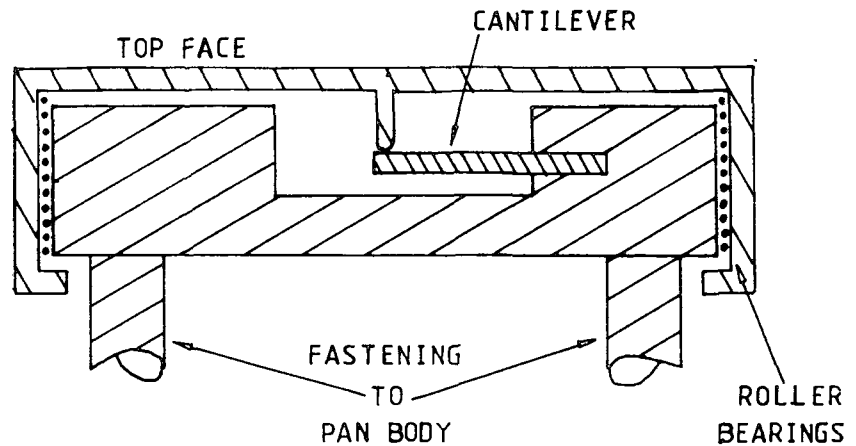

FIGURE 3.3. General detail of the kettle handle

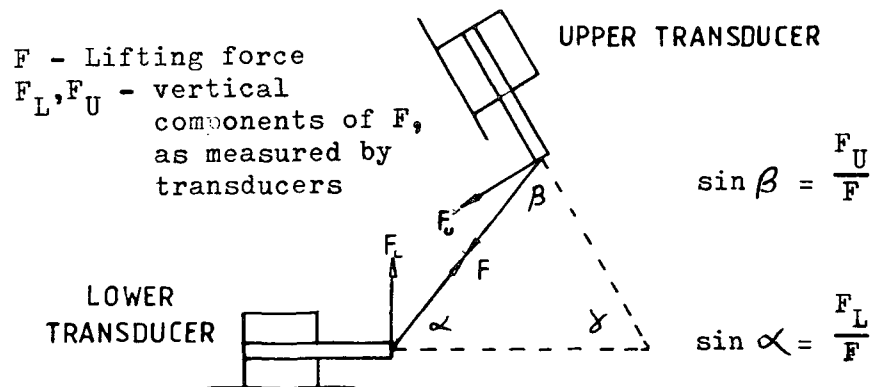

FIGURE 3.4. Calculation of pan body tilt and direction of pull

Direction of pull, $\alpha = \sin^{-1}(F_L/F)$

Angle of tilt, $\gamma = 180 - \alpha - [\sin^{-1}(F_U/F)]$

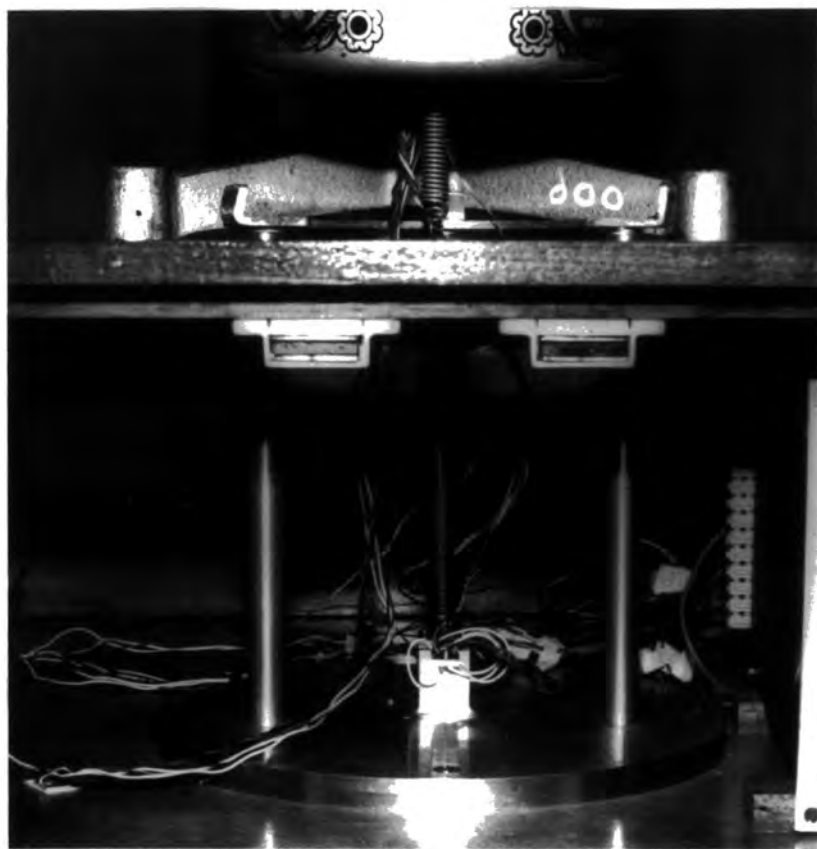

PLATE 3.4. Lift measurement

Initially, it was thought that this arrangement would be satisfactory. Unfortunately, the lifting techniques used were so variable, including variable degrees of pan body tilting and horizontal movement. This ensured that it was not always possible to obtain the true lifting force.

To improve this situation a third U-beam transducer, with a full bridge configuration was made up and tried, successfully, at the end of the project. This was located between the two restraining springs and therefore enabled a direct measure of the lifting force. With this new arrangement it will be possible, from the recorded forces, to calculate the angle of pan body tilt and the direction of pull of the lift (Figure 3.4.).

Plate 3.4. shows the rigid aluminium framework used to support the pan body and lift force measuring transducers. The pan rested on a 270 degree arc of aluminium connected by three legs, 12.5 mm diameter and 165 mm in length, to a bottom plate of 200 mm diameter and 10 mm thickness. The lower transducer was secured to this plate, which in turn was fastened to the top shelf of the wooden cabinet shown in Plate 3.1. This ensured that the pan was at a height, 910 mm, which is typical of a kitchen work-top or cooker.

3.1.5. Key unit (Plate 3.5.)

This device was designed by A Robertson (1981) as a final year project to investigate the variation of lateral pinch force and the torque, that the hand - wrist can apply to a simulated key, with pronation and supination.

The torque was measured using two full bridge strain gauged aluminium tubes, of different cross-sections to give two sensitivities of measurement. This allows accurate measurement of subjects of low

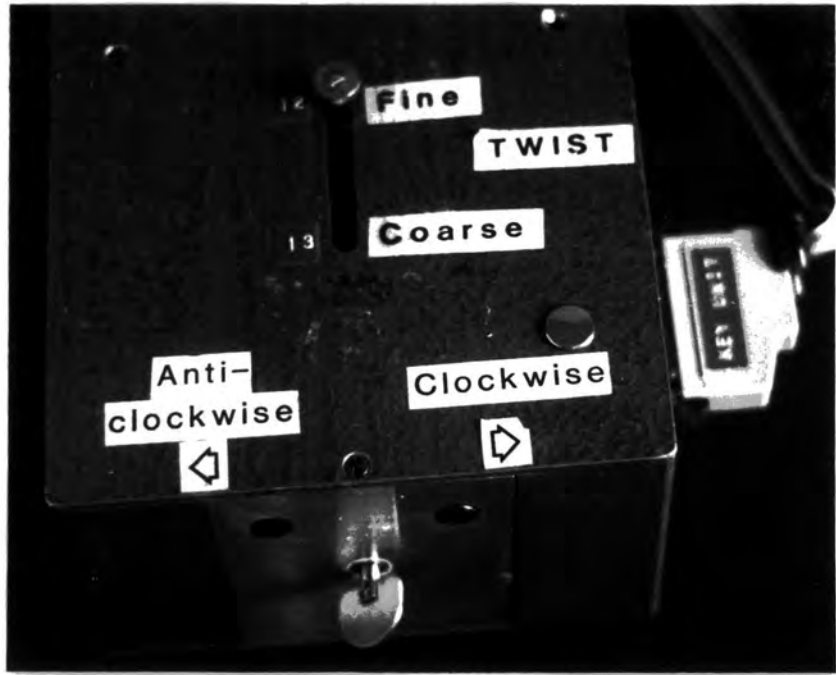

(a)



(b)

PLATE 3.5. Key unit a) key b) pinch

and high strength. A sliding ratchet mechanism was used to select the correct sensitivity and to fix the key at set angles, in fifteen degree steps, of pronation and supination.

Figure 3.5. shows the arrangement to measure the lateral pinch force. The applied force caused the bending of two aluminium cantilevers which were rigidly fixed together at one end. Strain gauges, in a full bridged configuration were secured to one cantilever for force measurement. Two sensitivities were arranged by having two devices; one with a smaller cross-section of cantilever for higher sensitivity.

The two pinch transducers were connected through gears to the torque tube. This ensured that the platens had the same rotation as the key.

3.1.6. Key unit attachments

Three attachments were designed to fix to the key unit to measure other parameters of hand function.

a) Tube twist

This consisted of two 150 mm long smooth tubes of 30 mm and 80 mm diameter, which were slotted over the simulated key. These could be twisted horizontally or vertically. Horizontally they could simulate a cloth wringing-out activity, while vertically they could be used to simulate container lids. The small tube representing say a bottle cap while the large tube could represent a jam jar lid.

b) Extension force

All the devices detailed so far have only involved finger flexion. To obtain a measurement of finger extension force a flat wooden block

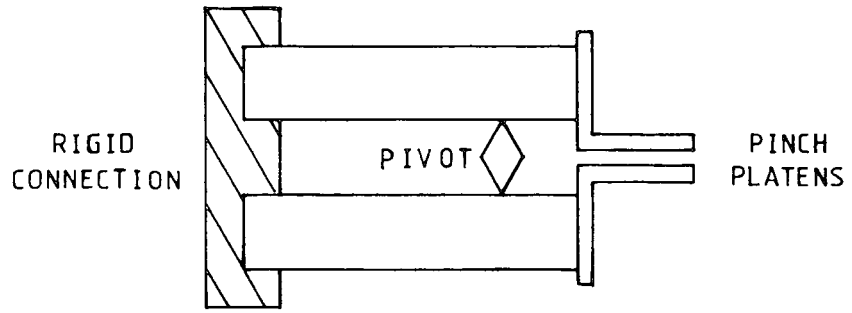

FIGURE 3.5. Arrangement of pinch measuring transducers

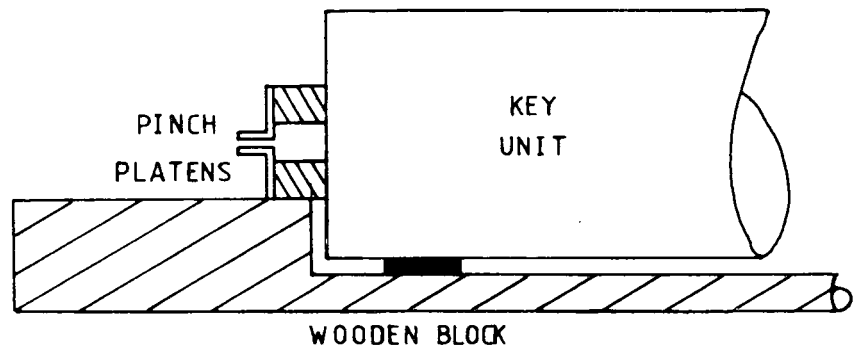

FIGURE 3.6. Arrangement of extension force measurement

was placed in front of the key unit so that the horizontal pinch platens were resting on the block (Figure 3.6.).

3.2. Electronic Circuitry

Figure 3.7. shows the basic system for obtaining the force detected by a single strain gauge bridge. To ensure that the amplifier has zero output at zero applied strain, the resistive unbalance, due to variations in the resistances of the strain gauges, was eliminated. These variations were caused by the manufacturing process and the fixing of the strain gauges to the cantilever. The balance was done by the bridge conditioner. The excitation voltage (5 V r.m.s. at 5 kHz) and quadrature (capacitive) unbalance control was provided by the amplifier.

When strained, the strain gauge bridge provided a few millivolts imbalance. The amplifier removed this from the carrier frequency of the excitation voltage and raised it to a few volts. This signal was then converted from this analogue form to a digital form by an eight bit analogue to digital converter (ADC). This digital signal, a number between 0 and 255, was transferred to the computer on eight lines, each line representing one bit of the digital code. The computer then converted this code to the applied force using the calibration factors stored in its memory.

In practice, the conditioning unit accepted up to ten bridge circuits and using relays it switched all four bridge connections simultaneously. The unit provided individual bridge balancing and manual or automatic selection of the bridge circuits. Automatic selection was achieved by using logic control signals from the computer. Bridges not selected were supplied with a current to reduce any 'warming up' effects of the strain gauges on selection.

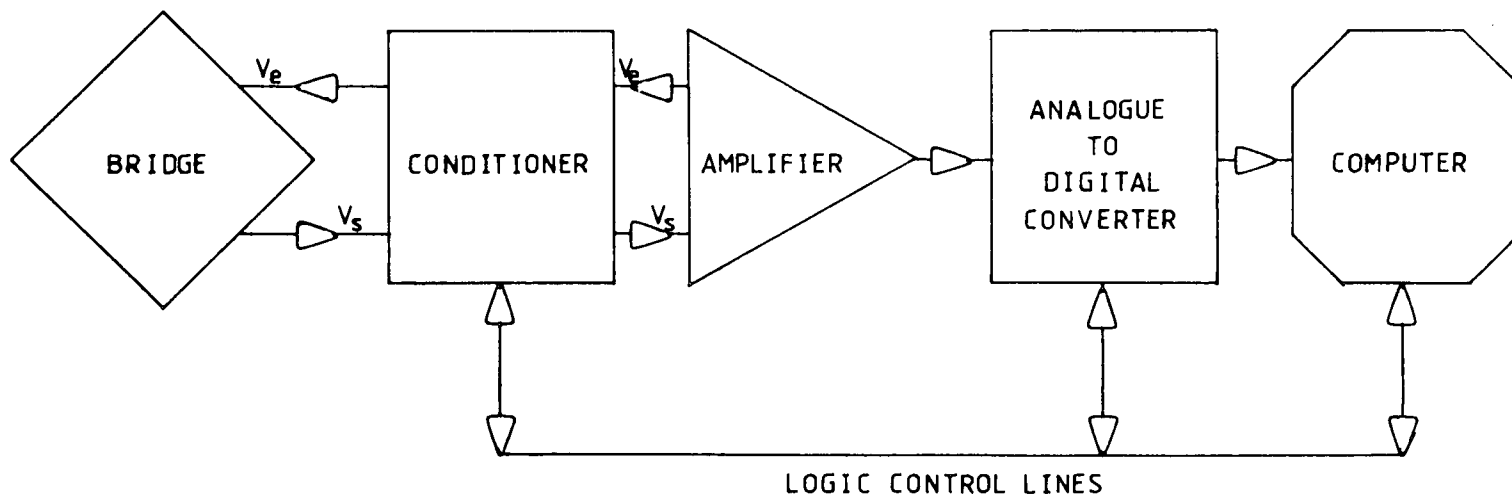

FIGURE 3.7. Schematic diagram of basic electronic circuitry

When selected, a bridge was connected directly to the amplifier. Any imbalance produced by straining the bridges was amplified to give an output, proportional to the applied strain, in a 0 V to 10 V range. A voltage divider circuit then reduced this to a 0 V to 2.5 V range; 2.5 V being the maximum rating of the ADC.

Initially, ten channels were sufficient because the individual devices on the key unit were manual selected (Figure 3.8.a). This proved to be a cumbersome arrangement, so a second 4-channel conditioning unit was built up using analogue semi-conductor switches instead of relays. This then allowed auto-selection of the key unit devices and independent balancing (Figure 3.8.b). The use of semi-conductor switches caused a reduction in sensitivity of the devices because of the inherent residual resistance when the switch was 'on'.

An eight input multiplexer was inserted between the amplifier and ADC. This allowed the sampling of signals other than from the strain gauge bridges. It was primarily inserted to allow the interface of the finger arthrograph (see paragraph 3.4.) with the system.

The multiplexer output was connected to the ADC input and to a voltmeter for visual monitoring of the amplified signal. The ADC output was connected via an eight line bus to an interface port in the computer. Figure 3.9. shows a schematic diagram of all the electronic circuits and the associated logic lines used to control the switching (paragraph 3.3.). The electronic circuitry was installed on the shelves of the wooden cabinet used to support the pan and kettle devices (Plate 3.1.).

The amplifier (Type 2028A), 10 channel conditioning unit (Type 2063) and power supply with voltmeter (Type 2034) were

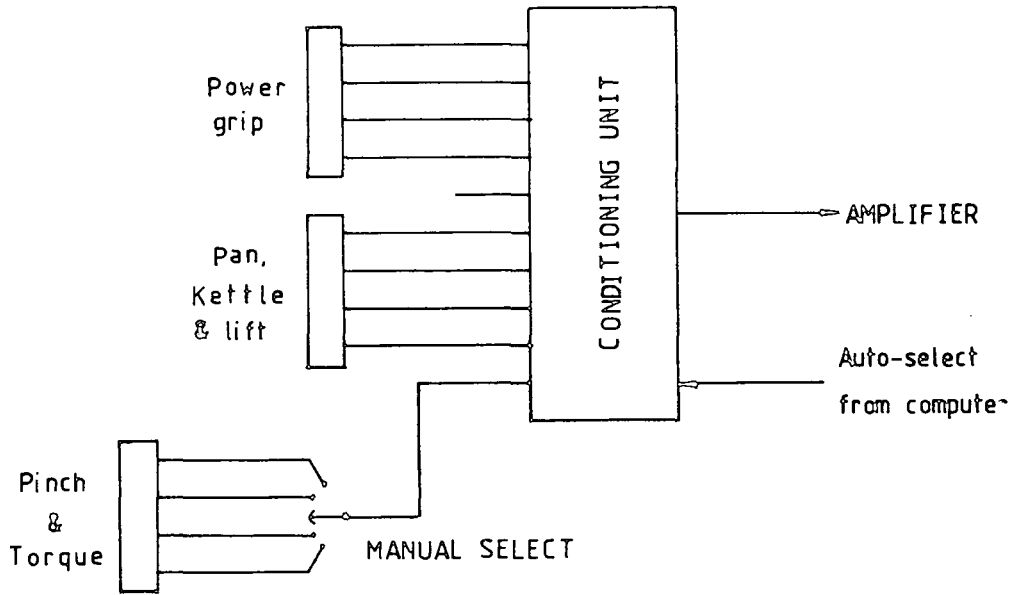

(a)

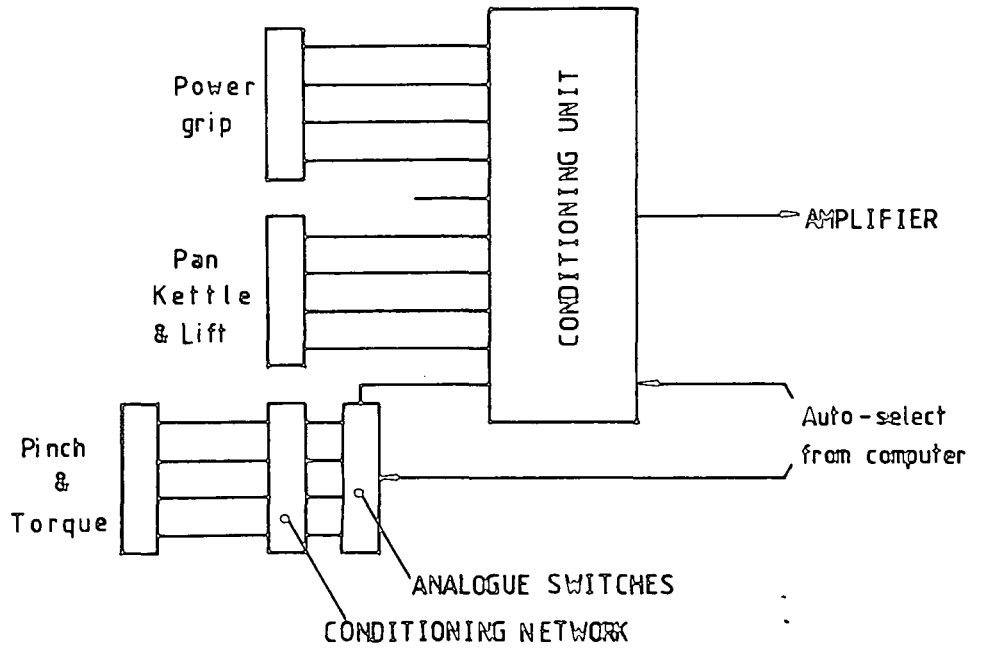

(b)

FIGURE 3.8. a) Manual selection of key unit devices

b) Automatic selection of key unit devices

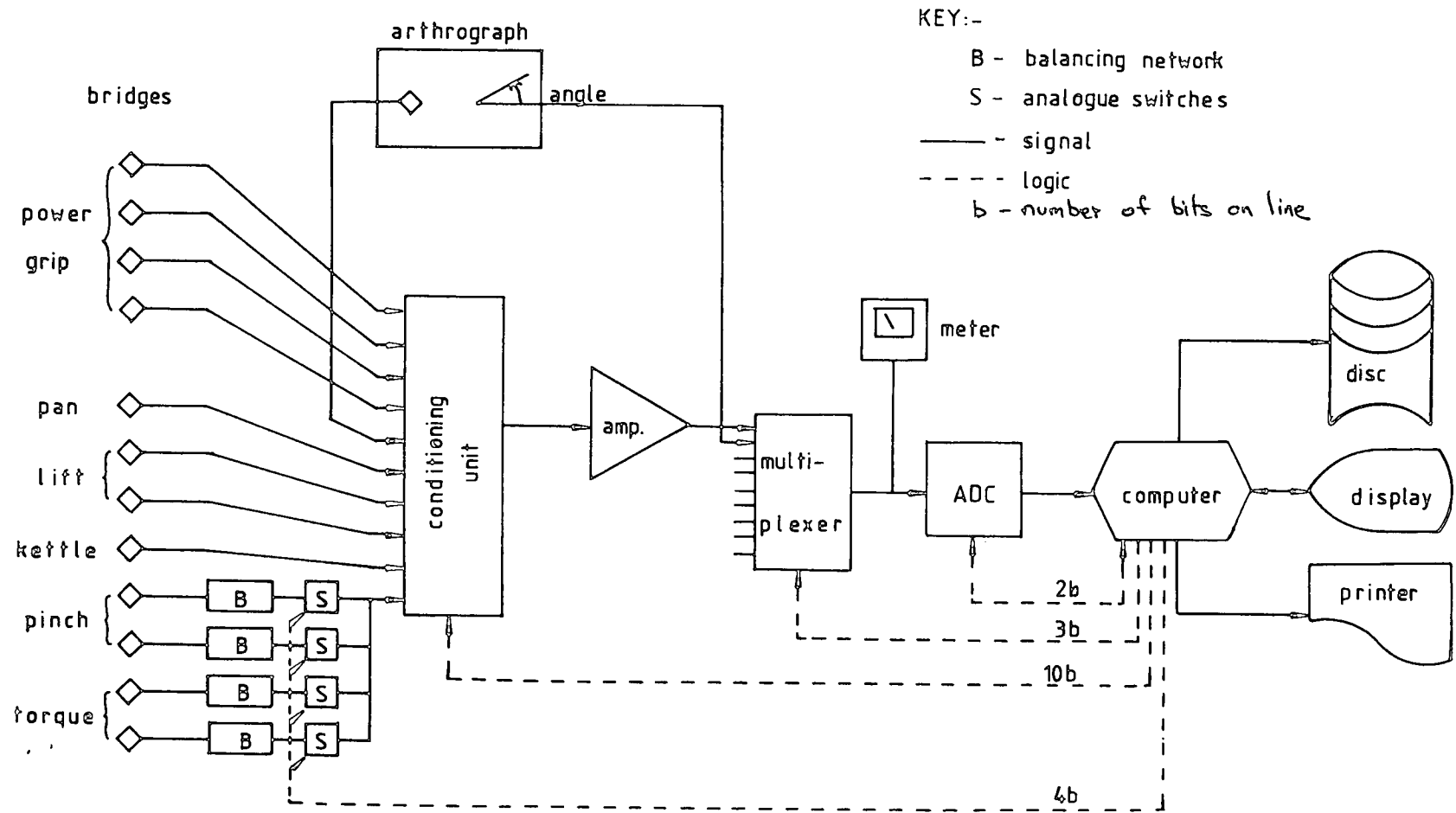

FIGURE 3.9. Schematic diagram of the electronic circuitry and logic lines

purchased from RDP Electronics Ltd., Wolverhampton. The rest of the circuitry was constructed during the course of the project. The circuit diagrams appear in Appendix 2.

3.3. Computer

This was an Apple Europlus II 48K microcomputer, supplied by Dawne Instruments, Gateshead. A display monitor, paper printer and two magnetic floppy disc drives completed the computer system. The computer and its peripheral devices can be seen in Plate 3.1.

In order to use the computer to control the system it had to be interfaced to the electronic circuitry. This was done using a Type D109 digital interface card supplied by Data Efficiency, Hemel Hempstead. The card plugged into a socket in the rear of the computer, providing thirty two separate lines for data transfer (input or output) and eight control lines to supervise the transfer. The computer, via its software, transmitted the required logic signals, to select the correct transducer, to the multiplexer and both conditioning units.

Data from the ADC, which also required controlling with logic signals, was directed to the memory registers of the D109. The software retrieved this data and after processing it, displayed the results in graphical and numerical form on the monitor. The results were also printed out on paper and stored on floppy disc. A fuller description of the operation of the D109 interface card is given in Appendix 3.

3.4. Arthrograph (Plate 3.6.)

During the course of the project it was decided to interface a finger arthrograph to the system. The arthrograph (Unsworth et al.

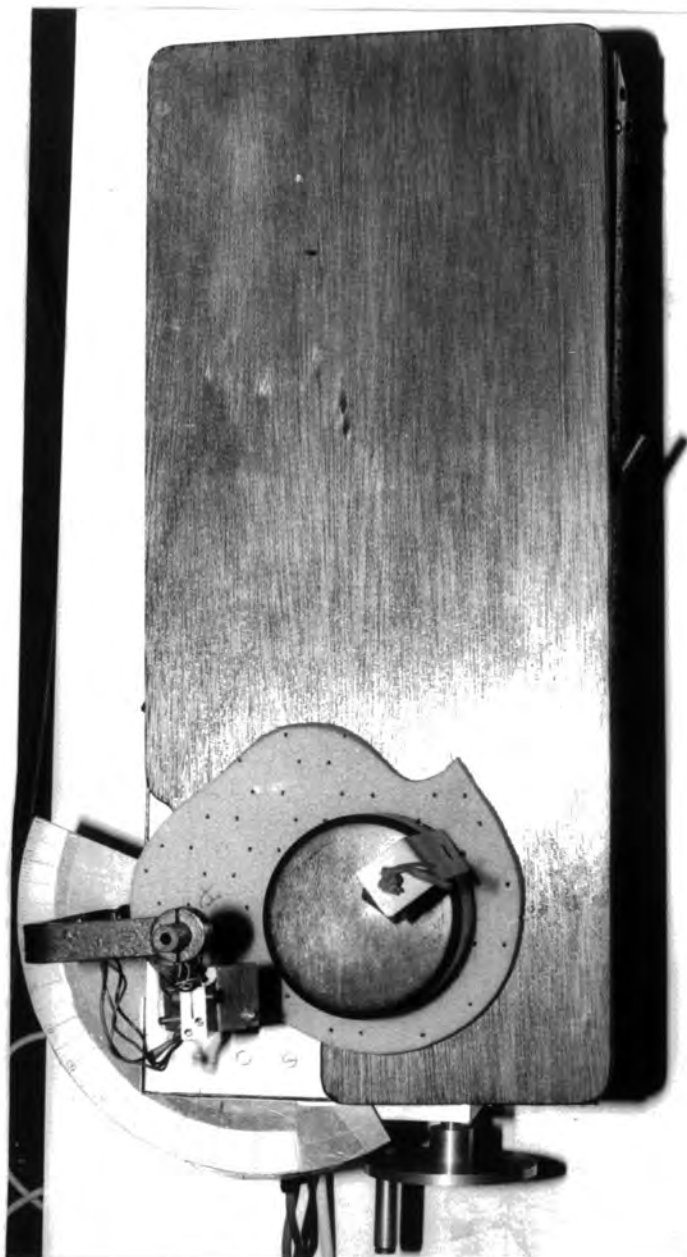

PLATE 3.6. Top view of arthrograph

1982) was used to measure the stiffness of the metacarpophalangeal (MCP) joint of the right hand index finger (Yung et al. 1983). The stiffness of the MCP joint was defined as the torque required to move the finger a known angular distance, in either flexion or extension, from its equilibrium position. This was the angular position of the finger where no flexor or extension tendon forces acted.

The forearm rested on top of the wooden platform with the fingers (except the index finger) wrapped loosely around the circular block. The index finger was secured by an elastic sling to an inverted 'V' holder (Plate 3.7.). This holder was oscillated over ± 4 degrees at a frequency of 0.1 Hz, and could be placed in any finger position from five degrees of extension to seventy degrees of flexion. The centre of rotation of the holder was aligned with the centre of rotation of the MCP joint using a small plastic tool that fitted over the MCP joint. The holder was connected to its axis of rotation by a full bridged strain gauged stainless steel cantilever. This measured the torque required to move the finger through the oscillation.

Angular position of the finger was measured using a potentiometer fastened to a main drive pulley. This was used as a voltage divider with the output being proportional to the angular position. In the first instance the arthrograph was connected to a flat bed XYt recorder; the torque and angular positions being platted on the vertical and horizontal axis respectively.

The finger was oscillated at ten degree intervals as it was moved from extension to flexion and vice versa. Figure 3.10. shows a typical recording obtained. Direct measurements from the recordings included finding the area of each loop, using a planimeter, which was

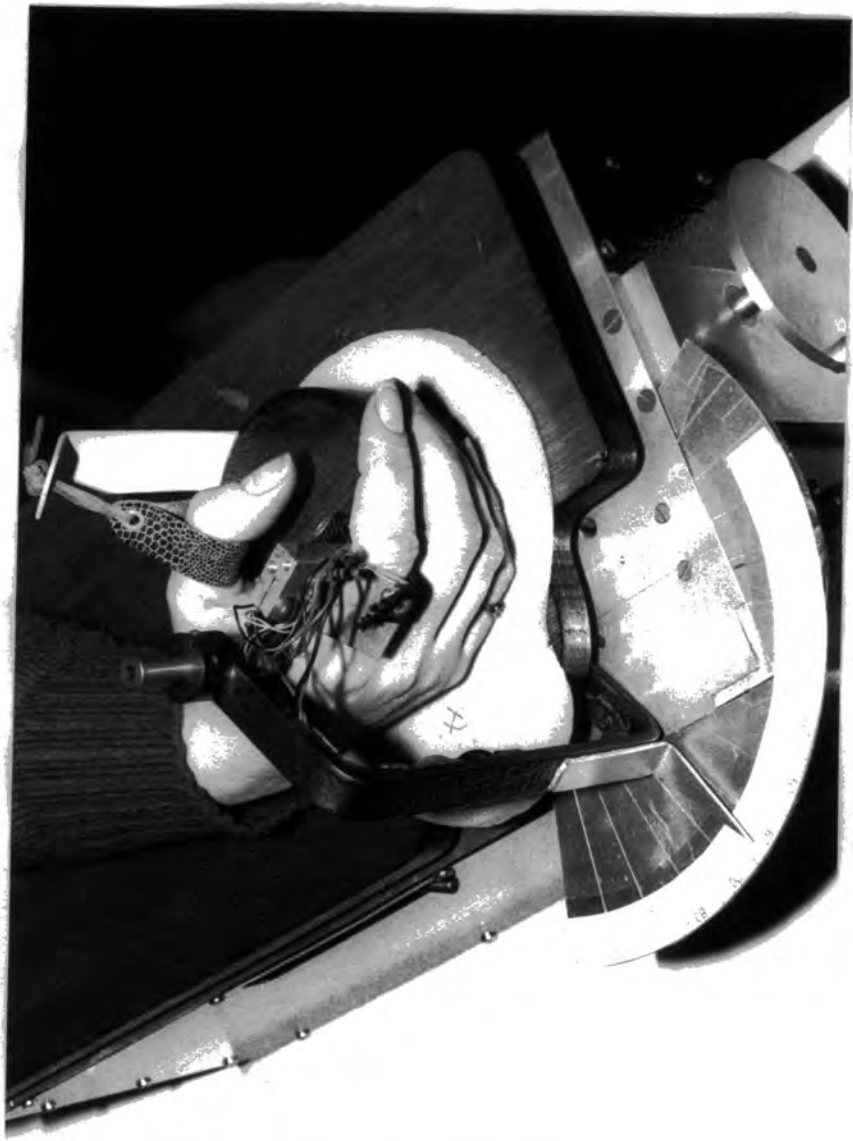

PLATE 3.7. Arthrograph finger holder

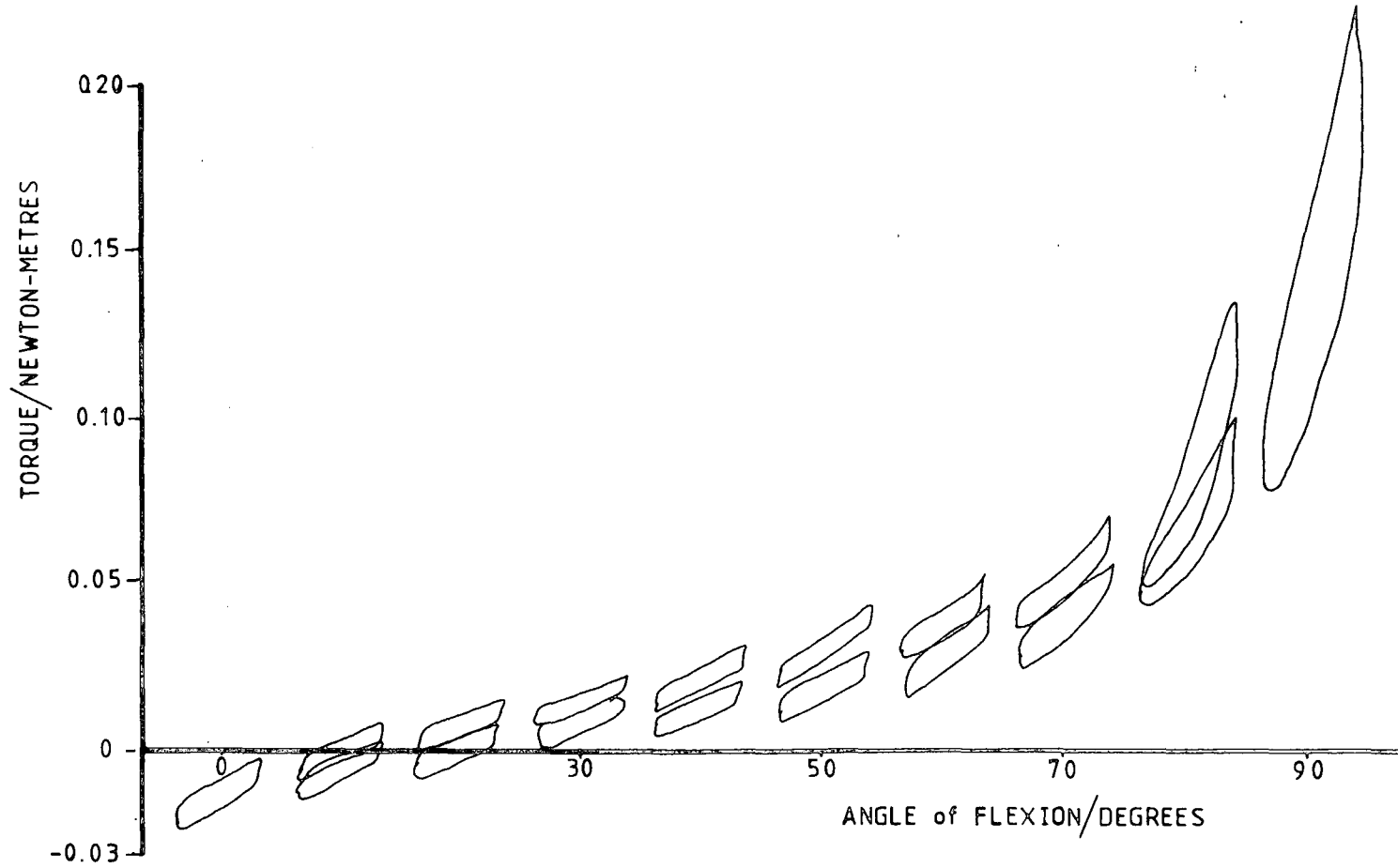

FIGURE 3.10. Typical arthrograph trace

the energy loss of the finger during movement. The equilibrium position and stiffness for flexor and extensor movements were obtained by joining the mid-points of each loop. Where this interpolation crossed the zero torque axis was the equilibrium position for that motion. Stiffness of the joint was obtained by finding the interpolated torque a fixed rotation from equilibrium.

By interfacing the arthrograph to the system, some of these tedious measurements and calculations could be done automatically. The interfacing was carried out by connecting the strain gauged bridge to the ten channel conditioning unit and the angular position potentiometer to a multiplexer channel. A program was written to control the electronic circuitry and to calculate all the results.

During initial trials of the interfaced system, the accuracy of the angular position potentiometer in measuring finger position, and hence the energy loss calculation, was found to be too restricted. This was because the potentiometer was used to measure both the overall position in flexion or extension (a seventy five degree range) and the position during oscillation (± 4 degrees). While this arrangement was satisfactory for the overall position and for recording on the XYt recorder, the position during oscillation was inaccurate. This was because the voltage change over this small range was too small and produced insufficient variation in the ADC output.

To remedy the situation, a second potentiometer was added. This was fastened to the transport cradle and driven directly by the scotch yoke mechanism using a rack and pinion. A schematic diagram of the arrangement is given in Figure 3.11. Due to the gearing, this second potentiometer moved over a ninety degree oscillation thus providing a much more satisfactory voltage change and hence improving the accuracy of the oscillation position and energy loss.

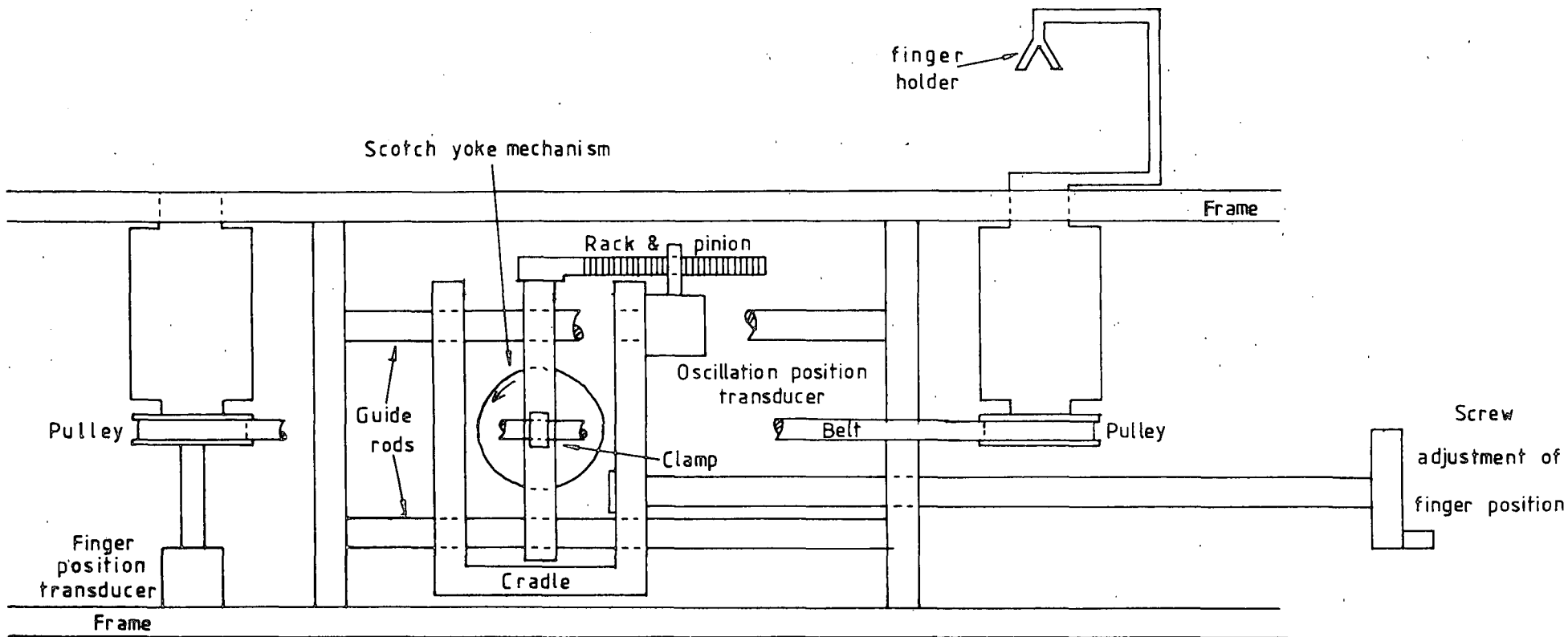

FIGURE 3.11. A diagram of the arthrograph drive mechanism

The first potentiometer was still required to measure the overall position because the second potentiometer's rotation was constant and did not vary with finger holder position. It was also used to drive the XYt to obtain a complete recording of all the measurement loops. The interface of the arthrograph with the rest of the system is shown in Figure 3.12.

At the same time as this modification it was realised that a further improvement in the operation could be obtained by increasing the amplitude of oscillation to twenty degrees. From an initial arbitrarily chosen position the finger was oscillated and since the finger now travelled through a large angle it would most probably pass through the equilibrium positions. These were then located using the computer and the finger holder moved so that it oscillated about the mean equilibrium position.

Prior to using the computer no easy method was available for finding the equilibrium positions. That was why several loops over a large angular range of finger movement were required. As the finger now oscillated about its equilibrium position a direct measure of MCP stiffness and energy loss was obtained. Also direct subject comparison would be possible as all subjects would be measured from the same anatomical position.

3.5. Software

3.5.1. Hand assessment

The software required to the system required three principal features.

a) Electronic circuit control was required to switch in the correct force transducer and its corresponding circuitry as and when required.

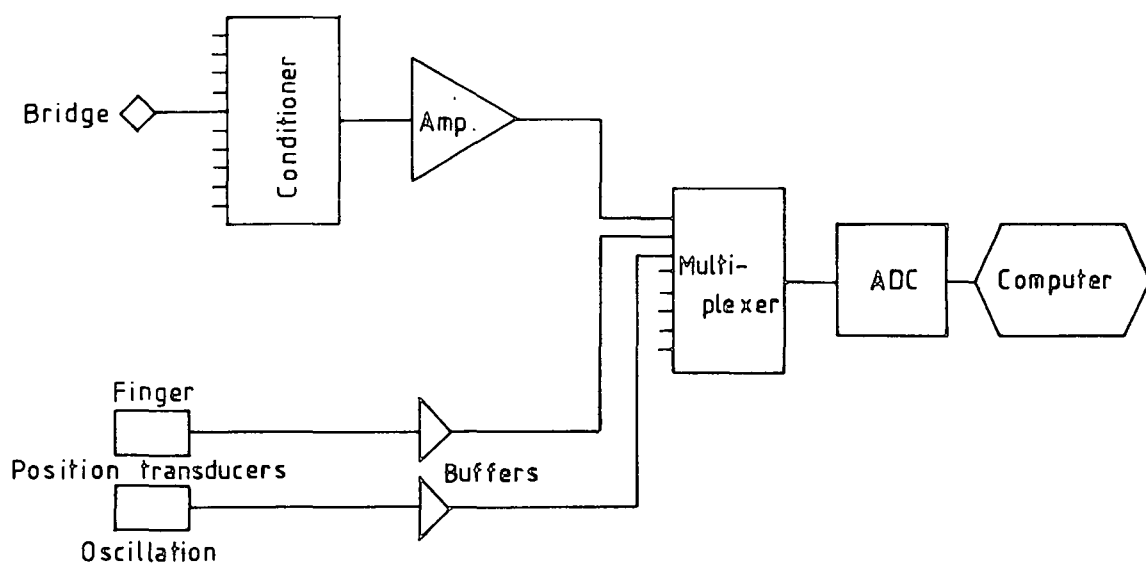

FIGURE 3.12. The interface of the arthrograph to the electronic circuitry

b) Data handling. The computer had to collect data from each transducer, process it and present the results. These then needed to be displayed on the computer monitor screen or printer and stored on magnetic floppy disc.

c) Simplicity of operation. This was an important design feature to enable a non-technical operator to use the system without special training. This meant keeping operator interaction to a minimum and as simple as possible with easy to follow instructions. Also, a simple display of the results was needed to ensure that they were quickly understood without resorting to special interpretation.

Throughout the development of the system the software was continually changed as simpler programming techniques were formulated and operating methods were improved. Figure 3.13. shows a flow-chart and program listing can be found in Appendices 4 and 5 respectively. From Figure 3.13. can be seen the main sections of the software. These are described below:-

a) Start up

On switching on the computer power supply, the controlling software was loaded automatically into the operational memory, from its floppy disc storage. It was intended that once started, as only hand assessment was carried out, there would be no necessity to stop the program. Therefore the first interaction required by the operator was to type in the date.

b) Initialisation

This section sets the operating registers of the D109 interface card. This defines their use, preparing them for circuit control and data handling. Appendix 3 gives a detailed account of the

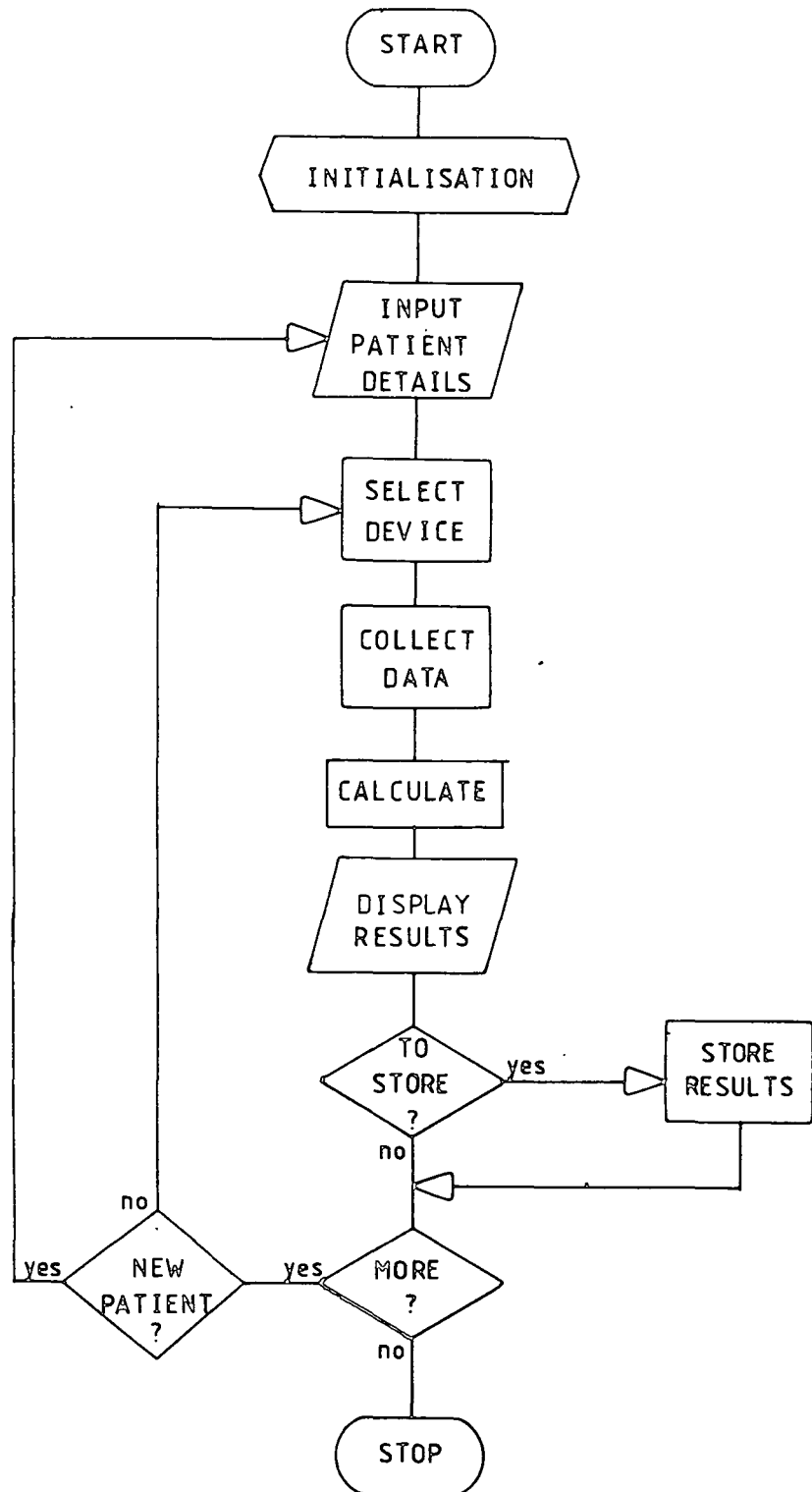

FIGURE 3.13. Flowchart showing outline of controlling software

initialisation and operation of this interface. Once initialised the data required for program operation was read from the software. This included the calibration factors and the conditioning unit and multiplexer switching values. These were all assigned to arrays within the program.

The operator was then prompted, by the computer, as to whether amplifier calibration or conditioning unit zeroing was required. It was found that both of these units were electrically stable. Therefore, it was only necessary to carry out this procedure infrequently. However, since this was a preliminary investigation, the calibration and zeroes were checked daily. This utilised a second program, listed in Appendix 6, which was automatically extracted from disc storage as required. When completed, the computer was returned to the start of the main program. Two programs were used in an effort to reduce the memory space required by the main program. The calibration and zeroing program was again designed so that non-technical operators could follow it through easily. With a little training the process could be done much quicker manually, using the voltmeter to check the calibration and zero signals. The program displayed simple to follow instructions. All the operator was required to do was to operate, when prompted, each control knob until the correct value was displayed on the monitor, and then to proceed to the next instruction.

c) Patient details

Plate 3.8. shows the monitor display for this section. It shows how the operator was prompted to type in brief details of the patient to be measured. These details were a test number, the patient's date of birth and their dominant hand.

```
PATIENTS' TEST NUMBER CONSISTS OF
      #####-*
WHERE ##### = HOSPITAL RECORD NUMBER
AND      * = PATIENTS' ASSESSMENT NUMBER

TEST NUMBER?-->
PATIENTS' DATE OF BIRTH?
-AS DY/MT/YR-->
PATIENTS' DOMINANT HAND?L/R-->
```

PLATE 3.8. Patient details display

d) Device menu

The next display (Plate 3.9.) listed the measuring devices, some control instructions and their corresponding codes. These control instructions will be described under part h) of this section. The operator selected a device by typing the correct code as indicated on the display. The necessary circuitry for that device was then switched by the computer. A check on the zero of each channel used by the device was then initiated. The output from each channel was detected and if any gave an ADC output of over five (less than 123 or greater than 133 for anti-clockwise and clockwise twists) an error message was displayed and the software returned to device menu display to enable recalibration. If no error was returned the slight zero errors obtained were stored to be subtracted from the test data collected. After this the display changed to a prompt telling the operator that all was ready and giving instructions on how to proceed with data collection.

e) Data collection

This was initiated by pressing the small button on either of the computers hand held controllers. For the power grip, pan and kettle devices data was collected for as long as the button was depressed. This technique was found necessary to accommodate the large variation in the time required for a patient to tackle the task. All the other devices had a satisfactory data collection using a fixed time, therefore it was necessary to keep the button depressed. Generally for the power grip, pan and kettle devices the collection time ranged from three to seven seconds. Individual finger tests (pulp pinch and extension) had a collection time of two seconds per finger and the other devices were fixed at four seconds.

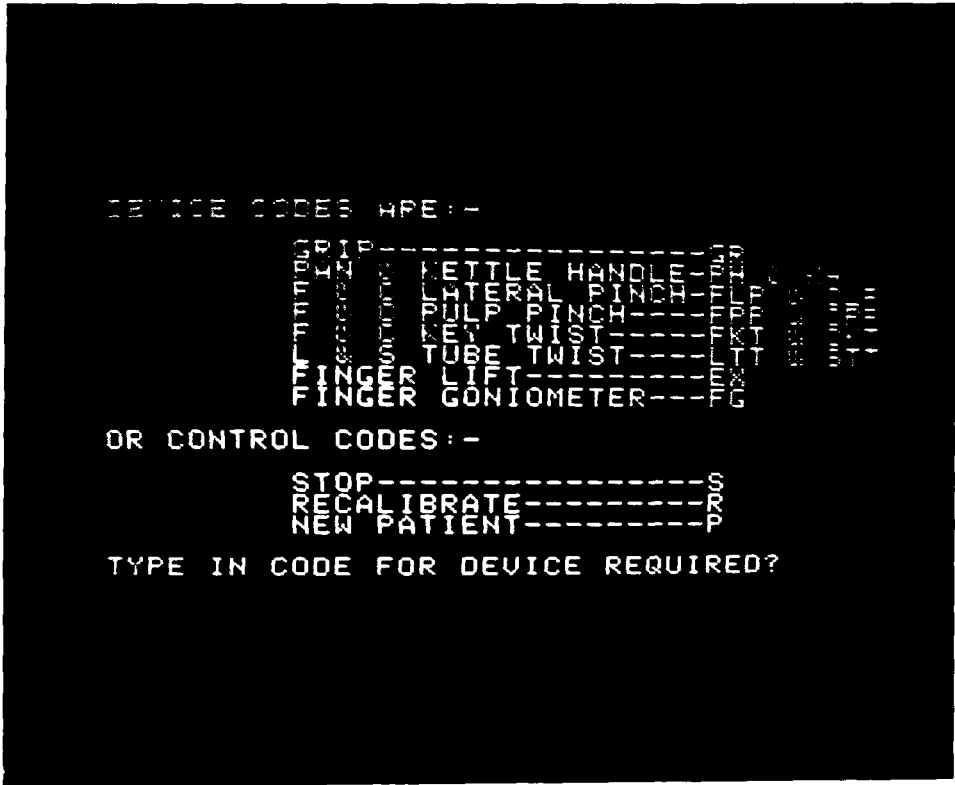

PLATE 3.9. Device menu display

f) Results

As soon as the data had been collected the program calculated the force results using the calibration factors. The results were then displayed in graphical form (Plate 3.10.a) followed by numerical form (Plate 3.10.b). The plates show as an example the results of a power grip test. The horizontal axis of the graph represents time (seconds) and the vertical axis the applied force (newtons). Both axes were variable and were set by the maximum value obtained during the test. The maximum values obtained from each transducer during a test were indicated on the plot by short vertical bars. In the case of the power grip an extra plot was added, the sum of the four transducers i.e. the power grip. This was plotted using plus signs with the maximum being indicated by a short horizontal line over the plus sign. These maximum results were displayed in the numerical display, which came into view immediately after the graphical display.

g) Storage

From these two displays the operator then received a prompt to ask if the results were to be stored on floppy disc. A 'YES' or 'Y' response initiated a storage routine in which the operator was required to type in the hand used in the test and, if necessary, the direction of twist. The results were stored sequentially on the floppy disc, to maximise disc use. After storage the details of the test were printed out on the printer (Figure 3.14.). After the first device test on a patient, the patient details and results were printed. Subsequently, in the same patient session, only the device type and the maximum results were printed. The software then returned to the device menu display.

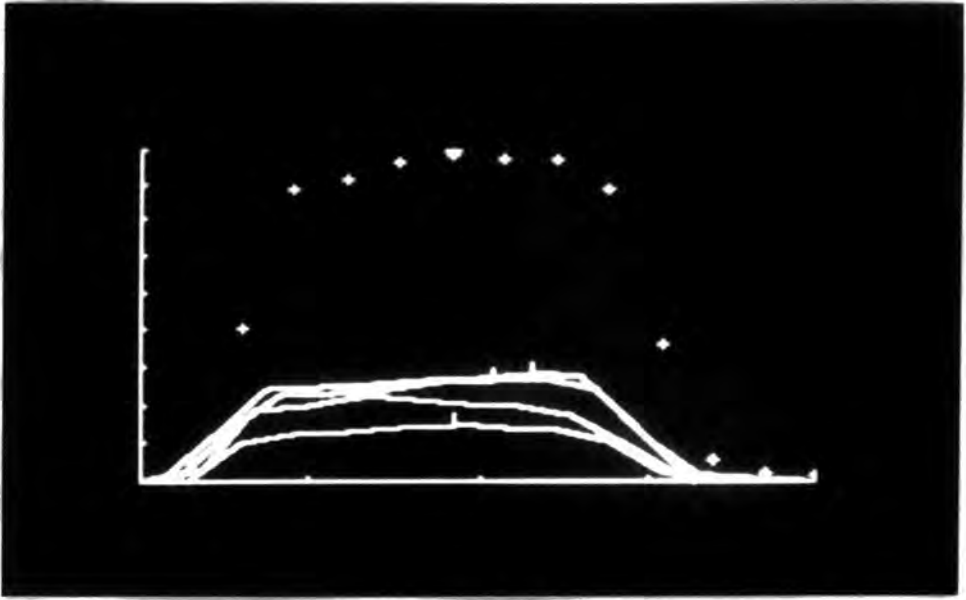

(a)

```

INDEX          MAXIMUM    = 109.92 NEWTONS
LOAD          MAXIMUM    = 176.11 NEWTONS
INCLINATION   MAXIMUM    = 143.26 NEWTONS
LITTLE END   MAXIMUM    = 68.43 NEWTONS
TOTAL FORCE   MAXIMUM    = 483.02 NEWTONS
@1.8 S COND H GRIP
IS DATA TO BE STORED ON DISC?Y/N-->
  
```

(b)

PLATE 3.10. a) Graphical display

b) Numerical display

```

RECORD FILE-->A158458-7-MRS L A OVERFIELD
GRIP DEVICE USED                                HAND USED----->L
DATE OF TEST-->18/05/83                        DATE OF BIRTH---->14/10/38
AGE = 44 YEARS 7 MONTHS                       DOMINANT HAND---->R
GRIP SPAN USED--->2                           GRIP SPAN USED--->2
14.75      32.02      39.33      16.59      100.05  CHANNEL MAXIMA

GRIP DEVICE USED                                HAND USED----->R
GRIP SPAN USED--->2                           GRIP SPAN USED--->2
40.21      36.95      35.11      24.88      114.6   CHANNEL MAXIMA

PAN HANDLE DEVICE USED                          HAND USED----->R
38.17      16.5       19.47      CHANNEL MAXIMA
38.9       GR @ MAX LIFT

PAN HANDLE DEVICE USED                          HAND USED----->L
22.9       19.23      12.88      CHANNEL MAXIMA
22.9       GR @ MAX LIFT

KETTLE HANDLE DEVICE USED                      HAND USED----->R
35.31      38.55      28.37      CHANNEL MAXIMA
3.92       GR @ MAX LIFT

KETTLE HANDLE DEVICE USED                      HAND USED----->L
31.88      38.93      13.22      CHANNEL MAXIMA
3.81       GR @ MAX LIFT

SMALL TUBE TWIST DEVICE USED                   HAND USED----->R
TWIST DIRECTION-->CW
3.11      -.13      MAX & MIN TORQUE

SMALL TUBE TWIST DEVICE USED                   HAND USED----->L
TWIST DIRECTION-->CW
2.87      -.13      MAX & MIN TORQUE

FINE KEY TWIST DEVICE USED                     HAND USED----->R
TWIST DIRECTION-->CW
.7        -.04      MAX & MIN TORQUE

FINE KEY TWIST DEVICE USED                     HAND USED----->L
TWIST DIRECTION-->CW
.8        -.81      MAX & MIN TORQUE

COARSE LATERAL PINCH DEVICE USED               HAND USED----->R
61.11     MAX

COARSE LATERAL PINCH DEVICE USED               HAND USED----->L
44.44     MAX

EXTENSOR LIFT DEVICE USED                      HAND USED----->L
FINGER MAX
3.39      3.39      2.26      3.01

EXTENSOR LIFT DEVICE USED                      HAND USED----->R
FINGER MAX
3.39      3.58      3.39      3.2

COARSE PULP PINCH DEVICE USED                 HAND USED----->R
FINGER MAX
27.78     27.78     22.22     13.89

COARSE PULP PINCH DEVICE USED                 HAND USED----->L
FINGER MAX
22.22     27.78     16.67     13.89

```

FIGURE 3.14. Print out of results

h) Device menu

From here it was possible to test the same patient again using the same device or one of the other devices. By using a control code (Plate 3.9.) the software could be instructed either to stop, return to the patient details display so that a second patient could be tested, or transfer to the calibration routine if it was felt necessary to check the amplifier and zero levels of the bridges.

Since only the maximum results were printed out during a measurement, it was necessary to provide another computer program, Appendix 7, to allow the operator to extract from the floppy disc the complete set of results from a measurement session. A typical print-out of these results can be found in Appendix 8. There was also another program to extract single device results.

3.5.2. Arthrograph

For the arthrograph, the software was required to control the electronic circuitry, collect the data of the ADC, and calculate and display the results. An outline flow-chart of the program is given in Figure 3.15.

The program started in the same way as that for hand assessment. First the D109 interface card had to be initialised, the program variables set and the calibration factors read. A prompt was displayed telling the operator to collect a zero strain reading prior to inserting the patient's finger in the holder. This was done by the computer as soon as the control button was pressed. After finger insertion, the operator was prompted to start the oscillation of the finger. Data was then collected, from the pressing of the control button, for a complete cycle. The data being collected in torque and angle pairs. The results, calculated from this data, were then



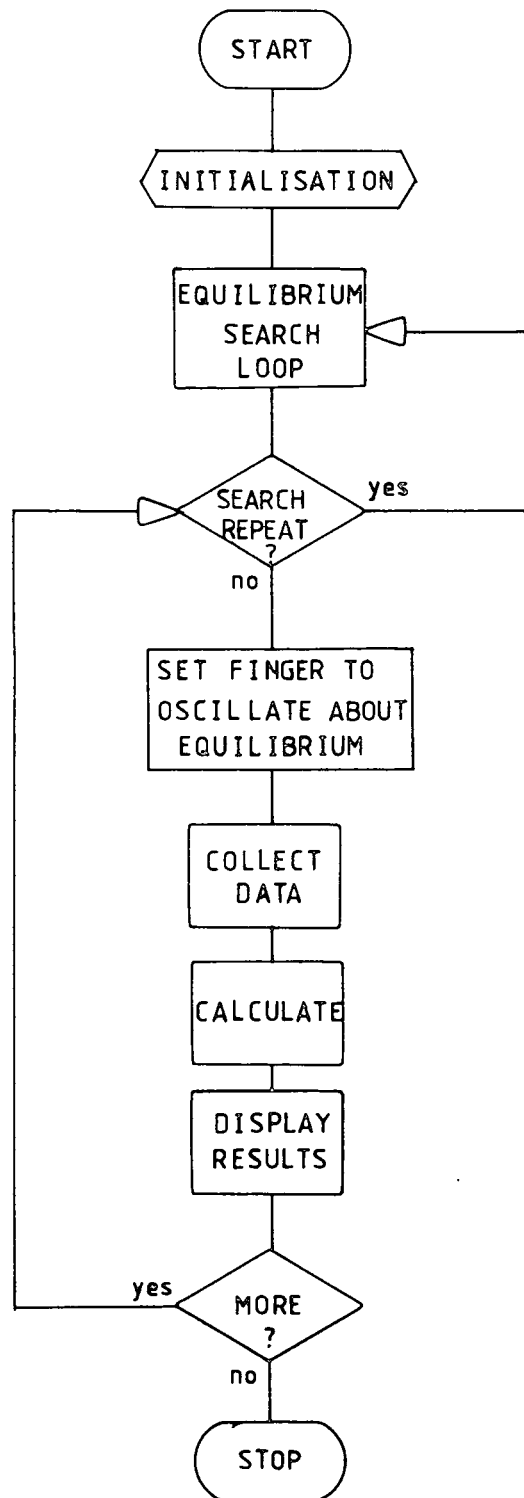

FIGURE 3.15. Flowchart showing outline of arthrograph controlling software

searched for points of zero torque or points either side of zero. The mean of these giving the equilibrium position which was then displayed on the monitor.

The operator then had the choice to either perform another equilibrium position search or to proceed with the test. Proceeding the operator manually rotated the finger holder, and finger, so that it oscillated about the previously found equilibrium position. Another data collection loop was initiated by pressing the control button. This time a trace was recorded on an XYt flat bed plotter and a full set of calculations were performed on the collected data. The calculations were the minimum to maximum torque, the mean slope, calculated using a regression equation on all the collected data, the loop area, calculated using Simpsons Rule, the equilibrium position of the finger as it moved in flexion and extension and finally the finger stiffness, calculated from the regression slope as the torque obtained at a fixed distance from equilibrium.

These results were displayed on the monitor and printed out. Another loop was then measured and when enough results were obtained another patient could be measured. At all points through the program simple to follow instructions were always given.

CHAPTER 4

MATERIALS AND METHOD

MATERIALS AND METHOD

4.1. Device Calibration

The calibration of each transducer was obtained by the stepwise addition, or subtraction, of load onto the transducer's operating surface. The load was applied to the power grip, pan and kettle devices using an Instron 3522 compression testing machine. The other devices had dead weights, previously checked using the Instron, hung from their operating surface. To calibrate the twist devices the dead weights were hung from a moment arm. Each device was calibrated several times and for each set of results a regression line was calculated between the applied load and the ADC output. The calibration factors were calculated as the mean value of the regression slopes obtained. These were inserted into the controlling software.

The arthrograph was calibrated for torque by hanging weights from a thread which passed over a low friction pulley to a tube fastened centrally in the 'V' holder. The angular calibration used a protractor attached to the arthrograph. These factors were also inserted into the relevant software.

To assess the accuracy and precision of each transducer, known loads were repeatedly applied, using either the Instron machine or hanging dead weights. The accuracy (variation due to systematic errors) was calculated as the mean percentage discrepancy between the applied load and the system's output. A guide to the precision (variation due to random errors) was calculated as the 95% confidence limits of the accuracy. These limits are the range between which there is a 95% confidence that the mean accuracy lies. They are given by:-

$$\text{limits} = t_{0.05} \times \frac{\sigma}{\sqrt{n}}$$

where $t_{0.05}$ = value of t for 95% confidence,

σ = standard deviation,

n = number of results.

4.2. Healthy Subjects

Volunteers from within the university and hospital departments were measured using each device to obtain an indication of the range of results to be expected from healthy subjects.

To assess subject variability of results, several subjects were repeatedly measured on the same device. Initially, the subjects had eight measurements taken consecutively over a twenty minute period. Each measurement was followed by an approximate two minute rest period in order to reduce muscle fatigue. However, it became apparent from personal observation that as well as muscle fatigue, patient motivation could also present a problem. Therefore, the measurements were split into two sets of four, each set being measured at the same time on two consecutive days, so as not to introduce any circadian variation.

4.3. Patients With Rheumatoid Arthritis

Volunteers from three sources were assessed objectively using the assessment system. The sources were:-

- i) A drug trial of drug treatment for rheumatoid arthritis
- ii) The Rheumatology out-patient clinic
- iii) The Rheumatology ward (in-patients)

4.3.1. The drug trial out-patient clinic

Patients attending this clinic were in an investigation of

second line treatment of rheumatoid arthritis. A gold preparation, for oral administration, was being assessed against penicillamine treatment, the effects of which are well documented. Gold has been used for a long time in the treatment of rheumatoid arthritis, but in its traditional form needs to be given as an intramuscular injection of sodium aurothiomalate.

The patients studied, Table 4.1., were generally in the early stages of the disease having very little or no hand deformity, or any other outward indication of disease activity. In the clinic the patients had their joint involvement assessed by the clinician using the Ritchie Articular Index (Ritchie et al. 1968). This involved the application of firm pressure to each joint and scoring according to the patient's reaction. The scoring was 0 no pain, 1 tender, 2 sore, and 3 very sore and patient withdraws. Grip strength was assessed using a cuff inflated to 30 mm of mercury. The proximal interphalangeal (PIP) joints had their circumferences measured, using a proprietary device, to assess any swelling. The device consisted of a spring loaded strip of plastic which curved around the finger. The circumference was registered on a 40 mm to 100 mm scale, though to read below 49 mm required manual retraction. Because of the rigidity and curvature of the plastic, changes in finger orientation could cause a 2 to 3 mm difference.

The patients also had to complete two visual analogue scales (VAS) to assess subjectively their pain and general condition. The scales were 100 mm long horizontal lines labelled on the left side with 'Couldn't be worse'. The right side was labelled with 'No pain' and 'Couldn't be better' for the pain and condition VAS respectively.

Blood samples were obtained for biochemical, haematological and

PATIENT	SEX	AGE	WHEN MEASURED (weeks from admission)	N
GMA	F	55	4,9,20	3
NA	F	58	0,4, //	2
AHD	M	65	0,16,20,23,28	5
DE	M	50	4,9,13,17,20,24	6
GD	M	50	0,6	2
GG	M	44	0, +	1
GH	F	73	0, *	1
TK	M	60	0,2,8	3
IEJ	F	64	8,16,20,23,28	5
LAO	F	45	2,4,8,12,16,20,24	7
DS	F	57	12,15,21,23,31	5
BS	F	51	0	1
ES	F	52	6,13,17,25,29	5

TABLE 4.1. Patients attending the drug trial clinic

N- Number of times measured

//- removed from trial, gastric trouble

+ - unable to delay, work

* - infirm lady, withdrew from study

immunological analyses. The biochemical analysis included sodium, potassium, urate etc., the haematological analysis included blood cell counts, plasma viscosity, haematocrit, haemoglobin etc. The immunological analysis measured the levels of the immunoglobulins (antibodies), proteins (albumin and globulin) in the blood and the rheumatoid factor.

4.3.2. Rheumatology out-patient clinic

These out-patients (Table 4.2.) were required to attend at regular intervals, from weekly to monthly, for injections, blood tests and clinical examination. They were long term patients, being very weak and with some hand deformity. Unfortunately, it was difficult to ensure that patients were regularly measured due to their social activities or state of general health.

4.3.3. Rheumatology ward

The system was moved into the ward in an attempt to obtain some short term monitoring. Here, ten patients (Table 4.3.) were measured every few days during their period of hospitalisation. They were admitted for assessment of and stabilisation of the disease activity or any other treatment found necessary e.g. joint injection or surgical intervention.

During their stay, the patients had daily physiotherapy and occupational therapy. The physiotherapy varied depending on the patient. For the hands it involved the use of hot wax, hot water, ice and ultrasonic treatment together with passive and active exercise. The hot wax was applied by dipping the hand, up to the wrist, six times into a wax bath maintained at 58°C. A polythene bag and thick blanket were used to insulate the waxed hand, to slow down its

PATIENT	SEX	AGE	WHEN MEASURED (weeks from start)	N
MA	F	47	0	1
CLB	M	40	0,12,22	3
OB	F	53	0	1
JC	F	39	0,4,7,13	4
JD	M	37	0,4,20	3
ECF	F	61	0,8,13,17	4
IH	F	42	0,4, //	2
EJ	M	50	0,16	2
SAK	F	40	0	1
GEL	M	66	0,4,17,20, +	4
JM	F	41	0,4,8, *	3
KO	F	61	0	1
DW	M	63	0,12,20,22, "	4
JW	M	62	0	1
JWn	M	65	0,8,12,24	4

TABLE 4.2. Patients attending the
rheumatology clinic

N= number of times measured

//- stopped attending

+ = hospitalisation from 7 to 11 weeks

" = hospitalisation from 4 to 6 weeks

* = foot in plaster, unable to attend

PATIENT	SEX	AGE	WHEN MEASURED (days from admission)	N
CWA	M	68	1,3,9,14,16,20	6
PMB	F	67	0,4,6,8,12	5
GB	M	84	1,4,8	3
HC	M	81	0,4	2
EC	F	55	0,2,6,8,10,14	6
EF	F	62	0,2,6	3
GM	M	69	0,3,7	3
RP	M	61	3,5,7,11	4
JS	M	74	0,2,6,8,10,14	6
JW	M	58	0,3,7	3

TABLE 4.3. Patients attending the
rheumatology ward

N= Number of times measured

cooling. When cold, about ten to fifteen minutes, the wax was peeled off and rolled into a ball by the patient and used for active exercises such as squeezing. Hot water treatment involved immersing the hand in a bath, initially at 40°C for around ten minutes. Ultrasonic treatment lasted only a few minutes and was used to stop the build up of scar tissue on tendons. Local swelling may also be reduced, the vibrations causing the break up of the oedema which can then disperse interstitially. Active exercise ranged from fine manipulation (small peg moving using all fingers) to power exercise (squeezing wax). Passive exercise by the physiotherapist was performed to improve a specific joints motion.

Occupational therapy consisted of tasks that required a degree of eye to hand co-ordination. Tasks such as cane weaving and cookery were used.

4.4. Physiotherapy Out-patient Hand Clinic

This was attended by patients with a wide variety of hand disorders, from arthritis to finger amputation. It was attempted to measure these patients at fortnightly intervals, but it was discovered that, in general, patients were reckoned to have sufficient improvement to be discharged after only four weeks. Therefore, only a small number of long term patients were measured. Table 4.4. details the patients measured. Again, the treatment given varied from patient to patient. As in the rheumatology ward it involved hot wax and water, ultrasonic treatment and exercise, both passive and active.

4.5. Method

On first showing a patient to the measuring system, they were

PATIENT	SEX	AGE	WIEN MEASURED (weeks from admission)	N
WA	M	62	0	1
JA	F	51	0,3	2
FB	F	50	0,2,4,7	4
JB	F	23	2,4,6,9	4
DC	F	58	2,4	2
GC	F	42	0,2	2
AKC	M	20	0,2,4	3
JF	M	54	0,2	2
NH	F	63	0,1	2
BH	F	50	2	1
NH	M	22	2,4	2
DJ	M	53	4,6,8	3
IL	M	28	1,2	2
PMc	M	29	0,2	2
AGM	F	49	5,7,10,18	4
PM	F	51	2,4	2
LM	F	46	0	1
DM	F	72	2,4,6,8,10	5
GR	M	55	0,1	2
JR	F	48	2,4	2
AGR	M	23	0,2,4,6	4
FS	M	64	12,14,16,19,28	5
VS	F	69	0,2,5	3
AES	F	46	0,2,5	3
LW	F	68	1,3	2

TABLE 4.4. Patients attending the physiotherapy clinic

N- number of times measured

seated in front of the cabinet and given a brief introduction to the project and a short summary of what they would be expected to do.

They were then asked about their general state of health, about their hands and how they coped with everyday tasks (Figure 4.1). For the patients from the rheumatology ward, a VAS was introduced. This was similar to that used in the drug trial but labelled at either end with 'Poorly' and 'Very well'. The patient placed a mark along the line in response to a question on how they subjectively assessed their hands.

All the patients had both hands measured using the power grip, pan, kettle, key and tube twist, lateral and pulp pinch and extension devices. The pan, kettle and pulp pinch required the patient to stand, while they remained seated for the rest.

For the pan and kettle devices the patient was required to lift the pan body, as much as they could, against the restraining springs. To do this, they were asked to lift by the appropriate handle as normally as possible. Plate 4.1. shows a typical pan lift.

Pulp pinch was measured by standing the key unit on its end on a wooden support on the platform attached to the cabinet. The patient squeezed the platens together, as hard as possible, using the pulps of the thumb and each finger in turn (Plate 4.2.). If possible all the fingers were measured. However, if the patient had a large amount of ulnar deviation, opposition of all fingers, by the thumb, was not always possible. To determine which pinch was to be used, the patients first gently squeezed the fine pinch platens. If they succeeded in closing the gap they were measured using the coarse pulp pinch platens.

For the power grip and other key unit devices the patients sat upright in a chair with forearms horizontal. In power grip the forearm rested on the chairarm with the elbow set at ninety degrees

PATIENT QUESTIONNAIRE

1. How are you feeling to-day? Very Quite Not so Poorly
 well well good

If not so good, what is wrong?

2. How are your hands to-day? Very Quite Not so Poorly
 well well good

Are they feeling any better Yes a Just a Same A bit A lot
 than last time you were here? lot little worse worse

How have they changed?

3. How are your fingers and Very Quite Not so Poorly
 thumbs to-day? well well good

Does any particular finger or thumb feel different? Yes/No

If so, which?

4. How do you cope with a saucepan?

5. How do you cope with a kettle?

6. How do you cope with keys?

7. How do you cope with lids?

8. What other handling activities cause you trouble?

FIGURE 4.1. Patient Questionnaire



PLATE 4.1. The pan lift

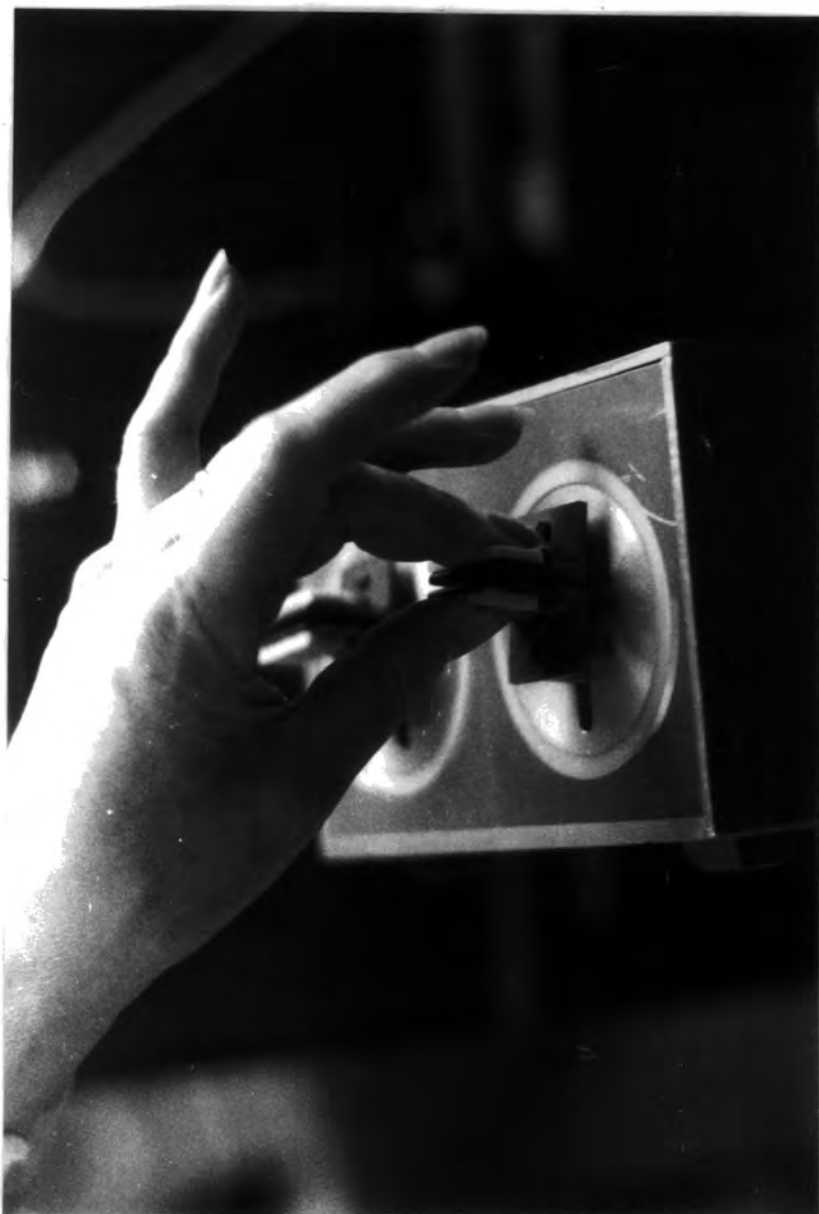

PLATE 4.2. The pulp pinch

and the device held vertically (Plate 4.3.). The key unit was placed on a small table in front of the patient. The elbow was therefore set at over ninety degrees because the unit was situated slightly forward of the patient's knees. It was not possible to accommodate the knees comfortably under the table. In all cases the fine key device was found adequate for maximum key torque measurement. Maximum effort was applied by the left hand anti-clockwise and by the right hand in a clockwise direction (Plate 4.4.). In tube twist the unit was set at right angles to the patient with tube inserted over the key. The patient gripped the tube by placing the fingers over the top. The tube was then twisted away from the patient, as in wringing out a cloth, as hard as possible (Plate 4.5.).

For lateral pinch, the pinch platens were rotated until they were vertical. The coarse platens were then squeezed together, as hard as possible, between the patient's thumb pulp and the lateral aspect of the medial phalanx of the index finger (Plate 4.6.).

Measurement of extension force was made by placing the key unit onto a baseboard as detailed in paragraph 3.1.5. The patient's hand was then placed palm down onto the supporting block with the finger to be measured under the lower fine pinch platen. The platens being
* rotated till horizontal first. Using soft pads the hand was raised until the finger nail just touched the underside of the platen. A small wedge was inserted above the upper platform to stop the transducer from lifting. All four fingers were measured, each extending as much as possible while the operator restrained the other fingers from lifting at the same time (Plate 4.7.).

For all devices the patients and subjects were allowed a single practice, so that they were aware of the 'feel' of the device. This also enabled them to adjust to their most comfortable position.



PLATE 4.3. The power grip

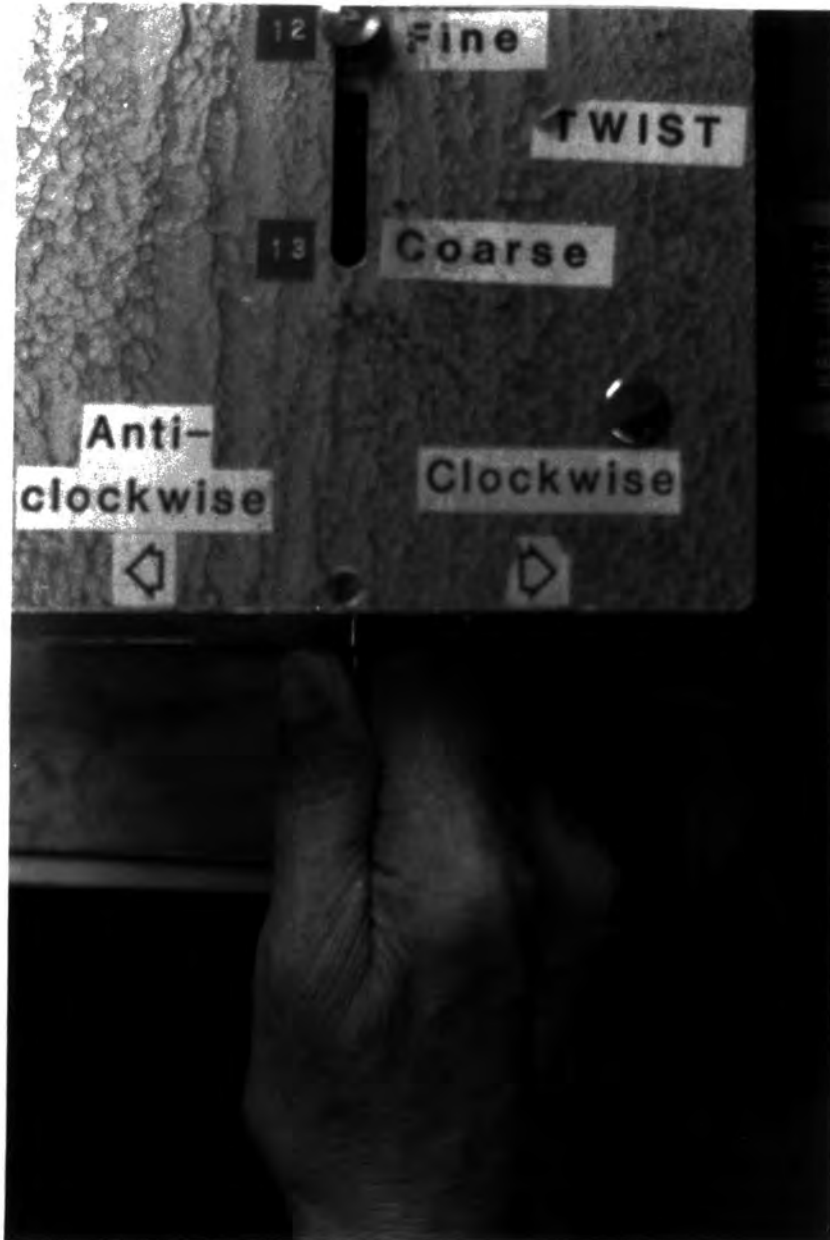

PLATE 4.4. The key twist



PLATE 4.5. The tube twist



PLATE 4.6. The lateral pinch



PLATE 4.7. The finger extension

Prior to each test vocal instructions were given. These were of the form:-

'Grip/lift/squeeze the device as hard/much as you can and hold it for a short time until told to relax.'

No instructions on the technique to be used and no encouragement during the measurement period were given.

Power grip, pan and kettle device data was collected for between four and eight seconds depending on the speed of the patient. Lateral pinch, key and tube twist had data collected for four seconds while the remaining devices had a data collection time of two seconds per finger.

Even though patients were measured only once per device per hand, a complete measurement session took approximately thirty minutes. However, during the time the majority of it was spent seated waiting for the system to perform its various tasks, calculating, displaying and storing the results.

CHAPTER 5RESULTS

Please note:-

The figures referred to in this chapter are located, in sequential order, after the text.

RESULTS

5.1. Calibration, Accuracy And Precision

The calibration factors, accuracy and precision of each transducer are given in Figure 5.1. The accuracy of the transducers ranged from -0.7% to 4.0% of the true value with a precision of better than $\pm 4.4\%$

5.2. Healthy Subject Measurement

Figures 5.2. to 5.8. are scatter diagrams of the maximum forces obtained, by healthy subjects, on each device. The mean, standard deviation, minimum, maximum and skewness values of the results are given, for each device, in Figure 5.9.

The scatter diagrams show very clearly the large range of forces that need to be accommodated when measuring a human population. This was also indicated by the relatively large standard deviations, and the range of the forces measured (the maximum minus the minimum values).

The pan and kettle results include the lower and upper transducer measurements of lifting force and two measurements of handle grip force. The lifting force transducers were rigidly fixed with their cantilevers fixed parallel to their respective bases. The lower transducer was fixed to the instrumentation cabinet and the upper one to the bottom of the pan body. Each transducer measured the component of lifting force perpendicular to the cantilever.

Examination of this arrangement reveals that five techniques of lifting a pan, or kettle, will give different relationships between the two transducers. These techniques are shown in Figure 5.10.

and are:-

- a) A vertical lift with a horizontal pan body.
- b) A non-vertical lift with a horizontal pan body.
- c) A vertical lift with a tilted pan body.
- d) A non-vertical lift, with the pan body at right angles to the lift and direction.
- e) A non-vertical lift with the pan body tilted to the lift direction.

When either device was lifted, the tilt of the pan body and the direction of lift, caused a reduction in the perpendicular components of the lifting force measured by each transducer. The reduction of the lower measurements was related to the direction of lift, while the upper measurements also depended on this as well as the body tilt. Therefore, with this transducer arrangement the true lifting force could not be measured or calculated.

The two handle grip forces measured were:-

- a) The maximum force applied to the device handle during the lifting period.
- b) The grip force applied to the handle coincident with the maximum lift of the device.

From the mean results in Figure 5.9., it can be seen that a few devices had a skewed distribution of results. Skewness is a measure of the assymetry of the population distribution, with increasing positive values indicating an increasing tendency for the populations to cluster to the left of the mean. Negative values cluster to the right of the mean. Of the forty eight distributions, fourteen

indicated significant skewness at the 5% level of significance and nine at the 1% level. The pan handle grip forces (both the maximum and that measured at maximum lift), the pan lifting force (upper transducer) and the kettle lifting forces (upper and lower) indicated bilateral skewness. Unilateral skewness was observed with the pan lifting force (lower) and both kettle handle grip forces and with two of the extension forces (the index and middle fingers). These skewed distributions are not readily apparent in the scatter diagrams (Figures 5.2. to 5.8.).

5.2.1. Subject variability

The means, standard deviations and coefficients of variation of the results obtained from the repeated measurement of a single subject are shown, for each device, in Figures 5.11. to 5.15. The coefficient of variation, defined by:-

$$C = \frac{\text{Standard Deviation}}{\text{Mean}} \times 100 \text{ per cent}$$

is a useful measure for describing the relative variation of a sample. Since it is a ratio of the standard deviation and the mean, it is independent of the units used.

The power grip, pan and lateral pinch results were obtained first using eight consecutive measurements. Secondly, they were obtained from two sets of four measurements taken at the same time on consecutive days.

Figure 5.16. compares both sets of results using the X statistic, and shows that, for each transducer, the mean coefficients of variation were similar. In the cases where there was significant difference, the split measurements had the larger coefficients

of variation.

A summary of the coefficients of variation obtained from the consecutive measurements, for each device, is given in Figure 5.16. and Figure 5.18. shows the same results in graphical form.

5.2.2. Finger contribution to power grip

Taking the maximum applied finger force as a percentage of the power grip maximum, a measure of the contribution of the fingers to the power grip was obtained. The healthy subject contributions are tabulated in Figure 5.19a and are shown as a scatter diagram in Figure 5.20. The results show that in either hand, the middle finger had the largest mean contribution (37.0% and 37.3%) followed by the ring finger (29.7% and 28.3%), index finger (18.0% and 19.5%) and the little finger (16.4% and 16.5%).

For comparison, the results for Ohtsuki (1981a) are also given in Figure 5.19a. A description of the method used by Ohtsuki has been given previously in paragraph 2.4.2. His results were calculated using the best of three exertions per subject. As in our work, the percentages were calculated using the maximum force obtained during the approximate five second exertion.

The absolute values for the combined four finger exertion in Ohtsuki's work were quoted at $383.2 \pm 49\text{N}$ (left hand \pm one standard deviation) and $429.2 \pm 48\text{N}$ (right hand). These were similar to the results obtained here of $335.4 \pm 88\text{N}$ (left) and $354.9 \pm 74\text{N}$ (right).

The maximum finger force and the maximum power grip do not always coincide. Therefore, several percentage contributions were calculated using the finger forces coincident with the power grip maxima. Both sets of results are compared in Figure 5.19b, and show that no difference exists between them. Therefore, it was not

necessary to obtain a statistical comparison.

5.2.3. Pan kettle lifting and handle grip forces

Figure 5.21. shows histograms of the differences between the measurements obtained from both lifting force transducers. Positive values indicate that the upper transducer, located within the pan body, recorded the higher force. Both histograms have a scattered distribution with medians of 3.8N and 6.8N for the pan and kettle populations respectively. Both populations can be seen to have a higher proportion of positive values, as indicated by the medians, showing that the upper transducer tended to record the highest forces.

Scatter diagrams of the upper transducer versus the lower transducer forces (maximum recorded) are shown in Figures 5.22. to 5.25., together with details of the corresponding regression analysis. This analysis shows the results to be well correlated with coefficients in the range 0.91 to 0.99. The left and right handed pan lifts had regression slopes of 0.72 and 0.66 with intercepts of 8.6N and 12.8N. The kettle lift regression slopes were 0.97 and 0.96 with intercepts of -3.9N and -1.1N for left and right handed lifts respectively. These results agree with the histogram results that the upper transducer records the higher forces. They also indicate a linear relationship, between the two measurements, throughout the measured range.

Histograms of the differences between the maximum handle grip forces and the maximum lift grip forces are shown in Figure 5.26. These show scattered populations with medians of 23N and 19N for the pan and kettle lifts respectively. The results are also plotted as scatter diagrams in Figures 5.27. to 5.30. together with the corresponding regression analyses. These show the correlation

coefficients to be in the range of 0.75 to 0.86 with regression line slopes of 0.90 and 0.74 for the pan lifts and 1.29 and 1.48 for the kettle lifts. Both sets had relatively high regression line intercepts of 40.5N and 63.3N for the pan lifts and 17.2N and 15.9N for the kettle lifts.

A slope of less than 1.0 as obtained for the pan lifts, would seem to indicate that the maximum grip force was less than the grip force at maximum lift. Examination of the results obtained (Appendices 9 to 11) and of the scatter diagrams reveals that the maximum grip force was always the larger. These low slopes can easily be accommodated by the degree of scatter and the large intercepts.

5.2.4. Force-time curves

Figures 5.31. to 5.33. show the force-time curves obtained from the power grip, pan and kettle measurements respectively. Force, newtons, is represented by the vertical axis and time, seconds, from the start of the measurement, by the horizontal axis. Both axes intersect at the origin and have variable maxima. The ordinate spacing is variable on the force axes, but the time axes all have the same unity spacing. The maxima and spacing values, for the force axes are given above each plot. The solid lines indicate the finger forces labelled with I, M, R or L for index, middle, ring or little fingers respectively. The power grip is represented by the plus signs. Maximum results are indicated by vertical marks on the finger curves and a horizontal mark on the power grip curve.

a) Power grip (Figure 5.31.)

No obvious pattern of the finger forces was apparent. The forces applied by each finger appear to remain constant during the power grip.

b) Pan and kettle lift (Figure 5.32. and Figure 5.33.)

Each device appears to have basic force patterns of:-

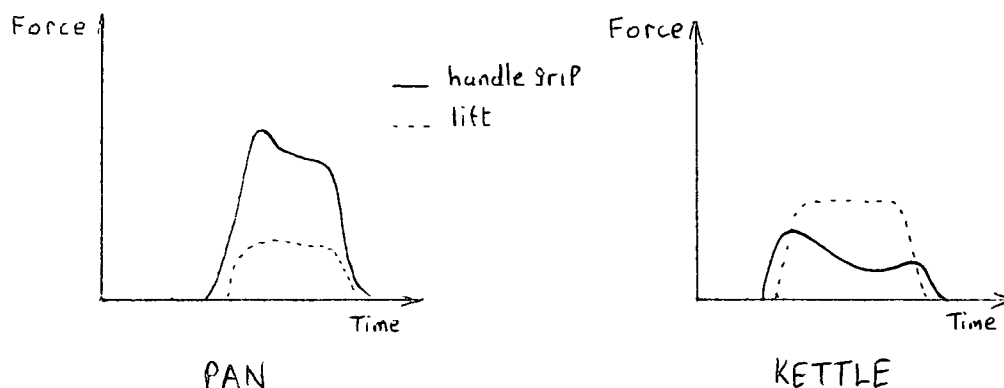

For the pan, the lifting and handle grip forces simultaneously increased to a maximum. The handle force then reduced slightly, while the lifting force remained steady. On release, both forces reduced rapidly. The handle force greatly exceeded the lifting force. This was opposite to the kettle lift where the handle grip was much less than the lifting force. The kettle handle gripping force had a maximum, either just prior to the lift or just as the lift was taken up. The handle force decreased during the lift, which remained steady. Both forces rapidly decreased on release.

5.2.5. Relationship between the lifting forces and handle grip forces

Scatter diagrams of the pan and kettle handle grip forces against the mean lifting forces are shown in Figures 5.34. to 5.41. The lifting force was taken as the mean of the maximum lower and upper lift measuring transducers. The regression analysis details the slopes, intercepts, correlation coefficients and zero correlation significances, are tabulated in Figure 5.42.

No relationship was indicated between the mean lifting force and

either the kettle handle grip forces or the pan handle grip force at maximum lift. However, significant correlation was obtained with the maximum pan handle grip force, with correlation coefficients of 0.56 and 0.59 for left and right handed lift respectively.

5.3. Initial Measurements On Patients With Rheumatoid Arthritis

Figure 5.43. details the mean results obtained from up to thirty eight patients with rheumatoid arthritis.

The standard deviations and range (maximum minus minimum) had relatively high values, the standard deviations being similar to their corresponding mean value. Both results indicate a large inter-patient variation, similar to that observed in the healthy subject results.

As opposed to the healthy subject results, most of the device results had a significant positive skewness, at the 5% level of significance. These results indicating a tendency for the measurements to cluster on the left hand side of the mean, that is towards the zero side of the force axis. Only ten of the forty eight distributions indicated no skewness (Probability > 0.05), that is a symmetrical distribution. Of these, three distributions were symmetrical bilaterally, and the other four were symmetrical unilaterally. In each case the opposing hand distribution indicated no skewness at between the 5% and the 1% significance levels.

Scatter diagrams of the initial measurements of patients with arthritis are given in Figures 5.44. to 5.50. These clearly show the wide range of measurements obtained and their clustering towards the zero end of the force axis. The skewness was most evident in the finger grip, pan lifting, the kettle handle maximum grip and the kettle lifting forces.

These initial measurements were obtained from patients attending three rheumatology clinics (Chapter 4). Figures 5.51. to 5.53. detail the results obtained split into their respective clinics. An Analysis of Variance (ANOVA) was obtained to determine whether there was any significant difference between the measurements obtained from the three sources. Figure 5.54. tabulates the ANOVA results obtained. The F-ratio was used to compare the population means of each source, while Cochran's C-test was used to test the homogeneity of the variances. Both tests revealed that in the majority of cases no significant difference (Probability ≥ 0.01) was detectable between the sources. From Figure 5.52. only a single F-ratio and three Cochran's C-tests have a Probability of < 0.01 .

5.3.1. Finger contribution to power grip

Figure 5.55a details the mean percentage finger contributions to the maximum power grip, obtained from the patients attending the three rheumatology clinics. A graphical comparison of the results to those obtained for healthy subjects is given in Figure 5.56., clearly showing the larger results variation obtained from the patients. This was confirmed by comparing the variances of the healthy and patient results using an F-ratio (Figure 5.55b). This showed that at the 2.5% level, with the exception of the right middle finger, there was a significant difference between the two groups. The means of the percentage contributions were compared using the X-statistic. Only three of the eight results showed any significant difference at the 2% level.

5.3.2. Pan and kettle lifting and handle grip forces

Histograms of the differences between the upper and lower lifting force measurements are given in Figure 5.57.

Both show a peaked distribution with a high frequency of positive differences. The medians of each distribution were 2.4N for the pan and 1.9N for the kettle lifting forces. Scatter diagrams of the upper transducer forces against the lower forces are shown in Figures 5.58. to 5.61. These show highly correlated relationships with coefficients of between 0.96 and 0.99. The slopes of the corresponding regression lines were all in the range of 0.76 to 0.92, indicating that the upper transducer recorded the higher forces.

Histograms of the differences between both handle gripping forces are given in Figures 5.62. Both distributions were less scattered than observed in healthy subjects (Figure 5.26.). The pan handle differences were concentrated close to zero with a median of 4.0N while the kettle handle had a more even distribution with a median of 12.6N. Scatter diagrams of the handle grip force at maximum lift against the maximum grip force (Figures 5.63 to 5.66.) indicate a high correlation between the two forces. The regression analysis revealed coefficients of 0.85 to 0.99 with regression line slopes of 0.93 to 1.09.

5.3.3. Force-time curves

These are shown in Figures 5.67. to 5.69. for the power grip, pan and kettle devices respectively. The horizontal axis represents the grip duration (seconds) and the vertical axis the applied force (newtons). The scaling being the same as described for the curves of the healthy subjects in paragraph 5.2.4.

a) Power grip (Figure 5.67)

No specific finger grip pattern can be observed though the individual finger forces do appear to vary during the power grip.

b) Pan and kettle (Figure 5.68 and Figure 5.69)

For the pan, the curves appeared to consist of two basic patterns:-

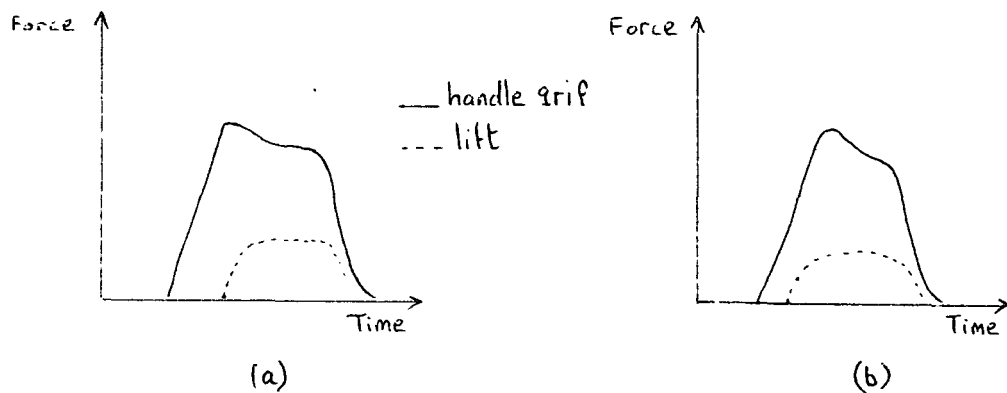

In curve (a) the handle gripping force rapidly increased until initiation of the lift, after which it relaxed slightly. When the lift was released the grip force decreased rapidly. Curve (b) was similar to that observed in the healthy subjects, described in paragraph 5.2.4. In both curves the handle grip force exceeded the lifting force. Omitting any curve that was difficult to place, the pan results were grouped according to their basic force-time curve. From Figure 5.68, an approximate measure of the lifting and handle grip forces was taken. These are tabulated in Figure 5.70, and show a mean lift of around 10N for curve (a) and 21N for curve (b). These means were significantly different, from each other, when compared using the X-statistic. A scatter diagram of the extracted results is also given in Figure 5.70.

The majority of the kettle force-time curves appeared in

the form:-

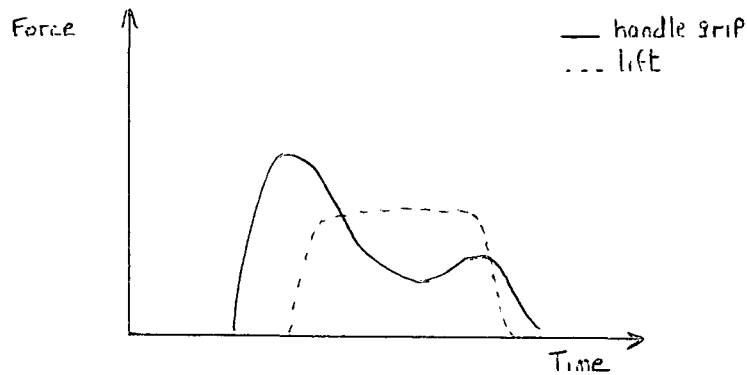

There were many variations. For example the handle grip force was sometimes higher than the lifting force and other times lower. One extreme variation makes the curve similar to pan curve (a) while in another no grip force was recorded. Essentially, the curve consisted of an initial high peak, which decreased rapidly as the lifting force increased. A smaller peak was in evidence as the lift was released.

Towards the end of the study two patients were measured who preferred another lifting method. All the above techniques placed the hand, palm downwards, over the handle, with the fingers wrapped downwards and around the handle. The second technique was the reverse of this with the hand placed, palm upwards, under the handle, with the fingers wrapped upwards and around the handle. Force-time curves for these are shown in Figure 5.71. and are similar to the initial kettle basic curve.

5.3.4. Relationship between the lifting force and handle grip force

Figures 5.72. to 5.79. show scatter diagrams of the handle grip forces against the mean lifting forces. The regression analysis is

detailed in Figure 5.80a. As for the healthy subject results, no relationship was found in the kettle results. However, a positive correlation was indicated for all the pan results. These had correlation coefficients ranging from 0.75 to 0.79. The regression slopes were about 1.6 and 2.0 for the left and right handed lifts respectively with approximately 23N intercepts.

Splitting the results into male and female, the regression analyses detailed in Figure 5.80b were obtained. This again shows correlation in the pan results with coefficients of between 0.64 and 0.81. The female results had the higher coefficients, 0.75 to 0.81 as opposed to the male, 0.64 to 0.74. Both groups had right handed regression slopes higher than the lift. The female slopes were about 1.80 and 2.96 while the male slopes were about 1.00 and 1.56. The intercepts of the slopes were around 12.9N and 40.8N for male and female respectively. There appeared to be no difference between the regression analyses of the handle grip forces.

5.4. Follow Up Of Patients With Arthritis

5.4.1. Drug trial

The follow up results for these patients are plotted out in Figures 5.81. to 5.92. and tabulated in Appendix 9. They alternate with the most relevant clinical results obtained from the drug trial study.

A standard format has been employed in the measurement plots, for this and the other clinics. The left hand page shows, from top to bottom the patients' self-assessment score, the power grip, the pan lift and the kettle lift results. The right hand page, again from top to bottom, shows the pulp and lateral pinch, the extension force and the key and small tube torque results.

The patients' self-assessment was a score of their own subjective feeling of the progression of their hands. It was taken from replies given to the preliminary questionnaire and was plotted using the following arbitrary scale:-

+2 units - a lot better
 +1 unit - a little better
 0 - no change
 -1 unit - a little worse
 -2 units - a lot worse

The drug trial study results displayed are the articular index, plasma viscosity, grip pressure, pain and general health visual analogue scales (VAS) and the treatment drug dosage. Also indicated is the period of device measurement.

Both IEJ (Figure 5.81. and 5.82.) and LAO (Figure 5.83. and Figure 5.84.) felt their hands improving steadily throughout the period of measurement. LAO, at the beginning and midway through did have periods of no change. IEJ had a low (less than 6) articular index, throughout, while LAO had higher values at 15 reducing steadily to a final value of 4. The maximum possible index is 78, therefore, 15 is still relatively low. The VAS for IEJ indicated a variable, but reducing amount of pain and a steady 'couldn't be better' general health assessment. LAO also had a variable pain assessment, but indicated no general improvement. Her general health appeared to recover after an initial deterioration. The plasma viscosity of IEJ was initially 1.90 cp which reduced to a final value of 1.62 cp. LAO again had very little overall change. Her plasma viscosity was initially 1.68 cp rising to 1.76 cp and then reducing to 1.59 cp.

Both patients were weak with power grip forces of less than 150N (IEJ) and 115N (LAO). Even though they had a large subjective improvement the results do not indicate much change. For IEJ the main change was a rise from 75N to 150N in the right hand power grip,

over the first four measurements. This was followed by a sudden decline to 85N for the final measurement. The right hand grip pressure, over the same period, also rose steadily (107 to 171 mm Hg) before falling on the final measurement to 137 mm Hg. A sudden decline in final measurements was also seen in all right hand results with the exception of the extension force. A fall was also noted in the left hand measurements of power and finger grip, lateral pinch and key and tube twist. The left hand lateral pinch showed a similar overall pattern to the right hand power grip, with a steady increase from 32N to 58N followed by a sudden decline to 44N. The left hand power grip had a minimum value on the third measurement. This was mirrored in the left hand measurements of the middle finger grip, kettle lift and key twisting forces. No minimum was noticeable in the grip pressure measurements.

For LAO the results had quite a bit of variation. The main changes occurring in the kettle lifting forces (left and right hands) which had an initial marked increase followed by a decline and subsequent recovery. Overall, the lifting forces increased from 5N to 35N and then fell to around 15N on the fourth measurement. Each pan lifting force had a similar pattern to the kettle with the right hand showing the most marked changes. This rose from 5N to an 18N maximum, declining slightly, but then recovering to 18N again on the final measurement. The left hand increased from 3N to a 12N maximum. This patient suffered a hand trauma prior to the fourth measurement, her right hand being knocked badly.

Another dramatic change occurred in the right hand tube twist torque. This rose from an initial steady value of around 1.6 Nm to a new steady value of about 3.2 Nm after the third measurement. Each hand with the key twist showed a steady overall improvement, though

the right hand declined from 0.9 Nm to 0.7 Nm over the final two measurements. The left hand increased from 0.3 Nm to a final value of 0.6 Nm.

The grip pressure measurements for each hand remained steady initially, but over the final half of the study period increased steadily. The left hand increased from 98 mm Hg to 157 mm Hg while the right hand rose from 89 mm Hg to 119 mm Hg. This increase was not so evident in either power grip results, there being quite a large variation about a general upward trend. The initial to final values for each hand were 59N to 100N (left hand) and 89N to 115N (right hand).

The self-assessment of AHD (Figure 5.85.) indicated a steady improvement in both hands. The right hand showed no change on the final assessment while the left hand had a slight relapse over the final two assessments. This pattern of change was mirrored in the power grip, finger grip, pan and kettle lifting and lateral pinch force measurements. The improved well being of the patient was also observed in the falling articular index and plasma viscosity (Figure 5.86.). The VAS, however, indicated very little change. The articular index and viscosity both had a slight upward turn over the final two measurements. This corresponds to the self-assessment and force measurements and with the patient who did not feel well over this period. This was because of an increased systemic joint stiffness. The decline in the left hand on the fourth measurement showed as a reduction in power grip from 280N to 200N. The grip pressure also fell from a maximum of 283 mm Hg to a minimum of 233 mm Hg. Prior to this, the power grip had risen from 171N and the grip pressure from 204 mm Hg over the same period. The right hand power grip rose from 185N before steadying at around 260N. Over the

same period, the right hand grip pressure remained steady at around 275 mm Hg and then declined to about 240 mm Hg. The left hand pan and kettle lifting forces both initially rose from 13N and 27N respectively to a maximum of 32N and 50N before steadying at about 25N and 40N for the final two measurements. The right hand measurements rose steadily from 13N and 33N to final steady values of around 35N and 45N respectively.

This patient also had a high middle finger grip force during his power grip on all except the initial measurements, when it was similar to the other fingers at about 36N. Subsequently it rose to over 100N, which it maintained. Inspection of the individual force-time curves (Figure 5.93.), from each measurement, revealed nothing extraordinary to account for this. Similarly the middle finger of the right hand was also strongest (Figure 5.94.). Also to be seen, on the third measurement, are the high peaks in the finger force just prior to grip release. By smoothing out these peaks, results that appear to be more consistent with the other measurements were obtained. The smoothed results are shown as dotted lines in Figure 5.85. The force-time curves in Figure 5.95. of the pan and kettle lifts show high peaks, especially in the lifting forces, during the initial phase of the lift. These were probably due to the patient's technique. He lifted them very quickly, even after being asked to proceed as normally as possible. This fast reaction caused an oscillation, as seen in Figure 5.94., to be set up between the patient and the restraining springs, until an equilibrium was obtained. Again, if these peaks are smoothed out, more appropriate results are obtained as indicated in Figure 5.85. by the chain dot plots.

Patient DE (Figure 5.87. and Figure 5.88.), over the period of

study, felt no subjective improvement in his hands. Initially, an improvement was felt, but this did not continue, his hands gradually worsening, but showing a slight improvement at the end. Similarly, both VAS had an initial improvement, followed by a relapse and then slow improvement. The relapse was more marked in the general health of VAS and coincides with a reduction in penicillamine dosage from 375 mg to 250 mg daily.

With a maximum result of 7, his articular index (Figure 5.88.) was very low. This maximum was matched by a peak in the plasma viscosity which overall remained quite high, not falling below 1.96 cp. The grip pressure measurements cannot show any change because only two measurements were below 300 mm Hg. This was the maximum of the dial gauge used to measure the cuff pressure.

Only the left handed power grip showed any similarity to the self-assessment. This initially increased from 213N to 250N, then declined to 188N before recovering to 232N. The right handed power grip declined steadily from 340N to 250N before a final recovery to 308N. This pattern was also followed by the right hand finger forces. These changes correspond to the patient's own feelings on his health. Most of the time he felt quite well except during the third and fourth measurements when he had increased joint stiffness.

No measurements were obtained from the kettle because the ↓ patient had sufficient strength to lift it against the protecting safety chain, even though a twin-rate spring had been installed to ensure a reasonable device range.

No significant changes were found in the measurements from the other devices.

Both patients DS and ES (Figures 5.89. to 5.92.) were poorly, having a lot of pain, high articular indices and plasma viscosities.

The articular index for DS (Figure 5.90.) varied between 14 and 29 while for ES (Figure 5.92.) it fell, unevenly, from 32 to 20, with a minimum of 15. The plasma viscosity for DS, over the period of device measurement, remained steady at between 2.23 cp and 2.31 cp. For ES it increased steadily from 1.72 cp to 2.06 cp. Neither self-assessment (Figure 5.89. and Figure 5.90.) indicated any improvement. DS feeling no change except for a slight deterioration at the end of the study period. ES felt a deterioration throughout the whole period.

In the clinical trial the VAS for DS both indicated very little in improvement. For ES the pain and health scores both coincided with each other, on all but the initial measurements. This patient felt at her best at the start of device measurement. This coincided with a minimum in the plasma viscosity. She then relapsed and her plasma viscosity steadily increased though she did feel slightly better.

Both of these patients were very weak, DS having a power grip of less than 70N and 44N for the left and right hands. A downward trend was noticeable in the power grip measurements. The grip pressure measurements were similar for each hand, remaining relatively constant at around 80 mm Hg.

Apart from showing the general weakness of DS, the other device measurements remained relatively unchanged over the device measurement period. During this period the patient had her drug regime changed from penicillamine to auranofin, because of haematuria and proteinuria. Unfortunately, neither of these cleared up and required hospitalisation, of the patient, for further investigation.

Most of the device measurements on ES (Figure 5.91.) indicated very little change, but, as for DS, show the overall weakness of the patient. Similar to DS, only the power grip measurements follow the

same downward trend as the self-assessment. For the left hand, a reduction from about 55N to about 20N while the right had decreased from 90N to 51N. The grip pressure measurements, over the same period, reduced from 70 mm Hg to about 40 mm Hg. The right hand, however, rose erratically from 106 mm Hg to 121 mm Hg before decreasing to 61 mm Hg.

In the majority of measurements, the left hand was much weaker. This was expected since the patient indicated a more painful left side.

5.4.2. Rheumatology out-patient clinic

The follow up results for these patients are plotted out in Figures 5.96. to 5.99. and tabulated in Appendix 10. The results are displayed in the same format as in the previous section.

It was only possible to obtain follow up results on four patients (two male and two female) with a series of four measurements.

The male patients both had a flare up of rheumatoid activity, requiring a two to three week stay in hospital, midway through the measurement period. Prior to hospitalisation both were feeling very poorly, having a great deal of pain, especially in the arms and shoulders.

While in hospital GEL (Figure 5.96.) had intra-articular local corticosteroid injections in each shoulder. This was to suppress the joint inflammation so as to relieve the pain and improve mobility. Associated with this was a course of Adrenocorticotrophic Hormone (ACTH) to stimulate the adrenal cortex to produce its own steroid hormone with which to reduce joint inflammation. Apart from feeling very much better in himself and feeling a large hand improvement, his

post hospitalisation results showed a striking change in the pan and kettle lifting forces. For each hand, the lifting forces increased from 5N to approximately 25N, for the pan, and 45N for the kettle. Other increases, though less dramatic, were seen in the power grip forces, both left and right handed, and in the right hand measurements of pulp pinch force and key twist torque.

Patient DWW (Figure 5.97.) while in hospital had a course of a non-steroid anti-inflammatory drug (NSAID) and antibiotics for a chest infection. Post hospitalisation he was still poorly and felt that each hand was deteriorating. Pre-hospitalisation only one measurement was obtained. Compared to this, the post hospitalisation measurements showed an initial slight increase followed by a fall off with a marked decrease on the final measurement. The patient also had a stomach complaint, dysphagia, but was not fit enough to undergo gastric surgery.

The female results show very little change. Patient JC (Figure 5.98.) never felt well, having a great deal of pain in her wrists and knees. She felt a gradual deterioration in her hands, which were very weak. A power grip force, that appeared to have a downward trend, of less than 53N being obtained.

Patient ECF (Figure 5.99.) appeared to be stable, feeling quite well in herself, with some joint pain, but not having any subjective change in her hand state. The results also showed very little change, though the right hand power grip reduced suddenly, after an initial 184N to 121N, but, subsequently remained steady. The pan and kettle lifting force measurements for each hand both had an initial increase from about 7N to about 12N and 22N respectively before steadying.

5.4.3. Rheumatology ward

These follow up results are plotted out in Figures 5.100. to 5.108. and tabulated in Appendix 11. Outwardly, it was quite significant to observe that most patients, after an initial settling in period, appeared to become more relaxed and happy with themselves in the ward. Of the ten patients tested, five were discharged after between nine and sixteen days hospitalisation and one after fifty six days. This patient (CWA) had been waiting for a carpal tunnel release (both wrists) and an operation on an infected toe. He was discharged nine days post operatively.

During their stay in hospital, five patients had intra-articular injections of steroid. These were:-

- i) PMB R & L knees injected
- ii) GB R elbow injected
- iii) EF R & L shoulder injected
- iv) JW R & L shoulder injected
- v) ENC R shoulder injected

ENC also had a transfusion of four pints of blood because of anaemia.

The VAS for PMB (Figure 5.100.) indicated a steady subjective hand improvement, the score reducing from 62 mm to 20 mm. A step increase was seen in the left hand power grip, from 60N to 75N, between the third and fourth measurements. The right hand also had a step increase from 80N to 120N, but this was between the second and fourth measurements. The kettle lifting forces increased from 10N to 30N for the left hand and to 50N for the right hand. Both lateral pinches increased, the left hand force measurement from 22N to 31N and the right from 33N to around 40N. The left hand key twist also increased from about 2.6 Nm up to 4.0 Nm. All these changes occurred after the knee injections. The other device measurements show some variation, but remained relatively steady.

Patient GB (Figure 5.101.) felt an improving hand condition as indicated by the VAS, which reduced from 43 mm to 17 mm. This improvement was also noticeable in the device measurements. The left hand power grip force increased from 45N to 150N and the right hand from 60N to 135N. Both the pan and kettle lifting forces with each hand increased, with most improvement being noticed in the left hand kettle and right hand pan lift measurements. The pan lifting forces increased from an initial value of 11N to 21N and 31N for the left and right hands. The kettle lifting forces for the left and right hands were initially 14N and 30N, both increasing to 42N and 30N respectively.

The right hand lateral pinch forces remained steady at about 65N, but the left hand had an initial increase from 11N to 67N, a level it maintained. The key and tube twist measurements both had an approximate tripling in forces measured. The key twist torque increasing from about 0.2 Nm up to about 0.8 Nm and the tube twist torque from 1.0 Nm and 0.8 Nm up to 3.2 Nm and 2.2 Nm for the left and right hands respectively. This patient had an elbow injection just before the final measurement, prior to being discharged. Therefore, no effect was observed.

The hand improvement VAS for LF (Figure 5.102.) showed a slight improvement, from 50 mm to 30 mm. The device measurements apart from showing the patient to be very weak, a power grip force of less than 40N was obtained, exhibited very little change. No effect was observed after the shoulder injections. The only major changes appeared to be an initial increase in the tube twist measurements, followed by a relapse. The left hand increased from 0.4 Nm to 1.2 Nm, then decreased to 0.7 Nm, while the right hand was initially 0.0 Nm, rising to 0.6 Nm and finishing at 0.4 Nm.

Another very weak patient was JW (Figure 5.103.) with a power grip of less than 60N. In the past he had silastic joint replacements fitted in all his MCP joints. Both hands had a large degree of ulnar deviation, which made it impossible to measure the extensor lift force. Following injections in each of his shoulders, the kettle lifting forces, for each hand, increased. The left hand from 15N to 40N and the right hand from 23N to 50N. Other devices also showed a marked increase post injection, the right power and finger grip and tube twist, but these improvements were not maintained.

In the power grip and tube twist measurement of RP (Figure 5.104.) the left hand was clearly the stronger. Both hands showed an initial improvement up to a steady value. Because of the difference between them, each hand was subjectively assessed separately using the VAS. The left hand had a subjective improvement from 45 mm down to 1 mm while the right hand showed an initial improvement from 95 mm to 40 mm, but subsequently deteriorated back to 75 mm.

The power grip forces increased from 190N to 300N, for the left hand, and from 60N to 140N for the right. The left and right hand tube twist torques increased from 3.4 Nm and 1.3 Nm to 5.5 Nm and 3.5 Nm respectively. No kettle measurements were available as the patient was able to lift the device against the transducer safety link. An increase from 16N to a steady 40N was obtained for the right hand pan lift. All the other device measurements generally maintained a steady value throughout the study period.

The majority of device results for JS (Figure 5.105.) showed a marked initial increase followed by a slight trend upwards. A similar trend being noticed in his VAS score, which was initially 62 mm, but

improved to 18 mm on the following assessment. Subsequent assessments continued the improvement to 5 mm.

Only the pulp pinch and extensor lift force measurements failed to show any similar effect. The power grip force initially increased from about 60N to about 130N. The kettle lifting forces of each hand reached the device maximum for the final three measurements, with initial values of 19N and 34N for the left and right hands respectively.

Of the three other patients, CWA (Figure 5.106.) had a marked decrease in power grip, lateral pinch and tube twist measurements, immediately post operatively. However, his hand assessment VAS score remained constant throughout the measurement period at about 60 mm. All the device measurements recovered, within a few days, to approximately their pre-operative level.

ENC's (Figure 5.107.) measurements contain quite a bit of variation, but appear to follow an upward trend. This was especially noticeable in the pan and kettle lifting force measurements. An increase from 1N to about 22N was obtained with the kettle, though the right hand measurements decreased finally to 12N. The pan lifting forces increased from 3N to 7N, for the left hand, and to 10N, for the right. This decreased to 7N on the final measurement.

This patient had a right shoulder intra-articular injection of corticosteroid a few hours prior to her fourth measurement and her blood transfusion was completed a few hours prior to her final measurement. No significant increase, apart from the general trend, was noticeable post injection.

Patient GM (Figure 5.108.) had a hand assessment VAS that improved from 58 mm to 28 mm. Correspondingly, the left hand power grip force increased from 60N to 165N, but the right hand, being very

weak at less than 70N, showed very little change. All the right hand measurements were much weaker than those of the left. Both left handed lifting forces increased, with the pan from 14N to 24N and the kettle from 12N to 35N. Conversely, the right hand lifting forces decreased, the pan from 8N to 4N and the kettle from 12N to 2N, though on the final measurement this recovered slightly to 6N. No other changes can be observed in the rest of the devices.

5.5. Physiotherapy Results

5.5.1. Initial results

Of the twenty one patients measured, six were attending the out-patient clinic for bilateral and fifteen for unilateral hand disorders. This breakdown was based on the patient's current disorder or complication and not on any previous history.

Figure 5.109. tabulates the initial measurements obtained from the patients with bilateral disorders. Figure 5.110. details a brief summary of these patients indicating their need for treatment. The measurements were all low with some patients appearing to have a differentiation between the left and right hands. For example, JF's right hand measurements were higher than his left hand. This agreed with his subjective viewpoint that the right was strongest. VS felt that her left hand was strongest and this was also reflected in her measurements.

Measurements on patients with unilateral hand disorders are tabulated in Figure 5.111. where the affected hand is indicated by the horizontal arrow. The patient details are given in Figure 5.112. which shows the wide range of hand disorders that are treated. From Figure 5.111. the measurements clearly show a differentiation between affected and unaffected hands. More specific differentiation can also

be noted:-

- a) AKC, with a clipped bone in his right index finger, had measurements which were lower than the corresponding left hand measurements in power grip and pulp pinch.
- b) LM, had Dupuytren's Contracture of the right little finger. The measurements on this finger were lower than the corresponding left hand results.

5.5.2. Follow-up results

These are plotted out in Figures 5.112. to 5.118. and tabulated in Appendix 12. Of the bilaterally affected patients FS and FB (Figure 5.113. and Figure 5.114.) had an improving self-assessment, both feeling quite well with very little pain. However, FS only showed an overall improvement in the lifting tasks, which increased from an initial 2N to about 10N for the remainder of the measurements. His other results all decreased on the second and third measurements, but subsequently recovered to the initial level.

FB generally had steady results except for the right hand, which tended to show an upward trend. Initially, this hand was very stiff but subsequently improved. This improvement can be seen in the measurements of power grip (93N rising to 122N), pan lifting force (4N rising to 10N), kettle lifting force (10N rising to 0.6 Nm) and tube torque (1.2 Nm rising to 1.8 Nm).

The patients with unilateral disorders all maintained a differentiation between their affected and unaffected hands. Both DM and AGM (Figure 5.115. and Figure 5.116.) were very weak (a power grip of less than 100N), but both had a steady subjective hand improvement. This improvement was not mirrored in the measurements of DM and only

found in the lifting tasks of AGM. Initially, AGM found it impossible to lift the pan, but on the final measurement a 7N lifting force was obtained. Her kettle lifting force, using either hand, also improved, with the right hand improving from 6N to 27N and her left hand from 12N to 38N.

Unlike the above, AGR (Figure 5.117.) was very strong with a power grip, for the unaffected hand, of over 400N. It was, therefore, thought only necessary to use the strength measuring devices. For the function devices high measurements would obviously have been obtained. Both power grip and nulp pinch on the infected left hand had rapidly increasing results. The power grip force rising from 100N to 360N, with the finger gripping forces increasing from around 50N to around 90N. The nulp pinch forces rose from an initial 23N to 41N range, to a final measurement range of 50N to 69N. The unaffected hand measurements remained steady, though a minimum was obtained on the second and third nulp pinch measurements.

Finally, JB (Figure 5.118.) felt no subjective improvement in her left hand. Even though she felt generally very well, she was becoming increasingly annoyed that no improvement appeared to be occurring in her right hand. This was confirmed by her results, which indicated, with some variation, no overall change. This apparent stagnation would be expected since several weeks would be needed for her digital nerve to regrow. The left hand measurements were a little higher than the right hand, and had a similar amount of variation, possibly caused by her feeling of dissatisfaction.

TRANSDUCER	CALIBRATION FACTOR (N/Integer)	SYSTEMIC ERROR (% \pm precision)
Index grip	0.746	4.0 \pm 2.1
Middle grip	0.812	0 \pm 2.8
Ring grip	0.712	1.2 \pm 1.5
Little grip	0.732	2.8 \pm 0.9
Pan handle	0.786	-0.5 \pm 0.3
Lower lift	2.77	1.0 \pm 0.5
Upper lift	2.92	2.7 \pm 1.0
Kettle handle	1.36	-0.7 \pm 1.5
Fine pinch	5.03	1.2 \pm 2.3
Coarse pinch	0.35	1.1 \pm 1.0
Fine twist	^a 22.92	2.4 \pm 4.4
Coarse twist	^a 7.72	3.1 \pm 1.6
New lift	2.14	0.1 \pm 0.3
ARTHROGRAPH		
Stiffness	^a 1.24x10 ⁻³	
Position	^b 1.03x10 ⁻²	
Oscillation	^b 2.68x10 ⁻³	

FIGURE 5.1. The calibration factors, accuracy and precision of the transducers, where precision = 95% confidence limits of the systemic error

a - units = Nm/Integer

b - units = degrees/Integer

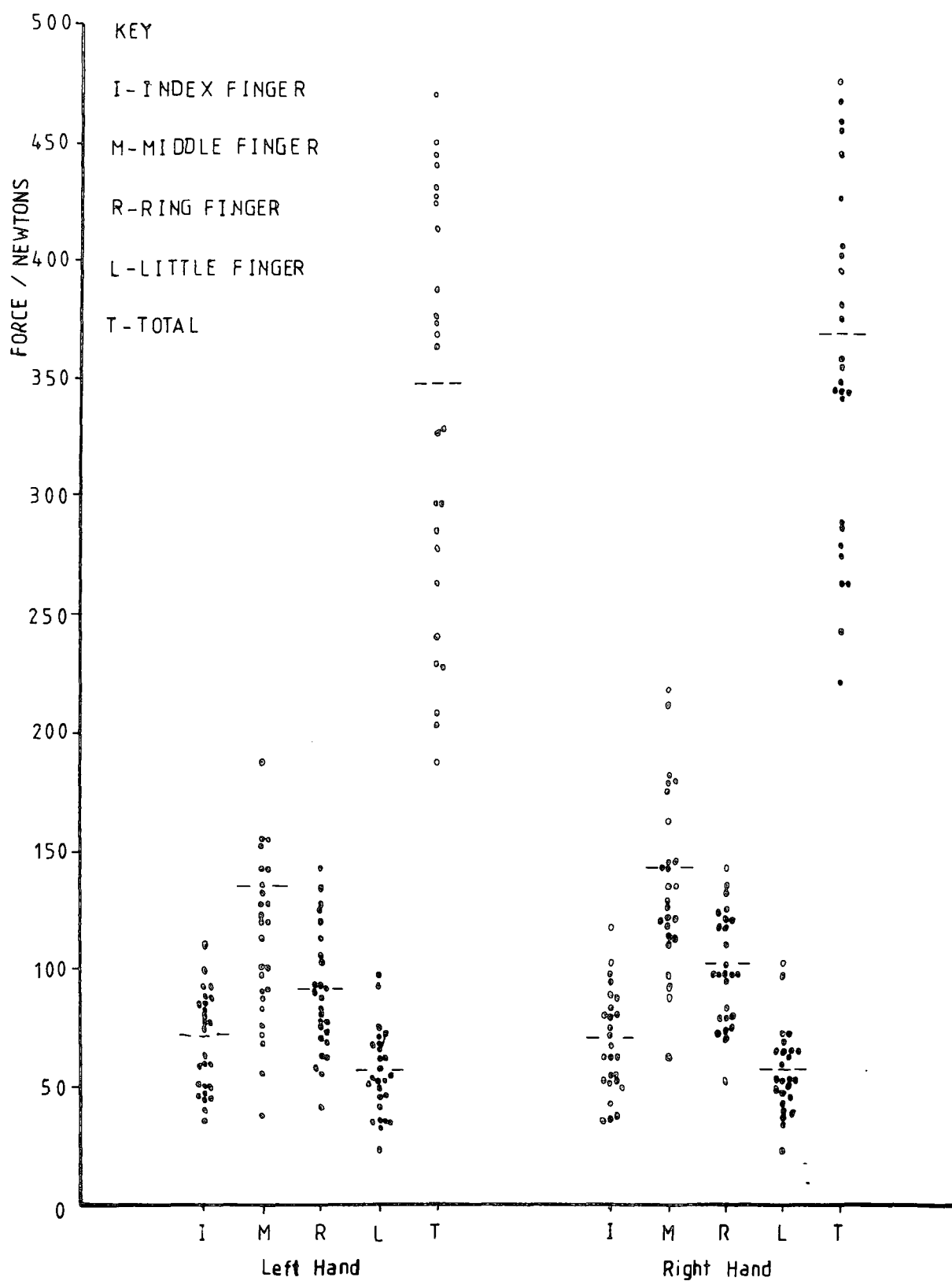

FIGURE 5.2. Scatter diagram of healthy subjects maximum power grip forces

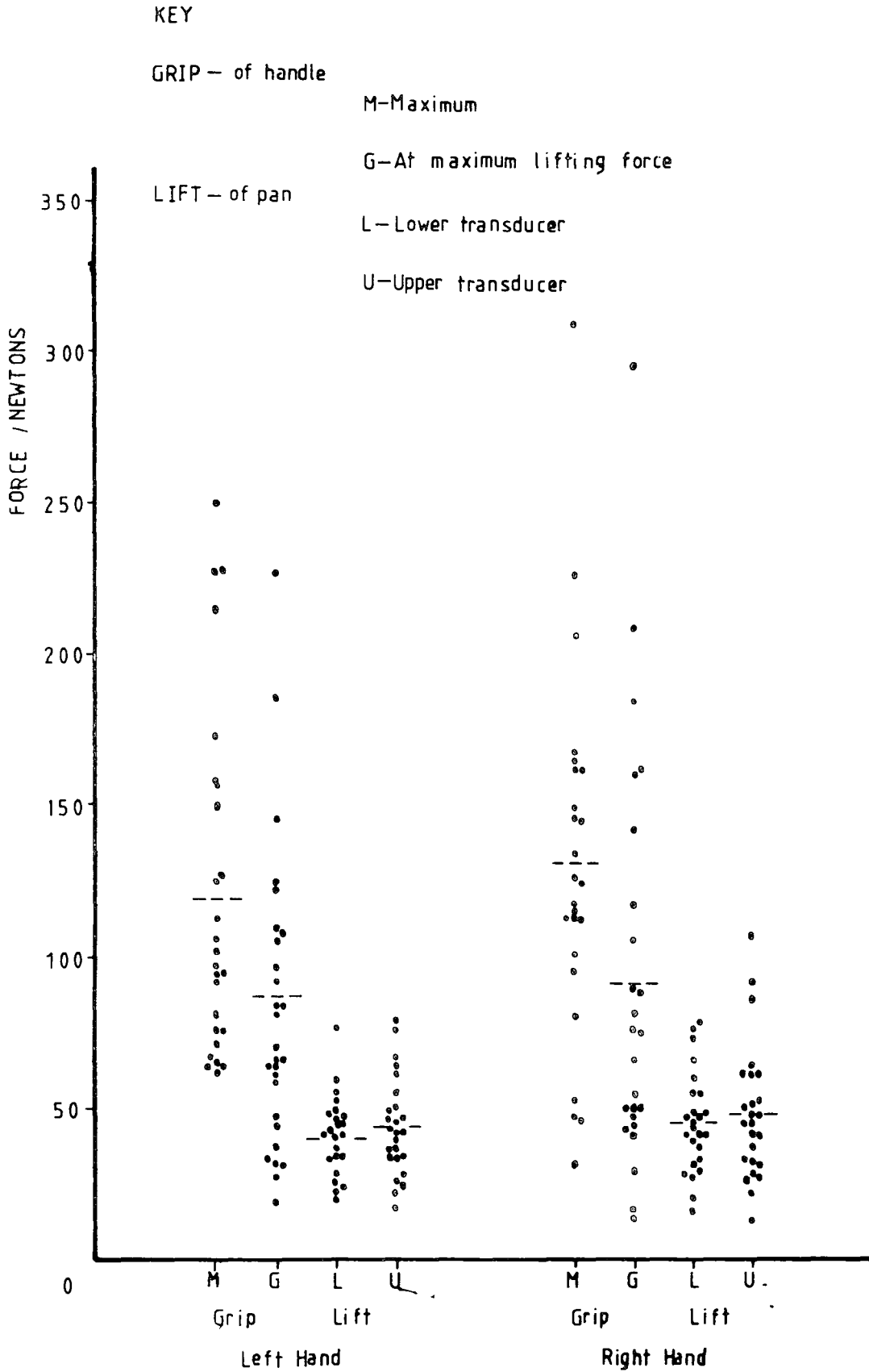

FIGURE 5.3. Scatter diagram of healthy subjects maximum pan forces

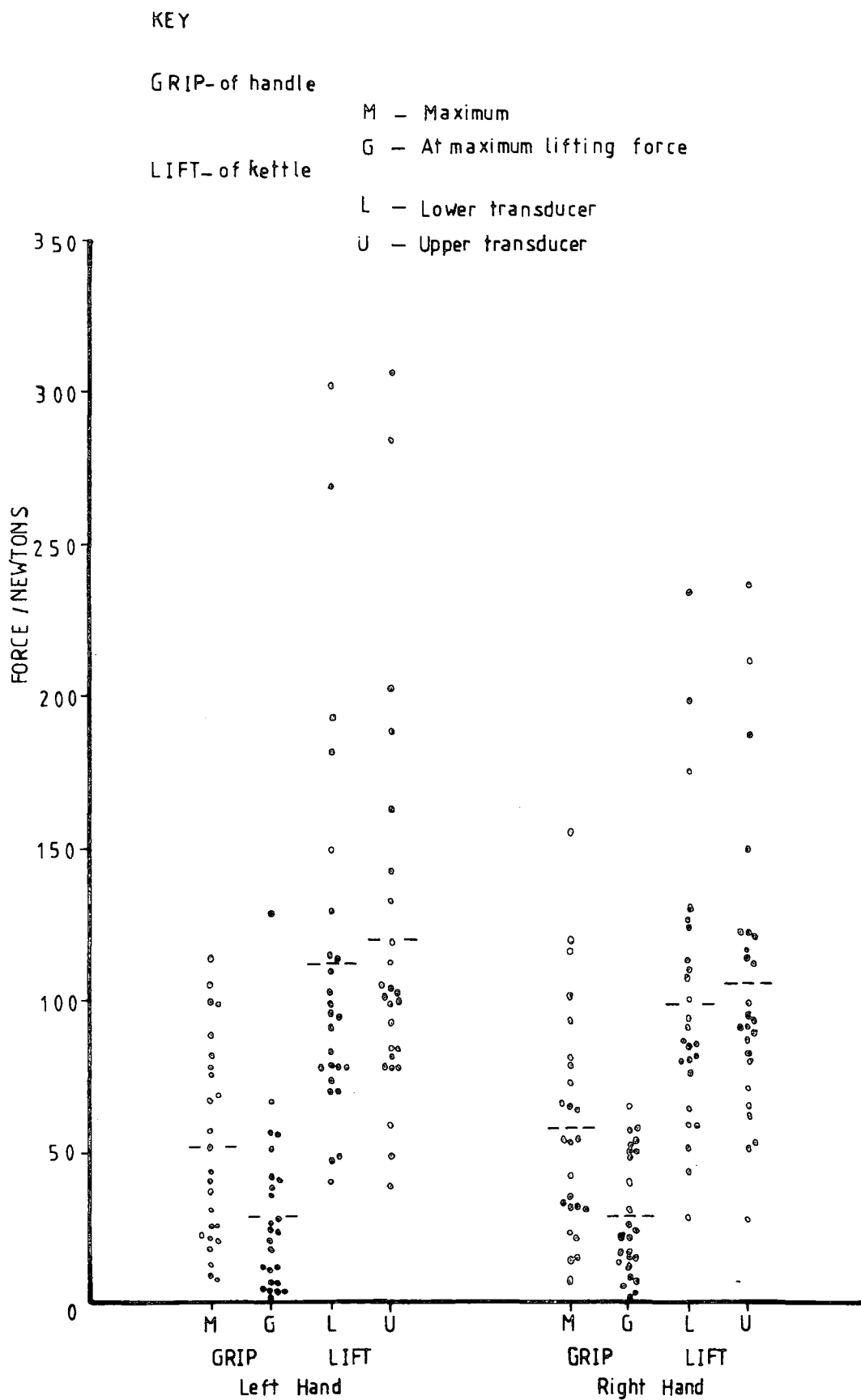

FIGURE 5.4. Scatter diagram of healthy subjects maximum kettle forces

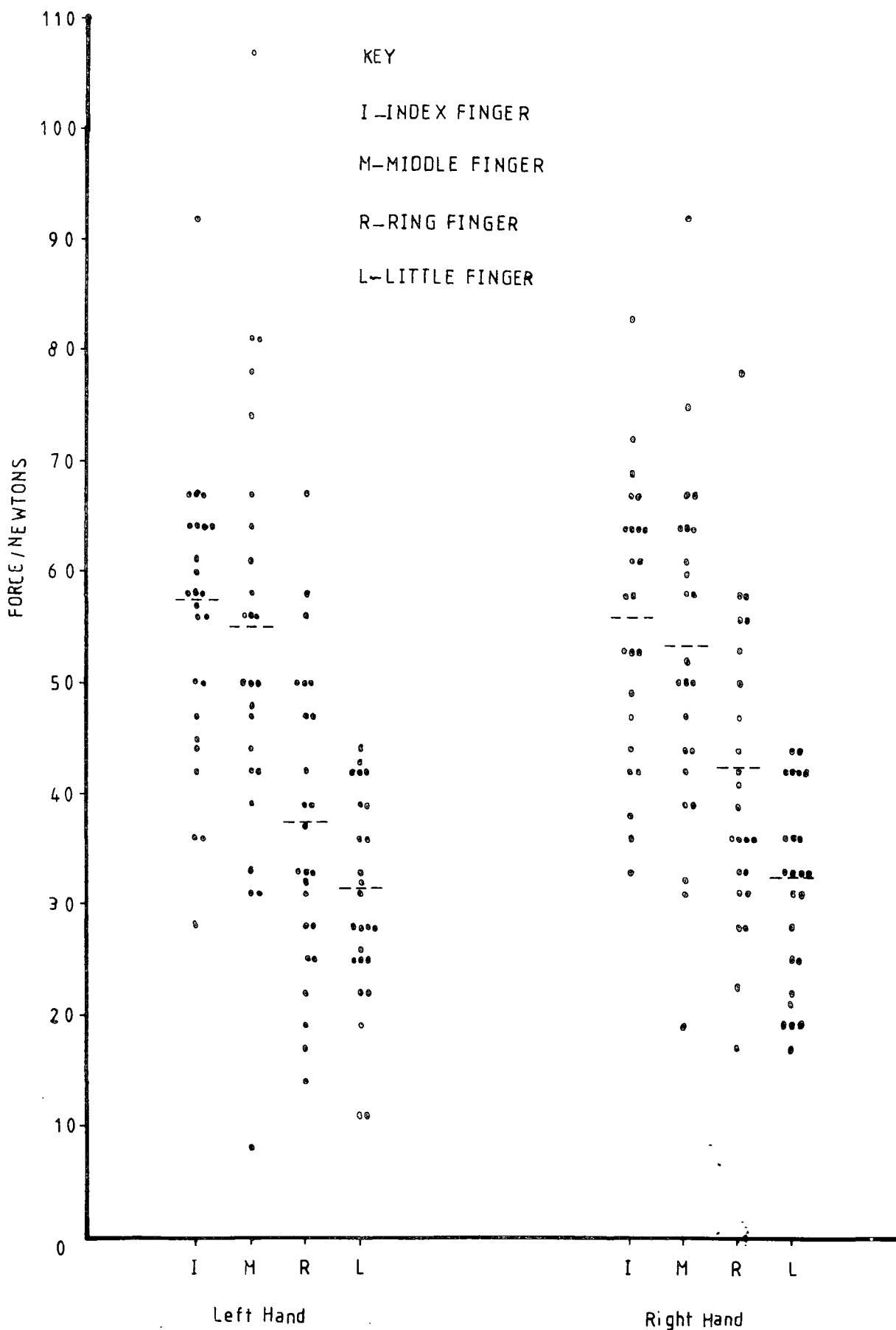

FIGURE 5.5. Scatter diagram of healthy subjects maximum pulp pinch forces

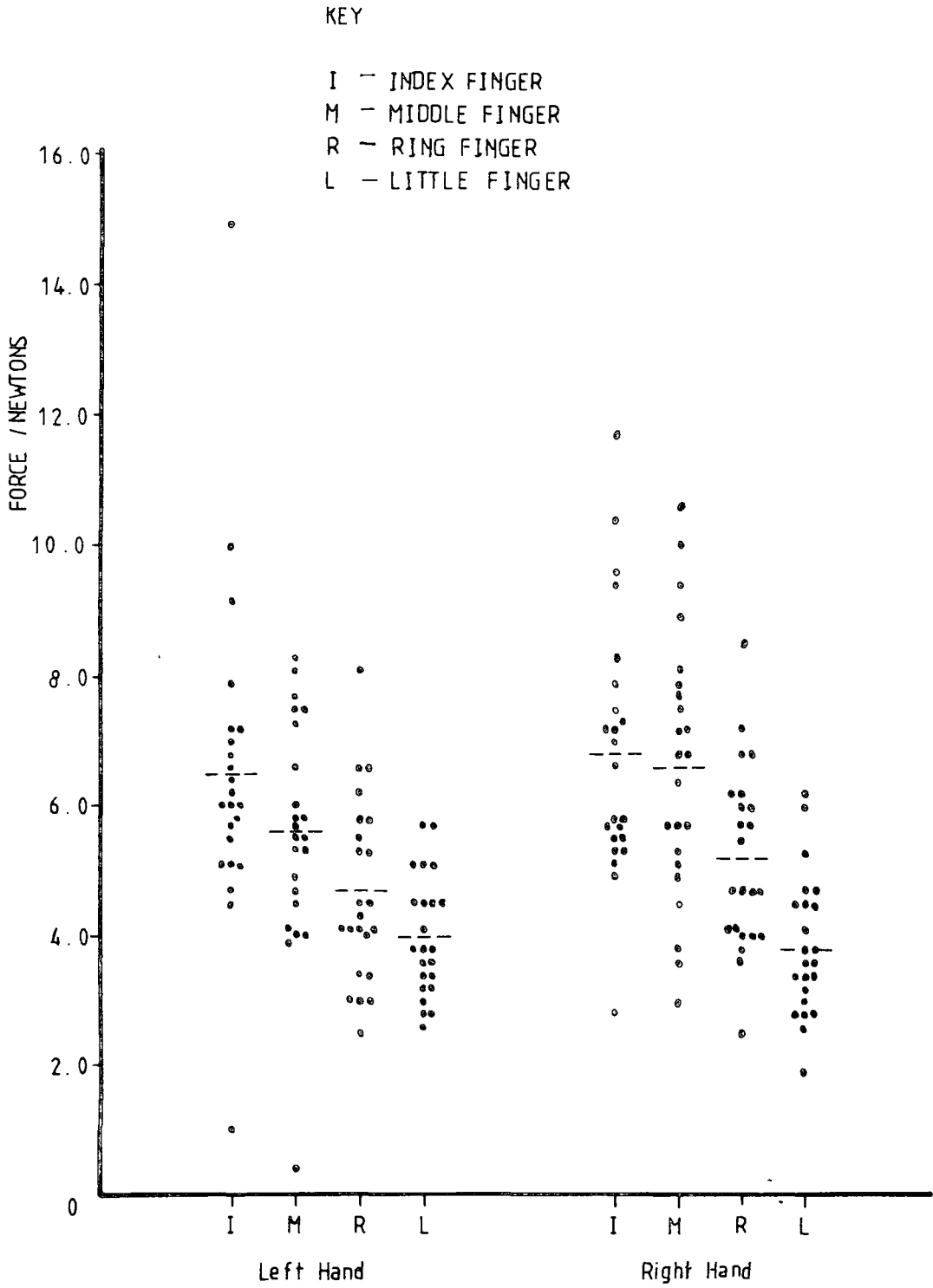

FIGURE 5.6. Scatter diagram of healthy subjects maximum finger extension forces

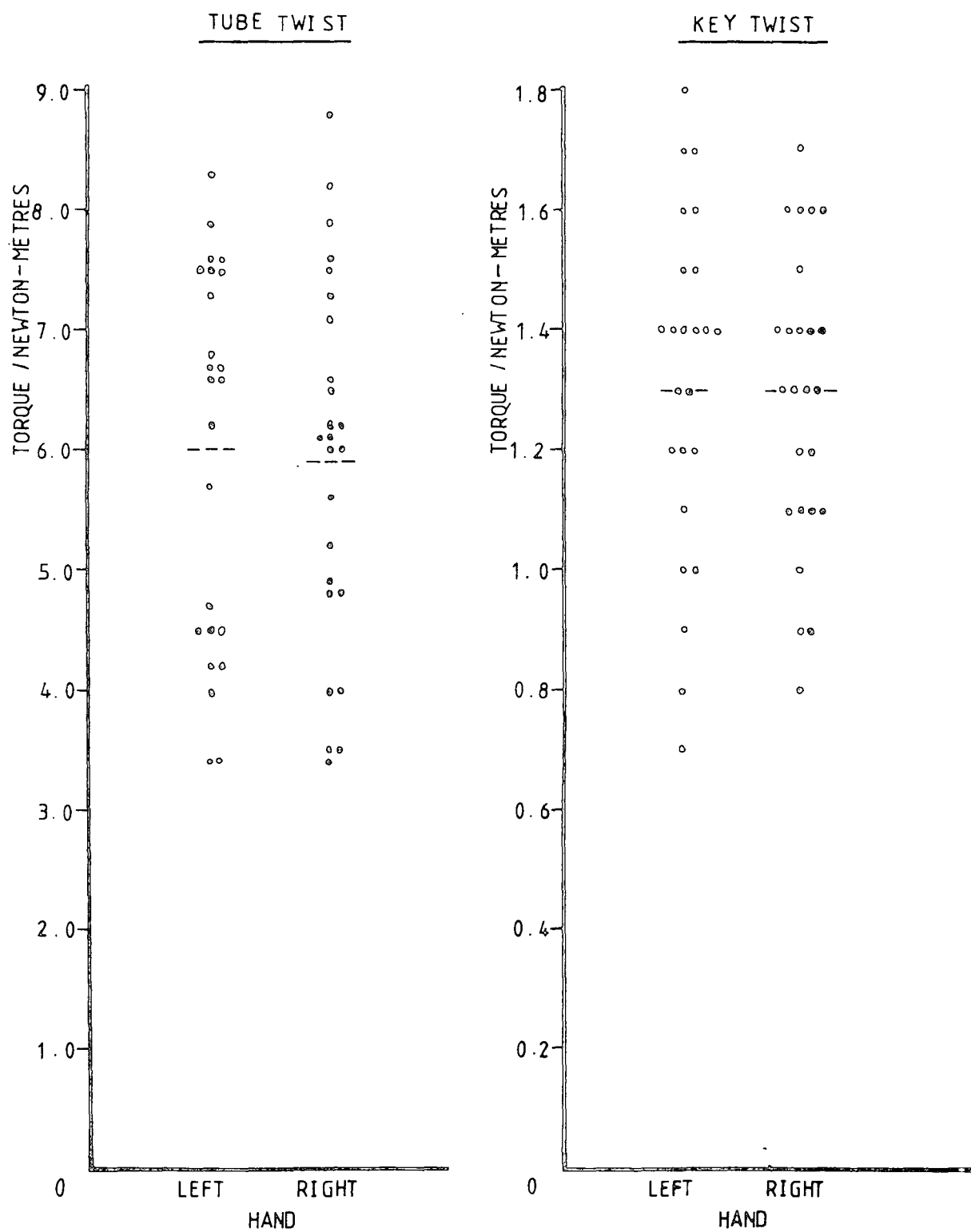

FIGURE 5.7. Scatter diagram of healthy subjects maximum key and tube torques

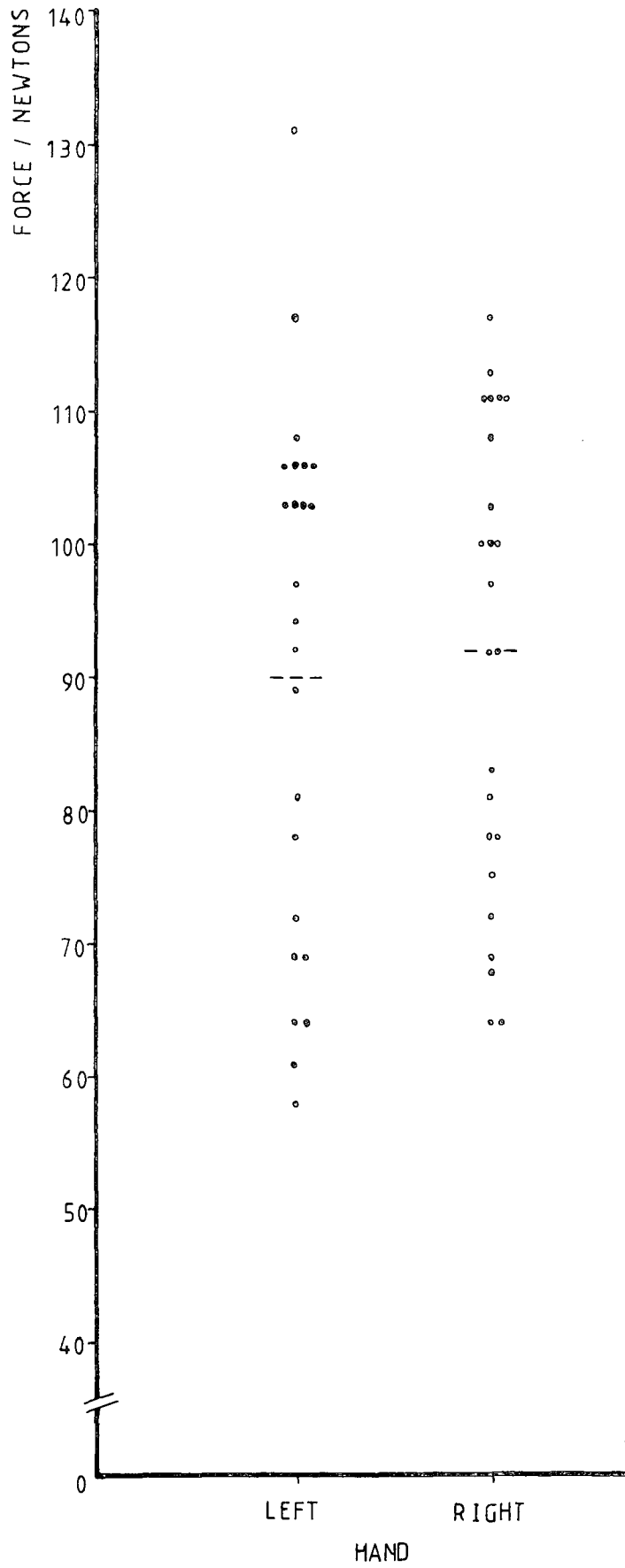

FIGURE 5.8. Scatter diagram of healthy subjects maximum lateral pinch forces

		LEFT HAND							RIGHT HAND						
DEVICE		MEAN	S	Min	Max	Sk	P	n	MEAN	S	Min	Max	Sk	P	n
POWER	In	68.4	21.1	36	110	0.1	>.05	26	68.3	21.9	35	117	0.4	>.05	26
GRIP	Mi	129.1	39.1	38	188	-0.4	>.05	26	137.1	37.3	62	218	0.4	>.05	26
	Ri	88.7	26.0	41	142	0.4	>.05	26	99.7	23.5	53	143	0.01	>.05	26
	Li	55.2	18.1	23	97	0.4	>.05	26	57.1	18.1	23	103	0.6	>.05	26
	TOTAL	335.4	88.0	187	469	-0.2	>.05	26	354.9	74.0	221	476	0	>.05	26
PAN	max grip	119.2	58.0	62	249	1.1	.01	25	131.0	61.3	31	309	0.8	<.05	25
	lo lift	39.9	12.8	20	76	0.8	>.01	25	44.6	15.9	16	76	0.3	>.05	25
	up lift	43.6	16.3	17	79	0.6	>.05	25	48.4	22.2	13	107	1.0	<.05	25
	max lift grip	87.4	48.1	19	227	1.2	<.01	25	91.5	67.7	13	295	1.4	<.01	25
KETTLE	max grip	52.2	33.3	8	114	0.4	>.05	25	58.1	38.0	7	156	0.8	>.05	25
	lo lift	111.9	64.2	40	302	1.8	<.01	25	99.5	47.3	29	234	1.3	<.01	25
	up lift	119.6	65.7	39	307	1.7	<.01	25	105.3	48.9	28	237	1.2	<.01	25
	max lift grip	29.1	28.3	1	129	2.0	<.01	25	28.6	20.9	2	65	0.4	>.05	25
PULP PINCH	In	55.6	13.2	28	92	0.2	>.05	25	55.9	12.6	33	83	-0.1	>.05	24
	Mi	53.8	19.5	8	99	0.1	>.05	25	52.9	15.8	19	92	0.2	>.05	24
	Ri	36.9	13.7	14	67	0.3	>.05	25	41.3	13.6	17	78	0.7	.05	24
	Li	30.3	9.4	11	44	-0.3	>.05	25	31.4	8.8	17	44	-0.1	>.05	24
EXTENSION	In	6.5	2.5	1.0	14.9	1.4	<.01	23	6.8	2.0	2.8	11.7	0.6	>.05	23
	Mi	5.6	1.8	0.4	8.3	-0.8	<.05	23	6.6	2.0	3.0	10.6	0.2	>.05	23
	Ri	4.7	1.4	2.5	8.1	0.6	>.05	23	5.2	1.4	2.5	8.5	0.4	>.05	23
	Li	4.0	0.9	2.6	5.7	0.4	>.05	23	3.9	1.1	1.9	6.2	0.5	>.05	23
KEY TWIST		1.3	0.3	0.7	1.8	-0.3	>.05	25	1.3	0.2	0.8	1.7	-0.2	>.05	24
TUBE TWIST		6.0	1.5	3.4	8.3	-0.3	>.05	25	5.9	1.6	3.4	8.8	0	>.05	24
LATERAL PINCH		89.9	20.0	58	131	0	>.05	25	91.5	17.6	64	117	-0.2	>.05	24

FIGURE 5.9. Mean forces (Newtons) obtained for healthy subjects
S - standard deviation
Sk - skewness
P - probability of no skewness
n - number of subjects

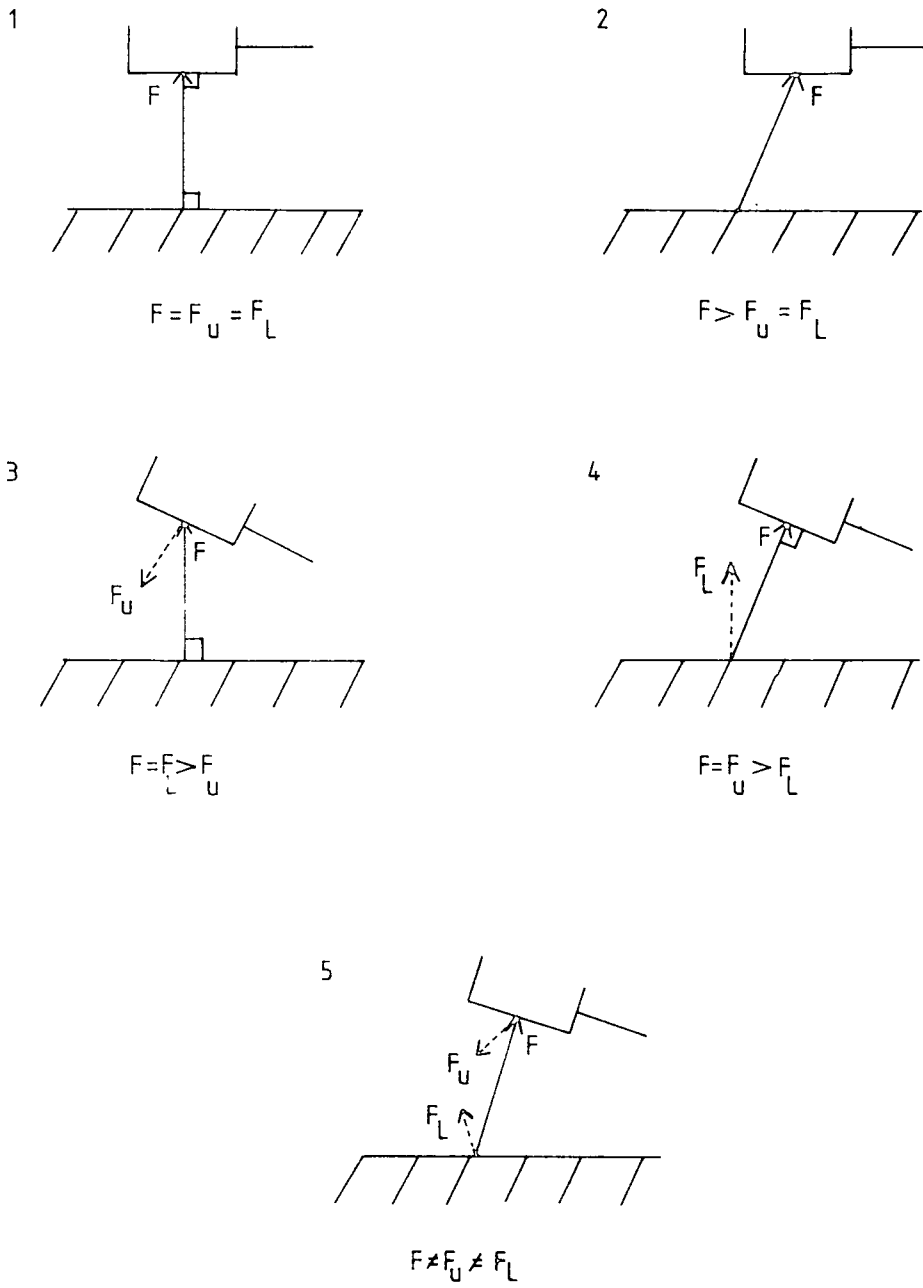

FIGURE 5.10. Techniques used in lifting a pan or kettle

FINGER	Index			Middle			Ring			Little			Total		
SUBJECT	\bar{x}	S	C	\bar{x}	S	C	\bar{x}	S	C	\bar{x}	S	C	\bar{x}	S	C
CONSECUTIVE MEASUREMENT															
1	110	12	10.9	154	18	11.7	112	13	11.6	68	10	14.7	439	23	6.4
2	43	12	27.9	126	13	10.3	125	10	8.0	65	7	10.8	354	24	6.8
3	44	4	9.1	100	15	15.0	76	7	9.2	52	10	19.2	263	16	6.1
4	68	12	17.6	135	11	8.1	97	7	7.2	47	8	17.0	343	13	3.8
5	54	7	13.0	92	24	26.1	97	13	13.4	43	9	20.9	279	27	9.7
6	91	3	3.3	161	12	7.5	128	11	8.6	78	7	9.0	448	23	5.1
7	90	9	10.0	142	25	17.6	105	9	8.6	91	10	11.0	419	43	10.3
8	65	14	21.5	103	17	16.5	48	3	6.3	87	10	11.5	283	14	4.9
9	74	17	23.0	90	30	33.3	73	21	28.8	41	7	17.1	262	19	7.3
10	42	8	19.0	75	10	13.3	68	6	8.8	66	9	13.6	241	18	7.5
MEAN			15.5			15.9			11.1			14.5			6.8
S			7.5			8.2			6.6			4.0			2.0

FIGURE 5.11. Power grip, subject variability(C)
 \bar{x} - mean result of subject(Newtons)
S - standard deviation

	Index			Middle			Ring			Little			Total		
SUBJECT	\bar{x}	S	C	\bar{x}	S	C	\bar{x}	S	C	\bar{x}	S	C	\bar{x}	S	C
SPLIT MEASUREMENT															
a	80	19	23.8	194	16	8.2	139	6	4.3	95	14	14.7	501	38	7.6
b	123	13	10.6	140	39	27.9	119	13	10.9	67	5	7.5	455	23	5.1
c	83	6	7.2	167	17	10.2	124	13	10.5	74	3	4.1	443	23	5.2
d	65	8	12.3	157	8	5.1	-	-	-	71	8	11.3	419	10	2.4
e	94	18	19.1	148	10	12.8	106	14	13.2	51	4	7.8	391	49	12.5
f	94	11	11.7	157	25	15.9	110	11	10.0	91	8	8.8	446	25	5.6
g	112	12	10.7	181	21	11.6	133	21	15.8	55	10	18.1	478	54	11.3
h	80	15	18.8	141	33	23.4	124	6	4.8	54	5	9.3	392	43	11.0
i	98	14	14.3	198	35	17.7	119	12	10.1	72	14	19.4	480	51	10.6
j	79	5	6.3	149	40	26.8	150	15	10.0	52	5	9.4	422	36	8.5
MEAN			13.5			16.0			10.0			11.0			8.0
S			5.6			7.9			3.6			4.9			3.3

FIGURE 5.11 (continued)

Power grip, subject variability(C)

\bar{x} - mean result of subject(Newtons)

S - standard deviation

SUBJECT	Maximum Grip			Lower Lift			Upper Lift			Grip at Max. Lift		
	\bar{x}	S	C	\bar{x}	S	C	\bar{x}	S	C	\bar{x}	S	C
CONSECUTIVE MEASUREMENT												
1	118	22	18.6	27	2	7.4	27	4	14.8	89	27	30.3
2	141	31	22	73	5	6.8	72	9	12.5	-	-	-
3	282	31	11.0	71	6	8.5	90	8	8.9	275	34	12.4
4	108	8	7.4	36	3	8.3	43	5	11.6	104	6	5.8
5	83	11	13.3	44	7	15.9	48	9	18.8	82	11	13.4
6	91	21	23.1	50	3	6.0	61	10	16.4	90	22	24.4
7	196	22	11.2	37	3	8.1	44	3	6.8	180	16	8.9
8	61	9	14.7	29	3	10.3	35	5	14.3	58	9	15.5
9	141	20	14.2	64	5	7.8	79	11	13.9	132	22	16.7
10	148	27	18.2	42	2	4.8	41	3	7.3	-	-	-
11	171	18	10.5	45	3	6.7	46	7	15.2	-	-	-
MEAN			14.9			8.2			12.8			15.9
S			5.0			2.9			3.8			8.0

FIGURE 5.12. Pan, subject variability(C)

\bar{x} - mean result of subject(Newtons)

S - standard deviation

SUBJECT	Maximum Grip			Lower Lift			Upper lift			Grip at Max. Lift		
	\bar{x}	S	C	\bar{x}	S	C	\bar{x}	S	C	\bar{x}	S	C
SPLIT MEASUREMENT												
a	114	26	22.8	39	6	15.4	37	7	18.9	94	15	16.0
b	99	9	9.1	53	3	5.7	56	18	32.1	89	10	11.2
c	62	24	38.7	36	7	19.4	38	14	36.8	66	11	16.7
d	92	27	29.3	19	2	10.5	17	4	23.5	76	19	15.0
e	138	22	15.9	37	4	10.8	36	8	22.2	112	21	18.8
f	118	20	16.9	38	4	10.5	39	8	20.5	105	24	22.9
g	46	18	39.1	23	11	47.8	33	13	39.3	43	17	39.5
h	156	16	10.3	45	3	6.7	59	12	20.3	140	18	12.9
MEAN			22.8			15.9			26.7			20.4
S			11.9			13.6			8.1			9.0

FIGURE 5.12 (continued) Pan, subject variability(C)

\bar{x} - mean result of subject(Newtons)

S - standard deviation

SUBJECT	Maximum Grip			Lower lift			Upper lift			Grip at max lift		
	\bar{x}	S	C	\bar{x}	S	C	\bar{x}	S	C	\bar{x}	S	C
1	24	6	25.0	46	4	8.7	47	4	8.5	15	3	20.0
2	41	6	14.6	138	13	9.4	146	18	12.3	23	6	26.0
3	17	6	35.3	87	11	12.6	89	12	13.5	6	2	33.3
4	50	11	22.0	72	7	9.7	82	9	11.0	30	9	30.0
5	33	11	33.3	96	9	9.4	96	11	11.5	24	9	37.5
6	52	33	63.5	79	16	20.3	88	18	20.5	32	19	59.4
7	11	4	36.4	128	15	11.7	128	17	13.3	8	3	37.5
MEAN			32.9			11.7			13.0			35.8
S			15.7			4.0			3.7			12.6

FIGURE 5.13. Kettle - subject variability(C)

\bar{x} - mean result of subject

S - standard deviation

SUBJECT	Index			Middle			Ring			Little		
	\bar{x}	S	C	\bar{x}	S	C	\bar{x}	S	C	\bar{x}	S	C
PULP PINCH												
1	56.95	3.64	6.4	50.00	5.15	10.3	36.51	6.09	16.7	32.29	5.74	17.8
2	67.46	5.25	7.8	73.61	6.47	8.8	57.99	5.64	9.7	42.71	5.54	13.0
3	22.22	7.42	10.3	60.42	5.30	8.8	40.62	4.68	11.5	32.99	5.02	15.2
4	68.75	4.39	6.4	66.67	9.27	13.9	49.65	10.01	20.0	34.38	5.34	15.5
5	37.50	2.97	7.9	31.95	3.32	10.4	17.46	2.64	15.1	20.83	1.49	7.1
6	48.61	8.27	17.0	51.59	5.28	10.2	36.46	2.32	6.4	19.44	2.10	10.8
7	58.33	3.64	6.2	38.54	5.83	15.1	39.24	3.47	8.8	31.25	3.23	10.3
8	45.14	1.96	4.3	48.26	4.91	10.2	32.99	1.78	5.4	22.22	3.32	15.0
MEAN			8.3			11.0			11.7			13.1
S			3.9			2.3			5.2			3.5

FIGURE 5.14. Pulp and lateral pinch, subject variability(C)

\bar{x} - mean result of subject(Newtons)

S - standard deviation

LATERAL PINCH						
	consecutive			split		
SUBJECT	\bar{x}	S	C	\bar{x}	S	C
a	94	6	6.4	95	6	6.3
b	100	7	7.0	103	3	2.9
c	102	8	7.8	110	14	12.7
d	91	7	7.7	94	6	6.4
e	90	4	4.4	90	3	3.3
f	102	3	2.9	99	5	5.1
g	93	4	4.3	94	5	5.3
h	108	4	3.7	108	3	2.8
i	86	5	5.8	90	8	8.9
MEAN			5.6			6.0
S			1.8			3.2

FIGURE 5.14 (continued)

Pulp and lateral pinch, subject variability(C)

\bar{x} - mean result of subject

S - standard deviation

Twist	Key			Tube		
SUBJECT	\bar{x}	S	C	\bar{x}	S	C
1	1.50	0.13	8.3	5.9	0.7	11.9
2	1.40	0.10	7.6	3.2	0.5	15.6
3	1.37	0.16	11.7	4.6	1.1	23.9
4	1.38	0.09	6.8	4.7	0.5	10.6
5	0.81	0.07	8.8	7.7	0.7	9.1
6	0.97	0.04	4.5	6.3	0.7	11.1
7	1.08	0.03	2.8	5.5	0.7	12.7
8	0.86	0.09	10.2	-	-	-
MEAN			7.6	-	-	13.6
S			2.9	-	-	5.0

FIGURE 5.15. Key and tube twist and extension force subject variability(C)

\bar{x} = mean result of subject(Newtons)
S = standard deviation

TRANSDUCER		CONSECUTIVE			SPLIT			X	P(X)
		\bar{x}	S	n	\bar{x}	S	n		
POWER	In	15.5	7.5	10	13.5	5.6	10	0.68	0.50
GRIP	Mi	15.9	8.2	10	16.0	7.9	10	0.03	0.98
	Ri	11.1	6.6	10	10.0	3.6	10	0.46	0.64
	Li	14.5	4.0	10	11.0	4.9	10	2.25	0.02
	Total	6.8	2.0	10	8.0	3.3	10	0.98	0.32
PAN	max grip	14.9	5.0	11	22.8	11.9	8	1.76	0.08
	lo lift	8.2	2.9	11	15.9	13.6	8	1.57	0.12
	up lift	12.8	3.8	11	26.7	8.1	8	4.50	<0.01
	max lift grip	15.9	8.0	8	20.4	9.0	8	-1.06	0.28
LATERAL PINCH		5.6	1.8	9	6.0	3.2	9	0.33	0.74

FIGURE 5.16. A comparison between the subject variability from consecutive and split measurement

\bar{x} - mean result

S - standard deviation

P(X) - probability of both measurements being the same

TRANSDUCER		RANGE		MEAN	S
		min	to max	(%)	
		(%)			
POWER	In	3.3	- 27.9	15.5	7.5
GRIP	Mi	7.5	- 33.3	15.9	8.2
	Ri	6.3	- 28.8	11.1	6.6
	Li	9.0	- 20.9	14.5	4.0
	Total	3.8	- 10.3	6.8	2.0
PAN	max grip	7.4	- 23.1	14.9	5.0
	lower lift	4.8	- 15.9	8.2	2.9
	upper lift	6.8	- 18.8	12.8	3.8
	max lift grip	5.8	- 30.3	15.9	8.0
KETTLE	max grip	14.6	- 63.5	32.9	15.7
	lower lift	9.4	- 20.3	11.7	4.0
	upper lift	3.5	- 20.5	13.0	3.7
	max lift grip	20.0	- 59.4	35.8	12.6
PULP	In	4.3	- 17.0	8.3	3.9
PINCH	Mi	8.8	- 15.1	11.0	2.3
	Ri	5.4	- 20.0	11.7	5.2
	Li	7.1	- 17.8	13.1	3.5
EXTENSION	In	1.8	- 10.2	6.0	2.9
	Mi	4.7	- 9.8	6.6	2.2
	Ri	4.2	- 16.1	8.6	5.1
	Li	5.8	- 16.7	8.8	3.8
KEY		2.8	- 11.7	7.6	2.9
TUBE		9.1	- 23.9	13.6	5.0
LATERAL PINCH		2.9	- 7.8	5.6	1.8

FIGURE 5.17. Summary table of subject variability
S = standard deviation

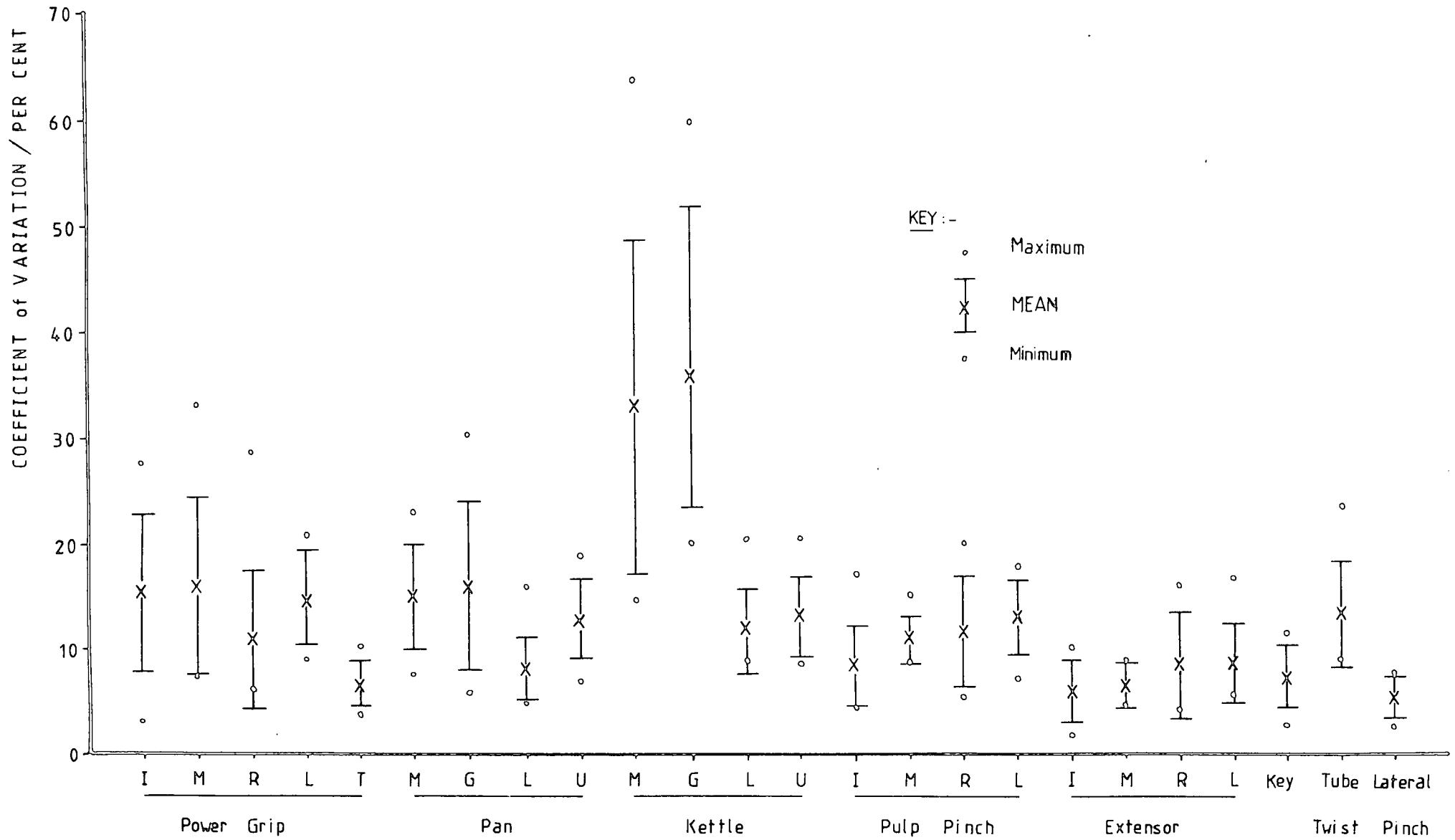

FIGURE 5.18. Diagram showing the subject variability of each transducer

		LEFT HAND				RIGHT HAND				
		In	Mi	Ri	Li	In	Mi	Ri	Li	n
THIS	\bar{x}	18.9	37.0	29.7	16.4	19.5	37.3	28.3	16.5	20
THESIS	S	4.0	5.8	6.2	3.8	4.2	6.2	4.4	4.8	
OHTSUKI	\bar{x}	23.2	33.9	27.7	15.2	24.7	32.8	27.0	15.5	10
	S	4.2	5.1	3.2	3.3	3.9	3.4	2.2	2.0	

FIGURE 5.19a. Percentage contribution of fingers to power grip in healthy subjects

\bar{x} - mean result

S - standard deviation

n - number of subjects measured

		LEFT HAND				RIGHT HAND			
		In	Mi	Ri	Li	In	Mi	Ri	Li
MAXIMUM	\bar{x}	20.0	36.5	29.7	15.9	19.6	36.9	29.2	16.0
	S	4.0	7.0	5.9	4.0	4.6	7.1	4.3	4.3
FORCE AT MAXIMUM POWER GRIP	\bar{x}	19.0	36.4	29.2	15.5	18.9	36.2	30.3	15.3
	S	4.4	7.1	5.6	4.0	4.6	7.5	5.2	4.1

FIGURE 5.19b. Comparison between percentage finger contribution measured at the power grip maximum and that using the maximum finger force

\bar{x} - mean result

S - standard deviation

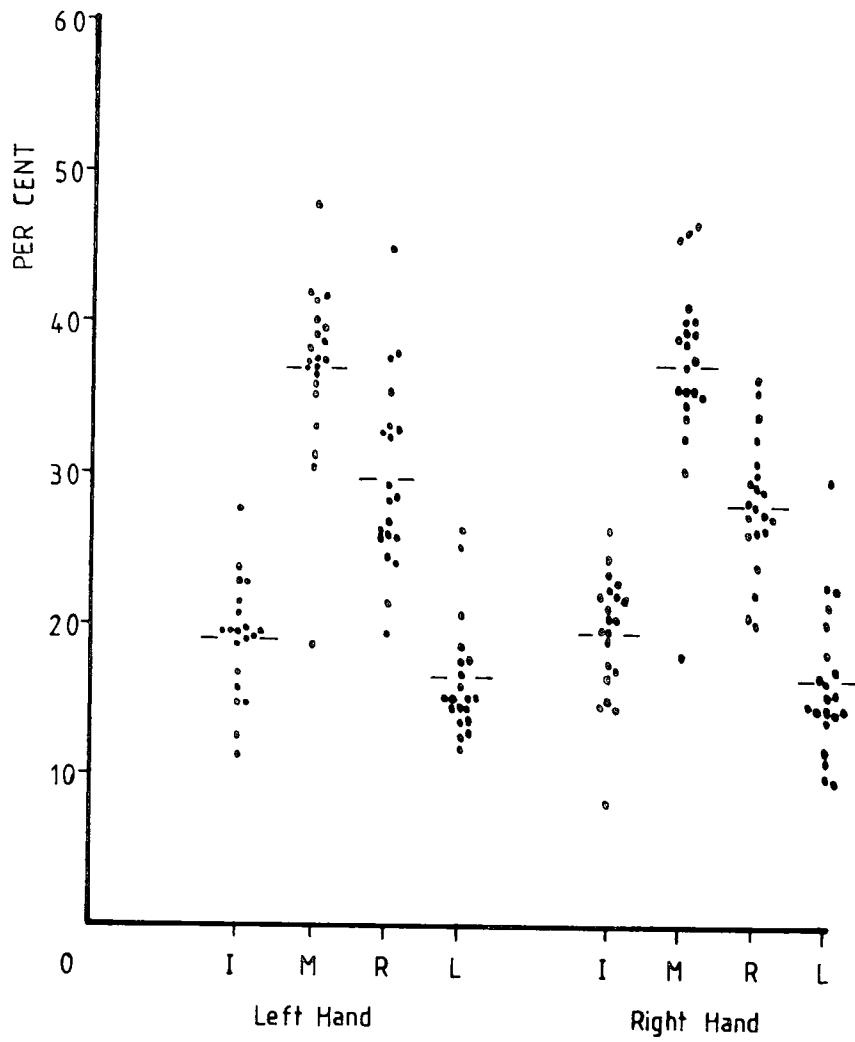

FIGURE 5.20. Scatter diagram of the finger-contribution to power grip in healthy subjects

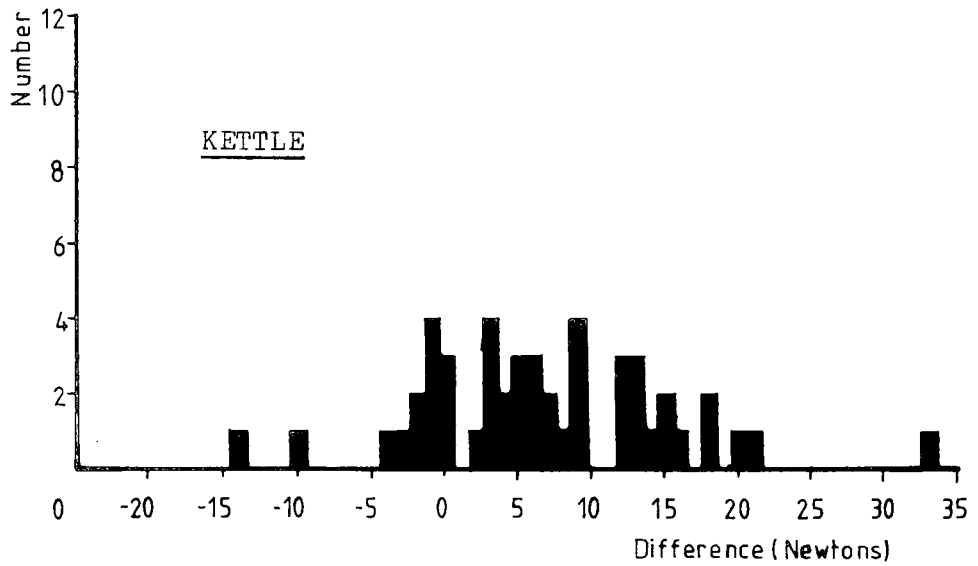
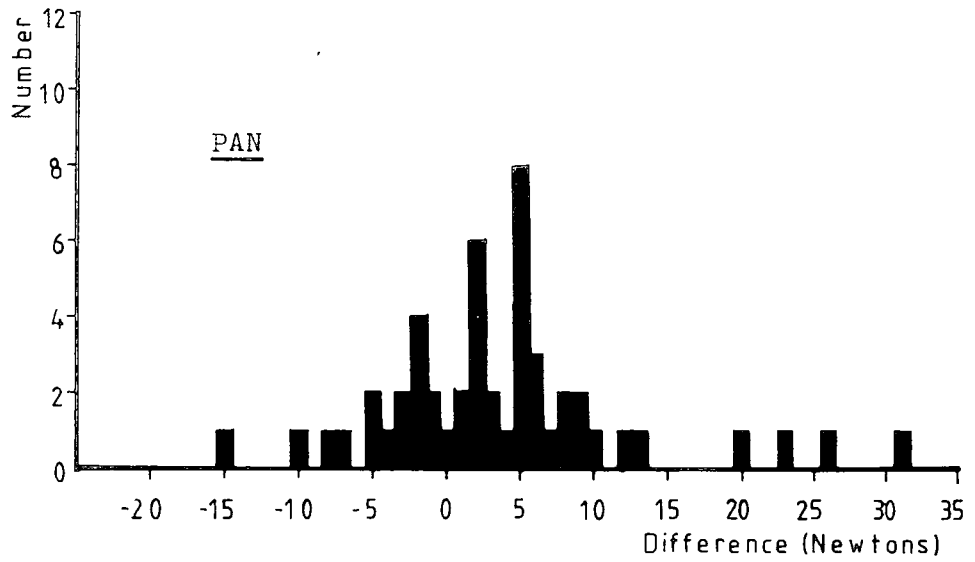

FIGURE 5.21. Histograms of differences between the upper and lower maximum lifting forces in healthy subjects .

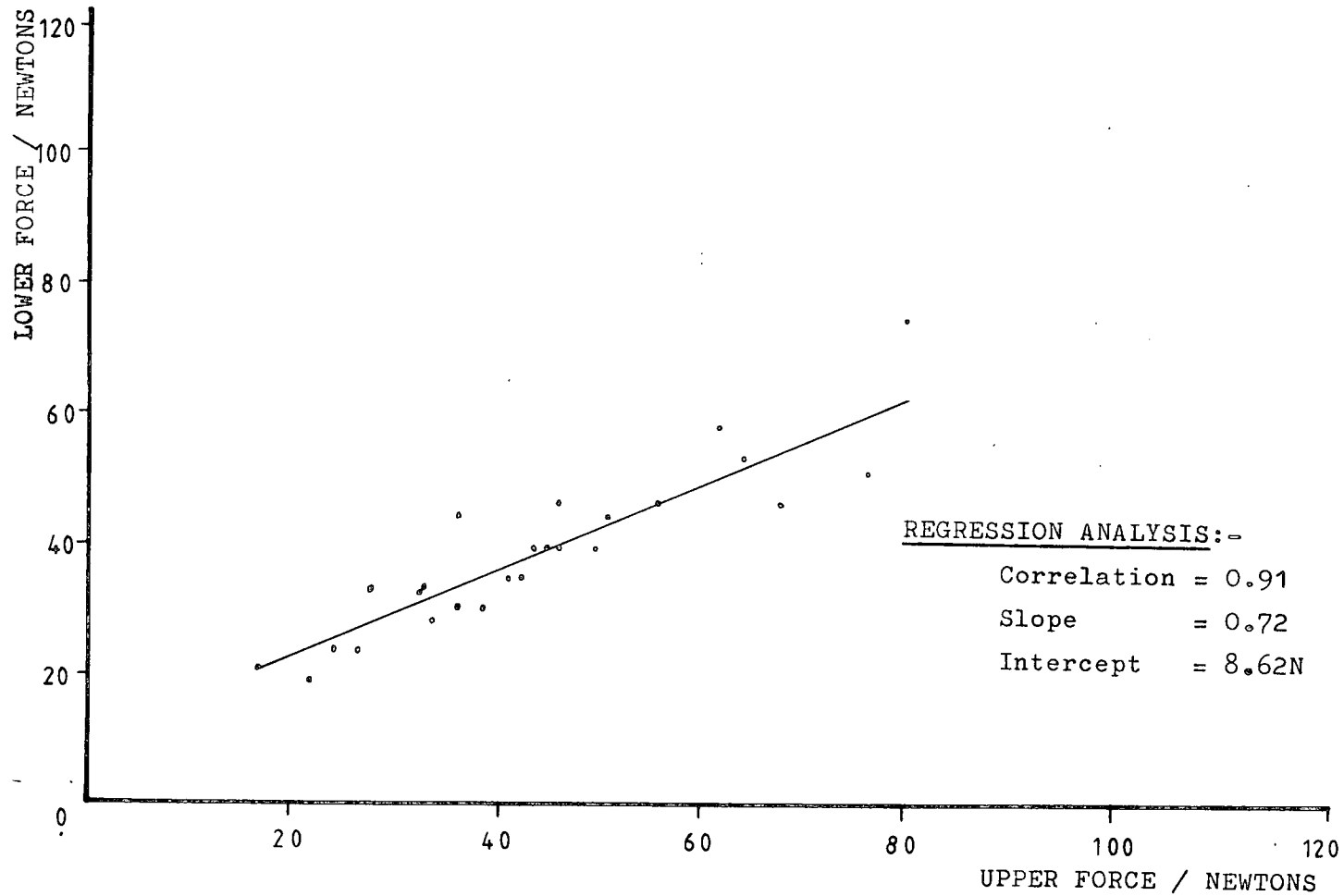

FIGURE 5.22. Scatter diagram and regression analysis: Upper versus lower lifting forces of healthy subjects - left handed pan lifts

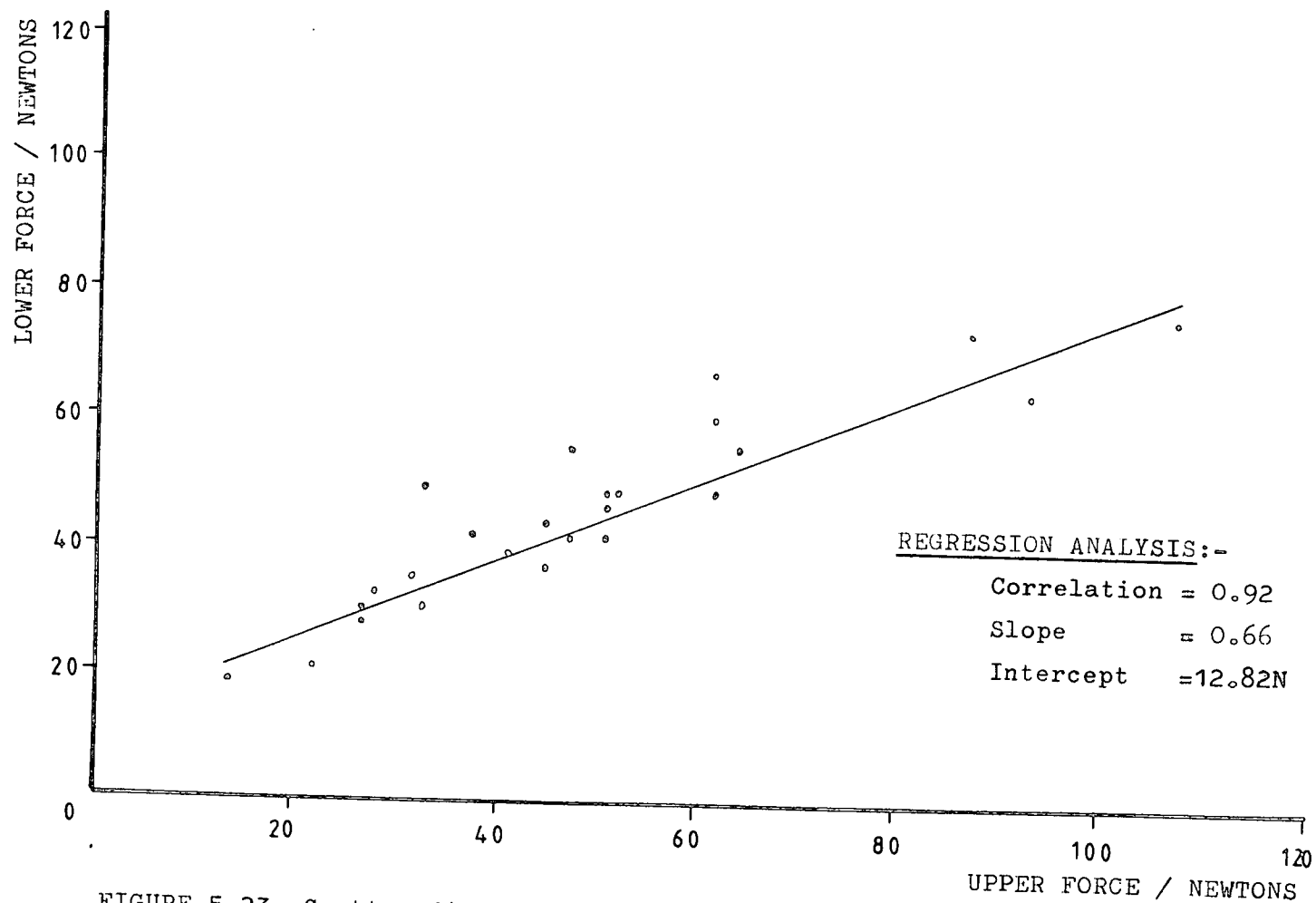

FIGURE 5.23. Scatter diagram and regression analysis: Upper versus lower lifting forces of healthy subjects - right hand pan lifts

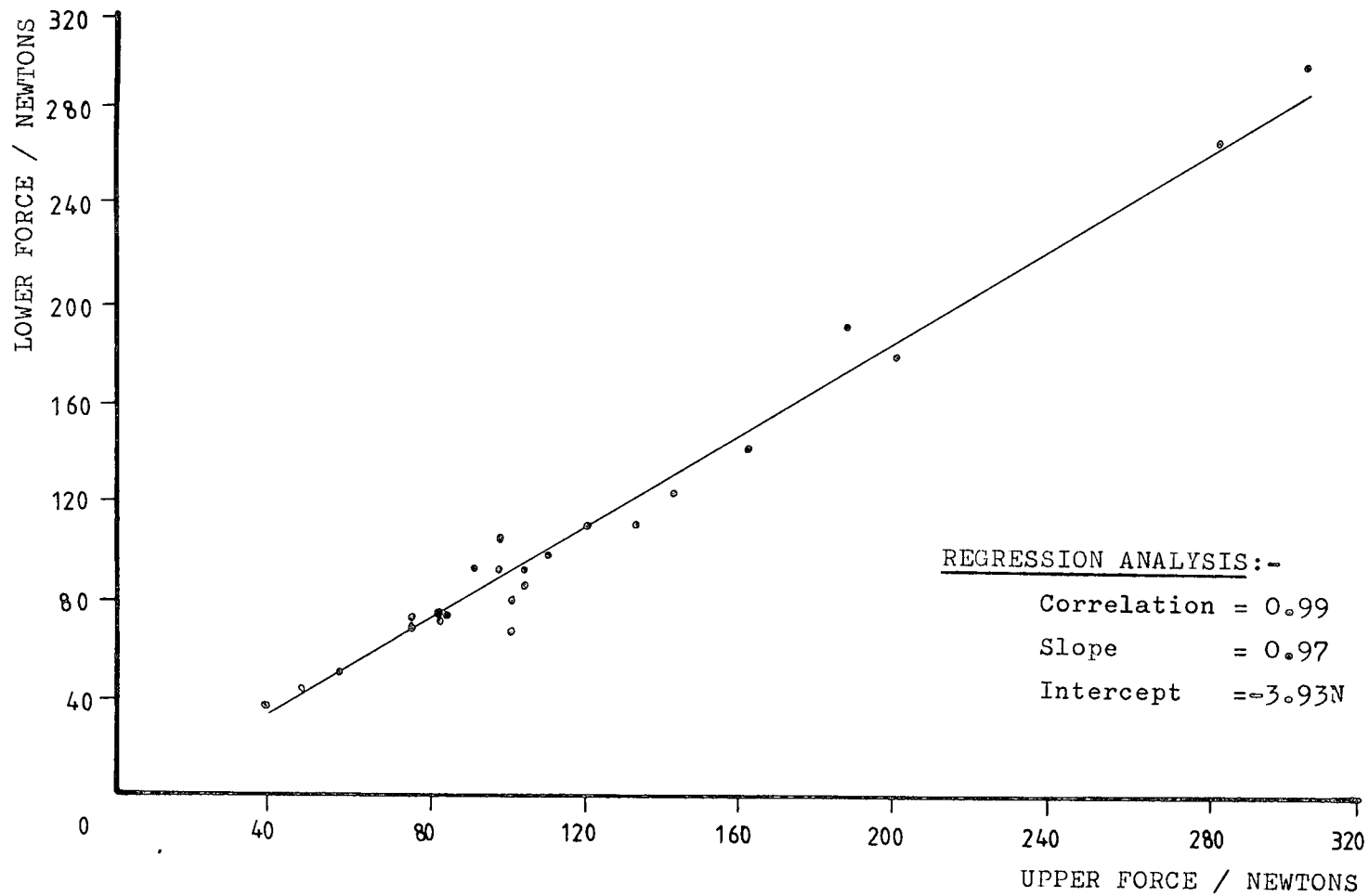

FIGURE 5.24. Scatter diagram and regression analysis: Upper versus lower lifting forces of healthy subjects - left hand kettle lifts

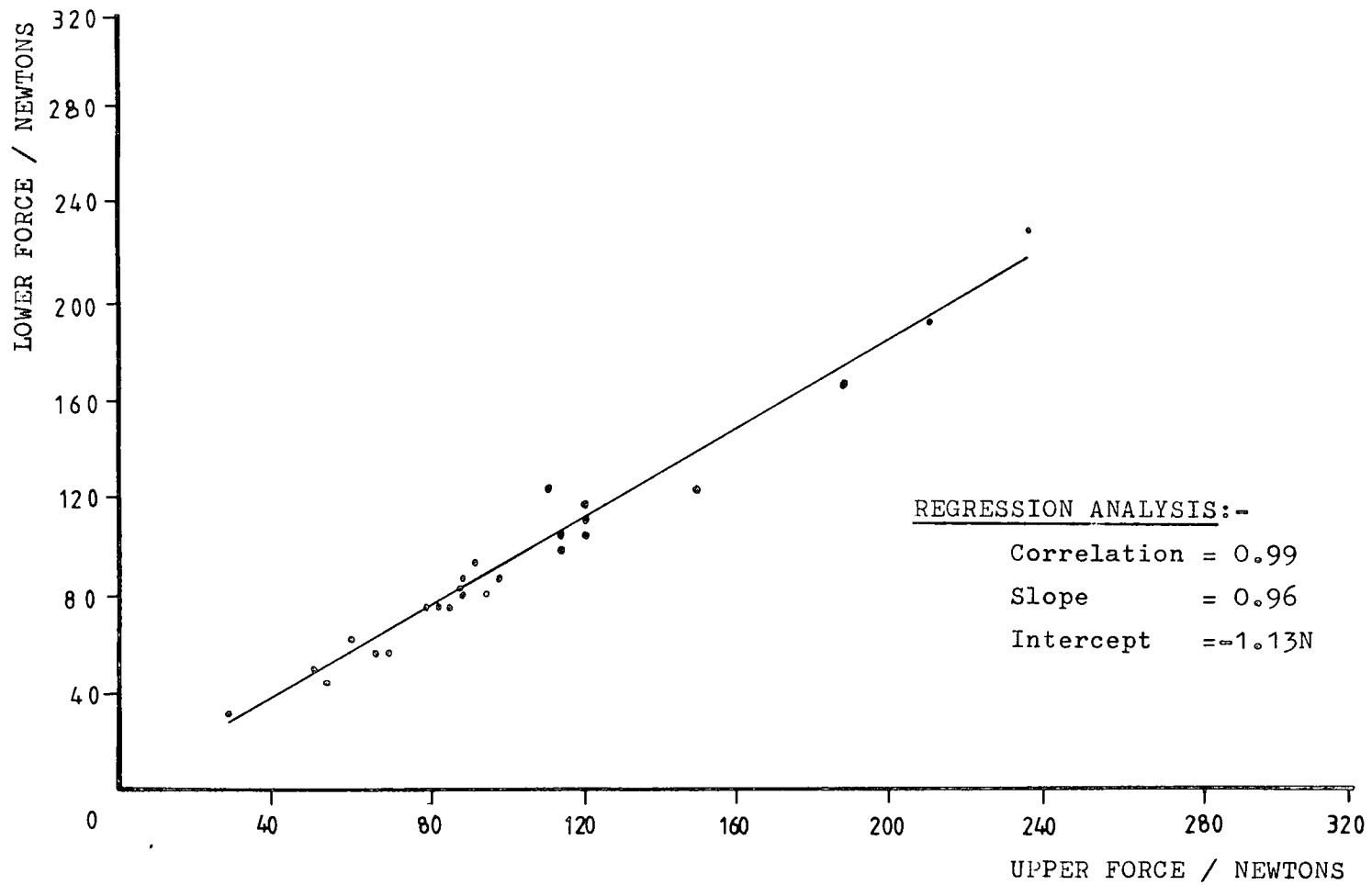

FIGURE 5.25. Scatter diagram and regression analysis: Upper versus lower lifting forces of healthy subjects - right hand kettle lifts

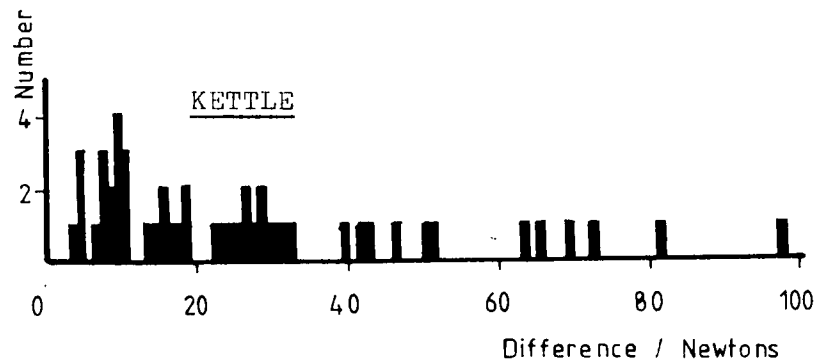
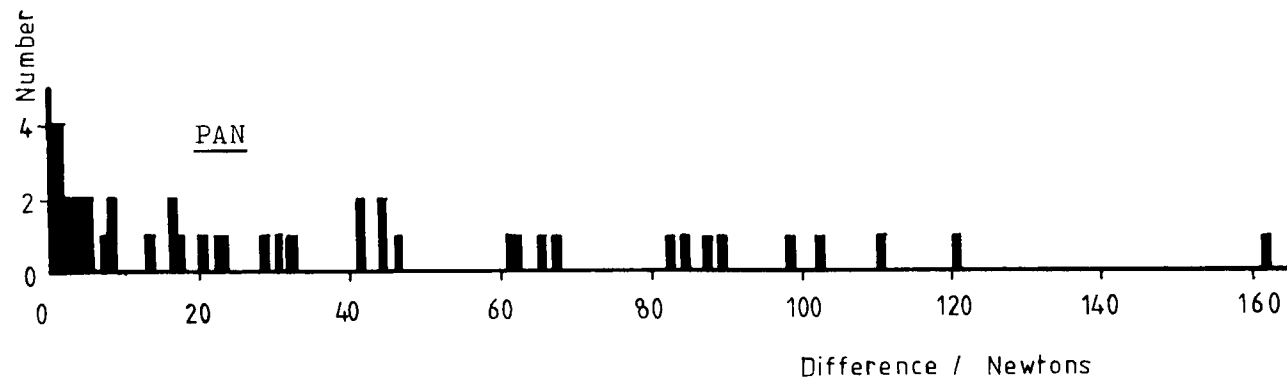

FIGURE 5.26. Histograms of the differences between the maximum handle grip force and the grip force at maximum lift in the pan and kettle lifts of healthy subjects

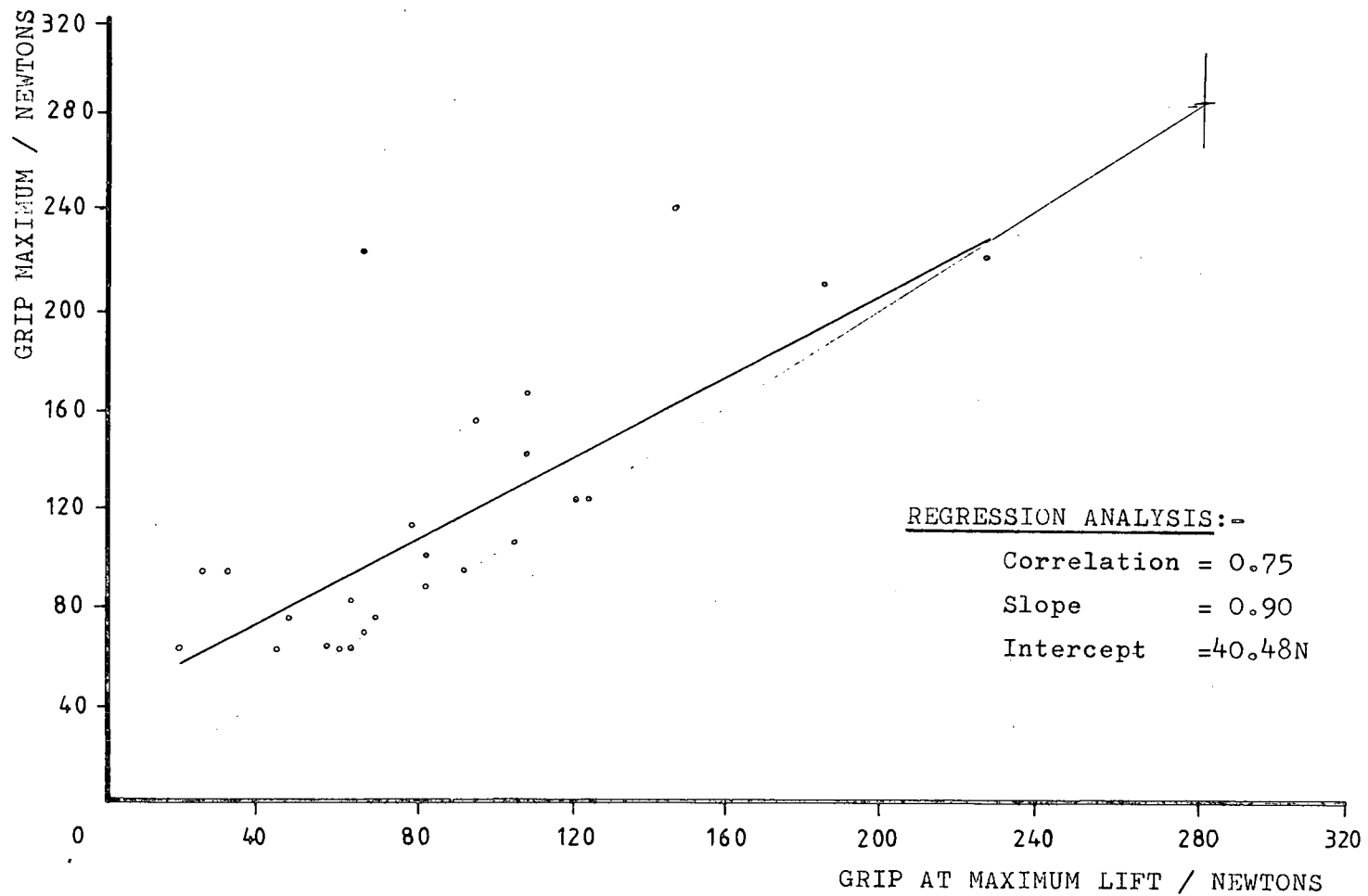

FIGURE 5.27. Scatter diagram and regression analysis of the handle grip force at maximum lift against the maximum handle grip force - left hand pan lifts of healthy subjects

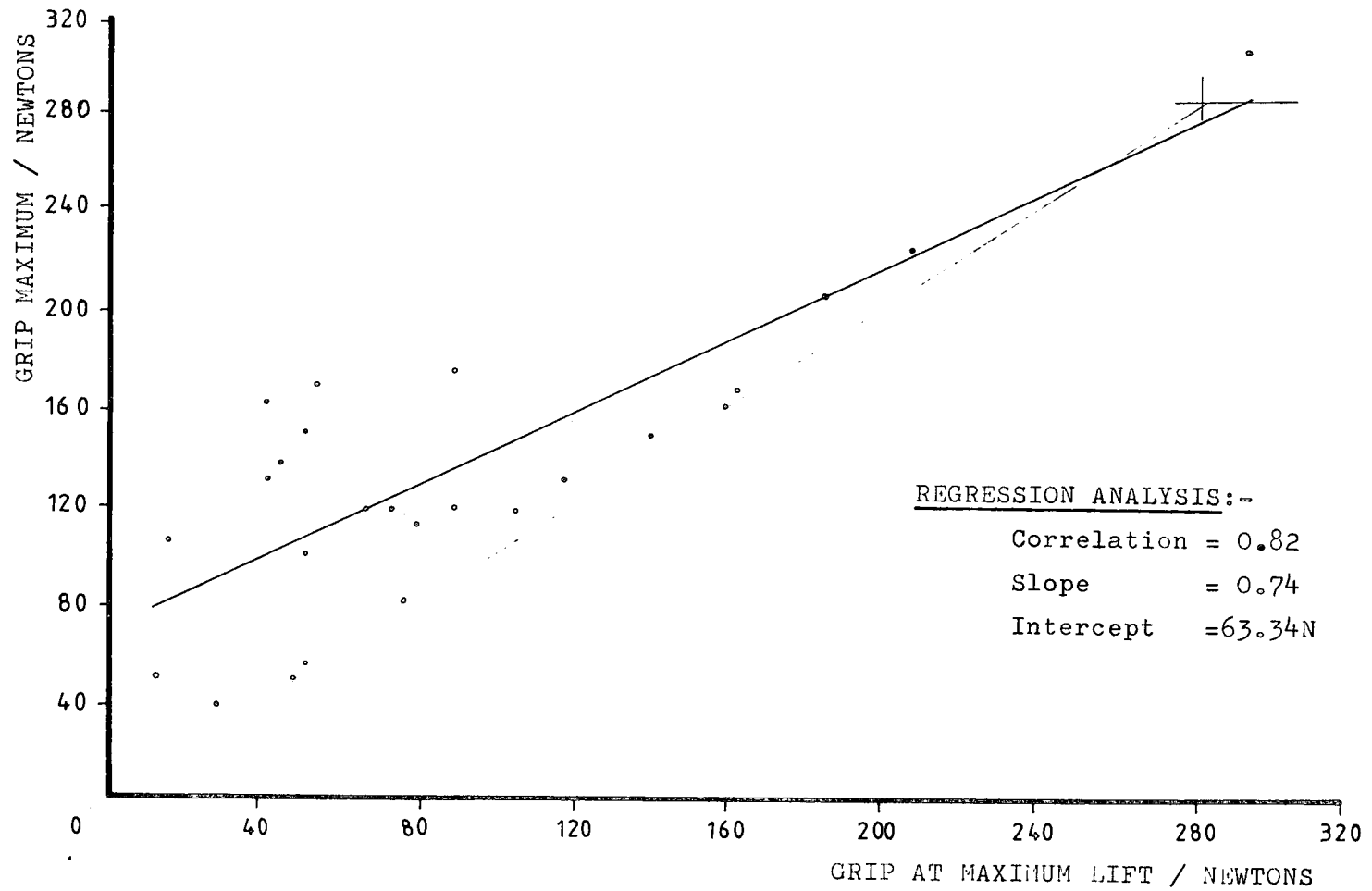

FIGURE 5.28. Scatter diagram and regression analysis of the handle grip force at maximum lift against the maximum handle grip force - right hand pan lifts of healthy subjects

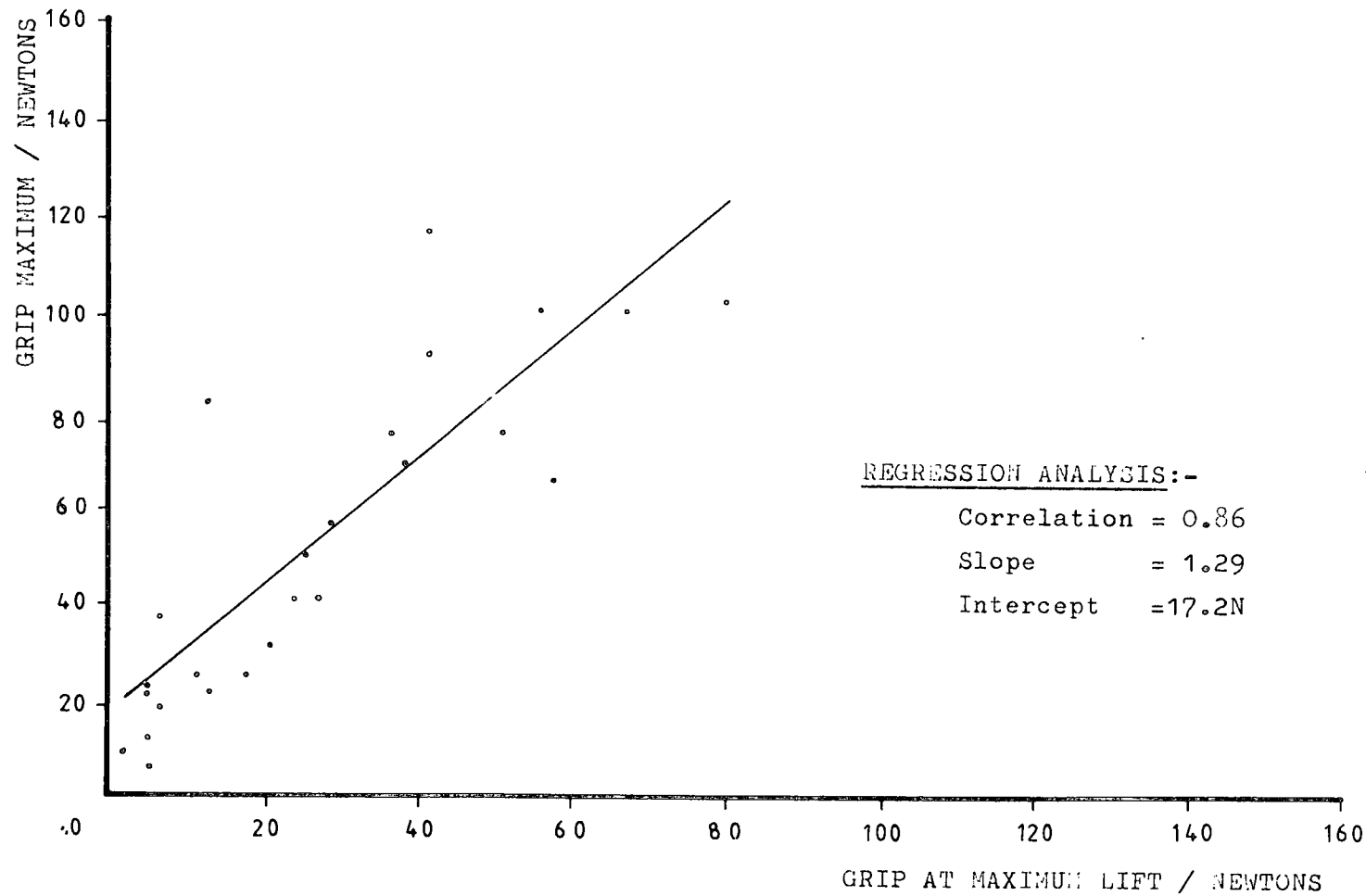

FIGURE 5.29. Scatter diagram and regression analysis of the handle grip force at maximum lift against the maximum handle grip force - left hand kettle lifts of healthy subjects

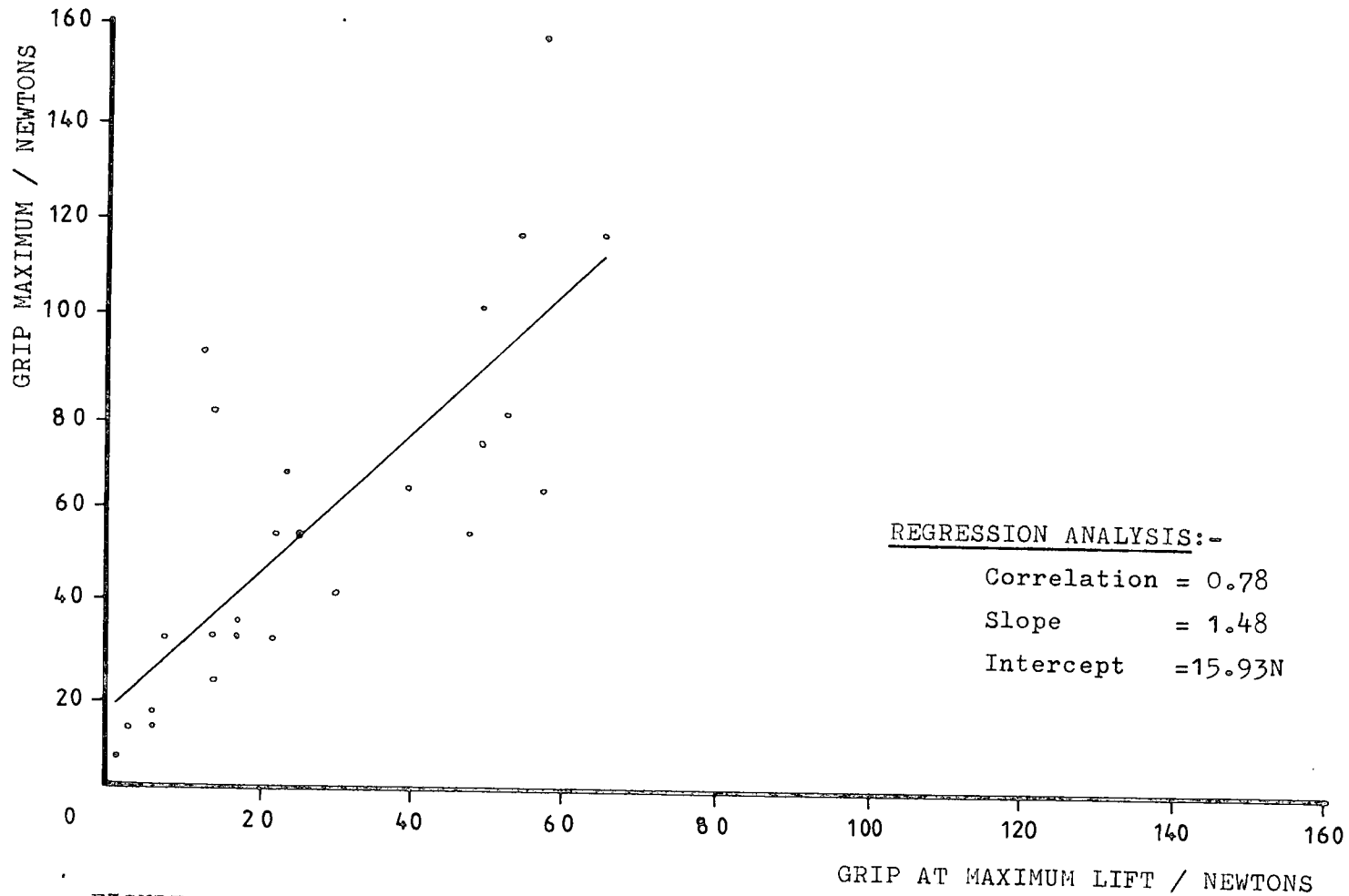

FIGURE 5.30. Scatter diagram and regression analysis of the handle grip force at maximum lift against the maximum handle grip force - right hand kettle lifts of healthy subjects

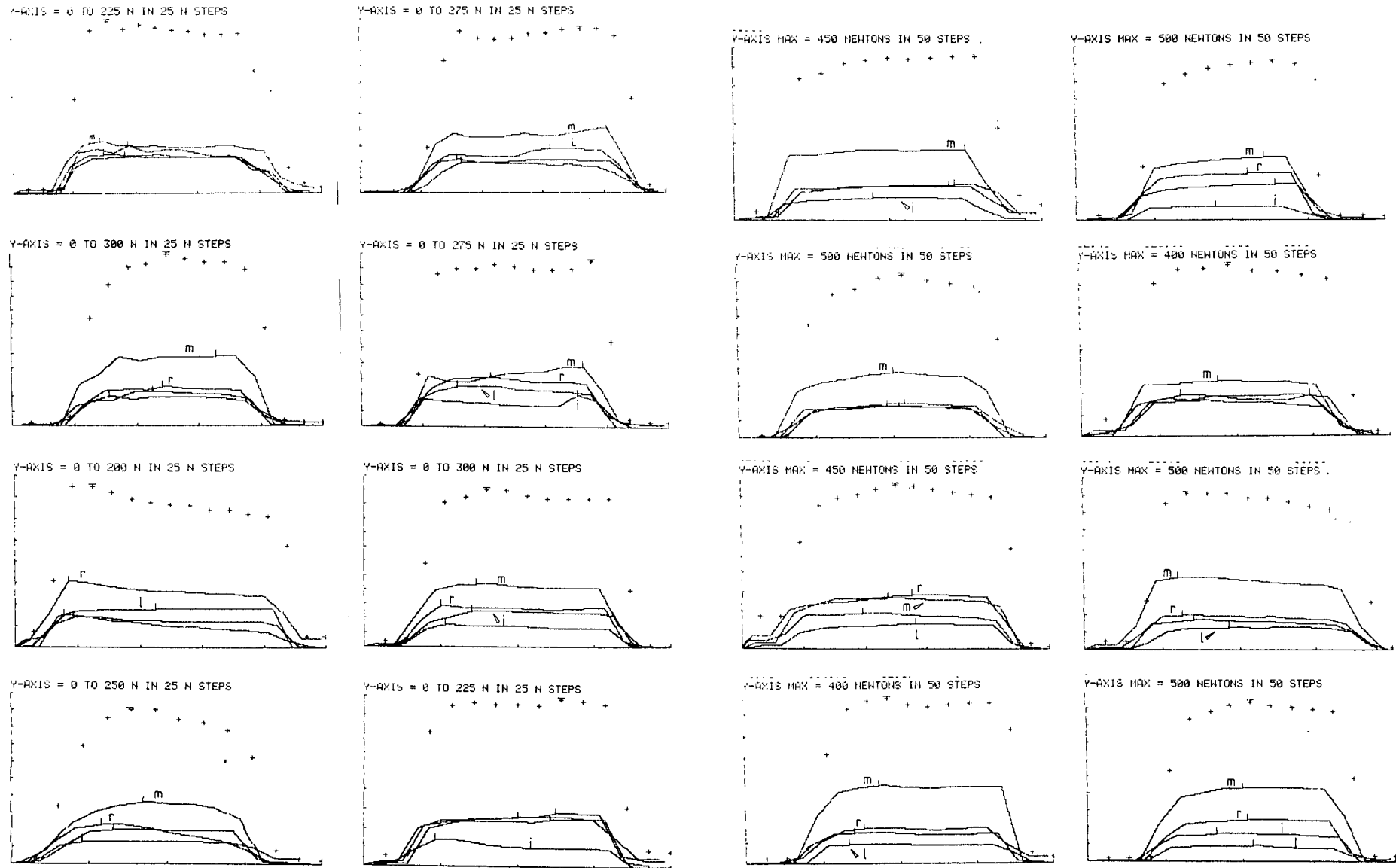

FIGURE 5.31. Force-time curves of healthy subjects' power grip

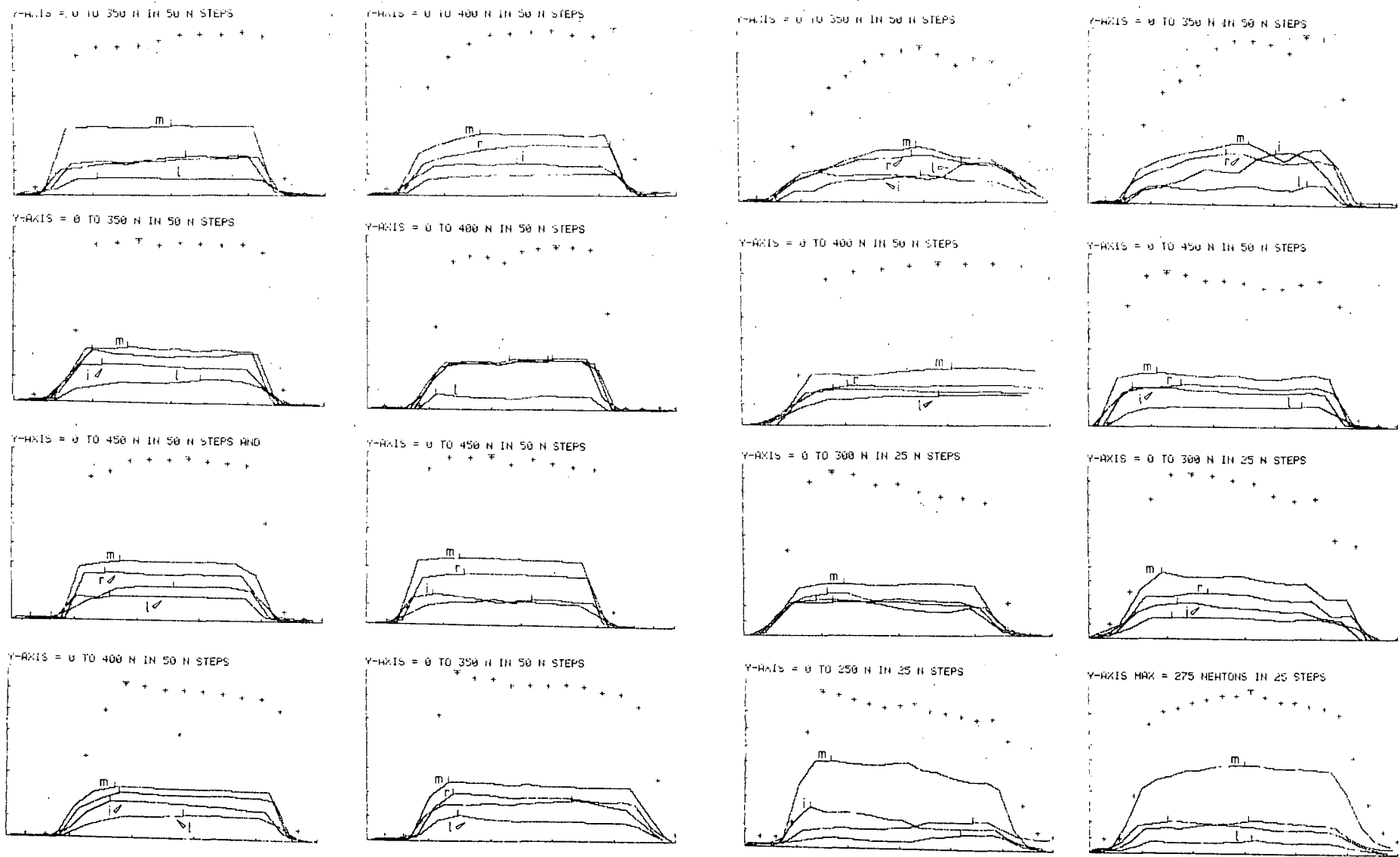

FIGURE 5.31.(continued) Force-time curves of healthy subjects' power grip

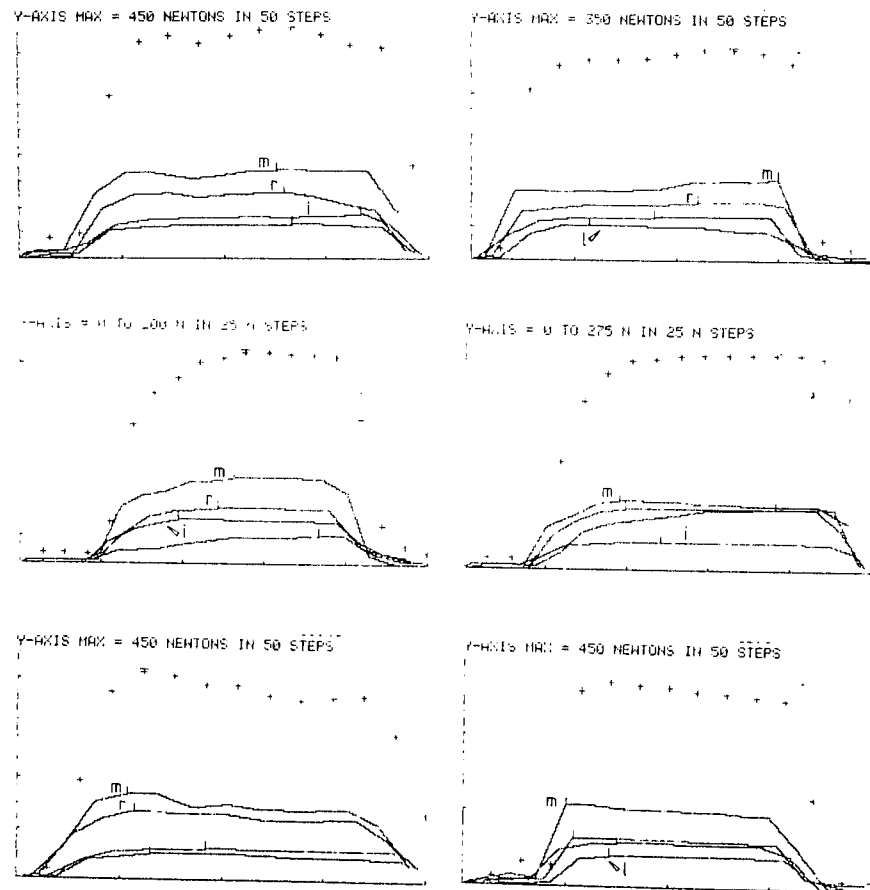

FIGURE 5.31.(continued) Force-time curves of healthy subjects' power grip

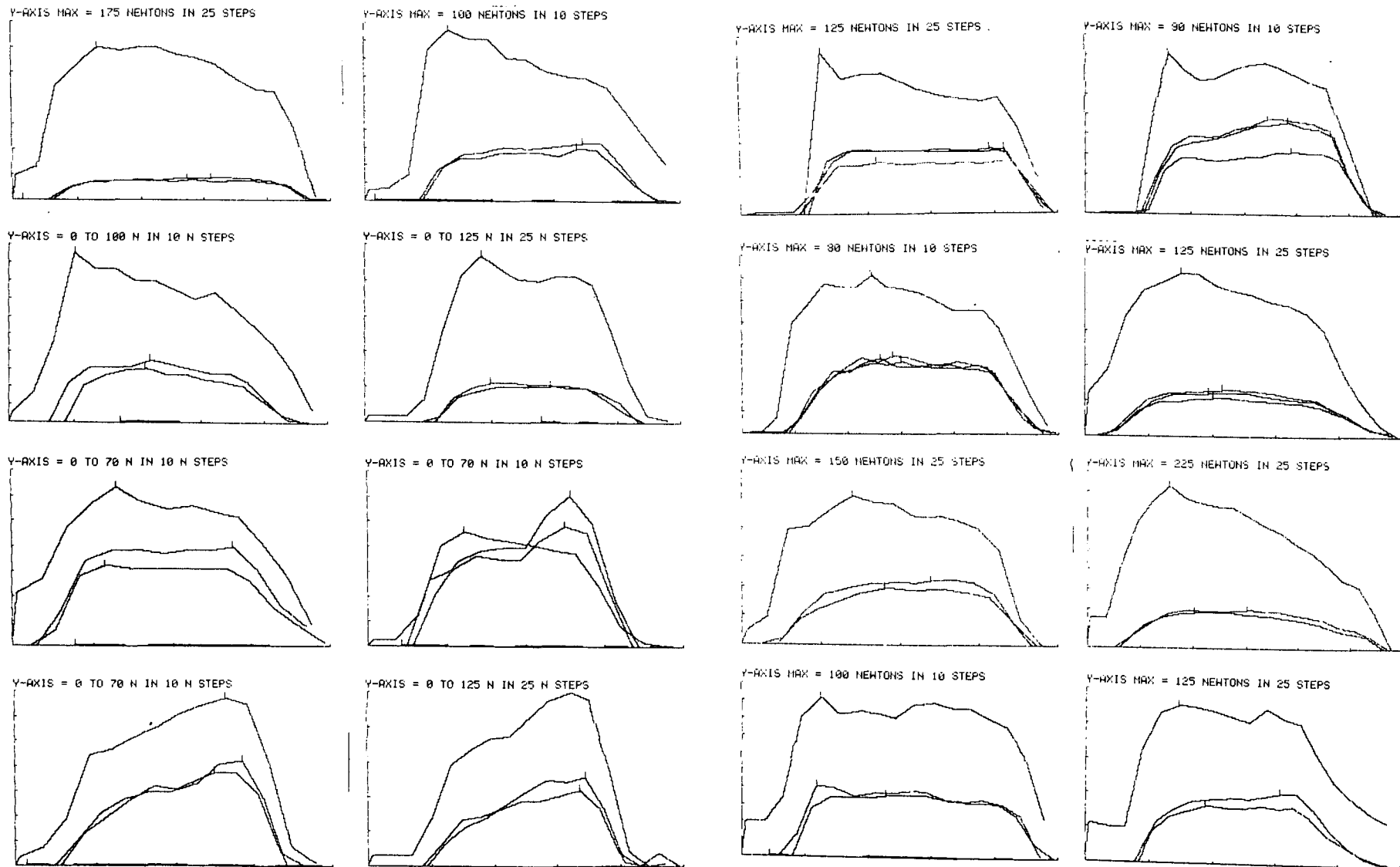

FIGURE 5.32. Force-time curves of healthy subjects' pan lift

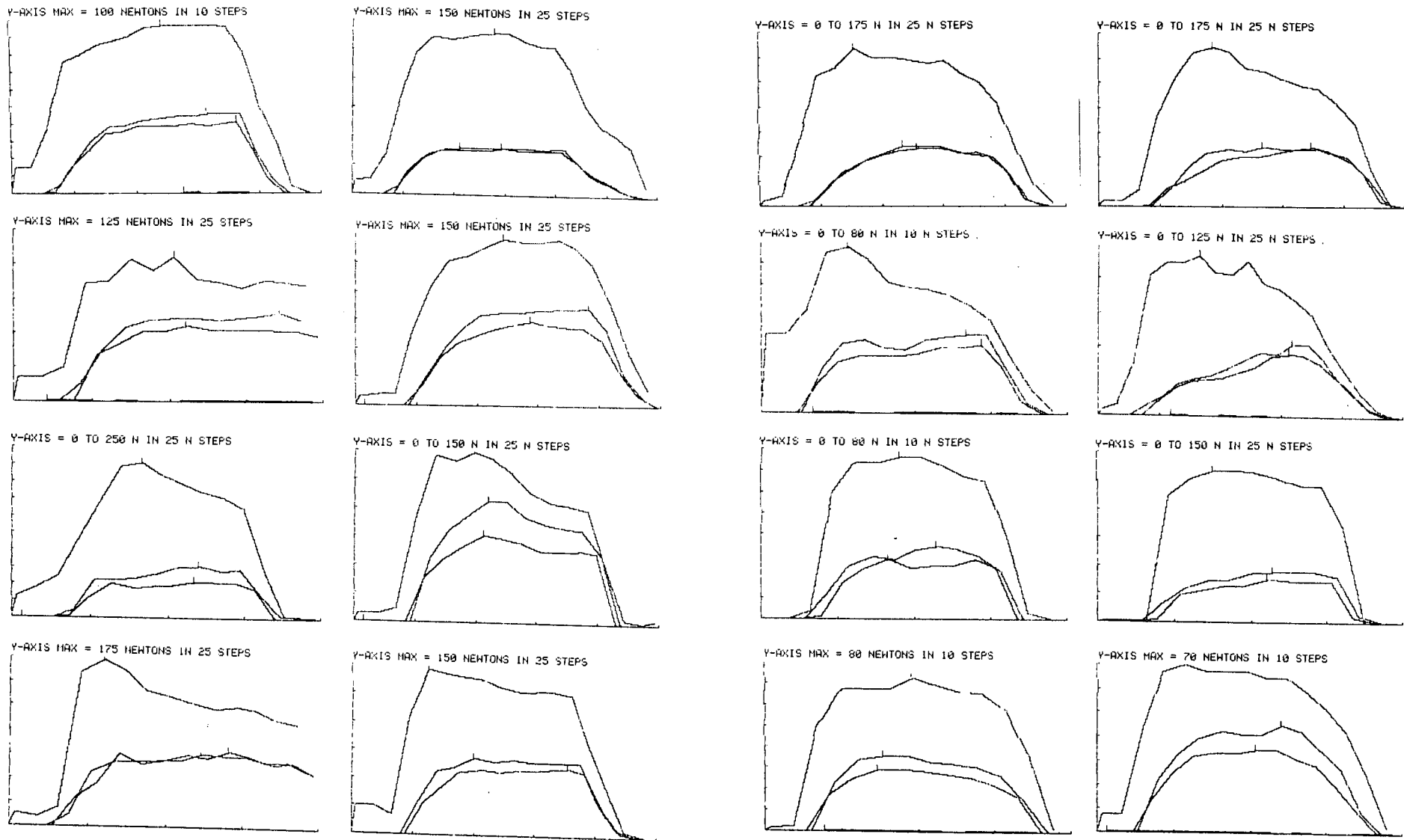

FIGURE 5.32.(continued) Force-time curves of healthy subjects' pan lift

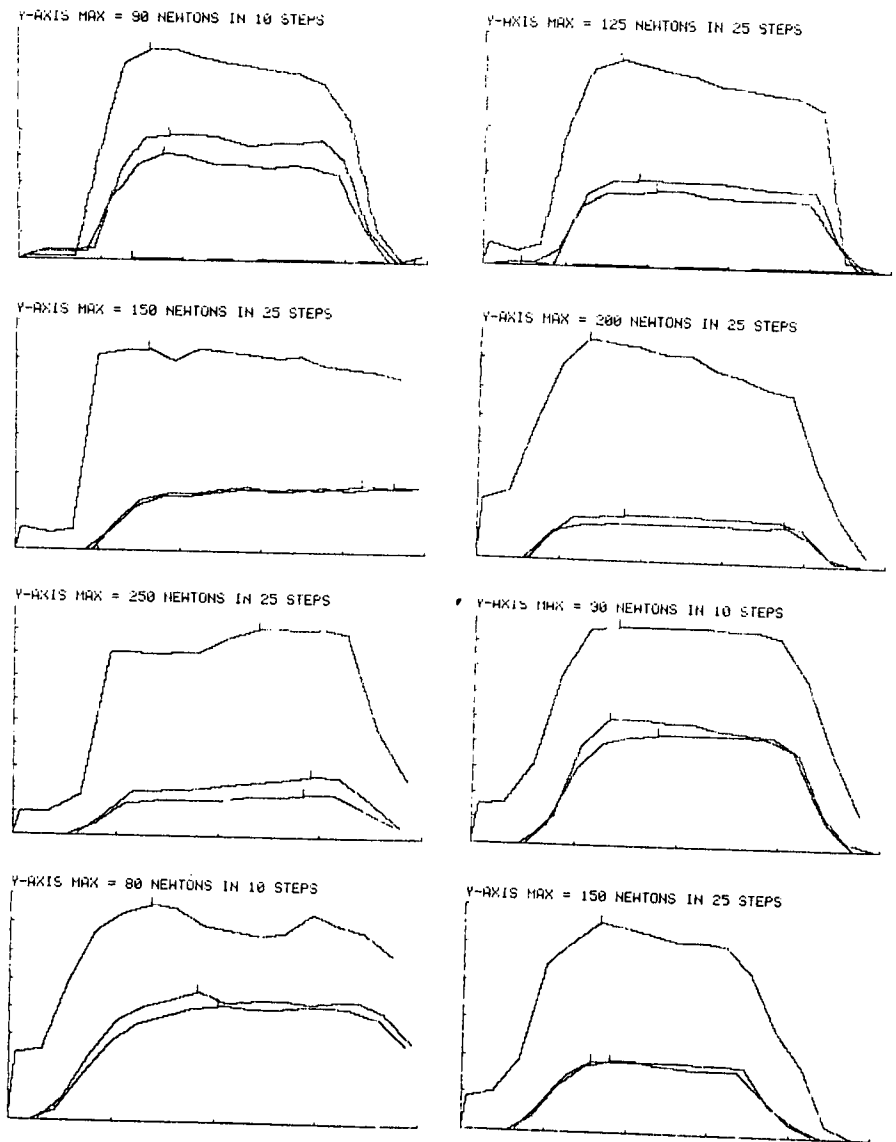

FIGURE 5.32.(continued) Force-time curves of healthy subjects' pan lift

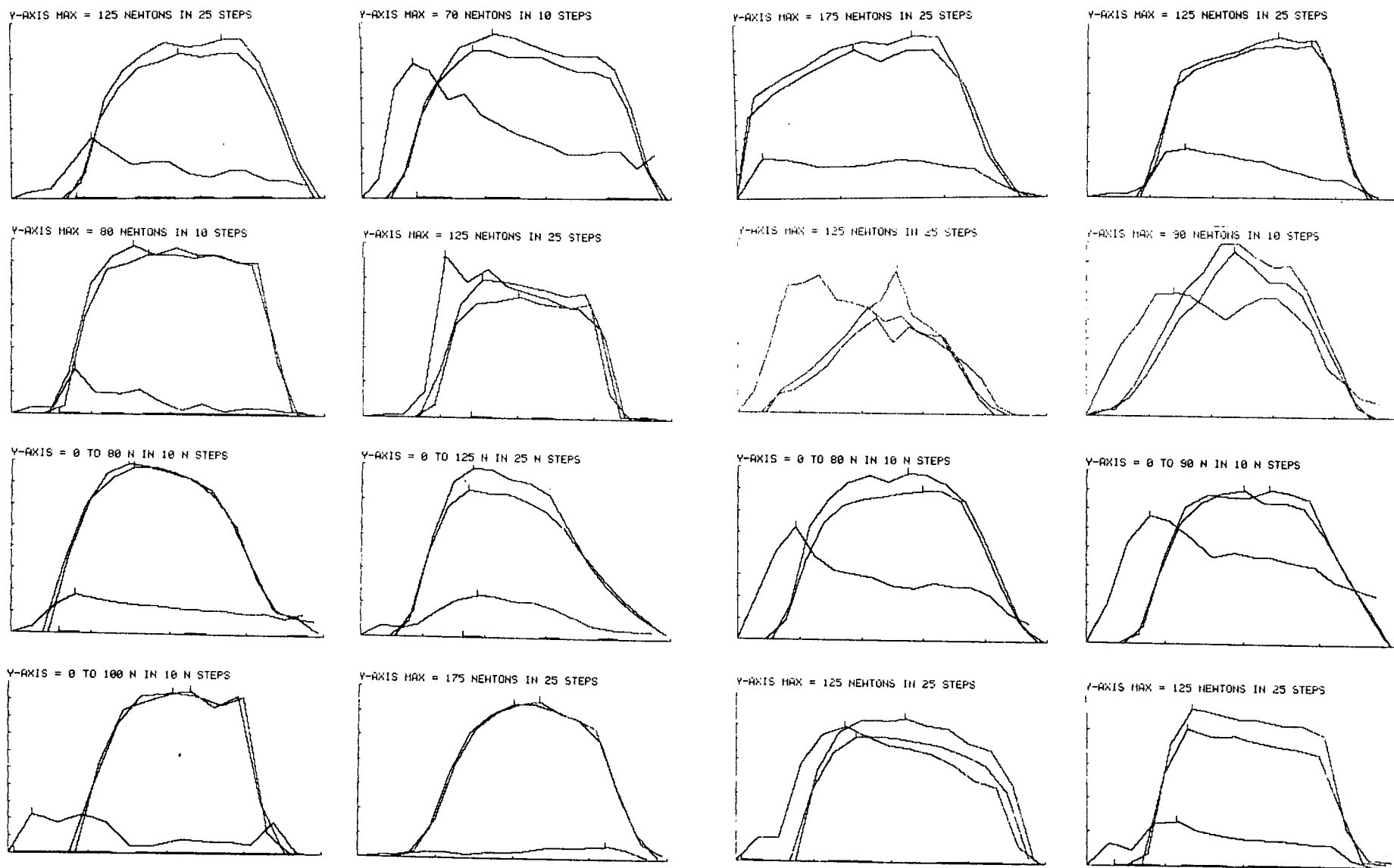

FIGURE 5.33. Force-time curves of healthy subjects' kettle lift

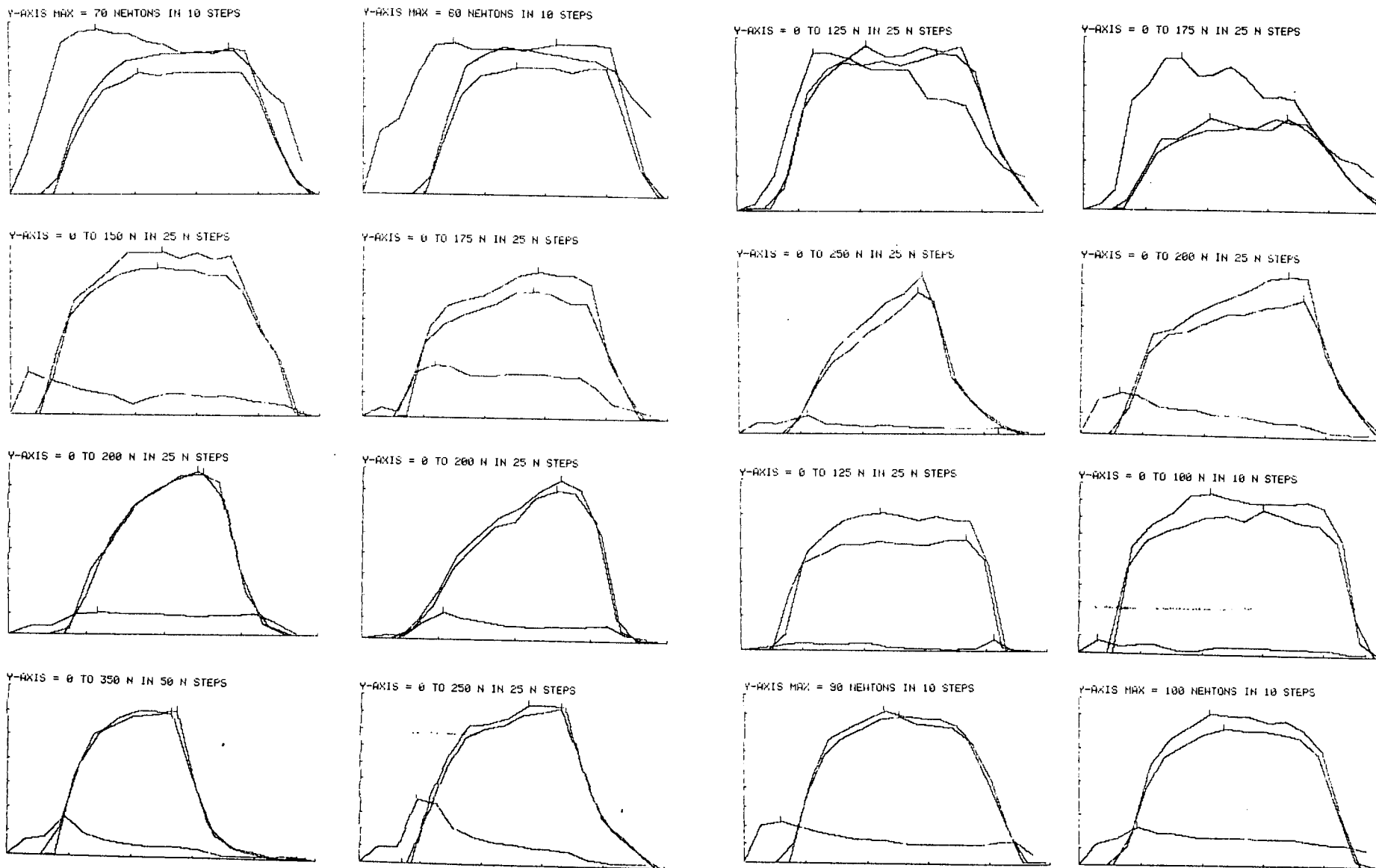

FIGURE 5.33.(continued) Force-time curves of healthy subjects' kettle lift

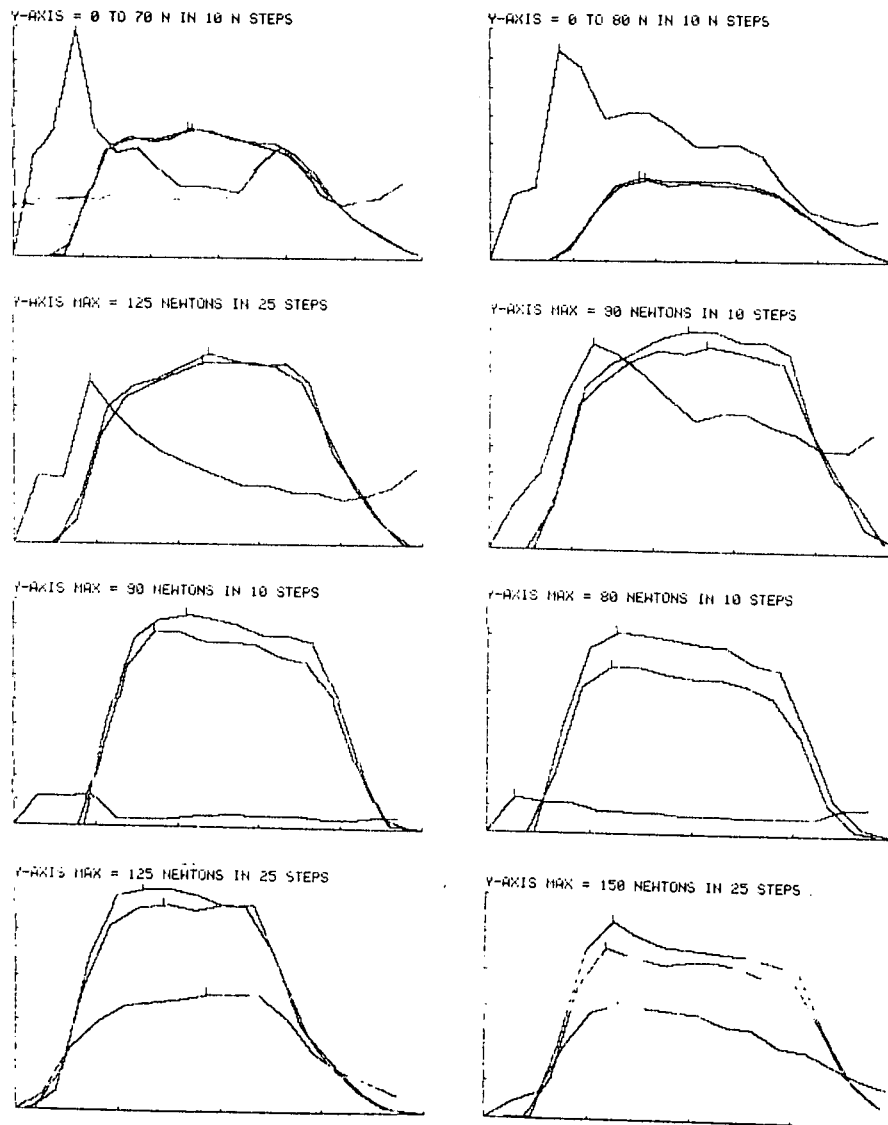

FIGURE 5.33.(continued) Force-time curves of healthy subjects' kettle lift

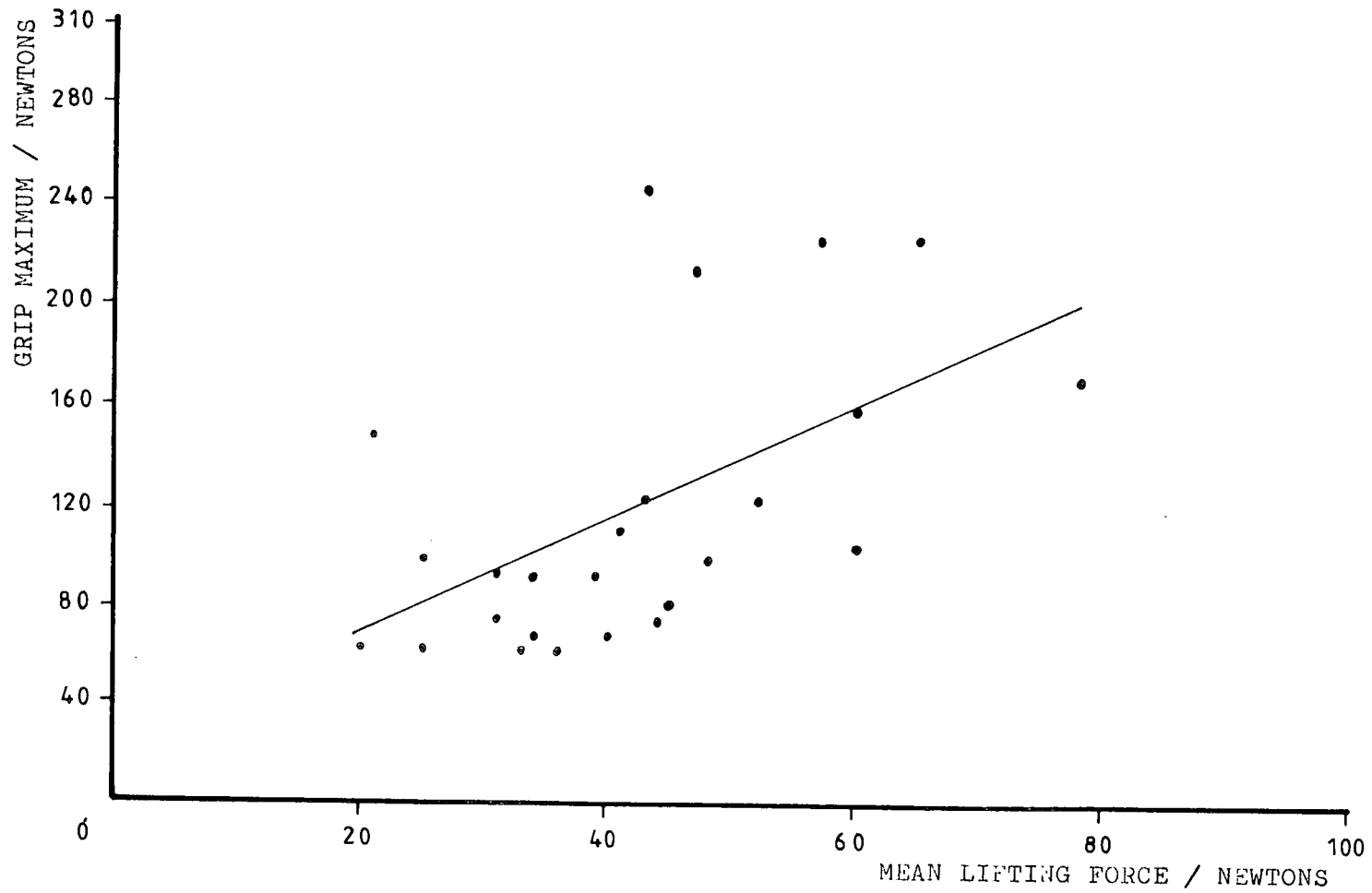

FIGURE 5.34. Scatter diagram of the mean pan lifting forces against the maximum handle grip forces for the left hand lifts of healthy subjects

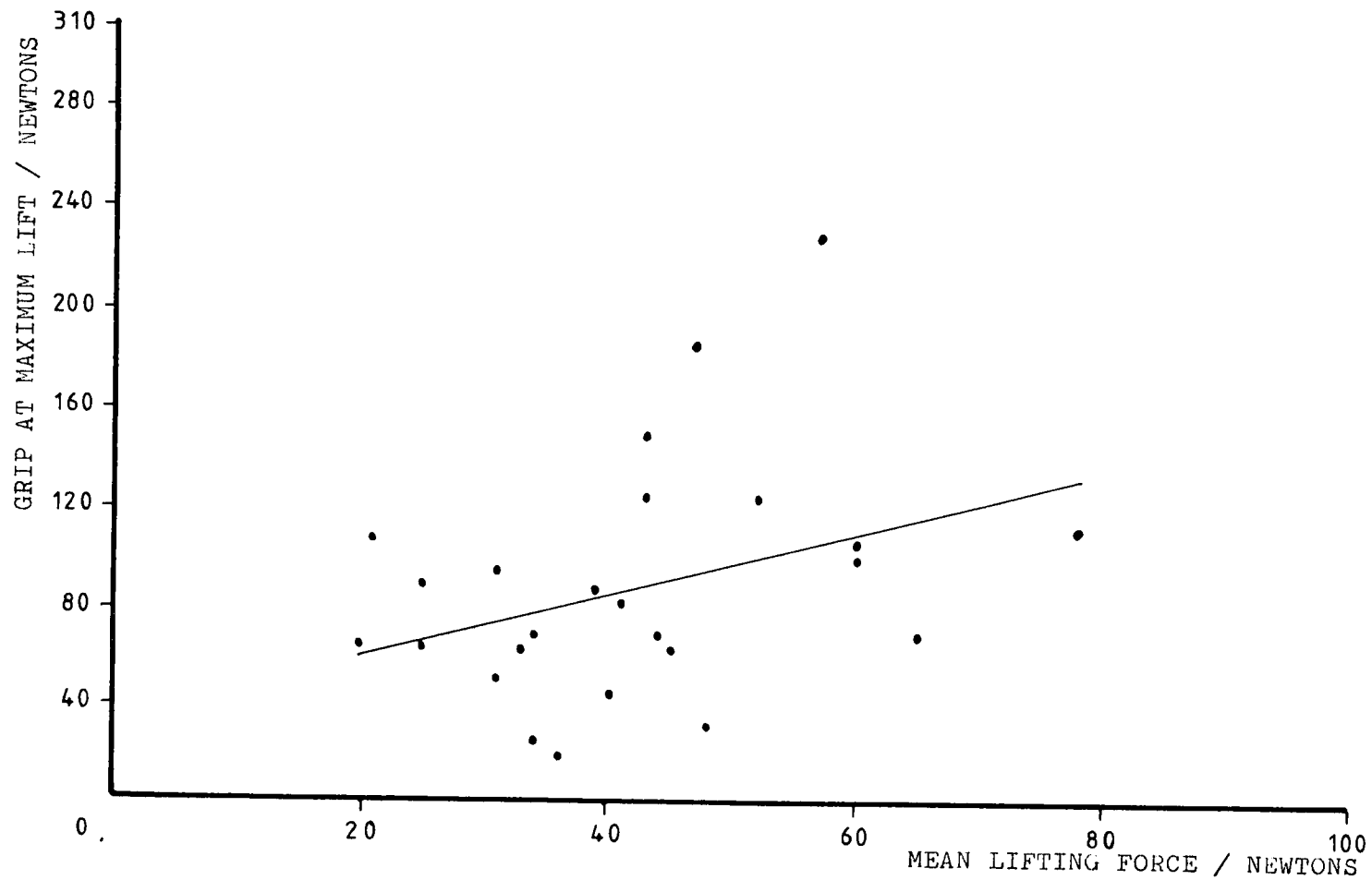

FIGURE 5.35. Scatter diagram of the mean pan lifting forces against the handle grip forces at maximum lift for left hand lifts of healthy subjects

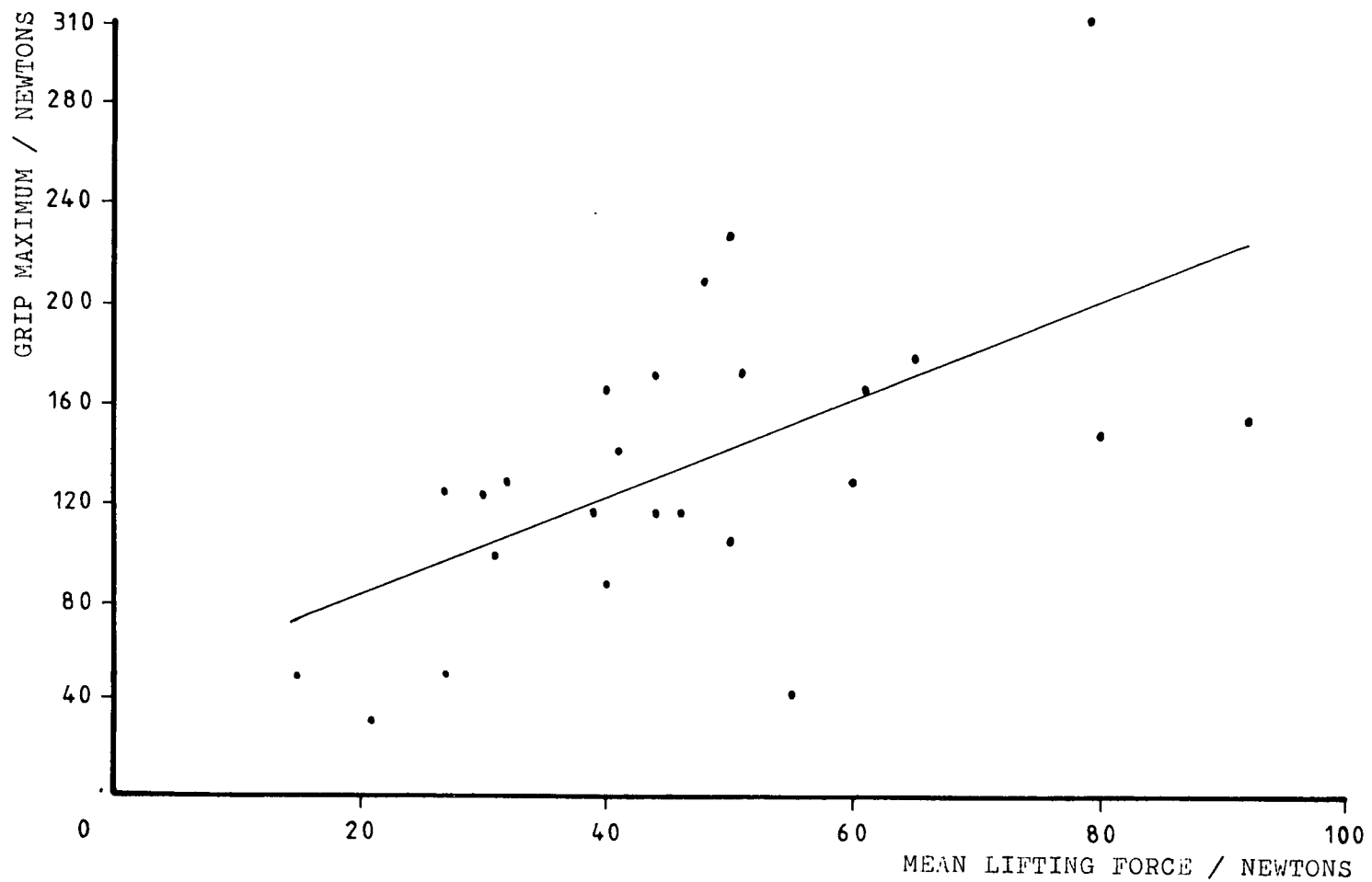

FIGURE 5.36. Scatter diagram of the mean pan lifting forces against the maximum handle grip forces for right hand lifts of healthy subjects

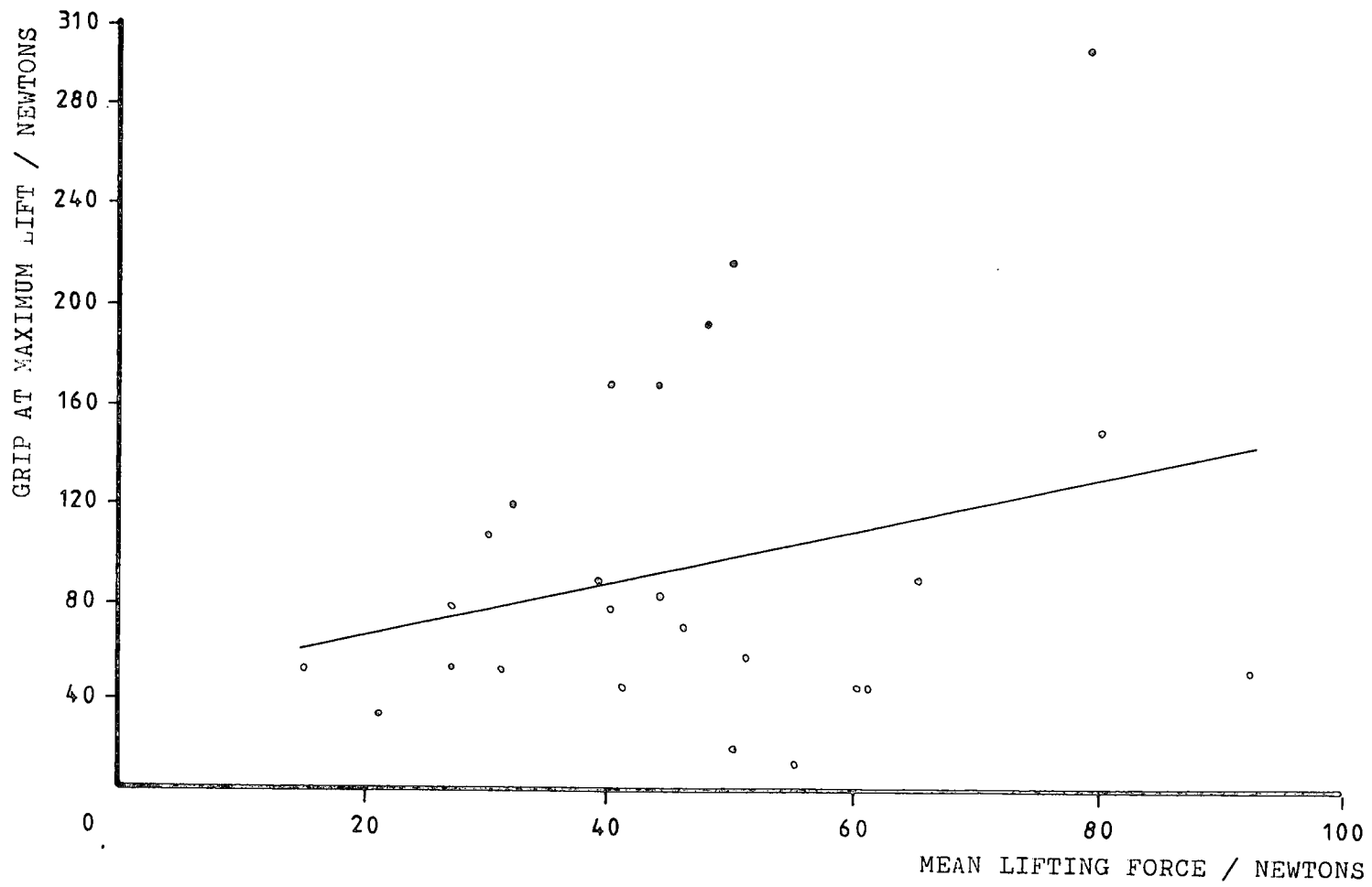

FIGURE 5.37. Scatter diagrams of the mean pan lifting forces against the handle grip forces at maximum lift for right hand lifts of healthy subjects

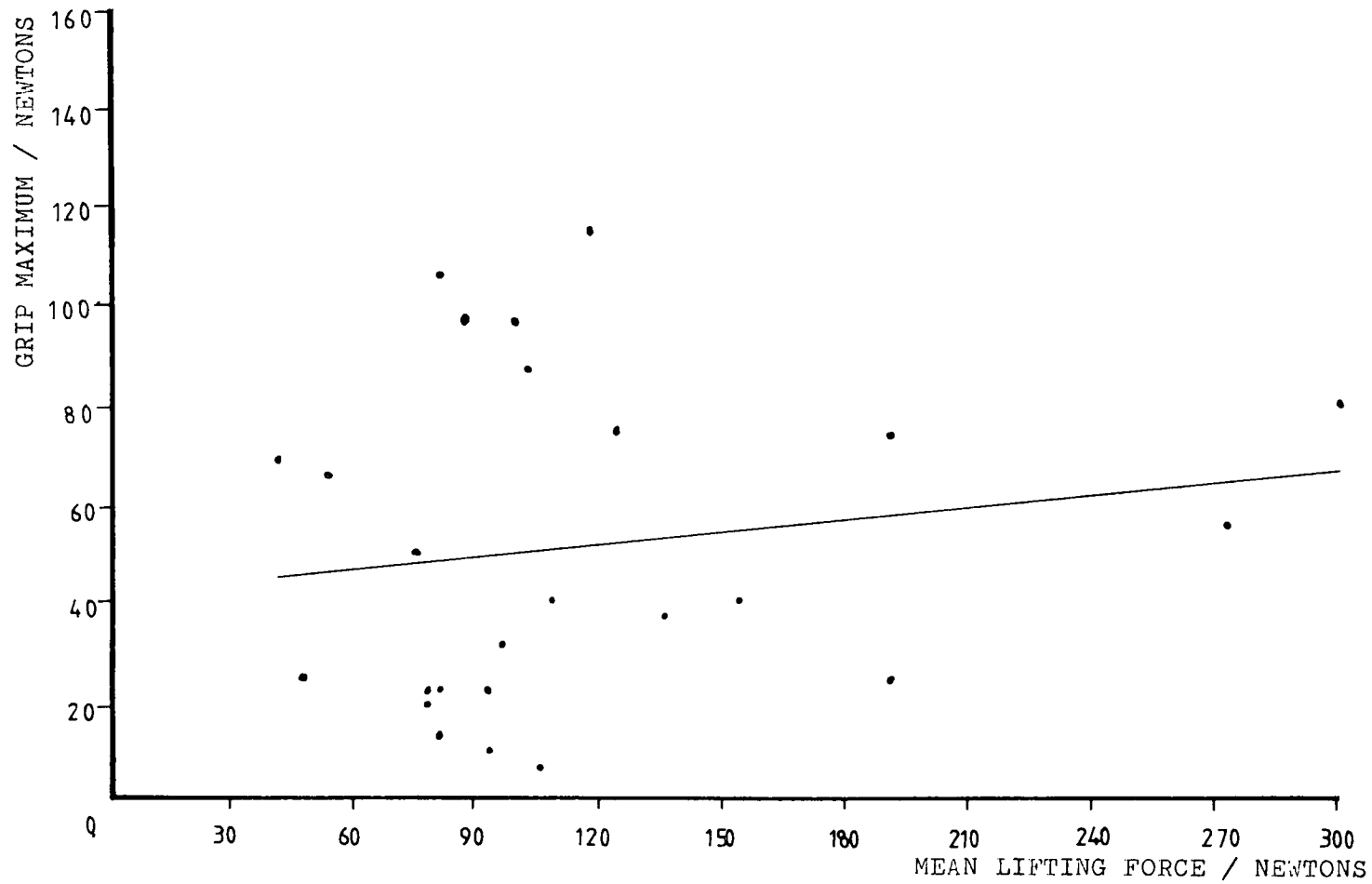

FIGURE 5.38 Scatter diagram of the mean kettle lifting forces against the maximum handle grip forces for left hand lifts of healthy subjects

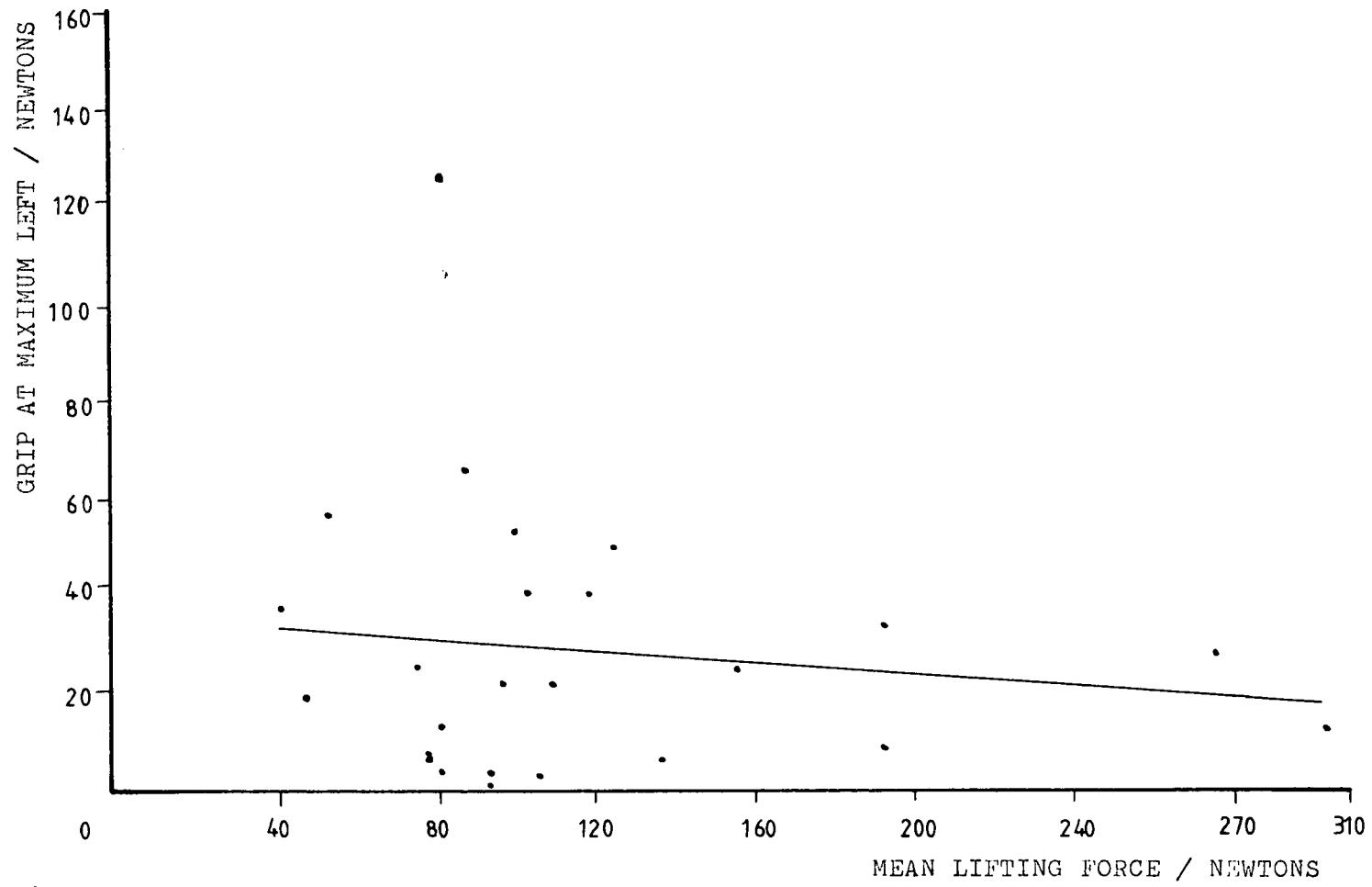

FIGURE 5.39. Scatter diagram of the mean kettle lifting forces against the handle grip forces at maximum lift for left hand lifts of healthy subjects

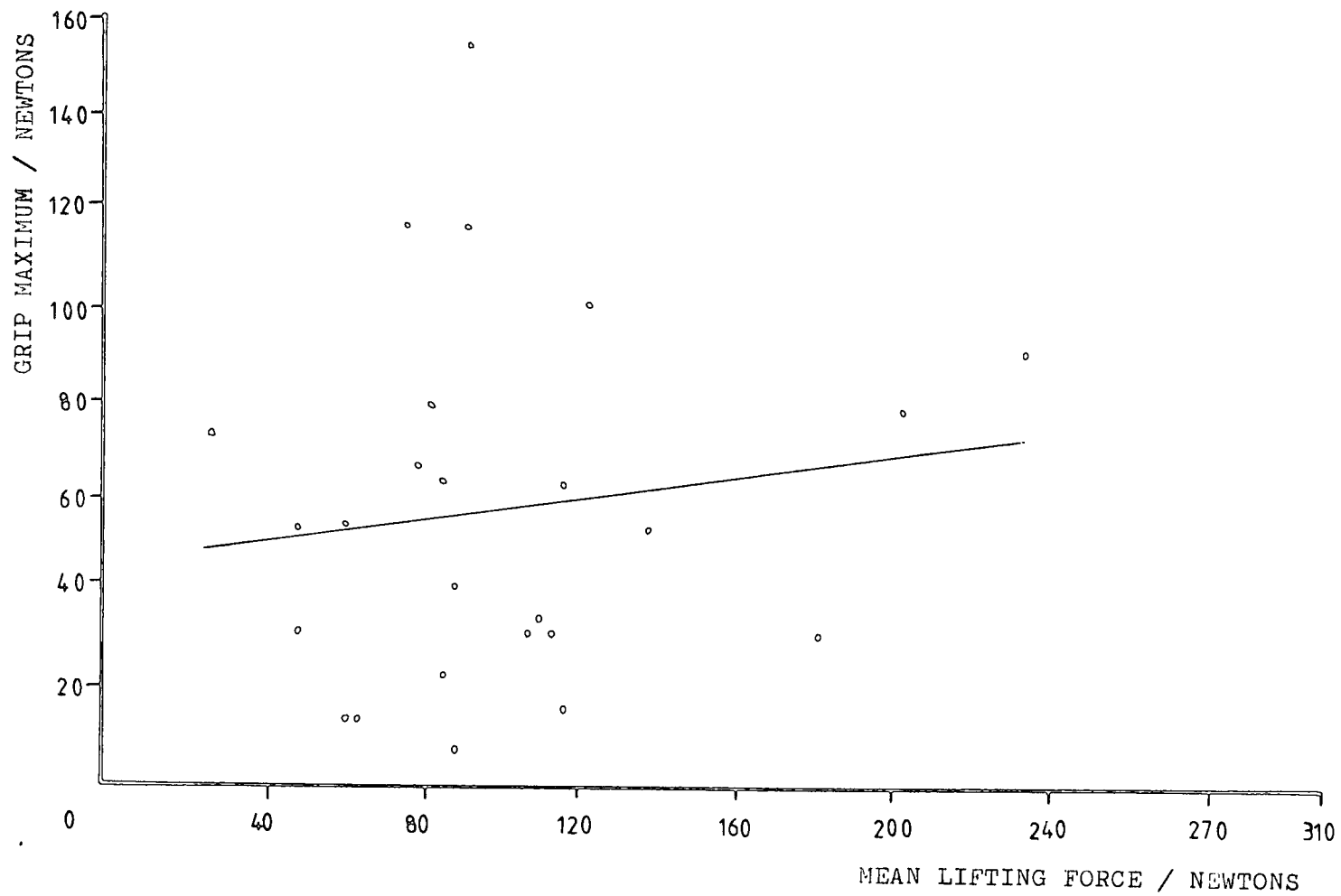

FIGURE 5.40. Scatter diagram of the mean kettle lifting forces against the maximum handle grip forces for the right hand lifts of healthy subjects

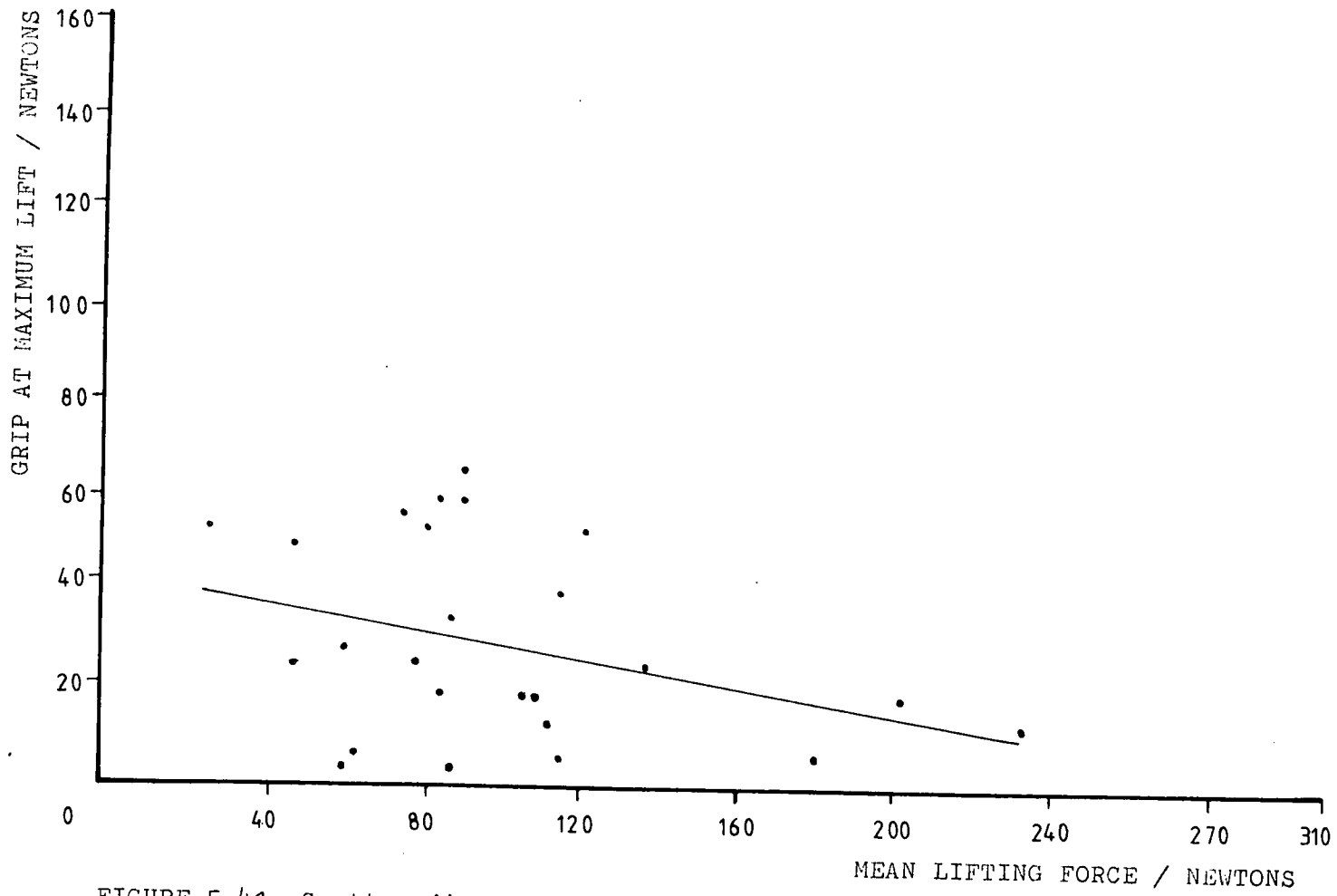

FIGURE 5.41. Scatter diagram of the mean kettle lifting forces against the handle grip forces at maximum lift for right hand lifts of healthy subjects

		Left Hand				Right Hand			
		Corr	Sl	In	Sig	Corr	Sl	In	Sig
PAN									
	max grip	0.560	2.28	23.8	0.0018	0.587	1.93	41.4	0.0010
	max lift grip	0.363	1.23	36.3	0.0374	0.277	1.00	44.8	0.0902
KETTLE									
	max grip	0.161	0.08	42.7	0.2210	0.141	0.11	46.6	0.2502
	max lift grip	-0.144	-0.06	36.4	0.2463	-0.323	-0.14	42.4	0.0575

FIGURE 5.42. Regression analysis of the mean lifting forces against the handle gripping forces of healthy subjects

Corr - Correlation coefficient
Sl - Regression line slope
In - Regression line intercept
Sig - significance of no correlation

		LEFT HAND						
DEVICE		MEAN ^a	SD	MIN	MAX	SK	P	N
POWER	In	22.2	17.8	0	81	1.5	<0.01	38
GRIP	Mi	37.8	28.0	1	137	1.4	<0.01	38
	Ri	32.1	26.7	2	100	0.9	>0.05 >0.01	38
	Li	23.0	16.9	0	64	0.9	>0.05 >0.01	38
	Total	110.9	70.1	30	291	0.8	>0.05 >0.01	38
PAN	max grip	46.2	29.0	0	110	0.6	>0.05*	36
	lo lift	11.9	11.8	0	50	1.6	<0.01	36
	up lift	14.6	14.9	0	62	1.7	<0.01	36
	max lift grip	41.5	26.2	0	98	0.5	>0.05*	36
KETTLE	max grip	32.2	22.9	0	97	0.9	<0.05 >0.01	37
	lo lift	22.9	27.2	0	99	1.9	<0.01	37
	up lift	25.7	29.0	0	99	1.6	<0.01	37
	max lift grip	18.1	18.6	0	84	1.6	<0.01	36
PULP	In	18.8	12.4	0	61	1.1	<0.01	38
PINCH	Mi	18.2	12.8	2	72	2.1	<0.01	38
	Ri	13.6	10.2	0	50	1.4	<0.01	38
	Li	11.5	6.6	0	28	0.6	0.05*	38
EXTENSION	In	2.6	1.8	0	7.7	0.6	>0.05*	31
	Mi	2.7	2.1	0.2	7.3	0.8	<0.05 >0.01	31
	Ri	1.9	2.1	0	9.4	2.1	<0.01	31
	Li	2.1	1.7	0	6.4	0.8	<0.05 >0.01	30
KEY		0.5 ^b	0.3	0.1	1.2	0.9	<0.05 >0.01	35
TUBE		2.1 ^b	1.2	0.4	5.4	1.1	<0.01	31
LATERAL PINCH		38.3	24.3	8	92	0.6	>0.05*	24

FIGURE 5.43. Mean results obtained on each transducer from patients with arthritis(a-all units Newtons except ^b-Newton-metres)

SD-Standard Deviation

P-Probability of no Skewness (*- none at 5% level)

N-Number

		RIGHT HAND						
DEVICE		MEAN ^a	SD	MIN	MAX	SK	P	N
POWER	In	25.8	18.6	4	73	1.2	<0.01	37
GRIP	Mi	37.9	30.0	6	120	1.4	<0.01	37
	Ri	32.2	22.2	4	81	0.7	≤ 0.05 > 0.01	37
	Li	21.9	18.5	1	72	1.3	<0.01	37
	Total	113.4	77.8	22	341	1.2	<0.01	37
PAN	max grip	53.9	33.6	0	127	0.5	>0.05*	36
	lo lift	12.1	11.4	0	53	1.9	<0.01	36
	up lift	14.2	13.6	0	64	1.9	<0.01	36
	max lift grip	48.4	31.9	0	125	0.7	≤ 0.05 > 0.01	36
KETTLE	max grip	25.9	17.9	1	89	1.4	<0.01	38
	lo lift	25.2	24.5	0	99	1.7	<0.01	38
	up lift	28.6	27.7	0	99	1.3	<0.01	38
	max lift grip	13.3	17.0	0	89	3.0	<0.01	38
PULP	In	19.9	12.5	2	58	1.1	<0.01	38
PINCH	Mi	17.4	10.7	5	44	0.7	≤ 0.05 > 0.01	38
	Ri	13.1	8.5	0	38	1.0	<0.01	38
	Li	9.7	5.5	0	19	0	>0.05*	38
EXTENSION	In	2.8	1.8	0	7.1	0.7	≤ 0.05 > 0.01	31
	Mi	3.0	2.0	0	8.1	0.6	>0.05*	31
	Ri	2.2	1.9	0	9.7	2.3	<0.01	31
	Li	2.0	1.6	0	6.0	0.7	≤ 0.05 > 0.01	31
KEY		0.5 ^b	0.3	0.04	1.2	0.4	>0.05*	38
TUBE		2.0 ^b	1.4	0	6.2	1.4	<0.01	31
LATERAL PINCH		43.3	21.8	8	7.8	0.2	>0.05*	24

FIGURE 5.43.(continued) Mean results obtained on each transducer from patients with arthritis (a=all units Newtons except b-Newton-metres)

SD-Standard Deviation

P-Probability of no skewness (*- none at 5% level)

N-Number

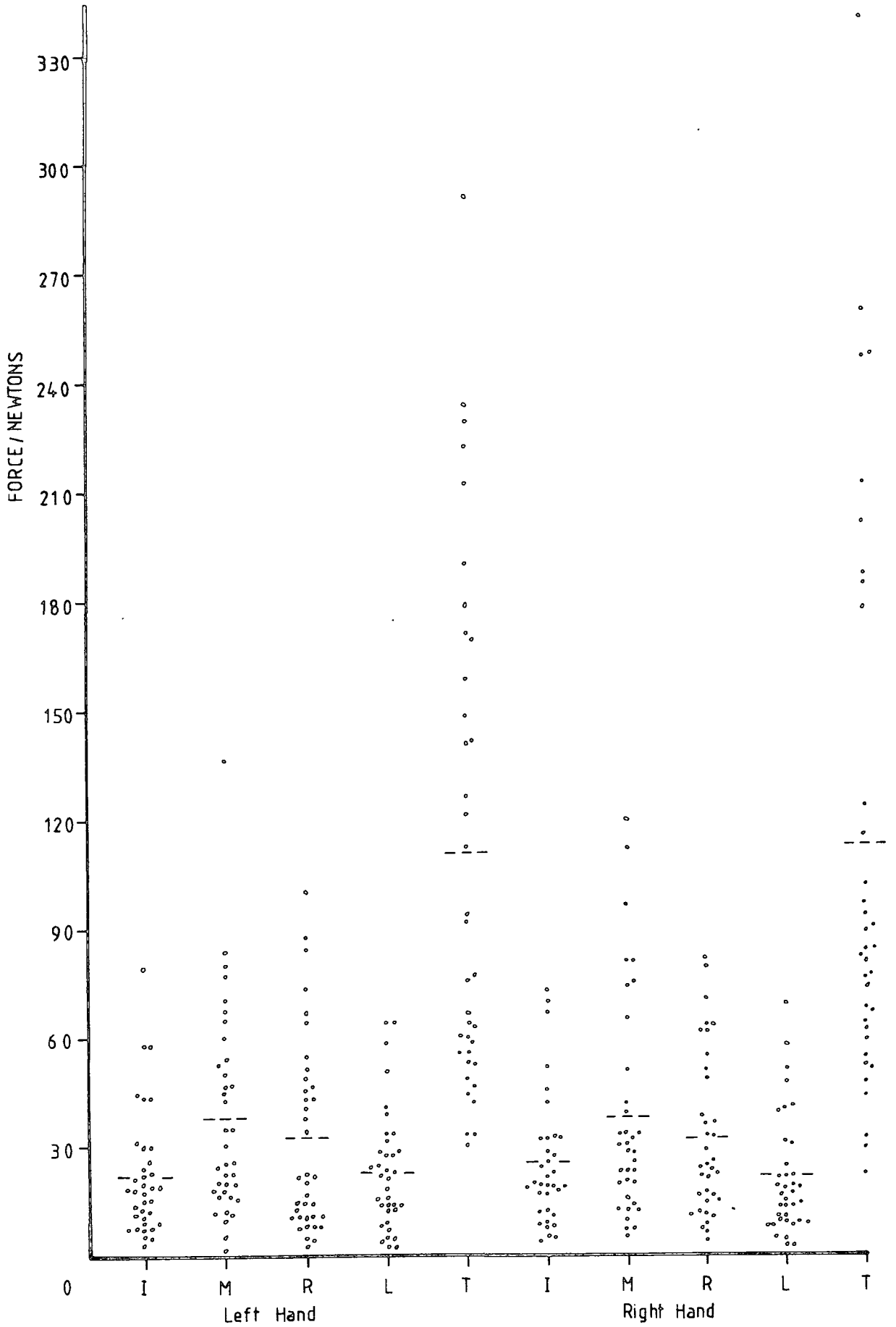

FIGURE 5.44. Scatter diagram of the maximum power grip forces from patients with arthritis

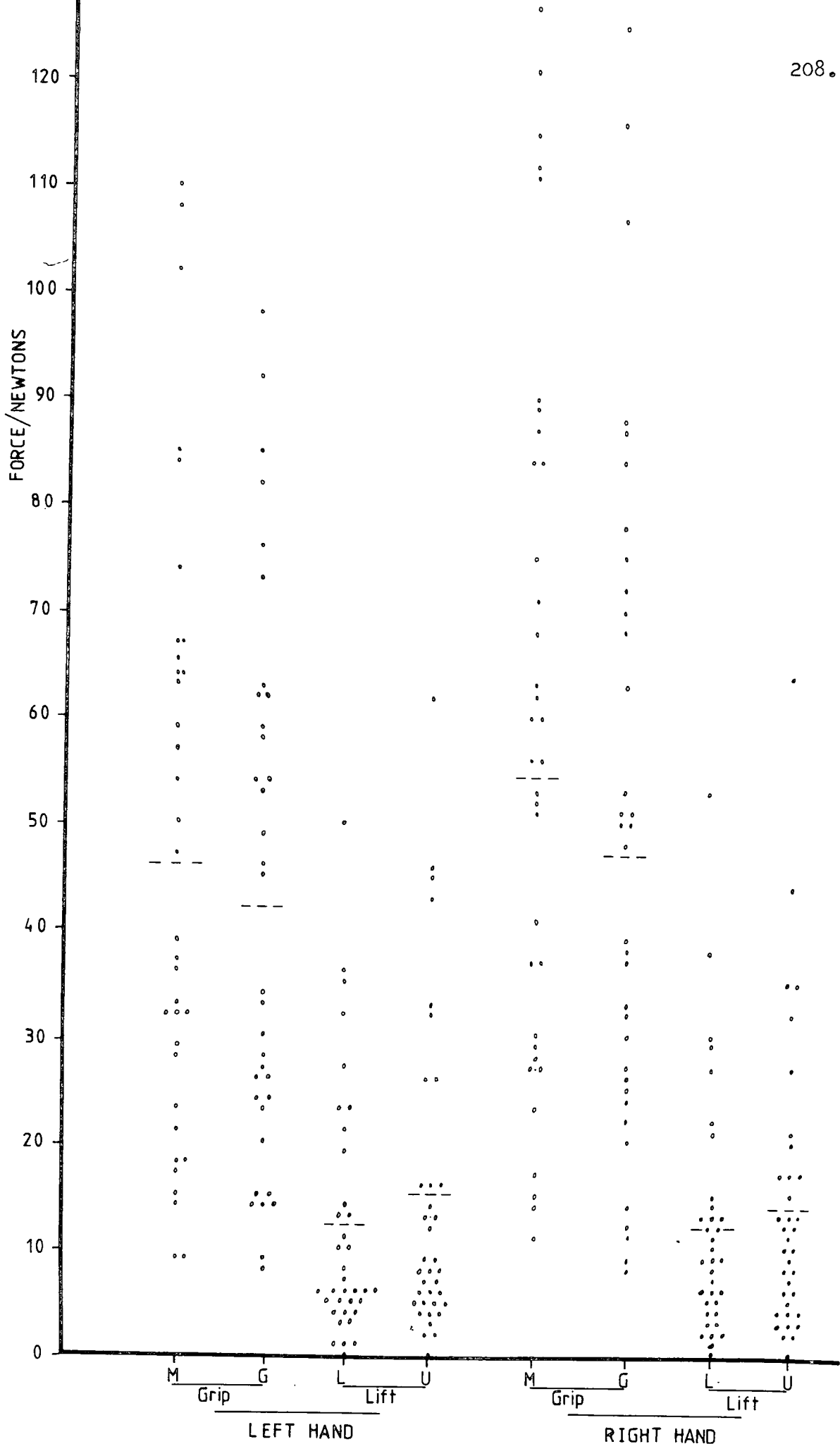

FIGURE 5.45. Scatter diagram of the maximum pan forces from patients with arthritis

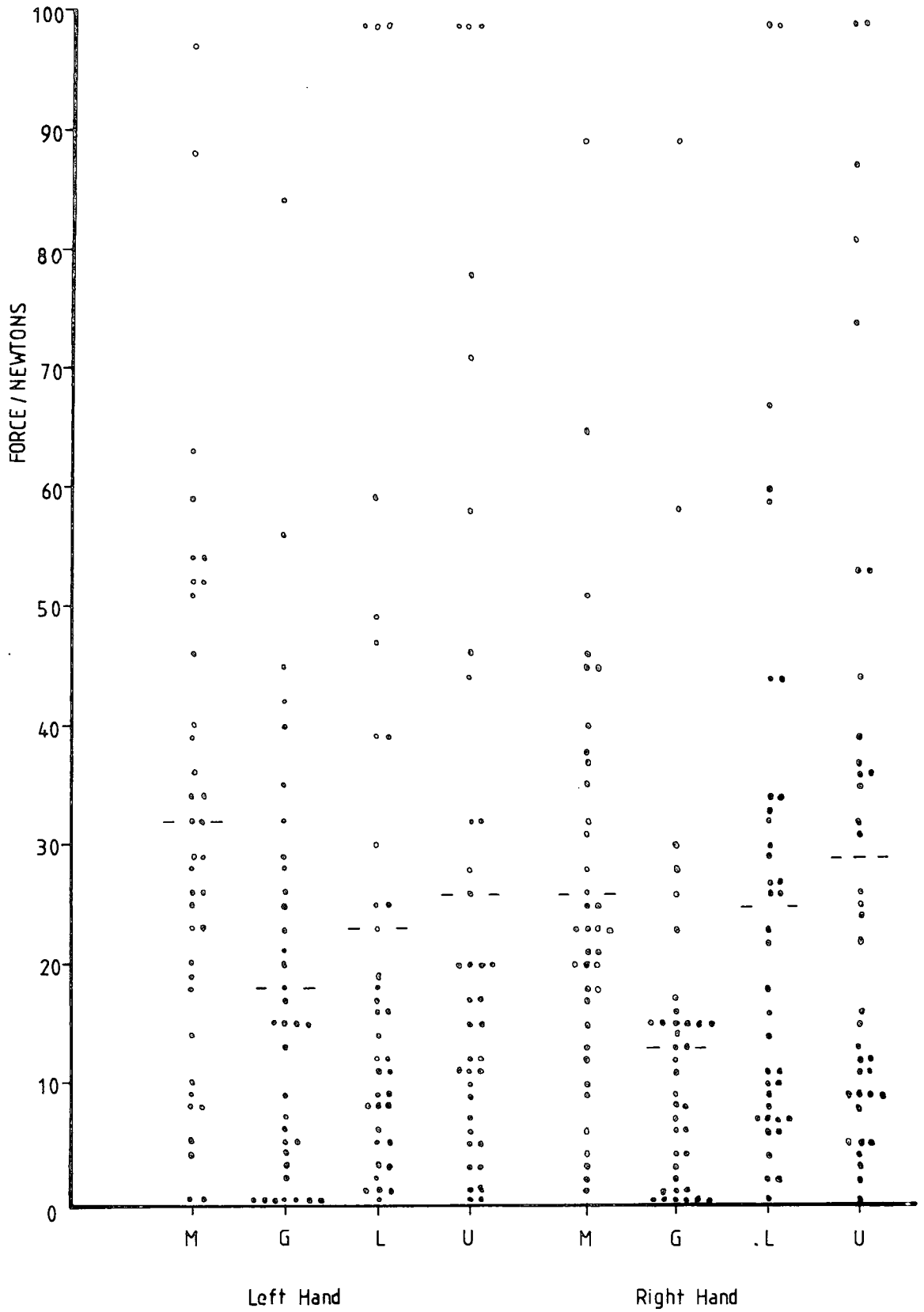

FIGURE 5.46. Scatter diagram of the maximum kettle forces from patients with arthritis

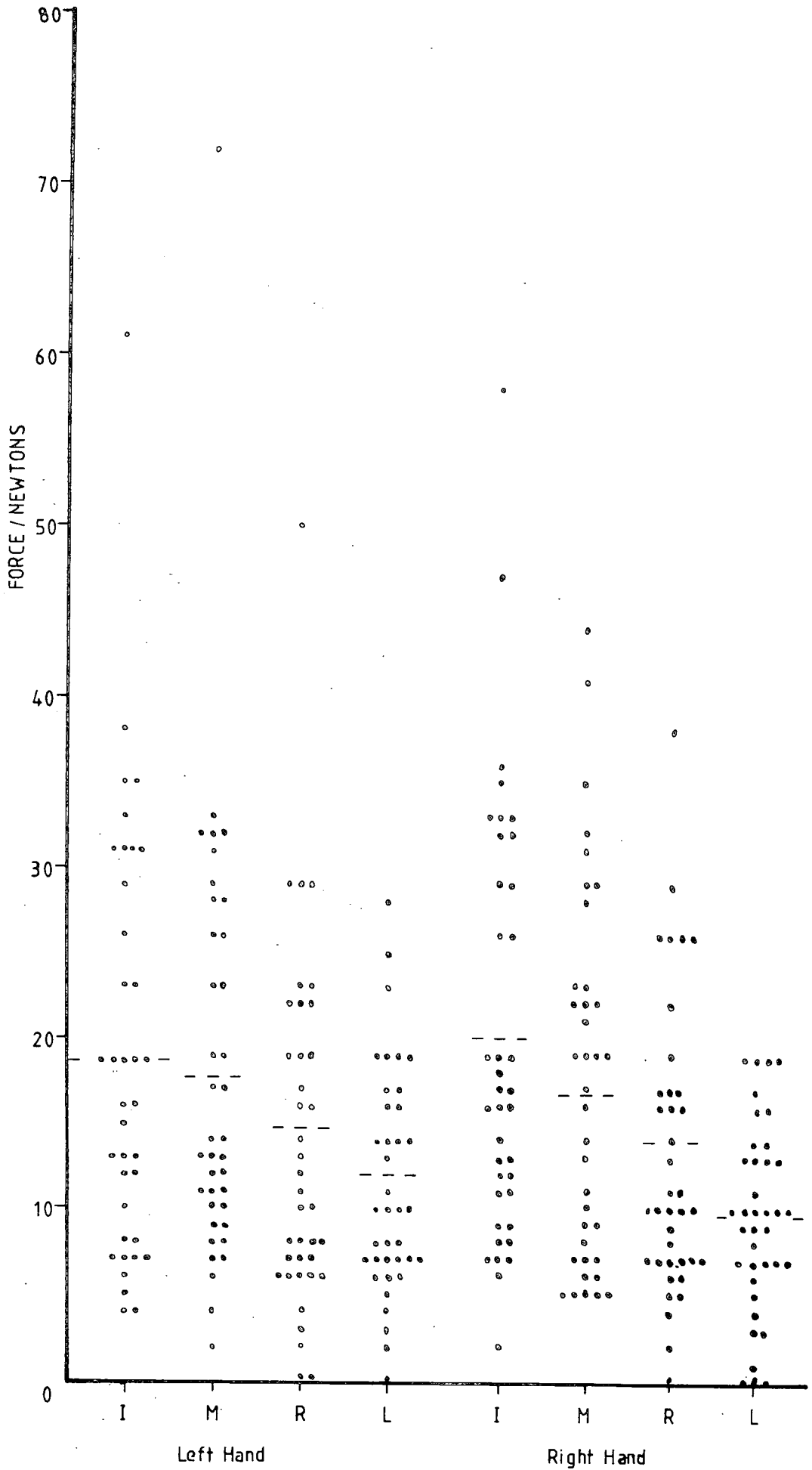

FIGURE 5.47. Scatter diagram of the maximum pulp pinch forces from patients with arthritis

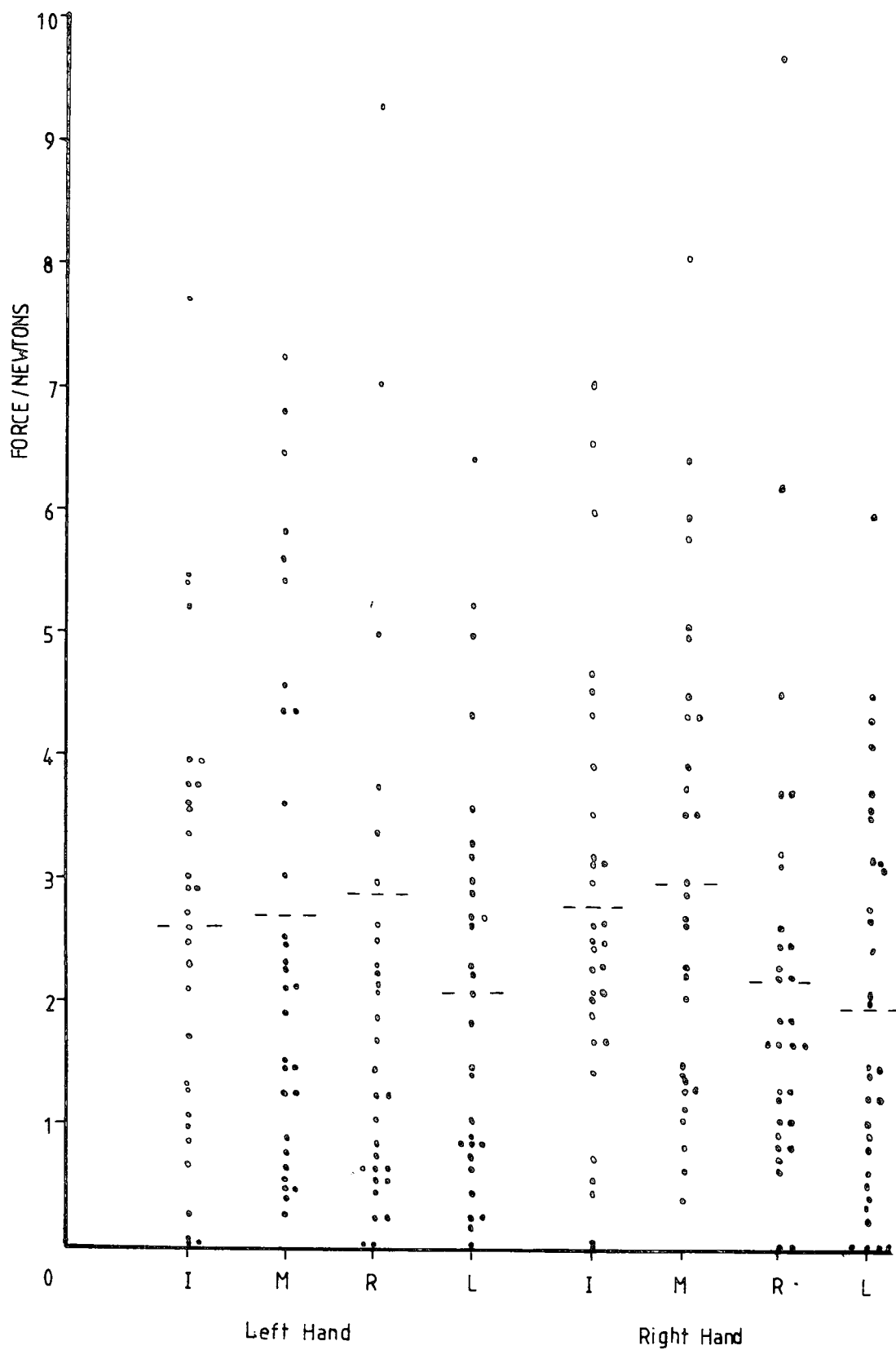

FIGURE 5.48. Scatter diagram of the maximum extension forces from patients with arthritis

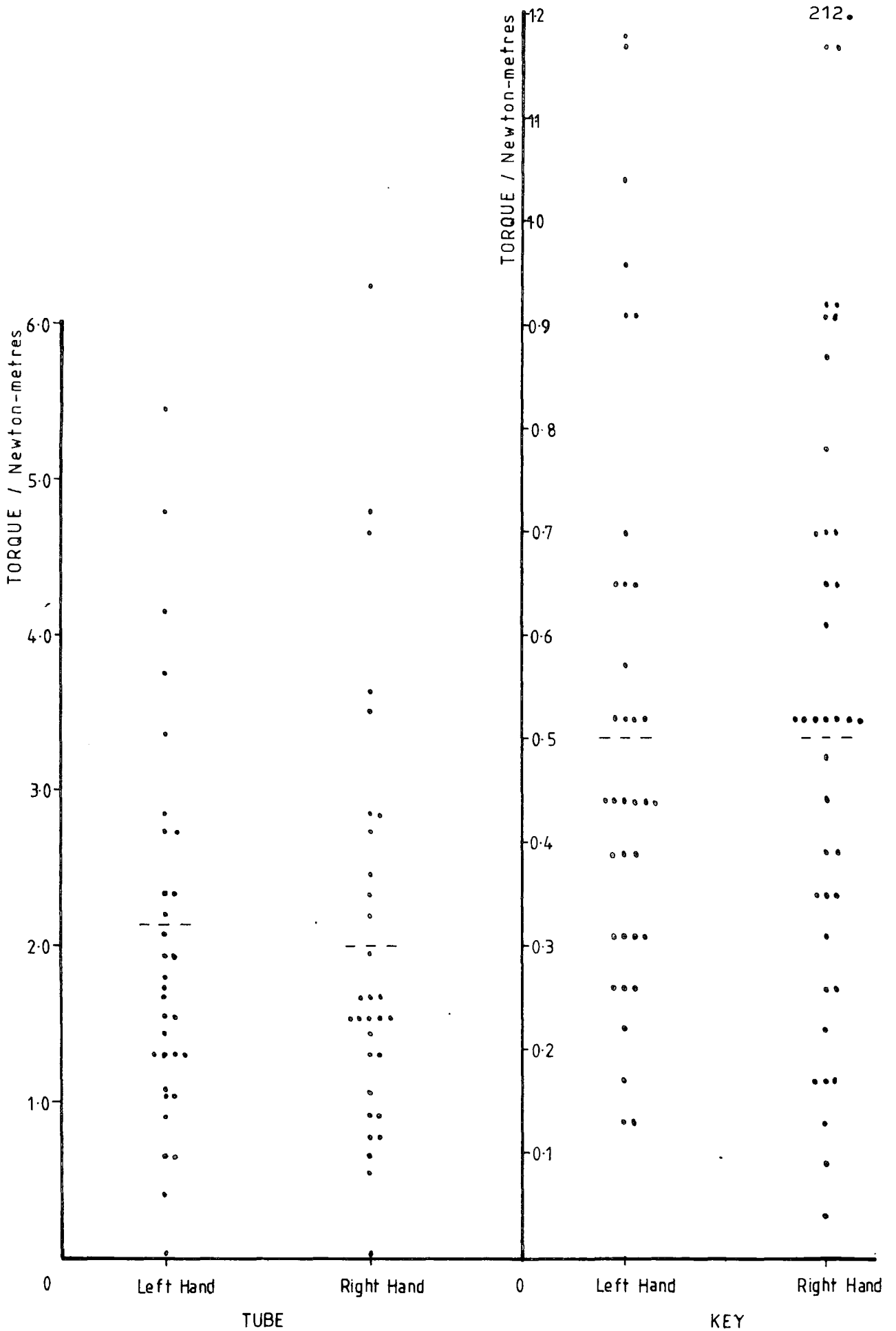

FIGURE 5.49. Scatter diagram of the maximum key and tube torques from patients with arthritis

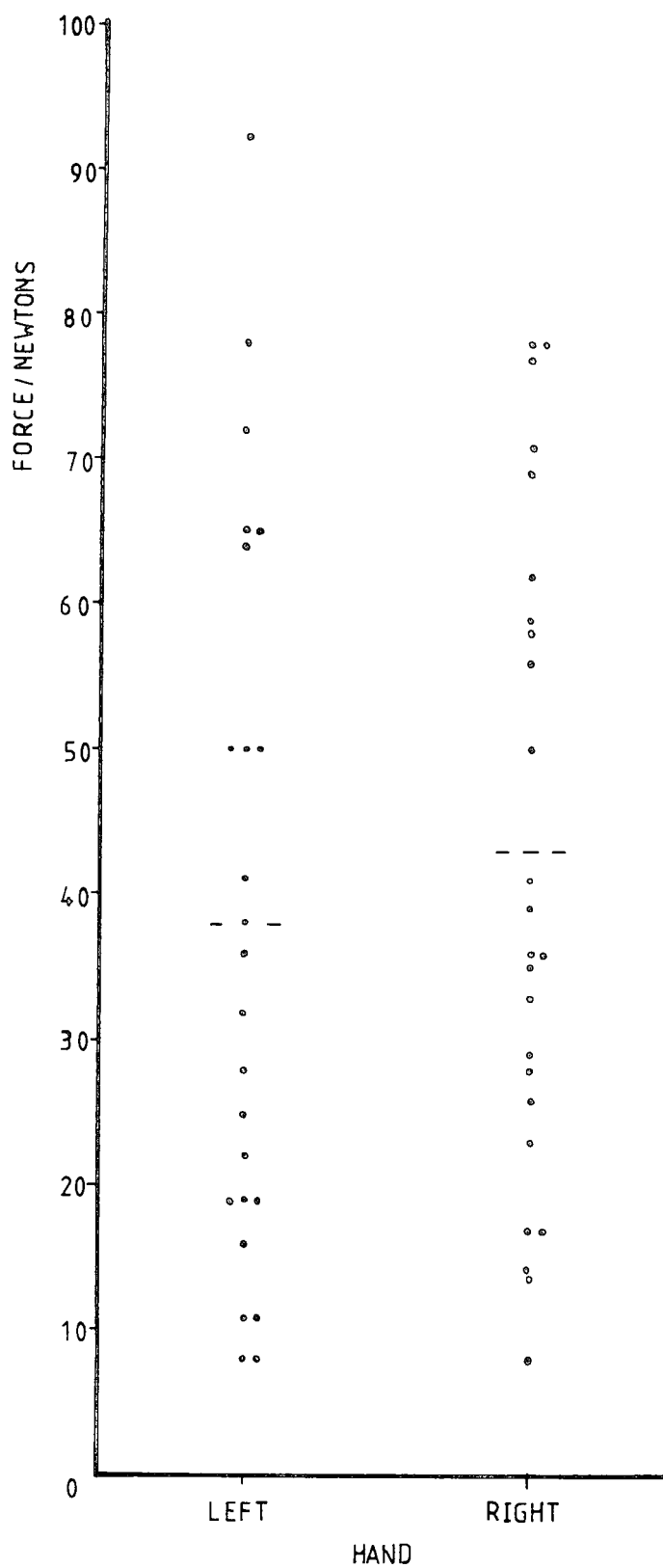

FIGURE 5.50. Scatter diagram of the maximum lateral pinch forces from patients with arthritis

TRANSDUCER		LEFT HAND					RIGHT HAND				
		MEAN ^a	S	MIN	MAX	n	MEAN ^a	S	MIN	MAX	n
POWER	In	34.0	21.2	12	81	13	30.3	21.0	5	73	13
GRIP	Mi	48.2	35.9	16	137	13	49.2	33.8	13	120	13
	Ri	34.2	28.3	2	100	13	38.6	26.0	8	81	13
	Li	23.5	17.3	5	59	13	26.7	20.0	8	69	13
Total		133.5	80.8	53	291	13	139.2	89.4	44	341	13
PAN	max grip	47.4	33.8	0	110	12	63.6	43.2	0	127	12
	lo lift	17.2	14.4	0	50	12	17.4	14.7	1	53	12
	up lift	19.8	18.6	2	62	12	20.4	17.8	3	64	12
	max lift grip	42.7	30.7	0	98	12	59.4	42.0	0	125	12
KETTLE	maxgrip	34.8	29.2	0	97	13	29.3	22.6	1	89	13
	lo lift	33.6	39.8	1	99	13	37.3	33.2	6	99	13
	up lift	36.7	35.9	0	99	13	41.1	36.7	5	99	13
	max lift grip	18.1	23.4	0	84	13	15.7	23.3	0	89	13
PULP	In	24.5	15.1	7	61	13	24.9	15.5	8	58	13
PINCH	Mi	23.2	17.0	7	72	13	20.8	12.4	5	44	13
	Ri	16.8	12.5	6	50	13	13.8	9.3	5	38	13
	Li	11.8	5.9	4	23	13	10.7	6.4	0	19	13
EXTENSION	In	3.4	2.0	0.9	7.7	10	3.1	2.2	0.8	7.1	10
	Mi	3.1	2.5	0.4	6.8	10	3.2	2.1	0.7	6.5	10
	Ri	1.6	1.2	0	3.8	10	2.0	1.2	0	3.8	10
	Li	1.7	1.6	0.2	5.0	10	1.9	1.6	0	4.6	10
KEY		0.7 ^b	0.3	0.1	1.2	13	0.7 ^b	0.3	0.2	1.2	13
TUBE		2.3 ^b	1.5	1.0	5.4	12	2.4 ^b	1.7	0.7	6.2	12
LATERAL PINCH		48.8	27.9	11	92	10	50.4	23.8	14	78	10

FIGURE 5.51. Mean results obtained from patients attending the drug trial clinic

a - Newtons, b - Newton metres
 S - standard deviation
 n - number of patients

TRANSDUCER		LEFT HAND					RIGHT HAND				
		MEAN ^a	S	MIN	MAX	n	MEAN ^a	S	MIN	MAX	n
POWER	In	16.3	14.1	0	48	15	29.2	20.3	4	68	14
GRIP	Mi	37.9	23.6	1	80	15	39.8	32.1	7	113	14
	Ri	35.2	26.1	5	86	15	35.5	22.0	4	70	14
	Li	30.0	17.3	0	64	15	27.7	18.5	8	72	14
	Total	115.6	63.7	23	236	15	126.8	77.7	22	260	14
PAN	max grip	47.4	28.3	9	108	15	57.7	28.5	14	112	15
	lo lift	9.9	8.9	0	32	15	10.9	10.1	0	38	15
	up lift	11.7	12.2	0	46	15	12.7	11.5	0	44	15
	max lift grip	43.2	25.5	8	85	15	5.5	25.2	9	87	15
KETTLE	maxgrip	30.1	20.5	0	62	15	22.9	16.1	3	65	15
	lo lift	14.9	14.4	0	49	15	19.9	17.8	0	59	15
	up lift	18.6	18.9	0	71	15	23.7	22.4	0	74	15
	max lift grip	20.1	18.5	0	56	14	13.7	15.0	0	58	15
PULP	In	15.5	10.2	0	35	15	18.1	10.1	2	35	15
PINCH	Mi	16.6	9.5	4	32	15	17.1	10.0	5	35	15
	Ri	13.4	8.7	2	29	15	14.4	9.0	0	29	15
	Li	10.6	5.3	3	19	15	8.5	5.8	0	19	15
EXTENSION	In	1.9	1.8	0	5.2	13	2.6	1.8	0	6.0	13
	Mi	2.8	2.3	0.2	7.3	13	3.5	2.2	0	8.1	13
	Ri	2.4	2.9	0	9.3	13	2.7	2.7	0	9.7	13
	Li	2.1	1.8	0	6.4	13	1.9	1.9	0	6.0	13
KEY		0.5 ^b	0.2	0.2	1.0	12	0.5 ^b	0.3	0.4	0.9	15
TUBE		2.2 ^b	1.0	0.7	4.2	9	2.4 ^b	1.2	0.5	4.7	9
LATERAL PINCH		40.0	20.1	16	65	4	48.5	24.2	23	77	4

FIGURE 5.52.

Mean results obtained from patients attending the rheumatology clinic

a - Newtons, b - Newton metres

S - standard deviation

n - number of patients

TRANSDUCER		LEFT HAND					RIGHT HAND				
		MEAN ^a	S	MIN	MAX	n	MEAN ^a	S	MIN	MAX	n
POWER	In	15.5	9.4	4	31	10	15.3	5.9	7	23	10
GRIP	Mi	24.1	16.7	5	60	10	20.8	8.6	6	33	10
	Ri	24.7	26.7	4	88	10	19.1	10.7	7	37	10
	Li	11.9	9.5	1	28	10	7.5	4.6	1	14	10
	Total	74.5	54.6	30	190	10	61.0	23.1	29	102	10
PAN	max grip	42.6	26.2	9	84	9	34.6	19.0	11	60	9
	lo lift	9.3	10.5	1	36	9	7.0	4.2	2	14	9
	up lift	12.6	13.3	2	45	9	8.4	5.9	2	17	9
	max lift grip	37.2	23.4	9	76	9	28.7	16.9	8	53	9
KETTLE	maxgrip	32.1	18.3	8	63	9	25.8	14.3	2	51	10
	lo lift	20.1	30.6	1	99	9	17.4	13.3	2	34	10
	up lift	21.8	30.6	1	99	9	19.6	15.2	2	39	10
	max lift grip	15.0	11.1	0	32	9	9.4	8.9	0	28	10
PULP	In	16.4	9.9	1	33	10	15.9	9.9	7	33	10
PINCH	Mi	14.0	9.3	2	31	10	13.5	8.7	5	31	10
	Ri	9.7	8.2	0	22	10	10.2	6.2	2	22	10
	Li	12.4	9.2	0	28	10	10.2	3.6	3	14	10
EXTENSION	In	3.0	1.4	0.9	5.5	8	2.6	1.0	0.6	4.0	8
	Mi	2.0	1.0	0.6	3.6	8	2.1	1.1	0.4	4.0	8
	Ri	1.5	1.1	0	3.0	8	1.8	0.9	0.8	3.3	8
	Li	2.7	1.5	0.8	5.3	7	2.1	1.3	0.4	4.1	8
KEY		0.4 ^b	0.3	0.2	1.2	10	0.3 ^b	0.2	0.1	0.7	10
TUBE		1.62 ^b	0.9	0.4	3.4	10	1.3 ^b	0.7	0	2.7	10
LATERAL PINCH		27.1	18.4	8	64	10	34.2	17.1	8	58	10

FIGURE 5.53.

Mean results obtained from patients
in the rheumatology ward

a - Newtons, b - Newton metres

S - standard deviation

n - number of patients

TRANSDUCER		LEFT HAND				RIGHT HAND			
		F	A	C	A	F	A	C	A
POWER	In	5.43	0.009	0.61	0.024	2.38	0.108	0.50	0.254
GRIP	Mi	2.23	0.122	0.61	0.024	2.83	0.073	0.51	0.214
	Ri	0.51	0.604	0.36	1.000	2.65	0.085	0.53	0.151
	Li	4.02	0.027	0.44	0.531	5.13	0.011	0.53	0.162
	total	2.18	0.128	0.48	0.286	3.66	0.036	0.55	0.109
PAN	max grip	0.09	0.915	0.43	0.563	2.23	0.124	0.61	0.030
	lo lift	1.31	0.283	0.54	0.118	2.50	0.097	0.64	0.016
	up lift	1.08	0.351	0.51	0.196	2.32	0.114	0.65	0.012
	max lift grip	0.16	0.856	0.44	0.530	2.76	0.078	0.66	0.010
KETTLE	maxgrip	0.14	0.866	0.53	0.149	0.43	0.656	0.52	0.147
	lo lift	1.75	0.189	0.50	0.237	2.68	0.083	0.69	0.003
	up lift	1.50	0.237	0.50	0.245	2.21	0.124	0.65	0.010
	max lift grip	0.20	0.820	0.54	0.125	0.39	0.683	0.64	0.012
PULP	In	2.21	0.125	0.53	0.129	1.80	0.180	0.55	0.097
PINCH	Mi	1.73	0.193	0.62	0.018	1.37	0.267	0.47	0.357
	Ri	1.43	0.252	0.52	0.153	0.79	0.460	0.42	0.640
	Li	0.24	0.791	0.57	0.059	0.62	0.545	0.47	0.316
EXTENSION	In	2.36	0.113	0.42	0.709	0.35	0.705	0.52	0.204
	Mi	0.64	0.537	0.49	0.362	1.27	0.295	0.47	0.450
	Ri	0.60	0.557	0.76	0.001	0.72	0.498	0.77	0.001
	Li	0.74	0.485	0.41	0.823	0.03	0.972	0.48	0.399
KEY		1.48	0.242	0.48	0.316	4.65	0.016	0.49	0.235
TUBE		1.05	0.364	0.55	0.146	2.19	0.131	0.60	0.066
LATERAL PINCH		2.21	0.135	0.51	0.336	1.59	0.227	0.40	0.884

FIGURE 5.54.

Comparison of results from the three clinics using ANOVA and Cochran's C - test

F - F factor (comparison of means)

C - Cochran's factor (comparison of variances)

A - Probability of the means/variances being the same

CLINIC	n	LEFT HAND				RIGHT HAND				
		In	Mi	Ri	Li	In	Mi	Ri	Li	
Trial	13	\bar{x}	28.3	35.7	23.2	18.2	22.5	34.5	26.8	21.3
		S	11.0	9.5	10.1	7.5	9.6	6.0	7.4	12.1
Rheum	15	\bar{x}	14.6	31.4	27.2	30.6	23.9	29.3	27.6	24.8
		S	6.8	12.5	9.5	17.2	10.9	10.7	7.9	14.1
Ward	10	\bar{x}	25.4	33.4	28.0	18.3	25.7	33.5	30.6	12.7
		S	20.2	11.9	10.8	10.8	10.8	7.4	12.1	6.8
All Patients	38	\bar{x}	22.7	33.4	26.0	22.8	23.9	32.3	28.1	20.3
		S	13.6	11.3	10.0	14.4	9.3	8.5	8.9	12.5
Healthy Subjects	20	\bar{x}	18.9	37.0	29.7	16.4	19.5	37.3	28.3	16.5
		S	4.0	5.8	6.2	3.8	4.2	6.2	4.4	4.8

FIGURE 5.55a. Percentage contribution of fingers to power grip

 \bar{x} - mean contributions(%)

S - standard deviation

n - number of subjects/patients

	LEFT HAND				RIGHT HAND			
	In	Mi	Ri	Li	In	Mi	Ri	Li
X	1.69	1.60	1.73	2.57	2.47	2.57	0.11	1.65
P(X)	0.10	0.10	0.08	0.02	0.02	0.02	0.92	0.10
F	11.6	3.8	2.6	14.4	4.9	1.9	4.1	6.8
P(F)	<0.01	<0.01	>0.01 <0.025	<0.01	<0.01	>0.05	<0.01	<0.01

FIGURE 5.55b. Comparison of finger contribution results; patient results against healthy subject results.

P(X) = Probability of both means being the same

P(F) = Probability of both variances being the same

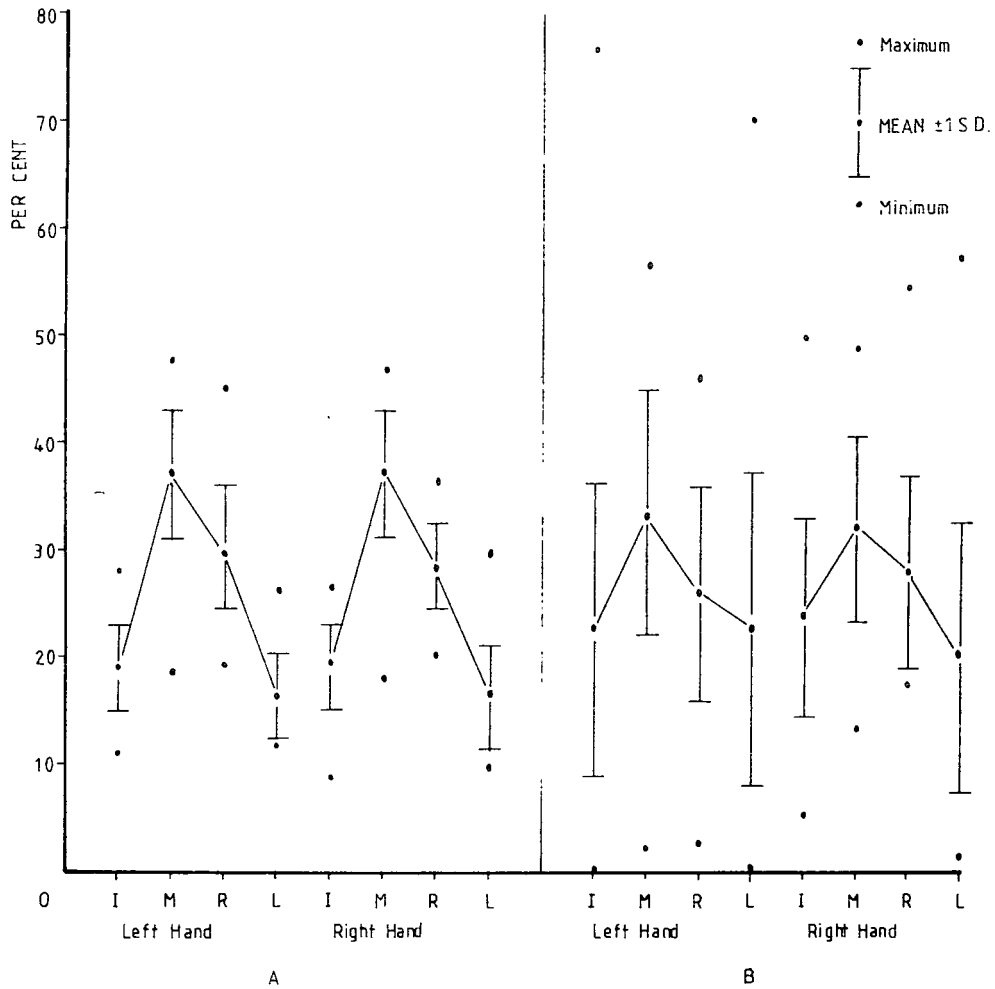

FIGURE 5.56. Diagram comparing the finger contribution to power grip of patients with arthritis (B) and healthy subjects(A)

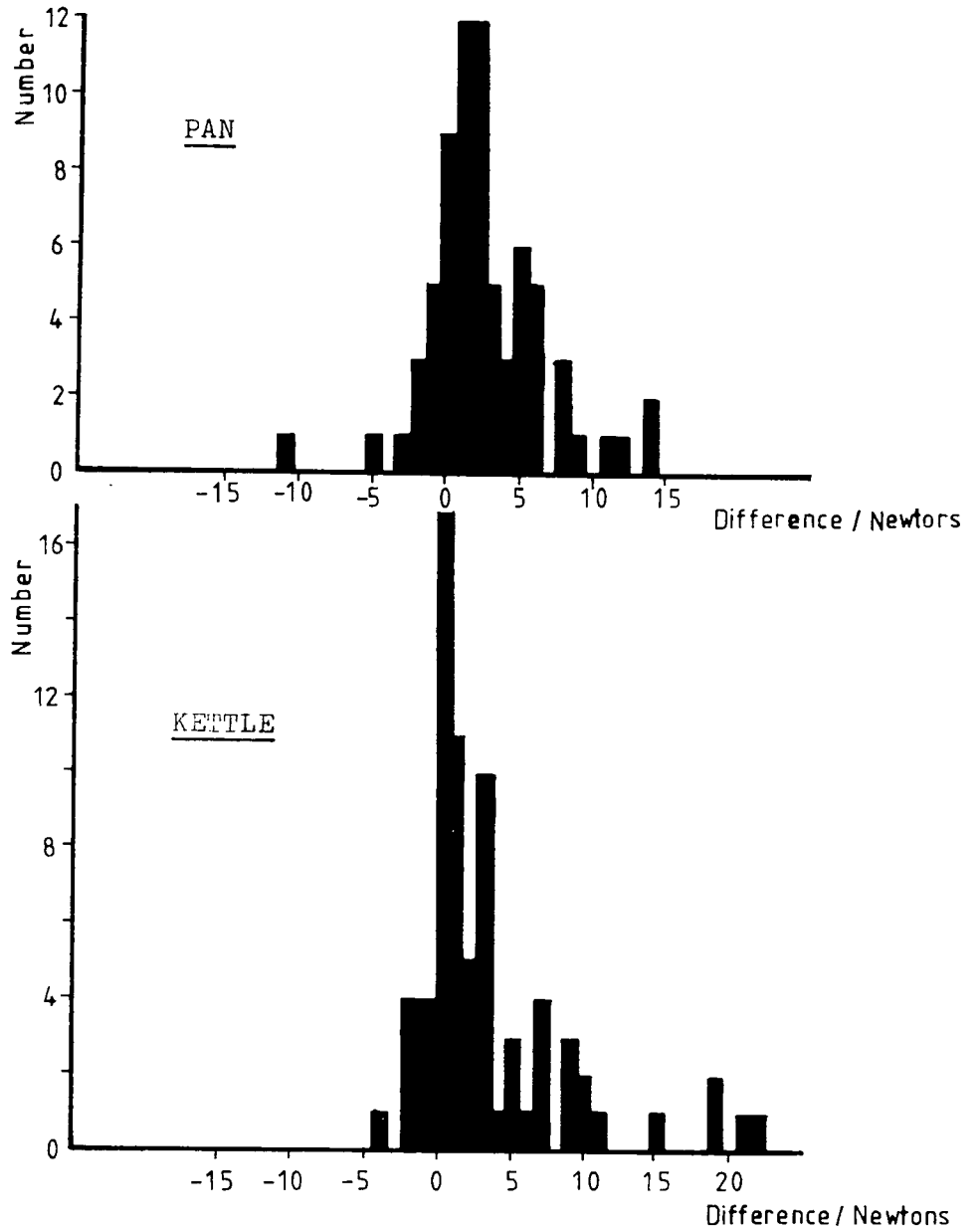

FIGURE 5.57. Histograms of differences between the upper and lower maximum lifting forces of patients with arthritis

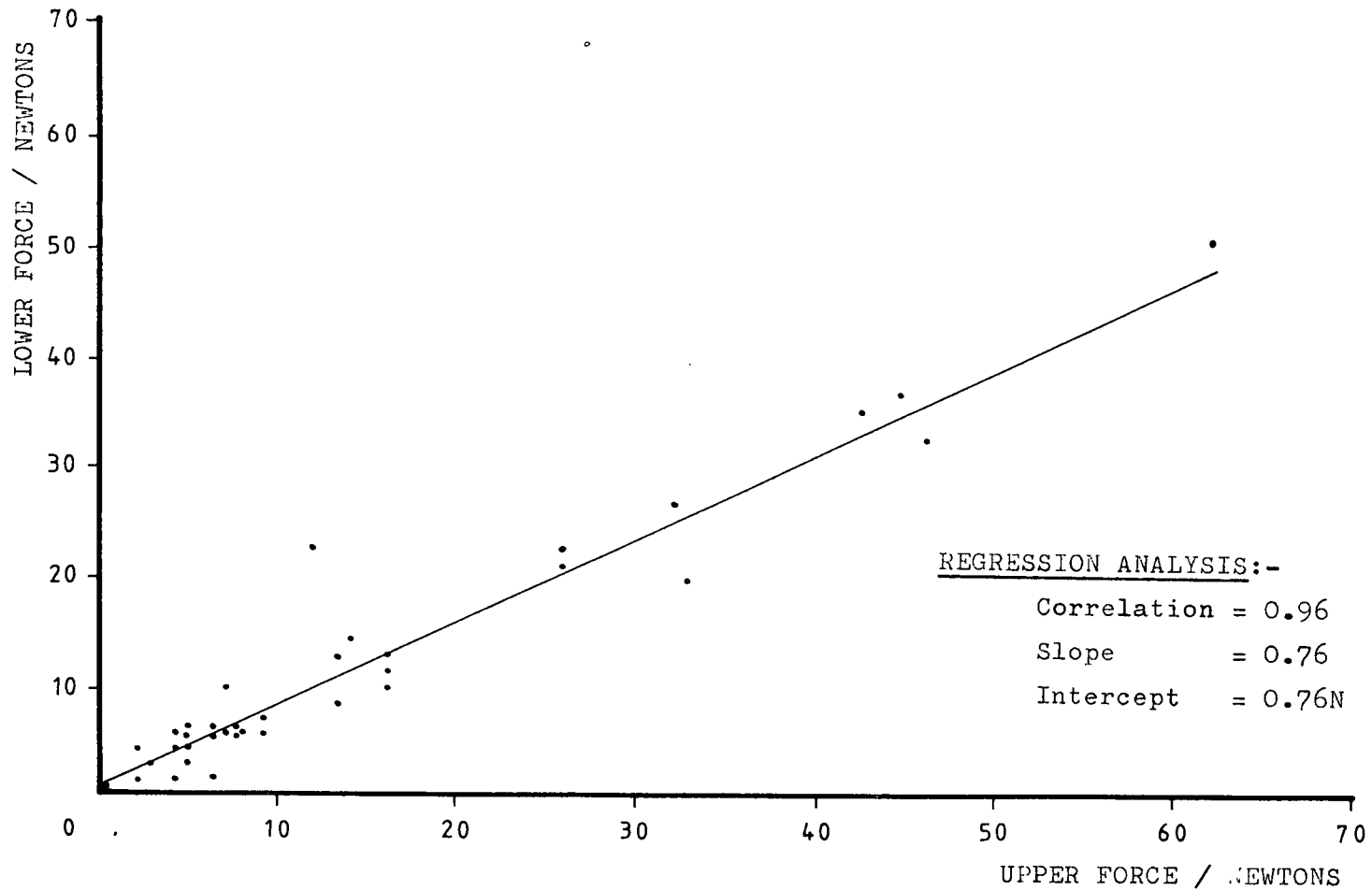

FIGURE 5.58. Scatter diagram and regression analysis of the upper lifting force measurement against the lower lifting force measurement in the left hand pan lift of patients with arthritis

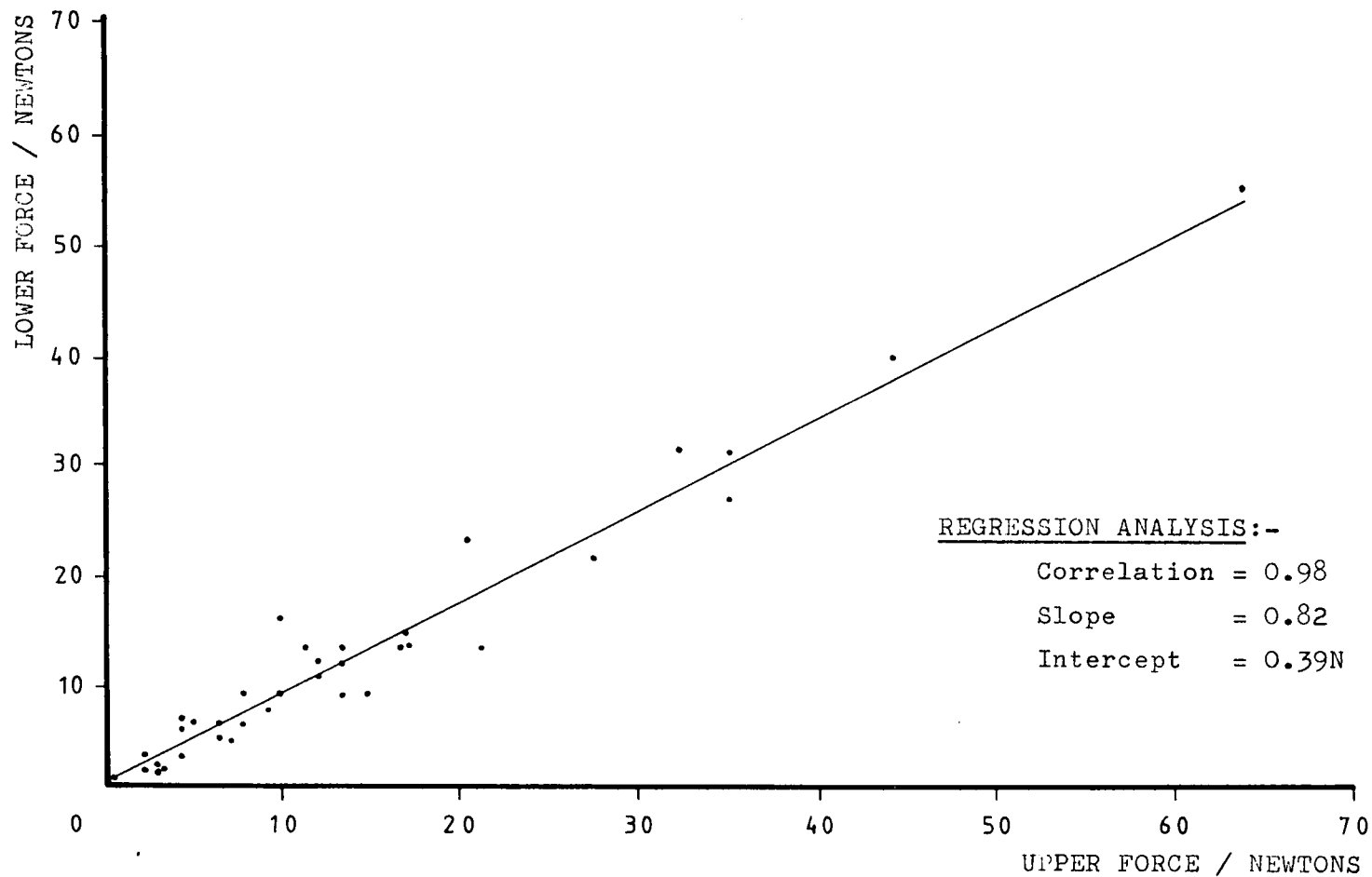

FIGURE 5.59. Scatter diagram and regression analysis of the upper lifting force measurement against the lower lifting force measurement in the right hand pan lift of patients with arthritis

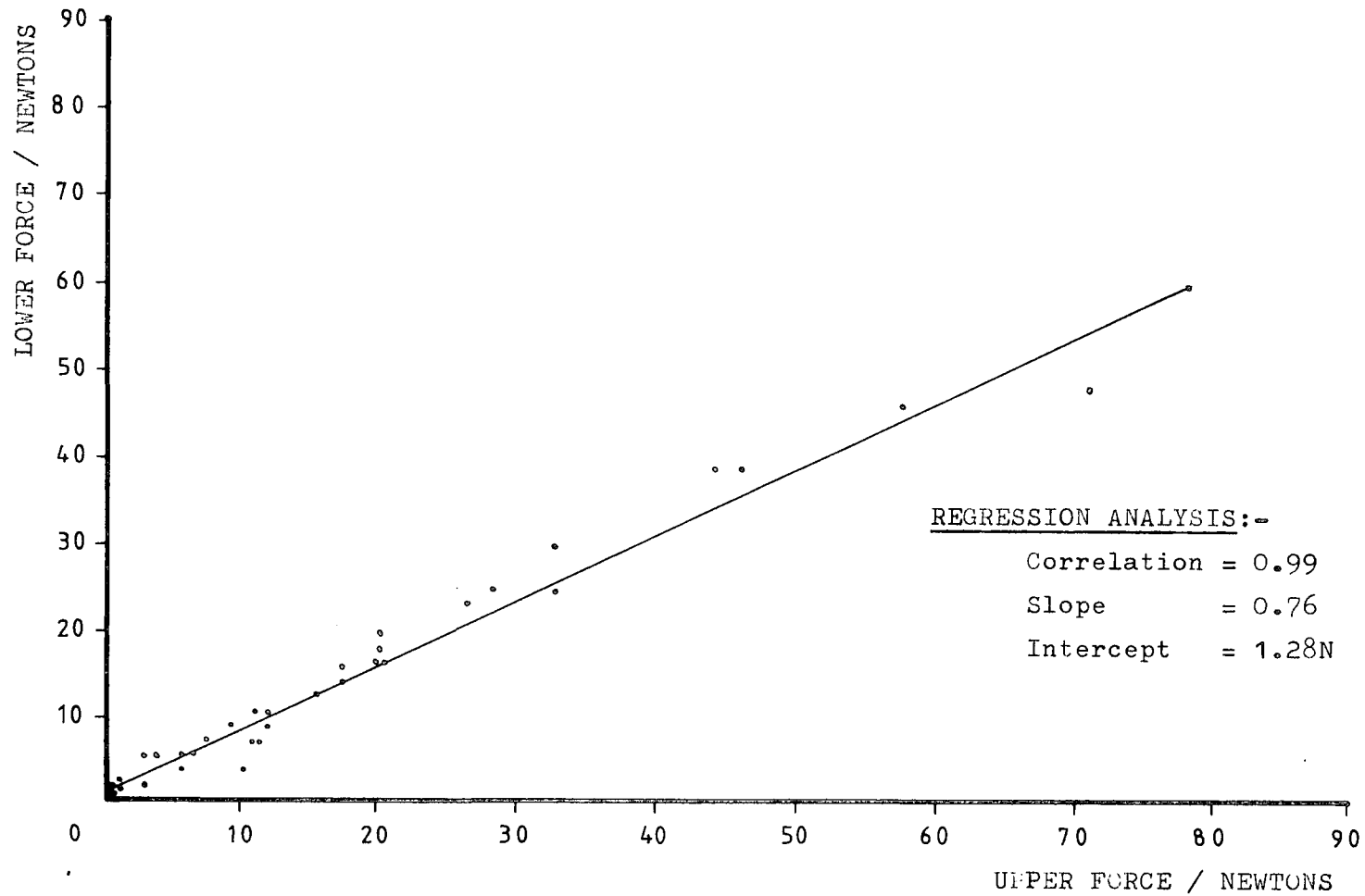

FIGURE 5.60. Scatter diagram and regression analysis of the upper lifting force measurement against the lower lifting force measurement in the left hand kettle lifts of patients with arthritis

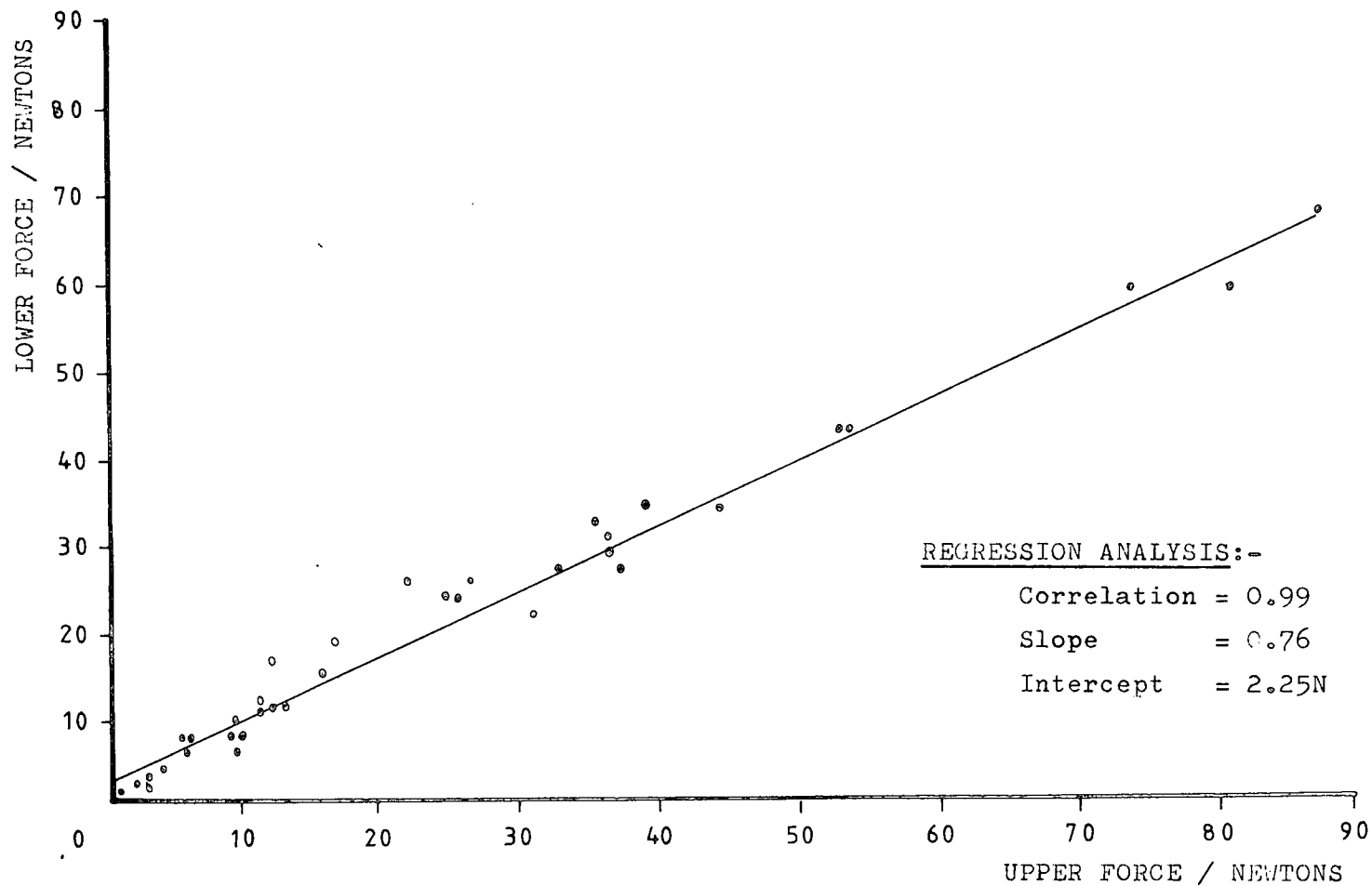

FIGURE 5.61. Scatter diagram and regression analysis of the upper lifting force measurement against the lower lifting force measurement in the right hand kettle lifts of patients with arthritis

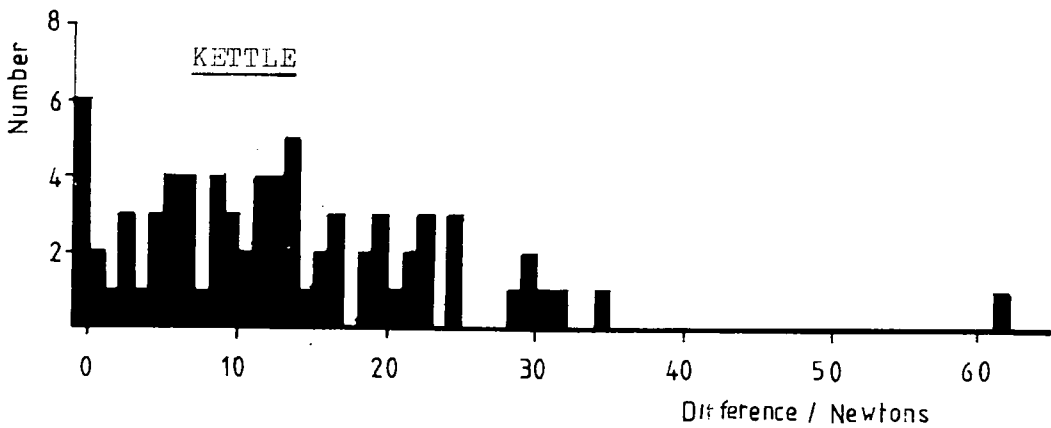
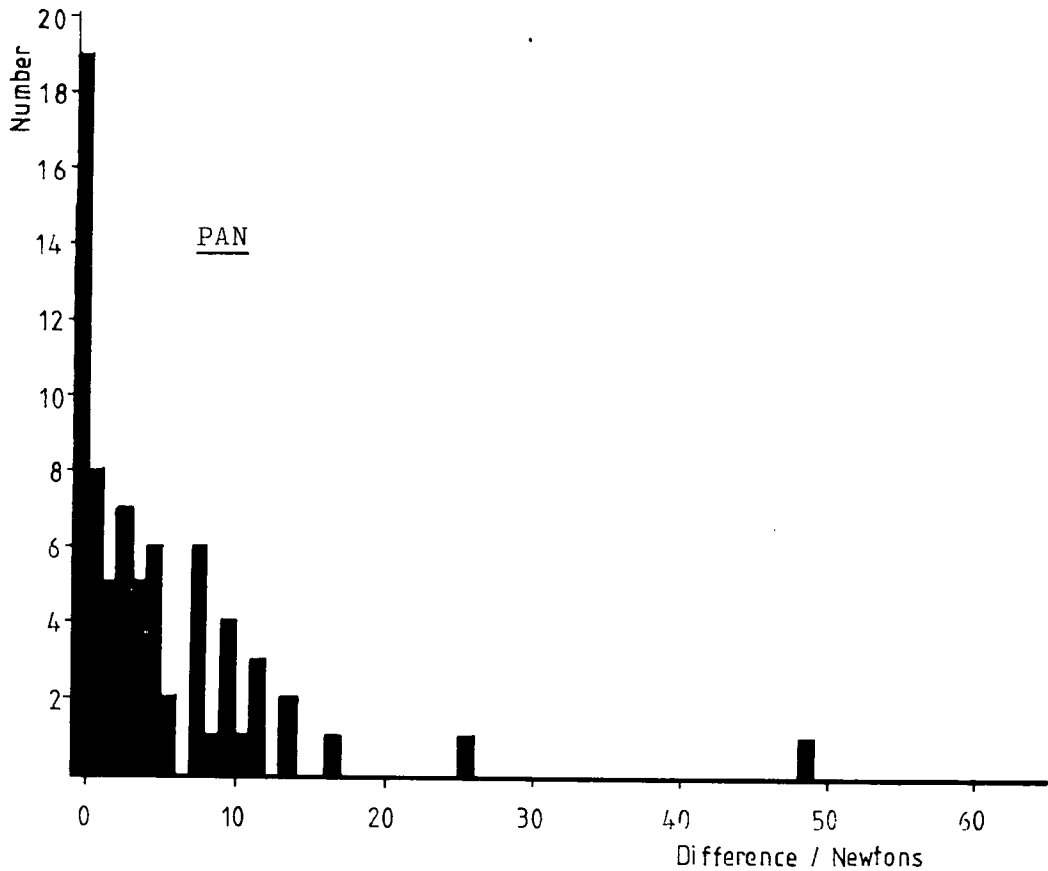

FIGURE 5.62. Histograms of the differences between the maximum handle grip forces and the grip forces at maximum lift in the pan and kettle lifts of patients with arthritis

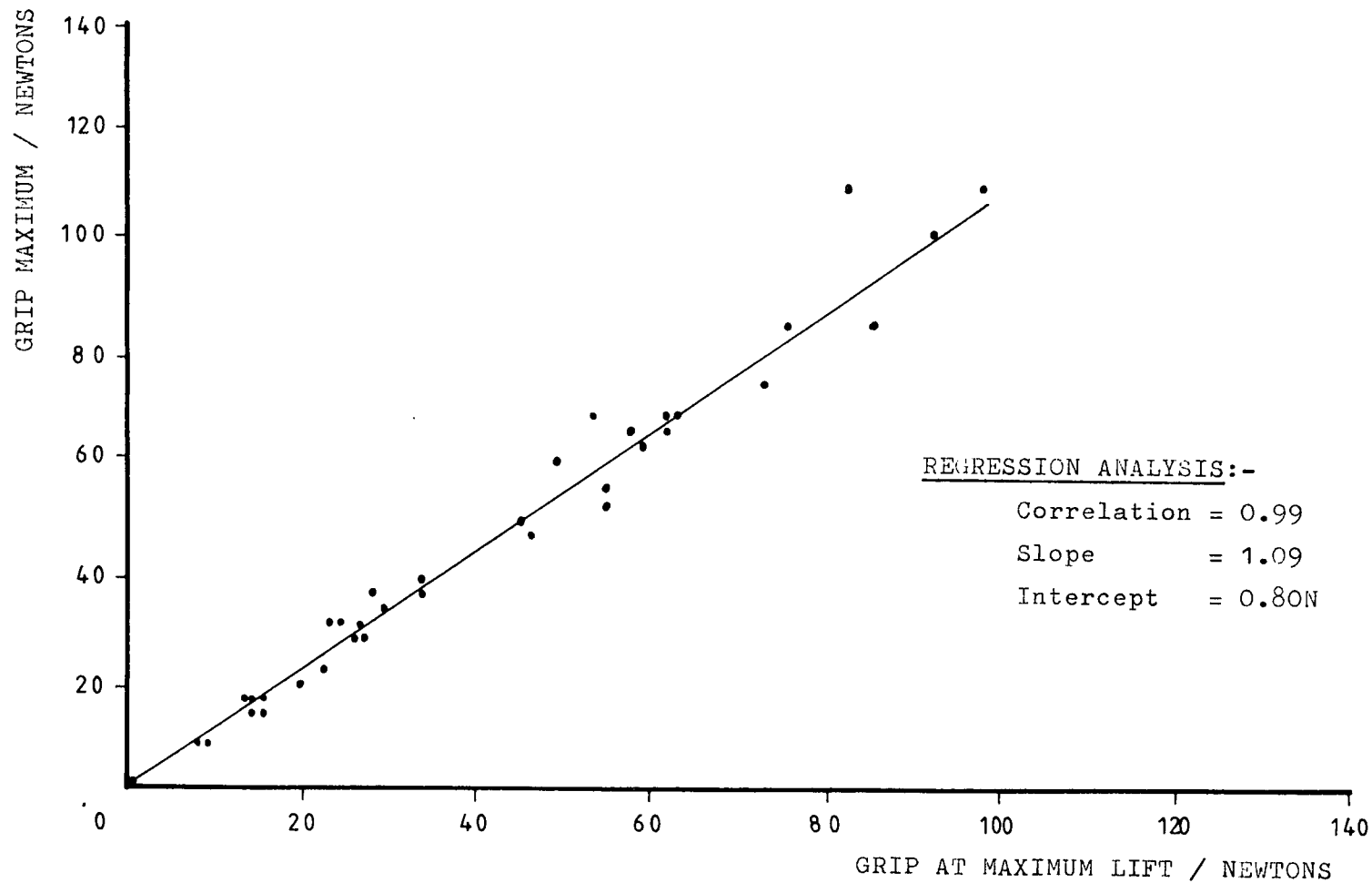

FIGURE 5.63. Scatter diagram and regression analysis of the handle grip force at maximum lift against the maximum handle grip force - left hand pan lifts of patients with arthritis

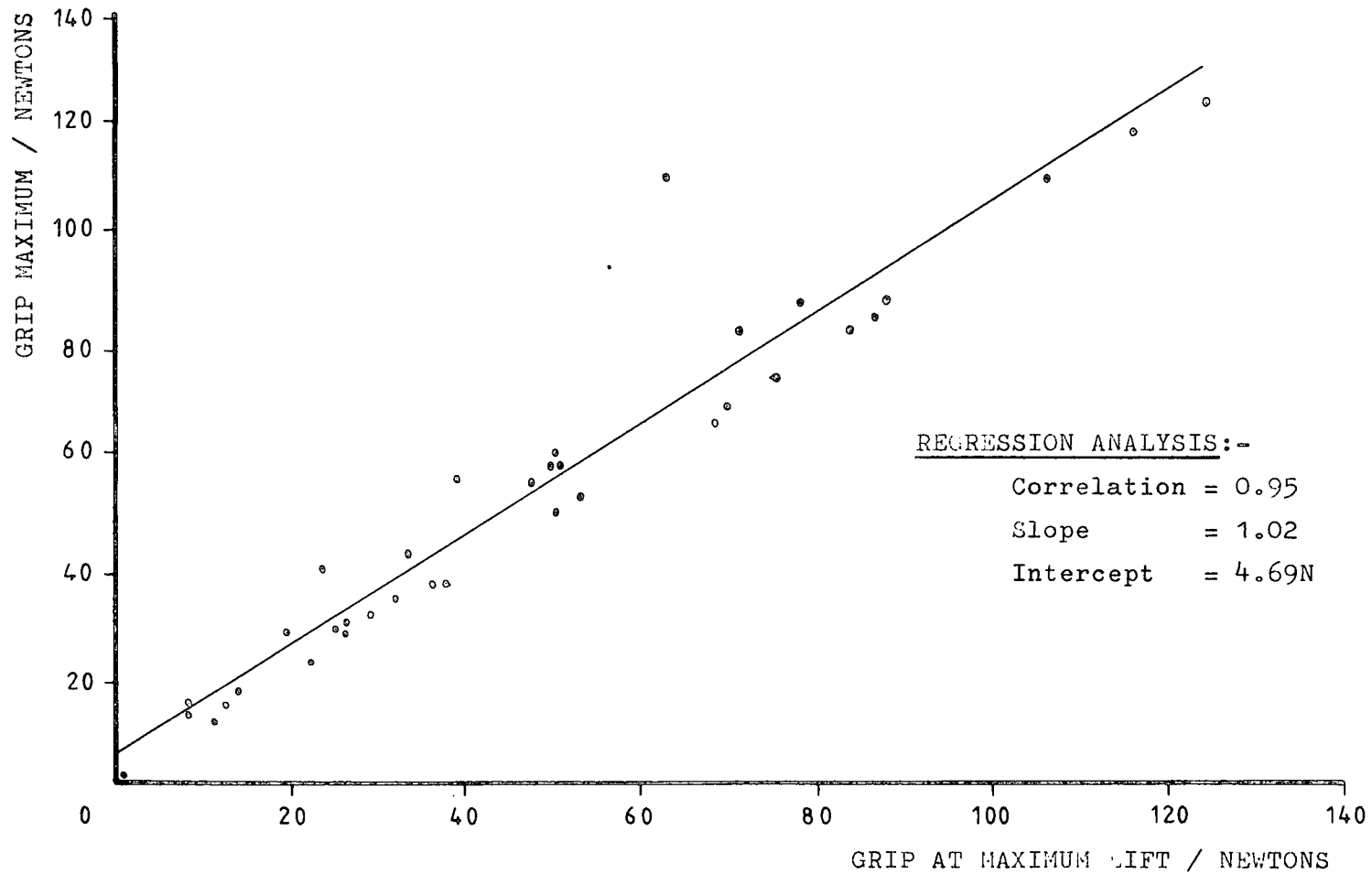

FIGURE 5.64. Scatter diagram and regression analysis of the handle grip force at maximum lift against the maximum handle grip force - right hand pan lifts of patients with arthritis

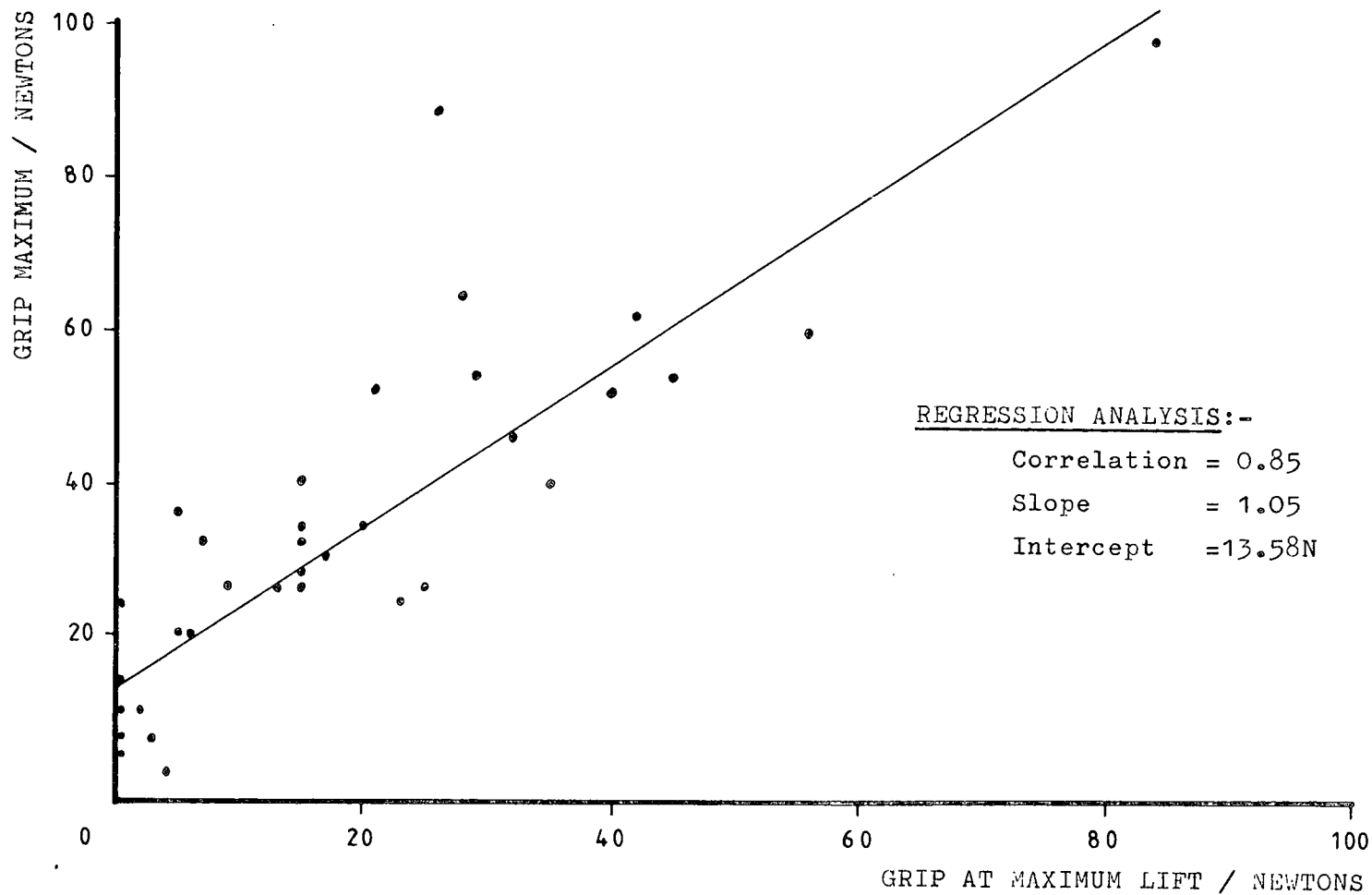

FIGURE 5.65. Scatter diagram and regression analysis of the handle grip force at maximum lift against the maximum handle grip force - left hand kettle lifts of patients with arthritis

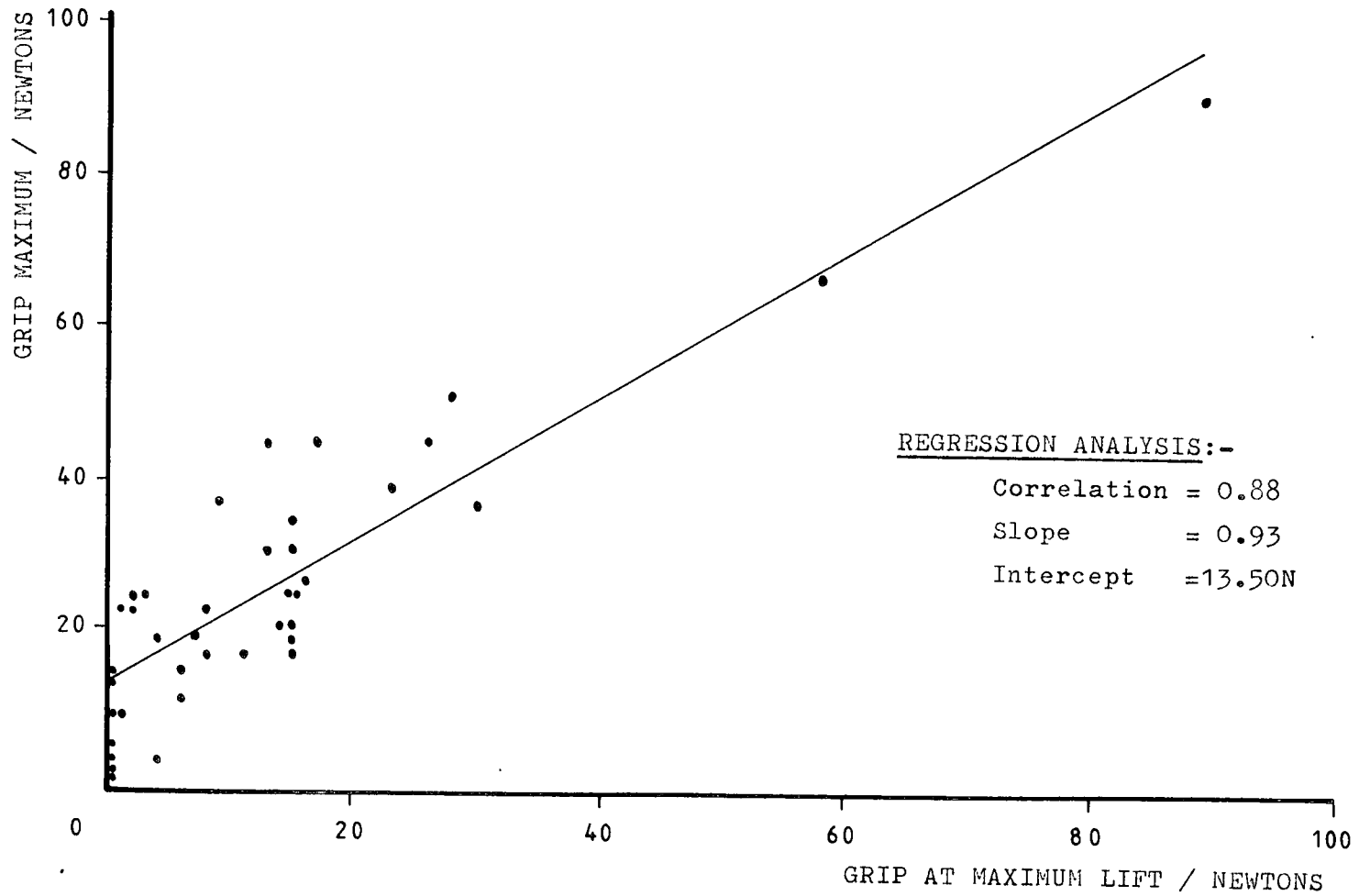

FIGURE 5.66. Scatter diagram and regression analysis of the handle grip force at maximum lift against the maximum handle grip force - right hand kettle lifts of patients with arthritis

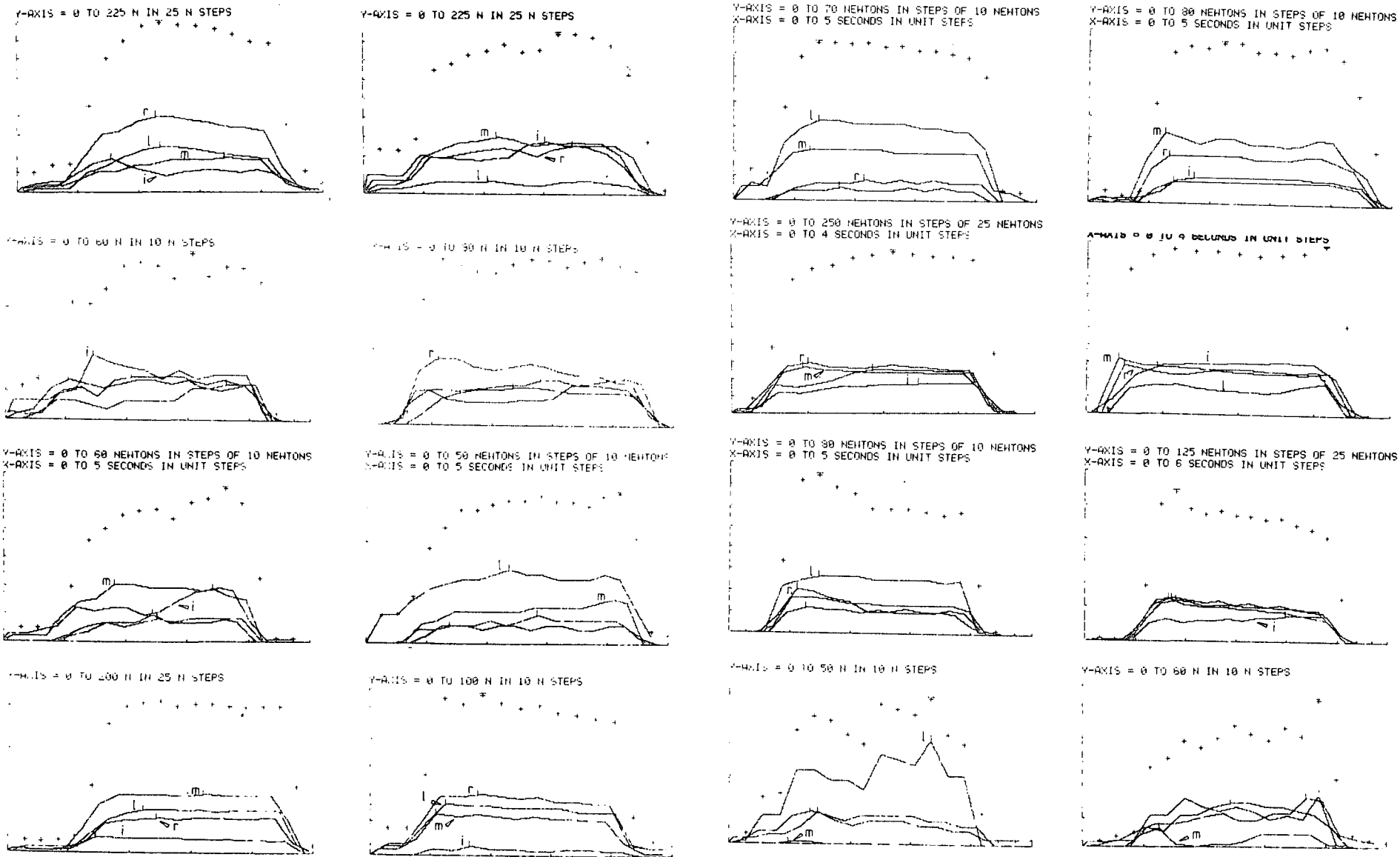
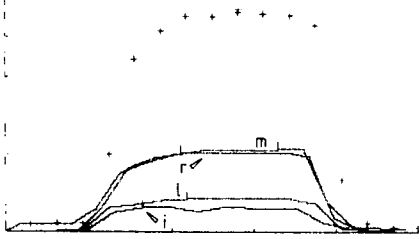
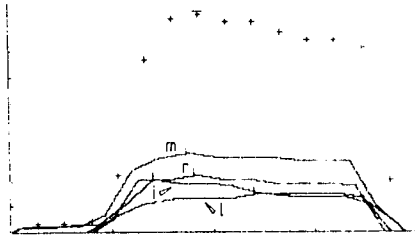

FIGURE 5.67. Force-time curves of power grip from patients with arthritis

Y-AXIS = 0 TO 150 NEWTONS IN STEPS OF 25 NEWTONS
X-AXIS = 0 TO 5 SECONDS IN UNIT STEPS



Y-AXIS = 0 TO 90 NEWTONS IN STEPS OF 10 NEWTONS
X-AXIS = 0 TO 4 SECONDS IN UNIT STEPS



Y-AXIS = 0 TO 225 N IN 25 N STEPS

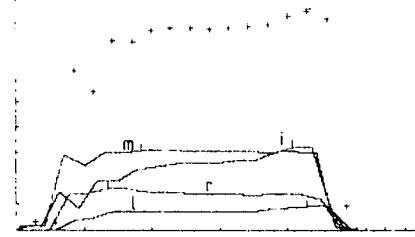

Y-AXIS = 0 TO 350 N IN 50 N STEPS

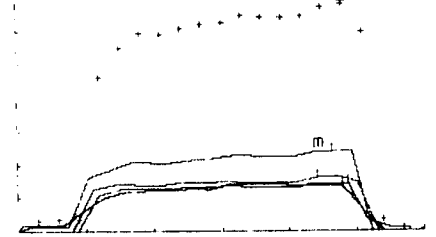

Y-AXIS = 0 TO 70 NEWTONS IN STEPS OF 10 NEWTONS
X-AXIS = 0 TO 5 SECONDS IN UNIT STEPS

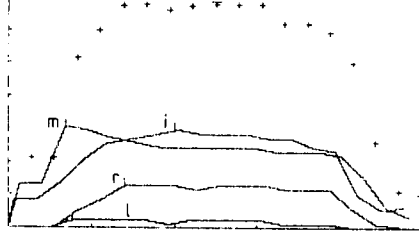

Y-AXIS = 0 TO 90 NEWTONS IN STEPS OF 10 NEWTONS
X-AXIS = 0 TO 6 SECONDS IN UNIT STEPS

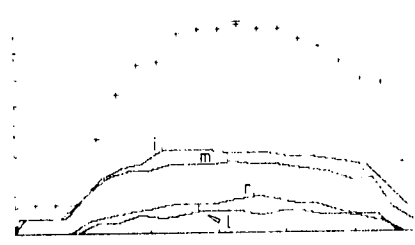

Y-AXIS = 0 TO 175 N IN 25 N STEPS

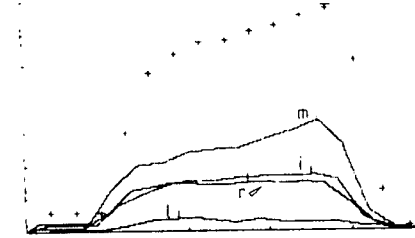

Y-AXIS = 0 TO 225 N IN 25 N STEPS

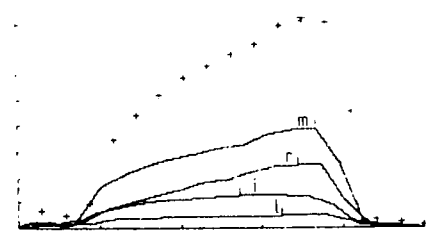

Y-AXIS = 0 TO 175 NEWTONS IN STEPS OF 25 NEWTONS
X-AXIS = 0 TO 5 SECONDS IN UNIT STEPS

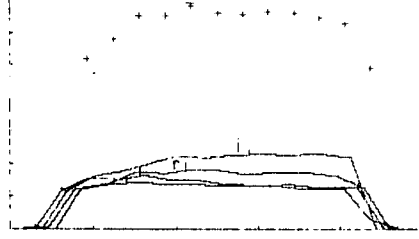

Y-AXIS = 0 TO 225 NEWTONS IN STEPS OF 25 NEWTONS
X-AXIS = 0 TO 5 SECONDS IN UNIT STEPS

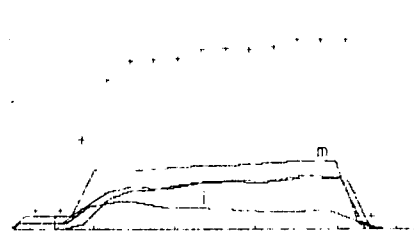

Y-AXIS = 0 TO 60 N IN 10 N STEPS

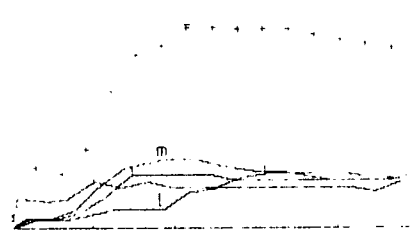

Y-AXIS = 0 TO 70 N IN 10 N STEPS

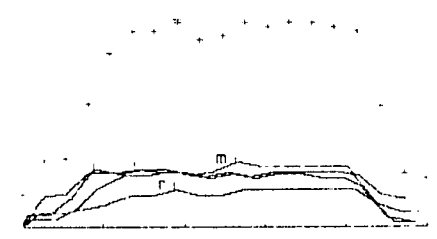

Y-AXIS = 0 TO 200 N IN 25 N STEPS

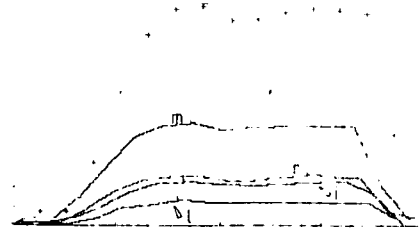

Y-AXIS = 0 TO 250 N IN 25 N STEPS

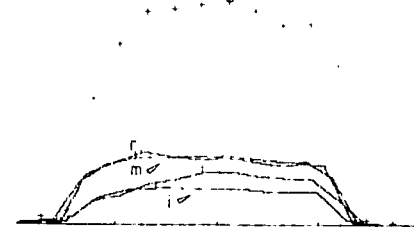

Y-AXIS = 0 TO 60 NEWTONS IN STEPS OF 10 NEWTONS
X-AXIS = 0 TO 5 SECONDS IN UNIT STEPS

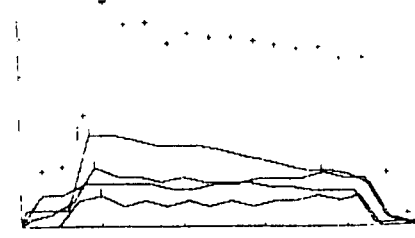

Y-AXIS = 0 TO 80 NEWTONS IN STEPS OF 10 NEWTONS
X-AXIS = 0 TO 6 SECONDS IN UNIT STEPS

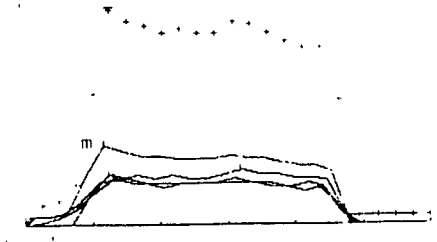

FIGURE 5.67.(continued) Force-time curves of power grip from patients with arthritis

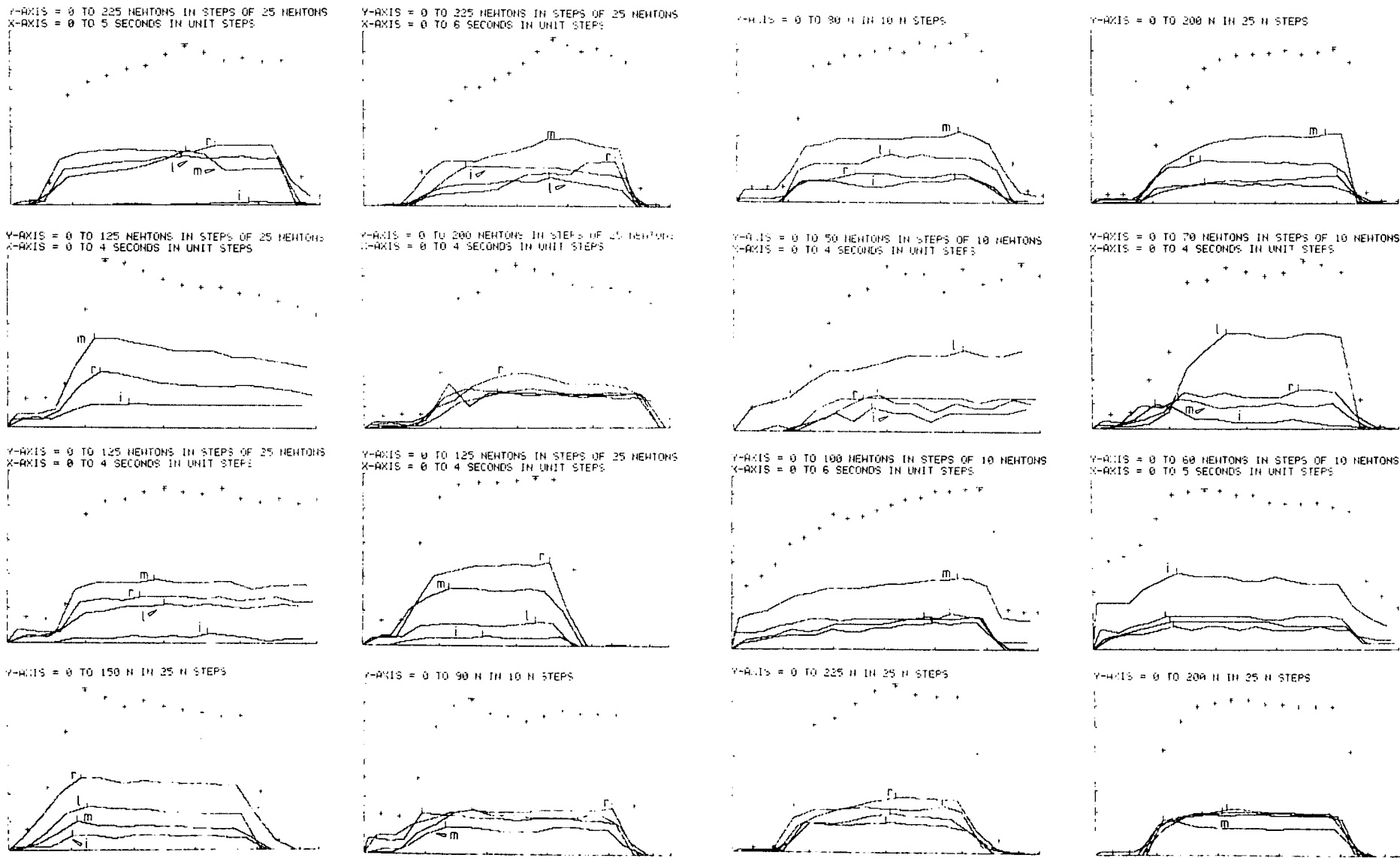

FIGURE 5.67.(continued) Force-time curves of power grip from patients with arthritis

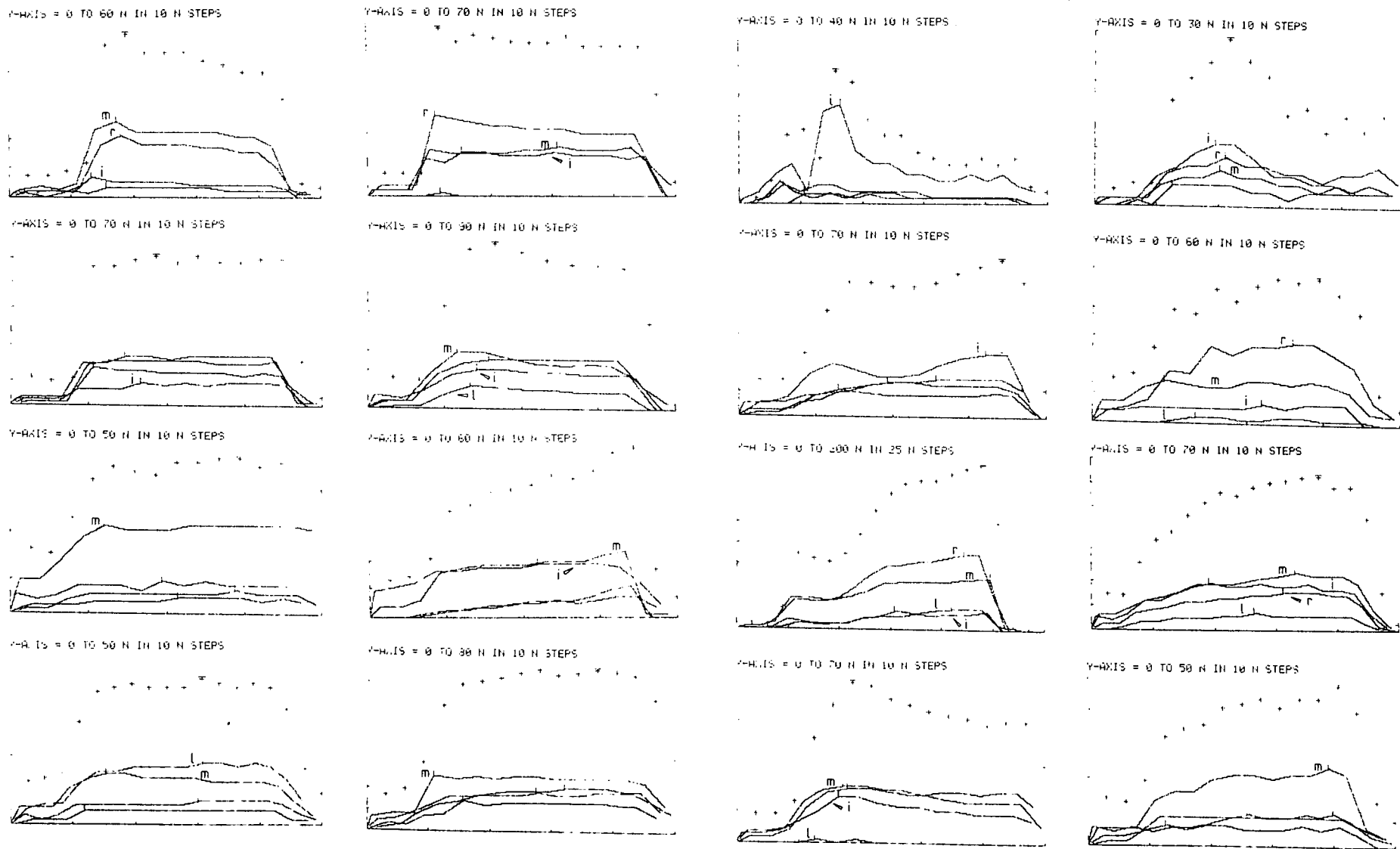
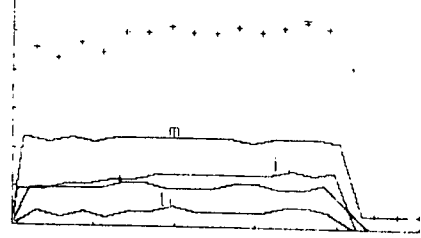
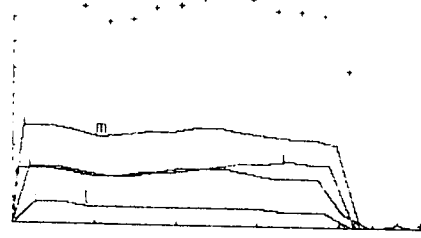

FIGURE 5.67.(continued) Force-time curves of power grip from patients with arthritis

Y-AXIS = 0 TO 60 NEWTONS IN STEPS OF 10 NEWTONS
X-AXIS = 0 TO 5 SECONDS IN UNIT STEPS



Y-AXIS = 0 TO 90 NEWTONS IN STEPS OF 10 NEWTONS
X-AXIS = 0 TO 5 SECONDS IN UNIT STEPS



Y-AXIS = 0 TO 150 NEWTONS IN STEPS OF 25 NEWTONS
X-AXIS = 0 TO 5 SECONDS IN UNIT STEPS

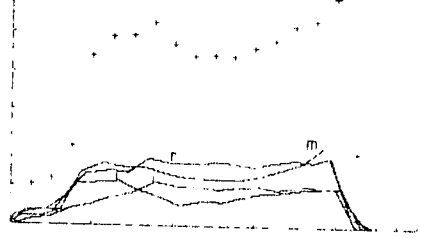

Y-AXIS = 0 TO 6 SECONDS IN UNIT STEPS

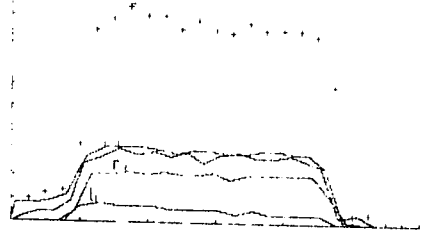

Y-AXIS = 0 TO 175 N IN 25 N STEPS

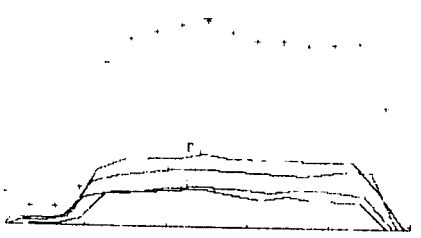

Y-AXIS = 0 TO 125 N IN 25 N STEPS

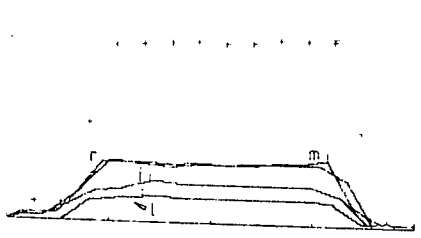

Y-AXIS = 0 TO 40 N IN 10 N STEPS

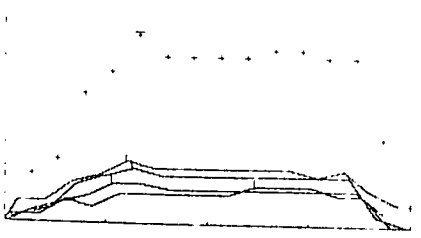

Y-AXIS = 0 TO 40 N IN 10 N STEPS

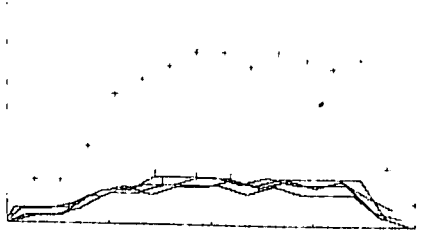

FIGURE 5.67.(continued) Force-time curves of power grip from patients with arthritis

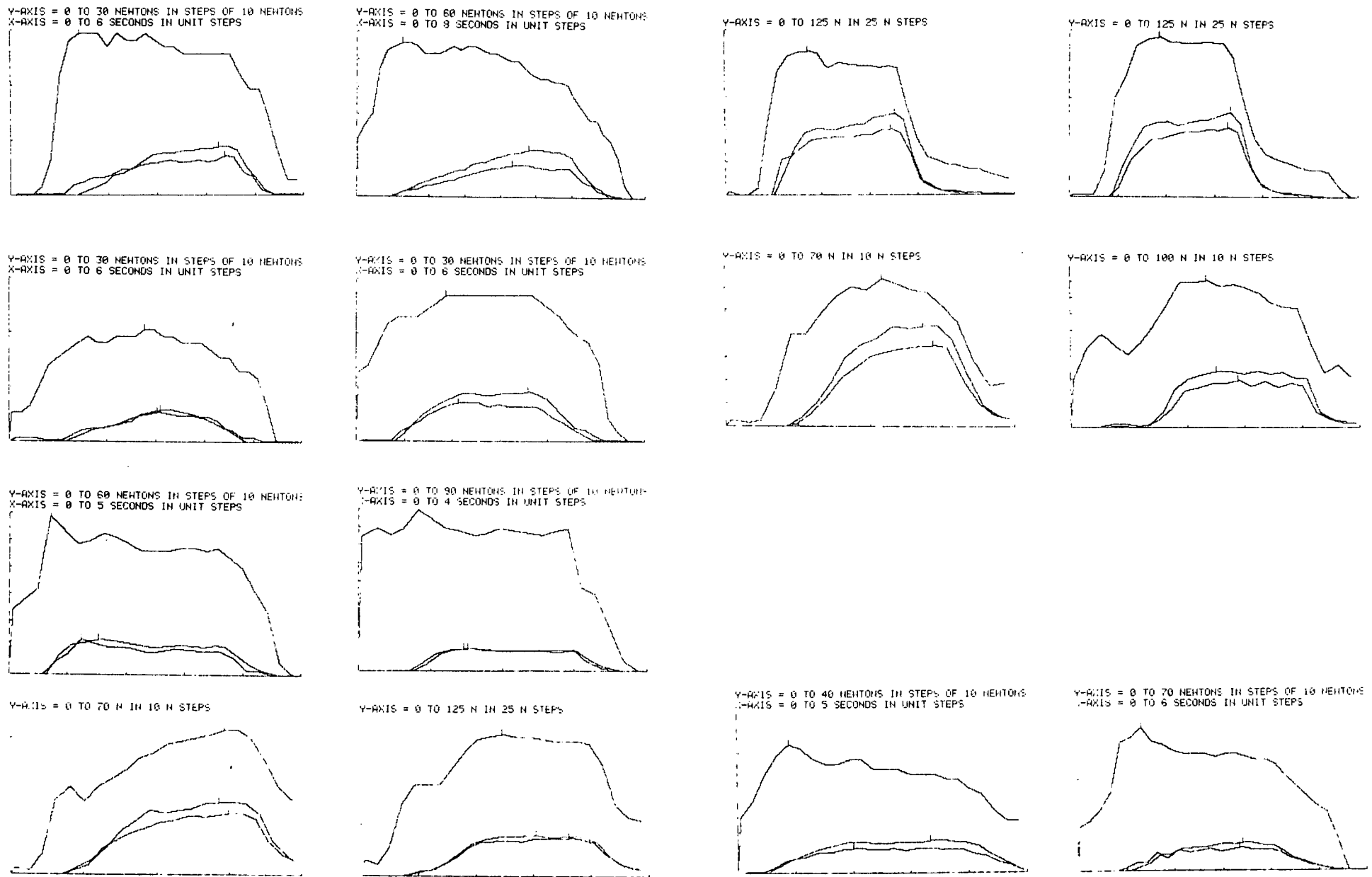

FIGURE 5.68. Force-time curves of pan lift from patients with arthritis

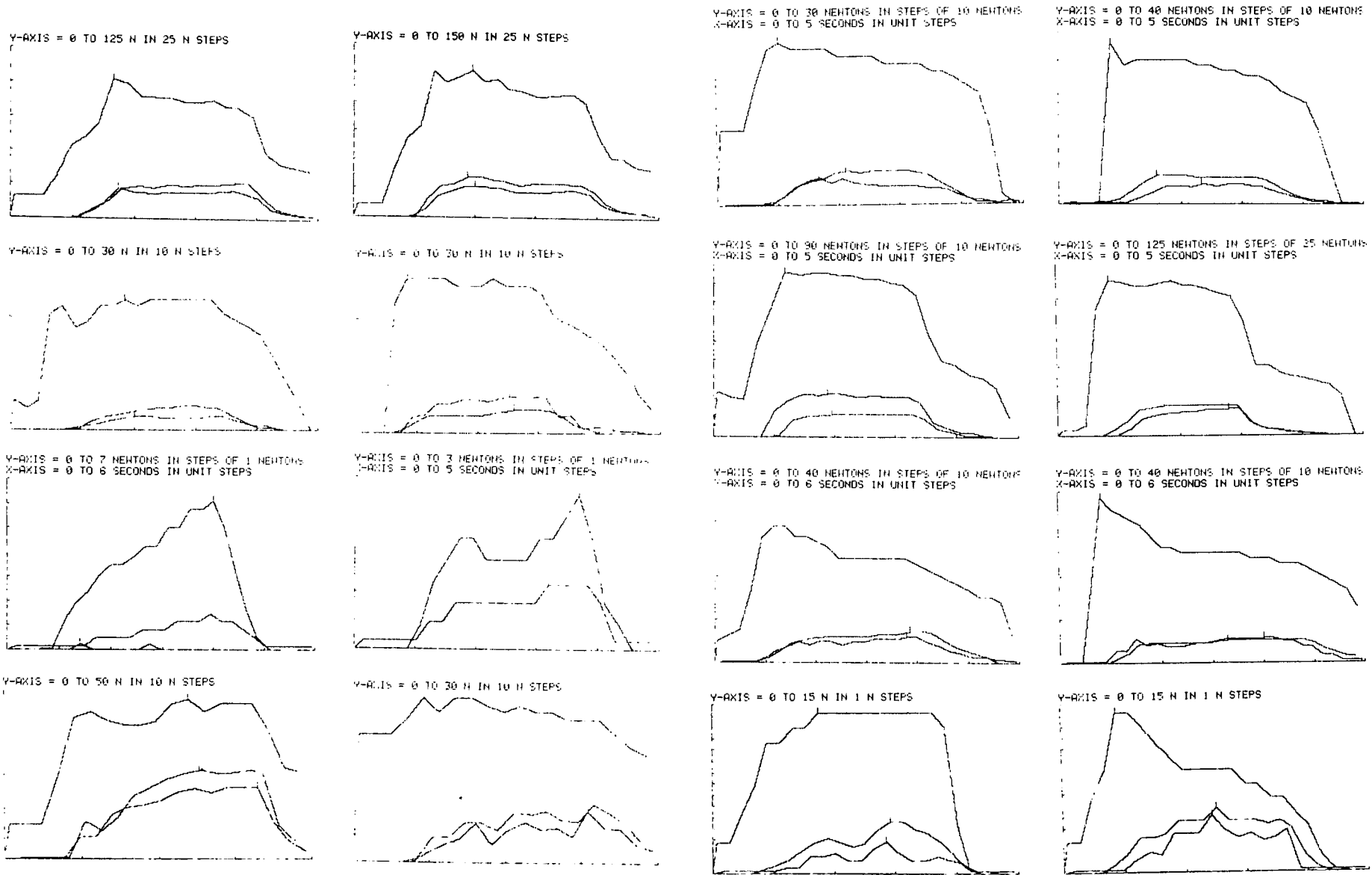

FIGURE 5.68.(continued) Force-time curves of pan lift from patients with arthritis

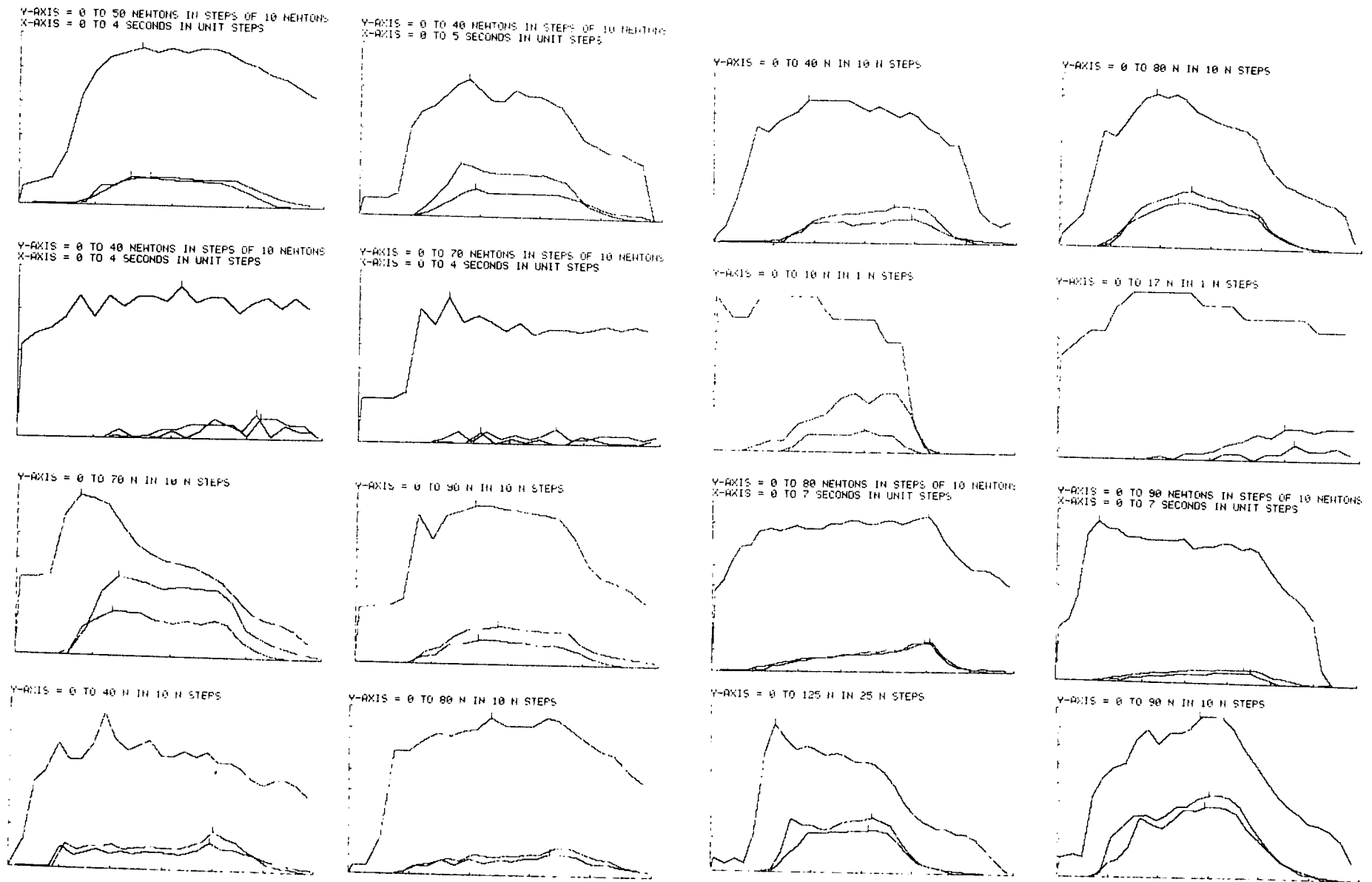
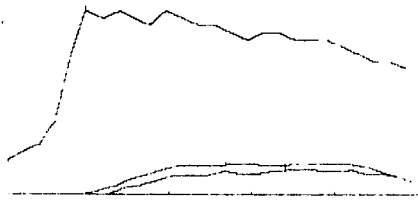
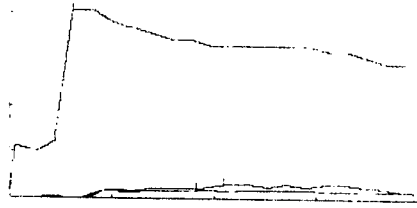

FIGURE 5.68.(continued) Force-time cueves of pan lift from patients with arthritis

Y-AXIS = 0 TO 40 N IN 10 N STEPS



Y-AXIS = 0 TO 50 N IN 10 N STEPS



Y-AXIS = 0 TO 12 N IN 1 N STEPS

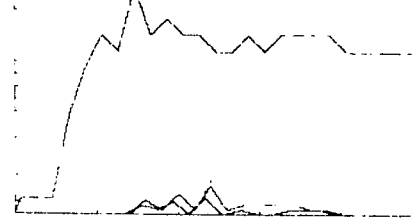

Y-AXIS = 0 TO 16 N IN 1 N STEPS

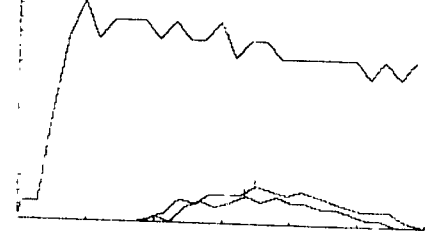

Y-AXIS = 0 TO 50 N IN 10 N STEPS



Y-AXIS = 0 TO 30 N IN 10 N STEPS



Y-AXIS = 0 TO 17 N IN 1 N STEPS

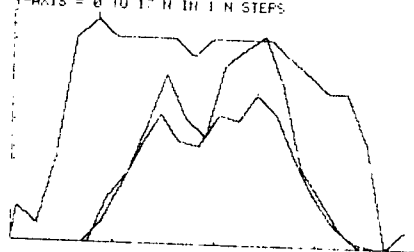

Y-AXIS = 0 TO 14 N IN 1 N STEPS

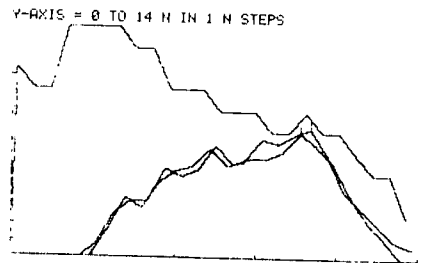

Y-AXIS = 0 TO 70 N IN 10 N STEPS

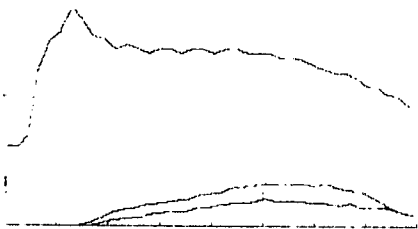

Y-AXIS = 0 TO 60 N IN 10 N STEPS



Y-AXIS = 0 TO 80 N IN 10 N STEPS

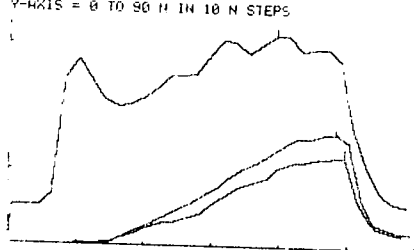

Y-AXIS = 0 TO 40 N IN 10 N STEPS

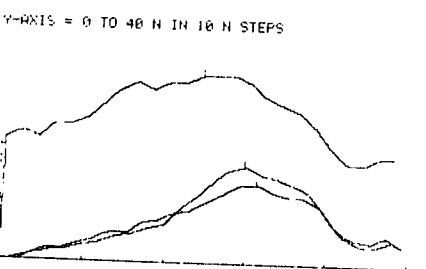

Y-AXIS = 0 TO 9 N IN 1 N STEPS

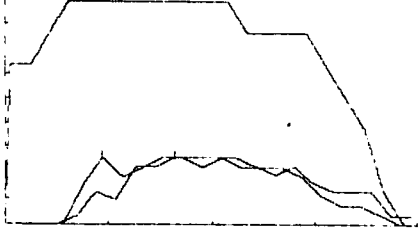

Y-AXIS = 0 TO 12 N IN 1 N STEPS

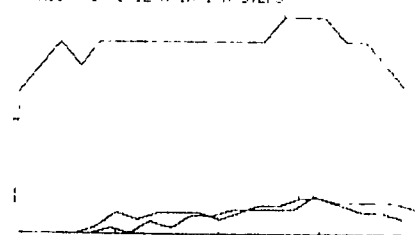

Y-AXIS = 0 TO 40 N IN 10 N STEPS

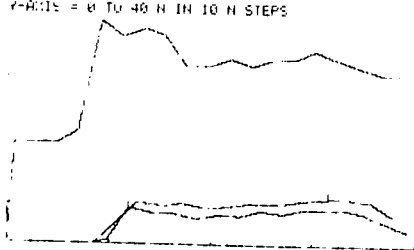

Y-AXIS = 0 TO 80 N IN 10 N STEPS

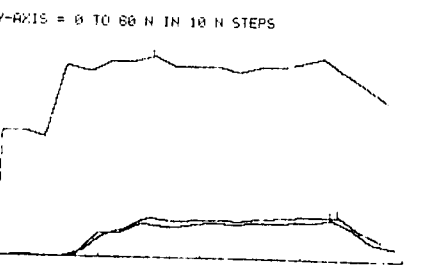

FIGURE 5.68.(continued) Force-time curves of pan lift from patients with arthritis

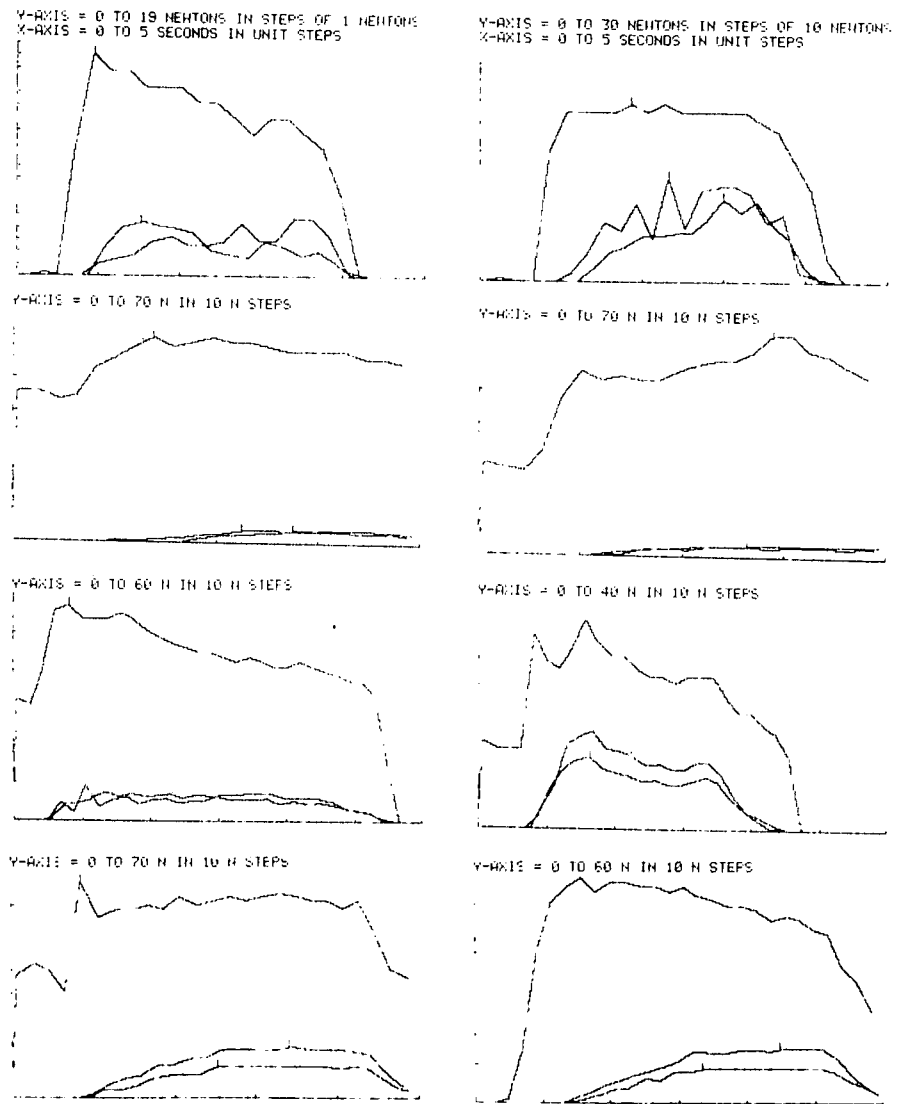

FIGURE 5.68.(continued) Force-time curves of pan lift from patients with arthritis

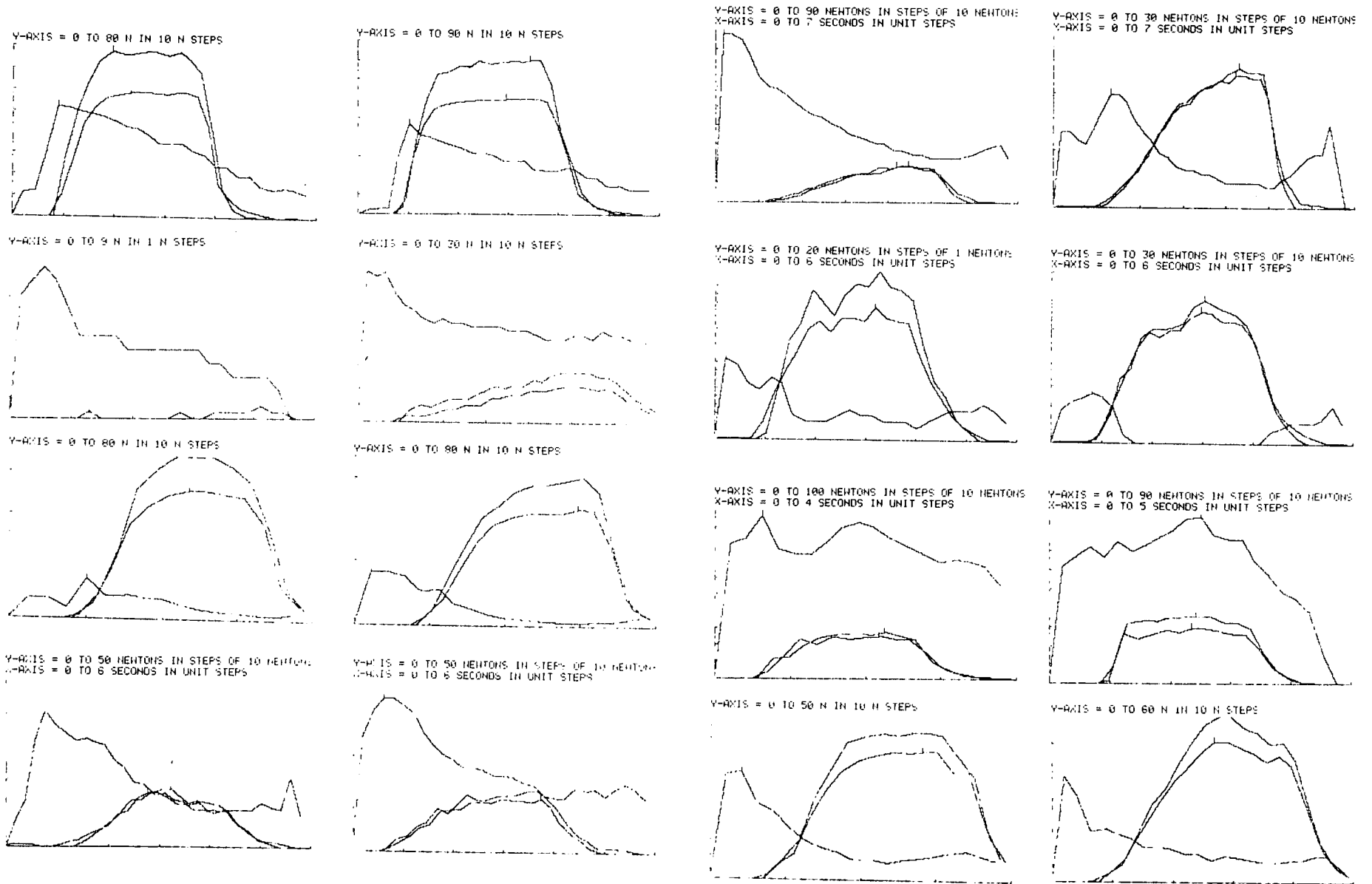

FIGURE 5.69. Force-time cuves of kettle lift from patients with arthritis

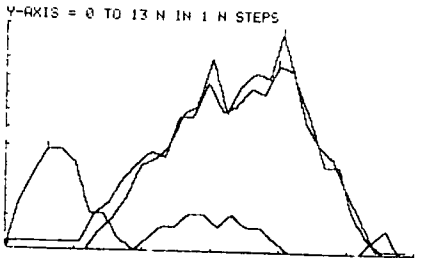
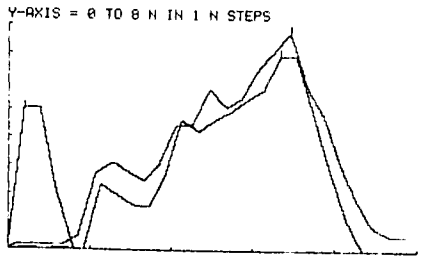
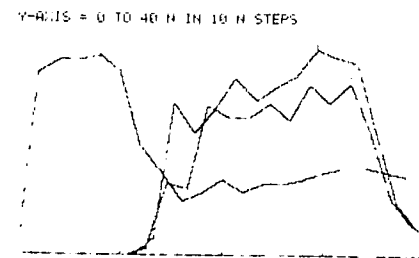
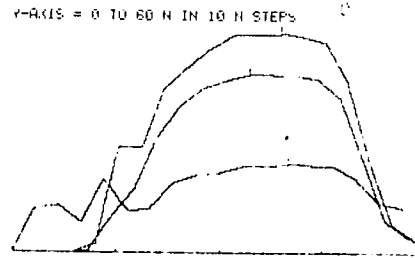
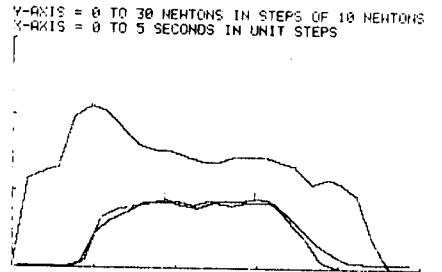
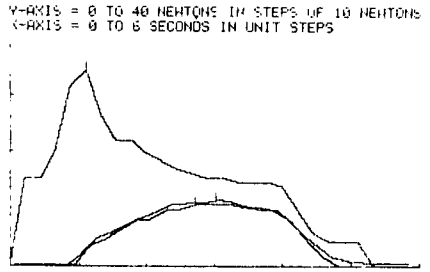
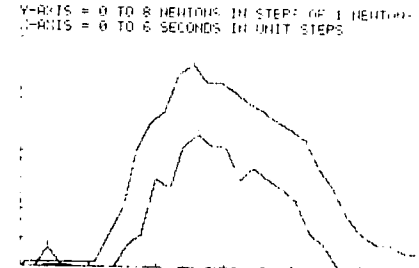
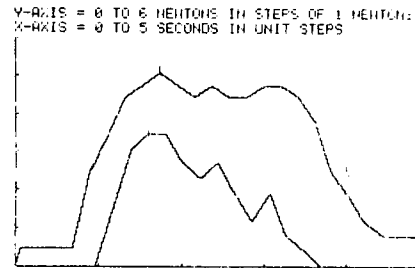
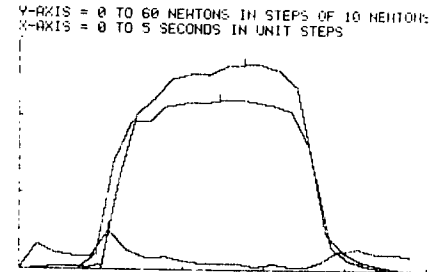
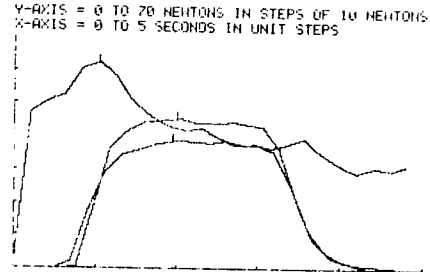
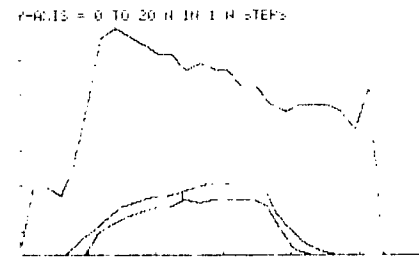
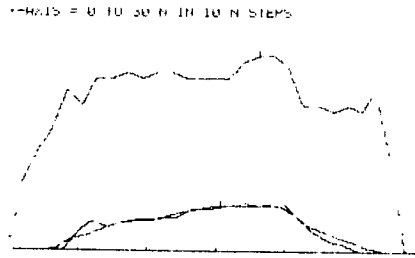
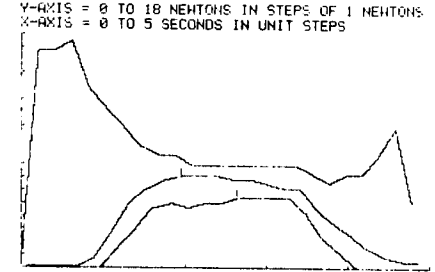
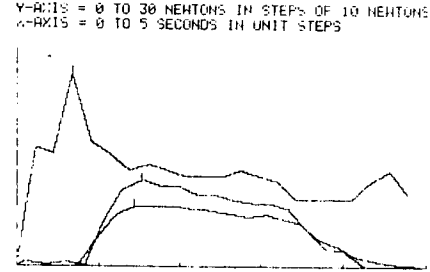
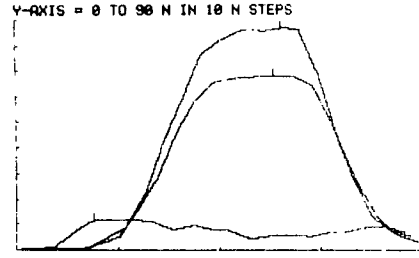
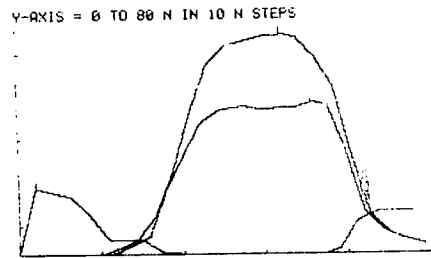
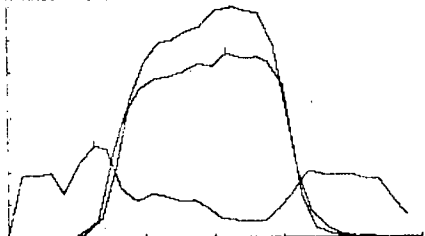
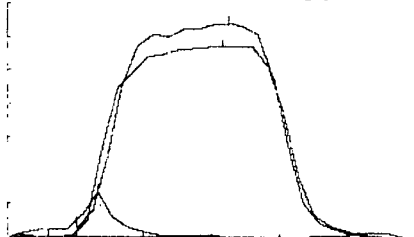

FIGURE 5.69.(continued) Force-time curves of kettle lift from patients with arthritis

Y-AXIS = 0 TO 70 NEWTONS IN STEPS OF 10 NEWTONS
X-AXIS = 0 TO 6 SECONDS IN UNIT STEPS



Y-AXIS = 0 TO 70 NEWTONS IN STEPS OF 10 NEWTONS
X-AXIS = 0 TO 6 SECONDS IN UNIT STEPS



Y-AXIS = 0 TO 40 N IN 10 N STEPS

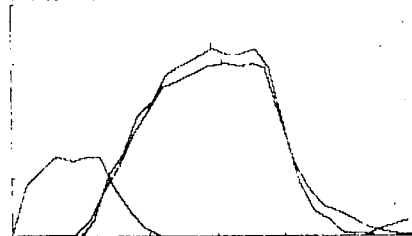

Y-AXIS = 0 TO 60 N IN 10 N STEPS

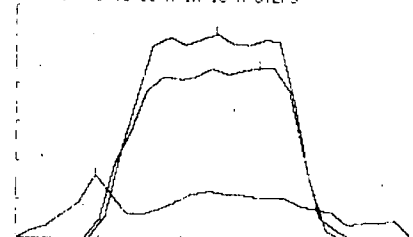

Y-AXIS = 0 TO 40 NEWTONS IN STEPS OF 10 NEWTONS
X-AXIS = 0 TO 4 SECONDS IN UNIT STEPS

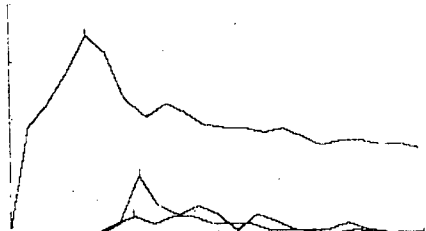

Y-AXIS = 0 TO 30 NEWTONS IN STEPS OF 10 NEWTONS
X-AXIS = 0 TO 4 SECONDS IN UNIT STEPS



Y-AXIS = 0 TO 30 N IN 10 N STEPS

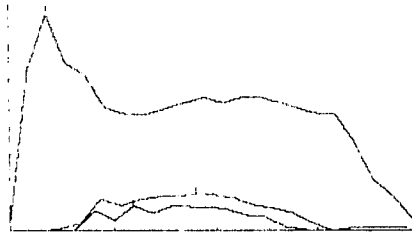

Y-AXIS = 0 TO 30 N IN 10 N STEPS

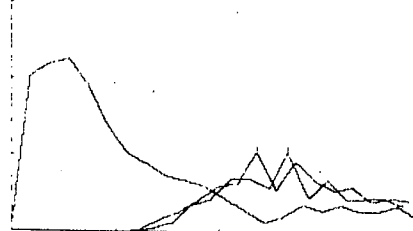

Y-AXIS = 0 TO 40 N IN 10 N STEPS



Y-AXIS = 0 TO 60 N IN 10 N STEPS

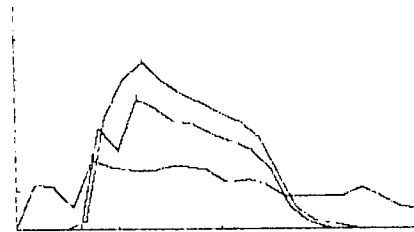

Y-AXIS = 0 TO 60 NEWTONS IN STEPS OF 10 NEWTONS
X-AXIS = 0 TO 6 SECONDS IN UNIT STEPS

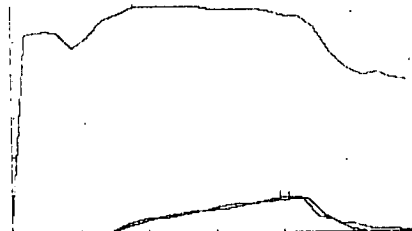

Y-AXIS = 0 TO 40 NEWTONS IN STEPS OF 10 NEWTONS
X-AXIS = 0 TO 7 SECONDS IN UNIT STEPS



Y-AXIS = 0 TO 12 N IN 1 N STEPS



Y-AXIS = 0 TO 9 N IN 1 N STEPS



Y-AXIS = 0 TO 80 N IN 10 N STEPS

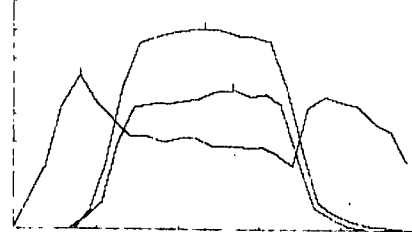

Y-AXIS = 0 TO 80 N IN 10 N STEPS

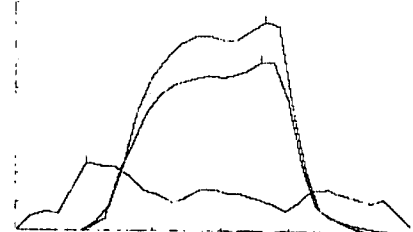

FIGURE 5.69.(continued) Force-time curves of kettle lift from patients with arthritis

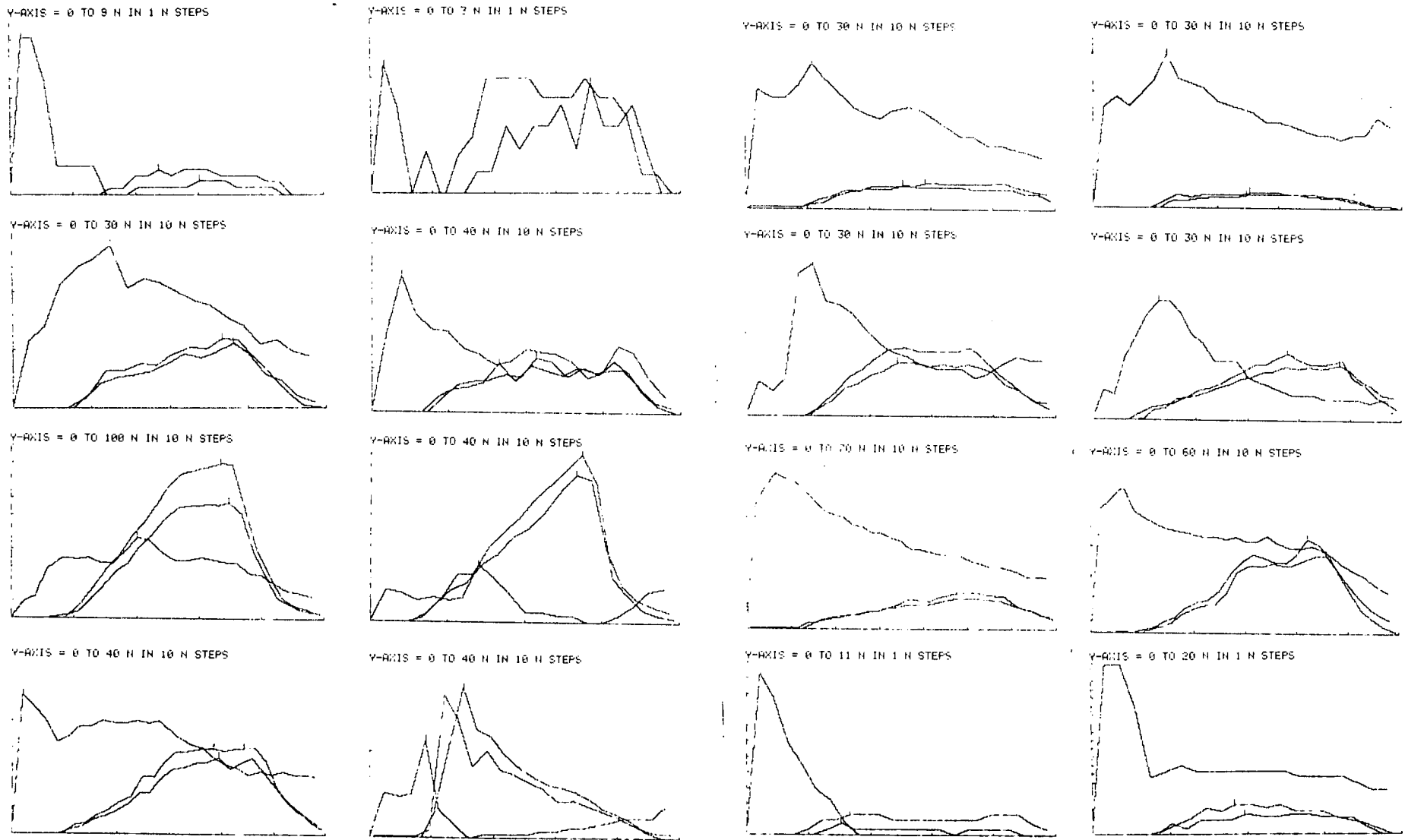

FIGURE 5.69.(continued) Force-time curves of kettle lifts from patients with arthritis

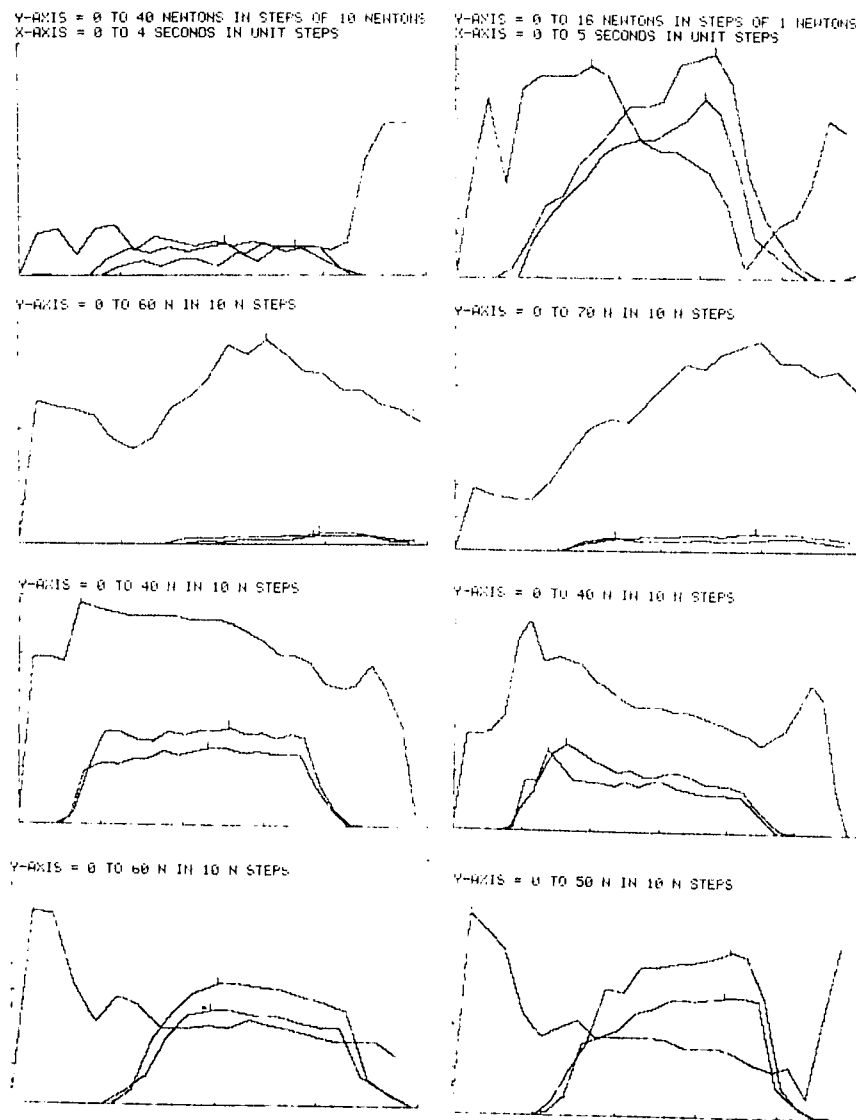
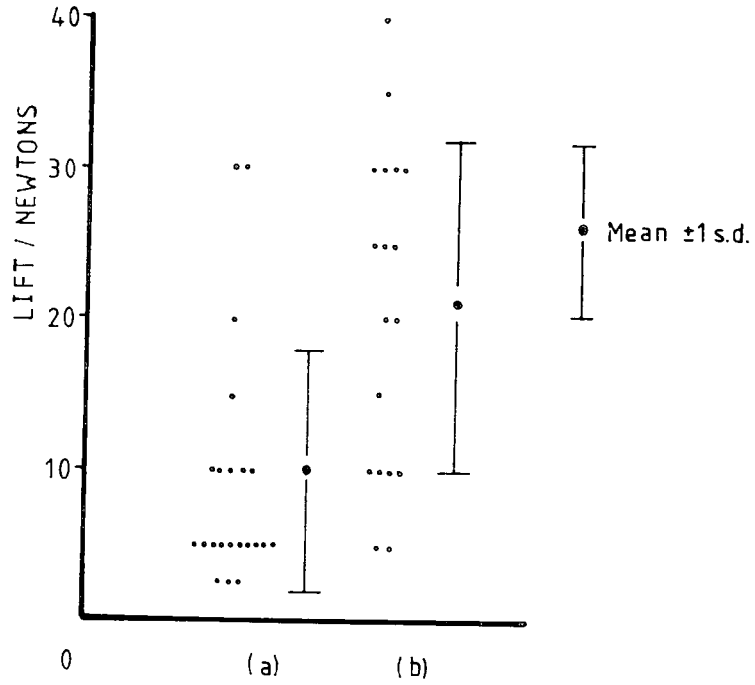

FIGURE 5.69.(continued) Force-time curves of kettle lifts from patients with arthritis



PATTERN				
	(a)		(b)	
	Approx max lift (N)	Approx max grip (N)	Approx max lift (N)	Approx max grip (N)
	10	30	5	20
	15	55	10	25
	10	40	30	60
	10	60	25	110
	5	25	35	60
	5	20	30	90
	5	35	20	100
	20	110	25	125
	5	30	5	45
	5	40	10	30
	5	15	25	80
	30	65	10	70
	5	80	20	70
	30	110	10	70
	5	30	30	80
	5	40	15	30
	5	50	40	80
	5	30	30	30
	10	65		
	5	16		
	5	14		
	10	60		
Mean	10		21	
S	8		11	

FIGURE 5.70. A comparison between the two basic force-time curves observed in the pan lift of patients with arthritis

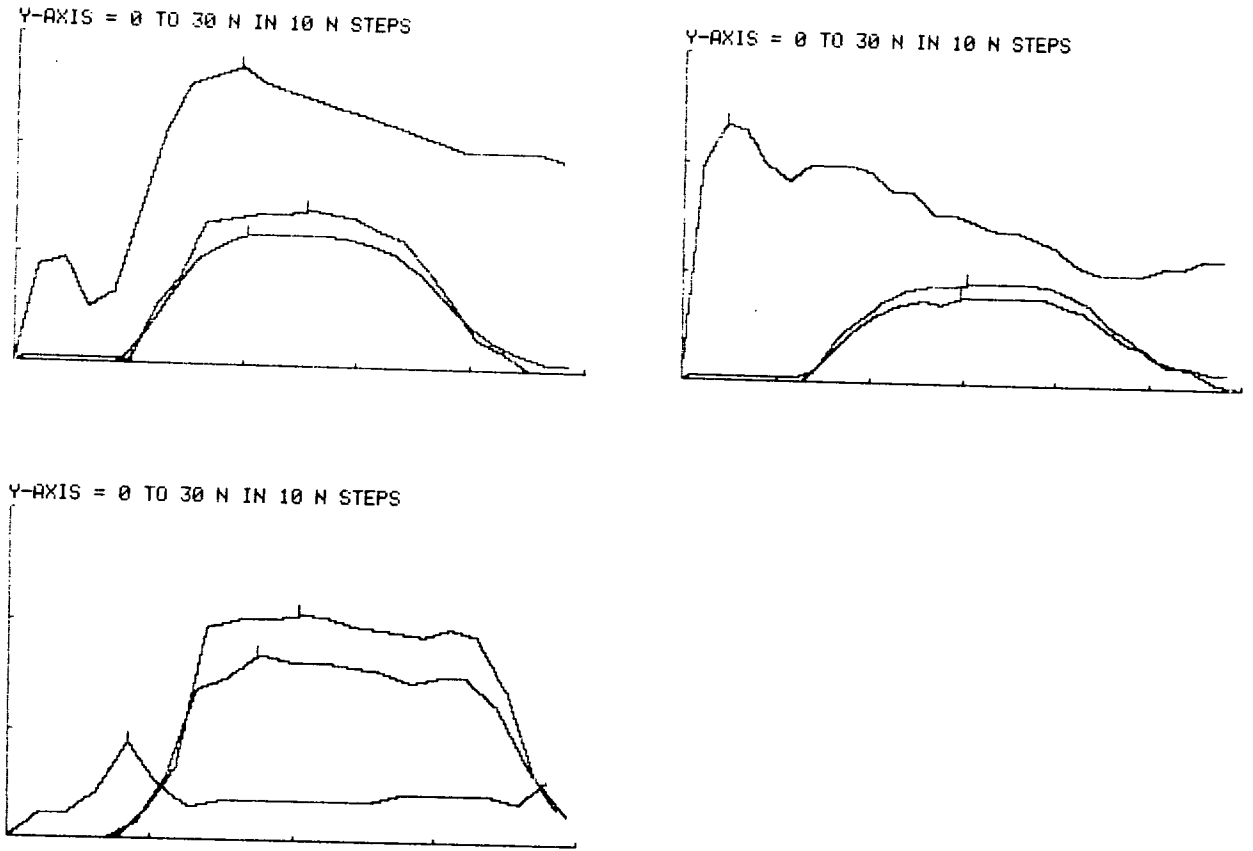

FIGURE 5.71. Force-time curves for underarm kettle lift

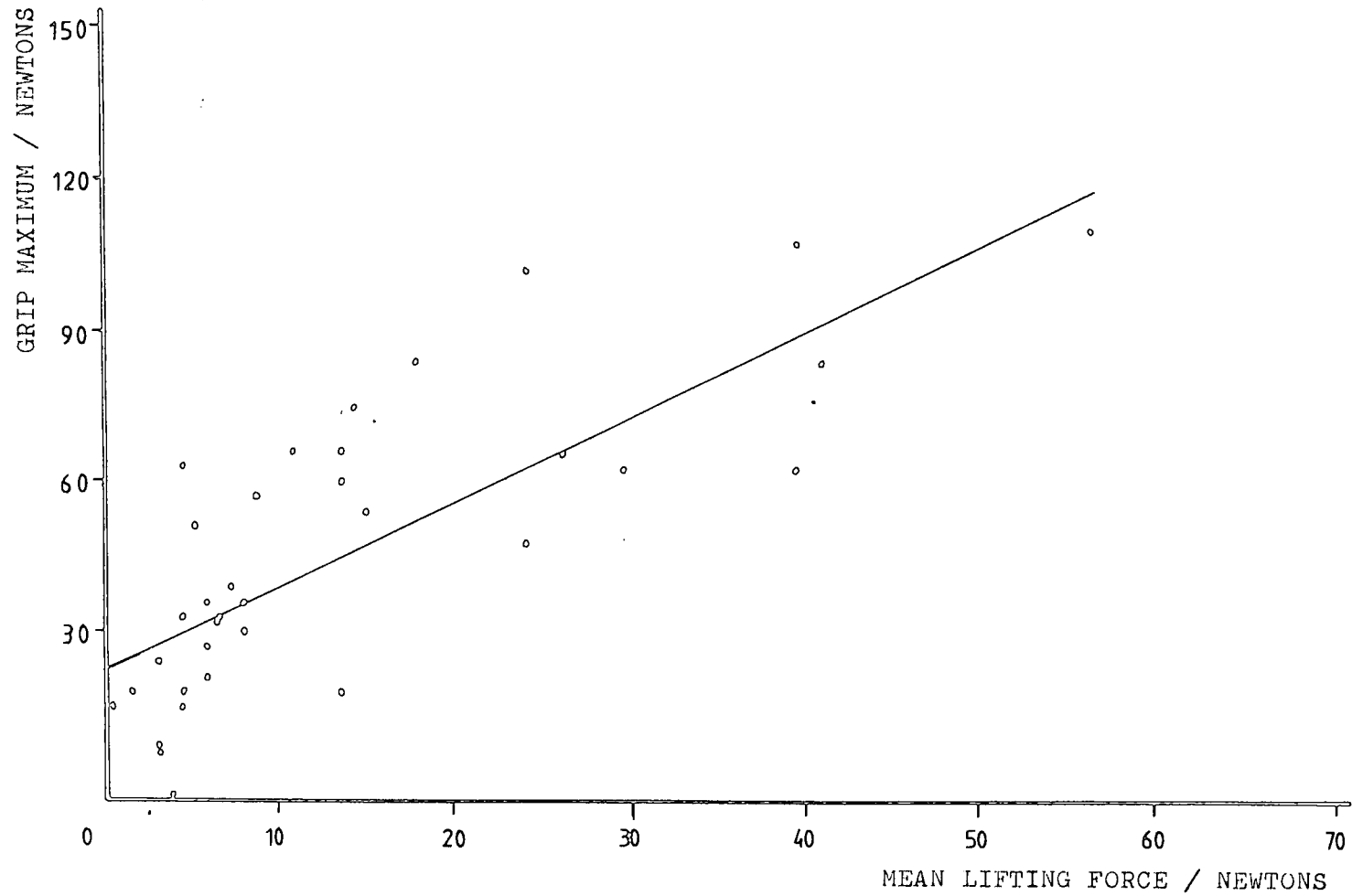

FIGURE 5.72. Scatter diagram of the mean pan lifting forces against the maximum handle grip forces for left hand lifts of patients with arthritis

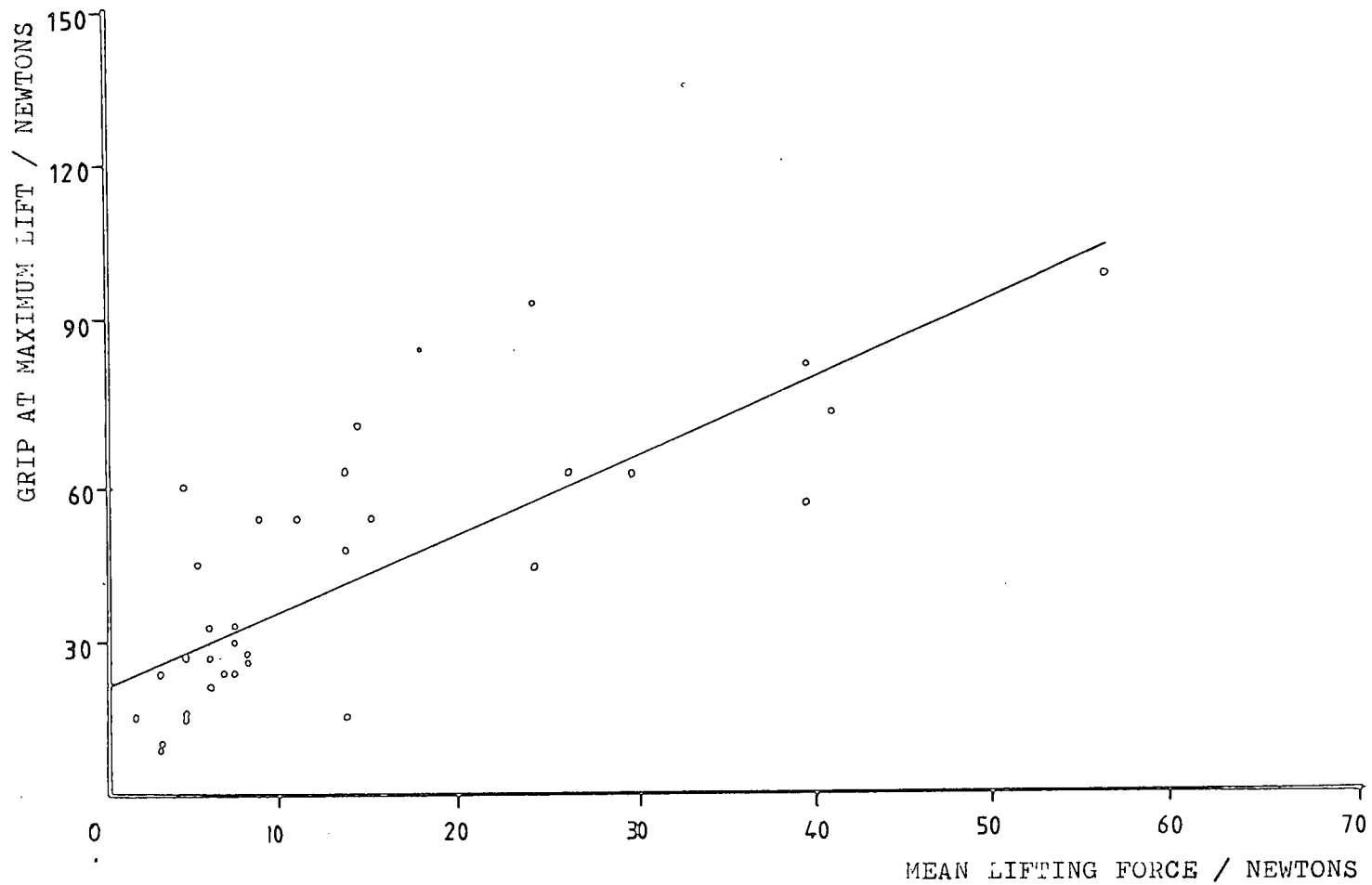

FIGURE 5.73. Scatter diagram of the mean pan lifting forces against the handle grip forces at maximum lift for left hand lifts of patients with arthritis

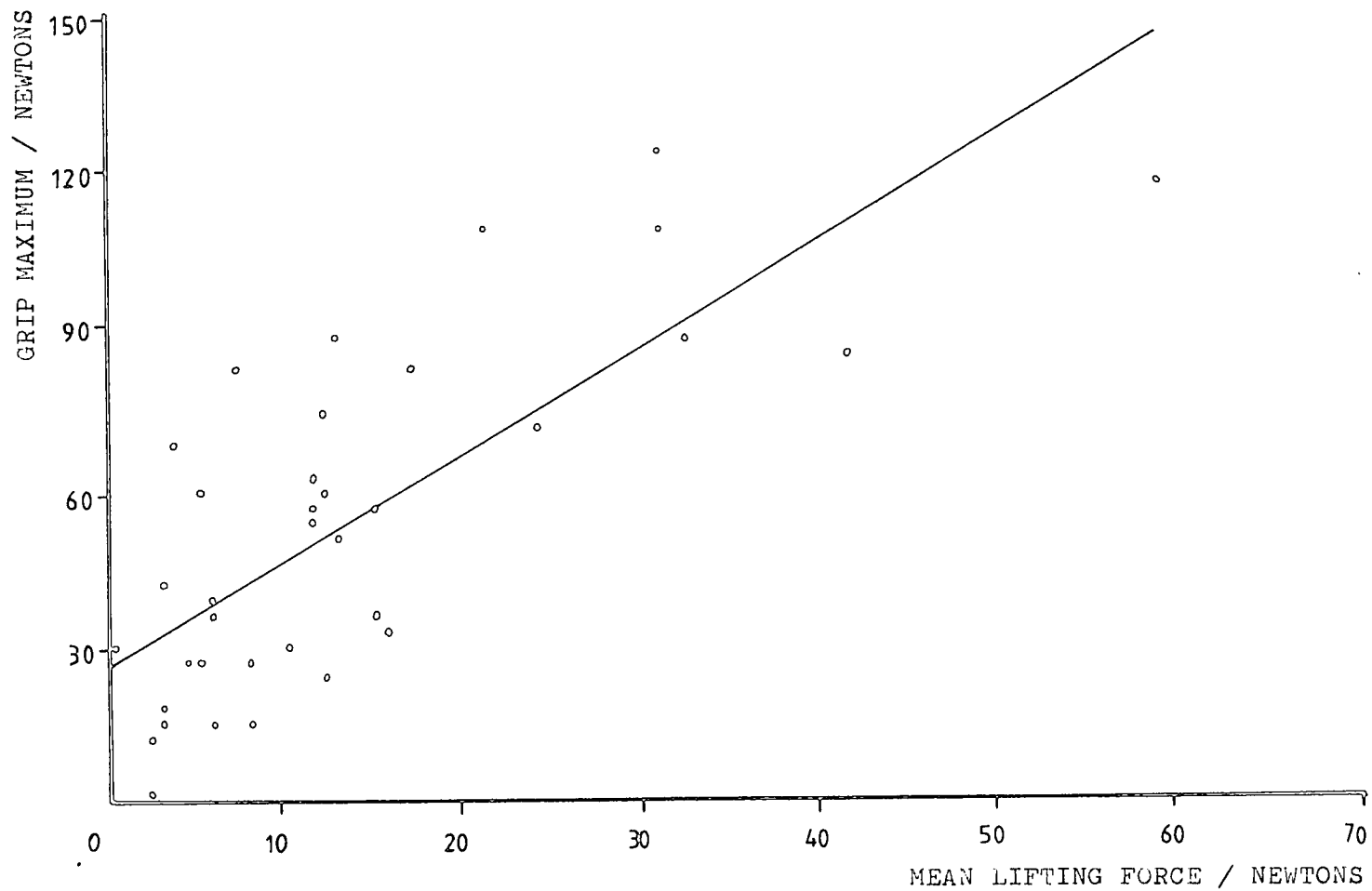

FIGURE 5.74. Scatter diagram of the mean pan lifting forces against the maximum handle grip forces for right hand lifts of patients with arthritis

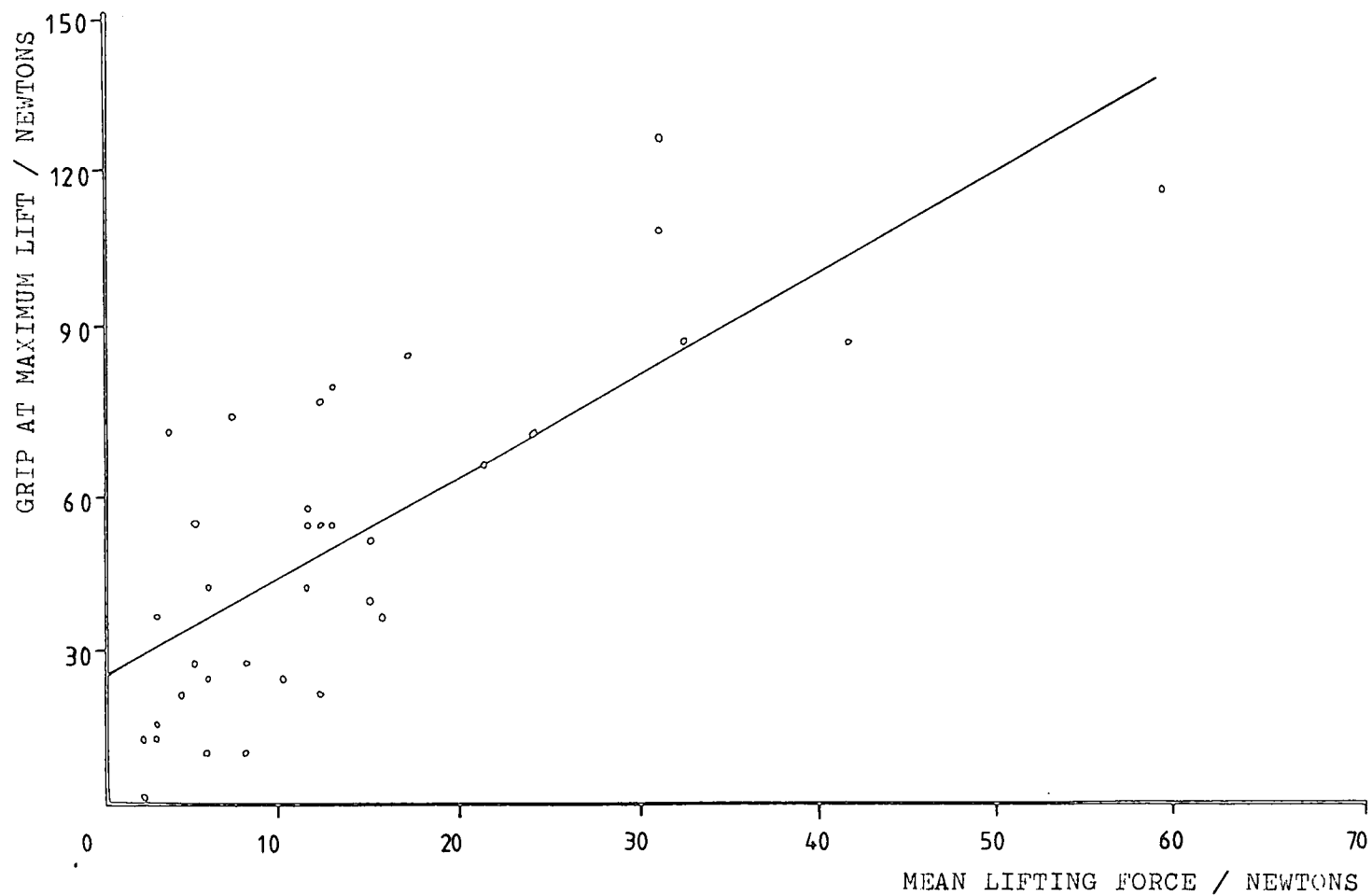

FIGURE 5.75. Scatter diagram of the mean pan lifting forces against the handle grip forces at maximum lift for right hand lifts of patients with arthritis

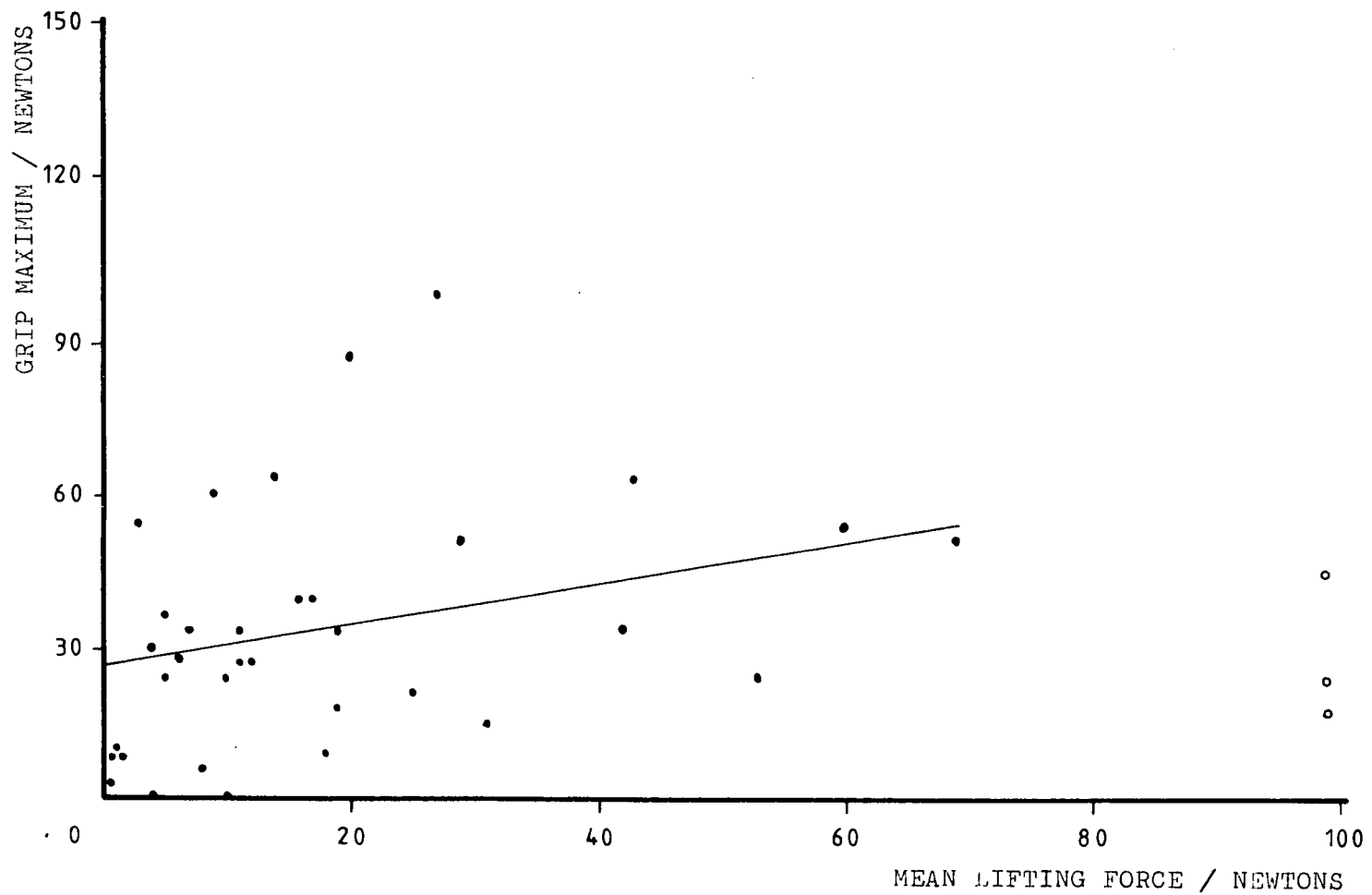

FIGURE 5.76. Scatter diagram of the mean kettle lifting forces against the maximum handle grip forces for left hand lifts of patients with arthritis

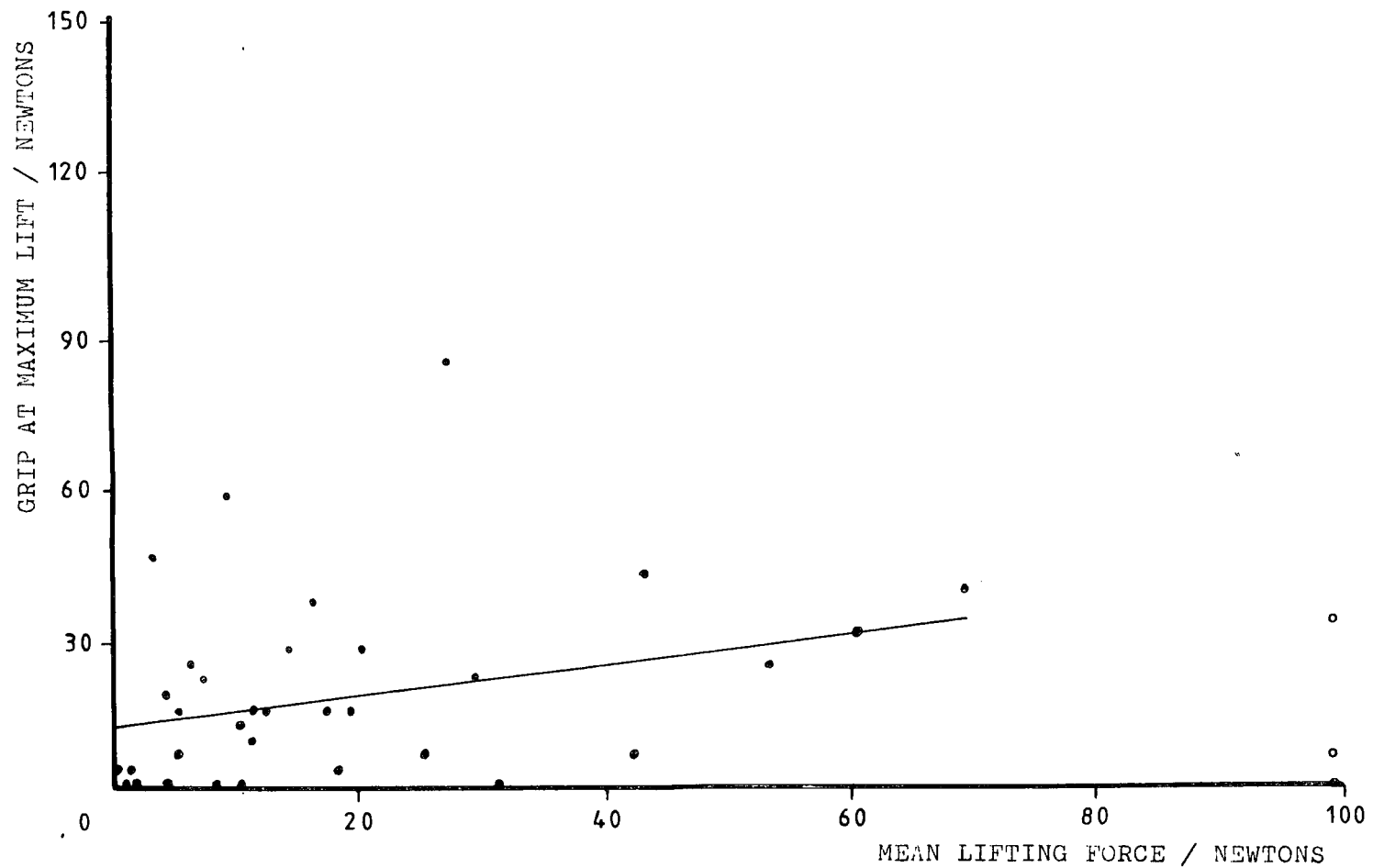

FIGURE 5.77. Scatter diagram of the mean kettle lifting forces against the handle grip forces at maximum lift for left hand lifts of patients with arthritis

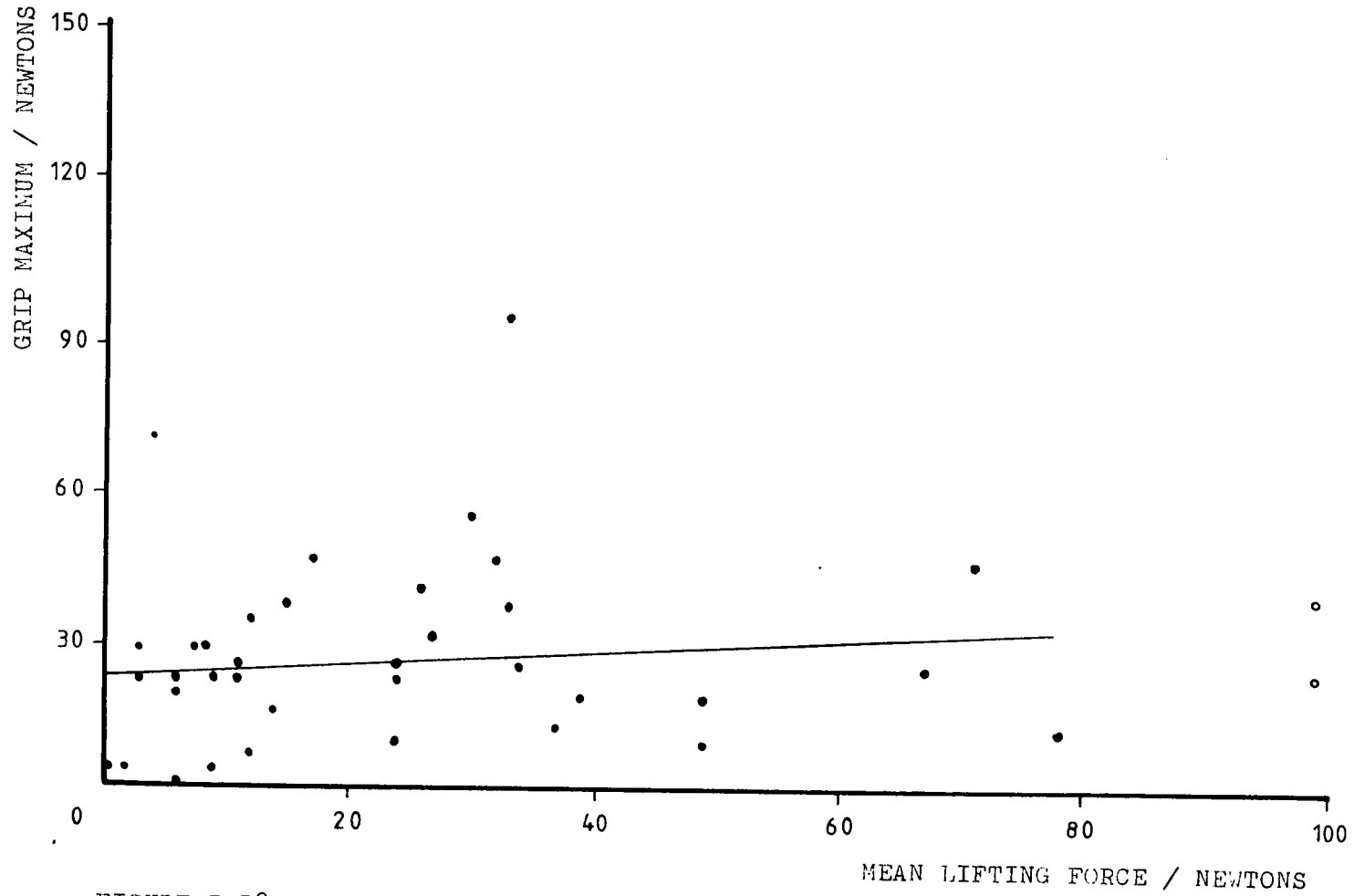

FIGURE 5.78. Scatter diagram of the mean kettle lifting forces against the maximum handle grip forces for right hand lifts of patients with arthritis

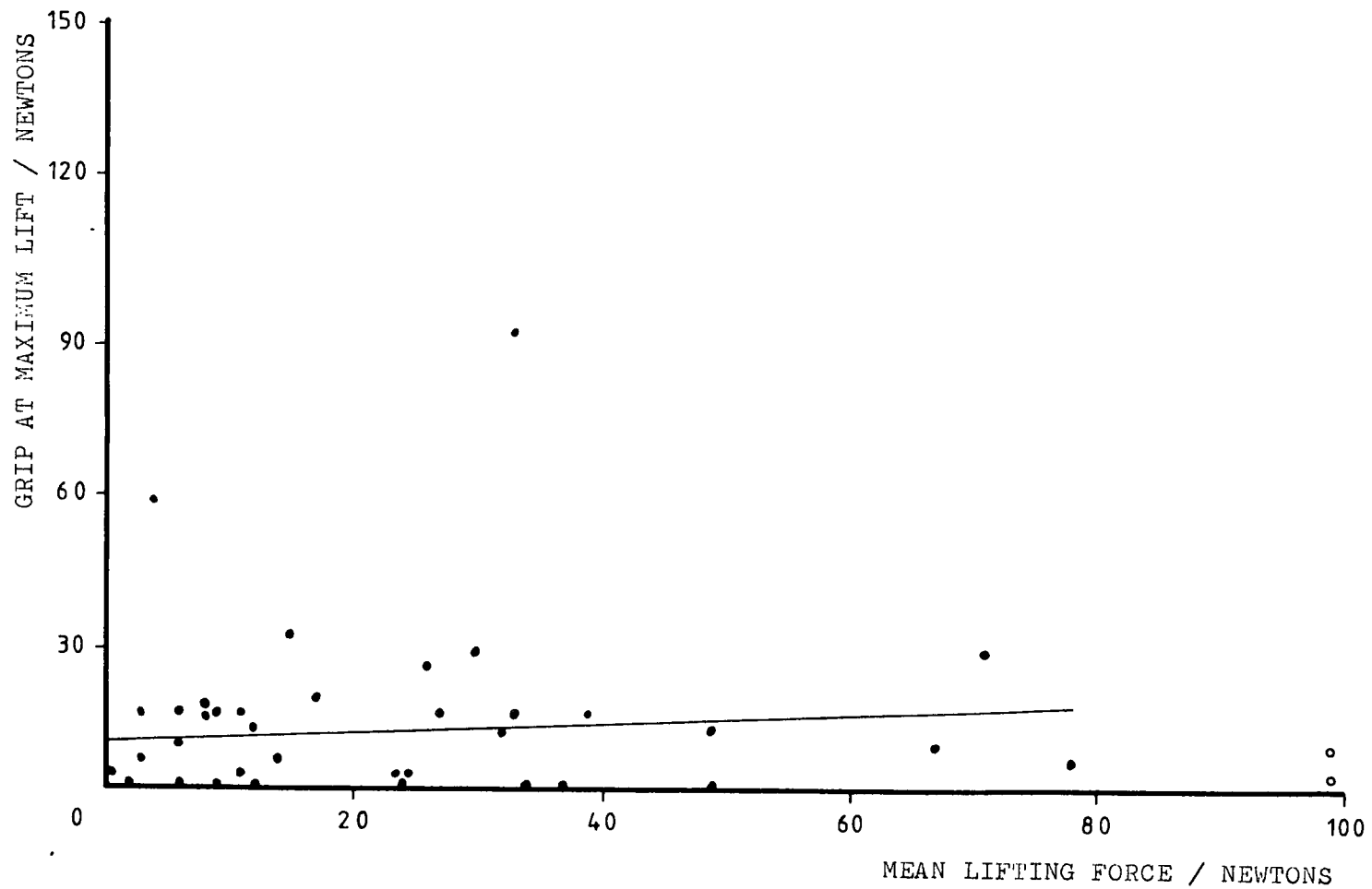

FIGURE 5.79. Scatter diagram of the mean kettle lifting forces against the handle grip forces at maximum lift for right hand lifts of patients with arthritis

	Left Hand				Right Hand			
	Corr	Sl	In	Sig	Corr	Sl	In	Sig
MALE AND FEMALE								
PAN								
max grip	0.79	1.73	23.3	0	0.75	2.04	27.0	0
max lift grip	0.77	1.53	21.2	0	0.78	2.02	21.9	0
KETTLE								
max grip	0.37	0.51	23.6	0.015	0.13	0.12	22.7	0.217 *
max lift grip	0.33	0.35	12.5	0.031	0.04	0.03	12.9	0.412 *

(a)

MALE								
PAN								
max grip	0.68	1.15	43.9	0.001	0.68	1.52	43.4	0.001
max lift grip	0.64	0.95	41.3	0.003	0.74	1.59	34.6	0
KETTLE								
max grip	0.20	0.20	42.3	0.245	0.30	0.28	44.7	0.131 "
max lift grip	0.01	0.01	33.0	0.489	0.26	0.27	29.8	0.164 "

FEMALE								
PAN								
max grip	0.77	1.85	14.7	0	0.75	2.95	14.2	0
max lift grip	0.81	1.80	12.1	0	0.76	2.96	10.4	0
KETTLE								
max grip	0.22	0.35	17.8	0.176	0.27	0.23	14.3	0.128
max lift grip	0.32	0.24	6.3	0.082	0.26	0.13	6.3	0.137

(b)

(a and b)

FIGURE 5.80^o Regression analysis of mean lifting forces against handle gripping forces

Corr = Correlation coefficient

Sl = Regression line slope

In = Regression line intercept

Sig = Significance of no correlation

* = does not include overloaded measurements

KEY

The following colour code applies for all subsequent colour figures:-

POWER GRIP, PINCH & EXTENSION

- Blue - Index finger
- Red - Middle finger
- Green - Ring finger
- Black - Little finger
- Blue - Total grip (Power Grip), Lateral (Pinch)

PAN & KETTLE

- Blue - Maximum handle grip
- Green - Grip at maximum lift
- Red - Mean lift

TWIST

- Blue - Tube
- Black - Key

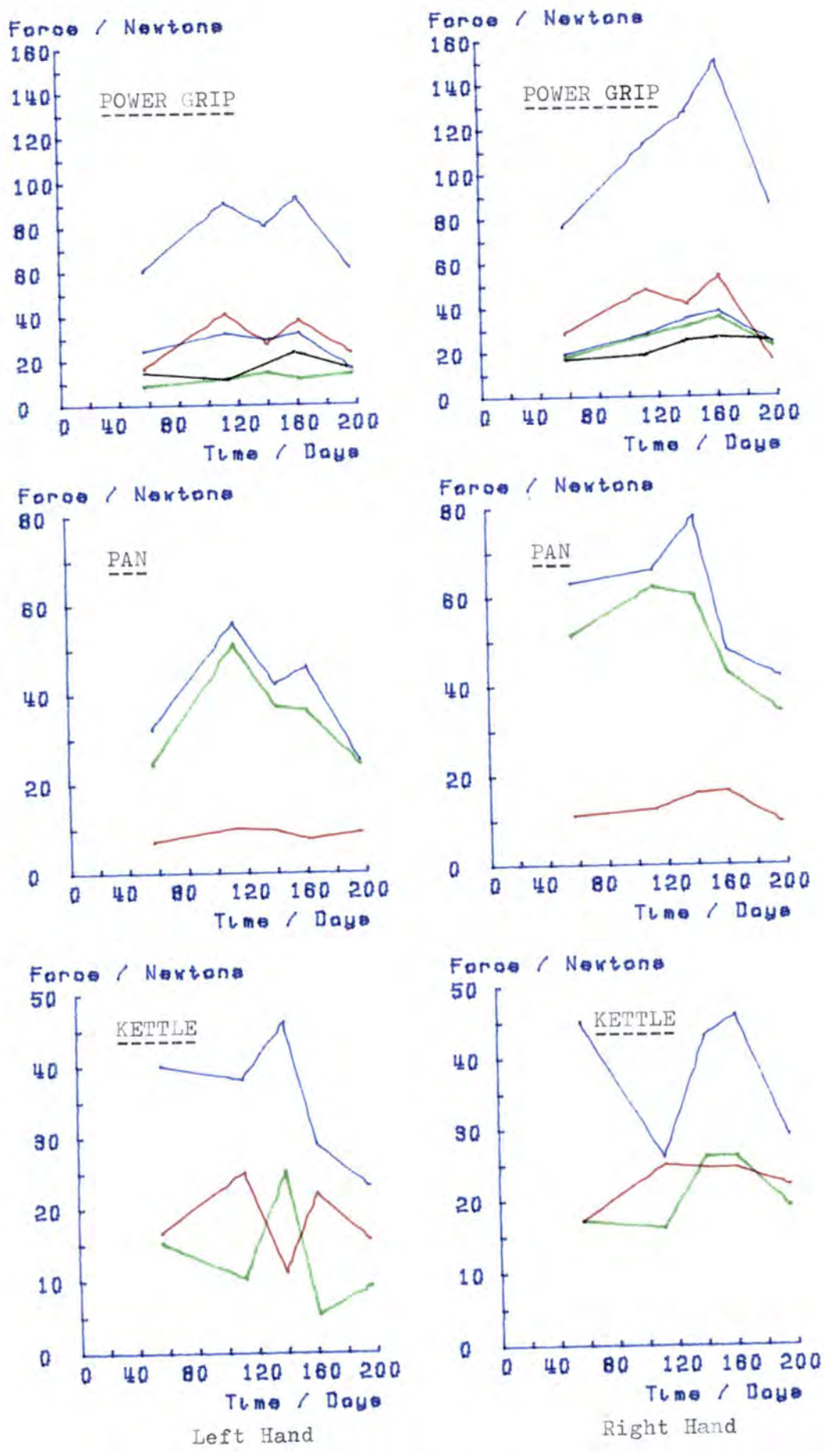
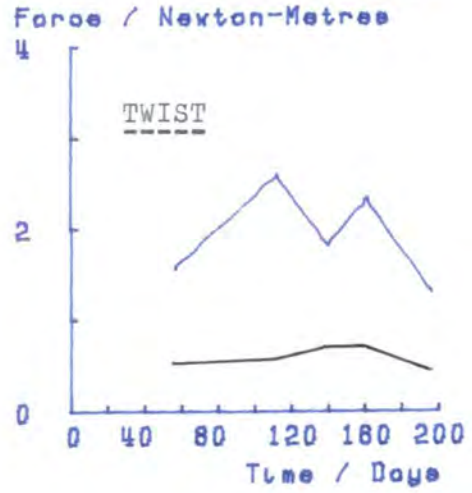
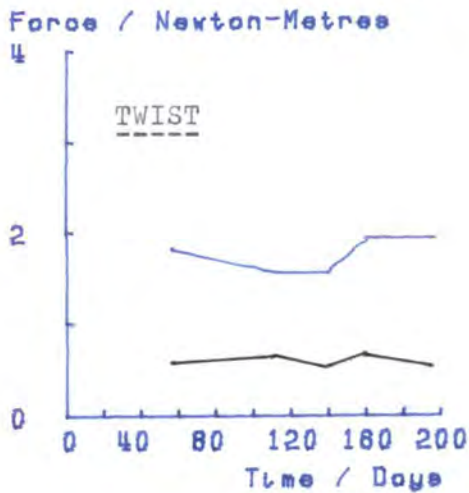
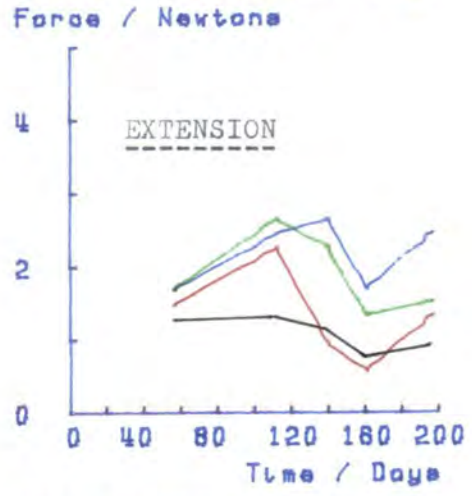
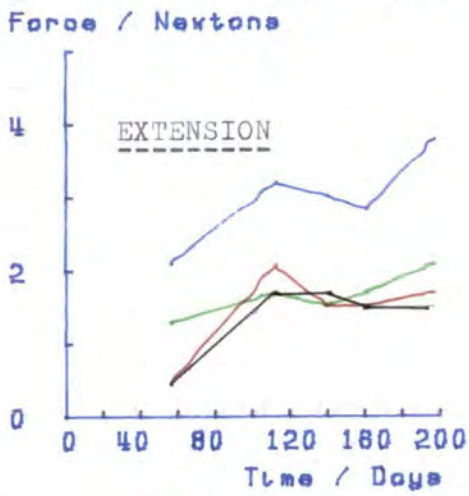
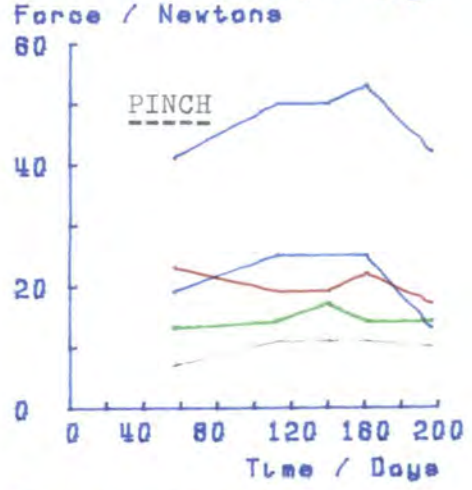
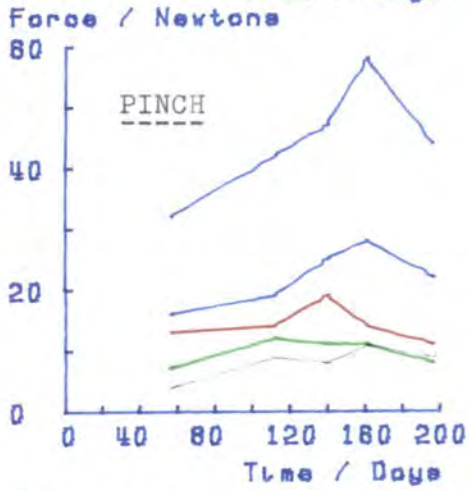
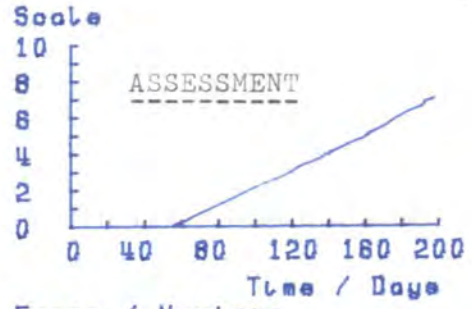
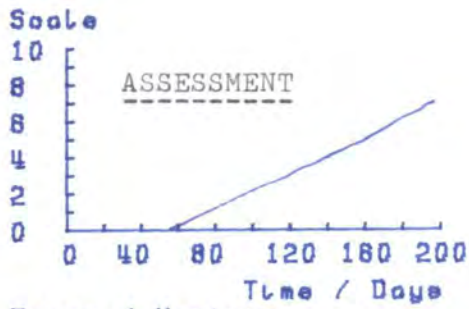

FIGURE 5.81.



Left Hand

Right Hand

FIGURE 5.81. Follow up results of IEJ

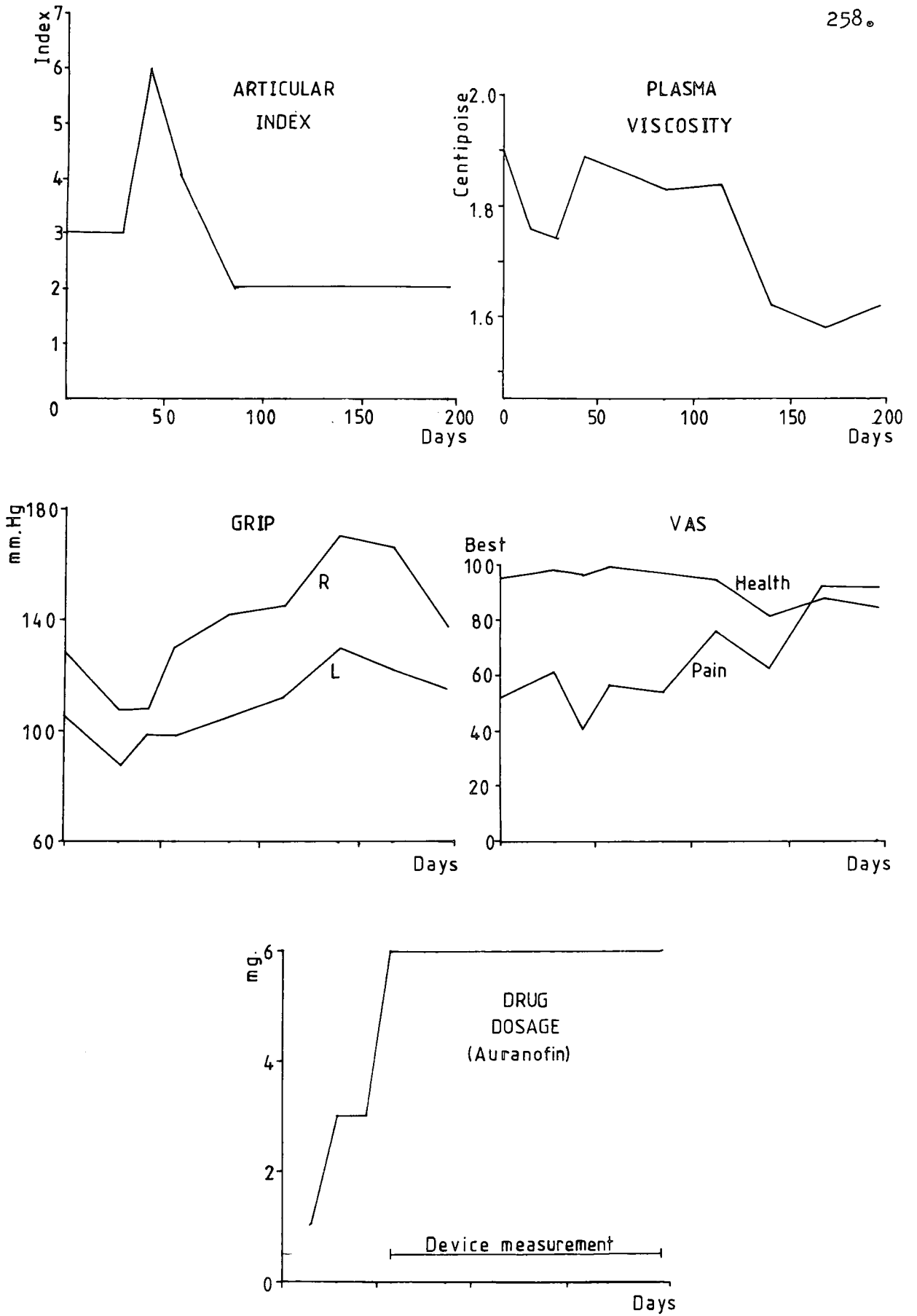
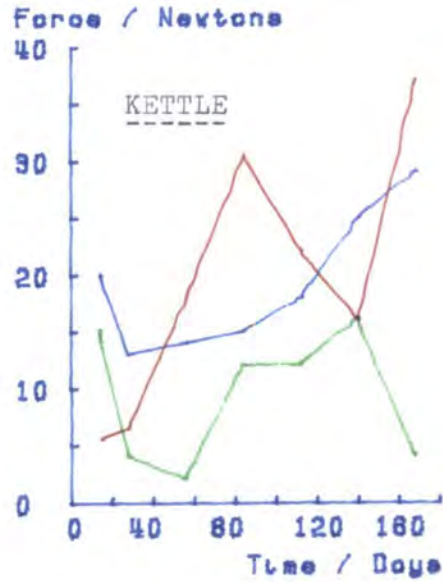
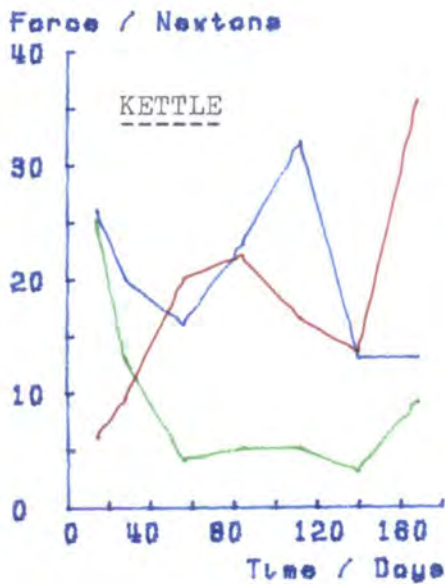
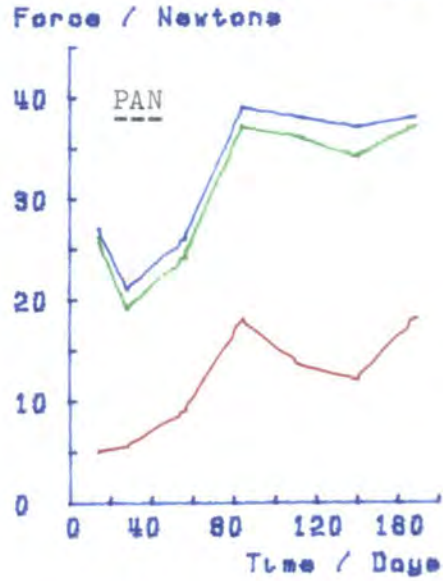
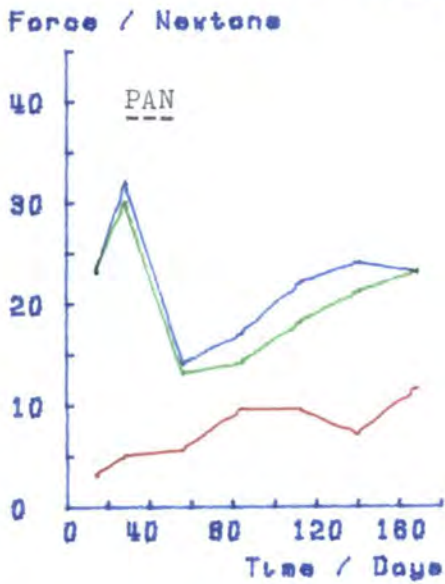
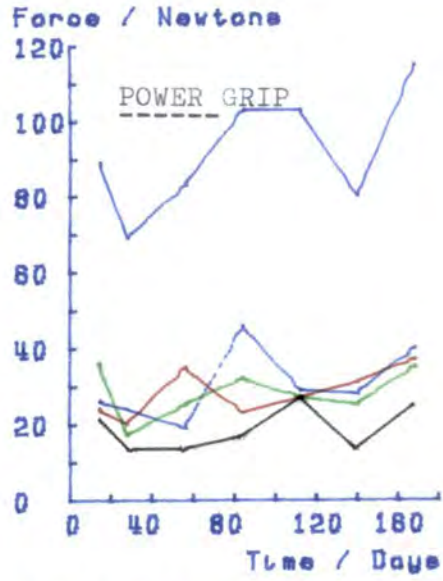
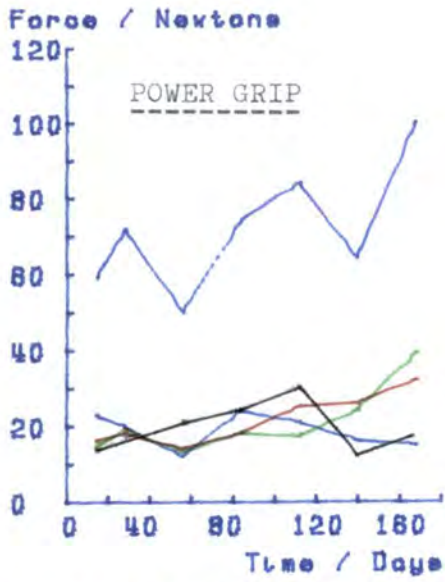

FIGURE 5.82. Clinical follow up results of IEJ



Left Hand

Right Hand

FIGURE 5.83.

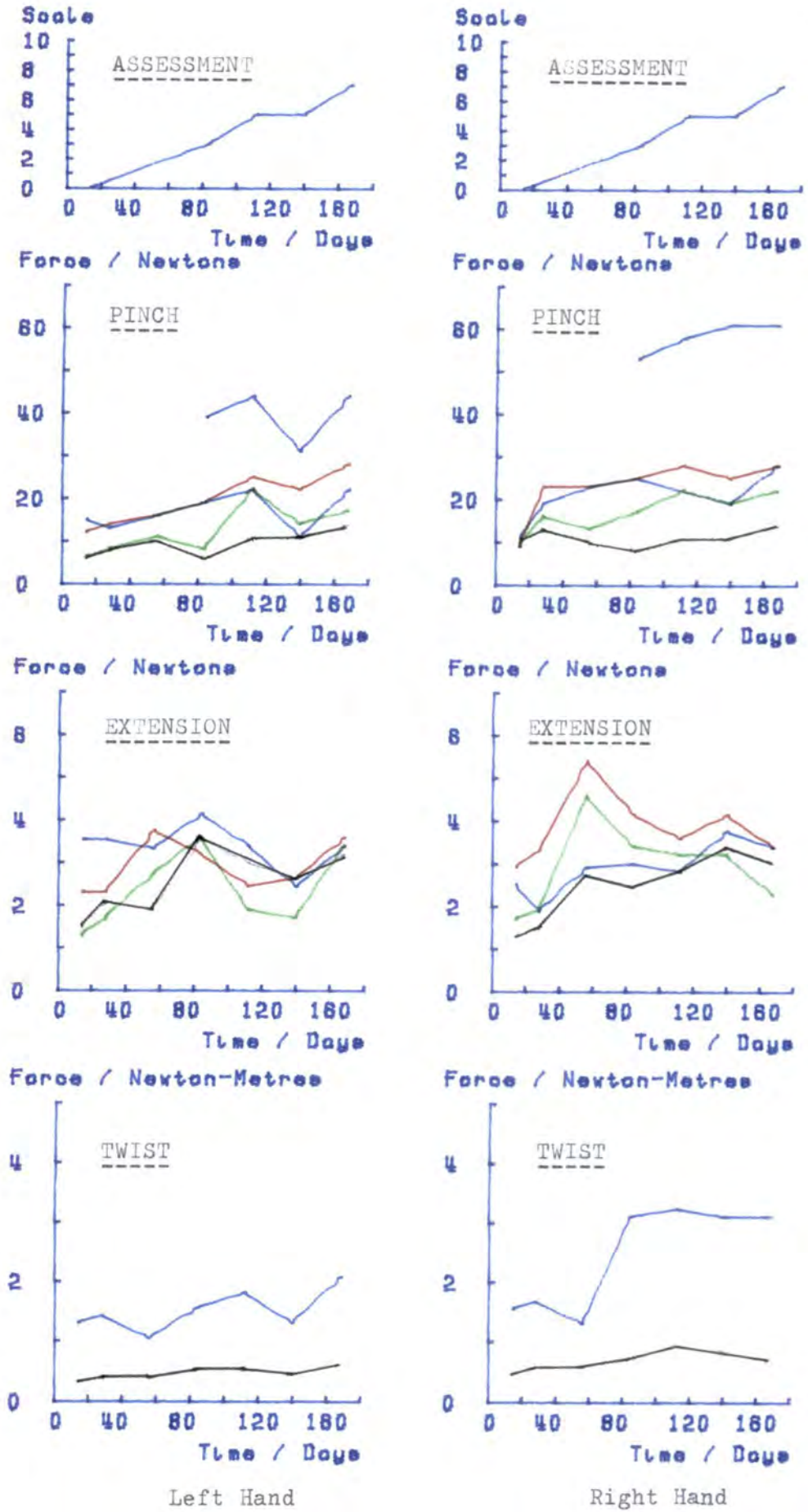

FIGURE 5.83. Follow up results of LAO

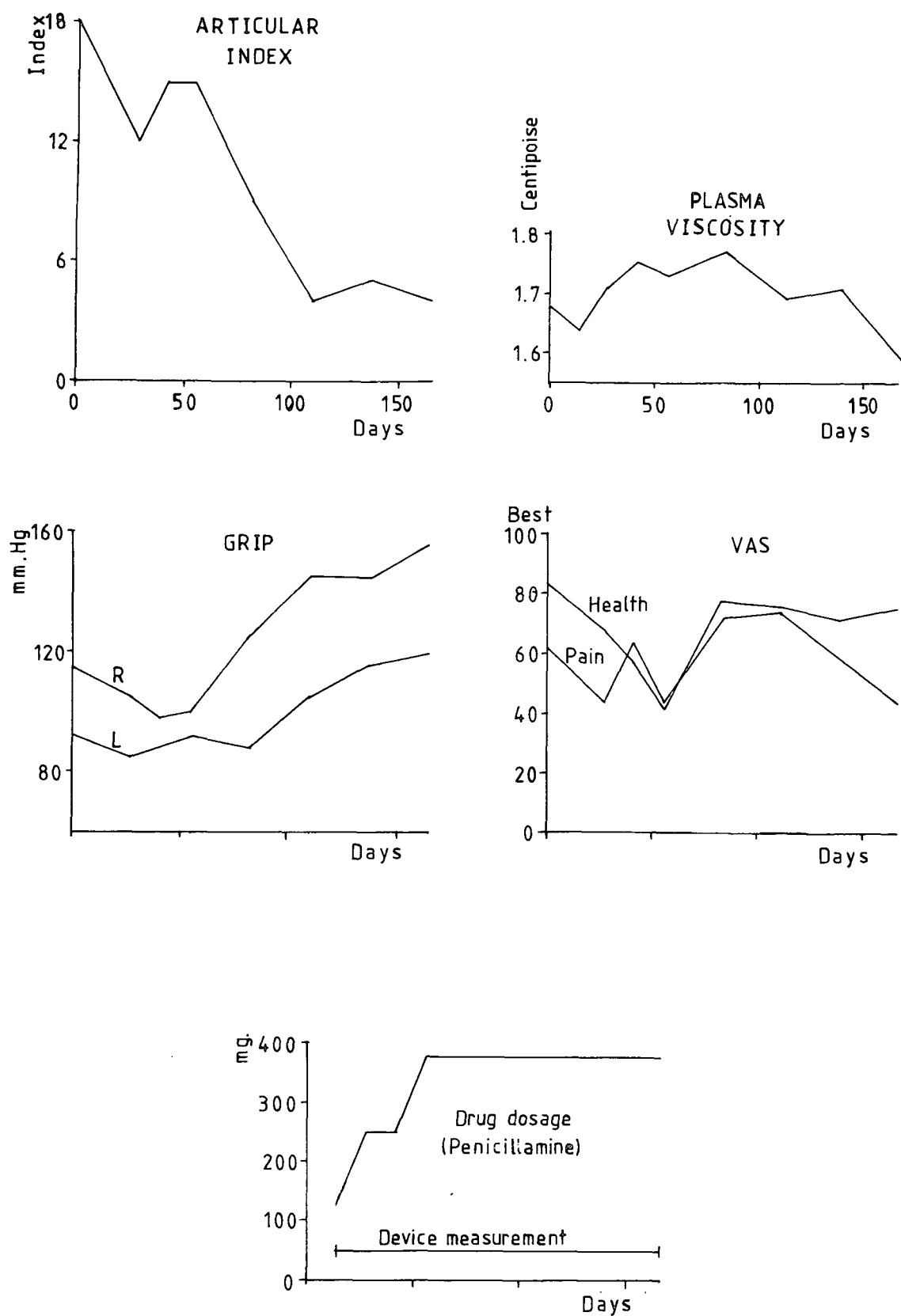
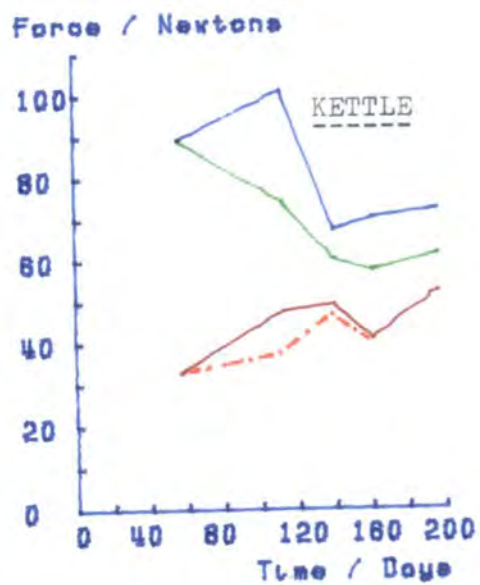
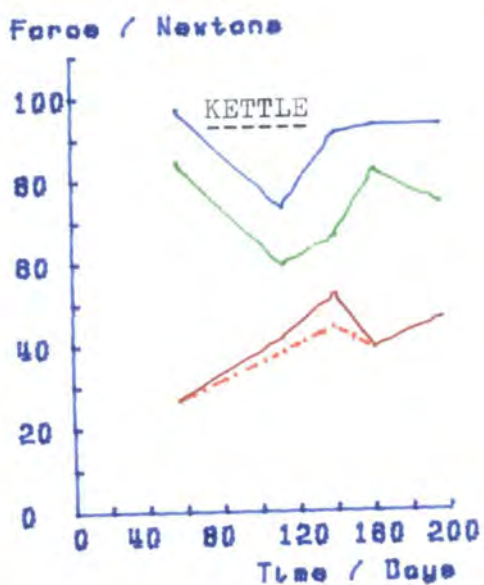
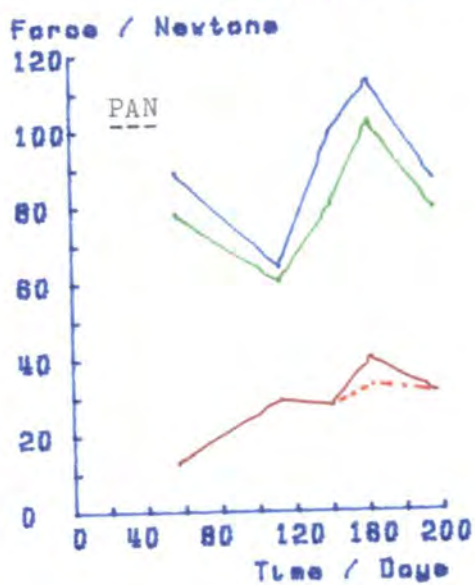
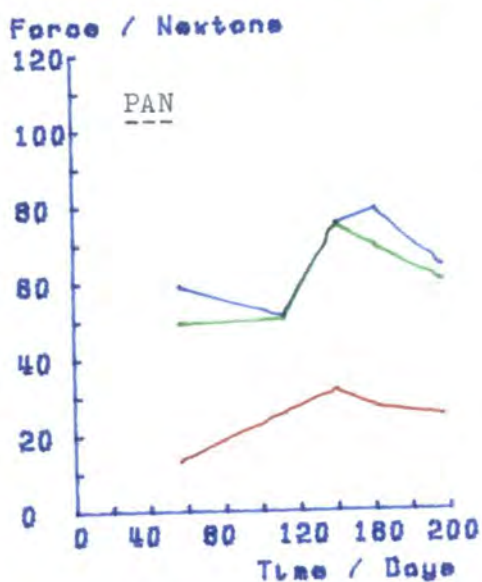
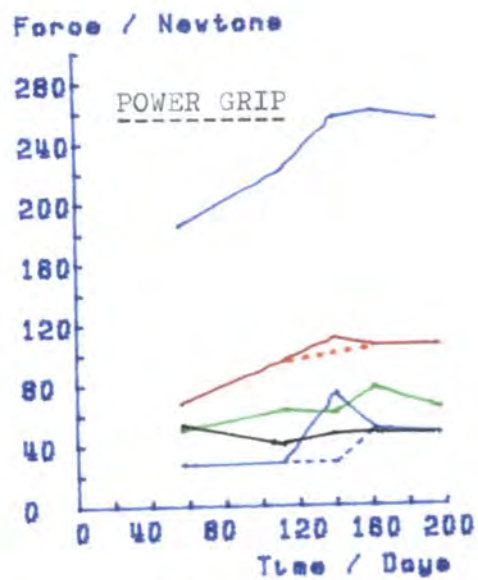
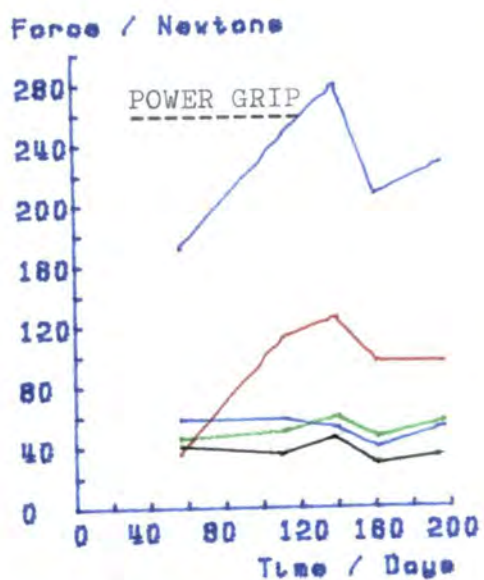

FIGURE 5.84. Clinical follow up results of LAO



Left Hand

Right Hand

FIGURE 5.85.

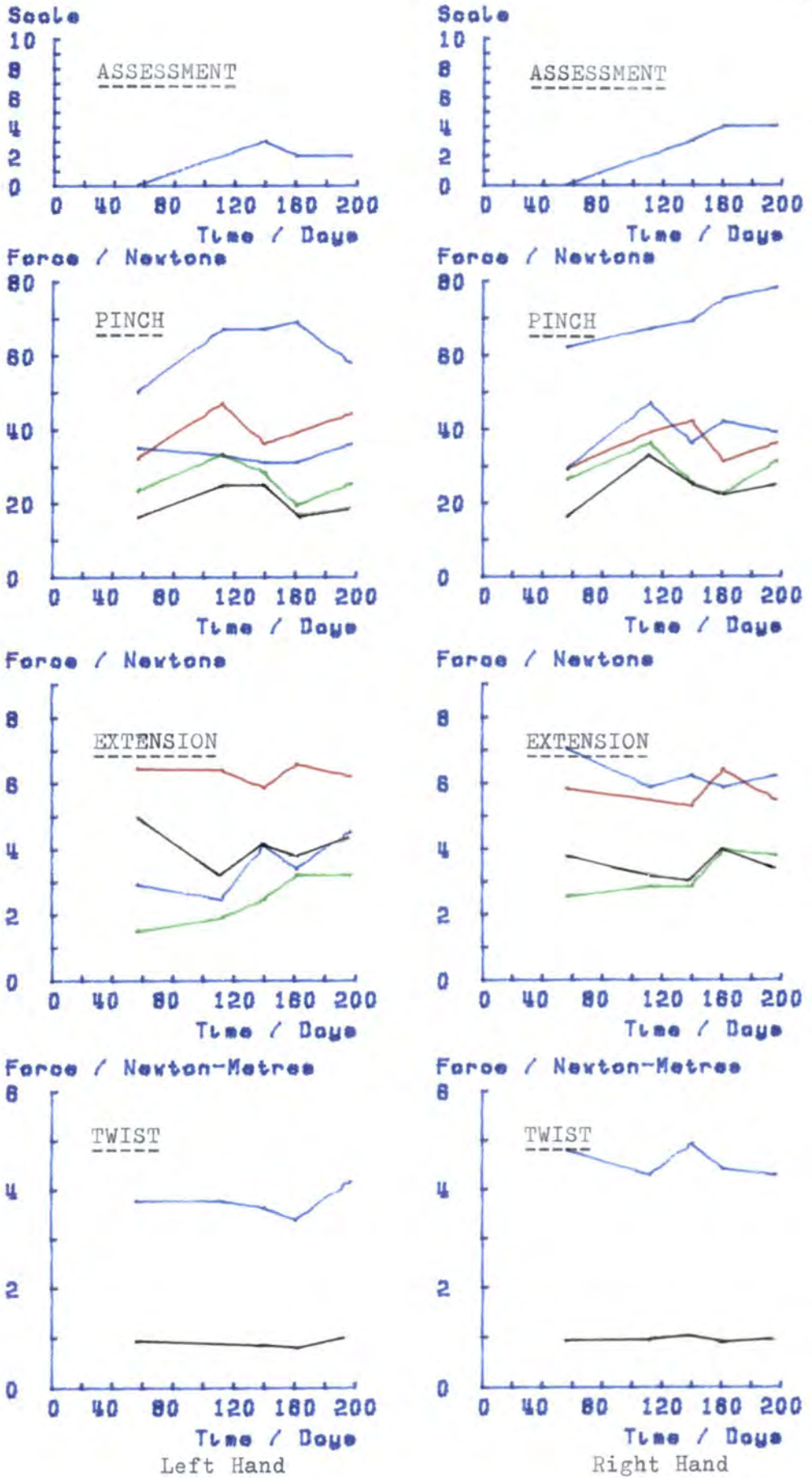

FIGURE 5.85. Follow up results of AHD

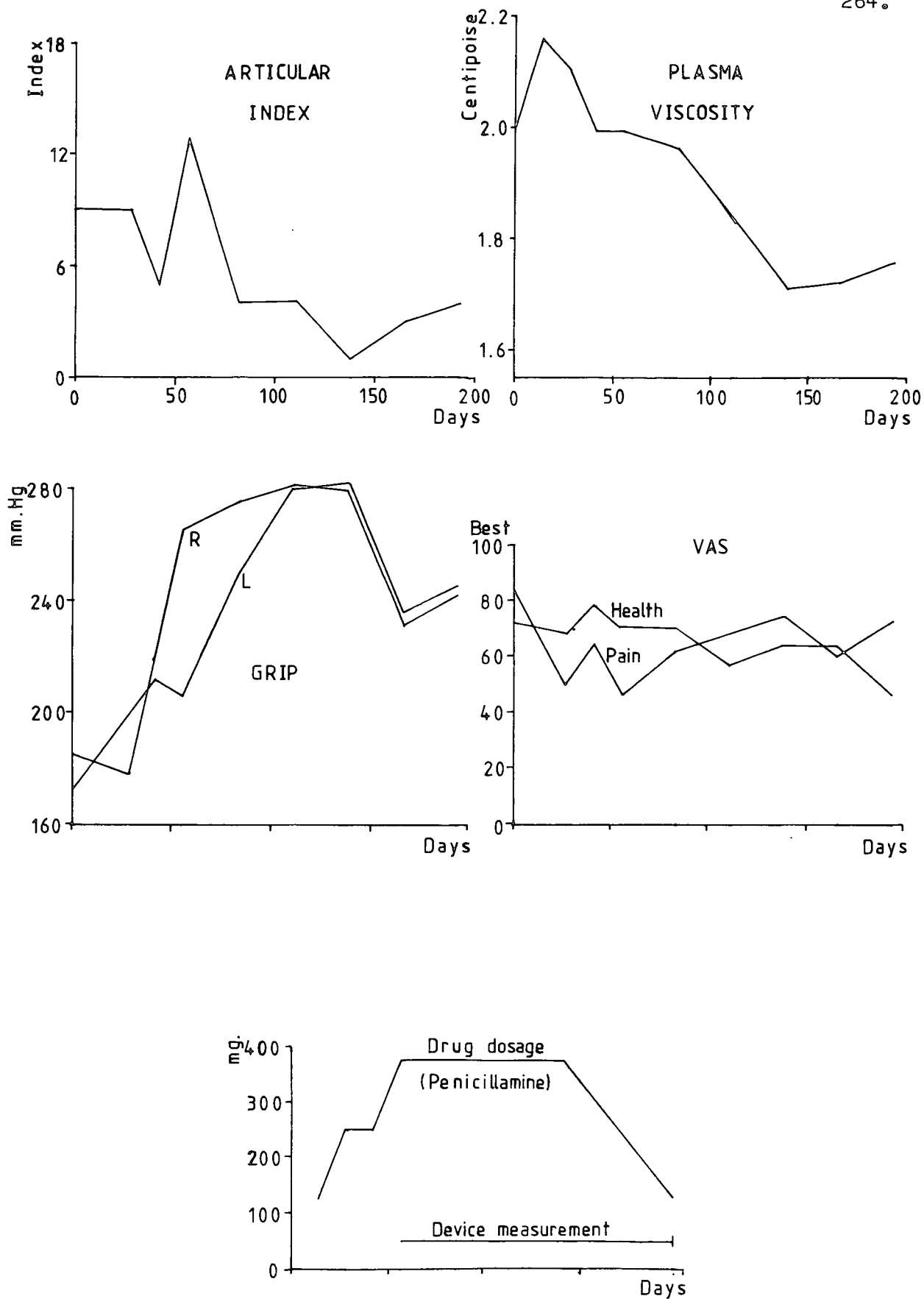
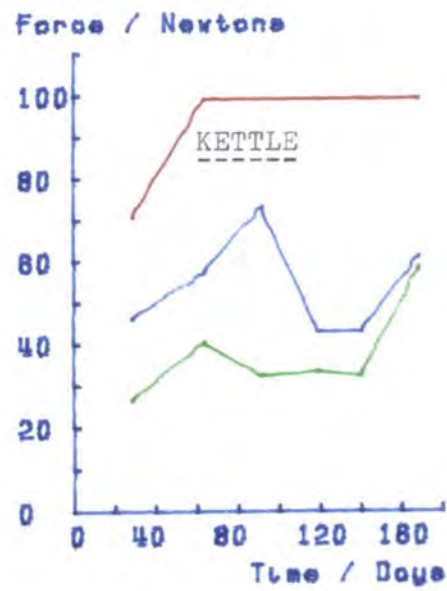
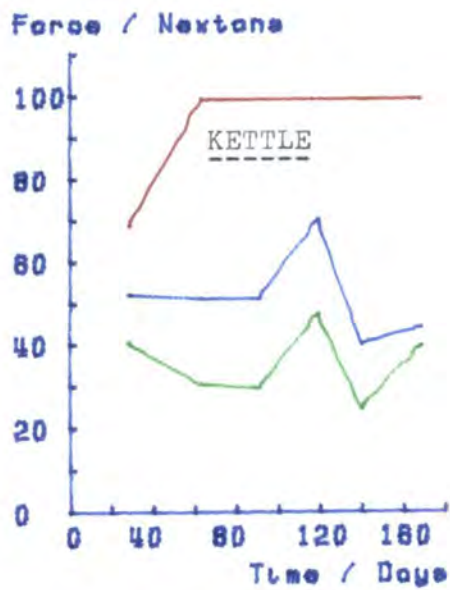
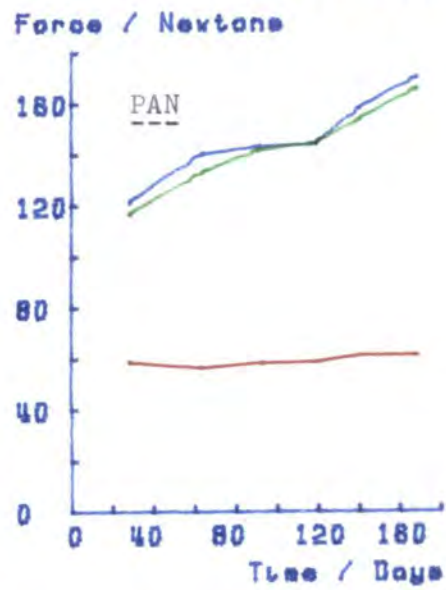
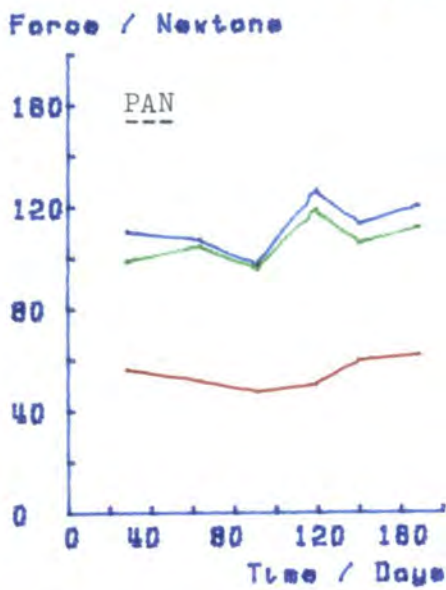
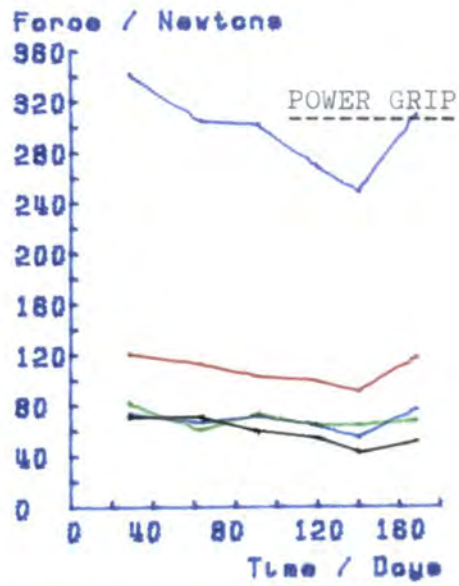
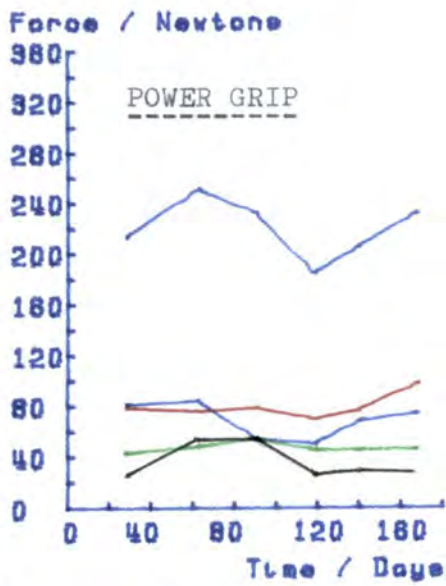

FIGURE 5.86. Clinical follow up results of AHD



Left Hand

Right Hand

FIGURE 5.87.

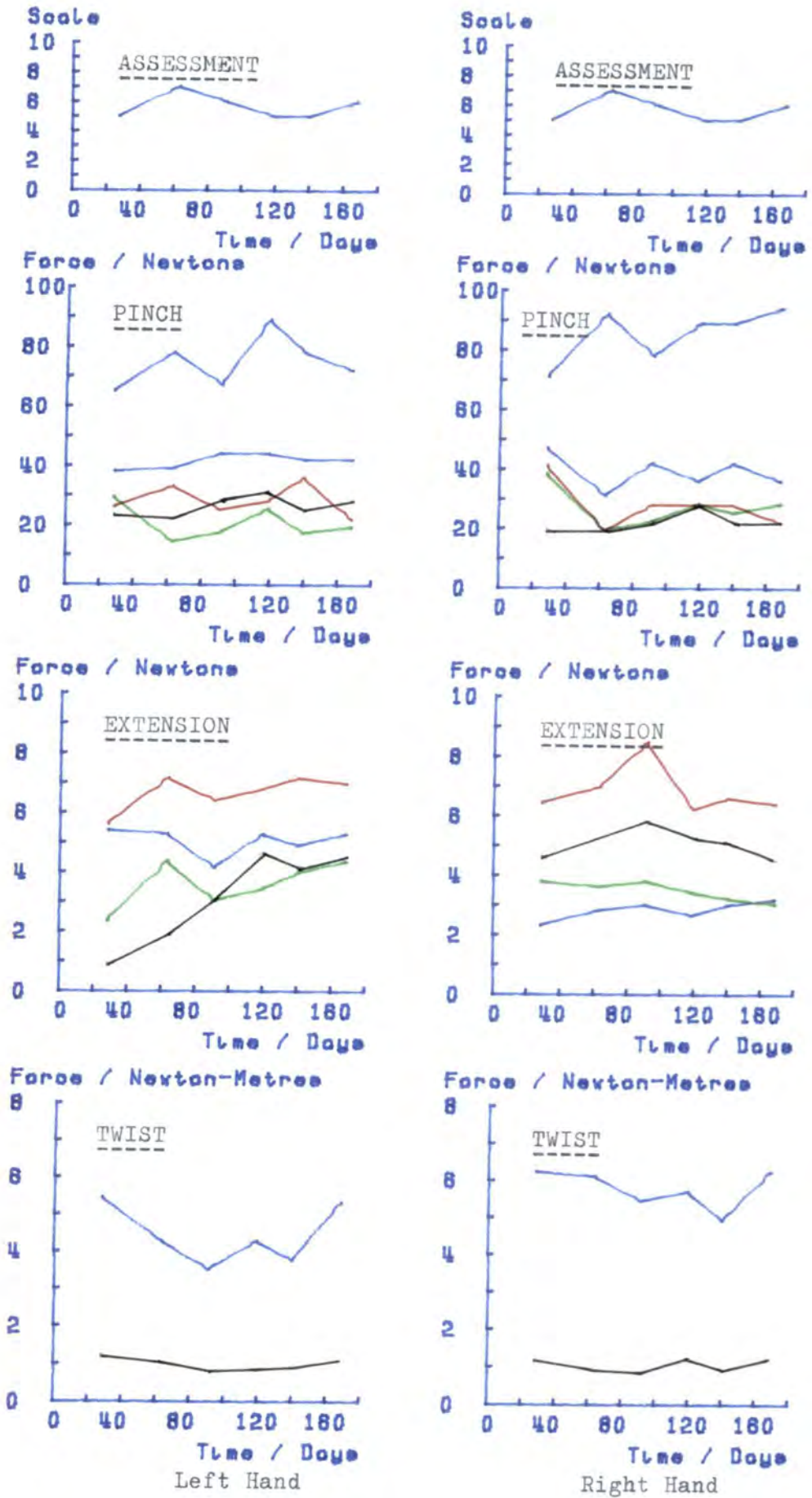

FIGURE 5.87. Follow up results of DE

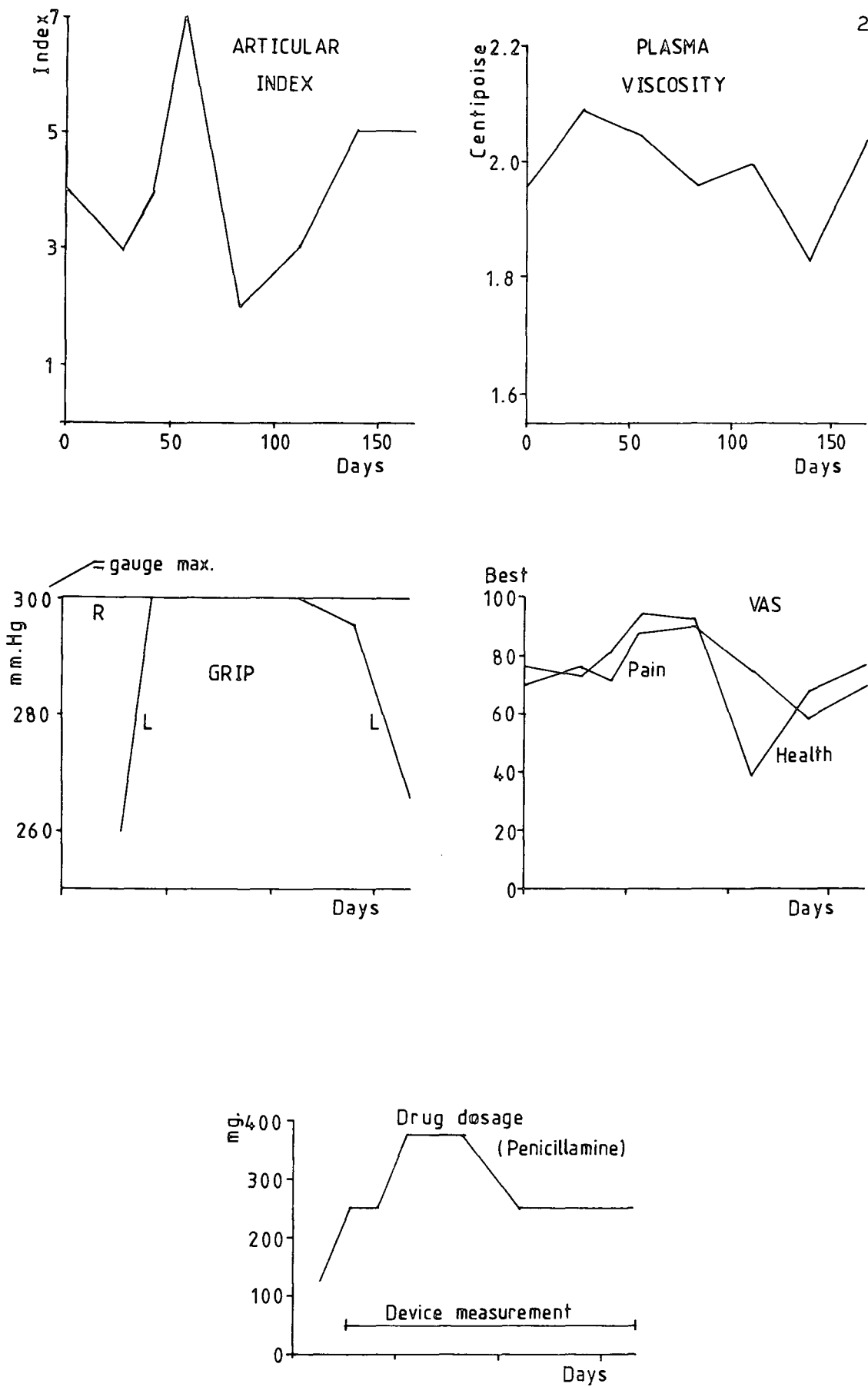

FIGURE 5.88. Clinical follow up results of DE

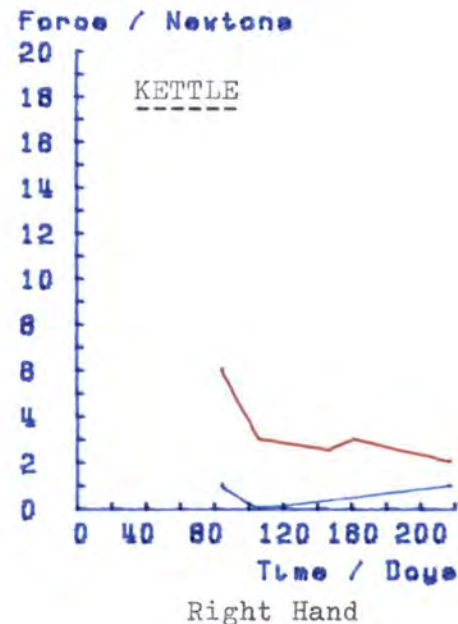
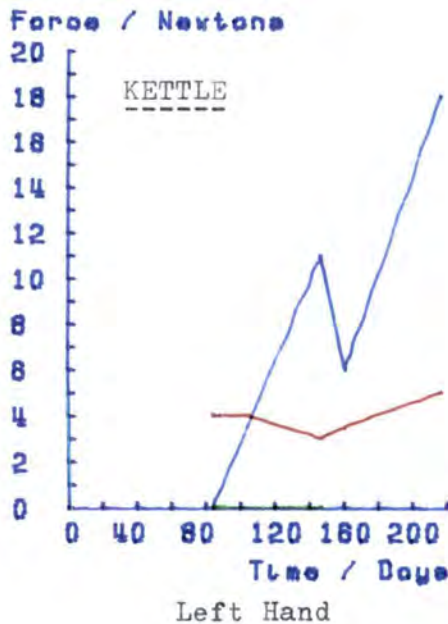
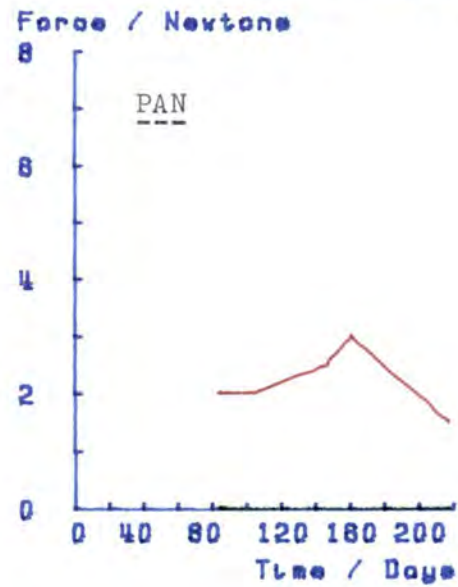
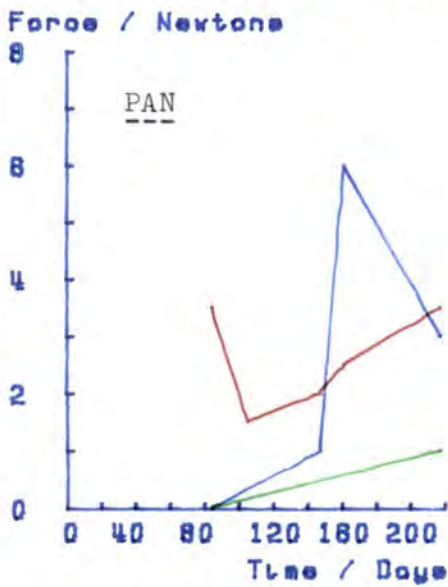
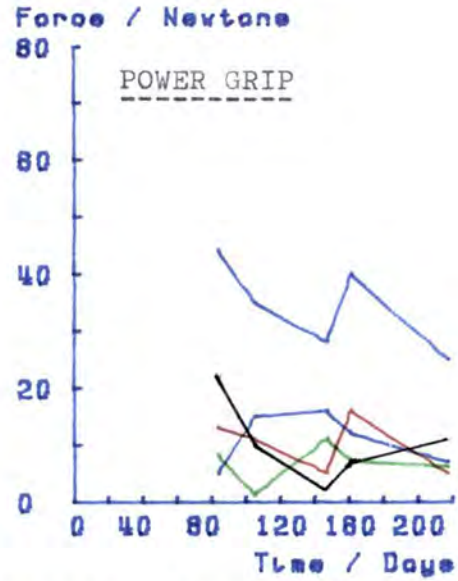
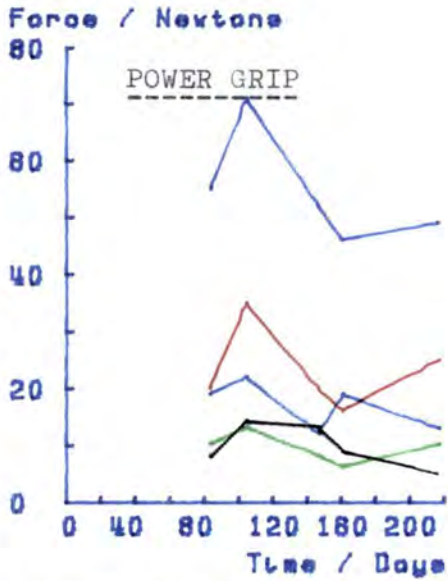

FIGURE 5.89.

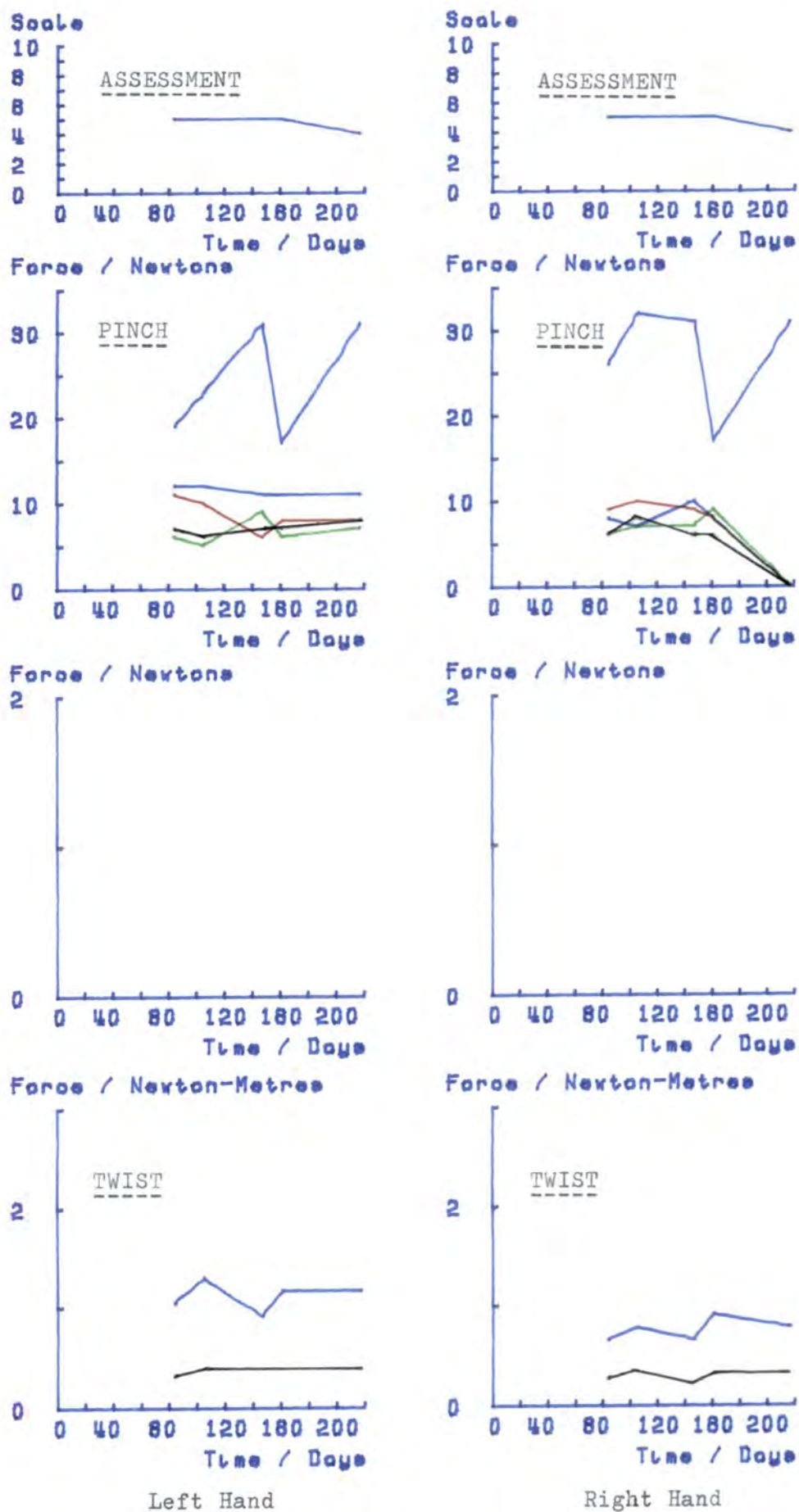

FIGURE 5.89. Follow up results of DS

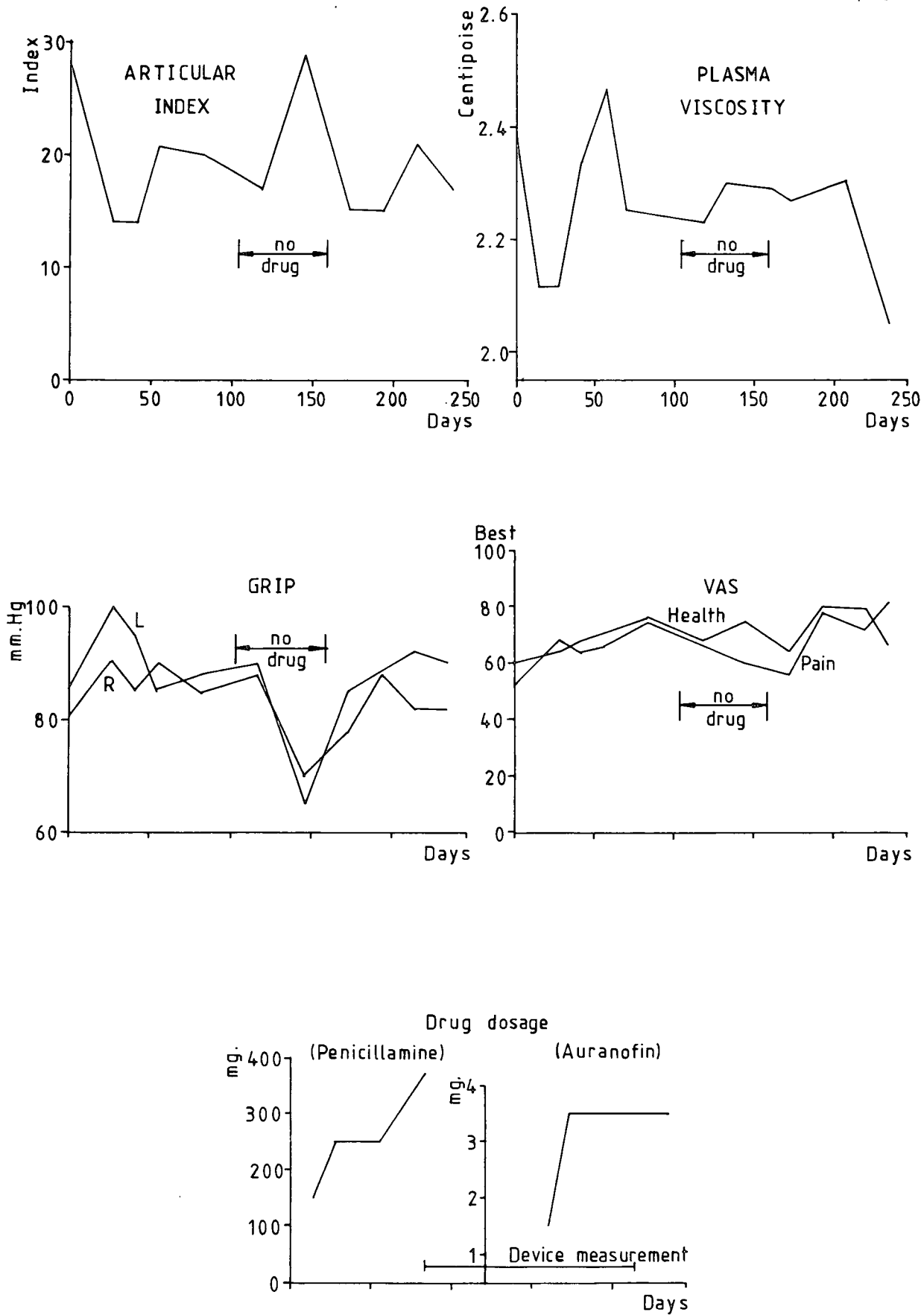
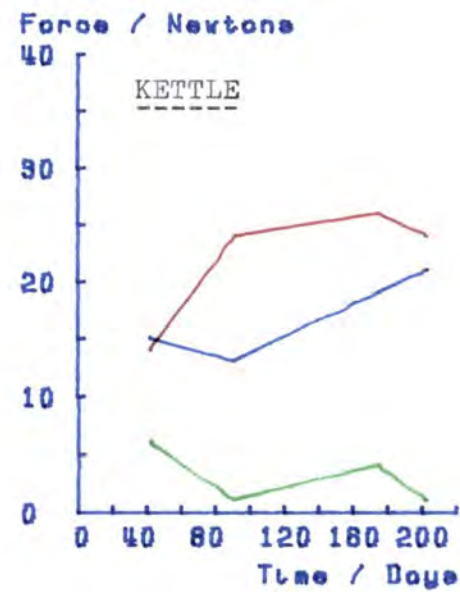
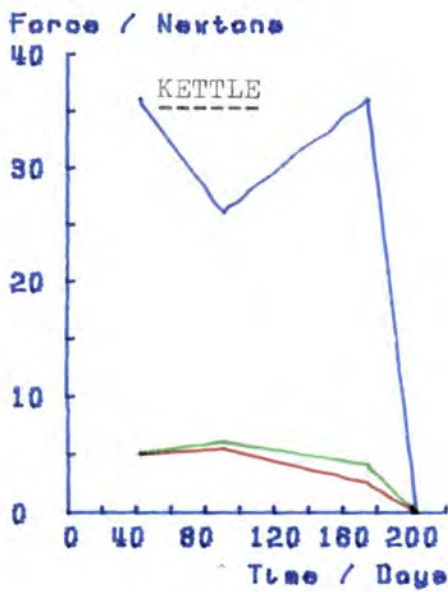
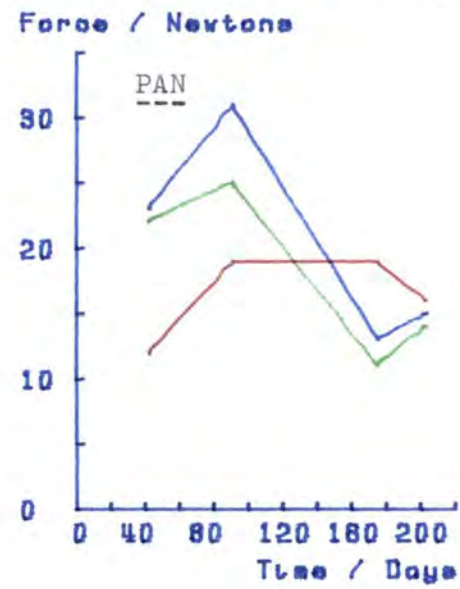
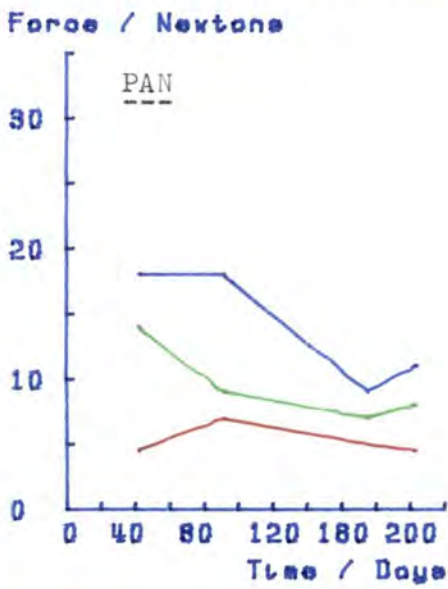
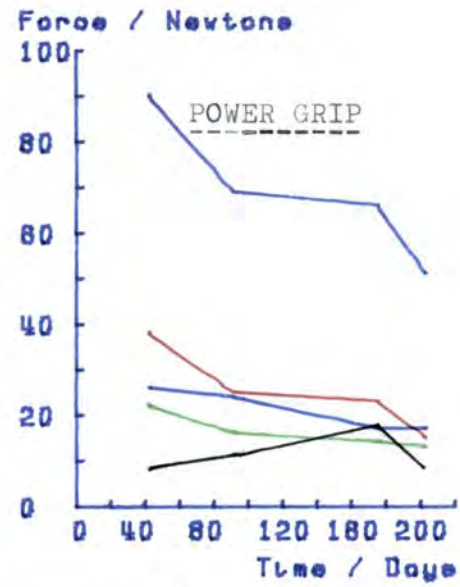
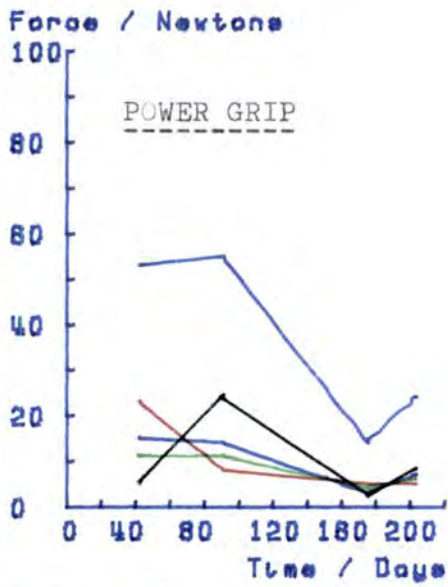

FIGURE 5.90. Clinical follow up results of DS



Left Hand

Right Hand

FIGURE 5.91.

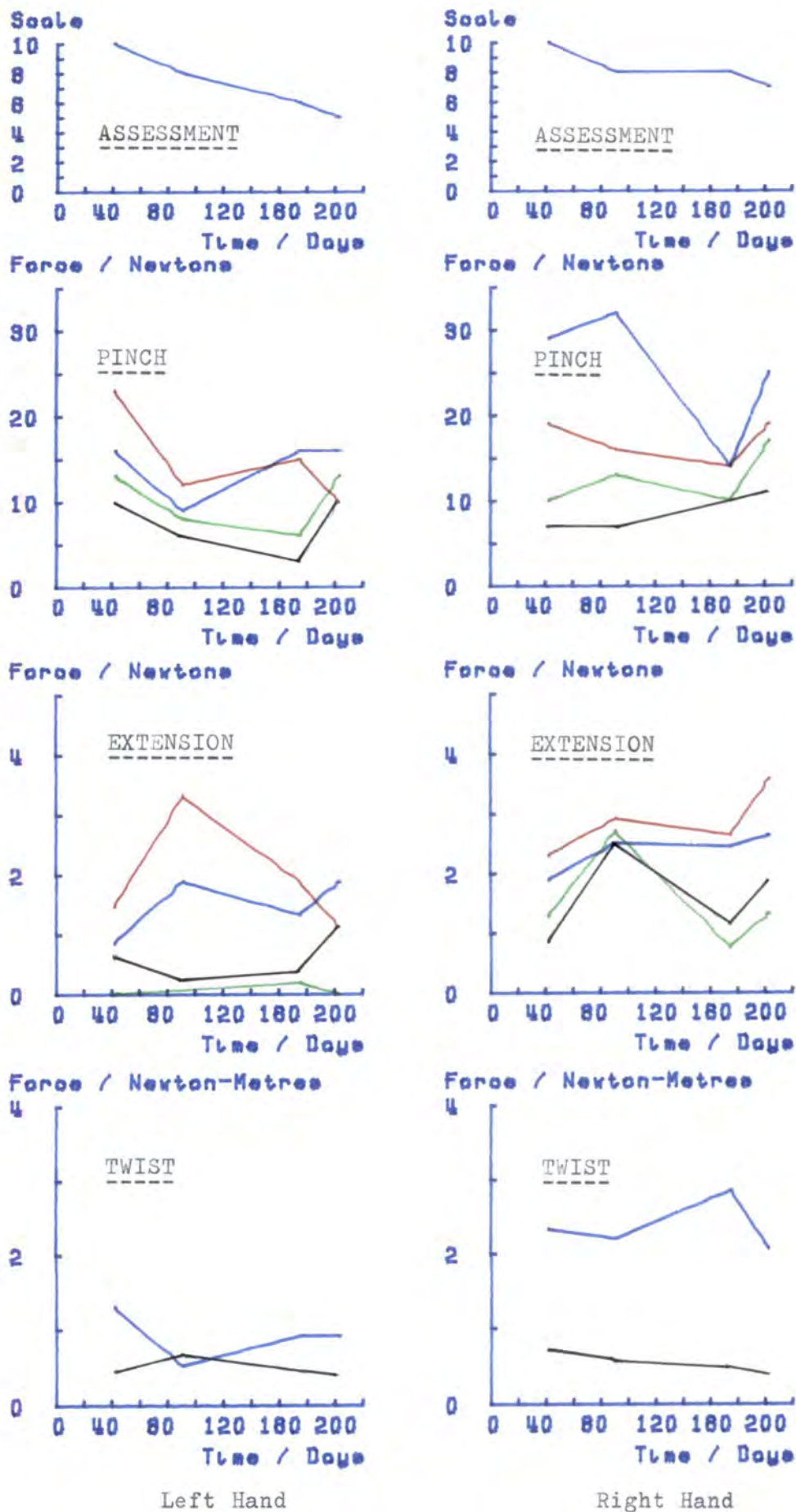

FIGURE 5.91. Follow up results of ES

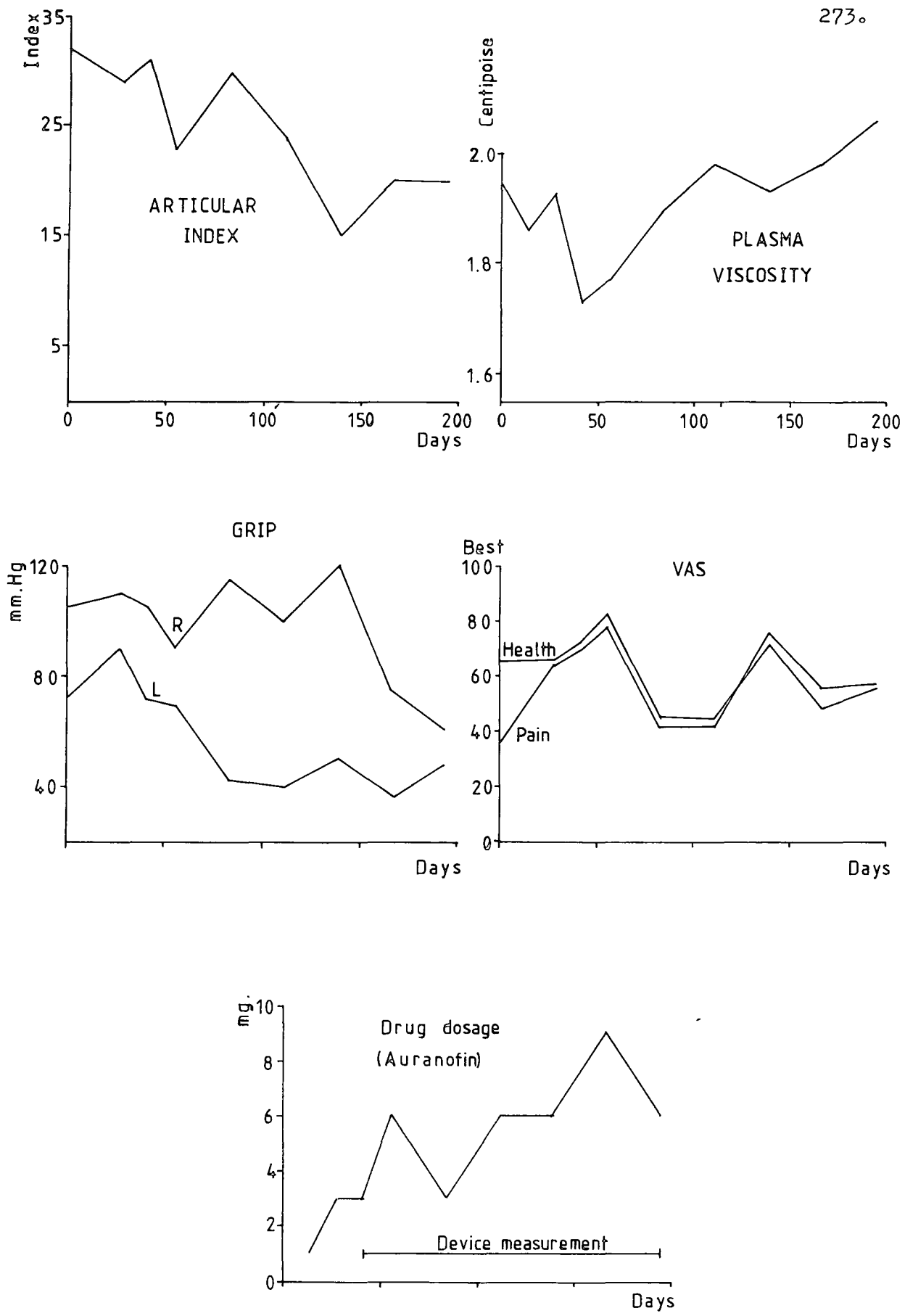
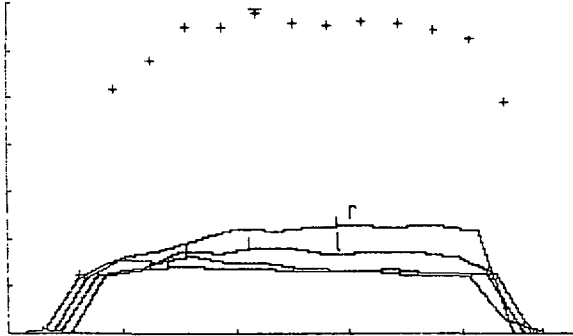

FIGURE 5.92. Clinical follow up results of ES

Y-AXIS = 0 TO 175 NEWTONS IN STEPS OF 25 NEWTON
 X-AXIS = 0 TO 5 SECONDS IN UNIT STEPS



+48 days

Y-AXIS = 0 TO 250 N IN 25 N STEPS

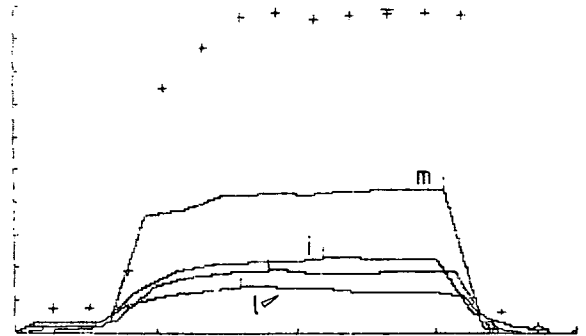

+112 days

Y-AXIS = 0 TO 300 N IN 25 N STEPS

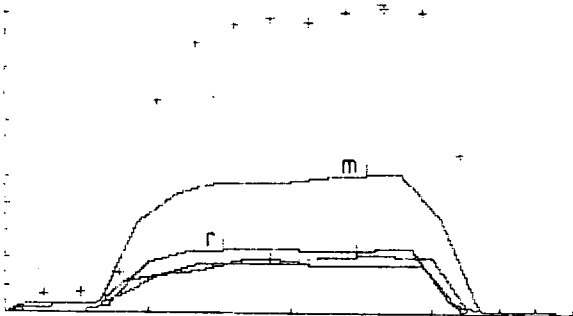

+140 days

Y-AXIS = 0 TO 225 N IN 25 N STEPS

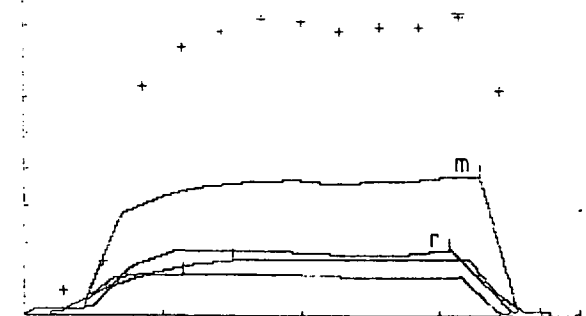

+161 days

Y-AXIS = 0 TO 250 N IN 25 N STEPS

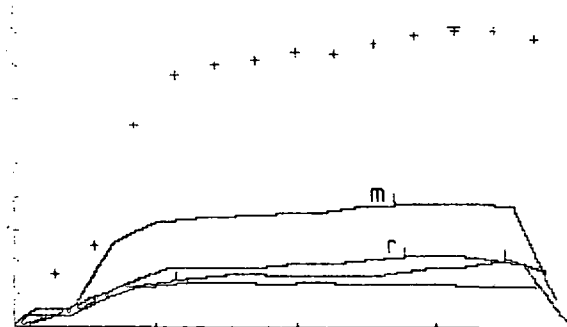

+176 days

FIGURE 5.93. Force-time curves of left hand power grip of AHD

Y-AXIS = 0 TO 225 NEWTONS IN STEPS OF 25 NEWTONS
 X-AXIS = 0 TO 5 SECONDS IN UNIT STEPS

Y-AXIS = 0 TO 225 N IN 25 N STEPS

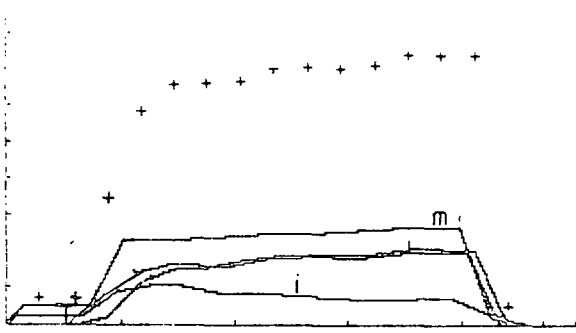

+48 days

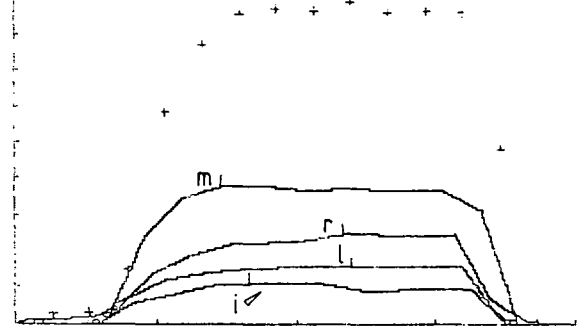

+112 days

Y-AXIS = 0 TO 275 N IN 25 N STEPS

Y-AXIS = 0 TO 275 N IN 25 N STEPS .

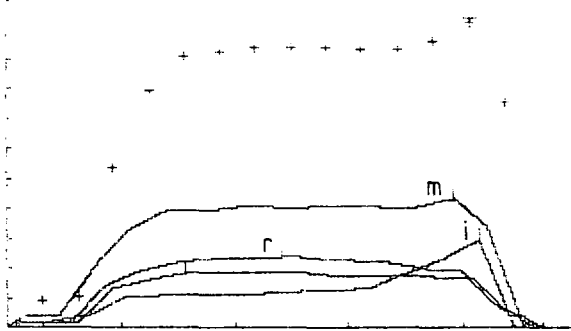

+140 days

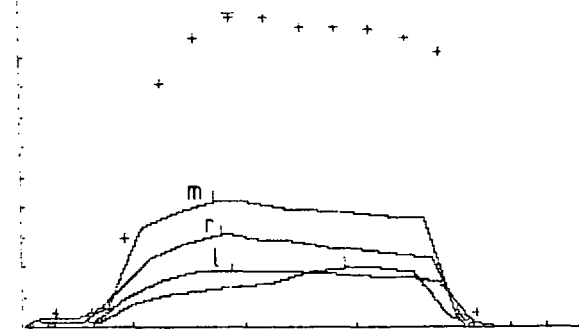

+161 days

Y-AXIS = 0 TO 275 N IN 25 N STEPS

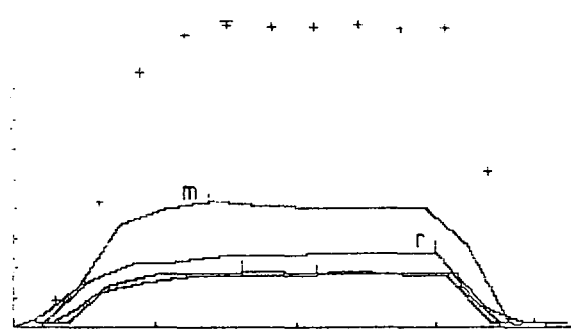

+176 days

FIGURE 5.94. Force-time curves of right hand power grip
 of AHD

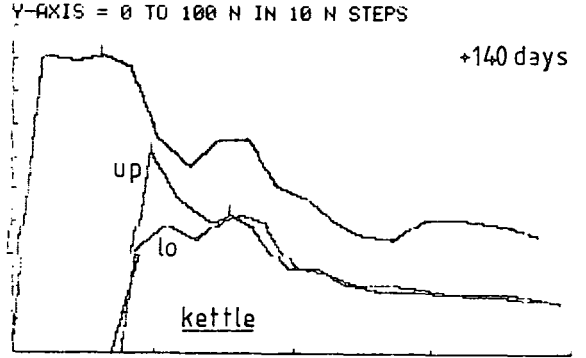
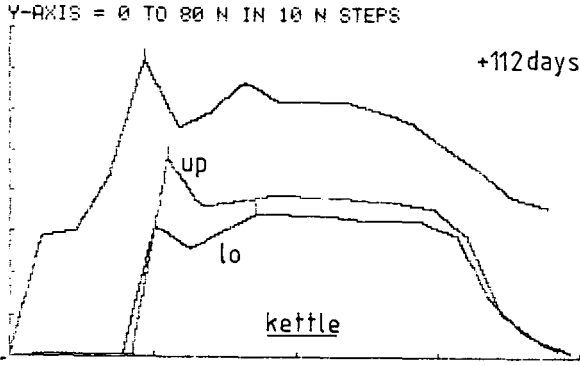

LEFT HAND

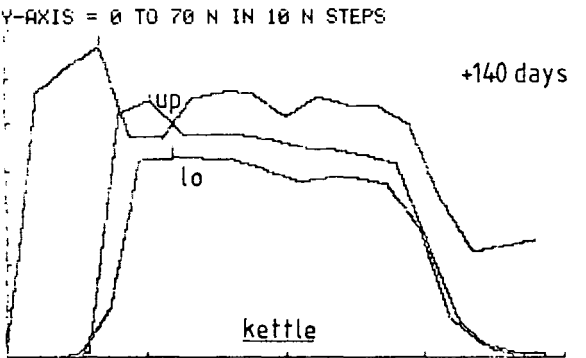
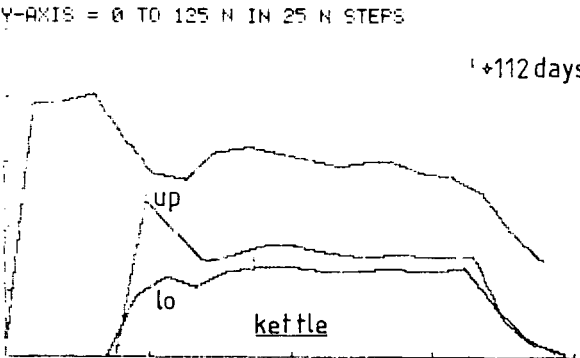
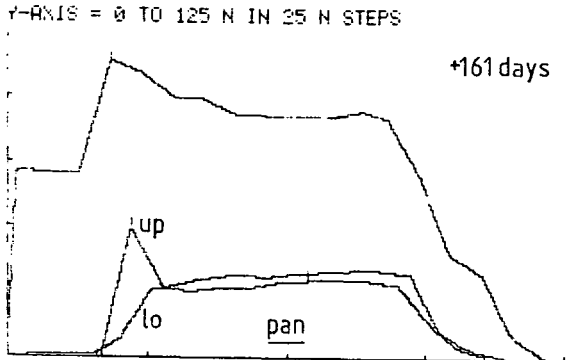
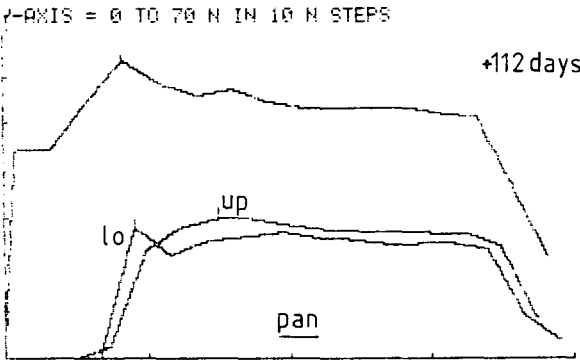

RIGHT HAND

FIGURE 5.95. Force-time curves of AHD pan and kettle lifts showing the peaks obtained

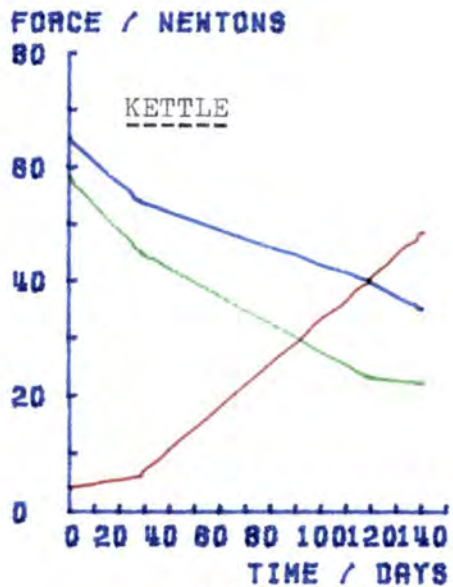
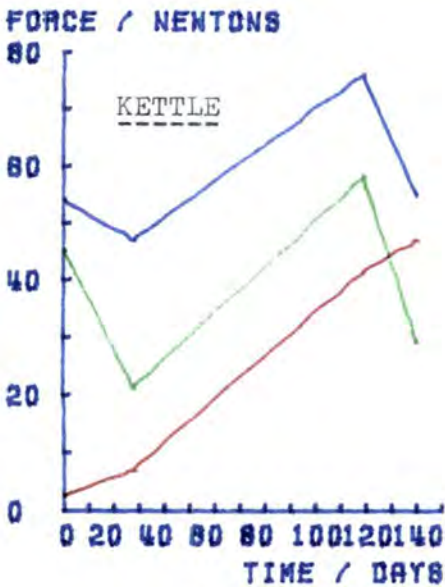
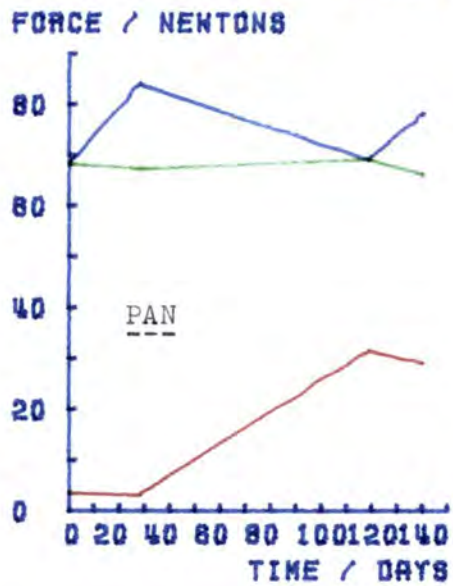
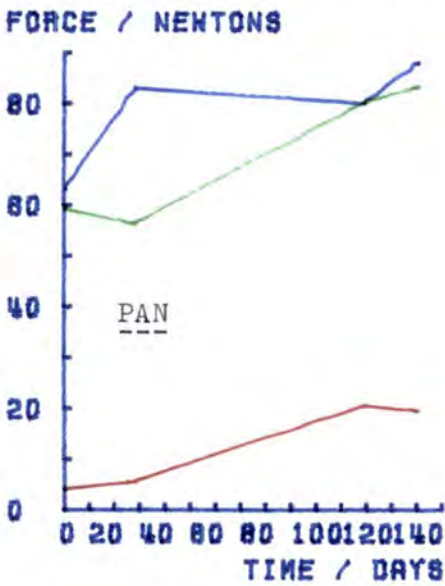
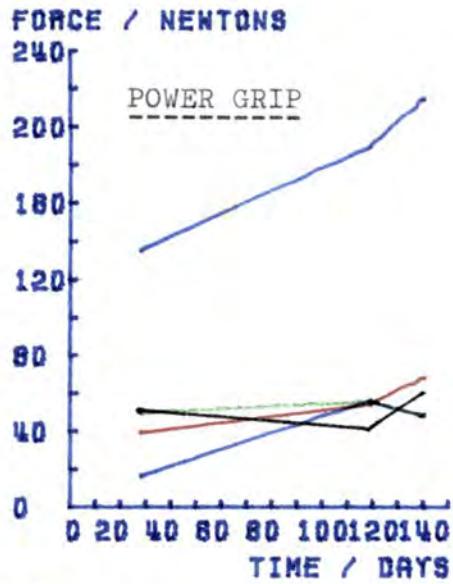
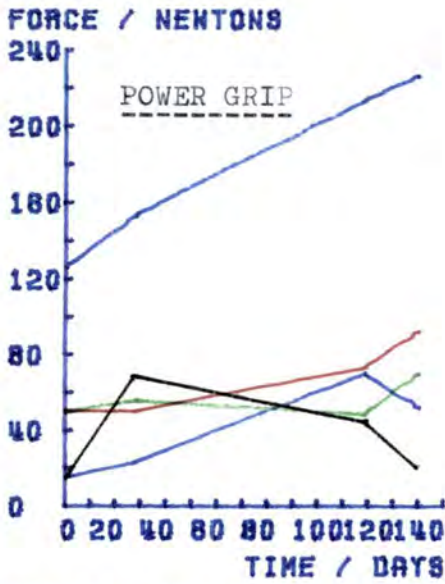

Left Hand

Right Hand

FIGURE 5.96.

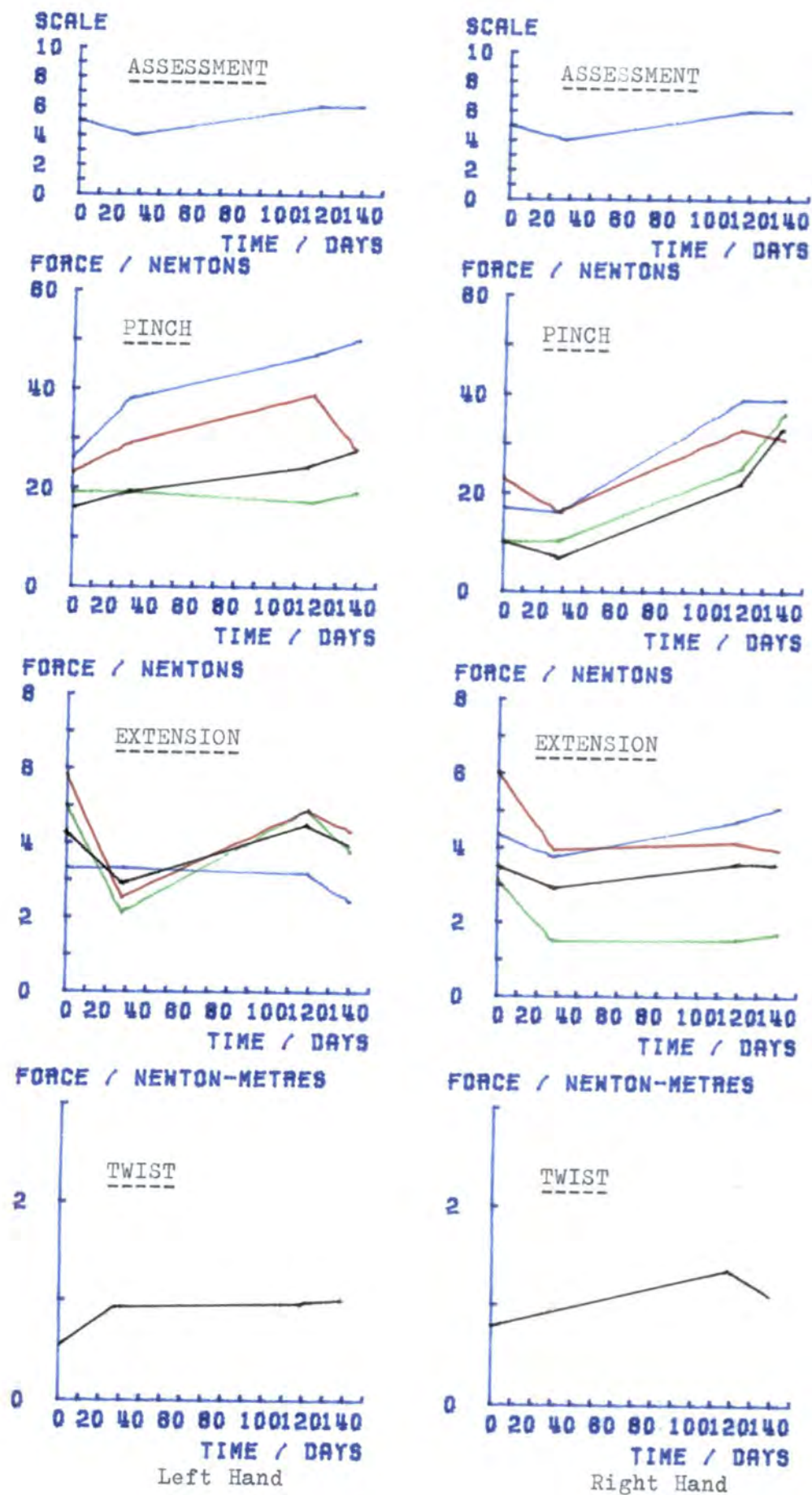
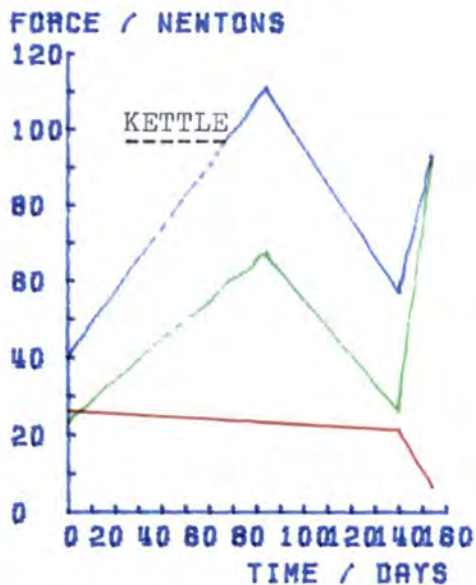
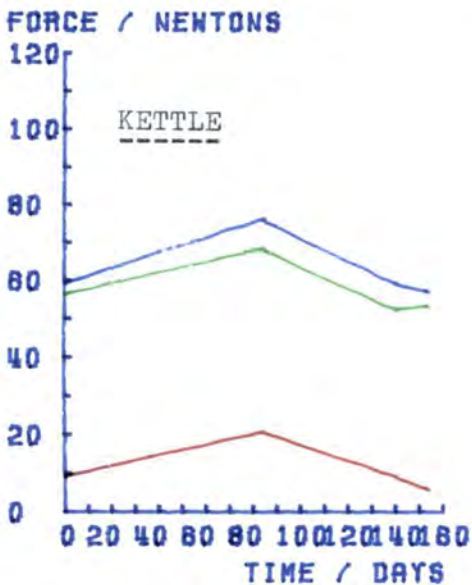
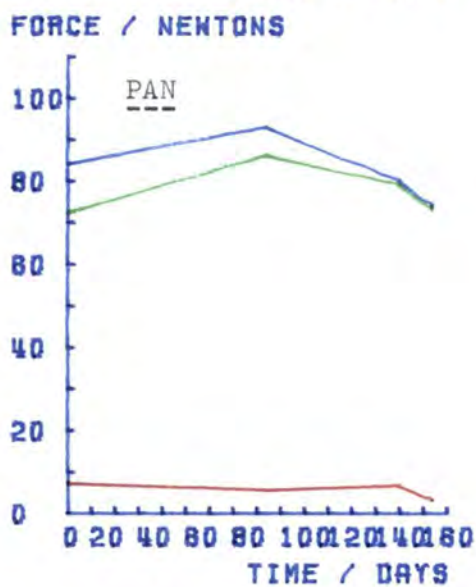
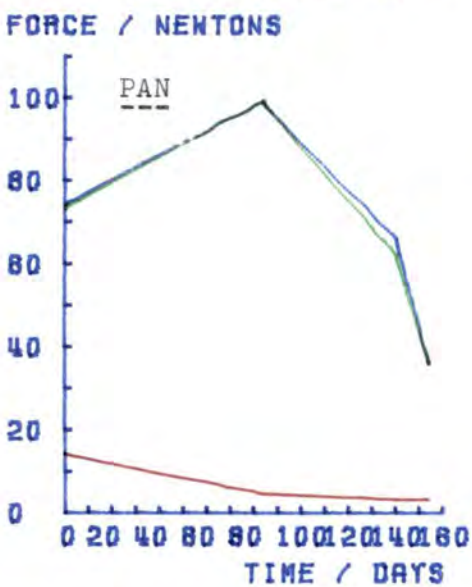
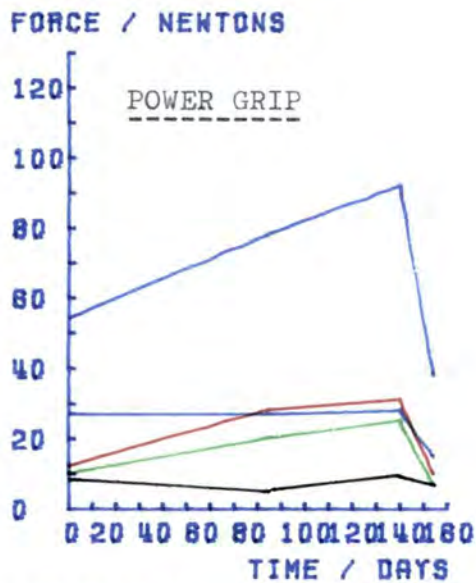
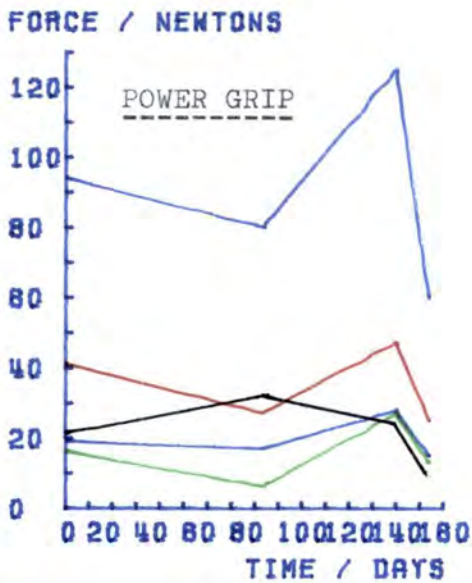

FIGURE 5.96. Follow up results of GEL
(period of hospitalisation 50 to 70 days)



Left Hand

Right Hand

FIGURE 5.97.

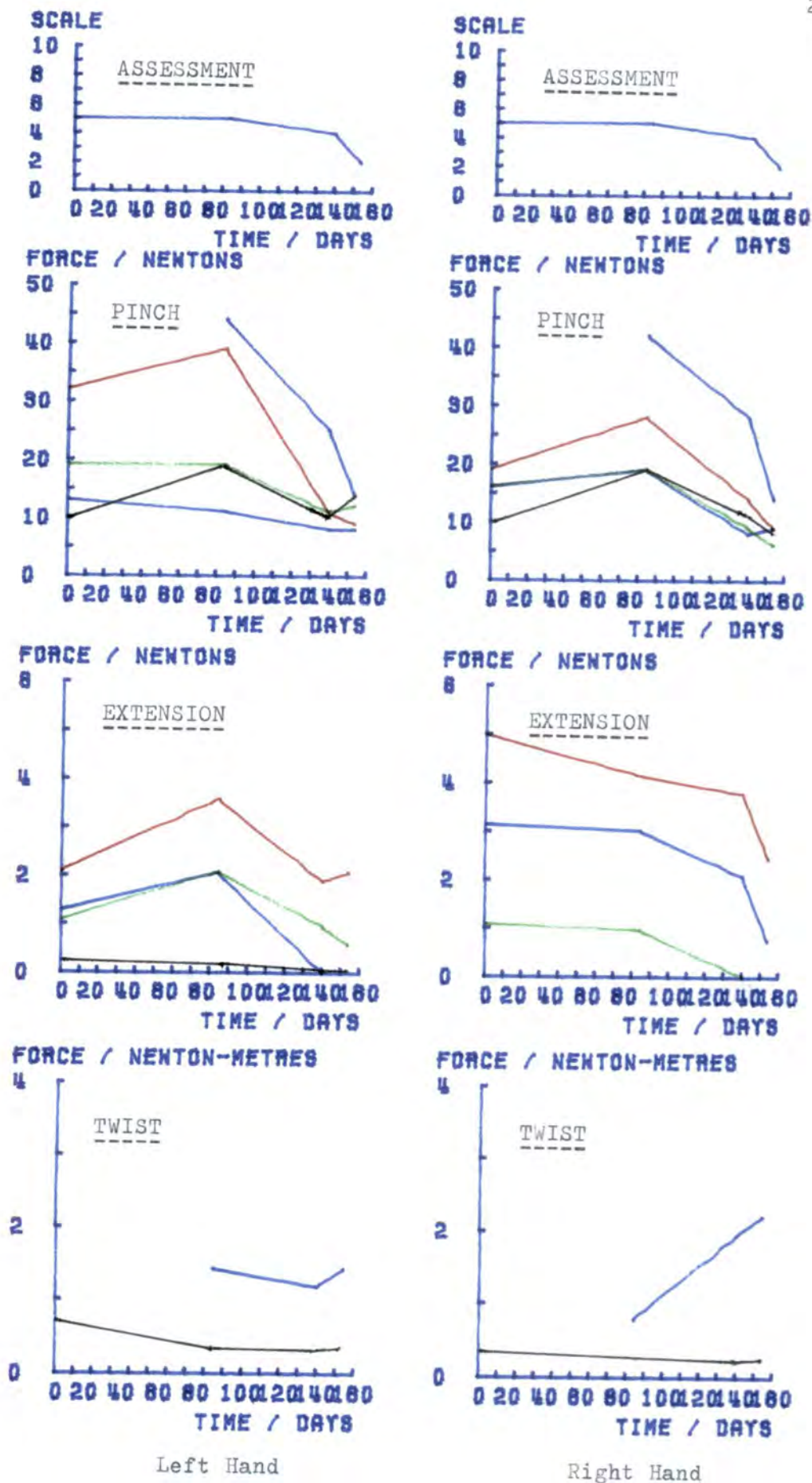

Left Hand

Right Hand

FIGURE 5.97. Follow up results of DWW
(period of hospitalisation 28 to 42 days)

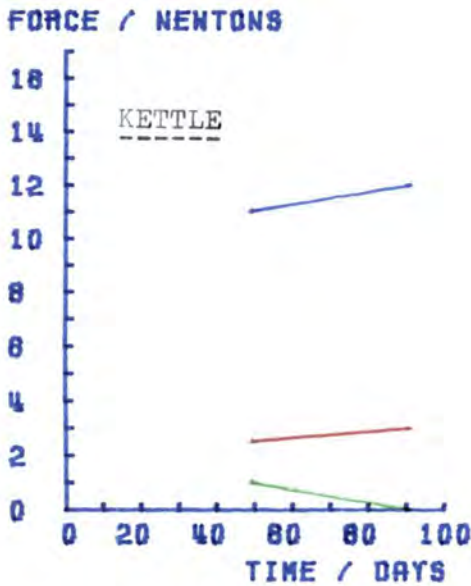
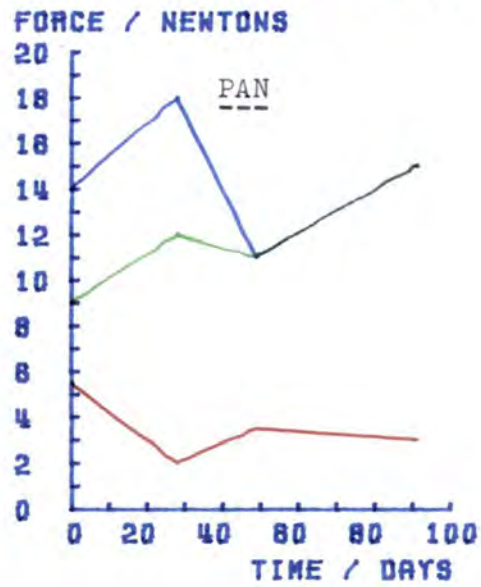
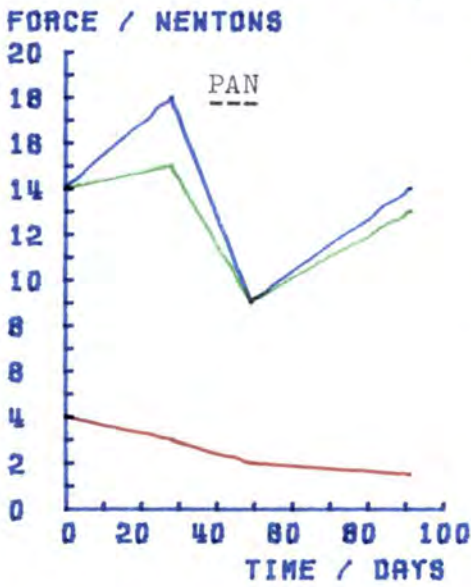
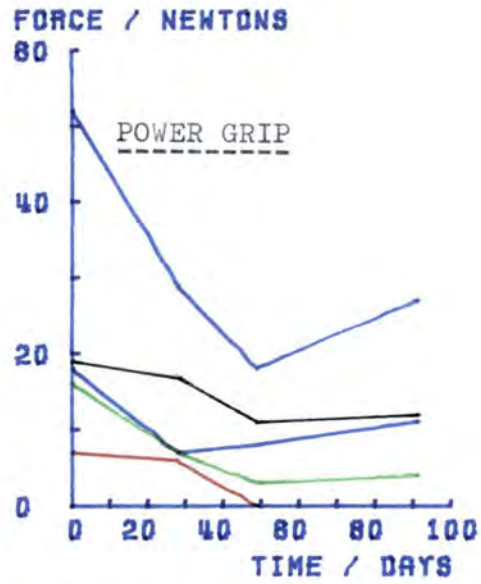
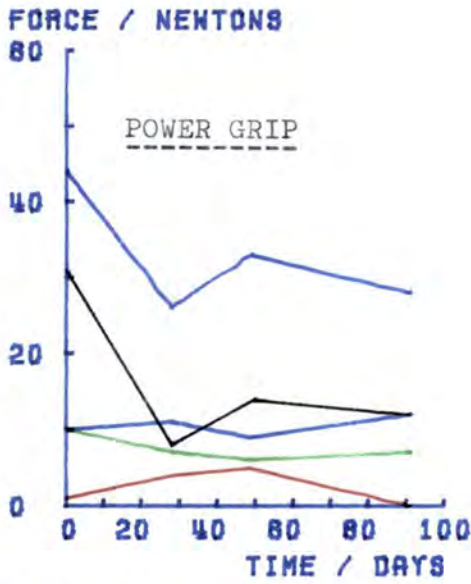

Left Hand

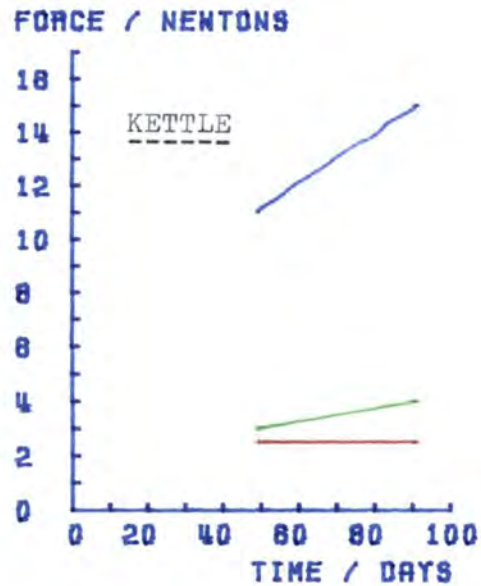

Right Hand

FIGURE 5.98.

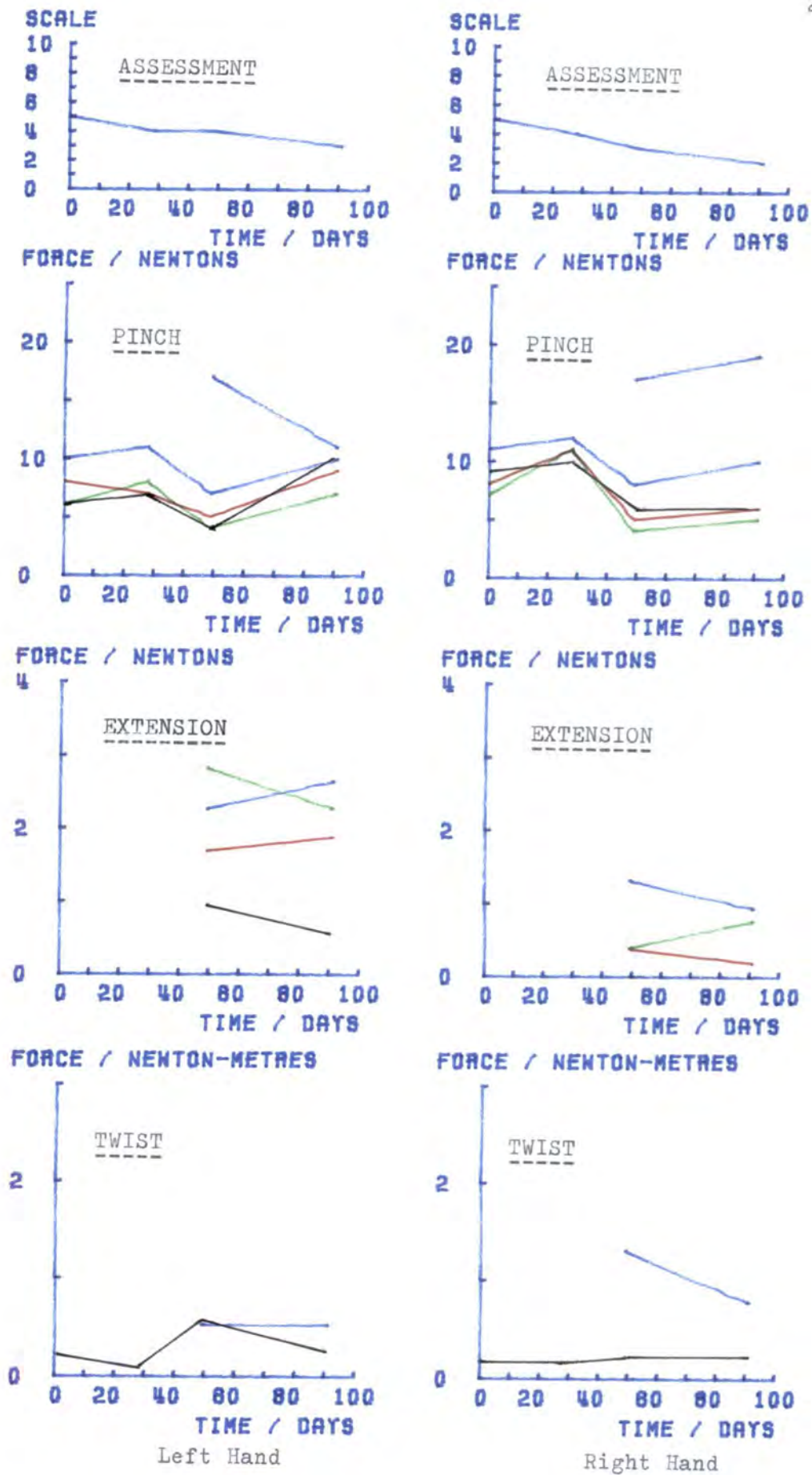
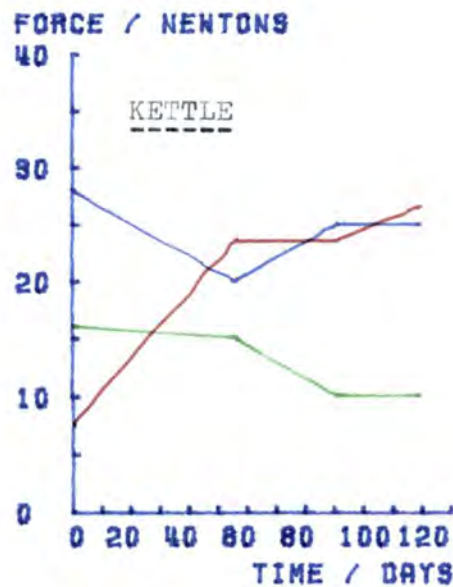
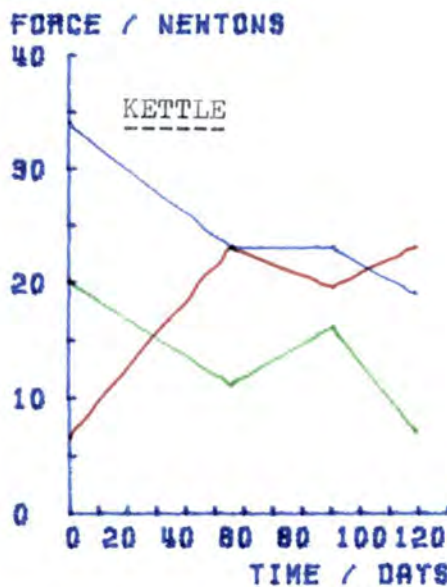
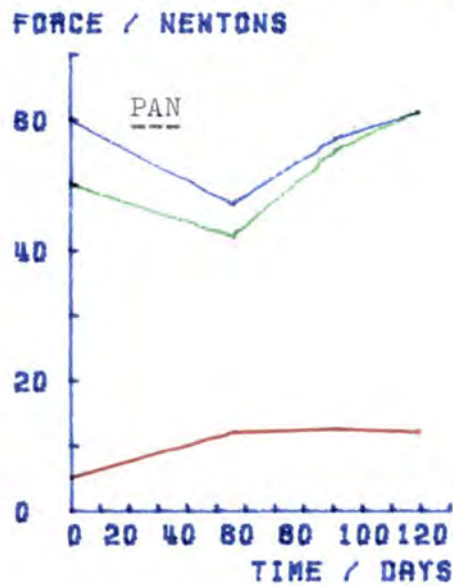
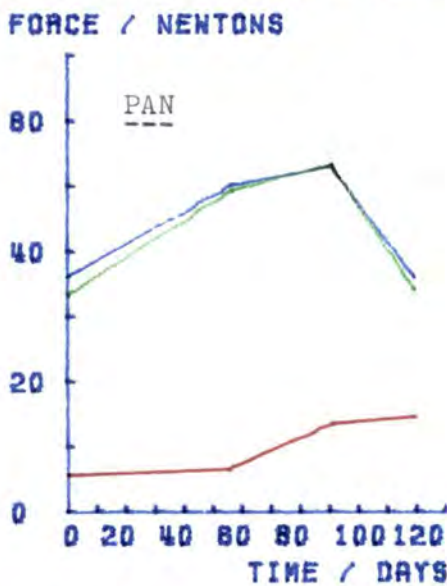
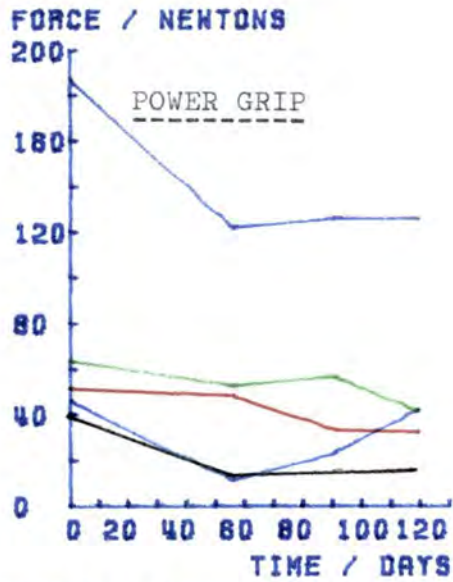
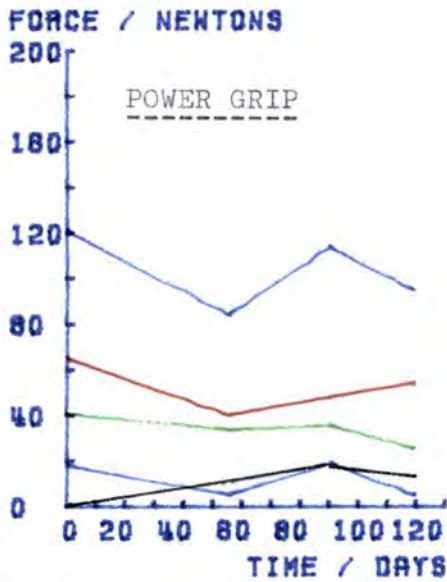

FIGURE 5.98. Follow up results of JC



Left Hand

Right Hand

FIGURE 5.99.

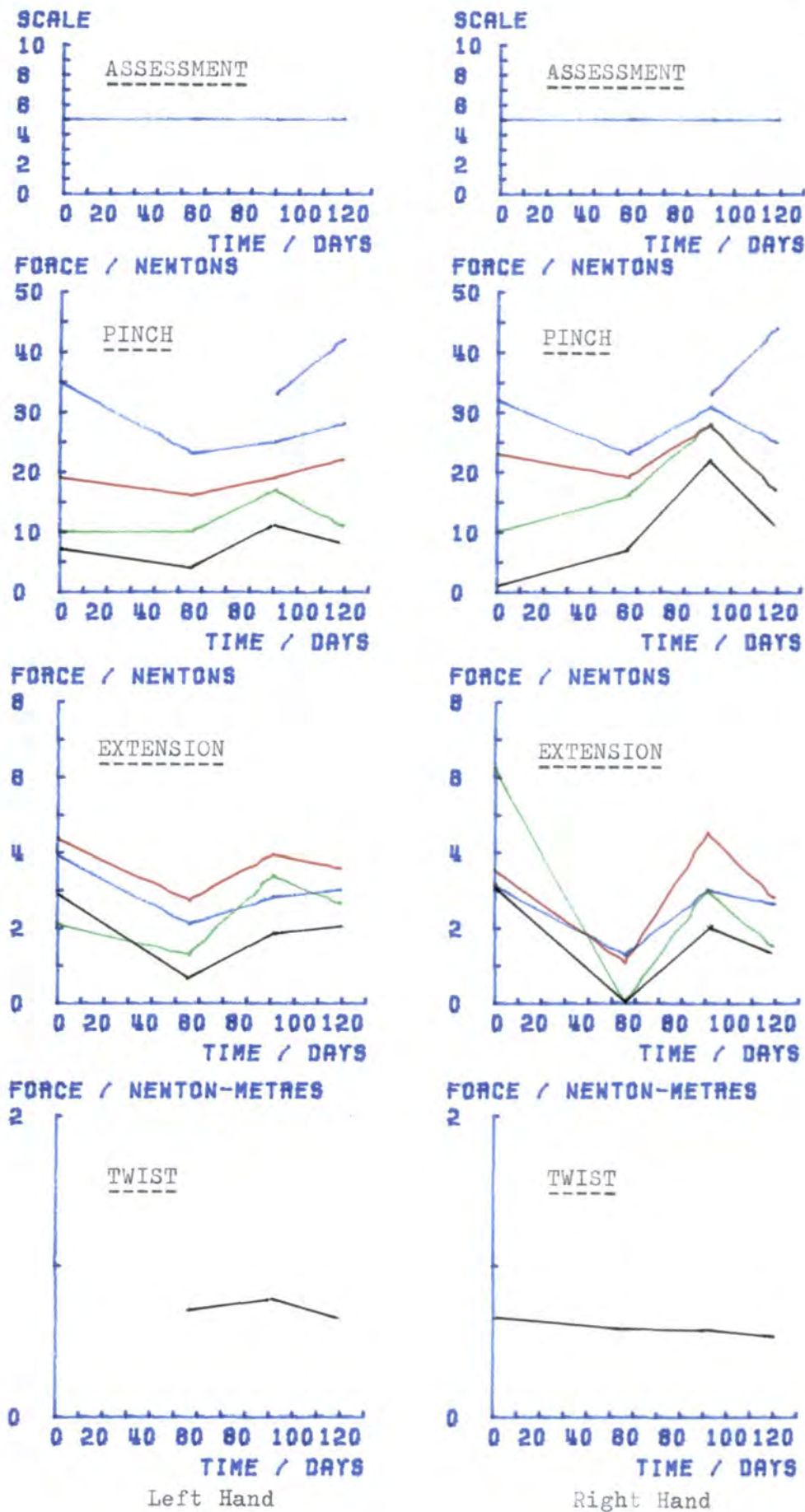
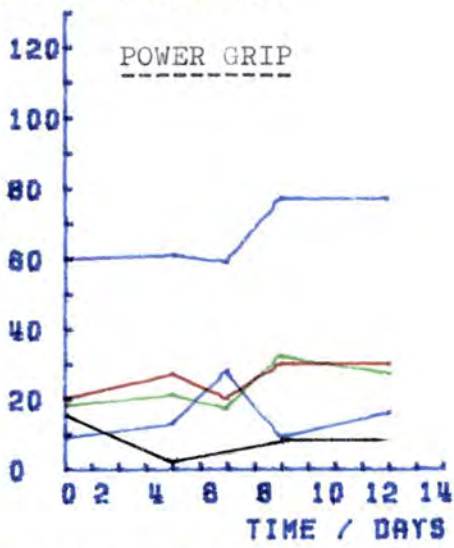
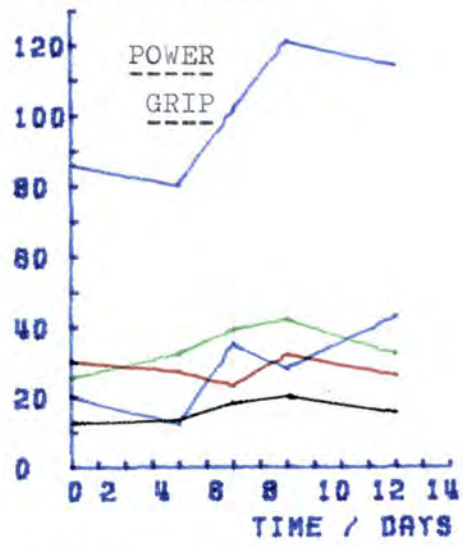

FIGURE 5.99. Follow up results of EF

FORCE / NEWTONS



FORCE / NEWTONS



FORCE / NEWTONS

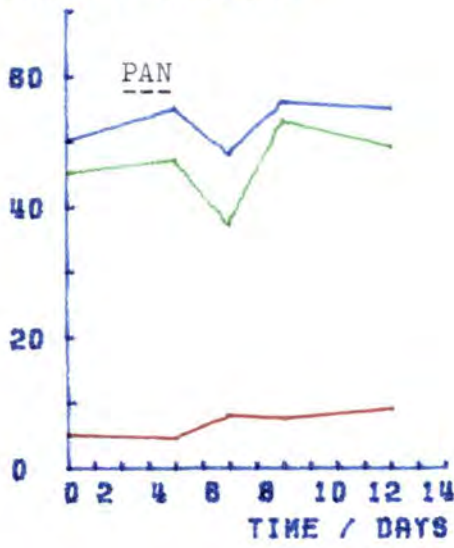

FORCE / NEWTONS

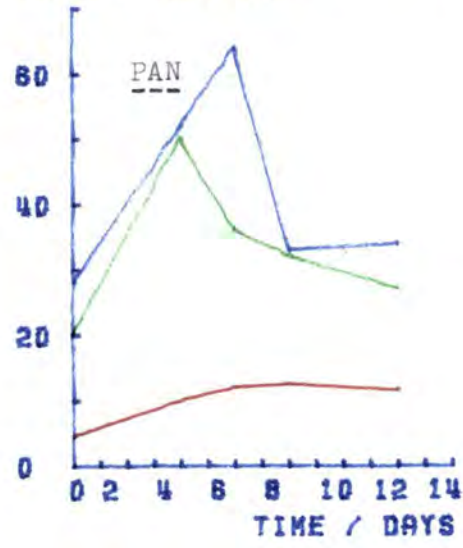

FORCE / NEWTONS

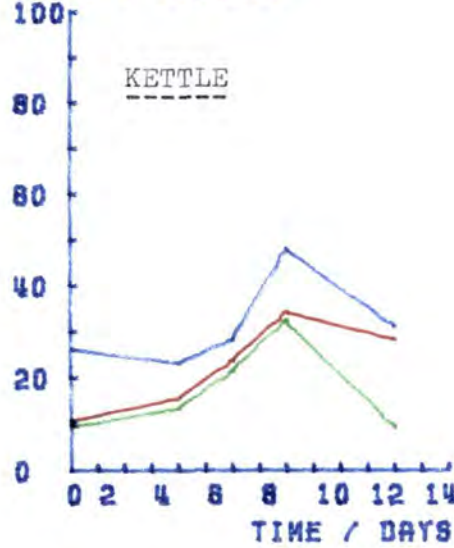

FORCE / NEWTONS

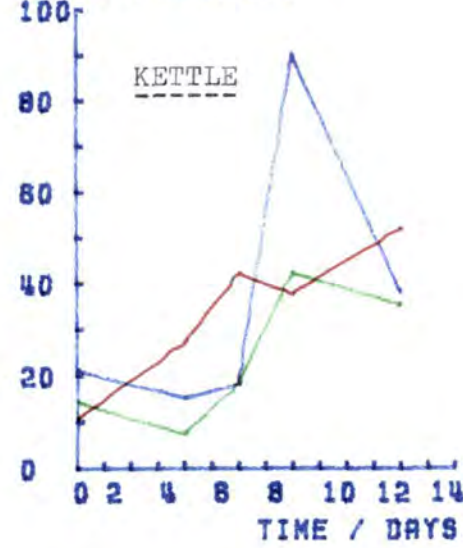

Left Hand

Right Hand

FIGURE 5.100.

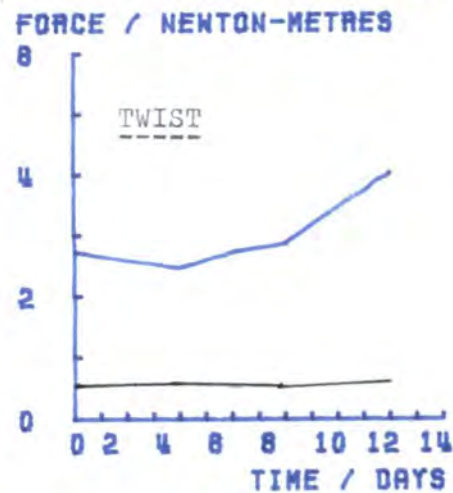
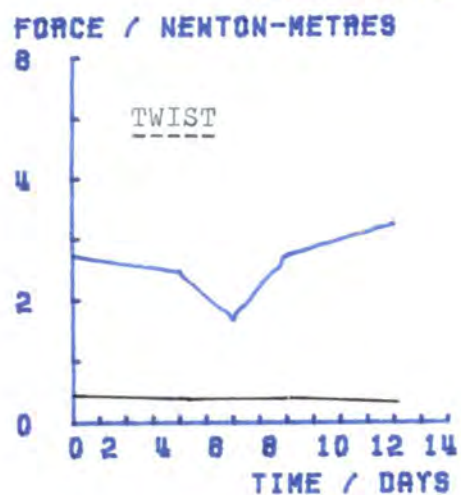
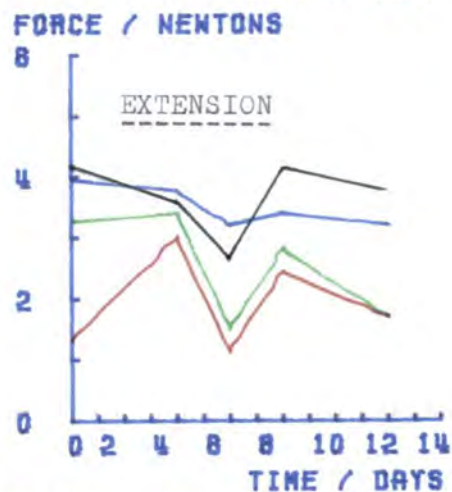
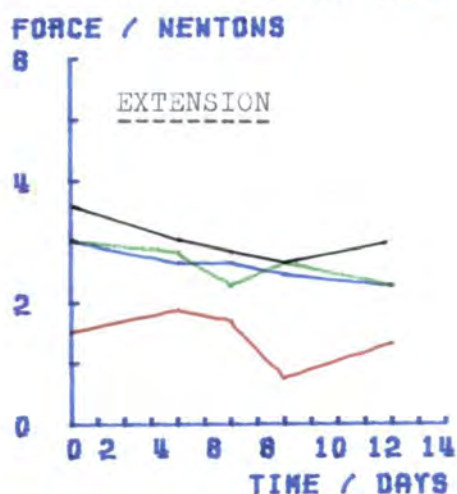
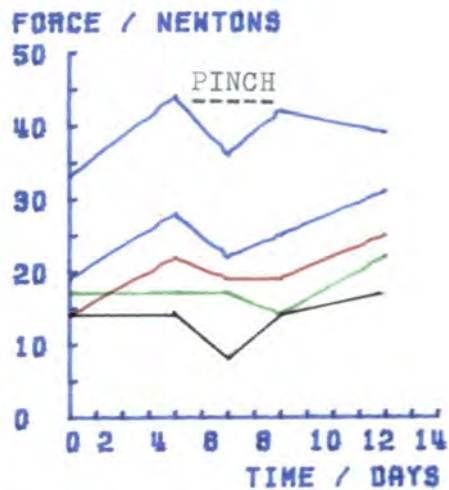
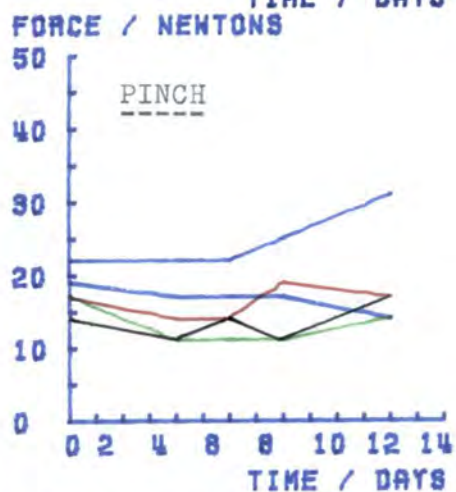
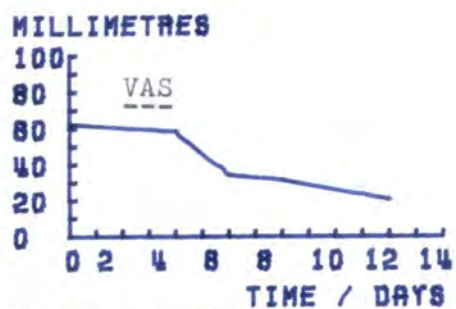

Left Hand

Right Hand

FIGURE 5.100. Follow up results of PMB

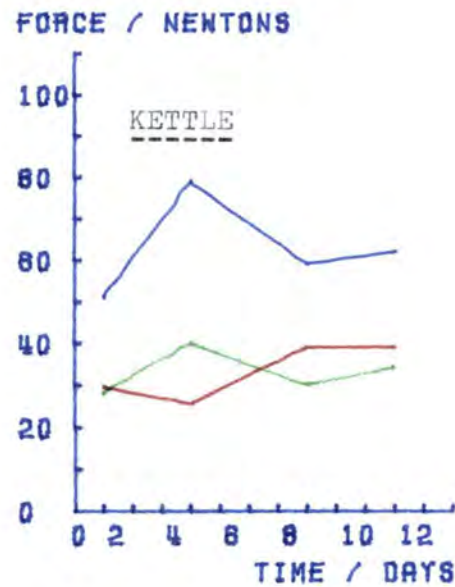
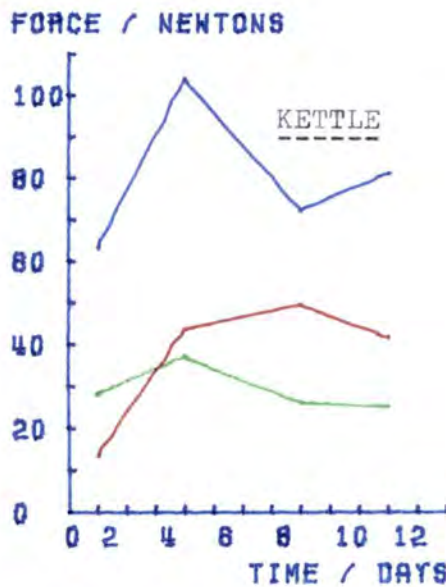
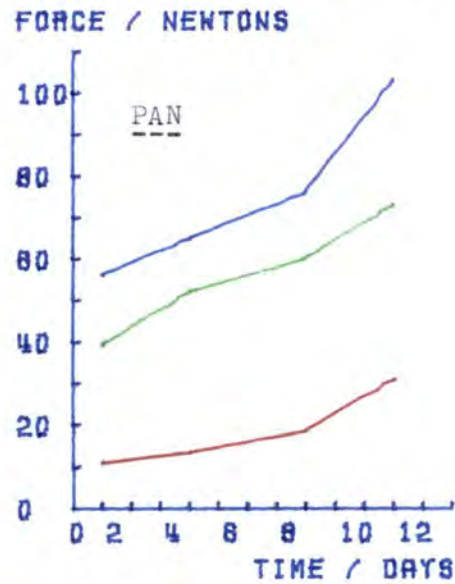
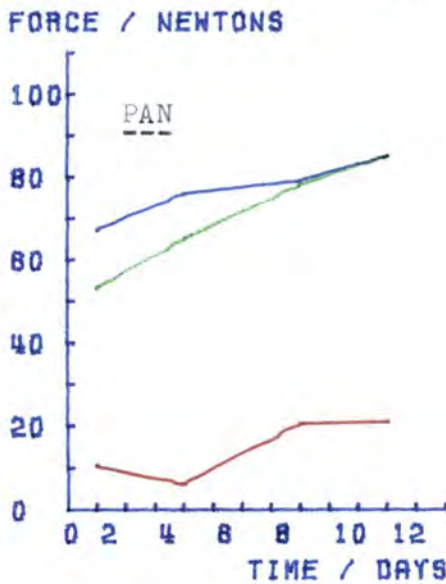
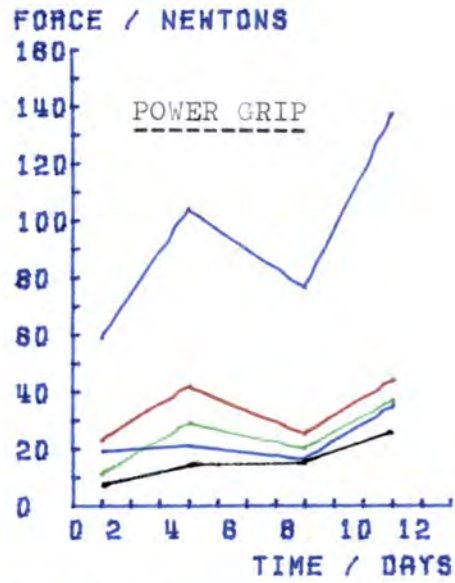
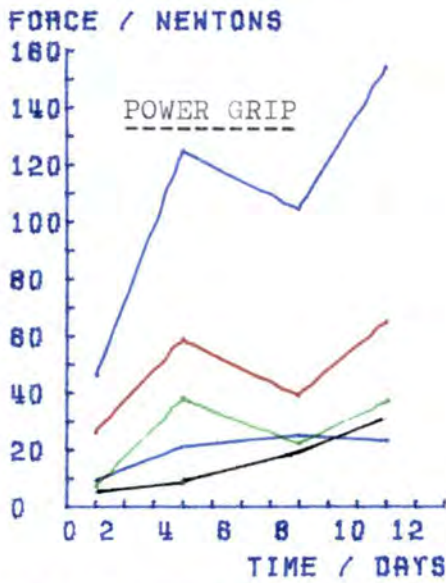

Left Hand

Right Hand

FIGURE 5.101

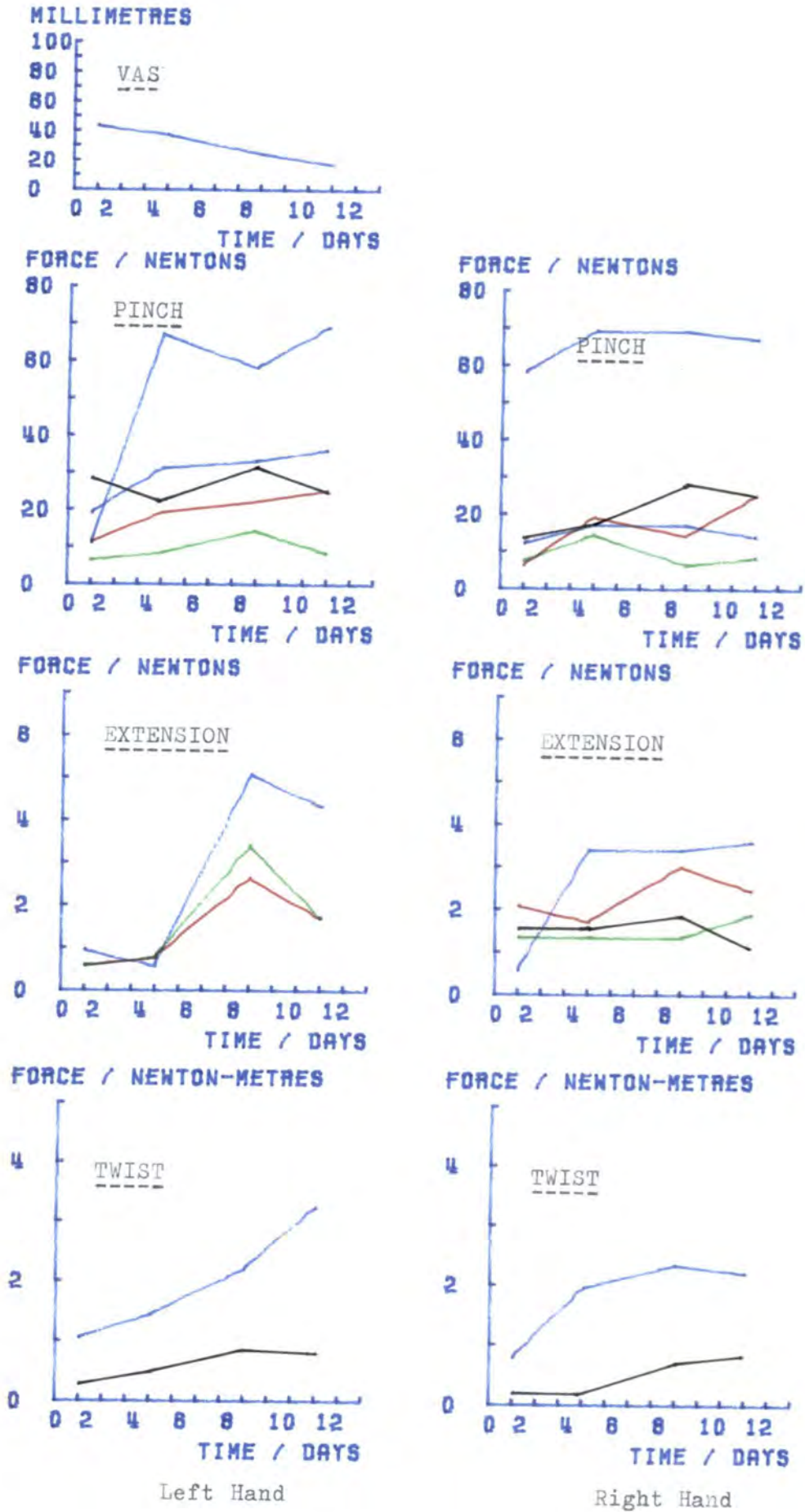
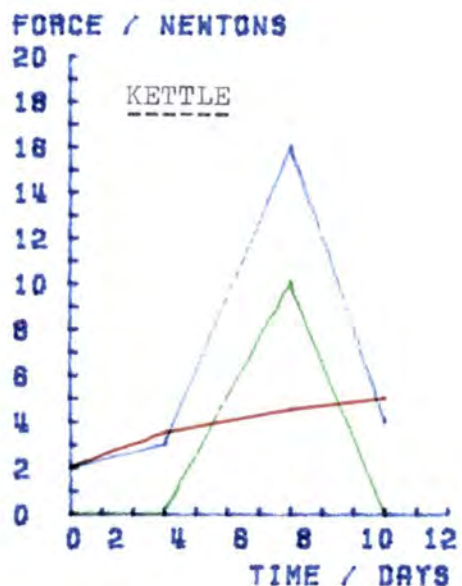
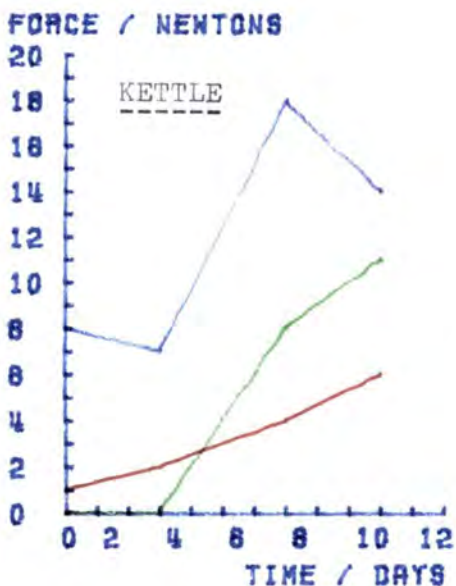
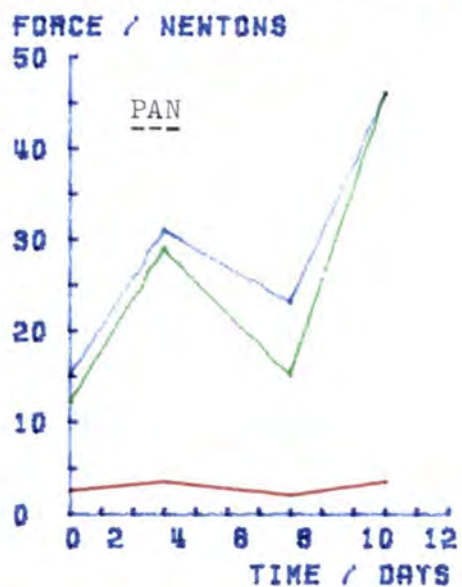
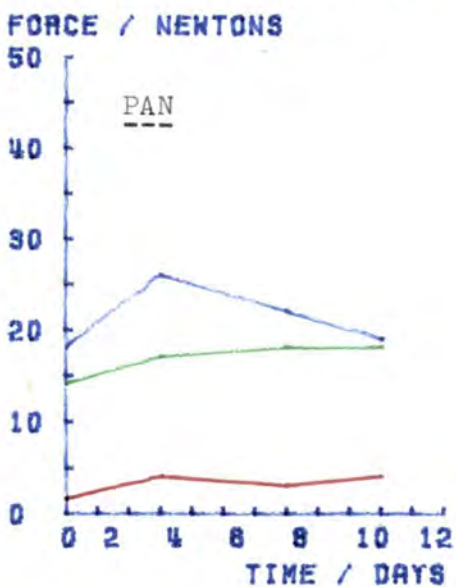
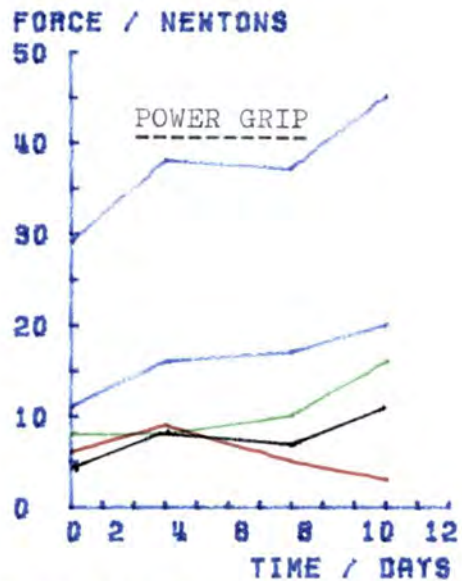
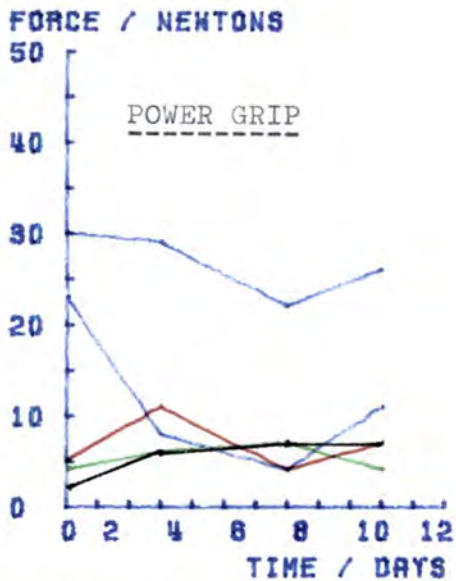

FIGURE 5.101. Follow up results of GB



Left Hand

Right Hand

FIGURE 5.102.

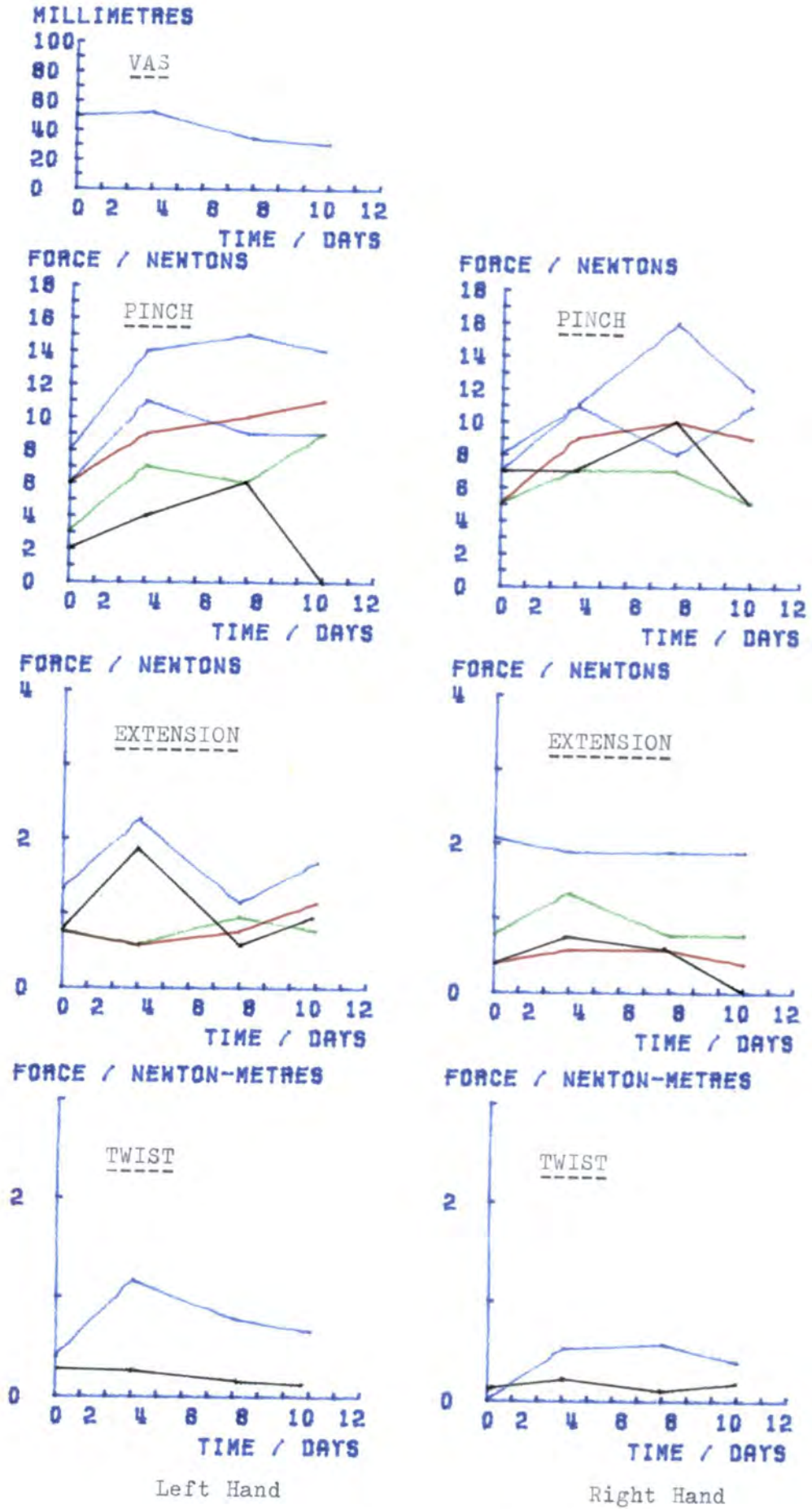
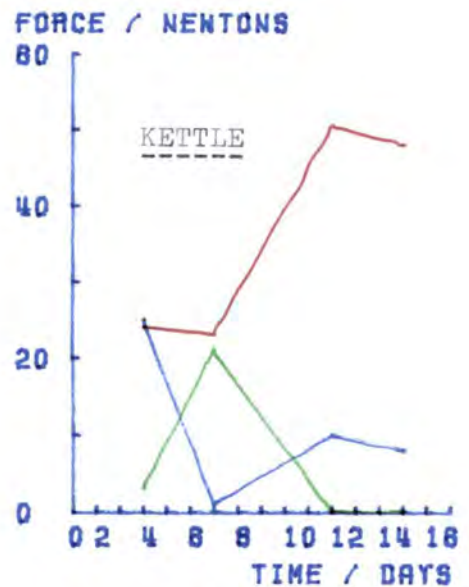
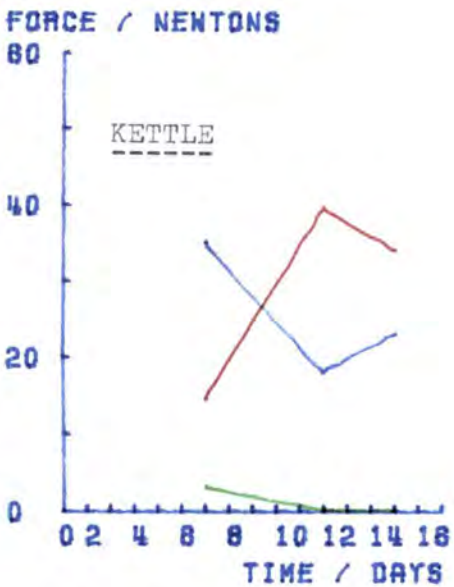
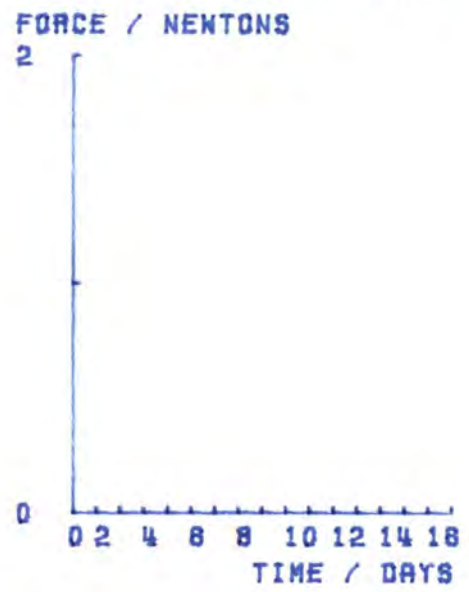
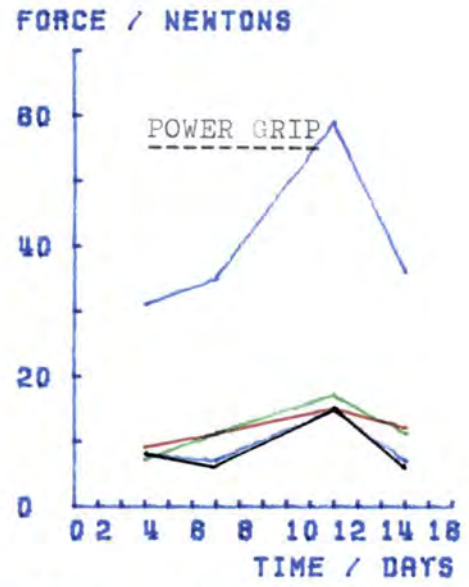
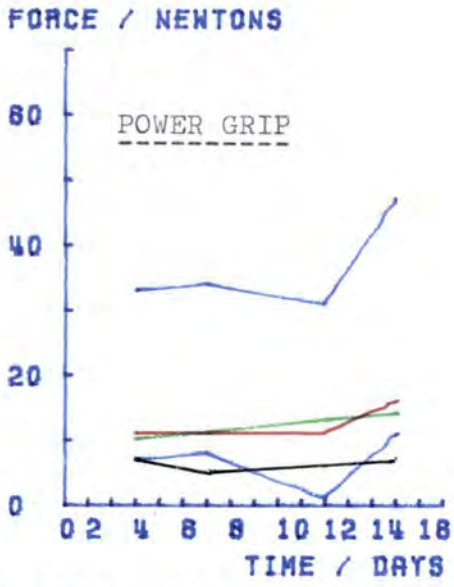

FIGURE 5.102. Follow up results of EF



Left Hand

Right Hand

FIGURE 5.103.

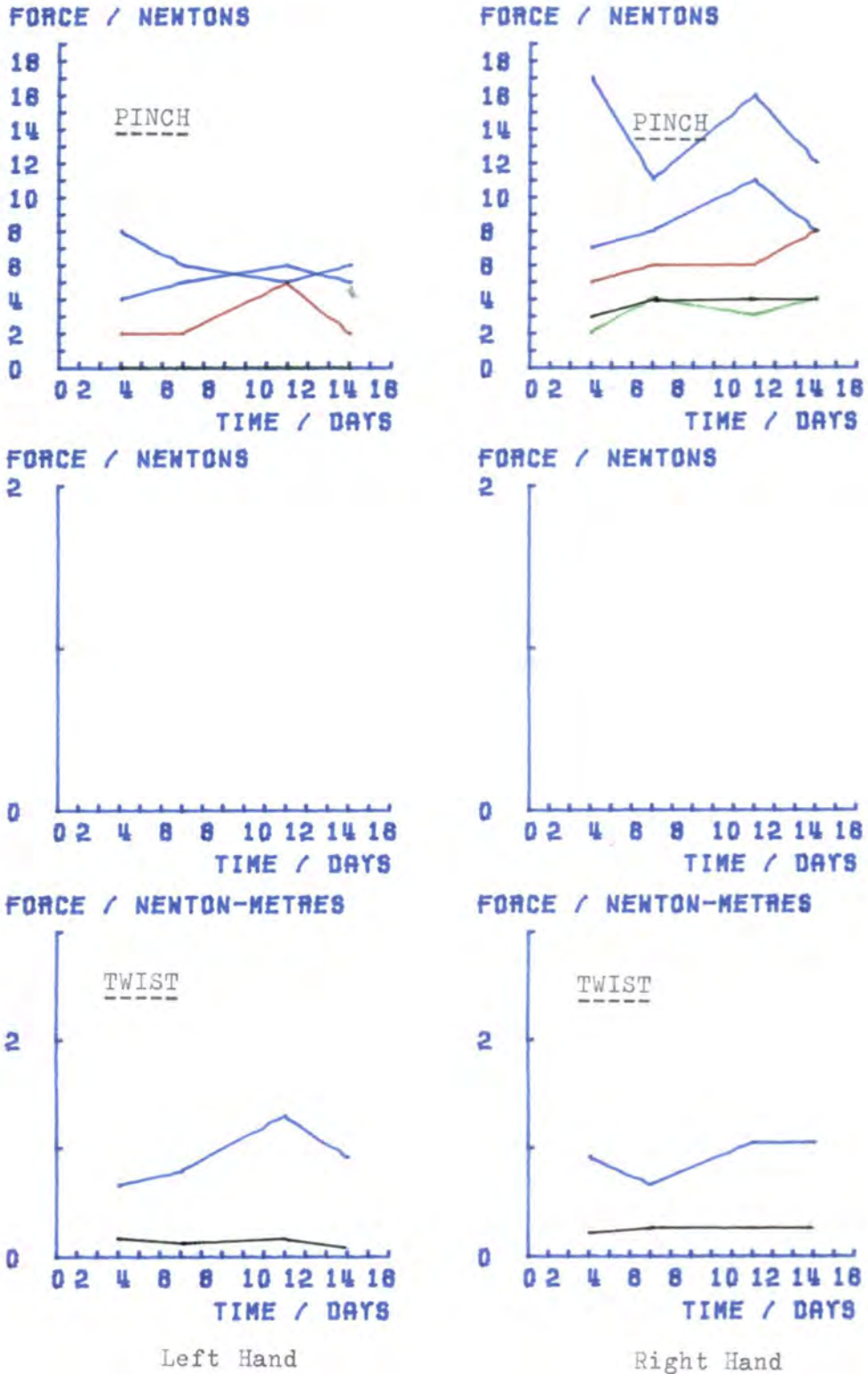

FIGURE 5.103. Follow up results of JW

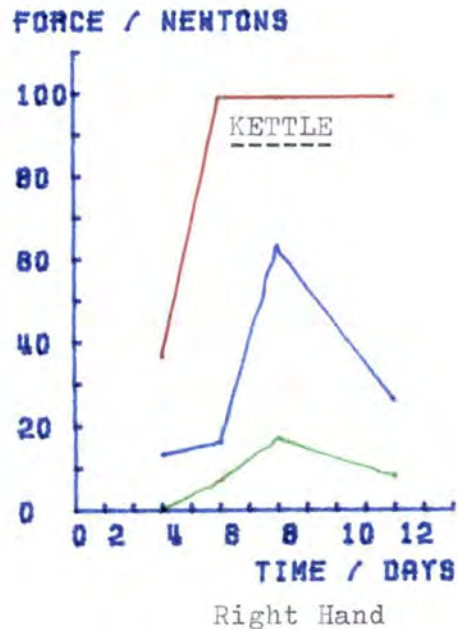
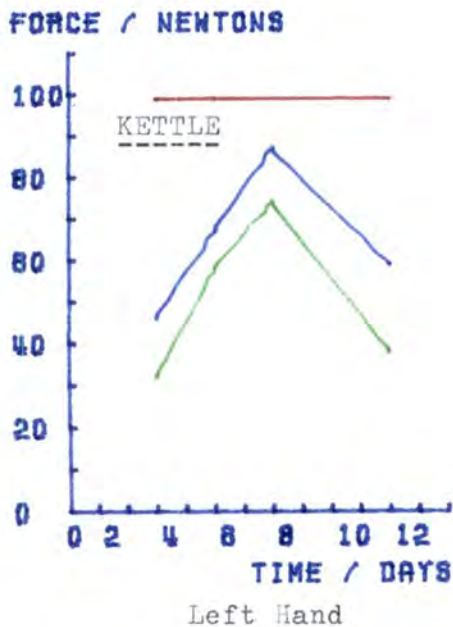
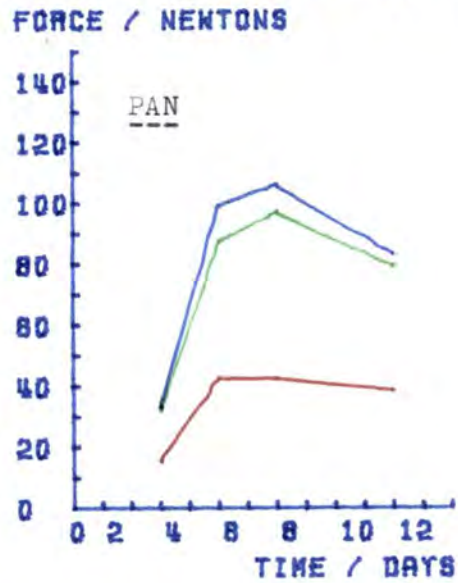
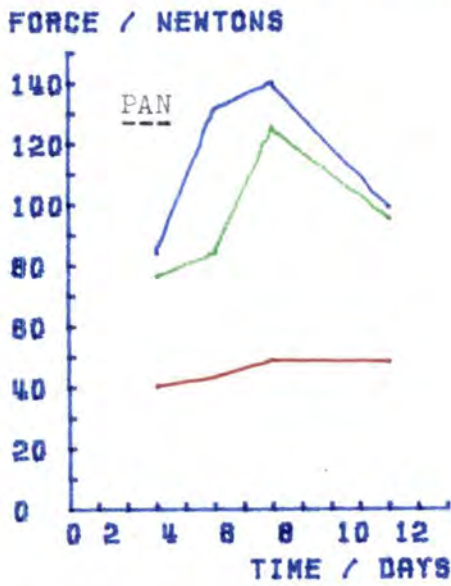
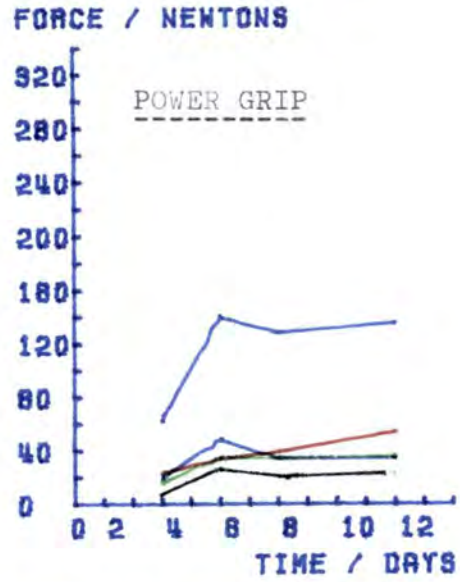
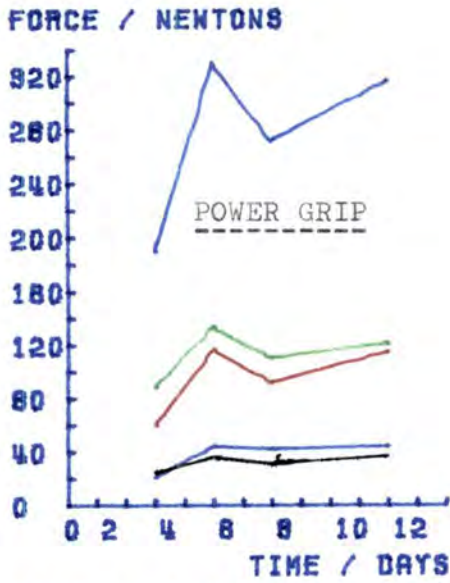

FIGURE 5.104.

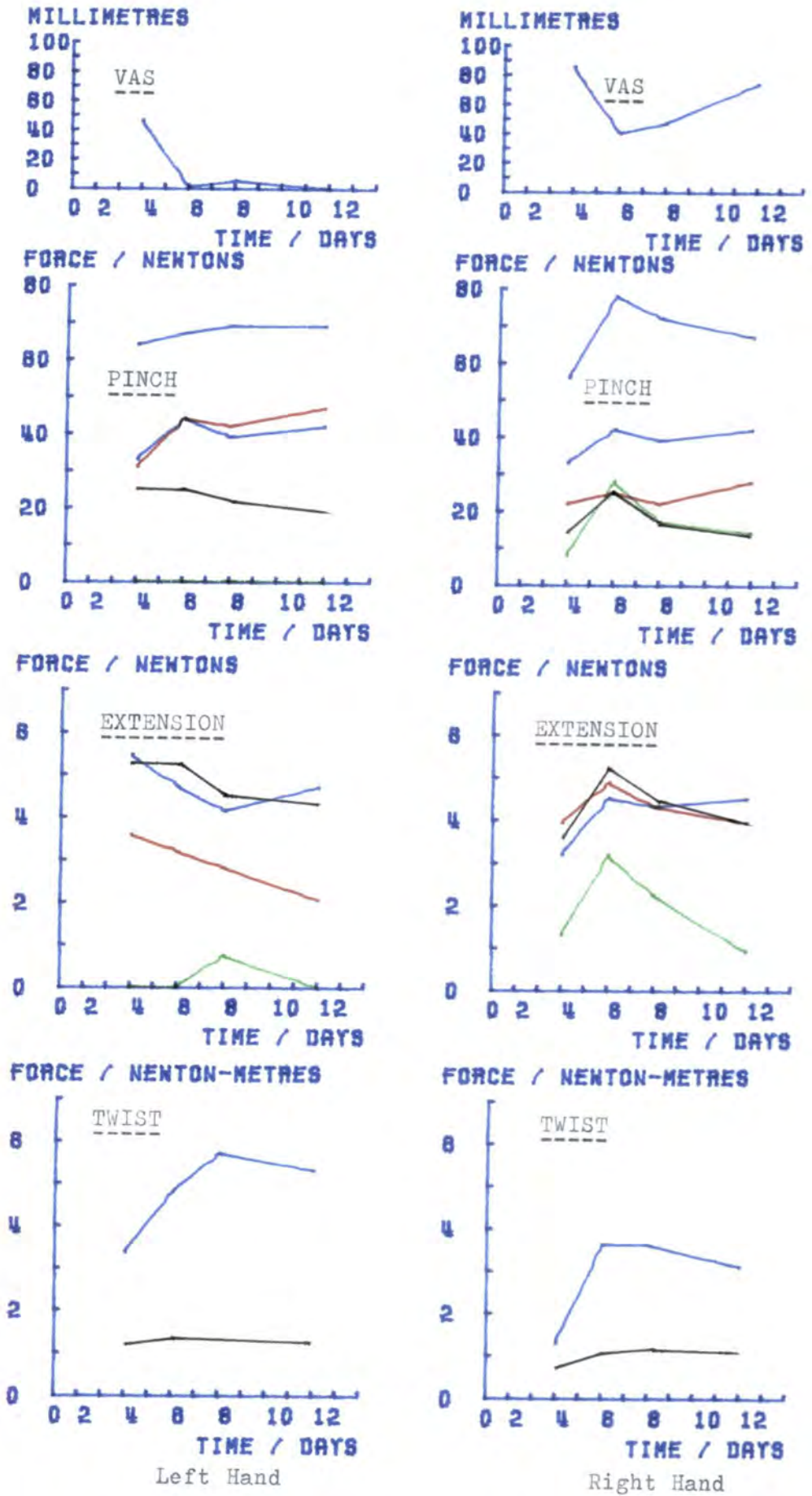
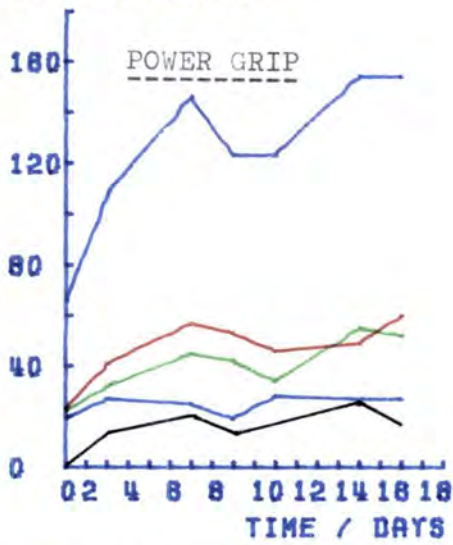
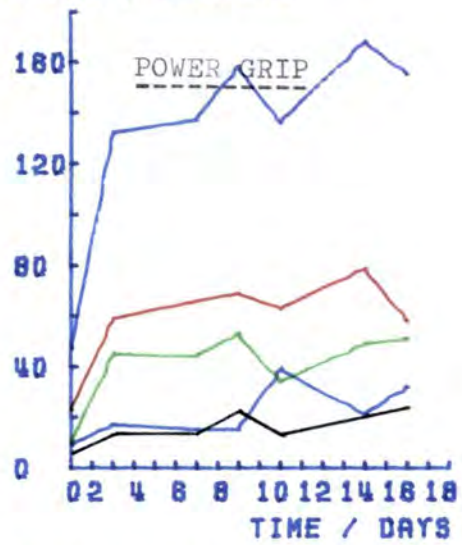

FIGURE 5.104. Follow up results of RP

FORCE / NEWTONS



FORCE / NEWTONS



FORCE / NEWTONS

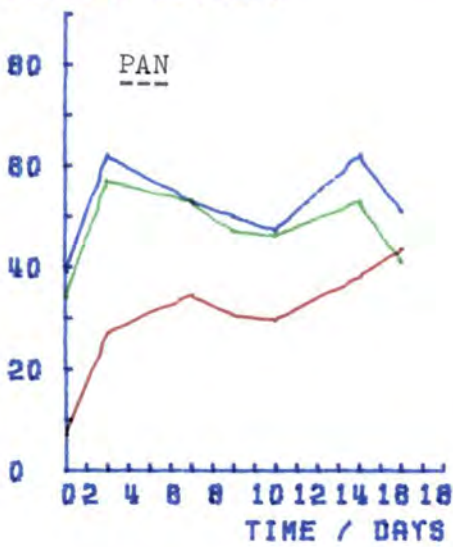

FORCE / NEWTONS

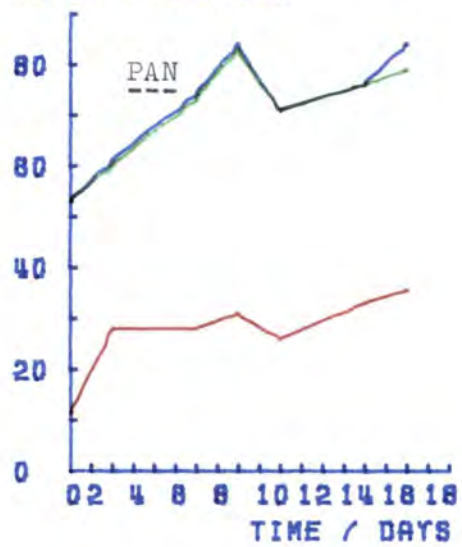

FORCE / NEWTONS

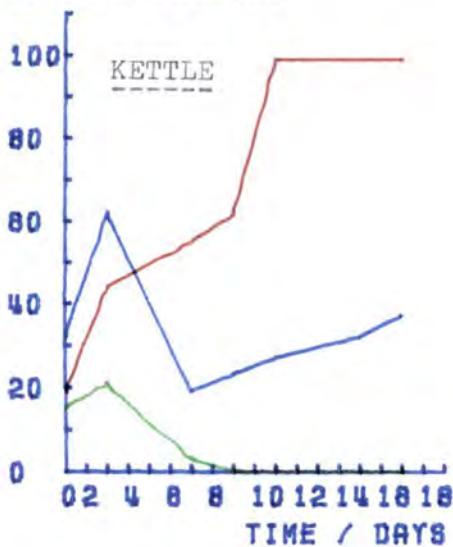

FORCE / NEWTONS

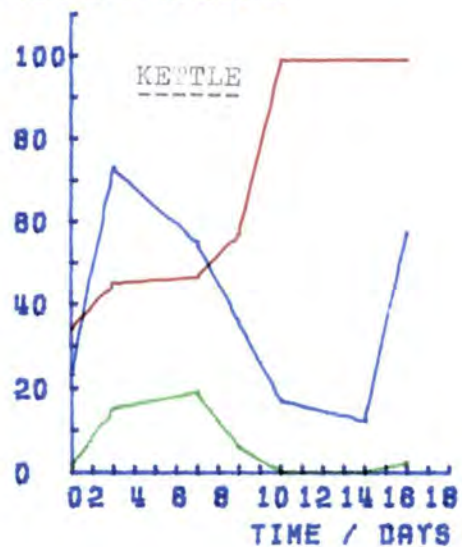

Left Hand

Right Hand

FIGURE 5.105.

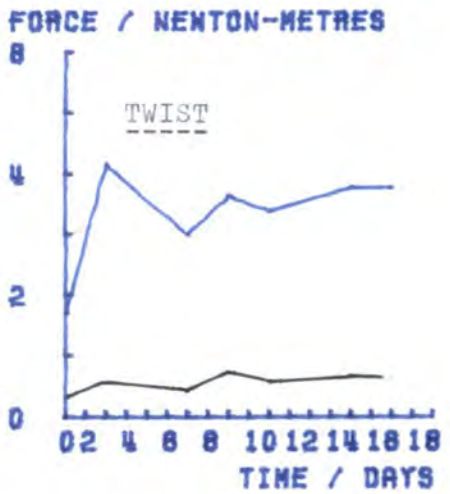
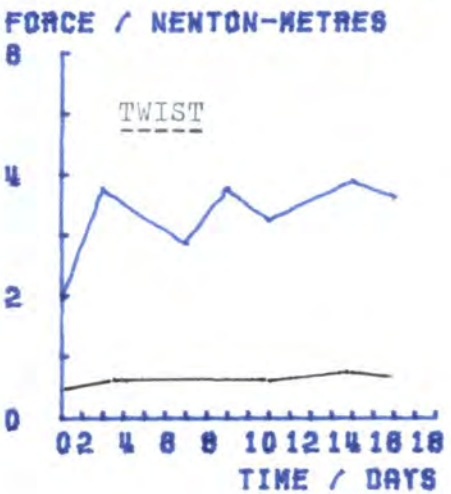
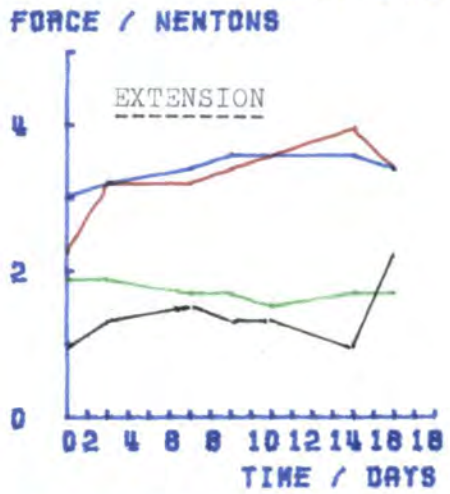
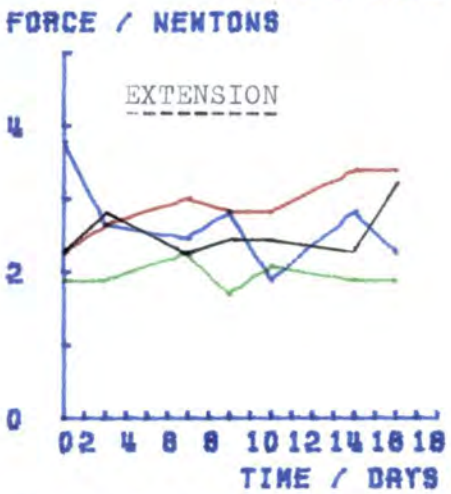
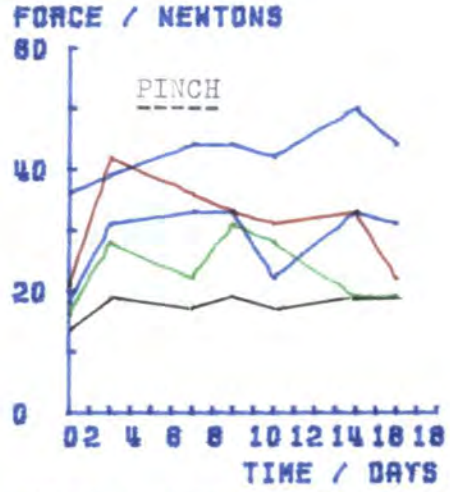
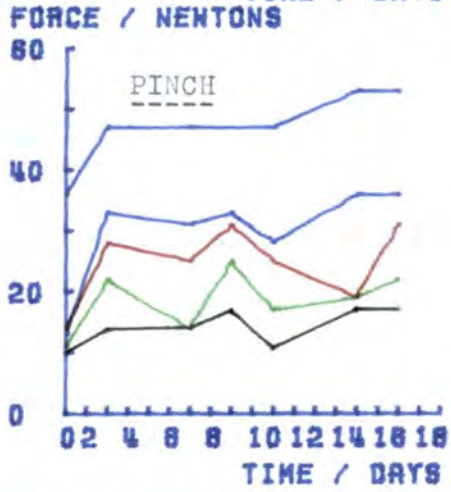
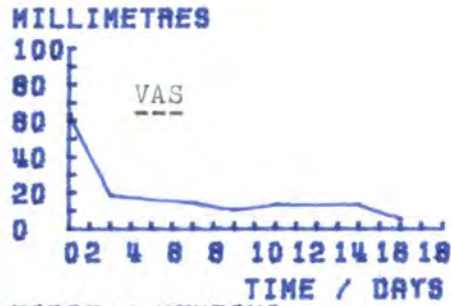

Left Hand

Right Hand

FIGURE 5.105. Follow up results of JS

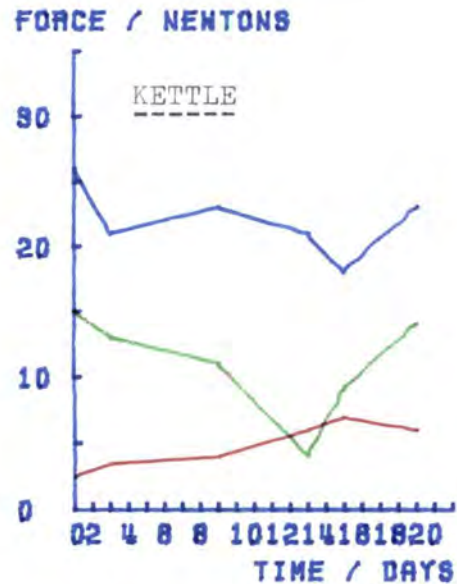
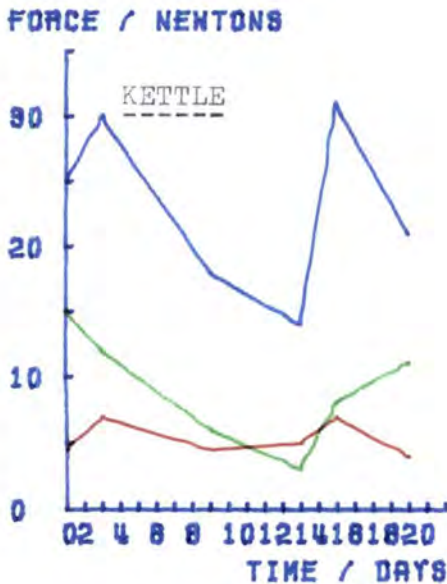
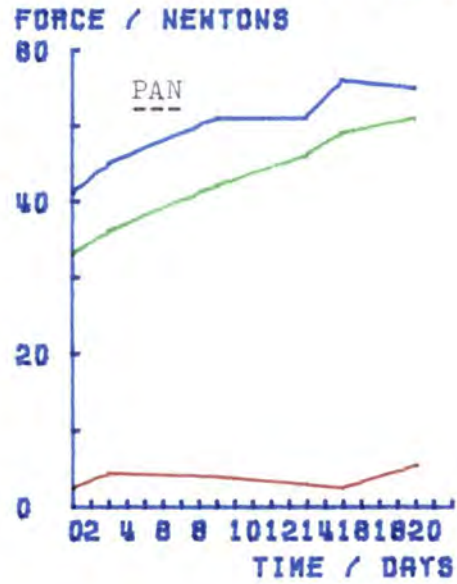
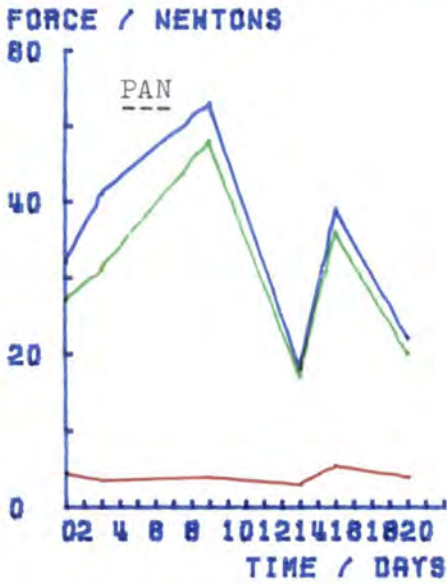
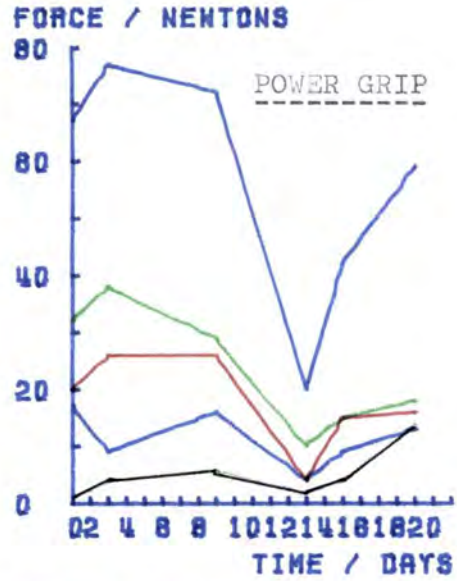
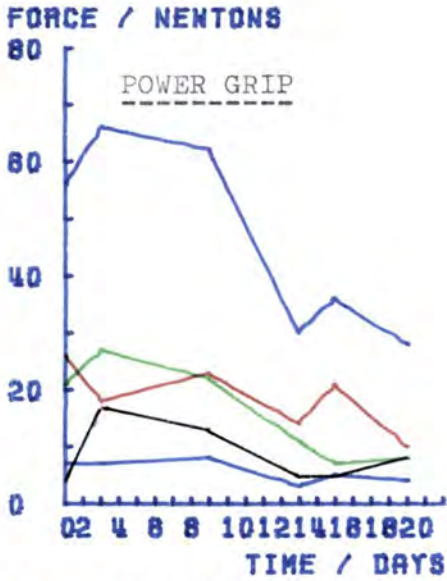

Left Hand

Right Hand

FIGURE 5.106.

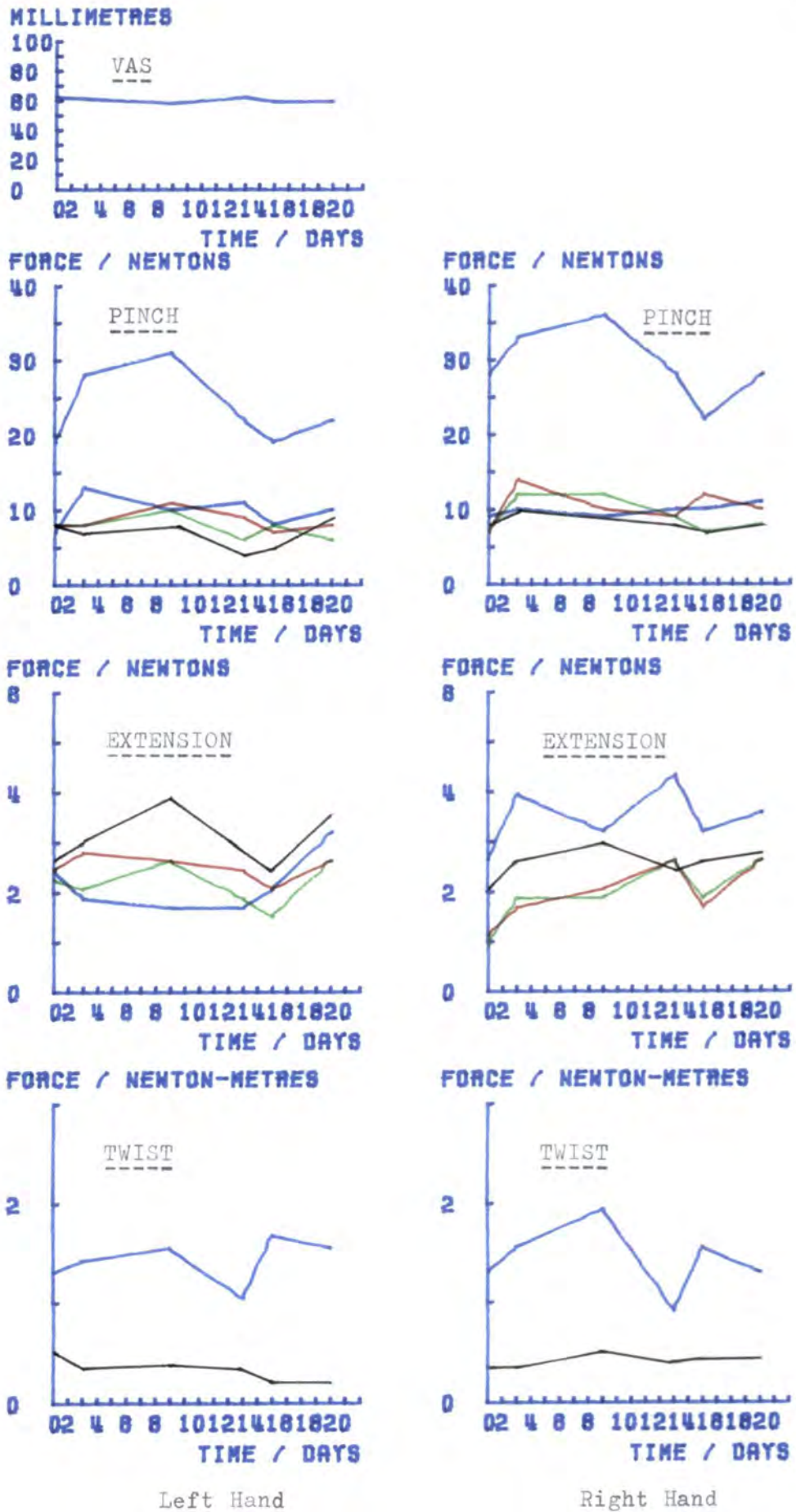
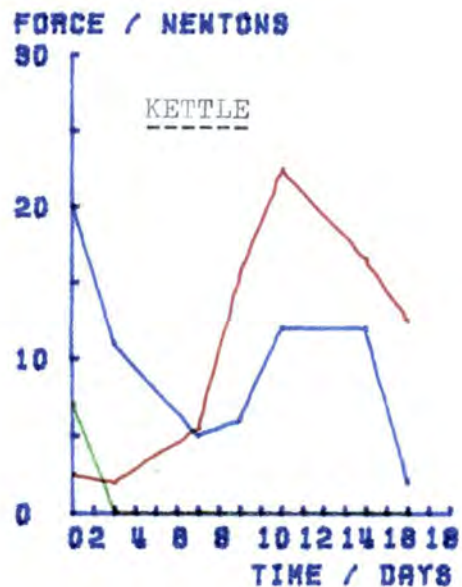
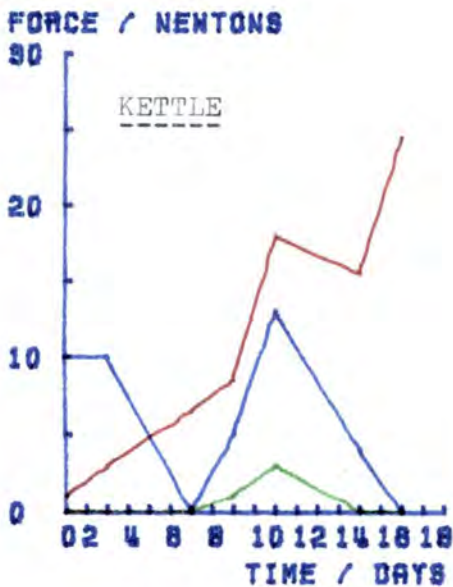
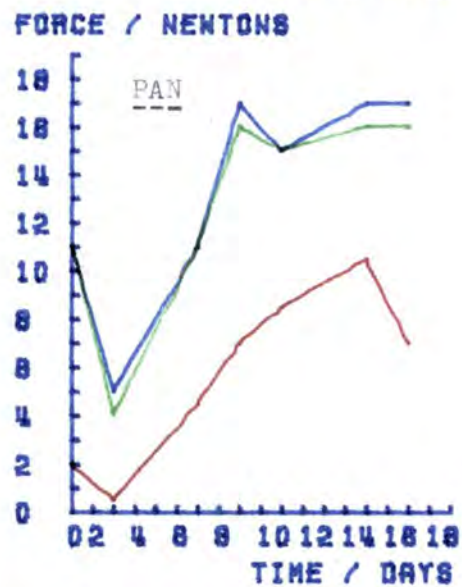
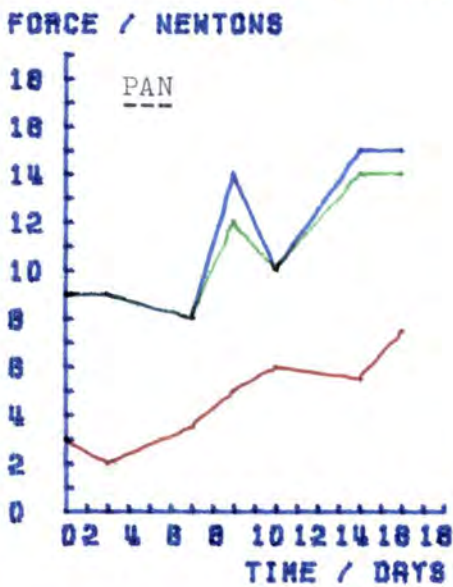
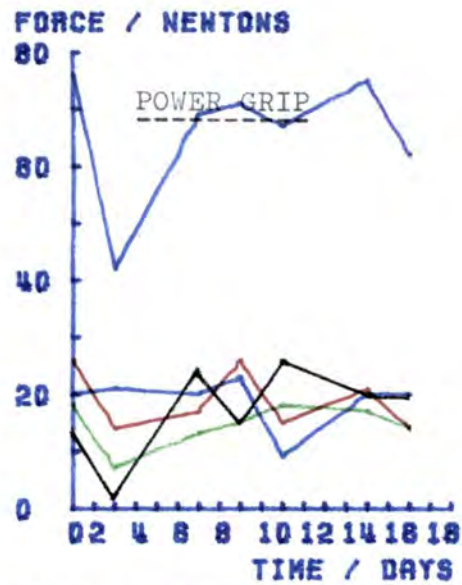
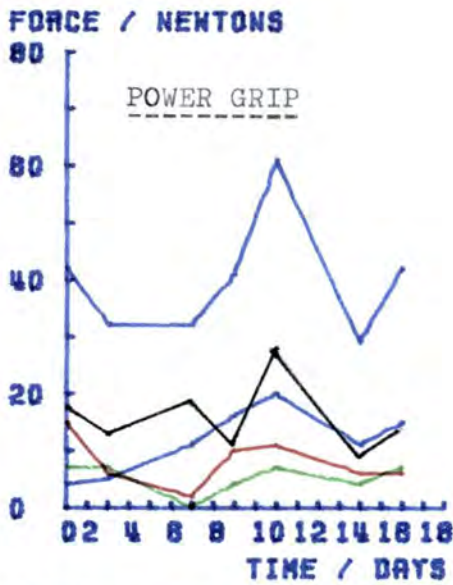

FIGURE 5.106. Follow up results of CWA
(operation on day 10)



Left Hand

Right Hand

FIGURE 5.107.

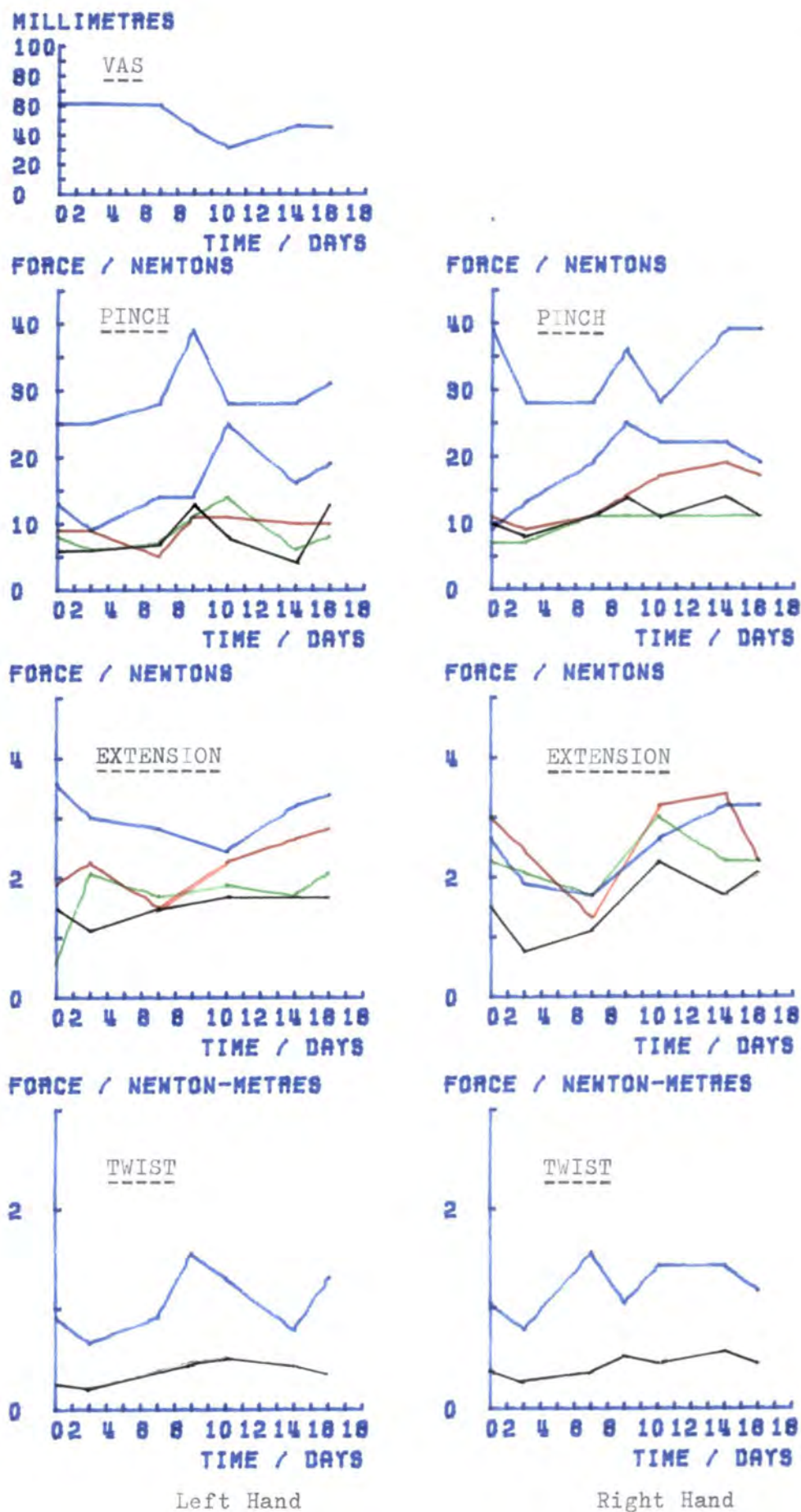
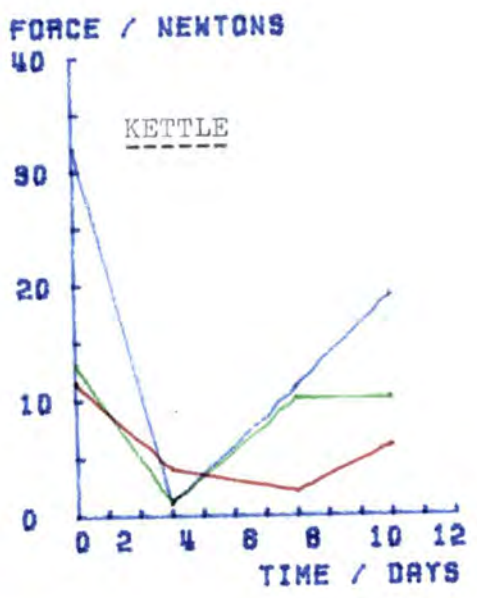
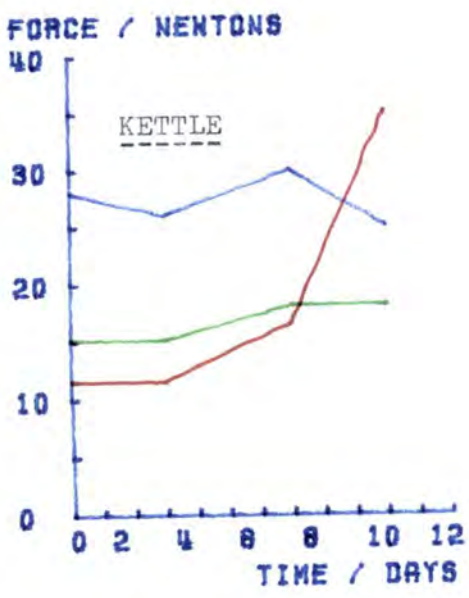
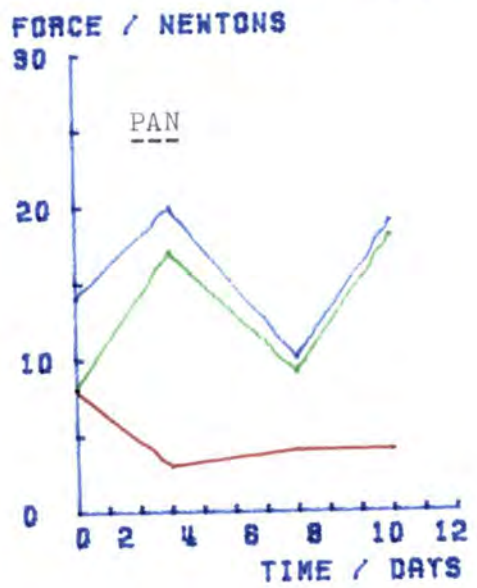
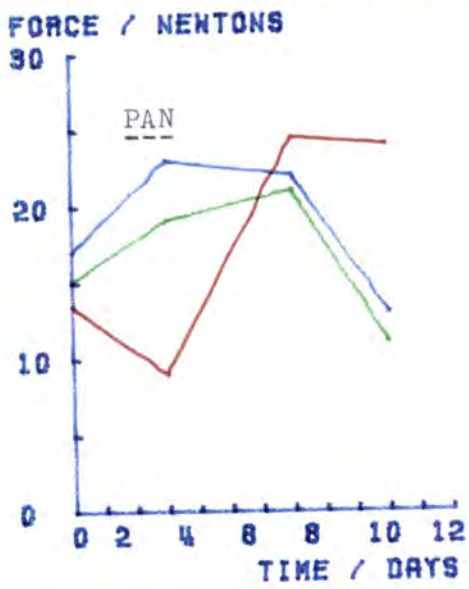
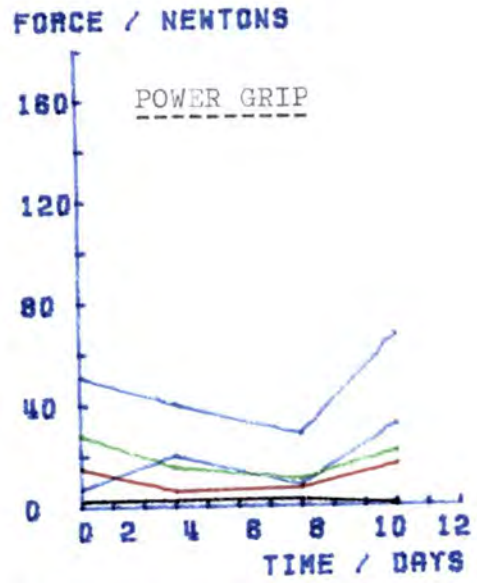

FIGURE 5.107. Follow up results of ENC



Left Hand

Right Hand

FIGURE 5.108.

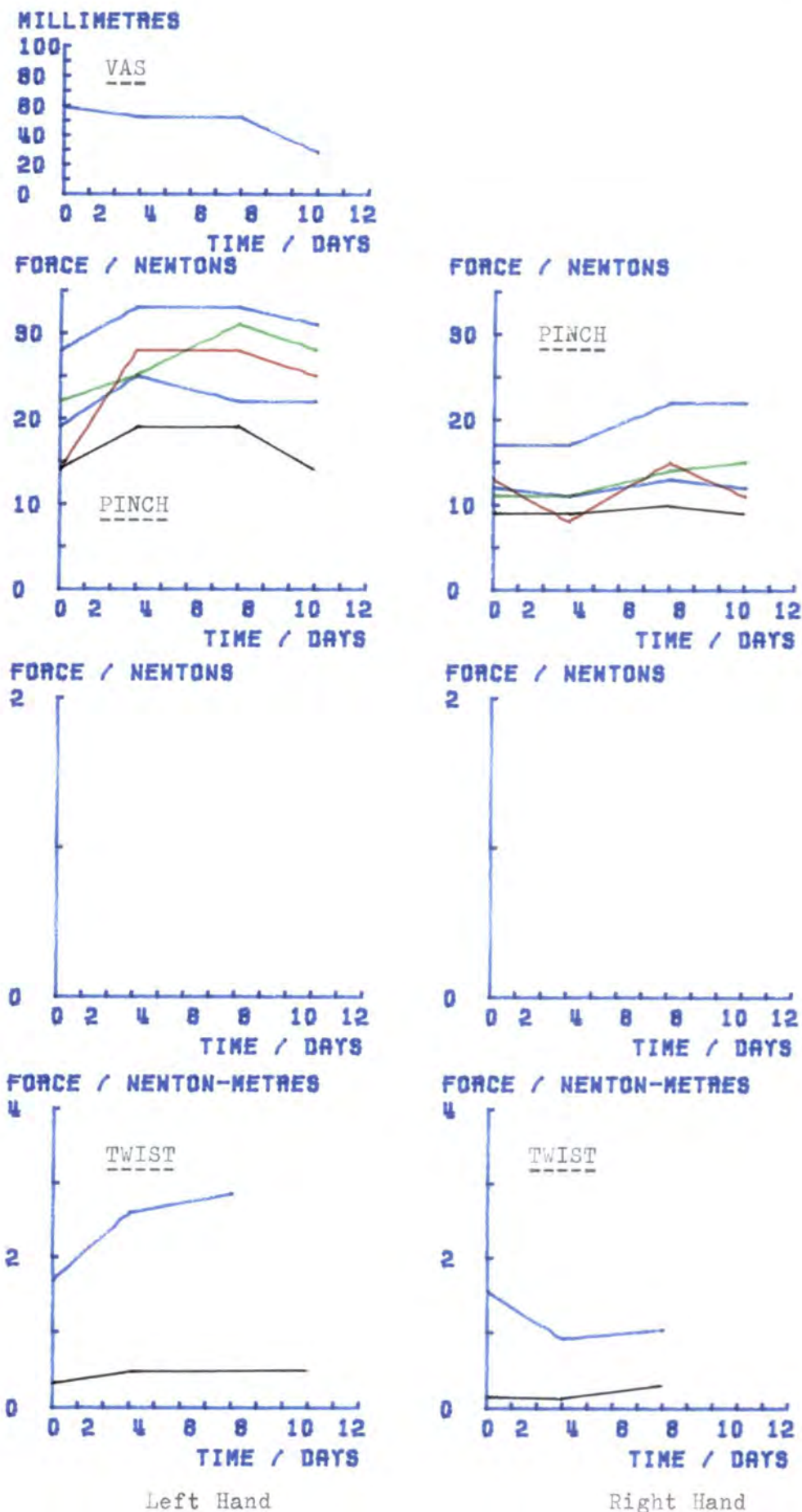

FIGURE 5.108. Follow up results of GM

PATIENT	SEX	HAND	POWER GRIP					PAN				KETTLE			
			In	Mi	Ri	Li	Tot	mg	lo	up	lg	mg	lo	up	lg
JA	F	L	31	40	39	40	150	63	9	8	1	62	22	27	48
		R	74	82	63	24	226	69	14	16	69	43	27	34	25
FB	F	L	28	28	19	25	93	28	7	8	28	15	8	9	5
		R	22	19	25	31	93	24	4	4	19	9	9	10	0
JF	M	L	15	19	8	4	46	46	1	0	-	9	2	1	-
		R	6	30	25	5	68	57	3	3	-	23	27	30	-
FS	M	L	46	39	49	28	143	42	4	6	37	31	3	6	27
		R	44	35	22	10	109	49	0	2	40	49	2	5	49
VS	F	L	46	32	13	40	127	52	24	30	50	44	47	60	4
		R	8	18	0	11	38	43	4	2	42	7	11	11	0
VT	F	L	15	17	13	14	59	23	0	1	16	6	0	0	0
		R	22	13	14	10	57	28	0	0	0	9	0	1	6

. FIGURE 5.109. Initial results of physiotherapy patients with bilateral hand disorders (all units are Newtons)

mg - max grip
lg - max lift grip

PATIENT	SEX	HAND	PULP PINCH				EXTENSION				KEY	TUBE	LAT. PINCH
			In	Mi	Ri	Li	In	Mi	Ri	Li			
JA	F	L	13	11	9	10	-	-	-	-	0.31	1.94	41
		R	26	10	19	7	-	-	-	-	0.48	2.98	53
FB	F	L	13	13	7	7	2.30	3.13	2.51	2.09	0.31	1.04	16
		R	16	16	11	13	2.51	3.95	2.71	2.09	0.35	1.30	29
JF	M	L	11	5	5	4	0.23	1.68	0.23	0	0.70	1.81	10
		R	19	19	11	6	3.75	3.13	1.47	2.92	0.74	2.07	44
FS	M	L	38	38	26	16	3.33	3.13	1.89	3.13	0.91	-	-
		R	32	32	10	4	2.92	3.33	4.16	2.71	0.39	-	-
VS	F	L	19	19	13	0	-	-	-	-	0.57	2.33	44
		R	29	19	16	0	-	-	-	-	0.48	0.65	29
VT	F	L	6	6	6	5	-	-	-	-	-	-	-
		R	10	9	6	7	-	-	-	-	-	-	-

FIGURE 5.109 (continued) : Initial results of physiotherapy patients with bilateral hand disorders. (all units are Newtons except key and tube which are Newton - metres.)

PATIENT	SEX	DOM. HAND	AGE	DISORDER
JA	F	R	50	OA - right and left thumbs
FB	F	R	50	RA - physiotherapy, post hospitalisation
JF	M	L	55	Raynauds disease(hand circulation)
FS	M	R	64	Loss of hand function (Viral Infection)
VS	F	R	69	RA - physiotherapy
VT	F	R	66	RA - right & left carpal tunnel release

FIGURE 5.110. Details of the bilateral hand disorders of patients attending the physiotherapy clinic

OA - Osteoarthritis

RA - Rheumatoid arthritis

PATIENT	SEX	HAND	POWER GRIP					PAN				KETTLE			
			In	Mi	Ri	Li	Tot	mg	lo	up	lg	mg	lo	up	lg
JB	F	L	56	65	48	33	195	55	17	21	51	34	23	32	23
		R	11	6	13	19	47	42	4	5	38	4	7	9	0
DC	F	L	51	43	28	34	154	113	38	52	106	61	51	68	58
		R	23	18	15	14	64	8	4	5	6	8	15	21	0
AKC	M	L	23	66	82	86	247	115	37	58	105	-	-	-	-
		R	79	150	111	57	393	213	46	59	205	-	-	-	-
GC	M	L	32	83	46	44	200	106	15	18	79	52	40	46	33
		R	9	5	0	0	14	15	3	3	15	10	17	18	4
NH	F	L	28	20	33	27	103	28	3	6	28	10	14	14	0
		R	14	12	16	8	50	7	0	2	4	0	9	8	0
BH	F	L	71	62	33	54	204	94	17	23	94	41	33	38	23
		R	26	51	16	14	106	37	3	9	30	4	5	6	0
NH	M	L	95	123	122	63	371	119	34	50	101	-	-	-	-
		R	14	16	37	25	110	15	11	13	15	0	26	25	0
AGM	F	L	30	46	33	45	153	88	17	19	78	33	15	10	33
		R	12	11	4	11	38	0	0	0	0	2	7	5	1

FIGURE 5.111a Initial results of physiotherapy patients with unilateral hand disorders (all units are in Newtons)
mg-max grip; lg-max lift grip

PATIENT	SEX	HAND	POWER GRIP					PAN				KETTLE			
			In	Mi	Ri	Li	Tot	mg	lo	up	lg	mg	lo	up	lg
PM	F	L	74	96	55	68	288	79	13	15	79	101	16	19	100
		R	20	22	22	33	92	63	6	7	56	29	9	9	27
LM	M	L	105	135	96	63	398	170	55	68	169	-	-	-	-
		R	92	85	52	9	233	196	54	60	196	-	-	-	-
DM	F	L	30	27	10	22	88	52	0	2	52	45	0	7	39
		R	19	12	8	11	45	14	0	0	-	5	0	0	-
JR	F	L	18	25	17	24	79	22	2	4	17	35	15	17	15
		R	8	9	5	11	30	14	0	1	8	1	4	3	0
AGR	M	L	60	35	40	41	177	-	-	-	-	-	-	-	-
		R	105	121	90	101	413	-	-	-	-	-	-	-	-
AES	F	L	3	1	1	4	6	22	0	1	22	8	2	2	3
		R	24	43	39	42	142	40	6	6	35	78	4	6	69
LW	F	L	34	59	31	30	151	45	4	5	41	34	8	10	30
		R	34	22	6	9	68	47	1	2	40	32	7	8	19

FIGURE 5.111a(continued) Initial results of physiotherapy patients with unilateral hand disorders (all units are in Newtons)
mg-max grip; lg-max lift grip

PATIENT	SEX	HAND	PULP PINCH				EXTENSION				KEY	TUBE	LAT. PINCH
			In	Mi	Ri	Li	In	Mi	Ri	Li			
JB	F	L	29	32	19	10	-	-	-	-	0.48	-	-
		R	4	7	11	14	-	-	-	-	0.13	-	-
DC	F	L	53	44	47	39	-	-	-	-	0.87	-	-
		R	19	14	14	8	-	-	-	-	0.44	-	-
AKC	M	L	13	23	19	16	6.23	4.99	6.02	5.40	0.39	-	-
		R	35	26	16	7	7.88	7.26	8.50	3.33	1.30	-	-
GC	M	L	33	39	22	22	-	-	-	-	0.74	1.68	47
		R	25	14	0	0	-	-	-	-	0.61	0.91	36
NH	F	L	19	26	16	10	-	-	-	-	0.61	1.94	-
		R	7	7	2	0	-	-	-	-	0.13	1.17	-
BH	F	L	50	16	4	4	1.27	5.19	5.40	3.95	1.17	3.24	-
		R	16	4	0	0	0.65	0.23	0	0	0.26	0.26	-
NH	M	L	44	38	26	19	-	-	-	-	1.17	-	-
		R	9	7	8	5	-	-	-	-	0.17	-	-
AGM	M	L	29	26	4	7	-	-	-	-	0.92	2.85	-
		R	3	3	3	1	-	-	-	-	0.31	0.52	-

FIGURE 5.111b Initial results of physiotherapy patients with unilateral hand disorders. (all units are Newtons except key and tube which are Newton-metres)

PATIENT	SEX	HAND	PULP PINCH				EXTENSION				KEY	TUBE	LAT. PINCH
			In	Mi	Ri	Li	In	Mi	Ri	Li			
PM	F	L	26	23	10	10	2.92	3.54	2.09	2.09	0.91	4.79	62
		R	12	9	8	5	3.33	4.16	3.33	3.33	0.48	1.81	41
LM	M	L	58	31	25	22	-	-	-	-	-	4.02	-
		R	61	53	33	6	-	-	-	-	-	2.85	-
DM	F	L	19	19	7	7	-	-	-	-	0.57	-	-
		R	10	4	4	7	-	-	-	-	0.22	-	-
JR	F	L	16	13	10	7	1.06	2.30	1.27	1.89	0.31	1.55	23
		R	12	9	11	7	0	0	0.65	0	0.26	1.17	16
AGR	M	L	41	41	23	29	4.57	0	0	2.09	-	-	-
		R	71	89	77	50	6.02	6.43	5.61	2.71	-	-	-
AES	F	L	4	7	8	5	-	-	-	-	-	0.65	-
		R	26	32	13	7	-	-	-	-	0.92	3.50	-
LW	F	L	25	19	8	11	1.69	2.45	1.51	1.51	0.39	2.20	42
		R	22	11	6	6	1.51	1.32	1.13	1.51	0.31	1.42	42

FIGURE 5.111b(continued) Initial results of physiotherapy patients with unilateral hand disorders (all units are Newtons except key and tube which are Newton-metres)

PATIENT	SEX	DOM. HAND	AGE	DISORDER
JB	F	R	23	RH-tendon & nerve palmar repair
DC	F	R	58	RH- wrist broken, nerve block; RA
AKC	M	L	20	LH-distal phalanx, index, chipped
GC	M	R	42	RH- amputation of ring & middle
NH	F	R	63	RH- elbow synovectomy & extensor tendon repair; RA
BH	F	R	50	RH- median nerve release RH & LH- carpal tunnel release
NH	M	R	22	RH- palmar dog bite, tendon repair
AGM	F	R	59	RH- septic pin site from broken bone on ulnar side palm
PM	F	R	51	RH- wrist broken & tendon graft index to thumb
LM	M	R	46	RH- Dupuytren's contracture, little
DM	F	R	72	RH- carpal tunnel release; RA
JR	F	R	48	RH- MCP joint implants & synovectomies; RA
AGR	M	L	23	LH- septic palm
AES	F	R	46	LH- infection index
LW	F	R	68	RH- Dupuytren's contracture; OA

FIGURE 5.112. Details of the unilateral hand disorders of patients attending the physiotherapy clinic

RA- Rheumatoid Arthritis
OA- Osteoarthritis

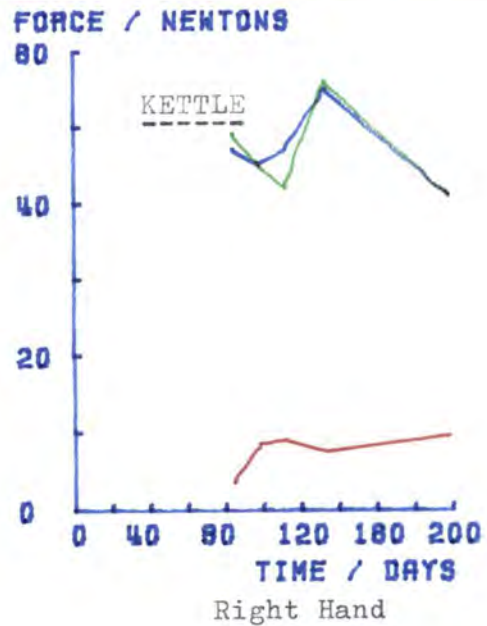
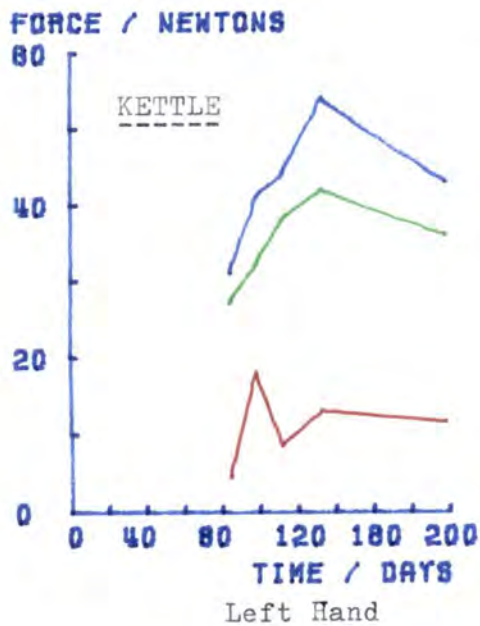
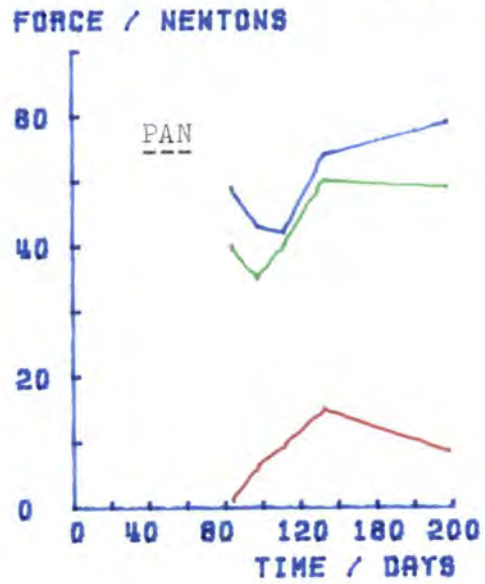
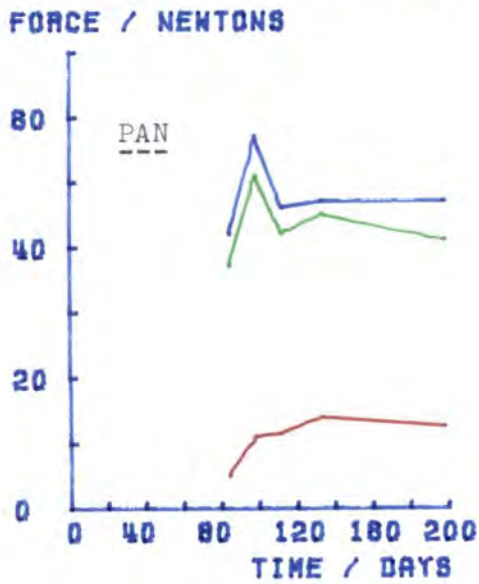
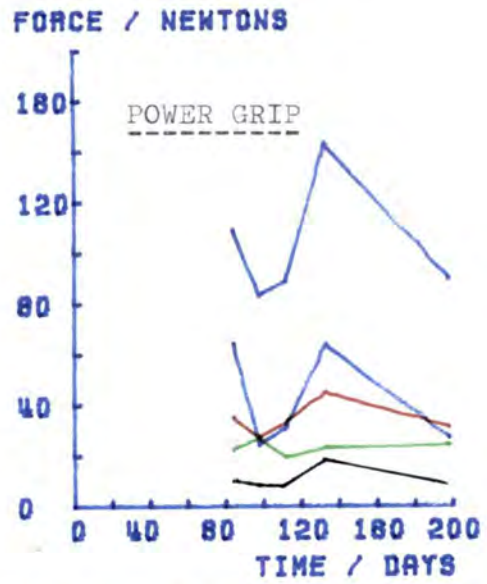
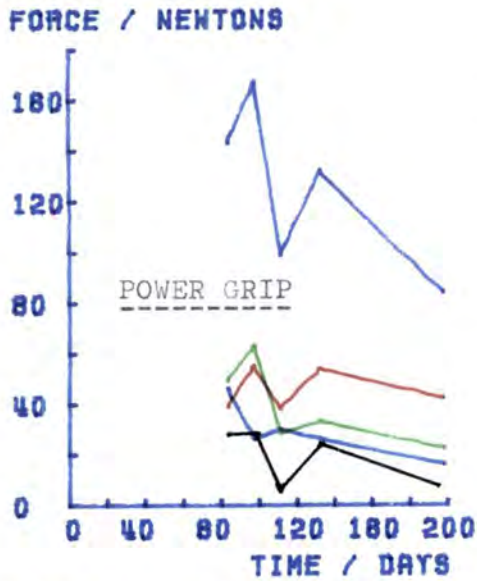
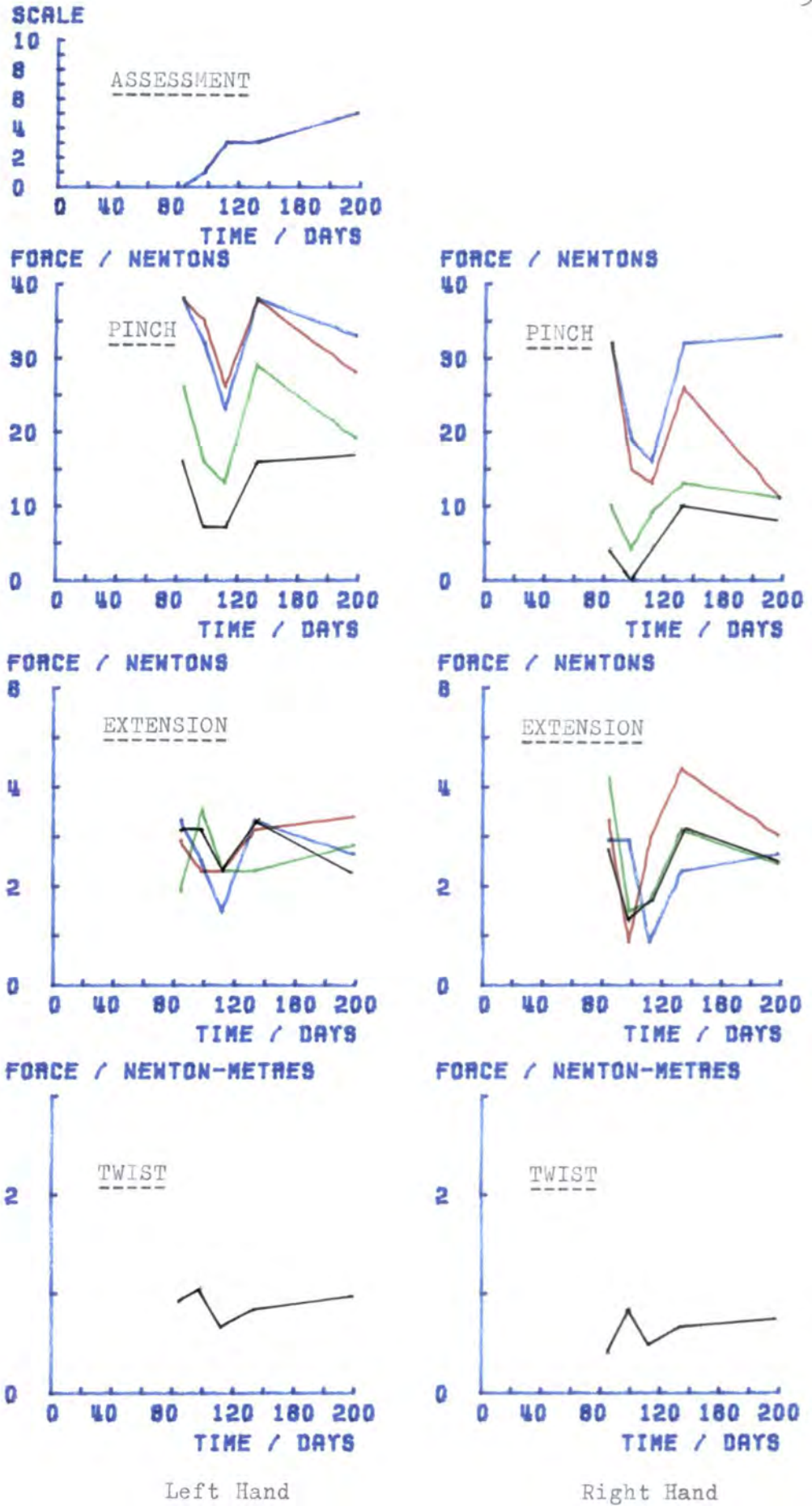

FIGURE 5.113.



Left Hand

Right Hand

FIGURE 5.113. Follow up results of FS

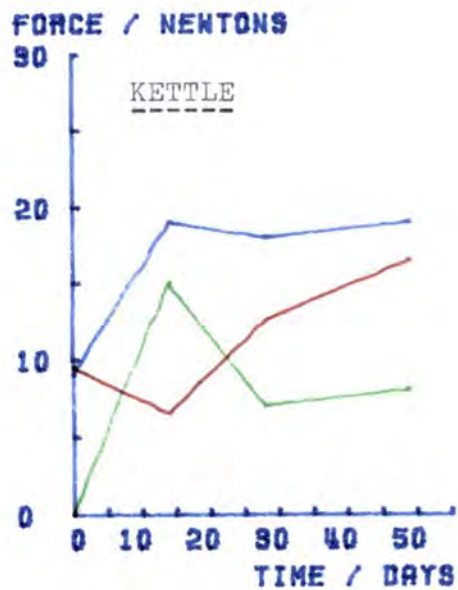
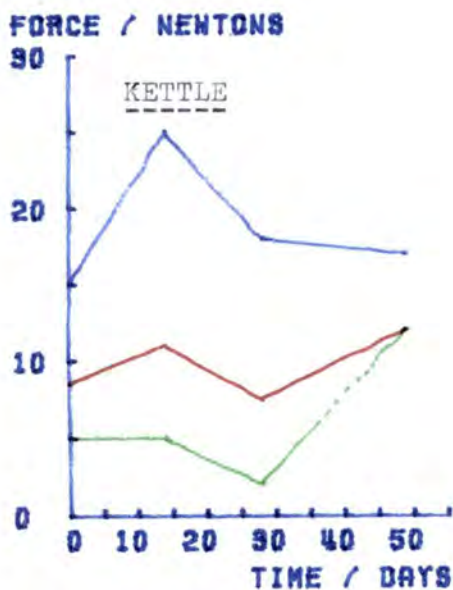
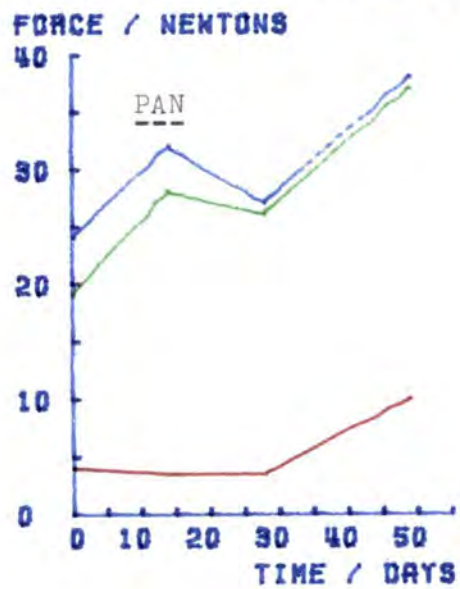
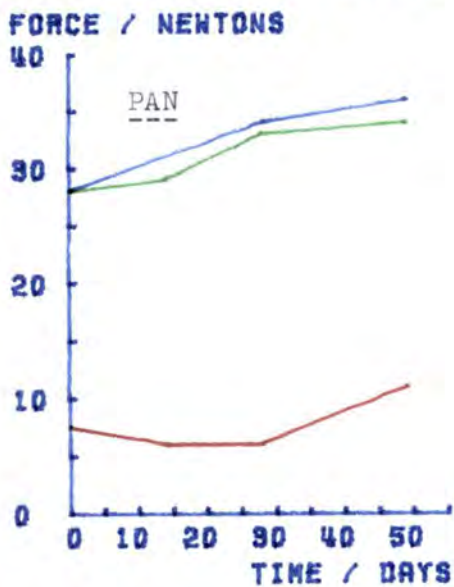
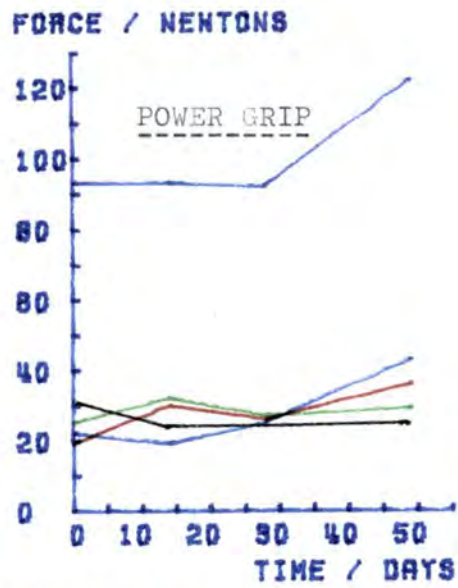
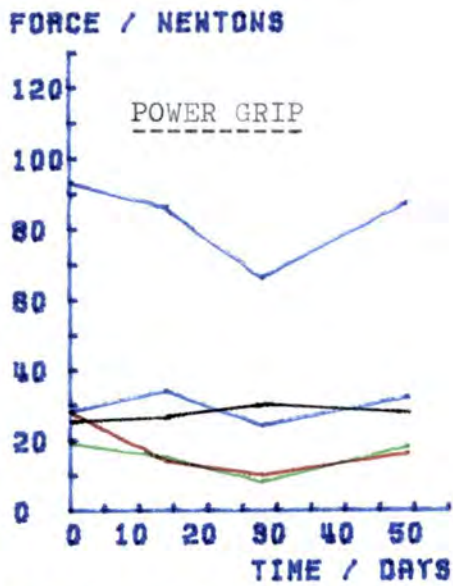

Left Hand

Right Hand

FIGURE 5.114.

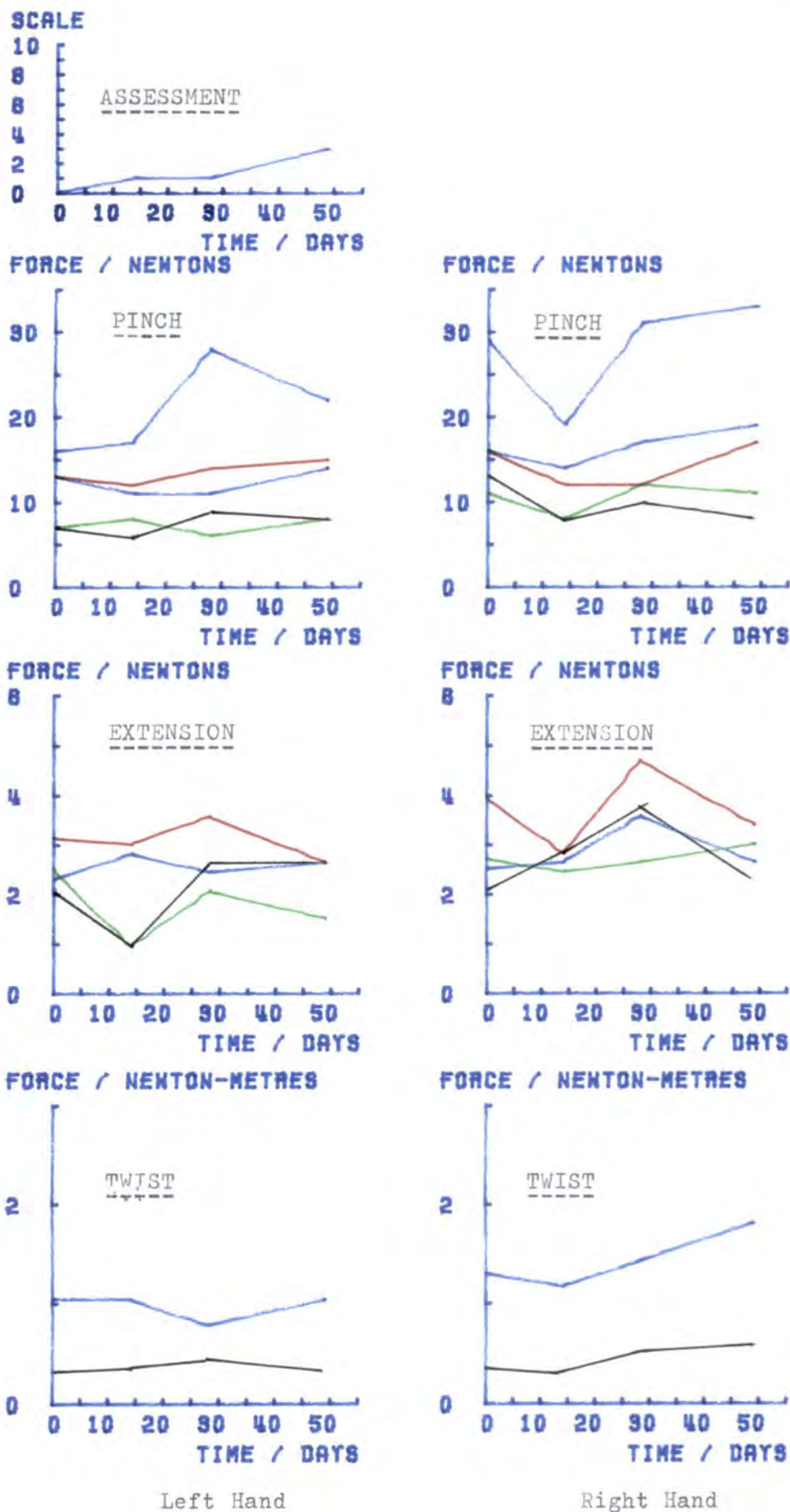

Left Hand

Right Hand

FIGURE 5.114. Follow up results of FB

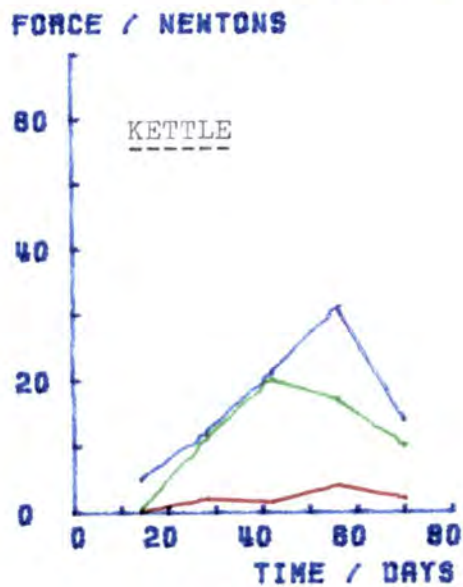
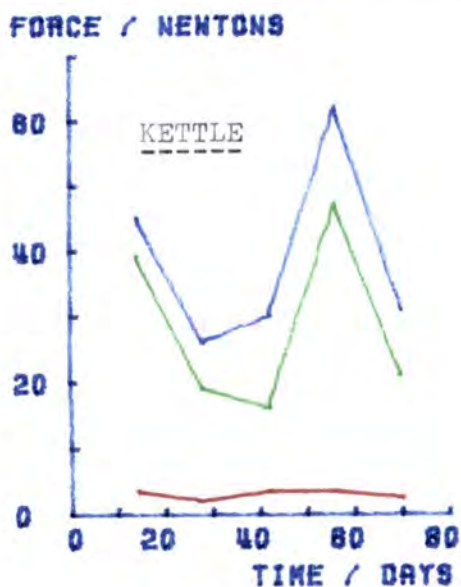
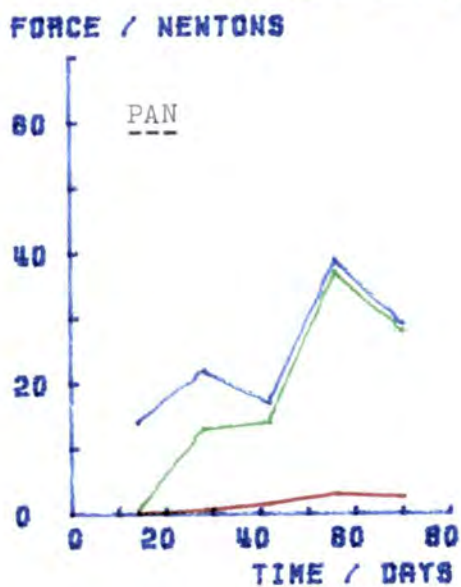
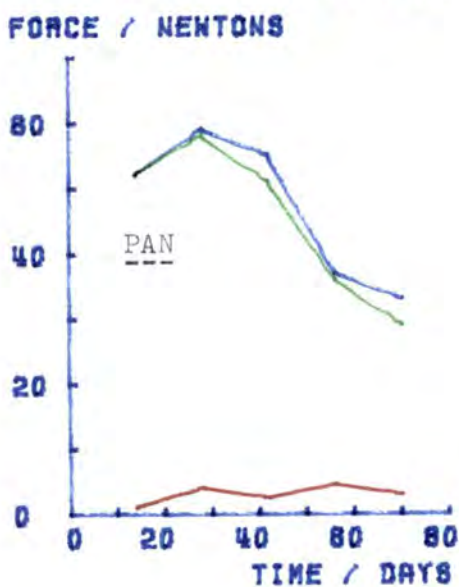
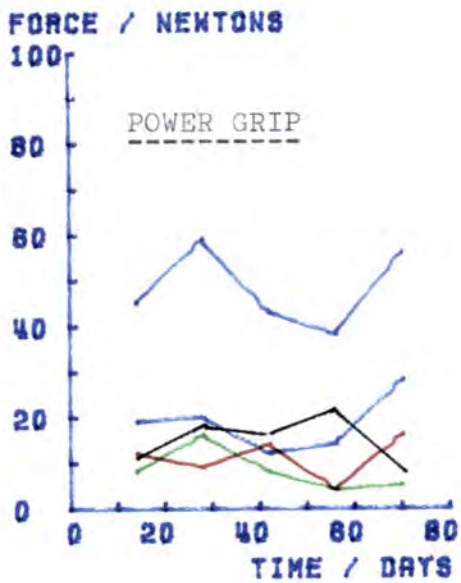
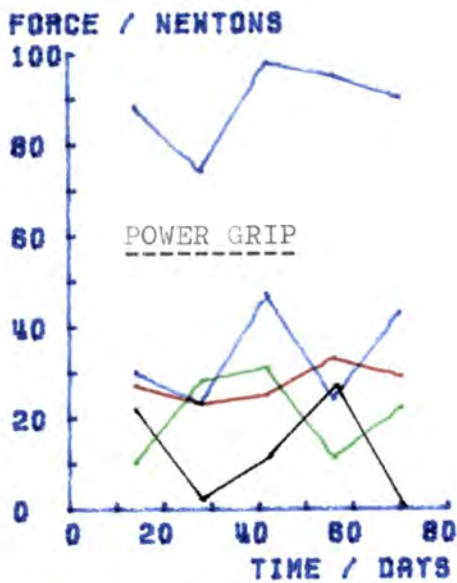

Left Hand

Right Hand

FIGURE 5.115.

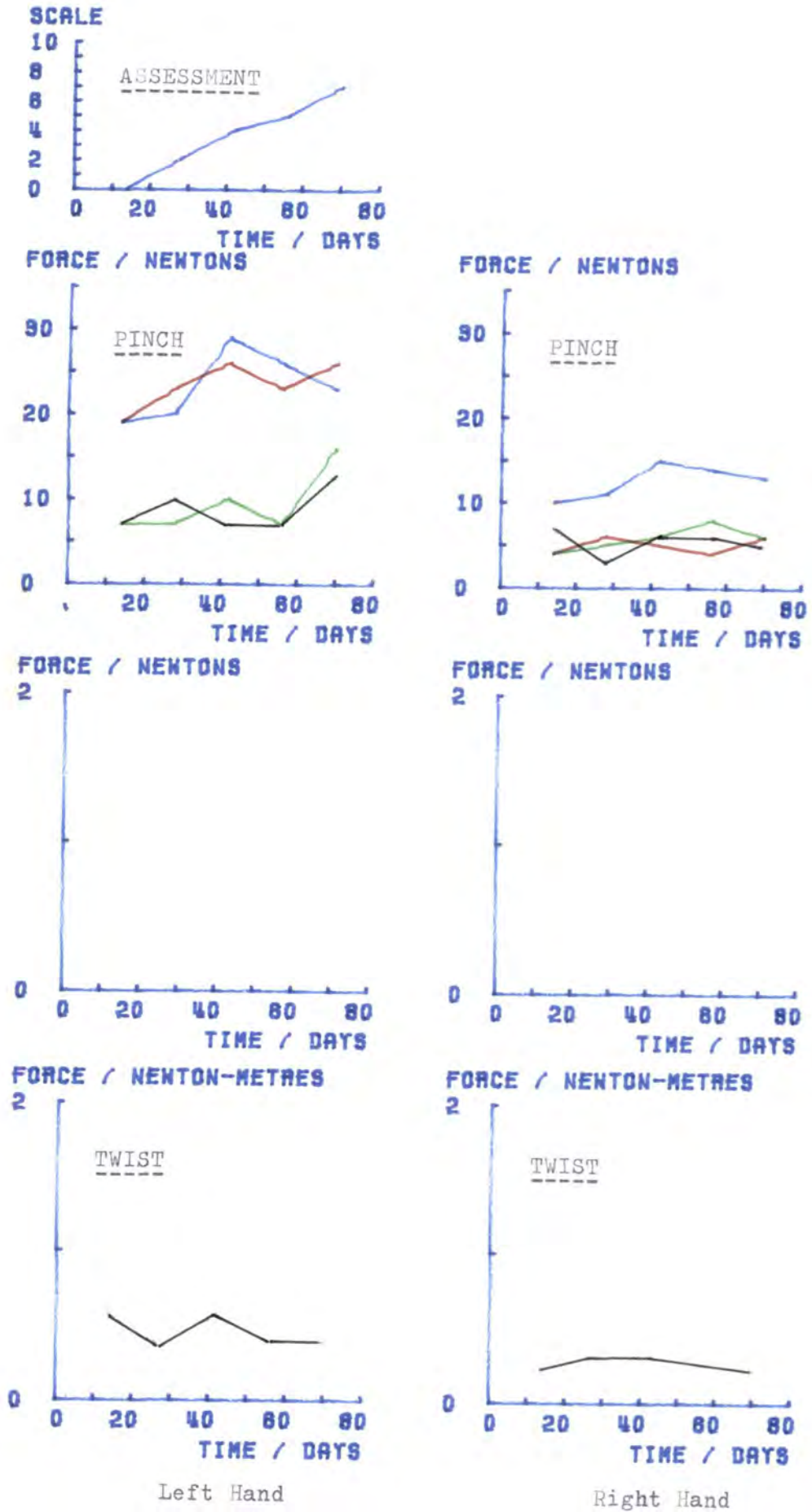

Left Hand

Right Hand

FIGURE 5.115. Follow up results of DM

FORCE / NEWTONS

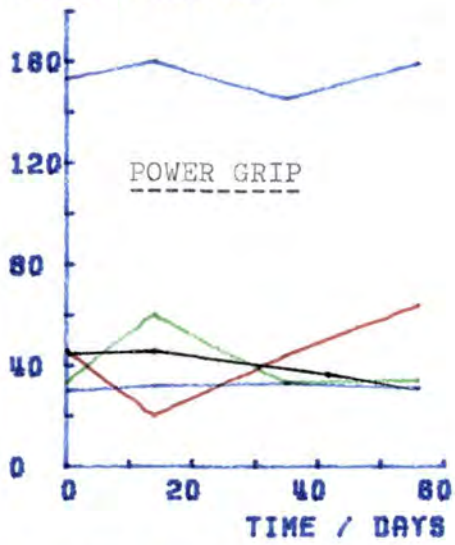

FORCE / NEWTONS

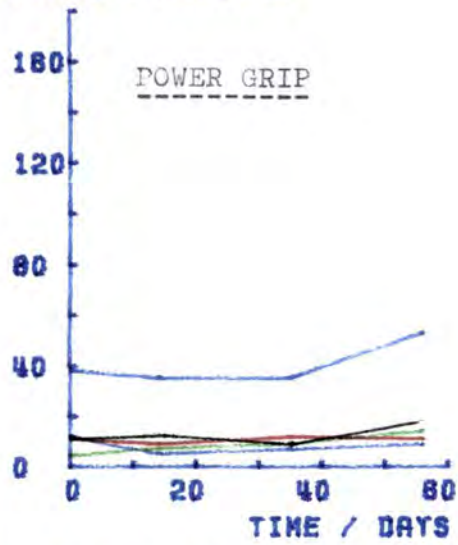

FORCE / NEWTONS

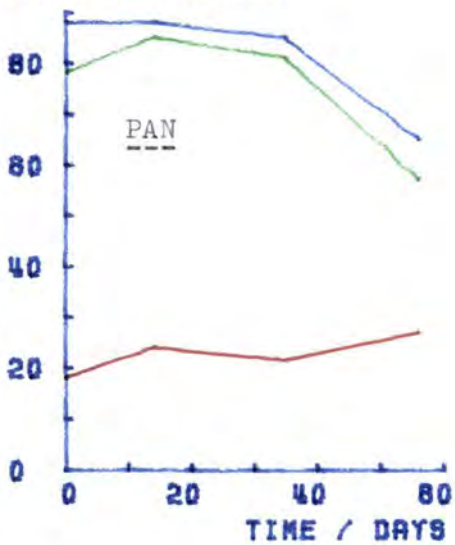

FORCE / NEWTONS

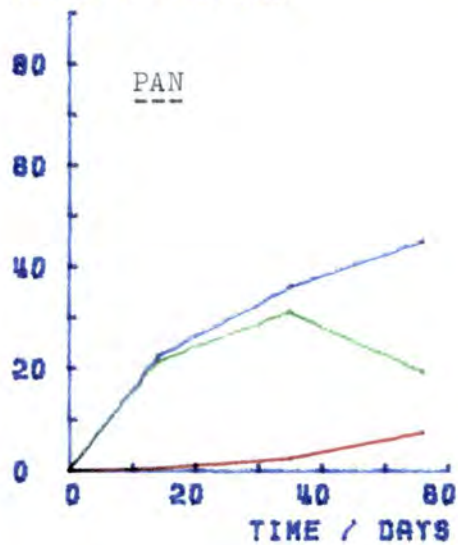

FORCE / NEWTONS

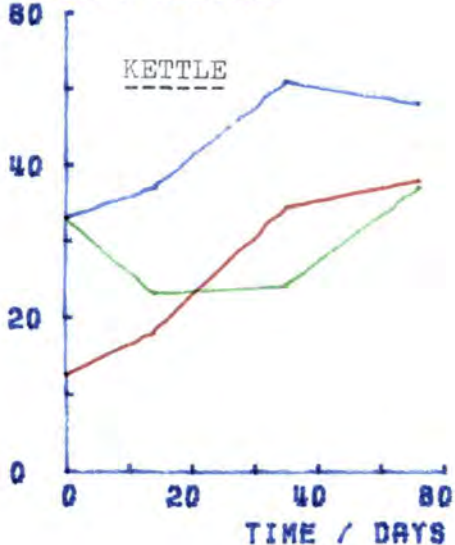

FORCE / NEWTONS

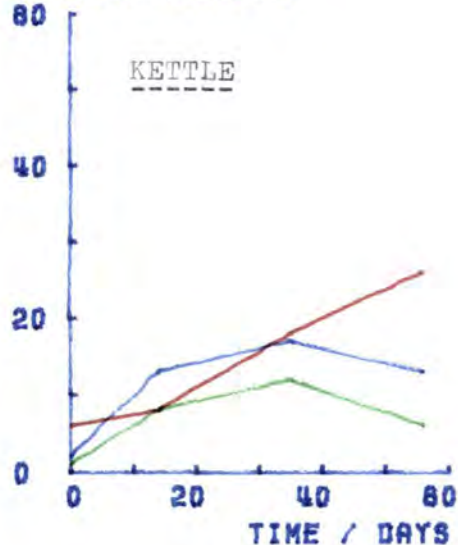

Left Hand

Right Hand

FIGURE 5.116

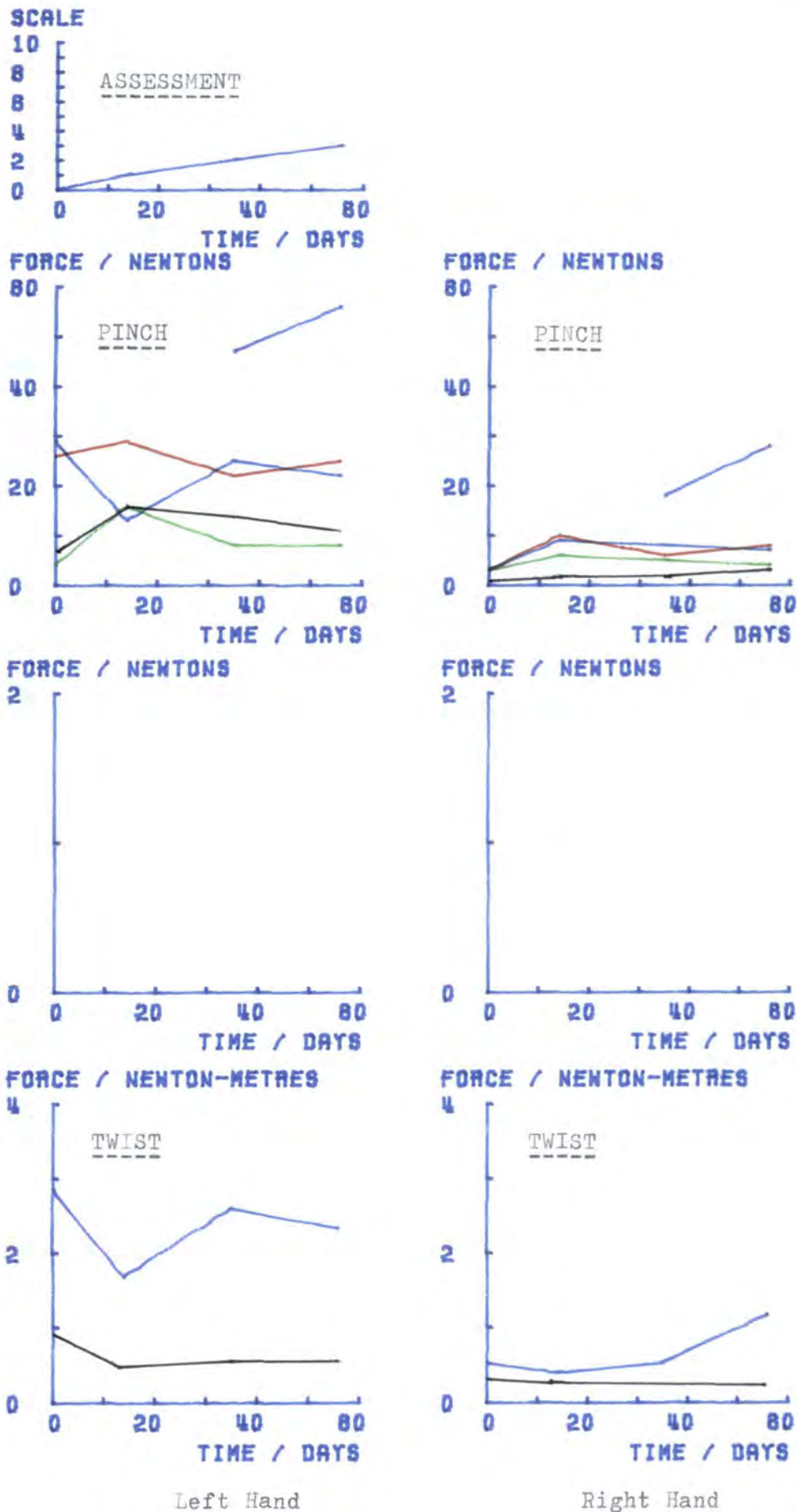
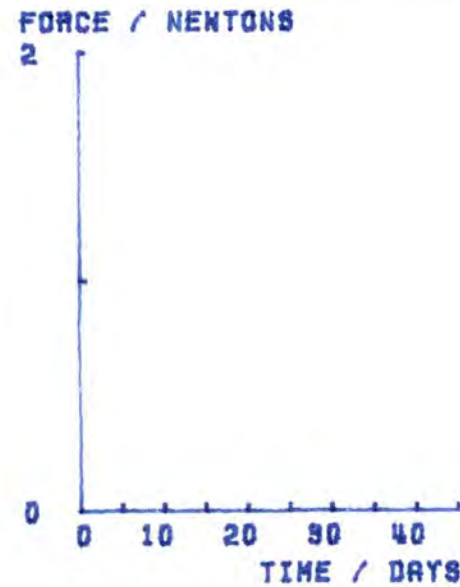
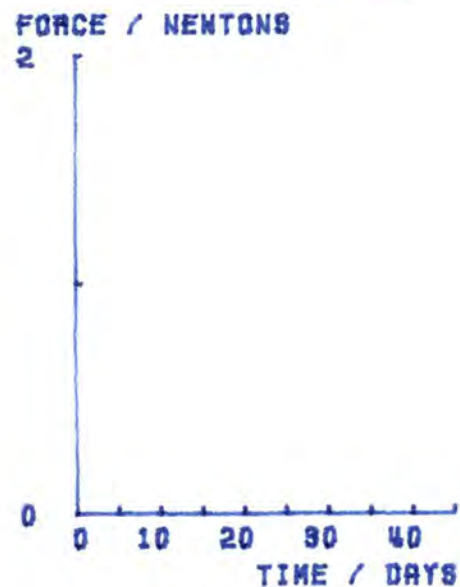
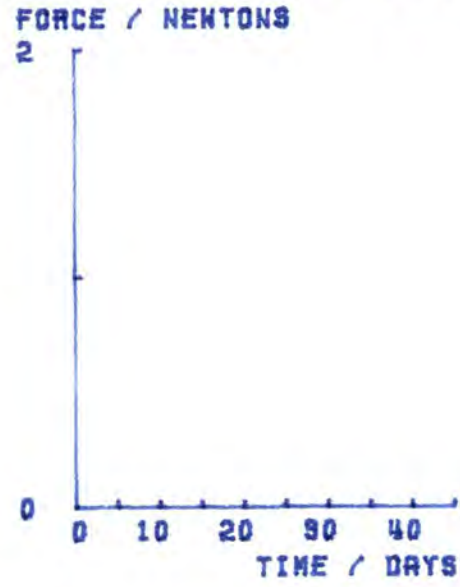
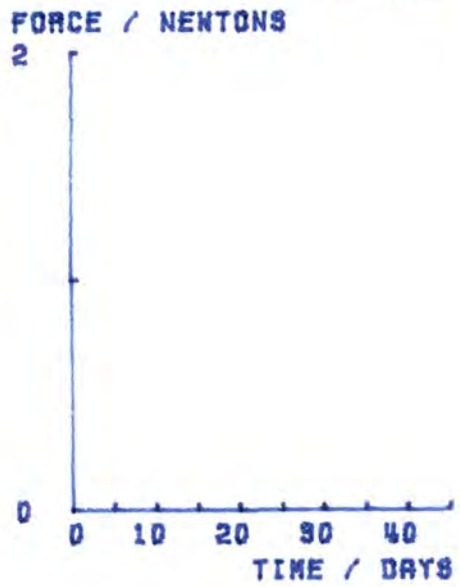
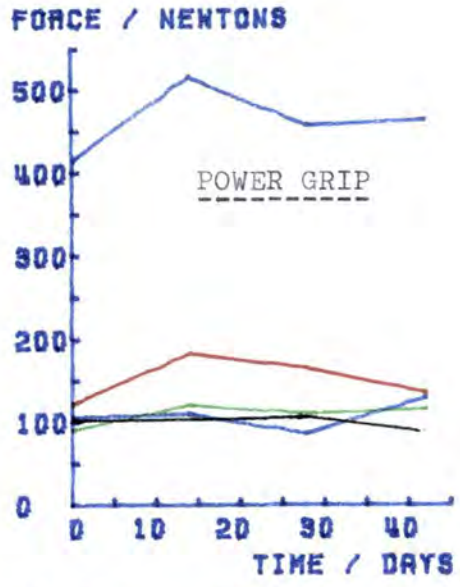
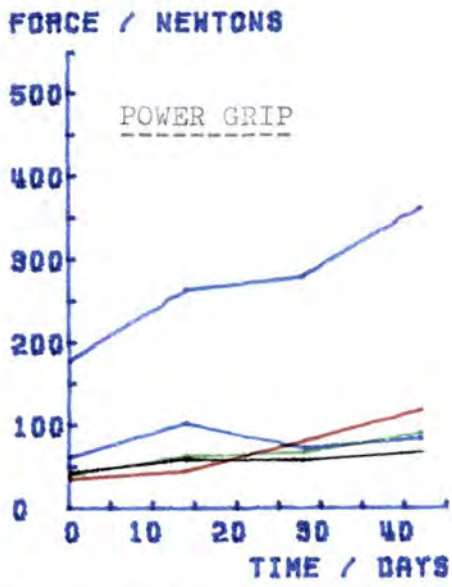

FIGURE 5.116. Follow up results of AGM



Left Hand

Right Hand

FIGURE 5.117.

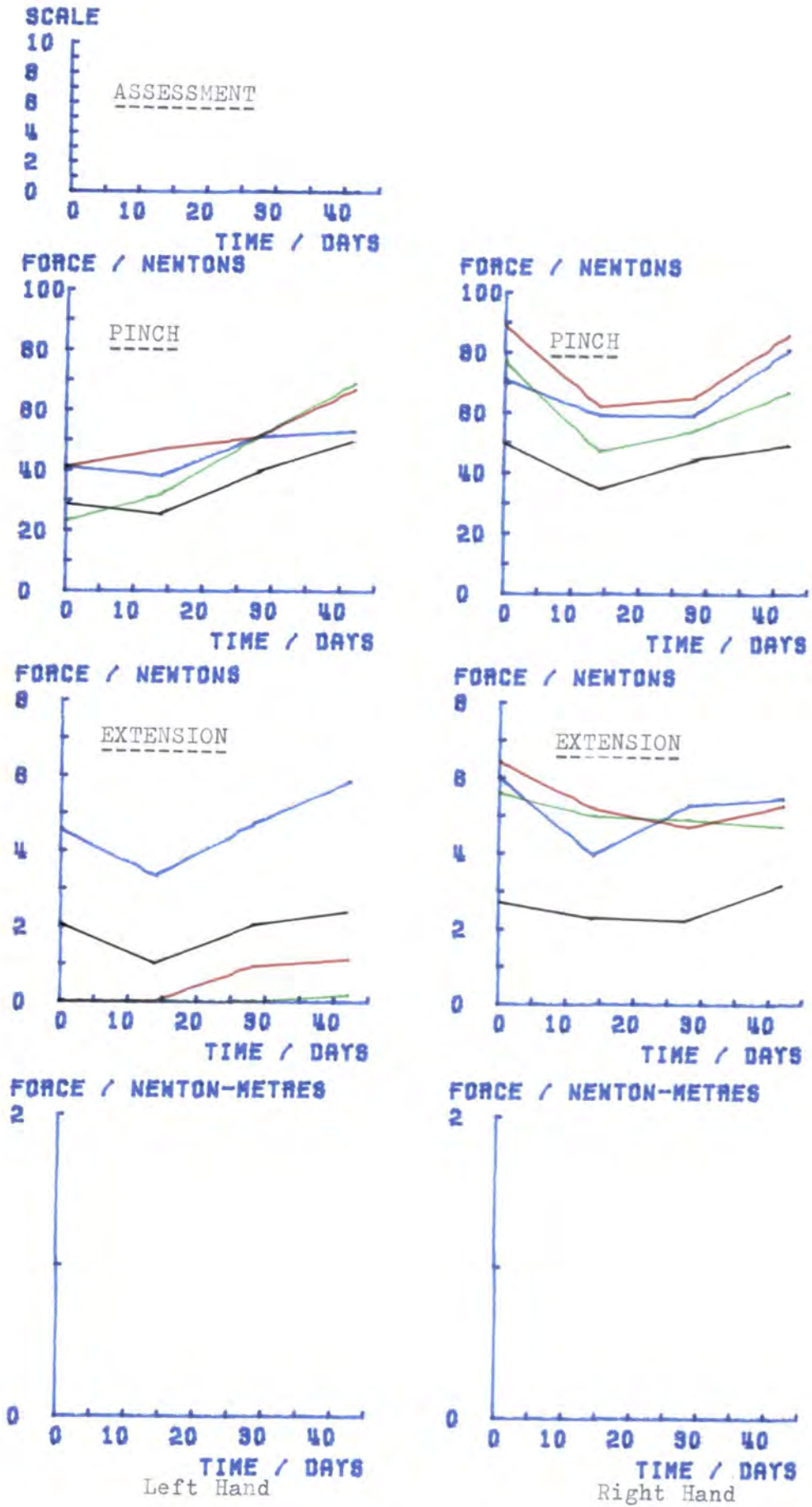
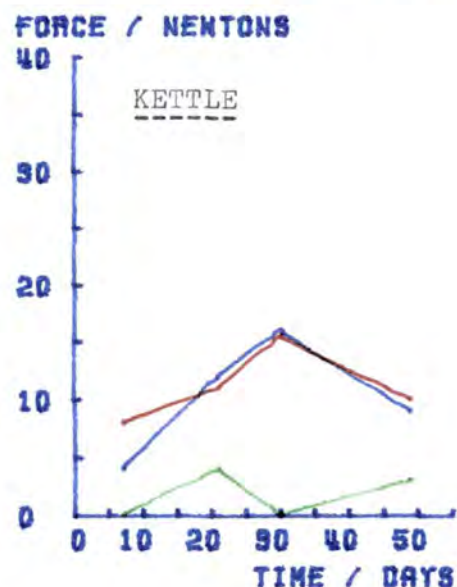
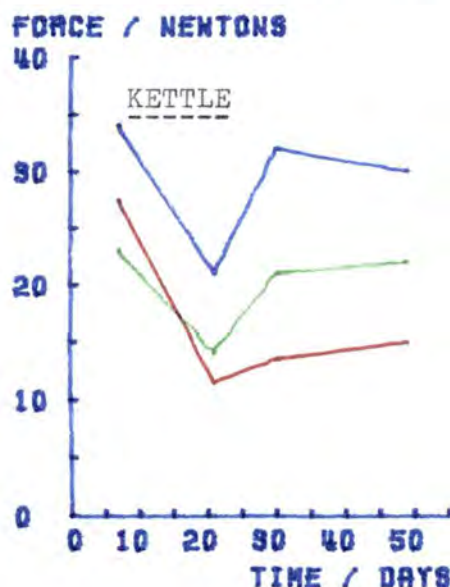
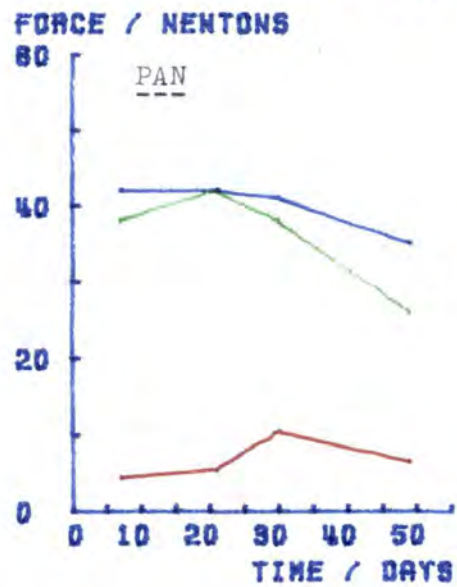
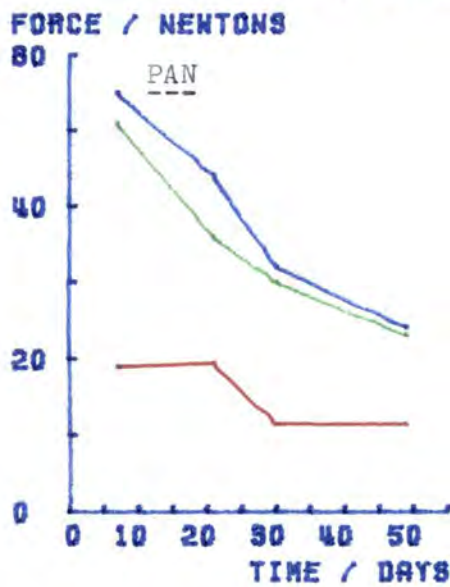
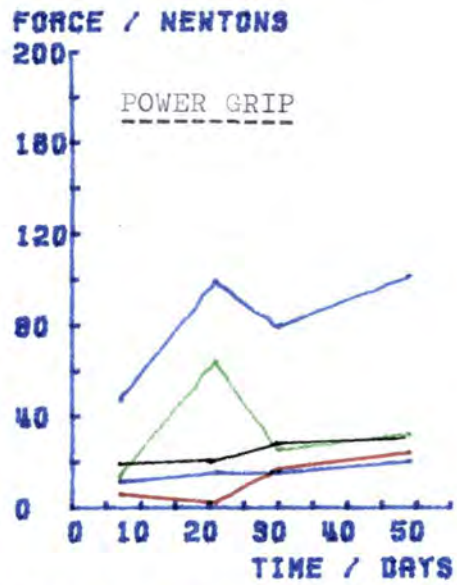
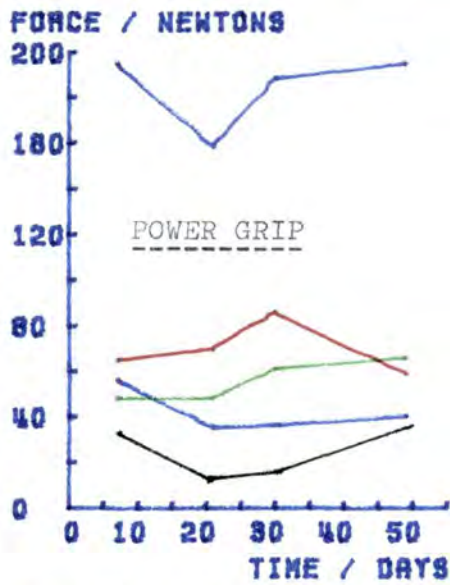

FIGURE 5.117. Follow up results of AGR



Left Hand

Right Hand

FIGURE 5.118.

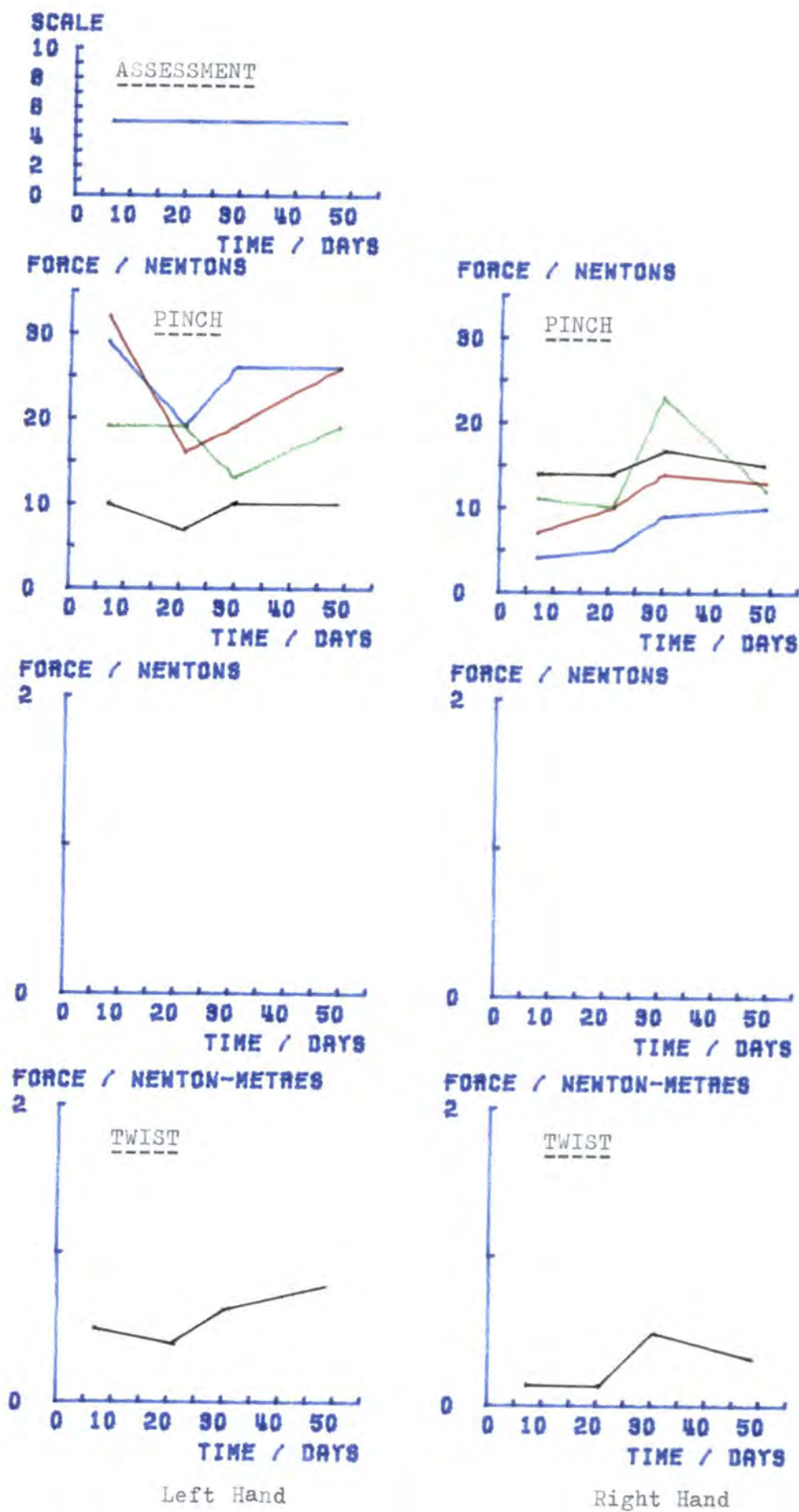

Left Hand

Right Hand

FIGURE 5.418. Follow up results of JB

CHAPTER 6

DISCUSSION

DISCUSSION

6.1. Calibration

Calibration of the device transducers revealed a reasonably accurate system. The accuracy of the transducers was in the range of -0.7% to 4.0% with a precision of better than $\pm 4.4\%$.

Minor inaccuracies in the system will be introduced by the strain gauges, electronic circuitry and primarily the analogue to digital conversion. In the electronic circuitry, losses may be caused by any of the circuit elements, for example the switching relays. However, these will probably be quite small, the non-linearity of the strain gauge amplifier is quoted at better than 0.1% of the full range. The analogue conversion has an inherent inaccuracy since it is not strictly linear, but step wise. Each step being 40 mV or 0.4% of the full scale amplifier output.

However, the most significant inaccuracy would be due to the calibration factor. The value inserted in the software is the mean result of several calibration tests and is, therefore, only an estimate of the true value. We can calculate limits, around the mean, between which we have a 95% confidence of finding the true mean. As indicated in Table 5.1. these limits are within $\pm 5.4\%$ of the mean calibration factor.

6.2. Handling Experience With The System

Over a period of several months, during subject measurement and with the system located in the hospital, no major breakdowns were encountered and no major design revisions were found necessary. The only revisions were of a continuous software development as operating experience grew and areas for improvement were identified.

The collection of power grip, pan and kettle device data was an early improvement. Initially, the data collection time was fixed at four seconds, but as soon as patient measurement was started, this was quickly recognised as inadequate. Patients with arthritis tend to be slower in accomplishing tasks than their healthy counterparts. The data collection was therefore changed from a fixed time, controlled by the software, to a variable time controlled by the operator.

The results output was also changed to reduce the length of the measurement session. Initially, the maximum results and the force-time curves were printed out during the session. This was time consuming and by eliminating the curve printing and compacting the format down to the minimum number of lines, the session length was reduced by about one third (down to approximately thirty minutes). As all the results were always stored on floppy disc, the full set of results and force-time curves could easily be printed out later when more time was available.

Operator interaction with the computer was reduced to a minimum by removing all unnecessary keyboard operations. Where convenient, single key responses were included and any unnecessary responses excluded.

Patient reaction to the system was good. No patient showed any apprehension on being introduced to it. Generally, a lot of interest was shown, especially at being 'connected to' a computer and then seeing the almost immediate display of their results.

The devices were found to be comfortable with no adverse reactions. Some discomfort was noted on some device measurements, which appeared to be caused by the awkwardness of the task or the feeling of a small amount of pain. This pain was a by-product of

both the maximum effort exertion required for the test and the disease progress, rather than being a direct cause of the measuring device.

The individual finger tasks, pulp pinch and extensor lift, were found to be the most awkward tests to perform, for both healthy subjects and patients. In pulp pinch the thumb to index finger pinch was satisfactory, but it became increasingly difficult as the effort was transferred to the middle, ring and little fingers. The main problem was in maintaining single finger measurement. With the middle, ring and little fingers there was an increasing tendency for either/or both of the adjacent fingers to interfere, by closing down on to the finger being measured or onto the pinch platen. If an individual finger condition could not be accomplished the operator had to restrain gently the offending fingers. The most probable explanation for this interference is that anatomically, when flexed, the fingers simultaneously adduct because of the direction in which the flexor tendons pull and the anatomical configuration of the MCP joint.

During pulp pinch measurement, it was observed in both healthy subjects and patients that the distal interphalangeal joint would sometimes shift position from flexion to extension. This again was more obvious with the middle, ring and little fingers. It could indicate a lack of joint stability under maximum effort with the joint exhibiting a dynamic change into a more stable configuration.

During extensor force measurement it was necessary to restrain gently the thumb and the fingers not being measured. This was not only to restrain their involuntary extension, but also to reduce the tendency of subjects to extend the fingers by pivoting or rotating the palm on the heel of the hand.

Involuntary extension of the fingers is due to the intertendinous connections in the dorsum of the hand, between the four extensor tendons. The index and little fingers are easier to extend because they each have an extra independent tendon.

A fundamental problem with the extensor force measurement that became evident was caused by the use of the flat pronated hand. This not only allowed the subject to pivot or rotate about the heel of the hand, but also limited the range of possible extension. In the healthy hand this would only be between five and thirty degrees and less in a diseased hand. An improved arrangement would be to arrange the MCP joints at 90° of flexion and measure the extension force as the fingers are extended from this position.

This might also make it easier to accommodate patients with ulnar deviated hands. In the current set up, this was not easy to do and in one case impossible (patient JW - Rheumatology ward).

Overall, the finger measurements have an associated awkwardness due to the anatomical construction and functioning of the hand. This ensures that the fingers are interdependent, working together in a common action. Only the index finger, because of its independent muscular network, can have independent control.

With the pan and kettle devices, it was not possible to obtain the right combination of lifting force measurement transducers and restraining springs. This was because of the wide range in lifting abilities obtained. Whereas patients with arthritis, being very weak, only needed a weak restraining spring, healthy subjects required a much stronger spring to reduce the movement available. With too great a movement the lift could not be defined as a true pan or kettle lift. During patient measurement, the twin-rate spring was generally acceptable, except in a couple of situations where the

kettle lift exceeded the transducer maximum of 100N. The transducers were rated at this value to ensure adequate sensitivity when measuring patients. However, this arrangement was unsatisfactory when measuring healthy subjects. For the pan it was only necessary to install stronger restraining springs to limit the lift movement. For the kettle, however, it was necessary to install higher rated transducers as well.

The aim of using restraining springs was to give movement to the device so that it was a close representation of the real thing. For patients the arrangement was satisfactory. However, for healthy subjects very high lifting forces were encountered especially in the kettle lift (up to approximately 300N). Ideally, all persons tested should lift the device the same amount. To fulfil this condition would require a feedback system that increased the resistance to motion in proportion to the lifting force. This would lead to an unnecessarily complicated hydraulic system. A simpler improved arrangement would utilise a damp pot (Figure 6.1.). For weak patients, the damping would be small since very little lift would be involved. For strong patients and subjects the damping resistance would easily be overcome and the damp pot would reach the limit of its movement. The lift would then be acting on a rigid system with pivots at either end to accommodate all lifting angles.

6.3. Initial Results

Both the results from healthy subjects and patients show clearly the wide range of forces that the system can accurately measure. These results confirm the high variation that is obtained patient to patient and subject to subject, making it difficult to consider any set of results as a norm. Therefore, any comparisons that are used

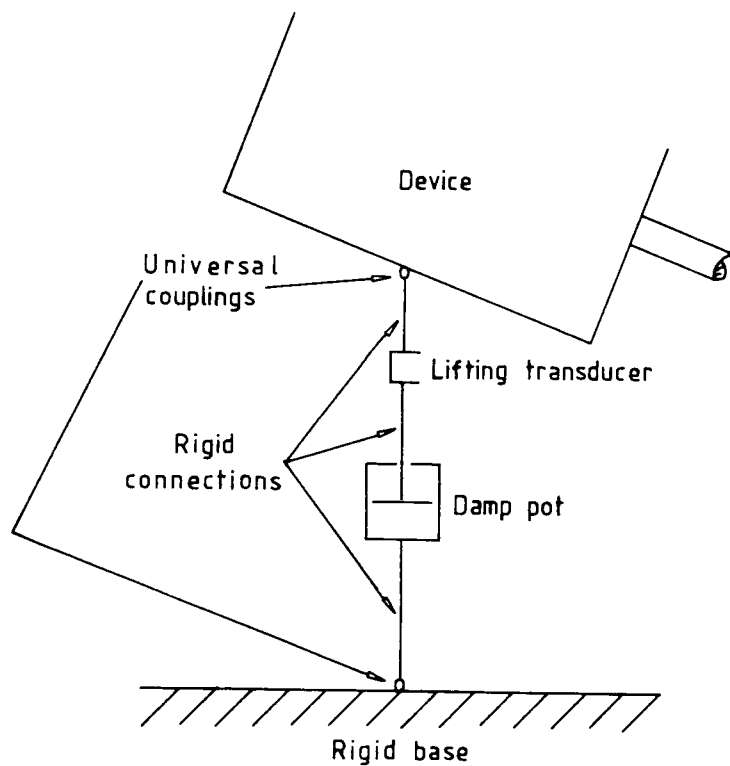

FIGURE 6.1. An improved arrangement for measuring the full range of lifting forces

to assess a persons progress to treatment must be confined to the previous results of that person. However, in any preliminary investigation of a new piece of equipment, comparisons between various groups must be made in order to assess the equipment's full canability.

The most obvious difference between the healthy subject and patient results is the clustering of the latter towards zero force. This is as expected since patients with arthritis are known to be weak. The clustering was shown by the scatter diagrams (Figures 5.44. to 5.50.) and skewness results (Figure 5.43.). The scatter diagrams (Figures 5.2. to 5.8.) and results (Figure 5.9.) of healthy subjects indicate no skewness. Therefore, the patients' results do not form a statistically normal population. This again limits any statistical comparison between the two populations. The mean of a set of results is statistically robust, therefore, it can always be used to compare two groups. The variance is not robust, therefore, it cannot be used in statistical comparison.

In comparing a subject or patient to his or her previous results care must be taken. It has been shown that each subject when repeatedly measured on a single device, exhibits a large variation. The mean coefficients of variation obtained, for all devices, range from 5.6% to 35.8% (Figure 5.16. and 5.17.). The lowest coefficient being obtained for the lateral pinch force measurement ($2.9\% \leq C \leq 7.8\%$) and the highest for the kettle handle grip at maximum lift ($20.0\% \leq C \leq 59.4\%$). The majority of the devices had mean coefficients of less than 15%, with their maxima falling below 20%.

The finger extension forces each had mean coefficients of less than 10%, with the ring and little fingers exhibiting a greater

variation than the others.

Of the pulp pinch forces, only the index finger had a mean coefficient under 10%, the others increasing towards the little finger. The variation of the fingers was similar though the middle finger was lower.

As the difficulty in performing these tasks was noted to increase towards the little finger (paragraph 6.2.) the tendency for increasing coefficients of variation in the same way is probably due to performance difficulties rather than any fundamental difference in the pulp pinch or extension of the fingers.

The functional tasks of pan and kettle lifting had the greatest overall variation. For each task the lifting forces had similar coefficients ($4.8\% \leq C \leq 20.5\%$) though the pan lower lifting force transducer did have a smaller mean coefficient.

Both kettle handle grip forces had extreme coefficients of variation ($14.6\% \leq C \leq 63.5\%$) while the pan handle grip forces were much lower, but still above average. The mean coefficients for the pan grip were about 15% with a large variation, $5.8\% \leq C \leq 30.3\%$, the grip at maximum lift having the widest range.

The extreme variation for kettle handle grip forces is probably because the forces involved were relatively low (less than 52N - Figure 5.13.). For the pan handle the grip forces were between 61N and 282N. Therefore, even if the kettle handle forces exhibited a similar absolute variation about the mean, as the pan handle, the kettle coefficient of variation would still be much higher.

Even though the total power grip had low coefficients ($3.8\% \leq C \leq 10.3\%$) the finger force variation was much higher ($3.8\% \leq C \leq 27.0\%$). This indicates that while the fingers, operating together, in a power grip, provide a fairly consistent maximum force,

the maximum forces produced by individual fingers in the grip are not consistent.

Again, as with the pan and kettle devices, the relative values of the forces involved must be considered. The fingers, obviously having a lower force than the power grip force, would give a higher coefficient of variation for a similar variance about the mean.

When using the coefficient of variation, care must be taken not to use the results in isolation. The mean and standard deviation must be considered as well to give a proper comparison between different populations of results. However, with each device, the results obviously show a significant amount of intra-subject variation. As the system has been shown to be accurate, these variations are most probably the effect of subject technique.

From observation during the repeatability trial, it was noticed that the most obvious causes to affect technique appeared to be muscle fatigue and subject motivation. Muscle fatigue was generally indicated by the subject performing limbering up type exercises during the rest period. Typically, this would involve rapid flexion and extension of the fingers, or elbow or both. Motivation is more difficult, because unfortunately it is a subjective assessment by the author based on observations of the subjects' attitudes and mannerisms during the trial.

However, no noticeable reduction was observed in the variability results obtained from measurements performed at the same time on two consecutive days, as opposed to those obtained in one continuous measurement session.

From this, we conclude that either fatigue and motivation are not a problem or that split measurement, while reducing both or one of these factors, has introduced another factor with a similar or

greater effect, i.e. a day to day variation.

To study this new factor would involve single daily measurements over a fairly long time scale, and the results compared for any daily or weekly variation.

Another major source of variation, especially in the pan and kettle functional tasks, could be caused by the measurement process itself. Even though it was impressed on the subjects, and patients, to perform the task as normally as possible, the very nature of the process makes them consciously aware of the task they are being asked to do. This awareness ensures that the subject, or patient, makes a conscious effort to perform the task as they think they normally would. Normally, functional tasks are intuitive, no conscious thought being required for its successful performance. There is no guarantee that the two modes, how they think they do and how they instinctively do the task, are the same.

Repeated measurement would make the subject even more aware of the task. They probably then start altering their technique through the trial in an attempt to improve themselves by obtaining a higher force or 'score'. Again, this is based on personal observation. To reduce this scoring technique, subjects were not allowed to see their force measurements ('scores') until they had completed the session, but reactions such as "I can do better next time" confirm the competitive spirit that some subjects gave to the proceedings.

This indicates that multi-performance tasks would be improved by single measurements per day. However, this would then be susceptible to the day to day variation mentioned above. Obviously, single measurement is preferable in that subjects and patients do not get an opportunity to change their technique as the tests proceed. In all our tests the patients were measured only once per device per day,

though they were given the opportunity of a single trial to familiarise themselves with the devices. In this way, intra-subject variation was, hopefully, kept to a minimum.

Comparing the power grip force-time curves of healthy subjects (Figure 5.31.) to those obtained from patients with arthritis (Figure 5.67.), it can be seen that the healthy subject finger forces are much steadier for the duration of the grip. In the patient curves, the finger forces can be seen to change substantially during the grip.

The percentage contribution of each finger to the power grip, of healthy subjects, also shows a more consistent pattern than that obtained from patients (Figure 5.55b). The mean values are approximately equal, but the standard deviations of the healthy subjects (3.8 to 6.2) are much lower than those from patients (8.5 to 14.4).

From the healthy subject results the middle and ring fingers can be seen to contribute over 65% (approximately 37% and 29% respectively) of the maximum power grip. The remainder is split almost equally between the index and little fingers (approximately 19% and 16% respectively). The middle and ring fingers appear to be responsible for the primary role of providing the grasping force in a power grip. The role of the index and little fingers is secondary, but since they still supply a significant portion, must be just as important.

An explanation could be that they provide a stabilising action, that resists any movement of the object being held. This movement being caused by the primary, middle and ring finger, grip force acting on the object's shape.

This arrangement appears contrary to what would be expected. In

a power grip, the thumb is primarily in opposition to the middle and index fingers. Therefore, it would be expected for these to provide the majority of the grip force.

Our results agree well with Ohtsuki (1981a), given in Figure 5.55a, even though his device was fundamentally different from the one used here. His apparatus is discussed in paragraph 2.4.2. The apparatus restrained the subject's forearm in a plaster cast, in a supinated position, with the fingers attached to their individual transducers. The finger force being measured by flexing the fingers against the transducers. This is an unnatural position and if used to measure patients, a large number would find difficulty in getting into it. This is contrary to ours, as the power grip is a natural position and is normally used in many daily activities, and can be used by both healthy subjects and patients. The thumb took no part in Ohtsuki's apparatus, whereas in ours it is an essential part of the power grip, forming one jaw of the vice, the fingers being the other jaw.

In the pan and kettle lift, three aspects can be studied:-

- a) The relationship between the upper and lower lifting force measurement.
- b) The relationship between the maximum handle grip forces and the handle grip forces at maximum lift.
- c) The relationship between the handle grip forces and the maximum lift forces.

Examination of the relationship between the upper and lower lifting force measurements reveal that, for both the pan and kettle, the results are highly correlated (coefficients between 0.91 and 0.99)

with regression slopes of less than 1.0 (lower over upper).

The pan lift results of both patients and healthy subjects had regression slopes of much less than 1.0 (0.66 to 0.82). From the lifting techniques displayed in Figure 5.10, a non-vertical lift and pan tilt is indicated. Tilting is expected, being a result of the increasing turning moment applied to the hand as the pan is lifted. Why this lift is non-vertical is difficult to answer for healthy subjects. For patients, it is brought about by the patients tilting their bodies backwards. This action was confirmed by observation. As the patients are in pain, they compensate for lack of movement by tilting their bodies to get the extra lift they require. This then causes a non-vertical lift of the pan.

The kettle lift results appear different for both groups. The healthy subject results, with slopes of close to 1.0 (0.96 and 0.97) indicate a vertical lift (Technique 1, Figure 5.10.). However, the results from patients indicate a similar non-vertical lift as seen with the pan. The healthy subject results are as expected, a vertical lift since the handle is directly over the kettle body. The patients' results are explained in the same way as the pan lift, in terms of a body tilt to compensate for the lack of shoulder movement.

Two basic force-time curves (Figure 6.2.) are evident for the pan lift, one being common to both healthy subjects and patients. Curve (b), apparently for higher lifting forces, shows the handle grip and the lifting forces increasing, simultaneously to a maximum. The other curve (a), for lower lifting forces, was only found in the patient results, and shows the handle grip force reaching its maximum prior to any attempted lift. From these curves, it appears that, in a high lift situation, subjects or patients alter their handle gripping force as the lift progresses. This is possibly a reaction to the increased

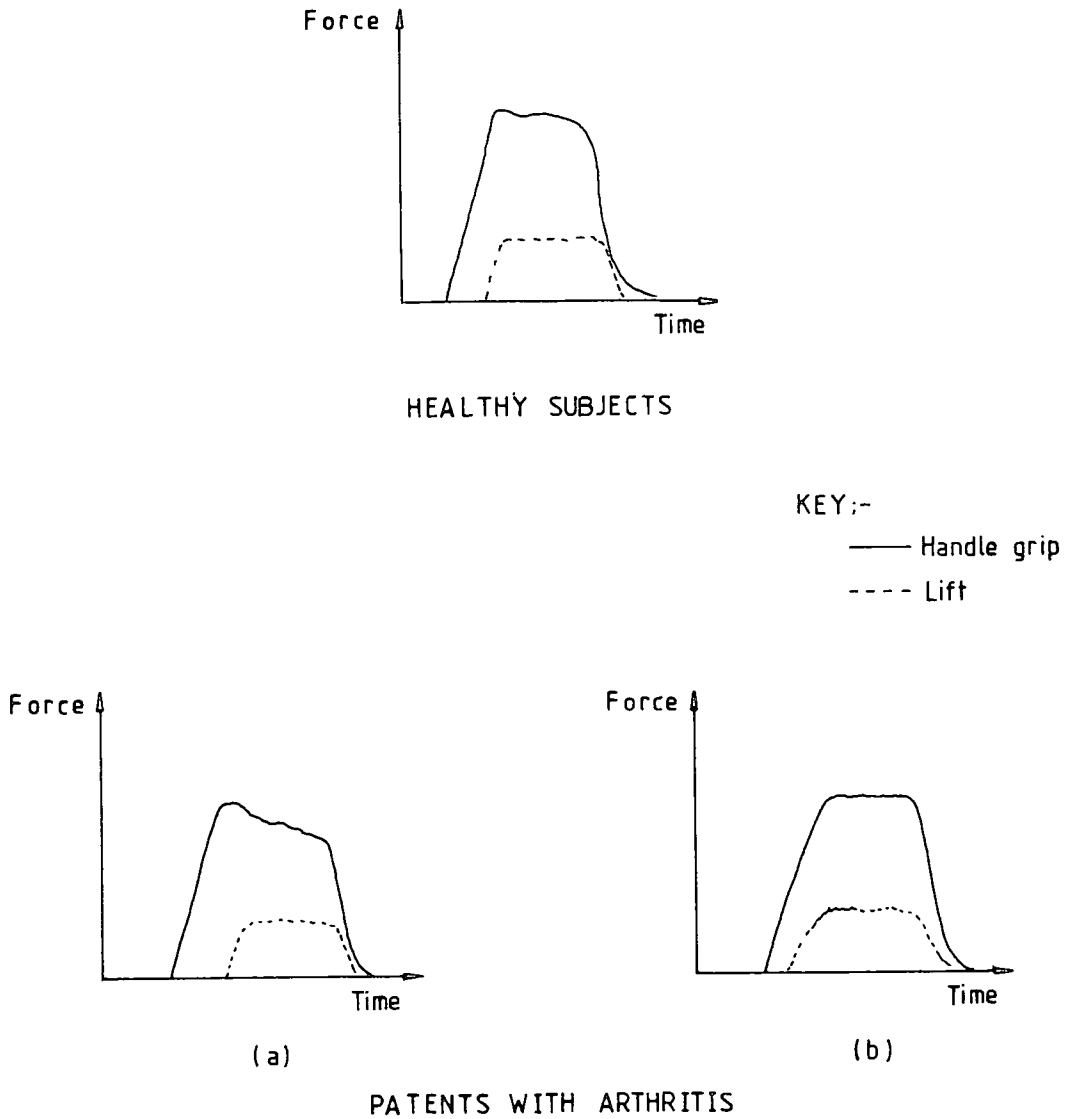

FIGURE 6.2. The basic force-time curves observed in the pan lift of healthy subjects and in patients with arthritis

turning movement imposed by the pan body and restraining springs. The low lift patients, because they know that they will have difficulty in lifting, grip the handle as hard as possible prior to lifting. This ensures that they have a good hold and therefore will have a relatively safe and satisfactory lift.

Examination of the relationship between the two handle grip forces tend to confirm the basic curves. The results (Figures 5.63. and 5.64.) for patients show a highly correlated (coefficients of 0.95 and 0.99) equality between the two grip forces. This equality would be expected in curve (b) as the grip force increases with the lift force and therefore the maximum grip force and the grip force at maximum lift coincide. For an equality to exist in curve (a) the handle grip force must be held constant during the initial phase of the pan lift.

Since the healthy subjects also have a basic curve similar to curve (b), an equality would be expected. However, these results (Figure 5.27. and Figure 5.28.) have regression slopes of less than 1.0 (0.90 and 0.74). They are more scattered, with correlation coefficients of 0.75 and 0.82, and they have significant intercepts of 40N and 63N. Therefore, there appears to be a maximum grip force below which there would be no handle grip force at maximum pan lift. Above this threshold, the grip relaxes between its maximum and the lift maximum by an amount which decreases slightly with grip force (slope < 1.0). This threshold could be the minimum handle grip force required for a pan lift. However, care should be taken in interpreting this since it is an extrapolation outside the measured range (Figure 5.27. and 5.28.). The results in this extrapolated region could easily have a different relationship than the other regions and curve down to the origin.

If as stated above the healthy subjects alter their grip to suit the amount of lift, a relationship would be expected between these two parameters. However, as can be seen from Figure 5.80a, no such relationship exists. The only reasonable correlation that exists is in the pan lift results of the patients with arthritis. Therefore, for healthy subjects it appears that the handle grip force is independent of the amount of lift. A relaxation of the grip force is evident during the lift which is possibly due to stress relaxation of the muscle.

Patients, however, appear to have a pan handle grip force that is dependent on the lift force (Figure 5.80a) and which remains steady during the lift. There is also very little difference to be seen between the regression analyses of the two pan handle grip forces, even when split into male and female groups (Figure 5.80b). This is as would be expected if the two forces are similar.

For the kettle lift, the same basic force-time curve was observed in healthy subjects and patients with arthritis (Figure 6.3.). This consisted of a peak in the kettle handle grip force just as the kettle lift was started. This was followed by reduction, sometimes to zero force, as the lift attained its maximum. A second peak, lower than the first, was sometimes seen as the kettle was replaced. The kettle lift generally involved very little handle grip force, this being lower than the lifting force. This was because the kettle, when lifted, appeared to be supported on the medial and distal phalanges in a 'hook grip'. Since the transducer was deliberately situated on the top of the handle, to ensure that the actual grip force was measured, the two peaks are probably due to the palm of the hand resting on the handle prior to and after the kettle lift. Very little relationship would therefore be expected between the two

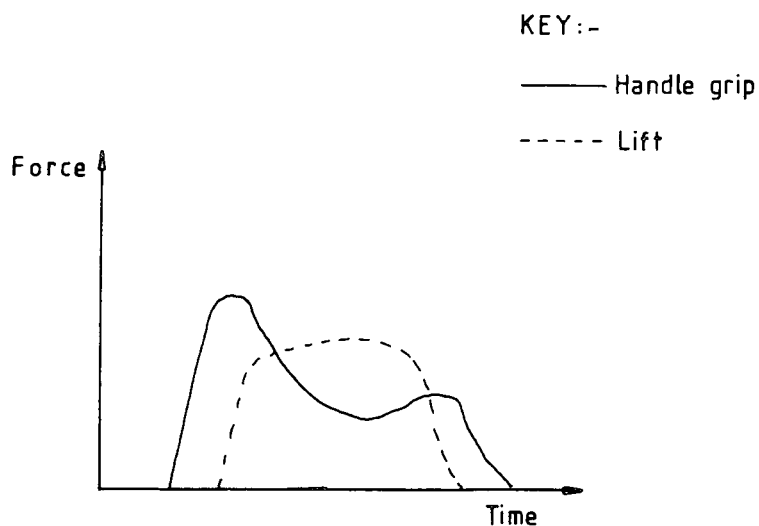

FIGURE 6.3. The basic force-time curve observed in the kettle lift of both healthy subjects and patients with arthritis

kettle handle grip forces.

Examining the kettle results (Figures 5.29., 5.30., 5.65. and 5.66.) shows that even though there appears to be a large degree of scatter there is a reasonable correlation between the two handle grip forces (correlation coefficients from 0.78 to 0.88). This occurs above a maximum grip threshold of between 13.5N and 17.2N (the regression slope intercepts). Between the two groups, the main difference is the steeper regression slope found in the healthy subject results (1.29 and 1.48, the patient results being 0.93 and 1.05).

It appears, in a kettle lift, that there is a threshold above which the handle is gripped by the hand, and below which it is just supported on the fingers. In a kettle lift a threshold could be accounted for by the reaction to the lift of the restraining springs i.e. the weight of the kettle. This would force the fingers of the hand to open and therefore reduce the grip force. Below the threshold the reaction force is enough to eliminate all the grip force.

For the patient results, the difference between the two grip forces appears to be constant throughout the grip force range, the regression slope being close to 1.0. In the healthy subject results, the difference appears to increase with the grip force (regression slope > 1.0). From Figure 5.80a, none of the kettle lifts show any correlation between the handle grip forces and the mean maximum lifting forces.

Therefore, in a kettle lift the handle is not just supported on the fingers, but is gripped as well. This grip does not depend on the amount of lift, but it is reduced during the lift. This is possibly because the weight of the kettle forces the fingers to open slightly.

In the pan and kettle lifts discussed above, the scatter diagrams used clearly have a large degree of scatter. This scatter is obviously the result of the inter-subject and inter-patient variation. However, in some cases a reasonable correlation was obtained, but because of the scatter, this could lead to false impressions being formed. Therefore, any conclusions that are drawn must be only used as guidelines and not as absolute rules.

6.4. Follow-up Results

These confirm how difficult it is to monitor any patient function. As expected, because of the large inter- and intra-patient variation (Figures 5.51. to 5.52.) it is not possible to merge together several sets of results in order to simplify appraisal of the system's performance. As in Chapter 5, each patient must be treated separately. However, with nineteen patients forming the core of the follow-up results, this is not practical for this discussion. Since all the points of interest have been referred to in the previous chapter, we shall confine ourselves solely to a discussion of the points that have relevance to whether or not the system is suitable as a monitor of hand function.

From an overall viewpoint, it is possible to observe encouraging signs. As shown in paragraph 5.2.1. individual device measurements have quite large variations. Even so, in several cases, the follow-up measurements can be seen to follow significant trends. There are also a number of cases in which the measurements suddenly deviate from the overall trend. This deviation being greater than any possible expected variation. Therefore, in all probability, the deviation would be caused by some change in the patient, either pathological or psychological. In most cases evidence exists of

similar changes in other device measurements, thereby lending support to the premise that the deviations are the effect of some patient change.

Pathological effects could include joint pain and/or stiffness. Psychological effects could be depression or just a 'can't be bothered today' feeling. No study was performed to locate the cause of any changes, these being beyond the scope of this project.

The most convenient way to find out if the system is capable of patient monitoring, would be to examine the results of patients whose treatment would be expected to yield some change in patient performance. The most obvious examples being pre- and post-operative or -injection.

Patient CWA (Figure 5.106.) was measured pre- and post-operatively. He had the release of the median nerve in the carpal tunnel performed on both wrists. As expected, there was a temporary post-operative decrease in his measurements of power grip, pan and kettle lifting, tube twisting and lateral pinch forces. This decrease would be due to the usual immediate after effects of surgery. These forces recovered in a few days, almost to their pre-operative level. Unfortunately, no further improvement would be expected for several weeks, since a released nerve needs this time to regrow.

It was also possible to obtain measurements prior to and after shoulder intra-articular injections in four patients (GEL, EF, JW and ENC, Figures 5.96., 5.102., 5.103. and 5.107.). Of these, two (EF and ENC) showed no significant changes while GEL and JW both had relatively large increases in their kettle lifting forces, with lesser effects noticeable in the power grip, lateral pinch and tube twisting force measurements. A large improvement in kettle lifting force would be expected, since a kettle is generally lifted by

pivoting the arm about the shoulder. Any reduction in joint pain, because of the anti-inflammatory action of the steroid, would extend the range of motion of the shoulder leading to a greater amount of lift. This is because, in general, kettle lifting does not involve a strong grip force, just a supporting action. Therefore, any improvement in the shoulder joint range means an increase in the hand movement, and as long as the patient is capable of making and maintaining a 'hook grip', an increase in lifting force.

Secondary improvement in other measurements would also be expected, since it is impossible to ensure that all the injected material stays in the selected joint. There would be a small systemic leakage which could be beneficial to other joints. This leakage is confirmed by the measurements of PMB (Figure 5.100.). She had an intra-articular steroid injection to the knees and her force measurements (power grip, kettle lift, lateral pinch and tube twist) indicated a subsequent general improvement.

From the above it appears that the kettle lift, power grip, pan lift, lateral pinch and tube twisting force measurements are the most sensitive to changes in patient performance. They have shown varying degrees of change in situations where change was expected. The remainder, pulp pinch, extension and key twist force measurements failed to show any significant changes during the period of study. The individual finger, pulp pinch and extension measurements have a large variation with no particular trend, appearing to vary about a steady value. Owing to the method used, it would not be expected for the extension to show much change. This is because the hand is fixed in a limited movement position. If the hand were fixed with the MCP joints flexed to ninety degrees, so that a large degree of extension was possible and therefore plenty of room for improvement, a

different picture from above might appear.

Several small changes were obtained in the key torque measurements, but again no consistent trend was observed. However, a large improvement in hand function would be needed to show a key torque increase because the moment arm of the key, its diameter, is very small. A typical aid for patients with arthritis is a modification to a key that increases its moment arm, so as to amplify the small twisting torque that they can apply.

From all the patient results the devices that appeared to be the most sensitive in indicating consistent change in patient performance, as opposed just to variability changes, were the power grip, pin and kettle, lateral pinch and tube twist devices.

From the drug trial study we were given the opportunity to compare our system to a typical drug assessment procedure. The contents of such an assessment would be expected to be well researched and to be able to reflect accurately the drugs' efficacy of treatment by monitoring the disease activity of the patient. As detailed in Chapter 4, the study consisted of a clinical examination and immunological and biochemical analyses of the patients' blood. The most relevant parts of the study, which were used as the indicators of disease activity were the Ritchie Articular index, plasma viscosity, grip pressure, PIP joint circumference measurement and pain and general health visual analogue scales. The plasma viscosity was the only quantitative measurement used, all the others were, at best, only semi-quantitative. The articular index and visual analogue scales were purely subjective. The former relied heavily on the clinician, who had to apply the same physical pressure to each joint, and to recognise the severity of the patients' reactions.

On inspection of the drug trial results (Figures 5.82., 5.84., 5.86., 5.88., 5.90. and 5.92.) they all appear to follow similar trends to each other. In most cases the articular index was too low for any improvement to be significant. Though in three cases * (LAO, AHD and ES) improvement was noticeable, but because their initial indices were higher than those of the other patients. Over the period of the study, the visual analogue scales showed little change, though they did vary from measurement to measurement. The PIP joint measurement also failed to show any significant change, though with the method used, only large changes would be noticeable.

Direct comparison between both sets of results was not possible, except between the grip pressure and power grip measurements. These all have similar trends except DE, where no comparison was possible because his grip pressure exceeded the maximum of the pressure recording dial gauge. This is an important limitation of the use of an inflated cuff to assess grip strength. The inflated cuff is widely used in assessing the progress of rheumatoid disease. However, in the early stages of the disease, many patients would be able to exceed the dial gauge limit. Therefore, an important aspect of their function cannot be monitored at an important stage of the disease progress. In our system, the power grip device fills this important gap and, simultaneously, provides additional information on the finger condition.

Generally, both sets of results were similar. Visible trends were not consistent within the measuring devices of a set, that is, both sets of results consisted of a mixture of agreeable and contradictory results. Also, all the devices, in each set, provided very variable results.

Overall, it appeared that the drug trial study results supported

those obtained from our study. That is the areas of agreement were more numerous than areas of contradiction. However, since we were only comparing six sets of results, we can not expect to obtain a complete picture. As a preliminary investigation it does, however, provide evidence that changes in patient performance registered on our system are related to changes in disease activity as monitored by the drug trial assessment.

Further evidence that the system is capable of monitoring change can be found in the results of patients from the Physiotherapy clinic. Here, especially in patients with unilateral hand disorders, the results (Figure 5.111.) show a clear differentiation between the hands. This is over a wide range of forces and for all the devices used.

The affected hand results are lower than the opposing hand on all devices. Even in patients where bilateral weakness was already evident, the most recent complication has further exacerbated their problem. AKC is an example of the system showing up more specific effects of an injury. He had a chipped distal phalanx in his left index finger. His left handed power grip was much reduced with the major contribution now coming from the ring and little fingers. The index pulp pinch and key twist forces were also reduced while no change was apparent in his other results.

Most of the other unilaterally affected patients had suffered major trauma and much lower results with all devices would be expected. Of the patients that had bilateral disorders, most were weak in both hands, though some differentiation could be seen. For example, JA and JF have weaker left hands and VS has a weaker right hand, indicated on all devices. No specific reason is obvious why there should be this differentiation. It is probable that it is just

another manifestation of the disease process.

Some differentiation between left and right hand forces would always be expected. As mentioned in Chapter 2, one hand can be shown to be weaker than the other. Also, no specific relationship can be used to define what forces would be expected from one hand, based on the opposite hand results. However, in unilateral disorders equality between each hand could be used, in the first instance, as a rule of thumb guide to assess any localised disorder. It could also be used to indicate a reasonable level that an injured hand should be able to heal to.

Of the patients that had any reasonable follow up, only two (AGM and AGR) would be expected to show short term improvement. AGR clearly showed continued improvement with his left hand, his opposite hand remaining relatively steady. AGM showed right hand improvement in the lifting tasks (left hand also) and tube twist tasks. Her other results indicated very little. The other patients would not be expected to improve greatly, two having arthritis, one a tendon and nerve repair and the other a generalised loss of hand function. However, none indicates any deterioration of their hands though FB does indicate slight improvement.

CHAPTER 7

CONCLUSION

CONCLUSION

This study has resulted in the development of a microcomputer controlled hand assessment system. The system connects together a blend of everyday activities and strength tasks through a microcomputer which performs all the necessary electronic switching and data handling. The everyday activities are pan and kettle lifting and key turning while the strength tasks are power grip, individual finger grip, pulp pinch, extension and tube twist. The system was developed with user friendly instructions to enable easy operation by non-technical staff with minimum training. In the clinical environment the system proved robust and reliable and most of the devices were found to be capable of accurately measuring the full range of forces encountered in a human population.

As a preliminary investigation into the system's capability of monitoring change in patient performance, several patients were tested over a period of several months. The initial results showed the wide variation that needs to be measured and the weakness of patients with rheumatoid arthritis. The follow up results from each device were found to follow the same general trends. When used alongside a typical clinical assessment, which was highly subjective compared with our system, both gave similar overall results. This indicates that the system developed was no worse than the current assessments in use.

Further evidence that the system was capable of detecting changes in patient performance was obtained from the results of patients pre- and post-injection and pre- and post-operatively. The results from patients with unilateral hand disorders also showed the same capability. These results revealed not only substantial differences between each hand, but also indicated more specific finger differences.

A more thorough study was possible of the power grip and the pan and kettle lifts. In power grip, even though patients with arthritis were, on average, much weaker, they retained the same average finger contribution to power grip. However, the patients' results did have a larger overall variation, the results of healthy subjects being more consistent and stable.

In the pan and kettle lifts it was possible to investigate the different techniques of lifting. In the pan lift the handle grip force was greater than the lifting force. When lifting, the patients appear to grip the handle, maintaining a constant grip throughout the lift until the pan is replaced. The handle grip also appears to be proportional to the lifting force. However, for healthy subjects this relationship does not appear to hold. In both groups, the pan, as expected, appears to be lifted in a non-vertical direction, with the handle tilted away from the horizontal.

The kettle techniques were similar for both groups except that the patients lifted non-vertically while healthy subjects lifted vertically. The results confirmed that the handle is positively gripped during a lift and does not just rest on the medial and distal phalanges.

The above findings were based on a study using the results collected from many patients and healthy subjects. However, one of the biggest advantages of this system, since it is quantitative, is that it gives clinicians and therapists the ability to monitor individual patients accurately. Even though the results did show the well correlated trends indicated, they also showed the large inter-subject/patient variation present. This makes it difficult to define a normal technique that should be utilised by a patient. The pan and kettle devices could be used, however, to demonstrate to a

patient how to alter their technique to improve their functional capability of these tasks.

This assessment system, since it provides an objective measurement capable of monitoring individual patients, would enable the clinician or therapist to gain valuable information. The combination of measurement devices would give information on the hand condition not readily available by other methods. Using this extra information the optimum treatment can be formulated or the treatment modified to correct any detrimental effects.

7.1. Suggestions For Future Work

Prior to any further work with the system, the pan and kettle lifting transducer should be modified to ensure that it is capable of measuring the full range of expected forces. Similarly, the extension force measurement procedure should be modified so that at the measurement position a large range of extension is possible.

The subject of this thesis should be continued and extended to provide a complete evaluation of the short and long term patient monitoring capability, of each device, attached to the system. This would involve monitoring a large number of patients with rheumatoid arthritis etc. The patients will be having either drug or surgical treatment or physical therapy.

Fundamental knowledge of the hand could be extended by using specific devices of the system. Circadian rhythm of the gripping forces could be evaluated as could the day to day variation. The former would involve both patients and healthy subjects while only healthy subjects would be required for the latter. Finger contribution to power grip and lifting techniques could be further evaluated to see how they alter under different conditions. For

example, the effect of object shape on finger contribution could be assessed. The system might also prove useful in demonstrating the usefulness of various therapeutic techniques.

Primarily, this thesis has been concerned with the development of a microcomputer controlled quantitative hand assessment system. After a preliminary investigation, it has been shown to be reliable and robust in use, and to be capable of detecting changes in patient performance.

7.2. Achievements and future work

The development of a hand assessment system for use in the clinical environment has been described. The system, an extension of previous assessments and ideas, contains a comprehensive blend of strength (total grip, finger grip, pulp pinch, lateral pinch and finger extension force) measurement and simulated functional measurement (pan lift, kettle lift, key twist and cloth wringing out tasks).

Initial results from healthy subjects and patients with arthritis have shown that the system gives accurate and reproducible results, that it is simple to operate, that it is robust and reliable, that it can be used over a wide range of measurement and that it is acceptable both to subjects and patients.

Therefore, this system, for the first time gives to rehabilitation medicine a quantifiable approach to hand assessment. Linking the elements of the system to a microcomputer substantially reduces the component of subjectivity due to observer variation, though the patient variation is obviously still present.

In designing the functional simulations some compromise was essential, especially in the pan and kettle lifts. Greater accuracy would have resulted if the pan body had been rigidly fixed to the transducer, thereby controlling any angular variation. However, to ensure that the simulations were as close as possible to reality, so that patients perception of the task was not diminished, it was considered desirable to incorporate a spring so that on lifting, the pan and kettle would move under the influence of the applied lifting forces.

Using the microcomputer ensured that operation of the equipment was kept simple. The control of the devices was automatic, as was the

data collection, calculation of results and their display. The only interactions required by the operator were simple choices or yes or no decisions (eg. i, Which device is required? and ii, Is data to be stored?). The software was written so that simple step by step instructions were presented to the operator. In this way therapists found that they could successfully use the system without extensive training.

The robustness and reliability of the system was demonstrated during the initial trials with healthy subjects and patients with arthritis. These results showed that the systems capability extended over the complete range from healthy subjects to patients. This feature is, again, something that has not been readily available in both strength and functional activities before.

Since the quantitative value of the system has been confirmed, variations seen in the single patient monitoring study can confidently been seen as real changes and not just changes related to errors in the equipment (ie. they are changes in the patient performance). The patient monitoring, reported here, obviously requires further study to evaluate more thoroughly the cause of the variations since the present study was aimed at evaluating the instrument and not the treatment.

The results of the total grip and finger grip measurements revealed an interesting distribution of the contributions each finger makes to the total grip force. It was found that the middle and ring fingers gave the major contribution to power grip (37% and 29% respectively) while the index and little fingers were significantly lower (19% and 16% respectively). This confirmed similar work by Ohtsuki(1981a) though it is contrary to the popular belief that the major contribution comes from the middle and ring fingers. Further

study is therefore warranted to investigate this observation in both subjects and patients and to investigate the effect on the distribution of different conditions (eg. object shape).

Measurements obtained from this system could be used as input to biomechanical analyses of the hand. These would be investigating the distribution of forces through the tendons or the forces encountered in joints. These results would give a greater confidence in the design of endo-prostheses.

As a preliminary study has now been performed with a quantitative system it would be possible to use it as an assessment standard. Against this the subjective assessments typically used by therapists, as well as therapeutic techniques, could be evaluated. If the assessments do not correlate with this standard, their value must be considered to be limited.

APPENDIX 1

MAXIMUM GRIP PRESSURE

OF THE HEALTHY HAND

MAXIMUM GRIP PRESSURE OF THE HEALTHY HANDA1.1. Introduction

A preliminary study was performed to evaluate the use of the inflated cuff in the assessment of grip strength. It was decided to assess three methods of measuring the pressure change using:-

- 1 a mercury column
- 2 a dial gauge from a proprietry grip tester
- 3 a pressure transducer

Finally the pressure transducer was used to study the effect of cuff size on maximum grip pressure.

The subjects that participated in the study were all volunteers from within the university department. There were thirteen males, from nineteen to fifty three years of age, and five females, from twenty to thirty seven years of age. They were measured seated, with their forearms horizontal, resting on the chair arms. They held an inflated cuff as comfortably as possible in their hands. On a vocal signal they gripped the bag as hard and as fast as possible, without moving their forearms off the chair arm. The grip was held for a few seconds and relaxed on another vocal signal. Each grip was repeated with alternate hands with a one minute rest period between grips. Three grips were obtained from each hand for each cuff size, the maximum grip pressure being their mean. There was a five minute rest period between different cuff sizes.

The rubber cuffs used were courtesy of Leyland Medical, Preston. Three sizes of cuff, Table A1.1., were chosen to give a good range of inflated diameters, without resorting to folding and rolling the cuff. The cuffs were covered in cotton material to give a comfortable surface for holding and to stop the rubber from stretching when gripped. If unconstrained, the cuff would tend to

WIDTH (mm)	LENGTH (mm)	INFLATED DIAMETER (mm)
57	108	36
85	200	54
120	277	76

TABLE A1.1. Details of the cuffs used

Inflated diameter = $(2 \times \text{width})/\text{PI}$
where $\text{PI} = 3.14159$

balloon out in the ungripped areas. Prior to use, the cuffs were inflated to a pressure of 20 mm of mercury.

A1.2. Results

The mercury column was found to be unsatisfactory since it was susceptible to jerking movements of the fingers. Even at maximum grip, a sudden extra effort on one finger could result in a large pressure change. The inertia of the mercury was also a problem. Large amplitude oscillations were always present whenever there was a pressure change. These took a long time (several seconds) to achieve a steady state. The oscillations also made it impossible to use a tell-tale since the maximum pressure recorded would not be the steady state condition.

The dial gauge only covered a 20 to 300 mm of mercury range, which was not adequate for healthy subject measurement. No tell-tale indicator was included to record the maximum reading, therefore the observer had to note the maximum as it happened.

The pressure transducer was satisfactory as its output could be recorded directly, against time, on a XYt recorder. Therefore, a pressure-time curve of the complete gripping cycle was obtained with very little information loss.

During the cuff diameter study, the subjects were all asked for their comments. Generally, they agreed that the cuffs were comfortable, but using the larger two bags, at maximum grip, was painful. This was because the skin on the fingertips was pinched between the finger nails and the cuff as the fingers indented the cuff. The female subjects also found the largest cuff to be bulky. With the smallest cuff, several subjects were able to make contact between their fingertips and palm. This was because the inflated

cuff provided very little resistance and the fingers could fully flex. Typical pressure-time curves obtained as shown in Figure A1.1.

The results obtained, cuff diameter against maximum grip pressure, for male and female, left and right hands, are given in Figures A1.2. to A1.5. Table A1.2. gives the details of the measurements obtained. The maximum grip pressures have a large inter-cuff variation with the smaller cuff having the largest. This can easily be seen in the Figures and is indicated by the standard deviations.

Table A1.3. shows the student t-test comparison between the maximum grip pressure means for each cuff diameter. The results show that the maximum grip pressures are statistically different, at the 5% level, between cuff diameters. There was one exception, the left hand results of males between the small and middle cuff.

Table A1.4. gives the results of a t and F-test comparison between the left and right hand maximum grip pressures. These show that, at the 5% level of significance, there was no difference between either hands maximum grip pressure.

A comparison between the male and female maximum grip pressures is given in Table A1.5. In all cases, except for the measurements of the left hand on the smaller cuff, there was significant difference between the maximal grip pressures of male and female subjects.

A1.3. Discussion

Primarily, this study indicated that the use of mercury columns and dial gauges was inadequate as quantitative grip pressure measuring devices. Both were difficult to read. The mercury column oscillated at every pressure change, therefore hiding the maximum pressure. It was also susceptible to any sudden finger muscle contraction. The

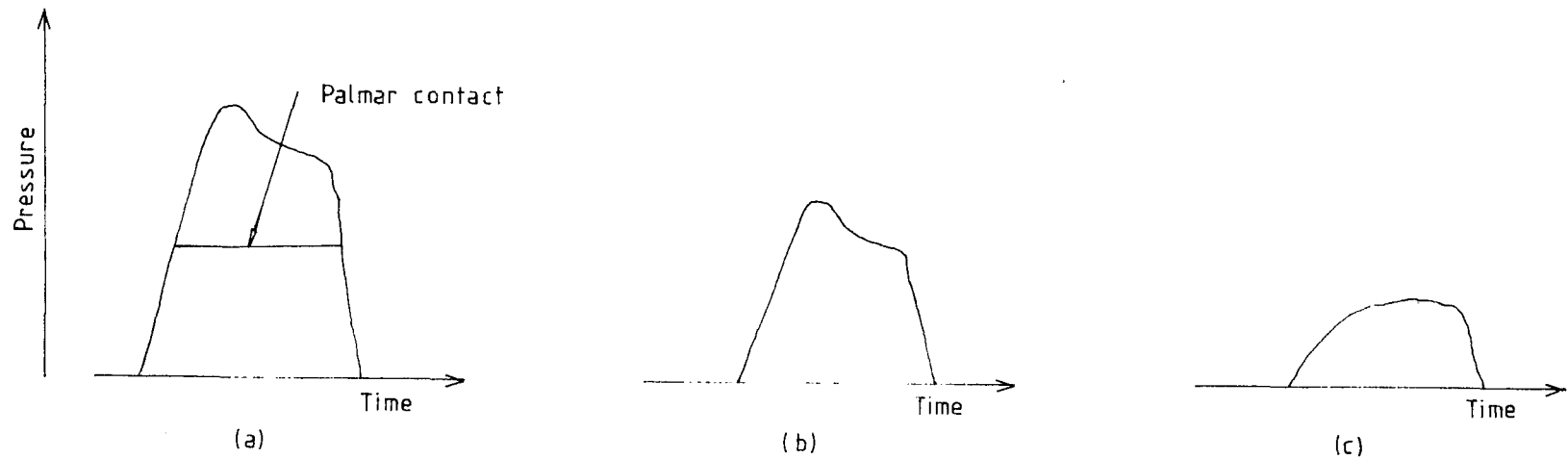

FIGURE A1.1 Typical pressure-time curves

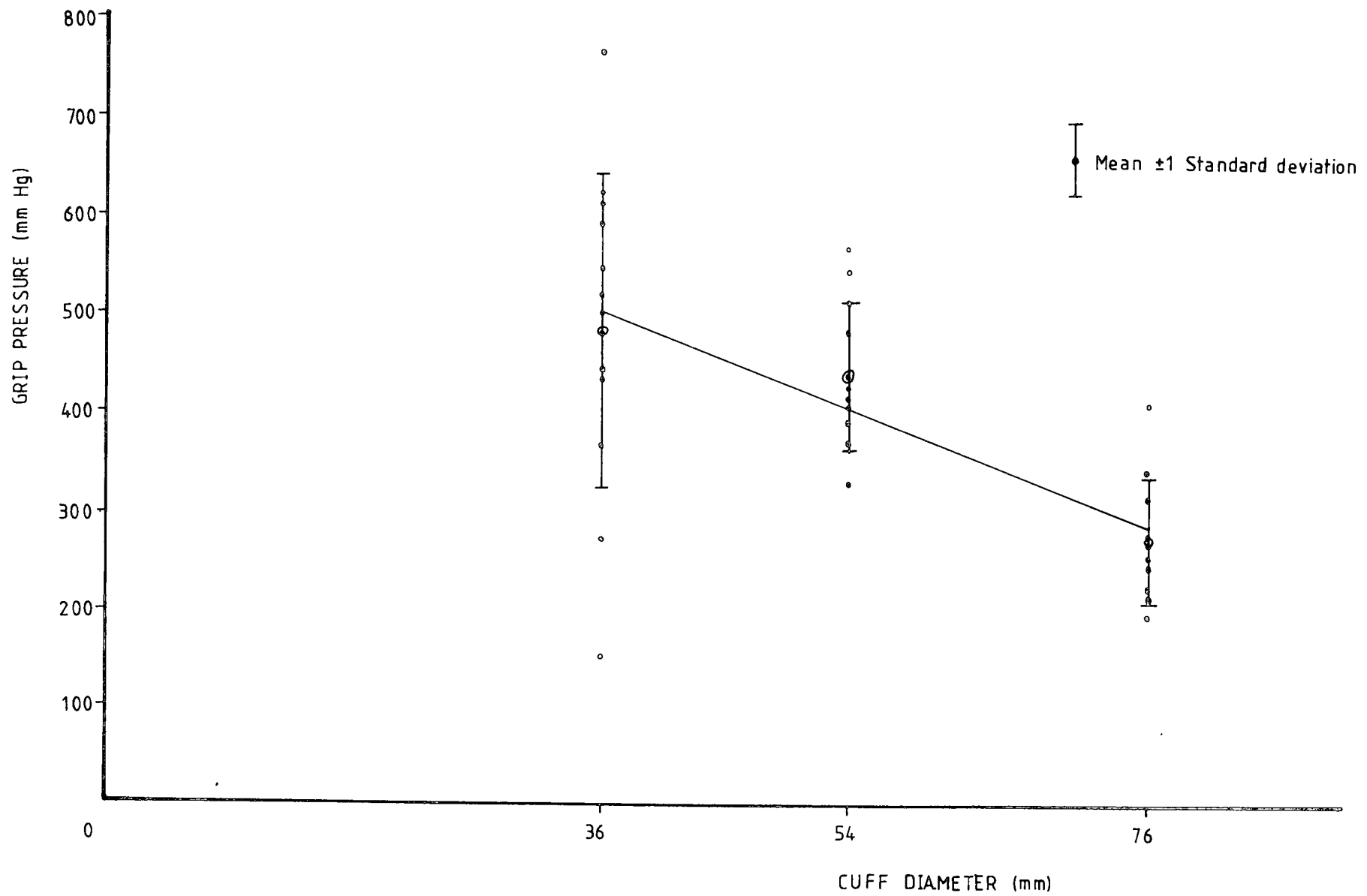

FIGURE A1.2. Maximum grip pressures of male subjects using the left hand

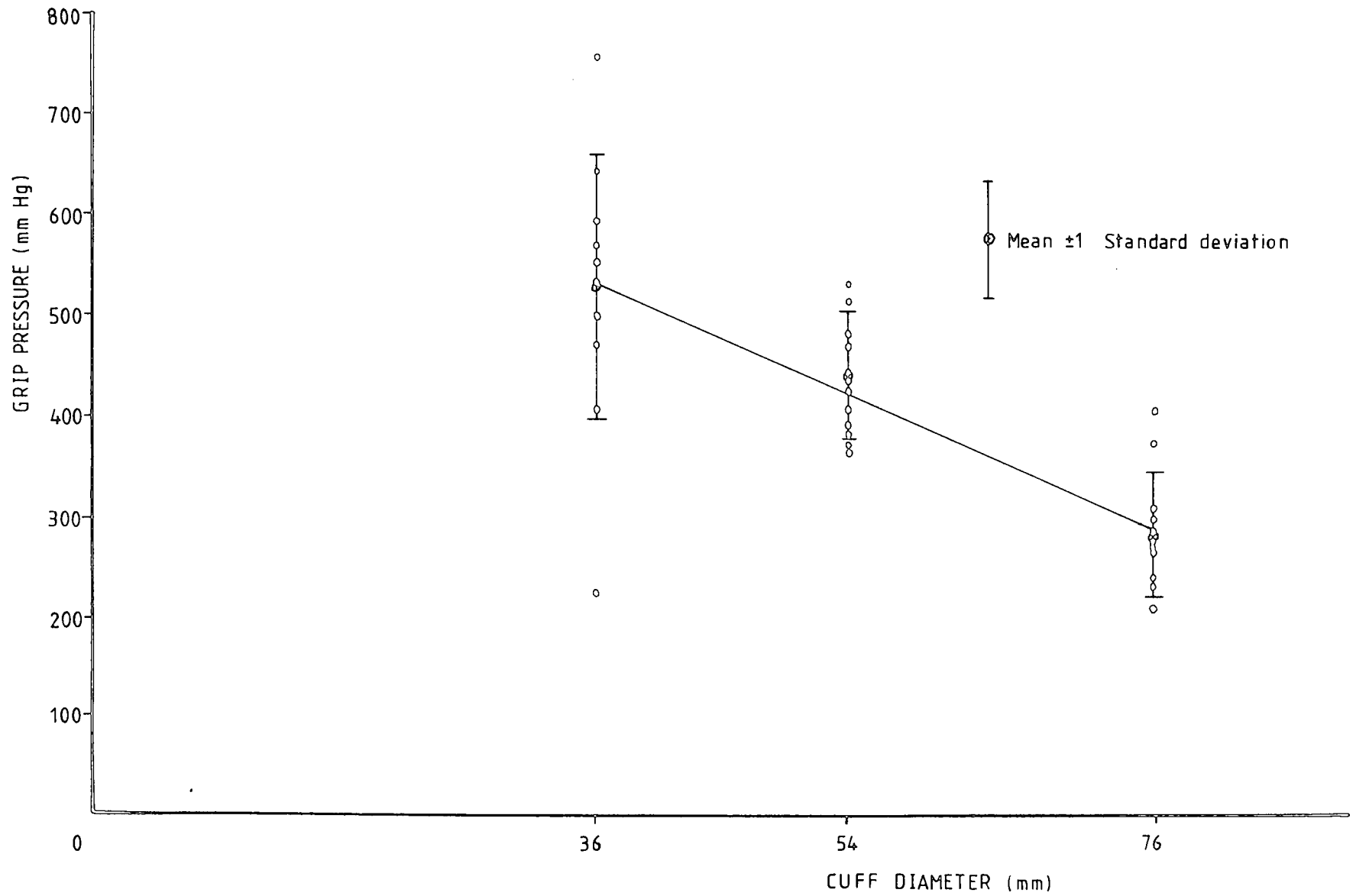

FIGURE A1.3. Maximum grip pressures of male subjects using the right hand

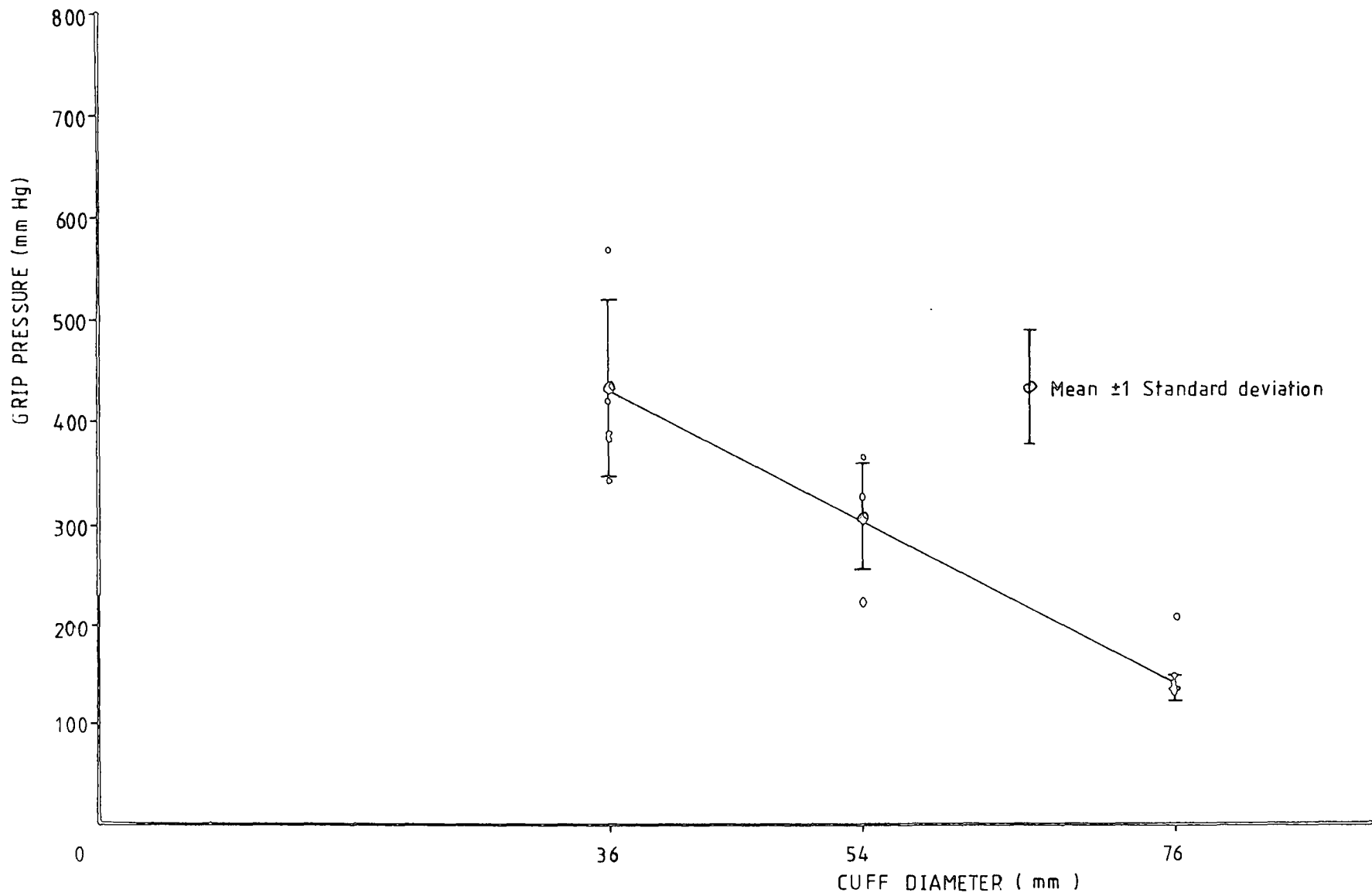

FIGURE A1.4. Maximum grip pressures of female subjects using the left hand

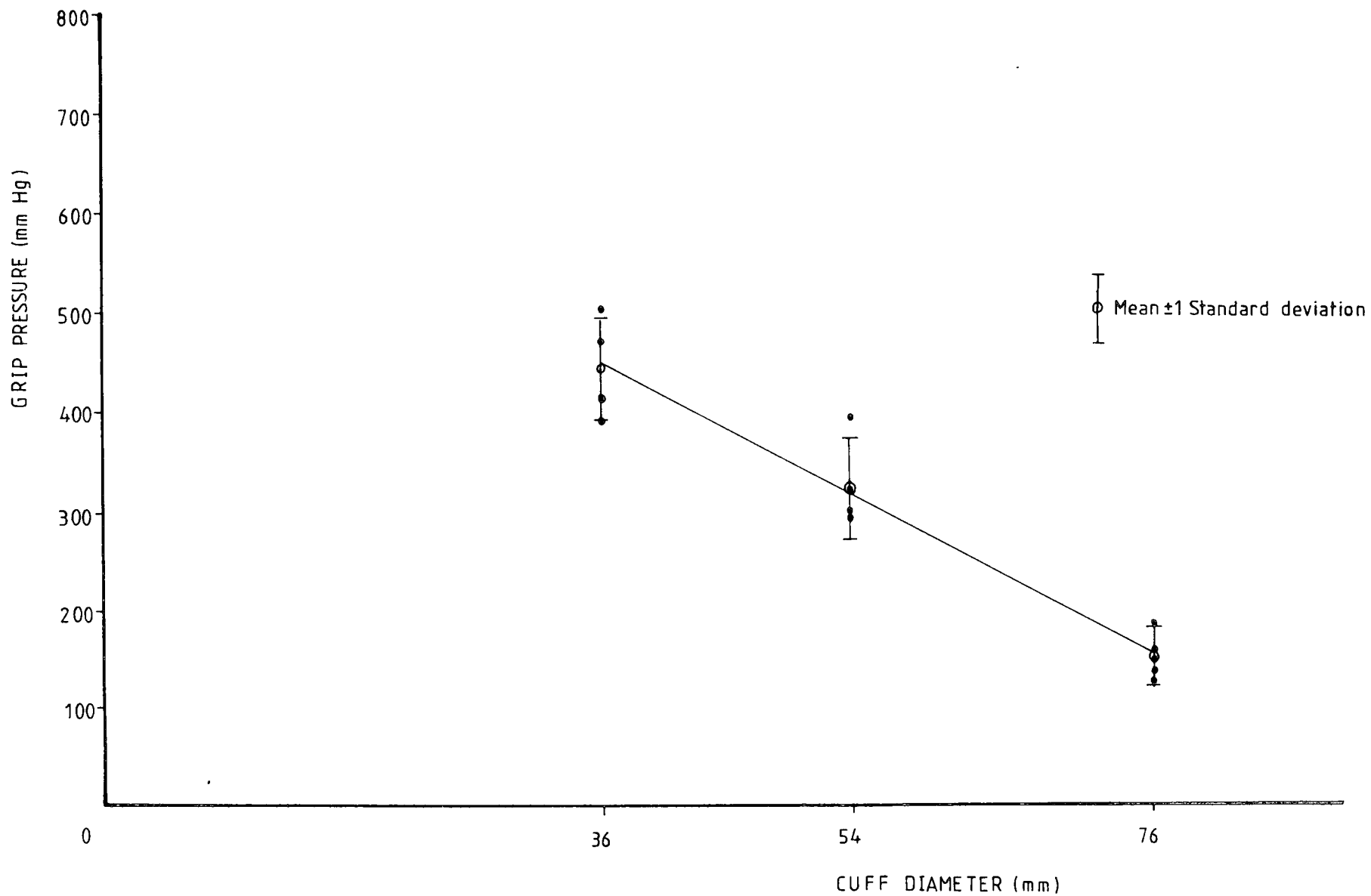

FIGURE A1.5. Maximum grip pressures of female subjects using the right hand

SEX	CUFF DIAMETER (mm)	HAND USED	n	MMP (mm.Hg)	S
MALE	36	L	13	485	159
		R	13	527	131
	54	L	13	437	72
		R	13	445	60
	76	L	13	273	61
		R	13	282	60
FEMALE	36	L	5	430	84
		R	5	436	54
	54	L	5	309	52
		R	5	327	43
	76	L	5	138	12
		R	5	151	27

TABLE A1.2. Details of the maximum grip pressures obtained from each cuff

n - number of subjects
MMP - mean maximal pressure
S - standard deviation

SEX	CUFF DIAMETER (mm)		54		76	
			L	R	L	R
MALE	36	L	1.8	-	7.8	-
		R	-	3.5	-	10.6
	54	L	-	-	10.9	-
		R	-	-	-	11.9
FEMALE	36	L	4.8	-	13.4	-
		R	-	6.2	-	17.8
	54	L	-	-	12.3	-
		R	-	-	-	12.9

TABLE A1.3: Details of the t-test comparison between cuff diameter

At the 5% level of significance
 $t = 2.2$ (male) and 2.8 (female)

SEX	CUFF DIAMETER (mm)	t FACTOR	f FACTOR
MALE (n=13)	36	1.3	1.5
	54	0.6	1.4
	76	0.7	1.0
FEMALE (n=5)	36	0.2	2.4
	54	1.0	1.5
	76	1.7	5.0

TABLE A1.4. Details of the t-test and f-test comparison between left and right hands.

At the 5% level of significance,
 t = 2.2 (male) and 2.8 (female)
 f = 2.7 (male) and 6.4 (female)

HAND USED	CUFF DIAMETER (mm)	t FACTOR
LEFT	36	1.3
	54	6.2
	76	8.5
RIGHT	36	2.6
	54	6.9
	76	7.9

TABLE A1.5: Details of the t-test comparison between male and female.

At the 5% level of significance,
 $t = 2.1$

The dial gauge had an inadequate range for healthy subject measurement and probably for a large proportion of patients with arthritis. It too was difficult to read the maximum pressure, relying on the observer to read the value directly.

The transducer system was superior because the pressure was recorded for the complete gripping cycle, therefore the maximum pressure could easily be measured from the recording, and any untypical responses could readily be seen e.g. impulses due to sudden finger contraction.

Using the transducer system it was found that the grip pressure depends on the cuff size, the pressure reducing with increasing cuff size. This would be expected since the larger the cuff, at equal pressures, the larger the force per unit area that is acting on the cuff's surface to inflate it. Therefore, the hand needs to supply a larger force to compress the cuff to provide the same pressure change i.e. using the same pressure, the cuff is more difficult to squeeze, the larger it is. Therefore, if the cuff is to be used, it is essential that its surface area is constant for all comparative measurements.

It must also be remembered that the cuff is not a quantitative measure of grip strength. It does not measure the applied force, but the pressure change brought about by squeezing the cuff.

It was also shown that there was no significant difference between left and right hand measurements for both sexes using all cuff sizes. And that male and female maximum pressures were significantly different on all but the left hand grip of the smallest cuff.

APPENDIX 2

CIRCUIT DIAGRAM

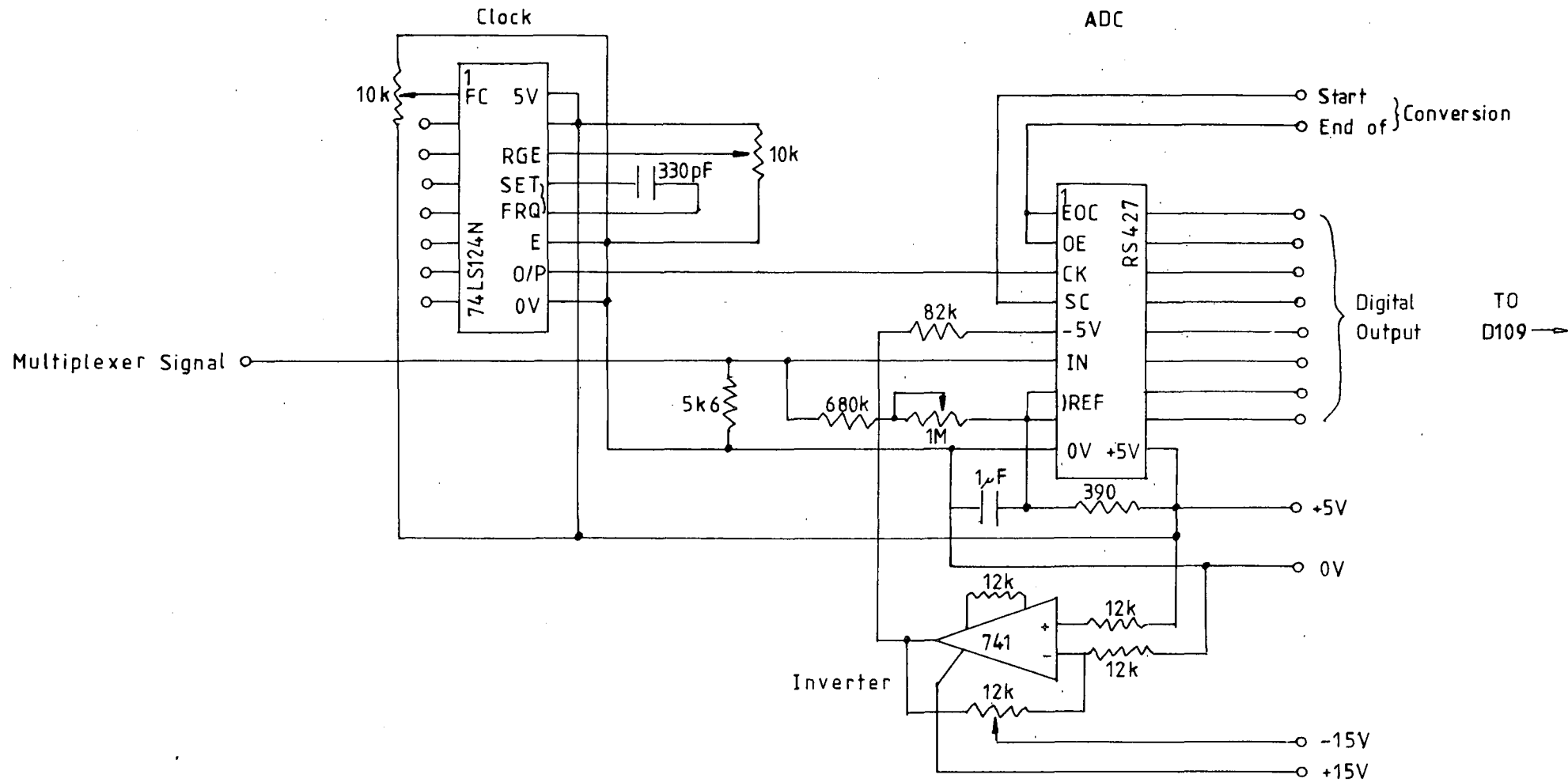

Analogue to digital converter circuitry

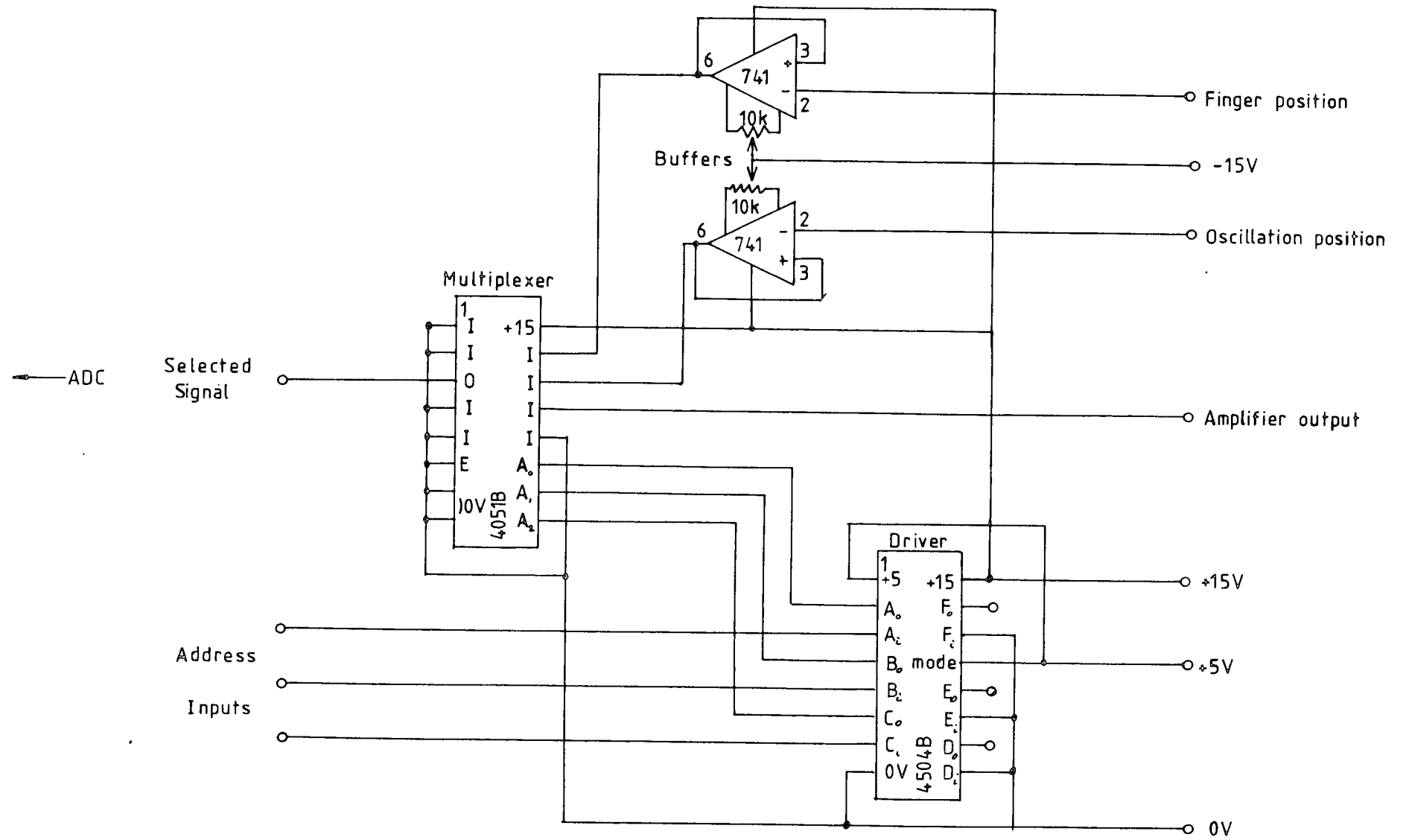

Multiplexer circuitry

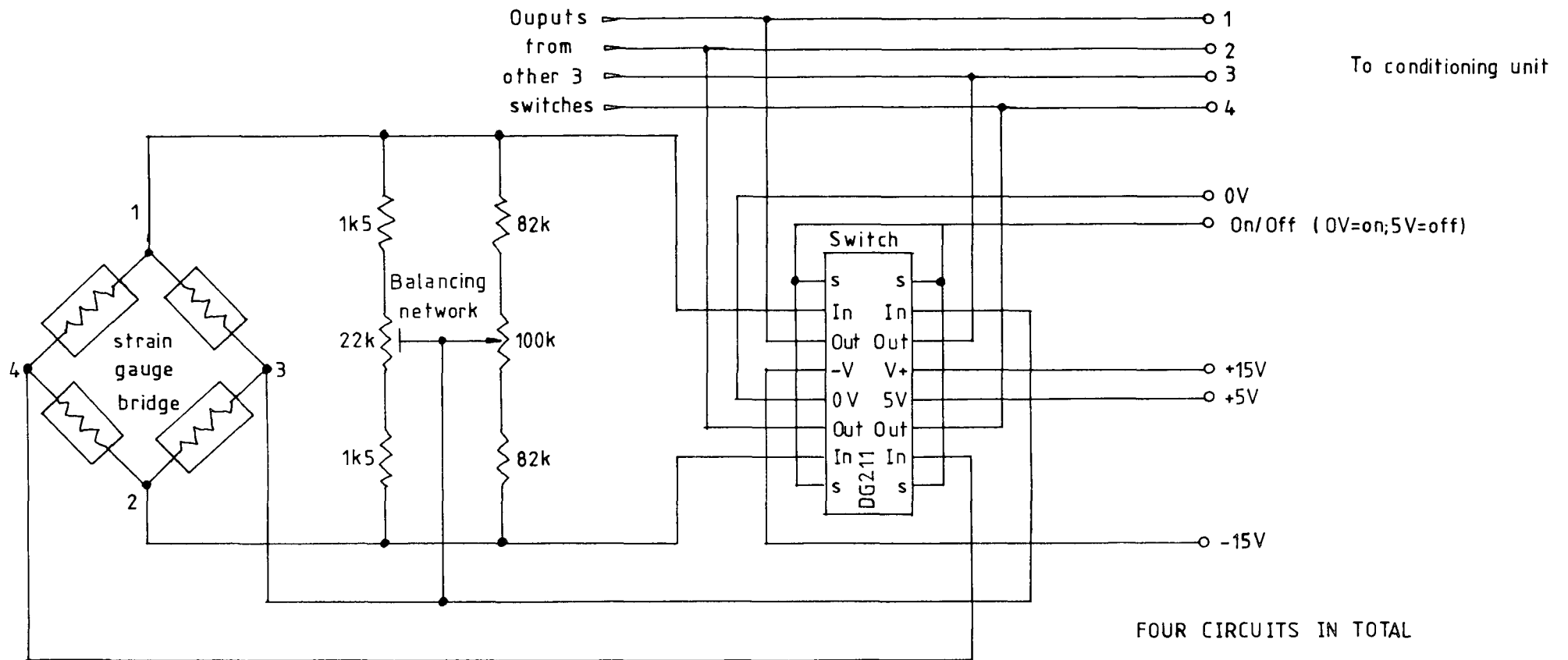

Key unit circuitry

APPENDIX 3

D109 INTERFACE CARD

D109 INTERFACE CARDA3.1. Description

The D109 interface card which slotted into a rear terminal connection of the Apple II microcomputer, enabled the transfer of information from external devices. The card consisted of thirty two, four 8-bit ports, bidirectional lines i.e. each line could act as either an input or output of information. The card had eight control lines which could either accept or transmit instructional signals or they could be used to provide a handshake facility with the external devices. A read handshake facility is where a 'Data Ready' signal is transmitted by the external device and a 'Data Taken' signal is transmitted by D109 to the device after the data has been collected. When used the control lines cause an interrupt signal which was recognised by the computer. The card also provided timers which were used to cause interrupts of fixed duration either continuously or as a single pulse. In one mode the timers could provide a square wave output, on a data line, of a pulse length defined by the timers.

A3.2. Initialisation

Prior to use the D109 had to be initialised to define its operational modes. This was accomplished via the software by giving the 8-bit registers on the card a certain value between 0 and 255. For example the ADC provided an 8-bit input to the computer. A register had to be defined as an input by assigning 255 (all bits set at 5V, TTL logic 1 (high)) to an accompanying register called the data direction register (DDR). If a register was required as an output the DDR was coded with 0, all bits low. All the registers used in this project are listed in Table A3.1. together with their function.

REGISTER	NAME	ASSIGNED VALUE	FUNCTION
0	INPUT/OUTPUT	-	KEY MULTIPLEXER SWITCHING
1	INPUT/OUTPUT		ADC OUTPUT
2	DDR	255	ASSIGNS R1 AS OUTPUT
3	DDR	0	ASSIGNS R0 AS INPUT
13	INTERRUPT	-	INTERRUPT TEST EOC
14	INTERRUPT ENABLE	129	PREPARES EOC INTERRUPT
16	INPUT/OUTPUT	-	} CONDITIONER UNIT SWITCHING AND SC PULSE
17	INPUT/OUTPUT	-	
18	DDR	255	ASSIGNS R16 AS OUTPUT
19	DDR	255	ASSIGNS R17 AS OUTPUT
20	LSB COUNTER	1	} SC PULSE DEFINITION
21	MSB COUNTER	0	
27	AUXILLARY	128	SETS TIMER MODE
30	INTERRUPT ENABLE	192	PREPARES TIMER INTERRUPT

TABLE A3.1: Details of the registers used on the D109

DDR - data direction register
 EOC - end of conversion
 SC - start conversion
 LSB - least significant byte
 MSB - most significant byte

Of the four ports only one was used as an input, register 1. Registers 0, 16 and 17 were set as outputs and used to control the system. To operate, the ADC first had to receive a 500 ns negative TTL pulse to initiate the conversion process, a 'Start Conversion' (SC) pulse. This SC pulse was defined using registers 20 and 21 and output on data line number 31. The SC pulse was 97^R ns long which meant register 20 was set at 1 and register 21 was set at 0.

When the conversion process was completed the ADC transmitted an 'End of Conversion' (EOC) signal. The EOC output line goes high, which was sensed by control line 1 (CL1). When the EOC was detected, the ADC output was latched to register 1 which could be read directly using the software. Once read, another SC pulse was transmitted, sending the EOC line low and restarting the conversion process.

The other registers were all used to transmit logic signals to the various electronic units. Register 0 used four lines (bits 0 to 3) to switch the key unit bridges, three lines (bits 4 to 6) to select the multiplexer input. Bit 7 was used to control the up/down position of the recording pen, on the flatbed XYt recorder, when using the finger arthrograph. Register 17 (bits 0 to 7) and register 16 (bits 0 to 2) were used for bridge selection of the 10-channel conditioning unit. Figure A3.1. shows a schematic diagram of the D109 connections.

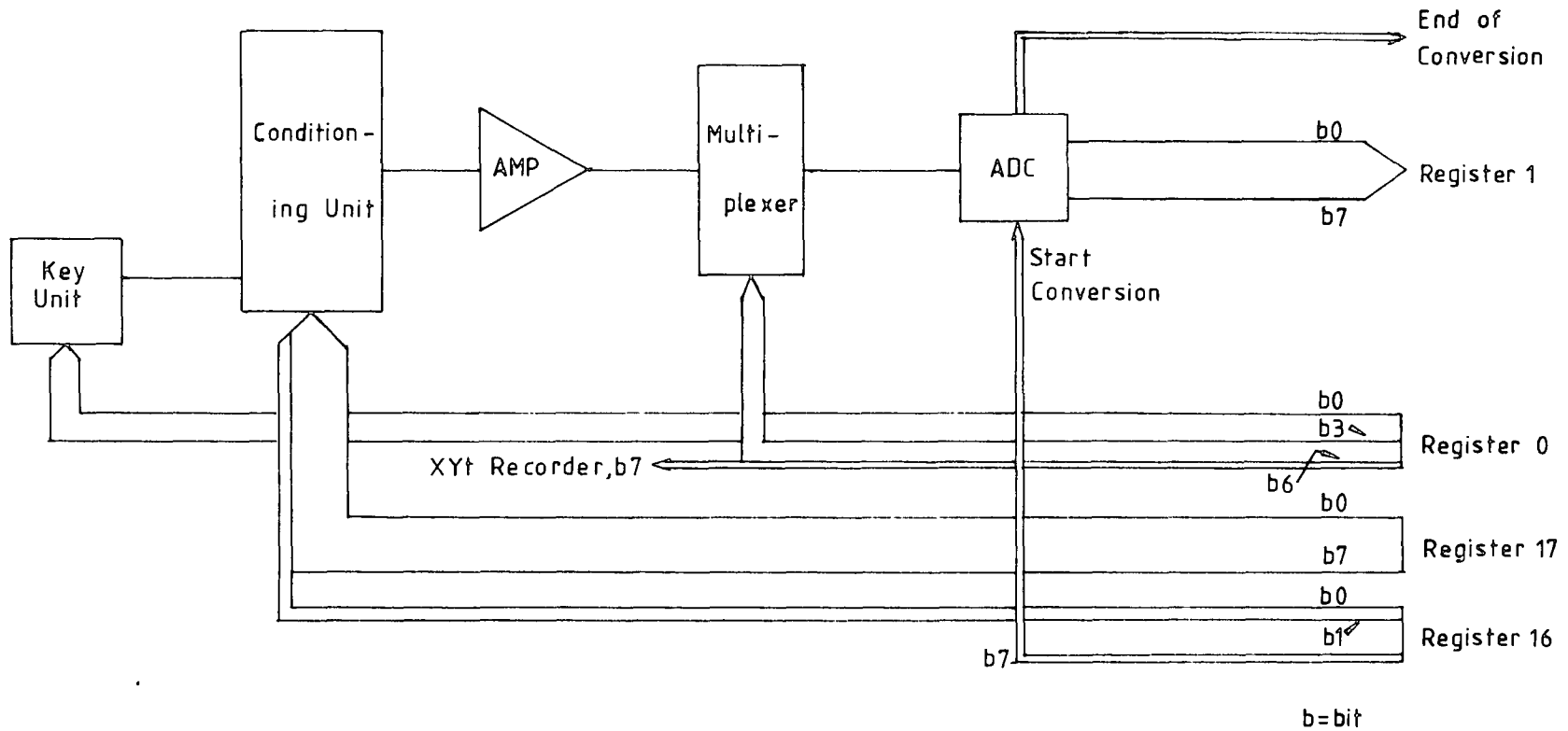
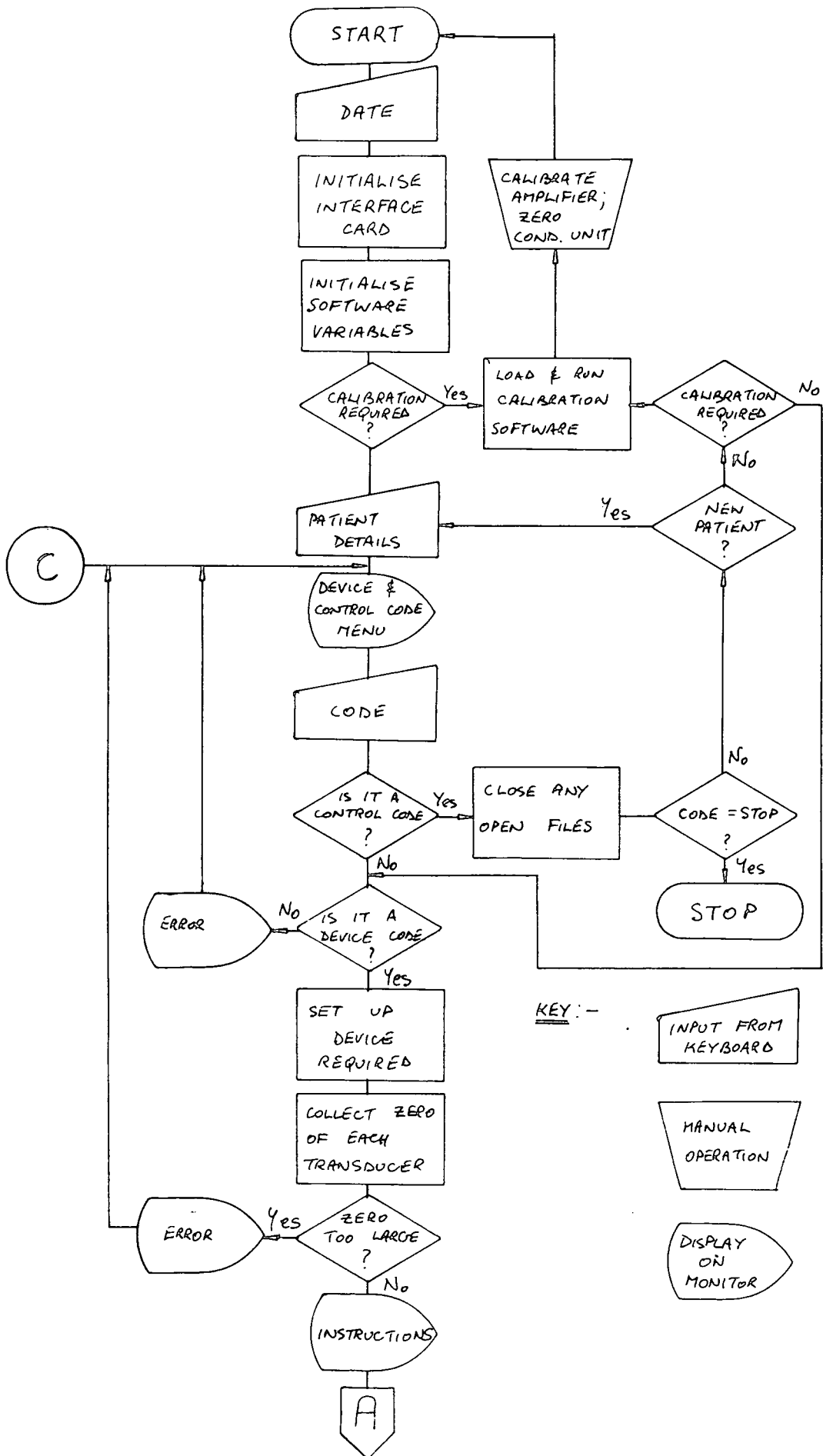
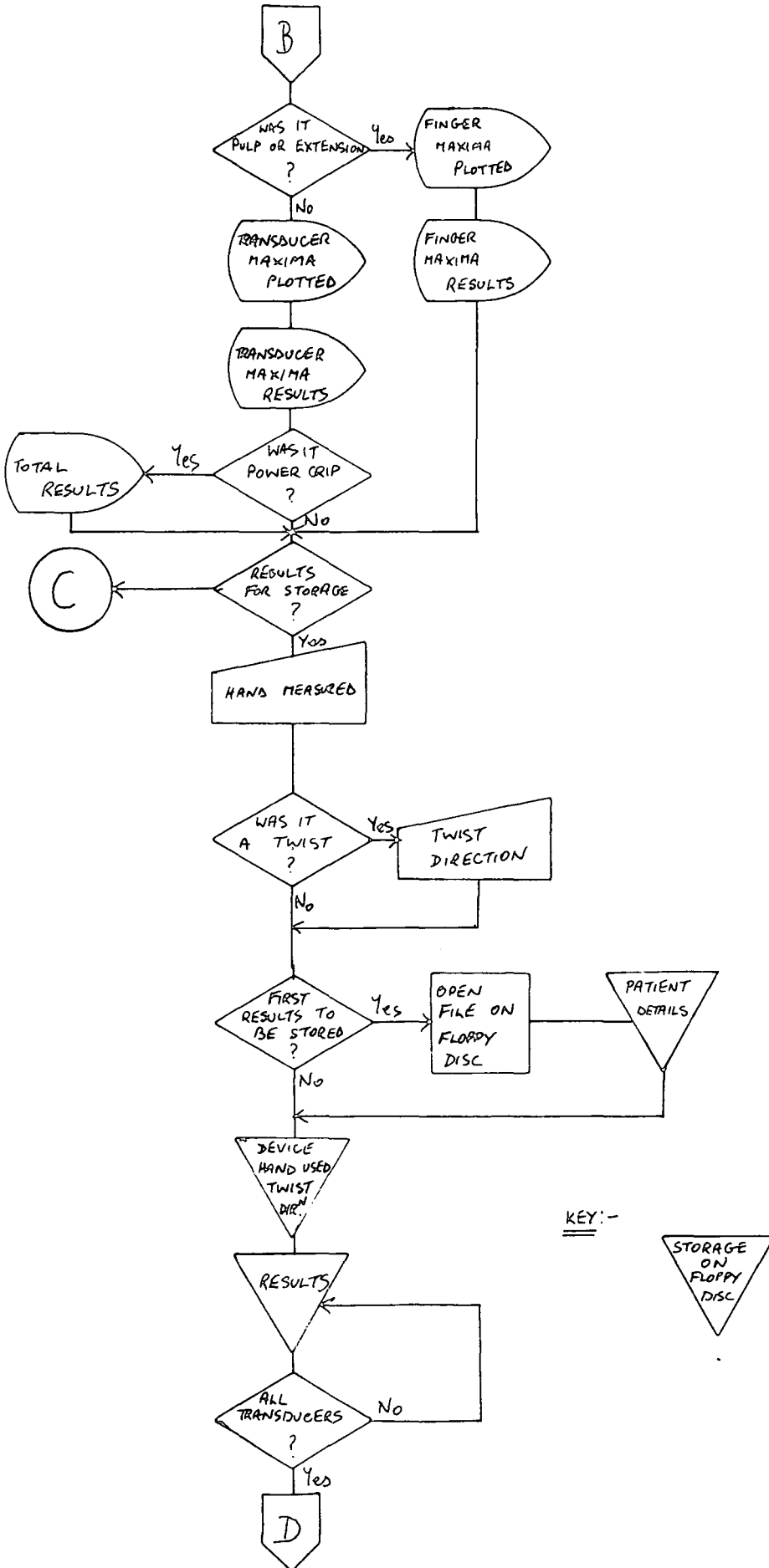

FIGURE A3.1. Details of the connections to the D109 interface card

APPENDIX 4

FLOWCHART OF CONTROLLING SOFTWARE





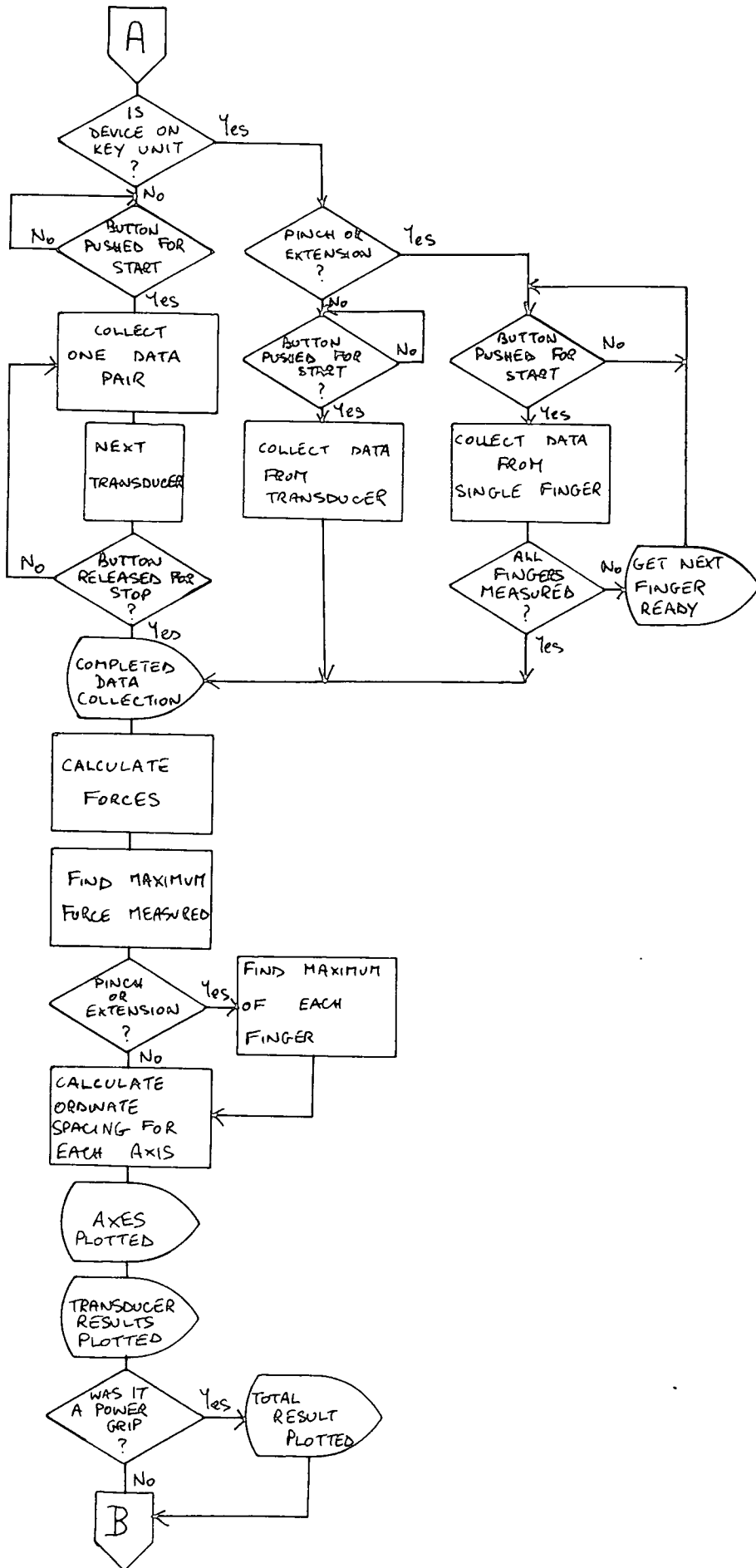

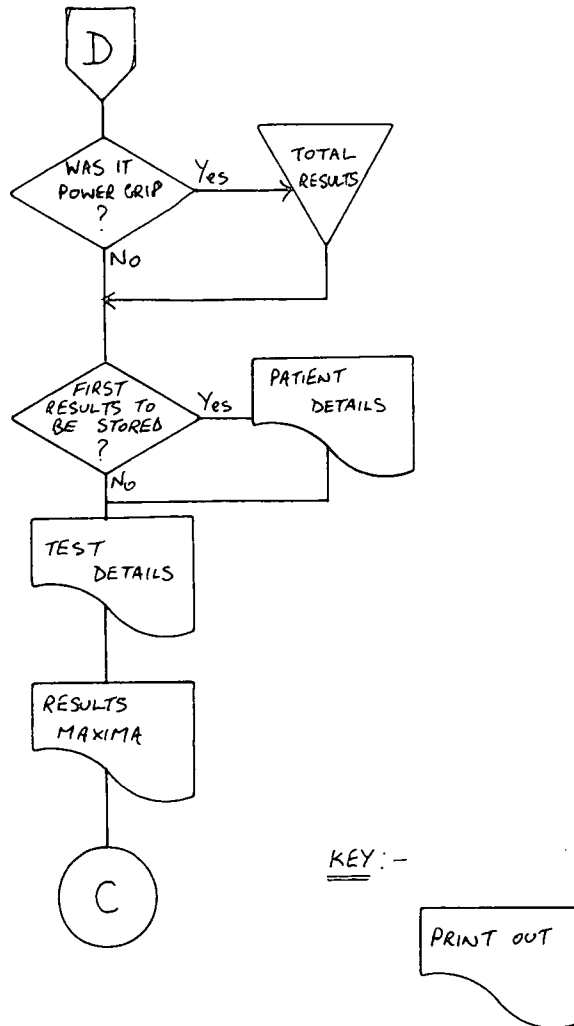

APPENDIX 5

CONTROLLING SOFTWARE LISTING

```

10 REM ***PROGRAMME---HAND---PROGRAMME***
20 REM
30 REM =====
40 REM A.R.JONES-UNI. OF DURHAM-07/08/82
50 REM =====
55 REM TO FULLY CONTROL THE HAND ASSESSMENT SYSTEM
56 REM TO ALLOW INDIVIDUAL SELECTION OF ANY DEVICE AND
57 REM THE COLLECTION OF DATA,CALCULATION, DISPLAY AND
58 REM STORAGE(ON DISC DRIVE 2) OF RESULTS
60 CALL - 936: UTAB 8
70 TEXT
80 CLEAR : HOME :D# = CHR# (4)
90 PRINT TAB(18);"HAND"
100 PRINT TAB(18);"====": PRINT
110 INPUT "TO-DAY'S DATE?-AS DY/MT/YR-->";DT#
115 REM INITIALISATION OF D109 INTERFACE CARD IN SLOT 2 OF APPLE
120 D109 = - 16384 + 2 * 256
130 B = D109 + 21:C = D109 + 17:D = D109 + 16
140 E = D109 + 13:F0 = D109 + 1:G = 0
150 POKE D109 + 19,255: POKE D109 + 18,255
160 POKE D109 + 2,255: POKE D109 + 17,254
170 POKE D109 + 0,143
180 POKE D109 + 16,255: POKE D109 + 3,0
190 POKE D109 + 11,0: POKE D109 + 14,129
200 POKE D109 + 30,192: POKE D109 + 27,128
210 POKE D109 + 20,1
220 DIM FIN$(9),SL(13)
230 DIM RC(13),RDC(13),SEL(20),NUM(200)
240 DIM FM(9),TM(9),RT(50),ZE(10)
250 DIM GN(30),GM$(30)
255 REM CALIBRATION FACTORS
260 DATA .746,.812,.712
270 DATA .844,.786,2.14
280 DATA .746,.760,1.362
290 DATA 5.31,.36
300 DATA 22.93,7.72
310 DATA INDEX,MIDDLE,RING,LITTLE
320 DATA PAN GRIP,LIFT,LOWER MOUNT
330 DATA UPPER MOUNT,KETTLE GRIP
335 REM CODES FOR STRAIN GAUGE BRIDGE SELECTION ON SCANNER UNITS
340 DATA 254, 3,253, 3,251,0
350 DATA 247, 3,238, 3,223,0
360 DATA 181, 3,127, 3,255,2
370 DATA 255, 1,255, 1,255,1
380 DATA 255,1
385 REM CODES FOR MULTIPLEXER INPUT SELECTION
390 DATA 0,0,0,143,0,0,0,0,0,143
400 DATA 142,0,142,139,142,135,141,142,0,141
405 REM STORE ABOVE CODES
410 FOR I = 1 TO 13: READ SL(I): NEXT
420 FOR I = 1 TO 9: READ FIN$(I): NEXT
430 FOR I = 1 TO 13: READ RC(I),RDC(I): NEXT
440 FOR I = 1 TO 20: READ SEL(I): NEXT
450 PRINT "IS AMPLIFIER CALIBRATION"
460 PRINT "OR SCANNER ZEROING REQUIRED, Y/N ?"
470 GET Y#
480 PRINT
490 IF Y# = "Y" THEN PRINT D#;"RUN HmPCAL.D1"
500 CALL - 936: UTAB 5
510 GO = 0

```

```

520 PRINT "PATIENTS' TEST NUMBER CONSISTS OF"
530 PRINT TAB( 12);"#####--+"
540 PRINT : PRINT "WHERE ##### = HOSPITAL RECORD NUMBER"
550 PRINT " AND * = PATIENTS' ASSESSMENT NUMBER"
560 PRINT : INPUT "TEST NUMBER?-->";TN#
570 PRINT "PATIENTS' DATE OF BIRTH?"
580 INPUT "--AS DY/MY/YR-->";DB#
590 INPUT "PATIENTS' DOMINANT HAND?L/R-->";DH#
600 PRINT D#;"PR#0": CALL - 336: VTAB 8
610 PRINT "DEVICE CODES ARE:--"
620 PRINT
630 PRINT TAB( 10);"GRIP-----GR"
640 PRINT TAB( 10);"PAN & KETTLE HANDLE-PH & KH"
650 PRINT TAB( 10);"F & C LATERAL PINCH-FLP & CLP"
660 PRINT TAB( 10);"F & C PULP PINCH----FPP & CPP"
670 PRINT TAB( 10);"F & C KEY THIST-----FKT & CKT"
680 PRINT TAB( 10);"L & S TUBE THIST----LTT & STT"
690 PRINT TAB( 10);"FINGER LIFT-----EX"
700 PRINT
710 PRINT "FOR CONTROL CODES:--"
720 PRINT
730 PRINT TAB( 10);"STOP-----S"
740 PRINT TAB( 10);"RECALIBRATE-----R"
750 PRINT TAB( 10);"NEW PATIENT-----P"
760 PRINT : PRINT "TYPE IN CODE FOR DEVICE REQUIRED";
770 INPUT DR#; IF DR# < > "S" THEN 790
780 PRINT D#;"CLOSE": END
790 IF DR# < > "R" THEN 820
800 REM SETTING OF PARAMETERS TO ALLOW SELECTION AND SCANNING OF REQUIR
D BRIDGES OF SELECTED DEVICE
810 PRINT D#;"CLOSE"
820 Y# = "Y": GOTO 480
830 IF DR# < > "P" THEN 850
840 PRINT D#;"CLOSE"
850 GOTO 900
860 N = 1:A = 10
870 IF DR# < > "GR" THEN 890
880 DV# = "GRIP":N = 4:A = 1
890 GOTO 1240
900 IF DR# < > "PH" THEN 920
910 DV# = "PAN HANDLE":N = 4:A = 5
920 GOTO 1240
930 IF DR# < > "KH" THEN 950
940 DV# = "KETTLE HANDLE":N = 4:A = 6
950 GOTO 1240
960 IF DR# < > "FLP" THEN 980
970 A = 10:DV# = "FINE LATERAL PINCH"
980 GOTO 1240
990 IF DR# < > "CLP" THEN 1010
1000 A = 11:DV# = "COARSE LATERAL PINCH"
1010 GOTO 1240
1020 IF DR# < > "FPP" THEN 1040
1030 A = 10:DV# = "FINE PULP PINCH"
1040 GOTO 1240
1050 IF DR# < > "CPP" THEN 1070
1060 A = 11:DV# = "COARSE PULP PINCH"
1070 GOTO 1240
1080 IF DR# < > "FKT" THEN 1100
1090 A = 12:DV# = "FINE KEY THIST"
1100 GOTO 1240
1110 IF DR# < > "CKT" THEN 1130
1120 A = 13:DV# = "COARSE KEY THIST"

```

```

1120 GOTO 1240
1130 IF DR# < > "LTI" THEN 1160
1140 A = 13:DV# = "LARGE TUBE THIST"
1150 GOTO 1240
1160 IF DR# < > "SIT" THEN 1190
1170 A = 13:DV# = "SMALL TUBE THIST"
1180 GOTO 1240
1190 IF DR# < > "EX" THEN 1220
1200 A = 10:DV# = "EXTENSOR LIFT"
1210 GOTO 1240
1220 PRINT : PRINT "NOT UNDERSTOOD!": PRINT "PLEASE TRY AGAIN"
1230 GOTO 760
1240 SS = SELV LEN (DV#): POKE D109 + 0,SS
1245 REM CHECK SELECTED DEVICE BRIDGES FOR ZERO ERROR
1250 FOR I = 0 TO N - 1
1260 POKE C,RO(A + I): POKE D,RO(A + I)
1270 FOR J = 1 TO 20: NEXT
1280 POKE B,6: WAIT E,1,254:ZE(I + 1) = PEEK (FO): NEXT
1281 UZ = 0:TZ = 0: IF RIGHT# (DR#,1) = "I" THEN TZ = 128
1282 FOR I = 1 TO N
1283 IF ZE(I) < TZ + 5 AND ZE(I) > TZ - 5 THEN 1286
1284 UZ = 1: PRINT "ZERO ERROR"
1285 PRINT : PRINT "CHANNEL #";I + A - 1; " ZERO = ";ZE(I)
1286 NEXT
1287 IF UZ = 0 THEN 1295
1288 PRINT : PRINT "PRESS <SPACE> TO CONTINUE"
1289 GET Y#: IF ASC (Y#) < > 32 THEN 1289: GOTO 600
1290 GOTO 600
1295 CALL - 936: INVERSE : PRINT DV#;" DEVICE": NORMAL : UTAB 8
1300 F = 5
1310 IF DR# = "GR" OR DR# = "PH" OR DR# = "KH" THEN 1380
1320 PRINT
1330 PRINT "ALLOW APPROX. 2 MINS FOR DEVICE"
1340 PRINT "TO WARM UP BEFORE STARTING"
1350 PRINT
1360 POKE D109 + 17,RO(10): POKE D109 + 16,RO(10)
1365 REM SET PARAMETERS FOR MULTIDIGITAL OPERATION
1370 IF DR# = "EX" OR RIGHT# (DR#,2) = "PP" THEN F = 1
1380 CT = 10: IF DR# = "EX" OR RIGHT# (DR#,2) = "PF" THEN CT = 8
1390 IF RIGHT# (DR#,1) = "T" OR RIGHT# (DR#,2) = "LP" THEN CT = 4
1400 PRINT "MAX DATA COLLECTION TIME IS ";CT;" SECONDS"
1450 PTS = INT ((CT + 16.0) + .5)
1470 POKE D109 + 20,1
1480 FOR I = 1 TO 200:NUM(I) = 0: NEXT
1490 PRINT : PRINT
1500 PRINT : PRINT : PRINT TAB( 10);
1510 INVERSE : PRINT "EVERYTHING IS READY": NORMAL : PRINT
1520 IF A > = 10 THEN GOTO 8000
1530 PRINT "DEPRESS EITHER RED START BUTTON TO"
1540 PRINT TAB( 8);"TO INITIATE SCAN"
1550 PRINT "KEEP DEPRESSED AND RELEASE WHEN COMPLETE"
1560 IF PEEK ( - 16286) > 127 OR PEEK ( - 16287) > 127 THEN 1590
1570 GOTO 1560
1574 REM
1575 REM DATA COLLECTION ROUTINE
1576 REM
1580 NP = 0
1590 AH = A
1600 FOR CH = 1 TO N
1610 NP = NP + 1: IF NP > PTS THEN 1680
1620 POKE C,RO(AH): POKE D,RO(AH)
1630 FOR I = 1 TO 12: NEXT

```

```

1640 POKE B%6: WAIT E%1,254:NUM(NP) = PEEK (FQ)
1650 AA = AA + 1: NEXT
1660 IF PEEK ( - 16286) < = 127 AND PEEK ( - 16287) < = 127 THEN 1680

1670 GOTO 1590
1680 PRINT : PRINT "SCAN COMPLETED"
1684 REM
1685 REM CALCULATION OF RESULTS
1686 REM
1690 PTS = NF:CT = INT (((PTS / 16) * 100) + .5) / 100 + 1
1700 FOR I = 1 TO N
1710 FNC(I) = 0:TRT(I) = 0: NEXT
1720 TRT = 0:FRT = 0:I = 0
1730 K = 0:SUM = 0
1740 FL = 0
1750 CALL - 936: VTAB 6
1760 PRINT : PRINT "CALCULATIONS PROCEEDING"
1770 PRINT : PRINT "I'M SORRY THIS WILL TAKE ME A SHORT TIME"
1780 MAX = 0
1785 REM CALCULATION OF APPLIED FORCES
1786 REM FINDING MAX OF EACH CHANNEL IN FORCE AND TIME
1787 REM FINDING MIN OF TORQUE AND TIME
1790 FOR J = 1 TO N
1800 FOR I = J TO PTS - 1 STEP N
1810 NUM(I) = (NUM(I) - ZC(J)) / SL(A + J - 1)
1820 NUM(I) = INT ((NUM(I) + 100) + .5) / 100
1830 IF RIGHT$(DR$,1) = "T" THEN 1850
1840 IF NUM(I) < 0 THEN NUM(I) = 0
1850 IF NUM(I) > FNC(J) THEN TRT(J) = I
1860 IF NUM(I) > FNC(J) THEN FNC(J) = NUM(I)
1870 IF NUM(I) < FL THEN TL = I
1880 IF NUM(I) < FL THEN FL = NUM(I)
1890 NEXT
1900 IF FNC(J) > MAX THEN MAX = FNC(J)
1910 NEXT
1920 SUM = 0:K = 0
1930 IF DR$ < > "GR" THEN 2020
1935 REM SUM OF FINGER FORCES TO GIVE TOTAL POWER GRIP FORCE
1936 REM FINDING MAX OF FORCE AND ITS TIME
1940 MAX = 0
1950 FOR I = 1 TO PTS - 1 STEP N
1960 FOR J = 1 TO N
1970 SUM = SUM + NUM(I + J - 1): NEXT J
1980 K = K + 1:RT(K) = SUM:SUM = 0
1990 IF RT(K) > MAX THEN TRT = K
2000 IF RT(K) > MAX THEN MAX = RT(K)
2010 NEXT
2020 OD = 50
2025 REM FINDING OF FORCE AXIS SPACING
2030 IF RIGHT$(DR$,2) = "FP" OR RIGHT$(DR$,1) = "X" THEN GOSUB 7000
2040 IF MAX < = 20 THEN OD = 1
2050 IF MAX > 20 AND MAX < = 100 THEN OD = 10
2060 IF MAX > 100 AND MAX < = 300 THEN OD = 25
2070 NOD = INT (MAX / OD) + 1
2080 Yn = NOD * OD
2090 MY = INT ( - FL) + 1
2100 IF RIGHT$(DR$,1) < > "T" THEN MY = 0
2110 XSC = 279 / CT:YSC = 158 / (Yn + MY)
2114 REM
2115 REM RESULTS PLOTTING ROUTINE
2116 REM

```

```

2120 HGR2 : HCOLOR= 3: HPLOT 0,159
2125 REM FORCE AXIS PLOTTING
2130 FOR I = 0 TO NDD + INT (( - FL / 00) + 1)
2140 Y% = INT (I * YSC + .5)
2150 IF Y% > 159 THEN Y% = 159
2160 IF Y% < 0 THEN Y% = 0
2170 HPLOT TO 0,159 - Y%
2180 HPLOT 2,159 - Y% TO 0,159 - Y%
2190 IF I < > NY THEN 2280
2195 REM TIME AXIS PLOTTING
2200 FOR J = 0 TO CT
2210 X% = INT (J * XSC + .5)
2220 IF X% > 279 THEN X% = 279
2230 IF X% < 0 THEN X% = 0
2240 HPLOT TO X%,159 - Y%
2250 HPLOT X%,157 - Y% TO X%,159 - Y%
2260 NEXT
2270 HPLOT 0,159 - Y%
2280 NEXT
2285 REM RESULTS PLOTTING
2290 XSC = 279 / PTS
2300 Y% = INT (MY * YSC + .5)
2310 IF Y% > 159 THEN Y% = 159
2320 IF Y% < 0 THEN Y% = 0
2330 HPLOT 0,159 - Y%
2340 FOR J = 1 TO N
2350 FOR I = J TO PTS - 1 STEP N
2360 Y = NUM(I) + MY
2370 Y% = INT (Y * YSC + .5)
2380 X% = INT (I * XSC + .5)
2390 IF Y% > 159 THEN Y% = 159
2400 IF Y% < 0 THEN Y% = 0
2410 IF X% > 279 THEN X% = 279
2420 IF X% < 0 THEN X% = 0
2430 HPLOT TO X%,159 - Y%
2440 Y1% = 154 - Y%
2450 IF Y1% < 0 THEN Y1% = 0
2455 REM PLOT OUT MAXIMUM TICS
2460 IF I = TMC(J) THEN HPLOT X%,Y1% TO X%,159 - Y%
2470 IF RIGHT$(DR$,1) < > "T" THEN 2490
2480 IF I = TL THEN HPLOT X%,154 - Y% TO X%,159 - Y%
2490 NEXT
2500 Y% = INT (MY * YSC + .5)
2510 HPLOT 0,159 - Y%
2520 NEXT
2530 IF DR$ < > "GR" THEN 2710
2535 REM PLOT OUT OF POWER GRIP
2540 FOR I = 1 TO PTS / 4
2550 Y% = INT (RT(I) * YSC + .5)
2560 X% = INT (I * 4 * XSC + .5)
2570 IF Y% < 0 THEN Y% = 0
2580 Y1% = Y% + 2:Y2% = Y% - 2
2590 IF Y1% > 159 THEN Y1% = 159
2600 IF Y2% < 0 THEN Y2% = 0
2610 HPLOT X%,159 - Y1% TO X%,159 - Y2%
2620 X1% = X% - 3:X2% = X% + 3
2630 IF X1% < 0 THEN X1% = 0
2640 IF X2% > 279 THEN X2% = 279
2650 IF I = TRT THEN HPLOT X1%,159 - Y1% TO X2%,159 - Y1%
2660 X1% = X% + 2:X2% = X% - 2
2670 IF X1% > 279 THEN X1% = 279
2680 IF X2% < 0 THEN X2% = 0
2690 HPLOT X1%,159 - Y% TO X2%,159 - Y%

```

```

2700 NEXT
2710 IF RIGHT$(DR$,2) = "PP" OR RIGHT$(DR$,1) = "X" THEN GOTO 750
2720 TEXT
2730 REM PRINT OUT OF RESULTS MAXIMA ON MONITOR
2730 IF A > = 10 THEN 2940
2740 IF DR$ < > "GR" THEN 2880
2750 FOR J = 1 TO N
2760 T = (CT / PTS) + TM(J)
2770 T = INT ((T * 100) + .5) / 100
2780 PRINT FIN$(J); " FINGER MAXIMUM";
2790 POKE 36,23
2800 PRINT "=";FM(J);" NEWTONS @ ";T;" SECONDS"
2810 NEXT
2820 T = (CT / (PTS / 4)) + TM1
2830 T = INT ((T * 100) + .5) / 100
2840 PRINT "TOTAL MAXIMUM GRIP";
2850 POKE 36,23
2860 PRINT "=";MAX;" NEWTONS @ ";T;" SECONDS"
2870 GOTO 3050
2880 FOR J = 1 TO N
2890 T = (CT / PTS) + TM(J)
2900 T = INT ((T * 100) + .5) / 100
2910 PRINT FIN$(A + J - 1); " MAXIMUM =" ;FM(J); " NEWTONS @ ";T;" SECONDS"
2920 NEXT
2930 GOTO 3050
2940 IF RIGHT$(DR$,1) < > "I" THEN 3020
2950 T = (CT / PTS) + TM(1)
2960 T = INT ((T * 100) + .5) / 100
2970 PRINT DV$;" MAXIMUM =" ;FM(1); " NEWTON-METRES @ ";T;" SECONDS"
2980 T = (CT / PTS) + TL
2990 T = INT ((T * 100) + .5) / 100
3000 PRINT DV$;" MINIMUM =" ;FL;" NEWTON-METRES @ ";T;" SECONDS"
3010 GOTO 3050
3020 T = (CT / PTS) + TM(1)
3030 T = INT ((T * 100) + .5) / 100
3040 PRINT DV$;" MAXIMUM =" ;FM(1); " NEWTONS @ ";T;" SECONDS"
3050 PRINT D$;"PR#0"
3060 PRINT
3070 PRINT "IS DATA TO BE STORED ON DISC?Y/N-->";
3080 GET Y$
3090 IF Y$ = "N" THEN 3140
3100 IF Y$ = "Y" THEN 3130
3110 PRINT "NOT UNDERSTOOD!!!!!"
3120 GOTO 3070
3130 GOTO 5000
3140 GOTO 600
5000 PRINT : PRINT
5010 PRINT TAB( 10);"DISC STORAGE ROUTINE"
5020 PRINT TAB( 10);"==== ====="
5030 DK = 2
5040 PRINT : INPUT "WHICH HAND USED?L/R-->";L$
5050 IF DR$ < > "GR" THEN 5070
5060 S = 2
5070 IF RIGHT$(DR$,1) > < "I" THEN 5090
5080 PRINT : INPUT "THIST DIRECTION?-LW/RCH-->";TD$
5090 UNERR GOTO 6000
5100 PRINT D$;"WRITE";TN$
5130 PRINT DR$: PRINT L$
5150 IF DR$ = "GR" THEN PRINT STR$(S)
5160 IF RIGHT$(DR$,1) = "I" THEN PRINT TD$
5170 PRINT STR$(PTS)

```

```

5180 FOR J = 1 TO N
5190 FOR I = J TO PTS - 1 STEP N
5200 PRINT STR$(NUM(I))
5210 NEXT
5220 PRINT STR$(FM(J)): PRINT STR$(TM(J))
5230 IF RIGHT$(DR$,1) < > "T" THEN 5250
5240 PRINT STR$(FL): PRINT STR$(TL)
5250 NEXT
5260 IF DR$ < > "GR" THEN 5310
5270 FOR I = 1 TO PTS / 4
5280 PRINT STR$(RT(I))
5290 NEXT
5300 PRINT STR$(MAX): PRINT STR$(TRT)
5310 POKE 218,0
5320 PRINT D$;"PR#1"
5330 PRINT
5340 Q0 = Q0 + 1: IF Q0 > 1 THEN 5360
5345 REM PRINT OUT OF RESULTS MAXIMA AND FILE DETAILS ON SILENTYPE
5350 PRINT "RECORD FILE-->";TN$
5360 PRINT DQ$;" DEVICE USED";
5370 POKE 36,40: PRINT "HAND USED----->";L$
5380 IF Q0 > 1 THEN 5480
5390 PRINT "DATE OF TEST-->";DT$;
5400 POKE 36,40: PRINT "DATE OF BIRTH---->";DB$
5410 AA = VAL ( RIGHT$( DT$,2)):BB = VAL ( RIGHT$( DB$,2))
5420 AB = VAL ( MID$( DT$,4,2)):AC = VAL ( MID$( DB$,4,2))
5430 AD = AB - AC: IF AD > 0 THEN 5450
5440 AD = (12 - AC) + AB:AA = AA - 1
5450 AE = VAL ( LEFT$( DT$,2)):AF = VAL ( LEFT$( DB$,2))
5460 AG = AE - AF: IF AG < 0 THEN AD = AD - 1
5470 PRINT "AGE = ";AA - BB;" YEARS ";AD;" MONTHS";
5480 POKE 36,40: PRINT "DOMINANT HAND---->";DH$
5490 IF DR$ < > "GR" THEN 5510
5500 POKE 36,40: PRINT "GRIP SPAN USED--->";S
5510 IF RIGHT$(DR$,1) < > "T" THEN 5530
5520 POKE 36,40: PRINT "TWIST DIRECTION-->";TD$
5530 IF A > = 10 THEN 5740
5540 FOR I = 1 TO N: PRINT FM(I); SPC( 5); NEXT
5550 IF DR$ = "GR" THEN PRINT MAX;
5560 PRINT " CHANNEL MAXIMA"
5570 IF RIGHT$(DR$,1) < > "H" THEN 5740
5580 Q0 = 0:II = 3:IX = - 2:IC = 0
5590 IF DR$ = "KH" THEN II = 2:I = 2
5600 FOR I = II TO PTS - 1 STEP N
5610 IF NUM(I) = FM(II) THEN Q0 = Q0 + NUM(I) + IX:IC = IC + 1
5620 NEXT
5720 Q0 = INT ((Q0 / II) * 100) + .5) / 100
5730 PRINT Q0; SPC( 5);"GR @ MAX LIFT"
5740 IF RIGHT$(DR$,1) = "T" THEN PRINT FM(1); SPC( 5);FL; SPC( 5);"M
& MIN TORQUE"
5745 IF RIGHT$(DR$,2) = "LP" THEN PRINT FM(1); SPC( 5);"MAX"
5750 IF RIGHT$(DR$,2) = "PP" OR RIGHT$(DR$,1) = "X" THEN 5770
5760 GOTO 600
5770 FOR I = 1 TO 4: PRINT FM(I); SPC( 5); NEXT
5780 PRINT "FINGER MAX"
5790 GOTO 600

```

```

6000 CODE = PEEK (222): POKE 216,0
6005 REM DISC HANDLING ERROR ROUTINE
6010 IF CODE < > 5 THEN 6070
6020 PRINT : PRINT TN$;" IS NOW OPEN FOR FIRST TIME"
6030 PRINT D$;"OPEN";TN$;"D2"
6040 PRINT D$;"WRITE";TN$
6050 PRINT DT$; PRINT JB$; PRINT DH$
6060 GOTO 5130
6070 IF CODE < > 9 THEN 6140
6075 PRINT D$;"CLOSE";TN$
6080 PRINT : PRINT "DISC 2 IS FULL"
6090 PRINT "REPLACE WITH A NEW INITIALISED DISC"
6100 PRINT : PRINT "PRESS <SPACE> WHEN READY"
6110 GET Y$: IF ASC (Y$) < > 32 THEN 6110
6120 PRINT : INPUT "NEW FILENAME?-->";TN$
6130 GOTO 6030
6140 PRINT : PRINT "ERROR CODE = ";CODE
6150 PRINT "PRESS <SPACE> TO RETURN TO DEVICE MENU"
6160 GET Y$: IF ASC (Y$) < > 32 THEN 6160
6170 GOTO 600
7000 FOR FF = 1 TO 4
7005 REM FINDING MAXIMA OF INDIVIDUAL FINGER RESULTS
7010 FM(FF) = 0
7020 FOR I = INT ((PTS * (FF - 1)) / 4) TO INT ((PTS * FF) / 4)
7030 IF NUM(I) > FM(FF) THEN FM(FF) = I
7040 IF NUM(I) > FM(FF) THEN FM(FF) = NUM(I)
7050 NEXT
7060 NEXT
7070 RETURN
7500 FOR FF = 1 TO 4
7505 REM PLOTTING OUT INDIVIDUAL FINGER MAXIMA TIC MARKS
7510 Y% = INT (FM(FF)) * YSC + .5)
7520 X% = INT (TM(FF)) * XSC + .5)
7530 Y1% = Y% + 5: IF Y1% > 159 THEN Y1% = 159
7540 HPLOT X%,159 - Y% TO X%,159 - Y1%
7550 NEXT
7560 TEXT
7570 FOR J = 1 TO 4
7580 PRINT FIN$(J);" FINGER MAXIMUM = ";FM(J);" NEWTONS"
7590 NEXT
7600 GOTO 3050
8000 PRINT "PRESS EITHER RED BUTTON TO START SCAN"
8005 REM DATA COLLECTION OF DEVICES IN KEY UNIT
8010 IF PEEK ( - 16286) > 127 OR PEEK ( - 16287) > 127 THEN 8030
8020 GOTO 8010
8030 PRINT : PRINT "O.K."
8040 NP = 0: POKE 0,RC(A): POKE 0,RC(B)
8050 NP = NP + 1: IF NP > PTS THEN 8150
8060 IF NP = INT ((PTS * F) / 4) THEN 8100
8070 FOR I = 1 TO 8
8080 POKE B,6: WAIT E,1,254:NUM(NP) = PEEK (FQ)
8090 GOTO 8050
8100 F = F + 1: IF F > 4 THEN 8150
8110 PRINT : PRINT "HAVE ";FIN$(F);" FINGER READY TO TEST"
8120 PRINT : PRINT "PRESS RED BUTTON TO CONTINUE"
8130 IF PEEK ( - 16286) < = 127 THEN 8130
8140 PRINT : PRINT "O.K.": GOTO 8050
8150 PRINT : PRINT "SCAN COMPLETED"
8160 GOTO 1700

```

APPENDIX 6

LISTING OF CALIBRATION SOFTWARE

```

5  REM          ***PROGRAMME---AMPCAL---PROGRAMME***
10  REM
15  REM  =====
20  REM  A.R.JONES-UNI. OF DURHAM-07/08/82
25  REM  =====
26  REM  AUTOMATICALLY CALLED BY HAND WHEN SCANNER AND AMPLIFIER
27  REM  REQUIRE ZEROING AND CALIBRATION
30  CALL  - 936: UTAB 8
35  TEXT
40  CLEAR : HOME : UTAB 8:D$ = CHR$(4)
45  D109 = - 16384 + 2 * 256
50  B = D109 + 21:C = D109 + 17:D = D109 + 16
55  E = D109 + 13:FF = D109 + 1:G = 0
60  PRINT TAB(17);"AMPCAL"
65  PRINT TAB(17);"=====": PRINT
75  POKE D109 + 19,255: POKE D109 + 18,255
80  POKE D109 + 2,255: POKE D109 + 17,254
85  POKE D109 + 0,143
90  POKE D109 + 16,255: POKE D109 + 3,0
95  POKE D109 + 11,0: POKE D109 + 14,129
100  POKE D109 + 30,192: POKE D109 + 27,128
110  DIM RC(13),RD(13)
130  DATA 254,3,253,3,251,3
140  DATA 247,3,239,3,223,3
150  DATA 191,3,127,3,255,2
160  DATA 255,1,255,1,255,1,255,1
170  FOR I = 1 TO 13
180  READ RC(I),RD(I): NEXT
3000  REM ***INSTRUMENT CALIB & ZERO
3010  PRINT : PRINT
3020  PRINT "DOES AMPLIFIER NEED CALIBRATING?Y/N";
3030  GET Y$: IF Y$ = "N" THEN 3380
3040  CALL  - 936: UTAB 8
3050  PRINT "PRESS A RED BUTTON AFTER EACH"
3060  PRINT "INSTRUCTION TO PROCEED"
3070  PRINT
3080  PRINT "PRESS A RED BUTTON NOW"
3090  IF PEEK ( - 16286 ) < = 127 AND PEEK ( - 16287 ) < = 127 THEN 309
3095  FOR I = 1 TO 200: NEXT
3100  CALL  - 936: UTAB 8
3110  PRINT "ON AMPLIFIER TURN:-"
3120  PRINT "      MODE SWITCH TO <C>"
3130  PRINT "      RANGE SWITCH TO <LVDT>"
3140  PRINT "      SCALE FACTOR DIAL TO <500>"
3150  IF PEEK ( - 16286 ) < = 127 AND PEEK ( - 16287 ) < = 127 THEN 315
3155  FOR I = 1 TO 200: NEXT
3160  POKE D109 + 17,RC(1): POKE D109 + 16,RD(1)
3170  MODE$ = "C"
3180  GOSUB 3700
3190  CALL  - 936: UTAB 8
3200  PRINT "ON AMPLIFIER TURN:-"
3210  PRINT "      MODE SWITCH TO <R>"
3220  PRINT "      RANGE SWITCH TO <1K>"
3230  PRINT "      SCALE FACTOR DIAL TO <480>"
3240  MODE$ = "R"
3250  IF PEEK ( - 16286 ) < = 127 AND PEEK ( - 16287 ) < = 127 THEN 3250
3255  FOR I = 1 TO 200: NEXT
3260  GOSUB 3700
3270  CALL  - 936: UTAB 8
3280  GOTO 3350

```

```

3280 GOTO 3350
3290 PRINT "ON AMPLIFIER TURN:-"
3300 PRINT "      MODE SWITCH TO <Z>"
3310 MODE$ = "Z"
3320 IF PEEK ( - 16286 ) < = 127 AND PEEK ( - 16287 ) < = 127 THEN 332

3325 FOR I = 1 TO 200: NEXT
3330 GOSUB 3700
3340 CALL - 936: UTAB 8
3350 PRINT "ON AMPLIFIER TURN:-"
3360 PRINT "      MODE SWITCH TO <N>"
3370 IF PEEK ( - 16286 ) < = 127 AND PEEK ( - 16287 ) < = 127 THEN 337

3375 FOR I = 1 TO 200: NEXT
3380 CALL - 936: UTAB 8
3390 PRINT TAB( 6);"AMPLIFIER IS NOW CALIBRATED"
3400 PRINT : PRINT "CONTROLS SHOULD BE AT:-"
3410 PRINT "      SCALE FACTOR DIAL AT <480>"
3420 PRINT "      MODE SWITCH AT <N>"
3430 PRINT "      RANGE SWITCH AT <1K>"
3440 PRINT
3450 PRINT TAB( 2);"NOW TO ZERO ALL DEVICES CONNECTED TO"
3460 PRINT TAB( 14);"SCANNER UNIT"
3470 PRINT :CC = 9
3475 PRINT : PRINT SPC( 5);"PRESS A RED BUTTON TO PROCEED"
3480 IF PEEK ( - 16286 ) < = 127 AND PEEK ( - 16287 ) < = 127 THEN 348

3485 FOR I = 1 TO 200: NEXT
3490 POKE D109 + 17,RC(CC): POKE D109 + 16,RC(CC)
3500 CALL - 936: UTAB 1
3510 PRINT TAB( 15);"CHANNEL #";CC: PRINT
3520 POKE D109 + 20,1: POKE D109 + 21,0
3530 WAIT D109 + 13,1,254
3540 ADC = PEEK ( D109 + 1 )
3550 PRINT "DEVICE OUTPUT=";ADC
3560 PRINT TAB( 4);"TURN EITHER SCANNER ZERO CONTROL"
3570 IF ADC > 0 THEN PRINT TAB( 10);"ON CHANNEL #";CC;" C/W"
3580 IF ADC = 0 THEN PRINT TAB( 10);"ON CHANNEL #";CC;" C/W"
3600 IF PEEK ( - 16286 ) < = 127 AND PEEK ( - 16287 ) < = 127 THEN 3500

3610 CC = CC - 1
3630 IF CC = 0 THEN 3660
3640 CALL - 936: UTAB 8
3650 GOTO 3490
3660 CALL - 936: UTAB 8
3670 PRINT TAB( 7);"SCANNER DEVICES NOW ZEROED"
3672 PRINT : PRINT SPC( 5);"PRESS A RED BUTTON TO PROCEED"
3675 IF PEEK ( - 16286 ) < = 127 AND PEEK ( - 16287 ) < = 127 THEN 3675

3680 GOSUB 5000
3690 PRINT CHR$( 4);"RUN HAND"
3700 CALL - 936: UTAB 1
3710 POKE D109 + 20,1: POKE D109 + 21,0
3720 WAIT D109 + 13,1,254
3730 ADC = PEEK ( D109 + 1 )
3740 PRINT "AMPLIFIER OUTPUT = ";ADC
3750 IF MODE$ = "R" THEN 3830
3760 IF MODE$ = "Z" THEN 3870
3770 IF ADC < 255 THEN PRINT "TURN ADJACENT POT C/W"
3780 IF ADC = 255 THEN PRINT "TURN ADJACENT POT A C/W"
3790 PRINT "NEEDS TO BE <255>"
3810 IF PEEK ( - 16286 ) < = 127 AND PEEK ( - 16287 ) < = 127 THEN 3700

```

```

3820 RETURN
3830 IF ADC > 0 THEN PRINT "TURN EITHER AMPLIFIER ZERO CONTROLS A C/W"
3840 IF ADC = 0 THEN PRINT "TURN EITHER AMPLIFIER ZERO CONTROL C/W"
3850 PRINT "NEEDS TO BE <0>"
3860 GOTO 3810
3870 IF ADC > 0 THEN PRINT "TURN ADJACENT POT A C/W"
3880 IF ADC = 0 THEN PRINT "TURN ADJACENT POT C/W"
3890 PRINT "NEEDS TO BE <0>"
3900 GOTO 3810
5000 DIM TH$(4),KUK(4)
5005 POKE D109 + 17,255: POKE D109 + 16,1
5010 DATA FINE PINCH,142,COARSE PINCH,141,FINE TWIST,139,COARSE TWIST,13
5
5020 FOR I = 1 TO 4: READ TH$(I),KUK(I): NEXT
5030 FOR I = 1 TO 4
5035 POKE D109 + 0,KUK(I)
5040 ME = 0: IF I > 2 THEN ME = 128
5050 CALL - 936: PRINT TAB( 11);TH$(I);" DEVICE"
5060 PRINT : POKE D109 + 20,1: POKE D109 + 21,0
5070 WAIT D109 + 13,1,254:ADC = PEEK (D109 + 1)
5080 PRINT "DEVICE O/P = ";ADC
5085 PRINT "OUTPUT SHOULD BE ";ME
5090 IF ADC > ME THEN PRINT TAB( 6);"FOR ";TH$(I);" DEVICE AC/W"
5100 IF ADC < = ME THEN PRINT TAB( 6);"FOR ";TH$(I);" DEVICE C/W"
5110 IF PEEK ( - 16286) < = 127 AND PEEK ( - 16287) < = 127 THEN 5050

5120 NEXT
5130 RETURN

```

APPENDIX 7

LISTING OF RESULTS EXTRACTION SOFTWARE

```

10 REM      PROGRAMME===EXTRACT===PROGRAMME
20 REM      =====
30 REM      A.R. JONES-UNI. OF DURHAM-18/11/82
40 REM      =====
50 REM      TO RETRIEVE DATA FROM DISC FILES
55 REM      COLLECTS ALL DATA OF ALL DEVICES
56 REM      AND GIVES PRINT OUT OF PLOTS & DATA
57 REM      PRINTS OUT ALL RESULTS FROM A GIVEN STARTING POINT
58 REM      ONLY FOR USE ON FILES STORED BEFORE NEW LIFTING TRANSDUCER INSTAL
    LED
59 REM      THAT IS ALL PATIENTS
60 REM
70 TEXT : HOME
80 CLEAR
90 CLEAR :D$ = CHR$(4);LP = 0
100 DIM NUM(250),FM(9),TM(9),RT(50)
110 DIM FIN$(8),GM$(30),GN$(30)
120 DATA INDEX,MIDDLE,RING,LITTLE,PAN HANDLE,LOWER MOUNT,UPPER MOUN
    T,KETTLE HANDLE
130 FOR I = 1 TO 8: READ FIN$(I): NEXT
136 REM INPUT STARTING POINT FOR EXTRACTION
140 INPUT "FILE REQUIRED?-->";TN$
150 INPUT "ON WHICH DISC?-->";DK
160 TN$ = "NO"
195 PRINT : PRINT "STARTING POINT FOR EXTRACTION"
196 INPUT "IS WITH DEVICE-->";SD$
197 INPUT "USING HAND----->";R$
210 PRINT
215 REM START RESULTS EXTRACTION
220 ONERR GOTO 5000
222 PRINT D$;"OPEN";TN$;" ";DK
224 PRINT D$;"READ";TN$
226 INPUT DT$,DB$,DH$
228 PRINT D$;"READ";TN$: INPUT DR$,L$
229 REM SET PARAMETERS FOR EXTRACTION OF RESULTS
230 IF DR$ = "GR" THEN DV$ = "GRIP"
240 IF DR$ = "PH" THEN DV$ = "PAN HANDLE"
250 IF DR$ = "KH" THEN DV$ = "KETTLE HANDLE"
260 IF DR$ = "FLP" THEN DV$ = "FINE LATERAL PINCH"
270 IF DR$ = "CLP" THEN DV$ = "COARSE LATERAL PINCH"
280 IF DR$ = "FPP" THEN DV$ = "FINE PULP PINCH"
290 IF DR$ = "CPP" THEN DV$ = "COARSE PULP PINCH"
300 IF DR$ = "FKT" THEN DV$ = "FINE KEY TWIST"
310 IF DR$ = "CKT" THEN DV$ = "COARSE KEY TWIST"
320 IF DR$ = "LTT" THEN DV$ = "LARGE TUBE TWIST"
330 IF DR$ = "STT" THEN DV$ = "SMALL TUBE TWIST"
340 IF DR$ = "EX" THEN DV$ = "EXTENSOR LIFT"
350 N = 1:A = 10
360 IF DR$ < > "GR" THEN 370
365 N = 4:A = 2: GOTO 450
370 IF DR$ < > "PH" THEN 380
375 N = 3:A = 6: GOTO 450
380 IF DR$ < > "KH" THEN 450
381 N = 3:A = 7: GOTO 450
440 REM EXTRACT FORCE RESULTS
450 IF DR$ = "GR" THEN INPUT S$
470 IF RIGHT$(DR$,1) = "T" THEN INPUT TD$
490 INPUT A$:PTS = VAL(A$)
500 CT = INT((PTS / 16.0)) + 1
510 FOR J = 1 TO N
520 FOR I = J TO PTS - 1 STEP N
530 INPUT A$:NUM(I) = VAL(A$)
540 NEXT
550 INPUT A$,B$
560 FM(J) = VAL(A$):TM(J) = VAL(B$)

```

```

560 FM(I) = VAL (A#):FM(J) = VAL (B#)
570 IF RIGHT$(DR#,1) < > "T" THEN 600
580 INPUT A#,B#
590 FL = VAL (A#):TL = VAL (B#)
600 NEXT
610 IF DR# < > "GR" THEN 670
620 FOR I = 1 TO PTS / 4
630 INPUT A#:RT(I) = VAL (A#)
640 NEXT
650 INPUT A#,B#
660 FRT = VAL (A#):TRT = VAL (B#)
670 POKE 216,0
680 HOME : PRINT DV#;" DEVICE": PRINT
682 PRINT L#;" HAND USED"
684 IF DR# = "GR" THEN PRINT "SPAM = ";S#
686 IF RIGHT$(DR#,1) = "T" THEN PRINT "TWIST DIRECTION = ";TD#
688 IF LP > = 1 THEN 890
689 REM CHECK IF DATA EXTRACTED IS STARTING POINT
690 IF DR# < > SD# THEN 228
692 IF L# < > R# THEN 228
699 REM PLOTTING ROUTINE
890 IF DR# = "GR" THEN 950
900 MAX = 0
910 FOR I = 1 TO N
920 IF FM(I) > MAX THEN MAX = FM(I)
930 NEXT
940 GOTO 955
950 MAX = FRT
955 IF RIGHT$(DR#,2) = "PP" OR RIGHT$(DR#,1) = "X" THEN GOSUB 6000
960 OD = 50
970 IF MAX < = 20 THEN OD = 1
980 IF MAX > 20 AND MAX < = 100 THEN OD = 10
990 IF MAX > 100 AND MAX < = 300 THEN OD = 25
1000 NOD = INT (MAX / OD) + 1
1010 YM = NOD * OD
1020 MY = INT ( - FL) + 1
1030 IF RIGHT$(DR#,1) < > "T" THEN MY = 0
1040 XSC = 279 / CT:YSC = 159 / (YM + MY)
1050 HGR2 : HCOLOR= 3: HPLOT 0,159
1055 REM PLOT OUT FORCE AXIS
1060 FOR I = 0 TO NOD + MY
1070 Y% = INT (I * YSC + .5)
1080 IF Y% > 159 THEN Y% = 159
1090 IF Y% < 0 THEN Y% = 0
1100 HPLOT TO 0,159 - Y%
1110 HPLOT 2,159 - Y% TO 0,159 - Y%
1120 IF I < > MY THEN 1210
1125 REM PLOT OUT TIME AXIS
1130 FOR J = 0 TO CT
1140 X% = INT (J * XSC + .5)
1150 IF X% > 279 THEN X% = 279
1160 IF X% < 0 THEN X% = 0
1170 HPLOT TO X%,159 - Y%
1180 HPLOT X%,157 - Y% TO X%,159 - Y%
1190 NEXT
1200 HPLOT 0,159 - Y%
1210 NEXT
1220 XSC = 279 / PTS
1230 Y% = INT (MY * YSC + .5)
1240 HPLOT 0,159 - Y%
1250 FOR J = 1 TO N
1260 FOR I = J TO PTS - 1 STEP N
1270 Y = NUM(I) + MY
1280 Y% = INT (Y * YSC + .5)

```

```

1290 X% = INT (I * XSC + .5)
1300 IF Y% > 159 THEN Y% = 159
1310 IF Y% < 0 THEN Y% = 0
1320 IF X% > 279 THEN X% = 279
1330 IF X% < 0 THEN X% = 0
1340 HPLOT TO X%,159 - Y%
1350 Y1% = 154 - Y%
1360 IF Y1% < 0 THEN Y1% = 0
1370 IF I = TM(J) THEN HPLOT X%,Y1% TO X%,159 - Y%
1380 IF RIGHT$(DR$,1) < > "T" THEN 1400
1390 IF I = TL THEN HPLOT X%,154 - Y% TO X%,159 - Y%
1400 NEXT
1410 Y% = INT (MY * YSC + .5)
1420 HPLOT 0,159 - Y%
1430 NEXT
1440 IF DR$ < > "GR" THEN 1585
1450 FOR I = 1 TO PTS / 4
1460 Y% = INT (RT(I) * YSC + .5)
1470 X% = INT (I * 4 * XSC + .5)
1480 IF Y% < 0 THEN Y% = 0
1490 Y1% = Y% + 2:Y2% = Y% - 2
1500 IF Y1% > 159 THEN Y1% = 159
1510 IF Y2% < 0 THEN Y2% = 0
1520 HPLOT X%,159 - Y1% TO X%,159 - Y2%
1530 IF I = TRT THEN HPLOT X% - 3,159 - Y1% TO X% + 3,159 - Y1%
1540 X1% = X% + 2:X2% = X% - 2
1550 IF X1% > 279 THEN X1% = 279
1560 IF X2% < 0 THEN X2% = 0
1570 HPLOT X1%,159 - Y% TO X2%,159 - Y%
1580 NEXT
1585 IF RIGHT$(DR$,2) = "PP" OR RIGHT$(DR$,1) = "X" THEN GOSUB 6400
1590 PRINT
1595 REM PRINT OUT FILE DETAILS+RESULTS ON SILENTYPE
1600 PRINT D$;"PR#1"
1610 PUKE 36,10
1620 FOR I = 1 TO 60
1630 PRINT "=";
1640 NEXT
1650 PRINT
1660 PRINT "EXTRACT";
1670 PUKE 36,40 - INT ((LEN (DV$ + " TEST")) / 2 + .5)
1680 PRINT DV$;" TEST": PRINT
1690 PRINT "RECORD NUMBER-->";TH$;
1702 LP = LP + 1
1705 IF LP > 1 THEN 1770
1710 PUKE 36,40: PRINT "DATE OF TEST = ";DT$
1715 PRINT "DATE OF BIRTH = ";DB$;
1720 AA = VAL ( RIGHT$(DT$,2)):BB = VAL ( RIGHT$(DB$,2))
1725 AB = VAL ( MID$(DT$,4,2)):AC = VAL ( MID$(DB$,4,2))
1730 AD = AB - AC: IF AD > 0 THEN 1740
1735 AD = (12 - AC) + AB:AA = AA + 1
1740 AE = VAL ( LEFT$(DT$,2)):AF = VAL ( LEFT$(DB$,2))
1745 AG = AE - AF: IF AG < 0 THEN AD = AD - 1
1750 PUKE 36,40: PRINT "AGE = ";AA - BB;" YEARS ";AD;" MONTHS"
1765 PRINT "DOMINANT HAND = ";DH$;
1770 PUKE 36,40: PRINT "HAND USED = ";L$
1771 IF DR$ = "FG" THEN 7012
1772 PUKE 36,40: IF DR$ = "GR" THEN PRINT "SPAN USED = ";S$
1775 PUKE 36,40: IF RIGHT$(DR$,1) = "T" THEN PRINT "TWIST DIRECTION = ";T0$
1810 PRINT
1820 IF RIGHT$(DR$,1) < > "T" THEN 1870

```

```

1830 PRINT "Y-AXIS MAX = ";YM;"NM AND MIN = "; - MY;" NM IN";OD;" NM STEP
      S & X-AXIS = 0 TO ";CT;" SECS IN UNIT STEPS"
1860 GOTO 1890
1870 PRINT "Y-AXIS = 0 TO ";YM;" N IN ";OD;" N STEPS AND X-AXIS = 0 TO ";
      CT;" SECS IN UNIT STEPS"
1890 POKE - 12525,64: POKE - 12524,0
1900 POKE - 12531,1
1910 PRINT CHR# (17)
1920 PRINT
1930 POKE - 12525,32: POKE - 12529,0
1935 TT = (CT / PTS) * 100
1940 IF A = 10 THEN 2145
1950 IF DR# < > "GR" THEN 2090
1960 FOR J = 1 TO N
1995 T = INT ((TT * TM(J)) + .5) / 100
2010 PRINT LEFT# (FIN#(J),1);"F=";FM(J);"N @ ";T;"S *";
2020 NEXT
2040 T = INT ((TT * 4) * TRT) + .5) / 100
2050 PRINT
2070 PRINT "COM=";FRT;"N @ ";T;" S"
2080 GOTO 2330
2090 FOR J = 1 TO N
2110 T = INT ((TT * TM(J)) + .5) / 100
2120 PRINT LEFT# (FIN#(A + J - 2),3);" =" ;FM(J);"N @ ";T;"S *";
2130 NEXT
2135 PRINT
2140 GOTO 2330
2145 IF RIGHT# (DR#,2) = "PP" OR RIGHT# (DR#,1) = "X" THEN GOTO 6200
2150 IF RIGHT# (DR#,1) < > "T" THEN 2230
2170 T = INT ((TT * TM(1)) + .5) / 100
2180 PRINT DV#;" MAXIMUM = ";FM(1);" NEWTON-METRES @ ";T;" SECONDS"
2190 T = INT ((TT * TL) + .5) / 100
2210 PRINT DV#;" MINIMUM = "FL;" NEWTON-METRES @ ";T;" SECONDS"
2220 GOTO 2330
2230 T = INT ((TT * TM(1)) + .5) / 100
2250 PRINT DV#;" MAXIMUM = ";FM(1);" NEWTONS @ ";T;" SECONDS"
2330 PRINT "GRIP DATA:-"
2335 IF A = 10 THEN 2430
2340 IF DR# = "GR" THEN 2412
2345 TB = - 12
2350 FOR I = 1 TO N
2355 POKE 36,TB + 20: PRINT FIN#(A + I - 2);
2360 TB = TB + 20: NEXT
2365 PRINT : GOTO 2430
2412 J = 1
2413 FOR TB = 10 TO 70 STEP 15
2414 POKE 36,TB: IF TB = 70 THEN PRINT "TOTAL": GOTO 2416
2415 PRINT FIN#(J);
2416 J = J + 1: NEXT
2417 I = 1: J = 1
2418 FOR TB = 10 TO 70 STEP 15
2419 POKE 36,TB: IF TB < > 70 GOTO 2421
2420 PRINT RT(J): J = J + 1: GOTO 2423
2421 PRINT NUM(I);
2422 I = I + 1: IF I > PTS THEN 2425
2423 NEXT
2424 IF I < = PTS THEN 2418
2425 GOTO 2650
2430 TB = 8: IF A = 10 THEN TB = 5
2440 FOR I = 1 TO PTS
2450 POKE 36,TB: PRINT NUM(I);
2460 IF A = 10 THEN TB = TB + 8: GOTO 2465

```

```

2461 TB = TB + 20
2465 IF A < 10 AND TB < 50 THEN 2500
2466 IF A > 10 AND TB < 75 THEN 2500
2470 TB = 8: IF A = 10 THEN TB = 5
2480 PRINT
2500 NEXT
2520 GOTO 2650
2650 PRINT : PRINT D$;"PR#0": TEXT
2660 GOTO 228
2670 PRINT "ANY MORE DATA EXTRACTION?Y/N"
2680 GET Y$: IF Y$ = "Y" THEN 140
2690 END
5000 CODE = PEEK (222)
5005 REM DISC HANDLING ERROR ROUTINE
5010 PRINT "CODE=";CODE
5020 POKE 216,0
5030 IF CODE < > 5 THEN 5070
5040 PRINT "END OF DATA ERROR"
5050 PRINT "DATA REQUIRED NOT FOUND PLEASE REINPUT"
5060 UTAB 1: GOTO 90
5065 IF CODE = 5 THEN PRINT "EN D OF DATA": PRINT D$;"CLOSE";TN$: GOTO 2
670
5070 IF CODE < > 6 THEN 5110
5080 PRINT "FILE NOT FOUND ERROR"
5090 PRINT "PLEASE REINPUT"
5100 UTAB 1: GOTO 140
5110 END
6000 FOR FF = 1 TO 4
6010 FM(FF) = 0
6020 FOR I = INT ((PTS * (FF - 1)) / 4) TO INT ((PTS * FF) / 4)
6025 IF NUM(I) > FM(FF) THEN TM(FF) = 1
6030 IF NUM(I) > FM(FF) THEN FM(FF) = NUM(I)
6040 NEXT
6050 NEXT
6065 MAX = 0
6070 FOR I = 1 TO 4
6075 IF FM(I) > MAX THEN MAX = FM(I)
6080 NEXT
6090 RETURN
6200 FOR J = 1 TO 4
6210 PRINT LEFT$(FIN$(J),1);"F= ";FM(J);"N *";
6220 NEXT
6225 PRINT
6230 GOTO 2330
6400 FOR FF = 1 TO 4
6405 REM PLOT OUT OF INDIVIDUAL FINGER MAXIMA TIC MARKS
6410 Y% = INT (FM(FF) * YSC + .5)
6420 X% = INT (TM(FF) * XSC + .5)
6430 Y1% = Y% + 5: IF Y1% > 159 THEN Y1% = 159
6440 H$PLOT X%,159 - Y% TO X%,159 - Y1%
6450 NEXT
6460 RETURN
7000 PRINT D$;"PR#1"
7010 GOTO 1600
7012 PRINT
7015 FOR I = 1 TO 24
7020 GPIQ"FL$YION ANGLE"
7030 IF I > 12 AND I < 17 THEN GP$ = "EXTENSION ANGLE"
7040 IF I > 16 AND I < 21 THEN GP$ = "OPPOSITION O.K. (MAX=Y,MIN=N)"
7050 IF I = 21 THEN GP$ = "MINIMUM DISTANCE (CJ.) = "
7060 IF I > 21 THEN GP$ = "FLEXION ANGLE"
7070 PRINT GM$(I);" ";GP$;" = ";GM(I);" DEGREES"
7075 NEXT
7080 PRINT : PRINT D$;"PR#0"
7090 GOTO 228

```

APPENDIX 8

PRINT-OUT OF PATIENTS' RESULTS

EXTRACT

GRIP TEST

386.

RECORD NUMBER-->A154440-6-MR D EVERITT DATE OF TEST = 25/05/83
 DATE OF BIRTH = 08/10/33 AGE = 51 YEARS 7 MONTHS
 DOMINANT HAND = R HAND USED = L
 SPAN USED = 2

Y-AXIS = 0 TO 250 N IN 25 N STEPS AND X-AXIS = 0 TO 5 SECS IN UNIT STEPS

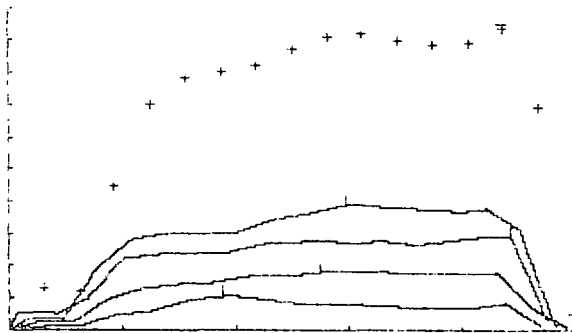

IF=73.73N @ 4.45S *MF=97.29N @ 2.97S *RF=44.94N @ 2.73S *LF=26.07N @ 1.88S *
 COM=232.26N @ 4.32 S
 GRIP DATA:-

INDEX	MIDDLE	RING	LITTLE	TOTAL
13.4	8.85	7.02	2.37	32.64
13.06	8.62	7.02	2.37	30.07
25.47	49.26	23.68	13.03	111.64
56.3	70.2	32.3	15.4	174.2
58.98	75.12	36.52	23.7	194.32
60.32	75.12	37.92	26.07	199.43
61.66	77.59	42.13	23.7	205.08
68.36	86.21	42.13	20.14	216.84
69.71	91.13	44.94	20.14	225.92
68.26	97.29	44.94	18.96	229.55
69.71	93.6	43.54	16.59	223.44
65.68	92.36	43.54	17.77	219.35
69.71	91.13	43.54	17.77	222.15
72.39	93.6	44.94	21.33	232.26
73.73	76.35	18.26	2.37	170.71
9.04	3.69	1.4	0	

EXTRACT

GRIP TEST

RECORD NUMBER-->A154440-6-MR D EVERITT HAND USED = R
 SPAN USED = 2

Y-AXIS = 0 TO 350 N IN 50 N STEPS AND X-AXIS = 0 TO 5 SECS IN UNIT STEPS

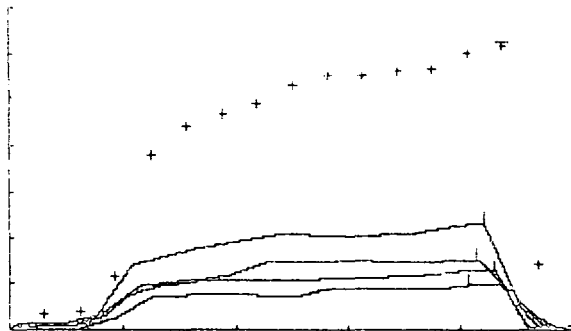

IF=76.41N @ 4.14S *MF=117N @ 4.22S *RF=66.01N @ 4.3S *LF=48.58N @ 4.06S *
 COM=308N @ 4.38 S
 GRIP DATA:-

INDEX	MIDDLE	RING	LITTLE	TOTAL
6.7	7.39	4.21	0	18.3
6.7	7.39	4.21	1.18	19.48
8.04	17.24	18.26	13.03	56.57
36.19	70.2	49.16	34.36	189.91
48.26	81.28	53.37	37.91	220.82
52.28	89.9	53.37	36.73	232.28
60.32	97.29	51.97	35.55	245.13
72.39	103.45	51.97	35.55	263.36
73.73	102.22	54.78	43.84	274.57
75.07	100.99	54.78	43.84	274.68
73.73	103.45	57.58	45.02	279.78
72.39	104.68	58.99	45.02	281.08
75.07	113.3	63.2	48.58	300.15
75.41	117	66.01	48.58	303
48.21	25.64	2.81	1.18	70.06
1.34	1.23	0	0	

EXTRACT

PAN HANDLE TEST

387.

RECORD NUMBER-->A154440-6-MR D EVERITT HAND USED = L

Y-AXIS = 0 TO 125 N IN 25 N STEPS AND X-AXIS = 0 TO 4 SECS IN UNIT STEPS

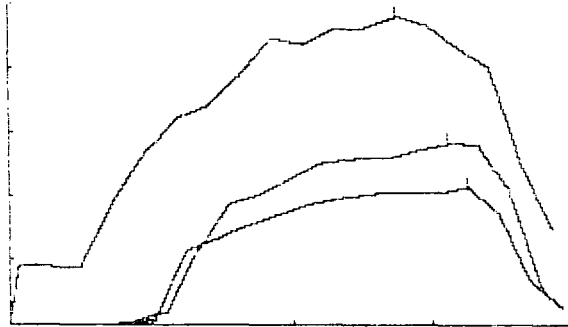

PAN =119.59N @ 2.74S *LOW =53.47N @ 3.26S *UPP =69.85N @ 3.11S *

GRIP DATA:-

PAN HANDLE	LOWER MOUNT	UPPER MOUNT
22.9	0	.38
21.63	0	.38
22.9	0	0
48.35	0	1.53
66.16	2.64	5.73
80.15	29.04	28.63
85.24	33.99	46.85
96.69	39.27	51.15
110.69	42.9	57.25
108.14	46.86	62.98
114.5	49.83	64.5
115.78	50.83	64.5
119.59	51.16	67.56
115.78	51.49	69.85
106.87	53.47	68.7
99.24	42.57	51.91
63.61	16.5	12.96
36.9	6.27	117

EXTRACT

PAN HANDLE TEST

RECORD NUMBER-->A154440-6-MR D EVERITT HAND USED = R

Y-AXIS = 0 TO 175 N IN 25 N STEPS AND X-AXIS = 0 TO 4 SECS IN UNIT STEPS



PAN =170.48N @ 2.73S *LOW =56.11N @ 2.98S *UPP =66.03N @ 2.86S *

GRIP DATA:-

PAN HANDLE	LOWER MOUNT	UPPER MOUNT
6.36	0	0
6.36	0	0
7.63	0	0
43.26	0	1.15
89.06	5.61	9.54
111.96	27.72	45.8
132.32	40.59	52.29
142.49	46.2	54.96
150.13	48.84	61.45
155.22	48.18	59.4
161.58	51.82	61.07
160.31	51.49	61.45
164.12	52.48	62.98
169.21	54.46	64.12
170.48	54.79	66.03
160.31	56.11	64.12
138.68	50.83	61.83
143.77	50.17	55.73
100.51	24.42	23.28
61.67	7.52	75

EXTRACT

KETTLE HANDLE TEST

388.

RECORD NUMBER-->A154440-6-MR D EVERITT HAND USED = R

Y-AXIS = 0 TO 90 N IN 10 N STEPS AND X-AXIS = 0 TO 4 SECS IN UNIT STEPS

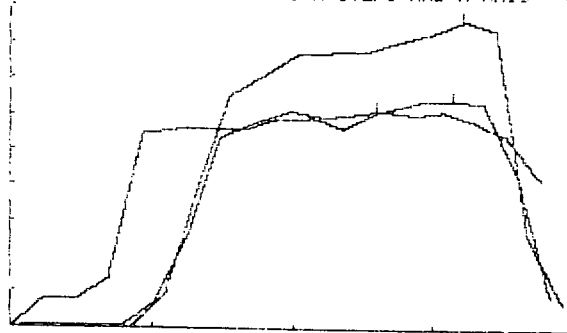

LOW =64.03N @ 3.14S *UPP =85.26N @ 3.22S *KET =60.94N @ 2.59S *

GRIP DATA:-

LOWER MOUNT	UPPER MOUNT	KETTLE HANDLE
.66	0	8.08
.66	0	8.08
.66	0	13.95
.66	1.38	55.07
7.59	9.92	55.8
26.73	39.69	55.8
53.8	65.65	55.8
57.76	71.37	58.74
61.39	77.1	59.47
59.41	77.48	55.8
60.4	77.48	60.94
61.72	80.15	60.21
63.7	82.82	60.94
64.03	86.26	58
63.04	83.21	53.6
42.57	25.57	41.85
8.91	7.63	61.83

EXTRACT

KETTLE HANDLE TEST

RECORD NUMBER-->A154440-6-MR D EVERITT HAND USED = L

Y-AXIS = 0 TO 100 N IN 10 N STEPS AND X-AXIS = 0 TO 4 SECS IN UNIT STEPS

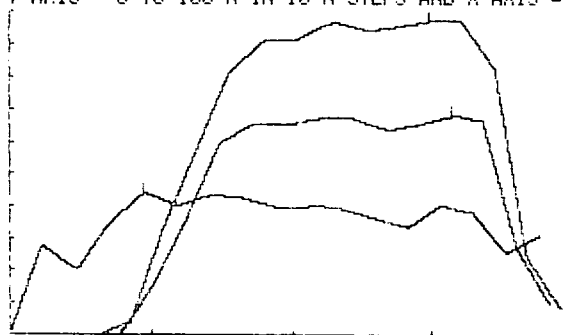

LOW =87.66N @ 3.14S *UPP =97.33N @ 2.98S *KET =44.05N @ .94S *

GRIP DATA:-

LOWER MOUNT	UPPER MOUNT	KETTLE HANDLE
0	0	27.9
0	0	19.82
0	0	34.51
.33	4.2	44.05
15.84	34.35	40.38
38.96	58.4	43.32
55.74	82.06	41.85
65.35	91.22	38.65
65.68	91.98	40.38
67	96.56	38.91
66.67	94.27	35.98
63.7	95.8	33.04
65.68	97.33	40.38
67.66	97.33	37.44
66.34	82.44	25.7
26.73	24.81	31.57
9.9	8.4	61.83

=====

EXTRACT COARSE PULP PINCH TEST

RECORD NUMBER-->A154440-6-MR D EVERITT HAND USED = L

Y-AXIS = 0 TO 50 N IN 10 N STEPS AND X-AXIS = 0 TO 9 SECS IN UNIT STEPS

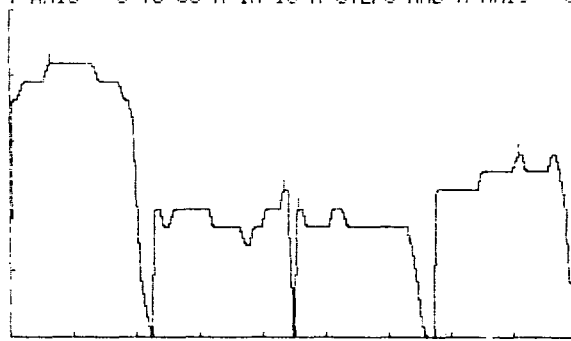

IF= 41.67N *MF= 22.22N *RF= 19.44N *LF= 27.78N *

GRIP DATA:-

36.11	36.11	38.89	38.89	38.89	38.89	38.89	38.89	38.89	41.67
41.67	41.67	41.67	41.67	41.67	41.67	41.67	41.67	41.67	41.67
41.67	38.89	38.89	38.89	38.89	38.89	38.89	38.89	36.11	36.11
33.33	19.44	8.33	2.78	0	19.44	19.44	19.44	16.67	16.67
19.44	19.44	19.44	19.44	19.44	19.44	19.44	19.44	19.44	19.44
16.67	16.67	16.67	16.67	16.67	16.67	16.67	16.67	13.89	13.89
16.67	16.67	16.67	19.44	19.44	19.44	19.44	22.22	22.22	22.22
0	19.44	19.44	16.67	16.67	16.67	16.67	16.67	16.67	16.67
19.44	19.44	19.44	16.67	16.67	16.67	16.67	16.67	16.67	16.67
16.67	16.67	16.67	16.67	16.67	16.67	16.67	16.67	16.67	16.67
13.89	8.33	2.78	0	0	0	22.22	22.22	22.22	22.22
22.22	22.22	22.22	22.22	22.22	22.22	22.22	22.22	25	25
25	25	25	25	25	25	27.78	27.78	27.78	25
25	25	25	25	25	25	27.78	27.78	25	19.44
8.33	0								

=====

EXTRACT COARSE PULP PINCH TEST

RECORD NUMBER-->A154440-6-MR D EVERITT HAND USED = R

Y-AXIS = 0 TO 40 N IN 10 N STEPS AND X-AXIS = 0 TO 9 SECS IN UNIT STEPS



IF= 36.11N *MF= 22.22N *RF= 27.78N *LF= 22.22N *

GRIP DATA:-

30.56	30.56	30.56	30.56	30.56	30.56	30.56	30.56	33.33	33.33
33.33	33.33	33.33	33.33	33.33	36.11	33.33	33.33	33.33	36.11
36.11	36.11	33.33	33.33	33.33	36.11	36.11	36.11	36.11	36.11
36.11	33.33	27.78	13.89	0	16.67	19.44	19.44	19.44	19.44
19.44	19.44	19.44	19.44	19.44	19.44	19.44	19.44	19.44	19.44
19.44	19.44	19.44	19.44	22.22	19.44	19.44	19.44	19.44	19.44
19.44	19.44	19.44	19.44	22.22	22.22	22.22	22.22	22.22	16.67
0	27.78	27.78	27.78	27.78	27.78	27.78	27.78	27.78	27.78
25	25	25	27.78	25	25	25	25	25	22.22
22.22	22.22	22.22	25	25	25	25	25	25	25
25	25	25	25	25	0	22.22	22.22	22.22	22.22
22.22	22.22	22.22	22.22	22.22	22.22	22.22	22.22	22.22	22.22
22.22	22.22	22.22	22.22	22.22	22.22	22.22	22.22	22.22	19.44
19.44	19.44	22.22	22.22	22.22	22.22	22.22	22.22	16.67	8.33
2.78	0								

EXTRACT

EXTENSOR LIFT TEST

RECORD NUMBER-->A154440-6-MR D EVERITT HAND USED = R

Y-AXIS = 0 TO 7 N IN 1 N STEPS AND X-AXIS = 0 TO 9 SECS IN UNIT STEPS

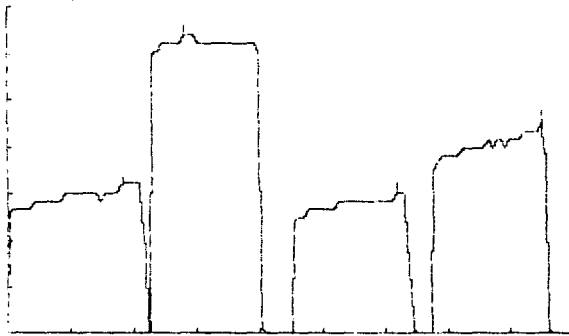

IF= 3.2N *MF= 6.4N *RF= 3.01N *LF= 4.52N *

GRIP DATA:-

2.82	2.82	2.82	2.82	2.82	2.82	2.82	2.82	2.82
3.01	3.01	2.82	3.01	3.01	3.01	3.01	3.01	3.2
3.2	3.2	3.2	1.88	0	6.03	6.03	6.21	6.21
6.21	6.21	6.21	6.4	6.4	6.4	6.21	6.21	6.21
6.21	6.21	6.21	6.21	6.21	6.21	6.21	6.21	6.21
6.21	6.21	6.03	0	0	0	0	0	0
0	2.45	2.45	2.45	2.64	2.64	2.64	2.64	2.64
2.64	2.64	2.82	2.82	2.82	2.82	2.82	2.82	2.82
2.82	2.82	2.82	2.82	2.82	2.82	3.01	3.01	3.01
1.88	0	0	0	0	0	3.58	3.77	3.77
3.77	3.77	3.77	3.95	3.95	3.95	3.95	3.95	3.95
4.14	3.95	4.14	4.14	3.95	4.14	4.14	4.14	4.33
4.33	4.33	4.33	4.52	3.77	0	0	0	0
0	0							

EXTRACT

EXTENSOR LIFT TEST

RECORD NUMBER-->A154440-6-MR D EVERITT HAND USED = L

Y-AXIS = 0 TO 7 N IN 1 N STEPS AND X-AXIS = 0 TO 9 SECS IN UNIT STEPS

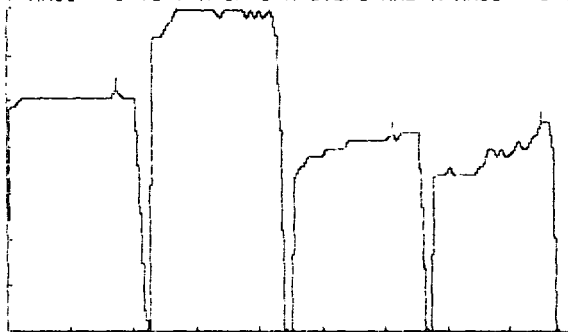

IF= 5.27N *MF= 6.97N *RF= 4.33N *LF= 4.52N *

GRIP DATA:-

4.9	4.9	5.08	5.08	5.08	5.08	5.08	5.08	5.08
5.08	5.08	5.08	5.08	5.08	5.08	5.08	5.08	5.08
5.08	5.08	5.08	5.08	5.08	5.08	5.27	5.08	5.08
5.08	5.08	3.58	.38	0	6.4	6.4	6.4	6.59
6.78	6.97	6.97	6.97	6.97	6.97	6.97	6.97	6.97
6.97	6.97	6.78	6.97	6.97	6.97	6.97	6.97	6.78
6.97	6.78	6.97	6.78	6.97	6.78	6.4	4.33	0
0	3.39	3.58	3.58	3.77	3.77	3.77	3.77	3.95
3.95	3.95	3.95	3.95	4.14	4.14	4.14	4.14	4.14
4.14	4.14	4.14	4.14	4.14	4.33	4.14	4.33	4.33
4.33	4.33	4.33	2.64	0	0	3.39	3.39	3.39
3.58	3.39	3.39	3.39	3.39	3.39	3.39	3.58	3.58
3.95	3.95	3.77	3.95	3.77	3.77	3.95	4.14	3.95
3.95	4.14	4.33	4.52	4.52	4.52	3.95	0	0
0	0							

=====

EXTRACT COARSE LATERAL PINCH TEST

RECORD NUMBER-->A154440-6-MR O EVERITT HAND USED = R

Y-AXIS = 0 TO 100 N IN 10 N STEPS AND X-AXIS = 0 TO 5 SECS IN UNIT STEPS



COARSE LATERAL PINCH MAXIMUM = 94.44 NEWTONS @ 3.59 SECONDS

GRIP DATA:-

2.78	2.78	2.78	2.78	2.78	2.78	5.56	13.89	36.11
52.78	61.11	66.67	72.22	75	77.78	80.56	80.56	80.56
80.56	83.33	83.33	83.33	83.33	83.33	83.33	83.33	83.33
83.33	83.33	83.33	83.33	86.11	86.11	88.89	88.89	88.89
88.89	88.89	88.89	88.89	88.89	88.89	88.89	88.89	91.67
94.44	91.67	91.67	91.67	88.89	72.22	27.78	2.78	0
0	0	0	0	0	0	0	0	0
0								

=====

EXTRACT COARSE LATERAL PINCH TEST

RECORD NUMBER-->A154440-6-MR O EVERITT HAND USED = L

Y-AXIS = 0 TO 80 N IN 10 N STEPS AND X-AXIS = 0 TO 5 SECS IN UNIT STEPS



COARSE LATERAL PINCH MAXIMUM = 72.22 NEWTONS @ 2.03 SECONDS

GRIP DATA:-

2.78	2.78	2.78	2.78	2.78	2.78	5.56	13.44	38.89
50	52.78	58.33	61.11	66.67	66.67	66.67	66.67	66.67
69.44	69.44	69.44	69.44	69.44	69.44	69.44	72.22	72.22
72.22	72.22	69.44	72.22	72.22	72.22	69.44	72.22	72.22
72.22	72.22	72.22	72.22	72.22	72.22	72.22	72.22	69.44
69.44	69.44	72.22	72.22	72.22	66.67	41.67	13.89	2.78
0	0	0	0	0	0	0	0	0
0								

=====

EXTRACT FINE KEY THIST TEST

RECORD NUMBER-->A154440-6-MR D EVERITT HAND USED = R
 THIST DIRECTION = CW

Y-AXIS MAX = 2NM AND MIN = -1 NM IN 1 NM STEPS & X-AXIS = 0 TO 5 SECS IN UNIT STE
 PS

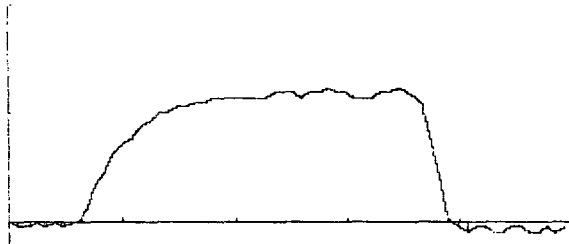

FINE KEY THIST MAXIMUM = 1.22 NEWTON-METRES @ 2.81 SECONDS
 FINE KEY THIST MINIMUM = -.09 NEWTON-METRES @ 4.06 SECONDS
 GRIP DATA:-

-.04	-.04	0	-.04	0	-.04	0	0	.13
.35	.48	.65	.74	.78	.87	.92	1	1
1.05	1.05	1.09	1.09	1.13	1.13	1.13	1.13	1.13
1.13	1.13	1.18	1.18	1.18	1.13	1.18	1.18	1.22
1.18	1.18	1.13	1.13	1.13	1.18	1.18	1.22	1.18
1.13	1.05	.74	.75	0	-.04	-.09	-.04	-.04
-.09	-.09	-.04	-.04	-.09	-.09	-.04	-.09	-.04
0								

=====

EXTRACT FINE KEY THIST TEST

RECORD NUMBER-->A154440-6-MR D EVERITT HAND USED = L
 THIST DIRECTION = CCW

Y-AXIS MAX = 1NM AND MIN = -2 NM IN 1 NM STEPS & X-AXIS = 0 TO 5 SECS IN UNIT STE
 PS

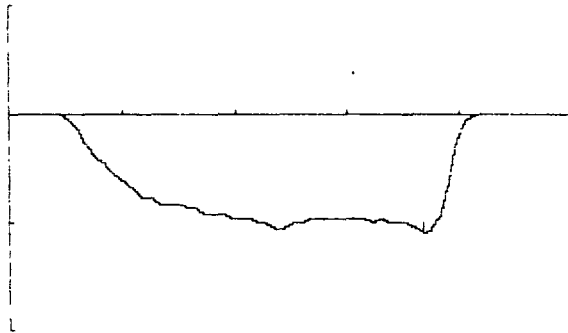

FINE KEY THIST MAXIMUM = 0 NEWTON-METRES @ 0 SECONDS
 FINE KEY THIST MINIMUM = -1.09 NEWTON-METRES @ 3.67 SECONDS
 GRIP DATA:-

0	0	0	0	0	0	-.09	-.17	-.31
-.44	-.48	-.57	-.65	-.7	-.78	-.78	-.83	-.83
-.83	-.87	-.87	-.92	-.92	-.92	-.96	-.96	-.96
-1	-1	-1.05	-1.05	-1	-1	-.96	-.96	-.96
-.96	-.96	-.96	-.96	-1	-.96	-1	-1	-1
-1.05	-1.09	-1.05	-.92	-.65	-.26	-.04	0	0
0	0	0	0	0	0	0	0	0
0								

APPENDIX 9

RESULTS OF PATIENTS FROM DRUG TRIAL

Days from start	Hand	POWER GRIP						PAN				KETTLE			PULP PINCH				EXTENSION				Key	Tube	Lp
		In	Mi	Ri	Li	Tot	Gr	Lo	Up	Mx	Gr	Lo	Up	Mx	In	Mi	Ri	Li	In	Mi	Ri	Li			
48	L	58	35	45	40	171	59	13	13	49	97	25	28	84	35	32	23	16	2.92	6.43	1.47	4.99	0.91	3.76	50
	R	27	67	49	52	185	89	12	13	78	89	29	36	89	29	29	26	16	7.05	5.81	2.51	3.75	0.91	4.79	62
112	L	58	112	49	36	246	51	23	28	50	73	35	48	59	33	47	33	25	2.45	6.40	1.88	3.20	0.87	3.76	67
	R	28	95	62	40	222	64	28	30	60	101	35	60	74	47	39	36	33	5.84	5.46	2.82	3.20	0.92	4.27	67
140	L	52	125	59	46	279	75	32	31	75	91	42	62	66	31	36	28	25	4.14	5.84	2.45	4.14	0.83	3.63	67
	R	74	110	60	46	256	99	26	29	80	67	43	55	60	36	42	25	25	6.21	5.27	2.82	3.01	1.00	4.92	69
161	L	39	96	45	28	206	79	25	29	69	93	38	40	82	31	39	19	17	3.39	6.59	3.20	3.77	0.78	3.37	69
	R	50	105	77	47	260	113	30	50	102	70	36	45	57	42	31	22	22	5.84	6.40	3.95	3.95	0.87	4.4	75
176	L	52	95	55	34	227	64	23	26	60	93	44	48	74	36	44	25	19	4.52	6.21	3.20	4.33	1.00	4.15	58
	R	47	105	63	45	254	87	29	33	79	72	49	55	61	39	36	31	25	6.21	5.46	3.77	3.39	0.92	4.27	78

Table A9.1 Results of AHD

PAN & KETTLE:-

Gr - maximum grip

Mx - grip at maximum lift - These abbreviations apply in all subsequent tables

Lp - lateral pinch

Days from start	Hand	POWER GRIP						PAN				KETTLE			PULP PINCH				EXTENSION				Key	Tube	Lp
		In	Mi	Ri	Li	Tot	Gr	Lo	Up	Mx	Gr	Lo	Up	Mx	In	Mi	Ri	Li	In	Mi	Ri	Li			
28	L	81	78	42	24	213	110	50	62	98	52	59	78	40	38	26	29	23	5.40	5.61	2.30	0.85	1.17	5.44	65
	R	73	120	81	69	341	121	53	64	116	46	60	81	26	47	41	38	19	2.30	6.13	3.75	4.57	1.17	6.22	71
63	L	84	75	47	53	251	107	47	56	104	51	M	30	39	33	14	22	5.27	7.16	4.33	1.88	1.04	4.27	78	
	R	66	112	59	70	304	140	51	61	132	57	M	40	31	19	19	19	2.82	6.97	3.58	5.27	0.91	6.09	92	
91	L	54	78	53	52	232	97	43	51	95	51	M	29	44	25	17	28	4.14	6.40	3.01	3.01	0.83	3.50	67	
	R	71	102	72	59	301	143	54	62	141	73	M	32	42	23	22	22	3.01	8.47	3.77	5.84	0.83	5.44	78	
119	L	50	69	44	25	184	126	45	55	118	70	M	47	44	28	25	31	5.27	6.78	3.39	4.71	0.87	4.27	89	
	R	64	99	63	53	269	144	52	65	144	43	M	33	36	28	28	28	2.64	6.21	3.39	5.27	1.18	5.70	89	
140	L	68	76	44	28	205	113	53	66	105	40	M	24	42	36	17	25	4.90	7.16	3.95	4.14	0.92	3.76	78	
	R	54	90	63	41	248	158	56	66	153	43	M	32	42	28	25	22	3.01	6.59	3.20	5.08	0.92	4.92	89	
168	L	74	97	45	26	232	120	53	70	111	44	M	39	42	22	19	28	5.27	6.97	4.33	4.52	1.09	5.31	72	
	R	76	117	66	49	308	170	56	66	165	61	M	58	36	22	28	22	3.20	6.4	3.01	4.52	1.22	6.22	94	

Table A9.2 Results of DE

M - maximum lift(greater than 99N)

Days from start	Hand	In	POWER GRIP				PAN				KETTLE				PULP PINCH				EXTENSION				Tube	Lp	
			Mi	Ri	Li	Tot	Gr	Lo	Up	Mx	Gr	Lo	Up	Mx	In	Mi	Ri	Li	In	Mi	Ri	Li			Key
56	L	24	16	8	14	60	32	6	8	24	40	16	17	15	16	13	7	4	2.09	0.44	1.27	0.44	0.57	1.81	32
	R	19	28	17	16	76	63	10	12	51	45	18	16	17	19	23	13	7	1.68	1.47	1.68	1.27	0.52	1.55	41
102	L	32	41	11	11	91	56	9	11	51	38	23	27	10	19	14	12	9	3.20	2.07	1.69	1.69	0.65	1.55	42
	R	28	48	27	19	113	66	11	14	62	26	24	26	16	25	19	14	11	2.45	2.26	2.64	1.32	0.57	2.59	50
140	L	29	27	14	18	80	42	8	11	37	46	11	11	25	25	19	11	8	3.01	1.51	1.51	1.69	0.52	1.55	47
	R	35	41	31	25	127	78	15	17	60	43	22	27	26	25	19	17	11	2.64	0.94	2.26	1.13	0.70	1.81	50
161	L	32	38	11	23	93	46	7	8	36	29	20	24	5	28	14	11	11	2.82	1.51	1.61	1.51	0.65	1.94	58
	R	38	54	35	26	150	48	16	17	43	46	23	26	26	25	22	14	11	1.69	0.56	1.32	0.75	0.70	2.33	53
196	L	16	23	13	15	61	25	8	10	24	23	24	17	9	22	11	8	9	3.77	1.69	2.07	1.51	0.52	1.94	44
	R	24	16	22	24	86	42	8	11	34	29	21	23	19	13	17	14	10	1.45	1.32	1.51	0.94	0.44	1.30	42

TABLE A9.3. Results of IEJ

Days from start	Hand	POWER GRIP						PAN				KETTLE				PULP PINCH				EXTENSION				Key	Tube	Lp
		In	Mi	Ri	Li	Tot	Gr	Lo	Up	Mx	Gr	Lo	Up	Mx	In	Mi	Ri	Li	In	Mi	Ri	Li				
14	L	23	16	14	13	59	23	4	2	23	26	6	6	25	15	12	6	6	3.54	2.30	1.27	1.47	0.31	1.30	-	
	R	26	24	36	21	89	27	6	4	26	20	6	5	15	11	9	9	10	2.51	2.92	1.68	1.27	0.44	1.55	-	
28	L	20	18	19	16	72	32	5	5	30	20	9	10	13	13	14	8	8	3.54	2.30	1.68	2.09	0.39	1.42	-	
	R	24	20	17	13	69	21	6	5	19	13	8	5	4	19	23	16	13	1.89	3.33	1.89	1.47	0.57	1.68	-	
56	L	12	14	13	21	50	14	5	6	13	16	19	21	4	16	16	11	10	3.33	3.75	2.71	1.89	0.39	1.04	-	
	R	19	35	25	13	83	26	9	9	24	14	18	18	2	23	23	13	10	2.92	5.40	4.57	2.71	0.57	1.30	-	
84	L	24	18	18	24	74	17	9	10	14	23	20	24	5	19	19	8	6	4.14	3.20	3.58	3.58	0.52	1.55	39	
	R	46	23	32	16	103	39	16	20	37	15	29	32	12	25	25	17	8	3.01	4.14	3.39	2.45	0.70	3.11	53	
112	L	21	25	17	30	84	22	9	10	18	32	15	18	5	22	25	22	11	3.39	2.45	1.88	3.01	0.52	1.81	44	
	R	29	27	27	26	103	38	12	15	30	18	21	23	12	22	28	22	11	2.82	3.58	3.20	2.82	0.92	3.24	58	
140	L	16	26	24	12	64	24	7	7	21	13	12	15	3	11	22	14	11	2.45	2.64	1.69	2.64	0.44	1.30	31	
	R	28	31	25	13	80	37	12	12	34	25	15	17	16	19	25	19	11	3.11	4.14	3.20	3.39	0.83	3.11	61	
168	L	15	32	39	17	100	23	10	13	23	13	32	39	9	22	28	17	14	3.39	3.58	3.39	3.20	0.61	2.07	44	
	R	40	37	35	25	115	38	17	19	37	29	35	39	4	28	28	22	14	3.39	3.39	2.26	3.01	0.70	3.11	61	

TABLE A9.4. Results of LAO

Days from start	Hand	POWER GRIP					PAN				KETTLE				PULP PINCH				EXTENSION				Key	Tube	Lp
		In	Mi	Ri	Li	Tot	Gr	Lo	Up	Mx	Gr	Lo	Up	Mx	In	Mi	Ri	Li	In	Mi	Ri	Li			
84	L	19	20	10	8	55		1	6	0	0	5	3	0	12	11	6	7					0.31	1.04	19
	R	5	13	8	22	44	0	1	3	0	1	7	5	0	8	9	6	6					0.26	0.65	26
105	L	22	35	13	14	71	1	1	2	0	8	4	4	2	12	10	5	6	No				0.39	1.30	23
	R	15	11	1	10	35	0	2	2	0	0	4	2	0	7	10	7	8					0.35	0.78	32
147	L	12	20	8	13	52	1	2	2	0	11	3	3	0	11	6	9	7					0.39	0.91	31
	R	16	5	11	2	28	0	2	3	0	0	3	2	0	10	9	7	6	Data				0.22	0.65	31
161	L	19	16	6	9	46	6	2	3	4	6	3	4	0	11	8	6	7					0.39	1.17	17
	R	12	16	7	7	40	3	2	4	2	4	3	3	0	8	8	9	6					0.31	0.91	17
217	L	13	25	10	5	49	3	3	4	1	18	4	6	11	11	8	7	8					0.39	1.17	31
	R	7	5	6	11	25	0	1	2	0	1	2	2	0			a						0.31	0.78	31

TABLE A9.5. Results of DS

a = no opposition

Days from start	Hand	POWER GRIP						PAN				KETTLE				PULP PINCH				EXTENSION				Key	Tube	Lp
		In	Mi	Ri	Li	Tot	Gr	Lo	Up	Mx	Gr	Lo	Up	Mx	In	Mi	Ri	Li	In	Mi	Ri	Li				
42	L	15	23	11	5	53	18	5	4	14	36	5	5	5	16	23	13	10	0.85	1.47	0	0.65	0.44	1.30		
	R	26	38	22	8	90	23	13	11	22	15	16	12	6	29	19	10	7	1.89	2.30	1.27	0.85	0.70	2.33		
91	L	14	8	11	24	55	18	7	7	9	26	5	6	6	9	12	8	6	1.89	3.33	1.89	0.23	0.65	0.52	No	
	R	24	25	16	11	69	31	17	21	25	13	22	26	1	32	16	13	7	2.51	2.92	2.71	2.51	0.57	2.20		
175	L	3	5	4	2	14	9	5	5	7	36	2	3	4	16	15	6	3	1.32	1.88	0.19	0.38	0.44	0.91		
	R	17	23	14	17	66	13	17	21	11	19	25	27	4	14	14	10	10	2.45	2.64	0.75	1.13	0.48	2.85	Data	
203	L	7	5	6	8	24	11	4	5	8	9	(17 ^a	21)	4	16	10	13	10	1.88	1.13	0	1.13	0.39	0.91		
	R	17	15	13	8	51	15	14	18	14	21	16	32	1	25	19	17	11	2.64	3.58	1.32	1.88	0.39	2.07		

TABLE A9.6. Results of ES

a - lifted under-arm

APPENDIX 10

RESULTS OF PATIENTS FROM RHEUMATOLOGY CLINIC

Days from start	Hand	POWER GRIP						PAN			KETTLE			PULP PINCH				EXTENSION				Key	Tube	Lp	
		In	Mi	Ri	Li	Tot	Gr	Lo	Up	Mx	Gr	Lo	Up	Mx	In	Mi	Ri	Li	In	Mi	Ri				Li
0	L	10	1	10	41	44	14	3	5	14	5	8	7	0	10	8	6	6	0.65	0.65	0.65	1.06	0.22	0.65	16
	R	18	7	16	19	52	14	5	6	9	6	10	13	0	11	8	7	9	0	0	0.85	0	0.17	1.42	23
28	L	11	4	7	8	26	18	3	3	15	-	-	-	-	11	7	8	7	-	-	-	-	0.09	-	-
	R	7	6	7	17	29	18	2	2	12	-	-	-	-	12	11	11	10	-	-	-	-	0.17	-	-
49	L	9	5	6	14	33	9	2	2	9	11	3	2	1	7	5	4	4	2.26	1.69	2.82	0.94	0.57	0.52	17
	R	8	0	3	11	18	11	3	4	11	11	2	3	3	8	5	4	6	1.32	0.38	0.38	0	0.22	1.30	17
91	L	12	0	7	12	28	14	1	2	13	12	3	3	0	10	9	7	10	2.64	1.88	2.26	0.56	0.26	0.52	11
	R	11	4	4	12	27	15	2	4	15	15	2	3	4	10	6	5	6	0.94	0.19	0.75	0	0.22	0.78	19

TABLE A10.1. Results of JC

Days from start	Hand	POWER GRIP						PAN			KETTLE			PULP PINCH				EXTENSION				Key	Tube	Lp	
		In	Mi	Ri	Li	Tot	Gr	Lo	Up	Mx	Gr	Lo	Up	Mx	In	Mi	Ri	Li	In	Mi	Ri				Li
0	L	18	65	40	0	121	36	6	5	33	34	3	10	20	35	19	10	7	3.95	4.37	2.09	2.92	-	-	-
	R	46	51	63	40	187	60	4	6	50	28	6	9	16	32	23	10	1	3.13	3.54	6.23	3.13	0.65	-	-
56	L	5	40	33	10	84	50	7	6	49	23	23	23	11	23	16	10	4	2.09	2.71	1.27	0.65	0.70	No	-
	R	11	48	52	13	122	47	12	12	42	20	23	24	15	23	19	16	7	1.27	1.06	0	0	0.57	-	-
91	L	19	48	35	18	114	53	13	14	53	23	19	20	16	25	19	17	11	2.82	3.95	3.39	1.88	0.78	-	33
	R	23	33	56	15	126	57	11	14	55	25	22	25	10	31	28	28	22	3.01	4.52	0	2.07	0.57	Data	33
119	L	5	54	25	13	95	36	13	16	34	19	24	22	7	28	22	11	8	3.01	3.58	2.64	2.07	0.65	-	42
	R	42	32	41	15	126	61	11	13	61	25	24	29	10	25	17	17	11	2.64	2.82	1.51	1.32	0.52	-	44

TABLE A10.2. Results of ECF

Days from start	Hand	POWER GRIP						PAN			KETTLE			PULP PINCH				EXTENSION			Key	Tube	Lp		
		In	Mi	Ri	Li	Tot	Gr	Lo	Up	Mx	Gr	Lo	Up	Mx	In	Mi	Ri	Li	In	Mi				Ri	Li
0	L	15	50	49	14	126	63	4	4	59	54	2	3	45	26	23	19	16	3.33	5.81	4.99	4.37	0.52		
	R	-	-	-	-	-	68	3	4	68	65	4	4	58	17	23	10	10	4.37	6.02	3.13	3.54	0.78		
28	L	23	50	55	68	153	83	8	3	56	47	8	6	21	38	29	19	19	3.33	2.51	2.09	2.92	0.92	No	
	R	16	39	49	51	135	84	4	2	67	54	6	6	45	16	16	10	7	3.75	3.95	1.47	2.92	0.92		
119	L	70	73	48	44	213	80	19	22	80	76	39	44	58	47	39	17	25	3.20	4.90	4.90	4.52	0.96	Data	
	R	56	54	55	41	189	69	29	34	69	40	37	43	23	39	33	25	22	4.71	4.14	1.51	3.58	1.35		
140	L	52	92	69	20	226	88	18	21	83	55	44	50	29	50	28	19	28	2.45	4.33	3.77	3.95	1.00		
	R	48	68	48	60	214	78	26	32	66	35	44	53	22	39	31	36	33	5.08	3.95	1.69	3.58	1.09		

TABLE A10.3. Results of GEL

Days from start	Hand	POWER GRIP					PAN				KETTLE				PULP PINCH				EXTENSION				Key	Tube	Lp
		In	Mi	Ri	Li	Tot	Gr	Lo	Up	Mx	Gr	Lo	Up	Mx	In	Mi	Ri	Li	In	Mi	Ri	Li			
0	L	19	41	16	21	94	74	14	14	73	59	9	9	56	13	32	19	10	1.27	2.09	1.06	0.23	0.70	-	-
	R	27	12	10	8	56	84	6	8	72	40	26	26	23	16	19	16	10	3.13	4.99	1.06	0	0.35	-	-
84	L	17	27	6	32	80	99	3	6	99	76	19	22	68	11	39	19	19	2.07	3.58	2.07	0.19	0.35	1.42	44
	R	27	28	20	5	78	93	5	6	86	111	22	24	67	19	28	19	19	3.01	4.14	0.94	0	0.26	0.78	42
140	L	28	47	27	24	125	66	2	4	62	59	8	10	52	8	11	11	10	0	1.88	0.94	0	0.31	1.17	25
	R	28	31	25	9	92	80	6	7	79	57	19	23	26	8	14	9	11	2.07	3.77	0	0	0.22	1.94	28
154	L	15	25	13	9	60	36	3	3	36	57	5	6	53	8	9	12	14	0.38	2.07	0.56	0.19	0.35	1.42	14
	R	15	10	7	6	38	74	3	3	73	93	5	8	91	9	9	6	8	0.75	2.45	0	X	0.26	2.20	14

TABLE A10.4. Results of DW

X - no opposition

Days from start	Hand	In	POWER GRIP				PAN				KETTLE			PULP PINCH				EXTENSION			Key	Tube	Lp		
			Mi	Ri	Li	Tot	Gr	Lo	Up	Mx	Gr	Lo	Up	Mx	In	Mi	Ri	Li	In	Mi				Ri	Li
0	L	30	53	46	25	149	57	10	7	54	39	14	17	35	23	29	23	19	5.19	5.40	7.05	6.43	0.52		
	R	32	33	22	8	94	37	13	17	37	37	14	15	30	35	29	19	13	2.30	3.54	4.57	4.37	0.52		
56	L	39	29	51	30	147	42	8	12	39	55	11	14	55	29	16	16	16	3.54	3.33	3.75	1.68	0.52		No
	R	40	55	20	18	132	40	9	11	38	18	11	11	10	19	19	26	19	0.65	1.06	1.68	2.71	0.52		
84	L	42	70	49	21	180	-	-	-	-	-	-	-	-	22	31	25	25	-	-	-	-	0.74		
	R	28	46	22	14	109	-	-	-	-	-	-	-	-	39	31	19	22	-	-	-	-	0.92		Data
168	L	23	53	48	33	155	69	7	9	63	29	12	15	18	36	36	25	28	2.82	3.20	2.45	1.88	0.57		
	R	35	59	42	15	147	47	7	11	43	23	7	8	12	31	25	22	22	1.51	1.32	0.94	2.26	0.39		

TABLE A10.5. Results of JW

APPENDIX 11

RESULTS OF PATIENTS FROM RHEUMATOLOGY WARD

Days from start	Hand	POWER GRIP						PAN			KETTLE			PULP PINCH				EXTENSION					Key	Tube	Lp
		In	Mi	Ri	Li	Tot	Gr	Lo	Up	Mx	Gr	Lo	Up	Mx	In	Mi	Ri	Li	In	Mi	Ri	Li			
36	L	7	26	21	4	56	32	4	5	27	25	5	4	15	7	8	8	8	2.45	2.45	2.26	2.64	0.52	1.30	19
	R	17	20	32	1	67	41	2	3	33	26	2	3	15	9	7	7	8	2.64	1.13	0.94	2.07	0.35	1.30	28
38	L	7	18	27	17	66	41	3	4	31	30	6	8	12	13	8	8	7	1.88	2.82	2.07	3.01	0.35	1.43	28
	R	9	26	38	4	77	45	4	5	36	21	4	3	13	10	14	12	10	3.95	1.67	1.88	2.64	0.35	1.55	33
44	L	8	23	22	13	62	53	3	5	48	18	4	5	6	10	11	10	8	1.69	2.64	2.64	3.95	0.39	1.55	31
	R	16	26	29	6	72	51	4	4	42	23	4	4	11	9	10	12	9	3.20	2.07	1.88	3.01	0.52	1.94	36
49	L	3	14	11	5	30	18	2	4	17	14	5	5	3	11	9	6	4	1.69	2.45	1.88	2.82	0.35	1.04	22
	R	4	4	10	2	20	51	2	4	46	21	6	6	4	10	9	9	8	4.33	2.64	2.64	2.45	0.39	0.91	28
51	L	5	21	7	5	36	39	5	6	36	31	6	8	8	8	7	8	5	2.07	2.07	1.51	2.45	0.22	1.68	19
	R	9	15	15	4	42	56	2	3	49	18	6	8	9	10	12	7	7	3.20	1.69	1.88	2.64	0.44	1.55	22
55	L	4	10	8	8	28	22	4	4	20	21	3	5	11	10	8	6	9	3.20	2.64	2.64	3.58	0.22	1.55	22
	R	13	16	18	14	59	55	4	7	51	23	5	7	14	11	10	8	8	3.58	2.64	2.64	2.82	0.44	1.30	28

TABLE A11.1. Results of CWA

Days from start	Hand	POWER GRIP					PAN				KETTLE			PULP PINCH				EXTENSION				Key	Tube	Lp	
		In	Mi	Ri	Li	Tot	Gr	Lo	Up	Mx	Gr	Lo	Up	Mx	In	Mi	Ri	Li	In	Mi	Ri				Li
0	L	9	20	18	15	60	50	5	5	45	26	9	12	9	19	17	17	14	3.01	1.51	3.01	3.58	0.44	2.72	22
	R	20	30	25	12	86	28	5	4	20	21	10	11	4	19	14	17	14	2.95	1.32	2.26	4.14	0.52	2.72	33
4	L	13	27	21	2	61	55	3	6	47	23	13	18	13	17	14	11	11	2.64	1.88	2.82	3.01	0.31	2.46	22
	R	12	27	32	13	80	52	11	9	50	15	15	19	7	-	22	17	14	3.77	3.01	3.39	3.58	0.57	2.46	44
6	L	28	20	17	4	59	48	8	8	37	28	21	26	21	17	14	11	14	2.64	1.69	2.26	2.82	0.39	1.68	22
	R	35	23	39	18	61	64	11	13	36	18	36	48	18	22	19	17	8	3.20	1.13	1.50	2.64	0.52	2.72	36
8	L	9	30	32	8	77	56	6	9	53	48	29	39	32	17	19	11	11	2.45	0.75	2.64	2.64	0.39	2.72	25
	R	28	32	42	20	121	33	13	13	32	90	34	41	42	25	19	14	14	3.39	2.45	2.82	4.14	0.52	2.85	42

TABLE A11.2. Results of PMB

Days from start	Hand	POWER GRIP						PAN			KETTLE			PULP PINCH				EXTENSION				Key	Tube	Lp	
		In	Mi	Ri	Li	Tot	Gr	Lo	Up	Mx	Gr	Lo	Up	Mx	In	Mi	Ri	Li	In	Mi	Ri				Li
1	L	9	26	7	5	46	67	8	13	53	63	12	15	28	19	11	6	28	0.94	0.56	0.56	X	0.26	1.04	11
	R	19	23	11	7	59	56	9	13	39	51	27	32	28	12	6	7	13	0.56	2.07	1.32	1.51	0.17	0.78	58
4	L	21	59	38	9	125	76	5	7	65	104	39	48	37	31	19	8	22	0.56	0.75	0.75	X	0.48	1.42	67
	R	21	42	29	14	104	65	11	16	52	79	24	27	40	17	19	14	17	3.39	1.69	1.32	1.51	0.17	1.94	69
8	L	25	39	22	19	104	79	17	24	78	72	44	55	26	33	22	14	31	5.08	2.64	3.39	1.51	0.83	2.20	58
	R	16	25	20	15	76	76	15	22	60	59	24	44	30	17	14	6	28	3.39	3.01	1.32	1.88	0.70	2.33	69
11	L	23	65	37	31	154	85	18	24	85	81	38	45	25	36	25	8	25	4.33	1.69	1.69	X	0.78	3.24	69
	R	35	44	37	26	137	103	25	37	73	62	32	46	34	14	25	8	25	3.58	2.45	1.88	1.13	0.83	2.20	67

TABLE A11.3. Results of GB

X = no opposition

Days from start	Hand	POWER GRIP						PAN			KETTLE				PULP PINCH				EXTENSION				Key	Tube	Lp
		In	Mi	Ri	Li	Tot	Gr	Lo	Up	Mx	Gr	Lo	Ip	Mx	In	Mi	Ri	Li	In	Mi	Ri	Li			
0	L	4	15	7	18	42	9	3	3	9	10	1	1	0	13	9	8	6	3.58	1.88	0.56	1.51	0.26	0.91	25
	R	20	26	28	24	76	11	2	2	11	20	2	3	7	904	11	7	10	2.64	3.01	2.26	1.51	0.39	1.04	39
2	L	5	6	7	13	32	9	1	3	9	10	3	3	0	9	9	6	6	3.01	2.26	2.07	1.13	0.22	0.65	25
	R	21	14	7	2	42	5	-	-	4	11	2	2	0	13	9	7	8	1.88	2.45	2.07	0.75	0.26	0.78	28
6	L	11	2	0	19	32	8	4	3	8	0	7	6	0	14	5	7	7	2.82	1.51	1.69	1.51	0.39	0.91	28
	R	20	17	13	24	69	11	4	5	11	5	5	6	0	19	11	11	11	1.69	1.32	1.69	1.13	0.35	1.55	28
8	L	16	10	4	11	41	14	4	6	12	5	7	10	1	14	11	11	13	-	-	-	-	0.48	1.55	39
	R	23	26	15	15	71	17	6	8	16	6	13	18	0	25	14	11	14	-	-	-	-	0.52	1.04	36
10	L	20	11	7	28	61	10	5	7	10	13	15	21	3	25	11	14	8	2.45	2.26	1.88	1.69	0.52	1.30	28
	R	9	15	18	26	67	15	8	9	15	12	19	26	0	22	17	11	11	2.64	3.20	3.01	2.26	0.44	1.42	28
14	L	11	6	4	9	29	15	5	6	14	4	13	18	0	17	9	6	4	3.20	2.64	1.69	1.69	0.44	0.78	28
	R	20	21	17	20	75	17	8	13	16	12	15	18	0	22	19	11	14	3.20	2.39	2.26	1.69	0.57	1.42	39
16	L	15	6	7	14	42	15	7	8	14	0	21	28	0	19	10	8	13	3.39	2.82	2.07	1.69	0.35	1.30	31
	R	20	14	14	20	62	17	6	8	16	2	10	15	0	19	17	11	11	3.20	2.26	2.26	2.07	0.44	1.17	39

TABLE A11.5. Results of ENC

Days from start	Hand	POWER GRIP						PAN				KETTLE			PULP PINCH				EXTENSION				Key	Tube	Lp
		In	Mi	Ri	Li	Tot	Gr	Lo	Up	Mx	Gr	Lo	Up	Mx	In	Mi	Ri	Li	In	Mi	Ri	Li			
0	L	23	5	4	2	30	18	1	2	14	8	1	1	0	6	6	3	2	1.32	0.75	0.75	0.75	0.26	0.39	8
	R	11	6	8	4	29	15	3	2	12	2	2	2	0	7	5	5	7	2.07	0.38	0.75	0.38	0.09	0	8
2	L	8	11	6	6	29	26	4	4	17	7	2	2	0	11	9	7	4	2.26	0.56	0.56	1.88	0.26	1.17	14
	R	16	9	8	8	38	31	3	4	29	3	4	3	0	1	9	7	7	1.88	0.56	1.32	0.75	0.22	0.52	11
6	L	4	4	7	7	22	22	3	3	18	18	3	5	8	9	10	6	6	1.13	0.75	0.94	0.56	0.17	0.78	15
	R	17	5	10	7	37	23	2	2	15	16	4	5	10	8	10	7	10	1.88	0.56	0.75	0.56	0.09	0.57	16
9	L	11	7	4	7	26	19	3	5	18	14	6	6	11	9	11	9	X	1.69	1.13	0.75	0.75	0.13	0.65	14
	R	20	3	16	11	45	46	3	4	46	4	4	6	0	11	9	5	5	1.88	0.38	0.75	0	0.17	0.39	12

TABLE A11.5. Results of EF

X = no opposition

Days from start	Hand	POWER GRIP						PAN			KETTLE			PULP PINCH				EXTENSION				Lp			
		In	Mi	Ri	Li	Tot	Gr	Lo	Up	Mx	Gr	Lo	Up	Mx	In	Mi	Ri	Li	In	Mi	Ri		Li	Key	Tube
1	L	25	11	14	15	63	17	11	16	15	28	11	12	15	19	14	22	14					0.31	1.68	28
	R	7	15	28	2	51	14	8	8	8	32	11	12	13	12	13	11	9					0.13	1.55	17
4	L	34	25	28	17	101	23	8	10	19	26	10	13	15	25	28	25	19		No			0.48	2.59	33
	R	20	6	15	2	40	20	3	3	17	1	3	5	1	11	8	11	9					0.13	0.91	17
8	L	46	47	51	24	165	22	21	28	21	30	14	19	18	22	28	31	19					0.48	2.85	33
	R	8	7	10	2	28	10	4	4	9	11	2	2	10	13	15	14	10		Data			0.31	1.04	22
11	L	55	32	42	26	151	13	21	27	11	25	38	32	18	22	15	28	14					0.48	-	31
	R	32	16	21	0	67	19	4	4	18	19	6	6	10	12	11	15	9					-	-	22

TABLE A11.6. Results of GM

Days from start	Hand	POWER GRIP						PAN			KETTLE			PULP PINCH					EXTENSION				Key	Tube	Lp
		In	Mi	Ri	Li	Tot	Gr	Lo	Up	Mx	Gr	Lo	Up	Mx	In	Mi	Ri	Li	In	Mi	Ri	Li			
3	L	21	60	88	24	190	84	36	45	76	46	M	32	33	31	X	25	5.46	3.58	X	5.27	1.18	3.37	64	
	R	19	23	15	7	62	33	14	17	32	13	M	0	33	22	8	14	3.20	3.95	1.32	3.50	0.70	1.30	56	
5	L	44	117	133	37	330	131	38	49	84	67	M	58	44	44	X	25	4.71	3.20	X	5.27	1.35	4.79	67	
	R	48	34	34	27	140	99	40	45	87	16	M	7	42	25	28	25	4.52	4.90	3.20	5.27	1.09	3.63	78	
7	L	42	92	110	32	271	140	45	53	125	87	M	74	39	42	X	22	4.14	2.83	X	-	1.35	5.70	69	
	R	34	39	34	21	128	106	40	45	97	63	M	17	39	22	17	17	4.33	4.33	2.26	4.52	1.18	3.63	72	
11	L	44	115	121	38	316	99	41	56	95	59	M	38	42	47	X	19	4.71	2.07	X	4.73	1.26	5.31	69	
	R	34	54	35	23	135	83	36	41	79	26	M	18	42	28	14	14	4.52	3.95	0.74	3.95	1.09	3.11	67	

TABLE A11.7. Results of RP

Table A11.7 Results of RP

M - maximum lift(greater then 99N)

X - ring finger distal phalanx amputated

Days from start	Hand	POWER GRIP						PAN				KETTLE			PULP PINCH				EXTENSION				Key	Tube	Lp
		In	Mi	Ri	Li	Tot	Gr	Lo	Up	Mx	Gr	Lo	Up	Mx	In	Mi	Ri	Li	In	Mi	Ri	Li			
0	L	19	23	22	1	66	39	6	8	34	32	18	20	15	13	14	11	10	3.77	2.26	1.88	2.26	0.44	1.94	36
	R	9	23	10	6	47	53	11	12	53	23	33	35	1	18	21	16	13	3.01	2.26	1.88	0.94	0.31	1.68	36
2	L	27	41	32	14	108	62	25	29	57	62	37	51	21	33	28	22	14	2.64	2.64	1.88	2.82	0.61	3.76	47
	R	17	59	45	14	132	61	26	30	60	73	40	50	15	31	42	28	19	3.20	3.20	1.88	1.32	0.57	4.15	39
6	L	25	57	45	21	146	53	29	40	53	19	47	63	3	31	25	14	14	2.45	3.01	2.26	2.26	0.65	2.85	47
	R	15	66	44	14	137	74	24	32	73	55	41	52	19	33	36	22	17	3.39	3.20	1.69	1.51	0.44	2.98	44
8	L	19	53	42	14	123	50	26	35	47	23	51	72	0	33	31	25	17	2.82	2.82	1.69	2.45	0.74	3.76	47
	R	15	69	53	23	158	84	24	38	83	36	46	68	6	33	33	31	19	3.56	3.39	2.07	1.32	0.65	3.63	44
10	L	28	46	34	18	123	47	26	33	46	27	M	0	28	25	17	11	1.88	2.82	1.88	2.45	0.61	3.24	47	
	R	39	63	34	14	136	71	23	29	71	17	M	0	22	31	28	17	3.58	3.58	1.51	1.32	0.57	3.37	42	
14	L	27	49	55	26	154	62	30	46	53	32	M	0	36	19	19	17	2.82	3.39	1.88	2.26	0.74	3.89	53	
	R	21	79	49	20	168	76	30	36	76	12	M	0	33	33	19	19	3.58	3.95	1.69	0.94	0.65	3.76	50	
16	L	27	60	52	17	154	51	34	53	41	37	M	0	36	31	22	17	2.26	3.39	1.88	3.20	0.65	3.63	53	
	R	32	58	51	25	155	84	31	40	79	57	M	2	31	22	19	19	3.39	3.39	1.69	2.26	0.61	3.76	44	

TABLE A11.8. Results of JS

M = maximum lift(greater than 99N)

Days from start	Hand	POWER GRIP					PAN				KETTLE				PULP PINCH				EXTENSION						
		In	Mi	Ri	Li	Tot	Gr	Lo	Up	Mx	Gr	Lo	Up	Mx	In	Mi	Ri	Li	In	Mi	Ri	Li	Key	Tube	Lp
3	L	7	11	10	7	33		U			-	-	-	-	4	2	X	X					0.17	0.65	8
	R	8	9	7	8	31		U			25	26	22	3	7	5	2	3					0.22	0.91	17
6	L	8	11	11	5	34		U			35	13	16	3	5	2	X	X			No		0.13	0.78	6
	R	7	11	11	6	35		U			1	20	26	21	8	6	4	4					0.26	0.65	11
11	L	1	11	13	6	31		U			18	34	45	0	6	5	X	X					0.17	1.30	5
	R	15	15	17	15	59		U			10	41	60	0	11	6	3	4			Data		0.26	1.04	15
14	L	11	16	14	7	47		U			23	29	39	0	5	2	X	X					0.09	0.91	6
	R	7	12	11	6	36		U			8	40	56	0	8	8	4	4					0.26	1.04	12

TABLE A11.9. Results of IW

U = unable to lift pan
X = no opposition

APPENDIX 12

RESULTS OF PATIENTS FROM PHYSIOTHERAPY

Days from start	Hand	POWER GRIP						PAN				KETTLE			PULP PINCH				EXTENSION				Key	Tube	Lp
		In	Mi	Ri	Li	Tot	Gr	Lo	Up	Mx	Gr	Lo	Up	Mx	In	Mi	Ri	Li	In	Mi	Ri	Li			
0	L	28	28	19	25	93	28	7	8	28	15	8	9	5	13	13	7	7	2.30	3.13	2.51	2.09	0.31	1.04	16
	R	22	19	25	31	93	24	4	4	19	9	9	10	0	16	16	11	13	2.51	3.95	2.71	2.09	0.35	1.30	29
14	L	34	4	15	27	86	31	5	7	29	25	10	12	5	11	12	8	6	2.82	3.01	0.94	0.94	0.35	1.04	17
	R	19	30	32	24	93	32	4	3	28	19	6	7	15	14	12	8	8	2.64	2.82	2.45	2.82	0.31	1.17	19
28	L	24	10	8	30	66	34	6	6	33	18	7	8	2	11	14	6	9	2.45	2.58	2.07	2.64	0.44	0.78	28
	R	25	26	27	24	92	27	4	3	26	18	12	13	7	17	12	12	10	3.58	4.71	2.65	3.77	0.52	1.42	31
49	L	32	16	18	28	87	36	10	12	34	17	11	13	12	14	15	8	8	2.64	2.65	1.51	2.64	0.31	1.04	22
	R	43	36	29	25	122	38	9	11	37	19	15	18	8	19	17	11	8	2.64	3.39	3.01	2.26	0.57	1.81	33

TABLE A12.1. Results of FB

Days from start	Hand	POWER GRIP						PAN			KETTLE			PULP PINCH				EXTENSION				Key	Tube	Lp	
		In	Mi	Ri	Li	Tot	Gr	Lo	Up	Mx	Gr	Lo	Up	Mx	In	Mi	Ri	Li	In	Mi	Ri				Li
7	L	56	65	48	33	195	55	17	21	51	34	23	32	23	29	32	19	10					0.48		
	R	11	6	13	19	47	42	4	5	38	4	7	9	0	4	7	11	14					0.13		
21	L	35	70	48	13	158	44	18	21	36	21	11	12	14	19	16	19	7		No		0.39	No		
	R	15	2	64	21	99	42	5	6	42	12	11	11	4	5	10	10	14				0.13			
30	L	36	86	61	16	188	32	11	12	30	32	12	15	21	26	19	13	10				0.61			
	R	15	17	25	28	79	41	10	11	38	16	17	14	0	10	15	15	17		Data		0.48	Data		
49	L	40	59	66	36	195	24	11	12	23	30	13	17	22	26	26	19	10				0.78			
	R	20	24	32	31	101	35	6	7	26	9	9	11	3	10	13	12	15				0.31			

TABLE A12.2. Results of JB

Days from start	Hand	POWER GRIP						PAN			KETTLE				PULP PINCH				EXTENSION				Key	Tube	Lp
		In	Mi	Ri	Li	Tot	Gr	Lo	Up	Mx	Gr	Lo	Up	Mx	In	Mi	Ri	Li	In	Mi	Ri	Li			
0	L	30	35	33	45	153	58	17	19	78	33	15	10	33	29	26	4	7					0.92	2.85	-
	R	12	11	4	11	38			U		2	7	5	1	3	3	3	1					0.31	0.54	-
14	L	32	20	60	49	160	88	22	26	85	37	17	19	23	13	29	16	16			No	0.48	1.68	-	
	R	5	9	7	13	35	22	0	1	21	13	9	7	8	9	10	6	2				0.26	0.39	-	
35	L	33	44	33	39	145	85	20	23	81	51	32	37	24	25	22	8	14				0.57	2.59	47	
	R	7	12	9	9	35	36	2	3	31	17	17	19	12	8	6	5	2			Data	0.26	0.52	8	
56	L	31	64	34	31	159	65	25	29	57	48	35	41	37	22	25	8	11				0.57	2.33	56	
	R	9	11	14	19	53	45	7	8	19	13	25	27	6	7	8	4	3				0.22	1.17	28	

TABLE A12.3. Results of AGM

U - Unable to lift pan

Days from start	Hand	POWER GRIP						PAN			KETTLE			PULP PINCH				EXTENSION				Key	Tube	Lp	
		In	Mi	Ri	Li	Tot	Gr	Lo	Up	Mx	Gr	Lo	Up	Mx	In	Mi	Ri	Li	In	Mi	Ri				Li
14	L	30	27	10	22	88	52	0	2	52	45	0	7	39	19	19	7	7					0.57		
	R	19	12	8	11	45	14	0	0	-	5	0	0	-	10	4	4	7					0.22		
28	L	23	23	28	2	74	59	4	4	58	26	2	2	19	20	23	7	10					0.35		
	R	20	9	16	18	59	22	0	1	13	12	2	2	11	11	6	5	3		No			0.31		No
42	L	47	25	31	11	98	55	2	3	51	30	4	3	16	29	26	10	7					0.57		
	R	12	14	8	16	43	17	1	2	14	21	2	1	20	15	5	6	6					0.31		
56	L	24	33	11	27	95	37	4	5	36	62	4	3	47	26	23	7	7					0.39		
	R	14	4	4	21	38	39	4	2	37	31	5	3	17	14	4	8	6		Data			0.26		Data
70	L	43	29	22	2	90	33	3	3	29	31	3	2	21	23	26	16	13					0.39		
	R	28	16	5	8	56	29	2	3	28	14	2	2	10	13	6	6	5					0.22		

TABLE A12.4. Results of DM

Days from start	Hand	POWER GRIP						PAN			KETTLE			PULP PINCH				EXTENSION			Key	Tube.	Lp		
		In	Mi	Ri	Li	Tot	Gr	Lo	Up	Mx	Gr	Lo	Up	Mx	In	Mi	Ri	Li	In	Mi				Ri	Li
84	L	46	39	49	28	143	42	4	6	37	31	3	6	27	38	38	26	16	3.33	3.13	1.89	3.13	0.91		
	R	44	35	22	10	109	49	0	2	49	49	2	5	49	32	32	19	4	2.92	3.33	4.16	2.71	0.39		
98	L	26	55	63	28	167	57	11	11	51	41	17	19	32	32	35	16	7	2.51	2.30	3.54	3.13	1.05	No	
	R	24	27	27	8	83	43	7	6	35	45	8	9	45	19	15	4	0	2.92	0.85	1.47	1.27	0.83		
112	L	30	38	28	5	99	46	12	11	42	44	8	9	38	23	26	13	7	1.47	2.30	2.30	2.30	0.65		
	R	31	33	19	8	89	42	9	10	40	47	9	9	42	16	13	9	4	0.85	2.92	1.68	1.68	0.48		
133	L	26	54	33	24	132	47	13	15	45	54	12	14	42	38	38	29	16	3.33	3.13	2.30	3.33	0.83	Data	
	R	64	45	23	18	143	54	14	16	50	55	7	8	56	32	26	13	10	2.30	4.37	3.13	3.13	0.65		
198	L	16	42	22	6	84	47	12	13	41	43	10	13	36	33	28	19	17	2.64	3.39	2.82	2.26	0.96		
	R	27	31	24	9	90	59	7	10	49	41	9	10	41	33	11	11	8	2.64	3.01	2.45	2.45	0.74		

TABLE A12.5. Results of FS

Days from start	Hand	POWER GRIP					PAN				KETTLE				PULP PINCH				EXTENSION				Key	Tube	Lp
		In	Mi	Ri	Li	Tot	Gr	Lo	Up	Mx	Gr	Lo	Up	Mx	In	Mi	Ri	Li	In	Mi	Ri	Li			
0	L	60	35	40	41	177								41	41	23	29	4.57	0	0	2.09				
	R	105	121	90	101	413								71	89	77	50	6.02	6.43	5.61	2.71				
14	L	102	45	63	60	263								38	47	32	26	3.31	0	0	1.06				
	R	109	183	120	65	515				No				59	62	47	35	3.95	5.19	4.99	2.30		No		
28	L	71	80	67	58	278								51	51	51	40	4.70	0.93	0	2.06				
	R	85	165	110	106	456				Data				59	65	54	45	5.27	4.70	4.89	2.25		Data		
42	L	84	118	90	69	361								53	67	69	50	5.44	1.13	0.19	2.45				
	R	129	135	115	59	463								81	86	67	50	5.46	5.27	4.71	3.20				

TABLE A12.6. Results of AGR

REFERENCES

REFERENCES

- An K N, Chao E Y S. and Askew L J (1980) Hand Strength Measurement Devices. Arch. Phys. Med. 61(8), 366-368
- Ansell B M (1969) Hand Assessment in Rheumatoid Arthritis. Ann. Rheum. Dis. 28(suppl), 77-78
- Askew L J, Beckett V L, An K N and Chao Y S (1983) Objective Evaluation of Hand Function in Schleroderma Patients to assess effectiveness of Physical Therapy. B. J. Rheum. 22, 224-232
- Bechtol C O (1954) Grip Test: Use of a Dynamometer with Adjustable Handle Spacing. J. Bone Joint Surg. 36A, 820-824
- Bell E, Jurek K and Wilson T (1976) Hand Skill Measurement - a Gauge for Treatment. Am. J. Occup. Th. 30(2), 80-86
- Bowers L E (1961) Investigation of the relationship of hand size and Lower Arm Girths to Hand Grip Strength as Measured by selected Hand Dynamometers. R. Quart. 32, 308-314
- Brand P W (1973) Evaluation of the Hand and its Function. Orthop. Clin. North Am. 4, 1127-1134
- Brewer K, Guyatt A R and Scott J T (1975) Comparing Grip Strength. Physio. 61(4), 118
- Cantrell E G (1975) Describing Hand Function. Nurs. Times. 71(40), 1577-1578
- (1976) Measurement of Weakness and Dysfunction in the Rheumatoid Hand. Rheumatol. Rehabil. 15(3), 182-184
- (1977) Natural History of the Rheumatoid Hand. Physio. 63(9), 287-289

- Carthum C J, Clawson D K and Decker J L (1969) Functional Assessment of the Rheumatoid Hand. Amer. J. Occup. Ther. 32,122-125
- Clawson D K, Souler W A, Carthum C J and Hymen M L (1971) Functional Assessment of the Rheumatoid Hand. Clin. Orthop. 77,203-210
- De Choisy J (1974) A New Method of Assessing Grip Strength and Wrist and Arm Movement in the Arthritic Patient. Rheumatol. Rehabil. Suppl.81-84
- Dickson R A and Nicolle F V (1972) The Assessment of Hand Function. I - Measurement of Individual Digits. Hand 4(3),207-214
- , Paice F and Nicolle F V (1973) The Assessment of Hand Function. II - Forces and Bone Density, a Relationship in the Hand. Hand. 5,15-24
- and Nicolle F V (1976) The Assessment of Hand Function. III - The Final Analysis. Hand. 8.110-114
- Downie W W, Leatham P A, Rhind V M, Pickup M E and Wright V E (1978) The Visual Analogue Scale in the Assessment of Grip Strength. Ann. Rheum. Dis. 37,382-384
- Dumont S (1968) Occupational Therapy in the Treatment of the Rheumatoid Hand. Occ. Ther. November,31-34
- Fernando M U and Robertson J C (1982) Grip 'Strength' in the Healthy. Rheum. Rehabil. 21,179-181
- Green M (1974) Hand Assessment. Occup. Ther. December,215-218
- Harkness J A L, Richter M B, Panayi G S, Van de Pette K, Unger A, Pownall R and Geddawi M (1982) Circadian Variation in Disease Activity in Rheumatoid Arthritis. BMJ. 284, 551-554
- Hazleton F T, Smidt G L, Flatt A E and Stephens R I (1975) The Influence of Wrist Position on the Force produced by the Finger Flexors. J. Biomech. 8(5),301-306

- Heyward V, McKeown B and Geesman R (1975) Comparison of the Stoelting Hand Grip Dynamometer and Linear Voltage Differential Transformer for Measuring Maximal Grip Strength. Res. Quart. 46,262-266
- Huskisson E C, Dieppe P A, Tucker A K and Cannell L B (1979) Another Look at Osteoarthritis. Ann. Rheum. Dis. 38, 423-428
- Ingpen M L (1968) The Quantitative Measurement of Joint Changes in Rheumatoid Arthritis. Ann. Phys. Med. 9(8),322-327
- Jacobson-Sollerman C and Sperling L (1976) Classification of Hand Grip. Am. J. Occup. Med. 18(6),395-398
- and ——— (1977) Grip Function of the Healthy Hand in a Standardised Hand Function Test - A Study of the Rancho Los Amigos Test. Sc. J. Rehab. Med. 9(3),123-129
- and ——— (1978) Evaluation of ADL function, especially Hand Function. Sc. J. Rehab. Med. S6,139-143
- Jebsen R H, Taylor N, Trieschmann R E, Trotter M J and Howard L A (1969) An Objective and Standardised Test of Hand Function. Arch. Phys. Med. Rehabil. 50(6),311-319
- Kellor M, Frost J, Silberberg N, Iversen I and Cummings R (1971) Hand Strength and Dexterity. Am. J. Occup Ther. 25, 77-83
- Kent R P (1978) 'Quantification of Stiffness in the Human Metacarpophalangeal Joint'. University of Durham, Department of Engineering - Final Year Project
- Kirkpatrick J E (1957) Evaluation of Grip Loss - A Factor of Permanent Partial Disability in California. Ind. Med. Surg. 26,285-289
- Kowanko I C, Pownall R, Knapp M S, Swannell A J and Mahoney P G C (1981) Circadian Variations in the Signs and Symptoms of Rheumatoid Arthritis and in the Therapeutic

- Effectiveness of Flurbiprofen at Different Times of Day. Br. J. Clin. Pharm. 11,477-484
- , Knapp M S, Pownall R and Swannell A J (1982) Domiciliary Self-Measurement in Rheumatoid Arthritis and the Demonstration of Circadian Rhythmicity. An. Rheum. Dis. 41,453-455
- Lansbury J (1957) Numerical Method of Evaluating the Status of Rheumatoid Arthritis. Ann. Rheum. Dis. 16,101-107
- (1958) Report of a Three year Study on the Systemic and Articular Indexes in Rheumatoid Arthritis - Theoretic and Clinical Considerations. Arth. Rheum. 1,505-522
- Lee P, Baxter A, Carson Dick W and Webb J (1974) An Assessment of Grip Strength Measurement in Rheumatoid Arthritis. Sc. J. Rheum. 3,17-23
- MacBain K P (1970) Assessment of Function in the Rheumatoid Hand. Canad. J. Occup. Ther. 37(3),95-102
- Malinen S, Virtanen K and Frick M H (1979) A New Electrical Equipment for Handgrip Testing. Ann. Clin. Res. 11(3) 118-120
- Montoye H J and Faulkner J A (1964) Determination of the Optimum Setting of an Adjustable Grip Dynamometer. Res. Quart. 35,29-36
- Mundale M O (1970) Relationship of Intermittant Isometric Exercise to Fatigue of Hand Grip. Arch. Phys. Med. Rehabil. 51,532-539
- Myers D B, Wilson K and Palmer D G (1979) Relative changes in Maximum Grip Strength, Work and Power Output during Hand Grip Assessment of Rheumatoid Patients in a drug Trial. P.U. Otago Med. 57(3),64-65
- , Grennan D M and Palmer D G (1980) Hand Grip Function in Patients with Rheumatoid Arthritis. Arch. Phys. Med.

61(8),369-373

- Napier J R (1956) The Prehensile Movements of the Human Hand.
J. Bone Joint Surg. 38 B(4),902-913
- Nwuga V C (1975) Grip Strength and Grip Endurance in Physical
Therapy Students. Arch. Phys. Med. 56(7),296-300
- Ohtsuki T (1981a) Inhibition of Individual Fingers during Grip
Strength Exertion. Ergonomics 24(1),21-36
- (1981 b) Decrease in Grip Strength Induced by Simultaneous
Bilateral Exertion with Reference to Finger Strength.
Ergonomics. 24(1),37-48
- Pearn J and Bullock K (1979) Portable Hand Grip Dynamometer.
Aust. Paedia. 15(2),107-109
- Pearson R, MacKinnon M J, Meek A P, Myers D B and Palmer D G
(1982) Diurnal and Sequential Grip Function in Normal
Subjects and the effects of Temperature Change and
Exercise of the Forearm on Grip Function in Patients
with Rheumatoid Arthritis and in Normal Controls.
Scand. J. Rheum. 11,113-118
- Peskett E B (1973) Rheumatoid Arthritis, I - Hand Assessment.
Occup. Ther. 36,527-530
- (1977) Hand Assessment: A Realistic Appraisal. Hand.
9(2),135-138
- Pronk C N A and Niesing R (1981) Measuring Hand Grip Force,
using a new Application Of Strain Gauges. Med. Biol.
Eng. Comp. 19,127-128
- Pryce J C (1980) The Wrist Position between Neutral and Ulnar
Deviation that Facilitates the Maximum Power Grip
Strength. J. Biomech. 13(6),505-511
- Purves W K, Berme N and Paul J P (1980) Hand Function,
Biomechanics and Disability. Eng. Med. 9(4),215-220
- and Berme N (1980) Resultant Finger Joint Loads in

Selected Activities. J. Biomed. Eng. 2,285-289

- Reikeras O (1983) Bilateral Differences of Normal Hand Strength.
Arch. Orthop. Trauma. Surg. 101,223-224
- Ritchie D M, Boyle J A, McInnes J M, Jasani M K, Dalakos T G,
Grievesson P and Buchannan W W (1968) Clinical Studies
with an Articular Index for the Assessment of Joint
Tenderness in Patients with Rheumatoid Arthritis.
Quart. J. Med. 37,393-406
- Robertson J C, Helliwell M G, Cantrell E G, Cawley M I D and
Ellis R M (1982) Circadian Variation in Disease Activity
in Rheumatoid Arthritis. BMJ. 284,1114-1115
- Royce J (1962) Force-time Characteristics of Exertion and
Release of Hand Grip Strength under Normal and Fatigue
Conditions. Res. Quart. 33,444-450
- Schmidt R T and Toews J V (1970) Grip Strength as Measured by
the Jamar Dynamometer. Arch. Phys. Med. 51,321-327
- Sheenan N J, Sheldon F and Marks D (1983) Grip Strength and
Torquometry in the Assessment of Hand Function in
Patients with Arthritis. B. J. Rheum. 22,
- Smith H B (1973) Smith Hand Function Evaluation. Amer. J. Occup.
Ther. 27(5);244-251
- Sperling L and Jacobson-Sollerman J (1977) Grip Pattern of Healthy
Hand During Eating. Sc. J. Rehab. Med. 9(3),115-121
- Swanson A B, Matev I B and de Groot G (1970) The Strength of
the Hand. Bull. Prosth. Res. 10,145-153
- Thorngre K G and Werner C O (1979) Normal Grip Strength. Act.
Orth. Sc. 50(3),255-259
- Toews J V (1964) A Grip Strength Study amongst Steelworkers.
Arch. Phys. Med. Rehab. 45(August),413-417
- Unsworth A, Yung P and Haslock I (1982) Measurement of Stiffness
in the Metacarpophalangeal Joint: The Arthrograph.