

Durham E-Theses

*Mechanistic studies of the decomposition reactions of
hexamine and some acetylated and nitrated
derivatives*

Patrick Aidan Cooney

How to cite:

Cooney, Patrick Aidan (1986) Mechanistic studies of the decomposition reactions of hexamine and some acetylated and nitrated derivatives. Doctoral thesis, Durham University.

Use policy

The full-text may be used and/or reproduced, and given to third parties in any format or medium, without prior permission or charge, for personal research or study, educational, or not-for-profit purposes provided that:

- a full bibliographic reference is made to the original source
- a <https://etheses.durham.ac.uk/id/eprint/7102/> is made to the metadata record in Durham E-Theses
- the full-text is not changed in any way

The full-text must not be sold in any format or medium without the formal permission of the copyright holders.

Please consult the [full Durham E-Theses policy](#) for further details.

MECHANISTIC STUDIES OF THE
DECOMPOSITION REACTIONS OF
HEXAMINE AND SOME
ACETYLATED AND NITRATED
DERIVATIVES

by

Aidan Patrick Cooney, B.Sc. Hons.(CNA)

A thesis submitted for the degree of Doctor of
Philosophy in the University of Durham, Department
of Chemistry 1986.

The copyright of this thesis rests with the author.
No quotation from it should be published without
his prior written consent and information derived
from it should be acknowledged.



13 FEB 1987

Thesis
1986 / C00

DECLARATION

The material in this thesis is the result of research carried out in the Department of Chemistry, University of Durham, between October 1983 and October 1986. It has not been submitted for any other degree, and is the author's own work, except where acknowledged by reference.

Mechanistic Studies of the Decomposition Reactions of
Hexamine and some Acetylated and Nitrated Derivatives

by Aidan Patrick Cooney

The protonation equilibria and decomposition reactions in aqueous hydrochloric acid of hexamethylenetetramine (hexamine) and its acetylated derivatives have been examined by u.v. and ^1H n.m.r. spectroscopy. pKa values at 25°C are: hexamethylenetetramine 4.89, 3,7-diacetyl-1,3,5,7-tetra-azabicyclo-[3.3.1.]nonane (DAPT) 0.7, 1,3,5,7-tetra-acetyl-1,3,5,7-tetra-azacyclo-octane (TAT) -2.5, and 1,3,5-triacetyl-1,3,5-triazacyclohexane (TRAT) -2.3. Rates of decomposition of the protonated substrates decrease in the order DAPT > TRAT > TAT > hexamethylenetetramine.

Reaction of hexamethylenetetramine with picryl acetate probably occurs via the N-acetyl-hexaminium cation.

$[^{15}\text{N}_4]$ -Hexamethylenetetramine, and $[^{15}\text{N}_4]$ -DAPT have been prepared starting from $^{15}\text{NH}_3$. Synthetic acetolysis reactions have been performed using mixtures of pure $[^{15}\text{N}_4]$ - and $[^{14}\text{N}_4]$ - compounds and the destination of the nitrogen isotopes in the products determined mass spectrometrically. The results show that relatively little isotopic mixing occurs in the acetylosis of hexamethylenetetramine to DAPT though the formation of some products with isotopic composition $[^{14}\text{N}_3\ ^{15}\text{N}_1]$ and $[^{14}\text{N}_1\ ^{15}\text{N}_3]$ indicates limited ring cleavage. The more severe conditions used in the formation of TRAT give rise to considerable isotopic scrambling. The acetolysis of DAPT

to give TAT occurs by selective cleavage of the methylene bridge.

¹H n.m.r. studies of the acetylosis of hexamethylenetetramine show that under anhydrous conditions in glacial acetic acid that very little DAPT is formed, the production of DAPT being favoured by the addition of water.

The decomposition of 3,7-dinitro-1,3,5,7-tetra-azabicyclo-[3.3.1.]nonane (DPT) was found to occur by two consecutive first order reactions. The variation with pH in rate of these reactions has been investigated and the effects of acid-base catalysts examined. The initial decomposition increases in rate in the presence of hydrochloric acid or sodium hydroxide. The intermediate produced from this reaction is relatively stable when $11 < \text{pH} < 3$ but decomposes rapidly at intermediate pH.

PUBLICATIONS

Some of the work reported in this thesis has been the subject of the following papers:

The Acid-Base Behaviour of Hexamine and its N-Acetyl Derivatives.

J. Chem. Soc. Perkin Trans. II, 1986, 835.

(A.P. Cooney, M.R. Crampton and P. Golding)

Nitrogen-15 Studies of the Mechanisms of Acetolysis of Hexamethylenetetramine and 3,7-Diacetyl-1,3,5,7-tetra-aza-bicyclo[3.3.1]nonane (DAPT)
To be published

(A.P. Cooney, M.R. Crampton and P. Golding)

The Stabilities of Meisenheimer Complexes. Part 39. Steric Effects on Rate and Equilibrium Constants for σ -Adduct Formation from Alkyl 2,4,6-Trinitrophenyl Ethers and Ethoxide Ions in Ethanol.

J. Chem. Soc. Perkin Trans. II, 1984, 1793.

(A.P. Cooney and M.R. Crampton)

ACKNOWLEDGEMENTS

I would like to thank my supervisor, Dr. M.R. Crampton, for his constant help and guidance during this work. I would also like to thank the members of the department, academic and technical, who helped in any way, particularly Colin Greenhalgh, Dr. M. Jones and T.F. Holmes.

I would also like to thank my industrial supervisor Dr. P. Golding for advice on synthetic methods employed and the handling of explosive materials.

Thanks are also due to the Procurement Executive, Ministry of Defence for the provision of a maintenance grant.

Finally, I would like to thank Shirley Stewart for taking the time to type this manuscript.

For Irene Cooney

CONTENTS

	Page
CHAPTER ONE: INTRODUCTION	1
1.1: General Properties of Hexamethylenetetramine	2
1.2: Salt and Complex Formation	
a: Salts with Acids	3
b: Complex Formation with phenols	5
c: Complex formation with Inorganic salts	6
d: Quaternary Salt Formation	6
1.3: Reactions with Sulphur and Sulphur Derivatives	7
1.4: Reactions with Halogens and Inorganic Halides	8
1.5: Reactions with Hydrogen Cyanide	9
1.6: Reactions with Hydrogen Peroxide	10
1.7: Introduction of Functional Groups via Hexaminium Salts	
a: Introduction of Amino Groups	10

	b: Introduction of Formyl Groups	12
	c: Introduction of Methyleneimine Groups	14
1.8.1:	Condensation with Benzylamine	15
1.8.2:	Formation of N,N-bis(halomethyl)- Carboxylic acid amides	16
1.8.3:	Reaction with Diazonium ions	18
1.9.1:	Nitrosation	23
1.9.2:	Acetolysis	25
1.9.3:	Nitrolysis	31
1.9.4:	Selective Cleavage of bicyclononanes	35
1.9.5:	Production of HMX via acetylated derivatives of Hexamethylenetetramine	38
CHAPTER TWO:	EXPERIMENTAL	41
2.1:	Materials	42
2.1.1:	Solvents	42
2.1.2:	Substrates	43

2.1.3:	Salts	47
2.1.4:	Buffer Solutions	47
2.2:	Measurement Techniques	49
2.2.1:	U.V. Measurement	49
2.2.2:	Mass Spectrometry	50
2.2.3:	N.m.r. Spectra	50
2.2.4:	pH Measurement	51
CHAPTER THREE: THE ACID-BASE BEHAVIOUR OF HEXAMETHYLENETETRAMINE AND ITS N-ACETYL DERIVATIVES		52
3.1:	Introduction	53
3.2:	Experimental	54
3.3:	Results and Discussion	56
3.3.1:	potentiometric Determination of pKa Values	56
3.3.2:	Decomposition of Hexamethylenetetramine in Acidic Solution	62

3.3.3:	Determination of $pK_{a,2}$ of Hexamethylenetetramine using N.m.r. Spectroscopy	68
3.3.4:	U.V. Absorbance Spectra	71
3.3.5:	Reaction of DAPT with Acid	73
3.3.6:	Reaction of TAT and TRAT with Acid	90
3.3.7:	Comparison of Hexamethylenetetramine, DAPT, TAT and TRAT	100
3.3.8:	Reaction with Picryl acetate	105
CHAPTER FOUR: A STUDY OF THE ACETOLYSIS OF HEXAMETHYLENETETRAMINE USING N.M.R. SPECTROSCOPY		115
4.1:	Introduction	116
4.2:	Experimental	118
4.3:	Results and Discussion	119
4.3.1:	Reaction of Hexamethylenetetramine with Acetic Anhydride in Acetic Acid	119
4.3.2:	Reaction of Hexamethylenetetramine with Acetic Anhydride in Chloroform	123

4.3.3:	Reaction of Hexamethylenetetramine with Acetyl Chloride	126
CHAPTER FIVE: NITROGEN-15 STUDIES OF THE MECHANISMS OF ACETOLYSIS OF HEXAMETHYLENETETRAMINE AND DAPT		133
5.1:	Introduction	134
5.2:	Experimental	136
5.3:	Results and Discussion	142
CHAPTER SIX THE ACID-BASE BEHAVIOUR OF 3,7-dinitro-1,3,5,7-tetra-azabicyclo[3.3.1]nonane (DPT)		155
6.1	Introduction	156
6.2	Experimental	158
6.3	Results and discussion	159
6.3.1	General Properties of DPT	159
6.3.2	U.v. Spectra	161
6.3.3	Decomposition of DPT in aqueous solution	168
6.3.3.1	Initial Reaction in Acid	168
6.3.3.2	Initial Reaction in Base	183
6.3.3.3	Initial pH independent Reaction in water	189

		(xii)
6.3.3.4	Second Reaction	191
6.3.3.5	Buffer Catalysis of Second Reaction	203
	a) Catalysis by Tris Buffer	203
	b) Catalysis by Sodium Acetate/Acetic Acid Buffer	206
	c) Catalysis by Potassium dihydrogen Orthophosphate Buffer	208
APPENDIX I STERIC EFFECTS ON RATE AND EQUILIBRIUM CONSTANTS FOR σ -ADDUCT FORMATION FROM ALKYL 2,4,6-TRINITROPHENYL ETHERS AND ETHOXIDE IONS IN ETHANOL		211
	Introduction	212
	Experimental	214
	Results and Discussion	215
APPENDIX II RESEARCH COLLOQUIA, SEMINARS, LECTURES AND CONFERENCES		230
	(A) Lectures organised by Durham University	231
	(B) Lectures organised by Durham Univeristy Chemical Society	237
	(C) Research Conferences	239
	(D) First Year Induction Course	239
REFERENCES		240

CHAPTER 1

INTRODUCTION

GENERAL PROPERTIES AND REACTIONS OF
HEXAMETHYLENETETRAMINE



1.1 Properties

Hexamethylenetetramine(1.1), $C_6H_{12}N_4$, 1,3,5,7-tetra-azatricyclo [3.3.1.1^{3.7}]-decane, known also as methanamine, hexamine, aminoform, formamin, urotropine, hexamethyleneamine and 1,3,5,7-tetra-azaadamantane, is formed in nearly quantitative yield from the condensation of ammonia and formaldehyde.¹

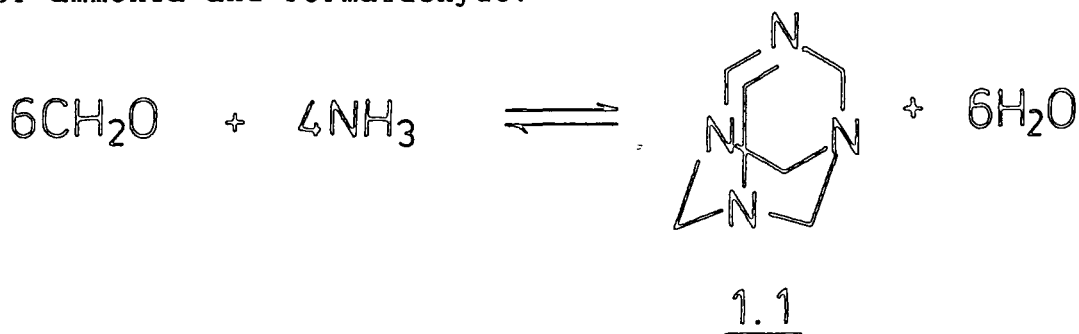

The compound is somewhat soluble in alcohols and slightly soluble in ether and aromatic hydrocarbons. With the exception of chloroform, in which it is fairly soluble, it is only slightly soluble in chlorinated aliphatics. Impure(1.1) may be recrystallized from solvents such as alcohol and chloroform.²

Pure water solutions of (1.1) are comparatively stable at ordinary temperatures, showing only an extremely slight degree of hydrolysis to formaldehyde and ammonia. The formaldehyde content of a pure solution, after standing for 15 hours at room temperature, is approximately 5 ppm. Hydrolysis may be appreciably reduced by the addition of small amounts (0.1 - 1%) of sodium carbonate and is accelerated by heating. Even at elevated temperatures however, the amount of hydrolysis in neutral, aqueous solution is still slight.

Although (1.1) does not normally occur in a hydrated form, a hexahydrate, $C_6H_{12}N_4 \cdot 6H_2O$ has been reported.² This is formed when a saturated aqueous solution is cooled to a temperature slightly above $0^\circ C$.

(1.1) has a symmetrical adamantane-like structure and the chemical and steric equivalence of the four nitrogen atoms has been demonstrated by various physico-chemical methods.^{3,4} In space, the nitrogen atoms occupy the summits of a tetrahedron, whereas the carbon atoms occupy the summits of an octahedron.

In addition to being an ammono-formaldehyde (1.1) is also a tertiary amine and shows the characteristic properties of such amines, forming innumerable salts, addition compounds and complexes. In this it resembles pyridine, triethylamine, etc., but differs in possessing a lower degree of basicity.

On protonation of one nitrogen atom, the (1.1) molecule loses its symmetry and various acid-catalysed fragmentation processes may thus occur.

Depending on the conditions, two, three, or more carbon-nitrogen subunits can be formed, or the reagent can serve as a source of formaldehyde and ammonia. Thus the reagent can be used in the synthesis of alicyclic or heterocyclic structures or it can be employed to introduce functional groups into suitable molecules.

1.2. Salt and Complex Formation

a. Salts with Acids:

The interactions of (1.1) with dilute organic and inorganic acids has been investigated.

With mineral acids (1.1) forms salts which are best isolated when formed in non-aqueous solvents or, in some cases, in cold aqueous solution.

The hydrochloride of (1.1), $C_6H_{12}N_4 \cdot HCl$ may be obtained by addition of aqueous hydrochloric acid to an alcoholic solution of the base or by the action of hydrogen chloride on a hot solution in absolute alcohol.⁵ By the action of excess hydrogen chloride, a compound having the composition $C_6H_{12}N_4 \cdot 2HCl$ is formed.⁶ This is believed to be a molecular compound of hydrogen chloride and the neutral salt.

The sulphate of (1.1) $(C_6H_{12}N_4)_2H_2SO_4$, is precipitated by the action of sulphuric acid on (1.1) in cold alcoholic solution.² Salts of (1.1) and many other inorganic acids including the hydrobromide, $C_6H_{12}N_4 \cdot HBr$, the hydroiodide, $C_6H_{12}N_4 \cdot HI$, the phosphates, $C_6H_{12}N_4 \cdot H_3PO_4$ and $5C_6H_{12}N_4 \cdot 6H_3PO_4 \cdot 10H_2O$, the perchlorate $C_6H_{12}N_4 \cdot HClO_4$ and the explosive chromates $2C_6H_{12}N_4 \cdot H_2Cr_2O_7$ and $2C_6H_{12}N_4 \cdot H_2Cr_4O_{13}$ have been reported.

A mononitrate of (1.1) may be obtained by the action of nitric acid on an aqueous solution of (1.1).^{7,8} With more concentrated acid a dinitrate, $C_6H_{12}N_4 \cdot 2HNO_3$ is produced.^{9,10}

The salts formed with organic acids may be isolated by combining (1.1) and acid in the theoretical proportions in concentrated aqueous solution and subjecting the product to vacuum evaporation.²

Salts of the higher fatty acids such as stearic or palmitic acids are obtained by heating with (1.1) until the mixture sets to a crystalline mass which is then dried on a

porcelain plate and recrystallized from alcohol.

It has been shown^{11,12} that in solution (even in the presence of a large excess of acid) less than 4 molecules of acid form donor-acceptor bonds with (1.1).

The number of acid molecules bound to (1.1) decreases with increasing acidity of the acid. With formic, acetic and chloroacetic acid three molecules of acid are bonded to (1.1). With hydrofluoric acid, complexes containing 1-4 molecules of HF per molecule of (1.1) are formed.

b. Complex Formation with Phenols:

A large number of complexes have been characterized produced from (1.1) and phenols. The triphenol $C_6H_{12}N_4 \cdot 3C_6H_5OH$ is obtained as a crystalline precipitate when concentrated aqueous solutions of (1.1) and phenol are mixed at room temperature. A product having the composition $C_6H_{12}N_4 \cdot C_6H_5OH$ has also been reported.²

(1.1) also forms hydrogen-bonded 1:1 complexes with 1,3-dihydroxybenzene and 1,3-dihydroxy-5-methylbenzene. Also a 1:2 complex is formed with 1,3-dihydroxy-2,5-dimethylbenzene.¹

It has been shown that mono-, di- and trinitrophenols are able to give molecular complexes with (1.1).¹³ The mononitrophenols form complexes through hydrogen bonding, however 2,4-dinitrophenol is able to form either a hydrogen-bonded or an n- π complex.

In the case of picric acid an n- π complex can form through the interaction of a non-bonding molecular orbital from (1.1) with the vacant π orbital of one of the nitro groups from the trinitrophenol. There is spectroscopic and

electrochemical evidence for the formation of these complexes.

c. Complex Formation with Inorganic Salts:

(1.1) forms addition compounds with a wide variety of inorganic salts including salts of alkali metals, alkaline earths and rare earths. Although many of these compounds tend to conform to the type formula, $Mx_n \cdot nC_6H_{12}N_4$, in which M stands for a metal ion of valence n, the number of molecules of combined (1.1) per mole of salt is often lower than this value and several different complexes are often formed with the same salt.

Complexes are reported with salts of lithium, sodium, silver, gold, strontium, mercury, uranium and several others.

d. Quaternary Salt Formation:

(1.1) forms quaternary salts in the manner characteristic of tertiary amines.

Reaction with alkyl halides in chloroform gives salts of the form (1.2).

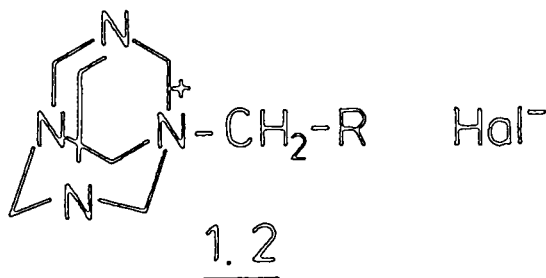

e.g. methyl iodide adds to (1.1) in absolute alcohol to give lustrous needle-like crystal of the product

$C_6H_{12}N_4 \cdot CH_3I$.^{1,2} The reaction takes place slowly at room temperature but more rapidly on heating. The methyl iodide

addition product is readily soluble in water, slightly soluble in cold alcohol and insoluble in cold ether and chloroform.

Related addition products are produced by the action of (1.1) on halogen derivatives of alcohols, aldehydes, ketones and esters. Quaternary salts (1.3) have been prepared from (1.1) and haloacetates or haloalkylnitriles

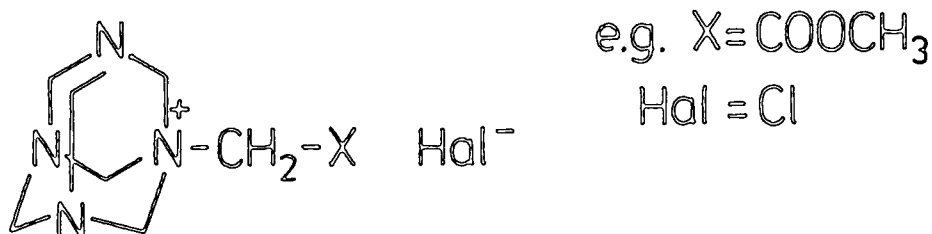

1.3

Some of these salts have been found to have bactericidal and fungicidal activity.

1.3. Reactions with Sulphur and Sulphur Derivatives

Heating (1.1) with sulphur at approximately 165°C generates hydrogen sulphide and a product is obtained which is partially soluble in water.² In solution highly coloured precipitates are obtained with metallic salts. Addition of lead acetate produces an orange-red precipitate of empirical formula Pb₂C₂N₂S₃.

An amorphous product is obtained when hydrogen sulphide reacts with (1.1) in hot aqueous or alcoholic solutions.²

The product obtained between (1.1) and sulphur dioxide depends upon the conditions employed. The addition product

$C_6H_{12}N_4 \cdot SO_2$ is produced when sulphur dioxide is passed into a hot solution of (1.1) in benzene. When the reaction is carried out in water or alcohols complex products are obtained.² A compound with empirical formula $C_6H_{22}N_4S_2O_{10}$ is obtained in hot methanol, however $C_5H_{11}N_3SO_3$ is produced in isopropanol or isobutanol.

1.4. Reactions with Halogens and Inorganic Halides

The explosive nitrogen trichloride is formed from an aqueous solution of (1.1) and chlorine.¹⁴ However, with sodium hypochlorite, chloro- derivatives are obtained.

These products are unstable and may explode on storage.

N-dichloropentamethylenetetramine

(3,7-dichloro-1,3,5,7-tetra-aza[3.3.1]bicy-

clononane) (1.4) is formed by addition of a dilute solution of sodium hypochlorite to a solution of (1.1).¹⁵

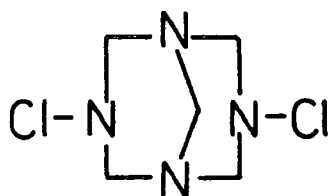

1.4

On heating to 78-82°C, the product explodes. A tetrachloro- derivative of (1.1) is claimed by Buratti.¹⁶

A crystalline orange-red tetrabromide, $C_6H_{12}N_4Br_4$ is formed when bromine reacts with (1.1) in chloroform solution.¹⁷ However this is converted to the yellow dibromide, $C_6H_{12}N_4Br_2$, on standing in air.

Similarly it is possible to form di- and tetra- iodine derivatives. A hexaiodide $C_6H_{12}N_6I_6$ can be prepared by the addition of ammonia and iodine to (1.1).

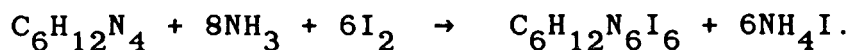

This is a violet-red powder which explodes on heating or sudden shock.² Hoehnel¹⁴ reports the production of mixed halides such as $C_6H_{12}N_4ICl$ by the action of halogen compounds on (1.1).

(1.1) also reacts with inorganic halides such as phosgene. A compound of composition $2C_6H_{12}N_4:COCl_2$ is produced from (1.1) and phosgene which melts at 187 - 190°C. During World War I a mixture of caustic soda, phenol, glycerine and (1.1) was used for the neutralization of phosgene. The following addition compounds have also been prepared:

$2C_6H_{12}N_4:PCl_3$, $2C_6H_{12}N_4:POCl_3$ and $2C_6H_{12}N_4:SO_2Cl_2$. These addition compounds are obtained by reacting (1.1) with the halide in an inert solvent.¹⁸

1.5. Reactions with Hydrogen Cyanide

In concentrated aqueous solution (1.1) reacts with hydrogen cyanide to give imidoacetonitrile, $HN(CH_2CN)_2$. Ammonia is liberated from the reaction mixture and dark-coloured by-products are produced. Better results are obtained if a catalytic quantity of sulphuric or hydrochloric acid is used.²

In more concentrate acid $N(CH_2CN)_3$ is also produced. The latter product can also be formed by the addition of hydrochloric acid to a solution of (1.1) and potassium cyanide.

1.6. Reactions with Hydrogen Peroxide

The addition compound $C_6H_{12}N_4 \cdot H_2O_2$ is the primary reaction product obtained from (1.1) and hydrogen peroxide. This material is obtained in almost quantitative yield by vacuum evaporation at 40-50°C of the solution obtained by dissolving (1.1) in a slight excess of 30% hydrogen peroxide. Decomposition takes place if the temperature is allowed to exceed 70°C.¹⁹

If the reaction is carried out in the presence of a substantial quantity of acid the primary explosive hexamethylenetriperoxidediamine (1.5) is formed.²⁰

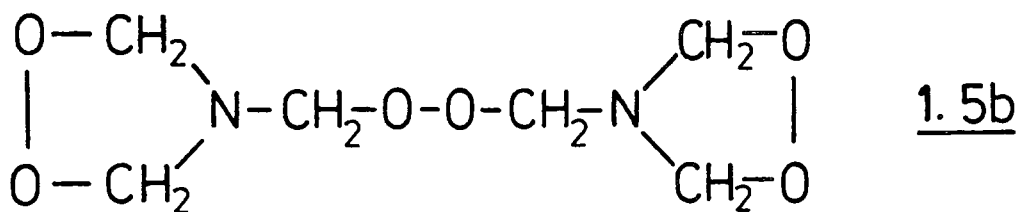
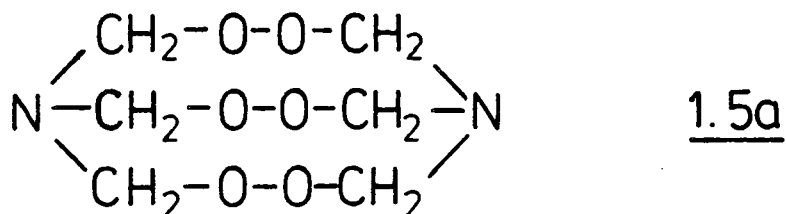

It is uncertain whether the substance has the structure (1.5a) or (1.5b) but it seems certain that there are -N-CH₂- and -O-O- groups present.²¹

1.7 Introduction of Functional Groups Via Hexaminium Salts

a. Introduction of Amino Groups via Hexaminium Salts:

The quaternary salts (1.2) formed from hexamethylenetetramine (1.1) and alkyl halides can be isolated when the reaction is conducted in non-hydroxylic solvents. However, in a hydroxylic medium these salts are

hydrolysed to products the nature of which depends upon the pH of the solution.²²

Acid hydrolysis of the hexaminium salt gives the corresponding primary amines. This reaction, named after Delepine, is an excellent method for the preparation of primary amines from alkyl halides without the formation of secondary amines.²³ The hydrolysis is best effected by a mixture of ethanol and concentrated hydrochloric acid, which removes the formaldehyde as the volatile diethyl formal.

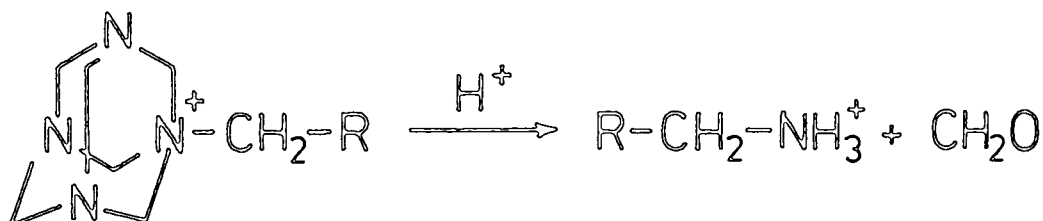

1.2

When a hexaminium salt is heated with formic acid, the corresponding fully methylated amine is obtained, e.g. dimethylbenzylamine from benzylhexaminium chloride.

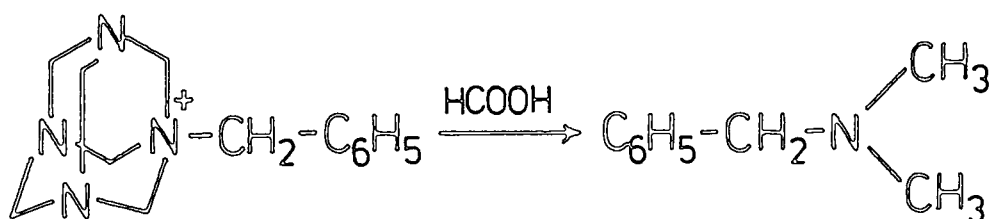

This is essentially an Eschweiler-Clarke methylation (reductive amination using formic acid as the reducing agent). In this reaction the hexaminium salt supplies both

the amine and the formaldehyde. The formic acid is oxidised to carbon dioxide.

b. Introduction of Formyl Groups via Hexaminium Salts:

On heating in aqueous or dilute alcoholic solution, the hexaminium salts (1.2) (preferably from benzyl halides and their structural analogues) undergo further reaction with the formation of aldehydes. This is known as the Sommelet reaction.²⁴

The method is of fairly general use for the preparation of aromatic and some heterocyclic aldehydes from the corresponding hexaminium salts.

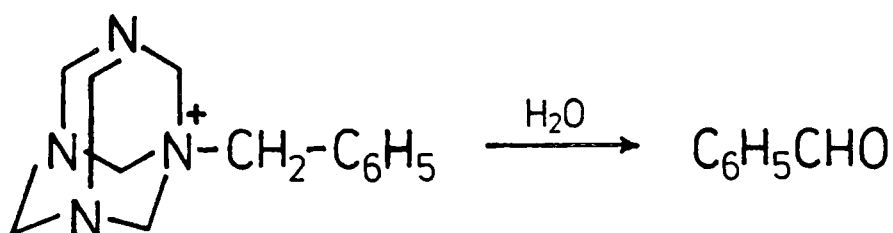

Angyal, Penman and Warwick²⁵ suggested that the Sommelet reaction proceeds by a hydride-ion transfer, the acceptor being the conjugate acid of methyleneimine (a sub-unit of hexamethylenetetramine).

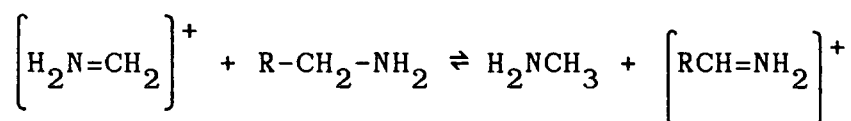

A generally accepted mechanism for the Sommelet reaction was proposed later^{26,27} (Scheme 1).

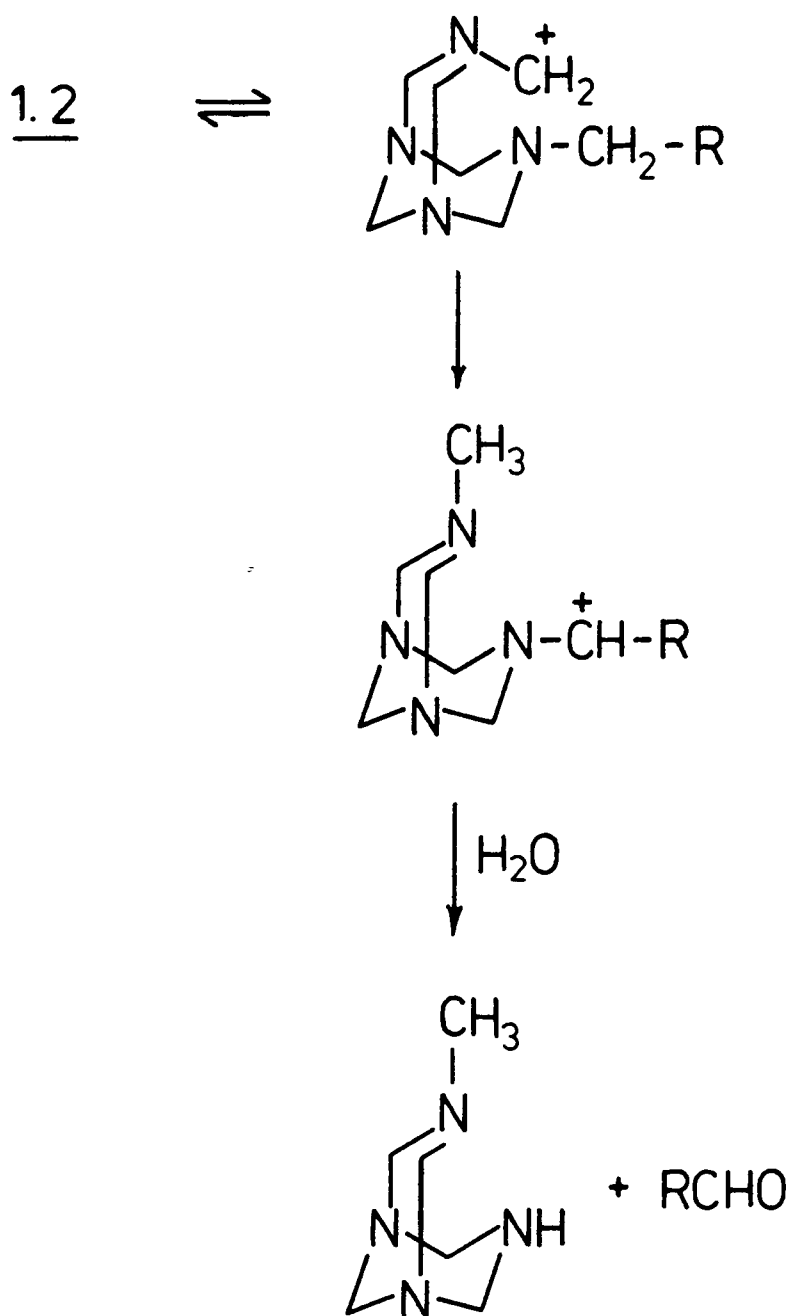

Scheme 1

The results were interpreted to indicate that the first stage of the reaction involves rupture of one of the three C-N bonds adjoining the quaternary nitrogen with the formation of a primary carbonium ion which then rearranges by a hydride ion transfer.

At a pH below 5 the amine formation tends to dominate (i.e. the Delepine reaction occurs).

Aliphatic aldehydes that contain a hydrogen atom attached to the α -carbon atom are not stable under the conditions of the Sommelet reaction and are rapidly converted into polymeric nitrogenous material.²⁸ However the aldehydes can be obtained if they are removed by steam distillation as soon as they are formed.

c. Introduction of Methyleneimine Groups via Hexaminium Salts:

At a pH value above 6, a side reaction occurs leading to the conversion of the hexaminium salt to a methyleneimine.² e.g. the quaternary salt formed from (1.1) and $C_6H_5CH_2Cl$ decomposes to give $C_6H_5-CH_2-N=CH_2$. The latter separates from the mixture and lowers the final yield of the aldehyde.

If the quaternary salt is decomposed in alkali or ammonia the product is predominantly the methyleneimine.²⁹ However, the methyleneimine obtained is not in the form of a simple monomer. Graymore obtained the product bis(benzyl-methyleneimine) by decomposing Hexamethylenetetramine-benzyl chloride in ammonia solution and refluxing for $1\frac{1}{2}$ hours. The same compound was also

obtained by reacting benzylamine with formaldehyde.

The actual structure of the dimer was not given and was simply reported as $(C_6H_5-CH_2-N=CH_2)_2$

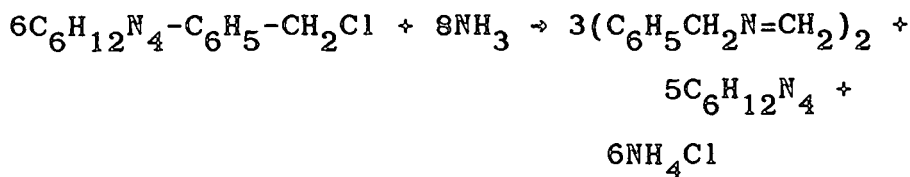

The corresponding primary amine was also obtained by hydrolysis of the methyleneimine by excess hydrochloric acid.

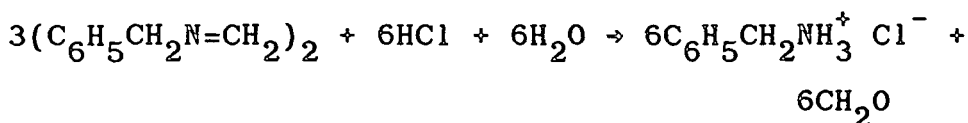

1.8.1. Condensation with Benzylamine

The reaction products of benzylamine and hexamethylenetetramine (1.1) depend upon both temperature and time.¹ This is due to the production of $C_6H_5-CH_2-N=CH_2$, which polymerizes when heated. When (1.1) and benzylamine are heated together for 30 minutes at 190°C the following reaction occurs.

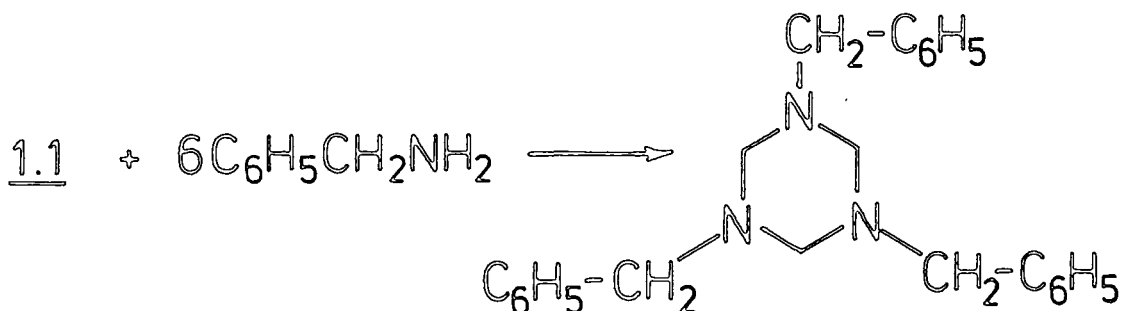

1.8.2. Formation of N,N-bis(halomethyl) - carboxylic acid amides from Hexamethylenetetramine

N,N-bis(chloromethyl) carboxamides (1.6)

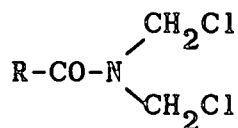

1.6

are accessible from hexamethylenetetramine (1.1) by amination splitting with acid chlorides.^{30,31}

When (1.1) is heated with acetyl chloride in a molar ratio of 6:1 at 120°C (1.6a) is obtained with a 63% yield

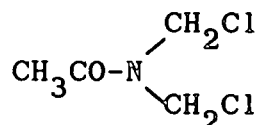

1.6a

Substituting with benzoyl chloride at 135°C gives (1.6b) in 40% yield.

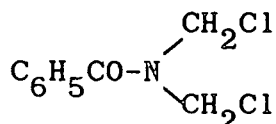

1.6b

The by-products (1.6c), (1.6d) and (1.6e) are also obtained in these reactions

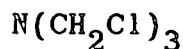

1.6c

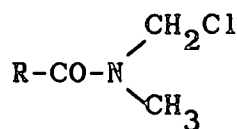
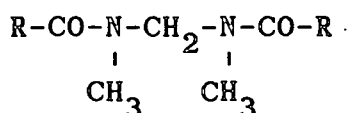
1.6d1.6e

(1.6d) and (1.6e) can be justified if methyleneimine $\text{CH}_2=\text{NH}$ or a derivative of the type $\text{CH}_2=\overset{|}{\text{N}}-$ is an intermediate in the reaction i.e. it is known that compounds of the type $\text{CH}_3-\overset{|}{\text{N}}-$ can be prepared from $\text{CH}_2=\overset{|}{\text{N}}-$ by reduction.³² Also a reaction of this type was proposed as a step in the Sommelet reaction as previously mentioned.^{26,27}

It is interesting to note that under less drastic conditions and in an inert solvent, cleavage of animal

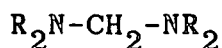

by acyl halides is the most convenient method for the preparation of iminium salts of the type (1.7).³³

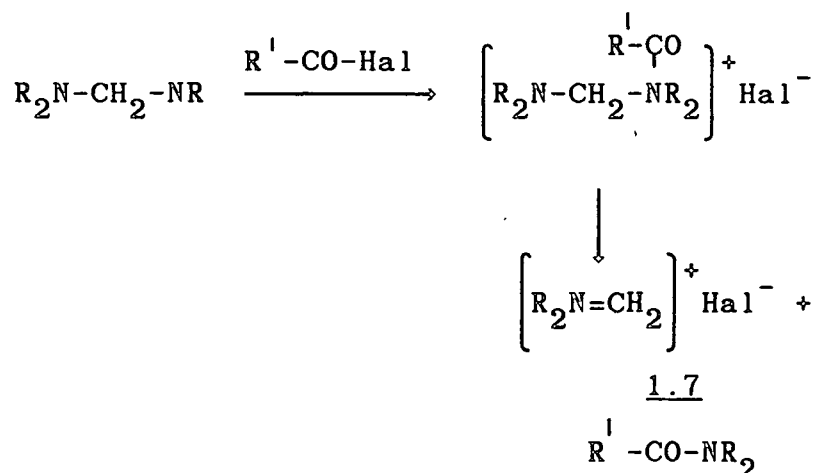

These iminium salts are usually written as being in

equilibrium with the covalent form

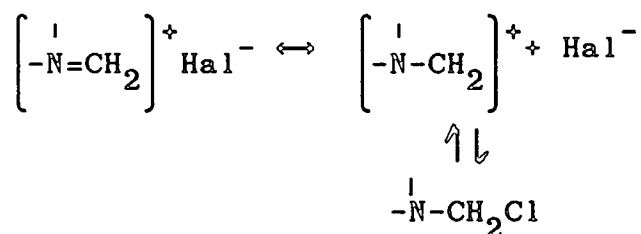

Because of their insolubility in inert solvents like ether, these salts precipitate easily. It is reasonable to assume that analogously to protonation of aminals such as hexamethylenetetramine (1.1) (and also their reaction with alkyl halides), in the first step an addition product is formed which subsequently undergoes decomposition to an iminium salt.

For cyclic aminals of the type (1.8), the product has predominantly covalent characteristics.

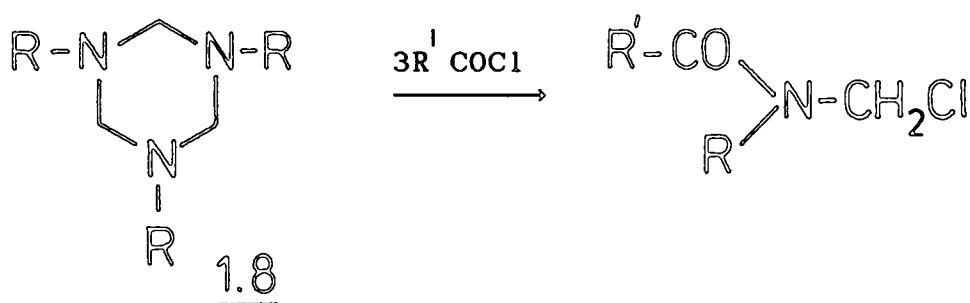

1.8.3 Reaction of Diazonium Ions with Hexamethylenetetramine

It has been reported that diazonium coupling with (1.1) affords the bis(aryldiazo-)tetraazabicyclononanes (1.9)^{34,35}

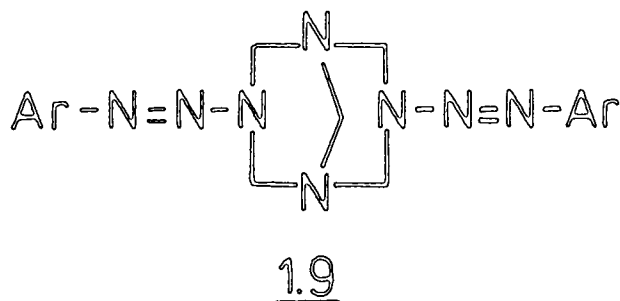

Recently several new examples of this novel class of bicycloheterocycle have been prepared and characterised.³⁶ Also these compounds have been prepared by reaction of the diazonium salts with an aqueous mixture of ammonia/formaldehyde.

A suggested mechanism for the conversion of (1.1) to (1.9) is shown (Scheme 2). Attachment of the electrophilic diazonium ion at one of the four equivalent nitrogen atoms of (1.1) produces a quaternary compound which initiates ring cleavage, typical of an aminal^{33,37} to give an iminium ion (2.1).

Hydrolysis of (2.1) and loss of formaldehyde leads to the mono(arylazo) tetrazabicyclononane (2.2).

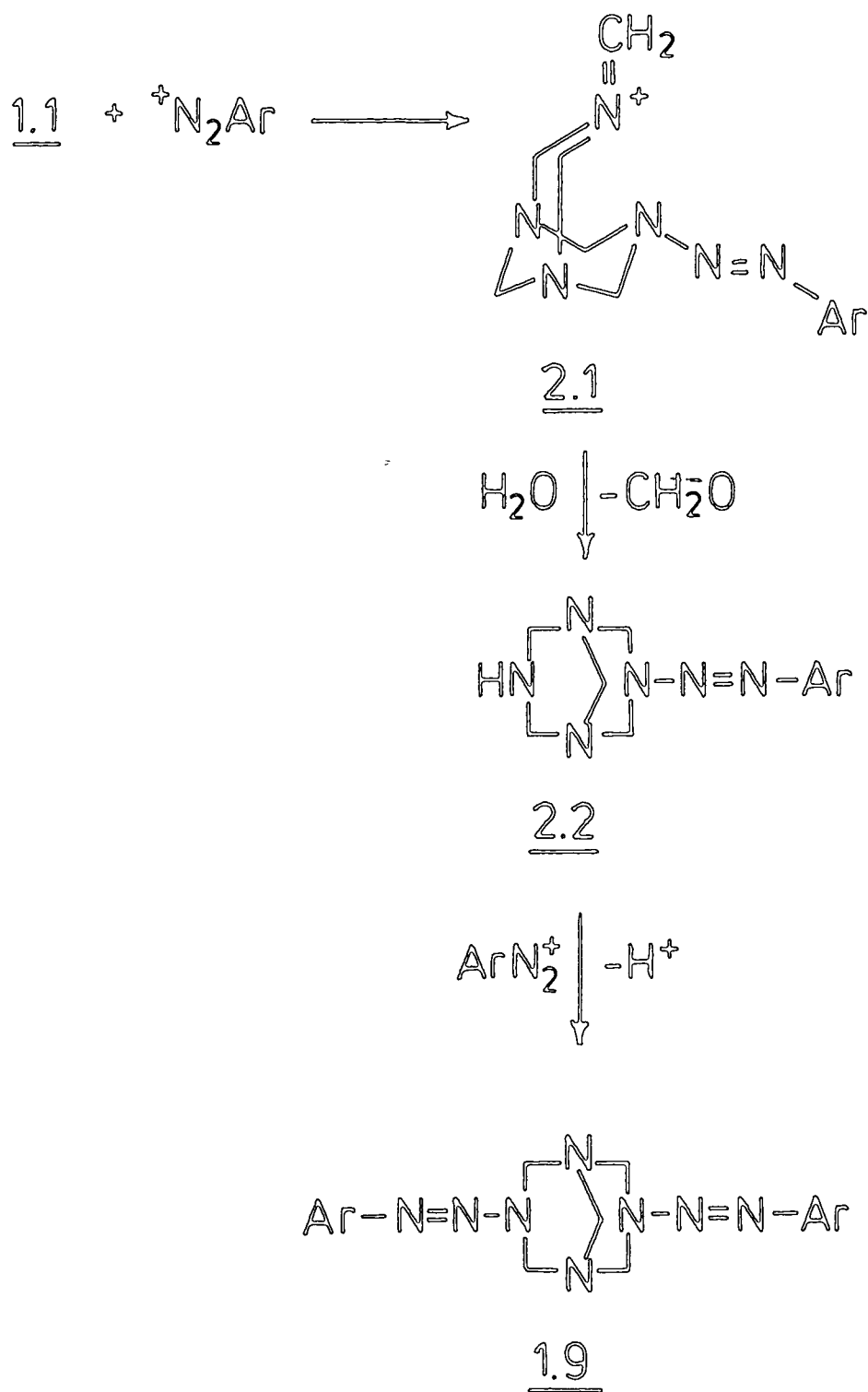

Scheme 2

It is known that hydrolysis of iminium ions occurs via a carbinolamine³⁸ and that carbinolamines can decompose to give off formaldehyde³⁷ which is rapidly hydrated.

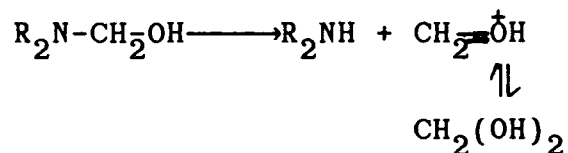

Further diazonium coupling to the secondary amino position of (2.2) gives the observed product (1.9).

The reluctance of (1.9) to undergo further diazo-coupling at the bridgehead nitrogen atoms may be due to the insolubility of (1.9) in the aqueous medium.

The bis(aryloxy)-tetra-aza bicyclononanes (1.9) are stable in aqueous buffer at pH 7.5, there being no change in the U.V. spectrum over a 24 hour period. However, slow decomposition does occur when dissolved in a mixture of acetone/phosphate buffer at pH 4.5. A suggested mechanism for the hydrolysis of (1.9) is shown in (Scheme 3).

The reaction is initiated by protonation to give the cation (2.3). Aminal type dissociation of (2.3) initiates a cascade of reactions resulting in the formation of the monohydroxymethyltriazene (2.4). Loss of formaldehyde from (2.4) gives the unstable triazene (2.5) which spontaneously loses nitrogen to give the aniline.

Formation of the ketone (2.6) is due to a Mannich reaction³⁹ of the aniline with formaldehyde released during hydrolysis, and acetone from the medium.

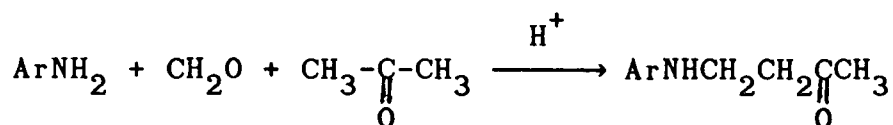

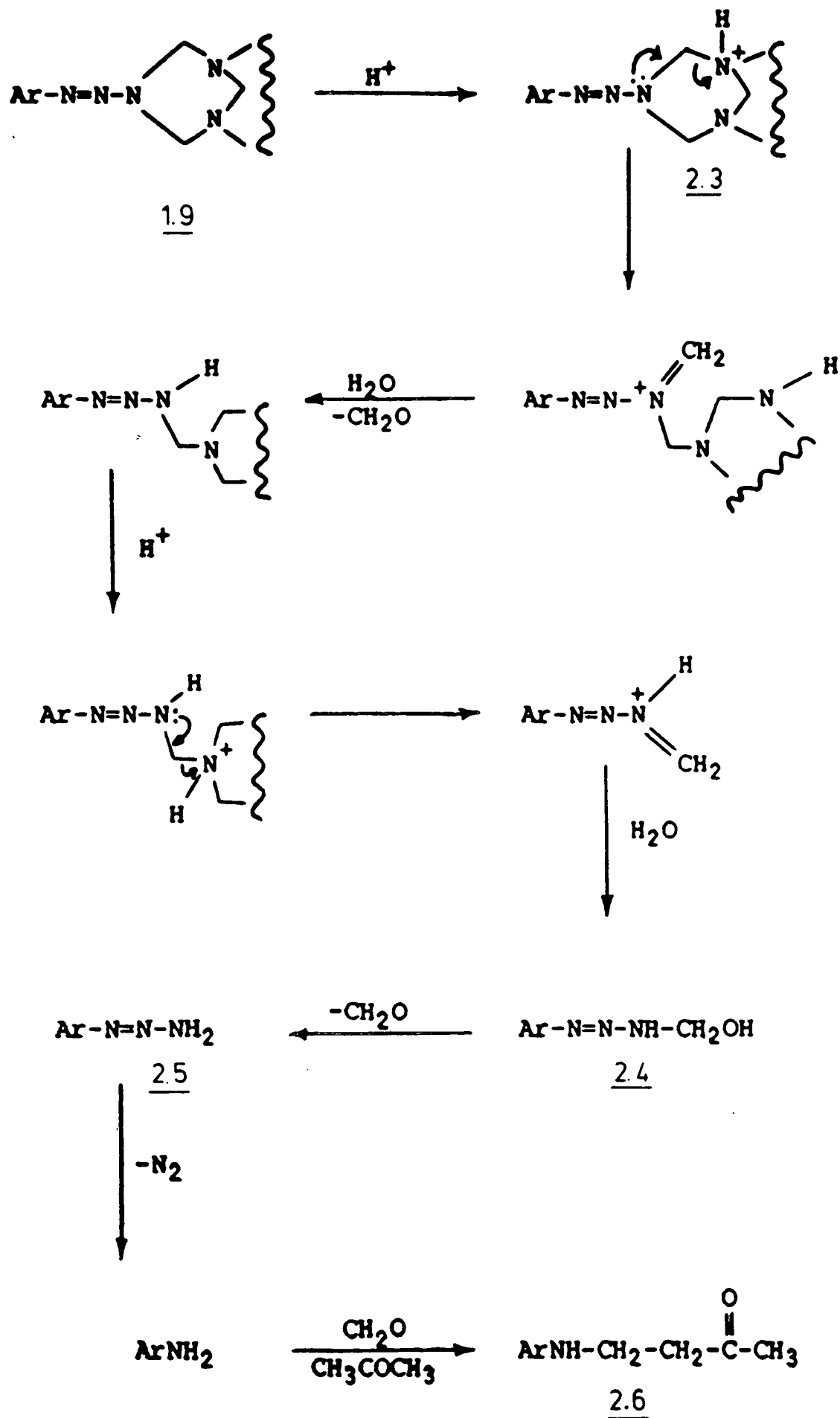

Scheme 3

Bis-(triazenyl-methyl)methylamines (2.8) can be obtained from diazonium coupling with methylamine/formaldehyde mixtures under appropriate conditions.⁴² These compounds are close structural analogues of (1.9).

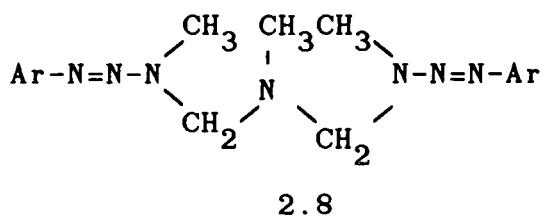

The bis-triazenes (2.8) undergo hydrolysis in phosphate buffer (with added DMSO) at pH 7.5 to give the corresponding arylamine, via the intermediate 1-aryl-3-methyl-triazene, ArN=N-NHMe; for example, the p-bromophenyl-bistriazene (Ar = p-Br.C₆H₄-) decays with a half-life of 12 minutes.⁴³ The ease of decomposition of (2.8) has been attributed to the amination character of the bis-triazene.⁴⁴

The lower reactivity of (1.9) towards hydrolysis compared to (2.8) suggests weaker basic character of the N1 or N5 nitrogens in (1.9) compared to the analogous amination-nitrogen in the bis-triazene. This could be due to the less-exposed nature of the nitrogen lone pairs because of the constraints of the bicyclic system.³⁶ The analogous nitrogen in the bis-triazene (2.8) has bonds which are much more mobile. This gives greater access for protonation.

1.9.1. Nitrosation of Hexamethylenetetramine

Degradative nitrosation of (1.1) in aqueous solution

occurs by the simultaneous addition of hydrochloric acid or acetic acid and a solution of sodium nitrite.⁴⁵ The pH of the solution determines the nature of the products.

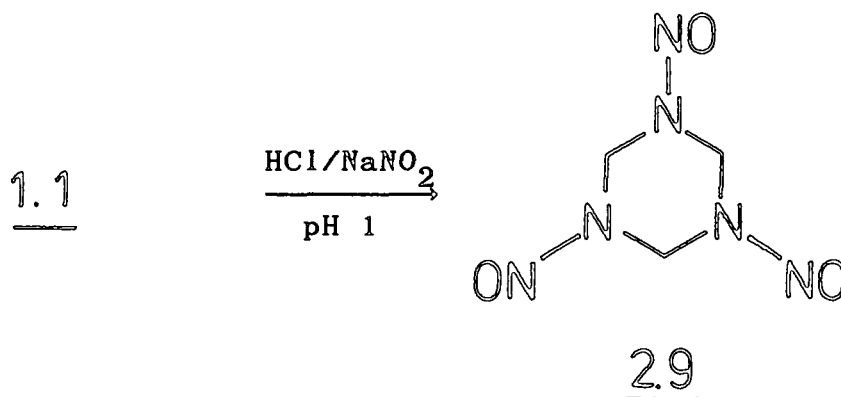

Thus in hydrochloric acid at pH 1 the trinitroso compound (2.9) is formed exclusively.

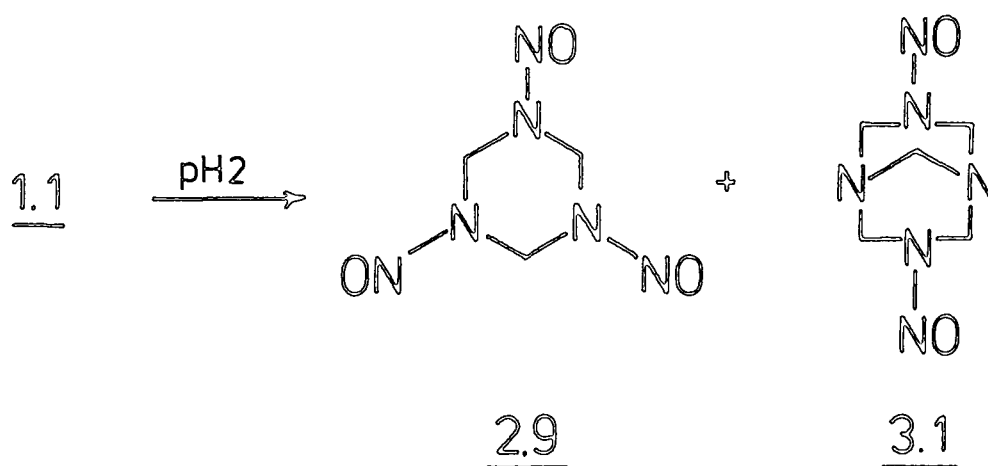

At pH 2 a mixture of (2.9) and the bicyclononane (3.1) is obtained.

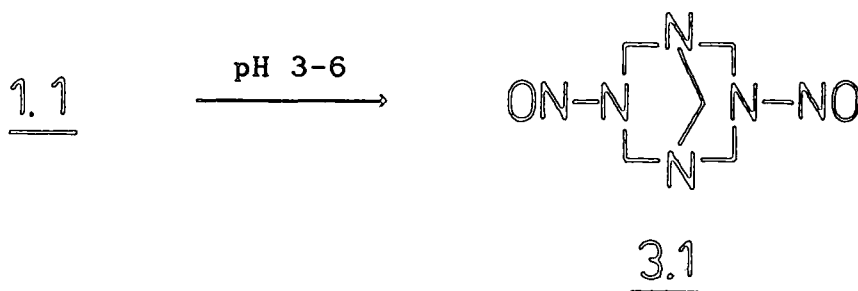

Between pH 3-6 the main product is (3.1).

When acetic acid is employed the only product over a wide range of conditions is the bicyclononane (3.1).

1.9.2. Acetolysis of Hexamethylenetetramine

The products of acetolysis of (1.1) depend very much on the conditions employed.

3,7-diacetyl-1,3,5,7-tetra-aza-bicyclo[3.3.1]nonane commonly known as DAPT (diacetylpentamethylenetetramine) (3.2) can easily be prepared from (1.1) and acetic anhydride in a good yield.⁴⁶

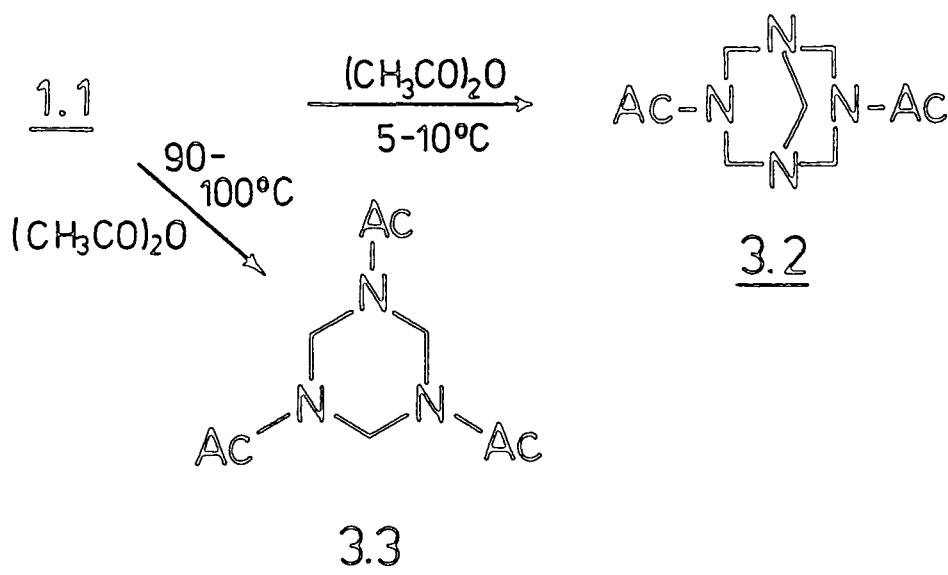

(3.2) is the main product at low temperature, however, at high temperature,

1,3,5-triacetyl-1,3,5-triazacyclohexane commonly known as TRAT (3.3) is formed.

Early attempts to prepare DAPT (3.2) under anhydrous conditions resulted in low yields.⁴⁷ Much greater yields are obtained in the presence of water.⁴⁶

Ogata and Kawasaki,⁴⁸ suggested that the effectiveness of water in promoting the formation of (3.2),

results from the following equilibrium

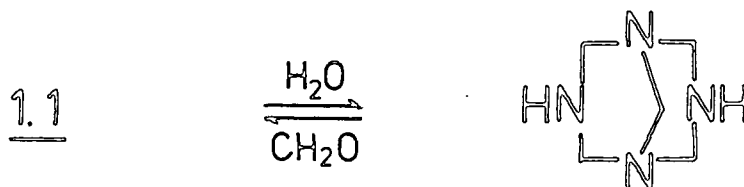

However this is unlikely (see Nitrogen-15 studies of acetolysis in later chapter)

The conversion of hexamethylenetetramine (1.1) to (3.2) DAPT, involves the loss of a methylene group, presumably as formaldehyde. The expected amount of formaldehyde was isolated as the dimedone derivative.⁴⁶

It was also found that the addition of ammonium acetate, at least an equivalent, to the formaldehyde produced, gave higher than theoretical yields. This suggests that hexamethylenetetramine is formed from the ammonium acetate and liberated formaldehyde.

If the reaction is carried out in the presence of an inorganic base, in an amount equivalent to the acetic acid produced, the yield is also found to rise.⁴⁶ The role of ammonium acetate and inorganic base is investigated in a later chapter of this thesis (see Nitrogen-15 studies of acetolysis).

A tetra-acetyl derivative of hexamethylenetetramine, 1,3,5,7-tetra-acetyl-1,3,5,7-tetra-azacyclooctane, commonly known as TAT (3.4), was originally prepared in 20% to 35% yield by refluxing DAPT (3.2) with acetic anhydride containing a trace of acetyl chloride.⁴⁹ It was later found that the yield could be raised by heating (3.2) with

pure acetic anhydride for 3 hours at 110°C. Higher yields have been obtained by using a mixture of acetyl chloride, acetic anhydride, anhydrous sodium acetate and glacial acetic acid. A mechanism was proposed for this process (Scheme 4) by Siele however it was not verified experimentally.

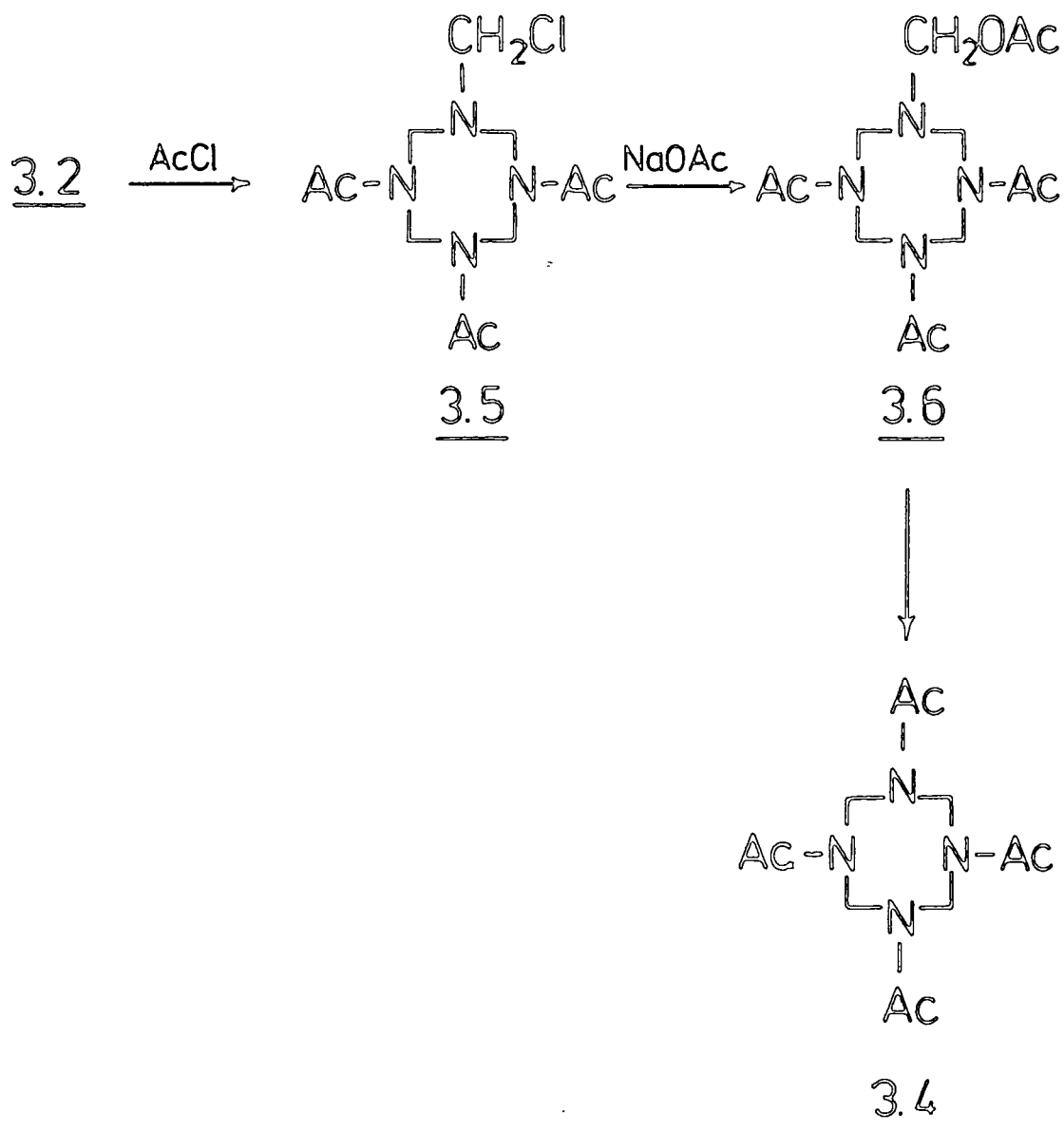

Scheme 4

A study by NMR spectrometry of this reaction showed the production of (3.5) to be unlikely.⁵¹

It was seen that when acetyl chloride was added to DAPT (3.2) in a sodium acetate/acetic acid mixture, (1:1 sodium acetate, acetyl chloride) the product (3.6) was formed.

It is known that species such as (3.5) are very susceptible to nucleophilic attack.³³ As said previously, iminium salts are usually written as being in equilibrium with the covalent form. So (3.5) could be written as

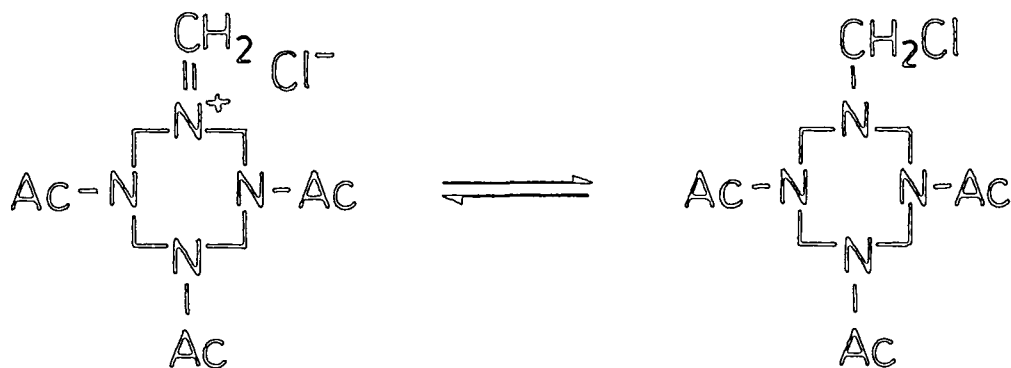

The covalent form probably predominating therefore it is not surprising that in the presence of sodium acetate that amination type cleavage gives (3.6), since the acetate ion is a more powerful nucleophile than the chloride ion in this medium. When acetyl chloride was added to DAPT(3.2) in a 1:1 ratio in acetic acid solution in the absence of sodium acetate, the product changed dramatically.

Addition of acetic anhydride to the reactant liquor did not produce TAT (3.4).

It is likely that the initial product produced on addition of acetyl chloride is (3.7). In the absence of

acetate ions, (3.7) may be stable and may not react with acetic anhydride to produce TAT (3.4).

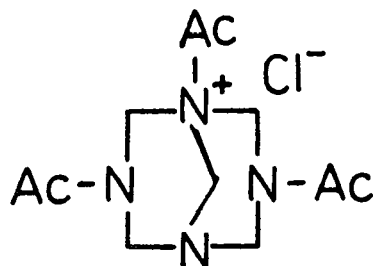

3.7

In contrast when acetic anhydride was added to (3.6), TAT (3.4) was formed gradually. Also it was seen that (3.6) was quite stable (little change after several hours in acetic acid solution).

Addition of H₂O to a solution of (3.6) resulted in the formation of (3.8)

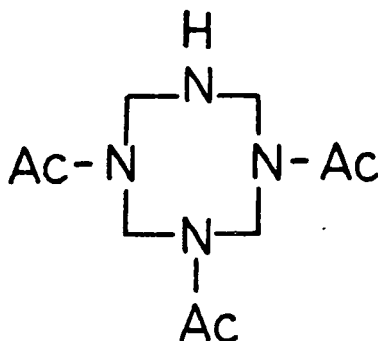

3.8

Furthermore, addition of acetic anhydride to the resulting solution produced TAT (3.4). The acetylation was found to be first order in (3.8) and acetic anhydride and to have a rate constant of $1.46 \times 10^{-4} \text{ l mol}^{-1} \text{ s}^{-1}$.

The intermediate (3.6) was also observed when DAPT

(3.2) was heated alone with acetic anhydride. Furthermore, it was found that the rates of conversion of (3.6) to TAT (3.4) were similar in the two different processes. However, it was found that the rates of production of (3.6) differed. It was therefore concluded that the conversion of (3.6) to TAT (3.4) is the rate determining step in the acetolysis reaction.

It was also found that the rates of acetolysis of DAPT (3.2) differed under anhydrous conditions and in the presence of water. This was interpreted as rapid conversion of (3.6) to (3.8) thus making the acetylation of (3.8) rate determining. The increase in reaction rate can be attributed to the difference in rate of acetylation of secondary and tertiary amines.

Ammonium acetate also promoted the reaction. This was attributed to liberated formaldehyde recombining with ammonium acetate to form hexamethylenetetramine (1.1) which could then be acetylated to give DAPT (3.2). The actual formation of DAPT (3.2) was observed by ^1H n.m.r.

1.9.3. Nitrolysis of Hexamethylenetetramine

There has been a great deal of work carried out on the nitrolysis of hexamethylenetetramine (1.1), so only a summary will be given in this introduction. For a more detailed description see papers by Wright and co-workers^{52,57}, Gillies, Williams and Winkler⁵⁸, and Marcus and Winkler⁵⁹.

Henning⁶⁰ reported that hexamethylenetetramine (1.1), on nitration produced a compound of formula $\text{C}_3\text{H}_6\text{O}_6\text{N}_6$. He prepared this compound by treating an aqueous solution of

(1.1) with nitric acid to obtain the nitrate and then adding the dried nitrate in small portions to nitric acid.

The chemical structure was clarified by Herz⁶¹ who also recognised its nature as an explosive. Its structure was found to be that of (3.9)

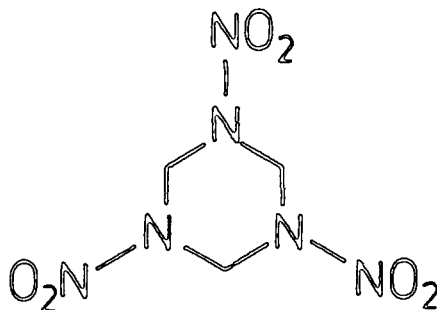

3.9

In 1925 Hale⁹ reported an improved method of preparation. Research carried out in connection with the development of a practical method for manufacturing this explosive for use in World War II resulted in outstanding technical improvements and a detailed knowledge of the chemistry involved.

Hale prepared (3.9) by gradual addition of hexamethylenetetramine (1.1) to an excess of 99.8% nitric acid at about -20°C .

According to Hale the reaction may be represented by the following equation:

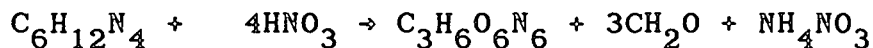

However Schnurr⁶² suggested the following

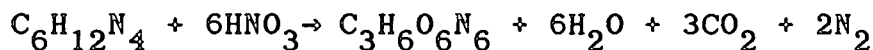

It is likely that the reaction proceeds according to both

equations simultaneously since ammonium nitrate, formaldehyde, carbon dioxide, nitrogen and water can all be detected in the products.

Some of the methylene groups and nitrogen atoms of hexamethylenetetramine (1.1) are therefore not utilized for the production of (3.9).

Early names for (3.9) were cyclonite, cyclotrimethylenetrinitramine and hexogen. The compound has more recently been known as RDX (1,3,5-trinitro-1,3,5-triazacyclohexane).

Apart from the main reactions shown in the nitrolysis of (1.1), side reactions take place. These are the decomposition of (1.1) to formaldehyde and ammonia

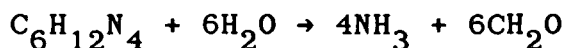

and the oxidation of formaldehyde by nitric acid

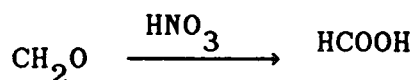

There are also other reactions which occur which result in other explosive substances.

Bachmann and Sheehan¹⁰ developed an improved process using ammonium nitrate and acetic anhydride.

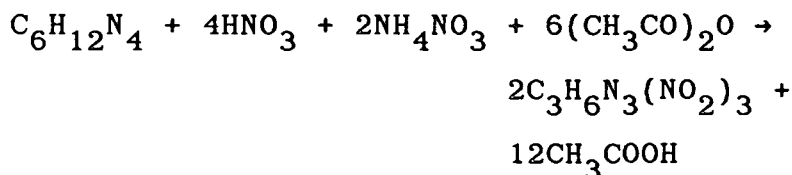

In a method worked out by Ebele,⁶³ RDX is prepared from paraformaldehyde, ammonium nitrate and acetic anhydride. In this method paraformaldehyde and ammonium nitrate undergo dehydration under the influence of acetic

anhydride with the formation of RDX

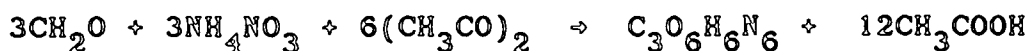

There are two different views on the mechanism of this reaction. The first is that hexamethylenetetramine (1.1) is initially synthesised and then undergoes nitrolysis. The second is that the transiently-formed methylene nitramine (4.1) is formed from formaldehyde and ammonium nitrate and then undergoes polymerization.⁶⁴

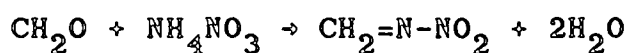

4.1

In both of the above methods for the production of RDX several side reactions also occur resulting in the formation of N-acetyl derivatives and nitramines. The by-product that has created most interest is 1,3,5,7-tetranitro-1,3,5,7-tetra-azacyclooctane commonly known as HMX (high melting explosive) (4.2).

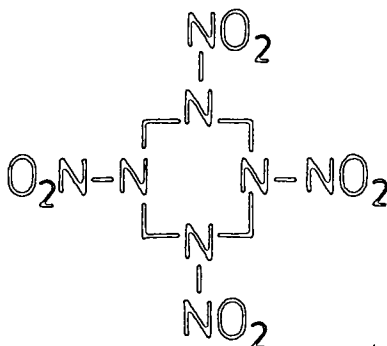

4.2

HMX (4.2) can be prepared by the nitrolysis of DPT (3,7-dinitro-1,3,5,7-tetra-aza-bicyclo[3.3.1]nonane)(4.3) which Wright and co-workers⁵⁴ synthesised by the

reaction of methylenediamine with dimethylol nitramide.

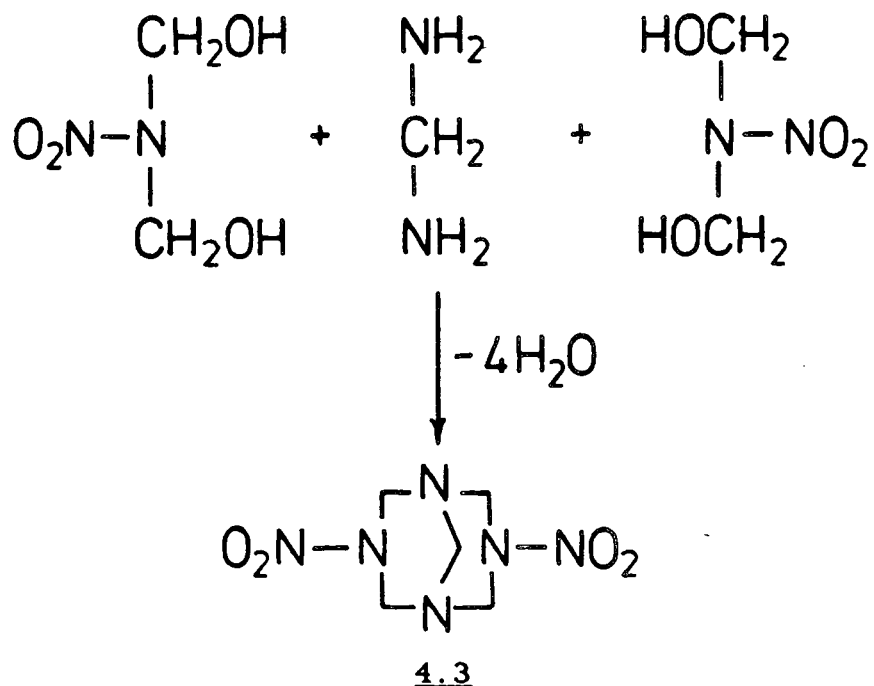

Wright and Chute⁶⁵ also obtained DPT (4.3) by treating hexamethylenetetramine with concentrated nitric acid, removing the RDX obtained and adjusting the mother liquor to a pH of approximately 5.6. It was suggested that dimethylol nitramide is the precursor to DPT in this process.

The early mechanisms given for the nitrolysis of hexamethylenetetramine (1.1) were written in terms of selective cleavage of carbon-nitrogen bonds. However, later work disagrees with this and suggests decomposition to smaller units and reformation to RDX and HMX (see later chapter on Nitrogen-15 studies).

1.9.4. Selective Cleavage of bicyclononanes

Yoshida and co-workers^{66,67} tried to develop a means of achieving selective cleavage to form an eight membered

ring exclusively.

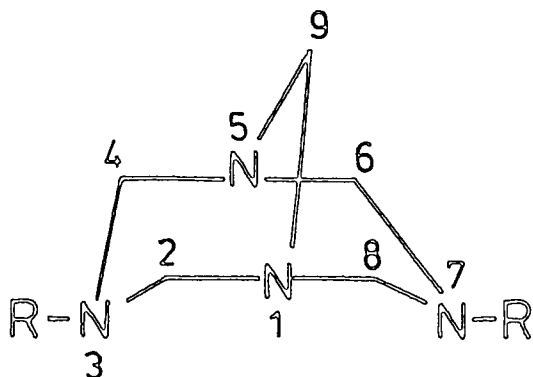

In order to form an eight-membered ring selectively, attack should be directed exclusively at carbon 9. Nucleophilic attack on carbon is strongly promoted by an adjacent positive site. Any attempt to promote nucleophilic attack on carbon 9 exclusively must be preceded by a marked reduction in the basicity of the 3 and 7 nitrogens. Thus the production of DAPT (3.2) achieves this through conversion of the 3 and 7 nitrogens into amide functions.

Reaction of DAPT with dinitrogen tetroxide gave a 62% yield of

1,5-diacetyl-3,7-dinitroso-1,3,5,7-tetra-azacyclooctane
(4.4)

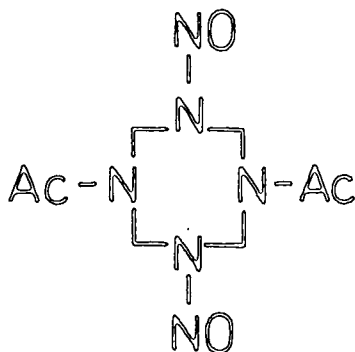

4.4

However, when the same reaction was carried out in

methylene chloride or chloroform a compound was obtained which was assigned the structure (4.5)

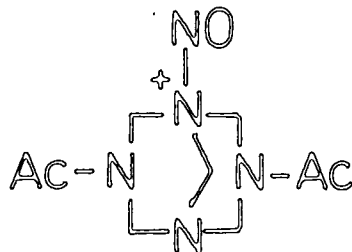

4.5

It is also possible that the structure is (4.6) which could be obtained by aminal-type cleavage.

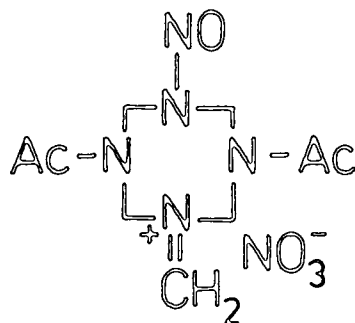

4.6

Elemental analysis would not distinguish (4.5) from (4.6).

In the conversion of DAPT (3.2) to (4.4) a diquatery intermediate (4.7) was postulated.

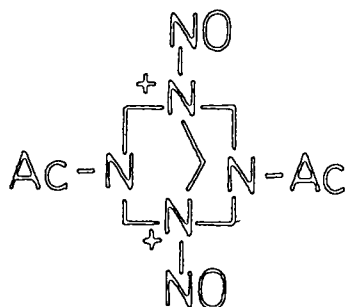

4.7

It was suggested that (4.7) would undergo hydrolytic cleavage to give (4.4). However it seems more likely that the molecule would cleave after the formation of a monoquaternary intermediate as in a typical aminal-type cleavage. A diquaternary intermediate has also been postulated in the conversion of DAPT(3.2) to TAT (3.4).⁵¹

1.9.5. Production of HMX via acetylated derivatives of Hexamethylenetetramine

HMX (4.2) is a powerful high explosive possessing significant advantages in both explosive performance and thermal stability over other explosives such as RDX (3.9). Due to its high cost (~ 3 to 4 times that of RDX) it finds use only in specialised ordnance such as shaped charges, where maximum explosive performance is needed.⁶⁸

Up till recently HMX (4.2) was manufactured by a modified version of the Bachmann RDX process. However, several new methods have been developed which result in greater yields of HMX⁴⁹ (4.2), these will be described briefly.

It is possible to convert TAT (3.4) directly to HMX (4.2) in high yield. This involves heating TAT (3.4) with a mixture of nitric acid and phosphorus pentoxide. The yield of HMX increases with the proportion of phosphorus pentoxide used.

A mixture of nitric acid and acetic anhydride resulted in low yields of HMX (4.2). Also attempts to nitrolyse DAPT (3.2) directly to HMX (4.2) using a nitric acid-phosphorus pentoxide system were unsuccessful resulting in low yields.

Yoshida and co-workers⁶⁷ showed that 1,5-diacetyl-3,7-dinitro-1,3,5,7-tetra-azacyclooctane commonly known as DADN (4.8), may be prepared by the nitrolysis of DAPT (3.2) using a mixture of nitric and sulphuric acids.

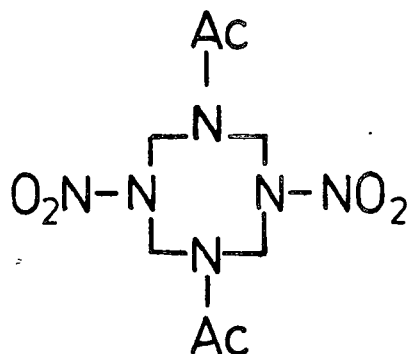

4.8

A "one-pot" operation has been developed to convert hexamethylenetetramine (1.1) to DADN (4.8) without isolating DAPT (3.2).⁶⁸

Initial attempts to convert DADN (4.8) directly to HMX (4.2) using nitric acid alone resulted in poor yields. However several new methods have been developed. The most encouraging seems to be a mixture of nitric acid and N_2O_5 . N_2O_5 is thought to be the actual nitrating agent in nitric acid/phosphorus pentoxide mixtures.⁴⁹

Yoshida and co-workers showed that DAPT (3.2) could be converted to 1,5-diacetyl-3-nitro-7-nitroso-1,3,5,7-tetra-azacyclooctane, commonly known as DANNO (4.9) using a mixture of nitric

acid and N_2O_4 (red fuming nitric acid).

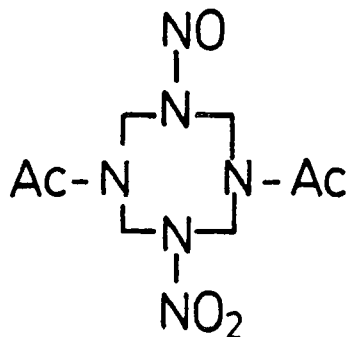

4.9

This suggested that this could be considered as a route to HMX (4.2) which would eliminate the use of sulphuric acid in the conversion of DAPT (3.2) to DADN (4.8). It was also shown that DANNO (4.9) can be converted to DADN in 95% yield using nitric acid alone.

Attempts to convert DANNO (4.9) directly to HMX (4.2) however, have been unsuccessful, resulting in poor yields compared to the DADN (4.8) method. Thus it appears that the DADN process is the most promising.

Study of the mechanisms involved for the conversion of hexamethylenetetramine (1.1) to HMX (4.2) by the various methods mentioned should help in discovering the most economical method for HMX (4.2) manufacture.

CHAPTER 2

EXPERIMENTAL

2.1. Materials

2.1.1. Solvents

Water: distilled water was boiled for 20 minutes to expel dissolved carbon dioxide. A soda-lime guard tube was subsequently used for protection from air.

Acetone: AnalaR grade, used without further treatment.

Acetic anhydride: Commercial grade, distilled before use.

1,4-dioxan: Spectroscopic grade, used as supplied.

Acetonitrile: HPLC grade, used as supplied.

Ammonia: Commercial grade, used as supplied.

Formaldehyde: AnalaR grade, used without further treatment.

Acetyl chloride: Commercial grade, distilled before use.

Chloroform: Spectroscopic grade, stabilized with ~ 0.75% ethanol. Passed through a column of Alumina before use to remove ethanol.

Hydrochloric acid: AnalaR grade, used without further treatment.

Perchloric acid: AnalaR grade, used without further treatment.

Acetic acid: glacial, pure for analysis dried before use with molecular sieve.

Nitric acid: prepared by dissolving potassium nitrate in pure sulphuric acid and distilling off the nitric acid under reduced pressure at room temperature.

Also obtained as a commercial sample, 'Fuming nitric acid' minimum assay 95%.

Hydrogen peroxide: volumetric solution, diluted as necessary.

Sulphuric acid: Analytical Reagent (98%) used without further treatment.

Ethanol: AnalaR grade, used without further treatment.

Deuterium oxide: commercial sample 99.8% used as supplied.

Deuterium chloride: commercial sample 20% solution in D_2O , further diluted with D_2O before use.

Chloroform-d: commercial sample 99.8% used as supplied.

DMSO- d_6 : commercial sample, used as supplied.

Acetonitrile- d_3 : commercial sample, used as supplied.

Acetone- d_6 : commercial sample, used as supplied.

Acetic acid- d_4 : commercial sample, used as supplied.

2.1.2. Substrates

Hexamethylenetetramine: commercial sample, used as supplied.

DAPT: to a slurry comprising hexamethylenetetramine (14g, 0.1 moles), ammonium acetate (6.2g, 0.08 moles) and water (7 ml) was added acetic anhydride (30.6g, 0.3 moles) dropwise over 60 minutes with stirring and cooling at 5-10°C. The solution was then stirred at 10°C for 30 minutes and evaporated to dryness. The solid was recrystallized from acetone m.p. 193-195°C (lit.⁴⁶, 193-195°C). The n.m.r spectrum of DAPT in deuterium oxide showed bands at δ 2.1 (s, acetyl), δ 4.4 (s, CH_2 bridge), with two AB quartets (J 13 Hz) due to CH_2 protons with shifts of δ 4.4 and δ 5.6, and δ 4.9 and δ 5.1 respectively. The spectrum is similar to that reported previously in $CDCl_3$.⁴⁶

TRAT: hexamethylenetetramine (10g, 0.07 moles) was added at room temperature with stirring to acetic anhydride (41g, 0.4 moles). A mild exotherm raised the temperature to 35°C, after which the mixture was heated for 2 hours at 98°C. The solution was cooled to 5°C, 200 ml of water was added, and the mixture stirred for 30 minutes. The solution was then reduced to a viscous yellow liquid by vacuum distillation. Water (25 ml) was added and the mixture cooled and stirred to induce precipitation. The solid product was recrystallized from absolute ethanol, m.p. 93-96°C (lit.⁶⁹, 93-96°C). N.m.r. spectrum in deuterium oxide showed bands at δ 2.22 (acetyl) and δ 5.3 (methylene), and is similar to that previously reported in deuteriochloroform.⁶⁹

Recrystallisation from hot water produced a hydrate mpt 71.5-73.5°C (lit.⁹⁸, 71.5-73.5°C). The n.m.r. spectrum in deuterium oxide showed the same spectrum as that of the anhydrous form.

TAT: two different methods were employed.

1) Acetyl chloride (7.4g, 0.094 moles) was added over 15 minutes to a stirred mixture of DAPT (10g, 0.047 moles), acetic anhydride (29g, 0.28 moles), anhydrous sodium acetate (15.5g, 0.19 moles) and glacial acetic acid (100 ml) at 5-10°C. The mixture was stirred at 5-10°C for 1 hour, diluted with water (100 ml) and stirred for 1 hour at 5-10°C. Sodium carbonate was added in sufficient amount to form a solid mass, which was extracted with chloroform.

Evaporation to dryness gave a solid glassy material. Trituration with ethanol gave crystals m.p. 153-158°C (lit.⁴⁹, 153-158°C).

The n.m.r. spectrum in deuterium oxide showed bands at $\delta 2.25$ (s, acetyl) and $\delta 5.14$ (s, methylene) and is similar to that previously reported in deuteriochloroform.⁷⁰

2) DAPT was heated with pure acetic anhydride for 3 hours at 110°C . Evaporation gave a glassy material which was triturated as previously. The n.m.r. spectrum in deuterium oxide was the same as above.

Picryl acetate: picryl acetate was prepared from picric acid and acetic anhydride in the presence of perchloric acid. Recrystallisation from light petroleum gave crystals m.p. 96°C (lit.⁷¹, 96°C). The n.m.r. spectrum in acetone- d_6 showed bands at $\delta 2.35$ (s, acetyl) and $\delta 9.15$ (s, ring C-H).

N-acetylaminoethanol: heating paraformaldehyde and acetamide in 1:1 molar ratio at 120°C in an autoclave for 10 hours gave⁷² a clear liquid containing N-acetylaminoethanol ($\text{CH}_3\text{CONHCH}_2\text{OH}$). The n.m.r. spectrum in acidic solution (1M deuterium chloride) showed bands at $\delta 2.1$ (s, acetyl) and $\delta 4.5$ (methylene).

N-acetylhexaminium chloride: addition of one equivalent of acetyl chloride to one equivalent of hexamethylenetetramine in dry chloroform gave immediate precipitation of a white, solid unstable in air. The mass spectrum (FAST ATOM BOMBARDMENT) gave a line at 184 corresponding to the protonated N-acetylhexaminium ion. The n.m.r. spectrum in dry DMSO-d_6 showed a broadened multiplet at $\delta 5.0$ (methylene) and a band at $\delta 2.3$ (s, acetyl).

Hexamethylenetetramine hydrochloride: hydrochloric acid was added dropwise to a solution of hexamethylenetetramine

in dry chloroform. The solid was recrystallised from ethanol. Microanalysis indicated the formula to be $C_6H_{13}N_4Cl$. The n.m.r. spectrum in deuterium oxide showed a single band at $\delta 5.0$ (methylene).

DPT: the method for DPT synthesis was supplied by the Ministry of Defence, R.A.R.D.E.⁷³

10g of hexamethylenetetramine was added gradually to 35g of nitric acid >95%, shaking vigorously and keeping at low temperature (between 0 and 10°C). When this was diluted with 100 ml of iced water RDX separated out as a white solid. This was filtered and immediately put into 40% aqueous sulphuric acid to allow decomposition. The liquid remaining after filtration was neutralised with an ammonia solution whilst keeping the temperature below 0°C. DPT separated out as a white crystalline substance which was washed with water and recrystallised from acetone, m.p. 211.5°C.⁷³ The n.m.r. spectrum in acetonitrile- d_3 showed a band at $\delta 4.14$ (s, CH_2 bridge) and an AB quartet (J 13 Hz) due to CH_2 protons with shifts of $\delta 4.9$ and $\delta 5.65$. The spectrum was similar to that reported previously in DMSO- d_6 .⁴⁰

Hexamethylenetetramine Picrate:

hexamethylenetetramine and picric acid were dissolved in absolute ethanol in a 1:1 ratio at room temperature.

A yellow precipitate was produced which was vacuum dried at room temperature m.p. 175-180°C crude (lit.¹³ 177-178°C).

The n.m.r. spectrum in DMSO- d_6 showed bands at $\delta 4.9$ (s, methylene) and $\delta 8.6$ (s, C-H Picrate).

DAPT Picrate: DAPT and picric acid were mixed in a 1:1

ratio in absolute ethanol. A yellow precipitate was produced which was vacuum dried at room temperature m.p. 124-126°C crude. (no literature value available)

The n.m.r. spectrum in DMSO-d₆ showed a band at δ2.0 (s, acetyl), a multiplet centred at δ4.5 and a band at δ8.6 (s, C-H Picrate)

2.1.3. Salts

Sodium chloride: commercial sample, oven dried.

Ammonium acetate: AnalaR grade, used as supplied.

Anhydrous sodium acetate: commercial sample, oven dried before use.

Sodium hydroxide: AnalaR grade pellets, used as supplied.

Sodium bicarbonate: AnalaR grade, used as supplied.

Potassium dihydrogen orthophosphate: AnalaR grade, used as supplied.

di-Sodium tetraborate (Borax): AnalaR grade, used as supplied.

tris(hydroxymethyl)aminomethane: AnalaR grade, used as supplied.

Sodium deuterioxide solution: dry, clean sodium was dissolved in deuterium oxide under nitrogen and the solution titrated with standard hydrochloric acid.

2.1.4. Buffer Solutions

Buffer solutions were made up by standard methods⁷⁴ and the pH tested using a PT1-6 universal digital pH meter (readings accurate to ± 0.02).

Borax buffer pH 11.3 - 8.1: 0.025M borax + 0.1M HCl

Sodium bicarbonate buffer pH 10.2: 0.05M NaHCO₃ + 0.1M NaOH

Potassium dihydrogen orthophosphate buffer pH 7.3 - 6.7:

0.1M KH_2PO_4 + 0.1MNaOH.

tris(hydroxymethyl)aminomethane buffer pH 7.6 - 6.7:

0.1M tris + 0.1M HCl

Acetic acid/sodium acetate buffer pH 5.3 - 3.8: CH_3COOH

and NaAc mixed together in H_2O .

Any dilution of the various buffer solutions was accompanied by the addition of NaCl to maintain constant ionic strength.

2.2. Measurement Techniques

2.2.1. Ultraviolet-visible Measurements

U.v.-visible measurements were made with a Pye Unicam SP8-100 instrument. Kinetic and equilibrium measurements were made at 25°C using freshly prepared solutions of reagents. Kinetics were in all cases run under first-order conditions and rate coefficients were determined by measuring the change in absorbance at an appropriate wavelength.

Absorbance measurements were taken manually and the observed rate constants calculated using an Apple IIe microcomputer which calculated the observed rate constants as follows.

Following a decrease in absorbance

$$-\frac{d[A]}{dt} = k_{\text{obs}}[A]$$

$$\int_a^{a-x} \frac{d[A]}{[A]} = - \int_0^t k_{\text{obs}} dt$$

$$\ln \left[\frac{a-x}{a} \right] = -k_{\text{obs}} t$$

$$\ln \left[\frac{a}{a-x} \right] = k_{\text{obs}} t$$

$$a = [A]_0 - [A]_{\infty} \quad \text{and} \quad a-x = [A] - [A]_{\infty}$$

$$\therefore \ln \left[\frac{[A]_0 - [A]_{\infty}}{[A] - [A]_{\infty}} \right] = k_{\text{obs}} t$$

$$[A]_0 - [A]_\infty = \text{constant}$$

$$\therefore \ln \left[[A] - [A]_\infty \right] = -k_{\text{obs}} t$$

A plot of $\ln \left[[A] - [A]_\infty \right]$ against time gives a slope of $-k_{\text{obs}}$.

Following an increase in absorbance gives a plot of $\ln \left[[A]_\infty - [A] \right]$ against time of slope $-k_{\text{obs}}$.

2.2.2. Mass Spectrometry

Mass spectrometric measurements were made using a 7070E instrument from V.G. Analytical Ltd. Measurements were made using mainly two methods of ionization, Electron Impact and Chemical Ionization (see N-15 isotope studies in later chapter for experimental details).

Fast Atom Bombardment was used in one particular case to determine the molecular weight of the cation present in N-acetylhexaminium chloride (the 1:1 product of hexamethylenetetramine and acetyl chloride). In this technique the salt was firstly dispersed in a glycerol matrix and bombarded with argon.

2.2.3. N.m.r. Spectra

N.m.r. spectra were recorded using either a Varian EM 360L (60 MHz) or a Bruker AC 250 (250 MHz) instrument.

Shift measurements are quoted as ' δ ' values relative to internal sodium 2,2-dimethyl-2-silapentane-5-sulphonate (DSS) or tetramethylsilane (TMS).

2.2.4. pH Measurements

pH measurements were carried out using a PT1-6 universal digital pH meter (readings accurate to ± 0.02).

CHAPTER 3

THE ACID-BASE BEHAVIOUR OF
HEXAMETHYLENETETRAMINE AND ITS
N-ACETYL DERIVATIVES

3.1 Introduction

Since it is known that yields of HMX (4.2) production are affected by the acidity of the reaction medium, an examination of the acid-base behaviour of hexamethylenetetramine (1.1) and its derivatives is warranted.

Tada, in an early study,⁷⁵ followed the decomposition of hexamethylenetetramine (1.1) in aqueous acid by titration of the unreacted acid. He found evidence for spontaneous decomposition of protonated hexamethylenetetramine and for the reaction of protonated hexamethylenetetramine with acid.

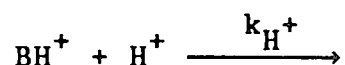
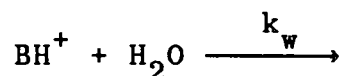

Reported values were $k_w = \underline{6.05 \times 10^{-6} \text{ s}^{-1}}$ and $k_{\text{H}^+} = \underline{6.33 \times 10^{-4} \text{ l.mol}^{-1} \text{ s}^{-1}}$ at 30°C.

In this chapter the acid-base behaviour of hexamethylenetetramine and its N-acetyl derivatives is examined. U.v. and n.m.r. results are included for the initial reversible protonation of the substrates and the kinetics of the subsequent decomposition reactions.⁷⁶ Results are also reported for reactions of hexamethylenetetramine (1.1) and DAPT (3.2) with picryl acetate.

3.2 Experimental

U.V. - visible measurements were made with a Pye Unicam SP8-100 instrument. Kinetic and equilibrium measurements were made at 25°C using freshly prepared solutions of reagents. Kinetics were in all cases run under first-order conditions and rate coefficients were determined by standard methods. (See Chapter 2)

¹H n.m.r. spectra were recorded with a Varian EM360L instrument using DSS or TMS as internal reference.

Formaldehyde determination

Formaldehyde was determined gravimetrically by precipitation as the dimedone

(5,5-dimethylcyclohexane-1,3,-dione) derivative (5.1).⁷⁷

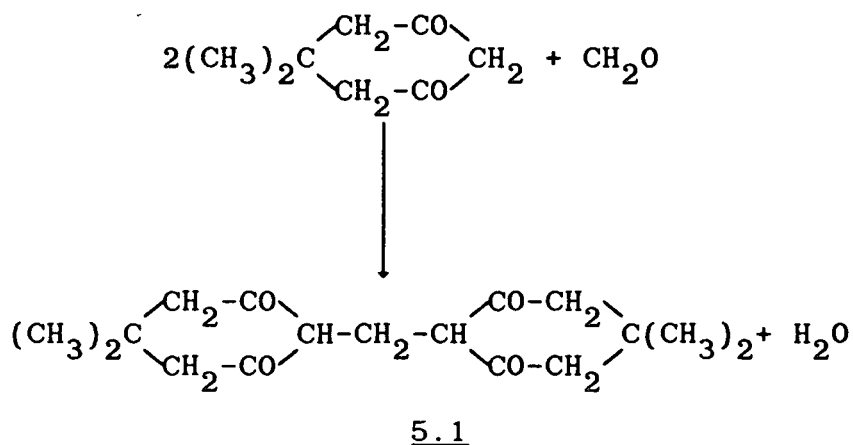

In a control experiment it was found that reaction of 2.9 mmol of formaldehyde with an excess of dimedone in water gave a precipitate which after drying under vacuum, was found to be 3.0 mmol of the adduct. Similarly 1.7 mmoles of formaldehyde produced 1.7 mmoles of the adduct. The formaldehyde released by reaction of DAPT (3.2) and TAT (3.4) in aqueous acid was determined in

this way. In a typical experiment, a known concentration of DAPT (3.2) or TAT (3.4) was made up in an appropriate concentration of hydrochloric acid at 25°C and allowed to stand for a given time, after which it was neutralised to pH 5-7 with aqueous sodium hydroxide solution and added to an excess of dimedone in water. The mixture was then left for 15 minutes and the resulting precipitate was filtered, dried under vacuum, and weighed.

pH Measurements

pH measurements were carried out using a PT1-6 universal digital pH meter. The pK_a value for hexamethylenetetramine (1.1) was determined by measuring the pH after the addition of known volumes of 0.1 M hydrochloric acid solution to 50 cm³ of 0.01 M hexamethylenetetramine (1.1) in water at 25°C. A pK_a value was determined according to the method of Albert and Serjeant⁷⁸ which allows for errors due to hydrogen ion concentration (see results). In a second experiment, an excess of acid was added to attempt diprotonation. The above procedure was repeated for DAPT (3.2).

Buffer solutions pH 6 and pH 7 were made up using KH_2PO_4 and NaOH, and pH 4 using potassium hydrogen phthalate tablets.

3.3 Results and Discussion

3.3.1. Potentiometric Determination of pK_a Values

Literature values for the pK_a of hexamethylenetetramine (1.1) are 6.30 at 25°C,⁷⁹ 5.18 at 45°C,⁷⁵ and 4.86 at 25°C.⁸⁰ Therefore we thought it important to obtain an accurate value for the pK_a of (1.1). (see Table 3.1)

A value of 4.89 ± 0.03 was obtained, which is in good agreement with the latter value above. Thus monoprotonated hexamethylenetetramine has an acid strength similar to that of acetic acid.⁸¹ Our measurements indicate that (1.1) is a considerably weaker base than 1-aza-adamantane(pK_a , 10.92), 1,3-diaza-adamantane(pK_a 8.80), or 1,3,5-triaza-adamantane(pK_a 6.63). The decrease in the basicity in the more substituted adamantanes will be to a certain extent, due to the interaction of the free electron pairs of the different nitrogens in the molecule.⁸⁰

Table 3.1

Addition of 0.1M HCl to 50 cm³ of 0.01M hexamethylenetetramine

0.1M HCl/cm ³	pH	$[H^+]_{eq}$ ^a M	$[BH^+]_{eq} + [H^+]_e$ ^b M	$[BH^+]_{eq}$ ^c M	$[B]_{stoich}$ ^d M	$[B]_{eq}$ ^e M	pK _a ^f
0	7.44						
0.49	5.79	1.6x10 ⁻⁶	9.7x10 ⁻⁴	9.68x10 ⁻⁴	9.90x10 ⁻³	8.9x10 ⁻³	4.83
0.98	5.45	3.5x10 ⁻³	1.92x10 ⁻³	1.92x10 ⁻³	9.81x10 ⁻³	7.89x10 ⁻³	4.84
1.47	5.25	5.6x10 ⁻⁶	2.86x10 ⁻³	2.85x10 ⁻³	9.71x10 ⁻³	6.86x10 ⁻³	4.87
1.96	5.08	8.3x10 ⁻⁶	3.76x10 ⁻³	3.75x10 ⁻³	9.62x10 ⁻³	5.87x10 ⁻³	4.89
2.45	4.91	1.2x10 ⁻⁵	4.67x10 ⁻³	4.66x10 ⁻³	9.53x10 ⁻³	4.87x10 ⁻³	4.89

a. $[H^+]_{eq}$ obtained from measured pH

b. $[BH^+]_{eq} + [H^+]_{eq}$ obtained from the known volume of HCl added.

c. $[BH^+]_{eq}$ obtained from b - a.

d. $[B]_{stoich}$ obtained from known hexamethylenetetramine concentration and dilution

e. $[B]_{eq}$ obtained from d - c

f. $pK_a = pH + \log_{10} \frac{[BH^+]_{eq}}{[B]_{eq}}$

Table 3.1 continued

Addition of 0.1M HCl to 50 cm³ of 0.01M hexamethylenetetramine

0.1M HCl/cm ³	pH	$\frac{[\text{H}^+]_{\text{eq}}}{\text{M}}$ ^a	$\frac{[\text{BH}^+]_{\text{eq}} + [\text{H}^+]_{\text{e}}}{\text{M}}$ ^b	$\frac{[\text{BH}^+]_{\text{eq}}}{\text{M}}$ ^c	$\frac{[\text{B}]_{\text{stoich}}}{\text{M}}$ ^d	$\frac{[\text{B}]_{\text{eq}}}{\text{M}}$ ^e	pK _a ^f
2.94	4.75	1.8x10 ⁻⁵	5.55x10 ⁻³	5.53x10 ⁻³	9.44x10 ⁻³	3.91x10 ⁻³	4.90
3.43	4.58	2.6x10 ⁻⁵	6.42x10 ⁻³	6.39x10 ⁻³	9.36x10 ⁻³	2.97x10 ⁻³	4.91
3.92	4.36	4.4x10 ⁻⁵	7.27x10 ⁻³	7.23x10 ⁻³	9.27x10 ⁻³	2.04x10 ⁻³	4.91
4.41	4.07	8.5x10 ⁻⁵	8.11x10 ⁻³	8.03x10 ⁻³	9.19x10 ⁻³	1.16x10 ⁻³	4.91
4.90	3.61	2.45x10 ⁻⁴	8.93x10 ⁻⁴	8.69x10 ⁻³	9.11x10 ⁻³	4.2x10 ⁻⁴	4.93

a. $[\text{H}^+]_{\text{eq}}$ obtained from measured pH

b. $[\text{BH}^+]_{\text{eq}} + [\text{H}^+]_{\text{eq}}$ obtained from the known volume of HCl added.

c. $[\text{BH}^+]_{\text{eq}}$ obtained from b - a.

d. $[\text{B}]_{\text{stoich}}$ obtained from known hexamethylenetetramine concentration and dilution

e. $[\text{B}]_{\text{eq}}$ obtained from d - c

$$f. \text{pK}_a = \text{pH} + \log_{10} \frac{[\text{BH}^+]_{\text{eq}}}{[\text{B}]_{\text{eq}}}$$

In an attempt to diprotonate (1.1) pH measurements indicated that no depletion of acid concentration, beyond that required for mono-protonation, occurred in solutions containing $\leq 0.01\text{M}$ acid (see Table 3.2).

An estimation of $\text{pK}_{a,2}$ can be made as follows:

$$K_{a,2} = \frac{[\text{BH}^+][\text{H}^+]}{[\text{BH}_2^{2+}]}$$

\therefore when $[\text{H}^+] = 10^{-2}\text{M}$ assuming that the maximum ratio $\text{BH}_2^{2+}:\text{BH}^+$ is 1:1 gives $K_{A,2} \geq 10^{-2}\text{mol l}^{-1}$

$\therefore \text{pK}_{a,2} \leq 2$

The pH measurements indicate that the actual ratio $\text{BH}^+:\text{BH}_2^{2+}$ is much greater than 1:1 so that the actual pK_a will be < 2 .

A similar experiment substituting DAPT (3.2) for hexamethylenetetramine (1.1), showed that negligible protonation occurred in 0.01 M aqueous acid (see Table 3.3)

Again we can estimate that the $\text{pK}_a < 2$.

Table 3.2

Addition of 0.2M HCl to 50 cm³ of 0.01M, hexamethylenetetramine

0.2M HCl/cm ³	pH	$\frac{[H^+]}{M}$	pK _a	$\frac{[H^+]}{M}$ *
0.5	5.51	3.0×10^{-6}	4.91	—
1.0	5.08	8.3×10^{-6}	4.90	—
1.5	4.70	2×10^{-5}	4.87	—
2.0	4.28	5.2×10^{-5}	4.87	—
2.5	3.30	5.0×10^{-4}		—
3.0	2.61	2.5×10^{-3}		1.9×10^{-3}
3.5	2.32	4.8×10^{-3}		3.7×10^{-3}
4.0	2.13	7.4×10^{-3}		5.5×10^{-3}
4.5	1.97	1.1×10^{-2}		7.3×10^{-3}
5.0	1.89	1.3×10^{-2}		9.1×10^{-3}

* assuming no diprotonation

Table 3.3Addition of 0.1M HCl to 50 cm³ of 0.01M DAPT

0.1M HCl/cm ³	pH	pH*
0	6.95	
0.5	2.93	3.0
1.0	2.61	2.71
1.5	2.30	2.54
2.0	2.22	2.41
2.5	2.15	2.32
3.0	2.08	2.25
3.5	2.02	2.18
4.0	1.97	2.13
4.5	1.93	2.08
5.0	1.89	2.04

* assuming no protonation

3.3.2. Decomposition of Hexamethylenetetramine in Acidic Solution

Although our measurements indicate that hexamethylenetetramine is a relatively weak base, it will be almost completely protonated in dilute acid solution

^1H n.m.r measurements, taken in deuterium oxide to minimise the effects of solvent absorption, gave a single band at $\delta 4.70$ for (1.1) which is in agreement with the literature value.⁴⁰ This indicates the equivalence of all the protons, which is to be expected from a consideration of the molecular model.⁸² Gradually increasing the concentration of deuterium chloride up to a molar ratio of hexamethylenetetramine:DCL, 1:1 caused a progressive shift to lower field, whilst maintaining a sharp singlet. Eventually a band at $\delta 5.0$ was obtained corresponding to the deuterated species (Figure 3.1.a).

Similarly, a solution, in deuterium oxide, of the salt hexamethylenetetramine hydrochloride gave a band at $\delta 5.0$ for the methylene protons of the protonated form. In agreement with Tada⁷⁵, who found a value of $6.05 \times 10^{-6} \text{ s}^{-1}$ for the decomposition of the protonated form in water at 30°C , n.m.r. spectra showed that little decomposition of the salt occurred over several days.

In more concentrated acid, the band due to the methylene protons shifted further downfield with increasing acid concentration eventually reaching $\delta 5.45$ corresponding to the dideuterated species (Figure 3.1.b).

In concentrated acid solution,
hexamethylenetetramine (1.1) decomposition was seen to be
more rapid.

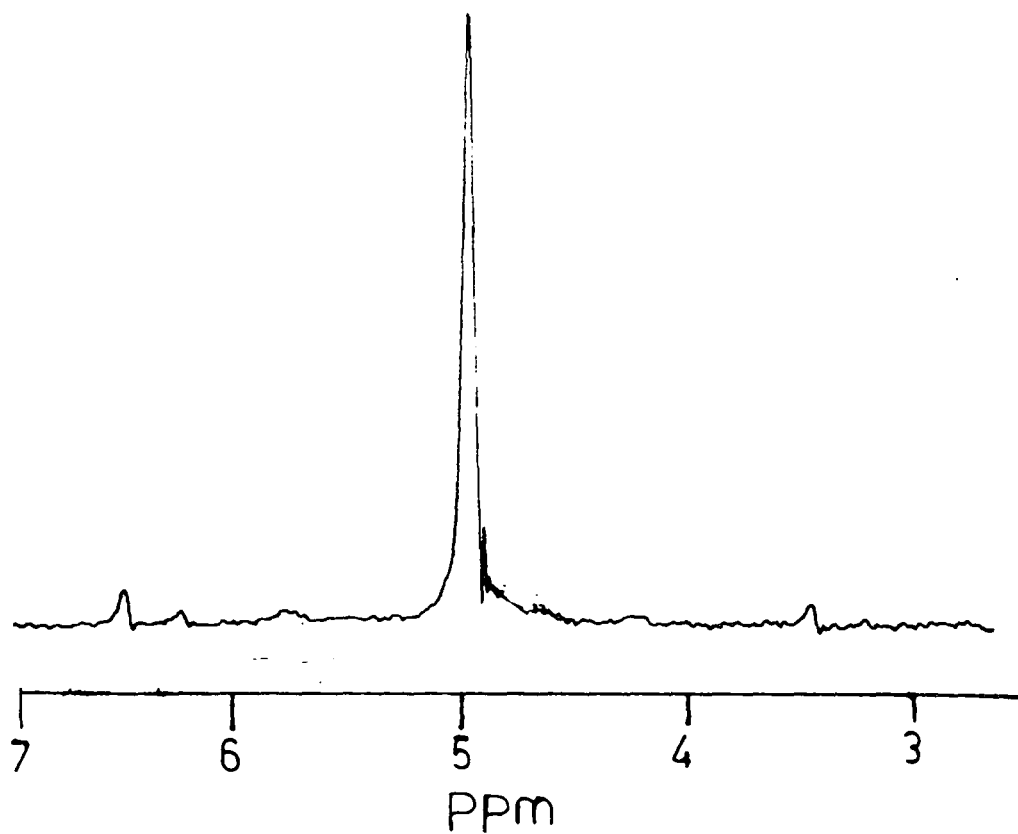

Fig. 3.1.a

monodeuterated hexamethylenetetramine

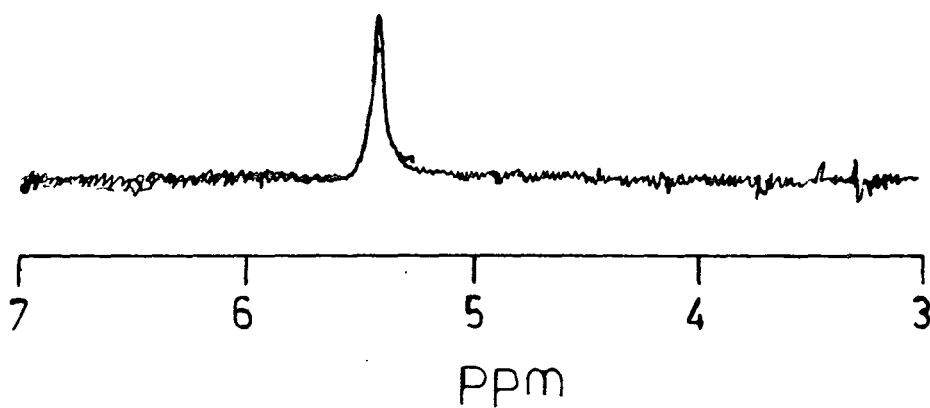

Fig. 3.1.b

dideuterated hexamethylenetetramine

N.m.r. measurements in 6.6M deuterium chloride in deuterium oxide showed the formation of a series of bands. Initially a band at $\delta 5.4$ was observed which was attributed to the dideuteronated species. As this band decreased in size, three other bands appeared at $\delta 4.7$, $\delta 4.8$ and $\delta 4.9$ (Figure 3.2). The band at $\delta 4.7$ was seen to gradually increase in size at the expense of the dideuteronated species, till eventually it was approximately equal in size to the peak at $\delta 4.8$. This was followed by an increase in size of the band at $\delta 4.9$. One of the bands between $\delta 4.7$ and $\delta 5.0$ is likely to be due to hydrated formaldehyde which normally occurs at $\delta 4.8$,³⁷ however it is difficult to assign a specific band to formaldehyde, due to the close proximity of the three bands.

The other bands are likely to result from the formation of NCH_2O and/or NCH_2N species,⁴⁰ which may be protonated in strongly acidic media: NCH_2O^- type methylenes normally give bands near $\delta 4.5$, and NCH_2N^- type methylenes appear near $\delta 3.5-4.0$, however protonation on the nitrogen will tend to give chemical shifts at lower field.

It is possible that one of the decomposition products of hexamethylenetetramine in acidic solution is the protonated salt of methylenediamine $\text{H}_2\text{N}-\text{CH}_2-\text{NH}_2$, which is thought to be an intermediate in the formation of (1.1) from formaldehyde and ammonia.⁴⁰

It is known that salts of the type $\text{H}_2\text{N}^+-\text{CH}_2\sim$ are stable under strongly acidic conditions. However, in

weakly acidic or basic solution, reactions occur to produce cyclic products.⁸³ Neutralization of the products of decomposition of (1.1) in 6.6 M DCl, with sodium deuterioxide, gave an n.m.r. spectrum which suggested that hexamethylenetetramine was reformed (Figure 3.3).

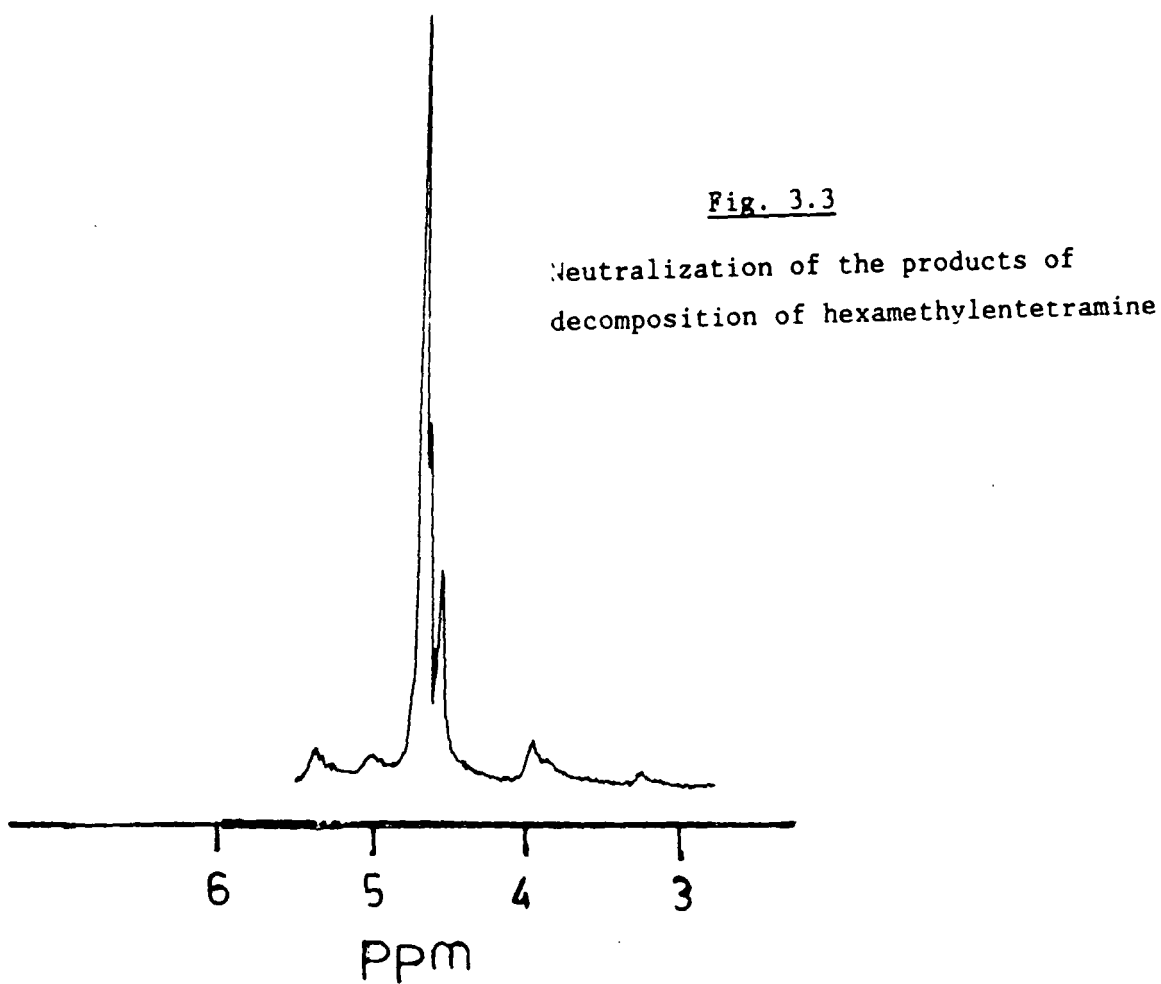
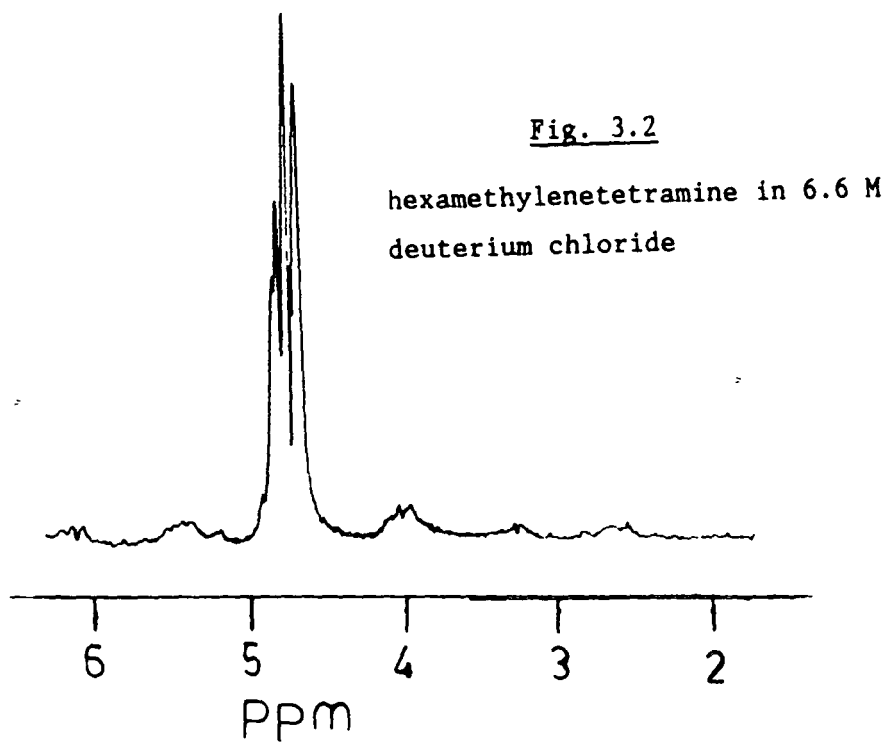

3.3.3. Determination of $pK_{a,2}$ of Hexamethylenetetramine using N.m.r. spectroscopy

In the determination of $pK_{a,2}$ of hexamethylenetetramine, it was necessary to work in concentrated acid solution. Since we estimated that $pK_{a,2} < 2$.

With the solutions of high acid concentration, pH is no longer a useful measure of acidity, due to medium effects. The effect of the interionic atmosphere on acidity can be expressed in terms of activity coefficients. All ionic activity coefficients become unity in sufficiently dilute solution, and they are usually less than unity in solutions of high ionic concentration.⁸⁴

If we insert activity coefficients as correction factors in the equilibrium constant expression for B and BH^+ we obtain

$$K_a = \frac{[B][H^+]}{[BH^+]} \cdot \frac{\gamma_B \gamma_{H^+}}{\gamma_{BH^+}}$$

Since B and BH^+ differ only by a proton it may be expected that the ratio γ_B/γ_{BH^+} is independent of the nature of B.

The quantity h_o is defined by:

$$h_o = K_a \frac{[BH^+]}{[B]} = [H^+] \cdot \frac{\gamma_{H^+} \gamma_B}{\gamma_{BH^+}}$$

In our case it is more convenient to use an acidity function defined by

$$H_o = -\log_{10} h_o = pK_a + \log_{10} \left[\frac{[B]}{[BH^+]} \right]$$

Since we are concerned with $pK_{a,2}$ of (1.1), the expression then becomes

$$H_o = pK_{a,2} + \log_{10} \left[\frac{[BH^+]}{[BH_2^{2+}]} \right]$$

It is now known that the acidity function is dependent on the chemical structure of the base. The literature now contains various acidity functions (for example, H_o' , H_o'' , and H_o''' for primary, secondary, and tertiary amines), each applicable to a restricted range of compounds.⁸⁵

Since hexamethylenetetramine is a tertiary amine the H_o''' is most applicable. Although acidity functions are dependent on the charge on the base, this will not greatly affect our results since the second protonation site of hexamethyl- enetetramine is distant from the first.

Previous measurements have indicated that the D_o''' acidity function may be assumed equal to H_o''' .⁸⁵⁻⁸⁷ Use of D_o''' gave a value of $pK_{a,2}$ of -1.25 ± 0.25 (Table 3.4) for the dideuteronated acid. Since D_2O is a weaker base than H_2O , the dissociation constant of the diprotonated hexamethylenetetramine is expected to be larger than that for the dideuterated species. Previous measurements suggest that the dissociation constant for the diprotonated acid would be expected to be ca. 2-3 times larger than the dideuteronated acid,⁸⁷ leading to a value of $pK_{a,2}$ of -1.7 ± 0.3 for diprotonated hexamethylenetetramine in water.

Table 3.4

^1H N.m.r. shifts corresponding to the conversion of monodeuterated hexamethylenetetramine^a to the dideuterated form in deuterium oxide.

[DCl]/M	[DCl] _{Free} /M	D ₀ ^c	δ^d	pK _{a,2} ^e
0.3	0.1		5.00	
1.0	0.78		5.05	
1.5	1.26	-0.55	5.10	-1.1
2.0	1.73	-0.87	5.15	-1.2
3.0	2.70	-1.41	5.23	-1.4
4.0	3.64	-1.89	5.35	-1.3
6.6	6.21	-3.06	5.43	
11.4 ^b	11.0 ^b		5.45	

- a. Stoichiometric concentration of hexamethylenetetramine is 0.20 M.
- b. This measurement was made in hydrochloric acid in water.
- c. From ref.86 the assumption is made that in these solutions values for D₀ are equal to values for H₀, see ref. 87.
- d. ^1H N.m.r. shifts of methylene protons.
- e. Calculated as $D_0''' + \log_{10} (\delta - 5.00) / (5.45 - \delta)$

3.3.4. Ultraviolet Absorbance Spectra

Both hexamethylenetetramine and its N-acetyl derivatives, were seen to absorb in the far u.v. region. In order to probe the usefulness of u.v. measurements in studies of these compounds we examined their u.v. absorption characteristics.

We found that in water DAPT (3.2) has λ_{\max} . 192 nm, ϵ 2.1×10^4 l mol⁻¹ cm⁻¹ and TAT has λ_{\max} . 196 nm, ϵ 4×10^4 l mol⁻¹ cm⁻¹. The λ_{\max} . of hexamethylenetetramine was at shorter wavelength <192 nm, so was difficult to measure accurately. Values of extinction coefficients at wavelengths 200-230 nm for starting materials and other species which may be present in reacting solutions are shown (Table 3.5)

Table 3.5

Values of extinction coefficients ($\text{l mol}^{-1}\text{cm}^{-1}$) in water
at 25° .

	Wavelength (nm)			
	200	210	220	230
hexamethylenetetramine	1,000	350	45	4
hexamethylenetetramine hydrochloride	-	100	40	-
DAPT	16,000	8,000	4,000	1,200
TAT	30,000	13,000	3,000	800
TRAT	-	10,000	2,000	450
Acetamide	800	150	50	10
Acetic acid	-	50	30	6
Hydrochloric acid	25	1	0.3	-

Formaldehyde and ammonium acetate do not show significant absorption above 200 nm. For all measurements involving hydrochloric acid the reference cell contained acid of the appropriate concentration.

3.3.5. Reaction of DAPT with Acid

U.v. measurements were effective in determining both the protonation equilibrium and the subsequent decomposition reaction. Measurements at 230 nm in 0-1 M aqueous hydrochloric acid showed two effects.

1. The initial absorbance at 230 nm decreased as the acid concentration increased.
2. A slow fading reaction was observed at 230 nm, eventually giving an absorbance close to zero.

The first effect is possibly due to protonation of DAPT (3.2)

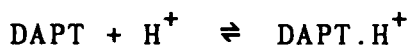

The acidity of the medium is best described by an acidity function.⁸⁵ In these fairly dilute solutions the various acidity functions for hydrochloric acid do not deviate markedly. However, since, as will be discussed later, protonation occurs on a tertiary nitrogen atom of DAPT (3.2), the H_o''' function is most appropriate.^{85,86}

Therefore we define the equilibrium constant, K, for protonation as follows

$$K = \frac{[\text{DAPT.H}^+]}{[\text{DAPT}] h_o'''}$$

The equilibrium constant K can be expressed in terms of absorbance measurements by the following equation

$$K = \frac{[A_o - A_\infty]}{[A - A_\infty] h_o'''}$$

where A = measured absorbance before the fading reaction

A_o = initial absorbance at zero acid concentration

A_∞ = limiting absorbance at high acid concentration

The data in Table 3.6 give a value of K of $5.5 \pm 1 \text{ l mol}^{-1}$.

This gives a value for K_a for DAPT.H^+ (the reciprocal of K) of ~ 0.18 $\therefore \text{p}K_a \sim 0.7$.

Following the initial rapid decrease in absorption, there was a slower fading reaction. Kinetic analysis indicated that the subsequent fading reaction followed a

Table 3.6

Equilibrium data for reaction of DAPT ($6 \times 10^{-4} \text{ M}$) with hydrochloric acid in water at 25°C .

[HCl]/M	$h_o'''^a$	Absorbance ^b (230 nm)	$K^c/\text{l mol}^{-1}$
0	-	0.75	
0.050	0.050	0.65	5.6
0.075	0.077	0.60	6.3
0.10	0.105	0.57	6.1
0.15	0.17	0.55	4.5
0.20	0.23	0.50	5.2
0.25	0.29	0.45	6.5
0.30	0.34	-	
0.40	0.49	-	
0.50	0.69	-	
0.70	1.12	-	
0.80	1.41	-	
0.90	1.78	0.33	
∞		0.29	

a. $h_o''' = \text{antilog}(-H_o)$

b. Initial value, before fading reaction

c. K calculated as $(A_o - A)/h_o (A - A_\infty)$.

first-order rate law. Thus plots of $\ln(A-A_\infty)$ versus time were linear. Specimen results are shown in Table 3.7.

Table 3.7

Specimen results for decomposition of DAPT in HCl solution at 25°C
 $[DAPT] = 6 \times 10^{-4} M$
 $[HCl] = 0.2 M$

<u>Time/s</u>	<u>Absorbance</u>
200	0.372
400	0.343
600	0.314
800	0.289
1,000	0.250
1,200	0.240
1,400	0.220
1,600	0.20

$$A_\infty = 0.018$$

Plot of $\ln [A-A_\infty]$ against time gives

$$k_{\text{obs}} = \underline{4.79 \times 10^{-4} \text{ s}^{-1}}$$

It was found that the first order rate coefficients for the slow fading reaction increased with increasing acidity of the medium but reached a limiting value at ca. 1 M acid (Figure 3.4).

Figure 3.4

Plot of k_{obs} versus $[\text{HCl}]$ for decomposition of DAPT ($6 \times 10^{-4} \text{ M}$) in HCl solution.

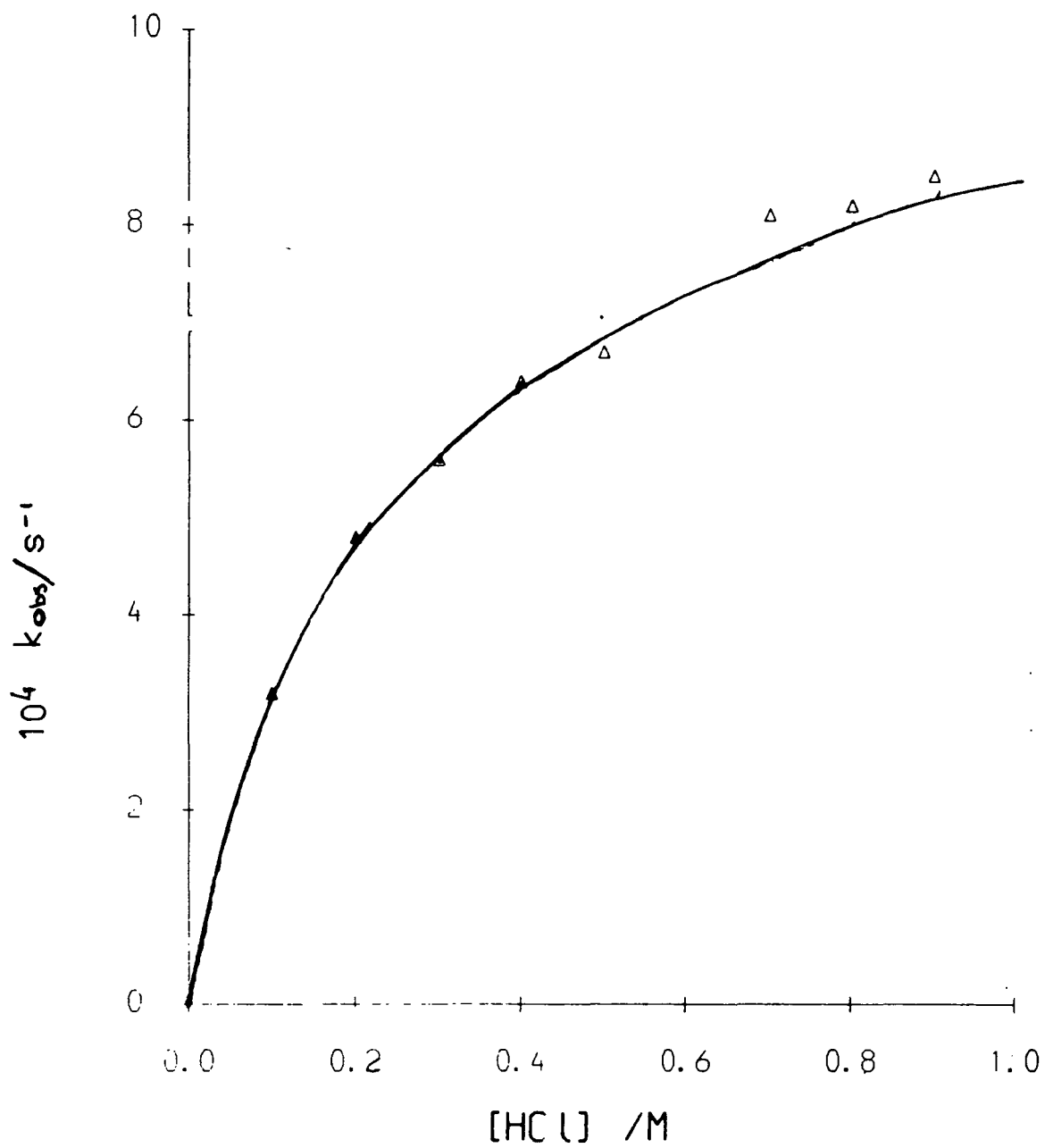

The decomposition of DAPT (3.2) in acid can be interpreted in terms of rate determining decomposition of the protonated substrate.



$$[\text{DAPT}] + [\text{DAPT.H}^+] + [\text{Products}] = \text{constant}$$

$$[\text{DAPTH}^+] = K [\text{DAPT}] [\text{H}^+]$$

$$\therefore [\text{DAPT}] + K [\text{DAPT}] [\text{H}^+] + [\text{Products}] = \text{constant}$$

$$[\text{DAPT}] \left[1 + K [\text{H}^+] \right] + [\text{Products}] = \text{constant}$$

$$\frac{d [\text{DAPT}]}{dt} \left[1 + K [\text{H}^+] \right] + \frac{dP}{dt} = 0$$

$$\text{rate} = k [\text{DAPTH}^+] = \frac{dP}{dt}$$

$$\frac{dP}{dt} = k K [\text{DAPT}] [\text{H}^+]$$

$$\therefore \frac{d [\text{DAPT}]}{dt} \left[1 + K [\text{H}^+] \right] + k K [\text{DAPT}] [\text{H}^+] = 0$$

$$-\frac{d [\text{DAPT}]}{dt} = k_{\text{obs}} [\text{DAPT}]$$

$$\therefore -k_{\text{obs}} [\text{DAPT}] \left[1 + K [\text{H}^+] \right] + k K [\text{DAPT}] [\text{H}^+] = 0$$

$$\therefore k_{\text{obs}} \left[1 + K [\text{H}^+] \right] = k K [\text{H}^+]$$

$$k_{\text{obs}} = \frac{k K [\text{H}^+]}{1 + K [\text{H}^+]}$$

Expressing the equation in terms of an acidity function gives

$$k_{\text{obs}} = \frac{k K h_o'''}{1 + K h_o'''}$$

Inversion of the equation gives

$$\frac{1}{k_{\text{obs}}} = \frac{1}{k K h_o'''} + \frac{1}{k}$$

A plot of $\frac{1}{k_{\text{obs}}}$ versus $\frac{1}{h_o'''}$ is shown in Figure 3.5 and

yields the values $k = (9 \pm 1 \times 10^{-4} \text{ s}^{-1})$ and

$$K = 5.0 \text{ l mol}^{-1}$$

The data, in Table 3.8, calculated using these values is in good agreement with the experimental data

Table 3.8

Rate data for reaction of DAPT (6×10^{-4} M) with hydrochloric acid in water at 25°C .

[HCl]/M	h_o'''	$10^4 k_{\text{obs}}/\text{s}^{-1}$	$10^4 k_{\text{calc}}^a$
0.1	0.105	3.2	3.1
0.2	0.23	4.8	4.8
0.3	0.34	5.6	5.7
0.4	0.49	6.4	6.4
0.5	0.69	6.7	7.0
0.7	1.12	8.1	7.6
0.8	1.41	8.2	7.9
0.9	1.78	8.5	8.1
∞			

a. Calculated from $k_{\text{obs}} = \frac{k K h_o'''}{1 + K h_o'''}$ with $k = \frac{9 \times 10^{-4} \text{s}^{-1}}{1}$

and $K = 5 \text{ l mol}^{-1}$.

The values of K obtained from the equilibrium and kinetic measurements are in reasonable agreement and lead to a pK_a value for DAPT of 0.7 ± 0.1

The rates of the fading reaction were also measured in deuterium oxide containing deuterium chloride. It is known^{85,87} that in dilute solutions the acidity functions for hydrochloric acid in water and deuterium chloride in deuterium oxide are identical. Values of rate coefficients were measured at seven acid concentrations and are given in Table 3.9.1. A plot of $1/k_{\text{obs}}$ versus

$1/d_0'''$ is shown in Figure 3.6 and yields a value for k of
 $(1 \pm 0.1) \times 10^{-3} \text{ s}^{-1}$

Figure 3.5

Plot of $1/k_{\text{obs}}$ versus $1/h_0'''$ for decomposition of DAPT (6×10^{-4} M) in HCl solution.

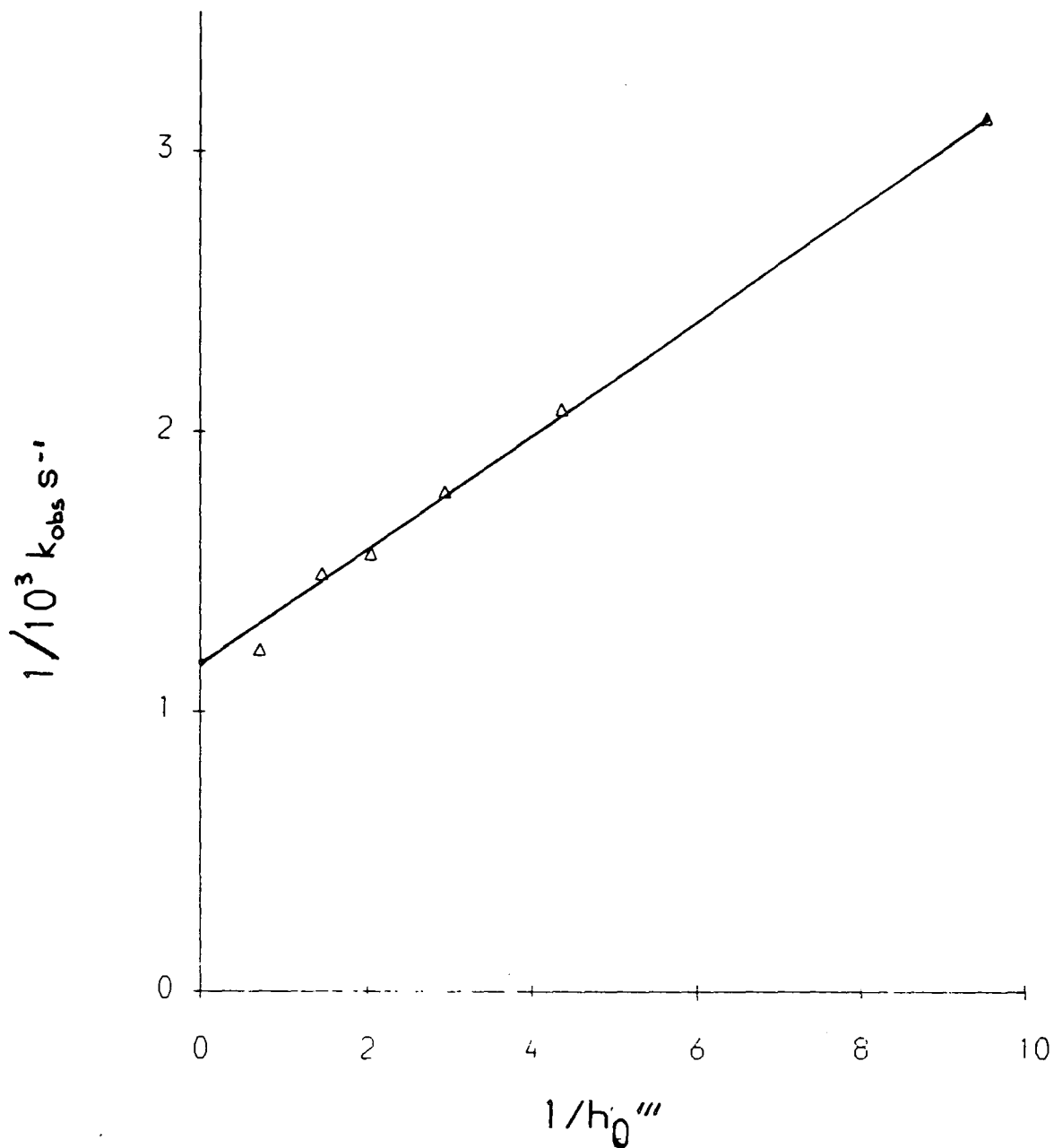

Figure 3.6

Plot of $1/k_{obs}$ versus $1/d_0'''$ for decomposition of DAPT (6×10^{-4} M) in DCl solution.

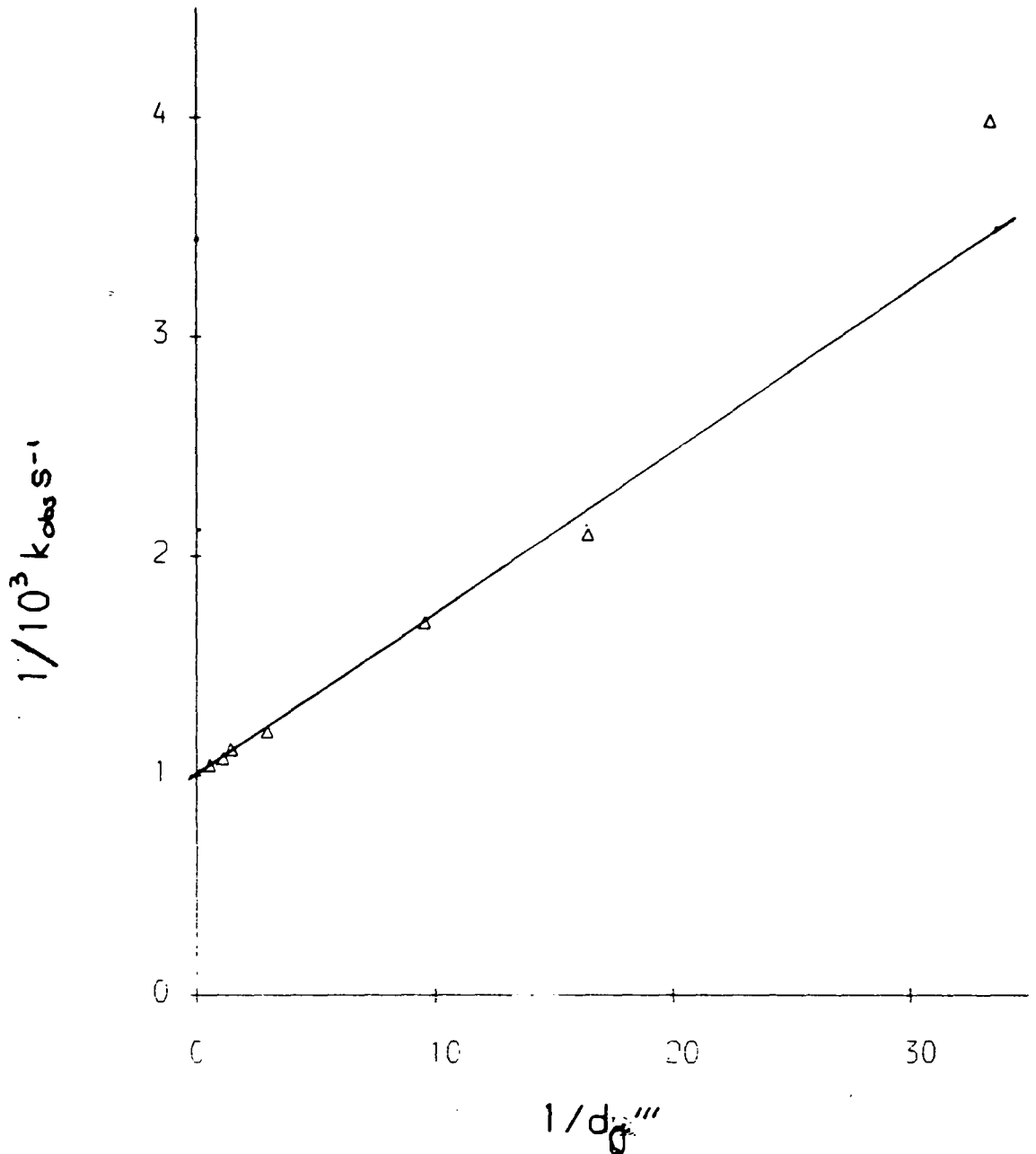

Table 3.9.1

Rate coefficients for the decomposition of DAPT in deuterium oxide containing deuterium chloride at 25°C.

[DC1]/M	d_o'''	$10^4 k_{obs}/s^{-1}$	$10^4 k_{calc}^a$
0.030	0.030	2.5	2.9
0.06	0.061	4.7	4.6
0.10	0.105	6.0	6.0
0.30	0.34	8.2	8.3
0.50	0.69	8.9	9.0
0.60	0.90	9.2	9.2
0.90	1.78	9.5	9.6

a. Calculated for $k_{obs} = \frac{k K d_o'''}{1 + K d_o''}$

with $k = 1 \times 10^{-3} s^{-1}$ and $K = 14 \text{ l mol}^{-1}$

This value is identical, within experimental error, with the value obtained in water.

The value for K of $14 \pm 1 \text{ l mol}^{-1}$, yielding a pK_a value in D_2O of 1.15 ± 0.05 , is ca. 3 times higher than the value in water. This result, which shows the higher basicity for DAPT (3.2) in deuterium oxide than in water is in accord with literature values^{87,88} for other nitrogen bases, and provides further evidence for the suggested mechanism of rate determining decomposition of $DAPT.H^+$ (i.e. the results suggest that the initial

equilibrium involves proton transfer). However, it is not entirely certain that ring cleavage does not occur in the initial equilibrium, as will be discussed later.

It was expected that the decomposition reaction of DAPT (3.2) in aqueous acid would produce formaldehyde, and in an experiment with 1 M hydrochloric acid the liberated formaldehyde was precipitated as the dimedone adduct.⁷⁷ This method of analysis is less accurate than the spectrophotometric measurements, but the data in Table 3.9.2 indicates that, after 2 hours, 3 moles of formaldehyde had been produced per mole of DAPT (3.2) at a rate compatible with the result in Table 3.8.

Table 3.9.2

Production of formaldehyde from DAPT in aqueous hydrochloric acid, 1 M, at 25°.

Time/s	Moles of Formaldehyde ^a produced per mole of DAPT	$10^4 k_{\text{obs}}^b / \text{s}^{-1}$
300	0.8 ± 0.2	11
600	1.2	9
1200	1.7	8
7200	2.8	8

a. Determined by precipitation as the dimedone adduct.

b. Using an 'infinity value' of 2.8 mol of formladehyde.

Further information regarding the decomposition products was obtained from ¹H n.m.r. measurements in D₂O. The spectrum of DAPT (3.2) in D₂O and also in CDCl₃ (Figure

3.7) consists of a singlet for the acetyl protons at $\delta 2.1$, a singlet for the methylene bridge protons at $\delta 4.4$, and 2 AB quartets (J 13 Hz) with shifts of $\delta 4.4$ and $\delta 5.6$, and $\delta 4.9$ and $\delta 5.1$ respectively.

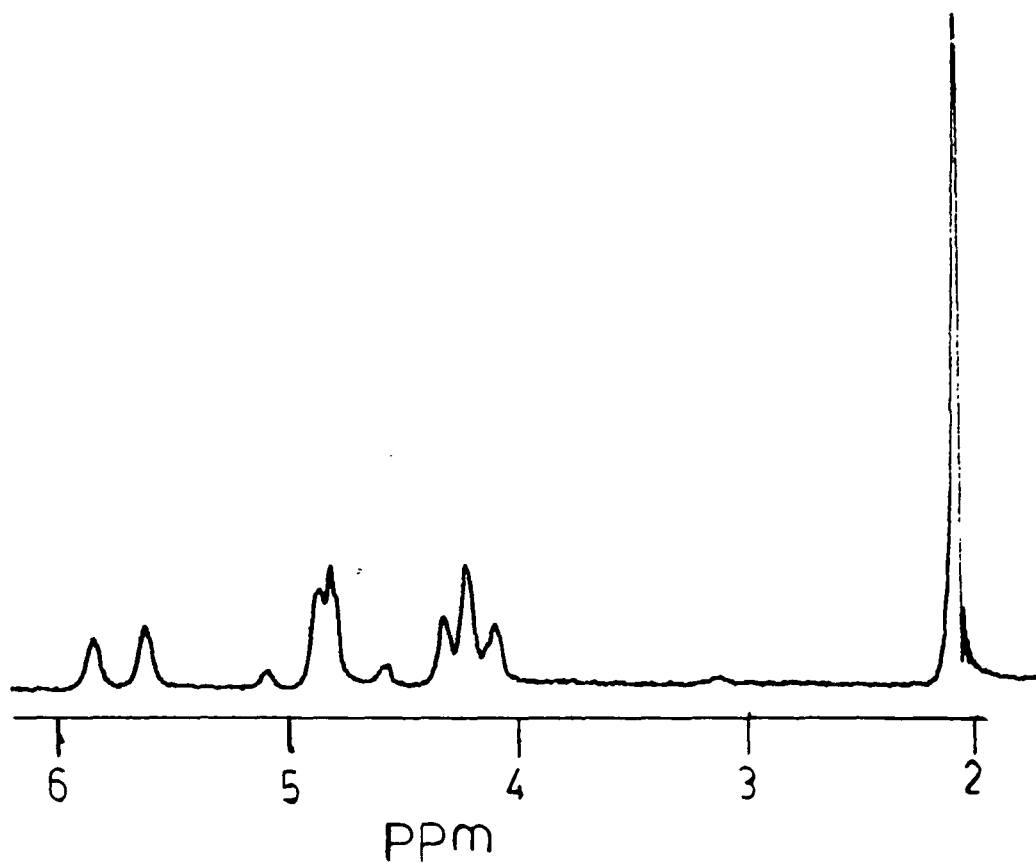

Fig. 3.7

^1H n.m.r. of DAPT in CDCl_3

The spectrum has been analysed previously³⁵ on the basis of restricted rotation about the N-C bonds of the acetyl functions, which leads to inequivalence of the axial and equatorial protons of the methylene groups.

To test the reversibility of the initial protonation reaction a solution of DAPT (3.2) in deuterium oxide containing 1 M deuterium chloride was allowed to stand for 45 seconds and was then neutralised with sodium deuterioxide solution. The spectrum of the neutralised solution was that of DAPT.

The decomposition of DAPT in 1 M deuterium chloride showed the gradual production of 2 main bands at $\delta 4.5$ and $\delta 4.8$ (Figure 3.8). The initial spectrum was difficult to interpret due to a relatively large band due to the presence of H_2O impurity in close proximity to the other bands.

However, bands were present which were similar to those in DAPT (3.2), which suggested that the spectrum may have consisted of a mixture of $DAPT.H^+$ and decomposition products. No other intermediates other than the assumed $DAPT.H^+$ and final products were observed. The band at $\delta 4.8$ which was seen to gradually increase in size was attributed to hydrated formaldehyde which normally occurs at this position.³⁷ The band at $\delta 4.5$ is at the position expected for NCH_2O hydrogens.⁴⁰ N-acetylaminoethanol ($CH_3CONHCH_2OH$) prepared from

acetamide and formaldehyde (see Chapter 2), gave bands at $\delta 2.1$ and $\delta 4.5$ in 1 M deuterium chloride i.e. the same positions in the decomposition products of DAPT.

Hence the data indicates that in 1 M acid the stoichiometry of the decomposition reaction is probably given by the following equation

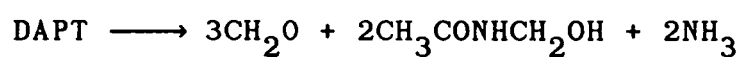

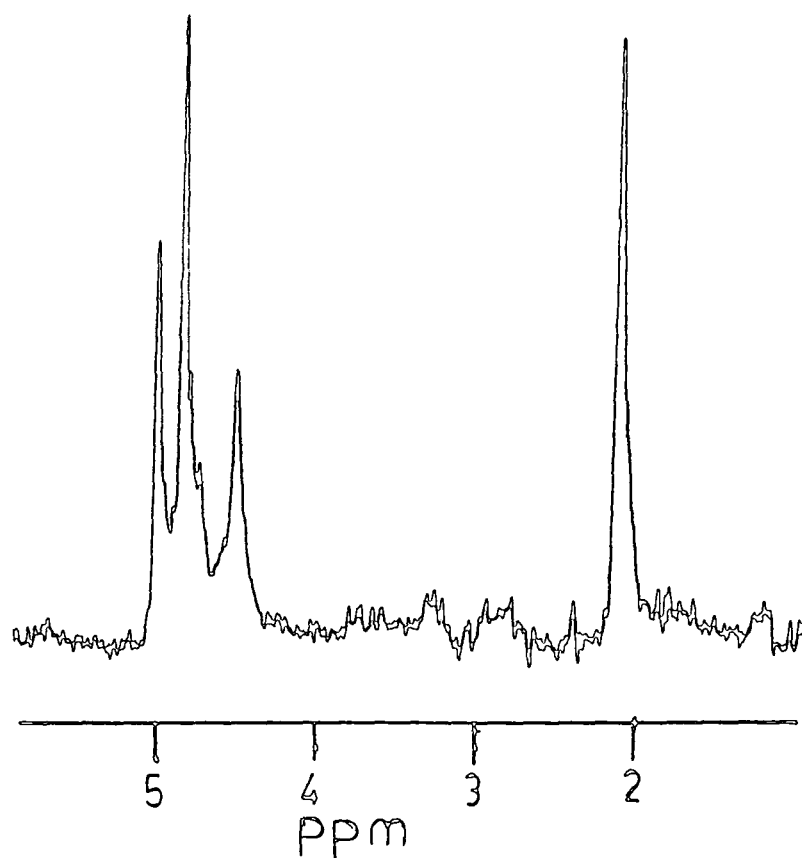

Fig. 3.8.

Products of decomposition of DAPT in 1 M deuterium chloride

If the initial equilibrium is indeed due to the production of DAPT.H^+ , the kinetic data, taken with the failure to observe intermediates other than protonated DAPT, indicates that the initial C-N bond breaking in the protonated substrate is rate determining.

3.3.6. Reaction of TAT and TRAT with Acid

In each of the compounds TAT (3.4) and TRAT (3.3), all of the nitrogen atoms carry acetyl groups and in accord with the very weakly basic nature of amides,⁸⁹ protonation occurred only in concentrated acid solutions.

Measurements shown in Table 3.9.3 of absorbances at 220 nm and use of the H_A acidity function,^{89,90} defined by the protonation of amides, give a value for the pK_a of TAT of -2.5 ± 0.3 .

In 10.2 M acid, where the substrate is largely protonated, a slow decrease in absorbance occurred at 220 nm giving a value of $k = \underline{2 \times 10^{-5} \text{ s}^{-1}}$ for the decomposition reaction.

Table 3.9.3

Prototonation of TAT in aqueous hydrochloric acid at 25°.

HCl/M	$-H_A^a$	Absorbance (220 nm)	$-pK_a^b$
0		0.65	
3.4	1.19	0.65	
5.7	1.92	0.60	2.43
8.0	2.60	0.57	2.80
8.2	2.65	0.55	2.69
8.4	2.70	0.50	2.30
8.6	2.75	0.49	2.25
10.2	3.25	0.47	

a. From reference 90

b. $pK_a = H_A + \log_{10}(A_0 - A)/(A - A_\infty)$, with A_∞ 0.44

The ^1H n.m.r. spectrum of TAT (3.4) in deuterium oxide showed bands at $\delta 2.25$ (acetyl) and $\delta 5.14$ (methylene), (Figure 3.9.1.a). In 6.6 M deuterium chloride solution, where TAT will be partially deuterated, the initial spectrum showed bands $\delta 2.35$ and $\delta 5.2$ (Figure 3.9.1.b). These bands very slowly decayed with time producing a band at $\delta 2.15$ attributed to acetic acid, and 3 other bands at $\delta 4.7 - \delta 4.8$ (Figure 3.9.1.c). The band at $\delta 4.8$ probably being due to hydrated formaldehyde. It is likely that the other bands are due to $\text{N-CH}_2\text{-N}$ or $\text{N-CH}_2\text{O}$

species which will be protonated in strongly acidic media as stated previously. After several days the bands at $\delta 4.7 - \delta 4.8$ were seen to decay to give a main band at $\delta 4.8$ (Figure 3.9.1d). This suggested total breakdown of TAT to give formaldehyde and acetic acid. This was confirmed gravimetrically by treatment with dimedone of a reaction mixture which had been left for ten days and then neutralised with sodium hydroxide. This indicated the formation of 3.8 ± 0.4 moles of formaldehyde per mole of TAT. Hence the data indicates that in 6.6 M acid the stoichiometry of the decomposition reaction is given by the following equation

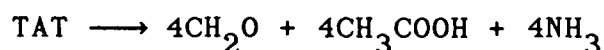

U.v. data for the protonation of TRAT (3.3) are in Table 3.9.4.

Fig.3.9.1.a

^1H n.m.r. of TAT in deuterium oxide

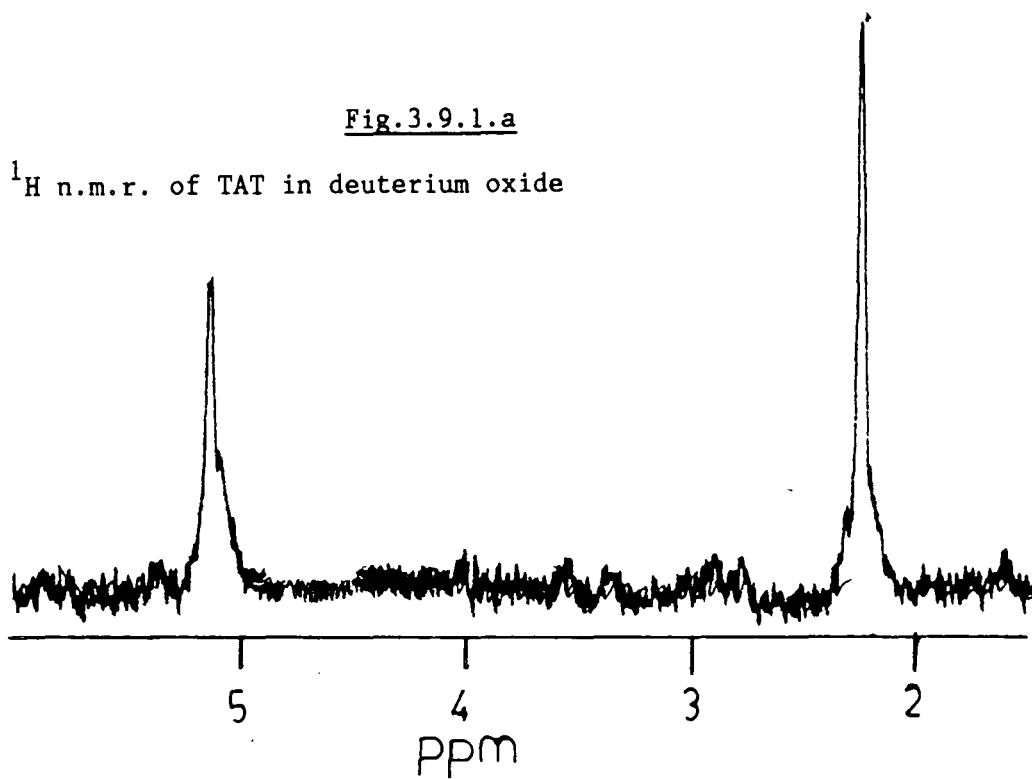

Fig. 3.9.1.b

Initial spectrum of TAT in 6.6 M deuterium chloride

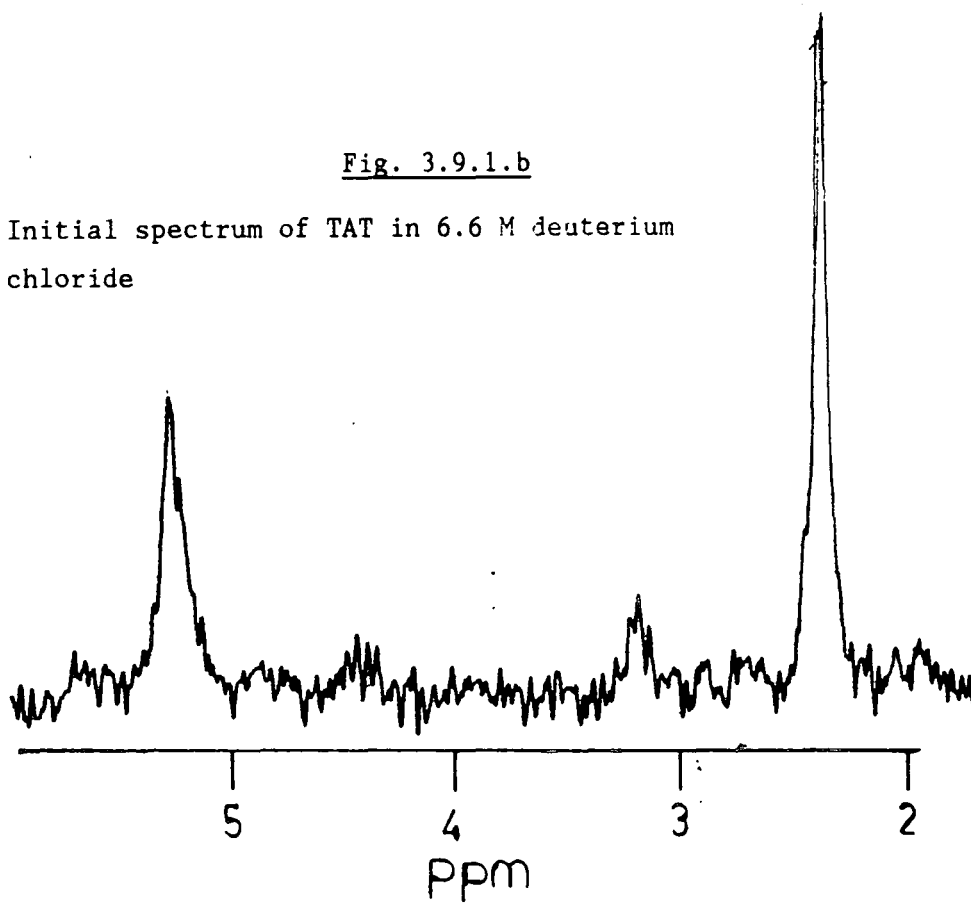

Fig. 3.9.1.c

Products of decomposition of TAT in 6.6 M
deuterium chloride

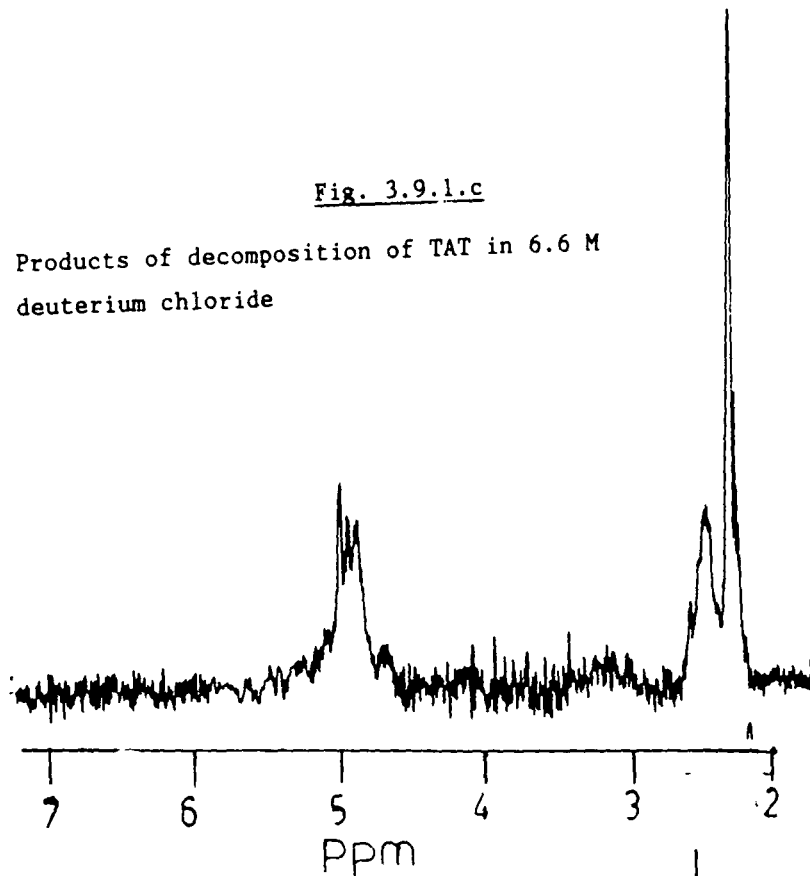

Fig. 3.9.1.d

Product of decomposition of TAT in 6.6 M
deuterium chloride after several days

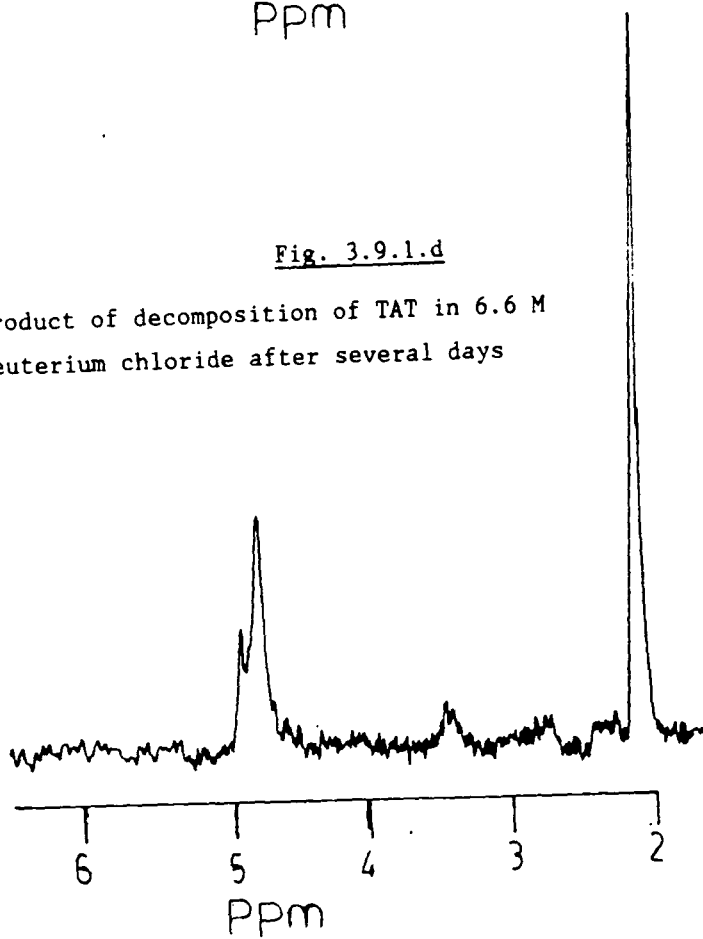

Table 3.9.4

Protonation of TRAT in aqueous hydrochloric acid at 25°C.

HCl/M	$-H_A^a$	Absorbance (230 nm)	$-pK_a^b$
0		0.53	
3.4	1.19	0.53	
5.7	1.92	0.49	2.43
6.8	2.24	0.455	2.34
8.0	2.60	0.405	2.16
9.1	2.91	0.395	2.33

a. From reference 90

b. $pK_a = H_A + \log_{10} (A_0 - A) / (A - A_\infty)$, with A_∞ 0.36

The data leads to a pK_a value of -2.3 ± 0.2 .

The n.m.r. spectrum of TRAT in deuterium oxide gave bands at $\delta 2.25$ (acetyl) and $\delta 5.3$ (methylene), (Figure 3.9.2.a). The initial spectrum in 6.6 M deuterium chloride showed bands at $\delta 2.35$ and $\delta 5.4$, (Figure 3.9.2.b). With time these bands were replaced by a strong band at $\delta 2.15$ attributed to acetic acid and 3 bands in the range $\delta 4.8 - \delta 5.0$. Eventually the bands between $\delta 4.8 - \delta 5.0$ gave way to a major band at $\delta 4.8$ which was attributed to formaldehyde (Figure 3.9.2.c). The n.m.r. spectra for the decomposition of TRAT (3.3) was very similar to TAT (3.4) and suggests a similar mechanism of decomposition. The n.m.r. data suggests that the stoichiometry of the decomposition reaction is given by the following equation

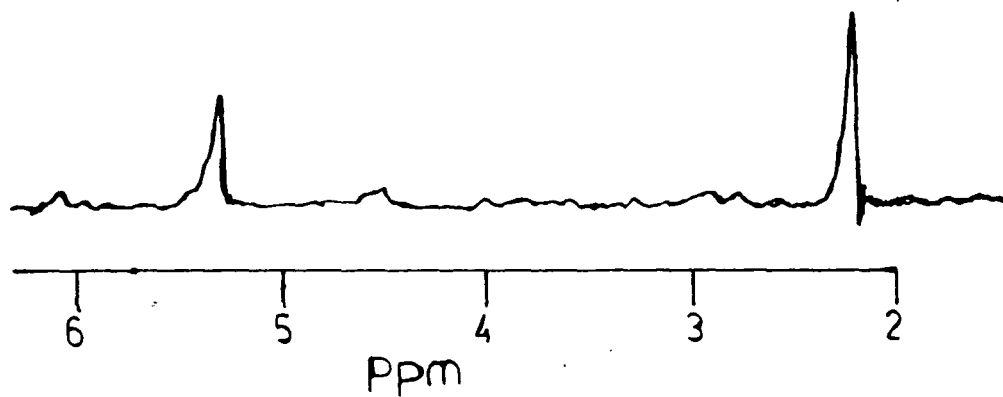

In 11.4 M hydrochloric acid where the substrate is largely protonated, the slow decrease in absorbance at 230 nm was used to obtain a value of $k = \underline{9 \times 10^{-5} \text{ s}^{-1}}$ at 25°C for the decomposition reaction, see Table 3.9.5 for specimen results.

Fig. 3.9.2.a ^1H n.m.r. fof TRAT in deuterium oxideFig. 3.9.2.b

Initial spetctrum of TRAT in 6.6 M deterium chloride

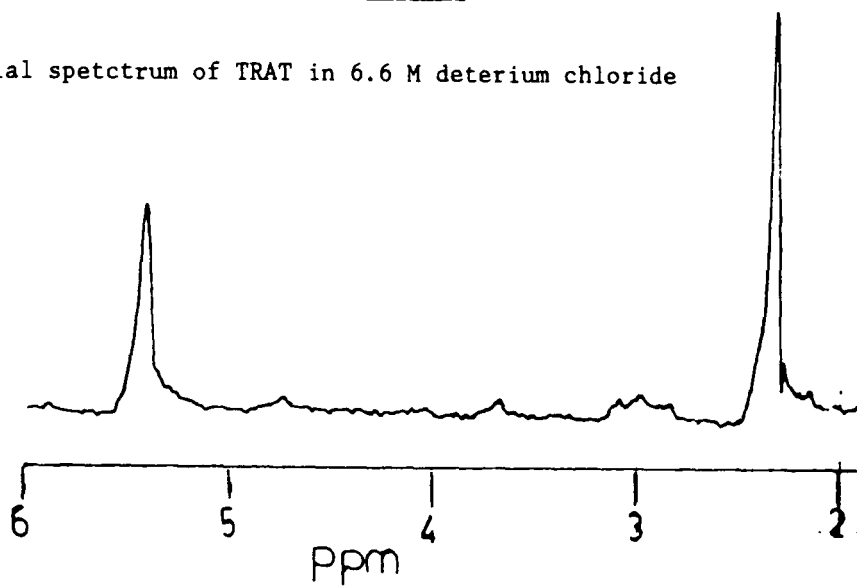

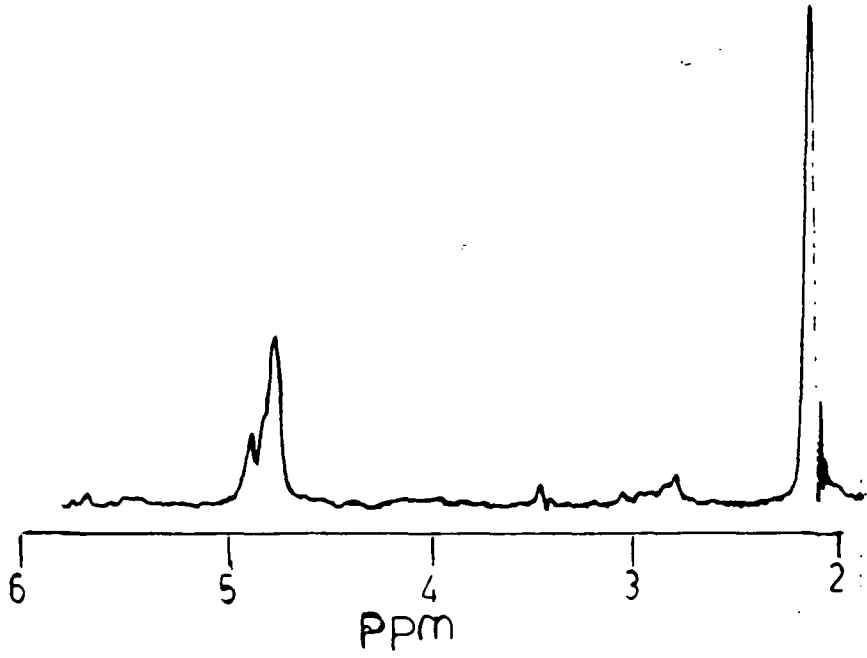

Fig. 3.9.2.c

Products of decomposition of TRAT in 6.6 M deuterium chloride

Table 3.9.5

Specimen results for decomposition of TRAT in HCl
(11.4 M) at 25°C.

Time/s	Absorbance
200	0.615
400	0.609
600	0.599
800	0.591
1,000	0.585
1,200	0.580
1,400	0.573
1,600	0.57

$$A_{\infty} = 0.234$$

Plot of $\ln [A - A_{\infty}]$ against time gives

$$k_{\text{obs}} = \underline{9 \times 10^{-5} \text{ s}^{-1}}.$$

3.3.7. Comparison of Hexamethylenetetramine, DAPT, TAT and TRAT

The data collected in Table 3.9.6 show that DAPT is a considerably weaker base than is hexamethylenetetramine. However, the basicity is greater than expected⁸⁹ for protonation of an amide function so structure (5.2) is indicated

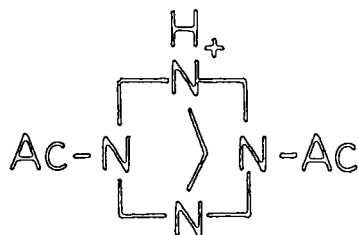

5.2

Protonation of TAT (3.4) and TRAT (3.3) must involve the amide group. However, even for amides⁸⁹ these are extremely feeble bases due to the cumulative electron-withdrawing effects of the acetyl groups.

Table 3.9.6

Comparison of pK_a values, and rate coefficients for decomposition of monoprotated bases in water at 25°C.

	pK_a	k/s^{-1}
Hexamethyl- enetetramine	4.89 ± 0.03^a	$6 \times 10^{-6} (30^\circ)^c$
	-1.7 ± 0.3^b	
DAPT	0.7 ± 0.1	9×10^{-4}
TAT	-2.5	2×10^{-5}
TRAT	-2.3	9×10^{-5}

- a. monoproteination
- b. diproteination
- c. from reference 75

There is considerable evidence to suggest that protonation of amides occurs on the oxygen atom rather than the nitrogen⁹¹

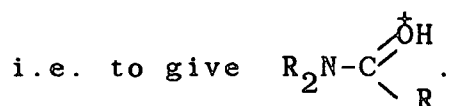

This explains the slight downfield shift of the acetyl protons on protonation of TAT and TRAT.

The first-order rate coefficients shown in Table 3.9.6 relate to the spontaneous decomposition of the protonated substrates in water. Although protonated



hexamethylenetetramine decomposes very slowly in water it should be noted that Tada⁷⁵ quotes a value at 30°C of $6.33 \times 10^{-4} \text{ l mol}^{-1} \text{ s}^{-1}$ for acid-catalysed decomposition of protonated hexamethylenetetramine i.e.



Thus in 1 M hydrochloric acid the observed rate coefficient for decomposition of hexamethylenetetramine ($6.33 \times 10^{-4} \text{ s}^{-1}$) will approach the value observed for DAPT in the same medium.

The data for the spontaneous decomposition of protonated hexamethylenetetramine suggest the following mechanism



i.e. in the protonated species the ring system is still intact. However, in the case of DAPT there are 2 possible mechanisms

1. Spontaneous decomposition of protonated DAPT.H⁺ (ring intact) or
2. Spontaneous decomposition of a methyleneiminium ion as follows.

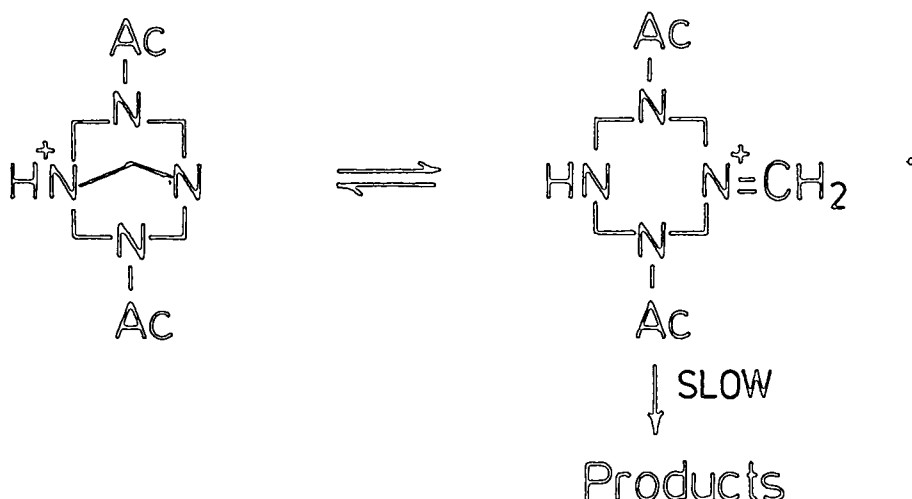

The results indicate that decomposition of DAPT.H⁺ is

faster than the decomposition of monoprotonated hexamethylenetetramine. This may be understood in terms of the electron demand within the protonated molecules. Monoprotonated hexamethylenetetramine has one positive charge pulling on the lone pairs of 3 other nitrogen atoms. Hence the electron pull is diluted and C-N bond cleavage is relatively slow. In the case of DAPT.H^+ little electron density will be available from the N-Ac functions hence the positive centre is effectively pulling directly on the lone pair from a single nitrogen atom. This will result in relatively fast C-N bond breaking.

The isotope effect observed on the equilibrium constant K for the reaction of DAPT with acid suggests that proton-transfer is occurring in the initial fast equilibrium, however it does not indicate whether or not ring cleavage has occurred. No isotope effect was observed on the rate constant k which suggests that proton transfer does not occur in the rate determining step. If the rate determining step is simply C-N bond cleavage then no isotope effect would be expected on the rate constant. Fast initial equilibrium processes involving formation of iminium ions are known,⁹² but only where initial C-N bond cleavage occurs easily i.e. for more basic substrates.

The initial step in the decomposition of TAT and TRAT involves cleavage of an N-acetyl bond to produce acetic acid. The slow decomposition of TAT and TRAT is in accord with the low reactivity expected for amides in

acidic conditions.⁹³

3.3.8 Reaction with Picryl Acetate

In relation to the formation of DAPT (3.2) from hexamethylenetetramine, the reaction of hexamethylenetetramine with picryl acetate was investigated. This is a very reactive acetylating agent and will readily transfer the acetyl group with the liberation of picrate ion.⁹⁴

The hydration of picryl acetate was studied at different pH in the absence and presence of hexamethylenetetramine respectively. In both cases, from measurements of the increase in absorbance at 400 nm, first order rate coefficients for the formation of picrate were determined.

Measurements in water at 25°C in the pH range 2-7 (Table 3.9.7) indicated a spontaneous reaction with $k = \underline{4.0 \times 10^{-3} \text{ s}^{-1}}$.

Table 3.9.7

Hydrolysis of picryl acetate ($4 \times 10^{-5} \text{ M}$) at 25°C.

pH	Buffer	$k_{\text{obs}} / \text{s}^{-1}$
2	10^{-2} M HCl	0.0037
4	phthalate	0.0039
6	phosphate	0.0043
7	phosphate	0 0044

First order rate coefficients for the formation of picrate in solutions containing hexamethylenetetramine

and hexamethylenetetramine/HCl mixtures are shown in Table 3.9.8. They indicate that formation of picrate is accelerated by hexamethylenetetramine but that protonated hexamethylenetetramine is unreactive.

The data can be represented by the equation below

$$k_{\text{obs}} = k_{\text{w}} + k_{\text{Hex}} [\text{Hexamethylenetetramine}]$$

A plot of k_{obs} against free hexamethylenetetramine giving $k_{\text{Hex}} = \underline{0.34 \text{ l mol}^{-1} \text{ s}^{-1}}$ (Figure 3.9.3). Possible modes of action of hexamethylenetetramine in the formation of picrate ions from picryl acetate are

1. general base catalysis
2. direct nucleophilic attack.

Table 3.9.8

Rate data for reaction of hexamethylenetetramine with picryl acetate (4×10^{-5} M) in water at 25°C.

$\frac{[\text{Hexamine}]_{\text{stoich}}^{\text{a}}}{\text{mol } \ell^{-1}}$	$\frac{[\text{HCl}]_{\text{stoich}}}{\text{mol } \ell^{-1}}$	$\frac{10^3 k_{\text{obs}}^{\text{c}}}{\text{s}^{-1}}$	$\frac{10^3 k_{\text{calc}}^{\text{d}}}{\text{s}^{-1}}$
0.025	0.013	7.9	8.0
0.050	0.025	12	12
0.10	0.050	21	21
0.20	0.10	35	38
0.025	0.050	4.1	4.0
0.10	0.20	3.8	4.0
0.20	0.40	4.0	4.0
0.005	0	6.3	5.7
0.010	0	7.6	7.4
0.050	0	24	21
0.10	0	40	38
0.050 ^b	0	24	
0.10 ^b	0	43	

a. $[\text{Hexamine}]_{\text{free}} = [\text{Hexamine}]_{\text{stoich}} - [\text{HCl}]_{\text{stoich}}$.

b. Solvent is deuterium oxide; $k_{\text{H}_2\text{O}}/k_{\text{D}_2\text{O}} = 1.0 \pm 0.1$.

c. Measured spectrophotometrically by formation of picrate at 400 nm.

d. Calculated from $k_{\text{obs}} = k_{\text{w}} + k_{\text{Hex}}[\text{Hexamethylenetetramine}]$
with $k_{\text{w}} = 4.0 \times 10^{-3} \text{ s}^{-1}$ and $k_{\text{Hex}} = 0.34 \text{ } \ell \text{ mol}^{-1} \text{ s}^{-1}$.

Figure 3.9.3

Reaction of picryl acetate (4×10^{-5})
with hexamethylenetetramine in
water at 25 C

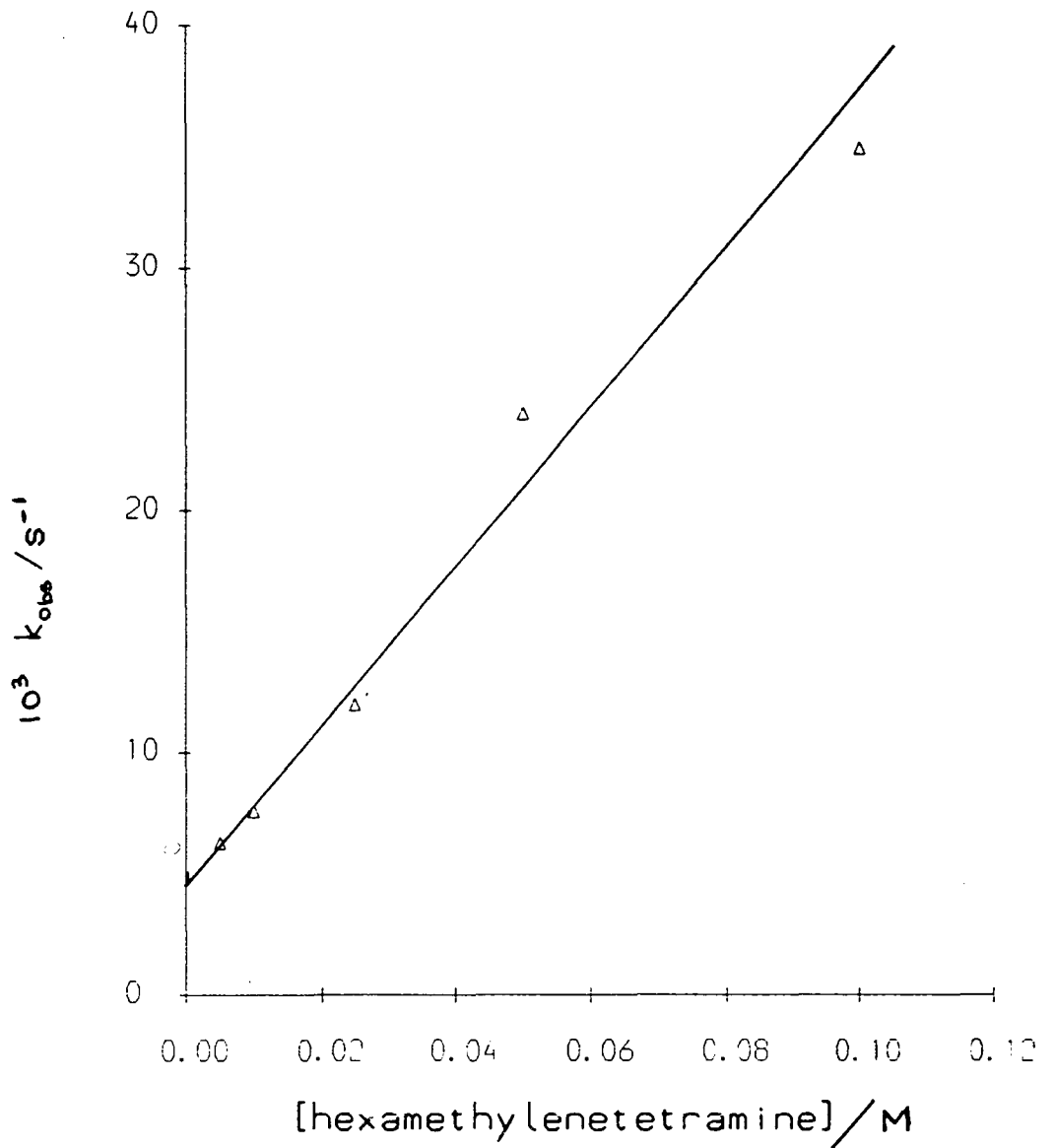

With general base catalysis the attack of a water molecule on the carbonyl group is assisted by partial bond formation to the base, therefore solvent isotope effects are useful in differentiating between general base and nucleophile catalysis. With general base catalysis k_H / k_D is usually >2 .⁹⁵ General base catalysis may therefore be ruled out since the solvent isotope effect (Table 3.9.8) of 1.0 ± 0.1 is lower than that required by this mechanism. Hence the reaction is likely to involve formation of an N-acetylhexaminium ion (5.3) (Scheme 5)

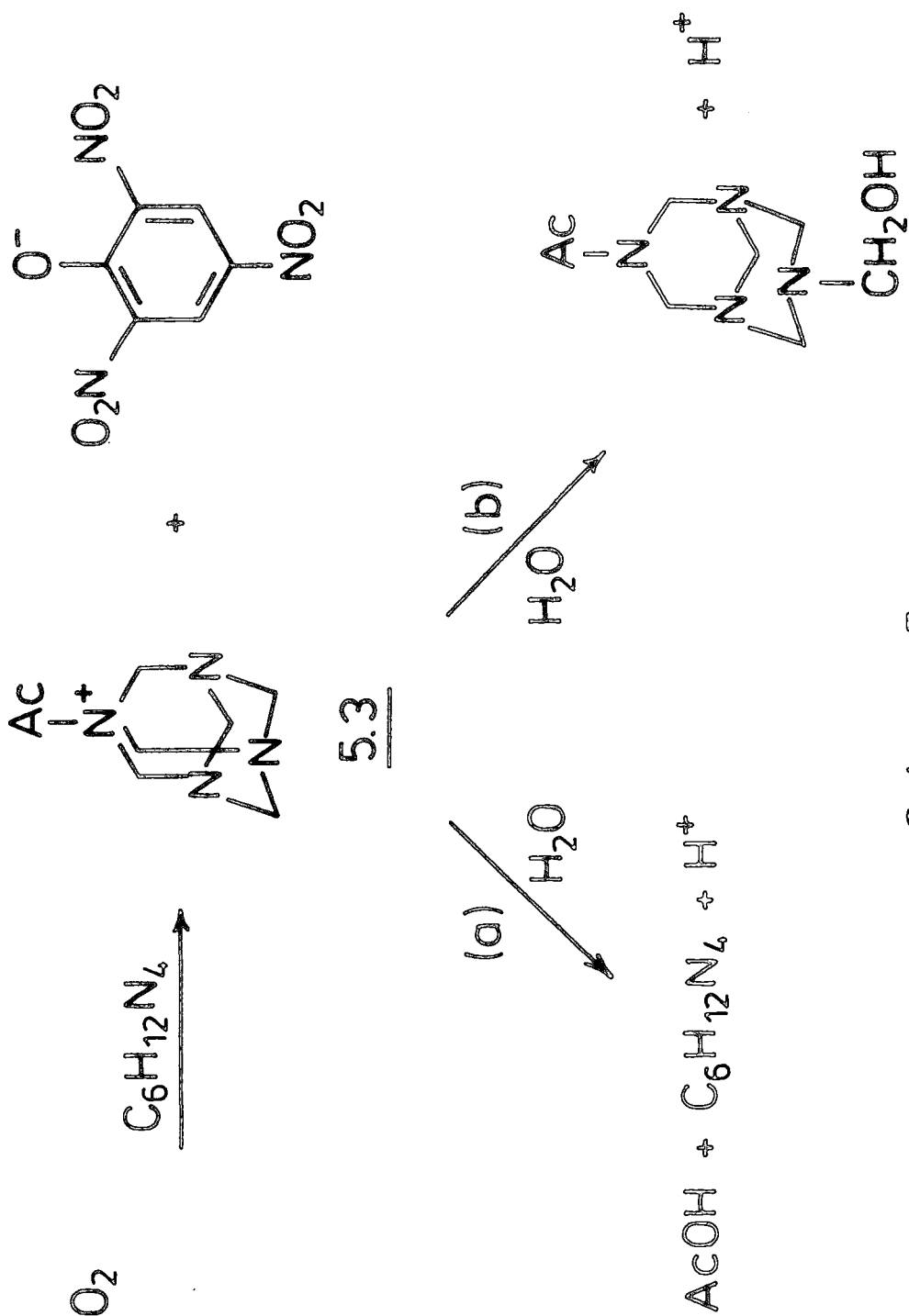
Scheme 5

The kinetic results do not allow us to determine the fate of the intermediate (5.3), since the first order rate coefficients obtained (k_{obs}) were for the first stage of the reaction i.e. the formation of picrate.

Possible fates of (5.3) are regeneration of hexamethylenetetramine [path (a) in Scheme 5], to give an example of nucleophilic catalyses.⁹⁴ Or cleavage of an $\overset{\oplus}{N}-CH_2$ bond [path (b)], resulting in decomposition, as in normal aminal cleavage.³⁶

The 1H n.m.r. spectrum of a 1:1 mixture of hexamethylenetetramine and picryl acetate in d_6 -DMSO gave bands at δ 1.90 (acetyl), δ 4.20 - δ 5.0, and δ 8.6 (picrate C-H), (Figure 3.9.4). This spectrum may contain bands due to N-acetylhexaminium ion (5.3), however it is not certain whether or not C-N bond cleavage has occurred.

On addition of D_2O the spectrum was seen to change (Figure 3.9.5). It is possible that one of the bands is due to protonated hexamethylenetetramine which usually gives a band at δ 5.0 in aqueous solution. The singlet at δ 4.05 is assigned to -OH protons (due to H_2O impurity in D_2O). It is difficult to assign the other bands around δ 4.3 - δ 5.0 since the amount of C-N bond cleavage is uncertain.

In agreement with the very weakly basic nature found for DAPT (3.2), it was found that no acceleration of picrate formation from picryl acetate was observed in solutions containing concentrations up to 0.4 M DAPT at $25^\circ C$ (Table 3.9.9).

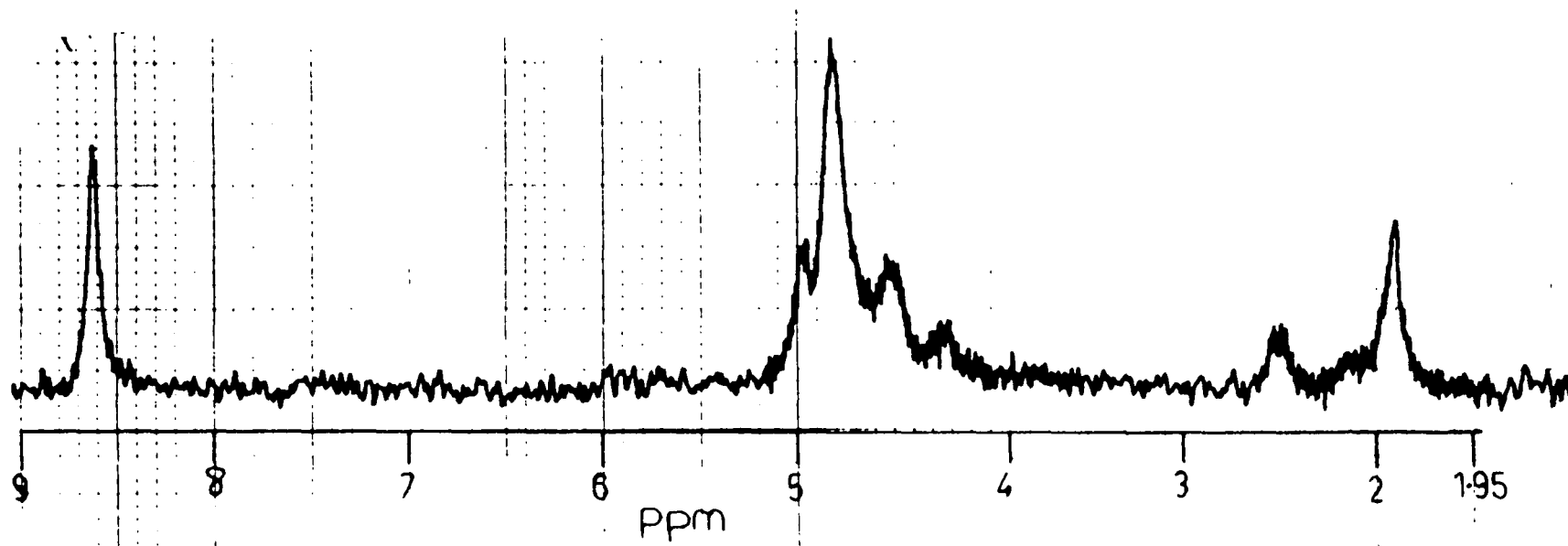

Fig. 3.9.4

^1H n.m.r. of 1:1 mixture of hexamethylenetetramine and picryl acetate in d_6 -DMSO

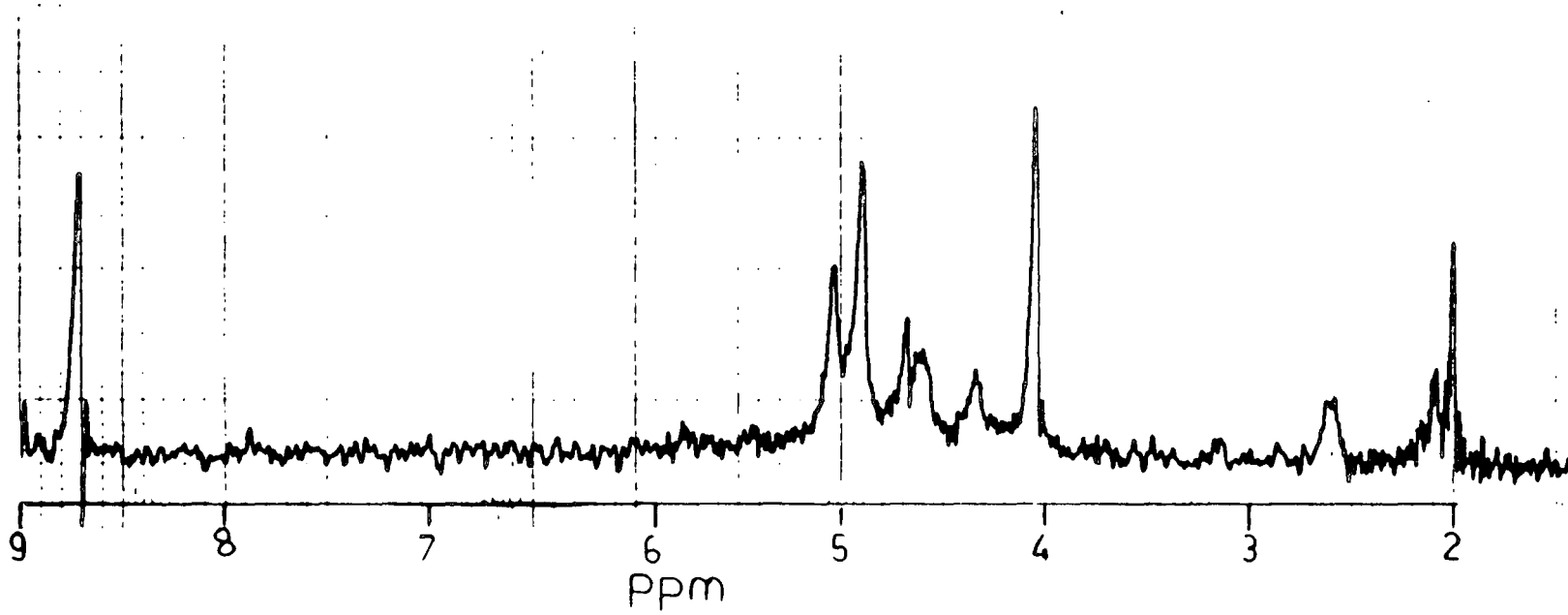

Fig. 3.9.5

Addition of D_2O to 1:1 mixture of hexamethylenetetramine and picryl acetate

Table 3.9.9

Rate data for reaction of DAPT with picryl acetate

(4×10^{-5} M) in water at 25°C.

[DAPT]/M	$10^3 k_{\text{obs}}/\text{s}^{-1}$
0	3.0
0.05	2.8
0.10	3.1
0.20	2.9
0.40	2.8

CHAPTER 4

A Study of the Acetolysis of
Hexamethylenetetramine
using N.m.r. Spectroscopy

4.1. Introduction

The acetolysis of hexamethylenetetramine (1.1) using acetic anhydride, has been studied since the 1930's,^{46,47,96,97}. The yield of DAPT (3.2) varies greatly depending on whether the reaction is carried out under anhydrous⁴⁷ conditions or in the presence of water.⁴⁶ As mentioned previously TRAT (3.3) is also formed in a yield depending on the conditions employed.^{69,98}

Wang Shaofang and Chen Ju⁹⁹ studied the acetolysis reaction under aqueous conditions using ¹H n.m.r.. They concluded that the formaldehyde formed in the reaction inhibits the change of the unreacted hexamethylenetetramine to DAPT (in the presence of added formaldehyde less the DAPT and more TRAT was produced). They also showed that under anhydrous conditions, in the presence of added ammonium acetate, the yields of DAPT increased and TRAT decreased. They concluded that under anhydrous conditions hexamethylenetetramine reacts with acetic anhydride to form an intermediate which reacts with ammonium acetate to produce DAPT (3.2) and hexamethylenetetramine (i.e. hexamethylenetetramine being reformed).

It was also suggested that under aqueous conditions, the ammonium acetate reacts with the liberated formaldehyde to form hexamethylenetetramine, removing the inhibiting effect of the formaldehyde thereby increasing the yield of DAPT.

In this Chapter the reaction of hexamethylenetetramine (1.1) with acetic anhydride under

anhydrous conditions in the absence of ammonium acetate is investigated, to determine why these conditions give such a low yield of DAPT (3.2). Results are also given for the aqueous reaction.

Results from initial studies on the product of the reaction of hexamethylenetetramine with acetyl chloride are also shown.

4.2 Experimental

The hexamethylenetetramine used was a commercial sample used as supplied. The acetic anhydride and acetyl chloride were distilled before use.

The glacial acetic acid used was analytical grade, dried before use with molecular sieve. Deuteriochloroform of 99.8% purity was obtained as a commercial sample and used as supplied. N.m.r. spectra were recorded using a Varian EM 360L (60 MHz) instrument. The proton chemical shifts were made with reference to either TMS, DSS or the acetyl band of acetic acid ($\delta 2.1$).

4.3 Results and Discussion

4.3.1 Reaction of Hexamethylenetetramine with Acetic Anhydride in Acetic Acid

When hexamethylenetetramine was dissolved in anhydrous glacial acetic acid a band was observed at $\delta 4.9$ which was attributed to partially protonated hexamethylenetetramine (Figure 4.1). No change in this spectrum was observed after several days.

A 1:1 mixture of hexamethylenetetramine and acetic anhydride in acetic acid under anhydrous conditions produced a mixture of products. After 5 minutes several bands were observed. The main bands observed were at $\delta 4.9$ (hexamethylenetetramine), a singlet at $\delta 5.2$, a singlet at $\delta 4.6$ and also small bands at positions expected for DAPT (3.2) (Figure 4.2). The main change with time appeared to be a slow decrease in intensity of the hexamethylenetetramine band and an increase in size of bands at $\delta 5.2$ and $\delta 4.6$ (Figure 4.3). It is possible that the band at $\delta 5.2$ is due to a species such as $\text{H}_2\text{NCH}_2\text{OAc}$ since the $-\text{CH}_2\text{OAc}$ methylene protons in the DAPT derivative (3.6) appear at this position.⁵¹

However, the relative size of this peak indicates that the ring system is no longer intact. It appears that under these conditions the main reaction is decomposition of hexamethylenetetramine to a species such as $\text{H}_2\text{NCH}_2\text{OAc}$, the formation of DAPT (3.2) being very slight. Increasing the concentration of acetic anhydride to a 1:2 ratio resulted in an increase in the reaction rate. Bands were observed

Fig. 4.1

^1H n.m.r. spectrum of hexamethylenetetramine in glacial acetic acid

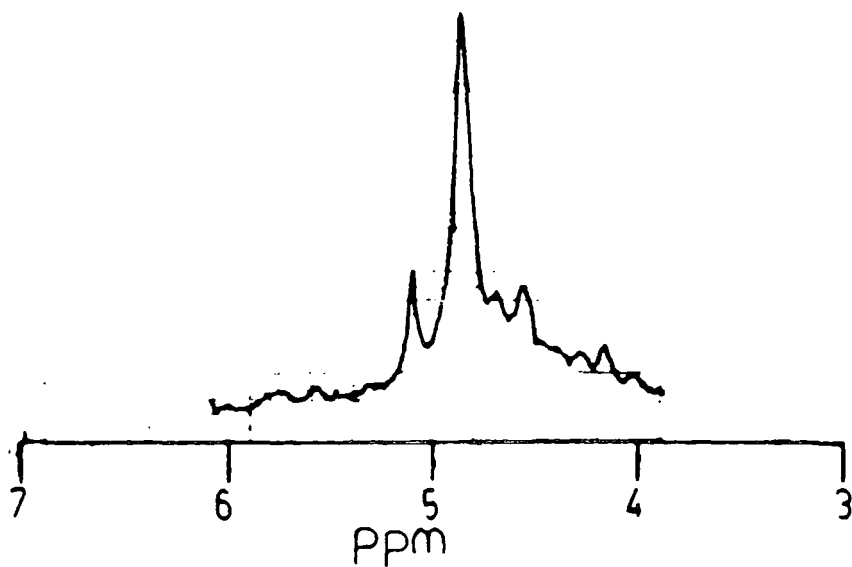
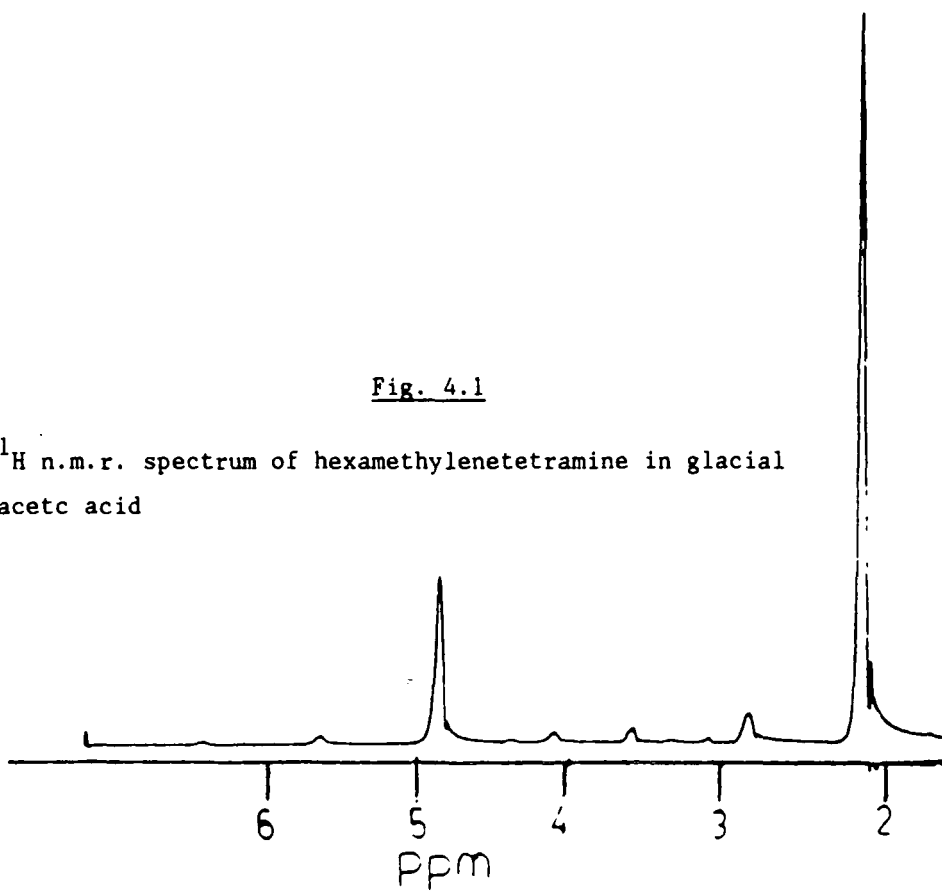

Fig. 4.2

1:1 mixture of hexamethylenetetramine and acetic anhydride in glacial acetic acid

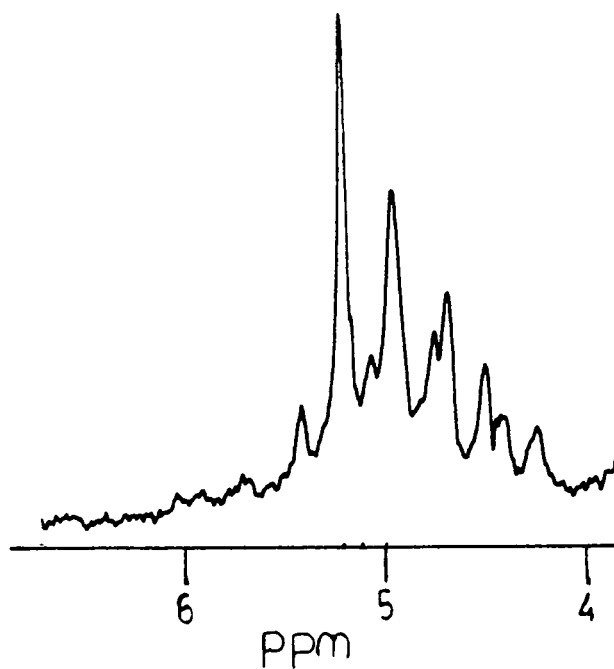

Fig.4.3

1:1 mixture of hexamethylenetetramine and acetic anhydride
in glacial acetic acid after 2 hours

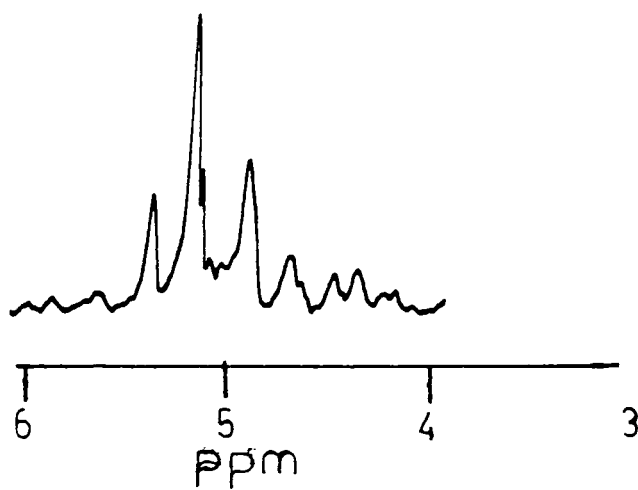

Fig. 4.4

2:1 ratio of acetic anhydride to hexamethylenetetramine

as before, however an additional band was seen at $\delta 5.4$ which may be attributed to TRAT (3.3) (Figure 4.4). With excess acetic anhydride the bands due to TRAT and also the band at $\delta 5.2$ appeared to be more intense. Also even with acetic anhydride in a large excess, the yield of DAPT still remained low. These results agree with previous suggestions that the yield of DAPT is promoted by the presence of water.

Also it appears that under these conditions the formaldehyde is split out in the form of a species such as H_2NCH_2OAc and not in the form of methylene diacetate $CH_2(OAc)_2$ as in the conversion of DAPT to TAT (3.4).⁵¹ The $CH_2(OAc)_2$ band appearing further downfield at approximately $\delta 5.7$.⁵¹

The 1H n.m.r. spectrum of hexamethylenetetramine in aqueous acetic acid was similar to that in glacial acetic acid, the methylene protons appearing at $\delta 4.9$. No apparent decomposition occurred over 30 minutes.

The 1H n.m.r. spectrum of the reaction of hexamethylenetetramine with excess acetic anhydride in aqueous acetic acid, showed the gradual increase in size of bands due to DAPT (3.2), TRAT and formaldehyde ($\delta 4.85$) (Figure 4.5). The bands at $\delta 4.6$ and $\delta 5.2$ which were seen under anhydrous conditions did not appear in the presence of water. It is noticeable that under anhydrous conditions the band at $\delta 5.2$ appears to be the most prominent, the band due to TRAT at $\delta 5.4$ being smaller. However under aqueous conditions the band at $\delta 5.2$ is absent.

Thus the results suggest that the ideal condition for

the production of DAPT would be to have both water and ammonium acetate present. The water producing the formaldehyde and the ammonium acetate removing it to reform hexamethylenetetramine.

4.3.2 Reaction of Hexamethylenetetramine with Acetic Anhydride in Chloroform

In deuteriochloroform the hexamethylenetetramine band appeared at $\delta 4.7$, the band due to the acetyl protons of acetic anhydride appearing at $\delta 2.2$ (Figure 4.6).

The ^1H n.m.r spectrum of a 2:1 mixture of acetic anhydride and hexamethylenetetramine is shown in (Figure 4.7). Two acetyl bands were observed at $\delta 2.2$ and $\delta 2.0$. The band at $\delta 2.2$ could either be due to unreacted acetic anhydride or an N-acetyl species (i.e. the N-acetyl protons of DAPT). The band at $\delta 2.0$ may be due to an N- CH_2OAc species, however no bands were observed around $\delta 5.2$ (the band at $\delta 5.2$ is glacial acetic acid was attributed to a species such as $\text{H}_2\text{N}-\text{CH}_2\text{OAc}$).

As can be seen in the spectrum, bands are present in the positions expected for DAPT, however the bands around $\delta 5.0$ do not appear to be very intense. The band at $\delta 4.7$ may be due to unreacted hexamethylenetetramine which may be hiding other bands. The spectrum did not change over 3 hours. Increasing the concentration of acetic anhydride to a 4:1 ratio initially did not appear to change the spectrum. However, after 2 hours bands in the positions expected for DAPT (3.2) were seen to be large in comparison to the 2:1 ratio (Figure 4.8). No band of any

significant size appeared in the position expected for
TRAT (3.3).

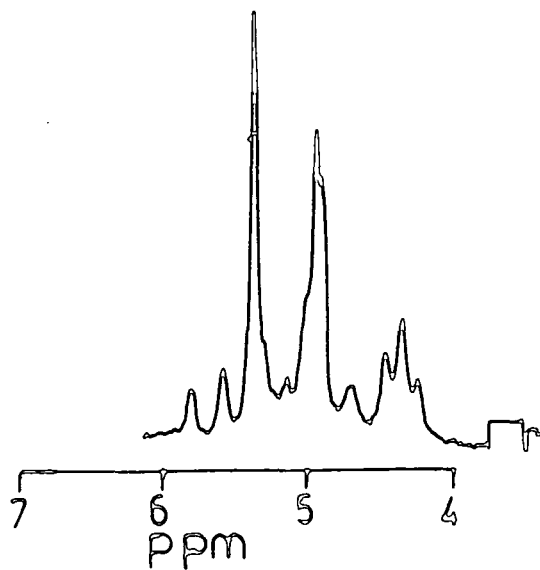

Fig. 4.5

Hexamethylenetetramine and excess acetic anhydride in aqueous
acetic acid

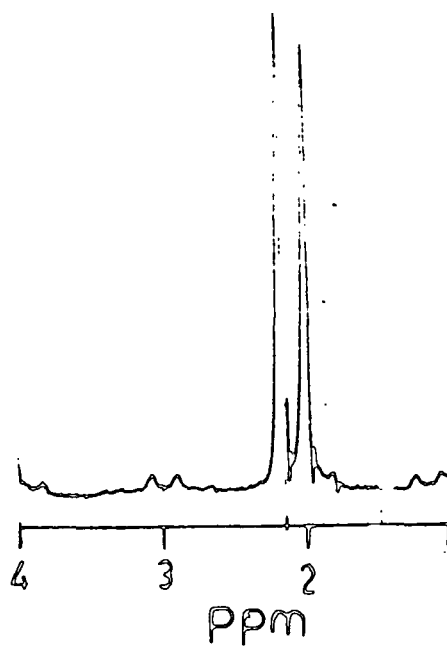

Fig. 4.6

Acetyl protons of acetic anhydride δ 2.2 in CDCl_3 reaction of
hexamethylenetetramine with acetic anhydride

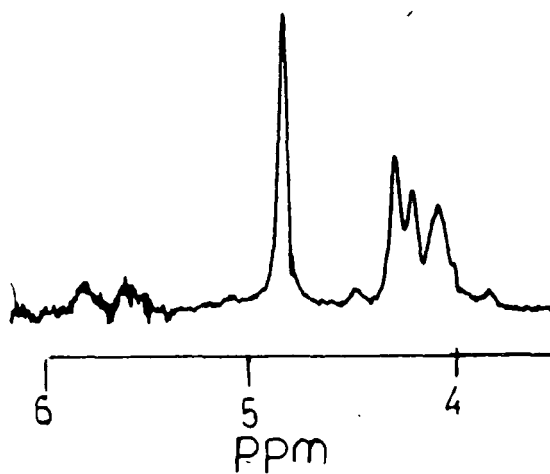

Fig. 4.7

2:1 mixture of acetic anhydride and hexamethylenetetramine in CDCl_3

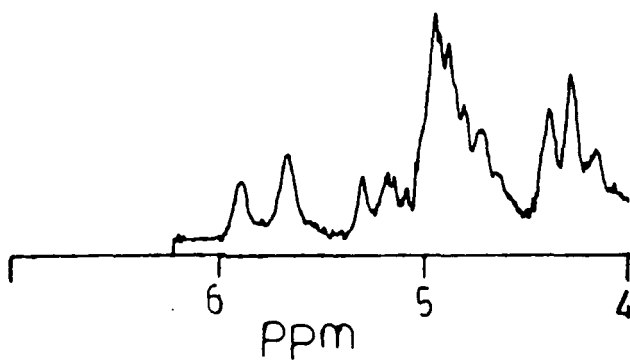

Fig. 4.8

2:1 mixture of acetic anhydride and hexamethylenetetramine after 2 hours

Thus these results suggest that the anhydrous reaction differs in the solvents glacial acetic acid and chloroform. In glacial acetic acid TRAT is formed in favour of DAPT, however in chloroform the yield of TRAT seems to be negligible.

4.3.3 Reaction of Hexamethylenetetramine with Acetyl chloride

As mentioned in Chapter 1 *N,N*-bis(chloromethyl)-carboxamides (1.6)

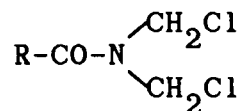

are accessible from hexamethylenetetramine by amination splitting with acid chlorides.^{30,31} However this reaction occurs at high temperature in a molar ratio of 6:1 acetyl chloride:hexamethylenetetramine. The product obtained with acetyl chloride $\text{CH}_3\text{CO-N}(\text{CH}_2\text{Cl})_2$ gives an n.m.r. spectrum in CD_3CN consisting of a band at $\delta 5.39$ ($\delta\text{CH}_2\text{Cl}$).

Also under less drastic conditions (room temperature) amination of the type $\text{R}_2\text{N-CH}_2\text{-NR}_2$ react with acyl halides to produce iminium salts $[\text{R}_2\text{N}=\text{CH}_2]^+\text{Hal}^-$. On this basis hexamethylenetetramine might be expected to undergo a similar reaction to produce a species of the type (5.4)

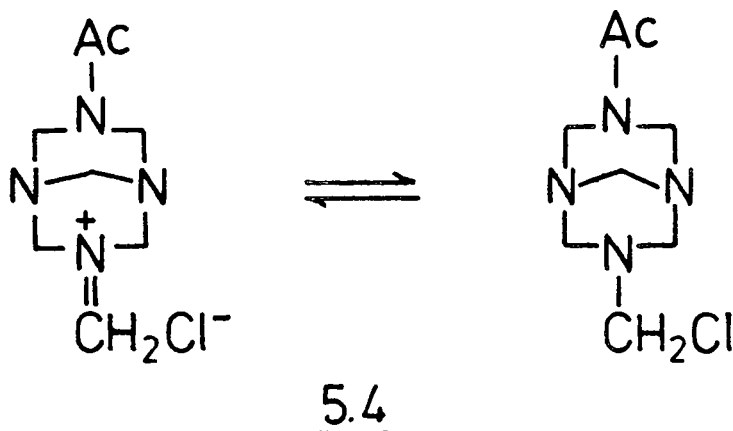

As mentioned in Chapter 1 quaternary salts of the type (1.2)

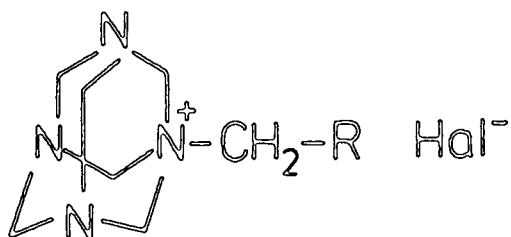

1.2

can be obtained from hexamethylenetetramine and suitable alkylating agents.^{1,2} The n.m.r. spectra of salts of the type (1.2) have been studied.¹⁰⁰ The n.m.r. spectrum of the salt (1.2), R= PhCHMe) in DMSO-d₆ gives an AB quartet (H_A, H_B at δ5.23, δ5.02, J_{AB} 12 Hz) for the six ring methylene protons adjacent to the positively charged nitrogen. The other six appear as a sharp singlet at δ4.53 apparently due to a cancellation of effects (the field effect of the positive pole and the benzene-ring anisotropy). Conversely, in the spectrum of the salt (1.2, R = CH₃) in DMSO-d₆ the lower field ring methylene protons appeared as a singlet at δ5.25 and these at higher field as an AB quartet (H_A, H_B at δ4.71, δ4.55, J_{AB} 12 Hz). ¹H n.m.r. data for several other mono and diquaternary salts of hexamethylenetetramine are available.^{101,82}

Reaction of hexamethylenetetramine and acetyl chloride in a 1:1 ratio in dry chloroform at room temperature resulted in the immediate precipitation of a white solid which was unstable in air. The mass spectrum (see Chapter 2) indicated the presence of either the N-acetyl hexaminium ion (5.3) or a species such as (5.4). i.e. it is unsure whether or not $\overset{\oplus}{N}$ -CH₂ bond cleavage has

occured.

Dissolving the white solid in DMSO- d_6 gave an n.m.r. spectrum consisting of broadened bands at $\delta 5.0$, $\delta 4.7$ and an acetyl band at $\delta 2.30$ (Figure 4.9.1). This spectrum is more compatible with a species such as (5.3) rather than (5.4), since the spectrum of (5.4) might be expected to be more complex.

On addition of a small amount of D_2O the spectrum was seen to change. Bands were seen at $\delta 5.15$, $\delta 4.9$, $\delta 4.6$ and $\delta 4.4$ (Figure 4.9.2). Changes also occurred at the acetyl position which suggested inequivalence of acetyl bands. This can be interpreted in 2 ways. Either

1. the quaternary salt reacts with D_2O to produce protonated hexamethylenetetramine and acetic acid i.e. simple hydrolysis of the $\overset{\oplus}{N}$ -Ac bond, or
2. $\overset{\oplus}{N}$ - CH_2 bond cleavage occurs. At this stage it is not entirely certain which process occurs.

The n.m.r. spectrum of the acetyl salt dissolved in D_2O (Figure 4.9.3) showed bands at positions expected for protonated hexamethylenetetramine and acetic acid as well as two other acetyl bands. This suggested that hydrolysis had occurred to reform hexamethylenetetramine however some ring cleavage must also have occurred.

Adding acetyl chloride to a solution of hexamethylenetetramine in glacial acetic acid produced a white precipitate which dissolved on shaking. The n.m.r. spectrum (Figure 4.9.4) initially consists of a sharp band at $\delta 5.2$, a small broad band at $\delta 5.4$ and a broad band centred around $\delta 4.7$. With time the broad bands were seen to decrease at the expense of the sharp band at $\delta 5.2$

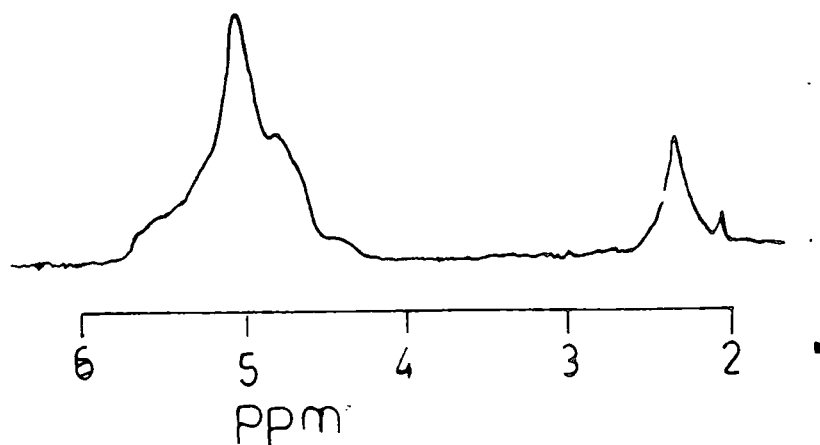

Fig. 4.9.1

^1H n.m.r. spectrum of acetyl salt of hexamethylenetetramine in DMSO-d_6

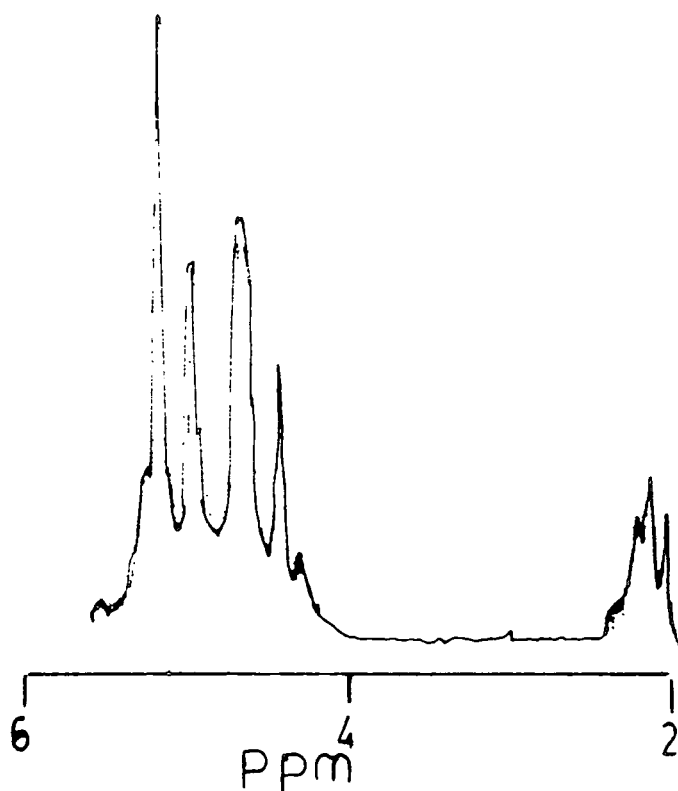

Fig. 4.9.2

Addition of D_2O to DMSO-d_6 solution of acetyl salt.

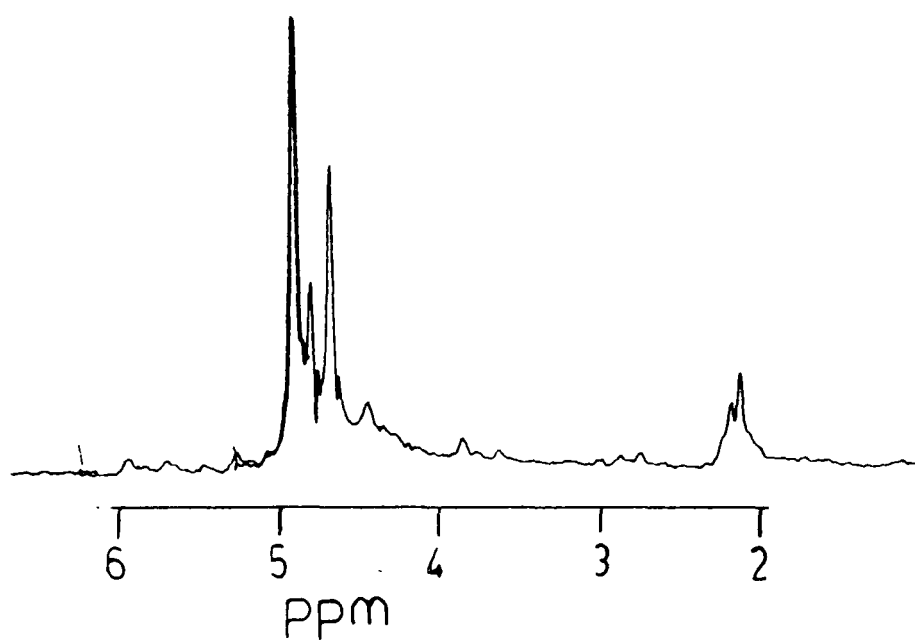

Fig. 4.9.3

Acetyl salt of hexamethylenetetramine in D_2O

(Figure 4.9.5). It is possible that initially the quaternary salt is formed which then converts to the species at $\delta 5.2$ which may be due to a species containing an $N\text{-CH}_2\text{OAc}$ group.

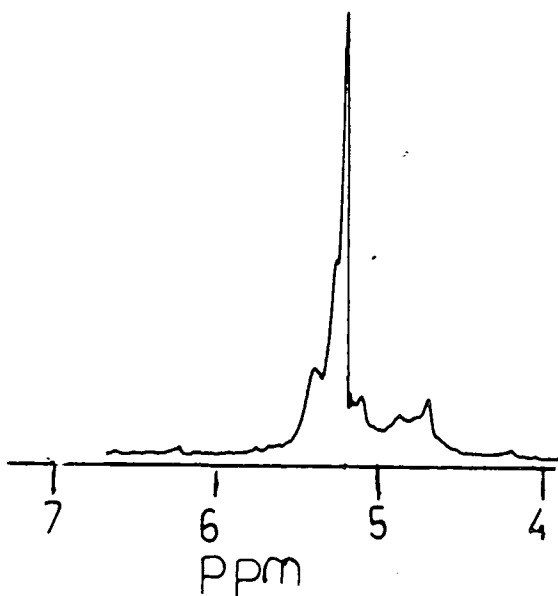

Fig. 4.9.4

Addition of acetyl chloride to solution of hexamethylenetetramine
in glacial acetic acid

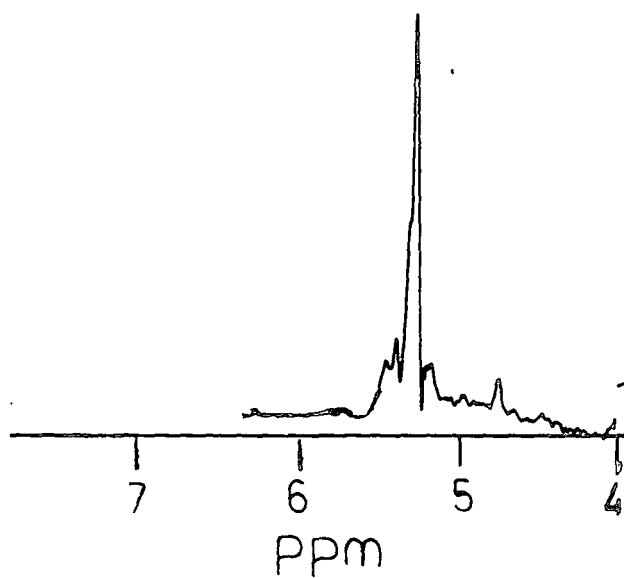

Fig. 4.9.5

Product of reaction of hexamethylenetetramine and acetyl chloride in glacial acetic acid after 20 mins.

CHAPTER 5

NITROGEN-15 STUDIES OF THE MECHANISMS
OF ACETOLYSIS OF
HEXAMETHYLENETETRAMINE AND DAPT

5.1 Introduction

Bachmann and co-workers^{10,102,103} showed that the nitrolysis of hexamethylenetetramine (1.1) with ammonium nitrate, nitric acid and acetic anhydride produced mixtures of the powerful explosives HMX (4.2), and RDX (3.9).

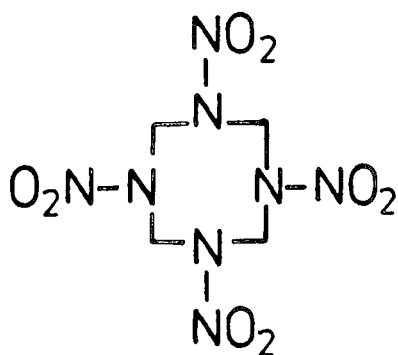

4.2

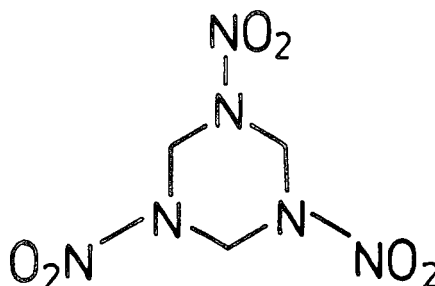

3.9

Mechanisms postulated^{10,52,102,103,104} for these reactions include the selective cleavage of hexamethylenetetramine, or the total cleavage to simple molecules followed by nitration and recombination. Evidence for the latter pathway has been adduced from studies using ¹⁴C and ¹⁵N isotopes as tracers.^{105,106} The ¹⁴C work showed that nitration to give HMX and RDX involved complete non-selective degradation of hexamethylenetetramine (1.1) to fragments containing chemically equivalent methylene groups, and that methylene groups derived from paraformaldehyde could enter into a common pool with those from (1.1) for the formation of the final products. However it was found that isotopic carbon exchange between unreacted hexamethylenetetramine and paraformaldehyde did not occur during nitration.¹⁰⁵ The use of ¹⁵NH₄NO₃ established the possibility of exchange of the amino nitrogens with hexamethylenetetramine during nitration.^{102,106} The tracer studies also showed that the

formation of HMX (4.2) from DPT (4.3), involved extensive decomposition rather than the simple cleavage of the methylene bridge.

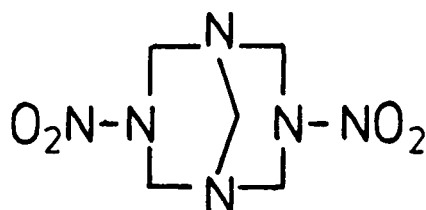

4.3

Recently methods for the preparation of HMX from hexamethylenetetramine have been reported⁴⁹ involving acetylation followed by nitrolysis. Hence there is current interest in acetolysis reactions. Following initial reports^{47,52,97} that reaction of hexamethylenetetramine with acetic anhydride produced DAPT (3.2), efficient methods for the synthesis of DAPT and TRAT (3.3) have been found. As mentioned in Chapter 1 DAPT is formed⁴⁶ in high yield when the reaction is carried out at 0-10⁰C in the presence of water and with the addition of either sodium hydroxide or ammonium acetate. The production of TRAT is favoured⁶⁹ by high temperature and anhydrous conditions. Acetylation of DAPT produces TAT (3.4).⁴⁹

In this Chapter studies of the mechanisms of acetolysis using ¹⁵N compounds are reported. The experiments were designed to assess the extent of ring-cleavage occurring during acetolysis reactions. The general strategy was to prepare starting materials containing ca. 100% ¹⁵N and to carry out synthetic reactions on mixtures of pure ¹⁵N and ¹⁴N compounds. The destination of the isotopes in the isolated products was determined mass-spectrometrically.

5.2 Experimental

Gaseous $^{15}\text{NH}_3$ was obtained from Amersham International (isotopic abundance 98%).

^{15}N -hexamethylenetetramine: 1 litre of gaseous $^{15}\text{NH}_3$ was reacted with excess aqueous formaldehyde solution at room temperature. To ensure complete mixing, a break-seal was fitted to the $^{15}\text{NH}_3$ container and the $^{15}\text{NH}_3$ transferred over to the formaldehyde under vacuum. The ^{15}N -hexamethylenetetramine produced was concentrated under reduced pressure.¹⁰⁷ Excess formaldehyde was converted to para-formaldehyde and removed by filtration, leaving a solution of hexamethylenetetramine which was evaporated under reduced pressure. The 2% abundance of $^{14}\text{NH}_3$ leads to the formation of a product with isotopic composition of ca. 92% [$^{15}\text{N}_4$]-hexamethylenetetramine and 8% [$^{15}\text{N}_3$][$^{14}\text{N}_1$]-hexamethylenetetramine.

^{15}N -DAPT: Reaction of the above product with acetic anhydride in the presence of aqueous sodium hydroxide at 0-10°C (using the same conditions precisely as used by Siele, Warman and Gilbert⁴⁶) produced ^{15}N -DAPT. The n.m.r. spectrum in CDCl_3 was similar to that reported previously.⁴⁶

Mass spectrometric measurements were made with 7070E instrument from V.G. Analytical Ltd. Measurements were made using two methods of ionization, Electron Impact and Chemical Ionization. In Electron Impact the molecular ion was monitored (mass M); measurements here were made with sufficiently low pressure of sample to avoid

self-protonation. Chemical ionization using iso-butane as reagent gas gave rise to the protonated species $(M + 1)^+$. When this technique was used results are quoted in terms of the parent species whose mass, M , is one unit smaller than that observed.

Preparative Experiments using Mixtures of 'Pure' ^{14}N and ^{15}N

Starting Materials

Seven separate experiments were performed using mixtures of starting materials containing nitrogen isotopes in natural abundance (designated ^{14}N material) with material derived from 98% $^{15}\text{NH}_4$ (designated ^{15}N material). The products, which had in all cases physical properties in good agreement with published data, were monitored by mass spectrometry.

The raw data were corrected for $(M + 1)$ and $(M + 2)$ contributions arising from ^{13}C and ^{15}N in natural abundance¹⁰⁸ (using tables of isotopic abundance ratios). Specimen results are given in Table 5.1.

Table 5.1

Specimen results. ^{14}N - ^{15}N hexamethylenetetramine recovered from experiment (e)

Peak	Observed Experimental Abundance	$-(M-1)^a$	$-(M+1)^b$ and $-(M+2)$	Normalized to $M = 100\%$
M-1	37.8	37.8	-	
M	100	94.84	91.74	100
M+1	17.7	13.65	6.02	6.56
M+2	13.8	10.72	9.97	10.87
M+3	32.4	8.15	7.39	8.06
M+4	65.8	64.16	64.10	69.9
M+5	4.34	4.34	0.04	0.044

a. after subtraction of (M-1) contribution of each peak due to incomplete protonation during chemical Ionization.

b. after subtraction of (M+1) and (M+2) contribution of each peak. For $^{14}\text{N}_4$ (M+1) = 8.2%

$^{15}\text{N}_4$ (M+1) = 6.68%

(M+2) = 0.3%

In some of the experiments it was also necessary to correct for an (M-1) peak due to incomplete protonation. The data reported gave the relative abundances of ^{14}N and ^{15}N in the products. Values given are accurate to ± 5 units.

- a) DAPT from ^{14}N -hexamethylenetetramine and ^{15}N -hexamethylenetetramine in acetic anhydride and water

To a mixture of ^{14}N -hexamethylenetetramine (0.5 g) and ^{15}N -hexamethylenetetramine (0.42 g) [overall atomic ratio $^{14}\text{N}:^{15}\text{N} = 100:78$] with water (0.5 g) was slowly added acetic anhydride (2 g) with stirring and cooling to 0-10°C. The mixture was stirred at 0-10°C for 30 minutes and then evaporated. The crude DAPT which separated was recrystallised twice from acetone.

- b) DAPT from ^{14}N -hexamethylenetetramine and ^{15}N -hexamethylenetetramine with acetic anhydride and aqueous sodium hydroxide

The method given in reference 46 was applied to a mixture of ^{14}N -hexamethylenetetramine (0.5 g) and ^{15}N -hexamethylenetetramine (0.42 g) [overall atomic ratio $^{14}\text{N}:^{15}\text{N} = 100:78$].

- c) DAPT from ^{14}N -hexamethylenetetramine and ^{15}N -hexamethylenetetramine using acetic anhydride and ammonium acetate

To a mixture of ^{14}N -hexamethylenetetramine (0.5 g, 3.6 mmol), ^{15}N -hexamethylenetetramine (0.42 g, 2.9 mmol) and ^{14}N -ammonium acetate (0.22 g, 2.9 mmol) with water (0.5 g) was slowly added acetic anhydride (2 g) with stirring at 0-10°C. The mixture was stirred at 0-10°C for 30 minutes and evaporated to yield DAPT which was recrystallised twice from acetone [overall atomic ratio $^{14}\text{N}:^{15}\text{N} = 100:65$]

d) DAPT from ^{15}N -hexamethylenetetramine and
 ^{14}N -ammonium acetate using acetic anhydride

The method in (c) was applied to a mixture of ^{15}N -hexamethylenetetramine (0.42 g, 2.9 mmol) and ^{14}N -ammonium acetate (0.28 g, 3.6 mmol). [overall atomic ratio $^{14}\text{N}:^{15}\text{N} = 34:100$]

e) Hexamethylenetetramine recovered from reaction of ^{14}N -hexamethylenetetramine and ^{15}N -hexamethylenetetramine with acetic anhydride and water

To a mixture of ^{14}N -hexamethylenetetramine (0.5 g) and ^{15}N -hexamethylenetetramine (0.42 g) [overall atomic ratio $^{14}\text{N}:^{15}\text{N} = 100:78$] with water (0.5 g) was slowly added acetic anhydride (0.7 g) with stirring at 10°C . The solution was stirred at 10°C for 30 minutes and then evaporated. In this case insufficient acetic anhydride was present for complete reaction and hexamethylene was separated from the residue and purified by crystallisation from acetone, in which it is less soluble than in DAPT.

f) TAT from ^{14}N -DAPT and ^{15}N -DAPT

A mixture of ^{14}N -DAPT (0.5 g) containing nitrogen isotopes in natural abundance and ^{15}N -DAPT (0.5 g) [overall atomic ratio of $^{14}\text{N}:^{15}\text{N} = 100:93$] was heated with acetic anhydride for 3 hours at 110°C to yield TAT as described previously.⁴⁹

g) TRAT from ^{14}N -hexamethylenetetramine and ^{15}N -hexamethylenetetramine using acetic anhydride

^{14}N -hexamethylenetetramine (0.5 g) and ^{15}N -hexamethylenetetramine (0.42 g) [overall atomic ratio $^{14}\text{N}:^{15}\text{N} = 100:78$] were reacted with excess acetic anhydride at 98°C as described in the literature.⁶⁹

5.3 Results and Discussion

In Table 5.2 results are given for compounds prepared with nitrogen in natural abundance (^{14}N 99.63%, ^{15}N 0.38%). The peaks with masses M+1 and M+2 are due to naturally occurring ^{13}C and ^{15}N as mentioned previously. Data are also given for hexamethylenetetramine and DAPT prepared from $^{15}\text{NH}_3$. In all cases the intensities of the M+1 and M+2 peaks, relative to M = 100, are in satisfactory agreement with those calculated theoretically using known natural abundances.¹⁰⁸ This agreement provides good evidence that our analytical technique is sound.

Table 5.2

Mass Spectroscopic Data for Starting Materials

Compound	Observed Intensities			Theoretical		
	M	M+1	M+2	M	M+1	M+2
^{14}N -hexamethylenetetramine	100	11	0.5	100	8	0.3
^{14}N -DAPT	100	13	1.5	100	12	1.0
^{14}N -TRAT	100	13	1.8	100	11	1.2
^{14}N -TAT	100	16	2.3	100	16	1.7
^{15}N -hexamethylenetetramine	100	6.5	0.2	100	6.7	0.2
^{15}N -DAPT ^a	100	10.3	1.0	100	10.1	1.0

a. An M-1 peak, relative intensity 8, is observed corresponding to DAPT with isotope composition [$^{15}\text{N}_3$][$^{14}\text{N}_1$]

Results obtained from experiments using Mixtures of 'Pure'
 ^{14}N and ^{15}N

Formation of DAPT from Hexamethylenetetramine

DAPT was prepared from hexamethylenetetramine by reaction with acetic anhydride in the presence of water at 0-10°C using known methods.⁴⁶ The results in Table 5.3 for experiments a) - d) indicate that relatively little isotope mixing has occurred.

The most abundant species are those containing the isotopically pure [$^{15}\text{N}_4$] and [$^{14}\text{N}_4$] compositions. For complete isotopic scrambling the species containing mixtures of isotopes would be most abundant. The behaviour during acetolysis thus contrasts markedly with that found during nitrolysis when complete^{105,106} randomisation of isotopes was observed.

Table 5.3

Relative Isotope Composition of DAPT prepared in experiments a) - d)

Experiment	[¹⁴ N ₄]	[¹⁴ N ₃ , ¹⁵ N ₁]	[¹⁴ N ₂ , ¹⁵ N ₂]	[¹⁴ N ₁ , ¹⁵ N ₃]	[¹⁴ N ₄]
a)	100	47	15	41	68
b)	100	45	<5	43	78
Random ^a	100	320	380	194	37
c)	100	46	12	42	58
d)	11	9	4	26	100

a. This is the relative distribution of isotopes expected for a random distribution with the starting composition used in a) and in b)

Mechanisms proposed for the formation of DAPT (3.2) from hexamethylenetetramine include initial cleavage of formaldehyde⁴⁸ to produce (5.5) followed by acetylation (equation i) and⁹⁹ initial acetylation followed by extrusion of formaldehyde and further acetylation (equation ii). The isotope measurements do not distinguish between these mechanisms. However (ii) is favoured since it is known⁷⁶ that hexamethylenetetramine reacts very readily with acetylating agents and also that the decomposition of hexamethylenetetramine occurs very slowly in the presence of aqueous hydrochloric acid where (5.5) would be protonated and reversal to (1.1) unlikely. The latter suggests that concentrations of (5.5) are likely to be too low to account for the observed reaction.

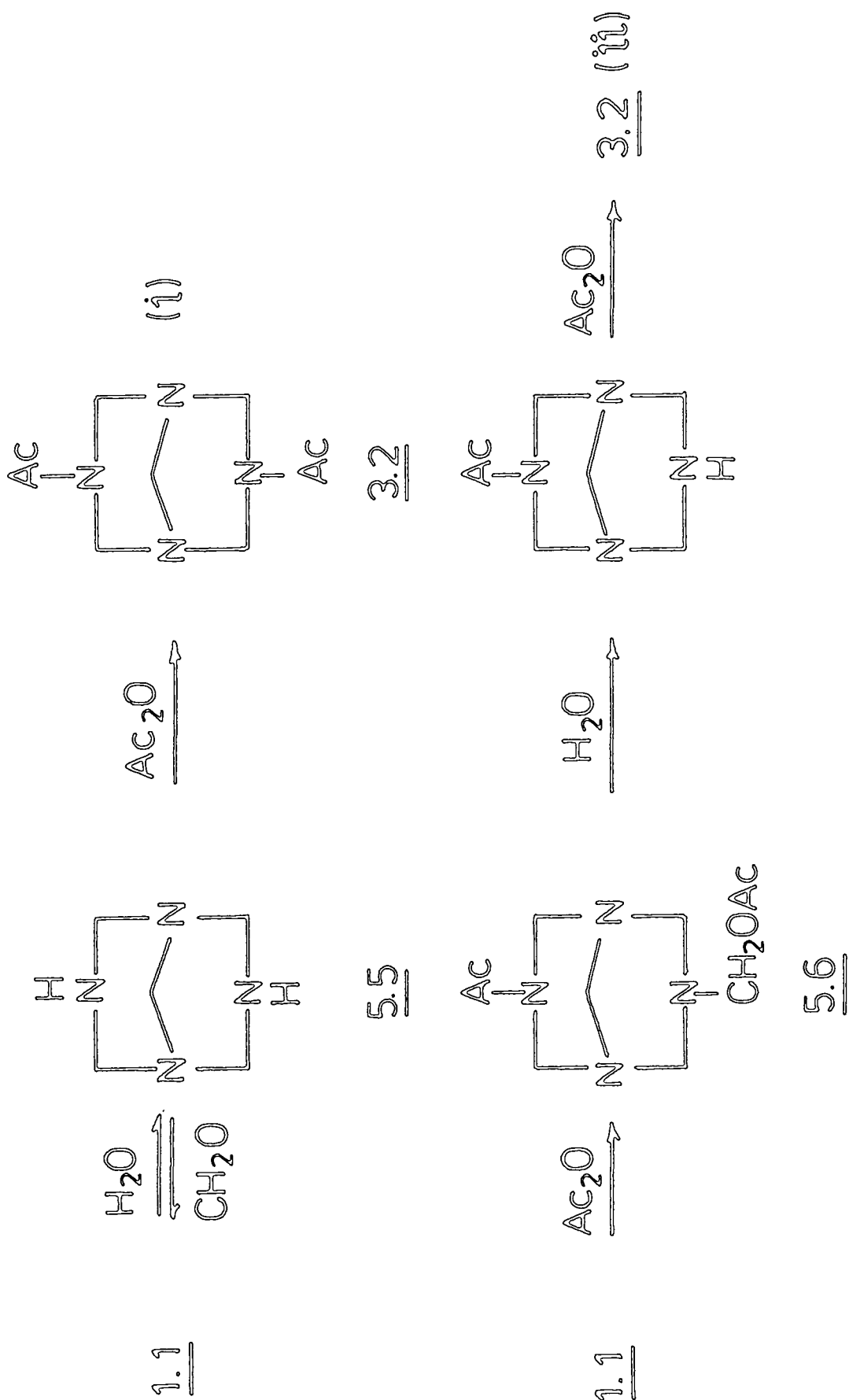

Nevertheless, our results indicate the formation of significant quantities of DAPT containing a 3:1 isotope ratio. The slightly higher ratio of $[^{14}\text{N}_1, ^{15}\text{N}_3]/[^{15}\text{N}_4]$ than of $[^{14}\text{N}_3, ^{15}\text{N}_1]/[^{14}\text{N}_4]$ can be attributed to the presence of the starting material of a little $[^{14}\text{N}_1, ^{15}\text{N}_3]$ -hexamethylene-tetramine (8% relative to $^{15}\text{N}_4$). The presence of the mixed products indicates that a certain amount of ring cleavage is occurring. Possibilities are i) exchange of nitrogen between hexamethylenetetramine molecules before acetylation or ii) exchange during acetylation, and these are considered in turn.

Bachmann and co-workers¹⁰² showed that in acetic acid at 65°C slow exchange occurred between ^{14}N -hexamethylenetetramine and ^{15}N -ammonium nitrate (ca. 15% exchange after 15 minutes). Under nitrolysis conditions exchange is rapid.¹⁰⁶ However, the conditions used in acetylation i.e. 0-10°C and low acidity are far less severe, and the observation experiment (e), that little isotopic scrambling occurred in hexamethylenetetramine recovered during the reaction indicates that it is unlikely that significant exchange is occurring between hexamethylenetetramine molecules.

Experiment (e) Hexamethylenetetramine recovered from reaction of ^{14}N -hexamethylenetetramine and ^{15}N -hexamethylenetetramine with acetic anhydride and water

The following relative isotopic abundances were obtained for the separated hexamethylenetetramine

$[^{14}\text{N}_4]$ 100; $[^{14}\text{N}_3, ^{15}\text{N}_5]$ 7; $[^{14}\text{N}_2, ^{15}\text{N}_2]$ 11; $[^{14}\text{N}_3, ^{15}\text{N}_1]$ 8;
 $[^{15}\text{N}_4]$ 70.

Hence it is concluded that it is likely that some exchange is occurring during acetolysis. This might involve the extrusion of ammonia. If this were the case then in experiment c) where the reaction mixture initially contains added ^{14}N -ammonium ions (which would be in rapid equilibrium with extruded ammonium) we would expect to observe a high ratio of $[^{14}\text{N}_1, ^{15}\text{N}_3]/[^{14}\text{N}_3, ^{15}\text{N}_1]$ products. This follows since the ammonia recombining to form the product would contain almost exclusively ^{14}N . The result in Table 5.3 negates this hypothesis. A possible mechanism for the partial isotopic scrambling observed might involve extrusion of a methyleneimine or a derivative. There is no direct evidence for such a mechanism, but that proposed in Scheme 6 would allow for the formation of some product containing a 3:1 isotopic ratio. Here cleavage of (5.6) by paths (A) or (B) will involve proton transfer from the solvent to nitrogen followed by, or synchronous with, N-C bond cleavage, or analogous reaction involving acetylation instead of protonation. Recombination of (5.7) with methyleneimine or derivative allows for the observed isotopic exchange.

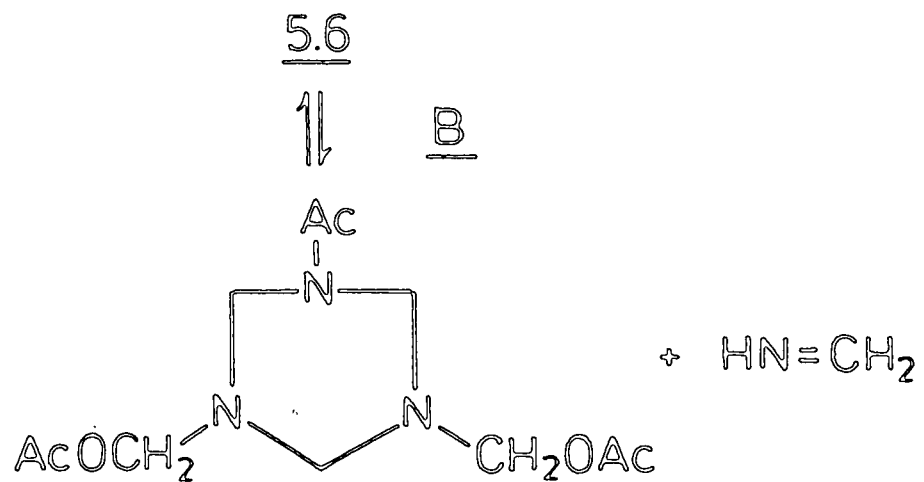
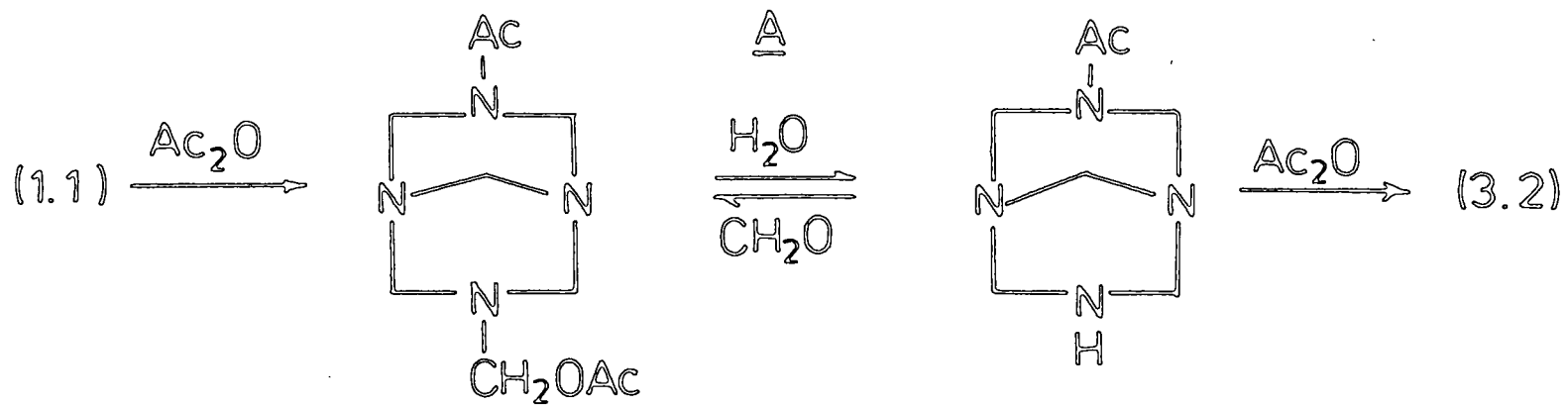

5.7

↓

Further cleavage

Scheme 6

Experimentally it was found⁴⁶ that addition of ammonium ions results in yields of DAPT greater than 100% based on hexamethylenetetramine, and it has been postulated that the liberated formaldehyde combines with the ammonia to reform hexamethylenetetramine.^{46,49} The result, in experiment (d), involving acetylation of ¹⁵N-hexamethylenetetramine in the presence of ¹⁴N-ammonium acetate is in accord with this hypothesis in that some [¹⁴N₄]-DAPT is produced. Further the formation, on a statistical basis, of a relatively large amount of the [¹⁴N₄]-DAPT indicated that equilibrium of (5.6) and (5.7) has reached a fairly advanced stage before extrusion of formaldehyde so that hexamethylenetetramine reformation occurs essentially subsequent to the initial [¹⁵N₄]-DAPT formation.

Formation of TAT from DAPT

The results from experiment (f) show that very little isotropically mixed product is formed during the acetolysis of DAPT to TAT indicating that selective cleavage of the methylene bridge occurs here, in accord with N.M.R. studies.⁵¹

Experiment (f) TAT from ¹⁴N-DAPT and ¹⁵N-DAPT

The relative isotopic abundances in the separated TAT were

[¹⁴N₄] 100; [¹⁴N₃, ¹⁵N] 11; [¹⁴N₂, ¹⁵N₂] 5; [¹⁴N₁, ¹⁵N₃] 5;
 [¹⁵N₄] 93.

Formation of TRAT from hexamethylenetetramine

TRAT was produced⁶⁹ by reaction of hexamethylene-

tetramine with excess acetic anhydride at 98-100°C. The isotopic distribution in the separated product, shown in Table 5.4, indicates that considerable scrambling has occurred, although there is not complete randomisation. It is possible that due to the much higher temperature used in this experiment exchange of nitrogen occurs in partially cleaved hexamethylenetetramine molecules before acetolysis. However this is probably less likely than exchange during acetolysis. Further cleavage of an intermediate such as (5.7) followed by recombination of molecules containing two nitrogen atoms with those containing one nitrogen atom would account for the observed isotopic distribution.

Table 5.4

Relative Isotopic composition of TRAT Prepared from
 ^{14}N -Hexamethylenetetramine and ^{15}N -hexamethylenetetramine

	$[^{14}\text{N}_3]$	$[^{14}\text{N}_2, ^{15}\text{N}_1]$	$[^{14}\text{N}_1, ^{15}\text{N}_2]$	$[^{15}\text{N}_3]$
Experimental	100	125	84	63
Calculated for Random distribution	100	237	185	47

The conclusion drawn from the experiments and related work^{46,69,99} is that formation of DAPT from hexamethylenetetramine is favoured by mild conditions and involved little ring cleavage. The results in this chapter also indicate that under more extreme conditions, extensive ring-cleavage occurs promoting formation of TRAT. It is also noteworthy that in , in agreement with Scheme 6, the formation of DAPT is favoured by the presence of water (see Chapter 4). ¹H N.m.r. measurements showing that in glacial acetic acid in the absence of water the formation of TRAT is favoured.¹⁰⁹

It is likely that the acidity of the reaction medium is a major factor in determining whether or not scrambling or selective cleavage occurs. Results given in Chapter 3,⁷⁶ showed that in strong acid hexamethylenetetramine decomposes relatively rapidly via a diprotonated species. Thus it is likely that in the nitration reaction, decomposition occurs prior to nitration. However, in the case of DAPT (3.2) formation the reaction medium is much less acidic so that decomposition prior to acetylation is not likely.

It was also found that DAPT (3.2) is much less basic than hexamethylenetetramine.⁷⁶ Thus in TAT (3.4) formation, there will be no decomposition prior to acetylation. Also the presence of the acetyl groups in DAPT promote selective cleavage during acetylation thereby virtually eliminating scrambling,^{66,67} hence the results in experiment (f).

It is uncertain at this moment whether the observed scrambling in TRAT (3.3) formation is solely due to the

high temperature of reaction. ^1H n.m.r. observations in Chapter 4 suggested that extensive ring cleavage may even be occurring at room temperature under anhydrous conditions.

CHAPTER 6

THE ACID-BASE BEHAVIOUR OF

3,7-dinitro-1,3,5,7-tetra-azabicyclo[3.3.1]nonane

(DPT)

6.1 Introduction

It has previously been suggested that DPT (4.3) is an intermediate in the formation of HMX (4.2) and RDX (3.9) in the Bachmann method of synthesis.^{105,106} Therefore an investigation into the acid-base behaviour of DPT is warranted.

A considerable amount of work has been carried out on nitroamines mainly due to their increasing importance as explosives.¹¹⁰⁻¹¹⁷

The behaviour of species of structure $\text{NO}_2\text{-NR-CH}_2\text{-NR}_2'$ in aqueous and alkaline solution has been investigated.¹¹⁴ Mechanisms postulated for their decomposition involve the formation of a nitroamine anion species $\text{NO}_2\text{-}\bar{\text{N}}\text{R}$. In acidic solution the aminomethylnitroamines $\text{NO}_2\text{-NR-CH}_2\text{NR}_2'$ were found to be stabilised, possibly by formation of the cation $\text{NO}_2\text{-NR-CH}_2\text{-}\overset{+}{\text{N}}\text{HR}_2'$.

The precipitation of DPT (4.3) from solutions of the monoammonium salt of methylenedinitroamine $\text{O}_2\text{NHN-CH}_2\text{-}\bar{\text{N}}\text{NO}_2 \text{ NH}_4^+$ in aqueous formaldehyde suggested nitramide NH_2NO_2 as an intermediate in the decomposition of the salt and lead to an investigation of the decomposition of methylenedinitroamine in aqueous solution. Methylenedinitroamine was found to decompose in 11 M-mineral acid, in 2 M-sodium hydroxide, and at pH 3-8. Considerable stability was found around pH 1 and pH 10. The decomposition at pH 3-8 lead finally to nitrous oxide and formaldehyde. The primary stage appearing to result in the liberation of nitramide NH_2NO_2 . It was suggested that decomposition proceeds specifically through the mono-ion $\text{O}_2\text{N-HN-CH}_2\text{-}\bar{\text{N}}\text{-NO}_2$ and that the un-ionised and the

doubly ionised materials were relatively stable. From determined dissociation constants¹¹⁷ ($pK_1 = 5.0$, $pK_2 = 6.6$) the proportion of the mono-ion at a given pH could be calculated.

The u.v. spectrum of DPT (4.3) has been investigated previously.¹¹⁸ The spectrum in neutral dioxane solution gave λ_{\max} 241 nm with $\epsilon = 11,000 \text{ l mol}^{-1} \text{ cm}^{-1}$. In 0.2 M hydrochloric acid, the maximum was seen to shift to 215 nm. It was concluded that the hypsochromic shift was due to decomposition of DPT and not simply due to quaternary salt formation. No mechanism was proposed for the decomposition. In this chapter the u.v. spectrum of DPT in acid and basic solution is examined in greater detail as well as its decomposition in order to determine the fate of DPT in these media and to relate this to the role of DPT in the Bachmann method of synthesis of RDX and HMX.

6.2 Experimental

DPT was prepared by the method given in Chapter 2, taking the usual safety precautions to discard RDX. 1,4-dioxan and acetonitrile were of spectroscopic and HPLC grade respectively. Buffer solutions were made up by standard methods (see Chapter 2) and the pH tested using the PT1-6 universal digital pH meter (accurate ± 0.02). U.v. measurements were made with a Pye Unicam SP8-100 instrument at 25°C as described previously. All kinetic runs were carried out under first-order conditions. Kinetic runs were carried out in 99% aqueous solution (1% acetonitrile), since DPT is insoluble in water.

The ^1H n.m.r. spectrum of DPT was recorded on a Bruker AC 250 instrument using an internal TMS reference.

6.3 Results and Discussions

6.3.1 General Properties of DPT

DPT (m.w. 218) gave m.p. 212°C from acetone (lit., 211.5°C ⁷³). The white solid was insoluble in water and slightly soluble in methanol. Greater solubility was achieved with acetonitrile and 1,4-dioxan. The ^1H n.m.r. spectrum in acetonitrile- d_3 solvent (Figure 6.1) gave a band at δ 4.14 (s, CH_2 bridge) and an AB quartet (J 13 Hz) due to CH_2 protons with shifts of δ 4.9 and δ 5.65. The spectrum has been examined previously⁴⁰ in terms of a flattened chair-chair conformation which is favoured in various heterocyclic bicyclo[3.3.1]nonanes.³⁵

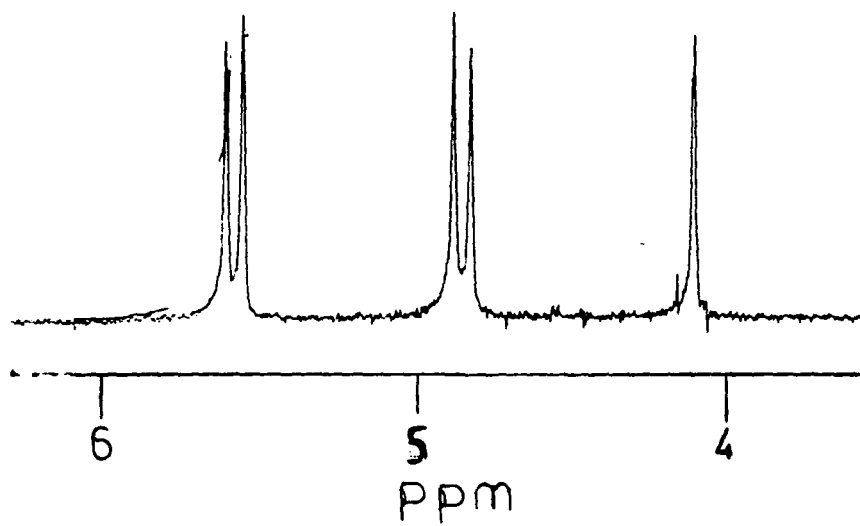

Fig 6.1

^1H n.m.r. of DPT in acetonitrile- d_3

6.3.2 U.v. spectra of DPT

In acetonitrile DPT gave λ_{\max} 240 nm with $\epsilon = 10,800$ (Figure 6.2). Extinction coefficients at wavelengths 300-230 nm are shown in Table 6.1. The u.v. spectrum was similar in 1,4-dioxan to that reported previously.¹¹⁸ In 0.1 M hydrochloric acid solution the maximum shifted to 212 nm with an increase in extinction coefficient, $\epsilon = 14,300$ (Figure 6.3).

In 0.2 M sodium hydroxide solution a shift to $\lambda_{\max} = 232$ nm was observed with $\epsilon = 19,000$ (Figure 6.4). At intermediate pH 7.2 the maximum appeared at 224 nm with $\epsilon = 14,300$ (Figure 6.5).

Table 6.1

Values of extinction coefficients (ϵ mol⁻¹ cm⁻¹) in acetonitrile at 25°C.

	Wavelength/nm			
	300	290	280	270
ϵ/l mol ⁻¹ cm ⁻¹	260	560	1,500	3,600

	Wavelength/nm			
	260	250	240	230
ϵ/l mol ⁻¹ cm ⁻¹	6,900	9,700	10,800	8,900

Fig. 6.2

U.v. spectrum of DPT in acetonitrile

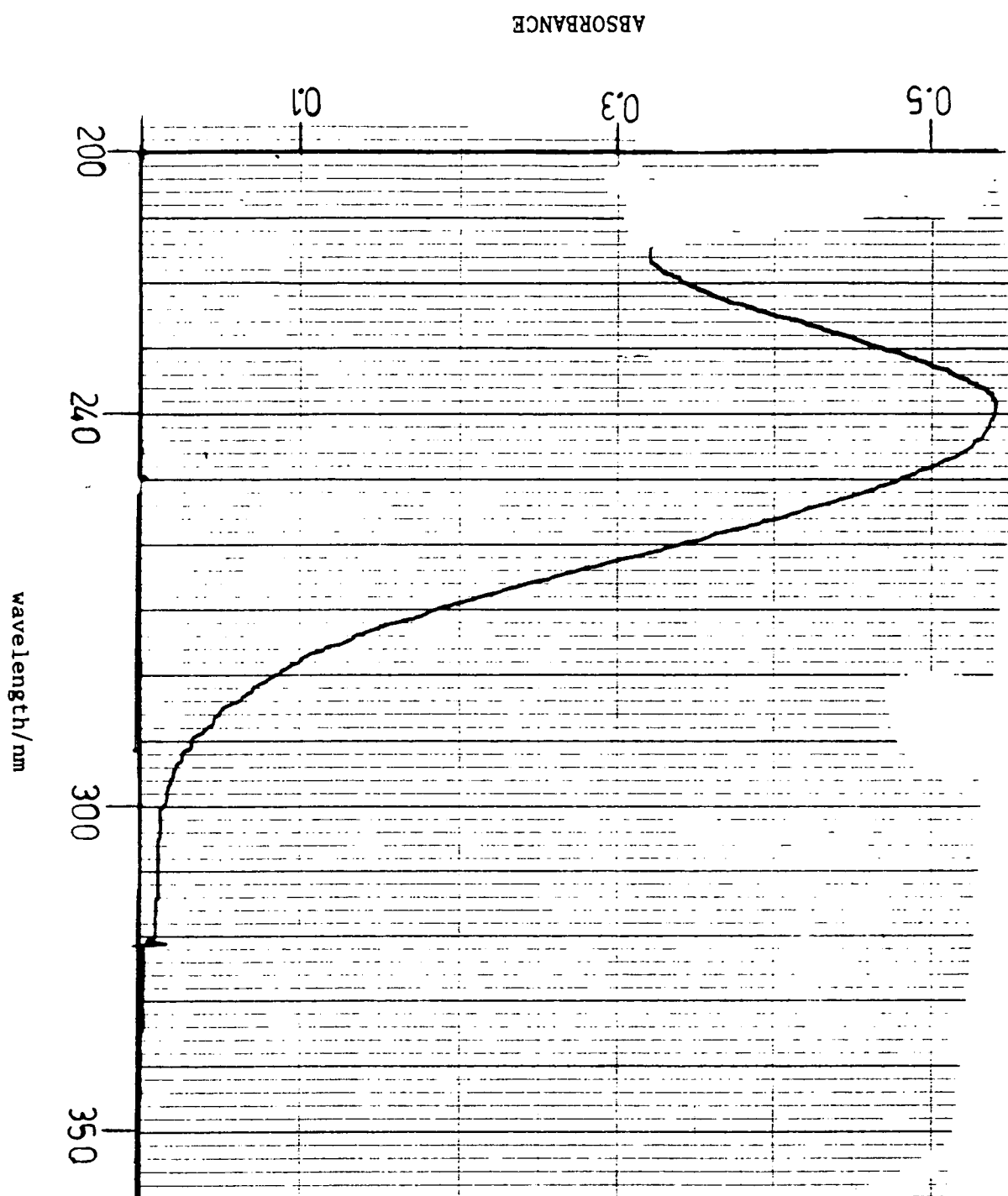
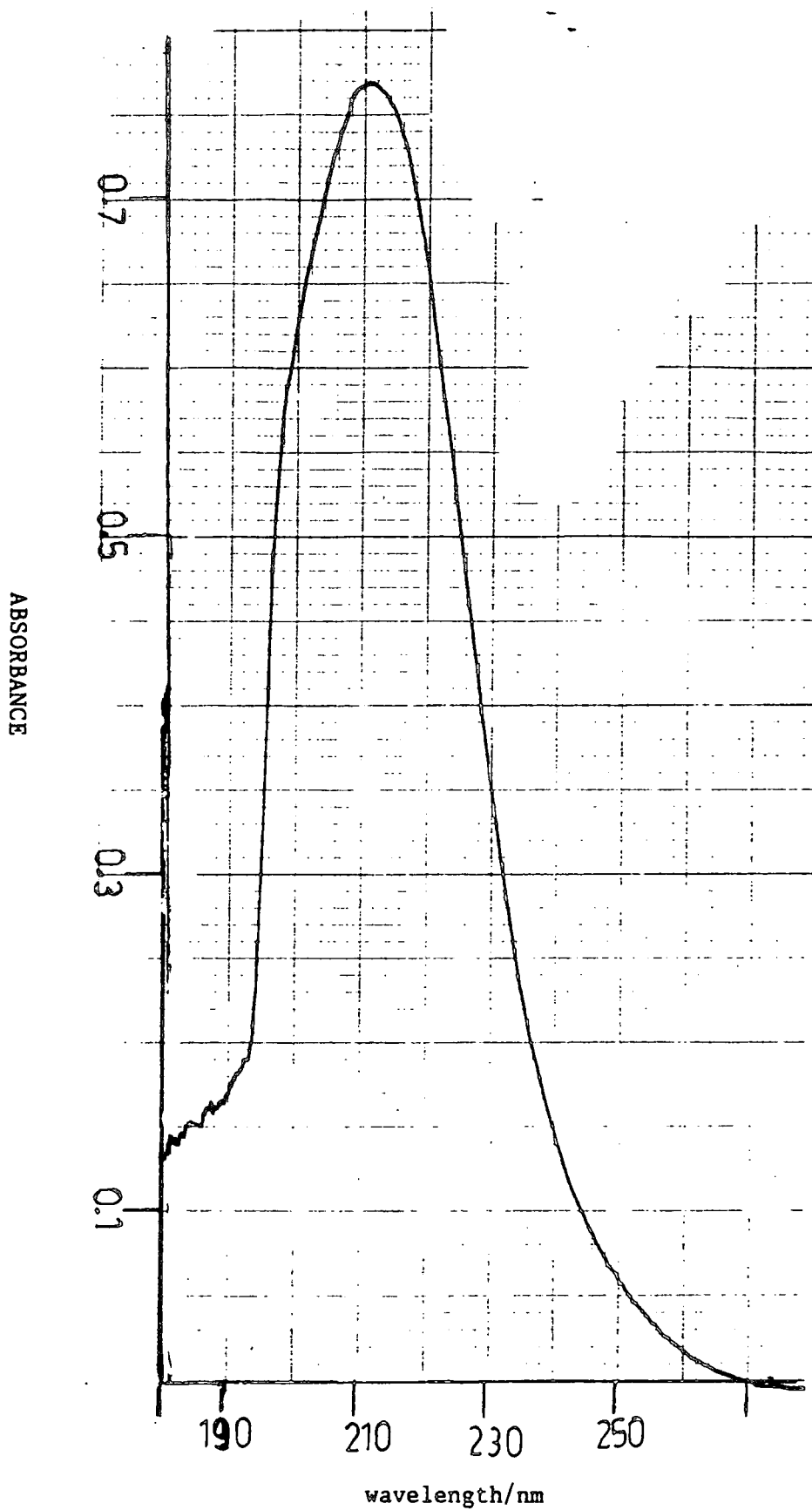

Fig. 6.3

U.v. spectrum of DPT in 0.1 M HCl



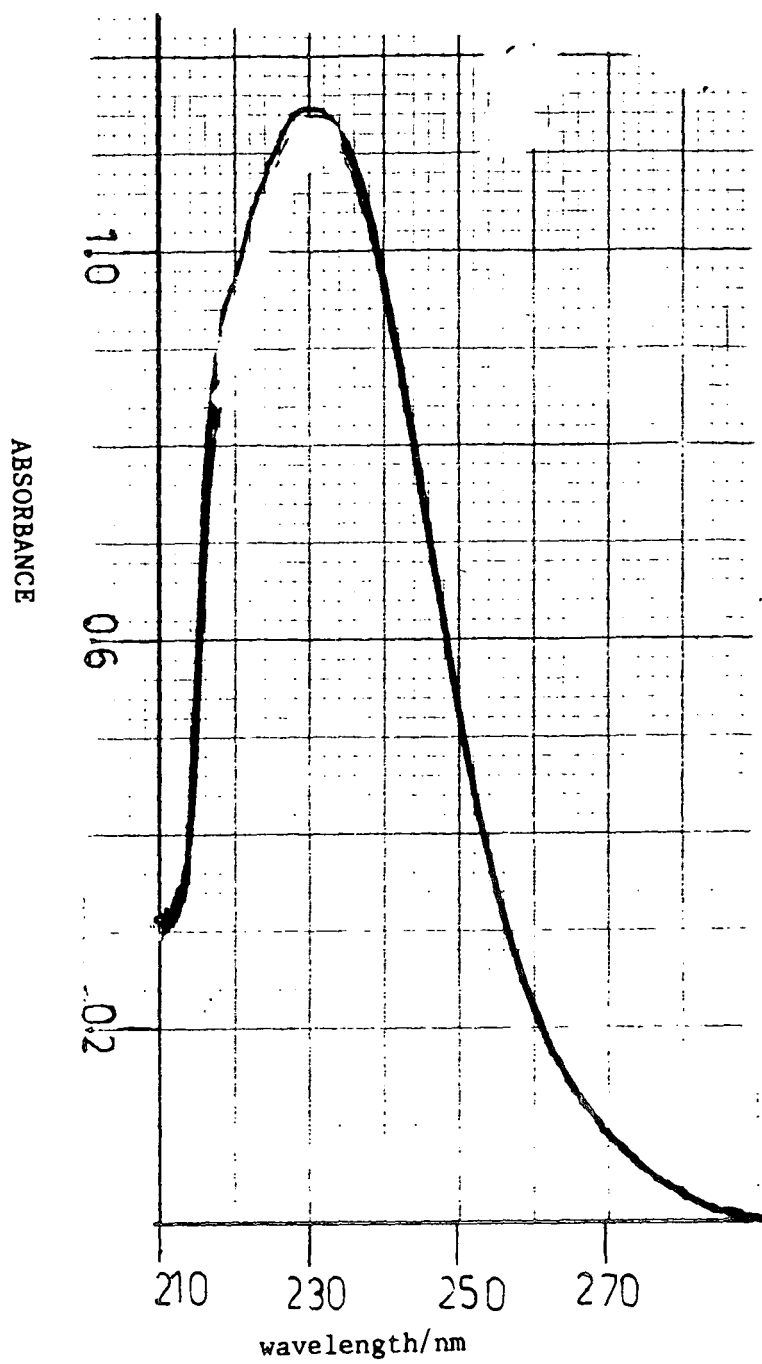
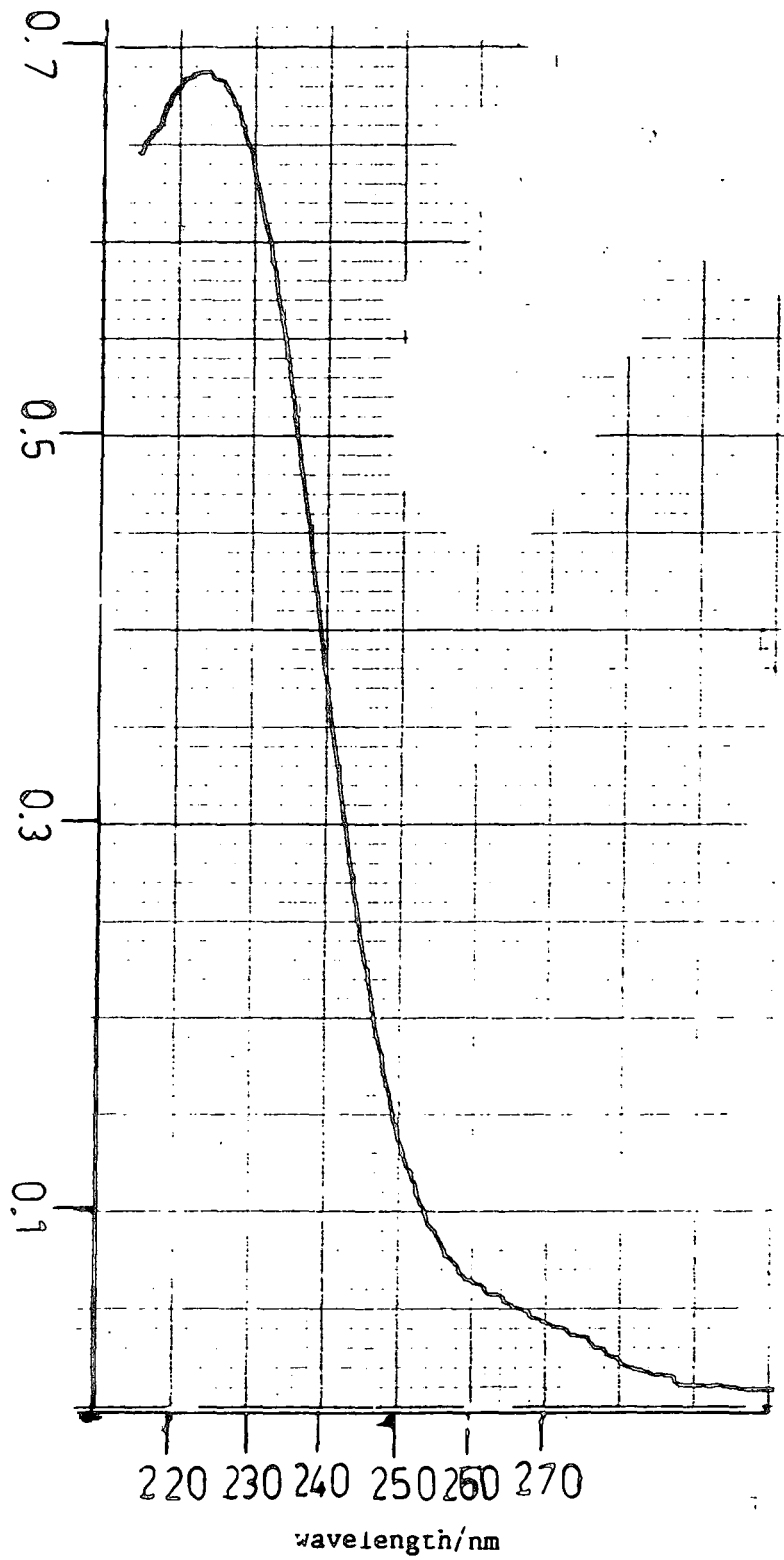

Fig. 6.4

U.v. spectrum of DPT in 0.2 M NaOH

Fig. 6.5

U.v. spectrum of DPT in aqueous solution



The spectroscopic literature contains only meagre references to aliphatic nitroamines, however certain generalisations can be made. The spectra of aqueous, alcoholic, or 1,4-dioxan solutions of both primary and secondary nitroamines tend to be relatively simple. One broad structureless band is usually seen, with λ_{\max} in the region 225-240 nm¹¹⁸

A. *Secondary Nitroamines*

For compounds containing one secondary nitroamine group per molecule the molecular extinction coefficient at the maximum is close to 5,500.

For a substance containing n secondary nitroamine groups ϵ_{\max} is close to 5,500 x n.

B. *Primary Nitroamines*

ϵ_{\max} is found to be approximately 7,000 for each primary nitroamine group. For a substance containing n primary nitroamine groups ϵ_{\max} is close to 7,000 x n.

C. *Spectra of Nitroamines in Alkaline Solution*

The absorption spectra of primary nitroamines in alkaline solution shows a significant increase in ϵ_{\max} and λ_{\max} is shifted to longer wavelength. Again the intensity at the maximum is a linear function of the number of primary nitroamine groups in the molecule i.e. $\epsilon_{\max} = 8,500 \times n$.

Secondary nitroamines e.g. DPT tend to be unstable in alkali. However, in cases where the compounds are sufficiently stable to enable spectra to be determined,

the wavelength of the maximum is unchanged from that observed in neutral solution.¹¹⁸

In acidic solution the spectra of both primary and secondary nitroamines are the same as in neutral solution.

It is possible to distinguish between compounds containing primary and secondary nitroamine groups providing that the presence of other functional groups are taken into account. Using the above generalisations A-C, it appears that the species produced when DPT is put into acidic solution contains two primary nitroamine groups ($\epsilon_{\max} = 14,000$). Also the spectrum obtained in alkaline solution gives an ϵ_{\max} which is close to that expected for two primary nitroamine groups ($\epsilon_{\max} = 17,000$). Therefore, as suggested in the introduction, DPT is indeed decomposing in aqueous solution.

It was also noticed that the absorption spectra of the products in acidic and basic solution were interconvertible, however these products were also seen to decompose with time.

6.3.3 Decomposition of DPT in Aqueous Solution

An aqueous solution of DPT (99% H₂O, 1% CH₃CN) gave a change in spectrum with time as shown in Figure 6.6. The λ_{max} was seen to gradually shift to shorter wavelength till the initial product was reached at λ 224 nm. A second process was also observed (Figure 6.7) resulting in complete fading of the u.v. absorption. In acidic and alkaline solution the second process was very slow.

6.3.3.1 Initial Reaction in Acid

Kinetic analysis indicated that the initial fading reaction followed a first-order rate law. Thus plots of $\ln (A-A_{\infty})$ versus time were linear. The reaction was followed as a decrease in absorbance at 250 nm. Specimen results are shown in Table 6.2.

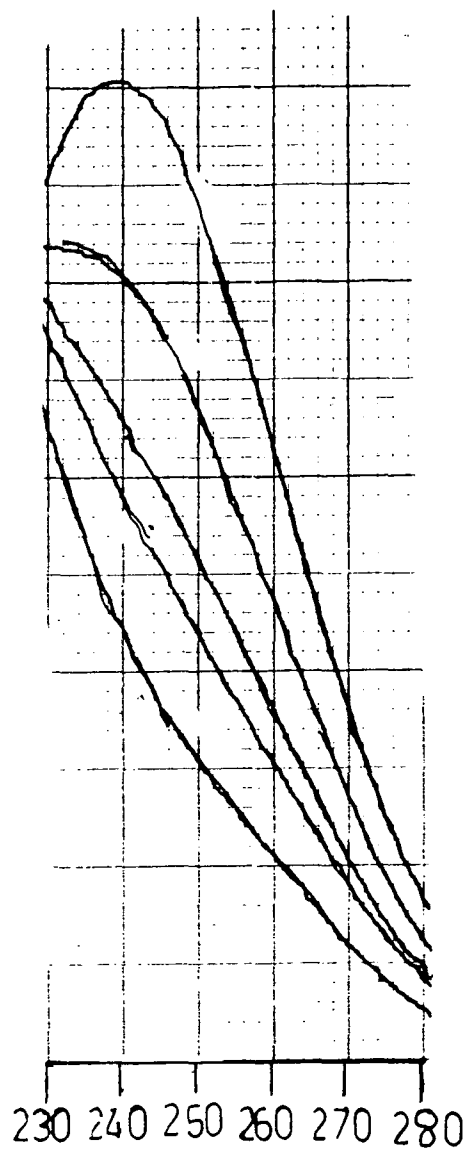

Fig. 6.6

Change in spectrum with time for DPT in aqueous solution

Fig. 6.7

Change in spectrum with time for product of initial reaction of DPT in aqueous solution

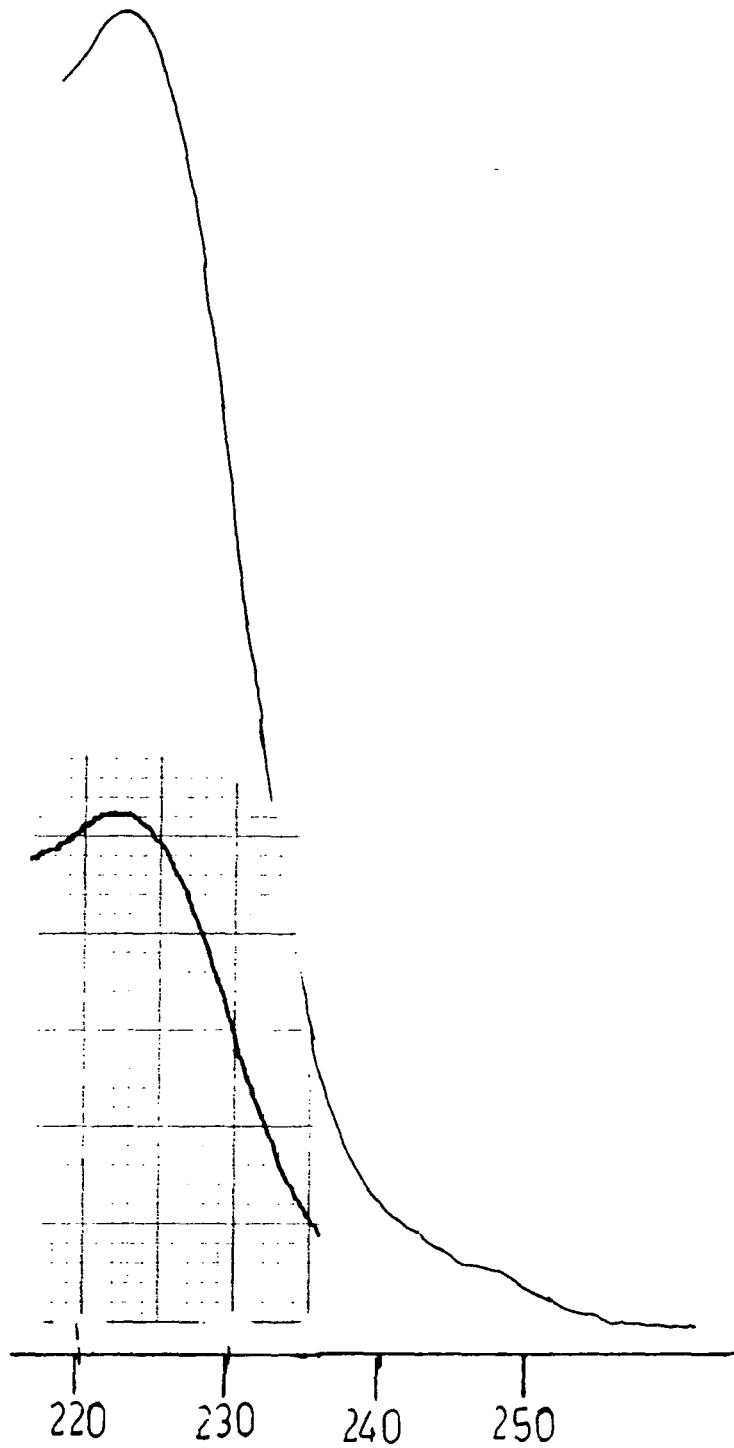

Table 6.2

Specimen results for the decomposition of DPT 2.2×10^{-5} M
in HCl 0.1 M (1% acetonitrile)

Time/s	Absorbance 250 nm
20	0.22
40	0.166
60	0.129
80	0.102
100	0.088
120	0.078
140	0.07

$$A_{\infty} = 0.05$$

A plot of $\ln[A - A_{\infty}]$ against time gives

$$k_{\text{obs}} = \underline{1.78 \times 10^{-2} \text{ s}^{-1}}$$

The rate coefficients for the initial fading reaction in acid were seen to increase with increasing acidity and reach a limiting value as with DAPT (see Chapter 3) (Figure 6.8).

The decomposition of DPT (4.3) in acid can be interpreted in terms of rate determining decomposition of either the protonated substrate or a ring-cleaved species both of which are referred to as DPT.H^+ in the following equation.

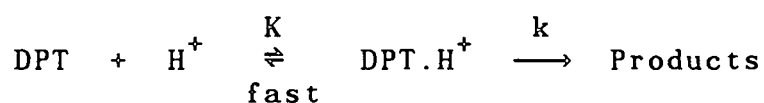

Thus, as with DPT, an equation can be derived of the form

$$k_{\text{obs}} = \frac{k K [\text{H}^+]}{1 + K[\text{H}^+]}$$

Figure 6.8

k_{obs} versus $[\text{HCl}]$ for initial decomposition reaction.

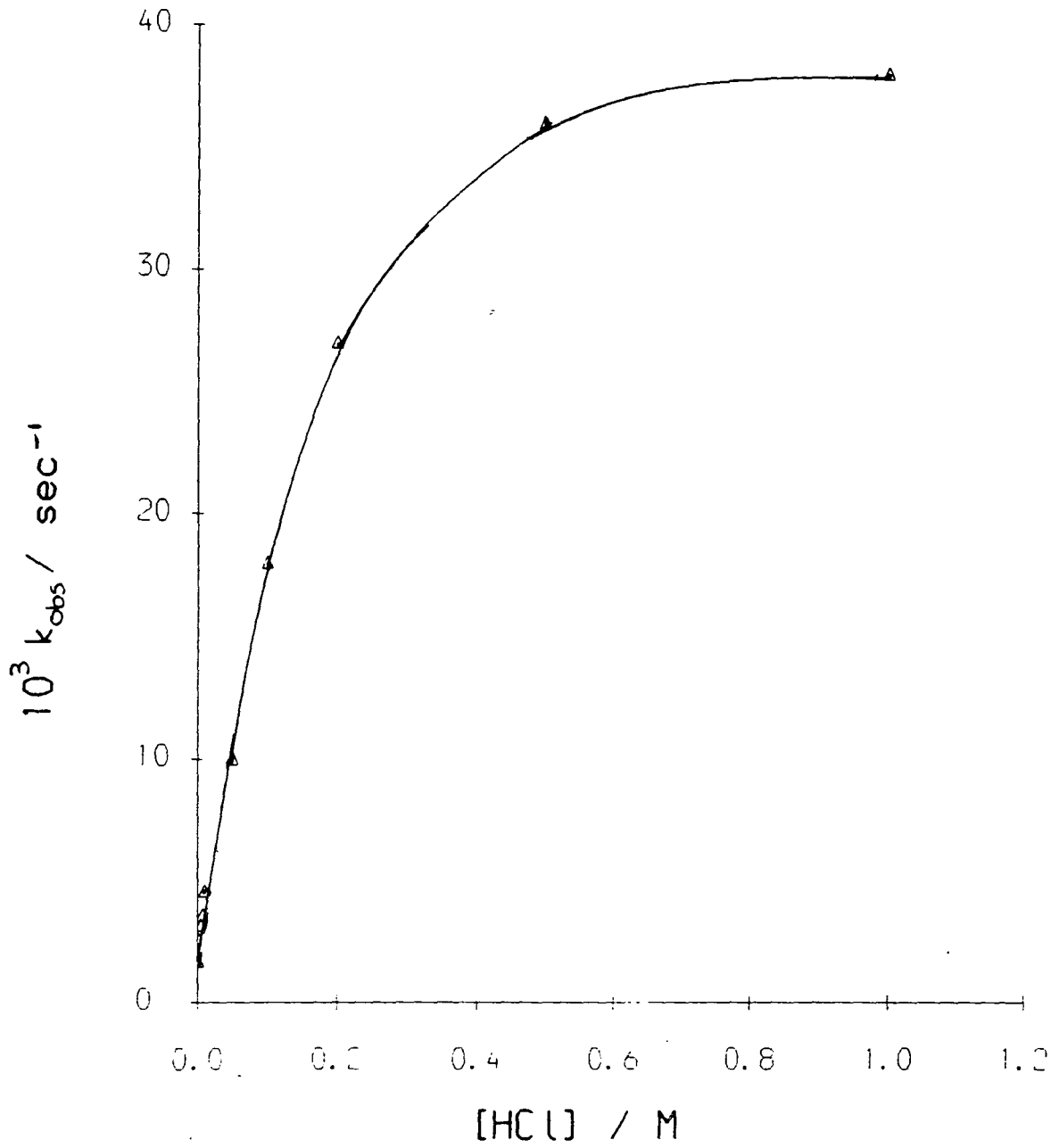

Extrapolation back to zero acid concentration gave a k_w value of $2 \times 10^{-3} \text{ s}^{-1}$. This was confirmed by observing the reaction in buffer pH 7.1 (Table 6.3).

Table 6.3

Decomposition of DPT in Tris Buffer (1% acetonitrile)

Tris Buffer concentration/M	pH	$k_{\text{obs}}/\text{s}^{-1}$
0.05	7.1	2.1×10^{-3}
0.025	7.1	1.9×10^{-3}
0.0125	7.1	2.0×10^{-3}

Solutions diluted with NaCl to maintain constant ionic strength.

It can be seen from Table 6.3 that no buffer catalysis was observed using Tris buffer and that $k_w = \underline{2.0 \times 10^{-3} \text{ s}^{-1}}$.

Thus an equation can be written of the form

$$k_{\text{obs}} = k_w + \frac{k K [\text{H}^+]}{1 + K [\text{H}^+]}$$

Expressing the equation in terms of an acidity function (see Chapter 3) gives

$$k_{\text{obs}} = k_w + \frac{k K [h_o''']}{1 + K [h_o''']}$$

Inversion of the equation gives

$$\frac{1}{k_{\text{obs}} - k_w} = \frac{1}{k K h_o'''} + \frac{1}{k}$$

A plot of $1/k_{\text{obs}} - k_w$ versus $1/h_o'''$ is shown in Figure 6.9.1

Figure 6.9.1

$1/k_{obs} - k_w$ versus $1/h_0$ for initial decomposition reaction.

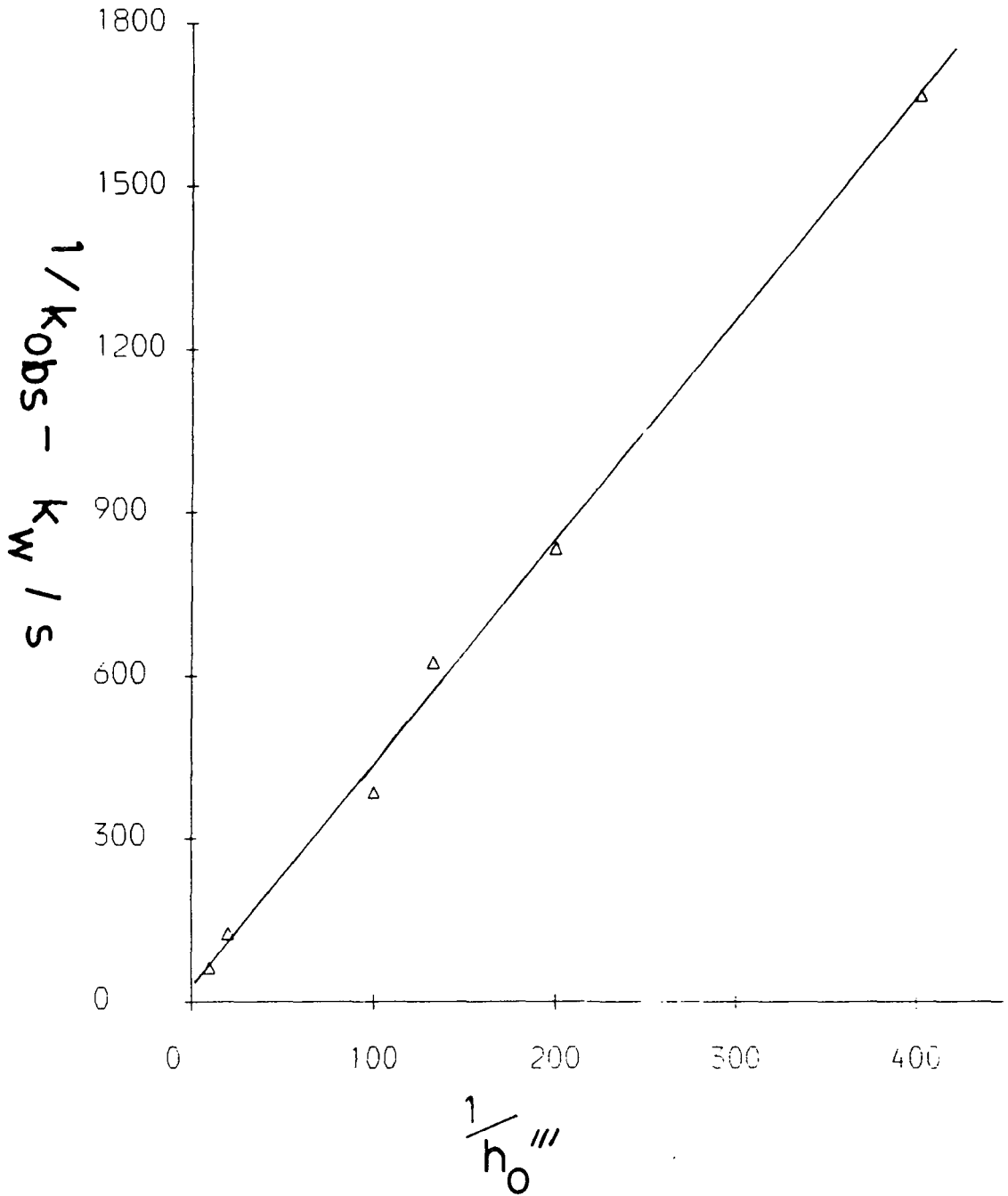

This yields the values $k = \underline{3.9 \times 10^{-2} \text{ s}^{-1}}$ and $K = \underline{6.25 \text{ l mol}^{-1}}$.

The data in Table 6.4, calculated using these values are in good agreement with the experimental data.

Table 6.4

Rate data for reaction of DPT ($5 \times 10^{-5} \text{ M}$) with hydrochloric acid (1% acetonitrile) at 25°C

[HCl]/M	h_o''' a	$k_{\text{obs}}/\text{s}^{-1}$	$k_{\text{calc}}/\text{s}^{-1}$ b
0.001	0.001	1.7×10^{-3}	
0.0025	0.0025	2.6×10^{-3}	2.6×10^{-3}
0.005	0.005	3.2×10^{-3}	3.2×10^{-3}
0.0075	0.0075	3.6×10^{-3}	3.7×10^{-3}
0.01	0.01	4.6×10^{-3}	4.3×10^{-3}
0.05	0.05	1.0×10^{-2}	1.1×10^{-2}
0.1	0.10	1.8×10^{-2}	1.7×10^{-2}
0.2	0.23	2.7×10^{-2}	2.5×10^{-2}
0.5	0.69	3.6×10^{-2}	3.4×10^{-2}
1.0		3.8×10^{-2}	

a. $h_o''' = \text{antilog} (-H_o''')$

b. calculated from $k_{\text{calc}} = k_w + \frac{k K h_o'''}{1 + K h_o'''}$

using $k_w = 2.0 \times 10^{-3} \text{ s}^{-1}$, $k = 3.9 \times 10^{-2} \text{ s}^{-1}$

and $K = 6.25 \text{ l mol}^{-1}$

If the initial equilibrium measured is simply protonation of DPT then the above data give a pK_a value of 0.8.

The rates of the fading reaction were also measured in deuterium oxide containing deuterium chloride. As mentioned in Chapter 3 it is known^{85,87} that in dilute solutions the acidity functions for hydrochloric acid in water and deuterium chloride in deuterium oxide are identical. As with HCl the rate coefficients for the initial fading reaction in DCl/D₂O were seen to increase with increasing acidity eventually reaching a limiting value. Extrapolation back to zero CCl concentration gave $k_w = \underline{1.4 \times 10^{-3} \text{ s}^{-1}}$ which is slightly less than in H₂O.

A plot of $1/k_{\text{obs}} - k_w$ versus $1/d_o'''$ is shown in Figure 6.9.2.

Figure 6.9.2

$1/k_{obs} - k_w$ versus $1/d_0'''$ for initial decomposition reaction.

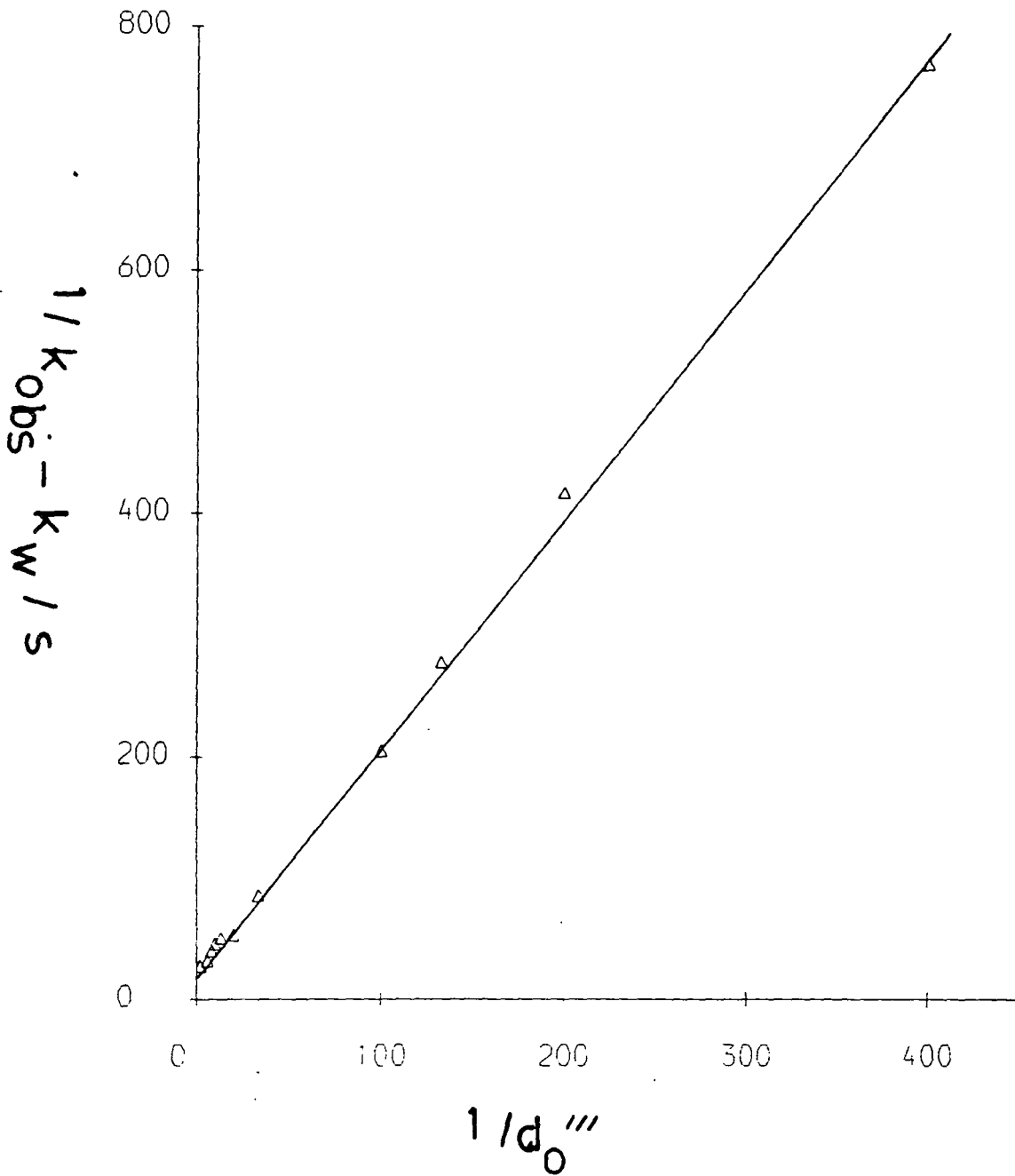

and yields the values of $k = 3.9 \times 10^{-2} \text{ s}^{-1}$ and $K = 14 \text{ l mol}^{-1}$.

The data in Table 6.5 calculated using these values is in good agreement with the experimental data.

As with the decomposition of DAPT (3.2) the rate constant is identical with the value obtained in water. The value for K of 14 l mol^{-1} yielding a $\text{p}K_a$ value in D_2O of 1.15 is ca. 3 times higher than the value in water. As with DAPT (3.2), this result shows the higher basicity for DPT (4.3) in deuterium oxide than in water and is in accord with literature values^{87,88} for other nitrogen bases.

Table 6.5

Rate data for reaction of DPT (5×10^{-5} M) with deuterium chloride (1% acetonitrile) at 25°C.

[DC1]/M	$d_o'''^a$	$k_{\text{obs}}/\text{s}^{-1}$	$k_{\text{calc}}/\text{s}^{-1}$
0.0025	0.0025	2.7×10^{-3}	2.7×10^{-3}
0.005	0.005	3.8×10^{-3}	4.0×10^{-3}
0.0075	0.0075	5.0×10^{-3}	5.1×10^{-3}
0.01	0.01	6.3×10^{-3}	6.2×10^{-3}
0.03	0.03	1.3×10^{-2}	1.3×10^{-2}
0.05	0.05	2.0×10^{-2}	1.8×10^{-2}
0.075	0.075	2.1×10^{-2}	2.1×10^{-2}
0.1	0.1	2.3×10^{-2}	2.4×10^{-2}
0.125	0.125	2.6×10^{-2}	2.5×10^{-2}
0.15	0.17	3.1×10^{-2}	2.9×10^{-2}
0.20	0.23	3.6×10^{-2}	3.1×10^{-2}
0.40	0.49	3.7×10^{-2}	3.5×10^{-2}

a. $d_o''' = \text{antilog}(-D_o''')$

b. calculated from $k_{\text{calc}} = k_w + \frac{k K d_o'''}{1 + K d_o'''}$

using $k_w = 1.4 \times 10^{-3} \text{ s}^{-1}$, $k = 3.9 \times 10^{-2} \text{ s}^{-1}$,

$K = 14 \text{ l mol}^{-1}$

However, it is not certain that the initial equilibrium measured is in fact simple protonation, only that it involves protonation. No isotope effect was observed on the rate constant k which suggests that proton transfer does not occur in the rate determining step. The data does not indicate whether the rate determining step is C-N bond breaking, hydrolysis of an iminium species, or conversion of a carbinolamine to an amine. Since the initial reaction in acid will involve a cascade of steps it is difficult to say exactly at what point the rate determining step occurs. This also applies to the decomposition of DAPT (3.2) in acid. Fife and co-workers⁹² investigated the hydrolysis of 2-(tert-butyl)-N-N'-dimethyl-1,3-imidazolidine, which contains an $\begin{matrix} \cdot \\ \text{N} \\ \cdot \end{matrix}$ -CH- $\begin{matrix} \cdot \\ \text{N} \\ \cdot \end{matrix}$ - system. They found the overall reaction to be ring opening to a cationic Schiff base (iminium ion) followed by subsequent hydrolysis to the aldehyde followed by hydration of the aldehyde. It was found that the rate determining step in the initial process was hydrolysis of the cationic Schiff base, the initial C-N bond breaking being rapid. The hydrolysis of Schiff bases has been extensively studied.¹¹⁹ It has been shown in the hydrolysis of Schiff bases that a pH-independent hydrolysis reaction occurs under basic conditions probably involving rate-determining attack of hydroxide on the protonated Schiff base. At pH values where the Schiff bases are predominantly protonated, attack of water on the protonated Schiff base takes place. Under still more acidic conditions, the decrease in rate

constant with decreasing pH is due to a change in rate-determining step with carbinolamine decomposition becoming rate limiting. Fife and co-workers⁹² obtained a value of $k_{\text{H}_2\text{O}}/k_{\text{D}_2\text{O}} = \underline{2.5}$ for the initial ring-opening process for the pH independent hydrolysis of 2-(tert-butyl)-N,N'-dimethyl-1,3-imidazolidine and concluded that proton transfer was possibly taking place in the critical transfer state.

The initial reaction of DPT (4.3) in H_2O was slightly bigger than in D_2O , however the value of $k_{\text{H}_2\text{O}}/k_{\text{D}_2\text{O}} = \underline{1.4}$ is small suggesting that proton transfer probably does not occur in the rate determining step.

6.3.3.2 Initial Reaction in Base

An initial first order decomposition reaction was observed in sodium hydroxide solution. As with acid the rate constants were seen to increase with base concentration eventually reaching a limiting value (Figure 6.9.3). The decomposition in base can be interpreted in terms of rate determining decomposition of an intermediate X which is probably a ring-cleaved species.

Figure 6.9.3

k_{obs} versus $[\text{NaOH}]$ for initial decomposition reaction in NaOH .

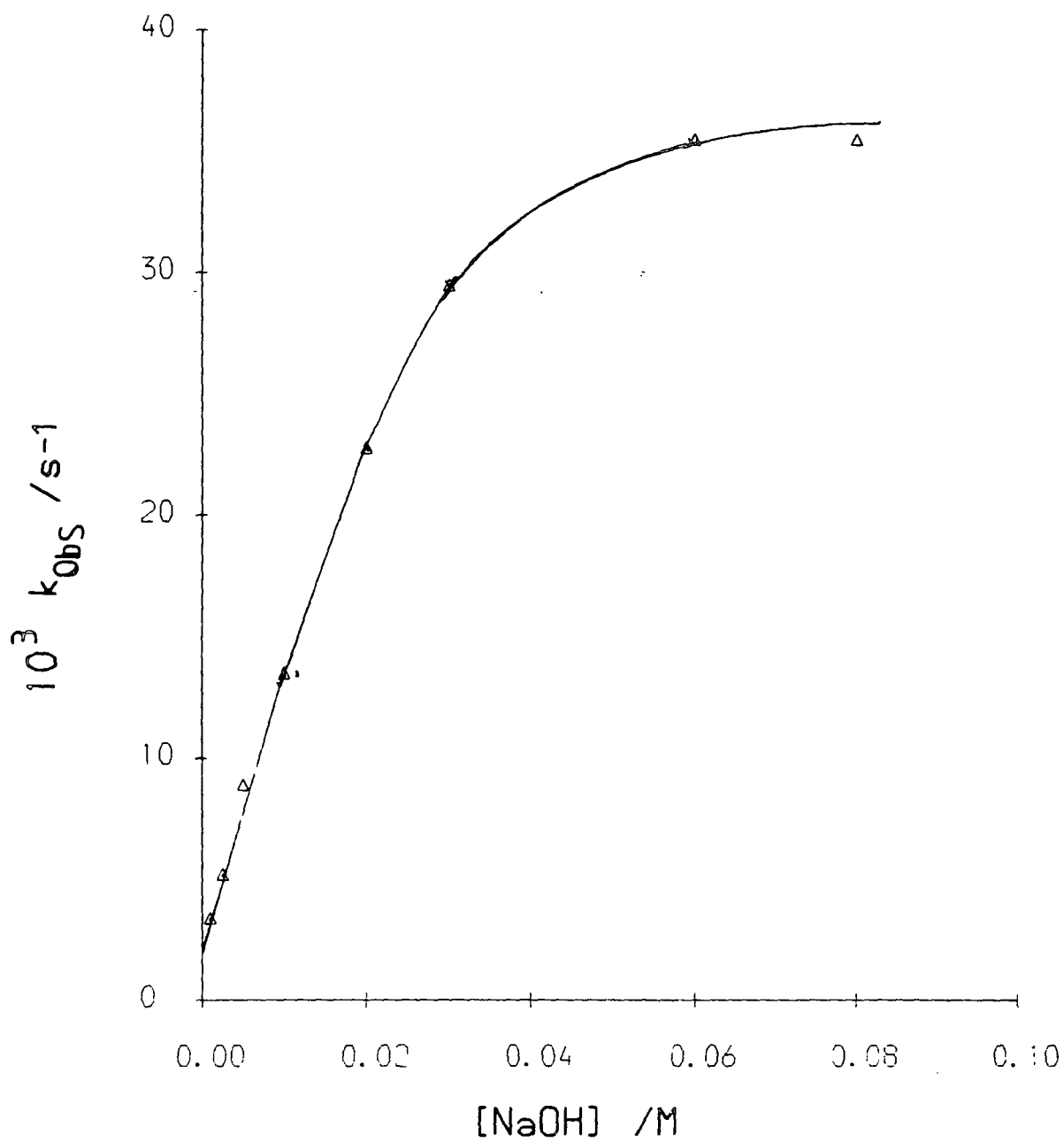



$$\therefore [P] + [X] + [D] = \text{constant}$$

$$\frac{d[P]}{dt} + \frac{d[X]}{dt} + \frac{d[D]}{dt} = 0$$

$$\frac{d[X]}{dt} = K_{OH} [OH^-] \cdot \frac{d[P]}{dt}$$

$$\frac{d[P]}{dt} \left[1 + K_{OH} [OH^-] \right] + \frac{d[D]}{dt} = 0$$

$$\frac{d[D]}{dt} = k[X]$$

$$\therefore \frac{d[P]}{dt} \left[1 + K_{OH} [OH^-] \right] + k K_{OH} [P] [OH^-] = 0$$

$$\frac{-d[P]}{dt} = k_{\text{obs}} [P]$$

$$\therefore k_{\text{obs}} \left[1 + K_{OH} [OH^-] \right] = k K_{OH} [OH^-]$$

$$\therefore k_{\text{obs}} = \frac{k K_{OH} [OH^-]}{1 + K_{OH} [OH^-]}$$

By extrapolating back to zero base concentration a k_w value of $2 \times 10^{-3} \text{ s}^{-1}$ is obtained for the water reaction.

A plot of $1/k_{\text{obs}} - k_w$ versus $1/[OH^-]$ is shown in [Figure 6.9.4](#) and gives the values $k = 5 \pm 1 \times 10^{-2} \text{ s}^{-1}$ and $K_{OH} = 30 \text{ l mol}^{-1}$. The data in [Table 6.6](#) calculated using

these values is in good agreement with the experimental data.

Figure 6.9.4

$1/k_{obs} - k_w$ versus $1/[OH^-]$ for initial decomposition reaction in NaOH.

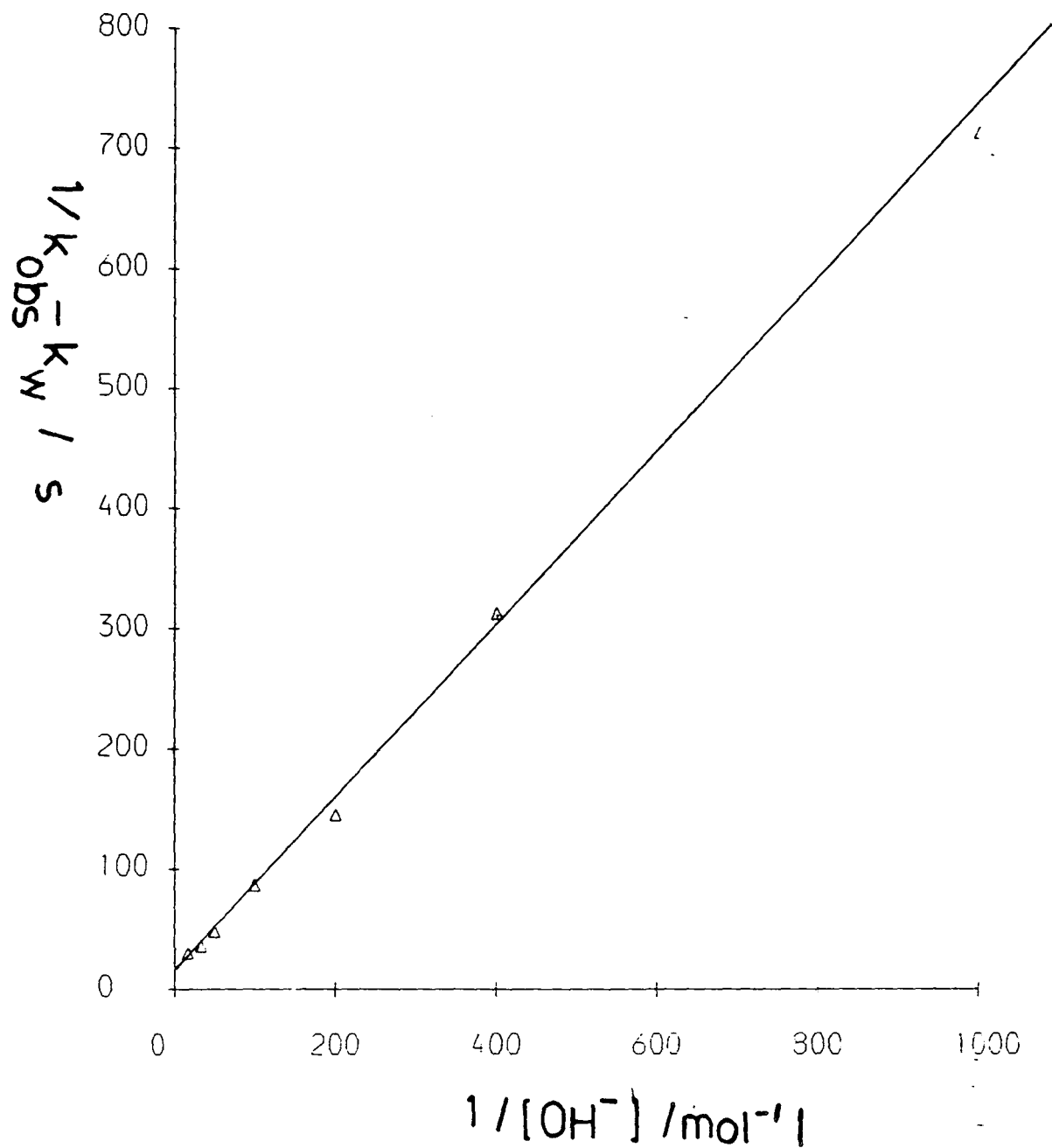

Table 6.6

Rate data for reaction of DPT (5×10^{-5} M) with sodium hydroxide solution (1% acetonitrile) at 25°C.

[NaOH]/M	$k_{\text{obs}}/\text{s}^{-1}$	$k_{\text{calc}}/\text{s}^{-1}$ ^a
0.001	3.4×10^{-3}	3.5×10^{-3}
0.0025	5.2×10^{-3}	5.5×10^{-3}
0.005	8.9×10^{-3}	8.5×10^{-3}
0.01	1.35×10^{-2}	1.35×10^{-3}
0.02	2.28×10^{-2}	2.1×10^{-3}
0.03	2.95×10^{-2}	2.6×10^{-3}
0.06	3.51×10^{-2}	3.4×10^{-3}
0.08	3.51×10^{-2}	
0.10	3.5×10^{-2}	

a. calculated from $k_{\text{calc}} = k_w + \frac{k K_{\text{OH}}[\text{NaOH}]}{1 + K_{\text{OH}}[\text{NaOH}]}$

using $k_w = 2 \times 10^{-3} \text{ s}^{-1}$

$k = 5 \times 10^{-2} \text{ s}^{-1}$

$K_{\text{OH}} = 30 \text{ l mol}^{-1}$

6.3.3.3 Initial pH independent Reaction in Water

As previously mentioned, extrapolation back to zero acid or base gives a value of $\underline{2 \times 10^{-3} \text{ s}^{-1}}$ for the initial reaction. The same value also being obtained with buffer pH 7.1.

A plot of $\log_{10} k_{\text{obs}}$ versus pH for the initial reaction in aqueous solution is shown in Figure 6.9.5 and shows a pH independent reaction over a wide pH range.

Figure 6.9.5

pH profile for initial decomposition reaction.

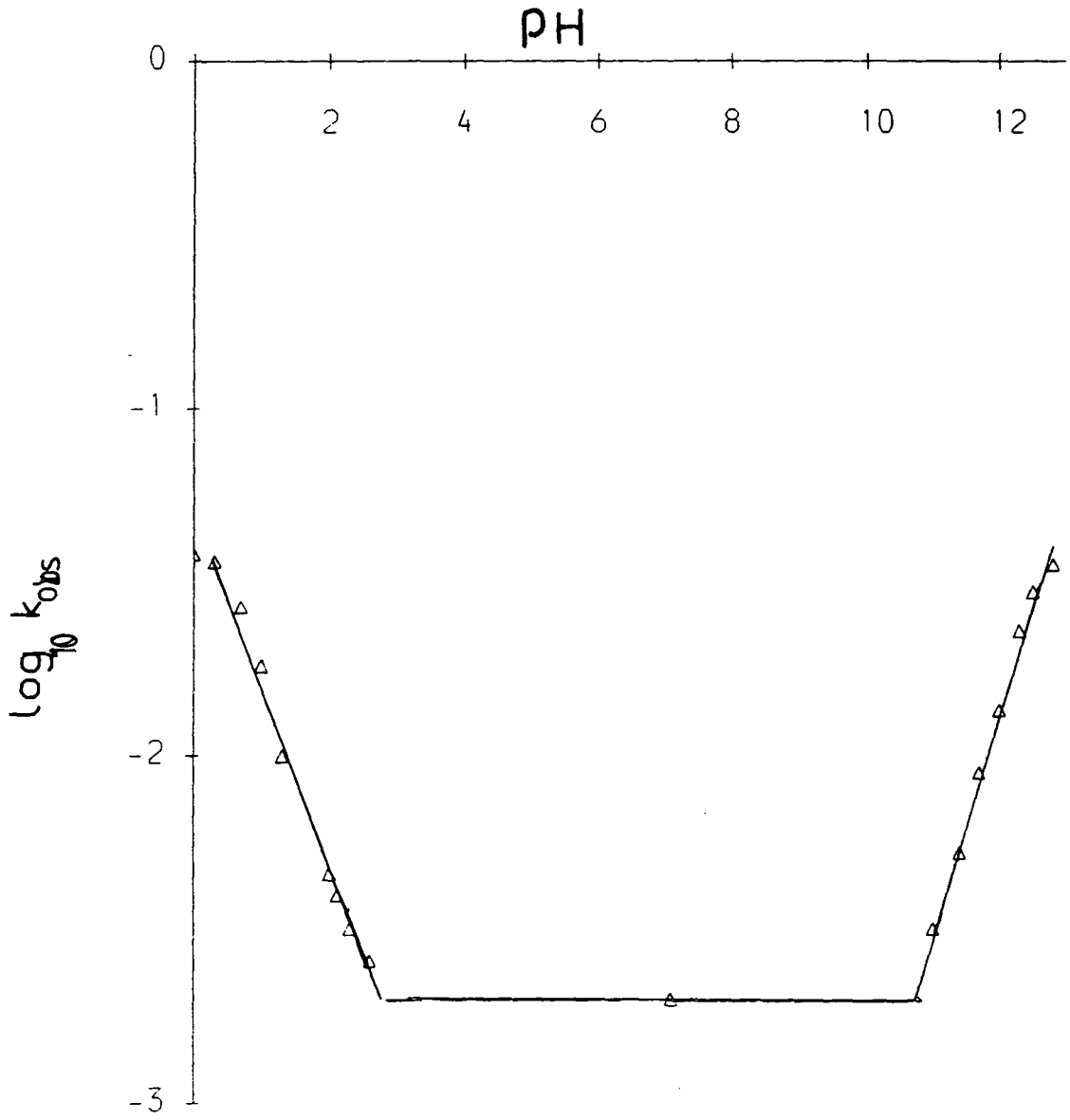

6.3.3.4 Second Reaction

The second reaction was seen to be quite slow in the region of $3 > \text{pH} > 11$, however at intermediate pH the rate of the second reaction was seen to approach the rate of the first reaction. This created difficulties in the direct measurement of the first and second processes.

At pH where the rate of the first and second reaction did not differ greatly, the second reaction was conducted independently of the first by the method shown below.

i) Methods of Measurement of Slow Reaction Direct Measurement of fading reaction.

The reaction was measured directly after completion of fast reaction. This was used in solutions where $11 < \text{pH} < 3$.

ii) Independent Measurement of fading reaction

The product of the first reaction was prepared in alkaline solution. This was then transferred to the reaction solution taking account of the added sodium hydroxide. The following amounts of reactants were used.

5 ml of stock solution of DPT in acetonitrile was added to 45 ml of 0.05 M sodium hydroxide in water. The reaction mixture was left for 5 minutes for the fast reaction to go to completion ($t_{1/2} = 20$ seconds). 5 ml of the resulting solution was then transferred to 45 ml of the appropriate buffer. This gave a final concentration of substrate of 2.27×10^{-5} M. The second reaction was measured as a decrease in

absorbance at 220 nm

Use of method ii) eliminated the need for complex mathematical treatment of results used for determining k_{obs} values for two consecutive first order reactions.^{120,121} Actual values for k_{obs} for the second reaction at different pH are shown in Table 6.7. A plot of k_{obs} versus pH is shown in Figure 6.9.6. The second reaction was found in some cases to be subject to catalysis by acidic and basic components of the buffer systems used. There the values quoted in Table 6.7 are those extrapolated to zero buffer concentration.

Table 6.7

Decomposition of Product of Initial Reaction in aqueous solution (2.27×10^{-5} M) at 25°C .

Medium [*]	pH	$\frac{k_{\text{obs}}}{\text{s}^{-1}}$	$\frac{\lambda_{\text{max}}}{\text{nm}}$	$\frac{\epsilon_{\text{max}}}{\text{l mol}^{-1} \text{cm}^{-1}}$
0.01 M NaOH	12	7×10^{-5}	232	1.9×10^4
0.025 M Borax	11.3	1.3×10^{-4}	232	1.9×10^4
0.025 M Borax	11.1	1.7×10^{-4}	232	1.9×10^4
0.025 M Borax	10.8	3.8×10^{-4}	232	1.9×10^4
0.0125 Borax	10.8	4.0×10^{-4}	232	1.9×10^4
0.025 M Borax	10.5	5.9×10^{-4}		
0.025 M Borax	10.15	1.1×10^{-3}	230	1.9×10^4
0.025 M NaHCO ₃	10.10	1.0×10^{-3}		
0.0125 M NaHCO ₃	10.10	1.0×10^{-3}		
0.00625 M NaHCO ₃	10.1	1.0×10^{-3}		
0.00313 M NaHCO ₃	10.1	1.0×10^{-3}		

^{*}Solutions made up to ionic strength I = 0.05 M with sodium chloride

Table 6.7 continued

Decomposition of Product of Initial Reaction in aqueous solution (2.27×10^{-5} M) at 25°C.

Medium ^{**}	pH	$\frac{k_{\text{obs}}}{\text{s}^{-1}}$	$\frac{\lambda_{\text{max}}}{\text{nm}}$	$\frac{\epsilon_{\text{max}}}{\text{l mol}^{-1} \text{cm}^{-1}}$
0.025 M Borax	10.0	1.5×10^{-3}		
"	9.9	1.7×10^{-3}	229	1.9×10^4
"	9.7	2.1×10^{-3}	228	
"	9.5	2.5×10^{-3}	227	
"	9.3	2.1×10^{-3}	226	1.9×10^4
"	9.1	2.0×10^{-3}	226	1.8×10^4
"	8.9	1.8×10^{-3}	224	1.7×10^4
"	8.5	1.6×10^{-3}	224	1.7×10^4
"	8.3	1.3×10^{-3}	224	1.6×10^4
"	8.1	1.2×10^{-3}	224	1.4×10^4
Tris buffer extrapolated to zero concentration	7.6	8×10^{-4}		
"	6.7	4×10^{-4}		
acetate buffer extrapolated to zero concentration	4.8	5×10^{-5}		
0.001 M HCl	3	4×10^{-5}		
0.01 M HCl	2	4×10^{-5}		

^{**}Solutions made up to ionic strength
I = 0.05 M with sodium chloride

Fig. 6.9.6

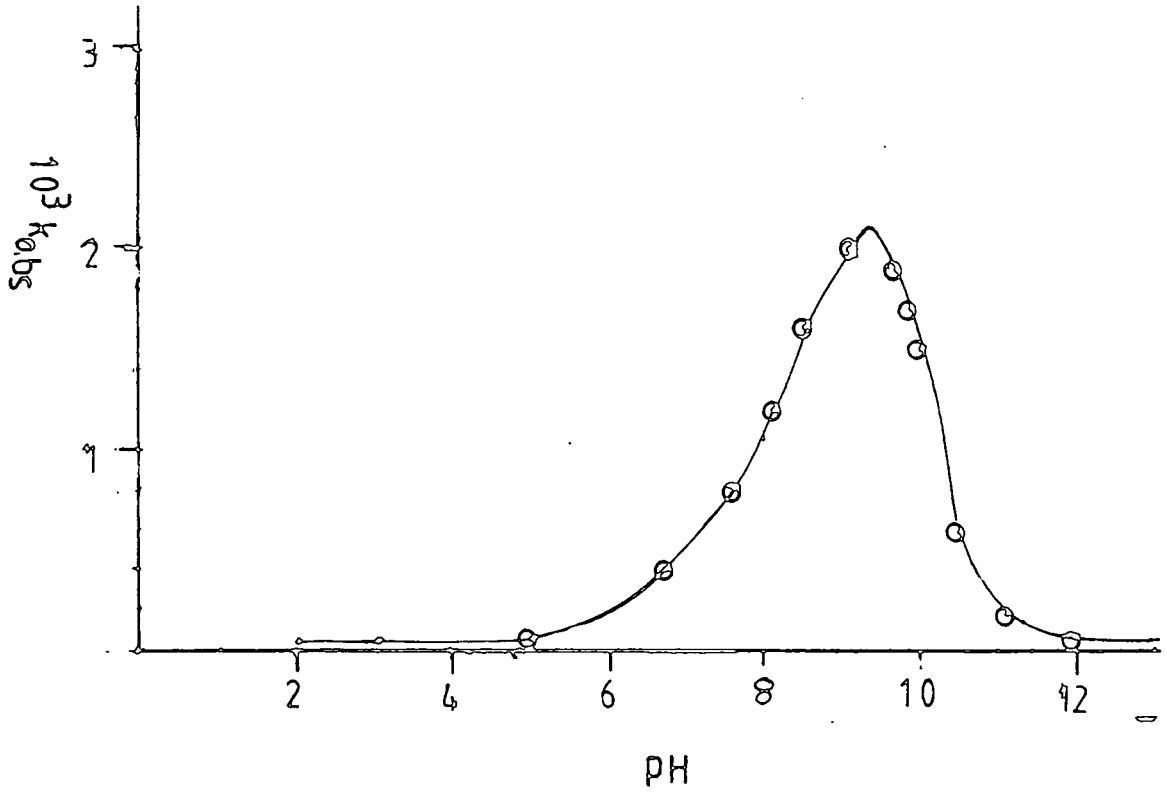

Plot of k_{obs} versus pH for decomposition of the product of the initial decomposition reaction of DPT in aqueous solution

Comparing the results with those previously obtained with methylenedinitroamine,¹¹⁶ (see introduction to Chapter 6) suggests 3 forms of the product of the fast reaction A, B and C.

A = species predominantly in alkaline media pH > 12

B = species present at intermediate pH

C = species predominantly in acidic media pH < 5

We can define $pK_B = \text{pH} + \log_{10} \frac{[B]}{[A]}$

and $pK_C = \text{pH} + \log_{10} \frac{[C]}{[B]}$

Assuming that B is the most reactive species then maximum value of k_{obs} obtained = $\frac{2.5 \times 10^{-3} \text{ s}^{-1}}{1} = k_B$. However, k_{obs} will also contain contributions from k_A and k_C .

$$k_{\text{calc}} = \frac{k_B[B]}{[A] + [B] + [C]} + \frac{k_A[A]}{[A] + [B] + [C]} + \frac{k_C[C]}{[A] + [B] + [C]}$$

From the rate data it can be estimated that $pK_B \approx 10$ and $pK_C \approx 8$.

Using these values rate constants can be calculated neglecting the small contributions from k_A and k_C

e.g. at pH 10.8 $10 = 10.8 + \log_{10} \frac{[B]}{[A]}$

$$\therefore k_{\text{calc}} = k_B \times 0.136 = \underline{3.4 \times 10^{-4} \text{ s}^{-1}}$$

The difference between k_{obs} and k_{calc} at pH 12 will be equal to k_A . Similarly the difference between k_{obs} and k_{calc} at low pH is equal to k_C .

k_{calc} values calculated assuming that [B] is the only reactive species are shown in Table 6.8.

Table 6.8

Rate constants calculated for decomposition of species [B].

pH	$k_{\text{obs}}/\text{s}^{-1}$	$k_{\text{calc}}/\text{s}^{-1}$
12	7×10^{-5}	2.5×10^{-5}
11.3	1.3×10^{-4}	1.20×10^{-4}
11.1	1.7×10^{-4}	1.8×10^{-4}
10.8	3.8×10^{-4}	3.4×10^{-4}
10.5	5.9×10^{-4}	6.0×10^{-4}
10.15	1.1×10^{-3}	1.0×10^{-3}
10.1	1.0×10^{-3}	1.1×10^{-4}
10.0	1.5×10^{-3}	1.3×10^{-3}
9.9	1.7×10^{-3}	1.4×10^{-3}
9.7	2.1×10^{-3}	1.7×10^{-3}
9.5	2.5×10^{-3}	1.9×10^{-3}

Table 6.8 continued

Rate constants calculated for decomposition of species [B].

pH	$k_{\text{obs}}/\text{s}^{-1}$	$k_{\text{calc}}/\text{s}^{-1}$
9.3	2.1×10^{-3}	2.1×10^{-3}
9.1	2.0×10^{-3}	2.0×10^{-3}
8.9	1.8×10^{-3}	1.9×10^{-3}
8.5	1.6×10^{-3}	1.7×10^{-3}
8.3	1.3×10^{-3}	1.4×10^{-3}
8.1	1.2×10^{-3}	1.1×10^{-3}
7.6	8×10^{-4}	7.1×10^{-4}
6.7	4×10^{-4}	1.2×10^{-4}
4.8	5×10^{-5}	1.6×10^{-6}
3	4×10^{-5}	2.5×10^{-8}
2	4×10^{-5}	2.5×10^{-9}

∴ at pH 12 $k_A = k_{\text{obs}} - k_{\text{calc}} = \frac{4.5 \times 10^{-5} \text{ s}^{-1}}{\text{}}$
 and at pH 2 $k_C = k_{\text{obs}} - k_{\text{calc}} = \frac{4.0 \times 10^{-5} \text{ s}^{-1}}{\text{}}$.

As mentioned in the introduction the pK values for methylenedinitroamine $\text{O}_2\text{N}-\text{HN}-\text{CH}_2-\text{NH}-\text{NO}_2$ were found to be $\text{pK}_1 = 5$, $\text{pK}_2 = 6.6$.¹¹⁷ It was suggested that the reactive species was $\text{O}_2\text{N}-\text{HN}-\text{CH}_2-\bar{\text{N}}-\text{NO}_2$ i.e. the monoanion and that the un-ionised and the dianionic species were relatively stable. This suggests that species [B] is not methylenedinitroamine but it may have a related structure.

Possible structures for [A], [B] and [C] are

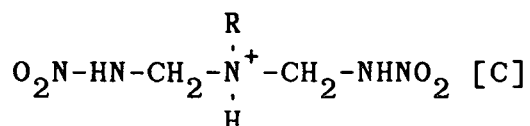
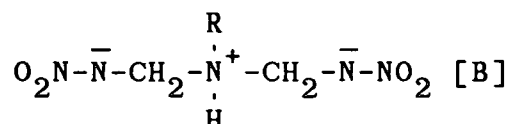
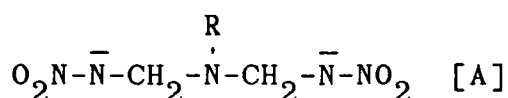

The pK_B value of ~ 10 suggests an amine function rather than a nitroamine function (pK_a of triethylamine = 10.75). Making a direct comparison to methylenedinitroamine it is understandable that species [A] and [C] would be relatively stable.

In the case of methylenedinitroamine,¹¹⁶ it was suggested that one nitroamino-group cannot facilitate the ejection of the other as a nitroamine anion, however, after mono-ionisation has taken place, the relatively greater availability of the electrons permits this rupture thus

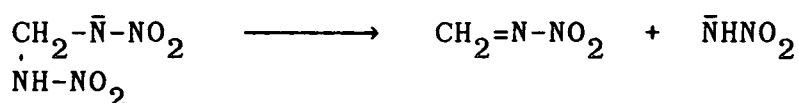

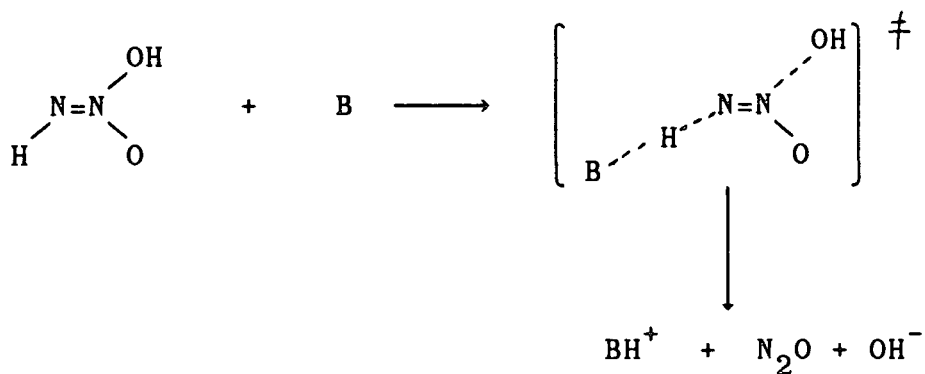

and also

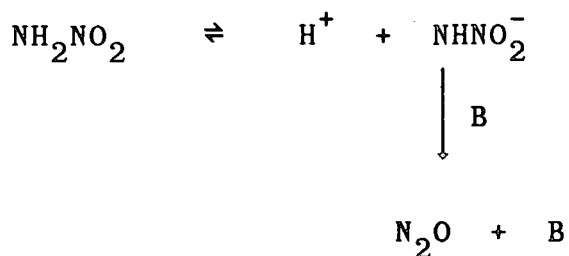

The pK_a of nitramide was found to be 6.55.¹²³

The results in this chapter show that the second decomposition reaction is not simply decomposition of nitramide since the pH profile of the reaction is different to that for the nitramide reaction.

It is difficult to give an exact structure of species [B] at this stage since it is not entirely certain whether the two nitramine functions are present on the same molecule or whether the molecule has cleaved further.

6.3.3.5 Buffer Catalysis of Second decomposition Reaction

a) Catalysis by Tris buffer

Observed rate constants for the decomposition of the product of the fast reaction in Tris buffer are shown in Table 6.9.1 . All solutions were made up to constant ionic strength using sodium chloride.

Extrapolation back to zero buffer concentration gives

$$k_0 = \underline{4 \times 10^{-4} \text{ s}^{-1}} \text{ at pH 6.7}$$

$$\text{and } k_0 = \underline{8 \times 10^{-4} \text{ s}^{-1}} \text{ at pH 7.6.}$$

At pH 6.7 it can be seen that

$$\frac{[\text{Tris}]}{[\text{TrisH}^+]} = 0.064$$

$$\therefore k_{\text{obs}} - k_0 = [\text{TrisH}^+][k_{\text{TrisH}^+} + 0.064k_{\text{Tris}}]$$

see Figure 6.9.7 graph A

$$\text{at pH 7.6 } \frac{[\text{Tris}]}{[\text{TrisH}^+]} = 0.25$$

$$\therefore k_{\text{obs}} - k_0 = [\text{TrisH}^+][k_{\text{TrisH}^+} + 0.25k_{\text{Tris}}]$$

see Figure 6.9.7 graph B

Table 6.9.1

Decomposition of product of fast reaction (2.27×10^{-5} M) in
Tris buffer at 25°C

$\frac{[\text{Tris}]}{\text{M}}$	$\frac{[\text{TrisH}^+]}{\text{M}}$	pH	$\frac{k_{\text{obs}}}{\text{s}^{-1}}$	$\frac{k_{\text{obs}} - k_0}{\text{s}^{-1}}$
3×10^{-3}	4.7×10^{-2}	6.7	2.3×10^{-3}	1.9×10^{-3}
1.5×10^{-3}	2.35×10^{-2}	6.7	1.6×10^{-3}	1.2×10^{-3}
7.5×10^{-4}	1.18×10^{-2}	6.7	1.2×10^{-3}	8×10^{-4}
3.75×10^{-4}	5.88×10^{-3}	6.7	6.5×10^{-4}	2.5×10^{-4}
1.88×10^{-4}	2.94×10^{-3}	6.7	5.4×10^{-4}	1.4×10^{-4}
1×10^{-2}	4×10^{-2}	7.6	4.2×10^{-3}	3.4×10^{-3}
5×10^{-3}	2×10^{-2}	7.6	2.7×10^{-3}	1.9×10^{-3}
2.5×10^{-3}	1×10^{-2}	7.6	1.52×10^{-3}	0.72×10^{-3}
1.25×10^{-3}	5×10^{-3}	7.6	1.3×10^{-3}	0.5×10^{-3}

Fig.6.9.7

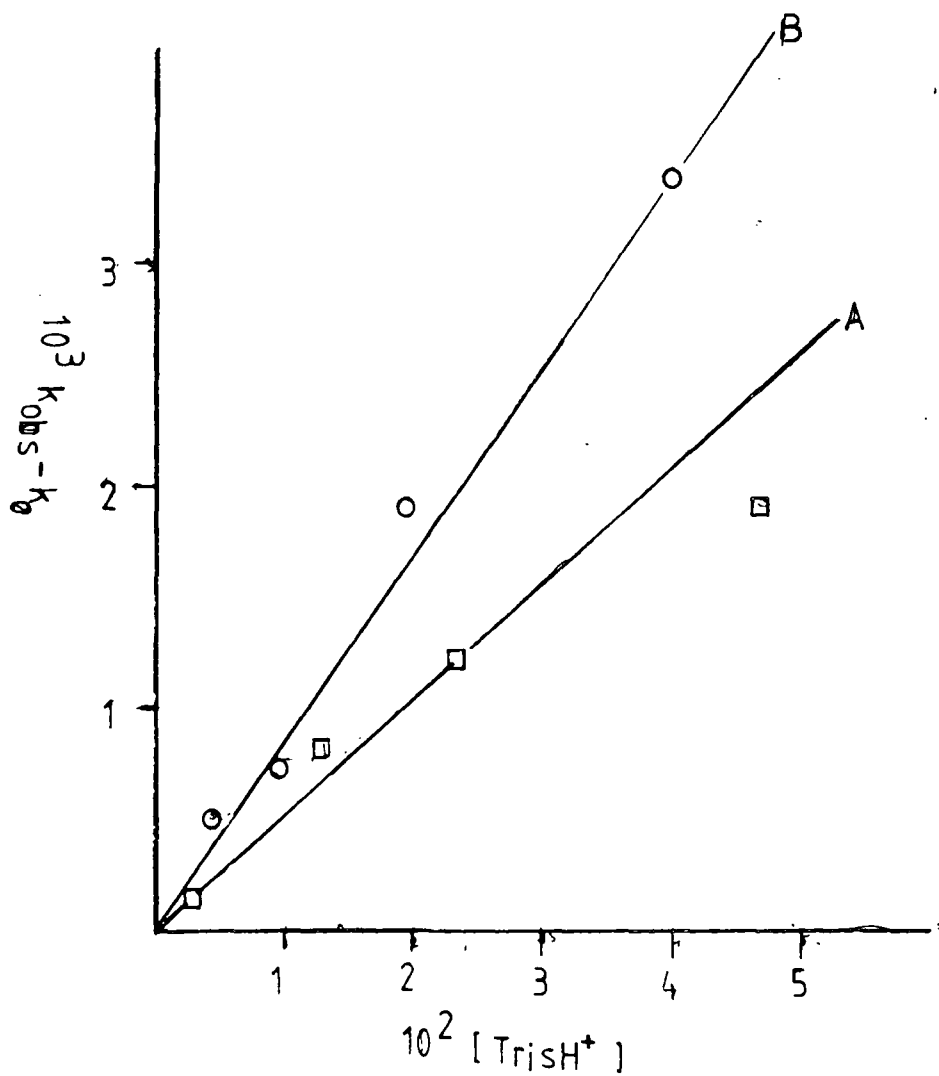

Plot of $k_{obs} - k_w$ versus $[TrisH^+]$ catalysis of Tris buffer in the decomposition of the product of the initial reaction of DPT in aqueous solution

From the slope of graph A, $0.05 = k_{\text{TrisH}^+} + 0.064$

k_{Tris}

From the slope of graph B, $0.085 = k_{\text{TrisH}^+} +$

$0.025k_{\text{Tris}}$

Subtraction gives $0.032 = 0.19 k_{\text{Tris}}$

$$\therefore k_{\text{Tris}} = \underline{0.17 \text{ l mol}^{-1} \text{ s}^{-1}}$$

$$k_{\text{TrisH}^+} = \underline{0.042 \text{ l mol}^{-1} \text{ s}^{-1}}$$

b) Catalysis by Sodium Acetate/Acetic Acid buffer

Observed rate constants for the decomposition of the product of the fast reaction in Sodium Acetate/Acetic Acid buffer are shown in Table 6.9.2. All solutions were made up to constant ionic strength using sodium chloride.

Table 6.9.2

[HAc]/M	[Ac ⁻]/M	pH	k _{obs} /s ⁻¹	k _{calc} /s ^{-1*}
0.005	0.001	3.9	9.8x10 ⁻⁵	9.75x10 ⁻⁵
0.01	0.002	3.9	1.45x10 ⁻⁴	1.45x10 ⁻⁵
0.02	0.004	3.9	2.3x10 ⁻⁴	2.4x10 ⁻⁴
0.0025	0.0025	4.5	2x10 ⁻⁴	1.7x10 ⁻⁴
0.005	0.005	4.5	3.8x10 ⁻⁴	3.0x10 ⁻⁴
0.01	0.01	4.5	6x10 ⁻⁴	5.3x10 ⁻⁴
0.001	0.005	5.3	3.1x10 ⁻⁴	2.9x10 ⁻⁴
0.002	0.01	5.3	5.6x10 ⁻⁴	5.3x10 ⁻⁴
0.004	0.02	5.3	1x10 ⁻³	1x10 ⁻³

*Calculated from $k_{\text{calc}} = k_w + k_{\text{Ac}^-} [\text{Ac}^-] + k_{\text{HAc}} [\text{HAc}]$

with $k_w, 5 \times 10^{-5}$

$k_{\text{Ac}^-}, 4.75 \times 10^{-2} \text{ l mol}^{-1} \text{ s}^{-1}$

$k_{\text{HAc}}, 0$

The observed rate constant can be written in terms of

$$k_{\text{obs}} = k_w + k_{\text{Ac}^-} [\text{Ac}^-] + k_{\text{AcH}} [\text{AcH}].$$

If it is assumed that $k_{\text{HAc}} = 0$ and $k_w = 5 \times 10^{-5} \text{ s}^{-1}$

(from extrapolation to zero buffer) then

$$k_{\text{Ac}^-} = \underline{4.75 \times 10^{-2} \text{ l mol}^{-1} \text{ s}^{-1}}.$$

c) Catalysis by Potassium dihydrogen Orthophosphate
buffer

Observed constants for the decomposition of the product of the fast reaction in phosphate buffer are shown in Table 6.9.3. All solutions were made up to constant ionic strength using sodium chloride.

Table 6.9.3

Decomposition of the product of the fast reaction (2.27×10^{-5} M) in phosphate buffer at 25°C .

$\frac{[\text{H}_2\text{PO}_4^-]}{\text{M}}$	$\frac{[\text{HPO}_4^{2-}]}{\text{M}}$	pH	$\frac{k_{\text{obs}}}{\text{s}^{-1}}$	$\frac{k_{\text{obs}} - k_0}{\text{s}^{-1}}$	$\frac{k_{\text{calc}}}{\text{s}^{-1}}$
0.0045	0.0205	7.3	2×10^{-2}	1.94×10^{-2}	1.96×10^{-2}
0.002	0.0103	7.4	9.4×10^{-3}	8.8×10^{-3}	9.9×10^{-3}
0.001	0.00515	7.24	4.8×10^{-3}	4.2×10^{-3}	5.0×10^{-3}
0.0072	0.0053	6.7	2×10^{-2}	1.96×10^{-2}	1.98×10^{-2}

If the catalytic coefficients of H_2PO_4^- and HPO_4^{2-} are a and b respectively then

$$1) \quad k_{\text{obs}} - k_0 = a[\text{H}_2\text{PO}_4^-] + b[\text{HPO}_4^{2-}]$$

$$2) \quad k_{\text{obs}} - k_0^1 = a[\text{H}_2\text{PO}_4^-] + b[\text{HPO}_4^{2-}]$$

$$\therefore 1.94 \times 10^{-2} = a \times 4.5 \times 10^{-3} + 2.05 \times 10^{-2} \times b$$

$$1.96 \times 10^{-2} = a \times 7.2 \times 10^{-3} + 5.3 \times 10^{-3} \times b$$

$$\therefore k_{\text{HPO}_4^{2-}} = b = \underline{0.42 \text{ l mol}^{-1} \text{ s}^{-1}}$$

$$\text{and } k_{\text{H}_2\text{PO}_4^-} = a = \underline{2.4 \text{ l mol}^{-1} \text{ s}^{-1}}.$$

Catalytic coefficients

Experiments with borax and bicarbonate buffers (Table 6.7) showed no evidence for catalysis of the second reaction by buffer components.

Values of catalytic coefficients are collected in Table 6.9.4 and it can be seen that there is no correlation between the catalytic coefficients and the pK_a values of the catalysts. It seems likely that specific chemical reactions may be occurring between the substrate and the catalysts rather than simple proton-transfers.

Table 6.9.4

Catalyst	<u>catalytic coefficient</u> $l \text{ mol}^{-1} \text{ s}^{-1}$	pK_a
Ac ⁻	4.75×10^{-2}	4.75
AcH	≈ 0	
Tris	0.17	8.1
TrisH ⁺	0.042	
H ₂ PO ₄ ⁻	2.4	7.2
HPO ₄ ²⁻	0.42	12.7
Borax	0	9.1
Bicarbonate	0	10.2

APPENDIX I

STERIC EFFECTS ON RATE AND EQUILIBRIUM
CONSTANTS FOR σ -ADDUCT FORMATION FROM
ALKYL 2,4,6-TRINITROPHENYL ETHERS
AND ETHOXIDE IONS IN ETHANOL

Introduction

σ -complexes have been studied in great depth with respect to stability, structure and their role as intermediates in nucleophilic aromatic substitution. Thus a large amount of literature exists on the subject and several reviews have been written (e.g. M.R. Crampton¹²⁶) The technique most often used for the determination of equilibrium constants in these reactions is visible spectroscopy. Complexation occurs at low base concentrations for reactive substrates, thus equilibrium constants can be determined directly by measurement of the absorbance at an appropriate wavelength. Benesi-Hildebrand plots can be used to determine A_{∞} . It can be shown that $1/A = 1/A_{\infty} + 1/K [\text{BASE}] \cdot A_{\infty}$. Therefore a plot of $1/A$ versus $1/[\text{BASE}]$ gives an intercept of $1/A_{\infty}$.

N.m.r. results show that the initial reversible reactions of alkyl 2,4,6-trinitrophenyl ethers with alkoxide ions yield σ -adducts. Attack at the unsubstituted 3-position is kinetically favoured but the isomeric adducts formed by reaction at the 1-position are thermodynamically more stable.¹²⁶⁻¹²⁸ The greater stability of the 1,1-adducts has been attributed to the inductive electron withdrawal of the -OR substituent at the 1-position,¹²⁹ the relief of the steric strain as this group is rotated from the ring-plane on adduct formation,^{127,129} and the stabilising effect of dialkoxy-substitution at an sp^3 -hybridised carbon atom.¹³⁰

Although kinetic measurements have been reported for several reactions of this type¹³⁰⁻¹³⁹ there has been no

systematic study of the variations in reactivity when a variety of alkyl ethers react with a single nucleophile in a common solvent. Results for the reactions of four alkyl 2,4,6-trinitrophenyl ethers with ethoxide ions in ethanol are given here. The reactions proceed as shown in

Scheme 1

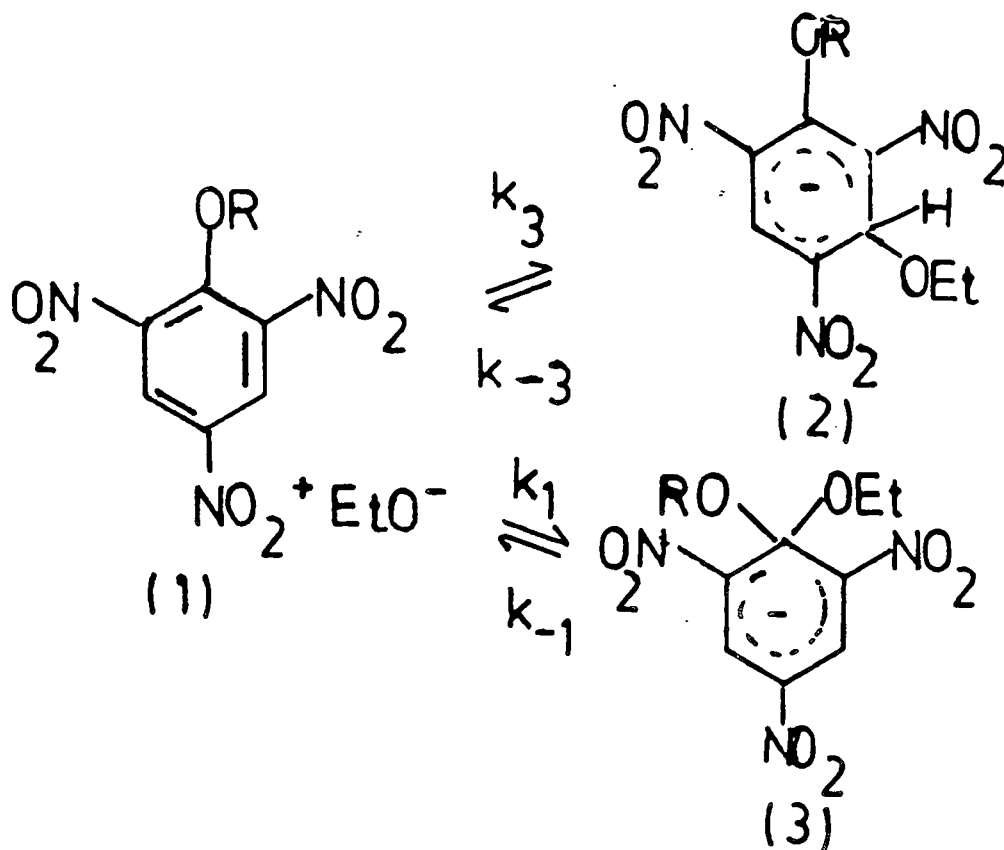

SCHEME 1

Experimental

Alkyl 2,4,6-trinitrophenyl ethers were prepared by reaction of picryl chloride with sodium alkoxide (1 mol equiv.) in the corresponding alcohol. Recrystallisation yielded materials with the following m.p.s.; (1;R = Me) 67°C (lit.,¹⁴⁰ 68°C), (1;R = Et) 80°C (lit.,¹⁴¹ 78.5°C), (1;R = Prⁿ) 41°C (lit.,¹⁴² 43°C), (1;R = Prⁱ) 95°C (lit.,¹⁴³ 95°C). AnalaR grade absolute ethanol was used without purification. Sodium ethoxide solutions were freshly prepared by reaction of clean sodium with ethanol under nitrogen and were titrated with standard acid.

Kinetic and equilibrium measurement were made with freshly prepared solutions of reagents using a Hi-Tech SF 3L stopped-flow spectrophotometer. All measurements were made under first-order conditions with the base concentration in large excess over the substrate concentration. Rate coefficients at 25°C are the mean of five separate determinations and are precise to ± 5%.

Results and Discussion

Adducts of structure types (2) and (3) absorb in the visible region and are expected to have rather similar spectral shapes.^{126,144} Examination of the systems at 480 nm by stopped-flow spectrophotometry showed the presence of two processes, both colour-forming, with well separated rates. Data are in Tables 7.1 to 7.4. In each case the faster process is attributed to formation of the 3- adduct (2), and with base in large excess equation (1) is applicable.

This equation is derived as follows

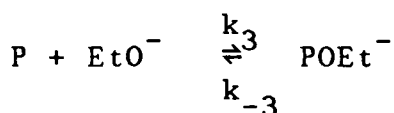

$$\frac{d[POEt^-]}{dt} = k_3[P][EtO^-] - k_{-3}[POEt^-]$$

$$[P]_{\text{stoich}} = [P] + [POEt^-]$$

$$\frac{d[POEt^-]}{dt} = k_3[EtO^-] \left[[P]_{\text{stoich}} - [POEt^-] \right] - k_{-3}[POEt^-]$$

$$\text{at equilibrium } \frac{d[POEt^-]}{dt} = 0$$

$$\therefore k_3 [EtO^-] \left[[P]_{\text{stoich}} - [POEt^-]_{\text{eq}} \right] - k_{-3} [POEt^-]_{\text{eq}} = 0$$

$$\text{and } \frac{d[POEt^-]}{dt} = k_3[EtO^-] \left[[POEt^-]_{\text{eq}} - [POEt^-] \right] + k_{-3} \left[[POEt^-]_{\text{eq}} - [POEt^-] \right]$$

$$\therefore \frac{d[\text{POEt}^-]}{dt} = \left[k_3[\text{EtO}^-] + k_{-3} \right] \left[[\text{POEt}^-]_{\text{eq}} - [\text{POEt}^-] \right]$$

$$k_{\text{obs}} = k_3[\text{EtO}^-] + k_{-3} = k_{\text{fast}} \quad (1)$$

Plots of k_{fast} versus base concentration allows values of k_3 and k_{-3} to be determined. Combination of these values gave values of $K_3 = k_3/k_{-3}$ which were in good agreement with those obtained from absorbance measurements measured at the completion of the faster reaction.

Table 7.1

Rate and equilibrium data for reaction of 2,4,6-trinitroanisole^a with sodium ethoxide in ethanol at 25^o.

[NaOEt] ^b /M	k _{fast} /s ⁻¹	k _{calc} ^c	A ^d (480)	K ₃ ^e /l mol ⁻¹	k _{slow} /s ⁻¹	k _{calc} ^f	A ^g (480)
0.0025	30	30	0.013	95	0.11	0.11	0.066
0.0050	35	36	0.022	96	0.19	0.19	0.066
0.0100	47	49	0.034	100	0.29	0.28	0.066
0.0150	63	62	0.040	95	0.33	0.34	0.066

a. Concentration is 2×10^{-5} M

b. All solutions made up to ionic strength I = 0.05 M with sodium perchlorate.

c. Calculated from equation (1) with k₃ 2500 l mol⁻¹s⁻¹ and k₋₃ 24 s⁻¹.

d. Measured at completion of the faster colour forming reaction, with cell of 2 mm pathlength. Benesi-Hilderbrand plot gives a value of 0.068 for complete conversion.

e. Calculated as A/(0.068 - A) [NaOEt].

f. Calculated from equation (3) with k₁ 58 l mol⁻¹s⁻¹ and K₃ 104 l mol⁻¹.

g. At completion of the slower colour forming reaction.

Table 7.1 continued

Rate and equilibrium data for reaction of 2,4,6-trinitroanisole^a with sodium ethoxide in ethanol at 25^o.

[NaOEt] ^b /M	k _{fast} /s ⁻¹	k _{calc} ^c	A ^d (480)	K ₃ ^e /ℓ mol ⁻¹	k _{slow} /s ⁻¹	k _{calc} ^f	A ^g (480)
0.0200	74	74	0.046	105	0.38	0.38	0.066
0.0300	99	99	0.051	100	0.41	0.42	0.066
0.0400	122	124	0.055	106	0.44	0.45	0.066
0.0500	149	149	-		0.45	0.47	0.063

a. Concentration is 2×10^{-5} M

b. All solutions made up to ionic strength I = 0.05 M with sodium perchlorate.

c. Calculated from equation (1) with k_3 2500 ℓ mol⁻¹s⁻¹ and k_{-3} 24 s⁻¹.

d. Measured at completion of the faster colour forming reaction, with cell of 2 mm pathlength. Benesi-Hilderbrand plot gives a value of 0.068 for complete conversion.

e. Calculated as $A/(0.068 - A)$ [NaOEt].

f. Calculated from equation (3) with k_1 58 ℓ mol⁻¹s⁻¹ and K_3 104 ℓ mol⁻¹.

g. At completion of the slower colour forming reaction.

Table 7.2

Rate and equilibrium data for reaction of 2,4,6-trinitrophenetole^a with sodium ethoxide in ethanol at 25^o.

[NaOEt] ^b /M	k _{fast} /s ⁻¹	k _{calc} ^c	A ^d (480)	K ₃ ^e /l mol ⁻¹	k _{slow} /s ⁻¹	k _{calc} ^f	A ^g (480)
0.0025	32	32	0.010	70	0.051	0.056	0.064
0.0050	37	36	0.016	63	0.093	0.097	0.062
0.0100	44	45	0.026	63	0.15	0.15	0.063
0.0150	51	54	0.033	65	0.20	0.19	0.063

a. Concentration is 2×10^{-5} M

b. All solutions made up to ionic strength, 0.05 M with sodium perchlorate.

c. Calculated from equation (1) with k_3 1800 l mol⁻¹s⁻¹ and k_{-3} 27 s⁻¹.

d. Measured at completion of the faster colour forming reaction, with cell of 2 mm pathlength. Benesi-Hilderbrand plot gives a value of 0.067 for complete conversion.

e. Calculated as $A/(0.067 - A)$ [NaOEt].

f. Calculated from equation (3) with k_1 26 l mol⁻¹s⁻¹ and K_3 67 l mol⁻¹.

g. At completion of the slower colour forming reaction.

Table 7.2 continued

Rate and equilibrium data for reaction of 2,4,6-trinitrophenetole^a with sodium ethoxide in ethanol at 25°.

[NaOEt] ^b /M	k _{fast} /s ⁻¹	k _{calc} ^c	A ^d (480)	K ₃ ^e /l mol ⁻¹	k _{slow} /s ⁻¹	k _{calc} ^f	A ^g (480)
0.0200	62	63	0.038	65	0.22	0.22	0.063
0.0300	75	81	0.046	73	0.26	0.26	0.063
0.0400	101	99	0.049	68	0.29	0.28	0.062
0.0500	122	117	0.052	69	0.31	0.31	0.62

a. Concentration is 2×10^{-5} M

b. All solutions made up to ionic strength, 0.05 M with sodium perchlorate.

c. Calculated from equation (1) with k_3 1800 l mol⁻¹ s⁻¹ and k_{-3} 27 s⁻¹.

d. Measured at completion of the faster colour forming reaction, with cell of 2 mm pathlength. Benesi-Hilderbrand plot gives a value of 0.067 for complete conversion.

e. Calculated as $A/(0.067 - A)$ [NaOEt].

f. Calculated from equation (3) with k_1 26 l mol⁻¹ s⁻¹ and K_3 67 l mol⁻¹.

g. At completion of the slower colour forming reaction.

Table 7.3

Rate and equilibrium data for reaction of *n*-propyl 2,4,6-trinitrophenyl ether^a with sodium ethoxide in ethanol at 25^o

[NaOEt] ^b /M	$k_{\text{fast}}/\text{s}^{-1}$	$k_{\text{calc}}^{\text{c}}$	$A^{\text{d}}(480)$	$K_3^{\text{e}}/l \text{ mol}^{-1}$	$k_{\text{slow}}/\text{s}^{-1}$	$k_{\text{calc}}^{\text{f}}$	$A^{\text{g}}(480)$
0.0025	36	33	0.008	61	0.050	0.046	0.058
0.0050	37	37	0.014	61	0.080	0.081	0.056
0.0100	47	46	0.022	58	0.13	0.13	0.057
0.0150	55	55	0.029	62	0.17	0.17	0.058

a. Concentration is $2 \times 10^{-5} \text{M}$

b. All solutions made up to ionic strength $I = 0.05 \text{ M}$ with sodium perchlorate.

c. Calculated from equation (1) with $k_3 1700 l \text{ mol}^{-1} \text{ s}^{-1}$ and $k_{-3} 29 \text{ s}^{-1}$.

d. Measured at completion of the faster colour forming reaction, with cell of 2 mm pathlength. Benesi-Hilderbrand plot gives a value of 0.060 for complete conversion.

e. Calculated as $A/(0.060 - A) [\text{NaOEt}]$.

f. Calculated from equation (3) with $k_1 21 l \text{ mol}^{-1} \text{ s}^{-1}$ and $K_3 59 l \text{ mol}^{-1}$.

g. At completion of the slower colour forming reaction.

Table 7.3 continued

Rate and equilibrium data for reaction of n-propyl 2,4,6-trinitrophenyl ether^a with sodium ethoxide in ethanol at 25^o.

[NaOEt] ^b /M	$k_{\text{fast}}/\text{s}^{-1}$	$k_{\text{calc}}^{\text{c}}$	$A^{\text{d}}(480)$	$K_3^{\text{e}}/l \text{ mol}^{-1}$	$k_{\text{slow}}/\text{s}^{-1}$	$k_{\text{calc}}^{\text{f}}$	$A^{\text{g}}(480)$
0.0200	66	63	0.034	65	0.19	0.19	0.058
0.0300	80	80	0.038	58	0.23	0.23	0.057
0.0400	95	97	0.042	58	0.27	0.25	0.057
0.0500	122	114	0.046	66	0.27	0.27	0.057

a. Concentration is $2 \times 10^{-5} \text{M}$

b. All solutions made up to ionic strength $I = 0.05 \text{ M}$ with sodium perchlorate.

c. Calculated from equation (1) with $k_3 1700 \text{ l mol}^{-1} \text{ s}^{-1}$ and $k_{-3} 29 \text{ s}^{-1}$.

d. Measured at completion of the faster colour forming reaction, with cell of 2 mm pathlength. Benesi-Hilderbrand plot gives a value of 0.060 for complete conversion.

e. Calculated as $A/(0.060 - A) [\text{NaOEt}]$.

f. Calculated from equation (3) with $k_1 21 \text{ l mol}^{-1} \text{ s}^{-1}$ and $K_3 59 \text{ l mol}^{-1}$.

g. At completion of the slower colour forming reaction.

Table 7.4

Rate and equilibrium data for reaction of *i*-propyl 2,4,6-trinitrophenyl^a ether with sodium ethoxide in ethanol at 25^o.

[NaOEt] ^b /M	k_{fast}/s^{-1}	k_{calc}^c	$A^d(480)$	$K_3^e/e \text{ mol}^{-1}$	k_{slow}/s^{-1}	k_{calc}^f	$A^g(480)$
0.0025	29	29	0.005	32	0.027	0.028	0.057
0.0050	31	32	0.011	39	0.053	0.051	0.057
0.0100	36	36	0.018	37	0.090	0.089	0.057
0.0150	40	41	0.023	35	0.12	0.12	0.058

a. Concentration is $2 \times 10^{-5} \text{ M}$

b. All solutions made up to ionic strength $I = 0.05 \text{ M}$ with sodium perchlorate.

c. Calculated from equation (1) with $k_3 \text{ } 950 \text{ } e \text{ mol}^{-1} \text{ s}^{-1}$ and $k_{-3} \text{ } 27 \text{ } s^{-1}$.

d. Measured at completion of the faster colour forming process with cell of 2 mm pathlength. Benesi-Hilderbrand plot gives a value of 0.067 for complete conversion.

e. Calculated as $A/(0.067 - A) [\text{NaOEt}]$.

f. Calculated from equation (3) with $k_1 \text{ } 12 \text{ } e \text{ mol}^{-1} \text{ s}^{-1}$ and $K_3 \text{ } 35 \text{ } e \text{ mol}^{-1}$.

g. At completion of the slower colour forming reaction.

Table 7.4 continued

Rate and equilibrium data for reaction of *i*-propyl 2,4,6-trinitrophenyl^a ether with sodium ethoxide in ethanol at 25^o.

[NaOEt] ^b /M	k _{fast} /s ⁻¹	k _{calc} ^c	A ^d (480)	K ₃ ^e /e mol ⁻¹	k _{slow} /s ⁻¹	k _{calc} ^f	A ^g (480)
0.0250	51	51	0.032	37	0.16	0.16	0.057
0.0350	60	60	0.036	33	0.19	0.19	0.057
0.0500	74	74	0.044	38	0.22	0.22	0.58

a. Concentration is 2×10^{-5} M

b. All solutions made up to ionic strength I = 0.05 M with sodium perchlorate.

c. Calculated from equation (1) with k₃ 950 e mol⁻¹ s⁻¹ and k₋₃ 27 s⁻¹.

d. Measured at completion of the faster colour forming process with cell of 2 mm pathlength. Benesi-Hilderbrand plot gives a value of 0.067 for complete conversion.

e. Calculated as A/(0.067 - A) [NaOEt].

f. Calculated from equation (3) with k₁ 12 e mol⁻¹ s⁻¹ and K₃ 35 e mol⁻¹.

g. At completion of the slower colour forming reaction.

The slower process involves attack at the 1-position, and allowing for the pre-equilibrium of substrate and 3-adduct we obtain equation (2).

This is derived as follows

$$\frac{d[3]}{dt} = k_1 [1] [\text{EtO}^-] - k_{-1} [3]$$

$$[1] + [2] + [3] = \text{constant}$$

$$K_3 = \frac{[2]}{[1][\text{EtO}^-]}$$

$$[1] \left[1 + K_3 [\text{EtO}^-] \right] + [3] = \text{constant}$$

$$\therefore \frac{d[3]}{dt} = \frac{k_1 [\text{EtO}^-] (\text{constant} - [3])}{(1 + K_3 [\text{EtO}^-])} - k_{-1} [3]$$

$$\text{at equilibrium } \frac{d[3]}{dt} = 0$$

$$\frac{k_1 [\text{EtO}^-] (\text{constant} - [3]_{\text{eq}})}{(1 + K_3 [\text{EtO}^-])} - k_{-1} [3]_{\text{eq}} = 0$$

$$\therefore \frac{d[3]}{dt} = \frac{k_1 [\text{EtO}^-]}{(1 + K_3 [\text{EtO}^-])} \left[[3]_{\text{eq}} - [3] + k_{-1} ([3]_{\text{eq}} - [3]) \right]$$

$$\frac{d[3]}{dt} = ([3]_{\text{eq}} - [3]) k_{\text{obs}}$$

$$\therefore k_{\text{obs}} = \frac{k_1[\text{EtO}^-]}{1 + K_3[\text{EtO}^-]} + k_{-1} = k_{\text{slow}} \quad (2)$$

The absorbances measured at completion of the slower process show that even at the lowest base concentration used conversion into adducts (3) is virtually complete. It is calculated that values of K_1 are $> 10^4 \text{ l mol}^{-1}$ so that under the experimental conditions values of k_{-1} are negligibly small and equation (2) approximates to equation (3)

$$k_{\text{slow}} = \frac{k_1[\text{EtO}^-]}{1 + K_3[\text{EtO}^-]} \quad (3)$$

In the presence of excess sodium ethoxide a third process should be observed involving conversion of adducts (3; R = alkyl) into (3; R = Et). However, the visible spectra of these species should be almost identical¹²⁶ and the rate of conversion governed by the expulsion of RO^- from (3) will be slow. Hence this process was not detected.

It is known that 1,1-dialkoxy adducts (3) are capable of complexing cations and that values of rate and equilibrium constants may be affected by such complexing.^{136,145,146} Hence a constant ion concentration, 0.05 M using sodium perchlorate as the added electrolyte) was maintained throughout. The results are summarised in Table 7.5.

Table 7.5

Summary of kinetic and equilibrium data for reaction with sodium ethoxide^a in ethanol at 25°

Substrate	$k_3/l \text{ mol}^{-1} \text{ s}^{-1}$	k_{-3}/s^{-1}	$K_3/l \text{ mol}^{-1}$	$k_1/l \text{ mol}^{-1} \text{ s}^{-1}$
1, R = Me ~	2500	24	104	58
1, R = Et ~	1800	27	67	26
1, R = nPr ~	1700	29	59	21
1, R = isoPr ~	950	27	35	12
1,3,5-TNB ^b	33000	27	1200	-

a. Measurements with the alkyl 2,4,6-trinitrophenyl ethers were made in solutions of ionic strength 0.05 M, using sodium perchlorate as compensating electrolyte.

b. The data, from reference¹³⁰ correspond to reaction at an unsubstituted ring position of 1,3,5-trinitrobenzene.

Values of the equilibrium constant K_3 , for reaction at an unsubstituted ring position, decrease as the substituent is changed along the series H, OMe, OPrⁿ, OPrⁱ. The fact that this variation is due entirely to changes in value of k_3 while values of k_{-3} are invariant may indicate that the transition state resembles the adducts rather than the reactants. The electronic effect of alkoxy substituents acting from the meta- position is expected to be mildly activating and to be almost independent of the nature of the alkyl group.¹⁴⁷ Hence it is clear that steric effects play the dominant role in this series. Since nitro-groups will exhibit their maximum electron withdrawing ability when they are coplanar with the ring, factors which inhibit such coplanarity are expected to decrease adduct stability. There is crystallographic evidence for severe steric interactions in 1-substituted-2,4- and 1-substituted-2,6-dinitrobenzenes,¹⁴⁸ and in particular, in 2,4,6-trinitrophenetale the nitro groups at the 2- and 6-position are rotated from the ring-plane by 32 and 61° respectively.¹⁴⁹ Although crystallographic data for the other alkyl ethers have not been reported it is likely that steric congestion and rotations of ortho-nitro-groups will increase with the size of the alkyl substituent. Adduct formation at the 3-position will not relieve this unfavourable steric interaction.

Reaction at the 1-position will result in relief of steric interaction as the alkoxy substituent is rotated from the ring-plane. Hence in the 1,1-adduct (3) the ortho-nitro-group may approach planarity with the

ring.^{150,151} This together with the other two factors mentioned in the introduction to this chapter accounts for the greater stability of 1,1-adducts than of their 1,3-isomers. The results here do not allow determination of the variation of values of K_1 with substituent but it is found that values of k_1 decrease monotonically with increasing size of the alkoxy group. This order reflects the F-strain, steric hindrance to approach of the nucleophile, expected in this series.^{144,152}

APPENDIX II

RESEARCH COLLOQUIA, SEMINARS, LECTURES
AND CONFERENCES

APPENDIX II
RESEARCH COLLOQUIA, SEMINARS, LECTURES
AND CONFERENCES

The Board of Studies in Chemistry requires that each postgraduate research thesis contains an appendix, listing:

- (A) all research colloquia, research seminars and lectures arranged by the Department of Chemistry during the period of the author's residence as a postgraduate student;
- (B) Lectures organised by Durham University Chemical Society;
- (C) all research conferences attended and papers presented by the author during the period when research for the thesis was carried out;
- (D) details of the postgraduate induction course.

(A) LECTURES ORGANISED BY DURHAM UNIVERSITY - 1983-1986

- 5.10.83 Prof. J.P. Maier (Basel, Switzerland) "Recent approaches to spectroscopic characterization of cations".
- 12.10.83 Dr. C.W. McLeleand (Port Elizabeth, Australia), "Cyclization of aryl alcohols through the intermediacy of alkoxy radicals and aryl radical cations.
- 19.10.83 Dr. N.W. Alcock (Warwick), "Aryl tellurium (IV) compounds, patterns of primary and secondary bonding".
- 26.10.83 Dr. R.H. Friend (Cavendish, Cambridge), "Electronic properties of conjugated polymers".
- 30.11.83 Prof. I.M.G. Cowie (Stirling), "Molecular interpretation of non-relaxation processes in polymer glasses".
- 2.11.83 Dr. G.M. Brooke (Durham), "The fate of the

- ortho-fluorine in 3,3-sigmatropic reactions involving polyfluoro-aryl and -hetero-aryl systems".
- 14.12.83 Prof. R.J. Donovan (Edinburgh), "Chemical and physical processes involving the ion-pair states of the halogen molecules".
- 10.1.84 Prof. R. Hester (York), "Nanosecond Laser Spectroscopy of Reaction Intermediates".
- 18.1.84 Prof. R.K. Harris (UEA), "Multi-nuclear solid state magnetic resonance".
- 8.2.84 Dr. B.T. Heaton (Kent), "Multi-nuclear NMR Studies".
- 15.2.84 Dr. R.M. Paton (Edinburgh), "Heterocyclic Synthesis using Nitrile Sulphides".
- 7.3.84 Dr. R.T. Walker (Birmingham), "Synthesis and Biological Properties of some 5-substituted Uracil Derivatives; yet another example of serendipity in Anti-viral Chemotherapy".
- 21.3.84 Dr. P. Sherwood (Newcastle), "X-ray photoelectron spectroscopic studies of electrode and other surfaces".
- 21.3.84 Dr. G. Beamson (Durham/Kratos), "EXAFS: General Principles and Applications".
- 23.3.84 Dr. A. Ceulemans (Leuven), "The Development of Field-Type models of the Bonding in Molecular Clusters".
- 2.4.84 Prof. K. O'Driscoll (Waterloo). "Chain Ending reactions in Free Radical Polymerisation".
- 3.4.84 Prof. C.H. Rochester (Dundee), "Infrared Studies of adsorption at the Solid-Liquid Interface".
- 25.4.84 Dr. R.M. Acheson (Biochemistry, Oxford), "Some Heterocyclic Detective Stories".
- 27.4.84 Dr. T. Albright (Houston, U.S.A.), "Sigmatropic Rearrangements in Organometallic Chemistry".
- 14.5.84 Prof. W.R. Dolbier (Florida, U.S.A.), "Cycloaddition Reactions of Fluorinated Allenes".
- 16.5.84 Dr. P.J. Garratt (UCL), "Synthesis with Dilithiated Vicinal Diesters and Carboximides".
- 22.5.84 Prof. F.C. de Schryver (Leuven), "The use of Luminescence in the study of micellar aggregates" and "Configurational and Conformational control in excited state complex formation".

- 23.5.84 Prof. M. Tada (Waseda, Japan), "Photochemistry of Dicyanopyrazine Derivatives".
- 31.5.84 Dr. A. Haaland (Oslo), "Electron Diffraction Studies of some Organometallic Compounds".
- 11.6.84 Dr. J.B. Street (IBM, California), "Conducting Polymers derived from Pyrroles".
- 19.9.84 Dr. C. Brown (IBM, California), "New Superbase reactions with organic compounds".
- 21.9.84 Dr. H.W. Gibson (Signal UOP, Illinois), "Isomerization of Polyacetylene".
- 19.10.84 Dr. A. Germain (Languedoc, Montpellier), "Anodic Oxidation of Perfluoro Organic Compounds in Perfluoroalkane Sulphonic Acids".
- 24.10.84 Prof. R.K. Harris (Durham), "N.M.R. of Solid Polymers"
- 28.10.84 Dr R. Snaith (Strathclyde), "Exploring Lithium Chemistry: Novel Structures, Bonding, and Reagents"
- 7.11.84 Prof. W.W. Porterfield (Hampden-Sydney College, USA), "There is no Borane Chemistry (only Geometry)"
- 7.11.84 Dr. H.S. Munro (Durham), "New Information from ESCA Data"
- 21.11.84 Mr. N. Everall (Durham), "Picosecond Pulsed Laser Raman Spectroscopy"
- 27.11.84 Dr. W.J. Feast (Durham), "A Plain Man's Guide to Polymeric Organic Metals"
- 28.11.84 Dr. T.A. Stephenson (Edinburgh), "Some recent Studies in Platinum Metal Chemistry"
- 12.12.84 Dr. K.B. Dillon (Durham), "³¹P NMR Studies of some Anionic Phosphorus Complexes"
11. 1.85 Emeritus Prof. H. Suchitzky (Salford), "Fruitful Fissions of Benzofuroxanes and Isobenzimidazoles (umpolung of *o*-phenylenediamine)"
13. 2.85 Dr. G.W.J. Fleet (Oxford), "Synthesis of some Alkaloids from Carbohydrate"
19. 2.85 Dr. D.J. Mincher (Durham), "Stereoselective Syntheses of Some Novel Anthracyclines Related to the Anti-cancer Drug Adriamycin and to the Steffimycin Antibiotics"
27. 2.85 Dr. R.E. Mulvey (Durham), "Some Unusual Lithium Complexes"
6. 3.85 Dr. P.J. Kocienski (Leeds), "Some Synthetic

Applications of Silicon-Mediated Annulation Reactions"

7. 3.85 Dr. P.J. Rodgers (I.C.I. plc Agricultural Division, Billingham), "Industrial Polymers from Bacteria"
12. 3.85 Prof. K.J. Packer (B.P. Ltd./East Anglia) "NMR Investigations of the Structure of Solid Polymers"
14. 3.85 Prof. A.R. Katritzky F.R.S. (Florida), "Some Adventures in Heterocyclic Chemistry"
20. 3.85 Dr. M. Poliakoff (Nottingham), "New Methods for Detecting Organometallic Intermediates in Solution"
28. 3.85 Prof. H. Ringsdorf (Mainz), "Polymeric Liposomes as Models for Biomembranes and Cells"
24. 4.85 Dr. M.C. Grossel (Bedford College, London) "Hydroxypyridine Dyes - Bleachable One-Dimensional Metals?"
25. 4.85 Major S.A. Shackelford (U.S. Air Force) "In Situ Mechanistic Studies on Condensed Phase Thermochemical Reaction Processes: Deuterium Isotope Effects in HMX Decomposition, Explosives and Combustion"
1. 5.85 Dr. D. Parker (I.C.I plc, Petrochemical and Plastics Division, Wilton) "Applications of Radioisotopes in Industrial Research"
7. 5.85 Prof. G.E. Coates (formerly of Wyoming, U.S.A.) "Chemical Education in England and America: Successes and Deficiencies"
8. 5.85 Prof. D. Tuck (Windsor, Ontario), "Lower Oxidation State Chemistry of Indium"
8. 5.85 Prof. G. Williams (U.C.W., Aberystwyth) "Liquid Crystalline Polymers"
9. 5.85 Prof. R.K. Harris (Durham), "Chemistry in a Spin: Nuclear Magnetic Resonance"
14. 5.85 Prof. J. Passmore (New Brunswick, U.S.A.), "The Synthesis and Characterisation of some Novel Selenium-Iodine Cations, aided by 77-Se NMR Spectroscopy"
15. 5.85 Dr. J.E. Packer (Auckland, New Zealand) "Studies of Free Radical Reactions in Aqueous Solution Using Ionising Radiation"
17. 5.85 Prof. I.D. Brown (McMaster University, Canada) "Bond Valence as a Model for Inorganic

Chemistry"

21. 5.85 Dr. D.L.H. Williams (Durham)
"Chemistry in Colour"
22. 5.85 Dr. M. Hudlicky (Blacksburg, U.S.A.)
Preferential Elimination of Hydrogen Fluoride
from Vicinal Bromofluorocompounds"
22. 5.85 Dr. R. Grimmett (Otago, New Zealand)
"Some Aspects of Nucleophilic Substitution in
Imidazoles"
4. 6.85 Dr. P.S. Belton (Food Research Institute,
Norwich)
"Analytical Photoacoustic Spectroscopy"
13. 6.85 Dr. D. Woolins (Imperial College, London)
"Metal - Sulphur - Nitrogen Complexes"
14. 6.85 Prof. Z. Rappoport (Hebrew University,
Jerusalem)
"The Rich Mechanistic World of Nucleophilic
Vinyllic Substitution"
19. 6.85 Dr. T.N. Mitchell (Dortmund), "Some Synthetic
and NMR-Spectroscopic Studies of Organotin
Compounds"
26. 6.85 Prof. G. Shaw (Bradford), "Synthetic Studies on
Imidazole Nucleosides and the Antibiotic
Coformycin"
12. 7.85 Dr. K. Laali (Hydrocarbon Research Institute,
University of Southern California, U.S.A.)
"Recent Developments in Superacid Chemistry and
Mechanistic Considerations in Electrophilic
Aromatic Substitutions: A Progress Report"
13. 9.85 Dr. V.S. Parmar (Delhi), "Enzyme Assisted ERC
Synthesis"
- 17.10.85 Dr. C.J. Ludman (Durham), "Some Thermochemical
Aspects of Explosions"
- 30.10.85 Dr. S.N. Whittleton (Durham), "An Investigation
of a Reaction Window"
- 5.11.85 Prof. M.J. O'Donnell (Indiana-Purdue University,
U.S.A.), "New Methodology for the Synthesis of
Amino Acids"
- 20.11.85 Dr. J.A.H. McBride (Sunderland Polytechnic)
"A Heterocyclic Tour on a Distorted Tricycle -
Biphenylene"
- 28.11.85 Prof. D.J. Waddington (York), "Resources for the
Chemistry Teacher"
15. 1.86 Prof. N. Sheppard (East Anglia), "Vibrational
and Spectroscopic Determinations of the
Structures of Molecules Chemisorbed on Metal

Surfaces"

23. 1.86 Prof. Sir Jack Lewis (Cambridge), "Some More Recent Aspects in the Cluster Chemistry of Ruthenium and Osmium Carbonyls"
29. 1.86 Dr. J.H. Clark (York), "Novel Fluoride Ion Reagents"
12. 2.86 Dr. J. Yarwood (Durham), "The Structure of Water in Liquid Crystals"
12. 2.86 Dr. O.S. Tee (Concordia University, Montreal, Canada), "Bromination of Phenols"
19. 2.86 Prof. G. Procter (Salford), "Approaches to the Synthesis of Some Natural Products"
26. 2.86 Ms. C. Till (Durham), "ESCA and Optical Emission Studies of the Plasma Polymerisation of Perfluoroaromatics"
5. 3.86 Dr. D. Hathway (Durham), "Herbicide Selectivity"
5. 3.86 Dr. M. Schroder (Edinburgh), "Studies on Macrocyclic Compounds"
12. 3.86 Dr. J.M. Brown (Oxford), "Chelate Control in Homogeneous Catalysis"
14. 5.86 Dr. P.R.R. Langridge-Smith (Edinburgh)
"Naked Metal Clusters - Synthesis, Characterisation, and Chemistry"
9. 6.86 Prof. R. Schmutzler (Braunschweig, W. Germany)
"Mixed Valence Diphosphorus Compounds"
23. 6.86 Prof. R.E. Wilde (Texas Technical University, U.S.A.), "Molecular Dynamic Processes from Vibrational Bandshapes"

(B) LECTURES ORGANISED BY DURHAM UNIVERSITY CHEMICAL SOCIETY DURING THE PERIOD 1983-1986

- 20.10.83 Prof. R.B. Cundall (Salford), "Explosives".
- 3.11.83 Dr. G. Richards (Oxford), "Quantum Pharmacology".
- 10.11.83 Prof. J.H. Ridd (U.C.L.), "Ipso-Attack in Electrophilic Aromatic Substitution".
- 17.11.83 Dr. J. Harrison (Sterling Organic), "Applied Chemistry and the Pharmaceutical Industry". (Joint Lecture with the Society of Chemical Industry)
- 24.11.83 Prof. D.A. King (Liverpool), "Chemistry in 2-dimensions".
- 1.12.83 Dr. J.D. Coyle (The Open University), "The Problem with Sunshine".
- 26.1.84 Prof. T.L. Blundell (Birkbeck College, London), "Biological Recognition: Interactions of Macromolecular Surfaces".
2. 2.84 Prof. N.B.H. Jonathan (Southampton), "Photoelectron Spectroscopy - A Radical Approach".
16. 2.84 Prof. D. Phillips (The Royal Institution), "Luminescence and Photochemistry - a Light Entertainment".
23. 2.84 Prof. F.G.A. Stone F.R.S. (Bristol). "The Use of Carbene and Carbyne Groups to Synthesise Metal Clusters". (The Waddington Memorial Lecture)
1. 3.84 Prof. A. Leadbetter (Rutherford Appleton Labs.), "Liquid Crystals".
8. 3.84 Prof. D. Chapman (Royal Free Hospital School of Medicine, London), "Phospholipids and Biomembranes: Basic Science and Future Techniques".
28. 3.84 Prof. H. Schmidbaur (Munich, F.R.G.), "Synthetic, Structural and Theoretical Aspects". (R.S.C. Centenary Lecture)
- 18.10.84 Dr. N. Logan (Nottingham), " N_2O_4 and Rocket Fuels".
- 24.10.85 Dr. J. Dewing (UMIST), "Zeolites - Small Holes, Big Opportunities"
- 31.10.85 Dr. P. Timms (Bristol), "Some Chemistry of Fireworks"
- 7.11.85 Prof. G. Ertl (Munich, W. Germany),

"Heterogeneous Catalysis"

- 14.11.85 Dr. S.G. Davies (Oxford), "Chirality Control and Molecular Recognition"
- 21.11.85 Prof. K.H. Jack (Newcastle), "Chemistry of Si-Al-O-N Engineering Ceramics"
- 28.11.85 Dr. B.A.J. Clark (Kodak Ltd.), "Chemistry and Principles of Colour Photography"
30. 1.86 Dr. N.J. Phillips (Loughborough), "Laser Holography"
13. 2.86 Prof. R. Grigg (Queen's, Belfast), "Thermal Generation of 1,3-Dipoles"
20. 2.86 Dr. C.J.F. Barnard (Johnson Matthey Group) "Platinum Anti-Cancer Drug Development"
27. 2.86 Prof. R.K. Harris (Durham), "The Magic of Solid State NMR"
6. 3.86 Dr. B. Iddon (Salford), "The Magic of Chemistry"

(C) RESEARCH CONFERENCES ATTENDED (* indicates Poster presentation)

Royal Society of Chemistry Organic Reactions
Mechanisms
Group, "Mechanistic Chemistry of Amines and their
Derivatives". 8 - 11 July 1985.

*The Acid-Base Behaviour of Hexamine and its N-Acetyl
Derivatives.

(D) FIRST YEAR INDUCTION COURSE, OCTOBER 1983

This course consists of a series of one hour lectures
on the services available in the department.

1. Departmental Organisation
2. Safety matters
3. Electrical appliances and infrared spectroscopy
4. Chromatography and Microanalysis
5. Atomic absorptiometry and inorganic analysis
6. Library facilities
7. Mass spectroscopy
8. Nuclear Magnetic resonance spectroscopy
9. Glassblowing technique.

REFERENCES

REFERENCES

1. N. Blažević, D. Kolbah, B. Belin, V. Sunjic and F. Kajfez, *Synthesis*, 1979, 161.
2. J.F. Walker, 'Formaldehyde', 3rd. ed., Reinhold, New York, 1964, Chapter 19.
3. A.F. Anderson, *Acta Crystallogr.*, 1957, 10, 107.
4. L.N. Becka and D.W.J. Cruickshank, *Acta Crystallogr.*, 1961, 14, 1092.
5. A. Butlerov, *Ann.*, 1860, 115, 323.
6. J. Altpeter, 'Das Hexamethylenetetramine und Seine Verwendung', Halle, Verlag von Wilhelm Knapp, 1931, 26.
7. M. Delepine, *Bull. Soc. Chim. France*, 1897, 13, 353.
8. M. Delepine, *Bull. Soc. Chim. France*, 1897, 17, 110.
9. G.C. Hale, *J. Am. Chem. Soc.*, 1925, 47, 2754.
10. W.E. Bachmann and J.C. Sheehan, *J. Am. Chem. Soc.*, 1949, 71, 1842.
11. D.I. Belkin, I.V. Belkina and M.J. Rozkin, *Zh. Org. Khim.*, 1970, 41, 3, 655.
12. A.A. Ennan, O.M. Brazovskaya and A.N. Chotobarev, *Zh. Obshch. Khim.*, 1975, 45, 706.
13. M. Vagaonescu and M. Ionescu, *Rev. Roum. Chim.*, 1971, 16, 105.
14. M. Hoehnel, *Arch. Pharm.*, 1899, 237, 693.
15. M. Delepine, *Bull. Soc. Chim. France.*, 1911, (4), 9, 1025.
16. R. Buratti, Swiss Patent, 1921, 90, 703; *Chem. Zentr.*, 1922, IV, 891.
17. M. Delepine, *Bull. Soc. Chim. France*, 1894 (3), 11, 552.
18. S. Braun, P. Kenpter, W. Kochmann, P. Lorenz, G. Braun, G. Schoeppe and U. Thust, East German Patent, 1982, 210, 050.
19. C.F. Von Girssewald, *Ber.*, 1912, 45, 2571.
20. J. Bebie, 'Manual of Explosives, Military Pyrotechnics and Chemical Warfare Agents', New York, MacMillan Co., 1943, 81.

21. T. Urbanski, 'Chemistry and Technology of Explosives', Pergamon Press, 1983, Vol. 3, 225.
22. S.J. Angyal, *Org. React.*, 1954, 8, 197.
23. M. Delapine, *Bull. Soc. Chim. France*, 1922, 31, 108.
24. M. Sommelet, *Compt. rend.*, 1913, 157, 852.
25. S.J. Angyal, P.R. Penman and G.P. Warwick, *J. Chem. Soc.*, 1953, 1742.
26. P. Le Henaff, *Compt. rend.*, 1961, 253, 2706.
27. P. Le Henaff, *Ann. Chim.*, 1962, 7, 367.
28. S.J. Angyal, P.R. Penman and G.P. Warwick, *J. Chem. Soc.*, 1953, 1740.
29. J. Graymore, *J. Chem. Soc.*, 1947, 1117.
30. H. Bohme, J.P. Denis and H.J. Drechsler, *Liebigs Ann. Chem.*, 1979, 10, 1447.
31. H. Bohme and K. Hartke, *Chem. Ber.*, 1960, 93, 1305.
32. J. March, 'Advanced Organic Chemistry: Reactions, Mechanisms and Structure', 2nd ed., McGraw-Hill International Book Company, 1977, 834.
33. H. Bohme, 'Iminium Salts in Organic Chemistry Part 1', H. Bohme and H.G. Viehe, Eds., Interscience, New York, 1976.
34. P. Duden and M. Scharff, *Justus Liebigs Ann. Chem.*, 1895, 288, 231.
35. L. Stefaniak, T. Urbanski, M. Witanowski, A.R. Farminer and G.A. Webb, *Tetrahedron*, 1974, 30, 3775.
36. R. Singer, K. Vaughan and D.L. Hooper, To be published 1986.
37. M.J. Gidley and J.K.M. Sanders, *J. Pharm. Pharmacol.*, 1983, 35, 712.
38. W.R. Abrams and R.G. Kallen, *J. Am. Chem. Soc.*, 1976, 98, 7777.
39. Ref. 32, P. 820
40. A.T. Nielson, D.W. Moore, M.D. Ogan and R.L. Atkins, *J. Org. Chem.*, 1979, 44, 10, 1678.
41. C.M. Hemens, H.W. Manning, K. Vaughan, R.J. LaFrance and Y. Tang, *Can. J. Chem.*, 1984, 62, 741.
42. H.W. Manning, C.M. Hemens, R.J. LaFrance, Y. Tang and K. Vaughan, *Can. J. Chem.*, 1984, 62, 749.

43. M. H. Akhtar, R.S. McDaniel, M. Feser and A.C. Oehlschlager, *Tetrahedron*, 1968, 24, 3899.
44. H.W. Manning, L.M. Cameron, R.J. LaFrance, K. Vaughan and R. Rajaraman, *Anti Cancer Design*, in press.
45. W.E. Bachmann and N.C. Deno, *J. Am. Chem. Soc.*, 1951, 73, 2777.
46. V.I. Siele, M. Warman and E.E. Gilbert, *J. Heterocycl. Chem.*, 1974, 11, 237.
47. M. Dominikiewicz, *Arch. Chemi. Farm.*, (Warsaw), 1935, 2, 78.
48. Y. Ogata and A. Kawasaki, 'The Chemistry of the Carbonyl Group', Interscience, New York, Vol. 2, 51.
49. I. Siele, M. Warman, J. Leccacorvi, R.W. Hutchinson, R. Motto, E.E. Gilbert, T.M. Benziger, M.D. Coburn, R.K. Rohwer and R.K. Davy, *Propellants and Explosives*, 1981, 6, 67.
50. V.I. Siele, U.S. Patent, 1976, 3, 979, 379.
51. Chen Ju and Wang Shao-Fang, *Propellants, Explosives, Pyrotechnics*, 1984, 9, 58.
52. G.F. Wright, E. Aristoff, J.A. Graham, R.H. Meen, and G.S. Myers, *Can. J. Research*, 1949, 27B, 520.
53. G.F. Wright, F.J. Brockman and D.C. Downing, *Can. J. Research*, 1949, 27B, 469.
54. G.F. Wright, W.J. Chute, D.C. Downing, A.F. McKay and G.S. Myers, *Can. J. Research*, 1949, 28B, 218.
55. G.F. Wright, W.J. Chute, A.F. McKay, R.H. Meen and G.S. Myers, *Can. J. Research*, 27B, 530.
56. G.F. Wright, A.F. McKay and H.H. Richmond, *Can. J. Research*, 1949, 27B, 462.
57. A. Gillies, H.L. Williams and C.A. Winkler, *Can. J. Research*, 1951, 29, 377.
59. R.A. Marcus and C.A. Winkler, *Can. J. Chem*, 1953, 31, 602.
60. G.F. Henning, German Patent, 1899, 104, 280.
61. E. von Herz, Swiss Patent, 1920, 88, 759.
62. Ref. 21, P.87.
63. Ref. 21, P.109.
64. Ref. 21, P.116.

65. G.F. Wright and W.J. Chute, U.S. Patent, 1954, 2, 678, 927.
66. H. Yoshida, G. Sen and B.S. Thyagarajan, *J. Heterocycl. Chem.*, 1973, 10, 279.
67. *Ibid.*, 1973, 10, 725.
68. M.D. Coburn and T.M. Benziger, U.S. Patent, 1975, 3,926, 953.
69. M. Warman, V.I. Siele and E.E. Gilbert, *J. Heterocycl. Chem.*, 1973, 10, 97.
70. L. Stefaniak, T. Urbanski, M. Witanoiski and H. Januszewski, *Roczniki. Chemii. Ann. Soc. Chim. Polonorum.*, 1969, 43, 1687.
71. A. Kirkien-Konasiewicz and A. Maccol, *J. Chem. Soc.*, 1964, 1267.
72. H. Bohme, R. Broese, A. Dick, F. Eiden and D. Schunemann, *Chem. Ber.*, 1959, 92, 1599; H. Bohem, A. Dick and G. Driesen, *Chem. Ber.* 1961, 94, 1879.
73. Correspondence with Ministry of Defence, Royal Armament Research and Development.
74. 'C.R.C. Handbook of Chemistry and Physics', Eds. R.C. Weast and M.J. Astle, C.R.C. Press Inc., 1982-1983, 63rd. edition, P.D.-155.
75. H. Tada, *J. Am. Chem. Soc.*, 1960, 82, 255.
76. A.P. Cooney and M.R. Crampton, *J. Chem. Soc. Perkin Trans. II*, 1986, 835.
77. A.I. Vogel, 'Practical Organic Chemistry', 3rd edn., Longmans, London, 1955, 332.
78. A. Albert and E.P. Serjeant, 'Ionisation Constants of Acids and Bases', Methuen, London, 1962.
79. R. Pummerer and J. Hofmann, *Ber. Dtsh. Chem. Res.*, 1923, 56, 1255.
80. L. Meurling, *Chem. Scr.*, 1975, 7, 23.
81. Ref. 74, P.D-171.
82. A.R. Farminer and G.A. Webb, *Organic Magnetic Resonance*, 1976, 8, 102.
83. H.H. Richmond, G.S. Myers and G.F. Wright, *J. Am. Chem. Soc.*, 1948, 70, 3659.
84. R.P. Bell, 'Acids and Bases their Quantitative Behaviour', second edition, Methuen and Co. Ltd., 1969, 40.

85. C.H. Rochester, 'Acidity Functions', Academic Press, London, 1970.
86. E.M. Arnett and G.W. Mach, *J. Am. Chem. Soc.*, 1964, 86, 2671; 1966, 88, 1177.
87. E. Hogfeldt and J. Bigeleisen, *J. Am. Chem. Soc.*, 1960, 82, 15.
88. K. Wiberg, *Chem. Rev.*, 1955, 55, 713.
89. R.B. Homer and C.D. Johnson, 'Chemistry of the Amides', ed. J. Zabicky, Wiley, London, 1970, 187.
90. K. Yates and J.C. Riordan, *Can. J. Chem.*, 1965, 43, 2328.
91. G.A. Olah, A.M. White and D.H. O'Brian, *Chemical Reviews*, 1970, 70, 561.
92. T.H. Fife, J.E.C. Hutchins and A.M. Pellino, *J. Am. Chem. Soc.*, 1978, 100, 6455.
93. B.C. Challis and J.A. Challis, 'Chemistry of the Amides', ed. J. Zabicky, Wiley, London, 1970, 731.
94. R.H. de Rossi and A. Nunez, *Int. J. Chem. Kinet.*, 1983, 15, 1099.
95. S.L. Johnson, *Adv. Phys. Org. Chem.*, 1967, 5, 237.
96. G.C. Basler, 'The Chemistry of Cyclonite', Ph.D. Thesis, 1943, Pennsylvania State University. (declassified in 1956), 175.
97. E.B. Hodge, *J. Org. Chem.*, 1972, 37, 2, 321.
98. M.A. Gradsten and N.W. Pollock, *J. Am. Chem. Soc.*, 1948, 70, 3079.
99. Wang Shaofang and Chen Ju, *Kexue Tongbao, Int. Ed.*, 1948, 29, 596.
100. J. Mckenna, J.M. Mckenna and B.A. Wesby, *J. Chem. Soc. Chem. Commun.*, 1970, 867.
101. J. Soloman, R.K. Momii, F.H. Jarke, A.J. Kacmarek, J.K. Raney and P.C. Adlaf, *Journal of Chemical and Engineering Data*, 1973, 18, 3, 335.
102. W.E. Bachman, W.J. Horton, E.L. Jenner, N.W. Macnaughton and L.B. Scott, *J. Am. Chem. Soc.*, 1951, 73, 2769.
103. W.E. Bachmann and E.L. Jenner, *J. Am. Chem. Soc.*, 1951, 73, 2773.
104. A.O. Ralph, J.G. MacHutchin and C.A. Winkler, *Can. J. Chem.*, 1951, 29, 725.
105. T.C. Castorina, F.S. Holahan, R.J. Graybush, J.V.R.

- Kaufman and S. Helf, *J. Am. Chem. Soc.*, 1960, 82, 1617.
106. T.C. Castorina and J.R. Autera, *Ind. Eng. Chem., Prod. Res. Develop.*, 1965, 4, 170.
107. S. Bulusu, J. Autera and T. AXenrod, *J. Labelled compounds and Radiopharmaceuticals*, 1980, 17, 707.
108. R.M. Silverstein, G.C. Bassler and T.C. Morrill, 'Spectrometric Identification of Organic Compounds', Fourth Edition, Wiley, 1981, 46.
109. A.P. Cooney, unpublished observations.
110. F. Chapman, *J. Chem. Soc.*, 1949, 1631.
111. R.C. Brian and A.H. Lamberton, *J. Chem. Soc.*, 1949, 1633.
112. D.Woodcock, *J. Chem. Soc.*, 1949, 1635.
113. F. Chapman, P.G. Owston and D. Woodcock, *J. Chem. Soc.*, 1949, 1639.
114. A.H. Lamberton, C. Lindley, P.G. Owston and J.C. Speakman, *J. Chem. Soc.*, 1949, 1641.
115. F. Chapman, P.G. Owston and D. Woodcock, *J. Chem. Soc.*, 1949, 1647.
116. A.H. Lamberton, C. Lindley and J.C. Speakman, *J. Chem. Soc.*, 1949, 1650.
117. C. Lindley and J.C. Speakman, *J. Chem. Soc.*, 1949, 1657.
118. R.N. Jones and G.D. Thorn, *Can. J. Res.*, 1949, 27B, 828.
119. W.P. Jencks, "Progress in Physical Organic Chemistry", 1964, 2, 63.
120. H. Maskill, "The Physical basis of Organic Chemistry", Oxford University Press, 1985, 268.
121. E.S. Swinbourne, "Analysis of Kinetic data", Nelson, 1971, 84.
122. A.J. Kresge and Y.C. Tang, *J. Chem. Soc. Chem. Commun.*, 1980, 309
123. A.J. Kresge, Y.C. Tang, A. Awwal and D.P. Onwood, *J. Chem. Soc. Chem. Commun.*, 1980, 310.
124. J.N. Bronsted and K.J. Pedersen, *Z. Phys. Chem.*, 1924, 108, 185.
125. R.P. Bell, "The Proton in Chemistry", 2nd Ed., Cornell Univ. Press, 1973, 160.

126. M.R. Crampton and V. Gold, *Adv. Phys. Org. Chem.*, 1969, 7, 211.
127. M.R. Crampton and V. Gold, *J. Chem. Soc. B*, 1966, 893.
128. K.L. Servis, *J. Am. Chem. Soc.*, 1965, 87, 5495.
129. V. Gold and C.H. Rochester, *J. Chem. Soc.*, 1964, 1692.
130. C.F. Bernasconi, *J. Am. Chem. Soc.*, 1970, 92, 4682.
131. J.B. Ainscough and E.F. Caldin, *J. Chem. Soc.*, 1956, 2528.
132. V. Gold. C.H. Rochester, *J. Chem. Soc.*, 1964, 1687.
133. J.H. Fendler, E.J. Fendler and C.E. Griffin, *J. Org. Chem.*, 1969, 34, 689.
134. P. Bemporad, G. Illuminati and F. Stegel, *J. Am. Chem. Soc.*, 1969, 91, 6742.
135. C.F. Bernasconi, *J. Am. Chem. Soc.*, 1971, 93, 6975.
136. M.R. Crampton and H.A. Khan, *J. Chem. Soc., Perkin Trans. II*, 1972, 2286; 1973, 1103.
137. M.R. Crampton, B. Gibson and F.W. Gilmore, *J. Chem. Soc., Perkin Trans. II*, 1979, 91.
138. A.D.A. Al Aruri and M.R. Crampton, *J. Chem. Res.*, 1980, (S) 140; (M) 2157.
139. M. Sasaki, N. Takisawa, F. Amita and J. Osugi, *J. Am. Chem. Soc.*, 1980, 102, 7268.
140. O.L. Brady and H.V. Horton, *J. Chem. Soc.*, 1925, 2230.
141. A. Hantzsch and H. Gorke, *Ber.*, 1906, 39, 1097.
142. C.L. Jackson and W.F. Boos, *Am. Chem. J.*, 1898, 20, 444.
143. L.K. Dyal, *J. Chem. Soc.*, 1960, 5160.
144. M.R. Crampton, *J. Chem. Soc. Perkin Trans. ?II*, 1977, 1442.
145. M.R. Crampton, *J. Chem. Soc. Perkin Trans. II*, 1975, 825.
146. A.D.A. Al Aruri and M.R. Crampton, *J. Chem. Res.*, 1982, (S) 60.
147. G.B. Barlin and D.D. Perrin, *Q. Rev. Chem. Soc.*, 1966, 20, 75.
148. E.A.H. Griffith, W.D. Chandler and B.E. Robertson,

- Can. J. Chem.*, 1972, 50, 2972; K. Gurton, W.D. Chandler and B.E. Robertson, *ibid.*, 1975, 53, 2093; V. Cody, J. Hazel and P.A. Lehman, *Acta Crystallogr. Sect. B.*, 1978, 34, 3449.
149. C.M. Gramaccioli, R. Destro and M. Simonetta, *Chem. Commun.*, 1967, 331; *Acta Crystallogr. Sect. B.*, 1968, 24, 129.
150. R. Destro, C.M. Gramaccioli and M. Simonetta, *Nature*, 1967, 215, 389; *Acta Crystallogr. Sect. B.*, 1968, 24, 129.
151. H. Ueda, N. Sakabe, J. Tanaka and A. Furusaki, *Nature.*, 1967, 215, 956; *Bull. Chem. Soc. Jpn.*, 1968, 41, 866.
152. G. Baldini, G. Doddi, G. Illuminati and F. Stegal, *J. Org. Chem.*, 1976, 41, 2153.

