

# Durham E-Theses

---

## *Functional aspects of gastropod mucus*

Rajshree Shirbate

### How to cite:

---

Shirbate, Rajshree (1987) Functional aspects of gastropod mucus. Doctoral thesis, Durham University.

### Use policy

---

The full-text may be used and/or reproduced, and given to third parties in any format or medium, without prior permission or charge, for personal research or study, educational, or not-for-profit purposes provided that:

- a full bibliographic reference is made to the original source
- a <https://etheses.durham.ac.uk/id/eprint/7099/> is made to the metadata record in Durham E-Theses
- the full-text is not changed in any way

The full-text must not be sold in any format or medium without the formal permission of the copyright holders.

Please consult the [full Durham E-Theses policy](#) for further details.

The copyright of this thesis rests with the author.  
No quotation from it should be published without  
his prior written consent and information derived  
from it should be acknowledged.

FUNCTIONAL ASPECTS OF GASTROPOD MUCUS

VOL. II

TABLES, FIGURES AND PLATES

A thesis presented in candidature for the  
degree of

Doctor of Philosophy

by

Rajshree Shirbhate, M.Sc. Nagpur, India.

Department of Zoology, University of Durham

Durham, March 1987.



MAR 1987

Thesis  
1987/SH1

## CONTENTS

### RESULTS

Tables 1 to 15

Figures 1 to 35

Plates 1 to 63

### COMPARISON

Tables 16 to 28

Figures 36 to 53

Plates 64 to 66

### DISCUSSION

Tables 29 and 30

Plate 67

## RESULTS

TABLE 1

A summary of the staining procedures used (the abbreviations used in subsequent tables are indicated in brackets).

<u>Stain</u>	<u>Function</u>	<u>Reference</u>
Mallory's Triple stain (Mall)	General	Grimstone & Skaer (1972)
Alcian Blue (pH 0.5)/Alcian Yellow (pH 2.5) (AB/AY )	Differentiate between sulphated and carboxylated M.P.S.	Ravetto (1964)
Alcian Blue (pH 0.5)/eosin (AB/Eo)	Differentiate between mucoprotein and sulphated mucopolysaccharide	
Diazotization coupling (Diazo)	Location of tyrosine containing proteins	Glenner & Lillie (1959)
Mercuric bromophenol blue (MBPB)	Location of protein amino groups	Bonhag (1955)
Periodic Acid Schiffs (P.A.S.)	Location of vic glycol groups	Pearse (1980)
Periodic Acid Diamine (P.A.D.)	Location of neutral mucopolysaccharides	Spicer (1965)
Alcian Blue (pH 2.5)/P.A.S. (AB/PAS)	Differentiation between acidic and neutral mucopolysaccharides	Mowry (1963)
Toluidene Blue (Tol Blue)	Metachromasia	Standard method (Pearse, 1980)
von Kossa (v. Kossa)	Calcium	Pearse (1980)
Alizarin Red (Al Red)	Calcium	Dahl (1952)
Sudan Black (Sud. Black)	Lipids	Chiffelle & Putt (1951) Ann Preece (1972)



TABLE 2

The staining responses of the pedal and opercular gland cell types in Pomatias elegans

<u>Procedures</u>	P1	P2	P3	P4	P5	P6	P7	P8	P9	P10	P11	P12	P13
Mall	R++	Bl++	-	Bl+++	-	Bl++	R/Bl+	Bl++	R+++	Bl+++	R+	R+++	-
AB/AY	-	-	B/G+++	Y/G++	-	B/G+++	-	Y/G++	-	G+	-	Bl++	-
AB/EO	R++	R++	Bl+	Bl++	R++	Bl+	R+	Bl++	-	Bl++	R+	Bl++	-
Diazo	Pu++	Pu++	-	-	Pu++	-	-	-	-	-	Pu++	Pu++	-
MBPB	Bl++	Bl++	-	-	Bl++	-	-	-	-	-	Bl++	Bl+++	-
PAS	R+++	R++	R+	R+++	R+++	R+	R+++	R+	R+++	-	R++	R++	R+++
PAD	Bla++	Br++	Bla++	Br+++	Br+++	Bla++	Br+++	Br++	Br+++	Bla++	Br+	Bla/Br++	Br++
AB/PAS	R++	R++	Bl++	Bl/Pu++	R+++	Bl++	R+++	Pu+++	R+++	Bl+++	R+	R++	R+++
Tol. Blue	-	-	Pu+++	-	-	Pu++	-	Pu++	-	Pu+++	-	-	-
V. Kossa	-	Bla+	-	Bla+	Bla+	Bla+	-	-	-	-	-	-	-
Al. Red	-	R+	-	R+	R+	R+	-	-	R+	-	R+	-	-
Sud Black	-	-	-	-	-	-	-	-	-	-	-	-	-

Key: Bl-Blue, Bla-Black, Br-Brown, G-Green, Pu-Purple, R-Red, Y-Yellow

TABLE 3

A summary of the properties of the pedal and opercular gland  
cell types in Pomatias elegans

<u>Cell type</u>	<u>Position</u>	<u>Size</u>	<u>Shape</u>	<u>Texture</u>	<u>Contents</u>
P1	Suprapedal gland (outer)	15-20 $\mu$ m	Flask	Granular/ Reticular	Protein
P2	"	10-12 $\mu$ m	Pyriiform	Granular	Neutral MPS + Protein + calcium
P3	"	40-80x 20-25 $\mu$ m	Club	Reticular	Acidic MPS
P4	Suprapedal gland (inner)	20-22 $\mu$ m	Irregular	Reticular	Acidic + neutral MPS + calcium
P5	Foot/Sole	45-60x 10-12 $\mu$ m	Flask	Reticular/ Granular	Neutral MPS + Protein + calcium
P6	Foot/Sole	80-100 $\mu$ m long 12-15 $\mu$	Pyriiform	Fibrous	Acidic MPS + Calcium
P7	Opercular region	40-45x 12-15 $\mu$ m	Flask	Fibrous	Neutral MPS
P8	Opercular region	40-45x 12-15 $\mu$ m	Flask	Fibrous	Acidic and neutral MPS
P9	Dorsal and lateral body surface	12-25 $\mu$ m	Goblet	Smooth	Neutral MPS
P10	"	12-25 $\mu$ m	Goblet	Smooth	Sulphated and carboxylated MPS
P11	"	12-25 $\mu$ m	Goblet	Finely granular	Neutral MPS + Protein
P12	Opercular region and body surface	12-25 $\mu$ m Granules 2-4 $\mu$ m	Goblet	Globular	Protein + Sulphated + neutral MPS
P13	Dorsal and lateral body surfaces	70-80x 10-12 $\mu$ m	Pyriiform	Granular/ Reticular	Neutral MPS

TABLE 4

The staining responses of the pedal and opercular gland  
cell types in Bithynia tentaculata

<u>Procedures</u>	B1	B2	B3	B4	B5	B6	B7	B8	B9
Mall	Bl+++	-	-	Bl++	R+	Y	Bl++	R++	-
AB/AY	Y/G++	Bl+++	Y/G+++	Y/G+	-	Y	Bl/G++	-	-
AB/EO	Bl+	Bl++	Bl++	Bl++	R++	Y	Bl++	R++	-
Diazo	Pu+++	-	-	Pu+++	Pu++	Y	-	Pu++	Pu++
MBPB	Bl+++	-	-	Bl+++	Bl+++	Y	-	Bl+	Bl+++
PAS	R+++	-	R+++	R+++	R++	Y	-	R++	R+++
PAD	Br+	Bla++	Br++	Br++	Br+++	Y	Bla++	Br++	-
AB/PAS	Bl/Pu++	Bl+++	Pu+++	Pu++	R+++	Y	Bl+++	R++	R+++
Tol. Blue	Pu+	Pu+++	Pu++	-	-	Y	Pu+++	-	-
V. Kossa	-	-	-	-	-	-	-	-	-
Al. Red	-	-	-	-	-	-	-	-	-
Sud. Black	-	-	-	-	-	-	-	-	-

Key: Bl-Blue, Bla-Black, Br-Brown, G-Green, Pu-Purple, R-Red, Y-Yellow

TABLE 5

A summary of the properties of the pedal and opercular  
gland cell types in Bithynia tentaculata

<u>Cell type</u>	<u>Position</u>	<u>Size</u>	<u>Shape</u>	<u>Texture</u>	<u>Contents</u>
B1	Anterior pedal gland	580µm long 12-18µ	Oval	Reticular/ Granular	Protein + Acidic and neutral MPS
B2	Foot/Sole	80-110x 25-45µm	Pyriiform	Reticular	Sulphated MPS
B3	Mid ventral foot surface	75-125x 25-45µm	Pyriiform	Fibrous	Acidic + neutral MPS
B4	Opercular region	25-40µm Granules 2-6µ	Goblet	Coarsely granular	Acidic/Neutral mucoprotein
B5	Opercular region	25-40µm	Goblet	Granular	Neutral mucoprotein
B6	Opercular region	25-40µm	Goblet	Granular	unknown
B7	Widespread on the foot	10-15µm	Goblet	Reticular	Sulphated and carboxylated MPS
B8	"	10-15µm	Goblet	Reticular	Neutral mucoprotein
B9	"	250-300x 10-12µm	Flask	Granular	Protein

TABLE 6

The staining responses of the pedal and opercular gland cell types in *Littorina littorea*

<u>Procedures</u>	L1	L2	L3	L4	L5	L6	L7	L8	L9	L10
Mall	R+	R++	Bl+	R/B+	R/Pu+	Bl+	R/Pu+	R++	Bl+++	R+
AB/AY	-	-	Bl++	Y/G+	-	Bl++	-	-	Bl++	-
AB/EO	R++	R++	Bl++	Bl++	R++	Bl++	R+	R+	Bl++	R++
Diazo	Pu++	-	-	-	Pu++	-	Pu++	Pu++	-	Pu++
MBPB	Bl++	Bl+++	-	-	Bl++	-	Bl++	Bl++	-	Bl++
PAS	R++	R+	R+	R+++	R++	-	R++	R+	-	R++
PAD	Br+	Br++	Bla++	Bla+++	Br+	-	Br+	-	Bla+++	Br+
AB/PAS	R++	R+	Bl++	R/Pu++	R++	Bl+++	R++	R+	Bl++	R+
Tol. Blue	Pu+	-	Pu++	Pu+++	-	Pu++	-	-	Pu+++	-
V. Kossa	-	-	Bla+	Bla++	-	-	-	-	-	-
Al. Red	-	-	R+	R++	-	-	-	-	-	-
Sud. Black	-	-	-	-	-	-	-	-	-	-

Key: Bl-Blue, Bla-Black, Br-Brown, G-Green, Pu-purple, R-Red, Y-Yellow

TABLE 7

A summary of the properties of the pedal and opercular  
gland cell types in *Littorina littorea*

<u>Cell Types</u>	<u>Position</u>	<u>Size</u>	<u>Shape</u>	<u>Texture</u>	<u>Contents</u>
L1	Ant. pedal gland	750 $\mu$ m long 10-20 $\mu$	Oval	Reticular	Mucoprotein
L2	Ant. pedal gland	150 $\mu$ m x 10-15 $\mu$ m	Oval	Granular	Neutral Mucoprotein
L3	Foot/sole	150-225x 10-15 $\mu$ m	Pyriform	Fibrous/ Reticular	Acidic MPS + calcium
L4	Foot/sole	200-275x 10-12 $\mu$ m	Pyriform	Reticular/ Granular	Acidic MPS + calcium
L5	Foot/sole	250-375x 8-10 $\mu$ m	Flask	Granular	Neutral Mucoprotein
L6	Opercular region	25-30x 8-10 $\mu$ m	Oval	Reticular	Acidic MPS
L7	Opercular region	25-30x 10-12 $\mu$ m	Oval	Globular	Mucoprotein
L8	Opercular region	25-30x 10-12 $\mu$ m	Oval	Solid	Protein
L9	Dorsal and lateral body surface	25-30 $\mu$ m	Goblet	Reticular	Sulphated MPS
L10	Dorsal and lateral body surface	25-30 $\mu$ m	Goblet	Granular	Neutral Mucoprotein

TABLE 8

The staining responses of the mantle edge and hypobranchial  
gland cell types in Pomatias elegans

<u>Procedures</u>	<u>Mantle edge gland cell types</u>		<u>Hypobranchial gland cell types</u>		
	P14	P15	P9	P10	P12
Mall	R/Bl+	R++	R++	Bl++	R+++
AB/AY	Y/G++	-	-	Y/G++	Bl++
AB/EO	Bl++	-	-	Bl++	Bl++
Diazo	-	Pu+	-	-	Pu+++
MBPB	-	Bl+	-	-	Bl+++
PAS	R+	R++	R+++	-	R+++
PAD	Br+	Br+++	Br++	Bla++	Bla/Br++
AB/PAS	Bl/Pu+++	R+++	R+++	Bl++	R+++
To1. blue	Pu+++	-	-	Pu+++	-
V. Kossa	-	-	-	-	-
Al. Red	-	-	R+	-	-
Sud. Black	-	-	-	-	-

Key: Bl-Blue, Bla-Black, Br-Brown, G-Green, Pu-Purple, R-Red, Y-Yellow

TABLE 9

A summary of the properties of the mantle edge and  
hypobranchial gland cell types in Pomatias elegans

<u>Cell Type</u>	<u>Position</u>	<u>Size</u>	<u>Shape</u>	<u>Texture</u>	<u>Contents</u>
P14	Mantle edge gland	10 - 12 $\mu\text{m}$	Oval	Reticular	Acidic MPS
P15	Mangle edge gland	8 - 10 $\mu\text{m}$	Oval	Reticular	Neutral mucoprotein
P9	Ubiquitous	20 - 25 $\mu\text{m}/$ 12 - 20 $\mu$	Goblet	Smooth	Neutral MPS
P10	Ubiquitous	20 - 25 $\mu\text{m}/$ 12 - 20 $\mu$	Goblet	Reticular	Sulphated and carboxylated MPS
P12	Ubiquitous	20 - 25 $\mu\text{m}/$ (Granules 2-4 $\mu$ ) 12 - 20 $\mu$	Goblet	Globular	Protein + sulphated + neutral MPS

TABLE 10

The staining responses of the mantle edge and hypobranchial  
gland cell types in Bithynia tentaculata

<u>Procedures</u>	<u>Mantle edge gland cell types</u>			<u>Hypobranchial gland cell types</u>	
	B7	B8	B10	B11	B12
Mall	Bl++	R+	R++	R+	Bl+
AB/AY	Bl/G++	Y+	-	Y/G+	-
AB/EO	Bl++	R+	R++	Bl+	R++
Diazo	-	Pu++	Pu+++	Pu++	Pu+++
MBPB	-	Bl++	Bl+++	Bl++	Bl+++
PAS	-	R+	R+	R++	R++
PAD	Bla++	Br++	Br+	Br+++	Br++
AB/PAS	Bl++	R++	R+	R/Pu+++	R++
Tol. Blue	Pu+++	-	-	Pu+	-
V. Kossa	-	-	-	-	-
Al. Red	-	-	-	-	-
Sud. Black	-	-	-	-	-

Key: Bl-Blue, Bla-Black, Br-Brown, G-Green, Pu-Purple, R-Red, Y-Yellow.

TABLE 11

A summary of the properties of the mantle edge and  
hypobranchial gland cell types in Bithynia tentaculata

<u>Cell Type</u>	<u>Position</u>	<u>Size</u>	<u>Shape</u>	<u>Texture</u>	<u>Contents</u>
B7	Ubiquitous	18 - 20 $\mu$ m	Goblet	Reticular	Sulphated and carboxylated MPS
B8	Ubiquitous	18 - 20 $\mu$ m	Goblet	Reticular	Neutral mucoprotein
B10	Mantle edge gland	5 - 7 $\mu$ m	Oval	Reticular	Neutral mucoprotein
B11	Hypo- branchial gland	25 - 30 x 8 - 10 $\mu$ m	Goblet	Fibrous/ Granular	Mucoprotein
B12	Hypo- branchial gland	25 - 35 x 10 - 12 $\mu$ m	Goblet	Globular	Neutral mucoprotein

TABLE 12

The staining responses of the mantle edge and hypobranchial  
gland cell types in *Littorina littorea*

<u>Procedures</u>	<u>Mantle edge gland cell types</u>			<u>Hypobranchial gland cell types</u>		
	L11	L12	L13	L14	L15	L16
Mall	R/Bl++	R+	Bl++	Bl++	Bl+	R+
AB/AY	Bl++	-	Bl++	Bl++	Bl++	-
AB/EO	Bl++	R+++	Bl++	Bl+++	Bl++	R++
Diazo	-	Pu+	-	-	-	Bl++
MBPB	-	Bl++	-	-	-	Pu+
PAS	R++	R+	-	R+	R+	R++
PAD	Br++	Br+	Bla++	Bla+++	Bla++	Br++
AB/PAS	Pu++	R+	Bl+++	Bl+++	Bl++	R+
Tol. Blue	Pu++	-	Pu++	Pu+++	Pu++	-
V. Kossa	-	-	-	-	-	-
Al. Red	-	-	-	-	-	-
Sud. Black	-	-	-	-	-	-

Key: Bl-Blue, Bla-Black, Br-Brown, G-Green, Pu-Purple, R-Red, Y-Yellow

TABLE 13

A summary of the properties of the mantle edge and  
hypobranchial gland cell types in Littorina littorea

<u>Cell Type</u>	<u>Position</u>	<u>Size</u>	<u>Shape</u>	<u>Texture</u>	<u>Contents</u>
L11	Dorsal mantle epithelium	60 - 70 x 5 - 8 $\mu$ m	Flask	Reticular	Sulphated and neutral MPS
L12	Mantle edge	325 x 210 $\mu$ m	Oval	Reticular	Neutral mucoprotein
L13	Mantle edge	50 - 20 $\mu$ m	Oval	Reticular	Sulphated MPS
L14	Hypo-branchial gland	25 - 40 x 8 - 10 $\mu$ m	Goblet	Frothy/ Granular	Acidic MPS
L15	Hypo-branchial gland	25 - 40 x 8 - 10 $\mu$ m	Goblet	Reticular	Acidic MPS
L16	Hypo-branchial gland	25 - 40 x 4 - 8 $\mu$ m	Goblet/ Club shaped	Reticular/ Granular	Neutral mucoprotein

TABLE 14

The staining responses of the gland cell types in *Limax pseudoflavus*

<u>Procedures</u>	1	2	3	4	5	6	7	8	9	10	11	12	13	14
Mall	-	R+++	Pi+++	Y	Bl++	Bl+	-	-	-	-	-	-	Bl++	-
AB/AY	G+++	-	-	Y	Y/G++	-	Y/G++	Y++	Y++	-	Y++	Y+	-	-
AB/EO	Bl+++	R++	R++	Y	Bl++	Bl+	Bl+++	Bl++	Bl+	-	Bl+	-	R++	Bl++
Diazo	-	Pu+++	Pu++	Y	-	-	-	-	-	-	-	-	Pu++	-
MBPB	-	Bl++	Bl+	Y	-	-	-	-	-	-	-	-	Bl+	-
PAS	Pi+	-	-	Y	R++	R++	-	R++	Pi++	R+++	R+++	Pi+	R++	R++
PAD	-	Bla+	Bla+	Y	Br+	Br++	-	Br++	Br++	Br+++	Br++	Br++	Br+++	Br++
AB/PAS	Bl+++	-	-	Y	Bl++	R++	Bl+++	Pu++	Bl/Pi++	R+++	Pu++	Bl/Pi+++	R++	Bl/Pu+++
Tol. Blue	Pu+++	-	-	Y	Pu+++	Pu+	Pu+++	Pu+	Pu++	Pu++	Pu+	Pu+	-	Pu+
V. Kossa	-	-	-	-	-	-	-	-	-	-	-	-	-	-
Al. Red	-	-	-	-	-	-	-	-	-	-	-	-	-	-
Sud. Black (wax sections)	-	Bla++	Bla++	Y	-	-	-	-	-	-	-	-	-	-
Sud. Black (frozen sections)	-	-	-	-	-	-	-	-	-	-	-	-	-	-

Key: Bl-Blue, Bla-Black, Br-Brown, G-Green, Pu-Purple, R-Red, Y-Yellow, Pi-Pink

TABLE 15

A summary of the properties of the gland cell types in

Limax pseudoflavus

<u>Cell type</u>	<u>Position</u>	<u>Size</u>	<u>Shape</u>	<u>Texture</u>	<u>Contents</u>
1	Dorsal surface	130-360x 60-140µm	Goblet	Fibrous	Sulphated and carboxylated MPS
2	Dorsal surface	200-600x 30-60µm	Clavate	Smooth	Protein
3	Dorsal surface	150-650x 35-80µm	Spatulate	Granular	Protein
4	Ubiquitous	130-600x 13-50µm	Elongate	Coarse granular	Unknown
5	Semper's Organ	30µm	Polygonal	Granular	Sulphated, carboxy- lated and neutral MPS
6	Suprapedal gland	500-600x 300-350µm	Polygonal	Reticulated	Weakly sulphated + neutral MPS
7	Ubiquitous	20-150x 3-7µm	Slender	Solid	Sulphated and carboxy- lated MPS
8	Peripodal groove	14-25µm	Oval	Finely granular	Weakly acidic and neutral MPS
9	Sole and groove	15-30µm	Round	Granular/ Reticular	Weakly acidic and neutral MPS
10	Sole, head and flanks	15-30µm	Oval	Granular	Neutral MPS
11	Pneumostome and lung	15µm	Round	Solid/ Reticular	Acidic and neutral MPS
12	Median foot gland	15µm	Oval	Finely Granular/ Reticular	Carboxylated and neutral MPS
13	Inferior foot gland	15-40µm	Polygonal	Granular	Neutral mucoprotein
14	Superior foot gland	20µm	Oval	Solid/ Reticular	Weakly acidic and neutral MPS

Figure 1 The general distribution of cell types in Pomatias elegans.

A The pedal and mantle edge gland cells. Arrows indicate the openings of the suprapedal gland and the tubulous gland into the pedal furrow.

B The pedal and opercular glandular cells.

M - Mantle; OG - Opercular groove; SPG - Suprapedal gland; SOC - Opercular cleft; T - Tubule. All other labels refer to cell types.

Fig.1

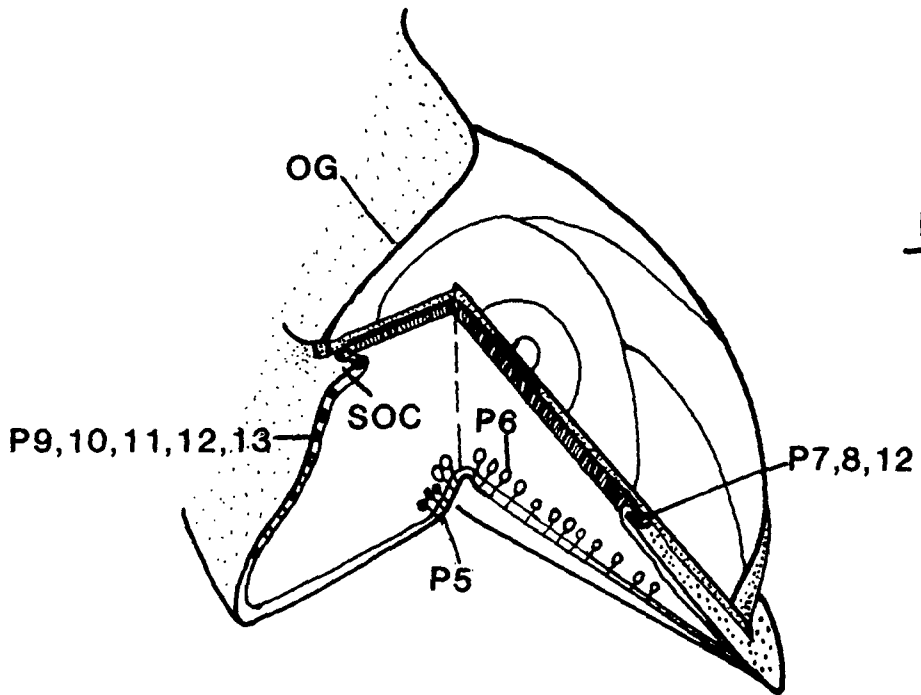
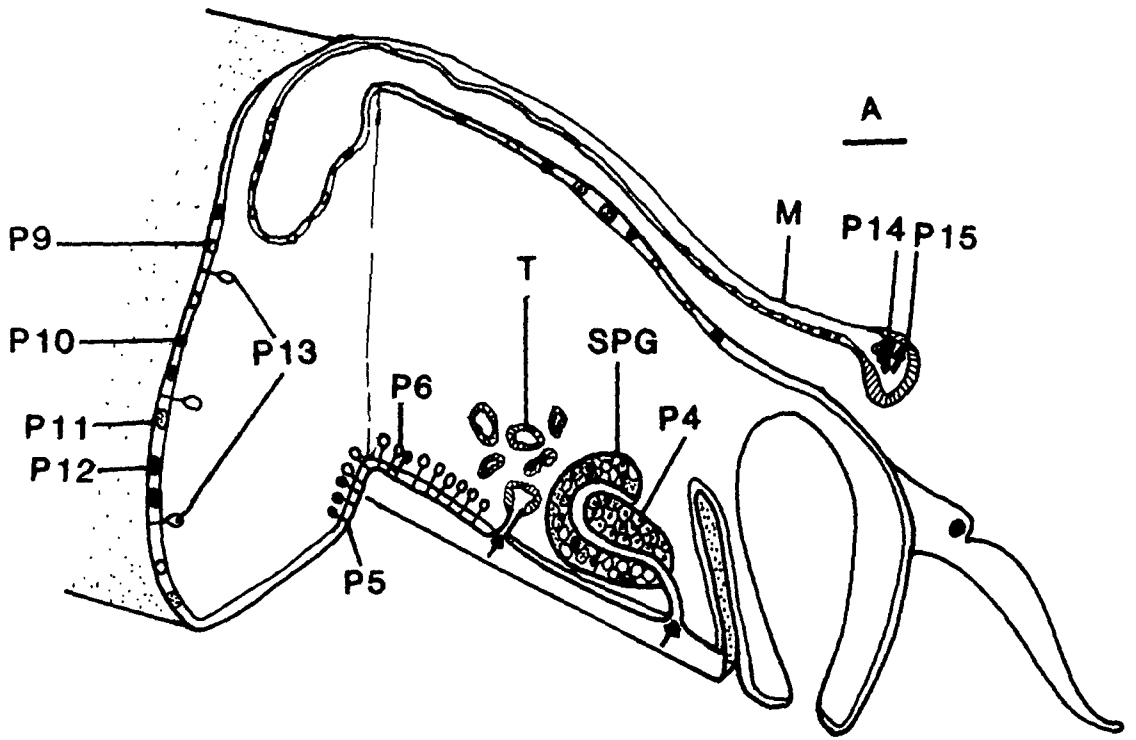

Figure 2 A transverse section through the foot of Pomatias elegans.

- a Reference diagram. The dotted line in the foot shows the plane of section.
- A The general distribution of pedal cells and those of the suprapedal gland, and the tubules of the tubulous gland.
- B The lateral epithelium.
- C The cells of the median pedal furrow.
- D The tubule.

C - Cilia; F - Foot; N - Nucleus; O - Operculum; SPG - Suprapedal gland; T - Tubule. All other labels refer to cell types.

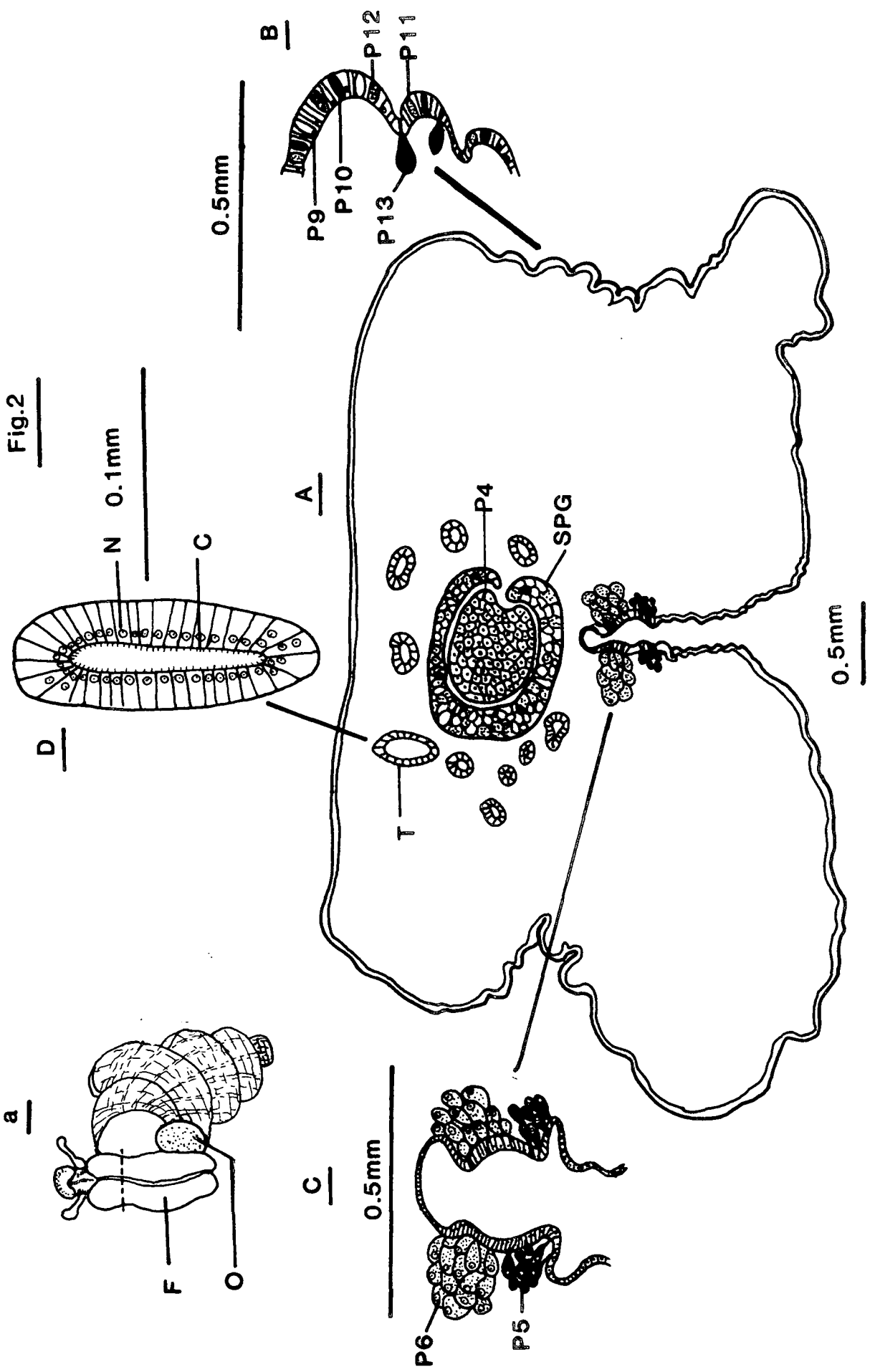

Figure 3 High power view of

A a part of a transverse section through the suprapedal gland of Pomatias elegans to show cell types P1, P2, P3 and P4. Note the ducts of P2 making their way between P3 cells.

B a transverse section through the lateral pedal epithelium of Pomatias elegans to show the goblet cell types P9, P10, P11 and P12.

D - Ducts; EN - Epidermal nuclei; N - Nucleus. All other labels refer to cell types.

**Fig.3**

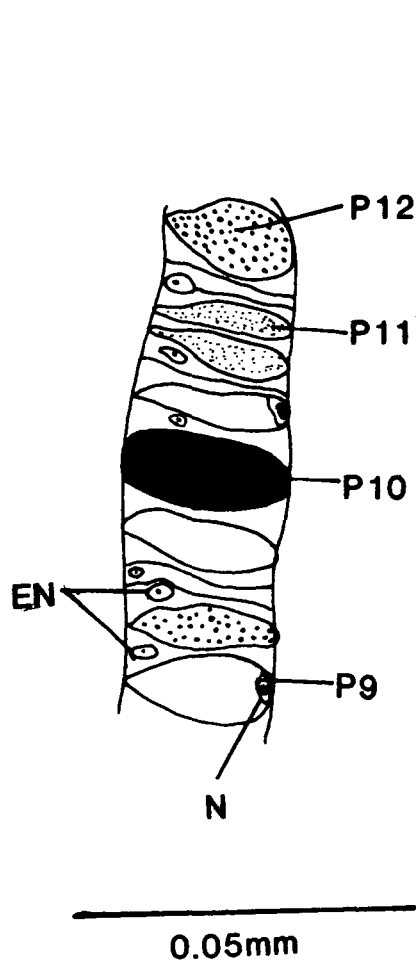
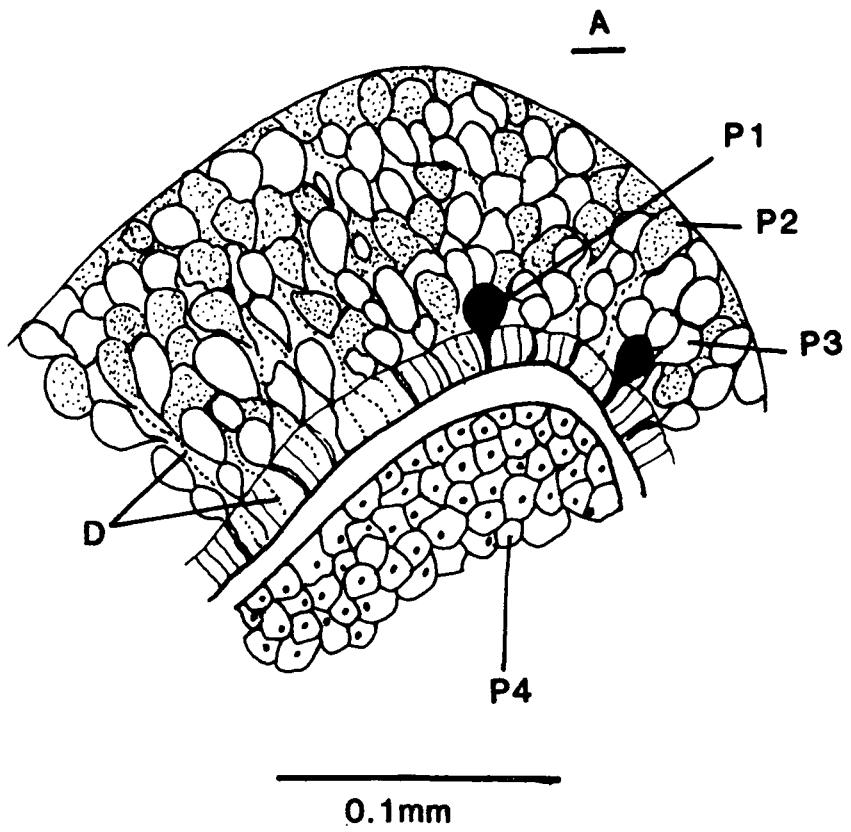

Figure 4 The general distribution of cell types in Bithynia tentaculata.

A The cells of the anterior pedal gland, the foot and the mantle edge.

B The cells of the opercular disc.

APG - Anterior pedal gland; M - Mantle; O - Operculum; OD - Opercular disc; S - Sole; SOC - Subopercular cleft. All other labels refer to cell types.

Fig.4

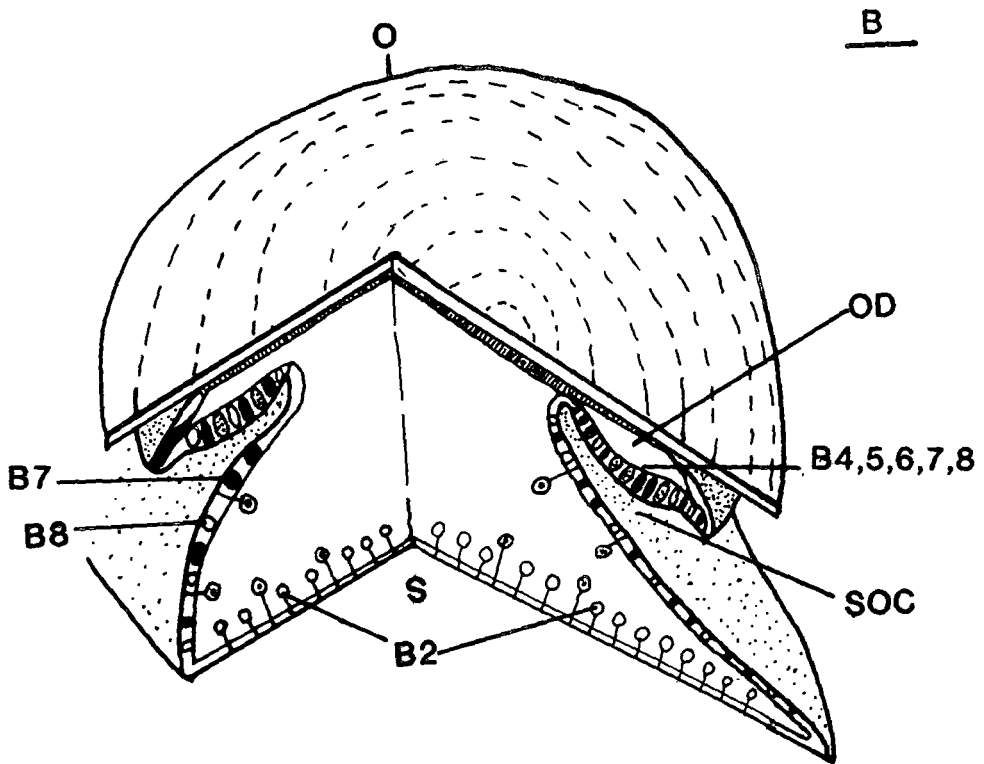
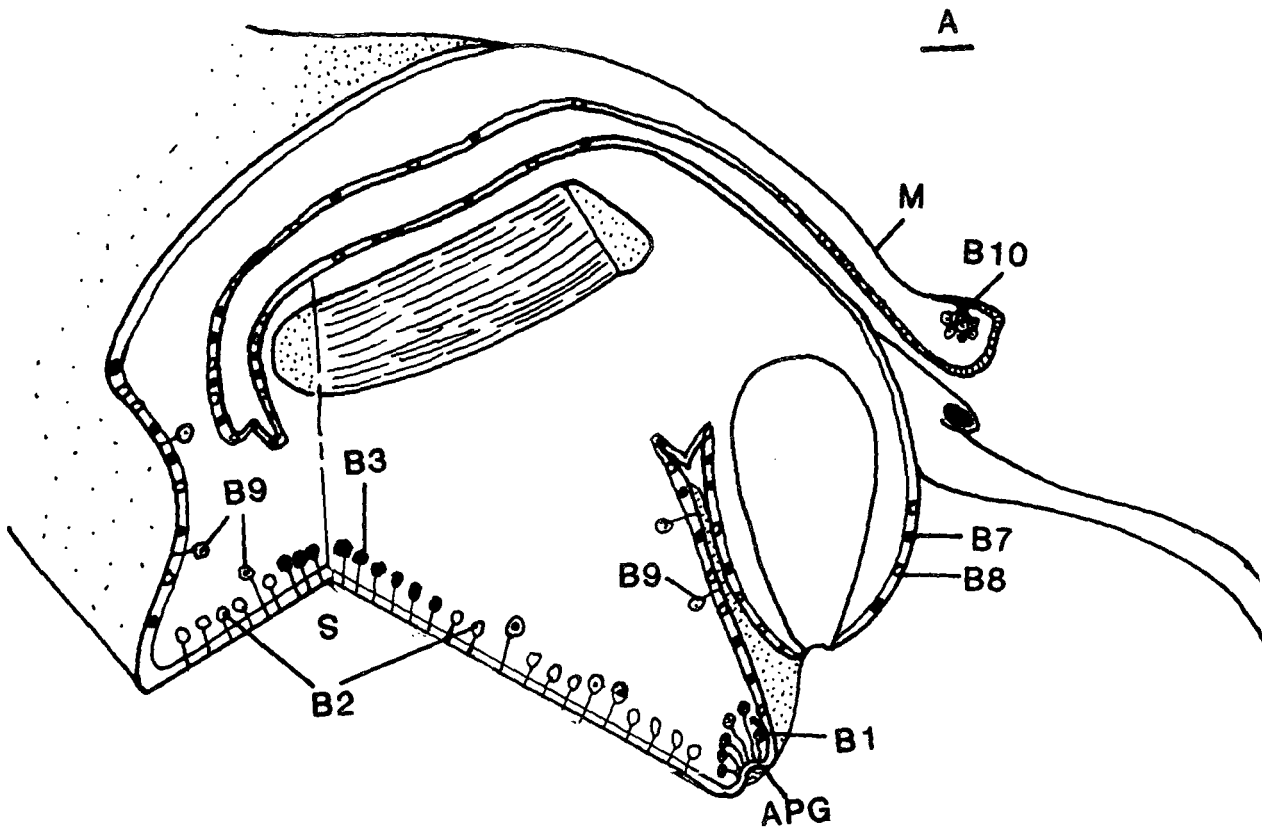
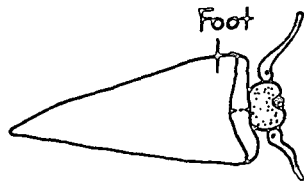

Figure 5

- a Reference diagram. The dotted line in the foot shows the plane of section (ref. Plate 14).
- A A longitudinal section through the anterior foot of Bithynia tentaculata to show the anterior pedal gland. Note the extension of cilia at the dorsal pedal surface.

C - Cilia; S - Sole. All other labels refer to cell types.

Fig.5



a

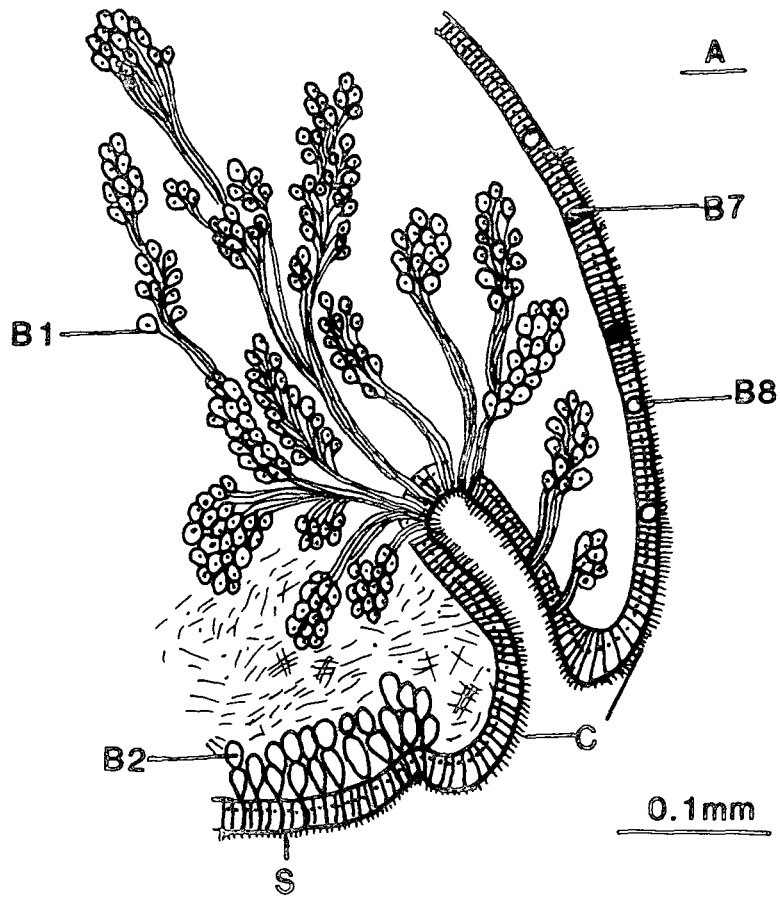

Figure 6 High power view of pedal cells of Bithynia  
tentaculata, in longitudinal section through the  
foot.

A Pedal cell type B2 from the anterior sole (ref. Plate  
15).

B Pedal cell type B3 from transverse fold in the mid line  
(ref. Plate 17).

C - Cilia; D - Duct; EN - Epidermal nuclei; M.F.- Muscle  
fibres; N - Nucleus; PG - Pigment granules; S - Sole.

Fig.6

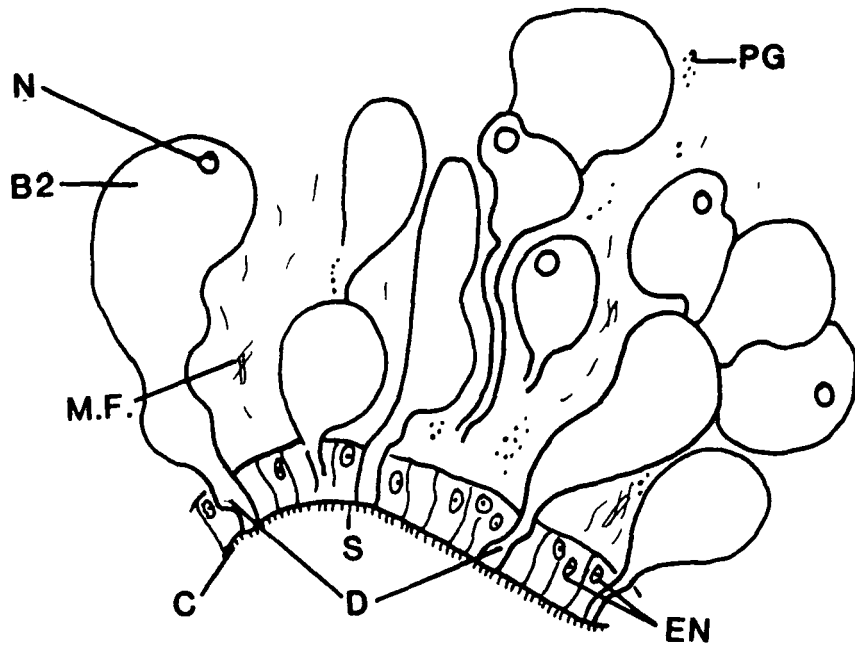

A

0.05mm

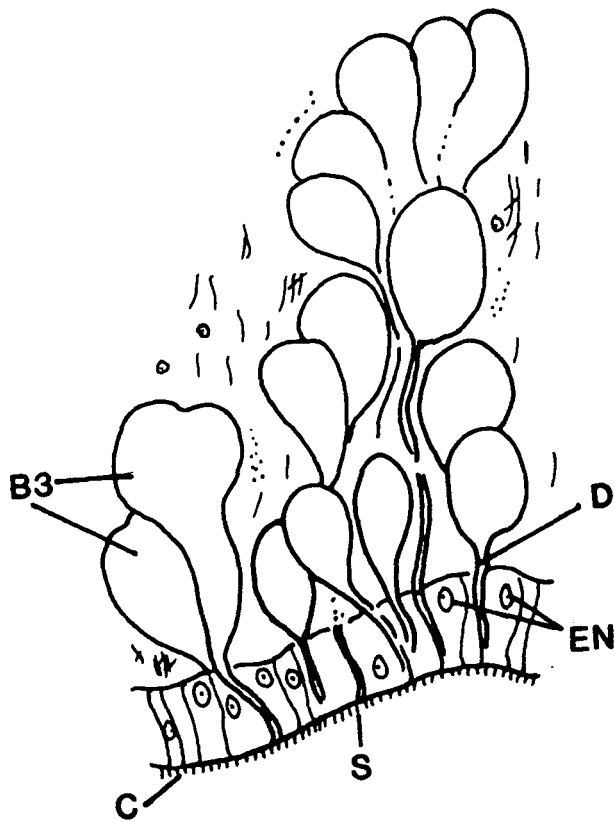

B

Figure 7 High power view of epidermal and subepidermal secretory cells in the dorsal pedal epithelium of Bithynia tentaculata in longitudinal section through the foot (ref. Plate 18A and C).

A Cell type B9.

B Goblet cell types B7 and B8.

DE - Dorsal epithelium; EC - Extruded contents; EN - Epidermal nuclei; G - Granular secretion; N - Nucleus; PG - Pigment granules. All other labels refer to cell types.

Fig.7

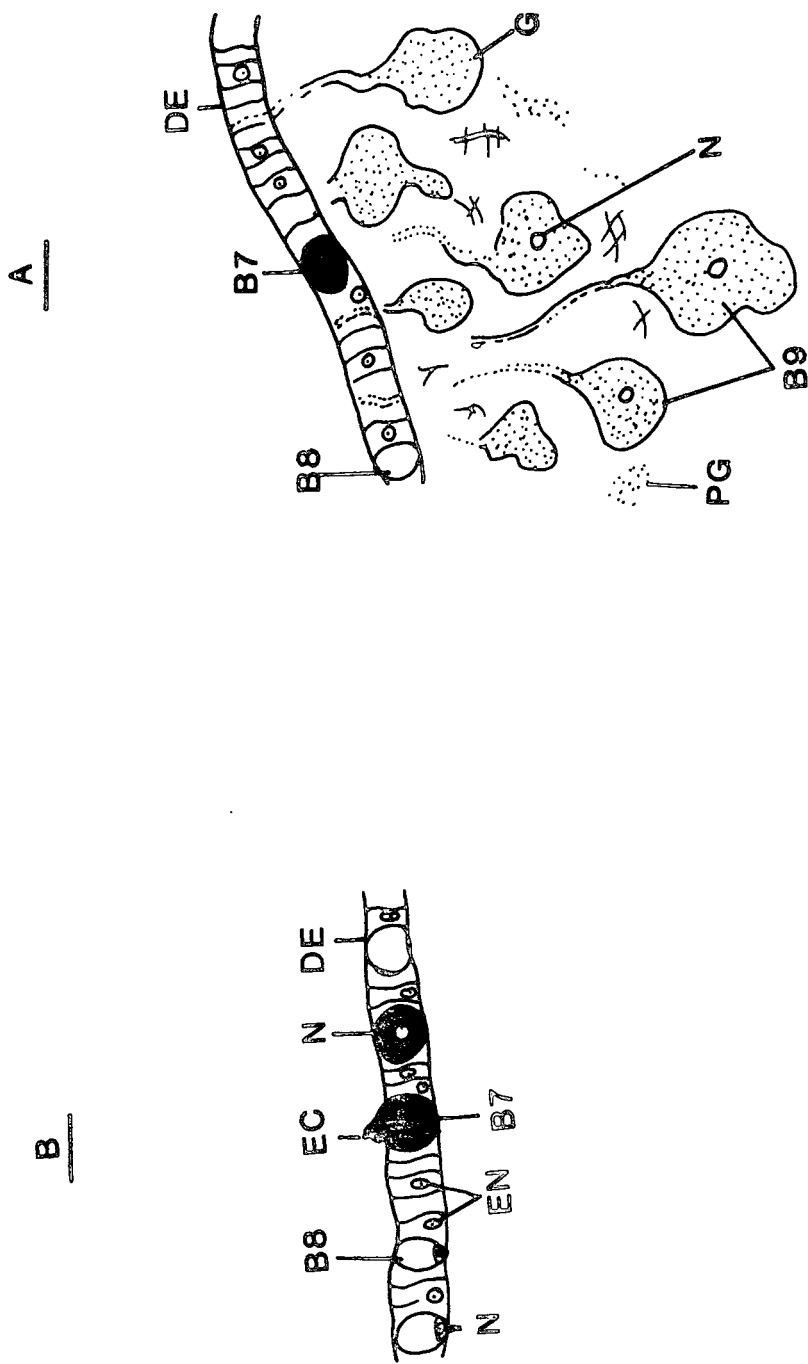

0.05mm

Figure 8 The general distribution of gland cell types in  
Littorina littorea.

A The pedal and mantle edge gland cells.

B The pedal and opercular gland cells.

APG - Anterior pedal gland; M - Mantle; O - Operculum; OG - Opercular groove; S - Sole; SOC - Subopercular cleft. All other labels refer to cell types.

Fig.8

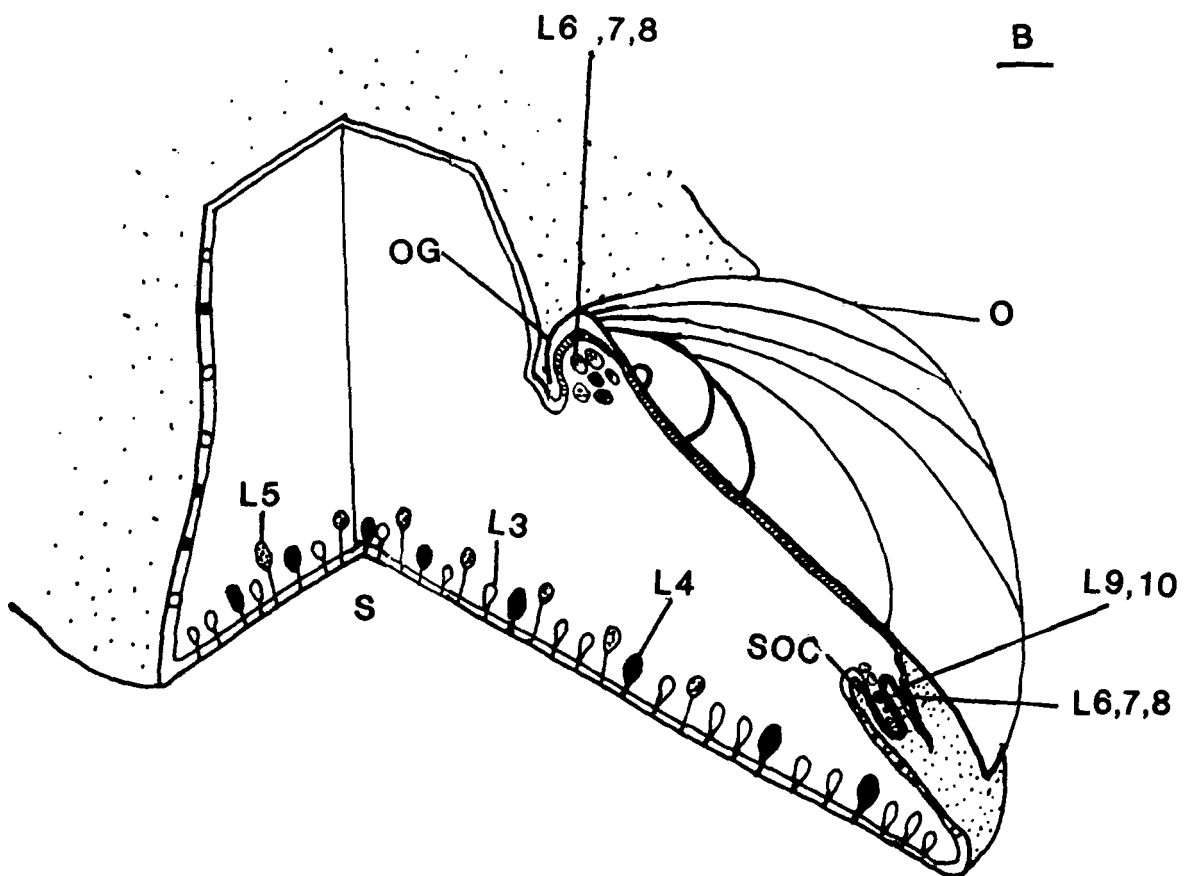
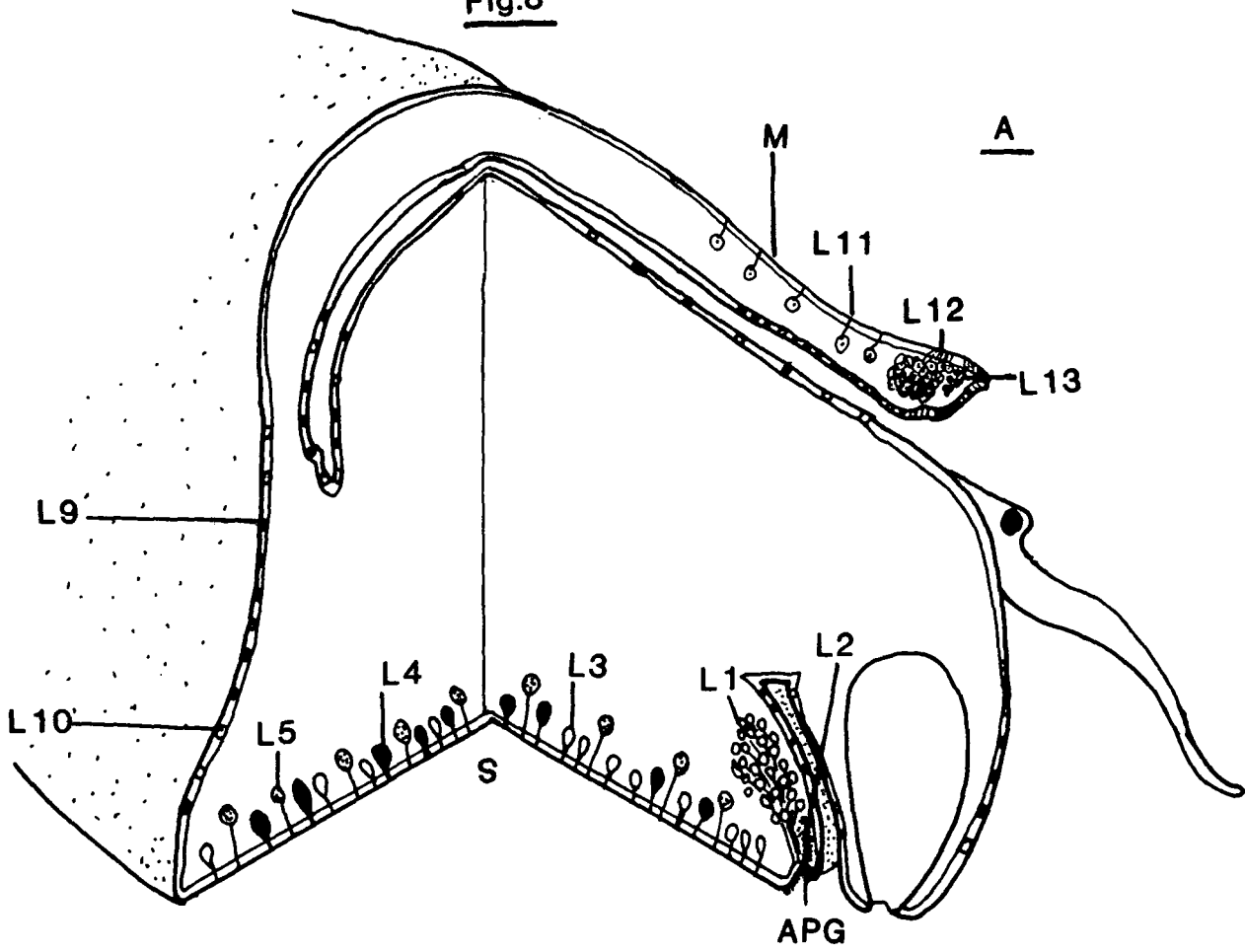

Reference diagram to show the planes of sections

of subsequent figures.

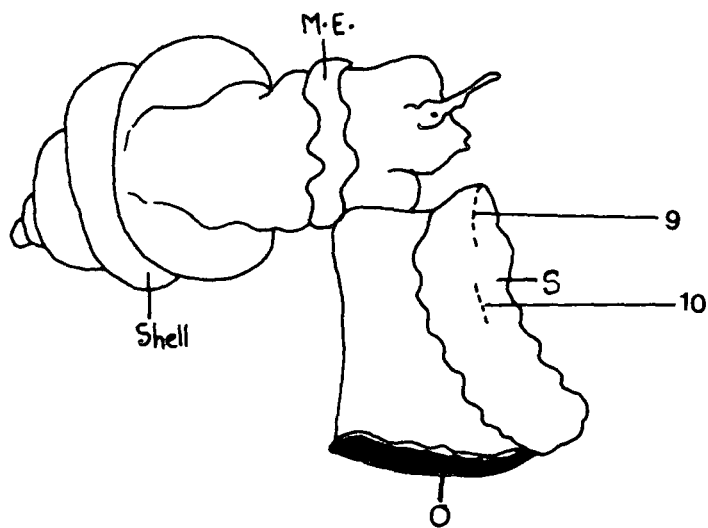

M.E. - Mantle edge ; O - Operculum ; S - Sole.

LITTORINA LITTOREA

Figure 9 A longitudinal section through the anterior foot of Littorina littorea to show the composition of the anterior pedal gland (ref. Plate 21).

D - Ducts; M.F.- Muscle fibres; N - Nucleus; PG - Pigment granules. All other labels refer to cell types.

**Fig.9**

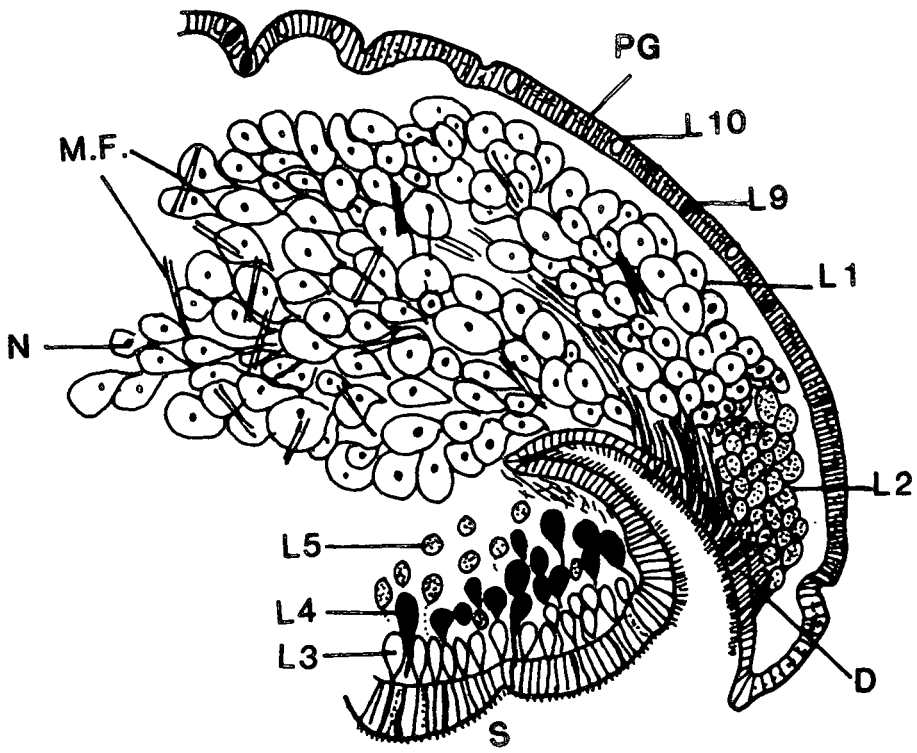

0.5mm



Figure 10 High power view of pedal cells of Littorina  
littorea in longitudinal section through the foot  
(ref. Plate 24A).

C - Cilia; D - Ducts; EN - Epidermal nuclei; N - Nucleus;  
S - Sole. All other labels refer to cell types.

Fig. 10

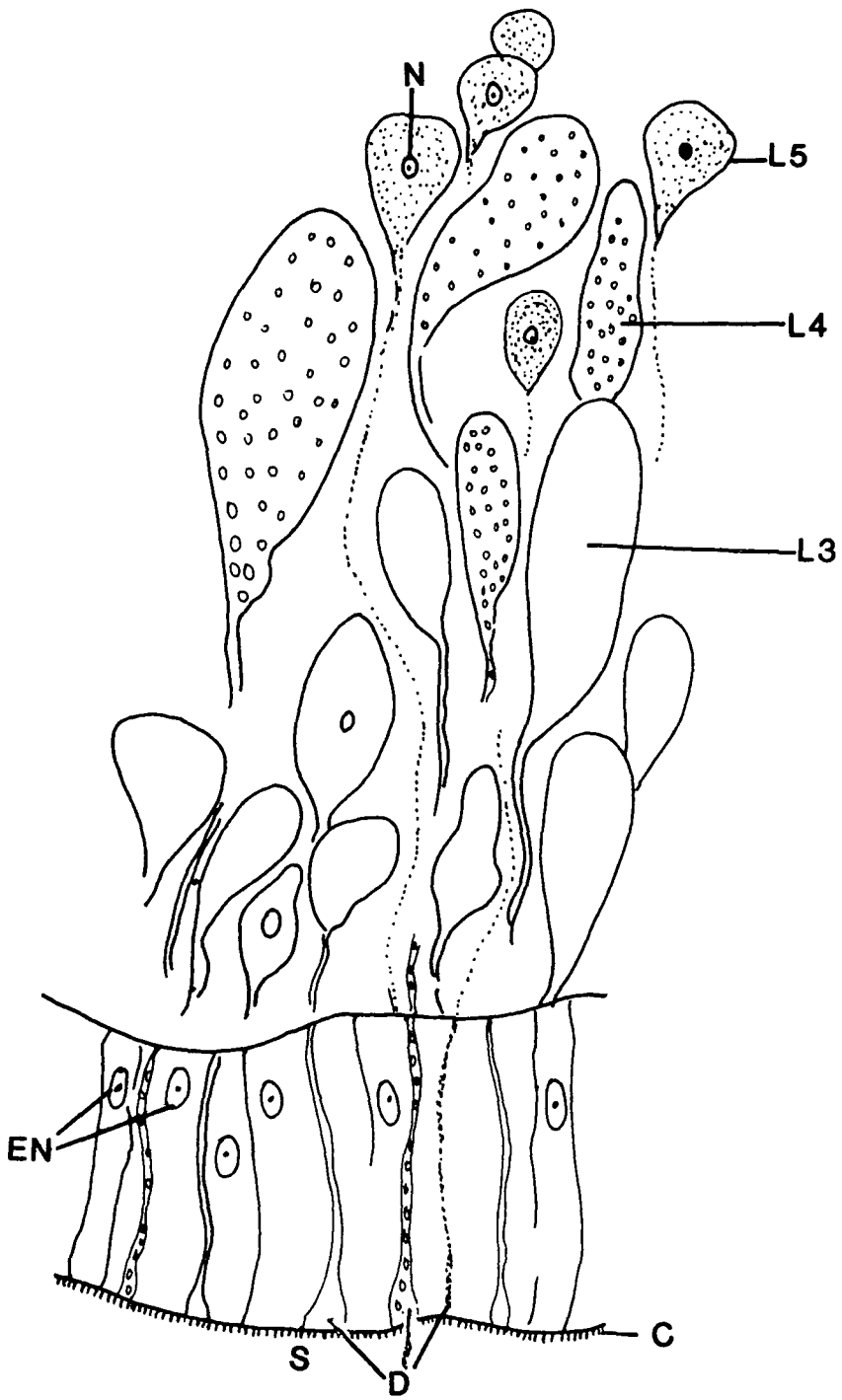

0.05mm

Figure 11 High power view of goblet cells of Littorina  
littorea in longitudinal sections through the  
foot, the mantle and the operculum.

A In dorsal pedal epithelium (ref. Plates 21B and 27).

B In ventral mantle epithelium (ref. Plate 43A).

C At the subopercular cleft (ref. Plate 36B).

Note the change in size of these goblet cells in  
different regions of the body.

N - Nucleus; PG - Pigment granules. All other labels refer  
to cell types.

Fig. 11

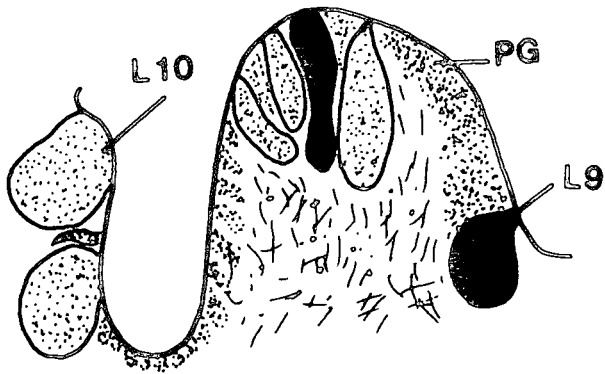
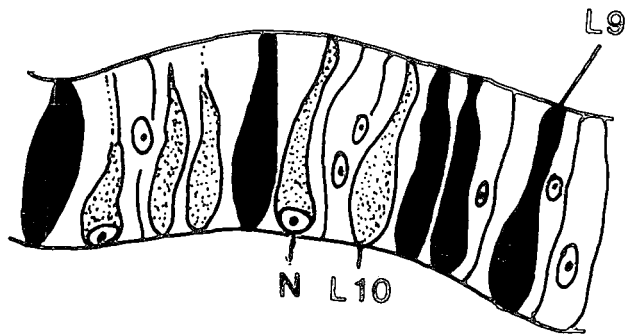
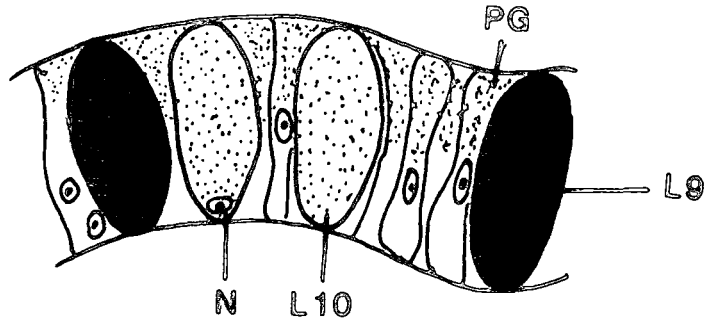

0.05mm

A

B

C

Figure 12 The opercular gland cells of Pomatias elegans.

- A A general outline of the foot in longitudinal section.
- B The opercular groove in transverse section.
- C The opercular cleft in transverse section.

OG - Opercular groove; SOC - Opercular cleft. All other labels refer to cell types.

Fig.12

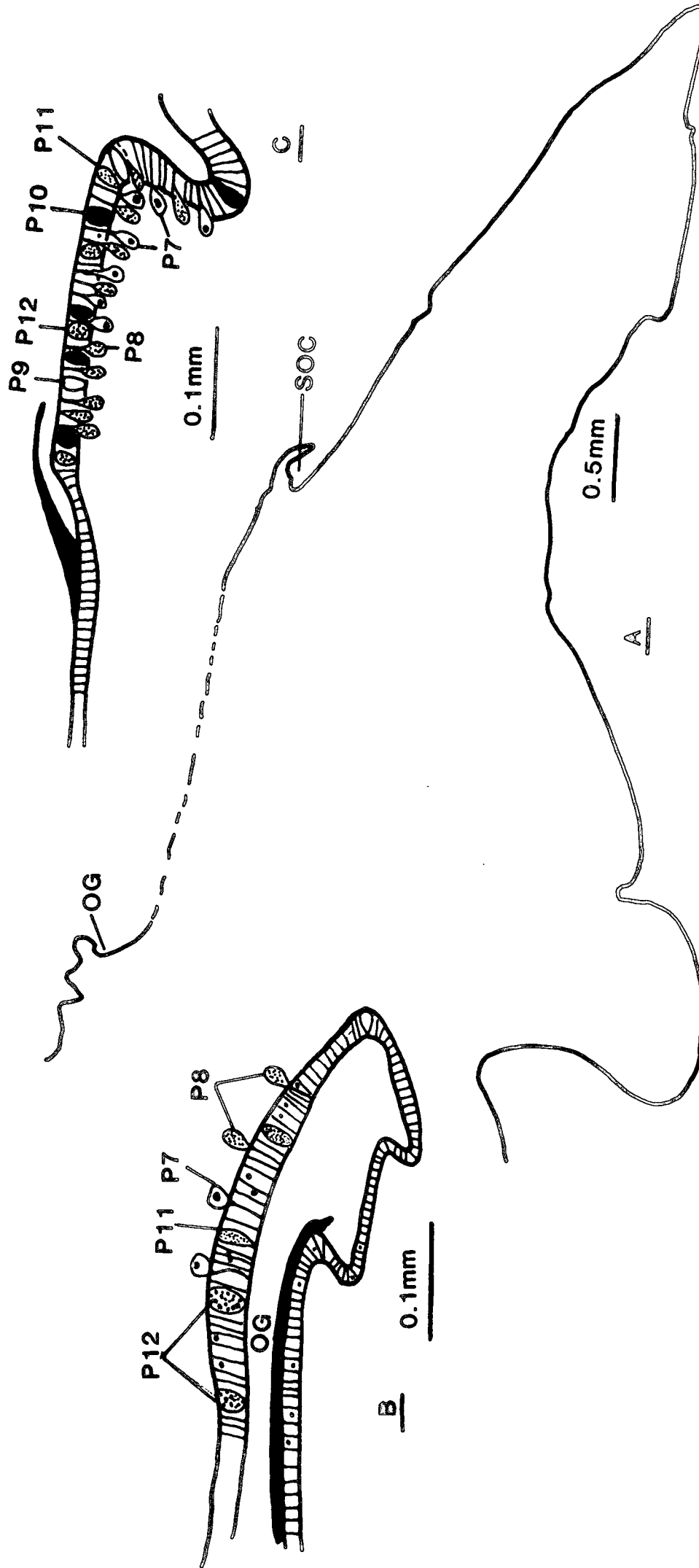
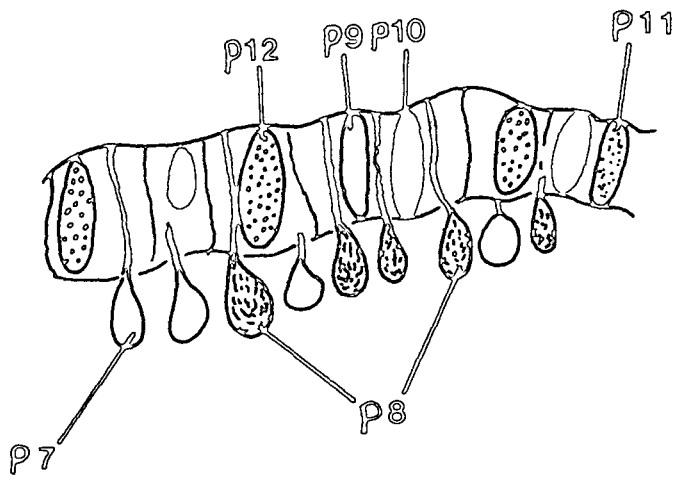

Figure 13 High power view of the opercular gland cells of  
Pomatias elegans from the opercular disc (ref.  
Plate 30A).

All labels refer to cell types.

Fig. 13



0.05mm

Figure 14 The opercular gland cells of Bithynia  
tentaculata.

- a Reference diagram. Dotted line shows the plane of section.
- A A general outline of the foot in longitudinal section.
- B High power view of the opercular disc to show the distribution of opercular secretory cells.
- C High power view of the opercular groove to show the opercular gland cell types.

F - Foot; O - Operculum; OD - Opercular disc; OG - Opercular groove; S - Sole; SOC - Subopercular cleft. All other labels refer to cell types.

Fig. 14

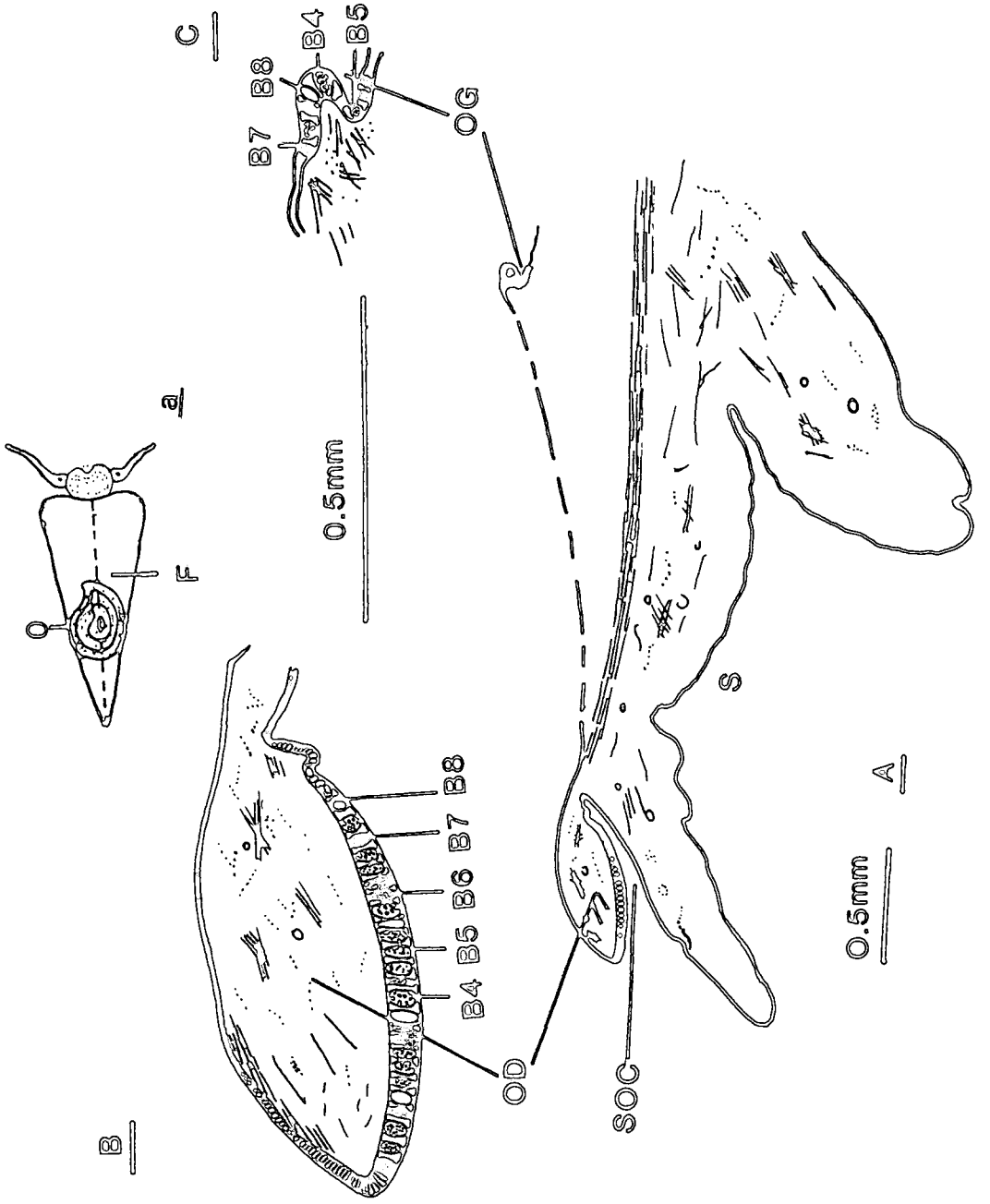

Figure 15 The opercular gland cells of Littorina littorea.

- a Reference diagram. Dotted line shows the plane of section.
- A A general outline of the whole foot in longitudinal section.
- B High power view of the distribution of opercular gland cell types at the opercular groove and the subopercular cleft.

O - Operculum; OG - Opercular groove; S - Sole; SOC - Subopercular cleft. All other labels refer to cell types.

Fig.15

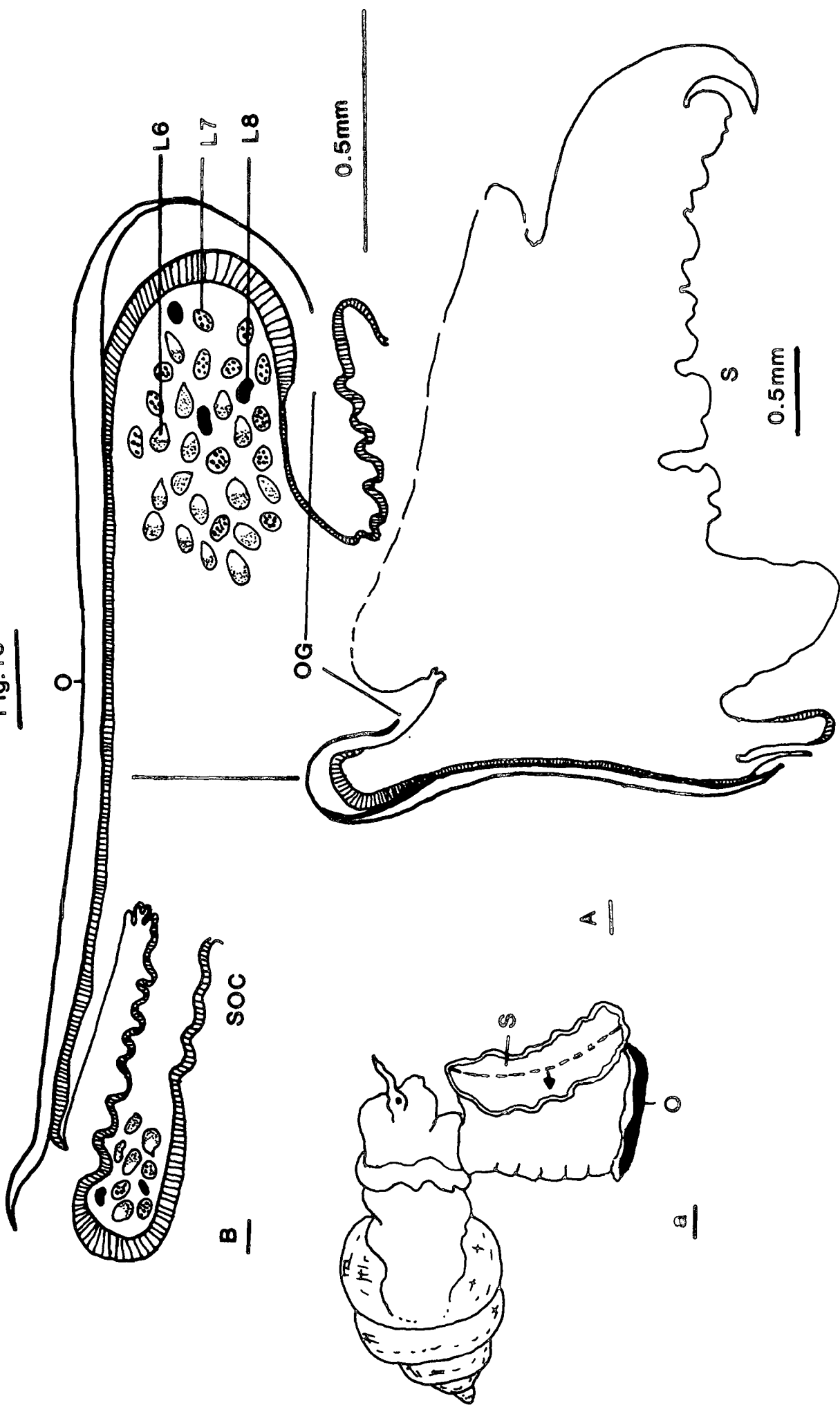

Figure 16 Mantle edge of Pomatias elegans.

- a Reference diagram. Dotted line shows the plane of section through the mantle.
- A A longitudinal section through the mantle edge of Pomatias elegans to show the two mantle edge glands opening to the dorsal aspect of the mantle edge and the structure of the dorsal and ventral mantle epithelium.

DE - Dorsal epithelium; M.E. - Mantle edge; VE - Ventral epithelium. All other labels refer to cell types.

Fig.16

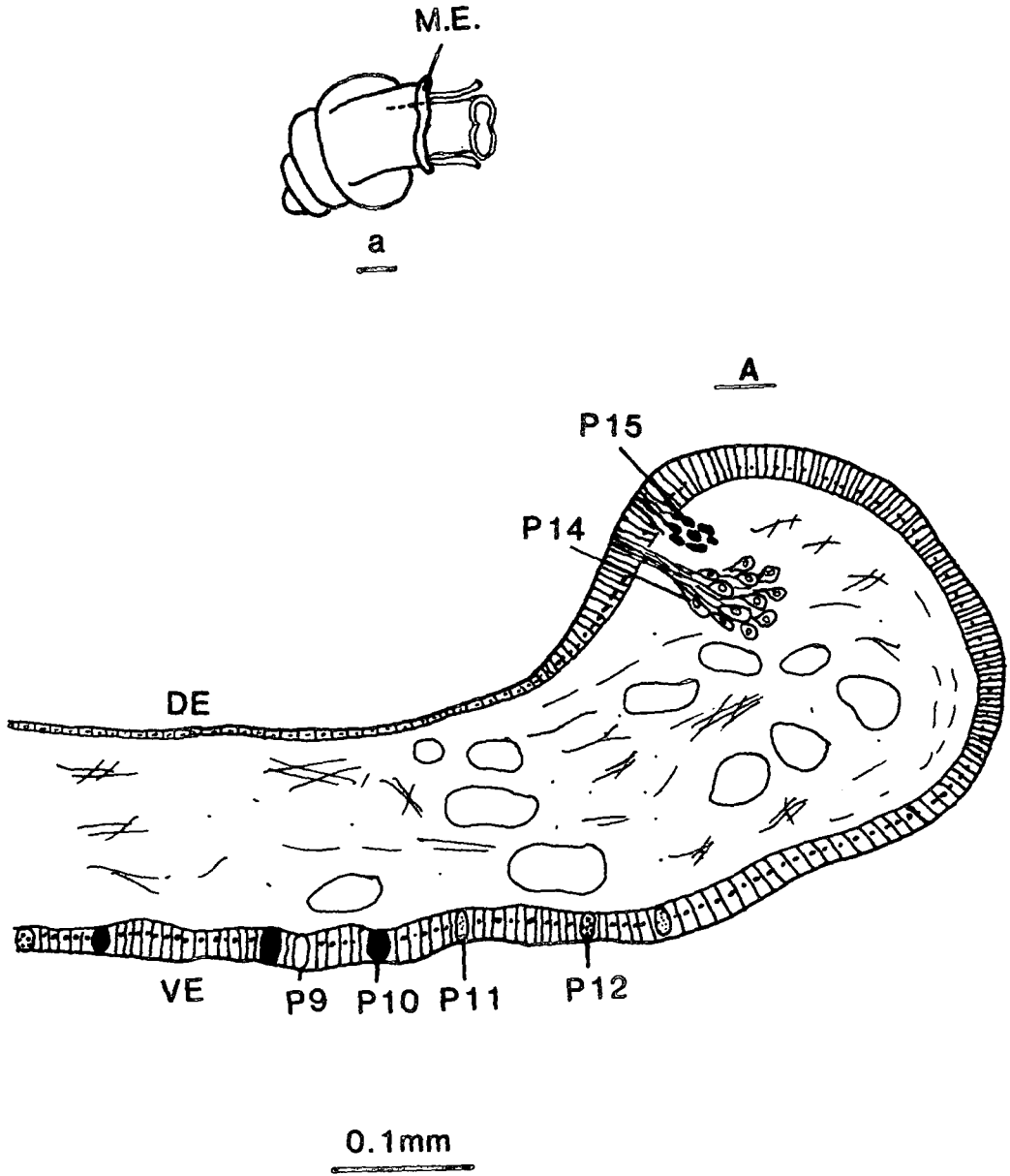

Figure 17 Mantle edge of Bithynia tentaculata.

a Reference diagram. Dotted line shows the plane of section through the mantle.

A A longitudinal section through the mantle edge of Bithynia tentaculata to show the structure of the mantle edge gland and the dorsal and ventral mantle epithelium.

DE - Dorsal epithelium; M.E. - Mantle edge; N - Nucleus; PG - Pigment granules; VE - Ventral epithelium. All other labels refer to cell types.

**Fig.17**

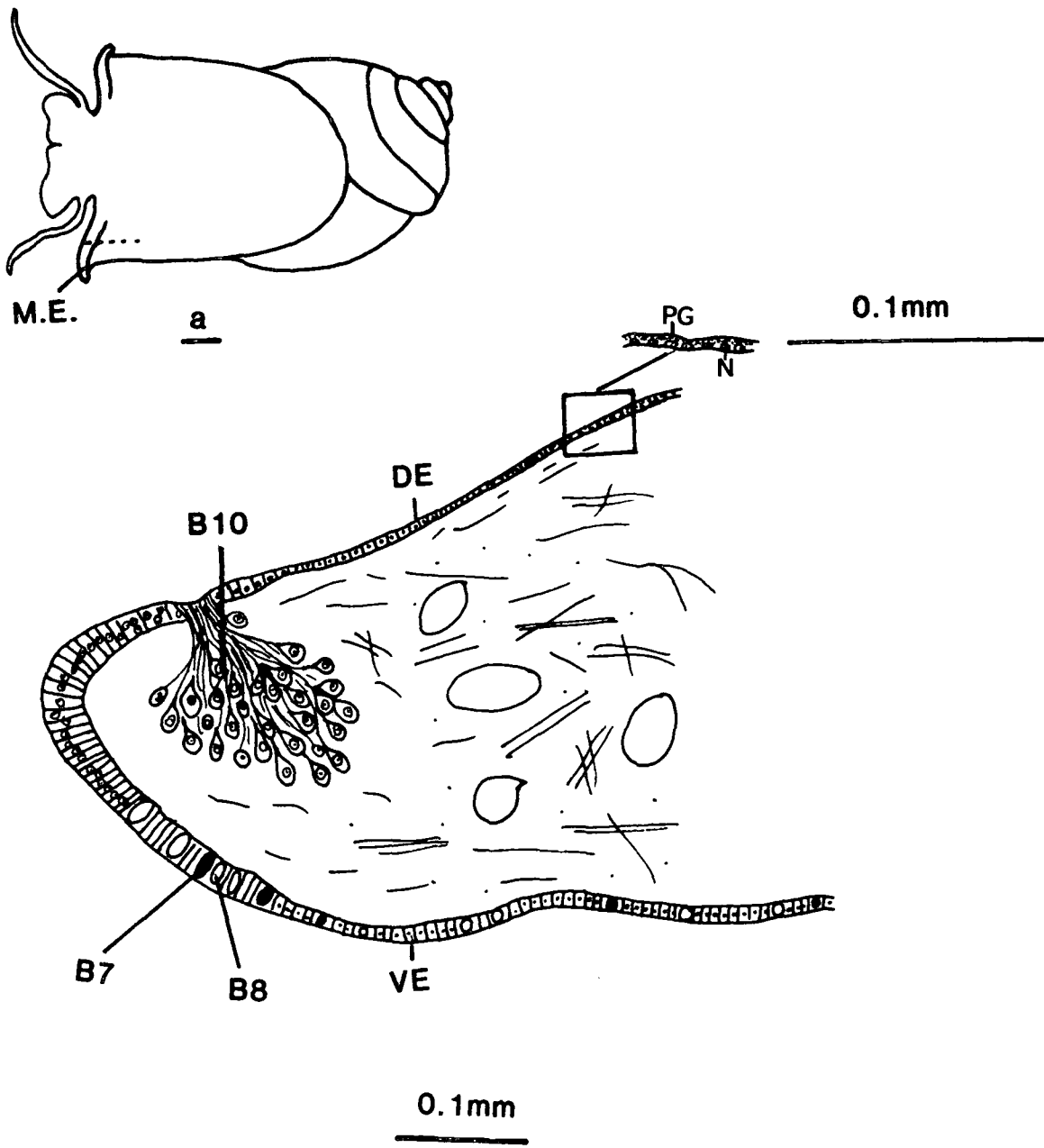
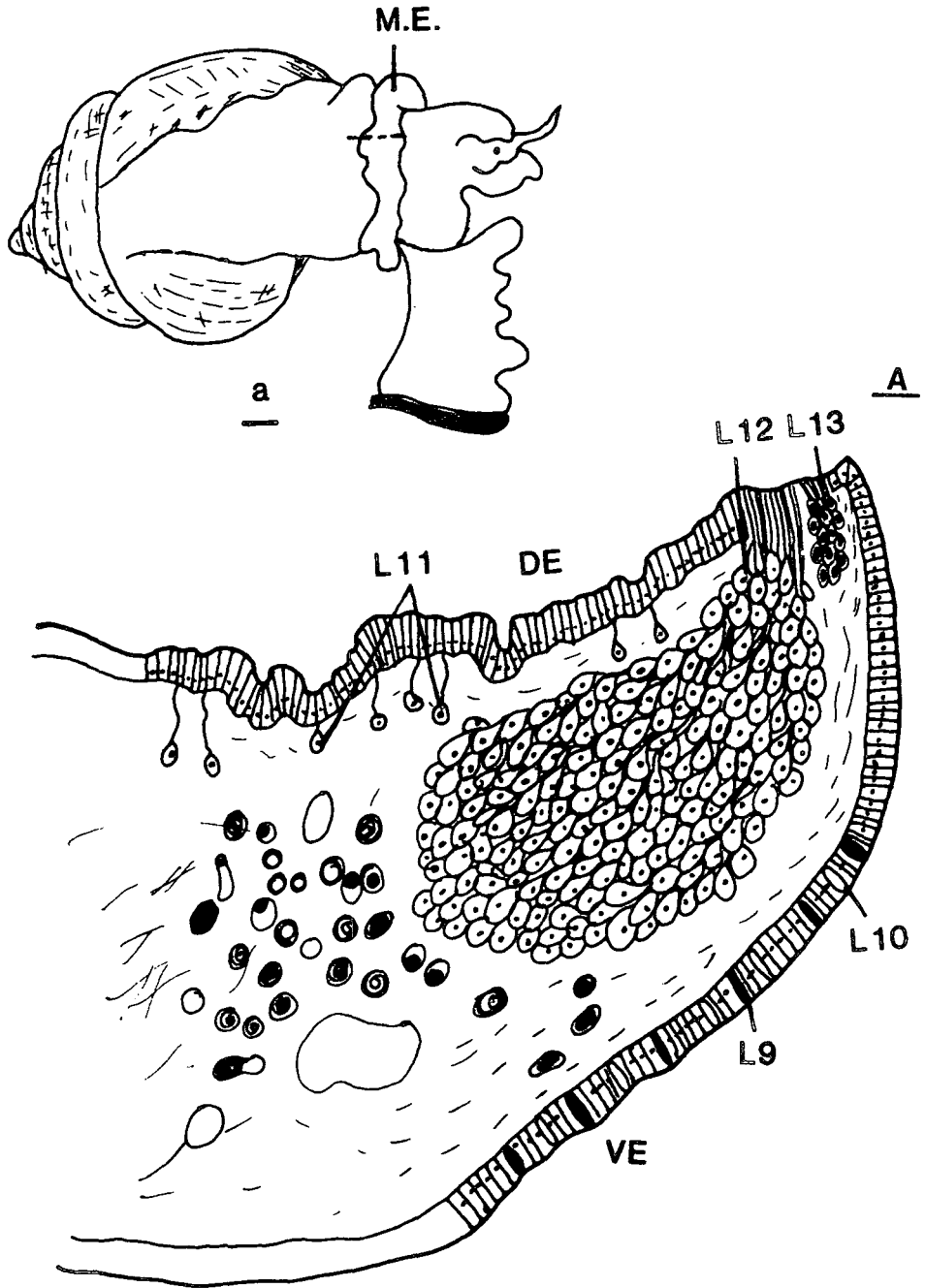

Figure 18 Mantle edge of Littorina littorea.

- a Reference diagram. Dotted line shows the plane of section through the mantle.
- A A longitudinal section through the mantle edge of Littorina littorea to show the structure of the mantle edge glands (L12 and L13) and the dorsal and ventral mantle epithelium. Note that in Littorina the dorsal mantle epithelium is made up of tall columnar cells and the ducts of the subepidermal gland cells (type L11) pass between these cells to open at the outside edge.

DE - Dorsal epithelium; M.E. - Mantle edge; VE - Ventral epithelium. All other labels refer to cell types.

Fig.18



0.1mm

Figure 19 High power view of the subepidermal gland cells (L11) of the dorsal mantle epithelium of Littorina littorea (ref. Plate 43B).

D - Ducts; DE - Dorsal epithelium; EN - Epidermal nuclei.

Fig.19

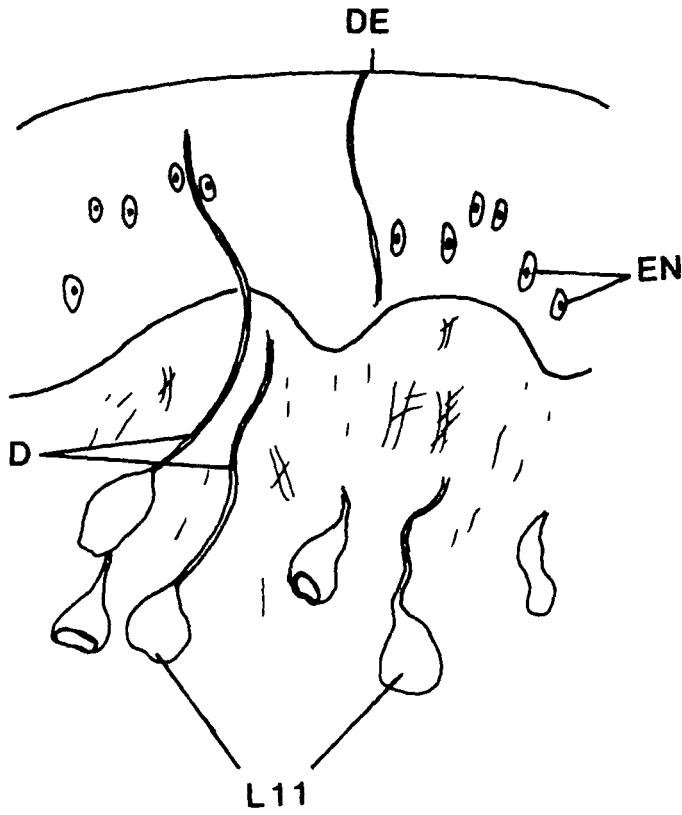

0.05mm

Figure 20 Hypobranchial gland of Pomatias elegans.

- a Reference diagram. Dotted line shows the plane of section through the mantle cavity of Pomatias elegans.
- A A transverse section through the mantle cavity to show the location of the hypobranchial glands in the rectal area and the central zone.
- B High power view of hypobranchial gland cell types in the rectal area.
- C High power view of hypobranchial gland cell types in the central zone.

DE - Dorsal epithelium; HG - Hypobranchial gland; M - Mantle; M.C. - Mantle cavity; R - Rectum; VE - Ventral epithelium. All other labels refer to cell types.

Fig.20

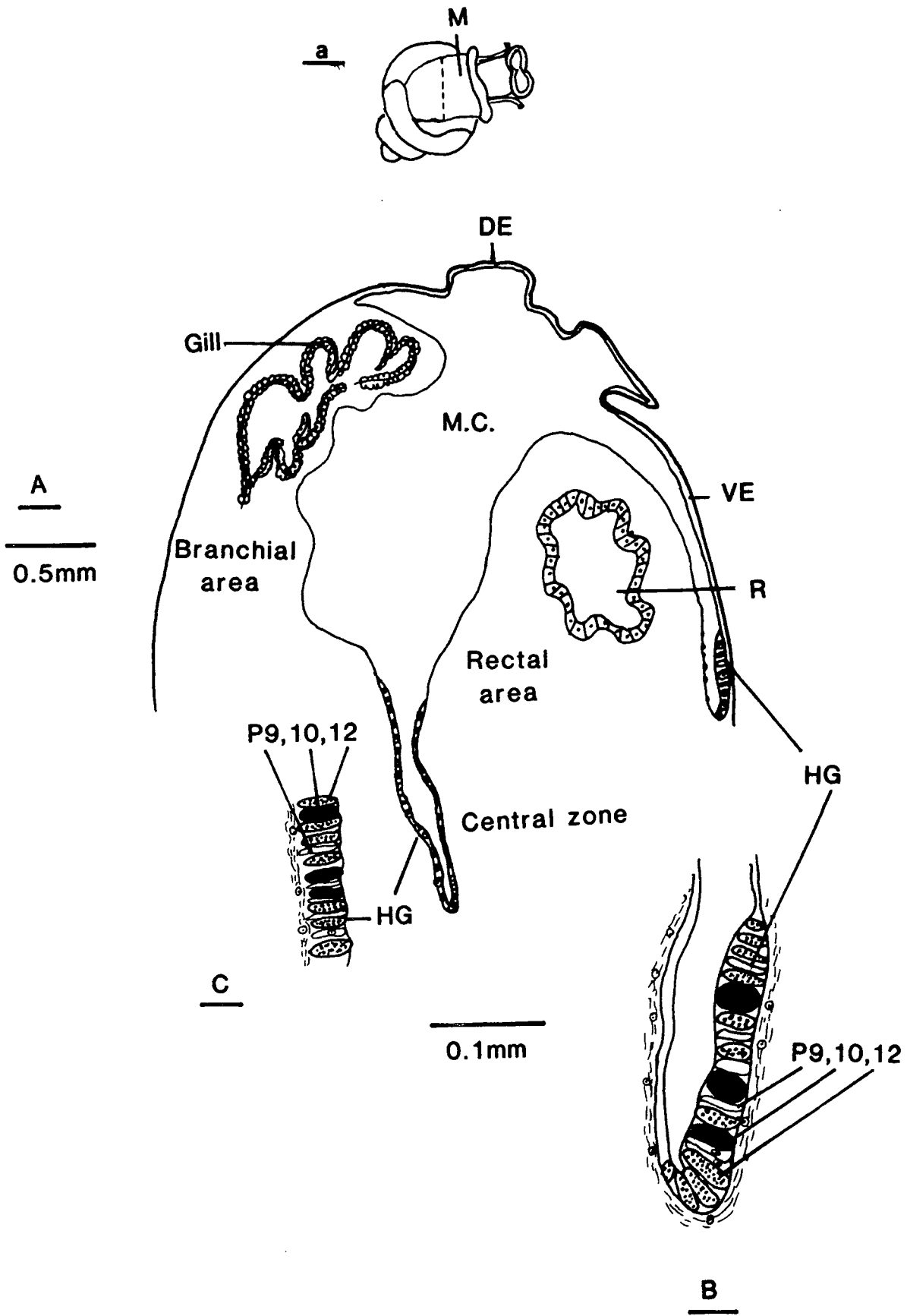

Figure 21 Hypobranchial gland of Bithynia tentaculata.

a Reference diagram. Dotted line shows the plane of section.

A A longitudinal section through the whole mantle of Bithynia to show the mantle edge, branchial area, hypobranchial gland and the rectal area.

B High power view of the hypobranchial gland cell types.

CT - Ctenidium; DE - Dorsal epithelium; M.E. - Mantle edge; HG - Hypobranchial gland; R - Rectum; VE - Ventral epithelium. All other labels refer to cell types.

Fig.21

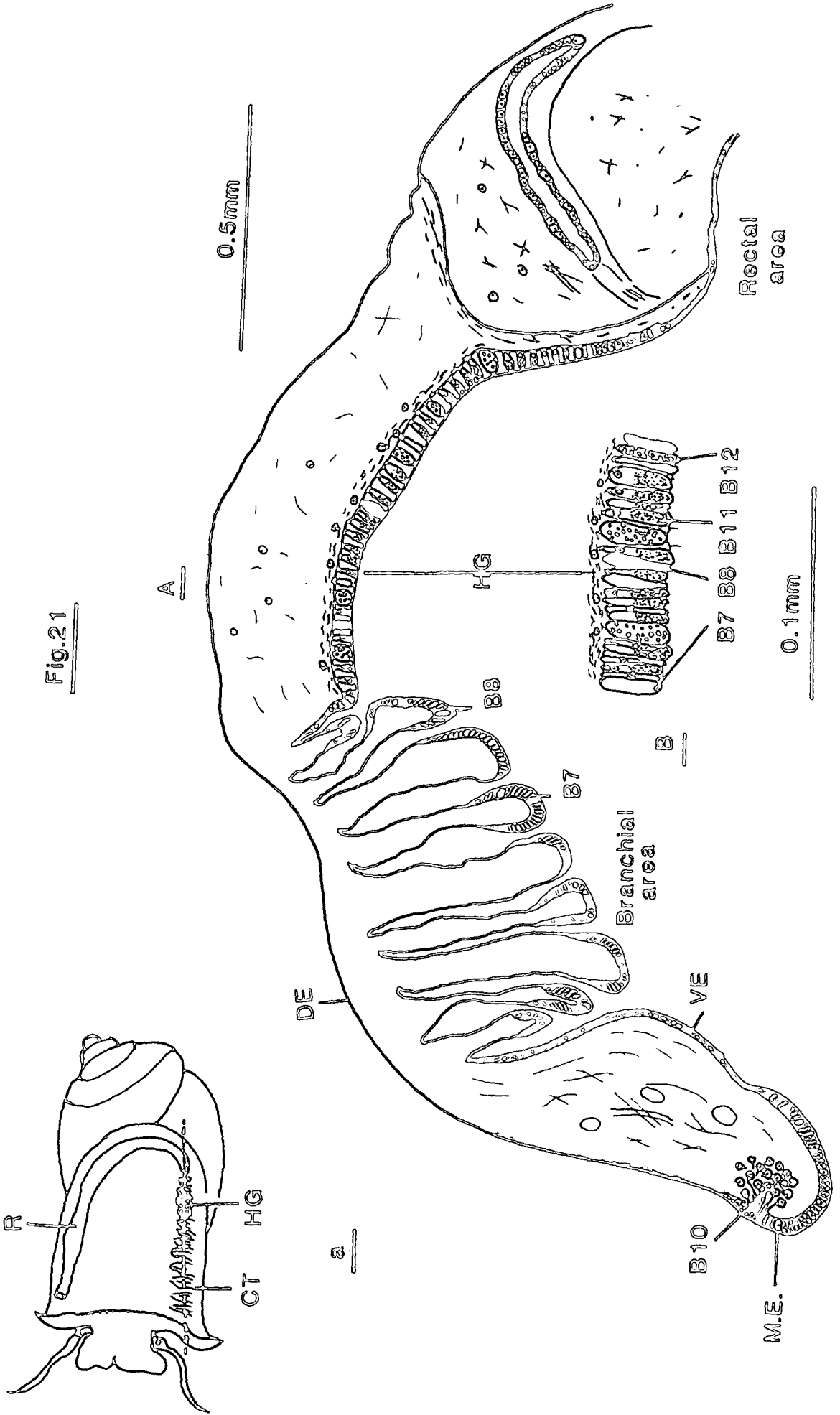
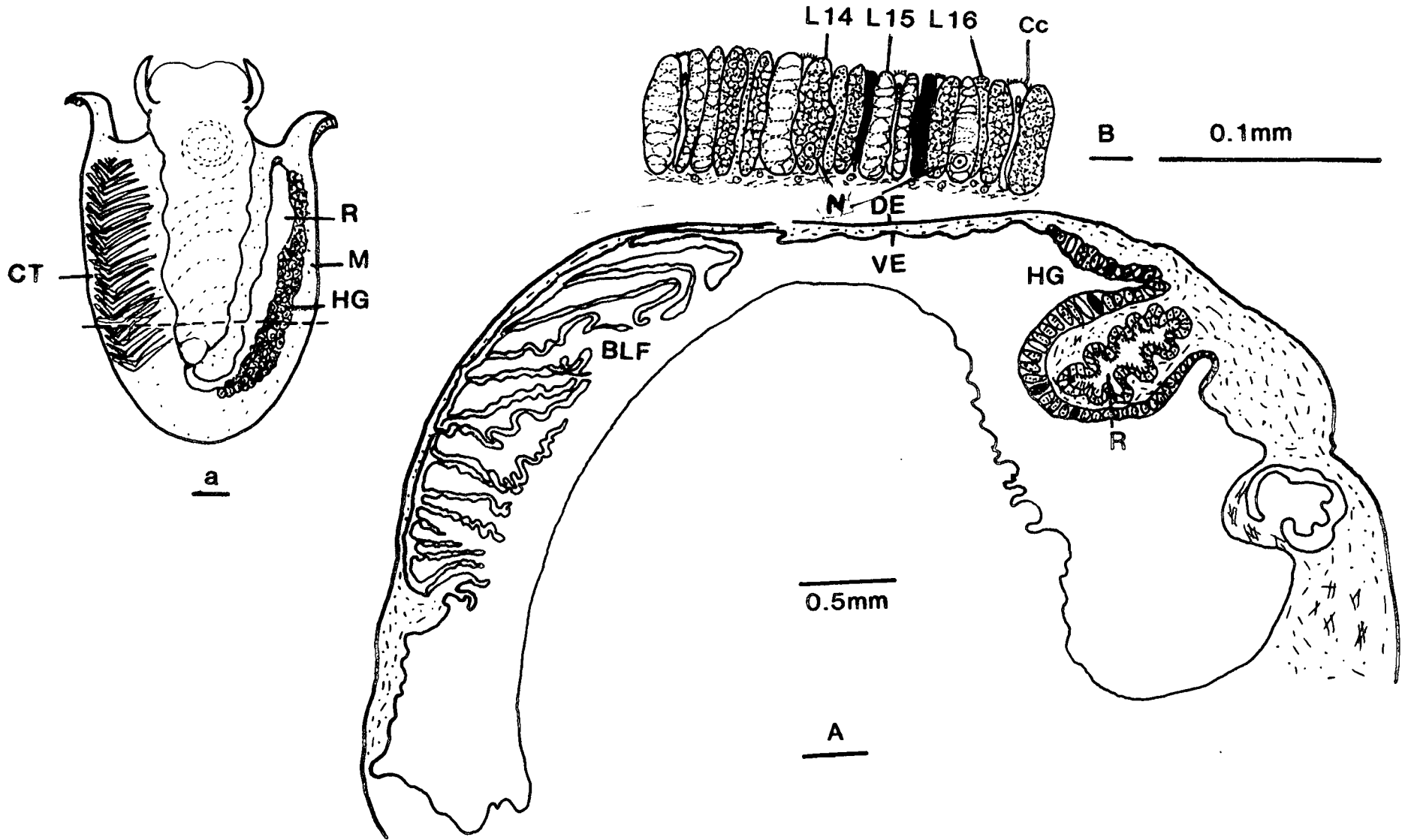

Figure 22 Hypobranchial gland of Littorina littorea.

- a Reference diagram. Dotted line shows the plane of the section through the mantle cavity.
- A A transverse section through the mantle cavity to show the hypobranchial gland.
- B High power view of the hypobranchial gland cell types.

BLF - Branchial leaflet; Cc - Ciliated cells; CT - Ctenidium; DE - Dorsal epithelium; HG - Hypobranchial gland; M - Mantle; N - Nuclei; R - Rectum; VE - Ventral epithelium.  
All other labels refer to cell types.

Fig22



Reference diagrams to show the planes of sections  
of subsequent figures.

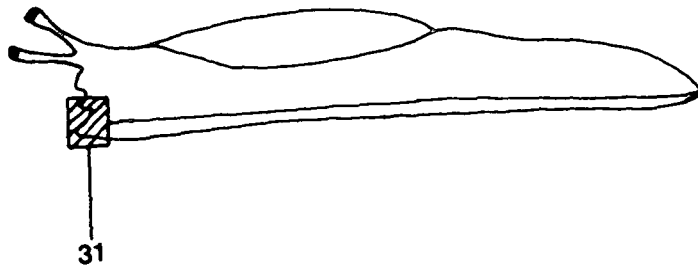
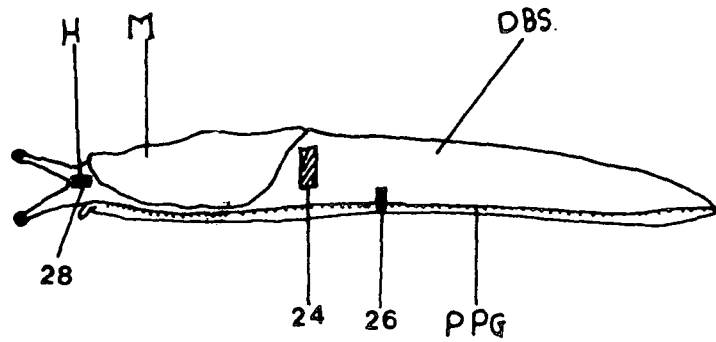

DBS-Dorsal body surface, H-Head, M-Mantle, P-Pneumostome,  
PPG-Peripodal groove.

LIMAX PSEUDOFLAVUS

---

Figure 23

- A A diagrammatic view of Limax pseudoflavus showing the areas of the body possessing mucus-producing glands. Ciliated areas are shown dotted.
- B Schematic drawing of anterior part of a longitudinal section of Limax to show the distribution of mucus-producing gland cells on the dorsal body surface, the head and the foot.

DBS - Dorsal body surface; H - head; IG - Inferior gland; M - Mantle; MG - Median gland; P - Pneumostome; PPG - Peripodal groove; S - Sole; SG - Superior gland; SO - Sempers organ; SPD - Suprapedal duct; SPG - Suprapedal gland; SPS - Suprapedal sinus. All other labels refer to cell types.

Fig.23

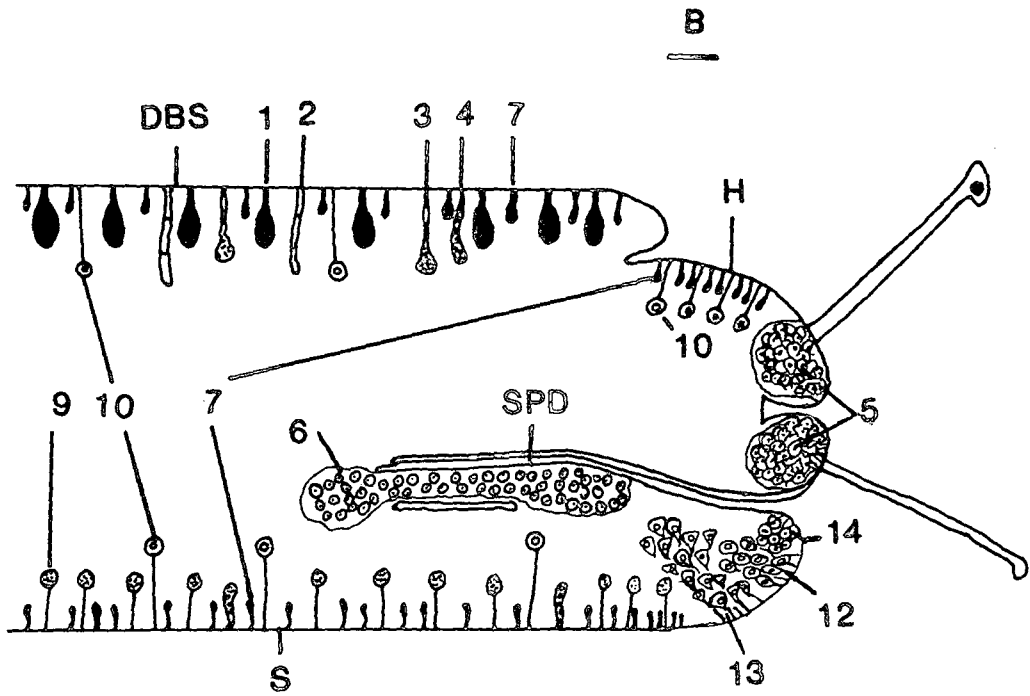
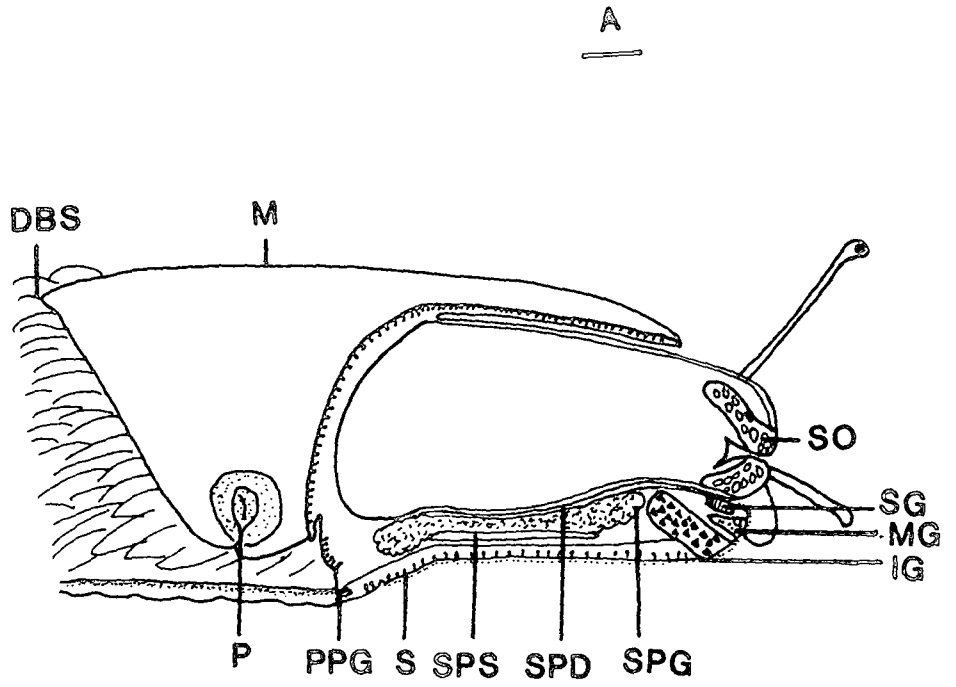
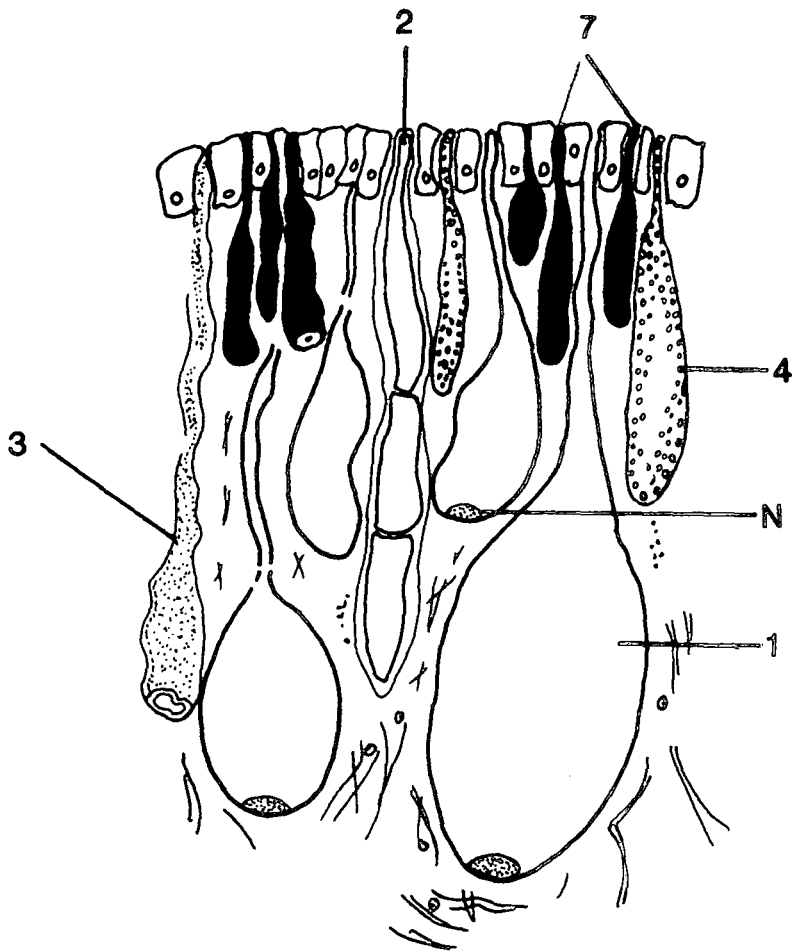

Figure 24 A transverse section through the dorsal body surface of Limax pseudoflavus to show the gland cell type in this area.'

N - Nucleus. All other labels refer to cell types.

**Fig.24**



**0.1mm**

Figure 25 High power view to show the detailed structure of cell types 2, 3 and 4 of Limax pseudoflavus.

G - Granular secretion; N - Nucleus.

Fig.25

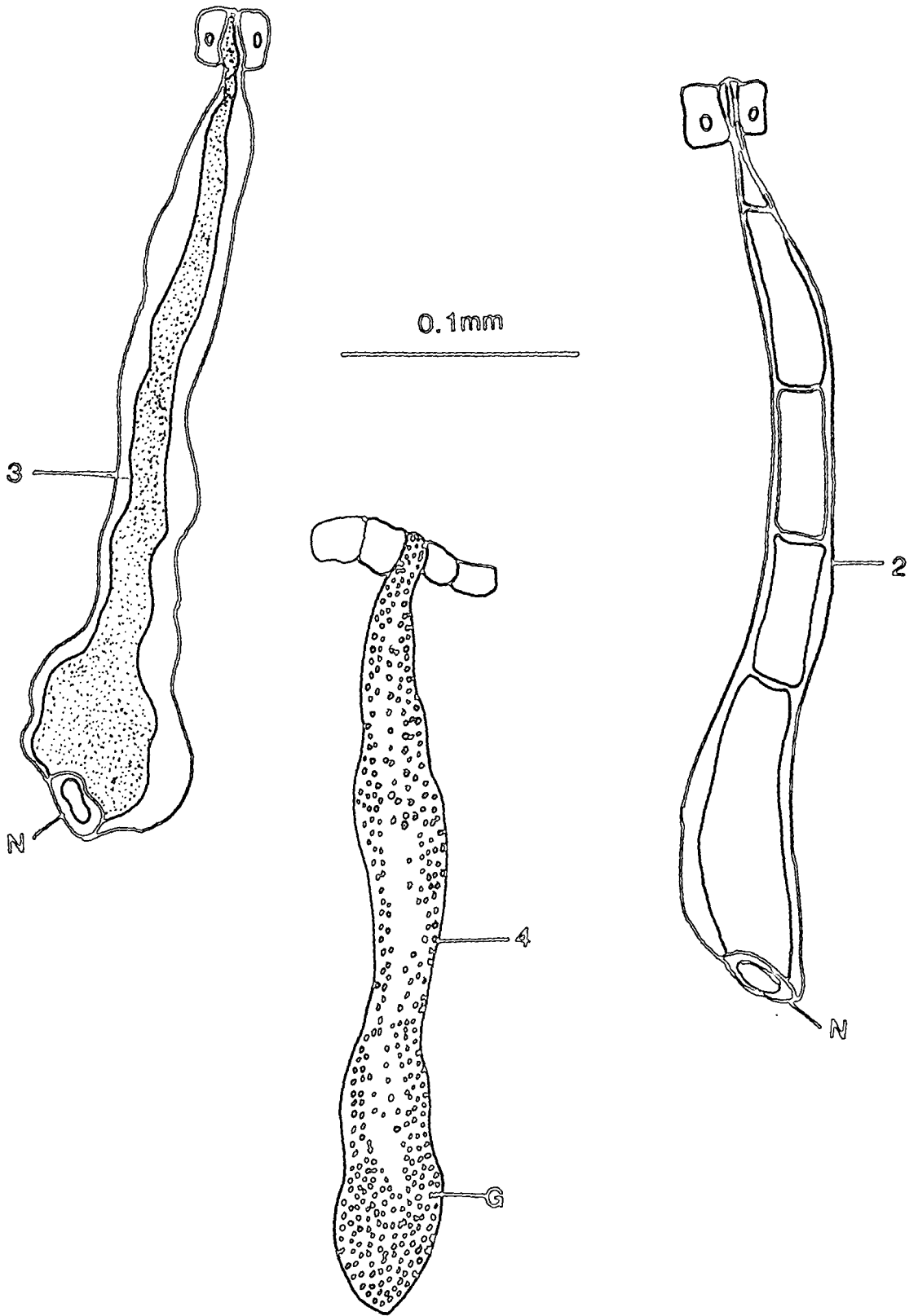

Figure 26

A A cross section through the peripodal groove of Limax pseudoflavus showing the distribution of secretory cells and the extent of ciliation.

B High power view of secretory cells at the peripodal groove.

C - Cilia; N - Nucleus; PPG - Peripodal groove. All other labels refer to cell types.

Fig.26

A

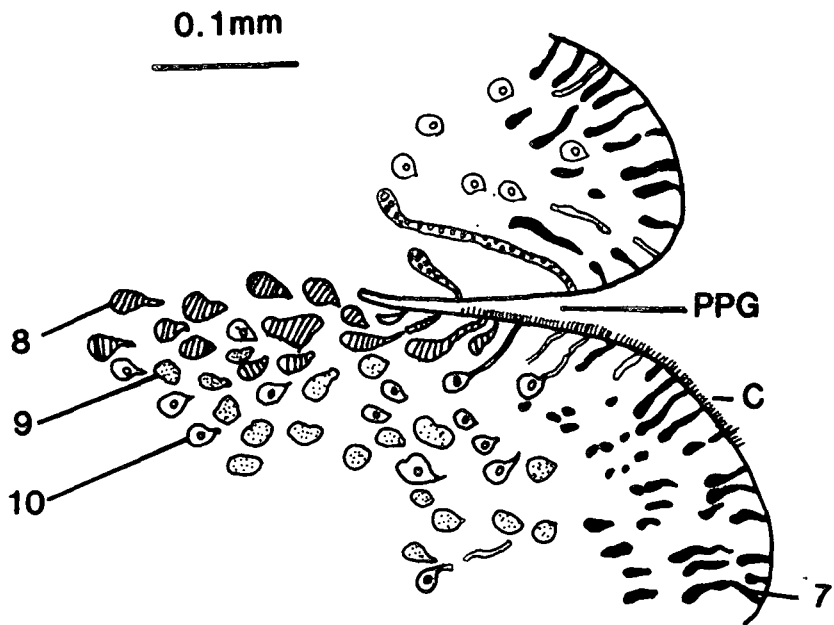

B

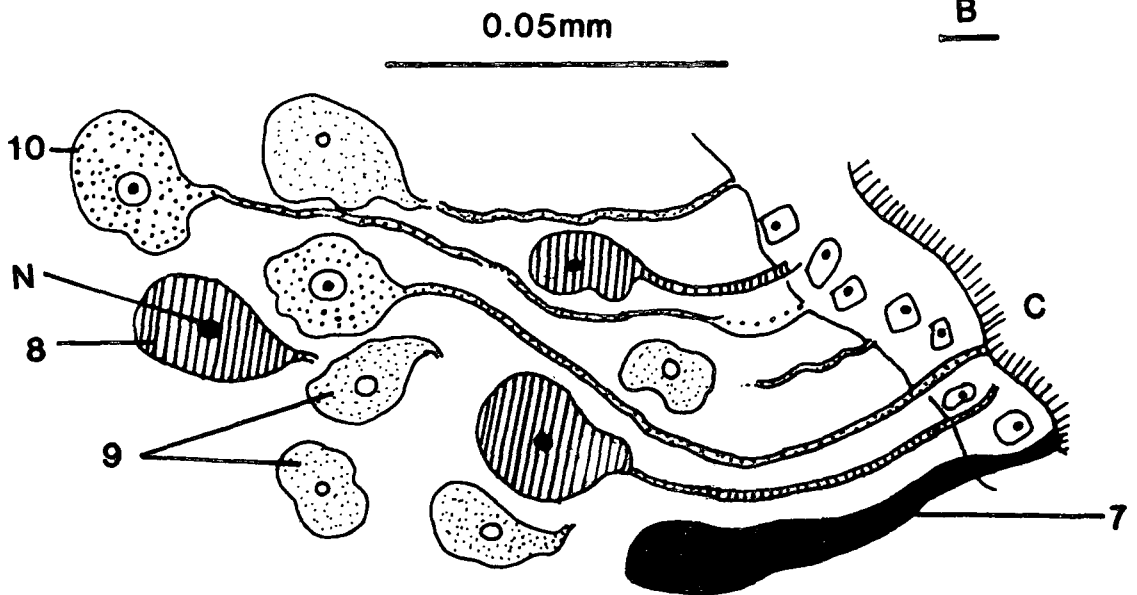

Figure 27 Mucus-secreting cells in the sole of Limax  
pseudoflavus.

- A A low power view of the area between the central and peripheral bands of the foot.
- B A high power view of the peripheral region.
- C A high power view of the central region.

C - Cilia; Solid cells - type 7; Cells with nuclei - type 10; Dotted cells - type 9; Cells with open circles - type 4.

Fig.27

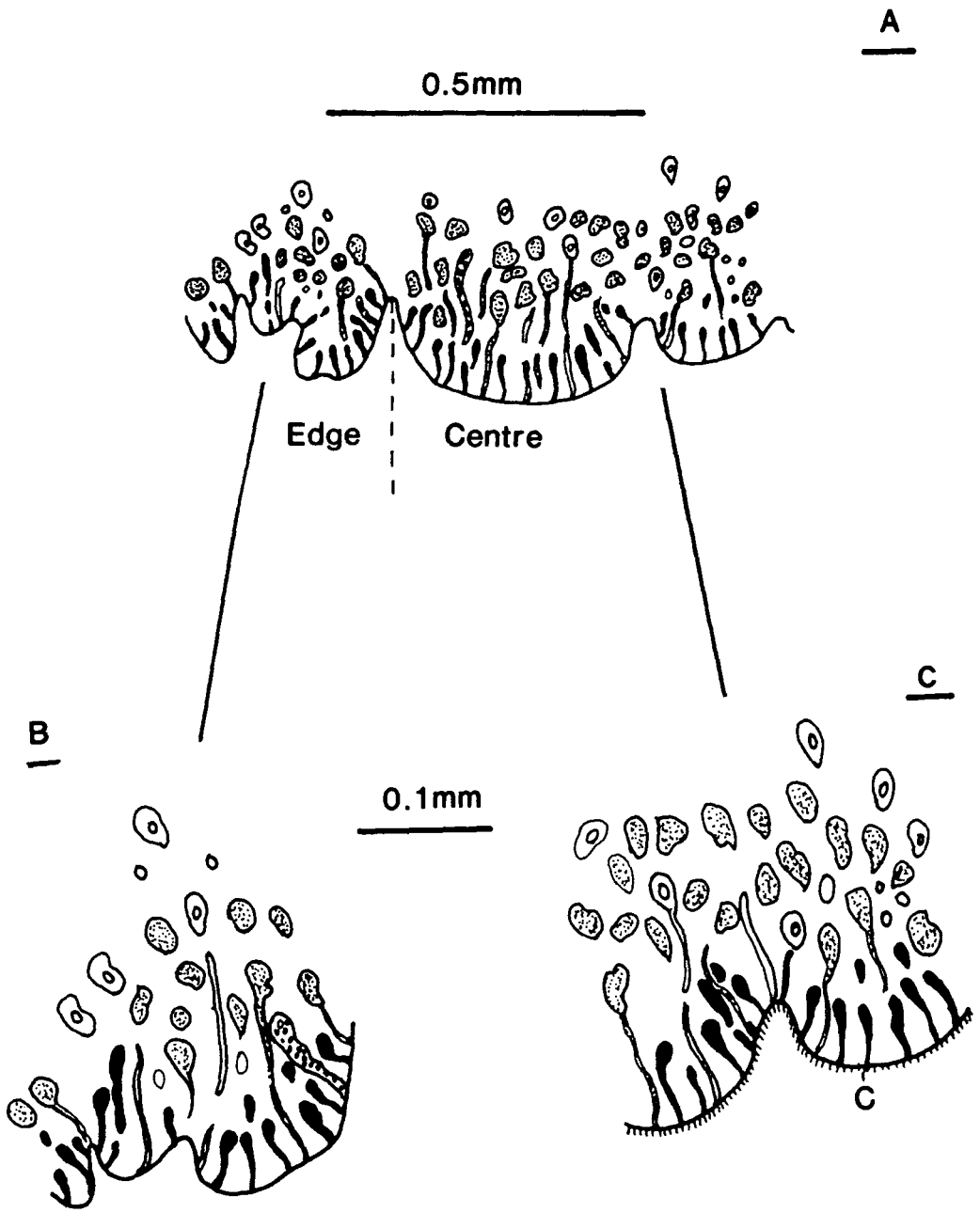

Figure 28 Mucus-secreting cells in the head of Limax  
pseudoflavus. High power view of cell types 7  
and 10 in longitudinal section through the head  
(ref. Plate 58).

EN - Epidermal nuclei; G - Granular secretion; N -Nucleus.

Fig28

0.05mm

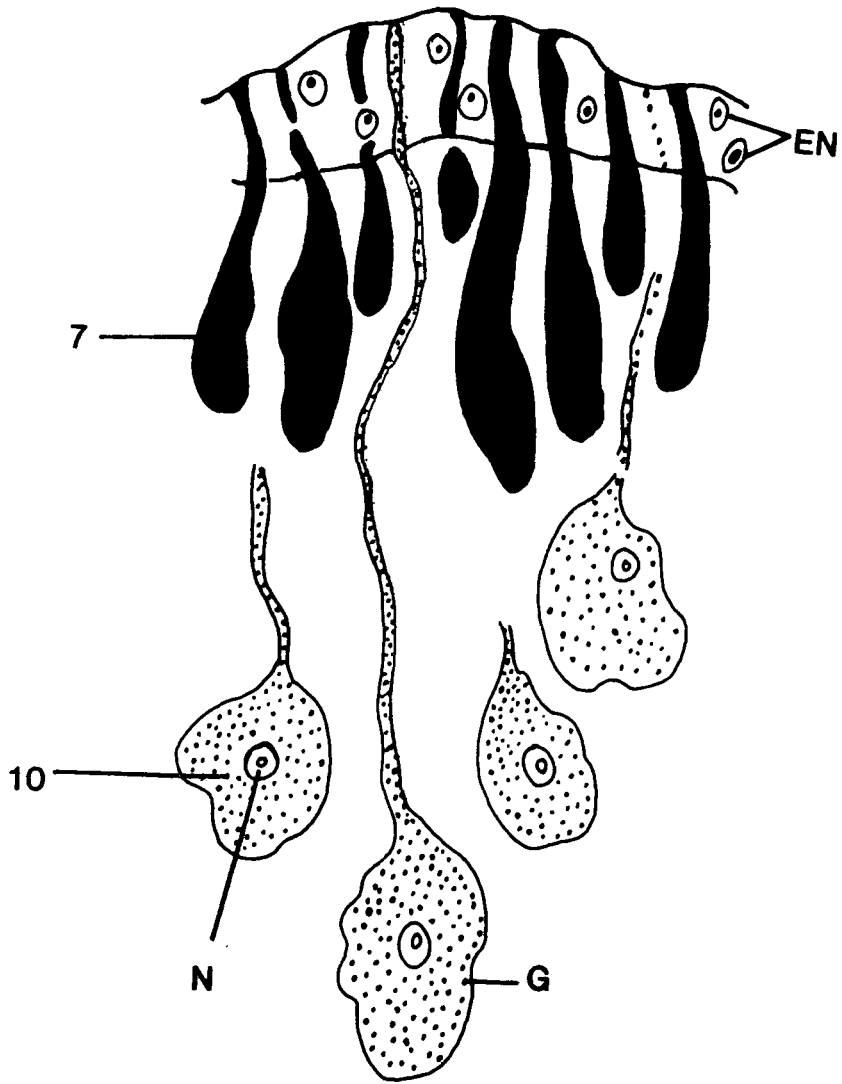

Figure 29 A transverse section through the suprapedal gland of Limax pseudoflavus showing the suprapedal duct, lateral prominences, central groove and the pedal gland mucocytes (type 6 cells).

CG - Central groove; L - Lumen; LP - Lateral prominences;  
M.F. - Muscle fibres; SPD - Suprapedal duct; 6 - Pedal gland mucocytes.

Fig.29

0.5mm

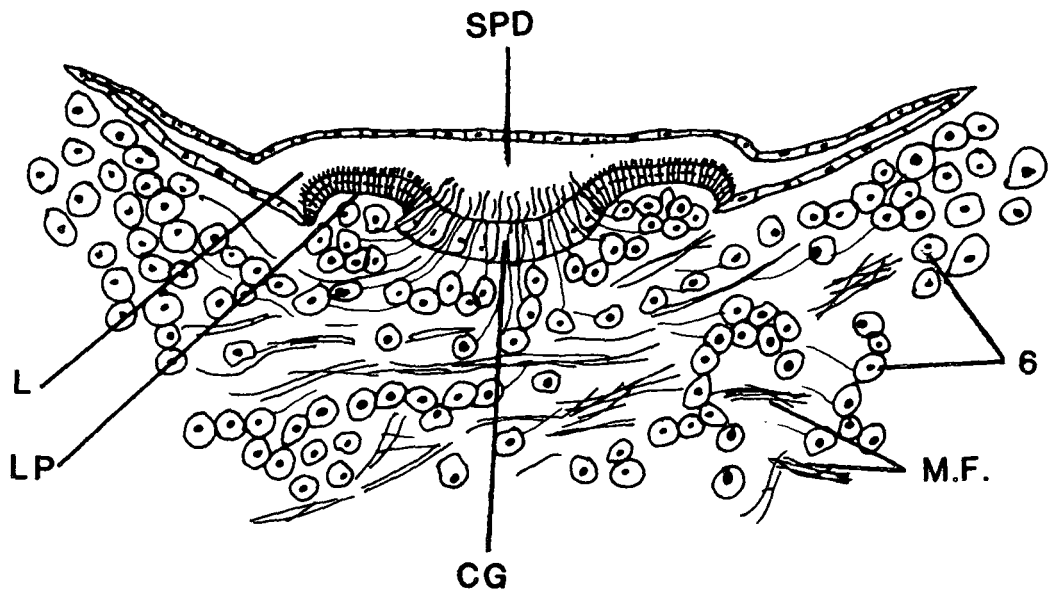

Figure 30

- A A longitudinal section of a juvenile Limax pseudoflavus showing the plane of section and the position of "landmarks" such as the eyes, the buccal mass and the root of the mantle.
- B B1, B2, B3, B4. Sections through the duct of the suprapedal gland showing changes in its shape and in the extent of ciliation (dotted region).
- C C1, C2, C3, C4. Transverse sections of whole animals showing the position and shape of the suprapedal gland and the suprapedal duct.

SO - Semper's organ; SPS - Suprapedal sinus; SPG - suprapedal gland.

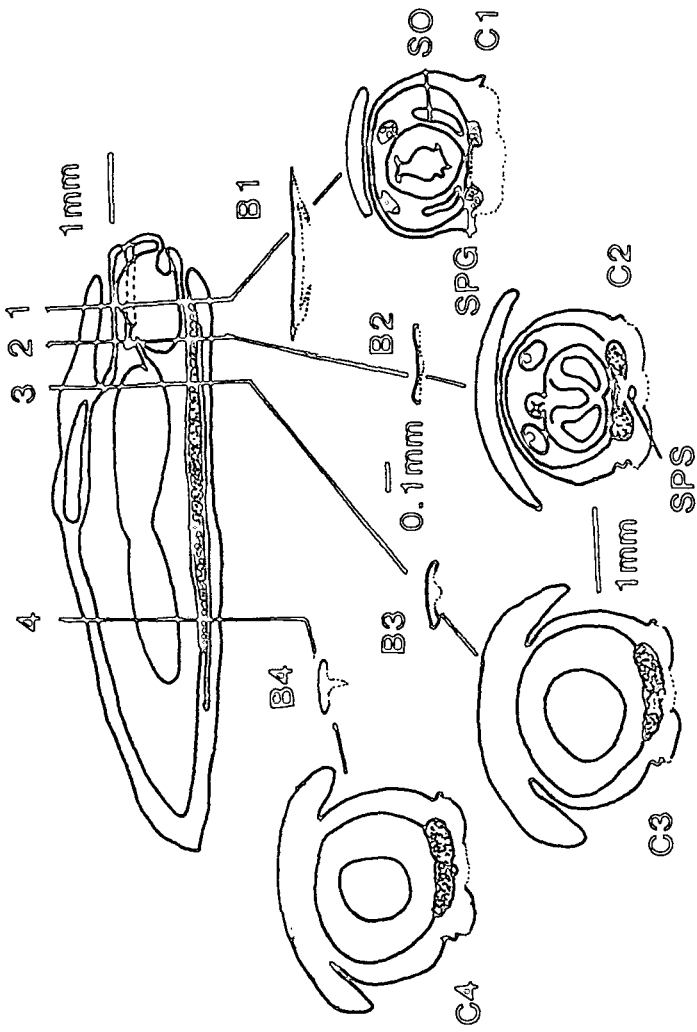

Fig.30

Figure 31 Mucus-secreting cells at the leading edge of the foot of Limax psdueoflavus.

A A longitudinal section through the anterior part of the foot showing the distribution of secretory cells and the extent of ciliation.

B High power view of gland cell type 13 showing the secretory granules, nucleus and the nature of the duct.

C - Cilia; D - Duct; G - Granular secretion; N - Nucleus; S - Sole. All other labels refer to cell types.

**Fig.31**

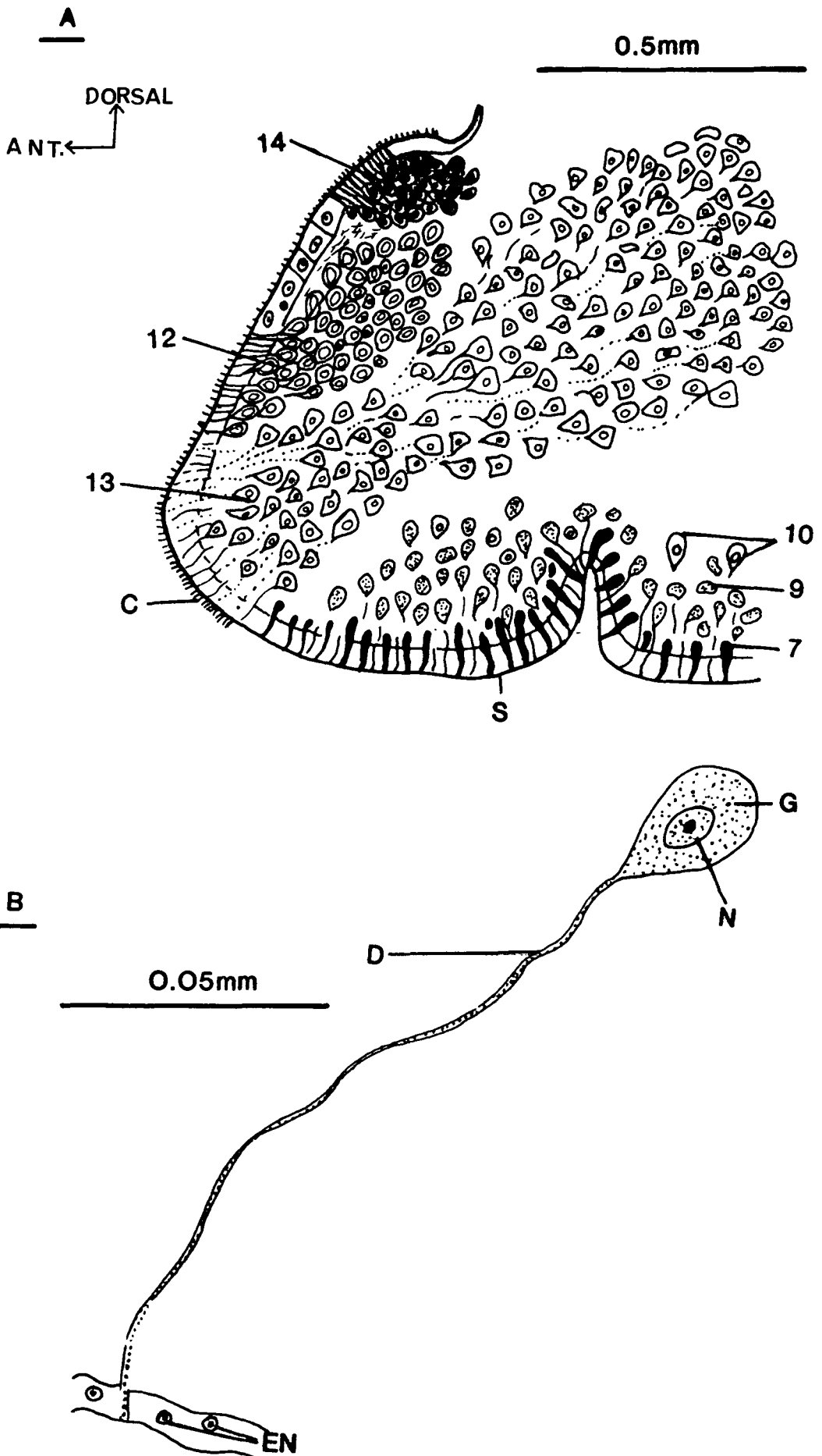

Figure 32 High power view of

A the lining of the duct of the pneumostome of Limax pseudoflavus (ref. Plate 62).

B the epidermis of the head of Limax pseudoflavus (ref. Plate 58).

Both areas are served by type 7 cells overlying area of type 10 cells producing a less acid mucus.

Fig32

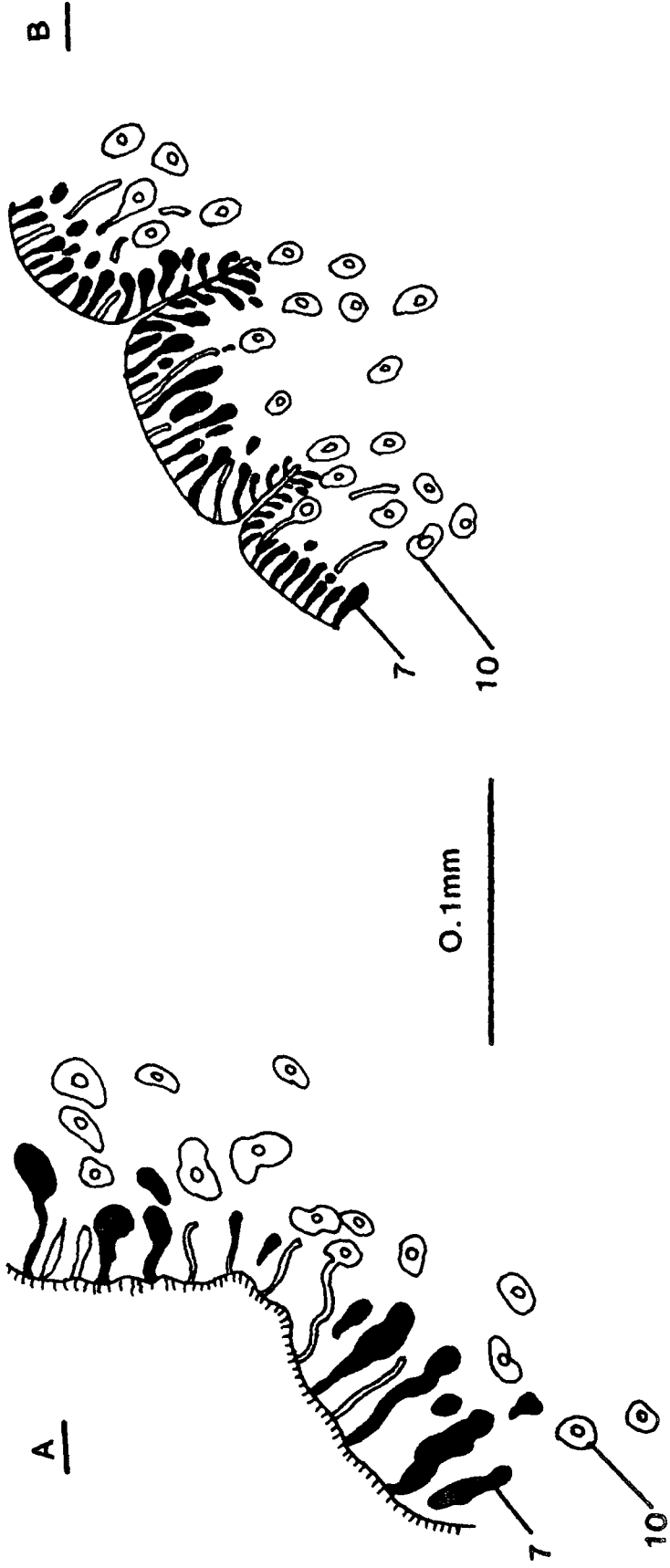

Figure 33

A A transverse section through the pneumostome of Limax pseudoflavus showing the pneumostome annulus and cilia.

B High power view of part of pneumostome annulus.

C - Cilia; M.F. - Muscle fibres; N - Nucleus; P.A. -  
Pneumostome annulus.

Fig.33

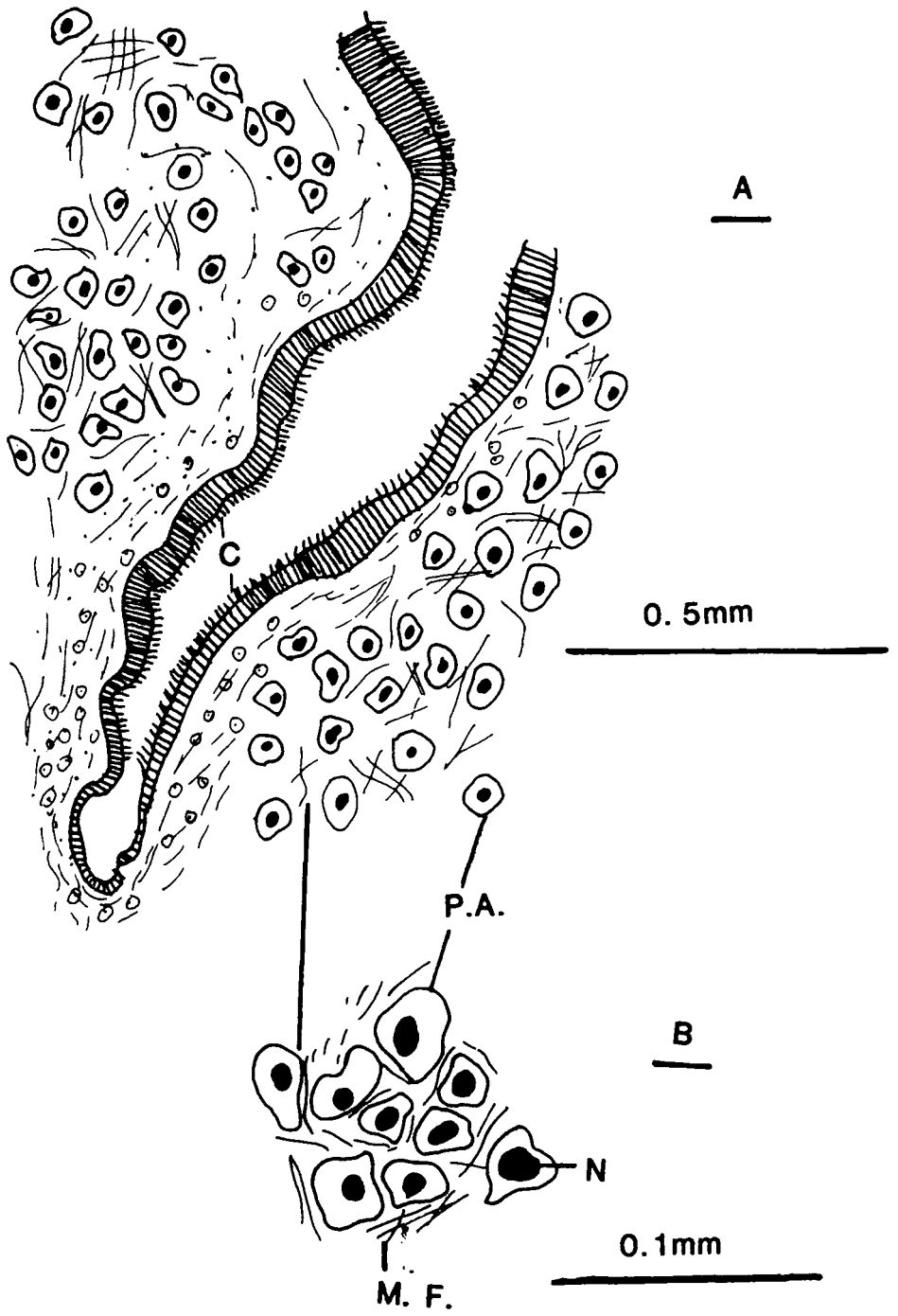

Figure 34 The movement of chalk particles blown on to the surface of Limax pseudoflavus. Particles radiate away from the pneumostome and accumulate laterally and dorsally. Particles moved ventrally are swept down below the peripodal groove. Particles below the peripodal groove move backwards with respect to the animal but remain stationary with respect to the ground.

Fig34

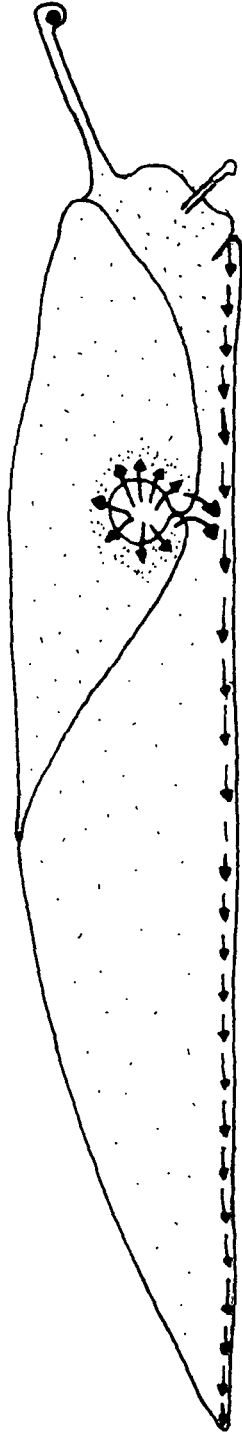
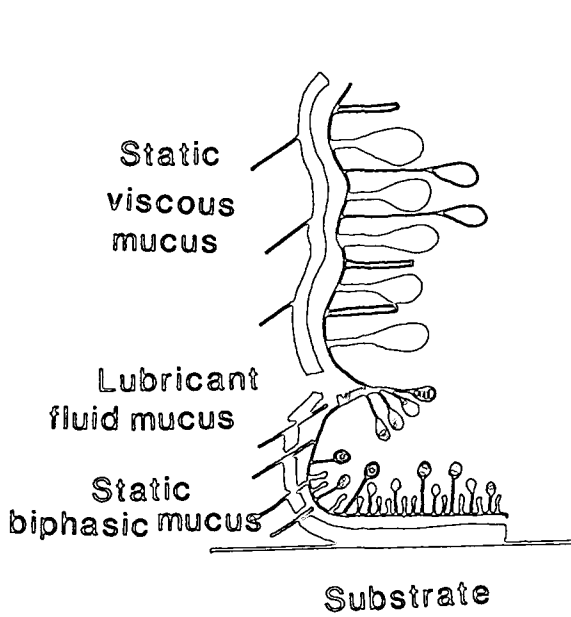
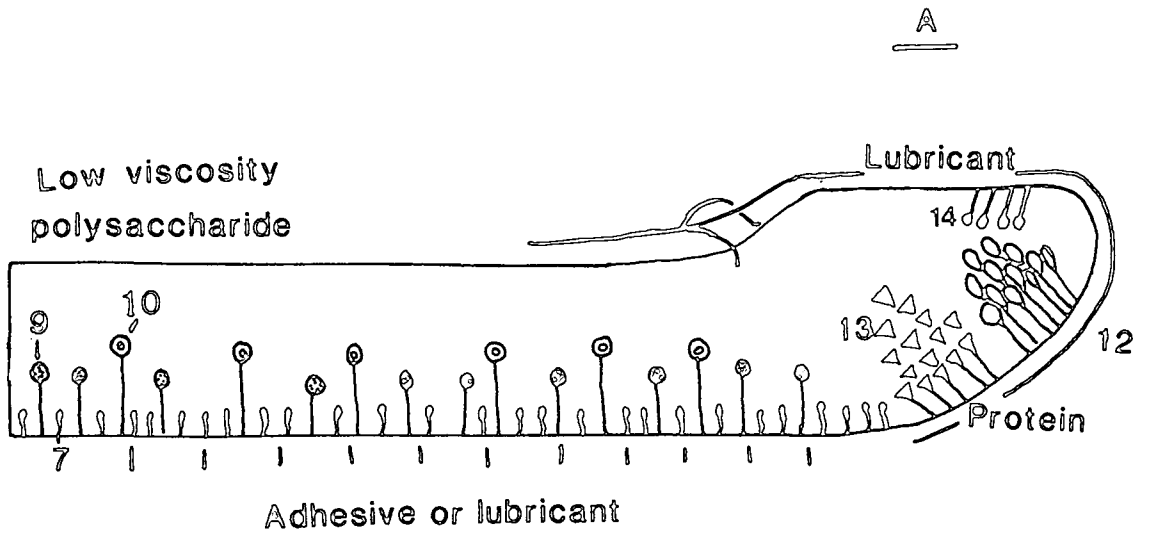

Figure 35

- A The suggested formation of pedal mucus by Limax pseudoflavus. Suprapedal gland mucus is spread out over the leading edge of the foot aided by a lubricant from the superior gland (14). Protein is added from inferior gland (13) to form a biphasic sol/gel system. Mucus from median gland (12) and cell types 9 and 10 allow for the detachment of the foot. Mucus from cell type 7 aids adhesion.
- B The two mucous sheets on the surface of a slug. The dorsal mucus remains static and the pedal mucus remains attached to the substrate. Both sheets are normally viscous and the movement of one relative to the other is aided by the insertion of a fluid mucus from the peripodal groove.

Fig35



Reference diagram to show the planes of sections

in subsequent plates.

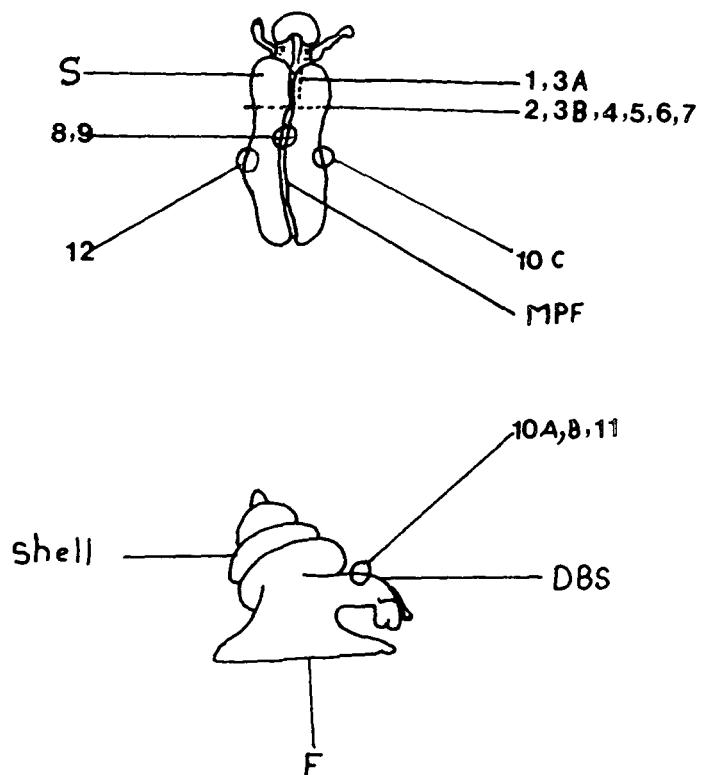

DBS- Dorsal body surface, F-Foot, MPF-Median pedal furrow, S-Sole

**POMATIAS ELEGANS**

---

Plate 1 Longitudinal sections through the foot of Pomatias elegans (ref. Figure 1).

A A part of a section stained with PAS showing the suprapedal gland and the suprapedal duct just before opening into the median pedal furrow (x 40).

Note cell types P5 and P6. In longitudinal section the ducts of P6 cells are not obvious as they mingle with brightly stained P5 cells.

B A part of a section stained by the diazo-coupling reaction. Arrows show the ducts of the suprapedal gland and tubulous gland opening into the median pedal furrow (x 40).

MPF - Median pedal furrow; SPD - Suprapedal duct; SPG - Suprapedal gland; T - Tubule. All other labels refer to cell types.

PLATE 1

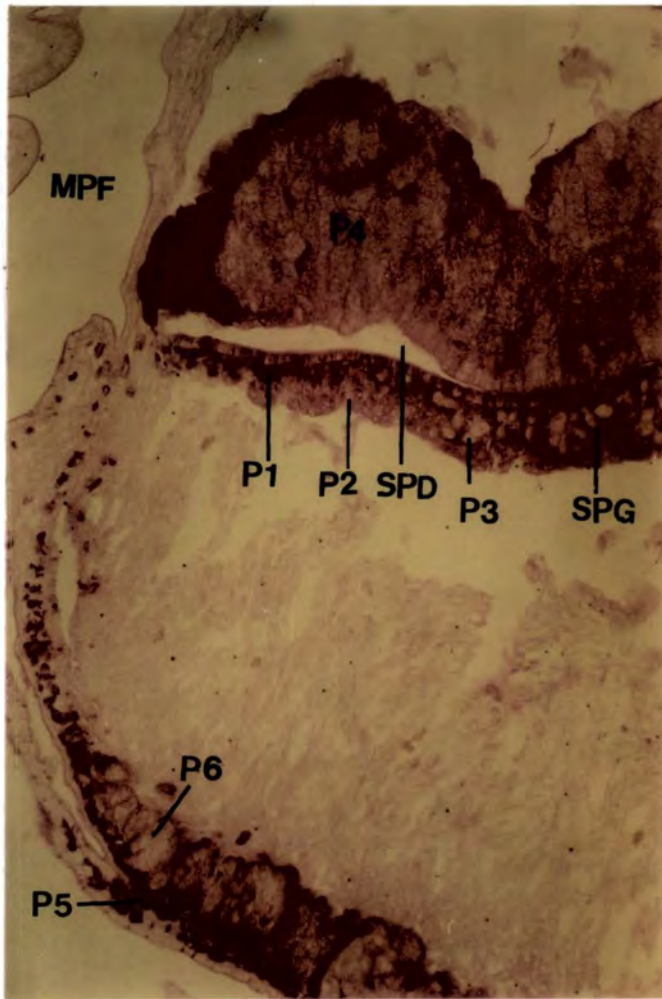

A



B

Plate 2 Transverse sections through the suprapedal gland  
of Pomatias elegans (ref. Figure 2).

- A High power view of a part of a section stained with PAS to show the duct epithelium of the outer part of the suprapedal gland and the gland cell types P1, P2, P3 and P4 (x 160).
- B High power view of gland cell types P2, P3 and P4 stained in Alcian Blue pH2.5/PAS. Note the ducts of P2 cells making their way between P3 cells (x 160).
- C Part of a suprapedal gland stained in Alcian Blue pH0.5/eosin. Note that most of the P3 cells appear empty (x 80).

D - Duct; DUE - Duct epithelium; SPD - Suprapedal duct. All other labels refer to cell types.



PLATE 2

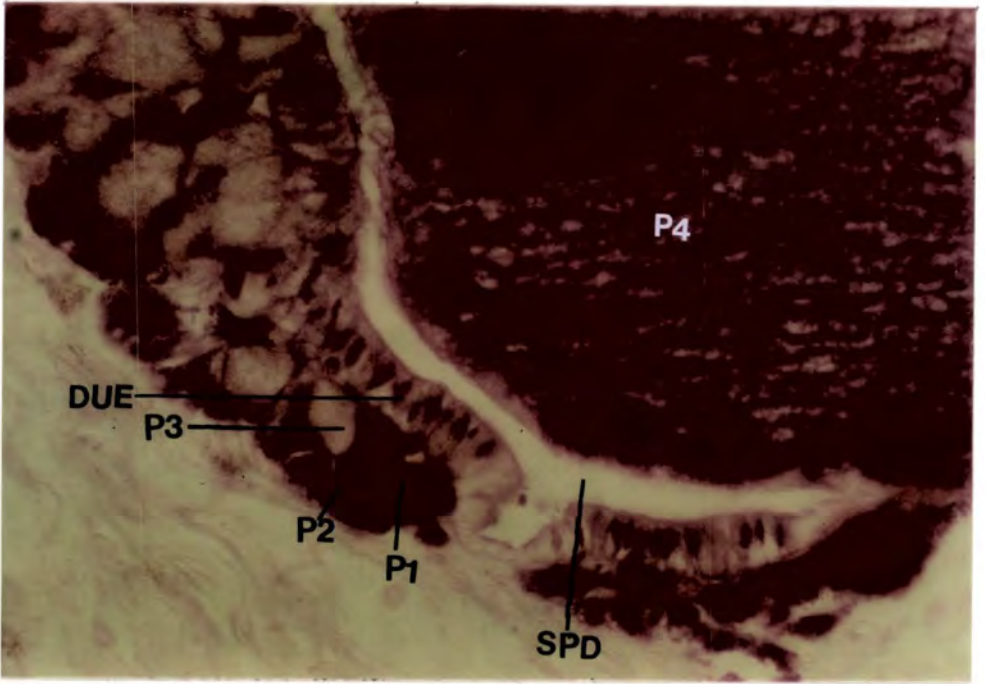

A

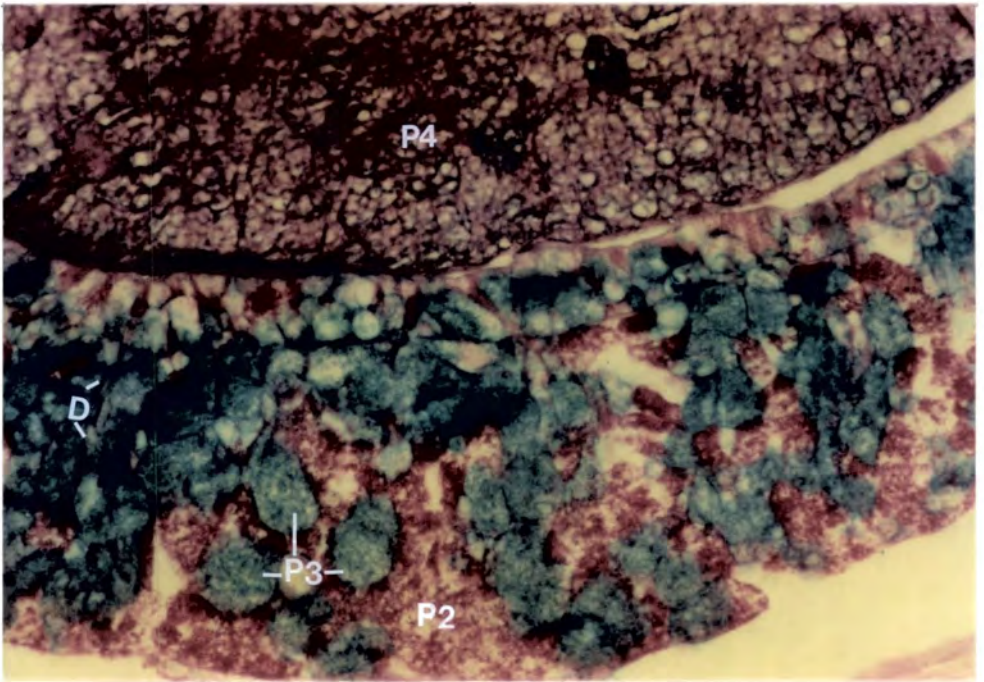

B

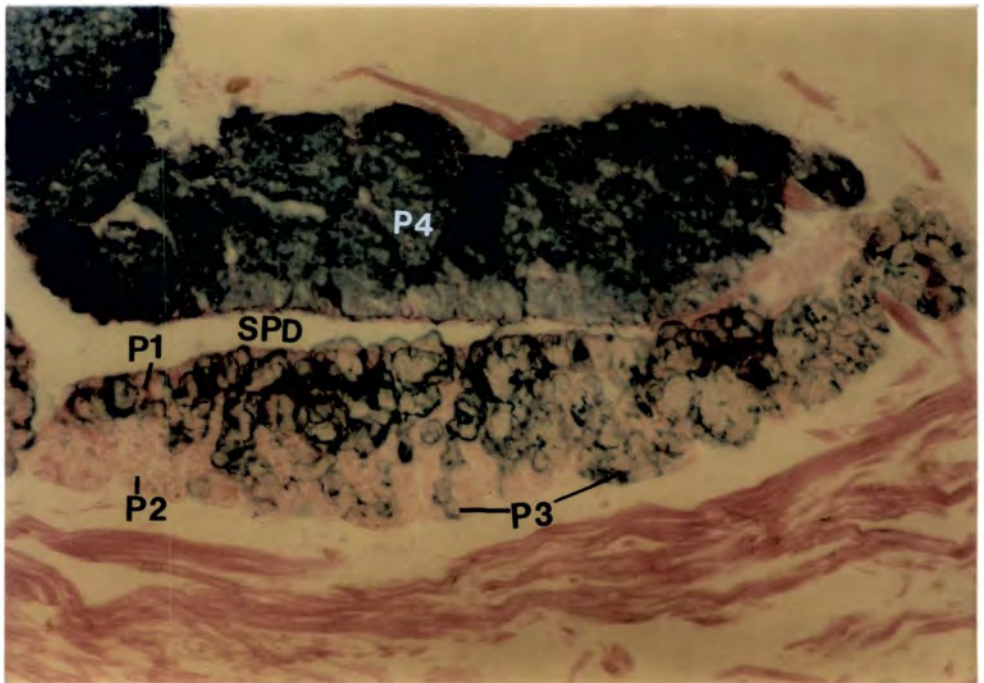

C

Plate 3 The staining responses of the suprapedal gland cells of Pomatias elegans for protein.

A High power view of part of the suprapedal gland in longitudinal section stained by the diazo-coupling reaction. Note the positive reactions for gland cell types P1 and P2 (x 160).

B High power view of part of the suprapedal gland in transverse section stained in mercuric bromophenol blue (x 160).

Note the positive reactions for gland cell types P1 and P2.

SPD - Suprapedal duct. All other labels refer to cell types.

PLATE 3

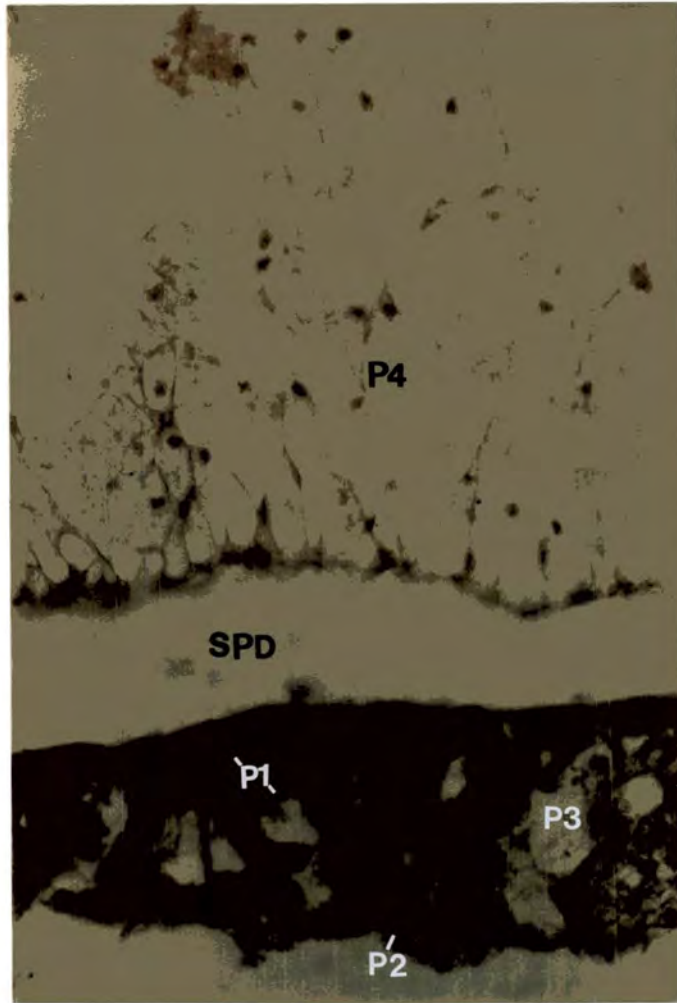

A

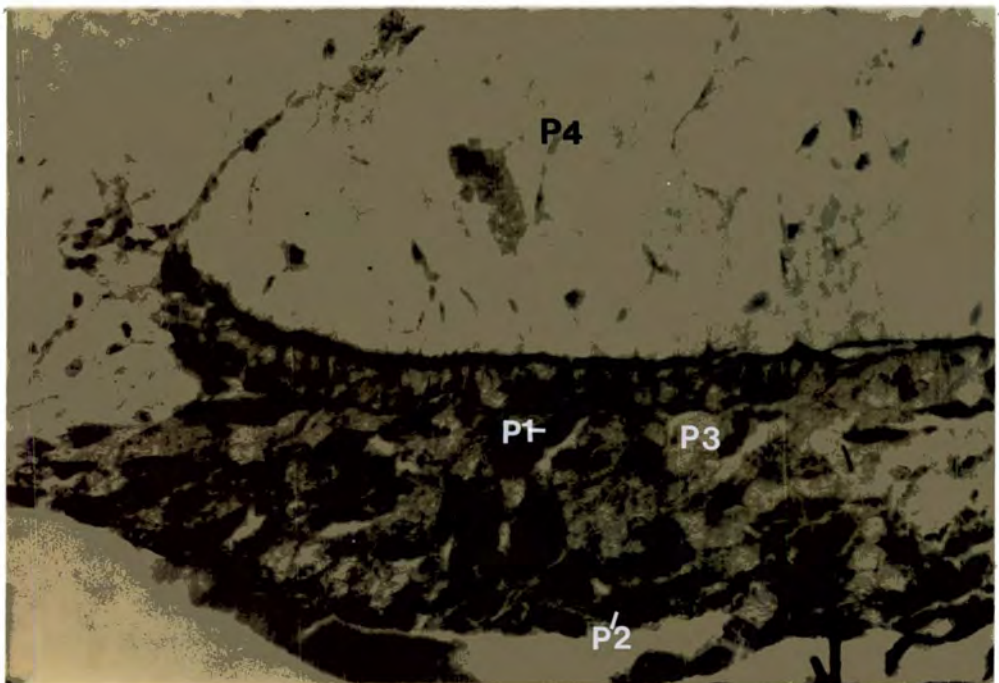

B

Plate 4 Transverse sections through the suprapedal gland  
of Pomatias elegans.

- A A part of an alcohol-fixed frozen section stained in Alizarin Red for calcium. Note the positive staining for gland cell types P2 and P4 (x 80).
- B High power view of a section of the inner part of the suprapedal gland stained in Alcian Blue pH 0.5/Alcian Yellow pH2.5. A yellow-green staining of P4 cells indicates the presence of sulphated and carboxylated mucopolysaccharides (x 160).

SPD - Suprapedal duct. All other labels refer to cell types.

PLATE 4

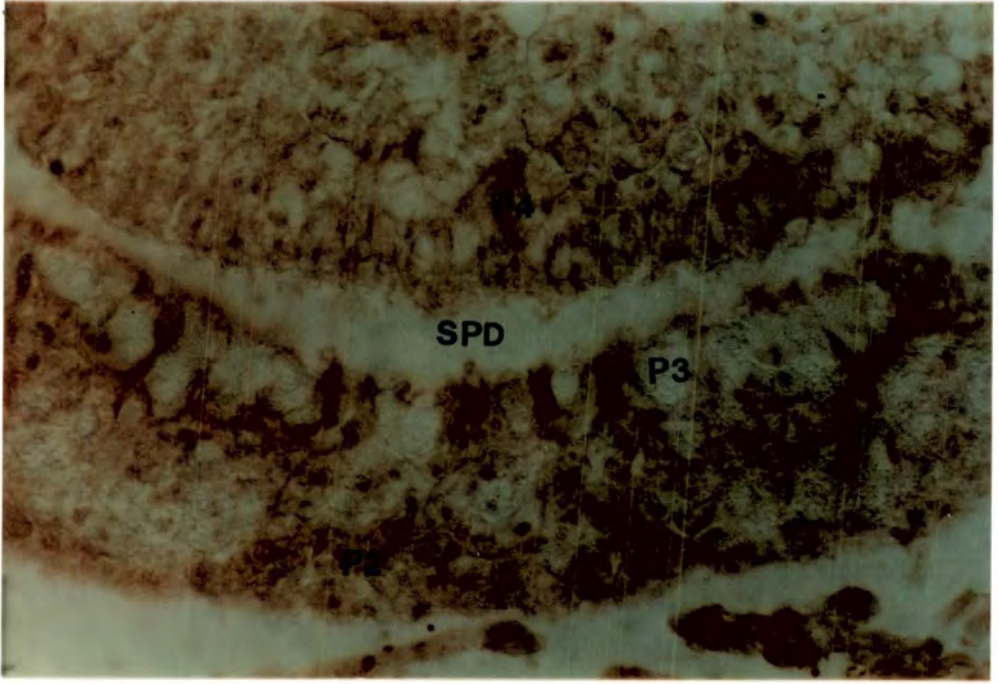

A

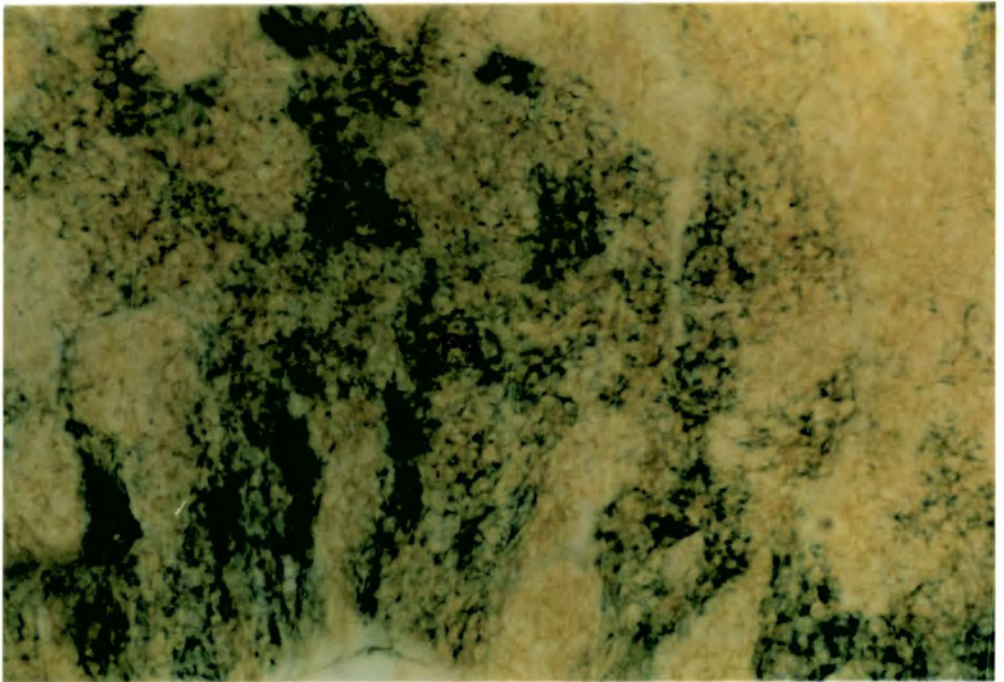

B

Plate 6 Transverse sections through the whole suprapedal gland of Pomatias elegans stained for neutral mucopolysaccharides.

A A section stained with PAS (x 40).

The red staining of P2 and P4 gland cells suggests the possibility of neutral mucopolysaccharide in their secretion.

B A section stained by PAD (x 40).

The bright brown colour of P4 cells indicates neutral mucopolysaccharide. Note the positive staining of P2 cells for neutral mucopolysaccharide, but their brown colour is obscured by the black colour of P3 gland cells which in turn indicates the presence of periodate-unreactive mucosubstances in their secretion.

PLATE 6

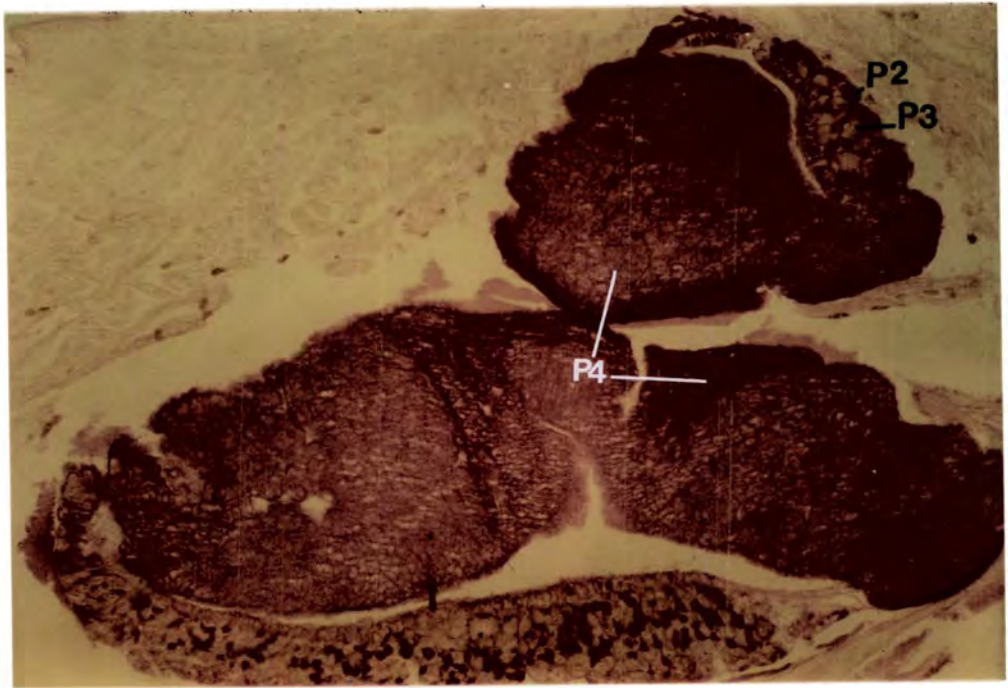

A

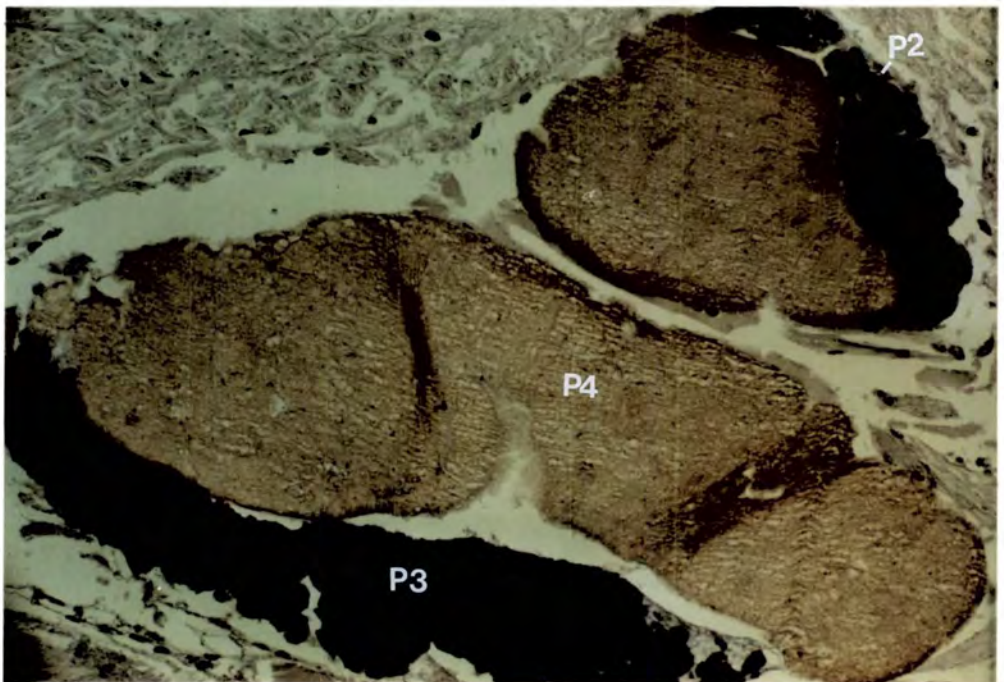

B

Plate 8 Transverse sections through the median pedal furrow of Pomatias elegans stained for acidic and neutral mucopolysaccharides (ref. Figure 2).

A A section stained in Alcian Blue pH2.5/PAS (x 40). Blue colour of P6 cells indicates the presence of acidic mucopolysaccharides.

B A section stained with PAS (x 40). Strong reaction of P5 cells with PAS suggests the possibility of neutral mucopolysaccharide in secretion.

C A section stained by PAD method (x 40). Brown colour of P5 cells confirms the presence of neutral mucopolysaccharide.

MF - Mucus film; MPF - Median pedal furrow. All other labels refer to cell types.

PLATE 8

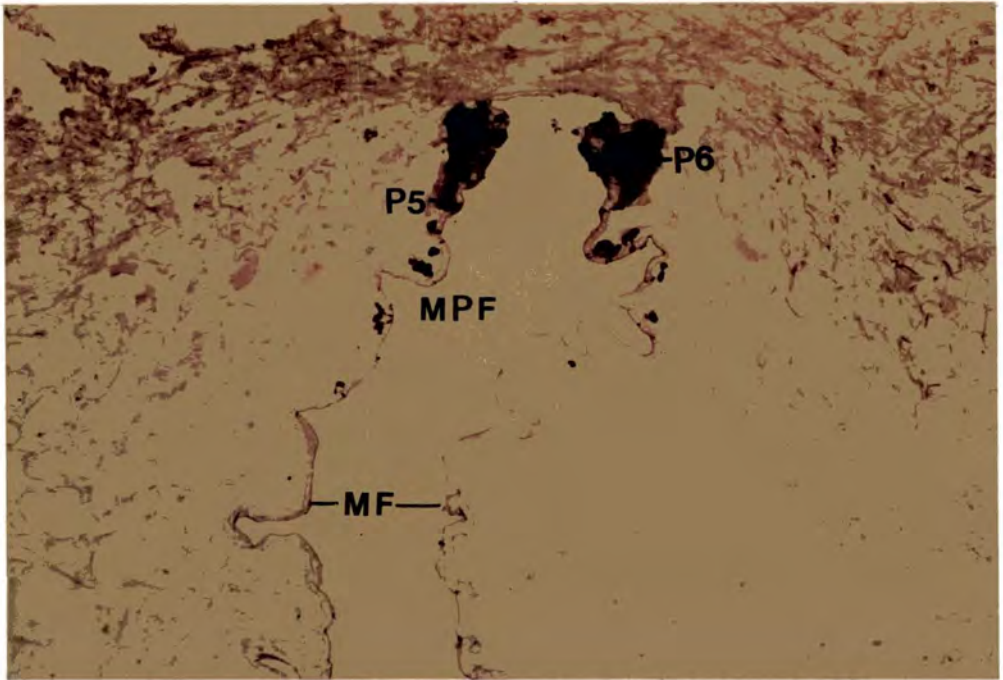

A

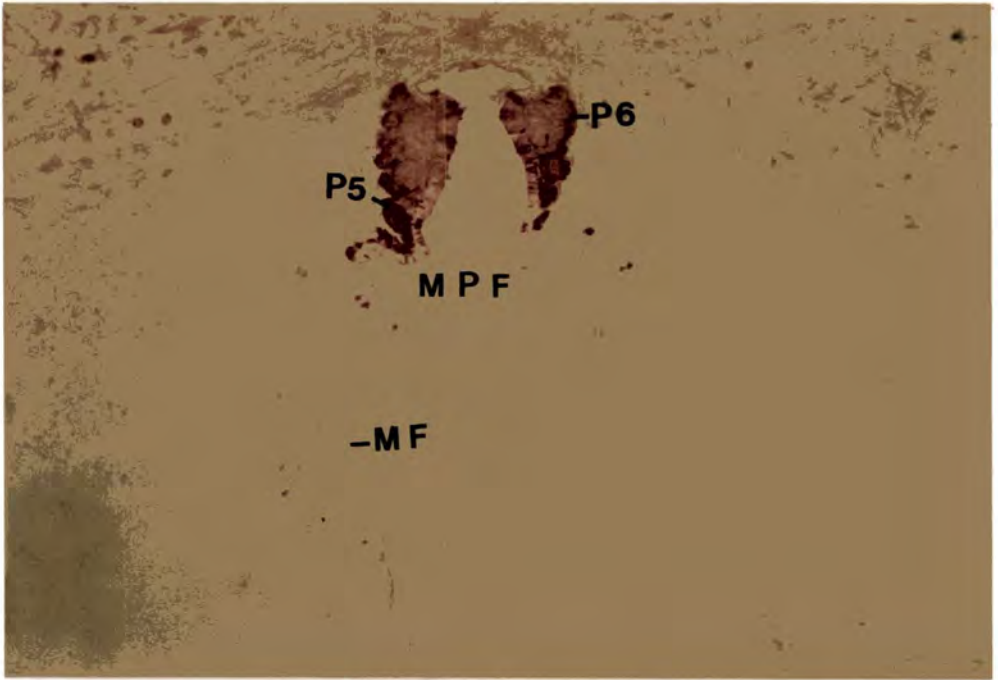

B

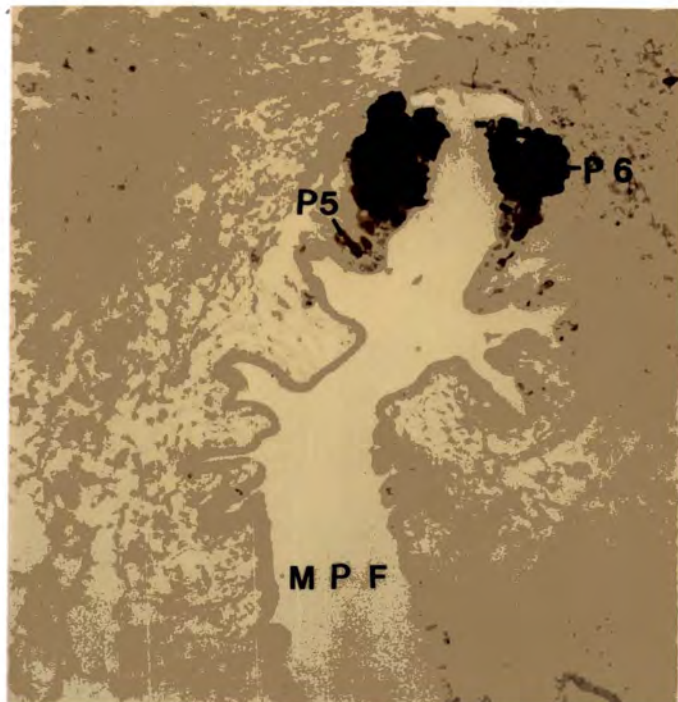

C

Plate 9    Transverse Sections through the foot of Pomatias  
elegans (x 40).

- A    A section stained in mercuric bromophenol blue. Blue staining of P5 cells indicates that the secretion is proteinaceous.
- B    Positive staining of P5 cells with PAS (B) and PAD (C)  
and  
C    shows that the secretion of these cells is neutral mucoprotein.

MPF - Median pedal furrow; SPG - Suprapedal gland. All other labels refer to cell types.

PLATE 9

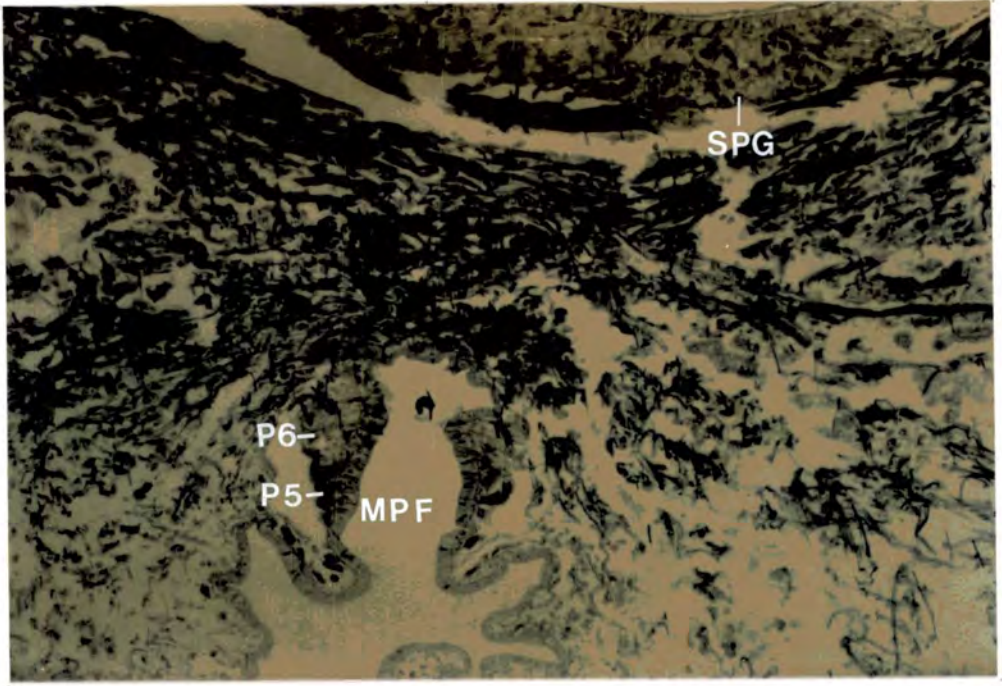

A

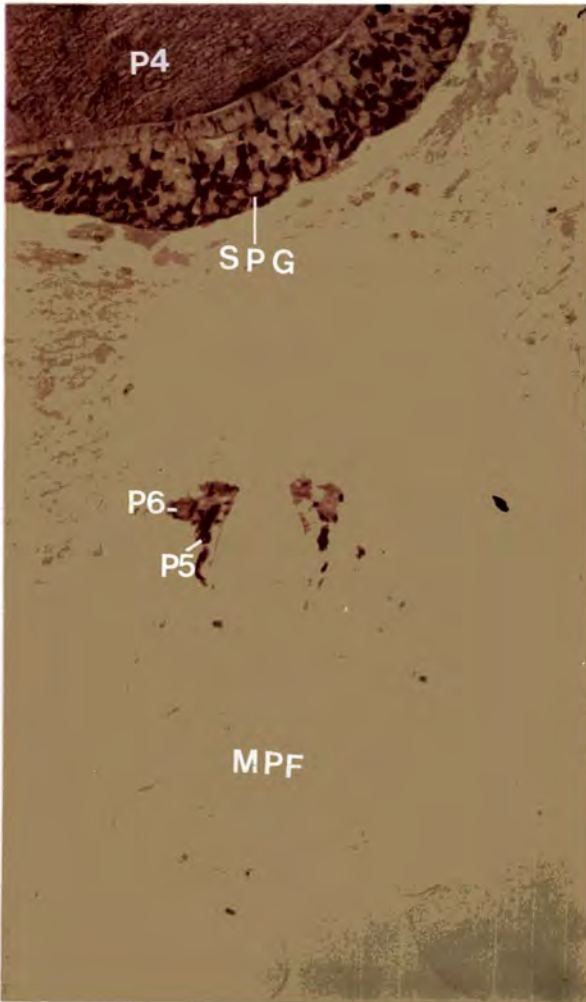

B

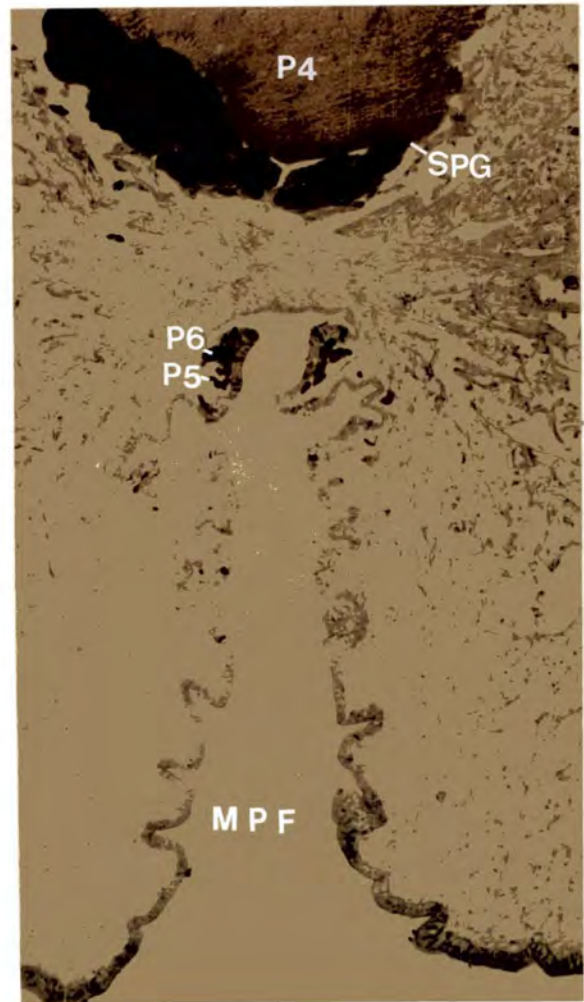

C

Plate 10 The staining responses of the goblet cell types of  
Pomatias elegans.

- A A longitudinal section of the dorsal body surface showing the goblet cell types P9, P11 and P12 stained with PAD (x 160).  
Brown colour of P9 and P11 cells indicates the presence of neutral mucopolysaccharide and the black/brown colour of P12 cells suggests the possibility of some neutral mucopolysaccharide in their secretion.
- B A longitudinal section through the dorsal body surface of Pomatias stained by the diazo-coupling reaction (x 160).  
The strong reaction of P12 cells indicates protein containing tyrosine.
- C A transverse section through the lateral pedal epidermis of Pomatias showing goblet cell types P11 (red) and P12 (blue) stained with Alcian Blue pH0.5/eosin (x 160).  
Light blue colour of P12 cells indicates sulphated mucopolysaccharides.

N - Nucleus. All other labels refer to cell types.

PLATE 10

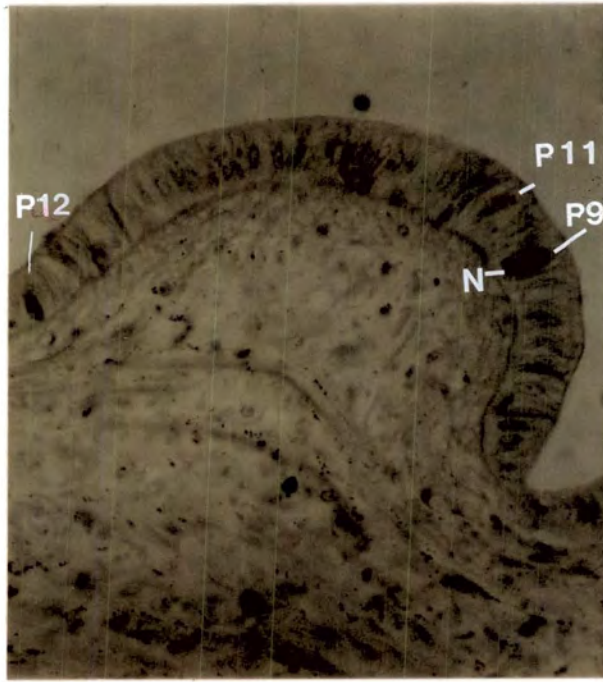

A

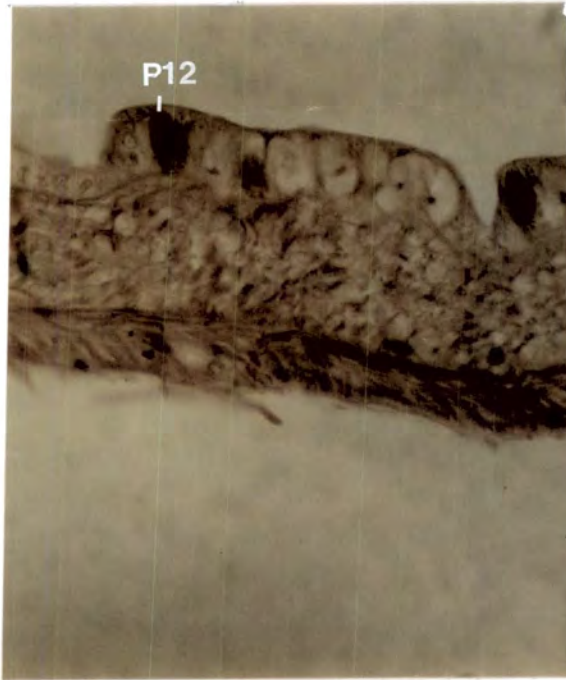

B

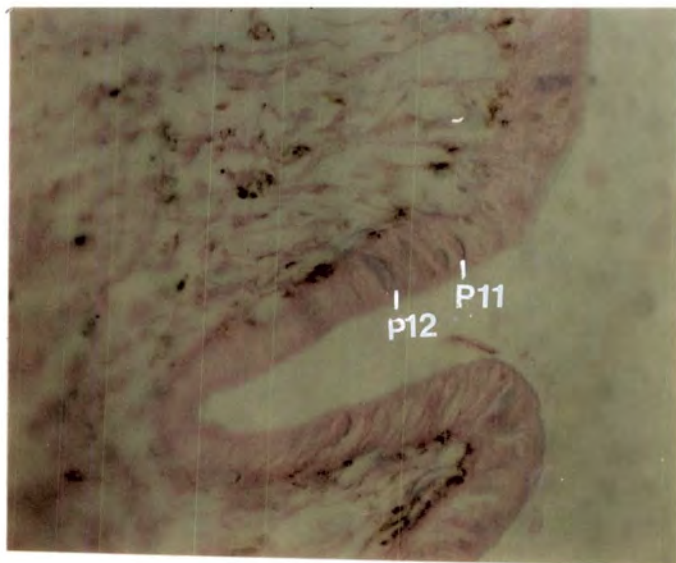

C

Plate 11 Longitudinal sections through the dorsal body surface of Pomatias to show the staining responses of goblet cell types P9, P10, P11 and P12 for acidic and neutral mucopolysaccharides.

A A section stained with PAS (x 160).

Note the strong response of P9 cells and the weak response of P12 cells to PAS.

B A section stained in Toluidine blue (x 160).

P10 cells show strong metachromasia in toluidine blue.

C A section stained with PAD (x 160).

The brown colour of P9 cells confirms the presence of neutral mucopolysaccharide. P12 cells stained only lightly and the black colour of P10 cells indicates periodate-unreactive mucosubstances.

All labels refer to cell types.

PLATE 11

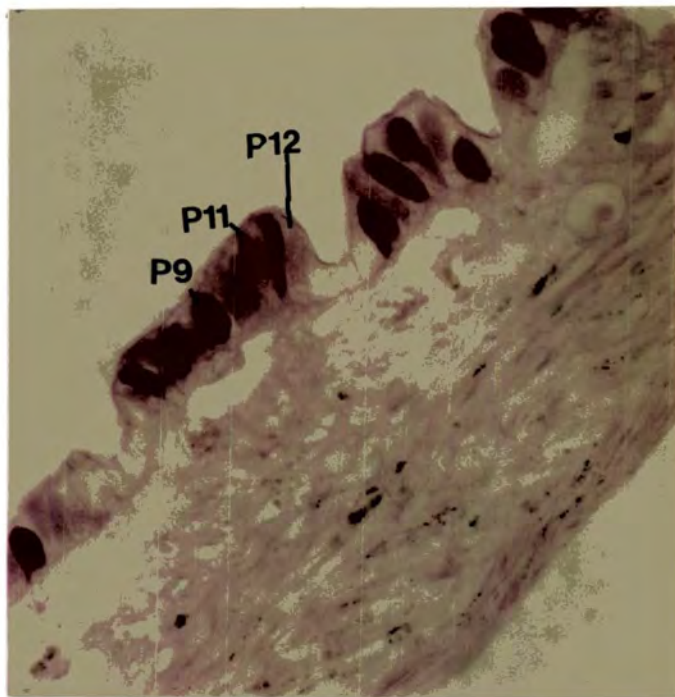

A

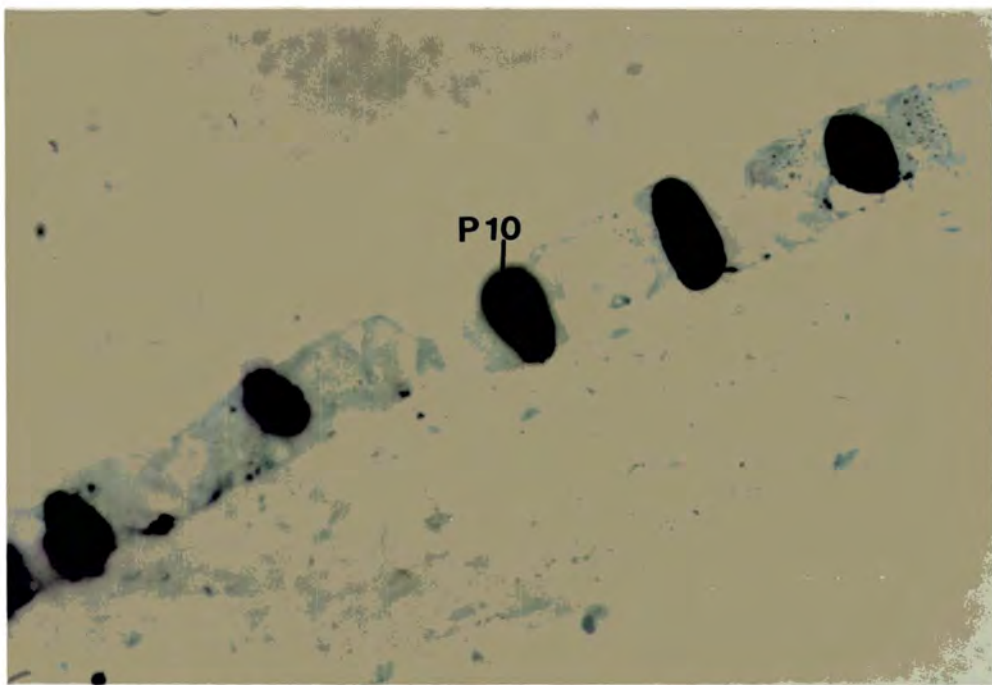

B

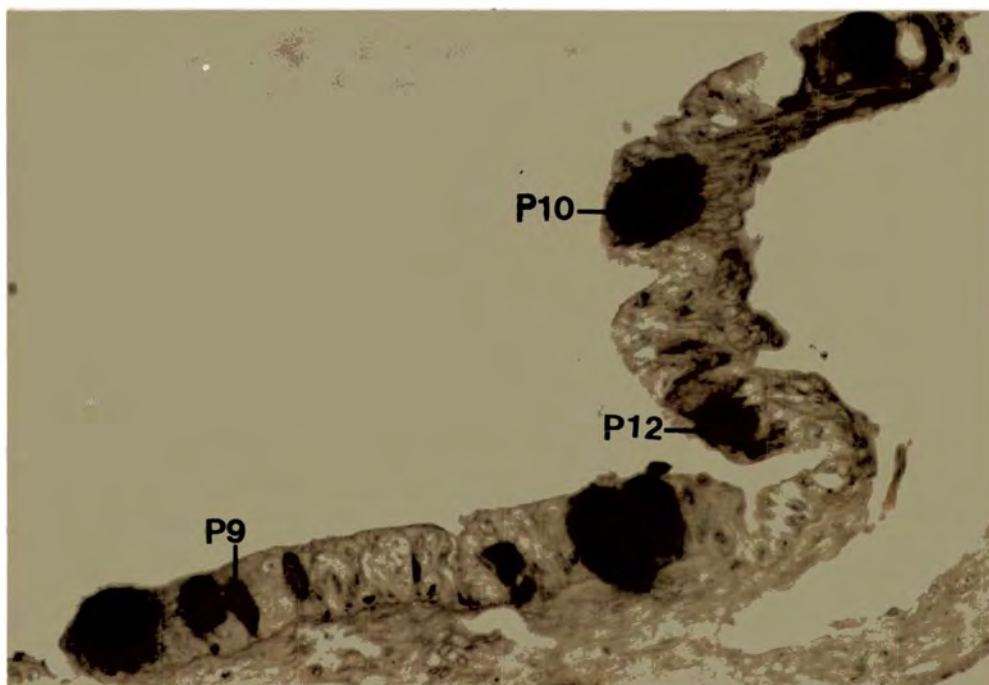

C

Plate 12 Transverse sections through the lateral pedal epithelium of Pomatias to show the staining responses of P13 cells.

A A section stained with PAS (x 80).

Red staining of P13 cells with PAS suggests the possibility of neutral mucopolysaccharide secretion.

B A section stained with PAD (x 80).

The brown colour of P13 cells with PAD confirms the presence of neutral mucopolysaccharide.

LPE - Lateral pedal epithelium. All other labels refer to cell types.

PLATE 12

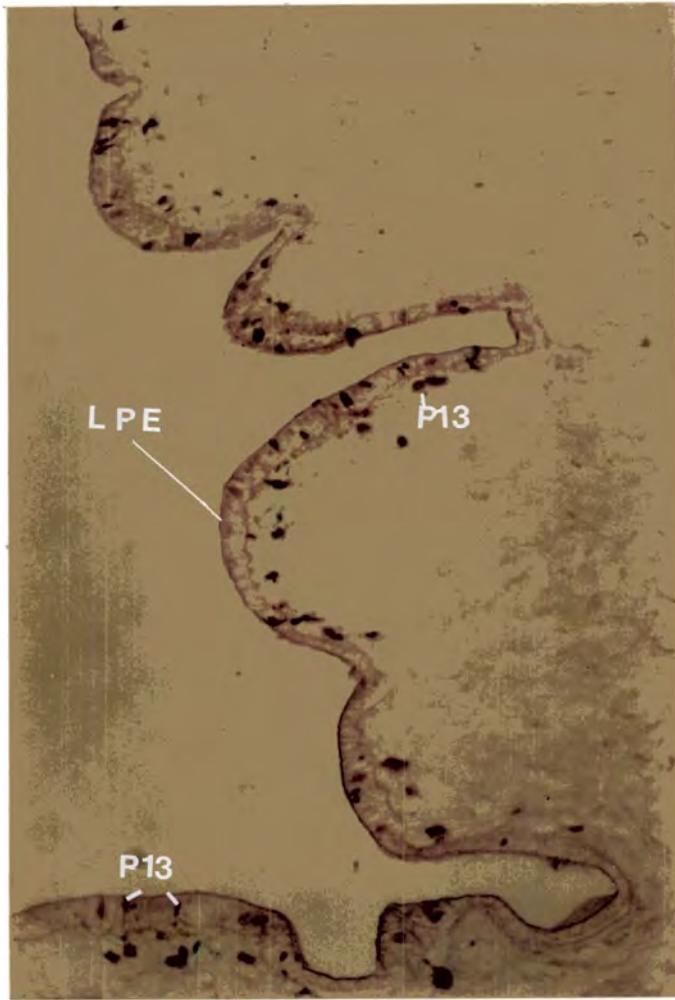

A

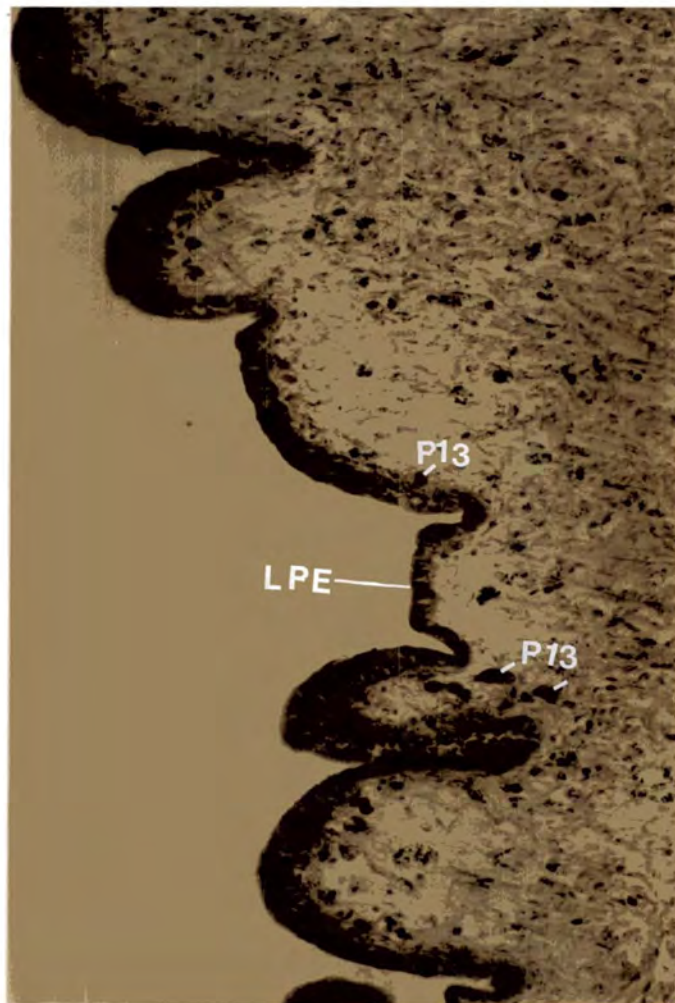

B

Plate 13 A longitudinal section through the whole foot of Bithynia tentaculata stained in Alcian Blue pH2.5/PAS to show the extent of glandular areas (x12).

APG - Anterior pedal gland; DE - Dorsal epithelium; OD - Opercular disc; OG - Opercular groove; S - Sole; SOC - Subopercular cleft. All other labels refer to cell types.

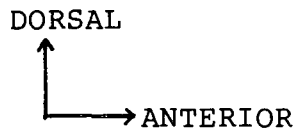

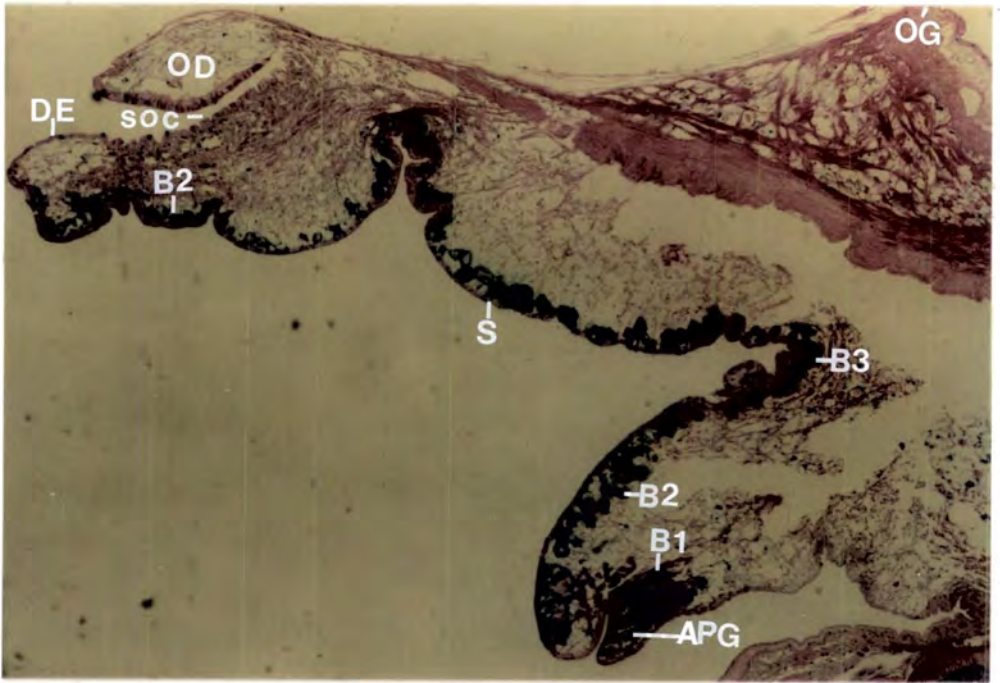

Plate 14 Longitudinal sections through the anterior foot of Bithynia tentaculata to show the staining responses of anterior pedal gland.

A A section stained by the diazo-coupling reaction (x 40).

Note the strong positive reaction of B1 cells.

B A section stained in Alcian Blue pH2.5/PAS (x 40).

A bluish-purple staining of B1 cells suggests that both alcinophilic and periodate-reactive groups are present.

C A section stained with the Alcian Blue pH0.5/Alcian Yellow pH2.5 method (x 40).

A yellow-green staining of B1 cells with this method indicates that acidic mucosubstances are composed of both sulphated and carboxylated groups.

APG - Anterior pedal gland; C - Cilia; S - Sole. All other labels refer to cell types.

DORSAL

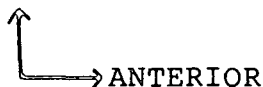

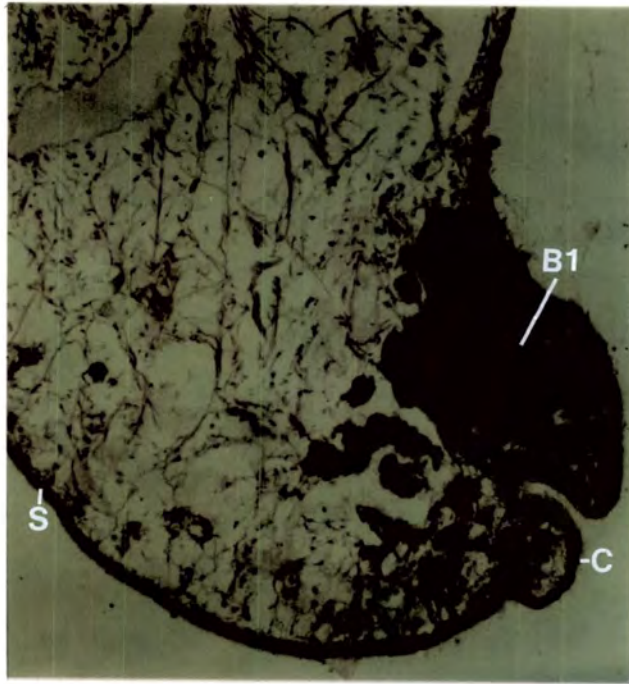

A

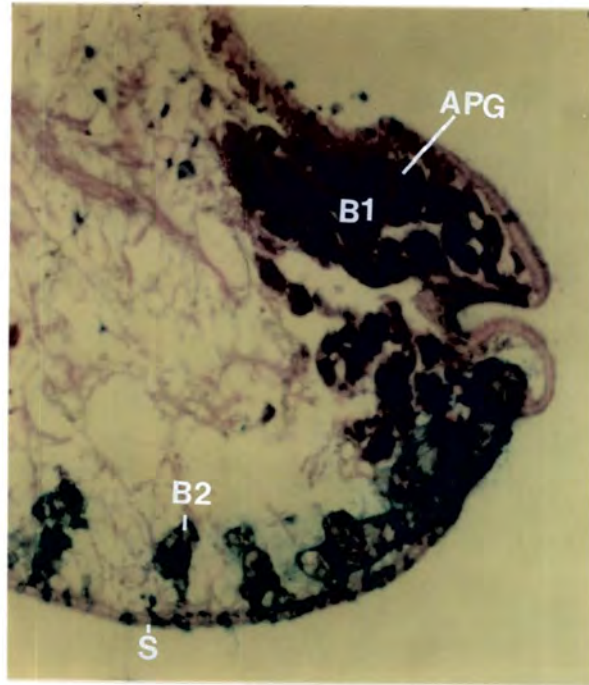

B

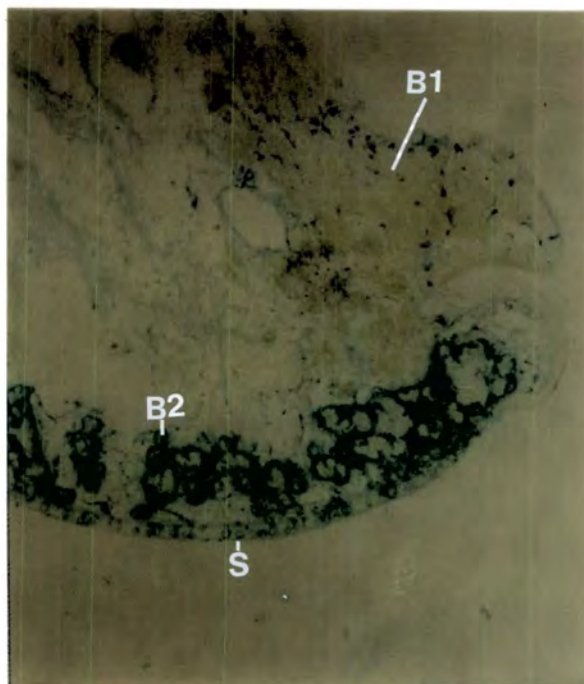

C

Plate 15 Longitudinal sections through the anterior foot of Bithynia tentaculata to show the staining responses of B1 cells for protein and mucopolysaccharides. Note the strong reaction of B1 cells for protein and the slight reactions for mucopolysaccharides (x 40).

A and B The strong positive responses of B1 cells to mercuric bromophenol blue (A) and the diazo-coupling reaction (B) confirm that secretion is proteinaceous containing tyrosine.

C, D and E Only slight responses are shown by B1 cells for acidic mucopolysaccharides, as indicated by the light yellow-green staining obtained with Alcian Blue pH0.5/Alcian Yellow pH2.5 (C) and a bluish-purple staining with Alcian Blue pH2.5/PAS (D). The light brown colour obtained by the PAD method indicates that some neutral mucopolysaccharide is also present (E).

APG - Anterior pedal gland; EC - Extruded contents; S - Sole. All other labels refer to cell types.

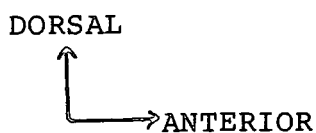

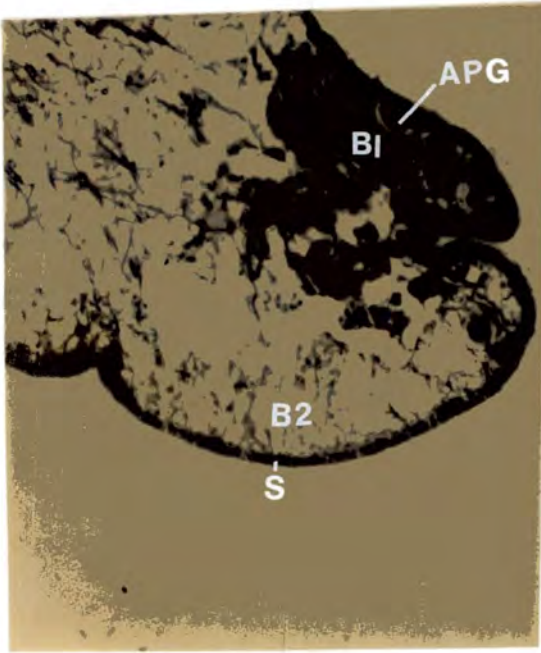

A

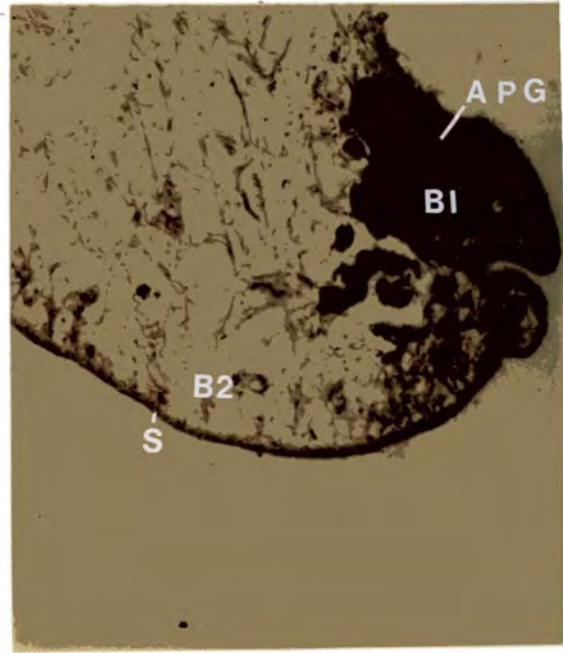

B

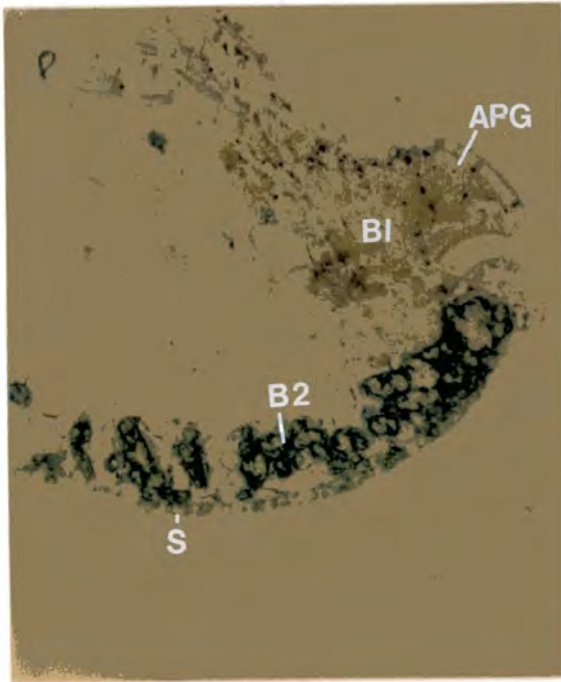

C

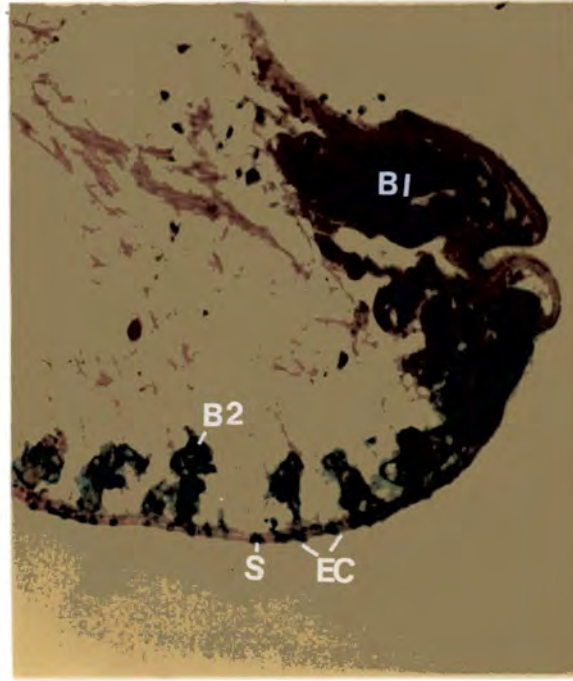

D

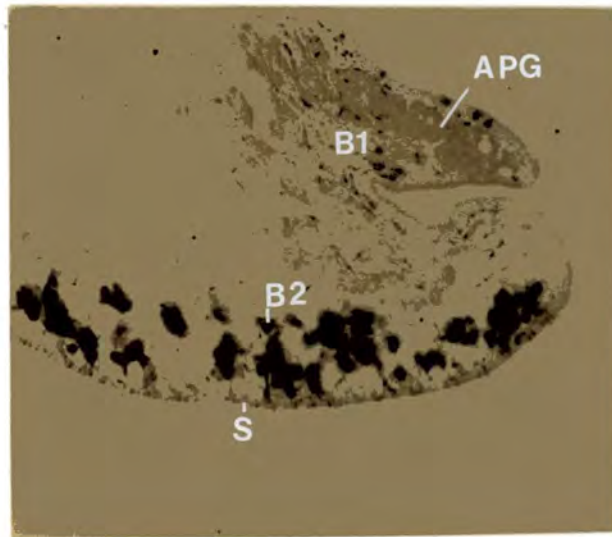

E

Plate 16 Longitudinal sections through the transverse fold of the foot of Bithynia tentaculata to show the staining responses of B2 and B3 cells for mucopolysaccharides.

- A A section stained in Toluidine blue (x 40).  
Note the strong  $\beta$ metachromasia shown by B2 cells and a slight  $\beta$ metachromasia by B3 cells in toluidine blue.
- B A section stained in Alcian Blue pH0.5/eosin (x 40).  
A blue staining of both B2 and B3 cells with this method indicates the presence of sulphated mucopolysaccharides in their secretion.
- C A section stained with PAD (x 40).  
The brown colour of B3 cells indicates neutral mucopolysaccharide and the black colour of B2 cells shows periodate-unreactive mucosubstances in their secretion.

D - Duct; S - Sole. all other labels refer to cell types.

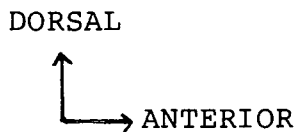

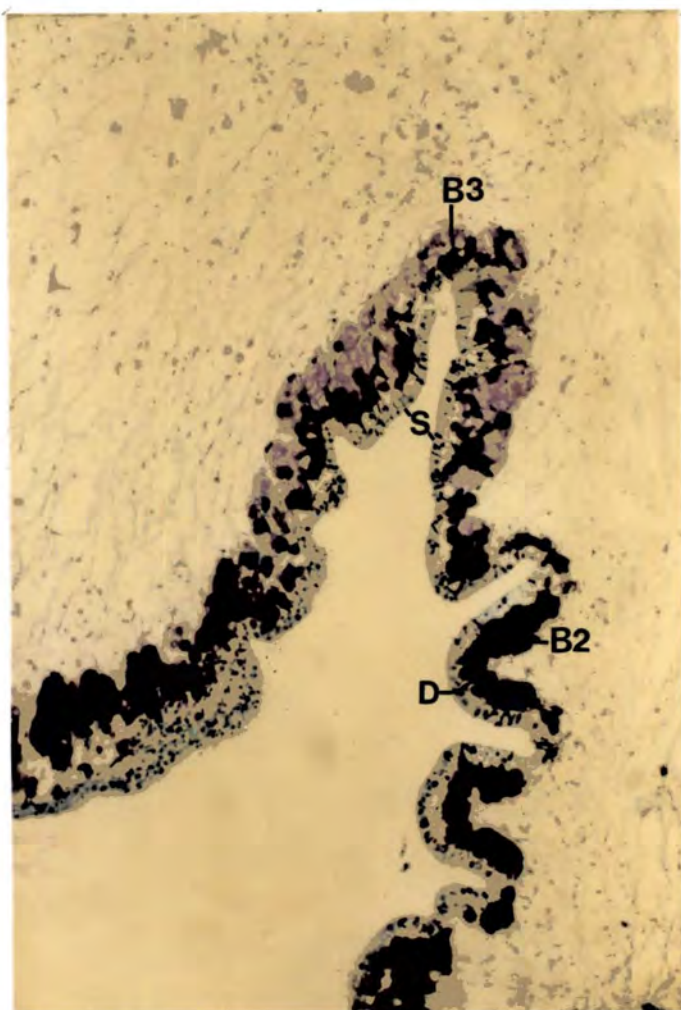

A

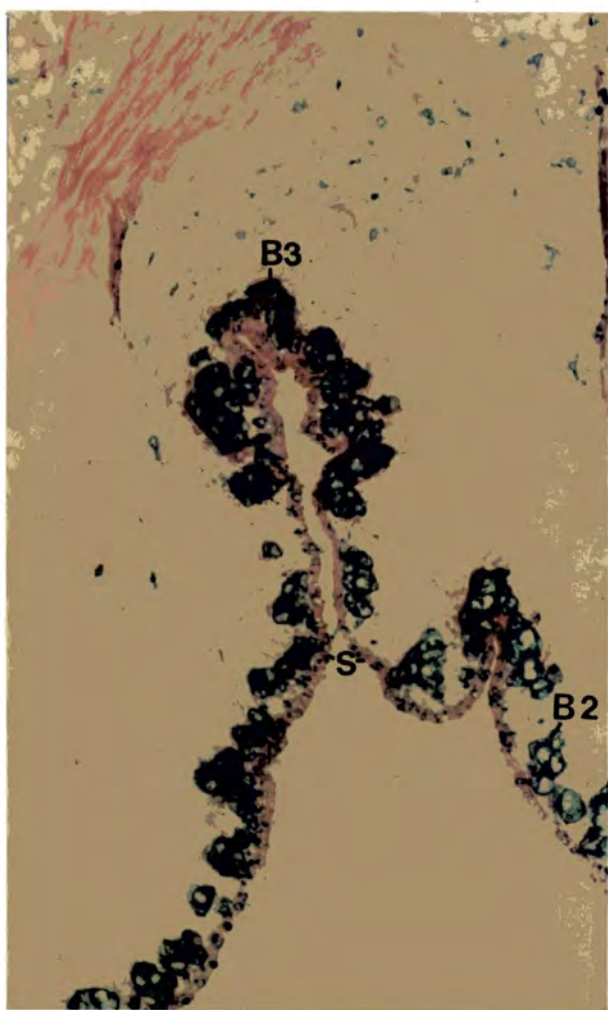

B

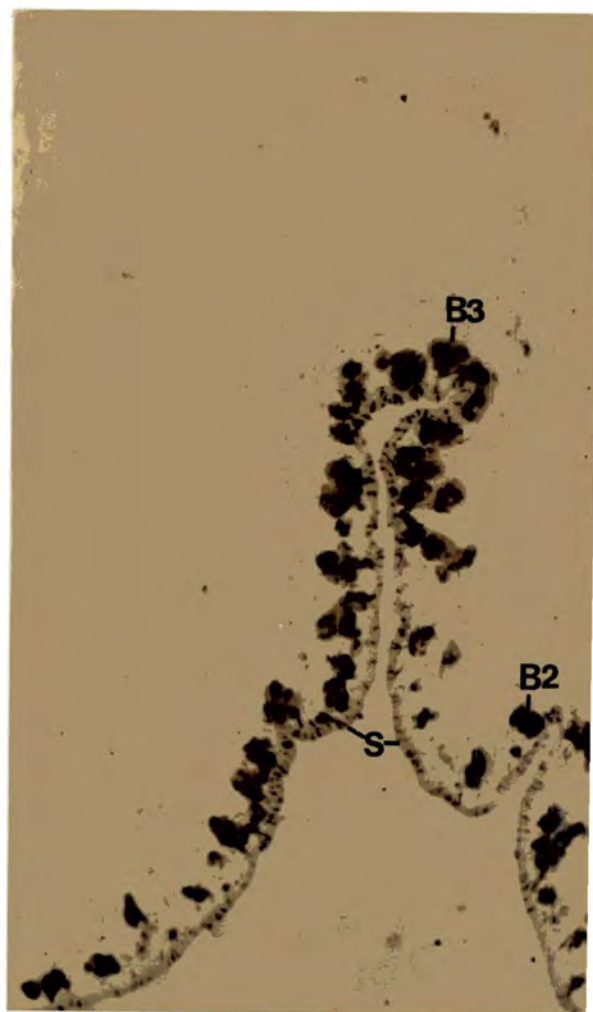

C

Plate 17 Longitudinal sections through the transverse fold of the foot of Bithynia tentaculata to show the different staining responses of B2 and B3 cells.

A A section stained in Alcian Blue pH2.5/PAS (x40).

A purple staining of B3 cells suggests that both alcinophilic components and periodate-reactive groups are present and the blue colour of B2 cells indicates acidic mucopolysaccharides.

B A section stained in Alcian Blue pH0.5/Alcian yellow pH2.5 (x 40).

The blue colour of B2 cells and the yellow-green colour of B3 cells with this method indicate that B2 cells are composed of only sulphated mucopolysaccharides and in the secretion of B3 cells both sulphated and carboxylated groups are present.

D - Duct; S - Sole. All other labels refer to cell types.

DORSAL



PLATE 17

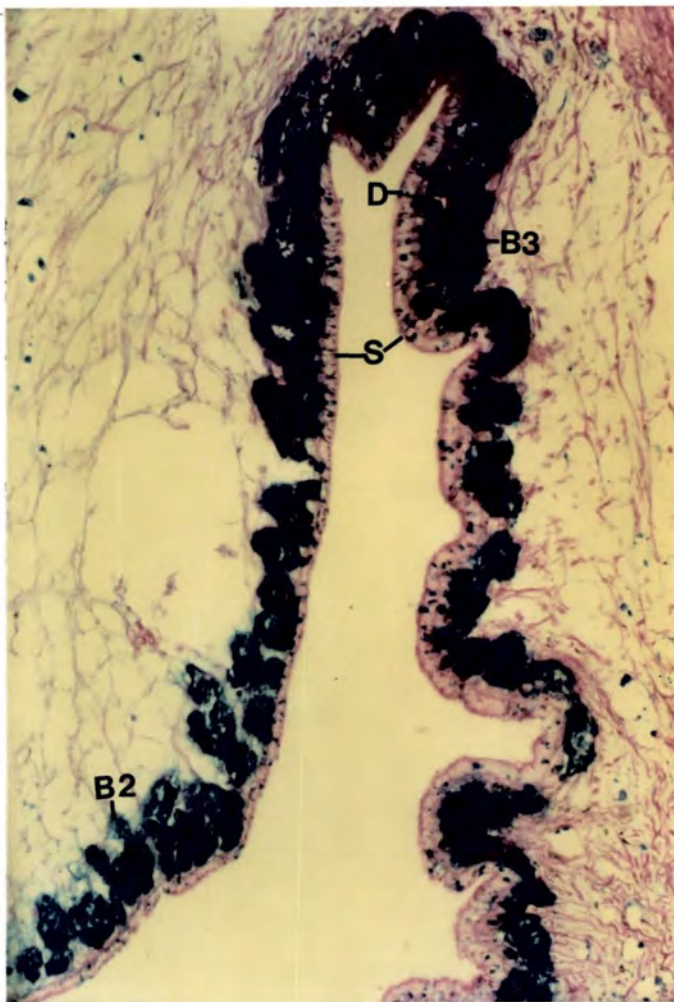

A

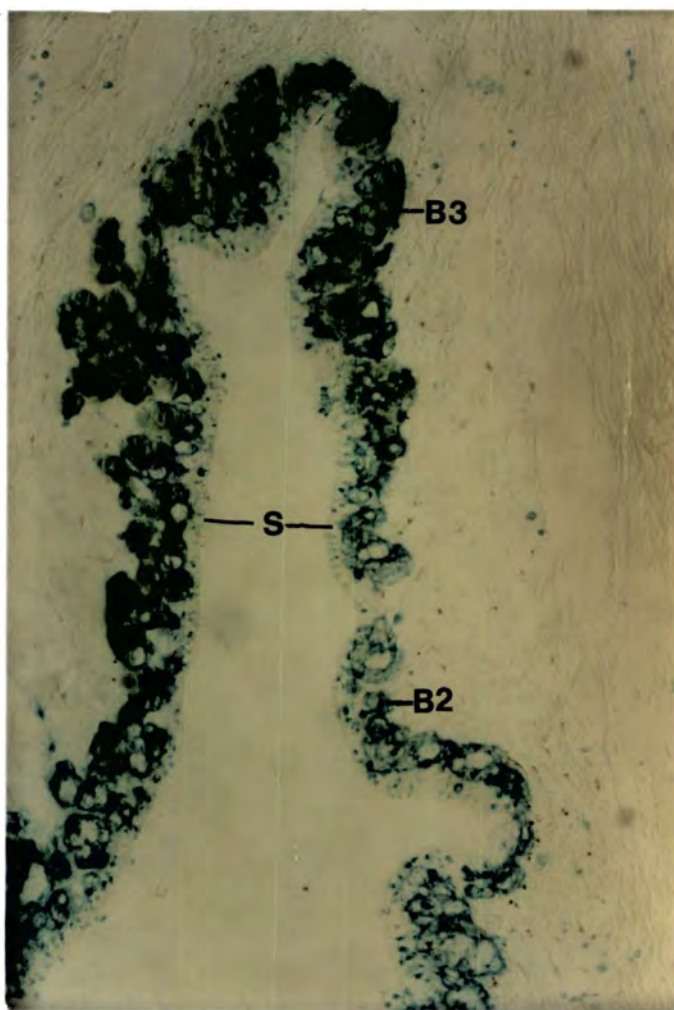

B

Plate 18 The staining responses of goblet cell types of  
Bithynia tentaculata.

- A A longitudinal section through the posterior foot of Bithynia stained in Alcian Blue pH2.5/PAS (x 80). Blue staining of B7 cells indicates acidic mucopolysaccharides in their secretion.
- B A longitudinal section through the epidermis joining the head and the foot of Bithynia stained in toluidine blue (x 80). B7 cells exhibit strong  $\beta$ metachromasia in toluidine blue.
- C A longitudinal section through the dorsal pedal epithelium of Bithynia stained with PAD (x 160). Black staining of B7 cells and a brown colour of B8 cells indicate periodate-unreactive mucosubstances in B7 cells and neutral mucopolysaccharides in the latter.

DE - Dorsal epithelium; S - Sole. All other labels refer to cell types.

PLATE 18



A

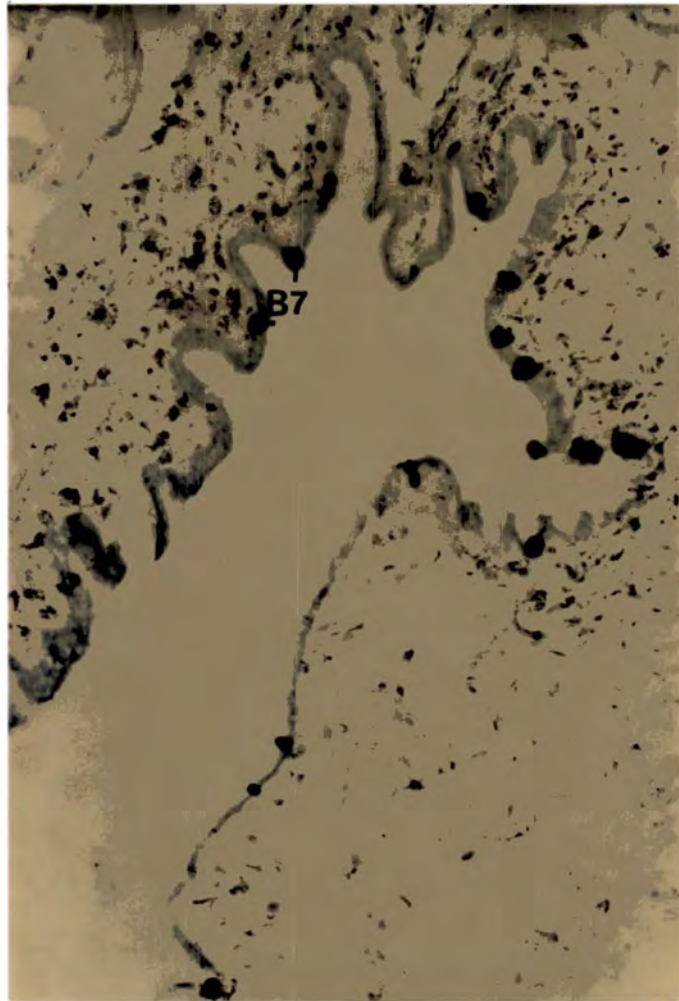

B

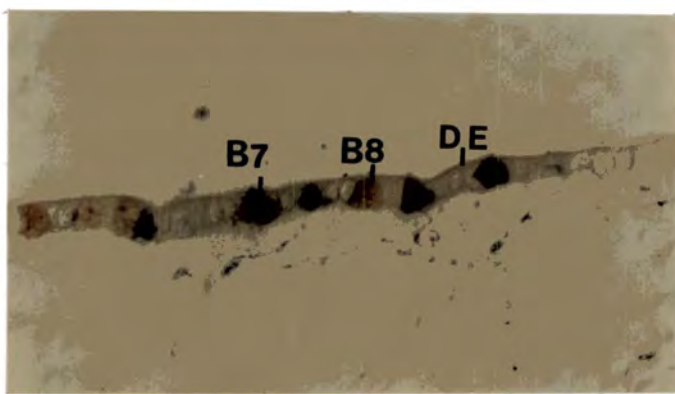

C

Plate 19 A part of a transverse section through the posterior foot of Bithynia tentaculata stained by the diazo-coupling reaction to show cell type B9 (x 80).

A strong positive reaction of B9 cells indicates protein containing tyrosine in secretion.

C - Cilia; N—Nucleus; S - Sole. All other labels refer to cell types.

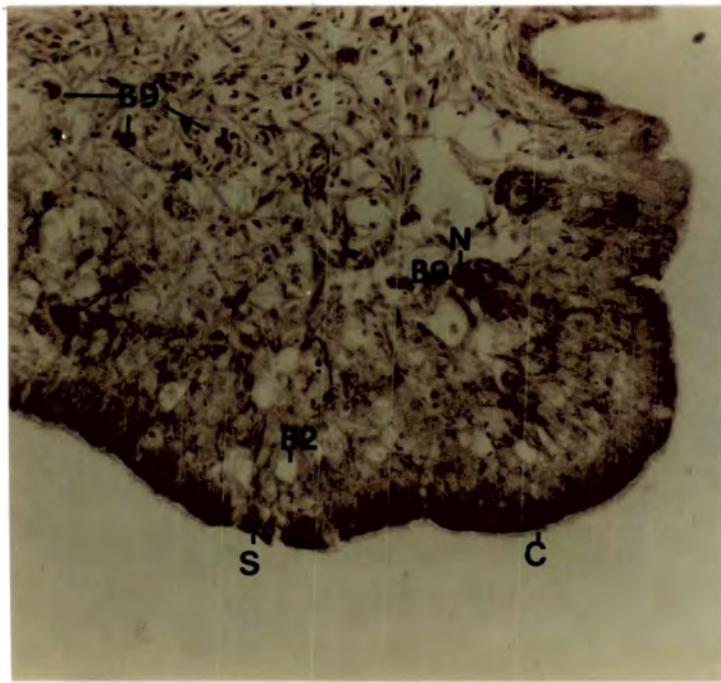

Reference diagrams to show the planes of sections  
in subsequent plates.

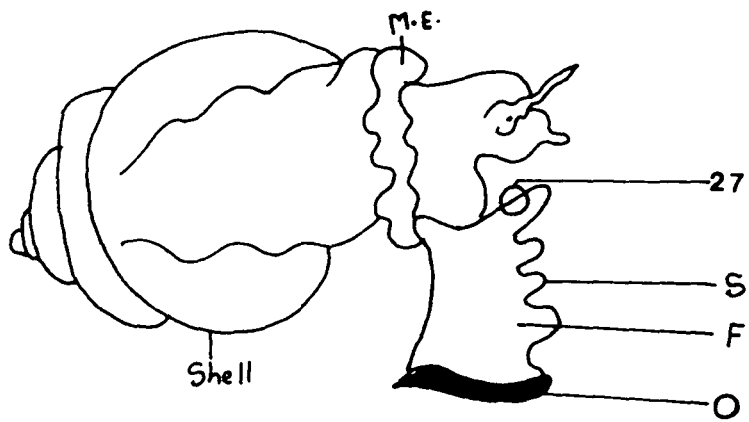
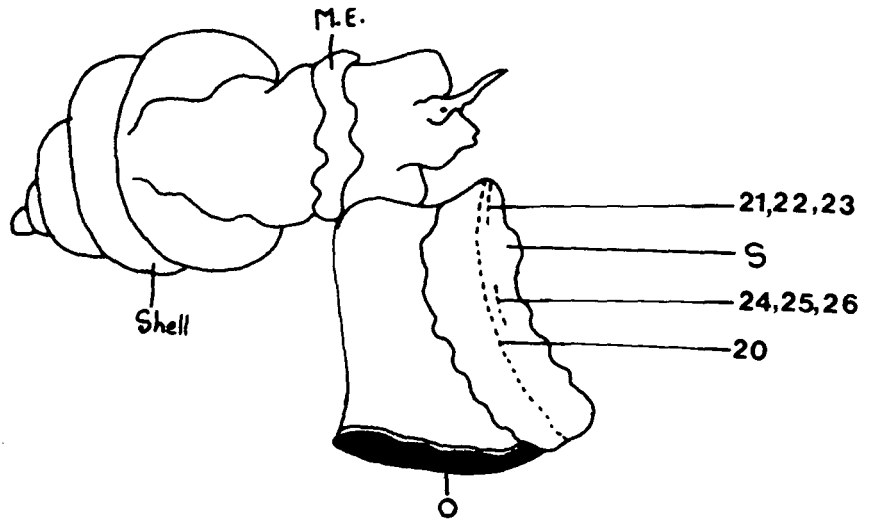

F-Foot, M.E.-Mantle edge, O-Operculum, S-Sole.

LITTORINA LITTOREA

Plate 20 A longitudinal section through the foot of  
Littorina littorea stained in Alcian Blue  
pH2.5/PAS to show the general distribution of  
pedal gland cells (x 12).

APG - Anterior pedal gland; DE - Dorsal epithelium; S -  
Sole. All other labels refer to cell types.

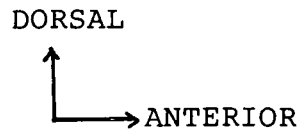

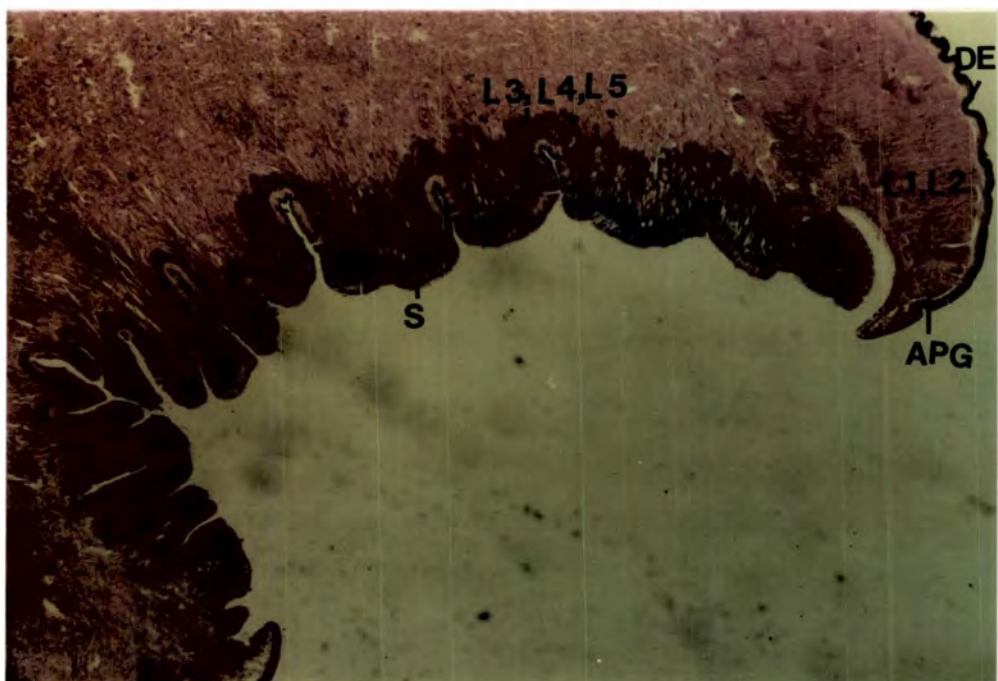

Plate 21 Longitudinal sections through the anterior foot of Littorina littorea to show the staining responses of pedal gland cells (x 40).

- A A section stained in mercuric bromophenol blue. Positive staining of L1 and L2 gland cells indicates their secretion is proteinaceous.
- B A section stained with PAS. Positive responses of L1, L2, L3, L4, L5 and L10 cells show periodate-reactive groups in their secretion.

APG - Anterior pedal gland; D - Duct; DE - Dorsal epithelium; PG - Pigment granules; S - Sole. All other labels refer to cell types.

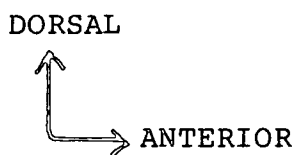
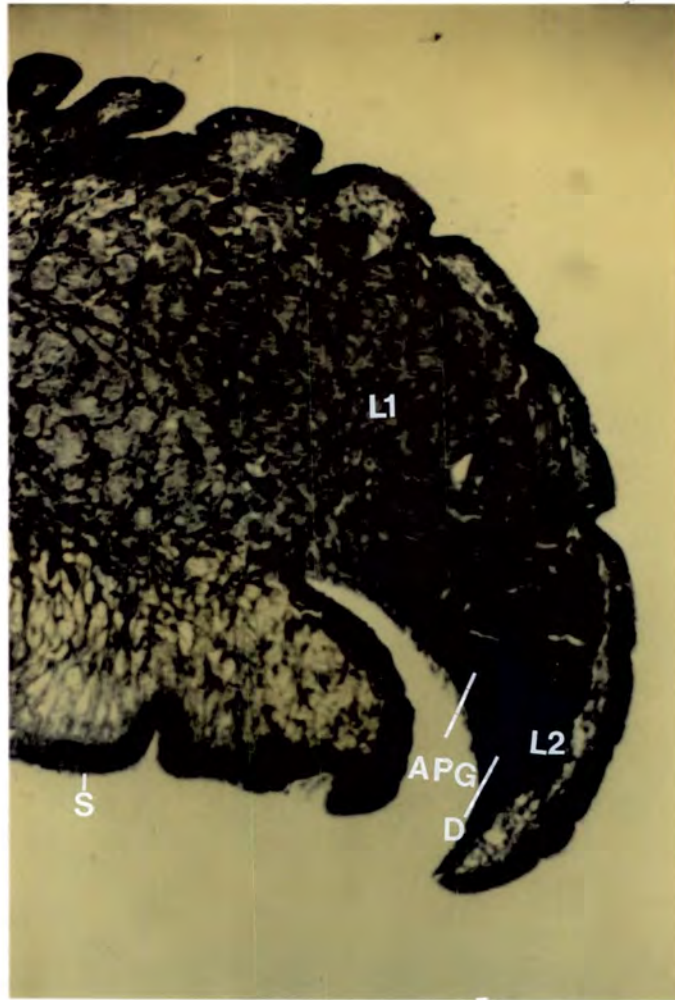
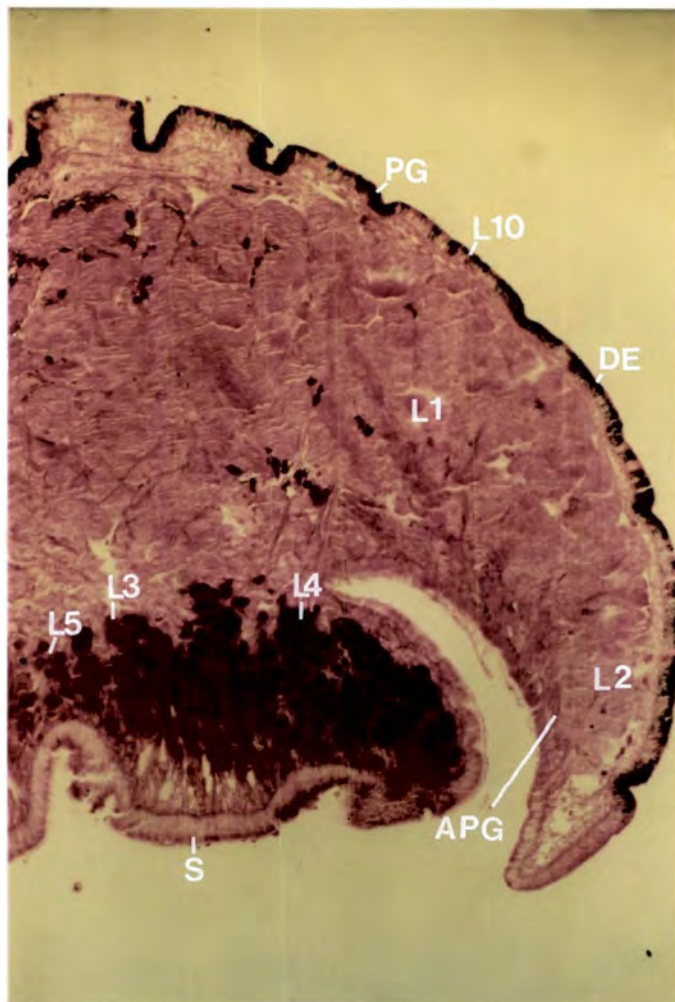

PLATE 21



A



B

Plate 22 A longitudinal section through the anterior foot of Littorina littorea stained by the diazo-coupling reaction (x 40).

Note the negative response of L2 cells which shows that tyrosine is not present. The positive reactions of L1 and L5 cells indicate the presence of protein containing tyrosine.

APG - Anterior pedal gland; C - Cilia; S - Sole; DE - Dorsal epithelium. All other labels refer to cell types.



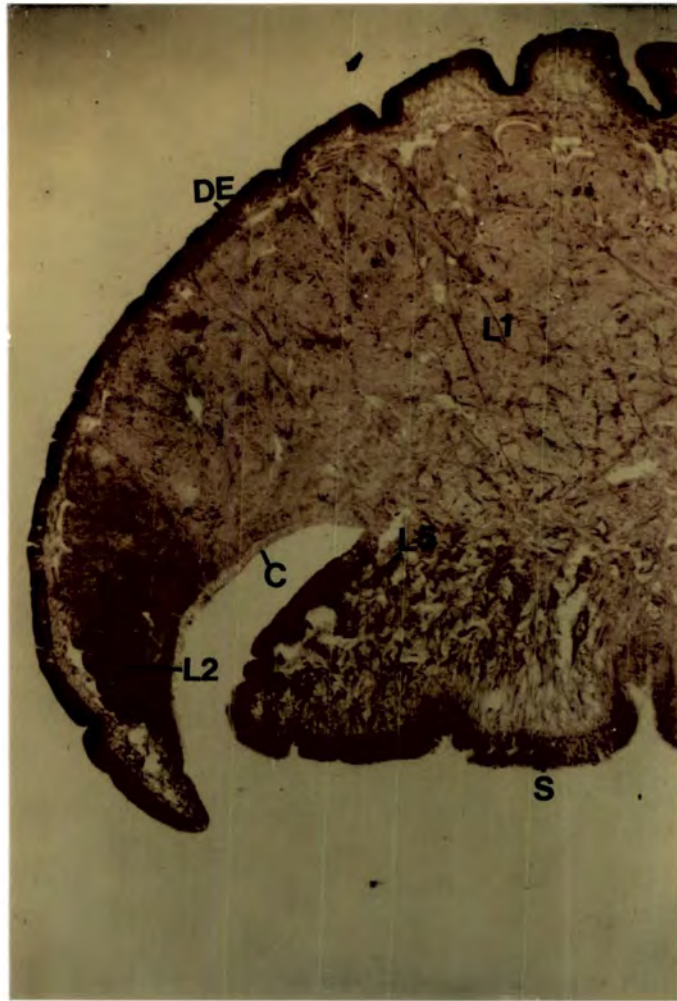

Plate 23 Longitudinal sections through the anterior foot of Littorina littorea to show the staining responses of the anterior pedal gland to test for acidic and neutral mucopolysaccharides (x 40).

A A section stained with PAD.

L1 cells are stained only slightly but L2 cells are stained brown indicating neutral mucopolysaccharide in their secretion.

B A section stained in Toluidine blue.

Note that L1 cells show slight metachromasia in toluidine blue but L2 cells responded negatively.

APG - Anterior pedal gland; S - Sole. All other labels refer to cell types.

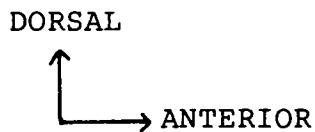

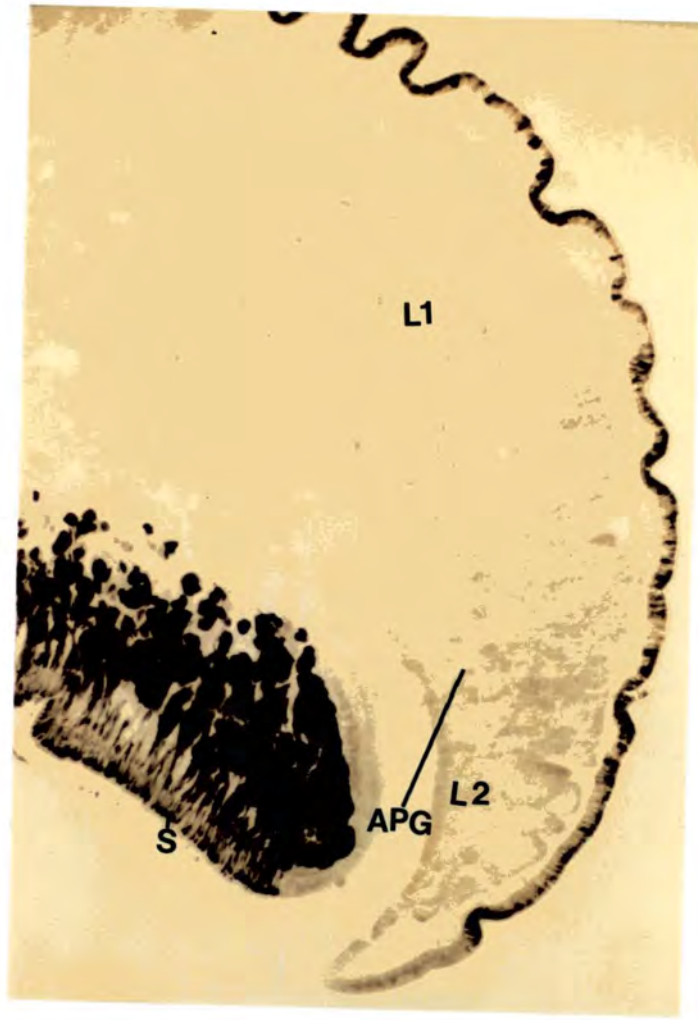

A

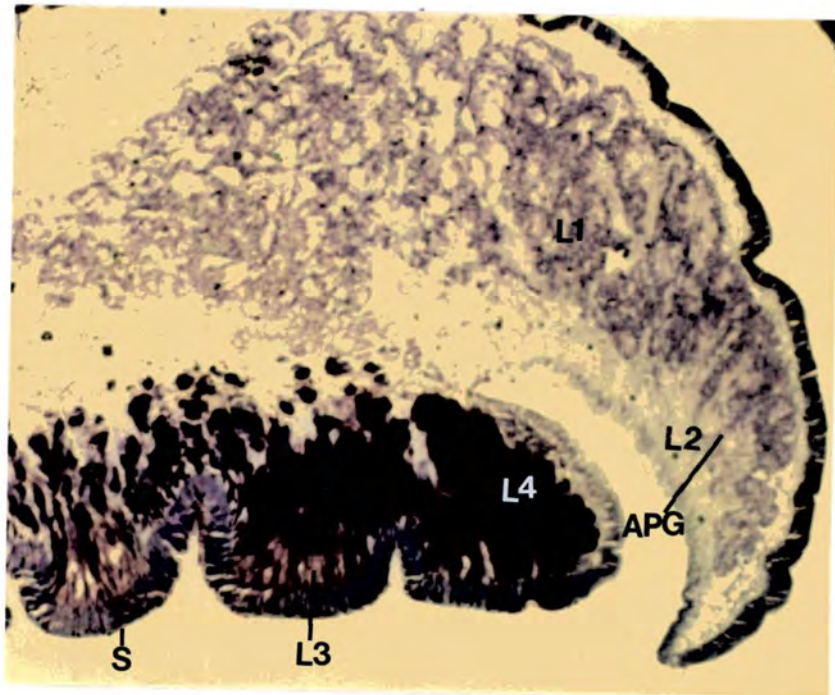

B

Plate 24 Longitudinal sections through the foot of  
Littorina littorea to show the staining responses  
of pedal cells.

A A section stained in Alcian Blue pH2.5/PAS (x 80).  
The blue colour of L3 cells and the purple colour of L4  
cells indicate acidic mucopolysaccharides in their  
secretion.

The red staining of L5 cells represents periodate  
reactive groups.

B A section stained in Toluidine blue (x 80).  
L4 cells show strong  $\beta$ metachromasia in toluidine blue  
but L3 cells responded only slightly.

C A section stained in Alizarin Red (x 40).  
The positive reactions of L3 and L4 cells indicate  
calcium in their contents.

EC - Extruded contents; S - sole. All other labels refer to  
cell types.

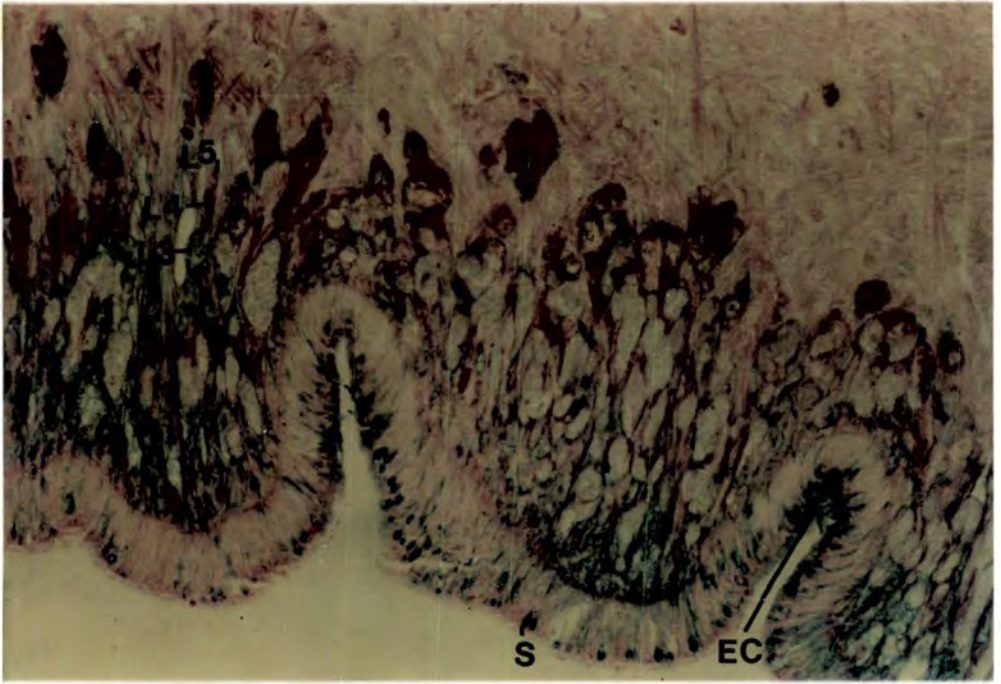

A

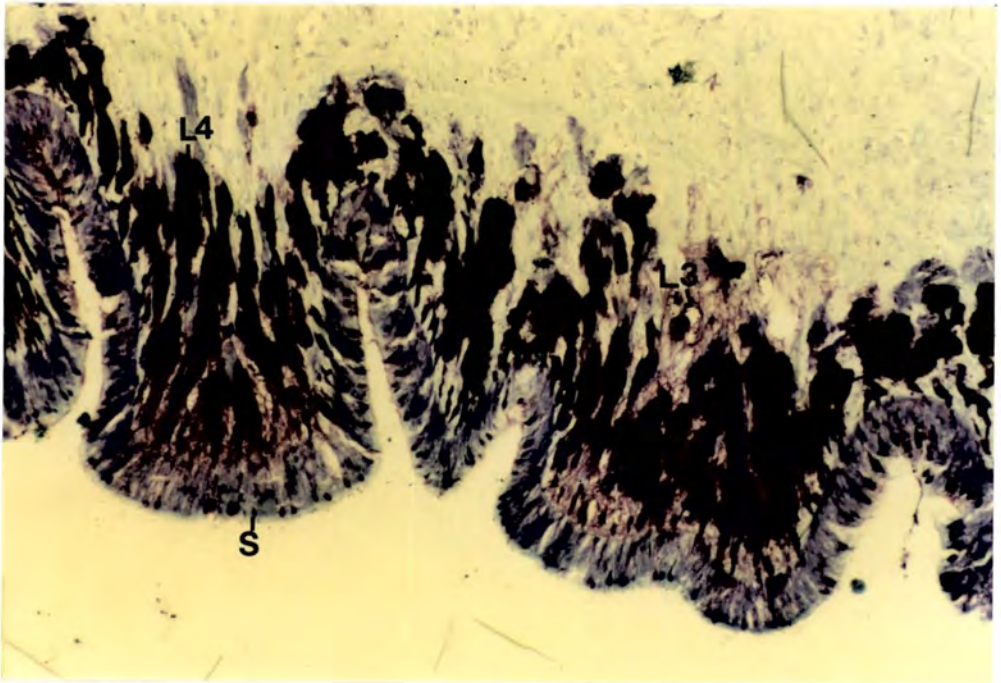

B

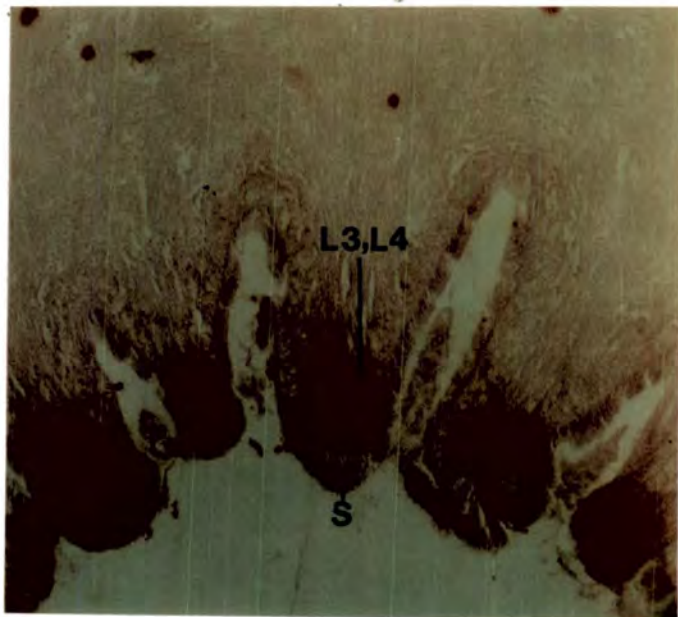

C

Plate 25 Longitudinal sections through the foot of  
Littorina littorea to show the staining responses  
of pedal cells for acidic and neutral  
mucopolysaccharides.

A A section stained in Alcian Blue pH0.5/eosin (x 80).  
The positive responses of L3 and L4 cells indicate  
sulphated mucopolysaccharides.

B A section stained with PAD (x 80).  
The black colour of L3 and L4 cells shows that they  
contain periodate-unreactive mucosubstances and the  
light brown colour of L5 cells suggests the presence of  
some neutral mucopolysaccharides in their secretion.

S - Sole. All other labels refer to cell types.



A

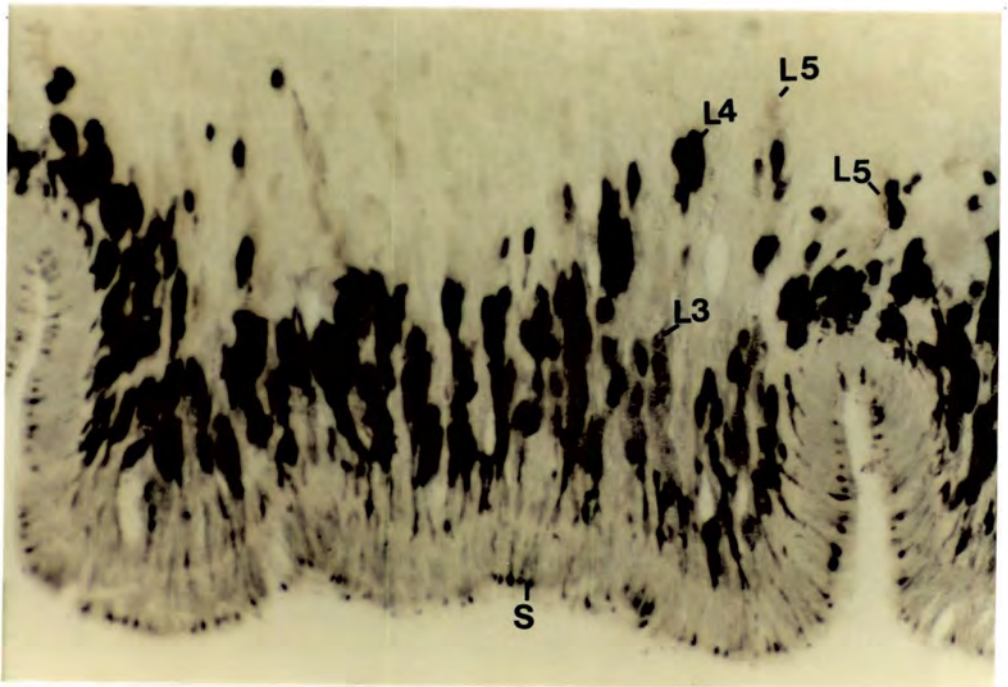

B

Reference diagrams to show the planes of sections

in subsequent plates

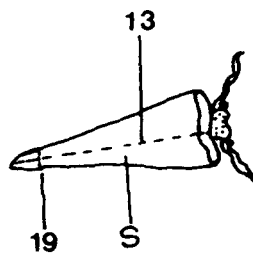
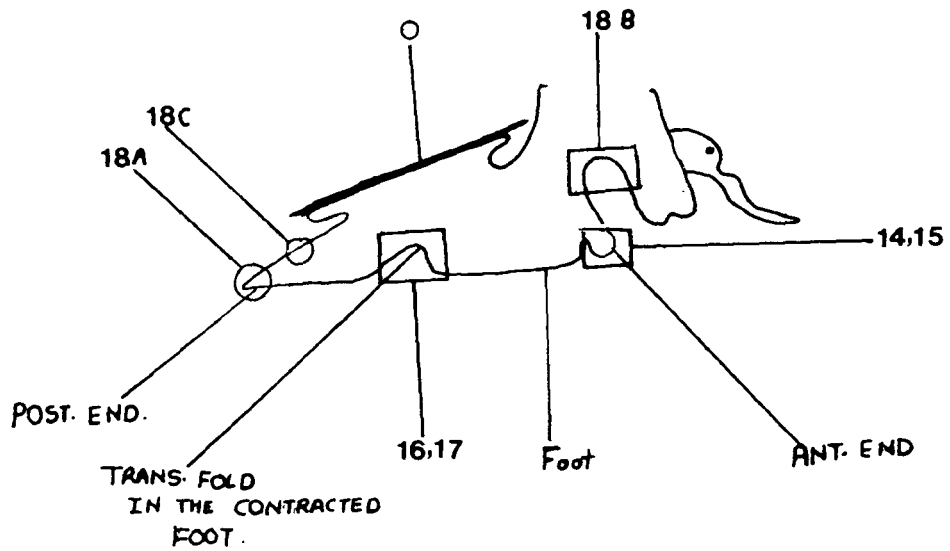

O-Operculum ; S-sole .

**BITHYNIA TENTACULATA**

---

Plate 26 Longitudinal sections through the foot of  
Littorina littorea to show the staining responses  
of L5 cells for protein (x 80).

A A section stained by the diazo-coupling reaction.  
The strong positive reaction of L5 cells shows the  
presence of protein containing tyrosine.

B A section stained with PAS.  
The positive responses of L3, L4 and L5 cells show  
periodate-reactive groups in their secretion.

C A section stained in mercuric bromophenol blue.  
The bright blue colour of L5 cells confirms that their  
secretion is proteinaceous. Note the granular contents  
of L5 cells.

G - Granular secretion, S - Sole. All other labels refer to  
cell types.

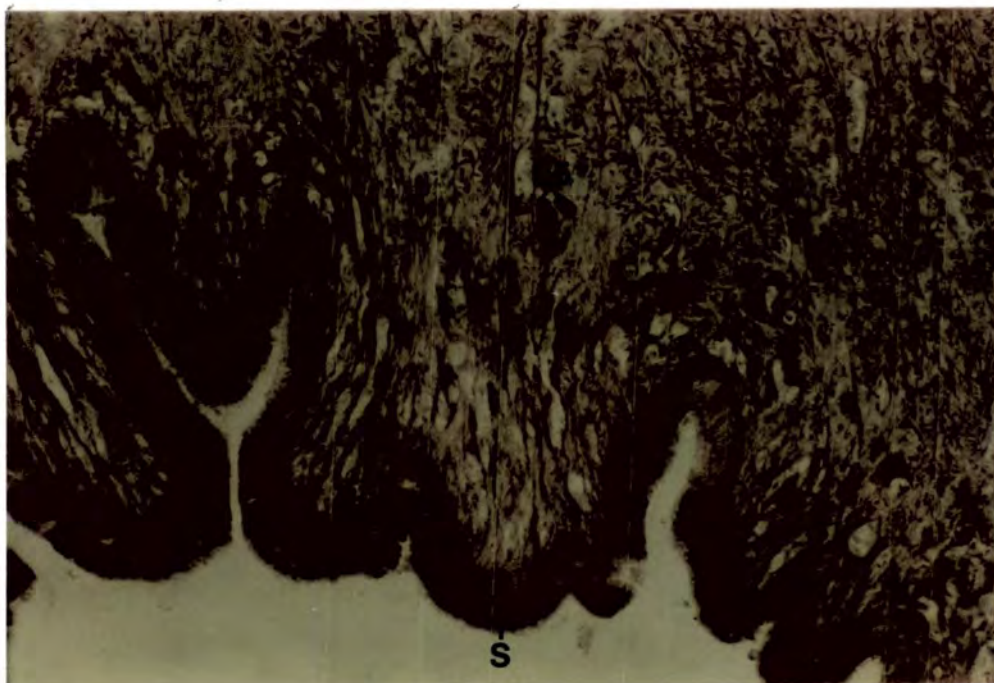

A



B

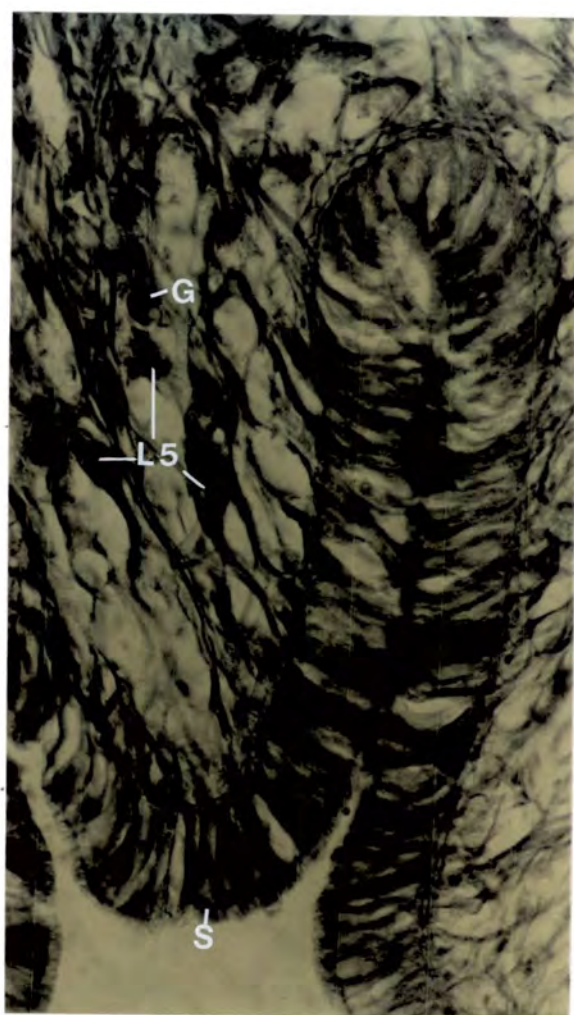

C

Plate 27 Longitudinal sections through the dorsal pedal epithelium of Littorina littorea to show the staining responses of goblet cell types for mucopolysaccharides and protein (x 160).

A A section stained in toluidine blue.

L9 cells show strong  $\beta$ metachromasia in toluidine blue.

B A section stained in Alcian Blue pH0.5/eosin.

The bright blue colour of L9 cells indicates that they contain sulphated mucopolysaccharides.

C A section stained by the diazo-coupling reaction.

The strong positive reaction by L10 cells shows that their secretion is proteinaceous containing tyrosine.

DE - Dorsal epithelium; PG - Pigment granules. All other labels refer to cell types.

PLATE 27



A

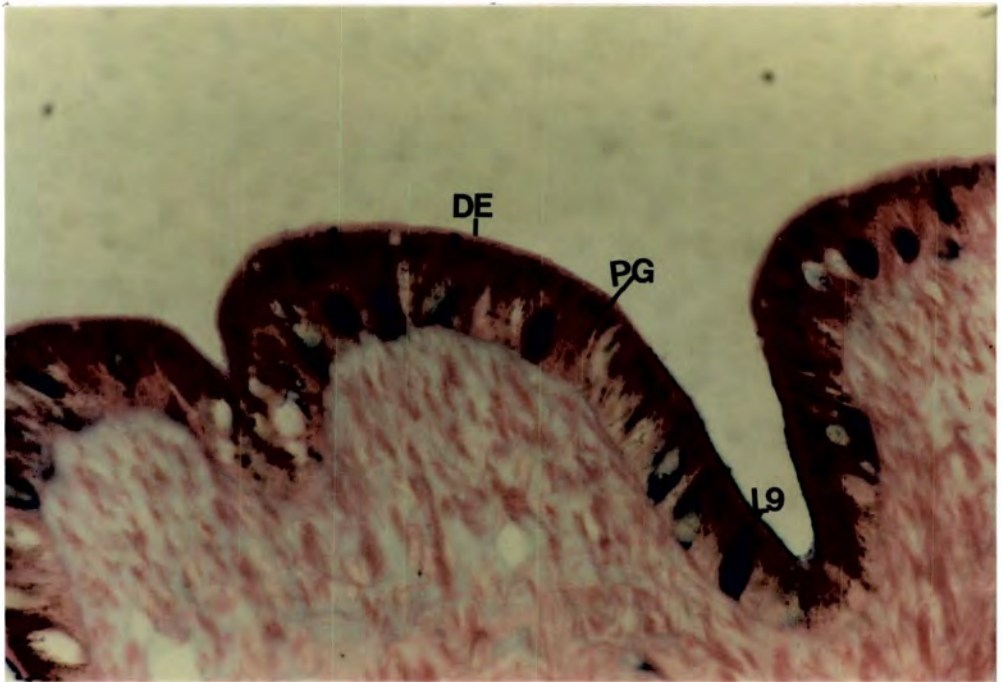

B

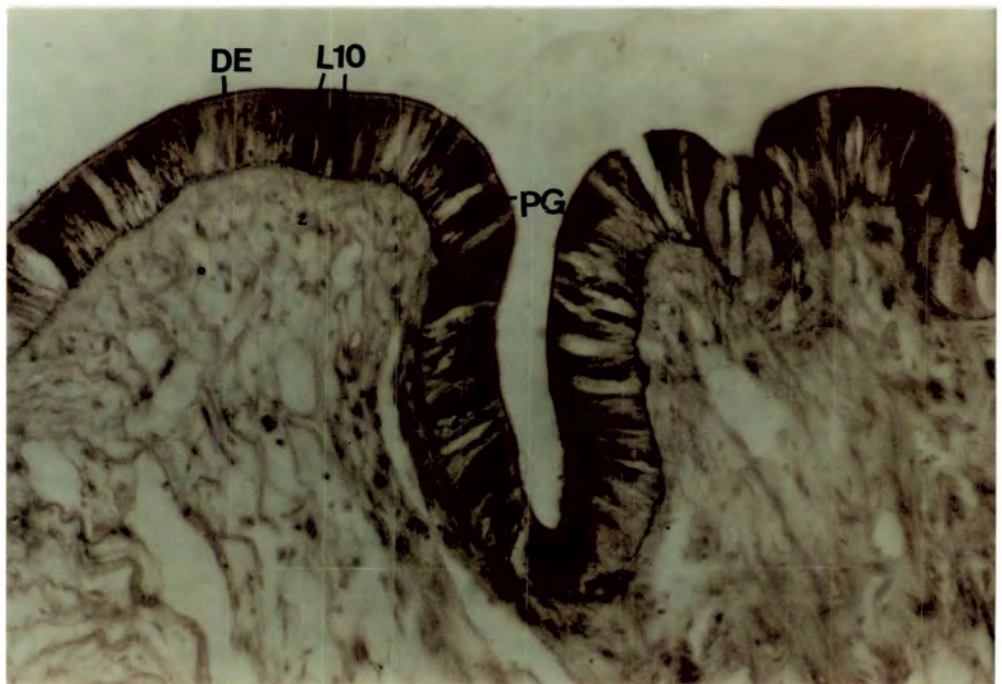

C

Plate 28 The distribution of opercular gland cells of the opercular groove of Pomatias elegans (ref. Figure 12).

A A transverse section through the opercular groove of Pomatias stained in Alcian Blue pH2.5/PAS (x 12).

B High power view of the opercular groove to show P7, P8 and P10 cells (x 40).

O - Operculum; OG - Opercular groove. All other labels refer to cell types.



A

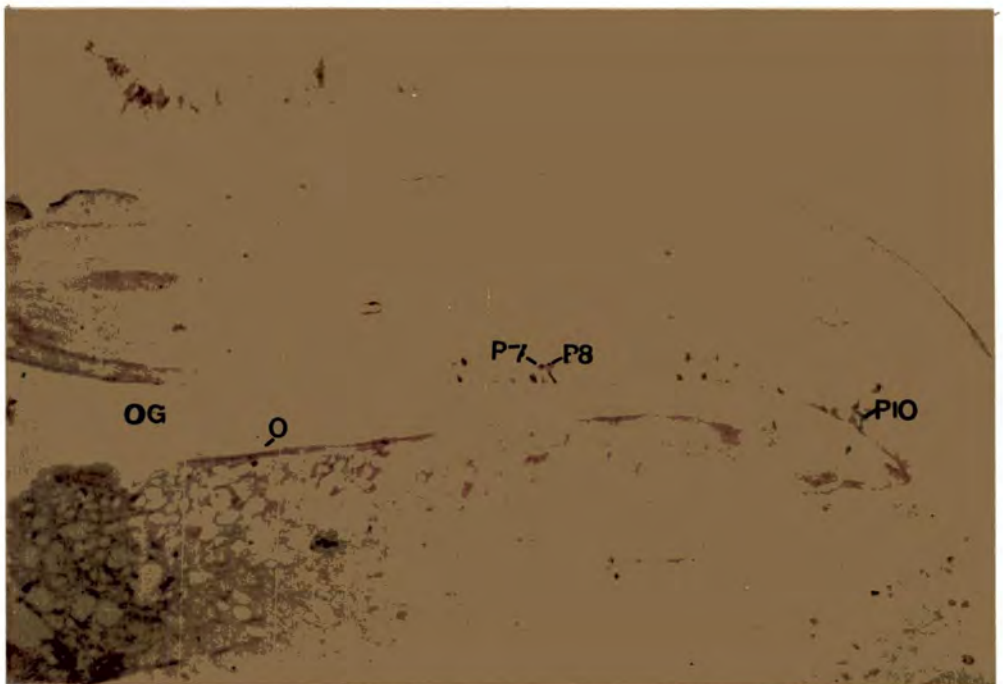

B

Plate 29 The distribution of opercular gland cells of the opercular disc of Pomatias elegans (ref. Figure 12).

- A A transverse section through the opercular disc of Pomatias stained in Alcian Blue pH2.5/PAS (x 40).
- B A transverse section through the opercular disc of Pomatias stained by the diazo-coupling reaction to show P12 cells (x 40).

O - Operculum. All other labels refer to cell types.

PLATE 29

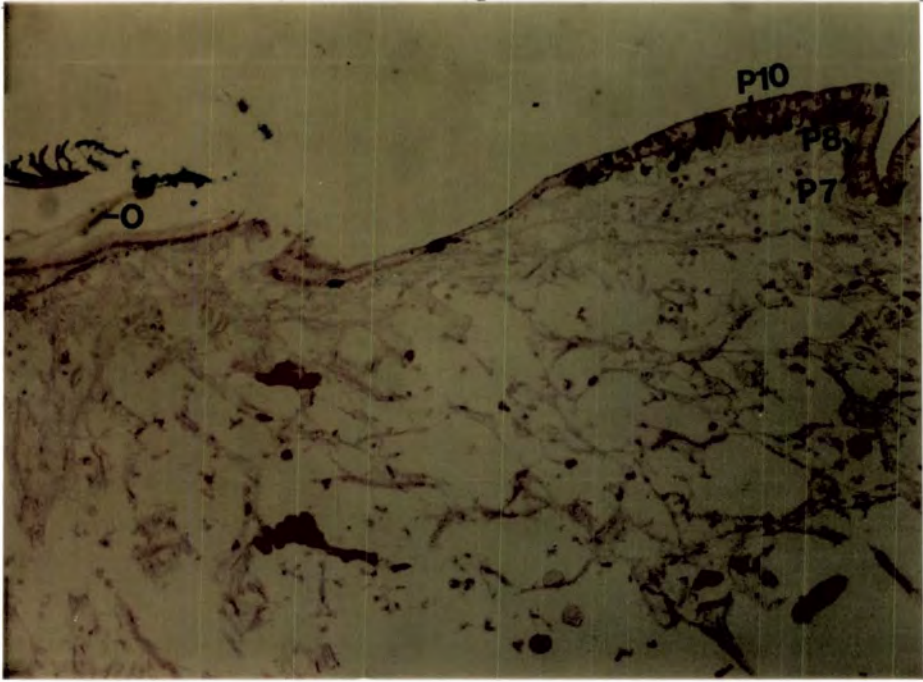

A

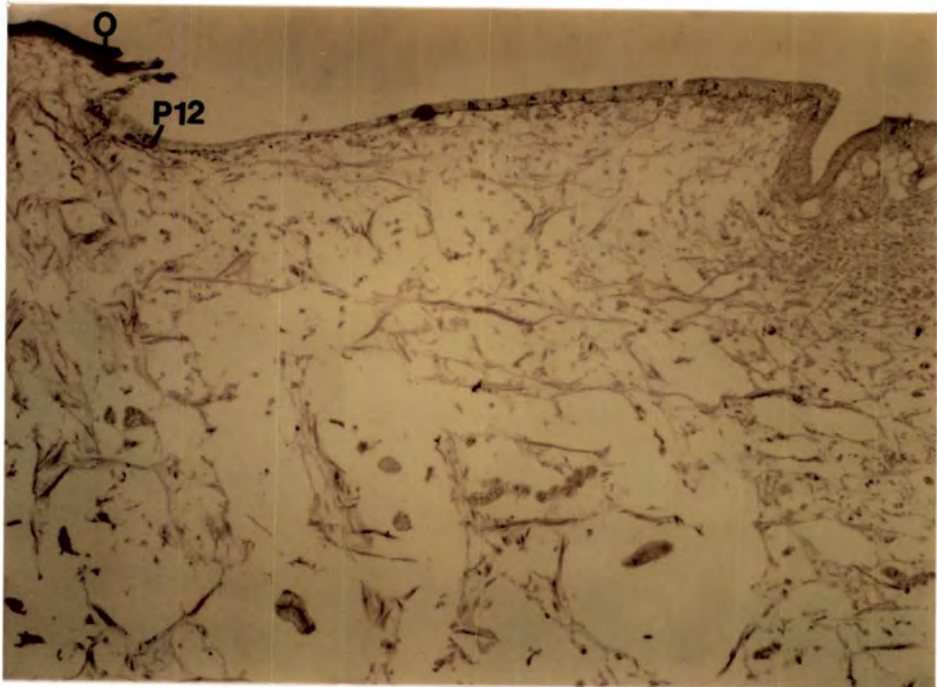

B

Plate 30 The staining responses of opercular gland cells of Pomatias elegans to tests for acidic and neutral mucopolysaccharides (x 160).

A High power view of a transverse section through the opercular disc of Pomatias stained in Alcian Blue pH2.5/PAS.

The red colour of P7 cells shows that periodate-reactive groups are present and the purple colour of P8 cells suggests that both acidic and periodate-reactive groups are present.

B High power view of a transverse section through the opercular disc of Pomatias stained with PAD.

The brown colour of P7 and P8 cells indicates neutral mucopolysaccharide in secretion.

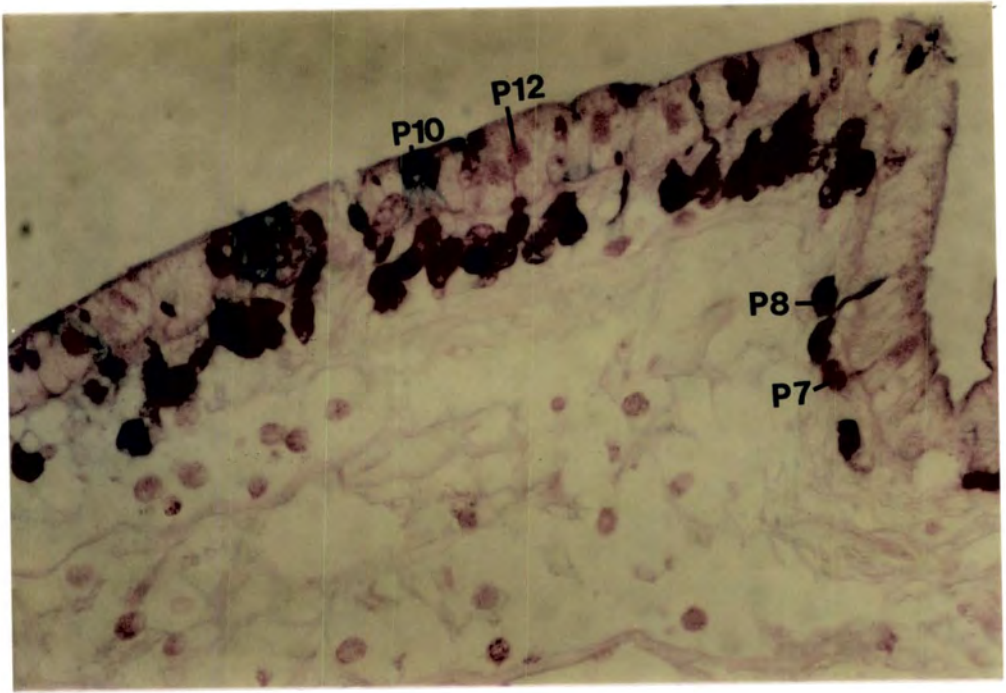

A

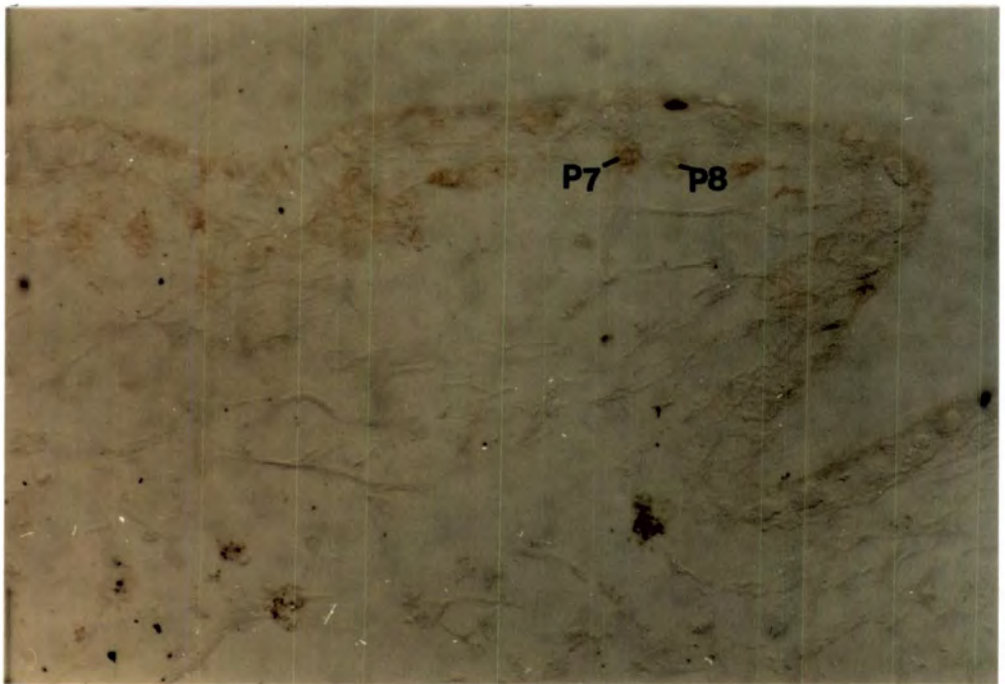

B

Plate 31 Opercular gland cells in Bithynia tentaculata  
(ref. Figure 14).

- A A longitudinal section through the whole foot of Bithynia stained by PAD to show the general view of the distribution of pedal and opercular gland cells (x 12).
- B High power view of the opercular disc to show B4, B5, B7 and B8 cells (x 80).
- C High power view of the opercular groove (x 80).

OD - Opercular disc; OG - Opercular groove; S - Sole; SOC - Subopercular cleft. All other labels refer to cell types.

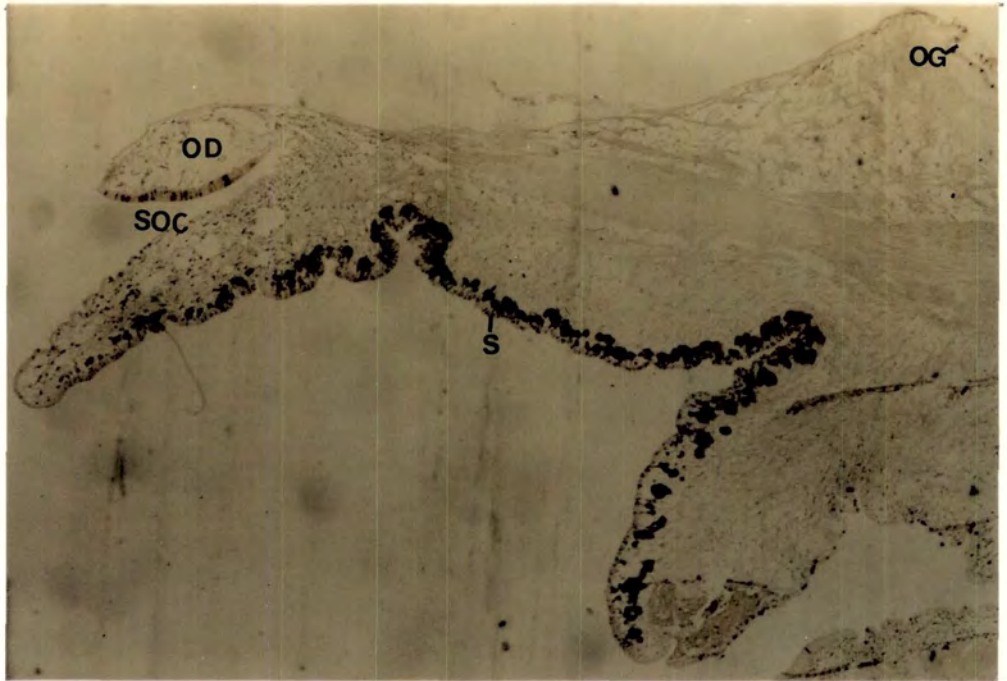

A

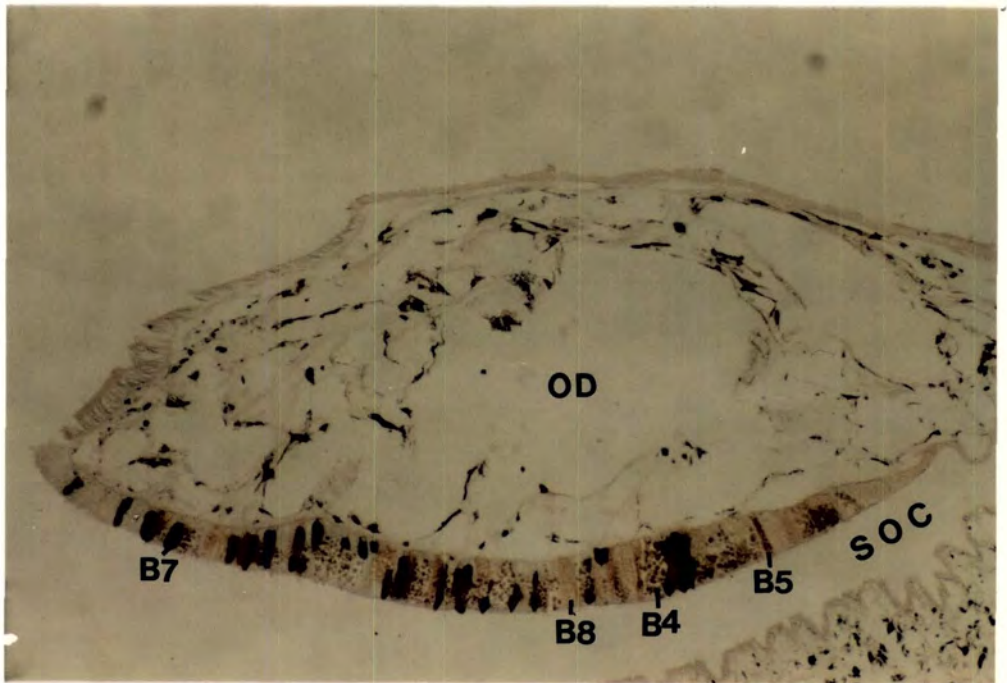

B

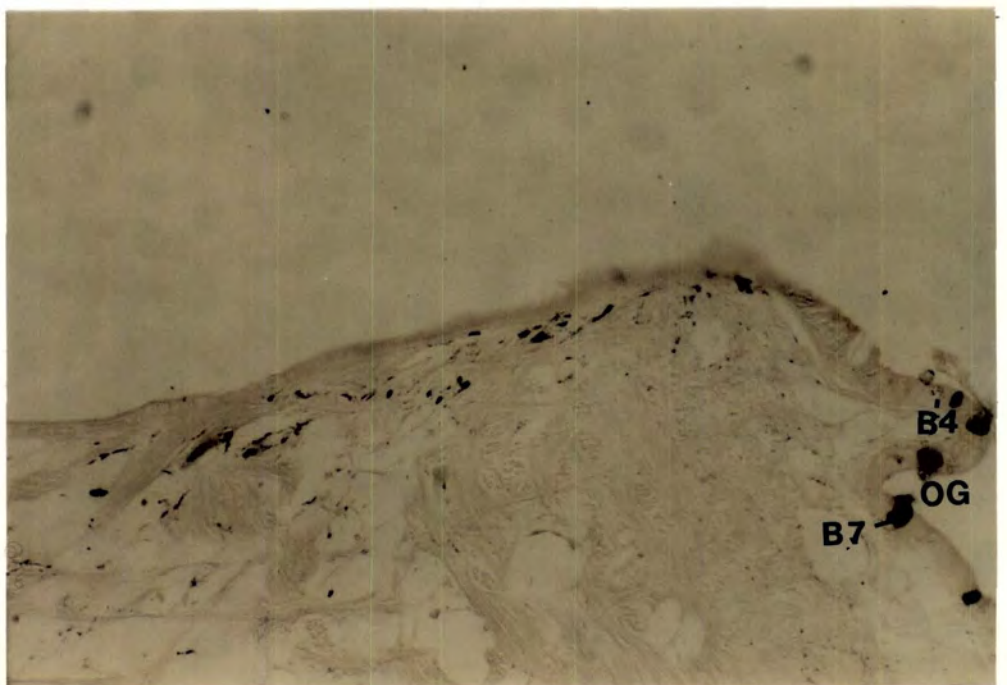

C

Plate 32

- A A longitudinal section through the posterior foot and the opercular disc of Bithynia tentaculata stained with PAS (x 40).
- B High power view of the opercular disc to show the positive responses of B4, B5 and B8 cells (x 80).

OD - Opercular disc; S - Sole; SOC - Subopercular cleft.

All other labels refer to cell types.

PLATE 32

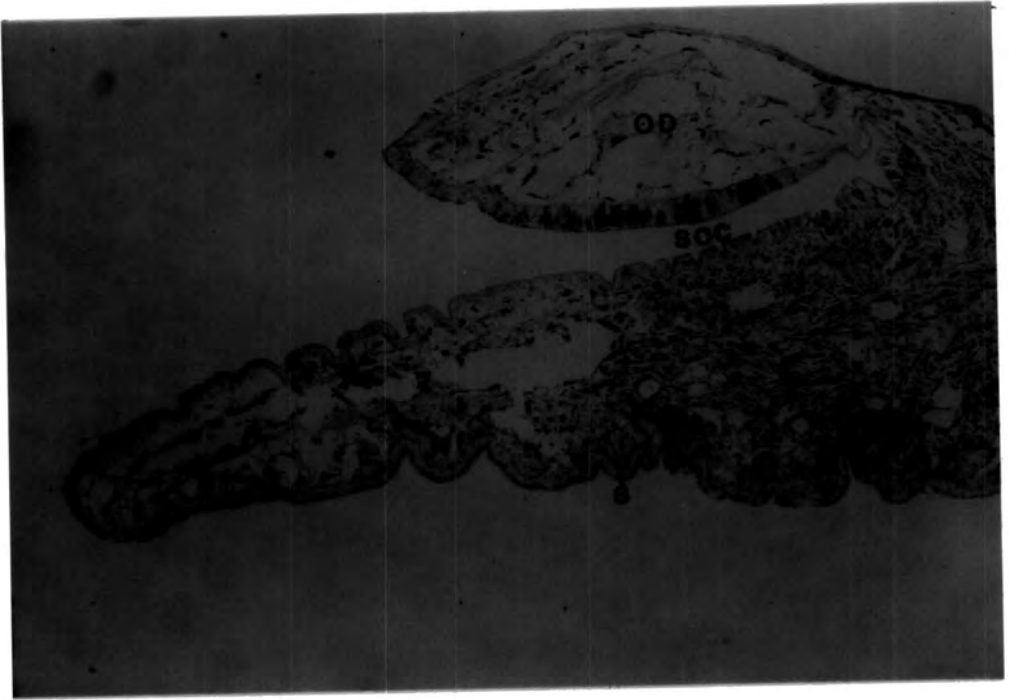

A

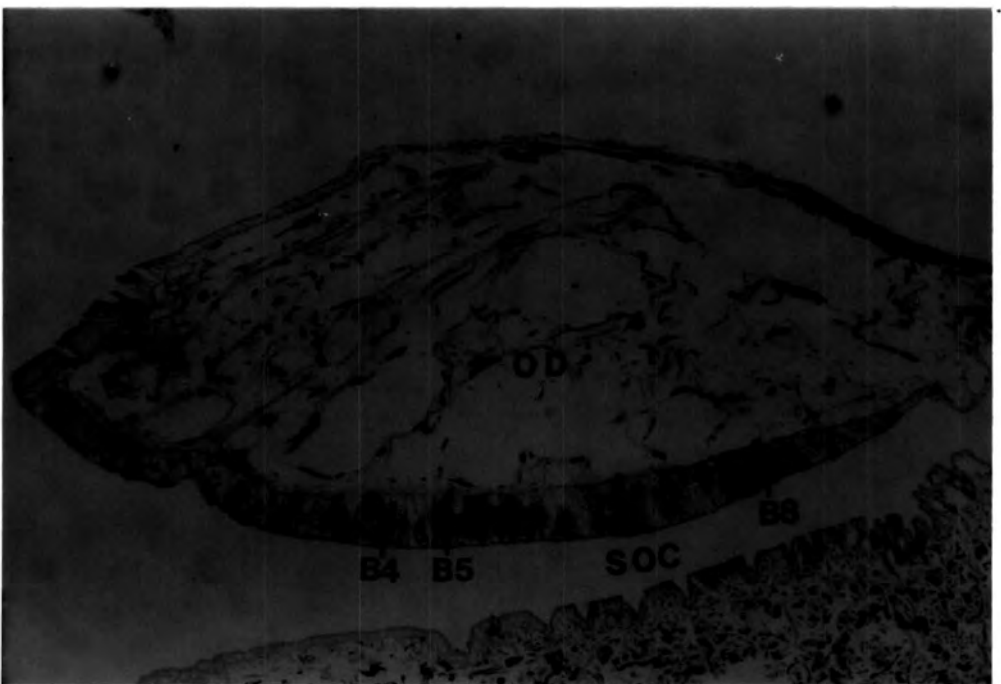

B

Plate 33 Longitudinal sections through the posterior foot and the opercular disc of Bithynia tentaculata to show the staining responses of opercular gland cells for acidic and neutral mucopolysaccharides (x 40).

A A section stained in Alcian Blue pH0.5/eosin.  
The light blue colour of B4 cells indicates sulphated mucopolysaccharides.

B A section stained with PAD.  
The brown colour of B4 and B5 cells shows that they contain neutral mucopolysaccharide.

C A section stained in Alcian Blue pH2.5/PAS.  
The purple colour of B4 cells suggests that they contain both acidic mucopolysaccharides and periodate-reactive groups.  
The bright red colour of B5 cells shows periodate-reactive groups in their secretion.

OD - Opercular disc; S - Sole. All other labels refer to cell types.

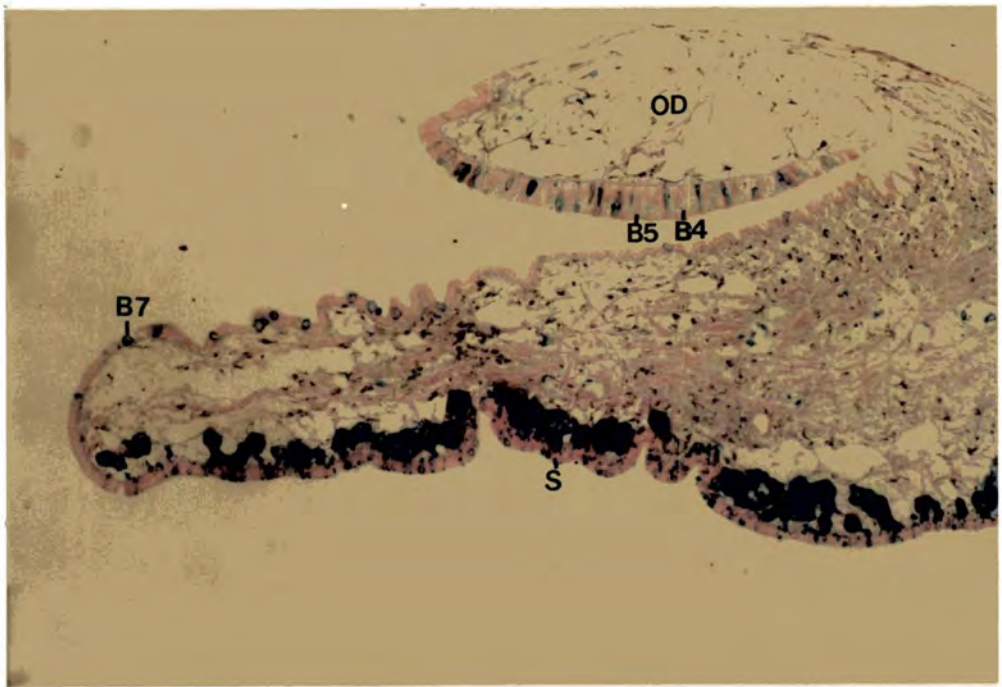

A

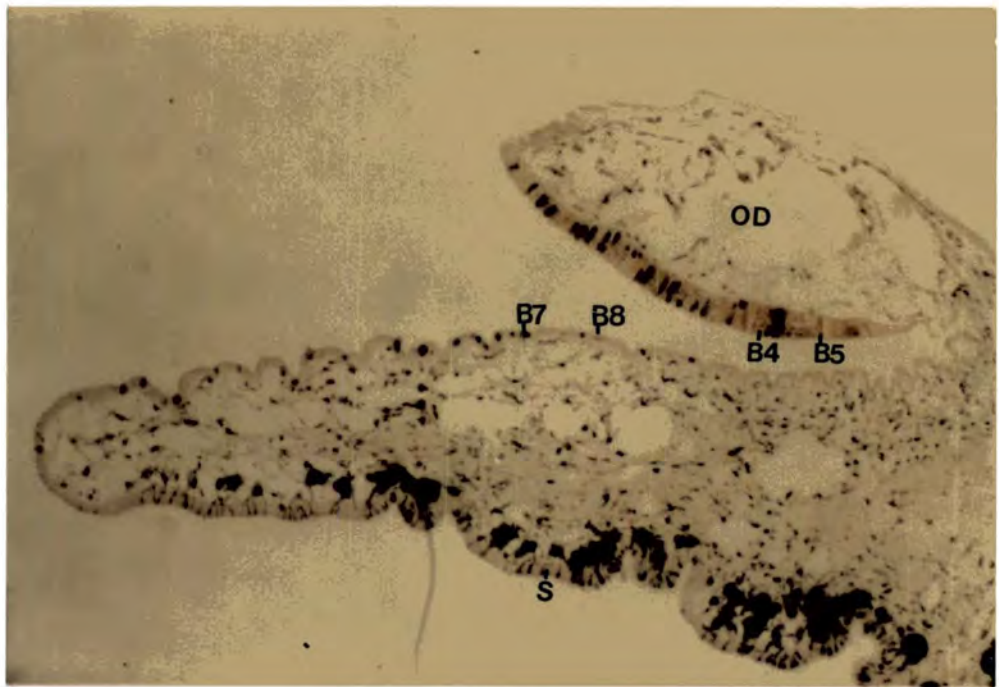

B

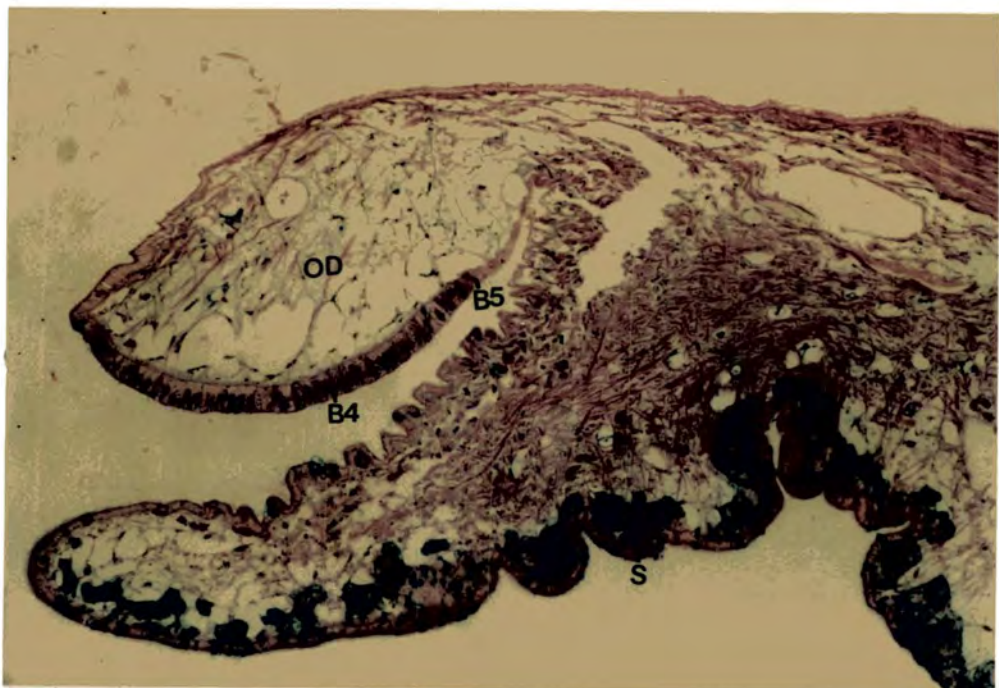

C

Plate 34 High power view of longitudinal sections through the opercular disc of Bithynia tentaculata to show the staining responses of opercular gland cells for protein (x 80).

A A section stained in mercuric bromophenol blue.

Blue staining of B4 and B5 cells indicates that the secretion is proteinaceous.

B A section stained by the diazo-coupling reaction.

The strong reactions of B4 and B5 cells show that they contain tyrosine.

OD - Opercular disc. All other labels refer to cell types.

PLATE 34

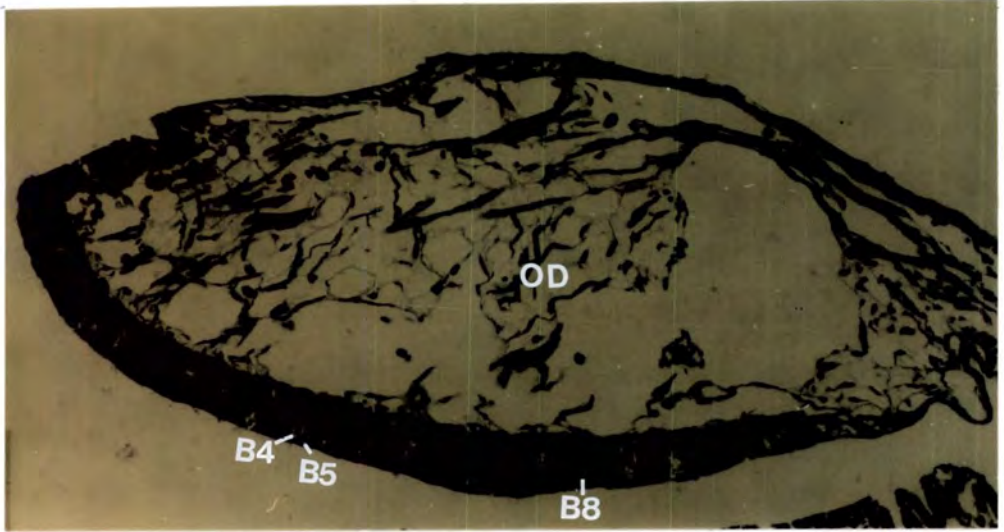

A

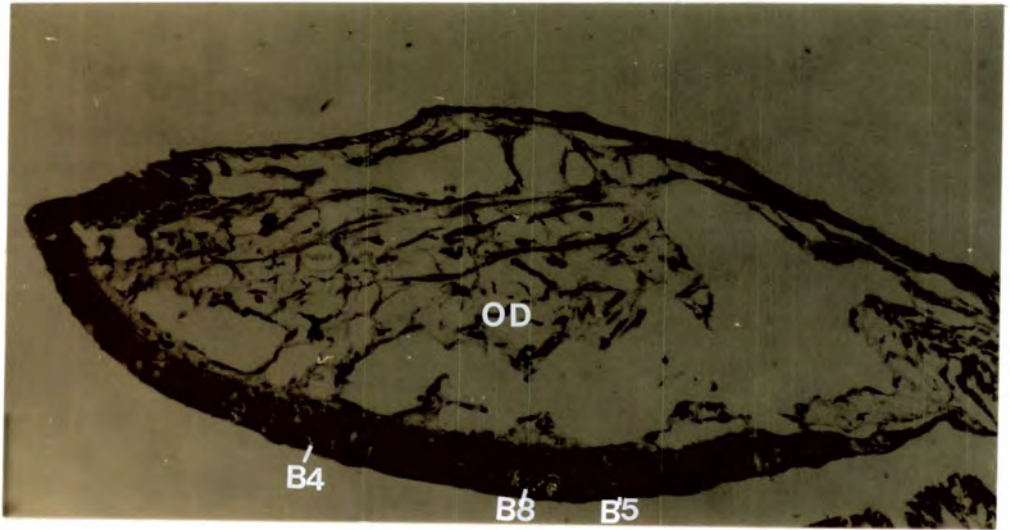

B

Plate 35 Sections through the operculum of Littorina  
littorea to show the distribution of Opercular  
gland cells at the Opercular groove and the  
subopercular cleft (ref. Figure 15).

A A section stained in Alcian Blue pH2.5/PAS (x 12).

B A section stained in mercuric bromophenol blue (x 12).

O - Operculum; OG - Opercular groove; S - Sole; SOC -  
Subopercular cleft. All other labels refer to cell types.

PLATE 35

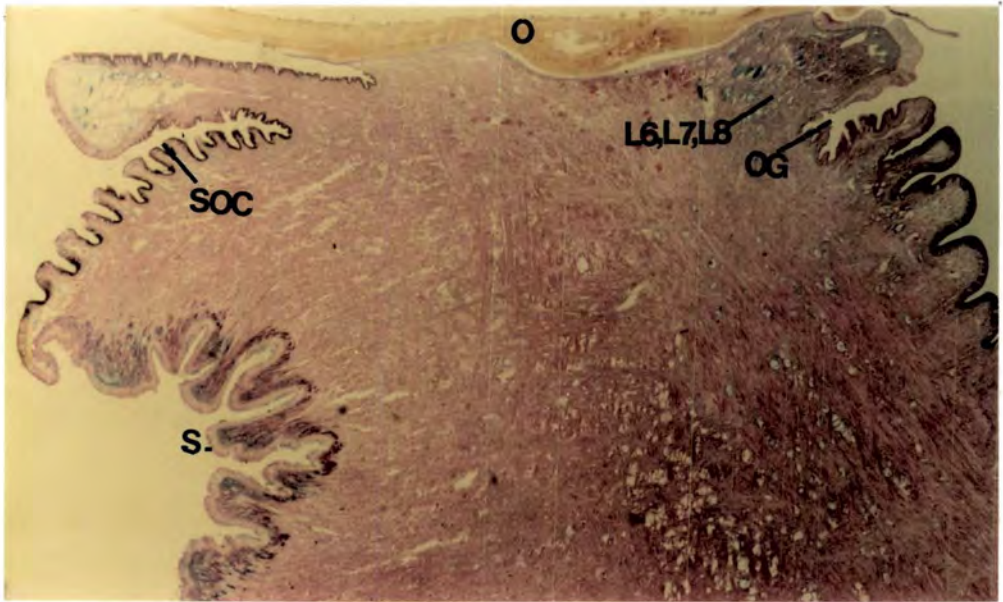

A



B

Plate 36 High power view of sections through the operculum of Littorina littorea to show the staining responses of L6, L7 and L8 cells in Alcian Blue pH2.5/PAS (x 80).

A A section through the opercular groove.

Note the large number of L6 and L7 cells at the opercular groove. The blue staining of L6 cells indicates secretion is acidic mucopolysaccharides. The red colour of L7 cells shows periodate-reactive groups in secretion. L8 cells responded only slightly.

B A section through the subopercular cleft.

A small number of L6 and L7 cells are present at the subopercular cleft. Note L9 and L10 goblet cell types.

E - Epithelium; O - Operculum; OG - Opercular groove; SOC - Subopercular cleft. All other labels refer to cell types.

PLATE 36

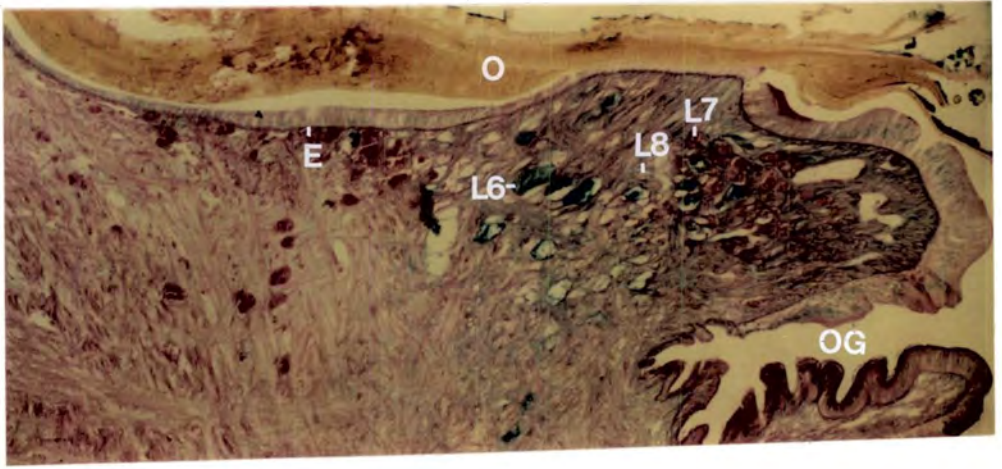

A

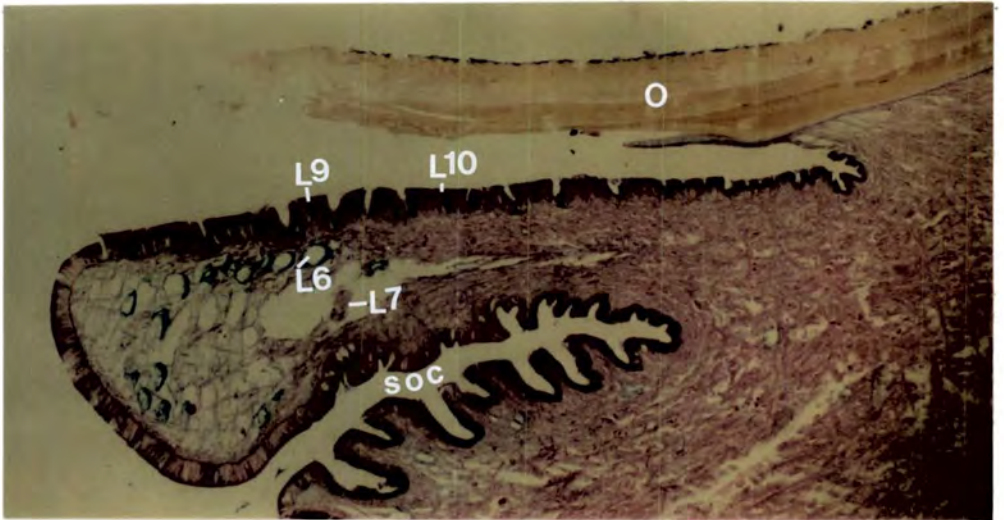

B

Plate 37 Sections through the operculum of Littorina  
littorea stained in Alcian Blue pH0.5/eosin  
(x 40).

A A section through the opercular groove.

B A section through the subopercular cleft.

The blue staining of L6 cells at the opercular groove  
and the subopercular cleft indicates sulphated  
mucopolysaccharides in secretion.

E - Epithelium; O - Operculum; OG - Opercular groove; SOC -  
Subopercular cleft. All other labels refer to cell types.

PLATE 37

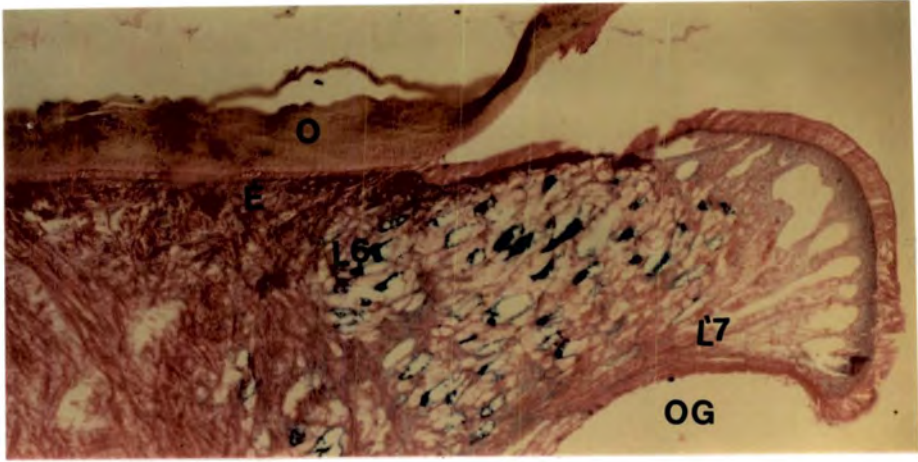

A

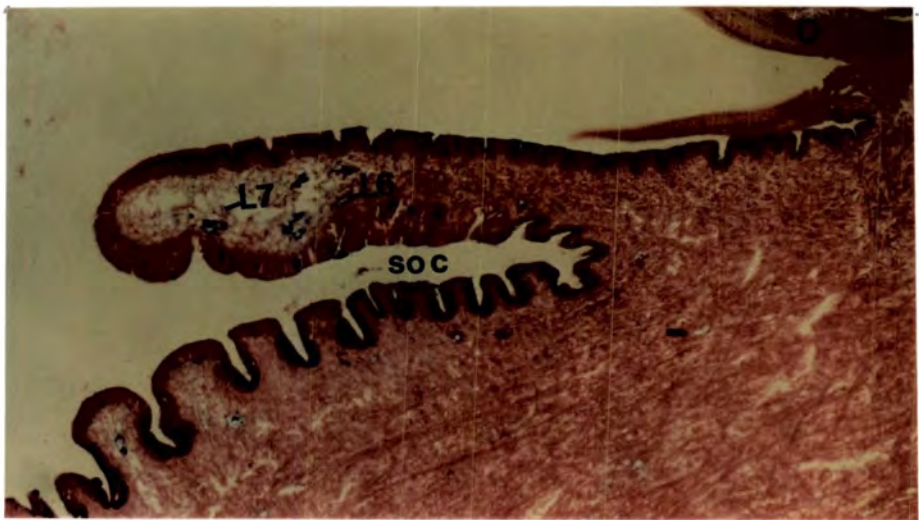

B

Plate 38 Sections through the opercular groove of Littorina littorea to show the staining responses of opercular gland cells for protein.

- A A section stained in mercuric bromophenol blue. Positive staining of L7 and L8 cells indicates proteinaceous secretion (x 160).
- B A section stained by the diazo-coupling reaction. The strong reaction of L7 cells show tyrosine in secretion (x 80).

O - Operculum; OG - Opercular groove. All other labels refer to cell types.

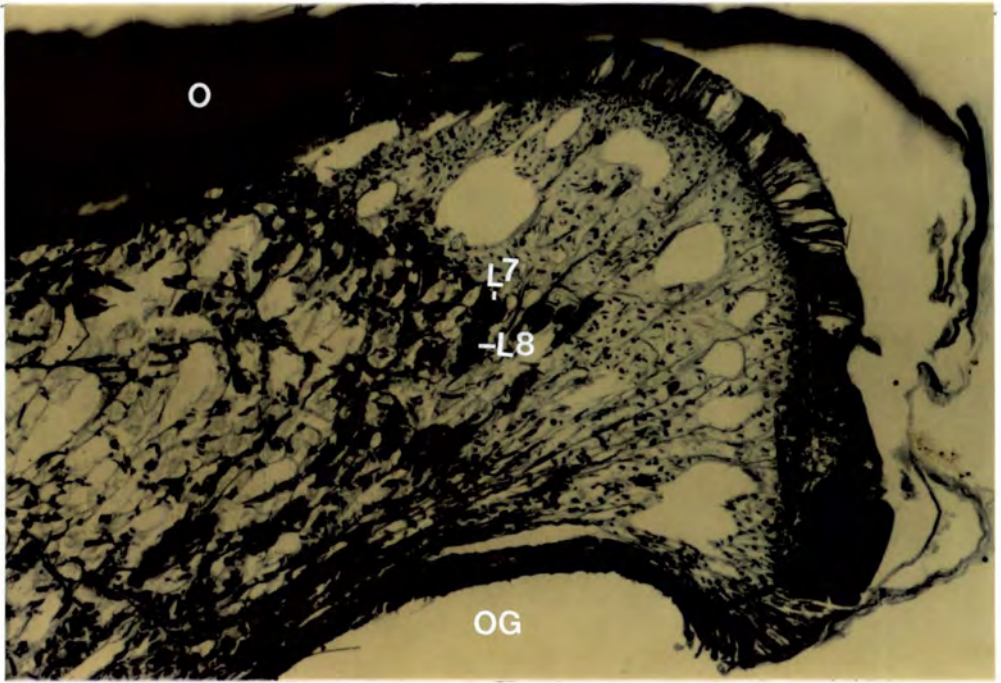

A

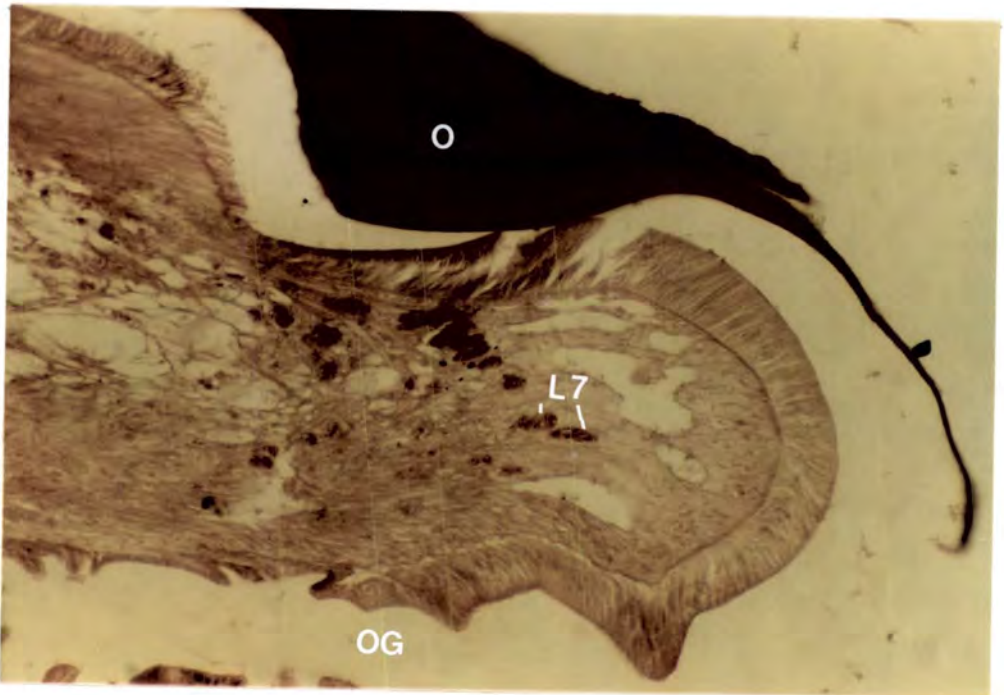

B

Plate 39 Sections through the opercular groove of Littorina littorea to show the staining responses of opercular gland cells for acidic and neutral mucopolysaccharides.

- A High power view of a section stained in Alcian Blue pH2.5/PAS. Note the ducts in between the epithelial cells. The blue colour of L6 cells indicates acidic mucopolysaccharides and the red colour of L7 and L8 cells suggests the secretion is neutral mucopolysaccharide (x 160).
- B A section stained with PAD (x 80). The light brown colour of L7 cells indicates some neutral mucopolysaccharide in secretion.

D - Duct; O - Operculum; OG - Opercular groove. All other labels refer to cell types.

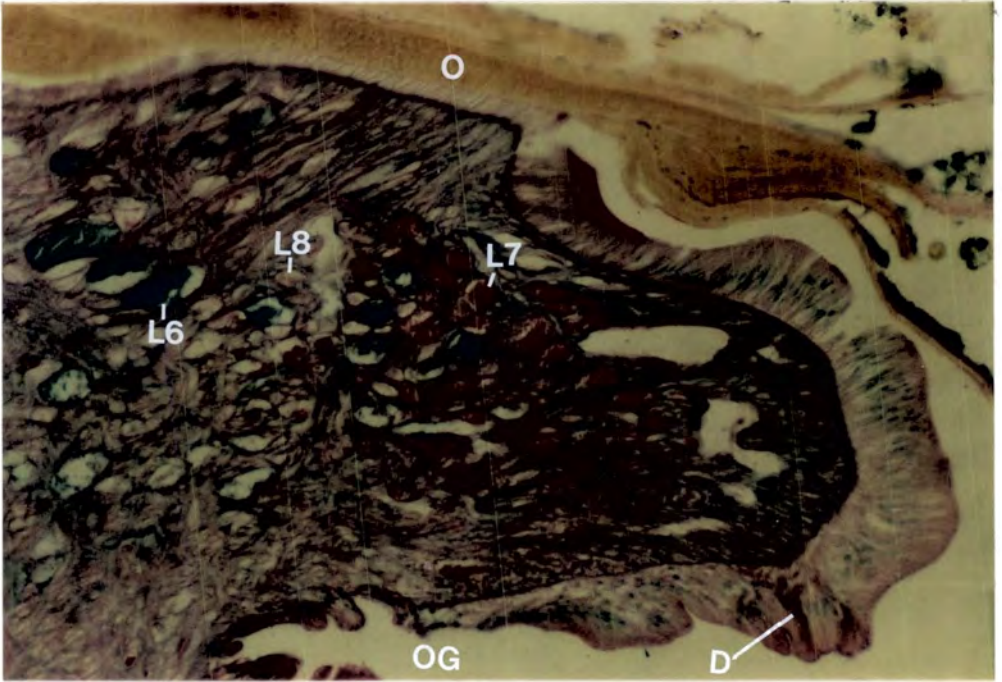

A

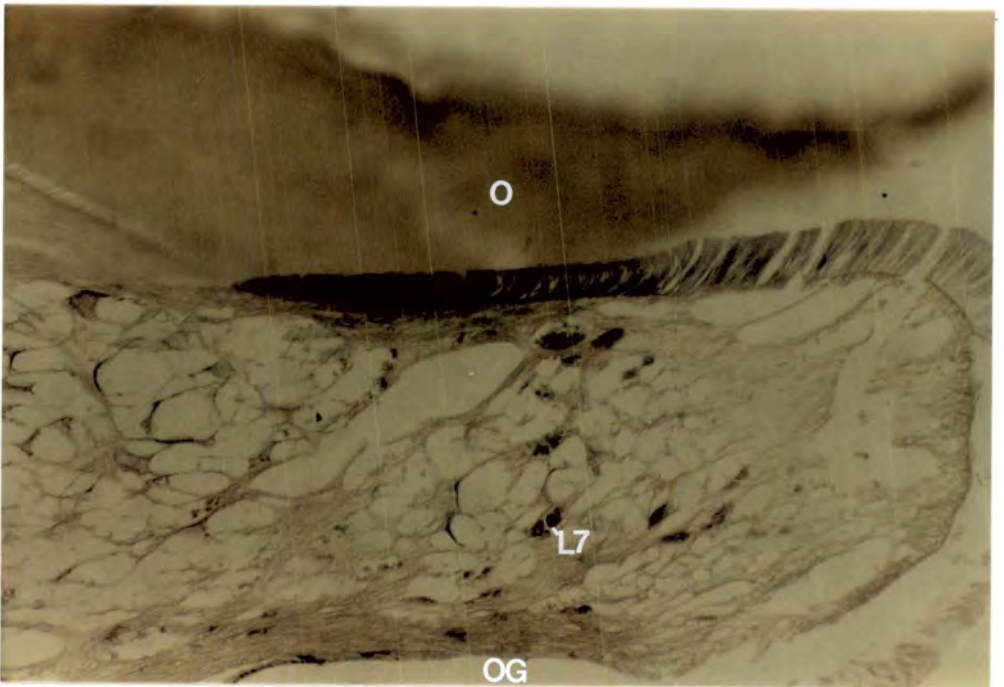

B

Plate 40 Longitudinal sections through the mantle of  
Pomatias elegans to show the staining responses of  
the mantle edge gland cells (ref. Figure 16).

- A A section stained in Alcian Blue pH2.5/PAS (x 80).  
The bluish-purple staining of P14 cells indicates  
acidic mucopolysaccharides and some periodate-reactive  
groups in secretion, and the red colour of P15 cells  
indicates neutral mucopolysaccharide.
- B A section stained with PAD (x 80).  
The light brown colour of P14 cells suggests that some  
neutral mucopolysaccharide may be present and the  
strong reaction of P15 cells confirms the secretion is  
neutral mucopolysaccharide.
- C A section stained with PAS to show the staining  
responses of goblet cell types of ventral epithelium  
(x 80).  
The positive responses of P9 and P12 cells indicate  
periodate-reactive groups in secretion.
- D A section stained with PAD (x 80).  
The brown colour of P9 cells confirms secretion is  
neutral mucopolysaccharide and the black/brown colour  
of P12 cells suggests that some neutral  
mucopolysaccharide may be present. The black colour of  
P10 cells indicates that their contents are  
periodate-unreactive mucosubstances.
- DE - Dorsal epithelium; VE - Ventral epithelium. All other  
labels refer to cell types.

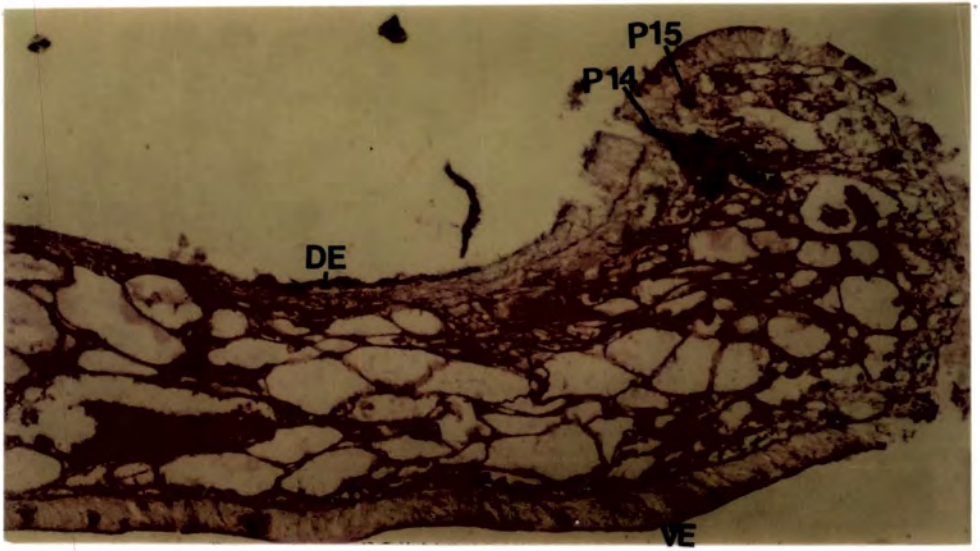

A

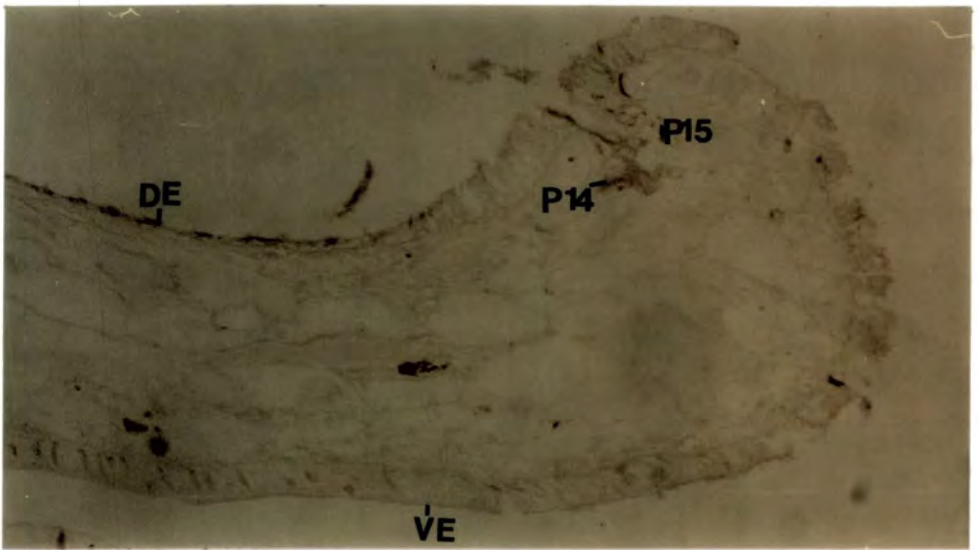

B

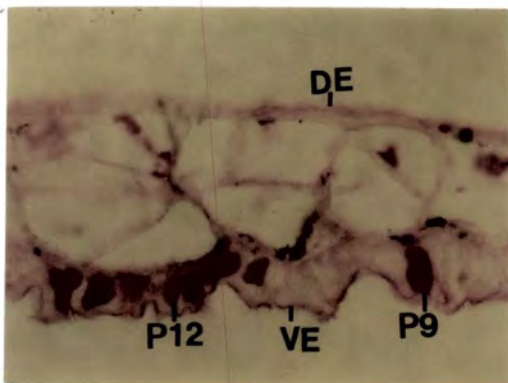

C

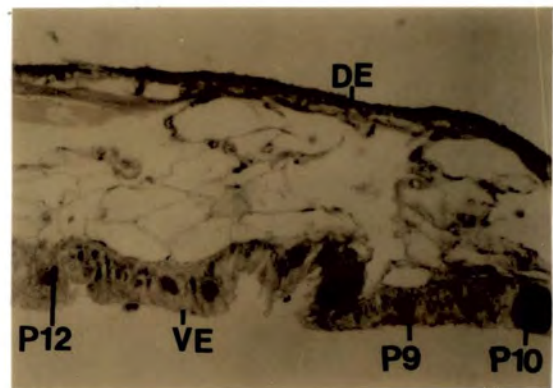

D

Plate 41 Longitudinal sections through the mantle edge of Bithynia tentaculata to show the staining responses of the mantle edge gland cells (ref. Figure 17).

A A section stained in mercuric bromophenol blue (x 80). The blue staining of B10 cells indicates that secretion is proteinaceous. Note the pigment granules of the dorsal mantle epithelium.

B A section stained by the diazo-coupling reaction (x 80). The strong reaction of B10 cells shows the presence of tyrosine in the secretion.

C High power view of the section stained by the diazo-coupling reaction to show a B10 cell with a large nucleus. Note the purple goblet cells (B8) of the ventral epithelium (x 160).

D A section stained with PAD to show the responses of B7 and B8 cells of the ventral mantle epithelium (x 80). Note that at the mantle edge B8 cells (brown) are more common than B7 cells (black).

DE - Dorsal epithelium; VE - Ventral epithelium; N - Nucleus; PG - Pigment granules. All other labels refer to cell types.

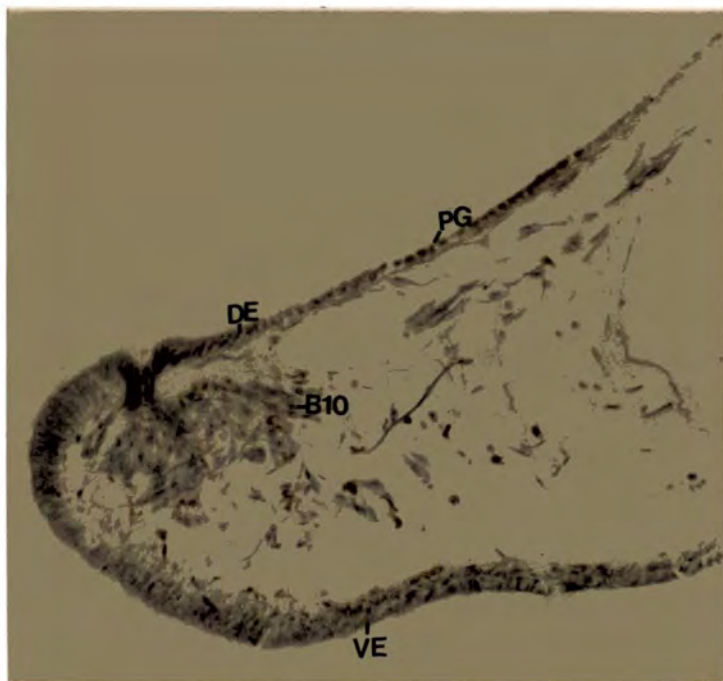

A



B

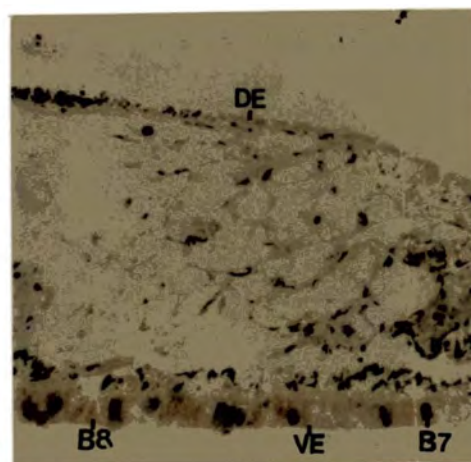
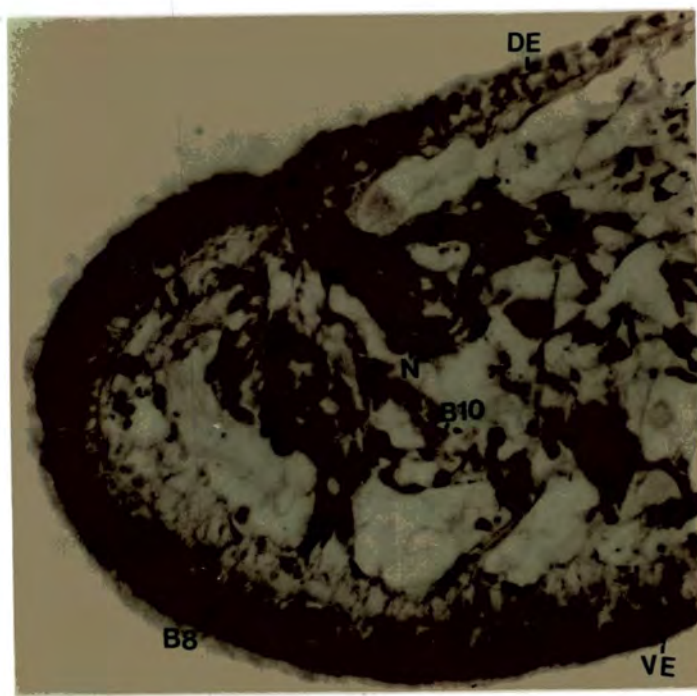

C

D

Plate 42 Longitudinal sections through the mantle edge of Littorina littorea to show the staining responses of the mantle edge gland cells for protein and mucopolysaccharides (ref. Figure 18).

A A section stained in mercuric bromophenol blue (x 80). The bright blue colour of L12 cells indicates their secretion is proteinaceous.

B A section stained by the diazo-coupling reaction (x 80).

The strong positive reaction of L12 cells shows they contain tyrosine.

Note L10 cells of ventral epithelium.

C A section stained in Alcian Blue pH0.5/eosin (x 80). The blue staining of L11 and L13 cells shows sulphated mucopolysaccharides in secretion.

DE - Dorsal epithelium; VE - Ventral epithelium. All other labels refer to cell types.

PLATE 42

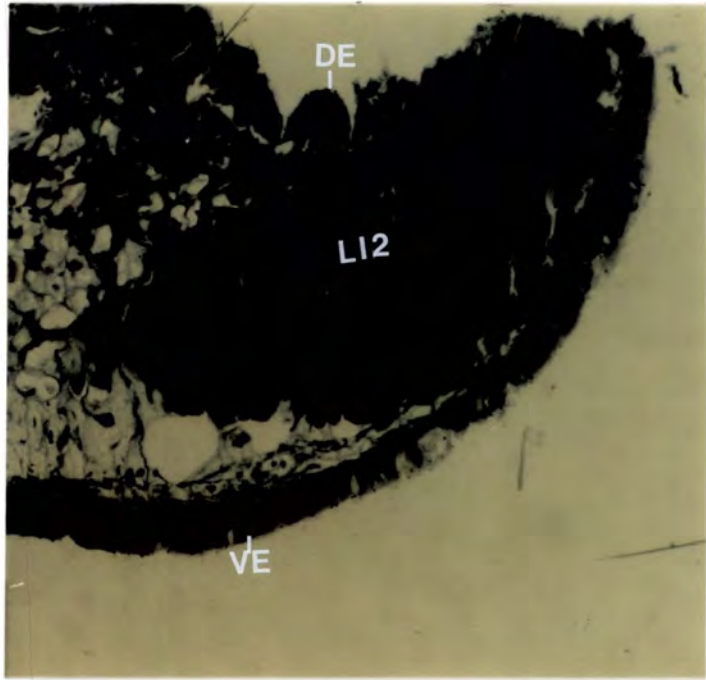

A

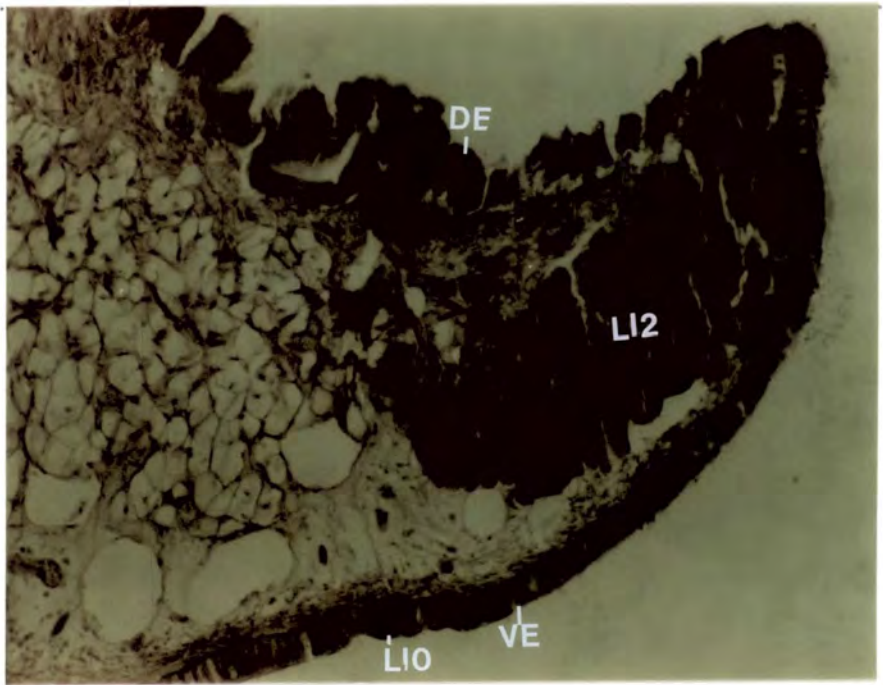

B

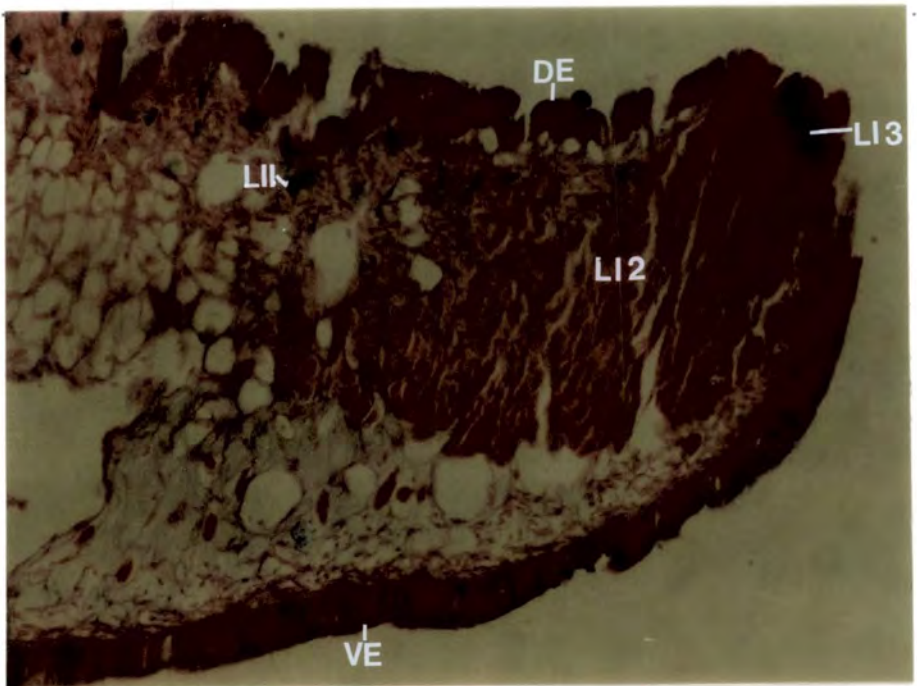

C

Plate 43

A A longitudinal section through the mantle edge of Littorina littorea stained in Alcian Blue pH2.5/PAS to show the staining responses of L9, L10, L11, L12 and L13 cells (x 40).

The blue colour of L9 and L13 cells shows the contents contain acidic mucopolysaccharides. The purple colour of L11 cell suggests that both acidic and neutral mucopolysaccharides may be present and the red colour of L10 and L12 cells indicates periodate-reactive groups in secretion.

B&C The staining responses of L11 cells of the mantle.

B High power view of a part of a longitudinal section through the dorsal mantle epithelium stained in Alcian Blue pH0.5/eosin. The blue colour of the L11 cells indicates sulphated mucopolysaccharide (x 160).

C A longitudinal section through the dorsal mantle epithelium stained with PAD (x 80).

The brown staining of L11 cells shows they also contain neutral mucopolysaccharides.

D - Duct; DE - Dorsal epithelium. VE - Ventral epithelium.

All other labels refer to cell types.

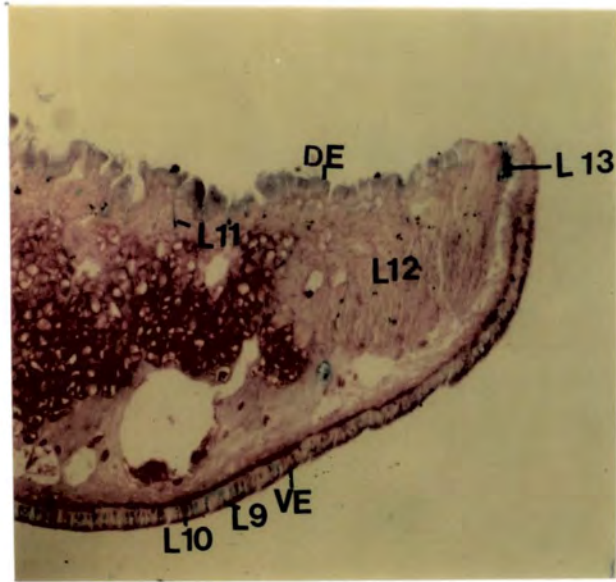

A

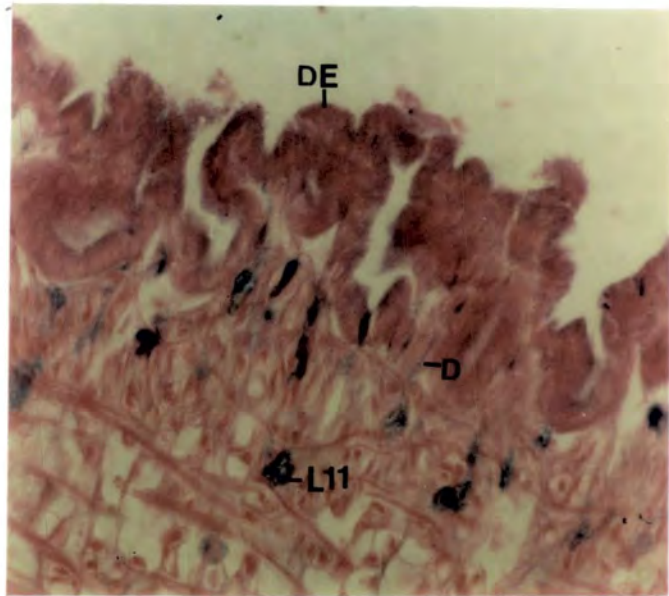

B

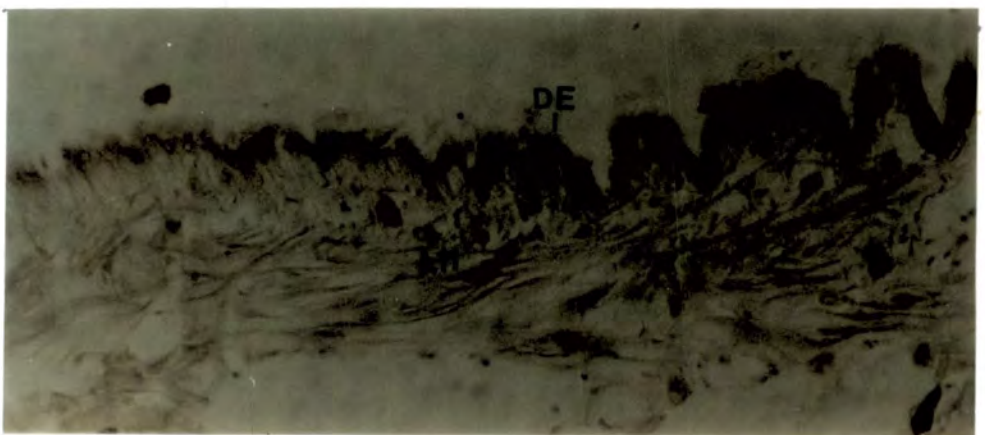

C

Plate 44 The hypobranchial gland of Pomatias elegans (ref. Figure 20).

- A A transverse section through the mantle cavity of Pomatias stained by the diazo-coupling reaction to show the location of hypobranchial glands in the rectal area and the central zone (x 12).
- B High power view of the hypobranchial gland in the central zone (x 160).
- C High power view of the hypobranchial gland in the rectal area (x 160).

Note the strong response of P12 cells to the diazo-coupling reaction.

DE - Dorsal epithelium; HG - Hypobranchial gland; M.C. - Mantle cavity; VE - Ventral epithelium. All other labels refer to cell types.

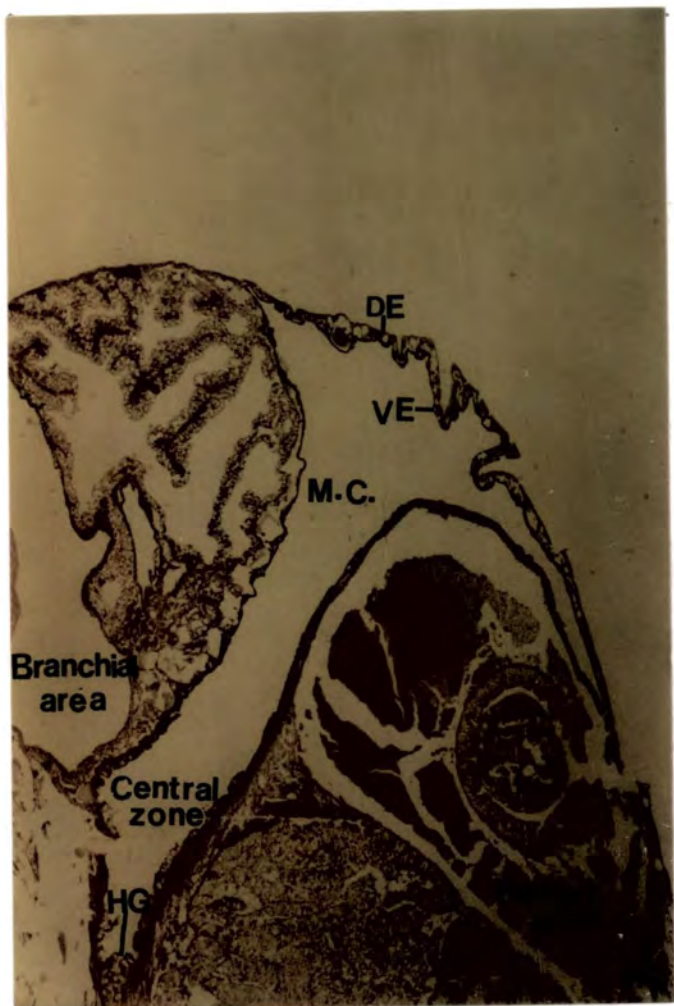

A

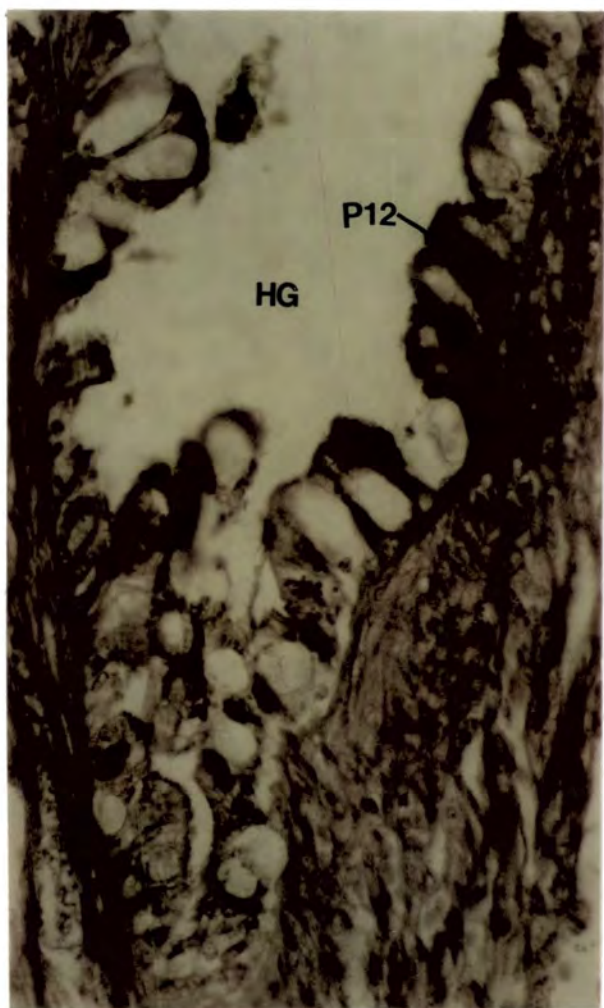

B

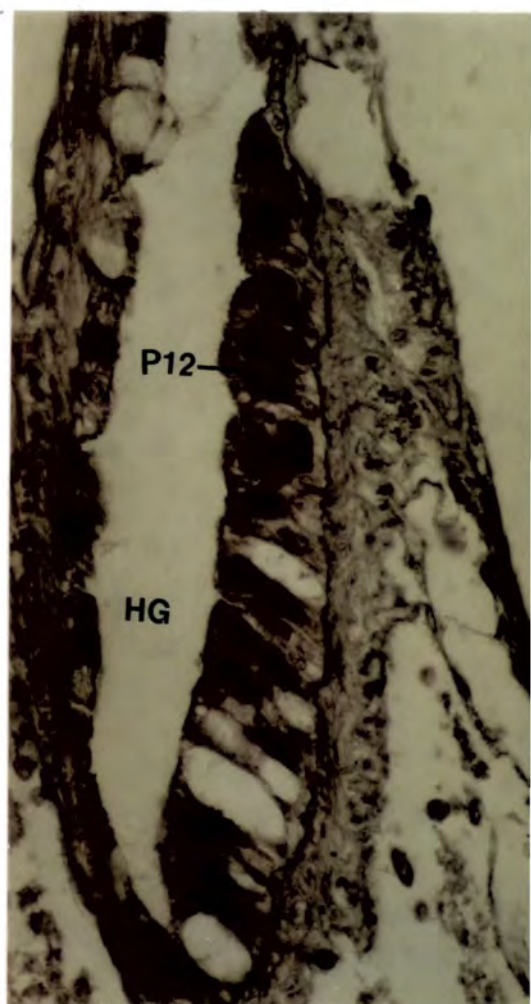

C

Plate 45 The staining responses of P9, P10 and P12 cells of the hypobranchial gland of Pomatias elegans to PAD (ref. Figure 20).

A A transverse section through the hypobranchial gland in the rectal area (x 160).

B A part of a transverse section through the hypobranchial gland in the central zone of the mantle cavity (x 160).

The brown colour of P9 cells indicates the secretion contains neutral mucopolysaccharide. The black/brown colour of P12 cells suggests the presence of both neutral mucopolysaccharide and periodate-unreactive mucosubstances.

The black colour of P10 cells shows their contents are periodate-unreactive mucosubstances.

All labels refer to cell types.

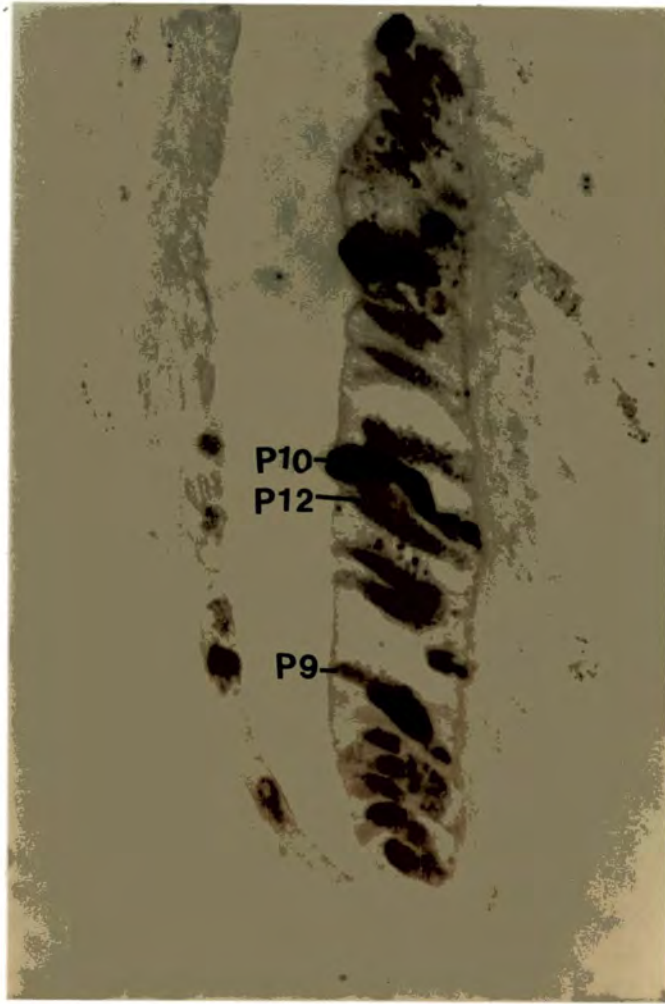

A

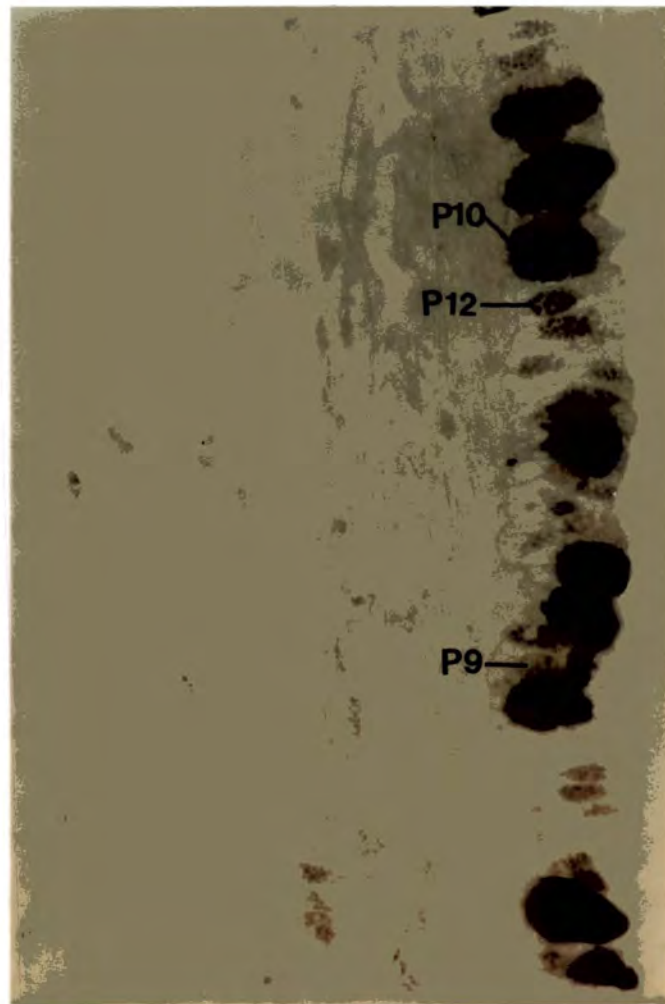

B

Plate 46 Hypobranchial gland of Bithynia tentaculata (ref. Figure 21).

A A longitudinal section through the whole mantle of Bithynia tentaculata stained by the diazo-coupling reaction to show the mantle edge, branchial area, hypobranchial gland and the rectal area (x 12).

B&C The staining responses of the hypobranchial gland cells for protein.

B High power view of the hypobranchial gland cells stained by the diazo-coupling reaction (x 160). The strong responses of B11 and B12 cells show the presence of tyrosine in their secretion.

C High power view of the hypobranchial gland cells stained in mercuric bromophenol blue (x 160). The blue staining of B11 and B12 cells confirms the secretion is proteinaceous.

DE - Dorsal epithelium; M.E. - Mantle edge; HG - Hypobranchial gland; VE - Ventral epithelium. All other labels refer to cell types.

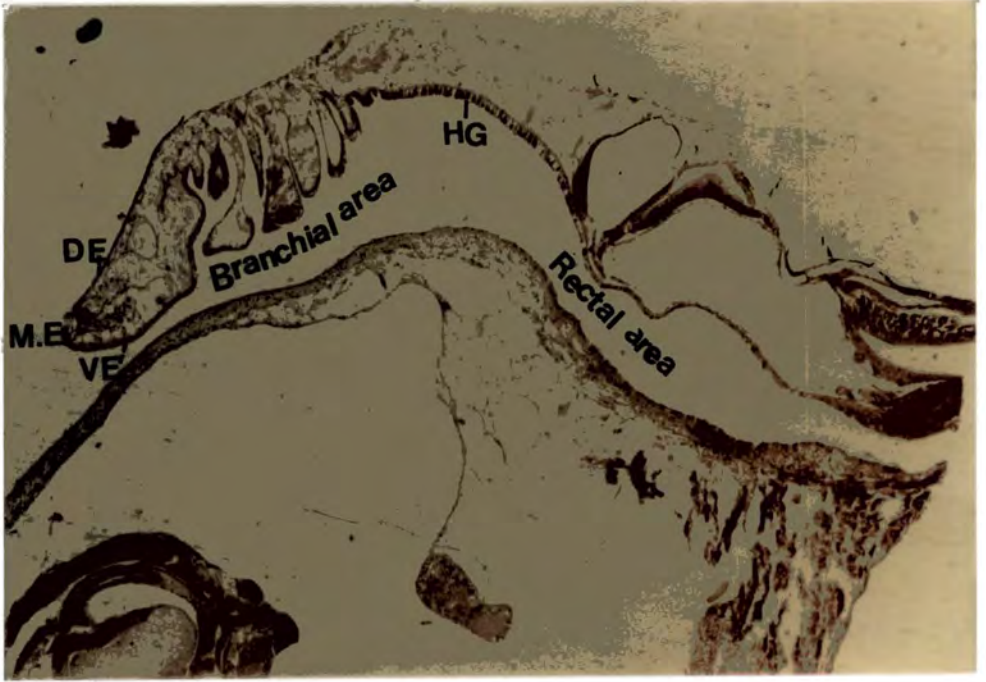

A



B



C

Plate 47 Longitudinal sections through the hypobranchial gland of Bithynia tentaculata to show the staining responses of the hypobranchial gland cells to acidic and neutral mucopolysaccharides.

A A section stained in Alcian Blue pH2.5/PAS (x 80).  
A reddish-purple colour of B11 cells suggests that both alcinophilic components and periodate-reactive groups may be present. A red colour of B12 cells indicates periodate-reactive groups.

B A section stained with PAD (x 160).  
A brown colour of B11 and B12 cells indicates neutral mucopolysaccharide in the secretion.

C A section stained in Alcian Blue pH0.5/Alcian Yellow pH2.5 (x 80).  
A yellow-green staining of B11 cells shows that acidic mucopolysaccharides are composed of sulphated and carboxylated groups.

D A section stained in Alcian Blue pH0.5/eosin (x 40).  
A blue staining of B11 cells confirms the presence of sulphated mucopolysaccharides in secretion.

DE - Dorsal mantle epithelium. All other labels refer to cell types.

PLATE 47

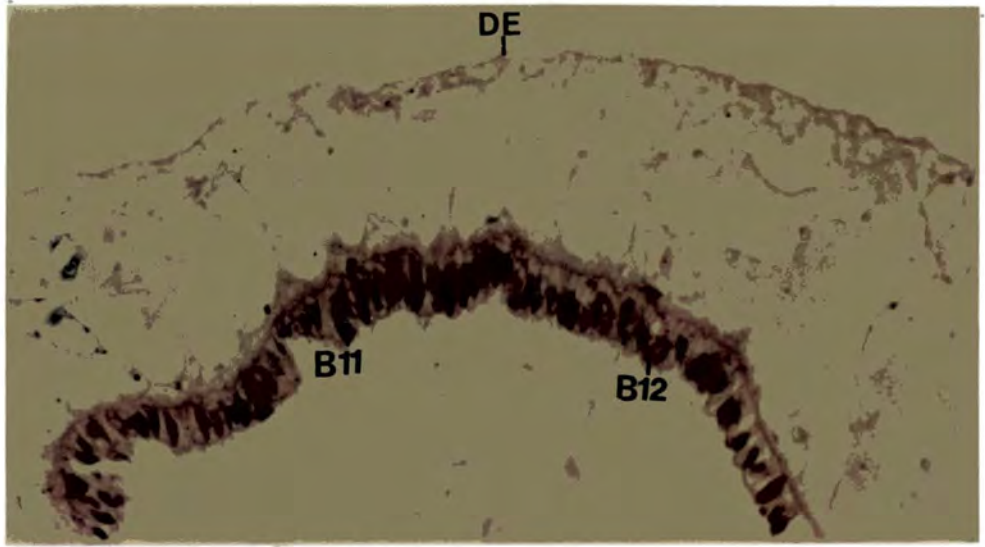

A

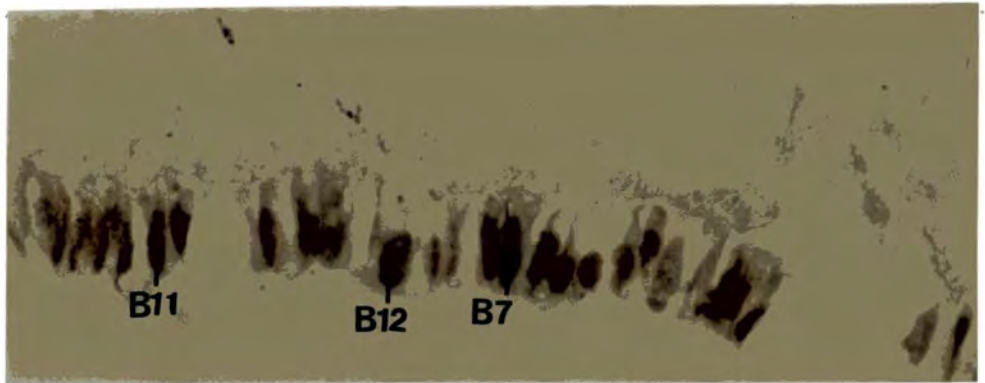

B

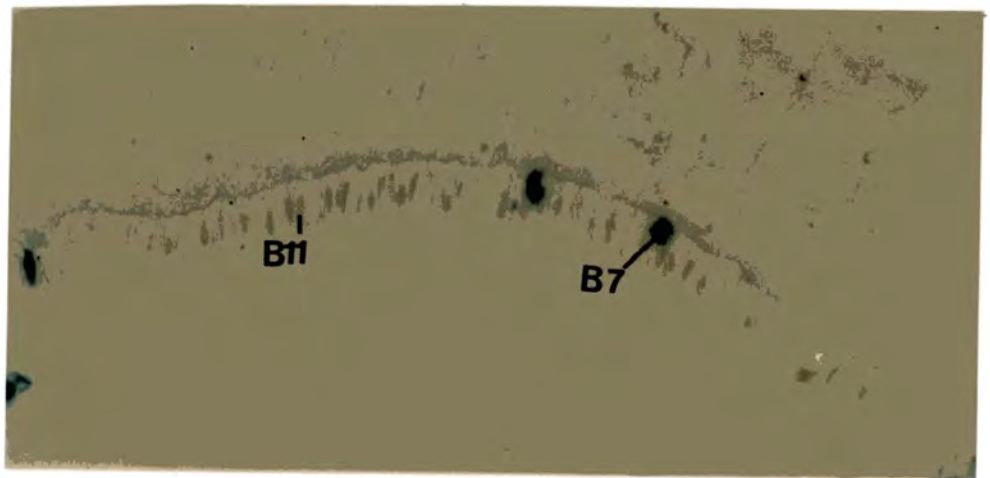

C

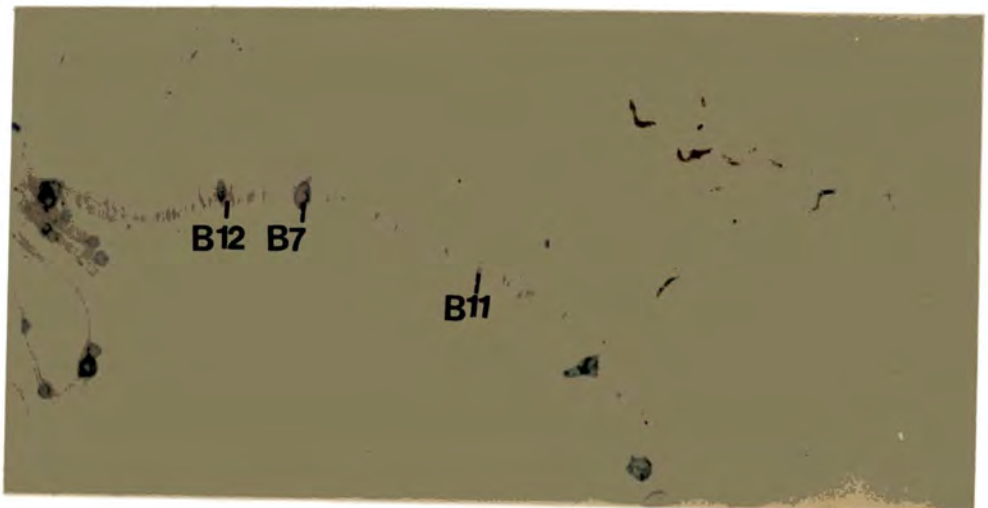

D

Plate 48 Hypobranchial gland of Littorina littorea (ref. Figure 22).

A A transverse section through the mantle cavity stained in Alcian Blue pH0.5/eosin to show the hypobranchial gland (x 12).

B A high power view of the hypobranchial gland cells from Plate 48A (x 160).

The blue staining of L14 and L15 cells indicates sulphated mucopolysaccharides.

C A part of a transverse section through the hypobranchial gland of Littorina stained in toluidine blue (x 160).

Note L14 cells exhibit strong  $\beta$ metachromasia in toluidine blue but L15 cells responded only slightly.

Cc - Cilia cells; DE - Dorsal epithelium; HG - Hypobranchial gland; M.C. - Mantle cavity; VE - ventral epithelium. All other labels refer to cell types.

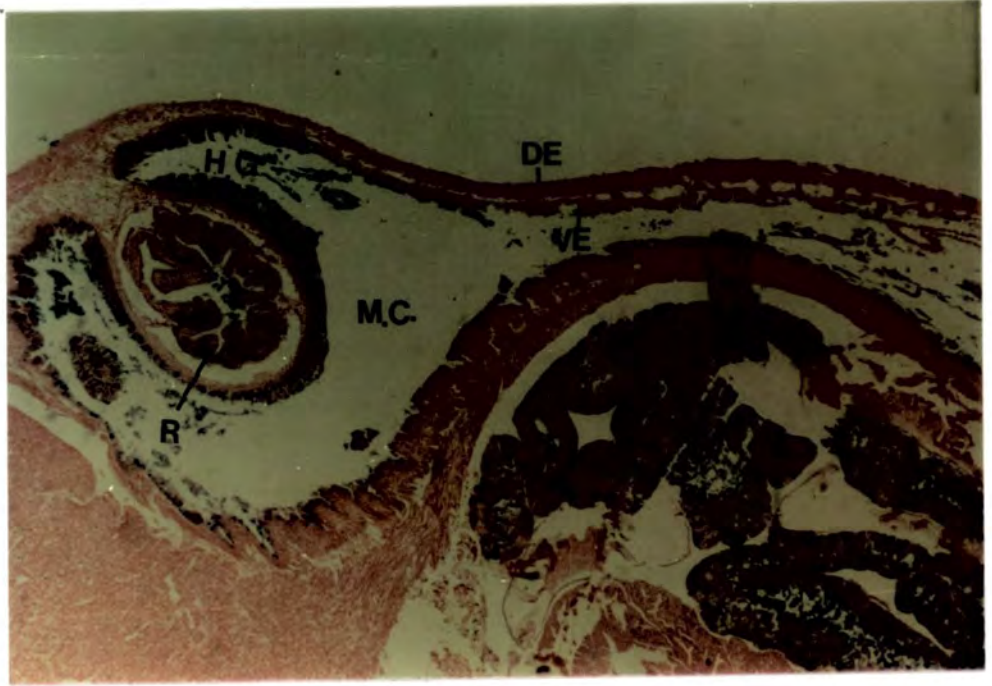

A



B

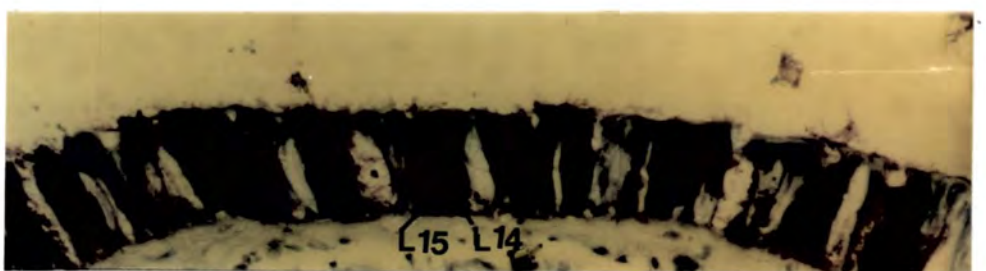

C

Plate 49 The staining responses of hypobranchial gland cells of Littorina littorea for acidic and neutral mucopolysaccharides.

- A A transverse section through the mantle cavity of Littorina stained in Alcian Blue pH2.5/PAS to show the hypobranchial gland (x12).
- B A high power view of the hypobranchial gland cells from Plate 49A (x 160).

The blue staining of L14 and L15 cells indicates the acidic mucopolysaccharides and the red colour of L16 cells indicates neutral mucopolysaccharides in their secretion.

- C A part of a transverse section through the hypobranchial gland of Littorina stained with PAD (x 160).

The black colour of L14 and L15 cells shows they contain periodate-unreactive mucosubstances.

The brown staining of L16 cells indicates neutral mucopolysaccharides in their secretion.

Cc - Cilia cells; DE - Dorsal epithelium; HG - Hypobranchial gland; M.C. - Mantle cavity; VE - Ventral epithelium. All other labels refer to cell types.

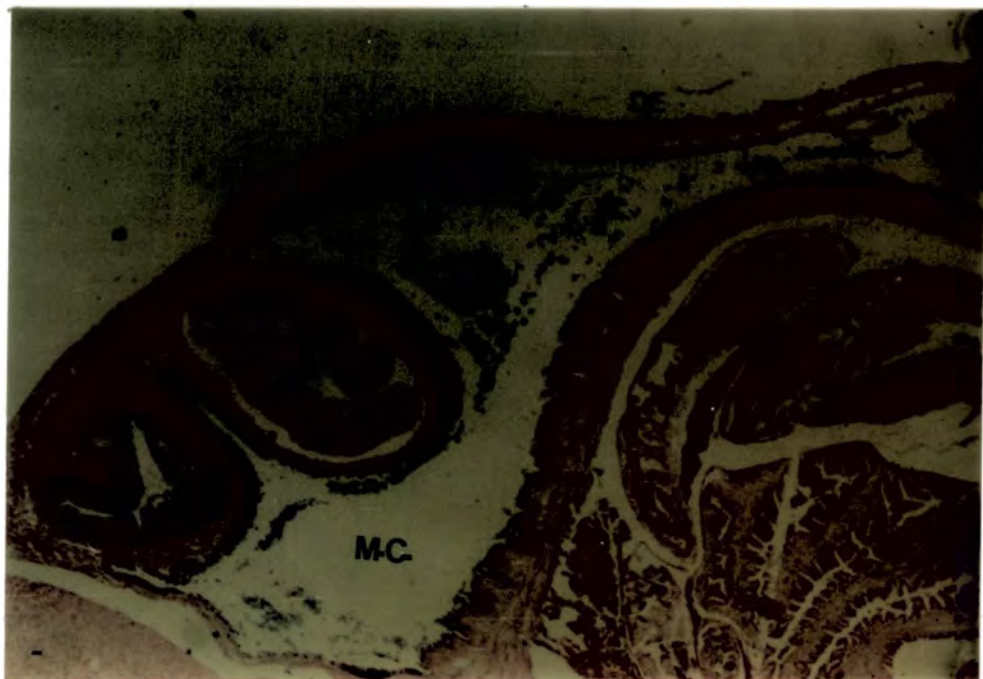

A

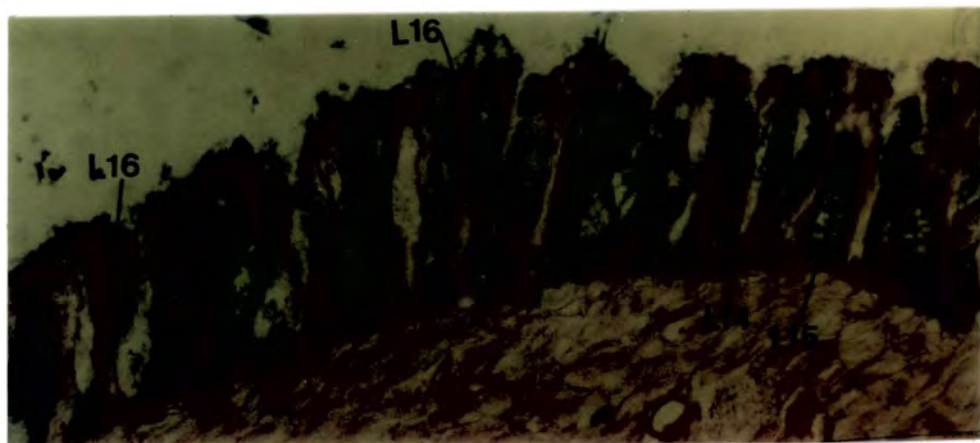

B

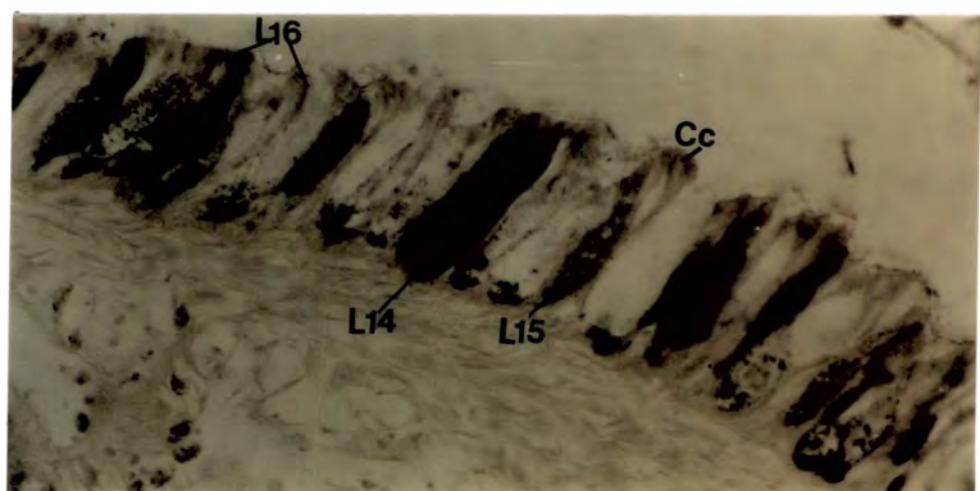

C

Plate 50 Transverse sections through the hypobranchial gland of Littorina littorea to show the staining responses of the hypobranchial gland cells.

A High power view of a part of the section stained with PAS (x 160).

L14, L15 and L16 cells reacted positively. Note the difference in the intensity of staining of L14 and L15 cells.

B A part of a transverse section stained by the diazo-coupling reaction (x 160).

Note the positive reaction of L16 cells.

C A part of a transverse section stained in mercuric bromophenol blue (x 160).

The blue staining of L16 cells indicates the secretion is proteinaceous.

R - Rectum. All other labels refer to cell types.

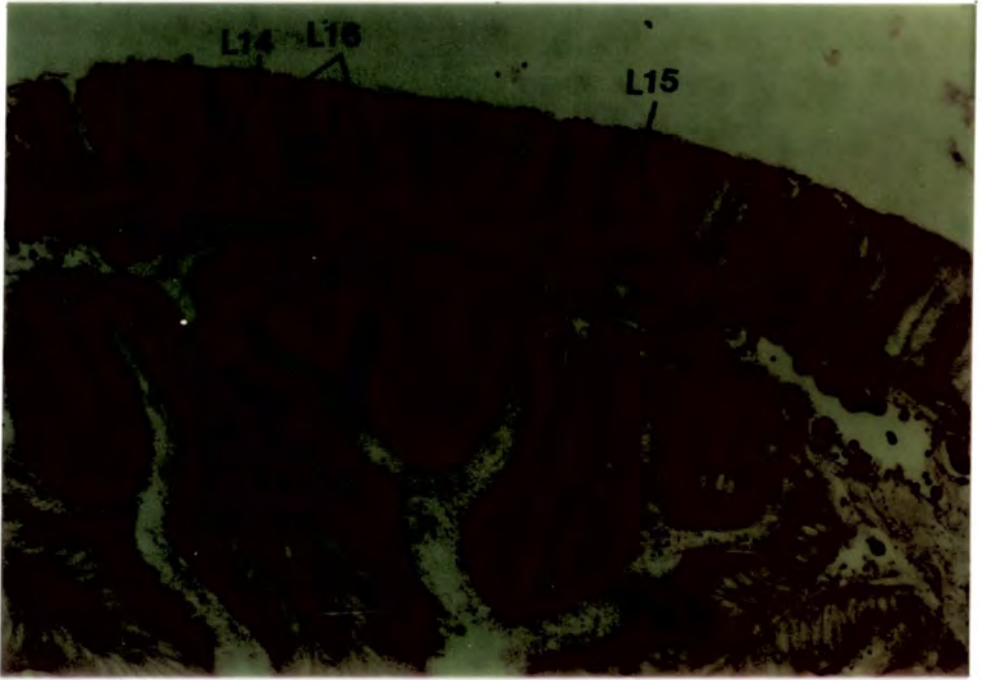

A



B



C

Reference diagrams to show the planes of sections

in subsequent plates.

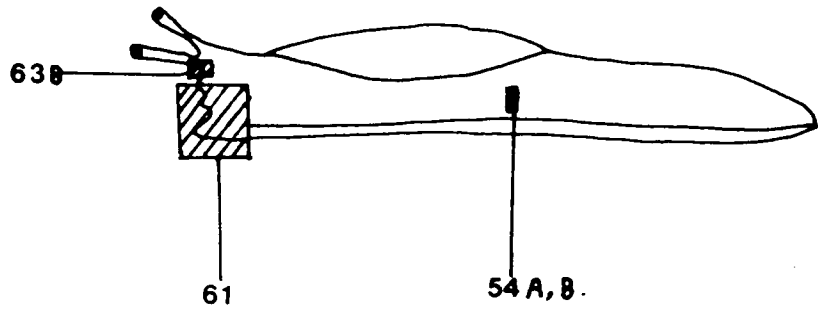
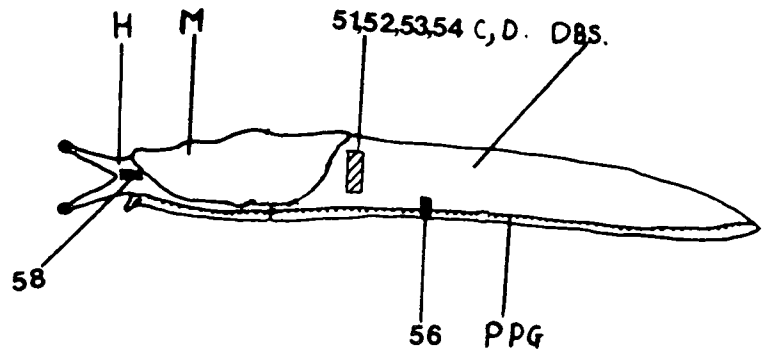

DBS-Dorsal body surface,H-Head,M-Mantle,P-Pneumostome,

PPG-Peripodal groove.

LIMAX PSEUDOFLAVUS

---

Plate 51 Transverse sections through the dorsal body  
surface of Limax pseudoflavus.

A A section stained in Mallory's triple stain to show  
cell types 1, 2, 3, 4 and 7 (x 160).

B A section stained in Alcian Blue pH2.5 (x 160).

Note the difference in the texture of the contents of  
cell types 1 and 7. Type 1 cells have fibrous contents  
and the secretion of type 7 cell is smooth in texture.

All labels refer to cell types.

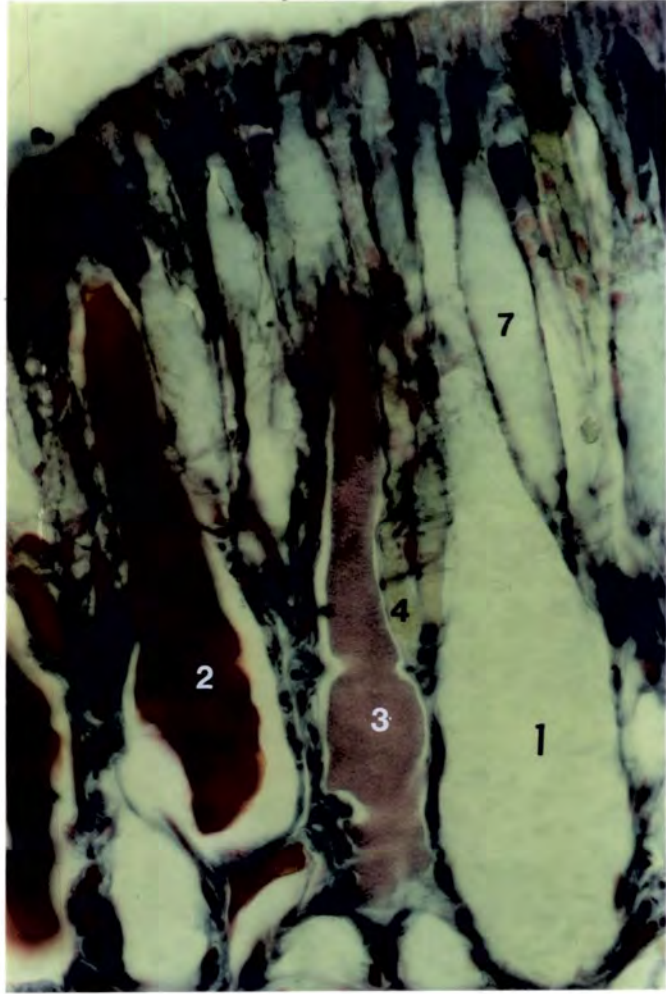

A

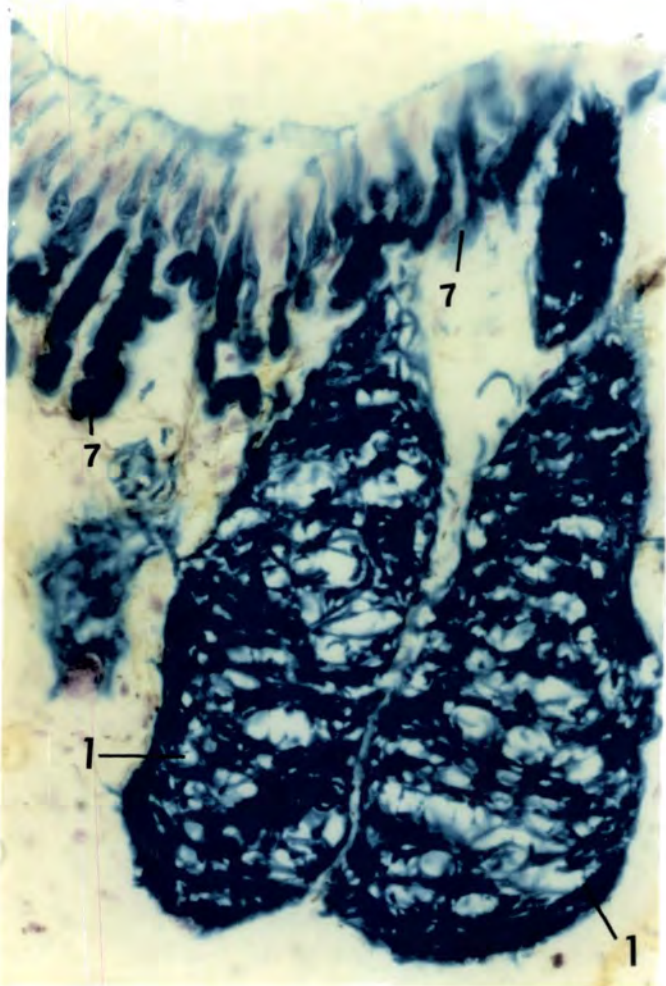

B

Plate 52 Transverse sections through the dorsal body surface of Limax pseudoflavus to show the staining responses of gland cells for protein.

A A section stained in Mallory's triple stain (x 160). The red colour of type 2 and the pink staining of type 3 cell suggests that protein may be present in their secretion. Note the nucleus of type 1 cell.

B A section stained in mercuric bromophenol blue (x 80). The positive reactions of type 2 and type 3 cells indicate their secretion is proteinaceous. Note the contents of type 2 cells are shrunk and split horizontally during preparation.

N - Nucleus. All other labels refer to cell types.

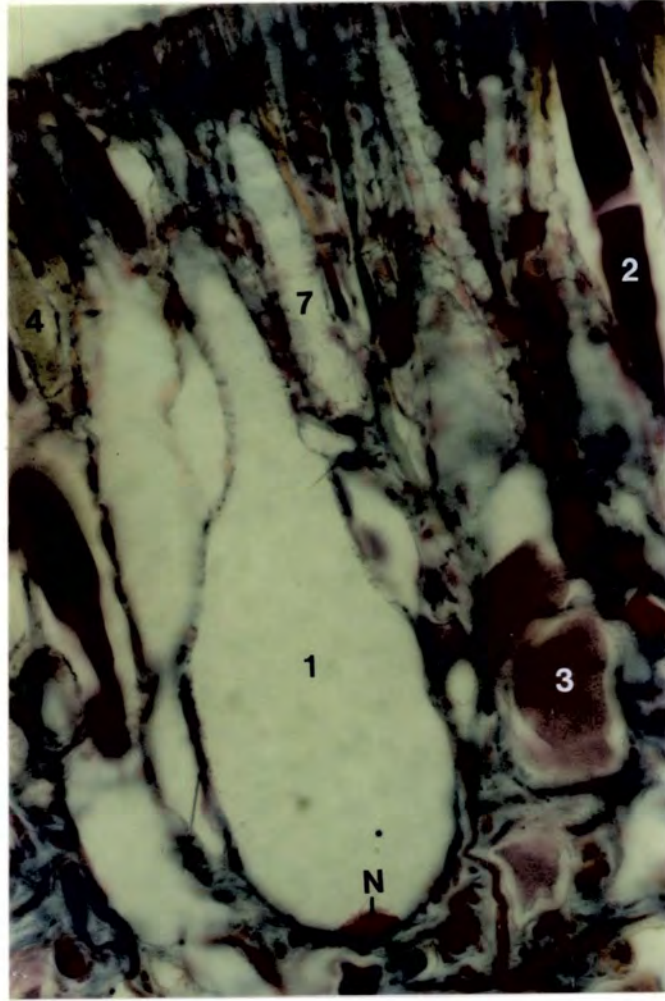

A



B

Plate 53 Transverse sections through the dorsal body surface of Limax pseudoflavus to show the staining responses of cell types 1 and 7 to acidic mucopolysaccharides.

- A A section stained in Alcian Blue pH2.5 (x 80).  
The bright blue colour of cell types 1 and 7 indicates acidic mucopolysaccharides.
- B A section stained in Alcian Blue pH 0.5/eosin (x 80).  
The positive staining of cell types 1 and 7 confirms the presence of sulphated mucopolysaccharides in secretion.
- C A section stained in Toluidine blue (x 80).  
Cell types 1 and 7 exhibit strong metachromasia in toluidine blue.

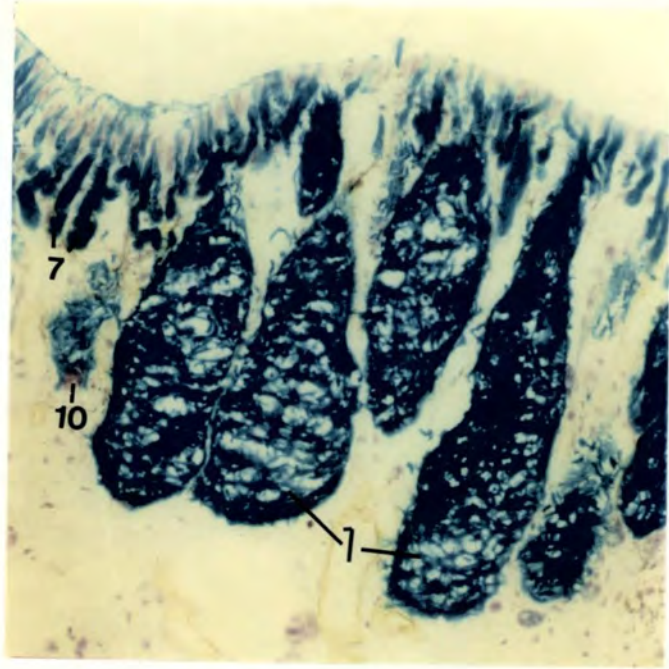

A

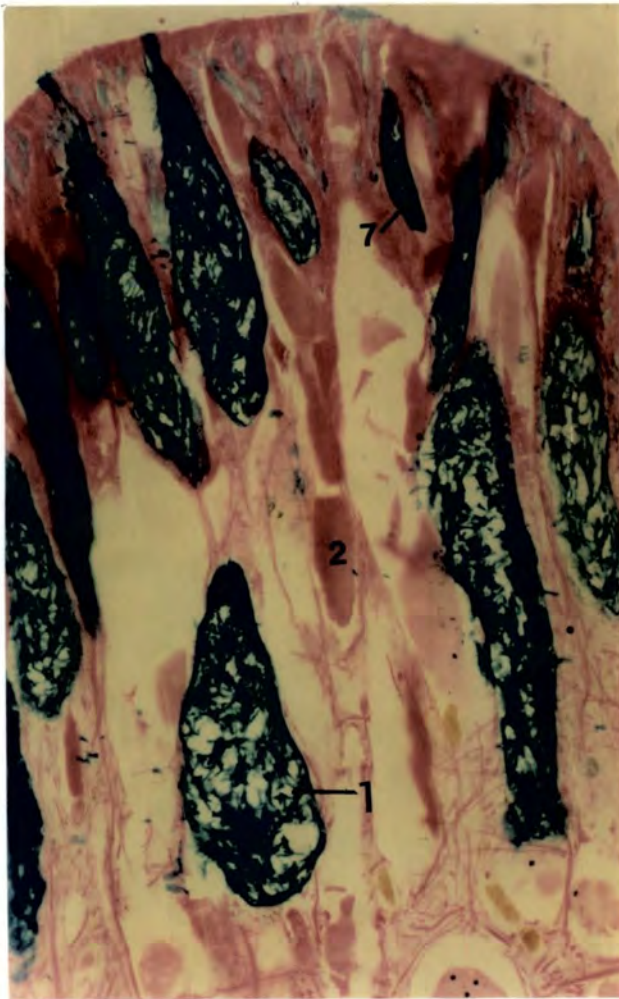

B

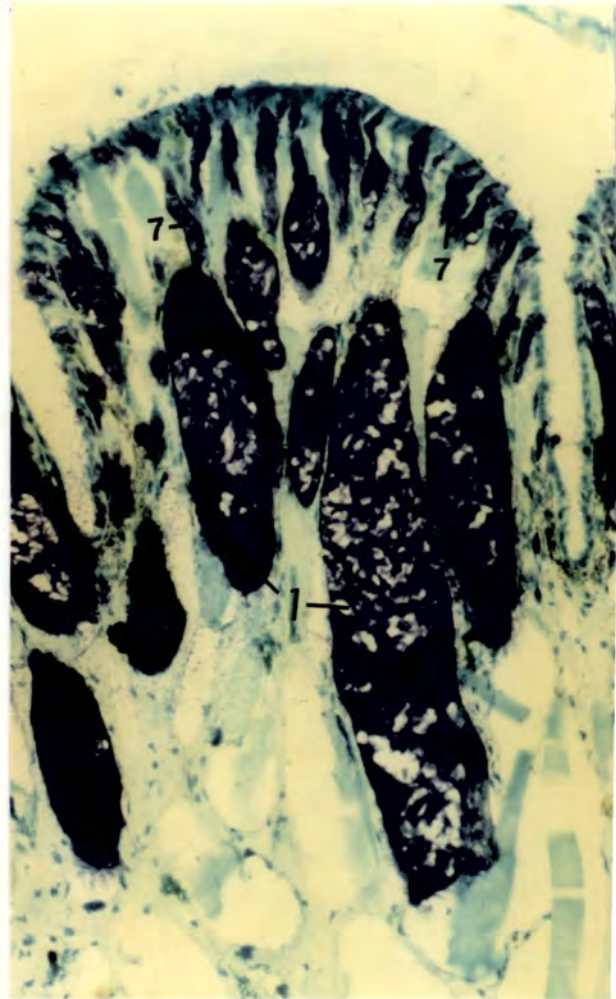

C

Plate 54 A to D Transverse sections through the dorsal and lateral body surfaces of Limax pseudoflavus.

- A A section stained in Alcian Blue pH2.5/PAS (x 160).
- B A section stained in Alcian Blue pH0.5/eosin (x 160).
- C A section stained in mercuric bromophenol blue (x 80).
- D A wax section stained with Sudan black. Note the positive staining of type 2 and type 3 cells (x 80). Note that the granular secretion of type 4 cells did not show a positive response to any procedures used and always stained yellow.

All labels refer to cell types.



A

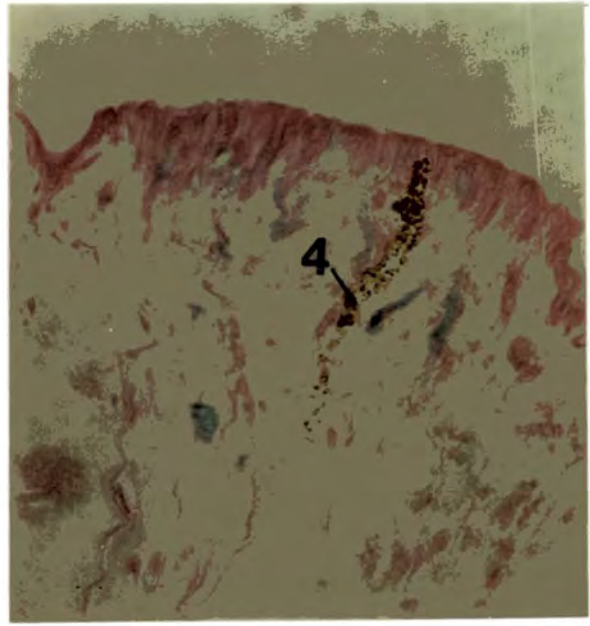

B

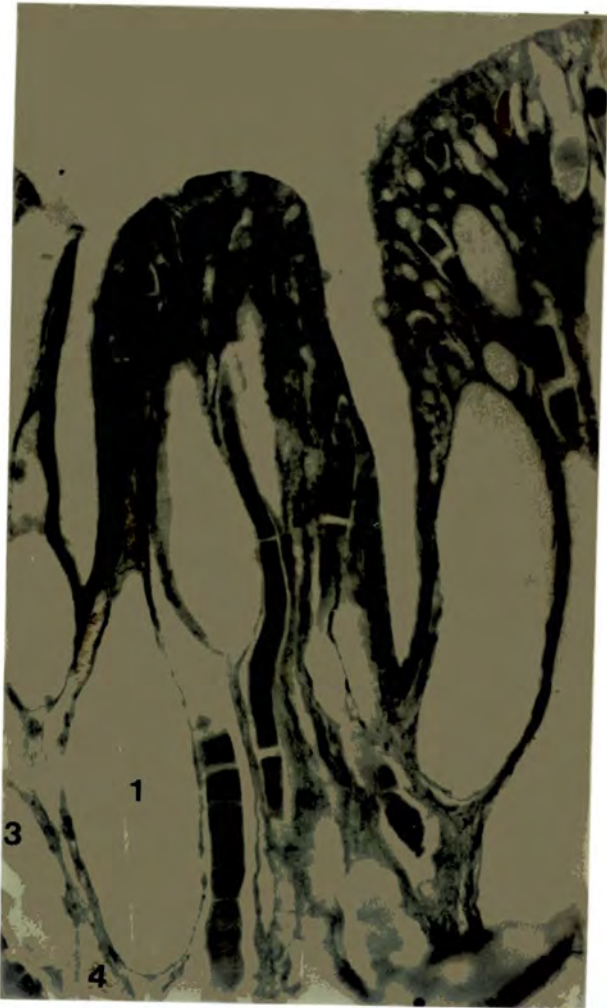

C

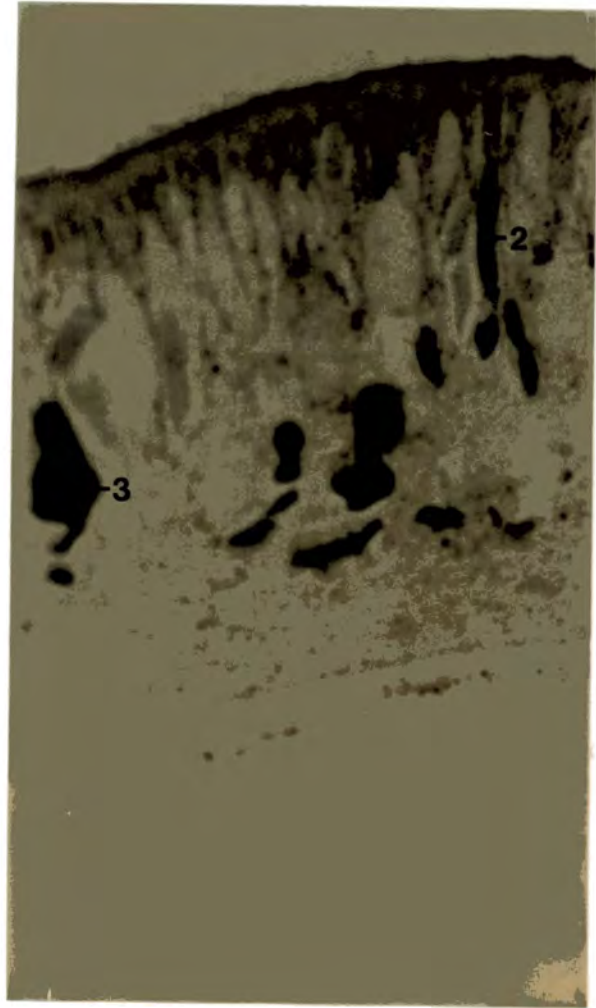

D

Plate 55 Scanning electron micrographs of Limax  
pseudoflavus.

A A scanning electron micrograph of the anterior of a slug (x 40).

B A scanning electron micrograph of the pneumostome indicating the extent of ciliation (x 30).

C - Cilia; DPG - Duct of the suprapedal gland; L - Lip; M - Mouth; PPG - Peripodal groove.

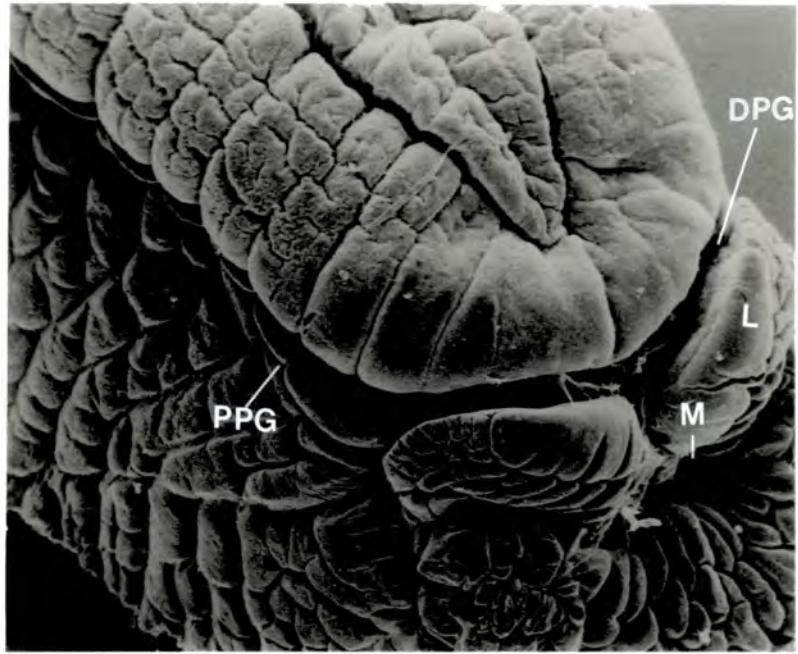

A



B

Plate 56 Transverse sections through the peripodal groove of Limax pseudoflavus to show secretory cells of the peripodal groove and the staining responses of type 8 cells.

A A section stained in Alcian Blue pH2.5/PAS (x 40). Note cell types 7, 8, 9 and 10. The purple colour of type 8 cells indicates the presence of acidic components and periodate-reactive groups in their secretion.

B High power view of a section stained in Alcian Blue pH0.5/eosin (x 80). The blue staining of B8 cells shows that they contain sulphated mucopolysaccharides. Note the cilia of the peripodal groove.

C - Cilia; PPG - peripodal groove; S - Sole. All other labels refer to cell types.

PLATE 56

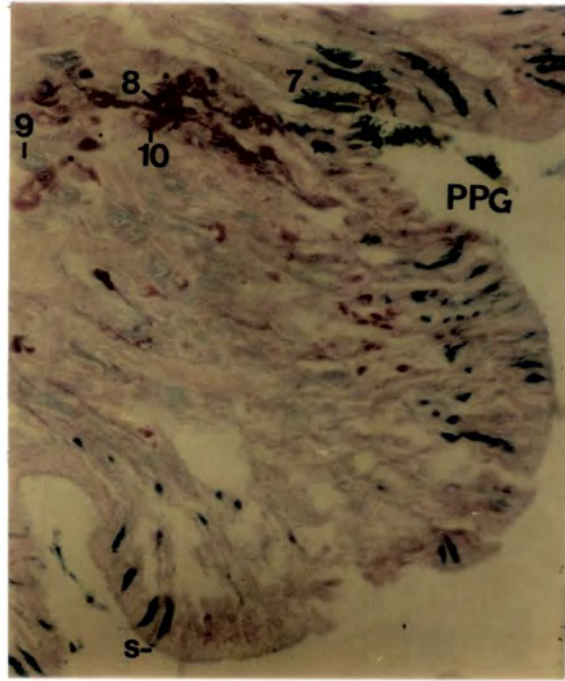

A

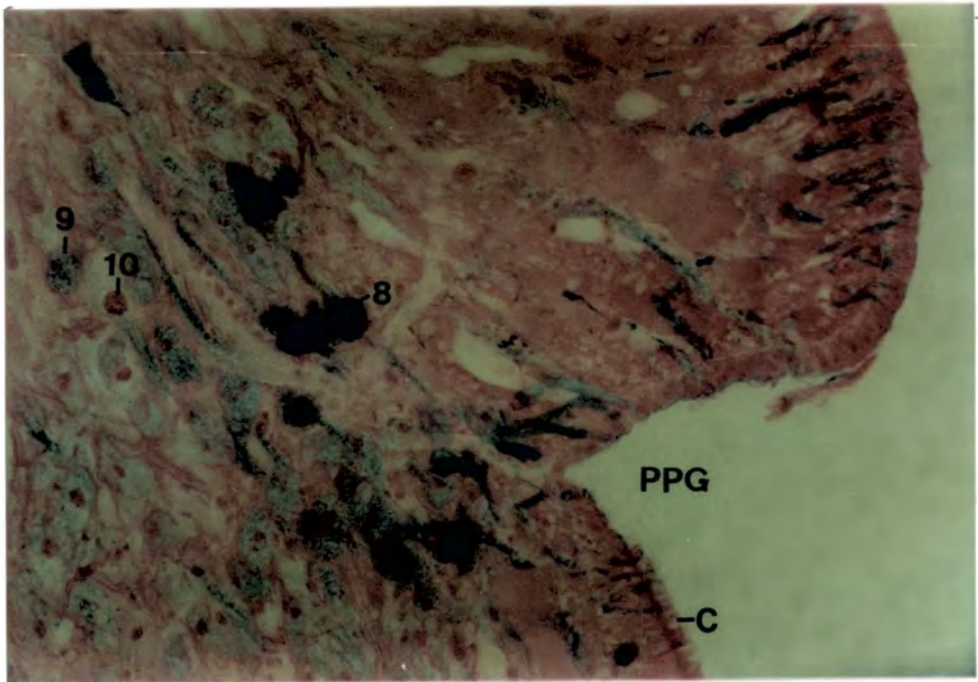

B

Plate 57 Transverse sections through the sole of Limax pseudoflavus to show the staining responses of secretory cells for acidic and neutral mucopolysaccharides.

A A section through an edge portion (unciliated) stained in Alcian Blue pH 2.5 (x 80).

The blue colour of type 9 cell indicates acidic mucopolysaccharide and the bright blue colour of type 7 cells shows strongly acidic mucopolysaccharides.

B A section through the central region (ciliated) stained with PAD (x 40).

The slight reaction of type 9 cells indicates the presence of some neutral mucopolysaccharide in secretion and the strong reaction of type 10 cells shows their contents have a large quantity of neutral mucopolysaccharides.

C - Cilia; D - Ducts; N - Nucleus; S - Sole. All other labels refer to cell types.

PLATE 57

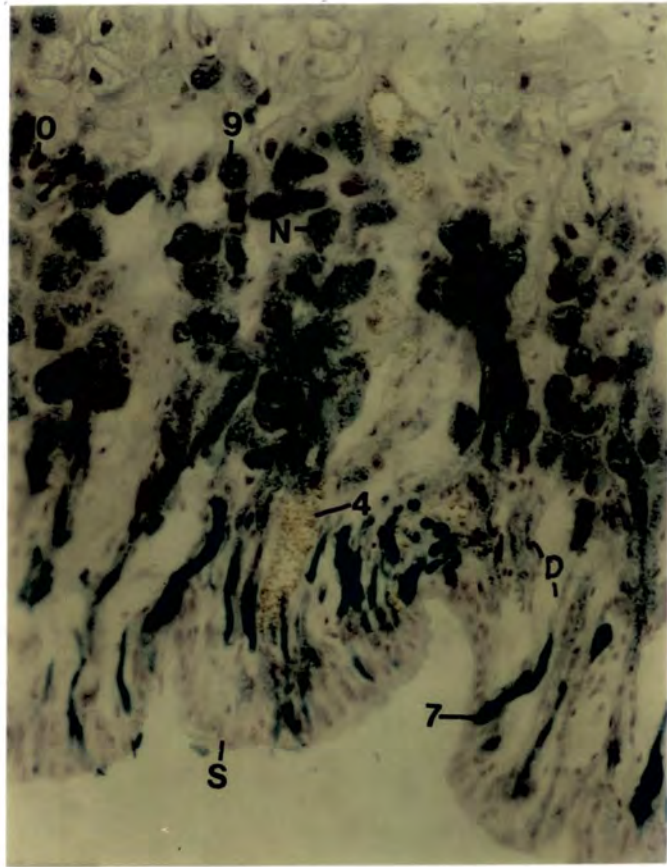

A

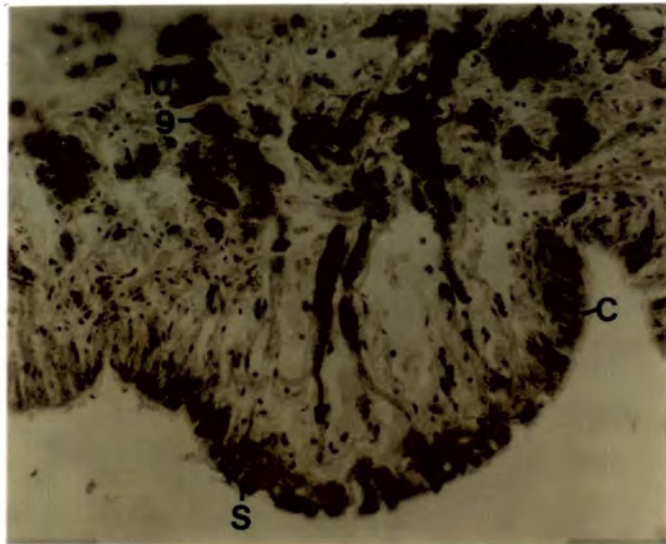

B

Plate 58 Longitudinal sections through the head of Limax pseudoflavus to show the distribution of mucus-secreting cells.

A A section stained in Alcian Blue pH2.5/PAS (x 80).

Note large numbers of cell types 7 and 10.

B A high power view to show the detailed structure of type 10 cell (x 160).

Note the granular secretion, centrally located nucleus and the fine ducts of type 10 cells.

D - Duct; G - Granular secretion; N - Nucleus. All other labels refer to cell types.

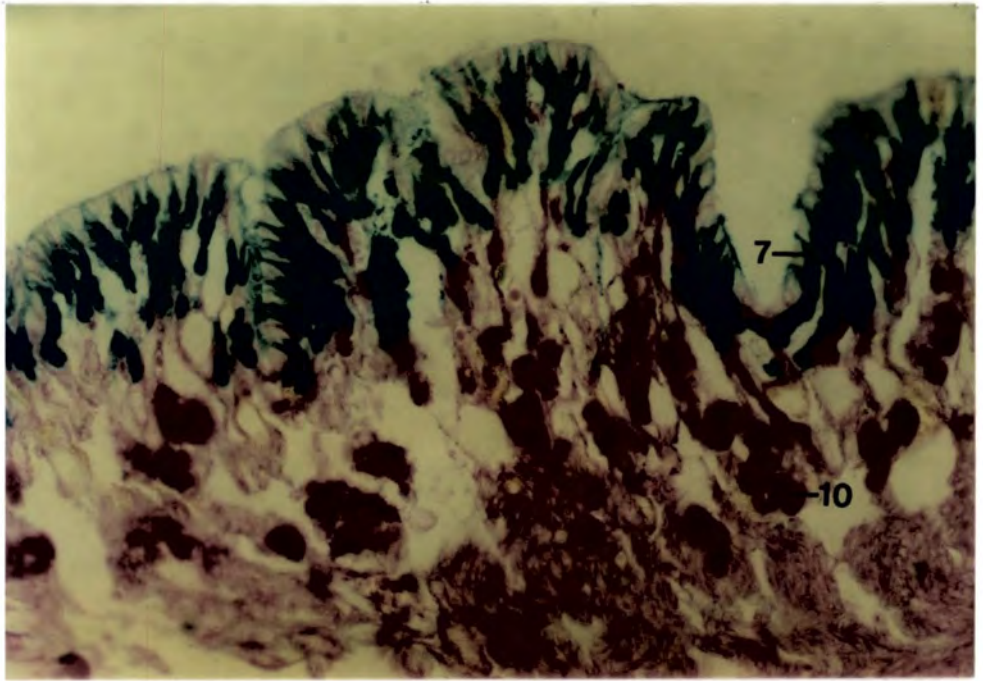

A

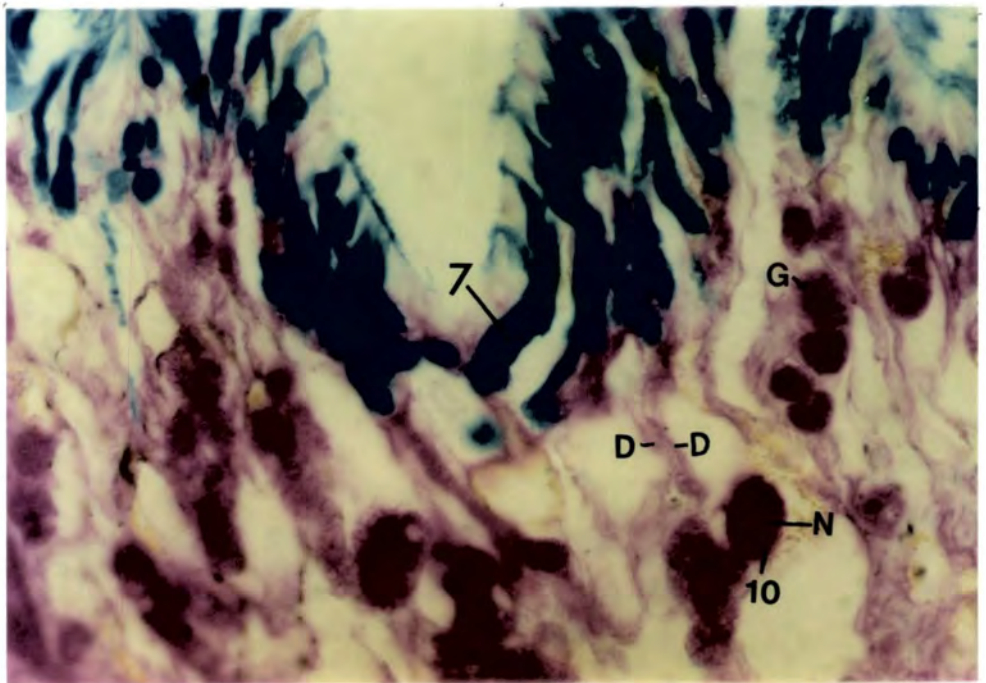

B

Plate 59 Transverse sections through the foot of Limax pseudoflavus to show the structure of the suprapedal gland and the staining responses of pedal gland mucocytes (type 6 cell).

- A A section stained in Alcian Blue pH0.5/eosin (x 40). The light blue colour of P6 cells indicates the presence of some sulphated mucopolysaccharides in their secretion. Note the change in the height of the epithelial cells of the dorsal epithelium, the lateral prominences and the central groove.
- B A section stained in Alcian Blue pH2.5/PAS (x 40). The strong positive reaction of type 6 cells with PAS suggests the presence of neutral mucopolysaccharide in secretion.
- C A part of a transverse section through the suprapedal gland stained with PAD (x 80). The brown colour of type 6 cells confirms the presence of neutral mucopolysaccharides in secretion.

C - Cilia; CG - central groove; DE - Dorsal epithelium; L - Lumen; LP - lateral prominence; N - Nucleus; SPD - Suprapedal duct. All other labels refer to cell type.

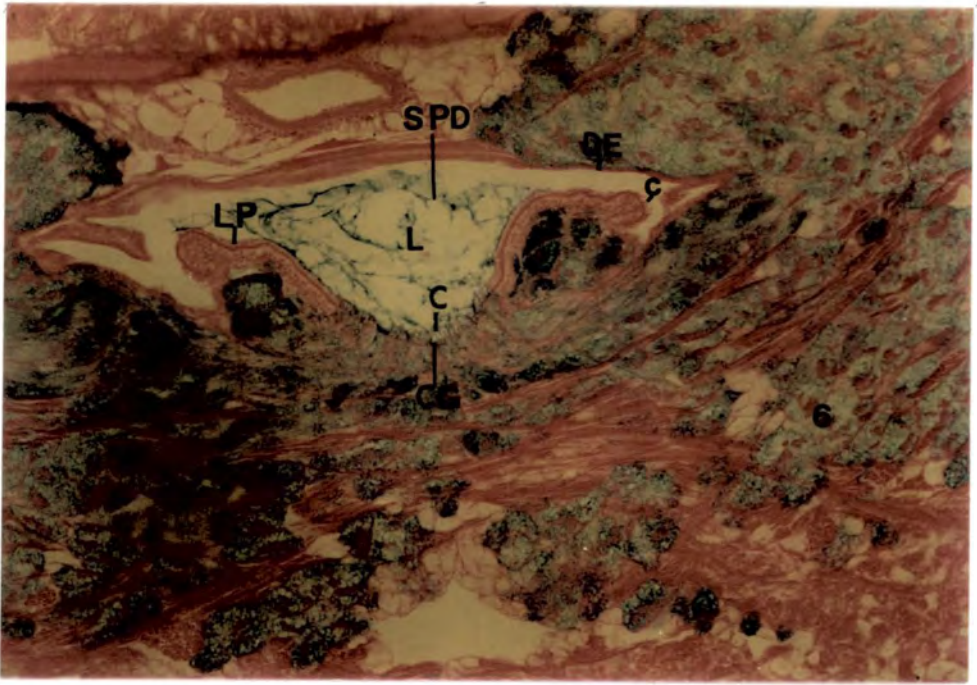

A

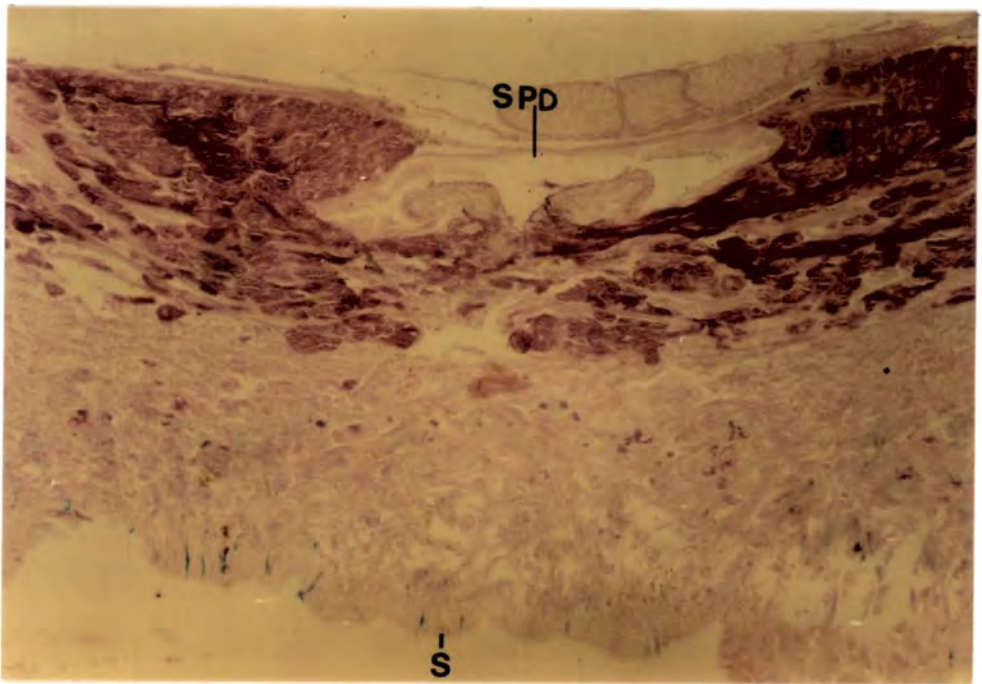

B

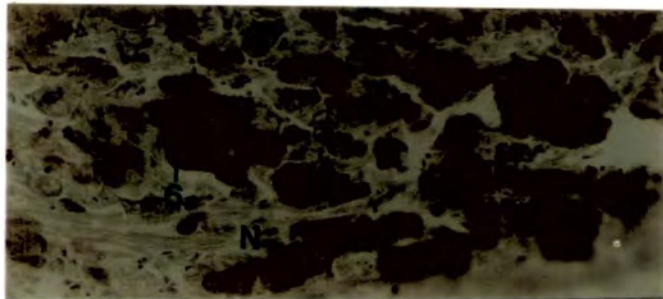

C

Plate 60 Transverse sections through the foot of Limax pseudoflavus showing the suprapedal gland. Note the change in the shapes of the suprapedal duct and the extent of ciliation.

A A section stained with Mallory's triple stain (x 80). Note the nuclei of type 6 cells. The blue colour of these cells indicates the presence of mucopolysaccharides.

B A section stained in Alcian Blue pH0.5/eosin (x 40). A slight response of type 6 cells indicates the presence of some sulphated mucopolysaccharides in their secretion.

C - Cilia; CG - Central groove; L - Lumen, LP - Lateral prominence; N - Nucleus, SPD - Suprapedal duct. All other labels refer to cell types.

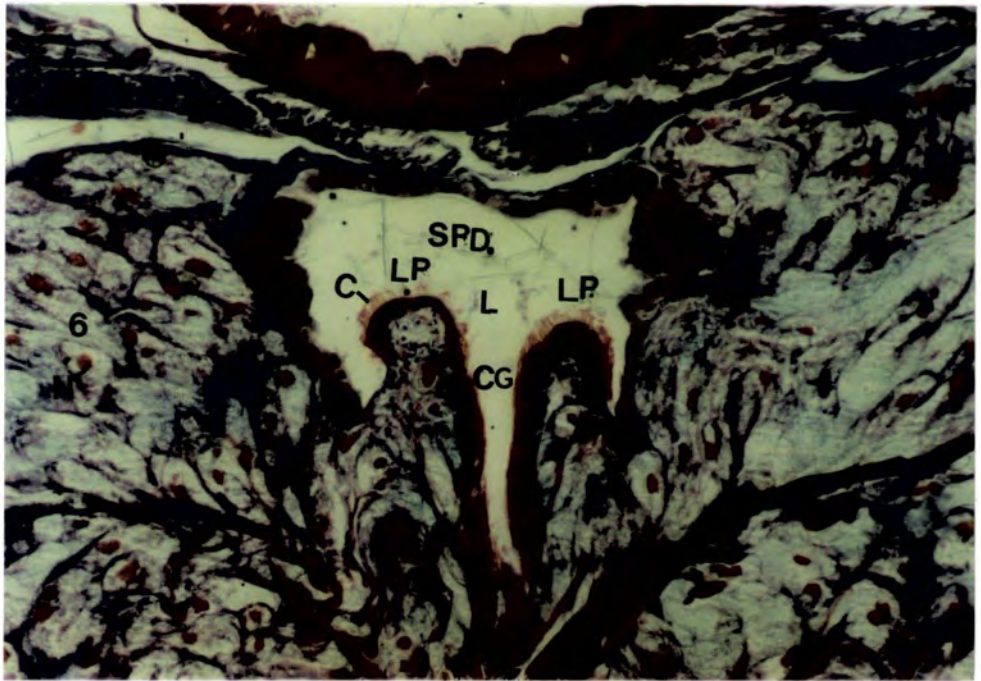

A

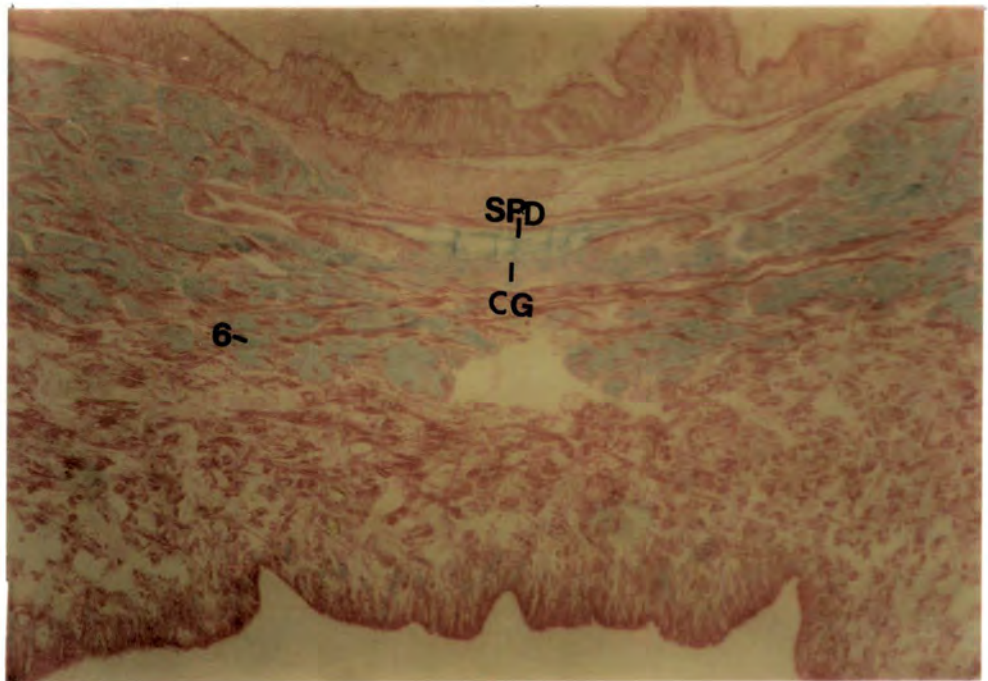

B

Plate 61

A A median longitudinal section through the anterior part of Limax pseudoflavus stained in Alcian Blue pH2.5/PAS, to show the mucus-secreting cells of the head and the leading edge of the foot (x 12).

B High power view of the leading edge of the foot from Plate 61A to show the staining responses of cell types 12, 13 and 14 (x 40).

The bluish-pink colour of type 12 cells indicates the acidic and periodate-reactive groups. The red colour of type 13 cells shows periodate-reactive groups in secretion and the purple colour of type 14 cells shows that both acidic components and periodate-reactive groups are present.

C High power view of a longitudinal section through the leading edge of the foot of Limax stained by the diazo-coupling reaction (x 40).

Positive reaction of type 13 cells shows their secretion is proteinaceous.

D - Duct; IG - Inferior gland; MG - Median gland; N - Nucleus; S - Sole; SG - Superior gland; SPG - Suprapedal gland; SO - Semper's organ. All other labels refer to cell types.

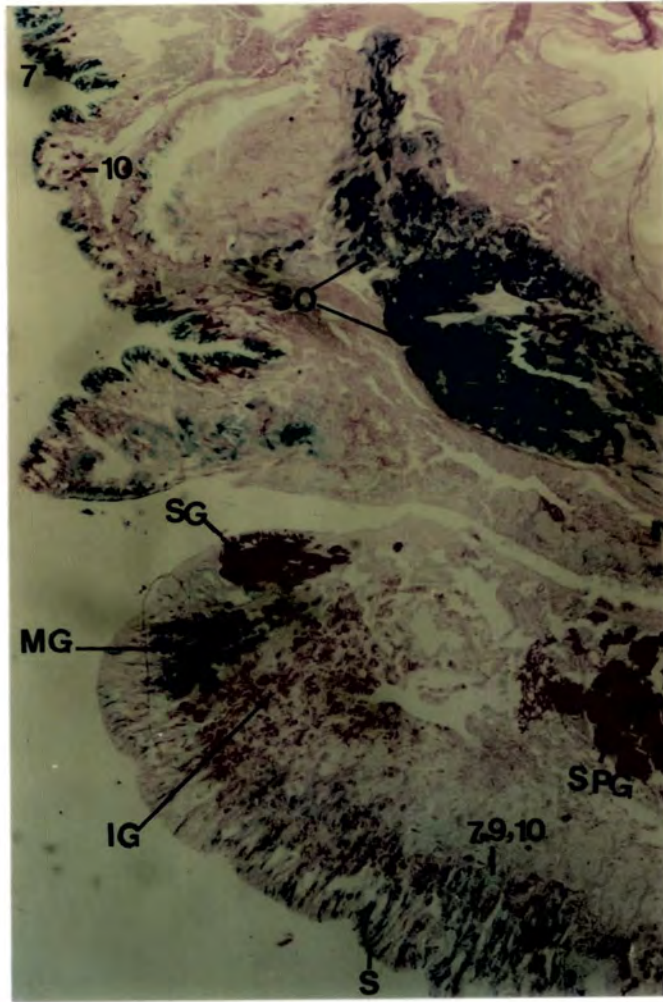

A

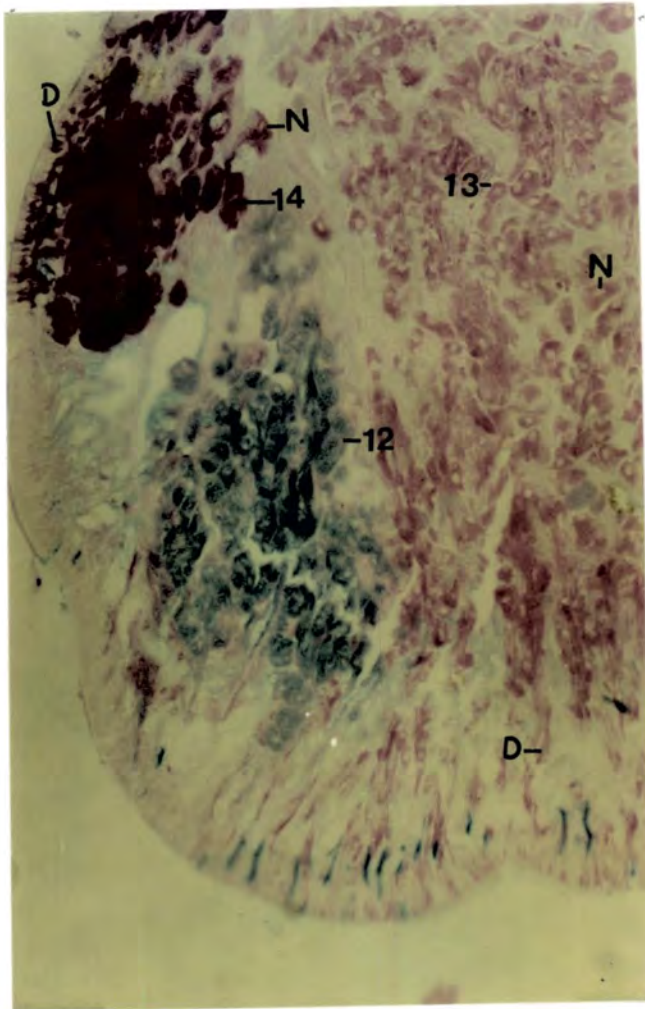

B

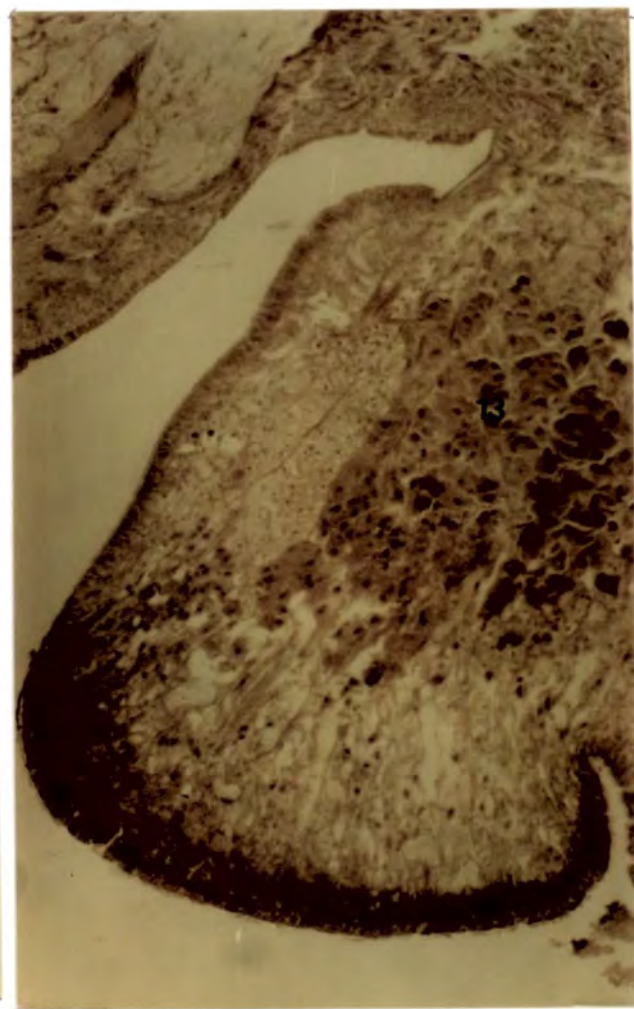

C

Plate 62 Transverse sections through the pneumostome of  
Limax pseudoflavus stained in Alcian Blue  
pH2.5/PAS to show the distribution of  
mucus-secreting cells.

- A A part of the section showing the lining of the duct of  
the pneumostome and cell types 7, 10 and 11 (x 40).
- B High power view of lung region to show type 11 cells  
(x 80).
- C High power view of the duct of pneumostome showing cell  
types 7 and 10 (x 160).

DP - Duct of pneumostome; L - Lung. All other labels refer  
to cell types.

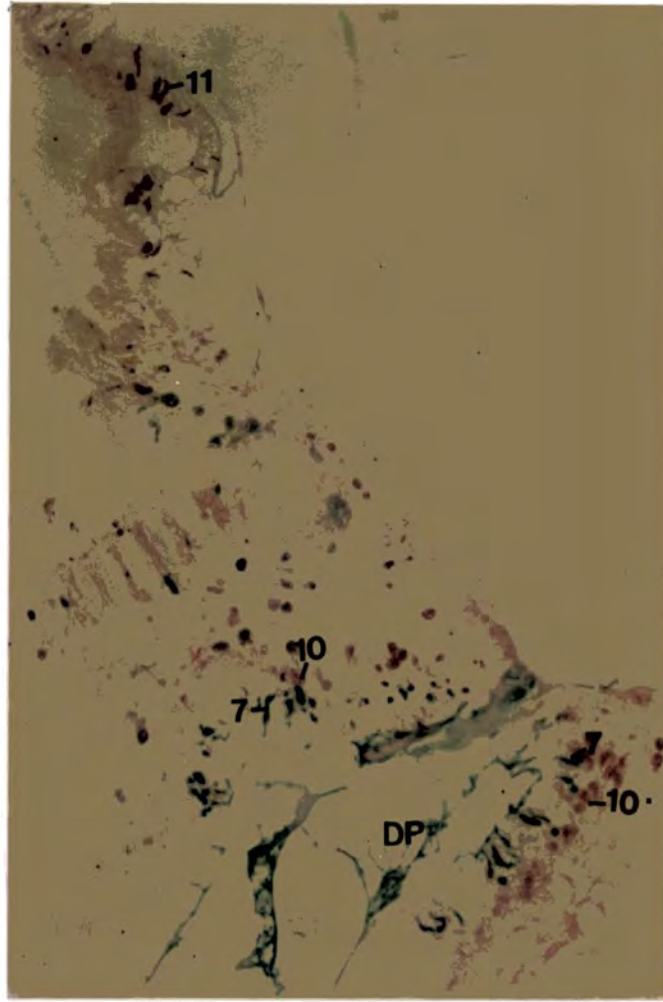

A

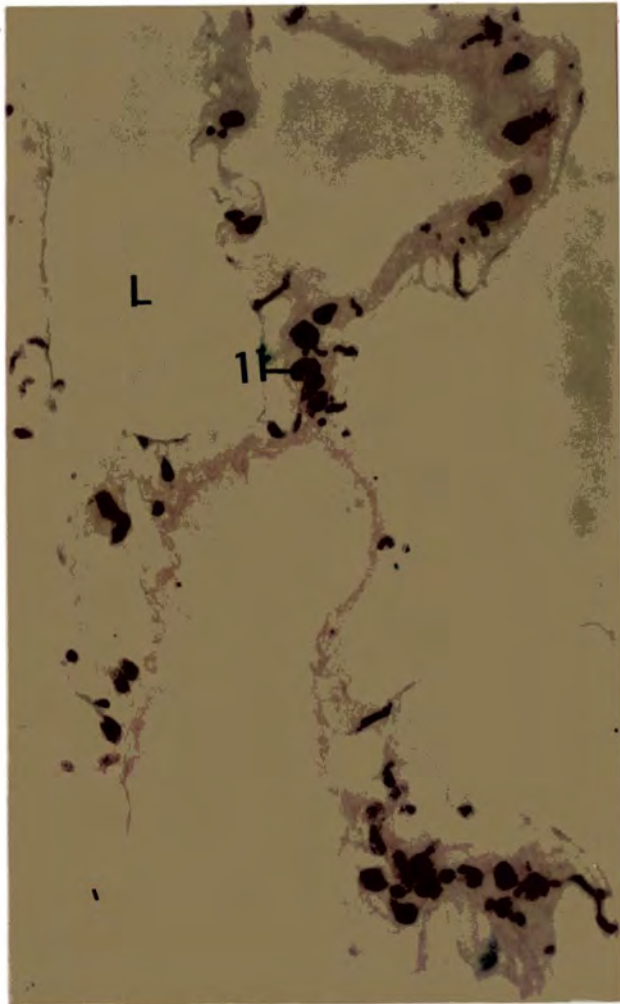

B

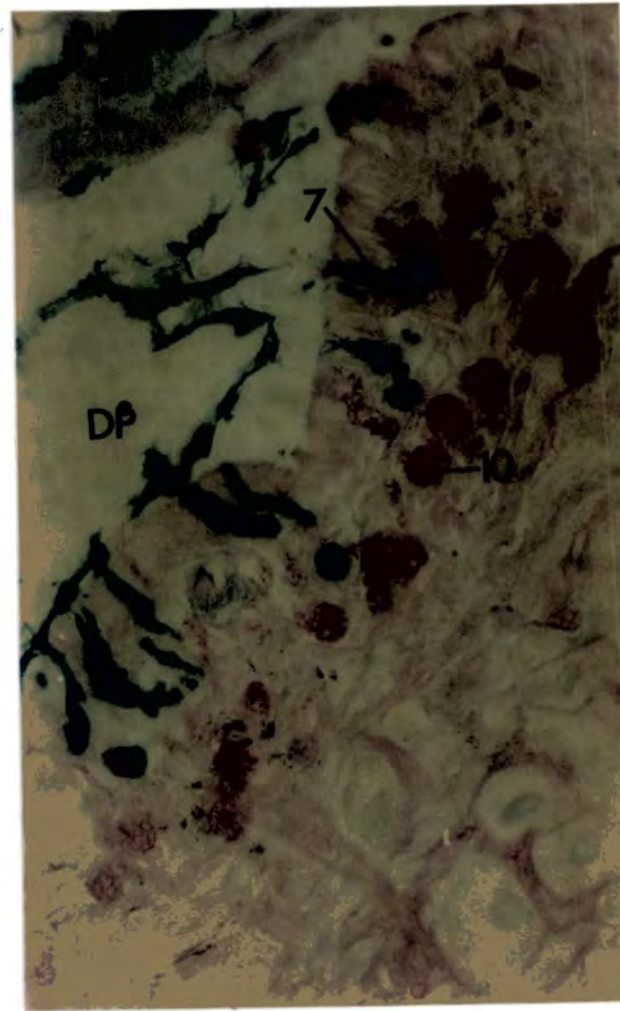

C

Plate 63

A A part of a transverse section through the pneumostome stained with Mallory's triple stain to show the pneumostome annulus and the cilia of the duct of the pneumostome (x 80).

B A part of a longitudinal section through the head of Limax pseudoflavus stained in Alcian Blue pH2.5/PAS to show Semper's organ (type 5 cells), (x 80).

C - Cilia; DP - Duct of pneumostome; N - Nucleus; PA - Pneumostome annulus. All other labels refer to cell types.

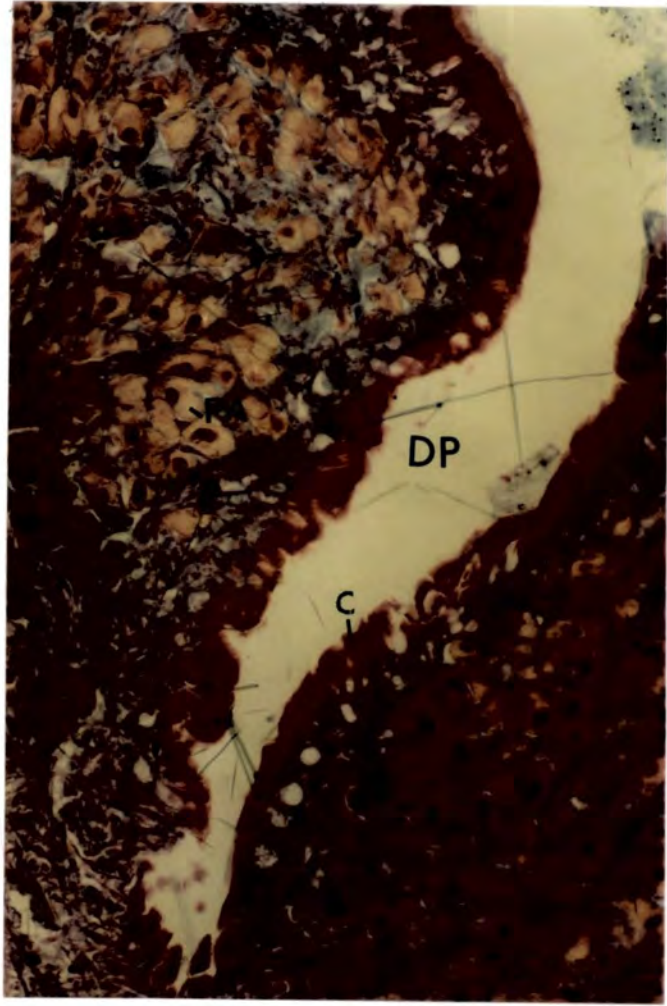

A

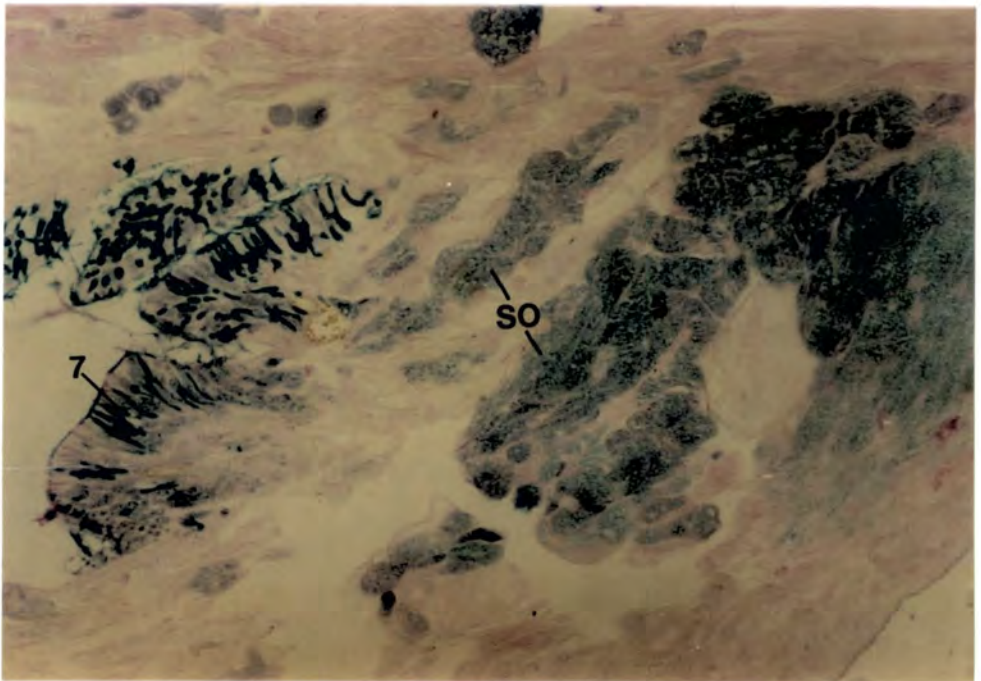

B

COMPARISON

TABLE 16

Comparison of the pedal gland cell types in the prosobranchs Pomatias, Bithynia, Littorina and the pulmonate slug Limax pseudoflavus

16A Acid MPS - Sole glandsHistochemical nature of the contents

<u>Species</u>	<u>Cell Type</u>	<u>Position</u>	<u>Acidic MPS</u>			<u>PAS</u>	<u>Neutral MPS</u>	<u>Protein</u>		<u>Ca+</u>	<u>Lipids</u>
			Alcian Blue pH 0.5	Alcian Blue pH 2.5	Tol Blue			MBPB	D.C.		
<u>Pomatias</u>	P6	Sole	✓	✓	✓	-	-	-	-	-	-
<u>Bithynia</u>	B2	Sole	✓	✓	✓	-	-	-	-	-	-
<u>Littorina</u>	L3	Sole	✓	✓	✓	-	-	-	-	-	-
<u>Limax</u>	7	Ubiquitous	✓	✓	✓	-	-	-	-	-	-

16B Neutral mucoprotein - Sole glandsHistochemical nature of the contents

<u>Species</u>	<u>Cell Type</u>	<u>Position</u>	<u>Acidic MPS</u>			<u>PAS</u>	<u>Neutral MPS</u>	<u>Protein</u>		<u>Ca+</u>	<u>Lipids</u>
			Alcian Blue pH 0.5	Alcian Blue pH 2.5	Tol Blue			MBPB	D.C.		
<u>Pomatias</u>	P5	Sole	-	-	-	✓	✓	✓	✓	-	-
<u>Littorina</u>	L5	Sole	-	-	-	✓	✓	✓	✓	-	-

16C Anterior pedal glands

Histochemical nature of the contents

<u>Species</u>	<u>Cell Type</u>	<u>Position</u>	<u>Acidic MPS</u>			<u>PAS</u>	<u>Neutral MPS</u>	<u>Protein</u>		<u>Ca+</u>	<u>Lipids</u>
			Alcian Blue pH 0.5	Alcian Blue pH 2.5	Tol Blue			MBPB	D.C.		
<u>Pomatias</u>	-	-	-	-	-	-	-	-	-	-	-
<u>Bithynia</u>	B1	Anterior pedal gland	✓	✓	✓	✓	✓	✓	✓	-	-
<u>Littorina</u>	L1	(Anterior pedal gland	-	-	✓	✓	✓	✓	✓	-	-
	L2	)	-	-	-	✓	✓	✓	-	-	-
<u>Limax</u>	12	(Leading edge of	-	✓	✓	✓	✓	-	-	-	-
	13	)	-	-	-	✓	✓	✓	✓	-	-
	14	(foot	✓	✓	✓	✓	✓	-	-	-	-

16D Suprapedal glands

Histochemical nature of the contents

<u>Species</u>	<u>Cell Type</u>	<u>Position</u>	<u>Acidic MPS</u>			<u>PAS</u>	<u>Neutral MPS</u>	<u>Protein</u>		<u>Ca+</u>	<u>Lipids</u>
			Alcian Blue pH 0.5	Alcian Blue pH 2.5	Tol Blue			MBPB	D.C.		
<u>Pomatias</u>	Supra-pedal gland	Foot	✓	✓	✓	✓	✓	✓	✓	✓	-
<u>Limax</u>	Supra-pedal gland	Foot	✓	-	-	✓	✓	-	-	-	-

16E Ubiquitous mucus glands

Histochemical nature of the contents

<u>Species</u>	<u>Cell Type</u>	<u>Position</u>	<u>Acidic MPS</u>			<u>PAS</u>	<u>Neutral MPS</u>	<u>Protein</u>		<u>Ca+</u>	<u>Lipids</u>
			Alcian Blue pH 0.5	Alcian Blue pH 2.5	Tol Blue			MBPB	D.C.		
<u>Pomatias</u>	P13	Foot & dorsal/lateral body surfaces	-	-	-	✓	✓	-	-	-	-
<u>Limax</u>	10	Foot & dorsal/lateral body surfaces	-	-	-	✓	✓	-	-	-	-

TABLE 17

Comparison of the cell types on the dorsal body surface of the prosobranchs Pomatias, Bithynia and Littorina

17A Acidic MPS - Goblet cells

Histochemical nature of the contents

<u>Species</u>	<u>Cell Type</u>	<u>Position</u>	<u>Acidic MPS</u>			<u>PAS</u>	<u>Neutral MPS</u>	<u>Protein</u>		<u>Ca+</u>	<u>Lipid</u>
			Alcian Blue pH 0.5	Alcian Blue pH 2.5	Tol Blue			MBPB	D.C.		
<u>Pomatias</u>	P10	Dorsal/ lateral body surfaces	✓	✓	✓	-	-	-	-	-	-
<u>Bithynia</u>	B7	Dorsal/ lateral body surfaces	✓	✓	✓	-	-	-	-	-	-
<u>Littorina</u>	L9	Dorsal/ lateral body surfaces	✓	✓	✓	-	-	-	-	-	-

17B Neutral mucoprotein - Goblet cells

Histochemical nature of the contents

<u>Species</u>	<u>Cell Type</u>	<u>Position</u>	<u>Acidic MPS</u>			<u>PAS</u>	<u>Neutral MPS</u>	<u>Protein</u>		<u>Ca+</u>	<u>Lipid</u>
			Alcian Blue pH 0.5	Alcian Blue pH 2.5	Tol Blue			MBPB	D.C.		
<u>Pomatias</u>	P11	Dorsal/ lateral body surfaces	-	-	-	✓	✓	✓	✓	-	-
<u>Bithynia</u>	B8	Dorsal/ lateral body surfaces	-	-	-	✓	✓	✓	✓	-	-
<u>Littorina</u>	L10	Dorsal/ lateral body surfaces	-	-	-	✓	✓	✓	✓	-	-

TABLE 18

Comparison of the findings on the pedal gland cells of Pomatias, Bithynia and Littorina in the present study with those of other prosobranchs.

<u>Author/Species</u>	<u>Cell Type</u>	<u>Nearest cell type equivalent in the present study</u>	<u>Position</u>	<u>Histochemical nature of the contents</u>									
				<u>Acidic MPS</u>			<u>PAS</u>	<u>Neutral MPS</u>	<u>Protein</u>		<u>Ca<sup>+</sup></u>	<u>Lipid</u>	
				Alcian Blue pH 0.5	Alcian Blue pH 2.5	Tol Blue			MBPB	D.C.			
Gainey (1976)	<u>Neritina</u>	Anterior mucocytes	B1,L1 and L2	Anterior part of the foot	✓	✓	-	-	-	-	-	-	-
	<u>Thais</u>	Anterior mucocytes	B1,L1 and L2	Anterior part of the foot	-	-	-	✓	-	-	-	-	-
	<u>Neritina</u>	Subepidermal mucocytes	P6,B2,L3	Sole	✓	✓	-	-	-	-	-	-	-
	<u>Thais</u>	Subepidermal mucocytes	P5,L5	Sole	-	-	-	✓	-	-	-	-	-
	<u>Thais</u>	Epidermal mucocytes	P10,B7,L9	Ubiquitous	✓	✓	-	-	-	-	-	-	-
	<u>Thais</u>	Epidermal mucocytes	P11,B8,L10	Ubiquitous	-	-	-	✓	-	-	-	-	-
Grenon and Walker (1978)	<u>Patella vulgata</u>	P2	B3	Sole	✓	✓	✓	✓	✓	-	-	-	-
	<u>Acmaea tessulata</u>	A2	B3	Sole	✓	✓	✓	✓	-	-	-	-	-
	<u>Patella</u> <u>Acmaea</u>	P6 A4	) )	L5	Sole	-	-	-	-	-	✓	✓	-
	<u>Patella</u> <u>Acmaea</u>	(Epidermal mucocytes	P10,B7,L9	Sole	✓	✓	✓	-	-	-	-	-	-

TABLE 19

Comparison of the findings on the dorsal surface gland cells of Limax pseudoflavus with those of other terrestrial pulmonates

<u>Author/Species</u>	<u>Cell Type</u>	<u>Nearest cell type equivalent in the present study</u>	<u>Position</u>	<u>Histochemical nature of the contents</u>								
				<u>Acidic MPS</u>			<u>PAS</u>	<u>Neutral MPS</u>	<u>Protein</u>		<u>Ca<sup>+</sup></u>	<u>Lipid</u>
				Alcian Blue pH 0.5	Alcian Blue pH 2.5	Tol Blue			MBPB	D.C.		
Bolognani Fantin & Bolognani (1964)	Mucocytes	1 and 7	Dorsal surface & sole	✓	-	✓	-	-	-	-	-	-
	Protein cells	2 and 3	Dorsal surface & sole	-	-	-	-	-	✓	✓	-	-
Campion (1961)	Type 'A'	1	Mantle	✓	-	✓	-	-	-	-	-	-
	Type 'B'	10	Mantle	-	-	-	✓	-	-	-	-	-
Arcadi (1963)	Basket cell complex	1	Dorsal surface	✓	✓	-	✓	-	-	-	-	-
	Granular cell complex	10	Dorsal & lateral surfaces & sole	-	-	-	✓	-	-	-	-	-
Chetail & Binot (1967)	Arion rufus M2	1	Dorsal surface	✓	✓	✓	-	✓	✓	✓	-	✓*
Lawrence (1972)	Arion hortensis M	1	Dorsal surface	✓	-	✓	-	-	-	-	-	-
	Pigment/protein cell	3	Dorsal surface	-	-	-	-	-	✓	✓	-	-
Cook (1986)	Veronicella floridana V9 & V11	1	Mantle	-	✓	✓	-	-	-	-	-	-
	V10	2,3.	Mantle	-	-	✓	✓	-	✓	-	-	-

\* No controls performed.

TABLE 20

Comparison of the findings on the pedal gland cells of Limax pseudoflavus  
with those of other terrestrial pulmonates

Author/Species	Cell Type	Nearest cell type equivalent in the present study	Position	Histochemical nature of the contents									
				Acidic MPS			PAS	Neutral MPS	Protein		Ca <sup>+</sup>	Lipid	
				Alcian Blue pH 0.5	Alcian Blue pH 2.5	Tol Blue			MBPB	D.C.			
Bolognani Fantin & Bolognani (1964)	<u>Helix pomatia</u> Phenolic cells	4	Sole	-	-	-	-	-	-	-	-	-	-
Campion (1961)	<u>Helix aspersa</u> Pigment cell	4	Sole	-	-	-	-	-	-	-	-	-	-
	Type 'C'	9	Sole	✓	✓	✓	-	-	-	-	-	-	-
	Type 'D'	10	Sole	-	-	-	✓	-	-	-	-	-	-
Chetail & Binot (1967)	<u>Arion rufus</u> al	6	Suprapedal gland	-	-	-	✓	✓	-	-	-	✓	*
	I	10	Sole	-	-	-	✓	✓	-	-	-	✓	*
	II	9	Sole	✓	✓	✓	✓	✓	-	-	-	-	-
	III	13	Anterior part of the foot	-	-	-	-	-	✓	✓	-	✓	*
Lawrence (1972)	<u>Arion hortensis</u> C	10	Sole	-	-	-	-	✓	✓	✓	-	-	-
	Peripodal groove mucocytes	8	Peripodal groove	✓	✓	✓	-	-	✓	✓	-	-	-
	Suprapedal gland mucocytes	6	Suprapedal gland	-	-	✓	✓	-	-	-	-	-	-
Cook (1986)	<u>Veronicella floridana</u> V2	6	Suprapedal gland	-	-	-	✓	✓	-	-	-	-	-
	V3 & V4	9	Sole	-	✓	✓	-	-	-	-	-	-	-
	V5	10	Sole	-	-	-	✓	✓	-	-	-	-	-
	V7 & V8	7,8,9,10	Foot margin	-	✓	✓	✓	✓	✓	✓	-	-	-

\* No controls performed.

TABLE 21

The staining responses of the gland cell types found in Lymnaea stagnalis

<u>Procedures</u>	Goblet cell	Muciparous gland cell type I	Muciparous gland cell type II	Foot sole gland cells	Lateral foot edge gland cells	Ant. pedal gland (type 10)	Ant. pedal gland (type 11)	Mantle edge gland cells
Mall	R++	Bl++	Bl+	Bl+	Bl++	Pu++	Pu++	Bl/Pu+
AB/AY	-	G+++	Y+	G++	YlG++	G++	G+	G++
AB/EO	R++	Bl++	R++	Bl++	Bl+++	Bl++	Bl+	Bl+
Diazo	Pu++	-	Pu++	-	-	-	-	-
MBPB	Bl++	-	Bl++	-	-	-	-	-
PAS	-	R+++	Pi++	R++	R+++	R+++	R+++	R++
PAD	-	Br+++	Br++	Br++	Br++	Br++	Br+	Br++
AB/PAS	-	R/Pu+++	Pi++	Pu/R++	Pu/R++	Bl/Pu++	Pu/R++	Bl/Pu+
Tol. Blue	-	Bl+++	-	Bl++	Bl++	Bl+++	Bl++	Bl+
V. Kossa	Bla++	-	-	-	-	-	-	-
Al. Red	R++	-	-	-	-	-	-	-
Sud. Black	-	+Bla	-	-	-	-	-	-

Key: Bl-Blue, Bla-Black, Pi-Pink, Pu-Purple, R-Red, Y-Yellow, G-Green

TABLE 22

A summary of the properties of the gland cell types in Lymnaea stagnalis

<u>Cell type</u>	<u>Position</u>	<u>Size</u>	<u>Shape</u>	<u>Texture</u>	<u>Contents</u>
Goblet cell type	Ubiquitous	4-9 $\mu$ m	Cuboidal	Smooth	Protein + calcium
Muciparous gland cell type I	Ubiquitous	35-110X 4-12 $\mu$ m	Elongated	Reticular	Acidic + neutral
Muciparous gland cell type II	Ubiquitous	50-100X 15-40 $\mu$ m	Pear shaped	Smooth/ Reticular	Mucoprotein
Foot sole gland cells	Foot sole	120-350X 7-10 $\mu$ m	Round	Reticular	Acidic and neutral MPS
Lateral foot edge gland cells	Lateral edge of the foot	50-95X 10-25 $\mu$ m	Clavate	Solid/ Reticular	Acidic and neutral MPS
Anterior pedal gland cells (type 10)	Dorsal surface of fore part of foot	190x350X 6-8 $\mu$ m	Oval	Reticular	Acidic and neutral MPS
Anterior pedal gland cells (type 11)	Dorsal surface of fore part of foot	490-915X 7-10 $\mu$ m	Oval	Granular	Acidic and neutral MPS
Mantle edge gland cells	Mantle edge	60-90X 8-10 $\mu$ m	Flask	Reticular	Acidic and neutral MPS

TABLE 23

Comparison of the findings on the pedal and dorsal surface gland cells of the gastropods in the present study with those of the fresh water pulmonate

<u>Author/Species</u>	<u>Cell Type</u>	<u>Nearest cell type equivalent in the present study</u>	<u>Position</u>	<u>Histochemical nature of the contents</u>											
				<u>Acidic MPS</u>			<u>PAS</u>	<u>Neutral MPS</u>	<u>Protein</u>		<u>Ca<sup>+</sup></u>	<u>Lipid</u>			
				Alcian Blue pH 0.5	Alcian Blue pH 2.5	Tol Blue			MBPB	D.C.					
Zylstra (1972)	<u>Lymnaea stagnalis</u>			Goblet cell type	P11, B8, L10	Ubiquitous	-	-	-	-	-	✓	✓	✓	-
				Muciparous type I	<u>Limax</u> cell type 7	Ubiquitous	✓	✓	✓	✓	✓	-	-	-	-
				Anterior pedal gland (type 11)	B1	Anterior part of the foot	✓	✓	✓	✓	✓	-	-	-	-
				Anterior pedal gland (type 10)	L2	Anterior part of the foot	✓	✓	✓	✓	✓	-	-	-	-
				Lateral foot edge gland	B3	Foot	✓	✓	✓	✓	✓	-	-	-	-

TABLE 24A

Comparison of the mantle edge structure of the prosobranchs  
Pomatias elegans, Bithynia tentaculata and Littorina littorea

	<u>Pomatias elegans</u>	<u>Bithynia tentaculata</u>	<u>Littorina littorea</u>
<u>Dorsal mantle epithelium</u>	Cuboid epithelium devoid of secretory cell types	Cuboid epithelium devoid of secretory cell types	Columnar epithelium with subepidermal gland cell (type L11)
<u>Ventral mantle epithelium</u>	Columnar epithelium interspersed with four goblet cell types	Columnar epithelium interspersed with two goblet cell types	Columnar epithelium interspersed with two goblet cell types
<u>Mantle edge</u>	Two mantle edge gland types. Supramarginal groove absent.	One mantle edge gland type. Supramarginal groove absent.	Two mantle edge gland types. Supramarginal groove absent

TABLE 24B

Comparison of the acidic MPS mantle edge gland cells of the prosobranchs Pomatias elegans, Bithynia tentaculata and Littorina littorea

<u>Species</u>	<u>Nearest gland cell type equivalent</u>	<u>Position</u>	<u>Histochemical nature of the contents</u>							<u>Ca<sup>+</sup></u>	<u>Lipid</u>
			<u>Acidic MPS</u>			<u>PAS</u>	<u>Neutral MPS</u>	<u>Protein</u>			
			Alcian Blue pH 0.5	Alcian Blue pH 2.5	Tol Blue			MBPB	D.C.		
<u>Pomatias</u>	P14	Mantle edge	✓	✓	✓	-	-	-	-	-	-
<u>Littorina</u>	L13	Mantle edge	✓	✓	✓	-	-	-	-	-	-

TABLE 24C

Comparison of the mucoprotein mantle edge gland cells of the prosobranchs Pomatias elegans, Bithynia tentaculata and Littorina littorea

<u>Author/Species</u>	<u>Nearest gland cell type equivalent</u>	<u>Position</u>	<u>Histochemical nature of the contents</u>							<u>Ca<sup>+</sup></u>	<u>Lipid</u>
			<u>Acidic MPS</u>			<u>PAS</u>	<u>Neutral MPS</u>	<u>Protein</u>			
			Alcian Blue pH 0.5	Alcian Blue pH 2.5	Tol Blue			MBPB	D.C.		
<u>Pomatias</u>	P15	Mantle edge	-	-	-	✓	✓	✓	✓	-	-
<u>Bithynia</u>	B10	Mantle edge	-	-	-	✓	±	✓	✓	-	-
<u>Littorina</u>	L12	Mantle edge	-	-	-	✓	✓	✓	✓	-	-

TABLE 25

Comparison of the mantle edge structure of Pomatias, Bithynia and Littorina with other prosobranchs

25A Acidic MPS - Mantle edge gland cells

<u>Author/Species</u>	<u>Cell Type</u>	<u>Nearest cell type equivalent in the present study</u>	<u>Position</u>	<u>Histochemical nature of the contents</u>								
				<u>Acidic MPS</u>			<u>PAS</u>	<u>Neutral MPS</u>	<u>Protein</u>		<u>Ca<sup>+</sup></u>	<u>Lipid</u>
				Alcian Blue pH 0.5	Alcian Blue pH 2.5	Tol Blue			MBPB	D.C.		
Walsh (1986)	<u>Busycon carica &amp; Busycon canaliculatum</u>	Type L11 in <u>Littorina</u>	Dorsal mantle epithelium	✓	-	✓	-	-	-	-	-	-
		P10,B7,L9	Ventral mantle epithelium	✓	✓	✓	-	-	-	-	-	-
Umadevi et al. (1984)	<u>Pila virens</u>	-	Dorsal mantle epithelium	✓	✓	✓	-	-	-	-	-	-
		P10,B7,L9	Ventral mantle epithelium	✓	✓	✓	-	-	-	-	-	-

25B Mucoprotein Mantle edge gland cells

<u>Author/Species</u>	<u>Cell Type</u>	<u>Nearest cell type equivalent in the present study</u>	<u>Position</u>	<u>Histochemical nature of the contents</u>								
				<u>Acidic MPS</u>			<u>PAS</u>	<u>Neutral MPS</u>	<u>Protein</u>		<u>Ca<sup>+</sup></u>	<u>Lipid</u>
				Alcian Blue pH 0.5	Alcian Blue pH 2.5	Tol Blue			MBPB	D.C.		
Walsh (1986) <u>Busycon carica</u> & <u>Busycon canaliculatum</u>	Epidermal mucocytes	P11,B8,L10	Ventral mantle epithelium	-	-	-	✓	-	-	-	-	-
	Supra-marginal gland	P15,L12	Mantle edge	-	-	-	✓	✓	✓	✓	-	-
	Distal supra-marginal gland	P14,L13	Mantle edge	✓	-	-	-	-	✓	-	-	-
Umadevi et al. (1984) <u>Pila virens</u>	Supra-marginal gland	-	Mantle edge	-	-	-	-	-	✓	-	-	-
	Shell gland	B10	Mantle edge	✓	✓	-	✓	-	✓	✓	✓*	✓*

\* No controls performed.

TABLE 26.

Comparison of the mantle edge structure of Pomatias, Bithynia and Littorina  
with terrestrial pulmonates

<u>Author/Species</u>	<u>Cell Type</u>	<u>Nearest cell type equivalent in the present study</u>	<u>Position</u>	<u>Histochemical nature of the contents</u>								
				<u>Acidic MPS</u>			<u>PAS</u>	<u>Neutral MPS</u>	<u>Protein</u>		<u>Ca<sup>+</sup></u>	<u>Lipid</u>
				Alcian Blue pH 0.5	Alcian Blue pH 2.5	Tol Blue			MBPB	D.C.		
Saleuddin (1970) and (1976)	<u>Helix pomatia</u>	-	Mantle edge	-	-	-	-	-	-	-	-	-
	<u>Helix aspersa</u>	-	Mantle edge	-	-	-	-	-	-	-	-	-
	<u>Helix pomatia</u>	-	Ventral mantle epithelium	✓	✓	-	-	-	-	-	-	-
	<u>Helix aspersa</u>	-	Ventral mantle epithelium	✓	✓	-	-	-	-	-	-	-

TABLE 27

Comparison of the mantle edge structure of Pomatias, Bithynia and Littorina  
with fresh water pulmonates

<u>Author/Species</u>	<u>Cell Type</u>	<u>Nearest cell type equivalent in the present study</u>	<u>Position</u>	<u>Histochemical nature of the contents</u>						<u>Ca<sup>+</sup></u>	<u>Lipid</u>
				<u>Acidic MPS</u>		<u>PAS</u>	<u>Neutral MPS</u>	<u>Protein</u>			
				Alcian Blue pH 0.5	Alcian Blue pH 2.5	Tol Blue		MBPB	D.C.		
Zylstra (1972)	<u>Lymnaea</u> <u>Biomphalaria</u>	P10, B7, L9	Ventral mantle epithelium	✓	✓	-	-	-	-	-	-
		P11, B8, L10	Ventral mantle epithelium	-	-	-	-	✓	-	-	-
Saleuddin (1979)	<u>Helisoma</u>	P14 and L13	Mantle edge	✓	✓	✓	-	-	-	-	-

TABLE 28

Comparison of the hypobranchial glands of Pomatias, Bithynia and Littorina  
with other prosobranchs

<u>Author/Species</u>	<u>Cell Type</u>	<u>Nearest cell type equivalent in the present study</u>	<u>Histochemical nature of the contents</u>										
			<u>Acidic MPS</u>			<u>PAS</u>	<u>Neutral MPS</u>	<u>Protein</u>		<u>Ca<sup>+</sup></u>	<u>Lipid</u>		
			Alcian Blue pH 0.5	Alcian Blue pH 2.5	Tol Blue			MBPB	D.C.				
Ronkin (1952)	<u>Busycon canaliculatum</u>	Mucocytes	L14 and L15	✓	✓	✓	-	-	-	-	-	-	-
Hunt (1973)	<u>Buccinum undatum</u>	'A'	L15	✓	✓	✓	-	-	✓	-	-	-	-
		'B'	L14	✓	✓	✓	-	-	✓	-	-	-	-
		Goblet cell type	L16	✓	✓	-	-	-	✓	-	-	-	-
Ottaviani (1978)	<u>Paludina vivipara</u>	Type 1	B12	-	-	-	✓	-	✓	-	-	-	-
		Type 2	B11	✓	✓	✓	✓	-	✓	✓	-	-	-
Bolognani & Fantin	<u>Murex</u>	1	P12, B12	-	-	-	✓	-	✓	-	-	-	-
		2	L16	-	-	-	✓	-	✓	-	-	-	-
Ottoviani (1981)	<u>Murex</u>	Mucocytes	L14, L15	✓	✓	✓	-	-	-	-	-	-	-
		1	B12	-	-	-	✓	-	✓	-	-	-	-
			2	B7	✓	✓	✓	-	-	-	-	-	-
	<u>Viviparus</u>	1	B12	-	-	-	✓	-	✓	-	-	-	-
		2	B7	✓	✓	✓	-	-	-	-	-	-	-
	<u>Pomatias</u>	1	P12	-	-	-	✓	-	-	-	-	-	✓*

\* No controls performed.

Figure 36A. A diagrammatic view of Pomatias elegans to show the suprapedal gland, the mucus-producing cells of the median longitudinal furrow and the epidermal and subepidermal secretory cells on the dorsal and lateral body surfaces.

Figure 36B. Schematic presentation of a transverse section through the foot of Pomatias to show the mucus-secreting cells in the suprapedal gland and at the median pedal furrow.

SPG - suprapedal gland. All other labels refer to cell types.

Fig. 36

A

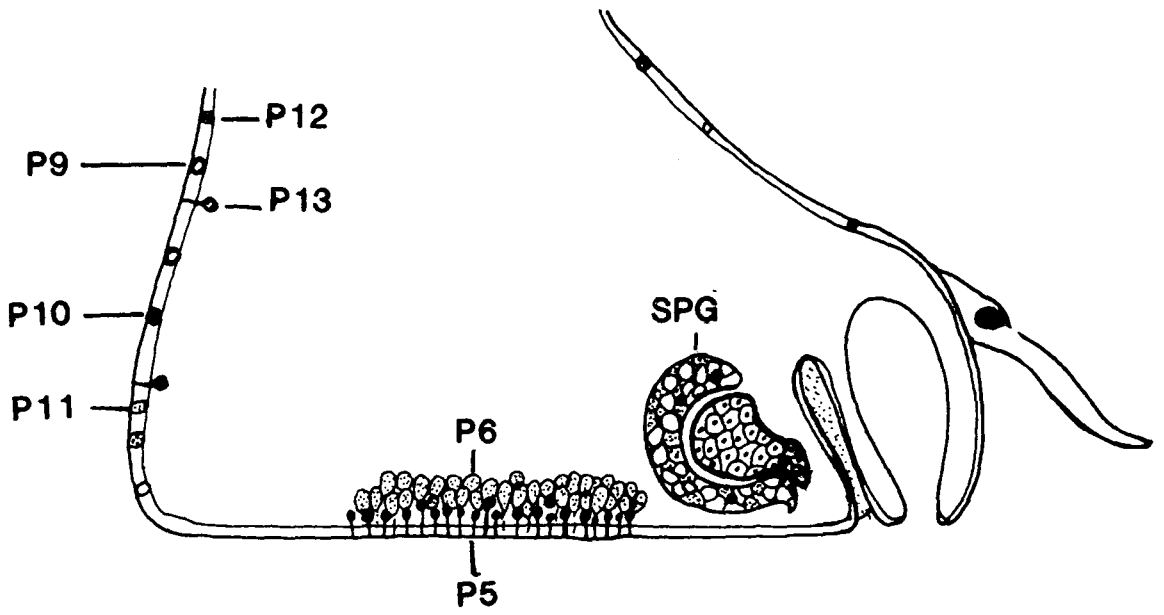

B

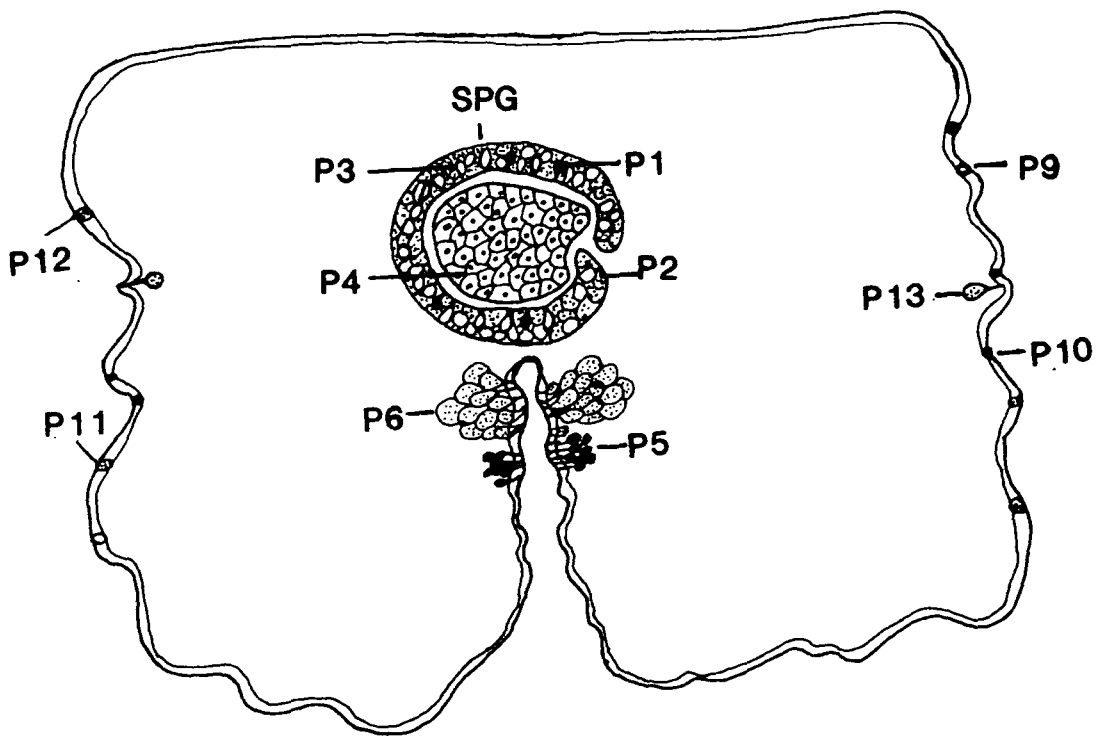

Figures 37 and 38. Schematic drawings to show the distribution of mucus-secreting cells on the dorsal and lateral body surfaces and the foot.

Fig. 37 Bithynia tentaculata.

Fig. 38. Littorina littorea.

APG - Anterior pedal gland. All other labels refer to cell types.

Figure 39. A diagrammatic view of Limax pseudoflavus to show the location of mucus-producing gland cells on the dorsal body surface, the head and the foot.

DBS - Dorsal body surface; H - Head; S - Sole; SO - Semper's organ; SPD - Suprapedal duct; SPG - Suprapedal gland; SPS - Suprapedal sinus. All other labels refer to cell types.

Fig. 37

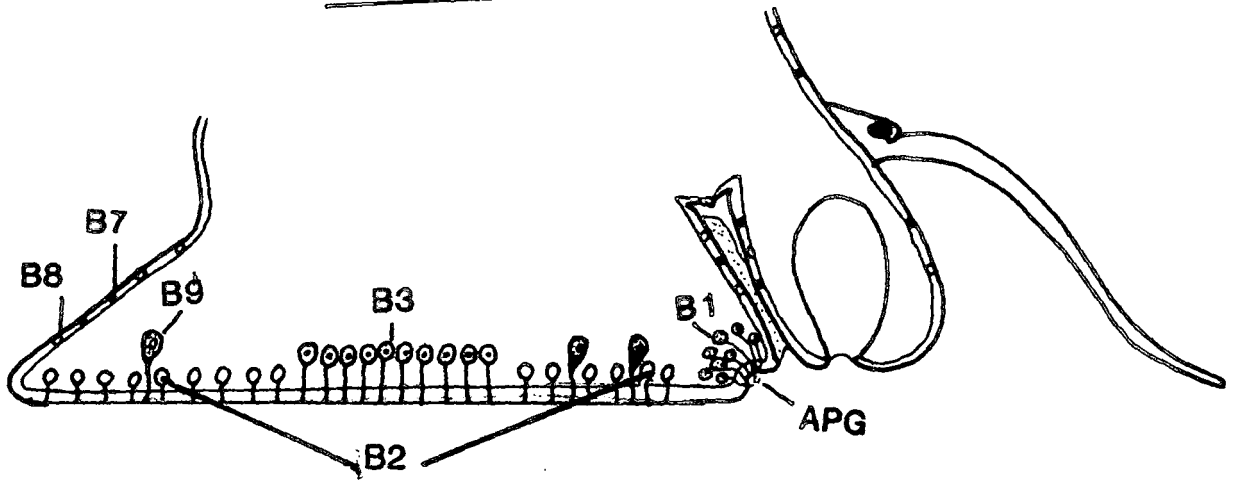

Fig. 38

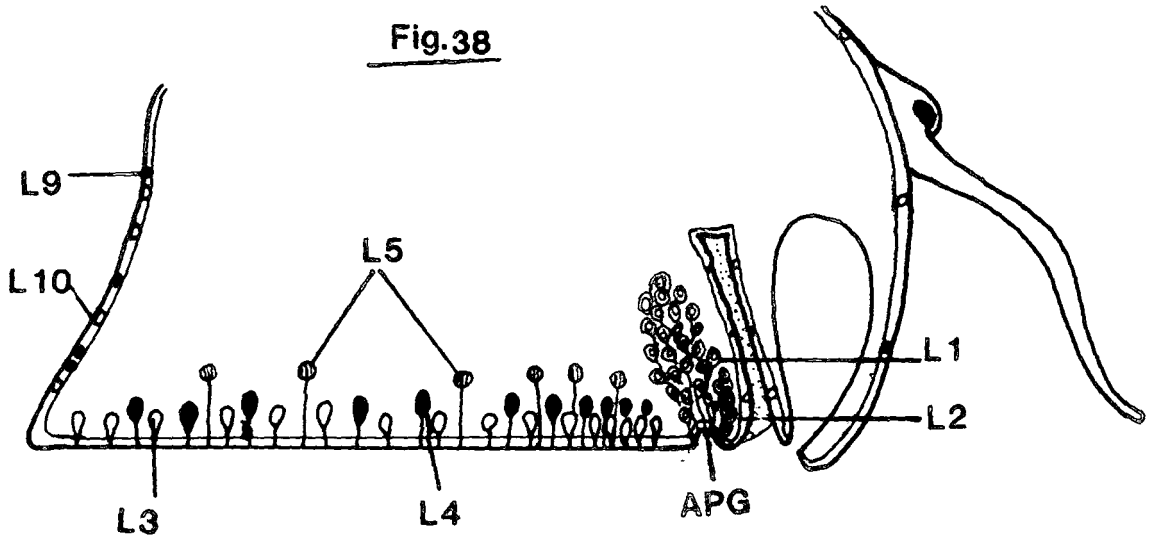

Fig. 39

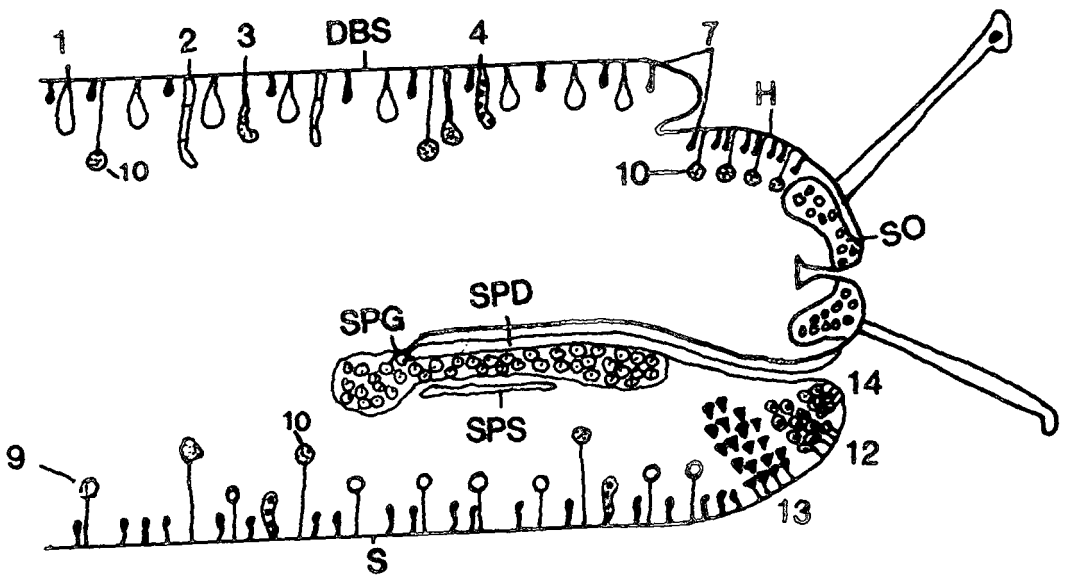

Figure 40A. Schematic drawing of a transverse section of Limax pseudoflavus to show the distribution of mucus producing glands in the foot.

C - Cilia; M - Mantle; PPG - Peripodal groove; S - Sole; SPD - Suprapedal duct; V - Position of Viscera. All other labels refer to cell types.

Figure 40B. Schematic presentation of a transverse section of the suprapedal gland of Limax pseudoflavus.

CG - Central groove; L - Lumen; LP - Lateral prominence; 6 - Pedal gland mucocytes.

Figure 41. Low power diagram to show the arrangement of the tissues of the foot of Discus rotundatus. (Redrawn from Elves, 1961).

C - Cilia; C.T. - Connective tissue; P.G. - Pedal gland; P.G.D. - Pedal gland duct; P.p.gr. - Peripodal groove; P.p.gl. - Peripodal gland; S.C. - Secretory cell.

Fig 40

A

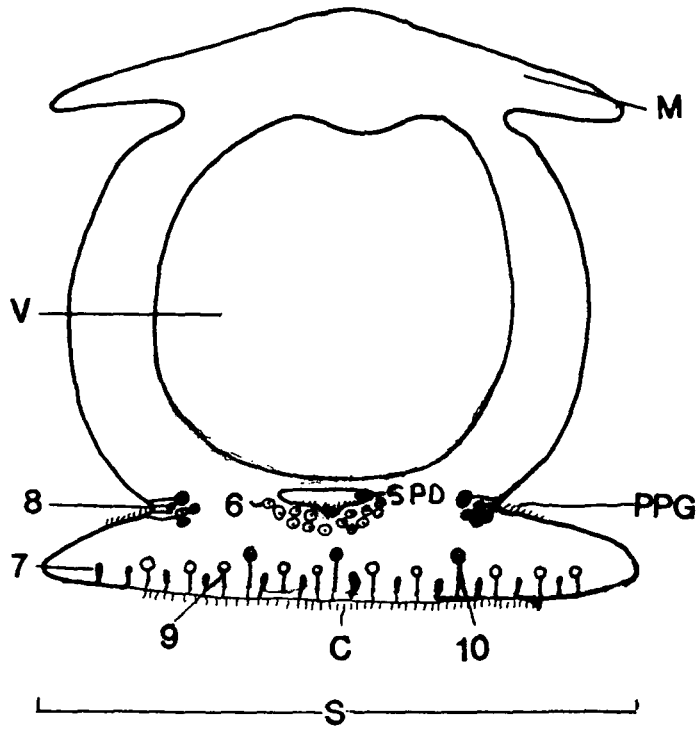

B

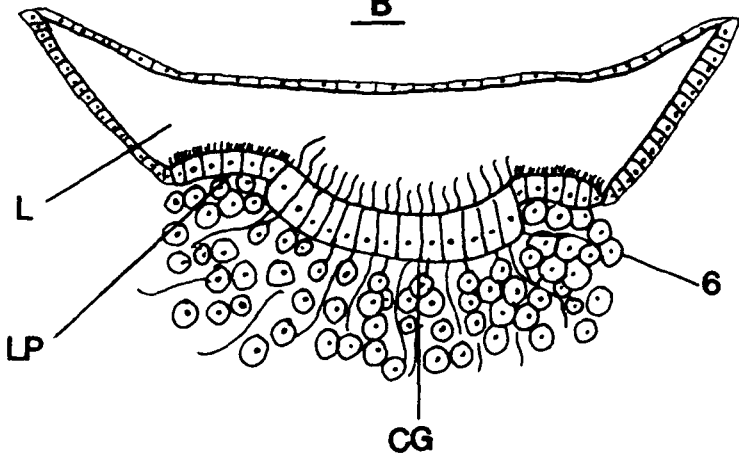
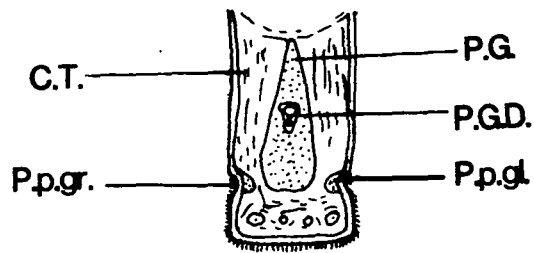

Fig 41



Cl S.C.

Figure 42. Schematic drawing of a longitudinal section of Lymnaea stagnalis to show the location of the epidermal and subepidermal gland cell types. (Redrawn from Zylstra, 1972).

1 - Goblet cell; 2 - Muciparous gland cell (type I); 3 - Muciparous gland cell (type II); 8 - Lateral foot edge gland cell; 9 - Foot sole gland cell; 10 - Posterior pedal gland cell (type I); 11 - Anterior pedal gland cell (type II); 12 - Lip gland cell type A.

Fig 42

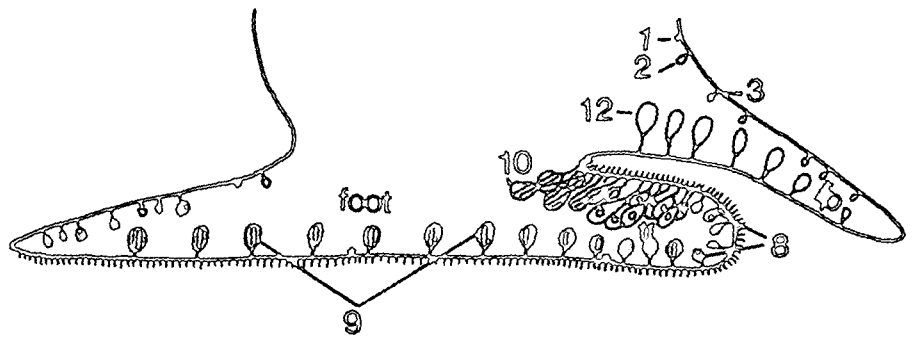

Figures 43 to 45. Schematic presentation of longitudinal sections of mantle edge to show the location of epidermal and subepidermal mucus gland cells in this area.

Fig. 43. Pomatias elegans.

Fig. 44. Bithynia tentaculata.

Fig. 45. Littorina littorea.

DE - Dorsal epithelium; VE - Ventral epithelium. All other labels refer to cell types.

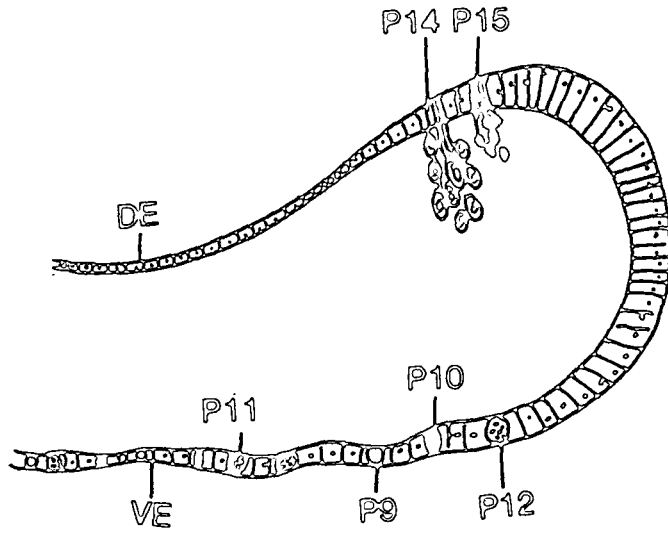

Fig 43

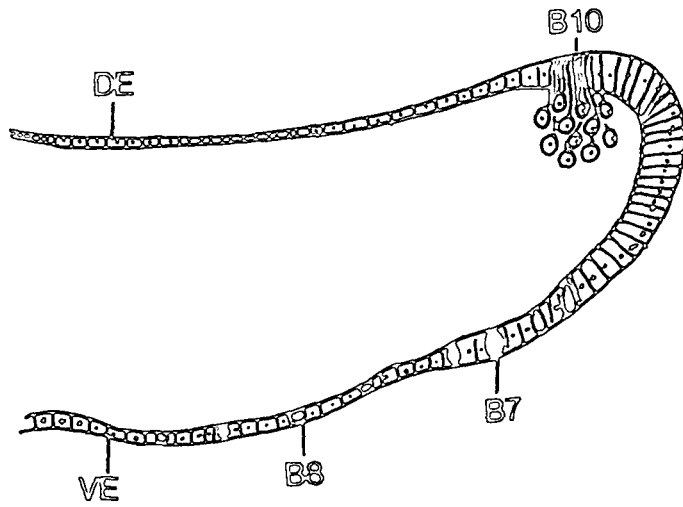

Fig. 44

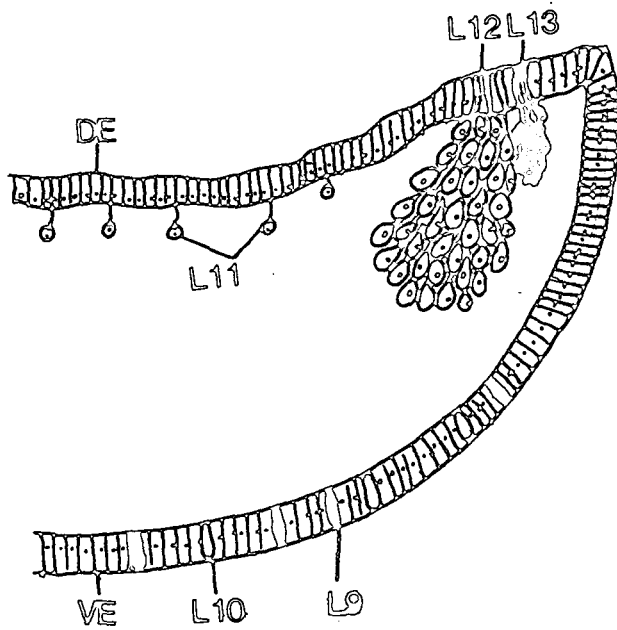

Fig 45

Figure 46. Sketch of the mantle edge of Pila virens.

(Drawn from plate in Umadevi et al., 1984).

DME - Dorsal mantle epithelium; GC - Goblet cell; SMG -  
Supramarginal groove; SMR - Supramarginal ridge; SHG - Shell  
gland; VME - Ventral mantle epithelium.

Fig 46

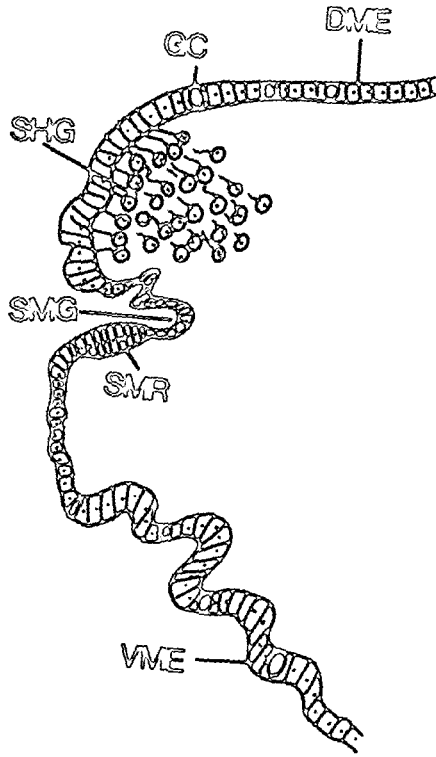

Figure 47. Schematic presentation of a cross section of mantle edge of Helix aspersa. (Redrawn from A.S.M. Saleuddin, 1976).

CC - Calcium cell; DE - Dorsal epithelium; MC - Mucus cells;  
PG - Periostracal gland; PGR - Periostracal groove; P -  
Periostracum; VE - Ventral epithelium.

Fig 47

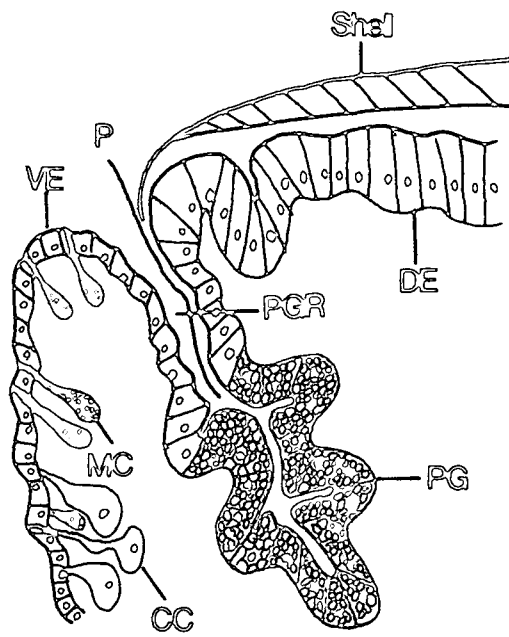

Figure 48A. Schematic drawing of a cross section of the mantle to show the location of the epidermal and subepidermal gland cell types in Lymnaea stagnalis.

(Redrawn from Zylstra, 1972).

2 - Muciparous gland cell (type I); 3 - Muciparous gland cell (type II); 4 - Mantle muciparous gland cell type B; 5 - Mantle muciparous gland cell type A; 6 - Mantle nonmuciparous gland cell type B; 7 - Mantle nonmuciparous gland cell type A.

Figure 48B. Sketch of the mantle edge of Lymnaea stagnalis

showing the approximate zonation of the mantle edge as indicated by the numbers 1,2(a,b,c), 3a,3b,4,5a. The various gland cell types and their distribution are represented by the symbols g1-g8; n1 and n2 refer to the sensory neurons located in the anterior periostracal groove (pg) and zone 4, respectively; n3 indicates the possible location of a motor neuron with axons leading to the base of zone 2 (the dotted connection indicates that the path of this axon has not been positively observed); ime - inner mantle epithelium; ome - outer mantle epithelium. (Redrawn from Zylstra et al., 1978).

Figure 49. Schematic presentation of a cross section of mantle edge in Heliosoma duryi. (Redrawn from Saleuddin, 1979).

de - Dorsal epithelium; meg - mantle edge gland; mc - mucus cell; pc - periostracal cells; pg - Periostracal groove; p - periostracum; r - receptor; ve - ventral epithelium.

Fig. 48

A

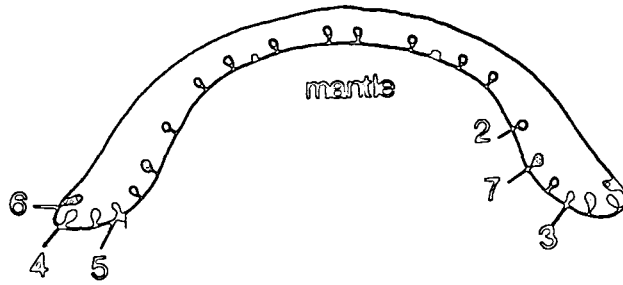

B

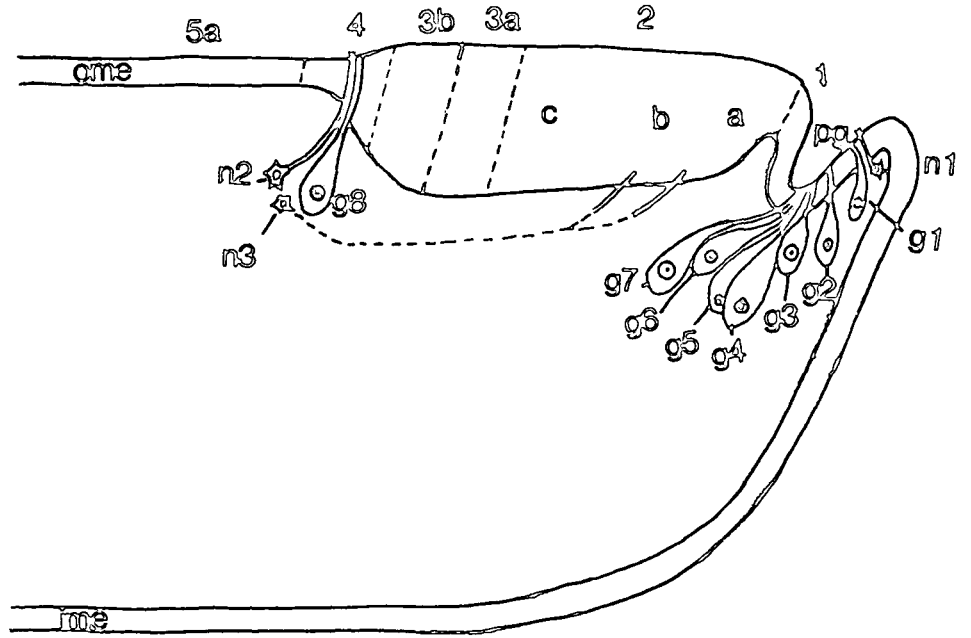
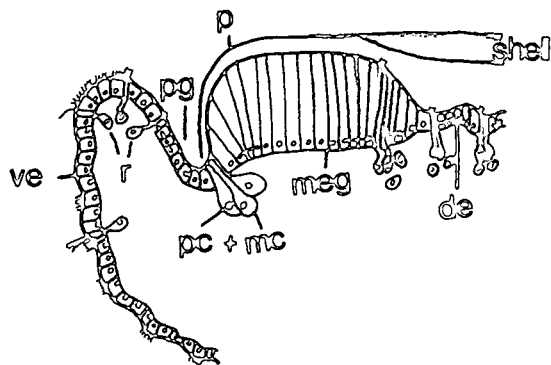

Fig. 49



Figures 50 to 53. Schematic drawings of the glandular epithelium of the hypobranchial glands to show the mucus producing hypobranchial gland cell types.

Fig. 50. Pomatias elegans.

Fig. 51. Bithynia tentaculata.

Fig. 52. Littorina littorea.

Fig. 53. Buccinum undatum.(Redrawn from Hunt, 1967).

Cc - Ciliated cell. All other labels refer to cell types.

Fig 50

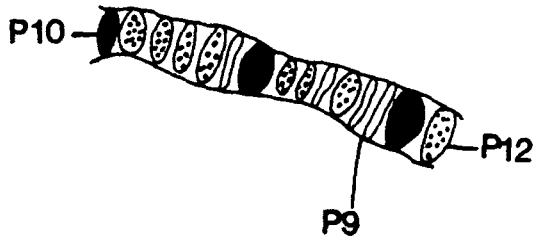

Fig 51

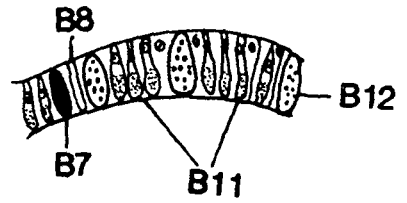

Fig 52

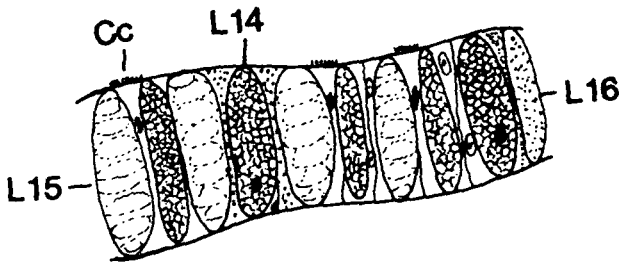

Fig 53

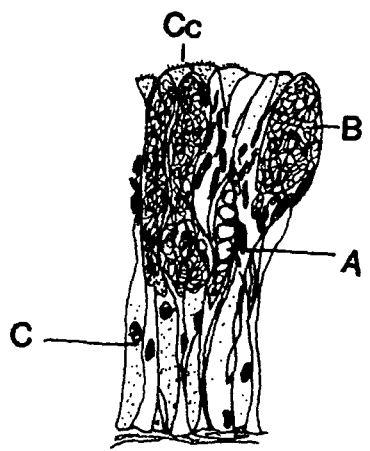

Plate 64 Cross sections of part of the head of Lymnaea stagnalis.

A A section stained in Mallory's triple stain, to show the epidermal goblet cell type. Note the contents being released (x 160).

B A section stained in PAD (x 160).  
Muciparous gland cell type I and muciparous gland cell type II stained brown which indicates the presence of neutral mucopolysaccharide in their secretion.

C A section stained by the diazo-coupling reaction (x 160).  
Muciparous gland cell type II stained purple which indicates the presence of protein in the secretion.

GC - Goblet cell; I - Muciparous gland cell type I; II - Muciparous gland cell type II.

PLATE 64

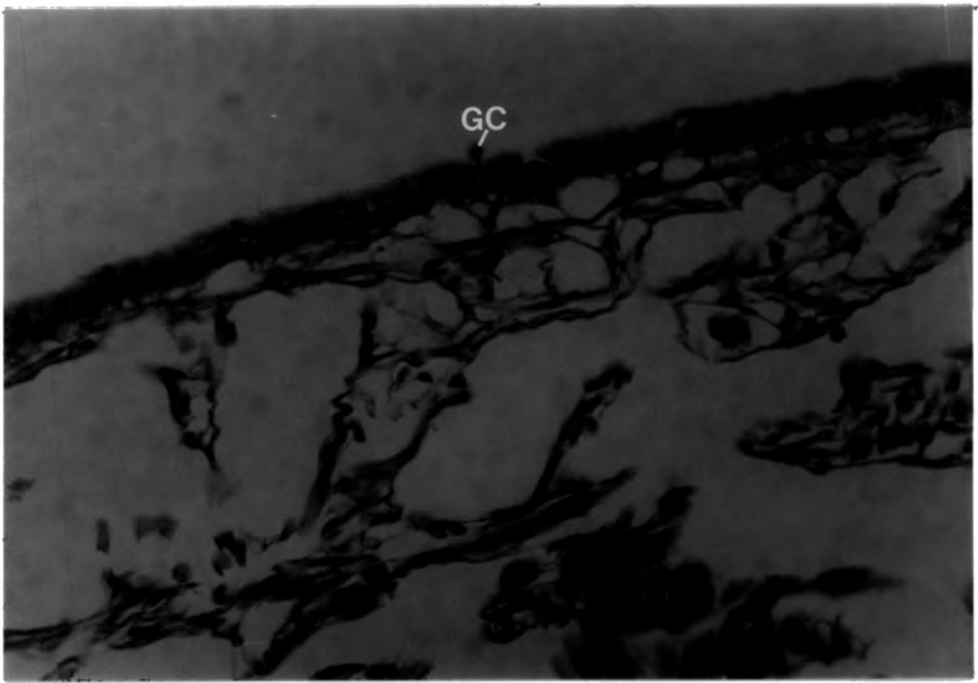

A

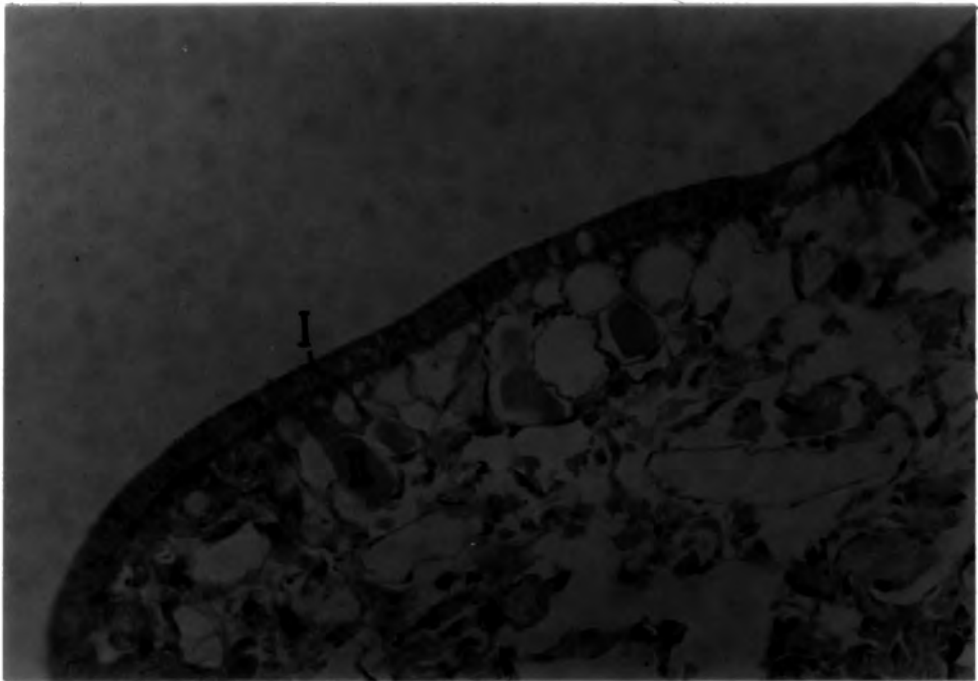

B

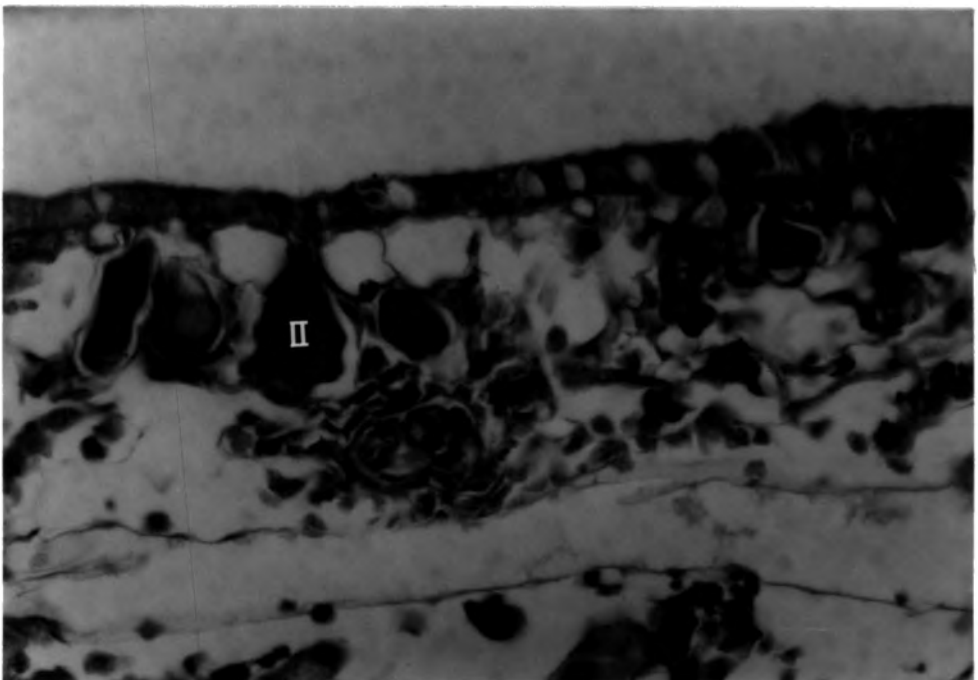

C

Plate 65 Cross sections of part of the head of Lymnaea  
stagnalis.

A A section stained in Alcian Blue pH0.5/eosin (x 80).  
Muciparous gland cell type I stained blue, which  
indicates the presence of sulphated mucopolysaccharide  
in their secretion.

B A section stained with PAS (x 80).  
Muciparous gland cell type I stained more intensely  
than Muciparous gland cell type II.

I - Muciparous gland cell type I; II - Muciparous gland cell  
type II.

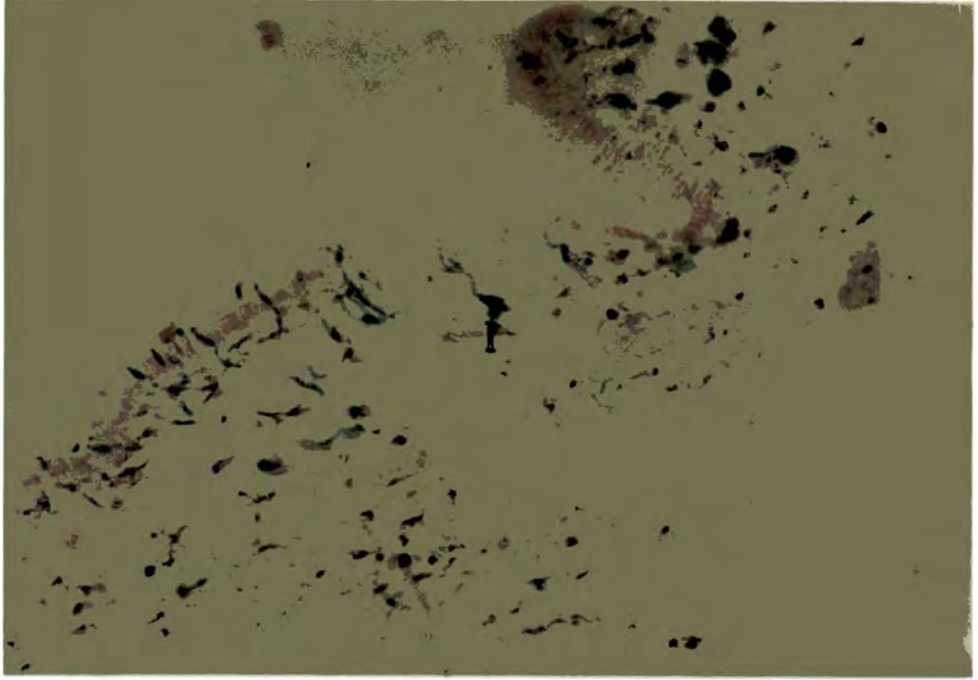

A

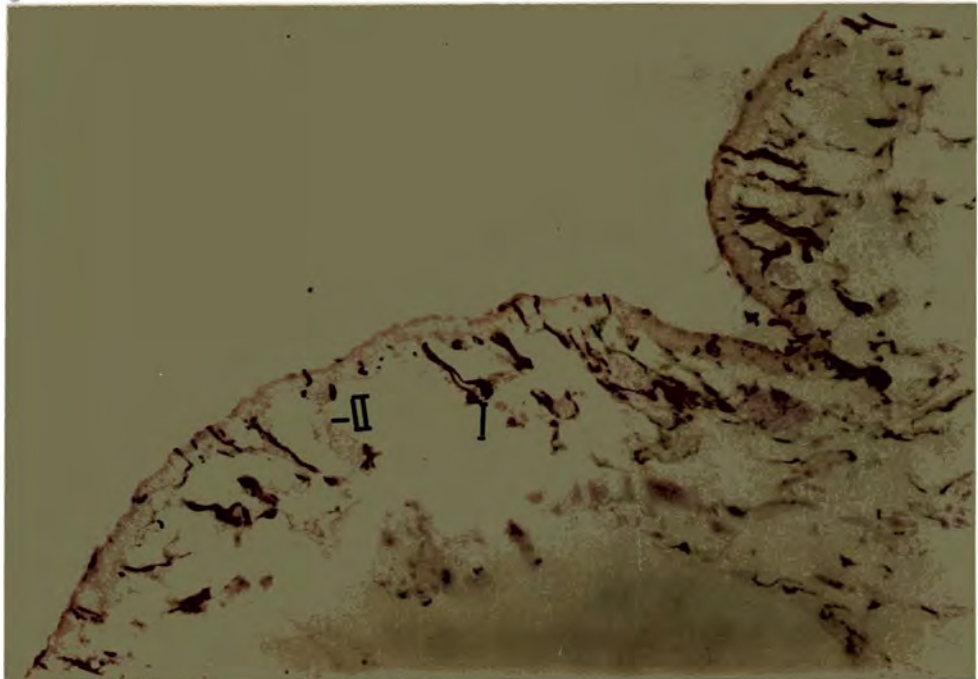

B

Plate 66 Longitudinal sections of the mantle edge of  
Lymnaea stagnalis (x 80).

A A section stained in Mallory's triple stain.

B A section stained in Alcian Blue pH0.5/Alcian Yellow  
pH2.5.

Note the mucus gland cells at the base of the  
periostracal groove and at the ventral epithelium.

D - Duct; DE - Dorsal epithelium, MC - Mucus gland cells;  
MEG - Mantle edge gland; PG - Periostracal groove; VE -  
Ventral epithelium.

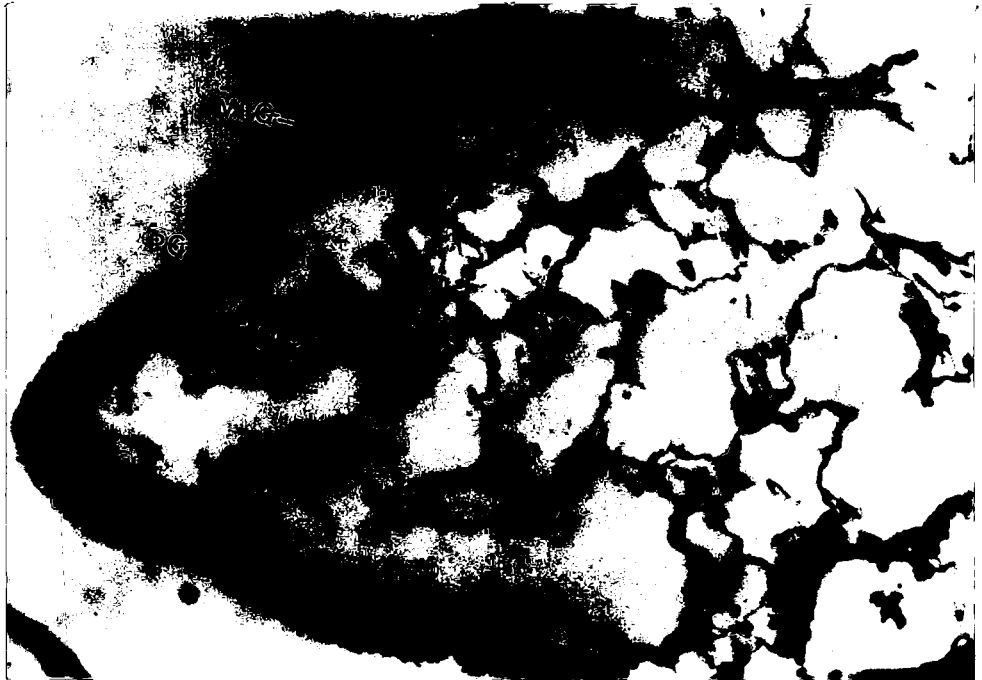

A



B

## DISCUSSION

TABLE 29

<u>Species</u>	<u>Habitat</u>	<u>No. of mantle edge gland clusters</u>	<u>Author</u>
<u>Acmaea</u>	Marine	3	Haller, 1894
<u>Lottia</u>	Marine	3	Fisher, 1904
<u>Scurria</u>	Marine	3	Thiem, 1917.
<u>Patella vulgata</u>	Marine	3	Personal observation
<u>Littorina littorea</u>	Marine	2	Present study
<u>Buccinum</u>	Marine	1	Tullberg (1882) Dakin (1912)
<u>Calyptraeids</u>	Marine	1	Kleinsteuber (1913)
<u>Viviparus</u>	Freshwater	1	<sup>n</sup> Anandale (1921) Starmuhlner (1952)
<u>Valvata</u>	Freshwater	1	Starmuhlner (1952)
<u>Bithynella</u>	Freshwater	1	Bregenzer (1916)
<u>Pila virens</u>	Freshwater	1	Umadevi et al. (1984)
<u>Bithynia tentaculata</u>	Freshwater	1	Present study
<u>Neritina</u>	Freshwater and Marine	1	Andrew 1935.
<u>Pomatias elegans</u>	Terrestrial	2	Present study.

TABLE 30

<u>Species</u>	<u>Habitat</u>	<u>Description of the hypobranchial gland cell types</u>	<u>Histochemical nature of the measure constituent of the hypobranchial gland contents</u>
<u>Littorina littorea</u>	Marine	Two types of mucocytes alternating with slender mucoprotein cells.	Acidic mucopolysaccharide
<u>Buccinum</u> Hunt (1973)	Marine	Acid mucin cells with slender protein cells	Acidic mucopolysaccharide
<u>Scissurella</u> Bourne (1910)	Marine	Two types of mucocytes alternating with slender cells	Mucocytes
<u>Helicinidae</u> Bourne (1911)	Marine	Cylindrical cells alternating with clear cells	Mucocytes
<u>Emarginula</u> Fretter and Graham (1962)	Marine	Clear cells alternating with slender supporting cells	Mucocytes?
<u>Puncturella</u> Fretter and Graham (1962)	Marine	Clear cells alternating with slender supporting cells	Mucocytes?
<u>Turbonilla</u>	Marine	Granular	Protein
<u>Pyramidelids</u>	Marine	Granular	Protein
<u>Omalogyra</u> Fretter and Graham (1962)	Marine	Granular	Protein
<u>Bithynia tentaculata</u>	Freshwater	Two types of granular cells	Protein
<u>Viviparus</u> Anandale 1921, Bolognani-Fantin and Ottaviani 1981	Freshwater	Cylindrical granular cells	Glycoprotein

Plate 67 Longitudinal section of the mantle edge of Patella  
vulgata stained in Alcian Blue pH2.5/PAS. Note 3  
sets of histochemically different gland cells  
opening at the dorsal aspect of the mantle edge  
(x 160).

D - Duct; DE - Dorsal epithelium; VE - Ventral epithelium.  
All other labels refers to the number of gland clusters.



PLATE 67

