

Durham E-Theses

Studies on the nitrosation of thiols in relation to vasodilatory action

Hanif M.S. Patel

How to cite:

Patel, Hanif M.S. (1989) Studies on the nitrosation of thiols in relation to vasodilatory action. Doctoral thesis, Durham University.

Use policy

The full-text may be used and/or reproduced, and given to third parties in any format or medium, without prior permission or charge, for personal research or study, educational, or not-for-profit purposes provided that:

- a full bibliographic reference is made to the original source
- a <https://etheses.durham.ac.uk/id/eprint/6728/> is made to the metadata record in Durham E-Theses
- the full-text is not changed in any way

The full-text must not be sold in any format or medium without the formal permission of the copyright holders.

Please consult the [full Durham E-Theses policy](#) for further details.

Studies on the Nitrosation of Thiols in
Relation to Vasodilatory Action

by

Hanif M. S. Patel, B.Sc. (C.N.A.A.)

(Trevelyan College)

The copyright of this thesis rests with the author.
No quotation from it should be published without
his prior written consent and information derived
from it should be acknowledged.

A thesis submitted for the degree of Doctor of Philosophy
of the University of Durham

October 1989



11 MAR 1991

To my family
and Susie

MEMORANDUM

The work for this thesis has been carried out in the Department of Chemistry at the University of Durham between October 1986 and July 1989. It is the original work of the author unless otherwise stated. None of this work has been submitted for any other degree.

ACKNOWLEDGEMENTS

I would like to express my profound gratitude and thanks to my supervisor, Dr. D.L.H. Williams for his patience, guidance and encouragement throughout this research.

I am also grateful to my colleagues Mike, John, Panchali, Shirlene, Andrew, Paula, Alan, Simon, Javid and Tim for their friendship and advice. I would also like to thank Mr. C. Greenhalgh for his invaluable help in writing the computer programs and for the maintenance of the spectrophotometers. Thanks are also due to Mrs. M. Butterfield for her friendliness and encouragement to tidy the laboratory.

Finally, I would like to thank Glaxo Group Research Ltd. for providing the funding for this research.

Studies on the nitrosation of thiols in relation to vasodilatory
action

ABSTRACT

A kinetic study of the nitrosation of L-cysteine, L-cysteine methyl and ethyl esters, N-acetyl-L-cysteine and glutathione by isopropyl nitrite in acid solution at 25°C was undertaken. The thiols exhibited identical rate laws and in all cases the observed rate constant was reduced by added isopropyl alcohol. The results were found to be consistent with the mechanism in which a rapid reversible acid-catalysed hydrolysis of isopropyl nitrite occurs to give nitrous acid, which then in its protonated form effects nitrosation. The third-order rate constant for the nitrosation of the thiols by isopropyl nitrite and the equilibrium constant for the formation of isopropyl nitrite were found to be in good agreement with the literature values obtained by direct measurement.

A similar kinetic study of the nitrosation of L-cysteine, L-cysteine methyl and ethyl esters, N-acetyl-L-cysteine, thioglycolic acid and glutathione by various alkyl nitrites, in water at 25°C, in the pH range 6-13 was undertaken. The pH dependence of the rate constant is consistent with a mechanism involving a direct nitrosation by alkyl nitrites with the thiolate anion (RS^-) of the thiol. A quantitative kinetic analysis yielded macroscopic and microscopic pK_a values for RSH ionisation in good agreement with the literature values. One exception is L-cysteine where the microscopic, pK_D , value (for $NH_2RSH \longrightarrow NH_2RS^-$) differs significantly from the literature value. In the case of simple alkyl nitrites (ethyl, isopropyl, isoamyl and t-butyl nitrites) steric effects appear to be the major influence in reactivity whereas electron-withdrawing substituents in the β -position greatly enhanced the rate constant. The results were found to satisfy Taft's equation and thus a correlation between structure and reactivity of the alkyl nitrites with the thiols was established. This work shows that at least *in vitro* a direct and rapid reaction occurs between alkyl nitrites and thiols at pH values likely to be encountered *in vivo*. This confirms that such reactions could occur *in vivo* and could be an important feature of the chain of events occurring during the vasodilatory action of alkyl nitrites.

Finally a preliminary investigation of the reaction of glyceryl trinitrate with cysteine, in oxygen and oxygen-free nitrogen atmosphere, in the pH range 6-13 was undertaken. In this case no evidence was found for the formation of S-nitrosocysteine or nitric oxide from glyceryl trinitrate in the presence or absence of cysteine. Thus the results could not confirm the hypothesis that glyceryl trinitrate owes its vasodilatory action to the formation of the intermediate, S-nitrosocysteine, from the reaction of nitric oxide (formed from glyceryl trinitrate) and cysteine.

CONTENTS

	<u>Page</u>
Chapter One : Introduction	
1.1 Mechanism of vascular smooth muscle relaxation by organic nitrates and organic nitrites	1
1.1.1 Introduction	1
1.1.2 Postulated mechanisms	2
1.2 Nitrosating Reagents	7
1.2.1 Acidic solution of nitrous acid	7
1.2.2 Nitrosyl halides	10
1.2.3 Nitrosyl thiocyanate and nitrosothiouronium ions	12
1.2.4 Nitric oxide	13
1.2.5 Nitrite ion	15
1.3 S-Nitrosation	16
1.3.1 Introduction	16
1.3.2 Nitrosation of thiols	17
1.3.3 Reactions of thionitrites	22
1.4 Reactions of alkyl nitrites	24
1.4.1 Introduction	24
1.4.2 Nitrosation by alkyl nitrites	25
1.4.3 The Barton reaction	30
References	31
Chapter Two : S-Nitrosation in Acid Solution	
2.1 Introduction	38
2.2 Nitrosation of L-cysteine	39
2.3 Nitrosation of L-cysteine methyl ester, L-cysteine ethyl ester, N-acetyl-L-cysteine and glutathione	51
2.4 Discussion	71

	<u>Page</u>
References	74
Chapter Three : S-nitrosation in mildly basic solution	
3.1 Introduction	75
3.2 Nitrosation of N-acetyl-L-cysteine and thioglycolic acid	77
3.3 Nitrosation of L-cysteine, L-cysteine methyl and ethyl esters and glutathione	91
3.4 Discussion	110
References	114
Chapter Four : Effect of β-electron-withdrawing substituents	
4.1 Introduction	116
4.2 Nitrosation of N-acetyl-L-cysteine and thioglycolic acid	116
4.3 Nitrosation of L-cysteine, L-cysteine methyl and ethyl esters and glutathione	128
4.4 Discussion	141
References	148
Chapter Five : Reactions of glyceryl trinitrate	
5.1 Introduction	149
5.1.1 Formation of S-nitrosocysteine	149
5.1.2 Activation of guanylate cyclase	152
5.1.3 Nitric oxide the endothelium-derived relaxing factor	153
5.2 Extraction of GTN from lactose adsorbate	155
5.3 Reactions with L-cysteine in acid and base conditions	155
5.4 Reactions in nitrogen atmosphere	158
5.5 Determination of nitric oxide	158
5.6 Discussion	161

	<u>Page</u>
References	164
Chapter Six : Experimental details	167
6.1 Experimental techniques used	167
6.1.1 U.V./visible spectrophotometry	167
6.1.2 Stopped-flow spectrophotometry	167
6.2 pH Measurements	170
6.3 Determination of the observed rate constant	170
6.4 Chemical reagents	173
6.5 Kinetic measurements	174
6.5.1 Nitrosation of thiols by isopropyl nitrite in acid solution	174
6.5.2 Nitrosation of thiols by alkyl nitrites in basic solution	178
References	182
Appendix	183

CHAPTER ONE

Introduction

1.1 Mechanism of vascular smooth muscle relaxation by organic nitrates and organic nitrites

1.1.1 Introduction

Many of the organic nitrates, such as ethylene glycol dinitrate, glyceryl trinitrate and mannitol hexanitrate, have powerful explosive properties and this gives rise to one of their principal uses. In particular, glyceryl trinitrate (GTN) is used as the major constituent of dynamite and ethylene glycol dinitrate is added when an explosive with antifreeze properties is required. The chief use of these explosives lies in mining, tunnelling and road building operations, their military usage being limited by lack of chemical stability, though some organic nitrates are incorporated as components of smokeless powder propellants.

Personnel engaged in the manufacture of these explosives experienced some effects ascribed to the vasodilatory action of these nitrates. The clinical effects of this occupational exposure were found to be lowered blood pressure, increased pulse rate, headache, dizziness and chest pains.¹⁻⁴ In addition to the observations made during human exposure, several aspects of the toxicology of the organic nitrate explosives have been investigated by animal studies.⁵⁻⁸

The vasodilatory properties of organic nitrates are responsible for the other major use of these compounds, as drugs for the treatment of angina, acute heart failure and hypertensive emergencies. A detailed description of organic nitrate administration and effects in clinical usage is given in Goodman and Gilman's standard work⁹ and several

reviews have appeared on the subject.^{10,11}

Similarly, organic nitrites, particularly amyl nitrite, have been used as vasodepressors since 1867¹² in the treatment of angina pectoris. Butyl nitrite was investigated as an alternative to amyl nitrite in the late 1880's.¹² It has essentially the same therapeutic effects as amyl nitrite but has not been used clinically to any extent. However, recently amyl nitrite has been used for non-medical purposes such as an agent for inducing a state of euphoria and as an aphrodisiac.¹³

The vasodilatory effects of organic nitrites have been found to be relaxation of involuntary muscles of the blood vessels which causes a lowering of the blood pressure and also vasodilation of the cerebral vessels which result in an increase of the intracranial pressure. The latter effect produces a "high" or euphoric effect which lasts about one minute. Peripheral vasodilation is also observed, with a flushing of neck and face.¹⁴ In addition to the vasodilatory effect, the toxic effect of inhalation of organic nitrites includes pulsation of the head, motor unrest, cyanosis, confusion, vertigo, weakness, yellow vision, soft thready pulse, fainting, and prolonged inhalation results in death from respiratory failure.¹⁵

Despite their long clinical use, their mechanism of action, both of organic nitrates and organic nitrites, is still uncertain.

1.1.2 Postulated mechanisms

In the last decade or so there have been several mechanisms postulated. These being:

1. GTN as a stimulant of prostaglandin synthesis.
2. Organic nitrate receptor.
3. Formation of S-nitrosothiol as an intermediate.

The hypothesis of GTN as a stimulant of prostaglandin synthesis proposes that GTN acts by inducing the synthesis and release of prostaglandin which then mediates vasodilation. This is an attractive hypothesis since prostacyclin is a potent vasodilator and is the major prostaglandin synthesised in the blood vessels. Increased prostacyclin levels have been reported following the addition of GTN to human endothelial cell cultures¹⁶ and to isolated bovine coronary arteries.¹⁷ The role of prostaglandins in GTN-induced vasodilation has been studied with isolated rabbit celiac and mesenteric arteries.¹⁸ However, from this study it was concluded that prostaglandins were not involved in GTN-induced vasodilation of isolated rabbit celiac and mesenteric arteries.¹⁹ This indicates that GTN does not induce vasodilation via increased synthesis of prostaglandins since the vascular endothelium is the major source of prostaglandin in blood vessels.

The hypothesis of a specific organic nitrate receptor was put forward by Needleman and coworkers.^{20,21} They found that aortic strips made tolerant to GTN in vitro were reversed by treating with sulphhydryl reducing agent, dithiothreitol. They envisioned an organic nitrate receptor containing a key sulphhydryl group on the active site with which the organic nitrates reacted (Figure 1.1).

Figure 1.1 Organic nitrate receptor

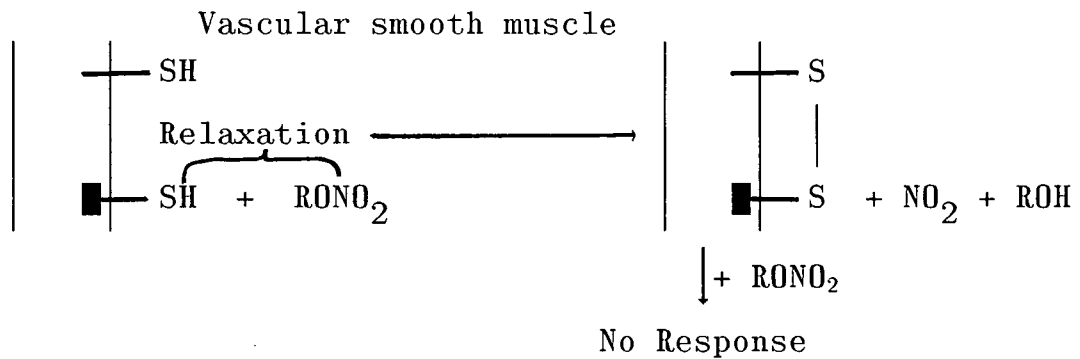

As a consequence of this reaction relaxation occurred accompanied by the denitration of the organic nitrate and the oxidation of the sulphhydryl group to the disulphide form. The model was also used by them to explain the tolerance. They suggested that since the key sulphhydryl group was in the oxidised form the receptor would have a very low affinity for organic nitrates. The effect of various sulphhydryl reagents (p-chloromercuribenzoate (PCMB), 5,5'-dithiobis(2-nitrobenzoic acid) (DTNB), ethacrynic acid (EA)) on GTN-induced vasodilation has been studied using isolated canine saphanous veins and dorsal pedal arteries precontracted with phenylephrine.²² Contrary to expectation, neither PCMB nor DTNB affected the GTN response. When EA was used partial inhibition of the GTN response was seen at high doses.²³ However, EA also inhibits vasodilation induced by a variety of agents in addition to organic nitrates so that its effect is clearly not confined to a specific organic nitrate receptor. Since only partial inhibition of the GTN response was seen with EA, other mechanisms are probably involved in GTN-induced relaxation. Furthermore, the existence of a specific organic nitrate receptor has not been demonstrated nor have

specific antagonists to organic nitrates been identified.

An interesting hypothesis concerning the mechanism of organic nitrite and organic nitrate induced vasodilation was proposed by Ignarro et. al.²⁴ They proposed that the organic nitrites and nitrates owed their action to the intracellular release or formation of nitric oxide which then reacts with SH-containing compounds to form S-nitrosothiols. The S-nitrosothiols then activate guanylate cyclase which in turn raises cyclic GMP levels resulting in vasodilation.

Evidence accumulated by various research groups over the years can be used to support this hypothesis. These studies have shown GTN and nitroprusside are capable of releasing nitric oxide (NO)^{25,26} and also that GTN, nitroprusside, NO, amyl nitrite, nitrosoguanidine and other nitrogen oxide-containing compounds activate soluble guanylate cyclase, but this enzyme activation required the presence of sulphhydryl group in the form of added thiols.^{26,27-32} These compounds also markedly elevate guanosine 3',5'-monophosphate (cyclic GMP) levels in vascular smooth muscle, platelets and various organs.^{26,27,33-38} The stimulation of cyclic GMP formation by these potent vascular smooth muscle relaxants³⁹ and the relaxation of precontracted strips of bovine coronary artery⁴⁰ and nonvascular smooth muscle by analogues of cyclic GMP,⁴¹ suggests that cyclic GMP is involved in smooth muscle relaxant effect of these compounds. The S-nitrosothiols formed by reacting the vasodilators with thiols were found to activate guanylate cyclase without added thiols, elevate tissue cyclic GMP levels, relax coronary arterial strips and

decrease systemic arterial pressure.^{25,28,42-44} It has been shown that methylene blue inhibits the same vasodilatory effects of S-nitrosothiols as it does for nitrogen oxide-containing vasodilators.^{26,27} Finally, in an anaesthetised cat the dose-related depressor effects of S-nitrosothiols were found to resemble those of nitroprusside and GTN.²⁴ Thus all these results would seem to support the hypothesis of the formation in smooth muscle of active, unstable S-nitrosothiols intermediates. A schematic diagram of the above hypothesis is presented in Figure 1.2

Figure 1.2 Schematic diagram of proposed mechanism by which organic nitrites and nitrates relax vascular smooth muscle

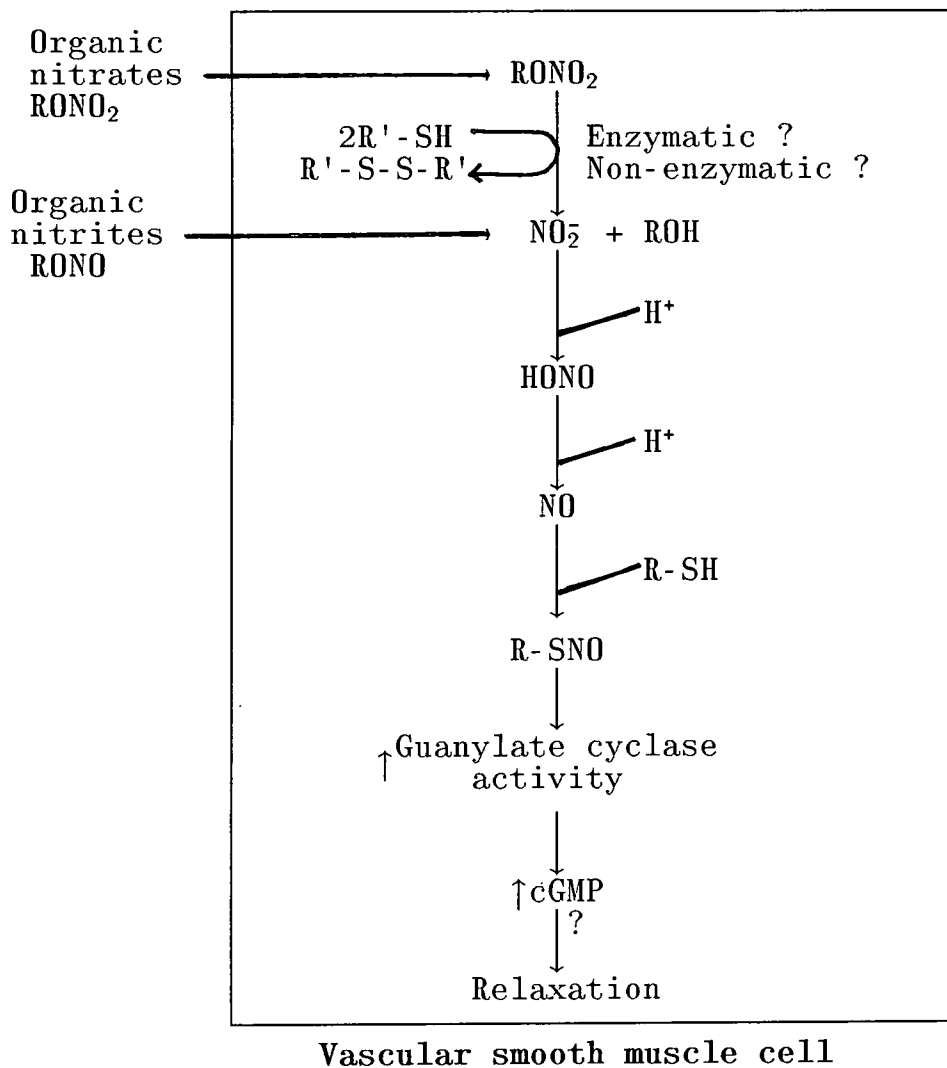

1.2 Nitrosating Reagents

1.2.1 Acidic solution of nitrous acid

Nitrous acid derived reagents are the most widely used nitrosating reagents in nitrosation and diazotisation. Solutions of nitrous acid are easily formed from nitrite salts and aqueous mineral acid. The solutions decompose very readily in the presence of acid (equation 1.1) and this has to be taken into account when quantitative work is carried out.



In aqueous solutions nitrous acid generates the nitrosating reagent dinitrogen trioxide N_2O_3 (equation 1.2).

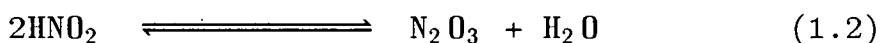

Early work on the nitrosation, deamination⁵⁴ and diazotisation⁵⁵ of amines established the third-order rate equation (equation 1.3).

$$\text{Rate} = K k [\text{Amine}] [\text{HNO}_2]^2 \quad (1.3)$$

This was later interpreted by Hammett⁴⁷ (Scheme 1.1) as the rate limiting attack by dinitrogen trioxide, generated from nitrous acid, on the free form of the amine.

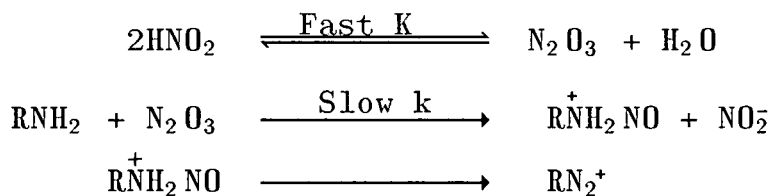

Scheme 1.1

The proposed mechanism was later confirmed by Hughes, Ingold and Ridd.^{48,49} However, with very reactive substances⁵⁰⁻⁵³ the rate limiting step becomes the formation of dinitrogen trioxide (equation 1.4), as the hydrolysis of dinitrogen trioxide to nitrous acid is slower than the reaction of the dinitrogen trioxide with the substrate. Thus the rate equation becomes second-order in nitrous acid concentration and zero-order in substrate concentration (equation 1.4).

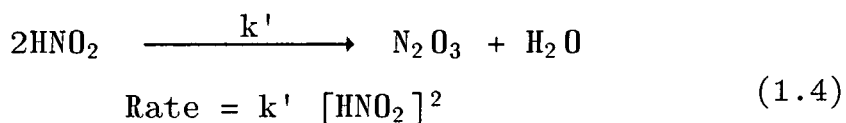

The equilibrium constant, K, for the formation of dinitrogen trioxide (Scheme 1.1) was recently determined⁵⁴ as $3.0 \times 10^{-3} \text{ l mol}^{-1}$, and using this value of K, the value of the rate constant, k (equation 1.3) for various amines⁵⁵, was found to be of the order of 10^8 . Thus the reactions of amines with dinitrogen trioxide are on or close to encounter controlled limit.

However, it was found that at high acidities and low concentration of nitrous acid the diazotisation of amines^{56,57} and the nitrosation of a range of other substrates⁵⁸⁻⁶⁰ followed the rate equation (equation 1.5),

where [S] is the concentration of substrate.

$$\text{Rate} = k [\text{S}] [\text{HNO}_2] [\text{H}^+] \quad (1.5)$$

This indicates a different mechanism to that involving nitrogen trioxide. In this case the mechanism proposed (Scheme 1.2) is one involving the nitrosating agent nitrous acidium ion, H_2NO_2^+ or nitrosonium ion, NO^+ which are kinetically indistinguishable.

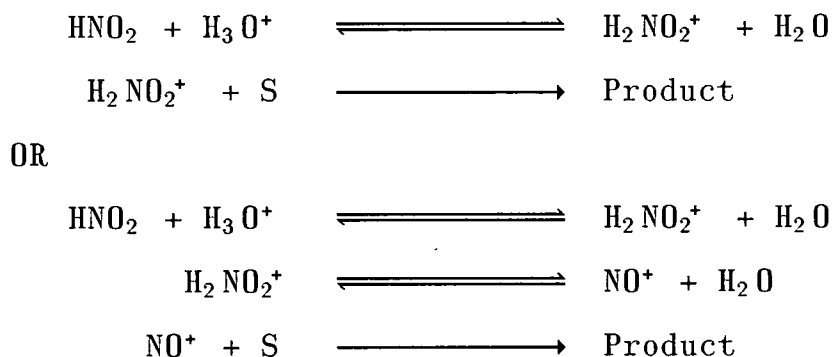

Scheme 1.2

As to which mechanism is correct there is a great deal of controversy. The only clear evidence is that at very high acidities, 60% perchloric acid, the nitrosating agent is the nitrosonium ion and its presence in such solutions has been confirmed spectroscopically.⁶¹⁻⁶² Recently it has been identified kinetically as the effective reagent in dilute acid for the nitrosation of alcohols and thiols in acetonitrile solvent using either alkyl nitrites or nitrous acid.⁶³ In contrast, there is no such evidence for the presence of nitrous acidium ion. There is a reasonable amount of evidence for and against each of the mechanisms but in neither case is the evidence presented totally

convincing. This evidence will not be discussed here as it is well documented and discussed in a book recently published.⁶⁴

1.2.2 Nitrosyl halides

Nitrosyl halides have long been used synthetically as nitrosating agents for a range of substrates. Schmid was the first to investigate the catalytic effect of halide ions when he studied the diazotisation of amines by hydrochloric and hydrobromic acid.^{65,66} From these results he established the rate equation (equation 1.6), where $[X^-]$ is the concentration of the halide ion.

$$\text{Rate} = k [\text{ArNH}_2] [\text{HNO}_2] [\text{H}^+] [\text{X}^-] \quad (1.6)$$

Since then a similar rate equation has been established for a range of substrates.⁶⁷⁻⁷⁴ The mechanism was first interpreted by Hammett⁴⁷ (Scheme 1.3) in terms of an initial equilibrium step involving the formation of the nitrosyl halide and then the subsequent rate-limiting attack on the free amine (substrate) by the nitrosyl halide .

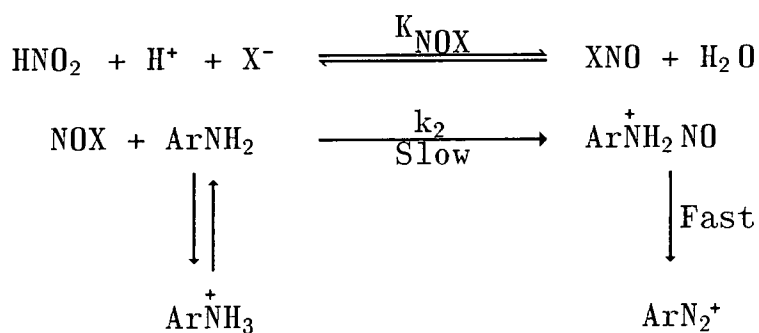

Scheme 1.3

From Scheme 1.3:

$$K_a = \frac{[\text{ArNH}_2] [\text{H}^+]}{[\text{Ar}\overset{+}{\text{N}}\text{H}_3]} \quad (1.12)$$

$$K_{\text{NOX}} = \frac{[\text{XNO}]}{[\text{HNO}_2] [\text{H}^+] [\text{X}^-]} \quad (1.13)$$

By assuming $[\text{ArNH}_2]_{\text{T}} = [\text{Ar}\overset{+}{\text{N}}\text{H}_3]$; $[\text{XNO}] \ll [\text{HNO}_2]_{\text{T}}$ and substituting equation (1.12) and (1.13) into equation (1.11), we get the rate equation (equation (1.14)) in terms of total concentration of amine, nitrous acid and halide ion added.

$$\text{Rate} = k_2 K_a K_{\text{NOX}} [\text{ArNH}_2]_{\text{T}} [\text{X}^-] [\text{HNO}_2]_{\text{T}} \quad (1.14)$$

The second-order rate constant, k_2 , can be determined as long as accurate values of K_{NOX} and K_a are known. The K_{NOX} values for both nitrosyl chloride and nitrosyl bromide have been determined spectrophotometrically by Schmid and Hallaba.⁷⁶ These values have been used to determine the values of k_2 for various substrates.⁶⁷⁻⁷⁴ This shows the expected trend of $\text{NOCl} > \text{NOBr}$ based on the electronegativity of the halogens. However, the sequence of the catalytic effect for halide ion is $\text{Br}^- > \text{Cl}^-$; this indicates that the magnitude of the K_{NOX} values govern the catalytic activity of these ions.

For very reactive species^{52,75,76} there is, in some cases a zero order substrate dependence, which is interpreted (as in the dinitrogen trioxide case) as rate-limiting XNO

formation.

Thus the rate equation for such reaction has been established (equation 1.15) and the third-order rate constant, k , determined.

$$\text{Rate} = k [\text{H}^+] [\text{HNO}_2] [\text{X}^-] \quad (1.15)$$

1.2.3 Nitrosyl thiocyanate and Nitrosothiouronium ions

The nitrosation of several substrates, by nitrosyl thiocyanate (NOSCN)^{52,77-82} and nitrosothiouronium ions ($(\text{NH}_2)_2\text{CSNO}^+$)^{77,80,83} has been observed. The mechanism (Scheme 1.4) is similar to that of nitrosation by nitrosyl halides in that the initial step is the formation of the nitrosating agent (i.e. NOSCN and $(\text{NH}_2)_2\text{CSNO}^+$) and then the rate-limiting attack of substrate by the nitrosating agent, where A is the substrate .

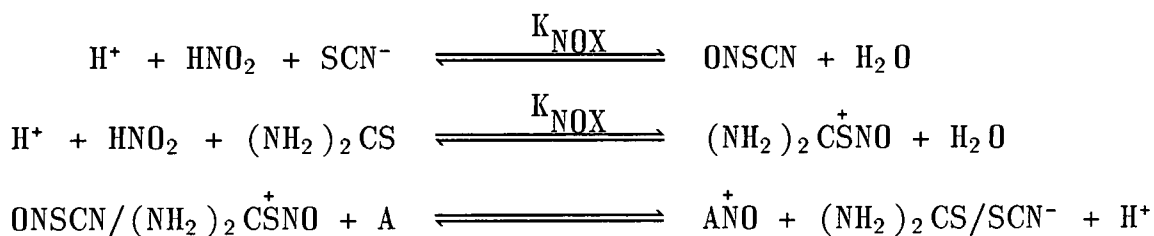

Scheme 1.4

In general it is found that the reactions which are catalysed by nitrosyl halides are also catalysed by thiocyanate ion and thiourea. As in the case of the nitrosyl halide the equilibrium constants, K_{NOX} , for the formation of nitrosyl thiocyanate⁸⁴ and nitrosothiouronium ion⁸⁵ have been determined and are $32 \text{ l}^2 \text{ mol}^{-2}$ at 20°C and $5000 \text{ l}^2 \text{ mol}^{-2}$ at

25°C respectively. Thus the second order rate constant, k_2 (equation 1.14), can be determined and the reactivity of the reagents compared. We find that the reactivity of these nitrosating agents is $\text{NOCl} > \text{NOBr} > \text{NOSCN} > \text{NO}^+\text{SC}(\text{NH}_2)_2$. However, the order of the catalytic activity of these ions has been found to be the reverse, that is $\text{SC}(\text{NH}_2)_2 > \text{SCN}^- > \text{Br}^- > \text{Cl}^-$, indicating that the magnitude of the rate constant, K_{NOX} , governs the catalytic activity of these ions. Thus thiourea is considered the most efficient catalyst for nitrosation.

1.2.4 Nitric oxide

Nitric oxide (NO) normally would not be considered as an effective nitrosating agent as it is easily oxidised to dinitrogen tetroxide and dinitrogen trioxide in the presence of oxygen. Thus these may be the reactive species in many of the reactions thought to be brought about by NO. However, it has been found that NO does act as a nitrosating agent⁸⁶ with thiols in oxygen free, basic solutions, and a mechanism (Scheme 1.5) involving free radical intermediates has been proposed.

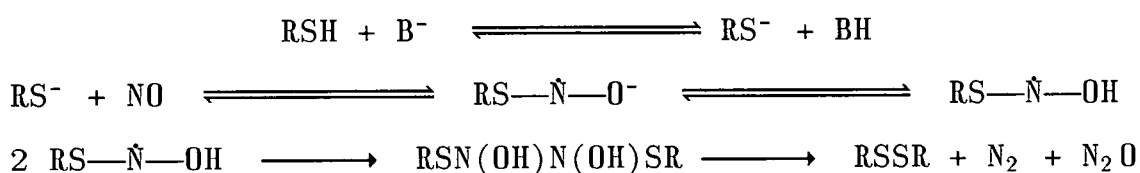

Scheme 1.5

It is also an effective nitrosating agent in the presence of some catalysts. Brackman and Smit⁸⁷ found that the

nitrosation of diethylamine occurred using nitric oxide and copper (II) salts (Scheme 1.6) via the intermediate copper-nitrosyl complex.

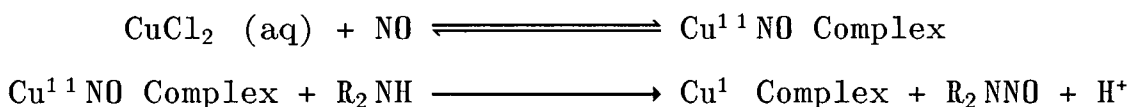

Scheme 1.6

In the case of catalysis by silver ion the nitric oxide is thought to react with the cation radical, produced from the oxidation of the amine, to form the nitrosamine (Scheme 1.7).

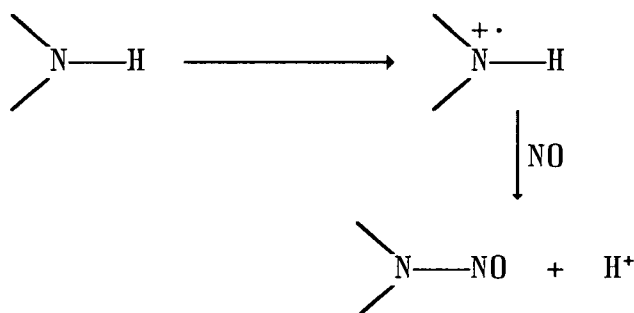

Scheme 1.7

The other reactions for forming nitroso compounds by nitric oxide are the reactions with radicals in the reaction medium. Good examples of these reactions are; the reaction of NO with triphenylmethyl radical⁸⁸ (equation 1.16) and cyclohexyl radicals,⁸⁹ generated from cyclohexane (Scheme 1.8), to form the blue nitroso product and the oxime of cyclohexanone respectively.

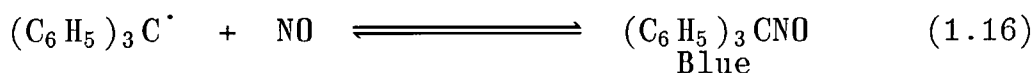

1.3 S-Nitrosation

1.3.1 Introduction

Recently a great interest in S-nitrosation reactions has arisen not only from synthetic and mechanistic aspects but also from the possible biological implication of this reaction in the mode of action of vasodilatory drugs,²⁴ as discussed in Section 1.1.2.

S-nitrosation reactions (Scheme 1.10) are generally faster than the corresponding O-nitrosation reactions (Scheme 1.11). However, whereas S-nitrosation is essentially an irreversible reaction, O-nitrosation is a reversible reaction. These differences can be explained in terms of difference in basicity and nucleophilicity between the sulphur and oxygen.⁸¹ Since sulphur is more polarisable than oxygen it would also be the more nucleophilic of the two, and thus S-nitrosation is more favoured than O-nitrosation. However, oxygen is significantly more basic than sulphur,⁹² and so the rate of the reverse reaction should be greater for the oxygen case than for the sulphur case. This means that the forward reaction is governed by the nucleophilicity (S-nitrosation > O-nitrosation) and the reverse reaction is governed by basicity (O-denitrosation > S-denitrosation).

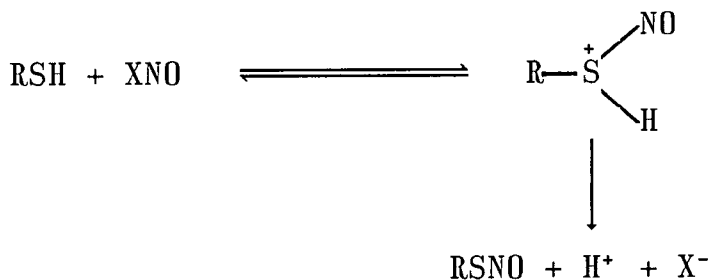

Scheme 1.10

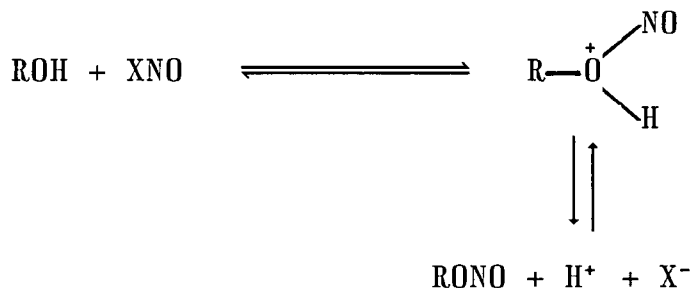

Scheme 1.11

1.3.2 Nitrosation of thiols

Formation of thionitrites or S-nitrosothiols from thiols has been known from as early as 1837 when a red coloured species was observed from reaction of thiols with nitrous acid⁹³ (equation 1.17).

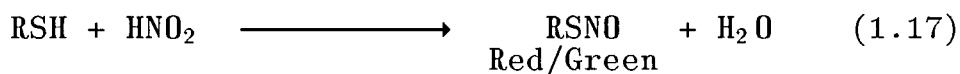

The coloured products observed from the reaction of nitrous acid with thiols were confirmed to be thionitrites by ¹⁵N N.M.R.⁹⁴ and E.S.R.⁹⁵ studies. The colouration property of thionitrites has led them to be used for the identification of thiols in solution⁹⁶ and as a quantitative test for nitrosyl sulphuric acid using thioglycolic acid as the reagent.⁹⁷ There is a comprehensive review⁹⁸ of the physical properties and reactions of thionitrites.

Thionitrites are generally very unstable and decompose to give disulphide and nitric oxide (equation 1.18).

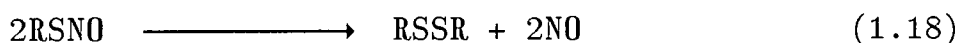

The formation of the disulphide from thionitrites is presumed to be by a homolytic mechanism, although other

non-radical pathways are possible. Even so, the first thionitrites were isolated as early as 1909 by Tasker and Jones.⁹⁹ They isolated phenyl thionitrite and ethyl thionitrite. Since then several thionitrites have been isolated and characterised. Examples include triphenylmethyl thionitrite (1.1),¹⁰⁰ t-butyl thionitrite (1.2),¹⁰¹ S-nitrosocysteine¹⁰² and S-nitroso-N-acetyl-D,L-penicilliamine (SNAP) (1.3).¹⁰³ The thionitrite derived from cysteine is difficult to isolate in the pure form and has to be stored at low temperature. However, t-butyl thionitrite is stable in the solid form for a few days at room temperature and SNAP is indefinitely stable as a solid and decomposes only slowly in solution. This shows that thionitrites with bulky groups attached to the atom bound to the sulphur atom are particularly stable and easy to isolate.

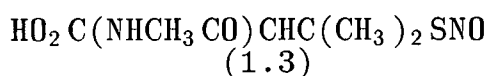
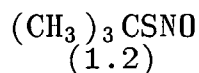
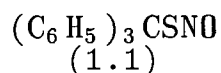

The best example of a S-nitrosation process is the reaction of thiols, both aliphatic and aromatic, with the usual nitrosation and diazotisation reagents such as nitrous acid,¹⁰⁴ dinitrogen tetroxide,¹⁰⁵ nitrosyl chloride¹⁰⁶ and alkyl nitrites¹⁰⁷ (equation 1.19)



Thus thionitrites can in principle be prepared from any nitrosating agent, but the easiest and most convenient synthetic procedure is either to react dinitrogen tetroxide with an equimolar amount of the thiol in an inert solvent at -10°C ¹⁰⁸ or by using t-butyl nitrite as a nitrosating reagent in chloroform¹⁰⁹ (equation 1.20). Both methods give rapid quantitative yields.

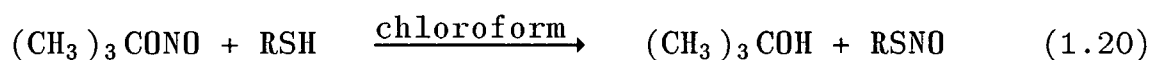

Mechanistically this area of nitrosation has only recently been studied in great detail and reviewed.⁶⁸ Kinetic investigation by Kresze and Winkler¹¹⁰ on the nitrosation of t-butyl thiol by nitrous acid in the absence of added nucleophiles established the rate equation (equation 1.21).

$$\text{Rate} = k [\text{HNO}_2] [\text{H}^+] [\text{RSH}] \quad (1.21)$$

Since then the same rate equation has been established for several thiols by various research groups.^{79,111} The rate equation is interpreted in terms (Scheme 1.12) of a rate-limiting electrophilic attack by nitrous acidium ion (H_2NO_2^+) or nitrosonium ion (NO^+) on the sulphur atom, followed by rapid proton loss from the protonated thionitrite.

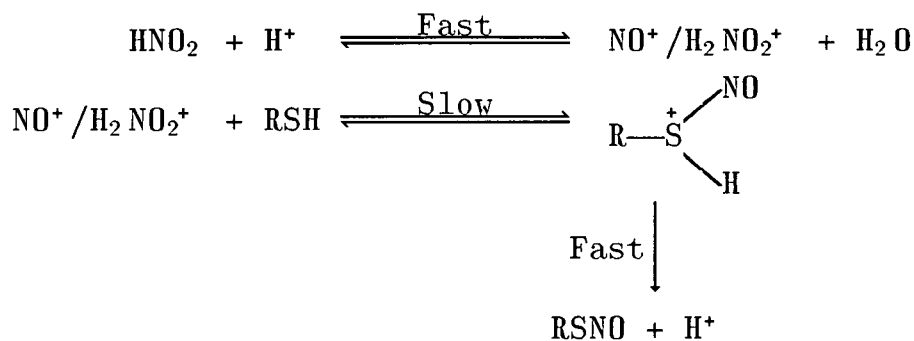

Scheme 1.12

The third-order rate constants, k (equation 1.21), determined for several thiols are summarized in table 1.1. Since the value for encounter-controlled limit⁶⁰ is thought to be $7,000 \text{ l}^2 \text{ mol}^{-2} \text{ s}^{-1}$, for the reaction involving neutral substrates, it shows that the nitrosation of several reactive thiols occurs at or close to encounter-controlled limit.

Table 1.1 Values of k for acid-catalysed nitrosation in water at 25°C

Substrate	$k/\text{l}^2 \text{ mol}^{-2} \text{ s}^{-1}$	Ref.
Cysteine	456,443	79,111
Cysteine methyl ester	213	77
Glutathione	1080	77
N-acetyl cysteine	1540	77
Thioglycolic acid	2630	77
$(\text{NH}_2)_2\text{CS}$	6960	111
Sulphanilic acid	7300	112
$\text{CS}(\text{NHMe})_2$	6610	111

The catalytic effect of added nucleophiles such as chloride, bromide and thiocyanate ion has been

investigated⁸¹ and found to be similar to that encountered for N-nitrosation, diazotisation and O-nitrosation reactions. The rate equation for the nitrosation of thiols by nitrous acid in the presence of added nucleophiles has been established (equation 1.22).

$$\text{Rate} = k_2 [\text{RSH}] [\text{XNO}] \quad (1.22)$$

The mechanism postulated (Scheme 1.13) for the catalysis of S-nitrosation is one in which the pre-equilibrium step is the formation of the NOX species, these then effect nitrosation of the substrate.

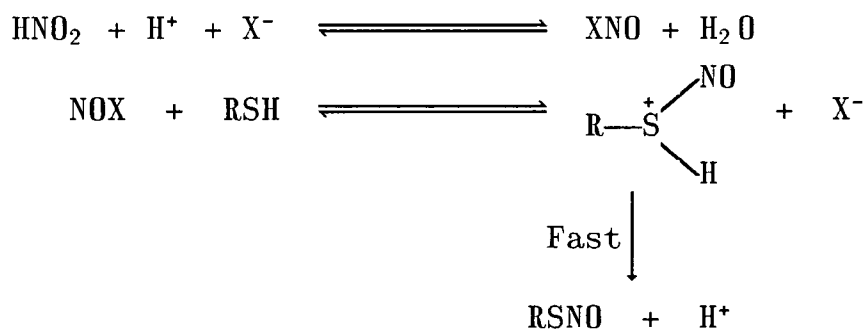

Scheme 1.13

The second-order rate constants, k_2 (equation 1.22), for attack by nitrosyl chloride, nitrosyl bromide and thiocyanate are given in table 1.2 for a number of thiols.

As expected from the electronegativity of the ions (X^-) the k_2 value decreases along the series nitrosyl chloride > nitrosyl bromide > nitrosyl thiocyanate. However, the order of catalytic activity of these ions has been found to be the reverse, that is $\text{SCN}^- > \text{Br}^- > \text{Cl}^-$,⁸¹ indicating, as for nitrosation reactions generally, that the magnitude of the

equilibrium constant, K_{XNO} , is the dominant factor in quantifying catalytic reactivity.

Table 1.2: Values of second-order rate constants, k_2 ($l \text{ mol}^{-1} \text{ s}^{-1}$) (Ref. 64), at 25°C

Substrate	NOCl	NOBr	NOSCN
Cysteine methyl ester	1.0×10^6	4.6×10^4	7.5×10^2
Cysteine	1.2×10^6	5.5×10^4	6.5×10^2
Glutathione	1.2×10^7	5.5×10^5	3.9×10^3
N-acetyl cysteine	1.0×10^7	4.5×10^5	1.6×10^3
Thioglycolic acid	1.4×10^7	1.0×10^6	2.5×10^4

1.3.3 Reactions of thionitrites

Thionitrites are generally very unstable and will decompose both thermally¹⁰³ and photochemically¹¹³ to give the disulphide and nitric oxide. Good yields of unsymmetrical disulphides are obtained when thionitrites are reacted with other thiols (equation 1.23).

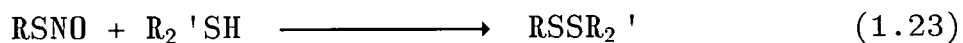

Oae and co-workers¹¹⁴ found that N-methylaniline was nitrosated by tertiary-butyl thionitrite to give N-nitroso-N-methylaniline. This reaction has been found in general for the nitrosation of secondary amines by thionitrites (equation 1.24).^{112,115,116} A great interest and concern was evoked in this reaction since this raises

the possibility of the formation of nitrosamines and nitrosoamides (both well established carcinogens¹¹⁷) from thionitrites. One concern is that this could occur *in vivo*, since it is to be expected that thionitrites would readily be formed in the acid environment of the stomach from naturally occurring thiols and sources of nitrite ion, and the NO group could then be transferred to amines and amides in the lower intestine.

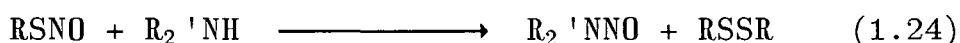

Thionitrites were also found to yield azo dyes after reacting with aniline hydrochloride and then coupling with β -naphthol (scheme 1.14).¹⁰³ They have also been used as synthetic routes to aryl halides¹⁰⁸ (equation 1.25) and also to alkyl nitrites from alcohols, although in the latter the yield is very low.¹¹⁸

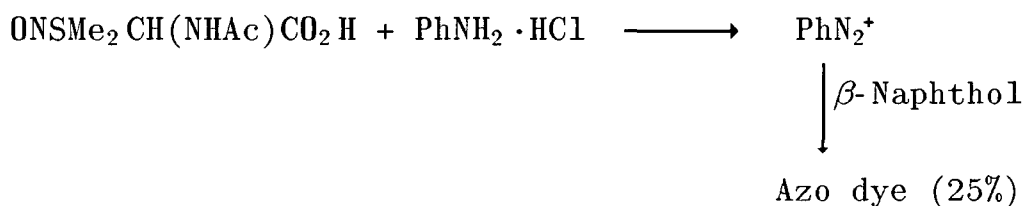

Scheme 1.14

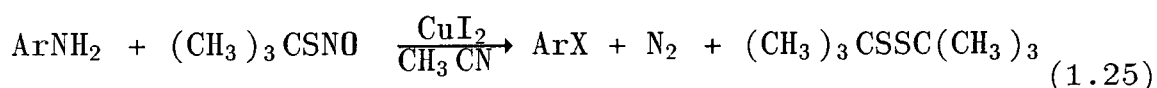

In none of the above reactions has it ever been determined whether the nitrosation occurs directly by the thionitrite or whether an effective nitrosating agent is formed from the thionitrite prior to nitrosation. However, it has been

found that in acid-catalysed reactions the nitroso group from the thionitrite can directly be transferred to water, halide ion, thiocyanate ion and thiourea (scheme 1.15).¹¹⁹ This reaction can only be completed by the removal of the nitrosyl species and at high acid concentration.

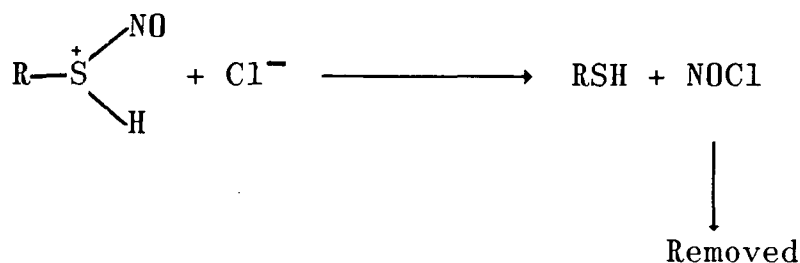

Scheme 1.15

1.4 Reactions of alkyl nitrites

1.4.1 Introduction

Alkyl nitrites are usually prepared from alcohols and nitrous acid (equation 1.26) and the reaction is the best-known example of O-nitrosation.¹²⁰ The reaction is reversible, rapid and general for any alkyl group, R, except for phenol where aromatic substitution by the nitroso group occurs.

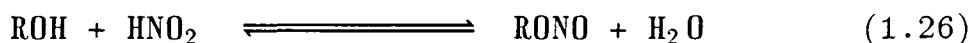

Alkyl nitrites can undergo both acidic-catalysed (equation 1.27) and base-catalysed (equation 1.28) hydrolysis.¹²¹ The former is generally much faster than the latter and the rate of the reaction is at or close to encounter limit.

used synthetic procedure (scheme 1.16).¹²⁴

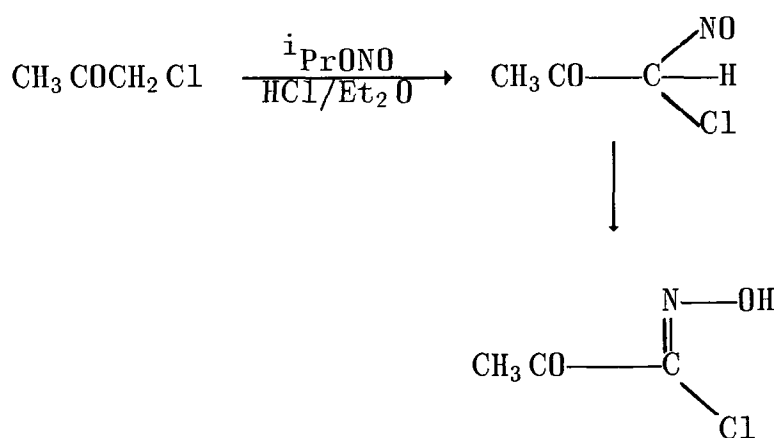

Scheme 1.16

Alkyl nitrites have also been used in synthetic reactions under aqueous and non-aqueous alkaline conditions. For example, in aqueous alkaline solution alkyl nitrites bearing β -electron-withdrawing groups have been used to nitrosate amines to give nitrosamines (equation 1.31),¹²⁵ whilst in an alcohol/ether solution, in the presence of sodium ethoxide, alkyl nitrites have been used to nitrosate cyclic ketones to give oximes (equation 1.32).¹²⁶

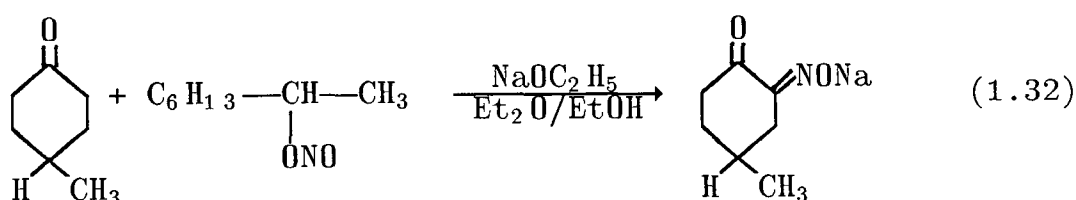
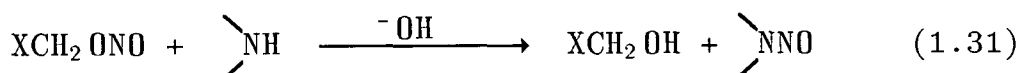

The nitrosation reactions of alkyl nitrites in aqueous acidic solutions have not been studied kinetically in great detail due to the rapid rate of hydrolysis of alkyl nitrites complicating the reaction. Until very recently it was never

shown whether the nitrosation reactions of alkyl nitrites in aqueous acidic solutions occurred via the nitrous acid formed or via the alkyl nitrite itself. This was clarified by the work of Crookes and Williams^{1 2 7} who studied the reaction of various substrates with 2-propyl nitrite and tertiary butyl nitrite in aqueous acid solution. They interpreted their results (scheme 1.17) in terms of an initial reversible hydrolysis step involving the formation of nitrous acid and then the subsequent rate-limiting attack on the substrate by the protonated form of nitrous acid.

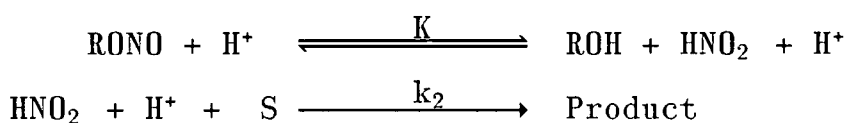

Scheme 1.17

They were also able to calculate the equilibrium constant, K, for the alkyl nitrite hydrolysis, from the kinetic analysis carried out on the study of the reduction of the observed rate constant by added aliphatic alcohols. These K values agreed with those determined independently.

The nitrosation of various substrates by alkyl nitrites in non-aqueous acid solutions has also been studied by various workers. Allen and Schonbaum^{1 2 8} investigated the reaction of 1-methylheptyl nitrite in acidified 1-propanol and found that the reaction was reversible, catalysed by chloride ion, inhibited by water, first-order in both [RONO] and [H⁺] and did not involve the asymmetric carbon centre. They proposed a mechanism (scheme 1.18) involving a direct reaction of the protonated alkyl nitrite with the alcohol.

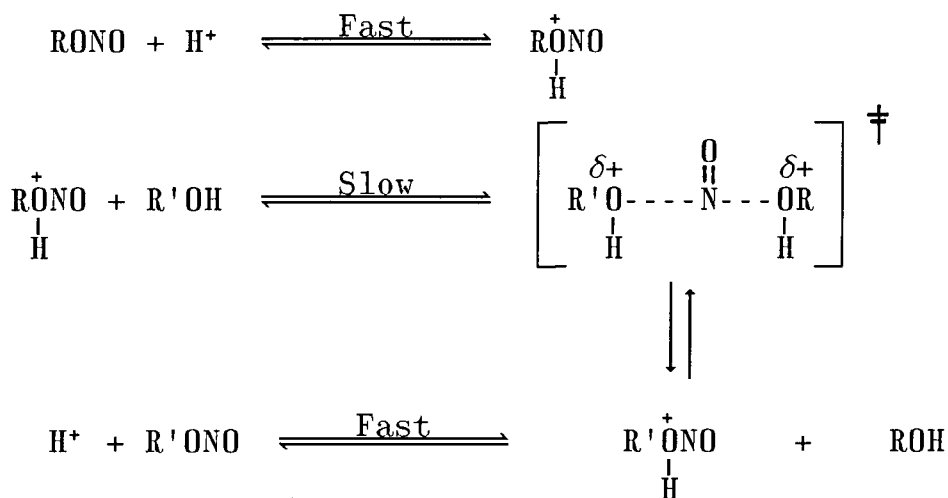

Scheme 1.18

A kinetic study of the reaction of n-propyl nitrite in acidic n-propanol with several aromatic amines was carried out in absence and presence of nucleophilic catalysts. The reaction is very slow in the absence of nucleophilic catalyst. However, in the presence of nucleophilic catalyst the reaction is rapid and this is interpreted in terms of a mechanism (scheme 1.19) involving a rapid equilibrium formation of nitrosyl species and then the rate-limiting attack of the free amine by the nitrosyl species.¹²⁹

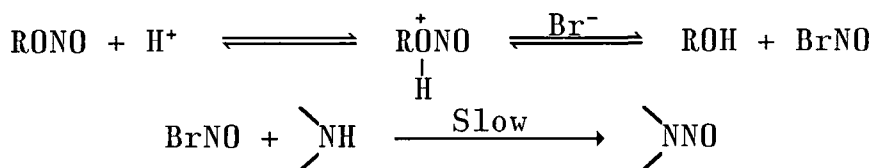

Scheme 1.19

Allen and Schonbaum¹³⁰ also investigated the kinetics of the alcoholysis of 1-methylheptyl nitrite in alkaline solution using 1-propanol as solvent. They found the reaction rate was proportional to both alkyl nitrite and

alkoxide concentration. Similar to acid-catalysed alcoholysis of 1-methylheptyl nitrite the reaction does not involve the asymmetric carbon centre and the mechanism proposed (scheme 1.20) is one of bimolecular nucleophilic attack by the alkoxide ion on the nitrogen atom of the alkyl nitrite.

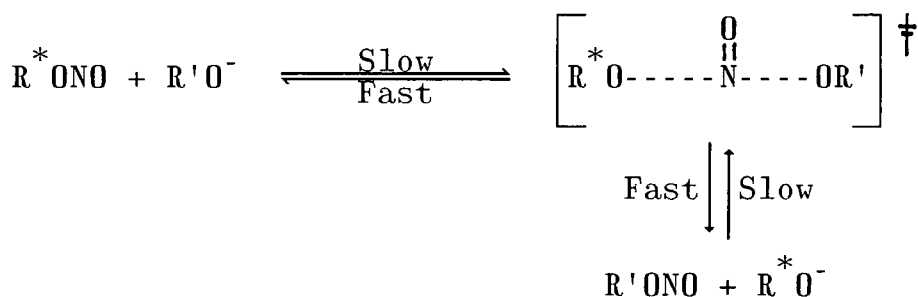

Followed by:



Scheme 1.20

The nitrosation of secondary aliphatic amines by alkyl nitrites in aqueous alkaline solution to give nitrosamines has been investigated by Casado and co-workers.¹³¹ From the results they interpreted the mechanism (scheme 1.21) in terms of the nucleophilic attack by the free base form of the amine at the nitrogen centre of the alkyl nitrite.

This mechanism was substantiated by the finding that the reactivities of structurally similar amines do not correlate with their basicities but with their vertical ionisation¹³² and the sigmoid-shaped of the second-order rate constant, k_2 , versus pH profile clearly shows that the reactive species is the free amine and not the protonated form. The evidence also clearly indicates that the reactions are orbital-controlled^{131, 133} and this is confirmed by the

reaction being particularly favourable with alkyl nitrites bearing β -electron withdrawing groups.^{125,133}

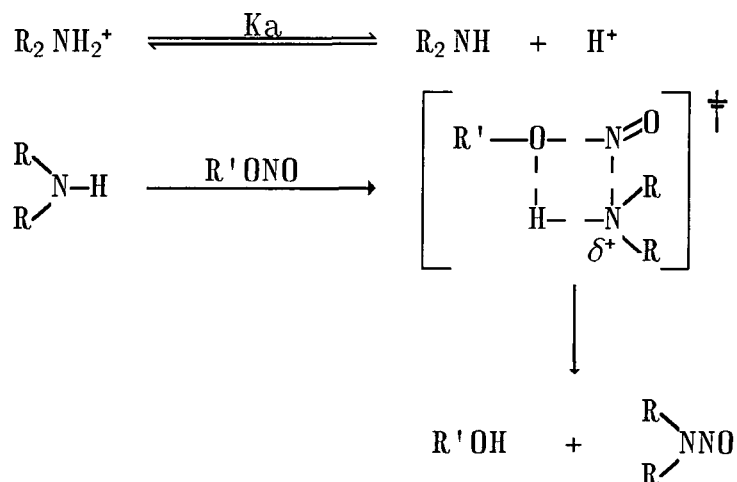

Scheme 1.21

1.4.3 The Barton reaction

The Barton reaction is one whereby a 1,5 rearrangement of the nitroso group in an alkyl nitrite occurs from oxygen to carbon to give 4-nitroso alcohols.¹³⁴ The reaction (scheme 1.22) involves photochemical homolysis of the alkyl nitrite to give the alkoxy radical from which the carbon radical is obtained by intermolecular abstraction of a hydrogen atom. This then reacts with nitric oxide to give the C-nitroso compound which is then found in its dimeric form or as the isomeric oxime.

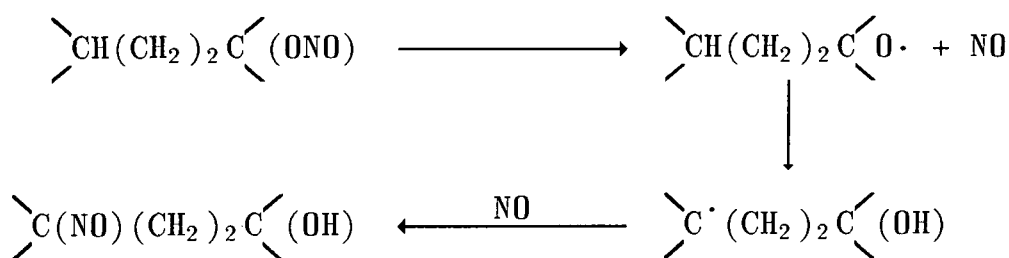

Scheme 1.22

References

1. I. Maccharini and E. Camarri, *Med. Lav.*, 1959, 50, 193.
2. P. Carmichael and J. Lieben, *Arch. Environ. Health*, 1963, 7, 424.
3. S. Forasman, N. Masreliez, G. Johansson, G. Sundell, O. Wilander and G. Bostrom, *Arch. Gewerbepath*, 1958, 16, 157.
4. M. Yamaguchi et al., *Bull. Nat. Inst. Ind. Health*, 1960, 4, 54.
5. E. Gross, M. Bock, and F. Hellrung, *Arch. Exp. Path. Pharmacol.*, 1942, 200, 271.
6. D. G. Clark and M. H. Litchfield, *Brit. J. Ind. Med.*, 1967, 24, 320.
7. D. G. Clark and M. H. Litchfield, *Toxicol. Appl. Pharmacol.*, 1972, 22, 128.
8. R. A. Jones, J. A. Strickland and J. Siegel, *Toxicol. Appl. Pharmacol.*, 1972, 22, 128.
9. M. Nickerson, in "*The Pharmacological Basis of Therapeutics*", 4th edition (L. S. Goodman and A. Gilman editors), Macmillan, New York, 1970, p745.
10. W. C. Bowman, M. S. Rand and G. B. West, in "*Textbook of Pharmacology*", Backwell Scientific Publications, Oxford, 1968.
11. P. J. Dempsey and T. Copper, *Am. Rev. Pharmacol.*, 1972, 12, 99 and reference therein.
12. T. Brunton, *Lancet*, 1867, 2, 97.
13. J. J. Goedert et al, *Lancet*, 1982, 2, 412.
14. S. L. Goodman and A. Gilman, in "*Pharmacological basis of Therapeutics*", 5th edition, Macmillan, New York, 1975.
15. T. J. Haley, *Clin. Toxicol.*, 1980, 16, 317.
16. R. I. Levin, E. A. Jaffe, B. B. Wekler and K. Tack-Goldman, *J. Clin. Inves.*, 1981, 67, 762.
17. K. Schror, L. Grodzinska and H. Darius, *Thromb. Res.*, 1981, 23, 59.
18. B. M. Bennett, J. A. Moffat, P. W. Armstrong and G. S. Marks, *Can. J. Physiol. Pharmacol.*, 1983, 61, 554.

19. R. F. Furchgott, J. V. Zawadzki and P. D. Cherry, in "Vasodilation" (P. M. Vanhoutte and I. Leusen editors), Raven Press, New York, p49.
20. P. Needleman, B. Jakschik and E. M. Johnson, *J. Pharmacol. Exp. Ther.*, 1973, 187, 324.
21. P. Needleman and E. M. Johnson, *J. Pharmacol. Exp. Ther.*, 1973, 184, 709.
22. J. A. Moffat, P. W. Armstrong and G. S. Marks, *Can. J. Physiol. Pharmacol.*, 1982, 60, 1261
23. J. A. Moffat, D. J. Rollwage, H. Abdollah and P. W. Armstrong, *J. Clin. Invest. Med. [Suppl. 1]*, 1982, 19.
24. L. J. Ignarro *et al*, *J. Pharmacol. Exp. Ther.*, 1981, 218, 739.
25. L. J. Ignarro *et al*, *FEBS Lett.*, 1980, 110, 275.
26. C. A. Gruetter *et al*, *Fed. Proc.*, 1980, 39, 743.
27. C. A. Gruetter *et al*, *J. Cyclic Nucleotides Res.*, 1979, 5, 211.
28. L. J. Ignarro and C. A. Gruetter, *Biochim. Biophys. Acta.*, 1980, 631, 221.
29. F. R. DeRubertis and P. A. Craven, *Science*, 1976, 193, 897.
30. F. R. DeRubertis and P. A. Craven, *J. Cyclic Nucleotide Res.*, 1977, 3, 23.
31. H. Kimura, C. K. Mittal and F. Murad, *Nature*, 1975, 257, 700.
32. S. Katsuki, W. Arnold, C. Mittal and F. Murad, *J. Cyclic Nucleotide Res.*, 1977, 3, 23.
33. K. D. Schultz, K. Schultz and G. Schultz, *Nature*, 1977, 265, 750.
34. B. T. Mellion, L. J. Ignarro, E. H. Ohlstein, E. G. Pontecorro, A. L. Hyman and P. J. Kadowitz, *Blood*, 1981, 57, 946.
35. J. Diamond and K. S. Blisard, *Mol. Pharmacol.*, 1976, 12, 688.
36. K. L. Axelsson, J. E. S. Wikberg and R. G. G. Anderson, *Life Science*, 1979, 24, 1779.
37. E. Bohme, H. Graf and G. Schultz, *Adv. Cyclic Nucleotide Res.*, 1978, 9, 131.
38. R. A. Jones and J. Diamond, *J. Pharmacol. Exp. Ther.*, 1979, 211, 480.

39. W. P. Arnold, C. K. Mittal, S. Katsuki and F. Murad, *Proc. Natl. Acad. Sci. U.S.A.*, 1977, 74, 3203.
40. S. A. Napoli, C. A. Gruetter, J. L. Ignarro and P. J. Kadowitz, *J. Pharmacol. Exp. Ther.*, 1980, 212, 469.
41. K. D. Schultz, E. Bohme, V. A. W. Kreye and G. Schultz, *Arch. Pharmacol.*, 1979, 306, 1.
42. L. J. Ignarro, B. K. Barry, D. Y. Gruetter, E. H. Ohlstein, C. A. Gruetter, P. J. Kadowitz and W. H. Baricos, *Biochim. Biophys. Acta*, 1981, 673, 394.
43. L. J. Ignarro, B. K. Barry, D. Y. Gruetter, J. C. Edwards, E. H. Ohlstein, C. A. Gruetter and W. H. Baricos, *Biochem. Biophys. Res. Commun.*, 1980, 94, 93.
44. L. J. Ignarro, P. J. Kadowitz and W. H. Baricos, *Arch. Biochem. Biophys.*, 1981, 208, 75.
45. T. W. J. Taylor, *J. Chem. Soc.*, 1982, 1099.
46. H. Schmid, *Z. Electrochem.*, 1936, 42, 579.
47. L. P. Hammett, in "*Physical Organic Chemistry*", McGraw-Hill Inc., New York, 1940, p294.
48. E. D. Hughes, C. K. Ingold and J. H. Ridd, *J. Chem. Soc.*, 1958, 65.
49. E. D. Hughes, C. K. Ingold and J. H. Ridd, *J. Chem. Soc.*, 1958, 65.
50. E. Kalatzis and J. H. Ridd, *J. Chem. Soc. (B)*, 1966, 529.
51. B.C. Challis and A.J. Lawson, *J. Chem. Soc., Perkin Trans. 2*, 1973, 918.
52. G. Stedman, *J. Chem. Soc.*, 1959, 2943, 2949.
53. J. Casdo, A. Castro and M. A. Lopez-Quintela, *Monatsh. Chem.*, 1981, 112, 1221.
54. G. Y. Markovits, S. E. Schwartz and L. Newman, *Inorg. Chem.*, 1981, 20, 445.
55. J. Casdo, A. Castro, J. R. Leis and M. A. Lopez-Quintela and M. Mosquera, *Monatsh. Chem.*, 1983, 114, 639.
56. E. D. Hughes, C. K. Ingold and J. H. Ridd, *J. Chem. Soc.*, 1958, 77.
57. L. F. Larkworthy, *J. Chem. Soc.*, 1959, 3304.
58. J. H. Ridd, *Quart. Rev.*, 1961, 15, 4148.
59. D. L. H. Williams, *Adv. Phys. Org. Chem.*, 1983, 19, 381 and reference therein.

60. J. H. Ridd, *Adv. Phys. Org. Chem.*, 1978, 16, 1.
61. K. Singer and P. A. Vamplew, *J. Chem. Soc.*, 1956, 3971.
62. N. S. Bayliss and D. W. Watts, *Chem. and Ind.*, 1955, 1353.
63. M. J. Crookes and D. L. H. Williams, *J. Chem. Soc., Chem. Commun.* 1988, 571.
64. D. L. H. Williams, in "*Nitrosation*", Cambridge University Press, Cambridge, 1988, and references therein.
65. H. Schmid and G. Muhr, *Ber.*, 1937, 70, 421.
66. H. Schmid, *Z. Elektrochem.*, 1937, 43, 626.
67. G. Stedman, *J. Chem. Soc.*, 1959, 2943, 2949.
68. D. L. H. Williams, *Chem. Soc. Rev.*, 1985, 14, 171 and references therein.
69. J. Casado, J. R. Gallastegui, M. Losada, L.C. Paz and J. V. Tato, *Acta Cient. Comp.*, 1982, 19, 209.
70. H. Schmid, *Monatsh Chem.*, 1954, 85, 424.
71. M. R. Crampton, J. T. Thompson and D. L. H. Williams, *J. Chem. Soc., Perkin Trans. 2*, 1979, 18.
72. H. Schmid and C. H. Essler, *Monatsh Chem.*, 1957, 88, 1110.
73. T. D. B. Morgan, G. Stedman and M. N. Hughes, *J. Chem. Soc. (B)*, 1968, 344.
74. B. C. Challis and R. J. Higgins, *J. Chem. Soc., Perkin Trans. 2*, 1975, 1498.
75. H. Schmid and E. Hallaba, *Monatsh. Chem.*, 1956, 87, 560.
76. E. D. Hughes and J. H. Ridd, *J. Chem. Soc.*, 1958, 82.
77. P. A. Morris and D. L. H. Williams, *J. Chem. Soc., Perkin Trans 2*, 1988, 513.
78. L. R. Dix and D. L. H. Williams, *J. Chem. Res. (S)*, 1984, 96.
79. L. R. Dix and D. L. H. Williams, *J. Chem. Soc., Perkin Trans. 2*, 1984, 109.
80. T. A. Meyer and D. L. H. Williams, *J. Chem. Soc., Perkin Trans. 2*, 1981, 361.
81. S. E. Aldred, D. L. H. Williams and M. Garley, *J. Chem. Soc., Perkin Trans. 2*, 1982, 777.

82. M. N. Hughes, G. Stedman and T. D. B. Morgan, *J. Chem. Soc. (B)*, 1968, 344.
83. M. Masui, C. Ueda, T. Yasuka and H. Ohmori, *Chem. Pharm. Bull.*, 1979, 27, 1274.
84. G. Stedman and P. A. E. Whinup, *J. Chem. Soc.*, 1963, 5796.
85. K. Al-Mallah, P. Collings and G. Stedman, *J. Chem. Soc., Dalton trans.*, 1974, 2469 and references therein.
86. W. A. Pryor, D. F. Church, C. K. Govindan and G. Crank, *J. Org. Chem.*, 1982, 47, 156.
87. W. Brackman and P. J. Smit, *Recl. Trav. Chim. Pays-bas.*, 1965, 84, 357, 372.
88. W. Schlenk, L. Mair and C. Birnhardt, *Chem. Ber.*, 1911, 44, 1169.
89. H. Metzger and E. Muller, *Chem. Ber.*, 1957, 90, 1179.
90. L. K. Keefer and P. P. Roller, *Science*, 181, 1245.
91. P. P. Roller, L. K. Keefer, in "*N-Nitroso compounds: Analysis, Formation and Occurrence*", (E. A. Walker, L. Grieciute, M. Castegnaro and M. Brozonyi. Eds.), IARC Scientific Publication 31, Lyon, 1980, p119.
92. K. F. Furull and J. C. Kotz, in "*Inorganic Chemistry*", W. B. Saunders Co., 1977, p270.
93. H. Lecher and W. Siefken, *Ber*, 1926, 59, 1314 and references therein.
94. R. Bonnett, R. Holleyhead, B. L. Johnson and E. W. Randall, *J. Chem. Soc., Perkin Trans. 1*, 1975, 2261.
95. G. C. Yang and A. Joshi, *J. Phys. Chem.*, 1980, 84, 228.
96. G. W. Ashworth and R. E. Keller, *Anal. Chem.*, 1967, 39, 373.
97. G. Robisch and E. Ludwig, *Z. chem.*, 1974, 14, 103.
98. S. Oae and K. Shinhama, *Org. Prep. Proced. Int.*, 1983, 15, 165 and references therein.
99. H. S. Tasker and H. O. Jones, *J. Chem. Soc.*, 1909, 95, 1917.
100. H. Rheinboldt, *Ber*, 1926, 59, 1311.
101. G. Kresze and U. Uhlich, *Chem. Ber.*, 1959, 92, 1048.
102. M. J. Dennis, R. C. Massey and D. J. McWeeny, *J. Sci. Food Agric.*, 1980, 31, 1195.

103. L. Field, R. V. Dilts, R. Ramanathan, P. G. Lenhert and G. E. Carnahan, *J. Chem. Soc., Chem. Commun.*, 1978, 249.
104. R. Bonnett and P. Nicolaidou, *J. Chem. Soc., Perkin Trans. 1*, 1979,
105. S. Oae, D. Fukushima and Y. H. Kim, *J. Chem. Soc., Chem. Comm.*, 1977, 407.
106. J. Mason, *J. Chem. Soc. (A)*, 1969, 1587.
107. S. E. Aldred and D. L. H. Williams, *J. Chem. Soc., Perkin Trans. 2*, 1981, 1021.
108. S. Oae, K. Shinhana, K. Fujimori and Y. H. Kim, *Bull. Chem. Soc. Jpn.*, 1980, 53, 775.
109. M. P. Doyle, J. W. Terpstra, R. A. Pickering and D. M. LePoire, *J. Org. Chem.*, 1983, 48, 3379.
110. G. Kresze and J. Winkler, *Chem. Ber.* 1963, 96, 1203.
111. P. Collings and K. Al-Mallah and G. Stedman, *J. Chem. Soc., Perkin Trans. 2*, 1975, 1734.
112. J. Fitzpatrick, T. A. Meyer, M. E. O'Neill and D. L. H. Williams, *J. Chem. Soc., Perkin Trans. 2*, 1984, 927.
113. J. Barrett, D. F. Debenham and J. Glauser, *J. Chem. Soc., Chem. Commun.*, 1965, 248.
114. S. Oae, Y. H. Kim, D. Fukushima and T. Takata, *Chem. Lett.*, 1977, 893.
115. S. Oae, D. Fukushima and Y. H. Kim. *J. Chem. Soc., Chem. Commun.*, 1974, 407.
116. M. J. Dennis, R. Davies and D.J. McWeeney, *J. Sci. Food. Agric.*, 1979, 30, 639.
117. P. N. Magee and J. M. Barnes, *Brit. J. Cancer*, 1956, 10, 114.
118. S. Oae, Y. H. Kim, D. Fukushima and K. Shinhama, *J. Chem. Soc., Perkin Trans. 1*, 1978, 227.
119. S. S. Al-Kaabi, D. L. H. Williams, R. Bonnett and S. L. Ooi, *J. Chem. Soc., Perkin Trans. 2*, 1982, 227.
120. W. H. Hartung and F. Crossley, *Org. Synth.*, 1943, coll. II, 363.
121. A. D. Allen, *J. Chem. Soc.*, 1954, 1968.
122. J. I. G. Cadogan, *J. Chem. Soc.*, 1962, 4257.
123. M. P. Doyle, B. Siegfried, R. C. Elliotand J. F. Delloria Jr., *J. Org. Chem.*, 1977, 42, 2431.

124. G. Hesse and G. Krehbiel, *Chem. Ber.*, 1955, 88, 130.
125. B. C. Challis and D. E. G. Shuker, *J. Chem. Soc., Chem. Commun.*, 1979, 315.
126. M. Pezold and R. L. Shriner, *J. Am. Chem. Soc.*, 1932, 54, 4707.
127. M. J. Crookes and D. L. H. Williams, *J. Chem. Soc., Perkin Trans. 2*, 1988, 1339.
128. A. D. Allen and G. R. Schonbaum, *Can. J. Chem. Commun.*, 1961, 39, 947.
129. S. E. Aldred and D. L. H. Williams, *J. Chem. Soc., Perkin Trans. 2*, 1981, 1021
130. A. D. Allen and G. R. Schonbaum, *Can. J. Chem. Commun.*, 1979, 315.
131. J. Casado, A. Castro, F. M. Lorenzo and F. Meijide, *Monatsh. Chem.*, 1986, 117, 335.
132. J. Casado, A. Castro, M. A. Lopez-Quintela and F. M. Lorenzo, *Bull Soc. Chim. Fr.*, 1987, 401.
133. S. Oae, N. Asai and K. Fujimori, *J. Chem. Soc., Perkin Trans. 2*, 1978, 1124.
134. D. H. R. Barton, J. H. Beaton, L. E. Geller and M. M. Pechet, *J. Am. Chem. Soc.*, 1960, 82, 2640.

CHAPTER TWO

S-nitrosation in acid solution

Thus the question that arises is whether the nitrosation by alkyl nitrites in aqueous acid solution occurs via the nitrous acid formed or via the alkyl nitrite itself. This was clarified very recently by the work of Williams and Crookes⁶ who interpreted, from their results, a mechanism (Scheme 2.2) in terms of an initial reversible hydrolysis step involving the formation of nitrous acid and then the subsequent rate-limiting attack on the substrate by the protonated form of nitrous acid.

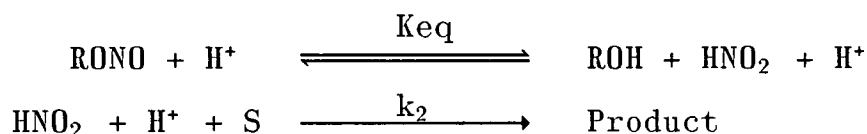

Scheme 2.2

2.2 Nitrosation of cysteine

Cysteine (2.1) is a naturally occurring amino acid and can exist in many forms depending on the pH of the solution. In acidic conditions cysteine exists partly as the zwitterion (2.2) and partly in the N-protonated form (2.3).

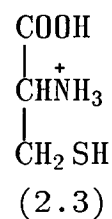
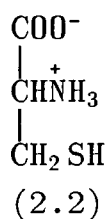
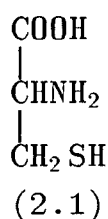

The pKa value, 1.9 ± 0.1 , for the carboxyl group of cysteine has been determined by various research groups.⁷⁻⁹ Thus the dominant form at high acidity would be the N-protonated form and at low acidity the zwitterion form.

Kinetic investigation by Stedman and co-workers¹⁰ on the nitrosation of cysteine (Cys) by nitrous acid in the absence of added nucleophiles established the rate equation (equation 2.2).

$$\text{Rate} = k [\text{H}^+] [\text{HNO}_2] [\text{cysteine}] \quad (2.2)$$

Since then the same rate equation has been established by other research groups.^{11,12} The catalytic effect of added nucleophiles (i.e. Cl^- , Br^- and SCN^-) on the nitrosation of cysteine has also been investigated and the rate equation (equation 2.3) established.^{11,12}

$$\text{Rate} = k [\text{HNO}_2] [\text{H}^+] [\text{cysteine}] [\text{X}^-] \quad (2.3)$$

The effect of added nucleophiles was found to be similar to that encountered for N-nitrosation, diazotisation and O-nitrosation reactions.

Recently, it has been found that both the zwitterion and the N-protonated form are reactive towards the nitrosonium ion (Scheme 2.3).¹³ The scheme proposed is based on the nitrosonium ion, NO^+ as the effective nitrosating agent. However, as mentioned earlier, in Chapter One, the nitrous acidium ion, H_2NO_2^+ , and NO^+ are kinetically indistinguishable and there is some uncertainty as to which is the effective nitrosating agent in aqueous acidic solutions.

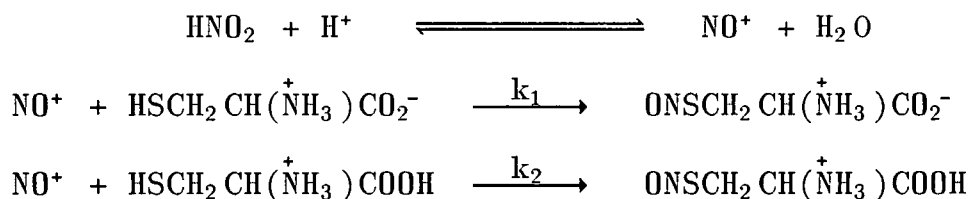

Scheme 2.3

The rate constants, k_1 and k_2 , were determined and it was found that the zwitterion is more reactive than the N-protonated form. The explanation given for this is that the zwitterion is a neutral molecule and thus would react faster with a charged species, NO^+ , than the N-protonated form which is a positively charged species.

However, there are no reports of the nitrosation of cysteine by alkyl nitrites in acidic conditions. The nitrosation of cysteine by isopropyl nitrite ($^i\text{PrONO}$) in aqueous acidic conditions in the absence of added nucleophiles was examined and the results presented below.

All the runs were carried out under conditions where the acid and cysteine concentrations were in large excess over the $^i\text{PrONO}$ concentration. Due to the nature of cysteine in acid conditions, some of the acid added would be used for the protonation of the carboxyl group of the zwitterion to form the N-protonation form. However, to ensure that the change in acid concentration due to the protonation was negligible, the concentration of acid used was in large excess of the cysteine concentration.

The reaction was followed by monitoring the increase in absorbance at 330nm due to the formation of the product, S-nitrosocysteine. In all cases good first-order behaviour was observed. The effect of variation of cysteine and acid

concentration on the observed first-order rate constant, k_0 , was investigated and the results are shown in tables 2.1 and 2.2.

Table 2.1 Dependence of k_0 on [cysteine] at 25°C

$$[{}^i\text{PrONO}] = 1.0 \times 10^{-4} \text{M}$$

$$[\text{HClO}_4] = 5.2 \times 10^{-2} \text{M}$$

10^2 [Cys]/M	k_0/s^{-1}
32.0	.525 ± .008
25.1	.435 ± .010
16.1	.275 ± .004
12.0	.206 ± .007
8.1	.137 ± .001
4.0	.069 ± .006

Table 2.2 Dependence of k_0 on [acid] at 25°C

$$[{}^i\text{PrONO}] = 1.0 \times 10^{-4} \text{M}$$

$$[\text{Cys}] = 1.1 \times 10^{-3} \text{M}$$

10^2 [H ⁺]/M	k_0/s^{-1}
2.6	.102 ± .004
3.9	.153 ± .001
5.2	.206 ± .003
6.5	.253 ± .001
7.8	.316 ± .003

Figure 2.1 Dependence of k_0 on [cysteine] and [acid] at 25°C

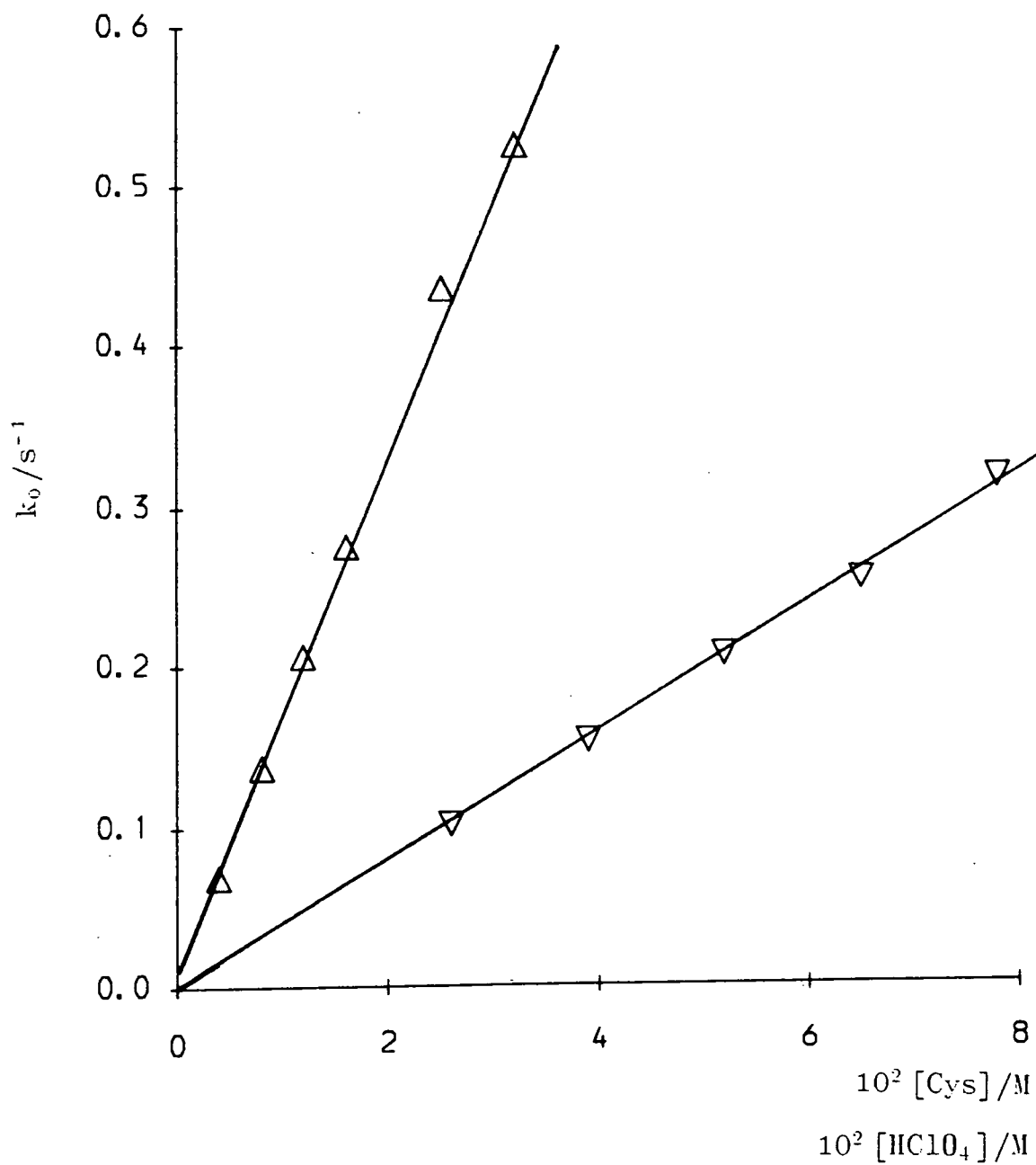

∇ [Cys] dependence
 Δ [HClO₄] dependence

The plots of k_0 versus [cysteine] and [acid] (Figure 2.1) are linear; indicating that under the conditions used the nitrosation of cysteine is first-order in [cysteine] and [acid]. This is consistent with the rate equation (equation 2.4).

$$\text{Rate} = k [\text{RONO}] [\text{H}^+] [\text{cysteine}] \quad (2.4)$$

However, k_0 was found to decrease on addition of isopropyl alcohol ($i\text{PrOH}$) and the results from the study of the variation of k_0 with added $i\text{PrOH}$ at three cysteine concentrations are shown in table 2.3 and Figure 2.2.

Table 2.3 Dependence of k_0 on [cysteine] at various [$i\text{PrOH}$] at 25°C

$$[i\text{PrONO}] = 1.0 \times 10^{-4} \text{M}$$

$$[\text{HClO}_4] = 5.2 \times 10^{-2} \text{M}$$

[$i\text{PrOH}$]/M	k_0/s^{-1}		
	a	b	c
.00	.394 ± .004	.157 ± .005	.090 ± .007
.10	.362 ± .003	.146 ± .002	.085 ± .005
.20	.340 ± .002	.136 ± .004	.078 ± .002
.40	.300 ± .001	.121 ± .003	.073 ± .004
.60	.270 ± .002	.110 ± .001	.068 ± .001

$$a = 2.51 \times 10^{-2} \text{M} [\text{Cys}]$$

$$b = 1.00 \times 10^{-2} \text{M} [\text{Cys}]$$

$$c = 5.00 \times 10^{-3} \text{M} [\text{Cys}]$$

The results are consistent with the mechanism (Scheme 2.4) involving the reversible acid-catalysed hydrolysis of ⁱPrONO to give nitrous acid which then in its protonated form effects nitrosation.

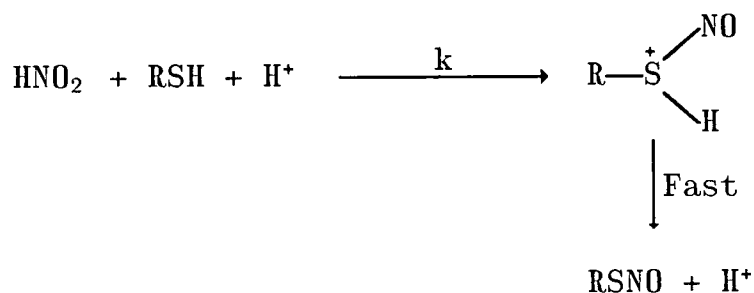
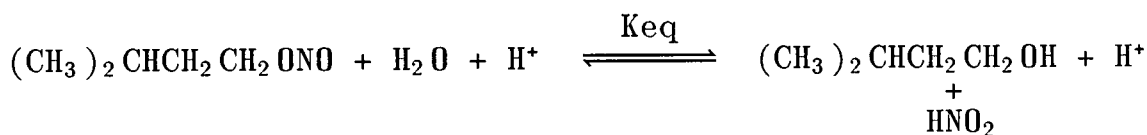

Scheme 2.4

Thus for the variation of k_0 with added acid and cysteine the derived rate equation is given below (equation 2.5).

$$\text{Rate} = k [\text{HNO}_2] [\text{H}^+] [\text{cysteine}]$$

From Scheme 2.4, assuming that the equilibrium hydrolysis is rapid:

$$\text{Keq} = \frac{[\text{ROH}] [\text{HNO}_2]}{[\text{RONO}]} \quad [\text{RONO}] = \frac{[\text{ROH}] [\text{HNO}_2]}{\text{Keq}}$$

$$\begin{aligned} [\text{Total Nitrite}] &= [\text{HNO}_2] + [\text{RONO}] \\ &= [\text{HNO}_2] + \frac{[\text{ROH}] [\text{HNO}_2]}{\text{Keq}} \end{aligned}$$

$$\text{Hence } [\text{HNO}_2] = \frac{[\text{Total Nitrite}] \text{Keq}}{\text{Keq} + [\text{ROH}]}$$

When no alcohol is added, $\text{Keq} \gg [\text{ROH}]$

$$\text{Rate} = k [\text{Total Nitrite}] [\text{Cys}] [\text{H}^+] \quad (2.5)$$

$$\text{where } k_0 = k [\text{H}^+] [\text{cysteine}]$$

The value of the third-order rate constant for the reaction of ${}^i\text{PrONO}$ with cysteine, k , can be obtained from the slope of the plots in Figure 2.1 and these were determined as $331 \text{ l}^2 \text{ mol}^{-2} \text{ s}^{-1}$ from the dependence of k_0 on [cysteine] and $361 \text{ l}^2 \text{ mol}^{-2} \text{ s}^{-1}$ from the dependence of k_0 on [acid].

The plot of k_0 versus [acid] shows a slight positive intercept which can be attributed to the reaction by both the zwitterion and N-protonated forms of cysteine. Since the two predominant forms react at different rates they must be considered separately in the reaction mechanism (Scheme 2.5).

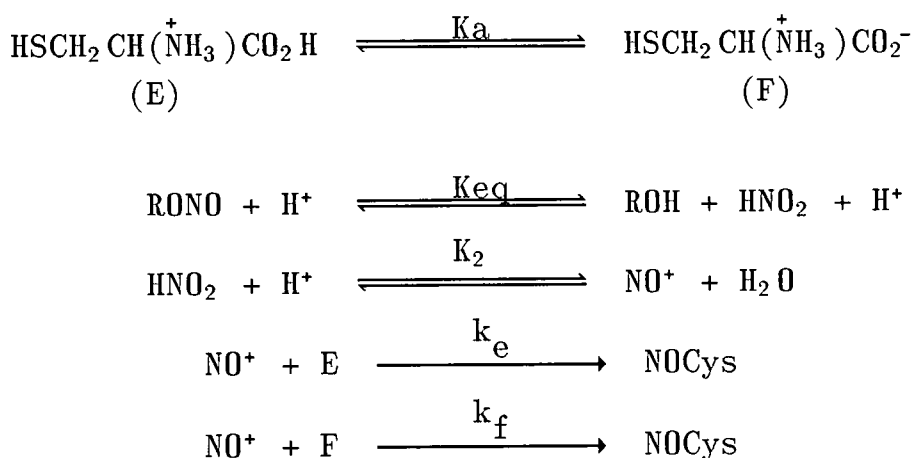

Scheme 2.5

The rate equation (equation 2.6) can then be derived for the proposed mechanism.

$$\text{Rate} = \sigma [\text{HNO}_2] [\text{H}^+] [\text{E}] + \pi [\text{HNO}_2] [\text{H}^+] [\text{F}]$$

$$\text{where: } \sigma = k_e K_2 \quad \text{and} \quad \pi = k_f K_2 K_a$$

From Scheme 2.5

$$[\text{E}] = \frac{[\text{Total Cys}] [\text{H}^+]}{K_a + [\text{H}^+]} \quad [\text{F}] = \frac{[\text{Total Cys}] K_a}{K_a + [\text{H}^+]}$$

$$\text{Rate} = \frac{\sigma [\text{T Cys}] [\text{H}^+]^2 [\text{HNO}_2]}{K_a + [\text{H}^+]} + \frac{\pi K_a [\text{T Cys}] [\text{H}^+] [\text{HNO}_2]}{K_a + [\text{H}^+]}$$

$$[\text{Total Nitrite}] = [\text{HNO}_2] + [\text{RONO}]$$

$$= [\text{HNO}_2] + \frac{[\text{ROH}] [\text{HNO}_2]}{K_{eq}}$$

$$[\text{HNO}_2] = \frac{[\text{T Nit}] K_{eq}}{K_{eq} + [\text{ROH}]}$$

$$\begin{aligned} \text{Rate} &= \frac{\sigma K_{eq} [\text{T Nit}] [\text{H}^+]^2 [\text{T Cys}]}{(K_{eq} + [\text{ROH}]) (K_a + [\text{H}^+])} \\ &+ \frac{\pi K_a K_{eq} [\text{T Nit}] [\text{H}^+] [\text{T Cys}]}{(K_{eq} + [\text{ROH}]) (K_a + [\text{H}^+])} \end{aligned}$$

When $K_{eq} \gg [\text{ROH}]$ and $[\text{H}^+] \gg K_a$

$$\text{Rate} = \sigma [\text{T Nit}] [\text{H}^+] [\text{T Cys}] + \pi K_a [\text{T Nit}] [\text{T Cys}] \quad (2.6)$$

$$\text{where } k_0 = \sigma [\text{H}^+] [\text{T Cys}] + \pi K_a [\text{T Cys}]$$

The values of $\sigma = 361 \text{ l}^2 \text{ mol}^{-2} \text{ s}^{-1}$ and $\pi = 23.34 \text{ l mol}^{-1} \text{ s}^{-1}$ were determined from the plot of k_0 against $[\text{H}^+]$ using $\text{pKa} = 1.92^1$, slope = $\sigma [\text{T Cys}]$ and intercept = $\pi \text{Ka} [\text{T Cyst}]$. The values obtained for σ and π allow k_e and k_f to be calculated, using $K_2 = 3 \times 10^{-7} \text{ l mol}^{-1}$ (Ref. 14), as $1.2 \times 10^9 \text{ l mol}^{-1} \text{ s}^{-1}$ and $6.5 \times 10^9 \text{ l mol}^{-1} \text{ s}^{-1}$ respectively. The values are similar to those obtained by Casado et al¹³ and they confirm that the positively charged species reacts more slowly than the zwitterion. The values of k_e and k_f would be considered to indicate that both reactions are close to being diffusion-controlled.

The rate equation (equation 2.7) can be derived for the dependence of k_0 on $[\text{}^i\text{PrOH}]$.

$$\text{Rate} = \frac{k \text{Keq} [\text{T Nit}] [\text{H}^+] [\text{Cys}]}{\text{Keq} + [\text{ROH}]} \quad (2.7)$$

$$\text{Where } k_0 = \frac{k \text{Keq} [\text{Cys}] [\text{H}^+]}{\text{Keq} + [\text{ROH}]}$$

$$k_0^{-1} = \frac{[\text{ROH}]}{k \text{Keq} [\text{Cys}] [\text{H}^+]} + \frac{1}{k [\text{Cys}] [\text{H}^+]} \quad (2.8)$$

The values of the third-order rate constant, k , and the equilibrium constant, Keq , for the hydrolysis of $\text{}^i\text{PrONO}$ can be obtained using equation (2.8). A plot of k_0^{-1} versus $[\text{}^i\text{PrOH}]$ is linear with:

$$\text{Gradient} = \frac{1}{k \text{Keq} [\text{Cys}] [\text{H}^+]}$$

$$\text{Intercept} = \frac{1}{k [\text{Cys}] [\text{H}^+]}$$

Hence the value of k can be obtained from the intercept and the value of K_{eq} can be obtained from the value of intercept/gradient. The plots of k_0^{-1} versus $[^i\text{PrONO}]$ for the experimental results are shown in Figure 2.2 and the analysis of the results are shown in table 2.4.

Table 2.4 Results from plots of k_0^{-1} versus $[^i\text{PrOH}]$

$10^2 [\text{Cys}] / \text{M}$	Gradient/ s l mol^{-1}	Intercept /s	K_{eq} mol l^{-1}	k $\text{l}^2 \text{ mol}^{-2} \text{ s}^{-1}$
2.51	2.00	2.55	1.28	300
1.00	4.56	6.40	1.40	300
0.50	7.79	11.18	1.44	344

The average value of K_{eq} , $1.37 \pm .09 \text{ mol l}^{-1}$, gives the value of the equilibrium constant for the formation of $^i\text{PrONO}$, K , as 0.73 l mol^{-1} at 25°C . This is in good agreement with the literature value¹⁵ of 0.56 l mol^{-1} for K measured directly at this temperature.

Similarly the values of k 331, 361 and 315 $\text{l}^2 \text{ mol}^{-2} \text{ s}^{-1}$ at 25°C obtained from the studies of the dependence of k_0 on $[\text{cysteine}]$, $[\text{acid}]$ and $[^i\text{PrOH}]$ respectively are in good agreement with the reported value¹² of k , $340 \text{ l}^2 \text{ mol}^{-2} \text{ s}^{-1}$ at 25°C , for the direct nitrous acid nitrosation of cysteine.

Figure 2.2 Dependence of k_0 on $[^i\text{PrOH}]$ at various $[\text{Cysteine}]$

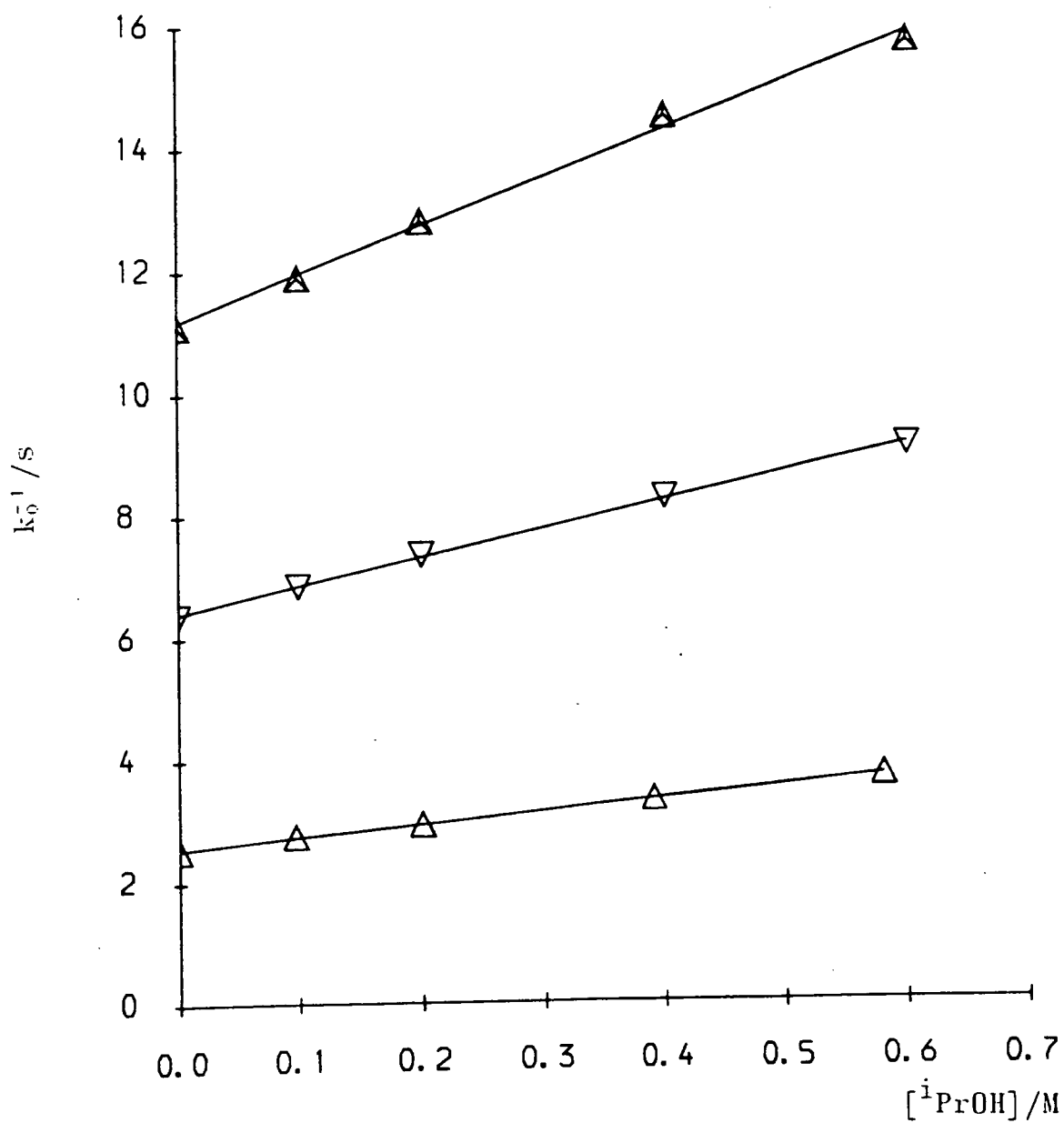

▲ $[\text{Cys}] = 5.00 \times 10^{-3} \text{ M}$

▽ $[\text{Cys}] = 1.00 \times 10^{-2} \text{ M}$

△ $[\text{Cys}] = 2.51 \times 10^{-2} \text{ M}$

2.3 Nitrosation of L-cysteine methyl ester, L-cysteine ethyl ester, N-acetyl-L-cysteine and glutathione

The nitrosation reactions of L-cysteine methyl ester (MeCys), N-acetyl-L-cysteine (N-Ac-Cys) and glutathione (GSH) by nitrous acid in the absence of added nucleophiles are all similar to that with L-cysteine and the rate equation (equation 2.9) and values of k, the third-order rate constant were found to be 213, 1540 and 1080 l² mol⁻² s⁻¹ for MeCys, N-Ac-Cys and GSH respectively.^{1 2}



As expected the reactions were also found to be catalysed by added nucleophiles and the reactivity sequence of the nitrosyl species was found to be the commonly encountered one of nitrosyl chloride > nitrosyl bromide > nitrosyl thiocyanate.^{1 2}

The initial product of the above reactions is thought to be the thionitrite derivative. However, in the case of MeCys when the reaction is carried out with excess of sodium nitrite over MeCys concentration at 0°C a product derived from N-nitrosation (2.4) has been isolated.^{1 6} The likely reaction is an initial S-nitrosation of MeCys followed by an S- to N- rearrangement of the nitroso group (similar to that proposed by Meyer and Williams^{1 7}) and finally the ring closure to give the product (2.4).

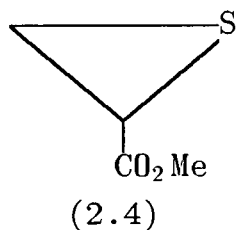

In the case of N-Ac-Cys, Bonnett¹⁸ and co-workers confirmed by ¹⁵N n.m.r. studies that the red solution formed when N-Ac-Cys is reacted with nitrous acid was indeed the thionitrite derivative of N-Ac-Cys.

The kinetic details are presented below, for the reactions with ⁱPrONO. Since the hydrochloride salts of MeCys and EtCys were used, only the dependence of the rate constant on [acid] at various [ⁱPrOH] was studied. However, in the case of the other two thiols the dependence of rate constant on [acid] and [RSH] at various [ⁱPrOH] was investigated.

All the reactions were carried out under conditions where the acid and thiol concentrations were in large excess over the ⁱPrONO concentration. Also the acid concentration used was in large excess of the thiol concentration to ensure that the change in acid concentration was negligible due to protonation of the thiol.

In all cases the reactions were followed by monitoring the increase in absorbance at 330nm due to the formation of the product, S-nitrosothiol. In all cases a good first-order behaviour was observed. The results showing the dependence of the observed first-order rate constant, k_o , on [acid] and [RSH] at various [ⁱPrOH] for each of the thiols studied are shown in tables 2.5-2.10 and Figures 2.3-2.8.

Table 2.6 Dependence of k_0 on [acid] at various [ⁱPrOH] at 25°C (for the nitrosation of MeCys by ⁱPrONO)

$$[{}^i\text{PrONO}] = 1.0 \times 10^{-4} \text{ M}$$

$$[\text{MeCys}] = 1.36 \times 10^{-2} \text{ M}$$

10^2 [H ⁺]/M	k_0/s^{-1}			
	a	b	c	d
36.50	1.286 ± .003	1.152 ± .004	1.089 ± .002	0.973 ± .004
18.25	0.643 ± .007	0.579 ± .002	0.540 ± .003	0.481 ± .006
9.13	0.322 ± .004	0.289 ± .003	0.272 ± .004	0.241 ± .003
4.56	0.163 ± .001	0.145 ± .004	0.138 ± .005	0.121 ± .005

$$a = 0\text{M } [{}^i\text{PrOH}],$$

$$b = .1\text{M } [{}^i\text{PrOH}],$$

$$c = .2\text{M } [{}^i\text{PrOH}],$$

$$d = .4\text{M } [{}^i\text{PrOH}]$$

Table 2.7 Dependence of k_0 on [acid] at various [ⁱPrOH] at 25°C (for the nitrosation of EtCys by ⁱPrONO)

$$[{}^i\text{PrONO}] = 1.0 \times 10^{-4} \text{ M}$$

$$[\text{EtCys}] = 1.41 \times 10^{-2} \text{ M}$$

10^2 [H ⁺]/M	k_0/s^{-1}			
	a	b	c	d
54.73	1.879 ± .009	1.759 ± .006	1.653 ± .009	1.472 ± .010
27.37	0.926 ± .005	0.877 ± .003	0.827 ± .010	0.736 ± .003
13.68	0.474 ± .001	0.440 ± .009	0.416 ± .006	0.368 ± .007
6.84	0.235 ± .003	0.223 ± .007	0.207 ± .003	0.184 ± .004

$$a = 0\text{M } [{}^i\text{PrOH}],$$

$$b = .1\text{M } [{}^i\text{PrOH}],$$

$$c = .2\text{M } [{}^i\text{PrOH}],$$

$$d = .4\text{M } [{}^i\text{PrOH}]$$

Table 2.7 Dependence of k_0 on [N-Ac-Cys] at various [ⁱPrOH] at 25°C

$$[{}^i\text{PrONO}] = 1.0 \times 10^{-4} \text{M}$$

$$[\text{HClO}_4] = 36.5 \times 10^{-2} \text{M}$$

10^2 [N-Ac-Cys] /M	k_0/s^{-1}			
	a	b	c	d
4.06	21.49 ± .12	20.06 ± .01	18.82 ± .03	16.60 ± .01
2.03	10.75 ± .02	10.04 ± .01	9.40 ± .01	8.30 ± .01
1.02	5.37 ± .03	5.02 ± .04	4.70 ± .01	4.17 ± .02
0.51	2.69 ± .02	2.51 ± .04	2.35 ± .01	2.07 ± .01

$$a = 0\text{M } [{}^i\text{PrOH}],$$

$$b = .1\text{M } [{}^i\text{PrOH}],$$

$$c = .2\text{M } [{}^i\text{PrOH}],$$

$$d = .4\text{M } [{}^i\text{PrOH}]$$

Table 2.8 Dependence of k_0 on [acid] at various [ⁱPrOH] at 25°C (for the nitrosation of N-Ac-Cys by ⁱPrONO)

$$[{}^i\text{PrONO}] = 1.0 \times 10^{-4} \text{M}$$

$$[\text{N-Ac-Cyst}] = 4.03 \times 10^{-2} \text{M}$$

10^2 [H ⁺]/M	k_0/s^{-1}			
	a	b	c	d
36.50	21.36 ± .11	20.07 ± .01	18.86 ± .01	16.74 ± .01
18.30	10.63 ± .01	10.03 ± .01	9.48 ± .01	8.38 ± .02
9.13	5.33 ± .02	5.04 ± .01	4.73 ± .02	4.19 ± .01
4.56	2.66 ± .01	2.52 ± .01	2.31 ± .01	2.10 ± .01

$$a = 0\text{M } [{}^i\text{PrOH}],$$

$$b = .1\text{M } [{}^i\text{PrOH}],$$

$$c = .2\text{M } [{}^i\text{PrOH}],$$

$$d = .4\text{M } [{}^i\text{PrOH}]$$

Table 2.9 Dependence of k_0 on [GSH] at various [i PrOH] at 25°C

$$[i\text{PrONO}] = 1.0 \times 10^{-4} \text{ M}$$

$$[\text{HClO}_4] = 36.5 \times 10^{-2} \text{ M}$$

10^2 [GSH] /M	k_0/s^{-1}			
	a	b	c	d
8.16	33.22 ± .08	31.02 ± .01	29.08 ± .01	25.85 ± .02
4.08	16.62 ± .03	15.51 ± .01	14.54 ± .02	12.93 ± .01
2.04	8.31 ± .09	7.76 ± .01	7.27 ± .01	6.47 ± .02
1.02	4.15 ± .02	3.88 ± .01	3.63 ± .01	3.22 ± .01

$$a = 0\text{M } [i\text{PrOH}],$$

$$b = .1\text{M } [i\text{PrOH}],$$

$$c = .2\text{M } [i\text{PrOH}],$$

$$d = .4\text{M } [i\text{PrOH}]$$

Table 2.10 Dependence of k_0 on [acid] at various [i PrOH] at 25°C (for the nitrosation of GSH by i PrONO)

$$[i\text{PrONO}] = 1.00 \times 10^{-4} \text{ M}$$

10^2 [H^+] /M	k_0/s^{-1}			
	a	b	c	d
36.50	16.63 ± .03	15.51 ± .01	14.54 ± .01	12.95 ± .01
18.25	8.32 ± .03	7.76 ± .03	7.27 ± .01	6.47 ± .01
9.13	4.16 ± .01	3.88 ± .01	3.63 ± .01	3.23 ± .02
4.56	2.08 ± .01	1.93 ± .02	1.81 ± .02	1.61 ± .02

$$a = 0\text{M } [i\text{PrOH}],$$

$$b = .1\text{M } [i\text{PrOH}],$$

$$c = .2\text{M } [i\text{PrOH}],$$

$$d = .4\text{M } [i\text{PrOH}]$$

Figure 2.3 Dependence of k_0 on [acid] at various [i PrOH] at 25°C (for nitrosation of MeCys by i PrONO)

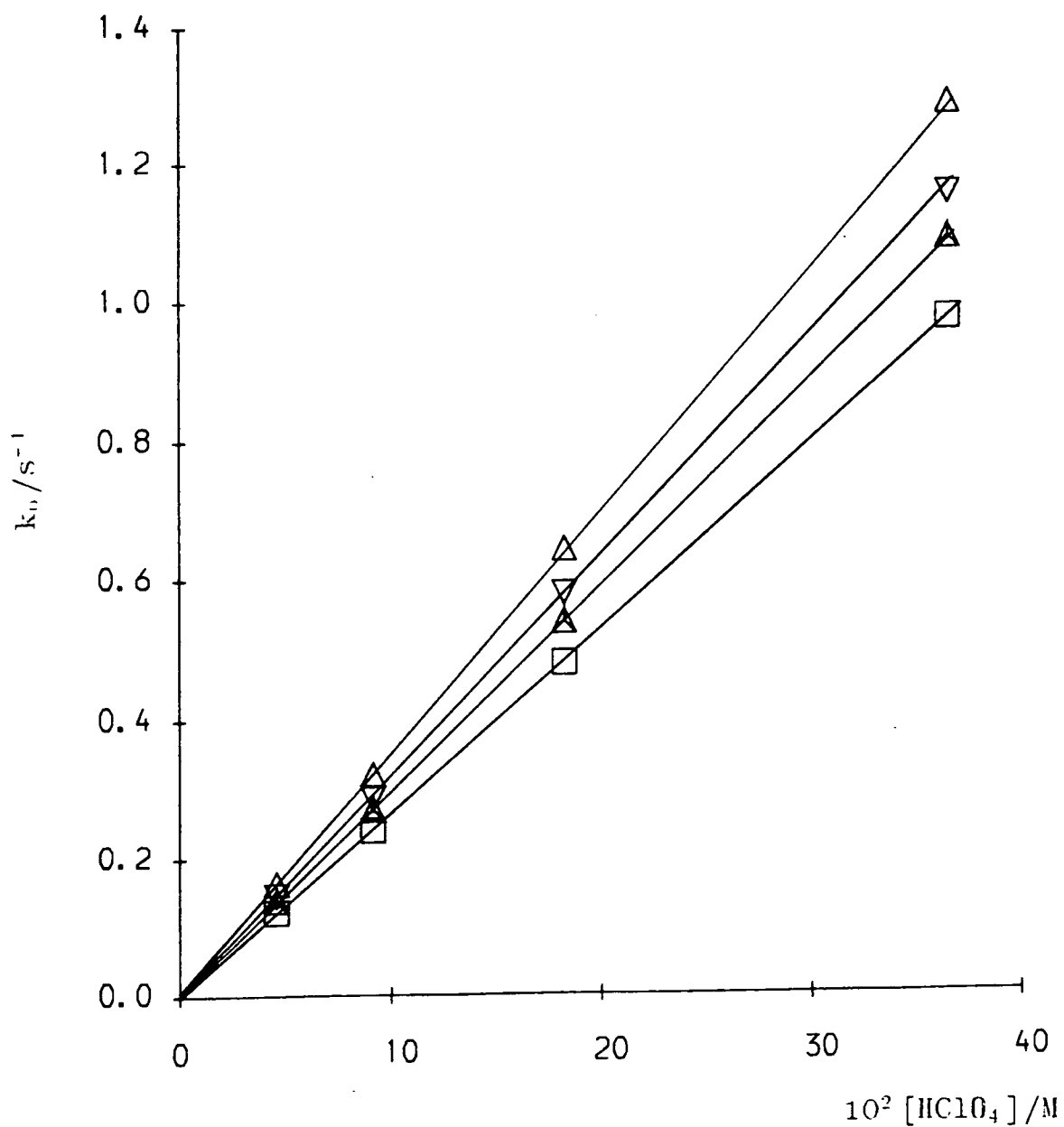

- [i PrOH] = .4M
- ▲ [i PrOH] = .2M
- ▽ [i PrOH] = .1M
- △ [i PrOH] = 0M

Figure 2.4 Dependence of k_0 on [acid] at various $[^i\text{PrOH}]$ at 25°C (for nitrosation of EtCys by $^i\text{PrONO}$)

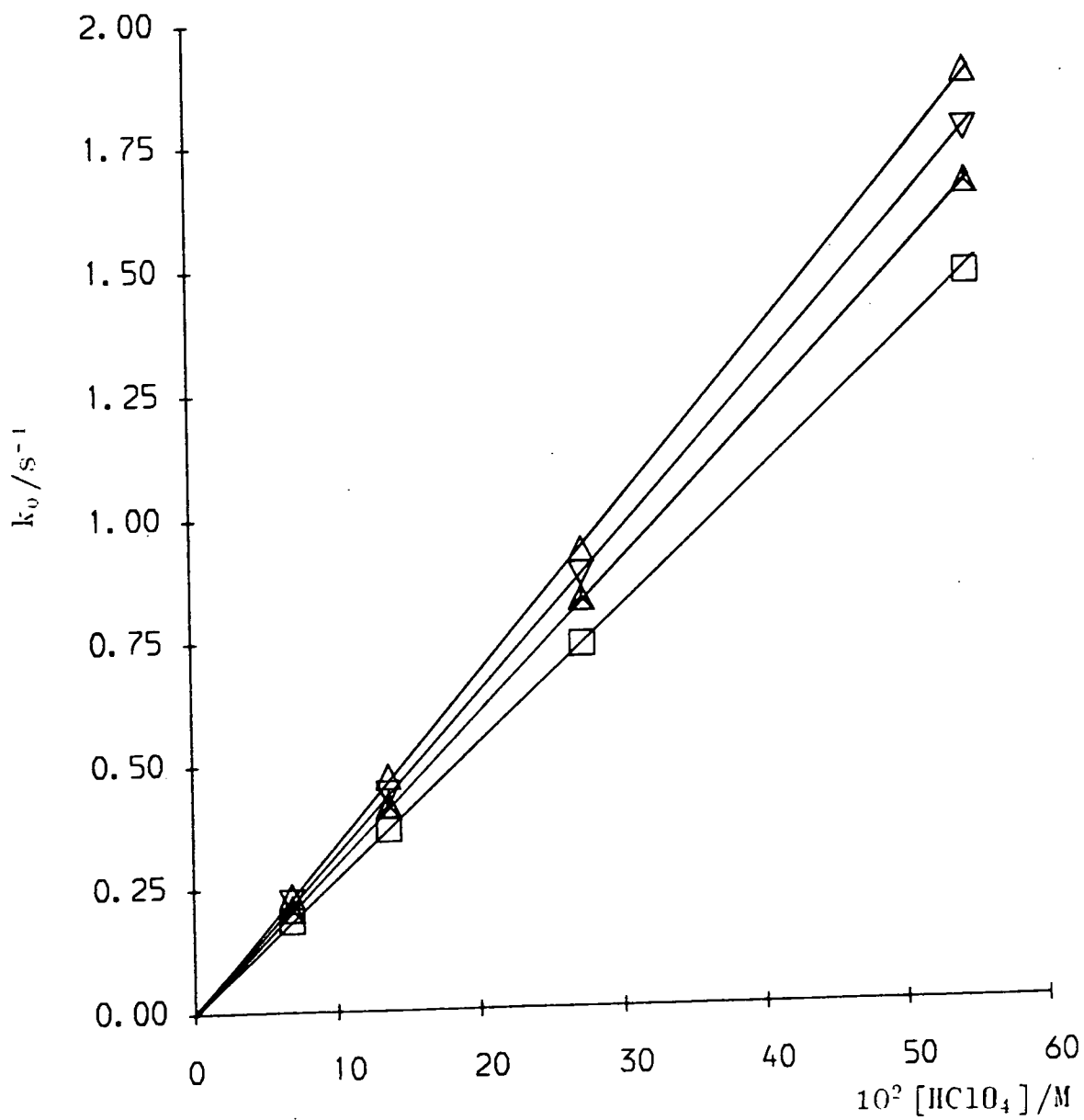

- $[^i\text{PrOH}] = .4\text{M}$
- ▲ $[^i\text{PrOH}] = .2\text{M}$
- ▽ $[^i\text{PrOH}] = .1\text{M}$
- △ $[^i\text{PrOH}] = 0\text{M}$

Figure 2.5 Dependence of k_0 on $[N\text{-Ac-Cys}]$ at various $[i\text{PrOH}]$ at 25°C

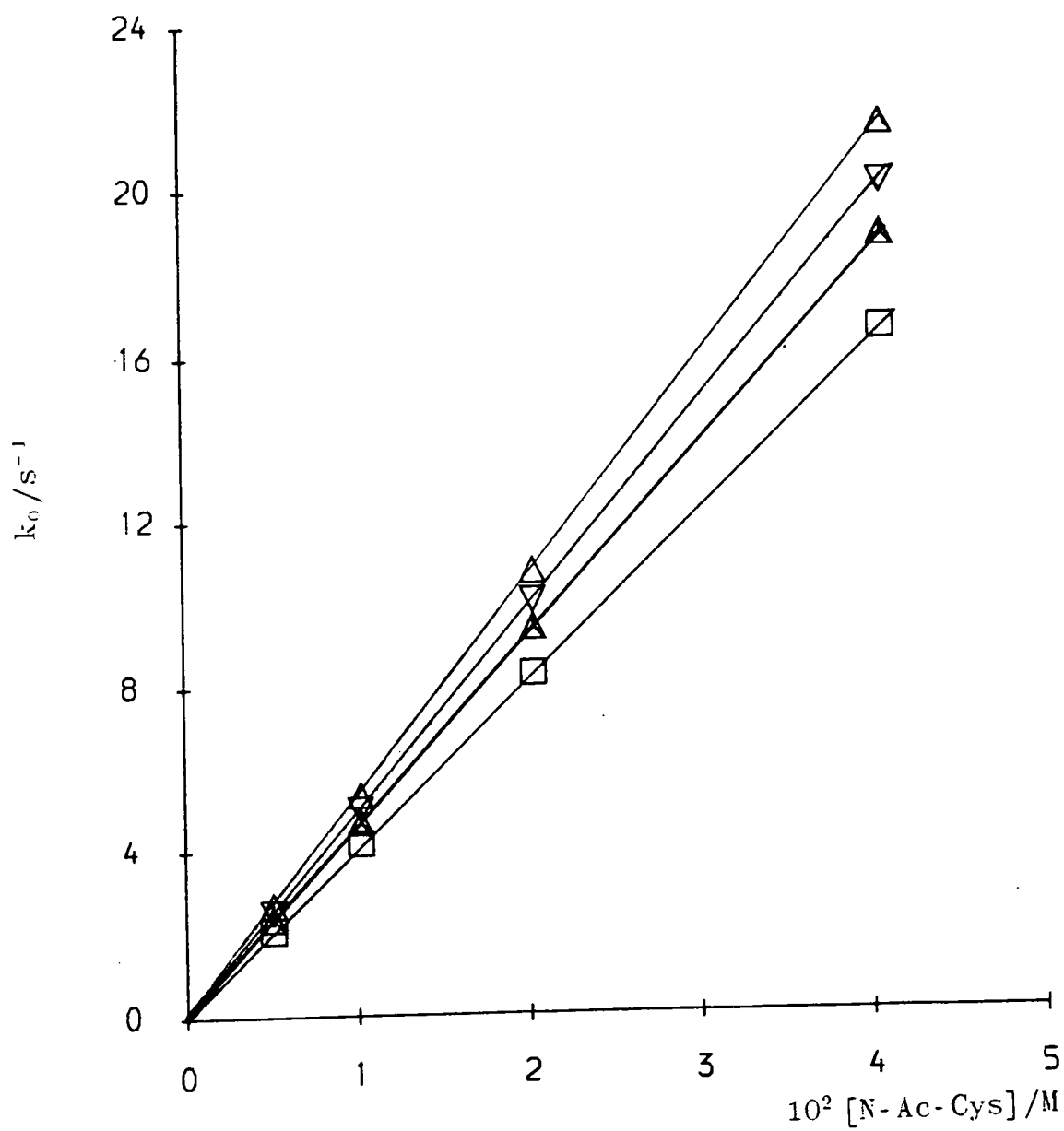

- $[i\text{PrOH}] = .4\text{M}$
- ▲ $[i\text{PrOH}] = .2\text{M}$
- ▽ $[i\text{PrOH}] = .1\text{M}$
- △ $[i\text{PrOH}] = 0\text{M}$

Figure 2.6 Dependence of k_0 on [acid] at various [i PrOH] at 25°C (for the nitrosation of N-Ac-Cys by i PrONO)

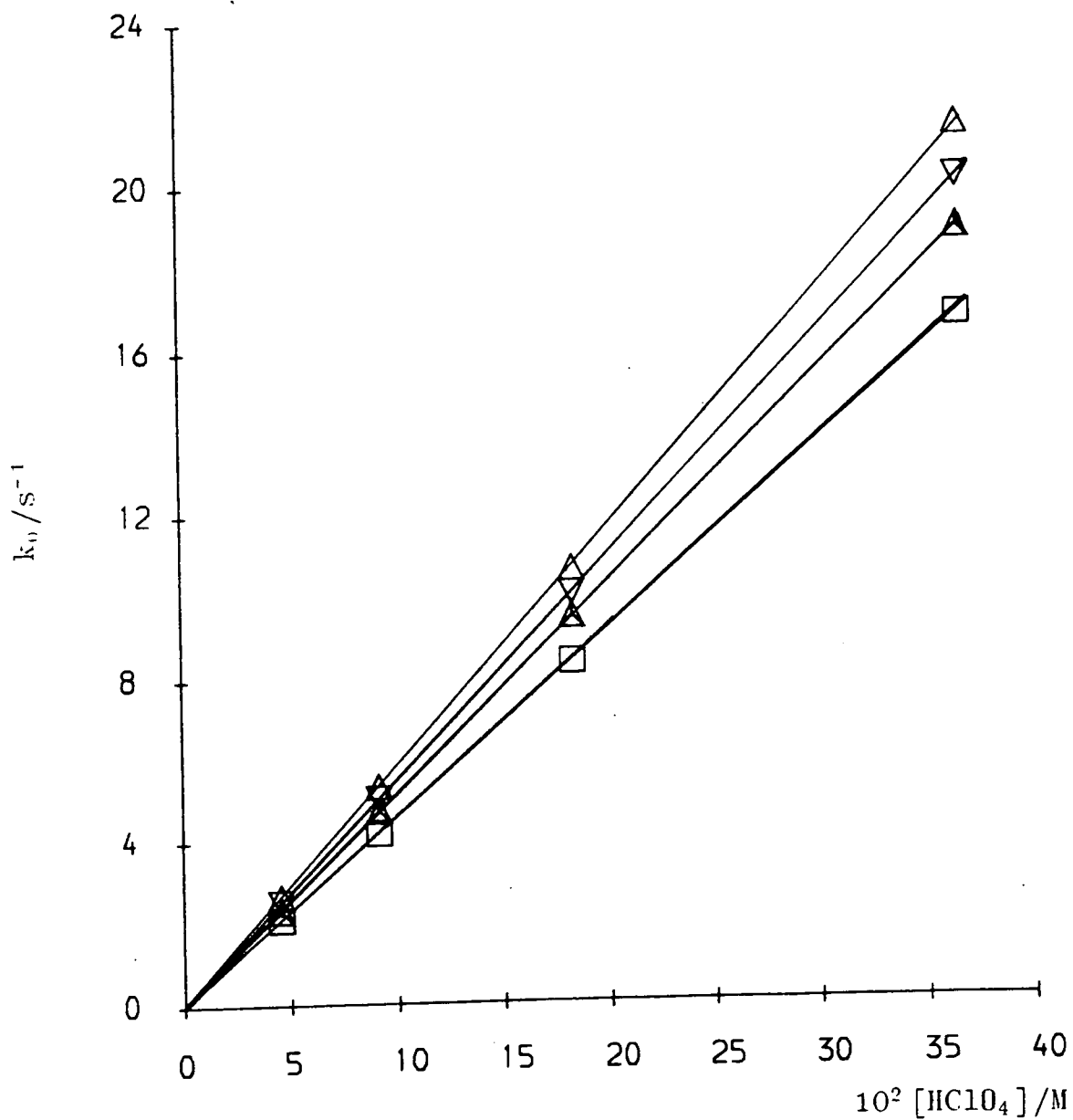

□ [i PrOH] = .4M

▲ [i PrOH] = .2M

▽ [i PrOH] = .1M

△ [i PrOH] = 0M

Figure 2.7 Dependence of k_0 on $[GSH]$ at various $[iPrOH]$ at $25^\circ C$

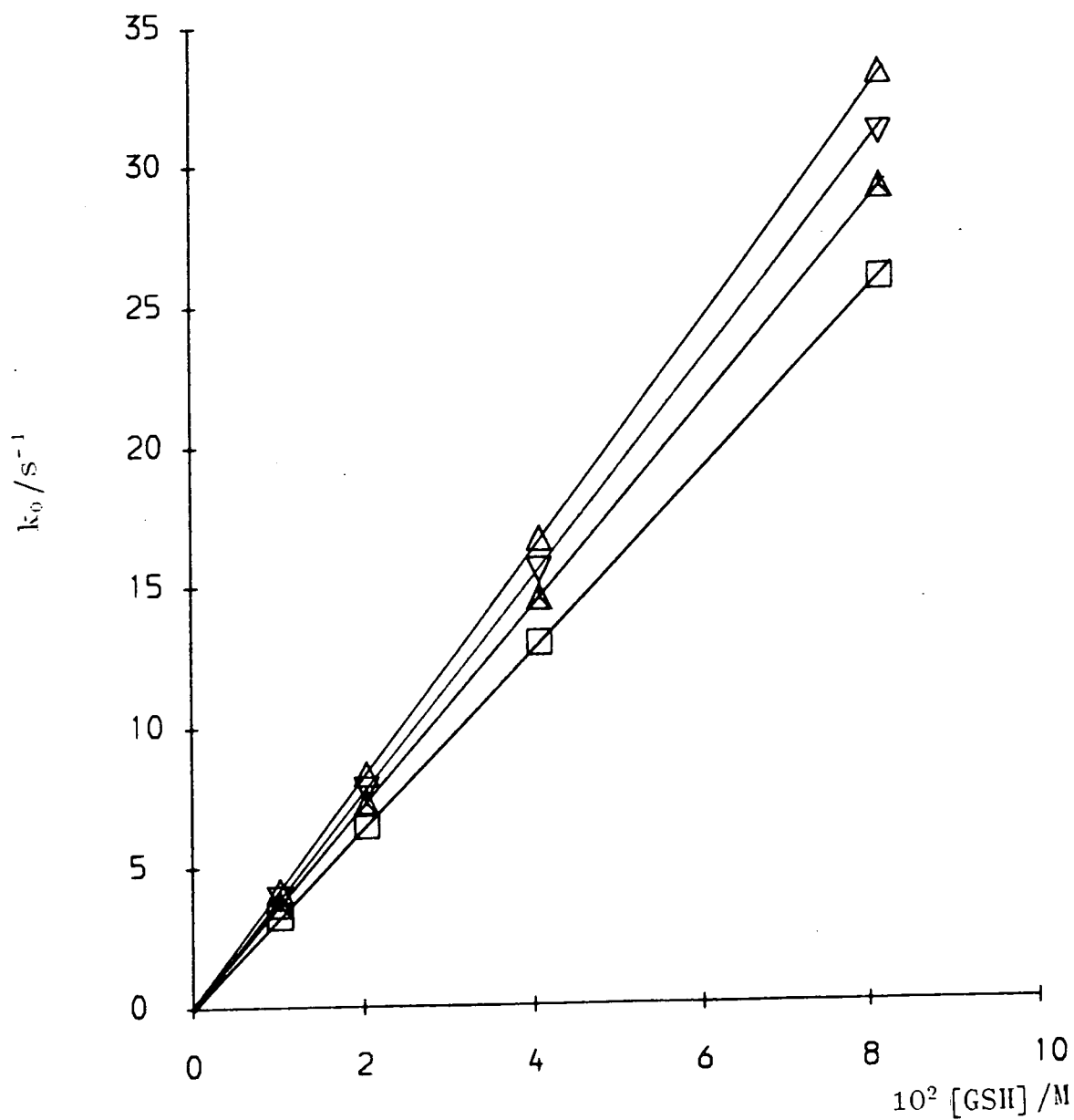

- $[iPrOH] = .4M$
- ▲ $[iPrOH] = .2M$
- ▽ $[iPrOH] = .1M$
- △ $[iPrOH] = 0M$

Figure 2.8 Dependence of k_0 on $[\text{acid}]$ at various $[\text{}^i\text{PrOH}]$ at 25°C (for the nitrosation of GSH by $\text{}^i\text{PrONO}$)

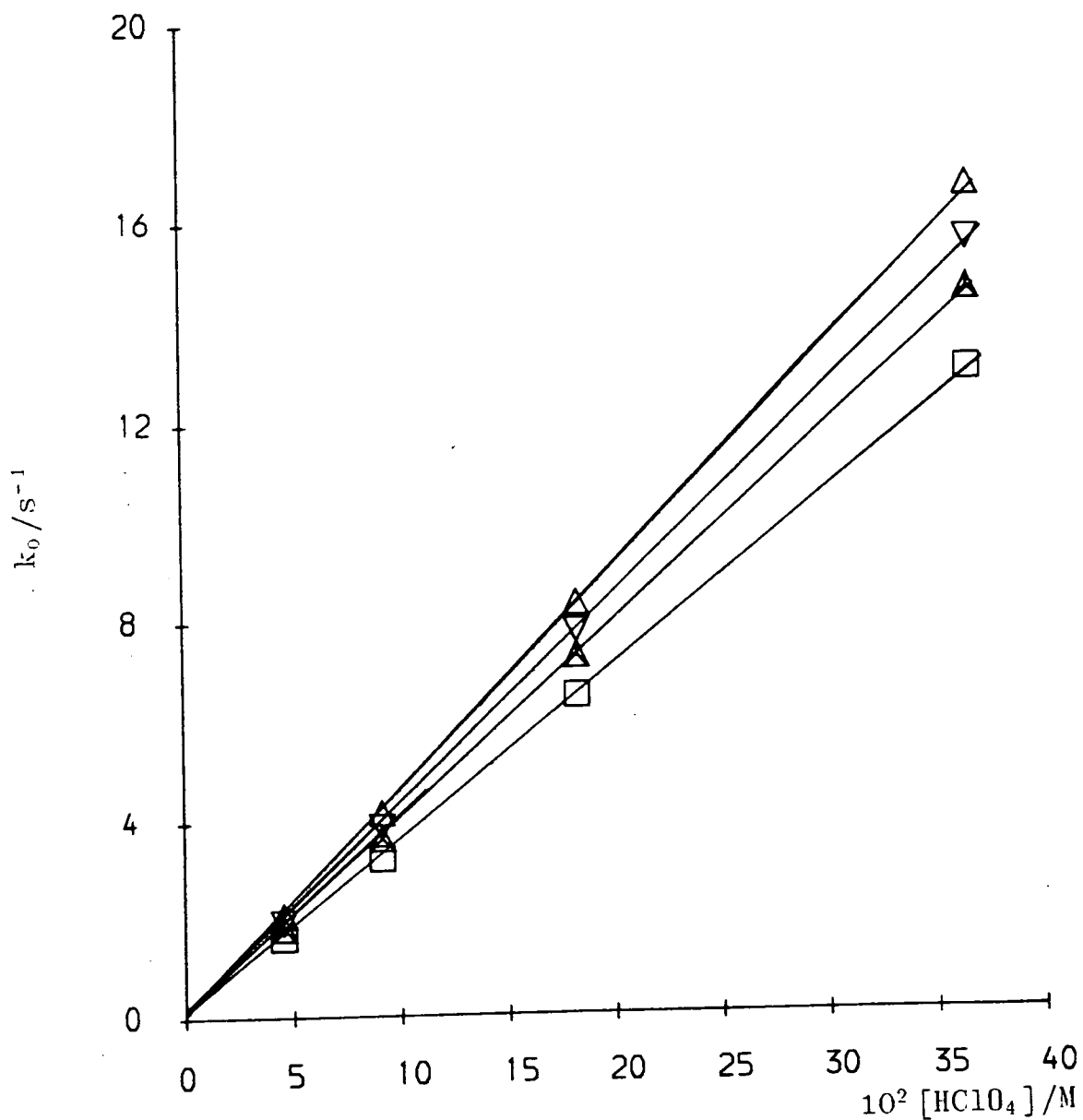

- $[\text{}^i\text{PrOH}] = .4\text{M}$
- ▲ $[\text{}^i\text{PrOH}] = .2\text{M}$
- ▽ $[\text{}^i\text{PrOH}] = .1\text{M}$
- △ $[\text{}^i\text{PrOH}] = 0\text{M}$

The plots of k_0 versus $[RSH]$ and $[acid]$ at various $[^iPrOH]$ (Figures 2.3-2.8) are all linear, and pass through the origin, indicating that under the conditions used the reactions are first-order with respect to $[RSH]$ and $[acid]$. This establishes the rate equation (equation 2.10).

$$\text{Rate} = k [RONO] [H^+] [RSH] \quad (2.10)$$

The plots of k_0 versus $[acid]$ for the nitrosation of MeCys, EtCys and N-Ac-Cys (Figures 2.3-2.7) show no positive intercept indicating that there is only one reactive form of these thiols. However, in the case of GSH the plot of k_0 versus $[acid]$ (Figure 2.8) shows a slight positive intercept indicating that GSH may be reacting in both the zwitterion and the N-protonated form. This is as expected since GSH, a naturally occurring tripeptide of glutamic acid, cysteine and glycine, can exist partly as the zwitterion and partly as the N-protonated form in acid conditions.

The kinetic pattern is very similar, in all cases, to that encountered for cysteine on addition of iPrOH . This implies that the reactions take place via the hydrolysis of isopropyl nitrite and that the nitrous acid formed effects the nitrosation of the thiols. Therefore the same expression for k_0 as that used for the nitrosation of cysteine can be used (equation 2.7).

The plots of k_0^{-1} versus $[^iPrOH]$ for the experimental results are shown in Figures 2.9-2.14 and the analysis of the results are shown in tables 2.11-2.16.

Figure 2.9 Dependence of k_0^{-1} on $[^i\text{PrOH}]$ added at various $[\text{acid}]$ (for the nitrosation of MeCys)

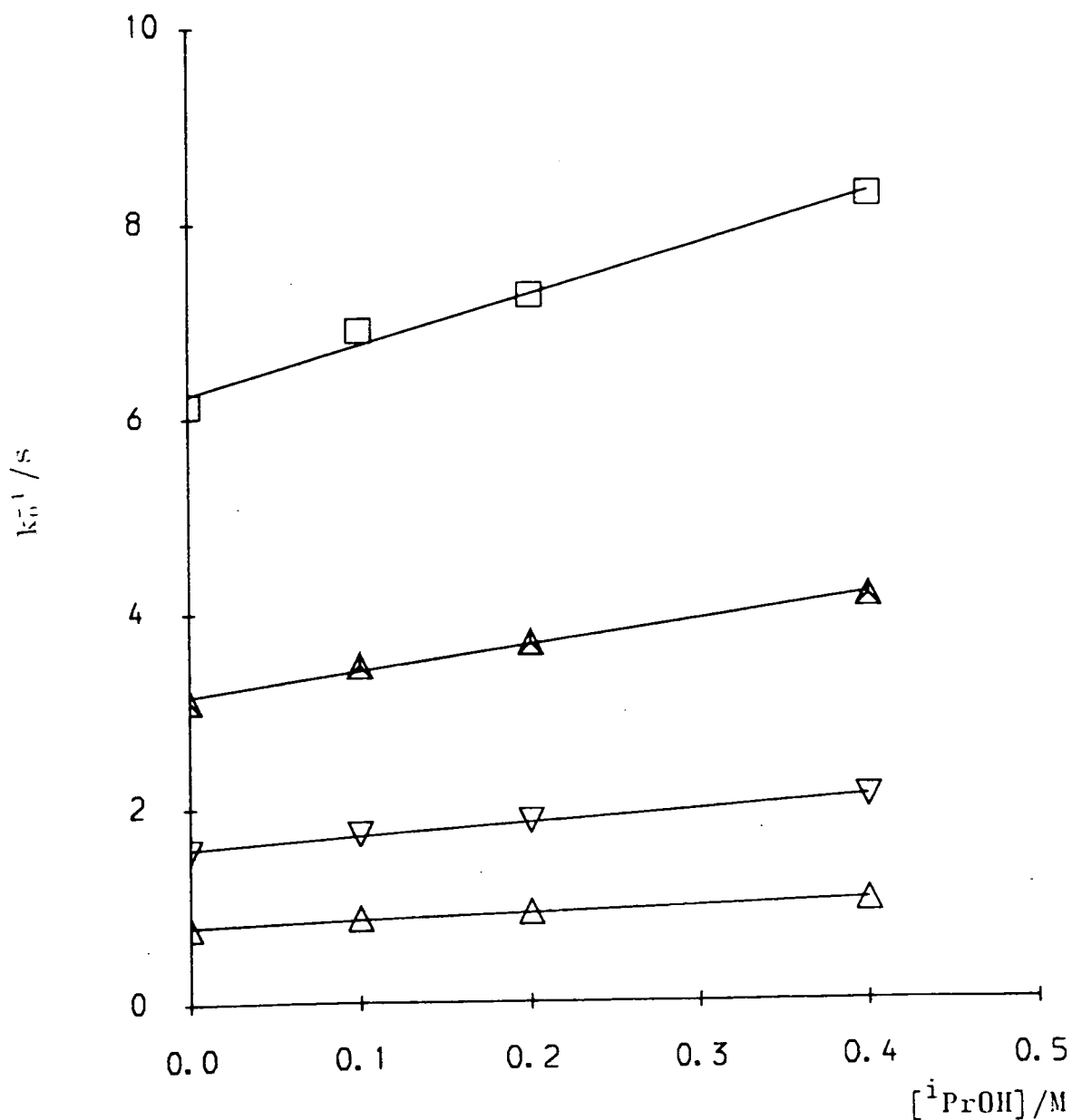

□ $[\text{HClO}_4] = 4.56 \times 10^{-2} \text{ M}$

▲ $[\text{HClO}_4] = 9.13 \times 10^{-2} \text{ M}$

▽ $[\text{HClO}_4] = 18.25 \times 10^{-2} \text{ M}$

△ $[\text{HClO}_4] = 36.50 \times 10^{-2} \text{ M}$

Figure 2.10 Dependence of k_0^{-1} on $[^i\text{PrOH}]$ added at various [acid] (for the nitrosation of EtCys)

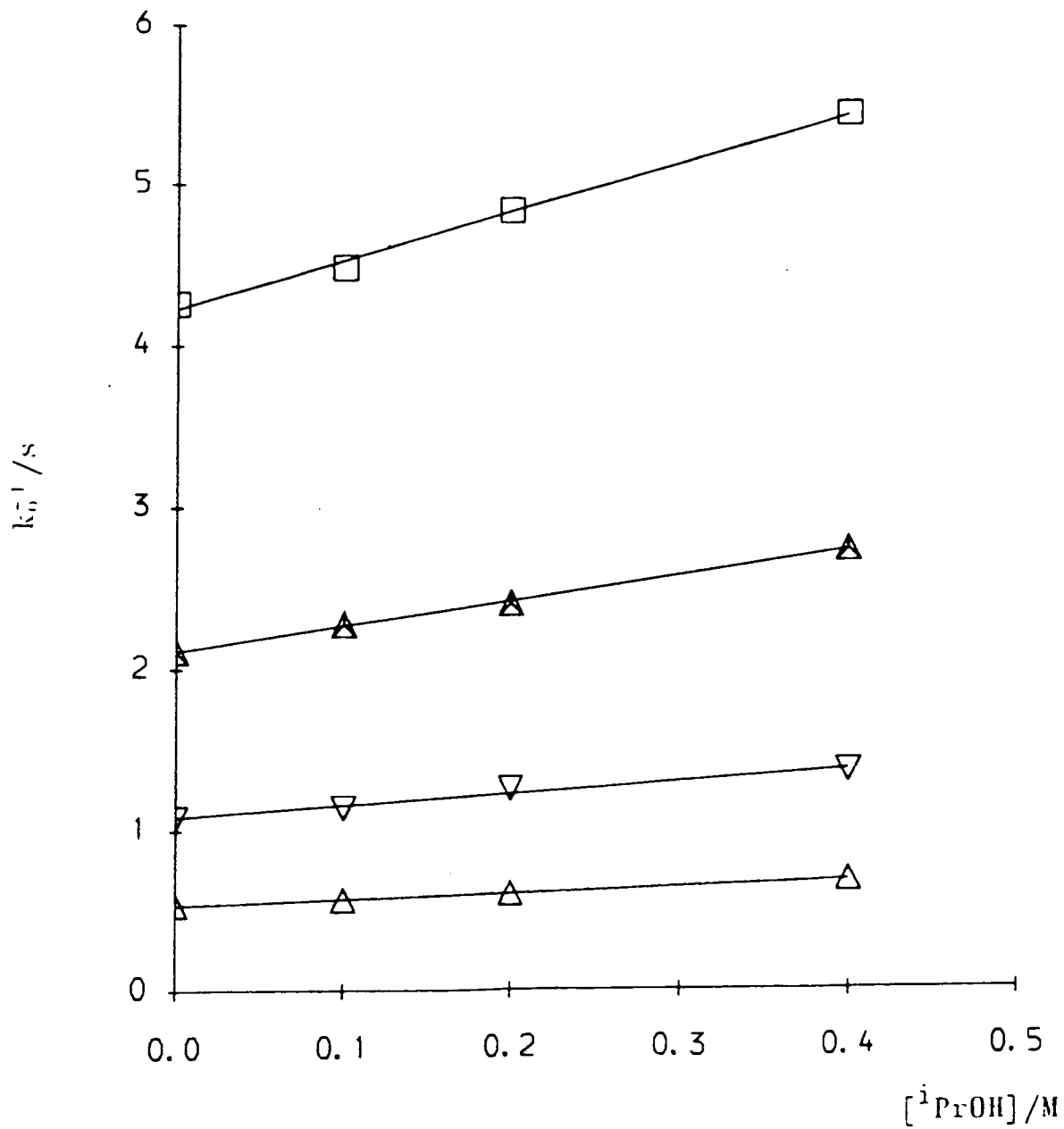

- $[\text{HClO}_4] = 6.84 \times 10^{-2} \text{M}$
- ▲ $[\text{HClO}_4] = 13.68 \times 10^{-2} \text{M}$
- ▽ $[\text{HClO}_4] = 27.37 \times 10^{-2} \text{M}$
- △ $[\text{HClO}_4] = 54.73 \times 10^{-2} \text{M}$

Figure 2.11 Dependence of k_0^{-1} on $[^i\text{PrOH}]$ added at various $[\text{N-Ac-Cys}]$

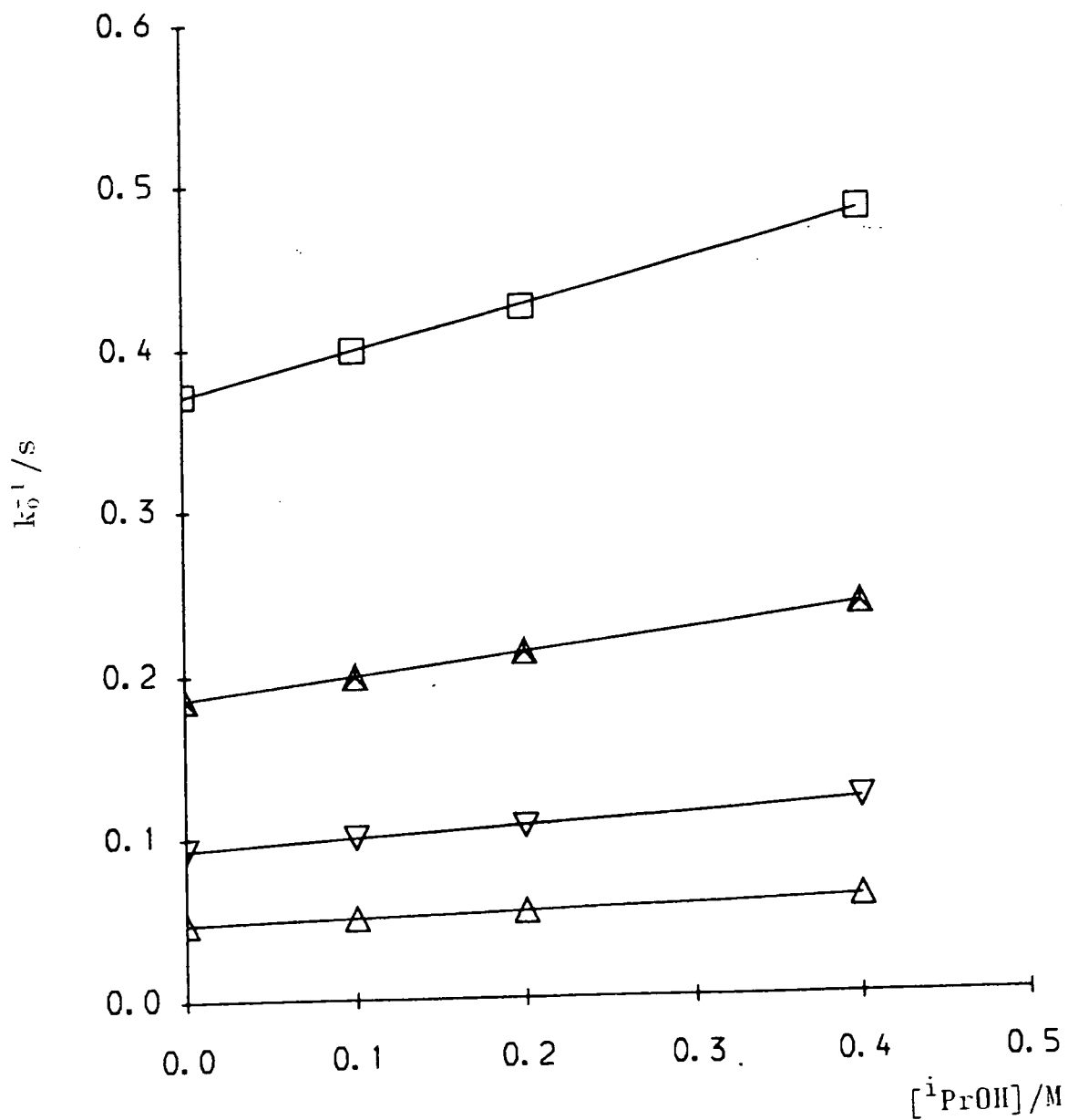

- $[\text{N-Ac-Cys}] = 0.51 \times 10^{-2} \text{M}$
- ▲ $[\text{N-Ac-Cys}] = 1.02 \times 10^{-2} \text{M}$
- ▽ $[\text{N-Ac-Cys}] = 2.03 \times 10^{-2} \text{M}$
- △ $[\text{N-Ac-Cys}] = 4.06 \times 10^{-2} \text{M}$

Figure 2.12 Dependence of k_0^{-1} on $[^i\text{PrOH}]$ added at various [acid] (for the nitrosation of N-Ac-Cys)

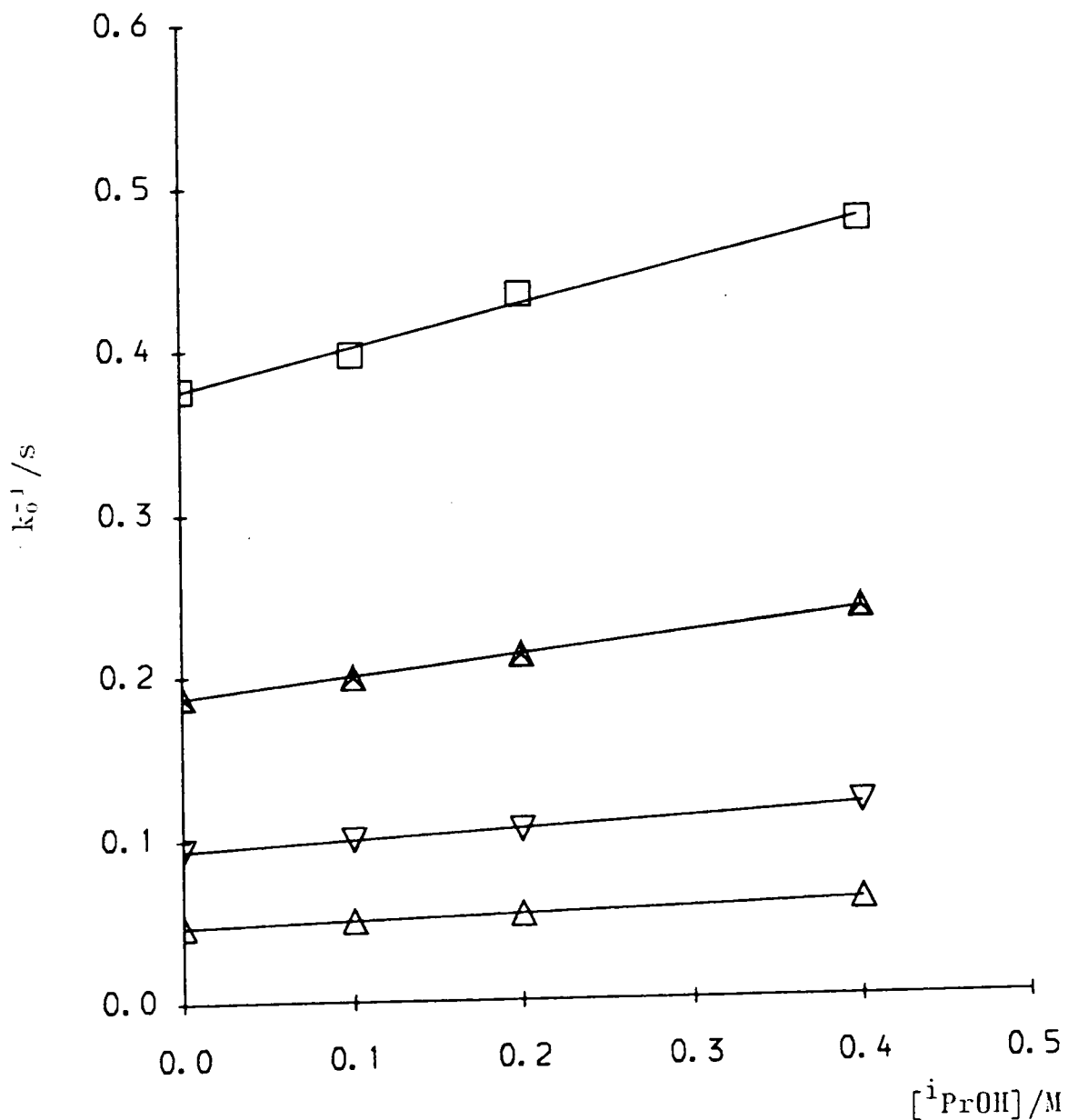

- $[\text{HClO}_4] = 4.56 \times 10^{-2} \text{ M}$
- ▲ $[\text{HClO}_4] = 9.13 \times 10^{-2} \text{ M}$
- ▽ $[\text{HClO}_4] = 18.25 \times 10^{-2} \text{ M}$
- △ $[\text{HClO}_4] = 36.50 \times 10^{-2} \text{ M}$

Figure 2.13 Dependence of k_0^{-1} on $[^i\text{PrOH}]$ added at various $[\text{GSH}]$

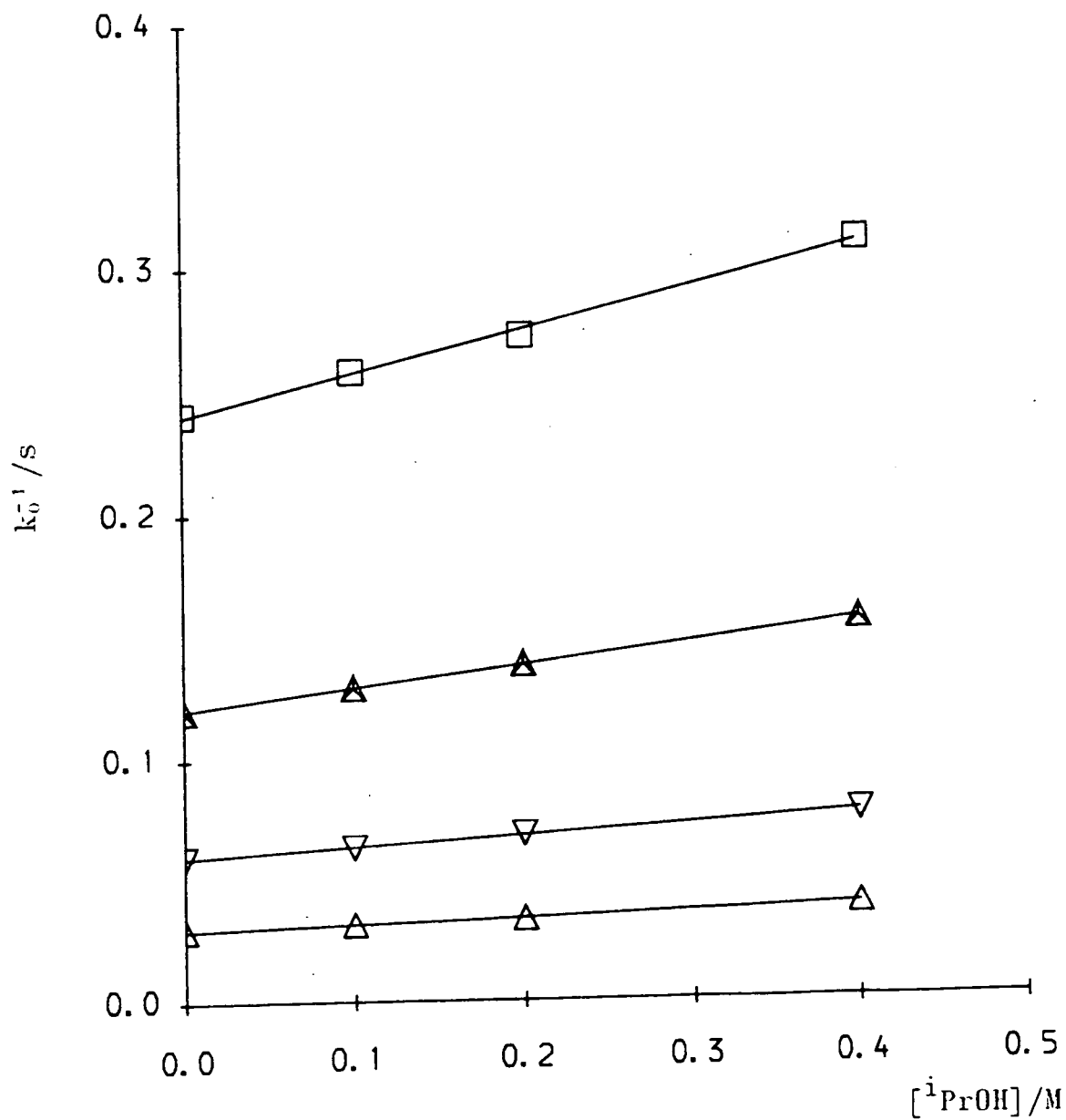

□ $[\text{GSH}] = 1.02 \times 10^{-2} \text{M}$

▲ $[\text{GSH}] = 2.04 \times 10^{-2} \text{M}$

▽ $[\text{GSH}] = 4.08 \times 10^{-2} \text{M}$

△ $[\text{GSH}] = 8.16 \times 10^{-2} \text{M}$

Figure 2.14 Dependence of k_0^{-1} on $[^i\text{PrOH}]$ added at various $[\text{acid}]$ (for the nitrosation of GSH)

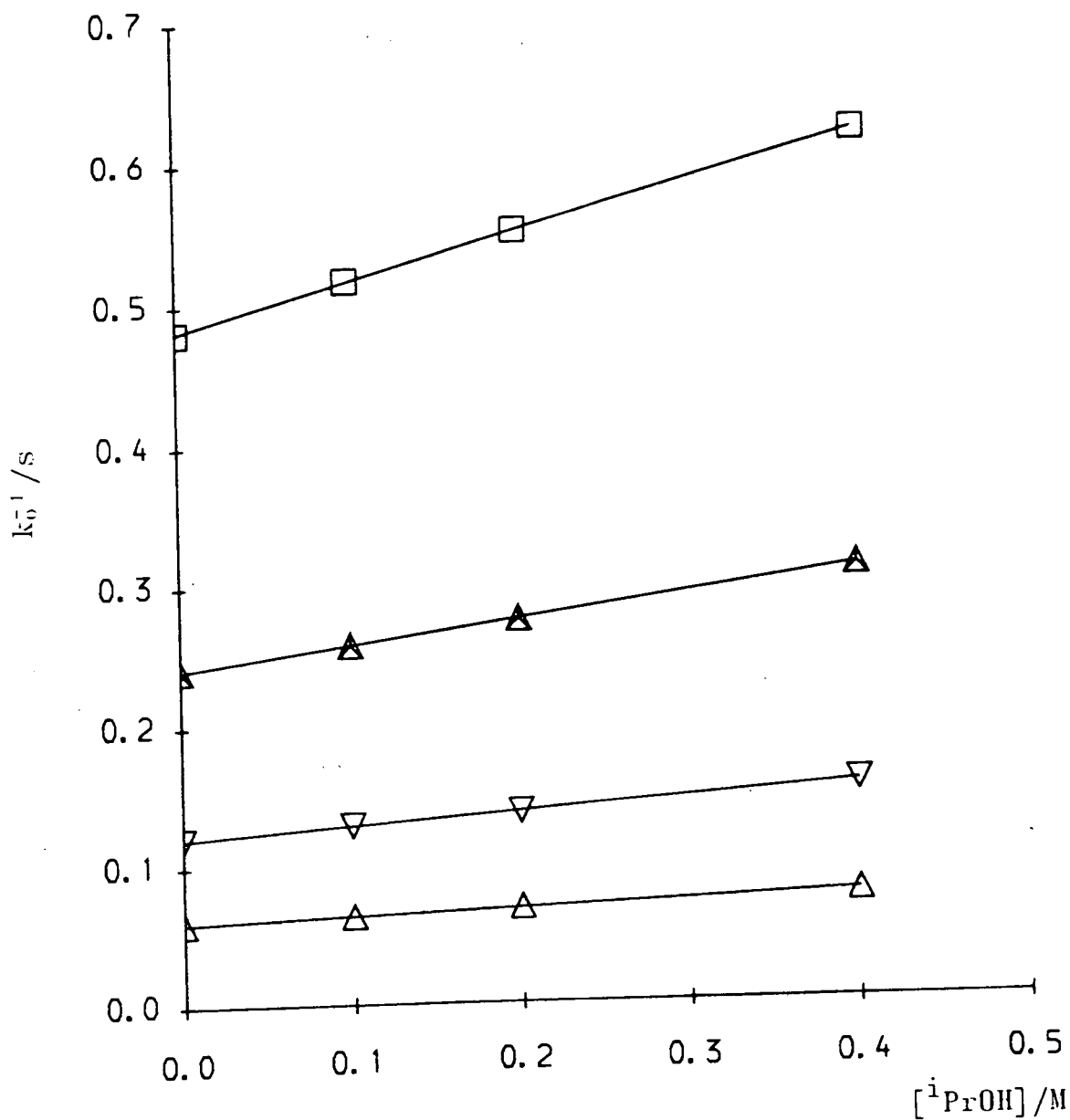

- $[\text{HClO}_4] = 4.56 \times 10^{-2} \text{ M}$
- ▲ $[\text{HClO}_4] = 9.13 \times 10^{-2} \text{ M}$
- ▽ $[\text{HClO}_4] = 18.25 \times 10^{-2} \text{ M}$
- △ $[\text{HClO}_4] = 36.50 \times 10^{-2} \text{ M}$

Table 2.11 Results from plots of k_0^{-1} versus $[^i\text{PrOH}]$
(for the nitrosation of MeCys by $^i\text{PrONO}$)

$10^2 [\text{H}^+]$ /M	Gradient/ s l mol ⁻¹	Intercept /s	Keq mol l ⁻¹	k l ² mol ⁻² s ⁻¹
36.50	0.580	0.797	1.37	253
18.25	1.206	1.590	1.32	253
9.13	2.349	3.179	1.35	253
4.56	4.920	6.263	1.27	257

Table 2.12 Results from plots of k_0^{-1} versus $[^i\text{PrOH}]$
(for the nitrosation of EtCys by $^i\text{PrONO}$)

$10^2 [\text{H}^+]$ /M	Gradient/ s l mol ⁻¹	Intercept /s	Keq mol l ⁻¹	k l ² mol ⁻² s ⁻¹
54.73	0.389	0.525	1.35	247
27.37	0.711	1.085	1.53	239
13.68	1.516	2.110	1.39	246
6.84	3.147	4.208	1.34	246

Table 2.13 Results from plots of k_0^{-1} versus $[^i\text{PrOH}]$
(for the nitrosation of N-Ac-Cys by $^i\text{PrONO}$)

10^2 [N-Ac-Cys]/M	Gradient/ s l mol ⁻¹	Intercept /s	Keq mol l ⁻¹	k l ² mol ⁻² s ⁻¹
4.06	0.033	0.047	1.44	1442
2.03	0.070	0.093	1.33	1454
1.02	0.135	0.186	1.37	1446
0.51	0.277	0.371	1.34	1447

Table 2.14 Results from plots of k_0^{-1} versus $[^i\text{PrOH}]$
(for the nitrosation of N-Ac-Cys by $^i\text{PrONO}$)

$10^2 [\text{H}^+]$ /M	Gradient/ s l mol ⁻¹	Intercept /s	Keq mol l ⁻¹	k l ² mol ⁻² s ⁻¹
36.50	0.033	0.047	1.44	1453
18.30	0.062	0.094	1.50	1449
9.13	0.129	0.187	1.45	1453
4.56	0.258	0.376	1.46	1449

Table 2.15 Results from plots of k_0^{-1} versus $[^i\text{PrOH}]$
(for the nitrosation of GSH by $^i\text{PrONO}$)

$10^2 [\text{GSH}]$ /M	Gradient/ s l mol ⁻¹	Intercept /s	Keq mol l ⁻¹	k l ² mol ⁻² s ⁻¹
8.16	0.023	0.030	1.32	1127
4.08	0.043	0.060	1.40	1119
2.04	0.087	0.120	1.38	1117
1.02	0.172	0.240	1.40	1118

Table 2.16 Results from plots of k_0^{-1} versus $[^i\text{PrOH}]$
(for the nitrosation of GSH by $^i\text{PrONO}$)

$10^2 [\text{H}^+]$ /M	Gradient/ s l mol ⁻¹	Intercept /s	Keq mol l ⁻¹	k l ² mol ⁻² s ⁻¹
36.50	0.043	0.060	1.40	1119
18.25	0.087	0.120	1.38	1119
9.13	0.173	0.241	1.40	1115
4.56	0.347	0.482	1.39	1116

The average values of K_{eq} , $1.39 \pm .06 \text{ mol l}^{-1}$, gives the value of the equilibrium constant for the formation of $^i\text{PrONO}$, K , as 0.72 l mol^{-1} at 25°C . This is in reasonable agreement with the literature value¹⁴ of 0.56 l mol^{-1} for K measured directly at this temperature.

Similarly the values of k , 254 ± 2 , 245 ± 3 , 1449 ± 9 and $1119 \pm 3 \text{ l}^2 \text{ mol}^{-2} \text{ s}^{-1}$ at 25°C , obtained for the nitrosation of MeCys, EtCys, N-Ac-Cys and GSH by $^i\text{PrONO}$ respectively are in good agreement with the reported values of k for the direct nitrous acid nitrosation of the respective thiols.¹²

2.4 Discussion

The rate equation (equation 2.12) was established for the reaction of $^i\text{PrONO}$ with the thiols used in aqueous acidic solution in the absence of added nucleophiles.

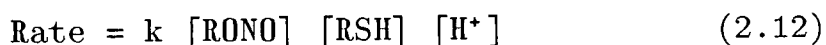

In this case the rate of the reaction was found to decrease on addition of $^i\text{PrOH}$ and no evidence was found for the direct reaction of the alkyl nitrite with the thiols used. Thus, the above rate equation together with the retardation effect of added ROH is interpreted in terms of a mechanism involving the rapid reversible acid-catalysed hydrolysis of alkyl nitrites to give nitrous acid which then in its protonated form effects nitrosation of the thiols.

The averaged third-order rate constants, k , determined for the thiols used are compared with literature values and summarised in table 2.17.

Table 2.17 Third-order rate constant, k , at 25°C in water

Thiol	This Study $k/l^2 \text{ mol}^{-2} \text{ s}^{-1}$	Lit. Values $k/l^2 \text{ mol}^{-2} \text{ s}^{-1}$
L-Cysteine	336	340
L-Cysteine-Me Ester	254	213
L-Cysteine-Et Ester	245	—
Glutathione	1119	1080
N-Acetyl-L-Cysteine	1449	1590

The third-order rate constants are in good agreement with those determined from the direct nitrosation by nitrous acid in aqueous acidic solution. The difference in the third-order rate constants observed for the thiols used can be explained, as in the case of direct nitrosation by nitrous acid, in terms of the electronic effects.

Comparison of the rate constants for the nitrosation of cysteine with that of the carboxylic esters of cysteine (i.e. Methyl and Ethyl Esters) shows that they are comparable. This is to be expected since changing from the carboxyl group to the ester groups would be expected to have little or no effect on the reactivity of the sulphur atom, since both groups have similar electronegativities.

In the case of the N-acetyl derivative the observed rate constant is significantly higher than that of cysteine. This could be due to stabilisation of the positive charge on the sulphur atom by the carbonyl group in the transition state (2.5).

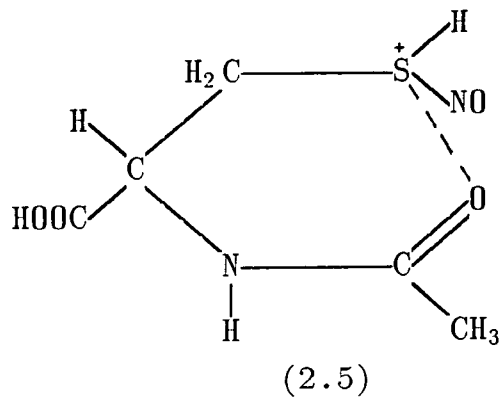

A similar stabilisation could also occur in the case of glutathione (2.6).

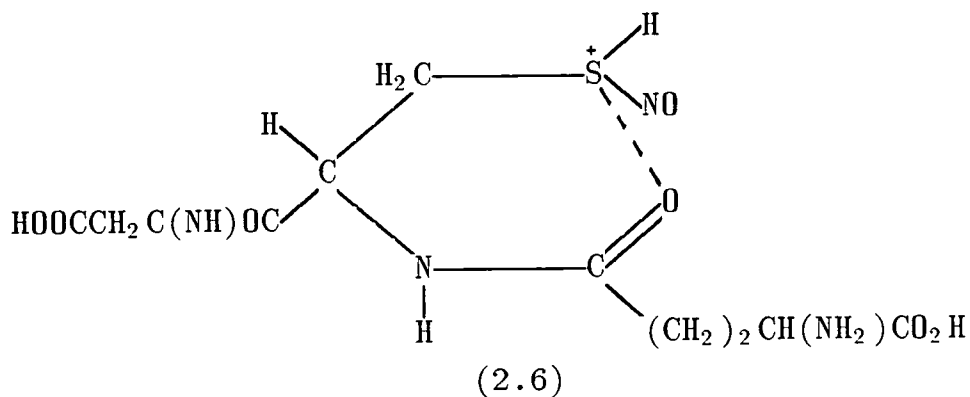

This could explain why the observed rate constant for the nitrosation of GSH is significantly higher than that of cysteine.

References

1. S. Oae, N. Asai and K. Fujimori, *J. Chem. Soc., Perkin Trans. 2*, 1978, 1124.
2. A. D. Allen and G. R. Schonbaum, *Can. J. Chem.*, 1961, 39, 947.
3. M. P. Doyle, J. W. Terpstra, R. A. Pickering and D. M. LePoire, *J. Org. Chem.*, 1983, 48, 3379.
4. A. D. Allen, *J. Chem. Soc.*, 1954, 1968.
5. S. E. Aldred, D. L. H. Williams and M. Garley, *J. Chem. Soc., Perkin Trans. 2*, 1982, 777.
6. M. J. Crookes and D. L. H. Williams, *J. Chem. Soc., Perkin Trans. 2*, 1988, 1339.
7. L. Pardeshi and R. A. Bhohe, *J. Indian Chem. Soc.*, 1980, 583.
8. E. J. Cohn and J. T. Edsall, in "*Proteins, Amino Acids and Peptides*", Reinhold Publishing Co., New York, 1943, p85.
9. A. Albert, *J. Biochem.*, 1950, 47, 531.
10. P. Collings, K. Al-Mallah and G. Stedman, *J. Chem. Soc. Perkin Trans. 2*, 1975, 1736.
11. L. R. Dix and D. L. H. Williams, *J. Chem. Soc., Perkin Trans. 2*, 1984, 109.
12. P. A. Morris and D. L. H. Williams, *J. Chem. Soc., Perkin Trans. 2*, 1988, 513.
13. J. Casado, A. Castro, J. R. Leis, M. Mosquera and M. E. Pena, *J. Chem. Soc. Perkin Trans. 2*, 1985, 1859.
14. H. Schmid, *Chem. Zig./Chem. Apparatur*, 1962, 86, 809.
15. J. Casado, F. M. Lorenzo, M. Mosquera and M. F. R. Prieto, *Can. J. Chem.*, 1984, 62, 136.
16. C. D. Maycock and R. J. Stoodley, *J. Chem. Soc., Perkin Trans. 1*, 1979, 1852.
17. T. A. Meyer and D. L. H. Williams, *J. Chem. Soc., Chem Comm.*, 1983, 1067.
18. R. Bonnett, R. Holleyhead, B. L. Johnson and E. W. Randall, *J. Chem. Soc., Perkin Trans. 1*, 1975, 2261.

CHAPTER THREE

S-nitrosation in mildly basic solution

3.1 Introduction

It has been shown (Chapter Two and Ref. 1) that alkyl nitrites in aqueous acidic conditions undergo rapid and reversible hydrolysis to give nitrous acid (or O-nitrosation of water) which then generates the true nitrosating agent NO^+ or H_2NO_2^+ . However, in basic and neutral solutions the hydrolysis (equation 3.1) has been found to be much slower² and yields nitrite ion, which is not normally a nitrosating agent.³

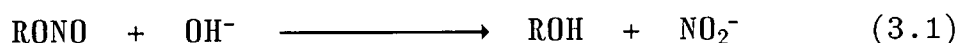

Nevertheless, nitrosation by alkyl nitrites under alkaline conditions, usually in alcohol solvents, is a more widely used reaction preparatively. Amines, alcohols, ketones, and nitro compounds and some hydrocarbons all undergo such reactions.⁴ The reactions with amines in aqueous alkaline solution to form nitrosamines are interpreted in terms of a direct reaction between the alkyl nitrite and the amines (Scheme 3.1) and is written as a synchronous process and not a two-stage addition-elimination.⁵⁻⁷ This interpretation is based on the evidence that the reactivities of the amines do not correlate with their basicities, but rather with their vertical ionisation potential and also the solvent isotope effect was found to be 2, implying that the proton transfer occurs in the same limiting step, so that the proposed transition state is a cyclic structure.

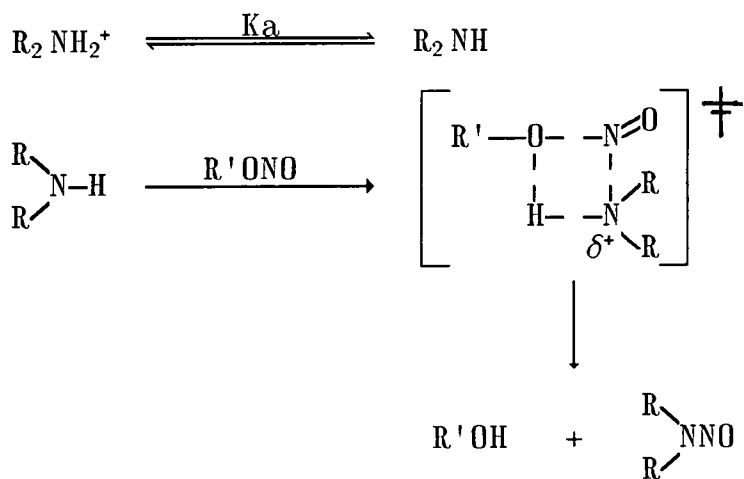

Scheme 3.1

The reaction is greatly favoured by the presence of electron-withdrawing substituent within the alkyl nitrite, as expected for an electrophilic process.⁸

The exchange of nitroso group between an alkyl nitrite and an alcohol also occurs readily in alkaline alcohol solution and probably involves the direct reaction with the alkoxide ion, since there is no reaction in neutral solution.⁴ Thiols also react with alkyl nitrites to give thionitrites,^{10,11} but nothing is known about the mechanism of these reactions. Such reactions are of some interest in connection with the well-known vasodilatory properties of alkyl nitrites, since it has been suggested¹² that alkyl nitrites may act in this way by first effecting S-nitrosation, *in vivo*, of tissue bound thiol groups. Subsequent reactions are then believed to involve enzyme activation by the thionitrite leading to smooth muscle relaxation.

A kinetic study of the nitrosation of L-cysteine, L-cysteine methyl and ethyl esters, N-acetyl-L-cysteine, thioglycolic acid and glutathione by three alkyl nitrites

with primary, secondary and tertiary structure (i.e. $i\text{AmONO}$, $i\text{PrONO}$, $t\text{BuONO}$) in the pH range 6-13 has been performed and the results are presented below.

3.2 Nitrosation of N-acetyl-L-cysteine and thioglycolic acid

The nitrosation of N-acetyl-L-cysteine (N-Ac-Cys) and thioglycolic acid (TGA) by isoamyl nitrite ($i\text{AmONO}$), isopropyl nitrite ($i\text{PrONO}$) and t-butyl nitrite ($t\text{BuONO}$) in aqueous neutral and basic conditions in the absence of added nucleophiles was examined. On mixing the solutions of alkyl nitrites and thiols a yellow coloured solution was formed with a broad absorption band at 330nm in the U.V./visible spectrum. This is typical of a thionitrite (S-nitroso) species in solution.¹¹ However, in no case was the thionitrite isolated, since they are generally very unstable in the pure form. The thionitrite derived from L-cysteine methyl ester has been isolated and characterised.¹³

All the reactions were carried out in aqueous buffer solutions at 25⁰C over the pH range 6-13 and under the conditions where the thiol concentration was in large excess over the alkyl nitrite concentration. The following buffer systems were used to cover the pH range under investigation:

<u>Buffer System</u>	<u>pH Range</u>
2- (HO ₂ C)C ₆ H ₄ CO ₂ K/NaOH	5.00 —→ 5.90
KH ₂ PO ₄ /NaOH	5.80 —→ 8.00
Na ₂ B ₄ O ₇ ·10H ₂ O/HClO ₄	8.00 —→ 9.10
Na ₂ B ₄ O ₇ ·10H ₂ O/NaOH	9.20 —→ 10.80
NaHPO ₄ /NaOH	10.90 —→ 12.00

The reactions were followed by monitoring the increase in absorbance at 330nm due to the formation of the thionitrite. In all cases good first-order behaviour was observed. The measured first-order constants, k_0 , were determined at each of four/five different thiol concentrations at each pH value. Two sets of the results for the reaction of $^i\text{PrONO}$ with N-Ac-Cys and TGA at pH 8 are shown in tables 3.1 and 3.2, whilst the rest of the data has not been included due to reason of space. The plots of k_0 versus [N-Ac-Cys] and [TGA] (Figure 3.1) at pH 8 are linear, passing through the origin, thus indicating that under the conditions used the nitrosation of N-Ac-Cys and TGA by $^i\text{PrONO}$ is first-order in [N-Ac-Cys] and [TGA]. This was found to be the same for the other alkyl nitrites at each of the pH values investigated.

Table 3.1 Dependence of k_0 on [N-Ac-Cys] at pH 8

$$[^i\text{PrONO}] = 1.0 \times 10^{-4} \text{M}$$

10^2 [N-Ac-Cys]/M	10^3 k_0 /s $^{-1}$
1.02	3.1 ± .07
2.04	6.3 ± .04
4.08	12.2 ± .02
8.16	24.5 ± .01
12.24	36.8 ± .02

Table 3.2 Dependence of k_0 on [TGA] at pH 8

$$[{}^i\text{PrONO}] = 1.0 \times 10^{-4} \text{M}$$

10^2 [TGA] /M	10^3 k_0/s^{-1}
0.98	2.65 \pm .03
1.96	5.27 \pm .01
3.92	10.33 \pm .06
7.86	21.25 \pm .03
11.76	31.75 \pm .04

Thus the rate equation (equation 3.2) was established, where k_2 is the derived second-order rate constant.

$$\text{Rate} = k_2 [\text{RSH}] [\text{RONO}] \quad (3.2)$$

The values of k_2 at each pH were determined from the plots of k_0 versus [RSH] (i.e. the gradient = k_2) and these are shown in tables 3.3 and 3.4 and only two plots of k_2 versus pH, for the reaction of N-Ac-Cys and TGA with ${}^i\text{AmONO}$ and ${}^i\text{PrONO}$ respectively (Figures 3.2 and 3.3), are included whilst the rest of the plots have not been included due to reasons of brevity.

Figure 3.1 Dependence of k_0 on [N-Ac-Cys] and [TGA] at pH 8

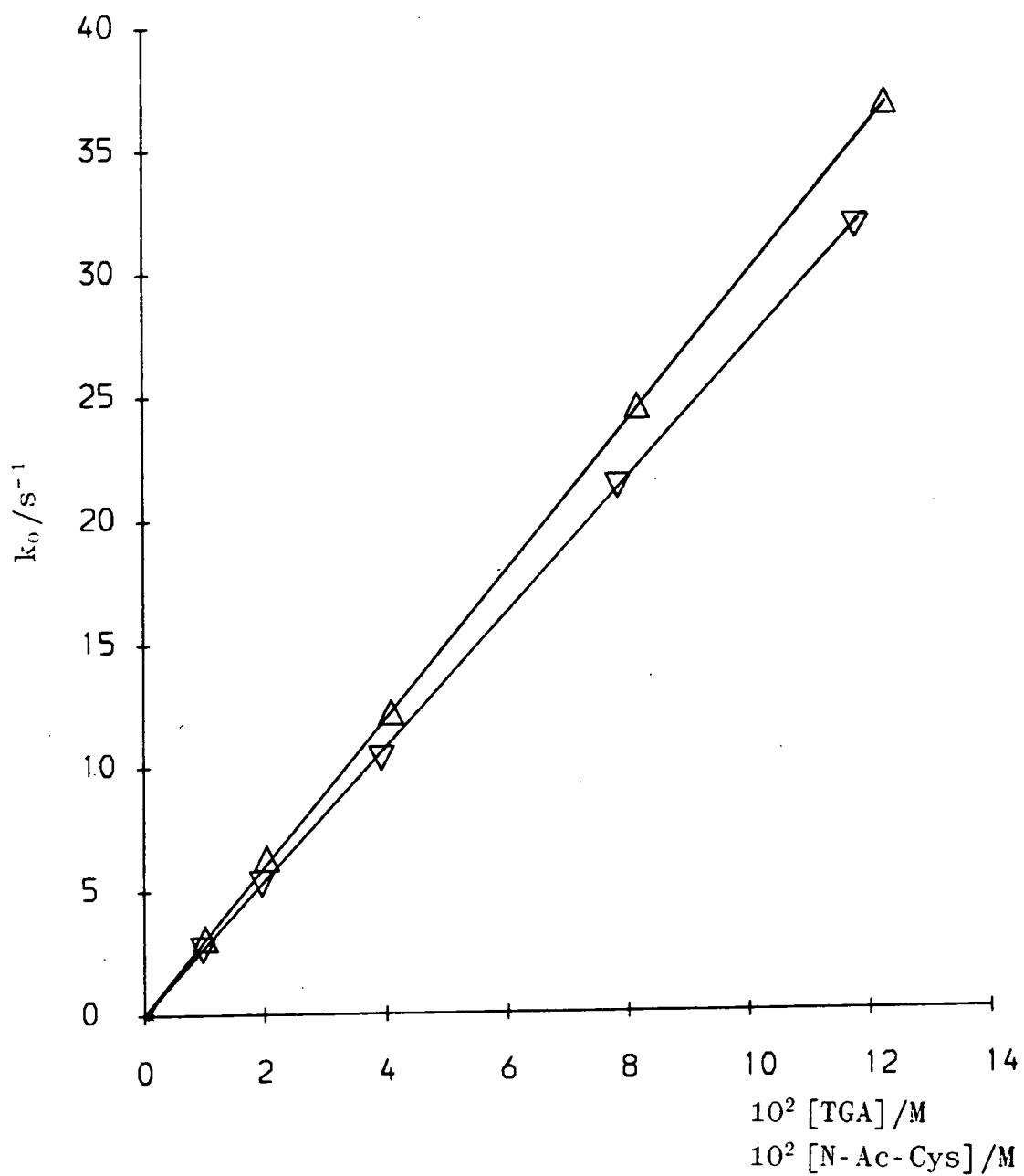

▽ [TGA] dependence
△ [N-Ac-Cys] dependence

Table 3.3 Second-order rate constants k_2 for the reactions of three alkyl nitrites with N-Ac-Cys as a function of pH of the solution

pH	$k_2 / \text{l mol}^{-1} \text{ s}^{-1}$		
	a	b	c
13.50	30.18	12.12	1.79
12.07	30.18	—	—
12.00	—	12.08	1.77
11.00	29.00	11.10	1.70
10.60	26.00	10.45	1.62
10.20	22.25	—	—
10.00	—	7.78	—
9.50	11.20	4.50	0.70
9.30	9.00	—	—
9.00	4.54	1.99	0.28
8.50	1.77	0.65	0.10
8.00	0.65	0.30	0.035
7.00	0.065	0.027	0.004
6.00	0.007	—	—

a = $i\text{AmONO}$ b = $i\text{PrONO}$ c = $t\text{BuONO}$

Table 3.4 Second-order rate constants k_2 for the reactions of three alkyl nitrites with TGA as a function of pH of the solution

pH	$k_2 / \text{l mol}^{-1} \text{ s}^{-1}$		
	a	b	c
13.50	74	29.60	4.96
12.54	75	—	—
12.10	—	29.70	4.90
11.40	68	27.80	4.60
10.80	57	—	—
10.70	—	22.39	3.53
10.00	48	—	—
10.50	—	19.20	3.00
10.40	—	13.60	2.38
10.00	—	11.33	1.85
9.60	15.60	—	—
9.40	9.29	3.96	0.74
9.15	—	2.58	0.53
8.90	3.91	—	—
8.60	—	0.79	0.14
8.00	0.49	0.27	0.040
7.00	0.047	0.022	0.005
6.00	0.006	0.003	—

a = $i\text{AmONO}$ b = $i\text{PrONO}$ c = $t\text{BuONO}$

Figure 3.2 pH- k_2 profile for the nitrosation of N-Ac-Cys by isoamyl nitrite

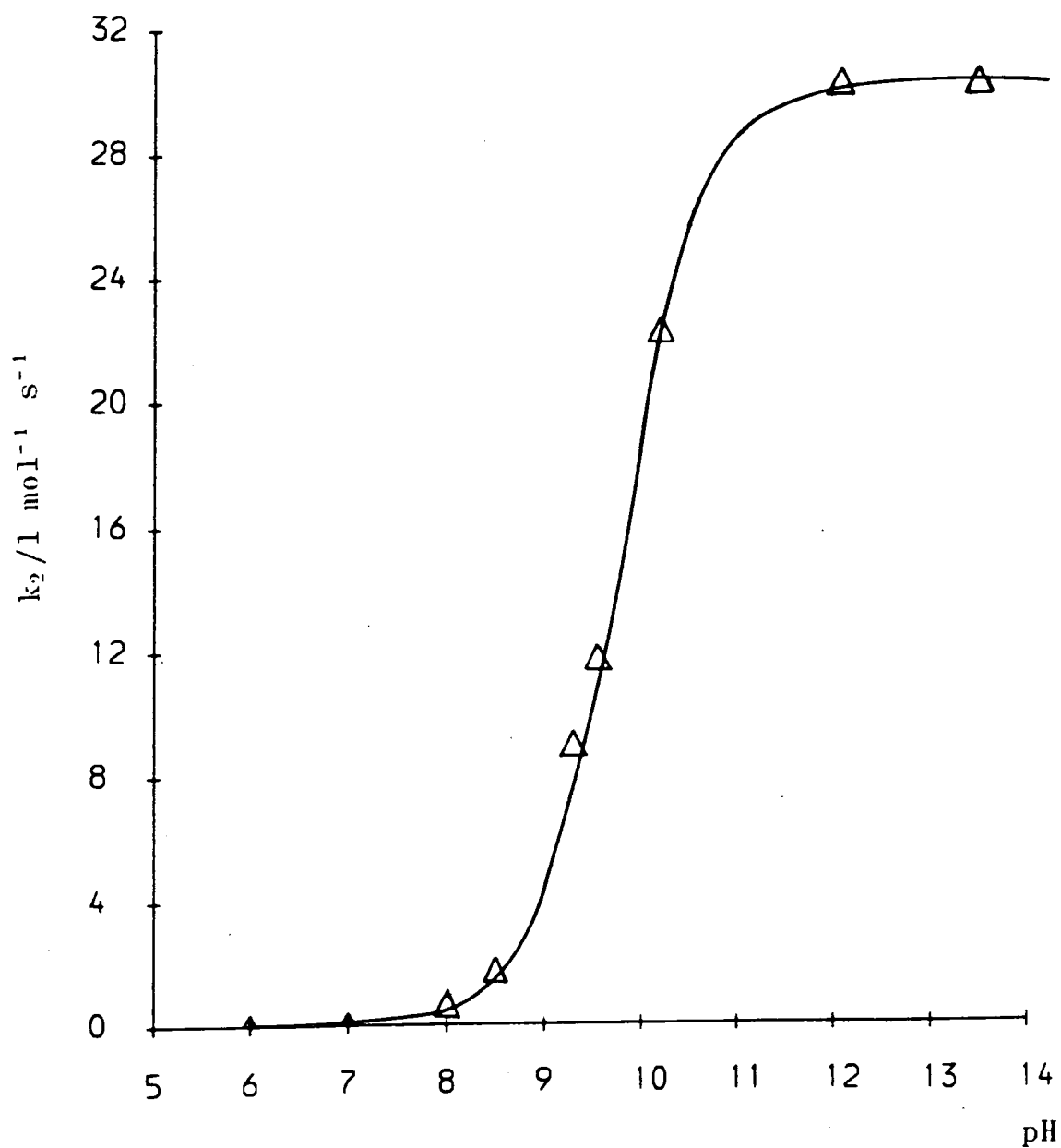
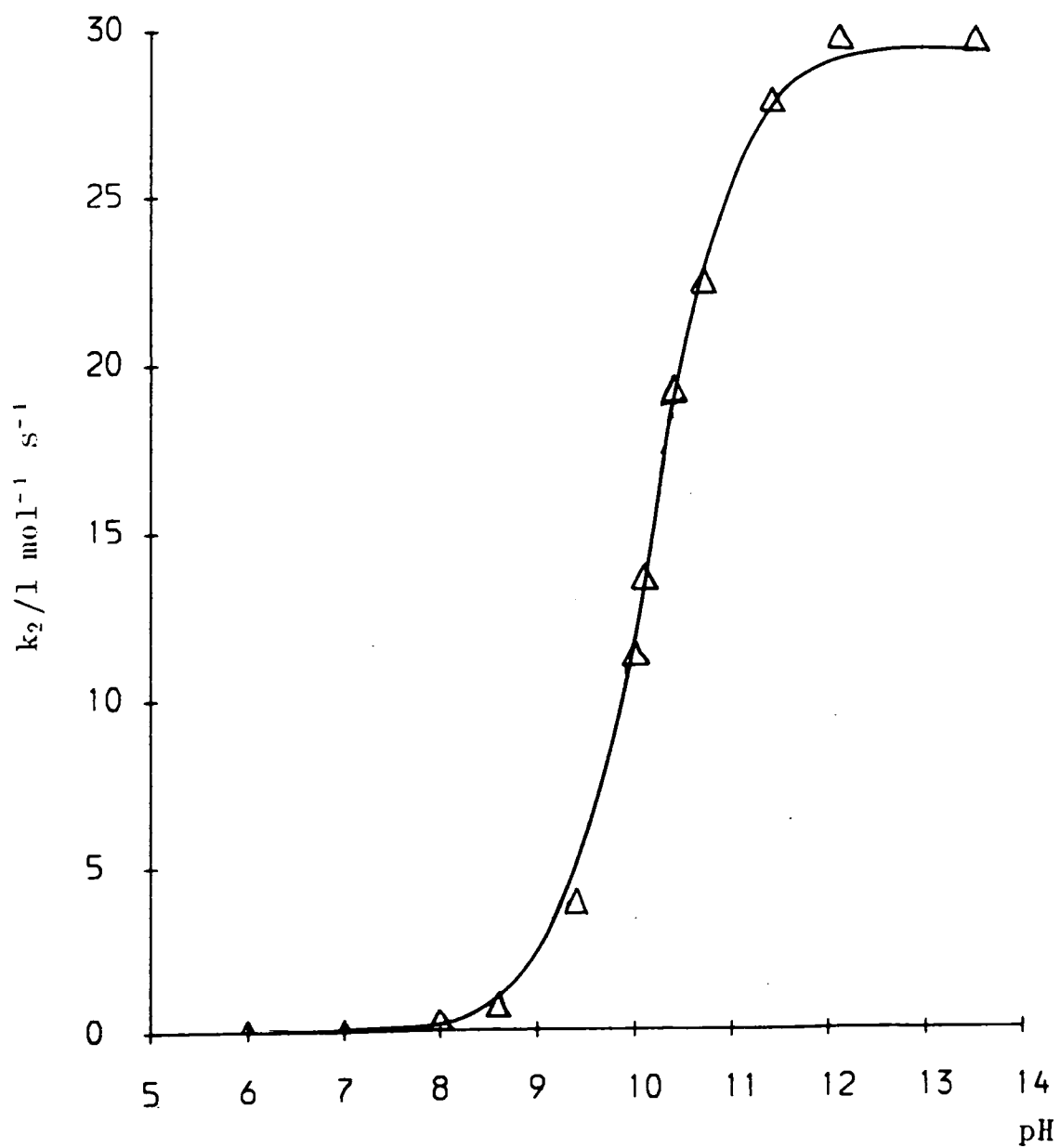
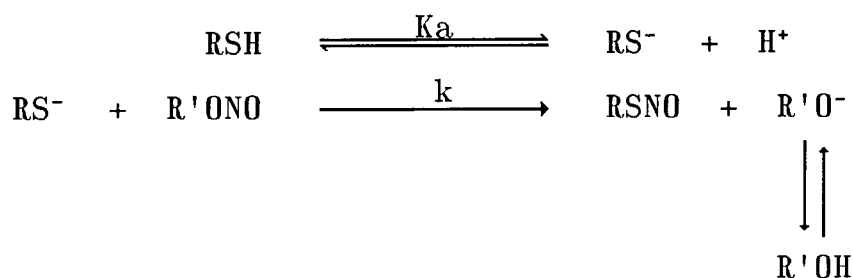

Figure 3.3 pH- k_2 profile for the nitrosation of TGA by isopropyl nitrite



As can be seen from the plots of k_2 versus pH (Figures 3.2 and 3.3) the reaction is very slow at low pH, but increases quite dramatically with pH until the rate constant levels off at pH > 10. This suggests that the reactive species is an anion form of N-Ac-Cys or TGA. The two possibilities are the ionisation of the carboxyl group or the thiol groups. The pKa values for the former is 3.1 and 3.42 for N-Ac-Cys¹⁴ and TGA¹⁵ respectively and for the latter it is 9.76 and 9.82 for N-Ac-Cys¹⁴ and TGA¹⁶ respectively. This indicates that the reaction occurs exclusively via the thiolate anion RS^- , which in these cases involves only one ionisation. The proposed outline mechanism is given in scheme 3.2, where K_a is the dissociation of RSH and k is the bimolecular rate constant for reaction of RS^- with alkyl nitrite.



Scheme 3.2

The derived expression for k_2 , the measured second-order rate constant expected from the Scheme 3.2 is given below (equation 3.4).

From Scheme 3.2:

$$\text{Rate} = k [\text{RS}^-] [\text{R}'\text{ONO}] \quad (3.3)$$

$$K_a = \frac{[RS^-] [H^+]}{[RSH]} \qquad [RSH] = \frac{[RS^-] [H^+]}{K_a}$$

$$[\text{Substrate}]_{\text{Total}} = [RS^-] + [RSH]$$

Substituting for [RSH] gives:

$$[\text{Sub.}]_T = [RS^-] + \frac{[RS^-] [H^+]}{K_a}$$

$$= [RS^-] \left(1 + \frac{[H^+]}{K_a} \right)$$

$$[RS^-] = \frac{[\text{Sub.}]_T K_a}{K_a + [H^+]}$$

Substituting for [RS⁻] in equation 2.3 gives:

$$\text{Rate} = \frac{k [\text{Sub}]_T K_a [\text{RONO}]}{k_a + [H^+]} = k_0 [\text{RONO}]$$

$$\text{Where } k_0 = \frac{k [\text{Sub}]_T K_a}{k_a + [H^+]}$$

$$\text{Hence } \frac{k_0}{[\text{Sub.}]_T} = \frac{k K_a}{K_a + [H^+]} = k_2 \qquad (3.4)$$

This (equation 3.4) predicts the observed levelling off of k_2 at high pH since $K_a \gg [H^+]$ and would give $k_2(\text{lim}) = k$, the second-order rate constant for the reaction of the alkyl nitrite with the thiolate ion.

This relationship can be tested by constructing k_2 -pH profiles using measured values of k_2 (lim) and the literature value for the dissociation constant, K_a and then comparing the profile with the experimental k_2 values. As can be seen from Figures 3.2 and 3.3, where the solid lines are the calculated curves and the points are the experimentally measured k_2 values, that there is good agreement in all cases.

Another way this relationship can be tested is by re-writing equation 3.4 in the form given below (equation 3.5).

$$k_2 = \frac{k K_a}{K_a + [H^+]}$$

$$\frac{1}{k_2} = \frac{K_a + [H^+]}{k K_a}$$

$$= \frac{1}{k} + \frac{[H^+]}{k K_a}$$

$$\frac{1}{k_2} - \frac{1}{k} = \frac{[H^+]}{k K_a}$$

$$\log (1/k_2 - 1/k) = -pH - \log kK_a \quad (3.5)$$

Thus a plot of the left-hand side (again using measured k_2 (lim) = k) against pH should be linear with a slope of -1 and from the intercept K_a may be obtained and compared with the literature values. The plots of $\log (1/k_2 - 1/k)$ against pH for the reaction of N-Ac-Cys and TGA with the

three alkyl nitrites are shown in Figures 3.4 and 3.5 and the analysis of the results are shown in tables 3.5 and 3.6.

Table 3.5 Results from plots of $\log (1/k_2 - 1/k)$ versus pH (for the nitrosation of N-Ac-Cys)

RONO	$k_2 (\text{lim}) / \text{l mol}^{-1} \text{ s}^{-1}$	Slope	Intercept	Calculated pKa
ⁱ AmONO	30.18	-0.969	7.966	9.45
ⁱ PrONO	12.10	-0.934	8.048	9.13
^t BuONO	1.78	-1.006	9.488	9.74

Table 3.5 Results from plots of $\log (1/k_2 - 1/k)$ versus pH (for the nitrosation of TGA)

RONO	$k_2 (\text{lim}) / \text{l mol}^{-1} \text{ s}^{-1}$	Slope	Intercept	Calculated pKa
ⁱ AmONO	74.50	-0.969	8.061	9.93
ⁱ PrONO	29.70	-0.971	8.414	9.89
^t BuONO	4.90	-0.926	8.775	9.47

In all cases good linear plots are obtained with slopes very close to -1. The averaged pKa values for RSH ionisations are 9.44 ± 0.31 for N-acetyl-L-cysteine, which agrees reasonably with the literature value¹⁴ of 9.76, and 9.76 ± 0.25 for thioglycolic acid which again is in good agreement with the range of values reported in the literature, 9.82,¹⁶ 10.10,¹⁷ 10.22¹⁸ and 10.32.¹⁹

The results are thus consistent with the reaction of alkyl nitrites with the thiolate ion of N-Ac-Cys and TGA.

Figure 3.4 Plots of $\log (1/k_2 - 1/k)$ against pH for the nitrosation of N-Ac-Cys

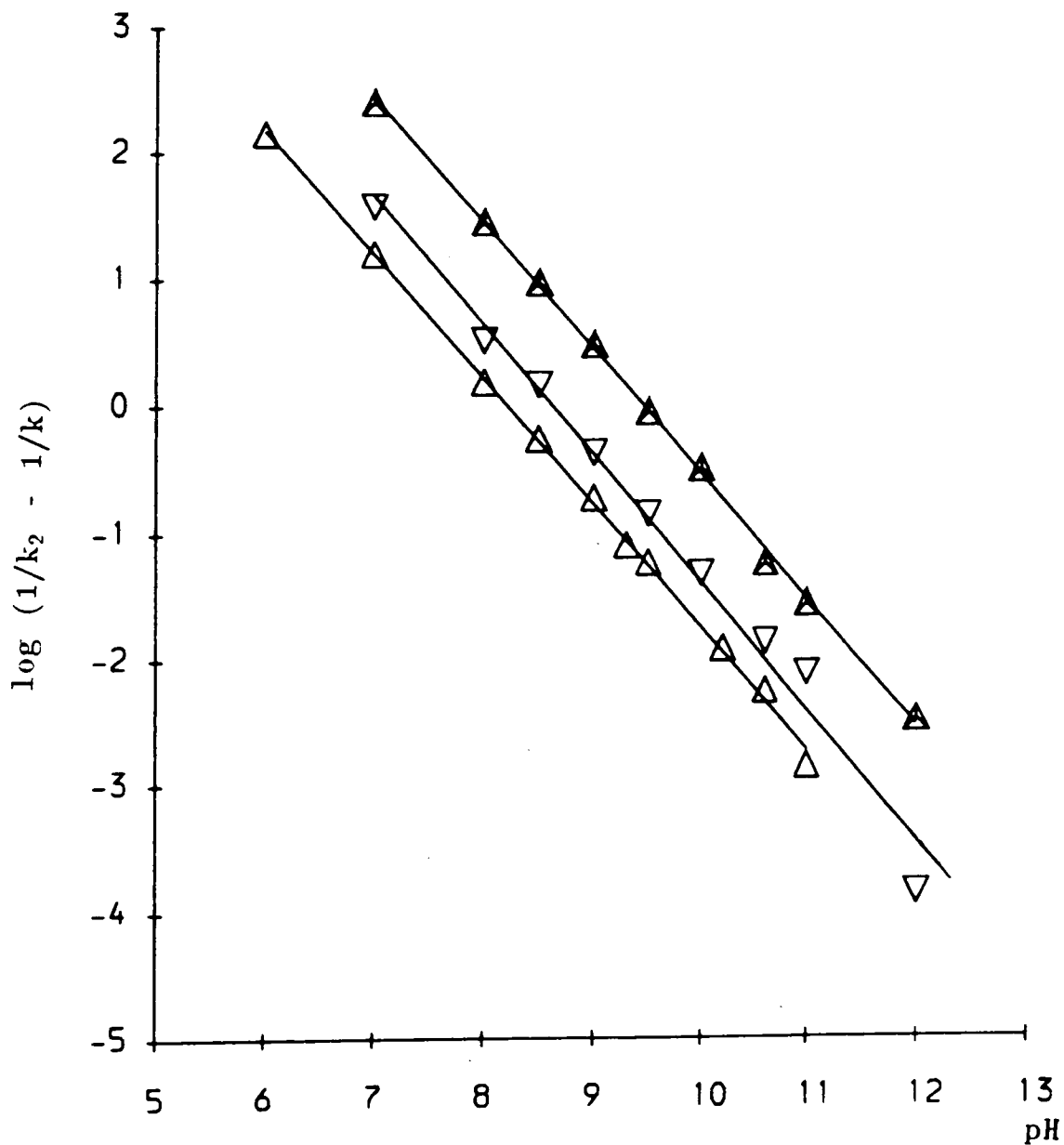

- ▲ by t-butyl nitrite
- ▽ by isopropyl nitrite
- △ by isoamyl nitrite

Figure 3.5 Plots of $\log (1/k_2 - 1/k)$ against pH for the nitrosation of TGA

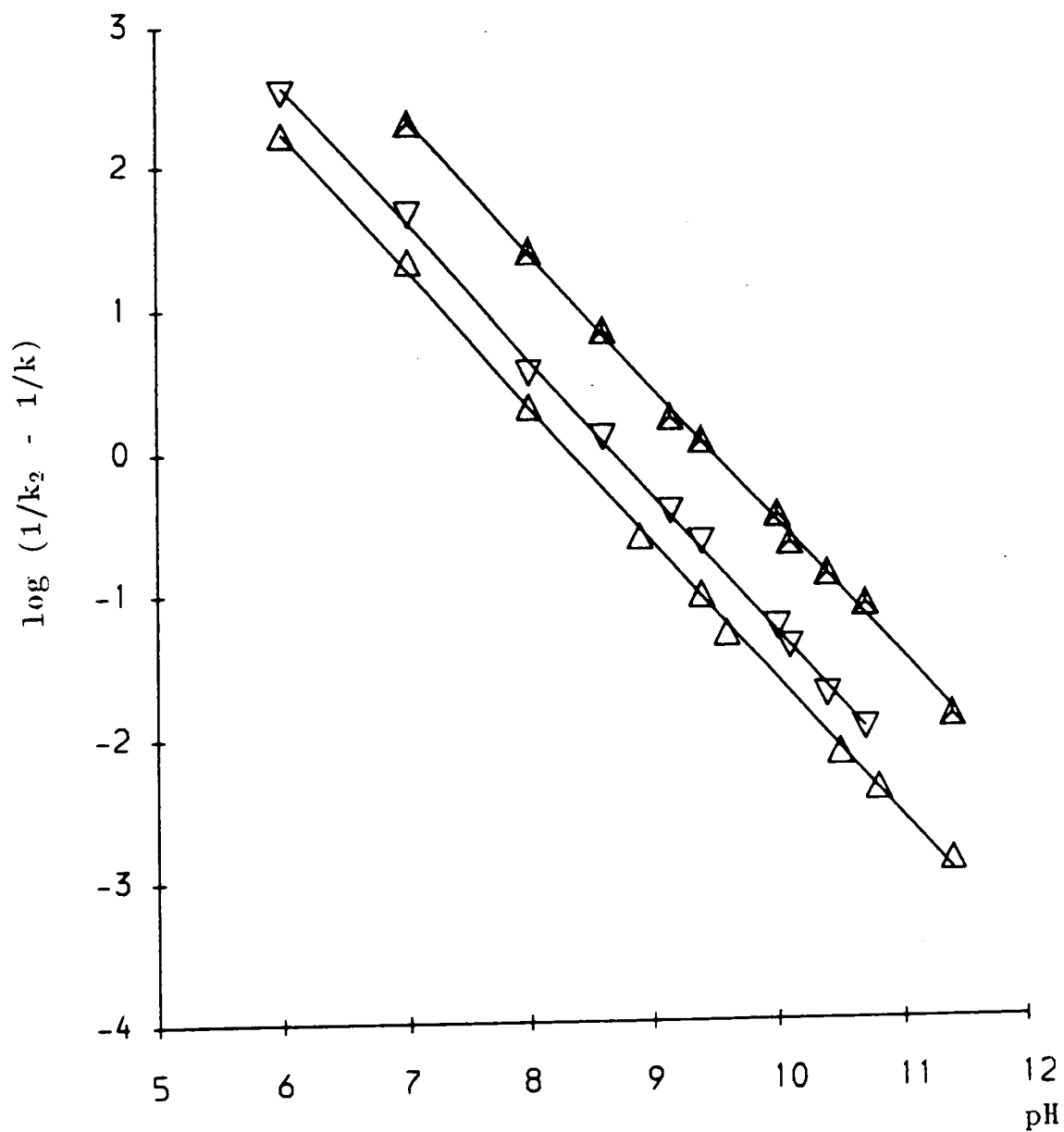

- ▲ by t-butyl nitrite
- ▽ by isopropyl nitrite
- △ by isoamyl nitrite

3.3 Nitrosation of L-cysteine, L-cysteine methyl and ethyl esters and glutathione

A kinetic study of the reaction of L-cysteine (Cys), L-cysteine methyl ester (MeCys), L-cysteine ethyl ester (EtCys) and glutathione (GSH) with ${}^i\text{AmONO}$, ${}^i\text{PrONO}$ and ${}^t\text{BuONO}$ was carried out in aqueous neutral and basic solutions. In all the cases a yellow coloured solution was formed when the solution of thiol was mixed with a solution of alkyl nitrite, typical of thionitrite species in solution^{1,2} and in no case was the thionitrite isolated. However, in the case of L-cysteine a white precipitate was formed when the solution was left for 20 minutes. The precipitate was isolated and characterised as the disulphide, cystine, by I.R. and elemental analysis. Disulphides are normally formed (equation 3.6) when unstable thionitrites decompose.



All the reactions were carried out under the same conditions as those used for the nitrosation of N-Ac-Cys and TGA by the three alkyl nitrites. In all cases good first-order behaviour was observed. The measured first-order rate constants, k_0 , were determined at each pH value for four/five different thiol concentrations. A set of results for each of the reaction of Cys, MeCys, EtCys and GSH with ${}^i\text{PrONO}$ are shown in tables 3.7-3.10. Whilst the rest of the data has not been included for reason of space.

Table 3.7 Dependence of k_0 on [Cysteine] at pH 7.5

$$[{}^i\text{PrONO}] = 1.0 \times 10^{-4}\text{M}$$

10^2 [Cysteine]/M	10^2 k_0/s^{-1}
1.93	3.51 \pm .07
3.87	6.97 \pm .07
5.42	9.75 \pm .05
7.72	14.20 \pm .02

Table 3.8 Dependence of k_0 on [MeCys] at pH 7.5

$$[{}^i\text{PrONO}] = 1.0 \times 10^{-4}\text{M}$$

10^2 [MeCys]/M	10^2 k_0/s^{-1}
0.94	1.83 \pm .03
1.89	3.58 \pm .04
3.77	7.06 \pm .01
7.54	14.10 \pm .02
15.08	28.21 \pm .03

Table 3.9 Dependence of k_0 on [EtCys] at pH 7.5

$$[{}^i\text{PrONO}] = 1.0 \times 10^{-4}\text{M}$$

10^2 [EtCys]/M	10^2 k_0/s^{-1}
0.97	1.65 \pm .03
1.94	3.22 \pm .01
3.88	6.51 \pm .04
7.76	12.89 \pm .01
15.52	25.76 \pm .03

Table 3.10 Dependence of k_0 on [GSH] at pH 7.5

$$[{}^i\text{PrONO}] = 1.0 \times 10^{-4}\text{M}$$

10^2 [GSH]/M	10^2 k_0/s^{-1}
1.05	0.43 \pm .01
2.10	0.87 \pm .03
4.20	1.76 \pm .04
8.40	3.44 \pm .02
12.60	5.17 \pm .03

The plots of k_0 versus [Cys], [MeCys], [EtCys] and [GSH] (Figure 3.6) at pH 7.5 are linear, passing through the origin, thus indicating that under the conditions used the nitrosation of Cys, MeCys, EtCys and GSH by ${}^i\text{PrONO}$ is first-order in [Cys], [MeCys], [EtCys] and [GSH]. This was found to be the same for the other alkyl nitrites at each of the pH values investigated. Thus a similar rate equation (equation 3.2) as the one for the nitrosation of N-Ac-Cys and TGA by alkyl nitrites was established.

The values of k_2 , the derived second-order rate constant, at each pH were determined from the plots of k_0 versus [RSH] and these are shown in tables 3.11-3.14. Again only four of the plots of k_2 versus pH (Figures 3.7-3.10) are included due to reasons of brevity.

Figure 3.6 Dependence of k_0 on [Cys], [MeCys], [EtCys] and [GSH] at pH 7.5

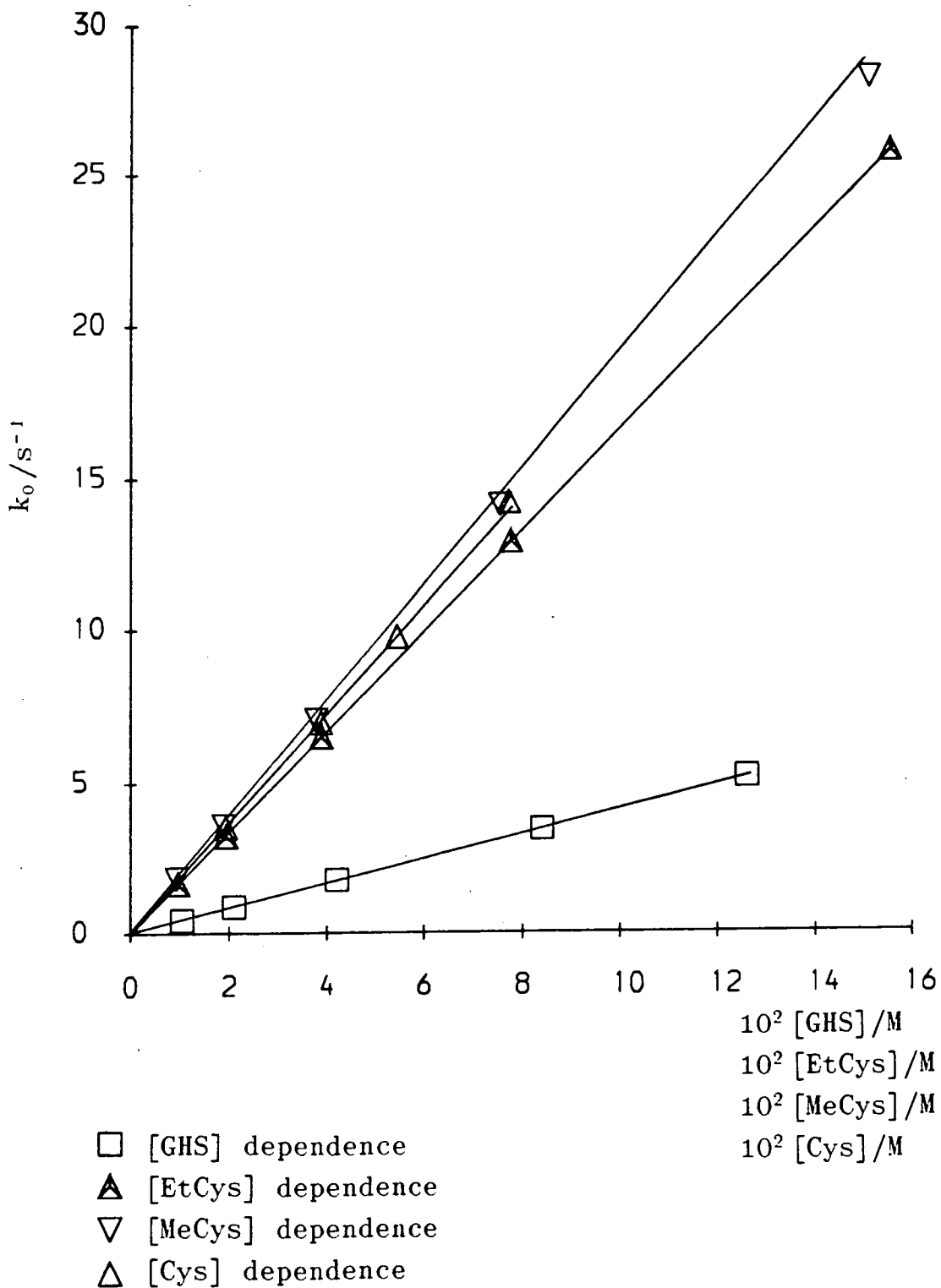

Table 3.11 Second-order rate constants k_2 for the reactions of three alkyl nitrites with cysteine as a function of the pH of the solution

pH	$k_2 / \text{l mol}^{-1} \text{ s}^{-1}$		
	a	b	c
13.40	—	11.40	—
12.45	—	11.80	—
12.20	26.90	—	1.69
11.20	27.00	11.30	—
11.00	—	—	1.71
10.06	26.50	—	—
10.00	—	11.30	1.60
9.60	—	—	—
9.20	23.00	9.60	1.48
8.75	19.00	—	—
8.55	—	—	1.09
8.50	15.10	6.62	—
8.25	11.40	—	—
8.10	—	3.72	0.64
8.00	—	—	—
7.90	6.61	—	—
7.75	—	2.07	—
7.50	2.88	1.24	0.25
7.00	1.05	0.47	0.073
6.50	0.37	0.20	0.020
6.00	0.10	0.058	—
5.50	—	0.064	—

a = ${}^i\text{AmONO}$ b = ${}^i\text{PrONO}$ c = ${}^t\text{BuONO}$

Table 3.12 Second-order rate constants k_2 for the reactions of three alkyl nitrites with MeCys as a function of the pH of the solution

pH	$k_2 / \text{l mol}^{-1} \text{ s}^{-1}$		
	a	b	c
13.50	24.50	12.40	1.62
12.00	24.50	12.00	1.62
11.00	—	11.97	1.58
10.50	23.20	11.63	1.55
10.00	21.40	10.67	1.49
9.60	17.60	—	—
9.50	—	8.69	1.15
9.30	14.50	—	—
9.00	12.90	5.39	0.71
8.60	7.60	—	—
8.50	—	3.48	0.45
8.00	5.00	2.40	0.33
7.50	3.81	1.87	0.25
7.00	2.93	1.50	0.19
6.50	1.67	0.90	0.10
6.00	0.74	0.37	0.039

a = $i\text{AmONO}$ b = $i\text{PrONO}$ c = $t\text{BuONO}$

Table 3.13 Second-order rate constants k_2 for the reactions of three alkyl nitrites with EtCys as a function of the pH of the solution

pH	$k_2 / \text{l mol}^{-1} \text{ s}^{-1}$		
	a	b	c
13.50	25.50	11.80	1.46
12.50	25.50	—	—
12.00	—	11.80	1.46
11.00	—	11.63	1.43
10.80	24.80	—	—
10.50	—	11.01	1.35
10.00	—	10.15	1.21
9.80	20.00	—	—
9.50	16.70	7.55	0.98
9.20	12.20	—	—
9.00	9.30	4.33	0.56
8.50	6.40	3.10	0.40
8.00	5.20	2.11	0.27
7.50	4.20	1.66	0.22
7.00	3.08	1.31	0.19
6.50	1.80	0.68	0.11
6.00	0.80	0.27	0.05

a = $i\text{AmONO}$ b = $i\text{PrONO}$ c = $t\text{BuONO}$

Table 3.14 Second-order rate constants k_2 for the reactions of three alkyl nitrites with GSH as a function of the pH of the solution

pH	$k_2 / \text{l mol}^{-1} \text{ s}^{-1}$		
	a	b	c
13.50	26.9	11.6	1.81
12.50	27.0	11.4	—
12.00	—	—	1.80
11.00	26.6	11.3	1.75
10.00	24.1	10.4	1.60
9.50	20.8	8.9	1.41
9.00	15.0	6.2	0.96
8.50	7.4	3.1	0.54
8.00	2.7	1.1	0.23
7.50	1.0	0.41	0.071
7.00	0.37	0.17	0.023
6.50	—	—	0.001
6.00	0.04	0.16	—

a = $i\text{AmONO}$ b = $i\text{PrONO}$ c = $t\text{BuONO}$

Figure 3.7 pH- k_2 profile for the nitrosation of Cys by t-butyl nitrite

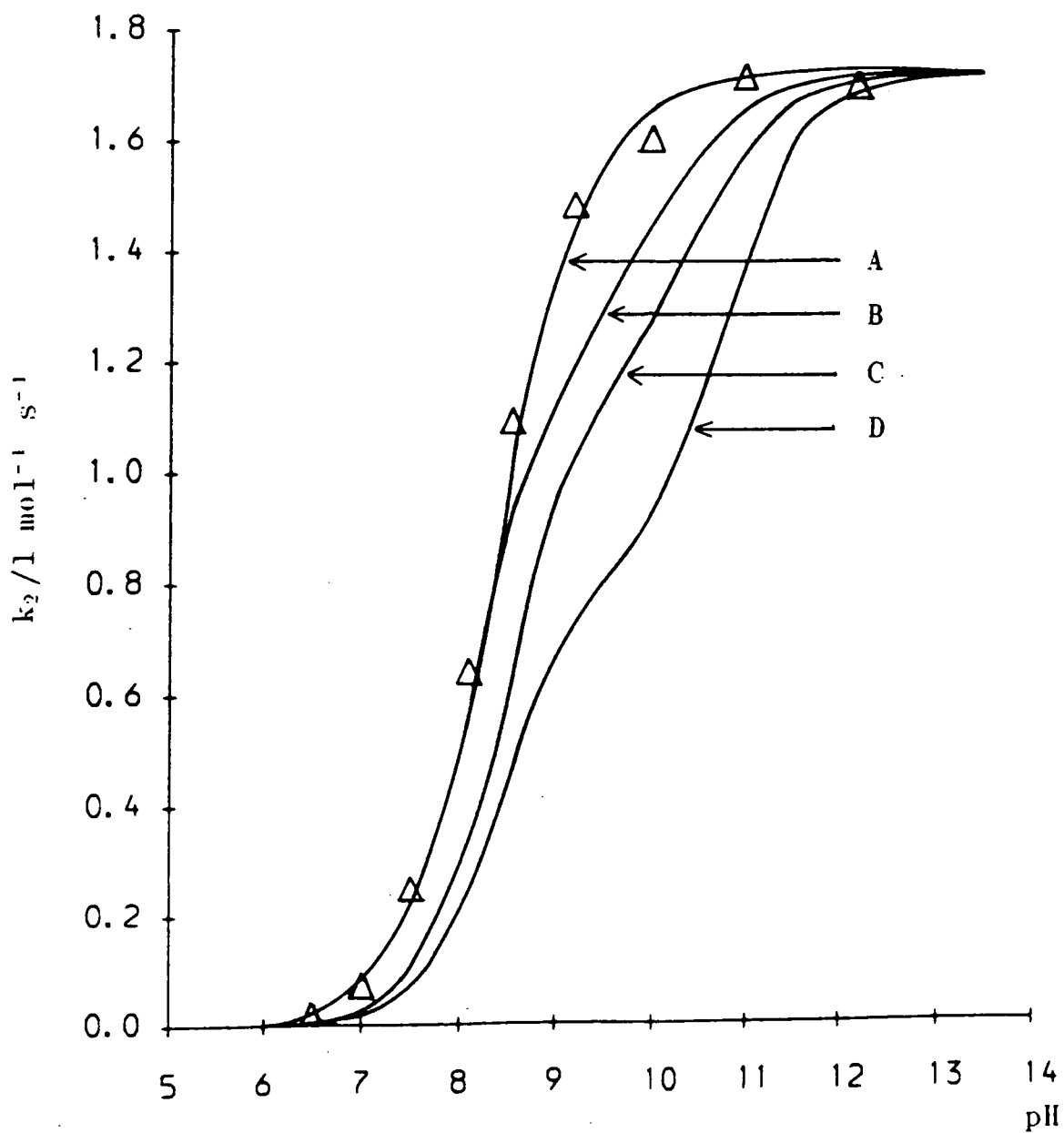

Figure 3.8 pH- k_2 profile for the nitrosation of MeCys by isoamyl nitrite

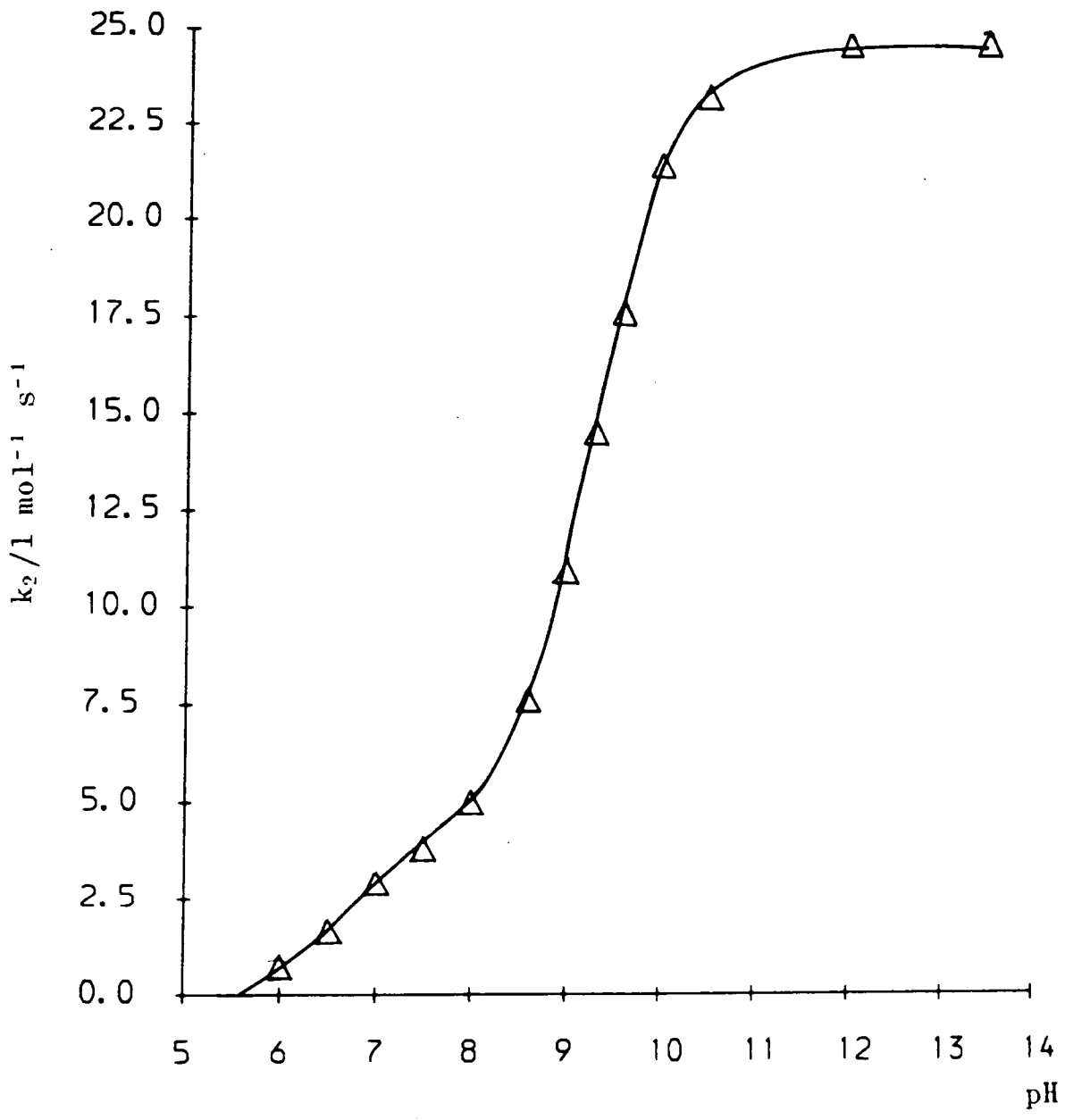

Figure 3.9 pH- k_2 profile for the nitrosation of EtCys by isopropyl nitrite

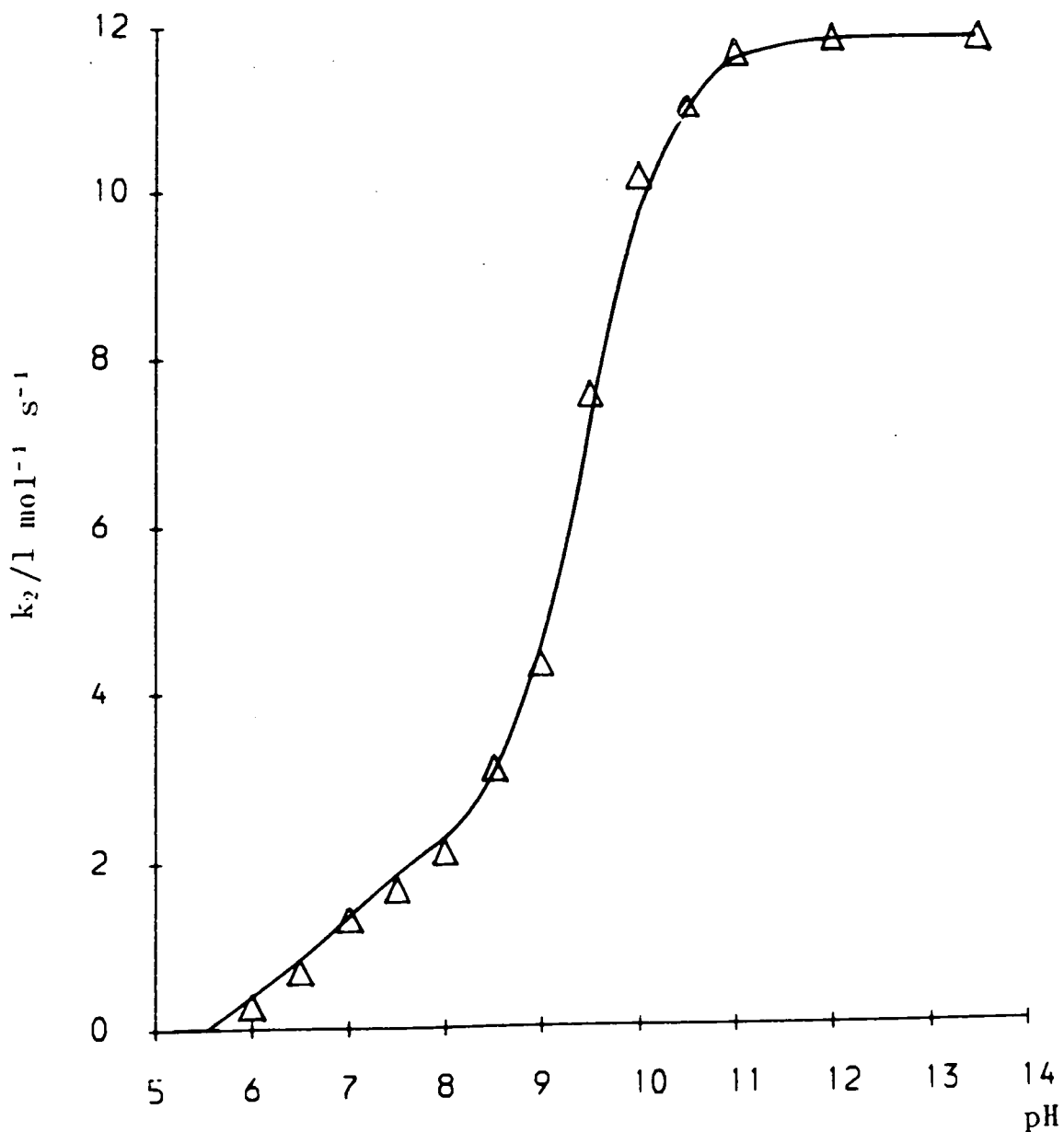
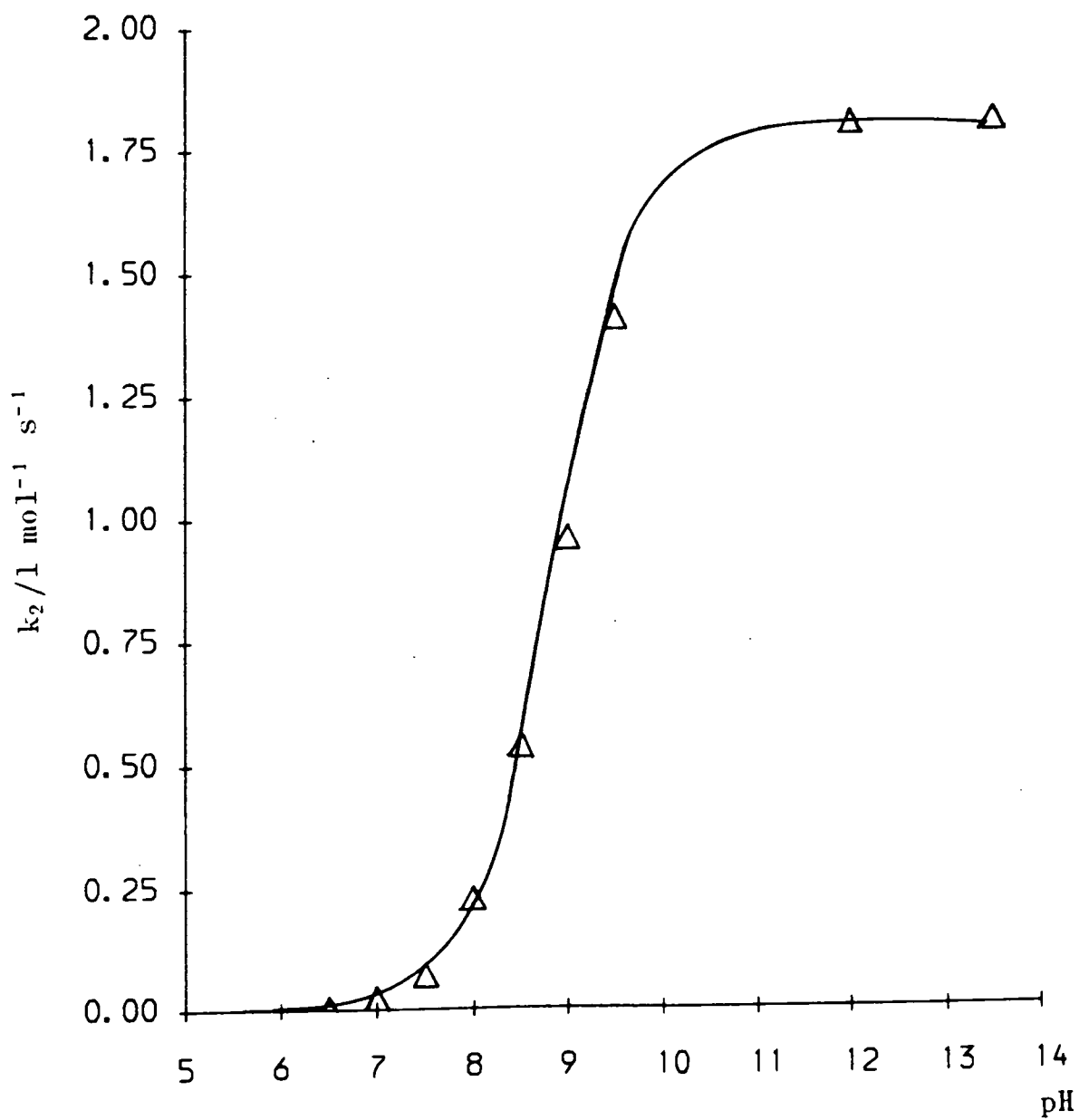
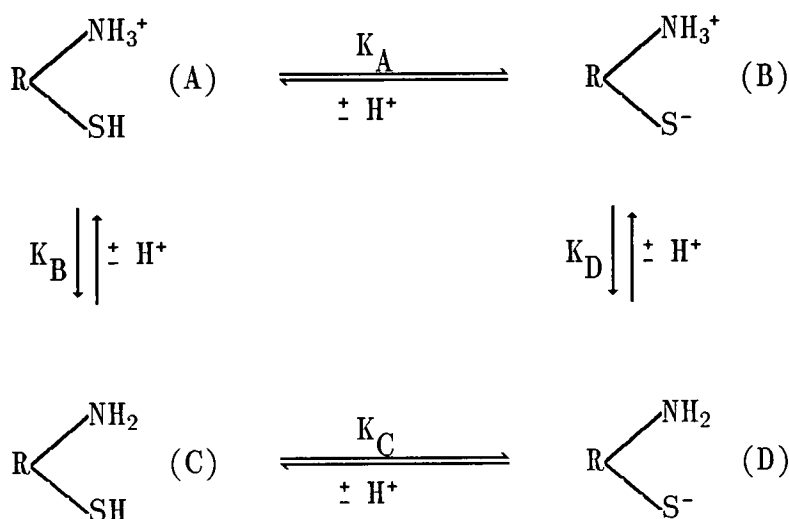

Figure 3.10 pH- k_2 profile for the nitrosation of GSH by t-butyl nitrite



The plots of k_2 versus pH (Figures 3.7 and 3.10) are similar to those for the nitrosation of N-Ac-Cys and TGA. However, in these cases the analysis of k_2 -pH profiles is complicated because of the simultaneous overlapping of the ionisation of $-\overset{+}{\text{N}}\text{H}_3$ and $-\text{SH}$. Thus equation (3.4) can not be used in these cases to calculate the k_2 -pH profiles as more than one ionisation has to be taken into account. The various equilibria that have to be taken into account are shown in Scheme 3.3. The first dissociation constant for the carboxylic acid group, K_1 , can be ignored as the carboxylic acid group, in all the thiols, is fully ionised in the pH range studied.



Scheme 3.3

The microscopic constants in Scheme 3.3 are K_A , K_B , K_C and K_D with their associated pKa values of $\text{p}K_A$, $\text{p}K_B$, $\text{p}K_C$ and $\text{p}K_D$. The macroscopic second and third dissociation constant K_2 and K_3 , for each of the thiols are given by equation (3.7) and (3.8).

$$K_2 = K_A + K_B \quad (3.7)$$

$$K_3^{-1} = K_C^{-1} + K_D^{-1} \quad (3.8)$$

From scheme 3.3:

$$K_A = \frac{[B][H^+]}{[A]} \quad K_B = \frac{[C][H^+]}{[A]} \quad (3.9)$$

$$K_C = \frac{[D][H^+]}{[C]} \quad K_D = \frac{[D][H^+]}{[B]}$$

Let F_1 represent the fraction of molecules from which the proton of the thiol group has ionised, and F_2 the fraction of molecules from which the proton of the amino group has ionised.

$$F_1 = \frac{[B] + [D]}{[A] + [B] + [C] + [D]} \quad (3.10)$$

$$F_2 = \frac{[C] + [D]}{[A] + [B] + [C] + [D]} \quad (3.11)$$

Substituting equation (3.9) into equations (3.10) and (3.11) gives:

$$F_1 = \frac{K_A/K_B + K_D/[H^+]}{[H^+]/K_B + K_A/K_D + 1 + K_D/[H^+]} \quad (3.12)$$

$$F_2 = \frac{1 + K_D/[H^+]}{[H^+]/K_B + K_A/K_D + 1 + K_D/[H^+]} \quad (3.13)$$

It is therefore possible to calculate the percentage of each of the four forms (A, B, C and D) at any pH value using equations (3.9) to (3.13) and the literature values of pK_A , pK_B , pK_C and pK_D . An example of such a calculation, for L-cysteine (Ref. 16), is shown in Figure 3.11. Similar calculations could be carried out for MeCys, EtCys and GSH. However, if the reaction of the alkyl nitrite is with the thiolate ion (RS^-) then the involvement of both B and D forms have to be considered. It is possible to calculate the percentage of thiolate ion (i.e. $\%[B] + \%[D]$) present at a set pH using equation (3.14), which is derived from substituting equation (3.12) into equation (3.10) and multiplying by 100.

$$\%[RS^-] = \frac{K_A/K_B + K_D/[H^+]}{[H^+]/K_B + K_A/K_D + 1 + K_D/[H^+]} \times 100 \quad (3.14)$$

$$k_2 = \frac{k(\text{lim}) \times \%[RS^-]}{100} \quad (3.15)$$

Profiles of k_2 -pH can now be constructed for the reactions of $^i\text{AmONO}$, $^i\text{PrONO}$ and $^t\text{BuONO}$ with Cys, MeCys, EtCys and GSH using equations (3.14) and (3.15).

Analysing the constructed k_2 -pH profiles with the experimental k_2 values, in the case of L-cysteine (Figures 3.7), where Curve B is deduced from the values reported by Reuben and Bruice;¹⁶ curve C from the data of Benesch and Benesch¹⁹ and also Elson and Edsall¹⁶ (which are very close together) and curve D from the results of Splittgerber and Chinander;²⁰ it can be seen that the results follow closely

Figure 3.11 Calculated percentage of each of the four forms of cysteine

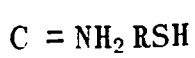
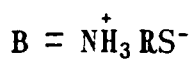
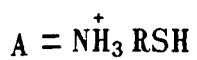
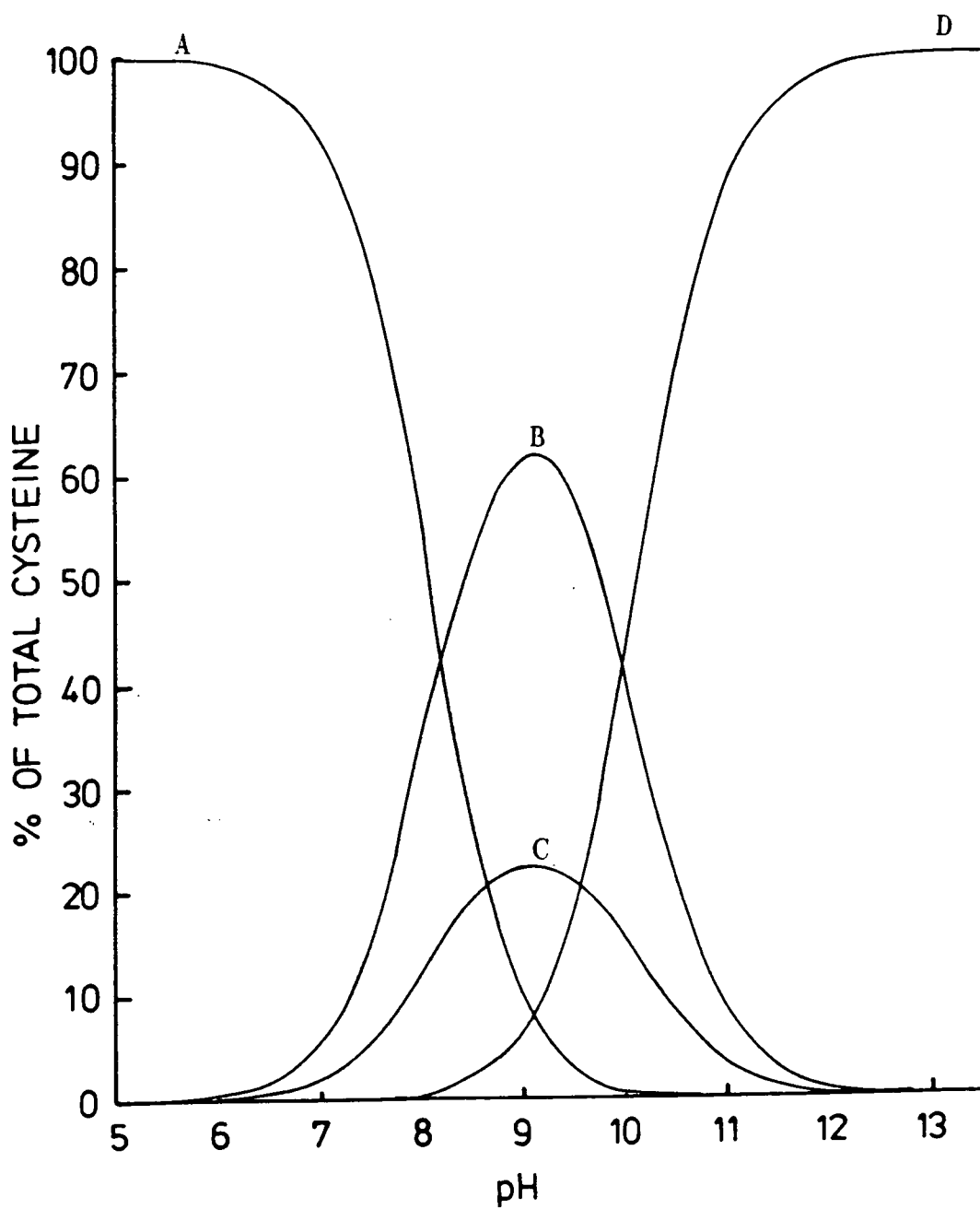

curve B up to $\text{pH} \approx 8.5$ and thereafter depart from it. The departure from curves C and D is even more marked, contrasting with the behaviour (see later) of the carboxylic acid esters, where there is an excellent agreement between the calculated and experimental values of second-order rate constant, k_2 . There are three possible reasons for the discrepancy in the L-cysteine results:- (a) The reactivity of the forms B and D may be different. Thus curve B could be corrected to match more closely with the experimental values of k_2 by assuming B is approximately 20% more reactive than D (see Figure 3.12). This does not really make a lot of sense, since one would expect any reactivity difference between B and D to be in the opposite sense, that is D more reactive than B. Also it is difficult to see why the thiolate ions from L-cysteine have a different reactivity if those from the carboxylate esters do not. (b) It is possible that one is neglecting the thiolate ions of the type $\text{CO}_2\text{H}-\text{CHNH}_2-\text{CH}_2\text{S}^-$ and/or $\text{CO}_2\text{H}-\text{CHNH}_3^+-\text{CH}_2\text{S}^-$, although these forms containing the unionised carboxylic acid groups would be expected to be present in very low concentrations at the pH values used. However, this explanation would account for the difference observed between L-cysteine and the carboxylic acid esters. (c) Another possibility is that the published pK_a values are in error. Indeed the range of values in the literature (leading to the significantly different curves B, C and D) is an indication of difficulty in obtaining the true values. A smooth curve, curve A on Figure 3.7, which best fits the experimental points was produced from the pK_a values of pK_A

Figure 3.12 Corrected (assuming B more reactive than D by 20%) pH profile for the nitrosation of Cys by tertiarybutyl nitrite

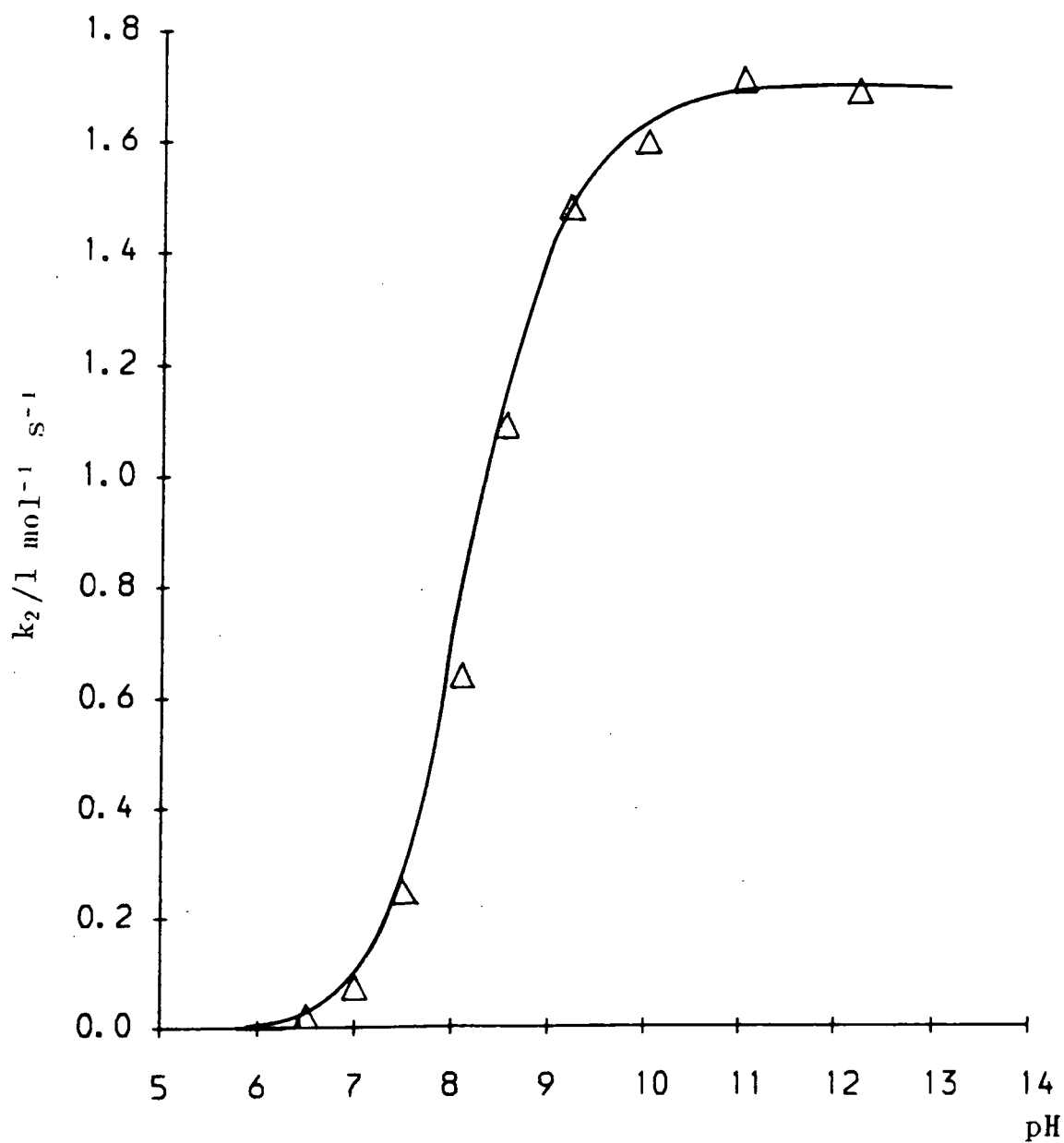

pK_A 8.21, pK_B 8.65, pK_C 8.96 and pK_D 8.52. This means that both pK_C and pK_D are approximately 1 pKa unit smaller than those deduced spectrophotometrically by Reuben and Bruice.¹⁶ There is even less of a correlation between k_2 and % ($[C] + [D]$), that is with the free $-NH_2$ group, so a mechanism involving N-nitrosation followed by N- to S- rearrangement of the nitroso group is not likely.

In the cases of the methyl and ethyl carboxylic esters of L-cysteine smooth curves (Figures 3.8 and 3.9), which fitted best to the experimental points, were computed using pK_A 7.45, pK_B 6.77, pK_C 8.41 and pK_D 9.09 for ethyl ester and pK_A 7.45, pK_B 6.77, pK_C 8.41 and pK_D 9.09 for methyl ester. The microscopic pKa values for the ethyl ester are in good agreement with the reported values (see table 3.15) and those of methyl ester are very similar to ethyl ester values but unfortunately there are no literature values of the microscopic pKa values for the methyl ester available for comparison. For the carboxylic esters the pK_A and pK_B values are smaller than those for L-cysteine and are reversed. This effect is explained by examining the effect of the carboxyl group on the acidity of the ammonium and sulphhydryl group. The α -carboxyl group in L-cysteine results in an increase in the acid strength of the ammonium group because the inductive effect of the carboxyl group outweighs the electrostatic effect of the negative charge. As the carboxyl group is modified, in the cases of the carboxylic ester of L-cysteine, its acid strengthening effect (particularly on the ammonium group) becomes even greater, since only the electrostatic effect is modified. As a result the acid strength of the ammonium group becomes

greater than that of the sulphhydryl group, hence the reason why the pK_A and pK_B values of the carboxylic ester of L-cysteine are smaller and reversed compared to L-cysteine.

Similarly, in the case of glutathione smooth curves (Figures 3.10), which fitted best to the experimental points, were computed using pK_A 8.72, pK_B 9.28, pK_C 9.82 and pK_D 8.72. These agree reasonably well with the literature values of Reuben and Bruice¹⁶ (see table 3.15).

3.4 Discussion

There is excellent agreement between the experimental and calculated k_2 values with the exception of some of the results for L-cysteine. As can be seen from table 3.15 that there is good agreement between the literature pK_a values for the ionisation of RSH and those derived from this study. Therefore it is clear from these results that alkyl nitrites generally react in aqueous neutral and mildly basic solutions with the thiolate anion of thiols. The effects of human plasma and buffer components on the rates of reactions were also investigated. Doubling the buffer concentration was found to change the values of the rate constants by < 5% and the addition of 50% plasma to the reaction medium was found to cause no change of the rate constant within 5%. Thus the reactions are not catalysed by any components of human plasma or by buffer components.

The combined results for $k(\text{lim})$ i.e k values for each of the reactions studied are summarised in table 3.16.

Table 3.15 Values of pKa for RSH ionisation from literature and this study

THIOL	pK _A	pK _B	pK _C	pK _D	Ref.
L-cysteine	8.21	8.65	10.00	9.56	16
	8.53	8.86	10.36	10.03	19
	8.50	8.85	10.35	10.00	17
	8.64	8.62	10.47	10.49	20
	8.21 [*]	8.65 [*]	8.97 [*]	8.52 [*]	
L-cysteine Et Ester	7.30	6.76	8.33	8.87	16
	7.45	6.77	8.41	9.09	19
	7.45 [*]	6.77 [*]	8.41 [*]	9.09 [*]	
L-Cysteine Me Ester	7.45 [*]	6.77 [*]	8.41 [*]	9.09 [*]	
Glutathione	8.72	9.47	9.47	8.72	16
	8.93	9.13	9.28	9.08	21
	8.72 [*]	9.28 [*]	9.28 [*]	8.72 [*]	
N-Acetyl-L-cysteine	9.44				14
	9.58 [*]				
Thioglycolic acid	9.82				16
	10.32				19
	10.01				17
	10.22				18
	9.76 [*]				

* values from this study

Table 3.16 Values of $k_2(\text{lim})$ for the reactions of three alkyl nitrites with six thiols

THIOL	$k_2 / \text{l mol}^{-1} \text{ s}^{-1}$		
	a	b	c
L-cysteine	27	11	1.7
L-cysteine Me Ester	25	12	1.6
L-cysteine Et Ester	26	12	1.5
N-acetyl-L-cysteine	30	12	1.8
Glutathione	27	11	1.8
Thioglycolic acid	75	30	4.9

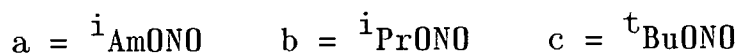

As expected, since there are no major structural changes in the thiols, their reactivities are very much the same, with the exception of thioglycolic acid which is consistently more reactive than the others by a factor of between two and three.

As to the reactivity of the alkyl nitrites, the sequence is primary nitrite > secondary nitrite > tertiary nitrite with ratios of 15:6:1. This could be attributed to the electron-releasing effect of α -methyl substituents. However, this may not be an electronic effect since the q and q_{R} values²¹ of the alkyl groups are not very different. The situation (equation 3.16) is similar to that occurring in the alkaline hydrolysis of alkyl acetate ester, where the reactivity trend $\text{Me} > \text{Et} > \text{}^i\text{Pr} > \text{}^t\text{Bu}$ is ascribed to a steric effect.

References

1. M. J. Crookes and D. L. H. Williams, *J. Chem. Soc., Perkin Trans. 2*, 1988, 1339.
2. S. Oae, N. Asai and K. Fujimori, *J. Chem. Soc., Perkin Trans. 2*, 1978, 571.
3. D. L. H. Williams, in "*Nitrosation*", Cambridge University Press, Cambridge, 1988 and references therein.
4. O. Touster, in "*Organic Reaction*", editor R. Adams, Wiley, New York, 1953, Vol. 7, p327.
5. J. Casado, A. Castro, F. M. Lorenzo and F. Meijide, *Monatsh. Chem.*, 1986, 117, 335.
6. J. Casado, A. Castro, M. A. Lopez-Quintela and F. M. Lorenzo, *Bull Soc. Chim. Fr.*, 1987, 401.
7. S. Oae, N. Asai and K. Fujimori, *J. Chem. Soc., Perkin Trans. 2*, 1978, 1124.
8. B. C. Challis and D. E. G. Shuker, *J. Chem. Soc., Perkin Trans. 2*, 1979, 315.
9. A. D. Allen and G. R. Schonbaum, *Can. J. Chem. Commun.*, 1979, 315.
10. H. Lecher and W. Siefken, *Chem. Ber.*, 1926, 59, 1314, 2594.
11. D. L. H. Williams, *Chem. Soc. Rev.*, 1985, 14, 171.
12. L. J. Ignarro, H. Lippert, J. C. Edwards, W. H. Baricos, A. L. Hyman, P. J. Kadowitz and C. A. Gruetter, *J. Pharmacol. Exp. Ther.*, 1981, 218, 739.
13. R. Bonnett, and P. Nicolaidon, *J. Chem. Soc., Perkin Trans. 1*, 1979, 1969.
14. R. H. Boggess, J. R. Abstier, S. Morelen, L. T. Taylor and J. W. Hughes, *Inorg. Chem.*, 1983, 22, 1273.
15. D. L. Leussing, *J. Am. Chem. Soc.*, 1958, 80, 4180.
16. D. M. E. Reuben and T. C. Bruice, *J. Am. Chem. Soc.*, 1976, 98, 114.
17. E. L. Elson and J. T. Edsall, *Biochem.*, 1962, 1, 1.
18. J. P. Danehy and C. J. Noel, *J. Am. Chem. Soc.*, 1960, 82, 2511.
19. R. E. Benesch and R. Benesch, *J. Am. Chem. Soc.*, 1955, 77, 5877.
20. A. G. Splittgerber and L. L. Chinander, *J. Chem. Ed.*, 1988, 65, 167.

21. D. L. Rabenstein, *J. Am. Chem. Soc.*, 1973, 95, 2792.

22. M. Charton, *Prog. Phys. Org. Chem.*, 1981, 13, 119.

CHAPTER FOUR

Effect of β -electron-withdrawing substituents

4.1 Introduction

It has been claimed¹ that alkyl nitrites bearing β -electron-withdrawing groups are very effective nitrosating agents of secondary amines in alkaline conditions (equation 4.1)

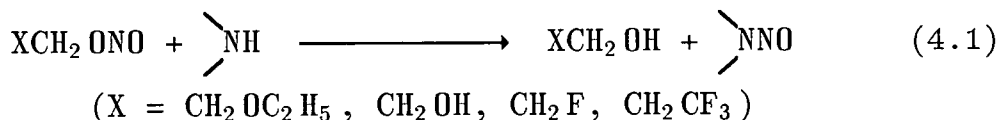

This was substantiated by the finding of Casado and co-workers² who found that the nitrosation of the secondary amine, dimethylamine, was much favoured by alkyl nitrites bearing β -electron-withdrawing substituents. These nitrites can be prepared independently or *in situ* from the corresponding alcohol and nitrosyl chloride (or in principle any nitrosating agent).

Thus in order to find any correlation between reactivity and structure of alkyl nitrites, a kinetic study of the nitrosation of L-cysteine, L-cysteine methyl ester, L-cysteine ethyl ester, glutathione, thioglycolic acid and N-acetyl-L-cysteine by various alkyl nitrites bearing β -electron-withdrawing substituents in the pH range 6-13, was investigated. The results are presented below.

4.2 Nitrosation of N-acetyl-L-cysteine and thioglycolic acid

A kinetic study of the reaction of N-acetyl-L-cysteine (N-Ac-Cys) and thioglycolic acid (TGA) with ethyl nitrite, 2-ethoxyethyl nitrite, 2-chloroethyl nitrite, 2-bromoethyl nitrite and 2-iodoethyl nitrite in aqueous neutral and basic conditions in the absence of added nucleophiles was carried

out.

All the reactions were carried out under the same conditions as those used for the nitrosation of N-Ac-Cys and TGA by $i\text{AmONO}$, $i\text{PrONO}$ and $t\text{BuONO}$ (see Chapter 3 pages 77 and 78). In all the cases good first-order behaviour was observed. The measured first-order rate constants, k_0 , were determined at each pH value for four different thiol concentrations. A set of results for the reaction of 2-bromoethyl nitrite with N-Ac-Cys and TGA are shown in tables 4.1 and 4.2, whilst the details of the rest of the data have not been included for reason of space. The plots of k_0 versus [N-Ac-Cys] and [TGA] (Figure 4.1) at pH 10 are linear passing through the origin, thus indicating that under the conditions used the nitrosation of N-Ac-Cys and TGA by 2-chloroethyl nitrite is first-order in [N-Ac-Cys] and [TGA]. This was found to be the same for the other alkyl nitrites at each of the pH values investigated. This establishes the rate equation (equation 4.2)

$$\text{Rate} = k_2 [\text{RSH}] [\text{RONO}] \quad (4.2)$$

Table 4.1 Dependence of k_0 on [N-Ac-Cys] at pH 10

$$[\text{Br}(\text{CH}_2)_2\text{ONO}] = 1 \times 10^{-4}\text{M}$$

10^2 [N-Ac-Cys]/M	k_0/s^{-1}
7.86	50.38 \pm .07
3.93	25.15 \pm .04
1.86	12.52 \pm .09
0.98	6.30 \pm .10

Table 4.2 Dependence of k_0 on [TGA] at pH 10

$$[\text{Br}(\text{CH}_2)_2\text{ONO}] = 1 \times 10^{-4}\text{M}$$

10^2 [TGA]/M	k_0/s^{-1}
7.97	$70.26 \pm .03$
3.99	$35.10 \pm .06$
1.99	$17.59 \pm .07$
1.00	$8.78 \pm .02$

The values of k_2 , the derived second-order rate constant, were determined from the plots of k_0 versus [RSH] at each pH and are shown in tables 4.3 and 4.4 and only two plots of k_0 versus pH, for the reaction of N-Ac-Cys and TGA with ethyl nitrite and 2-ethoxyethyl nitrite respectively (Figures 4.2 and 4.4), are included whilst the rest of the plots have not been included due to reasons of brevity.

Figure 4.1 Dependence of k_0 on [N-Ac-Cys] and [TGA] at pH 10

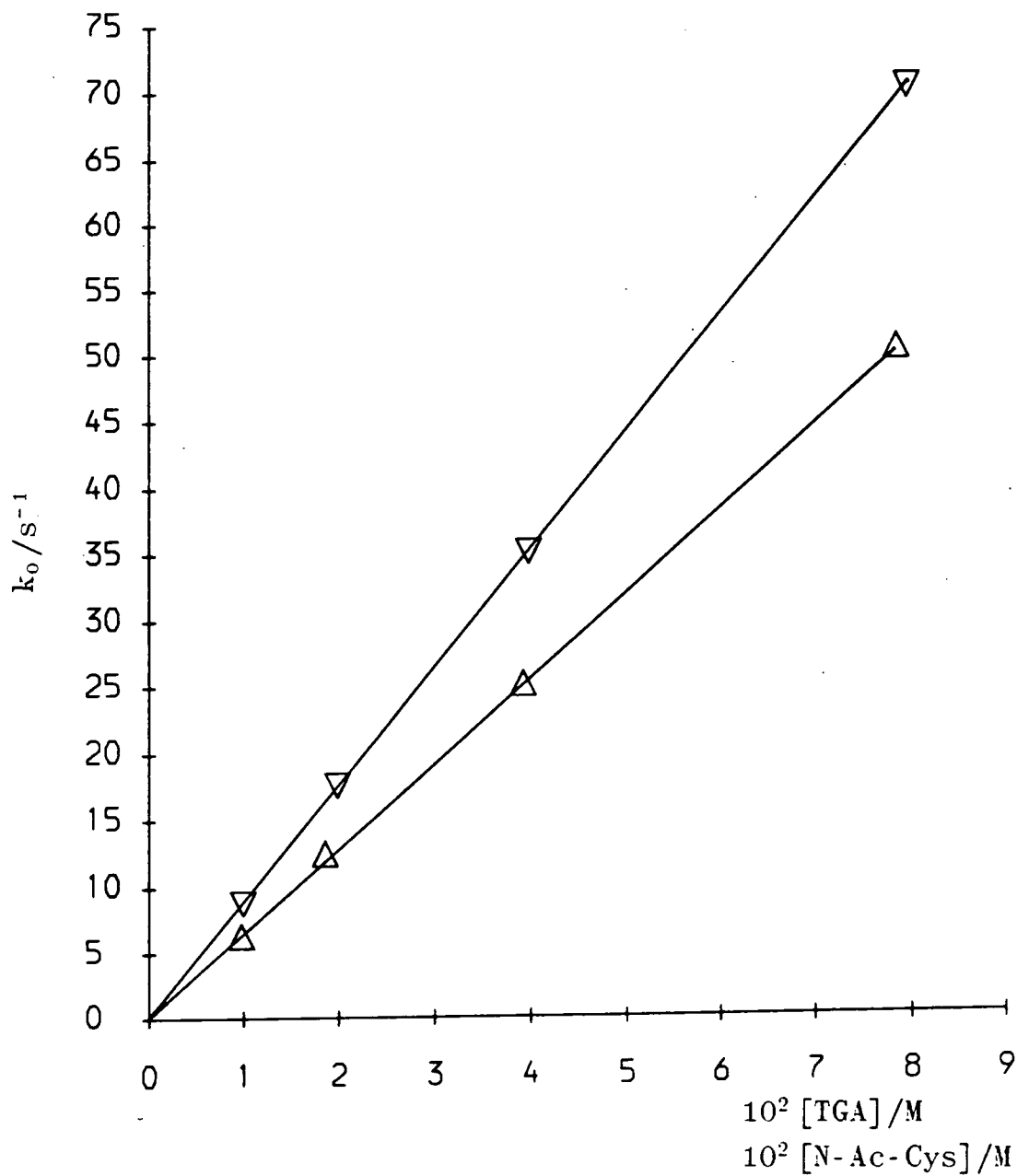

∇ [TGA] dependence
 \triangle [N-Ac-Cys] dependence

Table 4.3 Second-order rate constants k_2 for the reactions of five alkyl nitrites with N-Ac-Cys as a function of pH of the solution

pH	$k_2 / \text{l mol}^{-1} \text{ s}^{-1}$				
	a	b	c	d	e
13.50	1000	1025	1021	170	31.0
12.24	1014	—	—	—	31.0
12.00	—	1024	1019	168	—
11.00	955	960	960	160	29.1
10.60	875	888	888	—	26.8
10.00	607	641	645	106	21.8
9.70	458	—	—	—	—
9.60	—	—	—	68.3	11.8
9.50	—	358	360	—	—
9.30	—	—	—	42.0	9.0
9.20	215	—	—	—	—
9.10	—	—	—	28.2	—
9.00	—	150	148	—	4.27
8.70	—	—	—	13.1	—
8.50	—	54.1	51.9	—	1.75
8.40	44.4	—	—	—	—
8.10	—	—	—	4.0	—
8.00	—	17.1	17.4	—	.60
7.50	—	—	—	.98	—
7.00	4.90	—	—	—	.056
6.50	0.60	—	—	—	—
6.00	0.21	0.17	0.17	.033	.006

a = $\text{Cl}(\text{CH}_2)_2\text{ONO}$ b = $\text{Br}(\text{CH}_2)_2\text{ONO}$ c = $\text{I}(\text{CH}_2)_2\text{ONO}$

d = $\text{C}_2\text{H}_5\text{O}(\text{CH}_2)_2\text{ONO}$ e = $\text{C}_2\text{H}_5\text{ONO}$

Table 4.4 Second-order rate constants k_2 for the reactions of five alkyl nitrites with TGA as a function of pH of the solution

pH	$k_2 / \text{l mol}^{-1} \text{ s}^{-1}$				
	a	b	c	d	e
13.50	2255	2271	2260	418	74
12.50	—	—	—	415	75
12.00	2240	2249	2230	—	—
11.50	2139	—	—	390	69
11.00	—	1965	1960	—	—
10.80	1721	—	—	330	55
10.50	—	1520	1515	268	45
10.30	1193	—	—	—	—
10.00	—	881	879	170	30
9.80	651	—	—	—	—
9.60	—	—	—	84	16
9.50	—	385	377	—	—
9.40	—	—	—	54	9.4
9.30	265	—	—	—	—
9.00	145	138	137	—	—
8.90	—	—	—	21	3.4
8.80	81	—	—	—	—
8.50	—	40	42	—	—
8.30	28	—	—	—	—
8.00	13.7	13.9	14.1	2.8	.51
7.00	2.1	1.8	1.5	.30	.49
6.00	.16	.15	.15	.035	.006

a = $\text{Cl}(\text{CH}_2)_2\text{ONO}$ b = $\text{Br}(\text{CH}_2)_2\text{ONO}$ c = $\text{I}(\text{CH}_2)_2\text{ONO}$

d = $\text{C}_2\text{H}_5\text{O}(\text{CH}_2)_2\text{ONO}$ e = $\text{C}_2\text{H}_5\text{ONO}$

Figure 4.2 pH- k_2 profile for the nitrosation of N-Ac-Cys by ethyl nitrite

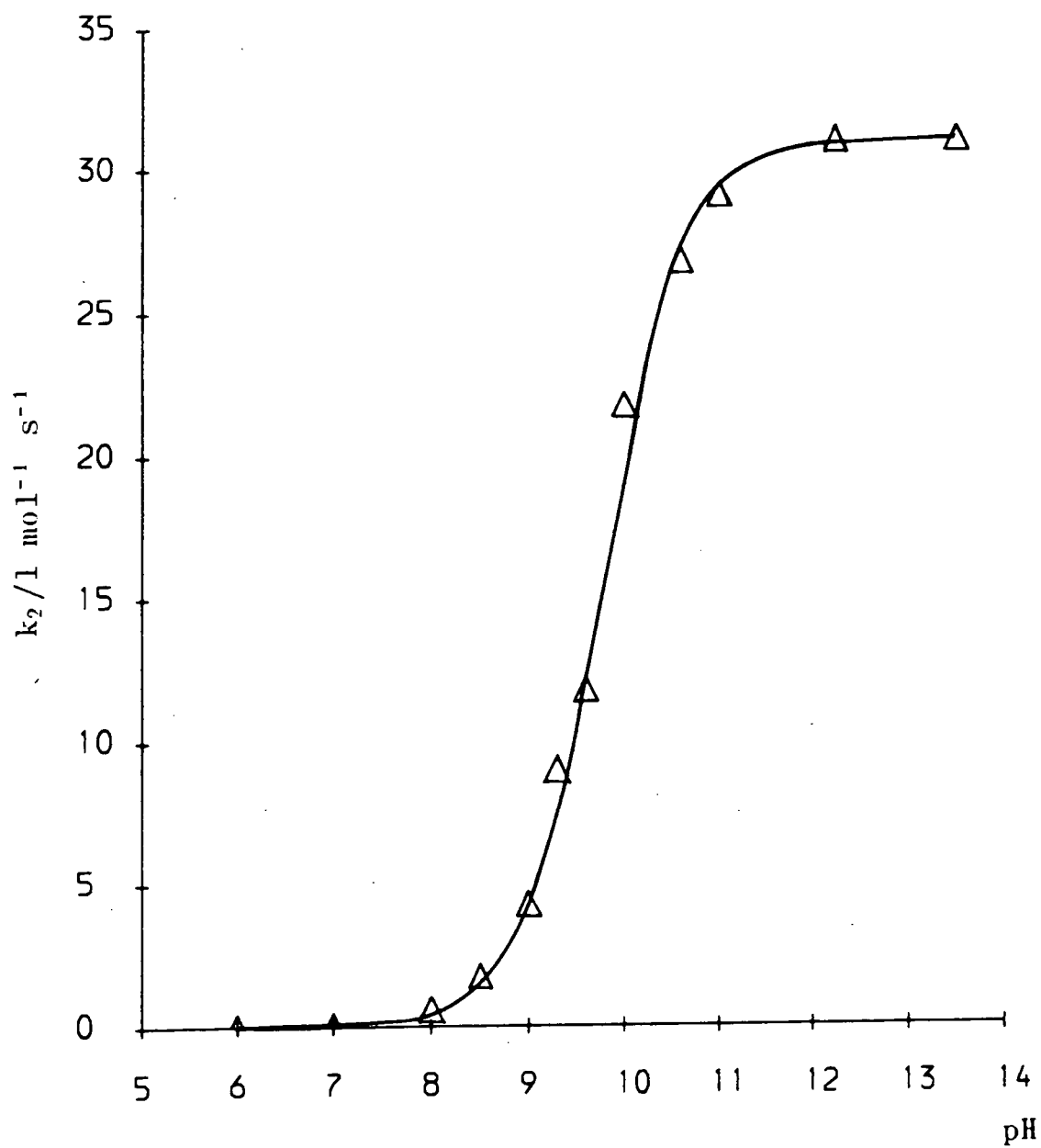
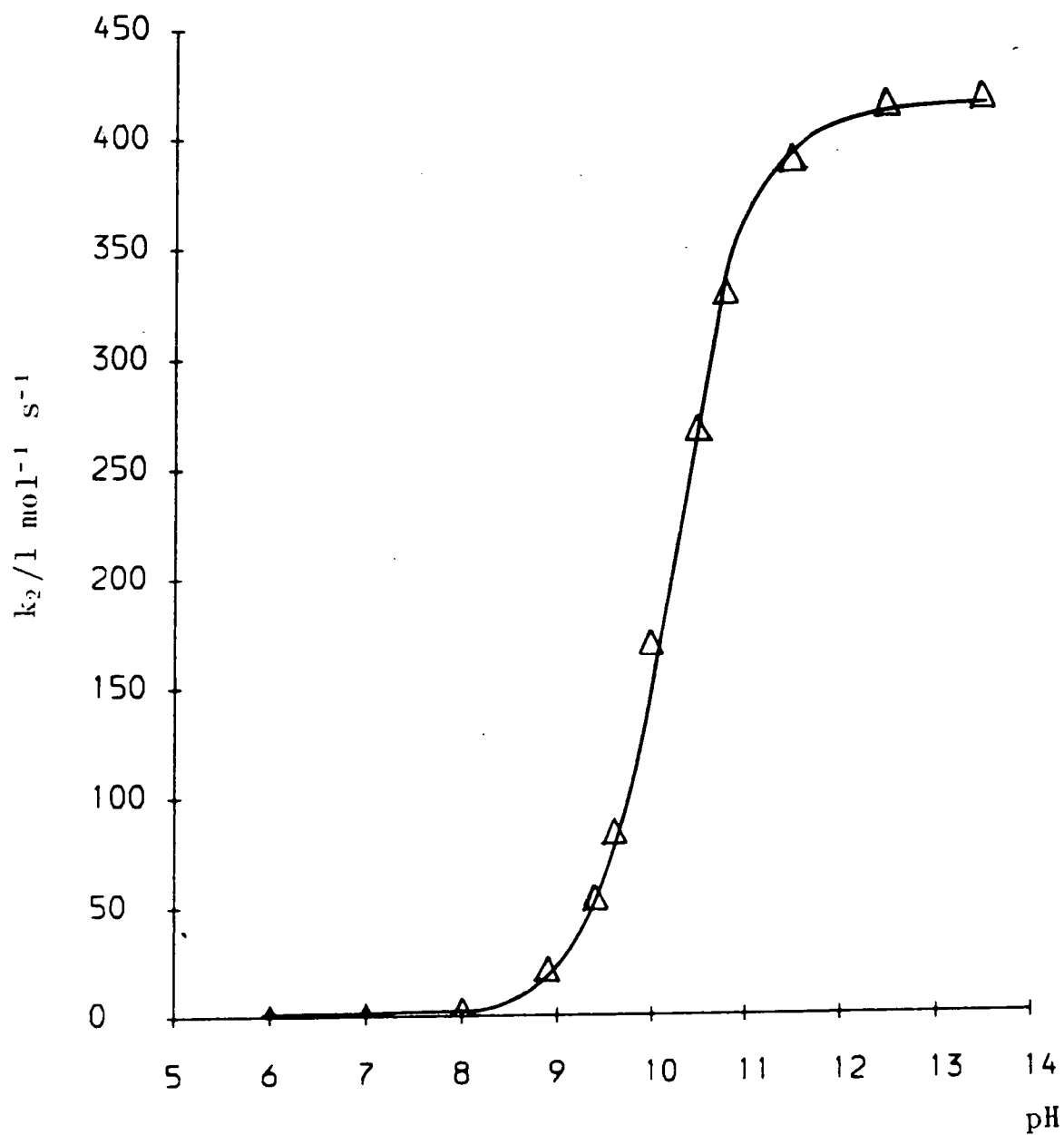

Figure 4.3 pH- k_2 profile for the nitrosation of TGA by 2-ethoxyethyl nitrite



As can be seen from the plots of k_2 versus pH (Figures 4.2 and 4.3) the kinetic pattern is very similar in all cases to that encountered for the nitrosation of N-Ac-Cys and TGA by $i\text{AmONO}$, $i\text{PrONO}$, and $t\text{BuONO}$. This shows that the reaction of alkyl nitrites (used in this study) with N-Ac-Cys and TGA in neutral and basic conditions takes place through the thiolate ion quite generally. Therefore, the analysis of the data can be carried out in a similar way as before using equations 4.3 and 4.4.

$$k_2 = \frac{k K_a}{K_a + [\text{H}^+]} \quad (4.3)$$

$$\log (1/k_2 - 1/k) = -\text{pH} - \log kK_a \quad (4.4)$$

It can be seen from Figures 4.2 and 4.3, where the solid lines are the calculated curves and the points are the experimentally measured k_2 values, that there is good agreement between calculated and experimental values of k_2 in all cases. Also the plots of $\log (1/k_2 - 1/k)$ versus pH (Figures 4.4 and 4.5) are in all cases good straight lines with slopes approximately equal to -1 and the analysis of the results from these plots are shown in the tables 4.5 and 4.6.

Table 4.5 Results from plots of $\log (1/k_2 - 1/k)$ versus pH
(for the nitrosation of N-Ac-Cys)

RONO	$k_2 (\text{lim}) /$ $l \text{ mol}^{-1} \text{ s}^{-1}$	Slope	Intercept	Calculated pKa
EtONO	31	-0.977	8.054	9.55
EtO(CH ₂) ₂ ONO	169	-0.990	7.435	9.66
Cl(CH ₂) ₂ ONO	1010	-0.976	6.543	9.55
Br(CH ₂) ₂ ONO	1030	-0.996	6.738	9.75
I(CH ₂) ₂ ONO	1020	-1.001	6.777	9.79

Table 4.6 Results from plots of $\log (1/k_2 - 1/k)$ versus pH
(for the nitrosation of TGA)

RONO	$k_2 (\text{lim}) /$ $l \text{ mol}^{-1} \text{ s}^{-1}$	Slope	Intercept	Calculated pKa
EtONO	75	-0.964	8.022	9.89
EtO(CH ₂) ₂ ONO	417	-0.973	7.321	9.94
Cl(CH ₂) ₂ ONO	2260	-0.977	6.632	9.99
Br(CH ₂) ₂ ONO	2240	-0.992	6.760	10.12
I(CH ₂) ₂ ONO	2260	-0.998	6.821	10.18

The averaged pKa for RSH ionisation is 9.66 ± 0.11 for N-acetyl-L-cysteine, which agrees reasonably with the literature value³ of 9.76, and 10.02 ± 0.12 for thioglycolic acid which again is in good agreement with the literature, 9.82⁴, 10.10⁵, 10.22⁶ and 10.32.⁷

Thus the results are consistent with the reaction of alkyl nitrites with the thiolate ion of N-Ac-Cys and TGA.

Figure 4.4 Plots of $\log (1/k_2 - 1/k)$ against pH for the nitrosation of N-Ac-Cys

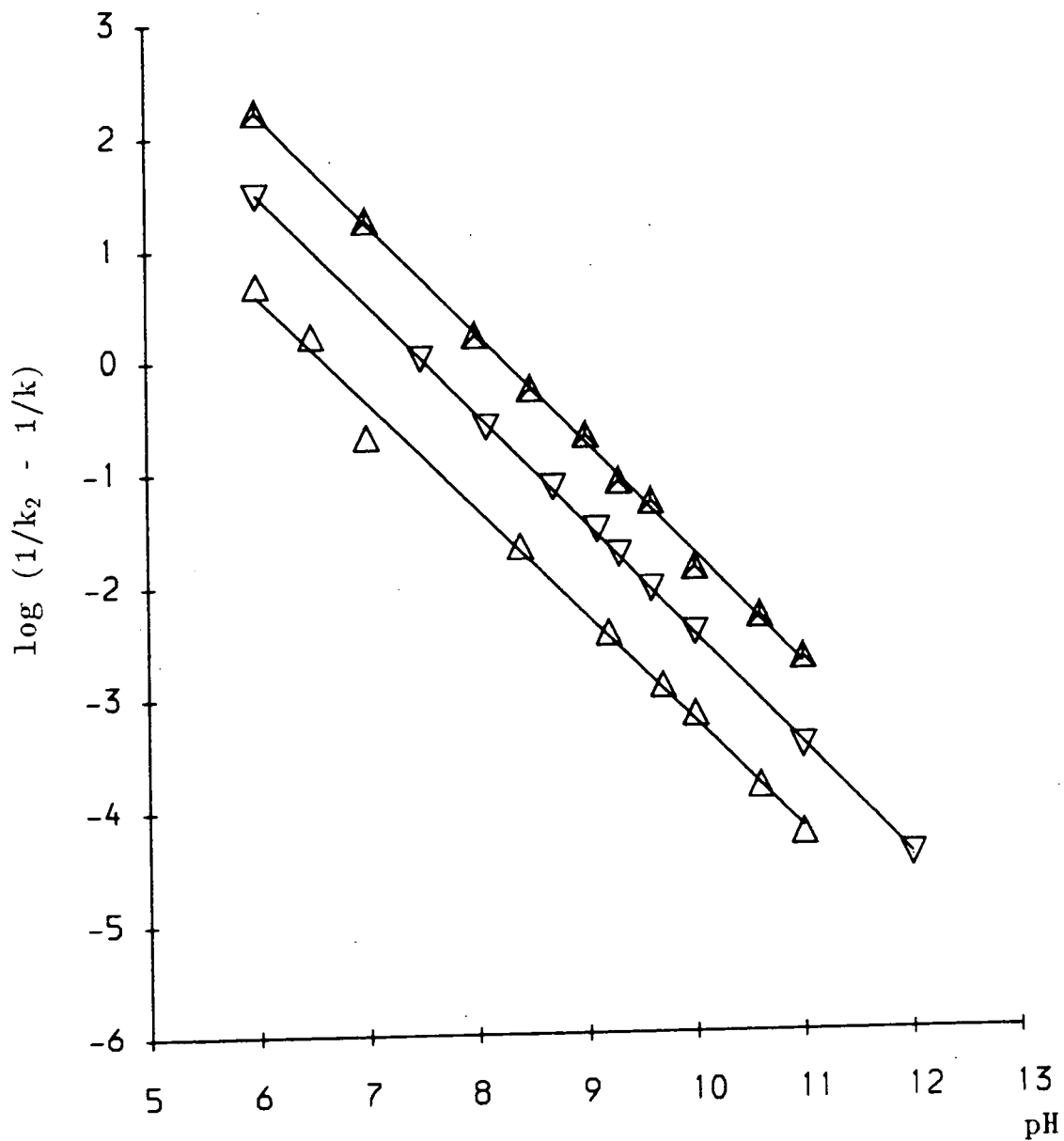

- ▲ by ethyl nitrite
- ▽ by 2-ethoxyethyl nitrite
- △ by 2-chloroethyl nitrite

Figure 4.5 Plots of $\log (1/k_2 - 1/k)$ against pH for the nitrosation of TGA

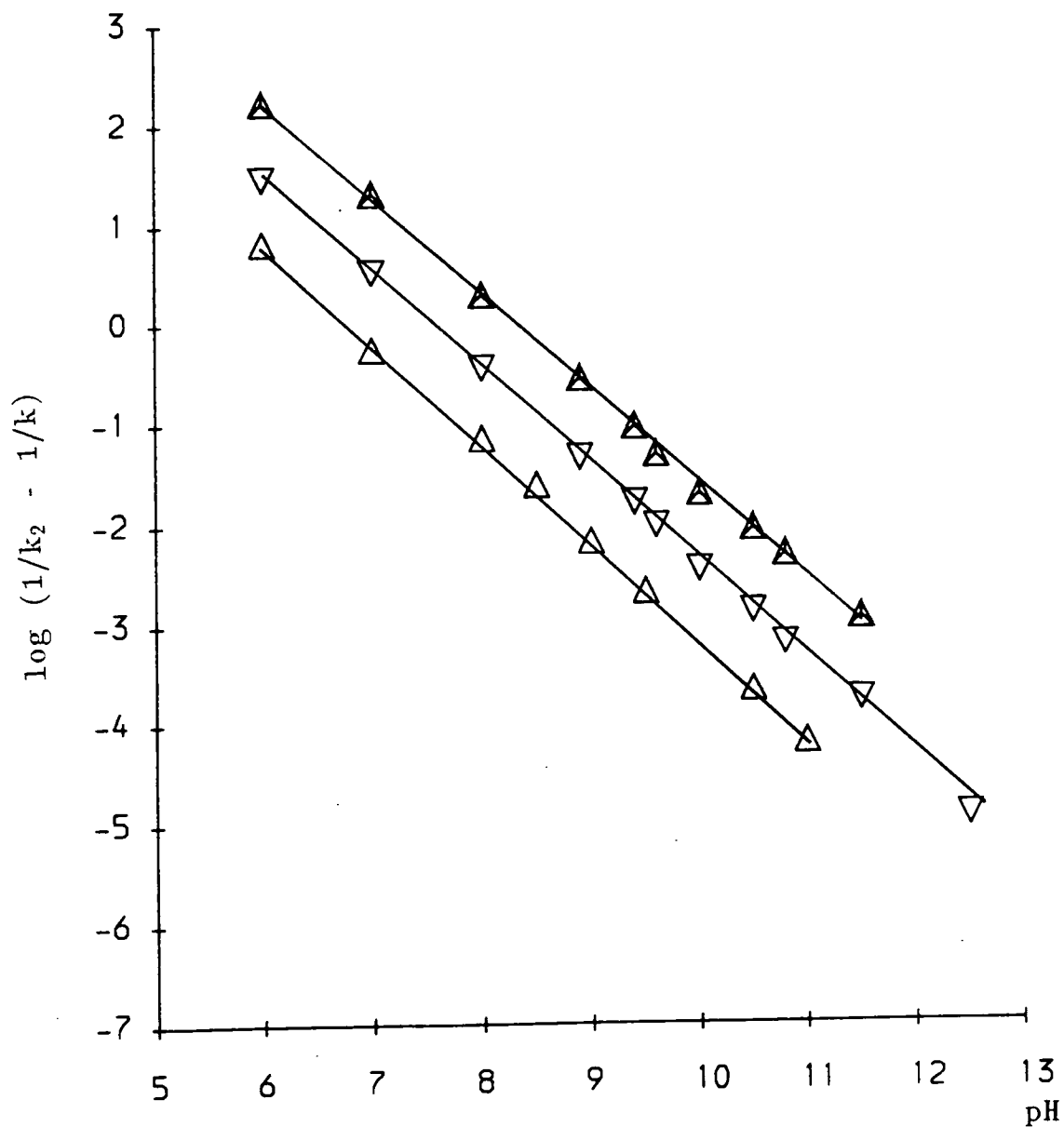

- ▲ by ethyl nitrite
- ▽ by 2-ethoxyethyl nitrite
- △ by 2-bromoethyl nitrite

4.3 Nitrosation of L-cysteine, L-cysteine methyl and ethyl esters and glutathione

A kinetic study of the reaction of L-cysteine (Cys), L-cysteine methyl ester (MeCys), L-cysteine ethyl ester (EtCys) and glutathione (GSH) with ethyl nitrite, 2-ethoxyethyl nitrite, 2-chloroethyl nitrite, 2-bromoethyl nitrite, 2-iodoethyl nitrite and 2,2-dichloroethyl nitrite in aqueous neutral and basic conditions in the absence of added nucleophiles was carried out. However, in the case of 2,2-dichloroethyl nitrite only the nitrosation of cysteine was investigated and could only be followed kinetically in the pH range 6-8.00 as the reaction was too fast to measure even by stopped-flow spectrophotometry. Although 2,2,2-trichloroethyl nitrite was synthesised it was found to react with L-cysteine at a rate which was too fast to measure by stopped-flow spectrophotometry at any pH value.

All the reactions were carried out under the same conditions as those used for the nitrosation of N-Ac-Cys and TGA. In all the cases good first-order behaviour was observed. The measured first-order rate constants, k_0 , were determined at each pH values for four different thiol concentrations. A set of results for the reaction of 2-bromoethyl nitrite with Cys, MeCys, EtCys and GSH are shown in tables 4.7-4.10, whilst the rest of the data has not been included for reason of space. The plots of k_0 versus [Cys], [MeCys], [EtCys] and [GSH] (Figure 4.5) at pH 7 are linear passing through the origin, thus indicating that under the conditions used the nitrosation of Cys, MeCys, EtCys and GSH by 2-bromoethyl nitrite is first-order in [Cys], [MeCys], [EtCys] and [GSH]. This was found to be

the same for the other alkyl nitrites at each of the pH values investigated. This establishes the rate equation similar to that for the nitrosation of N-Ac-Cys and TGA (equation 4.2).

Table 4.7 Dependence of k_0 on [Cys] at pH 7

$$[\text{Br}(\text{CH}_2)_2\text{ONO}] = 1 \times 10^{-4} \text{ M}$$

10^2 [Cys]/M	k_0/s^{-1}
8.60	$3.544 \pm .007$
4.30	$1.768 \pm .002$
2.15	$0.891 \pm .003$
1.08	$0.443 \pm .006$

Table 4.8 Dependence of k_0 on [MeCys] at pH 7

$$[\text{Br}(\text{CH}_2)_2\text{ONO}] = 1 \times 10^{-4} \text{ M}$$

10^2 [MeCys]/M	k_0/s^{-1}
7.98	$9.580 \pm .007$
3.99	$4.787 \pm .003$
2.00	$2.390 \pm .006$
1.00	$1.194 \pm .002$

Table 4.9 Dependence of k_0 on [EtCys] at pH 7

$$[\text{Br}(\text{CH}_2)_2\text{ONO}] = 1 \times 10^{-4} \text{ M}$$

10^2 [EtCys]/M	k_0/s^{-1}
7.92	$9.264 \pm .004$
3.96	$4.630 \pm .008$
1.98	$2.318 \pm .006$
0.99	$1.162 \pm .003$

Table 4.10 Dependence of k_0 on [GSH] at pH 7

$$[\text{Br}(\text{CH}_2)_2\text{ONO}] = 1 \times 10^{-4} \text{ M}$$

10^2 [GSH]/M	k_0/s^{-1}
8.24	$1.073 \pm .005$
4.12	$0.536 \pm .003$
2.06	$0.268 \pm .007$
1.03	$0.134 \pm .004$

The values of k_2 , the derived second-order rate constant, were determined from the plots of k_0 versus [RSH] at each pH and are shown in tables 4.11-4.14.

Figure 4.6 Dependence of k_0 on [Cys], [MeCys], [EtCys] and [GSH] at pH 7

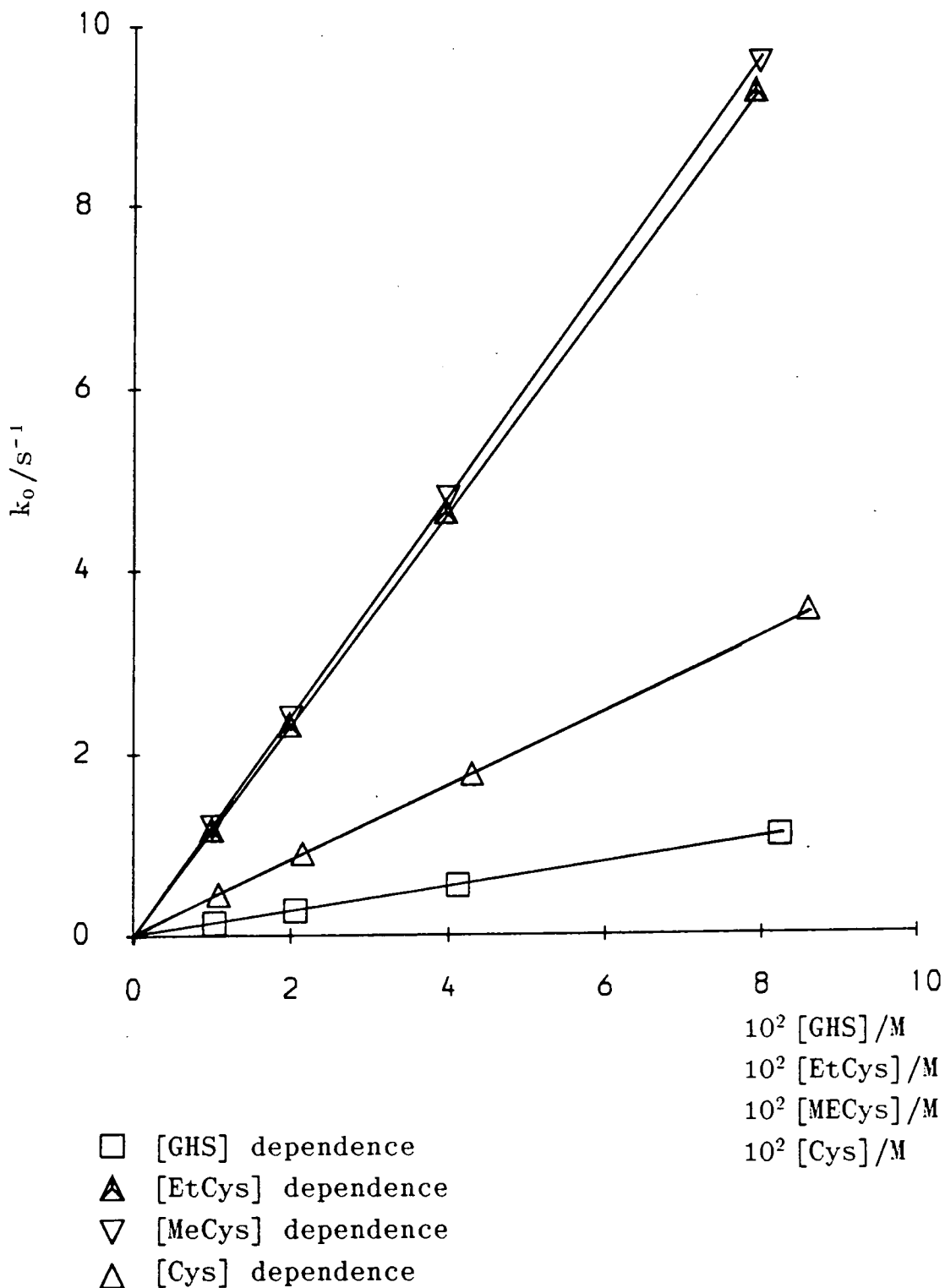

Table 4.11 Second-order rate constants k_2 for the reactions of six alkyl nitrites with Cys as a function of pH of the solution

pH	$k_2 / \text{l mol}^{-1} \text{ s}^{-1}$					
	a	b	c	d	e	f
12.90	1050	1010	1056	173	27.6	—
12.10	—	—	—	168	—	—
12.00	—	1058	1054	—	27.4	—
11.70	1038	—	—	—	—	—
11.00	—	1050	1043	167	27.7	—
10.90	1040	—	—	—	—	—
10.10	—	1022	1004	—	27.0	—
10.00	1027	—	—	—	—	—
9.50	—	—	—	155	—	—
9.40	946	—	—	—	—	—
9.00	—	823	828	139	22.3	—
8.90	772	—	—	—	—	—
8.50	620	667	—	94.6	15.9	—
8.10	—	396	393	—	9.3	—
8.00	329	—	—	50.7	—	3434
7.60	153	—	—	—	—	—
7.50	—	130	131	20.1	3.1	1518
7.00	41.2	44.3	41.7	6.9	1.12	550
6.60	—	18.0	17.5	2.6	0.43	224
6.50	14.1	—	—	—	—	—
6.10	—	—	—	1.2	—	—
6.00	4.0	4.5	4.3	—	0.10	58.9

a = $\text{Cl}(\text{CH}_2)_2\text{ONO}$ b = $\text{Br}(\text{CH}_2)_2\text{ONO}$ c = $\text{I}(\text{CH}_2)_2\text{ONO}$

d = $\text{C}_2\text{H}_5\text{O}(\text{CH}_2)_2\text{ONO}$ e = $\text{C}_2\text{H}_5\text{ONO}$ f = $\text{Cl}_2\text{CHCH}_2\text{ONO}$

Table 4.12 Second-order rate constants k_2 for the reactions of five alkyl nitrites with MeCys as a function of pH of the solution

pH	$k_2 / \text{l mol}^{-1} \text{ s}^{-1}$				
	a	b	c	d	e
13.50	—	1060	1058	150	24.5
13.00	1045	—	—	—	—
12.00	1057	1050	1056	150	24.3
11.00	1038	1041	1043	—	—
10.50	—	—	—	144	23.4
10.10	900	—	—	—	—
10.00	—	905	919	132	21.4
9.60	—	—	—	113	17.7
9.50	—	720	751	—	—
9.40	684	—	—	—	—
9.30	—	—	—	89	14.4
9.00	462	473	478	68	11.0
8.60	—	—	—	—	7.6
8.50	—	300	301	—	—
8.40	270	—	—	39	—
8.00	220	220	219	31	5.1
7.50	177	176	175	24	4.0
7.00	119	120	121	18	2.98
6.50	75	73	75	10	1.75
6.00	32	31	32	4.6	0.75

a = Cl(CH₂)₂ONO b = Br(CH₂)₂ONO c = I(CH₂)₂ONO

d = C₂H₅O(CH₂)₂ONO e = C₂H₅ONO

Table 4.13 Second-order rate constants k_2 for the reactions of five alkyl nitrites with EtCys as a function of pH of the solution

pH	$k_2 / \text{l mol}^{-1} \text{ s}^{-1}$				
	a	b	c	d	e
13.50	—	—	—	166	25.5
13.00	1100	1085	1085	—	—
12.50	—	—	—	—	25.3
12.40	—	—	—	163	—
12.00	1100	1085	1075	—	—
11.00	1095	1060	1060	160	—
10.80	—	—	—	—	24.7
10.50	—	—	—	154	—
10.10	925	926	920	—	—
9.80	—	—	—	—	19.1
9.60	—	694	695	124	—
9.50	—	—	—	—	15.9
9.40	627	—	—	99	—
9.20	—	—	—	—	12.2
9.00	404	390	399	60	9.2
8.50	260	265	270	38	6.8
8.00	225	210	210	30	5.7
7.60	165	—	—	—	—
7.50	—	170	175	26	4.2
7.00	119	117	129	18	3.1
6.50	70	74	75	12	1.7
6.00	42	35	34	4	0.90

a = $\text{Cl}(\text{CH}_2)_2\text{ONO}$ b = $\text{Br}(\text{CH}_2)_2\text{ONO}$ c = $\text{I}(\text{CH}_2)_2\text{ONO}$

d = $\text{C}_2\text{H}_5\text{O}(\text{CH}_2)_2\text{ONO}$ e = $\text{C}_2\text{H}_5\text{ONO}$

Table 4.14 Second-order rate constants k_2 for the reactions of five alkyl nitrites with GSH as a function of pH of the solution

pH	$k_2 / \text{l mol}^{-1} \text{ s}^{-1}$				
	a	b	c	d	e
13.50	1080	1056	1059	160	28.2
12.50	—	1054	1061	—	—
12.20	1060	—	—	157	27.6
11.00	1057	1045	1057	156	27.7
10.00	991	989	989	—	—
9.80	—	—	—	145	25.5
9.60	903	—	—	—	—
9.50	—	840	841	—	—
9.20	—	—	—	116	19.0
9.00	—	584	580	96	14.0
8.90	528	—	—	—	—
8.60	—	—	—	61	9.7
8.50	285	295	296	—	—
8.20	—	—	—	30	5.3
8.00	—	109	101	—	—
7.80	78	—	—	—	—
7.60	—	—	—	8.1	1.3
7.50	49	41	39	—	—
7.40	—	—	—	5.6	0.80
7.00	13	13	13	—	—
6.80	—	—	—	1.6	0.25
6.00	1.7	1.6	1.5	0.21	0.06

a = $\text{Cl}(\text{CH}_2)_2\text{ONO}$ b = $\text{Br}(\text{CH}_2)_2\text{ONO}$ c = $\text{I}(\text{CH}_2)_2\text{ONO}$

d = $\text{C}_2\text{H}_5\text{O}(\text{CH}_2)_2\text{ONO}$ e = $\text{C}_2\text{H}_5\text{ONO}$

Figure 4.7 pH- k_2 profile for the nitrosation of Cys by 2-chloroethyl nitrite

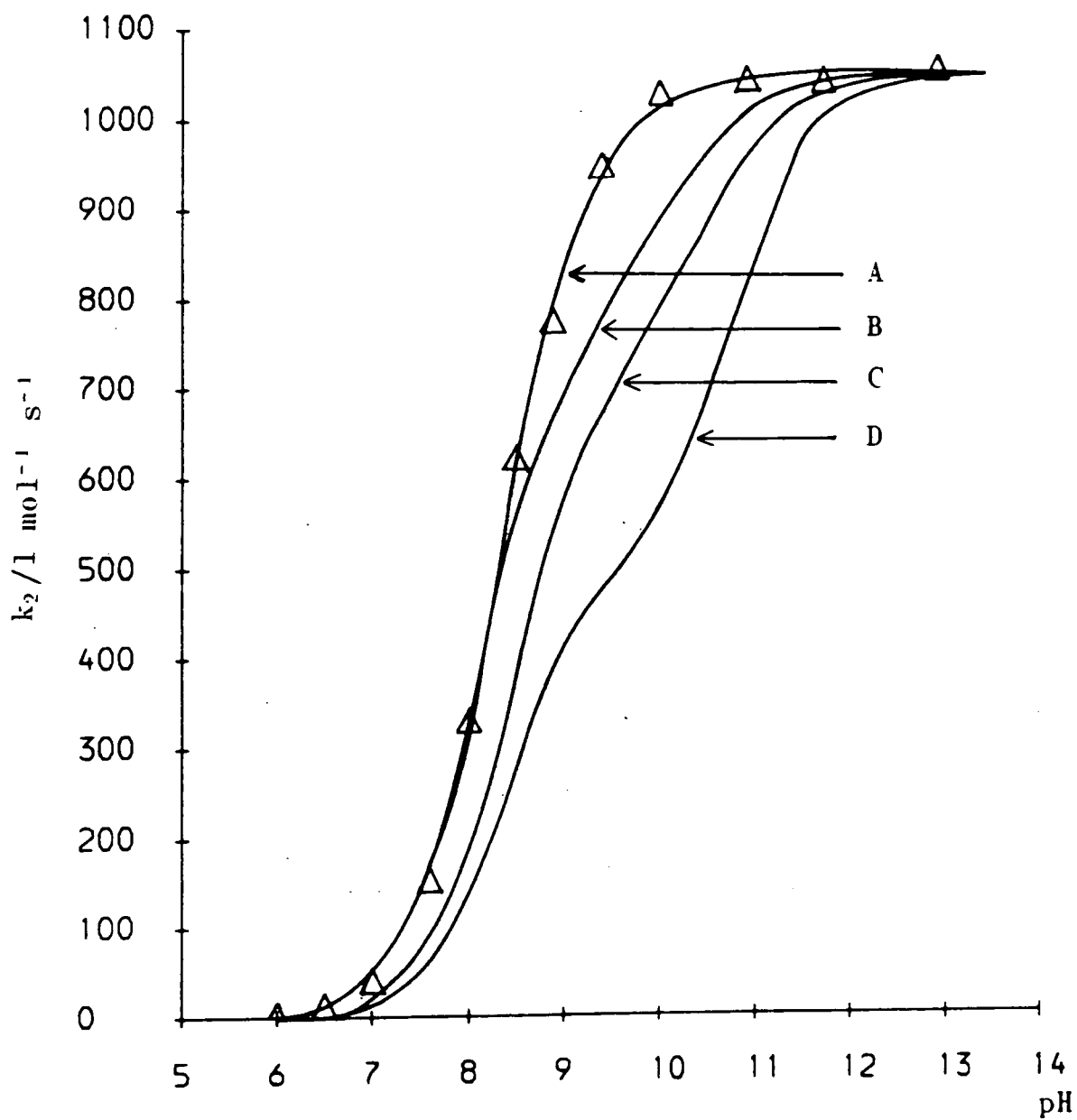

Figure 4.8 pH- k_2 profile for the nitrosation of MeCys by 2-bromoethyl nitrite

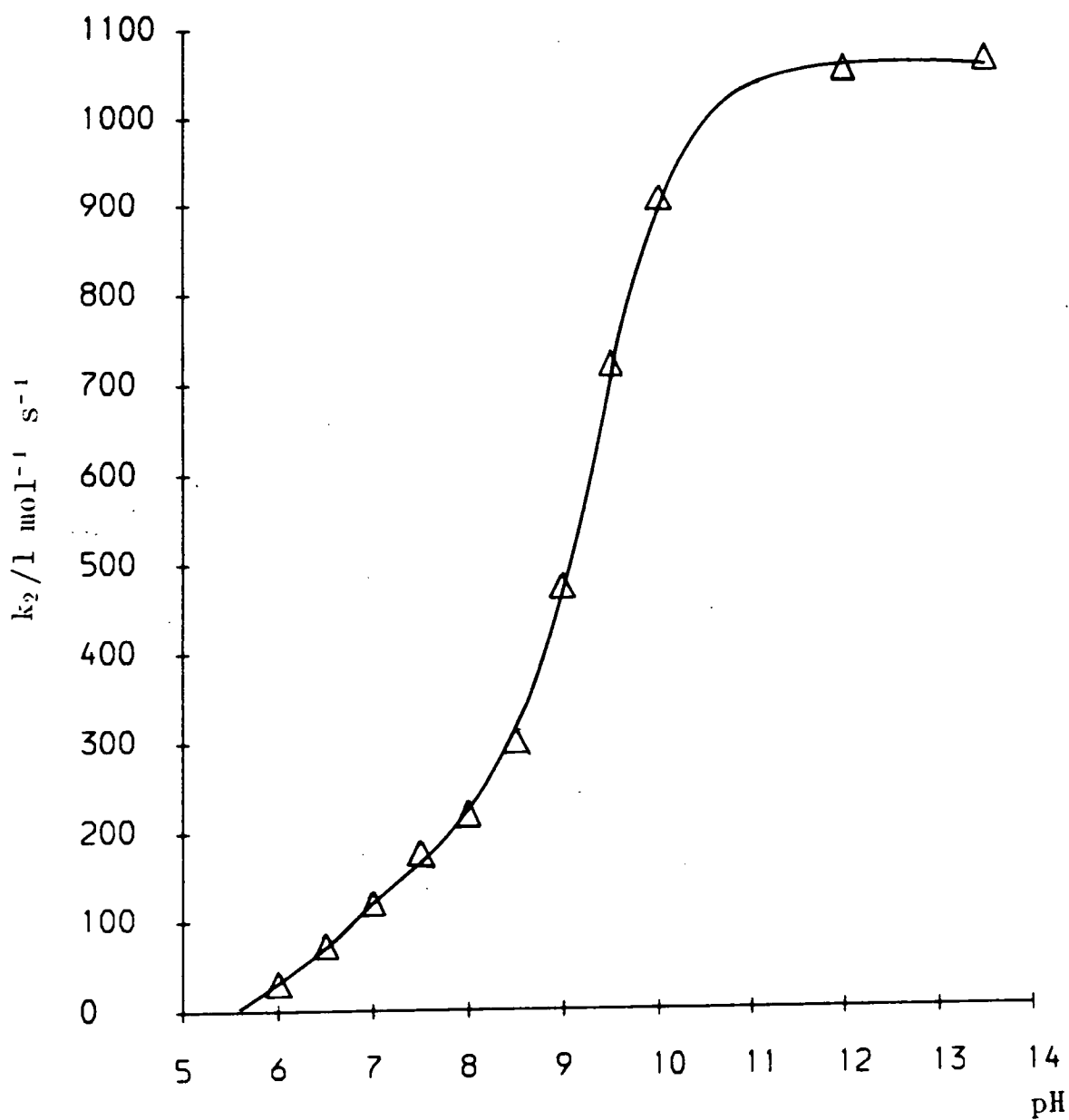

Figure 4.9 pH- k_2 profile for the nitrosation of EtCys by 2-iodoethyl nitrite

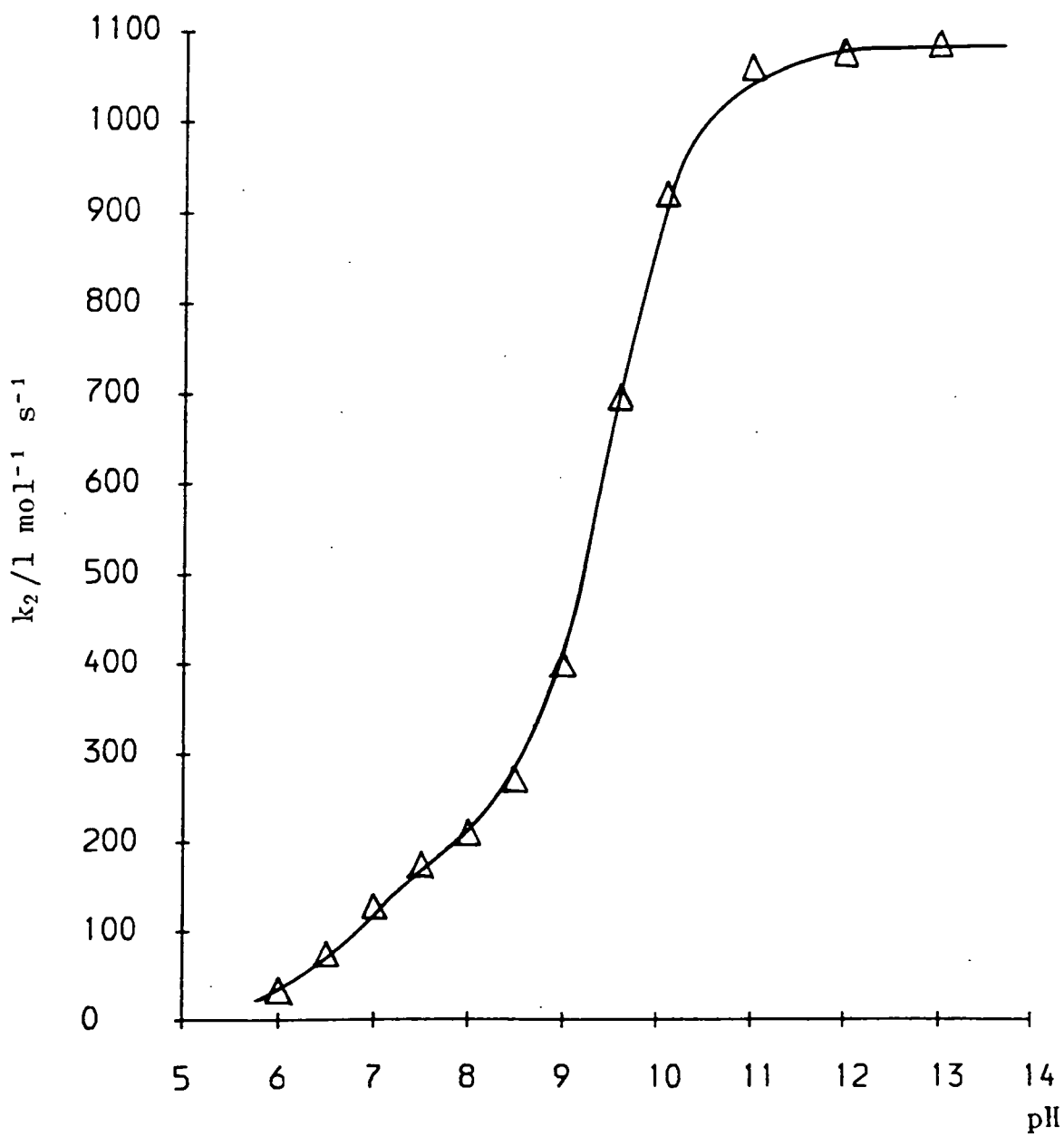
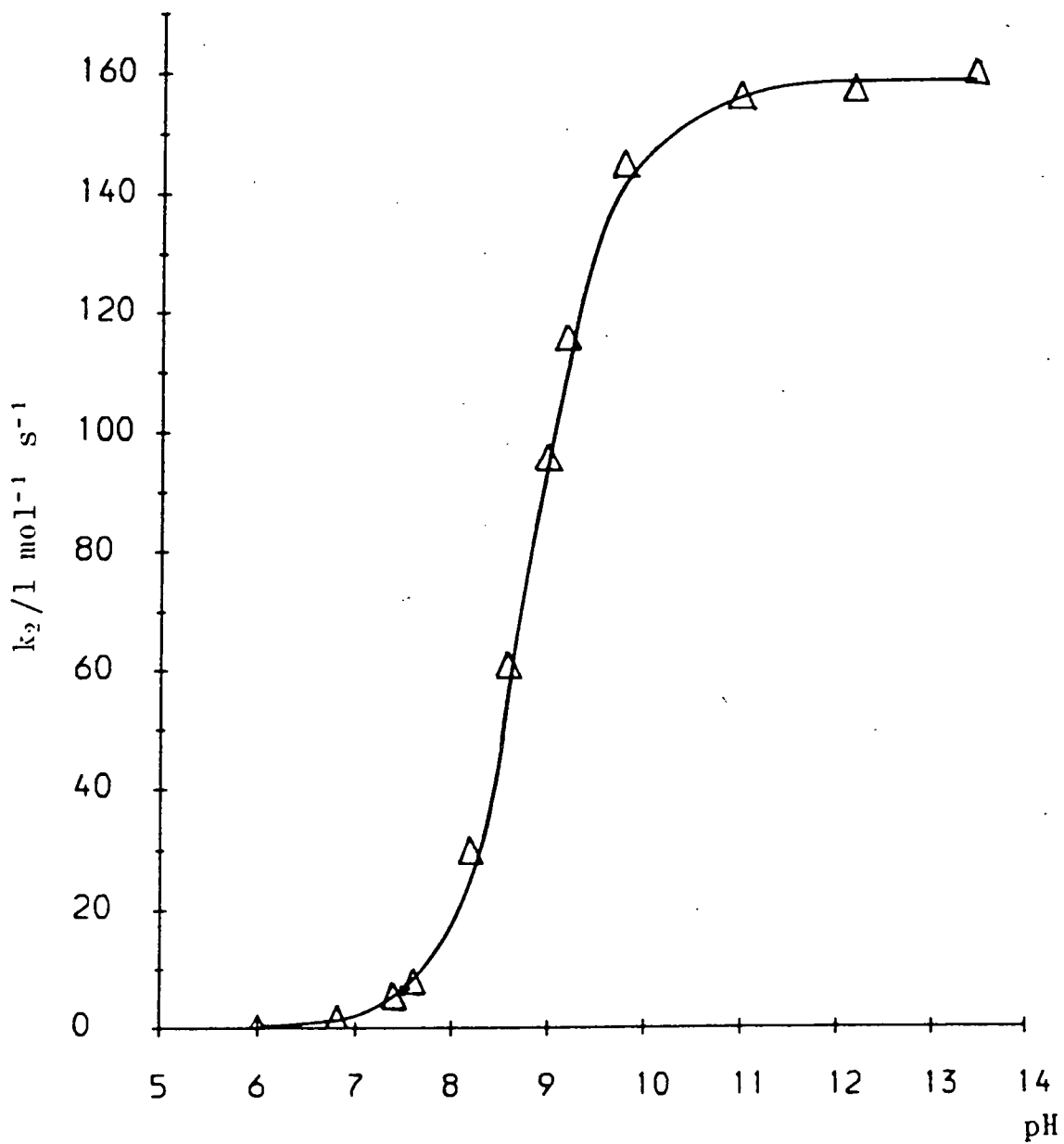

Figure 4.10 pH- k_2 profile for the nitrosation of GSH by 2-ethoxyethyl nitrite



As can be seen from the plots of k_2 versus pH (Figures 4.7-4.10) the kinetic pattern is very similar in all cases to that encountered for the nitrosation of these thiols by $i\text{AmONO}$, $i\text{PrONO}$ and $t\text{BuONO}$. Therefore the analysis of the data can be carried out in a similar way as before using equations 4.5 and 4.6.

$$\%[\text{RS}^-] = \frac{K_A/K_B + K_D/[\text{H}^+]}{[\text{H}^+]/K_B + K_A/K_D + 1 + K_D/[\text{H}^+]} \times 100 \quad (4.5)$$

$$k_2 = \frac{k(\text{lim}) \times \%[\text{RS}^-]}{100} \quad (4.6)$$

Thus k_2 -pH profiles can be constructed for all the reactions using equation 4.5 and 4.6. The k_2 -pH profiles (Figure 4.7) for L-cysteine are very similar to those encountered for the reactions with $i\text{AmONO}$, $i\text{PrONO}$ and $t\text{BuONO}$. That is, the results follow closely curve B upto pH 8.5 and thereafter depart from it. The explanation for this is similar to that given before for the nitrosation by $i\text{AmONO}$, $i\text{PrONO}$ and $t\text{BuONO}$.

In the case of the methyl and ethyl carboxylic ester of L-cysteine smooth curves (Figures 4.8 and 4.9), which fitted best to the experimental points, were computed using pK_A 7.45, pK_B 6.77, pK_C 8.41 and pK_D 9.09 for ethyl ester and pK_A 7.45, pK_B 6.77, pK_C 8.41 and pK_D 9.09 for methyl ester. The microscopic pK_a values for ethyl ester are in good agreement with the reported values (see table 4.15) and those of methyl ester are the same as those of the ethyl ester. However, as there are no literature values for the

microscopic pKa values for the methyl ester a comparison cannot be made with the results from this study.

Similarly, in the case of glutathione smooth curves (Figure 4.10), which fitted best to the experimental points, were computed using pK_A 8.72, pK_B 9.28, pK_C 9.82 and pK_D 8.72. These agree reasonably well with the literature values of Reuben and Bruice⁴ (see table 4.15)

4.4 Discussion

There is excellent agreement between the experimental and calculated k_2 values with the exception of some of the results for L-cysteine. As can be seen from table 4.15 that there is good agreement between the literature pKa values for the ionisation of RSH and those derived from this study. Therefore it is clear from these results that alkyl nitrites generally react in aqueous neutral and mildly basic conditions with the thiolate anion of thiols.

The combined results for $k(\text{lim})$ i.e. k values for each of the reactions studied are summarised in table 4.16. Again the results are similar to those for the nitrosation by $^i\text{AmONO}$, $^i\text{PrONO}$ and $^t\text{BuONO}$. That is the reactivities of the thiols are very much the same as before. There is very little difference in reactivity between the thiols except for thioglycolic acid which is consistently more reactive than the others by a factor of two and three.

Table 4.15 Values of pKa for RSH ionisation from literature and this study

THIOL	pK _A	pK _B	pK _C	pK _D	Ref.
L-cysteine	8.21	8.65	10.00	9.56	4
	8.53	8.86	10.36	10.03	7
	8.50	8.85	10.35	10.00	5
	8.64	8.62	10.47	10.49	8
	8.21 [*]	8.65 [*]	8.96 [*]	8.52 [*]	
L-cysteine Et Ester	7.30	6.76	8.33	8.87	4
	7.45	6.77	8.41	9.09	7
	7.45 [*]	6.77 [*]	8.41 [*]	9.09 [*]	
L-Cysteine Me Ester	7.45 [*]	6.77 [*]	8.41 [*]	9.09 [*]	
Glutathione	8.72	9.47	9.47	8.72	4
	8.93	9.13	9.28	9.08	9
	8.72 [*]	9.28 [*]	9.28 [*]	8.72 [*]	
N-Acetyl-L-cysteine	9.76				4
	9.66 [*]				
Thioglycolic acid	9.82				4
	10.32				7
	10.01				5
	10.22				6
	10.02 [*]				

* values from this study

Table 4.16 Values of k_2 (lim) for the reactions of six alkyl nitrites with six thiols

THIOL	$k_2 / \text{l mol}^{-1} \text{ s}^{-1}$					
	a	b	c	d	e	f
L-cysteine	9576	1045	1055	1060	169	28
L-cysteine Me Ester	—	1050	1055	1057	150	24
L-cysteine Et Ester	—	1100	1085	1080	165	25
N-acetyl-L-cysteine	—	1010	1030	1020	169	31
Glutathione	—	1070	1055	1060	159	28
Thioglycolic acid	—	2260	2240	2260	417	75

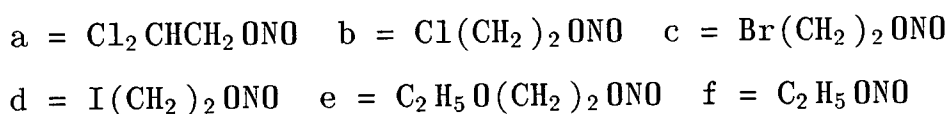

As for the reactivity of the alkyl nitrites used, it is clear that the presence of β -electron-withdrawing groups has a significant enhancing effect on the reactivity. This is to be expected for an electrophilic nitrosation process (equation 4.7).

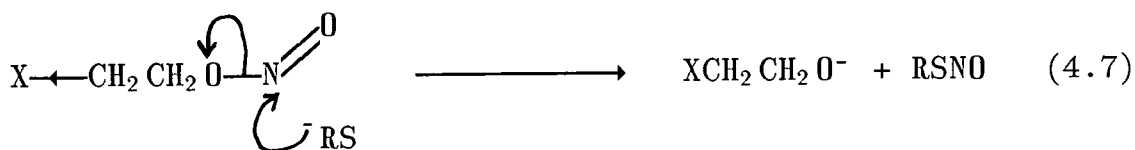

This effect of enhancement of the reactivity by β -electron withdrawing groups has also been shown for the reaction of alkyl nitrites with amines under similar conditions.² In this case the β -OC₂H₅ group was found to activate the reaction by a factor of about six, a β -halogen substituents by about thirty-eight and two β -chloro substituent by over four hundred. These effects can be explained by correlating

the results to a simple "Taft" relationship (equation 4.8).

$$\log k/k^{\text{Me}} = \rho^* \sigma^* + E_S \delta \quad (4.8)$$

Thus a correlation between the structure of alkyl nitrites and their reactivity can be shown by plotting $\log k$ versus σ^* . In the case of L-cysteine the values of $\log k$ and the known values of σ^* for the alkyl nitrites are shown in table 4.17.

Table 4.17 Values of σ^* and $\log k$ for the reaction of alkyl nitrites with L-cysteine

R-	σ^* (Ref. 10&11)	k /l mol ⁻¹ s ⁻¹	log k
Cl(CH ₂) ₂ -	.385	1045	3.02
Br(CH ₂) ₂ -	.400	1055	3.02
I(CH ₂) ₂ -	.378	1060	3.03
EtO(CH ₂) ₂ -	.233	169	2.23
Et-	-.100	28	1.45
ⁱ Pr-	-.190	11	1.04
^t Bu-	-.300	1.7	0.23

As can be seen from the plot of $\log k$ versus σ^* (Figure 4.11) there is a reasonable correlation satisfying Taft's equation between structure and reactivity of the alkyl nitrites with L-cysteine (this was also found to be the same with the other thiols used. Thus the parameters of Taft's equation can be determined from these plots and were

found to be $\rho^* = 3.6 \pm 0.10$ and $\log k^{\text{Me}} = 1.67 \pm 0.16$. The positive slope indicates a Substitution Nucleophilic Concerted bimolecular reaction (SNC_2) correlation and its value is in good agreement with the value obtained for the nitrosation of dimethylamine² by alkyl nitrites in basic conditions ($\rho^* = 3.89$) and for that obtained for the basic hydrolysis of nitrite ester ($\rho^* = 2.67$).^{1,2}

An exact parallel between the reactivities of RS^- and RO^- in these reactions cannot be drawn, although the nitroso group exchange between an alkyl nitrite and alkoxide ion has been demonstrated using the corresponding alcohol as solvent.^{1,3} Nevertheless, one would expect RS^- to be more reactive than RO^- and this interpretation is based on the difference in basicity and nucleophilicity between sulphur and oxygen.^{1,4} Since sulphur is more nucleophilic than oxygen, due to the fact that sulphur is more polarizable than oxygen, one would expect RS^- to be more susceptible than RO^- to an electrophilic attack. This difference in reactivity between sulphur and oxygen can be shown by comparing the reactivity of the nitrosation of N-acetylpenicillamine (a reasonably good model for t-butyl thiol) and t-butanol by nitrous acid. One finds that N-acetylpenicillamine is several orders of magnitude more reactive than t-butanol.^{1,5} Thus one would expect a similar behaviour when comparing the reactivity of RS^- and RO^- towards a direct electrophilic attack by alkyl nitrites.

However, an exact comparison between the thiolate ion (RS^-) and hydroxide ion (OH^-) can be drawn. In the case of 2-ethoxyethyl nitrite Challis and Shuker¹ found that the rate of hydrolysis to nitrite ion occurred in accordance

with the equation, $\text{rate} = 8.26 \times 10^{-4} \text{ (mol l}^{-1} \text{ s}^{-1}\text{)}$
[EtO(CH₂)₂ONO] [NaOH] at 25°C. Thus all the thiolate ions
used in this study are many orders of magnitude more
reactive than the hydroxide ion.

Figure 4.11 Plot of $\log k$ versus σ^* for the reaction of alkyl nitrites with L-cysteine

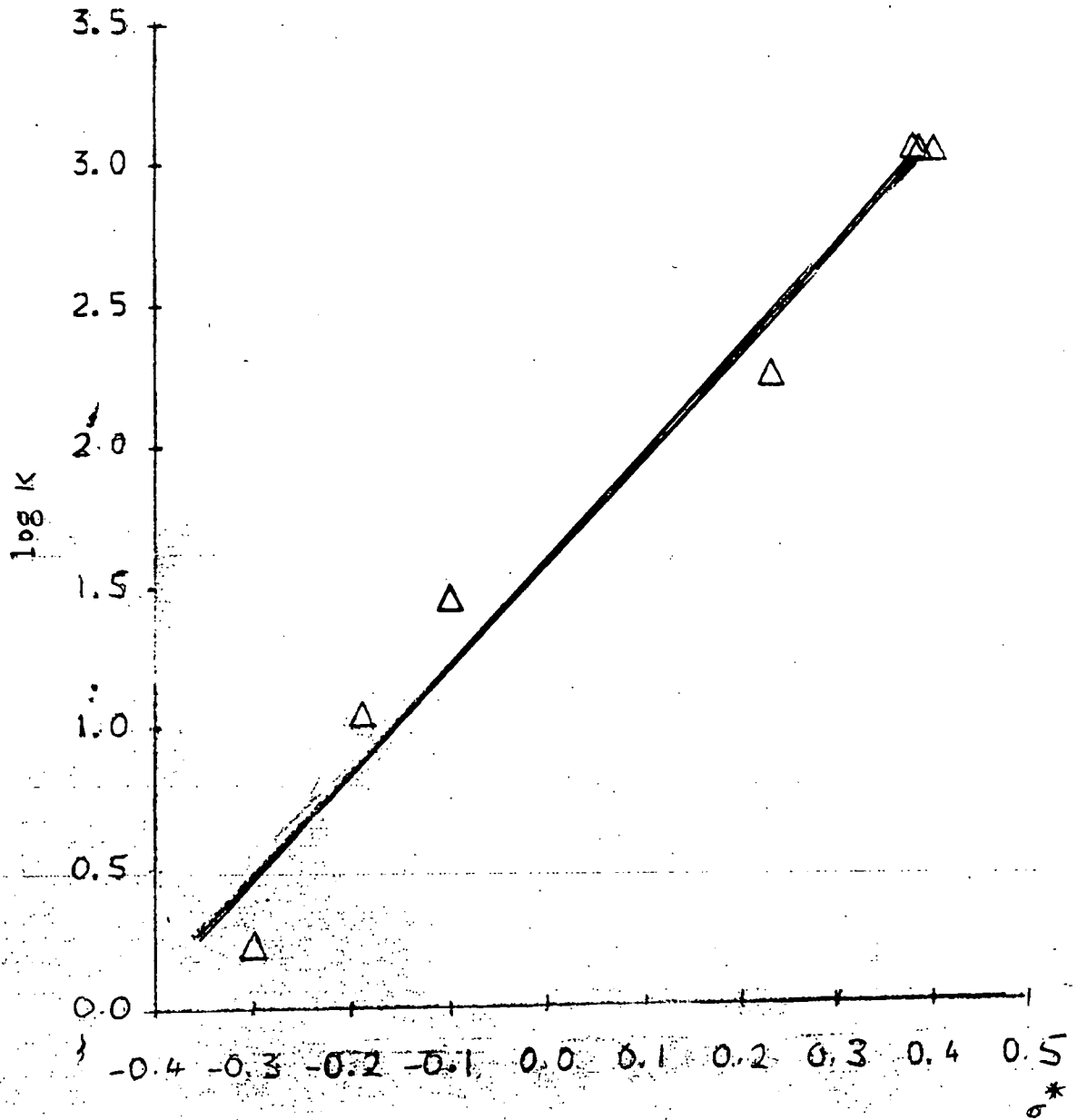

References

1. B. C. Challis and D. E. G. Shuker, *J. Chem. Soc., Perkin Trans. 2*, 1979, 315.
2. J. Casado, A. Castro, F. M. Lorenzo and F. Meijide, *Monatsh. Chem.*, 1986, 117, 335.
3. R. H. Boggess, J. R. Abstier, S. Morelen, L. T. Taylor and J. W. Hughes, *Inorg. Chem.*, 1983, 22, 1273.
4. D. M. E. Reuben and T. C. Bruice, *J. Am. Chem. Soc.*, 1976, 98, 114.
5. E. L. Elson and J. T. Edsall, *Biochem.*, 1962, 1, 1.
6. J. P. Danehy and C. J. Noel, *J. Am. Chem. Soc.*, 1960, 82, 2511.
7. R. E. Benesch and R. Benesch, *J. Am. Chem. Soc.*, 1955, 77, 5877.
8. A. G. Splittgerber and L. L. Chinander, *J. Chem. Ed.*, 1988, 65, 167.
9. D. L. Rabenstein, *J. Am. Chem. Soc.*, 1973, 95, 2792.
10. New Comprehensive Biochemistry Vol. 6, "*The Chemistry of Enzyme Action*", editor M. I. Page, Elsevier, Oxford. 1984, p158.
11. M. Charton, *Prog. Phys. Org. Chem.*, 1981, 13, 119.
12. S. Oae, N. Asai and K. Fujimori, *J. Chem. Soc., Perkin Trans. 2*, 1978, 571.
13. A. D. Allen and G. R. Schonbaum, *Can. J. Chem.*, 1961, 39, 947.
14. S. E. Aldred, D. L. H. Williams and M. Garley, *J. Chem. Soc., Perkin Trans. 2*, 1982, 777.
15. D. L. H. Williams, in "*Nitrosation*", Cambridge University Press, Cambridge, 1988, p 177 and references therein.

CHAPTER FIVE

Reactions of glyceryl trinitrate

5.1 Introduction

Although glyceryl trinitrate (GTN) has been used (over 100 years) for the treatment of angina, acute congestive heart failure and hypertensive emergencies, fundamental questions remain concerning its mode of action. However, one suggestion, as stated earlier (chapter one), has proposed that GTN owes its action to intracellular release of nitric oxide which then reacts with SH-containing compounds to form S-nitrosothiols. The S-nitrosothiols then activate cyclic GMP levels resulting in vasodilation.

5.1.1 Formation of S-nitrosocysteine

Ignarro and co-workers¹ claimed that GTN reacted with cysteine at near neutral pH in oxygen-free nitrogen atmosphere to give S-nitrosocysteine. This reaction was only observed in the pH range 6.5-7.5 and not in acidic and alkaline conditions. They proposed that the reaction involved initially the formation of nitrite ion from which nitric oxide was released and this then effected the nitrosation of cysteine to give S-nitrosocysteine. The explanation given for observing the formation of S-nitrosocysteine at near neutral pH only was that since the formation of nitrite ion is faster in alkaline conditions and the S-nitrosocysteine formation is faster in acid conditions, then it follows that the formation of S-nitrosocysteine from nitric oxide (released from nitrite ion) would occur at pH value conducive to both of the above reactions i.e. near neutral pH. It is very difficult to accept this proposition considering that nitric oxide has been found to be an ineffective nitrosating agent and also

the formation of nitric oxide from nitrite ion via the formation of nitrous acid is difficult to envisage given the chemistry involved. The proposal becomes more unconvincing considering that they found no evidence for the formation of S-nitrosothiol when GTN was reacted with other thiols.

However, on closer examination of the work one finds the reaction would be best interpreted as involving the nitrosation of SH group by the protonated form of nitrous acid. This interpretation is based on the fact that the amount of S-nitrosocysteine (maximum 6 umoles) formed is insignificant considering the amount of GTN (10 mmol) and cysteine (10 mmol) used and the small amount of S-nitrosocysteine formed may be due to very small amounts of nitrous acid being present at these pH values even though the pKa value of nitrous acid is 3.35 at 25°C.² Taking the pKa of nitrous acid into consideration, there is virtually no free nitrous acid in alkaline conditions and this would account for not finding any evidence for the formation of S-nitrosocysteine at pH values greater than 7.5. The explanation for not observing the formation of S-nitrosocysteine at pH values less than six is that at these pH values the reaction between GTN and cysteine does not give nitrite ion and thus there is no possibility of the presence of nitrous acid at these pH. Nevertheless, taking this interpretation into consideration one would expect a similar observation for the reaction of GTN with other thiols. As to why Ignarro and co-workers¹ did not observe the formation of S-nitrosothiol from the reaction of GTN and other thiols besides cysteine is unclear and confusing.

Similarly the interpretation of the reaction of sodium nitrite and cysteine in acid conditions to form S-nitrosocysteine was misinterpreted.¹ The reaction was interpreted as one involving the formation of nitric oxide (in the presence of hydrogen ion) which then effects the nitrosation of cysteine to form S-nitrosocysteine. However, this type of reaction has been established, by various research groups,³⁻⁶ as one involving the rate-limiting electrophilic attack by nitrous acidium ion (H_2NO_2^+) or nitrosonium ion (NO^+), and not nitric oxide, on the sulphur atom, followed by the rapid proton loss from the protonated thionitrite (Scheme 5.1).

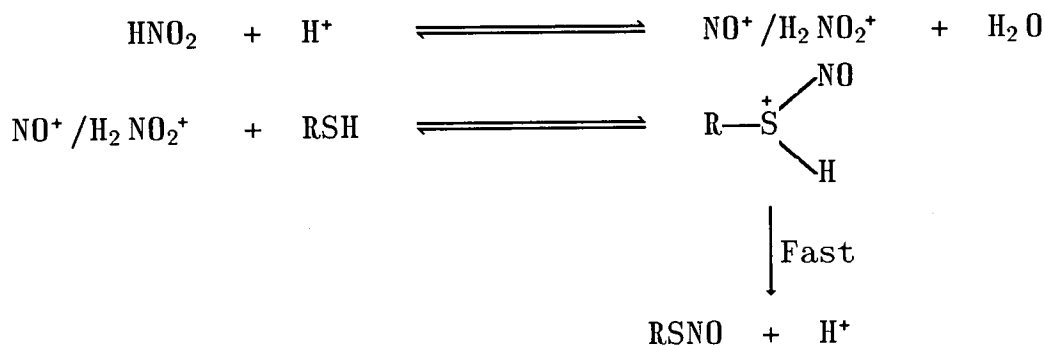

Scheme 5.1

A similar interpretation was used to explain the reaction of isoamyl nitrite with cysteine but as can be seen from chapters 2 to 4 Ignarro's interpretation is again incorrect.

5.1.2 Activation of guanylate cyclase

Guanylate cyclase (GTP pyrophosphate lyase) is an enzyme which catalyses the conversion of guanosine triphosphate (GTP) to guanosine 3',5'-monophosphate (cyclic GMP).⁷ It has been shown that GTN and sodium nitrite are very weak activators of soluble guanylate cyclase⁸⁻¹⁰ whereas nitric oxide and sodium nitroprusside are potent activators of soluble guanylate cyclase.^{11,12} However, it has been shown that the enzyme activation by GTN specifically requires the addition of cysteine, whereas the activation by sodium nitrite occurred in the presence of one of several thiols.¹³ The activation of guanylate cyclase by GTN in the presence of cysteine has been attributed to the reaction between nitric oxide, formed from GTN, and cysteine to form S-nitrosocysteine. This has been shown to be a potent activator of unpurified guanylate cyclase in the absence of added thiols.^{13,14-17} The activation of guanylate cyclase by S-nitrosothiols was found to be inhibited by methylene blue¹⁴⁻¹⁷ and this effect was also observed when nitric oxide was used to activate the enzyme.⁹ In the cases of nitric oxide, nitroprusside and sodium nitrite, the addition of thiols were found to enhance the activity of unpurified guanylate cyclase.¹⁵

Carven and DeRubertis¹⁸ initially reported that partially purified hepatic guanylate cyclase required the presence of haem for the activation of the enzyme by nitric oxide and nitrogen oxide-containing compounds. This suggestion was based on the finding that guanylate cyclase was insensitive to activation by nitric oxide and nitrogen oxide-containing compounds but this insensitivity was reversed by the

addition of haemoproteins. This suggestion has recently been substantiated by the findings that soluble guanylate cyclase purified from bovine lung in a form that is haem-deficient required the addition of haem in order to observe enzyme activation by nitric oxide, S-nitroso-N-acetylpenicillamine and nitrogen oxide-containing compounds but it was markedly activated by nitrosyl-haem complex (NO-haem) and protoporphyrin IX.¹⁹⁻²¹ Soluble guanylate cyclase, containing haem, purified from bovine lung was markedly activated by all of the above compounds in the absence of added haem. Similarly, a haem-deficient guanylate cyclase reconstituted with haem was markedly activated by all of the above compounds.

On the basis of these observations and the premise that nitric oxide react with thiols to give S-nitrosothiols Ignarro and co-workers suggested that S-nitrosothiols may be responsible for guanylate cyclase activation by nitric oxide and other nitrogen oxide-containing vasodilators.

5.1.3 Nitric oxide the endothelium-derived relaxing factor

Endothelial cells were first discovered by Furchgott²² to be obligatory in bringing about the relaxation of isolated arteries by acetylcholine. Since then several experiments carried out on isolated arteries from various species have confirmed that the presence of endothelial cells is indeed a prerequisite for bring about relaxation by acetylcholine, other neurohormonal substance, hormones and antacoids. These findings have also been confirmed in intact organisms.²³⁻²⁶

It is thought that the degree of contraction of the underlying smooth muscle by endothelial cells, when stimulated by acetylcholine (or other endothelium-dependent relaxing agent), is controlled by the release of vasodilator and/or vasoconstrictor substances. This belief has been substantiated by bioassay studies carried out on the endothelial cells from isolated blood vessels^{22,27,28} and also from the finding that endothelial cells in culture maintain the ability to produce the relaxing substance.^{29,30} The substance produced by the endothelial cells was termed by Furchgott as the endothelium-derived relaxing factor (EDRF).

Since the discovery of EDRF, it has been found to stimulate soluble guanylate cyclase of vascular smooth muscles and this results in an increase in the level of cyclic GMP.²³⁻²⁵ These are thought to be responsible for the sustained endothelium-dependent relaxation caused by acetylcholine (and other endothelium relaxants). Furthermore, studies demonstrated that EDRF was a labile humoral agent, with an extremely short half-life and was readily degraded by superoxide anions.^{27,28,30,31} However, not until very recently was it suggested by Furchgott³² that it was nitric oxide. This suggestion was substantiated by the findings of Palmer and co-workers.³³ They found that nitric oxide released from endothelial cell was indistinguishable from EDRF in terms of biological activity, stability and susceptibility to an inhibitor and to a potentiator. Thus it may be possible that nitrovasodilators which act by releasing nitric oxide can mimic the effects of EDRF.

A feasibility study of the reaction of GTN and cysteine to form S-nitrosocysteine and the possibility of forming nitric oxide from GTN was investigated and results presented below. Unfortunately, only a preliminary investigation was undertaken due to the constraint of time.

5.2 Extraction of GTN from lactose adsorbate

GTN was obtained as a 10% adsorbate on lactose (a gift from Glaxo Research Group Ltd.) and it was extracted from lactose by using diethyl ether as an extracting solvent. This was achieved by adding diethyl ether (50 ml) to the powder (5g) and continuously shaking the mixture for 10 minutes. The mixture was then filtered and the eluent collected and left standing overnight in a fume cupboard. The GTN obtained was then dissolved in 10% ethanol/distilled water mixture.

5.3 Reactions with cysteine in acid and base conditions

The possibility of S-nitrosation of cysteine by GTN under both acid and base conditions was investigated. A study was carried out using varying concentration of cysteine ($2 \rightarrow 20 \times 10^{-2} \text{M}$) and glyceryl trinitrate ($1 \rightarrow 2 \times 10^{-4} \text{M}$). In the acid conditions the concentration of perchloric acid used was also varied, whilst in the base conditions the reaction was investigated in the pH range 6-13.

In all the case investigated there was no evidence of the formation of S-nitrosocysteine. That is there was no broad peak at λ_{max} 330nm on the U.V./visible spectrum of the solution and also there was no yellow colour development

which is characteristic of S-nitrosothiols (thionitrite) species in solution.³⁴ However, when reactions were carried out under basic and neutral conditions a white precipitate was observed. This was isolated and characterised as the disulphide, cystine by I.R. and elemental analysis. The rate of formation of the disulphide was found to vary with pH and concentration of cysteine. It was found to be much (approx. 10 times) faster than the aerial oxidation of cysteine which occurred after approximately 10 hours. Thus it may be concluded that GTN oxidises cysteine to cystine whilst GTN itself undergoes reduction. The mechanism of this reaction is still uncertain since a kinetic study of the reaction could not be carried out due to the difficulties in finding an appropriate method for determining, quantitatively, the formation of precipitate.

A similar reaction was observed by Heppel and Hilmo³⁵ who found that reduced glutathione underwent a spontaneous reaction with GTN to give inorganic nitrite and oxidised glutathione. The reaction between GTN and reduced glutathione can be enzymically catalysed, is pH-dependent, and during this process 2 moles of reduced glutathione are oxidised for every mole of nitrite produced. The enzyme which catalyses the reaction is known as organic nitrate reductase or more correctly as glutathione: polyolnitrate oxidoreductase.³⁶ The most popular theory which accounts for the denitration of GTN by reaction with glutathione assumes the initial reduction of the nitrate group to a nitrite with the oxidation of glutathione to the disulphide (GSSG) and then the spontaneous hydrolysis of the organic nitrite group to give a partially denitrated product and

inorganic nitrite (Scheme 5.2).

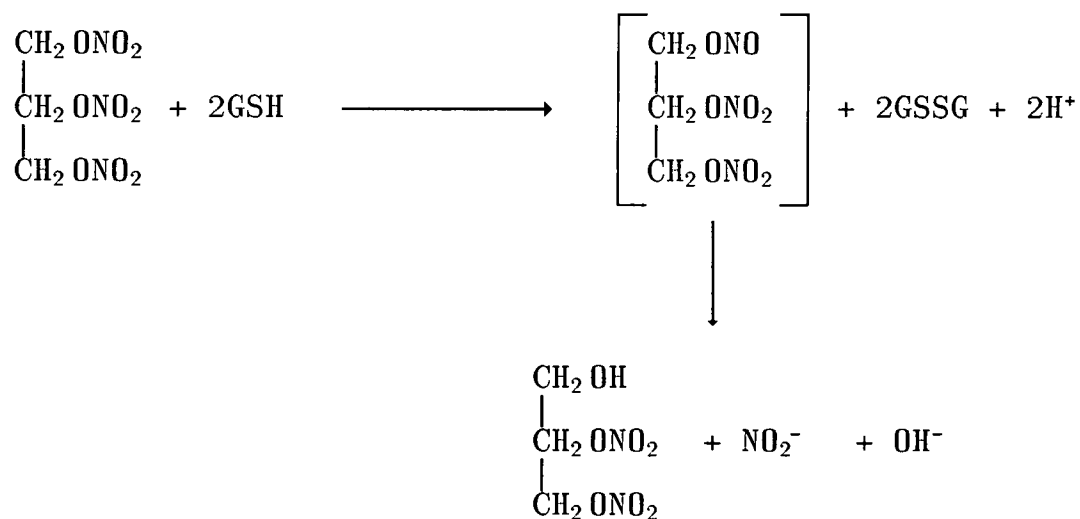

Scheme 5.2

It also assumes that the reduction occurs prior to hydrolysis because direct hydrolysis would give rise to nitrate ion which cannot be reduced to inorganic nitrite under the conditions of the reaction. However, the theory assumes the formation of an intermediate organic nitrite species whose existence has never been demonstrated during these studies. Thus the scheme although plausible lacks conclusive proof. Nevertheless, it could be used to explain the formation of cystine when GTN is reacted with cysteine in neutral and basic conditions.

The formation of nitrite ion in the above reactions was confirmed by diazotisation of sulphanilamide (4-amino-benzenesulphonamide) under acidic conditions and then coupling the product with N-(1-naphthyl)-ethylenediamine dihydrochloride by the procedure described by Vogel.³⁷

In all of the cases studied (base conditions) the formation of NO_2^- was confirmed using the above procedure.

5.4 Reactions in nitrogen atmosphere

Since the only difference between the above reactions and those carried out by Ignarro and co-workers¹ is that the reactions were carried out in oxygen atmosphere instead of an oxygen-free nitrogen atmosphere, it was decided to repeat the reactions in section 5.2 but this time in exactly the same conditions as those used by Ignarro and co-workers.¹

The solutions of GTN and cysteine were flushed with oxygen-free nitrogen, in a glove-box, for approximately forty minutes. The solutions were mixed and a sample of the solution was placed in a U.V. quartz cell and sealed using labfilm. Then U.V./visible scans (600nm-190nm) of the solution were taken at intervals of 5 mins for two hours. However, in all the cases studied no evidence of the formation of S-nitrosocysteine was observed. The reaction solution was tested for the presence of nitrite ion by the same procedure as described before. In all the cases studied the formation of nitrite ion was confirmed.

5.5 Determination of nitric oxide

As Ignarro's hypothesis is based on nitric oxide being the effective nitrosating agent it was decided to investigate the possibility of nitric oxide being formed from GTN itself or from the reaction of GTN and cysteine in neutral and basic conditions.

The reaction of GTN ($3 \times 10^{-3}M$) with cysteine ($1 \times 10^{-2}M$) in oxygen-free nitrogen atmosphere in the pH range 6-13 was carried out in a round-bottomed flask, attached with a tap-stopper, for one hour. Whether or not nitric oxide was formed in the reaction was investigated by analysing the vapour in the mass spectrometer. This was achieved by freezing and thawing out the solution several times and then finally freezing the solution and eluting the vapour into the mass spectrometer. As can be seen from the mass spectrum, of the reaction of GTN with cysteine at pH 7.5 (Figure 5.1), that there is no evidence of the formation of nitric oxide in this reaction. Similar results were obtained for the reactions carried out at various pH's in the pH range 6-13.

Figure 5.1 Mass spectrum for the reaction of GTN and cysteine in nitrogen atmosphere at pH 7.5

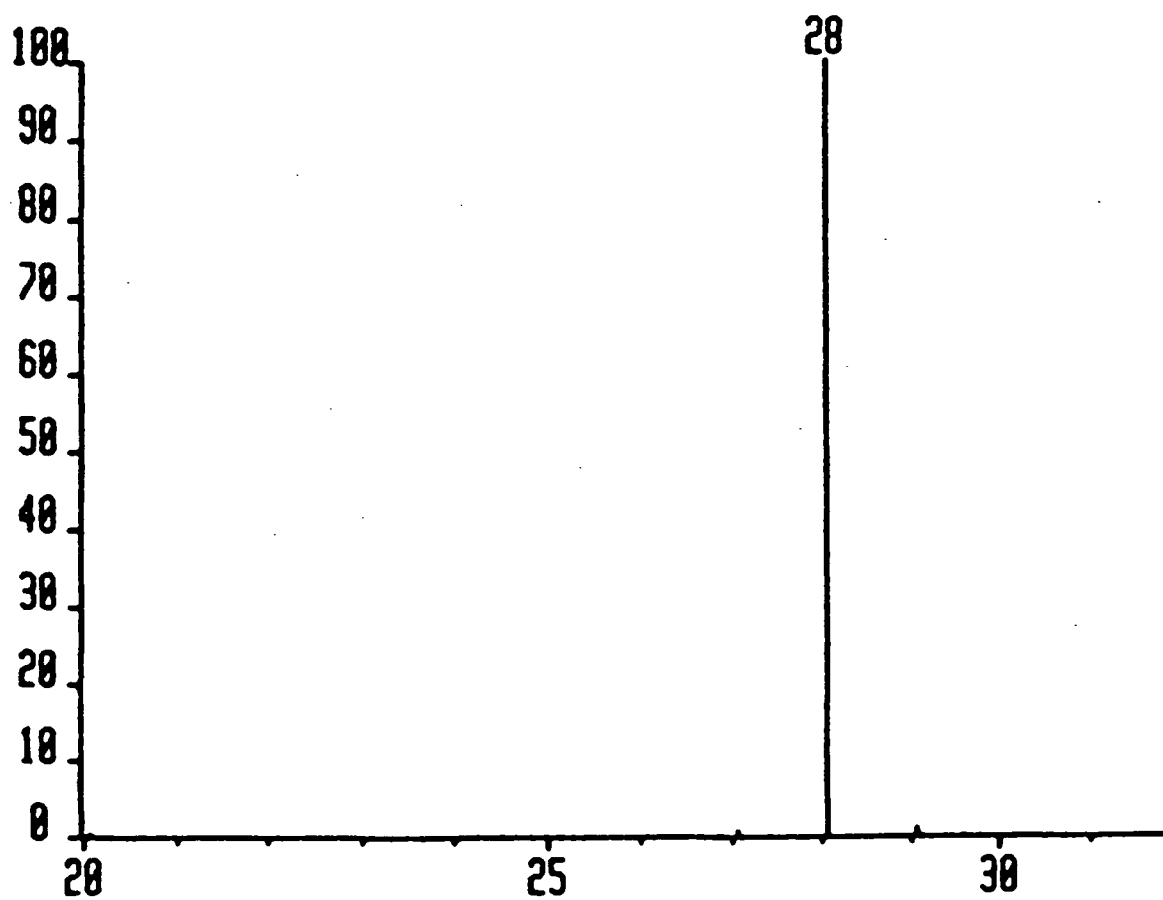

5.6 Discussion

In no case was there any evidence for the formation of S-nitrosocysteine from the reaction of GTN and cysteine. It was found that GTN is denitrated in the presence of cysteine, in oxygen-free nitrogen atmosphere, to release nitrite ion but in oxygen atmosphere the reaction involves the oxidation of cysteine to cystine and the reduction of GTN to nitrite ion plus other products. The results are inconsistent with those found by Ignarro and co-workers¹ except for the formation of nitrite ion. The question that arises from this is whether or not GTN owes its vasodilatory action to the formation of the intermediate, S-nitrosocysteine. The biological studies involving S-nitrosothiols do support the hypothesis that it can be an intermediate. However, the hypothesis centres on the formation of nitric oxide from the vasodilators (which is considered to be the effective nitrosating agent of tissue bound thiols) but it has been shown that nitric oxide is not formed from GTN in the presence or absence of cysteine at any pH within the pH range 6-13. Thus it seems from the preliminary studies carried out that GTN does not owe its action to the formation of S-nitrosothiol whereas the vasodilatory action of organic nitrites may be due to the formation of S-nitrosothiols. The reaction of the organic nitrites with thiols is not one involving nitric oxide, as proposed by Ignarro and co-workers,¹ but one involving the direct reaction of the organic nitrite with the thiolate ion of the thiol.

Having concluded that GTN does not owe its vasodilatory action to the formation of the intermediate S-nitrosothiol

one can hypothesise as to the possible mechanism of the action of GTN using the information derived from the preliminary study carried out and that derived from the literature. One of the possibilities is that GTN may owe its action to the formation of the disulphide from the reaction of GTN and thiol. It is generally believed that the oxidation-reduction reactions involving -SH groups govern the guanylate cyclase activity and the transformation of -SH to S-S is the potential mechanism of enzyme activation.³⁸⁻⁴¹ Thus the formation of the disulphide cystine from the reaction of GTN and cysteine in an oxygen atmosphere would cause the activation of guanylate cyclase and in turn increase the level of cyclic GMP and thus induce vasodilation. This theory could also be used to explain the vasodilatory effect of organic nitrites. In this case the mechanism would involve the nitrosation of the thiolate ion to form S-nitrosothiol which being unstable would decompose to give the disulphide and nitric oxide (equation 5.1).³⁴



The disulphide and nitric oxide would then cause the activation of the enzyme guanylate cyclase and thus induce vasodilation. However, recent studies carried out on partially purified hepatic soluble guanylate cyclase indicate that the disulphide instead of activating the enzyme actually inhibits it.^{14,16,42} Thus the hypothesis of the formation of the disulphide in the vasodilatory action of organic nitrites and nitrates should be viewed with

caution. The other possibility is that GTN may owe its action to the formation of nitric oxide. Although it has been shown that nitric oxide is not released from GTN or GTN plus cysteine in *in vitro* reactions, it may be possible that nitric oxide is released in *in vivo* reactions due to the action of an enzyme of the environment. If this is the case then it would account for the vasodilatory action of GTN since it has been observed that nitric oxide activates the enzyme guanylate cyclase in the absence of thiols but in the presence of haem.

In conclusion one can only say that more experimentation, especially on the possibility of the release of nitric oxide from GTN, is necessary to elucidate fully the mechanism by which GTN induces vascular smooth muscle relaxation.

References

1. L. J. Ignarro, H. Lippton, J. C. Edwards, W. H. Baricos, A. L. Hyman, P. J. Kadowitz and C. A. Gruetter, *J. Pharmacol. Exp. Ther.*, 1981, 218, 739.
2. M. Schumann, *Chem. Ber.*, 1900, 33, 527.
3. P. Collings, K. Al-Mallah and G. Stedman, *J. Chem. Soc., Perkin Trans. 2*, 1975, 1736.
4. L. R. Dix and D. L. H. Williams, *J. Chem. Soc., Perkin Trans 2*, 1984, 109.
5. P. A. Morris and D. L. H. Williams, *J. Chem. Soc., Perkin Trans 2*, 1988, 513.
6. J. Casado, F. M. Lorenzo, M. Mosquera and M. F. R. Prieto, *J. Chem. Soc., Perkin Trans 2*, 1985, 1859.
7. H. Kimura, C. K. Mittal and F. Murad, *Nature*, 1975, 257, 700.
8. S. Katsuki, W. Arnold, C. Mittal and F. Murad, *J. Cyclic Nucleotide Res.*, 1977, 3, 23.
9. W. P. Arnold, C. K. Mittal, S. Katsuki and F. Murad, *Proc. Natl. Acad. Sci. U.S.A.*, 1977, 74, 3203.
10. C. A. Gruetter, D. Y. Gruetter, B. K. Barry, P. J. Kadowitz and L. J. Ignarro, *The Pharmacologist*, 1979, 21, 247.
11. K. D. Schultz, K. Schultz and G. Schultz, *Nature*, 1977, 265, 750.
12. C. A. Gruetter, B. K. Barry, D. B. McNamara, D. Y. Gruetter, P. J. Kadowitz and L. J. Ignarro, *J. Cyclic Nucleotides Res.*, 1979, 5, 211.
13. L. J. Ignarro and C. A. Gruetter, *Biochim. Biophys. Acta*, 1980, 631, 221.
14. L. J. Ignarro, B. K. Barry, D. Y. Gruetter, J. C. Edwards, E. H. Ohlstein, C. A. Gruetter and W. H. Baricos, *Biochem. Biophys. Res. Commun.*, 1980, 94, 93.
15. L. J. Ignarro, J. C. Edwards, D. Y. Gruetter, B. K. Barry and C. A. Gruetter, *FEBS Lett.*, 1980, 110, 275.
16. L. J. Ignarro, P. J. Kadowitz and W. H. Baricos, *Arch. Biochem. Biophys.*, 1981, 208, 75.
17. L. J. Ignarro, B. K. Barry, D. Y. Gruetter, E. H. Ohlstein, C. A. Gruetter, P. J. Kadowitz and W. H. Baricos, *Biochim. Biophys. Acta*, 1981, 673, 394.
18. P. A. Craven and F. R. DeRubertis, *J. Biol. Chem.*, 1978, 253, 8433.

19. E. H. Ohlstein, K. S. Wood and L. J. Ignarro, *Arch. Biochem. Biophys.*, 1982, 218, 187.
20. L. J. Ignarro, J. N. Degnan, W. H. Baricos, P. J. Kadowitz and M. S. Wolin, *Biochim. Biophys. Acta*, 1982, 718, 49.
21. R. Gerzer, F. Hofmann and G. Schultz, *Eur. J. Biochem.*, 1981, 116, 479.
22. R. F. Furchgott and J. V. Zawadzki, *Nature*, 1980, 288, 373.
23. R. F. Furchgott, *Circ. Res.*, 1983, 53, 557.
24. M. J. Peach, *Hypertension*, 1985, 7, 194.
25. P. M. Vanhoutte, *Rev. Physiol*, 1986, 48, 307.
26. P. M. Vanhoutte, *New Pharmac. Sci.*, 1987, 2, 18.
27. T. M. Griffith, *Nature*, 1984, 308, 645.
28. G. M. Rubanyi, R. R. Lorenz and P. M. Vanhoutte, *Am. J. Physiol.*, 1985, 249, H95.
29. R. M. J. Palmer, A. G. Ferridge and S. Moncada, *Nature*, 1986, 327, 524.
30. R. J. Gryglewski, R. M. J. Palmer and S. Moncada, *Nature*, 1986, 320, 454.
31. G. M. Rubanyi and P. M. Vanhoutte, *Am. J. Physiol*, 1985, 250, H815.
32. R. F. Furchgott, in "*Mechanism of Vasodilation*", Raven, New York, 1987, and references therein.
33. R. M. J. Palmer, A. G. Ferridge and S. Moncada, *Nature*, 1987, 327, 524.
34. D. L. H. Williams, *Adv. Phys. Org. Chem.*, 1983, 19, 381 and references therein.
35. L. A. Heppel and R. J. Hilmo, *J. Biol. Chem.*, 1950, 183, 129.
36. P. Needleman and F. E. Hunter, *Mol. Pharmacol.*, 1965, 1, 77.
37. A. I. Vogel, in "*Textbook of Quantitative Inorganic Analysis*", 4th edition, Longman Group Ltd., London, 1978, and references therein
38. N. D. Goldberg and M. K. Haddox, *Annu. Rev. Biochem.*, 1977, 46, 337.

39. F. R. DeRubertis and P. A. Craven, *Biochim. Biophys. Acta*, 1977, 499, 337.
40. P. A. Craven and F. R. DeRubertis , *Biochim. Biophys. Acta*, 1977, 524, 231.
41. A. A. White, K. M. Crawford, C. S. Patt and P. J. Lad, *J. Biol. Chem.*, 1976, 251, 7304.
42. S. Katsuki, W. Arnold, C. Mittal and F. Murad, *J. Cyclic Nucleotide Res.*, 1977, , 23.

CHAPTER SIX

Experimental details

6.1 Experimental techniques used

Both conventional U.V./visible spectrophotometry and stopped-flow spectrophotometry were used for the determination of rate constants quoted in this thesis.

6.1.1 U.V./visible spectrophotometry

Rate measurements for the nitrosation of thiols by isopropyl nitrite, isoamyl nitrite and t-butyl nitrite in basic conditions (except those with half-life less than 10 seconds) were carried out by using either Perkin Elmer Lambda 3 or Philips PU8720 spectrophotometers.

Stock solution of the thiols and alkyl nitrite were made up in the appropriate buffer and thermostated in a water bath at 25⁰C. The required amount of the alkyl nitrite solution was added to the thiol solution (total volume 5ml) and after rapid mixing, a portion of the reaction mixture was transferred to a 1cm quartz cell and placed in a thermostated cell holder of the spectrophotometer. An identical cell containing the solvent was used as the reference. The difference in absorbance between the sample and reference cell was then monitored as a function of time.

6.1.2 Stopped-flow spectrophotometry

Rate measurements for the nitrosation of thiols by isopropyl nitrite in acid conditions and by various alkyl nitrites in basic conditions (except those with half-lives greater than 10 seconds) were carried out using a HI-TECH Scientific SF-3 series stopped-flow spectrophotometer. This is shown schematically in Figure 6.1.

Figure 6.1 Schematic Diagram of a Stopped-Flow Spectrophotometer

T = three way taps

M = mixing point

O = observation point

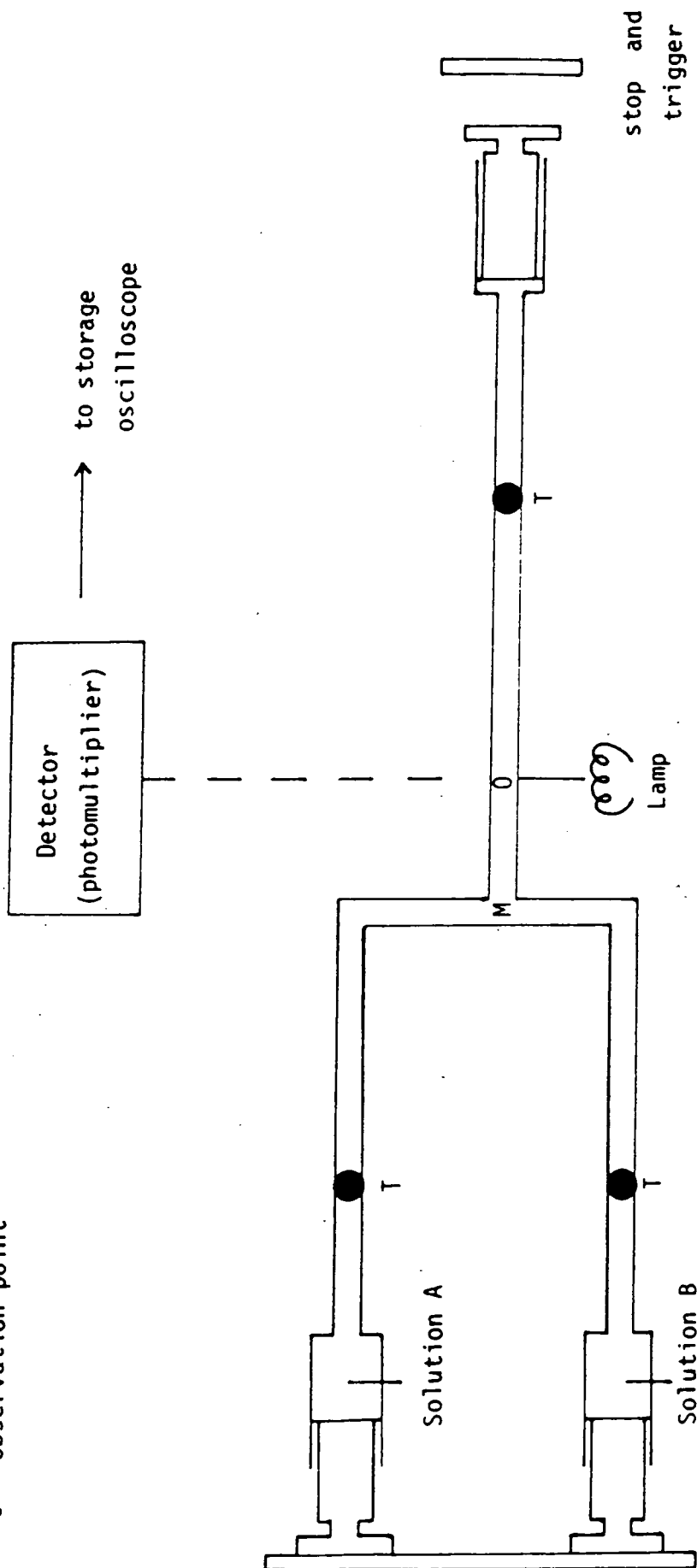

The two solutions, A and B (one normally being the alkyl nitrite and other containing all the other components of the reaction), are stored in reservoirs and from there enter two identical syringes. A single piston drives the two syringes so that equal volumes of each solution are mixed. On mixing, the concentration of each reactant present is halved. The reaction solution then flows into a third syringe. On filling, the plunger of this syringe is forced against a stop which halts the flow and at the same time the trigger which starts the monitoring of the reaction.

The reaction is followed by using a beam of monochromatic light which passes through the cell. The intensity of the beam is converted to an electrical signal and amplified by a photomultiplier, which has a voltage of approximately -6 volts across it. If this signal were to be used, the change in voltage due to the reaction proceeding would appear as a very small voltage change superimposed on the photomultiplier's standing output voltage, so an equal but opposite voltage is added to the standing voltage (biasing) allowing amplification by the recording equipment of the voltage change only. Therefore with just a non-absorbing solution at the observation point the final voltage is zero and any voltage change observed results from the progression of the reaction. The voltage changes were recorded and analysed to give the rate constant, by an Apple IIe microcomputer by either running a kinetic analysis program supplied by "HITECH" (via a fast analogue to digital converter) or by using the First-Order Rate Constant Evaluation (FORCE) program, written by Mr. C. Greenhalgh.

6.2 pH Measurements

All pH measurements were carried out using a PTI-6 Universal digital pH meter (accurate to ± 0.02 pH units).

6.3 Determination of the observed rate constant

The nitrosation of thiols by alkyl nitrites in acid and basic conditions were carried out under first-order conditions and the reactions were followed by monitoring the rate of appearance of the product with time.

For first-order reaction $R \longrightarrow P$ (where R is the reactant and P is the product) the rate of formation of the product or the rate of the disappearance of the reactant can be expressed by the equation 6.1.

$$-\frac{dR}{dt} = \frac{dP}{dt} = k [R] \quad (6.1)$$

Integrating equation 6.1 gives the expression for the observed first-order rate constant (equation 6.2).

$$k_o = \frac{1}{t} \ln \frac{[R]_o}{[R]_t} \quad (6.2)$$

Where $[R]_o$ and $[R]_t$ are the concentrations of the reactants at time $t = 0$ and $t = t$ respectively.

Using Beer-Lamberts law $A = \epsilon Cl$ (where A is the absorbance, ϵ is the molar extinction coefficient, C is the concentration and l is the pathlength) and assuming that the pathlength of the cell is 1cm the expression of the absorbance at time $t = 0$ and $t = t$ can be derived (equations 6.3 and 6.4).

$$A_0 = \epsilon_R [R]_0 \quad (6.3)$$

$$A_t = \epsilon_R [R]_t + \epsilon_P [P]_t \quad (6.4)$$

Since $[P]_t = [R]_0 - [R]_t$ substituting for $[P]_t$ into equation 6.4 gives:

$$A_t = \epsilon_R [R]_t + \epsilon_P ([R]_0 - [R]_t) \quad (6.5)$$

$$A_t = \epsilon_R [R]_t + \epsilon_P [R]_0 - \epsilon_P [R]_t \quad (6.5)$$

But $A_\infty = \epsilon_P [R]_0 = \epsilon_P [P]_\infty$ Since $[P]_\infty = [R]_0$

$$\text{Thus: } (A_t - A_\infty) = \epsilon_R [R]_t - \epsilon_P [R]_t$$

$$[R]_t = \frac{(A_t - A_\infty)}{(\epsilon_R - \epsilon_P)} \quad (6.6)$$

Similarly:

$$A_0 = \epsilon_R [R]_0$$

$$\text{and } A_\infty = \epsilon_P [P]_\infty = \epsilon_P [R]_0$$

$$(A_0 - A_\infty) = \epsilon_R [R]_0 - \epsilon_P [R]_0$$

$$[R]_0 = \frac{(A_0 - A_\infty)}{(\epsilon_R - \epsilon_P)} \quad (6.7)$$

Substituting equation 6.6 and 6.7 into equation 6.2 gives:

$$k_0 = \frac{1}{t} \ln \frac{(A_0 - A_\infty)}{(A_t - A_\infty)} \quad (6.8)$$

Rearranging equation 6.8 gives:

$$\ln (A_t - A_\infty) = -k_0 t + \ln (A_0 - A_\infty) \quad (6.9)$$

Therefore a plot of $\ln (A_t - A_\infty)$ or $\ln (A_\infty - A_t)$ versus t should be linear with a slope of $-k_0$. The infinity values, A_∞ , was determined after a period of ten half-lives and the appearance of absorbance was followed for at least two half-lives.

For experiments carried out using the stopped-flow technique the value was determined using the "FORCE" or "HITECH" kinetics program. The "FORCE" program calculates the value of k_0 from the slope of a plot of $\ln(V_\infty - V_t)$ versus time, t , where V is the output signal voltage, and under the experimental conditions used the voltage is proportional to the absorbance. In this case a linear regression combined with least squares fit method is used to calculate the value of k_0 . However, the "HITECH" program initially calculates the value of k_0 from the slope of a calculated plot of $\ln(V_\infty - V_t)$ versus time, then optimises this value iteratively, using non-linear regression analysis thus removing some of the errors inherent in using linear regression methods.

Owing to the errors in measuring fast reactions, the value of k_0 quoted for these reactions is the mean of at least five separate determinations and the error quoted is the standard deviation between the individual k_0 values.

6.4 Chemical reagents

All the alkyl nitrites used were prepared by the method of Noyes.¹ This preparation involves O-nitrosation of the alcohol by nitrous acid which is generated in situ from sodium nitrite and concentrated sulphuric acid (equation 6.10).

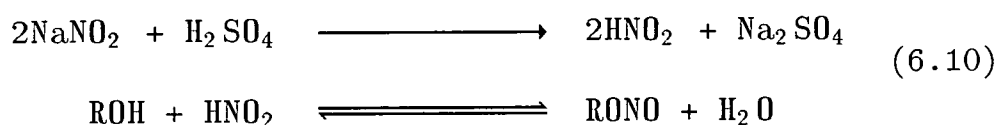

The reaction is carried out at 0°C in an ice bath and the alkyl nitrite separated from the aqueous layer and subsequently purified by fractional distillation (under reduced pressure for t-butyl nitrite). The sample is then analysed by n.m.r./U.V. and stored in the dark at 0-4°C. The alcohols, sodium nitrite and concentrated sulphuric acid used in these reactions were commercially available and used as supplied.

All the thiols used were purchased commercially and used as supplied.

The solutions of perchloric acid were prepared by diluting the required amount of 60-62% perchloric acid solution with distilled water. The acid solutions were then standardised against standard sodium hydroxide solution

using phenolphthalein indicator.

The salts, potassium hydrogen phthalate, potassium dihydrogen orthophosphate, borax and disodium hydrogen orthophosphate, used for preparing buffer solutions were purchased commercially and used as supplied.

6.5 Kinetic Measurements

6.5.1 Nitrosation of thiols by isopropyl nitrite in acid solution

The rate measurements were carried out using a HI-TECH Scientific SF-3 series stopped-flow spectrophotometer. The reaction was started, as explained earlier, by mixing together equal amounts of the two solutions, one containing $i\text{PrONO}$, the other containing the thiol and acid and $i\text{PrOH}$ where appropriate. The reaction was followed by monitoring the increase in absorbance at 330 nm due to the formation of the S-nitrosothiol. The conditions used were such that the concentrations of all the other species were in excess of the alkyl nitrite concentration, and good first order plots of $\ln(V_{\infty} - V_t)$ versus time were obtained. Typical kinetic runs for each of the thiols studied are shown in tables 6.1-6.5. Table 6.6 shows a typical set of individual k_0 values from which the mean k_0 value was determined.

Table 6.1 Nitrosation of Cysteine by $i\text{PrONO}$

$$[i\text{PrONO}] = 1 \times 10^{-4}\text{M} \quad [\text{HClO}_4] = 5.2 \times 10^{-2}\text{M}$$

$$[\text{Cys}] = 3.2 \times 10^{-2}\text{M}$$

V_t/mV	t/s	k_0/s^{-1}
194.7	0	—
219	0.5	.519
238	1.0	.523
253	1.5	.530
264	2.0	.528
273	2.5	.534
279	3.0	.525
284	3.5	.524
288	4.0	.525
291	4.5	.525
301	∞	—

$$k_0 = .526 \pm .004 \text{ s}^{-1}$$

Table 6.2 Nitrosation of L-cysteine methyl ester by $i\text{PrONO}$

$$[i\text{PrONO}] = 1 \times 10^{-4}\text{M} \quad [\text{HClO}_4] = 36.5 \times 10^{-2}\text{M}$$

$$[\text{MeCys}] = 1.36 \times 10^{-2}\text{M}$$

V_t/mV	t/s	k_0/s^{-1}
86.7	0	—
198.0	0.2	1.220
273.0	0.4	1.238
328.4	0.6	1.220
375.4	0.8	1.236
411.8	1.0	1.238
440.8	1.2	1.261
461.7	1.4	1.258
535.8	∞	—

$$k_0 = 1.239 \pm .016 \text{ s}^{-1}$$

Table 6.3 Nitrosation of L-cysteine ethyl ester by ⁱPrONO

$$[{}^i\text{PrONO}] = 1 \times 10^{-4} \text{ M}$$

$$[\text{HClO}_4] = 27.37 \times 10^{-2} \text{ M}$$

$$[\text{EtCys}] = 1.41 \times 10^{-2} \text{ M}$$

V_t/mV	t/s	k_0/s^{-1}
45.4	0	—
189.9	0.2	.927
281.0	0.4	.927
338.0	0.6	.925
374.1	0.8	.926
396.8	1.0	.926
411.1	1.2	.927
420.0	1.4	.925
389.9	∞	—

$$k_0 = .926 \pm .0009 \text{ s}^{-1}$$

Table 6.4 Nitrosation of N-acetyl-L-cysteine by ⁱPrONO

$$[{}^i\text{PrONO}] = 1 \times 10^{-4} \text{ M}$$

$$[\text{HClO}_4] = 36.5 \times 10^{-2} \text{ M}$$

$$[\text{N-Ac-Cys}] = 4.06 \times 10^{-2} \text{ M}$$

V_t/mV	t/s	k_0/s^{-1}
4.4	0	—
127.1	.02	21.46
207.0	.04	21.46
259.0	.06	21.46
292.8	.08	21.47
314.9	.10	21.46
329.2	.12	21.45
338.6	.14	21.47
356.0	∞	—

$$k_0 = 21.46 \pm .007 \text{ s}^{-1}$$

Table 6.5 Nitrosation of glutathione by $i\text{PrONO}$

$$[i\text{PrONO}] = 1 \times 10^{-4}\text{M}$$

$$[\text{HClO}_4] = 36.5 \times 10^{-2}\text{M}$$

$$[\text{GSH}] = 4.08 \times 10^{-2}\text{M}$$

V_t/mV	t/s	k_0/s^{-1}
77.8	0	—
204.0	.02	16.67
296.0	.04	16.65
361.0	.06	16.63
408.0	.08	16.55
441.2	.10	16.61
465.3	.12	16.61
482.6	.14	16.61
526.4	∞	—

$$k_0 = 16.62 \pm .04 \text{ s}^{-1}$$

Table 6.6 A typical set of duplicate runs.

The concentrations of the reagents are the same as in table 6.5

Run	k_0/s^{-1}
1	16.61
2	16.63
3	16.62
4	16.65
5	16.60

$$k_0 = 16.62 \pm .02 \text{ s}^{-1}$$

6.5.2 Nitrosation of thiols by alkyl nitrites in basic conditions

The rate measurements were carried out using one of the following: HI-TECH Scientific SF-3 series stopped-flow spectrophotometer, Perkin Elmer Lambda 3 spectrophotometer or Philips PU8720 spectrophotometer. The reaction was started by mixing the appropriate amount of the thiol solution with the alkyl nitrite solution. The reaction was followed by monitoring the increase in absorbance at 330nm due to the formation of S-nitrosothiol. The conditions used were such that the concentration of the thiol was in excess of the alkyl nitrite concentration and good first-order plots of $\ln(V_{\infty} - V_t)$ versus time were obtained. Typical kinetic runs for each of the thiols studied are shown in tables 6.7-6.12. Table 6.13 shows a typical set of individual k_0 values from which the mean k_0 value is determined.

Table 6.7 Nitrosation of Cysteine by i PrONO at pH 7.0

$$[i\text{PrONO}] = 1 \times 10^{-4} \text{M}$$

$$[\text{CYS}] = 5.2 \times 10^{-2} \text{M}$$

A_t	t/s	k_0/s^{-1}
.314	0	—
.347	4	.0254
.372	8	.0232
.396	12	.0228
.418	16	.0227
.439	20	.0227
.458	24	.0228
.656	∞	—

$$k_0 = .0233 \pm .001 \text{ s}^{-1}$$

Table 6.8 Nitrosation of L-Cysteine methyl ester by ^tBuONO at pH 8.5

$$[{}^t\text{BuONO}] = 1 \times 10^{-4} \text{ M}$$

$$[\text{MeCys}] = 10.0 \times 10^{-2} \text{ M}$$

A_t	t/s	k_0/s^{-1}
.134	0	—
.149	4	.0492
.159	8	.0442
.168	12	.0432
.176	16	.0433
.183	20	.0438
.189	24	.0443
.193	28	.0433
.198	32	.0448
.201	36	.0444
.218	∞	—

$$k_0 = .0445 \pm .002 \text{ s}^{-1}$$

Table 6.9 Nitrosation of L-Cysteine ethyl ester by ⁱAmONO at pH 6.0

$$[{}^i\text{AmONO}] = 1 \times 10^{-4} \text{ M}$$

$$[\text{EtCys}] = 2.02 \times 10^{-2} \text{ M}$$

A_t	t/s	k_0/s^{-1}
.273	0	—
.336	10	.0165
.388	20	.0162
.438	30	.0169
.473	40	.0164
.505	50	.0164
.532	60	.0163
.556	70	.0164
.575	80	.0163
.688	∞	—

$$k_0 = .0164 \pm .0002 \text{ s}^{-1}$$

Table 6.10 Nitrosation of N-acetyl-L-Cysteine by $\text{Br}(\text{CH}_2)_2\text{ONO}$ at pH 10.0

$$[\text{Br}(\text{CH}_2)_2\text{ONO}] = 1 \times 10^{-4} \text{ M}$$

$$[\text{N-Ac-Cyst}] = 7.86 \times 10^{-2} \text{ M}$$

V_t/mV	t/s	k_0/s^{-1}
111.2	0	—
297.9	.01	53.40
407.0	.02	53.30
471.5	.03	53.40
509.0	.04	53.35
531.0	.05	53.30
544.1	.06	53.42
552.0	.07	53.86
562.4	∞	—

$$k_0 = 53.43 \pm .19 \text{ s}^{-1}$$

Table 6.11 Nitrosation of glutathione by $\text{C}_2\text{H}_5\text{O}(\text{CH}_2)_2\text{ONO}$ at pH 9.2

$$[\text{C}_2\text{H}_5\text{O}(\text{CH}_2)_2\text{ONO}] = 1 \times 10^{-4} \text{ M}$$

$$[\text{GSH}] = 3.99 \times 10^{-2} \text{ M}$$

V_t/mV	t/s	k_0/s^{-1}
155.5	0	—
343.0	.10	4.635
461.0	.20	4.636
535.0	.30	4.631
581.9	.40	4.637
611.0	.50	4.627
629.7	.60	4.637
641.3	.70	4.636
661.0	∞	—

$$k_0 = 4.634 \pm .0038 \text{ s}^{-1}$$

Table 6.12 Nitrosation of thioglycolic acid by $\text{Cl}(\text{CH}_2)_2\text{ONO}$ at pH 9.0

$$[\text{Cl}(\text{CH}_2)_2\text{ONO}] = 1 \times 10^{-4}\text{M}$$

$$[\text{TGA}] = 1.99 \times 10^{-2}\text{M}$$

V_t/mV	t/s	k_0/s^{-1}
53.3	0	—
152.5	.10	2.907
227.0	.20	2.914
282.0	.30	2.904
323.5	.40	2.904
354.5	.50	2.903
378.0	.60	2.910
395.0	.70	2.902
446.6	∞	—

$$k_0 = 2.906 \pm .0043 \text{ s}^{-1}$$

Table 6.13 A typical set of duplicate runs.

The concentrations of the reagents are the same as in table 6.12

Run	k_0/s^{-1}
1	2.906
2	2.903
3	2.908
4	2.909
5	2.904

$$k_0 = 2.906 \pm .0025 \text{ s}^{-1}$$

References

1. W. A. Noyes, *Org. Synth.*, Coll. Vol. II, 1943, 108.

APPENDIX

**RESEARCH COLLOQUIA, SEMINARS, LECTURES
AND CONFERENCES**

The Board of Studies in Chemistry requires that each postgraduate research thesis contains an appendix listing:

(A) all research colloquia, seminars and lectures arranged by the Department of Chemistry during the period of the author's residence as a postgraduate student;

(B) lectures organised by Durham University Chemical Society;

(C) all research conferences attended and papers presented by the author during the period when research for the thesis was carried out;

(D) details of the postgraduate induction course.

(A) Research colloquia, seminars and lectures organised by
Durham University Chemistry Department, 1986-1989

(* denotes lectures attended)

- * 29.10.86 Prof. E.H. Wong (University of New Hampshire, U.S.A.), 'Coordination Chemistry of P-O-P Ligands'.
- * 05.11.86 Prof. D. Dopp (University of Duisburg), 'Cyclo-additions and Cyclo-reversions Involving Captodative Alkenes'.
- * 26.11.86 Dr. N.D.S. Canning (University of Durham), 'Surface Adsorption Studies of Relevance to Heterogeneous Ammonia Synthesis'.
- * 03.12.86 Dr. J. Miller (Dupont Central Research), 'Molecular Ferromagnets: Chemistry and Physical Properties'.
- 08.12.86 Prof. T. Dorfmuller (University of Bielefeld), 'Rotational Dynamics in Liquids and Polymers'.
- 28.01.87 Dr. W. Clegg (University of Newcastle-upon-Tyne), 'Carboxylate Complexes of Zinc: Charting a Structural Jungle'.
- 04.02.87 Prof. A. Thomson (University of East Anglia), 'Metalloproteins and Magneto-optics'.
- * 11.02.87 Dr. T. Shepherd (University of Durham), 'Pteridine Natural Products: Synthesis and Use in Chemotherapy'.
- 17.02.87 Prof. E.H. Wong (University of New Hampshire, U.S.A.), 'Symmetrical Shapes from Molecules to Art and Nature'.
- 04.03.87 Dr. R. Newman (University of Oxford), 'Change and Decay: A Carbon-13 CP/MAS NMR Study of Humification and Coalification Processes'.
- 11.03.87 Dr. R.D. Cannon (University of East Anglia), 'Electron Transfer in Polynuclear Complexes'.
- 17.03.87 Prof R.F. Hudson (University of Kent), 'Aspects of Organophosphorus Chemistry'.
- * 18.03.87 Prof. R.F. Hudson (University of Kent), 'Homolytic Rearrangements of Free Radical Stability'.
- * 27.03.87 Graduate Chemists (Northeast Polytechnics and Universities), R.S.C. Graduate Symposium.

- * 06.05.87 Dr. R. Bartsch (University of Sussex), 'Low Co-ordinated Phosphorus Compounds'.
- * 07.05.87 Dr. M. Harmer (I.C.I. Chemicals & Polymer Group), 'The Role of Organometallics in Advanced Materials'.
- 11.05.87 Prof. S. Pasykiewicz (Technical University, Warsaw), 'Thermal Decomposition of Methyl Copper and its Reactions with Trialkylaluminium'.
- 27.05.87 Dr. R.M. Blackburn (University of Sheffield), 'Phosphonates as Analogues of Biological Phosphate Esters'.
- * 24.06.87 Prof. S.M. Roberts (University of Exeter), 'Synthesis of Novel Antiviral Agents'.
- 26.06.87 Dr. C. Krespan (E.I. Dupont de Nemours), 'Nickel (0) and Iron (0) as Reagents in Organofluorine Chemistry'.
- 04.11.87 Mrs. M. Mapletoft (Durham Chemistry Teachers' Centre), 'Salters' Chemistry'.
- * 19.11.87 Dr. J. Davidson (Herriot-Watt University), 'Metal Promoted Oligomerisation Reactions of Alkynes'.
- * 10.12.87 Dr.C.J. Ludman (University of Durham), 'Explosives'.
- * 16.12.87 Mr. R.M. Swart (I.C.I.), 'The Interaction of Chemicals with Lipid Bilayers'.
- 16.03.88 Mr. L. Bossons (Durham Chemistry Teachers' Centre), 'GCSE Practical Assessment'.
- * 07.04.88 Prof. M.P. Hartshorn (University of Canterbury, New Zealand), 'Aspects of Ipso-Nitration'.
- 13.04.88 Mrs. E. Roberts (SATRO Officer for Sunderland), Talk - Durham Chemistry Teachers' Centre, 'Links Between Industry and Schools'.
- * 18.04.88 Prof. C.A. Nieto de Castro (University of Lisbon and Imperial College), 'Transport Properties of Non-polar Fluids'.
- * 19.04.88 Graduate Chemists (Northeast Polytechnics and Universities), R.S.C. Graduate Symposium.
- 24.04.88 Prof. D. Birchall (I.C.I Advanced Materials), 'Environmental Chemistry of Aluminium'.
- 27.04.88 Dr. J.A. Robinson (University of Southampton), 'Aspects of Antibiotic Biosynthesis'.
- 27.04.88 Dr. R. Richardson (University of Bristol), 'X-Ray Diffraction from Spread Monolayers'.

- 28.04.88 Prof. A. Pines (University of California, Berkeley, U.S.A.), 'Some Magnetic Moments'.
- * 11.05.88 Dr. W.A. McDonald (I.C.I. Wilton), 'Liquid Crystal Polymers'.
- 11.05.88 Dr. J. Sodeau (University of East Anglia), Durham Chemistry Teachers' Centre Lecture, 'Spray Cans, Smog and Society'.
- 08.06.88 Prof. J.-P. Majoral (Universite Paul Sabatier), 'Stabilisation by Complexation of Short-Lived Phosphorus Species'.
- * 29.06.88 Prof. G.A. Olah (University of Southern California), 'New Aspects of Hydrocarbon Chemistry'.
- 18.10.88 Dr. J. Dingwall (Ciba Geigy), 'Phosphorus-containing Amino Acids: Biologically Active Natural and Unnatural Products'.
- 18.10.88 Mr. F. Bollen (Durham Chemistry Teachers' Centre), 'The Use of SATIS in the classroom'.
- * 18.10.88 Dr. C.J. Ludman (Durham University), 'The Energetics of Explosives'.
- 09.11.88 Dr. G. Singh (Teesside Polytechnic), 'Towards Third Generation Anti-Leukaemics'.
- 16.11.88 Dr. K.A. McLauchlan (University of Oxford), 'The Effect of Magnetic Fields on Chemical Reactions'.
- * 02.12.88 Dr. G. Hardgrove (St. Olaf College, U.S.A.), 'Polymers in the Physical Chemistry Laboratory'.
- 09.12.88 Dr. C. Jaeger (Friedrich-Schiller University GDR), 'NMR investigations of Fast Ion Conductors of the NASICON Type'.
- 14.12.88 Dr. C. Mortimer (Durham University Teachers' Centre), 'The Hindenberg Disaster - An Excuse for Some Experiments'
- 25.1.89 Dr. L. Harwood (University of Oxford), 'Synthetic Approaches to Phorbols Via Intramolecular Furan Diels-Alder Reactions: Chemistry Under Pressure'
- 01.02.89 Mr. T. Cressey and Mr. D. Waters (Durham Chemistry Teachers' Centre), 'GCSE Chemistry 1988: A Coroner's Report'.
- * 13.02.89 Prof. R.R. Schrock (M.I.T.), 'Recent Advances in Living Metathesis'.

- * 15.02.89 Dr. A.R. Butler (St. Andrews University),
'Cancer in Linxiam: The Chemical Dimension'.
- 22.02.89 Dr. G. MacDougall (Edinburgh University),
'Vibrational Spectroscopy of Model Catalytic
Systems'.
- 01.03.89 Dr. R.J. Errington (University of Newcastle-
upon-Tyne), 'Polymetalate Assembly in Organic
Solvents'.
- 09.03.89 Dr. I. Marko (Sheffield University), 'Catalytic
Asymmetric Osmylation of Olefins'.
- 14.03.89 Mr. P. Revell (Durham Chemistry Teachers'
Centre), 'Implementing Broad and Balanced
Science 11-16'.
- 15.03.89 Dr. R. Aveyard (University of Hull),
'Surfactants at your Surface'.
- * 12.04.89 Graduate Chemists (Northeast Polytechnics and
Universities), R.S.C. Graduate Symposium.
- 20.04.89 Dr. M. Casey (University of Salford),
'Sulphoxides in Stereoselective Synthesis'.
- * 27.04.89 Dr. D. Crich (University College London), 'Some
Novel Uses of Free Radicals in Organic
Synthesis'.
- 03.05.89 Mr. A. Ashman (Durham Chemistry Teachers'
Centre), 'The Chemical Aspects of the National
Curriculum'.
- 03.05.89 Dr. P.C.B. Page (University of Liverpool),
'Stereocontrol of Organic Reactions Using
1,3-dithiane-1-oxides'.
- * 10.05.89 Prof. P.B. Wells (Hull University), 'Catalyst
Characterisation and Activity'.
- 11.05.89 Dr. J. Frey (Southampton University),
'Spectroscopy of the Reaction Path:
Photodissociation Raman Spectra of NOCl'.
- 16.05.89 Dr. R. Stibr (Czechoslovak Academy of Sciences),
'Recent Developments in the Chemistry of
Intermediate-Sited Carboranes'.
- * 17.05.89 Dr. C.J. Moody (Imperial College), 'Reactive
Intermediates in Heterocyclic Synthesis'.
- 23.05.89 Prof. P. Paetzold (Aachen), 'Iminoboranes
XB \equiv NR: Inorganic Acetylenes ?'.
- 14.06.89 Dr. M.E. Jones (Durham Chemistry Teachers'
Centre), 'GCSE and A-level Chemistry 1989'.

- 15.06.89 Prof. J. Pola (Czechoslovak Academy of Sciences),
'Carbon Dioxide Laser Induced Chemical Reactions
- New Pathways in Gas-Phase Chemistry'.
- 28.06.89 Dr. M.E. Jones (Durham Chemistry Teachers'
Centre), 'GCSE and A-level Chemistry 1989'.
- 11.07.89 Dr. D. Nicholls (Durham Chemistry Teachers'
Centre), 'Liquid Air Demonstration'.

(B) Lectures organised by Durham University Chemical
Society 1986-1989

(* denotes lectures attended)

- * 16.10.86 Prof. N.N. Greenwood (University of Leeds),
'Glorious Gaffes in Chemistry'.
- * 23.10.86 Prof. H.W. Kroto (University of Sussex),
'Chemistry in Stars, between Stars and in the
Laboratory'.
- * 30.10.86 Prof. D. Betteridge (B.P. Research), 'Can
Molecules Talk Intelligently'.
- * 06.11.86 Dr. R.M. Scrowston (University of Hull), 'From
Myth and Magic to Modern Medicine'.
- * 13.11.86 Prof. Sir G. Allen (Unilever Research),
'Biotechnology and the Future of the Chemical
Industry'.
- 20.11.86 Dr. A. Milne and Mr. S. Christie (International
Paints), 'Chemical Serendipity - A Real Life
Case Study'.
- * 27.11.86 Prof. R.L. Williams (Metropolitan Police
Forensic Science), 'Science and Crime'.
- 22.01.87 Prof. R.H. Ottewill (University of Bristol),
'Colloid Science: A Challenging Subject'.
- * 05.02.87 Dr. P. Hubberstey (University of Nottingham),
'Demonstration Lecture on Various Aspects of
Alkali Metal Chemistry'.
- * 12.02.87 Dr. D. Brown (I.C.I. Billingham), 'Industrial
Polymers from Bacteria'.
- * 19.02.87 Dr. M. Jarman (Institute of Cancer Research),
'The Design of Anti-Cancer Drugs'.
- 05.03.87 Prof. S.V. Ley (Imperial College), 'Fact and
Fantasy in Organic Synthesis'.
- * 09.03.87 Prof. F.G. Bordwell (Northeastern University,
U.S.A.), 'Carbon Anions, Radicals, Radical
Anions and Radical Cations'.

- * 12.03.87 Dr. E.M. Goodger (Cranfield Institute of Technology), 'Alternative Fuels for Transport'.
- * 15.10.87 Dr. M.J. Winter (University of Sheffield), 'Pyrotechnics (Demonstration Lecture)'.
- * 22.10.87 Prof. G.W. Gray (University of Hull), 'Liquid Crystals and their Applications'.
- * 29.10.87 Mrs. S. van Rose (Geological Museum), 'Chemistry of Volcanoes'.
- * 05.11.87 Dr. A.R. Butler (University of St. Andrews), 'Chinese Alchemy'.
- * 12.11.87 Prof. D. Seebach (E.T.H. Zurich), 'From Synthetic Methods to Mechanistic Insight'.
- * 19.11.87 Prof. P.G. Sammes (Smith, Kline and French), 'Chemical Aspects of Drug Development'.
- * 26.11.87 Dr. D.H. Williams (University of Cambridge), 'Molecular Recognition'.
- * 03.12.87 Dr. J. Howard (I.C.I. Wilton), 'Liquid Crystal Polymers'.
- * 21.01.88 Dr. F. Palmer (University of Nottingham), 'Luminescence (Demonstration Lecture)'.
- 28.01.88 Dr. A. Cairns-Smith (University of Glasgow), 'Clay Minerals and the Origin of Life'.
- * 11.02.88 Prof. J.J. Turner (University of Nottingham), 'Catching Organometallic Intermediates'.
- * 18.02 88 Dr. K. Borer (University of Durham Industrial Research Laboratories), 'The Brighton Bomb - A Forensic Science View'.
- * 25.02.88 Prof. A. Underhill, (University of Bangor), 'Molecular Electronics'.
- 03.03.88 Prof. W.A.G. Graham (University of Alberta, Canada), 'Rhodium and Iridium Complexes in the Activation of Carbon-Hydrogen Bonds'.
- * 06.10.88 Prof. R. Schmutzler (University of Braunschweig), 'Fluorophosphines Revisited - New Contributions to an Old Theme'.
- 21.10.88 Prof. P. von Rague Schleyer (University of Erlangen), 'The Fruitful Interplay Between Computational and Experimental Chemistry'.
- * 27.10.88 Prof. W.C. Rees (Imperial College), 'Some Very Heterocyclic Compounds'.
- * 10.11.88 Prof. J.I.G. Cadogan (B.P. Research), 'From Pure Science to Profit'.

- * 24.11.88 Dr. R.W. Walker and Dr. R.R. Baldwin (University of Hull), 'Combustion - Some Burning Problems'.
- * 01.12.88 Dr. R. Snaith (University of Cambridge), 'Egyptian Mummies - What, Where, Why and How ?'.
- 26.01.89 Prof. K.R. Jennings (University of Warwick), 'Chemistry of the Masses'.
- * 02.02.89 Prof. L.D. Hall (Addenbrookes' Hospital), 'NMR - A Window to the Human Body'.
- * 09.02.89 Prof. J. Baldwin (University of Oxford), '??'.
- * 16.02.89 Prof. J.B. Aylett (Queen Mary College), 'Silicon-based Chips: The Chemists Contribution'.
- 23.02.89 Dr. B.F.G. Johnson (University of Cambridge), 'The Binary Carbonyls'.

(C) Conferences attended

European Symposium on Organic Reactivity II, University of Padova, Italy, 27th August - 1st September 1989.

Poster presented: 'S-nitrosation under mild conditions using alkyl nitrites and a nitrososulphonamide'.

(D) First year induction course, October 1986

This course consists of a series of one hour lectures on the services available in the department.

1. Departmental organisation.
2. Safety matters.
3. Electrical appliances and infra-red spectroscopy.
4. Chromatography and microanalysis.
5. Atomic absorptiometry and inorganic analysis.
6. Library facilities.
7. Mass spectroscopy.
8. Nuclear magnetic resonance spectroscopy.
9. Glassblowing technique.

