

Durham E-Theses

Methodologies for the Evaluation and Mitigation of Distribution Network Risk

SIMON RICHARD BLAKE

How to cite:

BLAKE, SIMON RICHARD (2010) Methodologies for the Evaluation and Mitigation of Distribution Network Risk. Doctoral thesis, Durham University.

Use policy

The full-text may be used and/or reproduced, and given to third parties in any format or medium, without prior permission or charge, for personal research or study, educational, or not-for-profit purposes provided that:

- a full bibliographic reference is made to the original source
- a <https://etheses.durham.ac.uk/id/eprint/654/> is made to the metadata record in Durham E-Theses
- the full-text is not changed in any way

The full-text must not be sold in any format or medium without the formal permission of the copyright holders.

Please consult the [full Durham E-Theses policy](#) for further details.

Methodologies for the Evaluation and Mitigation of Distribution Network Risk

Simon Richard Blake

MA Oxon, MSc Newcastle,
MEd Leeds, MSc Dunelm

A Thesis presented for the Degree of
Doctor of Philosophy

Energy Group
School of Engineering and Computing Sciences
Durham University
UK

September 2010

Methodologies for the Evaluation and Mitigation of Distribution Network Risk

Simon Richard Blake

MA Oxon, MSc Newcastle, MEd Leeds, MSc Dunelm

ABSTRACT

Security of supply to customers is a major concern for electricity distribution network operators. This research concentrates in particular on the UK distribution system, and on sub-transmission and extra high voltage networks within that system. It seeks first to understand the principal causes of network risk and consequent loss of supply to customers as a result of faults at these voltage levels. It then develops a suite of methodologies to evaluate that risk, in terms of expected annual cost to the network operator, under a range of different scenarios and for both simple and complex network topologies. The scenarios considered include asset ageing, network automation and increasing utilisation as a consequence of electric vehicles and heat pumps. The methodologies also evaluate possible mitigation options, including active network management, and capital expenditure for both asset replacement and network reinforcement. A composite methodology is also developed, to consider combinations of scenarios and combinations of mitigation strategies. The thesis concludes by considering issues likely to affect the extent and possible increase of network risk over the period 2010-2030.

Declaration

The work in this thesis is based on research carried out within the Energy Group, School of Engineering and Computing Sciences, Durham University, United Kingdom. No part of this thesis has been submitted elsewhere for any other degree or qualification, and it is all my own work unless referenced to the contrary in the text.

Reference is made to work that is confidential and commercially restricted

Copyright © 2010 by Simon Richard Blake

“The copyright of this thesis rests with the author, No quotations from it should be published without the author’s prior written consent and information derived from it should be acknowledged”

Acknowledgments

This work was funded by CE Electric UK and Durham University

I would like to express my gratitude to all those who have helped with this research, in particular:

- Alan Creighton, my industrial supervisor at CE Electric UK.
- Chris Goodhand, David Miller and Mark Nicholson from CE Electric UK, who were regular members of the steering group for this project.
- Other colleagues from CE Electric UK who provided information and advice when required.
- All my colleagues within the Energy Group, past and present, for their help and friendship throughout the project.
- My academic supervisors, Professor Philip Taylor and Professor Peter Tavner, for their guidance and encouragement.
- My family, for their patience with me for the duration.

Nomenclature

On occasions, context-specific symbols are used in the thesis. These symbols are not included in the nomenclature below but are explained in context.

B	Scaling parameter giving Health Index as function of time
c	Scaling parameter giving failure probability as function of HI
C	Capital cost of project (£)
CI	Network risk cost of customer interruptions (£)
CML	Network risk cost of customer minutes lost (£)
CR	Network risk cost of repairs and asset deterioration (£)
D	Discount rate
DF	Probability that a second failure occurs before the first is restored
F	Impact matrix
G	Net gain by expenditure deferral (£)
H	Health Index (value on scale 0 to 10)
H₀	Initial value of health index for new asset
H(t)	Health index after t years
k	Scaling parameter giving failure probability as function of HI
L	Long restoration time (both the event and its probability)
M	Markov probability transition matrix
n	Number of trials in a Monte Carlo simulation
N	Number of zones in a network under consideration
NC	Number of customers at a given load point
NR_n	Network risk in year n
NR₀	Base level of network risk
OK	The event that a combination of failures causes no customer loss
p	Annual rate of increase in age-related probability of failure
p_i	Markov steady-state probability of being in state i

P	Probability of age-related transformer failure (HI calculations)
Q	Consequence rating
R	Proportion of customers who can be reconfigured at lower voltage
RT	Weighted average repair time
R_A	Scaling constant for calculating age-related failure rates
R_T	Age-related failure rate after T years
R_0	Rate of failures which do not depend on age
R_1	Customer rating (scale of 1 to 4)
R_2	System risk rating (scale of 1 to 4)
r_i	Allocated proportion of repair cost due to failure in zone i
S	Short restoration time (both the event and its probability)
t	Asset age in years
TI	Duration of a long restoration (minutes)
TNR	Total network risk (£)
T_s	Duration of a short restoration (minutes)
U	Unavailability of a circuit (hours per year)
UCI	Unit cost to DNO per interrupted customer (£)
UCML	Unit cost to DNO per customer minute lost (£)
UCR	Average unit cost per failure of repair and asset deterioration (£)
\mathbf{x}	Vector of Markov steady-state probabilities
Y	Number of hours per year
λ	Failure rate per year of a component or circuit
λ_1, λ_2	Failure rate of circuit 1, circuit 2 of a pair
$\lambda(Tx)$	Failure rate of component in bracket (transformer in this case)
$\lambda(Tx \text{ age})$	Rate of age-related failures only for a transformer
λ_{tot}	Total failure rate for a circuit (sum of component failure rates)

Acronyms

ACSR	Aluminium Core with Steel Reinforcement
ANM	Active Network Management
C1, C2	Circuit Breaker in location 1 or 2
CB	Circuit Breaker
CBRM	Condition Based Risk Management
CDI	Customer Dissatisfaction Index
CHP	Combined Heat and Power
CI	Customer Interruptions
CML	Customer Minutes Lost
COP	Coefficient Of Performance
DCF	Discounted Cash Flow
DF	Double Failure
DG	Distributed Generation
DNO	Distribution Network Operator
DPCR	Distribution Price Control Review
DSM	Demand Side Management
EHV	Extra High Voltage
ENA	Energy Networks Association
GDS	Generic Distribution System
GDS1 etc.	Generic Distribution System network number 1 etc.
GNT	Generalised Network Topology
GSP	Grid Supply Point
HI	Health Index
HILP	High Impact Low Probability
HV	High Voltage
IEEE	Institute of Electrical and Electronic Engineers

IIS	Interruption Incentive Scheme
LFY	Last Firm Year
LTDS	Long Term Development Statement
LV	Low Voltage
MANWEB	Merseyside And North Wales Electricity Board
MSR	Major System Risk
MV	Medium Voltage
n, n-0	Network intact
n-1	Network with one circuit outage
n-2	Network with two circuit outages
NAFIRS	National Fault and Interruption Reporting Scheme
NEDL	Northern Electricity Distribution Limited
OFGEM	Office of the Gas and Electricity Markets
pu	Per Unit
PZ	Protection Zone
S1, S2	Switch in location 1 or 2
SAIDI	System Average Interruption Duration Index
SAIFI	System Average Interruption Frequency Index
SP	Supply Point
SRC	System Risk Category
T, Tx	Transformer designation
TOR	Time for Outage Restoration
YEDL	Yorkshire Electricity Distribution Limited
Z1, Z2 etc.	Zone number 1, number 2 etc.

Author's Publication List

Conference Papers

S. R. Blake, P. C. Taylor, A. M. Creighton, "Distribution Network Risk Analysis", MedPower '08 Conference on Power Generation, Transmission and Distribution, Thessaloniki, Greece, November 2008

Simon Blake, Philip Taylor, Peter Tavner, Gavin Howarth, "An Investigation into Using Oil Replenishment Data as a Factor to Prioritise the Replacement of Extra High Voltage Electrical Cable", 18th Advances in Risk and Reliability Technology Symposium, Loughborough, UK, April 2009

Simon Blake, Philip Taylor, Alan Creighton, "Methodologies for the Analysis of both Short-Term and Long-Term Network Risk", CIRED 20th International Conference on Electricity Distribution, Prague, Czech Republic, June 2009

Simon Blake, Philip Taylor, Alan Creighton, David Miller, "Optimal Investment Planning through Balancing Load Growth with Network Risk", CIRED Workshop, Lyon, France, June 2010

Book Chapter

Simon Blake, Philip Taylor, "Aspects of Risk Assessment in Distribution System Asset Management: Case Studies", in Handbook of Power Systems II, pp. 449-480, Springer, ISBN 978-3-642-12685-7

Contents

Abstract	ii
Declaration	iii
Acknowledgements	iv
Nomenclature	v
Acronyms	vii
Author's Publication List	viii
Key to Symbols in Circuit Drawings	xxiii
1. Introduction and Research Objectives	1
1.1 The Electricity Industry in the UK	1
1.1.1 Distribution Network Operators	2
1.2 Distribution Networks	3
1.2.1 Sub-Transmission (132 kV)	3
1.2.2 Extra High Voltage (EHV) (66 kV, 33 kV)	3
1.2.3 Medium Voltages (20 kV, 11 kV, 6.6 kV)	4
1.3 Network Outages, Reliability and Risk	4
1.3.1 Network Reliability	5
1.3.2 Network Risk	6
1.4 Causes of Network Risk	9
1.5 Regulating and Measuring Risk	12
1.5.1 Design Standard P2/6	12
1.5.2 Comparing Design and Operational Standards	13
1.5.3 Other National Regulatory Regimes	14
1.5.4 Distributor Measures of Risk	15

1.6	Approaches to Evaluating Reliability and Risk	16
1.6.1	Network Modelling	16
1.6.2	Markov Modelling	17
1.6.3	Analytical Simulation	18
1.6.4	Monte Carlo Simulation	19
1.6.5	Software Tools Assessment	20
1.7	Increasing Utilisation	21
1.7.1	Projected Levels of Load Growth	21
1.7.2	Electric Vehicles	23
1.7.3	Heat Pumps	24
1.8	Economics of Distribution	25
1.8.1	CI and CMLs	25
1.8.2	Repair and Depreciation Costs	26
1.8.3	Capital Costs	27
1.8.4	Operating Costs	27
1.9	Research Background	28
1.10	Research Objectives	29
1.11	Structure of the Thesis	30
2.	Literature Review	32
2.1	Modelling Network Risk	32
2.1.1	Standard Approaches	32
2.1.2	Customer Costs	34
2.1.3	Applications of Probabilistic Methodologies	34
2.1.4	Extreme Weather Events	36
2.1.5	Operational Time Horizons	37
2.2	Risk Mitigation by Asset Replacement	38
2.3	Risk Mitigation by Network Reinforcement	40
2.4	Risk Mitigation by Increasing Automation	41
2.5	Risk Mitigation by Active Network Management	42
2.6	Other Strategies for Risk Mitigation	43
2.7	Literature Review: Conclusions	45
2.8	Building on Previous Research	46

3	Developing a Core Methodology	48
3.1	Components of Network Risk	49
	3.1.1 Repair and Depreciation Costs	50
	3.1.2 Customer Interruption Costs	51
	3.1.3 Customer Minutes Lost Costs	52
3.2	Total Network Risk	52
	3.2.1 Application to the Test Network	53
3.3	Extending the Core Methodology	53
	3.3.1 Monte Carlo Simulation Applied to the Test Network	54
	3.3.2 Construction Outage Risk	56
	3.3.3 Age-Related Failure Rates	57
3.4	Test Network Case Study: Reduced Risk with Reconductoring	59
	3.4.1 Construction Risk (Single Circuit)	60
	3.4.2 Triple Circuit Calculations	61
3.5	Core Methodology: Discussion	63
4	Developing a Generalised Methodology	65
4.1	Modelling Individual Loads	65
4.2	Standard Network Topologies	66
	4.2.1 Single Circuit to a Single Transformer Load Point	67
	4.2.2 Radial Paired Circuit to a Single Load Point	67
	4.2.3 Radial Paired Circuit to Two or More Load Points	68
	4.2.4 Other Standard Topologies	69
4.3	Complex Network Topologies	69
	4.3.1 Testing the GNT Approach	70
4.4	Abstract Modelling of Complex Networks	71
	4.4.1 Sketching Relevant Sections of Network	72
	4.4.2 Defining Zones	73
	4.4.3 Defining the Impact of (n-1) and (n-2) Failures	74
	4.4.4 Verifying that Power Flows and Voltage Drops are Acceptable	75
	4.4.5 Constructing the Asset Matrix	76
	4.4.6 Assembling Other Relevant Data	77

4.5	Model Calculations for Complex Networks	78
4.5.1	Evaluating Failure Probabilities for each Zone	78
4.5.2	Using these Probabilities to Weight Possible Impact	78
4.5.3	Calculating Expected Costs	80
4.6	Testing the Generic Methodology	82
4.6.1	Whitby West	82
4.6.2	Crowle	86
4.6.3	Balby	90
4.7	Generalised Methodology: Discussion	92
5	Methodology for Asset Replacement	94
5.1	Ageing Assets	94
5.1.1	66 kV Overhead Lines	95
5.1.2	Oil-Filled Cables	96
5.2	Transformer Replacement	97
5.2.1	Transformer Failure and Repair Data	97
5.2.2	Transformer Health Indices	98
5.3	Hartlepool Case Study	100
5.3.1	Relevance to Asset Replacement	101
5.3.2	Basic Network Risk at Amberton Road	102
5.3.3	Effect of Ageing on Network Risk in Hartlepool	103
5.3.4	Failure Rates and Risk as a Function of Time	104
5.3.5	Economic Consequences	106
5.4	Sensitivity Analysis	107
5.4.1	Unscheduled Repair and Asset Deterioration	106
5.4.2	Double Circuit Failure	107
5.4.3	Customer Disconnection Duration	110
5.4.4	Direct Costs to the Customer	111
5.4.5	Recalculating Network Risk	111
5.4.6	Monte Carlo Simulation	112
5.5	Economic Analysis and Optimal Year	113
5.5.1	Replacement in an Earlier Year	114
5.5.2	Finding an Optimal Year for Replacement	115
5.6	Implications for the Wider Network	117

5.6.1	Size of Transformer	118
5.6.2	Proportion of Transferrable Customers	119
5.6.3	Restoration Time	119
5.6.4	Double Failure Proportion	120
5.6.5	Customer Numbers	120
5.6.6	Failure Rate for Rest of Circuit	121
5.6.7	Health Index as a Function of Time	122
5.7	Risk Mitigation by Asset Replacement: Discussion	124
6	Methodology for Network Automation	127
6.1	Network Classification	127
6.2	Generic Networks	129
6.3	Rural Radial	131
6.3.1	Adding a Radio Controlled Switch S2	134
6.3.2	Adding a Circuit Breaker C2	135
6.3.3	Different Location: S1 or C1	136
6.3.4	More than One Switch or Circuit Breaker	136
6.3.5	Summary of Options	137
6.4	Rural Radial (Sensitivity Analysis)	138
6.4.1	Failure Rates	138
6.4.2	Double Failure Rate DF	139
6.4.3	Long Restoration Time TI	140
6.4.4	Short Restoration Time Ts	141
6.4.5	Higher Voltage Reconfigurability R	141
6.4.6	Number of Customers NC	142
6.4.7	Regulatory Unit Rewards and Penalties	142
6.4.8	Unit Cost of Repairs and Deterioration	142
6.5	Rural Ring 66 kV	143
6.5.1	Adding a Radio Controlled Switch S2	146
6.5.2	Adding a Circuit Breaker C2	148
6.5.3	Different Location: S1 or C1	149
6.6	Rural Meshed Network	151
6.7	Suburban Meshed Network	152
6.7.1	Network Risk with Switching Station	155

6.8	Urban Meshed 132 kV Network	157
6.8.1	Failure Rates and other Input Data	159
6.8.2	Base Run	160
6.8.3	Project: Doubling up Cable	161
6.9	Network Automation: Discussion	162
7	Methodology for Increasing Utilisation	166
7.1	Load Point Capacity	166
7.1.1	Rural Networks	168
7.1.2	Historic and Generic Load Profiles	169
7.2	Satisfying the Regulator and P2/6	172
7.2.1	Last Firm Year (LFY)	173
7.2.2	Complying with P2/6: Allowing for Peak Width	174
7.2.3	Complying with P2/6: Active Network Management	175
7.2.4	Complying with P2/6: Capital Investment	176
7.3	Analytical Methods	178
7.3.1	Generic Load Profiles	178
7.3.2	Discrete Steps of Load Size	179
7.3.3	Interpreting P2/6	181
7.3.4	Modelling Load Flow	182
7.3.5	Asset Ratings	183
7.3.6	Evaluating Network Risk	185
8	Increasing Utilisation Case Study	186
8.1	Choosing a Generic Case Study	186
8.1.1	Load Flow Modelling	187
8.1.2	Modelling beyond Load Flows	189
8.1.3	Network Geography	190
8.1.4	Loads and Ratings	191
8.1.5	Customer Numbers and 11 kV Feeders	191
8.1.6	Protection Zones	195
8.2	Basic Network Risk	197
8.3	Load Flows in the Case Study	198
8.4	Load Related Risk	199

8.5	Economic Analysis	201
8.5.1	Capital Projects only	202
8.5.2	Sensitivity Analysis	207
8.5.3	Active Network Management only	208
8.5.4	Capital Projects with ANM	211
8.5.5	Summary	212
8.6	Increasing Utilisation: Discussion	212
9	Developing a Composite Approach	217
9.1	Composite Approach Philosophy	218
9.2	Hartlepool Case Study	218
9.3	Stage One: Network Risk and Transformer Replacement	224
9.3.1	Basic Network Risk at Brenda Trading	224
9.3.2	Increasing Risk with Transformer Deterioration	225
9.4	Stage Two: Effects of Increasing Utilisation	229
9.4.1	Feeder Reconfiguration	229
9.4.2	Last Firm Year with 2.5% Load Growth	231
9.5	Stage Three: ANM and Automated Reconfiguration	232
9.5.1	Reconfigurability in 2015	235
9.5.2	Network Risk in 2015 at Brenda Trading	235
9.5.3	Extending the Last Firm Year	237
9.5.4	Economic Analysis	239
9.5.5	Benefits of Automation	239
9.6	Hartlepool Case Study: Conclusions and Discussion	240
9.7	Kirklees Case Study	243
9.8	Composite Approach: Conclusions	244
10	Discussion	246
10.1	Wider Relevance of the UK Situation	246
10.2	Elements of Total Network Risk	247
10.3	Anticipating Regulatory Change	248
10.4	Economic Analysis	250
10.5	Design versus Operations	251
10.6	Active Network Management	251

10.7	The ‘Last Firm Year’ Concept	253
10.8	Composite Approaches	253
10.9	Probabilistic Methodologies in the Industry	255
10.10	Data Quality and Reliability	256
11	Conclusions	257
11.1	Deeper Understanding	259
11.2	Double Circuit Failure and Restoration	259
11.3	Quantifying Network Risk	260
11.4	Changing Network Risk	260
11.5	Developing Methodologies	261
11.6	Mathematical Approaches and Models	262
11.7	Technical, Regulatory and Economic Aspects	263
11.8	Summary: Advances to Knowledge	264
11.9	Further Work: Knowledge Transfer Partnership	266
	References	267
Appendix A	Evaluating Modelling Techniques	277
A1	Test Network	277
A2	Network Modelling of the Test Network	279
A3	Discussion of Network Modelling	281
A4	Markov Modelling of the Test Network	282
A5	Markov Modelling of Non-Standard Networks	286
A6	Discussion of Markov Modelling	287
A7	Effect of Age-Related Asset Condition	288
A8	Effect of Double Circuit Failure (DF)	288
A9	Effect of Load Levels	290
A10	Effect of Lower Voltage Reconfiguration	290
A11	Financial Implications	291
A12	Modelling Dynamic Network Development	291
A13	Effect of Complex Topologies	292
A14	Monte Carlo Simulation	293

Appendix B	Software Tools Assessment	295
B1	Load Flows for Network Analysis	295
B2	Risk Assessment and Markov Analysis	298
B3	Monte Carlo Simulation	299
B4	CE Electric UK Software and Information Systems	300
B5	Software for User-friendly System	302
Appendix C	Distributor Measures of Network Risk	303
C1	Major System Risk	303
C2	Asset Serviceability Review	305
C3	Composite Risk Index	309
Appendix D	Basic Risk Calculation	312
D1	Data Preparation	312
D2	Model Calculations	314
Appendix E	Load Flow Analysis	317
E1	Load Flow with Network Intact	317
E2	P2/6 as Applied to the Case Study Network	317
E3	Base Run without Z1	318
E4	Asset Reinforcement without Z1	320
E5	ANM without Z1	321
E6	ANM in Conjunction with Asset Reinforcement	323
E7	Load Flows without Z2	324
E8	Load Flows without Z3	327
Appendix F	Load-Related Risk Calculations	329
F1	Key Assumptions	329
F2	Analysis with Network Intact	330
F3	Analysis of n-1 situation without Z1	330
F4	Analysis of n-1 situation without Z2	332
F5	Analysis of n-1 situation without Z3	333
F6	Analysis of n-2 situation without Z1 and Z2	334
F7	Analysis of n-2 situation without Z2 and Z3	336
F8	Analysis of n-2 situation without Z1 and Z3	337

List of Figures

1.1	Gas demand in a typical house, average daily profile	24
2.1	Optimising cost and risk simultaneously	36
2.2	The bathtub curve	38
3.1	Schematic of Test Network	48
3.2	Annualised network risk with and without construction project	61
4.1	Acklam topology	67
4.2	Denwick topology	68
4.3	Relevant network around Wheatley Park	72
4.4	Defining Zones at Wheatley Park	73
4.5	Configuration and zones at Whitby West	82
4.6	Network topology around Crowle	86
4.7	Zones at Crowle	87
4.8	Relevant network around Balby	90
4.9	Zones at Balby	91
5.1	Distribution of Health Index values for all EHV transformers	99
5.2	Hartlepool substations and 66 kV network	100
5.3	Old transformer at Amberton Road	101
5.4	Amberton Road schematic	102
5.5	Increasing failure rates	106
5.6	Frequency of repair and asset deterioration costs	109
5.7	Frequency of untransferrable customer disconnection duration	111
5.8	Failure rates for a typical exposed 33 kV rural circuit	122
5.9	Change of Health Index with time	124
6.1	Rural radial network	132
6.2	Rural ring 66 kV network	144
6.3	Actual meshed rural network supplying Ruthin	152
6.4	Meshed suburban network	153
6.5	132 kV supply to suburban mesh	154
6.6	Urban 132 kV ring within urban mesh	158
7.1	Load point example	167
7.2	Seasonal variation of load	170
7.3	Daily variation of load	170

7.4	Example of annual growth of overfirm hours	171
8.1	IPSA representation of case study network	188
8.2	Case study network geography	190
8.3	Winter ratings and base run loads in case study network	192
8.4	Possible arrangement of 11 kV feeders	193
8.5	Circuit Breakers and Protection Zones	196
9.1	Geographical arrangement of 66 kV network	219
9.2	66 kV circuits supplying Hartlepool	220
9.3	Transformer and 66 kV busbar at Brenda Trading	221
9.4	Mulgrave Road	222
9.5	Rift House	222
9.6	11 kV network in Hartlepool	223
9.7	11 kV reconfigurability MVA (before permanent transfer)	233
9.8	11 kV reconfigurability MVA (after permanent transfer)	234
9.9	Peak loads, customer numbers, and reconfigurability in 2015	236
11.1	Methodologies Flowchart	262
A1	Schematic of Test Network	277
A2	Overhead lines from Lackenby to Carlin How	279
A3	States and Transitions under normal 2-circuit operation	283
A4	Extra security from Tocketts Bridge interconnector during construction period	293
C1	Supply Point Utilisation	305
C2	Firm (orange) and non-firm (white dots) substations, YEDL	306
C3	Supply Point utilisation after ten years	307
E1	Network without Z1	319
E2	Network without Z2	325
E3	Network without Z3	327

List of Tables

1.1	Customer loss at different voltage levels	6
1.2	Faults on 66 and 33 kV networks, by component	10
1.3	Faults on 66 and 33 kV networks, by cause	10
1.4	P2/6 requirements for each demand group	13
3.1	Test network input parameters	53
3.2	Distributions of numbers and times of customers restored	55
3.3	Predicted past and future failure rates per km for EHV O/H line	58
3.4	Predicted failure rates per km for Lackenby – Guis. O/H line	59
3.5	Predicted failure rates for Lackenby – Guis. first circuit	59
3.6	Increasing network risk without conductor replacement	60
3.7	Triple circuit probabilities and costs	62
4.1	Impact Matrix for Wheatley Park	75
4.2	Asset Matrix for Wheatley Park	76
4.3	Failure Rate Matrix for Wheatley Park	78
4.4	Impact Matrix at Whitby West	83
4.5	Asset Matrix for Whitby West zones	84
4.6	Failure probabilities by zone at Whitby West	85
4.7	Impact Matrix at Crowle	87
4.8	Asset Matrix at Crowle	88
4.9	Failure probabilities by zone at Crowle	89
5.1	Network risk data at Amberton Road	103
5.2	Increasing transformer Health Index	104
5.3	Time dependent failure rates	104
5.4	Network risk increasing with time	105
5.5	Network risk in 2018, including sensitivity factors	112
5.6	Discounted cost comparison of replacement in 2015 and in 2018	115
5.7	Comparing 2010 replacement with 2015	115
5.8	Marginal gain by deferring expenditure by one year	117
5.9	Parameters which are and are not substation-dependent	117
5.10	Marginal gain by deferring expenditure by one year (larger Tx)	118
5.11	Effect of increased failure rates elsewhere in the circuit	122
6.1	Estimation of customer numbers	133

6.2	Impact matrix at load point 1126	137
6.3	Value to DNO of six switch or circuit breaker investment options	138
6.4	Sensitivity to changing DF	140
6.5	Estimation of customer numbers on rural 66 kV ring	145
6.6	Impact matrix for load 1102 with S2 or C2	147
6.7	Impact matrix for load 1108 with S2 or C2	148
6.8	Impact matrix for load 1102 with S1 or C1	149
6.9	Impact matrix for load 1102 with S1/C1 and S2/C2	149
6.10	Impact matrix for load 1108 with S1/C1 and S2/C2	150
6.11	Rural 66 kV ring: TNR with different automation options	150
6.12	Rural 66 kV ring: benefit of different automation options	150
6.13	Estimation of customer numbers (suburban mesh)	155
6.14	Components of network risk with switching station	157
6.15	Standard failure rates (adjusted) for 132 kV assets	160
7.1	Discretised annual variation of load	180
7.2	Discretised daily variation of load	180
8.1	Case study customer numbers and 11 kV feeders	194
8.2	Case study load flow summary	198
8.3	Summary of analyses in Appendix E	200
8.4	Impact of increased loads on network risk	201
8.5	Costs of minor project in 2016, redesign in 2022	204
8.6	Costs of redesign in 2016	205
8.7	Option 2 minus Option 1 (benefit of not deferring)	206
8.8	Costs of implementing ANM in 2013, redesign in 2016	210
8.9	Costs of minor project and ANM in 2013, redesign in 2019	211
8.10	RoRs for 2013 redesign, compared with different options	212
9.1	Peak loads at Hartlepool substations	223
9.2	Network risk data at Brenda Trading	224
9.3	Transformer age-related network risk at Brenda Trading	226
9.4	Load growth at constant 1.0% in Hartlepool	229
9.5	Hartlepool with 2.5% load growth, from 2010	231
9.6	Reconfigurability of 11 kV feeders in Hartlepool	232
A1	Circuit failure and repair data	280
A2	Markov Matrix for two circuits, four-states, six transitions	285

C1	Consequences of Failure	303
C2	Probability of Failure	304
C3	Matrix and Interpretation of Risk	304
C4	Summary of 173 Projects under Consideration	309
C5	Number of Substations in each Composite Risk Category	310
C6	Effect of SRC Weighting on Overall Ranking	311
D1	Impact of n-1 and n-2 failures for each case study load	312
D2	Case study Asset Matrix	313
D3	Failure rate matrix for case study	314
D4	Failure rates for each event in the case study	315
D5	Case study expected annual CI costs	315
D6	Case study expected annual CML costs	316
E1	Summary of LFY when Z1 is unavailable	323
F1	Dependence of power loss on incident start time	332

KEY TO SYMBOLS IN
CIRCUIT DRAWINGS

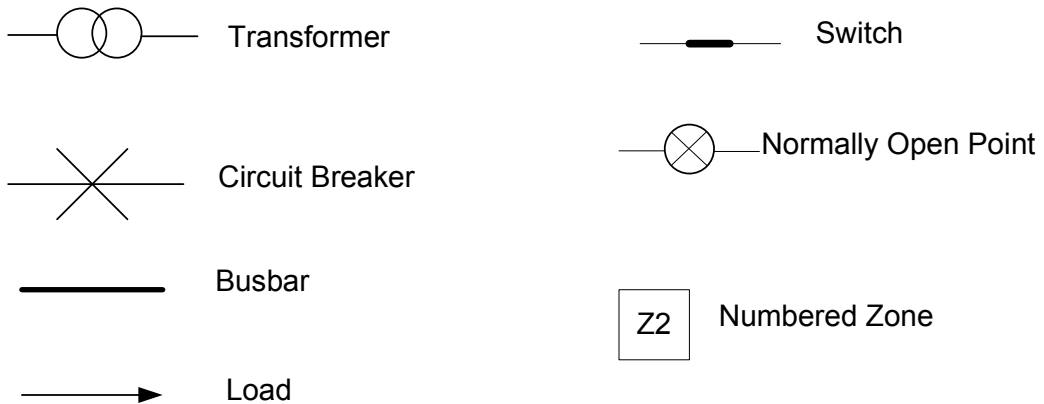

1. INTRODUCTION AND RESEARCH OBJECTIVES

1.1 The Electricity Industry in the UK

A number of features characterise the electricity industry in the UK, as compared to that in other industrialised countries in North America or mainland Europe. Generation is overwhelmingly dependent on fossil fuels (72% of the total energy in 2000, and expected to be 73% in 2010), traditionally coal, but over the past 20 years an increasing proportion of gas, which is now around half the total [1, 2]. Nuclear powered generators accounted for 25% of total electrical energy consumption in 2000, falling to 20% by 2010, a significant proportion, but much less than countries such as France with 77%. Hydro electricity is relatively scarce in the UK, and wind power has not been developed as much as it has in countries such as Denmark, Germany or Spain. Renewable electrical energy from all sources constituted only 4% of the total in 2000 (rising to 7% in 2010), as compared with almost 10% in the USA, and over 15% in France and Denmark [1, 2].

Since the electricity industry was privatised and unbundled in the late 1980s, generating stations have been owned by a number of different operating companies. Some own several generating stations, and some also have interests in other parts of the electricity industry, including Distribution Network Operators (DNOs) and supply companies. However, the UK industry regulator, OFGEM, requires them to operate these separate holdings independently.

Electricity transmission, from large generating stations to DNOs and large industrial customers, is carried out by a single company, the National Grid. This monopoly is regulated by OFGEM. Besides the transmission of energy, National Grid are also responsible for buying and selling as much energy, every half hour, as is necessary to balance the market for a commodity which cannot easily be stored in large quantities.

Within regions, the distribution of energy is carried out by Distribution Network Operators (DNOs). There are 14 of these DNOs in Great Britain, each of which has a license covering a defined geographical area. They are accountable to the industry regulator, OFGEM. These 14 DNOs are owned by 7 holding companies. They work together where necessary through the Energy Networks Association (ENA).

The supply of electrical energy – buying it from generators, and selling it to individual consumers – is carried out by supply companies. They pay the National Grid and the DNOs for the use of their assets to transport this energy. This division of utilities which were once integrated supply and distribution companies, and which are still integrated utilities in many other countries, is a distinguishing feature of the UK industry. It has a number of important consequences, in particular that DNOs cannot easily generate revenue from customers, but must deal with supply companies through a price mechanism overseen and regulated by OFGEM. This makes each DNO primarily an asset manager, with a portfolio of assets whose capital value is many times the annual revenue which they generate. For example, in the year ending March 2009 one DNO spent £72.8 M on operational activities, which is only around 5% of the balance sheet capital value of property, plant and equipment (£1339.1 M) [3].

1.1.1 Distribution Network Operators

One of the 7 holding companies for DNOs is CE Electric UK, who have provided sponsorship, supervision, data and assistance for the present research. CE Electric UK owns 2 DNOs, YEDL (covering mainly South and West Yorkshire and Humberside) and NEDL (covering mainly North Yorkshire and the North East of England). Some of the case studies that will be described later in this research are based on issues facing actual YEDL and NEDL networks.

Over recent years, with changes of ownership and of regulatory environment, the concept of asset management appears to have taken an increasingly central role within DNOs. At CE Electric UK, this is expressed in their Asset Management Policy [4], and their organisational structure.

The principal link with CE Electric UK for the present research has been through the Asset Management function, through whom contact has been made with other employees of CE Electric UK whose input has been essential to the present research. In particular, work experience was obtained with the Primary Engineering Projects team, who have responsibility for planning in detail and carrying out major construction projects on the EHV networks. This involved office experience, meetings with customers, training events, and working with a field engineer at a number of substation sites.

Useful work experience was also obtained with the operations control team, who operate the network on a day-to-day basis, both at NEDL and at YEDL, and with the network management team who support them. These experiences ensured that the present project was not carried out in a theoretical planning vacuum, but with detailed knowledge of what the plans being considered would mean on the ground, both as regards construction and as regards subsequent network operation.

1.2 Distribution Networks

The NEDL distribution network may be regarded as typical in many respects. It distributes electrical energy from 16 points of connection to the National Grid, called Grid Supply Points (GSPs) to just over 1.5 million industrial, commercial and domestic customers in the North East of England and North Yorkshire [5]. Nine separate voltage levels are involved, each of which has its own distinctive characteristics.

The highest voltages are 400 kV and 275 kV, used by the National Grid for transmission. The transmission network, and its reliability, lies outside the scope of the present research.

1.2.1 Sub-Transmission (132 kV)

The 132 kV network is essentially the remnant of the original national grid, installed in the 1930s. There are around 20000 km of 132 kV overhead line and underground cable spread fairly evenly throughout the UK [6]. This is the highest voltage network owned and operated by the DNOs. Only a limited number of engineers are qualified to work at this voltage level, which causes constraints in operating this part of the network. Within NEDL, only 8 of the 16 GSPs are supplying at this voltage, the other 8 are all at lower voltages.

The term 'sub-transmission' is used to describe the 132 kV network to reflect its original design concept and ownership, and the fact that in many countries circuits at this voltage are owned and operated by transmission companies, rather than by distribution companies [7].

1.2.2 Extra High Voltage (EHV) (66 kV, 33 kV)

There are around 3000 km of overhead line and 1000 km of underground cable in the UK operating at 66 kV. Although relatively abundant in the NEDL and YEDL regions, it is less common in other parts of the country. This is largely for historical reasons. It is robustly designed, and has a significantly better reliability record than the more common 33 kV EHV network [8].

The 33 kV network is spread throughout the UK, with around 25000 km of overhead line and 14000 km of underground cable. The present study concentrates on the reliability of the sub-transmission and EHV networks. These networks are characterised above all by their variety. They are less generic than either higher-voltage transmission networks, or the lower voltages which will be described next.

1.2.3 Medium Voltages (20 kV, 11 kV, 6.6 kV)

On the NEDL network, there are just under 300 primary substations. At primary substations, voltages are transformed from EHV and 132 kV down to medium voltages, of which the most common is 11 kV, with around 240000 km of circuits at this voltage level in the UK [8]. In NAFIRS data these voltages are referred to as High Voltages (HV), as distinct from EHV. This tends to be confusing, and so the designation Medium Voltage (MV) will be used in the present research, as it is in general use in most other countries.

The higher level of 20 kV is a distinctive feature of the NEDL region, where there are around 6300 km. It exists for historical reasons like the 66 kV, on account of the sparse density of population in the remoter parts of the region. Often, 20 kV and 11 kV are both used within a relatively small area. The lower voltage level of 6.6 kV, also a historical relic, is now relatively rare.

The present research is concerned mainly with EHV and 132 kV networks. However, in the event of faults at higher voltages, it is often possible to reconfigure the network at MV to reconnect a proportion of customers. For this reason, the design and operation (both normal and exceptional) of MV networks is relevant.

The secondary substations, where MV is transformed down to low voltage (LV, usually 0.4 kV phase-to-phase), and the LV networks themselves, lie outside the scope of the present research.

1.3 Network Outages, Reliability and Risk

The assets that are managed by each DNO include overhead lines and underground cables at each of the voltages described in Section 1.2, together with the substations where one voltage is transformed to another. These substations include the transformers themselves, and associated switchgear and protection equipment.

Most of the time, these assets are available to operate as designed, but on occasion they are not. These outages may be planned, as part of a maintenance, repair or construction activity, or they may be unplanned, as a result of weather, damage or malfunction. The *availability* of an asset measures the proportion of time for which it can operate as designed, excluding both planned and unplanned outages. The *reliability* of the asset excludes unplanned outages only. This reliability is generally well in excess of 99%. Indeed, it can be expressed as a number of nines, so that for example ‘six nines’ indicates a reliability of 99.9999%.

1.3.1 Network Reliability

When an asset fails, it will generally cause circuit breakers to trip and isolate the faulted asset from the rest of the distribution system, thereby protecting the remainder of the system from damage and from potential danger to personnel. The section of network thus isolated, often called a protection zone (PZ), will typically comprise a number of assets, including overhead line and/or underground cable, possibly one or more transformers, and associated switchgear and protection equipment including the breakers that have tripped at the edges of the zone. The PZ will then remain isolated until restoration work can be carried out. This restoration may include the repair of the failed asset and the return to service of all the assets in the PZ. Alternatively, the restoration may take place in stages, with each stage involving manual or automated switching, and the return to service of some but not all of the assets within the zone.

The reliability of a section of network such as a PZ depends on both the number of assets it contains, together with their separate reliabilities, and the restoration strategies available for part or all of the zone. A further complication comes from considering the impact on customers. At lower voltages, any outage, whether planned or unplanned, will result in the disconnection of a number of customers for a length of time. The duration of the disconnection may be as long as

it takes to repair the fault that has caused the outage, or it may be shorter if there are alternative supply routes by duplicated circuits, which is usually the case at higher voltages. Reliability from the customer's perspective is at the heart of the concept of network risk.

1.3.2 Network Risk

Network risk can be expressed in terms of the frequency of interruptions: This statistic is monitored by the regulator, OFGEM, as the average number of customer interruptions (CI) per 100 customers per year. Alternatively, it can be expressed in terms of the average duration of interruptions. One measure combines these two, so that an average interruption of 10 minutes twice per year gives an annual total of 20 customer minutes lost per year (CML). The average value of CML per customer across the whole DNO is a statistic which is also monitored by OFGEM.

From the customer's point of view, it does not matter whether the disconnection occurs at LV, MV or EHV. For the network operator, however, the distinction is important. National fault statistics for 2006/7 are shown in Table 1.1, which details, for those faults which involve customer disconnection only, the proportions of the total number of incidents, of CIs and of CMLs that arise from each of six separate categories.

Percentages (%)	Of Incidents	Of Customer Interruptions	Of Customer Minutes Lost
Pre-arranged outages	15.92	4.94	11.29
Faults at LV	66.85	11.77	22.91
Faults at MV	15.93	68.34	58.04
Faults at EHV	1.26	9.19	4.94
Faults at 132 kV	0.04	4.23	2.08
Transmission Faults	0.00	1.52	0.74

Table 1.1 – Customer loss at different voltage levels [8]

These statistics illustrate some significant features of network operations. Planned, pre-arranged outages account for nearly 16% of all incidents. However,

since they are generally at lower voltages (where there is no circuit duplication) they affect smaller numbers of customers, and so account for only 5% of customer interruptions (CI). But because these planned outages tend to last longer than the time taken to repair or to restore an unexpected fault, they account for over 11% of the total customer minutes lost (CML).

Unplanned faults at LV are the most common category of incident, accounting for two thirds of the total. But again, because they affect fewer customers (usually well below 100 for each incident), they account for only around 12% of CIs and (because there are no re-routing options, so the restoration takes as long as the repair) they account for a higher proportion, 23%, of CMLs.

MV faults account for the majority of CIs (68%), and also for the majority of CMLs (58%). Since the regulator, OFGEM, rewards or penalises each DNO on the overall or headline totals of these two figures, it is not surprising that the main efforts of DNOs are directed towards reducing these figures, and making the MV networks in particular more reliable. For this reason, and also because there is considerable generic similarity between MV feeders, the bulk of reliability research tends to be concentrated at this voltage level.

Unplanned faults which affect customer supply at EHV and 132 kV together account for only 1.3% of the total. This reflects both the robust design and the built-in duplication at these voltages, which means that only around 1 fault in 5 will result in customer disconnection. However, because any disconnection fault which does occur affects a large number of customers (typically several thousand), they account for over 13% of CIs. The proportion of CMLs is smaller, at 7%, because of the urgency of restoring such a large number of disconnected customers, and because of the flexibility of the network, allowing a proportion of customers to be restored by non-standard reconfiguration before any repair is complete.

Faults at transmission voltages are extremely rare, reflecting the robustness of that network. There were only 2 incidents during the year 2006-7, representing less than 0.01% of the total. However, because these infrequent events affect large numbers of customers (typically hundreds of thousands), their impact on CIs (1.52%) and on CMLs (0.74%) is much greater. They are sometimes designated high impact low probability (HILP) events, and because they invariably attract media attention, they tend to have a higher profile and attract more research interest than

events on the EHV and 132 kV networks, even though they account for only around one tenth as many CIs and CMLs.

The present research concentrates on two of the six categories listed in Table 1.1, namely EHV and 132 kV. It seeks to understand, quantify and find ways of mitigating the network risk that arises in these two categories. Although these categories together presently account for less than 14% of customer interruptions (and only around 7% of customer minutes lost), it was nonetheless decided to focus on these voltage levels for the following reasons:

- When incidents do occur, they have a high profile, and so DNOs are particularly concerned to reduce their frequency.
- There is a perception within the industry that risk is likely to increase in the future at these voltage levels, for a number of reasons including severe weather, deliberate damage and ageing assets.
- The investment decisions that need to be made at these voltages involve large capital sums, and so it is particularly important that they can be justified and that the optimal investment strategy is adopted wherever possible.
- There has in general been less previous research at these voltages than at both higher and lower voltages, so this shortfall needs to be addressed
- Specific research issues are a feature of networks at this voltage more than at higher or lower voltages, largely as a result of their more bespoke topology.

For the purposes of the present research, the term 'network risk' is defined as the expectation of loss resulting from faults on the EHV (including sub-transmission) system. This can be expressed as the product of likelihood and consequence:

$$TNR = \lambda \times CQ \quad (1)$$

Where TNR is the total network risk, λ is the frequency of a significant failure, and CQ is the consequence of that failure, involving numbers of customers and unit costs. These terms will be defined more precisely as methodologies are developed later in this thesis.

1.4 Causes of Network Risk

Network risk can be defined as the product of the likelihood of a failure with its consequences, summed over the range of all possible failures [9]. An extensive overview of the range of possible causes of network risk is set out in a paper by Nordgard et.al, based on a survey of 9 distribution companies in 3 different countries. [10]. Their classification includes aspects of risk which are not specifically network risk, including in particular safety [11, 12] and environmental [13, 14], but also aesthetics of power grid components, relationship with media, company mergers, outsourcing of services, and cooperation with other infrastructure services.

The classification includes factors which indirectly impact on network risk, including unpredictable regulatory framework, changes in owner demands with increasing profit expectations, vanishing competence and local knowledge, and uncertainty in load development in the network. Finally, Nordgard lists a number of factors which directly affect network risk. These include generally ageing infrastructure, reinvestment decisions, distributed generation, and increasing vulnerability due to adverse weather, severe faults, and increased utilisation of the network. Most of these factors will be identified as part of the background of increasing network risk in Section 1.9.

This categorisation of the possible causes of risk makes a useful starting point. Evaluating the relative likelihood and consequences of each of them, however, requires a reliable source of data.

The National Fault and Interruption Reporting Scheme, set up and administered by the Energy Networks Association, is potentially such a source [6, 8]. Each DNO in Great Britain is required to report all faults which occur on their network, whether or not the fault results in loss of supply to customers. These reports are aggregated and analysed by cause and by voltage level. During the year 2006/7, for example, there were almost 200 000 such incidents, mostly at medium or low voltage. Only 2522 of them were at EHV (33 kV or 66 kV). However, these 2522 incidents are classified according to the equipment affected (Table 1.2), and to the primary cause of the fault (Table 1.3). This database is a useful source of failure probabilities for subsequent work.

These NAFIRS data are gathered in, and are therefore relevant to, the UK, and perhaps to other countries with similar climate and level of technical infrastructure. By comparison, Brown's chapter on Interruption Causes is based in

the USA, where squirrels, snakes, fire ants, tornadoes, ice storms and heat storms are all described as significant risks [7]. He also quantifies some of the risks by equations, including transformer and cable insulation degradation as a function of temperature.

Total incidents on 66 and 33 kV	2522
Overhead Lines	1177
Underground Cables	578
Switchgear	216
Transformers	224
Other equipment	267

Table 1.2 – Faults on 66 and 33 kV networks, by component

Lightning	393	Related to age or wear	694
Wind and Gales	247	Safety issues	27
Falling Trees	175	Maintenance issues	40
Other weather-related	95	Protection inc. settings	44
Birds, animals, insects	88	Manufacture, Installation	60
Wilful damage	79	Other operational	67
Accidental damage	76	Unclassified or unknown	437

Table 1.3 – Faults on 66 and 33 kV networks, by cause

Other countries would exhibit different patterns. For example, one which has industrialised rapidly over the past 20-30 years is unlikely to find that 27% of their system faults arise from aged or worn equipment.

The problem facing the researcher in using a comprehensive data source such as NAFIRS is deciding to what extent to aggregate the data. The 2522 faults at EHV in Great Britain could be supplemented by 80 times as many at lower voltages, if this data is considered to be relevant. It would also be possible to include data from more than one year, if there is no significant pattern of change over that period. Conversely, only 12% of these 2522 faults occurred in the YEDL and NEDL regions,

where some of the case studies in the present research are based. Arguably, there might be sufficient regional differences in fault patterns to make data from elsewhere irrelevant or even misleading.

When it comes to estimating failure rates, there is a choice between using different rates for each component, or for each cause of failure, or for both together, as against a simple overall rate per 100 km of network. The advantage of subdivision is greater precision, the disadvantage is a smaller database for estimating each parameter, as well as greater reliance on the accuracy of the data-gathering process itself.

The NAFIRS data also contains information on the consequences of network failure. While 97% of faults at LV and 96% of faults at HV result in customer loss, the proportion at EHV is much lower, as a result of circuit duplication. For Great Britain it was 31%, reducing to 18% (because of more circuit duplication) if Scotland is excluded. Corresponding values for YEDL and NEDL in that year were 24% and 32% respectively. The average duration of a customer disconnection is also calculated, at 56 minutes (Great Britain), 55 minutes (England and Wales), 52 minutes (NEDL) and 26 minutes (YEDL).

Again, a decision has to be taken as regards which data to use in subsequent work. Does the much lower duration of customer interruptions in YEDL reflect a fundamentally different geography or circuit topology? Or is it just coincidence, based on a data set of only around 20 incidents? The available data is useful, but it has to be used with discrimination.

The question also arises as to whether network risk is increasing. NAFIRS reports on long-term trends in failure rates, and produces results which may appear surprising. Over the 20 year period to 2007, fault frequency is decreasing at all voltages and by a number of different measures [8]. In particular, the number of customer minutes lost (CML) due to EHV faults has roughly halved. This seems in marked contrast to industry perceptions, as discussed in [10] and in Section 1.9 of this thesis. It appears that, even though network reliability is increasing at present according to a range of statistical measures, there is a widespread and growing perception that this improvement will be threatened in the near future from a number of different directions, including accelerated asset deterioration and increasing utilisation of the networks.

1.5 Regulating and Measuring Risk

Increasing utilisation can lead to increased levels of risk throughout the network. [15]. Minimising this risk is one of the principal concerns of industry regulators throughout the developed world. In the UK, the regulator, OFGEM, lays down a range of standards for the design and operation of distribution networks. These standards will now be described and critically analysed.

1.5.1 Design Standard P2/6

Minimising network risk starts with the initial design and subsequent development of the network topology. The seminal document here is Engineering Recommendation P2/6, produced by the Energy Networks Association for the guidance of Distribution Network Operators (DNOs) such as YEDL and NEDL which together form CE Electric UK [16]. P2/6 specifies how long it should take to restore power supplies in the event of a single circuit outage, often referred to as (n-1), and also after a second circuit outage, that is a fault which occurs in one circuit while another nearby circuit is out for maintenance, often referred to as (n-2). It does not prescribe a maximum frequency for such outages. These recommendations are detailed in Table 1.4. It can be seen that the restoration requirement depends on the size of that part of the network which has lost power, as measured by the maximum demand in MW of that group of customers. The larger the group, the more onerous are the restoration requirements.

In particular, below 60 MW (and effectively below 100 MW) the specified (n-2) requirement is nil. This means that a network requires more redundancy to be built in at higher demand levels, typically in the supply to a Primary substation at EHV (66 or 33 kV), than is required for the local HV (20 or 11 kV) secondary distribution network. This requirement is reflected in differences in design philosophy between EHV and HV circuits. To appreciate such differences in detail, it is necessary to consider each class of supply separately. The practical consequences of these precisely specified requirements need to be worked out in detail at each location on the network, in conjunction with circuit maps, data and schematics available in the LTDS [17, 18]. This is done in the case studies in Chapters 3, 4, 8 and 9 in particular.

		Minimum Demand to be met after	
Class of Supply	Range of Group Demand	First Circuit Outage	Second Circuit Outage
A	Up to 1 MW	In repair time (Group Demand)	NIL
B	Over 1 MW to 12 MW	(a) Within 3 hours (Group Demand minus 1 MW) (b) In repair time (Group Demand)	NIL
C	Over 12 MW to 60 MW	(a) Within 15 minutes (Smaller of Group Demand minus 12 MW and 2/3 Group Demand) (b) Within 3 hours (Group Demand)	NIL
D	Over 60 to 300 MW	(a) Immediately (Group Demand minus up to 20 MW (Automatically disconnected)) (b) Within 3 hours (Group Demand)	(c) Within 3 hours (For Group Demands greater than 100 MW, smaller of Group Demand minus 100 MW and 1/3 Group Demand) (d) Within time to restore arranged outage (Group Demand)
E	Over 300 to 1500 MW	(a) Immediately (Group Demand)	(b) Immediately (All customers at 2/3 Group Demand) (c) Within time to restore arranged outage (Group Demand)
F	Over 1500 MW	GB SQSS	

Table 1.4 – P2/6 requirements for each demand group [26]

1.5.2. Comparing Design and Operational Standards

Whereas network design is governed by P2/6, network operation is subject to a different set of performance criteria. Of these, the most significant is the Interruption Incentive Scheme (IIS), as described in Section 1.3.2. For every network fault which results in loss of supply to customers, the number of customers interrupted for a period of longer than three minutes, the customer interruptions (CI), must be measured, recorded and reported. The duration of the interruption for each customer, the customer minutes lost (CML), must likewise be measured, recorded and reported. These figures are aggregated to give a CI and CML total for the incident.

One shortcoming of the IIS is that it measures average performance, taking no account of the variations between customers. So a good average figure could mask the fact that a minority of customers could be rather more seriously affected. To some extent, this is remedied by the guaranteed standards of performance, which require penalty payments to be made to individually affected customers if they are without electricity for over 18 hours.

The requirements of P2/6 are for network design, and have no direct impact on performance as compared with the more operational measures of IIS and GSP. It could be argued that having two sets of criteria is unnecessarily confusing, and that they should be merged. This issue was addressed in a report written by consultants KEMA [19].

The KEMA report identifies and discusses a number of potential shortcomings of the P2/6 design standard. One of them concerns Common Mode Failure. For example, two cable circuits may be electrically independent, but if they are routed through the same trench, they are liable to events (such as accidental JCB damage) which might take out both circuits simultaneously. This kind of multiple outage is clearly more serious than a single outage, and it is not adequately addressed by the first and second outage descriptors of P2/6.

Another issue is how group demand boundaries are defined, or rather, the fact that they are not defined. There is no definitive map produced by the DNO and approved by OFGEM to serve as an agreed reference point. This could lead to differences of opinion about whether a given network does or does not comply with P2/6.

Finally, there is the definition of 'maximum demand'. P2/6 specifies that maximum load will 'normally be based on the cold weather ratings, but if the Group Demand is likely to occur outside the cold weather period the ratings for the appropriate ambient conditions are to be used [16]. However the smoothing out of peak loads, although good in terms of higher asset utilisation, can make it harder to schedule planned maintenance outages, in particular major construction projects which were traditionally assigned to the lower-load summer months. This is further exacerbated by the increasing need for such construction outages as equipment ages.

1.5.3 Other National Regulatory Regimes

Across the globe, Network Operators are being monitored, assessed, rewarded and penalised based on the availability and reliability of their networks. This debate about the nature and possible modification of the UK regulatory system has echoes around the world. Although the present research concentrates in particular and in detail on the UK regulatory system, its general approach is equally applicable elsewhere, and could be adapted to the regulatory regimes of other

nations. The following examples highlight that, while emphases may vary from one country to another, the overriding issues remain the same.

A study in South Africa, based on customer responses to questionnaires, concluded that national standards were almost non-existent [20]. This highlights that the UK was one of the first countries to decentralise its electricity supply industry, and has therefore already developed a comparatively sophisticated regulatory system. This study also highlighted that large customers might want – and be prepared to pay for - different standards of reliability from the majority of smaller, domestic customers. In the UK, where CML is used instead of MWh not supplied, it could be argued that the system discriminates against larger customers. This discrimination has both advantages and disadvantages.

The limitations of measuring average performance were addressed by a Swedish paper which defined a Customer Dissatisfaction Index (CDI) [21]. This found that ‘there seems to be a rather sharp threshold value for the customer satisfaction regarding reliability of supply. Complaints started when a customer experienced more than three interruptions per year, or one interruption longer than 8 hours.’ On this basis, the CDI is defined as the proportion of customers who passed that threshold in any year. The study then used probability calculations to evaluate the expected impact of using the CDI, both on system costs and on network performance.

A Canadian study showed that their regulatory system is similar to that in the UK, with performance-based rewards and penalties [22]. One significant difference is that Canadian power utilities both manage the assets and supply electricity through them. The approach to network risk and reliability is bound to be affected by whether or not the operator has direct responsibility for supplying the customer. The study also demonstrated the importance of past data-collection for the accurate assessment of network risk.

1.5.4 *Distributor Measures of Risk*

In order to minimise the company’s exposure to network risk, as variously defined by the UK regulator, a DNO such as CE Electric UK needs to measure, monitor and manage the level of risk on its networks. Three of the ways in which this is currently done at CE Electric UK are described in Appendix C. Discussions with engineers from a number of other DNOs in the UK indicate that they all have

methods which are similar in overall approach, although perhaps different in detail. The three approaches described in Appendix C (Major Systems Risk, Asset Serviceability Review and Composite Risk Index) form part of the background to the methodologies which are developed in Chapters 3-9. They are referred to in those chapters where appropriate.

1.6 Approaches to Evaluating Reliability and Risk

In Section 2.1, a number of approaches to the probabilistic modelling of network reliability will be described. These approaches can also be extended to model and evaluate network risk. The different approaches can be grouped under four headings [7], which can be described as Network Modelling, Markov Modelling, Analytical Simulation, and Monte Carlo Simulation. It was decided that an early task in the present research would be to investigate all four of these approaches, and to apply each one in turn to a test network, a single representative section of an actual EHV network in the north east of England, owned and operated by CE Electric UK. In this way it would be possible to determine how useful each approach would be in the particular application that the project was focussing on, namely EHV networks in the UK, with their own particular design, operating, financial and regulatory characteristics. That investigation is detailed in Appendix A. The present section highlights the key conclusions that are relevant for this research.

1.6.1 Network Modelling

Network Modelling represents a physical network by a reliability network based on series and parallel network connections. When the Network Modelling technique is applied to the test network, the result is a customer unavailability of 12 minutes per decade. This value may be used for comparative purposes, but on its own it does not provide much information. This approach also has a number of shortcomings. In particular:

- A large amount of input data is required, and this has to be adjusted to allow for factors including the location and condition of each component. This data may not be easily available, and what is available may not be reliable.
- Connectivity is assumed to imply ability to supply customers. In particular, there is no distinction between peak times, when the remaining circuits may

be overloaded, and other times when they are not. In general, load level is not specifically taken into account in Network Modelling (although it would be possible to include it by, as a first approximation, adding a load factor to the location and condition factors already mentioned).

- Failure rates and time to repair are combined in the calculations, to give a static measure of customer supply reliability (minutes lost per decade), rather than any dynamic measure of the pattern of unavailability frequency and duration..
- All input figures used are average levels (e.g. of failure rates, or time to repair), so the output measures of reliability are also average figures. It is not possible to see how a 'bad year' might compare with this average year.
- Components in series are assumed to be mutually exclusive and independent, and so are circuits in parallel. This enables probabilities to be added (in series) and multiplied (in parallel). In practice, this is not the case, as will be illustrated in two respects in the following section.

In conclusion, Network Modelling is useful for gaining some understanding of network reliability, and it enables a number of circuits to be ranked for further investigation. But it would need to be adapted and extended to enable it to investigate and evaluate network risk. More detailed analysis requires the use of state-based methods such as Markov modelling, analytical simulation and Monte Carlo simulation.

1.6.2 Markov Modelling

Markov Modelling is the preferred method of classic reliability studies, for example as described in Billinton and Allan's seminal textbook [23]. Its distinctive approach is to define a number of possible states in which a system can exist, together with possible transitions between these states. A fixed probability of each transition occurring within a given time is then assigned, and a matrix drawn up of these probabilities. Mathematical Markov analysis of the matrix is then carried out (usually by computer) to calculate the overall probability that the system is in each of the permitted states. These probabilities can then be processed to derive indices of reliability, risk and cost.

Markov Modelling represents an improvement over Network Modelling in a number of significant respects. In particular, its ability to deal with several states, and the transitions between them, makes it a dynamic representation, and enables the non-independence of both failure and restoration to be effectively represented. It can deal with non-standard states of the network, although this soon becomes complicated both to represent and to compute.

Values of network reliability can be derived easily from the output of the Markov model. Calculations of network risk are less straightforward, and may require additional data and extensions to the methodology.

Markov Modelling is the preferred technique for modelling standard distribution networks, and as such is probably better suited to the more standardised topologies which are characteristic at lower voltage levels. At EHV, where topologies tend to be more individual, the standardised approach of Markov Modelling appears to be more limiting, as discussed in Appendix A.

One such limitation is that Markov Modelling is memory-less. The probability of transition from state A to state B is fixed, regardless of how the system reached state A. In practice, what happens next (e.g. decisions by Control Engineers) will depend to a great extent on what has gone before. Another limitation is the reliance on complex, specialised mathematics, which makes it less useful in an industrial setting. These limitations do not apply to the same extent to Analytical Simulation, which can be applied to a range of network risk issues.

1.6.3 Analytical Simulation

Analytical simulation is a heuristic, versatile and holistic approach to calculating network risk directly, as well as network reliability. The possible outcomes of each set of events are defined and weighted according to their likelihood. The results are then summed to give an overall measure of network risk, which includes the consequences of each possible outcome. It is essentially a bottom-up as opposed to a top-down approach, requiring detailed understanding of the particular section of network being considered. Because this approach is not applying a defined single technique such as Markov Modelling, but rather adapting the laws and methods of probability in general to a particular problem, a wide range of factors which affect network risk can be investigated in turn, and then combined as required. Some of these factors are described and explained in Appendix A, with

reference to the test network. It is apparent from consideration of these factors that Analytical Simulation is a flexible and holistic approach to modelling network risk. It can be adapted to a range of situations, including dynamic variability, non-standard configurations, and different operating assumptions. As such, it is particularly well-suited to the idiosyncratic topologies which are typical at EHV. It can also produce output in various forms, including financial, to meet the operational and regulatory requirements of DNOs.

One shortcoming of Analytical Simulation techniques is that, like Network Modelling and Markov Modelling, they still produce output measures based on the average level of risk, rather than the likely statistical variation from one year to the next. This variation – the maximum liability, as opposed to the expectation of loss - can be addressed by the use of Monte Carlo Simulation, as described in the following section.

Another possible shortcoming is that, because it is not a prescriptive methodology, it requires a greater depth of engineering understanding of the topology and operating characteristics of the section of network under consideration. This might make it more attractive to DNOs, who will see its innate relevance and applicability, while at the same time making it less attractive to observers at a distance, whether academic or regulatory, who may find it difficult to apply without that specialised knowledge of the network.

The overall conclusion is that, of the three approaches considered so far, this one seems the most suitable for modelling EHV networks. It will be seen in the following chapters that the methodologies developed in this research are all based on analytical simulation approaches and techniques.

1.6.4 Monte Carlo Simulation

Monte Carlo Simulation can be regarded as an extension of analytical simulation. Instead of using average values for input data, it allows these values to be modelled by probability distributions. This technique can model complex system behaviour, including all kinds of interdependency, and produces a distribution of possible results rather than expected values. The benefits of Monte Carlo Simulation are principally that:

- The uncertainty and variability inherent in the input data is accurately represented, rather than being obscured by the use of average values.

- It provides the opportunity to gain a deeper understanding of the risks inherent in EHV networks. As such, it makes a useful extension to methodologies based on Analytical Simulation.
- Within the industry, calculating the worst-case liability may be more significant than measuring the average level of network risk.

The disadvantages of Monte Carlo Simulation include computational intensity and slight imprecision, in that the use of random number streams means that multiple analysis on the same system will produce slightly different answers. These differences can be decreased by increasing the number of simulations, and therefore the computation time required. There is also the possibility that, because this approach is essentially statistical, certain rare but important combinations of events may fail to be sampled and therefore be overlooked in the analysis.

A further disadvantage is that assumptions need to be made about the shape of the underlying distribution for each input parameter. The available data (from NAFIRS, for example) will often only give a total or average value. In some cases there may be theoretical justification for assuming a particular distribution. For example, if failures are regarded as essentially random events, then a Poisson distribution for the number per year could be appropriate. But the distribution for the number of customers who could be quickly reconnected at a lower voltage, which might depend on time of day and the availability of alternative circuits, might be more uncertain.

Because of this uncertainty, it is perhaps more useful to carry out Monte Carlo Simulation in order to increase understanding than in order to produce reliable numerical results. The present research has therefore carried out Monte Carlo Simulations, as an extension of the developed methodologies, where such increased understanding was seen to be necessary. Examples are included in Chapter 3 and in Chapter 5 of the present thesis.

1.6.5 Software Tools Assessment

All these approaches to modelling network risk can be greatly helped by the use of appropriate software tools. As part of the present research, a number of possible tools were investigated and evaluated in terms of their potential usefulness

for the analysis to be undertaken. In the event, detailed software development did not form a significant part of the present research, although a functional specification was produced for the Generalised Methodology described in Chapter 4. However, the investigation of potentially useful software tools, both in the public domain and as used by CE Electric UK, was a valuable exercise, the results of which are described in detail in Appendix B.

1.7 Increasing Utilisation

The first of the factors which will be identified in Section 1.9 as tending to increase network risk is the increasing utilisation of the network. Higher levels of peak demand and broader peaks mean that there is less headroom in the network to reroute power flows in the event of planned or unplanned outages.

During the period from 1920 to 1970, consumption of electricity in the UK increased at an average annual rate of over 9% per year [1, 24]. In contrast, the years from 1970 to 2010 have seen much lower annual growth rates, averaging around 1% per year throughout that period. This change after 1970 has been less pronounced in other developed countries. In France, for example, an annual growth rate of around 6% in the 1960s decreased to around 3% in the period 1970-2000 [1].

One of the consequences of this slow growth rate has been a much slower rate of asset replacement in the electricity distribution industry. For example, a survey of the 33 kV transformers belonging to CE Electric UK shows that two thirds of the present stock were installed during the 1960s and 1970s, and are therefore reaching the end of their design lifetime [25].

A further consequence of this drop in growth rate is that there has been little opportunity for extensive redesign of the network, and so network architecture still reflects the design needs of an earlier generation. Also, most of the engineers who joined the distribution industry in the 1960s and earlier have retired, and so there are few engineers now working for DNOs who have any personal experience of engineering a rapidly expanding network.

1.7.1 Projected Levels of Load Growth

It is possible that load growth over the next 20 years will follow the established trend of the previous 40 years, averaging around 1% annually. One recent report produced for Ofgem outlines five possible scenarios for the period to

2050, ranging from a slight decrease in demand to the fastest growth rate still averaging less than 1% per year [26]. A successor report considers four scenarios, with growth rates up to 2025 averaging 1.4% in the fastest growth scenario [2].

These reports and their different scenarios are addressing issues which include:

- The rate of closing of heavy industry may have peaked.
- Increasing efficiency of domestic appliances may be reaching its limit.
- Increasing reliance on overseas nations of varying political stability for supplies of oil and gas.
- Carbon targets that require the substitution of low-carbon electricity for other fuels.
- Global shortfalls of oil and gas driving up fuel prices, which may decrease total energy consumption, but increase the proportion of energy use which involves electricity and its distribution.

These issues are also addressed in detail by David McKay in his seminal book 'Sustainable Energy without the Hot Air' [27]. He summarises current per capita energy consumption patterns in the UK as including 18 kWh/day for all electrical uses, 40 kWh/day for heating, and 40 kWh/day for transport. This is the total energy demand which needs to be reduced substantially over the next 20 to 40 years.

His proposal to reduce the heating load is by the use of ground-sourced and air-sourced heat pumps, combined with greater efficiency of house insulation. The combined effect would be to replace 40 kWh/day of fuel (mostly gas) with 12 kWh/day of electricity, releasing at least double that amount of heat from the ground or the air. His proposal to reduce the transport load is by extensive use of electric vehicles. This would replace 40 kWh/day of fuel (mostly oil-based) with 18 kWh/day of electricity.

Although net energy consumption is significantly reduced in this scenario, the electricity consumption is substantially increased, from 18 to 48 kWh/day, an increase of 167%. If this increase happened over the next 40 years, as McKay assumes, the annual growth rate would be around 2.5%. However, it may be that affordable oil and gas will not last as long as 40 years. To achieve the kind of

changes that McKay describes by 2030, in only 20 years, would require electrical loads to increase at an annual rate of 5%.

In the present thesis, McKay's baseline figure of 2.5% is the value assumed to be most likely. Although higher than the assumptions in the OFGEM reports [26, 2], it is still less than one third of the growth rate actually achieved during the period from 1920 to 1970. Also, even if the underlying average growth rate were around 1.5%, it would be unevenly distributed, and could well reach 2.5% in rural areas such as that assumed in the case study in Chapter 8.

1.7.2 Electric Vehicles

The rate at which electric vehicles penetrate the market depends on a number of factors, including their price, image, reliability, ease of recharging, battery lifetime, and driving performance. One report considers the possibility of fast charging points available in public locations, where an electric car could be fully charged at perhaps 20 kW in an hour or so [28]. However, it concludes that fast charging, even if available, will form an insignificant proportion of the total. Most recharging will be done slowly at home (at 3 kW, via a conventional 13 amp plug and socket), taking around 6-8 hours for a full charge, and rather less for the more usual partial charge. Slow charging points could also be available for commuters at their workplace, for use during the day.

For DNOs, the key question is the time of day when battery recharging occurs. If it happens mainly overnight, then peak demand would not increase significantly. However, if most consumers choose to recharge their vehicles as soon as they get home from work, then the load at peak times would increase by a greater percentage than total energy demand, requiring DNOs to invest in increased network capacity to meet this peak demand.

It seems most likely that the outcome will be somewhere between these two extremes. Accordingly, the baseline assumption in this thesis is that the peak is neither sharpened nor flattened as a result of electric vehicles, but retains more or less the same profile as at present. Therefore a 2.5% increase in energy demand will also require a 2.5% increase in peak power load, and the daily profile will remain the same. The seasonal impact of electric vehicles is also significant, and is addressed in the next section.

1.7.3 Heat Pumps

Heat pumps, either ground-sourced or air-sourced, are more common in continental Europe and in Japan than they are in the UK. Ground source heat pumps deliver enough heat energy for a warm (not hot) water-based central heating system, and also to pre-heat (rather than completely heat) the house hot water supply [29]. Air source heat pumps can power a warm air heating system only.

The rate of penetration of heat pumps into the home heating market is presently limited by their unfamiliarity, capital cost, installation cost, lack of maintenance infrastructure, and the need for supplementary heating (for hot water, and for fast space heating). It is also limited by the low price of gas in recent years, typically around one third of that of electricity per kWh to the domestic consumer. However, as heat pumps become more widespread (probably initially in new build housing estates), the problems of unfamiliarity, high cost, and lack of maintenance should reduce. If, in addition, the price of gas increases from one third towards one half that of electricity, the cheaper running costs of heat pumps compared with gas-fired boilers or CHP will become more significant.

As regards the impact of such growth on the DNOs, the significant issue, as with electrical vehicles, is how this increased demand affects the load profiles. Figure 1.1 shows a typical household gas demand profile, and this is taken as indicative for heat pump electricity demand.

It can be seen that the evening peak coincides with, and is even more pronounced than, the existing domestic electricity demand peak. However, with a sensitive DSM scheme, such peaks could be reduced, and in the present research it is assumed that sufficient DSM is effectively implemented to reduce the annual growth in evening peak power demand to 2.5%.

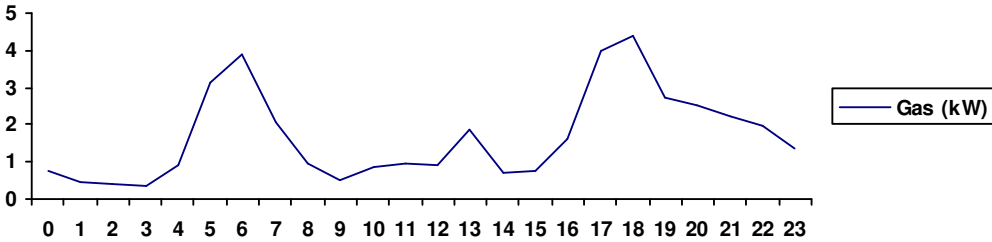

Figure 1.1 – Gas demand in a typical house, average daily profile [30]

The peak power demand does not only depend on the daily profile. It depends also to some extent on weekly variations, and to a greater extent on seasonal variation throughout the year, with domestic summer peaks around 75-80% of winter peaks. This percentage would tend to be increased by the addition of electric vehicles (where demand is unlikely to vary much throughout the year), but would tend to be reduced by the addition of heat pumps (where summer heating is minimal, and even summer air-conditioning, in the UK, is likely to be below 50% of the winter peak heating demand in most areas). For the purposes of the present research, it is assumed that these two imbalances cancel out, and that the seasonal profile, like the daily profile, remains constant in shape although the energy and power levels all increase by 2.5% per year.

1.8 Economics of Distribution

Using the definition in (1), network risk involves not only the expected values, or distributions of values, of CIs and CMLs, it also incorporates the financial implications for the DNO, and possibly for others, of each event. It is also useful to set against these costs of network risk the possible costs of mitigating it.

1.8.1 CIs and CMLs

The performance of each DNO is reviewed annually and compared with previous years, with other DNOs, and with the individual targets set by OFGEM as part of the Interruption Incentive Scheme (IIS) framework and guaranteed standards of performance. This performance is publicly reported and is subject to financial rewards and penalties [31]. In the year 2005/6, for example, the targets set for NEDL were 74.5 interruptions per 100 customers per year, and an average of 71.4 minutes lost per customer per year. Actual performance was around 10% better than this target (65.7 interruptions and 64.1 minutes lost), triggering a reward of £1.98 million. The YEDL performance was around 2% better than their slightly more demanding targets, triggering a reward of £0.38 million. Publicly available figures such as these, for all the DNOs, suggest an average cost of £6.00 per customer interruption, plus £0.10 per customer minute lost, which are used as standard throughout the present study.

There are also compensation payments for any customer who has been disconnected for a continuous period of over 18 hours. The cost of these

compensation payments could be included as an element of network risk, as could an estimated cost to each customer of the disconnection. The first of these costs is unlikely to be significant in a study of EHV network risk, as every precaution is taken to ensure that such payments are not triggered for the large number of customers involved. On the rare occasions where customers are disconnected for over 18 hours as a result of EHV or higher voltage faults, as occurred for example during the June 2007 floods in Sheffield, the event may be treated as exceptional and therefore does not trigger compensation payments.

The cost to the customer is more controversial. A number of studies seek to quantify and include this element of cost, and some are reviewed in Chapter 2, where the decision to exclude it from the present study is also set out and discussed.

1.8.2 Repair and Depreciation Costs

Besides any penalties triggered (or rewards foregone) by a circuit failure involving customer disconnection, there are further, more direct costs to the DNO as a result of such an event. These relate to the costs of repairing the network, made up of additional labour, materials and services to restore the circuits.

One example concerns the growing problem of cable theft. Thieves use increasingly sophisticated locating and digging equipment, and seem undeterred by the risks of digging into live cable. Quite apart from the danger to life involved, the cost of repairing the damaged cable can be in excess of £100k. There is also the indirect cost of the increased network risk during the time it takes to repair and restore the damaged cable.

A further indirect cost of network faults arises from the effect of such faults on the expected lifetime of circuit components. Suppose that a fault on an aged transformer results in the full substation load being carried by the remaining transformer for a period of several weeks. During that time, forced air and/or hydraulic cooling may be needed, and the transformer will run at a high temperature. The effect of this on transformer components, in particular the insulation, can be severe. It can be quantified in terms of transformer lifetime, which may be reduced by perhaps 10 years as a result. For a transformer costing perhaps £500k, with a nominal lifetime of 50 years, a 10 year reduction could be regarded as costing the DNO at least £100k.

Finally, it should be noted that a fault on just one circuit of two which duplicate one another, although it will not generally incur CI and CML costs, will still incur repair and depreciation costs. These costs cover a wide range of values, from nil (for a self-correcting fault) to well in excess of £100k. This particular probability distribution is perhaps the hardest of all to determine for the present research. The default value of £20k, used as an average cost per event in the case studies which follow, is at best a reasonable estimate over a very wide range of different events.

1.8.3 Capital Costs

The combined total of CI, CML, repair and depreciation costs can be aggregated to give a value for network risk, measured in £k, as explained in Chapter 3. This risk can be offset or reduced by various options to mitigate that risk, each of which incurs its own cost. The principal example of such costs is capital expenditure.

If an aged transformer is replaced by a new one, it can be expected that the frequency of future failure will be substantially reduced. The benefit of such reduction can be measured as a reduction in network risk, measured in £k. This annual reduction over the lifetime of the new transformer can be set against the total project cost of the replacement – including design, labour, materials and services as well as the new transformer itself.

Offsetting a future annual saving against an initial one-off capital cost requires some kind of discounted cash flow (DCF) analysis, the outcome of which will depend on the discount rate used. Analysis of this kind has been carried out in Chapter 5.

1.8.4 Operating Costs

Besides the capital cost of mitigating network risk, there may be increases to DNO operating costs. An additional circuit, for example, will require regular inspection and maintenance throughout its lifetime. This could be regarded as coming out of existing overhead at no extra cost, but it could also be costed in terms of the regular extra labour and materials required. This is particularly appropriate when such maintenance is contracted out, and has to be paid for directly.

The extra cost of network operations control is more problematic. In general, a new circuit would be absorbed into the existing overhead. But if its operation is complex, requiring significant active network management (ANM) particularly in the event of a fault, then additional labour costs would be incurred. While this could

probably be carried by the overhead for any single project, a number of projects all with complex ANM requirements might together require an increased level of manning, at least at certain times, in the network operations control room.

A further hidden cost of complex networks involving significant ANM is its possible impact on network robustness and stability. The more complex the operations, the greater the probability of them triggering a consequent fault elsewhere on the network, which represents an increase in network risk. While it is particularly hard to quantify an increase of this kind, its likelihood needs to be taken into account in any project involving increasing the complexity of network operations.

Finally, whilst any capital construction project should decrease network risk in the years after it has been completed, it will also tend to increase network risk during the period in which it is carried out. This is because there will be times when one circuit is disconnected as part of the construction project.

1.9 Research Background

The present research arises out of a concern about the likelihood of increasing levels of network risk during the period 2010-2030, in particular on EHV and sub-transmission circuits, and the impact that this would have on both DNOs and their customers. This concern is based on a number of factors, including:

- Utilisation of distribution networks is increasing, and as a result the latent network capability available to respond to unplanned events is reducing.
- There is increasing awareness of global warming, and severe weather conditions are occurring more frequently.
- Customer expectations of network performance, both overall and at times of specific network duress are increasing. .
- The existence of separate network planning and network operating standards can lead to uncertainty as to what is acceptable.
- There was a view that network risk / resilience may be a key element in the next Distribution Price Control Review in 2010. This proved to be the case, and the present research will help DNOs to respond to this new emphasis.

- There has been a significant increase in the amount of deliberate damage experienced around the network, in particular to facilitate cable thefts.
- There is a perceived threat of terrorist attack at vulnerable points on the network
- Increasing levels of penetration by distributed generation at all levels, within a network originally designed for uni-directional power flow and passive network management requires new ways of thinking and appropriate capital investment.
- Major assets were mostly installed during the 1950s, 60s and 70s. They are now reaching the end of their designed lifetimes, and there is uncertainty as to how rapidly they will fail and need replacing.
- The impending retirement of a large number of experienced engineers with unique technical skills and network familiarity may lead to a decreased ability to respond to unplanned events.

1.10 Research Objectives

Against this background, and with input from CE Electric UK [32], research objectives were developed to address the problems identified. These objectives are as follows:

1. To gain a deeper understanding of existing sub-transmission and extra high voltage distribution networks, adopting a systems approach to classifying the inherent causes and consequences of circuit failure.
2. To understand in particular the various causes and likelihoods of double circuit failure, and the time taken following such failure to restore supply to different groups of customers by automated or manual switching, network reconfiguration and asset repair.
3. To develop a holistic and transparent way of quantifying this network risk, leading to a universally applicable method of measurement which will enable the risks in different locations, or under different scenarios and assumptions, to be fairly and realistically compared.
4. To understand and quantify the possible impact of likely changes to the level of network risk in the future, with particular reference to the increasing age profile of major assets, and to increasing network utilisation as a

consequence of the greater use of electric vehicles and of heat pumps. To understand and quantify possible ways of mitigating this future risk, including network automation, capital investment, and active network management.

5. To develop versatile and applicable risk modelling and analysis methodologies, and apply them usefully, verifiably and effectively to a wide range of case studies, on both generic and actual CE Electric UK networks.
6. To understand and evaluate existing mathematical approaches to network risk, incorporating them where appropriate in the developed methodologies. To develop holistic, whole system models and solutions that could be used as practical decision support tools by CE Electric UK, other DNOs in the UK, the UK regulator Ofgem, and consultants within the industry.
7. To develop technically accurate models which also reflect the present UK regulatory environment, while being sufficiently versatile to be adapted to different regulatory environments elsewhere, or in the future. To incorporate financial information to produce fully costed solutions that can usefully inform DNO decision making processes.

1.11 Structure of this Thesis

The present introductory chapter, including research objectives, is followed by a detailed review of recent literature on distribution network risk, with an appraisal of its relevance to the present research, in Chapter 2.

This leads to the development and demonstration in Chapter 3 of a core methodology for evaluating network risk with respect to a case study based on a part of the actual UK network,. This core methodology is expanded in Chapter 4 into a generalised methodology, able to analyse the most complex network topologies.

In Chapters 5-8, the versatility and usefulness of this approach is explored by the development of further, problem-specific methodologies. Chapter 5 addresses the problem of the ageing asset base, and the need to replace it at a sustainable rate. Chapter 6 considers replacing manual switches with motorised, radio controlled switches, or even with fully automated circuit breakers, at critical nodes on the network. This can significantly reduce the time taken to reconnect groups of customers following a circuit failure, and the capital cost of such replacement can be justified, if the location and extent of the replacements are carefully determined.

Chapter 7 develops a methodology for evaluating the effects of increasing utilisation of the network, illustrated by a case study described in Chapter 8. Electric vehicles and heat pumps are important components of the drive for a low carbon economy, and could cause substantial growth in peak and average loads on the networks during the period 2010-2030. The question of how long the existing networks could cope with such growth, and to what extent minor capital investment and/or active network management could prolong that period and delay the need for major network redesign, is addressed by this methodology.

The three problems addressed in Chapters 5-8 are treated in isolation, using separate methodologies. However, in practice they often arise in combination. Ageing assets require replacement on a part of the network where utilisation is increasing, and where the resulting increase in risk can perhaps be mitigated by introducing some automation. Chapter 9 looks at such combined problems, and shows that a holistic, systems approach can generate new solutions by use of a composite methodology. Finally, Chapter 10 discusses some of the issues arising from previous chapters, and Chapter 11 sets out the conclusions of this research.

2. LITERATURE REVIEW

In this chapter, a critical review is provided of some of the most significant papers and other sources which have relevance for the present research. In the final conclusions section the principal findings of direct relevance to the present research are summarised, as well as how the present research builds on what has gone before.

2.1 Modelling Network Risk

In the literature reviewed so far, little use has been made of the mathematics of probability. Only in Table C2 in Appendix C is there an attempt to assign order of magnitude probabilities to possible failure events. There are a number of possible reasons for this, which are addressed in a paper by Bouwman et al. [33]. The authors conclude that the advantages of a probabilistic approach outweigh the disadvantages. Perhaps the most serious disadvantage is the need for more information, which can be hard or even impossible to obtain from the industry, although generic data may be available on an industry-wide scale [34]. In the UK electricity distribution industry, such information is collected and collated by the National Fault and Interruption Reporting Scheme [6, 8]. But, even so, it may be better to estimate the missing information based on what is available, rather than lose the greater understanding of complex situations afforded by the probabilistic methodologies.

2.1.1 Standard Approaches

The starting-point for any probabilistic analysis of electricity distribution systems is the classic treatment by Billinton and Allan, first published in 1984 and revised in 1996, and referenced by the majority of papers on this subject [23]. Probabilistic methods, in particular Markov analysis, are applied first to simpler, radial distribution networks, and then extended to more complex parallel and meshed networks. The treatment builds on the availability of reliable data on the causes and effects of network failures, in quantities sufficient to allow the accurate estimation of failure frequencies and restoration times. Given accurate input data, the resulting Markov analysis will

calculate the average frequency and duration of customer interruptions over a year.

With such precise input and processing, the methodology can be fine-tuned to include the effects of breakers not operating correctly, different weather conditions, and individual component manufacturers, none of which is addressed individually in the present research. The methodology also addresses a number of factors which are addressed individually in the present thesis, including calculating CIs and CMLs, different switching arrangements, load transfer possibilities at different levels of utilisation, the probability distributions of key input parameters such as failure rates, planned outages, double circuit failure, and temporary repair. While the present research takes a different approach to these calculations, and therefore does not use Billinton and Allan's equations directly, it has been informed throughout by their comprehensive and detailed approach to calculating Network Risk.

Extended techniques, which Billinton and Allan describe in later chapters of their book, have also been adapted to the present research, including multiple outages, selection between load transfer options, economic evaluation, and Monte Carlo simulation.

A later text book (2002) by Brown covers much of the same material as Billinton and Allan, but from a more industrial perspective [7]. He tends to concentrate in particular on reliability at medium voltages, whereas the present study is more concerned with EHV. However, much in his approach is relevant at these higher voltages, although the network architecture tends to be substantially different, with far greater inbuilt redundancy.

Network analysis can be carried out by component. This is possible and useful if there is reliable and sufficient data at a component level, particularly for MV networks which tend to be more generic. EHV networks are more individualised, and in the present research are therefore treated in a more lumped fashion. The most useful approach here is model reduction: deciding which components, which modes of failure, and which failure consequences can be lumped together without excessive loss of precision or accuracy to produce a more robust, more versatile, simpler model that will be more accessible, comprehensible and believable to the DNO engineers who will have to use it [7]

2.1.2 Customer Costs

A number of papers, often informed by surveys, seek to quantify the costs of outages to the customer, and to evaluate network reliability in these terms [35, 36]. One paper describes this as the ‘societal cost of avoided outages’ [37]. A Finnish study [38] analysed the cost of storm damage, broken down into customer outage costs, customer compensation fees, and fault repair costs. Adding together the outage costs to the customer and the compensation costs to the distributor seems like double counting. More significantly, the customer outage costs are generally based on the customers’ own estimate of these costs, which may be inflated. It is noted by distributors that such estimates, adjusted to give an annual expected outage cost, tend to be well in excess of what customers are prepared to pay for extra assets to remove or reduce the risk [39]. For this reason, the present research has not included indirect, customer-assessed outage costs in its measurement of network risk.

2.1.3 Applications of Probabilistic Methodologies

The probabilistic methodologies described in detail by Billinton and Allan, and by Brown, are at the heart of a number of studies. Increasingly, utilities are using the mathematics of probability to calculate and rank risks. Recent papers describe particular case-studies (one in Spain [40], and another in Sweden [41]) or more generalised applications [42 – 45]. One older paper uses linear programming on a defined set of operating states, responding to contingencies each with their own probability of occurrence, and seeks to minimize the load in MW that needs to be shed in order to contain each contingency [46]. This paper is based on a transmission network, and it is notable that most of the relevant literature is either based on transmission networks, or on MV local distribution networks. There is comparatively little published research at EHV and sub-transmission voltages.

Several papers use Monte Carlo simulation to model the variability inherent in distribution networks. Some use specific modelling techniques such as artificial neural networks to assess network reliability [47], while others use a more heuristic approach. Some are state-based, while others are sequential, representing the flow of time. One in particular, based on a case

study in the south of England, considered the possible effect of cascade tripping on the transmission network [37]. It concluded that the marginal cost of operating an expensive oil-burning generating station was outweighed by the reduction in network risk. Another paper used sequential Monte Carlo simulation for a composite system reliability assessment, with a load profile for each busbar and negative exponential distributions for both time to failure and time to repair, producing reliability indices for each load point [48]. A third paper compared two Monte Carlo methodologies, involving parallel and distributed processing, applied to a large network of over 2000 circuits, connecting over 1000 busbars [49]. It produced accurate estimates of reliability indices, and sought to minimize a defined customer damage function.

One useful paper from 2001 considers the balancing of cost and risk in network expansion projects [50]. The authors point out that this is usually done by assigning a cash value to the risk, and adding that into the overall cost of the project, which is then minimised. Their methodology involves calculating two parameters for each possible network scheme: the total cost, and the risk measured in expected kWh lost. These are plotted on a graph, and a line drawn through the points which minimise each possible linear combination of the two. When applied to a case-study involving expansion of a representative network, a curve was obtained with the shape shown in Figure 2.1.

Region A of the curve shows that, at the lowest levels of cost, risk tends to increase significantly for minimal extra cost saving. Conversely, region C shows that, at the lowest levels of risk, considerable extra cost is incurred for minimal reductions of risk. Region B contains those feasible solutions where cost and risk are well balanced. The selection of which of these solutions to choose depends on the relative values the selector assigns to cost and risk. But this process of choosing makes clear both the cost and the risk implications of the choice.

A paper from the USA highlights the complications of the current design process [51]. It goes on to use probabilistic models to design a meshed medium-voltage network for an urban central business district that

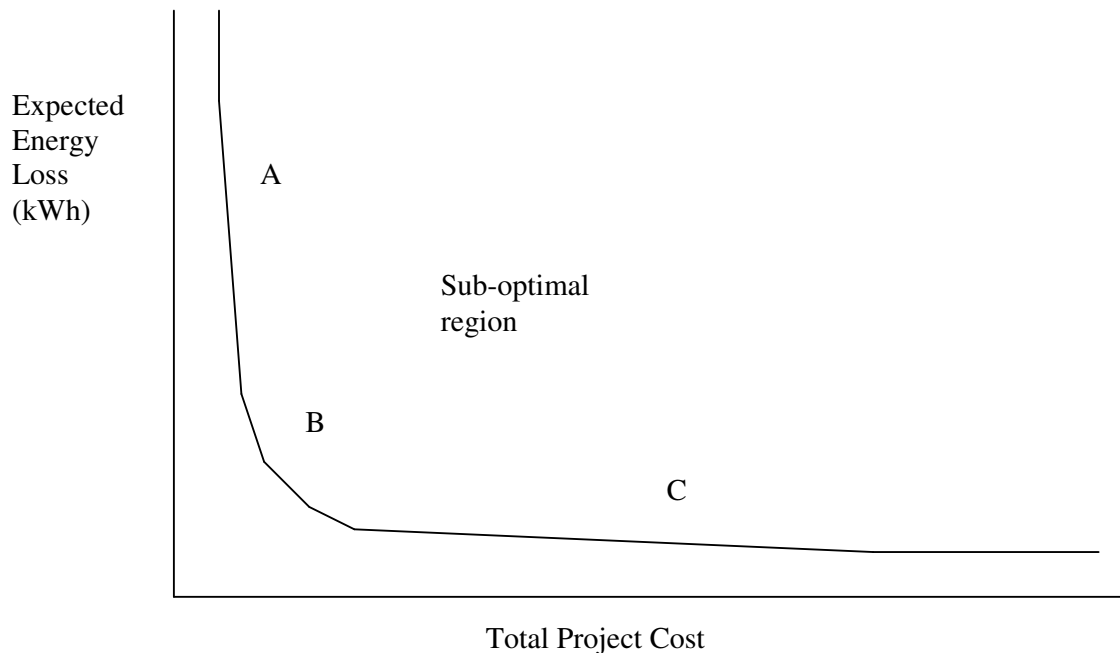

Figure 2.1 – Optimising cost and risk simultaneously

maximises reliability and minimises cost, again looking at the two measures separately and trading one off against the other.

Another paper looks at budget-constrained planning, seeking to choose projects which will optimise the ‘benefit’ by minimizing the number of MVA-hours not supplied [52]. The methodology developed proved highly effective, demonstrating that the first \$1M of capital expenditure saved 40 MVA-hr, while the next \$20M only saved an extra 5 MVA-hr.

2.1.4 Extreme Weather Events

One situation which greatly affects system reliability is bad weather. Events such as flooding or falling trees due to high winds, snow or ice cause line faults and interrupt the supply, increasing both CI and CML. The same bad weather may also limit the repair crew’s ability to reach or work on the fault, thereby further increasing CML.

One way of evaluating the likely effects of bad weather is by using Markov modelling techniques. Good and bad weather are then two different states, with probabilities of transition between them, and different rates of

failure and restoration within them for any given component. A recent study extended this to three different states – normal, adverse and extreme weather – with transitions and rates for each [53]. Cases were examined where, for example, 40% of total failures occurred in bad weather (adverse or extreme), and of these 10% occurred in extreme weather. The expected effects of this on measures of CI and CML (or, since this was in a Canadian context, SAIFI and SAIDI) were calculated. These figures can then be used to evaluate possible expenditure options

The Finnish study referred to earlier [38] analysed the cost of storm damage. Based on a case study using a rural 20kV network, it concluded that the impact of major disturbances could be reduced by increasing size of the maintenance and fault repair organisation and, more effectively, by changing the network topology by undergrounding circuits.

These two studies are based in countries – Canada and Finland – which regularly experience more extreme weather events than the UK. However, such events are becoming more common even in the UK. The floods of Summer 2007, which affected widespread parts of the country at different times, closed down a grid supply point connecting transmission to distribution systems in the centre of Sheffield for several days and led to customer power rationing. This illustrates that studies such as these are becoming increasingly relevant to network operations and planning in the UK.

2.1.5 Operational Time Horizons

The final paper reviewed in this section looks at the variability in levels of risk within an operational time-horizon of a few hours [54]. Its distinctive approach is to draw up a graph of likelihood against consequence (measured, for example, in CML). A point on the graph is plotted as the probability that the CML exceeds a certain value, and these points are joined together to form a characteristic curve, the risk profile. This approach is then applied to three distinct case studies. The first concerns the risk on a section of network under normal operating conditions. The second looks at the increased level of risk during network restoration, when one circuit is unavailable. The third evaluates the risk due to projected changes to the network. The methodology of [54] measures reliability using a range and not just average values. It looks

at the impact of operational changes and planned outages. It uses CML as a measure of cost, and uses Monte-Carlo simulation to produce a cumulative distribution. It is essentially a composite methodology, using a common framework to examine topological changes, changes to operational processes, and variability in asset condition. Its strength is that any combination of these changes can be evaluated together, rather than one at a time as is the case for most of the other papers discussed in this section.

2.2 Risk Mitigation by Asset Replacement

Having reviewed papers on the causes and modelling of network risk, attention now turns to papers on ways of mitigating that risk, starting with asset replacement. One aspect of risk which has been studied in detail is its application to the individual assets or components of a system. Data is gathered internationally, processed and published in journals and in books, of which the most relevant and comprehensive for this study is the IEEE Gold Book [34]. Standard textbooks use this data to build up probabilistic models, typically using Markov modelling, to evaluate probabilities and durations of system failure [7, 23].

All the textbooks agree that the probability of component failure depends significantly on the age of the component, according to the so-called 'bathtub curve', shown in Figure 2.2, with its three distinct sections: the

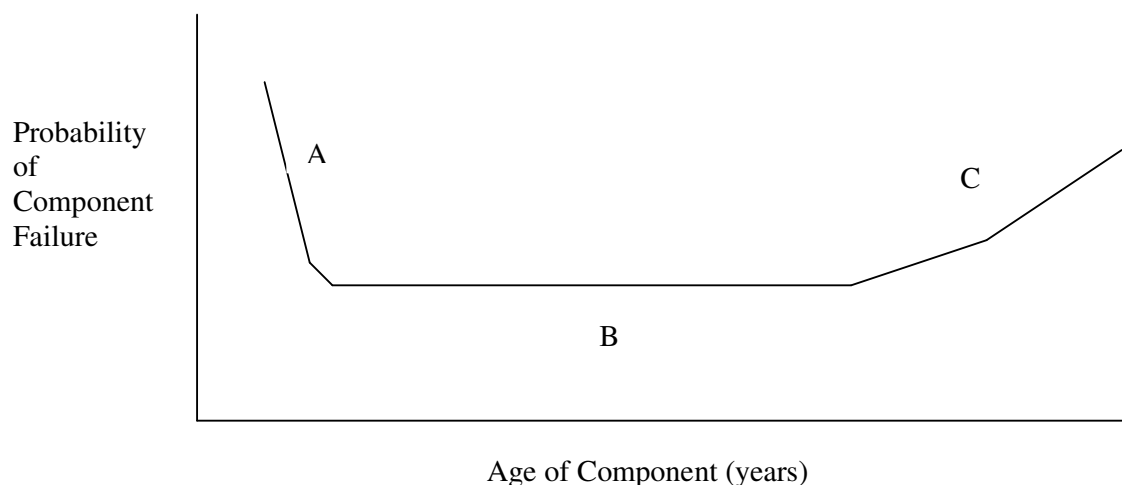

Figure 2.2 – The bathtub curve

Burn-in phase (A), the Useful-life phase (B) and the Wear-out phase (C).

Section C is the focus of asset replacement strategies. The precise shape of this part of the curve will vary from one component to another. The increase of failures may be sudden and substantial, or may be gradual and slight. It may contain discrete steps. Often, it can be modelled by a Weibull distribution, as is done in a recent paper which uses both Markov analysis and Monte-Carlo simulation to process the probabilities and consequences of failure [56]. The location parameter of the Weibull distribution corresponds to the component age at the commencement of wear-out, the shape parameter gives the rapidity of onset of the increase of failure rate, and the size parameter measures the factor by which the failure rate increases.

Knowing these parameters enables an optimal choice to be made between three alternative replacement strategies for ageing equipment:

- (i) Use it until it dies. This maximises its life, but the replacement is then unplanned and may result in a long outage at an inconvenient time.
- (ii) Use it until increasing failures herald its imminent demise, then initiate the replacement (e.g. purchase components) so that it is semi-planned. This is a compromise between planned and unplanned replacement
- (iii) Use it up to a pre-set retirement age based on accumulated data, followed by a fully planned replacement. This may result in the loss of possible useful life.

The second, compromise solution will often be the most economic, but it relies on the warning signals being available (corresponding to a slowly changing bathtub curve). This works to some extent for transformers, if the oil can be sampled and analysed regularly, but tends not to for components such as the 230kV cables in [56], which can increase failures rapidly and without warning.

The choice of replacement strategy might also be affected by the criticality of the component, as addressed in [57]. This uses inspection and evaluation of the state of components to implement condition based risk management (CBRM) techniques. In a further development of, Hughes and others use the concept of Health Index and ageing rate to derive a company-wide estimate of financial risk. Using this approach, it is possible to take a

wide variety of failure modes into account. In practice, sufficient data is unlikely to be available for all failure modes [58]. The approach is applied to a case study involving a population of 916 11 kV circuit breakers. As in [56], an optimal year for replacement is found, when the increase in asset risk exceeds the reduction in cost by not replacing the asset. This is then aggregated to produce an optimised replacement programme.

2.3 Risk Mitigation by Network Reinforcement

Replacing worn out assets is perhaps the most straightforward way to mitigate network risk. Network reinforcement is an alternative approach, which is generally more expensive and more far-reaching.

Where a national electricity distribution system is still growing at a rapid rate, there is potential for network reinforcement as a by-product of network expansion, as in e.g. [50]. But where growth rates have been around 1% or below, as has been the case in the UK for the past 40 years, there is less scope for such network reinforcement [24, 26]. It may be that the growth rates increase after 2010 with greater take-up of electric vehicles and heat pumps [2, 26, 27]. This would give a greater financial justification for network reinforcement and even significant redesign.

Without such growth, network reinforcement (for example, the installation of a third transformer at a heavily loaded substation) tends to be justified on the grounds of purely local load growth, with calculations to show that the substation in question would be excessively loaded, particularly under (n-1) conditions, when one circuit is experiencing either a planned or an unplanned outage.

However, if extra assets are to be installed, the construction project itself is likely to involve the loss of one or more circuits for a significant period of time. The risk reduction once the project is completed has to be set against what could be a significant increase in risk while the project is being carried out. A methodology is required which can be applied to detailed construction projects, to calculate the incremental risk incurred by a range of different possible construction schedules. This enables an optimal schedule to be selected, in terms of the balance between the cost of the schedule and the incremental risk it incurs.

2.4 Risk Mitigation by Increasing Automation

A number of papers investigate the gain in network reliability that can accrue from automation and network reconfiguration. Some are looking at reconfiguring the network operationally in its intact state (n-0), typically to reduce power losses. One paper concluded that this could not be done effectively on an urban MV network hour by hour, but could perhaps be more effective on a longer timescale, from month to month [59]. This paper also concluded that increased automation would not be cost-effective. However, another paper described a feeder reconfiguration algorithm, based on a heuristic methodology, and designed as an operating decision support tool. This also sought to minimise losses, and concluded that test results showed the methodology to be both efficient and robust [60].

Automation could be by motorising a manual switch, and installing a radio communication link, so that the switch can be activated remotely from the control room when off-load, without the need to dispatch a switching crew. It could be by installing a circuit breaker, which can be operated remotely on-load, even when a fault current is flowing. Or it could be a more sophisticated switch arrangement, with intelligent decision-making capability, constituting what is sometimes called a self-healing network.

Two papers which explore these topics, one from Netherlands [61] and another from Finland [62], are fairly theoretical in approach, and both deal with medium voltage (11kV) networks. More practically based is a case-study of the design of an offshore wind farm [63], which balances cost and risk in deciding the network topology (looped or radial), the level of switch control (manual, remote or fully automatic), and the level of standby generation (large, small or none). Although this particular application is somewhat specific, the issues raised apply more generally, in particular evaluating and (in this case) costing the increase in reliability which can be obtained by investing in interconnection, automation, standby generation, or a balanced combination of all three.

Self-healing networks take automation to a more advanced stage, whether on transmission networks [64] or on distribution circuits [65, 66, 67]. All three of these recent conference papers described prototypes (one in Denmark and two in the UK), and all of them were on MV circuits.

Consideration of self-healing EHV networks seems to be lagging behind both higher and lower voltage networks.

One paper applies the philosophy of active risk management to a case study based on a single medium voltage feeder, which can be automated by installing between 0 and 5 devices along the feeder. These devices could be reclosers, manual switches or automated switches, and the topology could be radial or looped. They use Monte Carlo simulations to quantify the probability of achieving each level of reliability in any given year [68].

Another paper considers the use of automation to facilitate a two-stage restoration process [69]. The authors use analytical simulation, and conclude that, compared to single-stage service restoration, two-stage restoration results in a lower SAIDI (equivalent to CML) for partially automated feeders. Their work at medium voltages has relevance to the somewhat different EHV topologies of the present study.

A German paper uses similar analytic methods to model restoration times. It points out that the restoration time of a customer can be influenced by both the switching time and the repair duration [70]. The switching time considers all measures taken by the distribution operator, including remote controlled and manually performed actions. Besides single faults, it also considers multiple faults, for example double earth faults. This consideration of double faults, and their likelihood, is a key consideration in the present research. But this German paper also combines a consideration of the assets installed, and of the strategies used to operate them, which leads on to the next section of this chapter.

2.5 Risk Mitigation by Active Network Management

The risk mitigation strategies described so far – asset replacement, network reinforcement and increasing automation – all require capital expenditure to be implemented. This section of the chapter looks at solutions which depend rather on changes to operating philosophy, which can be grouped under the heading of Active Network Management (ANM).

In their 2006 paper, Billinton and Wangdee look at the variations in network reliability that arise from different load shedding policies in emergency situations [71]. They conclude that a wide range of system

performance indices have unique characteristics, due to system topology and system operating conditions and strategies.

Perhaps the biggest impact that network operation has on availability is via the strategies adopted for post-fault service restoration. For example, by using a two-stage restoration strategy rather than a single-stage restoration strategy following a fault, CML can be significantly reduced [69]. In a case study on a simple circuit to illustrate the effect of this, the expected CML for the year was reduced by up to 11 minutes by using a two-stage strategy. To some extent, this is an investment decision (whether to automate the switches in the first place), but having done so, it is an operating decision to restore some customers earlier at the expense of restoring other customers later.

Within NEDL, planning for pre-arranged circuit outages, and coping with unplanned outages, are both greatly helped by the existence, in the NEDL control room, of Primary Substation Restoration Guides [72]. This information means that if, during a maintenance or extended construction outage of one circuit, the other were to fail, then as many customers as possible could be restored as quickly as possible by switching, either manual or radio-controlled or a combination of both. The same would apply in the case of common mode failure of both circuits simultaneously, or of a second circuit failing soon after a first circuit in response to its increased load.

2.6 Other Strategies for Risk Mitigation

To conclude this literature review, a brief overview is given of some papers relating to other possible strategies for risk mitigation. These could include maintenance, distributed generation, energy storage, and demand side management.

A paper based on the report of an international task force set up by IEEE in 1995 to investigate maintenance strategies and their effect on reliability, states that maintenance is becoming an important part of what is often called asset management. The paper goes on to report on the policies in place in a representative sample of 53 utilities in 6 countries. Most used scheduled maintenance or empirical forms of predictive maintenance based on periodic inspections. Mathematical models, deterministic or probabilistic, were rarely used [73]. The paper concluded that conditions cannot be

improved by maintenance for random failures, but that maintenance has an important role to play when failures are the consequence of aging.

Maintenance, and more particularly construction outage planning, needs to take account of the increased risk to operations. One paper, based on a Canadian case-study, used a model incorporating time shift simulation, end-of-life failure models and dynamic rating values for cables to calculate risk and evaluate different strategies, balancing the requirements of both maintenance and operations [74]. The KEMA report [19] considered that the increased number of major construction outages in the UK distribution networks was not adequately addressed by P2/6

Two papers addressed the issue of the duration of maintenance outages, which can on occasion result in increased CML or the triggering of compensation payments. One [75] used extensive data analysis to evaluate the effects on time of outage restoration (TOR) of time of occurrence of the outage (time of day, day of the week, month), of outage consequence (number of phases affected, which protection devices are activated by it), of the weather (which can affect repair access and duration), and of the cause of the outage. The other [76] examined in particular the effects of contracting out some or all of the maintenance activity. They examined alternative ways of modelling this, and concluded that the TOR could no longer be adequately represented by an exponential distribution.

The recent proliferation of small-scale generators has also had an impact on network risk. This has largely been for operational reasons; as well as the undermining of the protective system, DG can make the control of voltage levels and power factor more problematic, and this has tended to limit DG penetration [77]. From a reliability point of view there are also potential problems, as with anything which increases network complexity, but there are also potential advantages from having a greater diversity of infeeds to the distribution system. P2/6 recognises this by including a detailed set of tables whereby DG can be valued at a proportion of its capacity [16]. That proportion is a function of the location, availability, number of independent units, and intermittency of each DG site.

Another advantage is the possibility of islanding, in locations where load and generation capacities are reasonably well balanced. This can

significantly enhance reliability, as two recent papers argue [78, 79]. Overall, DG brings both threats and opportunities to distribution network reliability, but effective management of the network can minimise the first while maximising the second.

2.7 Literature Review: Conclusions

The subject of network risk draws on a number of different strands within the broad field of Power Systems, and combines them in various ways. This literature review has therefore ranged fairly widely, in an attempt to find material on which the present research can build. The main conclusions of this literature review are as follows:

- There are a number of standard approaches available for modelling distribution networks, many of which involve the use of probabilistic techniques. They tend to rely on the availability of good input data, and perhaps for this reason are not as widely used in industry as might be expected.
- Modelling has been applied to a wide range of networks and network issues. It can be applied to one particular failure mode, such as bad weather, or can it combine many causes of failure in a single model.
- Network risk can be costed and the total cost of capital expenditure and network risk can then be minimised. Alternatively, the function to be minimised can be some bivariate function of cost and risk.
- Customer costs, as defined by the customer, can be included as an element of total network risk, although this tends to introduce a significant element of uncertainty.
- One way of mitigating network risk is by asset replacement. An optimal strategy for asset replacement can be determined by use of techniques including the bathtub curve and condition monitoring.
- Network reinforcement is another possible risk mitigation strategy. It is costly and tends to be used mainly at times of substantial load growth. It introduces an element of increased network risk during what may be lengthy construction periods.

- Network automation is another useful risk mitigation strategy. It has been researched in particular at MV levels, where the risk is higher and the networks more generic. Automation solutions at EHV tend to be more bespoke, and have tended to receive less attention as a result.
- Other risk mitigation options include the imaginative use of active network management, the effective use of preventative maintenance, and the capacity credit afforded by distributed generation.

2.8 Building on Previous Research

This critical review of the literature has identified a number of limitations, and it is the aim of the present research to attempt to address some of those limitations. In particular, the papers reviewed in this chapter tend to approach issues of network risk from one of four distinct directions:

1. Engineering, involving detailed analysis of failure modes or of electrical load flows, leading to an engineering solution.
2. Mathematical, applying sophisticated analytical and probabilistic techniques to the problem, leading to a mathematical solution.
3. Power Systems, where logistic analysis of networks and restoration strategies leads to a technical industrial solution.
4. Regulatory and Commercial, where detailed enumeration and analysis of regulatory requirements and costs leads to an economic industrial solution.

One of the ways in which the present research aims to make a distinctive and significant contribution to knowledge is in combining these four approaches in a single suite of methodologies which will give roughly equal weight to engineering, mathematical, power systems and regulatory / commercial aspects of problems which involve network risk.

Second, there is a need to extend research from both transmission and MV levels into the generally more complicated sub-transmission and EHV networks, which have been less frequently researched. This involves a detailed understanding of network risk issues that are prominent at these voltages, in particular a focused analysis of the causes and varying impacts of double circuit failure.

While incorporating research findings from around the world, the present research concentrates on the network architectures and regulatory regime that apply presently in the UK. Although its findings will be of relevance for any national power system, and could be adapted to apply directly to it, it is intended primarily to address issues arising on UK power networks.

Finally, this requires the development of a suite of heuristic, versatile methodologies which adopt a systems approach and which can be applied to a variety of network issues, including asset replacement, network automation and increasing utilisation, both singly and in combination. These methodologies need to be transparent and accessible if they are to be of use both to the academic community and to the electricity distribution industry. It is the intention of the present research to provide such a holistic tool kit which can be of use in solving actual network risk problems which arise on EHV networks

3. DEVELOPING A CORE METHODOLOGY

In Section 1.6 and in Appendix A, a range of approaches to understanding and evaluating network reliability and risk was investigated. It was concluded that Analytical Simulation is the most versatile and appropriate base for developing methodologies to understand and calculate network risk in EHV circuits. During the first year of this research, a core methodology was developed and tested by applying it not only to the Test Network, shown in Figure 3.1, but also to a number of other parts of the NEDL and YEDL systems. These included dense urban configurations in central Leeds, relatively remote rural networks around the coastal town of Bridlington, and a sub-transmission 132 kV switching station near Wakefield. Generally, these case studies originated where there was need for network reinforcement or asset replacement.

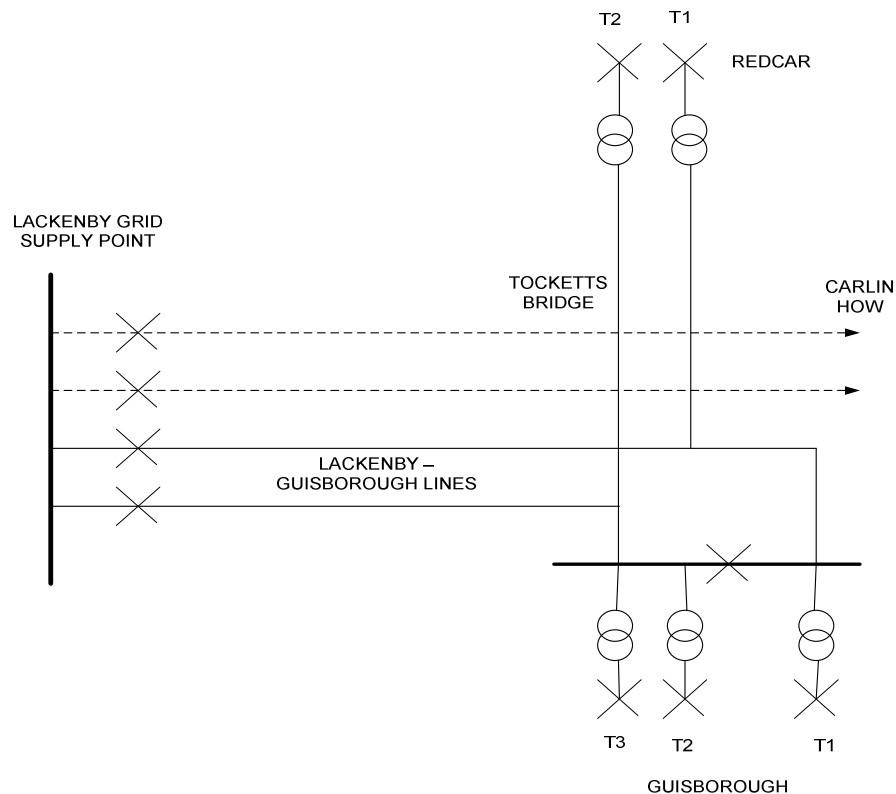

Figure 3.1 – Schematic of Test Network

In this chapter, the core methodology is described in detail, and illustrated by applying it to the Test Network, both under normal operation and during the proposed construction project, as described in Appendix A.

3.1 Components of Network Risk

The reliability of a circuit can be calculated from the average failure rate and the average time to repair that circuit. Reliability of customer supply is less straightforward, as it requires detailed knowledge of alternative supply routes for each customer. This can be quite complex, particularly where EHV circuits are involved.

Network risk combines circuit and/or customer supply reliability with measures of consequence, such as the number of customers affected. It can be expressed in terms of the expected values of regulatory parameters such as customer interruptions (CI) and customer minutes lost (CML), over a number of future years, as a result of failures to the circuits under consideration. Such measures are useful, but they leave out a number of other, less measurable aspects of risk, including safety, environment, and reputation, as detailed in [11-13].

Including such aspects of risk makes the evaluation more comprehensive, but at the same time gives rise to two complications. The first of these revolves around the question: Whose Network Risk? A narrow definition might consider only the risk as experienced by the DNO. A wider definition could include risk as experienced by customers, the general public, and even the national economy. The second complication is how to measure each aspect of risk in a way that enables one to be balanced against another.

The present research adopts a narrow focus in dealing with these issues. In the first place, intangible aspects, in particular safety, environmental impact, and company reputation, are excluded from the analysis. Second, Network Risk is evaluated in terms of its impact on the DNO alone. The impact on a customer as a result of disconnection is not separately assessed. Arguably, the penalties imposed by the regulator on the DNO in the event of excessive CI or CML should reflect the cost of customer impact. Finally, Network Risk is measured in expected cost to the DNO in pounds sterling (£).

Each component of network risk included in the core methodology, and in the methodologies derived from it, has to be expressible in expected £.

The disadvantage of such a narrow focus is that many aspects of network risk are omitted from quantitative consideration (although they are referred to qualitatively where appropriate). The advantage is that the network risk of a particular section of network under specified conditions can be expressed as a single value. The impact of changing one or more of the specified conditions can then be calculated in a transparent manner, and assessed. The level of risk in two or more different sections of network can also easily be compared. It was considered that this advantage outweighed the disadvantage, and that a narrow focus was accordingly to be preferred over a more inclusive definition of network risk.

Three components are calculated and summed to give the total network risk (TNR) of the section of network under consideration. Their contributions to TNR are shown in the following sections.

3.1.1 Repair and Depreciation Costs

These costs to the DNO were described and discussed in Section 1.8.2. In the core methodology, they are combined as a cost of repair (CR), as in (1):

$$CR = (\lambda_1 + \lambda_2) \times UCR \quad (1)$$

In (1), λ_1 represents the failure rate for the first of two parallel circuits, while λ_2 represents the failure rate for the second circuit. Their sum is the annual probability that one or other circuit fails. UCR is the unit cost, or average cost, of repair plus depreciation following a circuit failure. Points to note about (1) include

- The sum $\lambda_1 + \lambda_2$ includes the probability of both circuits failing. This assumes that, in the event of a double failure for whatever reason, including common mode failure, one of the two parallel circuits can be considered to fail initially, with the second as a consequential double failure.
- The sum $\lambda_1 + \lambda_2$ is appropriate for a simple, radial paired circuit. More complex topologies would require more complex combinations of failure rates, as detailed in Chapter 4.

- Repair and depreciation costs are incurred by a single circuit failure, even though this may not incur any loss of supply to customers.
- The average unit cost of repair is particularly difficult to estimate without extensive data analysis. When a notional cost allowance for asset deterioration is included, it becomes even more difficult. This is the input parameter that would probably benefit most from an accurate statistical treatment. This could then be input to Monte Carlo Simulation. A default value of £20000 is used in the present research.

3.1.2 Customer Interruption Costs

As described in section 1.8.1, the regulator imposes a penalty on the DNO if their annual company-wide CI total exceeds an agreed target. Conversely, they are rewarded if their CI total is below the target level. These rewards and penalties can be used to calculate a unit cost per customer interrupted, which has a default value in the present research of £6. The expected annual cost of customer interruptions in a section of network, CI , is given by (2):

$$CI = (\lambda_1 + \lambda_2) \times DF \times N \times UCI \quad (2)$$

In (2), λ_1 and λ_2 are circuit failure rates as in (1). DF is the probability that a second circuit fails before the first has been restored, for whatever reason, as described in Section 1.5.2. N is the number of customers affected, and UCI is the unit cost of a single customer disconnection. One point to note about (2) is that the input parameter DF is a composite variable representing a number of distinct and different possible events. What they have in common is that they lead to an (n-2) situation with consequent customer loss, in the case of a simple radial paired circuit. Estimating a value for DF can be done retrospectively using NAFIRS data on the proportion of EHV faults which have led to loss of customer supply.

It should also be noted that the customer number N is generally the total number of customers normally supplied by the section of network under consideration. This assumes that none of them can be restored by reconfiguration in under the threshold time for CIs of 3 minutes.

3.1.3 Customer Minutes Lost Costs

As described in section 1.8.1, the regulator also imposes a penalty on the DNO if their annual company-wide CML total exceeds an agreed target. Conversely, they are rewarded if their CML total is below the target level. These rewards and penalties can be used to calculate a unit cost per customer minute lost, which has a default value in the present research of £0.10. The expected annual cost of customer minutes lost in a section of network, CML , is given by (3):

$$CML = (\lambda_1 + \lambda_2) \times DF \times N \times (R \times Ts + (1 - R) \times TI) \times UCML \quad (3)$$

In (3), input variables are the same as in (2). In addition, R represents the proportion of customers who can be reconfigured at a lower voltage, either by remote radio control or manually, and Ts is the average time in minutes for which they are disconnected, before reconfiguration can take effect. TI is the longer time taken, on average, in minutes to restore the EHV supply in at least one circuit, and $UCML$ is the unit cost per customer minute lost. The first points to note about (3) is that the proportion R will depend principally on network topology at lower voltages, but may also depend on the time of day (for heavily loaded circuits), and on the condition and availability of the alternative routes.

Ts is dependent on the level and extent of automation on the lower voltage network, a topic discussed in more detail in Chapters 6 and 9. TI is a composite value, including many different kinds of fault and consequent repair or restoration times. Both Ts and TI have to include a significant proportion of faults which are effectively self-correcting, and which clear in a period of over 3 minutes, but probably under 10 minutes. This can be incorporated specifically in Monte Carlo Simulation.

3.2 Total Network Risk

The total network risk (TNR) can be obtained by summing the three components already discussed, as in (4):

$$TNR = CR + CI + CML \quad (4)$$

3.2.1. Application to the Test Network

Table 3.1 summarises the input parameters which will be used to evaluate TNR for the Test Network of Appendix A under normal operation.

λ_1	0.275	DF	0.20
λ_2	0.303	N	38500
UCR	20000	R	0.4
UCI	6	Ts	60
$UCML$	0.10	TI	180

Table 3.1 – Test network input parameters

With this input, the values of CR , CI and CML come to 11560, 26704 and 58747 respectively, giving a total network risk of £ 97012.

This value of around £97k is a measure of the normal level of EHV network risk at the Guisborough and Redcar primary substations in 2010 under normal operating conditions. It can be used as a base level of risk to enable these locations to be compared with others elsewhere on the network. It also enables the impact on network risk from changes to operating practices, or from construction projects, to be calculated.

3.3 Extending the Core Methodology

The core methodology for calculating network risk has now been defined, described and illustrated. This core methodology can be extended in a number of ways, in particular:

- The same equations can be applied to the same Test Network, but can incorporate variability by the use of Monte Carlo Simulation.
- The same equations can be applied to the Test Network under changed conditions, such as those encountered during a construction project.
- Additional equations can be introduced, to allow for complications such as the effect on failure rates of asset ageing and deterioration. If this is done to a small extent, as illustrated in the present chapter, it can be considered

to be merely an extension of the existing methodology. If, however, it is developed to its fullest extent, then there is effectively a new methodology, and this is the subject of Chapter 5.

3.3.1 Monte Carlo Simulation Applied to the Test Network

In this section, the core methodology is adapted for a Monte Carlo Simulation, and applied to the Test Network. The same equations (1) to (4) are embedded in the simulation model, and the input parameters of Table 3.1 are used except where specified.

The corresponding mean time between failures is then taken to be the mean of a negative exponential distribution. So, for example, the assumed failure rates of 0.275 and 0.303 per year per circuit equates to a time between failures of about 20 months. Using this as the mean of a distribution, there is then a 55% probability of no circuit failures, 33% probability of one failure, and 12% probability of two or more failures in any given year. These figures apply to a sample of 100 000 possible years, Although there is a finite probability of three or more failures, it was decided to limit it to two in the model, as this happening for any reason in any single year would probably trigger special remedial action which would make a third failure more unlikely.

The probability that any failure affected both circuits remained at 0.20, with the consequence that 5.9% of years involved a single customer interruption event, and 2.2% of years involved two customer interruption events. These figures are highly sensitive to the 0.20 value assumed for the double failure rate (DF).

As regards the duration of customer interruptions, it is assumed that 30% of customer interruptions last between 3 and 10 minutes, distributed uniformly. All 38 500 customers are assumed to be interrupted for the full duration in this case.

For the 70% of interruptions which last longer than 10 minutes, both the number of customers restored and the time taken to restore them at each stage are subject to variability, and modelled by distributions, as shown in Table 3.2. The data on which this is based comes from analysis of the 37 actual EHV interruption events which occurred on the YEDL and NEDL

networks during 2006-7. No distinction is made (given the small amount of data) as to location on the network or as to cause of failure.

<i>Restoration Stage</i>	<i>Customers Restored (and Distribution)</i>	<i>Time to Restore (Rectangular Distribution)</i>
Radio controlled 11 kV reconfiguration	7700 to 15400 rectangular	10 – 20 minutes
Manual 11 kV reconfiguration	3850 to 19250 Triangular	20 – 120 minutes
Restoration of 66 kV circuit only	11550 to 19250 rectangular	120 – 600 minutes

Table 3.2 – Distributions of numbers and times of customers restored

With these assumptions, running the model can produce estimates for the expected levels and for the distribution and impact of CI and CML. In this base run, the expected risk cost was £28 K for CI, £43 K for CML and £13 K for repairs, a total of £84 K. This figure can be compared with £97 K using the core methodology based on average values in the previous section. The small reduction is mainly in the CML costs, and is due to the slightly more optimistic assumptions as to distribution of numbers and times for customer restoration.

But Monte Carlo Simulation can also produce a range of possible results. More than 90% of sampled years will have no interruptions and no CML impact. At the other extreme, 5% of years will have a CML cost exceeding £400k. For 2% of years the impact will exceed £800k and in the worst 1% it will exceed £1 M. These variations are generated by the model as 90%, 95%, 98% and 99% percentiles respectively.

These results give a deeper understanding of the variability of network risk. However, it can be seen that a number of assumptions had to be made about the shape and associated parameters of the underlying probability distributions. Again, estimating these values led to greater understanding, but the lack of hard data on which to base these estimates does mean that the output has to be treated with a degree of circumspection.

3.3.2 Construction Outage Risk

In Appendix A, it was stated that the overhead lines from Lackenby to Guisborough can be expected to have a higher than average rate of failure, and this rate will increase each year as the lines age. Peak loads are also increasing beyond maximum line ratings, giving two distinct drivers for a possible future capital investment project.

One possible solution is to replace the existing conductors with others of greater cross sectional area, designed for a greater power flow. The present conductors are a type called Lynx, 175 mm² in cross-section and made of aluminium core with steel reinforcement (ACSR). They could be replaced by Zebra, for example, with a 400 mm² cross-section and a power rating about 70% greater.

The main driver for this project would be increasing capacity to remove the risk of infringing ground clearances under both planned and unplanned (n-1) outage conditions. Additional advantages would include replacing a conductor in poor physical condition with a new one, thereby reducing the probability of unplanned failure in the future, and also reducing power loss in the conductor itself.

Disadvantages would include the capital cost of the project [80], estimated at £1172 K , and also the increased system risk during the construction period, when one circuit is unavailable for an extended duration, around 4 months. Although the construction project would be planned to take place during the summer, when loads are lighter and the risk therefore lower, it would extend over two summer seasons (one for each circuit).

One way of minimising the risk to the system during the construction period might be to take advantage of the physical crossover at Tocketts Bridge, making a temporary interconnection between circuits for the duration of construction. This possibility will also be considered.

Evaluating this project includes balancing the capital cost of the project itself, plus the increase in network risk during construction, against the reduction in network risk as a result of renewed and uprated conductors, and the expected reduction in energy losses due to thicker conductors, during a period of 20-40 years following the project. This will be analysed in detail in Section 3.4

3.3.3 Age-Related Failure Rates

Section 2.5 reviewed some examples of the way in which asset failure rates can be expected to vary with asset age. Taking into account these examples, both from within and outside the electricity industry, it is possible to derive and construct a model for the effect of ageing on the probability of asset failure. Such a model should have the following features:

- A close approximation to the bathtub curve, with a roughly constant failure rate giving way at a certain critical time to an increasing rate.
- The increasing rate should be approximately exponential.
- It should be calibrated by group data and/or individual asset data as appropriate, provided that suitable data is available.

The overall failure rate should be made up of a constant rate not related to age, plus an age-related rate which would increase exponentially, as there seems no reason to adopt a more sophisticated curve on the available evidence, and there is theoretical justification for an exponential function. This gives an equation of the form of (5):

$$R_T = R_0 + R_A(1 + p)^N \quad (5)$$

Where N is the age of the asset in years

p is the annual rate of increase in age-related failures

R_0 is the rate of failure not related to age

R_A is a constant selected to fit the data available

and R_T is the total failure rate

This formula will be applied to 66kV overhead line, first as an asset group, and then for the Lackenby – Guisborough conductors in particular. NAFIRS data for 2006/7 analyses 1177 faults on EHV lines, of which 99 (8%) are attributed to age or wear. However, it seems likely that at least some of the remainder have a dependency on age. Wind (200 faults) may be more likely to damage older conductors, and unknown causes (197 faults) may be age-related too. It is therefore assumed that 20% of all faults are age-related.

The annual growth rate of these faults is not easy to derive directly from NAFIRS data, but a level of 5% is assumed. The overall failure rate is quoted in NAFIRS at 0.01 per km of line. Assuming an average asset age of 40 years, then input variables are $R_0 = 0.008$, $R_A = 0.000284$ and $p = 0.05$, giving increasing failure rates as shown in Table 3.3.

<i>Age</i>	0	10	20	30	40	50	60	70	80
<i>Rate</i>	.0083	.0085	.0088	.0092	.0100	.0112	.0133	.0166	.0221

Table 3.3 - Predicted past and future failure rates per km for EHV O/H line.

Table 3.3 shows quite clearly how the first 30 years contribute a growth of only 10%, which would be masked by the noise of fluctuations in the non-age-related rates due to weather in particular. At around the nominal conductor lifetime of 40 years, the failure rate starts to increase ever more rapidly, corresponding to phase C of the bathtub curve.

The Lackenby – Guisborough conductors differ from the average in that they carry large loads, and that they are liable to corrosion (near the coast, in a region of high pollution). They pass over some high ground (more liable to wind damage), and were found to be in poor condition at inspection. All these factors combined to give a high (poor) health index of 8.0 in the last definitive survey [81]. Translating this into parameters, it seems reasonable to assume a 50% higher non-age-related failure rate ($R_0 = 0.012$), as well as a 50% faster ageing than average, which would increase p from 5% to 7.5%, and decrease the design age to around 26 years for this location.

Using these parameters in (5) gives failure rates as shown in Table 3.4. The inclusion of ages 46 and 52 is to give predicted failure rates for the years 2014 and 2020, which figure in subsequent analysis. Note that the 2008 (40 year old) failure rate of 0.0201 per km is double the average for assets of similar age, which corresponds to the assumptions of earlier analysis, summarised in Table A1. Note also that the failure rate almost doubles each decade if the conductors are not replaced. It is also assumed that the failure

rate of the overhead line is predominantly due to conductors and fittings, with towers being a comparatively low risk.

<i>Age</i>	0	20	40	46	52	60	70	80	90
<i>Rate</i>	.0124	.0139	.0201	.0245	.0313	.0465	.0830	.1585	.3140

Table 3.4 - Predicted failure rates per km for Lackenby – Guis. O/H line.

3.4 Test Network Case Study: Reduced Risk with Reconductoring

Extensions to the core methodology have enabled it to be applied to a potential construction project on the Test Network, and to incorporate increasing failure rates as the assets age. These two extensions are now combined in a single case study which evaluates the potential costs and benefits of the proposed construction project.

The increasing failure rates per km of overhead line shown in Table 3.4 can be combined with the failure rates of other assets in the first Lackenby – Guisborough circuit, as was done in Table A1, to produce overall circuit failure rates which are shown in Table 3.5. The failure rates for the second circuit are similar, but increased by 0.028 per year on account of the extra transformer and switchgear for the industrial customer at Guisborough. For simplicity in this illustration, the effects of ageing of other assets in these circuits, which is less than that of the conductors, has not been included.

<i>Age</i>	0	20	40	46	52	60	70	80	90
<i>Rate</i>	.2324	.2408	.2750	.3002	.3382	.4234	.6275	1.051	1.921

Table 3.5 - Predicted failure rates for Lackenby – Guis. first circuit

Applying these increasing failure rates to equations (1) to (4) allows the increasing network risk without conductor replacement to be evaluated by the core methodology. The results for years from 2008 to 2038 are shown in Table 3.6. The expected cost of network risk per year increases from £97k in 2008 to £215k by 2038, if the conductors are not replaced.

Year	2008	2014	2020	2028	2038
Age	40	46	52	60	70
CR (£)	11560	12568	14088	17496	25660
CI (£)	26704	29032	32544	40416	59275
CML (£)	58748	63870	71595	88915	130404
TNR (£)	97012	105470	118227	146827	215339

Table 3.6 – Increasing network risk without conductor replacement

Conversely, with new conductors the failure rate for the first circuit could be expected to fall to 0.2324 in the first year of operation, increasing over the next 20 years to 0.2408. The corresponding value of *TNR* averages £84122 over those 20 years. The saving achieved by carrying out the project is therefore around £21k in 2014, increasing to £34k by 2020, £63k by 2028, and £131k by 2038. These are the benefits that can be set against the capital cost of £1172k for the reconductoring project. If this project were carried out in 2014, the un-discounted benefit would be £558k by 2028, rising to £1172k by around 2034, giving a crude payback time of around 20 years for the project, based on reduced failure rates alone.

3.4.1 Construction Risk (Single Circuit)

The calculations leading to this 20 year payback, however, do not take into account the added risk incurred during the construction period. When this is factored in, the project appears even less commercially attractive.

Without any interconnection at Tocketts Bridge, any failure of the single remaining circuit would incur customer loss. Assuming that the first circuit reconductoring (when the remaining circuit is still in poor condition) takes place in 2014, the failure rate is 0.6004 per year (assumed to be double the failure rate when both circuits are in operation, as discussed in Appendix A), giving a probability of customer loss of 0.2001 during a four month construction period. Applying equations (1) to (4) gives a *TNR* during that period of £ 151940

The corresponding probability of customer loss during the second four month construction period reduces to 0.1736, and the risk cost to £ 131818, a total for the eight months of £ 283758 K, as compared with £ 70313 for an eight month period in 2014 without reconductoring.

This equates to an added risk of £213.4 K incurred by doing the project, which is 10 times the annual risk reduction that the project could be expected to produce in 2014. So, quite apart from the project capital cost itself, it would take ten years of reduced risk due to reconductored lines to balance the extra risk incurred during the construction period. Figure 3.2 shows this result diagrammatically. The solid line shows increased risk during construction periods, followed by reduced risk afterwards. The dotted line shows the level of risk if the project is not carried out.

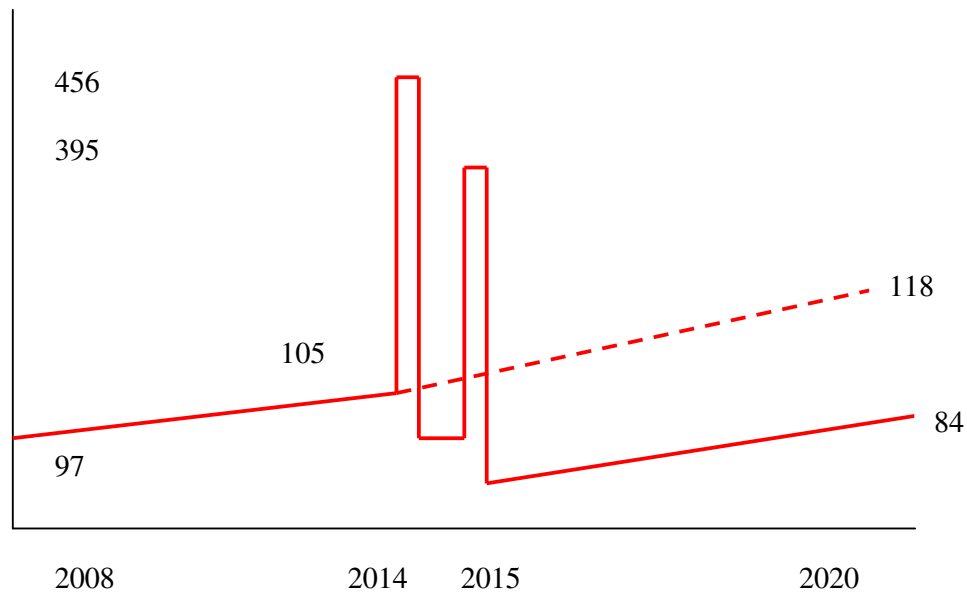

Figure 3.2 – Annualised network risk with and without construction project

3.4.2 Triple Circuit Calculations

With an interconnection at Tocketts Bridge during the construction phase, as shown in Figure A4, there are in effect three circuits to supply the whole East Cleveland system of four primary substations. This is a relatively complex network, but it can be evaluated using the extended core methodology, and making a number of assumptions, in particular:

- The annual failure probability for the remaining Lackenby – Guisborough feeder is likely to be higher than the 0.3002 when it operates as one of a matched pair, but lower than the 0.6004 when it operates on its own. Assume a probability of 0.450, with a similar value for the unaffected (but more heavily loaded than normal) Carlin How circuit, but a 50% higher value (0.675) for the third, interconnected circuit which supplies all the primary substations.
- Assume in addition that any failure has a probability 0.2 of affecting one other adjacent circuit (where circuits 1 and 3 are not adjacent), and $0.2 \times 0.2 = 0.04$ of affecting both other circuits.
- The probability of more than one incident during the construction period has been excluded in this analysis.
- 30% of customers at each primary substation can be reconnected at lower voltage in 15 minutes on average, and 70% cannot and so remain disconnected for 3 hours on average.

Then the probability of various outcomes during a four month construction period is as shown in Table 3.7. The consequence of each outcome is also shown in Table 3.7, in terms of the number of customers interrupted and the average interruption duration in minutes. Costs include *CR*, *CI*, and *CML*.

<i>Circuits Out</i>	<i>Probability</i>	<i>CI (total number)</i>	<i>CML (average)</i>	<i>Cost (£ K) per incident</i>
0	0.454	0	0	0 + 0 + 0
1	0.12	0	0	20 + 0 + 0
2	0.18	0	0	20 + 0 + 0
3	0.12	0	0	20 + 0 + 0
1 & 2	0.0525	38 500	130.5	20 + 231 + 502
2 & 3	0.0525	13 700	130.5	20 + 82 + 179
1, 2 & 3	0.021	52 200	130.5	20 + 313 + 681

Table 3.7 – Triple circuit probabilities and costs

The weighted average cost during the first construction period is then equal to £72.9k, which can be compared with the corresponding risk of £151.9k without interconnection at Tocketts Bridge, a saving of just under £80k, or £160k over both construction periods. If the cost of making the interconnection added less than this amount to the project cost, it would probably be worth doing.

3.5 Core Methodology: Discussion

A core methodology based on analytical simulation has been developed and demonstrated. In its basic form, it can produce a single value for the total network risk on any simply designed network, such as a double radial circuit to one or more load points. This enables the levels of network risk in different sections of the network to be evaluated and compared. The methodology can also be extended by the incorporation of Monte Carlo Simulation techniques to incorporate probability distribution inputs, and to produce probability distribution outputs.

Further extensions allow the core methodology to be applied to the proposed Lackenby – Guisborough reconductoring project on the Test Network. The results suggest that the case for replacement seems uneconomic at present, although as age-related failures follow an exponential growth model, that case becomes increasingly economically attractive with time. It can also demonstrate the potential benefit of a temporary expedient such as interconnection at Tocketts Bridge.

This core methodology, and its extensions, were tested by presenting the input assumptions, the methodology itself, and the results of each of the case studies to an expert audience of CE Electric UK engineers. They were able to suggest minor changes, which were incorporated at the time, but were in general satisfied that the methodology accurately and fairly represented the networks with which they were familiar. The case studies were also presented at conferences (MedPower 2008, CIRED 2009) to subject them to the scrutiny of a wider industrial and academic peer group.

CE Electric UK engineers also confirmed that this methodology would be useful in determining whether, when and how such construction projects should be carried out. In particular, there is often a choice between green field

and brown field projects. The green field approach may have a higher capital cost, in terms of land acquisition and planning costs, but may cause less network disruption, and correspondingly lower levels of network risk. This methodology enables the benefit of decreased risk to be measured in the same units (expected £) as the additional capital costs, and therefore directly compared.

The next challenge was to further extend the core methodology to enable it to be applied to more complex networks. It was intended to incorporate it into a software tool that could be used to evaluate and rank the network risk for all the substations on the CE network – over 700 in total – under a variety of different assumptions. A requirements analysis and functional specification were written for this software, and its development is continuing at the time of writing. It was found, however, that although the core methodology could be extended to networks of moderate complexity, the most complex networks of all required changes so extensive as to constitute a fresh approach, and effectively a new methodology. This new methodology is the subject of the next chapter.

4. DEVELOPING A GENERALISED METHODOLOGY

During the early stages of the present research, case studies were carried out on an ad hoc basis. Each section of network under consideration was modelled and tested individually, responding to its own particular features. This had the advantage of building up a greater understanding of the characteristics of a range of EHV networks under both normal and abnormal operating conditions. It also enabled different approaches and formulae to be assessed for suitability with respect to a wide variety of applications.

However, by the second year of the research it became increasingly apparent that a more generalised methodology would be required, not only to allow it to be formulated for a software functional specification which could be applied to any location on the network, but also to be of greater value to both academic and industrial researchers in terms of understanding the risk inherent in distribution networks. This chapter describes how that generalisation was carried out.

4.1 Modelling Individual Loads

The fundamental unit of the model, for which network risk will be evaluated, is the total load at one location. This load could be at medium voltage (20 kV, 11 kV or 6.6 kV), or at EHV (132 kV, 66 kV or 33 kV). This load could be negative, in the case of connected generation, or where there is both connected generation and load, and generation exceeds load on occasions. The risk to a section of network which includes a number of loads would be analysed by evaluating the risk for each constituent load in turn.

In the first instance, the model looks essentially at network connectivity. It does not calculate load flows or voltage constraints. These were considered to be adequately modelled by packages such as DINIS or IPSA, which could be used alongside this model where power flows or voltage drops are likely to be an issue. This is significant in cases where utilisation is increasing, as described in Chapter 7.

A load could be defined in a number of different ways, in particular:

- A single substation, as configured and operated at present, to derive a single-figure assessment of the present network risk for that load.
- A demand group of substations in a single geographical area (either with a common supply point, or with lower voltage interconnection), which would then be summed to derive an overall level of network risk.
- A set of several (probably geographically dispersed) substations for which reinforcement or replacement projects are being considered, and which may be competing for limited available capital.
- A single substation, for which a construction project (reinforcement, replacement or other justification) is being considered. In this case there would be a number of data entries, each one representing a different possible state (configuration and/or parameters) of that substation before, during (at various stages), or after a proposed construction project. A number of different options for that project could also be considered and compared, simply by entering the relevant data for each stage of each option.
- One or more substations, both at present and with various projected future changes to load, configuration or other parameters.
- One or more substations, with different values of certain parameters to investigate the sensitivity of the model results to those parameters.
- All the substations, at one or more voltage levels, in NEDL, or YEDL, or both. In the extreme case, this would require data for all 700 loads.

4.2 Standard Network Topologies

The first input for any load under consideration is to take account of the detailed network topology between the load and its supply point, including any other loads connected within the same Protection Zone(s) (PZ), and also any alternative supply points (and associated loads) connected to the load under consideration by closing a normally open point.

A small number of standard topologies account for over half the load points on the NEDL and YEDL networks, and two of these are detailed in the following sections. Other topologies are standard, but more complex (for example rings), and are dealt with generically later in the chapter.

4.2.1 *Single Circuit to a Single Transformer Load Point*

This is the simplest topology, with a high level of risk as any (n-1) event would disrupt supply to customers. For this reason, such circuits have been replaced over the years with more reliable double circuits, and there are only 8 loads on the NEDL network which can be modelled in this way. Each of them has added security provided by interconnection at lower voltages. However, in other distribution regions such as Northern Scotland where distances are greater and costs of duplication less easy to justify, single circuits are more common, and a greater level of network risk is accepted [6].

4.2.2 . *Radial Paired Circuit to a Single Load Point,*

At Acklam (see Figure 4.1), the relevant supplying network divides into two zones, each of which comprises a single circuit, forming a single PZ. This is the most common topology, and it effectively models almost 100 loads on the NEDL network. An (n-1) event incurs repair and deterioration costs, but only an (n-2) event, for whatever reason, also incurs customer interruption (CI and CML costs).

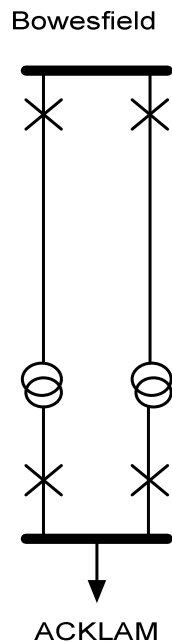

Figure 4.1 – Acklam topology

4.2.3 Radial Paired Circuit to Two or More Load Points

The most northerly load point on the NEDL network is at Denwick, in north Northumberland. It was of particular interest because of the potential for large amounts of connected wind farm generation. The supply point is at Linton, around 30 km to the south, and an intermediate primary substation at Warkworth is also supplied by the same 66 kV circuits, as shown in Figure 4.2

Although Denwick is geographically the more distant second load, it is shown in Fig. 4.2 as the load under consideration and therefore appears nearer. When it comes to defining parameters such as circuit section length, the sections to Warkworth are a few metres only, whereas the sections geographically extending from Warkworth to Denwick are over 10 km each. This enables treatment of each substation to be standardised.

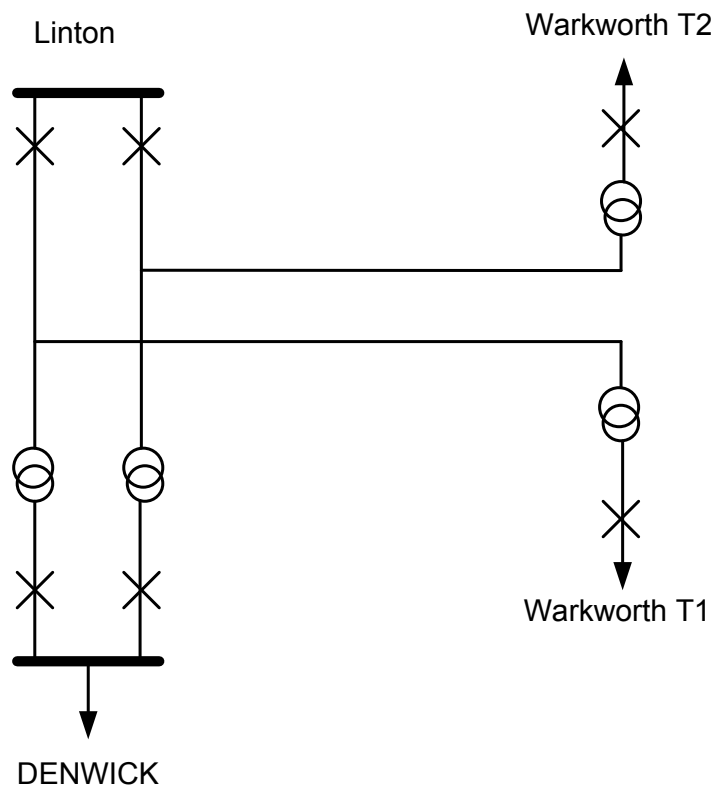

Figure 4.2 – Denwick topology

There are around 50 substations on the NEDL network which can be modelled by this topology, including about 20 which are sub-transmission

supply points, fed at 132 kV from grid supply points. Most are paired with one other load, but some are paired with two other loads. It would exceed security of supply standards to have more than three loads on a single circuit, particularly at 132 kV.

The case study examined in Appendix A and Chapter 3 could be considered as an example of this type, however the complication of the third transformer at Guisborough for a single industrial customer makes it non-standard. It would be up to the engineer modelling that section of network to determine whether to adapt this simple model, with different assets in each of the two PZs, or whether to use the method for more complex networks, as described later in this chapter. Either would be an adequate representation.

A further complication arises if loads are to be ranked according to risk. A section of circuit between Linton and Warkworth supplies both Denwick and Warkworth, and a decision needs to be made as regards the apportioning of repair and deterioration costs between these two loads. This apportioning could be equal, or in proportion to customer numbers, or in proportion to peak or average loads. Or it could all be allocated to the first load, Warkworth, as Denwick has to accept all the costs of its own 10 km extension.

4.2.4. Other Standard Topologies

It would be possible to define further standard topologies, such as the so-called 3 circuit kit, which is like a radial paired circuit to two or three load points, but with added zone separation in the form of circuit breakers. However, the location of these circuit breakers can vary, and this variation will fundamentally affect the risk calculations. It is probably therefore more useful to include such topologies with the more complex topologies, in particular rings, which tend to be non-standard and therefore require a different approach.

4.3 Complex Network Topologies

Based on the core methodology, an extension was originally proposed for generalising the simple network approach described above, to handle more complex and bespoke networks. However, there was some question as to the suitability of this proposed generic network topology (GNT) to model

complex parts of the network adequately. It was therefore agreed to test the proposed GNT on three particularly complex areas, and to modify it as necessary in the light of those tests. The areas chosen in consultation with CE Electric UK Engineers were:

1. Long 33 kV circuits running from Silsden supply point into the rural area around Skipton (YEDL).
2. The combined 66 kV and 33 kV rural circuits supplying the loads at Whitby and Whitby West (NEDL)
3. A group of urban and rural circuits at 66 kV running between the GSP at Thorpe Marsh and another supply point at Doncaster B.

4.3.1 Testing the GNT approach

It was initially hoped that the more complex topologies could be reduced to a GNT by making a sufficient number of simplifying assumptions. However, while the first two of the three areas could be modelled, although with some loss of detail, by the GNT, the third could not. The simplifications required to model the third topology using the extended core methodology were so many that the resulting model was no longer a recognisable representation of that part of the network. It did not, as a consequence, produce reliable results as regards the level of network risk. A different methodology would clearly be required for this third topology, and for others of comparable complexity.

There are five groups of circuits from Thorpe Marsh. In ascending order of complexity, they are:

1. Ring via Wheatley Park and ICI Fibres to Doncaster B
2. Ring via Kirk Sandall and Rockware to Doncaster B
3. Radials to Thorne, Stainforth, Trumfleet 66kV and (originally) Crowle, with connection via normally open points (NOP) to Ferrybridge and Cambleforth supply points.
4. Double ring via Askern, Brodsworth, Longlands Lane 66kV, Hickleton and Barnburgh to Doncaster B, with one NOP interconnection to Thurcroft.

5. Double ring via Markham Gates, Armthorpe, West Moor Park, West End Lane and Balby to Doncaster B, with a spur to Austerfield and two separate interconnections via NOPs to Thurcroft.

Besides complex topology, a characteristic of these circuits is the large number of circuit breakers (CBs), and therefore of protection zones (PZs). Even the most straightforward (Wheatley Park and ICI Fibres) is divided into 5 PZs by 10 CBs (6 at 66 kV and 4 at 11 kV). The alterations needed to squeeze this to fit the GNT were so great that the model was no longer an accurate representation of this part of the network. It would clearly be even less suitable for the more complex Thorpe Marsh circuits, although their very complexity tends to decrease the network risk. Risk arises in particular when such circuits are heavily loaded, or when they are not well-understood.

It was therefore decided to develop a methodology which would be less based on an actual network diagram, and more versatile as a result. This methodology is described in detail in the following sections, using the Wheatley Park primary load as a worked example. The methodology will then be applied to a number of other case studies.

4.4 Abstract Modelling of Complex Networks

Applying the model to a complex part of the network such as that supplying the Wheatley Park Primary load point requires a certain amount of expert knowledge from the engineer responsible for preparation of data for input into the model. In particular, the relevant sections of network have to be codified in a standard form, which accurately reflects the effects of all possible (n-1) and (n-2) events. In this approach, the definition of (n-2) has considerably wider scope than that specified by P2/6. It includes all kinds of double failure (DF). Double failure (DF), as described in Appendix A, can occur in a variety of ways:

1. Common mode failure, where a single cause results in simultaneous or almost simultaneous failure of two distinct circuits, for example the collapse of a tower carrying two circuits.
2. Load-related failure, where the failure of one circuit causes another circuit to carry an increased load, which results in failure of the

second circuit within a short time, whether or not the increased load exceeded the second circuit's design capacity.

3. A coincidental second outage, namely an unplanned failure while the first circuit was undergoing a planned outage for construction or maintenance (this is the specific circumstance addressed by P2/6)
4. A coincidental second failure following an unplanned first outage which had not yet been restored, for example as a result of a protracted repair time for the first failed asset.

The present approach does not distinguish between these four scenarios, as they all lead to similar consequences as regards network availability.

In the following section, 6 steps of data preparation are described in detail, and illustrated by the Wheatley Park case study. Although any of these steps could in principle be carried out by appropriate software, the programming would be complex and time-consuming. There are also possible advantages for the engineer responsible, in terms of network understanding, as a direct result of carrying out these 6 steps.

4.4.1 *Sketching Relevant Sections of Network*

Figure 4.3 shows a sketch of those sections of network relevant to the load at Wheatley Park. It includes all CBs, and would include any automated switches, but does not include isolation switches for CBs or transformers.

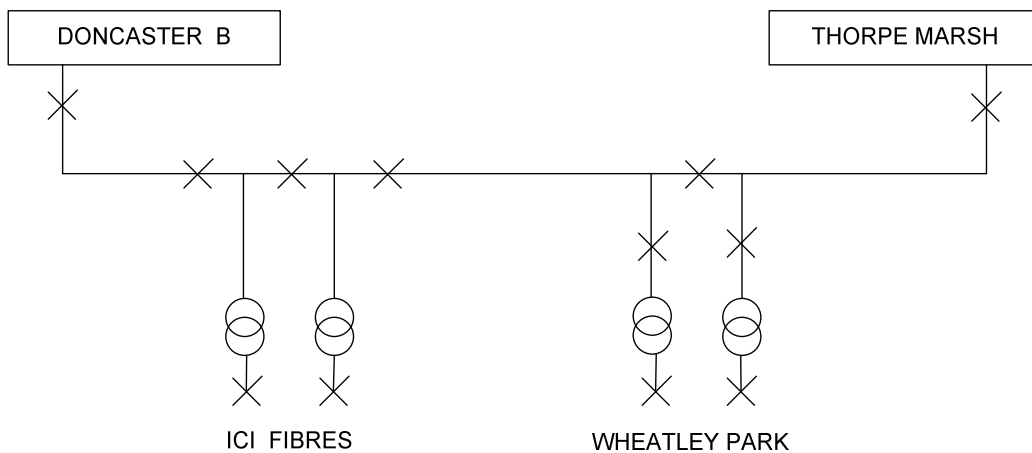

Figure 4.3 – Relevant network around Wheatley Park

Upstream supply to Doncaster B (YEDL) and Thorpe Marsh (NGT) is also not shown, nor is any of the 11 kV system beyond the 11 kV CBs. In this case it is fairly clear what needs to be included. In other cases, for example where there are alternative supply points beyond NOPs, it may be less clear.

4.4.2 Defining Zones

Figure 4.4 adds to the sketch in Figure 4.3 by defining distinct zones (with dotted lines), in this case a total of 6. The transformers at Wheatley Park and at ICI Fibres have been identified, and it can be seen that the 66 kV isolation switches at both ICI Fibres transformers have also been added, as if they were auto-controlled. This is because they will be treated as if they were auto-controlled in this case-study, for the purpose of illustrating certain additional aspects of the proposed methodology.

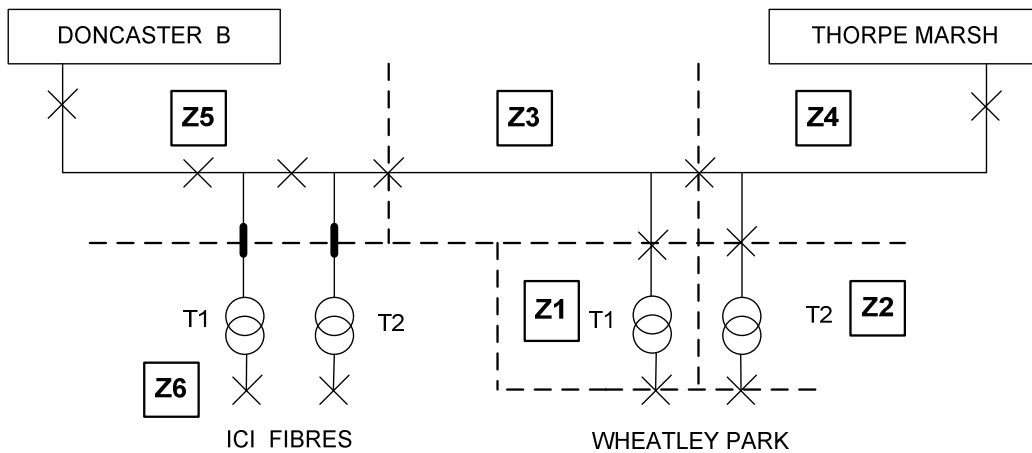

Figure 4.4 – Defining zones at Wheatley Park

The zones are defined in terms of the impact that a fault within the zone would have on supply to customers at Wheatley Park, under both (n-1) and (n-2) situations for all kinds of double failure (DF). It can be seen that, while zones Z1, Z2, Z3 and Z4 are distinct protection zones, Z5 includes parts of three separate PZs. This is because a fault anywhere within Z5 would have the same effect on supply to Wheatley Park. It is therefore also apparent that a different way of subdividing this area into zones would be required if, instead of Wheatley Park, the load point at ICI Fibres were being considered. Zone Z6

includes the two transformers at ICI Fibres with their 66 kV switches and 11 kV CBs, forming part of two separate PZs. Zone Z4 stops at the 66 kV CB at Thorpe Marsh, but the dotted line is not shown, as Z4 will also include parameters relating to the reliability of supply from Thorpe Marsh. Likewise, Z5 will also include parameters relating to the reliability of supply from Doncaster B.

4.4.3 Defining the Impact of (n-1) and (n-2) Failures

With reference to the zones as defined in Figure 4.4, it can be seen that no (n-1) failure would interrupt customer supply at the Wheatley Park load point. Some DFs would interrupt supply for a long period (for example a double transformer failure in Z1 and Z2, or a double line fault in Z4 and Z5). Some DFs would interrupt supply for a short period, until auto-switching could be carried out (for example, Z4 and Z6). And some DFs would not interrupt supply at all (for example, Z4 and Z2, which would not interrupt supply to Wheatley Park T1. Note that the 66 kV CB at Wheatley Park T2 is in both zones Z4 and Z2. This means that a single fault such as this CB opening and being unable to close would count as a DF in both zones, although it is only a single event. It would class, in effect, as a form of common mode failure.

It should be noted that this methodology does not consider (n-3) or higher events. These are considered to be very low probability, and much more complicated to model.

Table 4.1 shows an Impact Matrix, which summarises the probable impact on customer supplies at Wheatley Park for all DF combinations. The main diagonal of the matrix is used to show the impact of (n-1) failures in each zone. Clearly, the matrix is symmetric; even so, for N zones there are a total of $N(N+1) / 2$ separate impacts to be evaluated (21 in this example) by the engineer preparing the input data for the model. This could be time-consuming. However, it will enable the engineer to gain detailed understanding of this part of the network, and it enables the actual network topology to be ignored by the model in all subsequent calculations. The proposed software would include this impact matrix as part of the input data.

Zone	Z1	Z2	Z3	Z4	Z5	Z6
Z1	OK	L	OK	L	OK	OK
Z2	L	OK	L	OK	OK	OK
Z3	OK	L	OK	L	OK	OK
Z4	L	OK	L	OK	L	S
Z5	OK	OK	OK	L	OK	OK
Z6	OK	OK	OK	S	OK	OK

Table 4.1 – Impact Matrix for Wheatley Park (L = long restoration, S = short restoration, OK = no loss of customer supply likely)

4.4.4 Verifying that Power Flows and Voltage Drops are Acceptable

So far, no consideration has been given to power flows or voltage drops in the affected circuits. However, most (n-2) situations will result in non-standard circuit configurations and power flows. Even if a given situation appears OK as regards connectivity, it may result in overloading assets such as lines or cables beyond their design specification. Also, particularly in rural areas, the combination of unusually large power flows (both real and reactive) with long line or cable distances may result in unacceptable voltage drops. Where it is suspected that this might be the case, a separate network modelling exercise may be required (using a package such as IPSA or similar) to confirm that power flows and voltage drops are within acceptable limits. Where they are not, a designation of OK in the impact matrix may need to be reassessed.

In the Wheatley Park example, the lowest cable rating is 405 A (equivalent to 46 MVA at 66 kV), while the total peak load at ICI Fibres and Wheatley Park is around 35 MVA. This difference is large enough not to require detailed network analysis as regards power flows. As regards voltage drop, the total length of this circuit between Thorpe Marsh and Doncaster B is only 11.4 km, which is unlikely to give rise to excessive voltage drops.

4.4.5 Constructing the Asset Matrix

Each zone contains a range of assets, each of which has its own probability of failure. The number or length of each asset in each zone is required as part of the data input to the model. This data can be assembled from Figure 4.4, along with additional data sources such as a network diagram for lengths of line and cable. The results of this for Wheatley Park are shown in Table 4.2.

Zone	Km line	Km cable	Trans-formers	CBs and switches	Supply points	Repair cost allocation
Z1	0	0	1	2	0	1
Z2	0	0	1	2	0	1
Z3	2.4	0	0	3	0	0.5
Z4	3.9	2.3	0	3	1	1
Z5	1.2	1.6	0	6	1	0
Z6	0	0	2	4	0	0

Table 4.2 – Asset Matrix for Wheatley Park

Note that there is no distinction made between CBs of different voltages, or between CBs and automated switches, although this could be included if required. Note also the column to include supply point reliability. The final column is used to determine what proportion of repair cost should be allocated to Wheatley Park as opposed to other load points. In this case, it has been assumed that all assets from a point in Z3 between ICI Fibres and Wheatley Park up to and including the 66 kV CB at Thorpe Marsh are included, with the costs in Zone 3 being equally divided between ICI Fibres and Wheatley Park. Such allocations would be an engineer's decision, made subject to guidelines which would need to be formulated as a separate exercise.

4.4.6 Assembling Other Relevant Data

As well as the impact matrix and the asset matrix, other data would need to be determined at this stage, including:

- Unit costs per CI, per CML, and per repair (including all unscheduled repairs and asset deterioration), possibly subdivided according to the class of asset causing the first circuit failure. In this case study, default values of £6.00, £0.10 and £20000 are assumed.
- The time taken for a short restoration (including automated switching) and for a long restoration (without switching). In this case study, default values of 20 minutes and 200 minutes are assumed.
- The system risk category (4 for Wheatley Park) which is used to indicate the proportion of customers that can be restored in a short time by switching at a lower voltage level (11 kV). The default value of 20% is used in this case study.
- The number of customers (2800 at Wheatley Park).
- Annual failure rates for each class of asset at the appropriate voltage (66 kV). In this case study, the values used are
 - 1.2 per 100 km of overhead line
 - 1.5 per 100 km of underground cable
 - 2.2 per 100 transformers (including associated protection)
 - 0.6 per 100 CB/Switch (but generally counted in 2 zones)
 - 0.15 per supply point (and all categories of failure upstream)
- Adjustment factors for load point as compared with national averages based on location, load profile and asset condition
- The proportion of failures which could be expected to result in a DF (for whatever reason) at that location. A typical value might be 20%, based on past NAFIRS data, but this might be adjusted locally, in particular to take account of the calculation method described in the following section. The default value of 20% is used in this case study.

Following these six steps of data preparation, the methodology then performs the calculations detailed in the following section. These calculations are carried out manually in the examples which follow, but are suitable for

encoding as software if required. This methodology fully generalises, for complex networks, the core methodology first introduced in Chapter 3.

4.5 Model Calculations for Complex Networks

Once data has been prepared as detailed in Section 4.4, the methodology will then calculate risk parameters and expected costs as detailed in the following steps:

4.5.1 Evaluating Failure Probabilities for each Zone

The generic failure rates, multiplied by any local load adjustment factors, are then multiplied as appropriate by each term in the asset matrix to produce the Failure Rate Matrix shown in Table 4.3. This calculates the overall annual failure rate for each zone, which can be summed to give the overall failure rate for this part of the network (most failures not causing customer loss) of 0.656 per year.

Zone	λ (line)	λ (cable)	λ (Trans-formers)	λ (CBs and switches)	λ (Supply points)	λ (TOTAL)
Z1	0	0	0.022	0.012	0	0.034
Z2	0	0	0.022	0.012	0	0.034
Z3	0.029	0	0	0.018	0	0.047
Z4	0.047	0.034	0	0.018	0.150	0.249
Z5	0.014	0.024	0	0.036	0.150	0.224
Z6	0	0	0.044	0.024	0	0.068

Table 4.3 – Failure Rate Matrix for Wheatley Park

4.5.2 – Using these Probabilities to Weight Possible Impact.

Certain combinations of DF are likely to cause a long interruption, that is one which takes a long time to restore, referred to in this methodology as a ‘long restoration’, as summarised in Table 4.1. In this case study, the pairings that do so are (Z1 Z2), (Z2 Z3), (Z1 Z4), (Z3 Z4) and (Z4 Z5). For each of these pairings, the product of their associated λ -values can be calculated.

Calculating this product for each of the five pairings and then summing those products gives a value of 0.078699.

The only combination likely to cause a short restoration in this case study is (Z5 Z6), with a corresponding product of 0.015232. All other combinations do not cause customer loss (they are OK), and the sum of their products comes to 0.060576. Using these products to weight outcomes gives probabilities for a long restoration of 51%, for a short restoration of 10%, and for no customer loss of 39%.

The implications of this are as follows. In a notional period of 1000 years, this part of the network could be expected to experience $1000 \times 0.656 = 656$ failures. Of these 656, 20% or 131 would be double faults, and of these 131, 51% (67 failures) would cause long duration customer loss at Wheatley Park, that is once in every 15 years on average. Likewise 10% (13 failures) would cause short duration customer loss, and 39% (51 failures) would not cause customer loss.

The figure of once every 15 years seems higher than expected, and can be traced back to the unusually high failure rate of 0.150 attributed to the upstream supply. This illustrates how engineering judgment can be used to refine the model or its data input, and has been left unchanged here in order to illustrate that potential refining process.

This calculation may seem somewhat contrived, and its results could lead to a re-estimation of the parameter for the proportion of failures which result in DF. But the alternative would be to calculate this proportion for each ordered pairing of zones – so that DF(1,4) is the proportion of faults initially occurring in Zone 1 that lead to a second fault in Zone 4 before the first is restored. There would then need to be a separate estimation for DF(4,1), and for all other pairings, a total of $N(N-1)$ combinations, or 30 in this case. Making 30 estimates of what are fairly abstract probabilities would be unnecessarily complicated compared with making a single estimate of DF to apply to the whole of this part of the network, and the loss of accuracy in using a single estimate in this way is likely to be small.

4.5.3 Calculating Expected Costs

Expected repair and deterioration costs are calculated first. Each zone value for total failure probability λ_i (but excluding any supply point component) is multiplied by the proportion of that zone's repair costs allocated to the load point r_i (the final column of Table 4.2), and summed over the N protection zones, as in (1)

$$\lambda(CR) = \sum_{i=1}^N \lambda_i r_i. \quad (1)$$

For the case study, this gives a value of 0.1905. Multiplying this by the unit cost of repairs gives an expected annual repair cost that can be attributed to the load point under consideration, as in (2)

$$CR = \lambda(CR) \times UCR. \quad (2)$$

In this case study, that amount is £ 3810

The expected CI costs are calculated as the product of 5 parameters, as shown in (3):

$$CI = \lambda_{tot} \times DF \times (S + L) \times NC \times UCI \quad (3)$$

Where λ_{tot} is the annual failure probability (λ grand total from Table 4.3),
 DF is the proportion of these which cause double failure,
 S is the proportion of DFs which cause short duration customer loss,
 L is the proportion of DFs which cause long duration customer loss,
 NC is the number of customers usually supplied through the load point under consideration, and
 UCI is the unit cost per customer interrupted.

In the case study, this product is evaluated as £ 1345.

The expected CML costs are derived by summing three components, as in (4).

$$CML = \lambda_{tot} \times DF \times [(S \times Ts) + (L \times R \times Ts) + (L \times (1 - R) \times TI)] \times NC \times UCML \quad (4)$$

In (4), variables are the same as in (3), with in addition:

T_s is the average time taken in minutes for a short restoration

T_l is the average time taken in minutes for a long restoration

R is the average proportion of customers who can be restored by reconfiguration at a lower voltage, and

UCML is the unit cost per customer minute lost.

In (4), the first component inside the square brackets covers those events where short restoration at EHV is possible. The second component covers those customers who can be restored by lower voltage reconfiguration in a shorter time, on average, than longer EHV restoration would take. The third component covers those customers who cannot be restored by reconfiguration, and who must therefore wait a longer time, on average, to be restored at EHV.

In the case study, expected CML costs are evaluated at £ 3146.

The total network risk (*TNR*) is given by (5):

$$TNR = CR + CI + CML \quad (5)$$

In the case study, this gives a value for Wheatley Park of £ 8301. This is a relatively small figure when compared with the figures arising from other case studies, such as the Lackenby-Guisborough reconductoring described in Chapter 3. This is in part because of the relatively small number of customers at Wheatley Park, and in part because the very complexity of the circuits feeding that load results in a greater variety of reconfiguration options.

4.6 Testing the Generic Methodology

In the following sections, the methodology applied to Wheatley Park will be applied more briefly to a number of other load points, in order to test its general applicability and suitability for evaluating risk throughout the NEDL and YEDL networks.

4.6.1 Whitby West

Figure 4.5 shows the configuration of relevant circuits supplying the Whitby West load point on the NEDL network. Dotted lines show the division into zones. Z1 includes 2 PZs, as the CB at Ravenscar on the circuit from Scarborough Grid to Whitby and Whitby West does not affect security of supply to Whitby West. Z2 includes the whole PZ, excepting T1 at Thornton Dale. Although the switch which isolates it is not in fact automatically controlled, it is a useful exercise to apply the present methodology to evaluate the benefit of auto-controlling it. Z3 is the transformer at Ravenscar, beyond the CB, and Z4 is the transformer T1 at Thornton Dale. Table 4.4 then shows the Impact Matrix for these 4 zones:

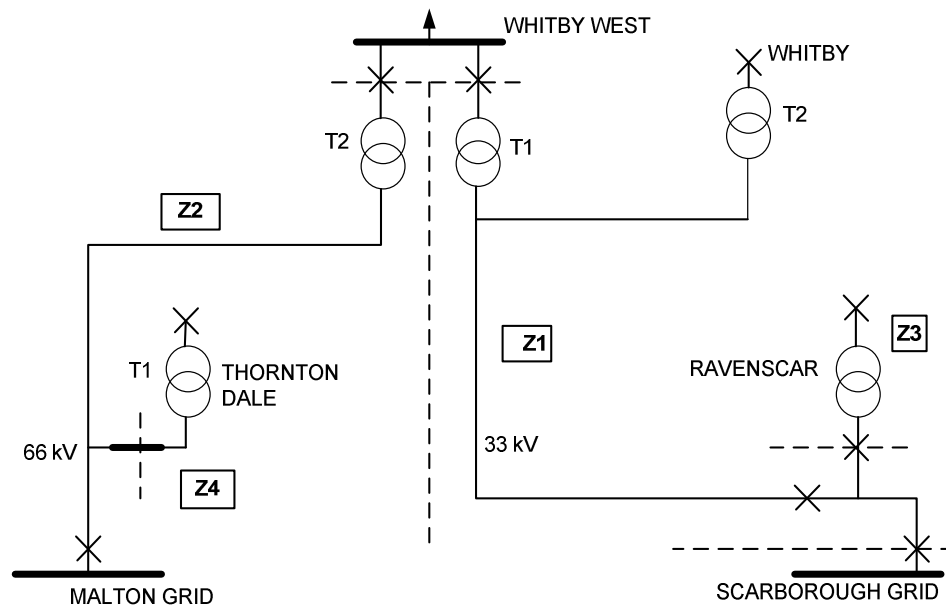

Figure 4.5 – Configuration and Zones at Whitby West

Zone	Z1	Z2	Z3	Z4
Z1	OK	L	OK	S / L
Z2	L	OK	OK	OK
Z3	OK	OK	OK	OK
Z4	S / L	OK	OK	OK

Table 4.4 – Impact Matrix at Whitby West

Inspection of the Impact Matrix shows that the zone Z3 is irrelevant to security of supply at Whitby West, and (since it is at Ravenscar) does not contribute to repair costs there either. In fact, it could have been left out of Figure 4.5 and Table 4.4 altogether. The reason for including it was to demonstrate how preparation of sketches and matrices can help the engineer doing it to gain a better appreciation of the part of the network under consideration. It will be omitted in subsequent analysis.

The designation S / L for (n-2) failure in zones Z1 and Z4 indicates the effect of having / not having auto-control over the transformer switch at Thornton Dale.

A formal network analysis has not been carried out, although the length of these rural lines suggests that voltage drop could be an issue, particularly if double failure of both circuits (one to Whitby not shown) from Malton Grid required the whole load of Whitby, Whitby West and Ravenscar to be fed by the single circuit from Scarborough Grid. However, since this circuit is of recent construction, it is assumed that network analysis under this (n-2) scenario has recently been done. and the results found to be acceptable.

Table 4.5 shows the Asset Matrix for the Whitby West zones. The long runs of line and cable are a feature of this relatively remote location. In this instance, the switch at Thornton Dale T1 has been included in both Z2 and Z4, but the other switches at Thornton Dale (not shown in Figure 4.5) have not been included. Such decisions are a matter of judgment, and would be subject to the expert input of the engineer carrying out the study. The same applies to the allocation of repair costs in Z1 (shared with Whitby and Ravenscar) and in Z2 (shared with Thornton Dale).

Zone	Km line	Km cable	Trans- formers	CBs and switches	Supply points	Repair cost allocation
Z1	0	37.2	2	5	1	0.35
Z2	39.3	2.6	1	3	1	0.7
Z4	0	0	1	2	0	0

Table 4.5 – Asset Matrix for Whitby West zones

Table 4.6 shows the calculation of failure probabilities within each zone. For simplicity, all relevant input parameters are the same as in the Wheatley Park case study, with the following exceptions:

- The time required for a long restoration is increased to 240 minutes, reflecting the geographical remoteness of the location.
- The system risk category for Whitby West is 2 (as it is for Whitby). It is assumed that 80% of customers could be transferred (probably to Whitby) in a short time in the event of (n-2) failure at Whitby West.
- The number of customers at Whitby West is 6700
- Line and cable failure rates on 33 kV circuits are historically significantly higher than on 66 kV circuits. In general, rates of 3.5 per 100 km of line and 4.0 per 100 km of cable will be used at 33 kV. In this case, the cable failure rate is halved to 2.0, reflecting that this particular cable is of recent (but not too recent) installation, and therefore likely to be at the bottom of the 'bathtub curve' as regards failure rates.
- The proportion of failure which are DF is likely to be smaller, as the feeders in Z1 and Z2 are geographically separate. A figure of 0.15 will be assumed.

Zone	λ (line)	λ (cable)	λ (Trans- formers)	λ (CBs and switches)	λ (Supply points)	λ (TOTAL)
Z1	0	0.744	0.044	0.030	0.150	0.968
Z2	0.472	0.039	0.022	0.018	0.150	0.701
Z4	0	0	0.022	0.012	0	0.034

Table 4.6 – Failure probabilities by zone at Whitby West

Impact weighting calculations then give 3% are OK (Z2-Z4), 92% are long (Z1-Z2), and 5% are short or long, depending on whether the switch at Thornton Dale is or is not auto-controlled.

Applying equations (1) to (5) to Whitby West gives values of CR, CI and CML of 13440, 9961 and 10625 respectively, leading to a total network risk of £ 34026, a considerably higher figure than that at Wheatley Park, as might be expected.

Recalculating with an automated switch at Thornton Dale decreases the expected CML cost by only £400 (to the nearest £100). This amount is unlikely to justify the additional capital cost of automation. However, the fact that such a figure can easily be derived indicates one of the benefits of using this methodology. As another example, automating the switches at the Thornton Dale end of the circuit from Thornton Dale to Whitby West, and also the circuit from Thornton Dale to Whitby (circuit not shown on Figure 4.5), would give substantially reduced risk to the customers at Thornton Dale, as it would reduce their dependency on the long, exposed double circuit across the North Yorkshire Moors.

Performing risk calculations for the load at Thornton Dale (System Risk Category 4, with 5800 customers, and an assumed DF rate of 25% for circuits mostly on either side of an old tower line) gives a reduction in the annual expected CML cost of £20.3k, which could well justify the capital cost of automating these switches. The impact of automation on operating costs is rather more complicated, as the increased costs of maintaining automated components has to be set against an expected reduction in site visits to operate the switches in the event of faults.

A methodology which addresses issues of network automation more directly is developed in Chapter 6.

The other two load points on this part of the network are Whitby and Ravenscar. The network topology at Whitby is almost identical to that at Whitby West, so the calculations would be essentially the same, and the end result would be very similar. In the case of Ravenscar, a single transformer means that, unlike Wheatley Park and Whitby West, a single (n-1) failure could cause loss of customer supply. This requires a slightly different calculation, which is illustrated in detail in the next case study.

4.6.2 Crowle

The load point at Crowle, which is in an isolated location west of Scunthorpe, serves 3200 customers through a single transformer. The relevant network topology is shown in Figure 4.6. It is characterised by:

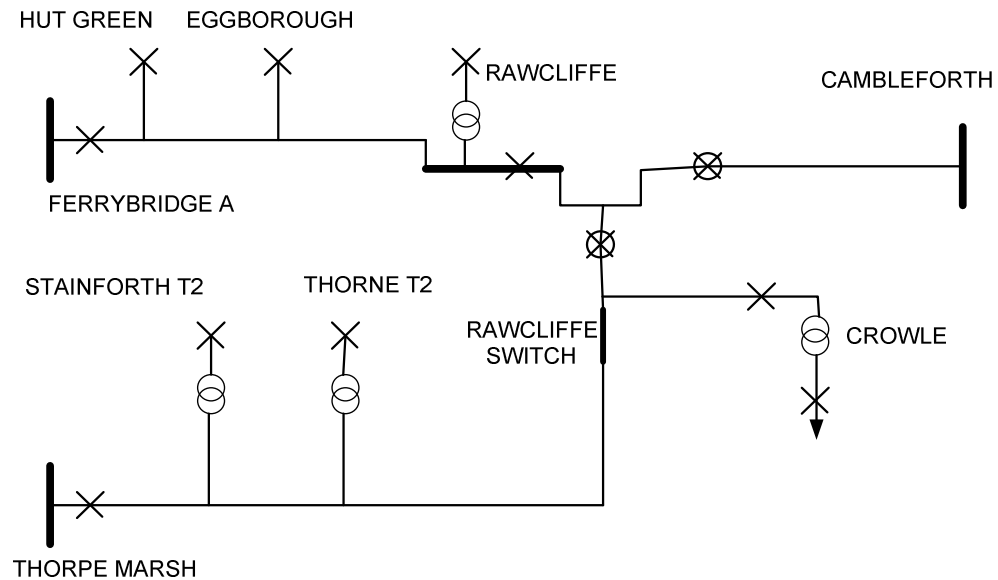

Figure 4.6 – Network Topology around Crowle

- Two normally open CBs and a switch (at Rawcliffe, thought to be non-automated, but assumed to be automated in this test of the methodology) allowing Crowle to be fed from 3 possible supply points.
- Long runs of single-circuit 66 kV overhead line, giving significant probability of (n-1) loss of supply to customers at Crowle..

- Uncertainty as to where Crowle is normally supplied from. The 2006-7 LTDS assumes Thorpe Marsh, as shown in Figure 4.6 and in the following analysis [18], but the 2006 Asset Serviceability Review suggests that Crowle is supplied from Ferrybridge A [80].
- Detail of loads and breakers between Cambleforth and its NOP has been omitted for the sake of clarity.

Identification of zones relevant to supply at Crowle is shown in Figure 4.7, and the corresponding Impact Matrix is in Table 4.7. Note that its main diagonal includes L for Z1 and S for Z2. These are (n-1) failures which result in customer loss of supply at Crowle.

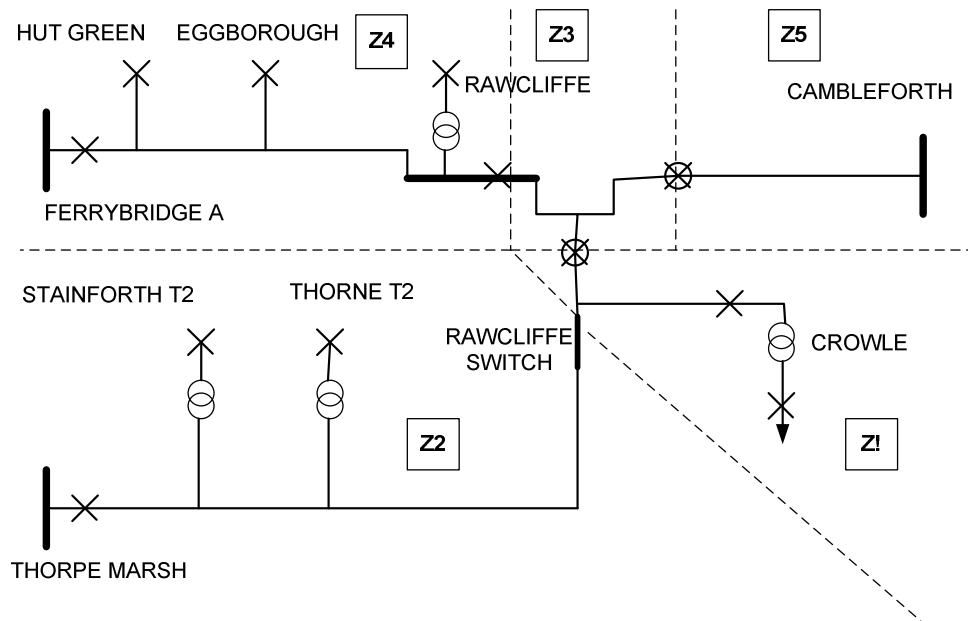

Figure 4.7 – Zones at Crowle

Zone	Z1	Z2	Z3	Z4	Z5
Z1	L	L	L	L	L
Z2	L	S	L	S	S
Z3	L	L	OK	OK	OK
Z4	L	S	OK	OK	OK
Z5	L	S	OK	OK	OK

Table 4.7 – Impact Matrix at Crowle

Looking at this Impact Matrix, it is clear that the restoration time for any (n-2) failure which includes Z4 is the same as for the corresponding (n-1) failure which does not include Z4. The same applies to Z5. The explanation can be seen by inspection of the network topology diagram. A failure of Z1 would result in loss of supply irrespective of the state of Z4 or Z5. A failure of Z2 could be restored in a short time by opening the Rawcliffe switch and closing or opening CBs automatically. If Z4 had also failed, supply could be restored from Cambleforth via Z5. Likewise, if Z5 had failed, supply could be restored from Ferrybridge A via Z4. Only if both Z4 and Z5 had failed, as well as Z2, would this not restore supply – and this methodology specifically does not consider (n-3) situations.

This means that the relevant network can be simplified by excluding Z4 and Z5. It is effectively assumed that, provided Z3 is operating correctly (including all CBs), then at least one of Ferrybridge A or Cambleforth would be able to supply the load at Crowle.

Given the length of the overhead lines, and the possible non-standard configurations in the event of circuit failure, it was decided to perform a basic load flow analysis. The lowest rated circuit can take 405 A (or 46 MVA), and this is adequate for all present and projected maximum loads. Voltage drop analysis was not carried out, although it probably should be done if there were an actual case study with decisions to be made.

Table 4.8 shows the Asset Matrix for the 3 remaining zones at Crowle.

Zone	Km line	Km cable	Trans-formers	CBs and switches	Supply points	Repair cost allocation
Z1	12.1	1.9	1	4	0	1
Z2	18.9	1.3	2	4	1	0.1
Z3	3.6	0.5	0	3	0	0

Table 4.8 – Asset Matrix at Crowle

Table 4.9 shows the calculation of failure probabilities within each zone. Again, for simplicity, all relevant input parameters are the same as in the Wheatley Park case study, with the following exceptions:

- The time required for a long restoration is increased to 240 minutes, reflecting the geographical remoteness of the location.
- The system risk category for Crowle is 2. It is assumed that 80% of customers could be transferred at 11 kV in a short time in the event of any failure of supply at Crowle.
- The number of customers at Crowle is 3200

Zone	λ (line)	λ (cable)	λ (Trans-formers)	λ (CBs and switches)	λ (Supply points)	λ (TOTAL)
Z1	0.145	0.028	0.022	0.024	0	0.219
Z2	0.227	0.019	0.044	0.024	0.150	0.464
Z3	0.043	0.007	0	0.018	0	0.068

Table 4.9 – Failure probabilities by zone at Crowle

All DFs are now long restoration, so the weighting is simply $L=100\%$. Applying equations (1) and (2) to this case study gives values for CR of 5008. The expected cost of CI needs to be made up of two distinct elements. The first, for (n-1) failure of either Z1 or Z2, applies equation (3) with $DF = 1.0$, and gives a value of 13113. The second element is for (n-2) failure when the first zone to fail is Z3, with $DF = 0.20$, calculated as in (3) to give a value of 261. The total CI cost is therefore £ 13374.

The CML cost is made up of 5 elements:

1. Long duration for 20% of customers due to single failure in Z1
2. Short duration for 80% of customers due to single failure in Z1
3. Short duration for all customers due to single failure in Z2
4. Long duration for 20% of customers due to DF starting in Z3
5. Short duration for 80% of customers due to DF starting in Z3

The total cost of CML can be calculated by summing these 5 elements, using an extended version of equation (4) to give £ 7733. Equation (5) gives the TNR at Crowle as £ 26115, a fairly high figure, as might be expected for a single-transformer load.

4.6.3 Balby

The final load point to be considered in this report is Balby, which lies to the SW of Doncaster on a junction of circuits, as shown in Figure 4.8.

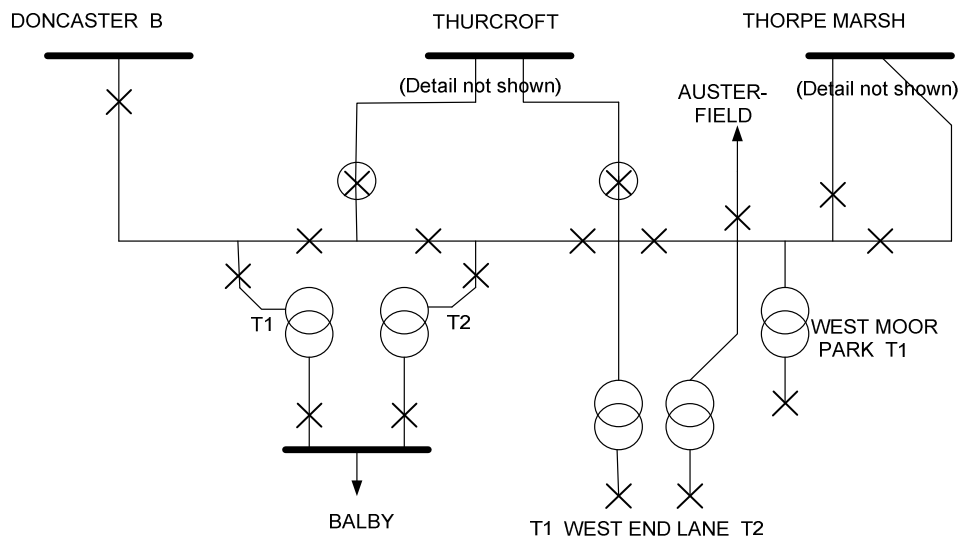

Figure 4.8 – Relevant Network Around Balby

The initial division into zones is shown in Figure 4.9. This load point was analysed along with all the others on the Thorpe Marsh / Doncaster B system, and is reported here as having perhaps the most complex topology of any on the network.

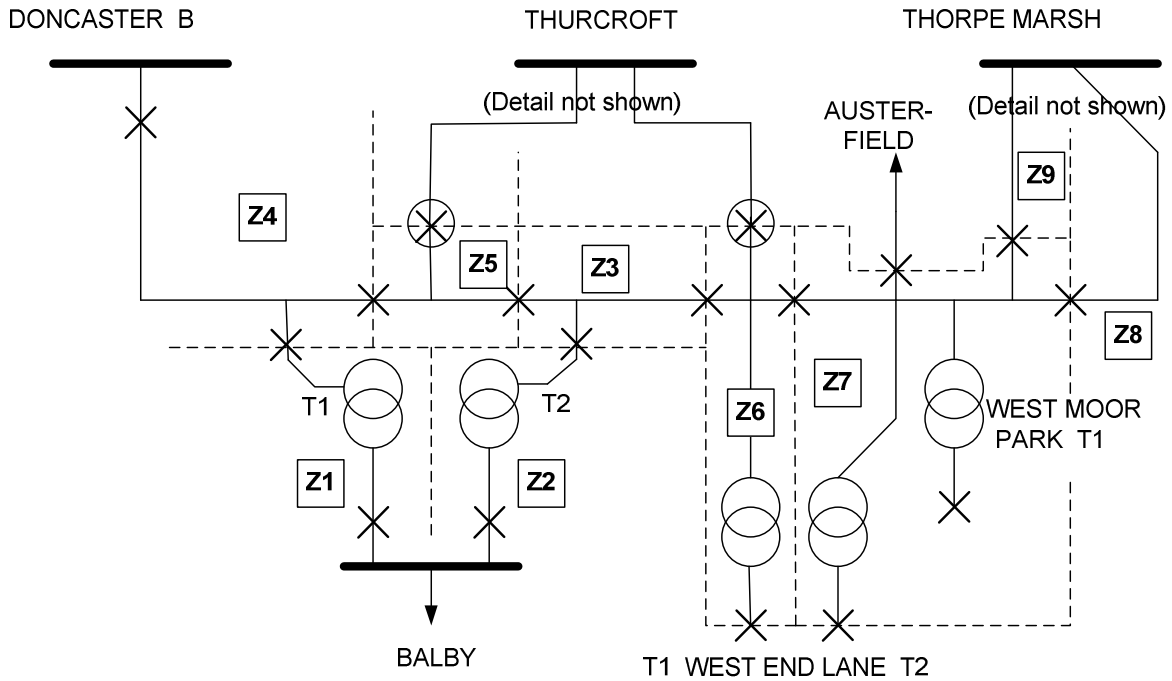

Figure 4.9 - Zones at Balby

The division is into 9 zones, numbered accordingly. No single failure causes customer loss at Balby, but some DFs do so. When they are analysed by constructing the Impact Matrix, however, it becomes clear that certain zones (Z5, Z8, Z9) cannot cause or be part of a DF involving customer loss at Balby. They only cause customer loss at (n-3) and above. It also becomes clear that Z7 has the same impact as Z6, and can therefore be included as part of it as regards Balby. The number of zones requiring further analysis, therefore, reduces to 5.

This further analysis is not shown here because it does not introduce any additional points that have not already been covered. The network risk at Balby is very small, partly because it is an industrial site with only 20 customers, and partly because the complexity of circuits, the variety of supply routes, and the short distances in this area make the probability of customer loss comparatively low.

4.7 Generalised Methodology: Discussion

This chapter first describes how the core methodology was used to calculate network risk for specified EHV loads connected to a range of different circuit topologies. While this core methodology was suitable for simple networks such as single or radial paired circuits, supplying one or more loads from a single supply point, it could not be directly applied to the more complex network topologies. While some of these topologies could be modelled using extensions to and adaptations of the core methodology, others could not, and required the development of a new methodology with a more generalised approach.

This methodology is not based on any particular network diagram, and is more versatile as a result. It requires initial expert input to analyse the network around the load point under consideration, defining distinct protection zones and assessing the impact on customer supply of the loss of any one zone, and of any pair of zones. The results of this analysis are expressed in matrix form. Other matrices are constructed to detail the assets in each zone, and to evaluate expected annual failure rates and the apportioning of repair costs for each zone.

These matrices are combined with other relevant data, in particular on repair times and network reconfigurability as well as unit costs, to calculate the expected costs of repairs, CIs and CMLs. The output format is the same as in the core methodology, although the calculations leading to the output include additional detail. This methodology can be extended to incorporate Monte Carlo Simulation, in much the same way as was shown for the core methodology in Chapter 3.

Besides producing results for the level of network risk at any given load point, the process of calculating it helps to gain a deeper understanding of that risk, in particular in complex networks where the security provided by extensive duplication and triplication of routes is not immediately obvious. This could have implications for initial network design. If, for example, the circuits supplying ICI Fibres and Wheatley Park had been modelled using this methodology, the value of including 10 circuit breakers could have been assessed. It would then have been shown that fewer could have been used, at significant capital cost saving, for only a minimal increase in network risk.

This generalised methodology has been tested by applying it to a number of actual load points on the NEDL and YEDL networks, of which four are described in detail in this chapter. Each of these load points illustrates different aspects of network complexity, and the methodology has proved suitable in each case.

This methodology would therefore be suitable for use as the basis for the development of software which could then be applied to both simple and complex network topologies anywhere on the CE Electric UK network. It has also been applied to other UK networks with different kinds of complexity, including the highly meshed networks of MANWEB in North Wales, described in more detail in one of the case studies in Chapter 6.

The methodology has also been used to solve problems in the design and operation of complex networks, such as the value of automating switches at different locations on those networks. In a particular example on the NEDL network, automating a particular switch at one location on the network would produce a risk reduction of £ 400 per year, which would probably not justify the capital expenditure. However, automating an adjacent switch would produce a risk reduction of over £ 20000, which probably would justify the expenditure.

Both the core methodology (for simple circuits) and the generalised methodology described in this chapter (for more complex circuits) can be applied to a wide range of network problems in this way. However, each class of problems has its own distinctive features, and it may prove more useful to develop a methodology specific to that particular class. This possibility is addressed, and the resulting methodologies described in detail, with respect to three distinct classes of network problem, in Chapters 5, 6 and 7.

5. METHODOLOGY FOR ASSET REPLACEMENT

In Section 3.3.3, the core methodology was extended to address the issue of ageing assets, and consequent increase in failure rates, using a relatively straightforward exponential model. However, for the network as a whole the problem of ageing assets, and the question of when to replace them, is a major concern. Issues affecting asset replacement were described in Section 2.2.

In this chapter, a methodology is developed which is based on the core methodology, but which also incorporates the health index approach to optimising asset replacement decisions, as one strategy for mitigating network risk.

5.1 Ageing assets

Figure 2.3 showed the 'bathtub curve', which demonstrates the way in which, for a typical component or asset, the probability of failure begins to increase rapidly after a certain age. During initial stages of research, this process was studied and illustrated with regard to human life expectancy [82], and also for other distribution network assets, of which the most significant was water pipes [83]. The particular relevance of water pipes is that the oldest of them are already around 150 years old, double the lifetime of the oldest electricity distribution assets. Their increasing failure rates, which fit the bathtub curve, therefore give some indication of what might be expected of electrical assets if they are allowed to age without replacement for 100 years or more.

Where electrical assets differ from the simple components for which the bathtub curve was developed, or from human life spans, or even from water pipes, is that when they fail they can generally be mended or refurbished and returned to service. Failure does not, therefore, imply automatic replacement. Rather, as failure rates increase, there will come a time when the annual cost of failure (expressed as total network risk, the sum of CI, CML, repair and deterioration costs) approaches or exceeds the annualised capital cost of replacing the asset. It is with that concept in mind that all DNOs have a programme of capital expenditure for asset replacement, subject to the scrutiny and approval of the regulator, OFGEM.

One way in which DNOs prioritise their ageing assets for replacement is by the use of health indices (HI) [58]. The HI of an asset is derived from a number of

condition-related and other parameters, according to a predetermined formula. For transformers, for example, the HI is a weighted sum of 13 different inputs. It can be expected to increase as an increasing, possibly exponential, function of time. The probability of failure is then taken to be an increasing, possibly exponential, function of HI. This model was at the heart of research carried out by EA Technology for a number of DNOs, including CE Electric UK, and is the basis of the HI analysis in the present chapter [84]. It underpins the expectation that there will come a year when the cost of not replacing the asset exceeds the cost of replacing it, and this is the theoretically optimal year for replacement.

In practice, the actual year of replacement will depend upon a number of other factors, including:

- The availability of limited resources, including capital and of engineering expertise, to be distributed between competing projects each year.
- The number of other assets requiring replacement in that year
- The age profile and HI profile of each asset group. If a 'bulge' of age-critical assets is anticipated (resulting from high investment levels in the 1960s and 1970s), it may be worth keeping ahead of this need by replacing some assets before the optimal date, to even out the expected workload
- The possibility of partial replacement of an asset, such as replacing just the worst-condition spans of an overhead line, or of reconductoring it without replacing any towers, or refurbishing a transformer.

During the present research, two preliminary studies of ageing assets were carried out, before the final study which is described in this chapter. The preliminary studies involved 66 kV overhead lines, and underground oil-filled cables, respectively. The final study concerns a pair of 66 / 11 kV transformers.

5.1.1 66 kV Overhead Lines

The construction project to re-conductor the 66 kV overhead lines from Lackenby to Guisborough was described in Chapter 3, in the context of extending and applying the core methodology. A simplified model of increasing failure rates was used, as shown in Table 3.3. This resulted from a more detailed study, carried out during the first year of the research, which looked critically at how the HI for

these overhead lines was derived and assembled, and how sensitive the HI and resulting failure rates were to a number of key assumptions. The critical analytical approach developed during this study was to prove useful for the research into transformer replacement, described in the present chapter.

5.1.2 Oil-Filled Cables

The second preliminary study concerned an older population of underground cables, impregnated with insulating oil. When the outer sheath of these cables breaks, oil leaks out and the pressure drops. Detecting this drop of pressure is a potentially useful indicator of deteriorating cable condition, and could perhaps be used as a predictor of the need for repair or even replacement.

This study was carried out during the second year of the research, and was presented as a paper to the 18th Advances in Risk and Reliability Technology Symposium in April 2009 [85]. The original aim of this study was to establish clear correlations between condition monitoring data, failure rates, direct and indirect costs of failure, and asset replacement. In the event, both the data itself, and clear correlations where the data was available, proved elusive. However, it was possible to make use of the data available to try to improve the calculation of the health index used by CE Electric UK to inform its asset replacement decision making process, although it was hard to assess objectively the extent to which the proposed algorithm is an improvement on the original method..

Two more general points emerged. The first concerned the wider applicability of this approach, both within and outside the electricity distribution industry. Many industries use health indices to prioritise asset replacement, and a critical appraisal of the basis on which they are calculated could be of benefit to the reliability of their decisions

The second concerned the value of health indices in general, as a way of summarising a wide range of condition monitoring and other relevant data. This study confirmed that the usefulness of a HI depends substantially on both the quality of the input data and the way in which it is combined. Health indices can be of great value to time-constrained decision makers for making more scientific, justifiable and effective decisions. But their use needs to be carefully monitored, and subject to critical appraisal and improvement where necessary

5.2 Transformer Replacement

The asset base which forms the focus of the present study is EHV transformers, with a primary voltage of 132 kV, 66 kV or 33 kV. There are around 1300 of these in YEDL and NEDL, located in 643 substations [86]. Most often, there are two independently supplied transformers feeding a common load at the secondary voltage, but some substations have only a single transformer, while others may have three or more. The case study used to illustrate issues relating to asset replacement is based at a two-transformer substation supplied at 66 kV in the town of Hartlepool, on the NE coast of England.

5.2.1 Transformer Failure and Repair Data

In general, EHV transformers are extremely reliable. Any fault which occurs anywhere in the UK must be reported to the Energy Networks Association, who maintain a database of such events, both nationally and by DNO [87]. This shows that, for example, in the year 2005-6 within the YEDL region there was only 1 such failure reported, and that incident was not due to ageing, but to a bird.

To gain a wider picture, it is necessary to cover more than one region, and more than one year. During the period 2006-2007, across the whole of the UK EHV network, there were 2522 faults reported, of which 224 were classed as transformer faults. Of these 73, or 33% were attributed to age or wear, and for a further 19% the cause was not known or specified. Assuming that half of this further 19% was also due to age or wear [84], it can be assumed that around 41% of all transformer faults are age-related, and can be expected to increase with age (section C of the bathtub curve). The other 59% of faults are not age related, and (except for a handful connected with section A of the bathtub curve) can be expected to occur at a fixed rate regardless of age (section B of the curve).

NAFIRS also analyses trends in the data over more than 1 year. For the five year period 2002-2007, the average fault rate for transformers (taking only those faults which resulted in equipment damage) was 0.9 per 100 units per year for 66 kV transformers, and 1.0 per 100 units per year for 33 kV transformers [8]. These figures can be compared with those relating to NEDL only, for all faults during the period 1997-2003, of 1.0 per 100 units per year (all voltages), and also for YEDL only (1.4 per 100 units per year) [84].

Also of interest is the time taken to repair the damage. In those instances where the repair was classed as urgent (possibly because customers were disconnected) the duration was 30.6 hours at 66 kV and 115 hours at 33 kV. Where the repair was classed as non-urgent, these repair times increased to 890.8 hours at 66 kV and 511.8 hours at 33 kV [8].

5.2.2 Transformer Health Indices

One model of the way in which failure rates might be expected to change with time was discussed in Chapter 3. Other models involve health indices. Following the EA Technology approach [84], an exponential relationship is assumed, of the form

$$H(t_1) = H(t_0)e^{B(t_1-t_0)} \quad (1)$$

Where B is a constant used to scale the equation. For example, if a transformer that has a value of H equal to 0.5 when new reaches a value of 5.5 after 51 years, which is fairly typical, then the value of B is 0.0462, and the value of H could be expected to reach 10.0 after a further 15 years. The asset lifetime could then be regarded as lying somewhere in the range 51-66 years.

A transformer in a less polluted area, or less heavily loaded, might have a lower value of B , such as 0.0345. It would then take 69 years for H to reach 5.5, and a further 20 years to reach 10.0, giving an indicative lifetime in the range 69-89 years.

Applying this analysis to the total population of transformers, with the distribution shown in Figure 5.1 at 2007 as a starting point, the CE Electric UK Asset Serviceability Review considers the impact in 5 years and in 10 years of different replacement rates [86]. At the Strategic Plan rate of 0.7% per year, the number of transformers 'at risk', with HI greater than 6.5, would increase from 31 in 2007, to 93 after 5 years and to 191 after 10 years. This could be seen as poor stewardship of the asset base. To maintain the HI profile at the 2007 level, a replacement rate over three times as great, 2.2% per year, would be required. This means replacing 27 transformers per year, an ambitious programme which would itself raise a number of concerns, in particular:

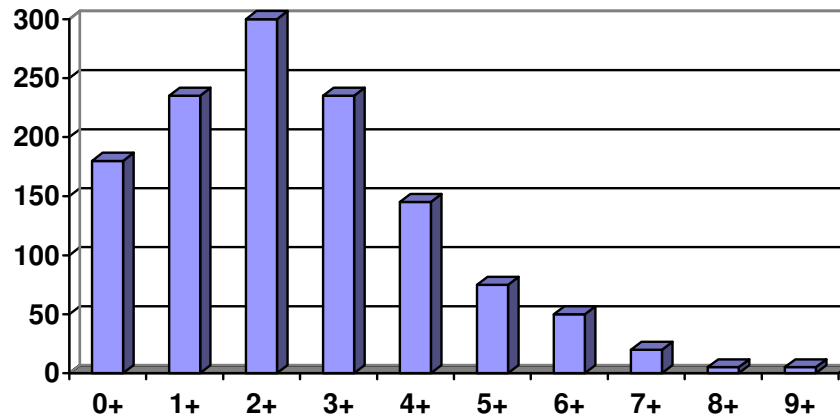

Figure 5.1 – Distribution of Health Index values for all EHV transformers

- Capital cost, which would be approaching £20M per year, or £200M over the whole 10 year period, at an indicative cost of £0.5M-1.0M per transformer, depending on local circumstances.
- The engineering and other resources needed to supervise and carry out so many projects might not be available, or might need to be diverted from other equally or even more important projects.
- Increased level of network risk during the long planned outages that would be required during the construction periods, some of which would have to be at times of peak load, if the projects were spread evenly throughout each year.
- The possibility that many of these replacements might not be justified, since even with a HI of 10.0, the probability of failure is still small compared with that of other assets such as line or cable. It could be that the majority of transformers could give satisfactorily reliable service for 100 or 150 years, but there is not yet sufficient evidence to decide that one way or the other.

In order to explore these areas of concern within the context of actual network operation, the Health Index approach will be applied, first to the particular case study in the NEDL 66 kV network, and then later to the network as a whole.

5.3 Hartlepool Case Study

Figure 5.2 shows the network in and around the town of Hartlepool. The Grid Supply Point at Hartmoor supplies Primary Substations at Amberton Road and at Brenda Trading, both of which have two 66/11 kV transformers. An additional industrial customer, Hartlepool Steel, is also supplied at 66 kV. There is also a 20 kV network supplied by 66/20 kV transformers at Hartmoor, which includes two small 20/11 kV substations at Mulgrave Road and at Rift House. There is an intricate, highly interconnected 11 kV network throughout the town, supplied by these two 66/11 kV and two 20/11 kV substations.

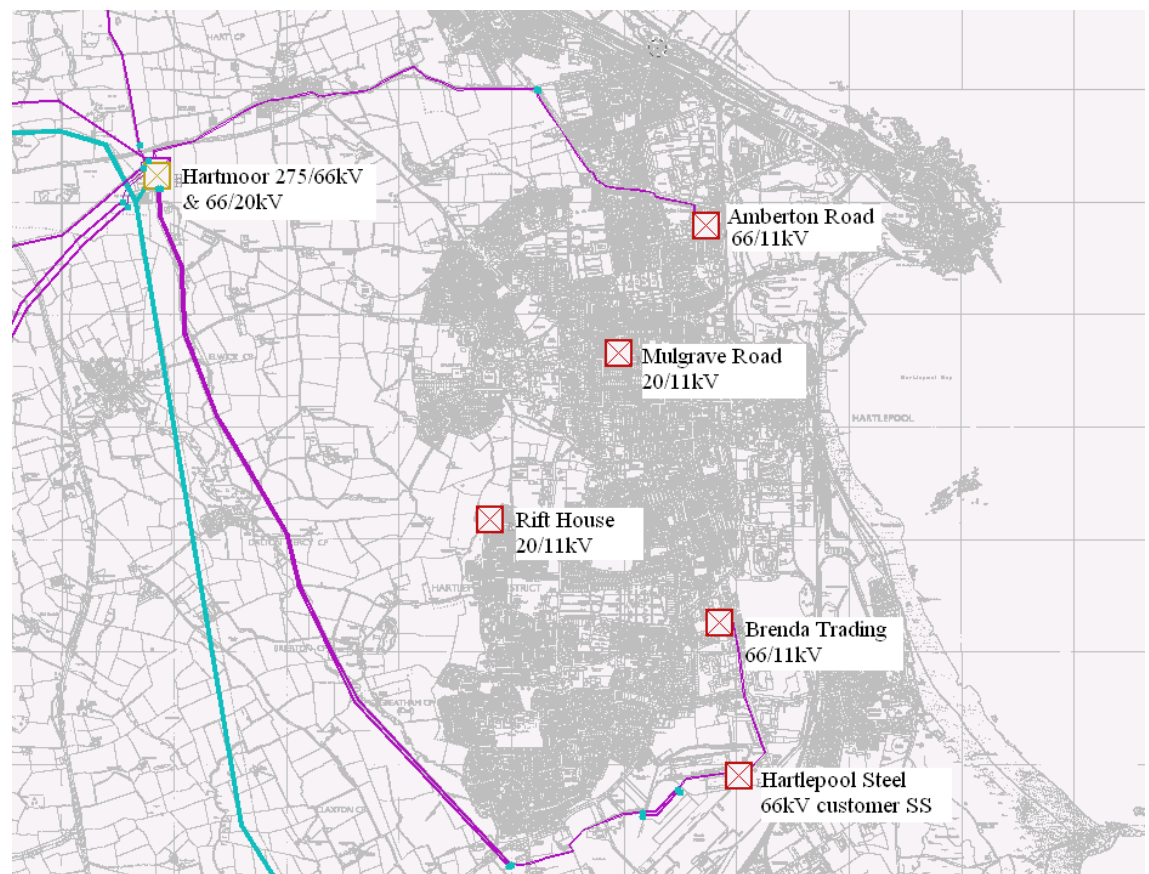

Figure 5.2 – Hartlepool substations and 66 kV network

In 2006, a functional specification was produced for the replacement of the two 66/11 kV transformers at Amberton Road [88]. They were both 45 years old and approaching the end of their nominal lifetime, as was the switchgear, and their HI was calculated to be 6.83, so replacement could perhaps be justified on the grounds of age or condition alone. However, there were additional

justifications for this project, based on capacity shortage and expected load growth in the Hartlepool area. The eventual decision was to replace the old transformers with new ones of increased capacity, a project costing £4.78M, of which the transformer component would cost £1.62M, and this project was in fact carried out during 2009. Figure 5.3 shows one of the old transformers which was replaced and scrapped (although it appears to be in good condition on the surface).



Figure 5.3 – Old transformer at Amberton Road

5.3.1 Relevance to Asset Replacement

In some ways, this project is not an example of asset replacement. The justification which carried weight was to do with network reinforcement, as a result of which the assets were not just replaced but extended, with a capacity increase of 16 MVA per transformer and associated 11 kV switchboard expansion, at an incremental cost of £1.10M over simply replacing the transformers.

It is significant to note that assets nearing the end of their nominal life were replaced with new ones, although age was not used as the principal justification. This is often the case, and a case study involving such a combination of justifications will be described in Chapter 9. The question that will be addressed in this chapter is whether, in the absence of network reinforcement issues, the

replacement of the Amberton Road transformers could have been justified on the grounds of age alone. Also, if it could not have been justified at age 45, at what age would asset replacement become justifiable in its own right?

5.3.2 Basic Network Risk at Amberton Road

The initial calculation that is required is to assess the level of network risk at Amberton Road in 2007, with 42 year old transformers, using the core methodology developed and illustrated in Chapter 3. This is done based on the network shown in Figure 5.4, and on the data shown in Table 5.1, and on a number of assumptions, in particular:

Figure 5.4— Amberton Road Schematic

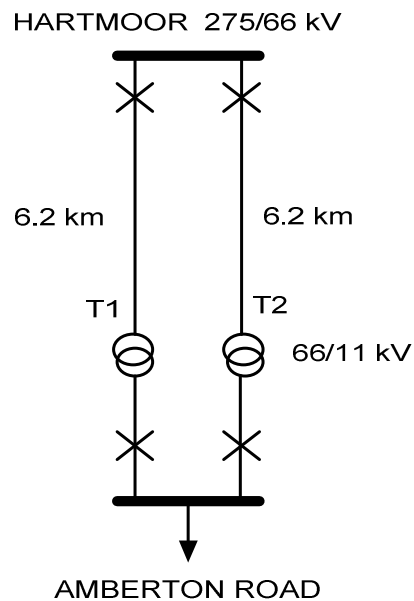

- The vestigial 66 kV busbar at Amberton Road, which was removed as part of the reconstruction there, has not been included.
- Amberton Road and its customers are considered in isolation.
- Average component failure rates are assumed in this location (probably optimistic, considering nearness to coast and to industrial pollution).
- The network risk calculated takes account of connectivity only. Additional load-related risk is not included at this stage.

Failure rates for 66 kV components: per km cable	0.011
Per CB (also 11 kV)	0.006
Per transformer (inc. protection)	0.022
Customers at Amberton Road	11 272
Proportion reconfigurable quickly at 11 kV (risk category 3)	50%
Average disconnection time for reconfigurable customers	15 minutes
Average disconnection time for other customers	150 minutes
Proportion of faults which affect both circuits	20%
Cost per CI	£6
Cost per CML	£0.10
Average unplanned repair cost (including asset deterioration)	£20000

Table 5.1 – Network risk data at Amberton Road

Based on the data in Table 5.1, the failure rate λ per circuit is 0.1022. Using the core methodology from Chapter 3, equations (1) to (4) in that chapter give values for *CR*, *CI* and *CML* of 4088, 2766 and 3803 respectively, with a total network risk of £ 10657.

5.3.3 Effect of Ageing on Network Risk in Hartlepool

The annual failure rate for each circuit at Amberton Road was calculated at 0.1022, or one failure every 10 years. The largest single component of this failure rate (0.0682, or 67%) is due to the cable. Of the remainder, 0.012 is due to the circuit breakers at either end (66 kV and 11 kV), 0.012 is due to protection equipment associated with the transformer, and only 0.010, or once in 100 years, is due to the transformer itself. Of that 0.010, only about one third is for reasons related to age and wear, and it is this component that can be expected to increase if the transformers are not replaced.

The exponential relationship of equation (1) $H(t_1) = H(t_0)e^{B(t_1-t_0)}$

is assumed. The Amberton Road transformers were aged 42 years in 2007, and their health index was 6.83. The value of HI when the transformers were new would not have been 0.0, even if the transformers were in perfect condition. The coastal location, and the relatively polluted environment downwind from industrial

Teesside, both of which are parameters used to calculate HI, would give a starting HI of around 1.63 [84]. This corresponds to a value of 0.0341 for B. Applying these parameters, the HI of each transformer might be expected to increase as shown in Table 5.2. Since HI is measured on a scale from 0 to 10, the maximum possible value of HI is 10.0, and this is reached after 53 years, in 2018, which can therefore be considered the maximum possible economic lifetime for this transformer.

Year	1965	2007	2010	2015	2018	2020
Age	0	42	45	50	53	55
HI	1.63	6.83	7.56	8.97	9.93	10.63

Table 5.2 – Increasing transformer Health Index

5.3.4 Failure Rates and Risk as a Function of Time

Age-related transformer failure rates are assumed to increase with HI (and therefore with time) according to equation (2) [84]:

$$P = Ke^{cH} \quad (2)$$

With values of C=0.6215 and K=0.0011, taken from the original Health Index calculation methodology [84], this gives failure rates as shown in Table 5.3. For clarity in this study, the assumption is that only the age-related transformer failure rate changes with time, and that the ageing of other assets (cable, circuit breakers and protection) does not affect their failure rates.

Year	1965	2000	2007	2010	2015	2018	2020
HI	1.63	5.38	6.83	7.56	8.97	9.93	10.63
$\lambda(Tx \text{ age})$	0.0030	0.0311	0.0767	0.1208	0.2901	0.5268	0.8139
$\lambda(Tx)$	0.0096	0.0377	0.0833	0.1274	0.2967	0.5334	0.8205
$\lambda(\text{circuit})$	0.1018	0.1299	0.1755	0.2196	0.3889	0.6256	0.9127

Table 5.3 – Time dependent failure rates

The value of $\lambda(\text{Tx age})$ is calculated by the formula. A constant value 0.0066 is then added for non-age-related transformer failures to give the overall transformer failure rate $\lambda(\text{Tx})$. Finally, a constant value 0.0922 is added to account for all failures of the other components (cable, circuit breakers and protection) to give a total figure for $\lambda(\text{circuit})$.

Comparing the values of $\lambda(\text{Tx age})$ with those of $\lambda(\text{Tx})$, it can be seen that for a new transformer in 1965, only 31% of transformer failures are age related (this includes effects of location and of pollution). This has increased to 82% by 2000, for an older-than-average transformer.

The number of transformer failures increases, as does the proportion of transformer failures which are age-related, so that by 2007 the transformer failure rate is once in 12 years, and the proportion is 92%. These values increase to once in 8 years and 95% by 2010, and to once in 2 years and 99% by 2018.

In the same way, the proportion of total circuit failures which can be attributed to the transformers increases from 29% in 2000 and 47% in 2007, through 58% in 2010 up to 85% by 2018. It should be noted that, for the purposes of the present case study, ageing effects in components other than the transformers have been discounted. This increasing rate, and increasing proportion, is clearly shown in Figure 5.5.

The impact of these increasing failure rates on overall network risk can be shown by scaling the results of the basic network risk calculation. It is assumed that all other parameters remain the same, in particular the average cost of an unscheduled repair, including asset deterioration (£20000), the proportion of failures which affect both circuits (0.20), and the average time taken to restore supply to customers (150 minutes).

The basic network risk of £10.7k is appropriate for the year 1965, when the transformers were new. It is increased to £18.3k by 2007, once the above average transformer age is taken into account. This increases further in each subsequent year, as shown in Table 5.4.

Year	2000	2007	2010	2015	2018	2020
Risk (£k)	13.5	18.3	22.9	40.6	65.2	95.2

Table 5.4 – Network risk increasing with time

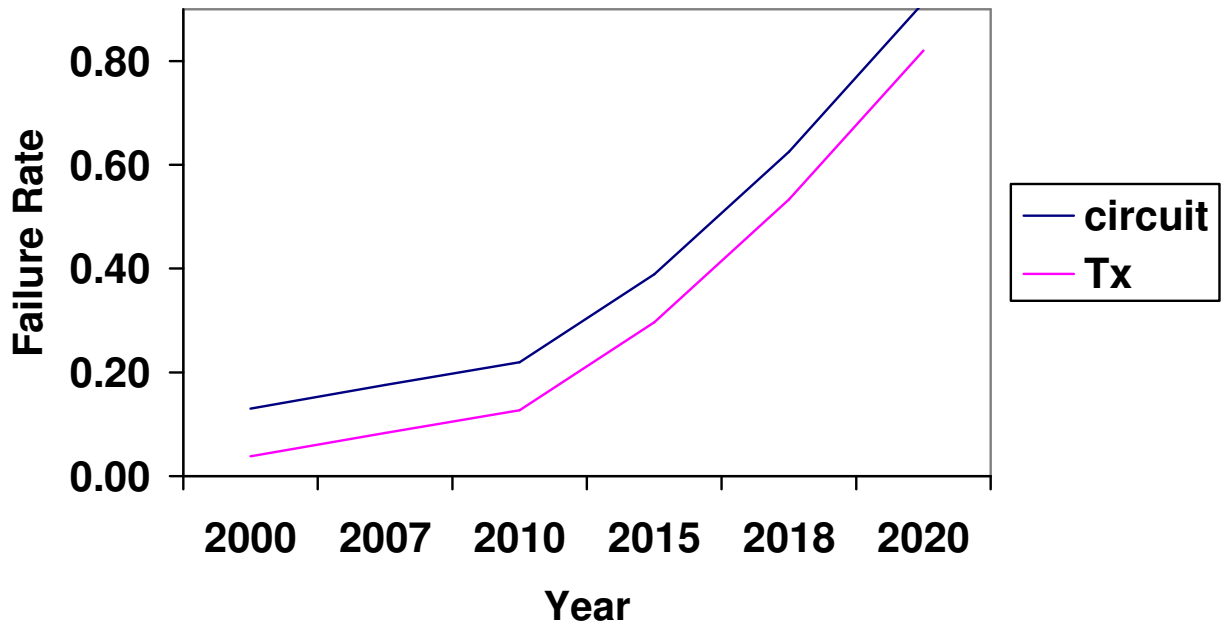

Figure 5.5 – Increasing failure rates

These values show a rapid increase after 2010 if the transformers are not replaced. In 2007, with 42 year old transformers, the level of network risk at Amberton Road was well below that of other primary substations which have been investigated, for example in Chapters 3 and 4. But by 2020, with 55 year old transformers, the level of network risk is much higher, and probably well above the CE Electric UK average.

5.3.5 Economic Consequences

However, these figures need to be seen in relation to the cost of mitigating them. The transformer component of the reinforcement / replacement project actually carried out at Amberton Road was £1.62M. The transformer component of a smaller project (16/32 MVA transformers instead of the 20/40 MVA transformers actually installed) might have been a proportionate figure, perhaps £1.3M. If this were done in 2020, it could perhaps reduce network risk from an expected annual figure of £95.2k back to the calculated basic value of £10.7k, an annual reduction of around £85k. This reduction is significant, but still under 7% of the capital cost

needed to achieve it, and therefore hard to justify at a 7% rate of return, particularly when the added network risk during the construction period is taken into account. This suggests one of two possible conclusions.

Either the asset replacement policy of CE Electric UK, and of other Distribution Network Operators, approved by the regulator OFGEM, is unduly cautious. Transformer failure rates, even when they are so old and worn as to give the maximum possible Health Index, are not high enough to justify the capital cost of replacing them. It would be more cost-effective to live with the increased frequency of failure. It is perhaps significant, in this context, that the Policy of CE Electric UK as regards their distribution transformers (11/0.4 kV) is to replace them only on irreparable failure.

Or, the second possibility is that the impact of increasing failure rates is greater than has been assumed, and would not be acceptable on either economic or social grounds. Some assumptions need to be questioned, and this is done in the sensitivity analysis which comprises the next section of this report. In particular, it may be that the concern is not about average levels of network risk, but about the likelihood of high impact events, in the worst year of a decade, or of a century, for example. The sensitivity analysis will therefore incorporate Monte Carlo simulation.

5.4 Sensitivity Analysis

The network risk of £65.2k per year in 2018 can be thought of as comprising two elements:

- The failure of a single circuit (T1 or T2, but not both), occurring approximately once per year, and costing £20k on average in unscheduled repair and asset deterioration costs. 85% of these failures can be attributed to a transformer.
- The failure of two circuits simultaneously, possibly due to common mode failure, possibly as a result of the loading on the second circuit, and possibly coincidental, but as a result of the time taken to restore the first, non-critical circuit. This would occur approximately once every 4 years, and would cost, in addition to the £20k repair component, an additional £160k in expected CIs and CMLs. Of these failures, 86% can be attributed to a transformer.

These frequencies and costs could increase if the underlying assumptions of the modelling were too conservative. Three assumptions in particular seem to be open to question:

- The figure of £20k for unscheduled repair and asset deterioration
- The frequency of simultaneous failure of two circuits
- The CML duration of an event resulting in customer disconnection

Each of these three assumptions will now be investigated in turn.

5.4.1 *Unscheduled Repair and Asset Deterioration*

The value of £20k has been assumed as a default value in all the case studies in the Network Risk Project to date. Clearly, it underestimates the cost of the most serious events. For example, when an underground cable is damaged maliciously in search of scrap copper worth perhaps £100, it can cost in excess of £100k to repair the damage. If the cyclic overloading of a transformer shortens its expected life by 5 years or 10%, then this can be costed at 10% of the replacement cost of a transformer, around £50k.

On the other hand, many events which cause the failure of a circuit for over 3 minutes, or even the failure of both circuits, are temporary in nature. A lightning strike which caused no permanent damage would cost much less than £20k to repair, and might cause no significant reduction of the lifetime of the asset affected. The value of £20k was chosen as an average figure to balance these extremes, in the absence of any available and reliable long-term data.

However, once the proportion of failures involving transformers increases from around 10% (when new, and in the basic calculation) to 85%, it seems likely that this average value of £20k would increase. Transformers are perhaps the most complex assets in any distribution network, and their repair is likely to be correspondingly more expensive in time and in materials than that of other assets. It also seems probable that accelerated ageing and deterioration would apply more readily to transformers than to other assets, particularly if loads are close to or in excess of transformer rating, as will often be the case for (n-1) events.

It might be reasonable to assume that the repair cost of a transformer fault would be £50k on average, while that of other assets would be £15k on average. If 10% of failures are transformer-based, then the weighted average cost is £ 18500,

which is reasonably close to the value of £20k originally assumed. However, when the proportion of transformer failures increases to 85%, the weighted average cost also increases, to £ 44700. In the sensitivity analysis which follows, an alternative average repair and deterioration cost of £45k will be assumed. The actual distribution of costs will be assumed to be as shown in Figure 5.6.

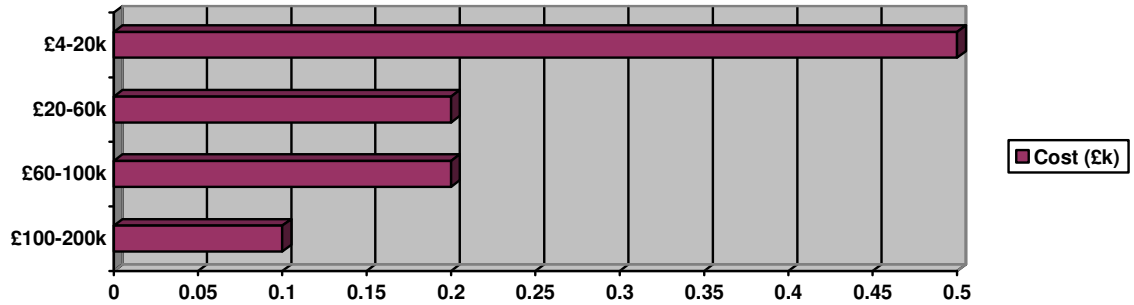

Figure 5.6 – Frequency of repair and asset deterioration costs

5.4.2 Double Circuit Failure

The value of 0.20 for *DF*, the proportion of failures which affect two circuits, was taken from NAFIRS data on the proportion of EHV failure events in England and Wales which caused customer loss [8]. In Scotland, which has a higher proportion of single-transformer supply points, the proportion was considerably higher. Historic values for CE Electric UK circuits are reasonably close to the England and Wales average.

However, it could be argued that transformer failures are more likely to affect two circuits than failures of other classes of asset, particularly if both transformers supplying a load are aged and worn. Unfortunately, the NAFIRS data is not sufficiently subdivided to uphold this argument. However, it seems likely that the double load on the remaining transformer during what would otherwise be an (n-1) event would more often precipitate a second transformer failure, particularly if that transformer were aged and worn, or loaded at or above rating, or both.

It is also significant that transformer repairs take a long time. NAFIRS data suggests that non-urgent repairs in the event of damage to 66 kV transformers takes on average 890.8 hours, or about 5 weeks. During that time, there is a significant probability of coincidental failure of the remaining transformer, even if it is not heavily loaded and/or in good condition. For any transformer, running at

double the normal load for 5 weeks must significantly increase the probability of failure during that time.

Again, once the proportion of failures involving transformers increases from 10% to 85%, it seems likely that the DF value of 0.20 would also increase. It might be reasonable to assume that the proportion of transformer faults causing double failure might be 0.50 on average, while that of other assets would be 0.15 on average. If 10% of failures are transformer-based, then the weighted average value of *DF* is 0.185, which is reasonably close to the value of 0.20 originally assumed. However, when the proportion of transformer failures increases to 85%, the weighted average value of DF also increases, to 0.447. In the sensitivity analysis which follows, an alternative proportion of double failures of 0.45 will be assumed.

5.4.3 Customer Disconnection Duration

In previous case studies, the average duration of disconnection for a customer who cannot be transferred a lower voltage has varied from 120 minutes in metropolitan urban areas to 240 minutes in remote rural areas. This difference is largely, although not entirely, due to the time needed for engineers to travel to the site and to locate the fault. The value of 150 minutes used in the present study reflects the relatively urban location of Hartlepool.

However, there is no allowance made for the relative difficulty of repairing or restoring different classes of asset. NAFIRS data gives an average urgent repair time for 66 kV transformers of 30.6 hours [8]. While, in many urgent cases, it will be possible to restore supply to many customers before the repair is complete – for example, by manual reconfiguration at 66 kV, or by non-standard transfers at 11 kV – the value of 30.6 hours suggests that 150 minutes may be an optimistic average for those faults which originate in transformers.

Once again, when the proportion of failures involving transformers increases from 10% to 85%, it seems likely that this average value of 150 minutes would increase. It might be reasonable to assume that the restoration time in the event of a transformer fault might be over twice as long, 6 hours (360 minutes) on average, while that of other assets might be 2 hours (120 minutes) on average. If 10% of failures are transformer-based, then the weighted average restoration time is 144 minutes, which is close to the value of 150 minutes originally assumed. However,

when the proportion of transformer failures increases to 85%, the weighted average restoration time also increases, to 324 minutes. In the sensitivity analysis which follows, an alternative average customer disconnection duration of 320 minutes, for those customers who cannot be transferred, will be assumed, distributed as shown in Figure 5.7.

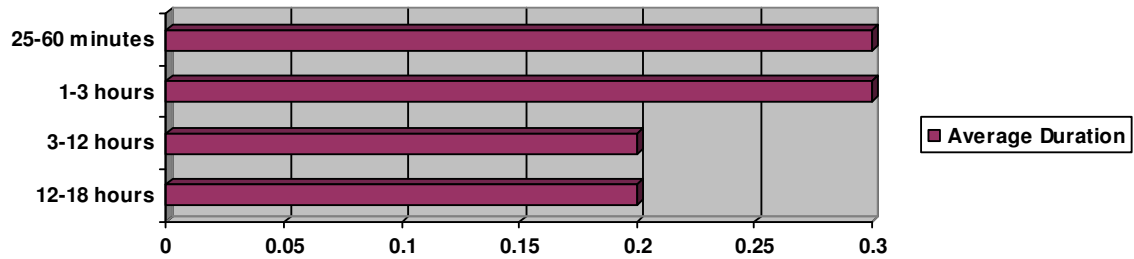

Figure 5.7 – Frequency of untransferrable customer disconnection duration

5.4.4 Direct Costs to the Customer

In the methodology developed and used in this and previous reports, the three components of network risk cost (repairs, CIs and CMLs) are all borne by the distribution network operator (DNO). In addition, and not considered by the methodology, there is the inconvenience to the customer. This can be separately assessed and evaluated, as in a number of other studies e.g. [21, 38]. One reason for not including this additional factor is the uncertainty of this measure, in particular the wide disparity between what customers claim to be the cost of an outage, and the premium that they are prepared to pay to eliminate the risk.

However, it could be argued that this cost, once evaluated, is an additional factor in determining whether to replace an ageing asset. As regards the DNO, this factor might appear as a loss of reputation, particularly as regards critical industrial customers. Although not directly costed in the sensitivity analysis which follows, this additional factor also needs to be considered in replacement decision-making.

5.4.5 Recalculating Network Risk

Average network risk calculations including the sensitivity factors defined in the previous section have been carried out for the year 2018, and the results are shown in Table 5.5. It can be seen that taking each factor separately increases the network risk by 37% (for increased customer disconnection time), by 48% (for

increased repair and deterioration costs), and by 77% (for increased proportion of double failures). However, including all three factors together increases the network risk by three times, to a total annual expected risk of £201k. The range of risk value over a number of years has been calculated using Monte Carlo Simulation, and the results are shown in the section following. The economic implications of this are then discussed.

Factors	CI (£k)	CML (£k)	Repair (£k)	TOTAL (£k)
None	16.9	23.3	25.0	65.2
Repair Cost £45k	16.9	23.3	56.3	96.5
Double Failure 0.45	38.1	52.4	25.0	115.5
Disconnect 320 min.	16.9	47.3	25.0	89.2
All three of these	38.1	106.3	56.3	200.7

Table 5.5 – Network risk in 2018, including sensitivity factors

5.4.6 Monte Carlo Simulation

The average cost to CE Electric UK of £201k per year in 2018 obscures the wide variability that can be expected between different years. As with both the core and generalised methodologies described in Chapters 3 and 4, Monte Carlo Simulation can be used to extend the present methodology.

A simulation was carried out, with the number of failures per year involving customer loss based on a Poisson distribution with mean 0.5630. The number of failures per year not involving customer loss was based on a second, independent Poisson distribution, with mean 0.6882. Repair costs and disconnection durations varied according to Figures 5.6 and 5.7, while all other parameters were fixed. Significant results from this simulation (covering 100 000 simulated years) were as follows:

- In 28 years out of 100, there are no failures on either circuit, and so the network risk cost is zero.
- The median year has a network risk cost of £85k, or just under half the expected value. Such a year might include a single, expensive repair without customer loss, or a single incident with customer loss, but fairly

quickly restored, or more than one incident, all of which had below average consequences.

- The 80th percentile (worst year in 5) has a risk cost of £356k.
- The 90th percentile (worst year in 10) has a risk cost of £595k
- The 95th percentile (worst year in 20) has a risk cost of £753k
- Finally, the 99th percentile (worst year in 100) has a risk cost of £1370k. This would probably represent a year with two or more incidents, all of which had above average consequences as regards both repair and customer loss.
- The average value of all these years comes to £201k.

This simulation gives a clear impression of the diversity between years that could be expected around 2018. Alternatively, it gives the results of considering 100 000 equally likely possibilities for what would actually occur in the year 2018, given that the transformers were not replaced, and based on all the assumptions already outlined.

5.5 Economic Analysis and Optimal Year

The capital cost of replacing two transformers with similar 16/32 MVA units has been estimated at £1.30M. To this should be added the increased network risk during the construction period. This could be evaluated in detail from the construction schedule. In the absence of such a schedule, this increase has been estimated as doubling the level of network risk during the year in which construction takes place. Assuming that this occurred in 2018, with all sensitivity factors included, this would add an additional £201k to the effective project cost, giving a total of £1.501k. Against this can be set the reduction of annual network risk from £201k back to the base level of £10.7k, a decrease of £190k.

If this decrease starts in the first year after construction, 2019, and continues for each year thereafter, then at a discount rate of 7%, the capital value of these reductions in 2018 comes to £2.524M. Subtracting the capital cost of the project gives a positive net present value (NPV) of £1.023M, suggesting that carrying out this replacement project in 2018 would be of positive benefit to the company.

5.5.1 Replacement in an Earlier Year

Given the benefit of replacing the transformers in 2018, when the Health Index for these transformers reaches 10.0, the question arises of whether a greater benefit might be gained by replacing them in an earlier year, say 2015, when the Health Index for these transformers would be expected to reach 9.0.

Applying the sensitivity analysis methodology to the situation in the year 2015, when 76% of failures would be expected to be due to the transformers, the appropriate values of each sensitivity factor are

- £41.6k as the average repair plus deterioration cost
- 0.416 as the proportion of failures which affect both circuits, and
- 302 minutes as the average disconnection time for customers who cannot be transferred at a lower voltage.

Using these values, the CI, CML and repair elements of network risk in 2015 come to £21.9k, £57.8k and £32.4k respectively, giving a total network risk in that year of £112.1k (as against £200.7 in 2018).

This value would also be the incremental construction risk, doubling in the year 2015 only, to give a total project cost of £1.412M. The risk reduction, based on this 2015 level, is the difference between £112.1k and the base level of £10.7k, which comes to £101.4k. The risk reductions which would be gained by doing the project in 2015 instead of 2018 apply in 2016, 2017 and 2018. They are £131k, £160k and £190k respectively.

Table 5.6 compares replacement in 2015 with replacement in 2018. It can be seen that the cost advantage of doing so is £561k in absolute terms, reducing to £204k when discounted at 7%. The fact that this discounted value is still positive implies that there would be relative benefit to CE Electric UK in replacing these transformers in 2015 (aged 50, with a Health Index of 9.0), as against replacing them in 2018 (aged 53, with a Health Index of 10.0). . This is, of course, assuming the higher risk values of the sensitivity analysis.

Year	CapEx	Construction Risk	Network Risk	Total	Discounted
2015	(1300)	(112)		(1412)	(1412)
2016			131	122	118
2017			160	160	138
2018	1300	201	190	1691	1360
Total	0	115	493	561	204

Table 5.6 – Discounted cost comparison of replacement in 2015 and in 2018

5.5.2 Finding an Optimal Year for Replacement

If replacement in 2015 is of greater benefit than replacement in 2018, it makes sense to try to find an optimal replacement year, using the same methodology. First, replacing the transformers five years earlier still, in 2010, will be compared with replacement in 2015. The network risk in 2010 comes to £ 49.9k, giving a project cost (including construction risk) of £1.350M, and a risk reduction in that year as a result of renewed transformers equal to £39.2k.

Table 5.7 is constructed like Table 5.6, and compares the 2010 project with one in 2015. The absolute cash advantage is smaller than that in Table 5.6 (£411k as against £561k), and the discounted cash advantage goes negative (-£92k as against £204k). This suggests that replacement in 2010 is slightly less

Year	CapEx	Construction Risk	Network Risk	Total	Discounted
2010	(1300)	(50)		(1350)	(1350)
2011			46	46	43
2012			55	55	48
2013			66	66	53
2014			81	81	61
2015	1300	112	101	1513	1053
Total	0	62	349	411	(92)

Table 5.7 – Comparing 2010 replacement with 2015

advantageous than in 2015. The optimal year might be 2013, or slightly earlier, or slightly later. Such fine tuning is probably not appropriate considering the broad assumptions (particularly as regards failure rates) on which this analysis has been based. However, as regards the methodology of this approach, it is possible to derive a formula to find the optimal year. Comparing capital expenditure in year N with the same expenditure in year $N+1$, there is one gain and two losses by deferring one year.

- The gain is given by equation (3)

$$C \times D \quad (3)$$

where C is the capital cost of the project, and D is the discount rate.

- The first loss is in increased construction risk, given by equation (4):

$$NR_{n+1} \times (1 - D) - NR_n \quad (4)$$

where NR_n is the network risk in year n , and NR_{n+1} is the risk the following year. If the growth in risk is less than the discount rate, this loss will become a gain.

- The second loss is the reduced network risk which would be available in year $n+1$ only if the capital project is undertaken in the earlier year. This loss is given by equation (5)

$$(NR_{n+1} - NR_0) \times (1 - D) \quad (5)$$

where NR_0 is the base level of network risk, with new assets (and excluding burn-in failures).

Combining these elements, the net gain G by deferring is given by (6):

$$G = C \times D + NR_0 \times (1 - D) + NR_n - 2 \times NR_{n+1} \times (1 - D) \quad (6)$$

When this amount is positive, there is benefit to the company by deferral, when it is negative, there is benefit in earlier expenditure. Applying this to the present example, the value of G in each year from 2011 to 2016 is shown in Table 5.8. It is apparent that there is benefit in deferral up to 2013 (worth a discounted £7k), but not in 2014 (when the benefit first becomes negative), and that the cost of deferral increases with each subsequent year. This shows that the optimal year for this capital expenditure would be 2014, when the transformers are 49 years old and have a Health Index of 8.7.

Year	2011	2012	2013	2014	2015	2016
Gain	+35	+24	+7	-15	-44	-81

Table 5.8 – Marginal gain by deferring expenditure by one year

5.6 Implications for the Wider Network

In the final section of this chapter, the approach developed and applied to the Amberton Road case study will be extended to the general case, which is any substation with two ageing transformers and a similar radial network topology. The methodology could also be extended to different topologies e.g. ring, meshed, or more than two transformers, although this has not been done here. The methodology could also be extended to other categories of ageing asset e.g. underground cable, overhead line, switchgear or protection. Again, this possibility for future work has not been carried out at this stage.

Table 5.9 lists the variables used in the case study. Those on the left are unlikely to change significantly from one substation to another, and are assumed to remain constant. Those on the right are likely to alter from one substation to

Non substation-dependent	Substation-dependent
	MW Size of transformer
Factor by which CR , DF and T(L) are increased for transformer faults	R Proportion of customers who can be transferred at a lower voltage
Ts Time taken, on average, to restore transferrable customers	TI Time taken, on average, to restore untransferrable customers
UCR Unit average cost: unscheduled repair and asset deterioration	DF Proportion of failures which affect both circuits
UCI Unit cost: customer interruption	NC Total number of customers
UCML Unit cost: cust. minutes. Lost	λ Failure rate for rest of circuit
K,c Parameters determining failure rate as a function of Health Index	B, H₀ Parameters determining Health Index as a function of time

Table 5.9 – Parameters which are and are not substation-dependent

another, and will be considered individually in the analysis which follows, which could be regarded as a sensitivity analysis on those 7 substation parameters.

Note that the factor by which repair costs, double failure probability and restoration times are increased for faults involving transformers, as opposed to other assets, as described in the sensitivity analysis in section 5.4, is assumed to remain the same for all substations. Note also that these sensitivity assumptions will continue to be applied in the following analysis.

5.6.1 Size of Transformer

The capital cost of replacement transformers depends on their size. A substation similar to Amberton Road, but including a single large industrial customer, might require replacement transformers of 50% greater capacity, and possibly costing 50% more to purchase and install.

Recalculating Table 5.6, comparing the years 2018 and 2015, with increased capital costs does not alter the undiscounted benefit of replacement in 2015, which remains at £608k. But it reduces the discounted benefit from £229k to just £102k. This is because, the more expensive the transformer replacement project is, the more advantage there is in deferring it for a longer period once discount factors are applied.

Likewise, recalculating Table 5.7, comparing 2015 with 2010, the undiscounted benefit of replacement in 2020 remains at £411k, but the discounted benefit changes from negative £92k to negative £290k, making it more attractive to defer replacement to or beyond 2015. Applying the formula, with the difference that now $C = 1950$ instead of 1300, gives the results shown in Table 5.10. The optimal year for replacement has shifted to 2016.

Year	2010	2012	2013	2014	2015	2016
Gain	+81	+70	+53	+31	+2	-35

Table 5.10 – Marginal gain by deferring expenditure by one year (larger Tx)

A 50% increase in capital cost equates, therefore, to a 2 year deferral of the replacement. The transformer age increases to 51, and the critical Health Index

increases from 8.7 to 9.3. Conversely, a decrease in the size and therefore the capital cost of the transformers to be replaced would mean that the optimal age becomes less than 49, at a HI of below 8.7.

5.6.2 Proportion of Transferrable Customers

Amberton Road is classed as Risk Category 3 in terms of the available transfer of customers at 11 kV. This is interpreted to mean that, on average, 50% of customers could be transferred. Other nearby substations are assigned to Risk Category 2, which is taken to mean that on average 80% of customers could be transferred. This difference equates to an average CML of 76 minutes, instead of 167 minutes at Risk Category 3, which in turn reduces the expected CML component of network risk by 54%, and total network risk by 29% or around £62k in 2018.

Recalculating as before suggests that, with lower levels of risk, capital investment could more advantageously be deferred, by around 2 years. This suggests that, while the transformers in a Risk Category 3 substation should be replaced at a HI of 8.7, those in an equivalent Risk Category 2 substation need not be replaced until the HI reaches 9.3.

5.6.3 Restoration Time

A similar argument applies to the time taken to restore a fault and to reconnect those customers who cannot be transferred. The earlier sensitivity analysis assumed that, for a transformer fault, this time would average 360 minutes. This would result in customer disconnection only in the event of a double fault, which is beyond the provisions of P2/6 at this level of demand. The disconnection duration depends on a number of factors, including the size, availability and experience of repair teams, and the availability of spares. There is a concern that, in order to reduce cost overheads, all these may tend to be reduced in the future, possibly leading to increased average duration of disconnection. There might also be longer expected disconnection times for substations in more remote locations.

If this average duration were to increase by 50%, to 540 minutes, the effect on average CML (across all customers and fault types) would be to increase it from 167 minutes to 244 minutes, corresponding to an increase in expected annual

network risk of £52k in 2018. Recalculation indicates that this would tend to make transformer replacement more urgent, by around 2 years, bringing the optimal year forward from 2014 to 2012. This corresponds to a reduction in critical HI, from 8.7 down to 8.1.

5.6.4 Double Failure Proportion

The assumption made in the earlier analysis was that 15% of non-transformer faults, and 50% of transformer faults, result in a double failure. These values could depend critically on a range of factors including network topology, types of asset, load size and variability, and maintenance and repair policies. If these percentages were increased by one third, to 20% and 67% respectively, then both CI and CML elements of network risk would be expected to increase by the same proportion, giving a total network risk increase of £47k. This would also tend to make transformer replacement more urgent by around 2 years, corresponding to a reduction in critical HI, from 8.7 down to 8.1.

5.6.5 Customer Numbers

The nearby Hartlepool substation at Brenda Trading is similar in most respects to Amberton Road, but has around 50% more customers. This increases the CI and CML components of network risk by 50%, or £70k. The effect of this is to make optimal transformer replacement more urgent by about 3 years, from 2014 to 2011, corresponding to a reduction in critical HI from 8.7 down to 7.8

It is instructive to compare this with the approach adopted by CE Electric UK in the Asset Serviceability Review [31]. Customer numbers are converted into a customer rating R_1 , from 1 to 4. This is combined with a system risk rating R_2 , also on a scale from 1 to 4. This system risk rating should perhaps be based on the substation Risk Category used to calculate reconfigurability, but the two do not seem to correspond. The two ratings are then combined to give a Consequence Rating Q , according to (7):

$$Q = \sqrt{R_1 \times R_2} \div 4 \quad (7)$$

This consequence rating, which can take values from 0.25 up to 1.00, is then multiplied by the Health Index to produce a ranking for prioritising replacement projects. Consider two substations, both with HI values of 8.0, system risk ratings

of 4, and customer ratings of 4 and 3 respectively. The first would retain its ranking value of 8.0, but the second would have its ranking reduced to 7.0. This is about the same difference, for one increment of customer numbers, as that between 8.7 and 7.8 obtained by using the present methodology.

5.6.6 Failure Rate for Rest of Circuit

Figure 5.5 showed that, for the Amberton Road substation, the failure rate in each circuit due to components other than transformers was at the comparatively low level of 0.0922 (one failure every 11 years). This was a result of the robustness of 66 kV assets, and the short distances involved.

For more remote substations, supplied at 33 kV, in more exposed locations, such as those to be examined in Chapters 6 and 7, these failure rates would be considerably higher. Figure 5.8 shows the effect of increasing this failure rate by a factor of 5, to 0.4610 or once in just over 2 years, a fairly typical value for such circuits.

It is still assumed that, unlike the transformer failure rates, these rest-of-circuit failure rates do not increase with time. Although this assumption is probably somewhat unrealistic, it is done to enable the effects of transformer ageing to be isolated for consideration.

Table 5.11 shows the effect of these increased failure rates on network risk. In 2010, the extra risk caused by the rest of the circuit is over £20k. This reduces to £16k by 2015, and disappears altogether by 2018. The reason for this is the methodology used for the first sensitivity analysis. Increasing overall failure rates are balanced by the decrease in average repair costs, double failure rates and restoration times as a result of decreasing the proportion of failures which are caused by transformers, from 85% down to 64%. Clearly, the methodology is over-compensating, and this is indicated by the apparent reduction in network risk in 2018, which does not reflect reality. The methodology should perhaps be refined in the light of more accurate data, if that were available.

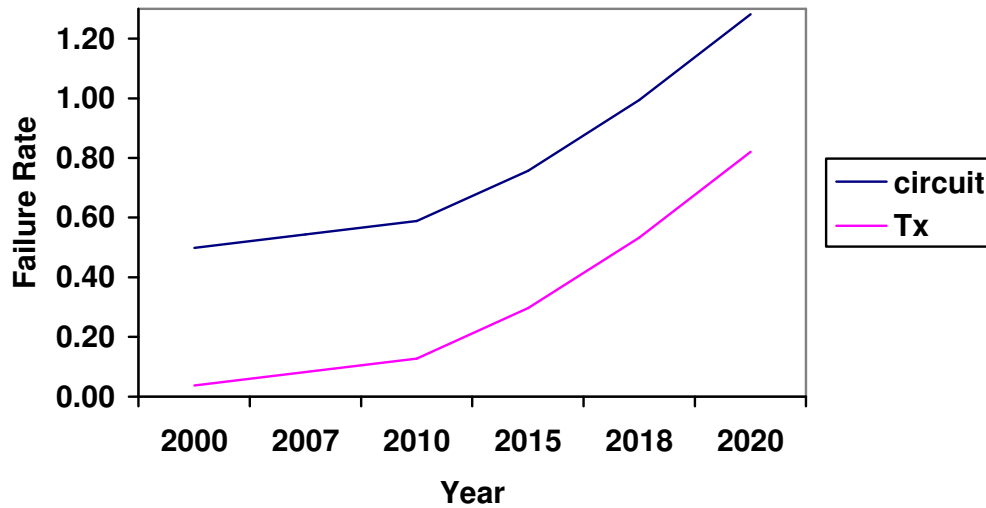

Figure 5.8 – Failure rates for a typical exposed 33 kV rural circuit

Year	2010	2015	2018
Risk ($\lambda=0.0922$)	£49.9k	£112.1k	£216.0k
Risk ($\lambda=0.4610$)	£70.1k	£128.8k	£213.7k

Table 5.11 – Effect of increased failure rates elsewhere in the circuit

To evaluate the effect of higher failure rates on optimal replacement year, it will be assumed that an increased network risk of £20k per year applies throughout the period under consideration. This would have the effect of advancing the optimal date by around 1 year, or decreasing the critical value of Health Index by around 0.3.

5.6.7 Health Index as a Function of Time

In the original derivation of Health Index, it was assumed to vary exponentially with time according to the equation

$$H(t_1) = H(t_0)e^{B(t_1-t_0)} \quad (1)$$

where B is a constant used to scale the equation, and $H(t_0)$ is the initial value, for an asset when it has passed through the burn-out phase. Clearly, for this equation to work, the value of $H(t_0)$, or more simply H_0 , must be greater than zero, and in

the original calculations a value of 0.5 was assumed [84]. However, the actual value of H_0 will depend on location factors, and for the Amberton Road transformers a figure of 1.63 was used (see section 5.3.3). This initial value greatly affects the way in which the HI (and therefore the failure rate) will be expected to increase with time. To some extent, this can be compensated by choosing a lower value for the other parameter, B , as was also done in section 5.3.3, using the actual value of HI at age 42 to scale the curve and derive a value for B . It should also be pointed out that this anomaly has been addressed in revisions to the original health index methodology [89]

However, this empirical approach makes it hard to generalise, from a case study in one location, to other locations throughout the network, with different initial values of H_0 . A deeper study of the way in which HI might be expected to vary with time would be required to produce a reliable method of prediction.

Another aspect of sensitivity is illustrated by Figure 5.9. The curve marked '15 year' is the expected change of HI with time for an asset which starts with $H=0.5$, and doubles every 15 years. The 20 year and 10 year curves are also shown. Suppose that an asset was assumed to follow the 15 year curve from installation, and therefore to have reached $H=2.0$ by age 30. However, actual inspection results at that time show that in fact $H=4.0$, as shown by the ellipse. The vertical dotted line shows the change that must be incorporated into projections for the health of the asset as a result of this inspection.

However, the issue remains as to the curve that this asset can now be expected to follow. It could be assumed that the inspection indicates that the asset has been following the 10 year curve for the past 30 years, and can be expected to continue to do so. Alternatively, the increase of HI could be interpreted as premature ageing (by 15 years), and the asset will follow a curve parallel to the 15 year curve, but displaced 15 years to the left. Or the increase of HI could be interpreted as a worsening of Health (by 2.0), and the asset will follow a curve parallel to the 15 year curve, but displaced by 2.0 upwards. These two alternatives are indicated by dotted lines. Which one (or the 10 year curve) should be anticipated for future growth of Health Index is not clear, but a case could be made for each of the three. Clearly, the use of Health Indices needs to be considered in more depth if it is to be a useful diagnostic tool for detailed asset planning.

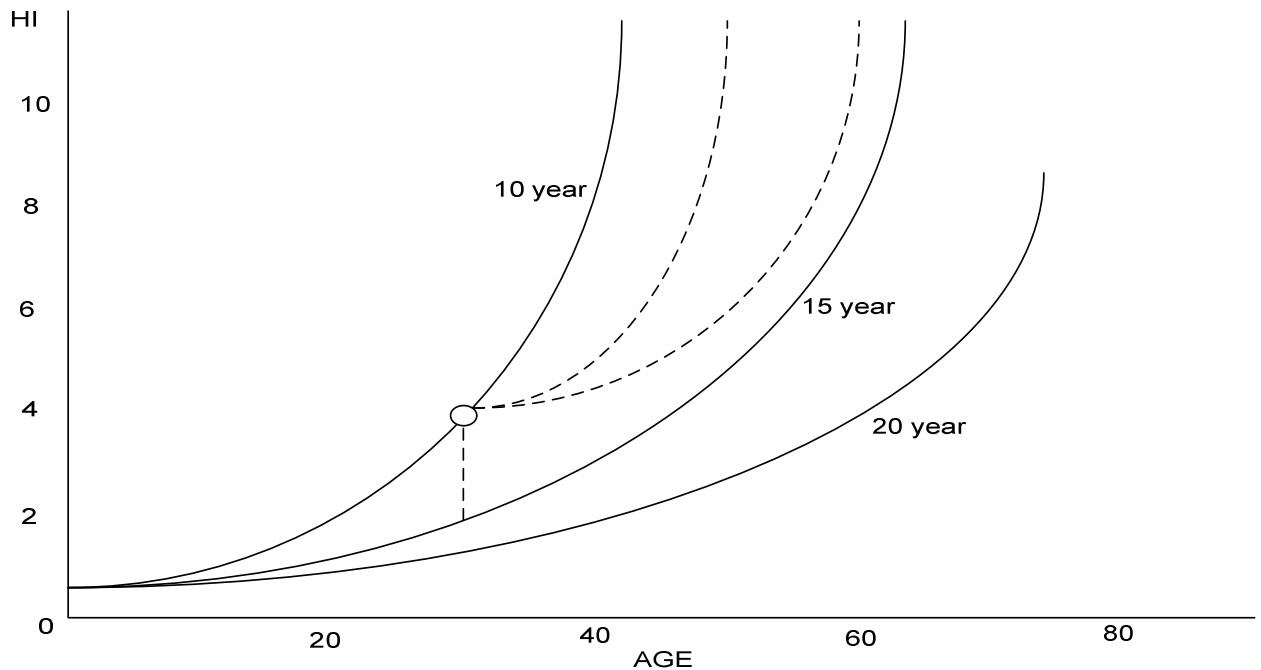

Figure 5.9 – Change of Health Index with time

5.7 Risk Mitigation by Asset Replacement: Discussion

In this chapter, a methodology has been developed for evaluating the effectiveness of network risk mitigation by asset replacement, in particular as a result of ageing. It includes a case study based on the actual replacement of two 66/11 kV transformers in Hartlepool, which was completed in 2009.

This methodology incorporates the following features:

- Health Indices, which are used throughout the electricity distribution industry to assess asset condition and likelihood of failure, are input at present levels, and predicted for each year in the future, together with the consequences of future increases in HI for network risk.
- The core methodology, developed in Chapter 3, is used to calculate an expected value in £ for total network risk. For more complex networks, the generalised methodology developed in Chapter 4 could be used instead.
- The reduction in network risk as a consequence of asset replacement in any given year is calculated, and balanced against both the capital cost of such replacement, and the temporary increase in network risk during the construction period. All cash flows are discounted at an appropriate rate.

- Input parameters including failure rates, proportion of double failures, and restoration times are not necessarily fixed, but can vary with the age of the assets and consequent changes to the frequency and pattern of component failures.
- The methodology can be extended to include variability of both input and output by the use of Monte Carlo Simulation.
- An algorithm is included to determine the optimal year in which to replace the asset, in terms of minimising the overall discounted cost to the distribution operator. This can also be expressed in terms of the HI at which asset replacement becomes more economic than living with increasing failure rates.
- Sensitivity analysis with respect to a range of input parameters shows that the optimal year for replacement, and the optimal HI for replacement, is sensitive to factors including transformer size, reconfigurability, and customer numbers.
- The sensitivity analysis also demonstrates that the methodology can be used to compare replacement options for each member of a whole group of assets, and to rank them in order of priority for replacement. An extension of this approach would also enable different groups of assets to be compared.

In the process of developing this methodology, a number of interesting issues have emerged. The first concerns the definition of failure. Conventional replacement theory usually considers components which are either working, or which have failed completely and require replacement, such as light bulbs. But a complex asset such as a transformer contains many hundreds of components. The failure of a transformer can usually be rectified by the replacement of just a few of these components. It is very rare for a failure event to require the replacement of a whole transformer [90]. In the same way, a 10 km underground cable can be considered as comprising 1000 10-metre sections. The failure of a cable will generally be restored by the replacement of one or two faulted sections. The decision to replace a whole cable may be an economic one, but is unlikely to be in response to a single failure event, as formal replacement theory tends to assume.

Other interventions, short of complete replacement, are also possible. These are often grouped under the heading of 'maintenance', which can include actions

as minor as a periodic routine check and oil replacement, or as major as a complete overhaul or refurbishment where many components are renewed. The effect of these interventions has been dealt with on occasion in the literature (Section 2.12.1), but has not been analysed in the present research. It could, however, be included as an extension to the methodology described in this chapter.

The value of preventative asset replacement is also called into question by the analysis in this chapter. Without extensive input parameter adjustments, as in Section 5.4, there seemed to be little economic justification for this policy, although it is universally accepted and practised throughout the industry as regards EHV assets. However, the much larger number of transformers and other assets at lower voltages are generally allowed to operate until they can no longer be repaired [90]. Perhaps this approach might be more economic at EHV as well, particularly since assets are generally duplicated at these voltages, and particularly at a time of increasing economic constraint.

Another issue arising from this chapter concerns the value and use of health indices as an aid to asset management. While CE Electric UK calculates the HI for a whole asset (such as a 15 km overhead line), other DNOs calculate a separate HI for each sub-component (individual towers, and individual spans) [91]. This detailed data-gathering and analysis could prove useful. However, the separate HI values are then added together to derive an average figure, which may obscure the fact that a few subcomponents are in a seriously deteriorated condition, for example. While health indices are potentially useful, and a decided improvement over not gathering data, or not analysing the data that has been gathered, they need to be used with care. Further research is needed to determine how they can be used most effectively for measuring, understanding and mitigating network risk.

It should also be realised that the conclusions in this chapter are based on data (on actual failure history, for example, and on repair and deterioration costs, and on the effects of ageing on failure rates) which are quite thin. It could be worth doing further work to substantially improve the quality of this data.

Finally, the present chapter considers the effects of asset ageing on asset replacement in isolation from other possible economic drivers. The additional effects of load increase, and the additional justification of network reinforcement, are addressed in a composite case study in Chapter 9.

6. METHODOLOGY FOR NETWORK AUTOMATION

While asset replacement, and consequent decrease of failure rates, is one way of mitigating network risk, it is relatively costly. An alternative and usually less costly option is to accept that failures will occur with increasing frequency as assets age, but to seek to minimise their impact on customers. One way of doing so is to automate the network, replacing manually operated isolating switches with switches which can be operated by radio remote control, initiated by the Network Control Engineer. This might reduce outage time, and possibly customer disconnection time, from perhaps 3 hours to 15 minutes, with a corresponding reduction in CMLs and therefore in Network Risk.

Replacing the switch with a circuit breaker (CB) is more expensive, but can reduce customer disconnection time still further, typically below 3 minutes, which would also avoid CIs. These relatively small capital investments provide control engineers with the option to reconfigure the network remotely. This is an example of Active Network Management (ANM), and is the subject of the present chapter, in which a methodology is developed for assessing the reduction in network risk that can occur as a result of such network automation.

6.1 Network Classification

In this chapter, the effects of implementing network automation, with consequent opportunities for remote reconfiguration, will be examined for a range of different topologies. The methodology has to be able to address and evaluate the specific characteristics of each network topology.

Networks can be defined in terms of both their general and their specific architecture. For general architecture, words such as *rural*, *urban* and *suburban* are often used. These are not precisely defined, but should be understood primarily in terms of their network properties rather than in terms of their geographic environment, although the two are closely correlated. For specific architecture, words such as *radial*, *ring* and *meshed* are used, and these can be more precisely defined. The definitions used in this research for both general and specific architecture are as follows:

Rural networks have low customer density, typically below 100 per square km, served by long circuits, typically over 10 km, comprising a small number of large and sometimes complex protection zones. The customer mix is primarily domestic, with typical peak loads of 2 kW or less per customer. Distribution is 80% or more by overhead line, often at non-standard voltages (66 kV instead of 33 kV, 20 kV instead of 11 kV) to reduce losses. The lines are sometimes in exposed locations, and there is less duplication of assets than in other locations.

Urban networks have high customer density, typically above 1000 customers per square km, served by much shorter circuits, typically around 1 km, comprising a large number of small and simple protection zones. The customer mix comprises significant numbers of commercial and/or industrial customers, some of whom have unusually sensitive loads, and this increases the average peak load to 5 kW or more. Distribution is 90% or more by underground cable, with less use of intermediate voltages (66 kV or 33 kV), transforming directly from 132 kV to 11 kV to avoid transformer losses. There may also be significant pockets of non-standard voltages such as 6.6 kV. There is more redundancy of assets than in other locations.

Suburban networks are intermediate, with typically 100 to 1000 customers per square km, circuits around 2 to 5 km in length, some commercial and industrial customers, with peak loads around 3 kW per customer on average. There is a mix of overhead line and underground cable, with duplication of circuits (but not triplication or more) being the most typical level of redundancy. Voltage levels of 132 kV, 33 kV and 11 kV are most common, with average-sized protection zones.

Radial networks consist of radial feeders, shown by Bayliss and Hardy [92] as single circuits feeding one or more single-transformer loads from a single supply point. In this research, the concept is extended to loads some of which may have two or more transformers, separately supplied in electrical terms, but from the same supply point and often by the same geographical route (two cables in a single trench, two lines on either side of the same tower). A radial feeder may also be teed off a more complex network.

Ring configurations consist of simple or complex ring circuits [92]. The simplest ring is a circuit which can be traced from a supply point, via one or

more different load points, back to the supply point. In the event of a break in the circuit, there will be an alternative route linking each load to the supply point. There will also generally be sufficient isolation (circuit breakers, radio switches or manual switches) to enable supply to be restored in the event of a short-circuit fault. More complex rings occur when they connect two different supply points via a series of loads, or when there are sub-rings or short-cuts giving three or more supply routes, or when the two or more transformers supplying a single load have different feeding arrangements.

Meshed networks are where the number and complexity of the rings is such that most loads can typically be fed by three or more routes, from three or more different supply points. There may be a number of interconnectors, interconnected distributors or express feeders to add to this variety [92]. It becomes impossible to determine which ring supplies which load, and so the network cannot easily be divided into constituent parts to evaluate reliability, but must be considered as a whole.

6.2 Generic Networks

All the case studies described in Chapters 3-5 have been based on actual locations within the CE Electric UK network. This has the advantage of direct applicability, but it lacks generality. Such generality is needed, in order to preserve CE Electric UK business confidentiality while still enabling academic validation and review. As an alternative, the GDS generic networks have been produced by a consortium of UK universities, based on typical networks as defined by the DNOs, and are accepted by the DNOs and by the academic community as being representative [93]. There are six such networks defined at sub-transmission and EHV voltages (33 to 132 kV), and some of them will be used in the case studies in the present chapter.

Generic networks include a detailed network diagram, with details of maximum loads, asset capacities, branch lengths and impedances, and other data needed for static power flow modelling. They do not include such details as geographic layout, failure and restoration rates, location of switches and circuit breakers, distinguishing between overhead line and underground cable, customer numbers, load profiles, and other data relevant to network reliability studies. This gives the researcher the task of estimating such parameters,

which adds to the work (such estimates need to be carefully justified), but also contributes to the freedom (such estimates cannot be challenged by the particularities of individual locations, as happens in case studies based on actual networks).

The case studies which follow are selected to demonstrate the full range of applications of the methodology, concerning the value of remote reconfiguration of networks in terms of customer reliability. Each case study is extended sufficiently to exhibit the diversity of the methodology, although in each case it could easily be further extended in a number of possible ways. The six case studies are intended to provide comprehensive coverage, as follows:

1. Adding one or two switches or circuit breakers to a long, radial branch of a rural 33 kV network (part of GDS2) with 3 loads along its length. Rural radial is generally the most vulnerable combination.
2. Sensitivity analysis based on changing in turn 8 variables or groups of variables in the above radial example. This demonstrates the range of sensitivity analyses that can be undertaken, and could be repeated for the other case studies in a similar way.
3. Rural rings are less vulnerable, and this case study investigates adding one or two switches or circuit breakers to a long, ring branch of a rural 66 kV network (another part of GDS2), also with 3 loads.
4. Rural meshed networks are not common, and are not represented by GDS. This brief case study addresses that condition, however, by considering an actual (not GDS) single load on the highly meshed MANWEB rural network in North Wales.
5. Suburban networks, like rural, can have radial, ring and meshed regions which can be analysed in the same way as their rural counterparts. The additional complexity involved in suburban architecture is seen in this case study, which investigates adding a substation with 4 circuit breakers at a nodal point of a meshed 33 kV suburban network, affecting 10 loads, part of GDS4.
6. Urban networks can also exhibit a range of architectures, although their level of risk is typically very low and therefore of less interest in a network risk study such as this. However, some uniquely urban

features are investigated by this case study. It concerns doubling a short length of cable in a 132 kV ring within a complex, meshed urban network, part of GDS5.

In the present research, the effect of remote reconfiguration on an actual (remote, rural) part of the CE Electric UK network was also investigated, but this detailed investigation is not described in the present chapter.

6.3 Rural Radial

Figure 6.1 shows a part of the GDS2 rural network [93]. It has been selected as an example of what are typically the most vulnerable parts of the whole UK sub-transmission network, characterised by:

- Long runs of overhead line, often in exposed locations.
- Single-transformer primary substations.
- Radial network configuration (several loads with no alternative routes).
- 33 kV assets (often scaled-up 11 kV designs, lacking in robustness)
- Supply points (typically 132/33 kV) which may themselves be similarly vulnerable.
- Manual, as opposed to automated or radio-controlled, switches.
- Remote locations, leading to longer than average restoration times.
- Limited interconnection with other primaries at lower (11 kV) voltages.

In Figure 6.1, the supply point, nodes and loads are numbered as in GDS2. The transformers are each 33/11 kV and of adequate capacity for the given load sizes, which are assumed to be peak loads. There are assumed to be four circuit breakers, shown as X in Figure 6.1. Three of them are on the 11 kV side of the transformers and one is downstream of the 33 kV busbar at the supply point. Together, they define a single, large protection zone including 40.8 km of overhead line (mostly, but perhaps including a small length of underground cable). Manual switches may exist in this protection zone, but they are not shown. In particular, they may already be at the two locations with dotted Xs, which are being considered for the installation of radio controlled switches or circuit breakers.

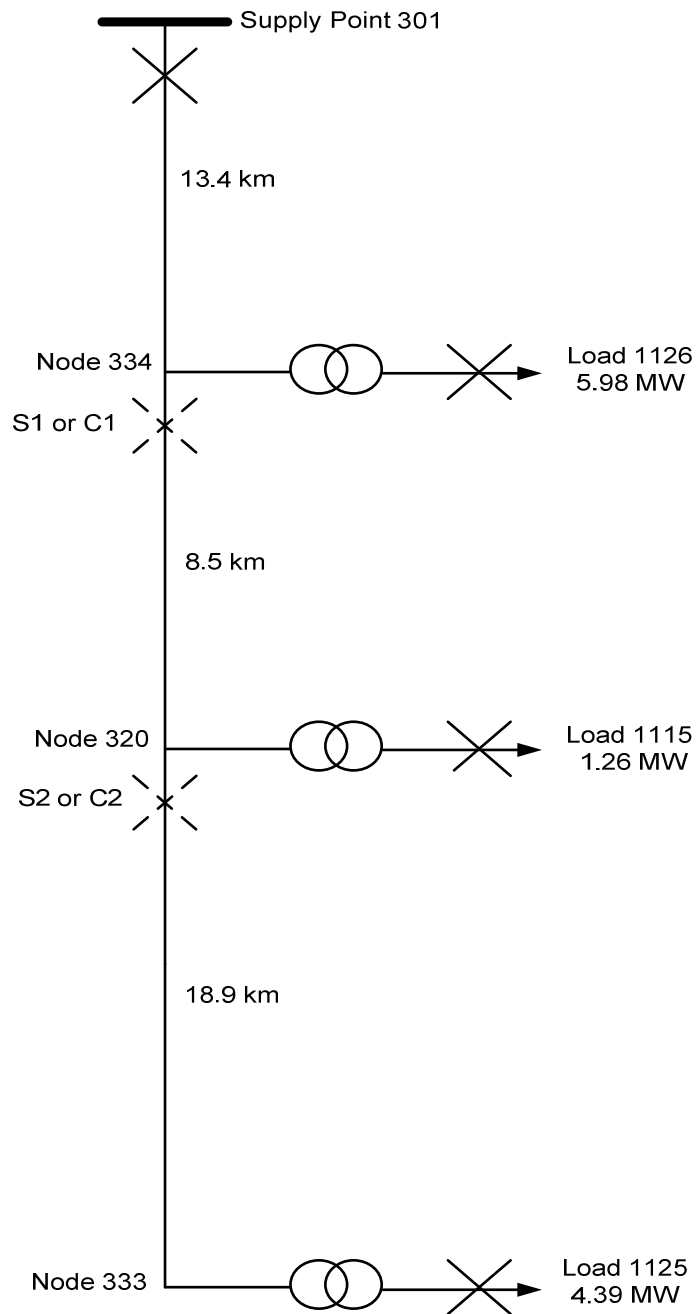

Figure 6.1 – Rural radial network

Input parameters have to be defined for this generic circuit, and the methodology enables this to be done where actual circuit data has not been supplied. These are detailed below, with explanations where necessary.

$\lambda(\text{line}) = 0.036$ failures per km per year, an average UK value for 33 kV [8].
 $\lambda(\text{cable}) = 0.036$ (also a historic value. As it is the same as for overhead line, the line/cable ratio need not be known)
 $\lambda(\text{transformer}) = 0.022$ (of which 0.012 is for associated protection assets)
 $\lambda(\text{switch/CB}) = 0.006$ which applies to the zones on either side of it
 $\lambda(\text{supply point}) = 0.150$ (including all upstream supply failures)
 $T_s = 20$ minutes (average remotely-controlled restoration time at all voltages)
 $T_I = 240$ minutes (20% above average levels on account of remote location)
 $R = 0.2$ (reconfigurability at 11 kV, a low value, typical for rural area)
 $UCI = 6$, $UCML = 0.10$, $UCR = 20000$ as in earlier chapters.

The input parameter for number of customers has been derived from the maximum load, based on actual data from the CE Electric UK network [27, 28, 80]. A representative rural part of the network was chosen (downstream from Silsden), and the number of customers per MVA of peak load was evaluated for each. The most rural areas, with fewest large consumers, had the greatest number of customers per MVA, typically around 700. Applying this to the GDS peak load data gives the results shown in Table 6.1.

<i>Load</i>	<i>Peak MW</i>	<i>Peak MVA_r</i>	<i>Peak MVA (to 2 d.p.)</i>	<i>Customers (nearest 100)</i>
1126	5.9752	1.9639	6.29	4400
1115	1.2561	0.4128	1.32	900
1125	4.3881	1.2799	4.57	3200

Table 6.1 – Estimation of customer numbers

The overall annual failure rate for the whole protection zone, containing 40.8 km of line/cable, 3 transformers, 4 circuit breakers and 1 supply point, is calculated at 1.709 per year. This may seem high, but it is consistent with experience on similar actual rural circuits. Then, applying the core methodology to this single zone, combining the 8500 customers at all three load points for ease of calculation, gives a network risk of 31180, 87159 and 284719 for *CR*, *CI* and *CML* respectively. Total annual network risk is then

£ 403 100 (to nearest £100). This is a very high figure, but it represents a high-risk part of the network, before any extra protection (in the form of automated or remotely controlled switching) has been installed.

6.3.1 Adding a Radio Controlled Switch S2

The benefit of a radio controlled switch in this location is realised when a fault occurs beyond the switch, and by opening it power can be restored to loads 1126 and 1115. With a manual switch in this location, the time taken to locate the fault, to send personnel to the switch and to open it safely can be several hours. The restoration time T_I , set at 240 minutes, is an average time for all manual fault restoration strategies, including such manual switch operation.

However, with a remotely operated switch (and associated fault detection and protection equipment), the switch can be opened, and power restored to upstream loads, in a much shorter time T_s , set at 20 minutes. The reduced time for which these customers are off supply is a measure of the value of installing such a switch. As against this, the extra assets can themselves fail, so the overall failure rate for this part of the network will increase slightly. However, it can be seen that this increase is outweighed by the benefits of the shorter restoration times.

There are now two zones, separated by S2. The overall failure rate for Z1, on the supply point side of S2, is 1.006, while the corresponding failure rate for Z2, beyond S2, is 0.714. Note that the total failure rate has increased by double the switch/CB rate of 0.006 because the newly installed remotely controlled switch at S2 counts in both zones. The failure rate of the manual switch which it may have replaced is considered to be negligible. Note also that this new switch does not need to be able to be opened on fault currents, or even on load currents.

One further parameter now needs to be estimated. This is DF, the 'double failure' probability that a fault initially occurring in Z2 leads to failure in Z1 before it is restored, for whatever reason. This value is set to 0.25, which is slightly above historic average levels, on account of the likely age, exposed location and light construction of this rural radial circuit..

The CI and CR elements of the risk have increased slightly, to £ 87720 and £ 31400 respectively, on account of the increased failure rate. The CML element at load point 1125 (which derives no benefit from the new switch) is also increased slightly, to £ 107878. So is the CML element at the other load points, in the event of a fault in zone Z1.

The CML element at the other load points in the event of a fault in zone Z2 is made up of two parts, one where there is consequential failure in Z1 (probability 0.25), and one where there is not (probability 0.75). Summing all these elements gives a total network risk of £ 353 600 (to the nearest £100). This represents a reduction of £ 49 500 from the base run value of risk. This reduction of almost £50k in expected costs to the DNO can be taken as the average annual value to the DNO of a project to install a radio controlled switch at location S2.

6.3.2 Adding a Circuit Breaker C2

The additional benefit of a circuit breaker, as against a radio controlled switch, is that it can be opened automatically on load, and also on fault currents. With the trigger levels correctly set, a fault in zone Z2 would result in breaker C2 opening before the breaker at supply point 301. This could be followed by auto-reclose procedures to restore supply in the event of the fault clearing by itself, without further intervention. If the fault does not clear by itself, then the breaker C2 would remain open, with any interruption to loads 1126 and 1115 lasting less than 3 minutes (such short duration interruptions do not count towards CI or CML).

The fast action of C2 is assumed to reduce the probability of double failure (and hence the value of DF) effectively to zero. The CI element of risk is therefore reduced for the two loads, giving a total CI value of 65015. The CML cost at these loads due to a fault in Z2 is also reduced, to zero. The total risk is then £ 306 700 (to nearest £100), a reduction of £ 96 400.

This indicates that the value to the DNO of installing a circuit breaker C2 is almost twice as great as installing a switch S2. As against this, the circuit breaker and its associated protection would almost certainly cost more than a radio controlled switch, so the overall project cost of installing one would also be greater.

6.3.3 Different Location: S1 or C1

The location S1/C1 is 8.5 km nearer the supply point than S2/C2. The advantage of choosing this location for dividing the circuit is that any fault occurring in that 8.5 km section would now be isolated beyond the dividing point, and could therefore be cleared to restore supply quickly to load 1126. As against this, load 1115 would now be isolated beyond the dividing point, and would therefore experience a decrease in reliability.

With the new dividing point, the redefined zone Z1 has a failure rate of 0.672. The corresponding failure rate for Z2, beyond S2, is 1.048. Reworking the calculations on this basis, the overall risk with a switch S1 across the three load points comes to £ 344 800 (to nearest £100), a reduction of £ 58 300. This can be compared with the reduction obtained by installing a switch at S2. It is 17% higher, suggesting that S1 is a marginally better location than S2 for installing a single switch. Of course, the customers at load point 1115, who lose out as a result, would not agree, and considerations such as the political sensitivity of the loads at 1115 would also contribute to any decision as to where to locate the switch.

In the same way, the risk reduction due to installing a circuit breaker at C1 can be calculated. Applying the same core methodology in this case gives a total risk of £ 287 600 (nearest £100), a reduction of £ 115 500. Again, this is almost double the reduction achieved by installing a switch S1, and it is 20% higher than the reduction achieved by locating a circuit breaker at C2.

6.3.4 More than One Switch or Circuit Breaker

If a single switch (either S1 or S2) can give significant risk reduction, then installing both S1 and S2 would give even greater reductions in risk. This option is now examined in detail. With two dividing points, there are now three zones to consider. Z1, nearest to the supply point (and including the risk arising from it), has failure rate 0.672. Z2, the zone between S1 and S2, has failure rate 0.346, and the final zone, Z3, has failure rate 0.714. The total CI and CR costs are again slightly increased, due to the extra assets, to 88332 and 34640 respectively. With three zones, it is necessary to incorporate the generalised methodology of Chapter 4, and to consider the impact matrix **F** at the load point 1126. This is shown in Table 6.2.

	Z1	Z2	Z3
Z1	L	L	L
Z2	L	S/N	S/N
Z3	L	S/N	S/N

Table 6.2 – Impact matrix at load point 1126

The entry S/N indicates a short interruption with switches installed, and no interruption with breakers installed. (The case with one switch and one breaker could also be considered). Applying the generalised methodology gives a CML cost of 79084 at this load. Similar (but simpler) calculations at the other two load points give 20287 at load point 1115 and 108631 at load point 1125. The total risk comes to £ 331 000 (to nearest £100), a reduction of £ 72 100. This is indeed greater than the reduction due to S2 alone (£ 49 900) or the reduction due to S1 alone (£ 58 300), but it is substantially less than the total of those two reductions. This suggests that the addition of a second switch is subject to a law of diminishing returns.

In the same way, the total risk with the installation of two circuit breakers, C1 and C2, can be evaluated. C1 reduces to 56492, CR remains at 34640, and CML reduces to 184541, giving a total of £ 275 700 (to nearest £100), a reduction of £ 127 400. Again, this is greater than either C1 alone or C2 alone, but substantially less than the total of them both. It would also be possible to evaluate the installation of combinations of switches and circuit breakers – S1 with C2, or S2 with C1 – but this does not demonstrate any new concepts, and has therefore not been shown.

6.3.5 Summary of Options

Table 6.3 summarises the value to the DNO responsible for this generic circuit of the six options evaluated in this section. These figures could be used, in conjunction with the projected capital costs of each project and other relevant financial and non-financial inputs (such as capital availability, company design standards, and the political sensitivity of customers at each location), for project selection.

Project	Value to DNO
S1	£ 58 300
S2	£ 49 500
S1 and S2	£ 72 100
C1	£ 115 500
C2	£ 96 400
C1 and C2	£ 127 400

Table 6.3 – Value to DNO of six switch or circuit breaker investment options

6.4 Rural Radial (Sensitivity Analysis)

In all the calculations of the previous section, assumptions have been made about suitable values for the input variables. These estimates incorporate relevant industrial data and experience, together with expert engineering input. But it is worth investigating the sensitivity of the results reached, both here and in subsequent sections, to variations in input data and related assumptions. This is now done for 8 separate groups of input data.

6.4.1 Failure Rates

Failure rates have been estimated using published NAFIRS data, incorporating the reports of all circuit failures across the UK over a 5 year period [8]. In general, historic average levels have been used at the relevant voltage (33 kV in this instance). This is justified for generic GDS networks. However, when the methodology is applied to actual networks, a number of factors could be considered to increase or decrease the failure rates, such as:

- The nature of the assets (manufacturer, design)
- The age of the assets
- The location of the assets (vulnerability to weather, corrosion, and accidental or deliberate damage)
- Any significant failure history
- Condition monitoring (oil samples, visual inspection reports)
- Load profiles (near design limits, unusually fluctuating loads)

The effect of an increased failure rate will in general be linear, with all elements of risk directly proportional to overall failure rates. So a 20% increase in overall failure rates would lead to a 20% higher value of network risk.

Increase in the failure rates of individual assets, or classes of asset, will increase the network risk proportionately. In the rural radial network, overhead lines account for around half of all failures, so a 20% increase in the failure rates of overhead lines (keeping other failure rates unchanged) would result in a 10% increase in network risk. Again, one sixth of the failures can be expected to occur to transformers (half to the transformers themselves, and half to the associated protection equipment). If a particular individual transformer is expected to have a high failure rate, say double the average, this would increase overall network risk by around 3%.

Perhaps the most uncertain failure rate assumption is that allocated to the supply point. This includes the supply point itself, the lines supplying it (typically at 132 kV), and the grid supply even further upstream. Without further detailed analysis of all these networks, it is difficult to fine-tune the assumed value of 0.150. Some industrial judgment has suggested that this value might be too high, even for a remote rural network. Since this element contributes just over one quarter of the total failure rate, the effect of halving the estimate would be to reduce total network risk by 13%.

6.4.2 Double Failure Rate DF

The value of DF was set to 0.25, a higher than average value, reflecting the likely vulnerability of these circuits. The higher the value of DF, the lower is the benefit to be derived from S or C. In the limit, if $DF = 1.0$, then all failures affect both zones, so there is no benefit from adding switches or circuit breakers. Indeed, the added failure rate due to S or C itself slightly increases the total risk. Between these values, and at lower values of DF, the effect of DF is linear. This is indicated in Table 6.4, applied to S2.

It can be seen that the value of switch S2 is not unduly sensitive to the value of DF, within a likely range of values. A similar analysis would apply to other switches or breakers or combinations of them.

<i>DF</i>	<i>Value of S2 (£)</i>
0.15	56 600
0.20	53 200
0.25	49 900
0.30	46 600

Table 6.4 – Sensitivity to changing DF

6.4.3 Long Restoration Time TI

The input value for TI is likely to be imprecise, as it represents the average of a wide range of restoration strategies, applied to a similarly wide range of different assets. NAFIRS data suggests that the average disconnection time for all EHV incidents is around 60 minutes, but this includes all those customers who can be quickly reconnected by remote reconfiguration at either EHV or at lower voltages [8]. For those who have to wait for full restoration of service, a larger value of say 200 minutes has been assumed, or (in this rural location) an even larger value of 240 minutes.

Other factors which would affect the value of TI include the presence of non-standard assets, the availability and experience of personnel, possible bad weather, and difficulty of access particularly in rural locations

Calculating the effect on risk of increasing TI by 20% (from 240 to 288 minutes) increases the base run risk by 14%, and the risks with S2 and with C2 by 11% and by 14% respectively. The differences, representing the value of the project, increase by 23% for S2 and by 15% for C2. This is a roughly linear effect, and it suggests that the value of remote reconfiguration increases approximately proportionately to any increase in TI.

Looking ahead, the possible difficulties foreseen by DNOs as described in Section 1.9 (greater variety of assets, shortages and inexperience of personnel, increased frequency of bad weather events, more traffic delays reaching remote locations) are likely to lead to increased values of TI in the future, and to a correspondingly greater benefit in undertaking remote reconfiguration or automation projects.

6.4.4 Short Restoration Time T_s

The effect of increasing the short restoration time (for customers who can be restored by automatic reconfiguration, e.g. at lower voltages in this case) can also be calculated. An increase of 50% in this value (from 20 to 30 minutes on average) increases the base run risk by £1700, the risk with S2 by £5200, and the risk with C2 by £900. The effect on benefits is to reduce the benefit of S2 by 5%, and to increase the benefit of C2 by 1%. In summary, this project is not very sensitive to large changes in T_s .

6.4.5 Higher Voltage Reconfigurability R

It is assumed that 20% of customers can be reconnected by lower voltage reconfiguration in time T_s . They might be supplied by an 11 kV feeder which is normally fed from a load point on the 33 kV rural radial under consideration, but whose far end is connected (via a normally open point) to an alternative load point, fed by different circuits. Opening the normally closed 11 kV circuit breaker and closing the normally open one would restore supply.

Research into self-healing networks at 11 kV has been very much in evidence at recent conferences [65-67], and this kind of reconfiguration could become truly automatic, i.e. within 3 minutes or considerably less. But, at present, such reconfiguration is likely to be as a result of operator decisions followed by radio control, so an outage of T_s , say 20 minutes, seems realistic.

Of course, for this to work, the alternative load point would need to be unaffected by the fault, i.e. on a different radial, or at least on a restorable part of the same radial. Estimating the reconfigurability of 11 kV networks under a whole range of different possible scenarios is far from straightforward.

Investment in a more flexible network architecture at 11 kV is one way of reducing network risk, as an alternative to automated switching at higher voltages. Such investment would reduce the value of higher voltage automation. For example, if the proportion of customers who can be switched at 11 kV on this rural network were doubled (from 20% to 40%), base run risk reduces by £37K, risk with S2 by £19k, and risk with C2 by £19k. The effect of this on the value of automation is to reduce it by 26% (for S2) and by 17% (for C2). This suggests that perhaps a choice should be made between these two investment options, rather than doing both at once.

6.4.6 Number of Customers NC

The assumption of 700 customers per 1 MVA was based on the least industrial/commercial load points on the CE Electric UK network. If the loads under consideration are in fact more industrial than the minimum, then the number of customers per MVA would decrease, and so would the total number of customers supplied by the load point (whose peak MVA is given by GDS). A 20% reduction in customer numbers would reduce the CI and CML elements of risk (but not the CR element) by 20%. In the present case study, this would reduce total network risk by around 19%, as CI and CML make up 95% of that total risk. This confirms that, with the present regulatory regime which is very much customer-number dependent, the more residential load points derive more benefit from the same investment than the more commercial or industrial load points.

6.4.7 Regulatory Unit Rewards and Penalties

For many years, DNOs have derived income from beating their targets for CI and CML. It could be argued that the regulatory system needs to be made more stringent, both as regards the targets themselves and as regards the cost of not meeting them. A doubling of the rates imposed by the regulator, the basis of UCI and UCML in this study, would have a similar effect on relevant components of risk. Since, in this case-study, CI and CML make up 95% of total network risk (only 5% is CR), then doubling these rates would increase all total risks by around 90%, and therefore also increase the value of automation projects by 90%. Since such projects might be expected to have a 40 year lifetime, project benefits are highly sensitive to likely future changes in the regulatory regime, as typified by possible changes in the reward and penalty rates and system.

6.4.8 Unit Cost of Repairs and Deterioration

The input value for repair cost (£ 20 000 has been assumed) is perhaps the most uncertain in the whole model. In part, this is because the repair required as a result of an unplanned outage could involve so many different interventions to a number of different components, ranging from the most straightforward maintenance checks through to complete asset

replacement. It is further complicated by including any impact on projected asset lifetime. Overrunning a transformer by 30% for 4 hours is likely to shorten its lifetime, but would it be by 1 year or by 10 years? And when would that occur, and how much should the cost be discounted with time?

In the present case study, only 5% of total risk cost is due to repair costs, so even doubling them would only increase total risk by around 5%. But later case studies, where there are more assets and more alternative routings, have higher values of CR and lower values of CI and CML. In this case, total risk is more skewed towards the CR element, and therefore more sensitive to changes in its average value.

6.5 Rural Ring 66 kV

Figure 6.2 shows another part of the GDS2 large rural network [93]. It has the following distinguishing features:

- Some long runs of overhead line, often in exposed locations. In particular, the distance between nodes 213 and 214 is greater than the whole of the rest of the ring. This can occur when a network is reconfigured, and legacy assets need to be used, although this makes the network design sub-optimal.
- Both single-transformer and double-transformer primary substations.
- Ring network configuration, giving two routes to loads 1108 and 1102, and a third independent route to load 1105 (detail not shown).
- 66 kV assets (often scaled-down 132 kV designs, with significantly greater robustness than at 33 kV)
- A single supply point at 132/66 kV which may itself be vulnerable.
- Manual, as opposed to automated or radio-controlled, switches.
- Remote locations, leading to longer than average restoration times.
- Limited interconnection with other primaries at lower (11 kV) voltages.

In Figure 6.2, the supply point, nodes and loads are numbered as in GDS2. The load point transformers are each 66/11 kV and of adequate capacity for the given load sizes, which are assumed to be peak loads. There are assumed to be eight circuit breakers, shown as X in Figure 6.2, of which

six define the ring protection zone. Four of the six are on the 11 kV side of the transformers and two are downstream of the 66 kV busbar at the supply point. Together, they define the single, large protection zone including 21.7 km of what is assumed to be entirely overhead line. Manual switches may exist in this protection zone, but they are not shown. In particular, they may already be at the two locations with dotted Xs, which are being considered for the installation of radio controlled switches or circuit breakers.

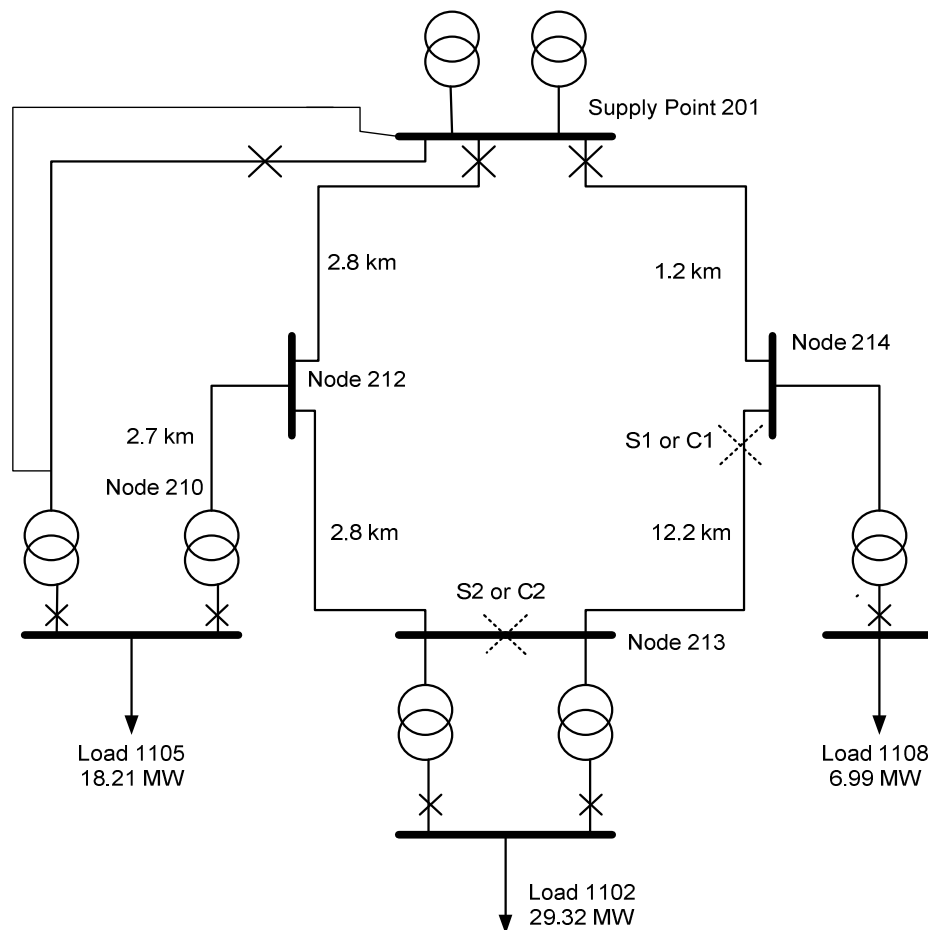

Figure 6.2 – Rural ring 66 kV network

Input parameters have to be defined for this circuit, as required by the core methodology. These are as in the radial 33 kV network, with the significant exception that $\lambda(\text{line}) = 0.012$ failures per km per year, an average UK value for 66 kV. Note that this is one third of the failure rate for 33 kV

overhead lines, reflecting the significantly greater robustness of 66 kV assets as compared with those at 33 kV.

The input parameter for number of customers has again been derived from the maximum load, based on actual data from the CE Electric UK network [27, 28, 80], but this time an average rural figure of 500 customers per MVA of peak load was evaluated for each, as in Table 6.5. Note that the total number of customers on these circuits is more than three times greater than on the 33 kV rural radial of the first case study.

<i>Load</i>	<i>Peak MW</i>	<i>Peak MVA</i>	<i>Peak MVA (to 2 d.p.)</i>	<i>Customers (nearest 100)</i>
1108	6.9906	2.5372	7.44	3700
1102	29.3223	10.6427	31.16	15600
1105	18.2097	6.6093	19.37	9700

Table 6.5 – Estimation of customer numbers on rural 66 kV ring

The overall annual failure rate for the whole protection zone, containing 21.7 km of line, 4 transformers, 6 circuit breakers and 1 supply point, is calculated at 0.534, under one third of the rate for the radial circuit.

Because this is a complex circuit, the generalised methodology must again be incorporated. Applying it to load 1102 in the first instance, gives values of 5376, 49982 and 163276 for *CR*, *CI* and *CML* respectively. with a total network risk of £ 218 600 (to nearest £100)

These calculations assume that 70% of the repair and deterioration costs are allocated to 1102. Proportions of 0.13 and 0.17 are similarly attributed to loads 1108 and 1105 respectively. On this basis, a similar calculation applied to load 1108 gives a total network risk of £ 51 600.

In the case of load 1105, a similar calculation is not appropriate. This is because the load is fed by two transformers, one of which is on the ring under consideration, and the other of which is supplied by a separate ring circuit (although from the same supply point), of which part is shown in Figure 6.2. Since the generalised methodology is designed to apply to single loads, it will

be applied in the present case study to load 1108 and to load 1102 only. However, in evaluating the benefit of adding automation, there may be some additional benefit (probably small) to the customers at load 1105.

6.5.1 Adding a Radio Controlled Switch S2

Location S2 is probably in the middle of a busbar, where a busbar circuit breaker would be the most appropriate asset to install. However, the methodology will first be applied to a possible radio-controlled switch at this location. The benefit of this for load 1102 is that a fault in one half of the ring can be cleared from the other half of the ring (including one of the two transformers), and the load supplied through one transformer. With a manual switch in this location, the time taken to locate the fault, to send personnel to the switch and to open it safely can be several hours. The restoration time T_I , set at 240 minutes, is an average time for all manual fault restoration strategies, including such manual switch operation.

However, with a remotely operated switch (and associated fault detection and protection equipment), the switch can be opened, and power restored to half the ring, in a much shorter time T_s , set at 20 minutes. The reduced time for which these customers are off supply is a measure of the value of installing such a switch. As against this, the extra assets can themselves fail, so the overall failure rate for this part of the network will increase slightly. However, it can be seen that this increase is outweighed by the benefits of the shorter restoration times.

The ring is divided into two zones, plus the supply point which can effectively be considered as a third zone, Z3. Then the failure rate for Z1, on the right of Figure 2, including load 1108 and 13.4 km of overhead line, is given by 0.229. The failure rate for Z2, the remainder of the ring, with 8.3 km of line, is 0.168, and the failure rate for Z3 (the supply point) is 0.150. The total of all three rates is 0.547.

The impact matrix **F** in this case is as shown in Table 6.6. Single failure to the supply point (zone Z3) requires a long restoration, as does double failure in zones Z1 and Z2. Single failure in zone Z1, or in zone Z2, requires a short restoration (with S2) or none at all (with C2). The designation (L)

indicates that this entry is not strictly applicable, as a single (n-1) fault in Z3 would itself be sufficient to require a long restoration time.

	Z1	Z2	Z3
Z1	S/N	L	(L)
Z2	L	S/N	(L)
Z3	(L)	(L)	L

Table 6.6 – Impact matrix for load 1102 with S2 or C2

One further parameter now needs to be estimated. This is DF, the ‘double failure’ probability that a fault initially occurring in Z2 leads to failure in Z1 before it is restored, for whatever reason, or a fault initially occurring in Z1 leads to failure in Z2. This value is set to 0.30, which is around 50% above historic average levels, mainly on account of the effect on a single transformer of carrying the full load for a number of hours. This is because the transformers are rated in GDS2 at 24 MVA (28.8 MVA continuous emergency rating), which is below the peak value of 31.16 MVA for this load.

The CR and CI elements of the risk have increased slightly, to 5558 and 51199 respectively, on account of the increased failure rate due to the additional switch. The CML element comes to 90950, giving a total risk of £ 147 700 (to the nearest £100), a reduction of £ 70 900, which estimates the value of switch S2 at load point 1102.

It should be noted that the CML calculation assumes that 20% of customers can be quickly restored at lower voltages, even in the event of a supply point failure. This would in practice require the alternative MV supply to be fed from a different 132 kV supply point. Whether this is a realistic assumption would depend on geographical or MV circuit details which are not included in the GDS networks.

The benefit of S2 at load 1108 can be similarly calculated. The division into zones and the failure rates are the same, but the impact matrix is not, as load 1108 lies entirely within zone Z1. Table 6.7 shows the revised impact matrix **F**:

	Z1	Z2	Z3
Z1	L	(L)	(L)
Z2	(L)	S/N	(L)
Z3	(L)	(L)	L

Table 6.7 – Impact matrix for load 1108 with S2 or C2

The risk calculation then gives a total risk for load 1108 of £ 45 200 (to nearest £100), a reduction of £ 6400 on the base run.

Comparing this reduction with the £ 70 900 at load 1102 shows that the benefit is increased by almost 10% when the smaller load is included. This could be considered as a sensitivity analysis of the effect of including all the loads that would benefit, instead of just the main load.

It becomes relevant if the benefit to load 1105 were to be considered. There are more customers here, but the circumstances under which switch S2 would bring benefits – essentially a double failure involving the other ring – are less likely. They could be evaluated in detail using the established methodology together with appropriate zoning and parameter assumptions. Or, as an alternative, an estimate of the added benefit could be made using the results of the above sensitivity analysis, to give an overall benefit of S2 as:£ 85 100 (adding 10% for each of 1108 and 1105) This kind of sensitivity analysis could be a more appropriate way of including the likely effects of a design modification on the wider network, without having to analyse it in detail.

6.5.2 Adding a Circuit Breaker C2

As in the radial case study, the additional benefit of a circuit breaker, as against a radio controlled switch, is that it can be opened automatically on load, and also on fault currents. The fast action of C2 is assumed to reduce the probability of double failure from the originally assumed 0.3 to a more average level of 0.2. The CI element of risk is therefore reduced for load 1102, giving a total CI value of 21472. This effectively means that customers are interrupted only if a double failure occurs on the ring affecting both sides

of C2, or if the failure is at the supply point. The CML value at 1102 is likewise reduced to 70141, while CR is unchanged at 5558. This gives a total risk of £ 97 200, a reduction of £ 121 400 on the base run, which is therefore the measure of the value of C2 at load point 1102. This is around 70% greater than the value of S2, a similar increase to that found in the radial case study.

6.5.3 Different Location: S1 or C1

The location S1/C1 is far less useful than S2/C2 to the load 1102, but could perhaps be more useful to load 1108, which (having only a single transformer) is perhaps more vulnerable. In this section, the methodology is used to evaluate the benefit of S1, C1, S1 with S2, and C1 with C2, at both 1102 and 1108.

With S1/C1 only, the zones Z1 and Z2 have new boundaries, and the corresponding failure rates are 0.054, 0.342 and 0.150. The impact matrix for 1102 is shown in Table 6.8. The impact matrix for 1108 is still as shown in Table 6.7. With both S1/C1 and S2/C2, there are now four zones (the fourth is between S1/C1 and S2/C2), with failure rates 0.054, 0.187, 0.168 and 0.150. The impact matrices at 1102 and at 1108 are shown in Tables 6.9 and 6.10.

	Z1	Z2	Z3
Z1	S/N	(L)	(L)
Z2	(L)	L	(L)
Z3	(L)	(L)	L

Table 6.8 – Impact matrix for load 1102 with S1 or C1

	Z1	Z2	Z3	Z4
Z1	S/N	S/N	L	(L)
Z2	S/N	S/N	L	(L)
Z3	L	L	S/N	(L)
Z4	(L)	(L)	(L)	L

Table 6.9 – Impact matrix for load 1102 with S1/C1 and S2/C2

	Z1	Z2	Z3	Z4
Z1	L	(L)	(L)	(L)
Z2	(L)	S/N	S/N	(L)
Z3	(L)	S/N	S/N	(L)
Z4	(L)	(L)	(L)	L

Table 6.10 – Impact matrix for load 1108 with S1/C1 and S2/C2

The value of DF for this ring remains at 0.3 with switches and 0.2 with circuit breakers. The proportion of double failure events in Table 6.9 which result in long restoration times can be calculated according to the generalised methodology, and is equal to 0.80.

The results of all calculations are summarised in Tables 6.11 and 6.12.

£	Risk at 1102	Risk at 1108	Total: 1102 + 1108
Base run	218 600	51 600	270 200
S2	147 700	45 200	192 900
C2	97 200	41 100	138 300
S1	213 200	37 200	250 400
C1	206 400	26 800	233 200
S1 plus S2	143 600	37 800	181 400
C1 plus C2	93 300	27 100	120 400

Table 6.11 – Rural 66 kV ring: TNR with different automation options

£	Benefit at 1102	Benefit at 1108	Total: 1102 + 1108
Base run	0	0	0
S2	70 900	6 400	77 300
C2	121 400	10 500	131 900
S1	5 400	14 400	19 800
C1	12 200	24 800	37 000
S1 plus S2	75 000	13 800	88 800
C1 plus C2	125 300	24 500	149 800

Table 6.12 – Rural 66 kV ring: benefit of different automation options

Significant results from this detailed analysis include:

- For load 1102, C2 is ten times more beneficial than C1, and S2 is over ten times more beneficial than S1
- For load 1108, conversely, S1 and C1 are 2 to 3 times more beneficial than S2 and C2 respectively.
- Overall, since 1102 is much the bigger load, S2/C2 have around 4 times the benefit of S1/C1
- There would be additional benefits, probably small in comparison, at other load points, in particular 1105.
- The overall extra benefit of automating at S1 in addition to S2 is around £11 000, and for C1 in addition to C2 around £18 000. These are around half the benefits of S1/C1 alone.
- In all combinations, the benefit of a circuit-breaker is around double that of a switch
- At load 1108, the marginal benefit of S2 in addition to S1, or C2 in addition to C1, is actually negative. The additional risk of extra assets outweighs the reduced risk as a result of fault clearing.

6.6 Rural Meshed Network

Just as a ring configuration is more complex and provides more network security than a simple radial connection, so a meshed configuration is still more complex, and provides still more network security. There is no fully meshed rural network in the GDS suite of six EHV networks. However, the UK distributor MANWEB has its own philosophy of network design [95], and has built and operates such networks. Figure 6.3 shows part of one meshed rural network, supplying the load at Ruthin in North Wales [96]. It can be seen that this load (and that at Llanarmon, linked to it by a double radial circuit) is supplied by no fewer than six independent 33 kV circuits, from five separate 132 kV supply points. This makes for an extremely low level of network risk, particularly as analysed by the present methodology.

The detailed analysis of network risk has not been carried out for the load point at Ruthin. This is in part because of lack of data (the LTDS maps provide basic geographical information, but not detail of circuits), and in part

because inspection of Figure 6.3 confirms that the level of network risk is likely to be extremely low.

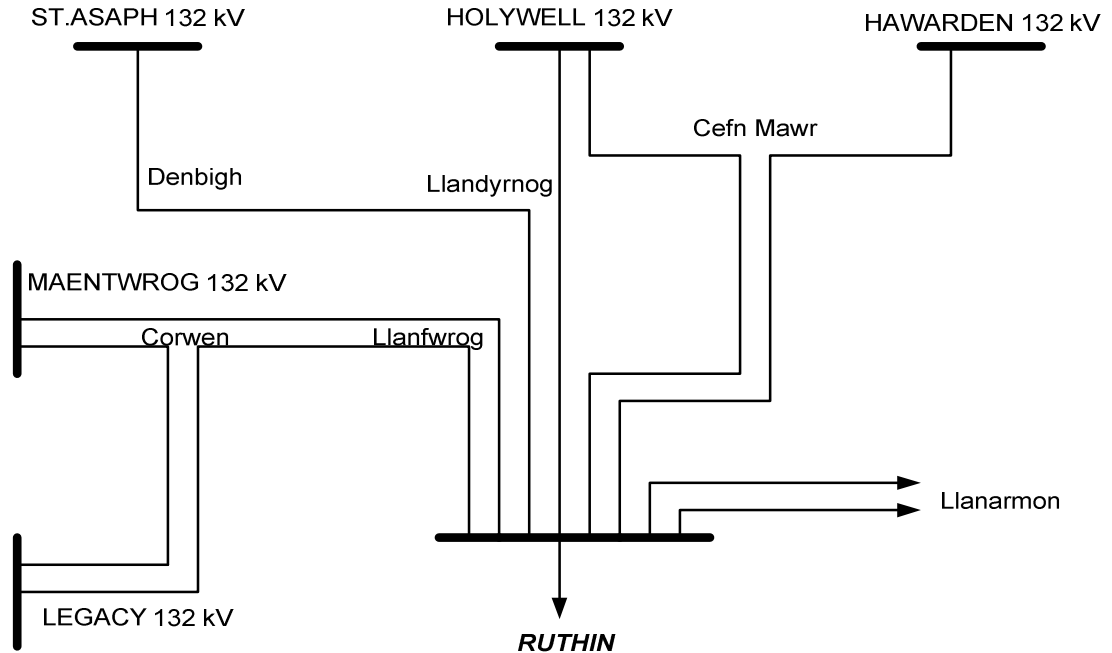

Figure 6.3 – Actual meshed rural network supplying Ruthin

6.7 Suburban Meshed Network

GDS4 is a meshed suburban network operating mainly at 33 kV [93]. This network comprises 10 independent circuits, of which the most complex is considered in this section, and is illustrated in Figure 6.4.

This 33 kV network supplies ten numbered load points, of which seven are at 11 kV and the other three (317, 318 and 319, distinguished by smaller arrowheads) are at 6.6 kV. The load point transformers and downstream circuit breakers have been omitted for clarity, but may be assumed. A further six circuit breakers at 33 kV at the three supply points define a single large protection zone. It is assumed that the breaker at 312 is normally open, and all others are normally closed.

Junction node-points also exist on this network at points 321, 342 and 336. The one at 336 is in a particularly strategic location, and the possibility of building a switching station with four additional circuit breakers (shown with dotted lines) is considered in this section.

Input parameters have to be defined for this circuit, as required by the methodology. These are detailed below, with explanations where necessary.

$\lambda(\text{line}) = 0.036$ failures per km per year, an average UK value for 33 kV.

$\lambda(\text{cable}) = 0.036$ (also a historic value, so line/cable ratio need not be known)

$\lambda(\text{transformer}) = 0.022$ (of which 0.012 is for associated protection assets)

$\lambda(\text{switch/CB}) = 0.006$ which applies to the zones on either side of it

$\lambda(\text{supply point}) = 0$ (see justification following)

$T_s = 20$ minutes (average remotely-controlled restoration time at all voltages)

$T_I = 200$ minutes (a national average level)

$R = 0.4$ (reconfigurability at 11 kV, a low value for a suburban area, because neighbouring primary substations are not independently supplied)

$UCI = 6$, $UCML = 0.10$, $UCR = 20000$ as in earlier chapters.

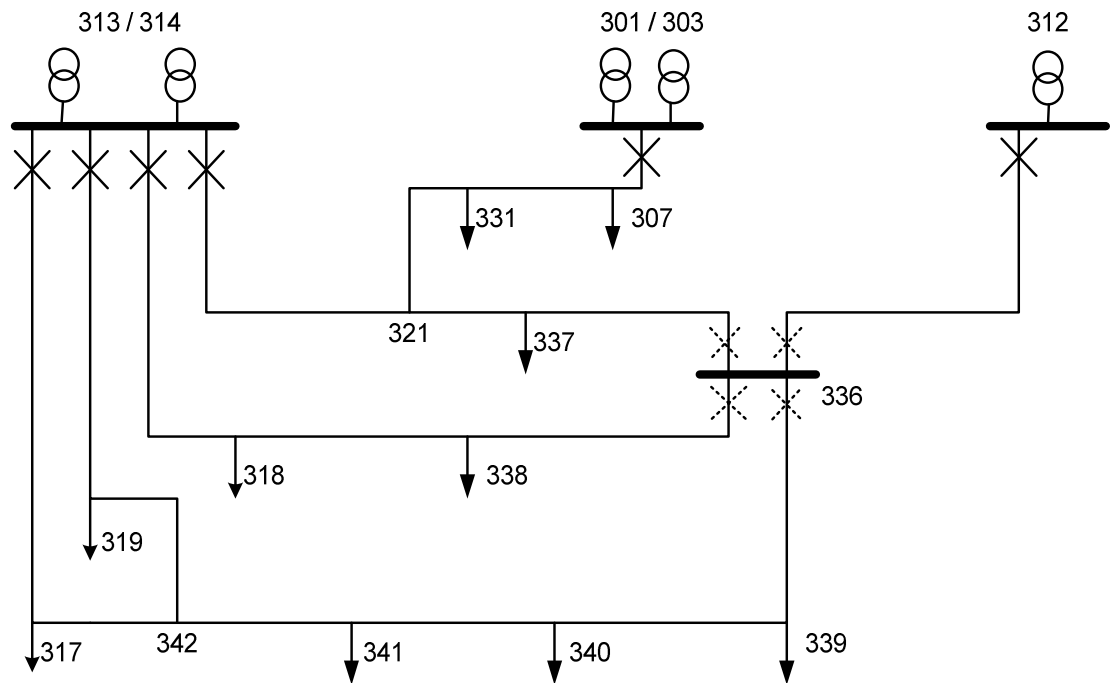

Figure 6.4 – Meshed suburban network

The reason why $\lambda(\text{supply point})$ has been set at zero is because of the security of supply both to and from the three 132/33 kV supply points. Figure 6.5 shows the relevant 132 kV network. Supply to the network consists of two

grid transformers (400/132 kV or 275/132 kV) each of 120 MVA capacity, plus interconnector 'A' which is rated at 222 MVA and interconnector 'B' rated at 100 MVA. Any two of these four supplies could easily support the total peak network load of 158 MVA, so there is considered to be (n-2) security at all times. As regards supply from the 132 kV network, there are 5 transformers each of 60 MVA capacity, any three of which could support the peak load, so again there is (n-2) security in terms of load flows for the whole network, and in terms of connectivity as well for any 3 out of 5 transformers operating as regards the subsection of the network that is being investigated here.

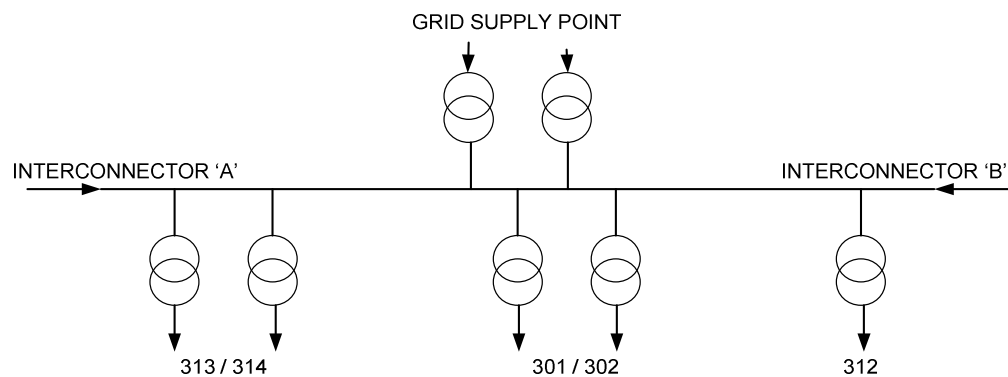

Figure 6.5 – 132 kV supply to suburban mesh

The input parameter for number of customers has again been derived from the maximum load, based on actual data from the CE Electric UK network [18, 19, 80]. A representative suburban part of the network was chosen, and the average number of customers per peak MVA was 350. Applying this to the GDS peak load data gives the results in Table 6.13.

Without the proposed switching station, the ten loads constitute a single protection zone. The overall annual failure rate for the whole protection zone, containing 21.1 km of line/cable, 10 transformers, and 16 circuit breakers is 1.076. This may seem high, but it is consistent with the extent and complexity of the single protection zone. It should perhaps be pointed out that the total number of customers supplied from all ten load points, 23 100, is the same as the number supplied from a single primary substation (with 2 X 66/11 kV transformers) in at least one location on the NEDL network.

<i>Load at load point</i>	<i>Peak MW</i>	<i>Peak MVA</i>	<i>Peak MVA (to 2 d.p.)</i>	<i>Customers (nearest 100)</i>
317	4.97	1.639	5.23	1800
318	7.141	2.355	7.52	2600
319	6.653	2.149	6.99	2400
337	5.324	1.756	5.61	2000
338	5.48	1.807	5.77	2000
339	6.183	2.04	6.51	2300
340	7.154	2.36	7.53	2600
341	6.788	2.239	7.15	2500
307	7.076	2.334	7.45	2600
331	6.321	2.085	6.66	2300

Table 6.13 – Estimation of customer numbers (suburban mesh)

Applying the methodology to this single zone, combining the 10 loads for ease of calculation, gives values of:21520, 149133 and 318151 for *CR*, *CI* and *CML* respectively, with a total network risk of £ 488 800 (to nearest £100) This is a high figure, but it represents a high-risk part of the network, before any extra network security (in the form of automated or remotely controlled switching) has been installed.

6.7.1 Network Risk with Switching Station

Adding the switching station as shown in Figure 6.4 divides this part of the network into four distinct zones, as follows:

- Z1, containing the loads at 307, 331 and 337, with 6 900 customers, 6.1 km of line/cable, 3 transformers and 6 circuit breakers, giving a total value of $\lambda = 0.3216$
- Z2, containing the loads at 318 and 338, with 4 600 customers, 2.8 km of line/cable, 2 transformers and 4 CBs, giving a total $\lambda = 0.1688$
- Z3, containing the loads at 317, 319, 339, 340 and 341, with 11 600 customers, 9.6 km of line/cable, 5 transformers and 8 CBs, giving a total value of $\lambda = 0.5036$

- Z4, with no loads or customers, 2.6 km of line/cable and 2 CBs, giving a total value of $\lambda = 0.1056$

In this meshed network, the impact of double failures is neither more nor less than that of the two component single failures added together, since each load is supplied in one and only one zone. The circumstances giving rise to double failures are limited, since the zones are largely isolated from one another both physically and electrically. Double failure could result from bad weather, from accidental or deliberate damage, or by coincidence. Adding these possible causes together, a value of $DF = 0.10$ (about half the typical value) will be used. The generalised methodology could be used to analyse the relative probabilities of consequent failure in each pair of zones. However, it is considered adequate simply to increase each zone's value of λ by 10%. In this case study, the effective values of λ in each of the four zones become respectively 0.354, 0.186, 0.554 and 0.116.

One further effect of the installation of a switching station would be to increase the value of R , the proportion of customers who could be restored at 11 kV or 6.6 kV. This is because the alternative supply route comes from a primary that is now in a separate protection zone. For example, a 6.6 kV feeder connected between load points 317 and 318 could be quickly restored in the event of a failure in Z3, because 318 is in Z2. It could also be quickly restored in the event of a failure in Z2, because 317 is in Z3. (This assumes that there are appropriate radio-controlled or self-acting switches at both ends of the feeder). Only in the event of a double failure affecting both Z2 and Z3 could supply not be restored. However, a feeder connected between load points 317 and 319 would derive no benefit from the proposed switching station, as both ends of the feeder are in Z3. It is assumed that the overall effect of these and similar examples is to increase the value of R from 0.4 without the switching station to 0.6 with the switching station.

With these assumptions, the expected network risk costs in this part of the network with the switching station can be calculated for each zone. The results of such calculations are summarised in Table 6.14.

The total network risk with the switching station has reduced from

£488 800 by almost two-thirds, to £172 000 (nearest £100), a reduction of £316 800. This is an estimate of the value of such a switching station to the distribution network operator. This reduction is what might be expected by dividing the protection zone customers into three separate zones (excluding the fourth zone, without customers). As a general rule, the level of risk might be expected to be roughly proportional to the average zone size, although more work would be needed to test this rule.

	Z1	Z2	Z3	Z4	Total
CI	14 656	5 134	38 558	0	58 348
CML	22 472	7 872	59 123	0	89 467
CR	7 080	3 720	11 080	2 320	24 200
TNR	44 208	16 726	108 761	2 320	172 015

Table 6.14 – Components of network risk with switching station

6.8 Urban Meshed 132 kV Network

The generic EHV network GD5 is an urban meshed network, operating mainly at 132 kV [93]. Its distinguishing characteristics include:

- Short lengths of underground cable, with no overhead line
- High levels of duplication of assets and of protection
- Different failure rates at 132 kV

These characteristics merit an additional case study on the most vulnerable part of this GD5 network, which is a ring within the mesh, as illustrated in Figure 6.6.

The ring is at 132 kV and is supplied directly from a grid supply point 103 with three 275 / 132 kV grid transformers, and also indirectly via supply point 116 which is fed by two direct and one indirect routes from the GSP plus a separate 132 kV interconnector. The (n-2) supply at both 103 and 116 substantially exceeds the maximum load on the ring, so will not be considered further, and λ for the supply will be set to zero.

The total length of the ring is only 1.69 km, but it supports 9 distinct loads at 4 separate locations, with a combined peak load of 111.43 MVA. Of

particular interest is point 123/124, at which there are two 132 / 33 kV transformers, two 33 kV loads (assumed to be industrial), and two 33 / 6.6 kV transformers for a single 6.6 kV load. From the perspective of the 132 kV ring, these three loads can be combined and considered as a single load of peak value 27.02 MVA, and this case study will consider the network risk for that combined load.

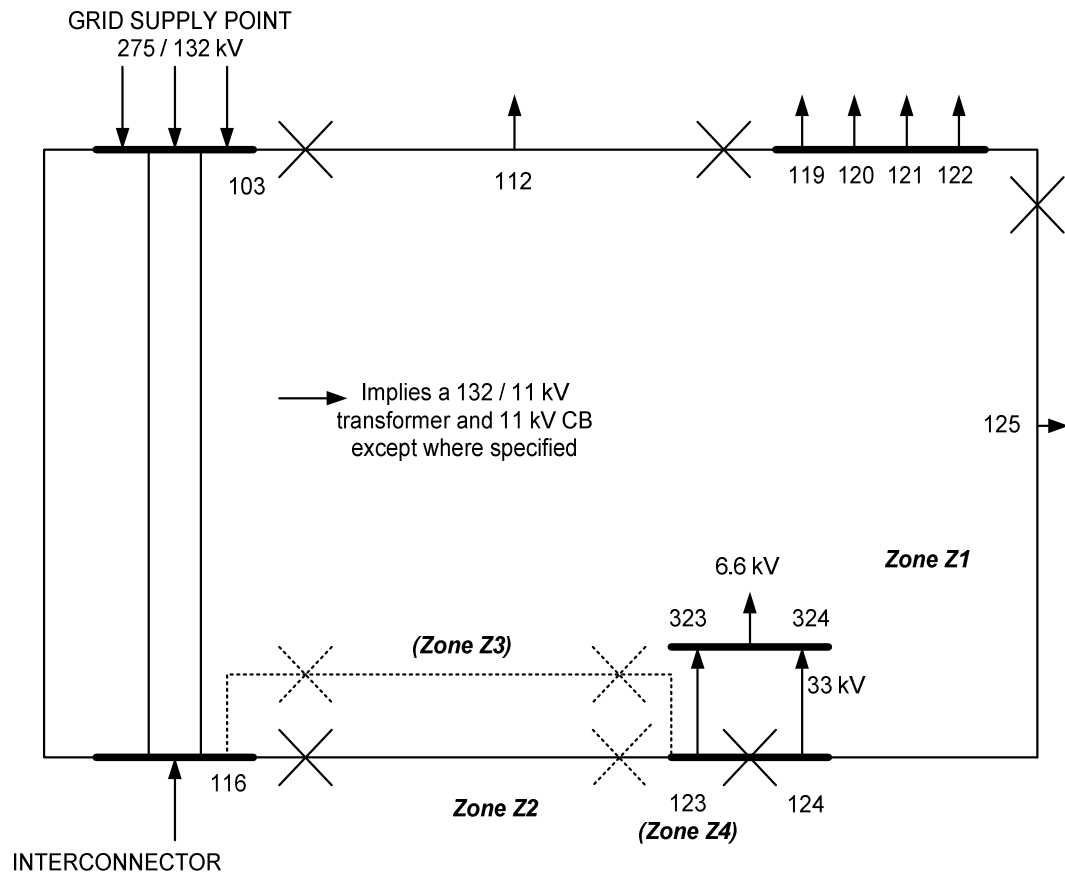

Figure 6.6 – Urban 132 kV ring within urban mesh

All the cables in the ring have a nominal rating of 100 MVA, with a peak rating of 110 MVA. At peak loads, this is slightly exceeded (assuming no diversity between loads), which could cause overload between points 103 and 112 in the event of a prolonged (n-1) outage between points 116 and 123. One solution could be to double the cable between 116 and 123 (shown as a dotted line in Figure 7.6), and it is this potential project which is evaluated in the case study.

The GDS networks do not specify protection, but it is assumed that there would be intermediate breakers as shown adjacent to 119 and 122, as well as a busbar breaker between 123 and 124, in addition to the normal breakers at the beginning and end of each feeder, and immediately downstream of each transformer. For clarity, the transformers and associated breakers are shown simply as arrows on Figure 6.6. The proposed project would also require three additional breakers, as shown (dotted).

The load at 123/124 is described in the GDS as a 'disturbing load' [93]. This is true not only in terms of power flow, but in terms of network risk. Because the voltages involved (33 kV and 6.6 kV) are unique to this point (all other loads are at 11 kV), there is effectively no lower voltage interconnection in the event of a failure in the 132 kV system. The number of customers affected is based on the 6.6 kV maximum load of 16.58 MVA, at a typical urban conversion factor of 200 customers per peak MVA, to give a total of 3300 customers. The additional two industrial customers supplied at 33 kV do not affect this total, although they may well be sensitive loads in their own right.

6.8.1 Failure Rates and other Input Data

The failure rates observed historically on 132 kV networks differ significantly from those at lower voltages, as a result of both more robust engineering and different network architecture. NAFIRS data for the whole of the UK during the five year period 2001-6 give raw failure rates of 0.004/km of overhead line, 0.021/km of underground cable, 0.023 per transformer, and 0.0057 per switch or circuit breaker [6]. But this only accounts for 1057 out of a total of 1664 faults. The remaining 607 occurred on protection and miscellaneous and other equipment (for example, reactors), of which there is more at 132 kV than at lower voltages, and of more complex design. This figure of 607 is 8 times greater proportionately than at lower voltages, and must be allocated among the other assets for the purposes of the present risk analysis.

It was decided to allocate the 'others' (188 faults) to line and cable, increasing their failure rates by 32%, and to allocate the 'protection' and 'miscellaneous' faults equally divided between transformers and switchgear,

which has the effect of increasing the transformer failure rate by 118% and the switchgear failure rate by 71%. This has the effects on standard failure rates as shown in Table 6.15.

Asset	Raw λ (132 kV)	Adjusted λ (132 kV)	cf 33 kV
Overhead Line	0.004 / km	0.005 / km	0.036 / km
Underground Cable	0.021 / km	0.028 / km	0.036 / km
Transformers	0.023 / Tx	0.050 / Tx	0.022 / Tx
Switches / Breakers	0.0057 / unit	0.010 / unit	0.006 / unit

Table 6.15 – Standard failure rates (adjusted) for 132 kV assets

These standard failure rates will be used in the present case study, which is assumed to represent a typical or average part of the network. Other input data is as follows:

$\lambda(\text{supply point}) = 0$ (as already stated)

$T_s = 20$ minutes (average remotely-controlled restoration time at all voltages)

$T_I = 160$ minutes (20% below average levels on account of compact urban location)

$DF = 0.20$ (around EHV average, decreased for 132 kV circuits, but increased because they are running close to capacity)

$R = 0$ (non-standard downstream voltages)

$UCI = 6$, $UCML = 0.10$, $UCR = 20000$ as in earlier case studies.

6.8.2 Base Run

As in the generalised methodology, the risk is evaluated at a single load point, for the 6.6 (and 33) kV loads there. In the base run, zone Z1 comprises the circuit from the breaker at the GSP 103 round to the busbar breaker between 123 and 124. This circuit, comprising three protection zones, 1.42 km of cable, 7 transformers, 4 CBs at 132 kV and 7 CBs at lower voltages (deemed to have the lower voltage failure rate in Table 7.15), has a total failure rate of 0.472. Zone Z2 is the single protection zone from the

breaker at supply point 116 to the busbar breaker between 123 and 124. It comprises 0.27 km of cable, 1 transformer, 2 CBs at 132 kV and 1 CB at 33 kV, giving a total failure rate of 0.084.

The double transformer provision and busbar breaker at 123 /124 means that only a double fault, in both Z1 and Z2, would lead to customer loss. This could be either a fault in Z1 with a consequent fault in Z2, or the other way around. Assuming 25% of faults on the ring have repair costs allocated to this load point, values of *CR*, *CI* and *CML* come to 2780, 2202 and 5871 respectively, giving a total base-run network risk of £ 10 900 expected per year (to the nearest £100).

6.8.3 Project: Doubling up Cable

Adding an extra cable with three extra breakers (needed to make it effective) increases the number of zones in the analysis to four. Z1 is unchanged, Z2, Z3 and Z4 (as defined in Figure 6.6) have failure rates 0.028, 0.028 and 0.086 respectively. The impact matrix for these four zones can be constructed, and the only double failure to cause customer loss is Z1 with Z4. Using the generalised methodology and summing the products of probabilities gives the proportion of double failures which involve these two zones to be 0.559. Calculations with the doubled cable then give values of 3070, 1359 and 3624 for *CR*, *CI* and *CML* respectively, making a total of £ 8 100 (to nearest £100).

In terms of network risk, a relatively expensive project (installing 0.27 km of cable and 3 circuit breakers in a crowded urban environment) reduces that risk by only £ 2 800. The reasons for this are

- The network is short and duplicated, so has overall low levels of risk to start with (base run).
- The newly duplicated asset (0.27 km of cable) itself had a very low level of risk.
- The addition of extra assets brings with it a correspondingly increased level of failures and consequent network risk.

It therefore seems unlikely that this project could be justified in terms of network risk alone. However, the overloading in the event of (n-1) failure at peak times at either end of the ring would provide an additional driver for this project, particularly in the event of future load growth. In this case, the section of circuit from 103 to 112 (0.36 km) should also be considered for doubling.

6.9 Network Automation: Discussion

In this chapter, the possibilities of network risk mitigation as a result of increased automation have been explored. The particular mitigation strategy considered is to install one or more switches or circuit breakers at critical locations on the network. Active Network Management in the event of a single or double failure would then permit the network to be remotely reconfigured, restoring supply more quickly to a proportion of customers.

A methodology has been developed in the present chapter to evaluate this strategy. Features of this methodology include:

- Versatility. The methodology can be applied to radial, ring or meshed networks in rural, suburban or urban environments, responding to the specific characteristics of each network. This has been illustrated by six case studies within the chapter.
- The methodology can be applied to both actual and generic networks. In the case of generic networks, it can be used to estimate parameters which have not been specified, including customer numbers, single and double failure rates, and levels of lower voltage interconnection.
- The methodology calculates the benefit at each load point of installing a particular asset at a particular location. The asset specification (whether it can act on normal or fault currents, whether it acts fully automatically or in response to radio control) can be incorporated into the methodology, and has been illustrated in the case studies by distinguishing between two different levels of automation, a 'switch' and a 'circuit-breaker'.
- The methodology can also assess the effects of changing the location of the proposed switch or circuit breaker. This requires discerning

analysis of each network topology, from the perspective of each load point which it supplies.

- The benefits of adding additional switches and circuit breakers can also be assessed, and their marginal benefit evaluated. In a subsequent case study on the actual CE Electric UK network (not reported here), 6 possible locations were evaluated both separately and together, and the optimal number of switches to install was found to be 2.
- The methodology lends itself to sensitivity analysis on the input data, illustrated here with reference to 8 separate input variables. This is a valuable feature in view of the uncertainty surrounding much of the available input data. This uncertainty applies in particular to generic networks, but is also a significant feature of analysing actual networks.
- The methodology incorporates the core methodology of Chapter 3 (for simple circuits), and/or the generalised methodology of Chapter 4 (for more complex networks) as appropriate. Although not separately shown, it can be extended by the use of Monte Carlo Simulation to allow probability distributions for both input and output.
- While full and detailed analysis of each load point is possible with this network automation methodology, it also allows simplifying assumptions to reduce the computational requirement, such as the estimated risk increase of 10% for including a peripheral load point, as discussed in Section 6.5.1
- As demonstrated in this chapter, the methodology is used to calculate risk mitigation as a result of increasing network automation, permitting remote reconfiguration of the network by active network management under fault conditions. An extension of the methodology, more fully demonstrated with respect to other methodologies in Chapter 5 and also in later chapters, combines this with cost estimates for capital expenditure and construction risk to produce a fully discounted cash flow for any particular network automation proposal.

The methodology has been demonstrated here by applying it to generic, rather than actual networks. This raises the question of the usefulness of such

generic networks. One advantage is that they can easily be accessed by other researchers within the academic community, so that results can be validated, and methodologies explored within a common domain. Another advantage is the avoidance of peripheral detail. When a case study based on an actual network is presented to, and discussed with, DNO engineers who are familiar with the location concerned, they tend to raise additional points, not previously known to the researcher, which may reduce the credibility of the case study without necessarily undermining the principles it was used to illustrate. This complication can be avoided by the use of generic networks.

Conversely, an advantage of using actual networks to demonstrate a methodology is that its relevance to real-life network issues is more easily shown, and this has been evident in discussions with DNO engineers, both in CE Electric UK and in other distribution companies, both in the UK and elsewhere. It is probably best to maintain a balance between generic and actual networks, and this has been the philosophy adopted in the present research.

A further issue has been highlighted by this chapter, in particular by the urban case study in Section 6.8. While automation may bring network risk reduction, there are also risk increases. Some of these are easily seen and evaluated, such as the increased failure probability incurred by the addition of the new asset itself, which could malfunction in various ways with various consequences. The added operational costs of the extra asset, such as inspection and maintenance, have also not been included. Other risk increases are less easy to evaluate, such as the increased complexity of the network as a result of automation, making decisions more complicated and operational mistakes more likely. For these intangible reasons, it may be that the benefits of automation are somewhat over-estimated by this methodology.

The findings of applying the methodology are significant, however. The greatest levels of network risk are typically in radial rural circuits, where the automation of a single switch could be worth £50k per year to the DNO if it is radio controlled, and double that amount if it is replaced by a circuit breaker. Changing the location of the automation project can increase this benefit by 20%. However, there is a diminishing return: installing automation at both locations only gives around 60-65% of the sum of both their benefits.

Sensitivity analysis carried out on this case study suggests that altering most parameters one at a time has a linear effect on risks and benefits. The most sensitive input parameter, over a 40 year time horizon, is probably changes to the regulatory regime.

The rural ring case study showed that the location of automation can be even more significant, with one of two potential locations giving four times the benefit of the other. The suburban mesh case study shows that building an automated switching station at a critical node point could produce an average annual benefit of over £300k. The suburban mesh case study also showed that the upstream network (for supply point failure rates) and the downstream network (for reconfigurability at lower voltages) both need to be considered in assessing network risk at a particular sub-transmission voltage.

The urban mesh case study highlighted the different failure rates which need to be applied at 132 kV. It also showed that, where there is already substantial protection and security, the added risk incurred by installing additional assets may almost outweigh the benefit they provide.

7. METHODOLOGY FOR INCREASING UTILISATION

A third issue that was identified as likely to become increasingly important to DNOs in the future is increasing utilisation. Section 1.7 identified the way in which increasing market penetration of both electric vehicles and heat pumps is likely to lead to significant load growth during the period 2010 to 2030. An annual growth rate of 2.5% was justified in Section 1.7 as a typical and representative level to be used as a baseline in the present research.

As loads increase, so do the number of occasions on which any given circuit is in danger of being overloaded, as a result of one or more of its components exceeding its rating. At CE Electric UK, there are around 700 load points supplied at extra-high voltages (EHV) of 33 kV and above. A single 2.5% increase in load could probably be absorbed at all these load points without further investment in the network. This level of increase is, after all, rather less than could be expected as the result of an exceptionally severe winter, for example. However, if this 2.5% increase were repeated year on year, starting in the year 2010, there would be a 28% increase by 2020 and a 63% increase by 2030. While there may be enough surplus capacity at some of the 700 load points to cope with increases of this magnitude even at peak times, at many of them there would not be enough surplus capacity.

7.1 Load Point Capacity

The capacity at a load point is not defined simply in terms of normal operation. For example, Figure 7.1 shows a load point supplying a peak load (in 2010) of 6 MW, equipped with 2 separately fed transformers, each rated to take up to 7.5 MW. Under normal operation, the 6 MW would be divided between them, each operating at 40% of capacity under peak loading (and at less than 40% for the rest of the time). By 2020, the peak load would be just over 7.5 MW. Under normal operation, this would still be well within the rating of two transformers. But there will be times when only one transformer is available, either planned (for maintenance) or unplanned (as a result of breakdown). Ideally, these events should not result in disruption to customer supplies, which is why there are two transformers when most of the time one

would have been sufficient. By 2020, the one remaining transformer would be operating at 3% over its rating (sometimes described as 103% overfirm) at peak times under these n-1 conditions.

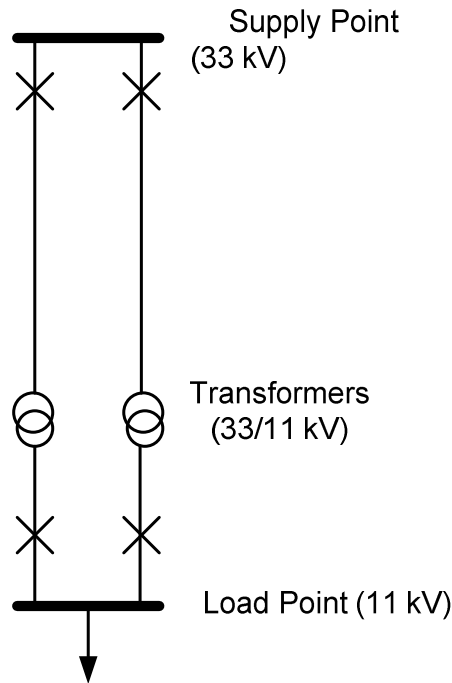

Figure 7.1 – Load Point example

It would normally be possible to overrun the transformer by 3% for a short time, until the period of peak demand had passed. But by 2030 the peak load would have increased to 9.8 MW, which is 131% overfirm under n-1 conditions. Running the transformer so far above its rating would soon cause life-shortening deterioration and possibly serious or even dangerous damage. To prevent this, some customers at least would have to be deliberately disconnected until the second transformer could be brought back from outage, however long that might take. This would contravene the requirements set out by the regulator, OFGEM, and detailed in the industry standard P2/6.

In this scenario of year on year increases in load, it would become necessary, sometime between 2020 and 2030 in the above example, to undertake substantial capital investment, such as installing an additional transformer or upgrading the existing transformers, to ensure that this part of

the network remained compliant with the regulator's requirements concerning security of supply. This is in addition to any capital investment required elsewhere on the network, either for this reason or for other reasons, including safety, new customer connections, and the replacement of worn out assets. There are a number of incentives, however, to avoid or at least to defer such capital investment if at all possible, including shortage of capital, the competing claims of asset renewal, shortage of skilled engineers, and possible difficulties in obtaining planning permission. A further reason to delay capital investment might be uncertainty about future requirements. At a time when the industry and the demands on it are changing quite rapidly, there is a risk that decisions about new assets (which have to last at least 40 years) may be shown to be sub-optimal only a few years after installation. It may therefore be advisable to postpone such decisions as long as possible in order to gain greater clarity as to exactly what will be required over the 40 year lifetime of the assets.

It therefore becomes important to study projections for increased load in some detail, in conjunction with load flow models of the region of network under consideration, both with the network intact and with a partial network following a failure. This is in order to determine for how many years each demand group (the customers of a particular load point or grouping of load points) will have their power needs met at the level of security required by OFGEM. This is the main indicator of how long capital expenditure in that region can reasonably be deferred, and it requires the development of a new methodology .

7.1.1 Rural Networks

While this approach can be useful for any part of the network, it is perhaps of particular importance for the more remote rural load points, in particular any that are already operating close to capacity. There are a number of reasons for this, including:

- Rural substations are often at the end of long, exposed stretches of overhead line, and therefore the frequency of network failure is particularly high

- The remote location can also lead to longer than average repair or restoration times in the event of asset failure
- The political sensitivity of power failures in remote regions, where they are frequent and may affect influential consumers.
- There are a number of rural substations which only have a single transformer, and therefore no backup in the event of failure except extensive reconfiguration at lower voltages, which is complicated and time consuming.
- It can be difficult to maintain voltage levels within statutory limits, particularly when the network is operating in a non-standard configuration as a consequence of (n-1) failure.
- The architecture tends to be radial, with few alternative routing possibilities at higher voltages as compared with urban and even some suburban architectures.
- More difficulties in obtaining planning permission for network extensions in sensitive rural locations decreases the number of options available for network expansion when it reaches capacity.

As a result, the present chapter will concentrate on the impact of increasing utilisation on weak, rural networks, although the findings have relevance to all parts of the network.

7.1.2 Historic and Generic Load Profiles

Projections of future load, both in quantity and in profile, tend to be based on historic data. Within CE Electric UK, as in other DNOs, historic data on loads at each load point on the EHV network is collected and is available for analysis if required. Such analysis can highlight patterns of demand for different types of load – urban, suburban, industrial, commercial, or rural. Although actual historic data could have been used in this research, the particularity of the source chosen, and of the year chosen, could be open to question. Instead, a generic source of data has been preferred.

The UK GDS project has used historic data to derive generic load profiles for different types of load, and these are available for research. In this chapter, a case study involving a rural network is investigated in depth, and

for this purpose the GDS Domestic E rural load profile is used throughout. Figure 7.2 shows the seasonal variation (week by week throughout the year) [96], and Figure 7.3 the daily variation [97], of load in this profile.

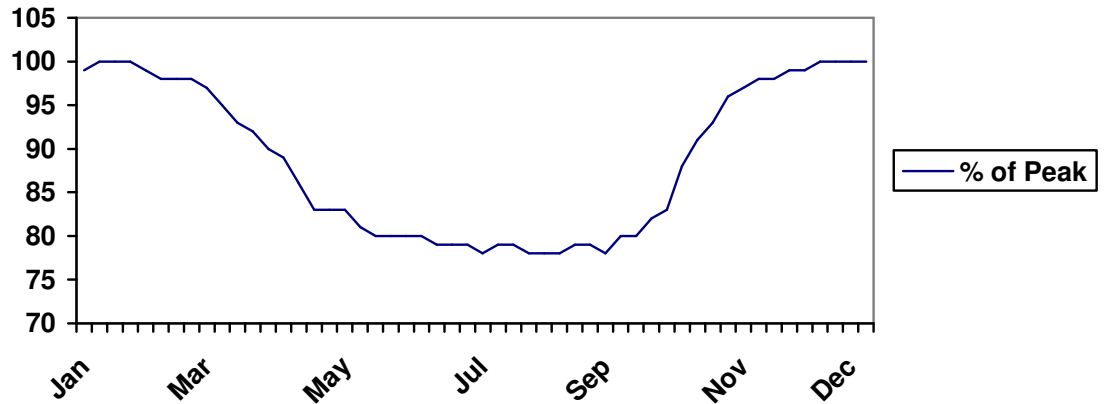

Figure 7.2 – Seasonal variation of load.

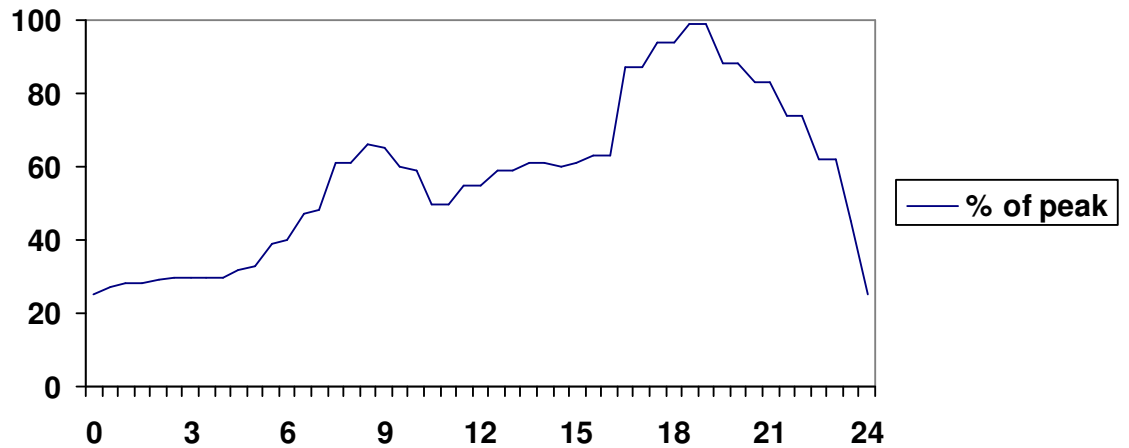

Figure 7.3 – Daily variation of load

The seasonal variation is almost sinusoidal in shape, corresponding roughly to hours of daylight. This means that peak loads vary very little (from 98% to 100% of the peak week) throughout 16 weeks of winter (from early November to the end of February). They also vary very little (from 78% to 80% of the peak week) throughout 18 weeks of summer (from mid May to mid

September). Almost all the variation (between 81% and 97%) occurs during 11 weeks of Spring and 7 weeks of Autumn.

In the context of 2.5% compounded annual growth rates, this means that the daily load profile in winter in a given year, say 2010, will be similar in shape and magnitude to the summer profile about 10 years later, in 2020. This result will be of use in predicting the effects of load growth in the case study.

The daily variation in load is much less regular, and much more extreme. Its critical feature is the evening peak, which reaches its maximum demand between about 18.30 and 19.30, but which requires over 85% of that maximum throughout a 4 hour period between 1630 and 2030. This is an average annual pattern. There is some correlation with the time of year – the winter daily peak tends to be around one hour earlier than the summer daily peak – but not so much correlation as to preclude treating the effects of time of day and time of year as being independent, for simplicity of analysis.

As overall load increases, the number of hours per year when the load exceeds the design rating of the assets, in particular under n-1 failure conditions – the situation described as ‘overfirm’ - will increase, as shown for the case study example in Figure 7.4. This gives some indication of the increasing level of risk with each successive year. However, the precise implications of this increase are more complicated, governed as they are by the detailed regulatory framework of standard P2/6. This is described in the following section.

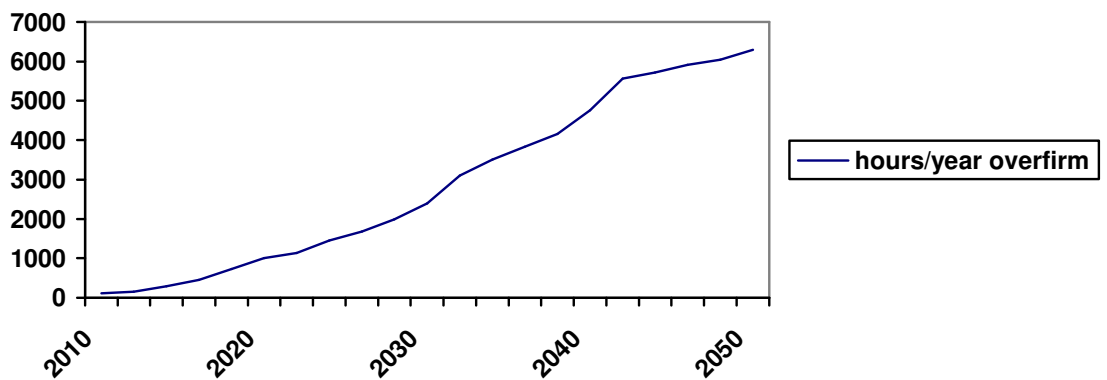

Figure 7.4 – Example of annual growth of overfirm hours

7.2 Satisfying the Regulator and P2/6

The regulatory requirement and design standard P2/6 regarding security of supply was described and discussed in detail in Section 1.5.1. This design standard looks at the worst case, and assumes a fairly passive mode of operation. If it requires all customers to have power supply restored within 3 hours, this includes an outage that happens at the worst possible time (start of the evening peak), and it excludes the use of mitigating operational measures, such as the overloading of a transformer in the hope or expectation that this will only be for a short time. As far as P2/6 is concerned, if power could not be restored to all customers within 3 hours, at the evening peak and without non-standard strategies, there would be a requirement to invest in strengthening the network, probably involving substantial capital expenditure.

However, in the event of such an unexpected outage during the evening peak, the DNO control engineers would immediately move into emergency mode. Although network management tends to be passive under normal operations, it becomes extremely active under failure conditions, in an attempt to restore supply to as many customers as possible, as quickly as possible, thereby minimising CIs (if restoration occurs within 3 minutes) and CMLs, and avoiding liability to pay compensation. If this can be done safely by overloading a transformer, without undue risk to the asset itself, then that will probably be what is done.

The difference between these two approaches – the design approach, addressed by Asset Management engineers, and the operational approach, implemented by Network Control engineers – is less significant at a time of low or zero load growth. If the network is not overfirm, then restoring connectivity is a necessary and sufficient condition for restoring power supply. It is quite clear from inspecting a circuit diagram whether and how this can be done. The core methodology developed in Chapter 3, and subsequent methodologies developed in Chapters 4, 5 and 6, all calculate an overall measure of Network Risk based on connectivity alone.

7.2.1 Last Firm Year (LFY)

The analysis becomes more complex, and the difference between Asset Management and Network Control approaches becomes more acute, during a period of load growth. In the simple example in the previous section – a single load point supplied by two transformers – the load would be 131% overfirm by 2030, contravening P2/6 even though connectivity had not been lost. In a more complex area of network, Figure 7.4 indicates that a part of the network which is overfirm for 1% of the time in 2010 could be overfirm for 27% of the time by 2030, and for 72% of the time by 2050. In this situation, it is not always sufficient to be able to restore connectivity. Even with a connecting path, there could be unacceptable voltage drops, or the overloading of expensive assets with possible resultant damage.

Even in 2010, the 1% overfirm could in theory be considered by the regulator to be a breach of compliance with P2/6. But in practice it would never be allowed by Network Control engineers to lead to customer loss. However, by 2030, even if a connecting path can be found, it would be more difficult for Network Control to restore supplies within 3 hours (or within 15 minutes for larger demand groups) following a peak time fault. They might be able to do so; but the Asset Management engineers would have been under regulatory pressure for some years by then to redesign or enhance the network at that point.

This report addresses such issues involving load growth by defining the concept of a last firm year (LFY) for a region of network. If, for example, the LFY were 2014, this means that any failure occurring during that year, at whatever time, should not leave customers unsupplied in numbers or for times in excess of those stipulated by P2/6, using standard restoration measures (which would need to be defined). However, it is possible to describe a failure scenario under 2015 loading which would leave some customers unsupplied for longer than the time permitted under P2/6, given that Network Control used only standard restoration methods. The fact that, in the event of such a failure, Network Control would probably be able to restore supplies by the use of one or more unconventional measures does not affect this strict, but realistic requirement for formal P2/6 compliance. By 2015, measures would have been required to strengthen the network at that location.

7.2.2 Complying with P2/6: Allowing for Peak Width

There is scope for debate between OFGEM and the DNO as to whether or not a particular section of the network complies with P2/6. It might be that the DNO is anxious to defer capital expenditure for as long as possible, perhaps due to a long list of more urgent projects elsewhere on the system. Conversely, it could be that the DNO wants to make a case for being granted revenue to provide capital to go ahead with a project, which will only be forthcoming if it can be shown that without it the network will be non-compliant.

One argument which could be used by either side to defer expenditure relies on the width of the evening peak load period. Figure 7.3 shows that the load is at over 85% of peak for a 4 hour period, from 1630 until 2030. In the example shown in Figure 7.1, peak loading passes the single transformer rating (7.5 MW) by the year 2019, suggesting that the LFY would be 2018. By the year 2026, peak load would be 8.86 MW. The load would be above 7.5 MW (the transformer rating, corresponding to 85% of the peak load) for 4 hours during the winter months. A fault occurring at the beginning of that 4 hour period, around 1630, would result in some customers having to be disconnected (in design theory, as opposed to operational practice) for those 4 hours, one hour in excess of the P2/6 requirement of 3 hours.

However, in 2024 the peak load would be 8.44 MW. The transformer rating of 7.5 MW is around 89% of this peak, and the evening load is only above 89% of peak for 2-3 hours. It would be acceptable as far as P2/6 is concerned (although not operationally) to disconnect say 2 MW of customers (exactly how much would depend on the precise arrangement of 11 kV feeders) for that 2-3 hour period, and avoid overloading the transformer at any stage, while remaining compliant.

The net effect of this paper exercise is to postpone the LFY from 2018 (based on peak loads only) to 2024 (based on the width of the peak, and the 3 hour ruling in P2/6 for this load group). Allowing for such notional load-shedding through the evening peak delays the LFY by 6 years, for a load profile of the kind modelled by the GDS Domestic E pattern. In the case study which follows, it will be assumed that this fixed 6 year extension is applicable throughout where appropriate.

7.2.3 Complying with P2/6: Active Network Management

The term 'Active Network Management' (ANM) is used to describe interventions, both automatic and operator-initiated, to reconfigure the network so as to optimise its performance. It is usually applied in the context of normal operations, for example to maximise the time during which a wind farm can be connected to the network. Generally, normal operations are allowed to happen in a relatively passive mode by the DNO. This is sometimes referred to as 'fit and forget' or 'if it ain't broken don't mend it'. The approach can be justified by the shortage of control engineers in the control room to oversee active network management, by the danger of making costly mistakes if routines become too complicated, and by the possible accelerated deterioration of assets as a result of more frequent switching. However, there is increasing pressure on DNOs to improve network performance under normal operations by a more positive espousal of ANM techniques.

It is less clear how appropriate the concept of ANM is to non-normal operations. It has already been suggested that a DNO operating in emergency mode works quite differently to operating in normal mode. There appears to be far more willingness to think creatively, to try ad hoc solutions, and to take appropriate risks. However, within the context of reconfiguring a network following one or more faults, the following definitions will be used.

Reconfiguration to restore connectivity is regarded as standard. If a load point is supplied by a single transformer which fails, then opening and closing 11kV switches to supply as many feeders as possible from a different transformer at another load point will be assumed to be done as soon as possible, generally within 15 minutes. Such reconfiguration follows procedures decided beforehand and written electronically or manually in folders for immediate reference in such an event. Doing this is assumed, and can always form part of P2/6 compliance. It is not regarded as ANM.

However, reconfiguring where there is already connectivity, to reduce load or to increase voltage, is another matter. There are generally more options available, and there may be no hard script to which to refer. The effect of reconfiguration on load flow and on voltages is not easy to predict without using a load flow model. The effects will vary according to the time of day, the predicted load profile, and even recent load flows (which affect transformer

temperatures). Reconfiguring to redistribute loads is definitely ANM. It requires experience, skill, and a certain amount of added risk. It cannot be assumed automatically as part of a test of P2/6 compliance, but must be specified and justified (e.g. that there will always be sufficiently skilled control engineers on duty whenever they might be needed i.e. at peak load times).

7.2.4 Complying with P2/6: Capital Investment

When allowance has been made both for peak width and, if appropriate, for ANM, there will still come a year when continued load growth causes a demand group to cease to be compliant with P2/6. At this stage, the only solution is capital investment (which will, of course, need to have been decided some years earlier, and implemented by the LFY). There are usually a number of possible projects to mitigate the overfirmness and restore compliance, and they fall into a number of distinct categories.

1. Adding switches (manual, radio controlled, or automatic circuit breakers) at a lower voltage. This breaks the feeders into smaller units for reconfiguration. It is an established solution which is often implemented to mitigate the effect of faults at lower voltages (typically 11 kV), and can be justified on these grounds alone. But there are also benefits in the event of faults at higher voltages (33 kV), giving more options for precise load balancing. A project of this kind might, at best, buy a one year deferment of alternative major capital projects.
2. Adding switches, circuit breakers or busbars into the 33 kV network to make smaller protection zones (PZ), which are therefore both less vulnerable to failure, and less disruptive when they do fail. In Figure 8.1, for example, each transformer is in the same PZ as the line feeding it, which may be quite exposed and several km in length. A 33 kV busbar and switches would enable both transformers to be fed by a single line in the event of the other line failing (provided that each line were sufficiently highly rated to support both transformers and the full load). This could be a cheaper alternative to installing an additional transformer.

3. Reinforcing sections of overhead line or underground cable. Often, network analysis will reveal quite small lengths of line or cable, typically adjacent to a supply point, before a tee, which become overloaded before the rest of the network. Doubling up the conductors here can buy several years of load growth.
4. Reinforcing the network at a lower voltage. Sometimes two 11 kV feeders fed from different load points can be geographically quite close. Making a link between them can provide an alternative path, not just for the two feeders themselves, but also to benefit the rest of the network. This kind of project is more likely to be justifiable in terms of 11 kV faults. The benefit at 33 kV is likely to be a year or two at most, and is also likely to be very complicated to analyse.
5. Eventually, the capacity of transformers will become the limiting factor, even after all switching and line reinforcement options have been explored. At this stage, there is no alternative but to expand transformer capacity at one or more locations, by either additional or enlarged transformers. The choice of location and transformer size then needs to be made with care, and with a view to expected developments over the next 40 years. The age and expected remaining lifetime of all the existing transformers will play a major part in making this decision.
6. Finally, not only the transformers, but the whole network becomes non-compliant (by 2050 the load growth at 2.5% per year adds up to 165%). A major re-design is then required. This is beyond the scope of the present research, which concentrates rather on deferring this stage for as long as possible.

This concludes the general overview of future load growth, planning for it, and incorporating regulatory requirements regarding network risk. These principles will be illustrated by reference to a specific case study, which is detailed in Chapter 8. But before that, certain features of the analytical simulation of increasing utilisation need to be specified.

7.3 Analytical Methods

Before proceeding to the detailed analysis of the case study, it is worth listing and describing the data sources and analytical techniques that could be used, some of which have already been introduced. Each of them, considered separately, is reasonably well-known and straightforward. However, combining them in a single piece of analysis constitutes a new methodology, addressing the issues of network risk which arise from a period of sustained high load growth and consequent increasing network utilisation.

7.3.1 Generic Load Profiles

The introduction of electric vehicles in substantial numbers may well affect the shape of both daily and annual load profiles. The introduction of substantial numbers of heat pumps will also possibly alter load profiles from their present shape. However, there is uncertainty as to precisely how the shape will change, with persuasive reasons both for a sharpening, and on the other hand for a flattening, of the evening peak. There are also ways in which the effects of heat pumps will tend to cancel out the effects of electric vehicles. It therefore seems reasonable to assume that, while the total load increases (by 2.5% per year as a base assumption), the shape of the daily and annual profiles remains the same from year to year. It is further assumed that, without excessive loss of accuracy, the daily and annual profiles can be treated as independent. There are a number of advantages of these assumptions, in particular:

- Sensitivity analysis on the assumed 2.5% growth rate can easily be carried out by stretching or shrinking the timescale. For example, a 1.5% growth rate for 5 years followed by a 3.0% growth rate for 15 years will give the same results for 2020 as the base run did for 2016, and the same results as the base run by 2030.
- The load flow at non-peak times in later years will be the same as peak load flows in earlier years. For example, the winter peak loads in 2012 will be the same as the summer peak loads in 2022, and the same as the winter loads at 1630 (increasing) and at 2130 (decreasing) in 2022. This enables a single load flow calculation to be used to analyse a

range of different scenarios. This significantly reduces the number of such calculations required, without excessive loss of accuracy.

- It is easier to justify, in discussions with the regulator, a load profile based on historic data, than it is to justify assumptions about the impact on that profile of a still uncertain future.

As regards the choice of load profile, a generic example based on historic data is preferred over historic data from a specific location, as it avoids the particularity of the year and the location chosen. Such data is also available in the public domain (which DNO data is not), and can therefore be used by other researchers to verify and to extend the present research.

7.3.2 Discrete Steps of Load Size

The peak load at any time is a continuous variable, and it would be possible to treat it as such, performing load flow analyses for infinitesimally small increments of load to find the exact load size at which, for example, an overhead line reaches its nominal rating.

However, this does not accurately reflect the relatively coarse way in which an actual network is controlled in practice, and it would also be computationally excessive. Loads have therefore been increased in 5% compounded increments. This is finely tuned enough to represent operational reality, as well as corresponding to two years growth given the base assumption of annual 2.5% load growth. A limited number of calculations is therefore required, corresponding to the peak loads in each year from 2010 until the network can no longer carry the load. (When that is depends on the precise nature of the network being investigated, for example which assets are out of service, and how feeders have been reconfigured).

Daily and annual profiles are then discretised to correspond to these 5% increments. Table 7.1 shows how this applies to annual variation, and Table 7.2 shows how it applies to daily variation.

In these tables, the level corresponds to the number of compounded 5% increments that have been added. Level 0 is the base run, corresponding to 2010 peak loads. Level -1 is the peak load two years earlier. It is set at 95.2% of the peak, because 95.2 multiplied by 1.05 is 100%, likewise 90.7 multiplied by $(1.05)^2$ is 100%, and so on.

<i>Level</i>	<i>Load (% of peak)</i>	<i>Dates</i>	<i>Weeks/year</i>
0	100.0	8 November – 28 February	16
-1	95.2	1-21 March, 18 Oct. – 7 Nov	6
-2	90.7	22 March – 12 April, 11-17 Oct.	4
-3	86.4	13-19 April, 4-10 October	2
-4	82.3	20 April – 17 May, 21 Sept- 3 Oct	6
-5	78.3	18 May – 20 September	18

Table 7.1 – Discretised annual variation of load

<i>Level</i>	<i>Load (% of peak)</i>	<i>Times</i>	<i>Hours/day (cumulative)</i>
0	100.0	1830 – 1930	1
-1	95.2	1730 – 1830	2
-2	90.7	1930 – 2030	3
-3	86.4	1630 – 1730	4
-4	82.3	2030 – 2130	5
-5	78.3	Nil	5
-6	74.6	2130 – 2230	6
-7	71.0	Nil	6
-8	67.7	Nil	6
-9	64.5	0830 - 0930, 1530 – 1630, 2230 – 2330	7

Table 7.2 – Discretised daily variation of load

The dates in Table 7.1 and the times in Table 7.2 are derived from the GDS Domestic E profile, with values rounded to the nearest 5% increment. The weeks/year column shows that the winter peak is applicable to as many as 16 weeks per year. The hours/day is a cumulative total, showing how the width of the evening peak varies with the cut off level at which the peak is considered to start and finish. The morning peak does not figure in the first 9

levels, and is therefore discounted for the purposes of assessing load-related network risk, which is applied only to failures which occur at times that affect the evening peak.

7.3.3 Interpreting P2/6

In the UK, the regulator Ofgem has set out a standard by which the security of supply to any load can be measured. This standard, P2/6, is essentially a design rather than an operational standard, as described in Sections 2.3.2 and 7.2. It prescribes particular levels at which load moves into a higher demand group, with more stringent network security requirements. It also prescribes particular critical times – 15 minutes and 3 hours – by which given proportions of demand must have been restored. These times (along with 3 minutes and 18 hours, specified in different regulations) determine how the network is designed and operated in practice.

Since P2/6 is the standard to which both Ofgem and the DNOs must refer, its requirements are treated as absolute in determining the LFY for a network, even though this is to some extent a paper exercise. In practice, the network could no doubt operate beyond that year, although at an increasing expected cost of CIs and CMLs. But, for the regulator, the LFY is binding. However, the precision of P2/6 can be used legitimately to defer the LFY, by invoking the 3 hour condition (disconnecting a proportion of customers for up to 3 hours, to tunnel through the evening peak) as described in Section 8.2.2. This has the effect of deferring LFY by a further 6 years in any given situation.

‘Tuning’ the research to the precise requirements of P2/6 is less than ideal in some ways. It applies only in the UK, and therefore is not directly relevant to other countries, although in general each nation’s regulatory regime will operate with a similar kind of standard. Therefore the approach adopted here can be applied in principle, although not in detail, elsewhere. More significant, perhaps, is that P2/6 could easily be changed within the timescale that this report considers, and indeed there are some recommendations for it to be changed, if not replaced altogether [19]. But, as with considering other nations, the replacement for P2/6 would impose its own constraints, and the approach detailed in this report would again be applicable in principle if not in detail to any successor standard to P2/6.

Most significant of all is the way in which the design standard of P2/6 does not correspond in several respects to operational reality. However, modelling the operational reality would be extremely complicated, needing to incorporate issues relating to psychology, management and random asset malfunction, all of which introduce considerable uncertainty. Imperfect though it may be, it still seems best to use the precisely defined standard P2/6 and the consequent concept of LFY to predict when capital expenditure (or extensions of ANM) would be required.

7.3.4 Modelling Load Flow

The GDS EHV networks, including the subsection of GDS 2 which constitutes the case study, have been adapted for IPSA load flow modelling as discussed in Chapter 8. This makes it relatively straightforward to determine at what level of load an asset exceeds its design rating, and may therefore need to be replaced. However, even with the simplifications introduced by fixed load profiles and discrete load steps, the number of computations required is still substantial. First, a number of different partial networks need to be considered, corresponding to the failure of different assets and PZs within the network. Then, within each partial network, a number of different options for the reconfiguration of feeders may need to be investigated and compared to find the optimum (i.e. the one which keeps the network firm for longest). Then the process needs to be repeated to incorporate a range of different possible capital investments to strengthen the network. Finally, a separate calculation has to be carried out for each discrete 5% step, starting with the base level (2010 peak load), then moving up and also possibly down from that level.

This computational task can be simplified in part by automating the process. Using the Python language, software has been developed to increment each load by 5% between successive IPSA computations. As a result, the sequence of runs for increasing overall load, relating to any specified partial network, with or without any given capital investment, and to each reconfiguration of load within that partial network, can be carried out as a single operation. This greatly reduces the time required to prepare the load flows. However, there is no comparably easy way to automate the

specification of partial networks, of capital investments, or the precise reconfiguration of feeders.

The load flows are at the heart of the process of determining the LFY of the case study network under various conditions. However, they have their limitations, and can therefore only be a useful subroutine within a wider analytical process. The specification of partial networks, capital project enhancements, and feeder reconfiguration has already been mentioned. A second limitation is that the demand load is unchanged by the actual load flow – it is effectively modelled as constant power, rather than constant resistance, which might be more realistic. A third limitation concerns the static nature of IPSA. It calculates load flow at a single moment, and cannot therefore incorporate essentially dynamic factors such as the effect of all the heat pumps being thermostatically switched on as soon as power supply is restored following an outage. Nor can it represent the thermal behaviour of a transformer or an overhead line as a function of time. That has to be analysed outside the load flow model. This in turn brings up the issue of asset ratings, which is considered next.

7.3.5 Asset Ratings

An overhead line with a nominal rating of 20 MVA will typically be protected by a circuit breaker set to a nominal level of perhaps 25 MVA. It will trip in a few milliseconds if a fault current flows, and in a few seconds if the power flow exceeds around 30 MVA [98].

Transformer protection is more complicated. Typically, a warning signal will be sent to the control room when its core temperature exceeds 120 °C, and it will trip automatically if the temperature exceeds 140 °C. When that occurs depends on a number of factors, including ambient temperature, whether or not the transformer has auxiliary oil cooling, and how hot it was to start with (which is itself a function of recent load history).

Voltage drop does not generally cause automatic tripping, and there is no warning in the CE Electric UK control rooms if e.g. a tap changer has reached its limiting position.

Operationally speaking, the control engineers will tend to respond to alarms and cut offs more than to actual power flows, and certainly more than

to predicted power flows. In design terms, the circuits should be robust enough to cope with all possible n-1 and n-2 events that are covered by P2/6.

Within the GDS networks, separate summer and winter ratings are specified for each asset. The summer rating is the one which is used in the IPSA model to flag up an overloaded asset. Winter ratings, not specifically used by IPSA, tend to be set 20% above summer ratings. This corresponds in general to industrial practice at 33 kV (at 132 kV there is also an intermediate spring/autumn rating). However, it does not correspond to industry operating practice, where in general the same rating is used all the year round, although somewhat loosely applied, particularly under non-standard operating conditions, as has been shown.

For network design, in one DNO, 'summer ratings' are held to apply from May to August, 'spring/autumn ratings' for March-April and September-November, and 'winter ratings' for December-February. At 33 kV, the switchover between winter and summer is placed in mid-spring (31 March), and between summer and winter in mid-autumn (15 October) [99].

Comparing this with Table 7.1, it can be seen that the most heavily loaded period to which summer ratings apply occurs during the first half of April, at which time loads are still around 90% of the winter peak. Perhaps this reflects user inertia – heating is still controlled to winter levels, although the actual outside temperature means that exposed overhead lines need to be reduced to their summer ratings. The net effect of this is to make the beginning of April in theory a time of greater network risk than the middle of winter, compared with which ratings are down by 20%, but loads are only down by 10%.

However, applying the whole reduced rating of 20% in one go at the beginning of April seems rather coarse, and probably does not reflect operational practice (which does not generally apply seasonal ratings). It seems more realistic to consider that, if an asset is operating near its winter rating during the winter evening peak, it will also be operating near its summer rating (20% less) during the summer evening peak (also 20% less), and operating near an average of the two ratings during spring and autumn evening peaks.

Making this simplifying assumption enables analysis to concentrate on winter peak loadings (the overall peak which is universally used and understood by designers and operators alike), comparing it with winter asset ratings. The assumption then is that, if a network is compliant under these conditions, it will effectively be compliant all the year round. Conversely, if a network is overloaded by this definition for a certain number of hours per day during the winter evening peak, it will be overloaded for a similar number of hours per day during the spring, summer and autumn evening peaks.

7.3.6 Evaluating Network Risk

The core and generalised methodologies developed in Chapters 3 and 4 calculate the expected annual cost of CIs and CMLs, and also the expected cost of unscheduled repairs and asset deterioration, to produce an overall measure of Network Risk.

These methodologies consider only the question of connectivity. Customers would be disconnected, and accrue CIs and CMLs, only if their connection to the network was broken. If the connecting path was intact, it is assumed that they can be supplied. The generalised methodology is applied in detail to the case study network in Section 8.2, to produce a baseline evaluation of Network Risk, applicable at all levels of network load.

The additional level of risk attributable to increased network utilisation can, in principle, be calculated in the same way. This would increase each year, as ever higher loads placed greater strain on the network, and increased the frequency of events where customers had to be deliberately disconnected to prevent assets being overloaded. This would continue each year until the LFY. This approach, forming part of the new methodology, is adopted in Section 8.4.

8. INCREASING UTILISATION CASE STUDY

8.1 Choosing a Generic Case Study

In Section 7.1.2, the use of generic as opposed to actual historic load profiles was justified on the grounds that the choice of which actual data to use could be open to question. The same principle applies to the selection of a representative network for a case study. While it would be possible to examine an actual part of the CE Electric UK network, as has been done in Chapters 3-5, this could introduce secondary issues which might only apply to that specific case. The choice of a generic network, as in Chapter 6, avoids these complications.

A second advantage of using a generic network such as those produced by the GDS project is that it is in the public domain, and therefore accessible to other researchers who might wish to validate or extend the present research. A third advantage is that detail which is not explicitly specified in the GDS network (for example, the precise location of circuit breakers) can be chosen by the researcher to illustrate key issues with greater clarity.

At EHV level (33 kV and above), GDS contains 6 distinct networks, covering rural, suburban and urban environments, and covering radial and meshed architectures. For the present case study, GDS network 2 was chosen, which represents a large rural network [93]. The high level characteristics of this model are specified as follows:

- Rural area
- Long circuit length
- Low customer density
- Mixed construction
- Radial topology
- Large overall size

The reasons for choosing a rural network were listed in Section 7.1.1. They included vulnerability, voltage drop, and the limited options available both for network development and for network operation. Likewise a radial architecture (which is common in rural areas, with the exception of North Wales [94, 95])

will be less robust in responding to increasing utilisation than a meshed architecture would be.

Within GDS 2, a subsection of the network was selected, and is illustrated (as an IPSA representation) in Figure 8.1. Its most significant features are as follows:

- The upstream supply at 132 kV is strong, and the supply point feeding node 302 contains 3 independent 132/33 kV transformers rated at 68 MVA each. The supply to node 302 at 33 kV can be considered reliable and adequate for the period of load growth being investigated, and is therefore excluded from the case study.
- The subsection comprising the case study consists of the three feeders from supply point 302 to nodes 307, 312 and 310, and all the loads downstream of those nodes.
- Some of these loads (in particular 1118) are close to the n-1 rating of their transformers, others have only a single transformer (1101, 1122), or are at the higher 33 kV voltage (324). These features make the case study interesting, and illustrate important features of real networks.
- The network includes long stretches of single overhead lines at 33 kV, all features which make it particularly vulnerable, but they are linked in a double ring, which gives several options for reconfiguration using ANM. Again, these features make the case study interesting and illustrative.
- The loads as specified in GDS 2 are taken to be peak loads in the year 2010. These loads will then be considered to increase at an annual compounded rate of 2.5%.

8.1.1 Load Flow Modelling

The GDS network specifies several key parameters for each part of the network, including:

- The power load (real MW and reactive MVA) at each load point
- The electrical properties (including reactance and resistance) of each line and transformer
- The length in km of each line

- The power ratings (summer and winter) of each line and of each transformer
- The range of tap settings on each transformer

These properties enable the network to be modelled by load flow packages such as IPSA, which will calculate power flows (real and reactive) between any pair of adjacent nodes, and also the voltages at each node. This shows that the base network as specified in GDS is not overloading any line or transformer, and that voltage levels are within statutory limits. Figure 8.1 shows the subsection of GDS 2 that constitutes the case study, as modelled in IPSA for load flow calculations.

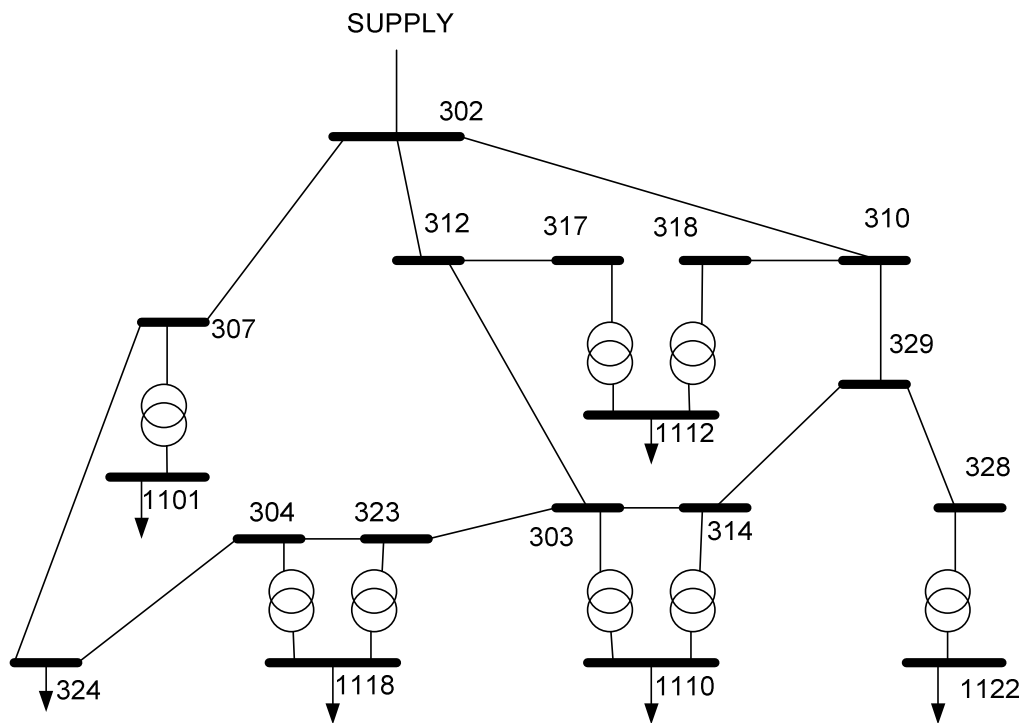

Figure 8.1 – IPSA representation of case study network

The IPSA model can then be modified, either by increasing loads (to represent future years), or by removing sections of network (to represent n-1 failures), or both. The results of load flows of this kind are presented in subsequent sections.

8.1.2 Modelling beyond Load Flows

There are, however, a number of significant features of the case study network which are not required as input data by IPSA, and which are consequently not specified by GDS. While these features do not directly affect the load flow, they do affect other aspects of network risk. The analytical simulation techniques which are applied in modelling this case study require many inputs which are not specified in GDS. In particular, these inputs include:

- The location on the network of manual switches, radio-controlled switches, and circuit breakers. These define the protection zones (PZs) into which the subsection of network can be divided in the event of n-1 and n-2 failure events.
- The geography of the network. Although line lengths are given (in km), this does not specify whether two electrically separate nodes might be physically close (and therefore able to be linked by a relatively inexpensive capital project). It also affects the probable lower voltage (11 kV in this case) network architecture.
- The 11 kV architecture itself is not specified. This is highly significant, as the possibilities for reconfiguring the system following loss of some portion of the 33 kV network depends critically on where the 11 kV feeders are supplied from, and on how they interconnect (typically through normally open points) with one another.
- The number of customers at each load point is not specified. This information is required for evaluating the cost to the DNO of CIs and CMLs in the event of a loss of supply.
- Data on failure rates and restoration times. In their absence, national data can be used as supplied to and correlated by NAFIRS [8]. Such data could be adjusted if it were considered that the case study network were in some respects atypical.

The assumptions made concerning these aspects of the case study are described in detail in the following sections.

8.1.3 Network Geography

The GDS case study as specified in Figure 8.1 must now be described in detail. Some features are specified by GDS, others must be created specifically for the present study. For example, the lengths in km of overhead line or underground cable between each pair of adjacent nodes are specified by GDS. But GDS does not specify whether each connection is in fact line,

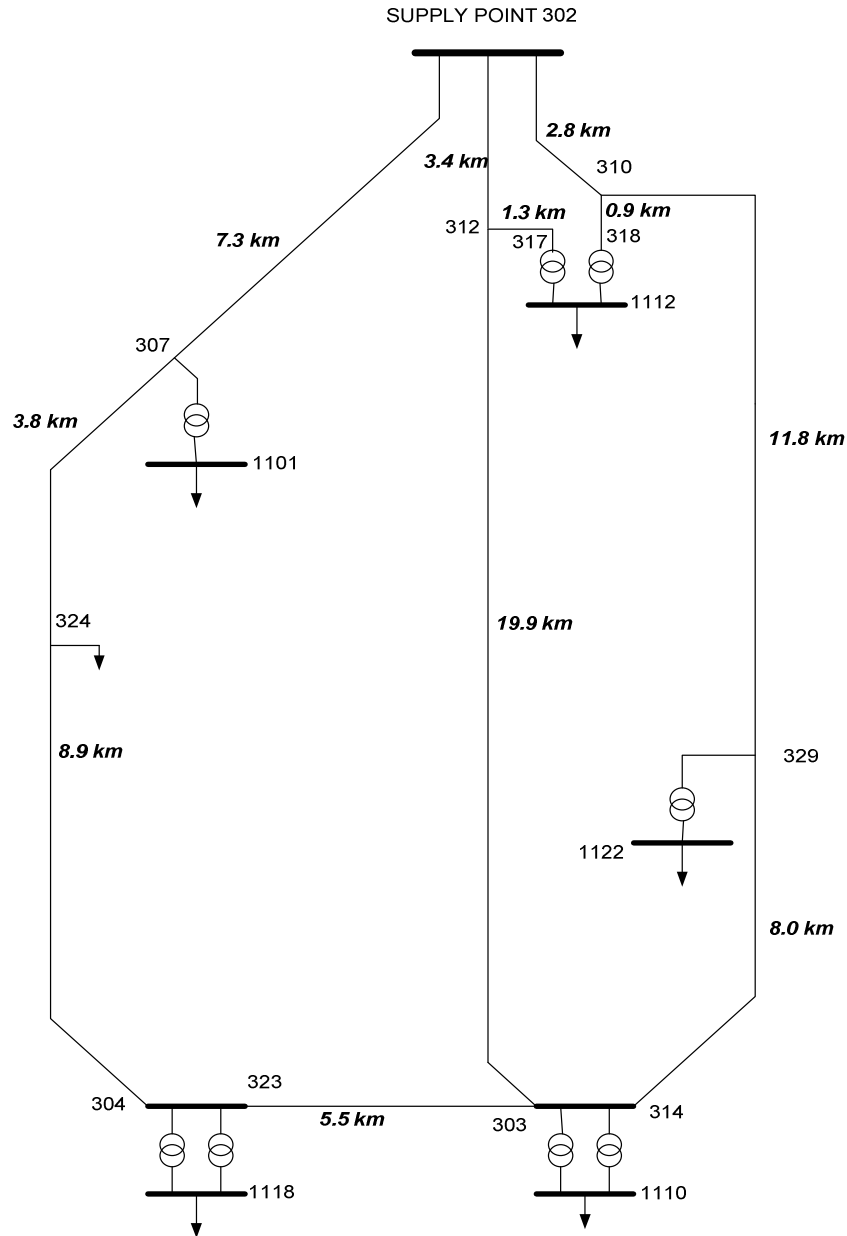

Figure 8.2 – Case study network geography

cable, or a mixture of the two. This information is not required for network analysis (so long as the resistances and reactances are known), but it does signify in network risk studies, as the failure rate per km is likely to depend on the nature of the connector. Most rural 33 kV networks are predominantly overhead line, and for the present study it will be assumed for simplicity that all connectors are in fact overhead line.

Neither does GDS specify the geography of the network. This affects network risk studies as the more remote locations will tend to have longer average reconnection times. It also determines the likely layout of 11 kV feeders, also not specified by GDS. Figure 8.2 shows a possible geography for the 33 kV network, with the GDS-specified line lengths. This geography will be assumed for the case study. One feature of this geography is that there is a clear separation between the three northern load points, closer to the supply point, and the three southern load points which are more remote.

8.1.4 Loads and Ratings

The GDS network specifies the ratings of each line and transformer (summer and winter), and the load at each load point (real and reactive power). These values are critical for network risk studies at times of increasing utilisation, and are shown in Figure 8.3, which indicates the winter ratings (in MVA) which are 20% above summer ratings, and the apparent power load (also in MVA). These power loads are used for the base case (winter peak loads in 2010), and are then increased or decreased in increments of 5%. All loads are at power factor 0.95. It is noticeable that the largest load, at 1118, is already close to being overfirm, at 90% of the single transformer winter rating under n-1 conditions. In practice, CE Electric UK would use summer transformer ratings, and define it to be already overfirm.

8.1.5 Customer Numbers and 11 kV Feeders

Figure 8.4 shows another aspect of the case study network which is not specified in GDS, namely the configuration of the lower voltage system. The layout shown in Figure 8.4 is simplified to show each feeder as a single dotted line, ignoring any tees or loops. These feeders all run from a load point at a primary substation to a normally open point, where they interconnect with

another feeder or another primary substation. This conjectural layout is based on actual layouts at similar locations on the CE Electric UK network. It is important for a network risk study such as this for indicating the 11 kV reconfiguration options, which in turn determine the expected value of CIs and CMLs, and also whether or not the network is likely to be compliant with P2/6.

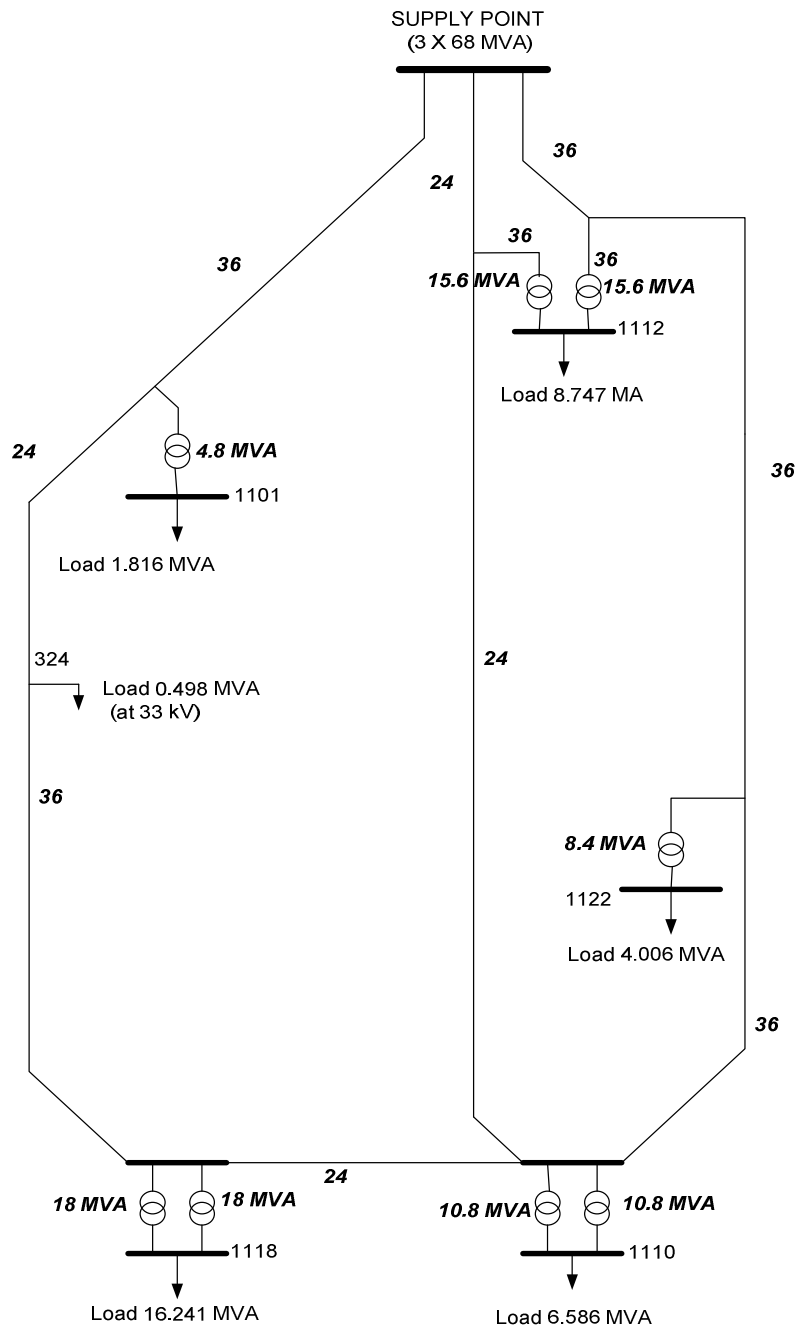

Figure 8.3 – Winter ratings and base run loads in case study network

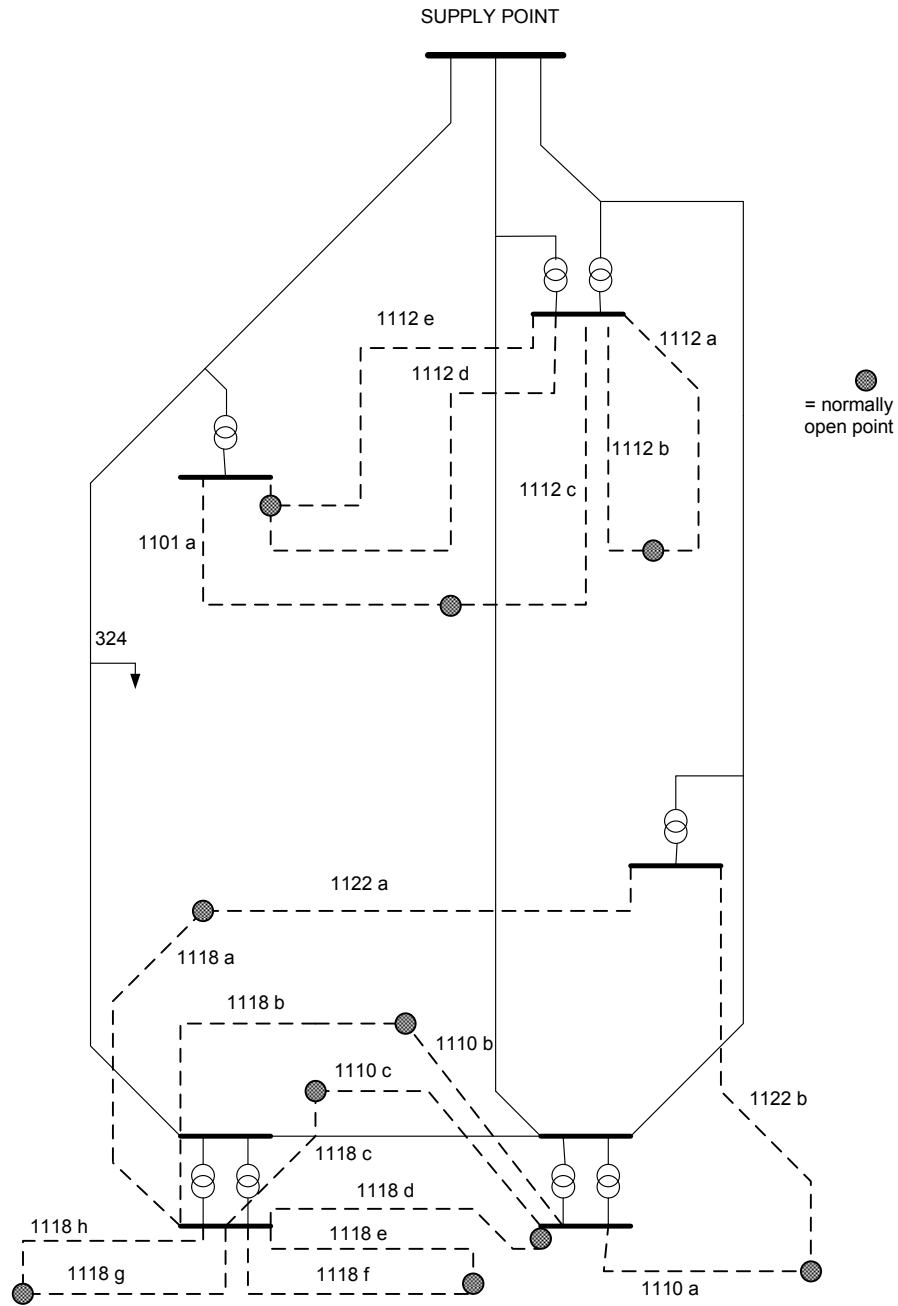

Figure 8.4 – Possible arrangement of 11 kV feeders

Another feature not specified by GDS is the number of customers at each load point, and on each 11 kV feeder. This is important, not only for evaluating the likely number of CIs and CMLs, but also for determining which of a number of possible network reconfiguration options is likely to be preferred by the control engineers in an n-1 situation. They are responsible for

minimising the cost of CIs and CMLs, and in a typical control room, those feeders with over 2000 customers are indicated as having a correspondingly high priority for reconnection, and for avoiding disconnection in the first place, if at all possible [72].

In the case study network, for example, the 33 kV load at point 324, which is set at 0.498 MVA, is assumed to be a single industrial customer, whose connection is such that there is no alternative supply route in the event of failure in the lines leading to node 324. The cost in CIs and CMLs for a single customer is small. It may be that this industrial customer has his own back-up generators, or that he is prepared to run the risk of occasional power failure rather than pay a large sum to have his connection strengthened.

For the other five load points, the number of customers is assumed to be proportional to the real power load, at a rate of 500 customers per MW in the base case (a typical value for rural customers on actual CE Electric UK networks). The number of feeders at each location is also assumed to be roughly proportional to the total number of customers, as shown in Table 8.1. For simplicity of subsequent analysis, the feeders from a single load point are assumed to be equal in size, both as regards number of customers and as regards load size in MW (and also in MVA).

<i>Load Point</i>	<i>Load MW</i>	<i>Customers (nearest 100)</i>	<i>Number of feeders</i>	<i>Customers per feeder</i>	<i>MVA per feeder</i>
1101	1.725	900	1	900	1.816
1110	6.275	3100	3	1000	2.195
1112	8.310	4200	5	800	1.749
1118	15.429	7700	8	1000	2.030
1122	3.806	1900	2	1000	2.003

Table 8.1 – Case study customer numbers and 11 kV feeders

8.1.6 Protection Zones

The final aspect of the case study which needs to be specified, and which is not specified in GDS, is the location of switches, whether manual, radio-controlled or automatic circuit breakers (CBs). This is perhaps the most important single piece of information as regards network risk case studies, since it defines the impact of a fault at any given location, and also the possibilities for network restoration.

On the 11 kV network, it is assumed that each feeder is protected by a CB at the primary substation, which can be opened or closed on fault current as well as normal currents. It is further assumed that the normally open points, as shown in Figure 8.4 by grey circles, are also equipped with automatic switches, all of which can be opened or closed by radio control as well as opening automatically when a fault current is detected. In addition, there may be a number of manual switches on the 11 kV feeders. These are not shown, as the time taken to locate the fault, send out a repair crew, and operate them manually following safety procedures could be several hours. Such an operation is classed as a restoration procedure equivalent to a repair, rather than a short-term reconfiguration.

Likewise on the 33 kV network, there will probably be a number of manual switches, particularly along the longer sections of overhead line. Again, opening or closing them is classed as a long repair-like restoration, rather than a short-term reconfiguration. Consequently, they are not specified as part of this network risk study.

As a minimum, it is assumed that each circuit leaving the supply point 302 is protected by a 33 kV CB, and that there are 11 kV CBs on the downstream side of each of the 8 transformers. There would also probably be a 33 kV CB at node 324, between the DNO network and the industrial customer. It seems likely that there would also be additional CBs on this section of network, to divide it into smaller, more manageable and useful protection zones (PZ). However, in rural networks such as this, the PZs are often quite large. Figure 8.5 shows the assumption for this case study, namely that there are only two additional CBs. They are in fact busbar breakers, located between nodes 304 and 323 at load 1118, and also between nodes 303 and 314 at load 1110.

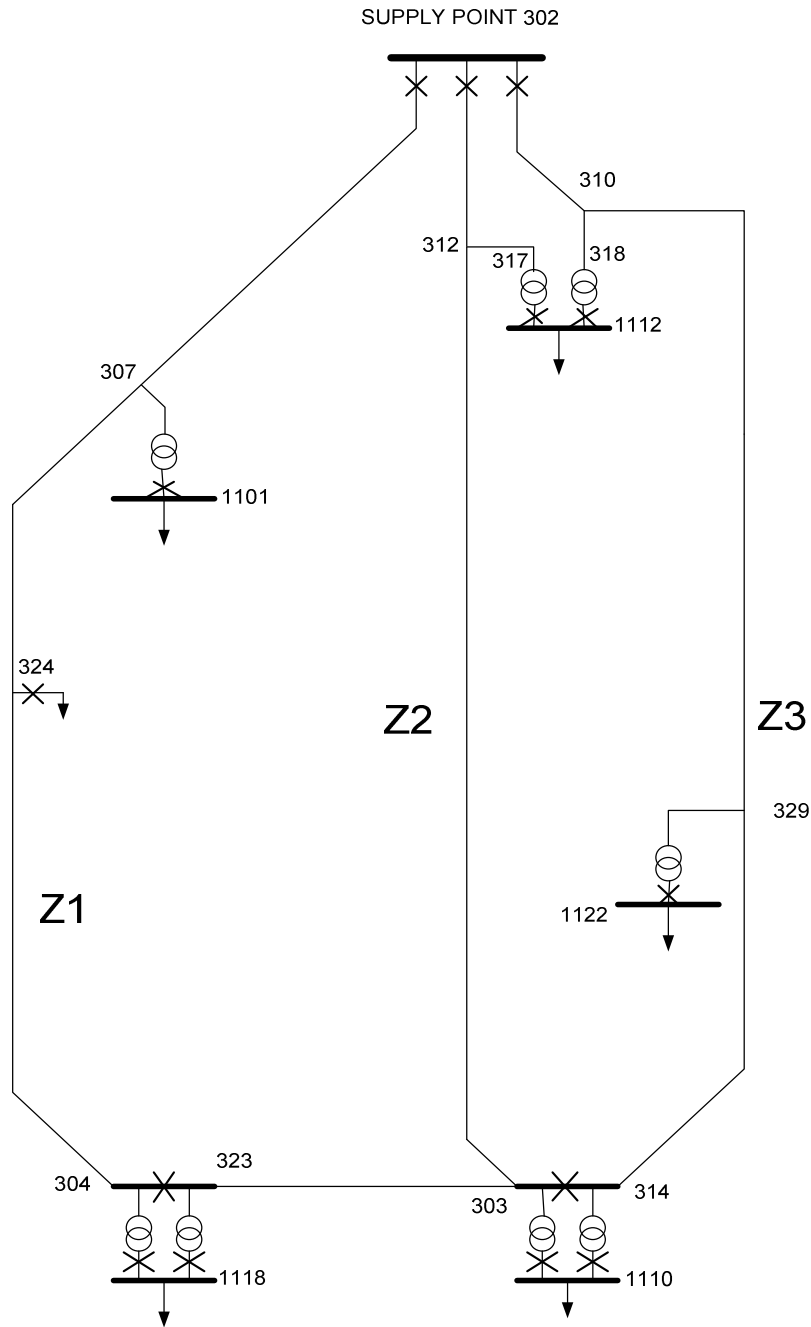

Figure 8.5 – Circuit Breakers and Protection Zones

These two busbar breakers effectively sub-divide the network into three protection zones, indicated in Figure 8.5 as Z1, Z2 and Z3. There are therefore eight different possible states of the network (seven of them following a fault or a planned outage):

- State 0: Normal operation, with Z1, Z2 and Z3 all functioning.
- State Z1: n-1 operation, with Z1 out of service. In this situation, load 324 is not supplied, and the 11 kV feeder from 1101 is reconfigured to be supplied from 1112. The load at 1118 is supplied by a single transformer, operating at 90% of its rating in 2010
- State Z2: n-1 operation, with Z2 out of service. In this situation, the loads at 1112, 1118 and 1110 are each supplied by a single transformer.
- State Z3. n-1 operation, with Z3 out of service. The feeders from 1122 are reconfigured to be supplied from 1118 or 1110. The loads at 1112 and 1110 are each supplied by a single transformer.
- State Z1/Z2. This is an n-2 situation, where both PZs Z1 and Z2 are out of service for whatever reason (coincident or consequent second failure). In this situation, there is no 33 kV supply to the loads at 1101, 324 and 1118. Only the three transformers in Z3 are operating, so there will inevitably be some loss of customer supply.
- State Z2/Z3: n-2 operation with only Z1 in service, and again with some inevitable customer loss of supply.
- State Z3/Z1: n-2 operation with only Z2 in service and some inevitable customer loss of supply.
- State Z1/Z2/Z3: n-3 operation with no supply to the whole sub-system.

In the analysis in Sections 8.2 to 8.4 and Appendices D, E and F, some or all of these eight states will need to be investigated in detail. There will also be evaluation of possible changes to this network, for example adding one or more additional CBs or switches to decrease the size and increase the number of PZs, thereby also increasing the number of possible states.

8.2 Basic Network Risk

The generalised methodology was specified in Chapter 4 to be applied to one load at a time, with software written accordingly. However, in this case study, the network risk for all six loads will be calculated in parallel. The steps

in applying the methodology are as previously defined in Chapter 4. Appendix D gives the calculation in detail.

The total expected CI cost comes to £36 200, and the total expected CML cost comes to £43 900 (both to the nearest £100). Adding these to the £58 400 repair cost gives an overall network risk in this part of the network of £138 500.

8.3 Load Flows in the Case Study

As has already been pointed out, the issue of increasing utilisation differs from those previously examined (asset replacement and remote reconfiguration) in a number of respects, of which perhaps the most significant is the criticality of load levels, as well as simple connectivity, in determining network risk.

In previous chapters, load flow modelling was required only as a check that ratings would not be exceeded by the measures recommended to mitigate risk. With increasing utilisation, however, exact load flow calculations become central to the analysis of the network. These calculations are detailed in Appendix E.

Table 8.2 shows in summary the findings of these calculations. For each of the three possible (n-1) events, the LFY has been determined first for the existing network without ANM. The next column shows the mitigating effect of minor capital expenditure, and the third column shows the mitigating effect of non-standard ANM. The final column shows the mitigating effect of using both capital expenditure and ANM in conjunction.

Network without	LFY with no change	LFY with capital only	LFY with ANM only	LFY with capital and ANM
Z1	2016	2026	2026	2032
Z2	2016	2028	2022	2028
Z3	2018	2022	2022	2030
Overall	2016	2022	2022	2028

Table 8.2 – Case study load flow summary

Points to note include:

- Taking the three scenarios overall, a network whose LFY is 2016 can extend that horizon by 6 years using ANM alone, by 6 years using capital investment alone, or by 12 years using both in conjunction.
- However, the capital investment required is different in each of the three scenarios, and all projects would be required to gain the benefits of extended P2/6 compliance.
- At 2.5% load growth, network redesign becomes necessary eventually. However, there are possible financial benefits in deferring redesign for a number of years. These are analysed in detail in Section 8.5.
- This analysis has only looked at P2/6 compliance, not at the increasing levels of network risk due to CIs and CMLs as loads increase. That issue is addressed in the next section, 8.4.

8.4 Load-Related Risk

In Section 8.2, the network risk across the six load points of the case study network was calculated. It came to £138 500 as an annual expected cost to the DNO, adding together elements for CIs, CMLs and repairs. The circumstances represented by this total were all due to loss of connectivity, and were mainly (not entirely) as a result of n-2 incidents. Because they did not depend on load, this cost would not directly increase as a result of increased utilisation. (There would perhaps be an indirect increase, if failure rates were higher at greater levels of load, but this has not been included).

In Section 8.3, the impact of a 2.5% annual load growth on load-related P2/6 compliance was investigated. The case study network was shown to be firm until 2016 without either capital investment or ANM. Piecemeal capital investment could extend this to 2022. Deploying ANM could also extend it to 2022, and both together could extend it to 2028. Beyond that date, a major network redesign and substantial capital investment would be required to ensure P2/6 compliance.

In this section, the approaches of Sections 8.2 and 8.3 are combined. It will be shown that, even in the base year of 2010, the figure of £138 500 underestimates the level of risk, as it does not allow for circumstances where

asset ratings prevent power supply even when there is a connecting path. As load grows, the number and duration of such circumstances increases, as does the resultant network risk cost. The full analysis of this combination of circumstances (assuming ANM, but no capital expenditure) is detailed in Appendix F. Table 8.3 summarises the results of the analyses carried out in Appendix F, for each of 3 possible (n-1) events, and each of 3 possible (n-2) events. It can be seen that the total extra cost due to loading of CIs plus CMLs is £26 400 (to the nearest £100) in 2010, increasing to £83 200 by 2022.

<i>Outage</i>	<i>2010 CIs (£)</i>	<i>2010 CMLs (£)</i>	<i>2022 CIs (£)</i>	<i>2022 CMLs (£)</i>
Z1	0	0	1098	1856
Z2	0	0	3559	7829
Z3	0	0	1302	2203
Z1 + Z2	742	1633	1930	6385
Z2 + Z3	2098	6316	6678	25272
Z1 + Z3	3249	12411	5128	19928
Total	6089	20360	19695	63473

Table 8.3 – Summary of analyses in Appendix F

The total network risk cost, including the element for unscheduled repair and asset deterioration (assumed not to increase with load) can be calculated, using these figures and those for connectivity-related risk from Section 8.2. The results are shown in Table 8.4 (all figures rounded to nearest £100)

The significance of these results is that consideration of connectivity alone, as in previous chapters, gives a reasonable estimate of network risk for a lightly loaded region of network (less than 90% overfirm in n-1 situations), but that this estimate becomes less realistic as loadings increase. In this case study of a heavily loaded network, approaching 100% overfirm in the base year of 2010, the effect of including load related risk is to increase the calculated risk by 19% (all from n-2 situations). However, increasing the load

by 2.5% per year increases the risk, so that by 2022, when the network is around 130% overfirm, using ANM but without any additional capital investment in the network, this risk has increased to 60% above the connectivity-only measure of risk as detailed in Section 8.2. This increase is mostly, but not entirely, from n-2 situations, and it would affect the ranking of a heavily loaded region of network as compared with a more lightly loaded region.

£/year expected	<i>Connectivity only</i>	<i>Plus 2010 load-related</i>	<i>Plus 2022 load-related</i>
Customer Interruptions	36 200	42 300 (+17%)	55 900 (+54%)
Customer Minutes Lost	43 900	64 300 (+46%)	107 400 (+145%)
Repairs and Asset Deterioration	58 400	58 400 (nil)	58 400 (nil)
Total	138 500	165 000 (+19%)	221 700 (+60%)

Table 8.4 – Impact of increased loads on network risk

There are implications here for the timing of capital investment projects. While deferring them until the last firm year (LFY) will save money, there will be a corresponding cost of deferment as regards the year-on-year increases in network risk. Balancing these costs and savings will be discussed and analysed in Section 8.5.

8.5 Economic Analysis

The economic evaluation of projects in the electricity supply industry can be treated in much the same way as projects in any other industry, including project phasing, discounting, cash flow and profit/investment ratio. These are all treated in Khatib's detailed work on the subject [100].

The electricity supply industry also presents problems particular to itself, such as the impact of electricity trading, and more recently of carbon constraints and possibly trading. A further consideration in the electricity supply industry is the incorporation of network risk into any financial evaluation, which is the principal focus of this present research. Again, Khatib sets out guidelines for doing this [100], and these are incorporated in the analysis in this section.

One complicating factor is due to the nature of a DNO. In Khatib, the electrical utility is assumed to be also a supply company, with a source of revenue that can be expected to increase later than, and as a result of, capital expenditure. This enables the rate of return for a project to be calculated in the conventional way, and compared with the cost of borrowing the capital (or the lost opportunity cost of not investing available capital elsewhere) to determine whether the project is worth doing.

In DNO projects, however, there is no direct revenue, only costs. The benefit of a project is to satisfy the regulator, and perhaps to avoid costs elsewhere. The rate of return can still be calculated, but it is effectively negative, and this requires care in interpreting the results, as will be shown.

8.5.1 Capital Projects only

In Section 8.3, it was concluded that capital projects alone, without any associated ANM, could have the effect of deferring a major redesign of the network for 6 years, from 2016 until 2022. In this chapter, the costs of these projects are set against the benefits of deferring a larger capital expenditure. The required projects are as follows (see Appendix E for justification)

- To mitigate the loss of circuit Z1, the transformer T2 at 1118 needs to be upgraded from a winter rating of 18 MVA to a rating of 24 MVA.
- To mitigate the loss of circuit Z2, the transformer T1 at 1118 needs to be upgraded from a winter rating of 18 MVA to a rating of 24 MVA.
- To mitigate the loss of circuit Z3, a radio controlled switch needs to be inserted into the line 303-323. This could be at the 1118 primary substation end of that line.

Taken together, upgrading two transformers and adding a switch at primary substation 1118 can be regarded as a single project. It is assumed that this would be a brown-field project, lasting around 6 months, with consequent disruption and increased network risk during the construction period.

The capital cost of such a project is hard to estimate, as much of the cost would depend on circumstances beyond the scope of this research. However, looking at the projected costs of similar projects planned by CE Electric UK [80], a reasonable figure might be £1.0 million to uprate the 2 transformers, and £100k to install the switch, a total project cost of £1.1M.

The cost of a major network redesign would be considerably higher. Exactly how much more would, of course, depend on the design details. Using £5.0M as the projected cost of building a new primary substation [80], a reasonable estimate for network redesign and construction, including typically both a new primary substation and new lines or cables, might be double this figure, and therefore a figure of £10.0M will be assumed. This figure is used whether the redesign takes place in 2016 or in 2022. It could be argued that the figure in 2022 should be lower, as doing the minor project should, if it is well-conceived, reduce the scope of the major redesign. As against this, the scope may need to increase if it is delayed 6 years (for example, as a result of new regulatory requirements). The best assumption is probably to use the same figure (in real terms) in both 2016 and 2022, and this is assumed.

Besides the capital costs involved, increased or decreased levels of network risk also have to be taken into account. This was evaluated in Section 8.4, including an allowance for utilisation, and a figure of £171.1k was calculated for the year 2010, rising to £227.8k by 2022. For the purposes of this study, those figures will be rounded to £170k in 2010, increasing by £5k per year thereafter if the network remains unchanged.

If a major network redesign is carried out, it is assumed that the high utilisation component of network risk is removed, and that the network risk reduces to £140k per year. This reduction does not apply following the lesser capital project, which is essentially a stop-gap.

However, during the construction period for the lesser project, network risk would be significantly increased. The extent and duration of that increased risk would depend on the implementation details of the construction

project. Detailed analyses of this kind have been carried out, with reference to planned projects on the actual CE Electric UK network, one of which was described in Chapter 3. In the present calculation, it will be assumed that the level of risk during the 6 month construction period increases by a factor of 3, meaning that the annual construction risk is doubled during the year of construction (assumed to be 2016).

The major network redesign, whether it is carried out in 2016 or in 2022, would also incur increased construction risk during its construction period. As this project affects a greater extent of network, and for a longer time, the impact on risk would be likely to be greater than for the lesser capital project. As against that, it is likely that most of this kind of redesign project could be carried out on a green-field site, with network disruption only at times of disconnection, connection, and specific construction tasks. It seems reasonable to assume that these two effects would balance out, and that a doubling of risk in the construction year would again be appropriate.

Tables 8.5 and 8.6 show these costs for the two options, namely

1. Minor project at 1118 in 2016, followed by redesign in 2022.
2. Network redesign in 2016.

	<i>Network Risk (£k)</i>	<i>Construction Risk (£k)</i>	<i>Capital Cost (£k)</i>	<i>Total Cost (£k)</i>	<i>Discounted at 7%</i>
2015	195			195	195
2016	200	200	1100	1500	1395
2017	205			205	177
2018	210			210	169
2019	215			215	161
2020	220			220	153
2021	225			225	146
2022	230	230	10000	10460	6294
2023	140			140	78
<i>TOTAL</i>	1840	430	11100	13370	8768

Table 8.5 – Costs of minor project in 2016, redesign in 2022

Each option is costed both in undiscounted cash terms, and with a discount rate of 7%, the value presently used by CE Electric UK to assess capital expenditure. Discounting is from a base year of 2015.

<i>Year</i>	<i>Network Risk (£k)</i>	<i>Construction Risk (£k)</i>	<i>Capital Cost (£k)</i>	<i>Total Cost (£k)</i>	<i>Discounted at 7%</i>
2015	195			195	195
2016	200	200	10000	10400	9672
2017	140			140	121
2018	140			140	113
2019	140			140	105
2020	140			140	97
2021	140			140	91
2022	140			140	84
2023	140			140	78
<i>TOTAL</i>	1375	200	10000	11575	10556

Table 8.6 – Costs of redesign in 2016

To compare these two options, it is useful to take the difference between them. This has been done by subtracting the numbers in option 2 from those in option 1. The results are shown in Table 8.7. The reason for subtracting this way round is to give a more conventional project cash flow, with net costs or expenditures (in brackets) early in the project, and net revenue, or cost reduction in this case, coming later on. What this means is that the 'project' being appraised is that of **not** doing the minor construction work, but rather of doing the major redesign 6 years earlier.

This involves an initial outlay (in 2016) of the cost difference between the major project and its minor alternative. The return comes in terms of lower network risk in 2018 to 2022, avoiding extra construction risk in 2022, and most of all avoiding a second construction project cost in 2022. In raw cash terms, this option produces a saving of £1.565M. However, if these figures are

discounted at 7%, the situation is reversed. The net present value (NPV) of pressing on with the major redesign goes negative, to a net cost of £1.788M, implying that, at this discount rate, the 'project' is not worth doing, and the alternative, i.e. the minor construction at 1118, is better value.

<i>Year</i>	<i>Network Risk (£k)</i>	<i>Construction Risk (£k)</i>	<i>Capital Cost (£k)</i>	<i>Total Cost (£k)</i>	<i>Discounted at 7%</i>
2015	0			0	0
2016	0	0	(8900)	(8900)	(8277)
2017	65			65	56
2018	70			70	56
2019	75			75	56
2020	80			80	56
2021	85			85	55
2022	90	230	10000	10320	6210
2023	0				0
<i>TOTAL</i>	465		1100	1565	(1788)

*Table 8.7 – Option 2 minus Option 1 (benefit of **not** deferring)*

All these figures are sensitive to changes in input values, and the effect of such changes will be explored in the sensitivity analysis following.

In addition, there are factors which have not been directly costed, but which would need to be taken into account in comparing the two options. One of these is that, in a time of load expansion and a changing network, the best solution for the following 40 years (the anticipated lifetime of a capital project) can be hard to predict with accuracy. At such times, waiting for an additional 6 years can bring greater clarity in discerning how the network should be developed, reducing the impact of '40 year lock-in'.

Another factor is the availability of engineering skills, both within and outside the DNO. It might be that these are expected to be more readily

available in 2016 than in 2022, and therefore perhaps the major work should be done in the earlier year, using that window of opportunity.

Again, the availability of capital depends on shareholders and on the regulator. Capital might be more readily available in 2022 than in 2016, or it might be less readily available. Financial forecasts for the DNO itself, for the industry, and for the wider economic climate, could therefore impact on this timing decision.

8.5.2 Sensitivity Analysis

The results shown in Tables 8.5, 8.6 and 8.7 have been subjected to sensitivity analysis on a range of variables. The results of this are as follows:

- *The discount rate chosen.* At zero, the second option gives a better NPV (lower cost), while at 7% the first option is better. The two are equal at a discount rate of 3.3%. This figure can therefore be considered to be the rate of return for the project of **not** deferring the major redesign, but rather doing it in 2016. If a higher 'return' is required, then the minor construction project becomes preferable.
- *The rate of load growth in the network.* In this study, an annual growth rate averaging 2.5% has been assumed, rather greater than the OFGEM predictions [2, 20], but conservative when compared with growth rates before 1970. If this rate were doubled, to 5.0%, then the effect of the minor project would be to defer major network redesign for only 3 years instead of 6. The redrawn versions of Tables 8.5 and 8.6 (now finishing in the year 2017) show that Option 1 costs £1.570M more in raw cash terms, but £0.432M less when discounted at 7%. This gives a rate of return for the earlier major redesign (in 2013 instead of 2016) of 5.5%, which is more attractive than the 3.3% at the lower load growth rate. This suggests that stop-gap projects such as the minor reconstruction become less attractive at higher load growths, as might be expected.

- Cost escalation of the major redesign.* If the capital cost of the major project were to escalate at 5% per year in real terms, which is a pattern that has been observed and exceeded in other parts of the electricity supply industry, particularly where there are construction constraints such as wind turbines [101], then it would be costed at £13.41 M instead of £10.0M in 2022. This would have the effect of trebling the gap between the two options in raw cost terms to £4.975M, and reversing the gap at a 7% discount rate to give Option 2 an advantage of £0.263M. This increases the rate of return to 7.4%, so that pressing on with the major project before real costs escalate becomes a more attractive option, provided that capital and manpower resources are available to do so.
- Level of network risk during construction.* It has been assumed that the extra risk incurred by either major or minor construction has the effect of doubling the overall risk during the construction year. However, there is a possibility that, particularly as loads increase, the extra risk could be substantially higher. Supposing that the risk were to be, not double, but four times the normal level in 2016, and six times the normal level in 2022. This would increase the raw difference to £2.485M, and would make the 7% discounted difference less negative, at -£1.234M, equating to a rate of return of 4.7%. Such increased, and increasing, levels of construction risk make it more desirable to do one construction project in place of two, and to do it earlier if possible, before the loads increase, and with them the level of risk.

8.5.3 Active Network Management only

As an alternative to capital investment, Section 8.3 considered the impact of active network management (ANM) on the case study network. It was shown that ANM, on its own, also had the potential to defer major network redesign for 6 years, at an average annual load growth of 2.5%.

The cost of implementing ANM on a small section of network comes in two forms. First, there is the cost of any incidental engineering works, such as

enabling a manual switch in a key location to be radio controlled, with associated protection. The cost of these works is likely to be an order of magnitude smaller than upgrading two transformers, and is estimated at £0.10M. Second, there is the extra work needed by control engineers. While this would be hard to measure for a single section of network, it could be substantial if sophisticated ANM were to be implemented across the whole network.

The cost assumption here is that, to implement sophisticated ANM across the whole network, and to do so effectively, would require an extra control engineer on shift at all times. 5 control engineers, with total employment costs of £1000k each per year, comes to £500k per year. Discounting this at 7% in perpetuity gives a one-off up-front capital cost of 15 years employment, or £7.5M. This is of the same order of magnitude as the capital costs that have been considered in this chapter (less than a major redesign, but more than a minor project). But it would benefit the whole network of a DNO, containing perhaps 600 primary substations, or 100 times as many as the case study network.

Apportioning this cost evenly across the whole network would give a one-off cost of £0.075M to be attributed to the case study network, in addition to the £0.10M on engineering works. This is shown in Table 8.8. As compared with the alternative Option 2, shown in Table 8.7, it costs £0.670M more in raw costs, and £2.828M less in discounted costs. This equates to a rate of return of only 1.3% for the earlier network redesign, in 2016, as opposed to the option of implementing ANM as described. It makes ANM seem an attractive and economical option.

As with capital investment, there are also a number of less tangible aspects of ANM which need to be acknowledged. The issues of 40 year lock-in, availability of engineering skills, and availability of capital apply to ANM-based deferment of major network redesign just as they do to minor capital project based deferment. In addition, there are three further factors.

Favouring ANM is its possible effect on the skills of the control engineers. Having to think about the network in more creative ways, and to make more complex decisions, could improve their understanding of the network and of how it responds. This would make them better able to make

informed and effective decisions, particularly in unplanned and extensive emergency situations where a fast and non-standard response is required.

<i>Year</i>	<i>Network Risk (£k)</i>	<i>Construction Risk (£k)</i>	<i>Capital Cost (£k)</i>	<i>Total Cost (£k)</i>	<i>Discounted at 7%</i>
2015	195			195	195
2016	200		175	375	349
2017	205			205	177
2018	210			210	169
2019	215			215	161
2020	220			220	153
2021	225			225	146
2022	230	230	10000	10460	6294
2023	140			140	84
<i>TOTAL</i>	1840	230	10175	12245	7728

Table 8.8 – Costs of implementing ANM in 2013, redesign in 2016

Conversely, the response of switches to signals is not 100% reliable. Studies have been carried out to determine the probability that a signal will not be received, or for various reasons will not be acted on [9]. There is also the possibility of false signals being returned to the control room and being acted upon, and also of spontaneous deployment of a switch when no signal has been received. Any increase to the complexity of the communications side of the network, as required by ANM, increases the likelihood of such events, which are potentially extremely disruptive.

A further issue is that the lifetime of components can be measured not in years but in the number of operations (e.g. for a switch), or the number of step-changes in load (e.g. for a cable) [102]. Increased use of ANM could substantially increase the frequency of such events, and therefore shorten the expected lifetime of these assets, perhaps by several years. While it is

beyond the scope of this research to estimate that effect quantitatively, it could significantly reduce the advantages of ANM.

8.5.4 Capital projects with ANM

The final economic evaluation in this chapter is for a combination of capital projects with ANM. Section 8.3 showed that this combination can defer the need for major network redesign by 12 years, from 2016 until 2028 in the case study. The capital investment required to do this was:

- Doubling the capacity of the 3.4 km section of overhead line between nodes 302 and 312, and
- Upgrading transformer T1 only at primary substation 1118.

<i>Year</i>	<i>Network Risk (£k)</i>	<i>Construction Risk (£k)</i>	<i>Capital Cost (£k)</i>	<i>Total Cost (£k)</i>	<i>Discounted at 7%</i>
2015	195			195	195
2016	200	200	975	1375	1279
2017	205			205	177
2018	210			210	169
2019	215			215	160
2020	220			220	153
2021	225			225	146
2022	230			230	138
2023	235			235	132
2024	240			240	125
2025	245			245	119
2026	250			250	113
2027	255			255	107
2028	260	260	10000	10520	4095
2029	140			140	51
TOTAL	3325	460	10975	14760	7159

Table 8.9 – Costs of minor project and ANM in 2013, redesign in 2019

The cost of replacing a single transformer is estimated at £0.5M, and of reconductoring 3.4 km of overhead line at £0.3 M, giving a total capital cost of £0.8 M, based on actual CE Electric UK estimates [80]. Adding to this the ANM capital of £0.175M gives a total requirement in the year 2016 of £0.975M. The costing of this project is shown in Table 8.9. In comparison, the total cost of network redesign in 2016 is as shown in Table 8.7, but extended by 6 years to give a total cost of £12.415M (£2.345M lower), and a discounted total of £10.925M (£3.766M higher). The rate of return for redesign in 2016, as compared with this ANM plus minor capital option, is 2.7%, making this option more attractive than minor capital projects alone, but less attractive than ANM alone.

8.5.5 Summary

Table 8.10 summarises the results found in this section. The lower the rate of return calculated for option 2 (redesign in 2016), the more attractive is the alternative being considered.

<i>Option</i>	<i>Rate of Return</i>
Costs of construction escalate at 5% per year	7.4 %
Load growth twice as great as in other runs	5.5 %
Construction network risk significantly higher	4.7 %
Minor capital investment only (base run)	3.3 %
Minor capital investment and ANM	2.7 %
ANM alone	1.3 %

Table 8.10 – RoRs for 2016 redesign, compared with different options

8.6 Increasing Utilisation: Discussion

In this chapter, the problems posed by increasing network utilisation as a result of increasing penetration of electric vehicles and/or heat pumps have been investigated. Mitigation strategies can be adopted before major network redesign becomes necessary, with the potential to defer the date of such

major redesign. These strategies include minor capital expenditure, more extensive active network management (ANM), or a combination of both.

An extensive methodology has been developed in the present chapter to evaluate these strategies. Features of this methodology include:

- Using the regulatory design standard P2/6, interpreted quite strictly and literally, to determine whether or not a network is compliant.
- Determining, for any given growth pattern for peak demand, when a network first breaches the strict requirements of P2/6, and therefore the last firm year (LFY) before this occurs.
- Using digitised load profiles (either generic, as illustrated in this chapter, or actual historic), with annual and daily patterns decoupled, and with shape unchanged by annual peak load growth, to predict future load patterns.
- The possibility of extending the LFY by 'tunnelling through' load peaks, where this can be done in compliance with P2/6.
- Allowing for seasonal asset ratings to be used in conjunction with seasonally varying loads.
- Applied to a generic case study, assumptions can be made as regards those parameters not specified in the generic network, including geography, customer numbers, protection zones, lower voltage interconnection, and whether circuits are overhead line or underground cable.
- The methodology has also been applied to actual networks. One example of this will be illustrated as part of Chapter 9.
- Standard load flow software is used to determine at what load levels the network first exceeds asset ratings at any point on the network. This is done both for the network intact, and also under all relevant n-1 and n-2 conditions.
- The network risk is not just calculated on the basis of connectivity alone as in the core and generalised methodologies. An incremental level of risk, based of load flows exceeding ratings for a proportion of each day, under each possible n-1 and n-2 condition, is included.

- For each possible n-1 condition, the ANM required to extend LFY for as long as possible is identified and specified.
- For each possible n-1 condition, the minor capital expenditure that would extend LFY for as long as possible is identified and specified. Combinations of ANM and minor capital expenditure are also identified and specified.
- Economic analysis of each possible project (ANM, capital expenditure, or both) is carried out, including discounting. Because of the unusual nature of DNO financing, this has to be carried out in a non-standard manner, effectively evaluating the benefit of *not* doing each project.
- Sensitivity analysis can be carried out on critical parameters, such as load growth rate, discount rate, construction cost escalation and level of increased network risk during construction periods.
- Although the methodology has been demonstrated in this chapter based on average values, it could also be extended by the use of Monte Carlo Simulation to incorporate probability distributions as both input and output.

The implications of the findings of the research described in this chapter for UK networks in general are significant and far-reaching. Accelerated load growth will require substantial capital investment in distribution network infrastructure during the period 2010-2030, and this investment must meet the anticipated needs of the next 40 years. The impact of load growth, and the consequent need for investment, is likely to be particularly acute in the more remote rural areas, which face issues including weak networks, voltage drops, high failure rates, long repair times, environmental constraints, and political sensitivity.

Active Network Management (ANM) is one way of making the network more robust, and thereby deferring the LFY. However, the concept of ANM is not as easy to define for a network with outages as it is for an intact network. In particular, control engineers operating in emergency mode, to preserve or restore power supply, will often adopt ANM strategies that might not be considered acceptable under normal operation. Alternatively, capital

expenditure on small projects can also be used to postpone the LFY, and therefore the need to undertake a larger project such as network redesign. The extra expense and disruption involved may on occasion be justified by being able to defer for several years a much larger capital expenditure.

In the case study considered, ANM alone extended the LFY by 6 years at a 2.5% load growth rate. Minor capital expenditure alone also extended it by 6 years, and ANM in conjunction with minor capital expenditure extended LFY by 12 years at a 2.5% growth rate. Economic analysis showed that all three of these options were attractive at discount rates of 4% and above.

A number of issues which could lead to further research were highlighted by the research described in this chapter. One of them concerns the use made by DNOs of asset ratings. Although design standards often specify seasonal ratings, the DNOs do not tend to use these operationally. In theory this could have the effect of increasing network risk, by disconnecting customers when it was not actually necessary to do so. Experimental and/or real-time measurement of transformer core temperatures might also give network operators the confidence to run transformers in excess of nameplate ratings, at higher load levels and for longer periods, under n-1 and n-2 conditions when circumstances required it.

The concept of load-related risk is a useful one, particularly at times and in locations where high levels of load growth are experienced or expected. Although more complicated to calculate than the connectivity-only network risk evaluated by the core methodology, it gives a more accurate measure of the actual network risk. If any of the methodologies developed and described in this research is to be used within the industry, it is debatable whether it should be the simpler core methodology, or the arguably more accurate load-related methodology described in this chapter.

The ANM described in this chapter relies substantially on network reconfiguration at lower voltages (11 kV). This requires the availability of certain 11 kV feeders following a 33 kV event. It might be desirable to define these specific feeders (one DNO delineates them as 'red routes' [91]), and thereby give them maintenance priority, to ensure that they would be available if required. The value of this exercise should be investigated further.

Finally, this chapter has considered in detail the issue of minor capital expenditure, as a means of deferring the major capital expenditure that will eventually be required if load growth continues. The economic analysis carried out could usefully be tightened up, in particular as regards input parameters such as the relative costs of major and minor projects, the true discount rate to use, and the likely increases in network risk during construction periods. It might also be advantageous to find ways of costing the less tangible aspects of minor projects, such as whether the delay in the major project might enable it to meet future needs more effectively, or whether uncertainty as to future growth rates might mean it could be dispensed with altogether.

This chapter has considered the problem of increasing utilisation in isolation, as the two previous chapters considered the problems of replacing ageing assets, and installing automation at critical locations, in isolation. However, in practice the long-term outlook for a section of network could involve any two of these problems simultaneously, or even all three. This will be the subject of Chapter 9.

8. INCREASING UTILISATION CASE STUDY

8.1 Choosing a Generic Case Study

In Section 7.1.2, the use of generic as opposed to actual historic load profiles was justified on the grounds that the choice of which actual data to use could be open to question. The same principle applies to the selection of a representative network for a case study. While it would be possible to examine an actual part of the CE Electric UK network, as has been done in Chapters 3-5, this could introduce secondary issues which might only apply to that specific case. The choice of a generic network, as in Chapter 6, avoids these complications.

A second advantage of using a generic network such as those produced by the GDS project is that it is in the public domain, and therefore accessible to other researchers who might wish to validate or extend the present research. A third advantage is that detail which is not explicitly specified in the GDS network (for example, the precise location of circuit breakers) can be chosen by the researcher to illustrate key issues with greater clarity.

At EHV level (33 kV and above), GDS contains 6 distinct networks, covering rural, suburban and urban environments, and covering radial and meshed architectures. For the present case study, GDS network 2 was chosen, which represents a large rural network [93]. The high level characteristics of this model are specified as follows:

- Rural area
- Long circuit length
- Low customer density
- Mixed construction
- Radial topology
- Large overall size

The reasons for choosing a rural network were listed in Section 7.1.1. They included vulnerability, voltage drop, and the limited options available both for network development and for network operation. Likewise a radial architecture (which is common in rural areas, with the exception of North Wales [94, 95])

will be less robust in responding to increasing utilisation than a meshed architecture would be.

Within GDS 2, a subsection of the network was selected, and is illustrated (as an IPSA representation) in Figure 8.1. Its most significant features are as follows:

- The upstream supply at 132 kV is strong, and the supply point feeding node 302 contains 3 independent 132/33 kV transformers rated at 68 MVA each. The supply to node 302 at 33 kV can be considered reliable and adequate for the period of load growth being investigated, and is therefore excluded from the case study.
- The subsection comprising the case study consists of the three feeders from supply point 302 to nodes 307, 312 and 310, and all the loads downstream of those nodes.
- Some of these loads (in particular 1118) are close to the n-1 rating of their transformers, others have only a single transformer (1101, 1122), or are at the higher 33 kV voltage (324). These features make the case study interesting, and illustrate important features of real networks.
- The network includes long stretches of single overhead lines at 33 kV, all features which make it particularly vulnerable, but they are linked in a double ring, which gives several options for reconfiguration using ANM. Again, these features make the case study interesting and illustrative.
- The loads as specified in GDS 2 are taken to be peak loads in the year 2010. These loads will then be considered to increase at an annual compounded rate of 2.5%.

8.1.1 Load Flow Modelling

The GDS network specifies several key parameters for each part of the network, including:

- The power load (real MW and reactive MVA) at each load point
- The electrical properties (including reactance and resistance) of each line and transformer
- The length in km of each line

- The power ratings (summer and winter) of each line and of each transformer
- The range of tap settings on each transformer

These properties enable the network to be modelled by load flow packages such as IPSA, which will calculate power flows (real and reactive) between any pair of adjacent nodes, and also the voltages at each node. This shows that the base network as specified in GDS is not overloading any line or transformer, and that voltage levels are within statutory limits. Figure 8.1 shows the subsection of GDS 2 that constitutes the case study, as modelled in IPSA for load flow calculations.

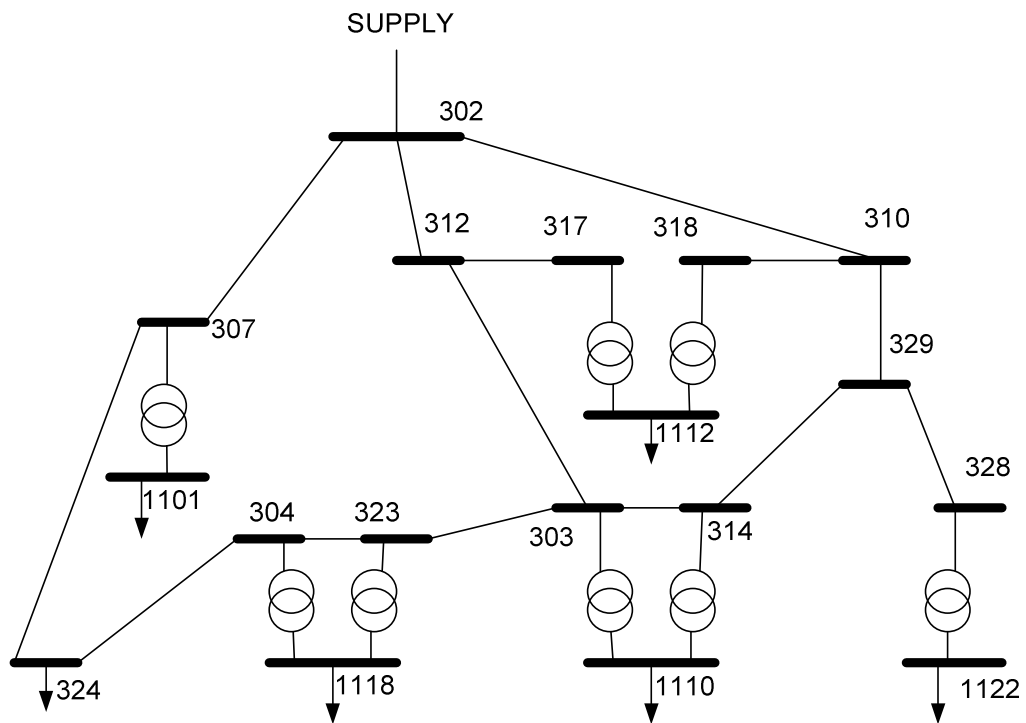

Figure 8.1 – IPSA representation of case study network

The IPSA model can then be modified, either by increasing loads (to represent future years), or by removing sections of network (to represent n-1 failures), or both. The results of load flows of this kind are presented in subsequent sections.

8.1.2 Modelling beyond Load Flows

There are, however, a number of significant features of the case study network which are not required as input data by IPSA, and which are consequently not specified by GDS. While these features do not directly affect the load flow, they do affect other aspects of network risk. The analytical simulation techniques which are applied in modelling this case study require many inputs which are not specified in GDS. In particular, these inputs include:

- The location on the network of manual switches, radio-controlled switches, and circuit breakers. These define the protection zones (PZs) into which the subsection of network can be divided in the event of n-1 and n-2 failure events.
- The geography of the network. Although line lengths are given (in km), this does not specify whether two electrically separate nodes might be physically close (and therefore able to be linked by a relatively inexpensive capital project). It also affects the probable lower voltage (11 kV in this case) network architecture.
- The 11 kV architecture itself is not specified. This is highly significant, as the possibilities for reconfiguring the system following loss of some portion of the 33 kV network depends critically on where the 11 kV feeders are supplied from, and on how they interconnect (typically through normally open points) with one another.
- The number of customers at each load point is not specified. This information is required for evaluating the cost to the DNO of CIs and CMLs in the event of a loss of supply.
- Data on failure rates and restoration times. In their absence, national data can be used as supplied to and correlated by NAFIRS [8]. Such data could be adjusted if it were considered that the case study network were in some respects atypical.

The assumptions made concerning these aspects of the case study are described in detail in the following sections.

8.1.3 Network Geography

The GDS case study as specified in Figure 8.1 must now be described in detail. Some features are specified by GDS, others must be created specifically for the present study. For example, the lengths in km of overhead line or underground cable between each pair of adjacent nodes are specified by GDS. But GDS does not specify whether each connection is in fact line,

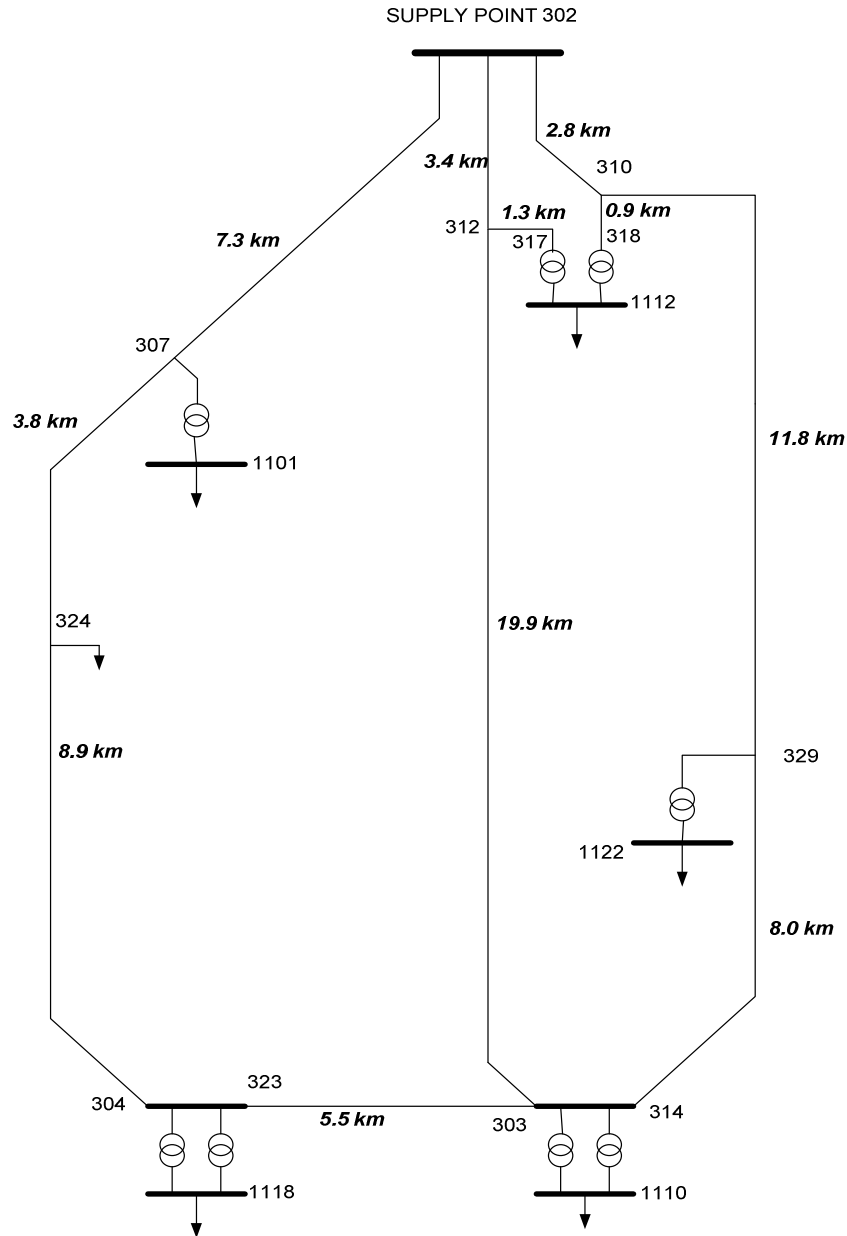

Figure 8.2 – Case study network geography

cable, or a mixture of the two. This information is not required for network analysis (so long as the resistances and reactances are known), but it does signify in network risk studies, as the failure rate per km is likely to depend on the nature of the connector. Most rural 33 kV networks are predominantly overhead line, and for the present study it will be assumed for simplicity that all connectors are in fact overhead line.

Neither does GDS specify the geography of the network. This affects network risk studies as the more remote locations will tend to have longer average reconnection times. It also determines the likely layout of 11 kV feeders, also not specified by GDS. Figure 8.2 shows a possible geography for the 33 kV network, with the GDS-specified line lengths. This geography will be assumed for the case study. One feature of this geography is that there is a clear separation between the three northern load points, closer to the supply point, and the three southern load points which are more remote.

8.1.4 Loads and Ratings

The GDS network specifies the ratings of each line and transformer (summer and winter), and the load at each load point (real and reactive power). These values are critical for network risk studies at times of increasing utilisation, and are shown in Figure 8.3, which indicates the winter ratings (in MVA) which are 20% above summer ratings, and the apparent power load (also in MVA). These power loads are used for the base case (winter peak loads in 2010), and are then increased or decreased in increments of 5%. All loads are at power factor 0.95. It is noticeable that the largest load, at 1118, is already close to being overfirm, at 90% of the single transformer winter rating under n-1 conditions. In practice, CE Electric UK would use summer transformer ratings, and define it to be already overfirm.

8.1.5 Customer Numbers and 11 kV Feeders

Figure 8.4 shows another aspect of the case study network which is not specified in GDS, namely the configuration of the lower voltage system. The layout shown in Figure 8.4 is simplified to show each feeder as a single dotted line, ignoring any tees or loops. These feeders all run from a load point at a primary substation to a normally open point, where they interconnect with

another feeder or another primary substation. This conjectural layout is based on actual layouts at similar locations on the CE Electric UK network. It is important for a network risk study such as this for indicating the 11 kV reconfiguration options, which in turn determine the expected value of CIs and CMLs, and also whether or not the network is likely to be compliant with P2/6.

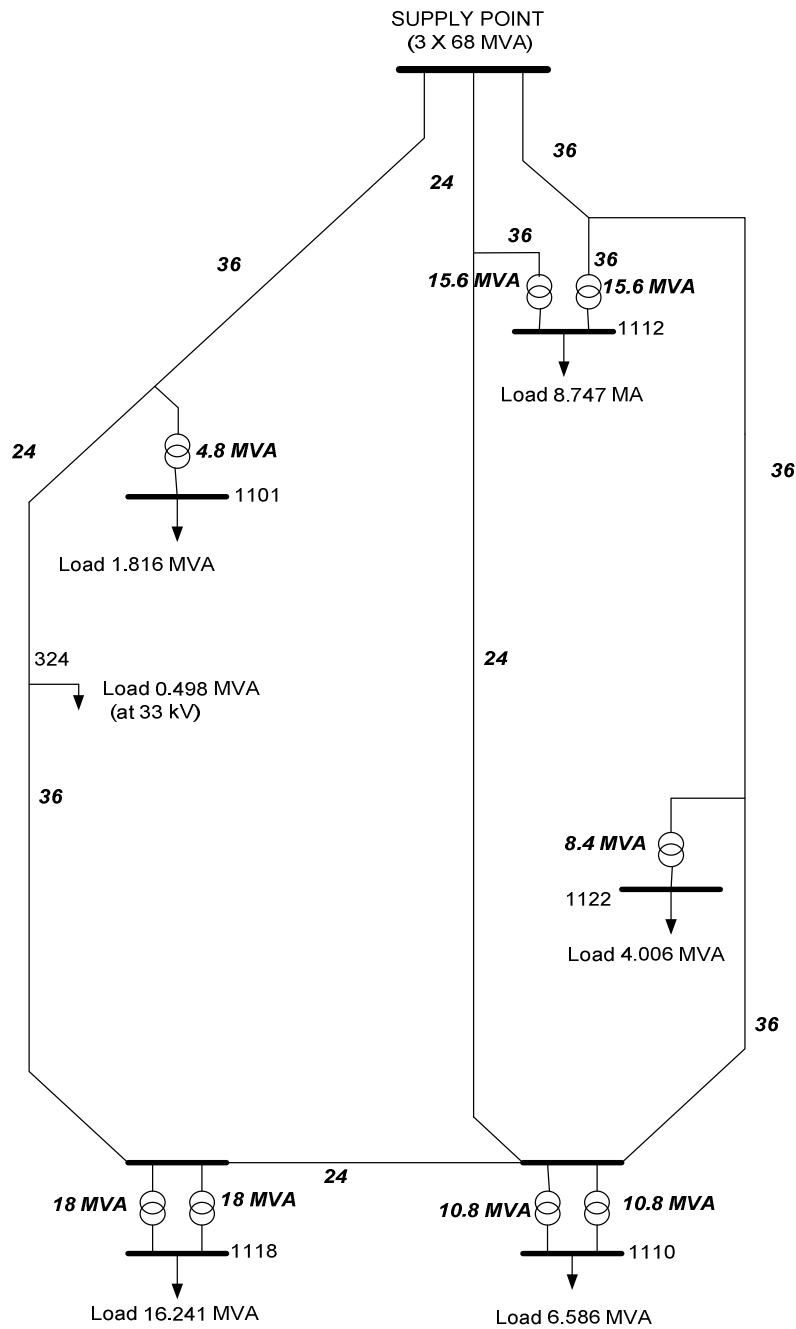

Figure 8.3 – Winter ratings and base run loads in case study network

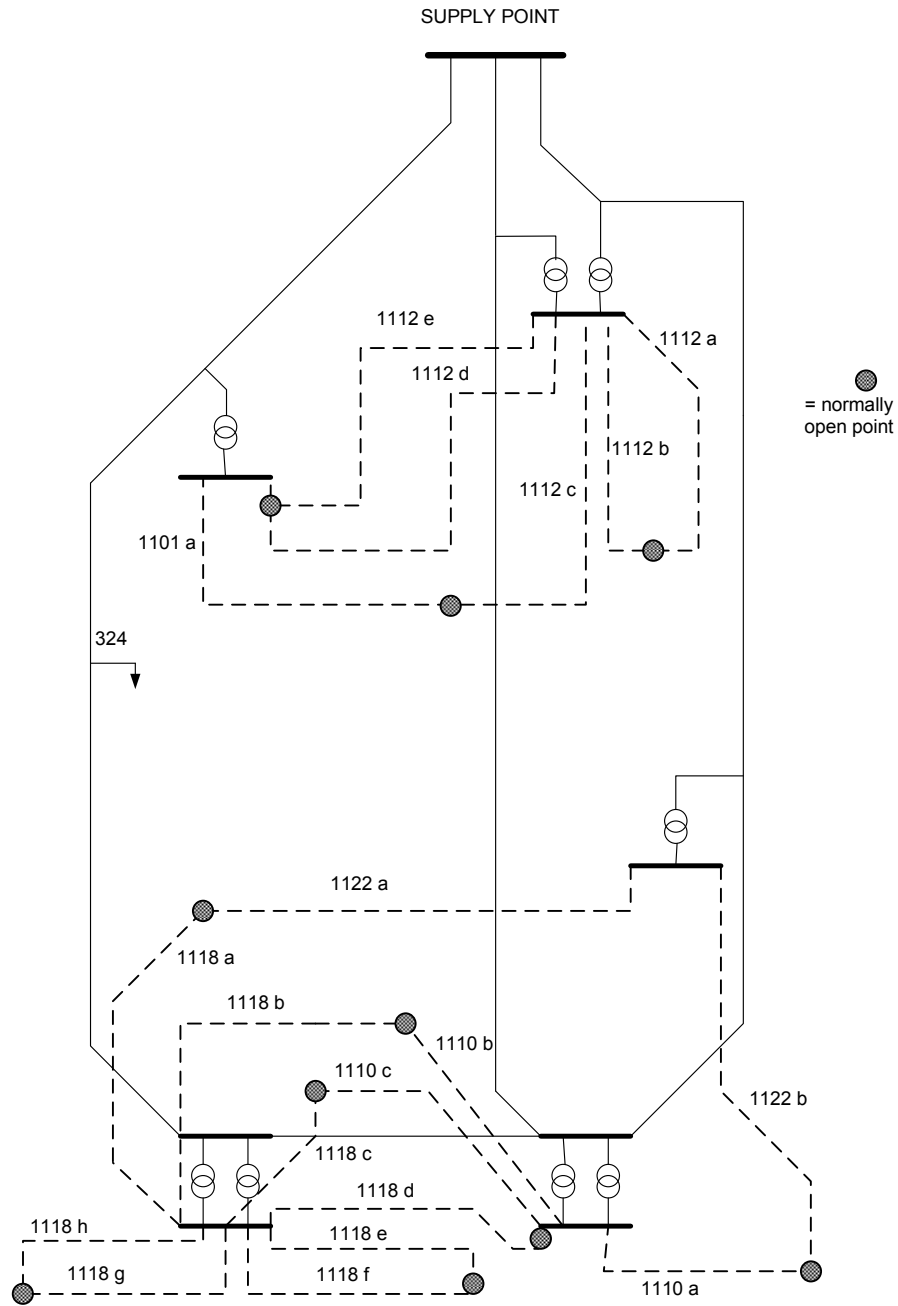

Figure 8.4 – Possible arrangement of 11 kV feeders

Another feature not specified by GDS is the number of customers at each load point, and on each 11 kV feeder. This is important, not only for evaluating the likely number of CIs and CMLs, but also for determining which of a number of possible network reconfiguration options is likely to be preferred by the control engineers in an n-1 situation. They are responsible for

minimising the cost of CIs and CMLs, and in a typical control room, those feeders with over 2000 customers are indicated as having a correspondingly high priority for reconnection, and for avoiding disconnection in the first place, if at all possible [72].

In the case study network, for example, the 33 kV load at point 324, which is set at 0.498 MVA, is assumed to be a single industrial customer, whose connection is such that there is no alternative supply route in the event of failure in the lines leading to node 324. The cost in CIs and CMLs for a single customer is small. It may be that this industrial customer has his own back-up generators, or that he is prepared to run the risk of occasional power failure rather than pay a large sum to have his connection strengthened.

For the other five load points, the number of customers is assumed to be proportional to the real power load, at a rate of 500 customers per MW in the base case (a typical value for rural customers on actual CE Electric UK networks). The number of feeders at each location is also assumed to be roughly proportional to the total number of customers, as shown in Table 8.1. For simplicity of subsequent analysis, the feeders from a single load point are assumed to be equal in size, both as regards number of customers and as regards load size in MW (and also in MVA).

<i>Load Point</i>	<i>Load MW</i>	<i>Customers (nearest 100)</i>	<i>Number of feeders</i>	<i>Customers per feeder</i>	<i>MVA per feeder</i>
1101	1.725	900	1	900	1.816
1110	6.275	3100	3	1000	2.195
1112	8.310	4200	5	800	1.749
1118	15.429	7700	8	1000	2.030
1122	3.806	1900	2	1000	2.003

Table 8.1 – Case study customer numbers and 11 kV feeders

8.1.6 Protection Zones

The final aspect of the case study which needs to be specified, and which is not specified in GDS, is the location of switches, whether manual, radio-controlled or automatic circuit breakers (CBs). This is perhaps the most important single piece of information as regards network risk case studies, since it defines the impact of a fault at any given location, and also the possibilities for network restoration.

On the 11 kV network, it is assumed that each feeder is protected by a CB at the primary substation, which can be opened or closed on fault current as well as normal currents. It is further assumed that the normally open points, as shown in Figure 8.4 by grey circles, are also equipped with automatic switches, all of which can be opened or closed by radio control as well as opening automatically when a fault current is detected. In addition, there may be a number of manual switches on the 11 kV feeders. These are not shown, as the time taken to locate the fault, send out a repair crew, and operate them manually following safety procedures could be several hours. Such an operation is classed as a restoration procedure equivalent to a repair, rather than a short-term reconfiguration.

Likewise on the 33 kV network, there will probably be a number of manual switches, particularly along the longer sections of overhead line. Again, opening or closing them is classed as a long repair-like restoration, rather than a short-term reconfiguration. Consequently, they are not specified as part of this network risk study.

As a minimum, it is assumed that each circuit leaving the supply point 302 is protected by a 33 kV CB, and that there are 11 kV CBs on the downstream side of each of the 8 transformers. There would also probably be a 33 kV CB at node 324, between the DNO network and the industrial customer. It seems likely that there would also be additional CBs on this section of network, to divide it into smaller, more manageable and useful protection zones (PZ). However, in rural networks such as this, the PZs are often quite large. Figure 8.5 shows the assumption for this case study, namely that there are only two additional CBs. They are in fact busbar breakers, located between nodes 304 and 323 at load 1118, and also between nodes 303 and 314 at load 1110.

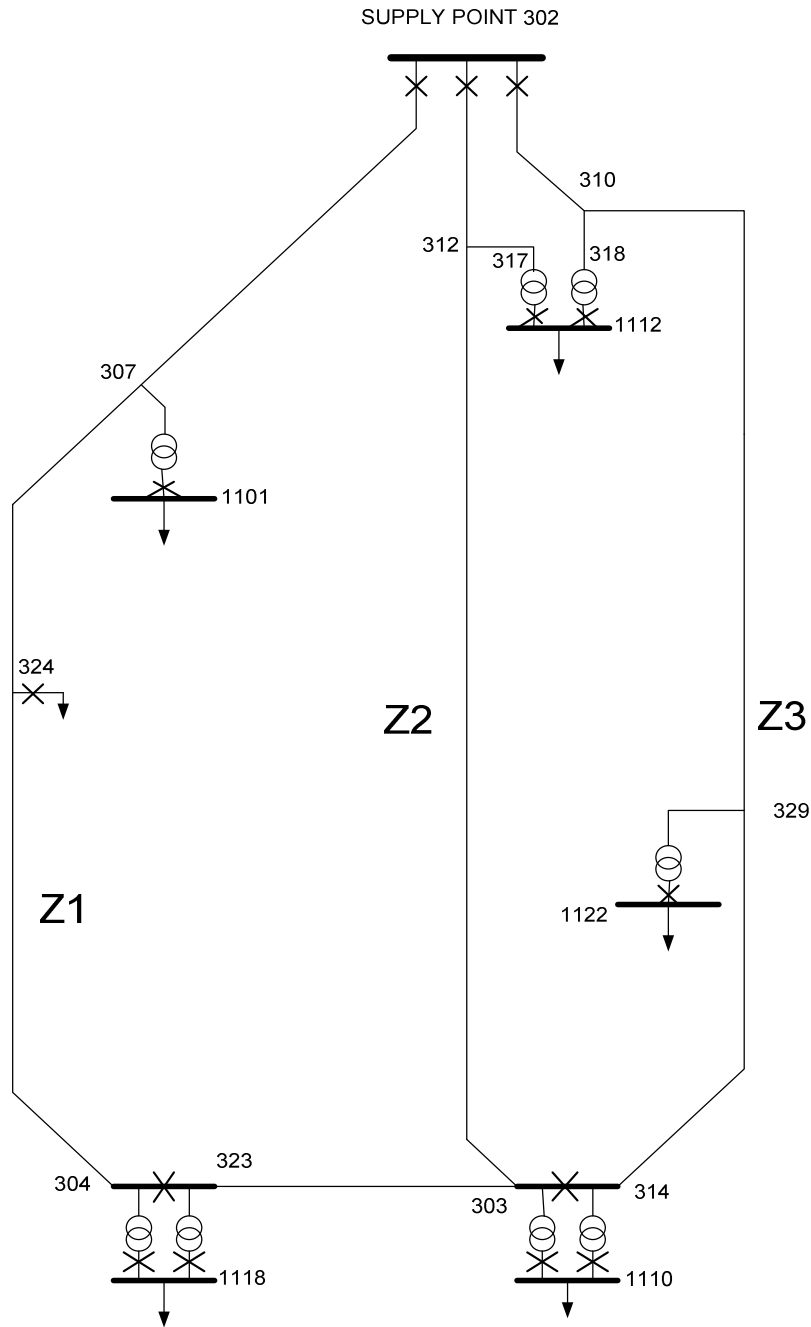

Figure 8.5 – Circuit Breakers and Protection Zones

These two busbar breakers effectively sub-divide the network into three protection zones, indicated in Figure 8.5 as Z1, Z2 and Z3. There are therefore eight different possible states of the network (seven of them following a fault or a planned outage):

- State 0: Normal operation, with Z1, Z2 and Z3 all functioning.
- State Z1: n-1 operation, with Z1 out of service. In this situation, load 324 is not supplied, and the 11 kV feeder from 1101 is reconfigured to be supplied from 1112. The load at 1118 is supplied by a single transformer, operating at 90% of its rating in 2010
- State Z2: n-1 operation, with Z2 out of service. In this situation, the loads at 1112, 1118 and 1110 are each supplied by a single transformer.
- State Z3. n-1 operation, with Z3 out of service. The feeders from 1122 are reconfigured to be supplied from 1118 or 1110. The loads at 1112 and 1110 are each supplied by a single transformer.
- State Z1/Z2. This is an n-2 situation, where both PZs Z1 and Z2 are out of service for whatever reason (coincident or consequent second failure). In this situation, there is no 33 kV supply to the loads at 1101, 324 and 1118. Only the three transformers in Z3 are operating, so there will inevitably be some loss of customer supply.
- State Z2/Z3: n-2 operation with only Z1 in service, and again with some inevitable customer loss of supply.
- State Z3/Z1: n-2 operation with only Z2 in service and some inevitable customer loss of supply.
- State Z1/Z2/Z3: n-3 operation with no supply to the whole sub-system.

In the analysis in Sections 8.2 to 8.4 and Appendices D, E and F, some or all of these eight states will need to be investigated in detail. There will also be evaluation of possible changes to this network, for example adding one or more additional CBs or switches to decrease the size and increase the number of PZs, thereby also increasing the number of possible states.

8.2 Basic Network Risk

The generalised methodology was specified in Chapter 4 to be applied to one load at a time, with software written accordingly. However, in this case study, the network risk for all six loads will be calculated in parallel. The steps

in applying the methodology are as previously defined in Chapter 4. Appendix D gives the calculation in detail.

The total expected CI cost comes to £36 200, and the total expected CML cost comes to £43 900 (both to the nearest £100). Adding these to the £58 400 repair cost gives an overall network risk in this part of the network of £138 500.

8.3 Load Flows in the Case Study

As has already been pointed out, the issue of increasing utilisation differs from those previously examined (asset replacement and remote reconfiguration) in a number of respects, of which perhaps the most significant is the criticality of load levels, as well as simple connectivity, in determining network risk.

In previous chapters, load flow modelling was required only as a check that ratings would not be exceeded by the measures recommended to mitigate risk. With increasing utilisation, however, exact load flow calculations become central to the analysis of the network. These calculations are detailed in Appendix E.

Table 8.2 shows in summary the findings of these calculations. For each of the three possible (n-1) events, the LFY has been determined first for the existing network without ANM. The next column shows the mitigating effect of minor capital expenditure, and the third column shows the mitigating effect of non-standard ANM. The final column shows the mitigating effect of using both capital expenditure and ANM in conjunction.

Network without	LFY with no change	LFY with capital only	LFY with ANM only	LFY with capital and ANM
Z1	2016	2026	2026	2032
Z2	2016	2028	2022	2028
Z3	2018	2022	2022	2030
Overall	2016	2022	2022	2028

Table 8.2 – Case study load flow summary

Points to note include:

- Taking the three scenarios overall, a network whose LFY is 2016 can extend that horizon by 6 years using ANM alone, by 6 years using capital investment alone, or by 12 years using both in conjunction.
- However, the capital investment required is different in each of the three scenarios, and all projects would be required to gain the benefits of extended P2/6 compliance.
- At 2.5% load growth, network redesign becomes necessary eventually. However, there are possible financial benefits in deferring redesign for a number of years. These are analysed in detail in Section 8.5.
- This analysis has only looked at P2/6 compliance, not at the increasing levels of network risk due to CIs and CMLs as loads increase. That issue is addressed in the next section, 8.4.

8.4 Load-Related Risk

In Section 8.2, the network risk across the six load points of the case study network was calculated. It came to £138 500 as an annual expected cost to the DNO, adding together elements for CIs, CMLs and repairs. The circumstances represented by this total were all due to loss of connectivity, and were mainly (not entirely) as a result of n-2 incidents. Because they did not depend on load, this cost would not directly increase as a result of increased utilisation. (There would perhaps be an indirect increase, if failure rates were higher at greater levels of load, but this has not been included).

In Section 8.3, the impact of a 2.5% annual load growth on load-related P2/6 compliance was investigated. The case study network was shown to be firm until 2016 without either capital investment or ANM. Piecemeal capital investment could extend this to 2022. Deploying ANM could also extend it to 2022, and both together could extend it to 2028. Beyond that date, a major network redesign and substantial capital investment would be required to ensure P2/6 compliance.

In this section, the approaches of Sections 8.2 and 8.3 are combined. It will be shown that, even in the base year of 2010, the figure of £138 500 underestimates the level of risk, as it does not allow for circumstances where

asset ratings prevent power supply even when there is a connecting path. As load grows, the number and duration of such circumstances increases, as does the resultant network risk cost. The full analysis of this combination of circumstances (assuming ANM, but no capital expenditure) is detailed in Appendix F. Table 8.3 summarises the results of the analyses carried out in Appendix F, for each of 3 possible (n-1) events, and each of 3 possible (n-2) events. It can be seen that the total extra cost due to loading of CIs plus CMLs is £26 400 (to the nearest £100) in 2010, increasing to £83 200 by 2022.

<i>Outage</i>	<i>2010 CIs (£)</i>	<i>2010 CMLs (£)</i>	<i>2022 CIs (£)</i>	<i>2022 CMLs (£)</i>
Z1	0	0	1098	1856
Z2	0	0	3559	7829
Z3	0	0	1302	2203
Z1 + Z2	742	1633	1930	6385
Z2 + Z3	2098	6316	6678	25272
Z1 + Z3	3249	12411	5128	19928
Total	6089	20360	19695	63473

Table 8.3 – Summary of analyses in Appendix F

The total network risk cost, including the element for unscheduled repair and asset deterioration (assumed not to increase with load) can be calculated, using these figures and those for connectivity-related risk from Section 8.2. The results are shown in Table 8.4 (all figures rounded to nearest £100)

The significance of these results is that consideration of connectivity alone, as in previous chapters, gives a reasonable estimate of network risk for a lightly loaded region of network (less than 90% overfirm in n-1 situations), but that this estimate becomes less realistic as loadings increase. In this case study of a heavily loaded network, approaching 100% overfirm in the base year of 2010, the effect of including load related risk is to increase the calculated risk by 19% (all from n-2 situations). However, increasing the load

by 2.5% per year increases the risk, so that by 2022, when the network is around 130% overfirm, using ANM but without any additional capital investment in the network, this risk has increased to 60% above the connectivity-only measure of risk as detailed in Section 8.2. This increase is mostly, but not entirely, from n-2 situations, and it would affect the ranking of a heavily loaded region of network as compared with a more lightly loaded region.

£/year expected	<i>Connectivity only</i>	<i>Plus 2010 load-related</i>	<i>Plus 2022 load-related</i>
Customer Interruptions	36 200	42 300 (+17%)	55 900 (+54%)
Customer Minutes Lost	43 900	64 300 (+46%)	107 400 (+145%)
Repairs and Asset Deterioration	58 400	58 400 (nil)	58 400 (nil)
Total	138 500	165 000 (+19%)	221 700 (+60%)

Table 8.4 – Impact of increased loads on network risk

There are implications here for the timing of capital investment projects. While deferring them until the last firm year (LFY) will save money, there will be a corresponding cost of deferment as regards the year-on-year increases in network risk. Balancing these costs and savings will be discussed and analysed in Section 8.5.

8.5 Economic Analysis

The economic evaluation of projects in the electricity supply industry can be treated in much the same way as projects in any other industry, including project phasing, discounting, cash flow and profit/investment ratio. These are all treated in Khatib's detailed work on the subject [100].

The electricity supply industry also presents problems particular to itself, such as the impact of electricity trading, and more recently of carbon constraints and possibly trading. A further consideration in the electricity supply industry is the incorporation of network risk into any financial evaluation, which is the principal focus of this present research. Again, Khatib sets out guidelines for doing this [100], and these are incorporated in the analysis in this section.

One complicating factor is due to the nature of a DNO. In Khatib, the electrical utility is assumed to be also a supply company, with a source of revenue that can be expected to increase later than, and as a result of, capital expenditure. This enables the rate of return for a project to be calculated in the conventional way, and compared with the cost of borrowing the capital (or the lost opportunity cost of not investing available capital elsewhere) to determine whether the project is worth doing.

In DNO projects, however, there is no direct revenue, only costs. The benefit of a project is to satisfy the regulator, and perhaps to avoid costs elsewhere. The rate of return can still be calculated, but it is effectively negative, and this requires care in interpreting the results, as will be shown.

8.5.1 Capital Projects only

In Section 8.3, it was concluded that capital projects alone, without any associated ANM, could have the effect of deferring a major redesign of the network for 6 years, from 2016 until 2022. In this chapter, the costs of these projects are set against the benefits of deferring a larger capital expenditure. The required projects are as follows (see Appendix E for justification)

- To mitigate the loss of circuit Z1, the transformer T2 at 1118 needs to be upgraded from a winter rating of 18 MVA to a rating of 24 MVA.
- To mitigate the loss of circuit Z2, the transformer T1 at 1118 needs to be upgraded from a winter rating of 18 MVA to a rating of 24 MVA.
- To mitigate the loss of circuit Z3, a radio controlled switch needs to be inserted into the line 303-323. This could be at the 1118 primary substation end of that line.

Taken together, upgrading two transformers and adding a switch at primary substation 1118 can be regarded as a single project. It is assumed that this would be a brown-field project, lasting around 6 months, with consequent disruption and increased network risk during the construction period.

The capital cost of such a project is hard to estimate, as much of the cost would depend on circumstances beyond the scope of this research. However, looking at the projected costs of similar projects planned by CE Electric UK [80], a reasonable figure might be £1.0 million to uprate the 2 transformers, and £100k to install the switch, a total project cost of £1.1M.

The cost of a major network redesign would be considerably higher. Exactly how much more would, of course, depend on the design details. Using £5.0M as the projected cost of building a new primary substation [80], a reasonable estimate for network redesign and construction, including typically both a new primary substation and new lines or cables, might be double this figure, and therefore a figure of £10.0M will be assumed. This figure is used whether the redesign takes place in 2016 or in 2022. It could be argued that the figure in 2022 should be lower, as doing the minor project should, if it is well-conceived, reduce the scope of the major redesign. As against this, the scope may need to increase if it is delayed 6 years (for example, as a result of new regulatory requirements). The best assumption is probably to use the same figure (in real terms) in both 2016 and 2022, and this is assumed.

Besides the capital costs involved, increased or decreased levels of network risk also have to be taken into account. This was evaluated in Section 8.4, including an allowance for utilisation, and a figure of £171.1k was calculated for the year 2010, rising to £227.8k by 2022. For the purposes of this study, those figures will be rounded to £170k in 2010, increasing by £5k per year thereafter if the network remains unchanged.

If a major network redesign is carried out, it is assumed that the high utilisation component of network risk is removed, and that the network risk reduces to £140k per year. This reduction does not apply following the lesser capital project, which is essentially a stop-gap.

However, during the construction period for the lesser project, network risk would be significantly increased. The extent and duration of that increased risk would depend on the implementation details of the construction

project. Detailed analyses of this kind have been carried out, with reference to planned projects on the actual CE Electric UK network, one of which was described in Chapter 3. In the present calculation, it will be assumed that the level of risk during the 6 month construction period increases by a factor of 3, meaning that the annual construction risk is doubled during the year of construction (assumed to be 2016).

The major network redesign, whether it is carried out in 2016 or in 2022, would also incur increased construction risk during its construction period. As this project affects a greater extent of network, and for a longer time, the impact on risk would be likely to be greater than for the lesser capital project. As against that, it is likely that most of this kind of redesign project could be carried out on a green-field site, with network disruption only at times of disconnection, connection, and specific construction tasks. It seems reasonable to assume that these two effects would balance out, and that a doubling of risk in the construction year would again be appropriate.

Tables 8.5 and 8.6 show these costs for the two options, namely

1. Minor project at 1118 in 2016, followed by redesign in 2022.
2. Network redesign in 2016.

	<i>Network Risk (£k)</i>	<i>Construction Risk (£k)</i>	<i>Capital Cost (£k)</i>	<i>Total Cost (£k)</i>	<i>Discounted at 7%</i>
2015	195			195	195
2016	200	200	1100	1500	1395
2017	205			205	177
2018	210			210	169
2019	215			215	161
2020	220			220	153
2021	225			225	146
2022	230	230	10000	10460	6294
2023	140			140	78
<i>TOTAL</i>	1840	430	11100	13370	8768

Table 8.5 – Costs of minor project in 2016, redesign in 2022

Each option is costed both in undiscounted cash terms, and with a discount rate of 7%, the value presently used by CE Electric UK to assess capital expenditure. Discounting is from a base year of 2015.

<i>Year</i>	<i>Network Risk (£k)</i>	<i>Construction Risk (£k)</i>	<i>Capital Cost (£k)</i>	<i>Total Cost (£k)</i>	<i>Discounted at 7%</i>
2015	195			195	195
2016	200	200	10000	10400	9672
2017	140			140	121
2018	140			140	113
2019	140			140	105
2020	140			140	97
2021	140			140	91
2022	140			140	84
2023	140			140	78
<i>TOTAL</i>	1375	200	10000	11575	10556

Table 8.6 – Costs of redesign in 2016

To compare these two options, it is useful to take the difference between them. This has been done by subtracting the numbers in option 2 from those in option 1. The results are shown in Table 8.7. The reason for subtracting this way round is to give a more conventional project cash flow, with net costs or expenditures (in brackets) early in the project, and net revenue, or cost reduction in this case, coming later on. What this means is that the 'project' being appraised is that of **not** doing the minor construction work, but rather of doing the major redesign 6 years earlier.

This involves an initial outlay (in 2016) of the cost difference between the major project and its minor alternative. The return comes in terms of lower network risk in 2018 to 2022, avoiding extra construction risk in 2022, and most of all avoiding a second construction project cost in 2022. In raw cash terms, this option produces a saving of £1.565M. However, if these figures are

discounted at 7%, the situation is reversed. The net present value (NPV) of pressing on with the major redesign goes negative, to a net cost of £1.788M, implying that, at this discount rate, the 'project' is not worth doing, and the alternative, i.e. the minor construction at 1118, is better value.

<i>Year</i>	<i>Network Risk (£k)</i>	<i>Construction Risk (£k)</i>	<i>Capital Cost (£k)</i>	<i>Total Cost (£k)</i>	<i>Discounted at 7%</i>
2015	0			0	0
2016	0	0	(8900)	(8900)	(8277)
2017	65			65	56
2018	70			70	56
2019	75			75	56
2020	80			80	56
2021	85			85	55
2022	90	230	10000	10320	6210
2023	0				0
<i>TOTAL</i>	465		1100	1565	(1788)

*Table 8.7 – Option 2 minus Option 1 (benefit of **not** deferring)*

All these figures are sensitive to changes in input values, and the effect of such changes will be explored in the sensitivity analysis following.

In addition, there are factors which have not been directly costed, but which would need to be taken into account in comparing the two options. One of these is that, in a time of load expansion and a changing network, the best solution for the following 40 years (the anticipated lifetime of a capital project) can be hard to predict with accuracy. At such times, waiting for an additional 6 years can bring greater clarity in discerning how the network should be developed, reducing the impact of '40 year lock-in'.

Another factor is the availability of engineering skills, both within and outside the DNO. It might be that these are expected to be more readily

available in 2016 than in 2022, and therefore perhaps the major work should be done in the earlier year, using that window of opportunity.

Again, the availability of capital depends on shareholders and on the regulator. Capital might be more readily available in 2022 than in 2016, or it might be less readily available. Financial forecasts for the DNO itself, for the industry, and for the wider economic climate, could therefore impact on this timing decision.

8.5.2 Sensitivity Analysis

The results shown in Tables 8.5, 8.6 and 8.7 have been subjected to sensitivity analysis on a range of variables. The results of this are as follows:

- *The discount rate chosen.* At zero, the second option gives a better NPV (lower cost), while at 7% the first option is better. The two are equal at a discount rate of 3.3%. This figure can therefore be considered to be the rate of return for the project of **not** deferring the major redesign, but rather doing it in 2016. If a higher 'return' is required, then the minor construction project becomes preferable.
- *The rate of load growth in the network.* In this study, an annual growth rate averaging 2.5% has been assumed, rather greater than the OFGEM predictions [2, 20], but conservative when compared with growth rates before 1970. If this rate were doubled, to 5.0%, then the effect of the minor project would be to defer major network redesign for only 3 years instead of 6. The redrawn versions of Tables 8.5 and 8.6 (now finishing in the year 2017) show that Option 1 costs £1.570M more in raw cash terms, but £0.432M less when discounted at 7%. This gives a rate of return for the earlier major redesign (in 2013 instead of 2016) of 5.5%, which is more attractive than the 3.3% at the lower load growth rate. This suggests that stop-gap projects such as the minor reconstruction become less attractive at higher load growths, as might be expected.

- Cost escalation of the major redesign.* If the capital cost of the major project were to escalate at 5% per year in real terms, which is a pattern that has been observed and exceeded in other parts of the electricity supply industry, particularly where there are construction constraints such as wind turbines [101], then it would be costed at £13.41 M instead of £10.0M in 2022. This would have the effect of trebling the gap between the two options in raw cost terms to £4.975M, and reversing the gap at a 7% discount rate to give Option 2 an advantage of £0.263M. This increases the rate of return to 7.4%, so that pressing on with the major project before real costs escalate becomes a more attractive option, provided that capital and manpower resources are available to do so.
- Level of network risk during construction.* It has been assumed that the extra risk incurred by either major or minor construction has the effect of doubling the overall risk during the construction year. However, there is a possibility that, particularly as loads increase, the extra risk could be substantially higher. Supposing that the risk were to be, not double, but four times the normal level in 2016, and six times the normal level in 2022. This would increase the raw difference to £2.485M, and would make the 7% discounted difference less negative, at -£1.234M, equating to a rate of return of 4.7%. Such increased, and increasing, levels of construction risk make it more desirable to do one construction project in place of two, and to do it earlier if possible, before the loads increase, and with them the level of risk.

8.5.3 Active Network Management only

As an alternative to capital investment, Section 8.3 considered the impact of active network management (ANM) on the case study network. It was shown that ANM, on its own, also had the potential to defer major network redesign for 6 years, at an average annual load growth of 2.5%.

The cost of implementing ANM on a small section of network comes in two forms. First, there is the cost of any incidental engineering works, such as

enabling a manual switch in a key location to be radio controlled, with associated protection. The cost of these works is likely to be an order of magnitude smaller than upgrading two transformers, and is estimated at £0.10M. Second, there is the extra work needed by control engineers. While this would be hard to measure for a single section of network, it could be substantial if sophisticated ANM were to be implemented across the whole network.

The cost assumption here is that, to implement sophisticated ANM across the whole network, and to do so effectively, would require an extra control engineer on shift at all times. 5 control engineers, with total employment costs of £1000k each per year, comes to £500k per year. Discounting this at 7% in perpetuity gives a one-off up-front capital cost of 15 years employment, or £7.5M. This is of the same order of magnitude as the capital costs that have been considered in this chapter (less than a major redesign, but more than a minor project). But it would benefit the whole network of a DNO, containing perhaps 600 primary substations, or 100 times as many as the case study network.

Apportioning this cost evenly across the whole network would give a one-off cost of £0.075M to be attributed to the case study network, in addition to the £0.10M on engineering works. This is shown in Table 8.8. As compared with the alternative Option 2, shown in Table 8.7, it costs £0.670M more in raw costs, and £2.828M less in discounted costs. This equates to a rate of return of only 1.3% for the earlier network redesign, in 2016, as opposed to the option of implementing ANM as described. It makes ANM seem an attractive and economical option.

As with capital investment, there are also a number of less tangible aspects of ANM which need to be acknowledged. The issues of 40 year lock-in, availability of engineering skills, and availability of capital apply to ANM-based deferment of major network redesign just as they do to minor capital project based deferment. In addition, there are three further factors.

Favouring ANM is its possible effect on the skills of the control engineers. Having to think about the network in more creative ways, and to make more complex decisions, could improve their understanding of the network and of how it responds. This would make them better able to make

informed and effective decisions, particularly in unplanned and extensive emergency situations where a fast and non-standard response is required.

<i>Year</i>	<i>Network Risk (£k)</i>	<i>Construction Risk (£k)</i>	<i>Capital Cost (£k)</i>	<i>Total Cost (£k)</i>	<i>Discounted at 7%</i>
2015	195			195	195
2016	200		175	375	349
2017	205			205	177
2018	210			210	169
2019	215			215	161
2020	220			220	153
2021	225			225	146
2022	230	230	10000	10460	6294
2023	140			140	84
<i>TOTAL</i>	1840	230	10175	12245	7728

Table 8.8 – Costs of implementing ANM in 2013, redesign in 2016

Conversely, the response of switches to signals is not 100% reliable. Studies have been carried out to determine the probability that a signal will not be received, or for various reasons will not be acted on [9]. There is also the possibility of false signals being returned to the control room and being acted upon, and also of spontaneous deployment of a switch when no signal has been received. Any increase to the complexity of the communications side of the network, as required by ANM, increases the likelihood of such events, which are potentially extremely disruptive.

A further issue is that the lifetime of components can be measured not in years but in the number of operations (e.g. for a switch), or the number of step-changes in load (e.g. for a cable) [102]. Increased use of ANM could substantially increase the frequency of such events, and therefore shorten the expected lifetime of these assets, perhaps by several years. While it is

beyond the scope of this research to estimate that effect quantitatively, it could significantly reduce the advantages of ANM.

8.5.4 Capital projects with ANM

The final economic evaluation in this chapter is for a combination of capital projects with ANM. Section 8.3 showed that this combination can defer the need for major network redesign by 12 years, from 2016 until 2028 in the case study. The capital investment required to do this was:

- Doubling the capacity of the 3.4 km section of overhead line between nodes 302 and 312, and
- Upgrading transformer T1 only at primary substation 1118.

<i>Year</i>	<i>Network Risk (£k)</i>	<i>Construction Risk (£k)</i>	<i>Capital Cost (£k)</i>	<i>Total Cost (£k)</i>	<i>Discounted at 7%</i>
2015	195			195	195
2016	200	200	975	1375	1279
2017	205			205	177
2018	210			210	169
2019	215			215	160
2020	220			220	153
2021	225			225	146
2022	230			230	138
2023	235			235	132
2024	240			240	125
2025	245			245	119
2026	250			250	113
2027	255			255	107
2028	260	260	10000	10520	4095
2029	140			140	51
TOTAL	3325	460	10975	14760	7159

Table 8.9 – Costs of minor project and ANM in 2013, redesign in 2019

The cost of replacing a single transformer is estimated at £0.5M, and of reconductoring 3.4 km of overhead line at £0.3 M, giving a total capital cost of £0.8 M, based on actual CE Electric UK estimates [80]. Adding to this the ANM capital of £0.175M gives a total requirement in the year 2016 of £0.975M. The costing of this project is shown in Table 8.9. In comparison, the total cost of network redesign in 2016 is as shown in Table 8.7, but extended by 6 years to give a total cost of £12.415M (£2.345M lower), and a discounted total of £10.925M (£3.766M higher). The rate of return for redesign in 2016, as compared with this ANM plus minor capital option, is 2.7%, making this option more attractive than minor capital projects alone, but less attractive than ANM alone.

8.5.5 Summary

Table 8.10 summarises the results found in this section. The lower the rate of return calculated for option 2 (redesign in 2016), the more attractive is the alternative being considered.

<i>Option</i>	<i>Rate of Return</i>
Costs of construction escalate at 5% per year	7.4 %
Load growth twice as great as in other runs	5.5 %
Construction network risk significantly higher	4.7 %
Minor capital investment only (base run)	3.3 %
Minor capital investment and ANM	2.7 %
ANM alone	1.3 %

Table 8.10 – RoRs for 2016 redesign, compared with different options

8.6 Increasing Utilisation: Discussion

In this chapter, the problems posed by increasing network utilisation as a result of increasing penetration of electric vehicles and/or heat pumps have been investigated. Mitigation strategies can be adopted before major network redesign becomes necessary, with the potential to defer the date of such

major redesign. These strategies include minor capital expenditure, more extensive active network management (ANM), or a combination of both.

An extensive methodology has been developed in the present chapter to evaluate these strategies. Features of this methodology include:

- Using the regulatory design standard P2/6, interpreted quite strictly and literally, to determine whether or not a network is compliant.
- Determining, for any given growth pattern for peak demand, when a network first breaches the strict requirements of P2/6, and therefore the last firm year (LFY) before this occurs.
- Using digitised load profiles (either generic, as illustrated in this chapter, or actual historic), with annual and daily patterns decoupled, and with shape unchanged by annual peak load growth, to predict future load patterns.
- The possibility of extending the LFY by 'tunnelling through' load peaks, where this can be done in compliance with P2/6.
- Allowing for seasonal asset ratings to be used in conjunction with seasonally varying loads.
- Applied to a generic case study, assumptions can be made as regards those parameters not specified in the generic network, including geography, customer numbers, protection zones, lower voltage interconnection, and whether circuits are overhead line or underground cable.
- The methodology has also been applied to actual networks. One example of this will be illustrated as part of Chapter 9.
- Standard load flow software is used to determine at what load levels the network first exceeds asset ratings at any point on the network. This is done both for the network intact, and also under all relevant n-1 and n-2 conditions.
- The network risk is not just calculated on the basis of connectivity alone as in the core and generalised methodologies. An incremental level of risk, based of load flows exceeding ratings for a proportion of each day, under each possible n-1 and n-2 condition, is included.

- For each possible n-1 condition, the ANM required to extend LFY for as long as possible is identified and specified.
- For each possible n-1 condition, the minor capital expenditure that would extend LFY for as long as possible is identified and specified. Combinations of ANM and minor capital expenditure are also identified and specified.
- Economic analysis of each possible project (ANM, capital expenditure, or both) is carried out, including discounting. Because of the unusual nature of DNO financing, this has to be carried out in a non-standard manner, effectively evaluating the benefit of *not* doing each project.
- Sensitivity analysis can be carried out on critical parameters, such as load growth rate, discount rate, construction cost escalation and level of increased network risk during construction periods.
- Although the methodology has been demonstrated in this chapter based on average values, it could also be extended by the use of Monte Carlo Simulation to incorporate probability distributions as both input and output.

The implications of the findings of the research described in this chapter for UK networks in general are significant and far-reaching. Accelerated load growth will require substantial capital investment in distribution network infrastructure during the period 2010-2030, and this investment must meet the anticipated needs of the next 40 years. The impact of load growth, and the consequent need for investment, is likely to be particularly acute in the more remote rural areas, which face issues including weak networks, voltage drops, high failure rates, long repair times, environmental constraints, and political sensitivity.

Active Network Management (ANM) is one way of making the network more robust, and thereby deferring the LFY. However, the concept of ANM is not as easy to define for a network with outages as it is for an intact network. In particular, control engineers operating in emergency mode, to preserve or restore power supply, will often adopt ANM strategies that might not be considered acceptable under normal operation. Alternatively, capital

expenditure on small projects can also be used to postpone the LFY, and therefore the need to undertake a larger project such as network redesign. The extra expense and disruption involved may on occasion be justified by being able to defer for several years a much larger capital expenditure.

In the case study considered, ANM alone extended the LFY by 6 years at a 2.5% load growth rate. Minor capital expenditure alone also extended it by 6 years, and ANM in conjunction with minor capital expenditure extended LFY by 12 years at a 2.5% growth rate. Economic analysis showed that all three of these options were attractive at discount rates of 4% and above.

A number of issues which could lead to further research were highlighted by the research described in this chapter. One of them concerns the use made by DNOs of asset ratings. Although design standards often specify seasonal ratings, the DNOs do not tend to use these operationally. In theory this could have the effect of increasing network risk, by disconnecting customers when it was not actually necessary to do so. Experimental and/or real-time measurement of transformer core temperatures might also give network operators the confidence to run transformers in excess of nameplate ratings, at higher load levels and for longer periods, under n-1 and n-2 conditions when circumstances required it.

The concept of load-related risk is a useful one, particularly at times and in locations where high levels of load growth are experienced or expected. Although more complicated to calculate than the connectivity-only network risk evaluated by the core methodology, it gives a more accurate measure of the actual network risk. If any of the methodologies developed and described in this research is to be used within the industry, it is debatable whether it should be the simpler core methodology, or the arguably more accurate load-related methodology described in this chapter.

The ANM described in this chapter relies substantially on network reconfiguration at lower voltages (11 kV). This requires the availability of certain 11 kV feeders following a 33 kV event. It might be desirable to define these specific feeders (one DNO delineates them as 'red routes' [91]), and thereby give them maintenance priority, to ensure that they would be available if required. The value of this exercise should be investigated further.

Finally, this chapter has considered in detail the issue of minor capital expenditure, as a means of deferring the major capital expenditure that will eventually be required if load growth continues. The economic analysis carried out could usefully be tightened up, in particular as regards input parameters such as the relative costs of major and minor projects, the true discount rate to use, and the likely increases in network risk during construction periods. It might also be advantageous to find ways of costing the less tangible aspects of minor projects, such as whether the delay in the major project might enable it to meet future needs more effectively, or whether uncertainty as to future growth rates might mean it could be dispensed with altogether.

This chapter has considered the problem of increasing utilisation in isolation, as the two previous chapters considered the problems of replacing ageing assets, and installing automation at critical locations, in isolation. However, in practice the long-term outlook for a section of network could involve any two of these problems simultaneously, or even all three. This will be the subject of Chapter 9.

9. DEVELOPING A COMPOSITE APPROACH

In chapters 5, 6 and 7, methodologies have been developed and described to measure and to find ways of mitigating network risk with respect to three areas of future concern for DNOs. These three areas are Asset Replacement, Remote Reconfiguration and Increasing Utilisation.

The regulator OFGEM tends to treat these areas as distinct, and this is reflected in the most recent Distribution Price Control Review (DPCR), implemented in April 2010 [103]. This DPCR requires the condition and health of each asset to be reported on a scale of 1 to 5, in order to assess the case for asset replacement. The DPCR separately requires the utilisation of each load point to be reported on a separate scale of 1 to 5, in order to assess the case for network reinforcement. Such separation of replacement and reinforcement is reflected in the way that DNOs such as CE Electric UK or Central Networks manage their capital expenditure plans and budgets [80]. Potential projects are each assigned a principal driver, which may be replacement, or reinforcement, or something else (for example, safety, or environmental concern).

In practice, however, the most cost-effective project may combine two or more drivers. If a transformer needs replacement on health grounds, it may be worth replacing it with a higher rated transformer, anticipating future load growth over the new transformer lifetime of at least 40 years. Conversely, if extra capacity is required on the network as a result of expected load growth, then this should be done if possible in a way which also retires aged assets, rather than new ones. Furthermore, the benefit of the new assets could be enhanced by the addition of automation, such as the potential for remote reconfiguration of the network either at the location of the new assets or elsewhere on the network.

These composite problems on the network require composite solutions, generally involving two or more of the methodologies previously developed. Therefore a composite approach is needed, selecting and applying appropriate methodologies in a systematic way, as will be described in the present chapter.

9.1 Composite Approach Philosophy

In this chapter, a composite approach is developed and described, suitable for applying to situations in which two or three areas of future concern are combined, and their interaction leads to an optimal solution that could not be reached by considering each area separately. However, the selection of appropriate methodologies, and deciding how and in what order to apply each of them, and then how to interpret the results, is not usually straightforward. It requires expert engineering input, and a detailed understanding of the network problem being addressed, as well as an understanding of the different methodologies that can be used. This requires a more heuristic approach than those described in Chapters 3 to 8. It has therefore been developed not theoretically but rather heuristically, with reference to a number of individual case studies.

Two of these case studies are described in the present chapter, both based on actual networks. The first, which is described in detail, is based on load growth, network reinforcement and transformer replacement in the Hartlepool area of the NEDL network. The second, which is described more briefly, involves distributed generation and the sub-transmission network, and is based in the Kirklees area of the YEDL network.

9.2 Hartlepool Case Study

The composite case study described in the following sections includes a number of interacting elements, in particular:

- Ageing transformers which will reach a 50 year nominal lifetime in 2018
- Possible annual load growth of 2.5% due to take up of electric vehicles and/or heat pumps
- Possible 11 kV load transfer between substations within the town, including network rationalisation by removal of one old substation
- Possible automation of 11 kV switchgear at critical locations
- Possible increased use of active network management.

The composite approach addresses all of these issues, both singly and together. First, however, the relevant network will be described in detail.

Figure 9.1 shows geographically the 66 kV network in and around the town of Hartlepool. It is in fact the same as Figure 5.2, as this case study is in the same area as the one used to illustrate the asset replacement methodology in Chapter 5. The Grid Supply Point at Hartmoor supplies Primary Substations at Amberton Road and at Brenda Trading, both of which have two 66/11 kV transformers. An additional industrial customer, Hartlepool Steel, is also supplied at 66 kV. There is also a 20 kV network (not shown in Figure 10.1) supplied by 66/20 kV transformers at Hartmoor, which includes two small 20/11 kV substations at Mulgrave Road and at Rift House. There is an intricate, highly interconnected 11 kV network throughout the town, shown in Figure 9.6, supplied by these two 66/11 kV and two 20/11 kV substations.

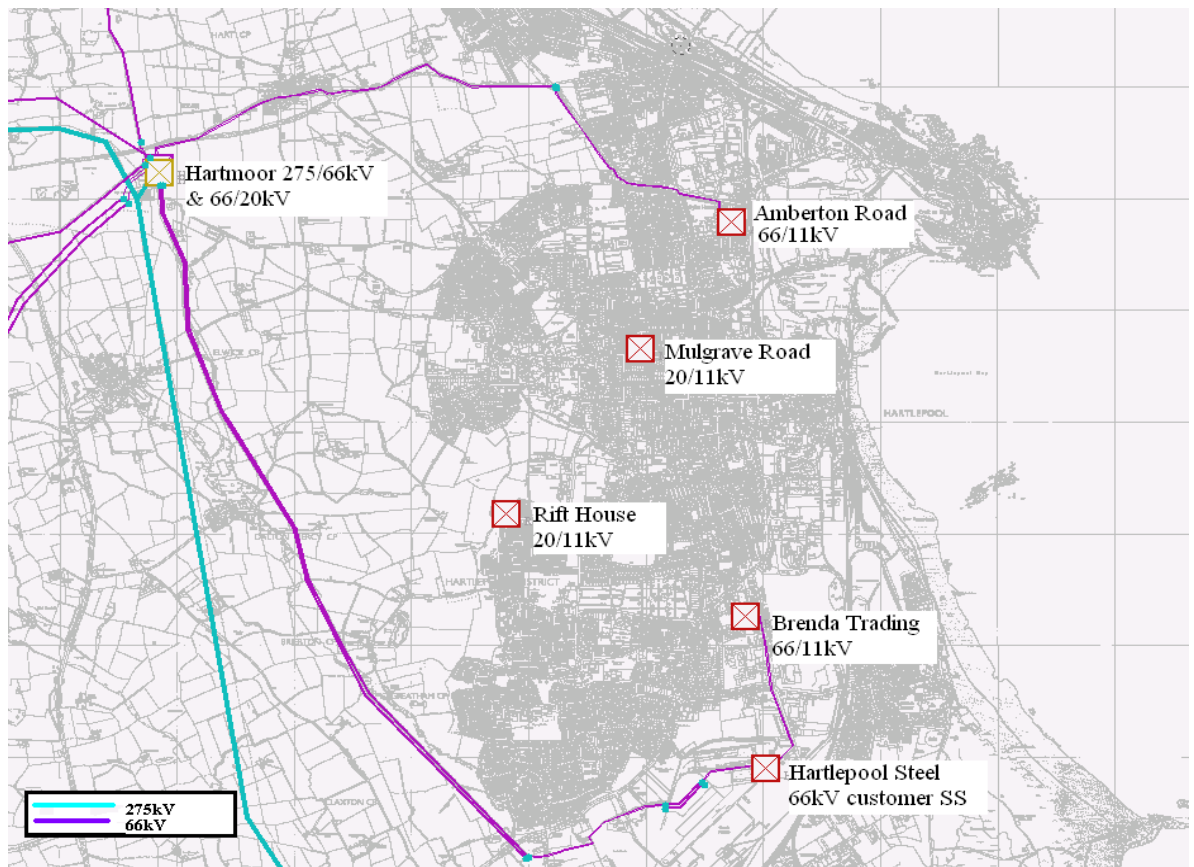

Figure 9.1 – Geographical arrangement of 66 kV network

Figure 9.2 shows a schematic of the 66 kV network supplying Hartlepool Points to note include:

- The three 66/11 kV transformers at Hartlepool Steel are not shown, as they are shielded from Brenda Trading by 66 kV circuit breakers.
- The 20 kV network supplying Mulgrave Road and Rift House (as well as many other customers) is shown as a dotted line, and not in detail.
- The Amberton Road substation had its ageing 12/24 MVA transformers replaced by larger 20/40 MVA transformers in 2009, as described in Chapter 6. Following this reinforcement and replacement capital project, it is intended to transfer some 11 kV feeders from Brenda Trading to Amberton Road, thereby decreasing peak loads at Brenda Trading. This has not yet been done, however.

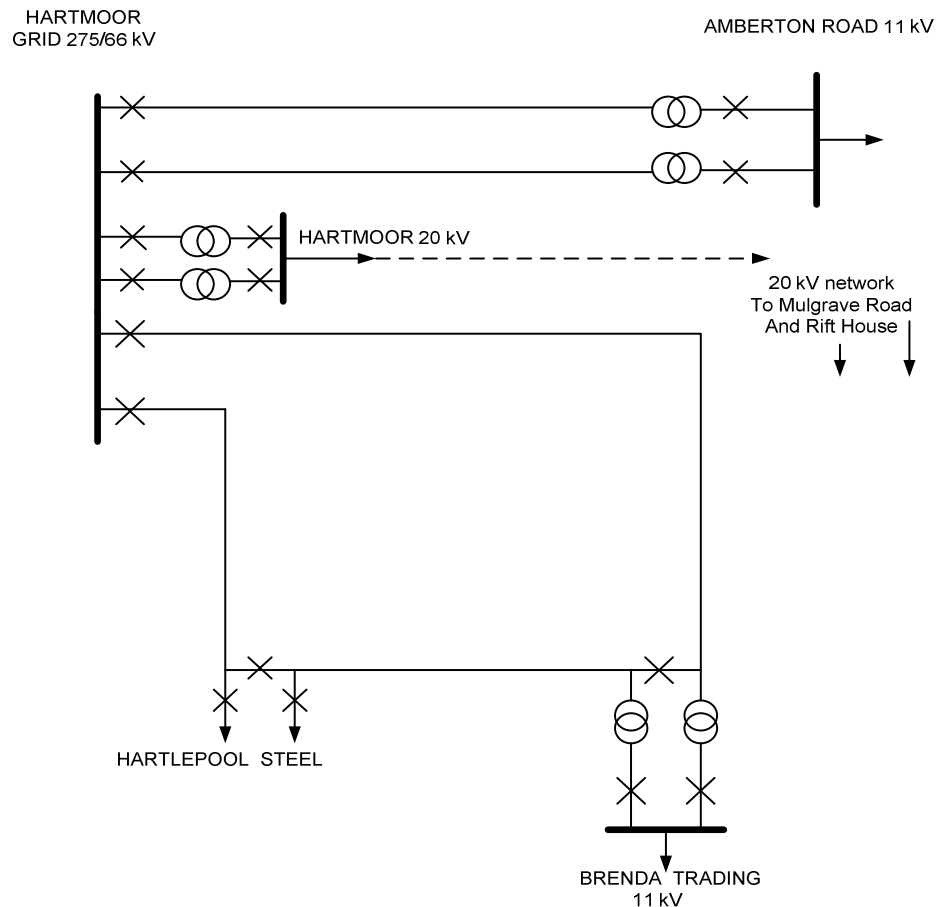

Figure 9.2 – 66 kV circuits supplying Hartlepool

Figure 9.3 shows one of the two 66/11 kV transformers in the Brenda Trading primary substation. These transformers were installed in 1968, and will therefore reach a 50 year nominal lifetime in 2018. The picture also shows 3-phase 66 kV busbar. This is because the circuits supplying Brenda Trading at 66 kV from the Grid Supply Point at Hartmoor are part of a ring which includes a 66 kV industrial customer, Hartlepool Steel.



Figure 9.3 – Transformer and 66 kV busbar at Brenda Trading

Figures 9.4 and 9.5 show the 20/11 kV substations at Mulgrave Road with two separately fed 20/11 kV transformers (nominally 10 MVA each, peak load 13 MVA each), and at Rift House, also with two 20/11 kV transformers (3 MVA each), singly fed. Mulgrave Road (Figure 9.4) looks old from the outside, but its transformers and switchgear are only 12 years old and are reported to be in good condition [104]. Rift House (Figure 9.5) however is reported to be in poor condition, and at the time of the Amberton Road appraisal it was stated that 'consideration should be given to its future use and possible removal from the network' [104]. Meanwhile, both these substations are also expected to have load transferred to Amberton Road.



Figure 9.4 – Mulgrave Road, above

Figure 9.5 – Rift House, below



Loads at all these substations were near or above firm capacities at the time of the Amberton Road project appraisal, as shown in Table 9.1. Load growth was expected to be at 1.0% per year, excluding possible commercial developments which could increase this substantially (although the customer requests for up to 30 MVA were considered to be optimistic). However, actual peak loads two years later (also shown in Table 9.1) were less than they had been in 2004/5 [17]. Table 9.1 also shows the proposed load transfers to Amberton Road following the commissioning of the new transformers there. It is against this background that the possibilities of replacement and of upsizing the Brenda Trading transformers is considered in this chapter. Figure 9.6 maps the 11 kV network in Hartlepool, which can be seen to be dense and comprehensive. This also affects the possible options for future network reinforcement in Hartlepool, as will be discussed in detail in Section 9.5.

Location	Firm Capacity (MVA)	2004/5 peak load (MVA)	2006/7 peak load (MVA)	proposed load transfer (MVA)
Amberton Road	24 (40)	26.60	23.95	+ 8.0
Brenda Trading	32	31.23	29.56	- 5.0
Mulgrave Road	13	13.40	13.1 approx	- 2.5
Rift House	3	2.91	2.8 approx	- 0.5
TOTAL	72 (88)	74.14		0

Table 9.1 – Peak loads at Hartlepool substations

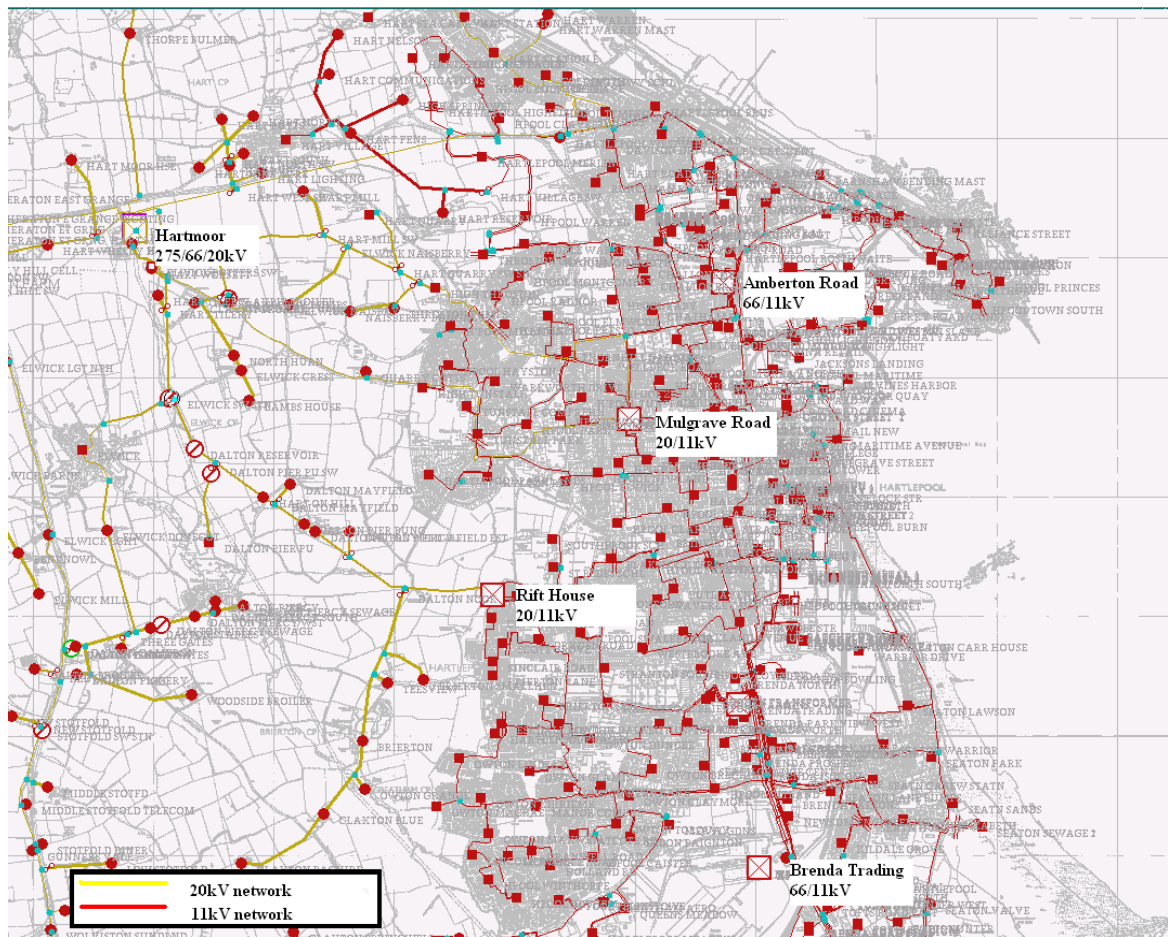

Figure 9.6 – 11 kV network in Hartlepool. Barred circles are 20 kV NOPs, red squares are 11 / 0.4 kV distribution substations

9.3 Stage One: Network Risk and Transformer Replacement.

The engineer addressing a composite case study such as this one in Hartlepool, including the five interacting elements listed at the start of Section 9.2, has to decide where to start. In this instance, it was decided to start with the ageing transformers themselves. The level of network risk at Brenda Trading is first calculated using the core methodology developed in Chapter 3, based on connectivity only, and making no allowance for transformer age or wear. The calculation is then repeated in Section 9.3.2, factoring in the age and wear of these two transformers, using the methodology of Chapter 5.

9.3.1 Basic Network Risk at Brenda Trading

Table 9.2 details the parameters used for the basic network risk calculation. It is also assumed that Brenda Trading and its customers are considered in isolation, and that average component failure rates as produced by NAFIRS apply to this location [8]. This is probably optimistic, considering nearness to coast and to industrial pollution.

Failure rates for 66 kV components: per km line	0.015
Per km cable	0.011
Per CB (also 11 kV)	0.006
Per transformer (inc. protection 0.01)	0.022
T1 / T2 circuits: Length of overhead line (km)	7.1 / 7.7
Length of underground cable (km)	3.8 / 3.8
Number of Transformers	1 / 1
Number of circuit breakers	6 / 3
Customers at Brenda Trading	19 098
Proportion reconfigurable quickly at 11 kV (risk category 2)	80%
Average disconnection time for reconfigurable customers	15 minutes
Average disconnection time for other customers	150 minutes
Proportion of faults which affect both circuits	20%
Cost per CI / per CML	£6 / £0.10
Average unplanned repair cost (including asset deterioration)	£20000

Table 9.2 – Network risk data at Brenda Trading

Using the core methodology equations from Chapter 3, failure rate for the T1 circuit is equal to 0.2063, and for the T2 circuit is equal to 0.1973. The double failure rate is then 0.0807. These rates give values of 8072, 9247 and 6473 for *CR*, *CI* and *CML* respectively. Total network risk is then an expected £23.8k per year, to the nearest £100. This is a lower figure than in other case studies (Chapters 3, 6 and 7), reflecting the robustness of 66 kV networks, the simple circuit topography, and the relatively short distances typical of urban networks. At the same time, it is more than double the level at Amberton Road of £10.7k (Chapter 5) This is due to the longer circuits, the presence of overhead line as well as cable, the extra switchgear introduced by the ring circuit, and the 50% higher customer numbers. It is mitigated in part by the greater reconfigurability (80% as opposed to 50%) at Brenda Trading.

One input parameter which could be underestimated, both here and in Chapter 5, is the average disconnection time for reconfigurable customers. The value of 15 minutes assumes that the relevant 11 kV normally open points are remotely controlled. In fact, more detailed investigation of the Hartlepool 11 kV network indicates that around 90% of them are not remotely controlled. The implications of this finding will be considered in more detail in Section 9.5, using the methodology developed in Chapter 6. Meanwhile, the input value of 15 minutes will be allowed to stand.

9.3.2 Increasing Risk with Transformer Deterioration

For this calculation, the Health Index methodology developed by EA Technology for CE Electric UK will be used, as detailed in [84] and [86], and as partially modified in [89]. One effect of this modification, as compared with the Amberton Road calculations in Chapter 5, is that all assets start with a Health Index (HI) equal to 0.5, even if they are in an exposed and/or polluted location. The effect of location is to increase the growth rate of the HI, according to (1):

$$H(t_1) = H(t_0)e^{B(t_1-t_0)} \quad (1)$$

where the growth rate parameter B can be estimated from factors including location, loading and transformer type (including manufacturer) for a new transformer. The parameter B can also be modified by subsequent HI estimations, based on inspection and analysis data. In the case of the two Brenda Trading transformers, HI calculations carried out in 2008 (when they were aged 40 years) gave a value of 4.43. Then B is calculated, using (2):

$$B = \frac{\log_e H(t) - \log_e H(0)}{t} \quad (2)$$

where t is the transformer age, 40 years in this example, $H(t)$ is the value of the health index at time t , 4.43 in this example, and $H(0)$ is the initial health index value of 0.5. This gives a value of 0.05454 for the parameter B .

The failure probability at any time t for a transformer due to age or wear is then calculated as a function of $H(t)$, using (3), the exponential formula and parameters from Chapter 5:

$$P = Ke^{cH} \quad (3)$$

where $c = 0.6215$ and $K = 0.0011$ as in Chapter 5. The overall transformer failure probability is then calculated by adding a factor of 0.0066 for non-age-related failures. A further factor of 0.1998 must then be added for the overall circuit failure rate to account for cable, switch and protection failures.

Failure rates as a result of these calculations are shown in Table 9.3.

Year	1968	1998	2008	2010	2015	2020	2023
Health Index	0.50	2.56	4.43	4.94	6.49	8.52	10.00
λ (Tx, age rel)	.0015	.0054	.0173	.0237	.0621	.2193	.5502
λ (Tx, total)	.0081	.0120	.0239	.0303	.0687	.2259	.5568
λ (per circuit)	.1979	.2018	.2137	.2201	.2585	.4157	.7466
Risk (£k)	23.3	23.8	25.2	26.0	30.5	49.0	88.1

Table 9.3 – Transformer age-related network risk at Brenda Trading

Significant issues arising from the figures in Table 9.3 include the following:

- The time-dependent network risk when the transformers were new in 1968 was slightly below the calculated basic network risk (£23.8k). The two figures become equal in 1998, when the transformers have reached an 'average' age of 30 years, and an 'average' HI of 2.56.
- The values of λ per circuit are averages of the T1 and T2 circuit values. They can be seen to increase from a rate of roughly one failure per circuit every 5 years from 1968 to 2010, increasing to one per 4 years in 2015, per 2.5 years in 2020, and per 1.3 years in 2023, when the transformer HI reaches its maximum (capped) value of 10.0.
- As in Chapter 5, it is assumed that the failure rates of all other assets in the circuit do not increase with time. Although probably unrealistic, this assumption allows the effects of ageing transformers to be studied in isolation.
- Total network risk is proportional to total failure rate per circuit. It increases slightly up to 2015, including a present 2010 value slightly above the basic network risk calculation. It then increases rapidly up to an assumed maximum value (since HI is capped) of £88.1k by 2023.

It is instructive to compare this maximum network risk value of £88.1 k with the capital cost of replacing the two aged transformers (55 years old in 2023) with new ones, at a capital cost (estimated in Chapter 5) of around £1.3 million. The increased network risk during the construction period, equivalent to one year's risk, should be added to this capital cost to give a total of £1.388 M. The benefit of the project would be to reduce the annual expected network risk from £88.1k down to the new transformer (1968) value of £23.3k, an annual reduction of around £65k. This reduction is 4.7% of the capital cost, and can therefore be regarded as an indicative rate of return for the replacement project. This rate of return is low (below the 7% used as a benchmark by CE Electric UK and in the present research), suggesting that transformer replacement is not financially attractive on its own merits alone.

There are three possible ways to respond to this conclusion:

1. Accept it as valid, and recommend a policy of not replacing transformers, but running them and repairing them as necessary until they can no longer physically be repaired. It is significant that this is the policy already adopted by CE Electric UK for its far more numerous and smaller distribution transformers (mostly 11 / 0.4 kV). It is also significant that the range of possible repairs is increasing, for example, one manufacturer is about to open an insulation reconditioning facility. It might be that transformers could be repaired almost indefinitely, perhaps well beyond 100 years, albeit at some financial cost and with the acceptance of higher circuit failure rates than at present.
2. Perform sensitivity analysis on the consequences of transformer failure. In particular, transformer failures might be expected to involve higher repair costs, longer restoration times, and an increased chance of double failure, than the failure of other assets. This was carried out in detail in Chapter 5, and is therefore not repeated here. In that study, the consequent cost of network risk as a result of all three sensitivity tests increased by a factor of three. This would increase the indicative rate of return in the present case study to around 14%, which would make transformer replacement on the grounds of age and wear alone a more attractive investment. Further calculations could then determine the optimal year for replacement, which in this case would be around 2020, at a HI of around 9.0.
3. Expand the problem by combining the need to replace ageing transformers with the need to reinforce the network at that load point, possibly with consequent benefits elsewhere on the network. This is what was done in 2009 at Amberton Road, and could be repeated if necessary at some time before 2023 at Brenda Trading, particularly if peak load growth is at a high rate during that period, as assumed in the increasing utilisation methodology of Chapter 7. This is considered in detail in the following section, as the second stage of the composite approach.
- 4.

9.4 Stage Two: Effects of Increasing Utilisation

Table 9.1 showed that the peak loads in 2004/5 at the four Hartlepool load points (two 66 / 11 kV primary substations, plus two 20 / 11 kV intermediate substations) totalled 74.14 MVA, which was 3% above the total firm capacity at these four substations of 72 kV. In the light of this, together with expected annual load growth of 1.0% and possible new large customers, it was decided not only to replace but also to uprate the two transformers at Amberton Road, from the existing 12/24 MVA rating to a new 20/40 MVA rating. The total peak load was now only 84% of the new total firm capacity of 88 MVA. At 1% annual load growth from 2004, this new firm capacity would not be reached for 17 years, or by 2021. By this time, as has been shown, the transformers at Brenda Trading would have health index approaching 10.0, with correspondingly high failure rates. A case could then be made for replacing them with larger transformers, thereby reinforcing the network and replacing aged assets at the same time. This likelihood was anticipated at the time of the Amberton Road transformer replacement appraisal [104].

9.4.1 Feeder Reconfiguration

However, in order to last until 2021 at 1.0% growth rates and without major new customers, the Hartlepool circuits would need to be balanced evenly (relative to firm capacity) between the four substations. Table 9.1 shows the proposed transfers following the construction project which was actually carried out in 2009. Table 9.4 shows how the loads following such a transfer could be expected to increase from 2004 to 2021.

<i>MVA</i>	<i>2004</i>	<i>2010</i>	<i>Transfer</i>	<i>2010</i>	<i>% firm</i>	<i>2020</i>	<i>% firm</i>
Amb.Rd.	26.60	28.24	+ 8.0	36.24	91	40.03	100
Brenda	31.23	33.15	- 5.0	28.15	88	31.09	97
Mulg.Rd.	13.40	14.22	- 2.5	11.72	90	12.95	100
Rift Ho.	2.91	3.09	- 0.5	2.59	86	2.86	95
<i>TOTAL</i>	74.14	78.70	0	78.70	89	86.93	99

Table 9.4 – Load growth at constant 1.0% in Hartlepool

The following points emerge from consideration of Table 9.4:

- By 2010, without transfer, all the other Hartlepool substations (apart from Amberton Road) have become overfirm. With the transfer as planned, all become well within their firm capacity, allowing for a further 10 years of load growth at 1.0%
- By 2020, two of the four substations have reached 100% of firm capacity. Although the network as a whole could grow for another 1 year, the granularity of feeders would probably prevent this possibility.
- P2/6 specifies that, for demand above 12 MW, all customers should be restored following a first outage within 3 hours (and the excess over 12 MW within 15 minutes). On a strict interpretation, where faults can last for over 3 hours, ratings cannot be exceeded, there is no possibility of 'tunnelling through' load peaks, and there is no possibility of demand reduction or load transfer to other load points, both Amberton Road and Mulgrave Road reach their last firm year (LFY) in 2020, with the LFY for Brenda Trading itself reached in 2023.
- In the original proposal for the new Amberton Road transformers, it was stated that Rift House was in poor condition and that 'consideration should be given to its future use and possible removal from the network' [104]. If this were done, and the Rift House load were to be transferred to Brenda Trading, then the LFY for Brenda Trading is moved forward to 2014.
- Although 1.0% load growth was assumed from 2004, the peak loads in 2006 were 5% (at Brenda Trading) and 10% (at Amberton Road) lower than two years earlier. This could have been on account of a milder winter, although customer numbers had also reduced slightly. It seems that the projected 1.0% increase in load may have been optimistic.
- Conversely, it has been assumed in Chapters 2 and 7 that increasing take up of Electric Vehicles and Heat Pumps could lead to an annual 2.5% increase in peak loads, starting in 2010.

9.4.2 Last Firm Year with 2.5% Load Growth

In the following analysis, it will be assumed that feeder reconfiguration takes place as originally planned, that 2010 peak loads are equal to those recorded in 2004 (i.e. zero net load growth during the period 2004-2010), and that peak load growth averages 2.5% per year from 2010 onwards. Table 9.5 shows the results of these assumptions.

<i>MVA</i>	<i>2010</i>	<i>% firm</i>	<i>2015</i>	<i>% firm</i>	<i>2015 - RH</i>	<i>% firm</i>
Amb.Rd.	34.60	86	39.15	98	39.15	98
Brenda	26.23	82	29.68	93	31.86	100
Mulg.Rd.	10.90	84	12.33	95	12.88	99
Rift Ho.	2.41	80	2.73	91	0	0
<i>TOTAL</i>	<i>74.14</i>	<i>84</i>	<i>83.89</i>	<i>95</i>	<i>83.89</i>	<i>99</i>

Table 9.5 – Hartlepool with 2.5% load growth, from 2010

It can be seen from Table 9.5 that although the network, reinforced by transformer upsizing at Amberton Road in 2009, is only utilised at 84% of firm capacity overall in 2010, this increases rapidly so that by 2015 it is utilised at 95% overall, and Amberton Road is at 98% utilisation. This makes 2015 the LFY for Amberton Road, and therefore (without further feeder transfers) for the Hartlepool network as a whole.

One further possibility which can be included by 2015 is also shown in Table 9.5. The load at Rift House could be reallocated to Brenda Trading (80%) and to Mulgrave Road (20%), allowing this poor condition substation to be shut down and removed from the network. The resulting load increases at Brenda Trading and at Mulgrave Road by 2015 are still within the firm capacities at these locations, which means that the LFY for the network remains at 2015 even with the removal of Rift House.

In Chapter 8, load-dependent network risk was calculated for the LFY. Detailed consideration of each possible n-1 and n-2 scenario enabled the additional level of risk dependent on load to be evaluated. In this present case study, the network topology is much simpler, and the LFY has been assessed

at this stage for each load point in isolation. There is therefore no incremental network risk as a consequence of increased loads.

However, a more versatile approach to n-1 events could extend the LFY significantly beyond 2015, although with an accompanying increase in load-related network risk. This Active Network Management (ANM) constitutes the third stage of the composite approach, and would involve active reconfiguration of 11 kV feeders following a fault on the 66 kV network. This stage incorporates the methodology developed in Chapter 6, and is discussed in the following section.

9.5 Stage Three: ANM and Automated Reconfiguration

As shown in Figure 9.6, the 11 kV network in Hartlepool is dense and complex, containing a number of open points between feeders which link two different substations, in particular linking Amberton Road with Brenda Trading.

<i>From</i>	<i>To</i>	<i>Number of feeders</i>	<i>Number of customers</i>	<i>Proportion of load</i>
Amberton Rd.	Mulgrave Rd.	2	2400	19%
Amberton Rd.	Brenda Trad.	2	1000	14%
Amberton Rd.	Mulg. or Brenda	1	300	10%
Amberton Rd.	No transfer	7	9000	57%
Mulgrave Rd.	Amberton Rd.	3	4100	47%
Mulgrave Rd.	Brenda Trad.	2	1500	31%
Mulgrave Rd.	No transfer	2	2600	22%
Rift House	Brenda Trad.	1	900	74%
Rift House	No transfer	1	300	26%
Brenda Trad.	Amberton Rd.	2	2600	18%
Brenda Trad.	Mulgrave Rd.	1	3200	14%
Brenda Trad.	Amb. or Mulg.	2	3000	17%
Brenda Trad.	Greatham	6	2400	12%
Brenda Trad.	No transfer	6	4400	27%

Table 9.6 – Reconfigurability of 11 kV feeders in Hartlepool

Detailed investigation and analysis of this 11 kV network has been carried out, before any permanent feeder transfer following the 2009 reinforcement project, and the results are summarised in Table 9.6. Figure 9.7 shows this information diagrammatically, using MVA levels as at 2010. Figure 9.8 updates this information to take account of likely load transfer in 2010.

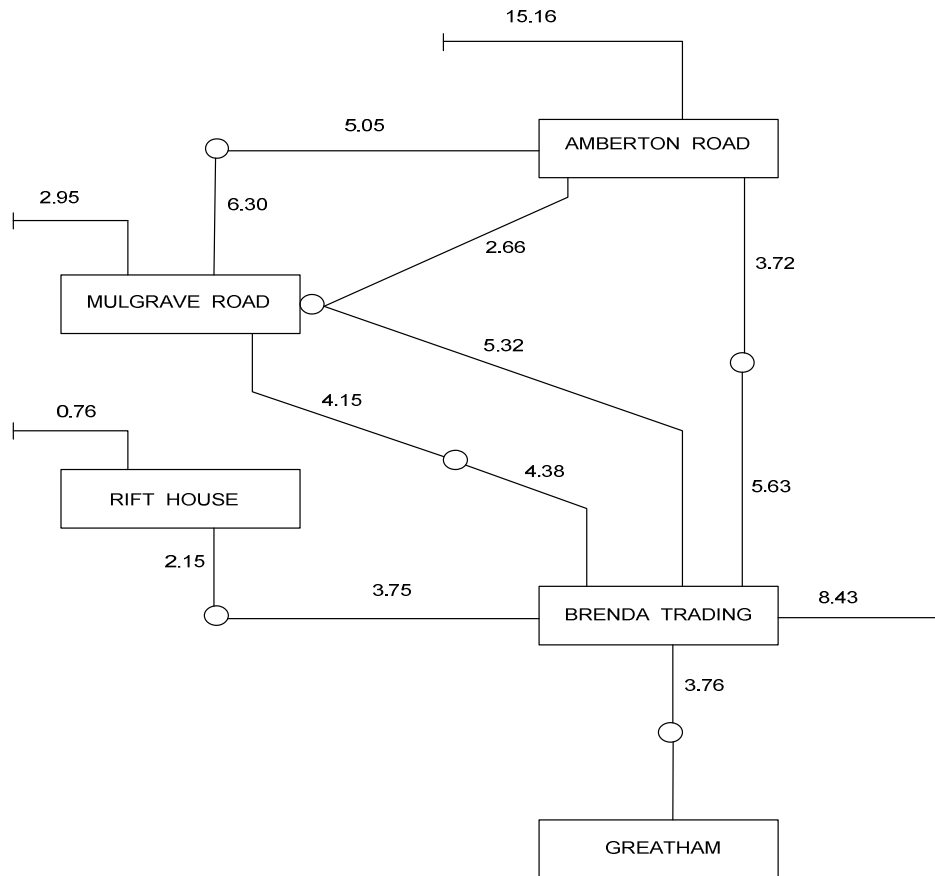

Figure 9.7 – 11 kV reconfigurability MVA (before permanent transfer)

Points to note in this analysis include:

- The System Risk Category 3 assigned to Amberton Road was assumed in Chapter 5 to imply that around 50% of customers could be transferred to other primary substations. The actual proportion is only 29% (or 43% of load), and none of it is outside Hartlepool

- Brenda Trading is assigned System Risk Category 2, and this was assumed to imply that around 80% of customers could be transferred. The actual proportion is 77% (or 73% of load), made up of 64% within the Hartlepool group, and 13% to the Greatham primary substation to the south of Hartlepool.
- 69% of customers at Mulgrave Road and 75% at Rift House are also transferrable.
- This 11 kV transfer takes place through 9 normally open points (NOP) within the group, plus another 5 between Brenda Trading and Greatham. Only 2 of these 14 NOPs are at present remotely controlled.

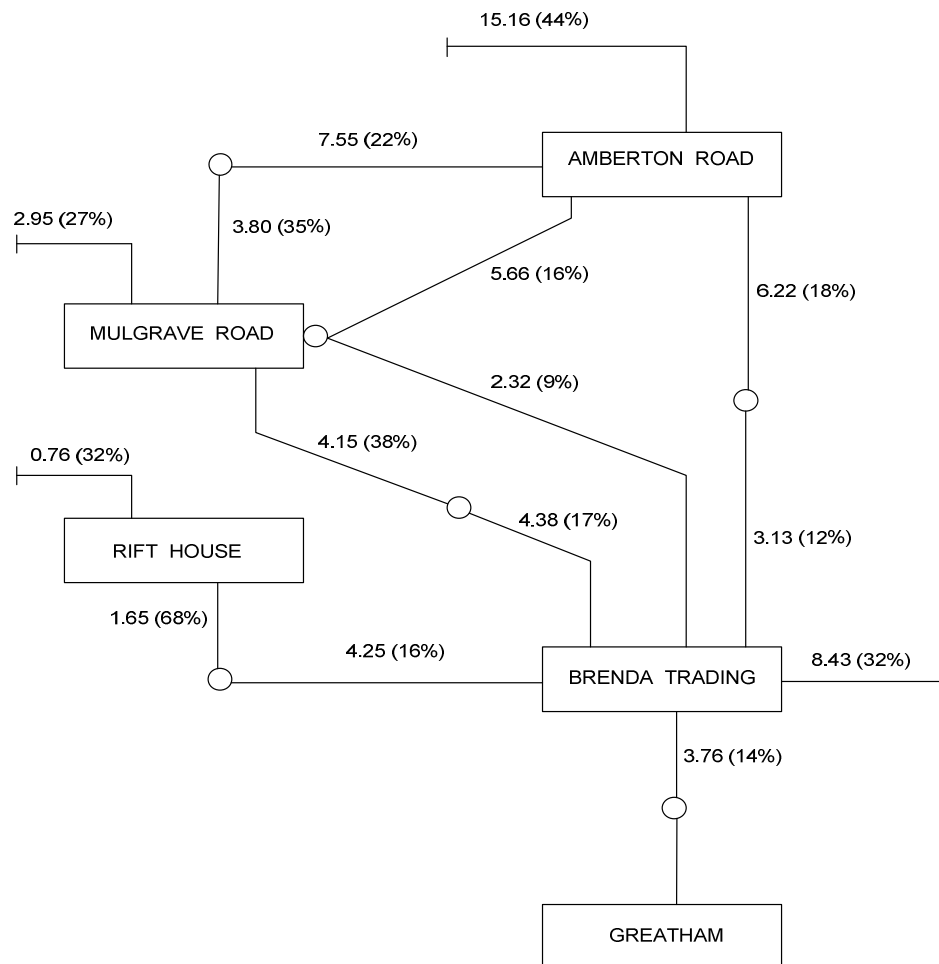

Figure 9.8 – 11 kV reconfigurability MVA (after permanent transfer)

A further complication arises from the low priority sometimes assigned to the repair of damaged 11 kV feeders when customers have not been disconnected as a result of the damage. The damage location simply becomes the new open point of that feeder, with all customers now supplied from the primary on their own side of the fault. This situation can continue for months, or in extreme cases for years. This means that individual 11 kV feeders cannot always be relied upon for mitigating faults at higher voltages. In rural locations, where particular feeders may have a unique connecting importance, this could cause a loss of versatility. In dense urban networks such as Hartlepool, it would be reasonable to allow for this by decreasing the percentage of customers or of load which can be reconfigured following a fault.

9.5.1 Reconfigurability in 2015

On the basis of the data presented in Table 9.5, the diagram in Figure 9.9 shows the same feeder allocation as 2010, but with all loads increased by 2.5% per year. Also, it is assumed that the substation at Rift House has been removed from the network, as recommended, with 80% of the load transferred to Brenda Trading and 20% to Mulgrave Road, where in both cases this transferred load is not reconfigurable. It seems likely that some minor construction work would have been necessary to enable this transfer to take place. The numbers in brackets in Figure 9.9 are the assumed customer numbers, giving new totals of 18 100 at Amberton Road, 16 000 at Brenda Trading, and 7 200 at Mulgrave Road. As indicated in Table 9.5, all three remaining substations are operating with peak loads close to 100% of firm capacity by 2015.

9.5.2 Network Risk in 2015 at Brenda Trading

Basic Network Risk was calculated at Brenda Trading, based on 2010 loads and conditions, in Section 9.3.1. It came to an annual expected total of £23.8k. When transformer deterioration was taken into account (in Section 9.3.2), the 2015 network risk increased to £30.5k. This risk is now recalculated, taking into account additional factors:

- Load has been permanently transferred out to Amberton Road, with new transformers. Load has also been permanently transferred in, following the assumed closure of Rift House substation. The net effect is to reduce customer numbers from 19 098 to 16 000.
- Following these transfers, only 7100 customers (44.4%) can now be reconfigured at 11 kV.
- Since almost all 11 kV open points are not radio controlled, the average time to reconfigure a customer at 11 kV is assumed to increase from 15 minutes to 90 minutes.

Recalculation gives values of 10340, 9927 and 20409 for *CR*, *CI*, and *CML* respectively, with a total network risk of £40.7k (to the nearest £100). This value of £40.7k will be used as the basis for subsequent calculations.

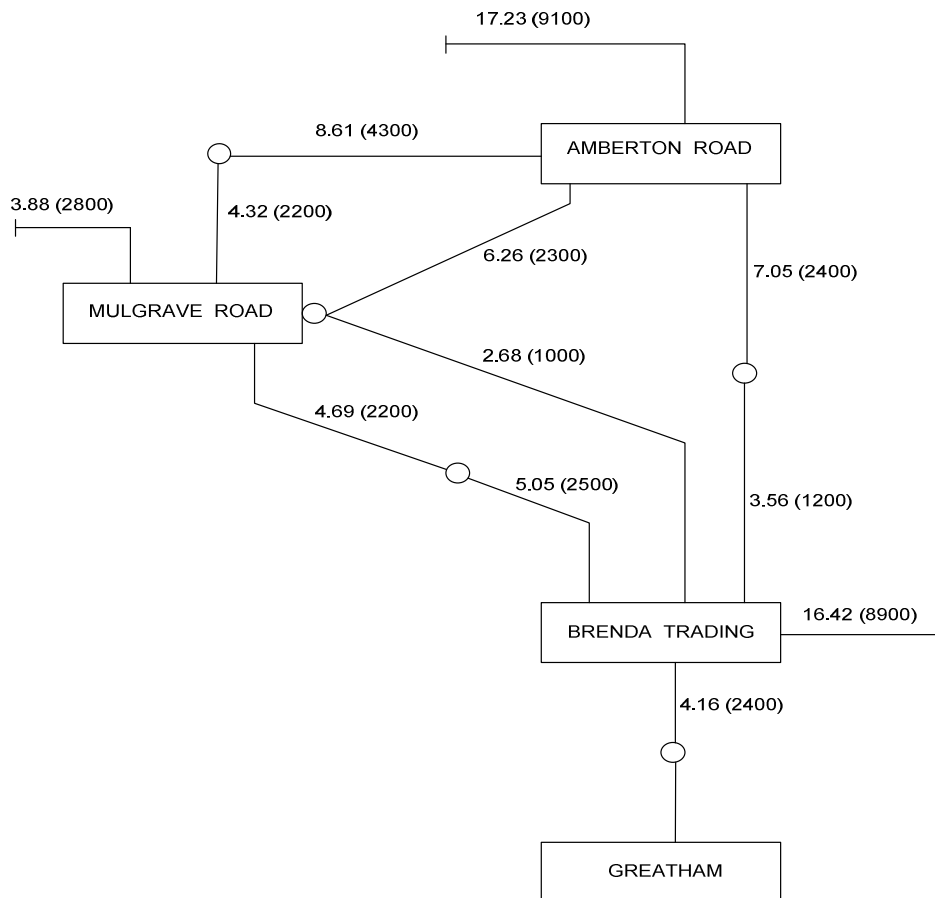

Figure 9.9 – Peak loads, customer numbers, and reconfigurability in 2015

9.5.3 Extending the Last Firm Year

In the analysis of Increasing Utilisation (2.5% annual load growth), it was seen that the LFY is 2015. At this date, all 3 substations (assuming the closure of Rift House) are operating with peak loads close to 100% of their firm capacity (i.e. on a single transformer). Considering each substation separately, any further increase in load would overload the single remaining transformer under n-1 conditions, and the restoration of all customers within 3 hours, as required by P2/6, could not be guaranteed.

However, if an Active Network Management (ANM) approach were considered, then the LFY under P2/6 could perhaps be extended. For example, by 2023 peak load at Brenda Trading following a further 8 years of peak load growth at 2.5% would be 38.83 MVA, or 6.83 MVA (21%) above the (n-1) single transformer firm rating of 32 MVA. Reconfiguring that excess 21% could be done manually, perhaps taking 90 minutes. This is still compliant with P2/6, which requires that all but 12.0 MW of load should be reconnected within 15 minutes under (n-1) conditions, and in 2023 all but 6.83 MVA (or a slightly smaller number of MW) can be reconnected (in fact, is never disconnected), even at peak loads.

This suggests that there is further scope for extending the LFY, using ANM to reconfigure 11 kV feeders strategically, even beyond 2023. However, a number of concerns make extension beyond that date questionable:

1. The transformers are ageing, and by 2023 their HI reaches 10.0, and the age-related network risk increases accordingly. While this might be acceptable at present loads, they might not cope with increased loads beyond that date.
2. In particular, these transformers are rated at 16 / 32 MVA. By 2023, the (n-0) or regular peak load at Brenda Trading has reached 19.4 MVA on each transformer, which is 21% above the lower nameplate rating. While this is probably a fairly conservative rating (a transformer which can carry 32 MVA with forced cooling could probably manage well over half that without forced cooling), it is still a regular overload on an aged transformer, particularly if as a result forced cooling were regularly required.

3. The more the load increases, the more 11 kV feeders would need to be reconfigured under (n-1) conditions. If they all need to be manually reconfigured, there might not be sufficient personnel available to carry it out. It would also become increasingly likely that essential 11 kV interconnection was unavailable due to incomplete repairs, as discussed in Section 9.5.
4. An ANM strategy which effectively treats three substations as a single, interdependent entity could arguably require to be treated as a single demand group under P2/6. The total 2023 demand on this group is 38.83 (Brenda Trading) + 15.71 (Mulgrave Road) + 47.70 (Amberton Road) = 102.24 MVA, which is in excess of 100 MW. At this demand level, there are also effectively (n-2) requirements under P2/6. Although these could demonstrably be met (by 6 transformers), it might be preferred to avoid the additional regulatory complication.

For all these reasons, it is considered that ANM could extend the LFY for Brenda Trading (and the other two substations) as far as 2023, but not beyond. The Network Risk cost in that year can be calculated, based on the following assumptions:

- The failure probability per circuit is increased from 0.2585 per year in 2015 to 0.7466 per year in 2023, as shown in Table 9.3.
- There are no increases to average repair costs, repair times or double failure probability, as explored in the sensitivity analysis in Chapter 5.
- In addition to the (n-2) failures costed in 2015, there are some (n-1) failures by 2023 that require customer disconnection. These are assumed to apply for 8 hours per day on average (at peak load times) throughout the year, and to affect 17% of customers (the 21% overfirm, assuming that there are no industrial customers to preferentially disconnect), who can all be reconfigured manually at 11 kV.

The (n-2) risk is then increased in the ratio $0.7466 / 0.2585$, to £117.5k. In addition, the CIs and CMLs under (n-1) conditions add a further £20.1k, giving a total network risk in 2023 of £137.6k.

9.5.4 Economic Analysis

As against this greatly increased network risk, it will have been possible to defer the replacement of the transformers at Brenda Trading by 8 years. Assuming the same capital cost of replacement as in Chapter 5, namely £1.3M, the value to CE Electric UK of such deferment could be estimated (at a discount rate of 7%) at £91k per year of deferment.

This can be compared with the risk reduction attainable by replacing the two transformers, from the calculated 2023 value of £137.6k back down to the initially calculated base value of £23.8k, a reduction of £113.8k, or 25% above the benefit of deferring the capital cost of replacement. A full economic analysis could be carried out, including the additional construction risk and a year-by-year discounted cash flow, as has been done in Chapters 5 and 8. For the present case study, it is considered sufficient to point out that, as the transformers age and network risk increases, there comes a year when the potential reduction in network risk begins to outweigh the benefit of deferred capital expenditure. In the present case study, this will occur a year or two before 2023, when the HI of the transformers is somewhere between 9.0 and 9.5.

9.5.5 Benefits of Automation

The foregoing analysis has evaluated the benefits of using ANM on the existing, mostly non-automated 11 kV circuits, against a background of ageing assets and increasing utilisation. The final consideration is whether there would be any benefit in automating these circuits.

It is assumed that any 11 kV circuit which connects two primary substations has an automated, remotely controlled circuit breaker at each end, and a non-automated normally open point (NOP) somewhere along it, at a location chosen to divide the load between the two substations in a preferred ratio. There are 12 such non-automated NOPs on this network, both between the three substations and between Brenda Trading and Greatham. It is assumed that automating all 12 of them, at a cost of £25k each or £300k in total, would be required to give the flexibility needed to operate the three substations as a single, reliably interconnected group through to 2023 and possibly beyond.

The saving achieved by this automation project would be in terms of reduced network risk, deferred capital expenditure, or both. The network risk reduction comes from decreasing the average time taken to reconnect a reconfigurable customer from 90 minutes with non-automated NOPs down to 15 minutes when they are automated. The annual value of such a decrease can be calculated. It comes to £5.5k in 2015, increasing to £25.9k by 2023. On this basis alone, the rate of return is only an unattractive 1.8% in 2015, increasing to an acceptable 8.6% by 2023, but reducing again once the ageing transformers have been replaced and network risk levels reduce. It seems that the benefits of NOP automation would not reduce the EHV risk for a sufficient number of years to make the project worthwhile.

However, automating NOPs on the 11 kV circuits might also decrease the time taken to reconnect customers in the event of failures on the 11 kV network itself. Since such failures are far more common than those on EHV networks, this could substantially increase the benefits accruing from such automation. However, detailed consideration and estimation of this reduction of 11 kV network risk lies outside the scope of the present research.

In terms of deferred capital expenditure, it is also not clear that automation would provide any tangible benefit. The extension of LFY from 2015 to 2023 was assumed to be achievable by ANM alone, even with manual NOPs. Extension beyond 2023 was considered doubtful for a number of reasons, which would not be alleviated by automation at 11 kV. It could be that, in practice, confidence to extend the LFY in the face of these doubts could be reinforced by 11 kV automation. But more detailed analysis of a number of factors would be required to determine whether or not this was the case.

9.6 Hartlepool Case Study: Conclusions and Discussion

Stage one of the composite approach was to focus on the ageing transformers at Brenda Trading, using the methodology developed in Chapter 5. The base level of network risk there, based on connectivity only, is £23.8k per year. This is a lower figure than in other case studies, reflecting the robustness of 66 kV networks, the simple circuit topography, and the relatively short distances typical of urban networks.

When the age and likely deterioration of the two 42-year-old (in 2010) 66 / 11 kV transformers at Brenda Trading is factored in, this level of risk increases to £26.0k, increasing further to £30.5k by 2015, and then more rapidly to £88.1k by 2023, when the Health Index of the transformers reaches its upper limit of 10.0. Even at a risk level of £88.1k, however, it does not appear to be cost-effective to replace these transformers on the grounds of age and deterioration alone, unless the consequences of failure are more severe than has been assumed. Further justification, based for example on increasing loads, would be required.

Stage two considered how the last firm year (LFY) might be affected, first by 11 kV load transfer, and then as a result of high levels of load growth. This used the methodology developed in Chapter 7 and illustrated in Chapter 8. Following the 2009 uprating of transformers at the other large Hartlepool primary substation, and consequent reallocation of loads, an assumed annual load growth of 1.0% would lead to the Hartlepool loads becoming too great for compliance with the regulation P2/6 by the year 2021, giving a Last Firm Year (LFY) of 2020. In fact, load growth between 2004 and 2010 has been minimal. But if load growth after 2010, due to increasing use of electric vehicles and heat pumps, were to average 2.5% per year, then the LFY for the Hartlepool network moves forward to 2015. By that date, it would be necessary to carry out a major capital project such as the replacement and uprating of the two Brenda Trading transformers, at an assumed cost of around £1.3M.

Stage three brought in the methodology of Chapter 6, showing that an ANM approach to (n-1) events could further extend LFY to 2023, and thereby delay the need to replace the ageing transformers. Network Automation in Hartlepool could be applied most effectively on the 11 kV network, where most of the normally open points (NOPs) are not automated as originally assumed, but are still manually operated. Mainly for this reason, the re-calculated 2015 network risk increases from £30.5k to £40.7k.

With or without 11 kV automation, active network management (ANM), using 11 kV reconfigurability to provide security of supply in the event of the n-1 failure of a 66 kV circuit, could effectively defer the LFY from 2015 to 2023, and possibly beyond.

Network risk by 2023 would be increased to £137.6k, of which £20.1k is due to (n-1) events as a result of increased loads. The remainder of the increase is due to (n-2) events, and is a result of transformer deterioration and consequent higher failure rates. As network risk increases, it becomes more economically attractive to replace the transformers. The optimal year for replacement is one or two years before 2023, when the transformer health index is between 9.0 and 9.5.

The incremental benefit as regards EHV network risk of automating the 12 NOPs on the 11 kV network increases from £5.5k in 2015 up to £25.9k in 2023. On this basis, it is probably not worth doing, but further analysis (including the impact of such automation on 11 kV failures) would be required to be assured of that conclusion.

As stated in Section 9.2, this Hartlepool case study includes a number of interacting elements, in particular

- Ageing transformers which will reach a 50 year nominal lifetime in 2018
- Possible annual load growth of 2.5% due to take up of electric vehicles and/or heat pumps
- Possible 11 kV load transfer between substations within the town, including network rationalisation by removal of one old substation
- Possible automation of 11 kV switchgear at critical locations
- Possible increased use of active network management.

The overall conclusion is that, in the event of annual 2.5% load growth, and with 11 kV reconfiguration including the elimination of Rift House substation, the replacement of the transformers at Brenda Trading with new, higher rated ones could be delayed until 2023, provided that an ANM approach to (n-1) events is adopted. This composite solution was reached by the sequential application of three major methodologies, and is probably closer to an optimal solution than could be reached by applying any or all of those methodologies in isolation.

9.7 Kirklees Case Study

This section describes, much more briefly than the previous case study, a second example based on the 132 kV supply to large 132 / 33 kV substations in the Kirklees area of West Yorkshire. The 132 kV network differs from those at 66 kV and 33 kV in a number of significant respects, including variety of topology (as a result of historical development), robustness, and maintenance issues.

The composite approach was used to explore and evaluate risk mitigation options on this network, including lower voltage (33 kV) reconfiguration, and both small and large construction projects on the 132 kV network itself. It was further used to assess the risk mitigation available as a result of distributed generation. Although similar to the approach described in the Hartlepool case study, it incorporated different methodologies, which are not separately described in the present thesis.

At an annual peak load growth of 2.5% per year from 2010, with realistic assumptions about 33 kV transfer and generation availability, the last firm year without capital investment at two of the substations was 2018. At a third substation, the technical LFY is 2016, but practically (without either minor capital project, beneficial generator connection contract, or both) it is 2010 at best. Beyond these dates, 132 kV capital projects will be needed to ensure P2/6 compliance. However, these projects bring no significant present benefit as regards the reduction of expected network risk.

Larger 132 kV capital projects, including new circuits, are worth considering, although they too cannot be justified as regards reduced network risk. However, the extra flexibility introduced by re-creating, in effect, a regional 132 kV grid, could bring significant improvements in longer-term network security.

Two points in particular for further consideration arose from this case study. The first concerns the nature of the 132 kV sub-transmission networks in the UK. Their design and history is part of the national transmission grid, but their present operation is part of the distribution system. In practice, these networks have characteristics of both transmission and distribution systems. In the present research, methodologies developed for distribution networks have been applied at sub-transmission level, and have produced useful

results. However, a case could be made for developing specialised methodologies just for this voltage. Further research would be required to determine whether or not such specialised methodologies are necessary or beneficial.

The second point concerns the value for network security of distributed generation. In the case study, four different generators led to four different conclusions as regards their value for mitigating network risk. Other generators could lead to other conclusions, and the level of capacity credit allowed by the regulator in P2/6 does not seem to reflect the practical value of each generator considered. A more relevant way of modelling the value of distributed generation, which is likely to increase in volume over the next 10-20 years, is needed. This also would require further research.

This case study has also demonstrated that a composite approach uncovers issues, and leads to solutions, that could not be reached by applying methodologies separately.

9.8 Composite Approach: Conclusions

In this chapter, the methodologies developed to evaluate issues of asset replacement in Chapter 5, network automation in Chapter 6, and increasing utilisation in Chapter 7 have been combined and applied to a case study which includes aspects of all three issues. A second case study has also been described, also using a composite approach but incorporating different methodologies. This holistic approach is less theoretically based than the three parent methodologies, but is instead based on the unique features of the case study under consideration, interpreted by expert engineering judgment. As a result, it is a more versatile technique than the parent methodologies. It is also potentially more powerful, in that it can explore the interrelationships of different factors applied to a single region of the network.

As can be seen from the above summary, the diverse issues of asset ageing, reallocation of loads, increasing utilisation, active network management, network automation, and major capital expenditure are all involved in making decisions about this area of network, and they cannot be considered separately and independently, as they impact on one another. They need to be analysed by a composite approach, which includes the core

methodology for calculating total network risk, health indices for estimating the change of failure rates with time, the concepts of last firm year for regulatory compliance and of optimal year for asset replacement, and a detailed understanding of network topology including reconfigurability at lower voltages.

For other applications, this composite methodology could also include aspects of any or all of the generalised methodology for complex networks (Chapter 4), discounted cash flow analysis (Chapter 7), and Monte Carlo Simulation (Chapter 3). It could also include extensions relating to factors not previously explored in this research, as was demonstrated in the second case study described in Section 9.7 with regard to two concepts in particular, namely sub-transmission networks and distributed generation.

The overall conclusion is that a composite problem on the network must first be recognised as such. It can then be treated by a composite approach, whereby expert engineering judgment is used first to formulate the problem concisely, and then to apply appropriate methodologies in sequence, but mutually interacting, to lead to a solution. This solution is likely to be closer to an optimal solution than could be achieved by applying the methodologies separately and in isolation.

10. DISCUSSION

At the end of each of the preceding chapters, a number of matters specific to each chapter have been identified and discussed. The present chapter addresses matters of wider relevance across the whole area of network risk and its possible mitigation.

10.1 International Relevance of the UK Situation

The introduction and literature review in Chapters 1 and 2 have drawn on papers from a number of other countries, based in each case on the power systems and regulatory regime of that country [20-22]. There have been useful lessons in these papers, of relevance to the present research. However, the present research is grounded very much in the particular power systems and regulatory regime that apply in the UK. Case studies have been based either on generic networks which are themselves based on a cross section of actual networks from across the UK, or on actual networks from within the UK, principally from two out of the 14 distribution regions. The question arises, to what extent is the present research relevant to network risk in other countries?

There are some significant differences between power systems in different countries. The voltage boundaries between transmission and distribution operators tend to be lower in general, and in some countries the EHV networks which are the focus of the present research are all owned, or operated, or both, by transmission companies whose operating philosophy is often quite different from that of a distributor [105, 106]. In many other countries, the distributor who owns and/or operates the network is also the supply company, as was once the case in the UK. This, too, tends to lead to a different operating philosophy, not least because the distributor in that case has access to a direct customer revenue stream. Furthermore, each country has its own distinctive and unique regulatory regime.

Conversely, the essentials of network risk are much the same in any country. All operators seek to minimise both the frequency and duration of customer interruptions, whatever the precise financial incentive to do so. All

operators also seek to minimise the repair cost, including possible accelerated asset deterioration, that may result from unplanned outages.. All operators have to manage a wide range of network topologies, some of which are considerably more complex than others. And all operators, particularly in developed countries, face the same issues of asset ageing, the possibility of network automation, and increasing utilisation due to either electric vehicles or heat pumps or both. Indeed, many countries are ahead of the UK in adopting these technologies.

While the methodologies as they have been developed in the present research are tailored to UK networks, they could relatively easily be adapted to reflect the different situation in another country. It might even be possible to generalise the methodologies sufficiently to make them non country specific. But this would require further research and development.

Evidence of the value of the present research for a wider community than just the UK comes from the reception that it has been given at international conferences. Papers have been accepted at such conferences in Greece, the Czech Republic and France as well as in the UK. At each of these conferences, the paper has been well-received and has generated significant interest, in one case leading to the invitation to contribute a chapter to the Power Systems Handbook, published in Germany in 2010. It seems that this research is indeed relevant to the wider international community.

10.2 Elements of Total Network Risk

The equations developed within the core methodology, and also used in the other methodologies, calculate total network risk as the sum of just three distinct elements: repair costs (including asset deterioration), customer interruptions, and customer minutes lost. All three are direct costs to the DNO. This formulation leaves out other elements which could also be regarded as significant.

One group of such elements is the less tangible cost to the DNO. This could include personal safety, whether of employees, contractors or the general public. It could include environmental integrity, company reputation, and energy efficiency. Other network risk studies have attempted to quantify and include such issues [11-14].

Another group of elements are costs borne outside the DNO, such as the cost to the national economy of a major outage. More precisely, the cost to a disconnected customer may be many times higher, particularly for industrial customers with sensitive processes, than the direct cost to the DNO. Again, other network risk studies have attempted to evaluate these costs. The reasons for not doing so and including them in the present research were outlined in Section 2.1.2.

The balance to be sought in formulating a total network risk equation is between inclusivity and credibility. The more elements that are included, the greater the likelihood of rogue results, and the harder it becomes to explain and justify the methodology. This is particularly so within the industry, where practising engineers are more likely to believe and accept a formula whose elements are straightforward and within their own experience. For this reason, the core methodology has only included the three elements outlined, each based on its own justifiable unit cost. It would be relatively straightforward, however, to extend the methodology to include other elements if this were considered to give a more representative evaluation of network risk.

10.3 Anticipating Regulatory Change

The methodologies developed by the present research reflect the regulatory regime in the UK as defined by the 4th Distribution Price Control Review (DPCR), which operated from April 2005 until March 2010. These DPCRs are renegotiated every 5 years, and the 5th DPCR came into force in April 2010. In many respects it continues the structure of the 4th DPCR, and in particular it does not in any way negate any of the assumptions on which the present network risk methodologies have been based. On the contrary, one of its new requirements is that each DNO should assess the health and condition of each of its assets on a scale (as yet undefined) from 1 (the best) to 5. Each DNO is also required to classify each load on a scale, again as yet undefined, from 1 (the least heavily loaded) to 5 (the most over-capacity) [103]. This attempt to quantify two of the most significant factors contributing to network risk is very much in keeping with the present research, and that research should be useful in helping DNOs to assign an appropriate point on the scales to each asset, and to each load.

The regulator OFGEM has also given notice that these individual classifications (called 'Tier 2') should be capable of being aggregated to give a single measure of health, and of load, for each DNO. This 'Tier 1' aggregation will form a part of the 6th DCPR, from April 2015. It should be formulated in a transparent way (as yet undecided), so that 'what if' questions can easily be answered, for example 'is £10M spent on renewing old transformers as effective in reducing network risk as spending that same £10M on network automation, or on demand side management schemes?' The present research, and developments of it, should be extremely helpful to DNOs as they seek to formulate Tier 1 aggregate measures in such a way that questions of this sort can be easily addressed and answered.

The reason that the present research is well-placed to assist with these new regulatory requirements is that such regulatory change, or something like it, was anticipated at the time when the research objectives were first formulated, back in 2006. This in turn points to the wider issue of anticipating regulatory change. The industry in general, and DNOs in particular, are planning on a long time horizon. Major capital investments, including significant network redesign, are planned up to 10 years ahead. When installed, they have to be fit for purpose for the lifetime of the assets, at least 40 years. This means forecasting how the requirements of the network are likely to change over a 50 year period. It is difficult enough to predict the likely changes in load profiles and peak loads, or in patterns of generation, over that period. Hardest of all, however, is anticipating how the regulatory regime might change in that time. A network designed to comply with the requirements of P2/6 might not comply, or might comply excessively generously, with its successor standards. It is hard to predict how these standards will develop, as such changes depend as much on human factors as on the underlying technology. However, effective management requires such changes to be anticipated if possible, and research such as that reported in this thesis has to be sufficiently versatile to respond to such regulatory changes when they occur, and indeed beforehand insofar as they can be foreseen.

10.4 Economic Analysis

One feature of all the methodologies in the present research has been that network risk is expressed in economic terms, as an expected cost in £k, or (using Monte Carlo Simulation) as a probability distribution of such costs. There are a number of advantages to this approach, not least that it meets the needs of the industry for a measure of network risk that they can easily appreciate, relate to and use. One way of using it is to incorporate it directly into discounted cash flow (DCF) analysis, as was done in Chapters 5 and 8 in particular.

The principal difficulty in using DCF analysis within the electricity distribution industry in the UK is that without a direct stream of customer revenue, it is difficult to identify benefits, let alone evaluate them. By quantifying network risk in financial terms, both before and after a proposed capital project, and indeed for several years in each direction, it is possible to define the potential benefit of any capital project with a reasonable degree of accuracy. The added network risk during construction periods can also be factored in, enabling different construction plans (in particular, green field versus brown field) to be fairly compared.

In the particular case of finding the value of deferring a major capital expenditure, addressed indirectly in Chapters 5 and 9 and more directly in Chapter 8, a variation on classical DCF analysis is required, in part because of the lack of a direct stream of customer revenue. Instead of finding the value of deferring expenditure, it proved more understandable to find the value of *not* deferring it, as this difference produced net expenditure in early years, followed by savings (in lieu of income) in later years, and this in turn produced a DCF that looked traditional, and that could therefore be used to calculate rates of return. The corollary is that a high rate of return means that the project should not be deferred, whereas a low rate of return means that the major project should be deferred, and minor stop-gap projects undertaken instead. This could well prove to be a helpful way for the industry to consider and evaluate major capital expenditure proposals of this kind. It also lends itself to the methodology (in chapters 5 and 9) of determining the optimal year in which to carry out an asset replacement project.

10.5 Design versus Operations

One of the themes that runs through the whole of the present research is the difference in approach between Network Design and Operations. To some extent, this reflects a similar difference in approach within the Network Management function itself, between normal and abnormal operations. Under normal circumstances, with the network operating as it should, Network Management tends to be cautious and conservative. This risk-averse approach is perhaps one of the reasons why 'normal circumstances' apply most of the time. Customer disconnections do occur, but they are far less frequent than, for example, delays or cancellations to train services.

This caution is apparent in the design standard P2/6. To comply with it, most EHV circuits are duplicated, so that a single (n-1) failure does not result in customer disconnection. This 100% margin is considerably greater than would be acceptable in many other industries, and is at the heart of the relatively high level of reliability in electricity distribution.

Similar caution is evident as regards scheduling maintenance, repairs and construction projects. The requirement of an 18 hour return-to-service time means that the work must be arranged so that the circuit under outage can be restored within 18 hours. This requires careful planning, and in some cases additional expense, but these are accepted as part of the risk-averse culture of Network Management.

Under abnormal operating conditions, however, the network management philosophy seems to change almost immediately. Although great care is still taken to protect people and assets, there is a far greater willingness to operate the network in imaginative ways in order to prevent or minimise customer disconnection where possible, and this is usually done quickly and effectively. Minimising network risk is done cautiously and conservatively at the design stage, but with imaginative flair when operational necessity dictates. Understanding network risk requires both these approaches to be understood, and to be embedded in the methodologies.

10.6 Active Network Management

The difference between design and operating philosophies also determines attitudes to Active Network Management. ANM involves taking an

imaginative approach to operating the network under normal (n-0) conditions. The payoff may be reducing the need for capital investment, or reducing electrical losses, or reducing operating costs in other ways, or being able to connect greater quantities of generation, or being able to load assets to higher ratings. The alternative, sometimes called 'fit and forget', involves operating the network in as straightforward a manner as possible. The payoff here is reduced numbers of engineers in the control room, and perhaps greater network reliability as a consequence of not pushing the network to its limits.

In the past, 'fit and forget' has been the preferred operating philosophy throughout the industry. With present-day targets including greater operating efficiency, there is increasing pressure to incorporate more ANM into normal network operations, and this is accepted, albeit with some apparent reluctance, by the Network Management function within DNOs.

However, the strategies used to keep customers connected under abnormal (n-1) or (n-2) conditions are, it could be argued, also a form of ANM, and one with which Network Management are comfortable and competent. This creative use of ANM lasts for the duration of the outage, and has been assumed to some extent in the present research. The question that arises, then, is the extent to which this observable ANM could become more widespread, given that the control engineers clearly have the competence and confidence to adopt it in an emergency.

In particular, the extension of such ANM to normal operations could achieve many of the benefits already outlined, such as reducing the need for capital expenditure. It could also lead to a relaxing of the design standard P2/6, if the deployment of ANM were regarded as normative. As against this, it could be argued that only the conservative approach currently adopted enables the high levels of reliability presently taken for granted to be attained. More non-standard practices would lead to greater risk, including communications failure, equipment breakdown and human error, which would in turn lead to increased failure frequencies. It could also be argued that a move away from 'fit and forget' would require more control engineers on each shift, with a consequent increase in operating costs.

10.7 The 'Last Firm Year' Concept

The concept of 'Last Firm Year' (LFY) was introduced in Chapter 7, and was also used in the case studies in Chapters 8 and 9. It was developed as a means of quantifying network risk at times of increasing utilisation. The main problem in using LFY is that assumptions have to be made concerning expected growth patterns. In the present research, an assumption of a 2.5% annual growth rate in both peak power and total energy demand has been made, with no significant change to load profiles. LFY has been determined in the case studies based on these assumptions.

However, forecasting demand is at best an imprecise exercise. It was shown in the case study in Chapter 9 that an assumed 1.0% annual growth rate from 2004 did not materialise, and that in the event peak demand decreased. While LFY is a useful concept, there would need to be considerably more accuracy and confidence in load forecasts to enable decisions to be taken based on it, for example a detailed capital expenditure programme.

One way of using LFY effectively would be to regard it simply as a ranking device. Slower load growth would delay the LFY of every circuit by a similar proportion, but would not greatly change the order in which circuits become over-firm, and therefore the order in which action has to be taken to increase their capacities.

Another way of using LFY more confidently might be to calculate it for a range of possible or likely load growth rates. This could lead to, for example, 3 values of LFY (slow, medium and fast load growth) for each circuit. Capital expenditure might then be prioritised for those circuits which would become over-firm within the next 5 or 10 years, even at slow rates of load growth.

While the concept needs to be treated with appropriate caution, it does seem a useful tool to enable DNOs to plan their capital expenditure systematically and effectively.

10.8 Composite Approaches

Chapters 5, 6 and 7 each addressed a separate single issue of concern to DNOs as they plan for the future. Keeping those issues separate reflects the way in which the industry is managed and regulated. For example,

the regulator OFGEM treats capital expenditure on asset replacement (dealt with in Chapter 5) as something quite distinct from capital expenditure on network reinforcement, whether by increasing automation (Chapter 6), or by adding assets to meet increasing demand (Chapters 7 and 8).

However, in practice it is not always so straightforward to distinguish between asset replacement and network reinforcement, as illustrated by the composite case study in Chapter 9. Replacing a worn out asset could be delayed, possibly by many years, if the load demand that requires supplying through that asset is not increasing, and even more if it is reducing naturally, or can be reduced deliberately by reconfiguring the network at a lower voltage. Conversely, replacing an ageing asset could be done some years before it is fully worn out, if that replacement (typically with a higher rated asset) forms part of a wider plan for network reinforcement.

Likewise, the need to reinforce an overloaded part of the network can usually be done in a number of different ways. Given that choice, the option which scraps an aged asset that would soon be due for replacement in its own right is likely to be more cost effective, and therefore preferred, over an option which involves replacing assets which are relatively new. Adding extra automation can also be included as part of a larger project, when no additional disruption is involved, where it might not be justifiable as a stand-alone project.

Chapter 9 also briefly extends this concept of multiple justification to sub-transmission voltages, including the option of establishing a local or regional sub-transmission grid for increased network security, and including also an evaluation of the capacity credit available by considering the value of embedded generation. Other features could also be included. Two that have not formed a part of the present research, but which would follow on naturally from it, are electrical energy storage, and demand side management.

The term 'composite methodology' has been used to describe a bespoke combination of the methodological approaches developed and described in the present research to a network problem which includes two or more strands. Where no strand might be able to justify capital expenditure in its own right, the combination of them all might justify the single project that addresses each of the different strands.

This has implications for the industry and for its capital investment planning and regulation. Keeping different categories of justification separate, as is presently done with asset replacement and network reinforcement, may seem simpler, but is likely to lead to sub-optimal solutions and less cost-effective allocations of the available capital. Using a composite methodological approach, as outlined in the present research, provides the opportunity to increase the value for money of such capital investment.

10.9 Probabilistic Methodologies in the Industry

What all the methodologies developed and described in the present research have in common is their grounding in the mathematics of probability. While this approach is familiar within the academic community, it is less common in the electricity distribution industry. CE Electric UK, the DNO most closely involved in the present research, uses probability only to a very limited extent, and then for orders of magnitude only rather than for precise calculations.

However, experience in the course of the present research, in particular presenting the methodologies and their case-study applications and conclusions to engineers from within the industry, has been uniformly encouraging. Engineers have understood the underlying mathematics of probability, and have appreciated its analytical power for producing a value of network risk measured in £k, which can then be combined with or set against both operating and capital costs measured in the same units.

Less straightforward, but also much appreciated, has been the use of Monte Carlo Simulation to build in the variability which is an inherent feature of network operation, and to produce results in the form of a probability distribution which also reflects this variability. In particular, presenting the 90th and 99th percentiles of network risk as the 'worst year in a decade' and the 'worst year in a century' has been a measure of network risk liability which makes sense to the engineers in the industry.

At present, probability is not used as a regulatory tool. The design standard P2/6 is expressed in black-and-white terms: 'all customers reconnected within 3 hours', regardless of circumstances. But the cost of designing and installing networks to comply with this absolute standard is

high, and may come to be regarded as unacceptably high in a future which may include greater restraints on expenditure. One way to resolve this dilemma could be to adopt design standards with a probabilistic component, for example 'no more than 5% of (n-1) events to involve customer disconnection', or 'fewer than 20% of customers to be disconnected for over 15 minutes'. The methodologies described in the present research would be extremely useful in evaluating and demonstrating the degree of regulatory compliance under this kind of regulatory regime.

10.10 Data Quality and Reliability

One area of difficulty which has been evident throughout the present research, and which has received comment in a number of sections of the present thesis, is to do with the availability and quality of data on network risk.

Where there is a statutory requirement to supply data, as is the case with the NAFIRS scheme, then a large quantity of data is available, and it has been collated in ways which have proved helpful in the present research. This applies in particular to overall component failure rates, and to the proportion of double failures. In other cases, the collated data can prove misleading, for example as regards repair times, which are not the same as restoration times.

Attempts within DNOs such as CE Electric UK and Central Networks to dig down to the source of the data that is supplied to NAFIRS, or that is used internally, e.g. for the calculation of health indices, can prove frustrating. Often, the raw material is sparse, and seems to have little objective basis, as with visual condition monitoring. Sometimes it appears that a failure is attributed to a cause, such as 'age and wear', because this is unlikely to be challenged. Such attributions may not be reliable.

The problem is that data collected for one purpose, such as statutory requirements, may not be suitable for a different purpose, such as the understanding and evaluation of network risk. An early priority in the continuation of the present research will be to define more precisely the data requirements, to see if and where such data is available, and to try to arrange for the regular collection of such data where it is not currently available. The first priority here would probably be to firm up repair and deterioration costs.

11. CONCLUSIONS

In Section 2.8, at the conclusion of the Literature Review, the aims of the present research were set out as regards addressing some of the limitations identified in the existing literature. Those aims can be summarised as follows:

- To make a distinctive and significant contribution to knowledge by combining four approaches in a single suite of methodologies which will give approximately equal weight to engineering, mathematical, power systems and regulatory / commercial aspects of problems which involve network risk.
- To extend research from both transmission and MV levels into the generally more complicated sub-transmission and EHV networks, which have been relatively less extensively addressed by the industrial and academic community. This involves a detailed understanding of network risk issues that are prominent at these voltages, in particular a focused analysis of the causes and varying impacts of double circuit failure.
- To concentrate on the network architectures and regulatory regime that apply presently in the UK. Although the findings of the present research will be of relevance for any national power system, and could be adapted to apply directly to that system, the research is intended primarily to address issues arising on UK power networks.
- To develop a suite of heuristic, versatile methodologies which adopt a systems approach and which can be applied to quantify network risk in a variety of circumstances. The methodologies can also be used to analyse and compare competing methods for mitigating network risk, including asset replacement, network automation, active network management and major or minor network reinforcement, both singly and in combination. These methodologies need to be transparent and accessible if they are to be of use both to the academic community and to the electricity distribution industry. It is the intention of the present research to provide such a holistic tool kit which can be of use in solving actual network risk problems which arise on EHV networks

In Section 1.10, the objectives for the present research were listed. In this concluding chapter, the achievements of the research will be measured against those objectives. Then, finally, the research will be evaluated in terms of the aims from Chapter 2, as listed above.

The objectives in Section 1.10 were:

1. To gain a deeper understanding of existing sub-transmission and extra high voltage distribution networks, adopting a systems approach to classifying the inherent causes and consequences of circuit failure.
2. To understand in particular the various causes and likelihoods of double circuit failure, and the time taken following such failure to restore supply to different groups of customers by automated or manual switching, network reconfiguration and asset repair.
3. To develop a holistic and transparent way of quantifying this network risk, leading to a universally applicable method of measurement which will enable the risks in different locations, or under different scenarios and assumptions, to be fairly and realistically compared.
4. To understand and quantify the possible impact of likely changes to the level of network risk in the future, with particular reference to the increasing age profile of major assets, and to increasing network utilisation as a consequence of the greater use of electric vehicles and of heat pumps. To understand and quantify possible ways of mitigating this future risk, including network automation, capital investment, and active network management.
5. To develop versatile and applicable risk modelling and analysis methodologies, and apply them usefully, verifiably and effectively to a wide range of case studies, on both generic and actual CE Electric UK networks.
6. To understand and evaluate existing mathematical approaches to network risk, incorporating them where appropriate in the developed methodologies. To develop holistic, whole system models and solutions that could be used as practical decision support tools by CE Electric UK, other DNOs in the UK, the UK regulator OFGEM, and consultants within the industry.
7. To develop technically accurate models which also reflect the present UK regulatory environment, while being sufficiently versatile to be adapted to different regulatory environments elsewhere, or in the future. To incorporate

financial information to produce fully costed solutions that can usefully inform DNO decision making processes.

11.1 Deeper Understanding

During this research, the EHV and sub-transmission circuit topologies of all 14 of the DNOs in Great Britain have been studied in some detail, with those of YEDL and NEDL studied in considerable, fine detail. Where there are significant differences between different DNOs, this has been identified (e.g. in Section 6.6). Generic networks based on elements of all 14 systems have also been used (in Chapters 6 and 8). The most significant characteristic of EHV and sub-transmission voltages, compared with other voltages, is the diversity of topologies.

The range of different causes of circuit failure has been investigated (1.4), but a systems approach has led to these being aggregated to give a single value of λ for each asset, covering all causes and based on historical data (1.3, 1.6). These asset-based values are then aggregated in series or in parallel as appropriate to produce values per circuit, which then form the basis for subsequent analysis.

The consequences of circuit failure have been investigated, distinguishing in particular between those which involve customer loss of supply (reflected in CIs and CMLs as well as direct costs to the customer) and those which need not involve customer loss (such as unscheduled repairs and possible asset deterioration). These form the basis of subsequent network risk modelling (3.1).

11.2 Double Circuit Failure and Restoration

Four distinct types of double circuit failure were identified, namely common mode failure, load-related failure, coincidental second failure during a planned outage, and coincidental second failure before an unplanned first failure has been repaired (Appendix A). These four types were aggregated to give a single value for DF, the probability of double failure for a particular pair of circuits, based on historical data and typically around 0.2. In more complex networks, with more than two circuits, the DF probabilities are dealt with in matrix form (4.4).

The time taken to restore customer supply depends not only on repair times, but also on reconfiguration options available. The systems approach adopted does not distinguish between causes of failure, nor the repair strategy, nor (except in 5.4) the asset which has failed. It does distinguish between minimal restoration times

(involving automatic circuit-breaker operation), short restoration times (involving radio-controlled, operator-initiated circuit reconfiguration) and long restoration times (including asset repair and all manual reconfigurations involving site visits) (3.1, 4.4). These times are allocated, based either on operational data or on detailed consideration of the network topology, to specific groups of customers.

These times, like all other input parameters in the network risk methodologies, can be specified either by average values, or by probability distributions which are then processed using Monte Carlo simulation.

11.3 Quantifying Network Risk

The core methodology developed in Chapter 3, and the methodologies based on it and developed in subsequent chapters, are based on an analytical simulation approach (1.6), and are both holistic and transparent as a result. The total network risk is quantified as an expected annual £k cost to the DNO, made up of three elements: the repair cost (including any asset deterioration), the frequency of customer interruptions (CI), and their duration (CML).

The core methodology can be applied to standard topologies, but to make it universally applicable it was necessary to develop a generalised methodology, as described in Chapter 4. The case studies outlined in Chapters 3 to 9 then demonstrate that these methodologies can be adapted to a variety of locations, scenarios and assumptions, which can then be compared, for example to evaluate the marginal value of switches, circuit breakers and combinations of them in different locations (6.3), and the sensitivity of this marginal value to different assumptions (6.4). For example, in one key case study location, the installation of a radio-controlled switch could reduce network risk by around £80k per year, giving a payback time of a few months. Installing a circuit breaker at that location could give even larger risk reductions, of around £130k per year. That these comparisons are fair and realistic has been tested by exposing them to the expert advice and assessment of DNO engineers.

11.4 Changing Network Risk

A number of potential increases to network risk in the future were identified (1.9), and three of these were chosen for further, detailed investigation. The increasing age profile of assets was discussed (2.2, 5.1) and was illustrated by a

case study based on actual circuits with aged transformers (5.3). Increasing utilisation was also investigated (1.7), as were the possible mitigation strategies of network reinforcement (2.3) and active network management (ANM) (2.5). These were illustrated by a case study based on a generic network, described in detail in Chapter 8, which included both capital expenditure and ANM as possible mitigation strategies, as well as combinations of the two. The conclusion was that a relatively minor capital expenditure project could defer the need for major network reinforcement at a time of high load growth by as much as 6 years. Imaginative use of ANM could also purchase a 6 year deferment, while using minor capital projects and ANM together could defer the need for major expenditure by 12 years.

The possibility of mitigating future network risk by increasing automation was illustrated by the generic case study in Chapter 6. Finally, the actual case study described in Chapter 9 contains all three elements of future network risk and possibilities for its mitigation.

11.5 Developing Methodologies

The case studies referred to in Section 11.4 were not addressed heuristically. In each case, an appropriate methodology was first developed, and then illustrated by applying it to one or more case studies. These methodologies, and the relationships between them, are shown schematically in Figure 11.1

The core methodology developed in Chapter 3 was sufficiently versatile to be extended in scope, both as regards complexity of network topology (the Generalised Methodology) and as regards variability of input and output parameters (Monte Carlo extension). This core methodology, with or without either the Generalised or Monte Carlo extensions (or with both, although this has not been illustrated directly) can then be adapted to particular situations. Three are fully developed in the present research (in Chapters 5, 6 and 7), and others will hopefully be developed in future.

It is possible to combine two or more particular situations, each with its associated methodology, by developing a Composite Methodology. This has been illustrated in Chapter 9, and Section 9.7 briefly describes a second illustration of this composite approach. Again, it is hoped that further composite methodologies will be developed in the future in response to particular network issues and combinations of issues.

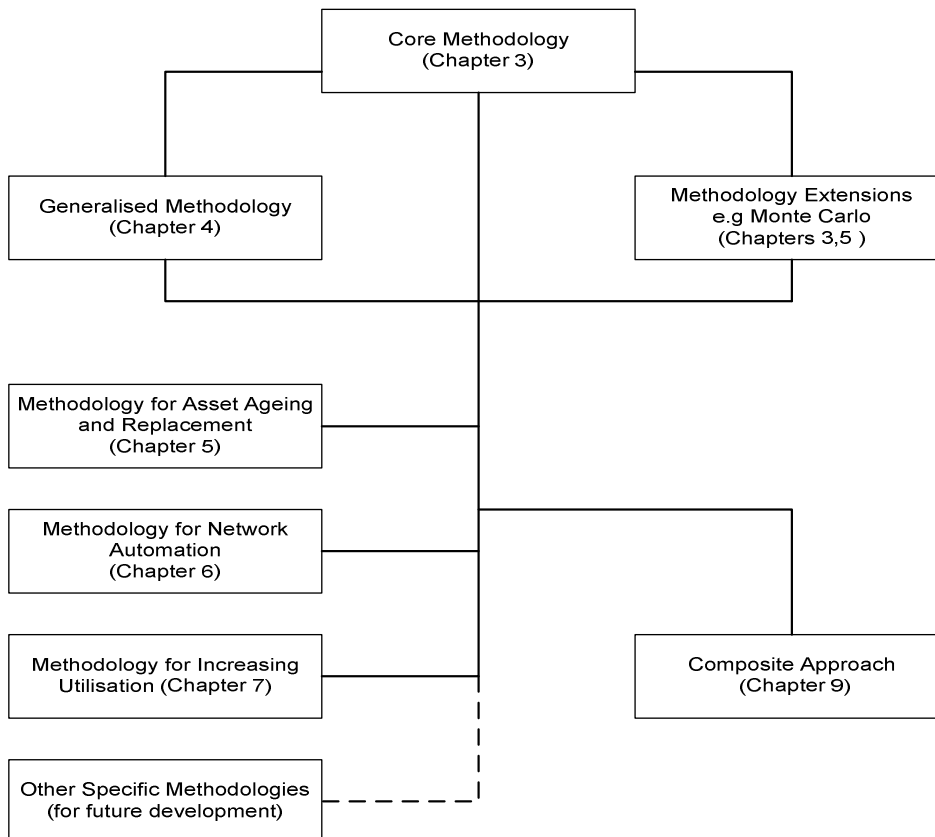

Figure 11.1 – Methodologies Flowchart

These methodologies have all been applied usefully, verifiably and effectively to a wide range of case studies, of which only the most significant have been described in the present thesis. The verification of them, and their effectiveness, has been demonstrated by testing them alongside experienced CE Electric UK engineers, and more widely by the response from the academic and industrial communities in meetings, seminars, workshops and conferences.

11.6 Mathematical Approaches and Models

The methodologies applied to network risk issues and problems were not developed in a vacuum. Existing mathematical techniques for the modelling and evaluation of network risk were studied and assimilated (1.6), and four approaches in particular were tested by applying them in turn to the same case study, in Appendix A. The Analytical Simulation approach was considered to be the most promising as regards developing holistic models, and is at the heart of all the methodologies.

It was originally intended to develop a model which could be applied to the whole system, in the form of a software tool, and possible software tools were therefore investigated (Appendix B). However, although a Software Functional Specification was produced to this end, and some software development carried out, that aspect of the present research remains incomplete. It is hoped to develop it further in the near future, to create a practical decision support tool that is useful to CE Electric UK and also elsewhere in the industry.

Meanwhile, the existing methodologies are available to CE Electric UK, and use is being made of them on an ad hoc basis. Aspects of them have also been discussed with other DNOs, in particular Central Networks (both East and West), and with consultants in the industry (in particular EA Technology). In particular, the evaluation of increasing network risk for ageing assets (typically increasing from a steady £20k per year to £100k or even more when an asset reaches a critical age or condition) is of current interest throughout the industry.

A Knowledge Transfer Partnership has been set up by CE Electric UK and Durham University for a three year period to facilitate the continuation of the present research and the development of practical applications.

11.7 Technical, Regulatory and Economic Aspects

The technical accuracy of the models has been assured by the close contact throughout the period of research with Asset Management Engineers, Construction Project Engineers, and Network Control Engineers at CE Electric UK and, to a lesser extent, at other DNOs. It has been further underwritten by the advice and support of colleagues in the Energy Research Group within the School of Engineering and Computing at Durham University.

The regulatory environment has been considered in detail throughout the research (see e.g. 1.5, 3.1, 7.2) and the methodologies reflect this. They are, however, sufficiently versatile to be of relevance outside the UK. Evidence of this is the interest shown in conference papers published and presented throughout Europe (in Italy, Greece, Czech Republic and France), and in the commissioning of a book chapter published in Germany in 2010. They are also sufficiently versatile to adapt to changes in the UK regulatory regime. This is evidenced by its applicability to the Tier 2 measures of network robustness introduced by OFGEM in the 5th

DCPR (2010) and to the declared Tier 1 extension of these measures to be in place by the 6th DCPR in 2015.

The financial background to the industry, and to DNOs in particular, has also been considered throughout the research (1.8), and fully costed solutions including detailed DCF analysis has been included in several of the case studies, and detailed in one of them (8.5). For example, carrying out a major construction project as early as possible gives an effective rate of return of only 3.3% (which is unattractive). However, if real construction costs are escalating at 5% per year, this rate of return increases to 7.4%, which makes the early major construction project more attractive than using minor construction options to defer it. This emphasis on the economic consequences ensures that the methodologies are useful to the DNOs to support their essential decision making.

11.8 Summary: Advances to Knowledge

As regards the aims of this research, summarised at the start of this chapter, it is now possible to assess to what extent they have been achieved, and with what impact.

The suite of methodologies developed in the present research does indeed combine engineering, mathematical, power systems and regulatory / commercial approaches to modelling network risk, giving appropriate weight to each. As a result, the methodologies enable real-world network problems faced by DNOs such as CE Electric UK to be formulated in sufficient depth, but without loss of clarity. The model then produces results which make sense both technically and economically, and which can be used to identify and to support robust and cost-effective solutions to these problems.

One example of how this research is beginning to influence CE Electric UK concerns the approach to asset replacement, summarised in Section 5.7, where it was stated that there seemed to be little economic justification for the policy of preventative asset replacement, although it was universally accepted and practised throughout the industry as regards EHV assets. It is interesting to note that the most recent long-term plan for major capital expenditure at CE Electric UK includes a large number of refurbishment projects for assets, where in previous plans these assets would have been scheduled for replacement.

A second example concerns issues of network automation, discussed in Chapter 6, which evaluates the benefits of different levels of automation. CE Electric UK are currently planning to adapt the radio control on some MV networks to allow full automation, responding to faults in under 3 minutes and thereby avoiding CI costs.

The variety and complexity of EHV networks addressed by the present research has enabled a wide variety of possible solutions to any given network problem to be formulated. For example, it has been shown that the last firm year in a period of rapid load growth can be extended not only by the usual solution of major capital investment, but also by the effective deployment of minor capital expenditure, active network management, lower voltage reconfiguration (either permanent or temporary), or most effectively, a combination of all three. In this way, the unit cost per MW of additional network capacity can be substantially decreased.

Concentrating this research on the UK networks and regulatory regime has also had its advantages. In particular, the most recent OFGEM price control review in April 2010 has begun to focus more specifically on measuring and mitigating network risk. In particular, it requires assets to be ranked according to health and according to load, not only in 2010 but also as expected in 2015, both with and without planned expenditures. This has been to some extent anticipated by the present research, which can be easily adapted to produce output of the kind required by OFGEM.

Looking ahead, OFGEM have also indicated that by the time of the next price control review in 2015, they will require DNOs to provide outputs which incorporate not only the extent of network risk, but also its likely consequences, and not only for individual assets but summed across the whole network. These so-called Tier 1 measures have yet to be formulated in detail, but again this has been to some extent anticipated by the present research, which should be useful in formulating a response to this latest regulatory requirement.

Finally, the provision of a holistic tool kit has been significantly advanced by the present research, although not yet to the point where it can be handed over to DNO engineers as a working, usable suite of programs. It can be and has been used by the present researcher to gain insight into a wide range of network issues, as described in the present thesis, and also in reports for CE Electric UK on other case studies which have not been included in this thesis. The value of the present

research, and its potential future impact, has been recognised by CE Electric UK, to the extent that they have set up a 3 year Knowledge Transfer Partnership with Durham University, as described in the following section.

11.9 Further Work: Knowledge Transfer Partnership

Those aspects of the present research which have not been concluded in this thesis, and other aspects which arise from the research, will hopefully be addressed as part of a three year Knowledge Transfer Partnership (KTP) undertaken for and with CE Electric UK and Durham University. This KTP is funded in part by the Technology Strategy Board, and in part by CE Electric UK. The present researcher is employed as KTP Associate for a 3 year period which started in December 2010. The overall goal of this KTP is to advance the methodologies that constitute the present research from a present technology readiness level 3 (exemplar, demonstration stage) to an eventual technology readiness level 8 (methodology and software for both basic and complex applications completed, documented and integrated into CE systems, and in regular use by CE engineers) [123].

As a result of this project, CE Electric UK expect to gain:

- Enhanced ability to assess the probability and extent of outages due to ageing and overload, leading to more efficient means of deferring investment for replacement or reinforcement; of minimising high-impact low-probability wide-area interruptions to supply; and of planning major outages to reduce overall cost.
- Reduction in the incidents which result in interrupted supply, and therefore fewer financial penalties.
- Prioritised investment in new or replacement infrastructure which will ensure that financial and manpower resources are used more efficiently.

To achieve this, 12 distinct project stages have been identified over the 3 years, including investigating existing and new data sources, extending the network risk software and methodology, and adapting it to appraise risk in emerging areas of work related to the low carbon economy. It is anticipated that significant further contributions to knowledge will emerge from this future research and development.

REFERENCES

- [1] G. Boyle, B. Everett, J. Ramage, 'Energy Systems and Sustainability', Oxford University Press, 2003
- [2] 'Project Discovery: Energy Market Scenarios', OFGEM Consultation Document, October 2009, accessed 15.09.10 via www.ofgem.gov.uk
- [3] NEDL Regulatory Accounts, 2008-9, accessed 15.09.10 via www.ce-electricuk.com
- [4] CE Electric UK Asset Management Policy (internal document)
- [5] Long Term Development Statement (2009), NEDL, accessed 15.09.10 via www.ce-electricuk.com
- [6] National Fault and Interruption Scheme, National System and Equipment Performance 2005/6, Supplement – 132 kV Systems and Scottish Transmission System, Energy Networks Association (confidential)
- [7] R. E. Brown, 'Electric Power Distribution Reliability', Marcel Dekker, New York, 2002
- [8] National Fault and Interruption Scheme, National System and Equipment Performance 2006/7, Energy Networks Association (confidential)
- [9] S. Kaplan, 'Risk assessment and risk analysis – basic concepts and terminology', from 'Risk management: Expanding horizons in nuclear power and other industries', 1991, pp. 11-28
- [10] D.E. Nordgard, K. Sand, O. Gjerde, M.D. Catrinu, J. Lassila, J. Partanen, S. Bonnoit, J. Aupied, 'A Risk Based Approach to Distribution System Asset Management and a Survey of Perceived Risk Exposure Among Distribution Companies', CIRED 19th International Conference on Electricity Distribution, Vienna 2007
- [11] G. Hamoud, J. Toneguzzo, C. Yung, 'Methodology for Assessing Safety Risk from Failure of Transmission Station Equipment', IEEE Trans. on Power Delivery (2007) pp 1972 -1978
- [12] Electric Power Research Institute, 'Design of Electric Industry Substations for Enhanced Ergonomics and Worker Safety', October 2008.

- [13] National Grid, 'Electrical Substation Sites – Contamination Survey and Risk Assessments'. Accessed 30.04.10 via www.entecuk.com
- [14] M. Fu, G. Chen, A. E. Davies, S. J. Sutton, D. Patel, 'Use of Fluorimetry in Determination of DDB Contamination in Soils from Underground Oil-filled Power Cable Leaks', IEE Proceedings, Science, Measurement and Technology, Volume 147 Issue 6, Nov. 2000, pp 296-300.
- [15] P. Schewe, 'Wired Together', Engineering & Technology magazine, IET, October 2007
- [16] Engineering Recommendation P2/6 'Security of Supply', Energy Network Association Engineering Directorate, July 2006
- [17] Long Term Development Statement (2009), NEDL, detailed data supplied by CE Electric UK
- [18] Long Term Development Statement (2009), YEDL, detailed data supplied by CE Electric UK
- [19] KEMA with Imperial College London, 'Final Report: Review of Distribution Network Design and Performance Criteria', G06-1646 Rev 003, OFGEM, 19 July 2007
- [20] J. Douglas, R. Millard and L. Fourie, PB Power – United Kingdom and South Africa, 'Reliability Worth for a Restructured Electricity Distribution Industry', CIRED 18th International Conference on Electricity Distribution, Turin, June 2005
- [21] M. Bollen, A. Holm, Y. He, P. Owe, 'A Customer-Oriented Approach Towards Reliability Indices', CIRED 19th International Conference on Electricity Distribution, Vienna, May 2007
- [22] R. Billinton, Z. Pan, 'Historic Performance-Based Distribution System Risk Assessment', IEEE Trans. On Power Delivery (2004), pp 1759-1765.
- [23] R. Billinton, R.N. Allan, 'Reliability Evaluation of Power Systems' 2nd edition, Plenum Press, 1996, Chapters 7-13
- [24] L. Hannah, 'Electricity before Nationalisation', Macmillan, London, 1979
- [25] CE Electric UK, 'Asset Serviceability Review 2007' (Internal CE Electric UK report)

- [26] G. Ault, D. Frame, N. Hughes, N. Strachan, 'Electricity Network Scenarios for Great Britain in 2050', Final report for Ofgem's LENS project, November 2008.
- [27] D. J. C. McKay, 'Sustainable Energy without the Hot Air', 2009. Downloaded from www.withouthotair.com, 15.03.10
- [28] Element Energy, Cambridge. 'Strategies for the Uptake of Electric Vehicles and Associated Infrastructure Implications', for The Committee on Climate Change, October 2009. Accessed 16.09.10 via hmccc.s3.amazonaws.com/Element_Energy
- [29] www.energysavingtrust.org.uk , accessed 13/11/09
- [30] UK Energy Research Centre, 'Milton Keynes Energy Park Dwellings 1990', Data from Dwelling 0831.
- [31] 2005/06 Electricity Distribution Quality of Service Report, OFGEM, 1 Dec 2006, accessed 15.09.10 via www.ofgem.gov.uk
- [32] P. C. Taylor, P. M. Tavner, 'CE Electric UK Distribution Network Risk. Proposed Research Programme'. Durham University, September 2006. (internal document)
- [33] S. Bouwman, G.A. Bloemhof, J.F.L. van Casteren, B. Taks, 'Advantages of Probabilistic System Analysis', CIRED 18th International Conference on Electricity Distribution, Turin, June 2005
- [34] IEEE Standard 493-1990: Recommended Practice for the Design of Reliable Industrial and Commercial Power Systems, IEEE, 1991
- [35] G. Tollefson, R. Billinton, G. Wacker, 'Comprehensive Bibliography on Reliability Worth and Electric Service Consumer Interruption Costs 1960-1990', IEEE Transactions on Power Systems, Vol.6, No.4, Nov. 1991, pp. 1508-1514
- [36] A. Makinen, J. Partanen, E. Lakervi, 'A Practical Approach for Estimating of Future Outage Costs in Power Distribution Networks', IEEE Transactions on Power Delivery, Vol.5, No.1, Jan.1990, pp. 311-316
- [37] M. A. Rios, D. S. Kirschen, D. Jayaweera, D. P. Nedic, R. N. Allan, 'Value of Security: modelling time-dependent phenomena and weather conditions', IEEE Transactions on Power Systems, Vol.17, No.3, 2002, pp 543-548

- [38] T. Kaipia, J. Lassila, J. Partanen, J. Lohjala, 'A Cost Analysis Method for Storm Caused Extensive Outages in Distribution Networks', CIRED 19th International Conference on Electricity Distribution, Vienna, May 2007
- [39] Opinion expressed by engineers at CE Electric UK in discussion, October 2008.
- [40] A. Arcos Vargas, 'But, Can We Afford the Current Level of Risk? A New Model for a New Age', CIRED 19th International Conference on Energy Distribution, Vienna, May 2007
- [41] P. Hilber, B. Hallgren, L. Bertling, 'Optimising the Replacement of Overhead Lines in Rural Distribution Systems with Respect to Reliability and Customer Value', CIRED 18th International Conference on Energy Distribution, Turin, June 2005
- [42] D.S. Kirschen, K.R.W. Bell, D.P. Nedic, D. Jayaweera, R.N. Allan, 'Computing the Value of Security', IEE Proceedings - Generation, Transmission and Distribution (2003), pp 673-678
- [43] S. Kazemi, M. Foluhi-Firuzabad, R. Billinton, 'Reliability Assessment of an Automated Distribution System', IET Generation, Transmission and Distribution, 2007, pp.223-233
- [44] M. Kruithof, J. Hodemaekers, R. Van Dijk, 'Quantitative Risk Assessment: A Key to Cost-Effective SAIFI and SAIDI Reduction', CIRED 18th International Conference on Electricity Distribution, Turin, June 2005
- [45] M. Delfanti, C. Bovo, M.S. Pasquadibisceglie, M. Pozzi, E. Zio, 'Indirect Monte Carlo Approach to Evaluate Reliability and Availability Indices of Distribution Networks', CIRED 18th International Conference on Electricity Distribution, Turin June 2005
- [46] R. Billinton, E. Khan, 'A security based approach to composite power system reliability evaluation', IEEE Transactions on Power Systems, Vol.7, No.1, Feb. 1992, pp.65-72
- [47] A.M. Leite de Silva, L. Chavas de Resende, L Antonio da Fonesca Menso, V Miranda, 'Composite Reliability Assessment Based on Monte Carlo Simulation and Artificial Neural Networks', IEEE Trans. on Power Systems (2007), pp 1202-1209

- [48] A. Sankarakrishnan, R. Billinton, 'Sequential Monte-Carlo Simulation for Composite Power System Reliability Analysis with Time Varying Loads', IEEE Transactions on Power Systems, volume 10, no. 3, Aug. 1995, pp.1540-1545
- [49] C. L. T. Borges, D. M. Falcao, J. C. O. Mello, A. C. G. Melo, 'Composite Reliability Evaluation by Sequential Monte Carlo Simulation on Parallel and Distributed Processing Environments', IEEE Transactions on Power Systems, Vol. 16, No. 2, May 2001, pp.203-209
- [50] I.J. Ramirez-Rosado, J.L. Bernal-Agustin, 'Reliability and Costs Optimisation for Distribution Networks Expansion Using an Evolutionary Algorithm', IEE Trans. on Power Systems (2001), pp. 111-118
- [51] L.A. Freeman, D.T. Van Zandt, L.J. Powell, 'Using a Probabilistic Design Process to Maximise Reliability and Minimize Cost in Urban Central Business Districts', CIRED 18th International Conference on Electricity Distribution, Turin, June 2005
- [52] R. E. Brown, M. M. Marshall, 'Budget Constrained Planning to Optimize Power System Reliability', IEEE Transactions on Power Systems, Vol.15, No.2, May 2000, pp.887-892
- [53] R. Billinton, J.R.Acharya, 'Weather-based Distribution System Reliability Evaluation', IEE Proceedings – Generation, Transmission and Distribution (2006), pp 499-506
- [54] J. McDonald, B. Pal, G. Strbac, P. Lang, 'Benefits of a Risk-Based Comparison of Electrical Distribution System Operation', CIRED 20th International Conference on Electricity Distribution, Prague, June 2009
- [55] J.D. Andrews, T.R. Moss, 'Reliability and Risk Assessment' 2nd edition, Professional Engineering Publishing, 2002
- [56] W. Li , J. Zhou, J. Lu, W. Yan, A Probabilistic Analysis Approach to Making Decision on Retirement of Aged Equipment in Transmission Systems', IEEE Trans. on Power Delivery (2007) pp 1891 -1896
- [57] D. Hughes, T. Pears, 'Condition Based Risk Management (CBRM), a Process to Link Engineering Knowledge and Practical Experience to Investment Planning – an Update'. CIRED 19th International Conference on Electricity Distribution, Vienna, May 2007

- [58] D. Hughes, P. Pschierer-Barnfather, T. Pears, 'Condition Based Risk Management (CBRM): Bringing Excellence in Asset Management into the Boardroom', CIRED 20th International Conference on Electricity Distribution, Prague, June 2009.
- [59] V. Borozan, N. Rajakovic, 'Application Assessments of Distribution Network Minimum Loss Reconfiguration', IEEE Transactions on Power Delivery, Vol.12, No.4, Oct. 1997, pp.1786-1792
- [60] Q. Zhou, D. Shirmohammadi, W. H. E. Liu, 'Distribution Reconfiguration for Operation Cost Reduction', IEEE Transactions on Power Systems, Vol.12, No.2, May 1997, pp.730-735
- [61] J.G. Sootweg, P.M. Van Oirsouw, 'Incorporating Reliability Calculations in Routine Network Planning: Theory and Practice', CIRED 18th International Conference on Electricity Distribution, Turin, June 2005
- [62] M. Oravasaari, J. Pylvanainen, J. Jarvinen, A. Maniken, P. Verho, 'Evaluation of Alternative MV Distribution Network Plans From Reliability Point of View', CIRED 18th International Conference on Electricity Distribution, Turin, June 2005
- [63] J. Pechey, P. Taylor, R. Dixon, M. Lawson, A. Dinning, 'The Role of Medium Voltage Electrical Design in Risk Management for Offshore Wind Farms', International Journal of Wind Engineering, Vol.28, No.5, 2004, pp.489-503
- [64] K. Moslehi, R. Kumar, 'First Aid for Power Grids', Power Engineer, IET Oct/Nov 2007
- [65] P. Deschamps, J-C. Orsini, 'On the Field Autonomous Automatism: A Complementary Way for Network Automation', CIRED 20th International Conference on Electricity Distribution, Prague, June 2009
- [66] P. W. Cox, 'Self-Healing Networks: Performance Improvement by Automated Switching Algorithm', CIRED 20th International Conference on Electricity Distribution, Prague, June 2009
- [67] D. Macleman, W. Bik, A. Jones, 'Evaluation of a Self Healing Distribution Automation Scheme on the Isle of Wight', CIRED 20th International Conference on Electricity Distribution, Prague, June 2009

- [68] R.E. Brown, J.H. Spare, 'Asset Management, Risk, and Distribution System Planning', IEEE PES Power System Conference and Exposition 2004
- [69] R.E. Brown, A.P. Hanson, 'Impact of Two-Stage Service Restoration on Distribution Reliability', IEEE Transactions on Power Systems (2001), pp 624-629
- [70] S. Krahl, S. Ohrem, H-J. Haubrich, 'Probability Distributions of Reliability Indices of Electrical Distribution Networks', CIRED 20th International Conference on Electricity Distribution, Prague, June 2009
- [71] R. Billinton, W. Wangdee, 'Predicting Bulk Electricity System Reliability Performance Indices Using Sequential Monte Carlo Simulation', IEEE Transactions on Power Delivery, Volume 21 No. 2, April 2006, pp 909-917.
- [72] Primary Substation Restoration Guide, Internal CE Electric UK working documents (2007)
- [73] J. Endrenyi, S. Aboresheid, R.N. Allan, G.J. Anders. S. Asgarpoor, R. Billinton, N. Chowdhury, E.N. Dialynas, M. Fipper, R.H. Fletcher, C. Grigg, J. McCalley, S. Meliopoulos, T.C. Mielnik, P. Nitu, N.D. Reppen, L. Salvaderi, A. Schneider, Ch. Singh, 'The Present Status of Maintenance Strategies and the Impact of Maintenance on Reliability', IEEE Trans. on Power Systems (2001), pp 638-646
- [74] W. Li, J. Korczynski, 'A Reliability-Based Approach to Transmission Maintenance Planning and its Application in BC Hydro System', IEEE Trans. on Power Delivery (2004), pp 303-308
- [75] M.-Y Chow, L.S. Taylor, M-S Chow, IEEE Trans. on Power Delivery (1996), pp 1652-1658
- [76] M. Scutariu, H. Albert, 'Corrective Maintenance Timetable in Restructured Distribution Environment', IEEE Trans. on Power Delivery (2007), pp 650-657
- [77] P.N. Vovos, A.E. Kiprakis, A.R. Wallace, G.P. Harrison, 'Centralized and Distributed Voltage Control: Impact on Distributed Generation Penetration', IEEE Trans. on Power Systems (2007), pp 476 – 483

- [78] B. Enacheanu, M. Fontela, Ch. Andrieu, Ha. Pham, A. Martin, Y. Besanger, 'New Control Strategies to Prevent Blackouts: Intentional Islanding Operation in Distribution Networks, CIRED 18th International Conference on Electricity Distribution, Turin, June 2005
- [79] M. Gauthier, C. Abbey, F. Katiraei, J-L. Pepin, M. Plamondon, G. Simard, 'Planned Islanding as a Distribution System Operation Tool for Reliability Enhancement', CIRED 19th International Conference on Electricity Distribution, Vienna, May 2007
- [80] CE Electric UK, 'Asset Serviceability Review 2006. The Review of the Serviceability of the 132 kV, 66 kV and 33 kV Networks and Major System Risk' (internal document)
- [81] CE Electric UK, 'Review of the Serviceability of Overhead Lines', 2007 (internal document)
- [82] www.statistics.gov.uk/cci/nugget.asp?id=168 Last accessed 20.09.10
- [83] www.yorkshirewater.com Last accessed 20.09.10
- [84] V. Burgess, D. T. Hughes, J. Beech, 'Implementing Condition Based Risk Management in CE Electric UK', EA Technology report for CE Electric UK, March 2004
- [85] S. Blake, P. Taylor, P. Tavner, G. Howarth, "An Investigation into Using Oil Replenishment Data as a Factor to Prioritise the Replacement of Extra High Voltage Electrical Cable", 18th Advances in Risk and Reliability Technology Symposium, Loughborough, UK, April 2009
- [86] CE Electric UK, 'Asset Serviceability Review 2007, Review of the Serviceability of EHV Plant' (internal report)
- [87] National Fault and Interruption Scheme, Yorkshire Electricity System and Equipment Performance 2002-6, Energy Networks Association (confidential)
- [88] P. Imrie, 'A Functional Specification for the replacement of plant at Amberton Road primary substation', January 2006, (CE Electric UK internal document).
- [89] J. Helm, CE Electric UK, 'Review of the Transformer Health Indices Project, August 2007' (internal document)
- [90] Discussions with Asset Management Engineers at CE Electric UK

- [91] Presentation by and subsequent discussions with A. Thomas, Asset Management Engineers responsible for assets register at Central Networks, 12 July 2010.
- [92] C. R. Bayliss and B. J. Hardy, 'Transmission and Distribution Electrical Engineering', third edition, Newnes (Elsevier), Oxford, 2007.
- [93] United Kingdom Generic Distribution System (UKGDS) Phase One, DTI Centre for Distributed Generation and Sustainable Electrical Energy
- [94] P.d'E.Stowell, MANWEB, 'A Review of Some Aspects of Electricity Distribution', 1956
- [95] Scottish Power Long Term Development Statement, 2007.
www.scottishpowered.com/Library_178.asp Last accessed 20.09.10
- [96] DTI Centre for Distributed Generation and Sustainable Electrical Energy, 'United Kingdom Generation Distribution System (UKGDS) Phase One Profile Data', One Year, Daily Mix.
- [97] DTI Centre for Distributed Generation and Sustainable Electrical Energy, 'United Kingdom Generation Distribution System (UKGDS) Phase One Profile Data', 24 Hours, Half-hourly Mix.
- [98] Discussions with D. Miller, Asset Management Engineer, CE Electric UK, November 2009.
- [99] D. A. Roberts, SP Power Systems Ltd., 'Network Management Systems For Active Distribution Networks – A Feasibility Study', Report K/EL/00310/REP URN 04/1361 for DTI, 2004
- [100] H. Khatib, 'Economic Evaluation of Projects in the Electricity Supply Industry', Institution of Electrical Engineers, 2003.
- [101] L. Fingersh, M. Hand, A. Laxson, 'Wind Turbine Design Cost and Scaling Model', National Renewable Energy Laboratory Technical Report, NREL/TP-500-40566, December 2006
- [102] Discussions with P. Lang, Asset Management Engineer, edf , November 2009
- [103] Distribution Price Control Review 5. Last accessed 20.09.10 via www.ofgem.gov.uk/Networks/ElecDist/PriceCtrls/DPCR5/
- [104] P. Imrie, 'An Investment Appraisal for the provision of additional 11kV capacity in Hartlepool', Internal CE Electric UK report, 2006.

- [105] www.ucte.org Last accessed 20.09.10
- [106] G. Palumbo, L. Panella, L. Ventura, 'Quality of service target planning and risk analysis for effective asset management – The Enel Distribuzione case study', CIRED workshop, Lyon, June 2010
- [107] www.ipsa-power.com Last accessed 10/08/08
- [108] www.itcsoftware.com Last accessed 10/08/08
- [109] Power Factory Manual, DigSILENT GmbH, Gomaringen, Germany, 2007
- [110] www.cyme.com/software/cymdistgateway Last accessed 10/08/08
- [111] www.abb.com/industries Last accessed 09/09/08
- [112] www.advanticagroup.com Last accessed 10/08/08
- [113] www.neplan.com Last accessed 10/08/08
- [114] www.simtec-gmbh.at Last accessed 09/09/08
- [115] L. Longley, 'Critical Analysis of Software', unpublished M.Eng research project, Durham University, May 2008.
- [116] www.arinc.com/products/raptor Last accessed 11/08/08
- [117] www.itemsoft.com Last accessed 11/08/08
- [118] www.isograph.com Last accessed 11/08/08
- [119] www.pti-us.com Last accessed 09/09/08
- [120] www.solver.com/risksolver Last accessed 12/09/09
- [121] CE Electric UK, 'Risk Assessment Methodology', Issue 4, June 2003 (internal document)
- [122] CE Electric UK, 'Load Driven Reinforcement 2006 Strategic Analysis Document' (internal document)
- [123] Network Risk Project, Grant Application and Proposal Form, Knowledge Transfer Partnerships (internal document)

the conservative assumption is that one feeder, say 1122a, is disconnected through the 2 hour peak, bringing the flow in 302-312 down from 26.221 MVA to 24.983 MVA, which is only 4% above rating, and regarded as acceptable.

The disconnection of a single feeder through a 2 hour peak is similar to the situation where Z1 is out, and is therefore governed by similar equations:

$$\begin{aligned} CI &= 0.801 \times 27.1\% \times 1000 \times 6 = 1302 \\ CML &= 0.801 \times 27.1\% \times 1.69 \times 60 \times 0.10 = 2203 \end{aligned} \quad (4)$$

The total incremental risk cost is just slightly greater than that due to loss of Z1.

F6 Analysis of n-2 situation without Z1 and Z2

Unlike the n-1 situations, the n-2 situations do not impose specific P2/6 constraints in this demand group. The requirement for the control engineers is therefore just to minimise CIs and CMLs consistent with safety and network security. However, all the n-2 situations lead to incremental load-related CIs and CMLs in the base year of 2010 as well as larger values in 2022.

With the loss of both Z1 and Z2, and the fast reconnection (15 minutes) of the 1101a feeder to be fed from 1112, the connectivity constraints mean that half the feeders from 1118 (which has lost both its transformers) will be disconnected for the outage duration, assumed to be 4 hours on average. This disconnection of feeders 1118e to h has already been accounted for in the connectivity-based calculation in Appendix D.

The other feeders from 1118 were assumed in Appendix D to be reconfigured to be fed from 1122 (1118a) or from 1110 (1118b, c and d). However, 1110 has also lost a transformer, and even at 2010 loads, this would require a peak load power flow of 14.041 MVA through the remaining transformer, which is only rated at 10.8 MVA (77% of 14.041 MVA). This indicates that 2 of the 3 feeders could not be transferred to 1110 at peak times, and that 1 of the 3 could not be transferred at shoulder times. This is a similar situation to that caused by the loss of Z2 alone in 2022, and so similar equations will be used:

$$\begin{aligned}
 CI &= 0.198 \times [27.1\% \times 2000 + 8.3\% \times 1000] \times 6 = 742 \\
 CML &= 0.198 \times [27.1\% \times 2.38 \times 2000 + 8.3\% \times 1.0 \times 1000] \times 60 \times 0.10 = 1633
 \end{aligned}
 \tag{5}$$

Moving forward to 2022, losing 2 feeders at peak times will no longer be sufficient to bring assets back within their rating. With all feeders connected at peak loading, a power flow of 19.147 MVA would be required through transformer T2 at 1110. The winter rating of this transformer is only 10.8 MVA, or 56% of 19.147 MVA. Although there are times of day when the power flow is usually below 56% of the peak, it would probably not be prudent to rely on that (below about 2/3 of peak levels). Accordingly, it is assumed that one feeder from 1118 will not be supplied from 1110 at whatever time the failure event occurs, and that in addition two feeders are disconnected at peak times, and one feeder is disconnected at shoulder times, as in 2010. The feeder 1118a, reconfigured to be fed from 1122, brings the load on that transformer up to 8.529 MVA at peak, only 1.5% above rating, and therefore acceptable.

Comparing 2022 with 2010, then, requires the additional loss of one feeder at all times. The incremental cost over 2010 is therefore given by:

$$\begin{aligned}
 CI &= 0.198 \times 1000 \times 6 = 1188 \\
 CML &= 0.198 \times 240 \times 1000 \times 0.1 = 4752
 \end{aligned}
 \tag{6}$$

where 240 minutes is used as the average duration of disconnection. The incremental cost in 2022 over the connectivity risk is $742 + 1188 = 1930$ for CIs, and $1633 + 4752 = 6385$ for CMLs. It seems at first sight surprising that this is less than that incurred by the loss of Z2 alone in the same year. But it must be remembered that these costs are incremental to the connectivity risk, which is nil in the case of losing Z2 alone, but which already includes the loss of 4 feeders from 1118 in the case of losing both Z1 and Z2. Also, there is a factor for the probability of the event, which for the n-2 event is only around one fifth of that for the n-1 event.

F7 Analysis of n-2 situation without Z2 and Z3

The loss of both Z2 and Z3 results in the loss of all supply to load points 1110, 1112 and 1122. As regards connectivity, 66% of 1110 and 50% of 1122 can be supplied from 1118, while 60% of 1112 can be supplied from 1101. However, even at 2010 loads, this would require peak power flow through 1101 transformer to be 7.674 MVA, compared with a winter rating of 4.8 MVA, which is only 63% (less than 2/3) of this amount. Accordingly, one of the 1112 feeders which could physically be connected would in fact be disconnected at whatever time the n-2 incident occurred. This reduces the peak loading on 1101 to 5.550 MVA (4.8 MVA = 86%) That would require the additional disconnection of another feeder only during a 2 hour evening peak.

At the southern end of the network, transformer T1 at 1118 would be connected to a peak load of 24.952 MVA, of which the 18 MVA rating is 72%. This would require disconnection of two feeders at peak, and one at shoulder times, according to the calculations first carried out for the loss of Z2 alone. The cost of this is given by the equations:

$$\begin{aligned} CI &= 0.213 \times [800 + 27.1\% \times 800 + 27.1\% \times 2000 + 8.3\% \times 1000] \times 6 = 2098 \\ CML &= 0.213 \times [240 \times 800 + 27.1\% \times 1.69 \times 60 \times 800 + \\ & 27.1\% \times 2.38 \times 60 \times 2000 + 8.3\% \times 1.0 \times 60 \times 1000] \times 0.10 = 6316 \end{aligned} \quad (7)$$

In these equations, the figure 800 relates to the average number of customers per 11 kV feeder at load point 1112, compared with the larger value of 1000 appropriate to southern load points (see Table 9.1).

Moving forward to 2022, the load that has to be shed at all times in the northern part of the network includes two feeders from 1112. The third can be reconfigured to be fed from 1101. This increases the peak load at 1101 to 4.968 MVA, only slightly (and acceptably) above the 4.8 MVA winter rating. So it transpires that, unusually in this particular case, there is no dependence on the time of day at which a fault occurs. One feeder can be reconfigured at any time, the other two cannot be reconfigured at any time.

In the southern part of the network, all the reconfigurable feeders (1110b, 1110c and 1122a) have to remain unsupplied at all times. Indeed, the normal load at 1118 now has a peak power demand of 24.009 MVA, as

against a winter rating of 18 MVA, requiring the disconnection of 2 feeders at peak and 1 at shoulder times. The overall cost in 2022 is given by the equations:

$$\begin{aligned}
 CI &= 0.213 \times [2 \times 800 + 3 \times 1000 + 27.1\% \times 2000 + 8.3\% \times 1000] \times 6 = 6678 \\
 CML &= 0.213 \times [240 \times 2 \times 800 + 240 \times 3 \times 1000 + \\
 &27.1\% \times 2.38 \times 60 \times 2000 + 8.3\% \times 1.0 \times 60 \times 1000] \times 0.10 = 25272
 \end{aligned}
 \tag{8}$$

F8 Analysis of n-2 situation without Z1 and Z3

In this final n-2 scenario, with the loads at 1101 and 1122 reconfigured, the critical asset is the overhead line 302-312, with a winter rating of 24 MVA. Even at 2010 loads, the peak requirement is for a flow in excess of 40 MVA. It is not possible to say exactly how much, as the IPSA model does not converge at this level. If 4 feeders are disconnected from 1118 and 2 feeders from 1112, the peak flow in line 302-312 is reduced to 31.643 MVA, of which the winter rating is 76%. This can be accommodated by losing a further 2 feeders from 1118 at peak and one feeder at shoulder times. This reduces the peak load through 302-312 to an acceptable level of 24.876 MVA, 4% above rating. The equations governing this are:

$$\begin{aligned}
 CI &= 0.087 \times [2 \times 800 + 4 \times 1000 + 27.1\% \times 2000 + 8.3\% \times 1000] \times 6 = 3249 \\
 CML &= 0.087 \times [240 \times 2 \times 800 + 240 \times 4 \times 1000 + \\
 &27.1\% \times 2.38 \times 60 \times 2000 + 8.3\% \times 1.0 \times 60 \times 1000] \times 0.10 = 12411
 \end{aligned}
 \tag{9}$$

By 2022, the extra incremental load shedding required as compared with 2010 is 2 more feeders from 1112 and 2 feeders from 1110. The incremental cost of this is given by:

$$\begin{aligned}
 CI &= 0.087 \times [2 \times 800 + 2 \times 1000] \times 6 = 1879 \\
 CML &= 0.087 \times [240 \times 2 \times 800 + 240 \times 2 \times 1000] \times 0.10 = 7517
 \end{aligned}
 \tag{10}$$

The incremental cost in 2022 over the connectivity risk is $3249 + 1879 = 5128$ for CIs, and $12411 + 7517 = 19928$ for CMLs.

Since the n-3 scenario of losing all three circuits is assumed to be of negligible probability, this concludes the analysis of scenarios.

the conservative assumption is that one feeder, say 1122a, is disconnected through the 2 hour peak, bringing the flow in 302-312 down from 26.221 MVA to 24.983 MVA, which is only 4% above rating, and regarded as acceptable.

The disconnection of a single feeder through a 2 hour peak is similar to the situation where Z1 is out, and is therefore governed by similar equations:

$$\begin{aligned} CI &= 0.801 \times 27.1\% \times 1000 \times 6 = 1302 \\ CML &= 0.801 \times 27.1\% \times 1.69 \times 60 \times 0.10 = 2203 \end{aligned} \quad (4)$$

The total incremental risk cost is just slightly greater than that due to loss of Z1.

F6 Analysis of n-2 situation without Z1 and Z2

Unlike the n-1 situations, the n-2 situations do not impose specific P2/6 constraints in this demand group. The requirement for the control engineers is therefore just to minimise CIs and CMLs consistent with safety and network security. However, all the n-2 situations lead to incremental load-related CIs and CMLs in the base year of 2010 as well as larger values in 2022.

With the loss of both Z1 and Z2, and the fast reconnection (15 minutes) of the 1101a feeder to be fed from 1112, the connectivity constraints mean that half the feeders from 1118 (which has lost both its transformers) will be disconnected for the outage duration, assumed to be 4 hours on average. This disconnection of feeders 1118e to h has already been accounted for in the connectivity-based calculation in Appendix D.

The other feeders from 1118 were assumed in Appendix D to be reconfigured to be fed from 1122 (1118a) or from 1110 (1118b, c and d). However, 1110 has also lost a transformer, and even at 2010 loads, this would require a peak load power flow of 14.041 MVA through the remaining transformer, which is only rated at 10.8 MVA (77% of 14.041 MVA). This indicates that 2 of the 3 feeders could not be transferred to 1110 at peak times, and that 1 of the 3 could not be transferred at shoulder times. This is a similar situation to that caused by the loss of Z2 alone in 2022, and so similar equations will be used:

$$\begin{aligned}
 CI &= 0.198 \times [27.1\% \times 2000 + 8.3\% \times 1000] \times 6 = 742 \\
 CML &= 0.198 \times [27.1\% \times 2.38 \times 2000 + 8.3\% \times 1.0 \times 1000] \times 60 \times 0.10 = 1633
 \end{aligned}
 \tag{5}$$

Moving forward to 2022, losing 2 feeders at peak times will no longer be sufficient to bring assets back within their rating. With all feeders connected at peak loading, a power flow of 19.147 MVA would be required through transformer T2 at 1110. The winter rating of this transformer is only 10.8 MVA, or 56% of 19.147 MVA. Although there are times of day when the power flow is usually below 56% of the peak, it would probably not be prudent to rely on that (below about 2/3 of peak levels). Accordingly, it is assumed that one feeder from 1118 will not be supplied from 1110 at whatever time the failure event occurs, and that in addition two feeders are disconnected at peak times, and one feeder is disconnected at shoulder times, as in 2010. The feeder 1118a, reconfigured to be fed from 1122, brings the load on that transformer up to 8.529 MVA at peak, only 1.5% above rating, and therefore acceptable.

Comparing 2022 with 2010, then, requires the additional loss of one feeder at all times. The incremental cost over 2010 is therefore given by:

$$\begin{aligned}
 CI &= 0.198 \times 1000 \times 6 = 1188 \\
 CML &= 0.198 \times 240 \times 1000 \times 0.1 = 4752
 \end{aligned}
 \tag{6}$$

where 240 minutes is used as the average duration of disconnection. The incremental cost in 2022 over the connectivity risk is $742 + 1188 = 1930$ for CIs, and $1633 + 4752 = 6385$ for CMLs. It seems at first sight surprising that this is less than that incurred by the loss of Z2 alone in the same year. But it must be remembered that these costs are incremental to the connectivity risk, which is nil in the case of losing Z2 alone, but which already includes the loss of 4 feeders from 1118 in the case of losing both Z1 and Z2. Also, there is a factor for the probability of the event, which for the n-2 event is only around one fifth of that for the n-1 event.

F7 Analysis of n-2 situation without Z2 and Z3

The loss of both Z2 and Z3 results in the loss of all supply to load points 1110, 1112 and 1122. As regards connectivity, 66% of 1110 and 50% of 1122 can be supplied from 1118, while 60% of 1112 can be supplied from 1101. However, even at 2010 loads, this would require peak power flow through 1101 transformer to be 7.674 MVA, compared with a winter rating of 4.8 MVA, which is only 63% (less than 2/3) of this amount. Accordingly, one of the 1112 feeders which could physically be connected would in fact be disconnected at whatever time the n-2 incident occurred. This reduces the peak loading on 1101 to 5.550 MVA (4.8 MVA = 86%) That would require the additional disconnection of another feeder only during a 2 hour evening peak.

At the southern end of the network, transformer T1 at 1118 would be connected to a peak load of 24.952 MVA, of which the 18 MVA rating is 72%. This would require disconnection of two feeders at peak, and one at shoulder times, according to the calculations first carried out for the loss of Z2 alone. The cost of this is given by the equations:

$$\begin{aligned} CI &= 0.213 \times [800 + 27.1\% \times 800 + 27.1\% \times 2000 + 8.3\% \times 1000] \times 6 = 2098 \\ CML &= 0.213 \times [240 \times 800 + 27.1\% \times 1.69 \times 60 \times 800 + \\ & 27.1\% \times 2.38 \times 60 \times 2000 + 8.3\% \times 1.0 \times 60 \times 1000] \times 0.10 = 6316 \end{aligned} \quad (7)$$

In these equations, the figure 800 relates to the average number of customers per 11 kV feeder at load point 1112, compared with the larger value of 1000 appropriate to southern load points (see Table 9.1).

Moving forward to 2022, the load that has to be shed at all times in the northern part of the network includes two feeders from 1112. The third can be reconfigured to be fed from 1101. This increases the peak load at 1101 to 4.968 MVA, only slightly (and acceptably) above the 4.8 MVA winter rating. So it transpires that, unusually in this particular case, there is no dependence on the time of day at which a fault occurs. One feeder can be reconfigured at any time, the other two cannot be reconfigured at any time.

In the southern part of the network, all the reconfigurable feeders (1110b, 1110c and 1122a) have to remain unsupplied at all times. Indeed, the normal load at 1118 now has a peak power demand of 24.009 MVA, as

against a winter rating of 18 MVA, requiring the disconnection of 2 feeders at peak and 1 at shoulder times. The overall cost in 2022 is given by the equations:

$$\begin{aligned}
 CI &= 0.213 \times [2 \times 800 + 3 \times 1000 + 27.1\% \times 2000 + 8.3\% \times 1000] \times 6 = 6678 \\
 CML &= 0.213 \times [240 \times 2 \times 800 + 240 \times 3 \times 1000 + \\
 &27.1\% \times 2.38 \times 60 \times 2000 + 8.3\% \times 1.0 \times 60 \times 1000] \times 0.10 = 25272
 \end{aligned}
 \tag{8}$$

F8 Analysis of n-2 situation without Z1 and Z3

In this final n-2 scenario, with the loads at 1101 and 1122 reconfigured, the critical asset is the overhead line 302-312, with a winter rating of 24 MVA. Even at 2010 loads, the peak requirement is for a flow in excess of 40 MVA. It is not possible to say exactly how much, as the IPSA model does not converge at this level. If 4 feeders are disconnected from 1118 and 2 feeders from 1112, the peak flow in line 302-312 is reduced to 31.643 MVA, of which the winter rating is 76%. This can be accommodated by losing a further 2 feeders from 1118 at peak and one feeder at shoulder times. This reduces the peak load through 302-312 to an acceptable level of 24.876 MVA, 4% above rating. The equations governing this are:

$$\begin{aligned}
 CI &= 0.087 \times [2 \times 800 + 4 \times 1000 + 27.1\% \times 2000 + 8.3\% \times 1000] \times 6 = 3249 \\
 CML &= 0.087 \times [240 \times 2 \times 800 + 240 \times 4 \times 1000 + \\
 &27.1\% \times 2.38 \times 60 \times 2000 + 8.3\% \times 1.0 \times 60 \times 1000] \times 0.10 = 12411
 \end{aligned}
 \tag{9}$$

By 2022, the extra incremental load shedding required as compared with 2010 is 2 more feeders from 1112 and 2 feeders from 1110. The incremental cost of this is given by:

$$\begin{aligned}
 CI &= 0.087 \times [2 \times 800 + 2 \times 1000] \times 6 = 1879 \\
 CML &= 0.087 \times [240 \times 2 \times 800 + 240 \times 2 \times 1000] \times 0.10 = 7517
 \end{aligned}
 \tag{10}$$

The incremental cost in 2022 over the connectivity risk is $3249 + 1879 = 5128$ for CIs, and $12411 + 7517 = 19928$ for CMLs.

Since the n-3 scenario of losing all three circuits is assumed to be of negligible probability, this concludes the analysis of scenarios.