

Durham E-Theses

Halogenated triazines and related systems

Peter Hoare

How to cite:

Hoare, Peter (1989) Halogenated triazines and related systems. Doctoral thesis, Durham University.

Use policy

The full-text may be used and/or reproduced, and given to third parties in any format or medium, without prior permission or charge, for personal research or study, educational, or not-for-profit purposes provided that:

- a full bibliographic reference is made to the original source
- a <https://etheses.durham.ac.uk/id/eprint/6514/> is made to the metadata record in Durham E-Theses
- the full-text is not changed in any way

The full-text must not be sold in any format or medium without the formal permission of the copyright holders.

Please consult the [full Durham E-Theses policy](#) for further details.

UNIVERSITY OF DURHAM

A THESIS

entitled

HALOGENATED TRIAZINES AND RELATED SYSTEMS

submitted by

PETER HOARE, B.Sc.

(Graduate Society)

The copyright of this thesis rests with the author.

No quotation from it should be published without

his prior written consent and information derived

from it should be acknowledged.

A candidate for the degree of Doctor of Philosophy

Department of Chemistry

1989



- 4 OCT 1989

To Mum and Dad

ACKNOWLEDGMENTS

I would like to thank my supervisor, Prof. R. D. Chambers, for his continued advice and encouragement during the course of this project. I would also like to thank Dr. M. R. Bryce for his co-supervision during my first-year.

Many thanks also to Dr. T. Shepherd for his advice, assistance and discussions, especially with the solution fluorination and low temperature photolysis work, and to Dr. C. J. Ludman for the use of the low temperature i.r. cell.

I would also like to thank Mr. T. F. Holmes for his valuable help and advice with apparatus and equipment, especially with the high pressure autoclave reactions.

Thanks are also due to Dr. M. Jones for discussions regarding mass spectrometry, and to Dr. R. S. Matthews for advice and discussions concerning n.m.r. spectroscopy.

I would additionally like to express my thanks to the many Departmental technical staff, including Mr. V. J. McNeilly (mass spectrometry), Mr. J. W. Banks (n.m.r. spectroscopy), the late Mr. J. A. Parkinson (g.l.c. and t.l.c.), Mrs. M. Cocks (elemental analyses), Mr. R. Hart and Mr. G. Haswell (glassblowing), and Mr. D. Hunter (chemicals and high pressure facilities).

I would also like to thank my friends and colleagues, both in the laboratory and the Graduate Society, for making my stay in Durham so enjoyable, especially the members of the Graduate Society Cricket and Boat Clubs.

Thanks are also due to the S.E.R.C. for the provision of a maintenance grant.

Finally, I would like to thank my parents for their continued encouragement and support, both moral and financial, throughout the period of my university education.

MEMORANDUM

The work described in this thesis was carried out in the Department of Chemistry at the University of Durham between October 1984 and November 1987.

This work has not previously been submitted, in part or whole, for a degree at this or any other university, and is the original work of the author except where specifically acknowledged by reference.

The copyright of this thesis rests with the author. No quotation from it should be published without his prior written consent, and information derived from it should be acknowledged.

NOMENCLATURE

A capital F in a ring denotes that the ring and all unmarked substituents are fully fluorinated.

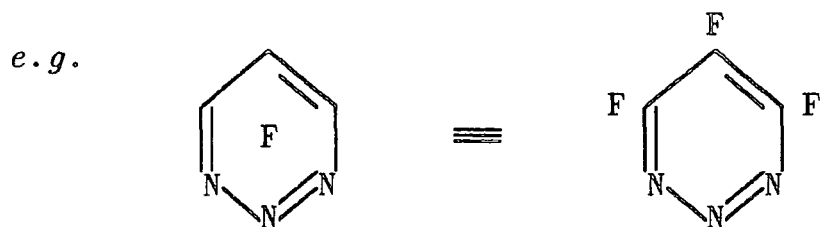

Similarly, Cl in a ring denotes that the ring and all unmarked substituents are fully chlorinated.

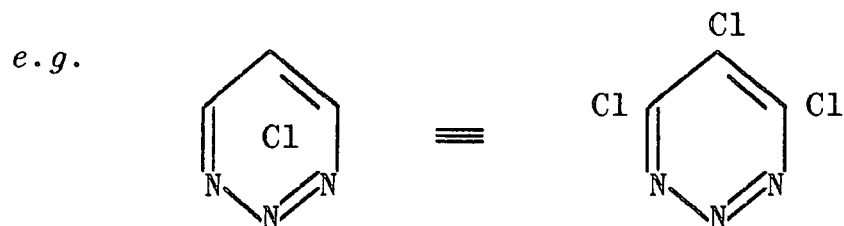

HALOGENATED TRIAZINES AND RELATED SYSTEMS

by
PETER HOARE

Trifluoro- and 5-chlorodifluoro-1,2,3-triazine were prepared from the vapour-phase fluorination of trichloro-1,2,3-triazine, and their reactions with several simple nucleophiles were investigated.

A new reagent system for the polyfluoroalkylation of the reactive trichloro-1,2,3- and -1,3,5-triazines under very mild conditions was developed with Dr. T. Shepherd. This system was also used to fluorinate various perchloro-heteroaromatics under mild conditions.

The photolysis of both trifluoro- and perfluoro-4,6-bis-isopropyl-1,2,3-triazines, at liquid nitrogen temperatures, provided conclusive evidence for the direct observation of both trifluoro- and perfluoro-2,4-bis-isopropyl-azetes and their respective dimers. Additionally, the transference photolysis of perfluoro-4,6-bis-isopropyl-1,2,3-triazine provided clear evidence that the dimerisation of perfluoro-2,4-bis-isopropylazete is a thermal process. The static photolysis of trifluoro-1,2,3-triazine produced a brown polymer, which was identified as poly(trifluoro-acrylonitrile).

The transference photolysis of perfluoro-3,5-bis-isopropylpyridazine was repeated, and the identities of two of the perfluoro-3-isopropylazete dimers were confirmed.

Some photolysis and pyrolysis reactions of both perfluoro-3,4,6-tris-isopropylpyridazine and perfluoro-4-(2'-methylpent-2'-yl)pyridazine were also investigated.

An improved synthetic route to hexachlorocinnoline was developed, but all attempts to produce fluorinated and perfluoroalkyl derivatives were unsuccessful.

Studies of the negative ion mass spectra and ^{13}C n.m.r. spectra of various series of halogenated and perfluoroalkyl-substituted heteroaromatics were also conducted.

CONTENTS

Acknowledgments	i
Memorandum	ii
Nomenclature	iii
Abstract	iv

INTRODUCTIONCHAPTER ONESOME ASPECTS OF THE CHEMISTRY OF HALOGENATED
DIAZINES AND TRIAZINES

1.A	Introduction	1
1.B	Synthesis of halogenated diazines and triazines	1
1.	Chlorination of heteroaromatics	2
a)	Diazines	2
b)	Triazines	6
2.	Fluorination of perchloroheteroaromatics	7
a)	Diazines	8
b)	Triazines	9
1.C	Nucleophilic aromatic substitution	10
1.	Effect of substituents on reactivity and orientation of nucleophilic attack	11
a)	Ring nitrogens	11
b)	Halogen substituents	13
c)	Perfluoroalkyl substituents	15
2.	Polyfluoroalkylation of perhaloheteroaromatics	18
1.D	Thermal and photochemical rearrangements of perfluoroheteroaromatics	21
1.	Thermal rearrangements of perfluoroalkylpyridazines	21
2.	Formation of valence isomers from fluorinated pyridines and pyridazines	24
1.E	Nitrogen elimination from halogenated 1,2,3- and 1,2,4-triazines	27
1.	Halogenated 1,2,4-triazines	28
a)	Trichloro-1,2,4-triazine	28

b) Trifluoro-1,2,4-triazine	29
c) Perfluoroalkyl-1,2,4-triazines	29
2. Halogenated 1,2,3-triazines	31
a) Trichloro-1,2,3-triazine	31
b) Trifluoro-1,2,3-triazine	31
c) Perfluoro-4,6-bis-isopropyl-1,2,3-triazine	32
d) Perfluoro-tris-isopropyl-1,2,3-triazine	33

DISCUSSION

CHAPTER TWO

SYNTHESIS AND CHEMISTRY OF HALOGENATED 1,2,3-TRIAZINES

2.A Introduction	35
2.B Synthesis of halogenated 1,2,3-triazines	35
1. Trichloro-1,2,3-triazine	35
2. Fluorinated 1,2,3-triazines	37
a) Introduction	37
b) Trifluoro-1,2,3-triazine	38
c) 5-chloro-4,6-difluoro-1,2,3-triazine	39
3. Attempted polyfluoroalkylation of trichloro-1,2,3-triazine	40
2.C Nucleophilic aromatic substitution reactions	42
1. Introduction	42
2. Trifluoro-1,2,3-triazine	43
a) With secondary amines	43
b) With methanol	44
c) With phenol	44
3. 5-chloro-4,6-difluoro-1,2,3-triazine	45
a) With secondary amines	45
b) With methanol	45
c) With phenol	46
2.D Attempted cycloaddition reactions of halogenated 1,2,3-triazines	47
1. Introduction	47
2. Trichloro-1,2,3-triazine	51
3. Trifluoro-1,2,3-triazine	54

CHAPTER THREE
SOLUTION FLUORINATIONS

3.A	Introduction	57
3.B	Polyfluoroalkylation of perchlorotriazines	57
1.	Trichloro-1,2,3-triazine	58
2.	Trichloro-1,3,5-triazine	60
3.C	Fluorination of perchloroheteroaromatics	62
1.	Using the diethyl ether/sulpholane solvent system	62
a)	Trichloro-1,3,5-triazine	63
b)	Trichloro-1,2,3-triazine	64
c)	Tetrachloropyrimidine	67
d)	Tetrachloropyridazine	69
2.	Using the di-n-butyl ether/sulpholane solvent system	70
a)	Tetrachloropyrimidine	70
b)	Tetrachloropyridazine	71
c)	Pentachloropyridine	71

CHAPTER FOUR
PHOTOLYSIS OF FLUORINATED 1,2,3-TRIAZINES

4.A	Introduction	73
4.B	Low temperature photolyses of fluorinated 1,2,3-triazines	75
1.	Experimental method	76
2.	Trifluoro-1,2,3-triazine	77
a)	Sampling of starting material	77
b)	Photolysis of trifluoro-1,2,3-triazine	78
c)	Sampling of pentafluoropyridine	87
d)	Photolysis of pentafluoropyridine	87
e)	Attempted trapping of trifluoroazete with furan	88
f)	Attempted co-photolysis of trifluoro-1,2,3-triazine and perfluoro-4,6-bis-isopropyl-1,2,3-triazine	90
3.	Perfluoro-4,6-bis-isopropyl-1,2,3-triazine	91
a)	Sampling of starting material	91

b) Photolysis of perfluoro-4,6-bis-isopropyl-1,2,3-triazine	92
c) Trapping of perfluoro-2,4-bis-isopropylazete with furan	93
4. Conclusions	94
4.C Transference photolysis of perfluoro-4,6-bis-isopropyl-1,2,3-triazine	95
1. Transference photolysis	96
2. Attempted trapping of perfluoro-2,4-bis-isopropylazete with furan	97
4.D Static photolysis of trifluoro-1,2,3-triazine	99

CHAPTER FIVE

CHEMISTRY OF SOME PERFLUOROISOPROPYLPYRIDAZINES

5.A Introduction	103
5.B Synthesis of polyfluoroalkylpyridazines	105
1. Polyfluoroalkylations of tetrafluoropyridazine	105
a) With hexafluoropropene	105
b) With perfluorocyclobutene	107
2. Polyfluoroalkylation of perfluoro-4-isopropylpyridazine with perfluoro-2-methylpent-2-ene	108
3. Polyfluoroalkylation of perfluoro-4,5-bis-isopropylpyridazine with tetrafluoroethylene	110
5.C Transference photolysis of perfluoro-3,5-bis-isopropylpyridazine	111
5.D Low temperature photolysis of polyfluoroisopropylpyridazines	127
1. Introduction	127
2. Perfluoro-4,5-bis-isopropylpyridazine	128
3. Perfluoro-3,5-bis-isopropylpyridazine	128
5.E Chemistry of perfluoro-3,4,6-tris-isopropylpyridazine	129
1. Introduction	129
2. Photolysis	130
3. Pyrolysis	132
4. Nucleophilic attack	135
a) With dimethylamine	135

b) With 2,3-dimethylbut-2-ene	137
-------------------------------	-----

CHAPTER SIX

CHEMISTRY OF PERFLUORO-4-(2'-METHYLPENT-2'-YL)PYRIDAZINE

6.A Introduction	139
6.B Synthesis	140
6.C Photolysis	143
1. Static	143
2. Transference	144
6.D Pyrolysis	146
1. Static	147
2. Flow	153

CHAPTER SEVEN

PREPARATION AND ATTEMPTED REACTIONS OF HEXACHLOROCINNOLINE

7.A Introduction	155
7.B Synthesis of hexachlorocinnoline	156
7.C Attempted fluorinations of hexachlorocinnoline	162
1. Introduction	162
2. Static	163
3. Vapour-phase	165
4. Solution	166
7.D Attempted polyfluoroalkylations of halocinnolines	169
1. Introduction	169
2. Hexachlorocinnoline	170
3. 5,7-dichlorotetrafluorocinnoline	172
7.E Other attempted reactions of hexachlorocinnoline	173
1. Nucleophilic aromatic substitution	173
a) With sodium methoxide	174
2. Photolysis	176
3. Attempted N-oxidation	176

CHAPTER EIGHT
NEGATIVE ION MASS SPECTRA OF SOME HALOGENATED AND
PERFLUOROALKYL-DIAZINES AND -1,2,3-TRIAZINES

8.A	Introduction	178
8.B	Negative ion mass spectrometry	179
1.	Formation of negative ions	179
2.	The stability of negative molecular ions	181
a)	Fluorine substitution	182
3.	Fragment formation	182
8.C	Halogenated pyridazines	183
8.D	Halogenated pyrazines	188
8.E	Halogenated 1,2,3-triazines	188

CHAPTER NINE

¹³C N.M.R. SPECTRA OF SOME HALOGENATED AND PERFLUOROALKYL-
DIAZINES AND -1,2,3-TRIAZINES

9.A	Introduction	194
9.B	Selected features of the spectra	194
1.	Halogenated pyridines	194
2.	Halogenated pyridazines	196
3.	Halogenated 1,2,3-triazines	200
4.	Conclusions	203
9.C	Potential methods for shift predictions	204
1.	The introduction of ring nitrogens into haloaromatics	205
2.	Introduction of perfluoroisopropyl groups into the pyridazine ring system	210
a)	Substituent chemical shift values	210
b)	Predictions using the calculated SCS values	211
3.	Attempted assignment of the ¹³ C n.m.r. spectrum of hexachlorocinnoline	213
4.	Conclusions	218

EXPERIMENTAL

Instrumentation	219
-----------------	-----

Reagents	220
----------	-----

CHAPTER TEN

EXPERIMENTAL FOR CHAPTER TWO

SYNTHESIS AND CHEMISTRY OF HALOGENATED 1,2,3-TRIAZINES

10.A Trichloro-1,2,3-triazine (<u>20</u>)	222
1. Starting materials	222
a) Pentachlorocyclopropane (<u>100</u>)	222
b) Tetrachlorocyclopropene (<u>19</u>)	223
2. Trichloro-1,2,3-triazine (<u>20</u>)	223
10.B Fluorinated 1,2,3-triazines	224
1. Trifluoro-1,2,3-triazine (<u>28</u>)	224
2. 5-chloro-4,6-difluoro-1,2,3-triazine (<u>102</u>)	225
10.C Attempted polyfluoroalkylation of trichloro-1,2,3-triazine (<u>20</u>)	226
1. Small scale	226
2. Larger scale	226
10.D Nucleophilic substitution reactions	227
1. Trichloro-1,2,3-triazine (<u>20</u>)	227
a) With methanol	227
2. Trifluoro-1,2,3-triazine (<u>28</u>)	228
a) With secondary amines	228
i) Pyrrolidine	228
ii) Piperidine	228
iii) Hexamethyleneimine	229
b) With methanol	229
c) With phenol	230
3. 5-chloro-4,6-difluoro-1,2,3-triazine (<u>102</u>)	230
a) With secondary amines	230
i) One equivalent of pyrrolidine	230
ii) Excess pyrrolidine	231
iii) One equivalent of hexamethyleneimine	231
b) With methanol	232
c) With phenol	232
i) One equivalent	232
ii) Two equivalents	233

10.E	Attempted cycloaddition reactions	233
1.	Trichloro-1,2,3-triazine (<u>20</u>)	233
a)	With enamines	233
i)	N-morpholino-1-cyclohexene (<u>131</u>)	233
ii)	Pyrrolidino-1-cyclopentene (<u>132</u>)	234
b)	With 2,3-dimethylbut-2-ene (<u>134</u>)	235
c)	With dihydrofuran (<u>135</u>)	235
i)	At 50°C	235
ii)	At 150°C	235
d)	With cyclopentene (<u>136</u>)	235
2.	Trifluoro-1,2,3-triazine (<u>28</u>)	236
a)	With pyrrolidino-1-cyclopentene (<u>132</u>)	236
b)	With pyrrolidino-1-cyclohexene (<u>137</u>)	236
3.	Trimethoxy-1,2,3-triazine (<u>110</u>)	237
a)	In solution	237
b)	In a sealed tube	237

CHAPTER ELEVEN

EXPERIMENTAL FOR CHAPTER THREE

SOLUTION FLUORINATIONS

11.A	Polyfluoroalkylation of perchlorotriazines	238
1.	Trichloro-1,2,3-triazine (<u>20</u>)	238
a)	Single step reaction	238
b)	Two stage reaction	239
2.	Trichloro-1,3,5-triazine (<u>139</u>)	239
a)	With caesium fluoride in sulpholane	239
b)	With potassium fluoride in diethyl ether/ sulpholane	240
i)	Single step reaction	240
ii)	Two stage reaction	241
11.B	Fluorination of perchloroheteroaromatics	241
1.	Using the diethyl ether/sulpholane solvent system	241
a)	Basic method	241
b)	Trichloro-1,3,5-triazine (<u>139</u>)	242
c)	Trichloro-1,2,3-triazine (<u>20</u>)	242
d)	Tetrachloropyrimidine (<u>8</u>)	242

e) Tetrachloropyridazine (3)	244
2. Using the di-n-butyl ether/sulpholane solvent system	244
a) Basic method	244
b) Tetrachloropyrimidine (8)	244
c) Tetrachloropyridazine (3)	244
d) Pentachloropyridine (143)	245

CHAPTER TWELVE

EXPERIMENTAL FOR CHAPTER FOUR

PHOTOLYSIS OF FLUORINATED 1,2,3-TRIAZINES

12.A Low temperature photolyses	246
1. Apparatus and experimental procedure	246
2. Trifluoro-1,2,3-triazine (28)	249
a) M.s. sampling of (28)	249
b) Photolysis of (28)	250
c) M.s. sampling of pentafluoropyridine (39)	250
d) Photolysis of (39)	252
e) Attempted trapping of azete (145) with furan	252
f) Co-photolysis of trifluoro-1,2,3-triazine (28) with perfluoro-4,6-bis-isopropyl-1,2,3- triazine (93)	253
3. Perfluoro-4,6-bis-isopropyl-1,2,3-triazine (93)	253
a) M.s. sampling of (93)	253
b) Photolysis of (93)	254
c) Trapping of azete (94) with furan	256
12.B Transference photolysis of perfluoro-4,6-bis- isopropyl-1,2,3-triazine (93)	258
1. At 254nm and 8mm Hg	258
2. Attempted trapping of azete (94)	258
12.C Static photolysis of trifluoro-1,2,3-triazine (28)	259

CHAPTER THIRTEEN

EXPERIMENTAL FOR CHAPTER FIVE

CHEMISTRY OF SOME PERFLUOROISOPROPYLPYRIDAZINES

13.A Synthesis of perfluoroisopropylpyridazines	260
---	-----

1. Perfluoro-4,5-bis-isopropylpyridazine (<u>60</u>)	260
2. Rearrangement of perfluoro-4,5-bis-isopropylpyridazine (<u>60</u>) with fluoride ion	260
3. Reaction of perfluoro-3,4,6-tris-isopropylpyridazine (<u>159</u>) and tetrafluoropyridazine (<u>21</u>) with fluoride ion	261
4. Reaction of tetrafluoropyridazine (<u>21</u>) with perfluorocyclobutene (<u>162</u>)	261
a) At room temperature	261
b) At 60°C	262
5. Reaction of perfluoro-4,5-bis-isopropylpyridazine (<u>60</u>) with tetrafluoroethylene	263
6. Reaction of perfluoro-4-isopropylpyridazine (<u>160</u>) with perfluoro-2-methylpent-2-ene (<u>167</u>)	264
a) At room temperature	264
b) At 60°C	264
13.B Transference photolysis of perfluoro-3,5-bis-isopropylpyridazine (<u>55</u>)	265
1. At 254nm	265
a) At 8mm Hg	265
b) At 4mm Hg	266
c) At 2mm Hg	266
2. At 300nm	267
13.C Low temperature photolyses of perfluoroalkylpyridazines	267
1. Perfluoro-4,5-bis-isopropylpyridazine (<u>60</u>)	267
2. Perfluoro-3,5-bis-isopropylpyridazine (<u>55</u>)	267
13.D Chemistry of perfluoro-3,4,6-trisisopropylpyridazine (<u>159</u>)	268
1. Photolysis	268
a) Under transference	268
b) In the vapour-phase	268
i) At 254nm	268
ii) At 366nm	268
c) In solution	269
2. Pyrolysis	269
3. Nucleophilic reactions	270

a) With dimethylamine	270
i) 5-dimethylamino-3,4,6-tris-isopropylpyridazine (188)	270
ii) Reaction of (188) with boron trifluoride- etherate	270
iii) Pyrolysis	271
iv) Photolysis	271
b) With 2,3-dimethylbut-2-ene (134)	271

CHAPTER FOURTEEN

EXPERIMENTAL FOR CHAPTER SIX

CHEMISTRY OF PERFLUORO-4-(2'-METHYLPENT-2'-YL)PYRIDAZINE

14.A Starting materials	273
1. Perfluoro-4-(2'-methylpent-2'-yl)pyridazine (169)	273
a) Perfluoro-2-methylpent-2-ene (167)	273
b) Perfluoro-4-(2'-methylpent-2'-yl)pyridazine (169)	273
2. Perfluoro-4-(2'-methylpent-2'-yl)pyrimidine (199)	274
14.B Photolysis	275
1. Under transference	275
a) At 254nm and 8mm Hg	275
b) At 254nm and 2mm Hg	275
c) At 300nm and 2mm Hg	276
d) At 300nm and 0.1mm Hg	276
e) Photochemical rearomatisation of (196)	276
2. Static	277
14.C Pyrolysis	277
1. Static	277
a) At 400°C	277
b) At 300°C	277
2. Perfluoro-4-(2'-methylpent-2'-yl)pyrimidine (199)	278
3. Flow	278

CHAPTER FIFTEEN
EXPERIMENTAL FOR CHAPTER SEVEN
PREPARATION AND ATTEMPTED REACTIONS OF HEXACHLOROCINNOLINE

15.A	Hexachlorocinnoline (<u>78</u>)	280
1.	Starting materials	280
	a) 4-hydroxycinnoline (<u>208</u>)	280
	b) 3-bromo-4-hydroxycinnoline (<u>209</u>)	280
	c) 3-bromo-4-chlorocinnoline (<u>210</u>)	281
	d) 3,4-dichlorocinnoline (<u>211</u>)	281
2.	Hexachlorocinnoline (<u>78</u>)	282
	a) From 3-bromo-4-chlorocinnoline (<u>210</u>)	282
	i) Small-scale	282
	ii) Large-scale	282
	b) From 3,4-dichlorocinnoline (<u>211</u>)	284
15.B	Attempted fluorinations of hexachlorocinnoline (<u>78</u>)	284
1.	Static	284
2.	Vapour-phase	285
3.	Solution	286
	a) In diethyl ether/sulpholane	286
	i) Atmospheric pressure	286
	ii) Sealed tube	286
	b) In di-n-butyl ether/sulpholane	287
	i) With potassium fluoride	287
	ii) With caesium fluoride	287
15.C	Attempted polyfluoroalkylations of halocinnolines	288
1.	Hexachlorocinnoline (<u>78</u>)	288
	a) With hexafluoropropene	288
	b) With perfluoro-tris-isopropyl-1,3,5-triazine (<u>84</u>)	289
2.	5,7-dichlorotetrafluorocinnoline (<u>215</u>)	290
	a) With hexafluoropropene	290
	b) With perfluoro-tris-isopropyl-1,3,5-triazine (<u>84</u>)	290
15.D	Other attempted reactions of hexachlorocinnoline (<u>78</u>)	291
1.	Nucleophilic aromatic substitution	291
	a) With sodium methoxide	291
	i) One equivalent	291
	ii) Two equivalents	291

2. Photolysis	292
a) In the vapour-phase	292
i) At 254nm	292
ii) At 366nm	292
b) In solution	293
3. Attempted N-oxidation	293

APPENDICES

<u>APPENDIX ONE</u>	
<u>N.M.R. SPECTRA</u>	294
<u>APPENDIX TWO</u>	
<u>I.R. SPECTRA</u>	315
<u>APPENDIX THREE</u>	
<u>MASS SPECTRA</u>	320
<u>APPENDIX FOUR</u>	
<u>DEPARTMENTAL RESEARCH LECTURES AND SEMINARS</u>	367
<u>REFERENCES</u>	376

INTRODUCTION

CHAPTER ONE

SOME ASPECTS OF THE CHEMISTRY OF HALOGENATED DIAZINES AND TRIAZINES

1.A Introduction

This chapter is not intended to be a comprehensive review of the synthesis and chemistry of the halogenated diazines and triazines, as several reviews are already available in the literature¹⁻⁵, but will give summaries of various aspects of the chemistry of these systems which are relevant as a background to the work presented in this thesis.

1.B Synthesis of halogenated diazines and triazines

This section is not intended to give an exhaustive list of syntheses of halogenated diazines and triazines, but gives examples for the preparation of each perhalo-heteroaromatic system which illustrate the methodologies developed for these syntheses. They are also practical laboratory routes to each heteroaromatic system, starting from readily available precursors.

An overall strategy for the synthesis of perfluoro-heteroaromatics has been developed¹ which involves the preparation of the perchloro compound from a partially chlorinated precursor, and the subsequent fluorination of the perchloro compound. The methodologies developed for each stage of this strategy will now be discussed in more detail.



1. Chlorination of heteroaromatics

The methodology for the synthesis of a wide range of perchloroheteroaromatic compounds has been developed in our laboratories, and may be divided into three steps:

- i) Formation of the heteroaromatic ring system by classical heterocyclic synthetic routes.
- ii) Partial chlorination of the ring, especially for the heterocyclic ring of benzo-fused systems.
- iii) Complete chlorination using electrophilic chlorinating species, either phosphorus pentachloride or a mixture of chlorine and aluminium trichloride.

The partial chlorination step is necessary as the electrophilic chlorination method, using Lewis acid catalysis, is believed to proceed *via* a co-ordination complex between the ring nitrogen and the Lewis acid, which deactivates the heterocyclic ring to further electrophilic attack⁶, *e.g.* for quinoline (1)⁷.

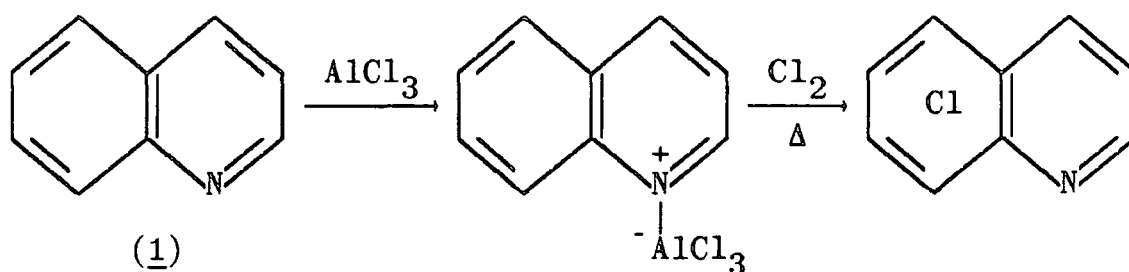

a) Diazines

An early preparative route to tetrachloropyridazine (3) started from dichloromaleic anhydride (2)⁸. However,

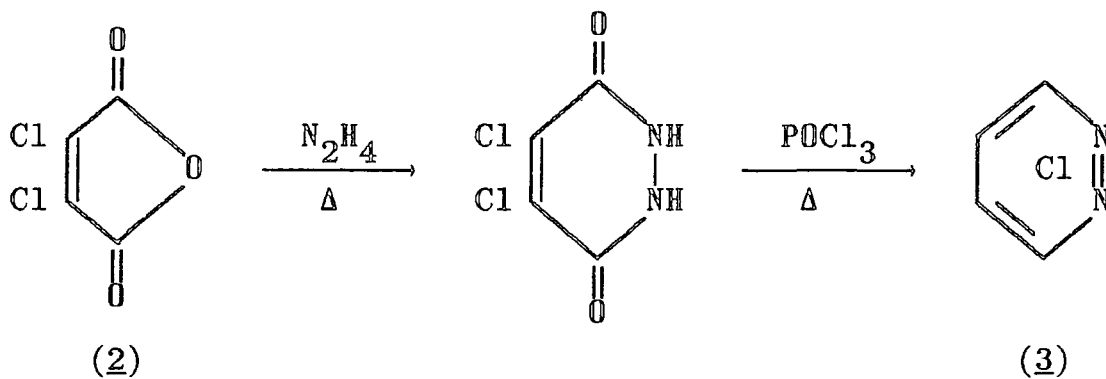

the high cost of the starting material (2) made this route impractical for larger scale preparations, and so a cheaper synthesis was developed in our laboratories from maleic anhydride (4)⁹. The final chlorination step was achieved using phosphorus pentachloride in an autoclave. Similarly,

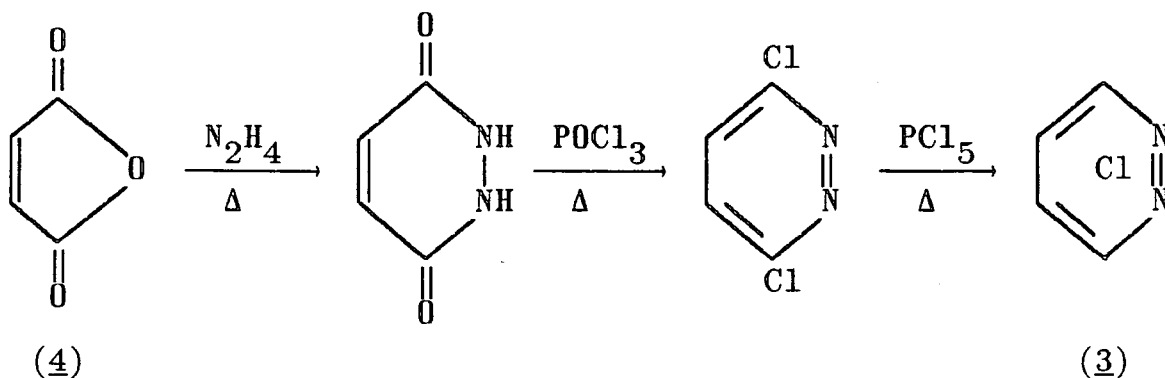

the benzo-fused derivative, hexachlorophthalazine (6), was also prepared in these laboratories using an analogous route starting from phthalic anhydride (5)¹⁰. In this case, however, the final chlorination step was achieved using a mixture of elemental chlorine and aluminium trichloride at atmospheric pressure. This method has become known as the "Swamping Catalyst" technique, because the aluminium trichloride is used in equivalent rather than genuinely catalytic amounts⁷.

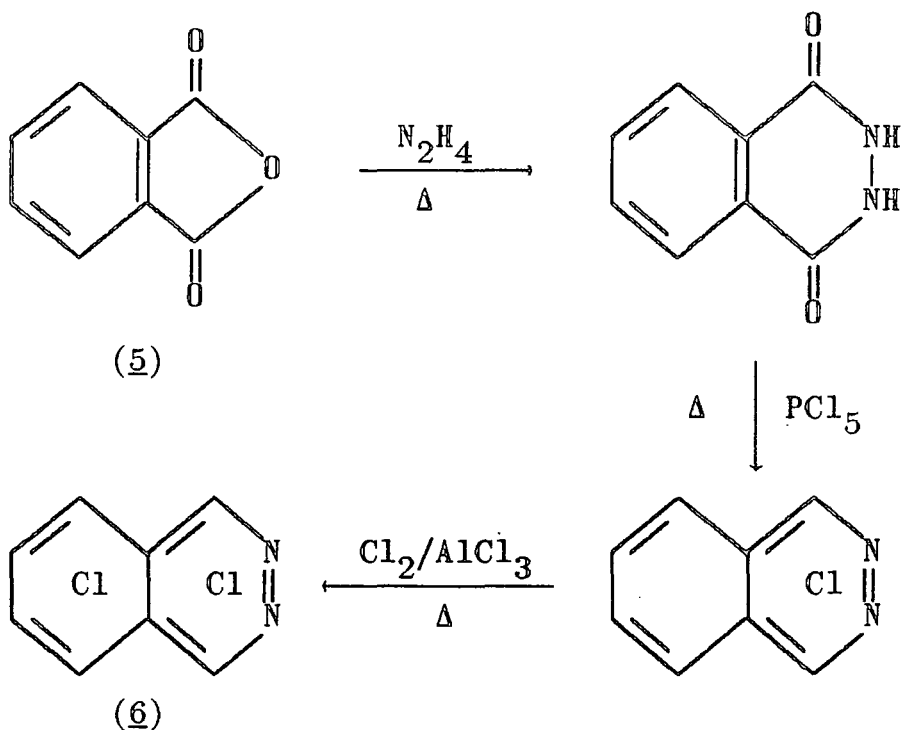

Tetrachloropyrimidine (8) is obtained from the chlorination of the readily available precursor barbituric acid (7) with phosphorus pentachloride in refluxing phosphorous oxychloride¹¹.

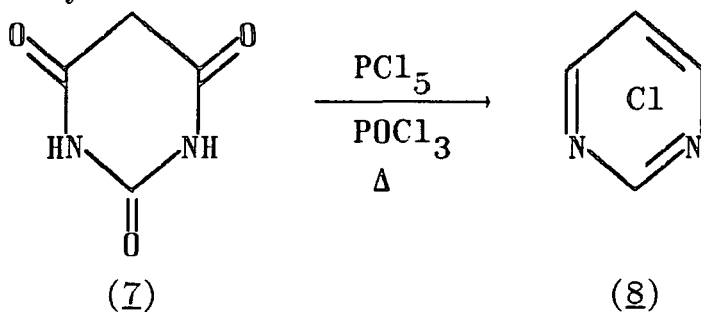

Hexachloroquinazoline (11) was prepared in our laboratories by a similar route from chlorination of the 2,4-dichloro derivative (10) with phosphorous pentachloride in an autoclave¹², with (10) obtained from the chlorination of benzoylene urea (9) using phosphorous pentachloride in refluxing phosphorous oxychloride¹³.

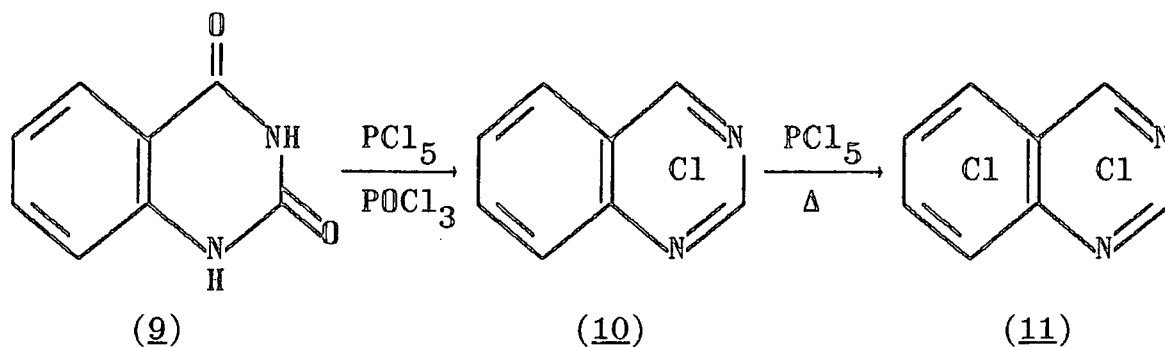

A preparative route to tetrachloropyrazine (14) was developed in these laboratories from pyrazine-2,3-dicarboxylic acid (13)¹⁴, which is itself obtained in two steps from *o*-phenylenediamine (12)¹⁵.

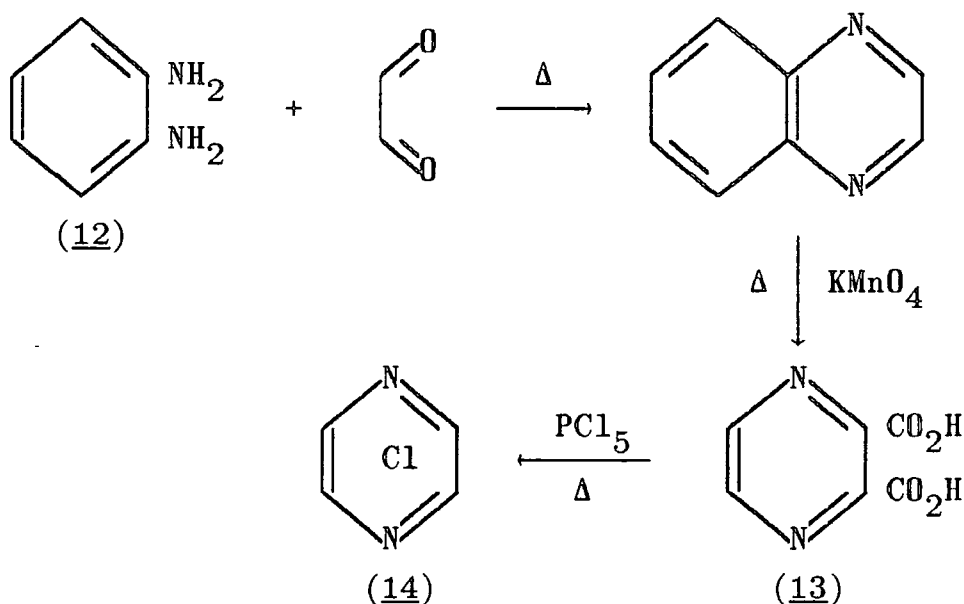

An early synthesis of hexachloroquinoxaline (16) was developed from tetrachloro-*o*-phenylenediamine (15) on a small scale, but gave only a low yield of (16)¹⁶. This is a rare example of a synthesis involving formation of the heterocyclic ring system from an already perchlorinated precursor. However, a more practical large scale synthesis of hexachloroquinoxaline (16) was developed from *o*-phenylenediamine (12) in our laboratories¹⁷.

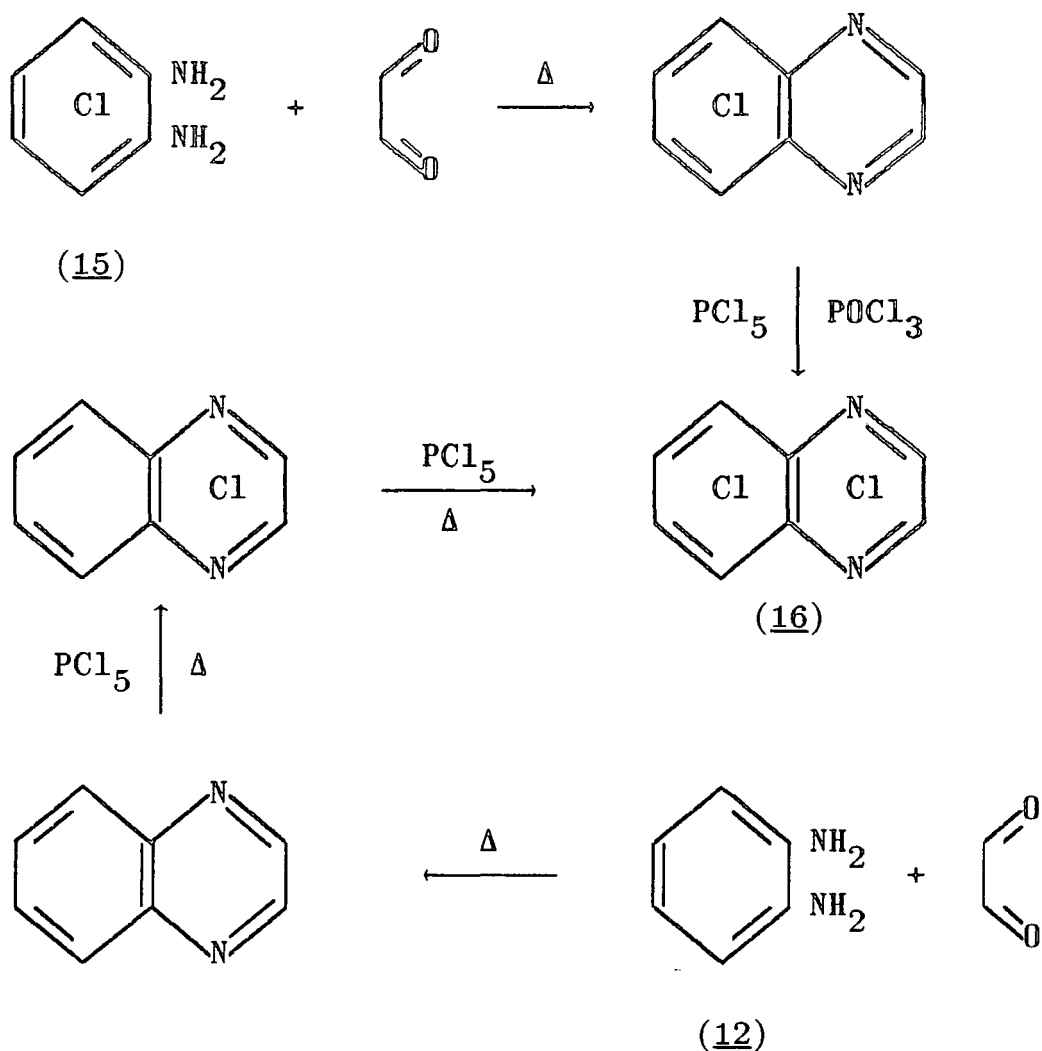

The only perchlorodiazine synthesis not described in this section is that for hexachlorocinnoline (78). The development of a large scale preparative route to this compound was one of the aims of this project, and is discussed in detail in Chapter Seven.

b) Triazines

Trichloro-1,2,4-triazine (18) was prepared on a small scale from the chlorination of 5-bromo-6-azauracil (17) with phosphorous pentachloride in refluxing phosphorous oxychloride¹⁸. A larger scale synthesis of (18) was

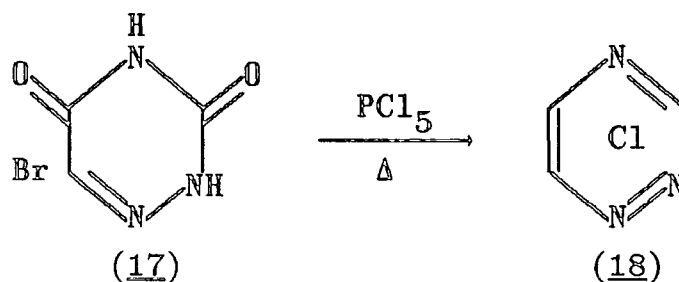

developed by a previous worker in these laboratories, from the same precursor, using phosphorous pentachloride in an autoclave¹⁹.

All the previous syntheses employ the same basic methodology discussed at the beginning of this section (1.B.1). However, the one perchloroheteroaromatic not made by this methodology is trichloro-1,2,3-triazine (20), which is prepared from the reaction between tetrachlorocyclopropene (19) and trimethylsilylazide²⁰. This different approach to the synthesis of (20) probably results from the fact that the parent 1,2,3-triazine has only comparatively recently been synthesised²¹.

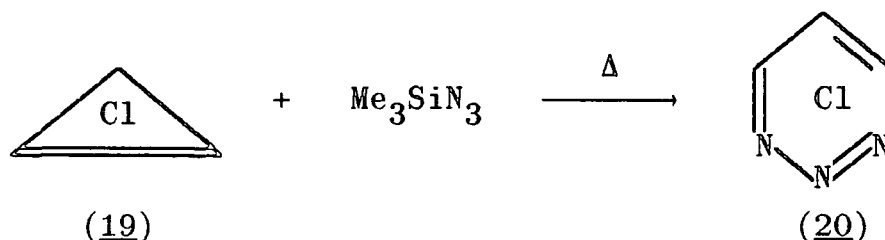

2. Fluorination of perchloroheteroaromatics

The most practical route to perfluoroheteroaromatics involves the use of potassium fluoride in a nucleophilic displacement of chlorine by fluorine from the corresponding perchloroheteroaromatics, which are electron-deficient and hence activated to nucleophilic attack. For most perchloro-

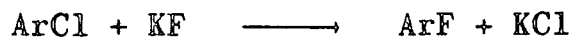

heteroaromatics, the reaction is carried out statically in an autoclave at high temperatures and in the absence of a solvent.

a) Diazines

Tetrafluoro-pyridazine (21)⁹, -pyrimidine (22)²² and -pyrazine (23)¹⁴ are all obtained from fluorination of the corresponding perchloro compounds in an autoclave with potassium fluoride.

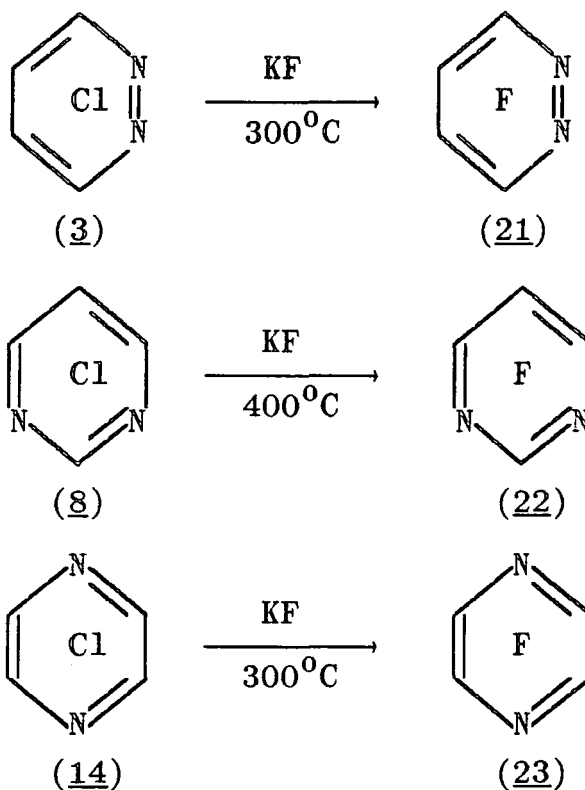

Similarly, hexachloro-phthalazine (6)¹⁰, -quinazoline (11)¹² and -quinoxaline (16)¹⁷ are also converted to the perfluorinated derivatives with potassium fluoride in an autoclave.

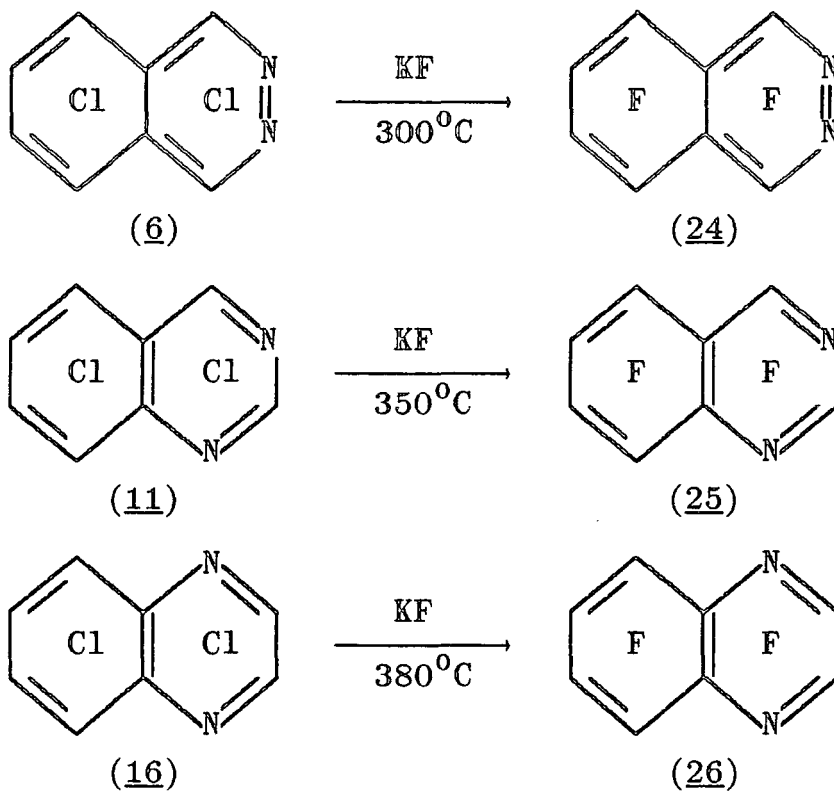

b) Triazines

The static fluorination method used to prepare the perfluorodiazines was found to be unsatisfactory for trichloro-1,2,4-triazine (18), as extensive decomposition occurred due to the thermal elimination of nitrogen from the perchloro compound¹⁹. This problem was overcome by Haszeldine and his co-workers, who developed a vapour-phase flow fluorination system to successfully fluorinate (18)²³. This method was subsequently used in our laboratories for the fluorination of trichloro-1,2,3-triazine (20)²⁴.

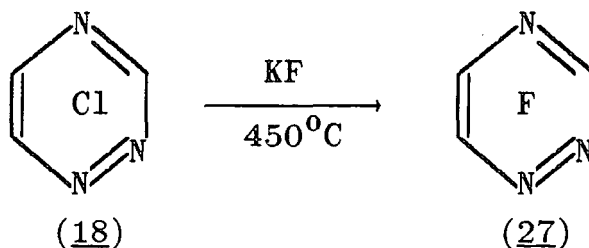

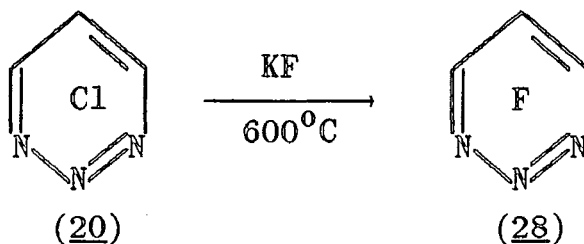

1.C Nucleophilic aromatic substitution

All perhaloaromatics are strongly activated to nucleophilic aromatic substitution as a result of their electron-withdrawing halogen substituents, which increase the electrophilicity of the aromatic ring by decreasing the electron-density in the ring. In addition, they also possess an excellent leaving group in the halide ion. The majority of nucleophilic aromatic substitution reactions of activated perhalo compounds are believed to occur *via* a two-step addition-elimination mechanism, with the first step generally rate-determining *i.e.* $k_2 \gg k_{-1}$ (Scheme 1.1). This is supported by the observed rates of substitution which decrease in the order $\text{F} \gg \text{Cl} > \text{Br} > \text{I}$, showing that there is little C-Hal bond-breaking in the rate determining step. This order follows the decreasing electronegativity of the halogens, and hence the degree of C-Hal bond polarisation in the substrate²⁵. Generally, fluoroaromatics react much

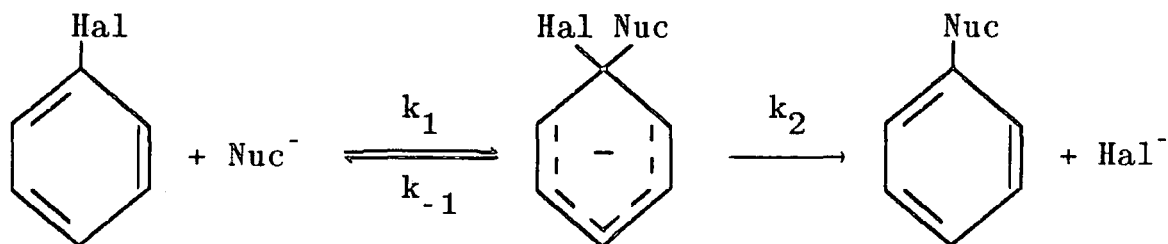

SCHEME 1.1

faster than the corresponding chloroaromatics, for a given nucleophile, because of this bond polarisation effect, *e.g.* for attack at the 4-position of pyridines (29) and (30) with aqueous ammonia²⁶, $k_F/k_{Cl} = 1.8 \times 10^3$. The structure of the

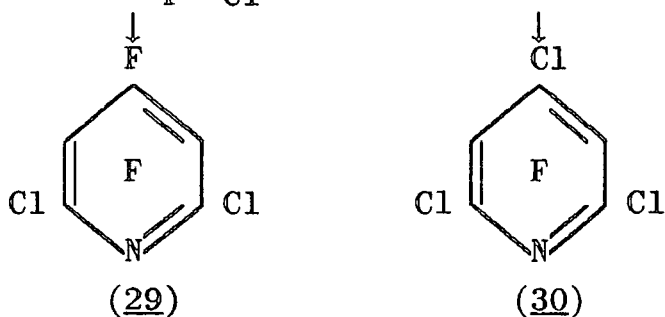

anionic σ -complex (31) which is a model for the transition-state of the rate-determining step consists of contributions from the resonance canonicals (31a) and (31b), of which (31a) is thought to be the major canonical, with the charge distribution greatest *para* to the site of attack, and this is supported by M. O. calculations²⁷.

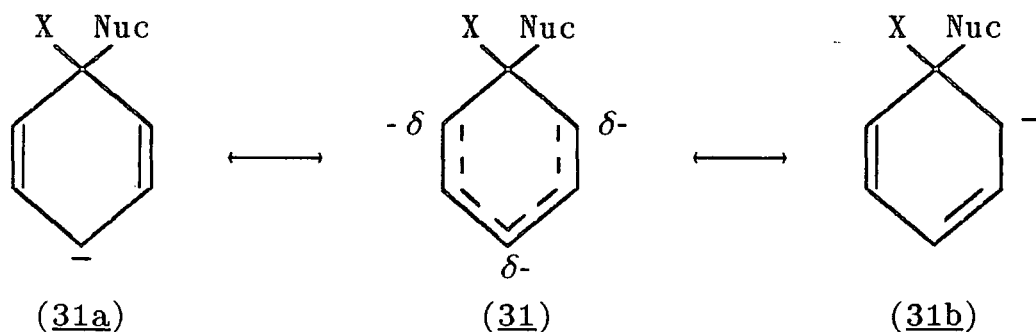

1. Effect of substituents on reactivity and orientation of nucleophilic attack

a) Ring nitrogens

Perhalo-N-heteroaromatics are further activated to nucleophilic aromatic substitution, relative to the corresponding benzenoid compounds, because of the effect of

the ring nitrogen(s). The relative rate constants measured for the attack of aqueous ammonia at the positions indicated show that enormous increases in reactivity occur across the series of perfluoroheteroaromatics²⁸.

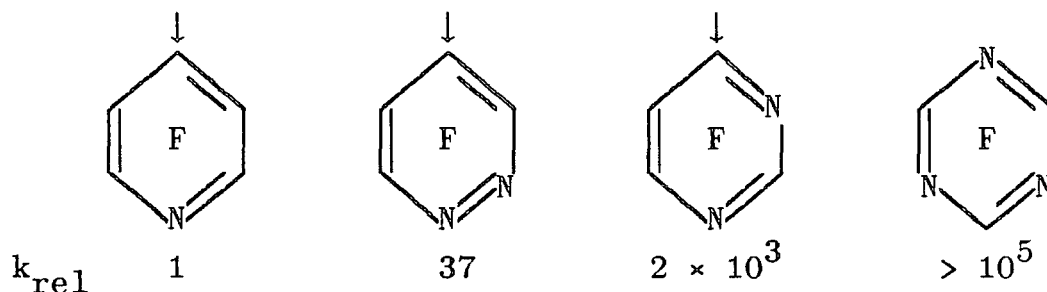

This additional reactivity results from a combination of two factors; i) inductive electron-withdrawal activating the substrate by increasing the electrophilicity of the sites *ortho* and *para* to ring nitrogen, and ii) preferential localisation of the negative charge onto the ring nitrogens in the transition-state (32). The relative activating

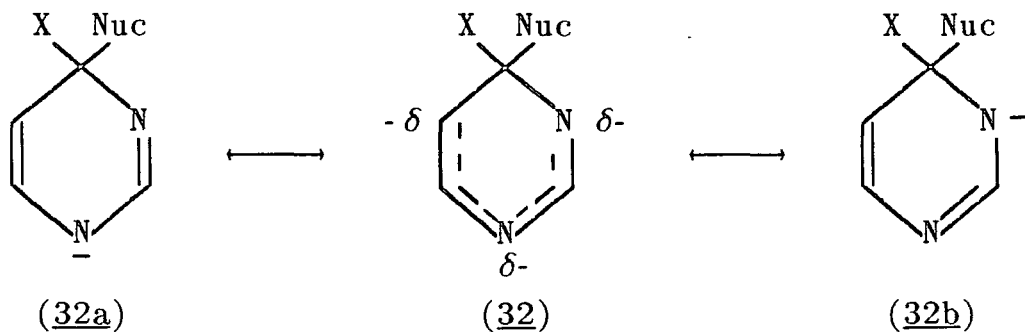

effects of a ring nitrogen *ortho*, *meta* and *para* to the site of nucleophilic attack have been determined by a kinetic study²⁸, which showed that =N- is very strongly activating in each position, relative to =CH- at the same position, and directs nucleophilic attack principally to the sites *ortho* and *para* to the ring nitrogen.

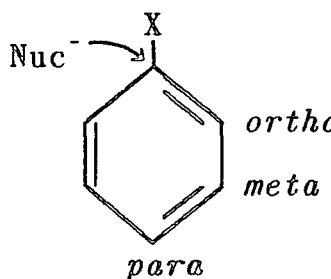
		Ring N	k_N/k_{CH}	k_{rel}
	<i>ortho</i>	<i>ortho</i>	6.2×10^4	73
	<i>meta</i>	<i>meta</i>	8.5×10^2	1
	<i>para</i>	<i>para</i>	2.3×10^5	271

b) Halogen substituents

The separate activating influences of fluorine²⁹ and chlorine³⁰ substituents *ortho*, *meta* and *para* to the site of nucleophilic attack have been determined experimentally, using a series of appropriately substituted pyridines with either aqueous ammonia or methoxide ion. The results indicate that, relative to hydrogen the same position, *ortho* and *meta* fluorines are strongly activating, whereas a *para* fluorine is slightly deactivating.

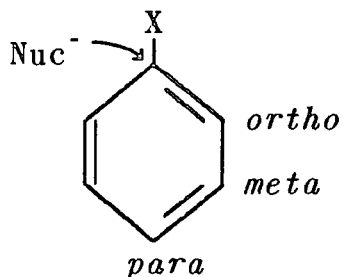
		Hal	k_F/k_H	k_{Cl}/k_H
	<i>ortho</i>	<i>ortho</i>	31.0	86.0
	<i>meta</i>	<i>meta</i>	23.0	24.0
	<i>para</i>	<i>para</i>	0.3	6.9

It is well established³¹ that a fluorine in situation (33) is strongly carbanion-stabilising due to inductive electron-withdrawal ($+I_\sigma$ effect), whereas in situation (34),

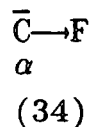
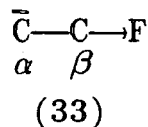

inductive electron-withdrawal ($+I_\sigma$) is strongly offset by electron-pair repulsions ($-I_\pi$ effect), with the net result that fluorine is destabilising relative to hydrogen at the same position.

With this information, and assuming the model for the transition-state already described (31), a rationalisation of these observed effects may be given²⁹.

The strong activating influence of a *meta* fluorine arises from its location in positions β to the localised negative charge centres in the transition-state (35), a situation where fluorine is known to be carbanion-stabilising³¹. The slightly deactivating effect of a *para* fluorine *versus* hydrogen must result from the destabilising $-I_\pi$ effect of fluorine directly bonded to a carbanionic centre being approximately offset by the stabilising $+I_\sigma$ effect (36). A similar activating effect to a *para* fluorine

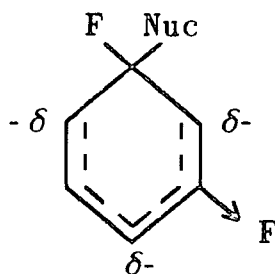

(35)

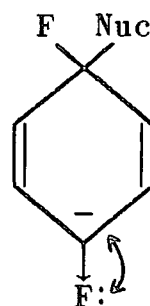

(36)

might also be expected for an *ortho* fluorine, but this is clearly not the case, as an *ortho* fluorine has a comparable activating effect to a *meta* fluorine. It has been suggested³² that this strongly activating effect of an *ortho* fluorine results from an ion-dipole interaction in the substrate, with the polar nature of the C-F bond *ortho* to the site of attack encouraging approach of the nucleophile by enhancing the electrophilicity of the ring carbon under attack (37a), which more than compensates for the destabilising $-I_\pi$ repulsions in the transition-state (37b).

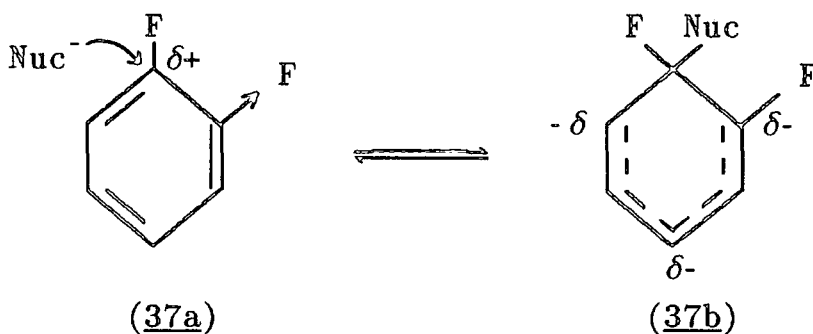

In contrast, chlorine is found to be strongly activating in all positions relative to hydrogen, with comparable activating effects to both *ortho* and *meta* fluorines, and a much greater activating effect than a *para* fluorine. This results from the greatly reduced $-I_{\pi}$ effect of chlorine relative to fluorine at the *para* position, and is consistent with the known carbanion stabilising ability of a chlorine bound directly to a carbanionic centre ($\bar{C}-Cl$)³³.

c) Perfluoroalkyl substituents

The separate activating effects of a substituent trifluoromethyl group *ortho*, *meta* and *para* to the position of nucleophilic attack, relative to hydrogen at the same position, have also been determined experimentally²⁸. These results show that a trifluoromethyl group is strongly activating in all positions, relative to both hydrogen and fluorine, and directs nucleophilic attack principally *para*.

Nuc ⁻ →	X	CF_3	k_{CF_3}/k_H	k_{CF_3}/k_F
	<i>ortho</i>	<i>ortho</i>	2.4×10^3	77
	<i>meta</i>	<i>meta</i>	3.5×10^2	15
	<i>para</i>	<i>para</i>	4.4×10^3	1.7×10^4

It is reasonable to suggest that these observations will apply to perfluoroalkyl groups in general, as the relative rates of substitution for a series of perfluoroalkylbenzenes with ammonia showed little variation with the increasing

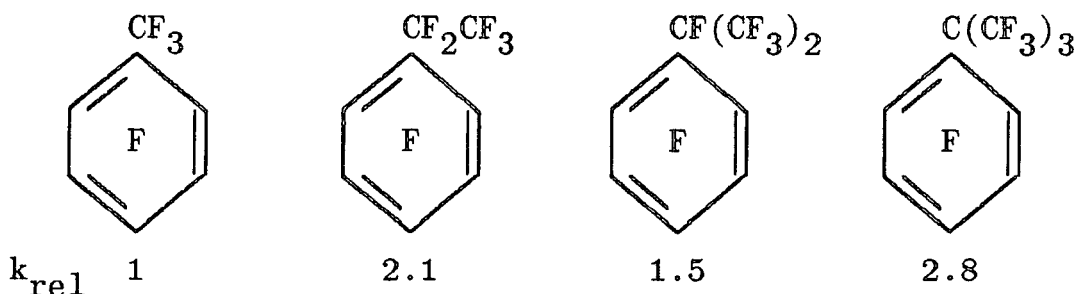

size of the perfluoroalkyl group³⁴. The strong activation and orientation effects of a *para* perfluoroalkyl group are easily explained by considering the transition-state (38), which has the maximum negative charge density in the *para* position²⁷. A perfluoroalkyl group in this position is

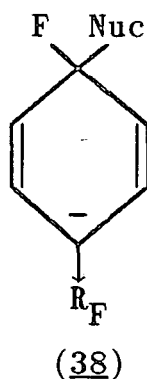

therefore strongly stabilising as a result of its very strong $+I_{\sigma}$ inductive effect³³, but unlike a *para* fluorine, it does not have the destabilising $-I_{\pi}$ repulsions, and hence the very strong activating and *para* orientating ability of a perfluoroalkyl group *versus* fluorine.

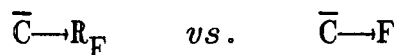

These observations show that a perfluoroalkyl group is not as strongly activating as a ring nitrogen, so in

perfluoroalkyl-heteroaromatics the ring nitrogens are expected to control the initial position of substitution by nucleophiles. However, as discussed in the following section (1.C.2) this is not always the case, especially for perfluoroheteroaromatics with several perfluoroalkyl substituents.

An early theory³⁵ advanced to explain the observed orientation of attack in substituted polyfluorobenzenes suggested that attack occurs exclusively *para* to the substituent to avoid the destabilising $-I_{\pi}$ repulsions of a *para* fluorine in the transition-state. However, it has since

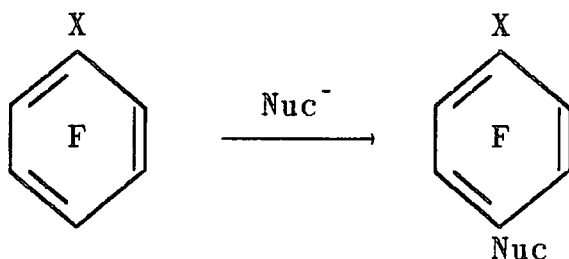

been shown experimentally²⁹ that a *para* fluorine is only slightly deactivating with respect to hydrogen, and this early theory did not take into account the greater orientation influences of *ortho* and *meta* fluorines, which are both strongly activating. A more complete rationale has been presented, which suggests that nucleophilic attack occurs so as to maximise the number of *ortho* and *meta* fluorines, largely ignoring the *para* fluorine. This rationale explains the orientation of attack observed in a number of polyfluoro-benzenes and -heteroaromatics, although for the heteroaromatic systems, the ring nitrogen will be the dominant influence governing the position of substitution.

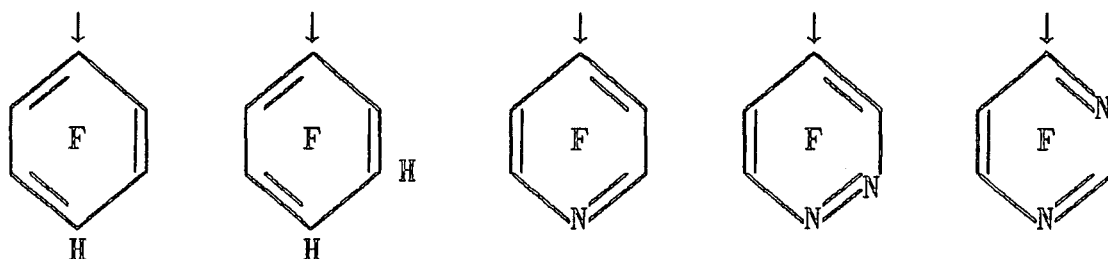

2. Polyfluoroalkylation of perhaloheteroaromatics

As discussed in the previous section (1.C.1), the principal reactions of polyhaloheteroaromatics are nucleophilic aromatic substitutions, and so it is possible to introduce perfluoroalkyl groups into these systems using perfluoroalkyl anions, generated from the appropriate precursor perfluoroalkene with fluoride ion in an aprotic solvent, usually tetraglyme or sulpholane. This process has been described as the nucleophilic equivalent³⁶ of the well-known Friedel-Crafts reaction in hydrocarbon chemistry.

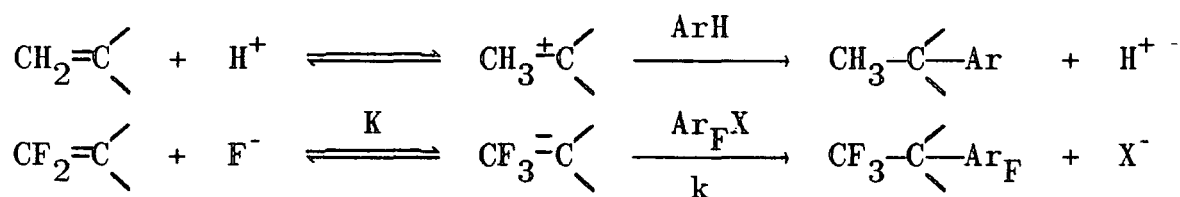

The observed reactivity of a perfluoroalkyl anion with a perfluoroheteroaromatic is the product of the equilibrium constant K for formation of the anion and the rate constant k for the reaction of the anion with the heteroaromatic, and this order of reactivity (Kk) is found to increase with the increasing size of the perfluoroalkyl anion¹. The fact that the perfluoro-t-butyl anion is the most efficient in poly-

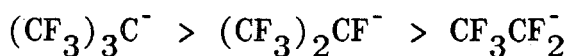

←—————
increasing stability

fluoroalkylation reactions indicates that the stability of the anion, and hence its equilibrium concentration (K), is the dominating factor governing the efficiency of reaction. The stability of perfluoroalkyl anions is found to increase as the number of destabilising electron-pair repulsions ($-I_{\pi}$) from α -fluorines are reduced¹.

The initial position of substitution is controlled principally by the influence of the ring nitrogens in all polyhaloheteroaromatics. However, for multiple perfluoroalkyl substitution, several factors must be considered:

- i) After two perfluoroalkyl groups are present these may control the position of further substitution.
- ii) Some of the reactions are reversible.
- iii) Steric effects, as substitution at the most activated position remaining may give steric crowding, and hence not the most thermodynamically stable product.

The reaction of the perfluoroethyl anion with pentafluoropyridine (39)³⁷ clearly shows that as the degree of polyfluoroalkylation increases, there is a change-over from ring nitrogen to the perfluoroalkyl groups as the dominant influence on the position of further substitution. The

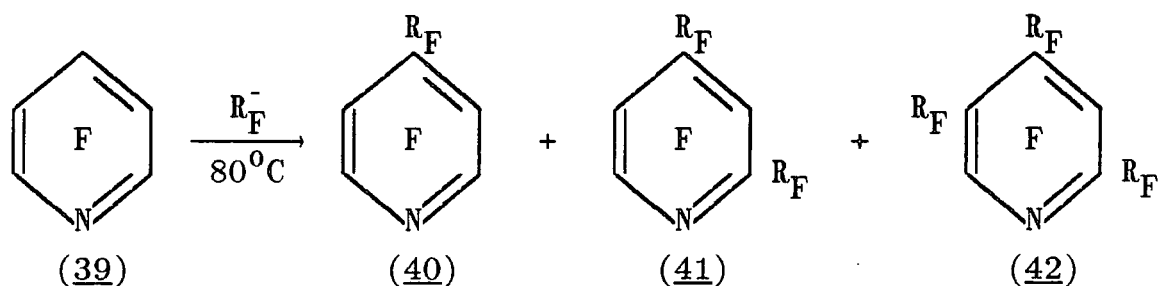

4-mono- and 2,4-bis-alkylpyridines, (40) and (41), are the expected products from the ring nitrogen controlling the initial orientation of substitution. However, the third perfluoroethyl group enters at the 5-position to give the 2,4,5-tris-alkyl derivative (42) which is clearly controlled by the *para* perfluoroalkyl group rather than the ring nitrogen, which would direct further substitution in (41) to the 6-position.

A combination of these effects can give rise to competition between kinetic or thermodynamic control of products, depending upon the perfluoroalkyl anion and the reaction conditions, and may be illustrated by the reaction of tetrafluoropyridazine (21) with various perfluoroalkyl anions at 80°C, considering only the formation of di-

#

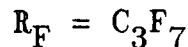
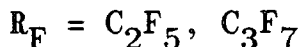
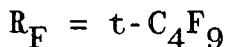
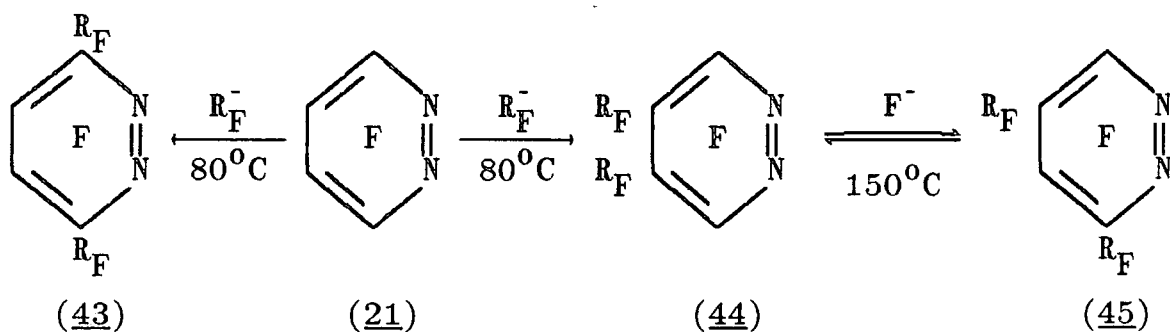

With the perfluoroethyl anion, the 4,5-bis-alkylpyridazine (44), arising from attack at the two most reactive sites in (21), was formed exclusively³⁷, and was not rearranged by fluoride ion at temperatures up to 150°C. Hence (44) is the kinetically controlled product. The perfluoroisopropyl anion also gave the 4,5-bis-alkyl derivative (44) as the initial

product at 80°C, but was rearranged with fluoride ion at 150°C to the more stable 3,5-isomer (45)³⁸, the thermodynamically controlled product. In contrast, the perfluoro-*t*-butyl anion³⁹ gave only the 3,6-bis-alkylpyridazine (43) at 80°C. This clearly illustrates that there is a change-over from kinetic to thermodynamic control of products with the increasing steric demands of the perfluoroalkyl group, with larger groups preferring the positions adjacent to ring nitrogen, where steric interactions are minimised⁴⁰.

1.D Thermal and photochemical rearrangements of perfluoro-heteroaromatics

1. Thermal rearrangements of perfluoroalkylpyridazines

Flow pyrolysis of perfluoro-tetra-alkylpyridazines (46) resulted in nitrogen elimination and fragmentation to the corresponding acetylenes (47) in high yields⁴¹. Analogous

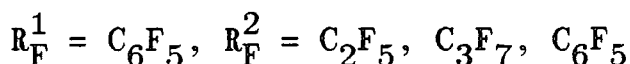
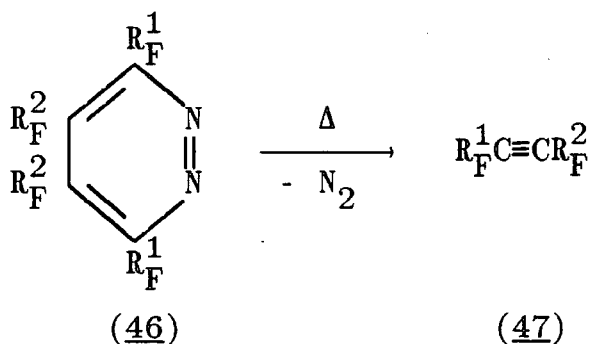

fragmentations are also observed for perfluoroalkyl-1,2,3-⁵⁹ and -1,2,4-triazines^{19,42}. The fact that only the unsymmetrically substituted acetylene (47) was formed rules out the possibility of an intermediate cyclobutadiene or

tetrahedrane.

Pyrolysis of a perfluoro-4,5-bis-alkylpyridazine (44), with fluorine in one or both positions adjacent to the ring nitrogens, gives rearrangement in high yields to the corresponding perfluoroalkylpyrimidine (48). Small amounts of a pyrazine derivative, (50) or (52), are also formed, the structure of which depends upon the substituent perfluoroalkyl group⁴³. This process is believed to be a highly

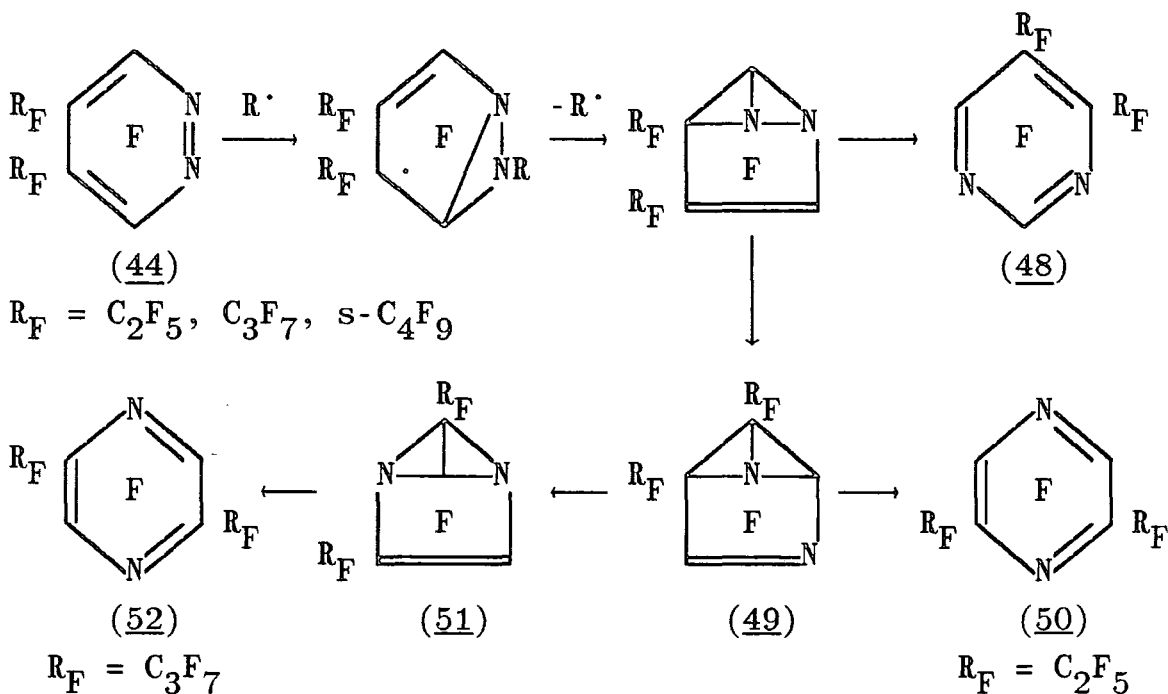

efficient radical promoted valence isomerisation *via* intermediate diazabenzvalenes⁴⁴, with this mechanism most easily accounting for the highly specific substituent patterns observed in the rearrangement products. It was also found that highly crowded molecules, such as perfluoro-3,4-dimethylhexane (53), acted as promoters for the

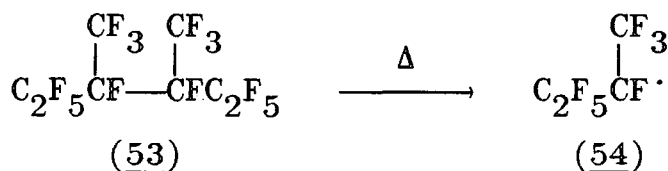

rearrangement⁴⁴, as presumably fission into perfluoroalkyl radicals (54) occurs under the pyrolysis conditions. Further evidence for this radical promotion comes from the pyrolysis of perfluoro-3,5-bis-isopropylpyridazine (55), which was rearranged to the corresponding pyrimidine derivative (56) in the presence of (53)⁴⁴, a process which was previously attempted unsuccessfully⁴³.

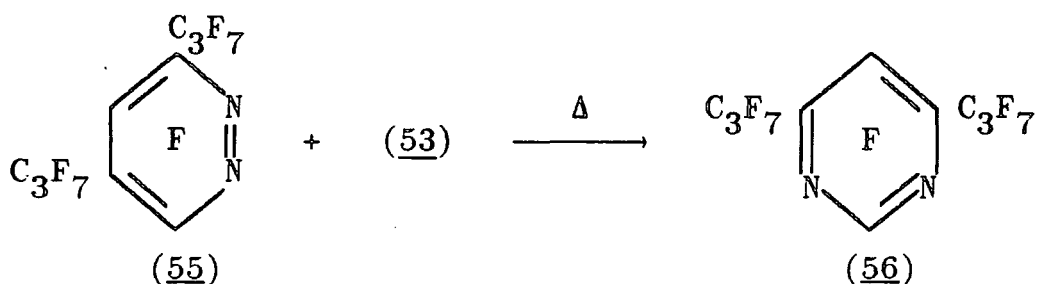

The formation of two different pyrazine isomers, depending upon the size of the perfluoroalkyl group, was suggested to result from steric crowding between adjacent perfluoroalkyl groups in the intermediate benzvalene (49)⁴³. The perfluoroisopropyl and -s-butyl groups were suggested to provide a greater driving force to separate the adjacent groups, by the rearrangement of (49) to (51), than the perfluoroethyl group, which has much lower steric requirements.

Perfluoro-4-alkylpyridazines (57) were also rearranged to the corresponding pyrimidines on pyrolysis, although in these cases, ≈ 1:1 mixtures of isomeric 4- (58) and 5- (59)

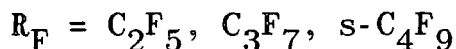
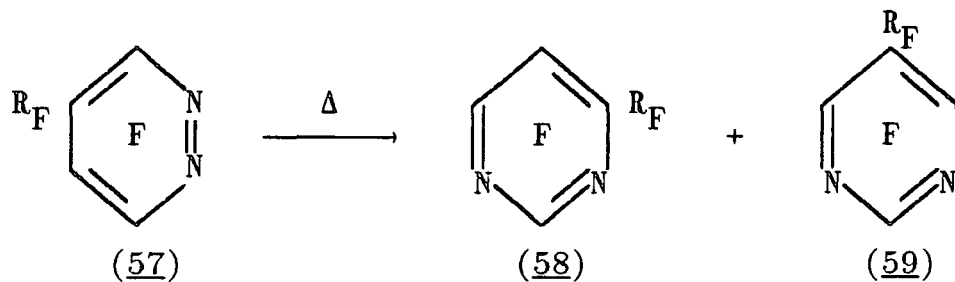

alkylpyrimidines were formed^{43,44}. This is also consistent with the radical promoted mechanism previously discussed, as for these unsymmetrically substituted pyridazines, radical attack can occur at either N-1 or N-2 of the pyridazine, giving a mixture of products.

The previous examples have all involved either fragmentation or rearrangement of the pyridazine ring. In certain cases, pyrolysis of a perfluoroalkylpyridazine can lead to fragmentation of the substituent perfluoroalkyl group. Thus the flow pyrolysis of perfluoro-4,5-bis-isopropylpyridazine (60) gave, as well as the expected pyrimidine and pyrazine, three other major products (61) - (63) resulting from the loss of CF_4 and C_2F_6 fragments from the two perfluoroisopropyl groups⁴³.

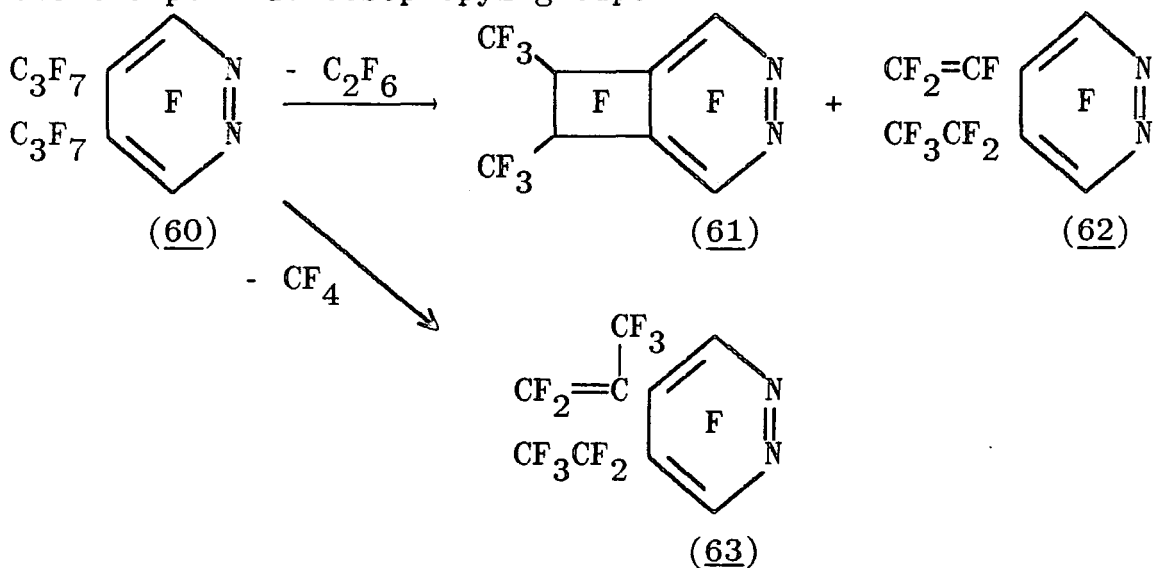

2. Formation of valence isomers from fluorinated pyridines and pyridazines

In the previous section, it was shown that the pyrolysis of perfluoroalkylpyridazines generally leads to

rearrangement to the corresponding pyrimidines *via* diaza-benzvalene intermediates, which are not isolable. In contrast, static photolysis of these pyridazines gives rearrangement to the corresponding pyrazine derivatives⁴⁵. This rearrangement also occurs *via* intermediate valence isomers, (64) and (65), which were subsequently isolated by photolysis of the pyridazines in a flow system⁴⁶. These

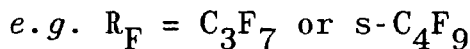
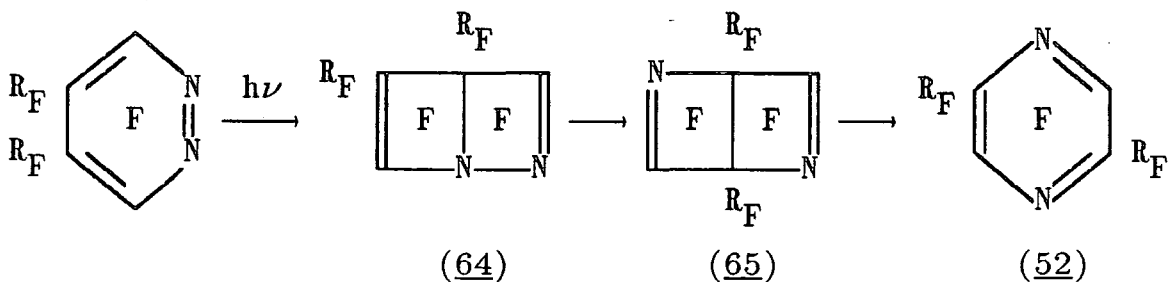
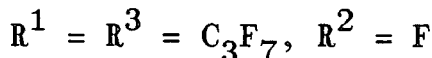
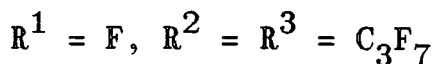
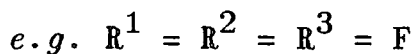
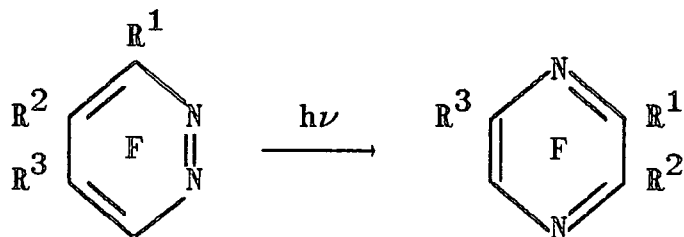

para-bonded species are the only reported valence isomers of an aromatic diazine, and are surprisingly stable. Valence isomer (64) may be converted to (65) on either heating or photolysis, which is a rare example of the conversion of an aromatic valence isomer into another *of the same type*⁴⁶. Similarly, (65) undergoes either thermal or photochemical rearomatisation to the pyrazine (52).

More recently, another set of perfluoroalkyl-substituted valence isomers possessing remarkable stabilities were isolated from the photolysis of perfluoroalkylpyridines. Hence pentakis(perfluoroethyl)pyridine (66) gave stable *para*-bonded (67) and azaprismane (68) valence isomers⁴⁷. Similarly, a perfluoroalkylpyridine (69) with three different perfluoroalkyl groups gave a

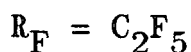
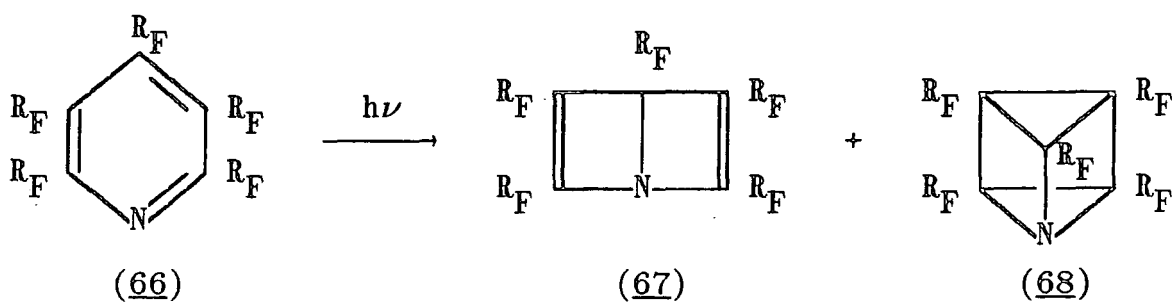

mixture of the *para*-bonded species (72) and two azaprismanes, (70) and (71), the structures of which were established by thermal rearomatisation to the corresponding pyridines⁴⁸. The first stable pyridine valence isomer with the alternative *para*-bonded structure (74) was isolated from the photolysis of perfluoro-2,4,6-tris-isopropylpyridine

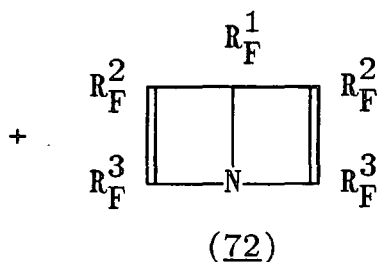
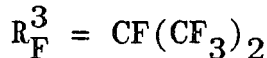
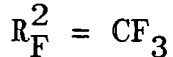
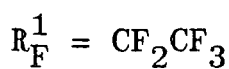
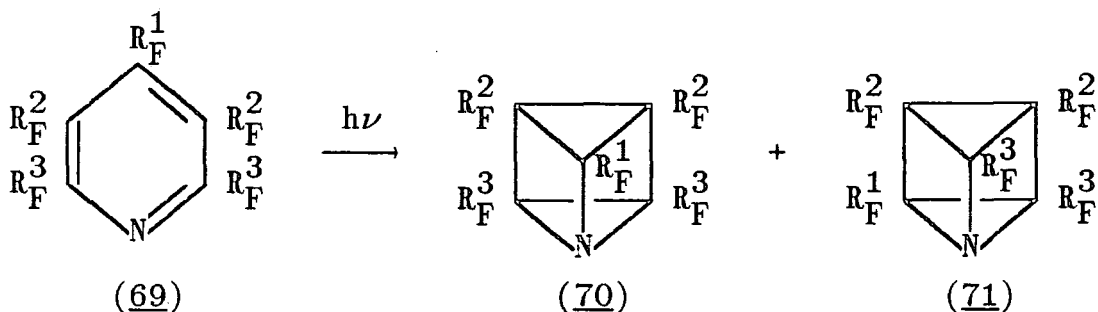

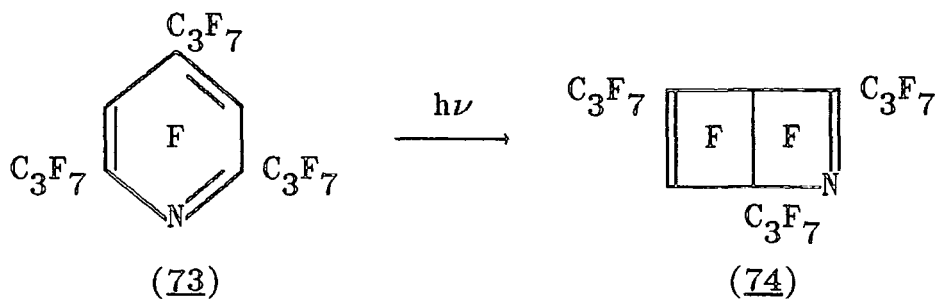

pyridine (73)⁴⁹.

1.E Nitrogen elimination from halogenated 1,2,3- and 1,2,4-triazines

Previous workers in our laboratories have investigated the thermal and photochemical elimination of nitrogen from halogenated and perfluoroalkyl-1,2,3- and 1,2,4-triazines, with the aim of generating stable azacyclobutadiene (azete) derivatives.

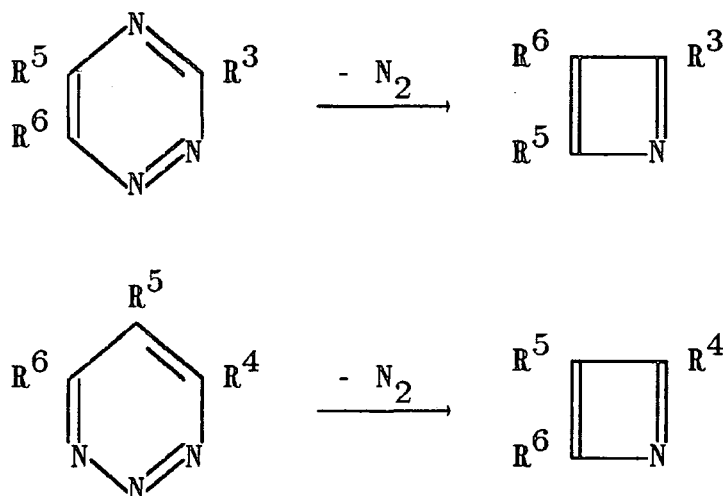

There have been many attempts to generate and trap unfused azetes, the main obstacle being their apparent ease of fragmentation to the corresponding acetylenes and nitriles⁵⁰. Theoretical calculations have suggested that the most promising derivatives could be polyfluoroazetes⁵¹. Perfluoroalkyl substitution could also stabilise the azete

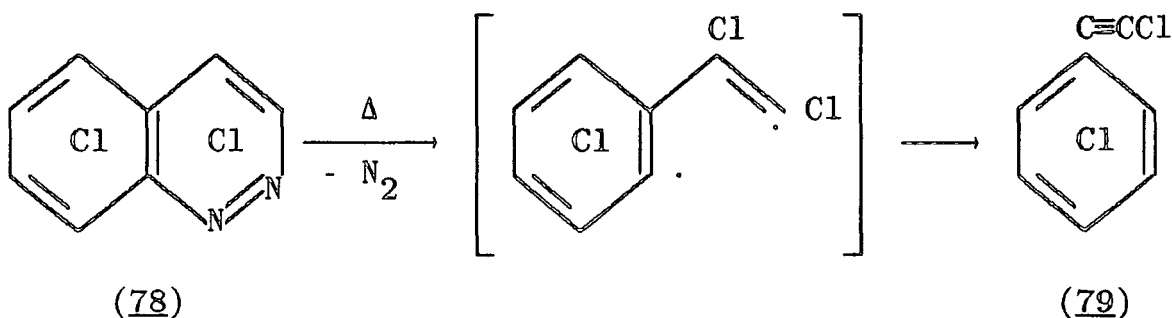

with the mechanism of formation of the acetylene (79) produced from the pyrolysis of hexachlorocinnoline (78)⁴¹.

b) Trifluoro-1,2,4-triazine

The pyrolysis and photolysis of trifluoro-1,2,4-triazine (27) was investigated by Haszeldine and his co-workers. Static pyrolysis⁴² of (27) resulted in the rearrangement to trifluoro-1,3,5-triazine (80), a process suggested to occur *via* a fragmentation pathway involving trimerisation of FCN. However, both photolysis and flash

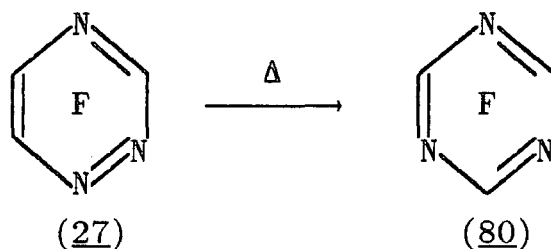

pyrolysis of (27) failed to give significant decomposition or rearrangement of the 1,2,4-triazine ring²³.

c) Perfluoroalkyl-1,2,4-triazines

Perfluoro-tris-isopropyl-1,2,4-triazine (81) gave almost quantitative conversion to the acetylene (82) and nitrile (83) upon either static¹⁹ or flash pyrolysis^{19,42}, whilst photolysis¹⁹ gave perfluoro-tris-isopropyl-1,3,5-

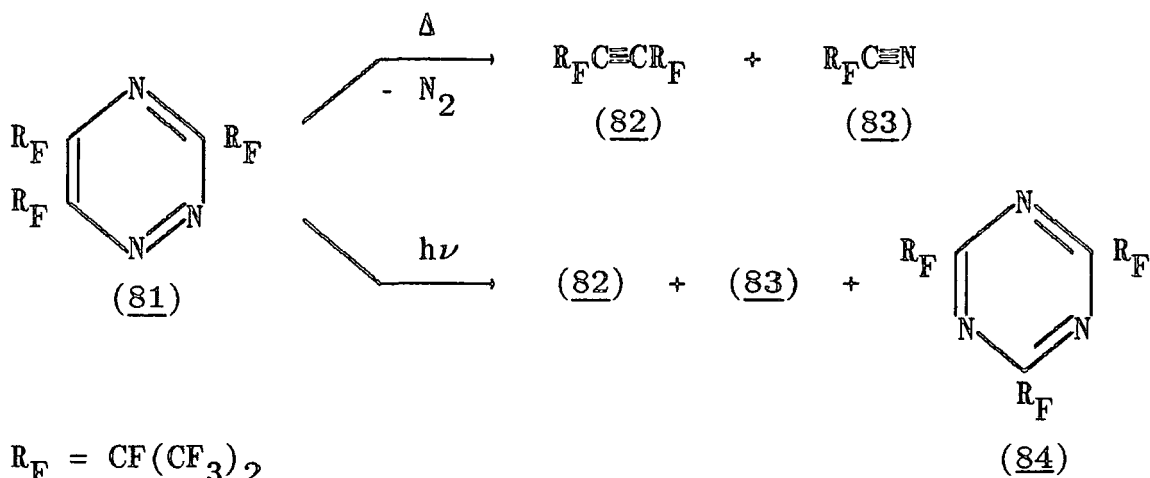

triazine (84) in addition to (82) and (83). The formation of (84) was suggested to involve an intermediate triaza-benzvalene (85), in an analogous process to that advanced previously to account for the specific thermal rearrangements of some perfluoroalkylpyridazines⁴⁴ (see 1.D.1).

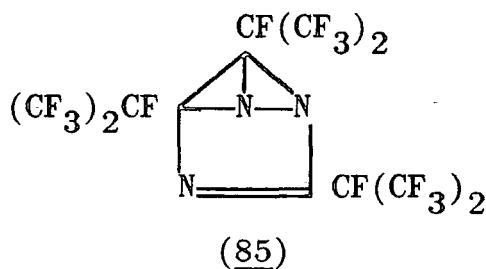

Similarly, flash pyrolysis of perfluoro-tris(dimethylamino)-1,2,4-triazine (86)⁴² also gave the corresponding acetylene (87) and nitrile (88).

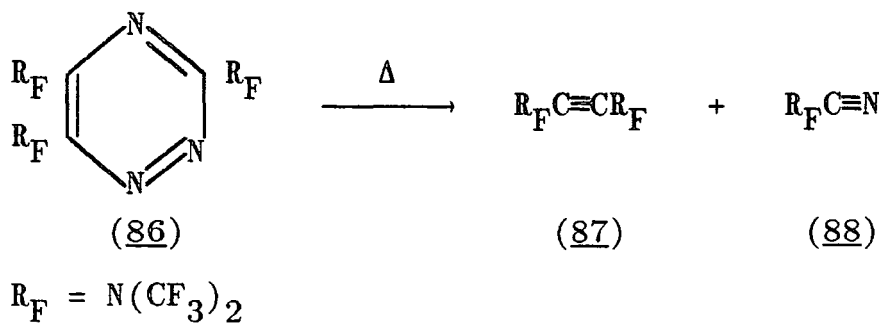

2. Halogenated-1,2,3-triazines^{59,60}a) Trichloro-1,2,3-triazine

The static pyrolysis of trichloro-1,2,3-triazine (20) gave trichloroacrylonitrile (77). The same product was obtained from the pyrolysis of trichloro-1,2,4-triazine (18)¹⁹, although in this case it was not possible to determine whether the acrylonitrile was formed *via* the intermediate azete (75) or the diradical species (75b).

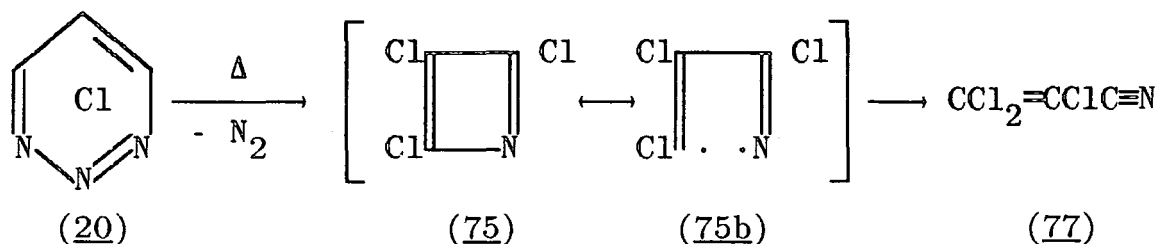
b) Trifluoro-1,2,3-triazine

Trifluoro-1,2,3-triazine (28) also gave the corresponding acrylonitrile (89) on static pyrolysis. This

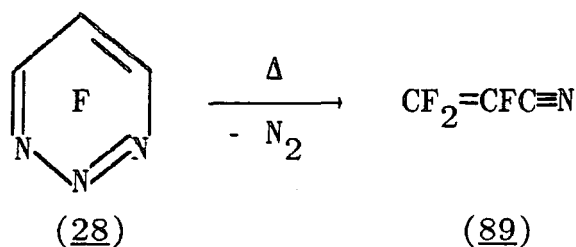

contrasts with the static pyrolysis of trifluoro-1,2,4-triazine (27), which rearranges to trifluoro-1,3,5-triazine (80)⁴². Photolysis of (28) in solution gave a polymeric product, which was tentatively identified as poly(trifluoroazete) (90). An attempt to trap the intermediate with hexafluoro-2-butyne (91) gave a different product (92), which was identified as a 1:1 co-polymer.

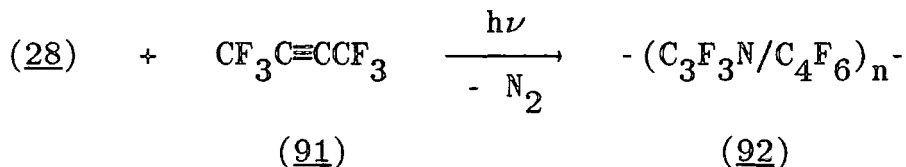
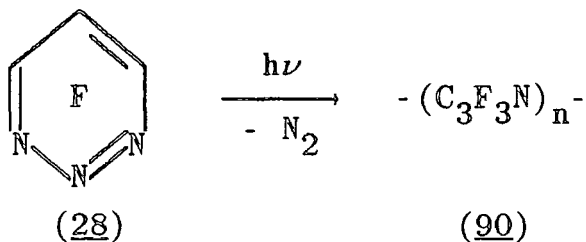

c) Perfluoro-4,6-bis-isopropyl-1,2,3-triazine

Photolysis of perfluoro-4,6-bis-isopropyl-1,2,3-triazine (93) in solution gave quantitative conversion to a dimer (95) of the corresponding azete (94), which provided clear evidence for the existence of the intermediate azete (94). The azete (94) was also trapped by cycloaddition with

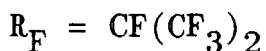
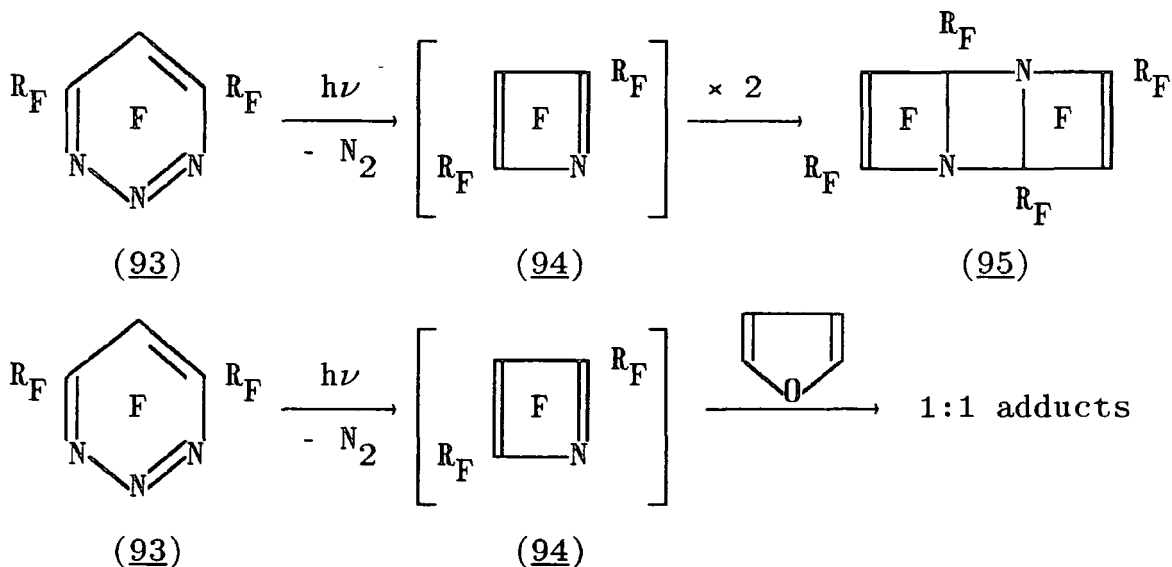

furan. However, static pyrolysis of (93) gave perfluoro-2,4,6-tris-isopropylpyrimidine (96), perfluoro-2,4,6-tris-isopropylpyridine (73) and perfluoroisobutyronitrile (83) as the major products, although perfluoro-3-methylbut-1-yne

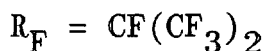
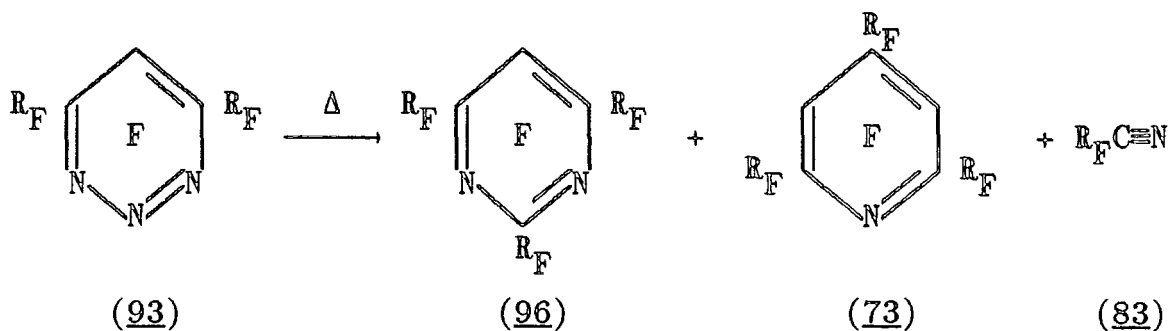

(97) and the azete dimer (95) were also formed as minor products. The formation of the pyrimidine (96) and pyridine (73) was explained in terms of $[2\pi + 2\pi + 2\pi]$ cycloadditions of the acetylene (97) and nitrile (83). In contrast, the flash pyrolysis of (93) gave quantitative conversion to the acetylene (97) and nitrile (83).

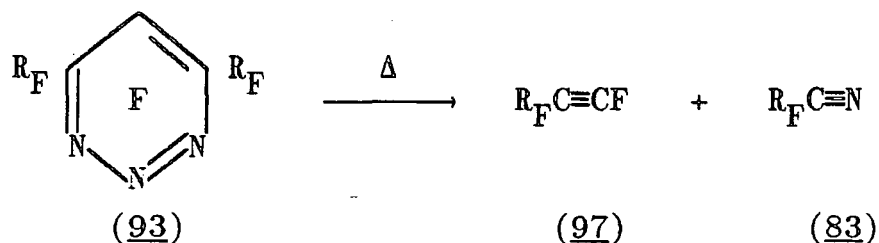

d) Perfluoro-tris-isopropyl-1,2,3-triazine

Pyrolysis and photolysis of perfluoro-tris-isopropyl-1,2,3-triazine (98) also gave quantitative conversion to the corresponding acetylene (82) and nitrile

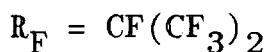
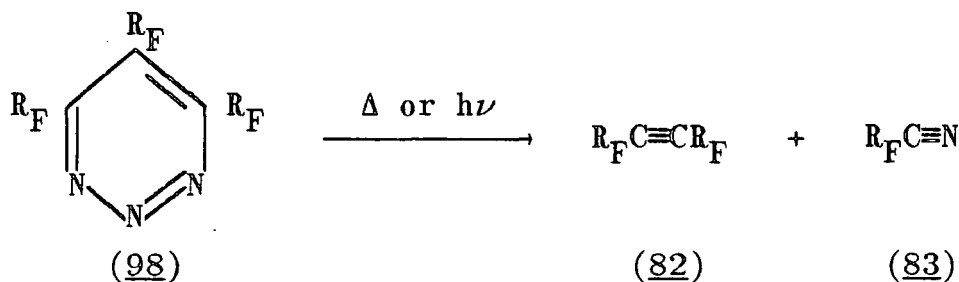

(83) in both cases. This is an analogous result to that observed previously for perfluoro-tris-isopropyl-1,2,4-triazine (81)^{19,42}.

DISCUSSION

CHAPTER TWO

SYNTHESIS AND CHEMISTRY OF HALOGENATED 1,2,3-TRIAZINES

2.A Introduction

A preliminary study into the generation and trapping of monocyclic azetes from fluorinated 1,2,3-triazine precursors was carried out in these laboratories by M. Tamura⁵⁹.

The initial aim of this project was to complete and extend this preliminary work on fluorinated azetes, and also to investigate other interesting aspects of the chemistry of halogenated 1,2,3-triazines.

The synthesis of fluorinated 1,2,3-triazine precursors required for this work was repeated, and the preparation of perfluoroisopropyl derivatives was attempted.

Nucleophilic aromatic substitution reactions of the fluorinated 1,2,3-triazines with simple nucleophiles are described, together with some attempted cycloaddition reactions.

2.B Synthesis of halogenated 1,2,3-triazines

1. Trichloro-1,2,3-triazine

The synthesis of trichloro-1,2,3-triazine (20) from the reaction of tetrachlorocyclopropene (19) with trimethylsilylazide (99) has been reported in the literature²⁰. Tetrachlorocyclopropene (19) is prepared in two steps from readily available precursors, as shown overleaf. This sequence of reactions was used to prepare the trichloro-

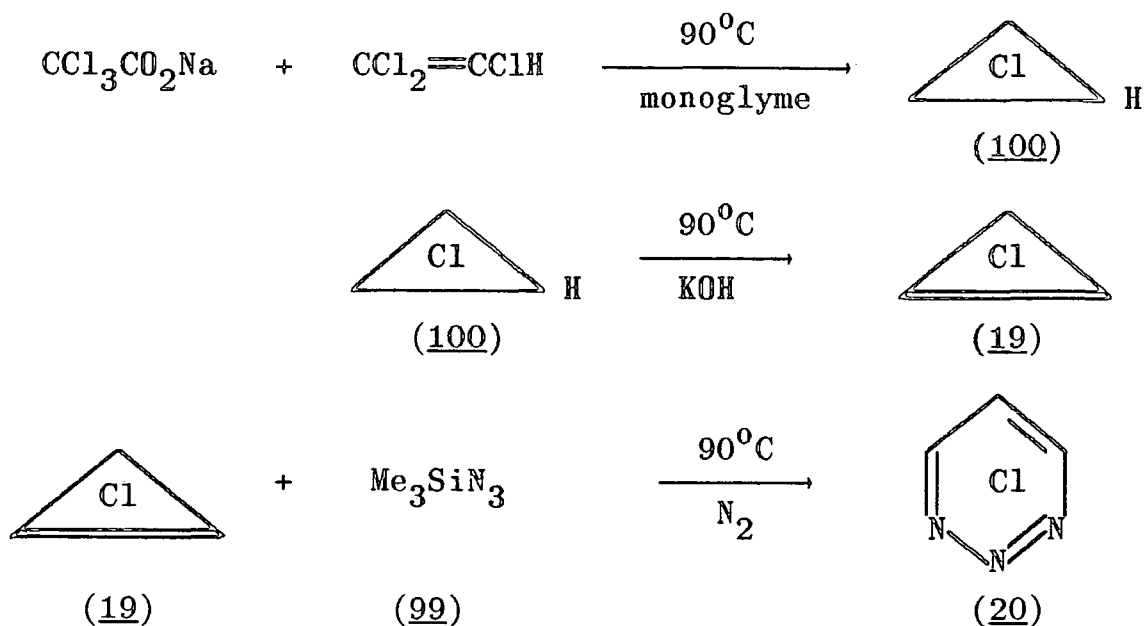

1,2,3-triazine (20) for this study, but various modifications were made to the experimental procedures described in the literature⁶¹.

We found that in the literature preparation of pentachlorocyclopropane (100), the initial step of drying the system by collecting the water in a Dean-Stark trap whilst refluxing the trichloroethylene was unnecessary. A similar yield of (100) to that reported in the literature was obtained simply by pre-drying the sodium trichloroacetate *in vacuo*, and then refluxing the acetate in trichloroethylene for several hours prior to the addition of monoglyme. Furthermore, the literature work-up, involving washing the product mixture with water, produced a large quantity of unwanted gelatinous material. An alternative work-up⁶², involving decanting off the organic layer and drenching the remaining silt layer with a small quantity of water, was found to be much more effective.

The purification of trichloro-1,2,3-triazine (20) was also modified from that described in the literature²⁰. The crude solid obtained after evaporation of excess starting materials was Soxhlet extracted twice with diethyl ether to remove insoluble azide derivatives, and then sublimed under vacuum to give pure trichloro-1,2,3-triazine (20).

2. Fluorinated 1,2,3-triazines

a) Introduction

One of the most useful synthetic routes to perfluorinated aromatics involves the use of alkali metal fluorides, usually potassium fluoride, in the nucleophilic displacement of chloride from activated aromatic systems¹.



The choice of the most effective fluorination conditions for a particular system is obviously important. Fluorinated 1,2,3-triazines have been prepared previously in our laboratories by M. Tamura from the vapour-phase flow fluorination of trichloro-1,2,3-triazine with potassium fluoride^{24,59}. This fluorination method was originally developed by Haszeldine and his co-workers to successfully perfluorinate the isomeric trichloro-1,2,4-triazine (18)²³. A two-stage process was used for the fluorination of

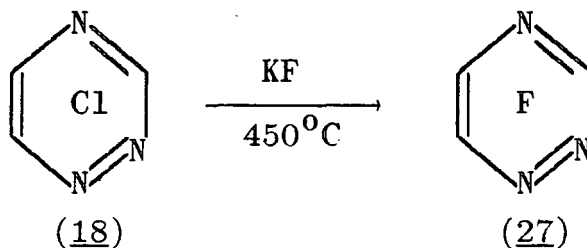

trichloro-1,2,3-triazine (20). The mono- and di-fluoro derivatives (101) and (102) obtained from the first step were recycled at a higher temperature, giving a good overall yield of trifluoro-1,2,3-triazine (28)^{24,59}.

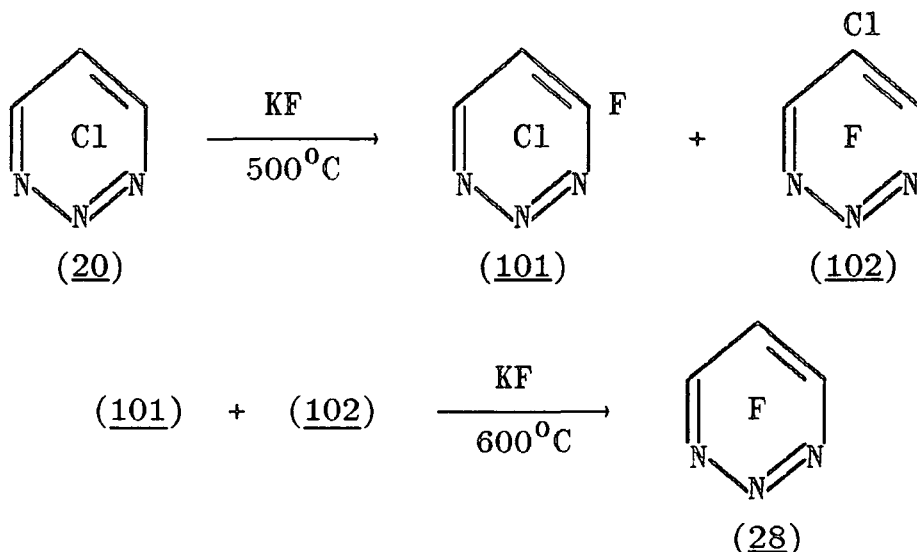

b) Trifluoro-1,2,3-triazine

The trifluoro-1,2,3-triazine required for this work was prepared using the vapour-phase flow fluorination method described above. However, we generally obtained moderate yields of the di- and tri-fluoro-1,2,3-triazines (102) and (28) in a single step at 500°C, and with no evidence for the monofluoro-1,2,3-triazine (101). This fluorination was repeated on several occasions and on two different scales, and as reported in detail in the experimental section

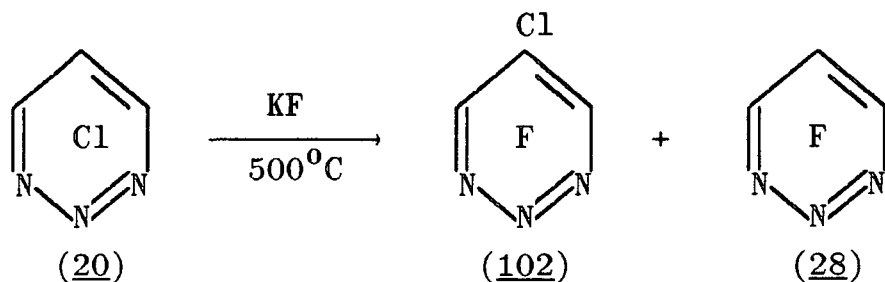

(10.B.1), the yields are not very reproducible. The overall isolated yield of fluorinated 1,2,3-triazines varied between 29 - 86%, with no apparent correlation between overall yield and the scale of the fluorination. As discussed in Chapter Three (3.C.1b), this flow fluorination method has now been superseded by a more reliable fluorination procedure, which gives both reproducible yields and no effective limit on the size to which the preparation may be scaled up.

Trifluoro-1,2,3-triazine (28) is a lachrymatory colourless liquid which appears to be moisture sensitive, forming a dark red oil with time, a similar process was observed for the isomeric trifluoro-1,2,4-triazine²³. It may be successfully stored under dry nitrogen for several months without significant decomposition. 5-chloro-4,6-difluoro-1,2,3-triazine (102) is a very pungent and lachrymatory low-melting solid, which appears to be much more moisture sensitive than the trifluoro derivative, as it shows significant discolouration after only several weeks storage under dry nitrogen.

c) 5-chloro-4,6-difluoro-1,2,3-triazine

The flow fluorination procedure may be modified to selectively produce the difluoro-1,2,3-triazine (102) simply by lowering the furnace temperature to 400°C. This gave a 58% yield of 5-chloro-4,6-difluoro-1,2,3-triazine (102), with only a trace of trifluoro-1,2,3-triazine.

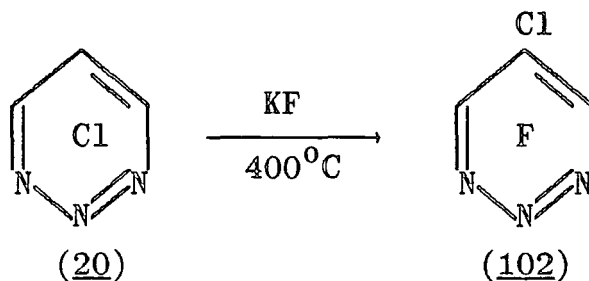

3. Attempted polyfluoroalkylation of trichloro-1,2,3-triazine

The polyfluoroalkylation of trichloro-1,2,3-triazine (20) with perfluoroisopropyl anions generated from hexafluoropropene and either caesium or potassium fluoride in tetraglyme or sulpholane was successfully achieved previously in our laboratories by M. Tamura⁵⁹. This gave a mixture containing mainly the 4,6-bis- and 4,5,6-tris-isopropyl-1,2,3-triazines (93) and (98), together with a small amount of the product (103) arising from nucleophilic attack of a further perfluoroisopropyl anion on the centre ring nitrogen of the tris-isopropyl derivative (98) (Scheme 2.1).

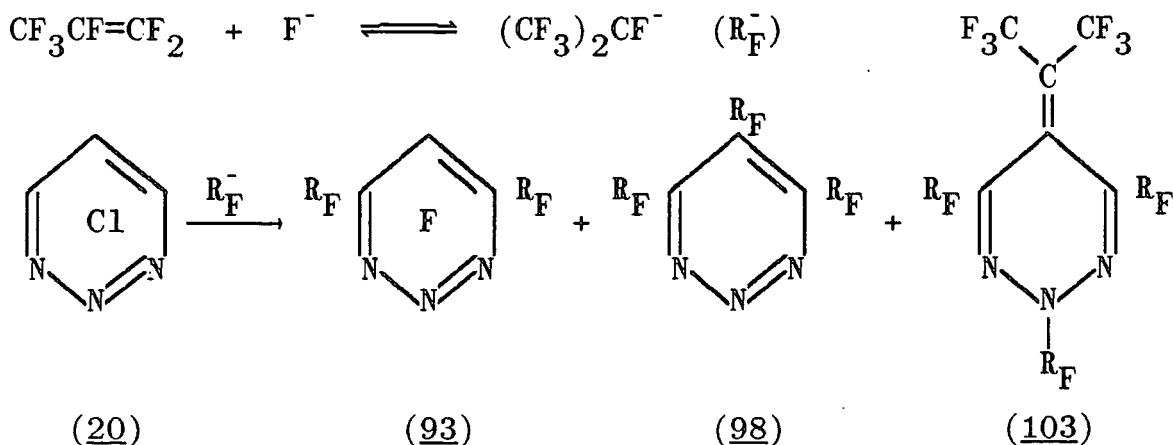

SCHEME 2.1

The first objective of this project was to repeat this synthesis of the perfluoroisopropyl-1,2,3-triazines, as these compounds are the precursors for the investigation into the generation and trapping of fluorinated azetes (see Chapter Four). However, we were unable to repeat the polyfluoroalkylation of trichloro-1,2,3-triazine with hexafluoropropene and caesium fluoride in tetraglyme at room temperature, the same conditions employed previously in these laboratories by Tamura⁵⁹. These small scale reactions gave a mixture of hexafluoropropene oligomers as the only isolated product. This fluoride ion induced oligomerisation occurs very readily⁶³, and always competes with the polyfluoroalkylation process (Scheme 2.2). However, the

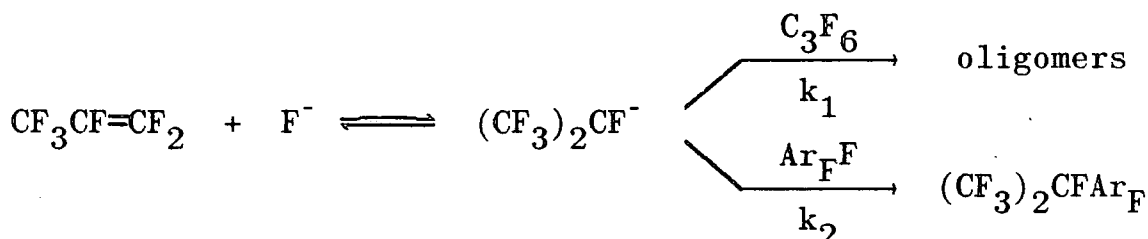

SCHEME 2.2

polyfluoroalkylation is usually the dominant process for the majority of highly activated halogenated aromatic systems, *i.e.* $k_2 \gg k_1$. The failure of this apparently reproducible synthesis of starting materials was unexpected, and various modifications to the basic procedure, including flame-drying the caesium fluoride, were made in an attempt to obtain the perfluoroisopropyl derivatives. The use of flame-dried caesium fluoride in the small scale reactions also gave only the mixture of hexafluoropropene oligomers. However, attempting the reaction on a larger scale gave traces of the

4,6-bis- (93) and 4,5,6-tris-isopropyl-1,2,3-triazines (98) detected by mass spectrometry, although the major product was still the mixture of oligomers. The reaction was repeated several times, but it was not possible to increase the proportion of perfluoroisopropyl-1,2,3-triazines in the product mixture.

The subsequent development of a modification to this procedure by Dr. T. Shepherd which resulted in the successful preparation of these perfluoroisopropyl derivatives is described in detail in Chapter Three (3.B).

2.C Nucleophilic aromatic substitution reactions

1. Introduction

There are several reports in the literature of some nucleophilic aromatic substitution reactions of trichloro-1,2,4-triazine^{64,65}, and more recently, the comparative reactions of trifluoro-1,2,4-triazine have been reported²³.

The only reported reactions of trichloro-1,2,3-triazine are some nucleophilic aromatic substitutions with simple nucleophiles²⁰. The order of reactivity of the positions on the trichloro-1,2,3-triazine ring to nucleophilic attack was found to be 4- >> 5-position. This is consistent with the ring nitrogen atoms governing the initial position of substitution, as described previously in Chapter One (1.C.1) for polyhaloheteroaromatics in general. However, the degree of substitution appears to depend upon the steric requirements of the nucleophiles. Thus di-isopropylamine gives only mono-substitution (104), whereas dimethylamine,

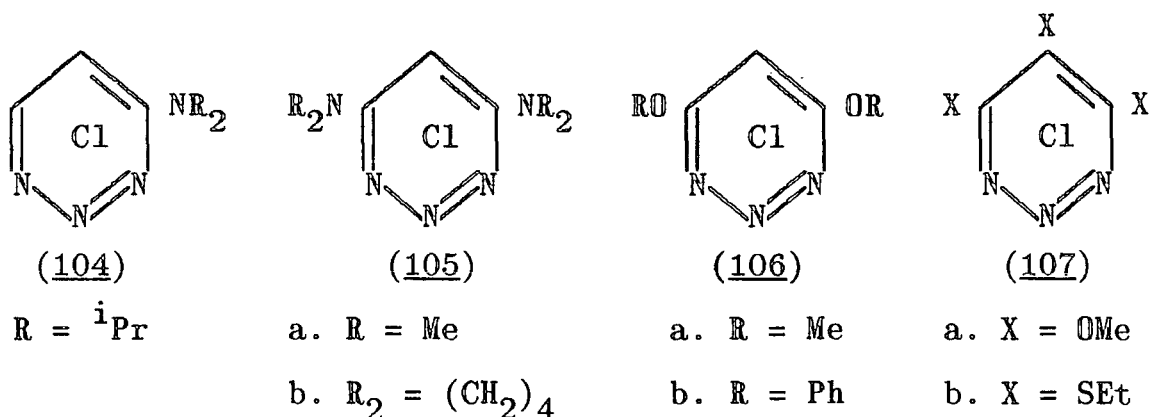

pyrrolidine, methoxide and phenoxide all give 4,6-disubstitution, yielding derivatives (105) and (106) respectively. Excess amounts of nucleophiles leads to trisubstitution (107).

In this section, some comparative nucleophilic aromatic substitution reactions of both trifluoro- and 5-chloro-4,6-difluoro-1,2,3-triazine are presented.

2. Trifluoro-1,2,3-triazine

a) With secondary amines

The reaction of trifluoro-1,2,3-triazine (28) with an excess of the cyclic secondary amines pyrrolidine (108a), piperidine (108b) and hexamethyleneimine (108c) in diethyl

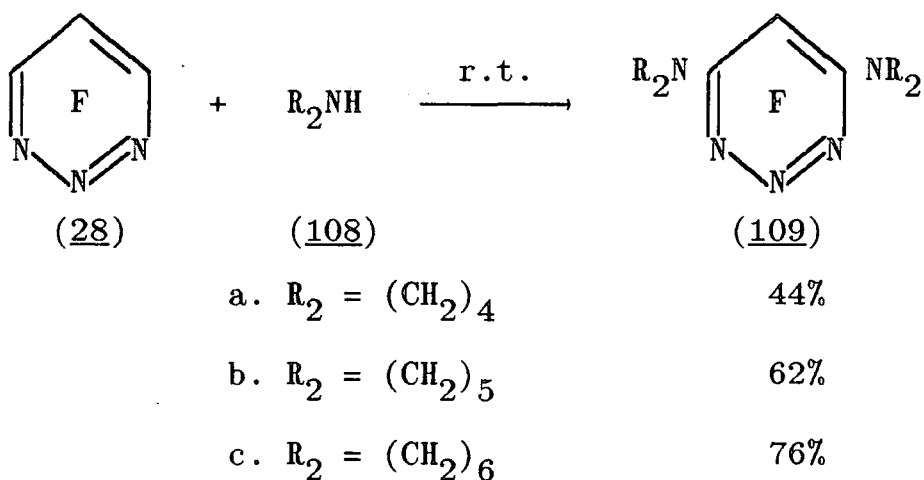

ether at room temperature gave moderate to good yields of the corresponding 4,6-bis(dialkylamino)-1,2,3-triazines (109a) - (109c).

b) With methanol

Trifluoro-1,2,3-triazine (28) gave a 71% yield of the known²⁰ trimethoxy-1,2,3-triazine (110) on refluxing in

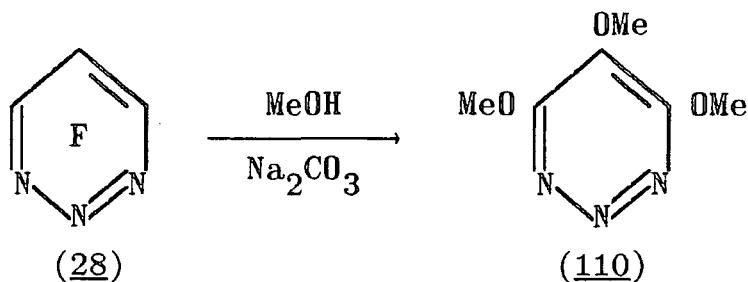

methanol. This clearly illustrates the greater reactivity of trifluoro-1,2,3-triazine (28) over the trichloro derivative (20), as the trimethoxy derivative (110) was previously prepared from trichloro-1,2,3-triazine (20) using an excess of sodium methoxide²⁰. Indeed, we found that refluxing (20) in methanol gave only a 5% yield of (110).

c) With phenol

The reaction of trifluoro-1,2,3-triazine (28) with two equivalents of phenol in dichloromethane gave the 4,6-disubstituted derivative (111) in 50% yield.

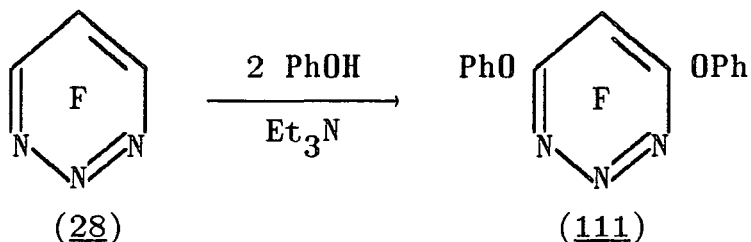

3. 5-chloro-4,6-difluoro-1,2,3-triazine

a) With secondary amines

The reaction of 5-chloro-4,6-difluoro-1,2,3-triazine (102) with one equivalent of the cyclic secondary amines pyrrolidine (108a) and hexamethyleneimine (108c) at room temperature in diethyl ether resulted in the formation of the corresponding 6-dialkylamino derivatives (112a) and (112c). Furthermore, the reaction of (102) with an excess of pyrrolidine (108a) in diethyl ether gave a 53% yield of the known²⁰ 5-chloro-4,6-dipyrrolidino-1,2,3-triazine (113).

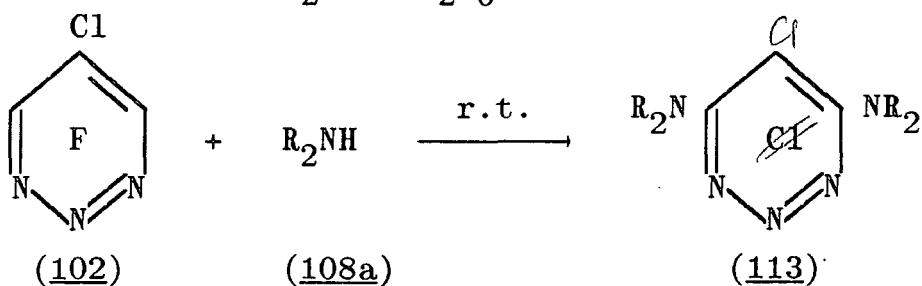
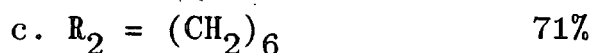
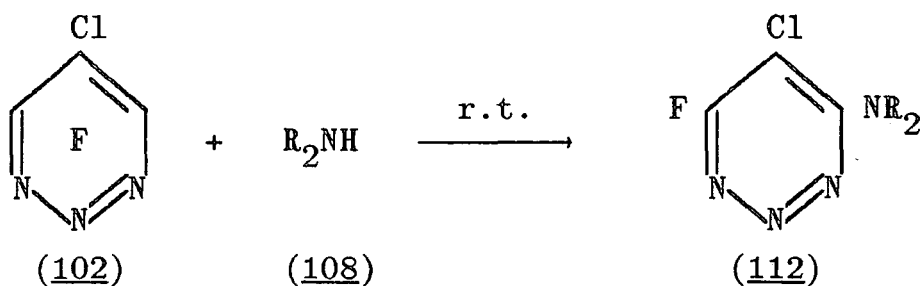

b) With methanol

5-chloro-4,6-difluoro-1,2,3-triazine (102) was refluxed in methanol to give a 55% yield of the known²⁰ 5-chloro-4,6-dimethoxy-1,2,3-triazine (114). This again shows that chloride is much harder to displace from

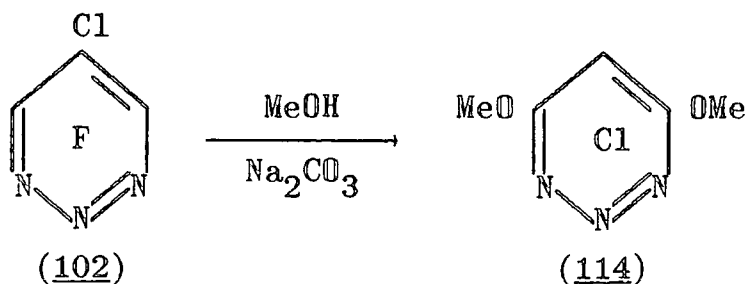

activated heteroaromatic systems than fluoride²⁶, as reaction of trifluoro-1,2,3-triazine (28) under the same conditions gave a good yield of the tri-substituted derivative (110) (see 2.C.1b).

c) With phenol

The reaction of (102) with one equivalent of phenol at room temperature in dichloromethane gave a 35% yield of 5-chloro-4-fluoro-6-phenoxy-1,2,3-triazine (115).

Furthermore, refluxing (102) with an excess of phenol in dichloromethane gave an 84% yield of the known²⁰ 5-chloro-4,6-diphenoxy-1,2,3-triazine (116).

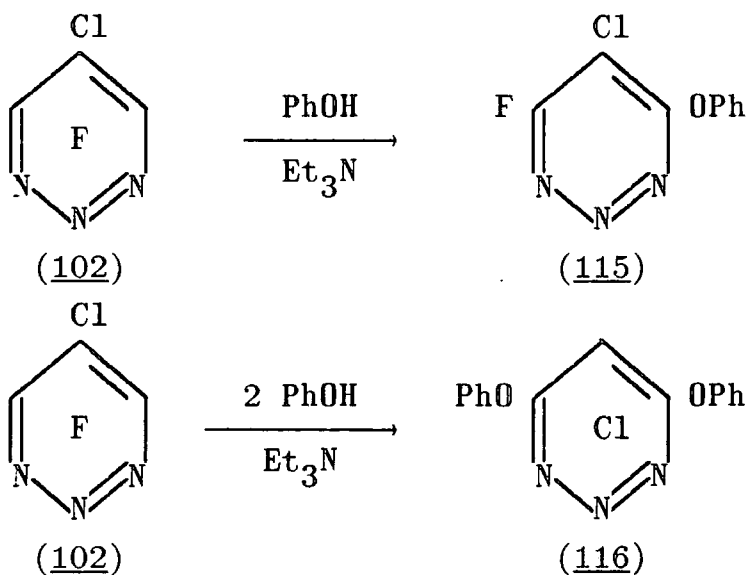

As would be expected, all these nucleophilic aromatic substitution reactions of trifluoro- and 5-chlorodifluoro-1,2,3-triazine give the analogous derivatives to those obtained from trichloro-1,2,3-triazine (20) with the same nucleophiles²⁰. However, whereas the preparation of the trimethoxy derivative of trichloro-1,2,3-triazine (20) required the use of sodium methoxide to effect substitution²⁰, the fluorinated 1,2,3-triazines are sufficiently reactive to undergo similar substitution with neutral methanol itself. This results from the greater ease of displacement of fluoride *versus* chloride from activated heteroaromatic systems²⁶. The observed order of attack on the positions of the trifluoro-1,2,3-triazine ring is also found to be 4- >> 5-position, with the initial positions of attack being controlled principally by the effect of the ring nitrogens²⁸.

2.D Attempted cycloaddition reactions of halogenated 1,2,3-triazines

1. Introduction

A preliminary study reported in a review indicated that 1,2,3-triazine (117) is capable of acting as an electron-deficient 1-azadiene in inverse electron demand Diels-Alder cycloadditions with electron-rich dienophiles such as enamines to give 2,3-disubstituted pyridines (118)⁶⁶. More recently, the cycloaddition reactions of 4-methyl-1,2,3-triazine (119) with various enamines have been described, giving moderate yields of the pyridines (120)⁶⁷.

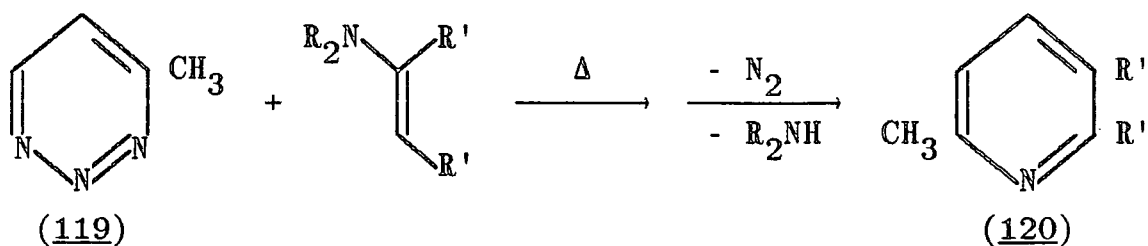
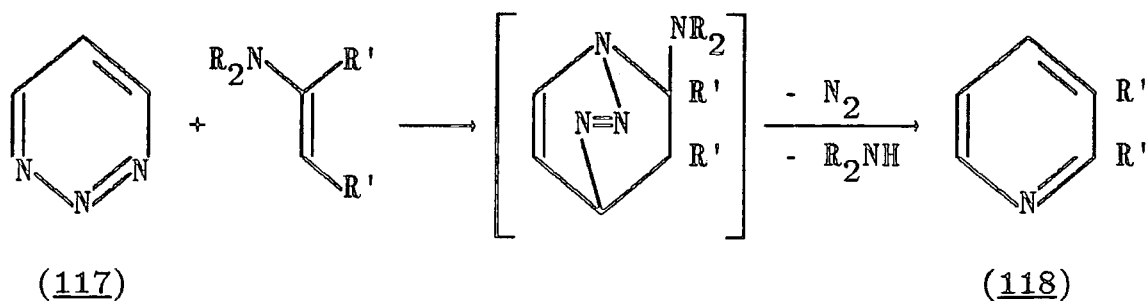

e.g. $R_2 = (CH_2)_4$, $R'_2 = (CH_2)_n$ $n = 4, 6, 8, 10$

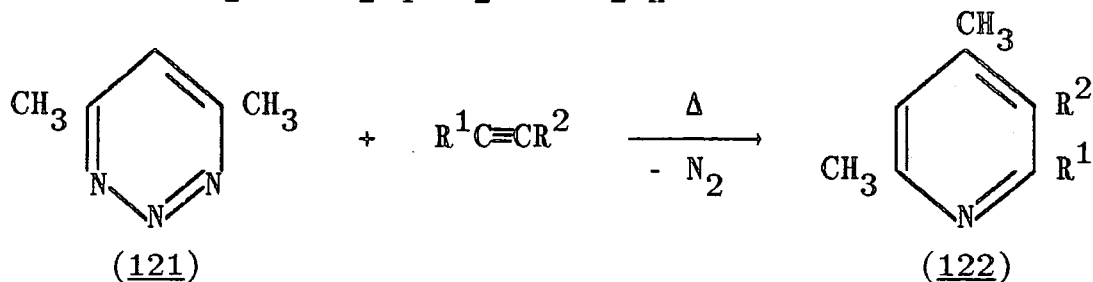

e.g. $R^1 = NEt_2$, $R^2 = CH_3$

$R^1 = Ph$, $R^2 = H$

Similarly, 4,6-dimethyl-1,2,3-triazine (121) gave moderate yields of 2,4-dimethylpyridine derivatives (122) from cycloadditions with substituted alkynes⁶⁸. These are both rare examples of Diels-Alder cycloadditions involving 1-azadienes^{66,69}. The isomeric 1,2,4-triazine (123) can act as an electron-deficient 2-azadiene in Diels-Alder cycloadditions⁶⁶. This type of cycloaddition is much more common, giving moderate to excellent yields of 3,4-di-substituted pyridines (124) with various enamines^{70,71}. Substituted 1,2,4-triazines (125) also undergo intramolecular cycloadditions with terminal alkynyl groups, again producing

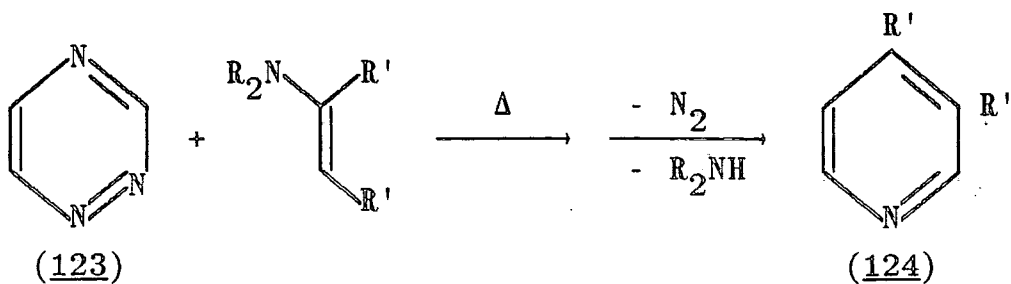

e.g. $R_2 = (\text{CH}_2)_4$, $R'_1 = (\text{CH}_2)_n$ $n = 3 - 5$

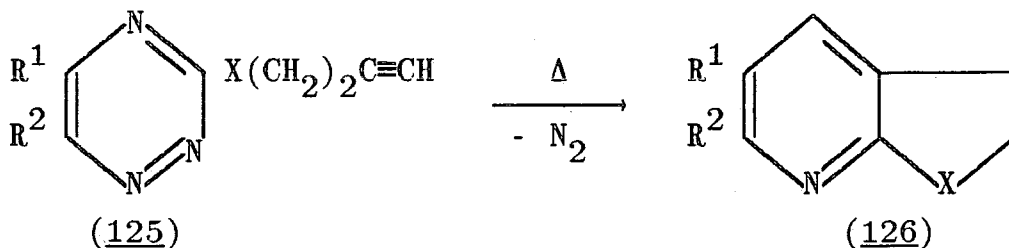

e.g. $X = \text{O}$, $R^1 = R^2 = \text{H}$ or CH_3

$X = \text{S}$, $R^1 = \text{Ph}$, $R^2 = \text{H}$

annelated pyridines (126)⁷². These inverse electron demand Diels-Alder reactions of 1,2,4-triazines with enamines and terminal alkynes are synthetically useful, resulting overall in the annelation of substituted pyridines, and have many applications in the important area of natural product synthesis.

Halogenated triazines are potentially more reactive systems for these inverse electron demand cycloadditions, as they are more electron-deficient than the parent triazines due to the strong inductive electron-withdrawing effects of the halogen substituents. The Diels-Alder reactions of both trichloro- and trifluoro-1,2,4-triazine with several simple alkenes have been reported⁷³. The reaction of trichloro-1,2,4-triazine (18) with the *cis*-alkenes (*Z*)-but-2-ene, cyclopentene and (*Z*)-cyclo-octene gave a good yield of the corresponding 2,6-dichloropyridine derivative (128) in each

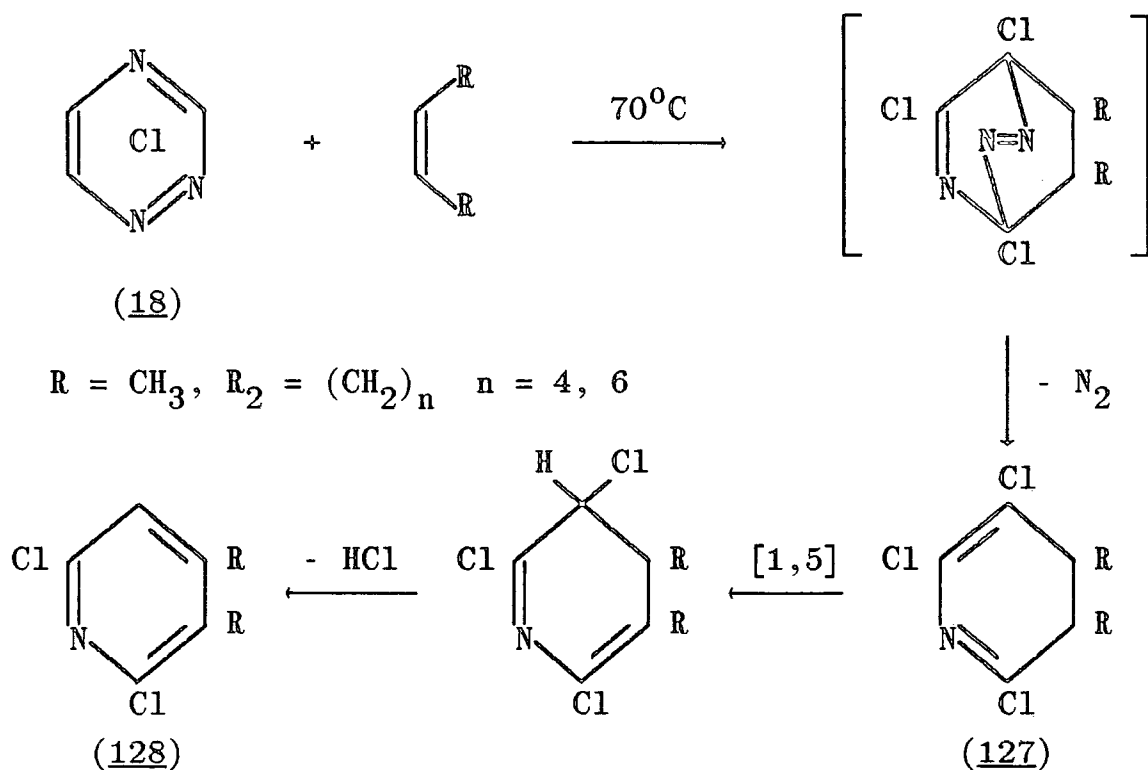

SCHEME 2.3

case (Scheme 2.3). The formation of the pyridines (128) was suggested to arise from initial Diels-Alder addition and loss of nitrogen to give the dihydropyridines (127), which undergo [1,5] sigmatropic hydrogen shifts and subsequent elimination of HCl to give the 2,6-dichloropyridines (128). In contrast, the addition of cyclopentene and (Z)-cyclooctene to trifluoro-1,2,4-triazine (27) gave moderate yields of the products (130) derived from addition of a second molecule of the alkene to the intermediate dihydropyridine (129) (Scheme 2.4).

There are no reports of any cycloaddition reactions of halogenated 1,2,3-triazines in the literature, and this prompted our investigation into this potentially very interesting aspect of halogenated 1,2,3-triazine chemistry.

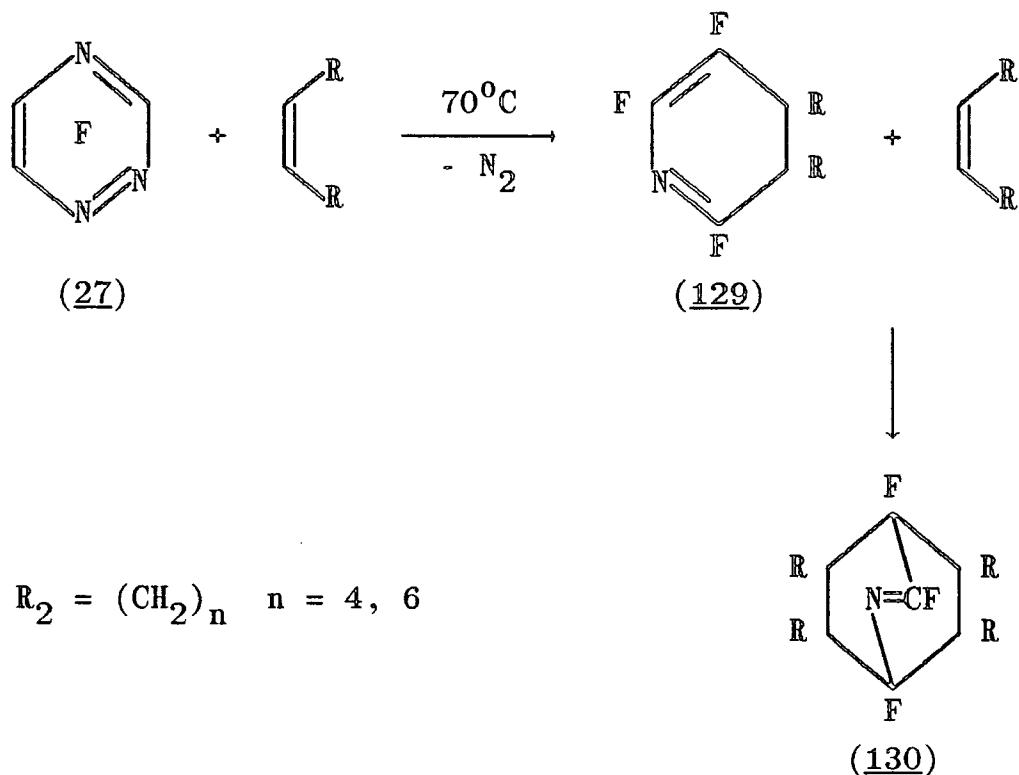

SCHEME 2.4

2. Trichloro-1,2,3-triazine

The initial inverse electron demand Diels-Alder cycloadditions were attempted between trichloro-1,2,3-triazine (20) as the electron-deficient 1-azadiene and the



(20)

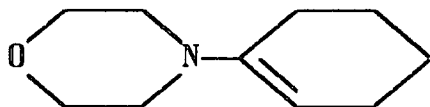

(131)

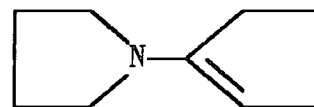

(132)

electron-rich enamines N-morpholino-1-cyclohexene (131) and pyrrolidino-1-cyclopentene (132).

Trichloro-1,2,3-triazine (20) was refluxed with one equivalent of N-morpholino-1-cyclohexene (131) in dry tetrahydrofuran, giving a multi-component solid product

which could not be separated by either vacuum sublimation or column chromatography. The reaction was repeated in chloroform, which is suggested to be a good solvent for this type of reaction⁷⁰, again giving an inseparable multi-component mixture.

The reaction of (20) with the more reactive⁷⁰ enamine pyrrolidino-1-cyclopentene (132) in dry tetrahydrofuran at room temperature under nitrogen gave a viscous oil on removal of the solvent, which contained the triazine (20) and enamine (132). A repeat of this reaction in refluxing tetrahydrofuran also yielded a viscous oil containing the starting materials (20) and (132). Furthermore, the i.r. spectrum of the crude oil showed an intense C=O absorption, which was presumed to result from the hydrolysis of the enamine (132) to the precursor amine (108a) and ketone (133), a process which is known to occur readily⁷⁴. Obviously using dry solvent under nitrogen was not sufficient to exclude moisture from the system, thus preventing this hydrolysis. The reaction was repeated in both refluxing tetrahydrofuran and dioxan in the presence of excess glacial acetic acid to suppress the enamine hydrolysis. This also afforded a viscous oil, again containing the triazine (20) and enamine (132). Another potential problem associated with the use of enamines for

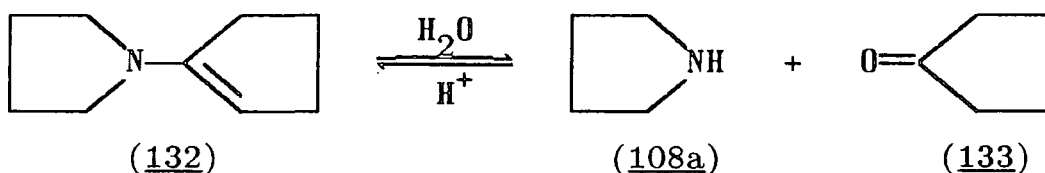

these cycloadditions to trichloro-1,2,3-triazine is that they are known to participate readily in nucleophilic processes, *e.g.* Michael-type additions⁷⁵. As discussed earlier in this chapter (2.C.1), trichloro-1,2,3-triazine is highly activated towards nucleophilic aromatic substitution²⁰, which may explain the complex product mixtures obtained from some of the attempted cycloaddition reactions. Further cycloadditions were attempted using the simple alkenes 2,3-dimethylbut-2-ene (134), dihydrofuran (135) and cyclopentene (136). No reaction was observed

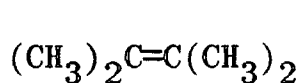
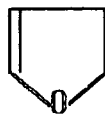
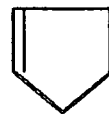
(134)(135)(136)

between trichloro-1,2,3-triazine (20) and 2,3-dimethylbut-2-ene (134) on refluxing in carbon tetrachloride. Similarly, refluxing (20) in dihydrofuran gave only recovered starting materials. However, heating (20) with dihydrofuran (135) or cyclopentene (136) in Carius tubes at 150°C gave mainly recovered triazine, together with polymeric material, presumably resulting from decomposition of the alkenes. There was no evidence for the formation of cycloadducts in either case. This contrasts with the reaction of trichloro-1,2,4-triazine with cyclopentene, when a good yield of the cycloadduct was formed⁷³. It was not possible to attempt these reactions under more forcing conditions, as trichloro-1,2,3-triazine decomposes completely at 180°C yielding trichloroacrylonitrile⁵⁹.

3. Trifluoro-1,2,3-triazine

Trifluoro-1,2,3-triazine (28) would be expected to be a more electron-deficient 1-azadiene than trichloro-1,2,3-triazine, and hence more reactive in inverse electron demand Diels-Alder reactions due to the greater electron-withdrawing ability of fluorine *versus* chlorine. Attempted cycloadditions to (28) used the electron-rich enamines pyrrolidino-1-cyclopentene (132) and -hexene (137). Small scale preliminary reactions were attempted between (28) and



(28)

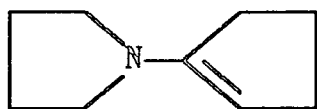

(132)

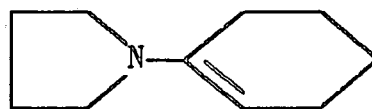

(137)

the two enamines in dry tetrahydrofuran in n.m.r. tubes at room temperature, with the aim of observing any possible cycloadditions by ^{19}F n.m.r spectroscopy. These gave immediate exothermic reactions, generating intractable tars in both cases. The reactions were repeated in dry diethyl ether under nitrogen at 0°C , giving a crystalline material in solution in both cases. However, all attempts to isolate this material by either filtration, removal of solvent *in vacuo*, or column chromatography resulted in the decomposition of the crystals to intractable tars, from which no material could be isolated.

As mentioned in the introduction to this section (2.D.1), the methyl-1,2,3-triazines are reported to undergo inverse electron demand cycloadditions with various

alkenes⁶⁷ and alkynes⁶⁸, giving moderate to good yields of substituted pyridine derivatives. Although the halogenated 1,2,3-triazines (20) and (28) are much more electron-deficient 1-azadienes than the methyl-1,2,3-triazines and hence should be more reactive towards cycloaddition with electron-rich enamines, they are also highly activated to attack by nucleophilic reagents. This may explain the production of multi-component mixtures and intractable tars from the attempted cycloadditions, resulting from nucleophilic attack of the enamines on the halogenated 1,2,3-triazines. The use of simple hydrocarbon alkenes with less nucleophilic character is one way of circumventing this problem, but the ones employed with trichloro-1,2,3-triazine (20) were obviously not sufficiently reactive to undergo cycloaddition to (20). These results contrast markedly with those of the isomeric trichloro- and trifluoro-1,2,4-triazines (18) and (27), which both readily undergo cycloadditions with simple alkenes⁷³. This may result from the fact that 1,2,4-triazines act as 2-azadienes in cycloaddition reactions, with attack of the dienophile at terminal carbon atoms of the diene. In contrast, the 1,2,3-triazines would act as 1-azadienes, involving addition of the dienophile to a terminal nitrogen atom, which must be a less favourable situation. This is supported by the fact that cycloadditions to 2-azadienes are much more common than those involving 1-azadienes⁶⁶.

Finally, a potentially "normal" electron demand Diels-Alder reaction, *i.e.* between an electron-rich diene

and an electron-deficient dienophile, was attempted using trimethoxy-1,2,3-triazine (110) and dimethyl acetylene-dicarboxylate (138). The acetylene (138) is known^{76,77} to behave as an electron-deficient dienophile in Diels-Alder

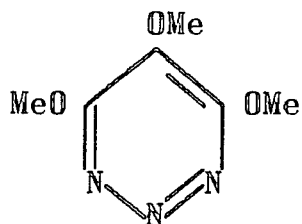
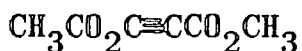
(110)(138)

reactions, and it was hoped that a 1,2,3-triazine (110) possessing three electron-donating methoxy substituents would be a sufficiently electron-rich 1-azadiene to undergo cycloaddition with the acetylene. However, refluxing a mixture of (110) and (138) in dry tetrahydrofuran, or heating in a sealed tube at 120⁰C gave only starting materials.

CHAPTER THREE

SOLUTION FLUORINATIONS

3.A Introduction

In the preceding Chapter (2.B.3) we reported our unsuccessful attempts to repeat the polyfluoroalkylation of trichloro-1,2,3-triazine using the standard procedure employed previously by M. Tamura.

In this Chapter, we describe a modification to this general polyfluoroalkylation procedure which resulted in the successful preparation of the perfluoroisopropyl-1,2,3-triazines, and a subsequent investigation of these modified conditions as a potential fluorinating system for various activated perchloroheteroaromatics.

3.B Polyfluoroalkylation of perchlorotriazines

A general procedure for the polyfluoroalkylation of perfluoroheteroaromatics has been developed in our laboratories³⁷, which involves the generation of perfluoroalkyl anions from an appropriate precursor perfluoroalkene with fluoride ion in an aprotic solvent, usually tetraglyme or sulpholane, and the subsequent reaction of these perfluoroalkyl anions with a suitably reactive perfluorinated heteroaromatic. However, the perchlorotriazines are sufficiently reactive to undergo both the

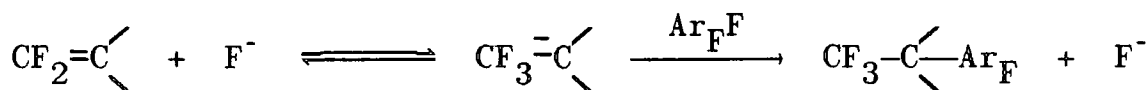

fluorination and polyfluoroalkylation steps simultaneously, and the direct polyfluoroalkylations of trichloro-1,2,3-²⁴ and -1,2,4-triazine¹⁹ have been reported in the literature.

1. Trichloro-1,2,3-triazine

This work on the polyfluoroalkylation of trichloro-1,2,3-triazine was done in collaboration with Dr. T. Shepherd.

The successful polyfluoroalkylation of trichloro-1,2,3-triazine (20) reported previously by M. Tamura⁵⁹ employed perfluoroisopropyl anions generated from hexafluoropropene and either caesium or potassium fluoride in tetraglyme or sulpholane. This gave a mixture of the 4,6-bis- (93) and 4,5,6-tris-isopropyl-1,2,3-triazines (98), together with a product (103) arising from nucleophilic attack of a further perfluoroisopropyl anion on the centre ring nitrogen of the tris-isopropyl derivative (98) (Scheme 3.1). The proportions of each of these derivatives in the product mixture depends

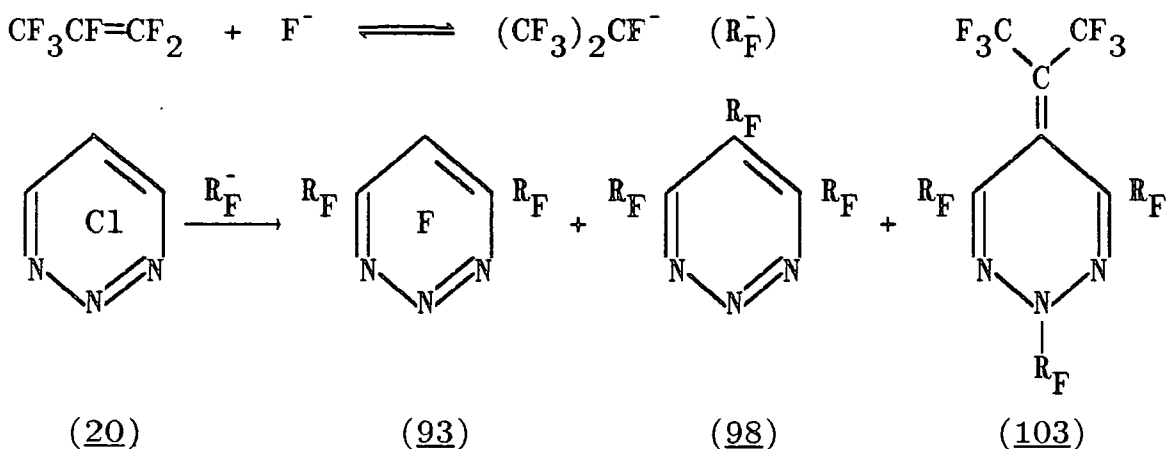

SCHEME 3.1

principally upon the reaction temperature, with (93) the major product at room temperature, whilst at higher temperatures, (103) is the predominant product.

It was observed during the various unsuccessful preparations described in Chapter Two that trichloro-1,2,3-triazine (20) has only a very low solubility in tetraglyme or sulpholane, which must limit the degree of contact between the triazine and the other reagents in the system, and so reducing the probability of reaction.

A possible solution to this problem would be to employ a co-solvent to increase the solubility of trichloro-1,2,3-triazine in the reaction system. Diethyl ether was chosen for the initial investigation, as trichloro-1,2,3-triazine is known to be very soluble in this solvent, which is used for the purification of (20).

The addition of diethyl ether to the polyfluoro-alkylation system with sulpholane at room temperature resulted in the successful production of the three perfluoroisopropyl-1,2,3-triazines (93), (98) and (103)²⁴. A diethyl ether:sulpholane ratio of \approx 2:1 by volume was employed, with this co-solvent system having several advantages over the single solvent systems used previously:

- i) Greater reproducibility of yields.
- ii) Reduction of reaction times. The addition of diethyl ether led to complete reaction in 24 - 48hr, whereas in its absence, complete reaction generally required between 4 - 7 days.
- iii) More reliable scale-up for larger scale synthesis.

iv) Selective control of the major derivative produced, depending principally upon the number of equivalents of hexafluoropropene used.

It was suggested previously^{19,24} that the initial step in the direct polyfluoroalkylation of the perchlorotriazines is the partial fluorination of the triazine in solution. The addition of diethyl ether would be expected to promote this initial step by increasing enormously the solubility of trichloro-1,2,3-triazine in the system, and hence its degree of contact with the source of fluoride ion. Our evidence for this supposition is given in the following section (3.C.1b), and this has led to the development of a more efficient two-stage process²⁴ for the polyfluoroalkylation of trichloro-1,2,3-triazine, involving i) partial fluorination of the triazine with potassium fluoride in diethyl ether and sulpholane, followed by ii) polyfluoroalkylation of the solution of partially fluorinated triazines in diethyl ether isolated from i) using hexafluoropropene and caesium fluoride, also in diethyl ether and sulpholane.

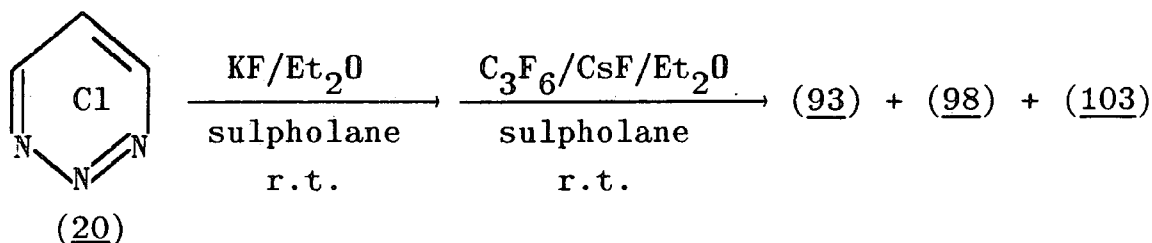

2. Trichloro-1,3,5-triazine

The remarkable effect of the addition of diethyl ether on the efficiency of the standard polyfluoroalkylation

system with trichloro-1,2,3-triazine is further illustrated from the polyfluoroalkylation of trichloro-1,3,5-triazine with the same system.

The reaction of (139) with hexafluoropropene and caesium fluoride in sulpholane at room temperature went to completion in 72hr, and gave a 61% yield of perfluoro-2,4,6-tris-isopropyl-1,3,5-triazine (84). We believe that this is

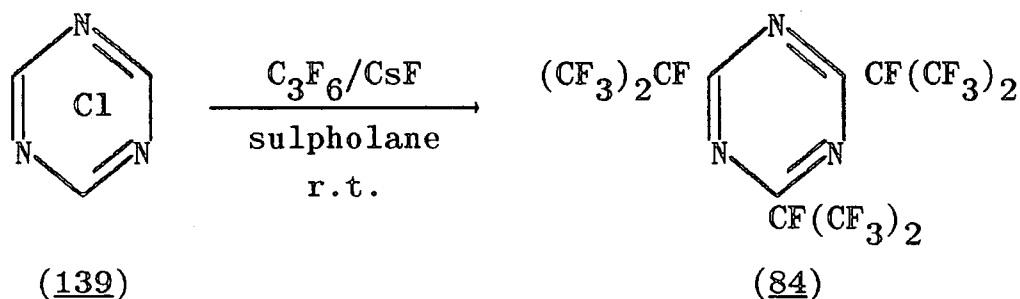

the first example of the direct polyfluoroalkylation of trichloro-1,3,5-triazine, as although the tris-perfluoro-isopropyl derivative (84) is a well-known compound in the literature, the previous reported preparations⁷⁸ have employed trifluoro-1,3,5-triazine as the precursor.

Polyfluoroalkylation of (139) using hexafluoropropene and potassium fluoride, and with the addition of diethyl ether, went to completion in only 24hr at room temperature, giving a 79% yield of the tris-isopropyl derivative (84). A comparison of these two results illustrates the significant effect of addition of diethyl ether to the general polyfluoroalkylation procedure. The polyfluoroalkylation of (139) with potassium fluoride (a less active fluoride ion source) in diethyl ether and sulpholane went to completion in a much shorter time than the corresponding polyfluoroalkylation of (139) using caesium fluoride (a very active

source of fluoride ion) in the absence of diethyl ether. The addition of diethyl ether to the polyfluoroalkylation system, primarily to increase the solubility of the trichloro-1,3,5-triazine, has, in addition, effectively enhanced the activity of potassium fluoride as a fluoride ion source to a level comparable with that of caesium fluoride, a quite remarkable effect.

A detailed study of the role of the diethyl ether in the system, and the use of this co-solvent system as a potential fluorination method for very reactive perchloro-heteroaromatics is discussed in the following section.

3.C Fluorination of perchloroheteroaromatics

The previous section described the addition of a diethyl ether co-solvent to the standard reaction system for polyfluoroalkylations developed in these laboratories, which resulted in the successful polyfluoroalkylation of trichloro-1,2,3-triazine. Polyfluoroalkylation with this two solvent system is suggested to occur *via* partially fluorinated 1,2,3-triazine intermediates, and so prompted this investigation into the use of potassium fluoride in dialkyl ether/sulpholane co-solvent systems as potential fluorinating media for various perchloroheteroaromatics.

1. Using the diethyl ether/sulpholane solvent system

It was decided to approach this investigation in a systematic manner by attempting the fluorination of several perchloroheteroaromatics in order of their decreasing

reactivity to nucleophilic aromatic substitution, and hence to displacement of chloride by fluoride ion. Fluorination of trichloro-1,3,5- and -1,2,3-triazines, tetrachloro-pyrimidine and -pyridazine were thus attempted, using anhydrous potassium fluoride in diethyl ether and sulpholane. All reactions were carried out at room temperature using an \approx 2:1 ratio of diethyl ether:sulpholane by volume, and three equivalents of potassium fluoride per fluorination site.

a) Trichloro-1,3,5-triazine

Fluorination of (139) with this system gave one product, identified as trifluoro-1,3,5-triazine (80) in 68% yield. Separate experiments were subsequently attempted to

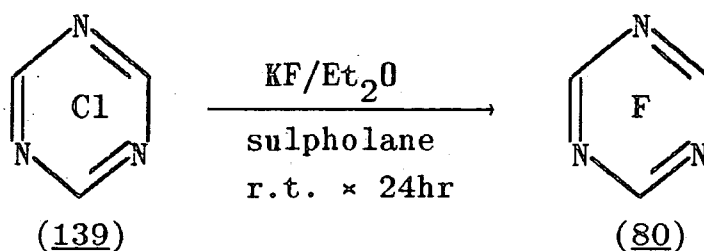

determine the effect of the relative amounts of the two solvents on this fluorination procedure. A 20:1 ratio of diethyl ether:sulpholane also gave trifluoro-1,3,5-triazine (80) as the sole product in 73% yield, whereas using only diethyl ether, no fluorination was observed. The latter result clearly shows that the presence of some sulpholane is necessary to provide a sufficient degree of solubility for the potassium fluoride to allow fluorination to proceed, which obviously cannot be provided solely by diethyl ether.

b) Trichloro-1,2,3-triazine

Trichloro-1,2,3-triazine (20) gave a mixture of 5-chlorodifluoro-1,2,3-triazine (102) and trifluoro-1,2,3-triazine (28). Several fluorinations were attempted with differing reaction periods, and the results of these are given in Table 3.1. These results clearly illustrate the marked effect that addition of the diethyl ether co-solvent has on the potassium fluoride/sulpholane solution fluorination system employed initially by M. Tamura to attempt the fluorination of trichloro-1,2,3-triazine, which gave only low yields of mono- (101) and di-fluoro-1,2,3-triazines (102) at temperatures up to 130°C⁵⁹. In contrast,

Table 3.1 Fluorination of trichloro-1,2,3-triazine (20) with the KF/diethyl ether/sulpholane system

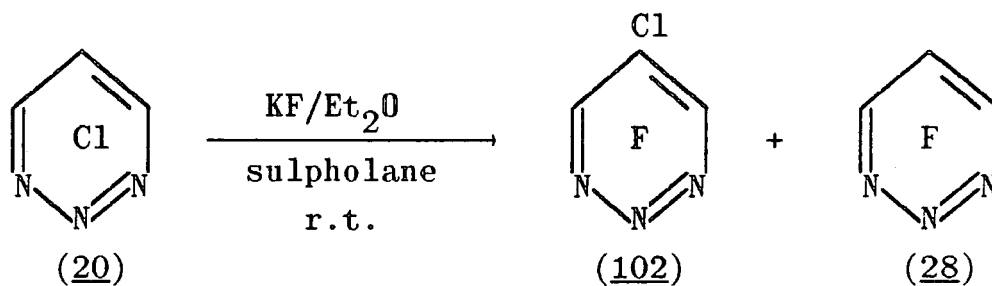

<u>Conditions</u>	<u>Conversion</u>	<u>Yield</u>	
		(<u>102</u>)	(<u>28</u>)
r.t. × 24hr	95%	82%	13%
r.t. × 48hr	75%	58%	17%
r.t. × 7 days	39%	21%	18%

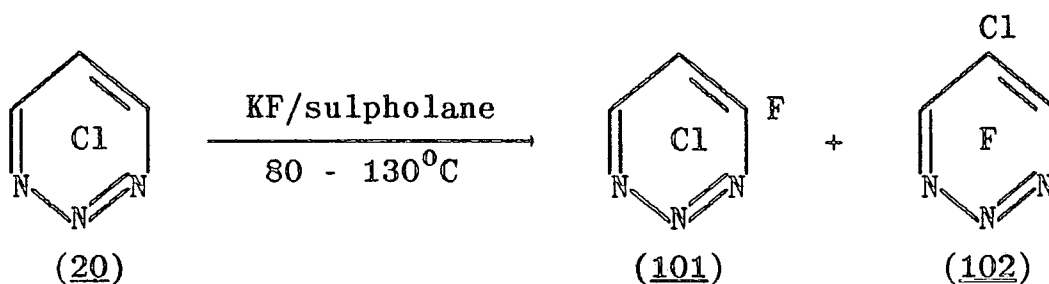

addition of diethyl ether gives moderate yields of the di- and tri-fluoro-1,2,3-triazines at room temperature. As discussed in the previous section (3.B.1), trichloro-1,2,3-triazine has low solubility in sulpholane, whereas it is extremely soluble in diethyl ether. The bulk of the diethyl ether containing the triazine forms an upper layer above the sulpholane in the reaction vessel, but there is a limited degree of solubility between the two solvents. This was demonstrated by stirring a mixture of diethyl ether and sulpholane for a few minutes, and then decanting off the ether layer. The subsequent removal of the ether under reduced pressure gave a small residue of sulpholane. This partial solubility between the two solvents may explain why this solvent system appears to be such an effective fluorinating medium under very mild conditions, as the partial solubility of diethyl ether (containing the trichloro-1,2,3-triazine) in sulpholane allows a much more intimate contact between the triazine and fluoride ion in the sulpholane than is possible in the absence of the diethyl ether, even if the temperature is increased significantly.

As might be anticipated, longer reaction times gave increased amounts of the fully fluorinated trifluoro

derivative (28), although the overall conversion of (20) to fluorinated products was significantly reduced. This is due to the formation of high molecular weight material in the system, which presumably results from the reactions between the trifluoro-1,2,3-triazine (28) and its anionic σ -complex (140), formed by the nucleophilic addition of fluoride ion to the triazine ring. The formation of a dimer of the isomeric trifluoro-1,2,4-triazine *via* a similar fluoride ion induced process has been reported²³.

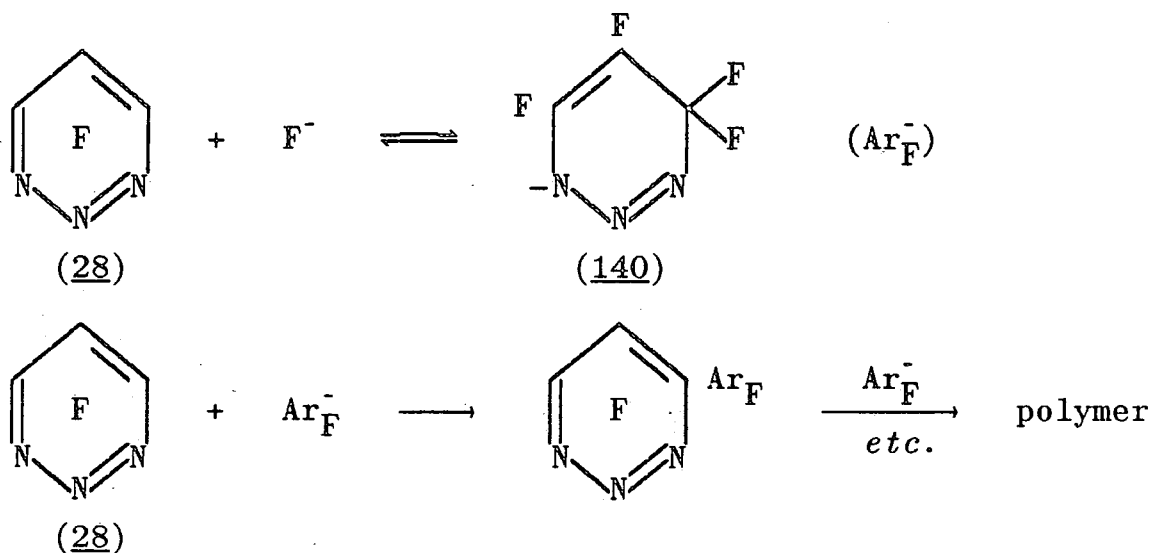

These results for the fluorination of trichloro-1,2,3-triazine also clearly confirm the suggestion advanced in the previous section (3.B.1) that the polyfluoroalkylation of trichloro-1,2,3-triazine using this solvent system does proceed *via* partially fluorinated 1,2,3-triazine intermediates.

The yields obtained from the shorter fluorinations of (20) compare very favourably with those from the vapour phase flow fluorination procedure previously employed to prepare these fluorinated 1,2,3-triazines (see 10.A.2a,

Table 10.1). However, this solution fluorination system has several advantages over the flow fluorination method:

- i) Much simpler experimental method.
- ii) Milder reaction conditions, which greatly reduces the significant losses of material found at higher temperatures, which results from thermal decomposition of the triazines.
- iii) More reproducible yields.
- iv) No limit on the size of scale-up.

Indeed, since the development of this alternative fluorination method, we have subsequently employed this route for the preparation of the fluorinated 1,2,3-triazines.

c) Tetrachloropyrimidine

Fluorination of (8) with potassium fluoride in diethyl ether and sulpholane for either 24 or 48 hrs gave a mixture of 2,5-dichlorodifluoropyrimidine (141) and 5-chlorotrifluoropyrimidine (142) in both cases (Table 3.2). The overall yield of fluorinated products was similar for both reactions, but with the longer reaction giving an increased proportion of the trifluoropyrimidine (142) in the product mixture. No fully fluorinated pyrimidine was

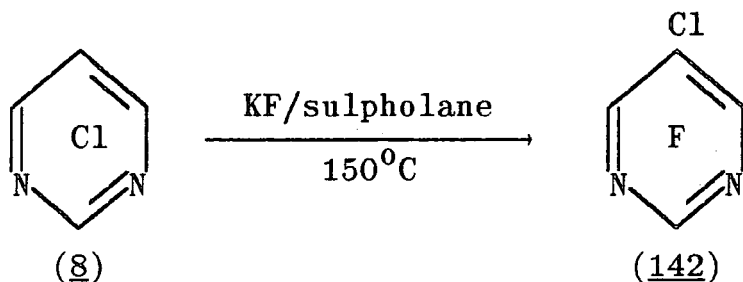
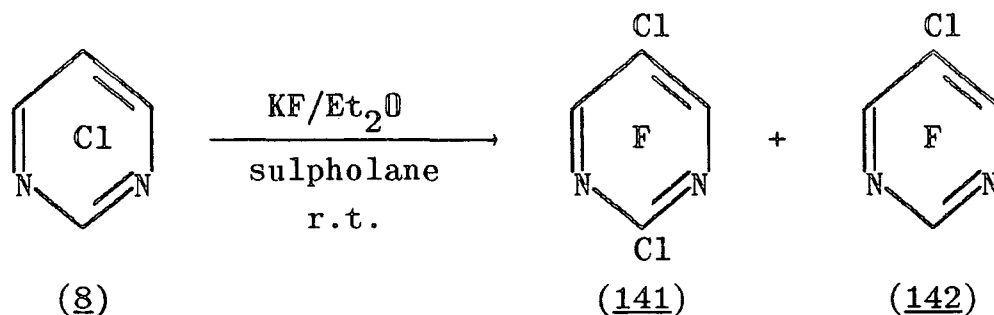

Table 3.2 Fluorination of tetrachloropyrimidine (8) with the KF/diethyl ether/sulpholane solvent system



<u>Conditions</u>	<u>Conversion</u>	<u>Yield</u>	
		(<u>141</u>)	(<u>142</u>)
r.t. × 24hr	80%	51%	29%
r.t. × 48hr	73%	33%	40%

detected in the product mixtures, which is consistent with the results reported previously by D. Pearce, who obtained 5-chlorotrifluoropyrimidine (142) as the sole product from the fluorination of (8) using potassium fluoride in sulpholane at 150°C⁴. This clearly highlights a major limitation of fluorinations in solution, which is either the boiling point or thermal stability of the solvents employed, and this severely restricts the usefulness of these procedures for the complete fluorination of less reactive perchloroaromatics, such as tetrachloropyrimidine.

d) Tetrachloropyridazine

Tetrachloropyridazine (3) did not undergo any fluorination using potassium fluoride in diethyl ether and sulpholane at room temperature, even with prolonged reaction times. Compound (3) is the least reactive of the series of perchloroheteroaromatics investigated, being ≈ 2 orders of magnitude less reactive towards nucleophilic substitution than tetrachloropyrimidine²⁸, and hence the failure to even partially fluorinate (3) using these very mild conditions is perhaps not unexpected. However, complete fluorination of

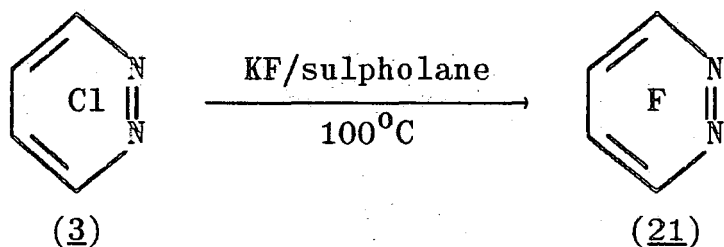

tetrachloropyridazine (3) in solution was achieved by D. Pearce, who again employed potassium fluoride in sulpholane at 100°C ⁴.

The latter two attempts highlighted the major limitation of this very mild system for complete fluorination of the less reactive perchlorodiazines. In general, an obvious remedy to the problem of incomplete reaction is to raise the reaction temperature. However, the limiting factor for this will be the boiling point of the more volatile solvent, in this case diethyl ether (b.p. 35°C). The volatility of diethyl ether effectively prevents the use of this fluorinating system at significantly higher than room temperature, and led us to consider an alternative

higher-boiling co-solvent, in which the perchloro-heteroaromatics are also soluble.

2. Using the di-n-butyl ether/sulpholane solvent system

In an attempt to extend the co-solvent methodology discussed in the preceding section to successfully perfluorinate the perchlorodiazines, a replacement solvent for diethyl ether was required. This solvent must have a significantly higher boiling point than diethyl ether, and be one in which the perchloroheteroaromatics are soluble at the reaction temperature. The most simple alternative was a homologue of diethyl ether, and hence di-n-butyl ether was chosen. This has a boiling point of 142°C, and also dissolves reasonable quantities of the perchlorodiazines at room temperature.

The fluorinations of perchloro-pyrimidine, -pyridazine and -pyridine were attempted using potassium fluoride in di-n-butyl ether and sulpholane at 140 - 150°C, with the same ratios of reagents as used in the previous fluorinations with diethyl ether as the co-solvent.

a) Tetrachloropyrimidine

Fluorination of (8) with potassium fluoride in di-n-butyl ether and sulpholane at 140°C gave a 46% yield of 5-chlorotrifluoropyrimidine (142). The same product was obtained in 44 - 56% yield by D. Pearce from fluorination of (8) with potassium fluoride in sulpholane alone at the same temperature⁴.

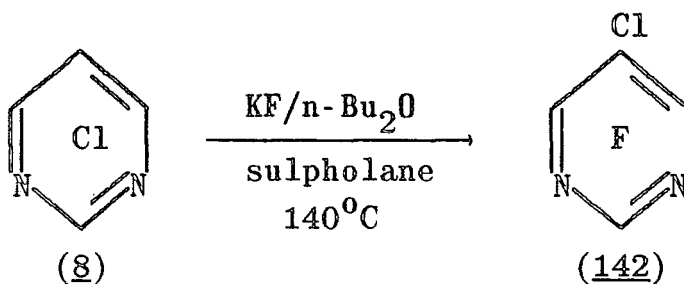

b) Tetrachloropyridazine

Tetrachloropyridazine (3) gave tetrafluoropyridazine (21) as the sole fluorinated product in 55% yield with potassium fluoride in di-n-butyl ether and sulpholane.

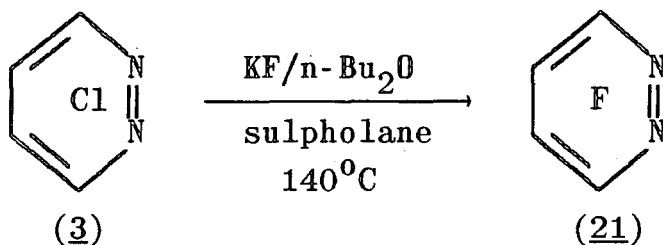

Again, the same product was obtained previously in 50% yield from the fluorination of (3) with potassium fluoride in sulpholane at 100°C⁴.

c) Pentachloropyridine

Fluorination of pentachloropyridine (143) with potassium fluoride in di-n-butyl ether and sulpholane at 150°C gave only 3,5-dichlorotrifluoropyridine (144) in 58% yield. As with the fluorinations of the perchlorodiazines using this co-solvent system, the same product (144) is

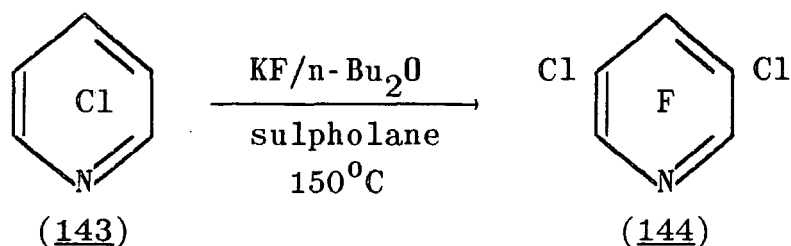

obtained in 54 - 68% yield from fluorination of pentachloropyridine (143) with potassium fluoride in sulpholane at 150 - 200°C^{4,79}.

The fluorination of perchloro-pyrimidine, -pyridazine and -pyridine with this solution fluorination system gives the same fluorinated products, and in similar yields, to those already obtainable using potassium fluoride in sulpholane alone⁴. It is concluded that there is no advantage in the use of this system over the methods already established for the perfluorination of these compounds.

CHAPTER FOUR

PHOTOLYSIS OF FLUORINATED 1,2,3-TRIAZINES4.A Introduction

A previous worker in these laboratories, M. Tamura, conducted a preliminary investigation into the generation of monocyclic azetes from fluorinated 1,2,3-triazine precursors^{59,60}. These attempts are summarised in detail in Chapter One (1.E). However, a synopsis of his initial work which is relevant as a background to the investigations described in this Chapter is given below.

The photolysis of perfluoro-4,6-bis-isopropyl-1,2,3-triazine (93) in solution gave a dimer (95) of the corresponding azete (94), whereas trifluoro-1,2,3-triazine (28) gave a polymer, which was suggested to be poly-(trifluoroazete) (90)⁵⁹. Furthermore, in order to attempt to observe azetes (94) and (145) directly by i.r. and mass

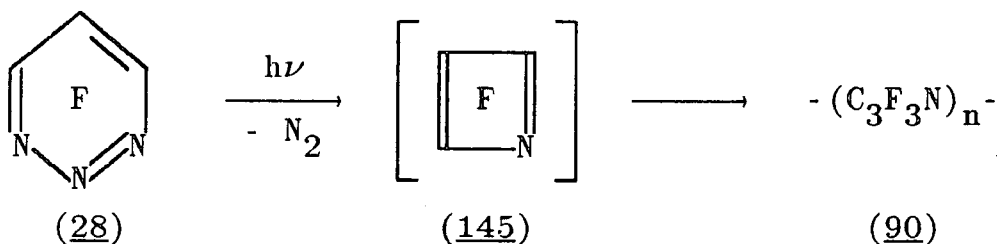
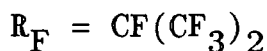
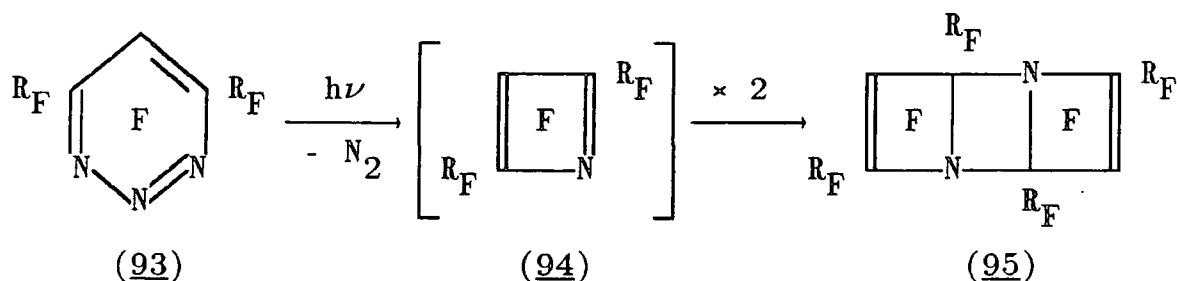

spectroscopy, the photolyses of triazines (28) and (93) were carried out at liquid nitrogen temperature (-196°C) on a KBr disc without matrix material^{59,60}. The i.r. spectra of the photolysates at -196°C were recorded, and then mass spectra were obtained as the systems warmed up towards room temperature. These spectra provided evidence for the existence of the azetes and their respective dimers. Thus the photolysis of trifluoro-1,2,3-triazine (28) at -196°C gave two new absorptions at 1675 and 1645 cm^{-1} in the i.r. spectrum, assigned to $\text{C}=\text{C}$ and $\text{C}=\text{N}$ in the azete (145). On warming up the system, the mass spectrum showed m/z 107 ($\text{C}_3\text{F}_3\text{N}$) corresponding to (145), and at higher temperatures m/z 169 was observed. This corresponds to $\text{C}_5\text{F}_5\text{N}$, which was suggested to result from the loss of FCN from the dimer of

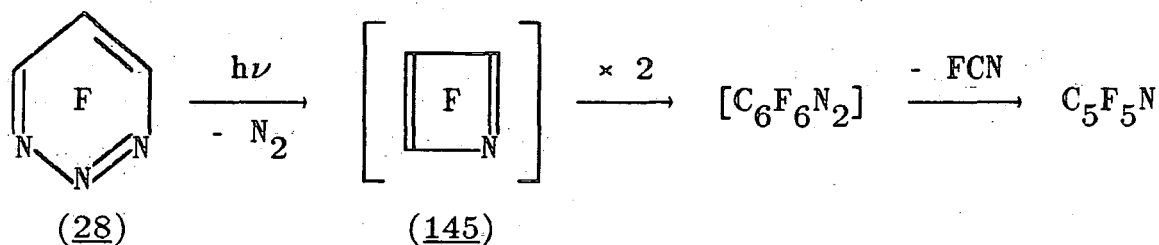

(145). Similarly, photolysis of perfluoro-4,6-bis-isopropyl-1,2,3-triazine (93) gave m/z 407 in the mass spectrum, corresponding to the azete (94), whilst at higher temperatures m/z 745 was observed, which is the $\text{M}^+ - \text{CF}_3$

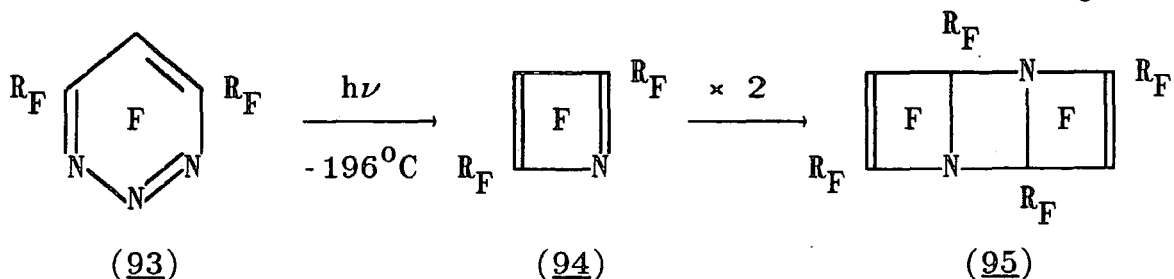

highest mass fragment ion of the azete dimer (95)⁵⁹. This suggested formation of azete (94) at low temperature, which dimerised as the temperature was raised.

These preliminary observations were potentially very interesting, but the data from the experiments were incomplete. We have repeated these low temperature photolysis experiments with the aim of confirming and completing the results from the preliminary work, and the results obtained are discussed in detail. Furthermore, attempts to observe 1:1 cycloadducts of the azetes with furan at low temperature using mass spectroscopy are presented.

In addition, the transference photolysis of perfluoro-4,6-bis-isopropyl-1,2,3-triazine has been investigated, with the aim of generating perfluoro-2,4-bis-isopropylazete by an alternative method to those employed previously.

The vapour-phase photolysis of trifluoro-1,2,3-triazine has been repeated, and a more detailed analysis of the structure of the polymeric product will be given.

4.B Low temperature photolyses of fluorinated 1,2,3-triazines

The photolysis experiments involving trifluoro-1,2,3-triazine were carried out by the author, and the experiments involving perfluoro-4,6-bis-isopropyl-1,2,3-triazine were carried out by Dr. T. Shepherd, but for completeness these two sets of results are presented and discussed together.

1. Experimental method

A detailed description of both the cell and procedure used for these experiments is given in the experimental section (12.A.1), with a brief outline given below.

The cell was evacuated for several hours prior to use under high vacuum, the liquid N₂ was added to the reservoir, and the plate allowed to cool. The triazine was condensed onto the plate through the vacuum line in a controlled manner, to give as thin a film of triazine as possible on the plate (indicated by a slight fogging of the plate). The i.r. spectrum of the triazine was recorded at -196°C, and the sample was then irradiated at 254nm for the required time. The i.r. spectrum of the product was recorded at -196°C, the liquid N₂ removed from the reservoir, and the cell connected to the mass spectrometer. The temperature of the KBr plate (as indicated by the temperature of the bottom of the reservoir) was monitored using a copper/constantan thermocouple as it warmed up towards room temperature.

The mass spectral data were acquired as follows. The spectrometer scanned at \approx 9s intervals recording all masses observed, but the printout obtained for each scan gave only the five most abundant masses (in terms of ion current) and the highest mass detected. At the end of an experiment, XY plots of the ion current for particular masses of interest with scan number (and hence time) were obtained, and using this with the temperature data (the temperature was recorded every \approx 10 scans, *i.e.* \approx 90s intervals), the results from each experiment could be interpreted.

2. Trifluoro-1,2,3-triazine

a) Sampling of starting material

The triazine (28) was deposited onto the plate at -196°C , the cell connected to the mass spectrometer and the isopentane slush bath added to the reservoir. The mass spectra and temperature were recorded from -73°C , with the following masses consistently detected from the given

m/z

107	-45°C	$\text{M}^+ - \text{N}_2$
135	-36°C	M^+

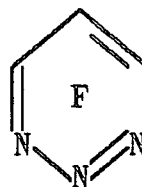

(28)

temperatures. This experiment was repeated with a thicker film of (28) to give the same result, which demonstrates that the rate of desorption of (28) from the plate is independent of film thickness. This is an important point, as the quantity of film deposited is determined roughly by observing the degree of fogging on the plate, and so it is virtually impossible to produce films of comparable thickness from one experiment to another. However, if the film thickness does not affect the rate of desorption of the triazine, then this allows direct comparison of the results from different experiments.

The other important point to note about this experiment is that the initial desorption of trifluoro-1,2,3-triazine from the plate at -45°C is characterised by detection of the m/z 107 fragment ion and not the m/z 135 molecular ion, which is not initially detected until $\approx 10^{\circ}\text{C}$ higher. This is

because in the EI+ mass spectrum of (28), the m/z 107 fragment ion is much more intense (39% base) than the m/z 135 molecular ion (12% base), and so as the trifluoro-1,2,3-triazine (28) begins to desorb from the plate, its initial concentration is too low to give a mass spectrum of sufficient intensity for the m/z 135 molecular ion to be detected.

b) Photolysis of trifluoro-1,2,3-triazine

The triazine (28) was deposited onto the plate at -196°C , the i.r. spectrum recorded, and then the film irradiated at 254nm for 3hr. The i.r. of the product on the plate at -196°C showed new significant absorptions at 1645 and 1680 cm^{-1} , which are assigned to C=C and C=N bonds in the azete (145) by comparison with appropriate model systems⁵⁹. After removing the liquid N_2 and replacing it with the isopentane slush bath, the cell was connected to the mass spectrometer and the following masses were detected from the given temperatures:

<u>m/z</u>			
169	-60°C	M^+	- FCN (dimer)
107	-58°C	M^+	(azete)
135	-43°C	M^+	(triazine)

There are several points to note from this experiment:

- i) The experiment has been repeated on several occasions to give essentially the same result, which clearly illustrates its reproducibility.
- ii) From the i.r. spectrum of the starting material

(28) *versus* the product at -196°C , it is impossible to completely photolyse away the triazine even after prolonged irradiation, irrespective of the film thickness. This contrasts with the low temperature photolysis of perfluoro-4,6-bis-isopropyl-1,2,3-triazine (93) (see 4.B.2b), where, from the i.r. spectrum of the product, most of the starting material is photolysed away after $\approx 2\text{hr}$.

iii) Mass 107 is observed at 13°C lower than it appears from the sampling of the starting material (28). This is conclusive evidence for the existence of the intermediate trifluoroazete (145).

iv) Mass 169 is detected consistently from -60°C . This corresponds to a molecular formula of $\text{C}_5\text{F}_5\text{N}$, formally pentafluoropyridine or a valence isomer thereof, which could arise from the dimerisation of trifluoroazete (145), followed by loss of FCN.

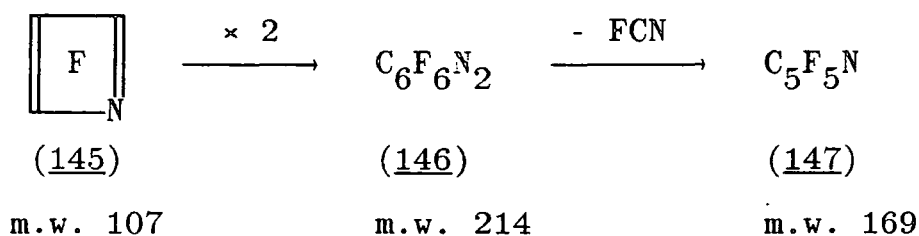

This suggests that trifluoroazete (145) is dimerising on the plate at low temperature, and poses several questions:

- (1) Is the dimerisation thermal or photochemical?
- (2) What is the structure of the dimer?
- (3) When does the loss of FCN from the dimer occur?

Firstly, it would seem unlikely that the dimerisation

occurs photochemically on the plate at -196°C , as in this case the azete would not be present as a discrete species to desorb from the plate as it warmed up, as observed experimentally. Although it is not possible to tell from the i.r. of the product whether the new absorptions correspond to the azete or the dimer, the i.r. spectrum of the photolysate at -196°C does not change after standing for several hours, which suggests that the new absorptions observed are due to the trifluoroazete (145), and not the dimer. The above argument does have the one proviso, that the dimer does not fragment in the mass spectrometer to give the azete as a fragment ion, but there is no way of substantiating this experimentally. However, the EI+ mass spectrum of the dimer (95) of perfluoro-2,4-bis-isopropylazete does not contain a m/z 407 fragment ion corresponding to the azete, and therefore it is reasonable to suggest that similar fragmentation will be observed in the mass spectrum of the trifluoroazete dimer (146). The available evidence suggests that the dimerisation is a thermal process, and occurs fairly slowly during warming up, as both the dimer and the azete are observed desorbing from the plate at about the same temperature.

Secondly, the azete can dimerise through either the C=C or C=N double bonds, giving rise to three possible structures for the dimer (148a) - (148c). Structure (148c) is unlikely, as this dimer could not obviously lose FCN to give the perfluoro-Dewar pyridine (147), and at the low temperatures that the dimer (146) is observed, any thermal

diene (95), the dimer of perfluoro-2,4-bis-isopropylazete (94), were also formed, together with the polymer obtained from the ambient temperature photolysis of trifluoro-1,2,3-triazine (28) in the vapour-phase. The formation of this polymer indicated that trifluoroazete (145) was produced in the co-photolysis, and hence that the pyridine (150) must be formed from co-dimerisation of the two azetes and *not* *via* a $[4\pi + 2\pi]$ cycloaddition of perfluoro-2,4-bis-isopropylazete (94) with trifluoro-1,2,3-triazine (28), which could not

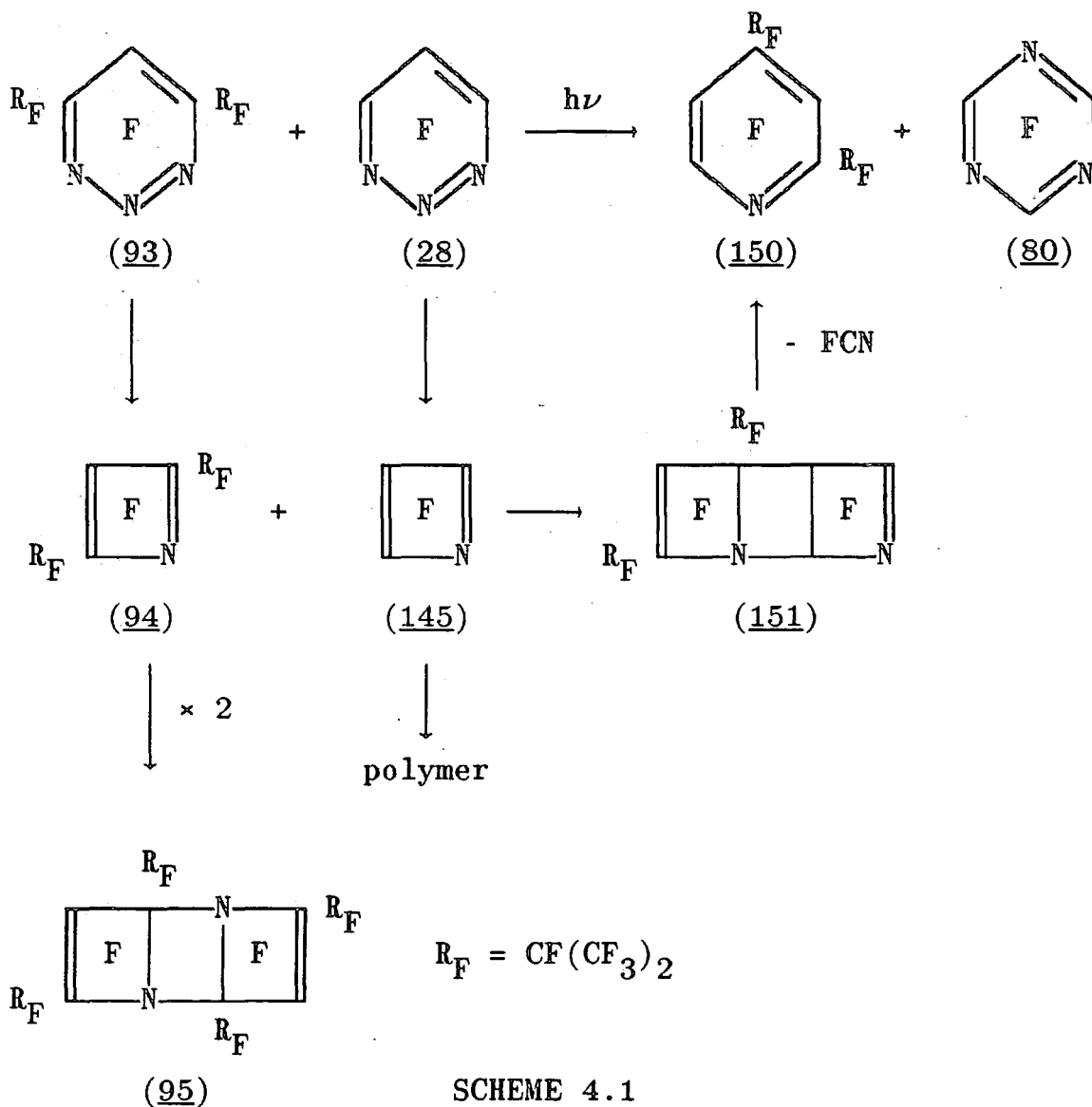

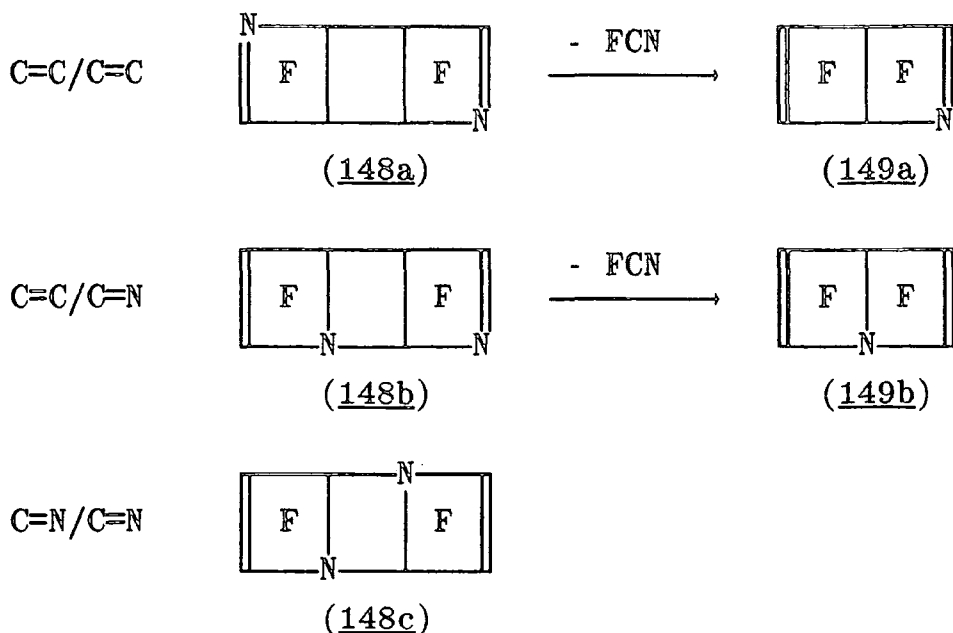

rearrangement of (148c) to either (148a) or (148b) which could lose FCN readily would be energetically unfavourable. This leaves structures (148a) and (148b), of which (148a) would be the more likely, as it results from coupling through the C=C double bonds, whereas (148b) would involve co-dimerisation between the C=C and C=N double bonds. Supportive evidence for dimerisation through C=C to give dimer (148a) comes from a co-photolysis experiment in which trifluoro-1,2,3-triazine (28) and perfluoro-4,6-bis-isopropyl-1,2,3-triazine (93) were irradiated in solution at ambient temperature⁵⁹ (Scheme 4.1). The major product was the perfluoro-2,4-bis-isopropylpyridine (150), arising from co-dimerisation of azetes (94) and (145), followed by loss of FCN from the dimer (151) and subsequent rearomatisation of the Dewar pyridine produced. Small quantities of trifluoro-1,3,5-triazine (80) and perfluoro-2,4,6,8-tetrakis-isopropyl-1,5-diazatricyclo[4.2.0.0^{2,5}]octa-3,7-

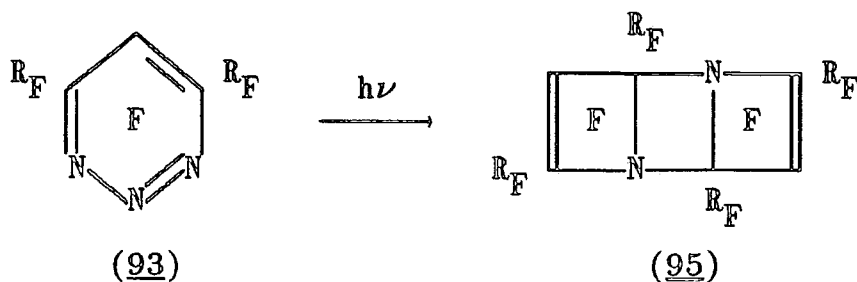

lead to the formation of the polymer. This co-dimerisation clearly shows the preferred orientation of dimerisation of the two azetes, with trifluoroazete (145) preferring to dimerise through C=C, whereas perfluoro-2,4-bis-isopropyl-azete (94) prefers to dimerise through C=N. This latter observation is also supported experimentally by the dimerisation of (94), produced from the ambient temperature photolysis of perfluoro-4,6-bis-isopropyl-1,2,3-triazine (93), which gives a quantitative yield of the C=N to C=N dimer (95)^{59,60}. This difference in the orientation of dimerisation of the two azetes is obviously a consequence of the differing effects of a perfluoroalkyl group *versus* a fluorine attached to the imine function.



These observations for the orientation of dimerisation of azetes generated from 1,2,3-triazine precursors are also substantiated from the structure of the azete dimer obtained by J. R. Maslakiewicz from the transference photolysis of perfluoro-3,5-bis-isopropylpyridazine (55) at ambient temperature⁸⁰ (Scheme 4.2). The major product was the perfluoro-2,6-bis-isopropylpyrazine (154), arising from the photochemical isomerisation of (55) through the *para*-bonded

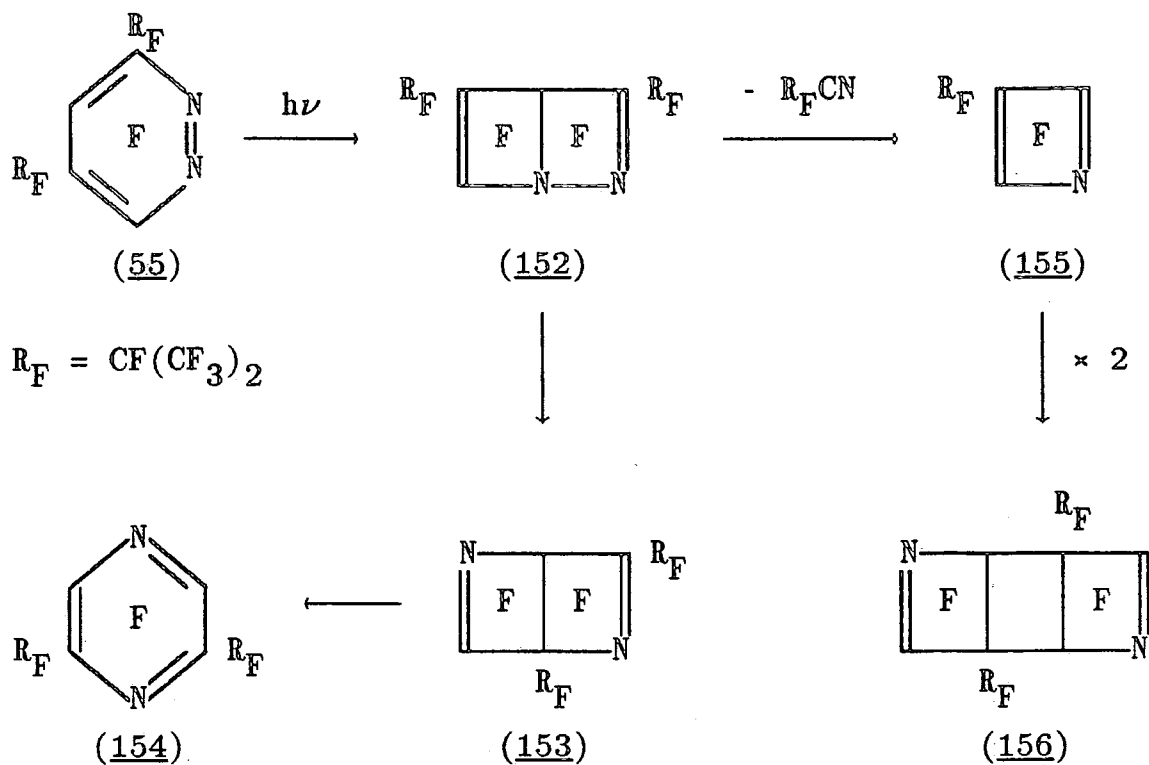

SCHEME 4.2

valence isomers (152) and (153). There were also several isomeric minor products, one of which was a dimer (156) of perfluoro-3-isopropylazete (155), generated from the loss of R_FCN from (152). The azete (155) has a fluorine attached to the imine function, and dimerises through $\text{C}=\text{C}$, the same orientation as trifluoroazete (145).

The differing regiochemistry observed for the dimerisation of azetes (94) and (155) may be due to the maximisation of stabilisation of the four-membered rings by perfluoroalkyl groups at the bridgehead positions in (156). The remarkable stabilising effect of perfluoroalkyl substituents on small rings is well documented^{52,81}, and similar stabilisation could occur equally for both $\text{C}=\text{N}$ and $\text{C}=\text{C}$ dimerisation of azete (94), and it appears that $\text{C}=\text{N}$ dimerisation is preferred, to give dimer (95). Although a

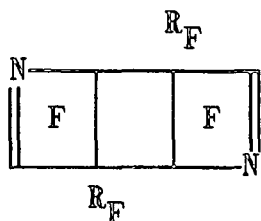

(156)

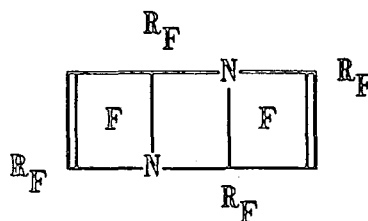

(95)

few examples of photochemical $[2\pi + 2\pi]$ cycloadditions have been reported for other systems⁸²⁻⁸⁵, we suggest that the dimerisation of (94) should be regarded as a $[4\pi + 2\pi]$ thermal process, since evidence presented later in this Chapter (4.C.1) shows that the dimerisation of (94) occurs after photolysis.

Thirdly, to the question of when the dimer (146) loses FCN. There are two possibilities, either i) the dimer loses FCN thermally on the plate or on desorption from the plate, giving m/z 169 due to the perfluoro-Dewar pyridine (147), or ii) the dimer desorbs off the plate into the mass spectrometer whereupon it loses FCN on ionisation, thus giving m/z 169 as the principal fragment ion. This differentiation is somewhat superfluous, as there is no way to experimentally distinguish between these two processes, although the second possibility would appear to be the more likely, especially as the dimer (146) is still detected as residual trifluoro-1,2,3-triazine is desorbing off the plate, indicating that the dimer (146) must be a relatively stable species. Indeed, the azete (145) could still be desorbing from the plate at these temperatures, *i.e.* $> -43^{\circ}\text{C}$, but it would be indistinguishable from the trifluoro-1,2,3-triazine m/z 107 fragment ion at these temperatures. A

variation on the low temperature photolysis experiment was carried out, but instead of sampling by mass spectroscopy as the plate warmed up, the change in the i.r. spectrum of the product was observed with the rise in temperature. The results of this are summarised below.

- i) From $\approx -90^{\circ}\text{C}$ to $\approx -60^{\circ}\text{C}$ the absorptions at 1645 and 1680 cm^{-1} reduced in intensity and eventually disappeared, whereas the intensities of the absorptions due to trifluoro-1,2,3-triazine remained effectively unchanged. This is probably the observation of the dimerisation of trifluoroazete (145) on the plate.
- ii) The intensities of the i.r. absorptions of the residual trifluoro-1,2,3-triazine remained constant from $\approx -60^{\circ}\text{C}$ to $\approx -45^{\circ}\text{C}$, at which point they began to diminish. This latter temperature corresponds to the point at which trifluoro-1,2,3-triazine desorbs off the plate into the mass spectrometer.
- iii) If the cell is allowed to warm up to room temperature, the i.r. of the plate residue shows several broad absorptions which correspond closely to that of the poly(trifluoroazete) polymer obtained from the photolysis of trifluoro-1,2,3-triazine in solution⁵⁹.

This is additional supporting evidence for the dimerisation of trifluoroazete being a thermal process occurring on the plate during warming up, and that the m/z 169 detected is the highest mass fragment ion of the dimer (146).

c) Sampling of pentafluoropyridine

As a result of observing a species suggested to be a perfluoro-Dewar pyridine from the low temperature photolysis of trifluoro-1,2,3-triazine, the sampling of pentafluoropyridine (39) into the mass spectrometer was attempted to observe the temperature at which (39) desorbs off the plate, as it is a reasonable assumption that the Dewar pyridine (149b) would isomerise to the pyridine (39) before, or more likely, during desorption off the plate. The sampling

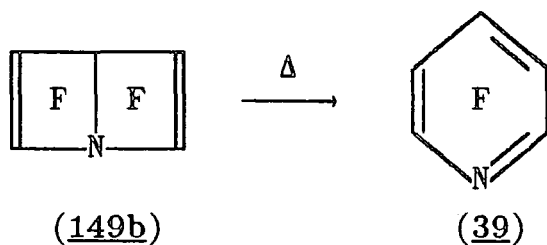

detected m/z 169 from -77°C . Note that the m/z 169 molecular ion of pentafluoropyridine is the base peak of its EI+ mass spectrum, and at low concentrations of the pyridine would be expected to be detected before any of the fragment ions. This is 17°C lower than m/z 169 is first observed in the trifluoro-1,2,3-triazine photolysis. This could be interpreted that the m/z 169 observed is not from a Dewar pyridine desorbing off the plate, but is from the less volatile trifluoroazete dimer desorbing off the plate and subsequently losing FCN in the mass spectrometer, but this cannot be substantiated experimentally.

d) Photolysis of pentafluoropyridine

The low temperature photolysis of pentafluoro-

pyridine (39) was attempted to see if the perfluoro-Dewar pyridine (149b) is generated, which would be indicated by observing m/z 169 significantly lower than -77°C , as it is well established that perfluorinated aromatic valence isomers are generally more volatile than the parent aromatic compounds⁸⁶. The pyridine was photolysed at 254nm for 3hr, and the i.r. spectrum at -196°C after photolysis showed no change from that of the pyridine (39). On mass spectroscopic sampling, m/z 169 was observed from -80°C , which is only 3°C lower than in the previous experiment. This is an interesting result, as it clearly shows that pentafluoropyridine does not photochemically isomerise to the Dewar pyridine at low temperature on the plate. This is consistent with the results of both R. Middleton⁸⁷, who could not achieve the same isomerisation under transference at 254nm, and Haszeldine and co-workers⁸⁸, who irradiated pentafluoropyridine statically in the vapour phase.

e) Attempted trapping of trifluoroazete with furan

As a result of the direct observation of trifluoroazete (145) from the photolysis of trifluoro-1,2,3-triazine (28) at low temperature, attempts were made to gain further evidence for the formation of the azete from the mass spectroscopic detection of its 1:1 cycloadduct with furan. Perfluoro-2,4-bis-isopropylazete (94) has been trapped in this manner from the photolysis of perfluoro-4,6-bis-isopropyl-1,2,3-triazine (93)^{59,60} in solution, and also from the low temperature photolysis of (93) (see 4.B.3c),

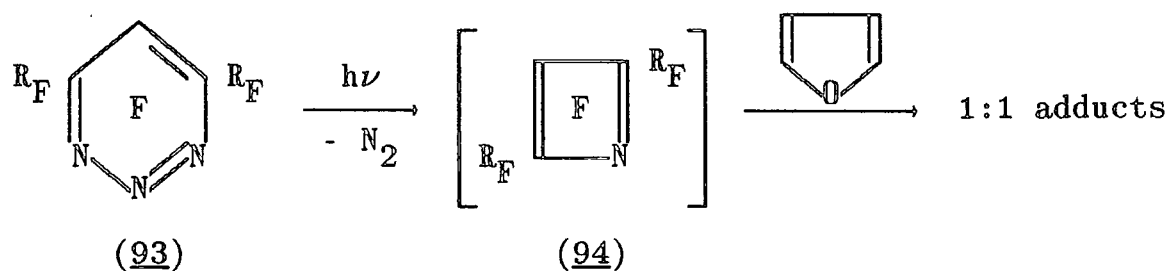

with furan added before the plate was allowed to warm up. The method for this trapping experiment is basically the same as for the low temperature photolysis discussed in the previous section, except that a thin film of furan is deposited onto the plate either i) over the top of the photolysate at -196°C immediately prior to m.s. sampling, or ii) onto the plate first at -196°C , and a thin film of the triazine deposited on top and then photolysed as before. The experiment was repeated several times, and the results for each experiment were similar, with m/z 169 featuring prominently in the mass spectral scans, but with m/z 175 (corresponding to the 1:1 azete:furan adduct) only occurring in one or two scans, if at all, in each experiment.

The only conclusion which may be drawn from these results is that dimerisation of trifluoroazete must be a much more favoured process at lower temperatures than the cycloaddition with furan, as both processes are believed to

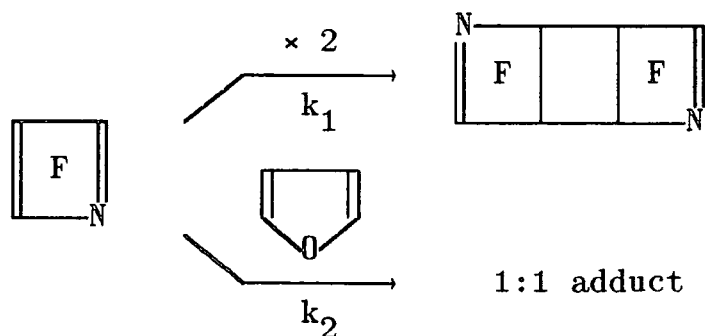

occur thermally, *i.e.* $k_1 \gg k_2$.

f) Attempted co-photolysis of trifluoro-1,2,3-triazine and perfluoro-4,6-bis-isopropyl-1,2,3-triazine

The co-photolysis of trifluoro-1,2,3-triazine (28) with perfluoro-4,6-bis-isopropyl-1,2,3-triazine (93) at ambient temperature in solution gave perfluoro-2,4-bis-isopropylpyridine (150) as the major product, which was suggested to result from the co-dimerisation of trifluoroazete (145) and perfluoro-2,4-bis-isopropylazete (94)⁵⁹.

This experiment was attempted at low temperature to see if the co-dimer (151), or fragmentation products thereof, could be detected by mass spectroscopy.

The basic experimental method was followed, with firstly as thin a film of trifluoro-1,2,3-triazine as possible deposited onto the plate, and as much of the film as possible photolysed away over \approx 4hr. A thin film of perfluoro-4,6-bis-isopropyl-1,2,3-triazine was then deposited over the top of this, and completely photolysed away over \approx 2hr.

After replacement of the liquid N_2 in the reservoir by the isopentane slush bath, the cell was connected to the mass spectrometer, and the photolysate sampled.

This gave, at lower temperatures, evidence for the trifluoroazete dimer (146), trifluoroazete (145), and eventually trifluoro-1,2,3-triazine (28), and as the cell approached room temperature, the masses for perfluoro-2,4-bis-isopropylazete (94) and its dimer (95) were detected.

After allowing the cell to warm up to room temperature under high vacuum, both perfluoro-4,6-bis-isopropyl-1,2,3-triazine (93) and the azete dimer (95) were detected by further mass spectroscopic sampling. There was no evidence for detection of the co-dimer (151).

3. Perfluoro-4,6-bis-isopropyl-1,2,3-triazine

a) Sampling of starting material

A thin film of (93) was deposited onto the KBr plate at -196°C , the liquid nitrogen was removed from the reservoir, and the mass spectra recorded as the cell warmed up towards room temperature. The following masses were detected consistently from the given temperatures. This is a similar result to that observed previously for trifluoro-1,2,3-triazine (28), in that the initial desorption of (93)

m/z

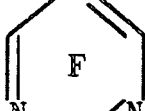
407	-10°C	$\text{M}^+ - \text{N}_2$	$(\text{CF}_3)_2\text{CF}$		$\text{CF}(\text{CF}_3)_2$
435	-5°C	M^+			

(93)

from the plate is characterised by the appearance of the m/z 407 fragment ion and not the m/z 435 molecular ion, which does not appear until $\approx 5^{\circ}\text{C}$ higher. This is also because in the EI+ mass spectrum of (93)⁵⁹, the m/z 407 fragment ion is of much greater intensity (26% base) than the very weak m/z 435 molecular ion (1% base), and hence as it begins to desorb from the plate, the initial concentration of triazine is too low to give a mass spectrum of sufficient intensity

to allow the detection of the m/z 435 molecular ion.

b) Photolysis of perfluoro-4,6-bis-isopropyl-1,2,3-triazine

A thin film of (93) was deposited onto the plate at -196°C , its i.r. spectrum recorded, and the film irradiated at 254nm for \approx 2hr. A comparison of the i.r. spectrum of the product on the plate with that of (93) showed that virtually all of the starting material had disappeared. The mass spectroscopic sampling consistently detected the following masses from the specified temperatures.

m/z	Temperature	Ion	Fragment
407	-30°C	M^+	(azete)
745	-15°C	$\text{M}^+ - \text{CF}_3$	(dimer)
435	-5°C	M^+	(triazine)

Again, this is clear evidence for the formation of the perfluoro-2,4-bis-isopropylazete (94), as m/z 407 is observed $\approx 20^{\circ}\text{C}$ lower than from the sampling of the starting material (93). Additionally, m/z 745 is detected from -15°C , which corresponds to the $\text{M}^+ - \text{CF}_3$ fragment ion from the azete dimer (95). This is the highest mass peak observed in the EI+ spectrum of (95)⁵⁹, and provides good evidence for

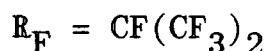
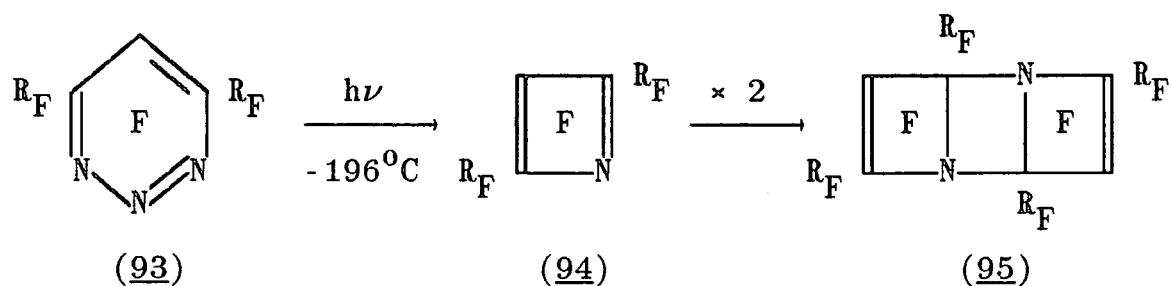

the formation of the dimer. Again, it should be clearly stated that the azete dimer (95) does not give a m/z 407 fragment ion corresponding to the azete (94) in its EI+ mass spectrum, thus confirming that the m/z 407 observed from -30°C is definitely from perfluoro-2,4-bis-isopropylazete (94).

c) Trapping of perfluoro-2,4-bis-isopropylazete with furan

The photolysis of perfluoro-4,6-bis-isopropyl-1,2,3-triazine (93) in solution in the presence of furan gave 1:1 cycloadducts of the azete (94) and furan^{59,60}. In analogous experiments to those attempted for trifluoro-1,2,3-triazine (see 4.B.2e), perfluoro-4,6-bis-isopropyl-1,2,3-triazine (93) was photolysed on the KBr plate at -196°C , and then furan was condensed on top of the photolysate prior to connection of the cell to the mass spectrometer. The given masses were consistently detected from the specified temperatures. These results are clear evidence for the formation of a 1:1 cycloadduct of the azete (94) and furan, as m/z 475, which corresponds to the molecular ion of the adduct, is detected from -10°C . Additionally, m/z 745 was

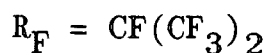
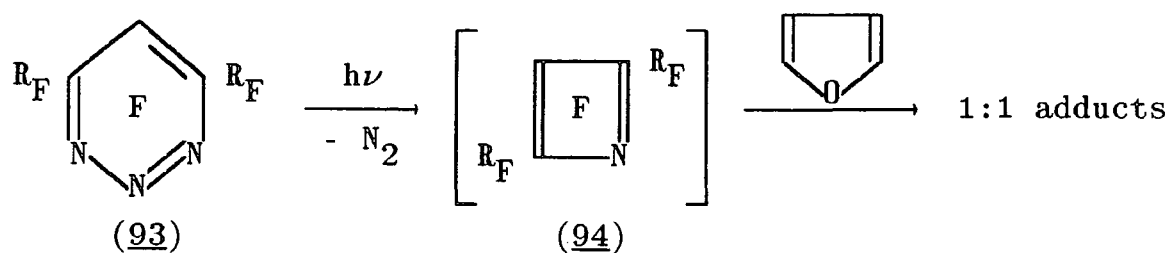

<u>m/z</u>		
745	-16°C	M ⁺ - CF ₃ (dimer)
475	-10°C	M ⁺ (1:1 adduct)

also observed from -16°C, which corresponds to the M⁺ - CF₃ fragment ion of the azete dimer (95). It should be noted that m/z 475 is not a fragment ion of the azete dimer (95), and hence that the detection of this mass must be due to a cycloadduct of the azete (94) with furan. This trapping thus provides definite evidence for the generation of perfluoro-2,4-bis-isopropylazete (94) at low temperature. These results contrast with the attempts to observe 1:1 cycloadducts between trifluoroazete (145) and furan discussed previously (see 4.B.2e), where no evidence for the formation of 1:1 adducts was found. Additionally, these results also contrast with the ambient temperature photolysis of (93) with furan, when only the cycloadducts were formed, and with no evidence for formation of the dimer⁵⁹, although the detection of dimer as well as the 1:1 adduct from the low temperature photolysis may simply result from the fact that the azete and furan are present on the plate in two separate layers, and so presumably dimerisation of the azete is as favourable as cycloaddition with furan.

4. Conclusions

- i) The photolysis of trifluoro-1,2,3-triazine at low temperature gave definitive evidence for the existence of both trifluoroazete and its dimer from i.r. and mass spectroscopy.

- ii) The precise structure of the trifluoroazete dimer is unclear, but it appears to dimerise in the opposite sense to perfluoro-2,4-bis-isopropylazete, *i.e.* through C=C rather than C=N, although the reasons for this are not clear. The preferred orientations of dimerisation for the two perfluoroisopropylazetes are suggested to result from maximising the stability of the four-membered rings at the bridgehead positions primarily by perfluoroalkyl groups and secondly by nitrogen atoms.
- iii) The attempted trapping of trifluoroazete with furan gave no conclusive evidence of 1:1 adducts, and the co-photolysis with perfluoro-4,6-bis-isopropyl-1,2,3-triazine was unsuccessful.
- iv) Photolysis of perfluoro-4,6-bis-isopropyl-1,2,3-triazine at low temperature also gave definitive evidence for the existence of both the corresponding perfluoro-2,4-bis-isopropylazete and the azete dimer by mass spectroscopy.
- v) Trapping experiments of perfluoro-2,4-bis-isopropylazete with furan gave clear evidence from mass spectroscopy for the formation of 1:1 adducts.

4.C Transference photolysis of perfluoro-4,6-bis-isopropyl-1,2,3-triazine

Static photolysis of perfluoro-4,6-bis-isopropyl-1,2,3-triazine (93) in solution or the vapour phase gave quantitative conversion to perfluoro-2,4,6,8-tetrakis-isopropyl-1,5-diazatricyclo[4.2.0.0^{2,5}]octa-3,7-diene (95),

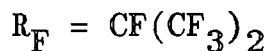
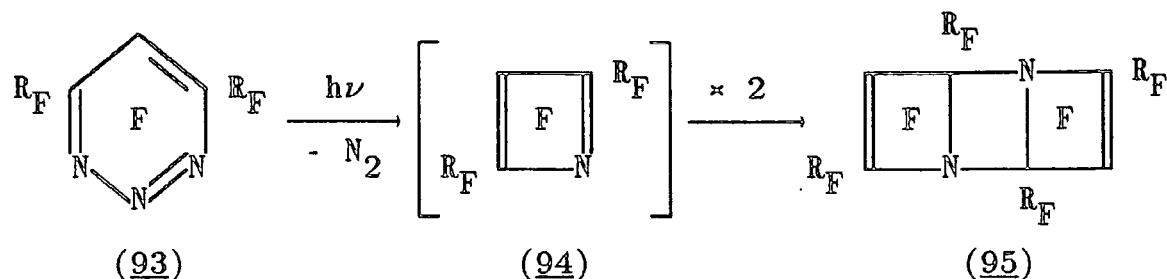

the dimer of perfluoro-2,4-bis-isopropylazete (94)^{59,60}.

Previous workers in our laboratories have developed the technique of photolysis whilst under vacuum transference to produce stable aromatic valence isomers from perfluoroalkylpyridines⁴⁸ and -pyridazines⁴⁶ (see 1.D.2).

The initial aim of this investigation was to see if the azete dimer (95) could be produced from the transference photolysis of perfluoro-4,6-bis-isopropyl-1,2,3-triazine (93), and if so, to subsequently attempt to trap the azete with furan.

1. Transference photolysis

Photolysis of perfluoro-4,6-bis-isopropyl-1,2,3-triazine (93) whilst under transference gave almost quantitative conversion to the azete dimer (95). This is consistent with the results from the static photolyses of (93) reported previously^{59,60}, and further illustrates the ease with which perfluoro-2,4-bis-isopropylazete is formed photochemically. However, this experiment also provides very good evidence that the dimerisation of the azete (94) is a thermal process. Although the azete (94) is generated in the vapour-phase by photolysis of the triazine (93), it is

extremely unlikely that the azete would be able to dimerise in the vapour-phase in such a large vessel, and hence the dimerisation most likely occurs in the cold-trap as it warms up to room temperature.

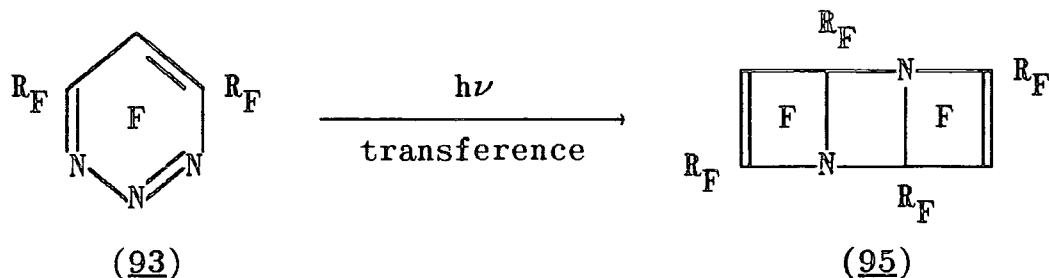

2. Attempted trapping of perfluoro-2,4-bis-isopropyl-azete with furan

Photolysis of perfluoro-4,6-bis-isopropyl-1,2,3-triazine (93) in solution in the presence of an excess of furan gave 1:1 cycloadducts of the azete (94) with furan⁵⁹.

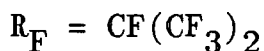
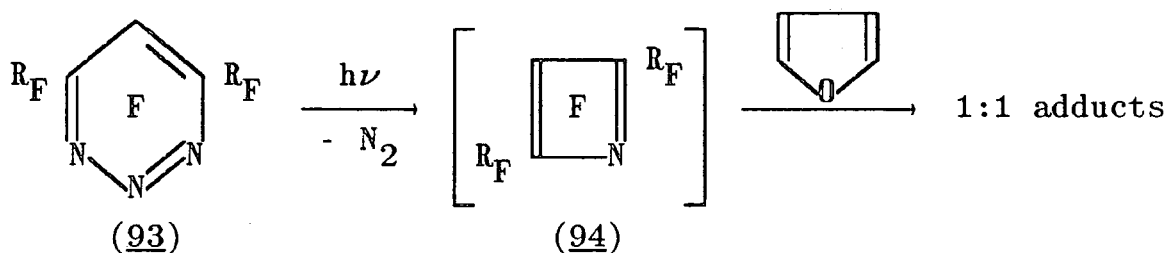

Earlier in this Chapter (see 4.B.3c) we demonstrated that similar adducts may be detected by mass spectroscopy from the low temperature photolysis of (93) in the presence of furan.

The result discussed in the preceding section (4.C.1) showed that perfluoro-2,4-bis-isopropylazete (94) is indeed produced from the transference photolysis of (93), and hence

analogous trapping of the azete with furan was attempted.

The basic method for the transference photolysis was followed, with an excess of furan present in the cold-trap. This experiment gave the azete dimer (95) as the major product, but a trace of a 1:1 adduct was also observed by m.s.-g.l.c. This probably results from poor contact between the azete and furan in the cold-trap, and hence why dimerisation is the preferred process, as it has been established that photolysis of the triazine (93) in solution with furan gives only the azete/furan cycloadducts, and not the dimer (95)⁵⁹.

The transference was repeated, but in this case allowing the furan to transfer with the triazine during photolysis. This gave a smaller overall quantity of products, but which contained a greater proportion of azete/furan cycloadduct. A significant proportion of the starting material did not transfer at all, and this is presumably due to the increased pressure in the system resulting from the presence of the volatile furan suppressing the transference of the triazine.

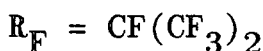
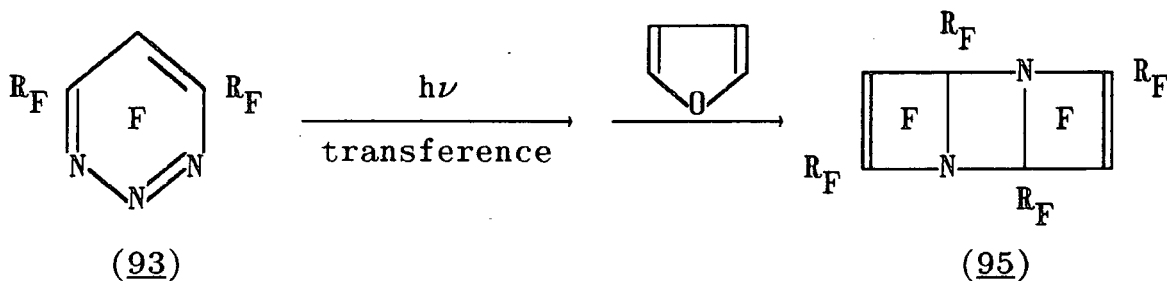

4.D Static photolysis of trifluoro-1,2,3-triazine

The photolysis of trifluoro-1,2,3-triazine (28) in the vapour-phase gave a brown polymeric material, which was tentatively identified as poly(trifluoroazete) by M. Tamura⁵⁹. This identification was based on the elemental analysis of the polymer, which corresponded approximately to loss of nitrogen from (28).

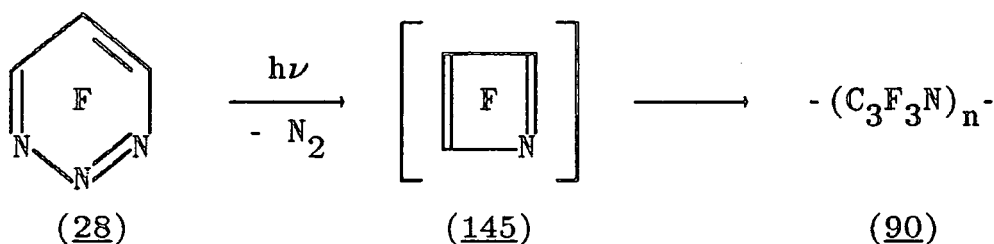

We have repeated this vapour-phase photolysis of (28), with the aim of elucidating the structure of the polymer in more detail.

Trifluoro-1,2,3-triazine (28) was irradiated at 254nm for 8 days, yielding a pale brown polymeric material. The i.r. spectrum of this polymer is identical with that of the polymer (90) obtained previously by Tamura⁵⁹, and contains broad absorptions centred at 3200 (vw), 1700 (m), 1350 (m, sh) and 1180 cm⁻¹ (m). Tamura suggested that the structure of the polymer was that of poly(trifluoroazete) (90), based upon elemental analysis. However, an alternative structure could be poly(trifluoroacrylonitrile) (157). The trifluoroacrylonitrile (89) may be formed from thermal ring opening of the photochemically generated trifluoroazete (145) to the diradical species (145a), followed by a skeletal rearrangement. A similar process has been postulated to

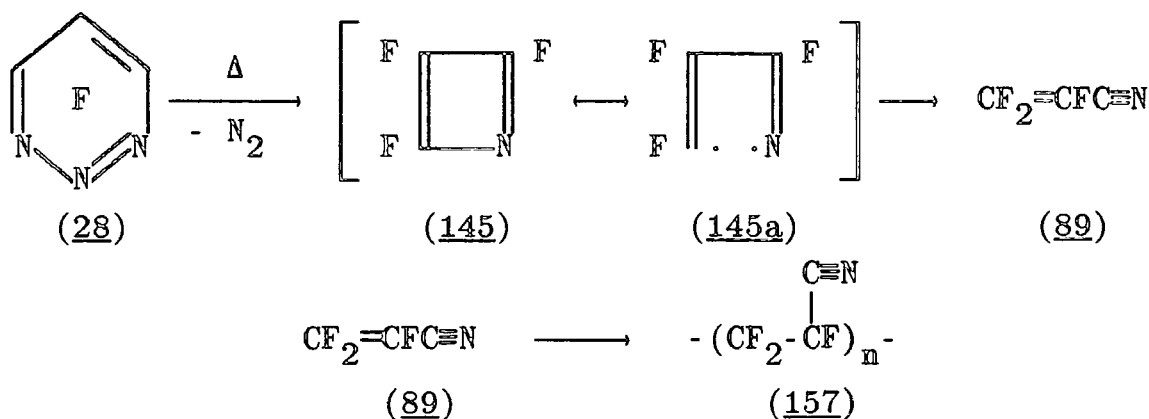

account for the formation of trifluoroacrylonitrile (89) from the pyrolysis of trifluoro-1,2,3-triazine (28)⁵⁹. The homopolymerisation of trifluoroacrylonitrile (89) by γ -ray irradiation is described in the literature⁸⁹, producing a brown polymer. The i.r. spectrum of poly(trifluoroacrylonitrile) showed broad absorptions centred at 3300 (m, N-H), 1710 (s, C=O), 1370 (m, sh) and 1100 cm^{-1} (s, C-F). Tamura discounted the possibility that the polymer (90) from trifluoro-1,2,3-triazine was poly(trifluoroacrylonitrile) on the grounds that its i.r. spectrum does not contain a characteristic C \equiv N absorption between 2000 - 2300 cm^{-1} . However, the i.r. spectrum of poly(trifluoroacrylonitrile) (157) contains only an extremely weak C \equiv N absorption at 2250 cm^{-1} , due to hydrolysis of the cyano groups in the polymer to primary amides (157a)⁸⁹. This explains the presence of the characteristic N-H and C=O absorptions in the i.r. spectrum of (157). The i.r. of our polymer does closely resemble that of poly(trifluoroacrylonitrile) in the

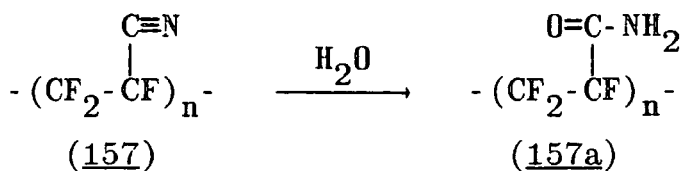

literature, with the same broad absorptions occurring at similar wavenumbers. The decomposition temperature in a nitrogen atmosphere for the poly(trifluoroacrylonitrile) described in the literature is 145°C. The decomposition temperature for our sample was determined by D.S.C. (Differential Scanning Calorimetry) as 155 - 162°C in an argon atmosphere. This difference may be because the two polymers were produced by different methods, and additionally, our polymer may not be a simple homopolymer of trifluoroacrylonitrile (89), but may also contain structural features arising from thermal or photochemical cyclo-additions of trifluoroacrylonitrile (89) with trifluoroazete (145) and trifluoro-1,2,3-triazine (28). Earlier in this Chapter (see 4.B.2b), it was observed that the same polymer is found on the KBr plate as the residue from the low temperature photolysis of trifluoro-1,2,3-triazine (28). Although this observation does not confirm which species may be involved in the overall polymerisation process, it does indicate that trifluoroazete (145) is clearly involved as an intermediate species, as the low temperature experiments definitely showed that trifluoroazete (145) is generated from the photolysis of trifluoro-1,2,3-triazine (28). Whatever the precise structure of the polymer (157), it is clear that the polymerisation is a highly efficient process, as there was no trifluoro-1,2,3-triazine (28) remaining after photolysis.

The available evidence presented here suggests that the original structural assignment for the polymer by Tamura is



incorrect, and that the structure is more likely that of poly(trifluoroacrylonitrile) (157).

CHAPTER FIVECHEMISTRY OF SOME PERFLUOROISOPROPYLPYRIDAZINES5.A Introduction

The photochemical rearrangements of perfluoroalkylpyridazines to the *para*-bonded valence isomers and corresponding pyrazines in a flow system have been extensively investigated in our laboratories^{46,86} (see 1.D.1).

However, the photolysis of perfluoro-3,5-bis-isopropylpyridazine (55) in a flow system gave, in addition to the expected valence isomer (153) and pyrazine (154), a mixture containing perfluoroisobutyronitrile and four isomeric compounds, each corresponding to a dimer of perfluoro-3-isopropylazete (155) (Scheme 5.1)^{80,86}. The proportion of these by-products increased with the pressure in the flow system, constituting up to 37% of the total product mixture. Isomers (158c) and (158d) were converted to (158b) on heating at 150°C. Compounds (158a) and (158b) were suggested⁸⁶ to be perfluoro-bis-isopropyl-diazacyclo-octa-tetraenes, with (158c) and (158d) as possible bicyclic and tricyclic valence isomers. The structures of these dimers (158a) - (158d) were tentatively assigned on the basis of their ¹⁹F n.m.r. spectra. Recent work by Tamura⁵⁹ and ourselves (see Chapter Four) has clearly established the preferred orientation of dimerisation and structure for the dimers of both trifluoro- (145) and perfluoro-2,4-bis-

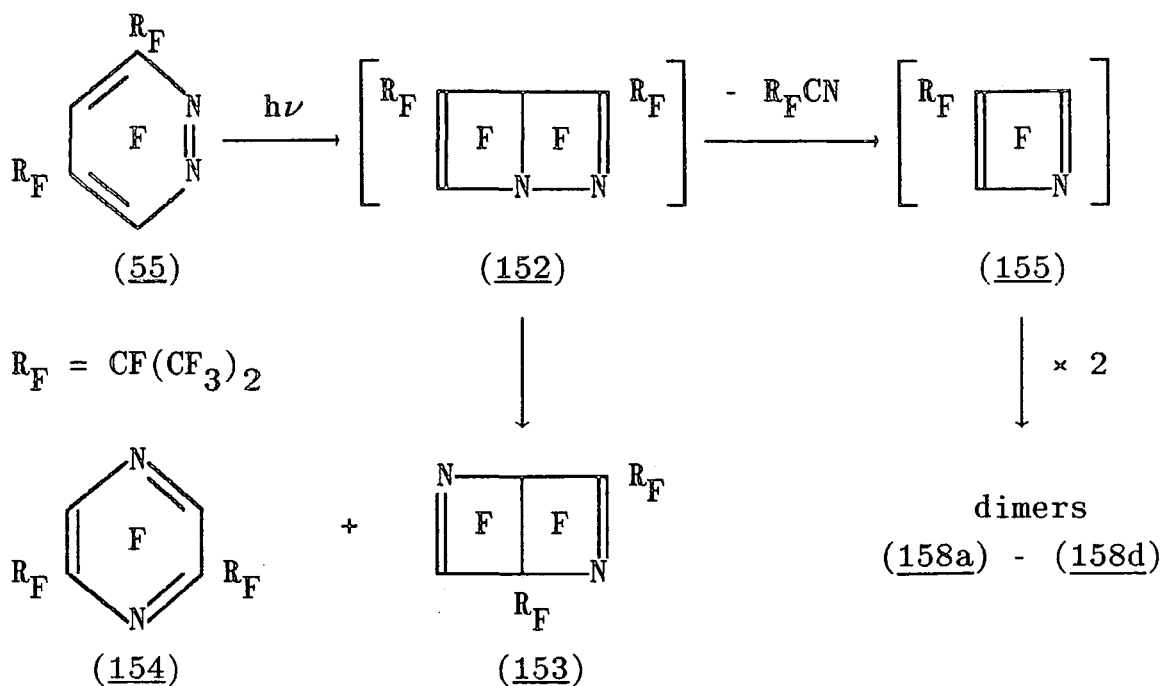

SCHEME 5.1

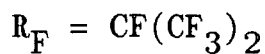
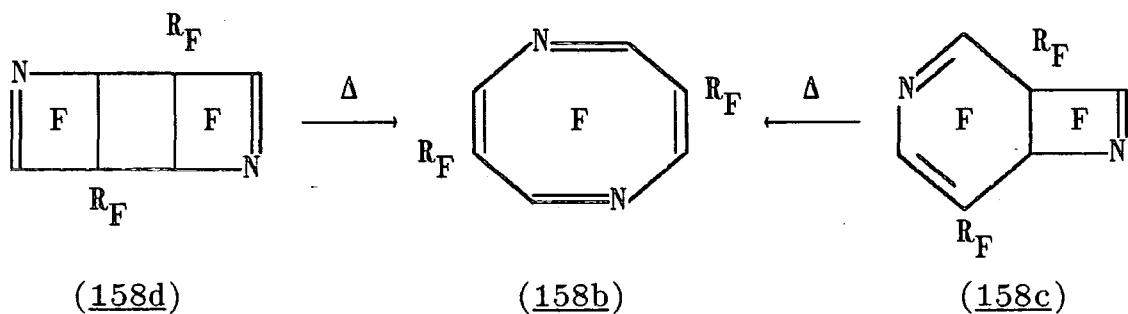

isopropyl-azetes (94), generated from fluorinated 1,2,3-triazine precursors. Perfluoro-3-isopropylazete (155) has a complimentary structure to that of perfluoro-2,4-bis-isopropylazete (94), with the positions of the perfluoro-isopropyl and fluorine substituents reversed. The unambiguous determination of the structure of the perfluoro-3-isopropylazete dimer could provide valuable information which would greatly aid a possible rationalisation for the preferred orientations of dimerisation of the fluorinated



(145)

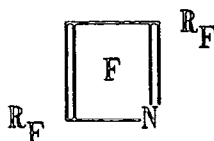

(94)

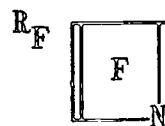

(155)

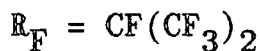

azetes.

The main objective of this study was to repeat the photolysis of perfluoro-3,5-bis-isopropylpyridazine, and to fully assign the structures of the azete dimer and its valence isomers using the data obtained from our studies of the other fluorinated azete systems.

Furthermore, the low temperature photolyses of various polyfluoroalkylpyridazines were attempted, using the techniques developed previously for studying fluorinated azetes, with the aim of observing any intermediate species, and the results are discussed.

Some thermal and photochemical reactions of perfluoro-3,4,6-tris-isopropylpyridazine are also described, together with our attempts to prepare other perfluoroalkylpyridazine derivatives for use in various pyrolysis and photolysis experiments.

5.B Synthesis of polyfluoroalkylpyridazines

1. Polyfluoroalkylations of tetrafluoropyridazine

a) With hexafluoropropene

Polyfluoroalkylation of tetrafluoropyridazine (21) with hexafluoropropene and caesium fluoride in sulpholane at room temperature gave a good yield of perfluoro-4,5-bis-

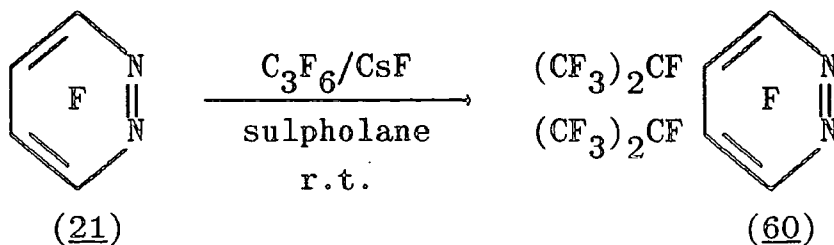

isopropylpyridazine (60)³⁸. Perfluoro-3,5-bis-isopropylpyridazine (55) was obtained in moderate yield from the rearrangement of (60) with fluoride ion in sulpholane at 120°C³⁸, which also gave low yields of the 4-mono- (160) and 3,4,6-tris-isopropyl-pyridazines (159). We also obtained a

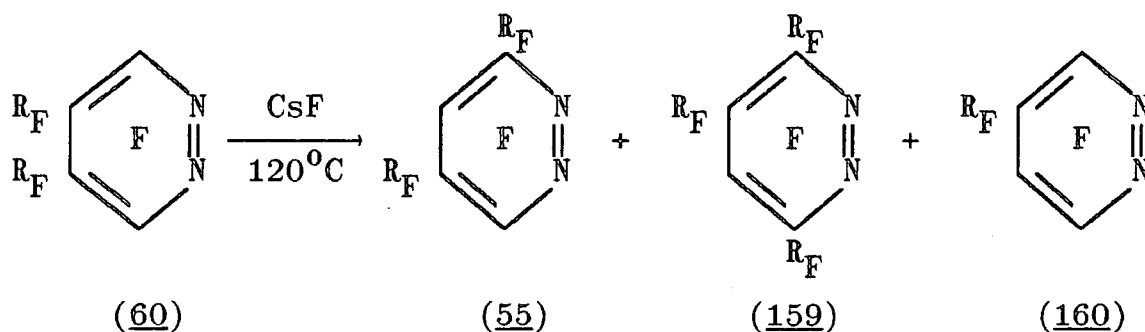

good yield of the 3,5-di-substituted derivative (55) from displacement of the perfluoroisopropyl group at the 3-position of perfluoro-3,4,6-tris-isopropylpyridazine (159) by fluoride ion in the presence of tetrafluoropyridazine (21) (Scheme 5.2). The same rearrangement was also observed previously by J. R. Maslakiewicz⁸⁶, and we had both

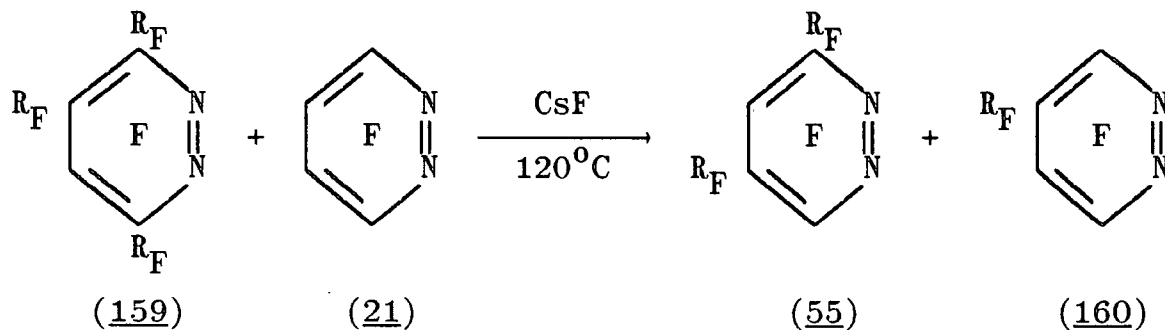

SCHEME 5.2

anticipated the displacement of the perfluoroisopropyl group at the 4-position to give the 3,6-di-substituted derivative (161) (Scheme 5.3). We required a 3,6-dialkylpyridazine for pyrolysis experiments (see 5.E.3), and this prompted our attempt to prepare the bis-ethyl derivative, which is described later (5.B.2).

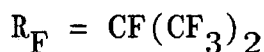
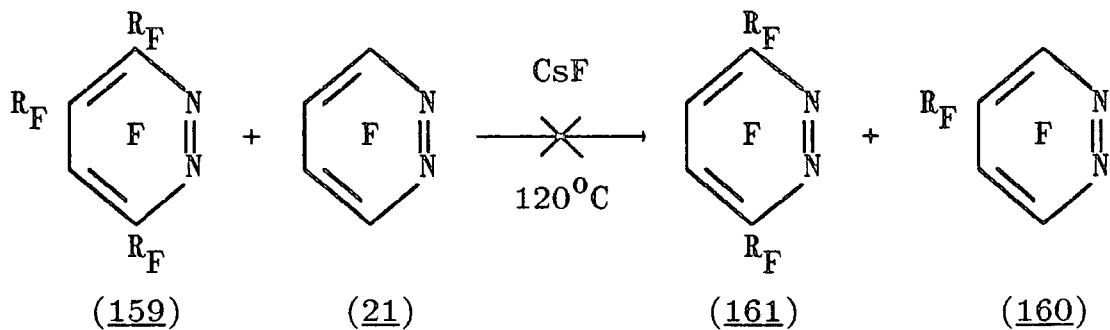

SCHEME 5.3

b) With perfluorocyclobutene

The isolation of valence isomers from the photolysis of various polyfluoroalkylpyridazines^{46,86} (see 1.D.2) has been attributed to the stabilising effects of perfluoroalkyl groups on small ring systems. However, it is not clear whether this stabilising effect is steric or electronic.

In an effort to probe this effect in more detail, it was decided to prepare various pyridazine derivatives possessing perfluoroalkyl substituents with high steric demands (see also 5.B.3 and Chapter Six).

The reaction of perfluorocyclobutene (162) with pentafluoropyridine (39) was studied some years ago in our laboratories⁹⁰. The major product at room temperature and atmospheric pressure was the trimer (164) of (162), but a

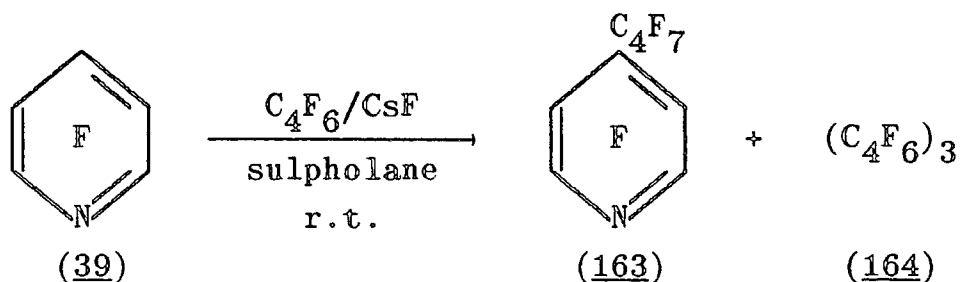

low yield of the mono-substituted pyridine (163) was also obtained.

Our reactions between tetrafluoropyridazine (21) and perfluorocyclobutene (162) at room temperature and atmospheric pressure gave mainly recovered tetrafluoropyridazine (21) together with the perfluorocyclobutene trimer (164), although a trace of a possible dialkylated derivative was detected by m.s.-g.l.c. A small-scale reaction at 60°C gave a slightly increased amount of this dialkylated derivative, which was still insufficient for isolation. Unfortunately, this reaction could not be repeated, and larger scale reactions at this and higher temperatures gave only the mixture of trimer and starting materials.

2. Polyfluoroalkylation of perfluoro-4-isopropylpyridazine with perfluoro-2-methylpent-2-ene

The preparation of perfluoro-4-(2'-methylpent-2'-yl)-pyridazine (169) from the reaction between the perfluoro-2-methylpent-2-yl anion (168) and tetrafluoropyridazine (21) at room temperature was originally reported by A. E. Bayliff⁵³, and our subsequent synthesis of this compound is described in detail in Chapter Six (6.B). However, both

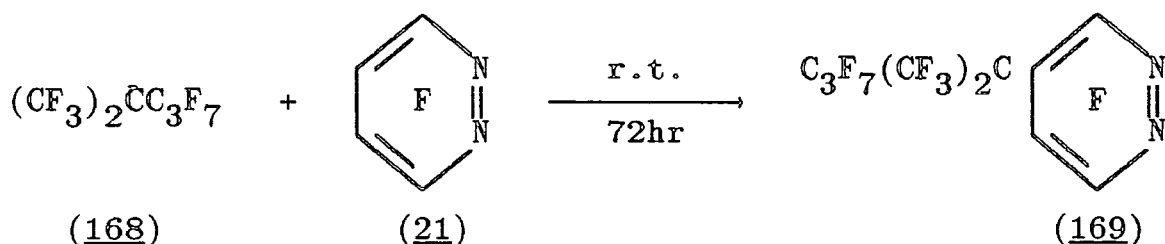
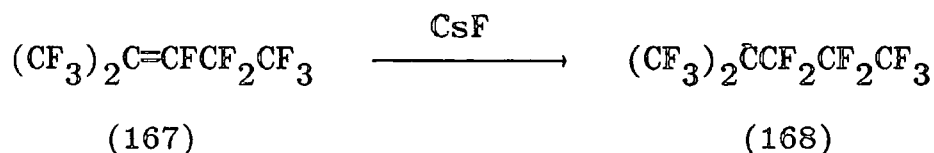

Bayliff and ourselves were unable to form the 4,5-disubstituted derivative of (169) at temperatures up to 120°C, and this is suggested to be a result of the steric hindrance of the perfluoro-2-methylpent-2-yl group at the 4-position blocking further attack of the anion (168) at the adjacent 5-position.

We decided to further probe the steric requirements of the perfluoro-2-methylpent-2-yl group by attempting the reaction of the anion (168) with perfluoro-4-isopropylpyridazine (160) to produce the unsymmetrically substituted 4,5-dialkylpyridazine (170).

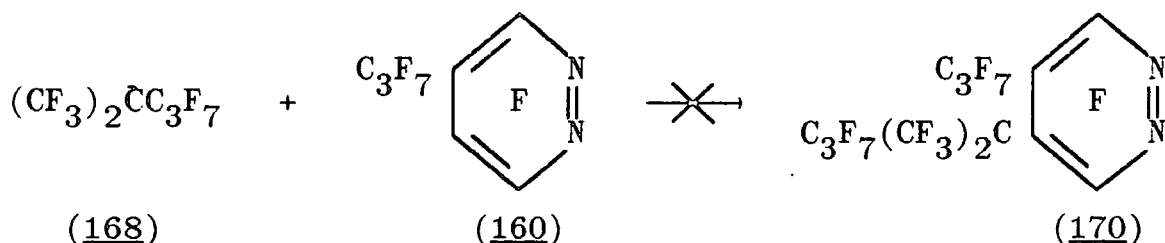

However, the reaction of the perfluoro-2-methylpent-2-yl anion (168) with (160) gave no evidence of any dialkylated products at temperatures up to 120°C, and it is concluded that the perfluoro-2-methylpent-2-yl anion (168) itself is too sterically demanding to attack the 5-position adjacent to the smaller perfluoroisopropyl group in (160).

3. Polyfluoroalkylation of perfluoro-4,5-bis-isopropylpyridazine with tetrafluoroethylene

As discussed in an earlier section (5.B.1a), we were unable to prepare perfluoro-3,6-bis-isopropylpyridazine, which we required for pyrolysis experiments (see 5.E.3), and hence a possible route to an alternative 3,6-dialkylpyridazine was devised (Scheme 5.4).

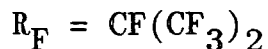
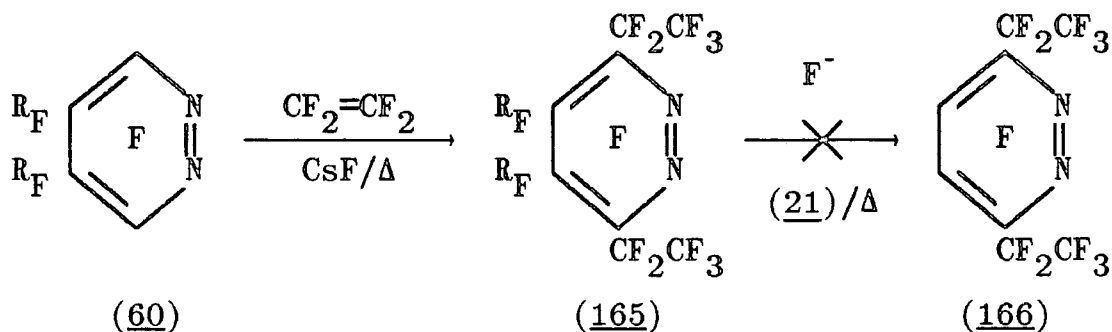

SCHEME 5.4

However, the polyfluoroalkylation of (60) with tetrafluoroethylene and caesium fluoride in sulpholane at 60°C gave a small quantity of a complex mixture of products. The major components were identified by m.s.-g.l.c. as tetrafluoroethylene oligomers (30%), a perfluoro-ethyl-bis-isopropylpyridazine (10%), perfluoro-3,4,6-tris-isopropylpyridazine (159) (11%), a perfluoro-bis-ethyl-bis-isopropylpyridazine (22%) and a perfluoro-tris-ethyl-isopropylpyridazine (10%). The mixture was far too complex to be separated by preparative scale g.l.c., as the capillary column was required to resolve the multi-component mixture sufficiently to allow the identification of the major components, and so this attempted synthesis of perfluoro-3,6-bis-ethylpyridazine (166) was not pursued further.

5.C Transference photolysis of perfluoro-3,5-bis-isopropylpyridazine

The purpose of this investigation was to repeat the photolysis of perfluoro-3,5-bis-isopropylpyridazine whilst under transference to obtain sufficient quantities of the four perfluoro-3-isopropylazete dimers (see 5.A) to confirm the tentative structural assignments made previously for these compounds, which were inadequate to allow full publication of the results.

The photolysis of perfluoro-3,5-bis-isopropylpyridazine (55) at 254nm whilst under transference at 8mm Hg pressure, identical conditions to those employed previously by Maslakiewicz⁸⁶, gave a mixture which was shown by m.s.-g.l.c. to contain perfluoroisobutyronitrile (83) (1%), the valence isomers (152) (1%) and (153) (<1%), two components with $m/z = 514$ (158a) (3%) and (158b) (2%), the pyrazine (154) (53%) and starting material (55) (28%), together with several other unidentified minor components (Scheme 5.5). The product mixture obtained previously contained four components with $m/z = 514$, corresponding to dimers of perfluoro-3-isopropylazete (155), which constituted up to 37% of the total product. The composition of our product is substantially different, and most significantly contains only two of the dimeric species, constituting only 5% of the total product mixture. Additionally, our mixture contains a greater proportion of the pyrazine (154) (53%) (*cf.* only 35% previously), suggesting that the rate of transference was too slow, allowing a greater degree of complete photo-

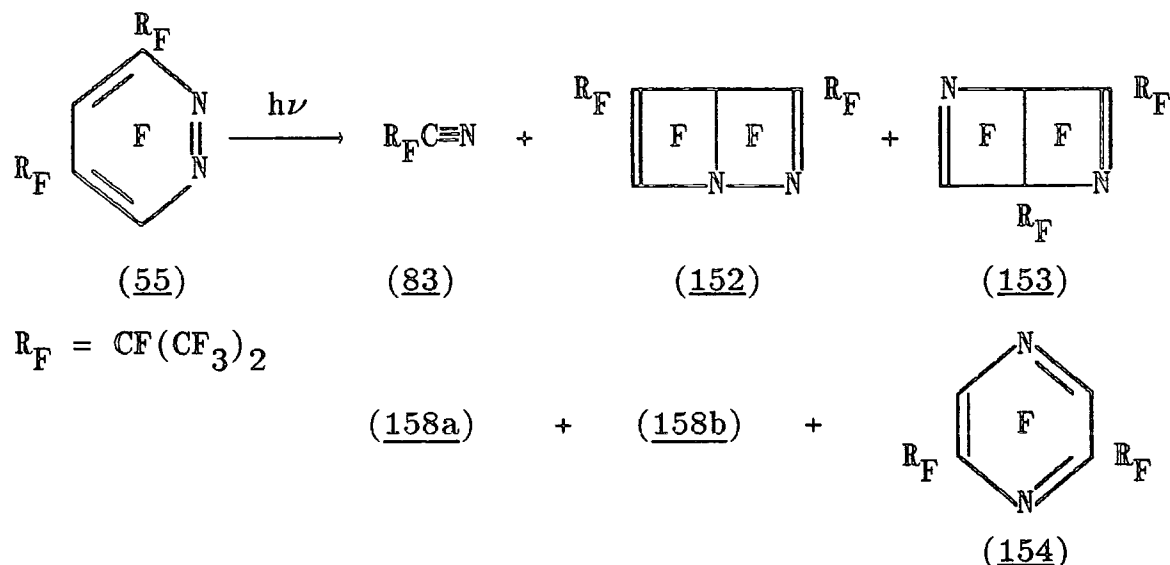

SCHEME 5.5

isomerisation to the pyrazine (154). In an effort to obtain the other two dimers, the transference photolysis of (55) was repeated at lower pressures (faster rates of transference), and the results are summarised in Table 5.1. These results show that increasing the rate of transference increased the proportion of starting material (55) and decreased the proportion of pyrazine (154) in the product mixture, which is consistent with the pyridazine (55)

Table 5.1 Effect of pressure on composition of product mixtures from transference photolysis of (55)

<u>Pressure</u> (mm Hg)	(83) %	(152) %	(153) %	(158a) %	(158b) %	(154) %	(55) %
2	<1	4	1	4	<1	12	70
4	1	8	2	5	1	25	51
8	1	1	<1	3	2	53	28

spending less time in the irradiation zone. Analogous results are obtained from the transference photolysis of perfluoro-4-(2'-methylpent-2-yl)pyridazine (169) at different rates (see Chapter Six, 6.C.2, Table 6.1). However, the proportions of the two dimers (158a) and (158b) in the product mixture were unaffected by the rate of transference, and more importantly, no additional components were detected. These observations contrast with those of Maslakiewicz, who found that the proportion of the four dimers significantly increased with slower rates of transference. Our results obviously do not support these earlier observations.

A further problem was encountered during our attempts to isolate pure samples of the two dimers (158a) and (158b). We found that they could not be separated from the mixture by preparative scale g.l.c. using the same column and conditions specified by Maslakiewicz, despite the fact that adequate separation was achieved on an analytical scale with the same column. Furthermore, all our attempts to separate the mixture on a preparative scale (typically $\geq 50\mu\text{l}$ per injection) using different temperatures and carrier gas flow rates were unsuccessful, as were attempts using several different preparative scale columns.

The successful isolation of the two dimers was eventually achieved, albeit only on a very small scale, using a technique we have developed recently in our laboratories for the isolation of minute quantities of compounds from complex product mixtures, which are

subsequently characterised by ^{19}F n.m.r. spectroscopy. The availability of an n.m.r. spectrometer with a Fourier transform facility permitted satisfactory ^{19}F m.m.r. spectra to be obtained from only milligram quantities of samples. As mentioned earlier, we were able to satisfactorily separate the mixture on an analytical scale with $1\mu\text{l}$ sample injections, and adequate separation was still possible using the analytical column in the preparative scale g.l.c. machine with $5\mu\text{l}$ sample injections. The required components, previously identified from the m.s.-g.l.c. of the mixture, were collected in traps cooled in liquid air in the usual way, except that in between runs the traps were kept at -78°C in a dry ice/acetone bath to prevent evaporation of the minute quantities of material being isolated. After five runs, each trap was washed out with a small quantity of d-chloroform to remove the sample, and the ^{19}F n.m.r. spectrum was recorded. Good resolution spectra with signal:noise ratios of greater than 30:1 were obtained from only 150 - 300 transients. It is estimated that there would be a maximum of $\approx 1\text{mg}$ of each dimer in solution, assuming 100% recovery from the g.l.c. isolation. This clearly illustrates the potential of this new technique for obtaining ^{19}F (or ^1H) n.m.r. spectra of compounds which are part of complex multi-component product mixtures not separable on a preparative scale, if spectroscopic identification of a particular compound is all that is required.

The ^{19}F n.m.r. spectra of the two dimers (158a) and (158b) are given in Table 5.2, and identifies them as the

Table 5.2 ^{19}F n.m.r. spectra of dimers (158a) and (158b)

(158a)		(158b)	
Shift (ppm)	Integral	Shift (ppm)	Integral
-12.6	1	-10.1	2
-26.1	1	-54.4	2
-55.0	2	-75.6	6
-75.5	12	-76.6	6
-177.4	2	-177.7	2

two monocyclic dimers assigned as perfluoro-bis-isopropyl-diazacyclo-octatetraenes by Maslakiewicz. Unfortunately, we were only able to isolate such minute quantities of these dimers, it was not possible to obtain ^{13}C n.m.r. spectra as originally intended, which would have greatly aided the unambiguous assignment of their structures. The two dimers which we have not detected are therefore the bicyclic (158c) and tricyclic (158d) isomers respectively, which were both reported to undergo thermal conversion to the diazacyclo-octatetraene (158b)⁸⁰. This supports our earlier conclusions that, in our hands, the major process, *i.e.* photochemical

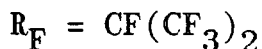
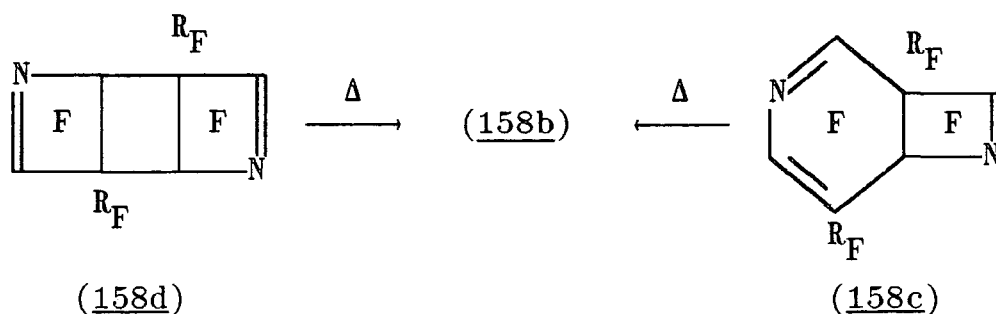

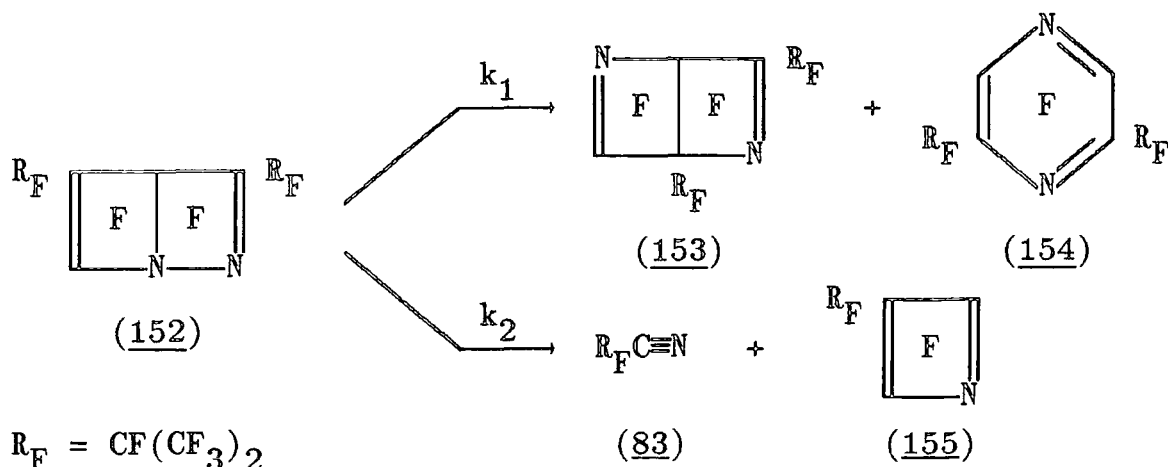

SCHEME 5.6

rearrangement of the valence isomer (152) to the pyrazine (154), is much more efficient than was previously reported, and predominates over the competing process of loss of R_FCN from (152) with concomitant formation of the azete (155), *i.e.* $k_1 \gg k_2$ (Scheme 5.6). However, the generation of small quantities of the diazacyclo-octatetraenes (158a) and (158b) suggests that the intermediate azete (155) and its dimer (158d) are formed, but that the dimer must spontaneously convert into the corresponding diazacyclo-octatetraene (158b) during the photolysis, possibly *via* the bicyclic isomer (158c). This does suggest that there is a large excess of energy in the system to cause this ring-opening to occur, which was not the case previously. The transference

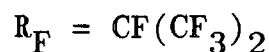
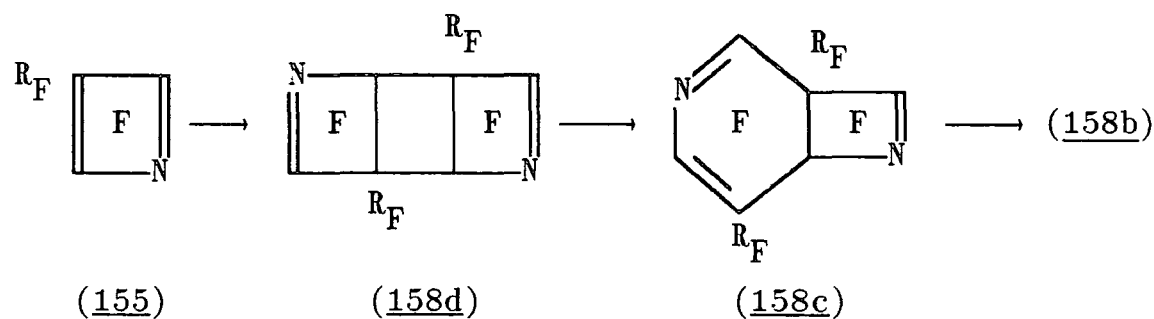

photolysis was repeated at 300nm (lower energy), but gave mainly recovered starting material (55) (81%), together with small amounts of the pyrazine (154) (12%) and valence isomer (152) (4%). There was no evidence for either of the dimers previously observed from the photolyses at 254nm. This indicates that, as suggested earlier, the fragmentation of the valence isomer (152) to generate the intermediate azete (155) requires the presence of a large excess of energy in the system, which is not available from photolysis at 300nm. Furthermore, heating the product mixture obtained from the transference at 4mm Hg pressure resulted in reduction of the proportions of the valence isomers (152) and (153), with enhancement of the proportions of the diazacyclo-octa-tetraene (158b) and pyrazine (154) in the product mixture. This is summarised in Table 5.3, and is consistent with both the elimination of R_FCN from (152) to give the azete (155) with subsequent dimerisation and ring-opening to (158b) (Scheme 5.7, route 1), and the thermal rearrangement of (152) to the pyrazine (154) (Scheme 5.7, route 2). The

Table 5.3 Variation in composition of transference product mixture on heating

	(83)	(152)	(153)	(158a)	(158b)	(154)	(55)
	%	%	%	%	%	%	%
Before	1	8	2	5	1	25	51
After	1	2	-	3	10	28	52

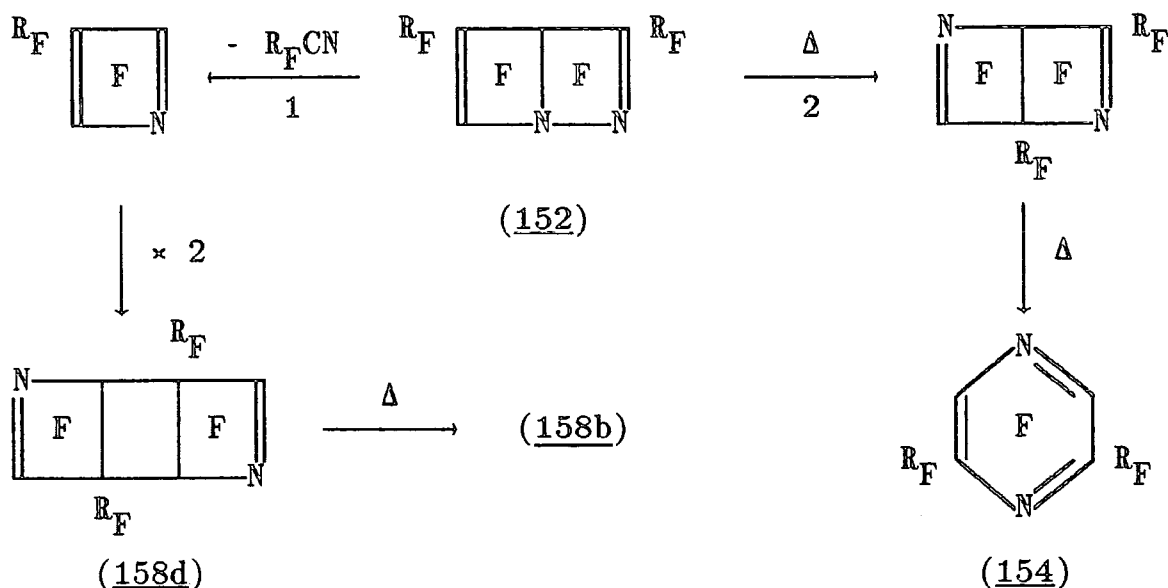

SCHEME 5.7

latter process is also observed for other valence isomers of this type⁴⁶. Clearly, our results from this photolysis differ markedly from those reported previously, with the expected rearrangement to the pyrazine derivative being a far more dominant process than formation of the dimers. The reasons for this difference are not understood, especially since there is no obvious explanation which has not been fully probed.

There are very few reports of diazacyclo-octatetraenes in the literature to use as model compounds for structural assignments. The formation of hexaphenyldiazacyclo-octatetraene (174) from the photolysis of triphenyl-1,2,4-triazafulvene (171) has been described⁹¹ (Scheme 5.8). The diazacyclo-octatetraene (174) was suggested to result from the dimerisation of triphenylazete (172) and subsequent ring-opening of the dimer (173). The structure of (174) was confirmed by pyrolysis at 300⁰C, which gave pentaphenyl-

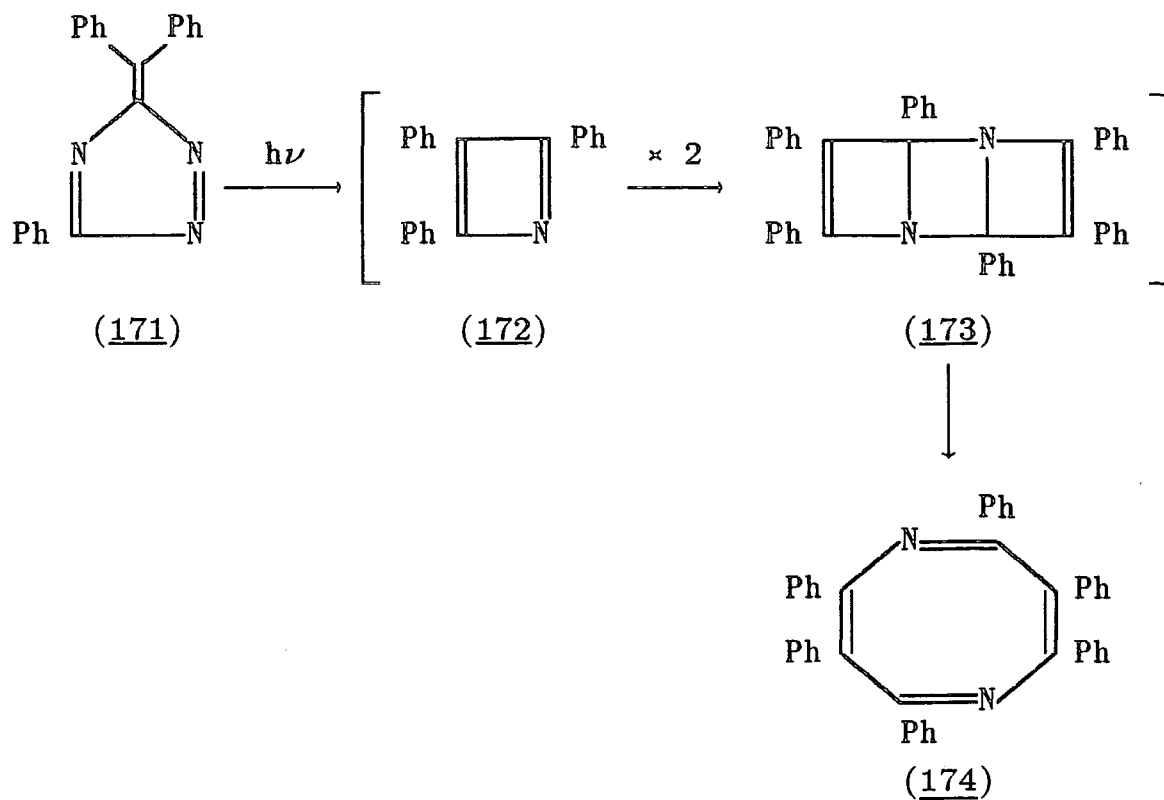

SCHEME 5.8

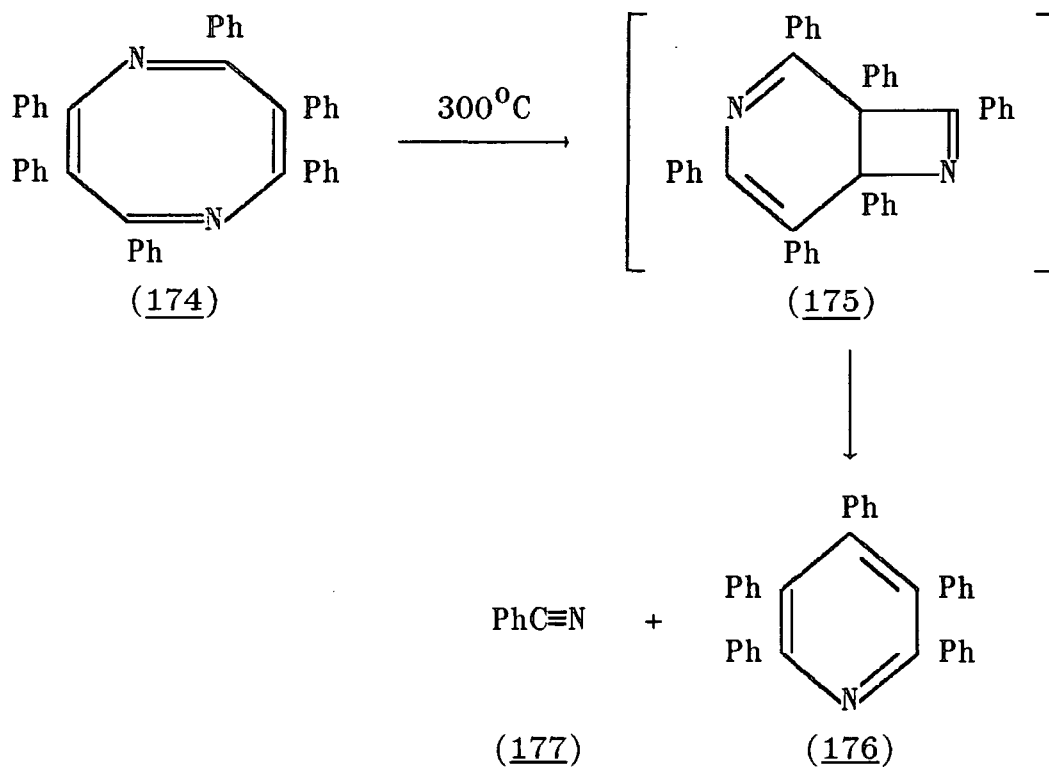

SCHEME 5.9

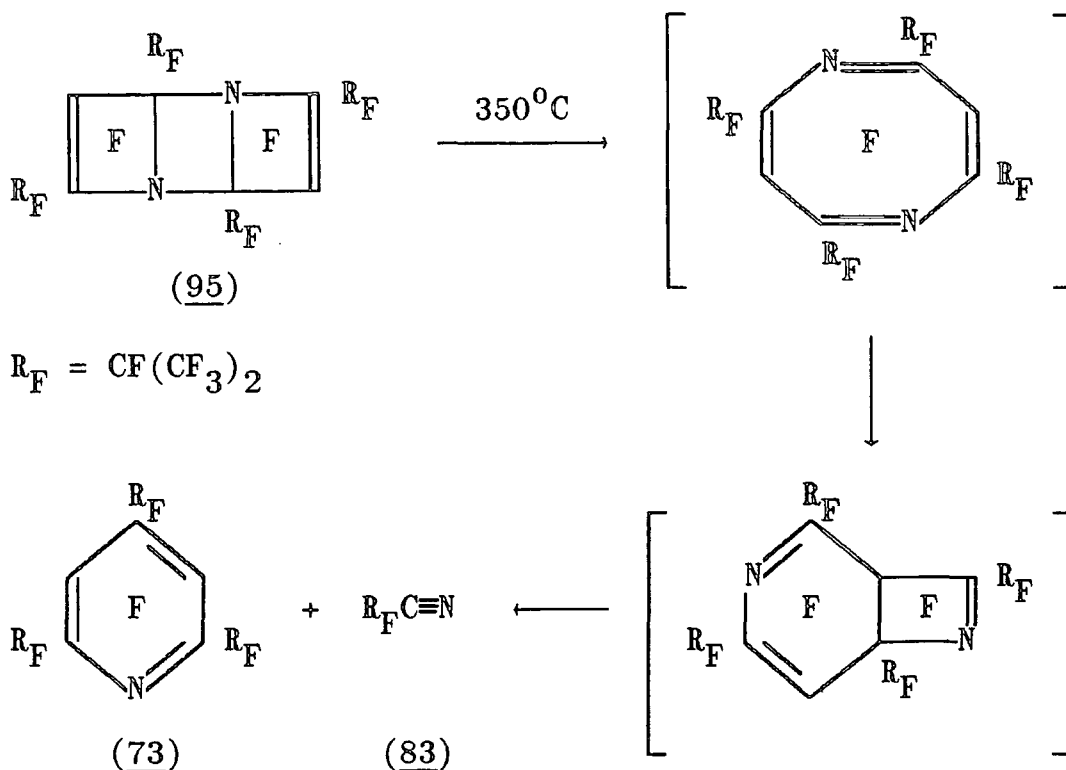

SCHEME 5.10

pyridine (176) and benzonitrile (177), possibly *via* the bicyclic isomer (175) (Scheme 5.9). A similar process was advanced recently to account for the formation of the pyridine (73) and nitrile (83) from the pyrolysis of the dimer (95) of perfluoro-2,4-bis-isopropylazete (94)⁵⁹ (Scheme 5.10). However, there are no perfluorinated diazacyclo-octatetraenes described in the literature, but it is reasonable to suggest that the dimer (158d) of perfluoro-3-isopropylazete (155) could ring-open to the diazacyclo-octatetraene (158b) by a similar process to that suggested for the formation of hexaphenyldiazacyclo-octatetraene (174). *

The ^{19}F n.m.r. spectra (Table 5.2) of both (158a) and (158b) show resonances attributable to two perfluoro-isopropyl groups. This leaves four single fluorines to be

assigned in each compound. Both compounds have resonances with very low chemical shift values, which are assigned as imine fluorines by comparison with similar values observed from model compounds⁸⁶. Compound (158a) has two different imine fluorines, whereas in isomer (158b) they are both equivalent. The remaining resonances in each isomer are identified as vinylic fluorines, from their characteristic chemical shift values⁸⁶. The spectra indicate that the structure of (158b) possesses a greater degree of symmetry than that of (158a).

There are six possible orientations of dimerisation of perfluoro-3-isopropylazete (155), and these are summarised in Table 5.4. However, as the ¹⁹F n.m.r. of the tricyclic azete dimer (158d)⁸⁶ obtained by Maslakiewicz (but not detected in our experiments) showed the presence of two imine fluorines, and no vinylic or tertiary ring fluorines, the dimerisation of perfluoro-3-isopropylazete (155) is concluded to be *via* C=C to C=C. Hence the diazacyclo-octa-tetraene (158b) formed from the thermal rearrangement of (158d) must have either structure (179A) or (179B).

Unfortunately, both these structures would fit the simple ¹⁹F n.m.r. spectrum observed for (158b), and it is not

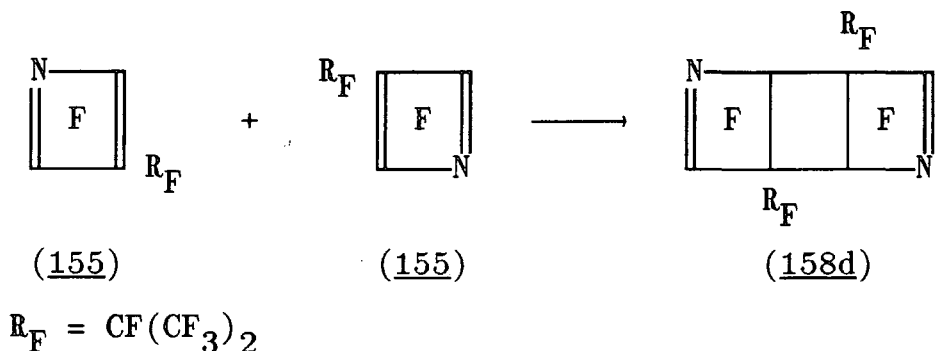
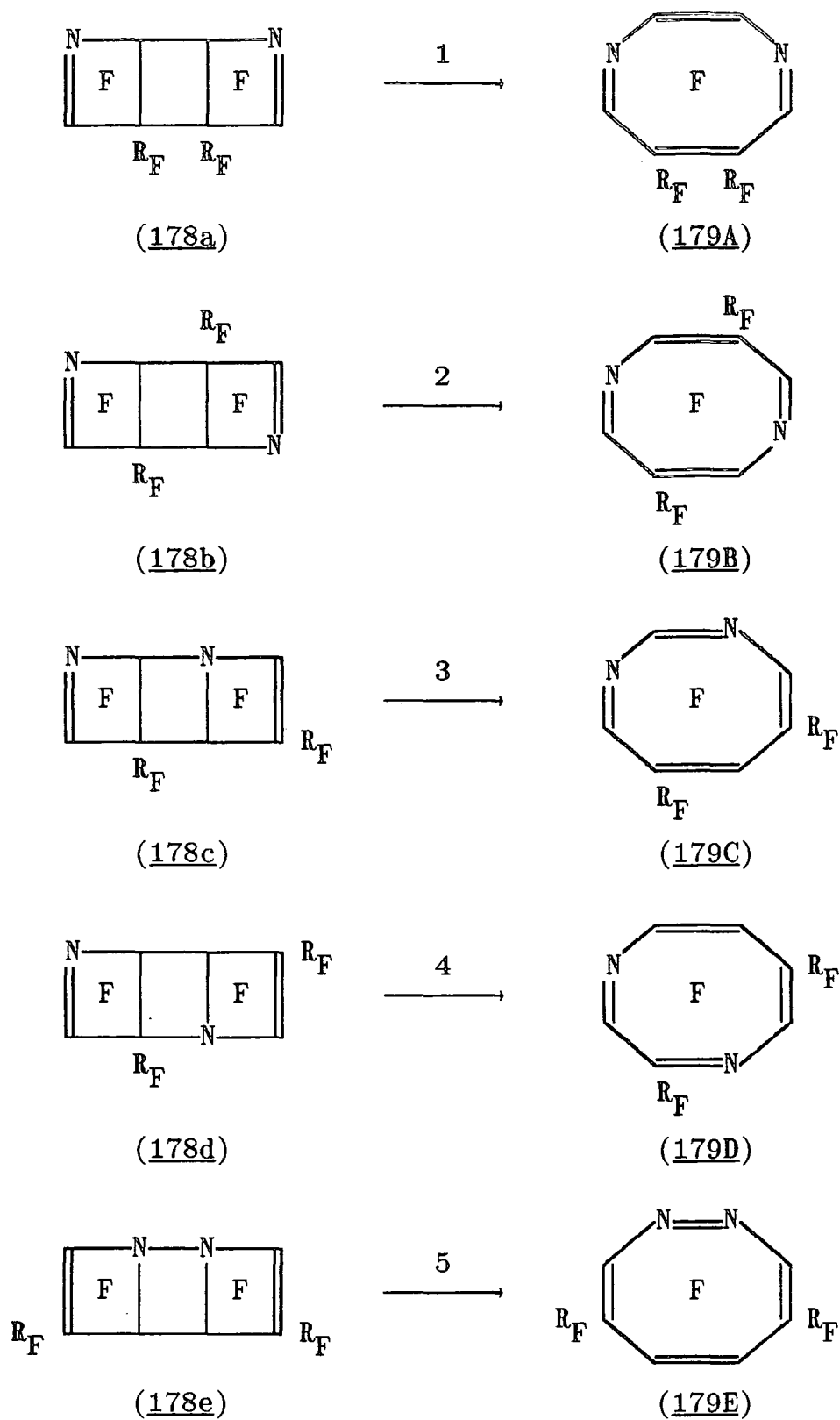
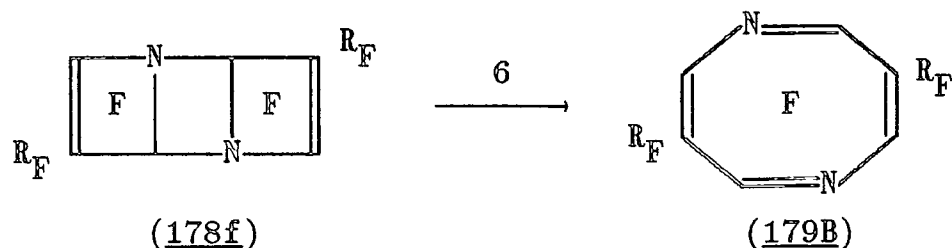
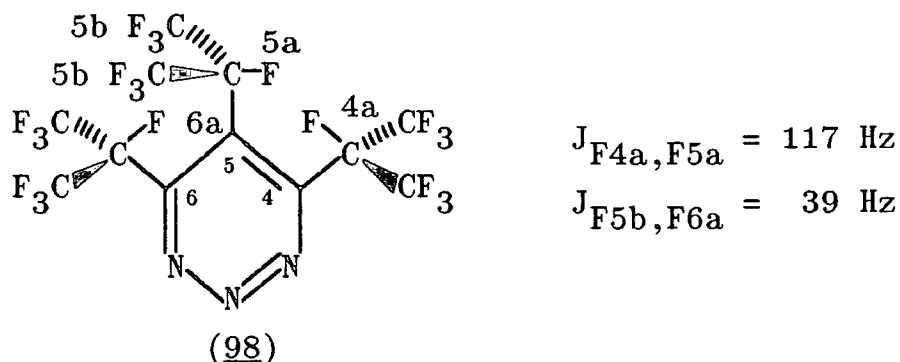

Table 5.4 Structures of possible diazacyclo-octatetraenes from dimerisation of perfluoro-3-isopropylazete





possible to distinguish between them from the available data. However, the spectrum of (158b) does show that the two perfluoroisopropyl groups may be inequivalent, as there are two separate resonances for the CF_3 's of these groups. This usually indicates steric crowding, which can only be exhibited by perfluoroisopropyl substituents at adjacent positions on a ring system, but there is only one resonance for the two tertiary fluorines of these groups, which does not show the characteristic large J_{FF} coupling constant usually found for sterically hindered perfluoroisopropyl groups, *e.g.* in (98)⁵⁹:



The attempted assignment of the structure of diazacyclo-octatetraene (158a) is much more difficult. It has two types of imine fluorine, but two equivalent vinylic fluorines. None of the structures (179A) - (179E) appear to satisfy these requirements, even if the possible

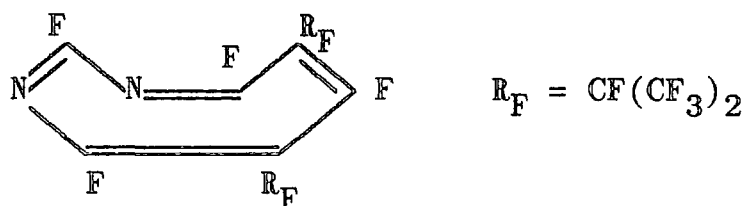

(179C)

stereochemical conformations of the diazacyclo-octatetraenes are considered. These are 8π anti-aromatic systems and presumably do not have planar structures with delocalised π -electrons, but adopt tub-shaped conformations like the parent cyclo-octatetraenes⁹², e.g. for (179C). However, even a consideration of the stereochemistry of structures (179A) - (179E) does not produce a diazacyclo-octatetraene with structural features which fit the observed ^{19}F n.m.r. spectrum of (158a).

The fragmentation patterns observed in the EI+ mass spectra of compounds can often be used to deduce structural information, especially for isomers. The principal fragment ions in the mass spectra of the hexa-aryldiazacyclo-octatetraenes (174) and (180) have been reported⁹¹, and are given in Table 5.5. Both these compounds show intense molecular ions and a generally similar fragmentation pattern. However, (174) gives a fragment ion corresponding to the precursor triphenylazete (172) ($m/z = 281$), whilst for (180) the competitive loss of acetylene *versus* nitrile fragments contrasts with the fragmentation of (174), which loses only nitrile fragments. It was hoped to relate the fragmentation patterns of (174) and (180) to those observed for the perfluoro-bis-isopropyldiazacyclo-octatetraenes

Table 5.5 Principal ions in the EI+ mass spectrum of hexa-aryldiazacyclo-octatetraenes (174) and (180)

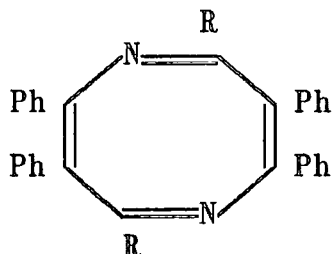

<u>(174)</u> R = Ph			<u>(180)</u> R = p-ClPh		
<u>m/z</u>	<u>% base</u>		<u>m/z</u>	<u>% base</u>	
562	100	M ⁺	630	100	M ⁺
485	10	M ⁺ - Ph	527	12	M ⁺ - PhCN
459	26	M ⁺ - PhCN	493	16	M ⁺ - ClPhCN
383	27	M ⁺ - Ph ₂ CN	452	13	M ⁺ - Ph ₂ C ₂
281	10	M ⁺ /2	417	16	M ⁺ - ClPhC ₂ Ph

(158a) and (158b), and hence to deduce additional structural information on these compounds. The principal ions in the mass spectra of the two perfluoro-bis-isopropyldiazacyclo-octatetraenes (158a) and (158b) are given in Table 5.6. This shows that the fragmentation patterns for each isomer are virtually identical, the only difference being that (158a) has significant fragment ions at $m/z = 345$ and 350 , corresponding to loss of C_3F_6N and C_3F_7 fragments respectively, whereas isomer (158b) does not undergo similar fragmentation. This additional fragmentation presumably

Table 5.6 Principal ions in the EI+ mass spectra of
diazacyclo-octatetraenes (158a) and (158b)

	(158a)	(158b)	
<u>m/z</u>	<u>% base</u>	<u>% base</u>	
514	19	18	M ⁺
495	35	32	M ⁺ - F
445	41	36	M ⁺ - CF ₃
350	12	1	M ⁺ - C ₃ F ₆ N
345	13	1	M ⁺ - C ₃ F ₇
183	12	13	C ₇ F ₁₃
143	100	100	C ₄ F ₅
93	41	42	C ₃ F ₃
69	33	25	CF ₃

results from the less symmetrical structure of (158a), which was observed earlier from the ¹⁹F n.m.r spectrum of (158a) *versus* that of (158b). However, these mass spectral data do not appear to provide any significant new information to aid the structural assignment of the fluorinated diazacyclo-octatetraenes.

In conclusion, this attempt to confirm the results obtained by Maslakiewicz from the transference photolysis of perfluoro-3,5-bis-isopropylpyridazine has given a different result, with only two of the four dimers of perfluoro-3-isopropylazete identified in the product mixture. However, although the previous results were published as a

preliminary communication⁸⁰, further confirmation was required before full publication. We are confident that our study has now confirmed the identities of the dimers observed in the preliminary work sufficiently for full publication of these results.

5.D Low temperature photolysis of perfluoroalkylpyridazines

1. Introduction

In Chapter Four (4.B), we described a technique which we have developed in our laboratories for the direct observation of fluorinated azetes by i.r. and mass spectroscopy from the photolysis of fluorinated 1,2,3-triazine precursors at low temperature.

Stable *para*-bonded valence isomers have been isolated from the ambient temperature photolyses of the perfluoro-bis-isopropylpyridazines (55) and (60) in a flow system⁴⁶.

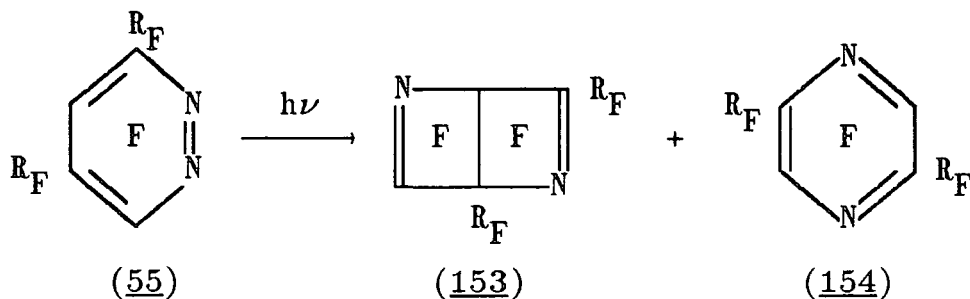
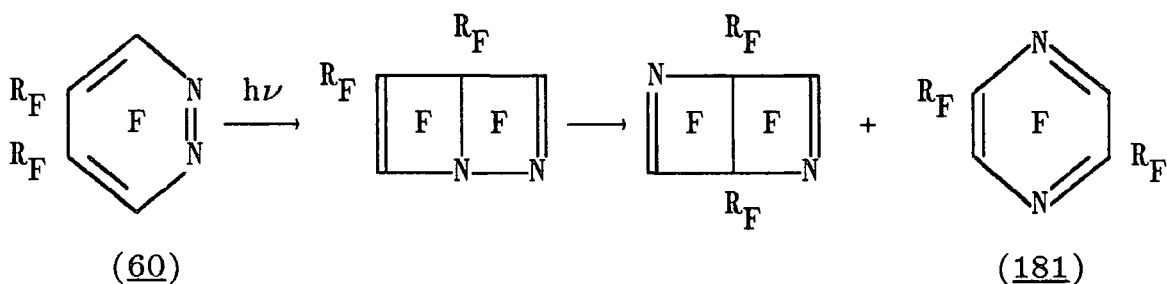

The aim of this investigation was to extend the scope of the low temperature photolysis technique by attempting to observe these valence isomers. Furthermore, it was hoped that this method would enable us to observe perfluoro-3-isopropylazete (155) directly, which is suggested to be the intermediate species in the production of the minor products from the photolysis of perfluoro-3,5-bis-isopropylpyridazine (55). This was discussed in detail in the preceding section (5.C).

2. Perfluoro-4,5-bis-isopropylpyridazine

The basic procedure for the low temperature photolysis outlined in Chapter Four (4.B.1) was employed. Perfluoro-4,5-bis-isopropylpyridazine (60) was deposited onto the KBr plate at -196°C , its i.r. spectrum recorded, and then irradiated at 254nm. No change in the i.r. spectrum was observed, even after irradiation for a total of 6hr. It would be expected, by analogy with the azete systems studied previously (see 4.B), that the photochemical generation of the valence isomer would be observed by the appearance of new absorptions in the C=C and C=N regions of the i.r. spectrum.

3. Perfluoro-3,5-bis-isopropylpyridazine

The low temperature photolysis of a thin film of perfluoro-3,5-bis-isopropylpyridazine (55) at 254nm also resulted in no visible change in the i.r. spectrum at -196°C after 8hr, and hence provided no evidence for the formation

of either the valence isomer or perfluoro-3-isopropylazete (155).

The *para*-bonded valence isomers of these two perfluoro-alkylpyridazines are formed readily by photolysis at ambient temperature⁴⁶. The failure to observe their photochemical formation at low temperatures must presumably result from the immediate thermal quenching of any excited states of the pyridazines, which for perfluoro-3,5-bis-isopropylpyridazine (55) prevents the fragmentation of the valence isomer (152) to give the perfluoro-3-isopropylazete (155). This contrasts with the results obtained from the low temperature photolyses of fluorinated 1,2,3-triazines (see 4.B) in which the azetes are readily formed at -196°C and observed by i.r. and mass spectroscopy.

5.E Chemistry of perfluoro-3,4,6-tris-isopropylpyridazine

1. Introduction

Perfluoro-3,4,6-tris-isopropylpyridazine (159) is obtained as a minor by-product from the fluoride ion catalysed rearrangement of perfluoro-4,5-bis-isopropylpyridazine (60) to the 3,5-isomer (55)³⁸ (see 5.B.1a). The

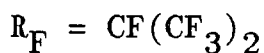
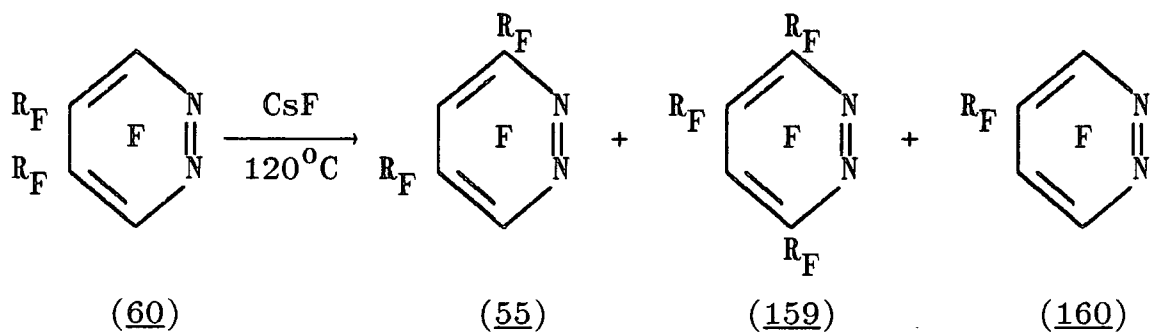

chemistry of this tris-isopropyl derivative (159) has not been investigated as extensively as that of the mono- (160) and bis-isopropylpyridazines (55) and (60). The availability of a reasonable quantity of (159) led us to examine some potentially interesting reactions of this compound.

2. Photolysis

It was suggested⁸⁶ that on photolysis in a flow system, perfluoro-3,4,6-tris-isopropylpyridazine (159) may also undergo a similar process to that observed for perfluoro-3,5-bis-isopropylpyridazine (55)^{80,86} (see 5.C), involving elimination of perfluoroisobutyronitrile (83) from possible *para*-bonded valence isomers (182) or (183) to give perfluoro-bis-isopropylazetes (94) or (184) (Scheme 5.11). Our interest in this process lies in the fact that one of the azetes which would be formed is perfluoro-2,4-bis-

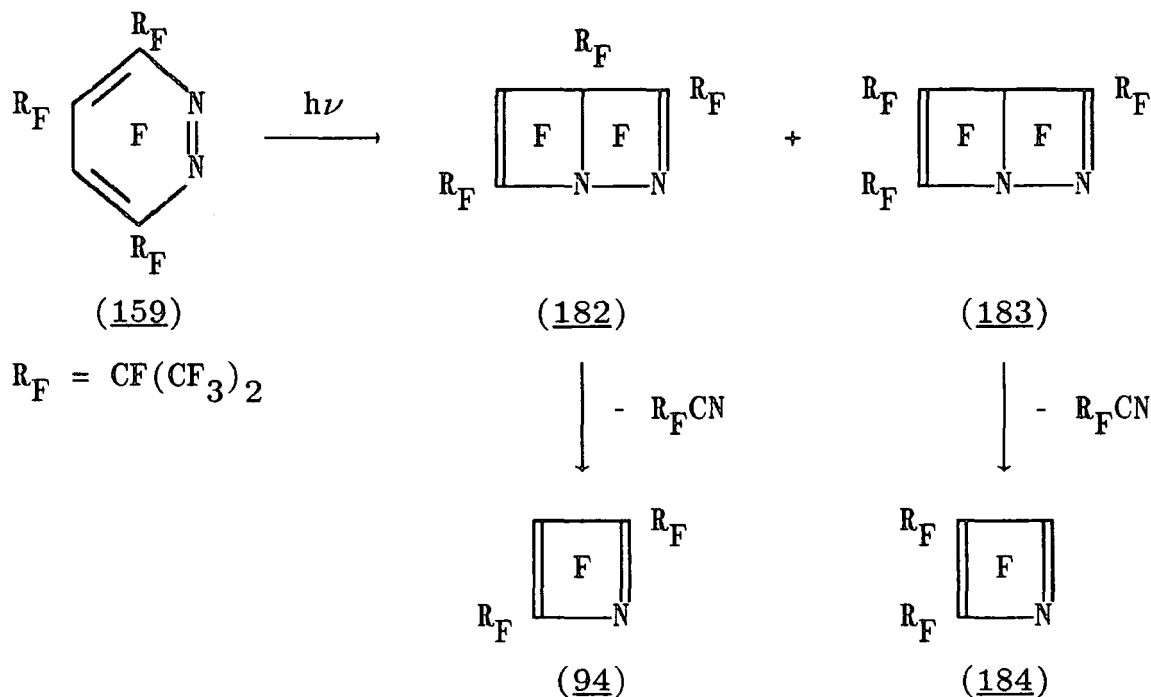

SCHEME 5.11

isopropylazete (94), which has already been fully characterised (see Chapter Four). However, the transference photolysis of perfluoro-3,4,6-tris-isopropylpyridazine (159) resulted in the complete recovery of starting material. Furthermore, static photolysis of (159) at both 254 and 366nm in the vapour-phase or at 254nm in solution also gave only recovered pyridazine (159). The remarkable stability of (159) with respect to photolysis was also observed by Maslakiewicz⁸⁶, and is surprising since it has a similar

Table 5.7 U.v. absorption maxima for some perfluoro-isopropylpyridazines⁸⁶

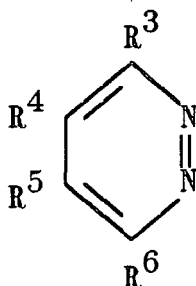

R ³ =	F	F	C ₃ F ₇	C ₃ F ₇
R ⁴ =	C ₃ F ₇	C ₃ F ₇	F	C ₃ F ₇
R ⁵ =	F	C ₃ F ₇	C ₃ F ₇	F
R ⁶ =	F	F	F	C ₃ F ₇
	(<u>160</u>)	(<u>60</u>)	(<u>55</u>)	(<u>159</u>)
λ_{\max} (nm)	265	279	259	255
ϵ	1921	4101	1942	1942

u.v. absorption maximum to those of the mono- (160) and bis-isopropyl-pyridazines (55) and (60) (Table 5.7), which all undergo highly efficient photochemical rearrangements to the corresponding pyrazines⁴⁵.

3. Pyrolysis

The flow pyrolysis of polyfluoroalkylpyridazines with perfluoroalkyl substituents flanking the ring nitrogens generally results in nitrogen elimination and fragmentation to the corresponding acetylenes in high yields⁴¹. This

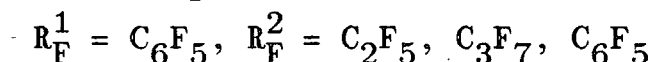
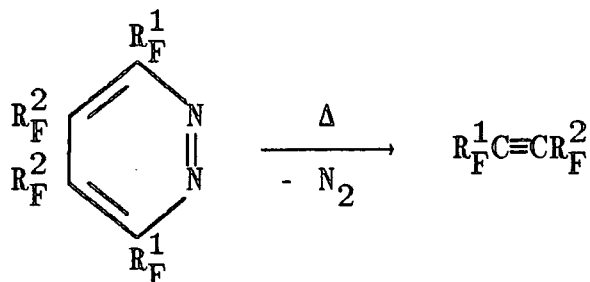

contrasts with the pyrolysis of polyfluoroalkylpyridazines with fluorine in one or both positions adjacent to the ring nitrogens, when rearrangement occurs to the corresponding pyrimidine derivatives⁴³ (see 1.D.1).

We anticipated that the vacuum pyrolysis of perfluoro-

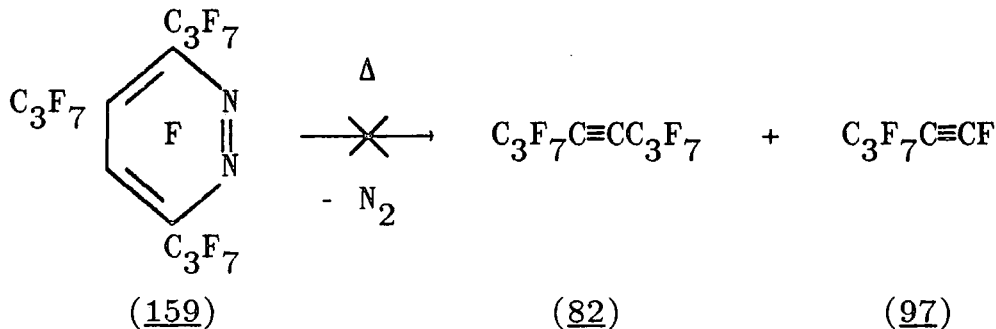

SCHEME 5.12

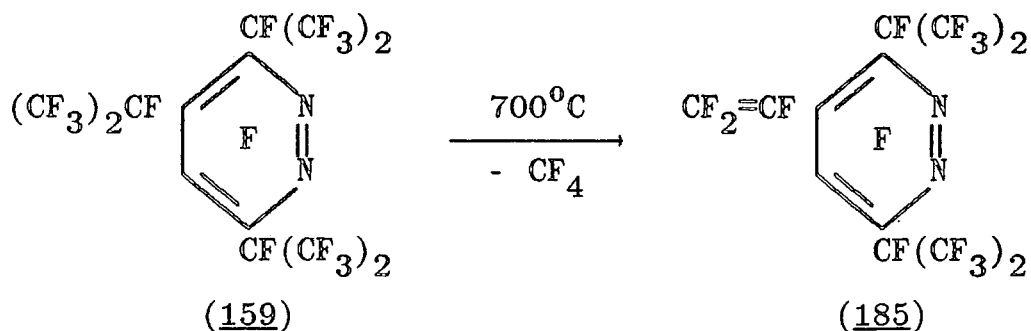

3,4,6-tris-isopropylpyridazine (159) would also result in nitrogen elimination and fragmentation to the perfluoro-isopropylacetylenes (82) and (97), by analogy with the above examples (Scheme 5.12). However, vacuum pyrolysis of (159) at 700°C gave one major product, identified as perfluoro-4-vinyl-3,6-bis-isopropylpyridazine (185) in 42% yield, together with an approximately equal amount of the starting material (159). The product (185) showed a molecular ion at $m/z = 514$ in its EI+ mass spectrum, corresponding to loss of CF_4 from (159). The i.r. spectrum of (185) contains a strong absorption at 1790 cm^{-1} , which compares with 1786 cm^{-1} for the perfluorovinyl group in perfluoro-4-vinyl-5-ethylpyridazine (62)⁴³. Furthermore, the ^{19}F n.m.r spectrum of (185) shows, in addition to the resonances from the two remaining perfluoroisopropyl groups, a resonance at -107.2 ppm for the aromatic ring fluorine at the 5-position, and three resonances at -91.6 , -110.0 and -166.7 ppm which are close to those previously observed at -95.5 , -109.7 and -170.3 ppm respectively for the perfluorovinyl substituent

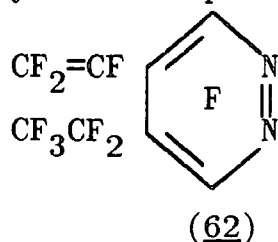

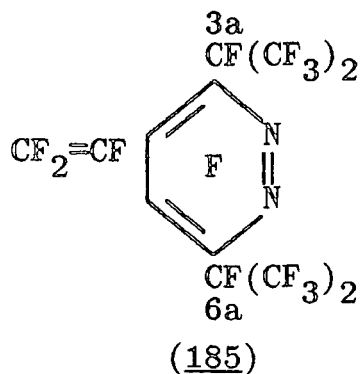

in (62)^{43,86}. It was established that fragmentation had occurred in the perfluoroisopropyl group at the 4-position from consideration of the resonances for the tertiary fluorines of the remaining perfluoroisopropyl substituents in (185). The ¹⁹F n.m.r spectrum of the starting material (159) shows two resonances for these tertiary fluorines at -177.2 (3a and 4a) and -188.5 ppm (6a) respectively. The product (185) also shows two tertiary fluorine resonances at -184.7 and -186.3 ppm. The fact that the values of these two shifts are very close together indicates that the two remaining perfluoroisopropyl substituents are located in very similar environments, which can only be at the 3- and 6-positions of the pyridazine ring in (185), clearly showing that it is the perfluoroisopropyl group at the 4-position which has fragmented. This might also be expected on thermodynamic grounds, as it greatly relieves the steric crowding between adjacent perfluoro-isopropyl groups at the 3- and 4-positions of the starting material (159).

The fragmentation of perfluoroisopropyl substituents has been observed previously from the flow pyrolysis of perfluoro-4,5-bis-isopropylpyridazine (60)^{43,86} (see 1.D.1). However, in that case fragmentation occurred from both

adjacent perfluoroisopropyl groups, whereas only one fragmented in perfluoro-3,4,6-tris-isopropylpyridazine (159). The high thermal stability of (159) is demonstrated by the recovery of a significant quantity of the starting material from the flow pyrolysis, and also that, unlike other perfluoroisopropylpyridazines⁴³, (159) does not undergo thermal rearrangement to the corresponding pyrimidine derivative in a static system⁴³. The reasons for this high thermal stability of (159) are unclear.

In an effort to ascertain whether other 3,6-bis-perfluoroalkylpyridazines would undergo nitrogen elimination and fragmentation to acetylenes on vacuum pyrolysis, as we originally anticipated for these compounds, attempts were made to prepare both perfluoro-3,6-bis-isopropyl- (161) (see 5.B.1) and -bis-ethyl-pyridazine (166) (see 5.B.3). However, these attempts were unsuccessful, and this line of work was not pursued further.

4. Nucleophilic attack

a) With dimethylamine

In a previous study^{93,94}, the reaction of perfluoro-3,5-bis-isopropylpyridazine (55) with excess dimethylamine in dimethylformamide at room temperature gave yellow crystals of the bis(dimethylamino) derivative (186) in high yield. However, on standing for several days the colour of (186) changed to purple and then became colourless. This process was accelerated by the addition of either water or boron trifluoride-diethyl ether. The

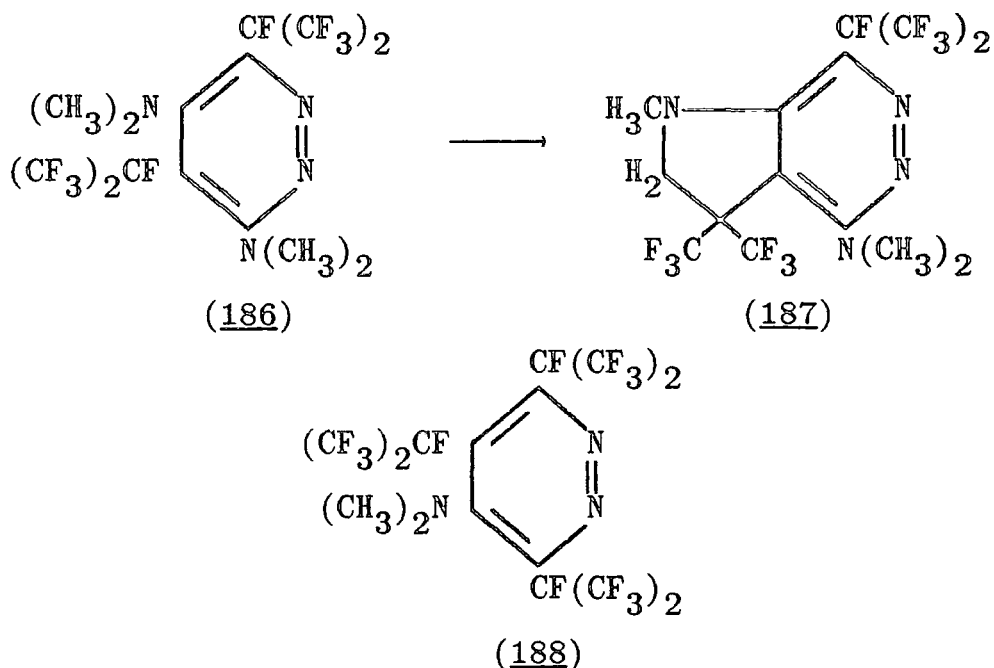

structure of the colourless product was established as an unusual bicyclic compound (187), formed by the cyclisation of adjacent dimethylamino and perfluoroisopropyl substituents. The 5-dimethylamino derivative of perfluoro-3,4,6-tris-isopropylpyridazine (188) was also prepared for the same study, but did not cyclise after prolonged heating at 120°C⁹³.

Our aim was to further investigate the effects of both pyrolysis and photolysis on (188).

The reaction of perfluoro-3,4,6-tris-isopropylpyridazine (159) with excess dimethylamine in dimethylformamide at room temperature gave an 86% yield of the

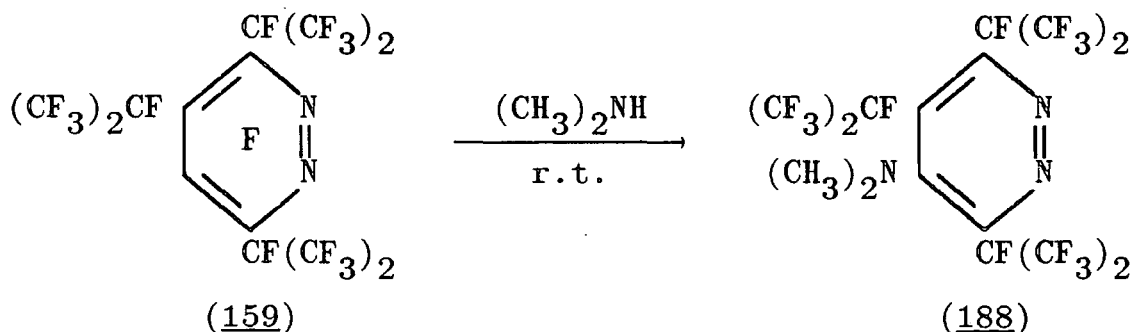

5-dimethylamino derivative (188). Heating (188) in a sealed tube at temperatures up to 150°C gave no evidence for any cyclisation process. Furthermore, the addition of boron trifluoride-etherate to a solution of (188) in diethyl ether also did not produce any colour change in solution, and no evidence of cyclisation was observed by ^{19}F n.m.r. spectroscopy, even after warming the solution for several hours.

The photolysis of 5-dimethylamino-3,4,6-tris-perfluoro-isopropylpyridazine (188) in the vapour-phase at both 254 and 366nm, and in solution at 254nm yielded only recovered starting material in each case. The photochemical stability of this derivative is similar to that of the parent compound (159) (see 5.E.2), and is also surprising since (188) has a much more intense u.v. absorption maximum ($\lambda_{\text{max}} = 275\text{nm}$, $\epsilon = 8236^{93}$) than (159) ($\lambda_{\text{max}} = 255\text{nm}$, $\epsilon = 1942^{86}$).

b) With 2,3-dimethylbut-2-ene

The reaction between perfluoro-tris-isopropyl-1,2,3-triazine (98) and 2,3-dimethylbut-2-ene at 70°C was studied previously in our laboratories, giving a green liquid product which was identified as a 1:1 adduct (189) resulting from initial nucleophilic attack of the alkene at the centre ring nitrogen of the 1,2,3-triazine ring^{59,95}. There are several recent reports of nucleophilic attack at ring nitrogen for various substituted 1,2,3-triazines^{96,97}, but similar processes for pyridazines are without precedent.

Perfluoro-3,4,6-tris-isopropylpyridazine (159) does

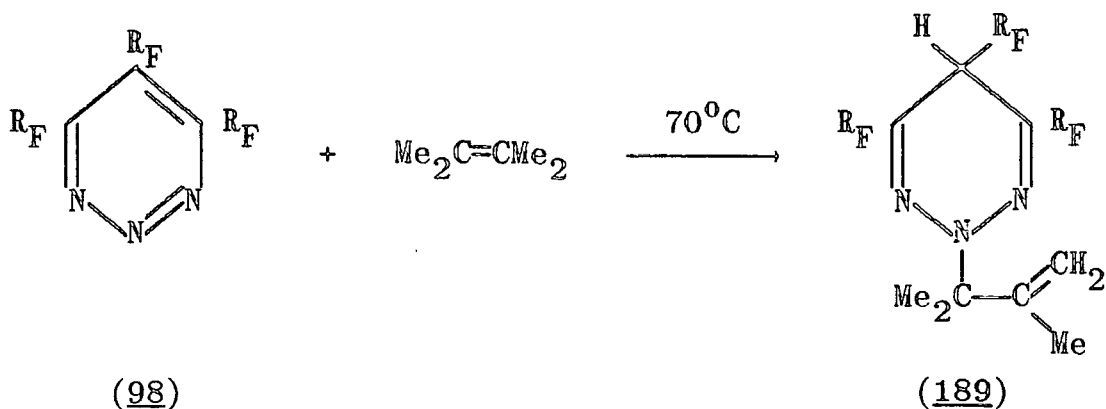

possess structural features which are not too dissimilar to those of (98) with respect to its susceptibility to nucleophilic attack at ring nitrogen, and it was hoped that an analogous reaction between (159) and 2,3-dimethylbut-2-ene might occur. However, prolonged heating of a mixture of (159) and 2,3-dimethylbut-2-ene at temperatures up to 150°C gave no evidence for any reaction.

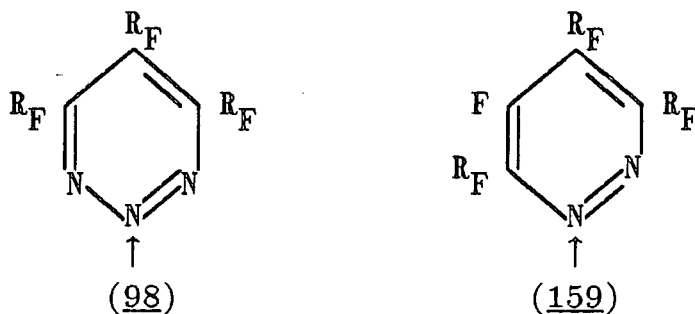

In conclusion, the results presented in this section clearly illustrate the remarkable thermal and photochemical stabilities of both perfluoro-3,4,6-tris-isopropylpyridazine (159) and its 5-dimethylamino derivative (188).

CHAPTER SIX

CHEMISTRY OF PERFLUORO-4-(2'-METHYLPENT-2'-YL)PYRIDAZINE6.A Introduction

The thermal and photochemical rearrangements of perfluoroalkylpyridazines have been extensively studied by previous workers in our laboratories^{41,43-46}. Photolysis of these pyridazines gave isolable valence isomers as intermediates in the rearrangement of the pyridazines to pyrazines⁴⁶. It is well established that perfluoroalkyl groups can stabilise small ring systems^{52,53,81}, although it is uncertain whether this is due to steric or electronic effects, and this has led to the isolation of the valence isomers of hexakis(perfluoroalkyl)benzenes, *e.g.* Dewar-benzene (189a), prismane (189b) and benzvalene (189c)^{58,81}.

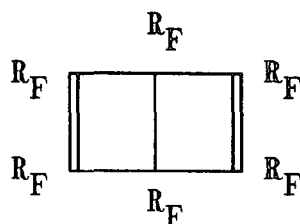
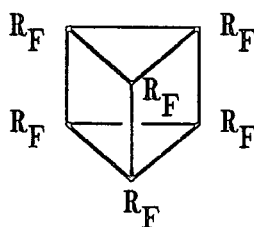
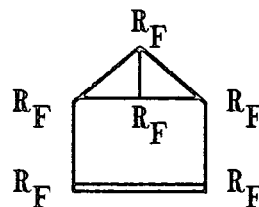
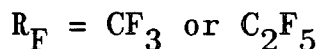
(189a)(189b)(189c)

The availability of perfluoro-4-(2'-methylpent-2'-yl)-pyridazine (169) prompted this investigation to observe the effect of a bulky perfluoroalkyl group on the thermal and photochemical reactions of (169) by comparison with other perfluoroalkylpyridazines previously reported⁴³⁻⁴⁶.

6.B Synthesis

Perfluoro-4-(2'-methylpent-2'-yl)pyridazine (169) has been prepared previously in our laboratories by A. E. Bayliff, in 66 - 77% yield, from the reaction between the perfluoro-2-methyl-pent-2-yl anion (168) and tetrafluoro-pyridazine (21) in tetraglyme⁵³. The anion (168) itself

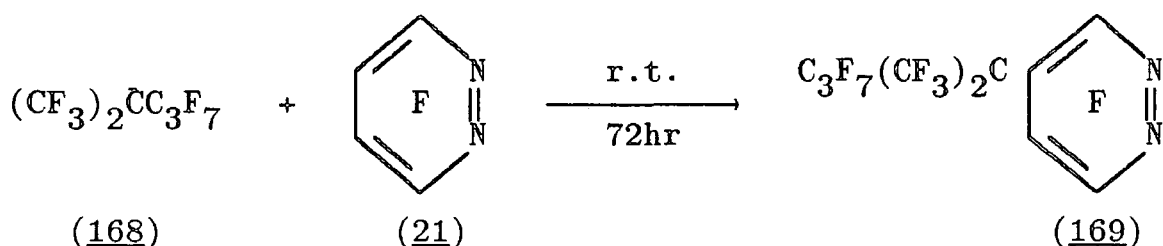

was prepared by stirring a solution of perfluoro-2-methyl-pent-2-ene (167) in tetraglyme with fluoride ion, and the precursor, perfluoro-2-methylpent-2-ene (167), was obtained in excellent yield (89 - 95%) from the fluoride ion induced dimerisation of hexafluoropropene (190)⁵³.

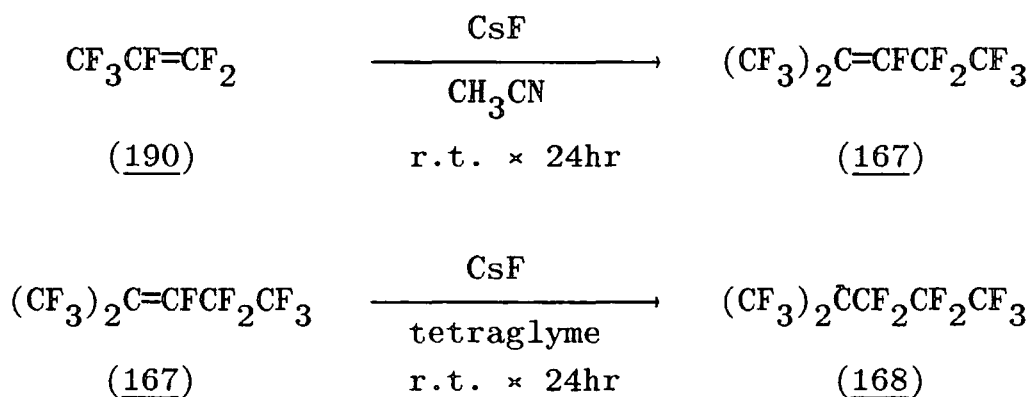

Surprisingly, both Bayliff⁵³ and ourselves were unable to form the 4,5-di-substituted derivative of (169) under a variety of conditions employed. It is suggested that this is due to the steric hindrance of the perfluoro-2-methylpent-2-yl group at the 4-position blocking further attack of the

anion (168) at the adjacent 5-position, since for perfluoroalkyl groups with lower steric requirements, *i.e.* perfluoro-ethyl, -isopropyl and -*s*-butyl, the 4,5-disubstituted derivatives were formed in good yields^{37,38,98}.

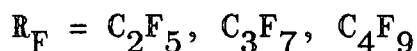
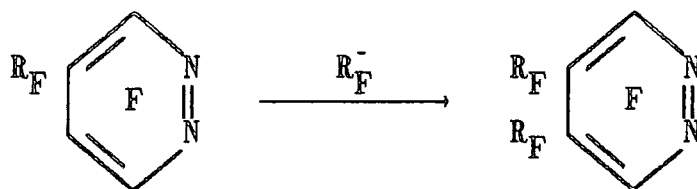

We had anticipated that tertiary anions would have behaved similarly in reactions with tetrafluoropyridazine (21), but reaction of the perfluoro-*t*-butyl anion (191) with (21) at room temperature gave only the 4-monoalkylpyridazine (192) in high yield³⁹. Compound (192) is the kinetic product,

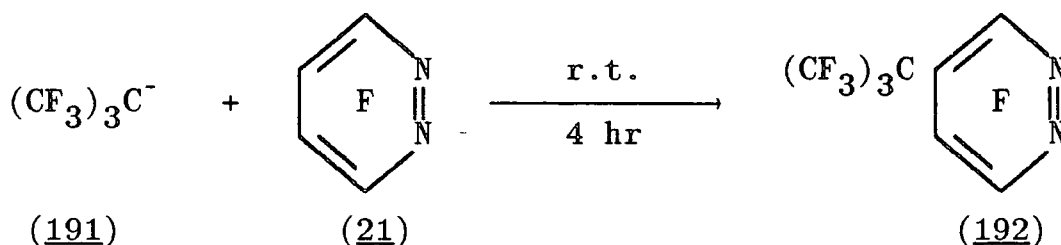

formed by attack of the carbanion (191) at the most reactive position of (21). However, at 80°C the reaction gave a good yield of the 3,6-dialkylpyridazine (193). This was suggested to occur *via* the series of equilibria³⁹ shown in Scheme 6.1

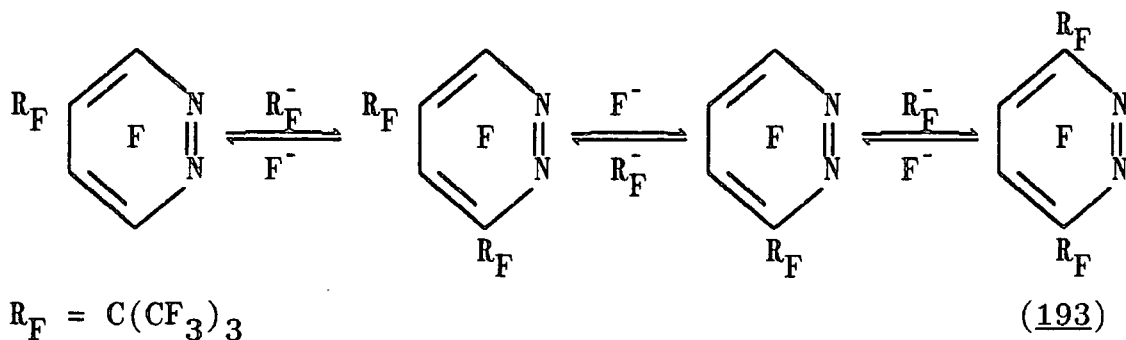

SCHEME 6.1

which lead to the production of the more stable thermodynamic product (193), with the bulky perfluoro-*t*-butyl groups situated adjacent to the ring nitrogens. This prevalence for the formation of the most stable isomer is found to increase with the increasing steric demand and stability of the perfluoroalkyl anion⁴⁰ (see 1.C.2). The inability of the perfluoro-2-methylpent-2-yl anion (168) to

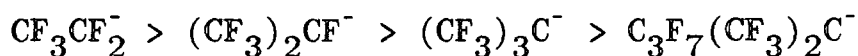

—————→
decreasing reactivity

give a di-substituted product at elevated temperatures must be due to its instability with respect to loss of fluoride ion to regenerate the parent alkene. The threshold temperature at which this process begins to occur for (168) was determined as 60 - 64°C by a variable temperature ¹⁹F n.m.r. study⁵³. That the instability of the anion limits its

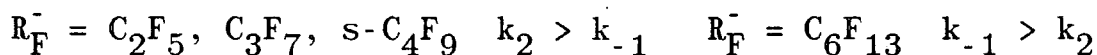
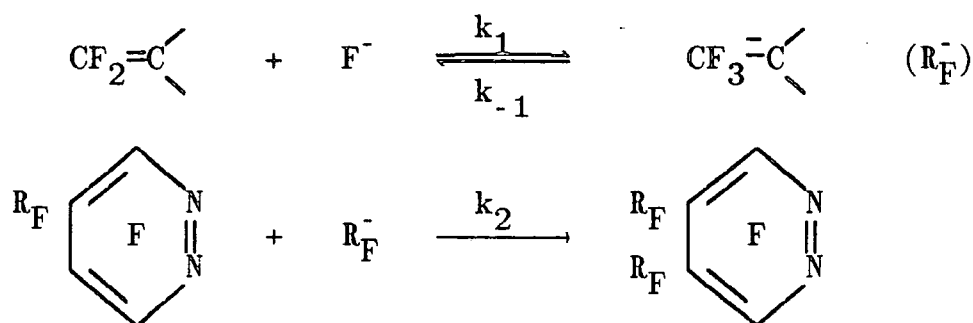

reactivity is further supported by our attempted reactions of the perfluoro-2-methylpent-2-yl anion (168) with perfluoro-4-isopropylpyridazine (see 5.B.2), when, under a variety of conditions, no di-alkylated products were obtained.

The perfluoro-4-(2'-methylpent-2'-yl)pyridazine (169) used for this work was prepared according to the procedure described by Bayliff, except that sulpholane was used as the solvent. The reaction was repeated several times, giving moderate yields (47 - 57%) of (169).

6.C Photolysis

Static photolysis of perfluoro-4-alkylpyridazines gave quantitative conversion to the corresponding perfluoroalkylpyrazines⁴⁵. These rearrangements were proposed to occur *via*

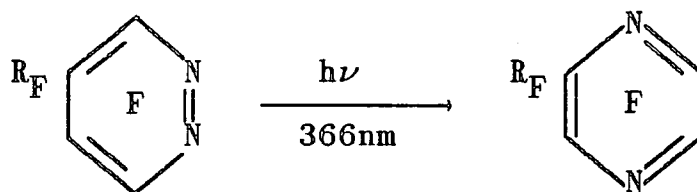

intermediate valence isomers (194), which were subsequently isolated by irradiation of the pyridazines whilst under transference⁴⁶. The valence isomers (194) rearomatised to the corresponding pyrazines on heating or photolysis⁴⁶.

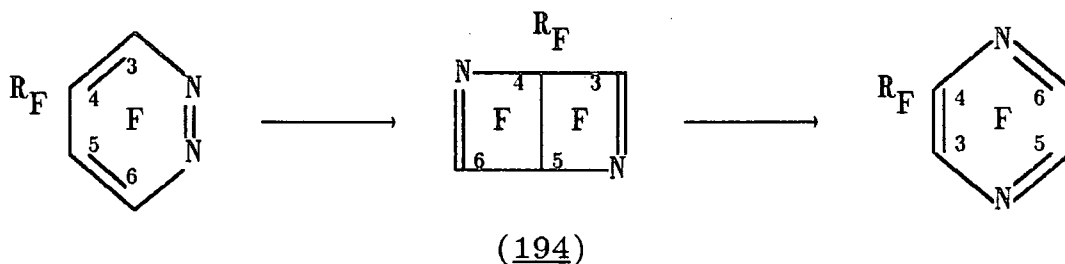

1. Static

Static photolysis of perfluoro-4-(2'-methylpent-2'-yl)pyridazine (169) in the vapour phase gave an almost quantitative conversion to the pyrazine (195). The ¹⁹F n.m.r. spectrum of (195) showed, apart from the resonances

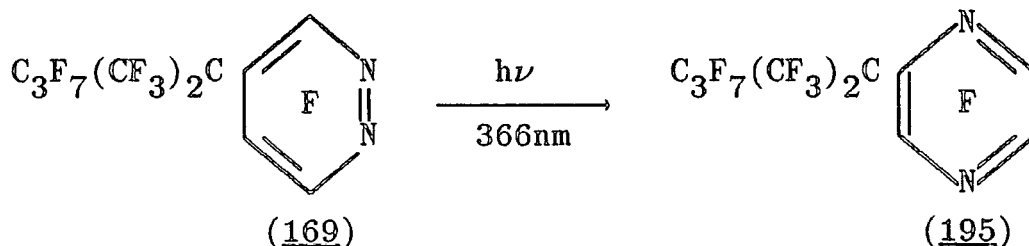

for the perfluoroalkyl group, three resonances corresponding to the aromatic ring fluorines, with similar chemical shift values and coupling constants to those observed for perfluoro-2-isopropylpyrazine⁸⁶.

2. Transference

Photolysis of (169) whilst under transference was attempted with the aim of isolating the intermediate valence

Table 6.1 Transference photolysis of (169)

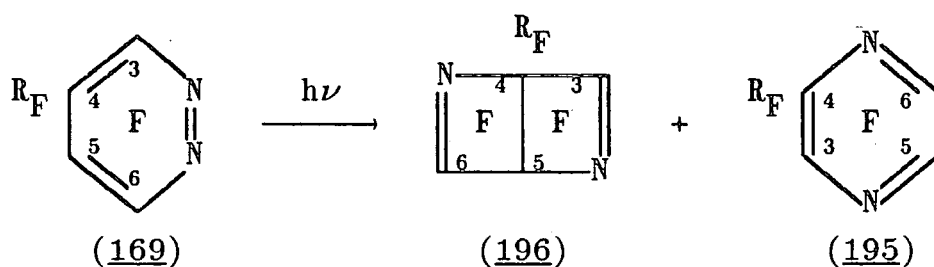

<u>Wavelength</u> (nm)	<u>Pressure</u> (mm Hg)	<u>(169)</u> %	<u>(196)</u> %	<u>(195)</u> %
254	8.0	-	-	95
254	2.0	3	31	57
300	2.0	4	55	38
300	0.1	15	68	16

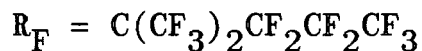

isomer. The results of several experiments are summarised in Table 6.1, which parallel those observed previously for other perfluoro-4-alkylpyridazines^{46,86}. Reducing the pressure in the transference system (increasing the rate of transference) increased the proportion of the valence isomer (196) and reduced the proportion of pyrazine (195) in the product mixture. A possible explanation is that the valence isomer (196) is removed more rapidly from the irradiation zone before further photochemical rearomatisation to the pyrazine could occur⁸⁶. Similarly, using a longer wavelength u.v. source (of correspondingly lower energy) also gave a greater proportion of the valence isomer in the product mixture.

In separate experiments, (196) was found to convert quantitatively to the pyrazine (195) upon either heating at 100°C or irradiation in the vapour phase.

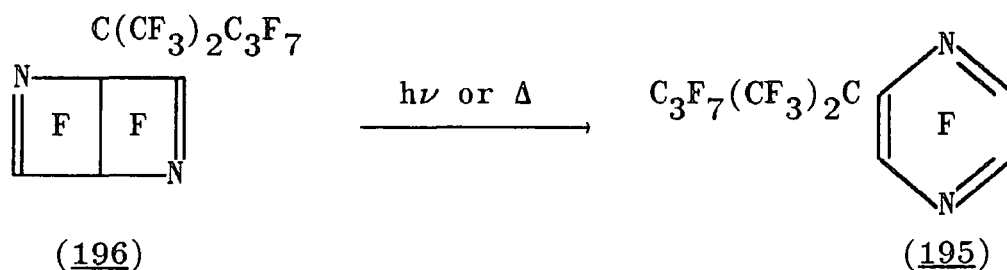

Perfluoro-1-(2'-methylpent-2'-yl)-2,5-diazabicyclo-[2.2.0]hexa-2,5-diene (196) shows a strong i.r. absorption at 1670 cm^{-1} (C=N) (*cf.* 1656 cm^{-1} in the 1-isopropyl derivative (197)⁸⁶). The ¹⁹F n.m.r. spectrum of (196) shows, apart from the resonances due to the perfluoro-2-methylpent-2-yl group, two resonances at -41.8 and -45.3

ppm, which are assigned to the 6- and 3- imine fluorines respectively (*cf.* -42.4 and -45.0 ppm in (197)), and a high field resonance at -164.7 ppm, assigned to the bridgehead fluorine at the 4-position (*cf.* -166.0 ppm in (197)). The resonance for the 3-fluorine also shows a more

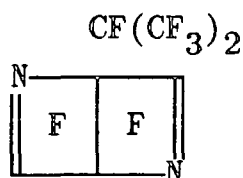

(197)

clearly defined fine structure than has been observed previously for perfluoro-2,5-diazabicyclohexadiene derivatives, allowing the couplings between the 3-fluorine and the other two ring fluorines to be assigned by comparison with those observed for perfluorobicyclo[2.2.0]-hexa-2,5-diene (198)⁹⁹.

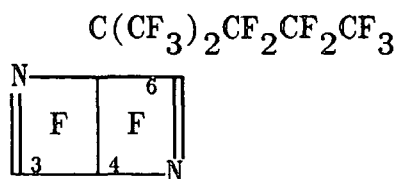

(196)

$$J_{3,6} = 15 \text{ Hz}$$

$$J_{3,4} = 11 \text{ Hz}$$

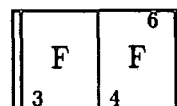

(198)

$$J_{3,6} = 14 \text{ Hz}$$

$$J_{3,4} = 7 \text{ Hz}$$

6.D Pyrolysis

Static pyrolysis of perfluoro-4-alkylpyridazines gave rearrangements to mixtures of the corresponding 4- and 5-alkylpyrimidines⁴⁴, which are believed to occur *via* diazabenzvalene intermediates. Flow pyrolysis of perfluoro-

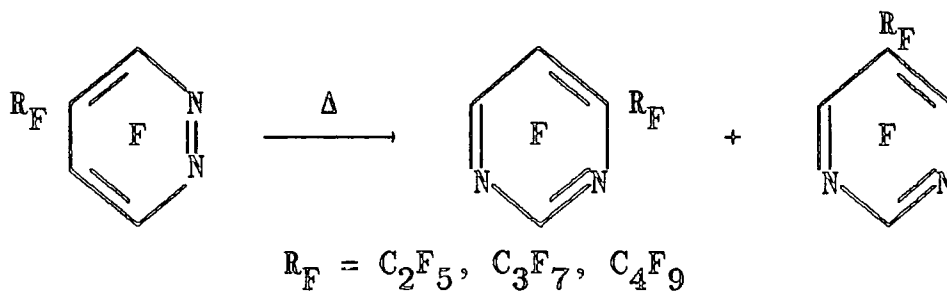

4-alkylpyridazines in a nitrogen stream also resulted in rearrangements to the corresponding perfluoroalkylpyrimidine derivatives⁴³.

1. Static

Static pyrolysis of perfluoro-4-(2'-methylpent-2'-yl)-pyridazine (169) in a Carius tube at 400°C for 16 hr resulted in the total decomposition of the pyridazine. However, repeating the experiment at 300°C gave a 60% recovery of material, of which 90% was a mixture of perfluoro-4-(2'-methylpent-2'-yl)pyrimidine (199) and perfluoro-5-(2'-methylpent-2'-yl)pyrimidine (200), together with several minor components and no recovered starting material (169).

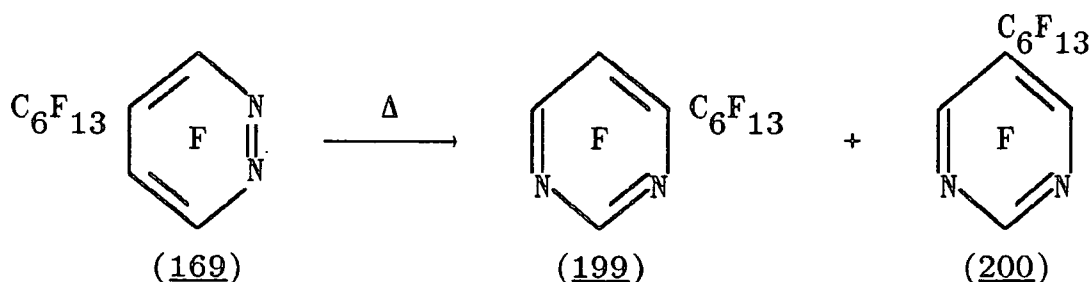

The mixture of pyrimidines was isolated by preparative scale g.l.c., and identified from the ¹⁹F n.m.r. of the mixture by comparison of the chemical shifts and coupling constants of the aromatic ring fluorines with the known values for the perfluoro-4- and -5-isopropylpyrimidines¹⁰⁰. The mixture was

shown by capillary g.l.c. and ^{19}F n.m.r. to consist of the 4- and 5-alkylpyrimidines (199) and (200) in a ratio of approximately 5:1, contrasting markedly with the other perfluoroalkylpyrimidine mixtures obtained previously, which all contained approximately equal amounts of the two pyrimidines⁴⁴. A summary of the results of the pyrolyses of perfluoro-4-alkylpyridazines are given in Table 6.2, which clearly shows that there is a change-over of the major

Table 6.2 Pyrolyses of perfluoro-4-alkylpyridazines

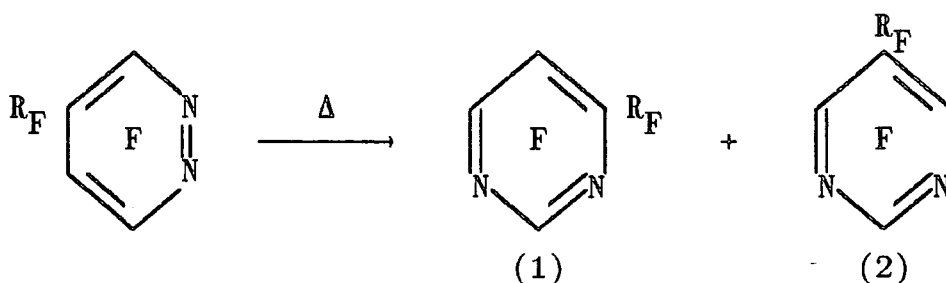

	R_F	T ($^\circ\text{C}$)	<u>Recovery</u>	<u>Conversion</u>	<u>(1):(2)</u>	<u>Ref</u>
a	C_2F_5	700*	69%	85%	1 : 1.4	43
b	C_3F_7	400	81%	16%	1 : 1.3	44
c		300 ⁺	97%	79%	1 : 1	44
d	C_4F_9	350	77%	32%	1 : 1	44
e		400	72%	94%	1 : 1	44
f	C_6F_{13}	400	0%			
g		300	60%	90%	5.4 : 1	

* flow pyrolysis in N_2 stream

⁺ in the presence of perfluoro-3,4-dimethylhexane (53)

isomer produced on increasing the size of the substituent perfluoroalkyl group.

The mechanism for the rearrangement is believed to be a radical-catalysed valence-isomerisation *via* intermediate diazabenzvalenes⁴⁴ (Scheme 6.2). This mechanism accounts for the formation of a mixture of 4- and 5-alkylpyrimidines from

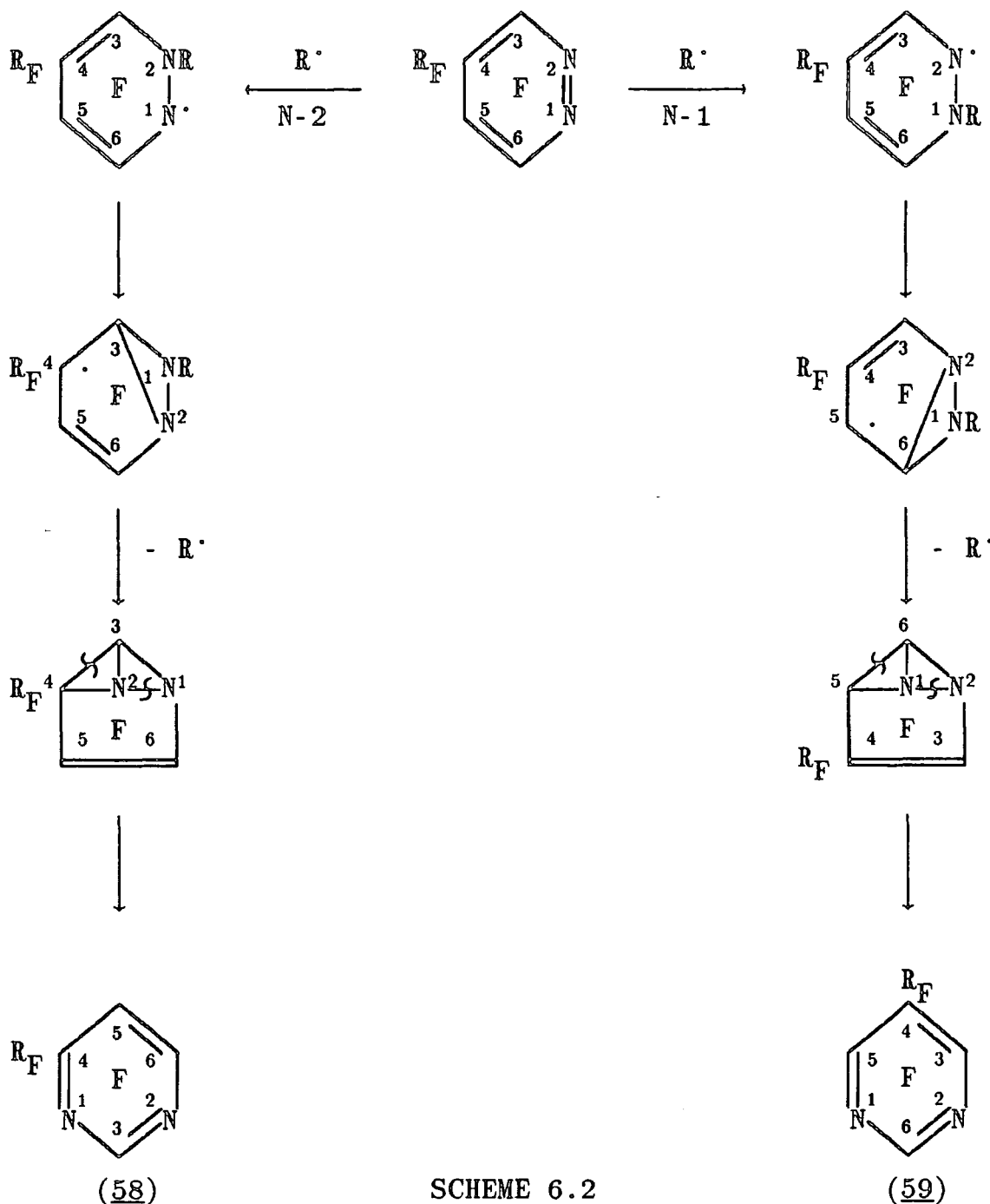

SCHEME 6.2

the pyrolysis of a 4-alkylpyridazine, as clearly attack of the radical R^\cdot can occur at either N-1 or N-2 of the pyridazine. The perfluoroalkyl derivatives previously investigated gave approximately equal amounts of each pyrimidine. Furthermore, the rearrangement occurred more easily with the increasing size of the perfluoroalkyl group (Table 6.2; b,e), and this was suggested to be due to increased stabilisation of the intermediate diaza-benzvalene¹⁰¹. However, the rearrangement was also promoted by the the addition of perfluoro-3,4-dimethylhexane (53). This molecule possesses a similar structure to that of the

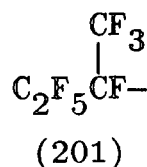
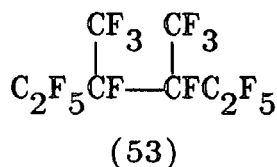

perfluoro-s-butyl group (201), and the effectiveness of (53) at promoting the rearrangement was explained in terms of the ease of fission of a C-C bond in (53) to form stable perfluoroalkyl radicals (54)⁴⁴. This is supported by the

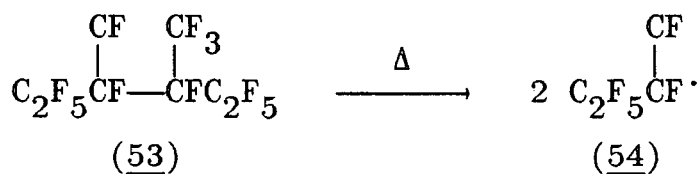

observation that in the presence of (53), perfluoro-4-isopropylpyridazine gave 79% conversion to the pyrimidines at 300°C, compared to only 16% conversion at 400°C in the absence of (53) (Table 6.2; b,c).

The results of the thermal rearrangement of perfluoro-4-(2'-methylpent-2'-yl)pyridazine (169) (Table 6.2; f,g) are in agreement with this radical promoted mechanism, but there are differences which warrant further explanation.

Firstly, the rearrangement of (169) occurred much more readily than for the perfluoro-*s*-butyl derivative, giving a very high conversion to the pyrimidines at 300°C. This must be a result of the increased ease of formation of stable perfluoroalkyl radicals from C-C bond fission in the substituent perfluoroalkyl group. The rearrangement of (169) to the pyrimidines is in effect autocatalytic, being promoted by perfluoroalkyl radicals produced from the thermal decomposition of the perfluoroalkyl group in (169). This may also explain why the perfluoro-*s*-butylpyridazine undergoes rearrangement much more easily than the other perfluoro-4-alkylpyridazines reported previously, as extrapolating from the results obtained for (169), increasing the size and degree of substitution of the perfluoroalkyl group would be expected to increase the probability of C-C bond fission to produce stable perfluoroalkyl radicals.

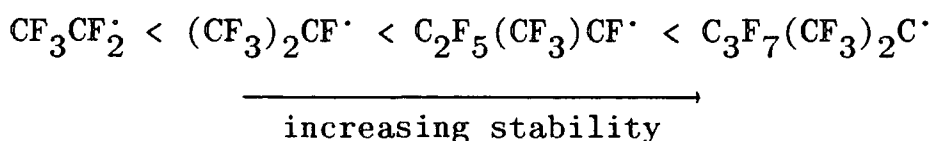

Secondly, the rearrangement of perfluoro-4-(2'-methylpent-2'-yl)pyridazine (169) gave predominantly the 4-alkylpyrimidine. This contrasts with all the other perfluoroalkylpyridazines in Table 6.2, which all gave \approx 1:1 mixtures of the 4- and 5-alkylpyrimidines. This may be explained in terms of the relative steric demands of the various perfluoroalkyl groups. It is well established from ^{19}F n.m.r. studies¹⁰² that perfluoroalkyl groups attached to a

heteroaromatic ring adopt preferred conformations relative to the adjacent substituents, and for very bulky perfluoroalkyl groups, *e.g.* perfluoro-*t*-butyl, the thermodynamically more stable derivatives are those with the perfluoroalkyl group adjacent to a ring nitrogen⁴⁰. The perfluoro-2-methylpent-2-yl group is also a very bulky perfluoroalkyl group, and would be therefore be expected to exhibit similar behaviour to that of the perfluoro-*t*-butyl group. The steric demands of a bulky perfluoroalkyl group will therefore tend to favour the formation of the thermodynamically more stable 4-alkylpyrimidine (58) *via* the mechanism given in Scheme 6.2, in which the perfluoroalkyl substituent is situated adjacent to a ring nitrogen. This may explain why the major product from the pyrolysis of perfluoro-4-(2'-methylpent-2'-yl)pyridazine (169) is the 4-alkylpyrimidine (199).

The possibility of equilibration between the two pyrimidine isomers (Scheme 6.2) to give the more stable derivative (58) during the pyrolysis was also considered, and was probed by the pyrolysis of the 4-alkylpyrimidine (199) under the same conditions as the pyridazine (169). The pyrimidine (199) was prepared directly from the reaction of the perfluoro-2-methylpent-2-yl anion (168) with an excess of tetrafluoropyrimidine (22) in sulpholane.

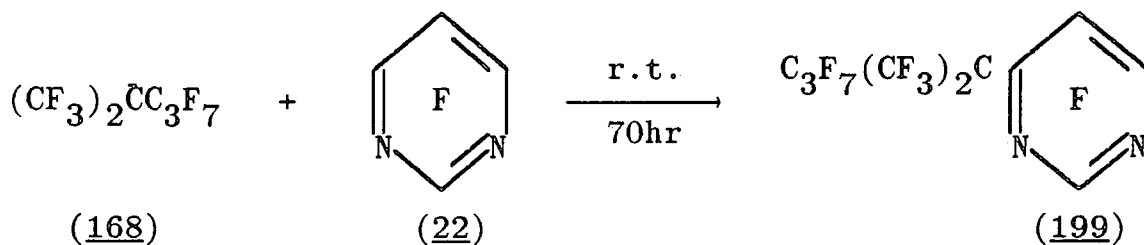

The static pyrolysis of (199) at 300°C gave only recovered starting material, thus demonstrating the thermodynamic stability of the 4-alkylpyrimidine (199).

2. Flow

Flow pyrolysis of perfluoro-4-(2'-methylpent-2'-yl)-pyridazine (169) at 650°C under high vacuum gave one major product which was identified as perfluoro-4-(2'-propenyl)-pyridazine (202) in 43% yield. The product (202) showed an

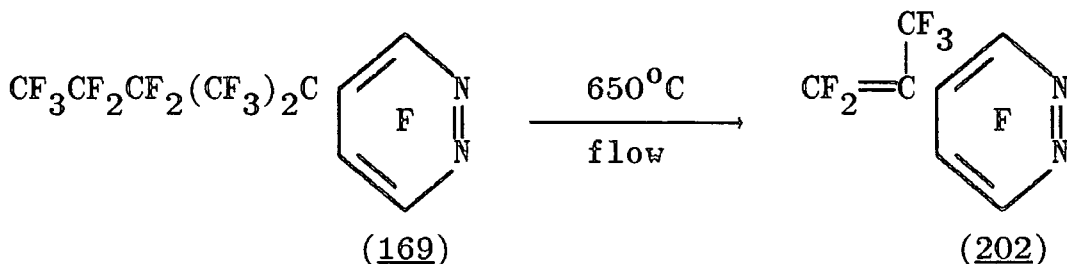

intense molecular ion peak at m/z 264 in both its EI+ and CI- mass spectra, corresponding to loss of C_3F_8 from (169), and a strong absorption at 1740 cm^{-1} in its i.r. spectrum. The ^{19}F n.m.r. spectrum of (202) contains six resonances in the ratio 3:1:1:1:1:1 in order of increasing chemical shifts. It shows the presence of three aromatic ring fluorines at -79.3 (3F), -99.0 (6F) and -121.8 ppm (5F). The coupling constants for the 6-fluorine of 32 Hz and 24 Hz respectively are similar to those in the starting material (169), showing that no rearrangement of the pyridazine ring had occurred. The chemical shifts for the perfluoro-2-propenyl group at -61.0, -67.5 and -68.0 ppm are close to those observed at -60.5, -69.3 and -69.6 ppm respectively for the perfluoro-2-propenyl substituent in perfluoro-4-

(2'-propenyl)-5-ethylpyridazine (63)^{43,86}.

The intense molecular ion peak in the CI- mass spectrum of (202) is indicative of a very stable molecular anion. This would be expected for a heteroaromatic possessing a substituent containing a π -system which is capable of conjugation with the π -system of the heteroaromatic to increase the degree of resonance stabilisation of the molecular anion (see Chapter Eight). Similar stabilisation of the molecular anion was found for pentafluorophenyl compounds with $C\equiv N$ or $C=O$ containing substituents¹⁰³.

The flow pyrolysis of a perfluoroalkylpyridazine resulting in the fragmentation of a substituent perfluoroalkyl group has also been observed for perfluoro-4,5-bis-isopropylpyridazine^{43,86} (see 1.D.1) and perfluoro-3,4,6-tris-isopropylpyridazine (see 5.E.3).

These results reinforce the suggestion advanced previously^{44,101} that static pyrolyses of perfluoroalkylpyridazines in the liquid phase must involve bimolecular processes resulting in the rearrangement of the pyridazine ring, as clearly in the vapour-phase pyrolyses of these systems, which involve much shorter contact times, it is a unimolecular process which predominates, resulting in the fragmentation of the perfluoroalkyl substituent.

CHAPTER SEVEN

PREPARATION AND ATTEMPTED REACTIONS OF HEXACHLOROCINNOLINE7.A Introduction

Some years ago, a previous worker in our laboratories, Dr. J. A. H. MacBride, devised a synthetic route to hexachlorocinnoline (78). The subsequent fluorination of (78) gave the corresponding hexafluoro derivative (203), which was found to isomerise to hexafluoroquinazoline (25) on photolysis¹⁰⁴. This was suggested to occur *via* the

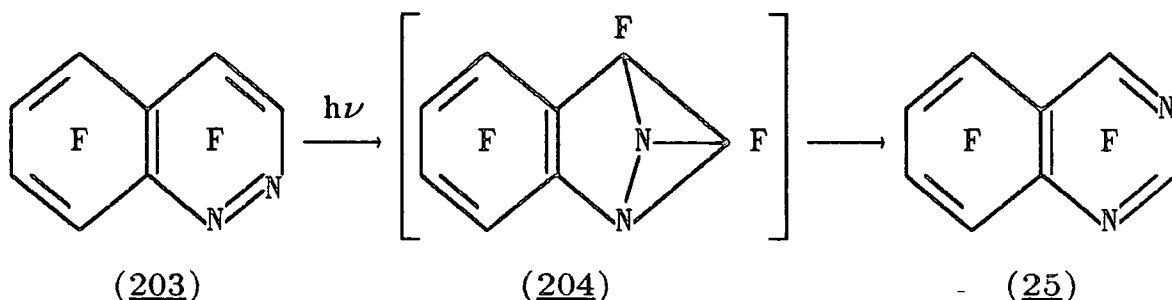

intermediate benzodiazabenzvalene (204), and contrasts with the photochemical isomerisation of tetrafluoropyridazine and its perfluoroalkyl derivatives to the corresponding pyrazines *via* intermediate *para*-bonded valence isomers (see 1.D.2). However, there are no reports of any stable azabenzvalene derivatives in the literature, although they have been suggested as intermediates in the thermal isomerisations of perfluoroalkylpyridazines (see 1.D.1).

Our reinvestigation of the halogenated cinnolines had several objectives. The initial aim was to develop a route to hexachlorocinnoline suitable for large scale synthesis, repeat the preparation of the perfluoro compound, and then

to confirm the identity of the photolysis product. The second objective was to attempt to synthesise perfluoroalkyl derivatives of the cinnoline system and investigate their photolysis, with the aim of isolating possible intermediate benzodiazabenzvalenes.

7.B Synthesis of hexachlorocinnoline

The previous synthetic route to hexachlorocinnoline (78) was developed in our laboratories by Dr. MacBride from 2,3-dichloroaniline (205) (Scheme 7.1)¹⁰⁴. This route contained eight steps, each one requiring purification of material from the previous step, and gave only a 7% overall yield of hexachlorocinnoline from (205). The immediate precursor to (78) was the tetrachloro derivative (206), which was perchlorinated with a mixture of elemental

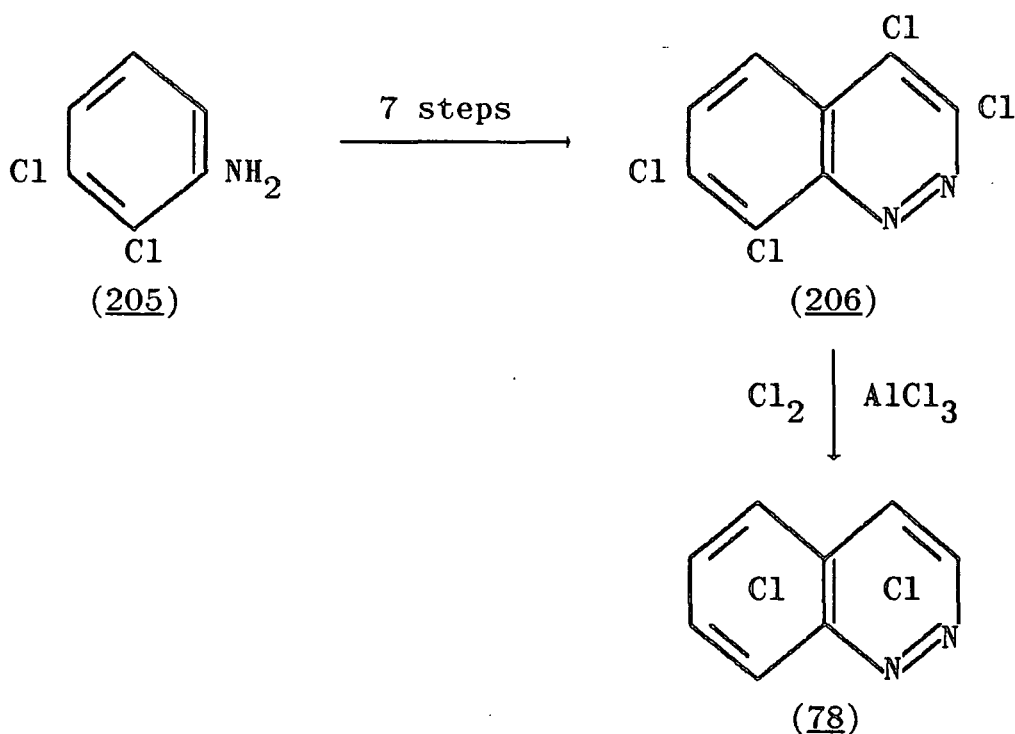

SCHEME 7.1

chlorine and aluminium trichloride at atmospheric pressure, the well-known "Swamping Catalyst" technique⁷. Later work in these laboratories on the development of synthetic routes to the other perchlorobenzodiazines (see 1.B.1) established that the precursor to the fully chlorinated compound need only be prechlorinated in the heterocyclic ring, and hence a possible shorter preparative route to hexachlorocinnoline (78) was recently suggested to us by Dr. MacBride¹⁰⁵ (Scheme 7.2). This route uses 3-bromo-4-chlorocinnoline (210) as the

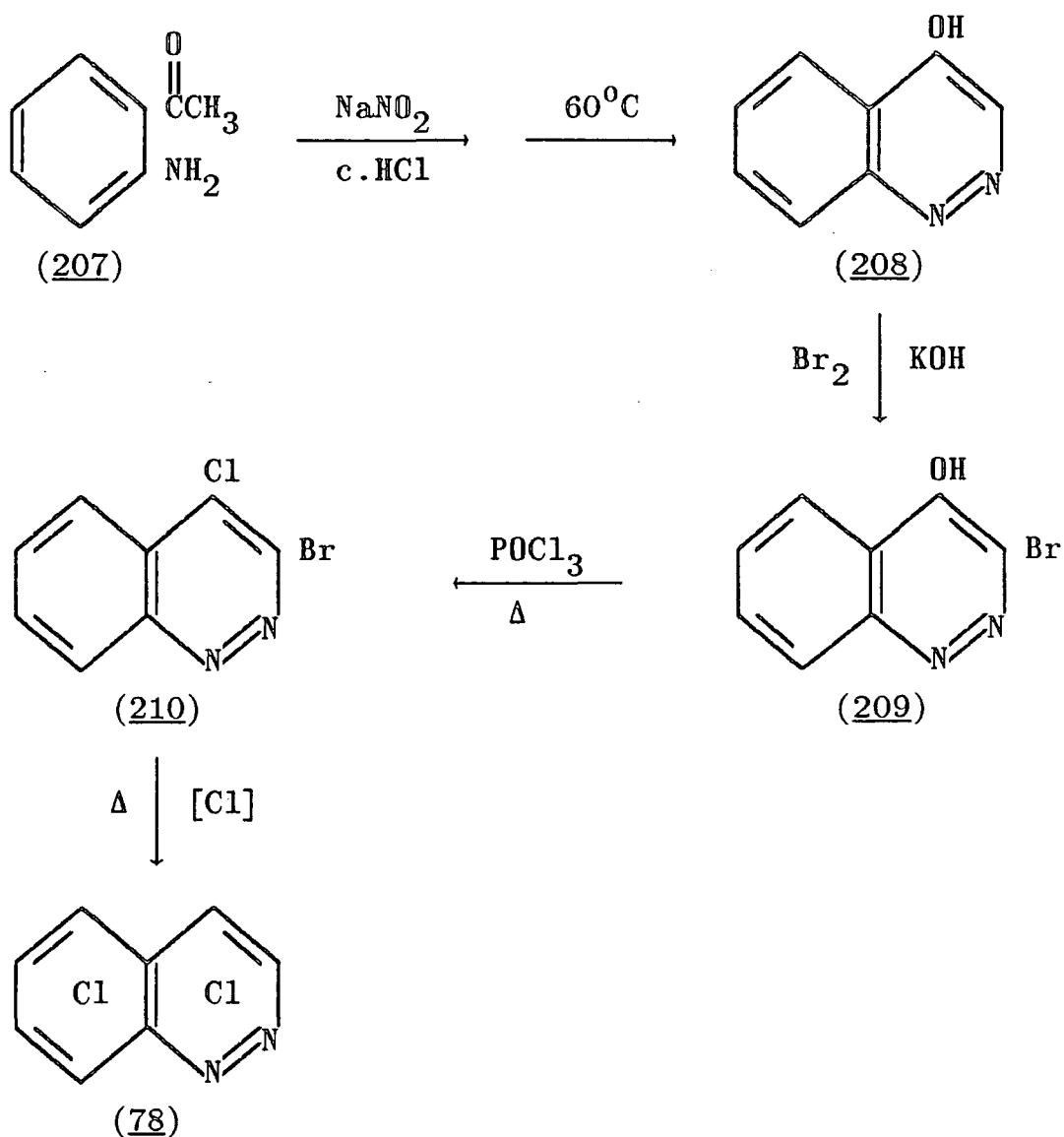

SCHEME 7.2

immediate precursor to (78), which is prepared in three steps from the readily available *o*-aminoacetophenone (207). MacBride and Leow¹⁰⁶ have modified the preparation of the intermediate 3-bromo-4-hydroxycinnoline (209) given in the literature¹⁰⁷ by combining the two steps, thus eliminating the unnecessary isolation of 4-hydroxycinnoline (208). This route therefore only required the development of the final step, *i.e.* the perchlorination of 3-bromo-4-chlorocinnoline (210).

o-aminoacetophenone (207) was diazotised with sodium nitrite in concentrated hydrochloric acid at 0°C and subsequently heated at 60°C to yield crude 4-hydroxycinnoline (208)¹⁰⁸, which upon bromination in aqueous sodium hydroxide gave a 77% overall yield of crude 3-bromo-4-hydroxycinnoline (209). 3-bromo-4-chlorocinnoline (210) was obtained in 89% crude yield by refluxing (209) in

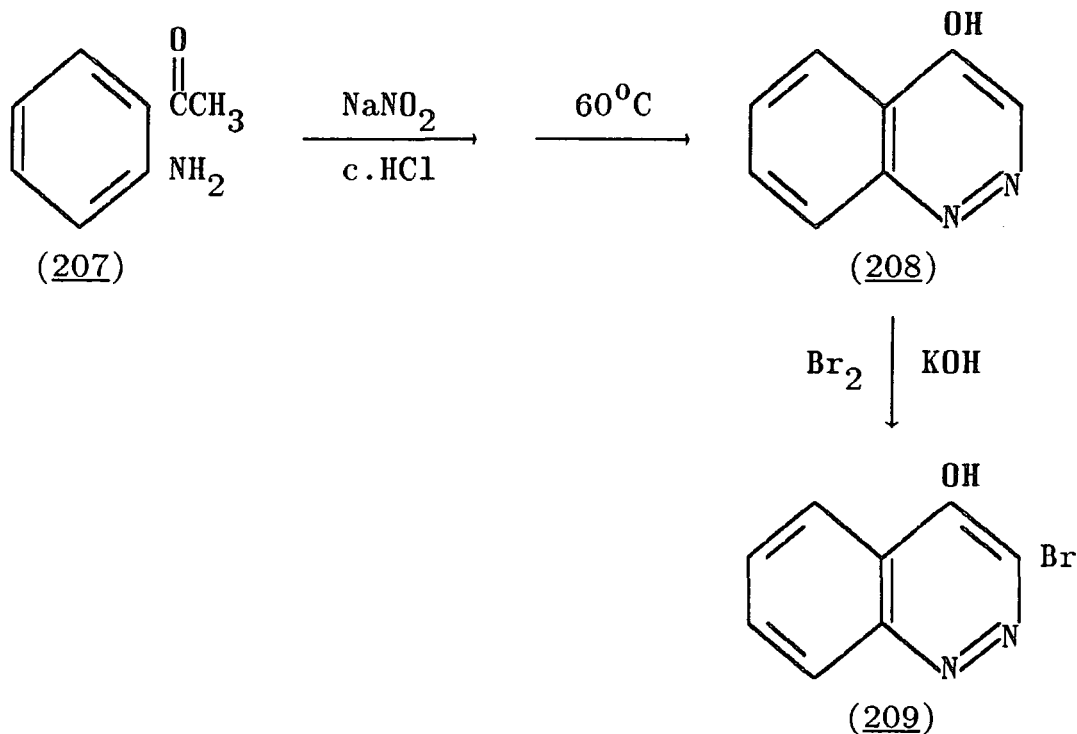

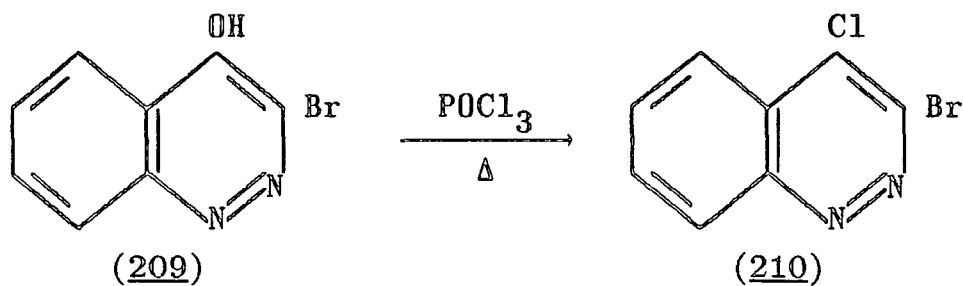

phosphorus oxychloride for a short period of time¹⁰⁹. One of the practical advantages of this route to hexachlorocinnoline (78) is that each step to the precursor, 3-bromo-4-chlorocinnoline (210), uses crude material from the previous step without further purification.

Initial attempts to chlorinate 3-bromo-4-chlorocinnoline (210) on a small scale used an intimate mixture crude (210) and phosphorus pentachloride in an autoclave. However, various reactions at temperatures of 200 - 350°C gave only mixtures of partially-chlorinated cinnolines.

However, hexachlorocinnoline (78) was eventually successfully prepared in moderate yields using the "Swamping Catalyst" technique of elemental chlorine and aluminium trichloride. This method usually involves heating a mixture of the partially halogenated precursor and aluminium trichloride in a stream of chlorine gas. However, this is no longer a practical laboratory procedure for large scale reactions employing several hundred grams of chlorine, due to the problem of adequate disposal of the large excess of chlorine. Hence we have developed a modification of this "Swamping Catalyst" technique as a static chlorination method under pressure in an autoclave. A mixture of 3-bromo-4-chlorocinnoline (210), aluminium trichloride and chlorine

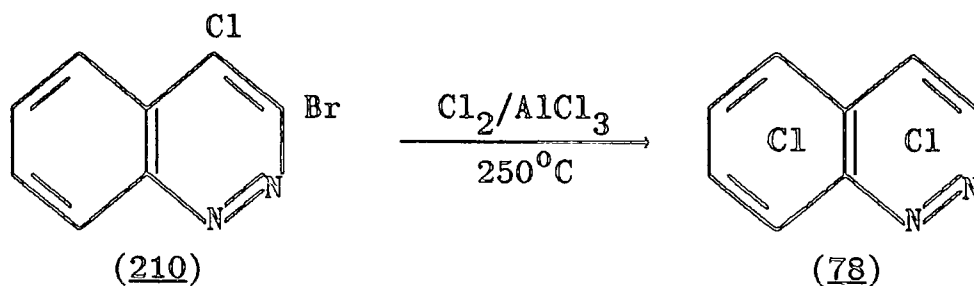

were heated in a nickel-lined autoclave at 250°C for 34 - 46hr. The reaction was carried out on several scales, using between 4 - 50g of the precursor (210), and in each case gave a moderate yield (45 - 52%) of hexachlorocinnoline (78). These reactions are summarised in the experimental section (see 15.A.2, Table 15.1). An investigation was made into increasing the yield of (78) from this chlorination reaction. Firstly, it was noted that there was negligible recovery of starting material on work-up, thus indicating that the problem was not one of incomplete reaction. Secondly, as discussed in Chapter One (1.B.1), the "Swamping Catalyst" chlorination method is believed to proceed *via* a 1:1 complex between the substrate and aluminium trichloride. These complexes are known to be more soluble in water than in chloroform³, and hence the existence of such a complex between hexachlorocinnoline (78) and aluminium trichloride, which would remain in the aqueous layer upon work-up, may explain the low isolated yields of (78). However, the previous preparation of hexachlorocinnoline (78)^{104,111} (see Scheme 7.1) employed an identical isolation procedure, giving 64 - 73% yields of (78), implying that the possible formation of a complex is not responsible for the size of the yields we obtained from the perchlorination step. Our

early large scale chlorinations were carried out using between seven and ten equivalents of aluminium trichloride, quantities which we subsequently considered to be excessive. However, a further large scale chlorination of (210) employing three equivalents of aluminium trichloride gave a 61% yield of hexachlorocinnoline (78), which was not significantly larger than those from the previous reactions with larger excesses of aluminium trichloride. Furthermore, a quantity of an unidentified gelatinous by-product was always produced, and it was thought that this may result from the presence of bromine in the system, generated from the 3-bromo-4-chlorocinnoline (210) precursor, which was poisoning the aluminium trichloride "catalyst". The obvious solution to this problem was to employ 3,4-dichlorocinnoline (211) as the precursor, which is prepared in good yield from a more vigorous chlorination of 3-bromo-4-hydroxycinnoline (209)¹¹⁰. However, large scale chlorination of (211) with chlorine and two equivalents of aluminium trichloride gave only a moderate yield (43%) of hexachlorocinnoline (78), although the quantity of the gelatinous by-product obtained was now negligible. We subsequently discovered during our attempts to fluorinate hexachlorocinnoline (78) (see 7.C.4) that significant decomposition of (78) occurs at

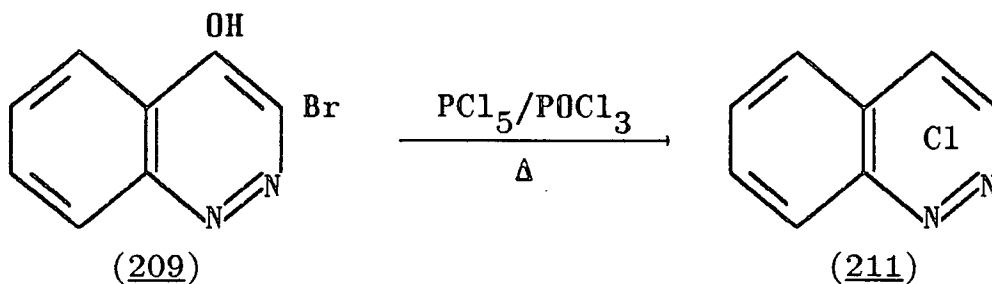

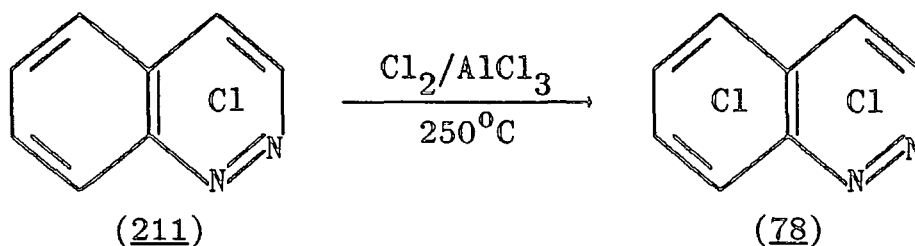

temperatures of 150°C and above. This is presumed to be the cause of the moderate yields of (78) from the chlorination of both 3-bromo-4-chlorocinnoline (210) and 3,4-dichlorocinnoline (211) at 250°C . However, attempted chlorinations of (211) at lower temperatures ($100 - 150^\circ\text{C}$), or for shorter periods of time, gave only mixtures of partially-chlorinated cinnolines.

It is concluded that 250°C for 48hr are the optimum conditions for the successful chlorination, and that it is not possible to significantly increase the yield of hexachlorocinnoline (78) from this reaction. However, our synthetic route to hexachlorocinnoline (78) gives a 42% overall yield of (78) from the initial precursor (*cf.* 7% for the previous route to (78)) and furthermore enables relatively large quantities of hexachlorocinnoline (78) to be prepared.

7.C Attempted fluorinations of hexachlorocinnoline

1. Introduction

The fluorination of hexachlorocinnoline (78) was previously attempted by Dr. J. A. H. MacBride using the static fluorination method developed in our laboratories (see 1.B.2). However, these fluorinations of (78) with

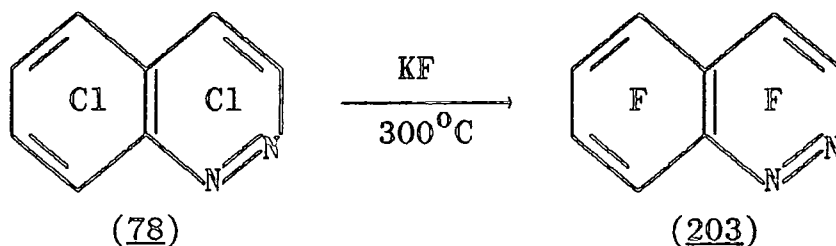

potassium fluoride in an autoclave at elevated temperatures were not very reproducible, giving at best only very low yields (7 - 15%) of hexafluorocinnoline (203) from mixtures containing mainly the tetra- and penta-fluoro derivatives¹¹¹. Furthermore, the overall recovery of fluorinated material from these reactions was also very low, contrasting with the fluorinations of the other perchlorobenzodiazines (see 1.B.2), which gave moderate to good yields of the corresponding perfluorinated derivatives. This presumably results from the lower thermal stability of hexachlorocinnoline (78) with respect to elimination of nitrogen and subsequent decomposition (see later).

2. Static

The fluorination of hexachlorocinnoline (78) with dry potassium fluoride in an autoclave at elevated temperatures was reinvestigated systematically. Several fluorinations were attempted at different temperatures, and with varying reaction periods at each temperature. The results of these fluorinations are given in detail in the experimental section (see 15.B.1, Table 15.2), which shows that only low recoveries of fluorinated materials were obtained. These product mixtures contained mainly the tetra- and penta-

fluorocinnolines, but in a few cases a small amount of hexafluorocinnoline (203) was also obtained. However, the products from these fluorinations were not characterised directly, but their identities were inferred from the ^{19}F n.m.r. and mass spectra of the mixtures, which revealed the presence of the corresponding 4-hydroxy derivatives of each compound. This is consistent with the previous observation that both hexafluoro- (203) and 5-chloropentafluorocinnoline (212) reacted rapidly with atmospheric moisture to give the 4-hydroxy derivatives (213) and (214) respectively^{104,111}.

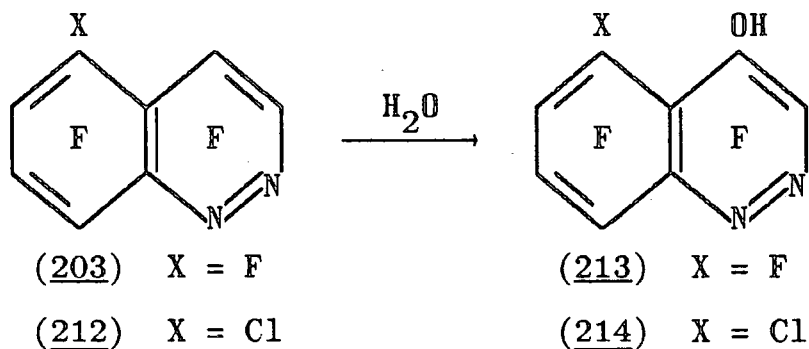

This apparently ready hydrolysis of the products most likely occurred during the isolation procedure, which is surprising since the work-up is carried out under high vacuum, with the cold-trap subsequently let down to an atmosphere of dry nitrogen. However, all our attempts to rigorously exclude moisture from the system, which included additional vacuum-drying of the potassium fluoride prior to the reaction, and handling the products under a dry nitrogen blanket after work-up, failed to prevent the hydrolysis occurring. However, this problem did not detract from the fact that, in our hands, this fluorination still only gave extremely low yields (5 - 15%) of hexafluorocinnoline (203).

This supports our earlier suggestion that the low recovery of fluorinated materials obtained from this procedure results from the decomposition of hexachlorocinnoline (78), or indeed hexafluorocinnoline (203), under the reaction conditions. Therefore, the use of fluorination methods in which the likelihood of such decomposition is reduced may give increased yields of the perfluoro compound.

3. Vapour-phase

The low yields of fluorinated cinnolines obtained from the static fluorination method described in the preceding section (7.C.2) were attributed to the decomposition of the starting material under the reaction conditions. Similar problems were also encountered during attempts to perfluorinate both trichloro-1,2,3-⁵⁹ and -1,2,4-triazine¹⁹ in a sealed system (see 1.B.2). The perfluoro derivatives of these triazines were successfully prepared in good yields using a vapour-phase flow fluorination technique²³. This only allows a very short contact time between the potassium fluoride and perchloroheteroaromatic, thus reducing the possibility of nitrogen elimination and subsequent decomposition of the starting material. Our application of this technique to the fluorination of trichloro-1,2,3-triazine (20) is described in Chapter Two (2.B.2).

This method therefore appeared to be ideal for the fluorination of hexachlorocinnoline (78). However, all our attempts to fluorinate (78) using this method at temperatures between 400 and 600°C gave only low recoveries

of material, which were complex mixtures of products. Furthermore, the ^{19}F n.m.r. and mass spectra indicated that both varying degrees of fluorination and decomposition of hexachlorocinnoline (78) had occurred. This method was not investigated further.

4. Solution

In Chapter Three (3.C) we described the development of a solution fluorination system employing a dialkyl ether and sulpholane as co-solvents with potassium fluoride. This system was able to completely fluorinate the very reactive perchlorotriazines under very mild conditions, and gave partial fluorinations of the less reactive perchlorodiazines at higher temperatures. The static and vapour-phase fluorination methods discussed in the preceding sections were both unsuitable for producing sizeable yields of hexafluorocinnoline (203) due to the decomposition of the starting material at the elevated temperatures necessary for these methods. It was hoped that the solution fluorination method would allow the preparation of hexafluorocinnoline (203) without the competing decomposition of the starting material.

The fluorination of hexachlorocinnoline with this method was investigated in a systematic manner by starting with the mildest reaction conditions, and then gradually increasing the severity of the conditions as required.

A solution of hexachlorocinnoline (78) in diethyl ether was stirred with potassium fluoride in sulpholane at room

temperature for several days, but gave no evidence of fluorination, and with a good recovery of starting material. Furthermore, increasing the reaction temperature to 45°C also did not yield any fluorinated products.

The next step was to employ di-n-butyl ether as the co-solvent, thus enabling temperatures of up to 150°C to be used. However, several fluorinations with these conditions, using both potassium and caesium fluorides, gave no evidence for fluorinated products, even after prolonged heating.

We had observed from a preliminary experiment that heating a mixture of pentachloropyridine (143), diethyl ether, sulpholane and potassium fluoride in a steel tube at 150°C on the rocking autoclave gave a mixture of partially fluorinated pyridines, with the 2,4,6-trifluoro derivative (144) as the major product. This result prompted us to attempt the fluorination of hexachlorocinnoline (78) under these conditions.

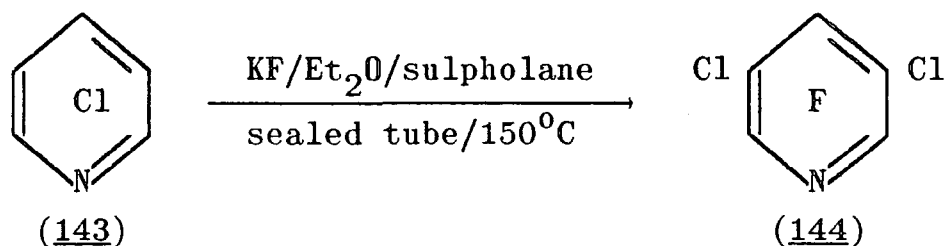

A mixture of hexachlorocinnoline (78), potassium fluoride, diethyl ether and sulpholane was heated in a steel tube at 150°C for 72hr with agitation in the rocking autoclave. The g.l.c. of the diethyl ether layer indicated only one product, which was identified by m.s.-g.l.c. as a tetrafluorodichlorocinnoline. The structure of the product

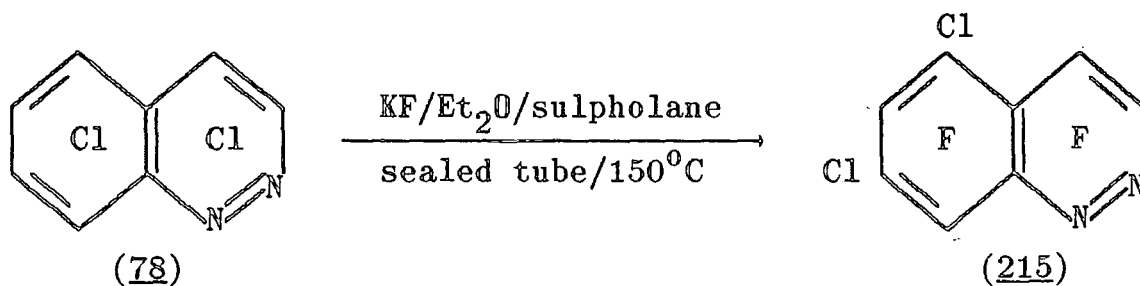

was assigned as the tetrafluoro derivative (215) from the ^{19}F n.m.r. spectrum of the diethyl ether solution which gave four resonances at -102.8 (6F), -107 (8F) and -141.3 ppm (4F). Surprisingly, compared to the fluorocinnolines obtained from the autoclave fluorinations (see 7.C.2), which underwent hydrolysis readily, 5,7-dichlorotetrafluorocinnoline (215) was relatively stable with respect to hydrolysis in the diethyl ether solution, and was characterised directly. However, allowing the solution of (215) to stand for several days resulted in the hydrolysis of (215) to the 4-hydroxy derivative (216), also identified from the ^{19}F n.m.r. of the solution, which showed three singlet resonances at -105.9 (3F), -120.3 (8F) and -129.7 ppm (6F). Similarly, all attempts to isolate the tetrafluoro compound (215) by removal of the solvent gave immediate hydrolysis to (216), even with stringent attempts to exclude moisture from the system. Crude estimates from g.l.c. indicated that the conversion of hexachlorocinnoline (78) to (215) by this fluorination method was very low. A

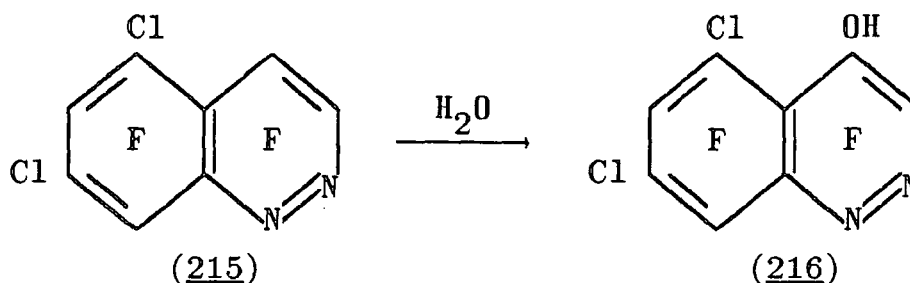

possible reason for this could be that some of the starting material decomposes under the reaction conditions, and this was probed by carrying out a blank reaction without the potassium fluoride. Only 75% of the starting material was recovered, which even allowing for material losses during the isolation procedure, clearly indicated that some decomposition of hexachlorocinnoline (78) occurs in a sealed system at 150°C. This explains why the moderate yields obtained from the preparations of hexachlorocinnoline (see 7.B) could not be increased, and also why the recoveries of fluorinated materials from the autoclave fluorinations (see 7.C.2) were low. However, repeating the sealed tube fluorination of (78) at a lower temperature (100°C) gave only a very small degree of fluorination.

We conclude that although the autoclave fluorinations did produce very low yields of hexafluorocinnoline (203), the extremely rapid hydrolysis of this compound during various work-up procedures prevented its isolation. Furthermore, significant decomposition of hexachlorocinnoline (78) occurs in a sealed system at temperatures above 150°C. Several alternative fluorination methods were investigated, but gave, at best, only partially fluorinated cinnolines.

7.D Attempted polyfluoroalkylations of halocinnolines

1. Introduction

As discussed at the beginning of this Chapter (7.A), the major objective of this investigation into the

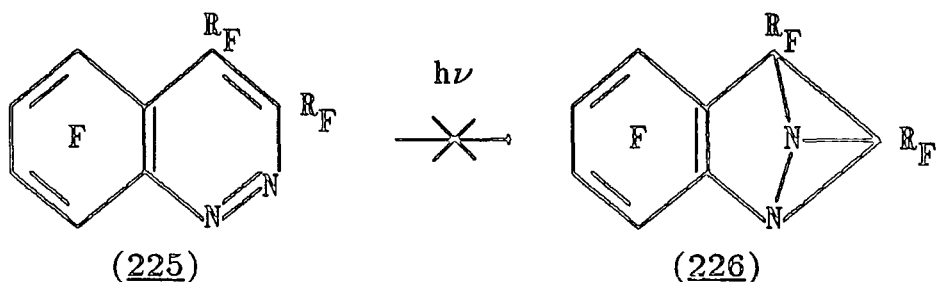

fluorinated cinnoline ring system was to prepare the 3,4-bis-perfluoroisopropyl derivative (225), with the aim of isolating the benzodiazabenzvalene (226) from photolysis experiments. A hexafluorobenzodiazabenzvalene (204) was postulated as the intermediate which most easily explained the photochemical isomerisation of hexafluorocinnoline (203) to hexafluoroquinazoline (25)¹⁰⁴ (see 7.A).

We had hoped to be able to polyfluoroalkylate hexafluorocinnoline (203) directly, but our failure to obtain this compound prompted our attempts to polyfluoroalkylate hexachlorocinnoline (78). However, there are no reports of any successful polyfluoroalkylations of perchloro-aza- and -diaz-naphthalenes, or of nonachloro-acridine³ in the literature, and indeed, the only perchloro-heteroaromatics which have been polyfluoroalkylated directly are the very reactive perchlorotriazines (see 3.B).

2. Hexachlorocinnoline

Our initial attempts to polyfluoroalkylate hexachlorocinnoline (78) employed the solvent system which we developed for the successful polyfluoroalkylation of trichloro-1,2,3-triazine (see 3.B.1).

The reaction of (78) with hexafluoropropene and caesium fluoride in diethyl ether and sulpholane at room temperature gave mainly a mixture of hexafluoropropene oligomers, although trace quantities of possible perfluoroisopropyl derivatives were detected by m.s.-g.l.c. However, repeating the reaction for a longer time or at 40°C did not increase the proportions of these derivatives in the product mixture.

As discussed previously in Chapter Two (2.B.3), one problem with this type of polyfluoroalkylation reaction is that the competing oligomerisation of the perfluoroalkene occurs much more easily than attack of the perfluoroisopropyl anion on the aromatic system. A possible solution to this problem would be to generate the perfluoroisopropyl anions directly in solution by displacing them from a suitable precursor with fluoride ion. The absence of hexafluoropropene from the system should eliminate the competing oligomerisation process, and hence would greatly favour the polyfluoroalkylation of the heteroaromatic. A preliminary experiment⁹⁵ indicated that perfluoro-tris-isopropyl-1,3,5-triazine (84) was capable of acting as such a perfluoroisopropyl anion source, which is consistent with the known reversibility of the polyfluoroalkylation process

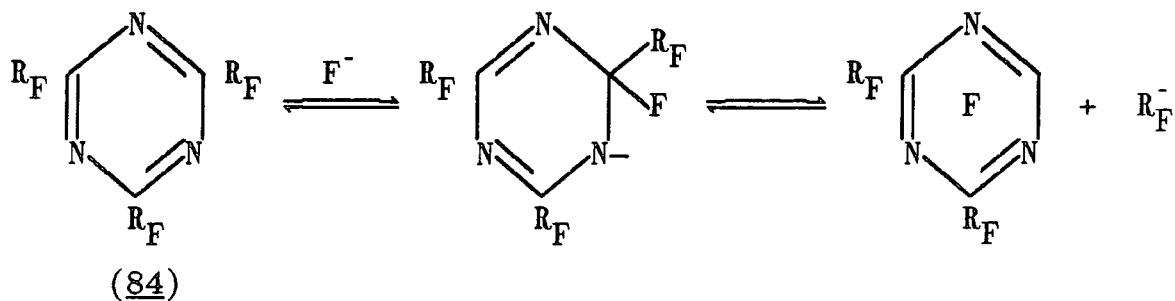

(see 1.C.2). The perfluoro-tris-isopropyl-1,3,5-triazine (84) was generated *in situ* in solution using the polyfluoroalkylation method described in Chapter Three (3.B.2) with potassium fluoride in diethyl ether and sulpholane, and then a solution of hexachlorocinnoline (78) in diethyl ether, together with a quantity of caesium fluoride, were added. However, there was no evidence for polyfluoroalkylation of (78) from several reactions carried out at either room temperature or on heating at 40°C. Furthermore, removal of the diethyl ether after addition of the hexachlorocinnoline (78) and then heating at 100°C also did not result in the successful polyfluoroalkylation of (78). We have shown that the polyfluoroalkylation of the perchlorotriazines proceeds *via* initial fluorination of the heteroaromatic (see 3.B and 3.C.1). The failure to polyfluoroalkylate hexachlorocinnoline (78) under the conditions employed is therefore presumably due to the inability of (78) to undergo even partial fluorination under these conditions, a fact we established earlier in this Chapter (see 7.C.4).

3. 5,7-dichlorotetrafluorocinnoline

Earlier in this Chapter (7.C.4), we described the preparation of 5,7-dichlorotetrafluorocinnoline (215) from the fluorination of hexachlorocinnoline (78) in a sealed tube. Our failures to directly polyfluoroalkylate hexachlorocinnoline (78) prompted us to attempt the analogous polyfluoroalkylations of (215), which should be

more reactive towards nucleophilic aromatic substitution than (78).

However, reaction of the diethyl ether solution of (215) with hexafluoropropene and caesium fluoride in sulpholane gave only hexafluoropropene oligomers and the 4-hydroxy derivative (216) of the starting material (215). Similarly, several perfluoroisopropyl exchange reactions between (215) and perfluoro-tris-isopropyl-1,3,5-triazine (84) attempted under various conditions were also unsuccessful.

7.E Other attempted reactions of hexachlorocinnoline

1. Nucleophilic aromatic substitution

There are no reports of any nucleophilic aromatic substitution reactions of polyhalocinnolines in the literature. A consideration of the relative activating and orientating effects of both the ring nitrogens and chlorine substituents (see 1.C.1) indicates that the order of substitution by nucleophiles on the various positions of hexachlorocinnoline (78) should be 4- > 3- >> benzenoid ring positions, controlled principally by the ring nitrogens. This is supported by the structures of the hydrolysis products from the fluorinated cinnolines (see 7.C.2 and

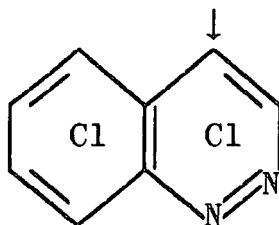

(78)

7.C.4), in which the fluorine at the most reactive 4-position was displaced by the nucleophile.

In this section, some attempted nucleophilic aromatic substitution reactions of hexachlorocinnoline (78) with sodium methoxide are described.

a) With sodium methoxide

Some methoxy-substituted derivatives of heptachloroquinoline and -isoquinoline were prepared by a previous worker in our laboratories, R. Daniels³, in an attempt to aid the unambiguous assignment of the ¹³C n.m.r. spectra of the parent perchloro compounds.

In Chapter Nine (9.C.3) we describe our attempts to assign the ¹³C n.m.r. spectrum of hexachlorocinnoline (78). This assignment would also be greatly aided by the availability of methoxy-derivatives with known positions of substitution. Our aim was thus to prepare several methoxy-substituted derivatives of hexachlorocinnoline (78).

The reaction of a suspension of hexachlorocinnoline (78) in methanol with one equivalent of sodium methoxide at room temperature gave a solid product on work-up, which was shown by t.l.c to be a mixture of the starting material (78) and a single product. The ¹H n.m.r. of the mixture showed only a singlet resonance at 4.1 ppm, which indicated a mono-substituted derivative, assigned tentatively as 4-methoxy-pentachlorocinnoline (217). This assignment is based on our earlier suggestion (see 7.E.1) that the 4-position in (78) is the most reactive towards nucleophilic substitution.

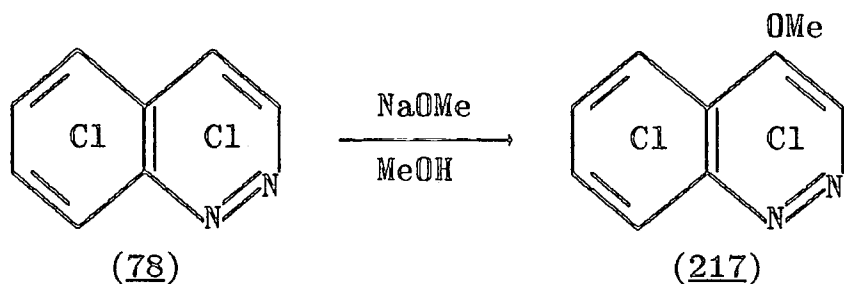

However, it was not possible to sufficiently purify this product (217) by recrystallisation from various solvents to obtain satisfactory analysis. Other attempts to isolate pure material by either column chromatography or vacuum sublimation were also unsuccessful.

The reaction of a suspension of hexachlorocinnoline (78) in methanol with two equivalents of sodium methoxide at room temperature gave a multi-component solid product, which t.l.c. indicated contained both the starting material and the mono-methoxy derivative (217), together with several other unidentified components. A repeat the reaction in refluxing methanol also gave a similar multi-component product. All attempts to isolate pure material from these mixtures by either recrystallisation, column chromatography, or vacuum sublimation were unsuccessful.

Our inability to isolate pure samples of the methoxy-derivatives may result from the extremely poor solubilities of these compounds in the various solvents. This problem of the low solubility of polychlorinated aromatic compounds in a wide range of common organic solvents has always severely hampered investigations into the chemistry of these systems^{2,3}.

2. Photolysis

Hexafluorocinnoline (203) was reported to isomerise to hexafluoroquinazoline (25) on photolysis¹⁰⁴. However, the photolysis of hexachlorocinnoline (78) at both 254nm and 366nm in the vapour-phase and 254nm in solution gave complete recovery of starting material in each case.

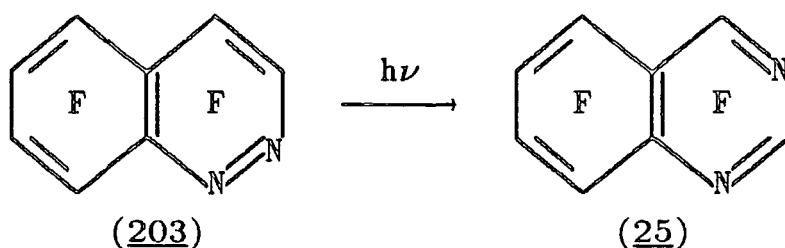

3. Attempted N-oxidation

Perchloro-N-heterocycles are much less basic than the corresponding hydrocarbon analogues due to the electron-withdrawing effects of the chlorine substituents. However, the basicity of the ring nitrogen is also expected to increase with the decreasing number of *ortho* chlorines³. Hexachlorocinnoline (78) should therefore be more basic than the other perchloro aza- and diaza-naphthalenes, as it has only one chlorine *ortho* to the ring nitrogens. Hence (78) should be the most favourable of these systems to study in an attempt to form the corresponding N-oxide, a process which requires a basic nitrogen atom. Some years ago, a reagent system which allowed the successful N-oxidation of weakly basic chlorinated N-heterocycles, such as pentachloropyridine (143), under relatively mild conditions was reported in the literature¹¹².

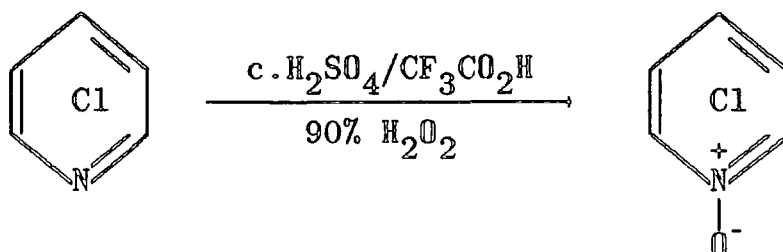

(143)

However, the attempted N-oxidation of hexachlorocinnoline (78) in a mixture of concentrated sulphuric acid and trifluoroacetic acid with 60% hydrogen peroxide at both room temperature and at 100°C gave only recovered starting material in each case.

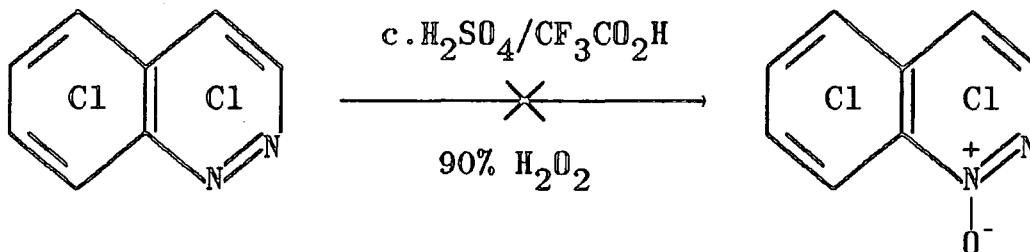

(78)

To conclude, our attempts to prepare various derivatives of hexachlorocinnoline (78) have generally proved unsuccessful, in most cases for reasons which are not immediately apparent. The reactions between (78) and sodium methoxide did give tentative evidence for the formation of methoxy-substituted derivatives, but these could not be isolated pure because of their extremely poor solubilities in all the usual organic solvents.

CHAPTER EIGHTNEGATIVE ION MASS SPECTRA OF SOME HALOGENATED AND
PERFLUOROALKYL-DIAZINES AND -1,2,3-TRIAZINES8.A Introduction

Negative ion mass spectrometry (CI-) is still a relatively new technique in mass spectrometry, when compared to the electron impact (EI+) and chemical ionisation (CI+) modes, and as such its potential use as a tool in the structure determination of organic molecules has not yet been fully explored.

There are very little data available in the literature on the CI- spectra of fluorinated organic compounds¹¹³ in general, and particularly of fluorinated aromatics and heteroaromatics¹¹⁴.

For negative ion mass spectrometry to be useful for the structure determination of organic molecules, it would be advantageous to be able to generate long-lived molecular anions in the mass spectrometer. The various structural requirements for the production of long-lived molecular anions have been reviewed¹¹⁵, and the molecular anion lifetimes of a series of nitro- and halo-substituted benzenes have been measured, and explained in terms of their electronic and molecular structures¹¹⁴. The CI- spectra of a series of substituted pentafluorophenyl compounds have also been reported¹⁰³.

The availability of series of halogenated and

perfluoroalkyl-heteroaromatics of known structures coupled with the lack of data on the Cl^- spectra of heteroaromatics in the literature prompted this investigation.

After an introduction to the technique of negative ion mass spectrometry, the results of the investigation into the Cl^- spectra of the series of pyridazines, pyrazines and 1,2,3-triazines will be discussed.

8.B Negative ion mass spectrometry^{115,116}

1. Formation of negative ions

The prerequisite for the formation of molecular negative ions detectable by mass spectrometry is the process of electron attachment (8.1). This electron attachment

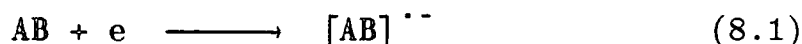

process is only possible when $E_a(\text{AB}) > 0$, where E_a is the electron affinity of the neutral molecule (AB). There are two types of electron attachment, depending upon the energy of the electrons; non-dissociative and dissociative.

Non-dissociative attachment (8.1) occurs at electron energies from 0 to a maximum of 2 eV, *i.e.* very low energy thermal or epithermal electrons. If the species $[\text{AB}]^{\cdot -}$ is not deactivated by radiative emission of its excess energy, or through collisions with other molecules, it can lose the electron again (autoionisation). This process occurs very rapidly in small molecules ($\approx 10^{-13}$ s), whereas in larger molecules, where the excess energy may be distributed over many internal degrees of freedom, the process occurs slowly enough ($> 10^{-6}$ s) for the anion $[\text{AB}]^{\cdot -}$ be detected in the

mass spectrometer.

Dissociative electron attachment occurs when, during electron attachment, the molecular anion $[AB]^{*-}$ possesses sufficient excess energy to cause its spontaneous dissociation (8.2). The negative charge will remain on the

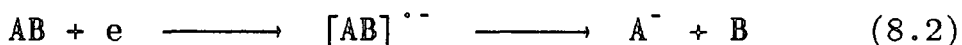

fragment with the greater E_a , *i.e.* for (8.2), $E_a(A) > E_a(B)$.

This process occurs for electron energies of between 2 and 15 eV. Clearly, to maximise the formation of molecular negative ions with minimal fragmentation, *i.e.* non-dissociative electron attachment, low energy thermal electrons are required. However, the direct production of primary electrons with such low energies is not practical in the mass spectrometer, but this problem has been overcome¹¹⁶ by employing a buffer gas, usually either isobutane, methane, argon or nitrogen, to moderate the energies of conventionally generated high energy (70 eV) primary electrons. The primary electrons (e_p) ionise the buffer gas (G) (8.3a) producing the required secondary thermal electrons (e_s), which can then undergo non-dissociative electron attachment to the neutral molecule (AB) (8.3b).

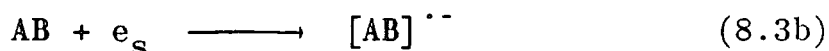
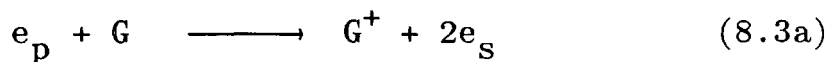

It should be stressed that these secondary thermal electrons are not monoenergetic, but by the nature of their formation will have a distribution of energies centred upon thermal energy values.

2. The stability of negative molecular ions

The essential requirement for the production of long-lived molecular ions is the presence of a low-lying unoccupied molecular orbital in the molecule, which can accept an electron¹¹⁵. This explains why alkanes, for example, cannot form stable molecular anions. Various studies have shown that intense molecular anions can be expected when, after electron attachment, the anion can be stabilised through resonance *via* a π -system. Examples of this include quinones¹¹⁷ (8.4) and nitro-substituted benzenes¹¹⁴ (8.5). These molecules capture thermal electrons

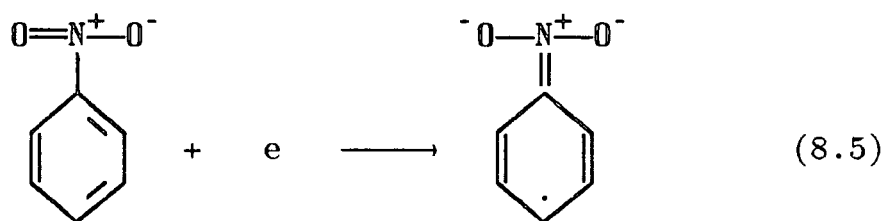
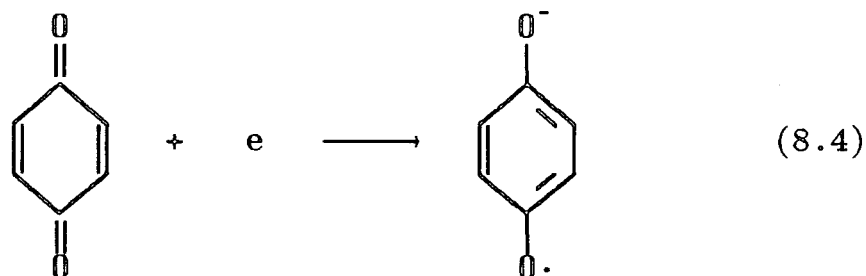

very efficiently and form long-lived molecular anions, unless the dissociative electron attachment process, which is usually very much faster, competes with molecular anion formation. This is supported by measurements of their autoionisation times¹¹⁴. Many results suggest that the electron is accommodated in a delocalised π -orbital over the entire molecule in these long-lived molecular anions, and highly electron-withdrawing substituents, such as $-\text{NO}_2$, $-\text{CN}$

and -CHO provide additional stabilisation by lowering the energy of the benzene ring due to charge migration from the ring to the substituent (the $-I_{\sigma}$ effect).

It is interesting to note that benzene, pyridine, pyridazine, pyrimidine and pyrazine did not give stable molecular anions in their CI- spectra¹¹⁴.

a) Fluorine substitution

Multiple fluorine substitution would be expected to give a more stable molecular anion than the unsubstituted derivative by further lowering of the energy of the π -electron state in which the electron is captured (increasing the E_a of the molecule). This is supported by the reported E_a values and autoionisation times of a series of benzenes with varying degrees of fluorine substitution¹¹⁸. Long-lived molecular anions from a series of substituted pentafluorophenyl compounds have also been reported¹⁰³, with their autoionisation times being significantly greater than the corresponding hydrocarbon analogues¹¹⁴. The strong C-F bond allows multiple fluorinated benzenes to form long-lived molecular anions by making the competing dissociative electron attachment process not energetically possible at thermal electron energies. Weaker C-Cl bonds, however, allow dissociative electron attachment to occur, and hence no long-lived molecular ions are formed.

3. Fragment formation

Some rules governing the fragmentation of negative ions

have been formulated^{119,120}, and are discussed in detail in a review¹¹⁵. They are briefly summarised here:

- i) In EI+ mass spectroscopy each fragment can carry the charge, whereas in CI- mass spectroscopy the ability to carry the charge depends upon the fragment possessing a positive E_a .
- ii) The probability of fragment anion formation roughly parallels the E_a of the uncharged species; for example, very intense Hal^- ions are often observed.
- iii) As autoionisation competes with fragment formation, rapid decay reactions involving simple bond cleavages are preferred over more complex fragmentation patterns involving rearrangements.

It should therefore be possible to find simple correlations which relate the structures of fragment ions with that of the parent molecule, and for compounds forming stable molecular anions, fragment ions specific to its structure can be expected.

8.C Halogenated pyridazines

The principal ions observed in the CI- spectra of the series of halogenated and perfluoroalkyl-substituted pyridazines are summarised in Table 8.1 together with their respective percentage intensities relative to the base peak.

The CI- spectrum of tetrachloropyridazine (3) showed a low intensity molecular ion, with more intense fragment ions corresponding to the $[\text{Cl}_2]^-$ and $[\text{Cl}]^-$ species. This is consistent with dissociative electron attachment resulting

Table 8.1 Principal ions in the negative ion mass spectra of halogenated and perfluoroalkyl-pyridazines

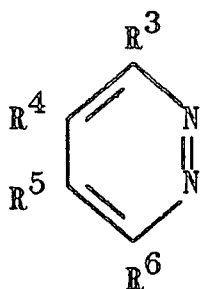

$R^3 =$	C1	F	F	F	F	R_F^1	R_F^1
$R^4 =$	C1	F	R_F^1	R_F^2	R_F^1	F	R_F^1
$R^5 =$	C1	F	F	F	R_F^1	R_F^1	F
$R^6 =$	C1	F	F	F	F	F	R_F^1
	(3) ^a	(21)	(160)	(169) ^b	(60) ^c	(55) ^d	(159) ^e
Ions	% base peak						
$[M]^{--}$	12	100	100	-	5	100	30
$[M - 2F]^{--}$	-	1	16	-	98	28	39
$[M - CF_3]^-$	-	-	7	22	21	2	2
$[M - C_3F_7]^-$	-	-	-	100	100	1	100

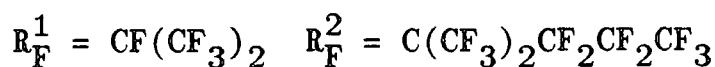

Other ions: ^a $[Cl_2]^{--}$, 100%; $[Cl]^-$, 59%
^b $[M - 133]^-$, 23%; $[M - C_3F_7, F]^{--}$, 11%
^c $[M - CF_3, 2F]^-$, 12%
^d $[M - N_2, CF_3]^-$, 12%
^e $[M - N_2, 2F]^{--}$, 15%; $[M - C_3F_7, 2F]^-$, 22%

from the ease of cleavage of the C-Cl bonds. In contrast, tetrafluoropyridazine (21) gave only a very intense molecular ion with no significant fragmentation. This reflects both the higher E_a of (21) and the greater strength of the C-F bonds, which results in a very stable molecular ion which cannot undergo fragmentation.

Similarly, perfluoro-4-isopropylpyridazine (160) also gave a high intensity molecular ion with a low intensity fragment ion resulting from loss of two fluorine atoms from (160). The lack of fragmentation observed for (21) under the same conditions suggests that the loss of fluorines occurs from the substituent perfluoroisopropyl group.

This $[M - 2F]^{--}$ ion is observed as a significant fragment ion in the CI- spectra of all the perfluoro-isopropylpyridazines investigated. The loss of the two fluorines from the isopropyl group to give a perfluoro-2'-propenyl group can be envisaged; this possesses a π -system capable of conjugation with the π -system of the hetero-aromatic to increase the degree of resonance stabilisation of the anion. Similar stabilisation of molecular ions was found for pentafluorophenyl compounds with $C\equiv N$ or $C=O$ containing substituents¹⁰³. This is supported by the observed CI- spectrum of perfluoro-4-(2'-propenyl)pyridazine

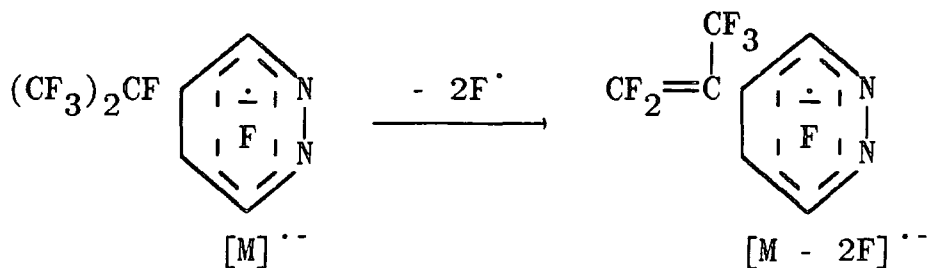

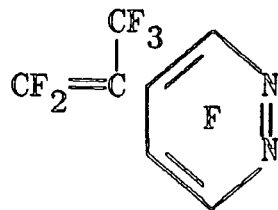

(202)

(202) which gave an intense molecular ion with only a small amount of fragmentation (see 6.D.2). In contrast to the 4-isopropyl derivative (160), perfluoro-4-(2'-methylpent-2'-yl)pyridazine (169) gave no stable $[M]^{+\cdot}$ or $[M - 2F]^{+\cdot}$ ions, but gave a low intensity fragment ion resulting from loss of CF_3^{\cdot} , and a very intense $[M - C_3F_7]^{-}$ ion. As discussed previously (see 8.B.3), fragmentation processes occurring at thermal electron energies tend to involve simple bond cleavages without rearrangement of the resulting fragment ion. It is therefore reasonable to suggest that the formation of the $[M - C_3F_7]^{-}$ ion results from the loss of the n-propyl fragment $CF_3CF_2CF_2^{\cdot}$ from the substituent *via* a simple C-C bond cleavage. The stability of the resulting

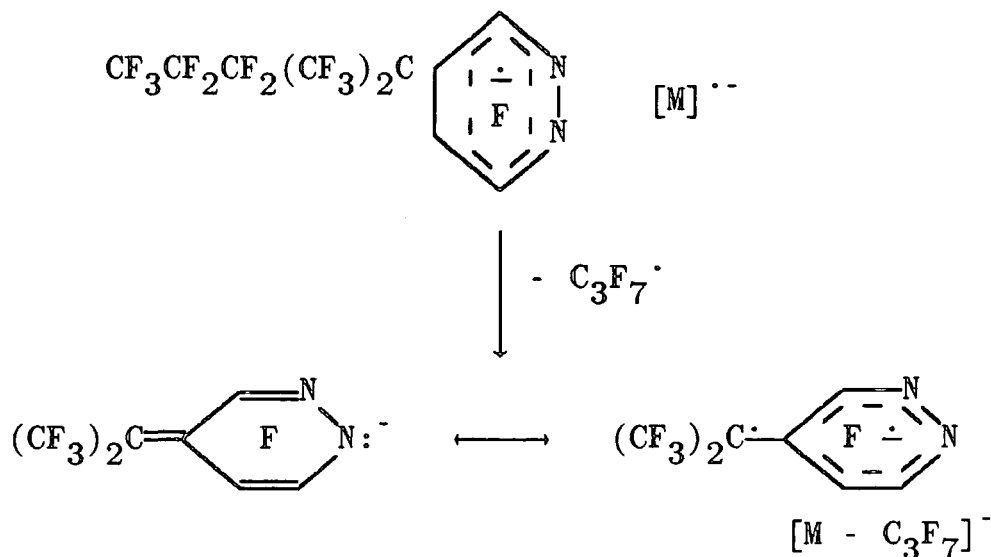

SCHEME 8.1

anion can be explained by resonance stabilisation *via* a *para*-quinoid type structure (Scheme 8.1).

An interesting contrast is provided by the CI- spectra of the two isomeric perfluoro-4,5-bis-isopropyl- and 3,5-bis-isopropylpyridazines (60) and (55). The 4,5-derivative (60) gave a very low intensity $[M]^{+\cdot}$ ion and very intense $[M - 2F]^{+\cdot}$ and $[M - C_3F_7]^{-}$ ions, whereas the 3,5-derivative (55) gave an intense molecular ion and a low intensity $[M - 2F]^{+\cdot}$ ion. The different spectra observed for these two compounds are clearly the result of their differing structures, with the 4,5-derivative preferring dissociative electron attachment, whereas the 3,5-derivative clearly prefers non-dissociative electron attachment.

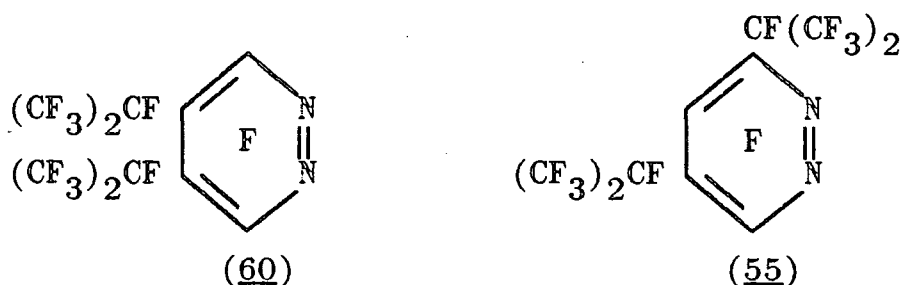

Perfluoro-3,4,6-tris-isopropylpyridazine (159) gave moderate intensity $[M]^{+\cdot}$ and $[M - 2F]^{+\cdot}$ ions and an intense $[M - C_3F_7]^{-}$ ion.

These results do not seem to reveal any general trends across the series of pyridazines investigated. Increasing the number of perfluoroisopropyl groups going across the series would be expected to significantly increase the corresponding E_a values of the pyridazines, due to their strong electron-withdrawing abilities (the $-I_\sigma$ effect), and so give increased molecular ion stabilities. However, this

is clearly not the case. All the perfluoroisopropylpyridazines gave significant $[M - 2F]^{-}$ ions, and those derivatives with two or more perfluoroisopropyl groups, or a larger perfluoroalkyl group, all gave intense $[M - C_3F_7]^{-}$ ions, with the exception of perfluoro-3,5-bis-isopropylpyridazine (55).

8.D Halogenated pyrazines

The principal ions observed in the CI- spectra of this series of compounds are summarised in Table 8.2. All of the pyrazines used for this investigation can be obtained in high yields from the photochemical rearrangement of the corresponding pyridazine derivative⁴⁵ (see 1.D.2), and indeed, all the perfluoroalkylpyrazines given in Table 8.2 were prepared in this manner. It is therefore interesting to notice that the CI- spectra of each of the pyrazines parallels that of the parent pyridazine from which it is derived, with the notable exception of tetrachloropyrazine (14). This contrasts markedly with tetrachloropyridazine (3) by giving an intense molecular ion and only one fragment ion corresponding to $[Cl]^{-}$. This does not fit in with the CI- spectra observed for all of the other chloro-diazines and -1,2,3-triazines investigated, which gave low intensity molecular ions and intense $[Cl_2]^{-}$ and $[Cl]^{-}$ fragment ions.

8.E Halogenated 1,2,3-triazines

The principal ions observed in the CI- spectra of the halogenated and perfluoroalkyl-substituted 1,2,3-triazines

Table 8.2 Principal ions in the negative ion mass spectra of halogenated and perfluoroalkyl-pyrazines

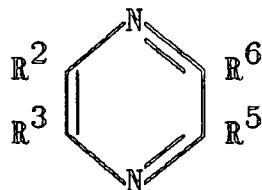

$R^2 =$	Cl	F	R_F^1	R_F^2	R_F^1	R_F^1
$R^3 =$	Cl	F	F	F	F	F
$R^5 =$	Cl	F	F	F	R_F^1	F
$R^6 =$	Cl	F	F	F	F	R_F^1
	(14) ^a	(23)	(218)	(195) ^b	(181)	(154)
Ions	% base peak					
$[M]^{--}$	82	100	100	-	64	100
$[M - 2F]^{--}$	-	-	8	-	3	16
$[M - CF_3]^-$	-	-	-	10	40	1
$[M - C_3F_7]^-$	-	-	-	100	100	16

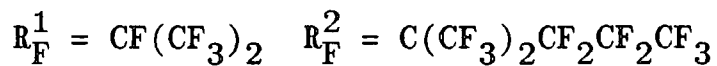

Other ions: ^a $[Cl]^-$, 38%

^b $[M - C_3F_7, F]^{--}$, 11%

are summarised in Table 8.3. All three chloro-substituted 1,2,3-triazines (20), (101) and (102) gave very low intensity molecular ions and intense $[\text{Cl}]^-$ fragment ions, and the di- and tri-chloro-1,2,3-triazines also gave moderate intensity $[\text{Cl}_2]^{--}$ ions. This can be explained in terms of dissociative electron attachment occurring with all three derivatives. There are slight increases in the intensities of the molecular ions on going from $\text{C}_3\text{N}_3\text{Cl}_3$ to $\text{C}_3\text{N}_3\text{ClF}_2$; this results from the increasing E_a values of the molecules on successive replacement of chlorine by fluorine. There are no significant fragment ions resulting from the loss of N_2 from the chloro-substituted derivatives; this contrasts with their EI+ spectra, which are characterised by moderate intensity fragment ions resulting from loss of N_2 from the parent molecular ion.

Trifluoro-1,2,3-triazine (28) also showed a low intensity molecular ion in its CI- spectrum, but also gave an intense $[\text{M} - \text{N}_2]^{--}$ ion. This contrasts sharply with the chloro-1,2,3-triazines. The low intensity $[\text{M}]^{--}$ ion is also a surprising feature of the CI- spectrum of (28), considering that the perfluorodiazines (21) and (23) both gave intense molecular ions with no fragmentation.

These observations may be explained in term of the relative bond energies and E_a values of the 1,2,3-triazine derivatives. The bond energies of C-Cl and C-N are very similar (339 *vs.* 305 kJ mol^{-1} respectively), and so the probabilities of fragmentation *via* cleavage of either a C-Cl or C-N bond are approximately equal. However, dissociative

Table 8.3 Principal ions in the negative ion mass spectra of halogenated and perfluoroalkyl-1,2,3-triazines

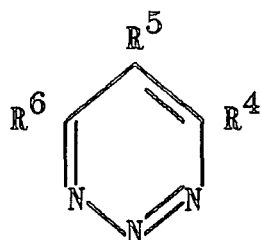

$R^4 =$	Cl	Cl	F	F	R_F	R_F
$R^5 =$	Cl	Cl	Cl	F	F	R_F
$R^6 =$	Cl	F	F	F	R_F	R_F
	(20)	(101)	(102)	(28)	(93) ^a	(98) ^b
Ions	% base peak					
$[M]^{--}$	1	2	7	6	7	9
$[Cl_2]^{--}$	43	13	-	-	-	-
$[Cl]^-$	100	100	100	-	-	-
$[M - N_2]^{--}$	-	2	1	100	-	-
$[M - 2F]^{--}$	-	-	-	-	28	5



Other ions: ^a $[M - N_2, 2F]^{--}$, 22%; $[M - N_2, CF_3]^-$, 17%;
 $[M - N_2, CF_3, 2F]^-$, 100%

^b $[M - N_2, CF_3, 2F]^-$, 12%; $[M - N_2, 2CF_3, 3F]^-$,
 48%; $[M - N_2, 2CF_3, 5F]^-$, 100%

electron attachment always occurs with the negative charge remaining on the fragment with the greater E_a . Chlorine has a much greater E_a than nitrogen, so the chloro-1,2,3-triazines fragment with the formation of very intense $[Cl]^-$ ions. For trifluoro-1,2,3-triazine (28) however, the C-F bond energy (485 kJ mol^{-1}) is much greater than the C-N bond energy, and hence in this case dissociation *via* loss of N_2 is preferred. This fragmentation pathway leaves the negative charge on the $[C_3F_3N]^-$ fragment, which will also have the greater E_a due to the highly electronegative fluorines.

The CI- spectra of the perfluoroisopropyl-1,2,3-triazines (93) and (98) both showed different fragmentation patterns to those of the halo-substituted derivatives. Perfluoro-4,6-bis-isopropyl-1,2,3-triazine (93) gave a very low intensity $[M]^-$ ion and an intense $[M - N_2, CF_3, 2F]^-$ ion. Low intensity fragment ions were also observed, corresponding to $[M - 2F]^-$, $[M - N_2, 2F]^-$ and $[M - N_2, CF_3]^-$ respectively. Most of the fragmentations involve loss of N_2 at some stage in the dissociation process; this is consistent with the similar N_2 loss from trifluoro-1,2,3-triazine (28). The CI- spectrum of perfluoro-tris-isopropyl-1,2,3-triazine (80) also showed a low intensity molecular ion with very intense and moderate intensity fragment ions,

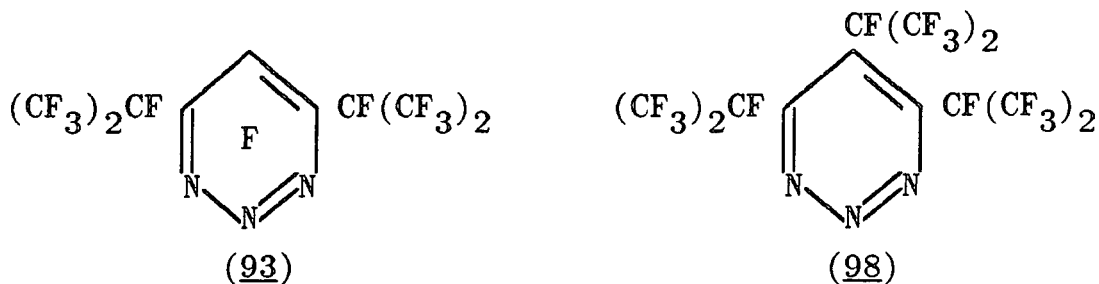

both resulting from multiple fragmentation of the triazine ring and the substituent perfluoroisopropyl groups. All these ions are also formed *via* loss of N_2 at some stage in the dissociation process. A somewhat surprising feature of the CI- spectra of the fluoro-1,2,3-triazines is that they do not give stable $[M]^{+-}$ ions and they very readily fragment *via* loss of N_2 . This N_2 loss is a characteristic fragmentation in the EI+ spectra of all the 1,2,3-triazines in Table 8.3, but at the very much lower electron energies involved for the production of CI- spectra (0 - 2 *vs.* 70 eV), the ease of N_2 extrusion from the 1,2,3-triazine ring serves to illustrate the very low thermal stabilities of these compounds.

CHAPTER NINE ^{13}C N.M.R. SPECTRA OF SOME HALOGENATED AND PERFLUOROALKYL-DIAZINES AND -1,2,3-TRIAZINES9.A Introduction

There are comparatively little data available in the literature on the ^{13}C n.m.r. spectra of halogenated and perfluoroalkyl-substituted heteroaromatics, although the spectra of a series of chlorofluoropyridines¹²¹ and various polyhalo-pyridines and -pyrimidines have been reported¹²².

This dearth of literature data and the availability of the series of halogenated and perfluoroalkyl-pyridazines and -1,2,3-triazines prompted this detailed investigation of the ^{13}C n.m.r. spectra of these compounds.

The spectra discussed were all obtained fluorine coupled, with this information used to unambiguously assign the majority of the ^{13}C n.m.r. resonances.

9.B Selected features of the spectra1. Halogenated pyridines

The detailed analysis of the ^{13}C n.m.r. spectra of these compounds described in the literature¹²¹ revealed that, for the ring carbons with fluorine substituents, a good correlation exists between the ^{13}C and ^{19}F chemical shifts of the 2-positions and the 3- and 4-positions. These data are summarised in Table 9.1, and indicates that the magnitude of the ^{19}F chemical shift value gives a better

Table 9.1 Ranges of ^{13}C and ^{19}F chemical shifts for some chlorofluoropyridines¹²¹

Ring N	^{13}C (ppm)	^{19}F (ppm)
<i>ortho</i>	144.3 → 155.8	-68.0 → -89.2
<i>meta, para</i>	134.3 → 164.8	-93.4 → -163.4

measure of the electron-density on the ring carbon than that of the ^{13}C chemical shift, as for both sets of positions the ranges of their ^{13}C chemical shift values are approximately the same, whereas the ^{19}F chemical shifts for the 2-positions are considerably lower than those for the 3- and 4-positions. This reflects the lower electron-density on the aromatic ring carbons at the 2-positions, *ortho* to ring nitrogen. Furthermore, a simple correlation is also found between the values of the $^1J_{\text{CF}}$ coupling constants and the ^{13}C chemical shifts of these ring carbons (Table 9.2), which also gives rise to two distinct ranges of values, depending

Table 9.2 Ranges of 1J values and ^{13}C chemical shifts for some chlorofluoropyridines¹²¹

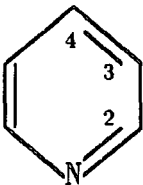
	$^1J_{\text{CF}}$	^{13}C (ppm)
2	240 - 249 Hz	144.3 → 155.8
3,4	260 - 270 Hz	134.3 → 164.8

upon the position of the ring carbon relative to ring nitrogen, with the magnitudes of these values being lowest for the carbons *ortho* to the ring nitrogen.

2. Halogenated pyridazines

In the previous section, it was indicated that a simple relationship existed between the ^{13}C and ^{19}F chemical shifts of fluoropyridines, which was dependent on the position of the ring carbon relative to the ring nitrogen. A similar analysis was applied to the fluoropyridazines, but the result obtained was not as straightforward as that for the pyridines. The values fall broadly into two ranges for the 3- and 4-positions, as would be expected, and are given in Table 9.3. The ^{13}C and ^{19}F chemical shifts for the 3-positions have only small ranges of values, and the lowest magnitude ^{19}F chemical shifts, this being consistent with these positions *ortho* to ring nitrogen, and so having the lowest electron-densities. The ^{13}C and ^{19}F chemical shifts for the 4-positions have a greater range of values than those for the 3-positions, but there is still a reasonable

Table 9.3 Ranges of ^{13}C and ^{19}F chemical shifts for fluoropyridazines

Pos.	^{13}C (ppm)	^{19}F (ppm)
3	159.0 → 163.5	-63.0 → -69.3
4	140.2 → 161.5	-100.0 → -144.9

correlation between them. However, there are three anomalous sets of values which do not fit into either of the series outlined above; these are for the 3-position of tetrafluoropyridazine (21) and the 6-positions of the 4-alkylpyridazines (160) and (169). These all have much larger ^{19}F chemical shifts, and hence greater electron-densities, than would be expected for carbons *ortho* to the ring nitrogen. In the case of the 4-alkylpyridazines (160) and (169), this clearly indicates that the substituent perfluoroalkyl group at the 4-position has a much greater effect on the ^{19}F chemical shift of the *ortho* fluorine at the 3-position than on the ^{13}C chemical shift of the ring carbon to which that fluorine is bonded, as the ^{13}C chemical shifts of the 3- and 6-positions of (160) and (169) differ by only 2.0 ppm in both cases, whereas their ^{19}F chemical shifts differ by 26.2 and 34.2 ppm respectively, over similar chemical shift ranges.

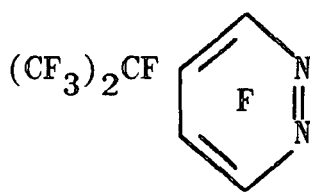
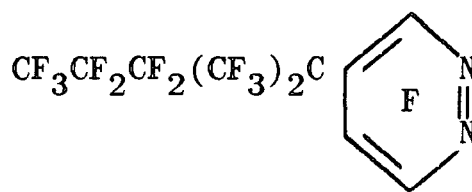
(21)(160)(169)

In contrast, the relationship between the values of the $^1\text{J}_{\text{CF}}$ coupling constants for the ring carbons with fluorine substituents and their ^{13}C chemical shifts does parallel that observed for the fluoropyridines (Table 9.4). There are two distinct ranges of values, for the 3-positions and 4-positions, with the magnitudes of the values for the

Table 9.4 Ranges of 1J values and ^{13}C chemical shifts for fluoropyridazines

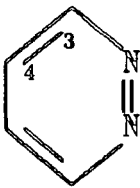
		$^1J_{CF}$	^{13}C (ppm)
3		239 - 249 Hz	157.0 → 160.9
4		286 - 298 Hz	140.2 → 159.8

positions *ortho* to ring nitrogen again being lowest, and similar to those observed for the fluoropyridines. However, although these $^1J_{CF}$ values have the same range for both the pyridines and pyridazines, the magnitudes of the ^{13}C chemical shifts associated with these positions *ortho* to ring nitrogen are greater for the pyridazines. These data are summarised in Table 9.5, and appear to reflect the greater electron-deficient nature of the fluorinated pyridazine ring system over the pyridine system, due to the effect of the additional ring nitrogen. However, there are

Table 9.5 Ranges of 1J values and ^{13}C chemical shifts for positions *ortho* to ring nitrogen in fluorinated pyridines and pyridazines

	$^1J_{CF}$	^{13}C (ppm)
Pyridine	240 - 249 Hz	144.3 - 155.8
Pyridazine	239 - 249 Hz	157.0 - 160.9

two sets of values which do not fit in with the results reported above, for the 4- and 6-positions of perfluoro-3,5-bis-isopropylpyridazine (55), which have the greatest ^{13}C chemical shift values observed for any of the hetero-aromatics studied (161.5 and 163.5 ppm), and $^1\text{J}_{\text{CF}}$ values intermediate between those of the two ranges for the 3- and 4-positions (267 and 273 Hz). This must be due to the net effect of the *meta* perfluoroisopropyl groups and the ring nitrogens giving one position a lower electron-density and the other position a higher electron-density than the similar positions in other perfluoroisopropylpyridazines.

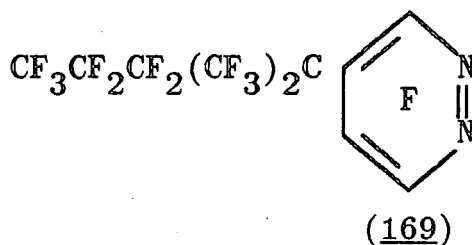
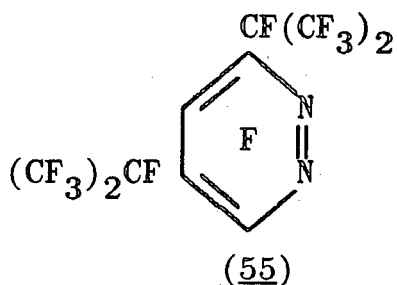

The perfluoroisopropyl derivatives were all found to have a $^2\text{J}_{\text{CF}}$ coupling constant between the aromatic ring carbon and the tertiary fluorine of the substituent perfluoroisopropyl group of 24 - 27 Hz. The small range of values for this coupling constant would suggest that it is indicative of a ring carbon bearing a perfluoroisopropyl substituent, and it will be seen later that similar values are also observed for perfluoroisopropyl-1,2,3-triazines.

The $^n\text{J}_{\text{CF}}$ coupling constants of the perfluoroalkyl group of perfluoro-4-(2'-methylpent-2'-yl)pyridazine (169) were assigned by comparison with those reported for perfluoro-2-methylpentyl bromide⁵³.

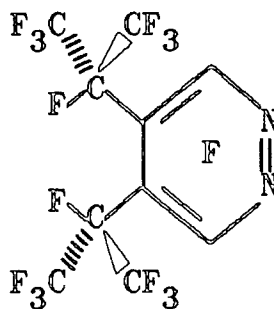

(60)

An interesting contrast is provided between the ^{13}C and ^{19}F n.m.r. spectra of perfluoro-4,5-bis-isopropylpyridazine (60). This molecule has a fixed conformation of its two adjacent perfluoroisopropyl groups resulting from restricted rotation due to their steric interactions, and this is clearly shown by the ^{19}F n.m.r. of (60), which has separate resonances for each perfluoroisopropyl group, despite the fact that the molecule appears to be symmetrical. The ^{13}C spectrum of (60) also shows separate resonances for the CF_3 's of the two alkyl groups, although they only differ by 0.1 ppm. Additionally, the fine structure of the couplings of the resonance due to the CF's of the two alkyl groups is not completely resolved, and this could be due to partial averaging of the couplings as a result of the restricted rotations between the two groups.

3. Halogenated 1,2,3-triazines

It is not possible to draw overall conclusions to either the correlations between the ^{13}C and ^{19}F chemical shifts of the ring carbons, or the relationship between $^1J_{\text{CF}}$ values and the ^{13}C chemical shifts for this ring system, as there were not a sufficient number of derivatives available.

However, there are similarities between the ^{13}C n.m.r. spectra of the 1,2,3-triazines and the other heteroaromatics investigated. For example, the 1,2,3-triazines also have the lowest $^1J_{\text{CF}}$ value for the carbons in the 4-position, *ortho* to ring nitrogen, although this value is 14 - 25 Hz larger than those observed for both the pyridines and pyridazines. In fact, the $^1J_{\text{CF}}$ values for the 1,2,3-triazines are all larger than those for the analogous positions, relative to ring nitrogen, in both the pyridines and pyridazines, and a summary of these $^1J_{\text{CF}}$ values is given in Table 9.6. Indeed, the $^1J_{\text{CF}}$ value of 315 Hz for the 5-position of perfluoro-4,6-bis-isopropyl-1,2,3-triazine (93) is 17 Hz larger than any other $^1J_{\text{CF}}$ coupling constant observed for a fluorinated heteroaromatic. This must result from the greater electron-deficient nature of the 1,2,3-triazine ring, relative to both the pyridine and pyridazine ring systems. Furthermore, for the perfluoroisopropyl derivatives, the $^2J_{\text{CF}}$ coupling constant between the ring carbon and the tertiary fluorine on the substituent perfluoroisopropyl group is found to be 24 - 30 Hz, which is very similar to the values observed for the perfluoroisopropylpyridazines. It would seem reasonable to conclude that the value of this coupling constant is indicative of a ring carbon with a perfluoroisopropyl

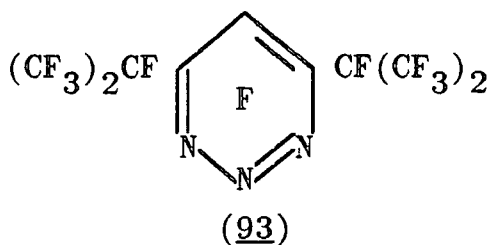
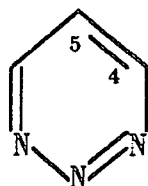
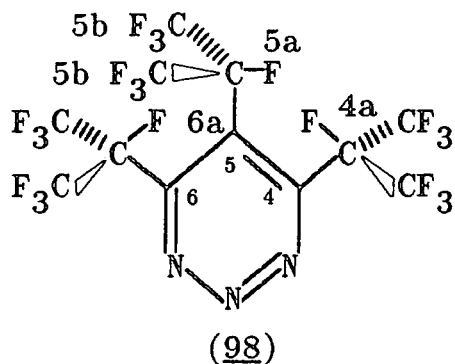

Table 9.6 Variation of 1J values relative to the position of the ring nitrogens for some fluorinated heteroaromatics

Ring N	pyridines	pyridazines	1,2,3-triazines
<i>ortho</i>	240 - 249 Hz	239 - 249 Hz	265 Hz
<i>meta,para</i>	260 - 270 Hz	286 - 298 Hz	298 - 315 Hz

substituent, and may reliably be used for spectral assignments, as its value does not appear to change significantly on moving from one heteroaromatic ring system to another. This is somewhat unusual, as one of the problems with attempting to unambiguously assign the coupling constants in the ^{13}C n.m.r. spectra of fluorinated heteroaromatics is that it is not usually possible to extrapolate coupling constant values from one ring system to another with a reasonable degree of reliability.

The ^{13}C and ^{19}F n.m.r. spectra of perfluoro-tris-isopropyl-1,2,3-triazine (98) also illustrate the effect that a fixed conformation of adjacent perfluoroisopropyl groups has on the observed n.m.r. spectra, which have



$$J_{\text{F}4\text{a},\text{F}5\text{a}} = 117 \text{ Hz}$$

$$J_{\text{F}5\text{b},\text{F}6\text{a}} = 39 \text{ Hz}$$

similar features to those for perfluoro-4,5-bis-isopropyl-pyridazine (60) discussed previously. The ^{19}F n.m.r. spectrum of (98)⁵⁹ shows separate resonances for each of the three perfluoroisopropyl groups, again despite the molecule appearing to be symmetrical. This is due to the alkyl groups adopting a fixed conformation as a result of restricted rotations, and is indicated by the differing values of the J_{FF} coupling constants between the two pairs of adjacent perfluoroisopropyl groups in (80), with these values being of similar magnitudes to those observed for perfluoroisopropyl-pyridines¹²³ and -pyrimidines¹⁰⁰. The ^{13}C n.m.r. spectrum of (98) also illustrates the same effect, but rather than showing separate resonances for the carbons of the perfluoroisopropyl groups, it has a separate resonance for each of the 1,2,3-triazine ring carbons. Indeed, the perfluoroisopropyl groups in (98) give rise to only two sets of resonances, one for the alkyl group at the 5-position, and the other for both alkyl groups at the 4- and 6-positions. It is suggested that this inequivalence of the three ring carbons in (98) results from the steric interactions between the perfluoroisopropyl groups distorting the symmetry of the 1,2,3-triazine ring.

4. Conclusions

- i) The relationship between the ^{13}C and ^{19}F chemical shifts of the ring carbons with fluorine substituents found for the pyridine system¹²¹ is also found to extend to the pyridazine system, with a few exceptions.

- ii) The magnitude of the ^{19}F chemical shift may be a better measure of the electron-density on a ring carbon than that of the ^{13}C chemical shift, as for both the pyridines and pyridazines, the ^{13}C chemical shift values cover approximately the same ranges, irrespective of the relative position to the ring nitrogen, whereas the ^{19}F chemical shift values are considerably lower for the positions *ortho* to ring nitrogen, which have the lowest electron-density
- iii) The magnitudes of the the $^1\text{J}_{\text{CF}}$ coupling constants for these ring carbons also appear to parallel the electron density on the ring carbon, with the more electron-deficient carbons *ortho* to ring nitrogen having the lowest $^1\text{J}_{\text{CF}}$ values.
- iv) The value of the $^2\text{J}_{\text{CF}}$ coupling constant between a ring carbon and the tertiary fluorine on a substituent perfluoroisopropyl group has only a small range of values, *i.e.* 24 - 30 Hz, which appear to be independent of the heteroaromatic ring system. It is suggested that this value is indicative of a substituent perfluoroisopropyl group, and as such may be used in the future assignments of the ^{13}C n.m.r. spectra of other perfluoroisopropyl-substituted heteroaromatic compounds.

9.C Potential methods for shift predictions

One of the problems associated with the study of chloroaromatic compounds is the limited number of probes

available for structure determination in these systems. ^{13}C n.m.r. spectroscopy is a potentially valuable technique for this purpose, but the acquisition of spectra is often hampered by poor solubilities and long relaxation times, although the latter may be overcome by employing either relaxation agents or long interpulse times. Furthermore, the prediction of ^{13}C chemical shifts in these systems has so far not proved to be straightforward, as anomalous variations in chemical shifts resulting from the steric interactions between *ortho* chlorines can reduce the accuracy of predictions^{124,125}.

This section will firstly examine the usefulness of a simple empirical predictive method¹²⁶ for the assignment of the ^{13}C n.m.r. spectra of the perhalo-diazines and -triazines, and the subsequent extension of this methodology to predict the shifts of the ring carbons in some known perfluoroisopropylpyridazines, and will conclude with an attempted assignment of the ^{13}C n.m.r. spectrum of hexachlorocinnoline.

1. The introduction of ring nitrogens into haloaromatics

The ^{13}C n.m.r. spectra of some perchloro-diazines and -triazines have been reported, and a potential method for predicting the ^{13}C chemical shifts of these compounds was discussed¹²¹. This used the chemical shift differences between hexachlorobenzene (219) and pentachloropyridine (143) to calculate the first order substituent chemical shift (SCS) values for the replacement of =CCl- by =N- into

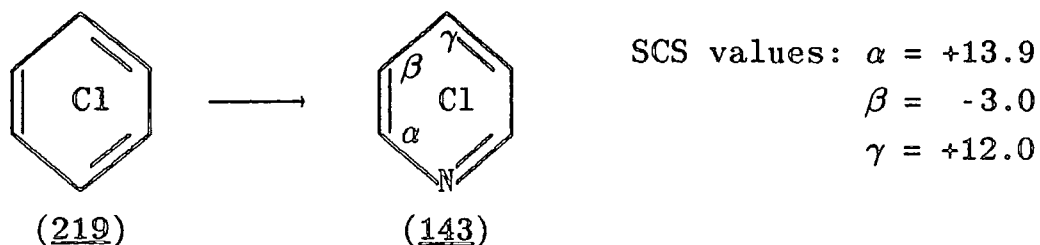

the perchloroaromatic ring. It is well established that for many ^1H , ^{19}F and ^{13}C n.m.r. studies of substituent chemical shifts, an adequate degree of predictive accuracy, relative to the chemical shift range, can be obtained by assuming the simple additivity of the SCS values obtained from model compounds¹²⁶. The SCS values derived above were used to calculate the ^{13}C chemical shifts for the perchloro-diazines and -1,2,4- and -1,3,5-triazines, assuming that the effect of the successive replacement of =CCl- by =N- was directly additive. However, there were sizeable discrepancies between these calculated values and the observed chemical shifts (± 8 ppm), and the use of second order SCS values¹²⁶, which attempt to take into account the mutual interactions between two or more ring nitrogen atoms, did not significantly improve these discrepancies. These second order terms are of the form $\alpha\beta/o$, which in this case signifies the factor arising from a carbon atom α to one ring nitrogen atom and β to the other, with the two nitrogen atoms *ortho* to each other.

The only perchloroheteroaromatic not covered by these predictions was trichloro-1,2,3-triazine (20), and the calculated first and second order chemical shifts for this compound are given in Table 9.7. Again, there are sizeable

Table 9.7 Experimental and calculated ^{13}C chemical shifts for trichloro-1,2,3-triazine (20)

		^{13}C shifts		Second order SCS and modified calculations
		Obs.	Calc. ^a	
	4,6	157.3	155.8	$\alpha\beta/o + \alpha\gamma/m + \beta\gamma/o = +7.3$
	5	132.5	138.9	$2\beta\gamma/o + \beta\beta/m = -8.8$
(20)		Second order calc. = 163.1, 130.1		

^a Direct predictions from first order SCS values





discrepancies between the observed and calculated values. However, although these significant differences exist between the observed and calculated ^{13}C chemical shift values for the perchloroheteroaromatics, they are reasonably good predictive results within the limits of this very simple empirical treatment, with the relative magnitudes of the calculated chemical shift values being sufficient to allow the correct assignment of the spectra.

A similar analysis may be performed for the series of perfluoro-diazines and -triazines, using the first order SCS values obtained from the ^{13}C chemical shift differences between hexafluorobenzene (220) and pentafluoropyridine (39)¹²⁷, and again assuming the direct additivity of the SCS values for replacement of =CF- by =N- in these compounds. The results of this analysis are given in Table 9.8, where the differences between the observed and calculated ^{13}C chemical shift values are also sizeable (± 14 ppm), and

consideration of the second order SCS terms did not significantly improve the agreements. However, as found previously for the perchloro-diazines and -triazines, the relative magnitudes of the predicted chemical shift values do permit the correct assignment of the spectra.

The perchloro- and perfluoro-diazines and -triazines all show significant departures from the direct additivity of SCS values of similar magnitudes (Cl ± 8 ppm, F ± 14 ppm). This suggests that it is the mutual interactions between the ring nitrogens, rather than the steric interactions between *ortho* halogens, which are the principal cause of these deviations from additivity, and this is supported by the predicted ^{13}C chemical shifts of the parent diazines and triazines obtained by an analogous method, *i.e.* using the SCS values for the replacement of $=\text{CH}-$ by $=\text{N}-$, which also show sizeable departures from direct additivity of similar magnitudes (± 8 ppm)¹²⁶. Furthermore, the greatest deviations from additivity are found for the systems with two or more *ortho* ring nitrogens, *i.e.* pyridazine and the 1,2,3- and 1,2,4-triazines, where the mutual interactions between the ring nitrogens are presumably largest. This dominating effect of the interactions between ring nitrogens reducing the accuracy of the predictive chemical shift calculations is further illustrated by reference to a heteroaromatic system in which these interactions do not occur, *i.e.* pyridine, where very good agreements are obtained between the predicted and observed ^{13}C chemical shifts of various substituted polyhalopyridines¹²², again assuming the direct

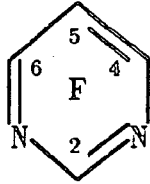
Table 9.8 Experimental and calculated ^{13}C chemical shifts for some perfluoro-diazines and -triazines¹²⁷

	^{13}C shifts		Second order SCS and modified calculations	
	Obs.	Calc. ^a		
 <p>(39)</p>				$\alpha = +13.9$ $\beta = -3.0$ $\gamma = +12.0$
C_6F_6 (220)	138.1			
 <p>(21)</p>	3,6 4,5	157.2 140.2	141.0 146.5	$\alpha\beta/o = +16.2$ $\beta\gamma/o = -6.3$
 <p>(22)</p>	2 4,6 5	153.8 161.3 130.2	151.5 157.0 130.5	$\alpha\alpha/m = +2.3$ $\alpha\gamma/m = +4.3$ $\beta\beta/m = -0.3$
 <p>(23)</p>		140.7	141.0	$\alpha\beta/p = -0.3$
 <p>(80)</p>		174.8	163.7	$\alpha\alpha/m + 2\alpha\gamma/m = +10.9$ Second order calc. = 174.6

	¹³ C shifts		Second order SCS and modified calculations
	Obs.	Calc. ^a	
 (28)	4,6	157.8 153.2	$\alpha\beta/o + \alpha\gamma/m + \beta\gamma/o = +14.2$
	5	132.8 142.7	$2\beta\gamma/o + \beta\beta/m = -12.9$
			Second order calc. = 167.4, 129.8

^a Direct predictions from first order SCS values

additivity of the SCS values.

2. Introduction of perfluoroisopropyl groups into the pyridazine ring system

A method analogous to that discussed in the previous section for predicting the ¹³C chemical shifts of perhalo-heteroaromatics on the replacement of =CCl- or =CF- by =N- may be applied to the replacement of fluorines by perfluoroisopropyl groups in the pyridazine ring system. The method involves calculation of the first order SCS values for the replacement of fluorine by perfluoroisopropyl at both the 3- and 4-positions of appropriately substituted pyridazine derivatives, and then assuming the direct additivity of these SCS values, to predict the ¹³C chemical shifts of the heteroaromatic ring carbons in other perfluoroisopropyl-pyridazines.

a) Substituent chemical shift values

The SCS values for the replacement of fluorine by perfluoroisopropyl at the 4-position were obtained by

comparison of the ^{13}C chemical shifts of tetrafluoropyridazine (21) and perfluoro-4-isopropylpyridazine (160).

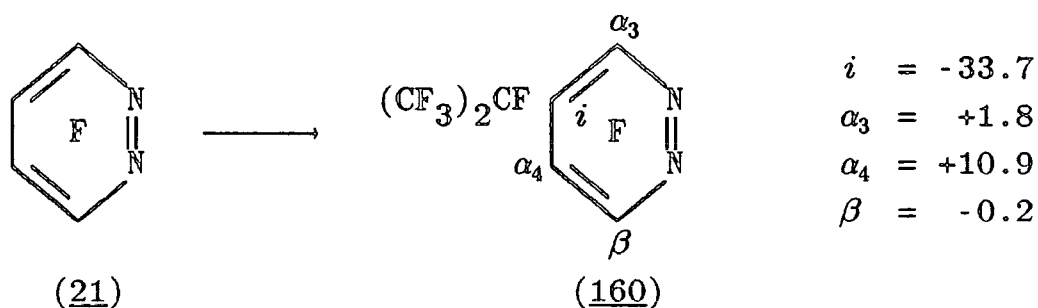

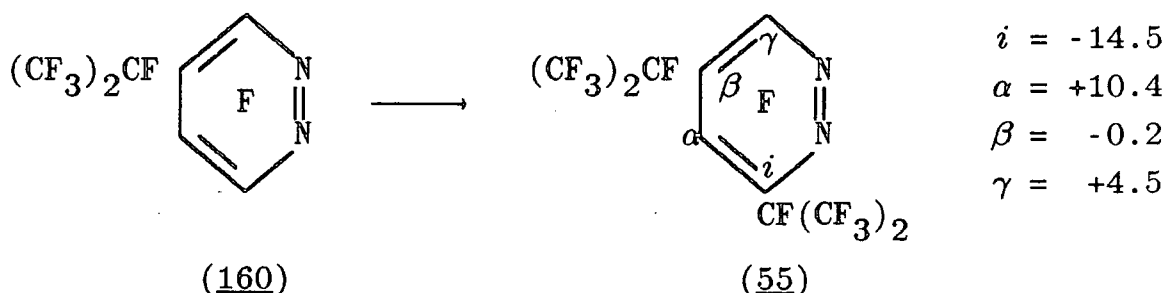

Similarly, the SCS values for replacement of the fluorine at the 3-position by a perfluoroisopropyl group were obtained by comparison of the ^{13}C chemical shifts of perfluoro-4-isopropylpyridazine (160) with those of perfluoro-3,5-bis-isopropylpyridazine (55).



b) Predictions using the calculated SCS values

The SCS values for a perfluoroisopropyl substituent at the 3- and 4- positions derived in the previous section were used to calculate the ^{13}C chemical shifts of the ring carbons in perfluoro-4,5-bis-isopropylpyridazine (60) and perfluoro-3,4,6-tris-isopropylpyridazine (159). The results are given in Table 9.9, which shows that there are small differences (± 4 ppm) between the observed and calculated values, but in each case the relative magnitudes of the chemical shifts are sufficient to permit the unambiguous

Table 9.9 Experimental and calculated ^{13}C chemical shifts
in some perfluoroisopropylpyridazines

		Obs.	Calc.
$(\text{CF}_3)_2\text{CF}$		3,6	160.9
$(\text{CF}_3)_2\text{CF}$		4,5	122.6
	(60)		
$(\text{CF}_3)_2\text{CF}$		3	151.7
		4	119.3
		5	158.9
		6	143.5
	(159)		

^a calculated from (160)

^b calculated from (55)

assignment of the ring carbon atoms. These small departures from additivity may be due to the steric effects of the adjacent perfluoroisopropyl groups causing a distortion of the symmetry of the heteroaromatic ring, as a similar departure from additivity as a result of steric effects was also observed for *ortho* chlorine atoms in various chloroaromatics^{124,125}.

It will be of interest to see if these results for the pyridazine system are found to extend to other perfluoroalkylheteroaromatics, as if generally applicable, they would

be a very useful aid for the assignment of spectra.

3. Attempted assignment of the ^{13}C n.m.r. spectrum of hexachlorocinnoline (78)

The empirical method discussed in 9.C.1 for predicting the ^{13}C shifts in monocyclic perchloroheteroaromatics may be extended to polycyclic systems. A previous worker in our laboratories, R. Daniels, attempted to assign the ^{13}C n.m.r. spectra of both heptachloro-quinoline (221) and -isoquinoline (222) by using the SCS values for the replacement of $=\text{CH}-$ by $=\text{CCl}-$ obtained from chlorobenzene¹²⁴, together with the assigned spectra of the parent heteroaromatics¹²⁸, to predict the ^{13}C n.m.r. shifts of both (221) and (222)³. The agreements between the observed and calculated shifts obtained by the above method were not very good, and only allowed partial assignment of each spectrum. However, the spectra of both heptachloro-quinoline (221) and -isoquinoline (222) have recently been fully assigned using a more sophisticated method to assign the shifts, which involves calculating the electron-density at each ring position, and relating this directly to the magnitude of the ^{13}C chemical shift¹²⁹. The complete assignment of the ^{13}C n.m.r. spectra of (221) and (222) allows the calculation of the SCS values for the replacement of $=\text{CCl}-$ by $=\text{N}-$ at both the 1- and 2-positions of octachloronaphthalene (223) (Table 9.10). These SCS values may be used together with the observed ^{13}C chemical shifts for octachloronaphthalene (223)¹²⁹, assuming the direct additivity of these values, to

Table 9.10 Substituent chemical shift (SCS) values for the replacement of =CCl- by =N- at the 1- and 2-positions of octachloronaphthalene (223)

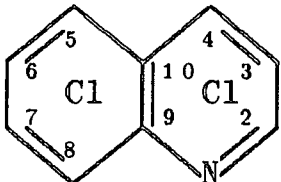
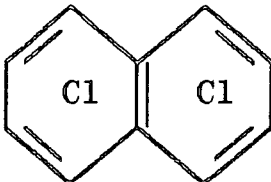
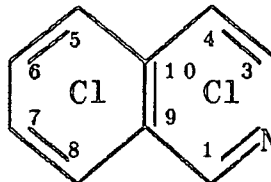
 <p>(221)</p>	$\xleftarrow{\text{N1}}$  <p>(223)</p>	$\xrightarrow{\text{N2}}$  <p>(222)</p>																																				
<table style="width: 100%; border-collapse: collapse;"> <tr><td style="width: 50px;">C2</td><td style="text-align: right;">+15.6</td></tr> <tr><td>C3</td><td style="text-align: right;">-3.5</td></tr> <tr><td>C4</td><td style="text-align: right;">+12.5</td></tr> <tr><td>C5</td><td style="text-align: right;">+4.0</td></tr> <tr><td>C6</td><td style="text-align: right;">+0.5</td></tr> <tr><td>C7</td><td style="text-align: right;">+0.5</td></tr> <tr><td>C8</td><td style="text-align: right;">-1.0</td></tr> <tr><td>C9</td><td style="text-align: right;">+12.1</td></tr> <tr><td>C10</td><td style="text-align: right;">-6.0</td></tr> </table>	C2	+15.6	C3	-3.5	C4	+12.5	C5	+4.0	C6	+0.5	C7	+0.5	C8	-1.0	C9	+12.1	C10	-6.0		<table style="width: 100%; border-collapse: collapse;"> <tr><td style="width: 50px;">C1</td><td style="text-align: right;">+17.4</td></tr> <tr><td>C3</td><td style="text-align: right;">+11.3</td></tr> <tr><td>C4</td><td style="text-align: right;">-4.2</td></tr> <tr><td>C5</td><td style="text-align: right;">+0.0</td></tr> <tr><td>C6</td><td style="text-align: right;">-0.1</td></tr> <tr><td>C7</td><td style="text-align: right;">-4.9</td></tr> <tr><td>C8</td><td style="text-align: right;">+7.1</td></tr> <tr><td>C9</td><td style="text-align: right;">-5.9</td></tr> <tr><td>C10</td><td style="text-align: right;">+10.3</td></tr> </table>	C1	+17.4	C3	+11.3	C4	-4.2	C5	+0.0	C6	-0.1	C7	-4.9	C8	+7.1	C9	-5.9	C10	+10.3
C2	+15.6																																					
C3	-3.5																																					
C4	+12.5																																					
C5	+4.0																																					
C6	+0.5																																					
C7	+0.5																																					
C8	-1.0																																					
C9	+12.1																																					
C10	-6.0																																					
C1	+17.4																																					
C3	+11.3																																					
C4	-4.2																																					
C5	+0.0																																					
C6	-0.1																																					
C7	-4.9																																					
C8	+7.1																																					
C9	-5.9																																					
C10	+10.3																																					

predict the shifts for hexachlorocinnoline (78). These values are given in Table 9.11 (Method 1), together with the shifts calculated using the SCS values¹²⁴ for replacement of =CH- by =CCl- and the assigned shifts for cinnoline (224)¹²⁸ (Method 2). The discrepancies between the predicted and observed chemical shift values are significant for both methods of calculation. However, method 2 appears to give closer agreement in terms of the relative magnitudes of the calculated shifts than method 1. This greater deviation of the shifts calculated using method 1 may again result from the mutual interactions between *ortho* nitrogen atoms, which these simple SCS values do not take into account, as was

Table 9.11 Experimental and calculated ^{13}C chemical shifts for hexachlorocinnoline (78)

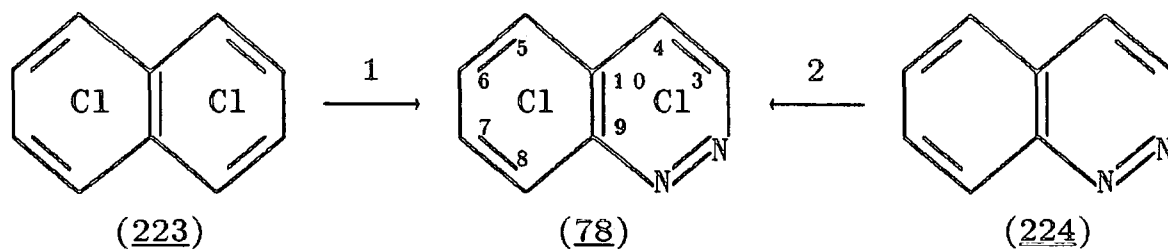

Calc.		Obs.
Method 1	Method 2	
(=CCl- → =N-)	(=CH- → =CCl-)	
C7 130.6	C10 127.7	123.4
C5 132.7	C4 130.2	126.8
C10 133.7	C5 133.1	130.8
C8 134.8	C8 134.7	134.0
C6 135.4	C7 139.3	135.5
C9 135.6	C6 139.5	139.3
C4 137.0	C9 151.5	144.8
C3 142.8	C3 151.8	153.1

observed previously for the perhalo-pyridazines, -1,2,3- and -1,2,4-triazines (see 9.C.1).

Although it is not possible to make a complete and unambiguous assignment of the ^{13}C n.m.r. spectrum of hexachlorocinnoline from the predicted chemical shift values given, a partial assignment of the spectrum may be attempted.

A comparison of the assigned ^{13}C chemical shifts of heptachloro-quinoline and -isoquinoline¹²⁹ with those of the parent heteroaromatics¹²⁸ shows that the correlation between

Table 9.12 Experimental and calculated ^{13}C chemical shifts for cinnoline (224) and hexachlorocinnoline (78)

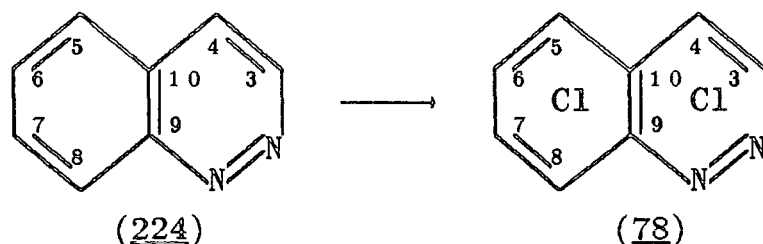

Calc.		Obs.	
(78)		(224)	(78)
C10	127.7	C4	123.4
C4	130.2	C10	126.8
C5	133.1	C5	130.8
C8	134.7	C8	134.0
C7	139.3	C7	135.5
C6	139.5	C6	139.3
C9	151.5	C3	144.8
C3	151.8	C9	153.1

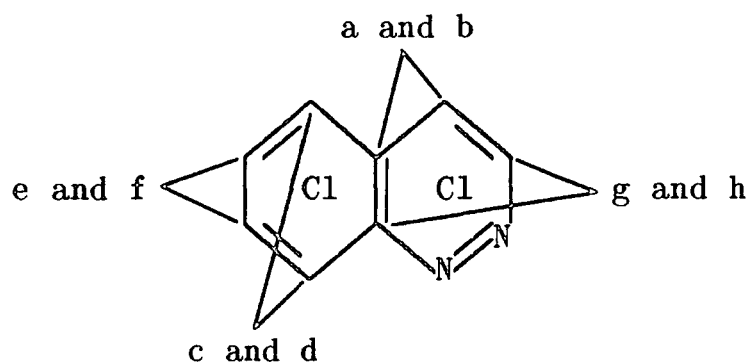

the magnitudes of the ^{13}C chemical shifts and their ring positions follow the same ordering for both systems, as it may be expected that replacement of the substituents on the ring (*i.e.* H by Cl) would have less of an effect on the ^{13}C

shifts than the replacement of part of the ring skeleton itself (*i.e.* $\equiv\text{CCl-}$ by $\equiv\text{N-}$). It would, therefore, not be unreasonable to see if this relationship also applies to the cinnoline ring system, where it is indeed found that the ordering of the magnitudes of the assigned shifts for cinnoline¹²⁸ (224) do broadly parallel those calculated for hexachlorocinnoline (78) using method 2 (Table 9.12). From this table it can be seen that it is possible to split up the observed shifts for hexachlorocinnoline (78) into four groups, namely for C4 & 10, C5 & 8, C6 & 7 and C3 & 9, and hence the partial assignment given below Table 9.12 is suggested. The greatest chemical shift values would be expected for the most electron-deficient carbons adjacent to the ring nitrogens, C3 and C9, and so shifts g and h are assigned to these two carbons. The remaining three pairs of shifts were then assigned in a similar manner.

The unambiguous assignment of the spectra of the perchloro-aza- and -diaz-naphthalenes would be greatly aided by the preparation of derivatives with known positions of substitution, when a comparison of the spectrum of a derivative with that of the parent compound would enable the shift of the substituted carbon to be assigned, as it would be expected that the magnitude of this shift would show the greatest change in value.

The preparation of several derivatives of hexachlorocinnoline (78) was attempted by the reaction of (78) with methoxide ion. However, for various reasons which are discussed in more detail in Chapter Seven (7.E.1a), it was

not possible to obtain any pure derivatives to aid the assignment of the ^{13}C spectrum of the parent compound.

4. Conclusions

- i) Simple empirical shift calculations, assuming the direct additivity of experimentally determined SCS values, are adequate for assigning the ^{13}C n.m.r. spectra of the perhalo-diazines and -triazines, where the relative magnitudes of the observed chemical shifts are reasonably well separated.
- ii) The above method is not sufficiently accurate to allow the complete assignments of the spectra of the perchloro-aza- and diaza-naphthalenes, in which the differences between observed chemical shifts may be as little as ± 1 ppm.
- iii) A relationship between the relative magnitudes of the ^{13}C chemical shifts and their ring positions exists for the perchloro-aza-naphthalenes and their parent heteroaromatics, which follow the same ordering for both systems. Partial assignments of the spectra of other polycyclic perchloroheteroaromatics, *e.g.* hexachlorocinnoline, may be attempted by similar comparisons of spectra.
- iv) For the polycyclic chloroaromatic systems, much more sophisticated calculations, which relate chemical shift values to electron-densities, must be employed to permit the complete and accurate assignment of these spectra.

EXPERIMENTAL

INSTRUMENTATION

I.r. spectra were obtained using either a Perkin-Elmer 457 or 577 Grating Infrared Spectrophotometer. Solid samples were recorded as KBr discs, and liquids and low-melting point solids as contact films between KBr plates.

N.m.r. spectra were recorded either on a Varian EM360L spectrometer operating at 60.0 MHz (^1H) or 56.4 MHz (^{19}F), a Hitachi Perkin-Elmer R-24B spectrometer operating at 60.0 MHz (^1H), or a Brüker AC250 spectrometer operating at 250.0 MHz (^1H), 235.3 MHz (^{19}F) or 62.9 MHz (^{13}C). Chemical shifts are quoted in ppm relative to external tetramethylsilane (^1H and ^{13}C) and fluorotrichloromethane (^{19}F), with downfield shifts positive.

Mass spectra were recorded either on an A.E.I. MS9 spectrometer (EI+) or a V.G. 7070E spectrometer (EI+ and CI-). M.s.-g.l.c. analyses were performed using the V.G. 7070E spectrometer linked to a Hewlett-Packard 5890A gas chromatograph, fitted with a crosslinked methyl silicone capillary column.

G.l.c. analyses were performed on a Pye-Unicam GCD gas chromatograph, using columns packed with 20% di-isodecyl phthalate on chromosorb P (column A), 20% Krytox on celite (column K), or 10% SE30 silicone gum rubber on celite (column O), or on a Hewlett-Packard 5890A gas chromatograph using the capillary column, both fitted with flame-ionisation detectors. Quantitative g.l.c. analyses were performed using the Hewlett-Packard 5890A linked to a

Spectra-Physics SP4200 computing integrator, calibrated with the appropriate standard solutions. Preparative-scale g.l.c. was carried out using a Varian Aerograph model 920 gas chromatograph, fitted with a cathrometer detector, using columns A, K and O.

Carbon, hydrogen and nitrogen analyses were obtained using a Perkin-Elmer 240 Elemental Analyser. Analyses for the halogens were performed by the literature method¹³⁰.

Boiling points and melting points were determined at atmospheric pressure, unless stated otherwise, and are uncorrected. Boiling points were recorded during fractional distillation, and melting points were obtained using a Reichert hot-stage microscope.

Differential Scanning Calorimetry was carried out in sealed aluminium pans using a Mettler FP85 TA cell linked to a Mettler FP80 central processor.

Photochemical reactions were carried out at 253.7nm (120W) and 300nm (85W) using a Rayonet RPR-208 reactor and at 366nm (25W) using a Hanovia Reading reactor.

REAGENTS

Unless otherwise stated, all chemicals were used as received from suppliers, without further purification.

Trichloroethylene was purified by fractional distillation at atmospheric pressure before use. Sulpholane, acetonitrile and dimethylformamide were purified by fractional vacuum distillation, with the middle fractions

collected over dried molecular sieve (type 4A) and stored under an atmosphere of dry nitrogen. Tetraglyme was purified by stirring with sodium metal at 95°C for 3hr, followed by fractional distillation under vacuum, with the middle fraction collected over dried molecular sieve (type 4A) and stored under dry nitrogen. Monoglyme was purified by distillation, and stored over sodium wire in a dry nitrogen atmosphere. Diethyl ether and di-n-butyl ether were dried over sodium wire.

Caesium and potassium fluorides were dried by heating at 180°C under high vacuum for several days, grinding to a powder in a glove-box under dry nitrogen, further heating under vacuum, and then stored under an atmosphere of dry nitrogen.

Tetrafluoropyridazine, tetrafluoropyrimidine and perfluorocyclobutene were prepared by technical staff.

CHAPTER TENEXPERIMENTAL FOR CHAPTER TWOSYNTHESIS AND CHEMISTRY OF HALOGENATED 1,2,3-TRIAZINES10.A Trichloro-1,2,3-triazine (20)1. Starting materialsa) Pentachlorocyclopropane (100)⁶²

Sodium trichloroacetate (270.0g, 1.46mol) which had been predried *in vacuo* (10^{-2} mm Hg at 90°C for 2hr) was added to trichloroethylene (1 litre) and the mixture stirred mechanically at 90°C for 3hr. Dry monoglyme (160ml) was then added, and the mixture heated at 90°C for a further 3 days. After allowing the mixture to cool and settle, the upper layer was decanted off, and the lower silt layer treated with 10ml of water and left to stand for several hours. Filtration of this treated lower layer provided more solvent, which was dried over CaCl₂ and combined with the decantate. Excess trichloroethylene was removed using a rotary evaporator, and fractional distillation of the residual oil gave pentachlorocyclopropane (100), a colourless oil (70.0g, 22% based on CCl₃CO₂Na used, b.p. 80 - 83°C (30mm Hg), lit.⁶¹ 80 - 85°C (30mm Hg)), identified by comparison of its g.l.c (column A, 80°C) with an authentic sample.

b) Tetrachlorocyclopropene (19)⁶²

A solution of potassium hydroxide (90.0g, 1.58mol) in water (110ml) was heated to 80°C with stirring, pentachlorocyclopropane (100) (120.0g, 0.56mol) was added dropwise, and the resulting mixture heated at 80°C for 1hr. The mixture was allowed to cool, and water (100ml) followed by cold c.HCl (25ml) were added. The lower organic layer was separated off, and dried over CaCl₂. Distillation gave tetrachlorocyclopropene (19), a colourless oil (59.0g, 59%, b.p. 70 - 74°C (100mm Hg), lit.⁶¹ 71 - 72°C (98mm Hg)), identified by comparison of its g.l.c (column A, 80°C) with an authentic sample.

2. Trichloro-1,2,3-triazine (20)²⁰

A mixture of tetrachlorocyclopropene (19) (62.3g, 0.35mol) and trimethylsilylazide (99) (44.4g, 0.39mol) was magnetically stirred at 90°C for 20hr under nitrogen. After removal of excess starting materials using a rotary evaporator, the solid residue was Soxhlet extracted twice with dry diethyl ether. The solvent was removed using a rotary evaporator, and the crude product sublimed at 80°C under high vacuum ($< 10^{-3}$ mm Hg) to give trichloro-1,2,3-triazine (20) as pale yellow crystals (19.4g, 27%, m.p. 111 - 113°C, lit.²⁰ 110 - 112°C) (Found: C, 19.6; N, 22.9; Cl, 58.0%. Calculated for C₃N₃Cl₃: C, 19.5; N, 22.8; Cl, 57.7%). N.m.r. spectrum no. 1 (¹³C), mass spectrum no. 1 (EI+).

10.B Fluorinated 1,2,3-triazines

1. Trifluoro-1,2,3-triazine (28)

Dry potassium fluoride was placed in a quartz pyrolysis tube (300 × 18mm) which had a glass rod (4mm) down the centre. The tube was heated in a furnace at 250°C for 2hr under high vacuum ($< 10^{-3}$ mm Hg), and after removal of the rod carefully to leave a small space along the axis, dried at 600°C for 3hr under high vacuum. The furnace was then cooled to 500°C, trichloro-1,2,3-triazine (20) (5.0g, 27.0mmol) was sublimed into the tube at $\approx 150^\circ\text{C}$ under high vacuum, and products were collected at the other end of the tube by traps cooled in liquid air. The product oil (3.9g) was shown by g.l.c. (column 0, 100°C) to consist of two major components. Separation by preparative scale g.l.c. (column 0, 100°C) gave trifluoro-1,2,3-triazine (28), a colourless oil (1.6g, 44%) (Found: C, 26.7; N, 31.1; F, 42.6%; M^+ , 135. $\text{C}_3\text{N}_3\text{F}_3$ requires C, 26.7; N, 31.1; F, 42.2%; M, 135). N.m.r. spectrum no. 3 (^{19}F and ^{13}C), i.r. spectrum no. 2, mass spectrum no. 3 (EI+), and 5-chloro-4,6-difluoro-1,2,3-triazine (102) as white crystals (1.7g, 42%, m.p. 43 - 46°C) (Found: C, 23.7; N, 27.8%; M^+ , 151. $\text{C}_3\text{N}_3\text{ClF}_2$ requires C, 23.8; N, 27.7%; M, 151). N.m.r. spectrum no. 2 (^{19}F and ^{13}C), i.r. spectrum no. 1, mass spectrum no. 2 (EI+).

The vapour-phase flow fluorination procedure described above was performed on several occasions. An illustrative example is given here, and the results of others are summarised in Table 10.1.

Table 10.1 Vapour-phase flow fluorinations of trichloro-1,2,3-triazine (20) with potassium fluoride

<u>Mass (20)</u>	<u>Conversion</u>	<u>Yield</u>	
		<u>(102)</u>	<u>(28)</u>
5.0g (27.1mmol)	29%	10%	19%
5.0g (27.1mmol)	37%	12%	25%
5.0g (27.1mmol)	59%	10%	49%
5.0g (27.1mmol)	60%	41%	19%
5.0g (27.1mmol)	86%	42%	44%
10.0g (54.2mmol)	42%	23%	19%
10.0g (54.2mmol)	47%	17%	30%

2. 5-chloro-4,6-difluoro-1,2,3-triazine (102)

The same procedure as in 10.B.1 was employed, except that the furnace temperature was maintained at 400°C during the fluorination. Trichloro-1,2,3-triazine (20) (5.0g, 27.0mmol) was sublimed through the tube at $\approx 150^{\circ}\text{C}$, and the product (3.4g) was collected in the liquid air cooled traps. Volatile material (0.5g) was removed from the crude product by vacuum transfer at room temperature, and shown to be a mixture of (28) and (102). Sublimation of the residual solid product at 80°C under high vacuum ($< 10^{-3}$ mm Hg) yielded 5-chloro-4,6-difluoro-1,2,3-triazine (102) (2.4g, 58%).

10.C Attempted polyfluoroalkylation of trichloro-1,2,3-triazine (20)

1. Small scale

Trichloro-1,2,3-triazine (20) (0.5g, 2.7mmol), caesium fluoride (2.7g, 17.8mmol) and tetraglyme (10ml) were placed in a dry 2-necked flask against a flow of dry nitrogen, a bladder containing hexafluoropropene (3.0g, 20.0mmol) was attached, and the flask cooled in liquid air and evacuated ($< 10^{-2}$ mm Hg). The mixture was allowed to warm up to room temperature, hexafluoropropene was admitted into the flask in one portion from the bladder, and the mixture vigorously stirred at room temperature for 5 days (by which time the bladder had completely deflated). A volatile product (1.7g), isolated by vacuum transfer and separated as a lower layer from tetraglyme, was shown by g.l.c. (column K, 80°C) to be a mixture of hexafluoropropene oligomers (identified by comparison with an authentic sample).

A modification to the above procedure was attempted, involving flame-drying the caesium fluoride prior to the reaction *in situ* in the flask under high vacuum ($< 10^{-3}$ mm Hg). This also gave the mixture of hexafluoropropene oligomers as the sole isolated product.

2. Larger scale

Trichloro-1,2,3-triazine (20) (2.2g, 11.9mmol) was polyfluoroalkylated with hexafluoropropene (4.0g, 26.7mmol) and flame-dried caesium fluoride (10.9g, 71.7mmol) in tetraglyme (20ml) using the method described above (10.C.1).

The work-up also gave a lower layer from tetraglyme (2.5g), which was shown by g.l.c.-m.s. (column K, 80°C) to consist mainly of hexafluoropropene oligomers (M^+ , 300 (dimers) and M^+ , 450 (trimers) respectively), together with a trace of perfluoro-4,6-bis-isopropyl-1,2,3-triazine (93) (M^+ , 435) and perfluoro-4,5,6-tris-isopropyl-1,2,3-triazine (98) (M^+ , 585). This reaction was repeated several times, but it was not possible to increase the proportion of the perfluoro-isopropyl-1,2,3-triazines in the product mixture sufficiently to allow isolation by preparative scale g.l.c.

10.D Nucleophilic substitution reactions

1. Trichloro-1,2,3-triazine (20)

a) With methanol

Trichloro-1,2,3-triazine (20) (600mg, 3.3mmol) and anhydrous sodium carbonate (0.5g, 4.7mmol) were refluxed in methanol (10ml) for 14hr. Excess methanol was removed using a rotary evaporator, and the residual solid was taken up in dichloromethane (30ml), washed with water (3 × 30ml) and dried over $MgSO_4$. Removal of the solvent *in vacuo* gave a white solid, which was shown by t.l.c. (alumina, 1:1 diethyl ether:n-hexane) to consist of two components, with one identified as the starting material (20). The solid was adsorbed onto alumina and run down a 110 × 22mm alumina column, using a 1:1 mixture of diethyl ether:n-hexane as eluant. This afforded a white solid which was recrystallised from ethanol to give trimethoxy-1,2,3-triazine (110) as white needles (26mg, 5%), identified by comparison of its 1H

n.m.r. and mass spectra with an authentic sample (10.D.2b).

2. Trifluoro-1,2,3-triazine (28)

a) With secondary amines

i) Pyrrolidine

A solution of pyrrolidine (1.8g, 25.4mmol) in diethyl ether (20ml) was added dropwise to a solution of trifluoro-1,2,3-triazine (28) (700mg, 5.2mmol) in diethyl ether (10ml), and the resultant mixture stirred at room temperature for 1hr. The solvent was removed using a rotary evaporator to give a residual white solid, which upon recrystallisation from ethanol gave 4,6-dipyrrolidino-5-fluoro-1,2,3-triazine (109a) as white needles (541mg, 44%, m.p. 136 - 138⁰C) (Found: C, 55.8; H, 6.9; N, 29.4; F, 7.7%; M⁺, 237. C₁₁H₁₆N₅F requires C, 55.7; H, 6.8; N, 29.5; F, 8.0%; M, 237). N.m.r. spectrum no. 6 (¹H and ¹⁹F), i.r. spectrum no. 3, mass spectrum no. 6 (EI+).

ii) Piperidine

A solution of piperidine (470mg, 5.5mmol) in diethyl ether (10ml) was added dropwise to a solution of (28) (150mg, 1.1mmol) in diethyl ether (5ml), and the resultant mixture stirred for 3hr at room temperature. Removal of the solvent using a rotary evaporator yielded a yellow solid which was recrystallised from ethanol to give 4,6-dipiperidino-5-fluoro-1,2,3-triazine (109b) as yellow crystals (183mg, 62%, m.p. 89 - 92⁰C) (Found: C, 58.7; H, 7.8; N, 26.7; F, 7.6%; M⁺, 265. C₁₃H₂₀N₅F requires C, 58.9;

H, 7.6; N, 26.4; F, 7.2%; M, 265). N.m.r. spectrum no. 7 (^1H and ^{19}F), i.r. spectrum no. 4, mass spectrum no. 7 (EI+).

iii) Hexamethyleneimine

A solution of hexamethyleneimine (584mg, 6.0mmol) in diethyl ether (10ml) was added dropwise to a solution of (28) (160mg, 1.2mmol) in diethyl ether (5ml), and the resultant solution stirred at room temperature for 4hr. The solvent was removed using a rotary evaporator to give a residual yellow oil, which slowly crystallised. Recrystallisation of the solid from ethanol gave 4,6-dihexamethyleneimino-5-fluoro-1,2,3-triazine (109c) as orange-brown crystals (265mg, 76%, m.p. 90 - 91 $^{\circ}\text{C}$) (Found: C, 61.7; H, 8.6; N, 24.2; F, 6.8%. $\text{C}_{15}\text{H}_{24}\text{N}_5\text{F}$ requires C, 61.4; H, 8.2; N, 23.9; F, 6.5%). N.m.r. spectrum no. 8 (^1H and ^{19}F), mass spectrum no. 8 (EI+).

b) With methanol

Trifluoro-1,2,3-triazine (28) (199mg, 1.5mmol) and anhydrous sodium carbonate (0.4g, 3.8mmol) were refluxed in methanol (10ml) for 3hr. Excess methanol was removed using a rotary evaporator to leave a residual yellow solid, which was taken up in dichloromethane (20ml), washed with water (3 \times 20ml) and dried over MgSO_4 . Removal of the solvent using a rotary evaporator gave a pale yellow solid, which was recrystallised from methanol to give trimethoxy-1,2,3-triazine (110) as white needles (178mg, 71%, m.p. 118 - 120 $^{\circ}\text{C}$, lit.²⁰ 115 - 117 $^{\circ}\text{C}$) (Found: C, 42.1; H, 5.6; N, 25.0%;

M^+ , 171. Calculated for $C_6H_9N_3O_3$: C, 42.1; H, 5.3; N, 24.6%;
M, 171). N.m.r. spectrum no. 9 (1H), mass spectrum no. 9
(EI+).

c) With phenol

A mixture of (28) (194mg, 1.4mmol), phenol (285mg, 3.0mmol) and triethylamine (0.5g, 5.0mmol) was refluxed in dichloromethane (10ml) for 2hr. The dichloromethane was washed with water (2 × 10ml) and dried over $CaCl_2$. Removal of the solvent using a rotary evaporator gave a brown powder, which was recrystallised from ethanol to yield 4,6-diphenoxy-5-fluoro-1,2,3-triazine (111) as a cream-coloured powder (205mg, 50%, m.p. 147 - 149°C) (Found: C, 63.5; H, 3.5; N, 14.4%; M^+ , 283. $C_{15}H_{10}N_3O_2F$ requires C, 63.5; H, 3.5; N, 14.8%; M, 283). N.m.r. spectrum no. 10 (1H and ^{19}F), mass spectrum no. 10 (EI+).

3. 5-chloro-4,6-difluoro-1,2,3-triazine (102)

a) With secondary amines

i) One equivalent of pyrrolidine

A solution of pyrrolidine (87mg, 1.2mmol) in diethyl ether (5ml) was added dropwise to a solution of 5-chloro-4,6-difluoro-1,2,3-triazine (102) (202mg, 1.3mmol) in diethyl ether (5ml), and the resulting mixture stirred at room temperature for 4hr. Removal of the solvent using a rotary evaporator gave an orange-brown solid, which was recrystallised from ethanol to give 5-chloro-4-fluoro-6-pyrrolidino-1,2,3-triazine (112a) as brown needles (73mg,

27%, m.p. 66 - 68°C) (Found: C, 41.7; H, 4.1; N, 28.1%; M⁺, 202. C₇H₈N₄ClF requires C, 41.5; H, 4.0; N, 27.7%; M, 202). N.m.r. spectrum no. 11 (¹H and ¹⁹F), mass spectrum no. 11 (EI+).

ii) Excess pyrrolidine

A solution of pyrrolidine (522mg, 7.4mmol) in diethyl ether (5ml) was added dropwise to a solution of (102) (179mg, 1.2mmol) in diethyl ether (5ml), and the resulting mixture stirred for 4hr at room temperature. The solvent was removed using a rotary evaporator, and the residual white solid was recrystallised from ethanol to yield 5-chloro-4,6-dipyrrolidino-1,2,3-triazine (113) as white needles (159mg, 53%, m.p. 153 - 156°C, lit.²⁰ 155 - 158°C) (Found: C, 51.9; H, 6.3; N, 27.2; Cl, 13.8%; M⁺, 253. Calculated for C₁₁H₁₆N₅Cl: C, 52.1; H, 6.3; N, 27.6%; M, 253). N.m.r. spectrum no. 12 (¹H), mass spectrum no. 12 (EI+).

iii) One equivalent of hexamethyleneimine

A solution of hexamethyleneimine (179mg, 1.8mmol) in diethyl ether (5ml) was added dropwise to a solution of (102) (265mg, 1.7mmol) in diethyl ether (10ml), and the mixture stirred at room temperature for 5hr. The solvent was removed using a rotary evaporator, and the residual yellow solid was recrystallised from ethanol to give 5-chloro-4-fluoro-6-hexamethyleneimino-1,2,3-triazine (112c) as orange-yellow crystals (284mg, 70%, m.p. 62 -

65°C) (Found: C, 46.9; H, 5.3; N, 24.6%. $C_9H_{12}N_4ClF$ requires C, 46.9; H, 5.2; N, 24.3%). N.m.r. spectrum no. 13 (1H and ^{19}F), mass spectrum no. 13 (EI+).

b) With methanol

A mixture of (102) (300mg, 2.0mmol) and anhydrous sodium carbonate (0.9g, 8.5mmol) was refluxed in methanol (15ml) for 3hr. Excess methanol was removed using a rotary evaporator to leave a white solid, which was taken up in diethyl ether (30ml), washed with water (3 × 30ml) and dried over $MgSO_4$. The solvent was removed using a rotary evaporator, and the residual white solid recrystallised from methanol to give 5-chloro-4,6-dimethoxy-1,2,3-triazine (114) as a white powder (192mg, 55%, m.p. 160 - 163°C (decomp.)) (Found: C, 34.2; H, 3.4; N, 23.8; Cl, 19.7%; M^+ , 175. $C_5H_6N_3O_2Cl$ requires C, 34.2; H, 3.4; N, 23.9; Cl, 20.2%; M , 171). N.m.r. spectrum no. 14 (1H), mass spectrum no. 14 (EI+).

c) With phenol

i) One equivalent

A mixture of (102) (215mg, 1.4mmol), phenol (138mg, 1.5mmol) and triethylamine (0.2g, 2.0mmol) in dichloromethane (10ml) was stirred at room temperature for 6hr. The dichloromethane was washed with water (2 × 10ml) and dried over $CaCl_2$. Removal of the solvent using a rotary evaporator gave a yellow solid, which was recrystallised from ethanol to yield 5-chloro-4-fluoro-6-phenoxy-1,2,3-

triazine (115) as a cream-coloured powder (111mg, 35%, m.p. 145 - 147°C) (Found: C, 48.1; H, 2.0; N, 18.2%; M^+ , 225. $C_9H_5N_3OClF$ requires C, 47.9; H, 2.2; N, 18.6%; M , 225). N.m.r. spectrum no. 15 (1H and ^{19}F), mass spectrum no. 15 (EI+).

ii) Two equivalents

A mixture of (102) (204mg, 1.3mmol), phenol (252mg, 2.7mmol) and triethylamine (0.5g, 5.0mmol) was refluxed in dichloromethane (10ml) for 4hr. The dichloromethane was washed with water (3 × 10ml) and dried over $CaCl_2$. The solvent was removed using a rotary evaporator, and the residual white solid was recrystallised from ethanol to give 5-chloro-4,6-diphenoxy-1,2,3-triazine (116) as white needles (340mg, 84%, m.p. 190 - 192°C, lit.²⁰ 188 - 191°C) (Found: C, 59.8; H, 3.6; N, 13.9; Cl, 11.3%. $C_{15}H_{10}N_3O_2Cl$ requires C, 60.1; H, 3.3; N, 14.0; Cl, 11.9%). N.m.r. spectrum no. 16 (1H), mass spectrum no. 16 (EI+).

10.E Attempted cycloaddition reactions

1. Trichloro-1,2,3-triazine (20)

a) With enamines

i) N-morpholino-1-cyclohexene (131)

A mixture of trichloro-1,2,3-triazine (20) (1.0g, 5.4mmol) and N-morpholino-1-cyclohexene (131) (0.9g, 5.4mmol) was refluxed in dry tetrahydrofuran (20ml) for 3hr. removal of the solvent using a rotary evaporator gave a brown solid, which was shown by t.l.c. (alumina, 1:1 diethyl

ether:n-hexane) to be a multi-component mixture. Attempted separation by both column chromatography (alumina, 1:1 diethyl ether:n-hexane as eluant) and vacuum sublimation did not yield any pure material.

The reaction was repeated in chloroform (20ml), again giving a multi-component solid product from which no pure material could be isolated.

ii) Pyrrolidino-1-cyclopentene (132)

A mixture of trichloro-1,2,3-triazine (20) (0.5g, 2.7mmol) and pyrrolidino-1-cyclopentene (132) (0.6g, 4.4mmol) in dry tetrahydrofuran (20ml) was stirred at room temperature under dry nitrogen for 5hr. The solvent was removed using a rotary evaporator to yield a viscous dark orange oil, which was shown by t.l.c. (alumina, 1:1 diethyl ether:n-hexane) to contain the triazine (20) and enamine (132).

The reaction was repeated in refluxing tetrahydrofuran (20ml) for 24hr under dry nitrogen, which also gave a viscous dark orange oil containing the starting materials (t.l.c., alumina, 1:1 diethyl ether:n-hexane).

The reaction was also attempted in both dry tetrahydrofuran (20ml) at 60^oC and dry dioxan (20ml) at 100^oC under dry nitrogen for 24hr, with the addition of glacial acetic acid (250 μ l). Work-up gave a viscous oil in each case, which was again shown by t.l.c. to contain the triazine (20) and enamine (132).

b) With 2,3-dimethylbut-2-ene (134)

A mixture of trichloro-1,2,3-triazine (20) (1.0g, 5.4mmol) and 2,3-dimethylbut-2-ene (134) (0.6g, 7.1mmol) in carbon tetrachloride (10ml) was heated at 75°C for 66hr. Removal of the solvent using a rotary evaporator gave recovered trichloro-1,2,3-triazine (20) (0.9g, 90%).

c) With dihydrofuran (135)i) At 50°C

Trichloro-1,2,3-triazine (20) (500mg, 2.7mmol) in dihydrofuran (2ml) was heated at 50°C for 16hr under dry nitrogen. The solvent was removed using a rotary evaporator to give recovered trichloro-1,2,3-triazine (20) (472mg, 94%).

ii) At 150°C

(20) (1.0g, 5.4mmol) and dihydrofuran (135) (2.0g, 28.6mmol) were sealed in a small Carius tube (130 × 16mm) under high vacuum ($< 10^{-3}$ mm Hg) and heated at 150°C for 18hr. The contents of the tube were extracted with diethyl ether (20ml), and the insoluble polymeric material removed by filtration. Evaporation of the solvent *in vacuo* gave recovered trichloro-1,2,3-triazine (20) (0.6g, 60%).

d) With cyclopentene (136)

(20) (1.0g, 5.4mmol) and cyclopentene (136) (2.0g, 29.4mmol) were sealed in a small Carius tube (130 × 16mm) under high vacuum ($< 10^{-3}$ mm Hg) and heated at 150°C for

20hr. The contents of the tube were extracted with diethyl ether (20ml), and the insoluble polymeric material separated by filtration. Removal of the solvent *in vacuo* yielded recovered trichloro-1,2,3-triazine (20) (0.7g, 70%).

2. Trifluoro-1,2,3-triazine (28)

a) With pyrrolidino-1-cyclopentene (132)

i) Pyrrolidino-1-cyclopentene (132) (32mg, 0.23mmol) was added to a solution of trifluoro-1,2,3-triazine (28) (32mg, 0.24mmol) in dry tetrahydrofuran (1ml) in an n.m.r. tube (5mm) at room temperature. An immediate exothermic reaction occurred, resulting in the production of an intractable tar in the tube.

ii) A solution of pyrrolidino-1-cyclopentene (132) (144mg, 1.1mmol) in dry diethyl ether (5ml) was added dropwise to a solution of (28) (147mg, 1.1mmol) in dry diethyl ether (5ml) at 0°C under nitrogen, and the resulting mixture stirred at 0°C for 6hr. A crystalline material was formed in solution, but all attempts at isolation by either filtration, evaporation of the solvent, or column chromatography (alumina, 1:1 diethyl ether:n-hexane as eluant) resulted in decomposition to an intractable tar, from which no material could be isolated.

b) With pyrrolidino-1-cyclohexene (137)

i) Pyrrolidino-1-cyclohexene (137) (36mg, 0.24mmol) was added to a solution of (28) (32mg, 0.24mmol) in dry tetrahydrofuran (1ml) in an n.m.r. tube (5mm) at room

temperature. A rapid exothermic reaction occurred, yielding an intractable tar in the tube.

ii) A solution of pyrrolidino-1-cyclohexene (137) (184mg, 1.2mmol) in dry diethyl ether (5ml) was added dropwise to a solution of (28) (161mg, 1.2mmol) in dry diethyl ether (5ml) at 0°C under nitrogen. The mixture was stirred at 0°C for 5hr, giving a crystalline material in solution. All attempts to isolate the crystals by either filtration, evaporation of the solvent *in vacuo*, or column chromatography (alumina, 1:1 diethyl ether:n-hexane as eluant) resulted in their decomposition into an intractable tar, from which no material could be isolated.

3. Trimethoxy-1,2,3-triazine (110)

a) In solution

A mixture of trimethoxy-1,2,3-triazine (110) (150mg, 0.88mmol) and dimethyl acetylenedicarboxylate (138) (133mg, 0.94mmol) was refluxed in dry tetrahydrofuran (10ml) for 65hr. Removal of the solvent using a rotary evaporator gave recovered trimethoxy-1,2,3-triazine (110) (136mg, 91%).

b) In a sealed tube

A mixture of (110) (150mg, 0.88mmol) and (138) (150mg, 1.1mmol) was sealed in a small Carius tube (130 × 16mm) under high vacuum ($< 10^{-3}$ mm Hg) and heated at 120°C for 18hr. The contents of the tube were extracted with diethyl ether (10ml), and removal of the solvent *in vacuo* yielded recovered (110) (127mg, 85%).

CHAPTER ELEVENEXPERIMENTAL FOR CHAPTER THREESOLUTION FLUORINATIONS11.A Polyfluoroalkylation of perchlorotriazines1. Trichloro-1,2,3-triazine (20) (with Dr. T. Shepherd)a) Single step reaction

Caesium fluoride (22.0g, 0.14mol) and sulpholane (50ml) were placed in a dry 2-necked flask against a flow of dry nitrogen, and a solution of trichloro-1,2,3-triazine (20) (4.0g, 21.6mmol) in diethyl ether (100ml) was added. A bladder containing hexafluoropropene (10.4g, 69.3mmol) was attached, and the flask cooled in liquid air and evacuated ($< 10^{-2}$ mm Hg). The mixture was allowed to warm up to room temperature, hexafluoropropene was admitted into the flask in one portion from the bladder, and the mixture stirred vigorously at room temperature for 48hr (by which time the bladder had completely deflated). Diethyl ether and volatile products were isolated by vacuum transfer, and removal of the diethyl ether *in vacuo* gave a yellow oil (8.6g), which was shown by g.l.c. (capillary) to contain three major components. Separation by preparative scale g.l.c. (Column K, 120°C) gave perfluoro-4,6-bis-isopropyl-1,2,3-triazine (93) as colourless crystals (3.7g, 39%), n.m.r spectrum no. 4 (^{13}C), mass spectrum no. 4 (CI-), perfluoro-4,5,6-tris-isopropyl-1,2,3-triazine (98) as a yellow oil (1.6g, 13%), n.m.r. spectrum no. 5 (^{13}C), mass spectrum no. 5 (CI-), and

perfluoro-2,4,6-tris-isopropyl-5-isopropylidene-1,2,3-triazacyclohexa-3,6-diene (103) as a yellow oil (1.3g, 8%), identified by comparison of their ^{19}F n.m.r. and g.l.c. (capillary) with those of authentic samples⁵⁹.

b) Two stage reaction

Potassium fluoride (3.6g, 62.1mmol) and sulpholane (20ml) were placed in a dry 2-necked flask against a flow of dry nitrogen, a solution of trichloro-1,2,3-triazine (20) (1.5g, 8.0mmol) in diethyl ether (30ml) was added, and the mixture stirred vigorously at room temperature for 24hr. The diethyl ether and fluorocarbon intermediates were isolated by vacuum transfer, added to a mixture of caesium fluoride (3.5g, 23.0mmol) and sulpholane (25ml) in a dry 2-necked flask, and a bladder containing hexafluoropropene (2.4g, 16.0mmol) was attached. The subsequent polyfluoroalkylation and work-up was as described previously (11.A.1a) for the single step reaction. Separation of the product oil (2.6g) by preparative scale g.l.c. (Column K, 120°C) gave (93) (1.7g, 48%), (98) (0.1g, 3%) and (103) (0.1g, 2%).

2. Trichloro-1,3,5-triazine (139)

a) With caesium fluoride in sulpholane

Trichloro-1,3,5-triazine (139) (2.0g, 10.8mmol), caesium fluoride (14.9g, 98.0mmol) and sulpholane (30ml) were introduced into a dry 2-necked flask against a dry nitrogen stream. A bladder containing hexafluoropropene (5.5g, 36.6mmol) was attached, and the flask cooled in

liquid air and evacuated ($< 10^{-2}$ mm Hg). The mixture was allowed to warm up to room temperature, hexafluoropropene was admitted into the flask in one portion, and the mixture vigorously stirred at room temperature for 72hr, after which time the bladder had completely deflated. Vacuum transfer from the sulpholane yielded colourless crystals of perfluoro-2,4,6-tris-isopropyl-1,3,5-triazine (84) (3.9g, 61%), identified by comparison of its ^{19}F n.m.r. and g.l.c. with those of an authentic sample⁷⁸.

b) With potassium fluoride in diethyl ether/sulpholane

i) Single step reaction

Potassium fluoride (6.0g, 0.10mol) and sulpholane (30ml) were placed in a dry 2-necked flask against a flow of dry nitrogen, and a solution of trichloro-1,3,5-triazine (139) (2.2g, 11.9mmol) in diethyl ether (30ml) was added. A bladder containing hexafluoropropene (5.8g, 38.7mmol) was attached, and the flask cooled in liquid air and evacuated ($< 10^{-2}$ mm Hg). The mixture was allowed to warm up to room temperature, and then stirred vigorously for 24hr whilst hexafluoropropene was admitted into the flask in portions from the bladder over this period (until the bladder had completely deflated). Diethyl ether and volatile products were isolated by vacuum transfer, and removal of the diethyl ether *in vacuo* gave perfluoro-2,4,6-tris-isopropyl-1,3,5-triazine (84) (5.5g, 79%).

ii) Two stage reaction

Trichloro-1,3,5-triazine (139) (1.0g, 5.4mmol) was polyfluoroalkylated with hexafluoropropene (2.8g, 18.7mmol) and potassium fluoride (2.8g, 48.3mmol) in diethyl ether (20ml) and sulpholane (10ml) using the method described above (11.A.2bi), except that after allowing the mixture to warm up to room temperature, it was vigorously stirred for several hours prior to the gradual addition of hexafluoropropene to the system over 24hr. The work-up again gave perfluoro-2,4,6-tris-isopropyl-1,3,5-triazine (84) (2.5g, 80%).

11.B Fluorination of perchloroheteroaromatics1. Using the diethyl ether/sulpholane solvent systema) Basic method

The required quantities of potassium fluoride and sulpholane were placed in a dry 2-necked flask against a flow of dry nitrogen, a solution of the perchloro-heteroaromatic in diethyl ether was added, and the mixture was stirred vigorously at room temperature. At the end of the reaction period, the bulk of the diethyl ether layer was removed by pipette, residual diethyl ether and volatile products were isolated from the sulpholane layer by vacuum transfer, and the two diethyl ether fractions were combined. Removal of the diethyl ether *in vacuo* gave an oil containing the fluorinated products, which were identified by m.s.-g.l.c. (capillary) and ^{19}F n.m.r. Yields were calculated from the peak areas of the g.l.c. traces, measured with an

electronic integrator calibrated using standard solutions.

b) Trichloro-1,3,5-triazine (139)

A mixture of trichloro-1,3,5-triazine (139) (0.6g, 3.3mmol), potassium fluoride (1.7g, 29.3mmol), diethyl ether (20ml) and sulpholane (10ml) was stirred vigorously at room temperature for 24hr. Work-up gave a colourless oil (0.3g), identified by ^{19}F n.m.r. as trifluoro-1,3,5-triazine (80) (68%).

The experiment was repeated with a 20:1 ratio of diethyl ether to sulpholane (20ml:1ml), which gave a 73% yield of (80). A further experiment using 50ml of diethyl ether without sulpholane did not give any fluorinated products on work-up.

c) Trichloro-1,2,3-triazine (20)

Mixtures of trichloro-1,2,3-triazine (20) (1.5g, 8.1mmol), potassium fluoride (3.6g, 62.1mmol), diethyl ether (30ml) and sulpholane (20ml) were stirred vigorously at room temperature for varying periods of time. Work-up gave a colourless oil in each case, which was shown by ^{19}F n.m.r. and g.l.c. (capillary) to be a mixture of 5-chloro-4,6-difluoro-1,2,3-triazine (102) and trifluoro-1,2,3-triazine (28). The results of these reactions are summarised in Table 11.1.

d) Tetrachloropyrimidine (8)

Mixtures of tetrachloropyrimidine (8) (0.7g,

Table 11.1 Fluorination of trichloro-1,2,3-triazine (20) with the KF/diethyl ether/sulpholane system

<u>Conditions</u>	<u>Conversion</u>	<u>Yield</u>	
		(102)	(28)
r.t. * 7 days	39%	21%	18%
r.t. * 48hr	75%	58%	17%
r.t. * 24hr	95%	82%	13%

3.2mmol), potassium fluoride (2.2g, 38.5mmol), diethyl ether (20ml) and sulpholane (10ml) were stirred vigorously at room temperature for 24 and 48hr respectively. In both cases the work-up gave a colourless oil, which was identified as a mixture of 2,4-dichlorodifluoropyrimidine (141) and 5-chlorotrifluoropyrimidine (142) by ^{19}F n.m.r. and g.l.c. (capillary). The results of these reactions are given in Table 11.2 below.

Table 11.2 Fluorination of tetrachloropyrimidine (8) with the KF/diethyl ether/sulpholane solvent system

<u>Conditions</u>	<u>Conversion</u>	<u>Yield</u>	
		(141)	(142)
r.t. * 24hr	80%	51%	29%
r.t. * 48hr	73%	33%	40%

e) Tetrachloropyridazine (3)

Mixtures of tetrachloropyridazine (3) (0.7g, 3.2mmol), potassium fluoride (2.2g, 38.5mmol), diethyl ether (20ml) and sulpholane (10ml) were stirred vigorously at room temperature for periods of up to 7 days. Work-up did not give any fluorinated products, as shown by ^{19}F n.m.r. and g.l.c. (capillary).

2. Using the di-n-butyl ether/sulpholane solvent systema) Basic method

The basic method is the same as that employed for the previous fluorinations (11.B.1a), except that a solution of the perchloroheteroaromatic in di-n-butyl ether was used. Fluorinated products were identified from the m.s.-g.l.c. (capillary) and ^{19}F n.m.r. of the di-n-butyl ether solutions.

b) Tetrachloropyrimidine (8)

A mixture of tetrachloropyrimidine (8) (2.0g, 10.8mmol), potassium fluoride (6.3g, 0.11mol), di-n-butyl ether (30ml) and sulpholane (5ml) was stirred vigorously at 140°C for 24hr. ^{19}F n.m.r. and m.s.-g.l.c. (capillary) of the di-n-butyl ether layer indicated one product, identified as 5-chlorotrifluoropyrimidine (142) (46%).

c) Tetrachloropyridazine (3)

A mixture of tetrachloropyridazine (3) (2.0g, 10.8mmol), potassium fluoride (6.9g, 0.12mol), di-n-butyl

ether (30ml) and sulpholane (5ml) was heated at 140°C for 24hr with vigorous stirring. ^{19}F n.m.r. and m.s.-g.l.c. (capillary) of the di-n-butyl ether layer showed a single product, which was identified as tetrafluoropyridazine (21) (55%).

d) Pentachloropyridine (143)

A mixture of pentachloropyridine (143) (2.0g, 8.0mmol), potassium fluoride (6.9g, 0.12mol), di-n-butyl ether (30ml) and sulpholane (5ml) was vigorously stirred at 150°C for 65hr. Analysis of the di-n-butyl ether layer by ^{19}F n.m.r. and m.s.-g.l.c. (capillary) indicated that the sole product was 3,5-dichlorotrifluoropyridine (144) (58%).

CHAPTER TWELVEEXPERIMENTAL FOR CHAPTER FOURPHOTOLYSIS OF FLUORINATED 1,2,3-TRIAZINES12.A Low temperature photolyses1. Apparatus and experimental procedure

The modified i.r. cell for low temperature study is shown in Figure 12.1. The basic cell was additionally equipped with a quartz window for u.v. irradiation. Two types of holder were used for the KBr plate on which the samples were deposited. Figure 12.2 illustrates a glass mounting for a standard aluminium i.r. plate-holder into which the KBr plate was mounted, whilst Figure 12.1 shows the alternative holder with the KBr plate mounted in a copper block. The cell with the glass mounting (Figure 12.2) was used for all experiments with perfluoro-4,6-bis-isopropyl-1,2,3-triazine (93). The photolyses with trifluoro-1,2,3-triazine (28) were initially attempted using the same cell, to allow direct comparison of results, but it was found that there was too great a temperature difference between the glass and the KBr plate, presumably due to poor contact between the glass and the aluminium plate holder, which always resulted in the deposition of the volatile trifluoro-1,2,3-triazine onto the glass surround rather than onto the KBr plate. The cell containing the alternative copper block mounting (Figure 12.1) was subsequently used for all the experiments with trifluoro-1,2,3-triazine (28).

APPARATUS FOR LOW TEMPERATURE PHOTOLYSIS

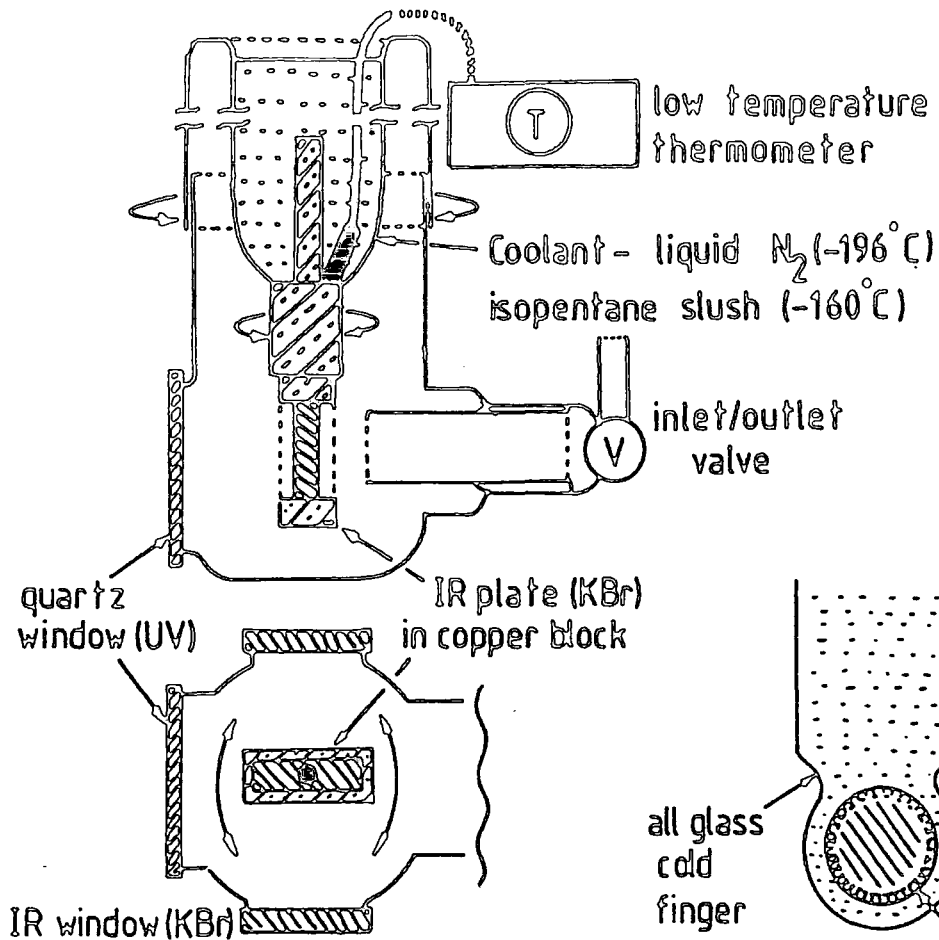

FIGURE 12.1

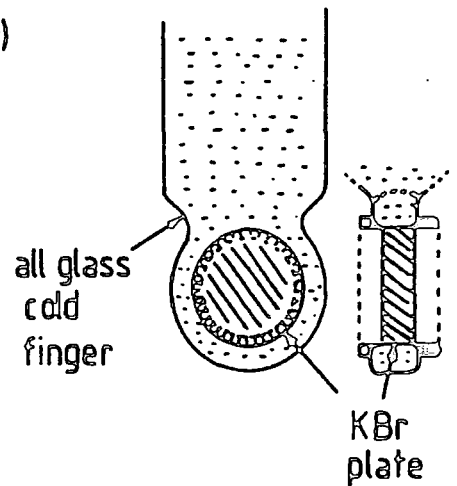

FIGURE 12.2

PROCEDURE FOR LOW TEMPERATURE PHOTOLYSIS

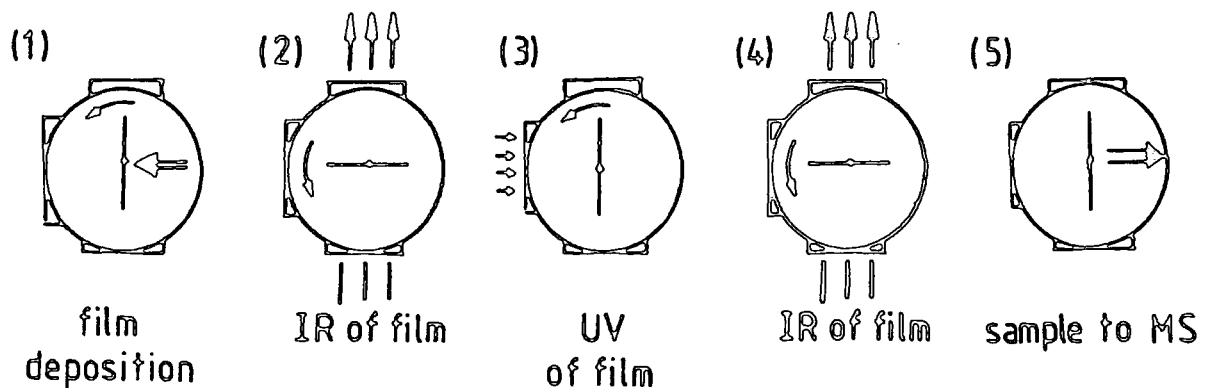

FIGURE 12.3

The detailed experimental procedure is described in the following paragraphs, and is summarised schematically, in terms of the position of the KBr plate, in Figure 12.3.

The cell was evacuated for several hours prior to use under high vacuum ($< 10^{-3}$ mm Hg), liquid N_2 was added to the reservoir, and the plate allowed to cool. The cell inlet system incorporated a glass sleeve (Figure 12.1) which could be moved up against the KBr plate prior to admitting the triazine into the cell through the vacuum line. This sleeve ensured that the triazine was deposited onto a defined area of the plate, and not the surrounding surfaces. The rate of deposition was carefully controlled *via* the the taps on the vacuum line to give as thin a film of triazine as possible on the plate (indicated by a slight fogging of the plate). The i.r. spectrum of the triazine was recorded at $-196^{\circ}C$, and the sample was then irradiated at 254nm for the required time. The i.r. spectrum of the product was recorded at $-196^{\circ}C$, the liquid N_2 removed from the reservoir, and the cell connected to the mass spectrometer. The temperature of the KBr plate (as indicated by the temperature of the bottom of the reservoir) was continuously monitored using a copper/constantan thermocouple as it warmed up towards room temperature. The cell with the glass mounting (Figure 12.2) was allowed to warm up without the addition of any coolant to control the rate of warming, whereas for the cell with the copper block mounting (Figure 12.1), at $\approx -155^{\circ}C$ an isopentane slush bath was added to the reservoir to control the rate of temperature rise of the plate as it warmed up.

The recorded temperatures given in this experimental section are not absolute, since they will depend upon the thermal characteristics of the individual cell employed. However, for each cell the rate of temperature rise was both consistent and reproducible over many experiments. This enables the direct comparison of results obtained using the same cell with a high degree of accuracy.

The mass spectral data were acquired as follows. The spectrometer scanned at ≈ 9 s intervals recording all masses observed, but the printout obtained for each scan gave only the five most abundant masses (in terms of ion current) and the highest mass detected. At the end of an experiment, XY plots of the ion current for particular masses of interest with scan number (and hence time) were obtained, and using this with the temperature data (the temperature was recorded every ≈ 10 scans, *i.e.* ≈ 90 s intervals), the results from each experiment could be interpreted.

2. Trifluoro-1,2,3-triazine (28)

a) M.s. sampling of (28)

Trifluoro-1,2,3-triazine (28) was deposited onto the plate and sampled into the mass spectrometer using the procedure described in 12.A.1. The following masses were consistently detected from the given temperatures.

m/z

107	-45°C	M ⁺ - N ₂
135	-36°C	M ⁺

b) Photolysis of (28)

(28) was deposited onto the plate at -196°C , i.r. spectrum no. 5, and then irradiated at 253.7nm for 3hr using the method given in 12.A.1, i.r. spectrum no. 6. Mass spectroscopic sampling gave the following masses detected consistently from the specified temperatures.

<u>m/z</u>			
169	-60°C	M^+ - FCN	dimer (<u>146</u>)
107	-58°C	M^+	azete (<u>145</u>)
135	-43°C	M^+	(<u>28</u>)

These results *versus* the starting material (28) (see 12.A.2a) are displayed in the form of a graph (Figure 12.4), which shows qualitatively when the principal masses associated with the starting material (28) and the photolysate were consistently detected with respect to the temperature of the KBr plate. The masses indicated below the line are those associated with trifluoro-1,2,3-triazine (28), whilst those above the line are from the photolysate.

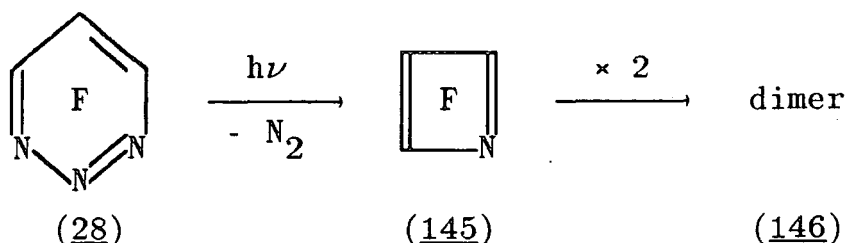
c) M.s. sampling of pentafluoropyridine (39)

Pentafluoropyridine (39) was deposited onto the plate, and sampled into the mass spectrometer using the procedure described in 12.A.1. The following mass was

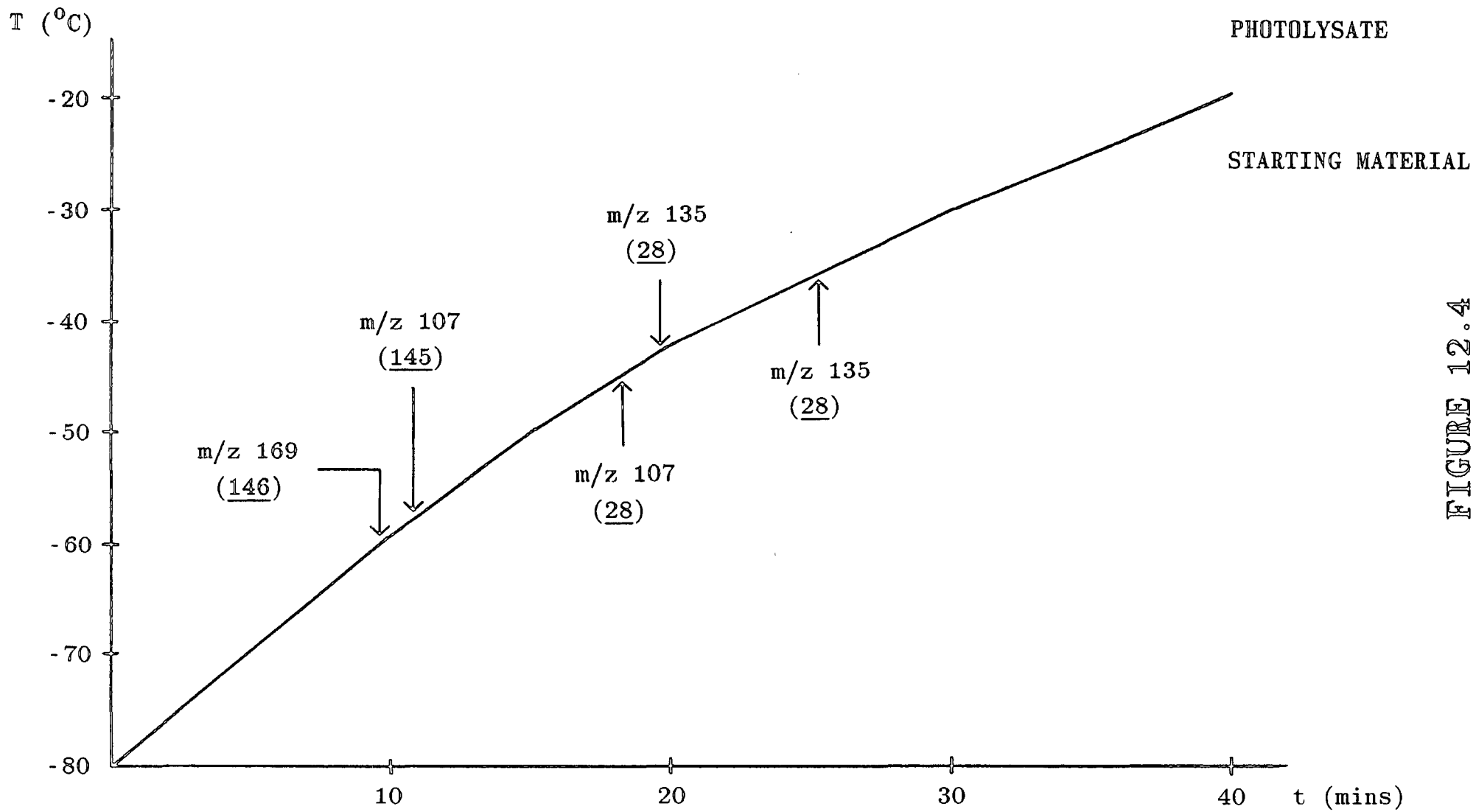

FIGURE 12.4

consistently detected from the given temperature.

<u>m/z</u>		
169	-77°C	M ⁺

d) Photolysis of (39)

(39) was deposited onto the plate at -196°C, its i.r. spectrum recorded, and then irradiated at 253.7nm for 3hr. The i.r. spectrum after photolysis showed no visible change. Mass spectroscopic sampling gave the following mass detected consistently from the given temperature.

<u>m/z</u>		
169	-80°C	M ⁺ (39)

e) Attempted trapping of azete (145) with furan

Trifluoro-1,2,3-triazine (28) was irradiated at 253.7nm for 4hr. A small quantity of furan was deposited on top of the photolysate prior to sampling into the mass spectrometer, which gave the following masses consistently detected from the specified temperatures.

<u>m/z</u>			
169	-63°C	M ⁺ - FCN	dimer (146)
107	-59°C	M ⁺	azete (145)
135	-44°C	M ⁺	(28)

There were no masses consistently detected which would correspond to a possible 1:1 adduct between trifluoroazete (145) and furan (M⁺, 175).

f) Co-photolysis of trifluoro-1,2,3-triazine (28) with perfluoro-4,6-bis-isopropyl-1,2,3-triazine (93)

Trifluoro-1,2,3-triazine (28) was deposited onto the plate and irradiated at 253.7nm for 4hr. Perfluoro-4,6-bis-isopropyl-1,2,3-triazine (93) was then deposited on top of the photolysed trifluoro-1,2,3-triazine, and irradiated at 253.7nm for 2hr. Sampling into the mass spectrometer gave the following results.

<u>m/z</u>			
169	-59°C	M ⁺ - FCN	dimer (146)
107	-57°C	M ⁺	azete (145)
135	-40°C	M ⁺	(28)
407	-32°C	M ⁺	azete (94)
745	-15°C	M ⁺ - CF ₃	dimer (95)
435	-4°C	M ⁺	(93)

No masses corresponding to a possible co-dimer of the two azetes (94) and (145) (M⁺, 514) were detected.

3. Perfluoro-4,6-bis-isopropyl-1,2,3-triazine (93)

(with Dr. T. Shepherd)

a) M.s. sampling of (93)

Perfluoro-4,6-bis-isopropyl-1,2,3-triazine (93) was deposited onto the plate and sampled into the mass spectrometer using the procedure described in 12.A.1. The following masses were consistently detected from the given temperatures.

<u>m/z</u>		
407	-10°C	M ⁺ - N ₂

435 -5°C M⁺b) Photolysis of (93)

(93) was deposited onto the plate at -196°C, i.r. spectrum no. 7, and then irradiated at 253.7nm for 2hr using the method given in 12.A.1, i.r. spectrum no. 8. Mass spectroscopic sampling gave the following masses detected consistently from the specified temperatures.

<u>m/z</u>			
407	-30°C	M ⁺	azete (<u>94</u>)
745	-15°C	M ⁺ - CF ₃	dimer (<u>95</u>)
435	-5°C	M ⁺	(<u>93</u>)

These results *versus* the starting material (93) (see 12.A.3a) are also displayed in the form of a graph (Figure 12.5), which shows qualitatively when the principal masses associated with the starting material (93) and the photolysate were detected consistently with respect to the KBr plate temperature. The masses indicated below the line are those associated with the starting material (93), whilst those above the line are from the photolysate.

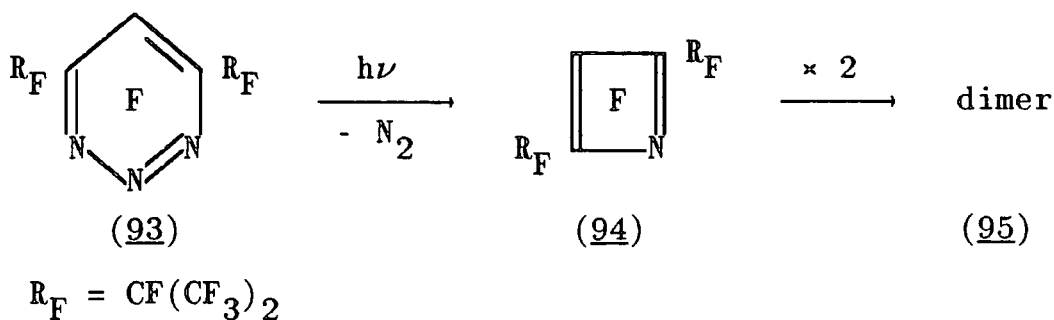

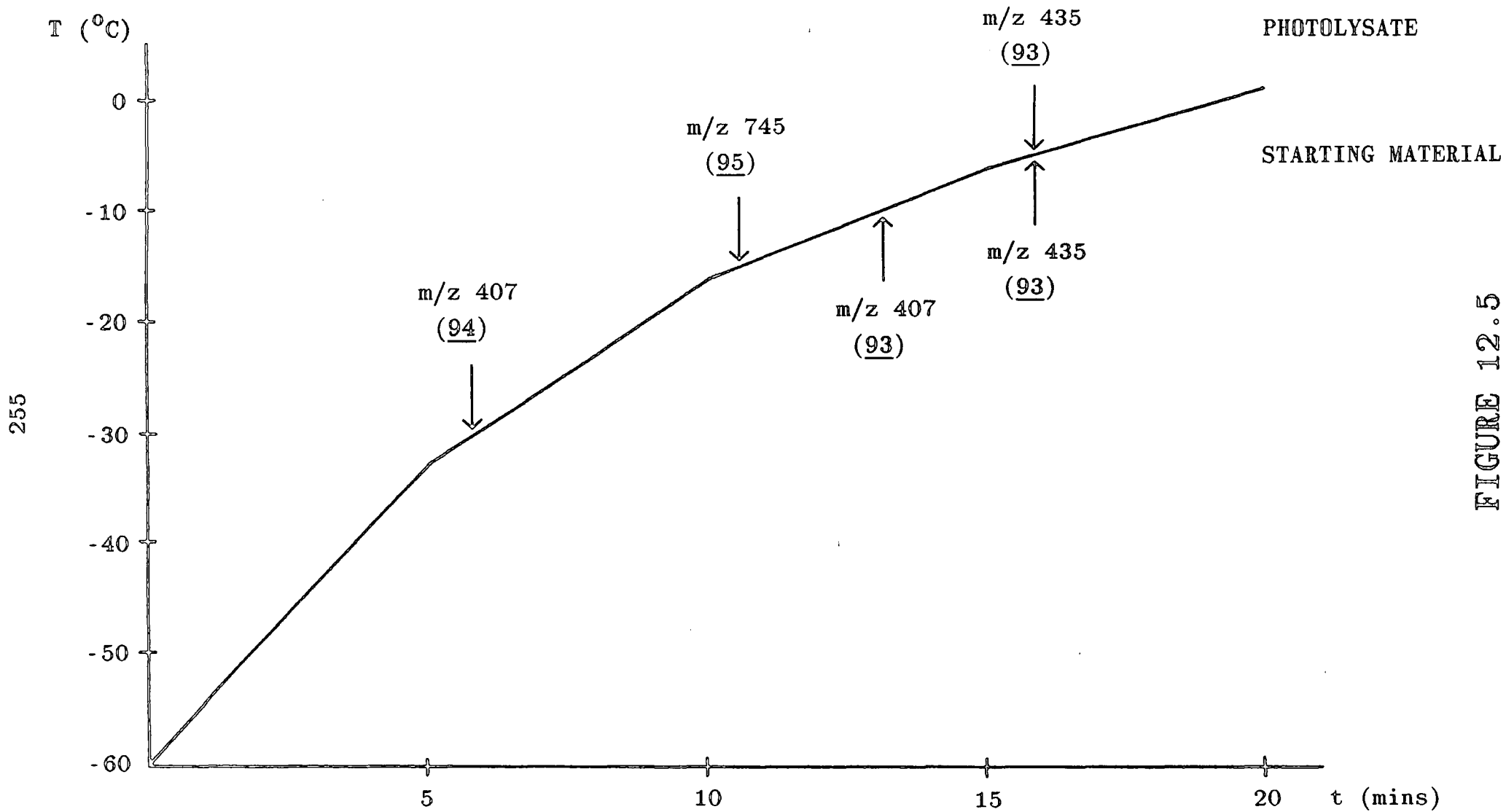

FIGURE 12.5

c) Trapping of azete (94) with furan

Perfluoro-4,6-bis-isopropyl-1,2,3-triazine (93) was irradiated at 253.7nm for 3hr. A small quantity of furan was deposited on top of the photolysate prior to mass spectroscopic sampling, which gave the following masses consistently detected from the given temperatures.

<u>m/z</u>			
407	-33°C	M ⁺	azete (<u>94</u>)
745	-16°C	M ⁺ - CF ₃	dimer (<u>95</u>)
475	-10°C	M ⁺	1:1 adduct (<u>94a</u>)
435	-6°C	M ⁺	(<u>93</u>)

These results are also presented graphically (Figure 12.6) *versus* the starting material (93) (see 12.A.3a), which shows qualitatively when the principal masses associated with the starting material (93) and the photolysate were detected consistently with respect to the temperature of the KBr plate. The masses indicated below the line are those associated with the starting material (93), whilst those above the line are from the photolysate.

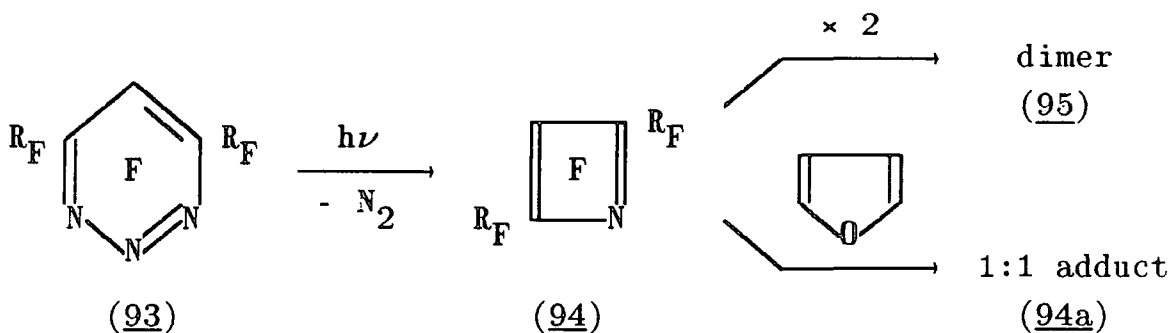

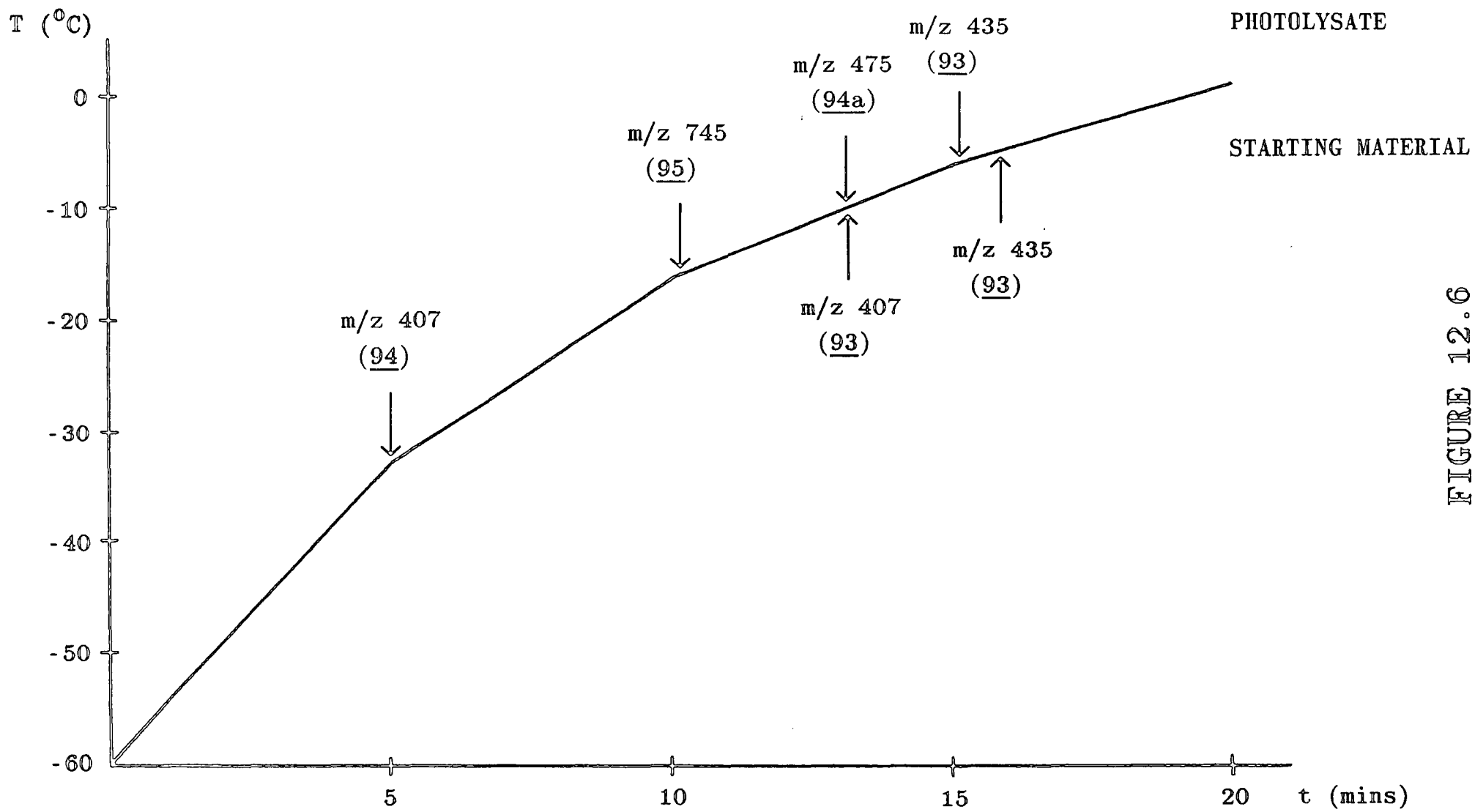

FIGURE 12.6

12.B Transference photolysis of perfluoro-4,6-bis-isopropyl-1,2,3-triazine (93)

1. At 254nm and 8mm Hg

Perfluoro-4,6-bis-isopropyl-1,2,3-triazine (93) (1.0g, 2.3mmol) was placed in the large silica transference vessel (360 × 100mm), the system was cooled in liquid air, evacuated, and the pressure set to 8mm Hg (air). The system was then irradiated at 253.7nm for 24hr whilst under transference, after which time all the starting material had transferred to the cold-trap. The transferred material (0.8g) was shown by g.l.c. (capillary) to consist of essentially one component, which was identified as perfluoro-2,4,6,8-tetrakis-isopropyl-1,5-diazatricyclo-[4.2.0.0^{2,5}]octa-3,7-diene (95) (86%) by comparison of its g.l.c. (capillary) and ¹⁹F n.m.r. with those of an authentic sample.

2. Attempted trapping of azete (94)

a) (93) (0.5g, 1.1mmol) was irradiated at 253.7nm and 8mm Hg pressure for 12hr whilst under transference, with furan (2.0g, 29.4mmol) transferred *in vacuo* to the cold-trap prior to photolysis. The contents of the trap were allowed to warm to room temperature, and was shown by g.l.c. (capillary) to consist mainly of the azete dimer (95), with a trace of a 1:1 adduct.

b) (93) (0.5g, 1.1mmol) was again irradiated at 253.7nm and 4mm Hg pressure for 12hr whilst under transference in the presence of furan (4.0g, 58.8mmol) which

was transferred *in vacuo* to the large silica vessel prior to photolysis. The products were again identified by g.l.c. (capillary) as mainly the azete dimer (95), with a trace of a 1:1 adduct.

12.C Static photolysis of trifluoro-1,2,3-triazine (28)

Trifluoro-1,2,3-triazine (28) (0.1g, 0.7mmol) was sealed in a silica tube (200 × 13mm) under high vacuum ($< 10^{-3}$ mm Hg), and irradiated at 253.7nm for 8 days. A light brown polymeric solid was formed on the walls of the tube, which was identified as poly(trifluoroacrylonitrile) (157) (Decomposition temperature in argon atmosphere 155 - 162°C, lit.⁸⁹ in nitrogen atmosphere 145°C). I.r. spectrum no. 9.

CHAPTER THIRTEENEXPERIMENTAL FOR CHAPTER FIVECHEMISTRY OF SOME PERFLUOROISOPROPYLPYRIDAZINES13.A Synthesis of perfluoroisopropylpyridazines1. Perfluoro-4,5-bis-isopropylpyridazine (60)⁸⁶

Tetrafluoropyridazine (21) (6.3g, 41.4mmol), caesium fluoride (1.0g, 6.6mmol) and sulpholane (30ml) were placed in a dry 2-necked flask against a flow of dry nitrogen, a bladder containing hexafluoropropene (14.2g, 94.7mmol) was attached, and the flask cooled in liquid air and evacuated ($< 10^{-2}$ mm Hg). The mixture was allowed to warm up to room temperature, hexafluoropropene was admitted into the flask in one portion from the bladder, and the mixture vigorously stirred at room temperature for 48hr. Vacuum transfer yielded perfluoro-4,5-bis-isopropylpyridazine (60) as white crystals (14.1g, 75%). N.m.r spectrum no. 20 (¹³C), i.r. spectrum no. 11, mass spectra no. 22 (EI+) and no. 23 (CI-).

2. Rearrangement of perfluoro-4,5-bis-isopropylpyridazine (60) with fluoride ion⁸⁶

A mixture of perfluoro-4,5-bis-isopropylpyridazine (60) (16.0g, 35.4mmol) and caesium fluoride (6.4g, 42.1mmol) in sulpholane (50ml) was stirred vigorously at 120°C for 21hr under nitrogen. A colourless oil (13.7g) isolated by vacuum transfer was shown by g.l.c. (column A, 80°C to consist of three major components. Separation by preparative

scale g.l.c. (column A, 120⁰C) gave perfluoro-3,4,6-tris-isopropylpyridazine (159) as white crystals (2.2g, 21%), n.m.r. spectrum no. 22 (¹³C), i.r. spectrum no. 13, mass spectra no. 26 (EI+) and no. 27 (CI-), perfluoro-3,5-bis-isopropylpyridazine (55) as a colourless oil (8.8g, 54%), n.m.r. spectrum no. 21 (¹³C), i.r. spectrum no. 12, mass spectra no. 24 (EI+) and no. 25 (CI-), and perfluoro-4-isopropylpyridazine (160) as a colourless oil (0.8g, 4%), n.m.r. spectrum no. 19 (¹³C), i.r. spectrum no. 10, mass spectra no. 20 (EI+) and no. 21 (CI-).

3. Reaction of perfluoro-3,4,6-tris-isopropylpyridazine (159) and tetrafluoropyridazine (21) with fluoride ion

A mixture of perfluoro-3,4,6-tris-isopropylpyridazine (159) (1.0g, 1.7mmol), tetrafluoropyridazine (21) (0.5g, 3.3mmol) and caesium fluoride (1.1g, 7.2mmol) in sulpholane (10ml) was vigorously stirred at 120⁰C for 48hr. A liquid product (0.7g) isolated by vacuum transfer was shown by g.l.c. (column A, 80⁰C) to be a mixture of (159) (5%), perfluoro-3,5-bis-isopropylpyridazine (55) (66%), and perfluoro-4-isopropylpyridazine (160) (27%).

4. Reaction of tetrafluoropyridazine (21) with perfluoro-cyclobutene

a) At room temperature

Tetrafluoropyridazine (21) (2.0g, 13.2mmol), caesium fluoride (1.3g, 8.6mmol) and sulpholane (10ml) were placed in a dry 2-necked flask against a flow of dry

nitrogen, a bladder containing perfluorocyclobutene (4.5g, 27.8mmol) was attached, and the flask cooled in liquid air and evacuated ($< 10^{-2}$ mm Hg). The mixture was allowed to warm up to room temperature, perfluorocyclobutene was admitted into the flask in one portion from the bladder, and the mixture vigorously stirred at room temperature for 108hr. A colourless oil (1.8g) isolated by vacuum transfer was shown by m.s.-g.l.c. (capillary) to contain mainly tetrafluoropyridazine (21) (45%) and perfluorocyclobutene trimer (164) (29%), together with a trace of a perfluoro-bis-cyclobutylpyridazine (5%) (M^+ , 476).

b) At 60°C

Tetrafluoropyridazine (21) (2.0g, 13.2mmol) was polyfluoroalkylated with perfluorocyclobutene (4.6g, 28.4mmol) and caesium fluoride (1.9g, 12.5mmol) in sulpholane (10ml) using the basic procedure described above (13.A.4a), except that after admitting the perfluorocyclobutene into the flask, the mixture was vigorously stirred at 60°C for 72hr. A colourless oil (0.8g) isolated by vacuum transfer was identified by m.s.-g.l.c. (capillary) as a mixture of tetrafluoropyridazine (21) (73%), perfluorocyclobutene trimer (164) (7%) and a perfluoro-bis-cyclobutylpyridazine (9%) (M^+ , 476).

Several larger scale reactions were attempted at temperatures up to 120°C in order to obtain a sufficient quantity of the perfluoro-bis-cyclobutylpyridazine to isolate by preparative scale g.l.c., but gave only mixtures

containing perfluorocyclobutene trimer (164) and recovered tetrafluoropyridazine (21).

5. Reaction of perfluoro-4,5-bis-isopropylpyridazine (60) with tetrafluoroethylene

a) A glass tube (300 × 22mm) was loosely packed with shredded poly(tetrafluoroethylene), evacuated to 0.05mm Hg, and heated in a furnace at 600°C for 0.5hr. Volatile products were collected in two liquid air cooled traps connected in series. The gaseous product (14.5g) was identified as essentially pure tetrafluoroethylene¹³¹ from its i.r. spectrum, and was used immediately for the next stage without further purification.

b) Perfluoro-4,5-bis-isopropylpyridazine (60) (3.0g, 6.6mmol), caesium fluoride (2.0g, 13.2mmol) and sulpholane (30ml) were placed in a dry 2-necked flask equipped with a condenser and gas bladder against a flow of dry nitrogen. The flask was evacuated to high vacuum ($< 10^{-2}$ mm Hg) and heated to 60°C. Tetrafluoroethylene (3.1g, 31.0mmol) from the above preparation (13.A.5a) was admitted into the system, and the mixture vigorously stirred at 60°C for 24hr. A yellow oil (1.8g) isolated by vacuum transfer was shown by m.s.-g.l.c. (capillary) to be a multi-component mixture, with the major constituents identified as tetrafluoroethylene oligomers (30%), a perfluoro-ethyl-bis-isopropylpyridazine (10%) (M^+ , 552), perfluoro-3,4,6-tris-isopropylpyridazine (159) (11%) (M^+ , 602), a perfluoro-bis-ethyl-bis-isopropylpyridazine (22%) (M^+ , 652) and a perfluoro-tris-

ethyl-isopropylpyridazine (10%) (M^+ , 602). The mixture was too complex to allow separation by preparative scale g.l.c.

6. Reaction of perfluoro-4-isopropylpyridazine (160) with perfluoro-2-methylpent-2-ene (167)

a) At room temperature

A mixture of perfluoro-2-methylpent-2-ene (167) (1.0g, 3.3mmol) and caesium fluoride (2.4g, 15.8mmol) in sulpholane (10ml) was stirred vigorously at room temperature for 24hr. Perfluoro-4-isopropylpyridazine (160) (1.0g, 3.3mmol) was then added, and the resultant mixture stirred for a further 24hr at room temperature. A colourless oil (1.7g) isolated by vacuum transfer was shown by g.l.c. (capillary) to be a mixture of (160) (53%) and (167) (47%).

b) At 60°C

The reaction in 13.A.6a above was repeated, except that after the addition of perfluoro-4-isopropylpyridazine (160), the mixture was vigorously stirred at 60°C for 24hr. Analysis of both the vacuum transferred material (1.6g) and the residual sulpholane by g.l.c. (capillary) showed them to contain only the starting materials (160) and (167).

A further repeat of the reaction at 120°C also gave only recovered starting materials.

13.B Transference photolysis of perfluoro-3,5-bis-isopropylpyridazine (55)

1. At 254nm

a) At 8mm Hg

Perfluoro-3,5-bis-isopropylpyridazine (55) (2.0g, 4.4mmol) was placed in the large silica transference vessel (360 × 100mm), the system was cooled in liquid air, evacuated, and the pressure set to 8mm Hg (air). The system was then irradiated at 253.7nm for 48hr whilst under transference, after which time all the starting material had transferred to the cold-trap. The transferred material (1.5g) was shown by m.s.-g.l.c. (capillary and column A, 60°C) to consist of perfluoroisobutyronitrile (83) (1%) (M^+ - F, 176), perfluoro-3,5-bis-isopropyl-1,2-diazabicyclo[2.2.0]hexa-2,5-diene (152) (1%) (M^+ , 452), perfluoro-1,3-bis-isopropyl-2,5-diazabicyclo[2.2.0]hexa-2,5-diene (153) (<1%) (M^+ , 452), two isomers (158a) (3%) (M^+ , 514) and (158b) (2%) (M^+ , 514), perfluoro-2,5-bis-isopropylpyrazine (154) (53%) (M^+ , 452) and the starting material (55) (28%) (M^+ , 452), together with several unidentified minor components. Very small quantities (\approx 1mg) of the two isomers (158a) and (158b) were eventually isolated from the mixture by preparative scale g.l.c. (analytical column A, room temperature) and identified as perfluoro-bis-isopropyldiazacyclo-octatetraenes (158a), n.m.r. spectrum no. 24 (^{19}F), mass spectrum no. 28 (EI+), and (158b), n.m.r. spectrum no. 25 (^{19}F), mass spectrum no. 29 (EI+).

b) At 4mm Hg

(55) (2.0g, 4.4mmol) was irradiated at 253.7nm for 48hr whilst under transference. The transferred material (1.3g) was shown by g.l.c. (capillary) to contain perfluoroisobutyronitrile (83) (1%), the valence isomers (152) (8%) and (153) (2%), the two perfluoro-bis-isopropyldiazacyclo-octatetraenes (158a) (5%) and (158b) (1%), the pyrazine (154) (25%) and the starting material (55) (51%), together with several unidentified minor components.

A small quantity (20 μ l) of the product mixture was sealed in a glass capillary tube and heated at 80°C for 6hr. Analysis of the liquid (20 μ l) by g.l.c. (capillary) showed it to consist of perfluoroisobutyronitrile (83) (1%), the valence isomer (152) (2%), the two perfluoro-bis-isopropyldiazacyclo-octatetraenes (158a) (3%) and (158b) (10%), the pyrazine (154) (28%) and the starting material (55) (52%), together with several unidentified minor components.

c) At 2mm Hg

(55) (2.0g, 4.4mmol) was irradiated at 253.7nm for 48hr whilst under transference. The transferred material (1.6g) was shown by g.l.c. (capillary) to contain perfluoroisobutyronitrile (83) (<1%), the valence isomers (152) (4%) and (153) (1%), the two perfluoro-bis-isopropyldiazacyclo-octatetraenes (158a) (4%) and (158b) (<1%), the pyrazine (154) (12%) and the starting material (55) (70%), together with several unidentified minor components.

2. At 300nm

(55) (2.0g, 4.4mmol) was irradiated at 300nm for 48hr whilst under transference at 8mm Hg pressure (air). The transferred material (1.4g) was shown by g.l.c. (capillary) to contain, the valence isomer (152) (4%), the pyrazine (154) (12%) and the starting material (55) (80%), together with several unidentified minor components. The two perfluoro-bis-isopropyldiazacyclo-octatetraenes (158a) and (158b) were not detected in the product mixture.

13.C Low temperature photolyses of perfluoroalkyl-pyridazines

1. Perfluoro-4,5-bis-isopropylpyridazine (60)

(60) was deposited onto the plate at -196°C , its i.r. spectrum recorded, and then irradiated at 253.7nm for 2hr using the method given in 12.A.1. No change in the i.r. spectrum was observed. Irradiation for a further 4hr also resulted in no visible change to the i.r. spectrum.

2. Perfluoro-3,5-bis-isopropylpyridazine (55)

(55) was deposited onto the plate at -196°C and its i.r. spectrum recorded. The pyridazine was then irradiated for 4hr at 253.7nm using the method given in 12.A.1, after which time there was no visible change in the i.r. spectrum. Irradiation for a further 4hr also resulted in no apparent change in the i.r. spectrum.

13.D Chemistry of perfluoro-3,4,6-tris-isopropylpyridazine
(159)

1. Photolysis

a) Under transference

Perfluoro-3,4,6-tris-isopropylpyridazine (159) (1.0g, 1.7mmol) was placed in the large silica transference vessel (360 × 100mm), the system cooled in liquid air, evacuated, and the pressure set to 5mm Hg (air). The system was irradiated at 253.7nm for 20hr whilst under transference, although not all the starting pyridazine (159) had transferred to the cold-trap. The transferred material (0.2g) was shown by g.l.c. (capillary) to be the pyridazine (159). The residual solid in the silica vessel was washed out with diethyl ether (20ml) and identified by g.l.c. (capillary) as the starting material (159).

b) In the vapour-phase

i) At 254nm

Perfluoro-3,4,6-tris-isopropylpyridazine (159) (0.5g, 0.83mmol) was sealed in a silica *rotaflo* tube (130 × 10mm) under high vacuum ($< 10^{-3}$ mm Hg) and irradiated at 253.7nm for 148hr. The solid material in the tube was washed out with diethyl ether (5ml), and identified by g.l.c. (capillary) as the starting material (159).

ii) At 366nm

(159) (0.5g, 0.83mmol) was sealed in a silica *rotaflo* tube (130 × 10mm) under high vacuum ($< 10^{-3}$ mm Hg)

and irradiated at 366nm for 155hr. The solid material in the tube was washed out with diethyl ether (3ml), and shown by g.l.c. (capillary) to be the starting material (159).

c) In solution

(159) (0.5g, 0.83mmol) in Arcton 113 (5ml) was sealed in a silica *rotaflo* tube (130 × 10mm) under high vacuum ($< 10^{-3}$ mm Hg) and irradiated at 253.7nm for 142hr. Analysis of the solution by g.l.c. (capillary) showed it to contain only the starting material (159).

2. Pyrolysis

Perfluoro-3,4,6-tris-isopropylpyridazine (159) (500mg, 0.83mmol) was passed through a quartz tube (250 × 15mm) loosely packed with type M quartz wool and heated to $700 \pm 3^{\circ}\text{C}$ (backing pressure 0.1mm Hg), and volatile products were collected in a liquid air-cooled trap. The yellow oil (385mg) was shown by g.l.c. (capillary) to contain mainly the starting material (159) (37%) and one product (39%), which was isolated by preparative scale g.l.c. (column A, 90°C) and identified as perfluoro-4-vinyl-3,6-bis-isopropylpyridazine (185) (127mg, 42% based on (159) used) (Found: C, 27.7%; N, 5.5%; M^+ , 514. $\text{C}_{12}\text{F}_{18}\text{N}_2$ requires C, 28.0%; N, 5.4%; M , 514). N.m.r. spectrum no. 25 (^{19}F), i.r. spectrum no. 14, mass spectrum no. 30 (EI+).

3. Nucleophilic reactionsa) With dimethylaminei) 5-dimethylamino-3,4,6-tris-perfluoroisopropylpyridazine (188)⁹³

Perfluoro-3,4,6-tris-isopropylpyridazine (159) (1.0g, 1.7mmol) and dry dimethylformamide (5ml) were placed in a *rotaflo* tube (200 × 16mm) which was cooled in liquid air, and dimethylamine (0.5g, 11.1mmol) transferred *in vacuo* into the tube. The mixture was allowed to warm up to room temperature, and vigorously stirred at room temperature for 22hr. The mixture was then poured into water (50ml), extracted with diethyl ether (50ml), and the ether layer washed with water (3 × 50ml) and dried over CaCl₂. Subsequent removal of the solvent using a rotary evaporator gave a pale yellow solid, which was recrystallised from n-hexane to give 5-dimethylamino-3,4,6-tris-perfluoro-isopropylpyridazine (188) as pale yellow crystals (0.9g, 86%, m.p. 125 - 127°C, lit.⁹³ 126 - 127°C). N.m.r. spectrum no. 26 (¹H and ¹⁹F).

ii) Reaction of (188) with boron trifluoride-etherate

A solution of (188) (0.5g, 0.80mmol) in dry diethyl ether (10ml) was cooled to 0°C (ice-water bath) and boron trifluoride-etherate (0.5ml, 3.9mmol) was added dropwise with stirring. The mixture was allowed to warm up to room temperature, with no colour change observed in solution. Subsequent refluxing of the mixture for 6hr also

resulted in no change in colour, and both the ^{19}F n.m.r. spectrum and g.l.c. (capillary) of the solution indicated only the presence of starting material (188).

iii) Pyrolysis

(188) (0.5g, 0.80mmol) was sealed in a small Carius tube (130 × 16mm) under high vacuum ($< 10^{-3}$ mm Hg) and heated at 150°C for 17hr. The contents of the tube were washed out with diethyl ether (5ml) and shown by g.l.c. (capillary) to be the starting material (188), with no evidence for a possible cyclisation product.

iv) Photolysis

(188) (0.2g, 0.32mmol) was sealed in a silica *rotaflo* tube (130 × 10mm) under high vacuum ($< 10^{-3}$ mm Hg) and irradiated at 253.7nm for 89hr. The residual solid was washed out of the tube with diethyl ether (5ml) and identified as the starting material (188) by g.l.c. (capillary).

Similar photolyses of (188) at 366nm for 104hr and at 253.7nm in Arcton 113 (4ml) for 83hr also gave only recovered starting material (188).

b) With 2,3-dimethylbut-2-ene

Perfluoro-3,4,6-tris-isopropylpyridazine (159) (0.3g, 0.50mmol) and 2,3-dimethylbut-2-ene (134) (1.0g, 11.9mmol) were sealed in a *rotaflo* tube (200 × 16mm) under

high vacuum ($< 10^{-3}$ mm Hg), and heated at 70°C for 96hr. No colour change was observed, and g.l.c. (capillary) of the mixture showed it to contain only the starting materials. Further heating at 150°C for 72hr also gave no apparent reaction, with g.l.c. (capillary) again indicating the presence of starting materials (134) and (159).

CHAPTER FOURTEENEXPERIMENTAL FOR CHAPTER SIXCHEMISTRY OF PERFLUORO-4-(2'-METHYLPENT-2'-YL)PYRIDAZINE14.A Starting materials1. Perfluoro-4-(2'-methylpent-2'-yl)pyridazinea) Perfluoro-2-methylpent-2-ene (167)⁵³

Caesium fluoride (5.4g, 35.5mmol) and acetonitrile (120ml) were placed in a large *rotaflo* tube (280 × 50mm) which was cooled in liquid air and hexafluoropropene (69.0g, 0.46mol) transferred *in vacuo* into the tube. The mixture was allowed to warm up to room temperature, when an exothermic reaction occurred (moderated by cooling in a cold water bath). The tube was then mechanically rotated for 68hr at room temperature, the lower layer (58.9g) removed, and shown by g.l.c. (column 0, 20°C) to be essentially pure perfluoro-2-methylpent-2-ene (167) (85%), identified by comparison of its ¹⁹F n.m.r. and g.l.c. with an authentic sample⁵³.

b) Perfluoro-4-(2'-methylpent-2'-yl)pyridazine (169)

A mixture containing perfluoro-2-methylpent-2-ene (167) (8.0g, 26.7mmol), caesium fluoride (7.5g, 49.3mmol) and sulpholane (20ml) was stirred vigorously at room temperature for 48hr. Tetrafluoropyridazine (21) (3.7g, 24.3mmol) was then added, and the mixture stirred for a further 90hr at room temperature. A colourless liquid (10.1g) isolated by vacuum transfer was shown by g.l.c.

(column A, 120°C) to be a mixture of (167) (18%), (21) (19%) and (169) (61%). Separation by preparative scale g.l.c. (column A, 120°C) gave pure perfluoro-4-(2'-methylpent-2'-yl)pyridazine (169)⁵³, a colourless oil (5.2g, 47%) (Found: C, 26.2; N, 6.4; F, 66.8%; M⁺, 452. Calculated for C₁₀F₁₆N₂: C, 26.5; N, 6.2; F, 67.3%; M, 452). N.m.r. spectrum no. 27 (¹⁹F and ¹³C), i.r. spectrum no. 15, mass spectra no. 31 (EI+) and no. 32 (CI-).

2. Perfluoro-4-(2'-methylpent-2'-yl)pyrimidine (199)

A mixture of perfluoro-2-methylpent-2-ene (167) (2.0g, 6.7mmol), caesium fluoride (2.8g, 18.4mmol) and sulpholane (10ml) was stirred vigorously at room temperature for 24hr. Tetrafluoropyrimidine (22) (1.4g, 9.2mmol) was then added, and the mixture stirred for a further 70hr at room temperature. A colourless liquid (2.5g) isolated by vacuum transfer was shown by g.l.c. (column A, 120°C) to be a mixture of (167) (10%), (22) (45%) and (199) (38%). Separation by preparative scale g.l.c. (column A, 120°C) gave pure perfluoro-4-(2'-methylpent-2'-yl)pyrimidine (199), a colourless oil (1.0g, 33% based on (167) used) (Found: C, 26.6; N, 6.4; F, 67.8%; M⁺, 452. C₁₀F₁₆N₂ requires C, 26.5; N, 6.2; F, 67.3%; M, 452). N.m.r. spectrum no. 28 (¹⁹F), i.r. spectrum no. 16, mass spectrum no. 33 (EI+).

14.B Photolysis

1. Under transference

a) At 254nm and 8mm Hg

Perfluoro-4-(2'-methylpent-2'-yl)pyridazine (169) (2.0g, 4.4mmol) was placed in the large silica transference vessel (360 × 100mm), the system was cooled in liquid air, evacuated, and the pressure set to 8mm Hg (air). The system was then irradiated at 253.7nm for 48hr whilst under transference, after which time all the starting material had transferred to the cold-trap. The transferred material (1.1g) was shown by g.l.c. (column A, 120°C) to consist of essentially one component (95%). Purification by preparative scale g.l.c. (column A, 120°C) gave perfluoro-2-(2'-methylpent-2'-yl)pyrazine (195), a colourless oil (Found: C, 26.2; N, 6.0; F, 66.9%; M⁺, 452. C₁₀F₁₆N₂ requires C, 26.5; N, 6.2; F, 67.3%; M, 452). N.m.r. spectrum no. 29 (¹⁹F), i.r. spectrum no. 17, mass spectra no. 34 (EI+) and no. 35 (CI-).

b) At 254nm and 2mm Hg

(169) (0.5g, 1.1mmol) was irradiated at 253.7nm and 2mm Hg pressure for 12hr whilst under transference. The transferred material (0.4g) was shown by g.l.c. (capillary) to consist of two major components, perfluoro-1-(2'-methylpent-2'-yl)-2,5-diazabicyclo[2.2.0]hexa-2,5-diene (196) (31%) (M⁺, 452), n.m.r. spectrum no. 29 (¹⁹F), mass spectrum no. 36 (EI+), and perfluoro-2-(2'-methylpent-2'-yl)pyrazine (195) (57%).

A small sample (20μl) of the mixture was sealed in

a glass tube and heated at 100°C for 12hr. G.l.c. analysis (capillary) of the product (20 μ l) showed it to be the pyrazine (195) (88%).

c) At 300nm and 2mm Hg

(169) (0.5g, 1.1mmol) was irradiated at 300nm and 2mm Hg pressure for 12hr whilst under transference. The transferred material (0.4g) was shown by g.l.c. (capillary) to consist mainly of the valence isomer (196) (54%) and pyrazine (195) (40%).

d) At 300nm and 0.1mm Hg

(169) (1.0 , 2.2mmol) was irradiated at 300nm and 0.1 mm Hg pressure for 10hr whilst under transference. The transferred material (0.9g) was shown by g.l.c. (capillary) to be a mixture of the valence isomer (196) (68%), pyrazine (195) (16%), and (169) (15%).

Attempted isolation of (196) by preparative scale g.l.c. (column A, 100°C) gave a liquid which by g.l.c. (capillary) was a mixture of (196) (14%) and (195) (86%). I.r. of the mixture no. 18.

e) Photochemical rearomatisation of (196)

A mixture of the valence isomer (196) (65%), pyrazine (195) (15%) and (169) (17%) (50mg) was sealed in a silica *rotaflo* tube (130 \times 10mm) under high vacuum ($< 10^{-3}$ mm Hg) and irradiated at 300nm for 12hr. The product (50mg) was shown by g.l.c. (capillary) to be a mixture of the pyrazine

(195) (80%) and (169) (17%).

2. Static

Perfluoro-4-(2'-methylpent-2'-yl)pyridazine (169) (0.1g, 0.22mmol) was sealed in a silica *rotaflo* tube (130 × 10mm) under high vacuum ($< 10^{-3}$ mm Hg) and irradiated at 366nm for 49hr. The product (0.1g) was shown by g.l.c. (capillary) and ^{19}F n.m.r. to be perfluoro-2-(2'-methylpent-2'-yl)pyrazine (195) (93%).

14.C Pyrolysis

1. Static

a) At 400°C

Perfluoro-4-(2'-methylpent-2'-yl)pyridazine (169) (0.5g, 1.1mmol) was sealed in a small Carius tube (130 × 16mm) under high vacuum ($< 10^{-3}$ mm Hg) and heated at 400°C for 16hr. Extensive decomposition occurred, and no volatile material could be isolated by vacuum transfer.

b) At 300°C

(169) (0.5g, 1.1mmol) was sealed in a small Carius tube (130 × 16mm) under high vacuum ($< 10^{-3}$ mm Hg), after first degassing the pyridazine three times *in vacuo* to remove dissolved oxygen, and heated at 300°C for 16hr. Vacuum transfer yielded a liquid product (0.3g, 60% recovery), shown by g.l.c. (capillary) to consist of two major components, which were isolated by preparative scale g.l.c. (Column A, 120°C) and identified as a mixture of

perfluoro-4-(2'-methylpent-2'-yl)pyrimidine (199) (76%), identified by comparison of its ^{19}F n.m.r. and g.l.c. with an authentic sample (14.A.2), and perfluoro-5-(2'-methylpent-2'-yl)pyrimidine (200) (14%), n.m.r. spectrum no. 31 (^{19}F), mass spectrum no. 37 (EI+). (Found: C, 26.2; N, 6.0; F, 67.8%; M^+ , 452. $\text{C}_{10}\text{F}_{16}\text{N}_2$ requires C, 26.5; N, 6.2; F, 67.3%; M, 452).

Small samples of (169) ($20\mu\text{l}$) were sealed in glass tubes and heated for 24hr at 150° , 200° , 250° , 280° and 300°C respectively. No significant isomerisation of (169) (as monitored by g.l.c. (capillary) and ^{19}F n.m.r.) was found to occur below 300°C .

2. Perfluoro-4-(2'-methylpent-2'-yl)pyrimidine (199)

(199) (0.5g, 1.1mmol) was sealed in a small Carius tube ($130 \times 16\text{mm}$) under high vacuum ($< 10^{-3}\text{mm Hg}$), after first degassing the pyrimidine three times *in vacuo*, and heated at 300°C for 21hr. Vacuum transfer yielded a liquid product (0.4g, 80% recovery), which was shown by ^{19}F n.m.r. and g.l.c. (capillary) to be the pyrimidine (199).

3. Flow

Perfluoro-4-(2'-methylpent-2'-yl)pyridazine (169) (0.8g, 1.8mmol) was passed through a quartz tube ($250 \times 15\text{mm}$) loosely packed with type M quartz wool and heated to 650°C (backing pressure 0.03 - 0.07mm Hg), and volatile products were collected in a liquid air-cooled trap. The product (0.3g) was shown by g.l.c. (capillary) to consist of

one major component, which was isolated by preparative scale g.l.c. (Column A, 120°C), and identified as perfluoro-4-(2'-propenyl)pyridazine (202), (0.2g, 43%) (M^+ , 264. $C_7F_8N_2$ requires M , 264). N.m.r. spectrum no. 32 (^{19}F), i.r. spectrum no. 19, mass spectra no. 38 (EI+) and no. 39 (CI-).

CHAPTER FIFTEENEXPERIMENTAL FOR CHAPTER SEVENPREPARATION AND ATTEMPTED REACTIONS OF HEXACHLOROCINNOLINE15.A Hexachlorocinnoline (78)1. Starting materialsa) 4-hydroxycinnoline (208)¹⁰⁸

A solution of o-aminoacetophenone (20.0g, 0.15mol) in concentrated hydrochloric acid (1000ml) was cooled in an ice-salt bath to $< 5^{\circ}\text{C}$ and diazotised by the dropwise addition of a solution of sodium nitrite (10.4g, 0.15mol) in 40ml water. The mixture was magnetically stirred at $< 5^{\circ}\text{C}$ for $\approx 10\text{min}$, and then heated at 60°C for 5hr. The solvent was removed using a rotary evaporator to give crude 4-hydroxycinnoline (208) as an orange-brown solid (34.0g). A small sample was recrystallised from ethanol (m.p. $225 - 227^{\circ}\text{C}$, lit.¹⁰⁸ $227 - 229^{\circ}\text{C}$).

b) 3-bromo-4-hydroxycinnoline (209)¹⁰⁷

Bromine (18ml, 55.8g, 0.35mol) was added dropwise over 1hr to a solution of the crude 4-hydroxycinnoline (208) (25.0g) in 5M sodium hydroxide (113.0g, 2.83mol in 570ml water). The resulting mixture was mechanically stirred at room temperature for 1hr, poured with stirring into a solution of glacial acetic acid (180ml) in water (570ml), and then filtered. The resulting solid was washed with ice-cold ethanol and dried to yield crude 3-bromo-4-hydroxy-

cinnoline (209) as a cream-coloured powder (18.8g, 77% crude yield from o-aminoacetophenone). A sample was recrystallised from ethanol (m.p. 274 - 276°C, lit.¹⁰⁷ 272 - 275°C).

c) 3-bromo-4-chlorocinnoline (210)¹⁰⁹

3-bromo-4-hydroxycinnoline (209) (20.0g, crude) was added to phosphorus oxychloride (120ml), and after the initial reaction had subsided, was refluxed in a pre-heated oil bath until all the cinnoline had dissolved, and then for a further 3min. The reaction mixture was poured slowly into ice-water (\approx 700ml) and stirred continuously until the ice had melted. The solution was filtered, and the resulting solid dried *in vacuo* to give crude 3-bromo-4-chlorocinnoline (210) as a brown powder (19.2g, 89% crude yield). A small sample was recrystallised from acetone (m.p. 151 - 154°C, lit.¹⁰⁹ 154 - 155°C).

d) 3,4-dichlorocinnoline (211)¹¹⁰

3-bromo-4-hydroxycinnoline (209) (10.0g, crude) was added to a mixture of phosphorus pentachloride (20.0g) in phosphorus oxychloride (50ml), and after the initial reaction had subsided, was refluxed in a pre-heated oil bath for 2hr. The reaction mixture was poured slowly onto ice (\approx 700ml) and stirred continuously until the ice had melted. The solution was filtered, and the resulting solid dried *in vacuo* to give crude 3,4-dichlorocinnoline (211) as a pale brown powder (7.5g, 85% crude yield). A small sample was recrystallised from petroleum ether (b.p. 60 - 80°C) (m.p.

123 - 126°C, lit.¹¹⁰ 126 - 127°C).

2. Hexachlorocinnoline (78)

a) From 3-bromo-4-chlorocinnoline (210)

i) Small scale

The required quantities of 3-bromo-4-chlorocinnoline (210) (crude) and powdered aluminium trichloride were placed in a 200ml capacity nickel-lined autoclave, which was frozen down in liquid air and evacuated. Chlorine was transferred *in vacuo* to the autoclave *via* a gas bulb (3000ml), and the autoclave was then sealed and heated in a furnace. At the end of the reaction period, the autoclave was allowed to cool and then vented. The contents were extracted with ice and chloroform (\approx 200ml of each), the chloroform layer washed with water (2 \times 200ml) and dried over CaCl_2 . Removal of the solvent using a rotary evaporator gave hexachlorocinnoline (78) as a pale yellow solid. Recrystallisation from n-hexane/toluene yielded pale yellow crystals (m.p. 189 - 191°C, lit.¹⁰⁴ 188 - 190°C. Found C, 28.4; N, 8.3; Cl, 63.2%; M^+ , 334. $\text{C}_8\text{Cl}_6\text{N}_2$ requires C, 28.5; N, 8.3; Cl, 63.2%; M, 334). N.m.r spectrum no. 33 (^{13}C), i.r. spectrum no. 20, mass spectrum no. 40 (EI+).

ii) Large scale

The required quantities of 3-bromo-4-chlorocinnoline (210) (crude) and powdered aluminium trichloride were placed in a 1.5dm³ nickel-lined autoclave, which was then sealed and evacuated, and pumping continued for \approx 30min

to remove hydrogen chloride. Liquid chlorine was run into the autoclave from a pre-weighed cylinder, and the autoclave was then heated in a furnace. At the end of the reaction period, the autoclave was allowed to cool, and the hydrogen chloride and excess chlorine were destroyed by venting through a solution of sodium hydroxide (115.0g) in water (3000ml). The contents were extracted with ice and chloroform (\approx 750ml of each), the chloroform layer washed with water (2×500 ml), and the aqueous washings extracted with chloroform (2×500 ml). The combined extracts were dried over CaCl_2 , and removal of the solvent using a rotary evaporator gave hexachlorocinnoline (78) as a pale yellow solid.

The results of all these successful chlorinations on both scales are summarised in Table 15.1.

Table 15.1 Chlorinations of 3-bromo-4-chlorocinnoline (210)

	(210)	AlCl_3	Cl_2	<u>Ratios</u>	<u>Conditions</u>	<u>Yield (78)</u>
1.	4.0g	22.0g	20.1g	1:10:17	$250^\circ\text{C} \times 34\text{hr}$	2.9g (52%)
2.	6.0g	32.9g	25.4g	1:10:15	$250^\circ\text{C} \times 34\text{hr}$	3.9g (47%)
3.	30.0g	112.9g	159.0g	1: 7:18	$250^\circ\text{C} \times 45\text{hr}$	18.8g (45%)
4.	50.0g	193.0g	217.0g	1: 7:15	$250^\circ\text{C} \times 46\text{hr}$	33.7g (49%)
5.	50.0g	83.0g	261.0g	1: 3:18	$250^\circ\text{C} \times 46\text{hr}$	42.5g (61%)

b) From 3,4-dichlorocinnoline (211)

The same procedure described in 15.A.2aii above was employed. A mixture of 3,4-dichlorocinnoline (211) (39.6g, 0.20mol) (crude), powdered aluminium trichloride (53.3g, 0.40mol) and chlorine (244.3g, 3.4mol) (ratio 1:2:17) was heated at 250°C for 48hr to give hexachlorocinnoline (78) (28.7g, 43%).

15.B Attempted fluorinations of hexachlorocinnoline (78)1. Static

An intimate mixture of the required quantities of hexachlorocinnoline (78) and dry potassium fluoride were sealed under vacuum in a 200ml capacity nickel-lined autoclave, which was placed in a pre-heated furnace and heated for the required period of time. At the end of the reaction period, the hot autoclave was connected to a liquid air-cooled trap whilst still in the furnace, and the fluorinated products were transferred *in vacuo* to the trap. The pale yellow solid products were removed from the trap against a flow of dry nitrogen, and their compositions determined by ^{19}F n.m.r. (acetone) and mass spectrometry. These products were shown to contain 4-hydroxypentafluorocinnoline (213) (M^+ , 236), 5-chloro-4-hydroxytetrafluorocinnoline (214) (M^+ , 252) and 5,7-dichloro-4-hydroxytrifluorocinnoline (216) (M^+ , 268).

The results of these fluorinations are summarised in Table 15.2.

Table 15.2 Attempted autoclave fluorinations of hexachlorocinnoline (78)

	<u>Mass</u> (78)	<u>Mass</u> KF	<u>Conditions</u>	<u>Mass of</u> <u>product</u>	<u>Composition</u> <u>of product</u>		
					(216)	(214)	(213)
1.	4.0g	23.9g	250 ⁰ C × 2hr	1.4g	75%	-	-
2.	3.0g	21.0g	250 ⁰ C × 3hr	1.0g	50%	50%	-
3.	3.0g	24.9g	250 ⁰ C × 6hr	0.3g	35%	65%	-
4.	3.0g	23.3g	290 ⁰ C × 12hr	0.2g	-	15%	85%
5.	4.0g	27.2g	300 ⁰ C × 2hr	0.5g	12%	57%	30%
6.	4.0g	23.7g	300 ⁰ C × 3hr	0.5g	4%	53%	43%
7.	4.0g	23.7g	300 ⁰ C × 4hr	0.8g	-	46%	54%
8.	4.0g	34.6g	350 ⁰ C × 3hr	-			

2. Vapour-phase

Dry potassium fluoride was placed in a quartz pyrolysis tube (300 × 18mm) which had a glass rod (4mm) down the centre. The tube was heated in a furnace at 250⁰C for 2hr under high vacuum (< 10⁻³mm Hg), and after careful removal of the rod to leave a small space along the axis, dried at 600⁰C for 3hr under high vacuum. The furnace was then cooled to 500⁰C, hexachlorocinnoline (78) (4.0g, 11.9mmol) was sublimed into the tube at ≈ 150⁰C under high vacuum, and products were collected at the other end of the tube by traps cooled in liquid air. The white crystalline solid product (0.4g) was shown by ¹⁹F n.m.r. (acetone) and

mass spectroscopy to be a multi-component mixture.

A repeat of this fluorination procedure with the furnace at 400°C yielded an off-white crystalline solid (0.7g), which ^{19}F n.m.r. (acetone) and mass spectroscopy also indicated was a complex mixture of products.

3. Solution

a) In diethyl ether/sulpholane

i) Atmospheric pressure

A mixture of hexachlorocinnoline (78) (1.0g, 3.0mmol), potassium fluoride (3.0g, 51.7mmol), diethyl ether (40ml) and sulpholane (10ml) was stirred vigorously at room temperature for 48hr. ^{19}F n.m.r. and g.l.c. (capillary) of the diethyl ether layer indicated that no fluorination had occurred. The mixture was heated at 45°C for a further 48hr with vigorous stirring, but again no evidence for fluorination was observed. The diethyl ether layer was separated from the mixture, and removal of the solvent *in vacuo* gave recovered starting material (78) (0.8g, 80%).

ii) Sealed tube

A mixture of hexachlorocinnoline (78) (2.0g, 5.9mmol), potassium fluoride (6.6g, 0.11mol), diethyl ether (30ml) and sulpholane (5ml) was sealed in a 70ml capacity steel tube under high vacuum, and heated in the rocking autoclave at 150°C for 72hr. The g.l.c. (capillary) of the diethyl ether layer indicated one product, which was identified by ^{19}F n.m.r. and m.s.-g.l.c. (capillary) as

5,7-dichlorotetrafluorocinnoline (215) (M^+ , 270; $C_8N_2Cl_2F_4$ requires M , 270). N.m.r. spectrum no. 34 (^{19}F). All attempts to isolate the product by removal of the solvent *in vacuo* resulted in the immediate hydrolysis to 5,7-dichloro-4-hydroxytrifluorocinnoline (216) (M^+ , 268; $C_8HN_2OCl_2F_3$ requires M , 268). N.m.r. spectrum no. 35 (^{19}F).

A control experiment was carried out under the same conditions as the fluorination, but in the absence of potassium fluoride. At the end of the reaction period, the diethyl ether layer was separated from the mixture and subsequent removal of the solvent *in vacuo* gave recovered hexachlorocinnoline (78) (1.5g, 75%).

b) In di-n-butyl ether/sulpholane

i) With potassium fluoride

A mixture of hexachlorocinnoline (78) (1.0g, 3.0mmol), potassium fluoride (3.1g, 53.4mmol), di-n-butyl ether (30ml) and sulpholane (5ml) was vigorously stirred at $150^{\circ}C$ for 48hr. Analysis of the di-n-butyl ether layer by ^{19}F n.m.r. and g.l.c. (capillary) indicated that no fluorination had occurred. The di-n-butyl ether layer was separated from the mixture, and removal of the solvent *in vacuo* gave recovered starting material (78) (0.9g, 90%).

ii) With caesium fluoride

A mixture of hexachlorocinnoline (78) (1.0g, 3.0mmol), caesium fluoride (8.2g, 53.9mmol), di-n-butyl ether (30ml) and sulpholane (5ml) was vigorously stirred at

150°C for 48hr. ^{19}F n.m.r. and g.l.c. (capillary) of the di-n-butyl ether layer showed that no fluorination had occurred. The di-n-butyl ether layer was separated from the mixture, and subsequent removal of the solvent *in vacuo* gave recovered starting material (78) (0.8g, 80%).

15.C Attempted polyfluoroalkylations of halocinnolines

1. Hexachlorocinnoline (78)

a) With hexafluoropropene

Caesium fluoride (4.1g, 27.0mmol) and sulpholane (10ml) were placed in a dry 2-necked flask against a flow of dry nitrogen, and a solution of hexachlorocinnoline (78) (1.0g, 3.0mmol) in diethyl ether (20ml) was added. A bladder containing hexafluoropropene (1.0g, 6.7mmol) was attached, and the flask cooled in liquid air and evacuated ($< 10^{-2}$ mm Hg). The mixture was allowed to warm up to room temperature, hexafluoropropene was admitted into the flask in one portion from the bladder, and the mixture stirred vigorously at room temperature for 72hr. The diethyl ether layer was separated from the mixture and subsequent removal of the solvent *in vacuo* gave a yellow oil (0.3g), which was shown by m.s.-g.l.c. (capillary) to consist mainly of hexafluoropropene oligomers, but with trace quantities of possible perfluoroisopropyl derivatives.

A repeat of the reaction at 40°C also gave a yellow oil (0.4g), which again consisted mainly of the mixture of hexafluoropropene oligomers, but also with trace amounts of possible perfluoroalkyl derivatives as shown by m.s.-g.l.c.

b) With perfluoro-tris-isopropyl-1,3,5-triazine (84)

Trichloro-1,3,5-triazine (139) (2.2g, 11.9mmol) was polyfluoroalkylated with hexafluoropropene (5.8g, 38.7mmol) and potassium fluoride (6.0g, 0.10mol) in diethyl ether (30ml) and sulpholane (30ml) using the method described in Chapter Eleven (11.A.2bi). The presence of perfluoro-tris-isopropyl-1,3,5-triazine (84) in solution was confirmed from the ^{19}F n.m.r. of the diethyl ether layer. A solution of hexachlorocinnoline (78) (1.5g, 4.5mmol) in diethyl ether (20ml) and caesium fluoride (4.7g, 30.9mmol) were then added, and the resultant mixture vigorously stirred at room temperature for 48hr. ^{19}F n.m.r. and g.l.c. (capillary) of the diethyl ether layer showed only the presence of starting materials. The diethyl ether layer was separated from the mixture and the solvent removed *in vacuo* to give only a mixture of the starting materials (78) and (84).

The reaction was repeated, except that after the addition of a solution of hexachlorocinnoline (78), the mixture was stirred vigorously at 40⁰C for 48hr. This also gave no evidence for polyfluoroalkylation of (78), and good recoveries of starting materials were obtained on work-up.

In a further reaction, the diethyl ether was removed by vacuum transfer at room temperature prior to the addition of hexachlorocinnoline (78) and caesium fluoride, and the resulting mixture vigorously stirred at 100⁰C for 24hr. This also did not give any evidence for the polyfluoroalkylation of (78).

2. 5,7-dichlorotetrafluorocinnoline (215)a) With hexafluoropropene

The solution of 5,7-dichlorotetrafluorocinnoline (215) in diethyl ether from 15.B.3a_{ii} (20ml) was polyfluoroalkylated with hexafluoropropene (1.0g, 6.7mmol) and caesium fluoride (2.2g, 14.5mmol) in sulpholane (5ml) using the basic method described in Chapter Eleven (11.A.1a). The ¹⁹F n.m.r. and g.l.c. (capillary) of the diethyl ether layer showed only the presence of 5,7-dichloro-4-hydroxy-trifluorocinnoline (216) and hexafluoropropene oligomers, with no evidence for any possible perfluoroisopropyl derivatives of (215).

b) With perfluoro-tris-isopropyl-1,3,5-triazine (84)

The basic method described in 15.C.2b was followed, except that the solution of 5,7-dichlorotetrafluorocinnoline (215) in diethyl ether from 15.B.3a_{ii} (20ml) together with caesium fluoride (1.5g, 9.9mmol) were added after the formation of the perfluoro-tris-isopropyl-1,3,5-triazine (84). However, several attempts of this reaction with vigorous stirring at both room temperature and at 45°C all gave no evidence for the polyfluoroalkylation of (215), with the ¹⁹F n.m.r. of the diethyl ether layer indicating only the presence of 5,7-dichloro-4-hydroxy-trifluorocinnoline (216).

15.D Other attempted reactions of hexachlorocinnoline (78)

1. Nucleophilic aromatic substitutions

a) With sodium methoxide

i) One equivalent

A suspension of hexachlorocinnoline (78) (1.0g, 3.0mmol) in methanol (25ml) was treated with a solution of sodium (59mg, 2.6mmol) in methanol (5ml) and the resulting mixture stirred vigorously at room temperature for 3hr. The solution was poured into water (50ml) and the resulting precipitate filtered off and washed with water. The cream-coloured solid (0.8g) was shown by t.l.c. (alumina, 1:1 diethyl ether:n-hexane) to contain only one product together with the starting material (78). The ^1H n.m.r. of the solid, which was difficult to obtain due to its extremely poor solubility, indicated a mono-substituted derivative, which was tentatively assigned as 4-methoxypentachlorocinnoline (217). However, various attempts to purify the product by either recrystallisation from various solvents, column chromatography, or vacuum sublimation were all unsuccessful.

ii) Two equivalents

A suspension of hexachlorocinnoline (78) (1.0g, 3.0mmol) in methanol (25ml) was treated with a solution of sodium (135mg, 5.9mmol) in methanol (5ml) and the resulting mixture stirred vigorously at room temperature for 3hr. The solution was poured into water (50ml) and the resulting precipitate filtered off and washed with water. The cream-coloured solid (0.7g) was shown by t.l.c. (alumina, 1:1

diethyl ether:n-hexane) to contain several products together with the starting material (78). The ^1H n.m.r. of the mixture, which was again only sparingly soluble, indicated that the major product was the mono-methoxy derivative (217). However, all attempts to separate the products by recrystallisation from various solvents, column chromatography, or vacuum sublimation did not give a pure sample of any methoxy-derivative.

A repeat of the reaction in refluxing methanol also gave a mixture of products and starting material (78), with the major product again identified from ^1H n.m.r. as the mono-methoxy derivative (217).

2. Photolysis

a) In the vapour-phase

i) At 254nm

Hexachlorocinnoline (78) (0.5g, 1.5mmol) was sealed in a silica *rotaflo* tube (130 × 10mm) under high vacuum ($< 10^{-3}$ mm Hg) and irradiated at 253.7nm for 106hr. The solid material in the tube was washed out with chloroform (5ml), and shown by t.l.c. (alumina, 1:1 diethyl ether:n-hexane) to be the starting material (78), by comparison with an authentic sample.

ii) At 366nm

(78) (0.5g, 1.5mmol) was sealed in a silica *rotaflo* tube (130 × 10mm) under high vacuum ($< 10^{-3}$ mm Hg) and irradiated at 366nm for 137hr. The solid material in the

tube was washed out with chloroform (5ml), and shown by t.l.c. (alumina, 1:1 diethyl ether:n-hexane) to be the starting material (78).

b) In solution

(78) (0.5g, 1.5mmol) in toluene (10ml) was sealed in a silica *rotaflo* tube (250 × 18mm) under high vacuum ($< 10^{-3}$ mm Hg) and irradiated at 253.7nm for 145hr. The solvent was removed using a rotary evaporator, and the solid residue shown to be the starting material (78) by t.l.c. (alumina, 1:1 diethyl ether:n-hexane).

3. Attempted N-oxidation¹¹²

A solution of hexachlorocinnoline (78) (1.0g, 3.0mmol) in a mixture of concentrated sulphuric acid (20ml) and trifluoroacetic acid (40ml) was cooled to 0°C (ice-salt bath), treated with 60% hydrogen peroxide (1ml), and stirred vigorously at room temperature for 24hr. The solution was poured into ice-water (200ml), and the resulting precipitate filtered off and washed with water. The residual solid (0.8g) was shown by t.l.c. (alumina, 1:1 diethyl ether:n-hexane) to be the starting material (78).

A repeat of the reaction at a temperature of 100°C for 15hr also gave only recovered starting material (78) (0.9g).

APPENDICES

APPENDIX ONEN.M.R. SPECTRA

1. Trichloro-1,2,3-triazine (20) (^{13}C)
2. 5-chloro-4,6-difluoro-1,2,3-triazine (102) (^{19}F and ^{13}C)
3. Trifluoro-1,2,3-triazine (28) (^{19}F and ^{13}C)
4. Perfluoro-4,6-bis-isopropyl-1,2,3-triazine (93) (^{13}C)
5. Perfluoro-4,5,6-tris-isopropyl-1,2,3-triazine (98) (^{13}C)
6. 4,6-dipyrrolidino-5-fluoro-1,2,3-triazine (109a) (^1H and ^{19}F)
7. 4,6-dipiperidino-5-fluoro-1,2,3-triazine (109b) (^1H and ^{19}F)
8. 4,6-dihexamethyleneimino-5-fluoro-1,2,3-triazine (109c) (^1H and ^{19}F)
9. Trimethoxy-1,2,3-triazine (110) (^1H)
10. 4,6-diphenoxy-5-fluoro-1,2,3-triazine (111) (^1H and ^{19}F)
11. 5-chloro-4-fluoro-6-pyrrolidino-1,2,3-triazine (112a) (^1H and ^{19}F)
12. 5-chloro-4,6-dipyrrolidino-1,2,3-triazine (113) (^1H)
13. 5-chloro-4-fluoro-6-hexamethyleneimino-1,2,3-triazine (112c) (^1H and ^{19}F)
14. 5-chloro-4,6-dimethoxy-1,2,3-triazine (114) (^1H)
15. 5-chloro-4-fluoro-6-phenoxy-1,2,3-triazine (115) (^1H and ^{19}F)
16. 5-chloro-4,6-diphenoxy-1,2,3-triazine (116) (^1H)
17. Tetrachloropyridazine (3) (^{13}C)
18. Tetrafluoropyridazine (21) (^{13}C)
19. Perfluoro-4-isopropylpyridazine (160) (^{13}C)

20. Perfluoro-4,5-bis-isopropylpyridazine (60) (^{13}C)
21. Perfluoro-3,5-bis-isopropylpyridazine (55) (^{13}C)
22. Perfluoro-3,4,6-tris-isopropylpyridazine (159) (^{13}C)
23. Perfluoro-4-vinyl-3,6-bis-isopropylpyridazine (185) (^{19}F)
24. Perfluoro-bis-isopropyldiazacyclo-octatetraene (158a) (^{19}F)
25. Perfluoro-bis-isopropyldiazacyclo-octatetraene (158b) (^{19}F)
26. 5-dimethylamino-3,4,6-tris-perfluoroisopropylpyridazine
(188) (^1H and ^{19}F)
27. Perfluoro-4-(2'-methylpent-2'-yl)pyridazine (169) (^{19}F and
 ^{13}C)
28. Perfluoro-4-(2'-methylpent-2'-yl)pyrimidine (199) (^{19}F)
29. Perfluoro-2-(2'-methylpent-2'-yl)pyrazine (195) (^{19}F)
30. Perfluoro-1-(2'-methylpent-2'-yl)-2,5-diazabicyclo[2.2.0]-
hexa-2,5-diene (196) (^{19}F)
31. Perfluoro-5-(2'-methylpent-2'-yl)pyrimidine (200) (^{19}F)
32. Perfluoro-4-(2'-propenyl)pyridazine (202) (^{19}F)
33. Hexachlorocinnoline (78) (^{13}C)
34. 5,7-dichlorotetrafluorocinnoline (215) (^{19}F)
35. 5,7-dichloro-4-hydroxy-trifluorocinnoline (216) (^{19}F)

The following abbreviations are used in this appendix:

S	singlet	Hex	hextet
D	doublet	Sept	septet
T	triplet	M	multiplet
Q	quartet		

1. Trichloro-1,2,3-triazine (20)

	<u>Shift (ppm)</u>	<u>Multiplicity</u>	<u>Assignment</u>
^{13}C	132.5	S	5
	157.3	S	4,6

2. 5-chloro-4,6-difluoro-1,2,3-triazine (102)

	<u>Shift (ppm)</u>	<u>Multiplicity</u>	<u>Integral</u>	<u>Assignment</u>
^{19}F	-79.8	S	2	4,6
^{13}C	108.0	T $^2J_{\text{C5},\text{F4}} = 26 \text{ Hz}$		5
	164.9	D $^1J_{\text{CF}} = 265 \text{ Hz}$		4,6

3. Trifluoro-1,2,3-triazine (28)

	<u>Shift (ppm)</u>	<u>Multiplicity</u>	<u>Integral</u>	<u>Assignment</u>
^{19}F	-96.3	D $J_{4,5} = 23$ Hz	2	4,6
	-166.0	T $J_{5,4} = 23$ Hz	1	5
^{13}C	132.8	D of T $^1J_{\text{CF}} = 298$ Hz $^2J_{\text{C5,F4}} = 19$ Hz		5
	157.8	D $^1J_{\text{CF}} = 265$ Hz		4,6

4. Perfluoro-4,6-bis-isopropyl-1,2,3-triazine (93)



	<u>Shift (ppm)</u>	<u>Multiplicity</u>	<u>Assignment</u>
^{13}C	91.1	D of Sept $^1J_{\text{CF}} = 214$ Hz $^2J_{\text{C4a,F4b}} = 35$ Hz	4a,6a
	119.3	Q of D $^1J_{\text{CF}} = 289$ Hz $^2J_{\text{C4b,F4a}} = 27$ Hz	4b,6b
	141.6	D $^2J_{\text{C4,F4a}} = 24$ Hz	4,6
	154.6	D $^1J_{\text{CF}} = 315$ Hz	5

5. Perfluoro-4,5,6-tris-isopropyl-1,2,3-triazine (98)

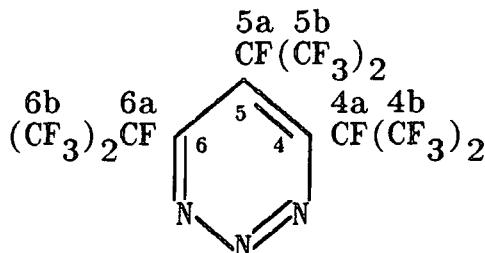

	<u>Shift (ppm)</u>	<u>Multiplicity</u>		<u>Assignment</u>
^{13}C	92.8	D of Sept	$^1J_{\text{CF}} = 217 \text{ Hz}$ $^2J_{\text{C4a,F4b}} = 34 \text{ Hz}$	4a,6a
	93.8	D of Sept	$^1J_{\text{CF}} = 175 \text{ Hz}$ $^2J_{\text{C5a,F5b}} = 37 \text{ Hz}$	5a
	118.0	D	$^2J_{\text{C5,F5a}} = 30 \text{ Hz}$	5
	118.9	Q of D	$^1J_{\text{CF}} = 289 \text{ Hz}$ $^2J_{\text{C5b,F5a}} = 26 \text{ Hz}$	5b
	119.0	Q of D	$^1J_{\text{CF}} = 288 \text{ Hz}$ $^2J_{\text{C4b,F4a}} = 28 \text{ Hz}$	4b,6b
	145.5	D of D	$^2J_{\text{C4,F4a}} = 29 \text{ Hz}$ $^3J_{\text{CF}} = 3 \text{ Hz}$	4
	148.1	D	$^2J_{\text{C6,F6a}} = 28 \text{ Hz}$	6

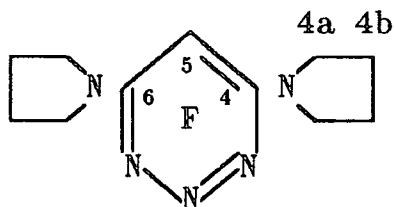
6. 4,6-dipyrrolidino-5-fluoro-1,2,3-triazine (109a)

	<u>Shift (ppm)</u>	<u>Multiplicity</u>	<u>Integral</u>	<u>Assignment</u>
^1H	2.0	M	4	4b
	3.8	M	4	4a
^{19}F	-175.2	S	1	5

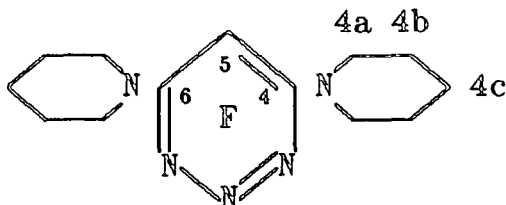
7. 4,6-dipiperidino-5-fluoro-1,2,3-triazine (109b)

	<u>Shift (ppm)</u>	<u>Multiplicity</u>	<u>Integral</u>	<u>Assignment</u>
^1H	1.7	M	6	4b,4c
	3.7	M	4	4a
^{19}F	-159.0	S	1	5

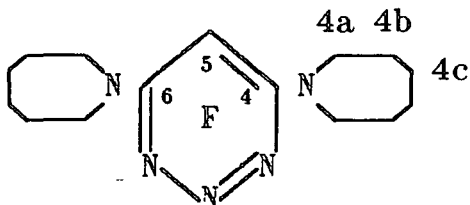
8. 4,6-dihexamethyleneimino-5-fluoro-1,2,3-triazine (109c)

	<u>Shift (ppm)</u>	<u>Multiplicity</u>	<u>Integral</u>	<u>Assignment</u>
^1H	1.7	M	8	4b,4c
	3.8	M	4	4a
^{19}F	-168.7	S	1	5

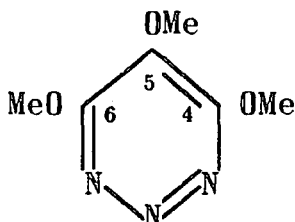
9. Trimethoxy-1,2,3-triazine (110)

	<u>Shift (ppm)</u>	<u>Multiplicity</u>	<u>Integral</u>	<u>Assignment</u>
^1H	4.1	S	3	5
	4.3	S	6	4,6

10. 4,6-diphenoxy-5-fluoro-1,2,3-triazine (111)

	<u>Shift (ppm)</u>	<u>Multiplicity</u>	<u>Integral</u>	<u>Assignment</u>
^1H	7.3	M	10	Ph
^{19}F	-168.5	S	1	5

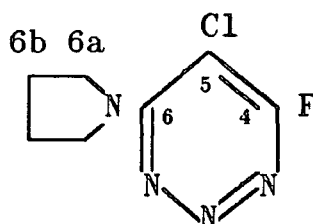
11. 5-chloro-4-fluoro-6-pyrrolidino-1,2,3-triazine (112a)

	<u>Shift (ppm)</u>	<u>Multiplicity</u>	<u>Integral</u>	<u>Assignment</u>
^1H	2.0	M	4	6b
	3.9	M	4	6a
^{19}F	-88.8	S	1	4

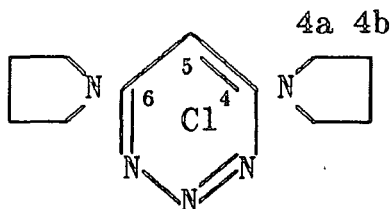
12. 5-chloro-4,6-dipyrrolidino-1,2,3-triazine (113)

	<u>Shift (ppm)</u>	<u>Multiplicity</u>	<u>Integral</u>	<u>Assignment</u>
^1H	2.0	M	4	4b
	3.8	M	4	4a

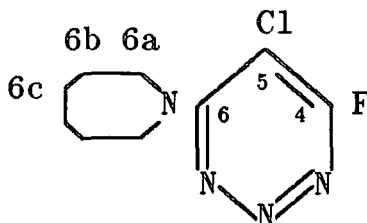
13. 5-chloro-4-fluoro-6-hexamethyleneimino-1,2,3-triazine (112c)

	<u>Shift (ppm)</u>	<u>Multiplicity</u>	<u>Integral</u>	<u>Assignment</u>
^1H	1.6	M	8	6b,6c
	4.0	M	4	6a
^{19}F	-87.8	S	1	4

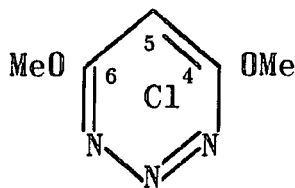
14. 5-chloro-4,6-dimethoxy-1,2,3-triazine (114)

	<u>Shift (ppm)</u>	<u>Multiplicity</u>	<u>Integral</u>	<u>Assignment</u>
^1H	4.2	S	6	4a,6a

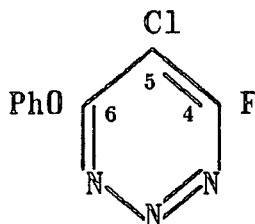
15. 5-chloro-4-fluoro-6-phenoxy-1,2,3-triazine (115)

	<u>Shift (ppm)</u>	<u>Multiplicity</u>	<u>Integral</u>	<u>Assignment</u>
^1H	7.4	M	5	Ph
^{19}F	-83.3	S	1	4

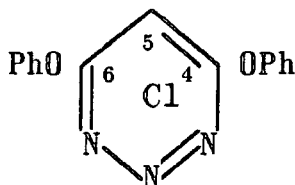
16. 5-chloro-4,6-diphenoxy-1,2,3-triazine (116)

	<u>Shift (ppm)</u>	<u>Multiplicity</u>	<u>Integral</u>	<u>Assignment</u>
^1H	7.3	M	10	Ph

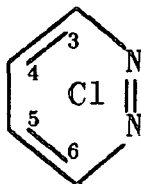
17. Tetrachloropyridazine (3)

	<u>Shift (ppm)</u>	<u>Multiplicity</u>	<u>Assignment</u>
^{13}C	137.1	S	4,5
	154.0	S	3,6

18. Tetrafluoropyridazine (21)

	<u>Shift (ppm)</u>	<u>Multiplicity</u>	<u>Assignment</u>
^{13}C	140.2	D $^1J_{\text{CF}} = 286 \text{ Hz}$	4,5
	157.2	D $^1J_{\text{CF}} = 249 \text{ Hz}$	3,6

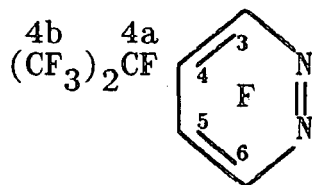
19. Perfluoro-4-isopropylpyridazine (160)

	<u>Shift (ppm)</u>	<u>Multiplicity</u>	<u>Assignment</u>
^{13}C	90.2	D of Sept $^1J_{\text{CF}} = 214 \text{ Hz}$ $^2J_{\text{C4a}, \text{F4b}} = 37 \text{ Hz}$	4a
	106.5	D of D of $^2J_{\text{C4}, \text{F4a}} = 27 \text{ Hz}$ D of D $^2J_{\text{C4}, \text{F3}} = 27 \text{ Hz}$ $^3J_{\text{C4}, \text{F4b}} = 4 \text{ Hz}$ $^3J_{\text{CF}} = 4 \text{ Hz}$	4
	119.0	Q of D $^1J_{\text{CF}} = 288 \text{ Hz}$ $^2J_{\text{C4b}, \text{F4a}} = 27 \text{ Hz}$	4b
	151.1	D $^1J_{\text{CF}} = 298 \text{ Hz}$	5

19. (continued)

<u>Shift</u> (ppm)	<u>Multiplicity</u>		<u>Assignment</u>
157.0	D of D	$^1J_{CF} = 242 \text{ Hz}$ $^2J_{C6,F5} = 14 \text{ Hz}$	6
159.0	D	$^1J_{CF} = 246 \text{ Hz}$	3

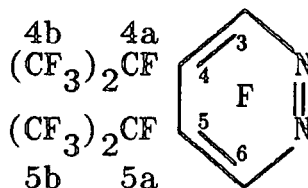
20. Perfluoro-4,5-bis-isopropylpyridazine (60)

	<u>Shift</u> (ppm)	<u>Multiplicity</u>		<u>Assignment</u>
^{13}C	92.3	D of M	$^1J_{CF} = 224 \text{ Hz}$ $^2J_{CF} = 35 \text{ Hz}$	4a,5a
	119.3	Q of D	$^1J_{CF} = 290 \text{ Hz}$ $^2J_{C4b,F4a} = 14 \text{ Hz}$	4b or 5b
	119.4	Q of D	$^1J_{CF} = 290 \text{ Hz}$ $^2J_{C4b,F4a} = 14 \text{ Hz}$	5b or 4b
	122.6	Complex M		4,5
	160.9	D	$^1J_{CF} = 239 \text{ Hz}$	3,6

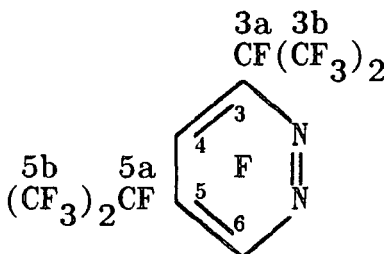
21. Perfluoro-3,5-bis-isopropylpyridazine (55)

	<u>Shift (ppm)</u>	<u>Multiplicity</u>		<u>Assignment</u>
^{13}C	91.5	D of Sept	$^1\text{J}_{\text{CF}} = 210 \text{ Hz}$	3a, 5a
			$^2\text{J}_{\text{C3a, F3b}} = 34 \text{ Hz}$	
	106.3	D of D of	$^2\text{J}_{\text{C5, F5a}} = 25 \text{ Hz}$	5
		D of D	$^2\text{J}_{\text{C5, F6}} = 25 \text{ Hz}$	
			$^3\text{J}_{\text{C5, F5b}} = 4 \text{ Hz}$	
			$^3\text{J}_{\text{CF}} = 4 \text{ Hz}$	
	119.6	Q of D	$^1\text{J}_{\text{CF}} = 288 \text{ Hz}$	3b or 5b
			$^2\text{J}_{\text{C3b, F3a}} = 20 \text{ Hz}$	
119.9	Q of D	$^1\text{J}_{\text{CF}} = 288 \text{ Hz}$	5b or 3b	
		$^2\text{J}_{\text{C3b, F3a}} = 20 \text{ Hz}$		
		$^2\text{J}_{\text{C3, F4}} = 17 \text{ Hz}$	3	
142.5	D	$^1\text{J}_{\text{CF}} = 273 \text{ Hz}$	4 or 6	
161.5	D	$^1\text{J}_{\text{CF}} = 267 \text{ Hz}$	6 or 4	

22. Perfluoro-3,4,6-tris-isopropylpyridazine (159)

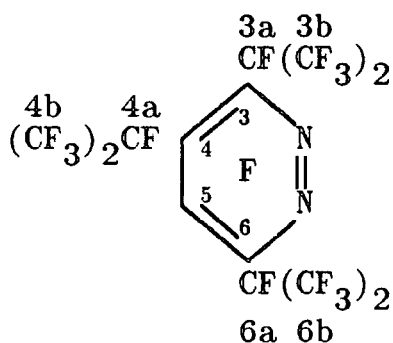

	<u>Shift (ppm)</u>	<u>Multiplicity</u>		<u>Assignment</u>
^{13}C	91.8	Complex M		3a, 4a, 6a
	119.1	Q of D	$^1\text{J}_{\text{CF}} = 289 \text{ Hz}$	3b, 6b
			$^2\text{J}_{\text{C3b, F3a}} = 13 \text{ Hz}$	

22. (continued)

<u>Shift (ppm)</u>	<u>Multiplicity</u>		<u>Assignment</u>
119.3	D of D	${}^2J_{C4, F4a} = 26 \text{ Hz}$ ${}^2J_{CF} = 11 \text{ Hz}$	4
119.5	Q of D	${}^1J_{CF} = 288 \text{ Hz}$ ${}^2J_{C4b, F4a} = 11 \text{ Hz}$	4b
143.5	D of D	${}^2J_{C6, F6a} = 24 \text{ Hz}$ ${}^2J_{CF} = 9 \text{ Hz}$	6
151.7	D	${}^2J_{C3, F3a} = 26 \text{ Hz}$	3
159.8	D of D	${}^1J_{CF} = 292 \text{ Hz}$ ${}^3J_{CF} = 7 \text{ Hz}$	5

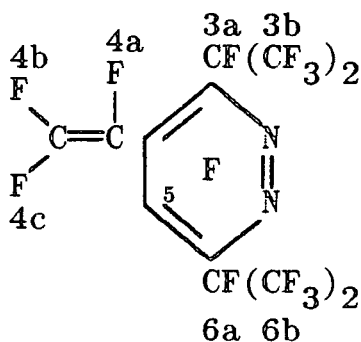
23. Perfluoro-4-vinyl-3,6-bis-isopropylpyridazine (185)

	<u>Shift (ppm)</u>	<u>Multiplicity</u>		<u>Integral</u>	<u>Assignment</u>
${}^{19}F$	-73.9	S		6	3b
	-74.2	S		6	6b
	-91.6	D of D	$J_{4b, 4c} = 60 \text{ Hz}$ $J_{4b, 4a} = 30 \text{ Hz}$	1	4b
	-107.2	D	$J_{5, 6a} = 45 \text{ Hz}$	1	5
	-110.0	D of D	$J_{4c, 4a} = 117 \text{ Hz}$ $J_{4c, 4b} = 55 \text{ Hz}$	1	4c

23. (continued)

	<u>Shift (ppm)</u>	<u>Multiplicity</u>		<u>Integral</u>	<u>Assignment</u>
	-166.7	D of M	$J_{4a,4c} = 122 \text{ Hz}$	1	4a
	-184.7	D	$J_{6a,5} = 47 \text{ Hz}$	1	6a
	-186.3	D	$J_{3a,4c} = 33 \text{ Hz}$	1	3a

24. Perfluoro-bis-isopropyldiazacyclo-octatetraene (158a)

	<u>Shift (ppm)</u>	<u>Multiplicity</u>		<u>Integral</u>	<u>Assignment</u>
¹⁹ F	-12.6	S		1	imine F
	-26.1	S		1	imine F
	-55.0	S		2	vinyllic F
	-75.5	S		12	(CF ₃) ₂ CF
	-177.4	S		2	(CF ₃) ₂ CF

25. Perfluoro-bis-isopropyldiazacyclo-octatetraene (158b)

	<u>Shift (ppm)</u>	<u>Multiplicity</u>		<u>Integral</u>	<u>Assignment</u>
¹⁹ F	-10.1	S		2	imine F
	-54.4	S		2	vinyllic F
	-75.6	S		6	(CF ₃) ₂ CF
	-76.6	S		6	(CF ₃) ₂ CF
	-177.6	S		2	(CF ₃) ₂ CF

26. 5-dimethylamino-3,4,6-tris-perfluoroisopropylpyridazine
(188)

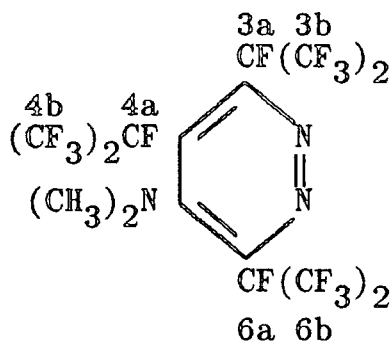

	<u>Shift (ppm)</u>	<u>Multiplicity</u>		<u>Integral</u>	<u>Assignment</u>
^1H	3.5	D of D	$J = 4 \text{ Hz}$ $J = 2 \text{ Hz}$	6	5a
^{19}F	-69.8	D	$J_{4b,3a} = 38 \text{ Hz}$	6	4b
	-73.0	S		12	3b,6b
	-154.0	M (br)		1	3a
	-177.0	M (br)		1	4a
	-182.5	M (br)		1	6a

27. Perfluoro-4-(2'-methylpent-2'-yl)pyridazine (169)

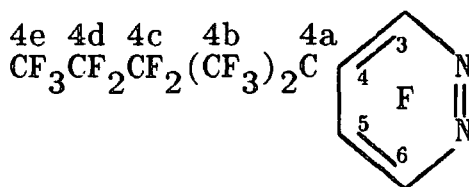

	<u>Shift (ppm)</u>	<u>Multiplicity</u>		<u>Integral</u>	<u>Assignment</u>
^{19}F	-59.3	M		6	4b
	-63.0	M (br)		1	3
	-82.3	T	$J_{4e,4c} = 11 \text{ Hz}$	3	4e

27. (continued)

<u>Shift</u> (ppm)	<u>Multiplicity</u>	<u>Integral</u>	<u>Assignment</u>
-97.2	D of D $J_{6,5} = 32 \text{ Hz}$ $J_{6,3} = 23 \text{ Hz}$	1	6
-104.8	M	2	4c
-107.0	M (br)	1	5
-123.8	M	2	4d

^{13}C	Shift (ppm)	Multiplicity	Integral	Assignment
	64.3	Sept $^2J_{\text{C4a,F4b}} = 27 \text{ Hz}$		4a
	107.2	D $^2J_{\text{CF}} = 31 \text{ Hz}$		4
	109.4	T of Hex $^1J_{\text{CF}} = 273 \text{ Hz}$ $^2J_{\text{C4d,F4c,4e}} = 38 \text{ Hz}$		4d
	114.4	T of T $^1J_{\text{CF}} = 275 \text{ Hz}$ $^2J_{\text{C4c,F4d}} = 34 \text{ Hz}$		4c
	117.2	Q of T $^1J_{\text{CF}} = 289 \text{ Hz}$ $^2J_{\text{C4e,F4d}} = 34 \text{ Hz}$		4e
	120.7	Q $^1J_{\text{CF}} = 292 \text{ Hz}$		4b
	150.4	D of D $^1J_{\text{CF}} = 298 \text{ Hz}$ $^2J_{\text{C5,F6}} = 30 \text{ Hz}$		5
	157.6	D of D $^1J_{\text{CF}} = 249 \text{ Hz}$ $^2J_{\text{C6,F5}} = 15 \text{ Hz}$		6
	159.6	D $^1J_{\text{CF}} = 248 \text{ Hz}$		3

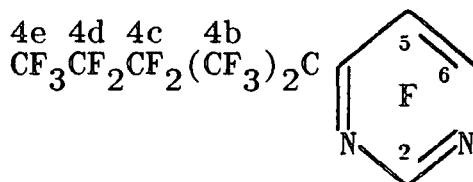
28. Perfluoro-4-(2'-methylpent-2'-yl)pyrimidine (199)

	<u>Shift (ppm)</u>	<u>Multiplicity</u>		<u>Integral</u>	<u>Assignment</u>
^{19}F	-46.8	D	$J_{2,5} = 30 \text{ Hz}$	1	2
	-60.3	M		6	4b
	-71.3	D	$J_{6,5} = 15 \text{ Hz}$	1	6
	-82.8	T	$J_{4e,4c} = 13 \text{ Hz}$	3	4e
	-106.5	M		2	4c
	-124.7	M		2	4d
	-144.8	M (br)		1	5

29. Perfluoro-2-(2'-methylpent-2'-yl)pyrazine (195)

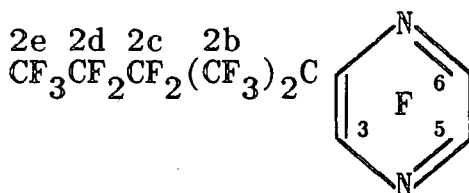

	<u>Shift (ppm)</u>	<u>Multiplicity</u>		<u>Integral</u>	<u>Assignment</u>
^{19}F	-60.7	M		6	2b
	-69.5	M (br)		1	3
	-82.5	T	$J_{2e,2c} = 13 \text{ Hz}$	3	2e
	-84.7	D of D	$J_{5,6} = 21 \text{ Hz}$ $J_{5,3} = 6 \text{ Hz}$	1	5
	-93.0	D of D	$J_{6,3} = 45 \text{ Hz}$ $J_{6,5} = 19 \text{ Hz}$	1	6
	-105.8	M		2	2c
	-123.8	M		2	2d

30. Perfluoro-1-(2'-methylpent-2'-yl)-2,5-diazabicyclo[2.2.0]-hexa-2,5-diene (196)

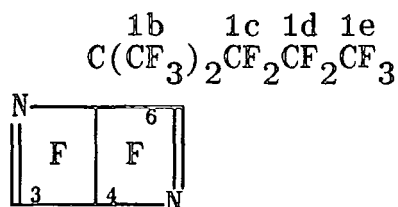

	<u>Shift (ppm)</u>	<u>Multiplicity</u>		<u>Integral</u>	<u>Assignment</u>
^{19}F	-41.8	M		1	6
	-45.3	D of D	$J_{3,6} = 15 \text{ Hz}$ $J_{3,4} = 11 \text{ Hz}$	1	3
	-62.5	M		6	1b
	-82.7	T	$J_{1e,1c} = 13 \text{ Hz}$	3	1e
	-105.0	M		2	1c
	-123.8	M		2	1d
	-164.7	M		1	4

31. Perfluoro-5-(2'-methylpent-2'-yl)pyrimidine (200)

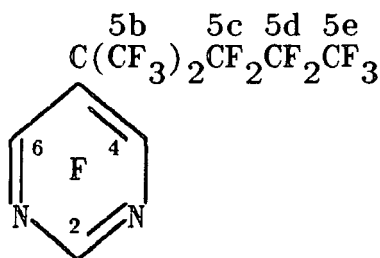

	<u>Shift (ppm)</u>	<u>Multiplicity</u>		<u>Integral</u>	<u>Assignment</u>
^{19}F	-41.0	S		1	2
	-60.7	M		6	5b
	-66.7	D of M	$J_{4,2} = 38 \text{ Hz}$	2	4,6
	-83.0	T	$J_{5e,5c} = 13 \text{ Hz}$	3	5e

31. (continued)

<u>Shift (ppm)</u>	<u>Multiplicity</u>	<u>Integral</u>	<u>Assignment</u>
-106.5	M	2	5c
-124.7	M	2	5d

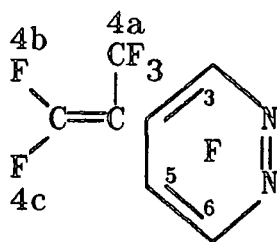
32. Perfluoro-4-(2'-propenyl)pyridazine (202)

	<u>Shift (ppm)</u>	<u>Multiplicity</u>		<u>Integral</u>	<u>Assignment</u>
¹⁹ F	-61.0	M		3	4a
	-67.5	Q	$J_{4b,4a} = 11 \text{ Hz}$	1	4b
	-68.0	D of Q	$J_{4c,4b} = 11 \text{ Hz}$ $J_{4c,4a} = 12 \text{ Hz}$	1	4c
	-79.3	M (br)		1	3
	-99.0	D of D	$J_{6,3} = 32 \text{ Hz}$ $J_{6,5} = 24 \text{ Hz}$	1	6
	-121.8	M		1	5

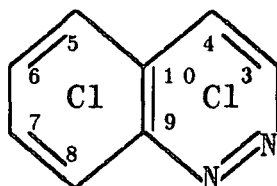
33. Hexachlorocinnoline (78)

	<u>Shift (ppm)</u>	<u>Multiplicity</u>	<u>Assignment</u>
¹³ C	123.4	S	4 or 10

33. (continued)

<u>Shift (ppm)</u>	<u>Multiplicity</u>	<u>Assignment</u>
126.8	S	10 or 4
130.8	S	5 or 8
134.0	S	8 or 5
135.5	S	6 or 7
139.3	S	7 or 6
144.8	S	9 or 3
153.1	S	3 or 9

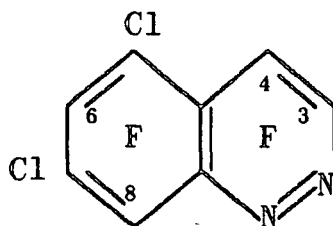
34. 5,7-dichlorotetrafluorocinnoline (215)

	<u>Shift (ppm)</u>	<u>Multiplicity</u>		<u>Integral</u>	<u>Assignment</u>
^{19}F	-102.8	D of D	$J_{6,4} = 8 \text{ Hz}$ $J_{6,8} = 5 \text{ Hz}$	1	6
	-107.2	D of D	$J_{3,4} = 26 \text{ Hz}$ $J_{3,6} = 4 \text{ Hz}$	1	3
	-119.6	D	$J_{8,6} = 7 \text{ Hz}$	1	8
	-141.3	D of D	$J_{4,3} = 24 \text{ Hz}$ $J_{4,6} = 10 \text{ Hz}$	1	4

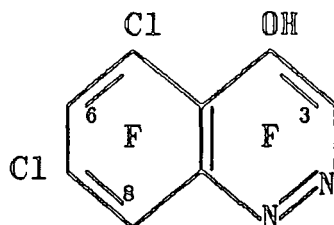
35. 5,7-dichloro-4-hydroxy-trifluorocinnoline (216)

	<u>Shift</u> (ppm)	<u>Multiplicity</u>	<u>Integral</u>	<u>Assignment</u>
^{19}F	-105.9	S	1	3
	-120.3	S	1	8
	-129.7	S	1	6

APPENDIX TWOI.R. SPECTRA

1. 5-chloro-4,6-difluoro-1,2,3-triazine (102)
2. Trifluoro-1,2,3-triazine (28)
3. 4,6-dipyrrolidino-5-fluoro-1,2,3-triazine (109a)
4. 4,6-dipiperidino-5-fluoro-1,2,3-triazine (109b)
5. Trifluoro-1,2,3-triazine (28) at -196°C
6. Photolysate from (28) at -196°C
7. Perfluoro-4,6-bis-isopropyl-1,2,3-triazine (93) at -196°C
8. Photolysate from (93) at -196°C
9. Poly(trifluoroacrylonitrile) (157)
10. Perfluoro-4-isopropylpyridazine (160)
11. Perfluoro-4,5-bis-isopropylpyridazine (60)
12. Perfluoro-3,5-bis-isopropylpyridazine (55)
13. Perfluoro-3,4,6-tris-isopropylpyridazine (159)
14. Perfluoro-4-vinyl-3,6-bis-isopropylpyridazine (185)
15. Perfluoro-4-(2'-methylpent-2'-yl)pyridazine (169)
16. Perfluoro-4-(2'-methylpent-2'-yl)pyrimidine (199)
17. Perfluoro-2-(2'-methylpent-2'-yl)pyrazine (195)
18. Mixture of perfluoro-1-(2'-methylpent-2'-yl)-2,5-diaza-bicyclo[2.2.0]hexa-2,5-diene (196) (14%) and (195) (86%)
19. Perfluoro-4-(2'-propenyl)pyridazine (202)
20. Hexachlorocinnoline (78)

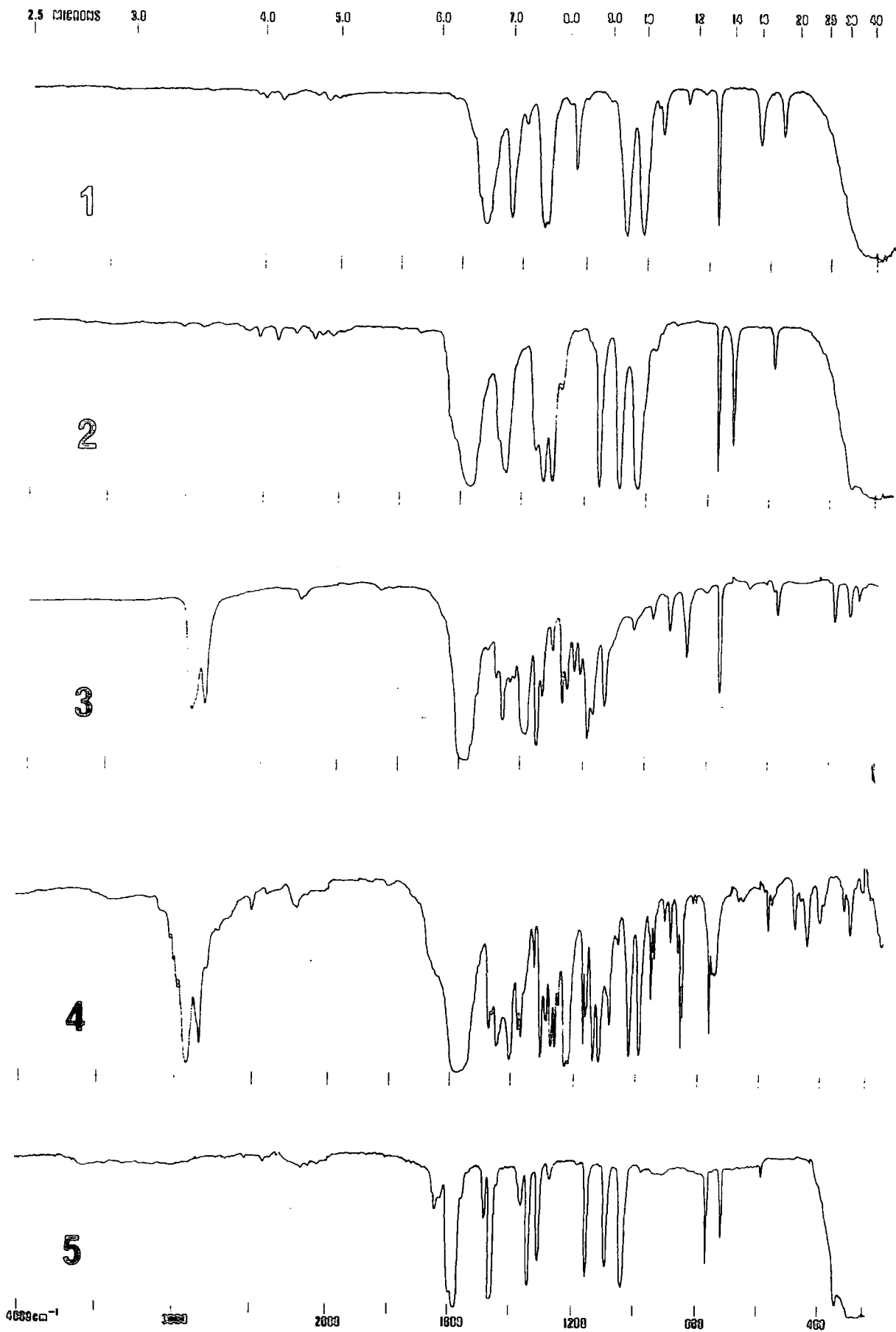

2.5 MICRONS 3.0 4.0 5.0 6.0 7.0 8.0 9.0 10 12 15 15 20 25 30 40

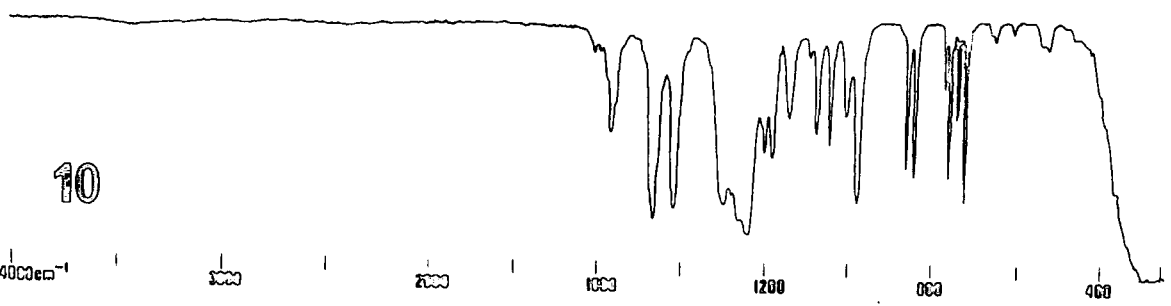
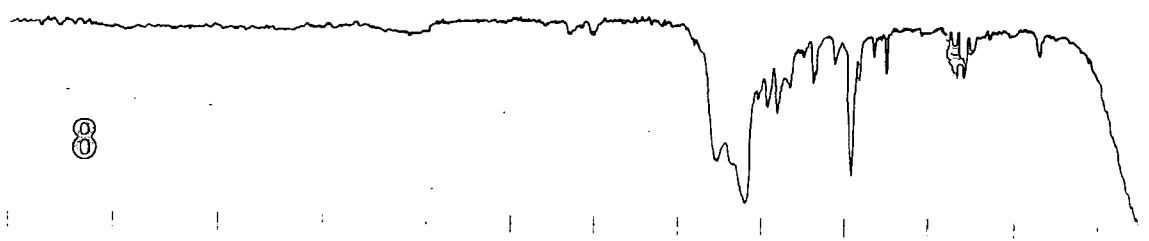
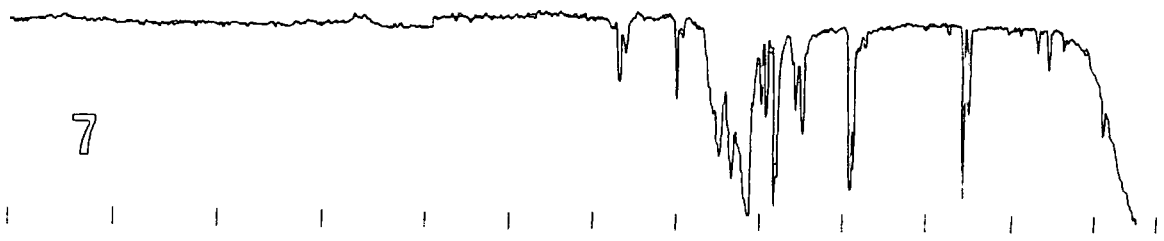
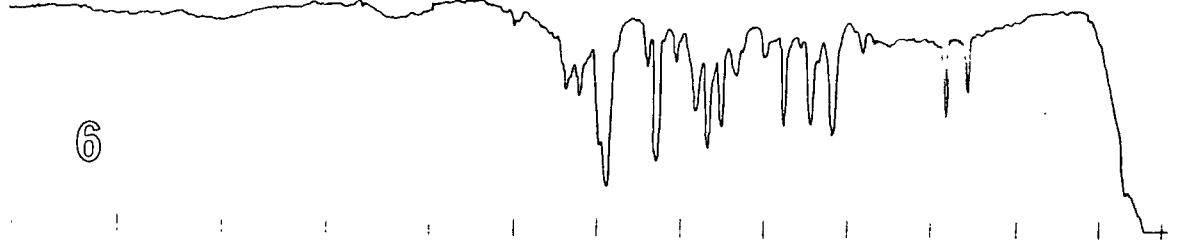

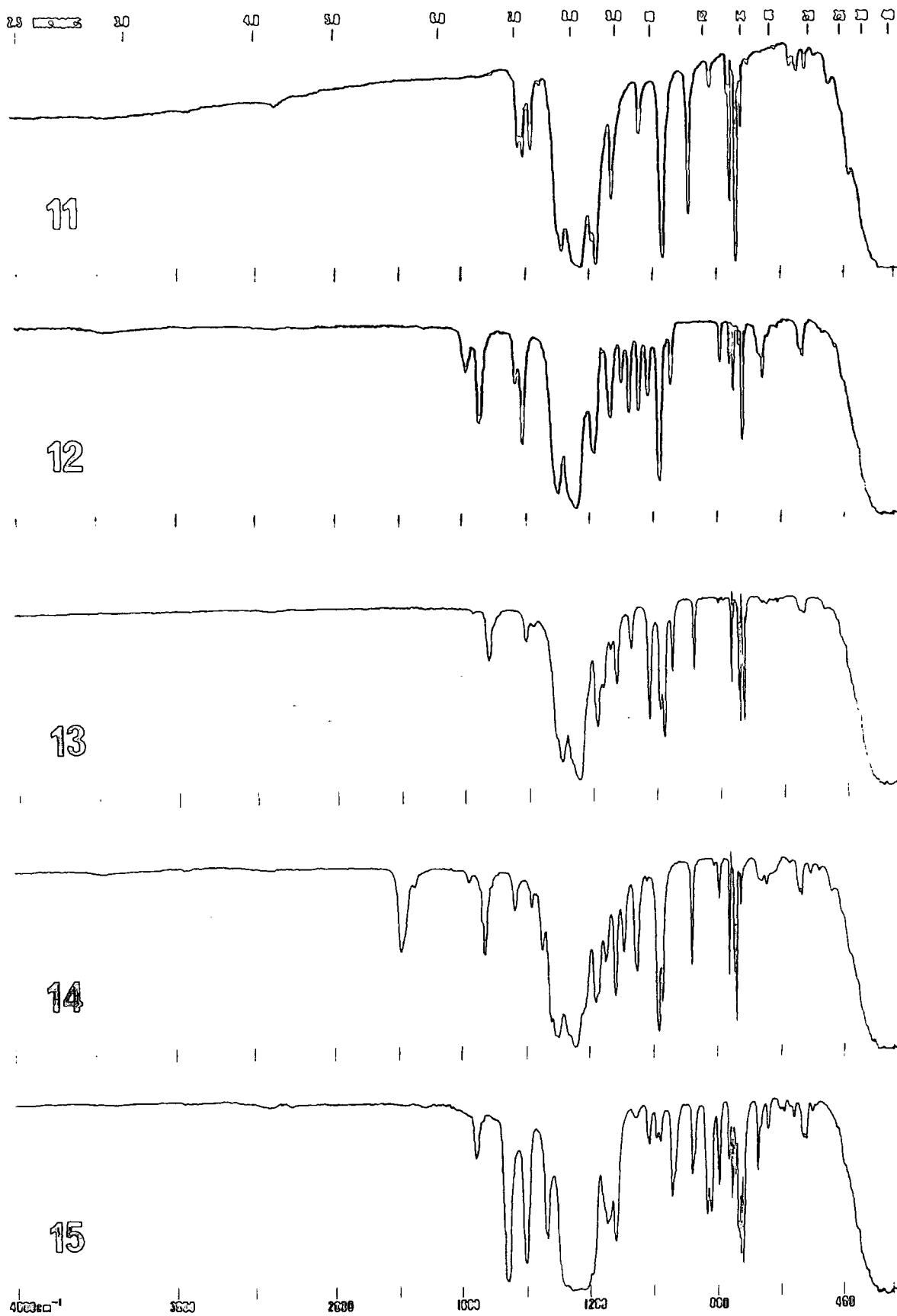

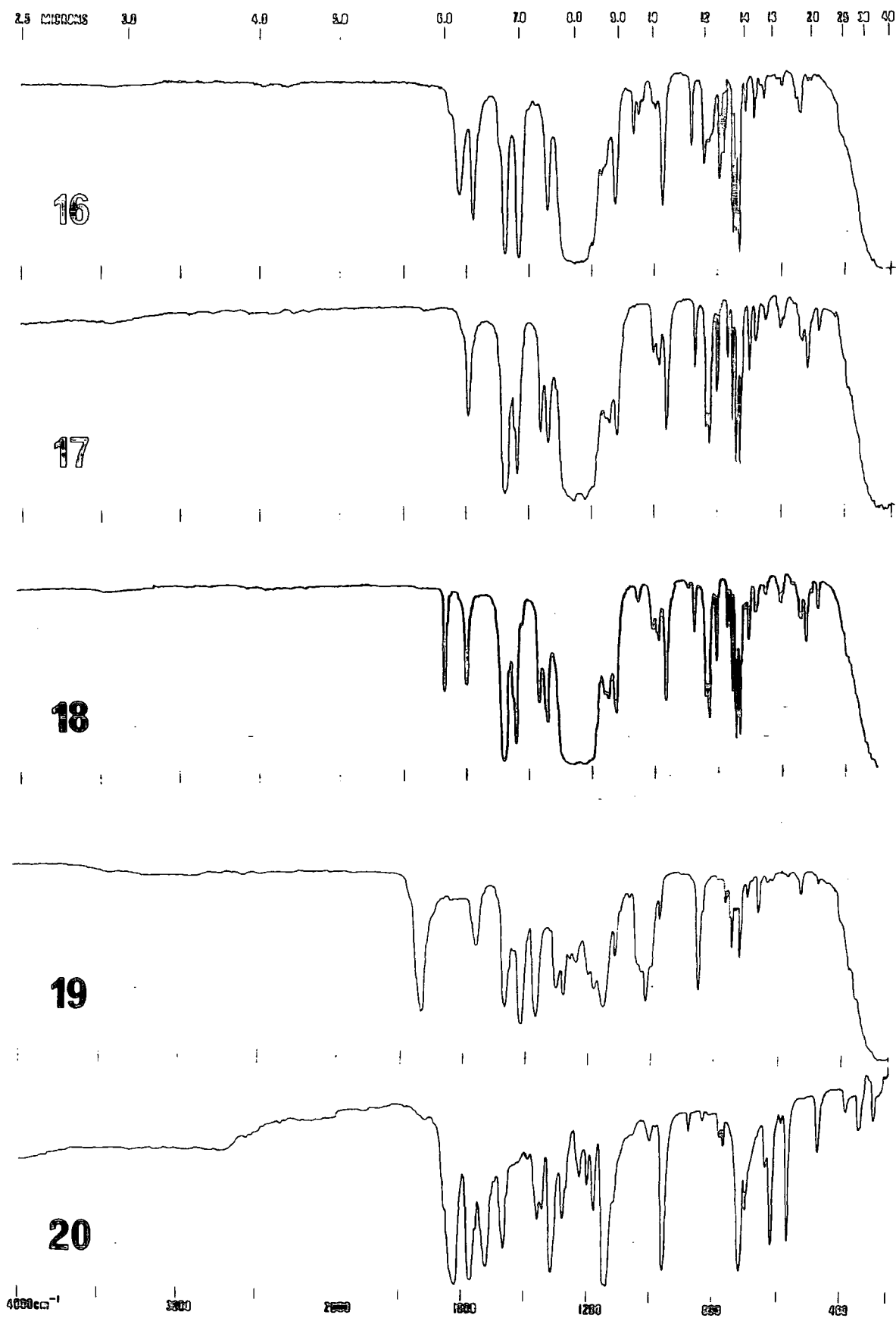

APPENDIX THREEMASS SPECTRA

1. Trichloro-1,2,3-triazine (20) (EI+)
2. 5-chloro-4,6-difluoro-1,2,3-triazine (102) (EI+)
3. Trifluoro-1,2,3-triazine (28) (EI+)
4. Perfluoro-4,6-bis-isopropyl-1,2,3-triazine (93) (CI-)
5. Perfluoro-4,5,6-tris-isopropyl-1,2,3-triazine (98) (CI-)
6. 4,6-dipyrrolidino-5-fluoro-1,2,3-triazine (109a) (EI+)
7. 4,6-dipiperidino-5-fluoro-1,2,3-triazine (109b) (EI+)
8. 4,6-dihexamethyleneimino-5-fluoro-1,2,3-triazine (109c) (EI+)
9. Trimethoxy-1,2,3-triazine (110) (EI+)
10. 4,6-diphenoxy-5-fluoro-1,2,3-triazine (111) (EI+)
11. 5-chloro-4-fluoro-6-pyrrolidino-1,2,3-triazine (112a) (EI+)
12. 5-chloro-4,6-dipyrrolidino-1,2,3-triazine (113) (EI+)
13. 5-chloro-4-fluoro-6-hexamethyleneimino-1,2,3-triazine (112c) (EI+)
14. 5-chloro-4,6-dimethoxy-1,2,3-triazine (114) (EI+)
15. 5-chloro-4-fluoro-6-phenoxy-1,2,3-triazine (115) (EI+)
16. 5-chloro-4,6-diphenoxy-1,2,3-triazine (116) (EI+)
17. Pentafluoropyridine (39) (EI+)
18. Tetrachloropyridazine (3) (CI-)
19. Tetrafluoropyridazine (21) (CI-)
20. Perfluoro-4-isopropylpyridazine (160) (EI+)
21. Perfluoro-4-isopropylpyridazine (160) (CI-)
22. Perfluoro-4,5-bis-isopropylpyridazine (60) (EI+)
23. Perfluoro-4,5-bis-isopropylpyridazine (60) (CI-)

24. Perfluoro-3,5-bis-isopropylpyridazine (55) (EI+)
25. Perfluoro-3,5-bis-isopropylpyridazine (55) (CI-)
26. Perfluoro-3,4,6-tris-isopropylpyridazine (159) (EI+)
27. Perfluoro-3,4,6-tris-isopropylpyridazine (159) (CI-)
28. Perfluoro-bis-isopropyl diazacyclo-octatetraene (158a) (EI+)
29. Perfluoro-bis-isopropyl diazacyclo-octatetraene (158b) (EI+)
30. Perfluoro-4-vinyl-3,6-bis-isopropylpyridazine (185) (EI+)
31. Perfluoro-4-(2'-methylpent-2'-yl)pyridazine (169) (EI+)
32. Perfluoro-4-(2'-methylpent-2'-yl)pyridazine (169) (CI-)
33. Perfluoro-4-(2'-methylpent-2'-yl)pyrimidine (199) (EI+)
34. Perfluoro-2-(2'-methylpent-2'-yl)pyrazine (195) (EI+)
35. Perfluoro-2-(2'-methylpent-2'-yl)pyrazine (195) (CI-)
36. Perfluoro-1-(2'-methylpent-2'-yl)-2,5-diazabicyclo[2.2.0]-hexa-2,5-diene (196) (EI+)
37. Perfluoro-5-(2'-methylpent-2'-yl)pyrimidine (200) (EI+)
38. Perfluoro-4-(2'-propenyl)pyridazine (202) (EI+)
39. Perfluoro-4-(2'-propenyl)pyridazine (202) (CI-)
40. Hexachlorocinnoline (78) (EI+)
41. Tetrachloropyrazine (14) (CI-)
42. Tetrafluoropyrazine (23) (CI-)
43. Perfluoro-2-isopropylpyrazine (218) (CI-)
44. Perfluoro-2,5-bis-isopropylpyrazine (181) (CI-)
45. Perfluoro-2,6-bis-isopropylpyrazine (154) (CI-)

1

PHTCTX S P. HORRE E. I. POS
 CAL: CALTS STR:

16-OCT-84
 0148

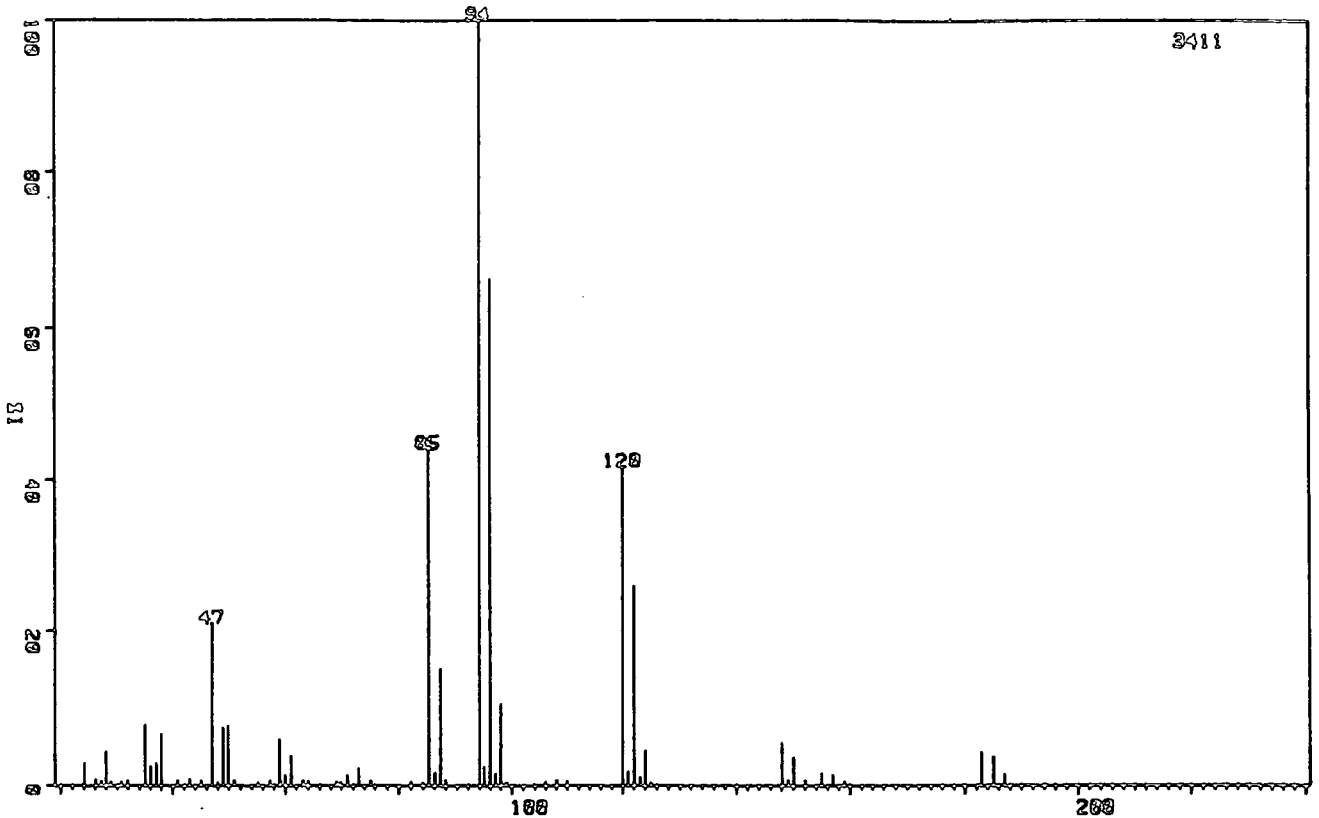

MASS	ZHT.	BASE		
24.23	2.73	84.01	0.38	
26.20	0.79	85.05	44.15	
27.15	0.44	86.05	1.55	
28.03	4.22	87.03	14.95	
28.93	0.50	88.00	0.64	
30.79	0.38	94.00	100.00	
31.88	0.59	95.01	2.35	
35.02	7.62	96.00	66.26	
36.04	2.40	97.00	1.50	
36.98	2.79	97.97	10.41	
37.96	6.36	98.95	0.32	
40.87	0.62	106.01	0.41	
43.00	0.62	107.97	0.70	
43.04	0.91	109.89	0.44	
43.08	0.62	119.92	41.75	
46.99	20.93	120.96	1.67	
47.94	0.41	121.98	25.86	
48.88	7.27	123.01	1.06	
49.83	7.45	124.01	4.40	
50.89	0.62	125.02	0.35	
55.11	0.35	148.00	5.42	
57.11	0.62	149.03	0.59	
58.92	5.83	149.96	3.55	
58.99	0.47	152.00	0.70	
59.85	1.26	155.00	1.58	
60.90	3.69	156.98	1.38	
63.01	0.56	158.94	0.50	
64.07	0.47	183.00	4.16	
69.06	0.38	185.00	3.64	
69.87	0.38	187.00	1.38	
69.93	0.32			
70.95	1.23			
73.03	2.17			
75.06	0.56			
81.96	0.47			

2

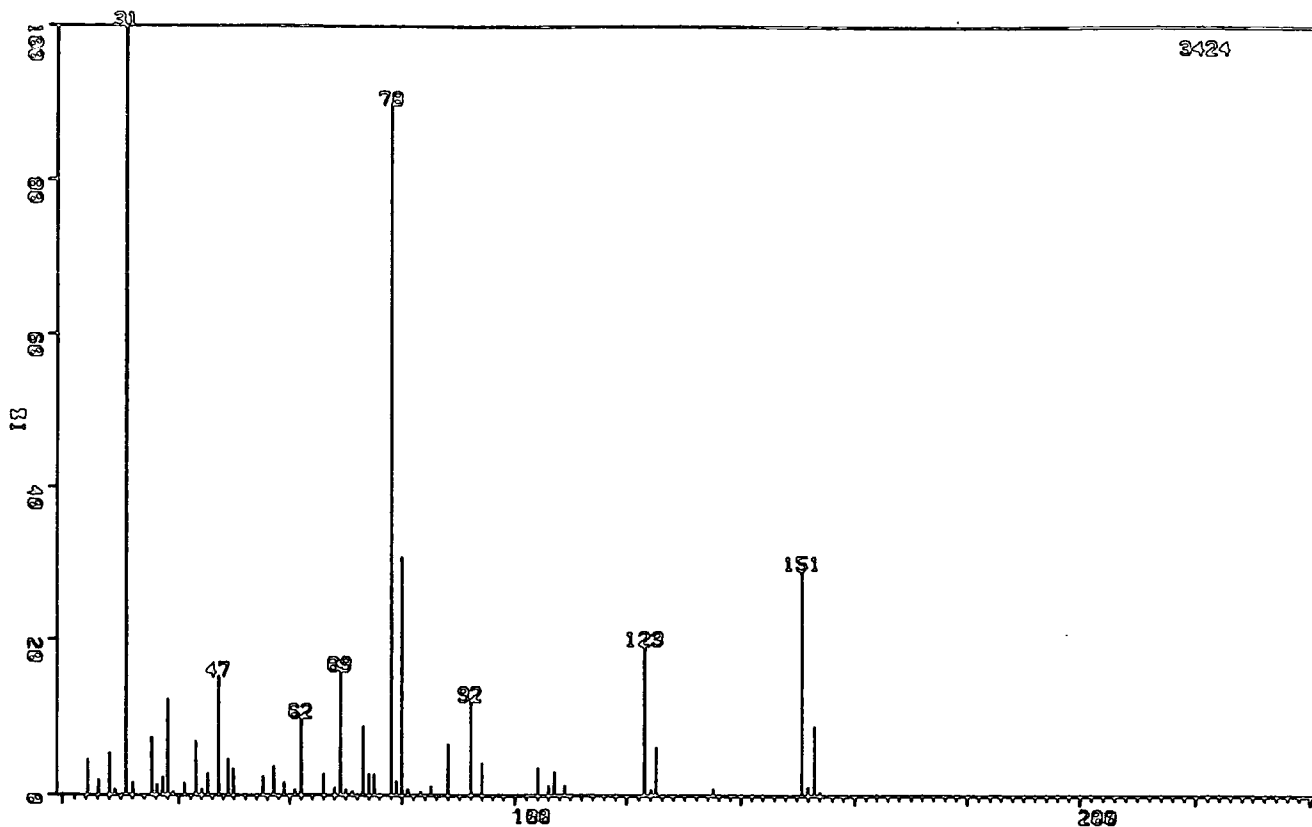
PHMFTX 2 P. HOARE
CAL: CALT1 STA:24-JUL-85
0:25

MASS	ZHT.	MASS	ZHT.
	BASE		
24.41	4.64	71.04	0.50
26.36	2.02	73.00	9.02
28.17	5.58	74.06	2.77
29.05	0.76	75.04	2.66
30.93	100.00	77.98	89.72
32.03	1.66	78.95	1.84
35.14	7.59	79.88	30.84
36.14	0.47	80.95	0.67
36.16	1.40	81.06	0.73
37.09	2.39	83.15	0.38
38.06	12.47	85.06	1.17
38.97	0.38	88.04	6.75
40.96	1.58	91.99	12.35
43.07	7.13	94.03	4.29
43.08	0.38	104.03	3.65
43.12	1.52	106.03	1.26
44.11	0.73	107.04	3.10
45.11	2.89	108.95	1.31
45.15	0.67	122.95	19.33
47.04	15.30	123.97	0.73
48.92	4.76	124.96	6.43
49.87	3.45	134.99	0.91
55.08	2.48	150.88	29.35
55.13	1.05	151.95	1.17
57.05	3.83	152.95	9.08
57.11	1.08	153.97	0.47
58.92	1.69		
58.99	0.55		
60.89	0.76		
62.01	10.16		
66.04	2.83		
67.99	0.93		
68.97	16.00		
69.03	1.78		
69.91	0.67		

3

PHTFTX 4 P. MORAE
 ORL:ORLY1 STA:

11-JUN-85
 0142

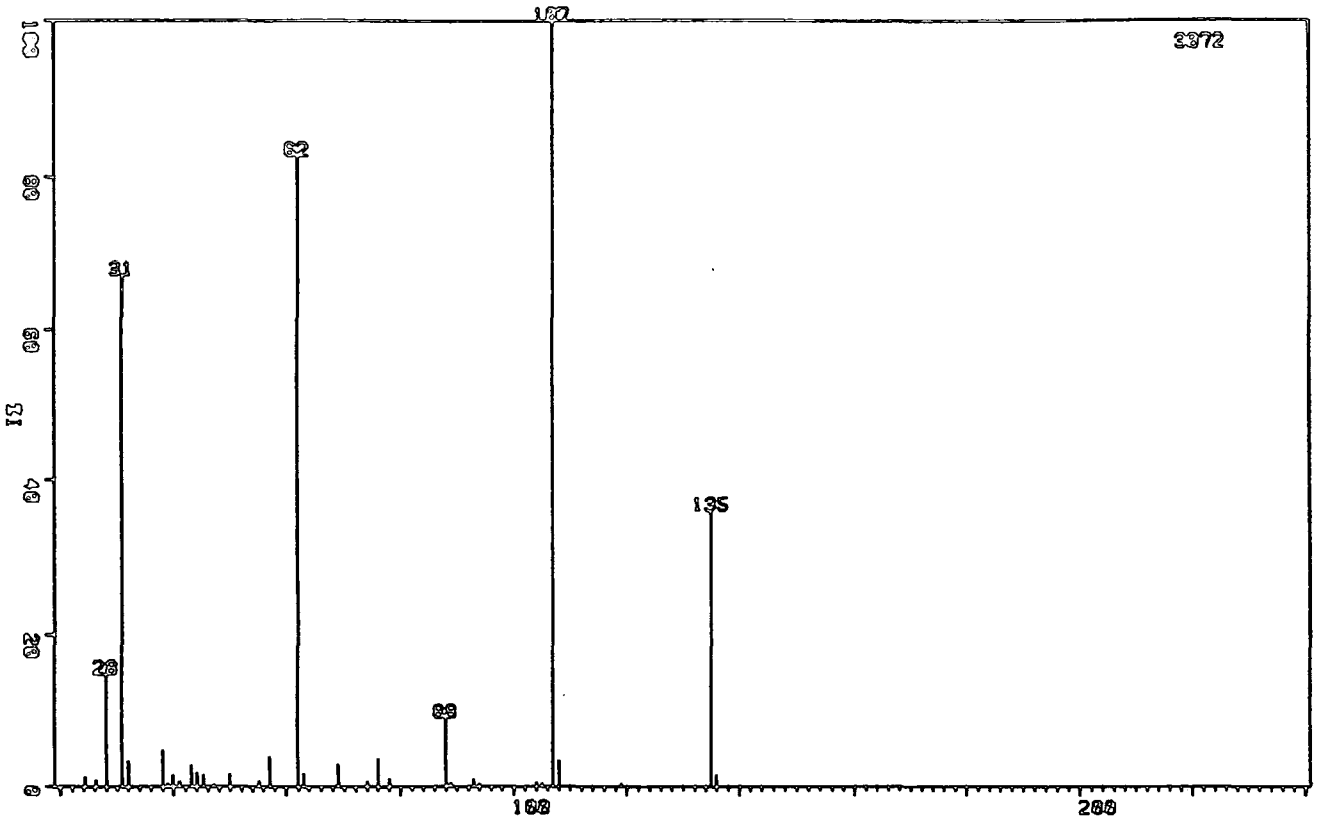

MASS	%HT. BASE
24.40	1.27
26.36	0.81
28.17	14.94
30.93	67.19
32.03	3.35
38.06	4.85
38.99	0.29
39.82	1.53
40.97	0.65
43.07	2.80
43.12	0.72
44.09	1.73
45.11	1.53
47.04	0.26
49.86	1.66
55.08	0.72
55.13	0.42
57.05	3.94
57.11	0.75
61.98	82.75
63.02	1.69
68.94	2.99
69.00	0.29
74.03	0.68
76.04	3.71
77.95	1.04
87.98	9.24
88.94	0.42
92.99	0.94
93.96	0.33
103.97	0.55
105.08	0.33
106.98	100.00
107.96	3.45
118.97	0.29
134.93	35.94
135.93	1.53

4

PHPIT0590 x1 8pd=46 7-JAN-88 12:20:03:28 7CE C1-
 Bp#=300 I=9.0v H#=565 TIC=220330000 Rcnt: Sys:MOAR
 GC=60° Cal:PFK11

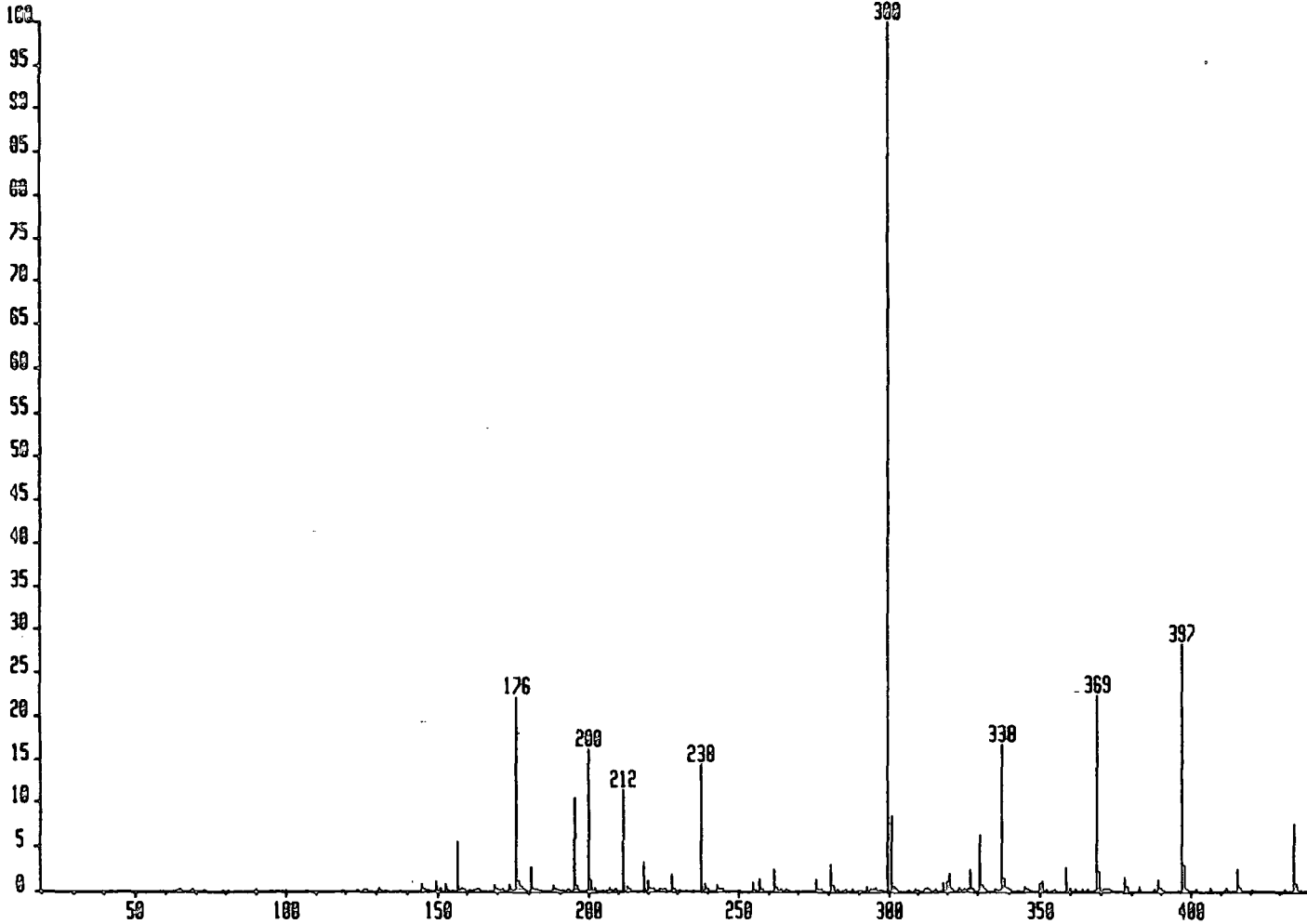

Mass	% Base	Mass	% Base	Mass	% Base
156.91	5.43	211.88	11.28	368.81	22.27
157.91	0.28	212.88	0.50	369.22	0.04
158.92	0.08	213.89	0.14	369.58	0.03
160.94	0.05	218.88	3.13	369.81	2.07
161.91	0.07	219.89	1.06	370.83	0.15
162.93	0.11	220.89	0.21	371.80	0.08
163.91	0.15	221.91	0.09	372.82	0.13
168.90	0.64	223.87	0.10	373.78	0.07
169.92	0.10	224.93	0.05	377.81	1.45
170.91	0.05	225.88	0.10	378.82	0.40
171.92	0.18	227.88	1.81	382.81	0.41
173.90	0.66	228.88	0.14	388.81	1.15
174.92	0.04	230.88	0.07	389.81	0.36
175.57	0.02	232.85	0.06	390.77	0.03
175.60	0.02	234.89	0.03	395.67	0.04
175.91	22.06	237.86	14.28	396.79	28.11
176.91	1.07	299.83	100.00 F	397.45	0.04
177.91	0.44	300.84	8.24 F	397.80	2.89
178.92	0.11	330.82	6.17	398.79	0.12
180.91	2.68	331.82	0.59	401.78	0.12
181.91	0.21	332.83	0.15	406.78	0.31
182.88	0.02	335.82	0.09	411.80	0.24
190.93	0.03	336.87	0.03	415.78	2.31
192.90	0.09	337.19	0.03	416.79	0.29
194.90	10.42	337.27	0.05	420.77	0.05
195.90	0.46	337.82	16.56	431.76	0.08
199.65	0.05	338.82	1.33	434.77	7.40
199.90	16.06	339.83	0.26	435.77	0.76

5

PMP1061o ml 0gd=55 7-JAN-00 12:20:04:14 70E Cl-
 SpR=324 I=16v Ho=604 TIC=199621620 Acnt: Sys HOAR
 GC= 75° Cal PFK11

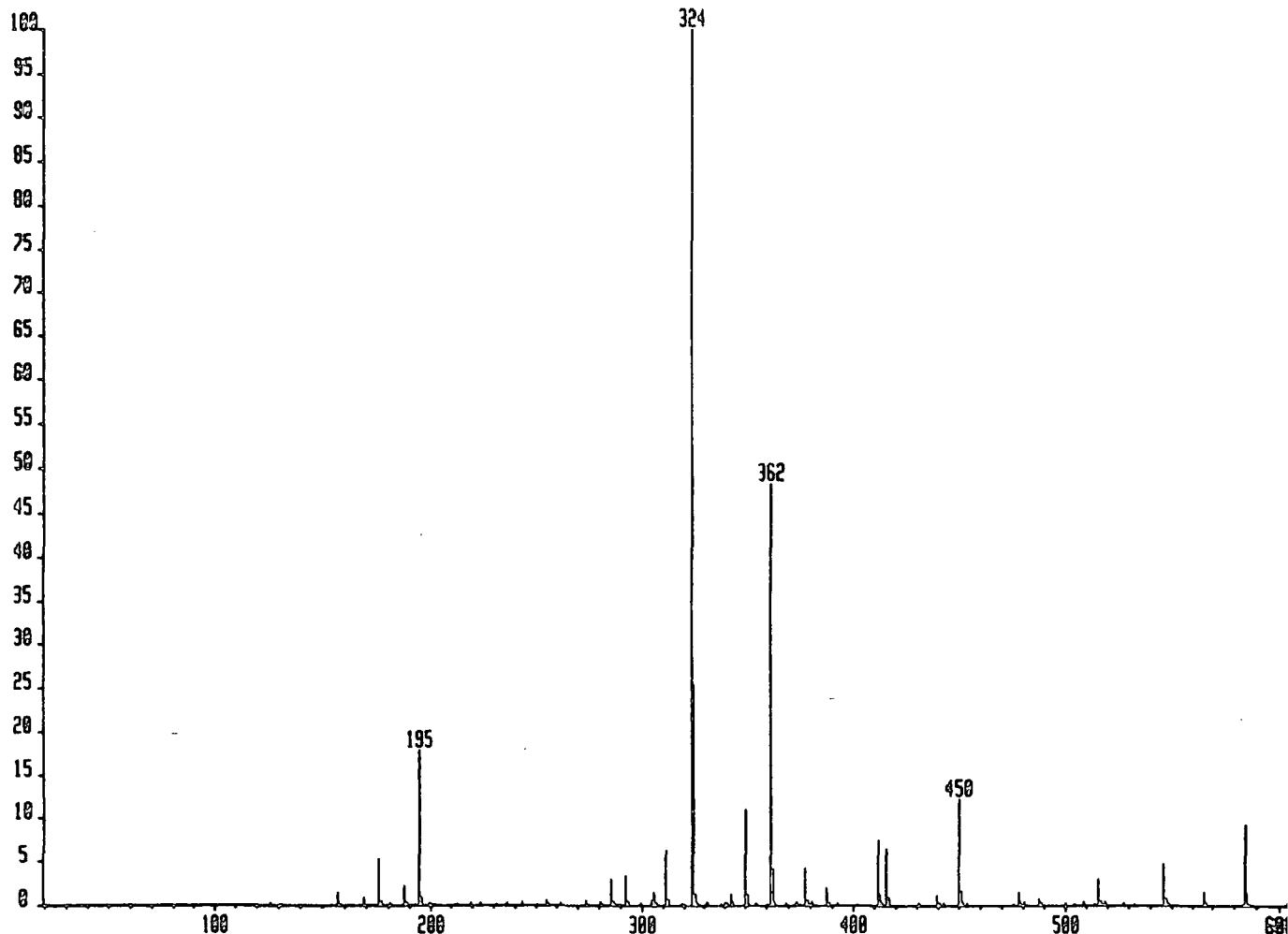

Mass	Z	Base					
175.90	5.26		361.79	48.25	F	480.72	0.23
176.89	0.23		362.80	3.95	F	487.71	0.53
180.91	0.09		377.79	4.12		488.71	0.08
187.89	2.10		378.79	0.48		488.85	0.03
188.90	0.11		379.80	0.05		499.71	0.11
192.87	0.07		380.76	0.29		504.66	0.05
194.49	0.03		387.78	1.97		508.71	0.31
194.57	0.04		388.77	0.21		513.68	0.06
194.89	17.79		392.78	0.09		513.86	0.05
195.89	0.78		401.74	0.05		515.72	2.82
199.89	0.22		411.76	7.46		516.72	0.33
311.81	6.26		412.76	0.98		518.71	0.31
312.81	0.59		413.74	0.08		519.67	0.03
318.80	0.11		415.76	6.33		527.67	0.14
319.78	0.03		416.76	0.69		532.71	0.04
320.39	0.04		430.71	0.08		546.70	4.55
320.47	0.03		430.82	0.04		547.70	0.54
320.58	0.05		431.72	0.06		548.79	0.04
323.88	100.00	FO	439.76	1.04		565.69	1.37
324.78	25.35	F	440.76	0.16		566.69	0.18
325.78	1.13	F	442.75	0.19		583.85	0.04
349.81	11.00		448.97	0.03		584.02	0.05
350.34	0.02		449.08	0.05		584.68	9.19
350.81	1.19		449.74	12.14		585.10	0.03

PHSIBX 4 P. HOARE
CAL: CALY1 STRA:

22-JUL-85
0142

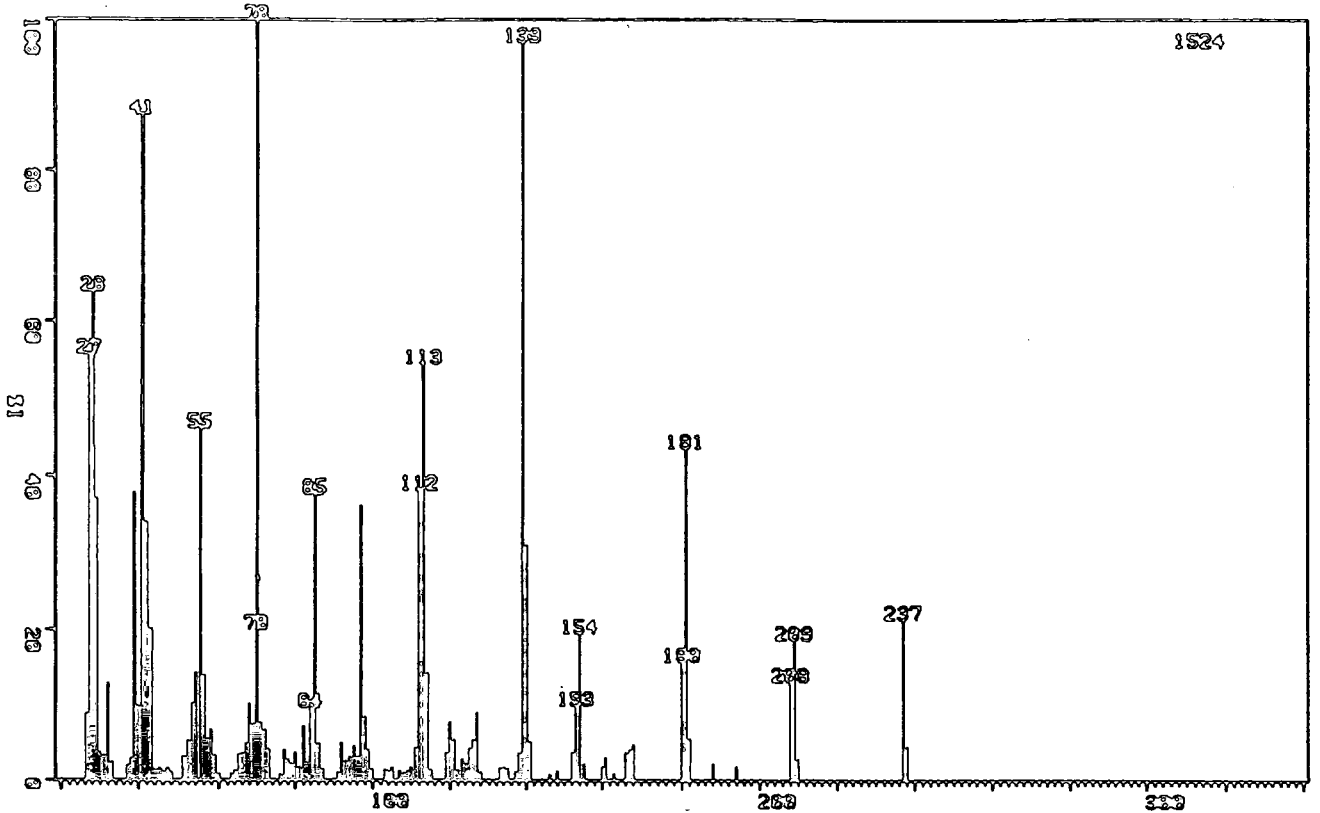

MASS	%HT.	BASE					
26.37	8.92	57.12	5.51	95.06	4.53	140.97	5.12
27.29	55.84	58.03	6.82	96.06	3.02	146.03	0.72
28.17	64.04	58.97	3.35	96.99	36.15	148.01	1.25
28.18	28.54	59.91	0.85	97.06	1.18	151.98	3.74
28.19	43.57	63.06	0.85	97.98	8.46	153.00	10.10
29.02	1.38	64.08	1.25	98.96	4.00	154.04	19.69
29.05	37.14	65.10	3.48	99.92	1.44	155.04	2.17
29.88	3.74	66.06	3.61	103.01	1.38	159.96	1.84
30.93	2.82	67.06	4.99	104.03	1.25	160.99	3.02
30.95	3.35	68.03	10.17	105.03	1.71	163.05	0.79
32.03	12.93	68.98	7.48	107.02	1.25	166.01	3.74
33.13	2.36	69.88	20.14	108.01	0.98	167.01	4.13
37.13	1.97	69.96	100.00	108.99	1.18	168.00	4.79
38.07	2.95	70.96	7.68	109.90	1.77	179.94	15.88
38.99	37.99	71.02	5.77	110.95	4.40	180.97	43.57
39.82	3.15	72.02	6.76	112.00	38.32	181.99	5.51
39.88	9.91	73.07	4.20	113.03	54.53	188.01	2.23
40.97	87.60	74.08	0.72	114.05	14.24	194.01	1.90
42.05	34.12	77.06	4.13	115.06	1.38	208.00	13.32
43.12	20.08	78.04	2.69	118.97	3.74	208.99	18.83
44.09	1.31	79.00	2.17	119.93	7.81	209.97	2.89
44.16	1.25	79.95	3.74	120.97	5.38	236.99	21.52
45.10	0.72	81.02	1.77	122.00	1.31	237.99	4.53
45.13	1.38	82.06	7.22	123.04	2.82		
45.15	1.71	83.05	2.30	124.00	2.17		
46.12	1.12	83.11	1.51	125.01	4.27		
47.07	1.51	84.04	9.84	126.02	5.38		
47.10	1.57	84.11	0.85	127.01	9.06		
48.03	1.12	85.03	37.80	127.99	1.05		
50.95	3.15	85.10	0.98	133.01	1.71		
52.02	5.31	86.04	4.92	134.03	1.77		
53.08	10.24	87.02	1.44	135.05	1.51		
54.11	14.30	90.95	0.98	136.99	1.12		
55.13	46.19	91.99	5.05	137.97	3.61		
56.14	14.04	93.03	2.56	138.97	97.11		
57.06	4.66	94.04	3.08	139.93	31.17		

7

PHS3X 5
CAL: CALYI

P. MORRE
STAI

22-JUL-85
0.50

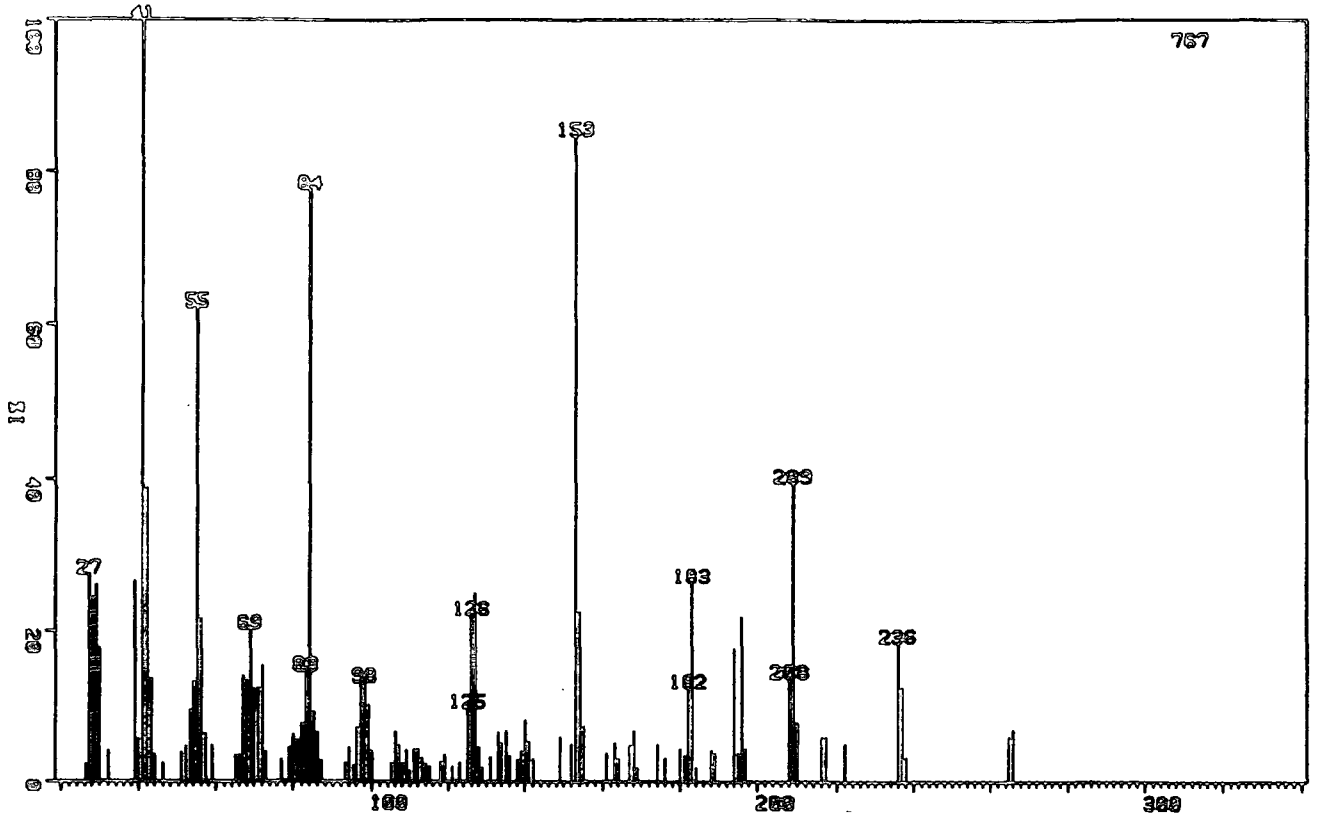

MASS	ZHT.	BASE					
26.35	2.35	82.06	7.69	134.01	5.08	216.97	5.87
27.29	27.51	83.10	14.73	135.03	6.78	221.93	4.95
28.17	24.38	84.09	77.71	136.01	3.39	235.94	18.51
29.04	25.95	85.09	9.26	137.98	2.87	236.96	12.52
29.87	17.60	86.06	6.52	138.94	4.04	237.95	3.26
32.01	4.04	87.04	2.74	139.91	8.21	264.93	6.00
38.97	26.47	93.04	2.48	140.94	5.22	265.92	6.91
39.81	2.87	94.06	4.56	141.98	3.00		
39.87	5.61	95.08	2.09	148.98	5.87		
40.95	100.00	96.08	7.17	151.95	4.95		
42.04	38.72	97.02	13.56	152.99	84.75		
43.10	13.69	98.01	13.30	154.01	22.56		
44.13	3.52	98.98	10.17	155.01	7.30		
46.09	2.48	99.94	4.04	160.97	3.78		
50.93	3.91	105.04	2.48	163.01	5.08		
52.00	4.69	106.05	6.65	164.03	3.00		
53.06	9.52	107.04	4.82	166.98	4.82		
54.09	13.30	108.03	2.48	167.97	6.65		
55.11	62.19	108.99	4.17	168.95	1.83		
56.10	21.64	109.94	1.43	174.01	4.95		
57.09	6.39	110.95	4.30	176.00	3.13		
58.96	4.82	111.98	4.30	179.90	4.30		
65.07	3.52	113.01	3.13	180.93	3.39		
66.06	3.52	114.03	2.22	181.95	12.52		
67.06	14.08	115.03	1.96	182.99	26.47		
68.03	13.43	117.97	2.61	183.99	1.83		
68.99	20.34	118.96	3.52	187.99	4.17		
69.88	12.39	120.95	1.96	188.97	3.78		
69.96	4.30	123.01	2.48	193.96	17.60		
70.96	12.39	124.99	9.91	194.98	3.78		
72.02	15.38	126.00	22.16	195.97	21.90		
73.07	3.91	127.01	25.03	196.97	4.30		
77.07	2.87	127.99	4.56	207.95	13.82		
79.01	4.56	128.96	1.83	208.94	39.63		
79.95	6.26	130.96	3.26	209.92	7.82		
81.01	5.48	133.00	6.52	215.97	5.87		

8

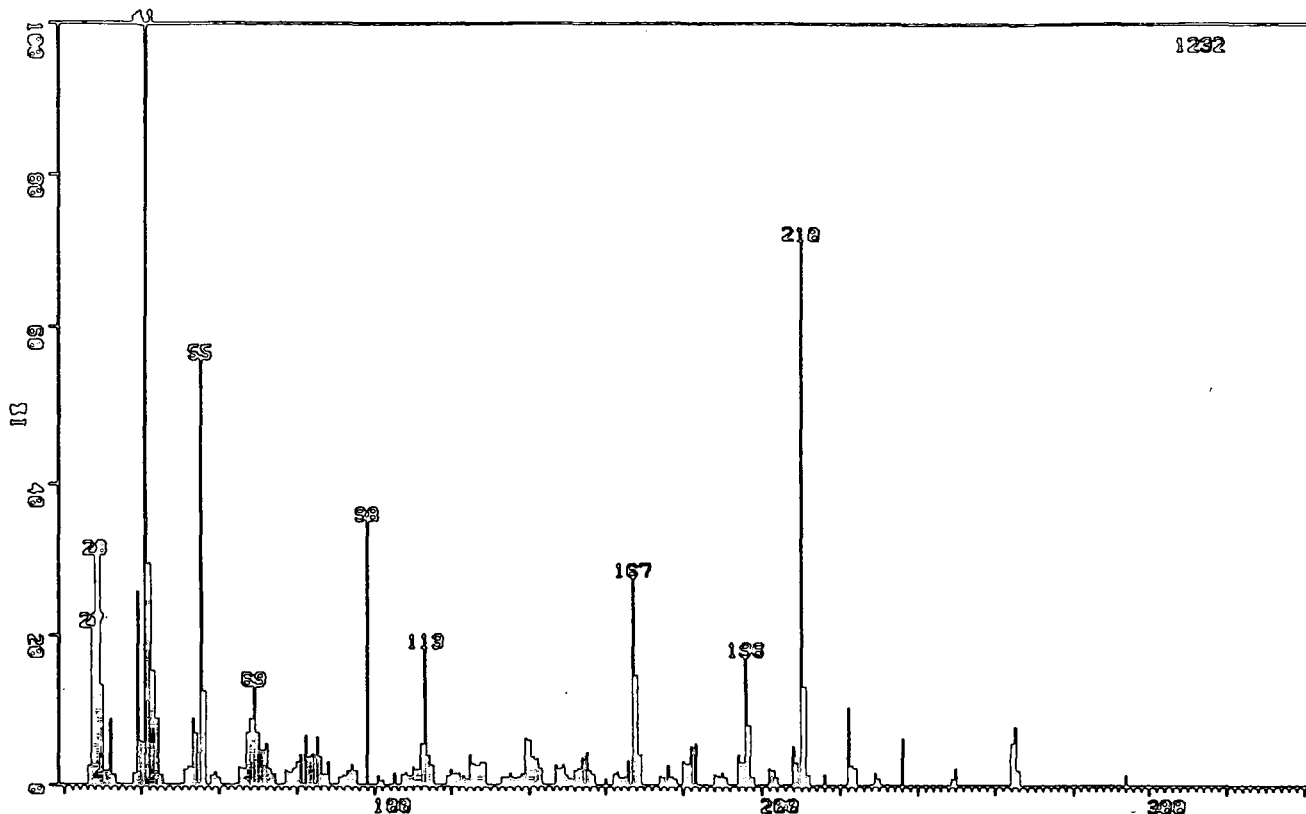
PHS4X 34 P. HORRE
CAL: CALY1 STA:23-JUL-85
4:59

MASS ZMT.
BASE

26.37	2.52	70.97	4.63	118.95	1.22	164.05	1.06	229.02	1.70
27.30	21.19	71.04	1.06	119.94	2.11	165.03	1.14	229.99	0.89
28.17	30.84	72.03	5.52	120.98	1.54	166.01	3.33	236.02	6.33
28.19	10.80	73.07	2.19	122.01	1.62	167.02	27.84	248.98	0.89
29.02	0.97	74.10	1.46	123.04	1.22	168.00	14.69	249.97	2.35
29.05	32.63	77.06	1.95	124.01	0.89	168.99	4.14	264.03	5.68
29.88	13.31	78.02	1.70	125.01	4.14	174.02	1.22	265.05	7.87
30.93	0.73	79.00	2.19	126.01	2.84	175.03	1.06	266.04	2.03
30.95	1.87	79.94	3.08	127.00	2.68	176.04	2.68	294.04	1.46
32.03	8.77	81.00	4.06	127.99	3.08	177.04	1.06		
33.13	1.38	82.05	6.57	128.96	3.08	178.02	0.81		
38.07	1.54	83.04	0.89	133.02	1.14	179.95	3.25		
38.99	25.73	83.10	3.65	134.04	1.06	180.98	2.92		
39.83	2.84	84.08	4.14	135.04	1.70	182.00	5.28		
39.89	5.84	85.07	6.41	136.05	1.06	183.02	5.60		
40.98	100.00	86.08	3.73	137.04	1.06	188.02	1.46		
42.06	29.55	87.06	1.38	137.98	1.46	189.00	1.22		
43.12	15.26	88.05	3.00	138.96	6.25	189.98	1.70		
44.17	8.93	91.00	1.06	139.93	6.01	191.02	1.06		
45.16	1.38	92.04	1.22	140.97	3.81	194.02	4.14		
50.96	2.03	93.07	1.87	142.01	3.57	195.03	3.00		
52.03	2.44	94.09	2.68	143.02	2.27	196.02	17.29		
53.09	8.93	95.11	1.95	147.03	2.68	197.02	8.04		
54.12	6.90	98.06	35.31	148.01	2.27	198.01	1.14		
55.14	55.93	100.99	1.22	149.01	2.76	202.02	2.27		
56.14	12.50	102.02	0.65	149.98	1.38	203.03	2.03		
58.04	1.22	105.06	1.62	150.97	0.81	204.06	1.06		
58.99	1.79	107.04	1.46	151.99	2.03	208.01	5.28		
59.91	0.97	108.03	1.70	153.00	2.27	209.00	3.08		
65.12	2.35	109.00	1.22	154.03	3.65	209.99	71.43		
66.08	2.19	109.96	2.44	155.04	4.38	211.00	13.23		
67.07	7.06	110.95	2.11	156.03	2.03	212.03	1.46		
68.03	8.93	112.00	5.52	157.04	1.54	216.04	1.54		
69.00	13.39	113.01	18.43	159.96	0.89	222.00	10.39		
69.88	7.06	114.03	4.06	162.02	1.54	223.00	2.68		
69.97	5.60	115.03	2.68	163.05	1.79	224.04	2.35		

9

PH58X 5 P. HOARE
 CRICATI STA:

29-JUL-85
 0.50

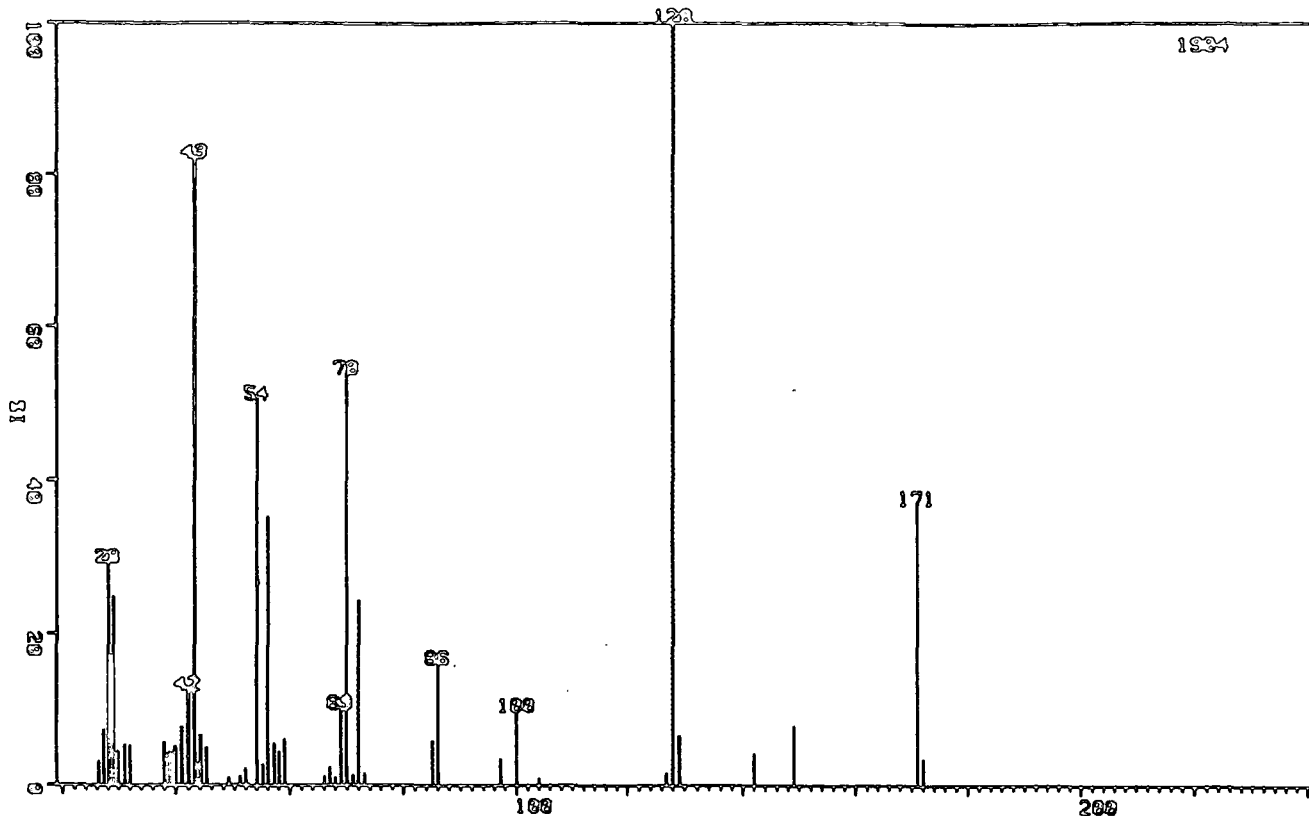

MASS	ZHT.	MASS	ZHT.
	BASE		
26.36	1.42	68.03	1.00
26.37	3.20	68.99	10.08
27.29	7.35	69.91	53.73
28.17	29.46	70.96	1.31
28.18	17.17	72.06	24.32
29.03	24.79	73.09	1.52
29.05	4.20	85.10	5.88
29.86	4.46	86.11	16.12
30.95	5.41	97.05	3.52
32.03	5.20	99.97	9.82
38.07	5.78	104.06	0.95
38.99	4.41	126.89	1.68
39.86	1.68	128.03	100.00
39.89	5.20	129.00	6.62
40.97	7.77	141.92	4.25
42.03	3.83	149.00	7.88
42.06	12.71	171.03	36.97
43.10	82.35	172.04	3.52
44.11	2.94		
44.14	2.26		
44.17	6.67		
45.16	5.04		
48.96	1.05		
50.96	1.16		
52.04	2.21		
54.09	50.37		
55.11	2.73		
55.15	1.21		
56.10	35.29		
56.15	1.10		
57.09	5.51		
57.14	3.78		
58.05	4.41		
58.99	6.09		
66.08	1.16		
67.06	2.36		

PH97AX 5 P. MORRE
CAL: CAL731 STR:

14-NOV-85
0.51

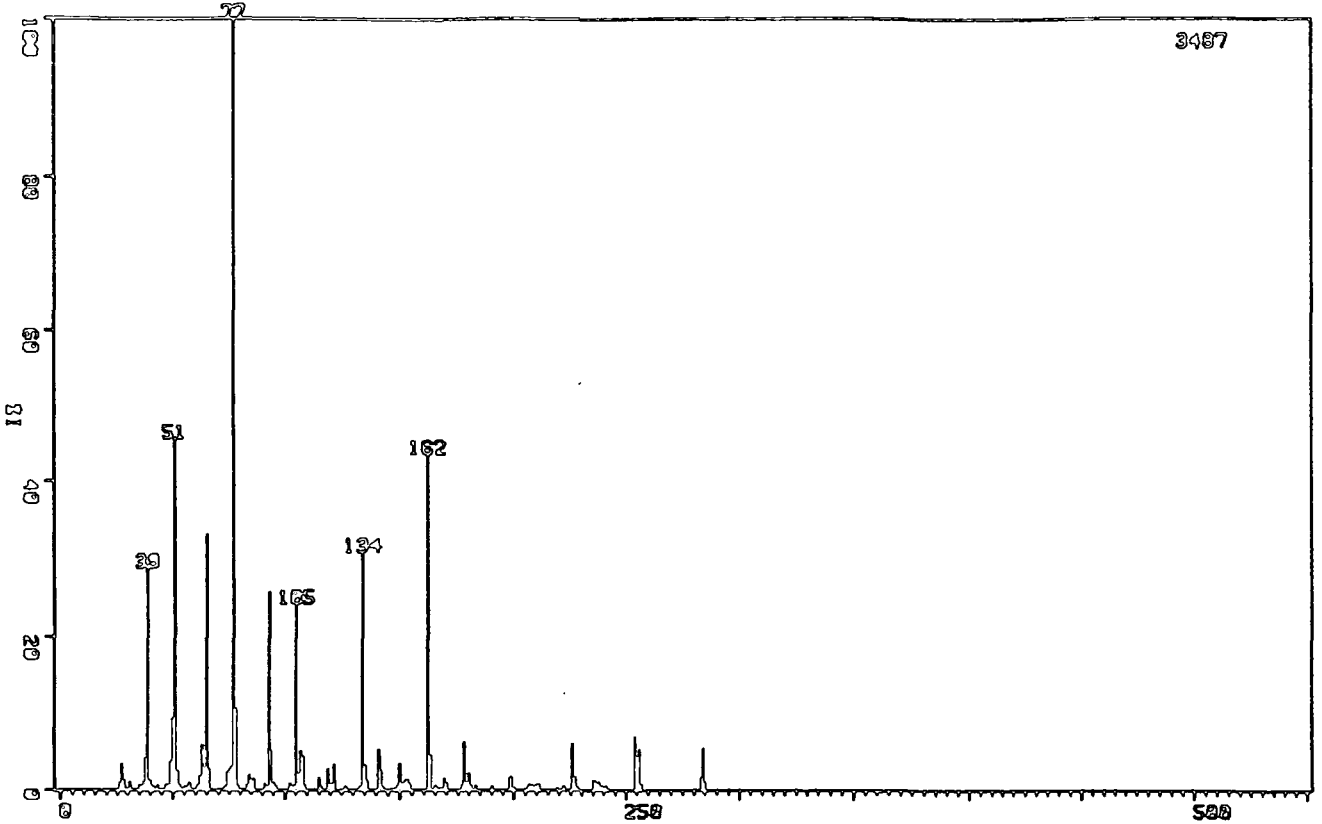

HAAS	ZHT.	BASE					
26.30	0.95	78.99	0.43	151.04	0.66	241.01	0.43
27.23	3.41	83.04	0.60	152.07	1.12	254.06	6.94
28.11	1.20	83.98	1.92	153.11	1.41	255.06	4.30
28.97	0.29	85.04	0.46	154.10	0.83	256.07	5.25
30.87	1.00	85.98	1.43	162.00	43.68	257.07	0.77
30.89	0.52	90.99	0.83	163.02	4.45	283.07	1.63
35.10	0.63	92.02	0.37	165.07	0.52	284.10	5.48
37.10	1.12	93.05	25.81	167.05	0.26	285.09	1.00
38.05	4.13	94.07	5.13	169.02	1.55	328.16	0.32
38.97	28.88	95.08	0.95	170.00	0.86	334.16	0.37
39.87	1.18	96.07	0.54	177.02	0.54		
40.95	0.49	102.03	0.86	178.01	6.25		
43.12	0.52	103.07	0.63	179.01	0.95		
47.05	0.69	104.09	0.37	180.01	2.18		
48.01	0.37	105.08	24.32	181.03	0.60		
48.95	3.64	106.08	2.06	183.06	0.54		
49.90	9.35	107.06	5.05	190.00	0.49		
50.92	1.26	108.05	4.33	198.05	1.69		
50.97	45.74	109.02	0.60	199.04	1.72		
52.04	2.44	115.11	1.63	200.03	0.32		
53.07	0.57	116.09	0.37	206.08	0.34		
55.13	0.40	119.00	2.72	207.07	0.83		
57.08	0.86	119.98	0.75	208.05	0.57		
60.99	0.49	121.00	0.72	210.01	0.66		
62.05	1.78	122.04	3.33	211.05	0.75		
63.10	5.85	127.07	0.37	219.04	0.26		
64.10	2.78	133.06	0.29	222.07	0.43		
65.10	33.04	134.08	30.86	226.09	6.14		
66.09	2.67	135.08	3.15	227.10	1.69		
73.03	0.29	136.08	1.12	228.05	0.34		
74.06	2.29	141.06	5.25	235.07	1.23		
75.08	2.58	142.09	2.47	236.06	1.23		
76.07	3.01	143.11	0.32	237.05	0.37		
77.06	100.00	149.02	0.54	238.04	1.09		
78.04	10.58	150.01	3.47	239.03	0.49		

11

PHS9X 2 P. HORRE
CAL: CALTSI STRA

14-NOV-85
0:26

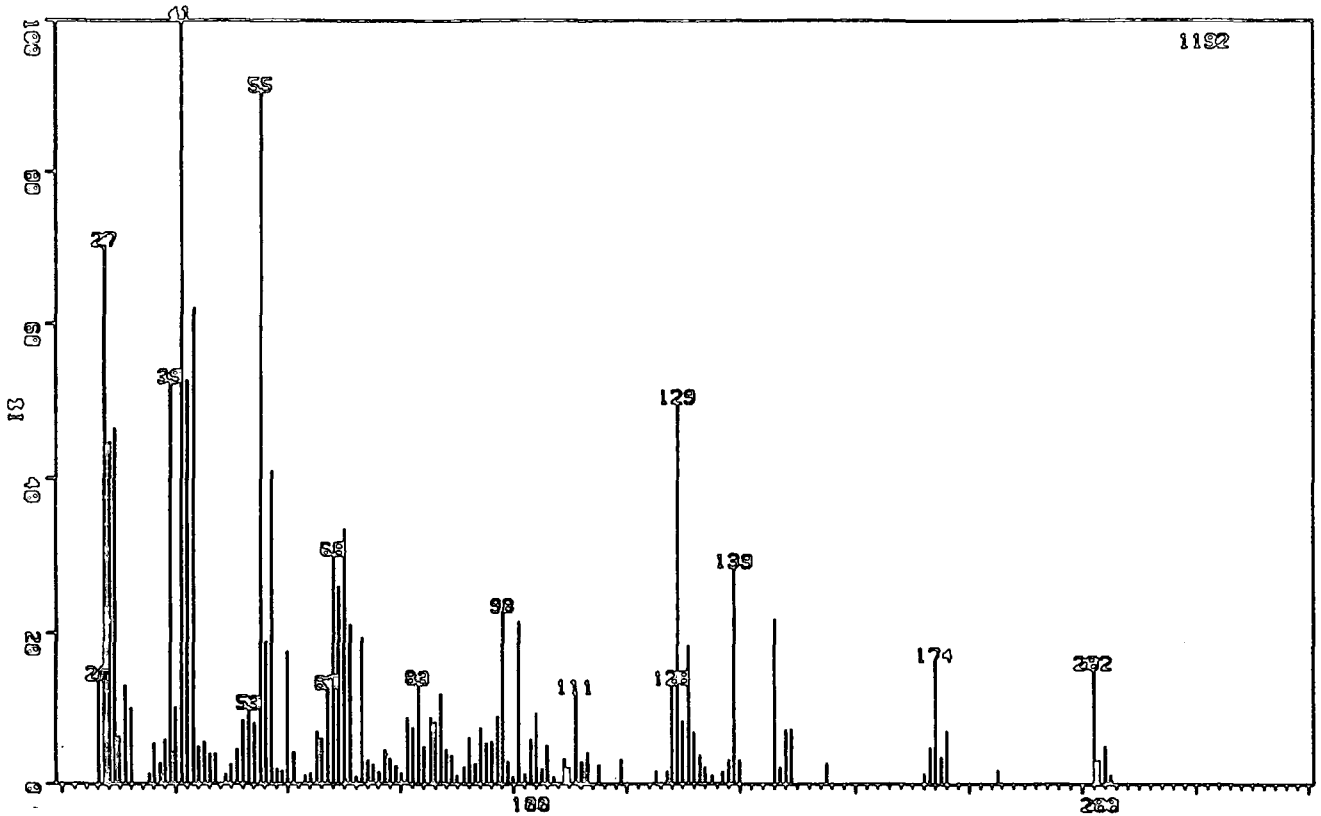

MASS	ZMT. BASE						
26.30	13.93	57.10	5.45	87.93	4.53	127.09	1.68
27.23	70.30	57.14	40.94	88.90	3.78	127.97	13.34
28.11	44.63	58.10	1.93	89.86	1.01	128.95	49.58
28.12	29.95	59.02	1.76	90.99	2.18	129.92	8.31
28.13	34.23	59.93	17.62	91.95	6.21	130.94	18.29
28.96	8.64	60.99	4.28	92.03	4.11	131.94	6.88
29.00	46.31	63.08	1.09	93.07	2.68	132.95	3.78
29.82	6.29	64.11	1.43	94.00	2.43	133.96	2.18
30.86	13.00	65.11	6.96	94.09	7.47	135.08	1.09
30.88	1.76	66.01	1.68	95.11	5.37	137.02	1.59
31.97	10.07	66.07	6.04	96.07	5.62	138.01	3.19
35.10	1.43	67.07	12.67	97.05	8.98	138.98	28.78
36.10	5.37	68.03	30.29	98.03	22.90	139.97	3.10
37.09	2.77	68.99	26.09	98.99	1.76	145.99	21.90
38.04	5.87	69.93	33.64	99.04	2.94	147.00	2.18
38.96	52.35	71.01	21.06	99.89	0.92	147.95	7.21
39.80	4.28	72.07	0.92	100.96	21.48	148.94	7.30
39.86	10.15	73.03	19.30	101.03	1.93	155.02	2.77
40.94	100.00	74.02	3.10	102.00	1.26	172.00	1.43
42.03	52.43	74.07	1.43	103.02	5.87	173.01	4.87
43.10	62.00	75.02	2.52	104.01	9.40	174.02	16.36
44.10	4.95	76.02	1.51	105.02	1.93	175.02	3.52
44.15	2.60	77.03	4.45	106.03	5.12	176.03	7.13
45.12	5.62	77.95	3.36	107.12	0.92	185.15	1.85
46.11	3.94	78.01	2.10	109.05	3.36	201.99	15.35
47.05	4.03	78.98	2.35	109.96	2.10	202.99	3.19
48.93	1.26	79.93	1.43	111.02	12.08	204.00	5.03
49.88	2.52	81.00	8.72	112.07	2.94	205.01	1.26
50.96	4.61	82.05	7.38	113.01	1.85		
52.03	8.47	83.07	13.34	113.07	4.28		
53.09	10.07	84.09	4.95	113.14	2.60		
54.13	8.14	85.11	8.89	115.07	2.52		
55.15	90.69	85.98	8.22	118.93	1.43		
56.11	13.34	86.97	12.00	118.99	3.36		
56.15	18.88	87.02	3.52	125.12	1.68		

12

PH152090 x1 0gd=3 25-MAR-07 14:20:02:21 70E EI+
 0pH=0 I=1.0v Hn=448 TIC=168306000 Rcnt: Sys: FID
 Text: P.MOORE Cal: PFK

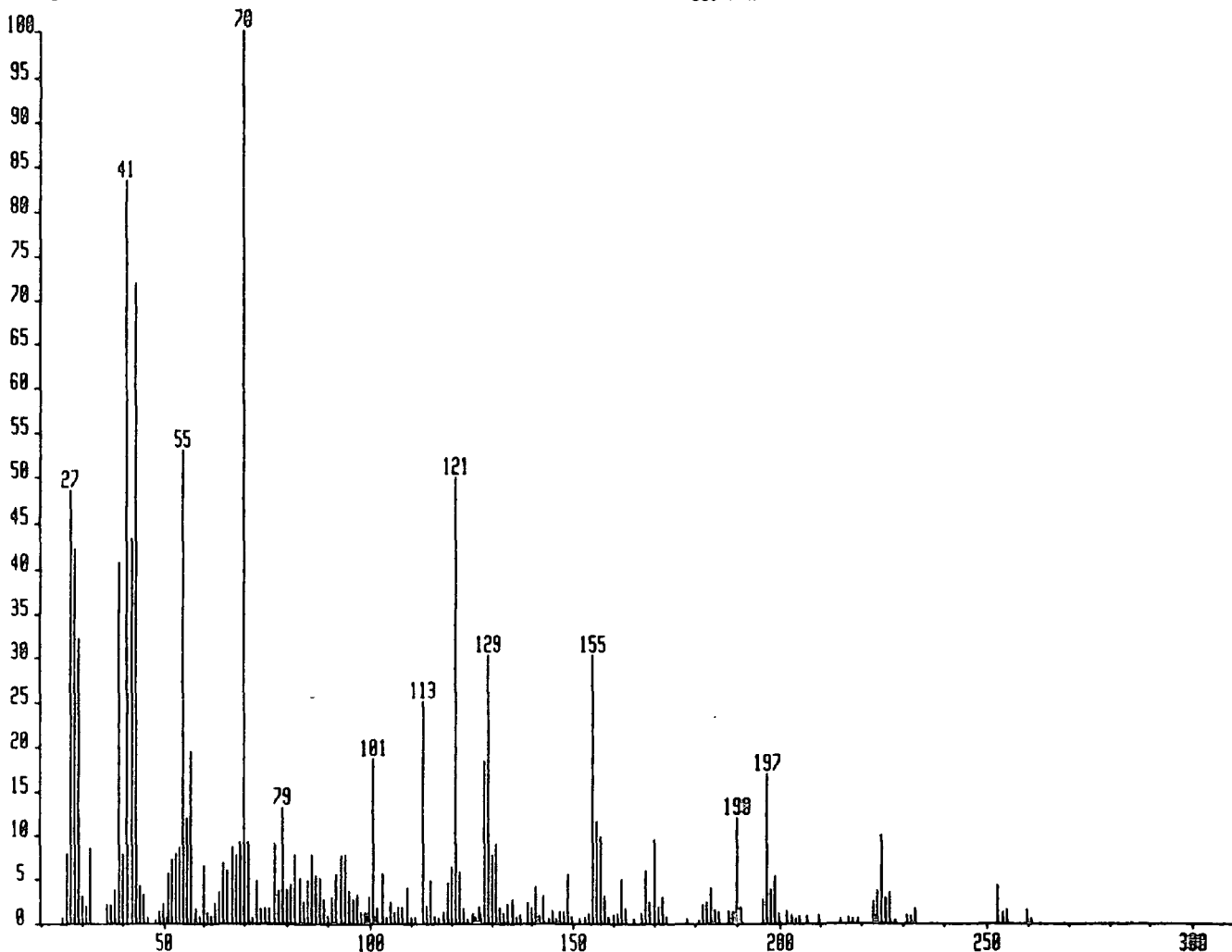

Mass	% Base					
26.99	40.55		66.97	8.70	169.86	9.52
27.97	42.13 F		67.97	7.60	170.86	1.67
27.99	22.04 F		68.98	9.16	189.91	11.93
28.00	26.42 F		69.98	100.00	190.91	1.77
28.97	3.11		71.00	9.23	195.83	2.62
29.01	32.08		76.94	9.00	196.84	16.82
30.00	3.08		77.94	3.63	197.84	3.76
30.98	1.84		78.94	13.03	198.84	5.37
31.95	8.42		100.88	18.52	223.83	3.64
35.94	2.00		100.94	0.60	224.84	9.89
36.97	2.02		101.89	1.61	225.83	2.74
37.97	3.78		102.88	5.65	226.83	3.34
38.98	40.77		112.85	24.98	227.85	0.31
39.92	1.45		113.87	1.89	230.81	0.81
39.98	7.76		119.93	6.28	231.82	0.75
40.99	83.43		120.94	49.94	232.83	1.62
41.99	43.25		121.94	5.75	252.81	4.20
42.97	4.98 F		127.88	18.31	253.82	1.16
43.00	71.86 F		128.89	30.27	254.81	1.42
51.96	7.26		129.87	7.59	259.77	1.41
52.97	7.87		130.88	8.86	260.79	0.45
53.98	8.68		154.85	30.20		
54.99	53.00		155.86	11.49		
56.00	11.89		156.86	9.74		
57.00	19.46					

PH83X 6 P. HORRE EI
CALICLUP15 STA:

24-OCT-85
0:57

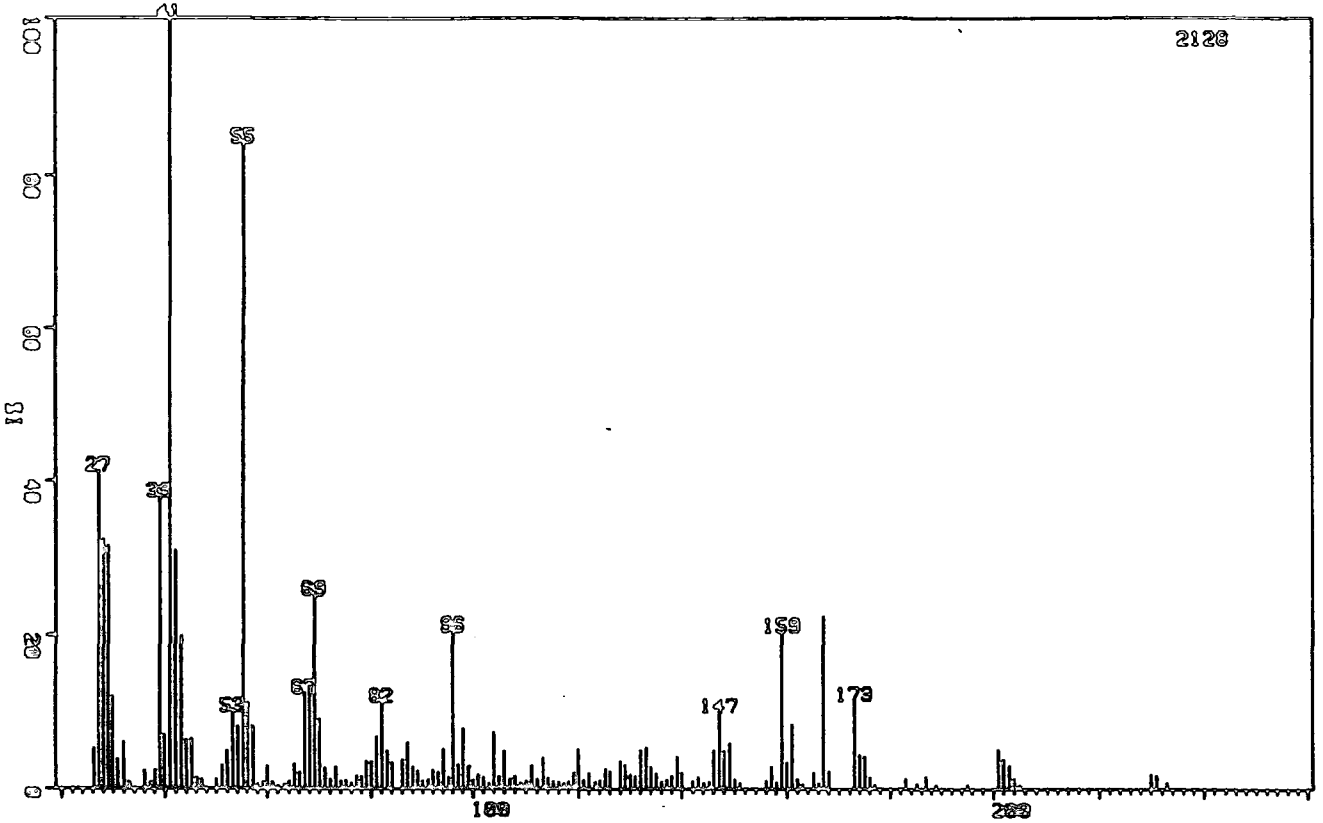

MASS ZHT.
BASE

26.28	5.31	59.87	0.56	88.94	2.35	116.02	0.89	147.98	4.93
27.21	41.35	59.91	3.05	89.90	1.03	117.02	0.70	148.96	6.02
28.10	32.28	60.92	0.94	91.01	1.27	117.96	0.75	149.93	1.27
28.11	14.99	60.97	0.61	91.98	2.49	118.02	0.94	151.00	0.85
28.96	2.87	62.01	0.42	92.06	1.50	118.93	1.60	156.03	1.13
28.98	31.34	63.06	0.61	93.01	0.70	119.00	2.11	157.03	2.96
29.81	12.12	64.08	1.03	93.09	2.21	119.89	5.22	158.00	0.89
30.85	3.90	65.11	3.24	94.02	0.80	120.01	1.79	158.95	20.44
30.87	1.79	66.08	2.21	94.11	5.26	120.95	1.17	159.92	3.43
31.96	6.11	67.07	12.64	95.09	1.46	121.05	0.70	160.94	8.55
33.06	0.89	68.03	13.49	96.10	20.63	121.98	1.64	161.97	1.32
36.09	2.40	68.99	25.14	97.06	3.15	122.09	2.02	162.99	0.70
37.09	0.80	69.91	9.16	98.06	7.94	123.09	0.99	165.08	2.16
38.00	0.94	70.94	2.77	98.97	2.87	124.08	1.08	166.08	0.80
38.03	2.49	71.01	2.49	99.04	1.03	125.07	2.68	167.07	22.42
38.96	37.97	72.00	1.22	99.90	1.17	126.10	2.30	168.05	2.35
39.80	2.44	72.99	1.50	99.97	0.52	128.00	3.71	172.98	11.75
39.86	7.10	73.04	2.82	100.97	1.88	128.99	3.20	174.01	4.46
40.94	100.00	74.01	1.03	102.01	1.55	129.95	1.97	175.01	4.28
42.03	30.83	75.02	1.13	103.03	0.75	130.96	1.69	176.00	1.55
43.10	19.92	76.03	0.75	104.02	7.47	131.95	5.12	176.98	0.56
44.12	6.39	77.04	1.79	105.02	1.60	132.03	0.89	183.03	1.41
45.12	6.53	77.95	1.27	105.09	1.36	132.98	5.50	185.04	0.75
46.11	1.46	78.01	1.60	106.02	4.93	133.99	2.87	187.00	1.64
47.04	1.22	78.99	3.67	106.09	1.03	135.00	2.02	188.95	0.52
49.88	1.27	79.85	0.61	107.01	1.13	135.99	0.99	195.07	0.56
50.95	3.01	79.97	3.62	107.10	1.22	137.04	1.27	200.97	5.26
52.02	4.98	81.04	6.81	107.97	1.69	138.03	1.69	201.99	3.99
53.09	10.20	82.07	11.51	108.07	0.42	139.01	4.28	203.02	3.15
54.12	8.18	83.11	4.93	109.04	0.75	139.99	2.21	204.03	1.41
55.14	84.16	84.09	3.43	109.96	1.03	142.01	1.03	205.05	0.52
56.14	11.33	86.01	3.81	111.01	3.05	143.03	1.55	229.96	1.97
57.07	1.17	86.08	0.66	112.02	1.32	144.04	0.85	231.00	1.83
57.12	8.22	87.00	6.11	113.04	4.09	145.04	0.99	233.00	0.89
58.03	0.61	87.05	0.75	114.04	1.41	145.99	5.12		
59.00	0.99	87.98	2.87	115.02	0.94	147.01	10.20		

14

PHS1AX 9 P. HOARE EI
CALICLPI5 STA:

23-OCT-85
1:28

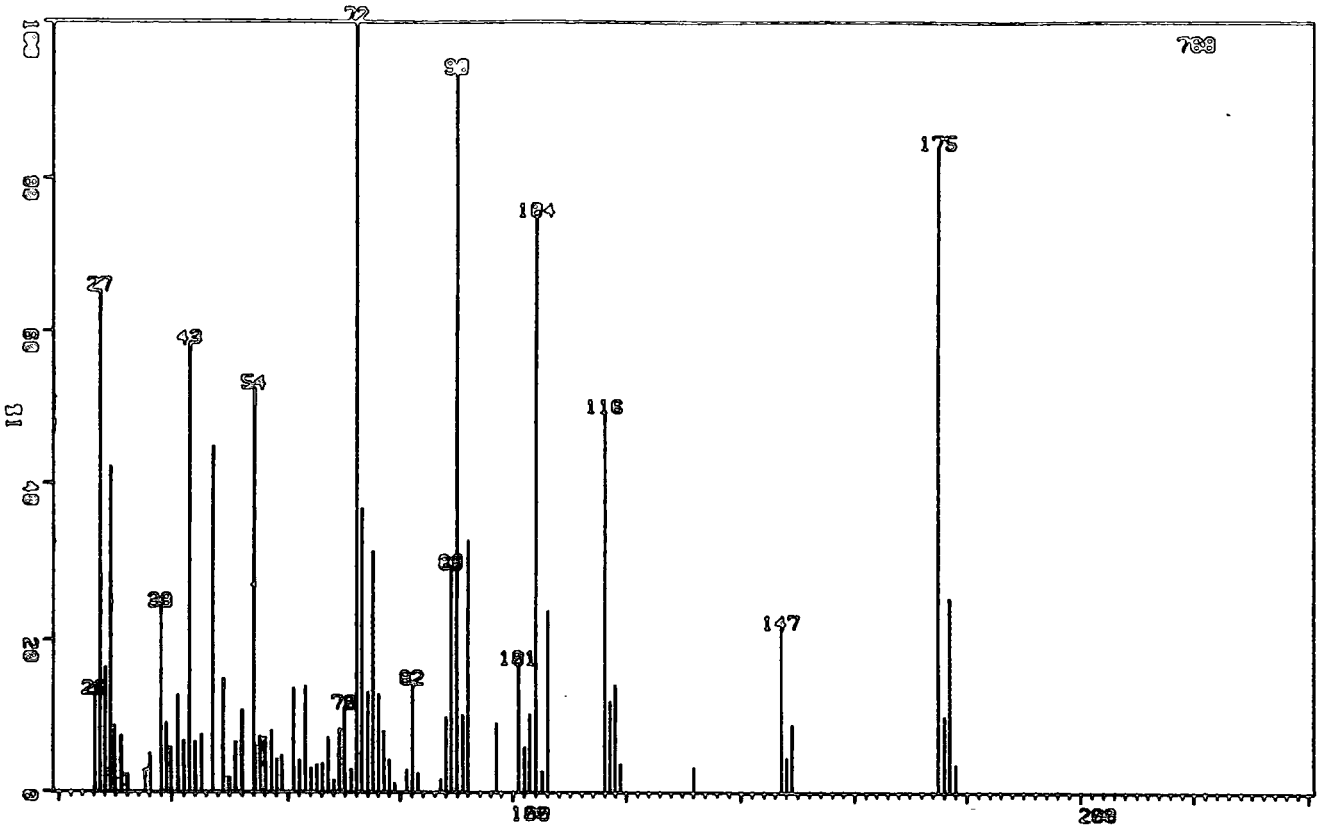

MASS	ZHT. BASE				
26.28	12.89	60.92	13.67	105.02	2.73
27.21	65.23	61.98	4.17	106.02	23.83
28.10	16.41	63.01	13.93	116.01	49.35
28.95	42.19	64.05	3.12	116.98	11.98
28.98	5.34	65.03	3.52	117.97	14.19
29.79	8.72	66.07	3.78	118.92	3.78
30.87	7.42	67.05	7.16	131.96	3.26
31.96	2.34	68.07	1.56	147.00	21.61
35.09	2.99	68.98	5.47	147.98	4.56
36.09	5.08	69.02	8.33	148.96	8.98
38.02	24.35	69.89	11.07	174.99	83.98
38.95	9.11	70.00	2.47	176.00	10.03
39.83	3.39	71.07	2.99	176.98	25.39
39.85	5.86	72.07	100.00	177.98	3.65
40.94	12.76	73.03	36.72		
41.99	3.52	73.11	5.08		
42.03	6.77	74.03	13.15		
43.07	58.33	75.02	31.25		
44.11	1.95	76.05	12.89		
44.14	6.64	77.00	7.94		
45.13	7.55	78.00	4.17		
47.04	44.92	78.96	1.17		
48.93	14.97	81.03	2.99		
49.87	1.95	82.03	14.32		
50.91	4.69	83.05	2.47		
50.94	6.64	87.00	1.69		
52.02	10.81	88.00	9.90		
54.07	52.47	88.95	29.17		
54.11	6.12	89.91	93.62		
55.14	7.29	90.93	10.16		
56.09	7.16	91.98	32.68		
56.14	3.91	97.03	9.11		
57.13	8.07	100.92	16.93		
58.04	4.30	101.96	5.86		
58.93	2.34	102.97	10.29		
58.97	4.82	104.01	75.00		

15

PH990270 x1 Bgd=26 25-ARR-07 14:14:0:02:57 70E EI+
 BpA=0 I=3.6v Ha=227 TIC=135425008 Acnt: Sys:ACE
 Text:P.KORRE Cal:PFK

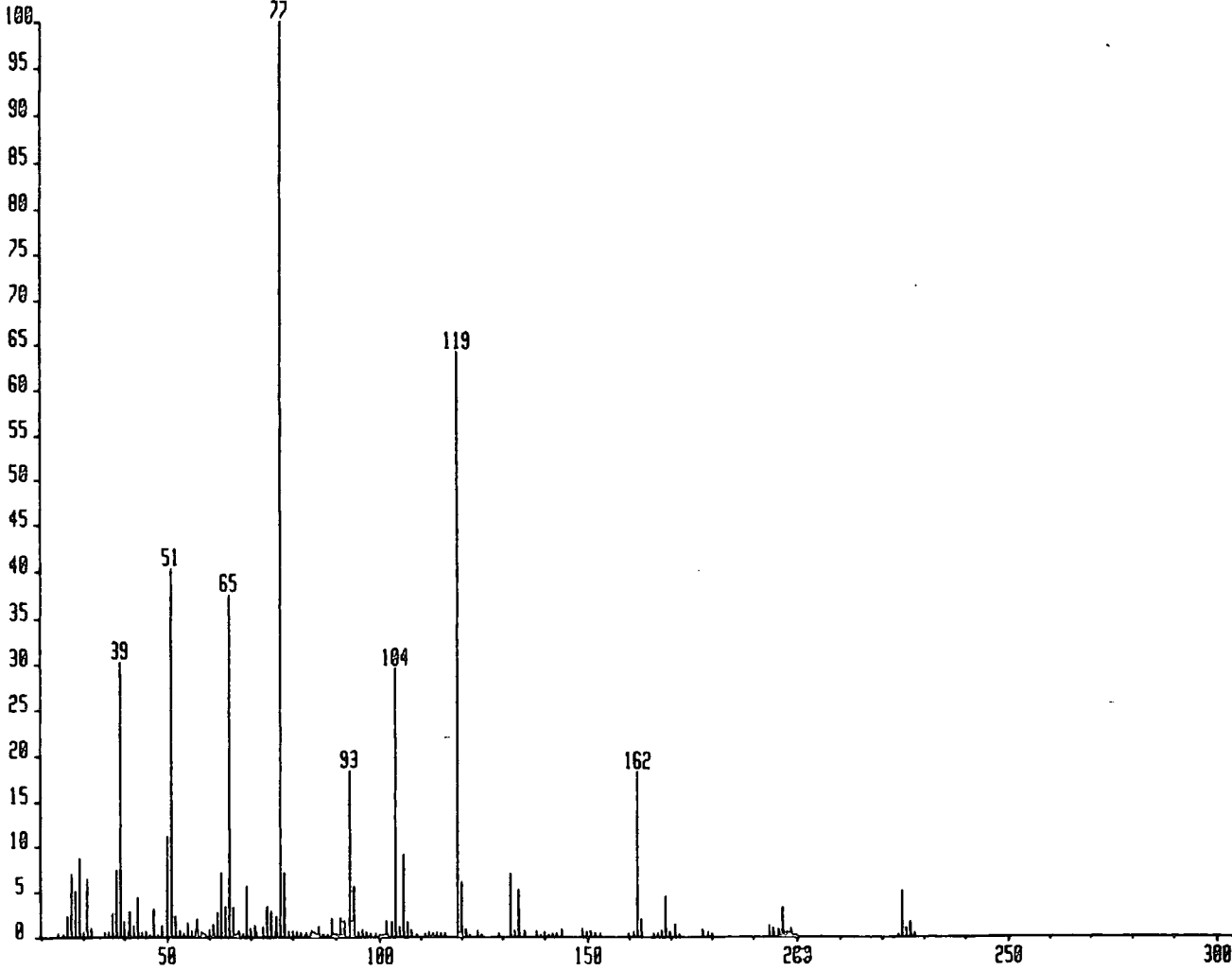

Mass	% Base						
25.99	2.10	73.94	3.27	115.85	0.30	159.90	0.29
27.00	6.89	74.95	2.75	118.92	64.12	160.87	0.40
27.99	9.06	75.96	2.18	119.83	0.27	161.87	18.12
29.02	8.61	76.97	100.00	119.92	6.00	162.88	1.87
30.97	6.34	77.89	1.96	120.87	0.10	165.84	0.31
36.98	2.39	77.97	6.98	120.93	0.65	166.86	0.34
37.98	7.35	86.01	1.11	121.82	0.17	167.84	0.58
38.99	30.17	88.95	2.02	123.89	0.54	168.84	4.40
39.99	1.56	90.96	1.94	124.88	0.12	169.84	0.50
41.00	2.80	91.88	1.77	128.96	0.23	170.84	1.30
42.01	1.09	92.94	18.23	131.84	6.91 F	171.83	0.14
43.02	4.27	93.87	1.62 F	131.92	2.05 F	177.83	0.66
46.93	3.02	93.95	5.66 F	132.89	0.55	178.84	0.45
48.92	1.06	100.02	0.15	133.84	2.44 F	179.83	0.32
48.96	1.11	100.87	0.17	133.91	5.16 F	193.80	1.16
49.97	11.07	100.96	0.11	134.91	0.53	194.81	0.85
50.98	40.16	101.03	0.15	137.88	0.64	195.81	0.66
51.98	2.17	101.88	1.79	138.89	0.21	196.80	3.10
55.01	1.45	101.94	0.16	139.87	0.40	197.80	0.46
57.02	1.93	102.87	0.15	140.86	0.21	198.80	0.89
60.96	1.35	102.94	1.60	141.86	0.29	199.80	0.15
61.96	2.61	103.87	29.57	142.90	0.33	223.78	0.15
62.97	7.03	104.91	0.99	143.90	0.71	224.78	4.99
63.97	3.33	105.87	9.01	148.87	0.84	225.78	0.86
64.98	37.36	106.92	1.64	149.86	0.42	226.77	1.52
65.98	3.10	107.93	0.65	150.87	0.62	227.78	0.26
68.94	5.54	109.00	0.13	151.86	0.33		
71.02	1.11	111.01	0.24	152.86	0.32		

16

PH245H0380 n1 8pd=9 7-JUL-87 14:20:02(2:5) EI
 SpA=0 I=10v Mn=504 TIC=382398332 Scan: Sys:RSC
 P.NORAE PT=0 Ccl:PF126
 °H20.0

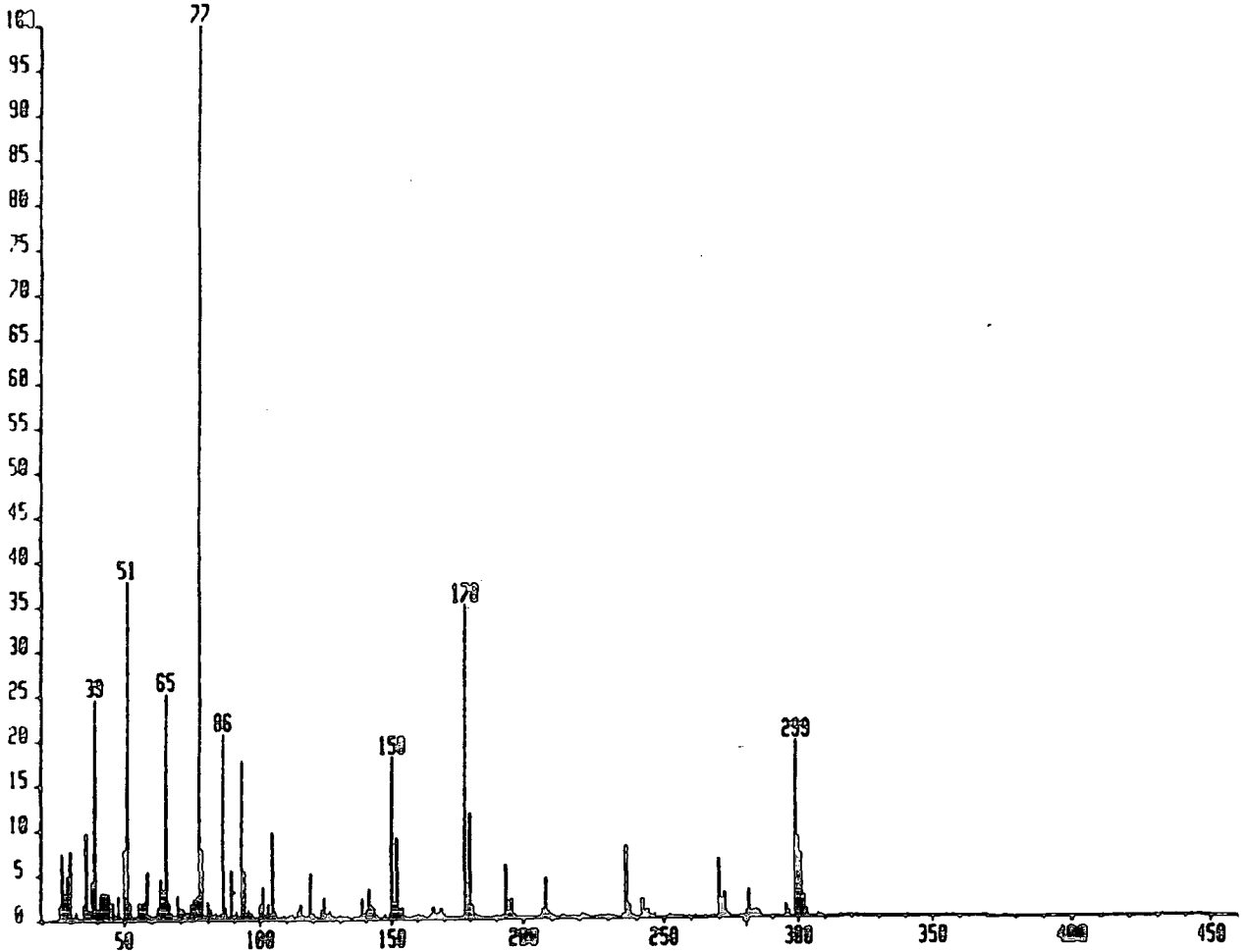

Mass	% Base	Mass	% Base	Mass	% Base	Mass	% Base
26.81	7.23	60.02	0.33	120.10	0.40	180.08	11.49
27.81	2.93	61.01	0.53	121.12	0.21	181.11	1.27
28.84	4.79	62.02	1.42	123.06	0.88	182.11	0.23
29.84	7.97	62.98	1.40 F	124.06	2.27	193.09	0.34
30.84	0.29	63.03	4.43 F F	125.08	0.52	194.07	5.70
31.82	0.88	63.97	3.11 F F	126.07	0.78	195.09	0.64
34.82	1.61	64.04	2.11 F F	130.09	0.26	196.08	1.91
39.83	9.98	65.06	29.22	133.09	0.23	197.10	0.27
36.83	0.93	66.06	1.89	137.14	0.28	207.14	0.76
36.87	1.11	67.07	0.37	138.07	2.19	208.16	4.19
37.89	3.03 F	68.08	0.50	139.10	0.27	209.16	0.58
37.89	4.19 F	69.10	2.61	140.11	0.70	221.18	0.30
38.90	24.98	73.04	2.12	141.11	3.14	239.16	0.34
39.91	1.18	76.05	2.43	142.13	1.43	236.16	7.81
40.93	2.86	77.06	100.00 O	143.10	1.13	237.17	1.33
41.94	3.09	78.06	7.98	144.10	0.23	242.13	2.02
42.96	2.80	79.05	0.49	147.13	0.23	243.14	0.44
43.95	2.71	86.12	30.69	149.10	0.56	244.13	0.70
44.93	0.32	87.11	1.28	150.07	17.87	270.09	6.43
49.91	2.00	88.09	0.32	151.08	1.69	271.13	1.76
46.92	0.53	89.07	9.39	152.07	8.82	272.12	2.51
47.91	2.90	90.07	0.50	153.09	0.86	273.14	0.63
48.95	0.47	91.08	0.82	154.08	1.06	299.19	0.98
49.98	7.79	92.07	8.29	159.10	0.23	300.16	0.44
50.99	37.80	93.07	17.87	160.10	0.31	301.16	0.39
52.00	2.00	94.08	9.18	165.10	0.32		
58.05	9.37	109.07	9.49	166.08	1.11		
59.04	0.38	106.09	0.72	178.07	34.79		
				179.08	3.64		

17

PHFPD11o #1 Bgd=1 11-ARY-87 14:31:01:09 70E E1-
 SpA=0 I=1.1v Ka=170 TIC=33076000 Rcnt: Sys:ACE
 Text:P.HOARE Cal:PFK27

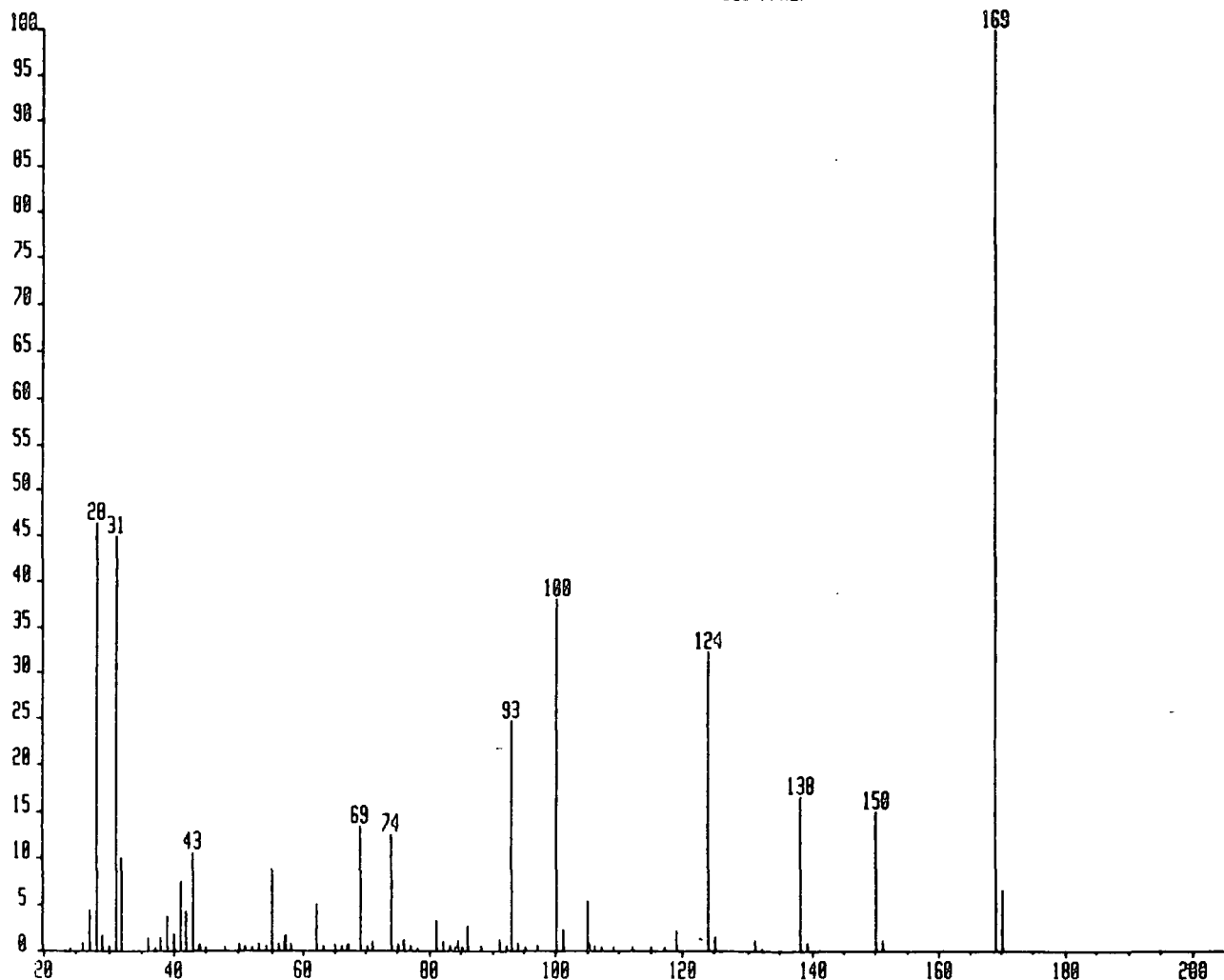

Mass	% Base	Mass	% Base
27.05	4.28	105.10	5.34
28.04	46.37	105.17	0.69
29.07	1.58	106.10	0.46
31.03	44.83	107.10	0.25
32.02	10.14	109.21	0.39
36.04	1.25	112.11	0.32
38.05	1.28	115.16	0.39
39.06	3.67	117.18	0.25
40.00	1.74	119.11	1.99
41.08	7.49	119.20	0.36
42.09	4.21	124.11	32.30
43.06	2.64	125.11	1.37
43.10	10.49	131.12	1.00
55.06	8.74	132.11	0.14
55.11	1.82	138.12	16.46
57.13	1.54	139.12	0.76
62.06	4.92	150.13	14.85
69.06	13.21	151.13	0.98
69.14	1.04	169.14	100.00
74.07	12.41	170.14	6.91
81.08	3.13	170.22	0.27
84.58	1.07		
86.08	2.61		
91.14	1.18		
93.08	24.60		
100.10	37.95		
101.10	2.15		

18

PHCPZX0260 x1 89d=11 17-JUL-87 15:10:02:22 702 C1-
 SpA=0 I=5.5v No=223 TIC=112825000 Rent: Sys:RDE
 P.HOARE PT=0 Czl:PFKAJ17

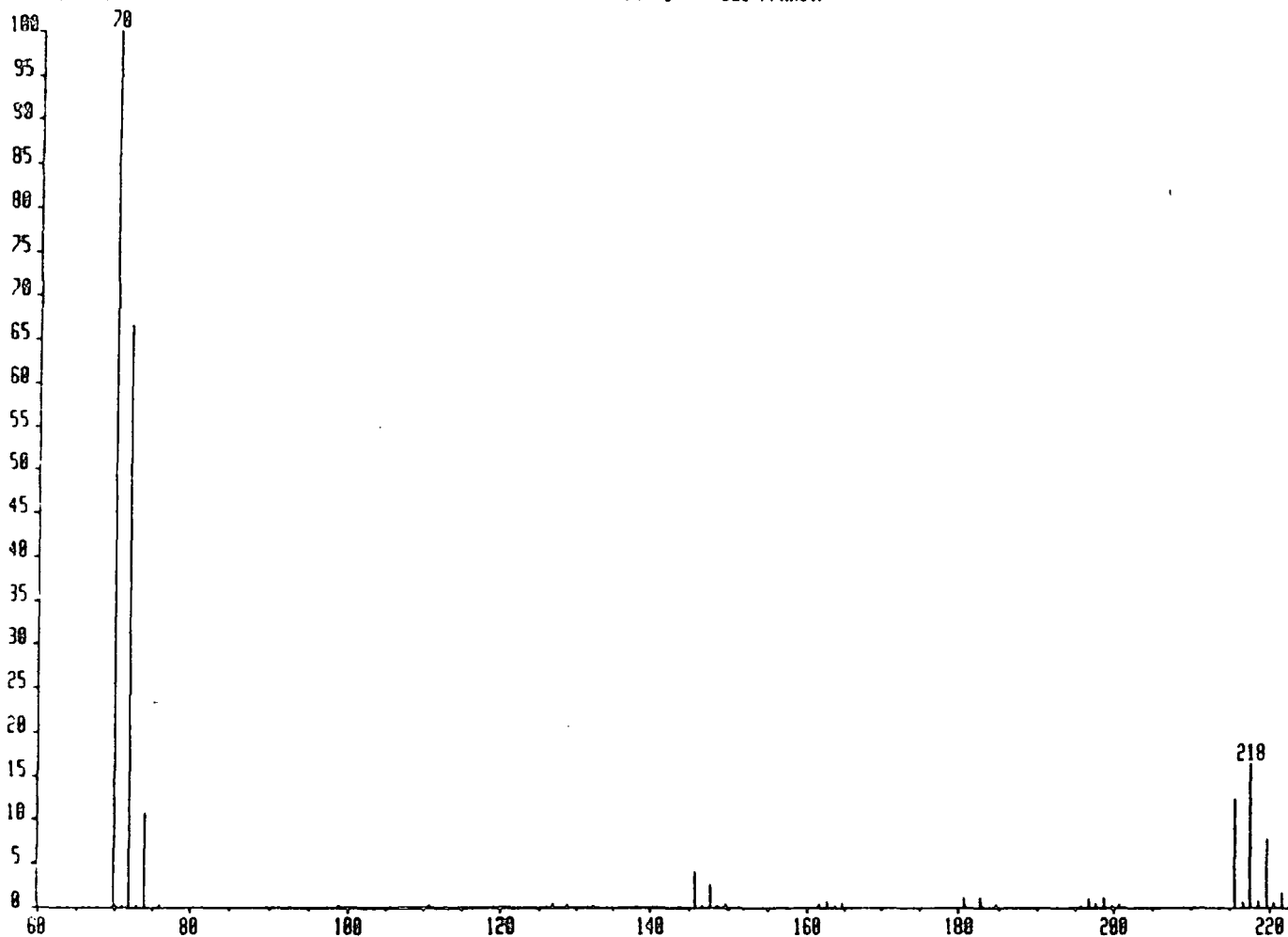

Mass	% Base
34.90	59.07
36.89	19.21
69.82	100.00
70.83	0.21
71.81	66.59
72.82	0.14
73.81	10.63
75.88	0.29
98.82	0.11
110.81	0.18
126.78	0.32
145.74	3.99
146.79	0.20
147.74	2.49
180.67	1.02
182.67	0.99
196.66	0.99
197.67	0.24
198.65	1.03
199.66	0.13
200.69	0.32
215.60	12.26
216.60	0.64
217.61	16.39
218.61	0.80
219.59	7.72
220.60	0.40
221.59	1.69

19

P11FP210230 ml Pys=15 22-JUL-07 16:20:02-07 XE Cl-
 CpA=0 I=1.4v K=3.0 TIC=12383239 Cont: Sys:RDE
 P.MORSE PI=0 Cl:PFK

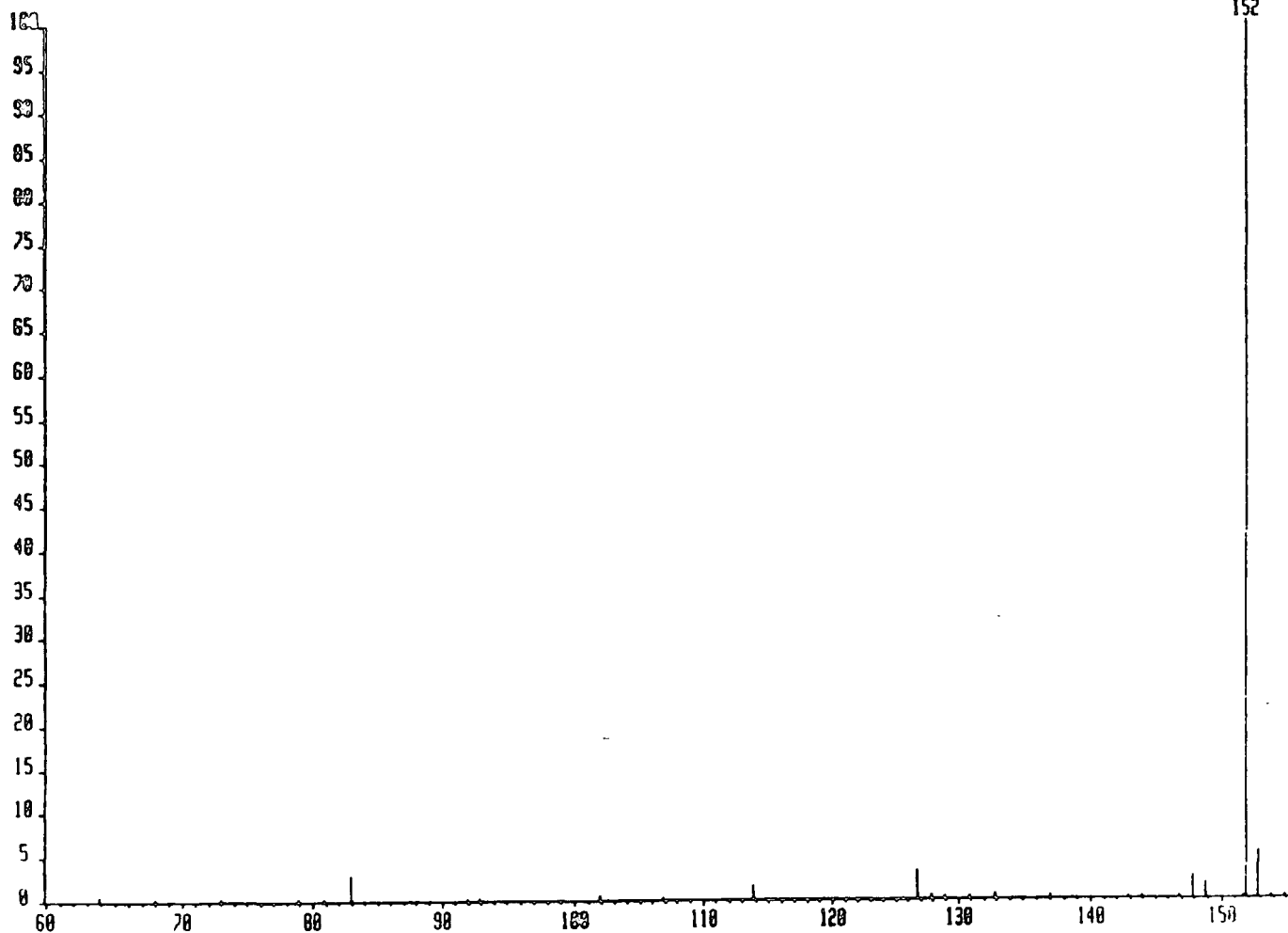

Mass	% Base
63.90	0.40
67.95	0.12
72.95	0.13
78.80	0.12
80.79	0.14
82.88	2.81
91.89	0.14
92.91	0.11
101.89	0.39
106.85	0.21
113.85	1.45
126.74	3.14
127.86	0.25
128.89	0.22
130.88	0.10
132.83	0.42
136.92	0.34
142.87	0.17
143.87	0.10
146.89	0.19
147.82	2.93
148.81	1.97
151.98	0.12
151.81	100.00
152.81	9.14

20

PH242037o x1 Bgd=34 14-APR-87 13:55:00:04:05 78E EI+
 @pR=0 I=11cvs Mo=303 TIC=42421000 Acnt: Sys:MOORE
 Text: Cal:PFK

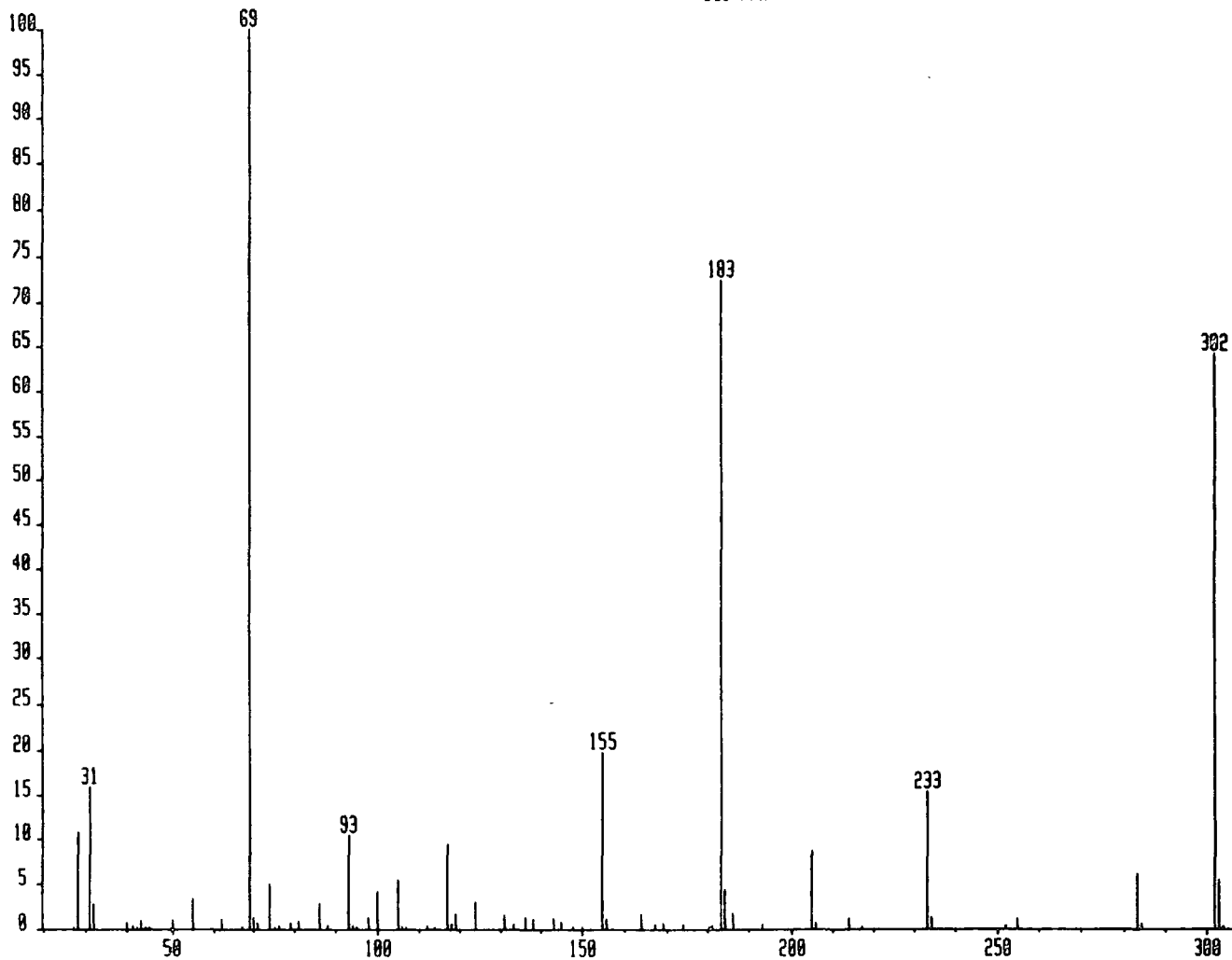

Mass	% Base	Mass	% Base
28.01	10.86	184.99	19.66
31.00	19.82	189.99	1.06
31.99	2.72	193.99	1.94
39.99	0.69	198.99	0.97
43.05	0.81	199.00	72.44
49.99	0.99	204.00	4.32
59.00	3.30	205.99	1.68
62.00	0.96	209.99	0.98
68.99	100.00	213.99	1.09
70.00	1.09	233.00	19.24
71.00	0.97	234.00	1.08
74.00	4.99	244.99	0.99
79.00	0.61	262.99	6.02
81.00	0.73	301.99	64.16
86.00	2.80	302.99	9.37
92.99	10.43		
99.00	1.13		
100.00	3.98		
104.99	8.90		
116.99	9.32		
118.99	1.97		
123.99	2.83		
130.99	1.40		
139.99	1.14		
137.99	0.98		
142.99	1.14		
149.00	0.74		

21

PHSS0510 ml Bgd=16 20-SEP-07 11:10:03:31 762 CI-
 BpA=332 I=16v K=419 TIC=8371832 SI Rent: Sys:KORR
 P.KORRE GC=50 Cel:PFKMG

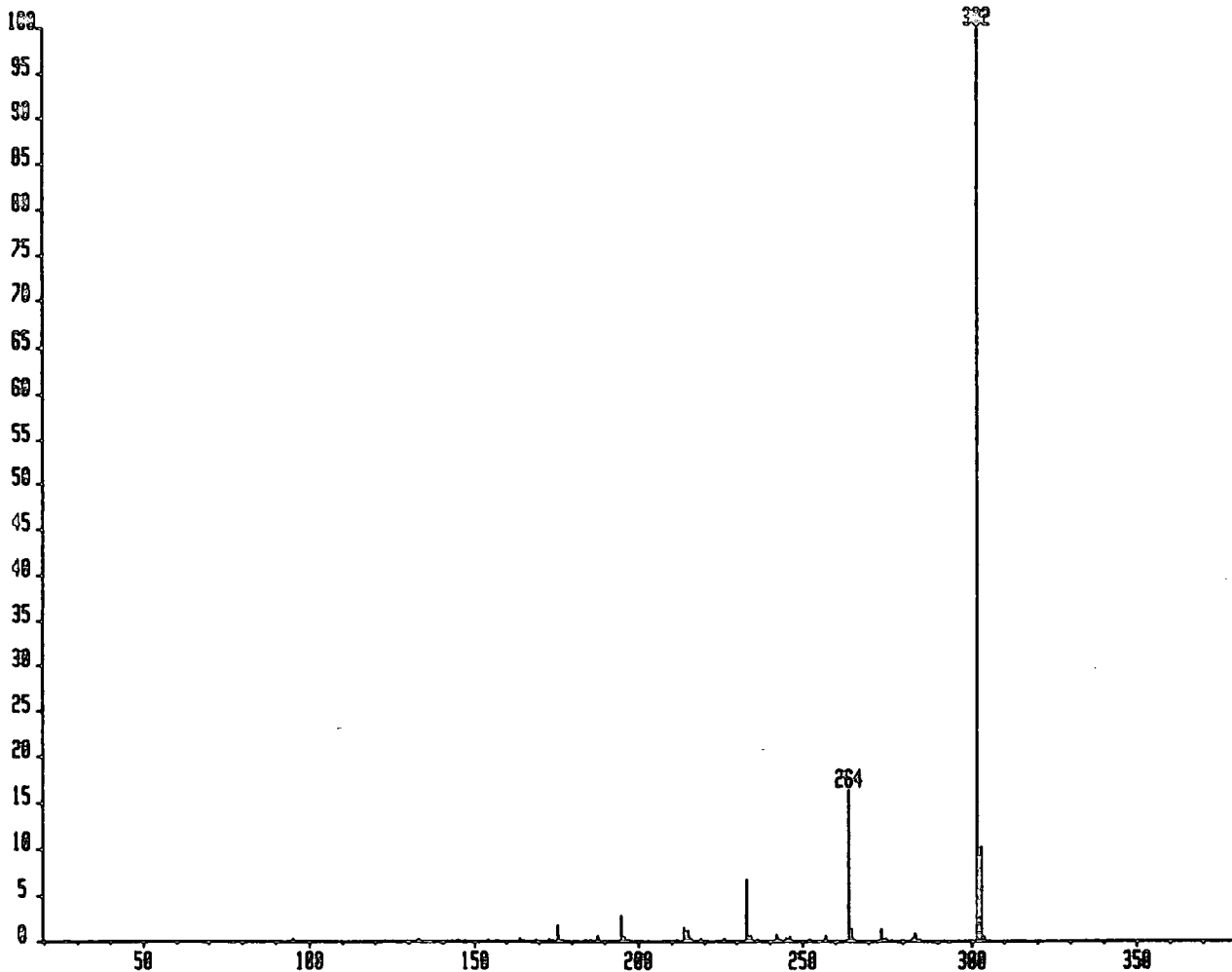

Mass	% Base
179.99	1.60
187.99	0.51
194.98	2.65
213.99	1.29
215.00	0.97
232.97	6.60
241.98	0.58
263.99	16.14
264.99	1.24
273.98	1.25
284.00	0.79
301.97	100.00 FD
302.98	10.04 F

22

PH2420460 κ1 Bgd=43 14-APR-07 13:55:04:49 70E EI+
 OpR=0 I=26.0vs Ho=453 TIC=52054000 Acnt: Sys:MOARE
 Text: Cal:PFK

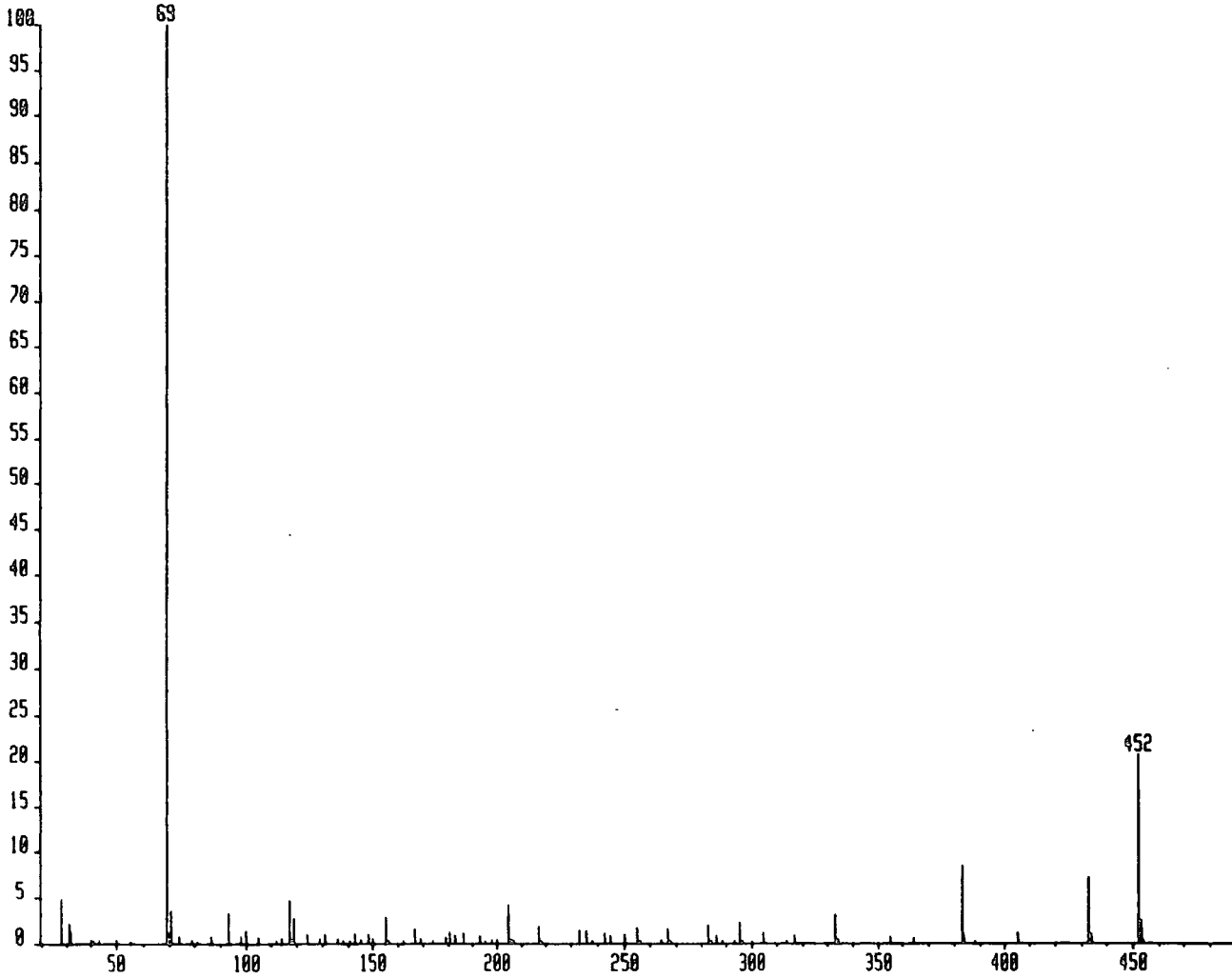

Mass	% Base	Mass	% Base
28.01	4.70	232.99	1.25
31.00	2.01	235.99	1.29
31.99	1.14	242.99	0.99
69.99	100.00	244.99	0.67
70.00	1.04	249.99	0.85
71.00	3.46	254.99	1.60
73.99	0.74	266.99	1.47
85.99	0.65	282.99	1.90
92.99	3.17	285.97	0.79
97.99	0.68	294.99	2.19
99.99	1.23	304.96	1.05
104.99	0.54	316.97	0.76
116.99	4.58	332.99	3.02
118.99	2.53	354.97	0.54
123.99	0.91	382.99	8.28
130.99	0.91	383.99	0.89
142.99	0.82	404.99	0.95
147.99	0.90	432.97	7.03
154.99	2.70	433.97	0.83
166.99	1.51	451.99	20.58
178.99	0.54	452.99	2.27
180.99	1.18		
182.99	0.73		
185.99	1.01		
192.99	0.76		
204.99	4.07		
216.97	1.74		

23

PH750530 n1 Bgd=39 14-DEC-87 11:50:03:01 7SE E1-
 BpH=0 l=10w Hc=584 TIC=200476200 Rent: Sys: KDA9
 GC= 100° Cal: PFK14KIG

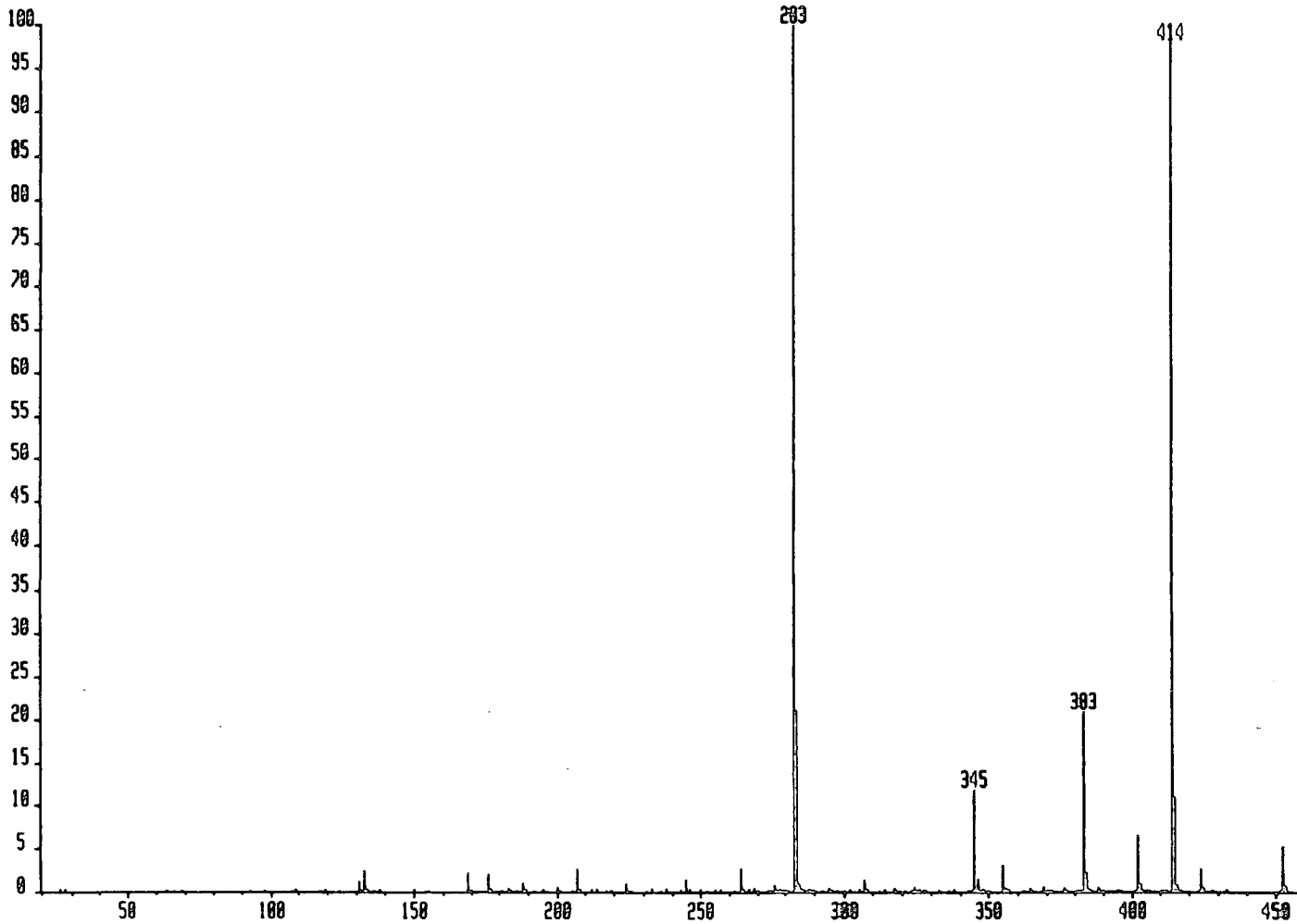

HA55	X DASE
282.99	100.00 FD
283.93	20.87 F
284.52	0.09
300.98	11.71
305.29	0.02
308.98	1.37
307.01	0.05
347.97	0.00
349.99	0.02
350.97	3.03
382.97	20.71
383.38	0.02
383.57	0.05
383.73	0.02
383.98	2.09
413.97	97.93 F
410.98	10.78 F
423.96	2.58
451.98	5.22
452.53	0.02
452.98	0.57

24

PH23001060 x1 0gd=53 26-ARR-87 14:42:0:06:41 70E E1*
 SpA=0 I=5.1v Ho=453 TIC=138673000 Acnt: Sys:HOARE
 Text:P.HOARE Cal:PF(20)

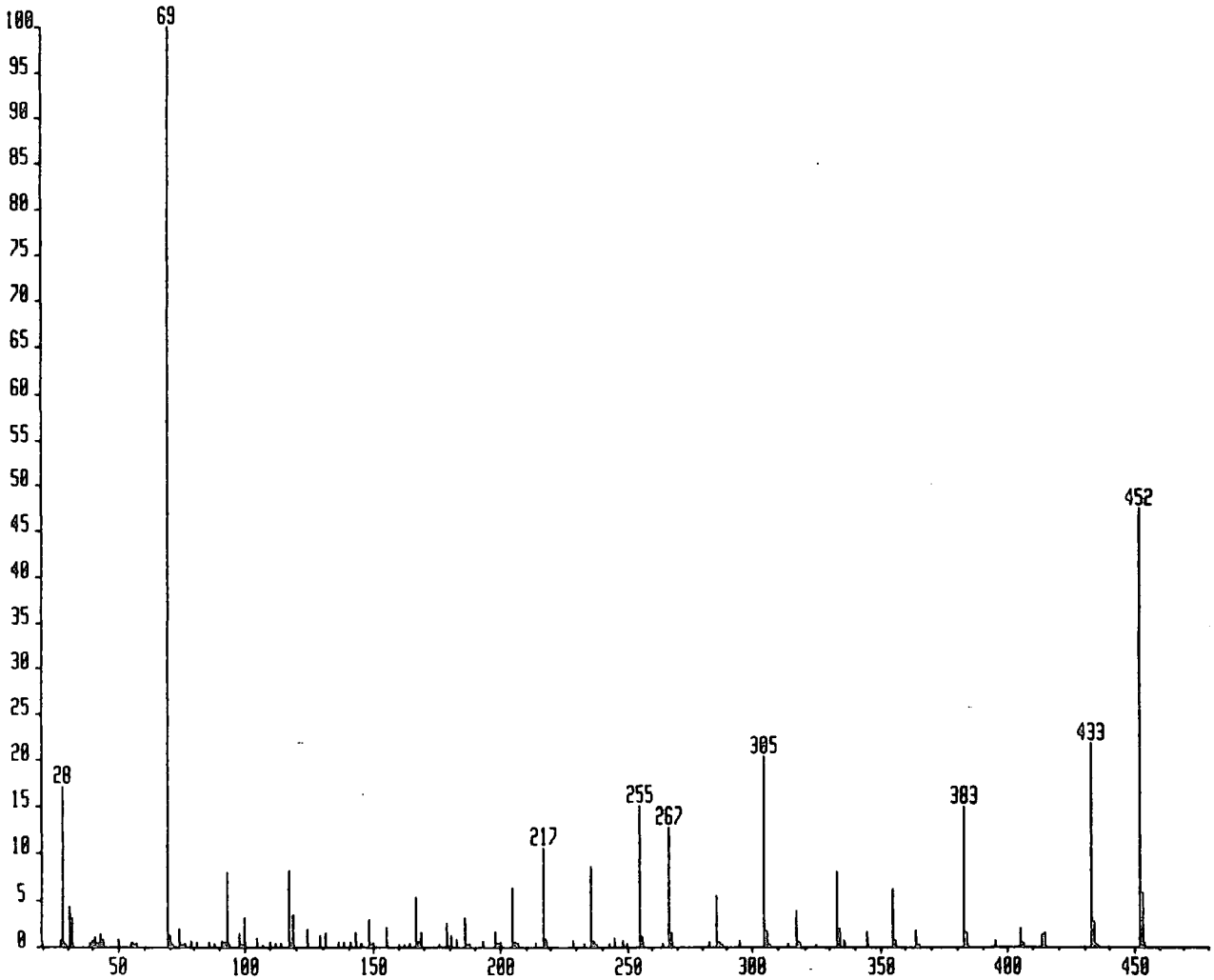

Mass	% Base	Mass	% Base	Mass	% Base
26.81	0.60	188.97	1.37	344.98	1.56
27.80	16.97	178.97	2.43	354.97	6.17
30.81	4.34	180.97	1.09	355.97	0.63
31.81	3.06	182.98	0.71	363.97	1.79
39.84	0.58	185.97	3.06	382.80	1.43
40.92	0.96	192.97	0.64	382.98	14.77
42.95	1.28	197.98	1.53	383.97	1.42
43.89	0.71	204.97	6.37	394.97	0.56
49.94	0.67	216.97	10.49	404.94	1.86
68.98	100.00	217.97	0.69	413.91	1.18
69.98	1.09	228.97	0.87	414.89	1.38
73.97	1.82	235.96	8.62	432.98	21.74
78.95	0.64	236.97	0.51	433.96	2.65
91.03	0.84	244.98	0.83	451.98	47.42
92.97	7.96	247.97	0.62	452.97	9.70
97.98	1.39	254.97	14.98		
99.98	3.11	255.98	0.94		
104.98	0.85	266.96	12.59		
116.97	8.19	267.97	1.48		
118.97	3.51	288.96	5.48		
123.97	1.86	284.96	0.62		
128.97	1.15	304.98	20.25		
130.97	1.37	305.96	1.54		
142.97	1.42	316.96	3.92		
147.97	2.87	332.96	8.01		
154.97	2.04	333.96	1.94		
166.97	5.34	335.96	0.54		

25

PH950640 #1 Cgd=16 24-SEP-07 11:10:04:24 XCI CI-
 BpA=452 I=10v K=471 TIC=124731020 SU Ront: Sys:K1172
 P.KORRE GC=50 Cal:PF7K126

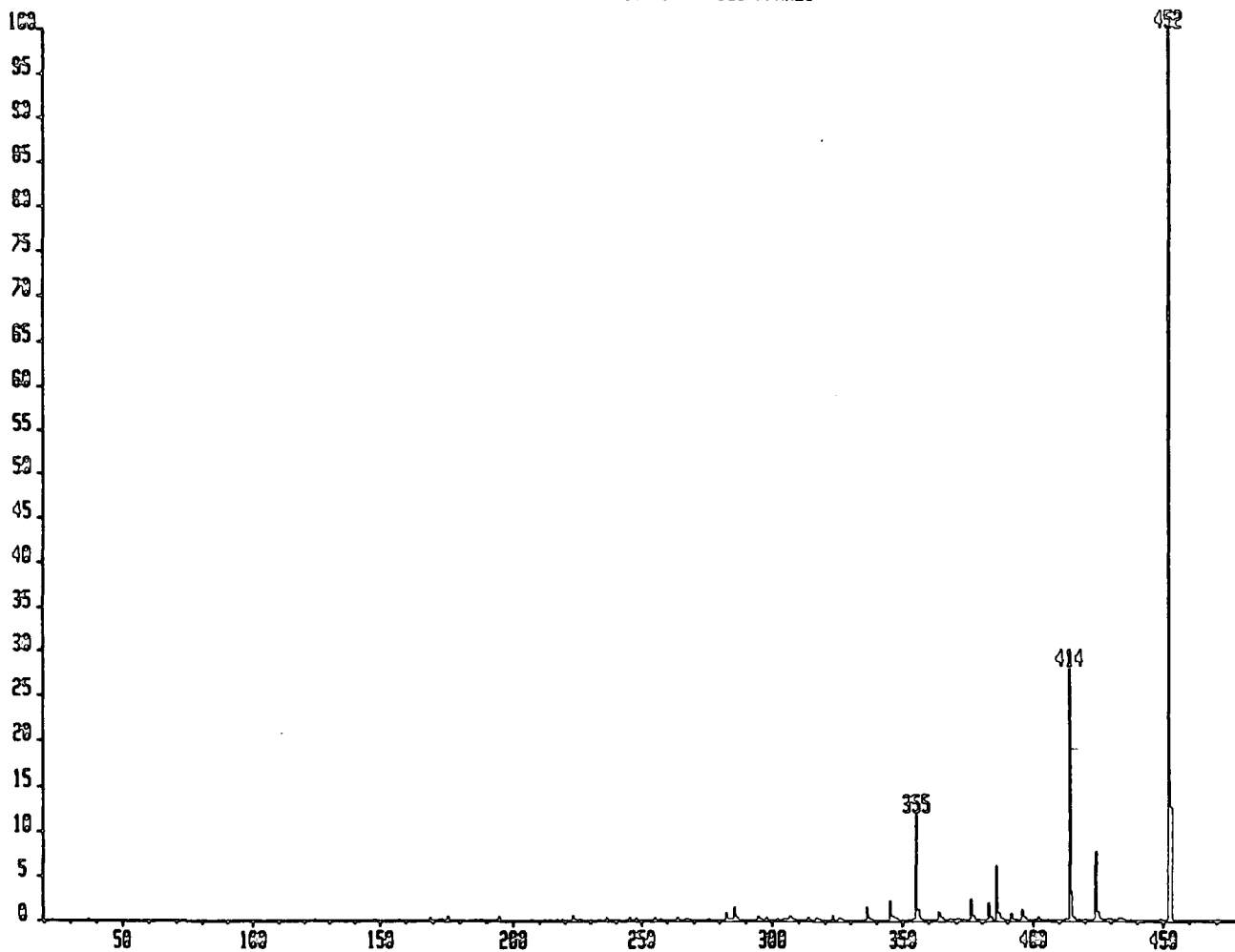

Time	% Area
283.00	0.78
289.98	1.37
322.99	0.50
339.97	1.32
344.99	2.10
354.98	11.68
359.99	1.09
363.99	0.79
379.96	2.18
382.97	1.71
399.97	6.10
396.98	0.60
391.99	0.61
396.00	1.09
413.98	27.92 F
419.00	3.03 F
423.97	7.67
424.98	0.81
451.99	100.00 FO
453.04	12.62 F

26

PH23801150 n1 Bgd=111 26-ARR-87 14-42-8 07:15 70E EI+
 BpA=0 I=3.9v Ha=602 TIC=88675000 Rcnt: Sys:MOORE
 Text:P.MOORE Cal:PFK20

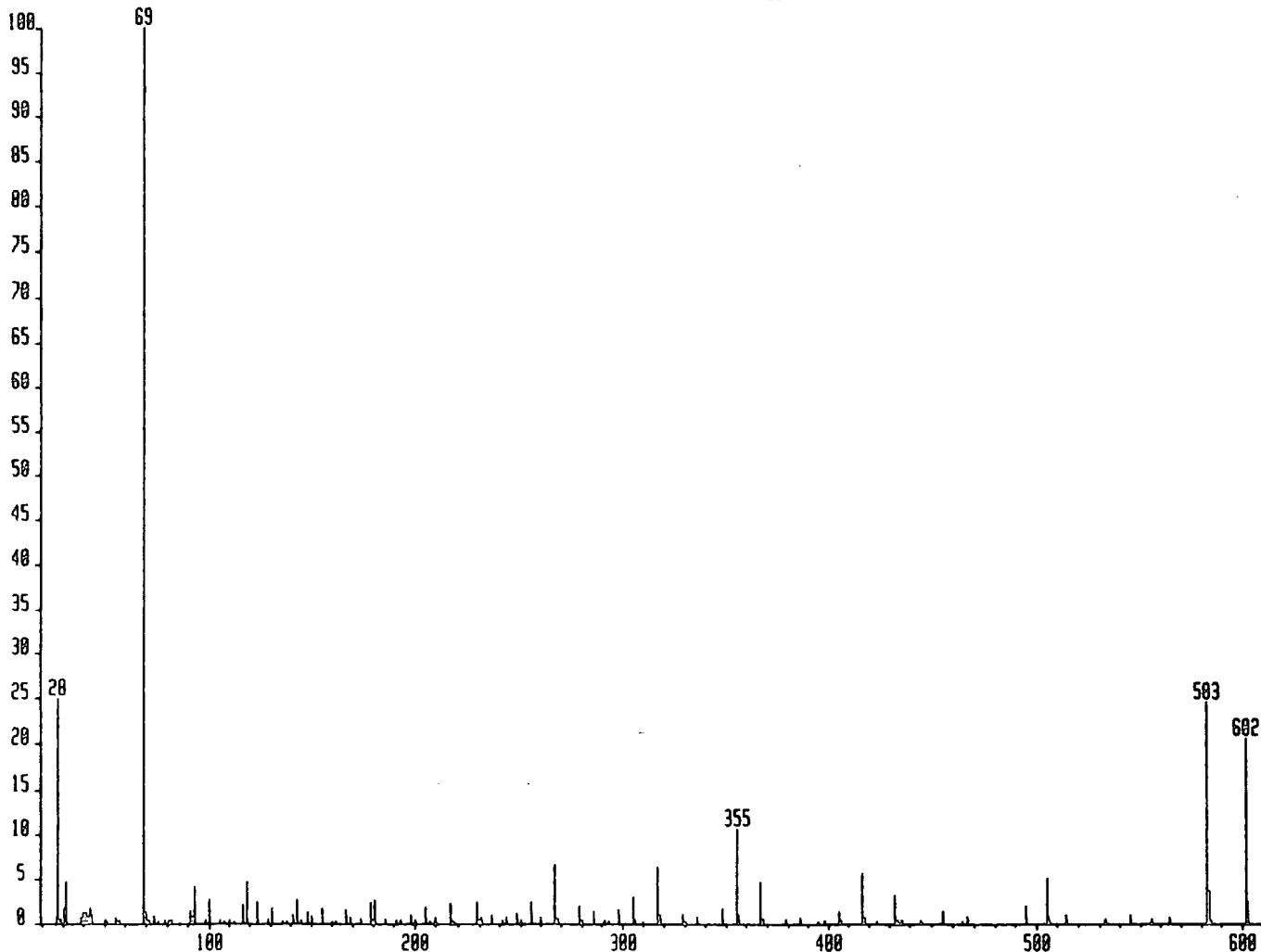

Mass	% Base	Mass	% Base	Mass	% Base
26.91	0.65	154.98	1.95	356.01	0.90
27.90	24.91	166.98	1.51	366.99	4.54
30.92	1.63	168.99	0.54	388.97	0.64
31.91	4.85	178.99	2.23	404.97	1.30
38.90	0.53	180.98	2.86	416.92	5.64
39.94	1.20	197.98	0.91	417.94	0.60
40.93	1.14	204.98	1.75	432.97	3.16
41.94	0.59	209.97	0.82	454.98	1.30
42.92	0.55	216.98	2.19	466.98	0.72
42.96	1.61	228.99	2.25	494.99	1.63
43.98	0.87	230.98	0.54	505.00	5.09
55.01	0.52	235.97	0.91	506.00	0.51
68.98	100.00	242.97	0.61	513.98	0.93
69.98	1.22	247.98	1.06	544.97	0.83
73.97	0.71	254.98	2.34	563.96	0.59
91.03	1.26	259.99	0.60	582.98	24.49
92.04	0.51	268.99	6.59	583.99	3.58
92.97	4.01	278.99	1.84	601.95	20.49
98.98	2.53	285.97	1.35	602.97	2.33
116.98	2.00	297.97	1.38		
118.98	4.59	304.98	2.92		
123.98	2.25	316.98	6.36		
130.98	1.59	317.98	0.80		
140.98	0.91	328.98	0.94		
142.98	2.59	335.97	0.75		
147.98	1.14	347.98	1.54		
149.97	0.77	355.00	10.65		

27

PH350680 ml Bgd=16 24-SEP-97 11:10:04:45 702 C1-
 Bp#433 I=4.50 Ms=604 TIC=845822223 SU Rank: Sys:KORR
 P.KORRE GC= 97 Cel:PFM26

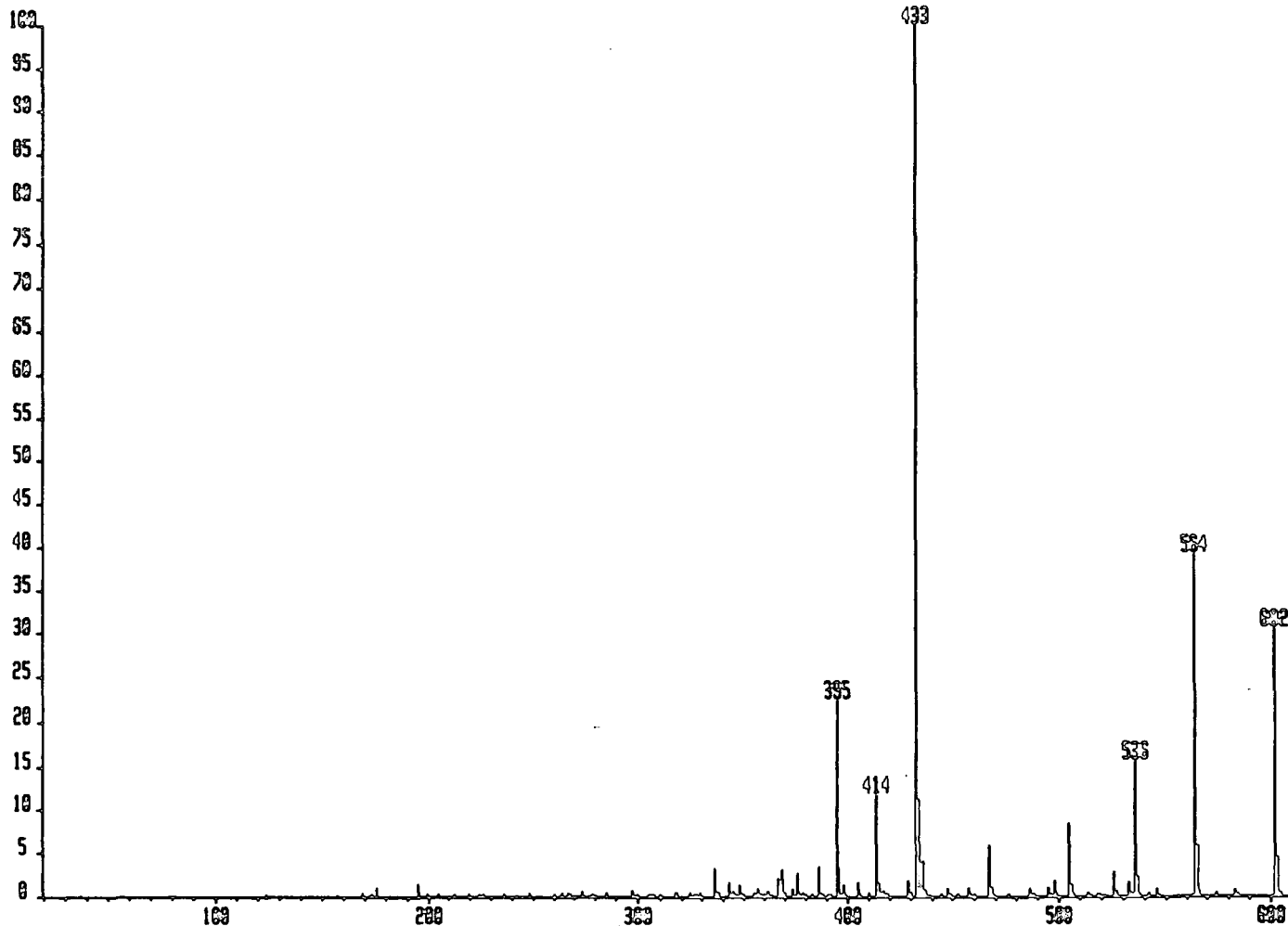

Time	Area	Height	Width
179.99	0.03	489.97	0.01
194.98	1.27	494.98	0.08
297.98	0.62	497.98	1.66
339.97	3.13	504.99	0.32
342.98	1.47	509.99	1.21
347.99	1.19	529.98	2.60
356.99	0.79	532.96	1.94
344.96	1.93	539.94	19.42
369.97	2.96	536.94	2.09
373.96	0.77	549.99	0.71
379.96	2.90	564.07	38.94 F
389.97	3.33	569.11	9.61 F
394.98	22.26	582.93	0.99
399.99	3.14	602.00	30.42 F
397.99	1.29	603.02	4.32 F
404.99	1.48		
414.00	11.99		
419.00	1.33		
428.97	1.66		
432.94	100.00 F		
433.97	11.18 F		
434.98	0.60		
439.96	3.03		
436.97	0.99		
447.98	0.74		
497.00	0.91		
446.99	9.79		
467.99	0.89		

28

PH2400570 x1 Bgd=55 26-~~APR~~-87 16:42:03 35 78E EI+
 BpH=0 I=3.0v Ha=0 TIC=00690623 Acnt: Sys:HOARE
 Text:P.HOARE Cal:PFK20

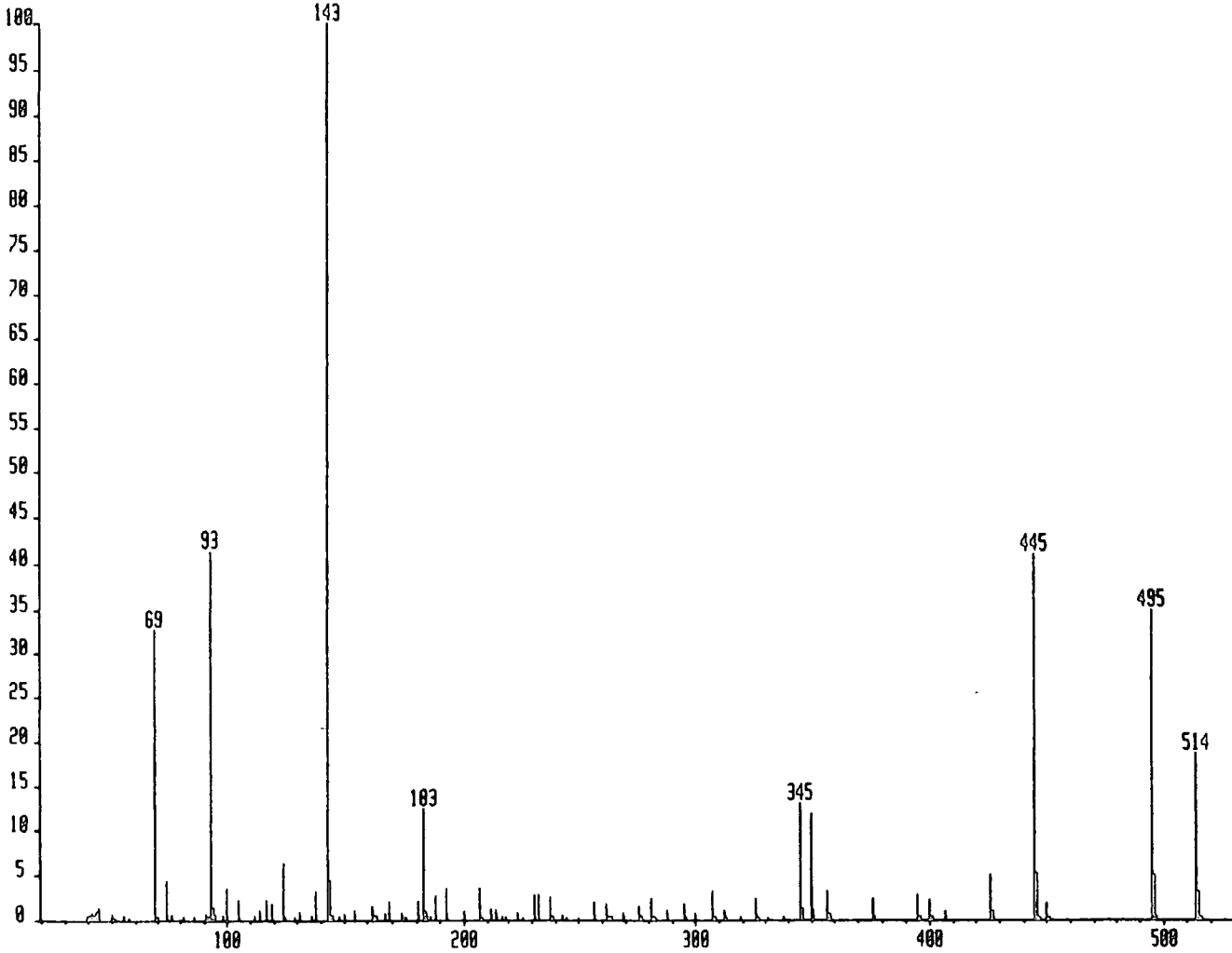

Mass	% Base	Mass	% Base	Mass	% Base
41.33	0.75	182.97	12.35	356.96	3.15
43.32	0.85	183.97	0.88	357.97	0.51
44.24	1.22	187.96	2.58	378.94	2.35
50.16	0.59	192.95	3.39	384.94	2.67
68.98	32.68	199.96	0.81	399.93	2.18
73.96	4.30	206.97	3.52	406.91	0.81
91.02	0.53	211.98	1.08	425.90	4.91
92.98	41.31	213.97	0.97	426.91	0.83
93.97	1.31	223.96	0.71	444.94	40.83
94.97	0.51	230.96	2.77	448.94	5.10
99.97	3.47	232.96	2.70	449.92	1.73
104.98	2.16	237.95	2.43	494.92	34.86
113.98	0.94	256.97	1.91	488.93	4.92
116.97	2.12	261.96	1.71	513.92	18.56
118.97	1.75	268.96	0.78	514.91	3.00
123.97	6.40	275.96	1.37		
130.97	0.80	280.95	2.35		
137.97	3.12	287.95	0.96		
142.96	100.00	294.95	1.70		
143.97	4.26	299.95	0.65		
149.97	0.53	306.95	3.13		
154.96	0.96	311.94	0.98		
161.97	1.45	325.95	2.31		
166.96	0.65	344.95	12.81		
168.97	1.99	345.96	1.08		
173.96	0.79	349.95	11.83		
180.97	1.94	350.95	1.02		

29

PH2480880 x1 8gd=78 26-6AR-87 16:42:00 05:03 7GE EI+
 0pR=0 I=2.3v Wn=0 TIC=62868888 Acnt: Sys:HOARE
 Text:P.HOARE Cal:PFK20

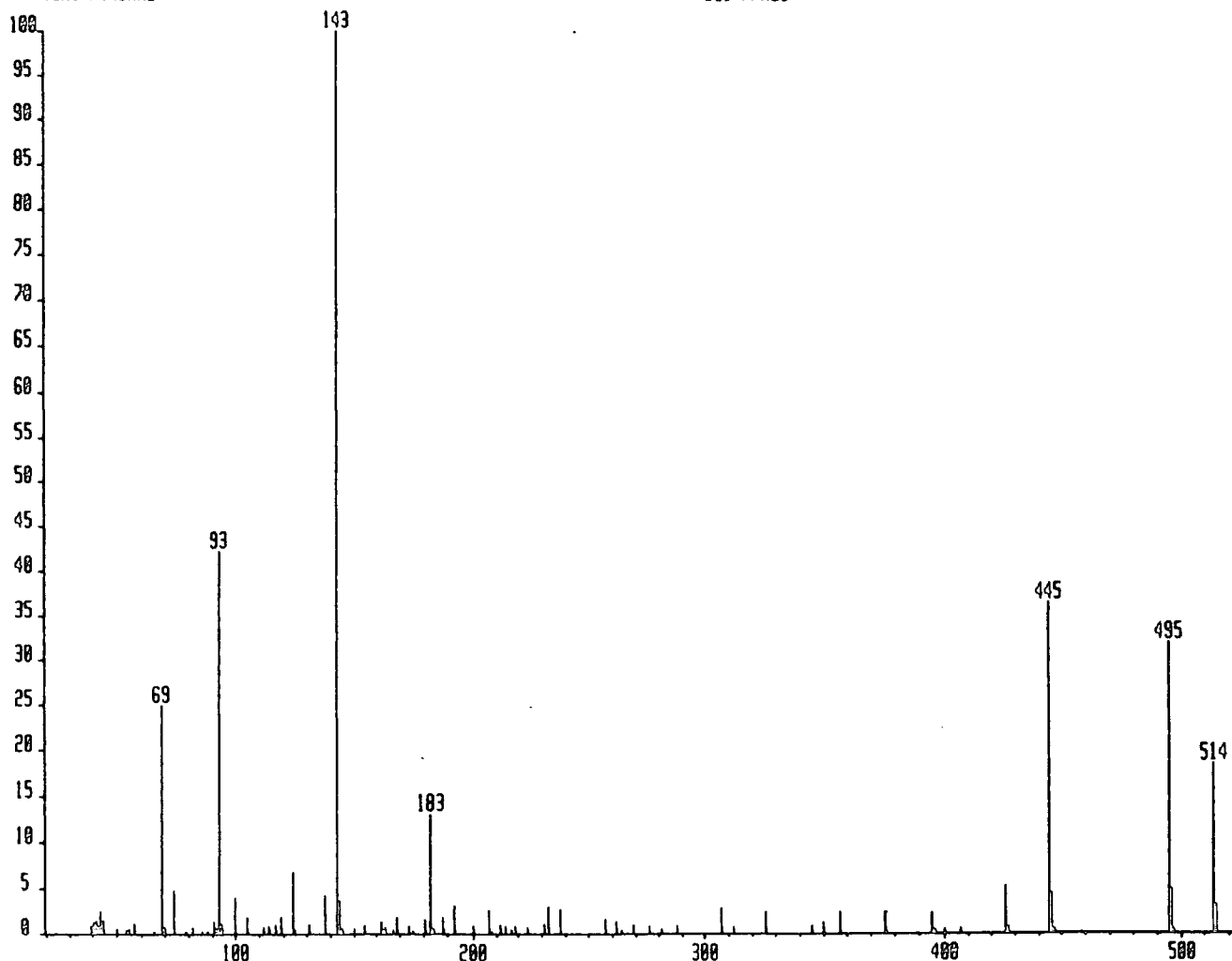

Mass	% Base	Mass	% Base	Mass	% Base
30.38	0.68	161.97	1.08	388.96	2.24
40.27	1.18	163.97	0.81	378.96	2.37
41.33	1.33	168.97	1.66	394.96	2.12
42.32	0.78	173.97	0.72	426.91	5.21
43.28	0.72	180.97	1.48	426.93	0.64
43.32	2.25	182.97	13.02	444.96	38.21
44.24	1.26	187.97	1.73	448.96	4.37
67.18	1.03	192.96	3.01	494.94	31.81
68.98	24.86	198.97	0.70	498.96	4.77
70.05	0.83	206.97	2.48	513.93	18.24
73.96	4.77	211.97	0.81	514.92	3.07
81.99	0.62	213.97	0.67		
91.02	1.30	218.97	0.70		
92.96	42.10	223.96	0.60		
93.97	1.05	230.96	0.88		
99.98	3.94	232.96	2.85		
104.98	1.74	237.96	2.64		
111.98	0.81	256.98	1.84		
113.98	0.72	261.96	1.28		
116.97	0.82	268.96	0.82		
118.97	1.70	275.96	0.72		
123.97	6.89	287.96	0.88		
130.97	0.93	306.96	2.73		
137.97	4.14	311.96	0.80		
142.96	100.00	326.96	2.31		
143.96	3.60	344.96	0.74		
184.97	0.68	348.96	1.08		

30

PH23601390 #1 Bgd=127 11-ARR-87 16:57:0:00:40 78E EI
 BpA=69 T=507Cv M=515 TIC=17732000 EN Acnt: Sys: MORRE
 Text: Cal: PFKGC

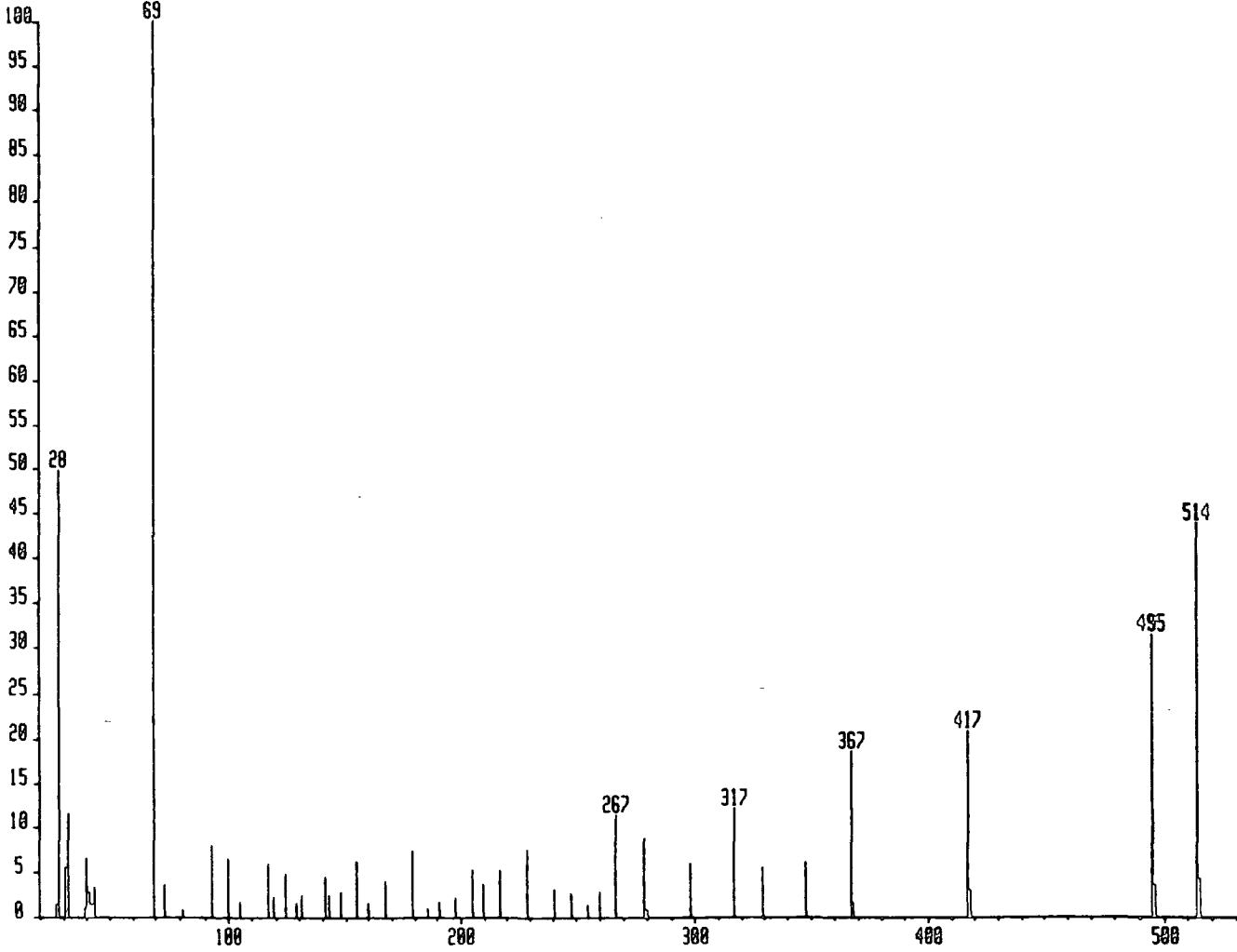

Mass	% Mass	Mass	% Mass
27.02	1.27	103.00	0.06
28.00	49.70	109.07	1.56
30.00	5.53	127.06	2.02
31.00	11.50	204.06	3.14
30.02	0.00	200.06	3.01
39.06	6.54	216.07	3.24
41.03	2.64	220.00	7.42
42.04	1.32	240.06	3.01
43.06	3.11	247.06	2.57
60.00	100.00	254.04	1.30
73.00	3.43	250.06	2.75
01.00	0.78	256.06	11.32
02.00	7.94	270.04	0.75
00.00	0.51	270.06	0.70
104.07	1.53	297.06	3.07
110.00	3.04	310.04	12.09
110.07	2.21	320.04	3.40
123.00	4.80	347.03	6.05
120.00	1.51	300.03	10.53 H
130.07	2.34	307.06	1.51
140.00	4.41	416.02	20.01
142.07	2.20	417.02	2.03
147.00	2.70	404.01	31.40 H
154.07	0.13	405.04	3.50
150.07	1.45	513.01	43.04 H
166.07	3.04	514.00	4.20
170.07	7.27		

31

PH289093o x1 Bgd=47 26-AUG-87 14:00:03:12 79E EI+
 BpR=0 I=10v Ha=521 TIC=379582318 Rcnt: Sys:HOFR
 GC= 95° Cal:PFK17A

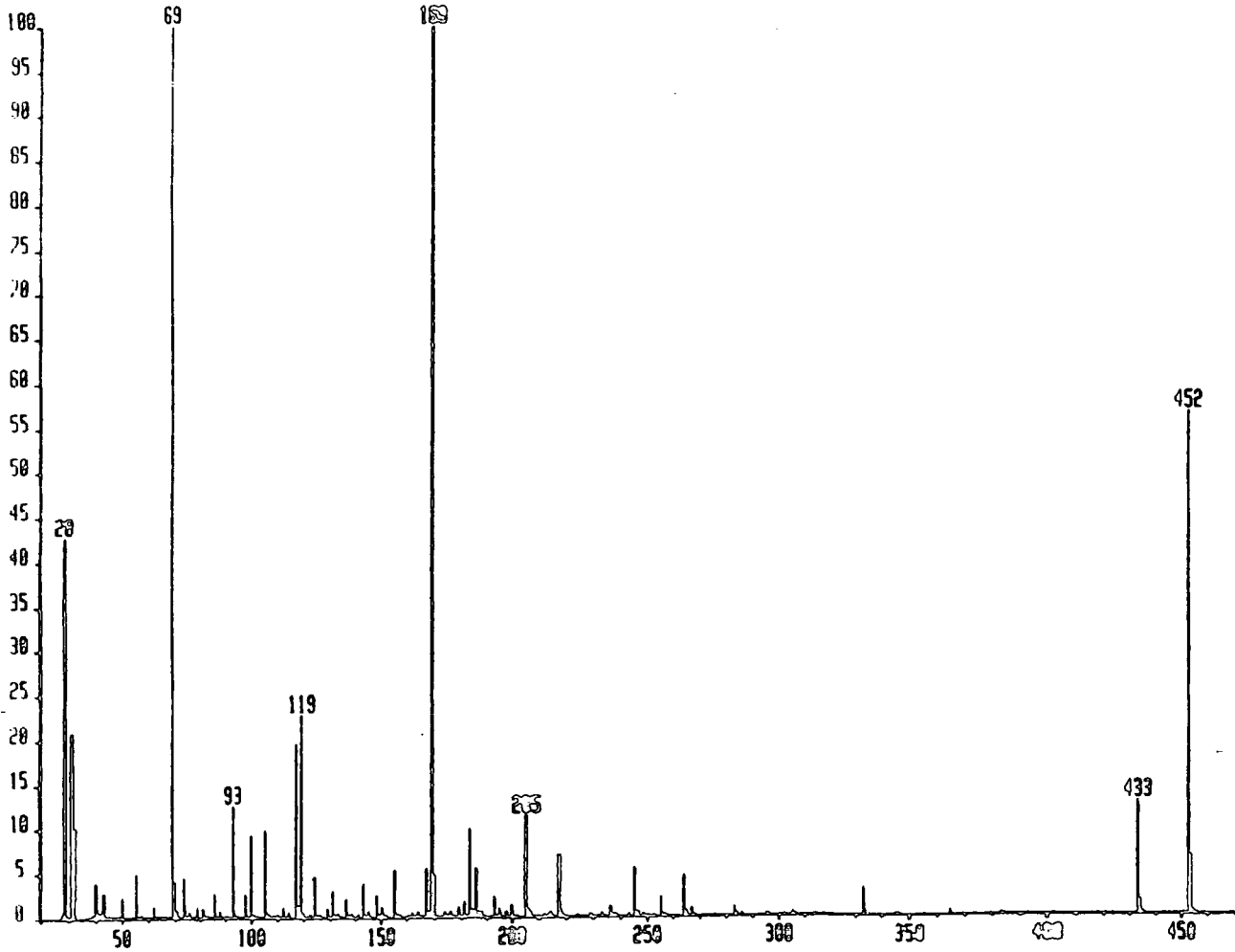

Mass	% Base	Mass	% Base
50.04	2.20	170.11	4.95
55.04	4.88	179.12	0.89
62.04	1.24	181.12	1.48
69.06	100.00	183.12	9.72
70.05	3.94	186.12	5.35
71.05	0.77	193.13	2.03
74.04	4.47	200.13	1.17
79.05	1.19	201.15	0.07
81.05	1.02	202.14	0.01
86.06	2.70	205.14	11.22
93.07	12.44	217.16	6.80
98.08	2.45	245.17	5.38
100.08	9.16	245.75	0.01
105.08	9.78	246.18	0.43
112.09	1.10	248.17	0.17
117.09	19.45	249.14	0.03
118.09	1.14	250.17	0.05
119.08	22.67	252.17	0.05
124.09	4.43	252.24	0.03
129.10	0.93	255.17	2.10
131.10	2.77	256.17	0.16
136.09	1.86	264.20	4.49
143.10	3.64	333.29	3.04
148.11	2.37	433.33	12.68
150.11	0.98	434.34	1.49
155.11	9.24	452.33	56.90
167.11	9.39	452.88	0.04
169.14	100.00	453.34	6.93

32

PH299003 ml Bgd=77 14-DEC-87 14:10:05:45
BpR=0 I=16v H=432 TIC=143963328

EI-
Rent: Sys:KORR
GC= 107³ Cal:PFK14NEG

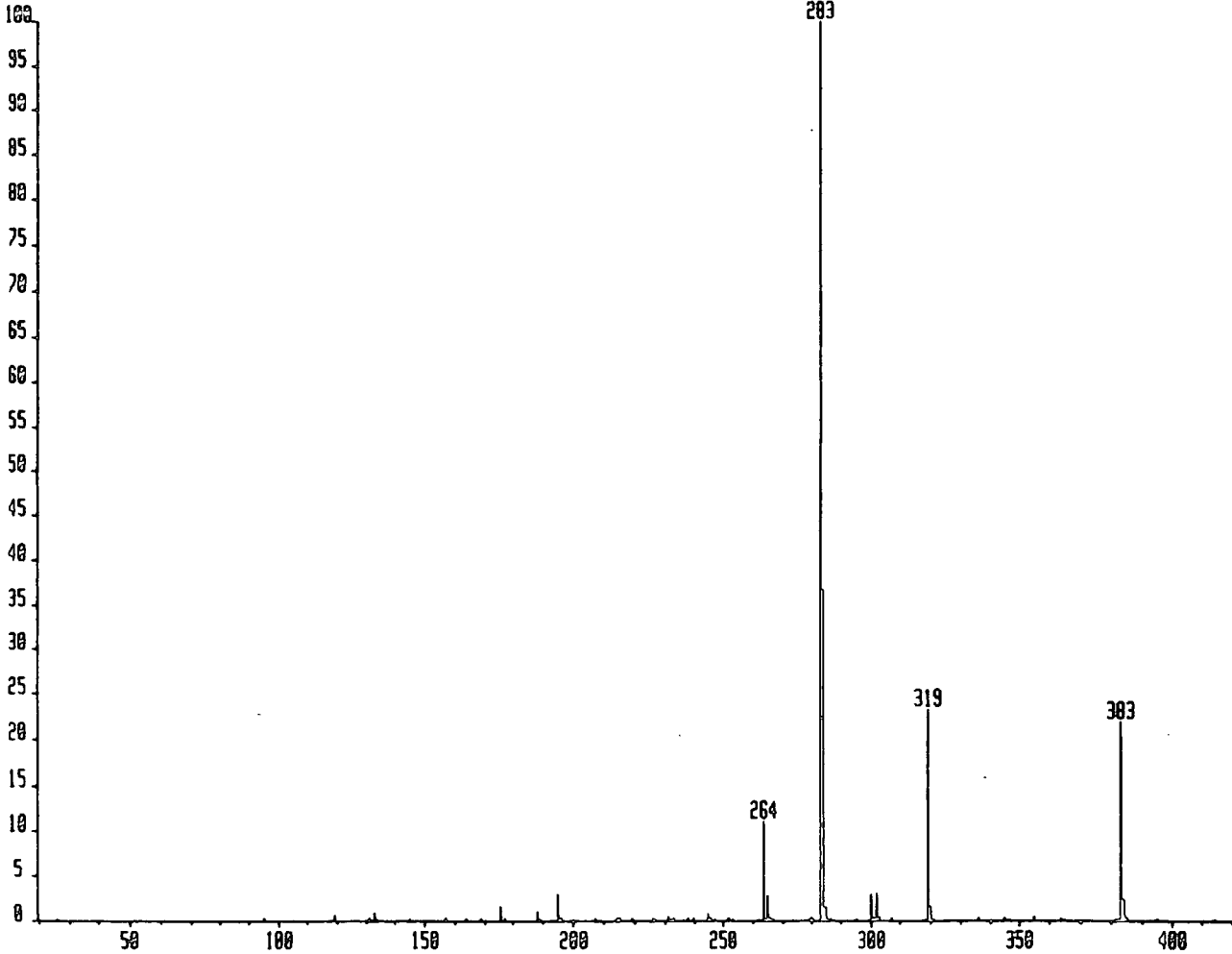

MASS	I	BASE		
263.96	10.92	299.93	2.03	
264.32	0.01	300.10	0.02	
264.76	0.02	300.92	0.16	
264.94	2.72	301.94	2.98	
265.11	0.02	318.91	23.16	
265.15	0.02	319.21	0.03	
265.94	0.22	319.55	0.02	
266.89	0.02	319.61	0.02	
266.97	0.02	319.92	1.41	
278.81	0.02	320.95	0.05	
278.87	0.04	321.02	0.01	
278.97	0.07	335.91	0.07	
279.09	0.03	335.98	0.01	
279.17	0.02	344.93	0.09	
279.24	0.02	354.80	0.03	
279.28	0.03	354.90	0.22	
279.35	0.04	363.91	0.10	
279.53	0.03	364.92	0.07	
279.58	0.02	381.10	0.02	
279.61	0.05	381.70	0.04	
279.66	0.03	381.05	0.03	
279.71	0.03	381.93	0.03	
279.95	0.08	382.02	0.06	
280.12	0.02	382.11	0.03	
283.01	109.80 F	382.90	21.03	
283.93	36.56 F	383.91	2.19	
284.96	1.37 F			

33

PH315E0650 x1 0gd=60 14-DEC-07 15:10:04:29 70E EI+
 0pR=0 I=10v H=521 TIC=315594016 Rcnt: Sys:KOR3
 GC= 70° Cal:PFK11

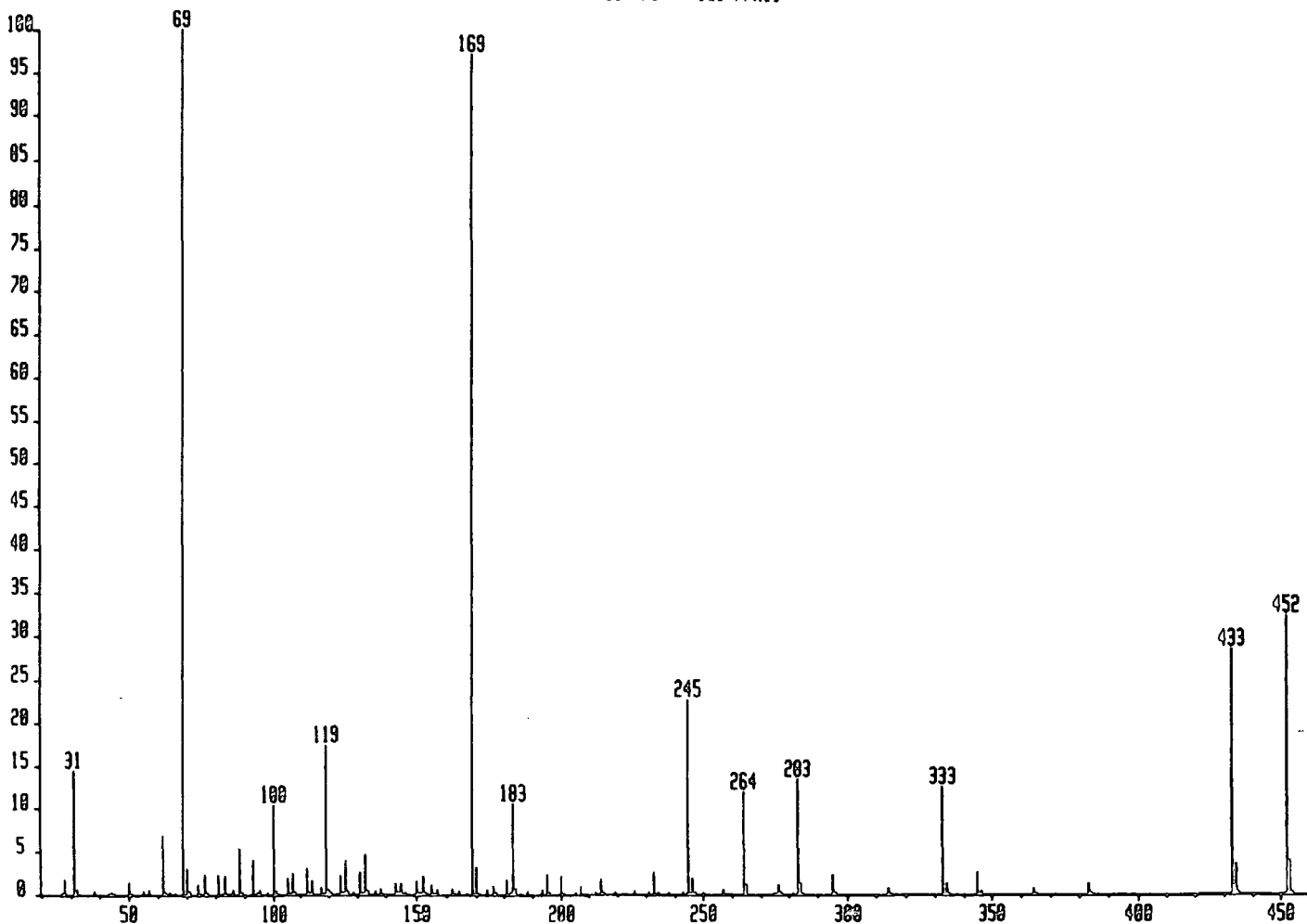

MASS	X	BASE				
20.00	1.62		170.02	3.07	276.03	1.03
31.00	10.35		181.02	1.70	277.04	0.13
50.01	1.29		183.02	10.58	281.02	0.03
62.01	0.03		195.03	2.25	283.03	13.34
69.01	100.00	0	209.02	2.11	284.03	1.16
70.01	2.90		201.03	0.13	285.06	0.04
70.01	1.03		205.02	0.18	295.03	2.17
76.01	2.23		207.03	0.90	296.04	0.17
81.01	2.28		208.03	0.07	310.03	0.68
83.02	2.01		212.03	0.09	315.04	0.07
98.01	5.34		214.03	1.63	333.03	12.00
93.01	3.96		215.03	0.11	334.04	1.10
100.01	10.39		219.03	0.19	335.01	0.04
105.01	1.71		226.03	0.29	345.04	2.52
107.01	2.31		231.02	0.19	346.04	0.25
112.01	2.94		233.03	2.50	364.04	0.55
114.01	1.55		236.03	0.18	365.05	0.07
119.01	17.39		238.03	0.09	383.04	1.22
120.02	2.05		263.03	0.11	384.05	0.12
126.02	3.83		264.55	0.03	433.04	28.40
131.02	2.50		264.59	0.04	434.05	3.33
133.03	0.62		264.71	0.04	435.05	0.18
143.02	1.12		265.03	22.74	451.28	0.03
145.03	1.24		265.25	0.02	452.05	32.29
150.02	1.09		245.42	0.02	452.65	0.02
152.02	2.13		246.03	1.84	453.05	3.85
155.01	1.02		264.03	11.91		
169.01	97.19		265.04	1.06		

34

PH305E1061o x1 Bgd=57 7-JAN-83 14:00:04:15 70E EI+
 BpR=0 I=5.2v No=452 TIC=111522003 Rcnt: Sys:KORR
 GC= 75° Cst:PFK11

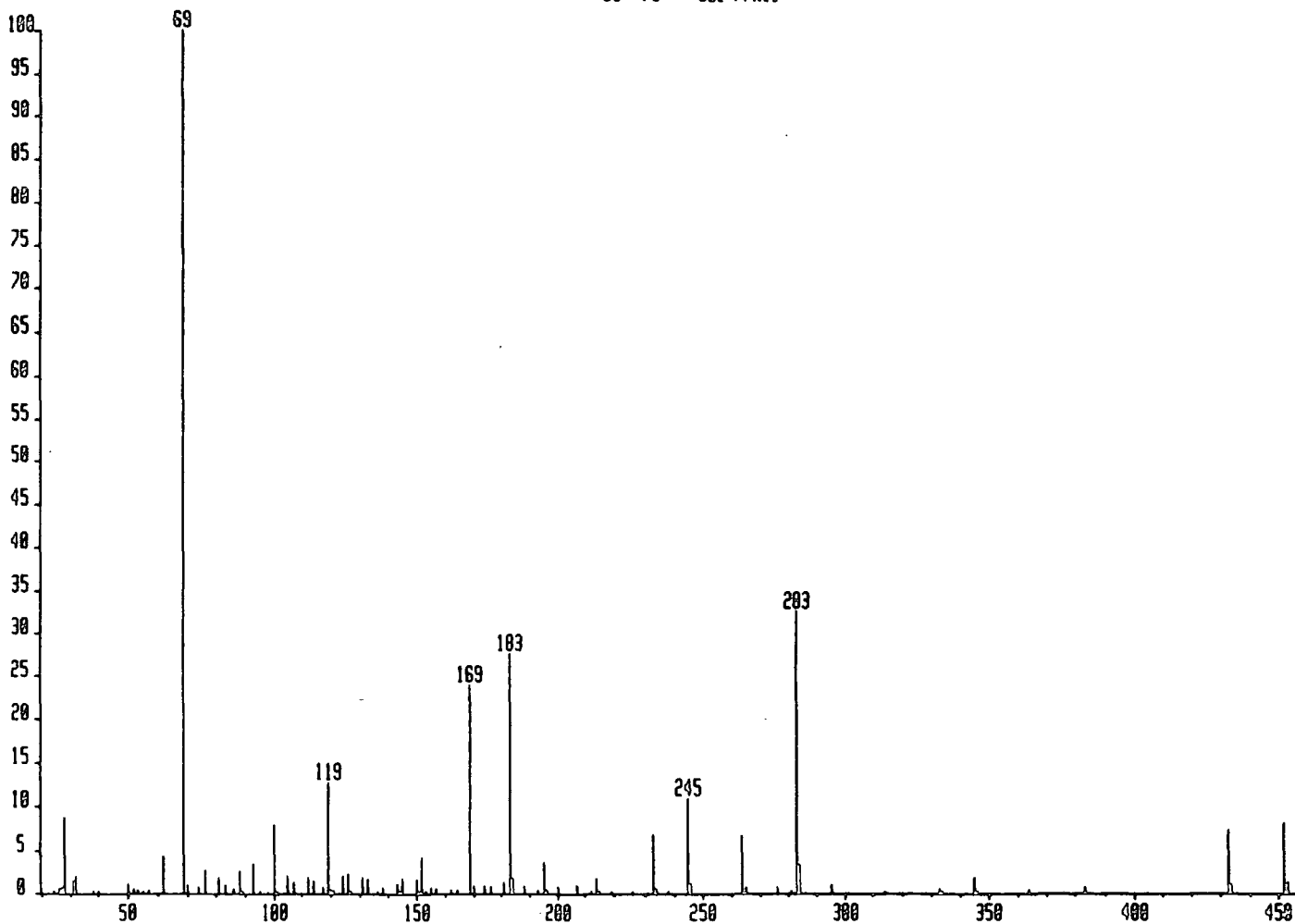

Mass	% Base
28.01	8.69
62.01	4.36
69.01	100.00
76.01	2.74
88.01	2.94
93.01	3.44
100.00	7.79
119.00	12.99
126.01	2.21
132.00	4.19
168.99	23.78
182.99	27.56
194.99	3.61
232.97	6.76
244.96	10.84
263.99	6.61
282.94	32.39
283.95	3.28
313.91	0.14
332.92	0.91
333.96	0.16
344.92	1.76
349.90	0.12
363.90	0.27
382.91	0.92
432.87	7.19
433.87	0.85
451.85	8.08
492.86	1.17

35

PH385061o x1 0gd=57 7-JAN-88 12:00:04:15 78E C1-
 BpH=0 I=10v No=514 TIC=110150000 Rcnt: Sys:KORR
 GC=76° Cal:PFK11

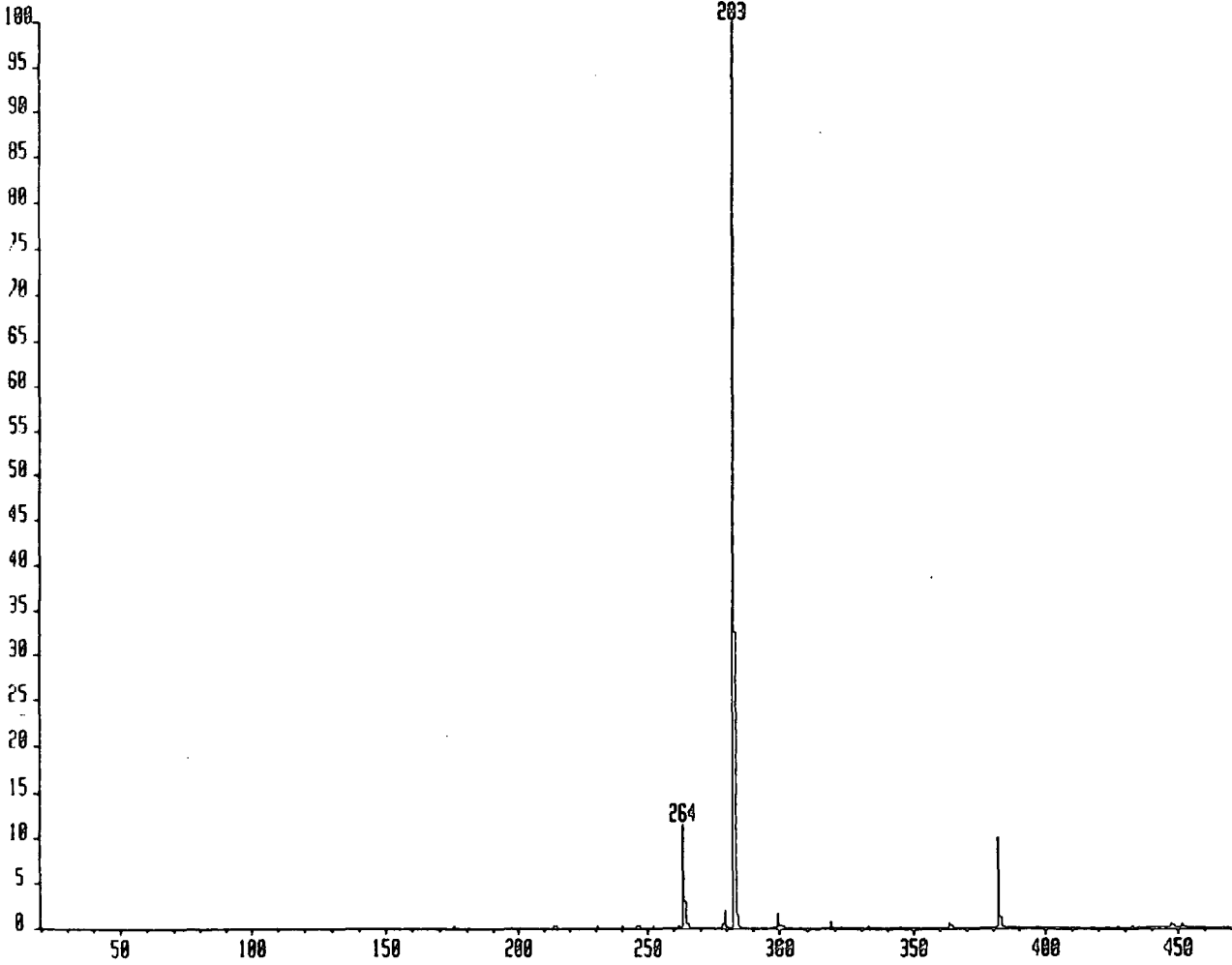

Time (min)	% Area	Label
213.73	0.21	
214.72	0.14	
230.69	0.09	
239.68	0.12	
239.78	0.06	
249.70	0.08	
246.69	0.09	
291.68	0.20	
261.64	0.20	
263.66	11.39	
264.66	2.83	
269.66	0.23	
278.69	0.29	
279.27	0.02	
279.43	0.04	
279.66	1.79	
279.92	0.06	
280.02	0.03	
282.70	100.00	FD
283.62	32.49	F
284.64	1.34	F
284.94	0.09	
285.01	0.02	
285.07	0.03	
285.19	0.03	
285.62	0.09	
285.69	0.04	
298.62	0.07	
299.61	1.94	
300.60	0.12	
301.61	0.09	
318.98	0.99	
332.36	0.11	
344.92	0.04	
363.91	0.42	
364.93	0.10	
381.98	0.02	
382.90	9.96	
383.90	1.10	
384.94	0.07	
427.41	0.04	
432.42	0.11	
447.42	0.30	
448.42	0.11	
451.40	0.37	
452.38	0.04	

36

PH335E1040 x1 Bgd=37 7-JAN-88 14:00:02:49 7%I EI+
 BpA=0 I=4.4u Ma=452 TIC=113998000 Rcont: Sys:KORR
 GC= 61° Cal:PFK11

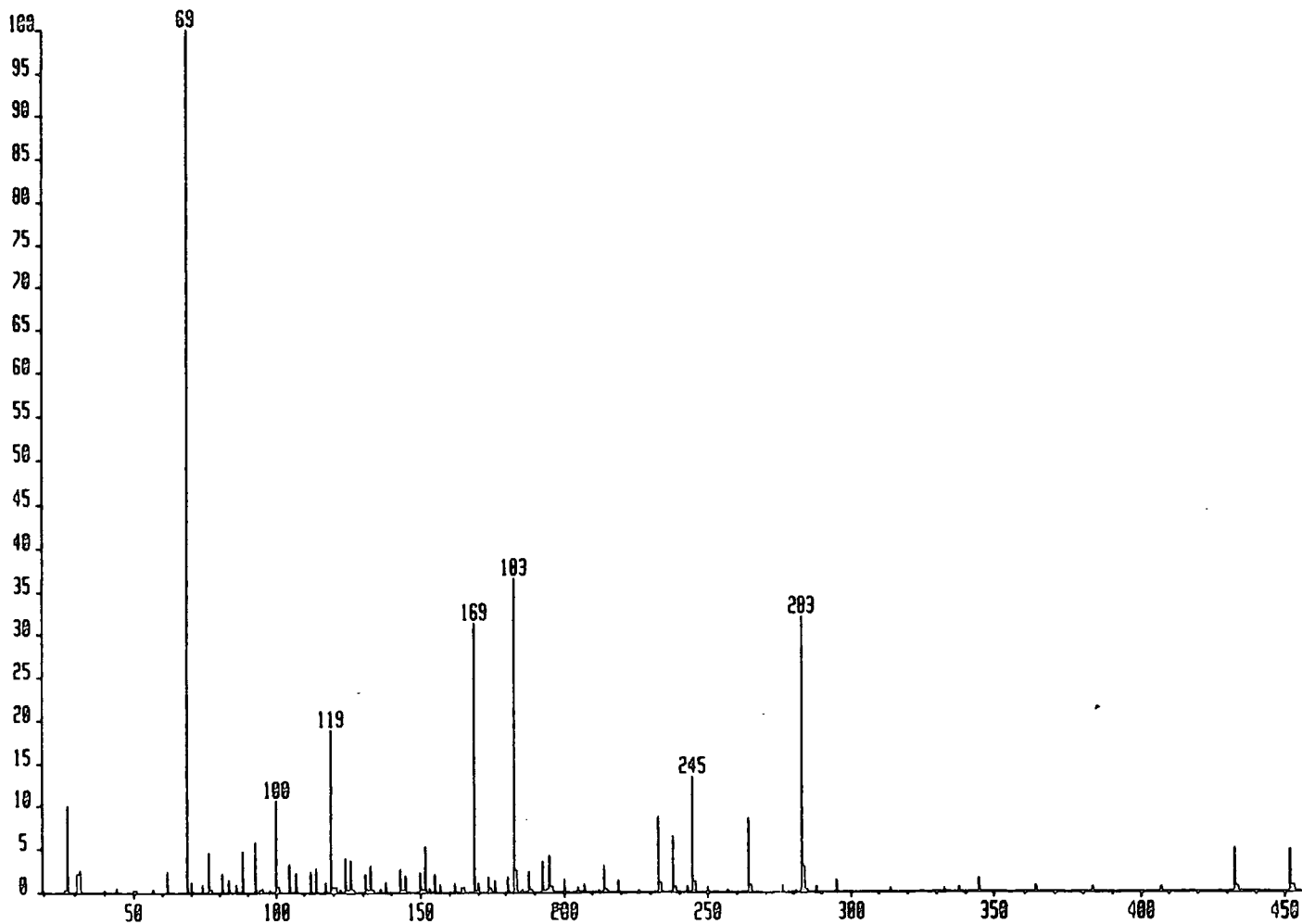

Mass	% Base	Mass	% Base
28.01	9.88	244.97	13.33
32.00	2.44	263.96	8.51
62.01	2.21	282.95	31.97
69.01	100.00	283.95	2.83
76.01	4.46	313.94	0.36
81.01	2.09	332.92	0.36
88.01	4.60	337.91	0.39
93.01	9.67	344.93	1.34
100.01	10.92	363.90	0.53
105.00	3.11	382.90	0.51
107.01	2.11	406.89	0.43
112.00	2.23	432.87	4.92
114.01	2.73	433.88	0.52
119.00	18.88	451.86	4.73
124.00	3.85	452.86	0.53
126.01	3.56		
133.01	2.91		
143.00	2.53		
150.00	2.07		
192.00	9.13		
168.98	31.29		
182.99	36.49		
183.99	2.43		
187.99	2.29		
192.98	3.36		
194.99	4.15		
213.98	2.96		
232.97	8.53		
237.97	6.30		

37

PH315E0670 m1 Bgd=66 10-DEC-07 15:10:04:37 70E EI+
 BpR=0 I=10v Ma=521 TIC=234C31C23 Rcnt: Sys:MDR3
 GC= 79⁰ Cal: PFK11

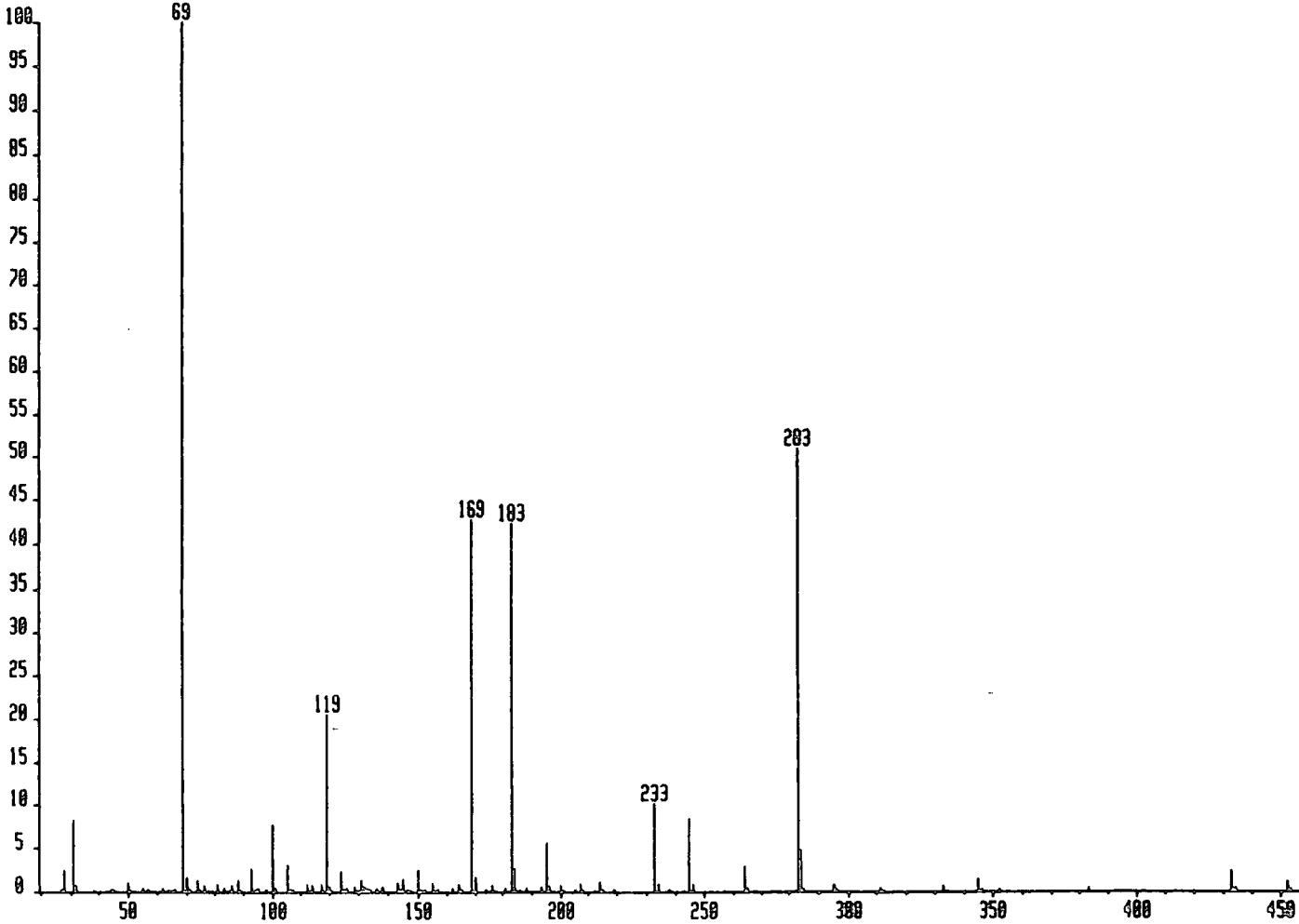

MASS	X	BASE		
26.00	2.39	233.02	10.10	
31.00	0.15	234.02	0.76	
49.01	100.00 0	238.02	0.11	
70.01	1.50	243.01	0.07	
74.01	1.13	245.02	8.32	
88.01	1.12	246.02	0.80	
93.01	2.00	257.03	0.03	
100.01	7.00	264.02	2.76	
105.01	2.91	265.02	0.25	
119.01	20.51	282.06	0.02	
120.01	2.23	283.01	90.91	
131.00	1.25	283.41	0.04	
145.02	1.31	284.02	4.60	
150.01	2.37	285.03	0.15	
169.01	02.71	295.02	0.71	
170.01	1.52	296.02	0.08	
183.02	02.20	311.02	0.30	
184.02	2.55	312.02	0.04	
195.02	5.50	333.02	0.55	
200.02	0.59	334.05	0.04	
201.01	0.04	345.03	1.36	
205.01	0.12	346.02	0.15	
207.02	0.79	352.02	0.16	
208.03	0.05	383.02	0.37	
212.02	0.03	433.01	2.17	
214.02	1.01	434.01	0.30	
215.03	0.11	452.02	0.97	
219.02	0.16	453.03	0.12	

38

PH299RE0410 ml Bgd=31 14-DEC-87 14:50:02:50 7SE EI+
 BpH=0 I=Cv Ka=333 TIC=323467000 Rcnt: Sys:K083
 GC= 61° Cal:PFK11

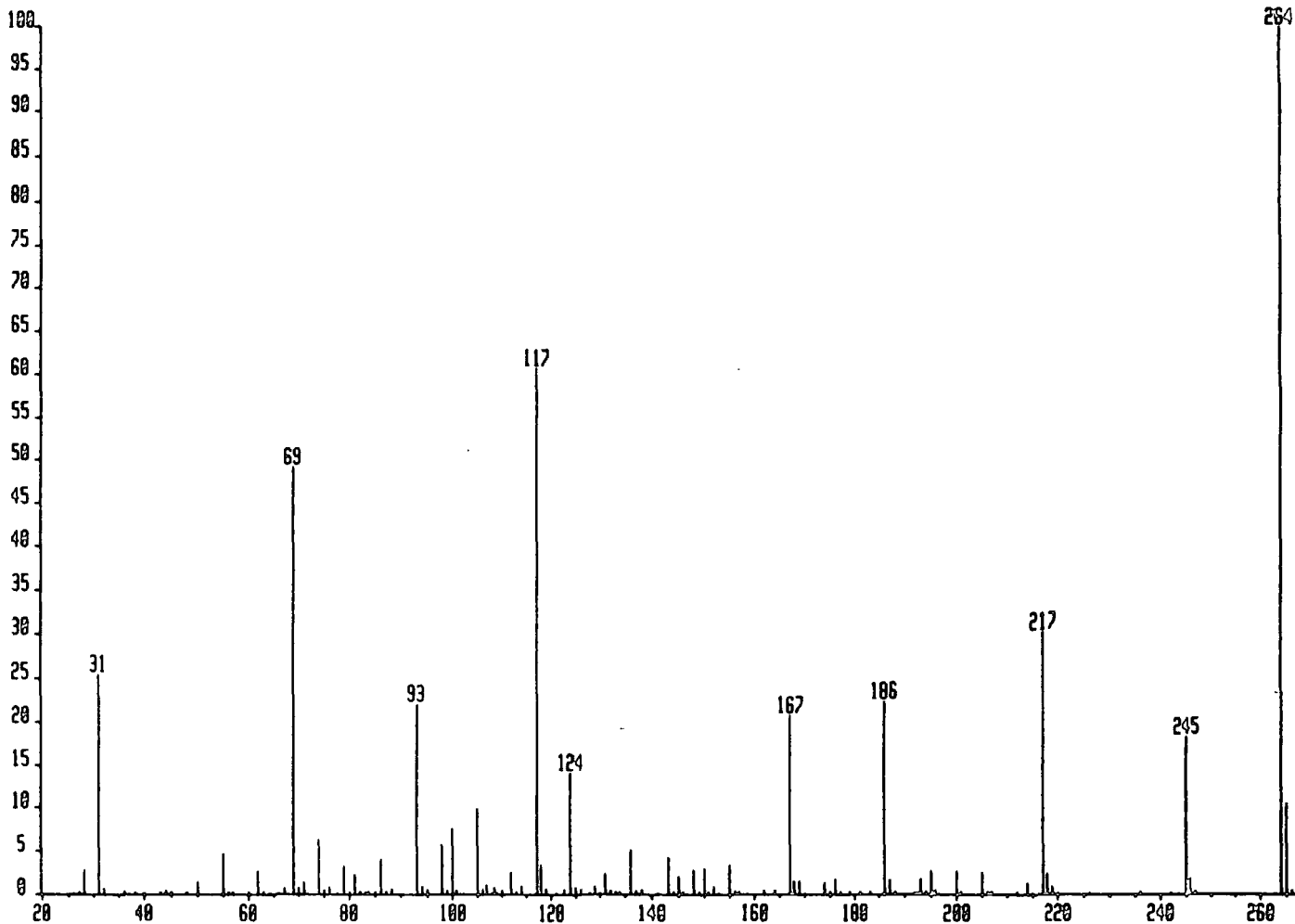

MASS	% BASE	MASS	% BASE
20.00	2.73	169.01	1.36
31.00	25.26	170.00	1.25
50.00	1.33	176.01	1.62
55.00	4.66	186.00	22.17
62.01	2.00	187.01	1.43
69.00	49.02	193.01	1.68
71.01	1.15	195.01	2.57
74.00	0.20	200.01	2.48
79.00	3.07	201.02	0.17
81.00	2.05	205.00	2.39
86.00	1.86	206.02	0.17
93.00	21.97	207.02	0.08
98.01	5.57	212.00	0.11
100.01	7.40	214.01	1.14
105.00	9.00	215.02	0.06
112.00	2.38	217.01	30.05
117.00	60.65	218.01	2.15
110.01	3.33	219.01	0.72
120.00	13.07	220.02	0.04
131.00	2.25	225.99	0.06
136.00	5.07	226.05	0.05
143.00	4.17	236.01	0.12
145.01	1.86	242.02	0.06
148.00	2.67	245.01	18.05
150.01	2.01	246.02	1.60
155.00	3.19	244.01	100.00 0
167.00	20.50	245.02	10.40
168.01	1.27		

39

PH299R0620 #1 Bpd=56 14-DEC-07 12:20:04:16 70E EI-
0pA=0 I=10v K=1162 TIC=226587000 Rcnt: Sys:HOAR
GC= 76° Cal:PFK14HEG

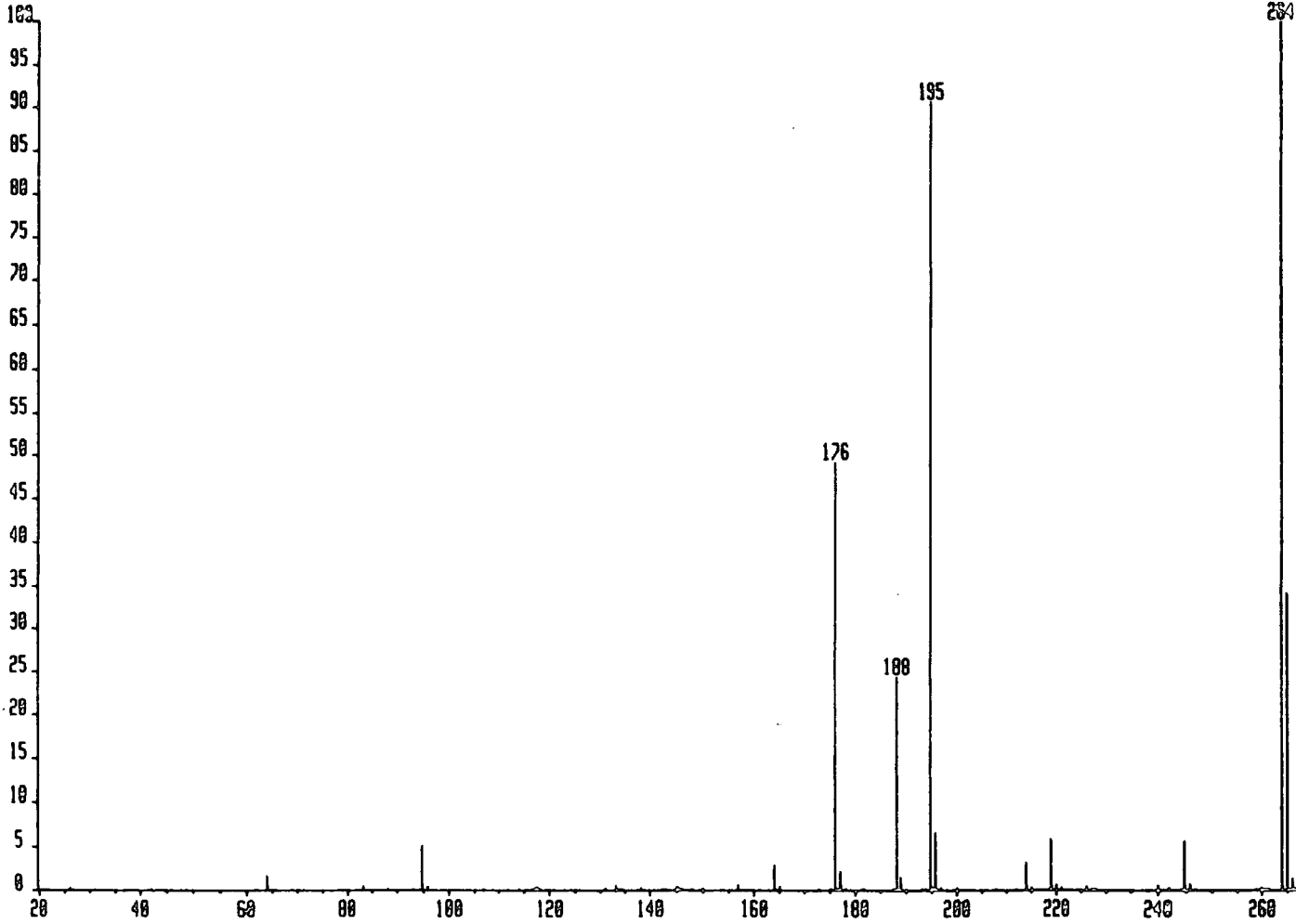

MASS	% BASE
63.95	1.49
96.98	4.99
163.99	2.81
175.98	49.17
176.90	2.08
187.98	20.27
188.90	1.31
194.98	90.02
199.90	6.51
200.06	0.03
208.01	0.01
211.97	0.04
213.98	3.16
216.99	0.18
218.70	0.02
218.79	0.03
218.97	5.72
244.97	5.65
245.98	0.58
264.04	100.00 F0
264.98	34.06 F

40

PH128X 5 P. HORRE EI
CAL: CALY31 STA:

14-FEB-85
0:52

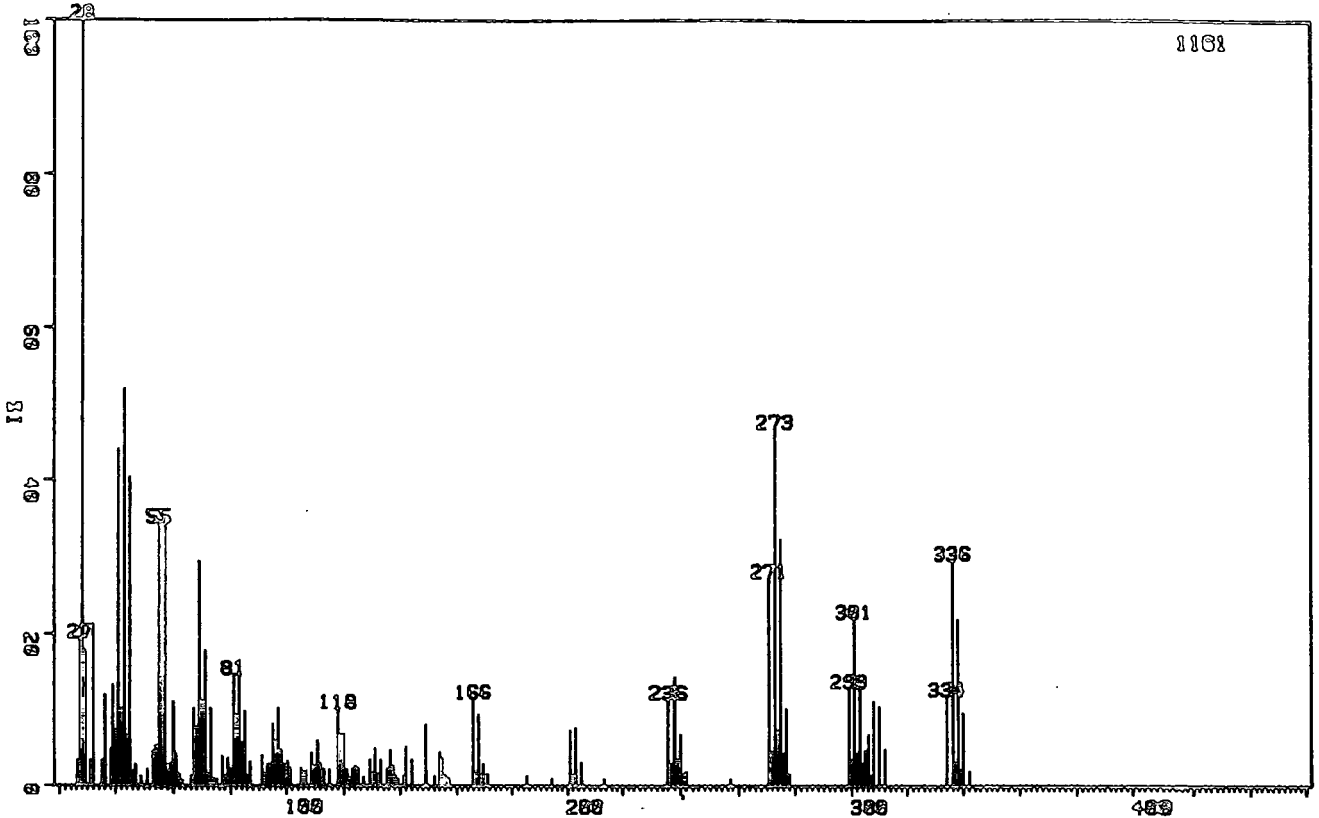

MASS	%HT.	BASE							
26.30	3.36	59.92	11.11	95.97	2.24	130.92	5.00	235.86	11.54
27.23	19.55	60.99	4.22	96.06	5.94	131.94	1.64	236.23	1.46
28.11	100.00	62.03	1.64	96.93	2.15	132.96	3.36	236.83	2.93
28.96	10.51	63.08	0.78	96.97	1.29	135.08	1.03	237.86	14.47
28.99	17.83	64.13	1.29	97.05	10.34	135.13	2.15	238.92	3.53
30.88	3.36	67.09	10.25	97.94	2.50	135.41	2.24	239.91	6.80
31.97	21.27	68.07	7.75	98.02	4.65	136.08	1.12	240.94	1.46
35.10	3.36	69.02	29.63	99.01	2.93	136.39	4.65	241.92	1.89
36.10	11.97	69.97	11.20	100.32	3.27	137.10	2.33	257.30	0.95
38.00	4.82	70.91	3.19	100.96	1.81	137.39	2.58	270.84	27.56
38.96	13.35	71.03	17.92	101.37	2.33	138.09	1.38	271.91	4.57
39.80	7.32	72.04	1.55	105.05	2.41	139.07	0.95	272.88	46.86
39.86	3.01	72.08	1.12	105.92	1.81	141.01	1.29	273.94	7.32
40.94	44.01	73.06	10.16	107.05	1.98	141.89	5.17	274.91	32.39
42.00	1.89	74.08	0.95	108.89	2.67	143.95	3.53	275.94	4.31
42.03	10.08	75.07	0.86	109.04	4.39	148.98	8.10	276.91	10.25
43.10	51.94	77.06	3.88	110.00	2.58	149.08	1.64	298.91	13.01
44.08	5.25	78.03	1.29	110.90	0.86	152.12	1.29	299.90	3.36
44.11	5.94	79.00	3.70	111.06	6.03	153.89	4.48	300.92	22.22
44.14	6.55	79.95	2.24	112.09	3.01	154.90	3.70	301.94	4.31
45.10	6.12	81.01	14.73	113.07	1.98	155.92	1.38	302.94	13.18
45.13	40.31	82.05	9.30	113.14	2.24	157.11	1.12	303.96	3.01
46.10	1.89	82.98	3.88	115.05	2.15	165.91	11.63	304.93	4.65
47.04	2.84	83.09	16.54	117.88	10.25	166.90	1.72	305.92	6.80
48.93	1.29	84.01	3.01	118.90	6.63	167.03	1.46	306.94	1.29
50.96	2.24	84.10	5.68	119.87	6.80	167.91	9.39	307.91	11.20
53.09	4.57	85.11	9.82	120.95	2.15	168.90	1.46	309.87	10.51
54.13	3.34	85.98	1.29	121.11	1.72	169.88	2.93	311.94	4.91
55.11	3.53	87.00	3.19	122.12	1.12	171.10	1.64	333.97	11.97
55.15	34.45	90.94	4.05	123.10	2.24	185.17	1.29	335.95	29.80
56.15	14.38	91.99	1.72	124.02	2.58	193.92	1.03	336.98	3.10
57.10	2.15	93.03	2.93	124.14	1.79	200.83	7.32	337.93	22.05
57.14	35.14	94.03	2.93	125.10	2.33	201.90	1.46	338.96	2.15
58.10	1.81	94.94	3.53	127.03	1.21	202.93	7.75	339.91	9.56
59.02	3.01	95.06	8.18	129.00	3.45	204.94	3.10	341.96	1.98

41

PMCPYZ000 x1 8yd-6 6-JAN-83 15:30:00:51 70E C1-
 0pR=0 I=10v Na=444 TIC=238202000 Acnt: Sys:GCE
 P.HOARE PT= 0° C2: PFK11

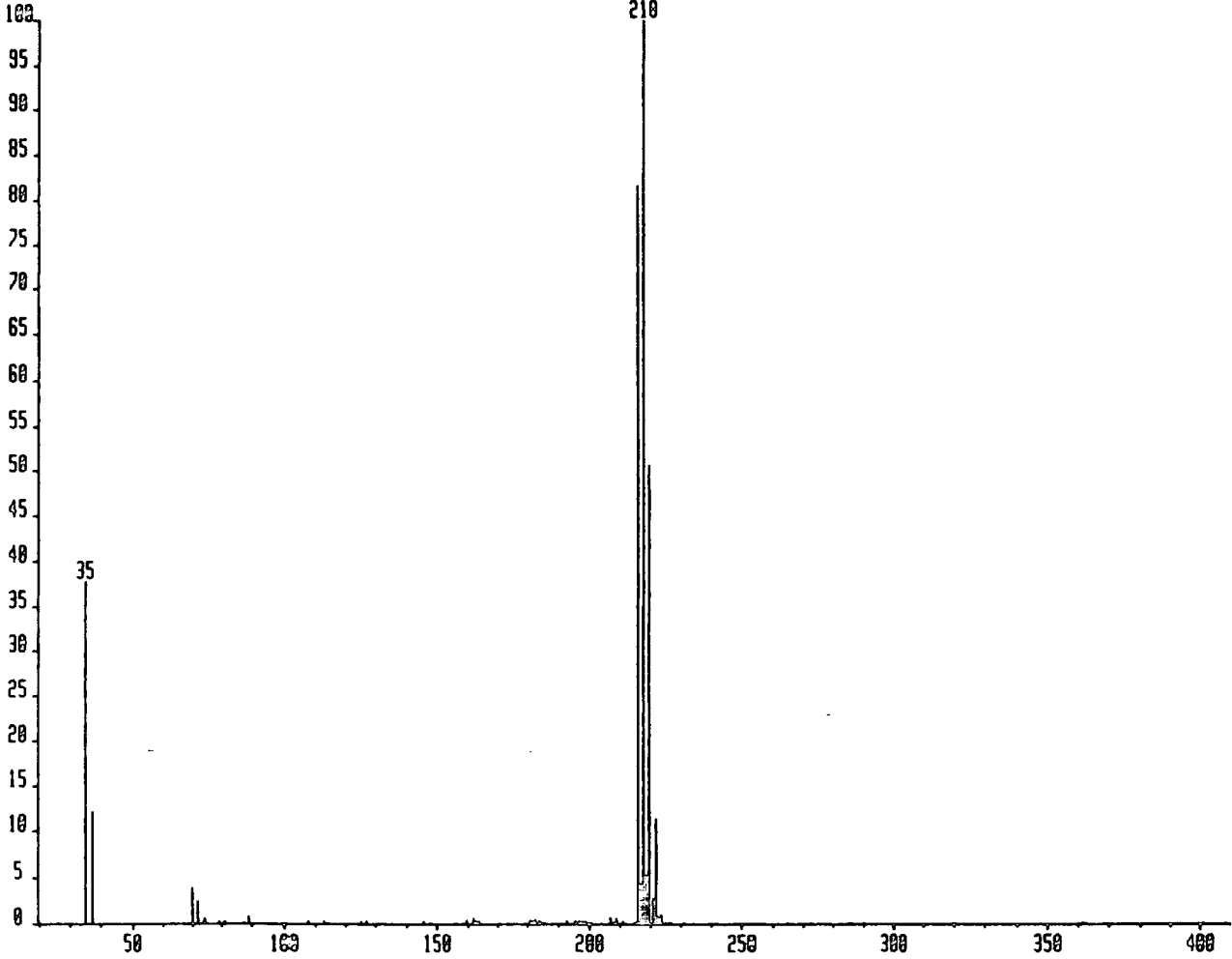

Mass	% Base	Mass	% Base
34.93	37.64	206.88	0.04
36.93	11.99	207.74	0.04
69.87	3.79	208.73	0.44
71.87	2.40	210.73	0.18
107.84	0.08	214.64	0.09
112.88	0.14	214.69	0.04
113.93	0.04	214.75	0.03
124.89	0.08	215.69	81.63
126.86	0.08	216.20	0.08
145.82	0.09	216.28	0.07
147.82	0.05	216.39	0.07
159.81	0.24	216.68	4.23 F
161.80	0.38	217.68	100.00 FO
162.81	0.11	218.20	0.05
163.80	0.14	218.28	0.06
180.75	0.24	218.36	0.03
181.76	0.22	218.47	0.05
182.75	0.28	218.68	5.16 F
183.76	0.17	219.68	50.63 F
184.76	0.07	220.68	2.64
185.76	0.06	221.68	11.28
192.83	0.16	221.86	0.06
195.76	0.18	221.91	0.03
196.75	0.14	222.68	0.55
197.75	0.11	223.67	0.85
198.74	0.18		
199.74	0.05		
200.73	0.07		
206.73	0.58		

42

PWTFP0530 ul Bgd=15 22-JUL-87 16:20:02:03 XI CI-
 Qm=0 I=1.4u H=231 TIC=1233333 Rent: Sys:RCE
 P.KORRE PI=00 Ctl:PFK

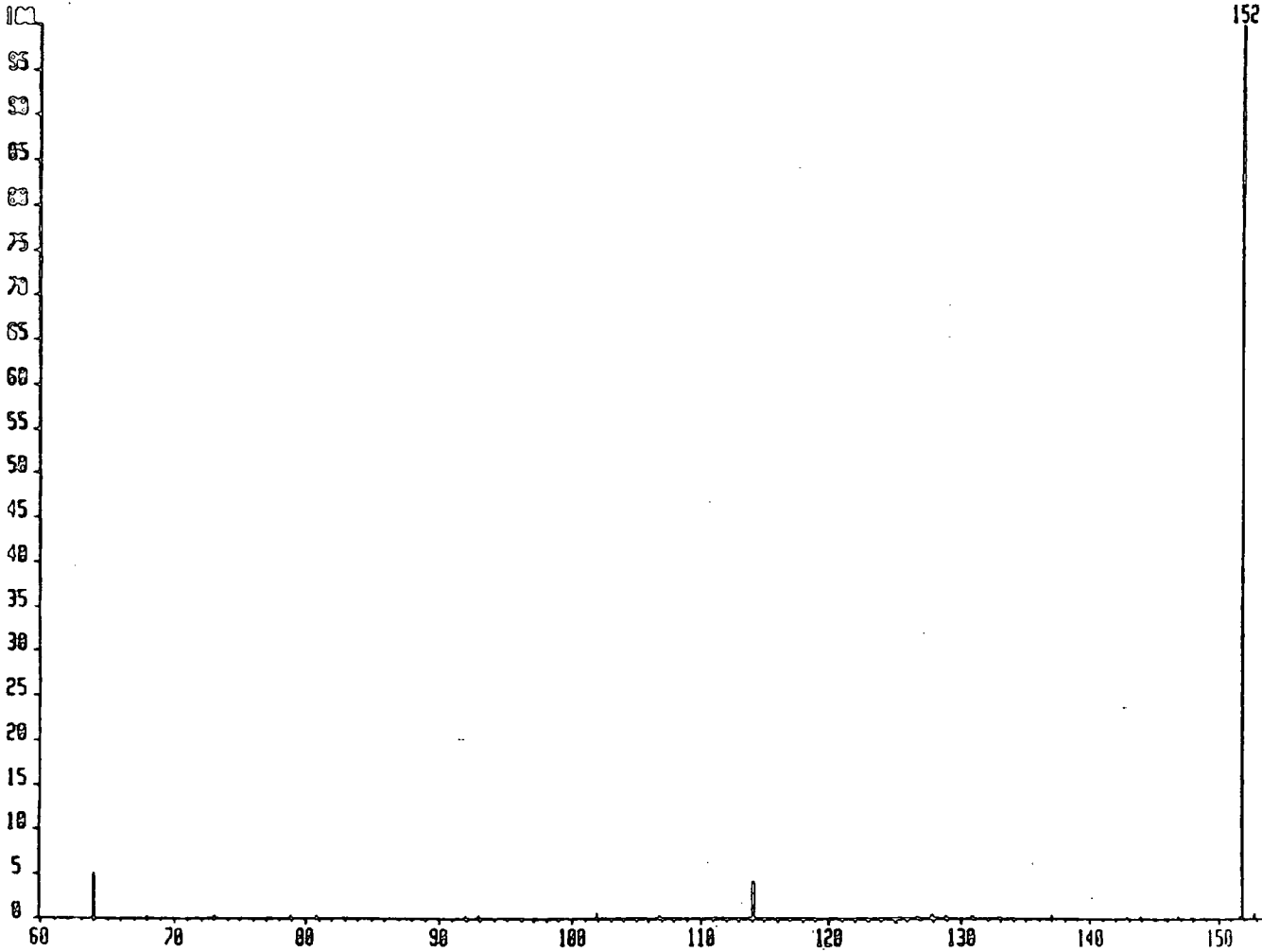

Mass	Z Base	Mass	Z Base
25.94	0.21	140.10	0.08
34.92	0.04	148.14	0.38
34.92	0.03	149.12	0.11
41.96	0.09	150.76	0.01
57.00	0.02	150.80	0.05
64.01	6.47	150.92	0.05
69.02	0.42	151.10	0.02
69.01	0.10	151.13	0.09
71.03	0.21	152.05	6.74 F
76.02	0.05	152.12	100.00 FO
76.03	0.05	152.53	0.10
78.95	0.19	152.57	0.09
80.95	0.19	152.62	0.12
83.03	2.25	152.64	0.05
84.05	0.13	152.67	0.05
85.03	0.14	152.72	0.03
88.05	0.34	152.77	0.13
95.06	0.07	152.87	0.12
102.07	0.55	152.93	0.03
103.06	0.04	153.13	25.14
107.07	0.08		
114.09	4.87		
115.09	0.31		
121.10	0.88		
127.01	1.43		
128.10	0.40		
130.10	0.23		
133.11	0.91		
134.12	0.02		

43

PH303037o x1 Bgd=33 7-JRM-00 10:10:02:34 76E C1-
 0pR=0 I=10v Ho=304 TIC=96949920 Acnt: Sys:KIRX
 GC= 59° Czl:PFK11

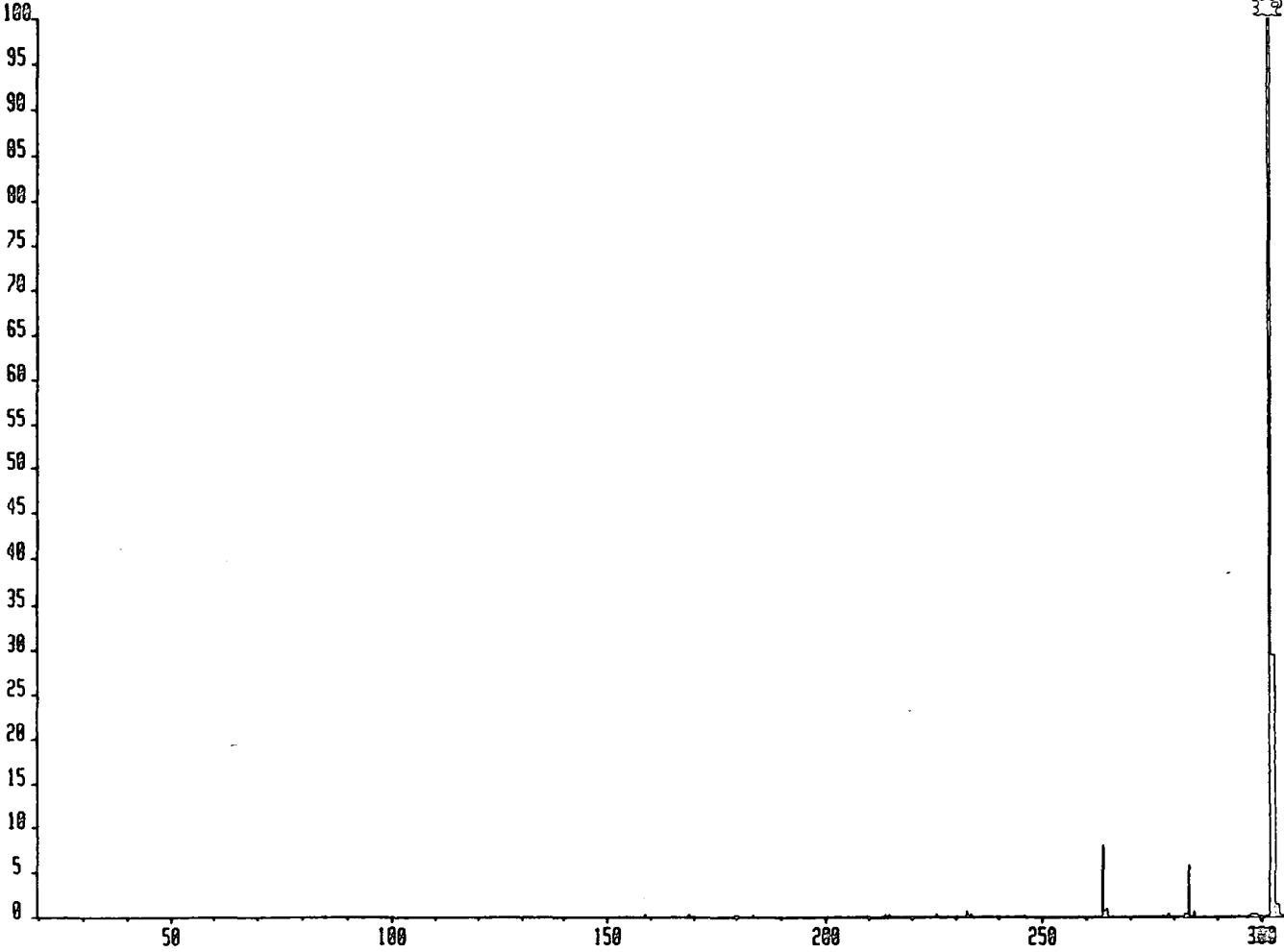

Mass	% Base
213.78	0.18
214.79	0.16
225.76	0.09
232.76	0.42
233.77	0.18
245.77	0.07
263.73	7.88
264.73	0.74
277.71	0.04
278.72	0.12
282.70	0.30
283.71	5.65
284.71	0.51
297.59	0.02
297.70	0.14
298.68	0.19
298.89	0.03
298.97	0.04
299.10	0.04
301.74	100.00 F0
302.68	29.31 F
303.67	1.12
303.95	0.05
304.02	0.03
304.67	0.05

44

PH317045o x1 Bgd=41 11-JAN-88 16:30:03:07 76E E1-
 BpR=0 I=10v Ho=1158 TIC=239505000 Acnt: Sys:MOAR
 GC= 64° Cal:PFK11KEG

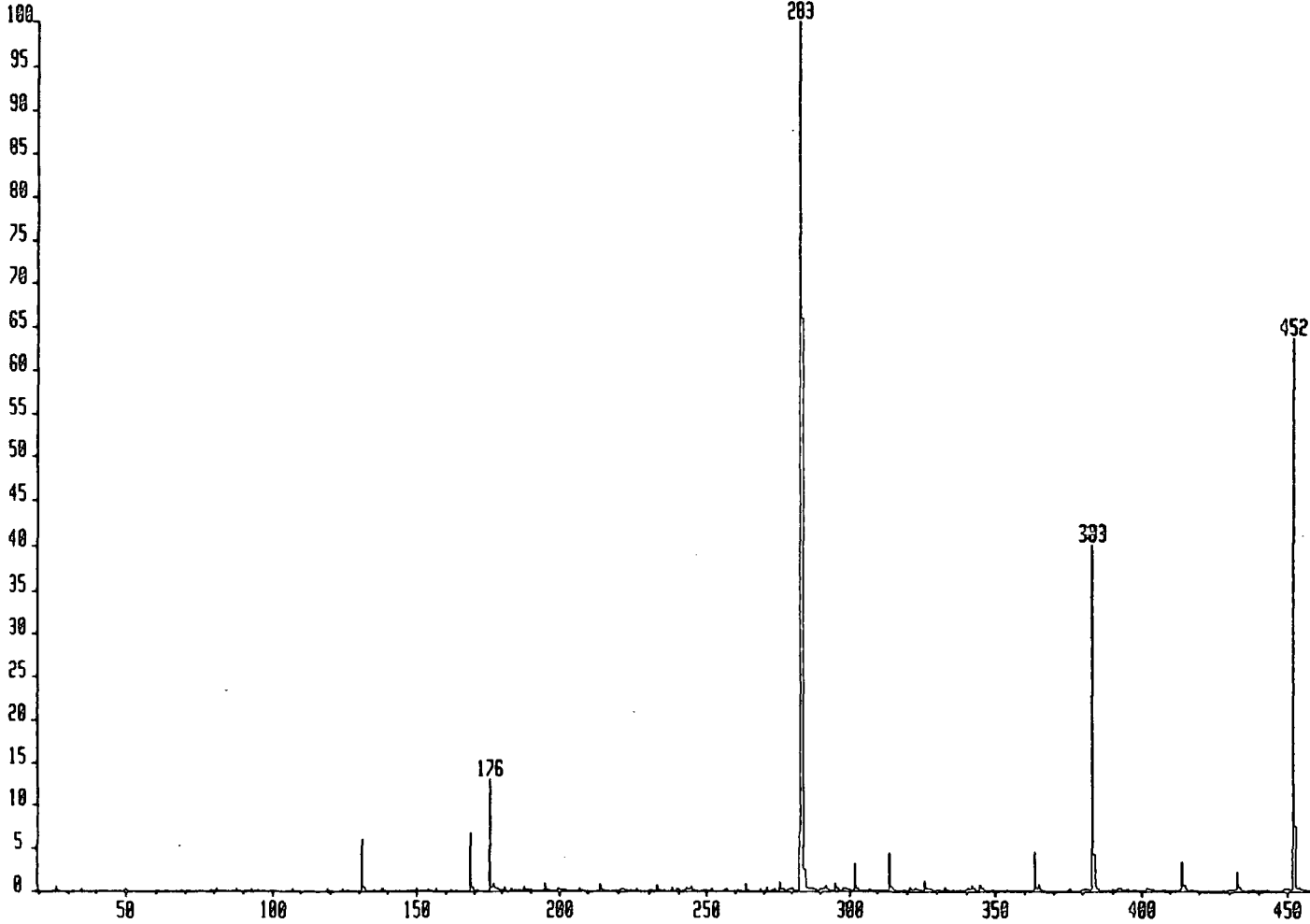

Mass	% Base
130.94	9.89
168.93	6.63
175.93	12.86
282.73	6.89 F
282.88	100.00 FD
283.88	65.95 F
284.34	0.23
284.45	0.07
284.59	0.06
284.89	2.37
301.88	3.19
313.87	4.37
323.86	1.00
363.87	4.49
382.84	39.96
383.21	0.03
383.28	0.07
383.41	0.09
383.84	4.17
413.82	3.21
432.81	2.12
451.78	63.80 F
452.80	7.50 F

45

PH2100450 n1 6gd=41 7-JRM-C 10:40:03:00 70E C1-
 BpH=452 I=10v Ha=621 TIC=117523 Rcnt: Sys:WDRZ
 GC= 64⁰ Cal: PFK11

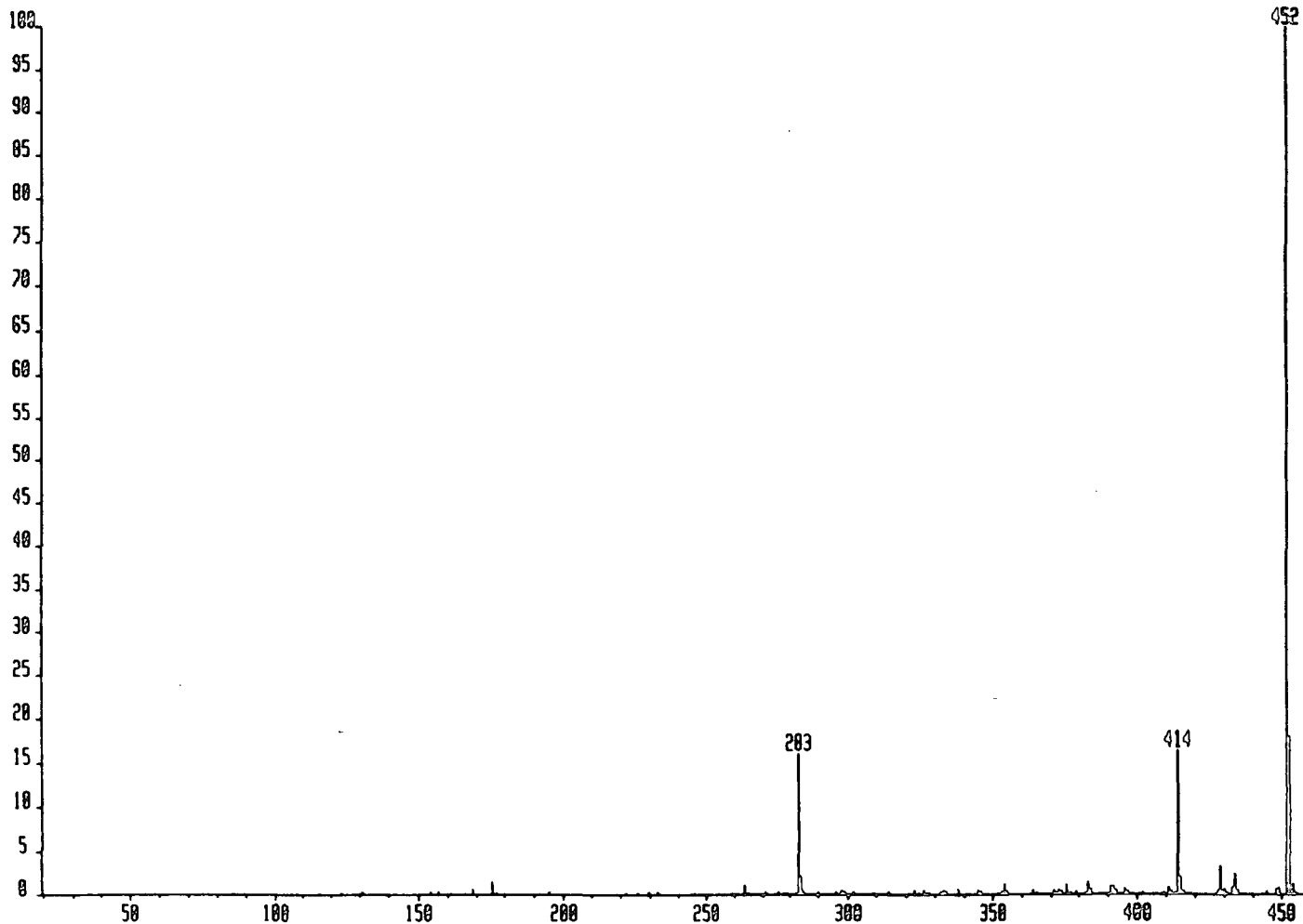

Mass	% Base	Mass	% Base	Mass	% Base
123.89	0.09	301.91	0.09	382.88	1.17
130.92	0.08	308.91	0.06	383.88	0.46
153.94	0.13	313.94	0.10	391.88	0.78
156.95	0.16	320.93	0.02	392.88	0.24
168.95	0.46	322.89	0.35	395.88	0.50
175.95	1.28	323.90	0.06	396.89	0.09
176.97	0.06	325.89	0.32	401.86	0.07
194.95	0.21	326.88	0.06	408.82	0.07
221.96	0.02	327.93	0.04	410.87	0.63
225.91	0.05	331.87	0.07	411.83	0.08
229.84	0.14	332.89	0.24	412.93	0.05
232.90	0.09	333.88	0.14	413.19	0.04
245.91	0.06	340.91	0.04	413.83	16.16
258.90	0.05	344.90	0.35	414.83	1.80
263.93	0.90	345.90	0.14	415.84	0.19
264.93	0.05	351.89	0.05	427.86	0.25
270.92	0.10	352.93	0.11	428.87	3.18
275.91	0.08	353.91	1.00	429.88	0.41
277.93	0.06	354.91	0.18	430.90	0.07
277.97	0.03	363.89	0.31	432.87	0.55
278.91	0.05	364.87	0.03	433.87	2.27
282.28	0.02	370.90	0.33	434.87	0.27
282.91	15.83	371.93	0.04	444.84	0.07
283.92	1.90	372.91	0.36	447.85	0.51
284.92	0.12	373.89	0.22	448.29	0.05
289.92	0.14	375.88	0.87	448.84	0.65
295.93	0.16	376.90	0.07	451.81	100.00 F0
297.92	0.25	378.91	0.09	452.85	17.80 F
298.92	0.14	381.92	0.07	453.84	1.04

APPENDIX FOURDEPARTMENTAL RESEARCH LECTURES AND SEMINARS

The Board of Studies in Chemistry requires that each postgraduate thesis contains an appendix listing:

- a) All research colloquia, seminars and lectures arranged by the Department of Chemistry during the author's period of residence as a postgraduate student.
- b) All research conferences attended and papers presented by the author during the period in which the research for the thesis was carried out.

a) Research Colloquia, Seminars and Lectures

1984

- * 18 October Dr. N. Logan (University of Nottingham), " N_2O_4 and Rocket Fuels".
- 19 October Dr. A. Germain (Univeriste du Languedoc, Montpellier), "*Anodic Oxidation of Perfluoro Organic Compounds in Perfluorosulphonic Acids*".
- 24 October Prof. R. K. Harris (University of Durham), "*N.m.r. of Solid Polymers*".
- * 25 October Dr. W. J. Feast (University of Durham), "*Syntheses of Conjugated Polymers - How and Why?*".
- 7 November Dr. H. S. Munro (University of Durham), "*New Information from E.S.C.A. Data*".
- 7 November Prof. W. W. Porterfield (Hampden Sidney College, U.S.A.), "*There is no Borane Chemistry, only Geometry*".
- * 8 November Prof. B. J. Aylett (Queen Mary College, University of London), "*Silicon - Dead Common or Refined?*".
- * 15 November Prof. B. T. Golding (University of Newcastle-upon-Tyne), "*The Vitamin B₁₂ Mystery*".
- 21 November Dr. W. J. Feast (University of Durham), "*A Plain Man's Guide to Polymeric Organic Metals*".

- * 22 November Prof. D. T. Clark (I.C.I. plc, New Science Group),
"Structure, Bonding, Reactivity and Synthesis as Revealed by E.S.C.A.".
- 28 November Dr. T. A. Stephenson (University of Edinburgh),
"Some Recent Studies in Platinum Metal Chemistry".
- * 29 November Prof. C. J. M. Stirling (University College of
North Wales, Bangor), *"Molecules Taking the Strain"*.
- * 6 December Prof. R. D. Chambers (University of Durham), *"The Unusual World of Fluorine"*.

1985

- * 24 January Dr. A. K. Covington (University of Newcastle-upon-Tyne), *"Chemistry with Chips"*.
- * 31 January Dr. M. L. H. Green (University of Oxford), *"Naked Atoms and Negligee Ligands"*.
- * 7 February Prof. A. Ledwith (Pilkington Brothers plc), *"Glass as a High Technology Material"*.
- 13 February Dr. G. W. J. Fleet (University of Oxford),
"Synthesis of some Alkaloids from Carbohydrates".
- * 14 February Dr. J. A. Salthouse (University of Manchester),
"Son et Lumiere (A Chemical Energy Show)".
- 19 February Dr. D. J. Mincher (University of Durham),
"Stereoselective Syntheses of some Novel Anthracyclines Related to the Anti-Cancer Drug Adriamycin and to the Steffimycin Antibiotics".
- * 21 February Prof. P. M. Maitlis, F.R.S. (University of Sheffield), *"What Use is Rhodium?"*.
- 27 February Dr. R. E. Mulvey (University of Durham), *"Some Unusual Lithium Complexes"*.
- 7 March Dr. P. J. Rodgers (I.C.I. plc, Agricultural Division, Billingham), *"Industrial Polymers from Bacteria"*.
- * 7 March Dr. P. W. Atkins (University of Oxford), *"Magnetic Reactions"*.

- 12 March Prof. K. J. Packer (B.P. Research Centre), "*N.m.r. Investigations of the Structure of Solid Polymers*".
- * 14 March Prof. A. J. Katritzky, F.R.S. (University of Florida), "*Some Adventures in Heterocyclic Chemistry*".
- 21 March Dr. M. Poliakoff (University of Nottingham), "*New Methods for Detecting Organometallic Intermediates in Solution*".
- 28 March Prof. H. Ringsdorf (Organic Chemistry Institute, University of Mainz), "*Polymeric Liposomes as Models for Biomembranes and Cells*".
- 24 April Dr. M. C. Grosel (Bedford College, University of London), "*Hydroxypyridone Dyes - Bleachable One-Dimensional Metals*".
- * 1 May Dr. D. Parker (I.C.I. plc, Petrochemicals and Plastics Division, Wilton), "*Applications of Radioisotopes in Industrial Research*".
- 7 May Prof. G. E. Coates (formerly University of Wyoming), "*Chemical Education in Britain and America: Successes and Deficiencies*".
- 8 May Prof. D. Tuck (University of Windsor, Ontario), "*Lower Oxidation State Chemistry of Indium*".
- 8 May Prof. G. Williams (University College of Wales, Aberystwyth), "*Liquid Crystalline Polymers*".
- 9 May Prof. R. K. Harris (University of Durham), "*Chemistry in a Spin*".
- 14 May Prof. J. Passmore (University of New Brunswick), "*The Synthesis and Characterisation of some Novel Selenium-Iodine Cations, Aided by ^{77}Se n.m.r. Spectroscopy*".
- 15 May Dr. J. E. Packer (University of Auckland, New Zealand), "*Studies of Free Radical Reactions in Aqueous Solution using Ionising Radiation*".
- 17 May Prof. I. D. Brown (Institute for Materials Research, McMaster University, Canada), "*Bond Valence as a Model for Inorganic Chemistry*".

- 21 May Dr. D. L. H. Williams (University of Durham),
"Chemistry in Colour".
- 22 May Dr. R. Grimmett (University of Otago, Dunedin, New
 Zealand), *"Some Aspects of Nucleophilic
 Substitution in Imidazoles"*.
- * 22 May Dr. M. Hudlicky (Virginia State University,
 Blacksburg), *"Preferential Elimination of Hydrogen
 Fluoride from Vicinal Bromofluorocarbons"*.
- 13 June Dr. D. Woollins (Imperial College, University of
 London), *"Metal-Sulphur-Nitrogen Complexes"*.
- 14 June Prof. Z. Rappoport (The Hebrew University,
 Jerusalem), *"The Rich Mechanistic World of
 Nucleophilic Vinylic Substitution"*.
- 19 June Dr. T. N. Mitchell (University of Dortmund), *"Some
 Synthetic and n.m.r. Spectroscopic Studies of
 Organotin Compounds"*.
- 26 June Prof. G. Shaw (University of Bradford), *"Some
 Synthetic Studies in Imidazole Nucleosides and the
 Antibiotic Coformycin"*.
- 12 July Dr. K. Laali (Hydrocarbon Research Institute,
 University of Southern California), *"Recent
 Developments in Superacid Chemistry and
 Mechanistic Considerations in Electrophilic
 Aromatic Substitutions; A Progress Report"*.
- 13 September Dr. V. S. Palmer (University of Delhi), *"Enzyme
 Assisted ERC Synthesis"*.
- * 17 October Dr. C. J. Ludman (University of Durham), *"Some
 Thermochemical Aspects of Explosions"*.
- * 24 October Dr. J. Dewing (U.M.I.S.T.), *"Zeolites - Small
 Holes, Big Opportunities"*.
- 30 October Dr. S. N. Whittleton (University of Durham), *"An
 Investigation of a Reaction Window"*.
- * 31 October Dr. P. Timms (University of Bristol), *"Some
 Chemistry of Fireworks"*.
- 5 November Prof. M. J. O'Donnell (Indiana-Perdue University),
*"New Methodology for the Synthesis of Amino
 Acids"*.

- * 7 November Prof. G. Ertl (University of Munich),
"Heterogeneous Catalysis".
- * 14 November Dr. S. G. Davies (University of Oxford),
"Chirality Control and Molecular Recognition".
- * 20 November Dr. J. A. H. MacBride (Sunderland Polytechnic), *"A Heterocyclic Tour on a Distorted Tricycle - Biphenylene"*.
- * 21 November Prof. K. H. Jack, F.R.S. (University of Newcastle-upon-Tyne), *"Chemistry of Si-Al-O-N Engineering Ceramics"*.
- * 28 November Dr. B. A. J. Clark (Kodak Ltd.), *"Chemistry and Principles of Colour Photography"*.

1986

- 15 January Prof. N. Sheppard (University of East Anglia),
"Vibrational and Spectroscopic Determinations of the Structures of Molecules Chemisorbed on Metal Surfaces".
- * 23 January Prof. Sir Jack Lewis, F.R.S. (University of Cambridge), *"Some More Recent Aspects in the Cluster Chemistry of Ruthenium and Osmium Carbonyls"*.
- * 29 January Dr. J. H. Clark (University of York), *"Novel Fluoride Ion Reagents"*.
- * 30 January Mr. N. J. Phillips (University of Loughborough),
"Laser Holography".
- 12 February Dr. J. Yarwood (University of Durham), *"The Structure of Water in Liquid Crystals"*.
- 12 February Prof. O. S. Tee (Concordia University, Montreal),
"Bromination of Phenols".
- * 13 February Prof. R. Grigg (Queen's University, Belfast),
"Thermal Generation of 1,3-Dipoles".
- 19 February Prof. G. Procter (University of Salford),
"Approaches to the Synthesis of some Natural Products".
- * 20 February Dr. C. J. F. Barnard (Johnson Matthey Group),
"Platinum Anti-Cancer Drug Development".

- 26 February Miss C. Till (University of Durham), "*E.S.C.A. and Optical Emission Studies of the Plasma Polymerisation of Perfluoroaromatics*".
- * 27 February Prof. R. K. Harris (University of Durham), "*The Magic of Solid State N.M.R.*".
- 5 March Dr. D. Hathaway (University of Durham), "*Herbicide Selectivity*".
- 5 March Dr. D. M. Schroder (University of Edinburgh), "*Studies on Macrocyclic Complexes*".
- * 6 March Dr. B. Iddon (University of Salford), "*The Magic of Chemistry*".
- 12 March Dr. J. M. Brown (University of Oxford), "*Chelate Control in Homogeneous Catalysis*".
- 14 May Dr. P. R. R. Langridge-Smith (University of Cambridge), "*Naked Metal Clusters - Synthesis, Characterisation, and Chemistry*".
- 9 June Prof. R. Schmutzler (University of Braunschweig), "*Mixed Valence Diphosphorus Compounds*".
- 23 June Prof. R. E. Wilde (Texas Technical University), "*Molecular Dynamic Processes from Vibrational Bandshapes*".
- * 16 October Prof. N. N. Greenwood (University of Leeds), "*Glorious Gaffes in Chemistry*".
- * 23 October Prof. H. W. Kroto (University of Sussex), "*Chemistry in Stars, Between Stars, and in the Laboratory*".
- 29 October Prof. E. H. Wong (University of New Hampshire, U.S.A), "*Co-ordination Chemistry of P-O-P Ligands*".
- * 5 November Prof. D. Döpp (University of Duisburg), "*Cyclo-Additions and Cyclo-Reversions Involving Capto-Dative Alkenes*".
- * 6 November Dr. R. M. Scowston (University of Hull), "*From Myth and Magic to Modern Medicine*".
- * 13 November Prof. Sir Geoffrey Allen (Unilever Research), "*Biotechnology and the Future of the Chemical Industry*".

- * 20 November Mr. S. Christie (International Paints), "*Chemical Serendipity - A Real Life Case Study*".
- 26 November Dr. N. D. S. Canning (University of Durham), "*Surface Adsorption Studies of Relevance to Heterogeneous Ammonia Synthesis*".
- * 27 November Prof. R. L. Williams (Metropolitan Police Forensic Science Laboratories), "*Science and Crime*".
- 3 December Dr. J. Miller (Du Pont Central Research, U.S.A.), "*Molecular Ferromagnets; Chemistry and Physical Properties*".
- 8 December Prof. T. Dorfmueller (University of Bielefeld), "*Rotational Dynamics in Liquids and Polymers*".

1987

- 22 January Prof. R. H. Ottewill (University of Bristol), "*Colloid Science - A Challenging Subject*".
- 28 January Dr. W. Clegg (University of Newcastle-upon-Tyne), "*Carboxylate Complexes of Zinc; Charting a Structural Jungle*".
- 4 February Prof. A. Thomson (University of East Anglia), "*Metalloproteins and Magneto-Optics*".
- * 5 February Dr. P. Hubberstey (University of Nottingham), "*Various Aspects of Alkali Metal Chemistry*".
- * 11 February Dr. T. Shepherd (University of Durham), "*Pteridine Natural Products; Synthesis and Use in Chemotherapy*".
- 12 February Dr. P. J. Rodgers (I.C.I. plc, Billingham), "*Industrial Polymers from Bacteria*".
- 17 February Prof. E. H. Wong (University of New Hampshire, U.S.A.), "*Symmetrical Shapes from Molecules to Art and Nature*".
- * 19 February Dr. M. Jarman (Institute of Cancer Research), "*The Design of Anti-Cancer Drugs*".
- 4 March Dr. R. Newman (University of Oxford), "*Change and Decay: A Carbon-13 CP/MAS Study of Humification and Coalification Processes*".

- * 5 March Prof. S. V. Ley (Imperial College, University of London), "*Fact and Fantasy in Organic Synthesis*".
- * 9 March Prof. F. G. Bordwell (North Eastern University, U.S.A.), "*Carbon Anions, Radicals, Radical Anions and Radical Cations*".
- 11 March Dr. R. D. Cannon (University of East Anglia), "*Electron Transfer in Polynuclear Complexes*".
- 12 March Dr. E. M. Goodger (Cranfield Institute of Technology), "*Alternative Fuels for Transport*".
- 17 March Prof. R. F. Hudson (University of Kent), "*Aspects of Organophosphorus Chemistry*".
- 18 March Prof. R. F. Hudson (University of Kent), "*Homolytic Rearrangements of Free Radical Stability*".
- 6 May Dr. R. Bartsch (University of Sussex), "*Low Co-ordinated Phosphorus Compounds*".
- 7 May Dr. M. Harmer (I.C.I. plc, Chemicals and Polymers Group), "*The Role of Organometallics in Advanced Materials*".
- 11 May Prof. S. Pasynkiewicz (Technical University, Warsaw), "*Thermal Decomposition of Methyl Copper and its Reactions with Trialkylaluminium*".
- 27 May Dr. M. Blackburn (University of Sheffield), "*Phosphonates as Analogues of Biological Phosphate Esters*".
- * 24 June Prof. S. M. Roberts (University of Exeter), "*Synthesis of Novel Antiviral Agents*".
- * 26 June Dr. C. Krespan (E.I. Du Pont de Nemours), "*Nickel (0) and Iron (0) as Reagents in Organofluorine Chemistry*".

b) Research Conferences attended

18th Sheffield Symposium on "*Modern Aspects of Stereochemistry*", Sheffield, 19 December 1984.
Graduate Symposium, Durham, 29 March 1985.

19th Sheffield Symposium on "*Modern Aspects of Stereochemistry*", Sheffield, 18 December 1985.

R.S.C. Residential Course on "*Modern Aspects of Heterocyclic Chemistry*", Nottingham, 24 - 27 March 1986.

Graduate Symposium, Durham, 16 April 1986.

Postgraduate Heterocyclic Symposium, Aston, 2 July 1986.

Graduate Symposium, Durham, 27 March 1987.

REFERENCES

REFERENCES

1. R. D. Chambers and C. R. Sargent, *Adv. Heterocyclic Chem.*, 1981, 28, 1.
2. B. Iddon and H. Suschitzky in "Polychloroaromatic Compounds" (ed. H. Suschitzky), p198. Plenum, 1974.
3. R. Daniels, Ph.D. Thesis, University of Durham, 1974.
4. D. Pearce, Ph.D. Thesis, University of Durham, 1976.
5. G. G. Yakobson, T. D. Petrova, and L. S. Kobrina, *Fluorine Chem. Revs.*, 1974, 7, 115.
6. D. E. Pearson, W. W. Hargrove, J. K. T. Chow, and B. R. Suthers, *J. Org. Chem.*, 1961, 26, 789.
7. M. Gordon and D. E. Pearson, *J. Org. Chem.*, 1964, 29, 329.
8. P. Coad, R. A. Coad, S. Clough, J. Hyepock, R. Salisbury, and C. Wilkins, *J. Org. Chem.*, 1963, 28, 218.
9. R. D. Chambers, J. A. H. MacBride, and W. K. R. Musgrave, *J. Chem. Soc. (C)*, 1968, 2116.
10. R. D. Chambers, J. A. H. MacBride, W. K. R. Musgrave, and I. S. Reilly, *Tetrahedron lett.*, 1970, 57.
11. S. J. Childress and R. C. McKee, *J. Am. Chem. Soc.*, 1950, 72, 4271.
12. C. G. Allison, R. D. Chambers, J. A. H. MacBride, and W. K. R. Musgrave, *Tetrahedron lett.*, 1970, 1979.
13. N. A. Lange, W. S. Roush, and H. J. Asbeck, *J. Am. Chem. Soc.*, 1930, 52, 3696.

14. C. G. Allison, R. D. Chambers, J. A. H. MacBride, and W. K. R. Musgrave, *J. Chem. Soc. (C)*, 1970, 1023.
15. R. G. Jones and K. C. McLaughlin, *Org. Synth., Coll. vol. 4*, 1963, 824.
16. D. E. Burton, A. J. Lambie, D. W. J. Lane, G. T. Newbold, and A. Percival, *J. Chem. Soc. (C)*, 1968, 1268.
17. C. G. Allison, R. D. Chambers, J. A. H. MacBride, and W. K. R. Musgrave, *J. Fluorine Chem.*, 1971, 1, 59.
18. B. A. Loving, C. E. Snyder, G. L. Whittier, and K. R. Fountain, *J. Heterocyclic Chem.*, 1971, 8, 1095.
19. R. D. Chambers, W. K. R. Musgrave, and D. E. Wood, *J. Chem. Soc., Perkin Trans. 1*, 1979, 1978.
20. R. Gompper and K. Schönafinger, *Chem. Ber.*, 1979, 112, 1529.
21. A. Ohsawa, H. Arai, H. Ohnishi, and H. Igeta, *J. Chem. Soc., Chem. Commun.*, 1981, 1174.
22. R. E. Banks, D. S. Field, and R. N. Haszeldine, *J. Chem. Soc. (C)*, 1967, 1822.
23. M. G. Barlow, R. N. Haszeldine, C. Simon, D. J. Simpkin, and G. Ziervogel, *J. Chem. Soc., Perkin Trans. 1*, 1982, 1251.
24. R. D. Chambers, T. Shepherd, and M. Tamura, *Tetrahedron*, 1988, 44, 2583.
25. J. Miller, "Aromatic Nucleophilic Substitution", Elsevier, 1968.
26. M. J. Seabury, Ph.D. Thesis, University of Durham, 1984.

27. J. Burdon, I. W. Parsons, and E. J. Avramidies, *J. Chem. Soc., Perkin Trans. 1*, 1979, 1268.
28. R. D. Chambers, P. A. Martin, J. S. Waterhouse, D. L. H. Williams, and B. Anderson, *J. Fluorine Chem.*, 1982, 20, 507.
29. R. D. Chambers, J. S. Waterhouse, and D. L. H. Williams, *J. Chem. Soc., Perkin Trans. 2*, 1977, 585.
30. R. D. Chambers, D. Close, W. K. R. Musgrave, J. S. Waterhouse, and D. L. H. Williams, *J. Chem. Soc., Perkin Trans. 2*, 1977, 1774.
31. R. D. Chambers and M. R. Bryce in "Comprehensive Carbanion Chemistry" (ed. E. Buncl and T. Durst), Part C, p271. Elsevier, 1987.
32. R. D. Chambers, D. Close, and D. L. H. Williams, *J. Chem. Soc., Perkin Trans. 2*, 1980, 778.
33. K. J. Klabunde and D. J. Burton, *J. Am. Chem. Soc.*, 1972, 94, 5985.
34. R. D. Chambers, J. S. Waterhouse, and D. L. H. Williams, *Tetrahedron lett.*, 1974, 743.
35. J. Burdon, *Tetrahedron*, 1965, 21, 3373.
36. R. D. Chambers, J. A. Jackson, W. K. R. Musgrave, and R. A. Storey, *J. Chem. Soc. (C)*, 1968, 2221.
37. R. D. Chambers and M. Y. Gribble, *J. Chem. Soc., Perkin Trans. 1*, 1973, 1405.
38. R. D. Chambers, Yu. A. Cheburkov, J. A. H. MacBride, and W. K. R. Musgrave, *J. Chem. Soc. (C)*, 1971, 532.

39. S. L. Bell, R. D. Chambers, M. Y. Gribble, and J. R. Maslakiewicz, *J. Chem. Soc., Perkin Trans. 1*, 1973, 1716.
40. R. D. Chambers, R. P. Corbally, M. Y. Gribble, and W. K. R. Musgrave, *Chem. Commun.*, 1971, 1345.
41. R. D. Chambers, M. Clark, J. A. H. MacBride, W. K. R. Musgrave, and K. C. Srivastava, *J. Chem. Soc., Perkin Trans. 1*, 1974, 125.
42. M. G. Barlow, R. N. Haszeldine, and C. Simon, *J. Chem. Soc., Perkin Trans. 1*, 1980, 2254.
43. R. D. Chambers, M. Clark, J. R. Maslakiewicz, W. K. R. Musgrave, and P. G. Urben, *J. Chem. Soc., Perkin Trans. 1*, 1974, 1513.
44. R. D. Chambers and C. R. Sargent, *J. Chem. Soc., Perkin Trans. 1*, 1981, 1071.
45. R. D. Chambers, J. A. H. MacBride, J. R. Maslakiewicz, and K. C. Srivastava, *J. Chem. Soc., Perkin Trans. 1*, 1975, 396.
46. R. D. Chambers, J. R. Maslakiewicz, and K. C. Srivastava, *J. Chem. Soc., Perkin Trans. 1*, 1975, 1130.
47. M. G. Barlow, R. N. Haszeldine, and J. G. Dingwall, *J. Chem. Soc., Perkin Trans. 1*, 1973, 1542.
48. R. D. Chambers and R. Middleton, *J. Chem. Soc., Perkin Trans. 1*, 1977, 1500.
49. R. D. Chambers and R. Middleton, *J. Chem. Soc., Chem. Commun.*, 1977, 154.

50. D. E. Davies and R. C. Storr in "Comprehensive Heterocyclic Chemistry" (ed. A. R. Katritzky and C. W. Rees), vol. 7, p278. Pergamon, 1984.
51. B. A. Hess and L. J. Schaad, *J. Org. Chem.*, 1976, 41, 3058.
52. A. Greenberg, J. F. Liebman, and D. Van Vechten, *Tetrahedron*, 1980, 36, 1161.
53. A. E. Bayliff, Ph.D. Thesis, University of Durham, 1986.
54. Y. Kobayashi, I. Kumadaki, A. Osawa, Y. Hanzawa, and M. Honda, *Tetrahedron lett.*, 1975, 3001.
55. L. P. Pelosi and W. T. Miller, *J. Am. Chem. Soc.*, 1976, 98, 4311.
56. R. N. Warrener, E. E. Nunn, and M. N. Paddon-Row, *Tetrahedron lett.*, 1976, 2639.
57. S. Masamune, T. Machiguchi, and M. Aratani, *J. Am. Chem. Soc.*, 1977, 99, 3524.
58. M. G. Barlow, R. N. Haszeldine, and R. Hubbard, *J. Chem. Soc. (C)*, 1970, 1232.
59. M. Tamura, Ph.D. Thesis, University of Durham, 1984.
60. R. D. Chambers, M. Tamura, T. Shepherd, and C. J. Ludman, *J. Chem. Soc., Chem. Commun.*, 1987, 1699.
61. J. Sepiol and R. L. Soulen, *J. Org. Chem.*, 1975, 40, 3791.
62. S.-K. Choi and W.-K. Suk, *Bull. Korean Chem. Soc.*, 1981, 2, 83.
63. W. Brunskill, W. T. Flowers, R. Gregory, and R. N. Haszeldine, *Chem. Commun.*, 1970, 1444.

64. A. Piskala, J. Gut, and F. Sorm, *Collect. Czech. Chem. Commun.*, 1975, 40, 2680.
65. A. Piskala and F. Sorm, *Collect. Czech. Chem. Commun.*, 1976, 41, 465.
66. D. L. Boger, *Tetrahedron*, 1983, 39, 2869.
67. T. Sugita, J. Koyama, K. Tagahara, and Y. Suzuta, *Heterocycles*, 1985, 23, 2789.
68. T. Itoh, A. Ohsawa, M. Okada, T. Kaihoh, and H. Igeta, *Chem. Pharm. Bull.*, 1985, 33, 3050.
69. Y. S. Cheng, F. W. Fowler, and A. T. Lupo, *J. Am. Chem. Soc.*, 1981, 103, 2090.
70. D. L. Boger and J. S. Panek, *J. Org. Chem.*, 1981, 46, 2179.
71. D. L. Boger, J. S. Panek, and M. M. Meier, *J. Org. Chem.*, 1982, 47, 895.
72. E. C. Taylor and J. E. Macor, *Tetrahedron Lett.*, 1985, 2419; *ibid.*, 1986, 431.
73. M. G. Barlow, R. N. Haszeldine, and D. J. Simpkin, *J. Chem. Soc., Perkin Trans. 1*, 1982, 1245.
74. J. D. Roberts and M. C. Caserio, "Basic Principles of Organic Chemistry", Benjamin, 1977. p702.
75. R. K. Mackie and D. M. Smith, "Guidebook to Organic Synthesis", Longman, 1982. p100.
76. J. Wolinsky and R. B. Logan, *J. Org. Chem.*, 1970, 35, 3205.
77. R. K. Hill and R. M. Carlson, *J. Org. Chem.*, 1965, 30, 2414.

78. R. L. Dressler and J. A. Young, *J. Org. Chem.*, 1967, 32, 2004.
79. R. D. Chambers, J. Hutchinson and W. K. R. Musgrave, *J. Chem. Soc.*, 1964, 3573.
80. R. D. Chambers and J. R. Maslakiewicz, *J. Chem. Soc., Chem. Commun.*, 1976, 1005.
81. D. M. Lemal, J. V. Staros and V. Austel, *J. Am. Chem. Soc.*, 1969, 91, 3373.
82. R. O. Kan and R. L. Fury, *J. Am. Chem. Soc.*, 1968, 90, 1666.
83. D. Lawrenz, S. Mohr and B. Wendländer, *J. Chem. Soc., Chem. Commun.*, 1984, 863.
84. S. Fery-Forgues and N. Paillous, *J. Org. Chem.*, 1986, 51, 672.
85. J. Roussilhe, E. Fargin, A. Lopez, B. Despax and N. Paillous, *J. Org. Chem.*, 1983, 48, 3736.
86. J. R. Maslakiewicz, Ph.D. Thesis, University of Durham, 1974.
87. R. Middleton, Ph.D. Thesis, University of Durham, 1977.
88. R. E. Banks, W. M. Cheng, R. N. Haszeldine and G. Shaw, *J. Chem. Soc. (C)*, 1970, 55.
89. O. Matsuda, G. K. Kostov, Y. Tabata and S. Machi, *J. Appl. Polym. Sci.*, 1979, 24, 1053.
90. R. D. Chambers, M. Y. Gribble, and E. Marper, *J. Chem. Soc., Perkin Trans. 1*, 1973, 1710.
91. E. M. Burgess and J. P. Sanchez, *J. Org. Chem.*, 1974, 39, 940.

92. L. A. Paquette, *Tetrahedron*, 1975, 31, 2855.
93. D. E. Wood, Ph.D. Thesis, University of Durham, 1978.
94. R. D. Chambers, M. J. Silvester, M. Tamura, and D. E. Wood, *J. Chem. Soc., Chem. Commun.*, 1982, 1412.
95. T. Shepherd, unpublished observation.
96. R. D. Chambers, M. Tamura, J. A. K. Howard, and O. Johnson, *J. Chem. Soc., Chem. Commun.*, 1987, 1697.
97. T. Kaihoh, A. Ohsawa, T. Itoh, and H. Igeta, *Heterocycles*, 1985, 23, 204.
98. R. D. Chambers, J. A. Jackson, S. Partington, P. D. Philpot and A. C. Young, *J. Fluorine Chem.*, 1975, 6, 5.
99. L. Cavalli and G. Rigatti, *J. Chem. Soc. (B)*, 1969, 253.
100. C. J. Drayton, W. T. Flowers and R. N. Haszeldine, *J. Chem. Soc. (C)*, 1971, 2750.
101. C. R. Sargent, Ph.D. Thesis, University of Durham, 1978.
102. R. D. Chambers, J. A. Jackson, W. K. R. Musgrave, L. H. Sutcliffe and G. J. T. Tiddy, *Chem. Commun.*, 1969, 178; *Tetrahedron*, 1970, 26, 71.
103. I. K. Gregor and M. Guilhaus, *J. Fluorine Chem.*, 1983, 23, 549.
104. R. D. Chambers, J. A. H. MacBride, and W. K. R. Musgrave, *Chem. Commun.*, 1970, 739.
105. J. A. H. MacBride, personal communication.
106. M. L. Leow and J. A. H. MacBride, unpublished result.

107. D. E. Ames, R. F. Chapman, H. Z. Kucharska, and D. Waite, *J. Chem. Soc.*, 1965, 5391.
108. K. Schofield and J. C. E. Simpson, *J. Chem. Soc.*, 1945, 520.
109. E. J. Alford and K. Schofield, *J. Chem. Soc.*, 1953, 609.
110. K. Schofield and T. Swain, *J. Chem. Soc.*, 1950, 384.
111. R. D. Chambers and J. A. H. MacBride, unpublished results.
112. G. E. Chivers and H. Suschitzky, *J. Chem. Soc. (C)*, 1971, 2867.
113. E. M. Chait, W. B. Askew and C. B. Matthews, *Org. Mass Spectrom.*, 1969, 2, 1135.
114. A. Hadjiantoniou, L. G. Christophorou and J. G. Carter, *J. Chem. Soc., Faraday Trans. 2*, 1973, 69, 1691.
115. H. Budzikiewicz, *Angew. Chem., Int. Ed. Engl.*, 1981, 20, 624.
116. M. Guilhaus, Ph.D. Thesis, University of New South Wales.
117. A. C. Ho, J. H. Bowie and A. Fry, *J. Chem. Soc. (B)*, 1971, 530.
118. J. R. Frazier, L. C. Christophorou, J. G. Carter and H. Schweinler, *J. Chem. Phys.*, 1978, 69, 3807.
119. V. I. Khvostenko and S. R. Rafikov, *Dokl. Akad. Nauk SSSR*, 1975, 220, 892.
120. V. I. Khvostenko and S. R. Rafikov, *Proc. Acad. Sci. USSR*, 1975, 220, 107.

121. R. D. Chambers, R. S. Matthews, W. K. R. Musgrave and P. G. Urben, *Org. Magn. Reson.*, 1980, 13, 363.
122. B. Iddon, A. G. Mack, H. Suschitzky, J. A. Taylor and B. J. Wakefield, *J. Chem. Soc., Perkin Trans. 1*, 1980, 1370.
123. R. S. Matthews, *J. Magn. Reson.*, 1978, 30, 537.
124. A. R. Tarpley and J. H. Goldstein, *J. Phys. Chem.*, 1972, 76, 515.
125. N. K. Wilson, *J. Am. Chem. Soc.*, 1975, 97, 3573.
126. E. R. Malinowski, *J. Phys. Chem.*, 1972, 76, 1589.
127. R. S. Matthews, personal communication.
128. R. J. Pugmire, D. M. Grant, M. J. Robins and R. K. Robins, *J. Am. Chem. Soc.*, 1969, 91, 6381.
129. R. S. Matthews and J. W. Banks, unpublished results.
130. R. E. Banks, F. Cuthbertson, and W. K. R. Musgrave, *Anal. Chim. Acta.*, 1955, 13, 442.
131. E. E. Lewis and M. A. Naylor, *J. Am. Chem. Soc.*, 1947, 69, 1968.

