

Durham E-Theses

Polyfluorinated Aromatic Systems for Liquid Crystal Display Applications

MATTHEW ROBERT CARGILL

How to cite:

CARGILL, MATTHEW ROBERT (2011) Polyfluorinated Aromatic Systems for Liquid Crystal Display Applications. Doctoral thesis, Durham University.

Use policy

The full-text may be used and/or reproduced, and given to third parties in any format or medium, without prior permission or charge, for personal research or study, educational, or not-for-profit purposes provided that:

- a full bibliographic reference is made to the original source
- a <https://etheses.durham.ac.uk/id/eprint/642/> is made to the metadata record in Durham E-Theses
- the full-text is not changed in any way

The full-text must not be sold in any format or medium without the formal permission of the copyright holders.

Please consult the [full Durham E-Theses policy](#) for further details.

Durham University

A Thesis Entitled

Polyfluorinated Aromatic Systems for Liquid Crystal Display Applications

By

MATTHEW ROBERT CARGILL

(Trevelyan College)

A candidate for the degree of Doctor of Philosophy

Department of Chemistry, Durham University

2011

Abstract

This thesis is concerned with the syntheses of a range of polyfluorinated biphenyl ether derivatives for use as dopants in commercial LC materials, so that overall display performance may be improved. Reactions of hexa- and penta-fluorobenzene with sodium phenoxide in polar aprotic solvents (MeCN, THF) and under mild reaction conditions (45–50 °C, 4–65 h) afford moderate yields of pentafluorophenoxybenzene and 1,2,4,5-tetrafluoro-3-phenoxybenzene, respectively. S_NAr reactions of sodium phenoxide with less electrophilic 1,2,3,4-tetra- and 1,2,3,5-tetra-fluorobenzene under microwave irradiation (150 °C, 30 mins) furnish good yields of 1,2,4-trifluoro-3-phenoxybenzene and 1,2,5-trifluoro-3-phenoxybenzene, respectively. Similar S_NAr methodology is used to access a series of 1,2,4,5-tetra- and 1,2,4-tri-fluoro-3-(4-n-alkylphenoxy)benzene derivatives in good yield. A two-step S_NAr -hydrodebromination procedure to access trifluorophenoxybenzene systems from highly electrophilic dibromotetrafluorobenzene derivatives is also developed, and provides a practical synthetic route to 1,2,4-trifluoro-5-phenoxybenzene. Finally, a three-step S_NAr -diazotisation-reductive diazotisation pathway is developed for the syntheses of difluorophenoxybenzene derivatives, which are not accessible by direct S_NAr reactions of sodium phenoxide with corresponding trifluorobenzene derivatives. The use of these polyfluorinated biphenyl ether systems as dopants for LC materials is assessed by a range of electro-optical measurements.

Highly fluorinated nitrobenzene systems are compatible substrates for palladium-catalysed Suzuki-Miyaura and Heck-type cross-coupling reactions involving C-F bond activation. Cross-coupling reactions of pentafluoronitrobenzene with a range of boronic acids and protected ester equivalents bearing electron-withdrawing or electron-donating substituents in the *meta*- and *para*- positions, with respect to the C-B bond, are described. For example, Reaction of pentafluoronitrobenzene with 5,5-dimethyl-2-phenyl-1,3,2-dioxaborinane in the presence of catalytic quantities of Pd(PPh₃)₄ and using KF/alumina as the preferred base (DMF, 150 °C, 15 mins, μW) affords 2,3,4,5-tetrafluoro-6-nitrobiphenyl in good yield (80 %). The nitro group is crucial to the success of the cross-coupling processes and is believed to facilitate the oxidative addition step by directing the palladium catalyst into the adjacent C-F bond by a predominantly S_NAr -type mechanism.

Acknowledgements

I would like to thank Professor Graham Sandford and Dr. Gordon Love, my academic supervisors, for their invaluable help and support throughout the course of my Ph.D. I would also like to thank Dr. Pinar Kilickiran, Miss. Gabriele Nelles, Miss. Nadine Hollfelder and Mr. Frank Pleis for their advice and tuition and SONY and EPSRC for funding.

This research would not have been possible without the help of the highly professional technical staff at Durham University, namely: Dr. Alan Kenwright, Mr. Ian McKeag, Mrs. Catherine Heffernan (NMR); Dr. Mike Jones, Dr. Lara Turner, Dr. Jackie Mosely (Mass spectrometry); Mrs. Jarika Dostal and Miss. Judith Magee (Elemental analysis); Dr. Dmitrii Yufit (X-ray crystallography); Mr. Lenny Lauchlan and Dr. Aileen Congreve (Chromatography); Mr. Malcom Richardson and Mr. Peter Coyne (Glassblowing) and Mr. Dave Hunter (High Pressure Facilities).

Finally, I would like to thank all members of the fluorine group, both past and present, particularly Professor Richard Chambers, Dr. Graham Patterson, Mr. Ian Wilson, Mr. Christopher McPake, Miss. Jessica Breen, Dr. Lawrence Hill, Mr. Geoffrey Fuller and Dr. Christopher Hargreaves.

Memorandum

The work described in this thesis was carried out at Durham University between October 2007 and December 2010. This thesis is the work of the author, except where acknowledged by reference, and has not been submitted for any other degree. The copyright of this thesis rests with the author. No quotation from it should be published without the prior written consent and information derived from it should be acknowledged.

This work has been presented, in part, at:

9th RSC Fluorine Subject Meeting, Southampton, UK
September 2009

Departmental Organic Chemistry Seminar, Durham University, UK
June 2010

16th European Symposium on Fluorine Chemistry, Ljubljana, Slovenia
July 2010

ACS National Meetings & Exposition, Boston, Massachusetts, USA
August 2010

10th RSC Fluorine Subject Meeting, Durham, UK
September 2010

Nomenclature and Abbreviations

Chemical

| | |
|-------|-------------------------------------------------------------|
| acac | acetylacetonate |
| BINAP | 2,2'-bis(diphenylphosphino)-1,1'-binaphthyl |
| COD | 1,5-cyclooctadiene |
| dba | dibenzylideneacetone |
| DMA | dimethylacetamide |
| DME | 1,2-dimethoxyethane |
| DMF | dimethylformamide |
| DMI | 1,3-dimethyl-2-imidazolidinone |
| dmpe | 1,2-bis(dimethylphosphino)ethane |
| DMPU | <i>N,N'</i> -dimethyl-3,4,5,6-tetrahydro-2(1H)-pyrimidinone |
| DMSO | dimethylsulfoxide |
| dppe | 1,2-bis(diphenylphosphino)ethane |
| dppf | 1,1'-bis(diphenylphosphino)ferrocene |
| dppp | 1,1'-bis(diphenylphosphino)propane |
| EDG | electron donating group |
| EWG | electron withdrawing group |
| IPr | 1,3-diisopropylimidazolinylidene |
| LDA | lithium diisopropylamide |
| MeCN | acetonitrile (methyl cyanide) |
| Mes | mesityl (2,4,6-trimethylphenyl) |
| NHC | <i>N</i> -heterocyclic carbene |
| NMP | <i>N</i> -methyl-2-pyrrolidone |
| THF | tetrahydrofuran |

General

| | |
|----------|----------------------|
| Δ | heat |
| F | Faraday Constant |
| h | Planck's Constant |
| k_B | Boltzmann's Constant |

| | |
|---------------|-----------------------|
| μw | microwave irradiation |
| N | number of molecules |
| rt | room temperature |
| T | temperature |

Liquid Crystal

| | |
|------------------------------|------------------------------------------------------------------|
| AP | anti-parallel (LC) |
| C_{\parallel} | capacitance parallel to LC cell plates |
| C_{\perp} | capacitance perpendicular to LC cell plates |
| d | LC cell gap |
| DSC | differential scanning calorimetry |
| FoM | figure of merit |
| ITO | indium tin oxide |
| K_{22} | bend elastic constant |
| LC | liquid crystal |
| -LC | dielectrically negative LC |
| +LC | dielectrically positive LC |
| LCD | liquid crystal display |
| n_{parallel} | refractive index parallel to LC director |
| $n_{\text{perpendicular}}$ | refractive index perpendicular to LC director |
| \mathbf{n} | LC alignment director |
| S | LC order parameter |
| TN | twisted nematic (LC) |
| $T_{\text{Cr-N}}$ | solid crystal-isotropic liquid transition temperature |
| $T_{\text{N-I}}$ | nematic-isotropic liquid transition temperature (clearing point) |
| VA | vertically aligned (LC) |
| VHR | voltage holding ratio |
| V_{on} | switching voltage |
| V_{th} | threshold voltage |
| γ_1 | rotational viscosity |
| $\Delta\epsilon$ | dielectric anisotropy |
| ϵ_0 | permittivity of free space |
| $\epsilon_{\text{parallel}}$ | dielectric permittivity parallel to LC director |

| | |
|-----------------------------------|------------------------------------------------------|
| $\epsilon_{\text{perpendicular}}$ | dielectric permittivity perpendicular to LC director |
| $\Delta\alpha$ | polarisability anisotropy |
| Δn | birefringence |
| μ | dipole moment |
| τ_{decay} | decay time |
| τ_{response} | response time |
| τ_{rise} | rise time |

NMR Characterisation

| | |
|------|------------------------------------------|
| COSY | correlated spectroscopy |
| HMBC | heteronuclear multiple bond correlation |
| HSQC | heteronuclear single quantum correlation |
| NMR | nuclear magnetic resonance |

Contents

| | |
|--------------------------------------------------------------------------------|-----------|
| Chapter 1: Introduction | 1 |
| 1.1 Overview..... | 1 |
| 1.2 Liquid Crystal Display Technology..... | 1 |
| 1.2.1 Physical Properties of Liquid Crystals..... | 1 |
| 1.2.2 Twisted–Nematic Liquid Crystal Cells..... | 5 |
| 1.2.3 Requirements of LC Materials for use in Display Devices | 6 |
| 1.3 Aspects of Organofluorine Chemistry | 9 |
| 1.3.1 Overview | 9 |
| 1.3.2 Syntheses of Perfluorinated Aromatic Systems..... | 10 |
| 1.3.2.1 Saturation–Rearomatisation Processes..... | 10 |
| 1.3.2.2 Direct Replacements of Chlorine for Fluorine..... | 11 |
| 1.3.3 Reactivity Profile for Perfluorinated Aromatic Systems..... | 13 |
| 1.3.3.1 S _N Ar Reactions of Perfluoroaromatic Systems..... | 16 |
| 1.3.3.2 S _N Ar Reactions of Pentafluorobenzene Derivatives | 17 |
| 1.3.3.3 S _N Ar Reactions of Tetrafluorobenzene Systems..... | 22 |
| 1.3.3.4 S _N Ar Reactions of Tri– and Di–fluorobenzene Systems | 24 |
| 1.4 C–F Bond Activation..... | 26 |
| 1.4.1 Catalytic C–F Bond Activation | 27 |
| 1.4.1.1 Catalytic C–F Bond Activation with Palladium | 28 |
| 1.4.1.2 Catalytic C–F Bond Activation with Nickel..... | 38 |
| 1.5 Summary..... | 46 |
| 1.6 Aims | 47 |
| 1.6 References to Chapter 1 | 51 |
| Chapter 2: Syntheses of Fluorinated Biphenyl Ether Derivatives | 55 |
| 2.1 Introduction..... | 55 |
| 2.2 Aims and Approach..... | 55 |
| 2.3 Synthetic Strategy..... | 59 |

| | |
|--------------------------------------------------------------------------------------------------------------------------------------------------|-----------|
| 2.4 Results and Discussion | 63 |
| 2.4.1 Strategy 1: Dopant Synthesis by Nucleophilic Aromatic Substitution Reactions of Phenoxide Derivatives with Polyfluorobenzene Systems | 63 |
| 2.4.1.1 Reactions of Sodium Phenoxide with Polyfluorobenzene Derivatives | 63 |
| 2.4.1.2 Syntheses of Alkylated Polyfluorobiphenyl Ether Derivatives | 68 |
| 2.4.2 Strategy 2: Syntheses of Trifluorophenoxybenzene Derivatives by the Development of a Two-Step S_NAr -Hydrodebromination Protocol..... | 70 |
| 2.4.2.1 Step 1: S_NAr Reactions of Dibromotetrafluorobenzene Systems with Sodium Phenoxide..... | 70 |
| 2.4.2.2 Step 2: Palladium-catalysed Hydrodebromination Reactions of Dibromotrifluorophenoxybenzene Derivatives | 74 |
| 2.4.3 Strategy 3: Dopant Synthesis by a Three-Step Directed S_NAr -Reduction-Diazotisation Pathway..... | 76 |
| 2.4.3.1 Step 1: S_NAr Reactions of Sodium Phenoxide with Fluorinated Nitrobenzene Derivatives | 76 |
| 2.4.3.2 Step 2: Palladium-catalysed Reduction Reactions of Nitrobenzene Derivatives to Corresponding Aniline Systems | 82 |
| 2.4.3.3 Step 3: Reductive Diazotisation Processes | 84 |
| 2.4.4 Strategy 4: Syntheses of Polyfluorinated Biaryl Ether Derivatives by Copper-Mediated and Palladium-Catalysed Processes | 88 |
| 2.4.4.1 Dopant Synthesis by Chan-Lam Type Procedures | 88 |
| 2.4.4.2 Dopant Synthesis by Buchwald-Hartwig Type Procedures | 90 |
| 2.5 Conclusions | 92 |
| 2.6 References to Chapter 2..... | 94 |
| Chapter 3: Electro-optical Testing of Polyfluorinated Biphenyl Ether Derivatives | 96 |
| 3.1 Introduction | 96 |
| 3.2 Results and Discussion | 96 |
| 3.2.1 Phase 1: Initial Screening Studies..... | 96 |
| 3.2.2 Phase 2: Alkylated Polyfluorobiphenyl Ether Derivatives..... | 100 |
| 3.2.2.1 Introduction | 100 |

| | |
|-----------------------------------------------------------------------------------------------------------------------|----------------|
| 3.2.2.2 Results and Discussion..... | 101 |
| 3.2.2.3 EO Performance of Dopants in –LC Host MLC2038 | 101 |
| 3.2.2.4 EO Performance of Dopants in +LC Host SY5524 | 106 |
| 3.2.3 Phase 3: Effect of Dopant Dipole Moment on LC Performance | 108 |
| 3.2.3.1 Introduction | 108 |
| 3.2.3.2 Results and Discussion..... | 110 |
| 3.2.3.3 EO Performance of Dopants in –LC Host MLC2038 | 110 |
| 3.2.3.4 EO Performance of Dopants in –LC Host LC2 | 112 |
| 3.3 Conclusions | 116 |
| 3.4 References to Chapter 3..... | 118 |
| Chapter 4: Palladium–catalysed C–F Bond Activation of Fluoroaromatic Systems | 119 |
| 4.1 Introduction..... | 119 |
| 4.2 Aims and Approach..... | 120 |
| 4.3 Results and Discussion | 123 |
| 4.3.1 Optimisation of the Cross–coupling Procedure..... | 123 |
| 4.3.2 Palladium–catalysed Suzuki–Miyaura Cross–coupling Reactions of Highly Fluorinated Nitrobenzene Derivatives..... | 125 |
| 4.3.2.1 Cross–coupling Reactions of Pentafluoronitrobenzene..... | 125 |
| 4.3.2.2 Cross–coupling Reactions of Tetrafluoronitrobenzene Derivatives | 130 |
| 4.3.2.3 Cross–coupling Reactions of Trifluoronitrobenzene Derivatives | 137 |
| 4.3.2.4 Cross–coupling Reactions of Substituted Pentafluorobenzene Systems | 139 |
| 4.3.3 Heck–type Reactions of Polyfluorinated Nitrobenzene Systems | 139 |
| 4.3.4 Cross–coupling Reactions of Polyfluorinated Heterocyclic Systems | 145 |
| 4.4 Conclusions | 151 |
| 4.5 References to Chapter 4..... | 153 |
| Chapter 5: Experimental Section | 155 |
| 5.1 General..... | 155 |
| 5.2 Experimental Data to Chapter 2 | 157 |
| 5.3 Experimental Data to Chapter 3 | 196 |

| | |
|------------------------------------------|-----|
| 5.4 Experimental Data to Chapter 4 | 199 |
| 5.5 References to Chapter 5 | 222 |

Chapter 1

Introduction

1.1 Overview

Liquid crystal display (LCD) devices have now largely replaced conventional cathode-ray tube (CRT) displays due to their superior resolution, reduced power consumption, weight and size. Nevertheless, as consumer demand for larger screen sizes continues to grow, the response times of modern LCD devices need to be improved to prevent moving-image blurring, or ‘ghosting’, which becomes increasingly apparent for fast moving objects on large displays. The focus of this thesis is to improve the response, or switching times of commercially available LC systems to improve the quality of the next generation of LCDs by adopting a ‘doping’ strategy involving the incorporation of various fluorinated biphenyl ether derivatives. Consequently, this introduction will provide background information on relevant aspects of LCD technology and fluoroaromatic chemistry.

1.2 Liquid Crystal Display Technology

1.2.1 Physical Properties of Liquid Crystals

The first observation of liquid crystalline behaviour is generally credited to Reinitzer, in the late 19th century, when he recorded the appearance of an unusual cloudy phase as a sample of cholesterol benzoate was melted.^{1,2} As the temperature was increased, the cloudy phase disappeared to give a colourless liquid. Today, we understand this ‘double-melting’ phenomenon to be a phase transition between the crystalline solid to a less ordered, but still anisotropic liquid mesophase. Cholesterol benzoate is now categorised as one of a growing class of molecules that are known to exhibit a nematic mesophase, that is, a fluid state of matter that displays no long-range translational order yet, which retains a high degree of macroscopic orientational order. The nematic mesophase may be accessed, reversibly, either by cooling the isotropic liquid or by melting the solid crystalline material and such materials are termed thermotropic liquid crystals.³

In addition to the nematic phase, a number of distinct mesophases exhibiting various degrees of translational and orientational order also exist, although it is the least ordered, thermotropic nematic mesophase that is most commonly encountered in LCD devices.⁴

Systems that exhibit nematic LC mesophases tend to be formulated from rigid rod-like molecules, which are able to efficiently pack alongside one another. As the corresponding solid is melted, the strong lateral intermolecular interactions between constituent molecules allow orientational order to be retained as translational order is lost. The axis of preferred orientation of molecules of the nematic bulk is defined by a unitless vector known as the director, \mathbf{n} , and the overall degree of LC alignment may be described by the order parameter, S , where θ is the angle the long molecular axis makes with \mathbf{n} [Equation 1].⁵

$$S = \frac{1}{2} \langle 3 \cos^2 \theta - 1 \rangle \quad (1)$$

The value of S for a nematic LC lies between 1, for a perfectly crystalline solid, and 0 for an isotropic liquid and the greater the value of S , the more anisotropic the system. Important physical properties of nematic LCs include their dielectric anisotropy, $\Delta\epsilon$, birefringence, Δn , and nematic to isotropic liquid transition temperature (clearing point), T_{NI} .

The dielectric anisotropy of an LC mixture is defined as the difference between the dielectric permittivity parallel and perpendicular to \mathbf{n} , and determines how strongly a nematic fluid will interact with an applied electric field in an LC device [Equation 2].

$$\Delta\epsilon = \epsilon_{\text{parallel}} - \epsilon_{\text{perpendicular}} \quad (2)$$

The dielectric anisotropy of a single molecule is determined by its dipole moment, μ , and the angle at which the dipole moment makes to the effective orientation axis of the molecule, β . The Maier-Meier equation may be used to predict the dielectric anisotropy of a bulk nematic LC system by approximating each constituent molecule to a solid cylinder [Equation 3].⁶

If the largest component of the dipole moment of an LC molecule lies parallel to its orientation axis, the bulk material will have a positive dielectric anisotropy. Conversely, if the largest component of the dipole moment is perpendicular to the orientation axis, the bulk LC will have a negative dielectric anisotropy.

$$\Delta\varepsilon = \frac{NhF}{\varepsilon_0} \left\{ \Delta\alpha - F \frac{\mu^2}{2k_B T} (1 - 3\cos^2 \beta) \right\} S \quad (3)$$

Important considerations for designing new LC systems include, therefore, the magnitude and orientation of dipole moment and polarisability anisotropy, $\Delta\alpha$, of each constituent molecule and the orientation parameter, S . Structurally, long, rigid, highly polar molecules are expected to be highly dielectrically anisotropic, whereas the placement of polar substituents parallel or perpendicular to the long axis of the molecule will determine whether the system is dielectrically positive or negative. Examples of typical LC molecules (**1–3**) of various dielectric anisotropies are presented in Table 1.

Table 1. Dielectric anisotropies of several LC materials (**1–3**)⁶

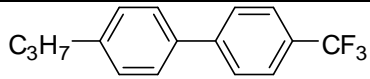
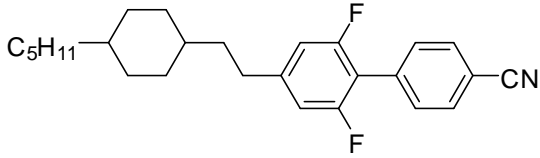
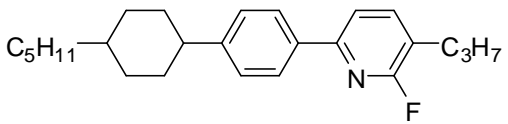
| Liquid Crystal Material | Dielectric Anisotropy |
|---------------------------------------------------------------------------------------------------------------------------------|-----------------------|
|  <p style="text-align: center;">1</p> | 14.2 |
|  <p style="text-align: center;">2</p> | 22.4 |
|  <p style="text-align: center;">3</p> | -3.1 |

The optical anisotropy, or birefringence, of an LC mixture is defined as the difference between the refractive indices parallel and perpendicular to \mathbf{n} , and determines the optical performance of an LC device [Equation 4].

$$\Delta n = n_{\text{parallel}} - n_{\text{perpendicular}} \quad (4)$$

Several examples of typical liquid crystals (**4–6**) used for practical applications which display a range of birefringence values are shown in Table 2.⁷

Table 2. Birefringence values of several LC materials (**4–6**)⁷

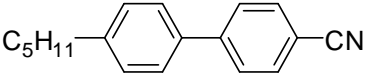
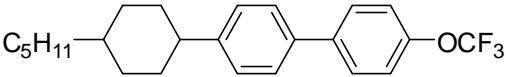
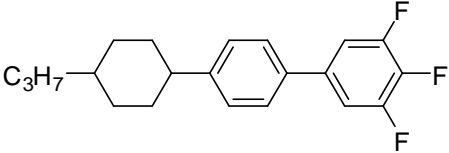
| Liquid Crystal Material | Birefringence |
|-----------------------------------------------------------------------------------------------|---------------|
|  4 | 0.18 |
|  5 | 0.14 |
|  6 | 0.09 |

The relationship between molecular structure and transition temperatures of thermotropic LC systems is well studied and, in general, the incorporation of lateral substituents or long, flexible chains, linking groups or saturated rings, tends to disrupt molecular packing and so reduce mesophase transition temperatures [Table 3].⁸

Table 3. Transition temperatures of several LC materials (**7–9**)⁸

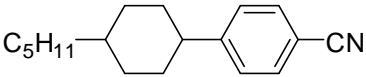
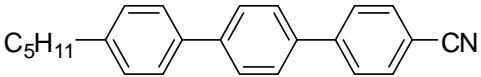
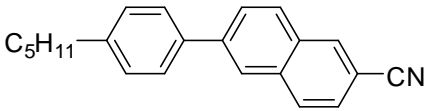
| Liquid Crystal Material | T _{Cr-N} / °C | T _{N-I} / °C |
|-------------------------------------------------------------------------------------------------|------------------------|-----------------------|
|  7 | 31.0 | 55.0 |
|  8 | 130.0 | 239.0 |
|  9 | 68.0 | 130.0 |

The viscosities of nematic systems are affected in a similar manner, with interrupted molecular packing tending to result in reduced intermolecular interactions between bulk LC molecules and the formation of less viscous materials.

1.2.2 Twisted-Nematic Liquid Crystal Cells

Whilst there have been many developments in modern LCD technology, the principal operation of most display devices is based on that of the original twisted nematic (TN) LC cell.⁹ In a typical TN cell, a dielectrically positive nematic LC system is doped with a small quantity of an enantiopure chiral additive and sandwiched between indium tin oxide (ITO) plates, bearing internal molecular alignment layers and a set of orthogonally crossed polarisers. The nematic phase is twisted into a helical structure by the chiral additive and the molecular alignment layers position LC molecules at each boundary so that they lie parallel to the transmission axis of each polariser [Figure 1].¹⁰

Figure 1. Schematic representation of a conventional TN cell¹⁰

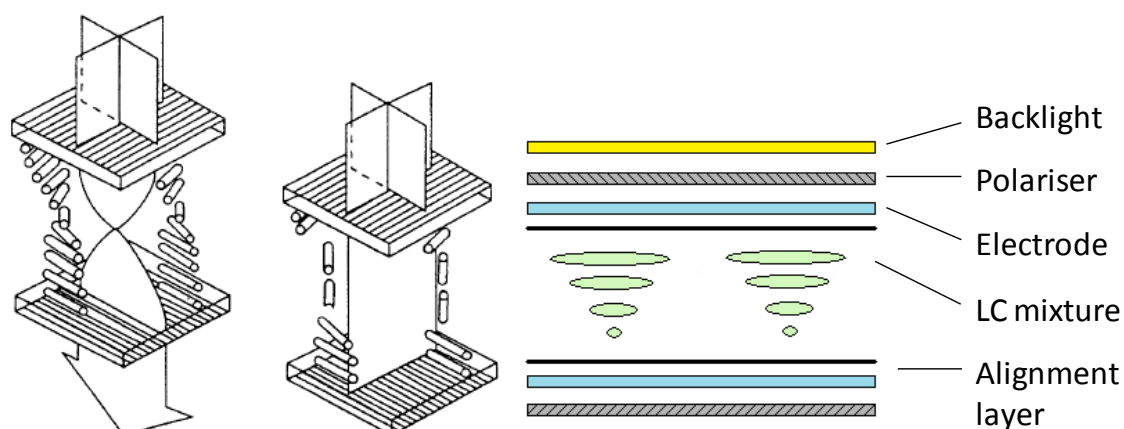

In the absence of an external electric field, incident light is plane-polarised as it passes through the first polariser and is rotated through 90° as it travels along the helical structure of the twisted LC host, and so is able to exit the second polariser, creating a so-called ‘bright-when-off’ state. Upon application of an external electric field, the equilibrium helical orientation of the host phase is disrupted and the incident light is no longer guided through the second polariser, making the device appear ‘dark-when-on’.

Early LCDs were constructed from arrays of TN LC cells, each of which was responsible for an individual picture element, or pixel. Each pixel was connected by two

electrodes to a control device, which would address each one individually to determine the overall visual output of the display. In order to produce more complicated, larger displays, multiplex-addressing technology was developed whereby each pixel could be switched in time by sequentially addressing a series of rows and columns of LC cells. However, the image contrast of these devices is poor because it is not possible to switch the LC phase sufficiently rapidly enough to achieve a high quality image, although the advent of super-twisted nematic displays offers some improvement in performance.

A major breakthrough in image quality came when microscopic thin-film transistors (TFTs) were used to control the LC cells by active matrix (AM) addressing. This development allowed for the rapid switching of each pixel and overcame the cumbersome process of attaching wires to each cell, although response times were still not sufficiently rapid to meet consumer demand and only narrow viewing angles were offered. Modern AM-TFT displays, therefore, tend to be fabricated to switch by other mechanisms, including in-plane switching (IPS) and multi-domain vertically-aligned (MVA) modes which can provide excellent viewing angles and rapid response times.

1.2.3 Requirements of LC Materials for use in Display Devices

In order for a liquid crystal material to be suitable for use in a display device it needs to satisfy the following criteria: (1) the nematic mesophase must be employed over the operating temperature range of the device; (2) the nematic-isotropic transition temperature must be greater than the maximum operating temperature of the device; (3) it must remain chemically, photochemically, electrochemically and thermally stable; (4) it must have excellent voltage holding properties to minimize visual ‘flicker’; and (5) it should impart rapid response times to rival those of alternative display technology.

It is now relatively straightforward to produce nematic materials with suitably wide nematic phase ranges and sufficiently high clearing points that they may be used for display applications and relationships between molecular structure and bulk LC properties are well understood. Nevertheless, no single liquid crystal molecule has been identified that satisfies *all* of the necessary technological requirements and modern LC systems are actually formulated from, typically, 10–20 molecular components that work together to create the final LC mixture. Each of these molecular components, referred to

as ‘dopants’, must also be stable under the operating conditions of the device and should provide a significant improvement in display performance. In addition, dopant species should not detrimentally affect the properties of the LC host phase to such an extent that it is unable to meet the five aforementioned demands for use in display technology.

LC materials used in modern AM displays must have an excellent electronic resistivity so that a constant voltage may be retained until the state of the pixel is refreshed by the control system, as measured by its voltage holding ratio (VHR). Before AM technology was developed, LC molecules bearing highly polarisable cyano groups were widely used in display devices due to their high dielectric anisotropies and chemical stabilities. However, the tendency of the cyano group to coordinate with ions from the fabric of the LC cells acts to lower the VHR of the device beyond the acceptable threshold for AM switching. Highly polar fluoroaromatic molecules have recently emerged as a solution to this problem as they form bulk systems of high dielectric anisotropy, which do not leech ions from the LC cell.

A highly important requirement of an LCD screen is that it must be of sufficiently fast response time that moving-image blurring is not problematic. The response time is defined as the length of time required to switch an LC cell on and then off again and dictates the maximum rate at which visual information can be displayed. The length of time required to switch the cell on is defined as the cell’s rise time, and primarily depends on the rotational viscosity, γ_1 , of the cell and the strength of the applied electric field, V_{on} , relative to the threshold voltage, V_{th} , required to disrupt the molecular order in the LC bulk material. The reverse switching process is defined as the cell’s decay time, a process determined by the rate at which the equilibrium structure of the LC phase is reformed after the removal of the electric field. Both parameters also depend on the cell gap, d , and the overall elasticity of the system, K [Equations 5–7].⁵

$$\tau_{\text{response}} = \tau_{\text{rise}} + \tau_{\text{decay}} \quad (5)$$

$$\tau_{\text{rise}} = \frac{\gamma_1 d^2}{\pi^2 K \left(\frac{V_{\text{on}}^2}{V_{\text{th}}^2} - 1 \right)} \quad (6)$$

$$\tau_{\text{decay}} = \frac{\gamma_1 d^2}{\pi^2 K} \quad (7)$$

Whilst the rise time of an LC cell may be improved by increasing the driving voltage applied to the system, this also has the undesirable effect of increasing power consumption and so reduces overall device efficiency. Shortening the LC cell gap is also a possibility for improving device performance although, to satisfy the Gooch-Tarry equation, this is limited by availability of LC hosts of sufficiently high birefringence [Equation 8].¹¹ If host materials of reduced birefringence are employed in cells which are too narrow, then device contrast and viewing angle are compromised.

$$T(u) = \frac{1}{2} \frac{\sin^2 \left(\frac{\pi}{2} \sqrt{1+u^2} \right)}{1+u^2} = 0; \quad u = 2d \frac{\Delta n}{\lambda} \quad (8)$$

Therefore, as the applied voltage and LC cell gap cannot be practically reduced, the threshold voltage, rotational viscosity and elasticity of an LC system are arguably the most important parameters to consider when fabricating fast response time LCD devices. To this end, there have been several recent reports concerning the doping of small quantities of nanoparticulate material into various commercial nematic hosts to improve their respective performance.¹²⁻¹⁵ Carbon nanotubes and inorganic $\text{Sn}_2\text{P}_2\text{S}_6$ nanoparticles have been found to be particularly effective at reducing overall LC threshold voltage by increasing the dielectric anisotropy of the host system [Equation 9].¹⁶⁻¹⁸

$$V_{\text{th}} = \pi \sqrt{\frac{K}{\epsilon_0 \Delta \epsilon}} \quad (9)$$

In this work, a similar doping strategy will be employed to improve the response times of commercially available liquid crystal mixtures. As discussed, the AM switching mode of modern LCD technology requires LC mixtures fabricated from high resistivity compounds and fluorinated organic molecules have been highlighted as suitable systems for this purpose. To aid with the understanding of our work, a discussion concerning the relevant aspects of organofluorine chemistry will be presented in the following section.

1.3. Aspects of Organofluorine Chemistry

1.3.1 Overview

This thesis is concerned with organic transformations of fluorinated aromatic systems by nucleophilic aromatic substitution and palladium-catalysed C–F bond activation processes. Presented in this section, therefore, is a review of the relevant aspects of the synthesis and corresponding reactivity profile of fluorinated aromatic systems.

Fluorine is estimated to be the 17th most abundant element on the planet yet surprisingly, there are relatively few naturally occurring molecules that contain C–F bonds. Thus, almost all fluorocarbons are man-made and further research will inevitably lead to the discovery of new and important products. C–F bonds are relatively short and highly ionic in nature and so it is not surprising that they are amongst the strongest in organic chemistry. The introduction of fluorine into an organic molecule can have a profound effect on its metabolic stability, lipophilicity, polarity and acidity and, consequently, fluorinated systems are widely employed for a diverse range of commercial applications.¹⁹

Economically, the most viable source of fluorine is from the mineral fluorspar, CaF₂, which is mixed with concentrated sulfuric acid to produce hydrogen fluoride and isolated in its anhydrous form by distillation. Anhydrous hydrogen fluoride is a highly corrosive substance that fumes in air, although with careful handling it may be used to synthesise fluorinated molecules upon direct reaction with organic systems, or by first converting it to fluorine gas or associated metal fluorides.²⁰

Elemental fluorine was first isolated in 1886 by Moissan and is a toxic and flammable gas with a pungent odour similar to that of chlorine. F₂ is a strong oxidising agent and is highly reactive towards nucleophilic attack due to the weak homonuclear F–F bond. Today, elemental fluorine is produced on an industrial scale by the electrolysis of hydrogen fluoride in the presence of potassium fluoride using methodology developed over a century earlier.²⁰

Metal fluorides are also commonly manufactured from anhydrous hydrogen fluoride and an appropriate metal hydroxide or metal carbonate species followed by the removal of water. Metal fluorides tend to be corrosive and very hygroscopic, although they are usually preferred for laboratory scale fluorinations as they are solid materials that are much easier to handle than either hydrogen fluoride or fluorine gas. Other common fluorinating agents include antimony pentafluoride and bromine, chlorine and cobalt trifluorides.¹⁹

1.3.2 Syntheses of Perfluorinated Aromatic Systems

1.3.2.1 Saturation-Rearomatisation Processes

The first reported synthesis of the parent fluoroaromatic derivative, hexafluorobenzene (**11**), was documented by McBee *et al.* in 1947 and involved a two step saturation/reductive-dehalogenation procedure from hexachlorobenzene (**10**). The first step of the reaction involves the addition of two equivalents of bromine trifluoride to the aromatic system to afford a halogenated cyclohexane, which is further fluorinated with one equivalent of antimony pentafluoride. The saturated system is then dehalogenated with elemental zinc in ethanol to afford the perfluoroaromatic system [Scheme 1].²¹

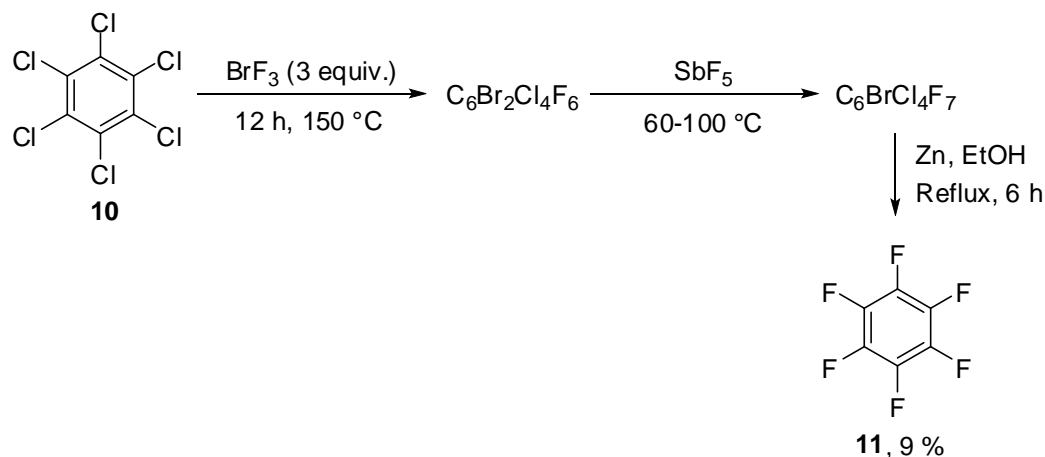
Scheme 1. First reported synthesis of hexafluorobenzene (**11**)²¹

The total yield of halogenated products was 53% based on starting hexachlorobenzene although a number of partially fluorinated and partially dehalogenated species were produced and the isolated yield of hexafluorobenzene was low.

Today, perfluorinated aromatic systems are usually synthesised by a two-step saturation-rearomatisation procedure, first reported in 1959²² and subsequently developed by Fowler,²³ in which an aromatic hydrocarbon is passed over cobalt trifluoride at elevated temperatures to generate a perfluorinated saturated system, which is then rearomatised by further heating over, typically, iron, iron (III) oxide or nickel [Scheme 2]. Once all of the cobalt trifluoride has been consumed, it can be regenerated by passing elemental fluorine gas through the reaction vessel.

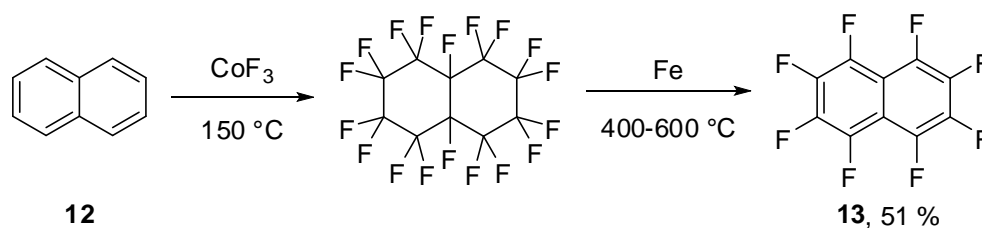
Scheme 2. First reported synthesis of perfluronaphthalene (**13**) from naphthalene (**12**)²²

1.3.2.2 Direct Replacement of Chlorine for Fluorine

Finger demonstrated that alkali metal fluorides are sufficiently reactive that they may be used to generate aromatic C–F bonds from polychlorinated starting materials.²⁴ Highly polar solvents were found to be advantageous for these fluorination reactions and it is

imperative that water is excluded from the reaction vessel so that the nucleophilicity of the fluoride ion is not reduced. As a representative example, in 1965, Fuller reported the successful fluorination of perchloronaphthalene (**14**) with potassium fluoride in sulfolane to afford the perfluorinated system (**13**) in moderate yield [Scheme 3].²⁵

Scheme 3. Synthesis of perfluoronaphthalene (**13**) from perchloronaphthalene (**14**)²⁵

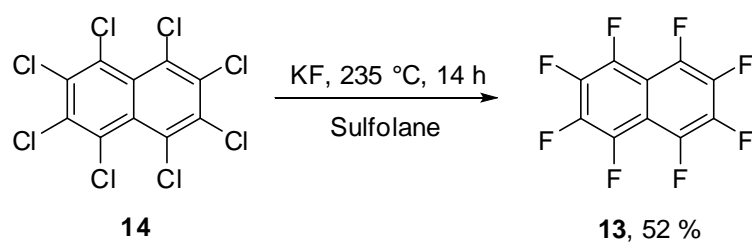

High pressure, solvent-free methodology has also been developed for the fluorination of polychlorinated aromatic and heterocyclic systems to afford, for example, hexafluorobenzene (**11**) and perfluoroquinoline (**16**) [Table 4].

Table 4. Fluorination of perchlorinated systems with potassium fluoride

| Substrate | Conditions | Product | Yield / % | Ref. |
|----------------------------------------------|----------------|----------------------------------------------|-----------|------|
| <p style="text-align: center;">10</p> | KF, 450-500 °C | <p style="text-align: center;">11</p> | 21 | [26] |
| <p style="text-align: center;">15</p> | KF, 470 °C | <p style="text-align: center;">16</p> | 71 | [27] |

The corresponding chlorinated materials for both heterocyclic and aromatic systems are usually synthesised in a two-step procedure in which partial chlorination is achieved with chlorine gas, followed by complete chlorination with phosphorus pentachloride at high temperatures [Scheme 4].²⁷

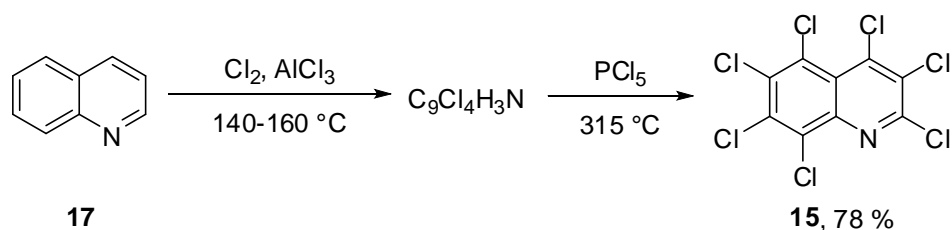
Scheme 4. Synthesis of heptachloroquinoline (**15**) from quinoline (**17**)²⁷

The fluorination reactions presented in this section represent the most commonly employed synthetic methodology for the synthesis of perfluorinated aromatic and heterocyclic molecules.

1.3.3 Reactivity Profile of Perfluorinated Aromatic Systems

A wide range of perfluorinated aromatic and heterocyclic materials are now commercially available and the chemistry of these systems continues to develop and has been reviewed.²⁸ In contrast to the electrophilic aromatic substitution reactivity profile displayed by conventional benzenoid systems, perfluoroaromatic derivatives are highly activated towards nucleophilic attack due to the presence of multiple electron withdrawing ring fluorine substituents.

The majority of reactions of perfluoroaromatic systems proceed by the two-step addition-elimination nucleophilic aromatic substitution ($\text{S}_{\text{N}}\text{Ar}$) mechanism. The first step of the reaction is rate determining and involves the breaking of the aromaticity of the fluoroaromatic ring and formation of the corresponding Meisenheimer intermediate. Aromaticity is rapidly regained as the Meisenheimer intermediate collapses *via* the ejection of fluoride *ipso* to the site of initial nucleophilic attack [Figure 2].¹⁹

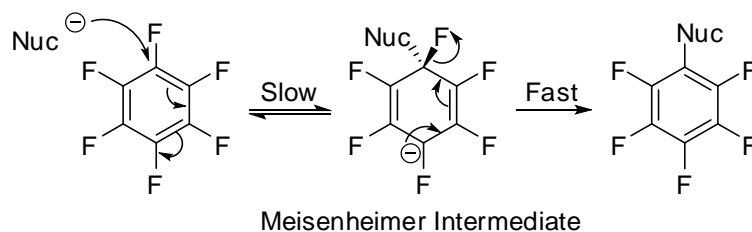
Figure 2. Mechanism of nucleophilic aromatic substitution¹⁹

As the first step is rate determining, the nature of the leaving group does not affect the overall rate of reaction, which instead depends on the electrophilicity of the aromatic

ring and the electronic stabilisation of the Meisenheimer intermediate. Thus, highly fluorinated systems are observed to be more reactive towards S_NAr processes than their chlorinated or brominated counterparts, despite the requirement that, overall, a much stronger C–F bond must be cleaved.

In general, additional ring fluorine substituents positioned *ortho* and *meta* to the site of nucleophilic attack are found to increase the rates of typical S_NAr reactions of fluoroaromatic systems, whilst fluorine located *para* to the site of substitution is found to be slightly deactivating, with respect to ring hydrogen in the same position [Table 5].²⁹

Table 5. Relative activating effects of *ortho*, *meta* and *para* fluorine substituents for S_NAr reactions of polyfluorobenzene derivatives with sodium methoxide.²⁹

| Fluorine Position | k_F/k_H |
|-------------------|-----------|
| <i>Ortho</i> | 57 |
| <i>Meta</i> | 106 |
| <i>Para</i> | 0.43 |

These data may be rationalised by dividing the relative activating effects of additional fluorine substituents into two components; the increase in the electrophilicity of the initial state and the stabilisation of the negative charge of the Meisenheimer intermediate.

In the initial state, a fluorine atom can be expected to remove electron density from proximal carbon atoms of the aromatic system, thereby increasing the attractive electrostatic interactions between the ring and an incoming nucleophile. In this respect, fluorine substituents *ortho* to the site of nucleophilic attack are highly activating, whilst those positioned further away are less influential [Figure 3].

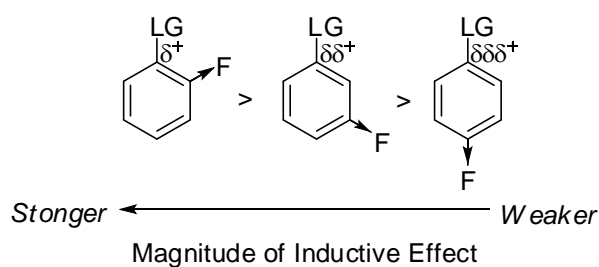
Figure 3. Initial state activation by additional ring fluorine substituents

In the Meisenheimer intermediate, the formal negative charge may be delocalised on to the three carbon atoms *ortho* and *para* to the site of initial substitution [Figure 4]. Fluorine substituents positioned β - to this negative charge and, therefore, *meta* to the site of nucleophilic attack, are strongly inductively stabilising and reduce the activation energy for typical S_NAr processes.

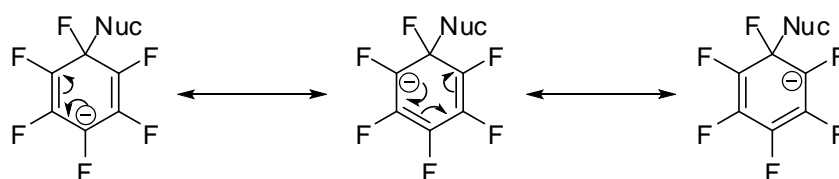
Figure 4. Canonical structures of a typical Meisenheimer intermediate

Interestingly, a fluorine atom positioned α - to the negative charge is overall destabilising due to electrostatic repulsions between the negative charge of the sp^2 hybridised carbon atom and the non-bonding p-electrons of the fluorine substituent. The short length of the C–F bond and excellent degree of orbital overlap are primarily responsible for these unfavourable interactions [Figure 5].

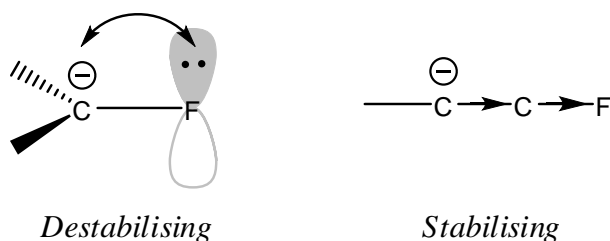
Figure 5. Electrostatic interactions of fluorine α - and β - to a negative charge

Even though *ortho* fluorine substituents are expected to destabilise the Meisenheimer intermediate, their powerful activation of the initial state dominates and the net result is strongly activating. For S_NAr reactions of polyfluorinated systems, the activating effects

of multiple fluorine atoms are compounded and, as a general rule, it is found that an incoming nucleophile will react preferentially at the C–F bond activated by the greatest number of *ortho* and *meta* ring fluorine substituents.

1.3.3.1 S_NAr Reactions of Perfluoroaromatic Systems

In this review, perfluoroaromatic systems are regarded as those in which all the aromatic C–H bonds have been replaced by C–F bonds, the simplest of which is hexafluorobenzene. S_NAr reactions of this substrate are well documented and a selection of relevant and literature examples have been selected for further discussion [Table 6].

Table 6. Representative S_NAr reactions of hexafluorobenzene (**11**)

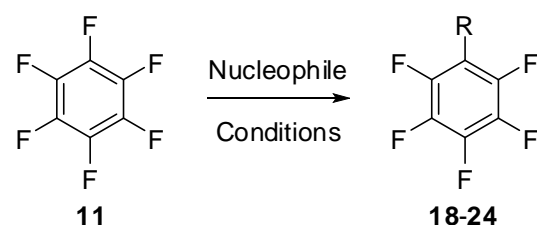

| R | Conditions | Product (Yield / %) | Ref. |
|------------------|---------------------------------------------------|---------------------|------|
| H | LiAlH ₄ , Diethyl ether, reflux, 8 h | 18 (61) | [30] |
| Ph | PhLi, Diethyl ether, rt, 24 h | 19 (17) | [30] |
| Ph | PhMgBr, THF, reflux, 11 h | 19 (7) | [31] |
| Et | EtMgBr, THF, rt, 23 h | 20 (56) | [31] |
| NMe ₂ | Me ₂ NH, H ₂ O, 235 °C, 2 h | 21 (65) | [30] |
| OPh | PhOK, DMF, 120 °C, 30 mins | 22 (31) | [30] |
| OEt | EtOK, EtOH, reflux, 1 h | 23 (56) | [32] |
| SH | NaSH, Pyridine, reflux, 5 mins | 24 (66) | [33] |

The symmetrical structure of hexafluorobenzene means that there are no regioselectivity issues concerning the first nucleophilic substitution, and these representative S_NAr reactions indicate how a broad range of substituted pentafluorobenzene derivatives may be produced in a single synthetic step.

Reaction of lithium aluminium hydride with hexafluorobenzene is a useful process for accessing pentafluorobenzene, in good yield. It should be noted that although early arylation and alkylation reactions of hexafluorobenzene with phenyllithium and

phenylmagnesium bromide were low yielding, more recent synthetic investigations have demonstrated a range of similar, more efficient C–C bond forming processes.^{34,35}

Occasionally, some disubstituted product is isolated in S_NAr reactions of hexafluorobenzene, especially when the newly incorporated functional group is actually more activating than fluorine itself. This process is exemplified by the reaction of equimolar quantities of sodium thiomethoxide with an excess of hexafluorobenzene (**11**), which results in approximately equal quantities of the respective mono- and di-substituted adducts (**25** and **26**) [Scheme 5].³⁶

Scheme 5. Reaction of hexafluorobenzene (**11**) with sodium thiomethoxide³⁶

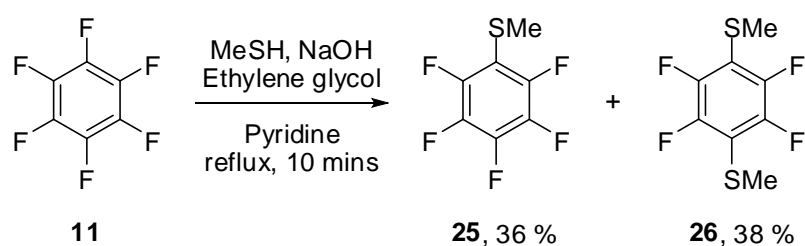

1.3.3.2 S_NAr Reactions of Pentafluorobenzene Derivatives

Pentafluorobenzene derivatives, synthesised by S_NAr reactions of hexafluorobenzene, remain highly activated to further nucleophilic substitution processes because of the presence of multiple electron withdrawing fluorine atoms on the aromatic ring. Indeed, pentafluorobenzene itself is actually found to be more reactive than hexafluorobenzene due to the removal of a deactivating *para* fluorine substituent and S_NAr reactions of this system have been thoroughly studied [Table 7].

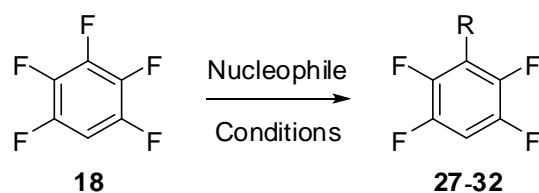
Table 7. Representative S_NAr reactions of pentafluorobenzene (**18**)

| R | Conditions | Product (Yield / %) | Ref. |
|-------------------------------|---------------------------------------------------------------------------------------|------------------------|------|
| NH ₂ | NH ₃ , H ₂ O, EtOH, 167 °C, 18 h | 27 (64) | [37] |
| N(Ph)H | PhNHLi, THF/aniline, 90 °C, 30 mins | 28 (89) | [38] |
| N(Ph)Me | LiNH ₂ / <i>N</i> -methylaniline, rt, 1 h | 29 (50) | [38] |
| N ₂ H ₃ | N ₂ H ₄ ·H ₂ O, H ₂ O, EtOH, reflux, 75 h | 30 (63) | [37] |
| NHOH | NH ₂ OH·HCl, NEt ₃ , dioxane, 110 °C, 2 h | 31 (70) | [39] |
| SPh | PhSK, pyridine, reflux, 10 mins | 32 (57) | [33] |

It is worth commenting that most organolithium and Grignard reagents are not usually compatible with polyfluorinated systems bearing relatively acidic ring hydrogen atoms as metallation of the aromatic system tends to occur in preference to nucleophilic substitution.³¹ However, S_NAr reactions of pentafluorophenyl lithium with pentafluorobenzene are successful as any lithium-proton exchange between the two reactants just affords one equivalent pentafluorophenyl lithium and pentafluorobenzene.⁴⁰

Unlike hexafluorobenzene, pentafluorobenzene derivatives have three chemically inequivalent C–F bonds at which nucleophilic attack may occur. In the vast majority of cases, nucleophilic substitution transpires preferentially at the site *para* to the substituent, as this is the site activated by the greatest number of activating *ortho* and *meta* fluorine atoms [Table 8].

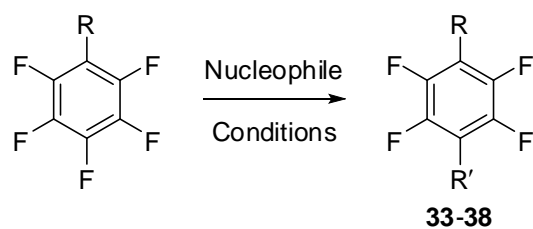
Table 8. Representative S_NAr reactions of substituted pentafluorobenzene derivatives

| R | R' | Conditions | Product (Yield / %) | Ref. |
|-------------------------------|---------------------------------|-----------------------------------------------------|------------------------|------|
| Me | MeO | NaOMe, MeOH, reflux, 72 h | 33 (55) | [41] |
| CF ₃ | SPh | KSPH, pyridine, reflux, 5 mins | 34 (46) | [42] |
| C ₆ F ₅ | C ₂ H ₅ | EtMgBr, THF, 0 °C–rt, 30 mins | 35 (56) | [43] |
| Ph | SH | NaSH, DMF, 110 °C, 5 mins | 36 (63) | [44] |
| CN | C ₆ F ₅ O | C ₆ F ₅ ONa, acetone, rt, 3 d | 37 (82) | [45] |
| Br | NH ₂ | NH ₄ OH, 200 °C, 2 h | 38 (77) | [30] |

The electronic properties of the substituent do not significantly influence the outcome of typical S_NAr reactions as the combined activating effects of the pendant fluorine atoms tend to dominate. There are, however, several conditions under which a significant variation from total selectivity *para* to the substituent is observed.

Firstly, S_NAr reactions of pentafluoroaniline with ammonia, primary and secondary amines and alkoxide nucleophiles are found to occur predominantly *meta* to the ring amino group. Corresponding reactions of pentafluoro-*N*-methylaniline afford approximately equal quantities of *meta*- and *para*-substituted derivatives while almost exclusive *para* substitution is observed for reactions of pentafluoro-*N,N*-dimethylaniline. It is believed that mesomeric donation of electron density from the amino group into the aromatic ring strongly deactivates the *ortho* and *para* sites towards nucleophilic attack. The dimethylamino group of pentafluoro-*N,N*-dimethylaniline is much larger and is forced to twist perpendicular to the ring, meaning the lone-pair can no longer conjugate with the system and so cannot effectively deactivate the *ortho* and *para* sites [Table 9].⁴⁶

Table 9. Representative S_NAr reactions of pentafluoroaniline, pentafluoro-*N*-methylaniline and pentafluoro-*N,N*-dimethylaniline⁴⁶

| Isomer Distribution / % | | | | |
|-------------------------|--------------------|----------|----------|----------|
| Substrate | Nucleophile | <i>o</i> | <i>m</i> | <i>p</i> |
| | NH ₃ | 0 | 87 | 13 |
| | MeNH ₂ | 0 | 88 | 12 |
| | Me ₂ NH | 0 | 90 | 10 |
| | NaOMe | 5 | 79 | 16 |
| | NH ₃ | 0 | 40 | 60 |
| | MeNH ₂ | 0 | 60 | 40 |
| | Me ₂ NH | 0 | 52 | 48 |
| | NaOMe | 5 | 43 | 52 |
| | NH ₃ | 0 | 7 | 93 |
| | MeNH ₂ | 0 | 6 | 94 |
| | Me ₂ NH | 3 | 5 | 92 |
| | NaOMe | 1 | 2 | 97 |

Similarly, reaction of excess potassium hydroxide with pentafluorophenol (**39**) results in the formation of the *meta*-substituted diol (**40**), although this time it is an oxyanion, rather than a nitrogen lone-pair, which strongly deactivates the *ortho* and *para* sites [Scheme 6].⁴¹

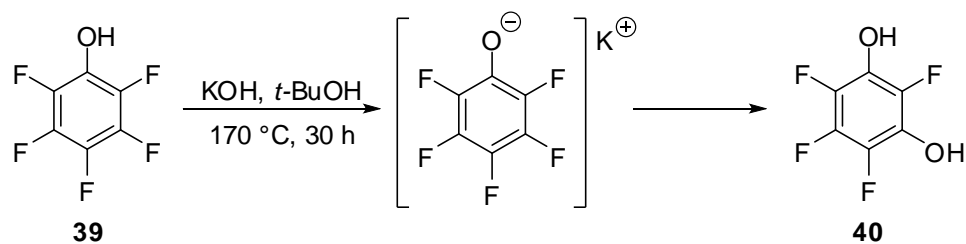
Scheme 6. Reaction of excess potassium hydroxide with pentafluorophenol (**39**)

Increased *ortho* functionalisation is frequently observed in S_NAr reactions of substituted pentafluorobenzene derivatives bearing substituents capable of providing significant directing interactions with an approaching nucleophile. Classic examples include S_NAr reactions of pentafluoronitrobenzene⁴⁷ (**41**) and pentafluorobenzaldehyde⁴⁸ (**43**) [Scheme 7].

Scheme 7. Representative examples of directed S_NAr reactions of pentafluoronitrobenzene (**41**) and pentafluorobenzaldehyde (**43**)

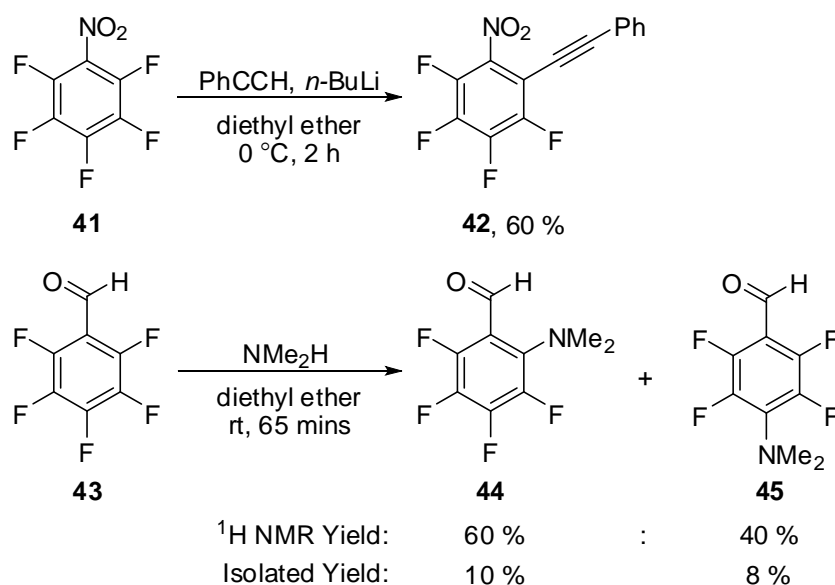

The extent of *ortho* substitution is highly solvent dependant as polar solvents tend to disrupt electrostatic nucleophile-electrophile interactions and, therefore, reduce the quantity of *ortho*-functionalised product. This effect is obvious in documented amination reactions of pentafluoronitrobenzene (**41**), whereby the proportion of *ortho*-*para* substitution is determined by the polarity of the reaction medium [Scheme 8].⁴⁹

Scheme 8. Amination reactions of pentafluoronitrobenzene (**41**) in benzene and nitromethane

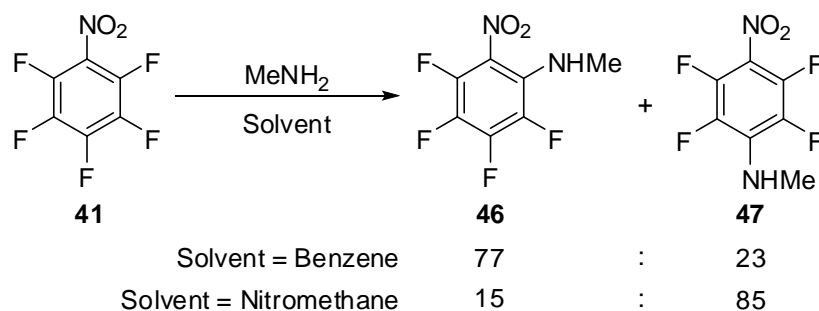

When designing synthetic routes to new, fluorinated systems from highly fluorinated aromatic substrates it is necessary to consider how the presence of additional fluorine substituents and any additional directing groups and the polarity of the solvent are likely to affect the structure of the product. In general, however, S_NAr reactions of highly fluorinated systems in polar solvents can be expected to yield the product arising from preferential nucleophilic attack at the site activated by the greatest number of *ortho* and *meta* fluorine substituents, irrespective of any additional functionality.

1.3.3.3 S_NAr Reactions of Tetrafluorobenzene Systems

Nucleophilic aromatic substitution reactions of less electrophilic tetrafluorobenzene derivatives (**49**, **52** and **55**) are rarer than those of penta- and hexafluorobenzene and often require harsh reaction conditions and highly nucleophilic reagents. 1,2,4,5-Tetrafluorobenzene (**55**) is the least reactive isomer of the series as nucleophilic substitution is only possible at a site activated by just two, rather than three ring fluorine substituents [Scheme 9].

Scheme 9. Methoxy- and amino-defluorination reactions of tetrafluorobenzene derivatives (**49**, **52** and **55**)

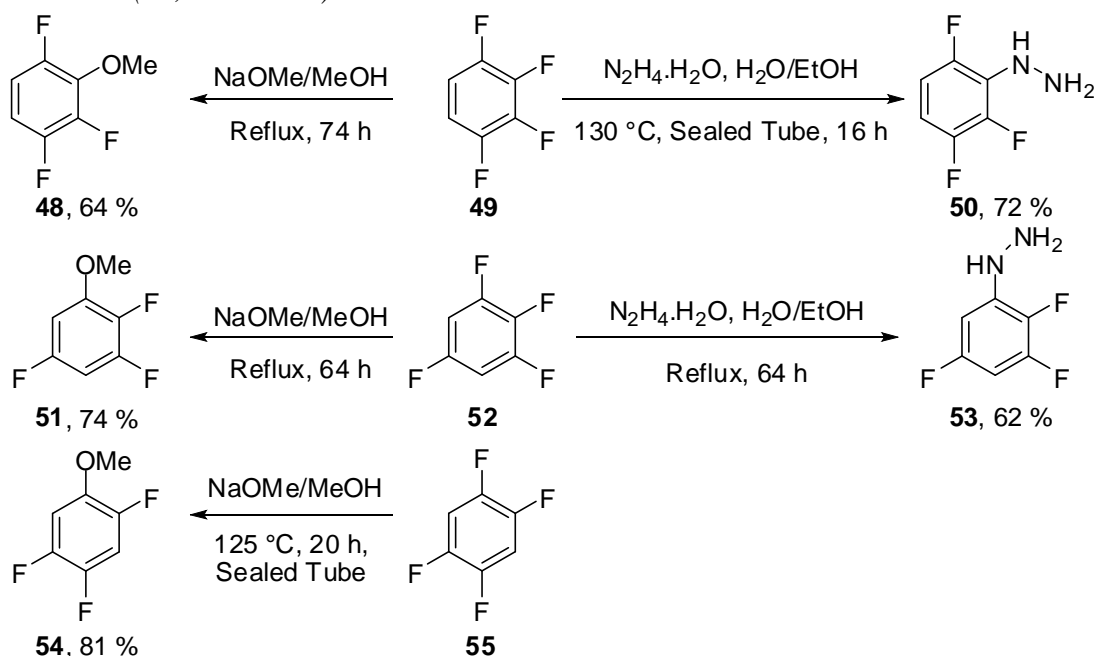

More recently, polysubstitution reactions of the tetrafluorobenzene systems were demonstrated with highly reactive sodium pyrazol-1-ide⁵⁰ and various sulfur⁵¹⁻⁵³ nucleophiles and only small quantities of the monosubstituted adducts were observed as

the products of initial nucleophilic aromatic substitution are more electrophilic than the corresponding starting material [Scheme 10].

Scheme 10. Representative S_NAr polysubstitution reactions of tetrafluorobenzene derivatives (**49**, **52** and **55**) with nitrogen⁵⁰ and sulfur^{52,53} nucleophiles

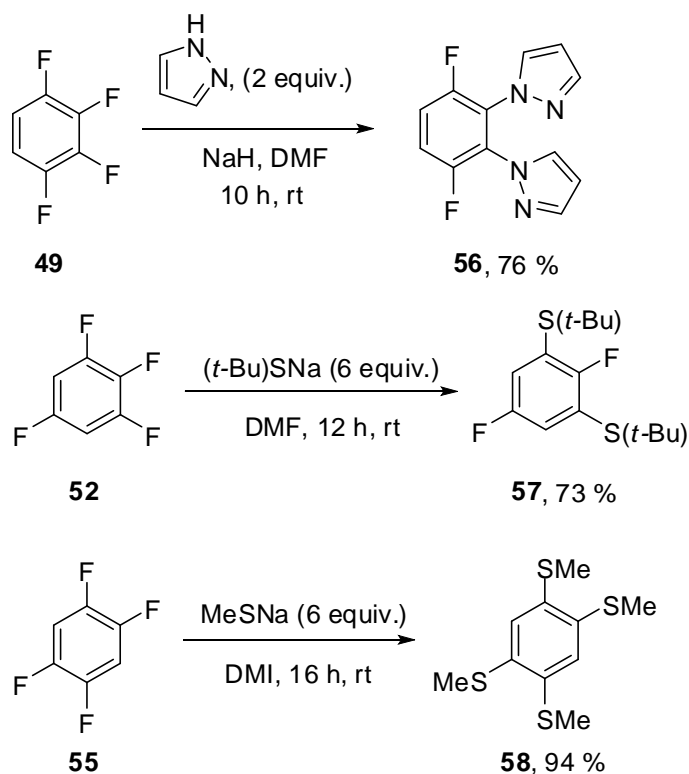

In the majority of cases, highly polar solvents are required to affect S_NAr reactions of less fluorinated systems to assist with the stabilisation of the corresponding Meisenheimer intermediate.

In 2004, a series of annulation reactions of 1,2,4,5-tetrafluorobenzene (**55**) with aromatic 1,2-diol nucleophiles were demonstrated in the syntheses of several annulated dioxins [Scheme 11].⁵⁴

Scheme 11. Representative synthesis of an annulated dioxin derivative (**59**) from 1,2,4,5-tetrafluorobenzene (**55**) and 2,3-dihydrobenzo[*b*][1,4]dioxine-6,7-diol

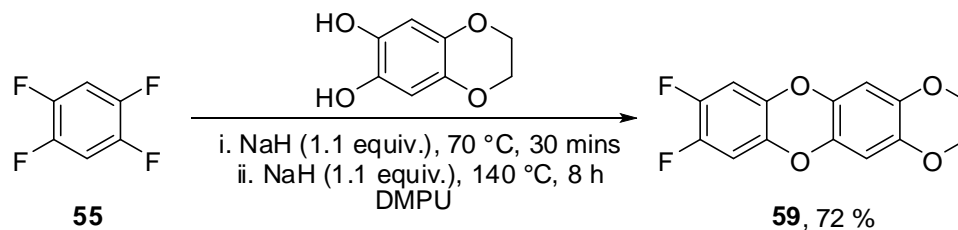

The second, ring-closing step required prolonged heating at elevated temperatures and a second equivalent of sodium hydride to further activate the phenolic hydroxyl group.

1.3.3.4 S_NAr Reactions of Tri- and Di-fluorobenzene Systems

Direct S_NAr reactions of unfunctionalised tri- and di-fluorobenzene systems are very rare indeed and most of the available literature regarding corresponding monosubstitution reactions is presented by Iino,⁵⁵ Orjales⁵⁶ and Kowalczyk⁵⁷ although several additional examples involving reactions of alkoxide nucleophiles with 1,2- and 1,3-difluorobenzene in highly polar solvents have also been published.⁵⁸⁻⁶²

The work of Iino and Orjales is concerned with the production of biologically active materials and a key synthetic step in each procedure was the deprotonation and subsequent S_NAr reaction of a hydroxyl group with the corresponding fluorobenzene derivative. 1,2,4-Trifluorobenzene (**60**) was the only system studied for which there is a choice of sites at which nucleophilic attack may occur, with preferential substitution at the 2-position being observed as this is the site activated by the greatest number of *ortho* and *meta* ring fluorine substituents [Scheme 12].

Scheme 12. Representative S_NAr reactions of some di- and tri-fluorobenzene derivatives^{55,56}

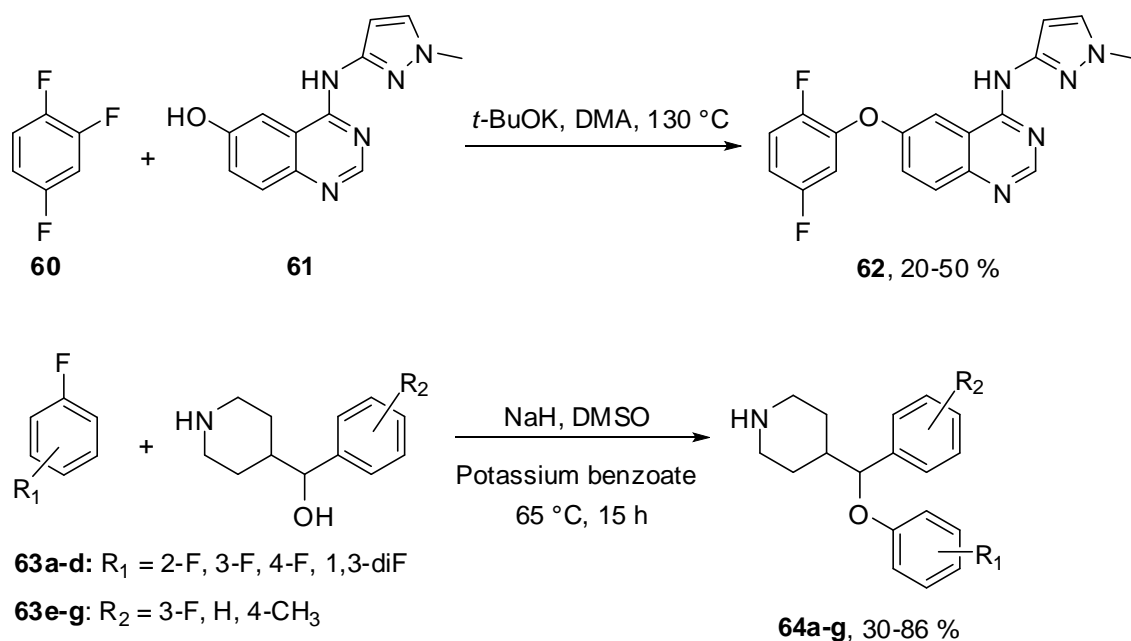

Kowalczyk studied reactions of 1,2,3-trifluorobenzene (**66**) with some stabilised enolates and the formation of a mixture of substitution products corresponding to nucleophilic attack at both the 1- and 2-positions of the starting material were observed. The corresponding reaction of 1,2,4-trifluorobenzene (**60**) resulted in exclusive replacement of the fluorine atom at the 2-position, in agreement with the work of Iino and Orjales [Scheme 13].

Scheme 13. Reactions of 1,2,4-trifluorobenzene (**60**) and 1,2,3-trifluorobenzene (**66**) with a stabilised enolate salt⁵⁷

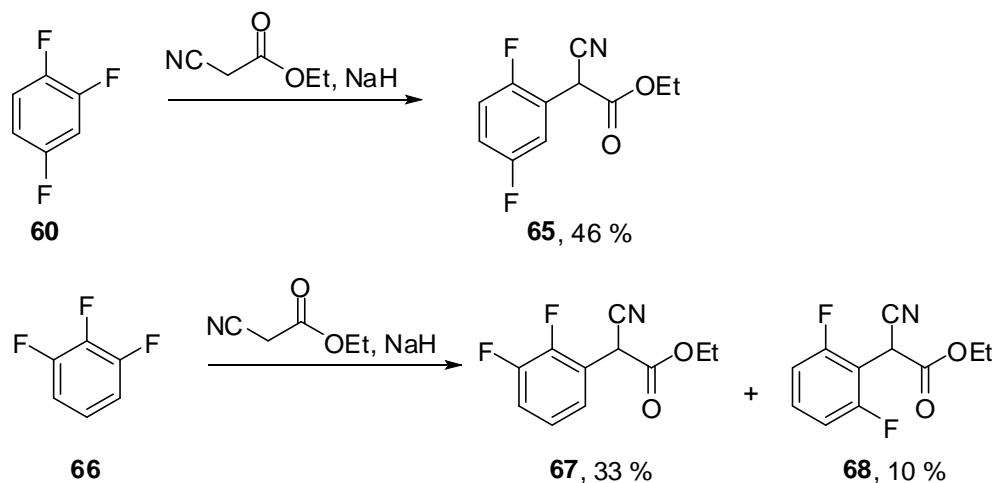

Complete substitution reactions in which all ring fluorine atoms are replaced by sodium pyrazolide, under the aforementioned conditions of Ivashchuk and Sorokin,⁵⁰ or with a variety of sulfur nucleophiles^{53,63,64} have also been demonstrated [Scheme 14].

Scheme 14. Representative reactions of 1,2-difluorobenzene (**69**) and 1,3,5-trifluorobenzene (**71**) with sodium pyrazolide and sodium 2-methylpropane-2-thiolate⁵³

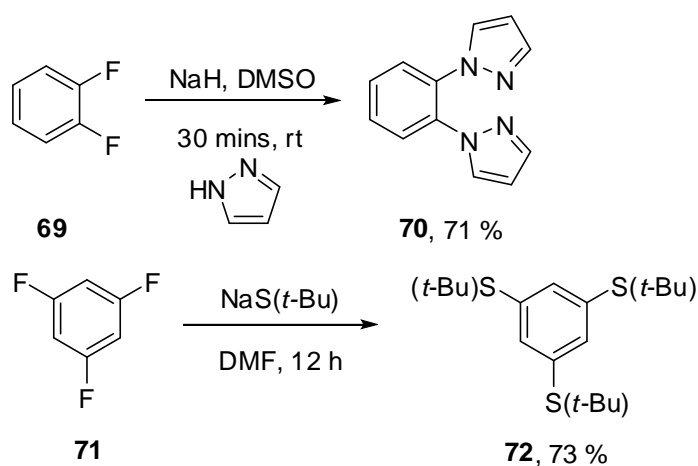

1.4 C–F Bond Activation

Highly fluorinated aromatic systems may be functionalised by S_NAr processes whereby the presence of multiple electronegative fluorine substituents acts to increase the overall electrophilicity of the aromatic ring. Several reactions of hexafluorobenzene and various perfluorinated heterocyclic systems with organolithium and Grignard reagents have been demonstrated and provide a direct method for the formation of carbon-carbon (C–C) bonds to afford a range of polyfluorinated materials [Table 6].

Corresponding reactions of polyfluorinated systems such as pentafluorobenzene (**18**), which possess a relatively acid ring hydrogen substituent, tend to undergo proton transfer from the aromatic substrate to the organometallic coupling reagent to generate an anionic system (**73**), which may be trapped with a suitable electrophile [Scheme 15].³¹

Scheme 15. Synthesis of pentafluorobenzoic acid (**74**) by reaction of ethyl magnesium bromide with pentafluorobenzene (**18**) and subsequent trapping with carbon dioxide³¹

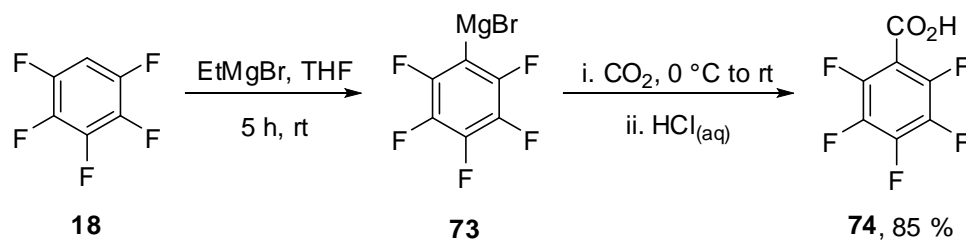

Another, very useful and more general method for the formation of C–C bonds from aryl systems involves metal-catalysed cross-coupling reactions of aryl halides with alkyl or aryl boronic acids in Suzuki-Miyaura processes. Typically, aryl iodides and bromides are used as the electrophilic coupling partner in these reactions as oxidative addition of the metal catalyst into the relatively weak carbon-halogen bond is straightforward. Corresponding reactions of aryl chlorides are less common due to the increased strength of the C–Cl bond, although there have been significant developments in this field concerning metal complexes bearing N-heterocyclic carbene ligands and bulky, electron-donating monodentate phosphine ligands.⁶⁵

Nevertheless, metal-mediated C–F bond activation remains a significant challenge due to the very high strength of the C–F bond and research into developing this area of chemistry further has been intensifying over the last decade.⁶⁶⁻⁶⁸ Upon searching the chemical literature, however, it is apparent that most publications are concerned with either stoichiometric C–F activation, in which equimolar quantities of metal catalyst are required, or which represent catalytic functionalisation reactions of monofluorinated aromatic systems to yield non-fluorinated products. Thus, further studies into catalytic C–F activation reactions of polyfluorinated aromatics materials are required. Presented in this section is a discussion concerning relevant aspects of metal-mediated aromatic C–F bond activation with a particular focus on catalytic C–C bond forming reactions.

1.4.1 Catalytic C–F Bond Activation

Very few reports concerning either stoichiometric or catalytic C–F bond activation have so far been published and, as mentioned previously, most of the available literature

describes the activation and subsequent functionalisation reactions of monofluorinated aromatic systems.

1.4.1.1 Catalytic C–F Bond Activation with Palladium

The first report of palladium-catalysed C–F activation was published in 1999 by Widdowson in which a range of fluoroarenetricarbonylchromium(0) complexes were observed to undergo successful Suzuki-Miyaura type coupling reactions with several substituted boronic acids in moderate to good yield [Scheme 16].⁶⁹

Scheme 16. Representative Suzuki reactions of fluoroarenetricarbonylchromium(0) (**75**) and 4-(fluoromethoxybenzene)tricarbonylchromium(0) (**77**)

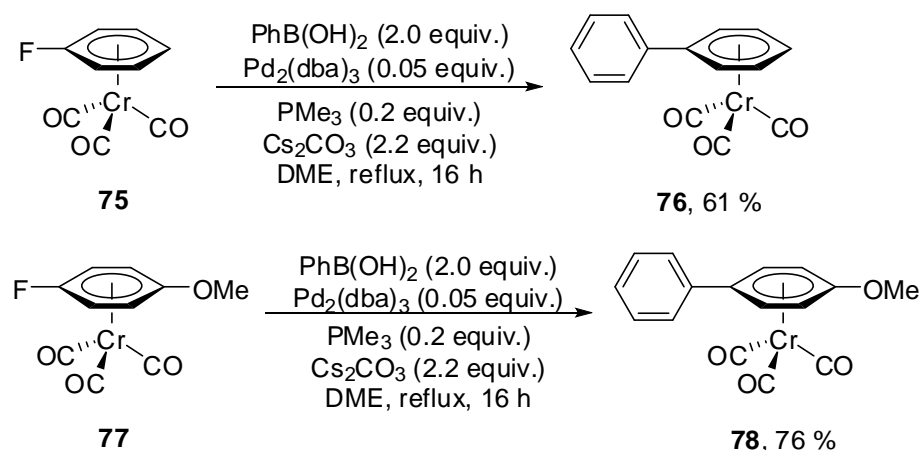

The coordination of the fluoroaromatic ring to the chromium centre was crucial to the success of the coupling procedure, although no further mechanistic information was deduced. The following year, Widdowson reported several additional C–F activation reactions of the same fluoroarenetricarbonylchromium(0) complexes with a range of boronic acids bearing electron-donating and electron-withdrawing substituents in comparable yields to those of his original publication.⁷⁰ Particularly interesting was the unprecedented activation of a C–F bond in the presence of a weaker C–Cl bond, although the latter was positioned on the boronic acid rather than the coordinated fluoroaromatic system [Scheme 17].

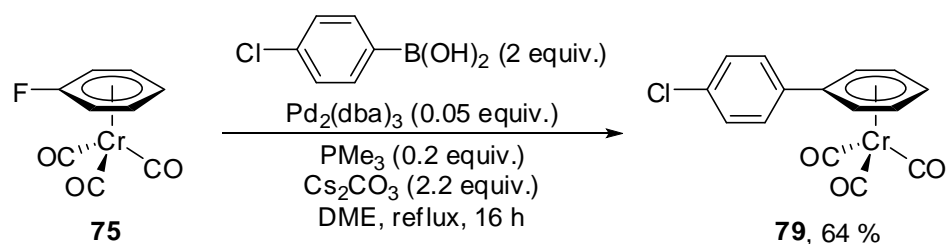
Scheme 17. Preferential C–F activation in the presence of a weaker C–Cl bond

The nature of the oxidative addition step remains unknown although the authors suggest two possible mechanistic pathways: a single-step concerted oxidative addition of the palladium catalyst into the C–F bond; or an addition-elimination process in which the palladium centre acts as a nucleophile to generate an anionic intermediate, which subsequently ejects a fluoride ion as the aromaticity of the ring is recovered [Figure 18].

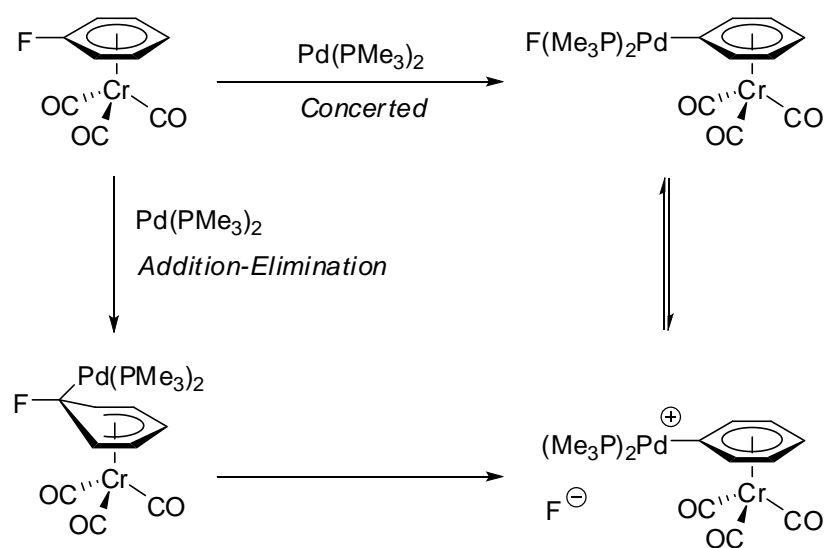
Figure 18. Proposed mechanistic pathways for the oxidative addition of the palladium into catalyst into the C–F bond of fluorobenzenechromium(0) systems

The same group also presented several analogous Stille type coupling reactions with vinyltributylstannane to afford a series of chromium-complexed styrene derivatives, although isolated yields were, on average, slightly reduced relative to the corresponding Suzuki processes [Scheme 19].

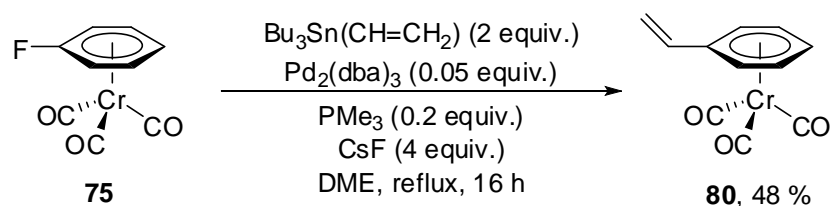
Scheme 19. Representative palladium-catalysed Stille coupling involving a C–F bond

It is noteworthy that no attempt was made to separate any of the coupled organic systems from the coordination sphere of their respective chromium centre.

The first successful examples of palladium-catalysed C–F activation reactions of non-coordinated fluoroaromatic systems were simultaneously reported by the groups of Yu⁷¹ and Widdowson⁷² in 2003. Yu's studies began with the elucidation of a successful palladium-catalysed amination protocol for 2-fluoronitrobenzene (**81**) with 4-*tert*-butylaniline (**82**) and, following initial screening procedures, $\text{Pd}(\text{PPh}_3)_4$ and Cs_2CO_3 were identified as a particularly effective catalyst-base combination for the coupling reactions [Scheme 20].

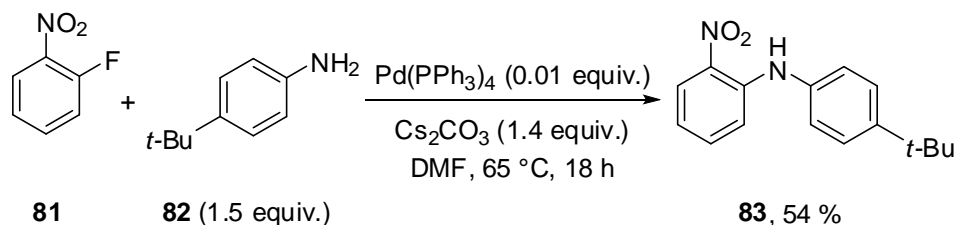
Scheme 20. Representative palladium-catalysed amination of 2-fluoronitrobenzene (**81**) with 4-*tert*-butylaniline (**82**)

In the absence of any palladium catalyst, the competing nucleophilic aromatic substitution reaction was observed to be very slow under the same reaction conditions and afforded no more than 7% of target material (**83**) after 24 hours of heating, confirming the active role of the catalyst.

Yu subsequently extended this methodology to corresponding Stille and Suzuki cross-coupling reactions of several monofluoronitrobenzene derivatives, which needed to be activated by an additional electron-withdrawing substituent located *para* to the nitro group [Scheme 21].

Scheme 21. Representative Stille and Suzuki reactions of two functionalised monofluoroaromatic systems (**84** and **86**) under the conditions of Yu

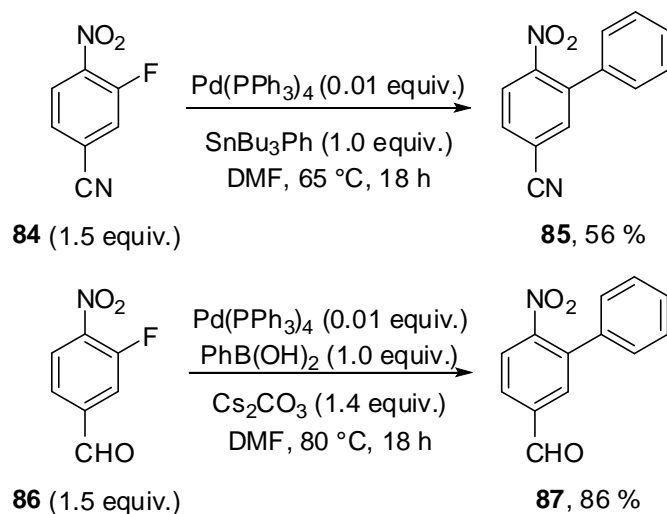

Similarly, Widdowson also described several palladium-catalysed cross-coupling reactions of highly electrophilic monofluoronitrobenzene systems and, crucially, it was discovered that the nitro group must be positioned *ortho* to the ring fluorine substituent in order for the arylation procedure to be successful [Scheme 22].⁷²

Scheme 22. Representative palladium-catalysed Suzuki reactions of functionalised monofluoronitrobenzene systems (**83**, **85** and **87**) under the conditions of Widdowson

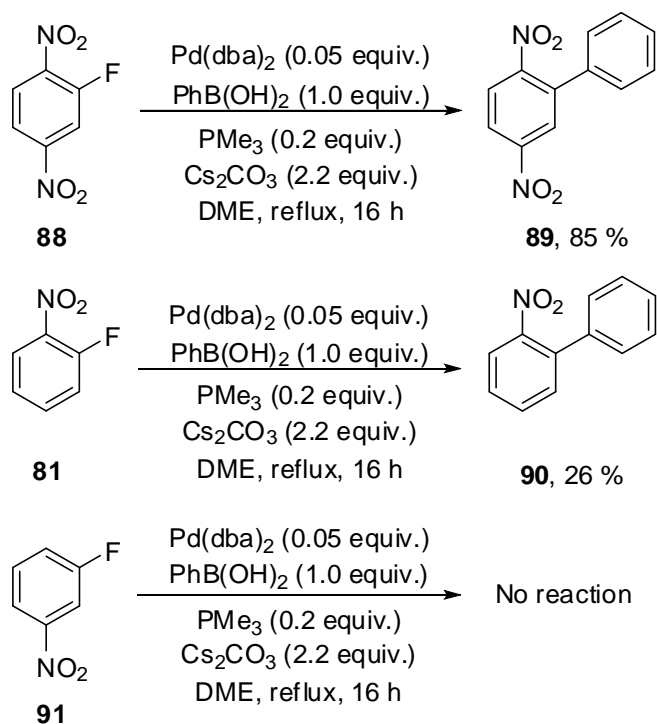

Rzepa, in collaboration with Widdowson, began to probe the mechanistic aspects of the aforementioned coupling reactions by conducting a series of *ab initio* calculations, which were targeted at understanding the apparently decisive role of the *ortho* nitro substituent. Their calculations revealed that, in addition to its strong electron-withdrawing properties, the nitro group is able to strongly coordinate to the incoming palladium centre through one of its pendant oxygen atoms. This directing interaction acts to significantly reduce the overall activation energy required for oxidative addition of the palladium-catalyst into the strong C–F bond and explains why both the ring nitro and fluorine substituents must be located mutually *ortho* to one another.

Rzepa also comments that the oxidative addition step may occur by either a conventional concerted process or by a stepwise addition-elimination mechanism similar to that of a typical S_NAr process, although neither Yu nor Widdowson were able to confidently ascertain which mechanistic pathway is correct for their respective coupling procedures [Figure 23].

Figure 23. Plausible mechanistic pathways for oxidative addition of the palladium catalyst into the C–F bond of fluorinated nitrobenzene derivatives

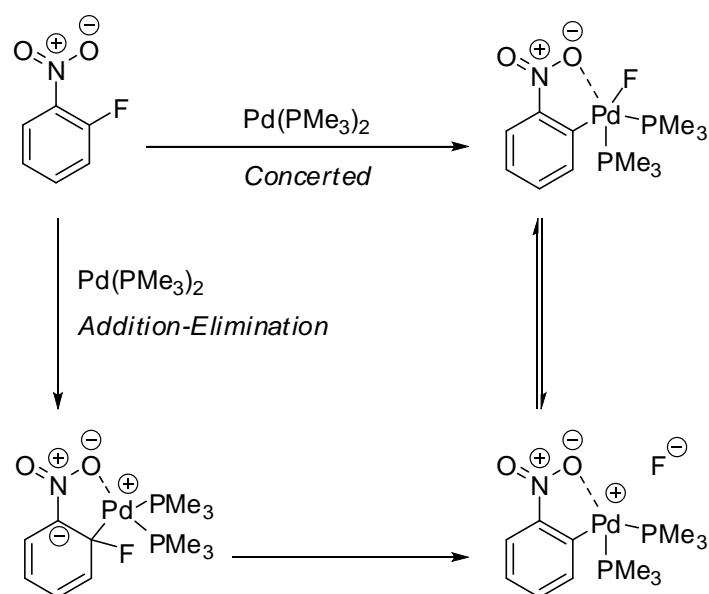

Yu also published a second, collaborative theoretical paper which studied how the activation energy for oxidative addition of a palladium catalyst into the C–F bond of a monofluoroaromatic substrate is affected by the presence of a number of additional electron withdrawing substituents.⁷³ In agreement with Rzepa's calculations, a nitro

group located *ortho* to the fluorine substituent was found to significantly reduce the activation energy for oxidative addition, although the placement of cyano, aldehyde and methyl ester groups at the same position were found to be largely ineffectual. Furthermore, their study revealed that the carboxylate group was another potentially very highly activating substituent as it may also coordinate strongly to an approaching palladium centre. This prediction was confirmed experimentally in corresponding Stille and Suzuki reactions of 2-fluoro-4-nitrobenzoic acid (**92**), albeit in reduced yield with respect to analogous nitro-mediated processes [Scheme 24].

Scheme 24. Suzuki and Stille reactions of 2-fluoro-4-nitrobenzoic acid (**92**)

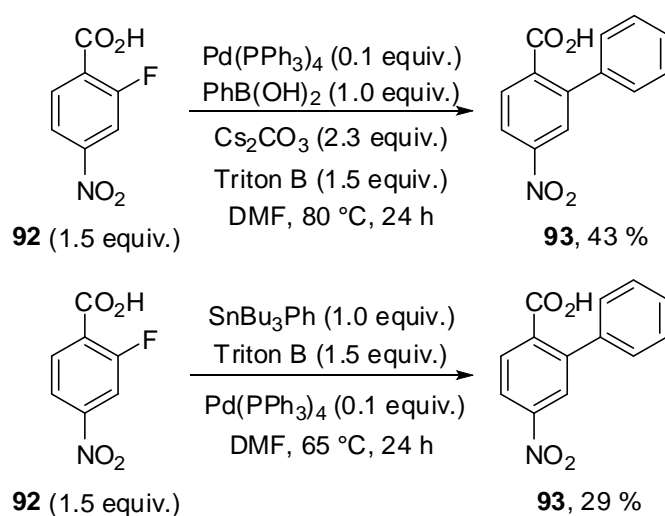

In 2004 Mikami extended the synthetic work of Yu and Widdowson by using a chiral cationic palladium (II) catalyst and described a highly efficient Suzuki coupling reaction of 1-fluoro-2,4-dinitrobenzene (**94**) with phenylboronic acid, although no further mechanistic details were provided [Scheme 25].⁷⁴

Scheme 25. Suzuki reaction of 1-fluoro-2,4-dinitrobenzene (**94**) with phenylboronic acid under the conditions of Mikami

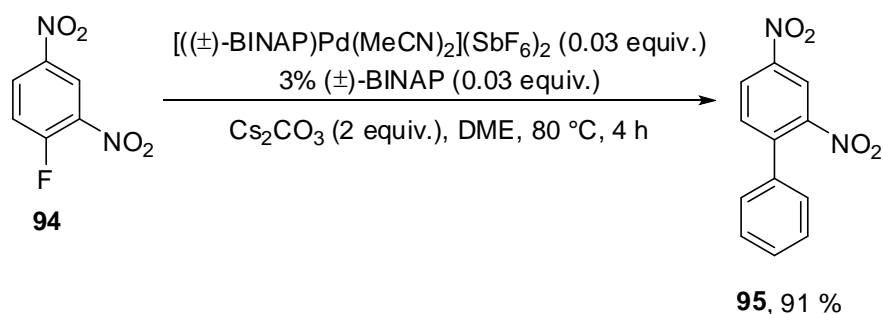

Palladium-catalysed cross-coupling reactions of fluorinated aromatic or heterocyclic systems which do not bear an additional directing group are very rare indeed, although in 2006 Braun reported catalytic hydrodefluorination and Stille reactions of pentafluoropyridine. Key to the success of these processes was the identification of *trans*-[PdF(4-C₅NF₄)(P(*i*-Pr)₃)₂] (**97**) as an active catalyst, which was pre-synthesised in good yield by the oxidative addition of a stoichiometric quantity of Pd(P(*i*-Pr)₃)₂ into pentafluoropyridine (**96**) [Scheme 26].⁷⁵

Scheme 26. Catalyst synthesis and hydrodefluorination and Stille reactions of pentafluoropyridine (**96**) under the conditions of Braun

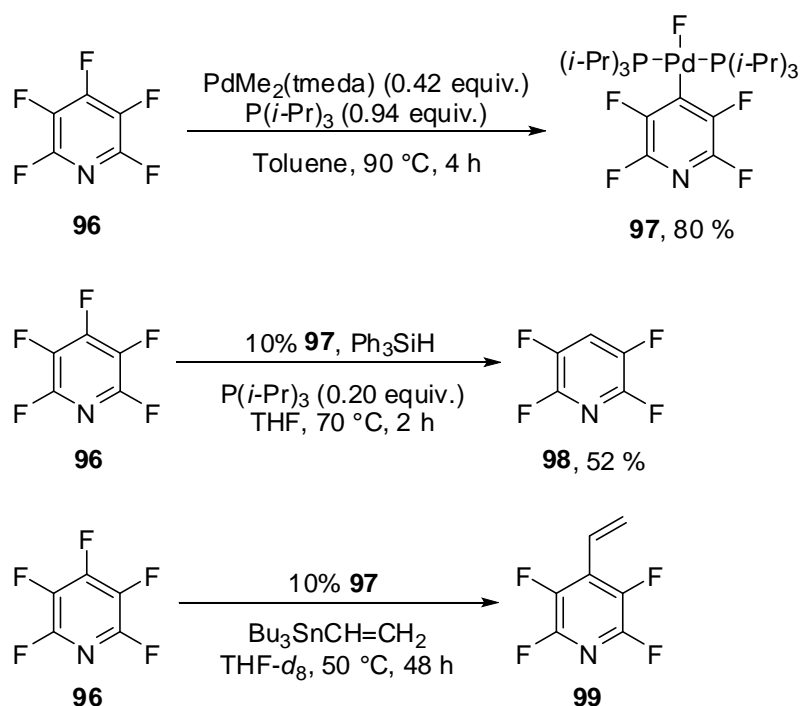

The hydrodefluorination reaction was successful in moderate yield although a relatively large catalyst loading was required to achieve complete conversion of starting material to products. The corresponding Stille reaction was only carried out on a very small scale and no yield of cross-coupled product **99** was provided.

In the early 1970s it was discovered that organomagnesium reagents could be used as the nucleophilic coupling partner for metal-catalysed C–C bond formation processes, now referred to as Kumada coupling reactions.⁷⁶ In 2005 this methodology was successfully extended to C–F activation reactions of fluorinated aromatic systems by Dankwardt⁷⁷ and Saeki.⁷⁸

The palladium-catalysed protocol presented by Dankwardt concerned the functionalisation of monofluorinated aromatic systems with phenylmagnesium chloride either by conventional thermal heating or under microwave irradiation conditions. The cross-coupling procedure was successful in the absence of any ligand whatsoever, although the yield of product was generally improved when suitable phosphine ligands were introduced [Scheme 27].

Scheme 27. Representative Kumada coupling reactions of monofluorinated aromatic systems (**100**, **102** and **104**) under the conditions of Dankwardt

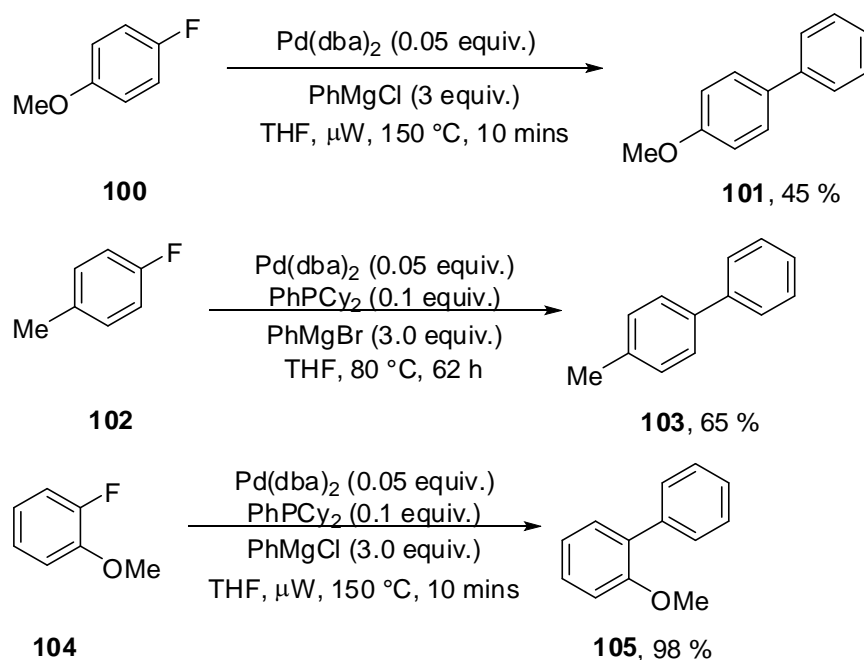

Saeki *et al.* developed a similar palladium-catalysed Kumada coupling protocol for a range of di- and trifluorobenzene derivatives, although unlike the work Dankwardt, their methodology could not be extended to monofluorinated aromatic systems. Saeki also observed that 1,2-difluorobenzene was considerably more reactive than either 1,3- or 1,4-difluorobenzene and that the trifluorobenzene systems were more reactive than their less fluorinated, less electrophilic counterparts [Scheme 28].

Scheme 28. Kumada reactions of polyfluorobenzene systems under the conditions of Saeki

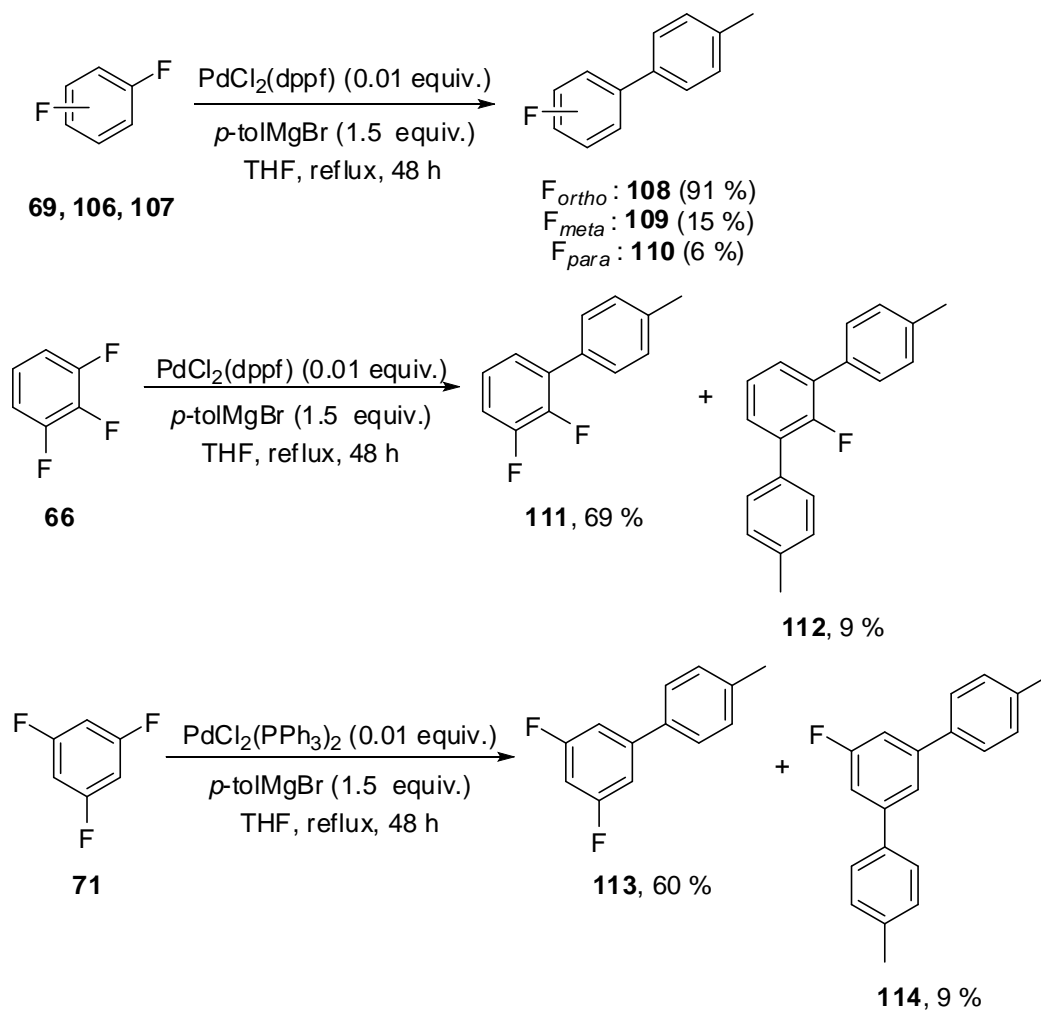

Although this review is focussed on the catalytic transformations of aryl fluorides, it is worth mentioning that Saeki also demonstrated a successful palladium-catalysed cross-coupling reaction of a *gem*-difluoroalkene (**115**) with an arylzinc reagent. The *Z*-isomer (**116**) was formed in preference to the *E*-isomer, presumably due to steric effects, although a significant quantity of difunctionalised material (**117**) was also obtained [Scheme 29].

Scheme 29. Palladium-catalysed cross-coupling reaction of an arylzinc reagent with a gem-difluoroalkene (**115**)

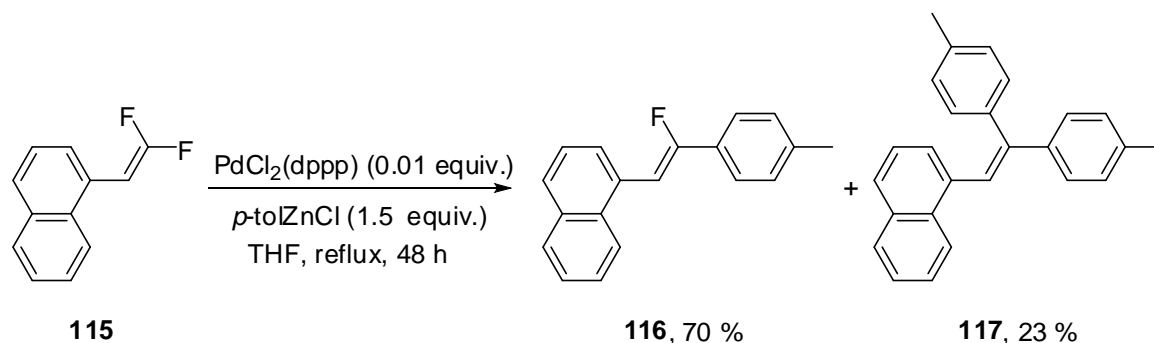

The most recent example of palladium-catalysed C–F bond activation by a Kumada-type process was published in 2008 by Manabe in which a variety of fluoroaromatic systems bearing electron-donating substituents *ortho* to the vulnerable fluorine atom were successfully cross-coupled with a series of arylmagnesium bromide reagents.⁷⁹ Hydroxy groups were observed to greatly accelerate the rate of reaction to afford high yields of cross-coupled material. C–F bonds could also be activated in the presence of weaker C–Cl bonds present on the same aromatic ring if a hydroxy or amino group was located *ortho* to the fluorine substituent [Scheme 30].

Scheme 30. Representative examples of palladium-catalysed Kumada reactions of functionalised fluorobenzene derivatives (**118**, **120** and **122**) under the conditions of Manabe

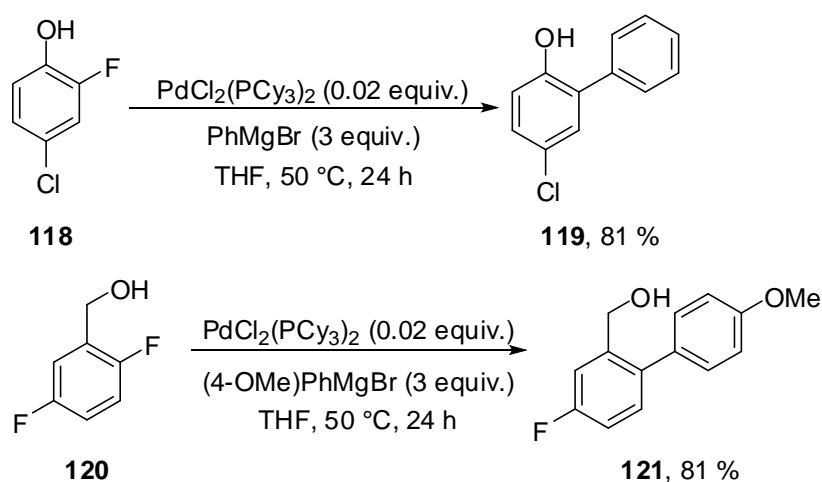

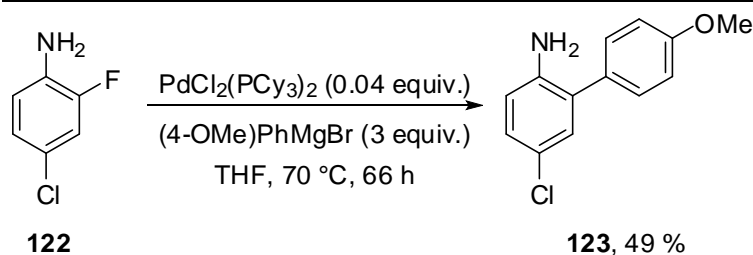

The work of Manabe concludes this review of homogeneous catalytic palladium-catalysed C–F bond activation reactions, however there are several reports concerning corresponding stoichiometric^{75,80-82} and heterogeneous⁸³ functionalisation reactions of fluorinated aromatic and heterocyclic systems.

1.4.1.2 Catalytic C–F Bond Activation with Nickel

Corresponding nickel-mediated C–F activation reactions of fluorinated aromatic and heterocyclic systems are more common than palladium-processes, although most publications are concerned with the synthesis and reactivity of stoichiometric nickel (II) fluoride complexes of polyfluorinated species from nickel(0) precursors. In total, there are actually approximately equal numbers of papers regarding *catalytic* C–F activation with nickel as there are with palladium and most of these processes involve modified Kumada coupling procedures, as first demonstrated in 1973 [Scheme 31].⁷⁶

Scheme 31. *Nickel-catalysed cross-coupling reaction of fluorobenzene (124) with isopropylmagnesium chloride*

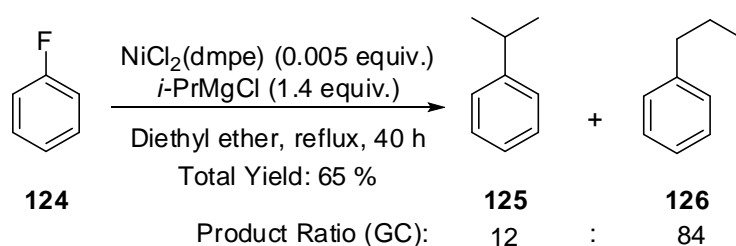

Kumada observed that the major product of the coupling reaction of fluorobenzene with isopropylmagnesium chloride was actually the linear, rather than the expected branched isomer, due to a rearrangement of the alkane on the nickel-catalyst by conventional β -hydride elimination/alkene insertion processes.

This methodology was not developed further until 2001, when Herrmann discovered that N-heterocyclic carbene ligands were highly effective in nickel-catalysed coupling reactions of fluoroaromatic systems with Grignard reagents under ambient conditions.⁸⁴ The strong electron-donating properties of N-heterocyclic carbene (NHC) ligands enables the generation of electron-rich nickel centres which are ideal for insertion into strong aromatic C–F bonds [Scheme 32].

Scheme 32. Representative Kumada reactions of substituted fluorobenzene derivative **127** with a variety of arylmagnesium bromides under the conditions of Herrmann

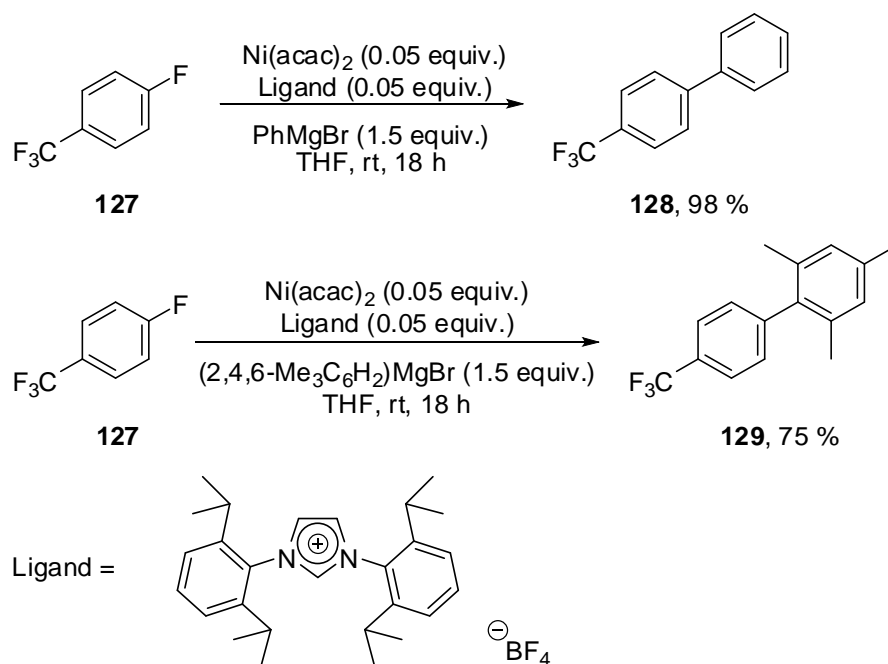

Reactions of monofluoroaromatic systems bearing electron-withdrawing substituents were found to be the most efficient whilst bulky Grignard reagents could also be tolerated.

In an interesting development, Inamoto subsequently demonstrated that a novel NHC-derived Ni(II)-pincer complex was also effective for the catalysis of Suzuki coupling reactions of monofluorinated systems in moderate to good yield and under very mild conditions.⁸⁵ The nickel catalyst (**132**) was pre-synthesised over a two-step procedure by a nucleophilic aromatic substitution reaction of 1-methyl-1*H*-imidazole with 2,6-dibromopyridine (**130**) in a sealed vessel, followed by coordination of the nickel centre to the tridentate ligand (**131**) [Scheme 33].⁸⁶

Scheme 33. Catalyst synthesis and representative Kumada coupling reactions of monofluorinated aromatic systems under the conditions of Inamoto

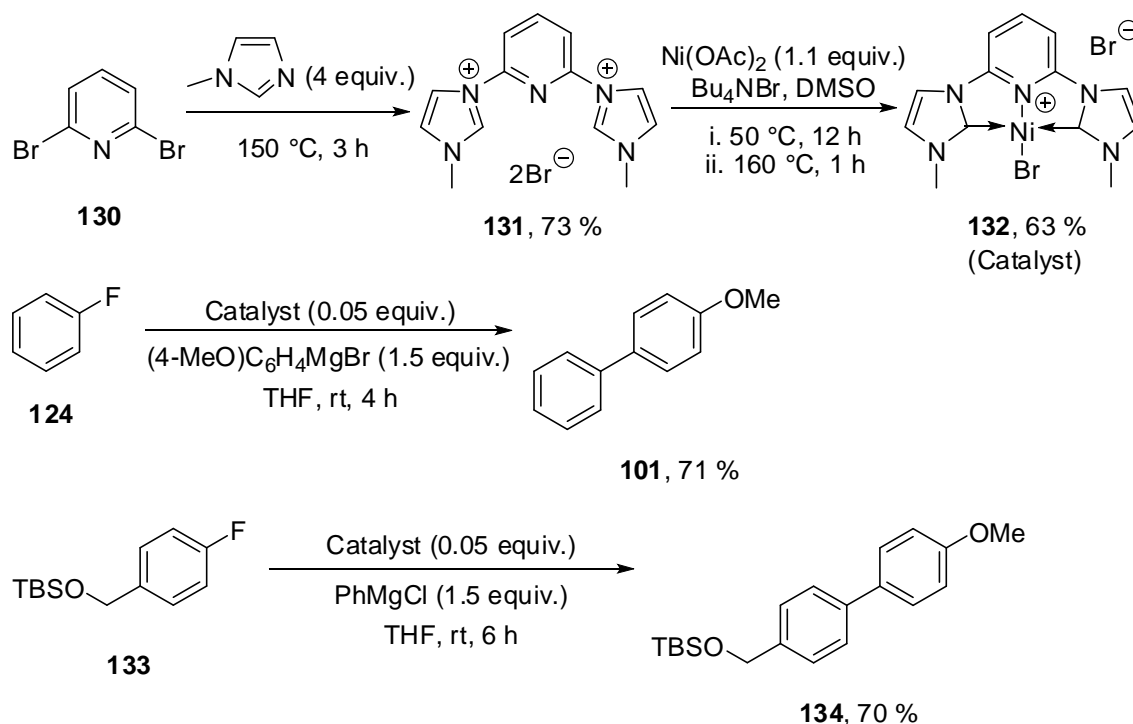

It is worth mentioning that, in addition to typical C–C bond forming procedures, N-heterocyclic carbene ligands have also shown significant potential in nickel-catalysed hydrodefluorination reactions of unactivated monofluorinated aromatic systems and pyridine derivatives.⁸⁷

In 2002 Mongin speculated that more electrophilic heterocyclic systems should be suitable substrates for corresponding nickel-catalysed Kumada reactions with common, less electron-donating phosphine ligands. Indeed, cross-coupling reactions of a range of fluorinated pyridine, pyrazine, pyridazine, quinoline and quinazoline systems were successful with nickel catalysts activated by a number of bidentate phosphines [Scheme 34].⁸⁸

Scheme 34. Representative Kumada coupling reactions of fluorinated heterocyclic systems (**135** and **137**) under the conditions of Mongin

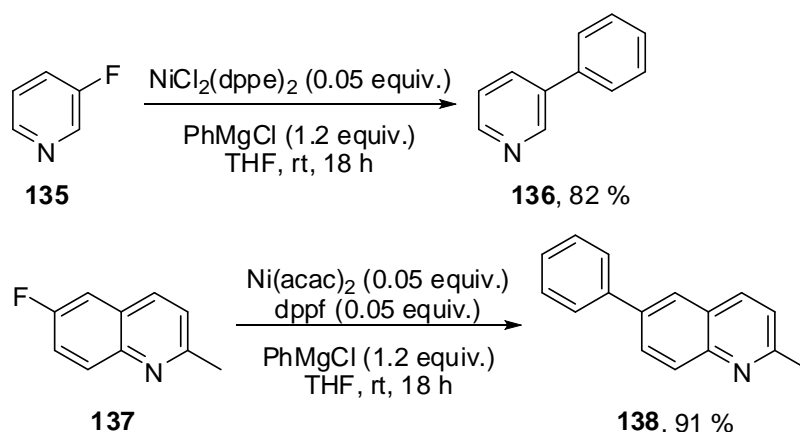

Mongin also extended this methodology to corresponding reactions of less electrophilic aromatic systems, although these processes were generally less efficient than those of Herrmann due to the reduced electron density of the nickel-phosphine catalyst. Several years later, two independent research programmes which were also interested in developing palladium-catalysed C–F activation procedures, both Saeki⁷⁸ and Dankwardt⁷⁷ confirmed that nickel-phosphine and phosphite complexes are suitable catalysts for Kumada reactions of unactivated fluorobenzenes, although polysubstitution was found to be problematic for polyfluorinated substrates [Scheme 35].

Scheme 35. Representative Kumada coupling reactions of fluoroaromatic systems under the conditions of Saeki (top) and Dankwardt (bottom)

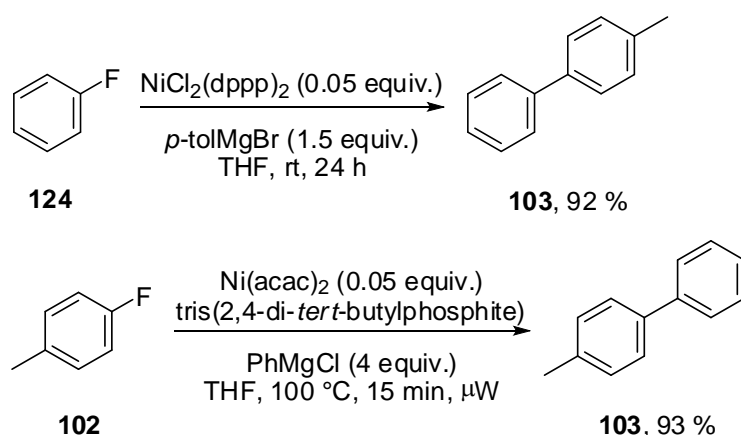

More recently, a range of bulky phosphine oxides have also been shown to be effective ligands for Kumada reactions of a variety of monofluorinated aromatic and heterocyclic systems in good to excellent yield [Scheme 36].^{89,90} It was proposed that the phosphine

oxide is deprotonated *in situ* to form electron-rich anionic phosphorus ligands, which are then able to significantly increase the electron density of the nickel centre relative to the standard phosphine ligands.

Scheme 36. Representative Kumada coupling reactions of monofluorinated aromatic systems (**100** and **139**) under the conditions of Ackermann

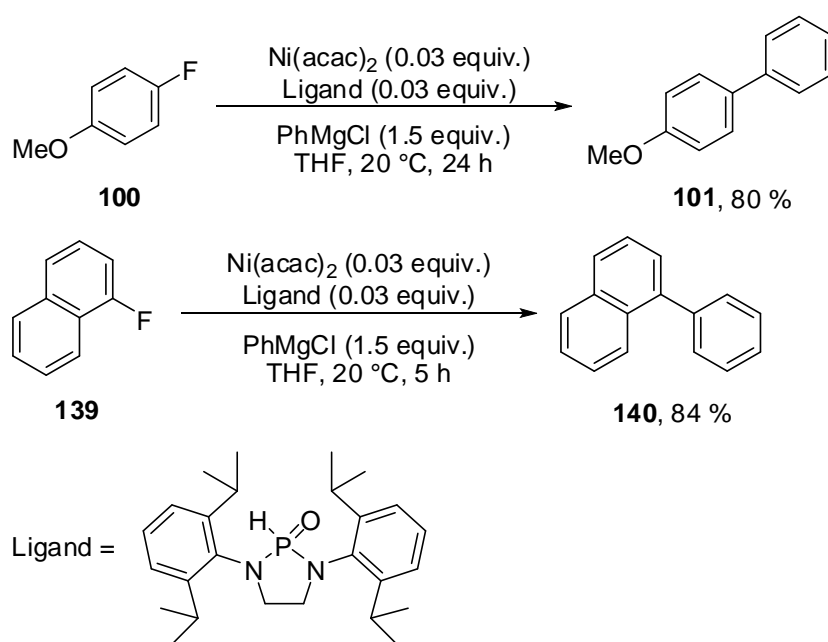

The latest example of C–F activation by a nickel-catalysed Kumada reaction was demonstrated in 2008 by Shi in which 1-fluoronaphthalene (**141**) and fluorobenzene (**124**) were coupled with methylmagnesium bromide in excellent yield [Scheme 37].⁹¹

Scheme 37. Kumada reactions of 1-fluoronaphthalene (**141**) and fluorobenzene (**124**) with methylmagnesium bromide under the condition of Shi

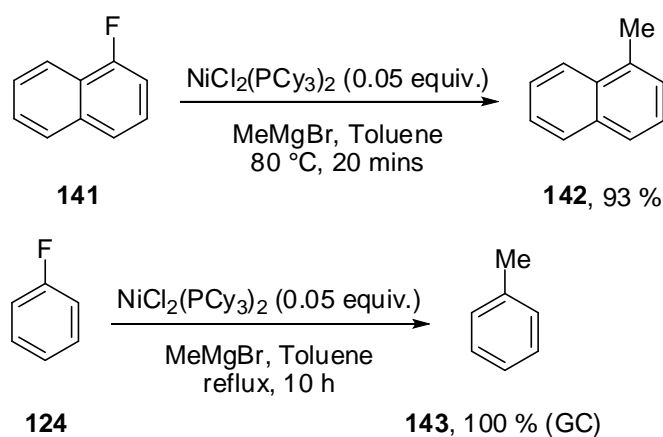

In addition to Kumada coupling reactions, considerable developments in nickel-catalysed Suzuki and Stille coupling reactions of polyfluorinated heterocyclic materials have also been reported. Specifically, in 1997 Perutz discovered that pentafluoropyridine (**96**) is susceptible to oxidative addition by electron-rich nickel-phosphine complexes at the 2-position [Scheme 38].⁹²

Scheme 38. Synthesis of *trans*-[NiF(2-C₅F₄N)(PEt₃)₂] (**144**)⁹²

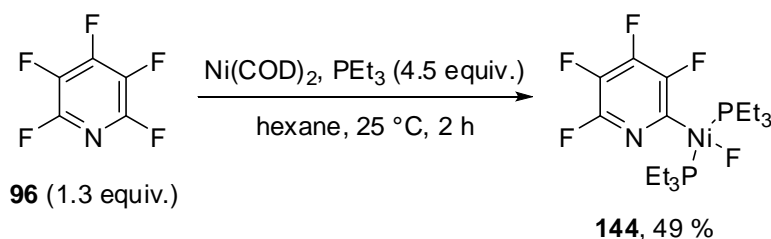

Nickel(II) complex (**144**) was subsequently found to be catalytically active for Stille vinylation reactions of pentafluoropyridine itself, to provide a rare synthetic route to functionalised 2,3,4,5-tetrafluoropyridine derivatives which are conventionally very difficult to access [Scheme 39].⁹³

Scheme 39. Nickel-catalysed Stille reaction of pentafluoropyridine (**96**)

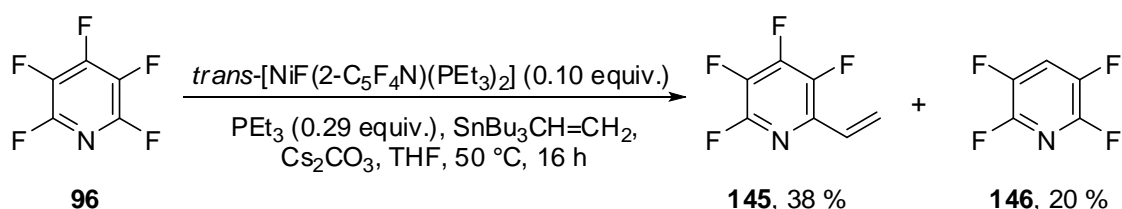

Although the recorded yield of vinylated material (**145**) was low, this reaction represents the first example of a metal-catalysed C–C coupling reaction involving C–F activation of a polyfluorinated molecule. Additionally, competing hydrodefluorination processes were problematic and, strangely, no cross-coupled product was observed when Ni(COD)₂ and an appropriate phosphine ligand were employed to generate the catalytic species *in situ*.

In 2005, Braun applied similar methodology to develop an equivalent nickel-catalysed Suzuki protocol for reactions of highly electrophilic 2,4,6-trifluoro-5-chloropyrimidine (**147**) with several arylboronic acid derivatives in moderate to good yield [Scheme

40].⁹⁴ Particularly interesting is the chemoselective functionalisation of two C–F bonds in the presence of a much weaker C–Cl bond.

Scheme 40. Catalyst synthesis and representative nickel-catalysed Suzuki reactions of 2,4,6-trifluoro-5-chloropyrimidine (**147**)

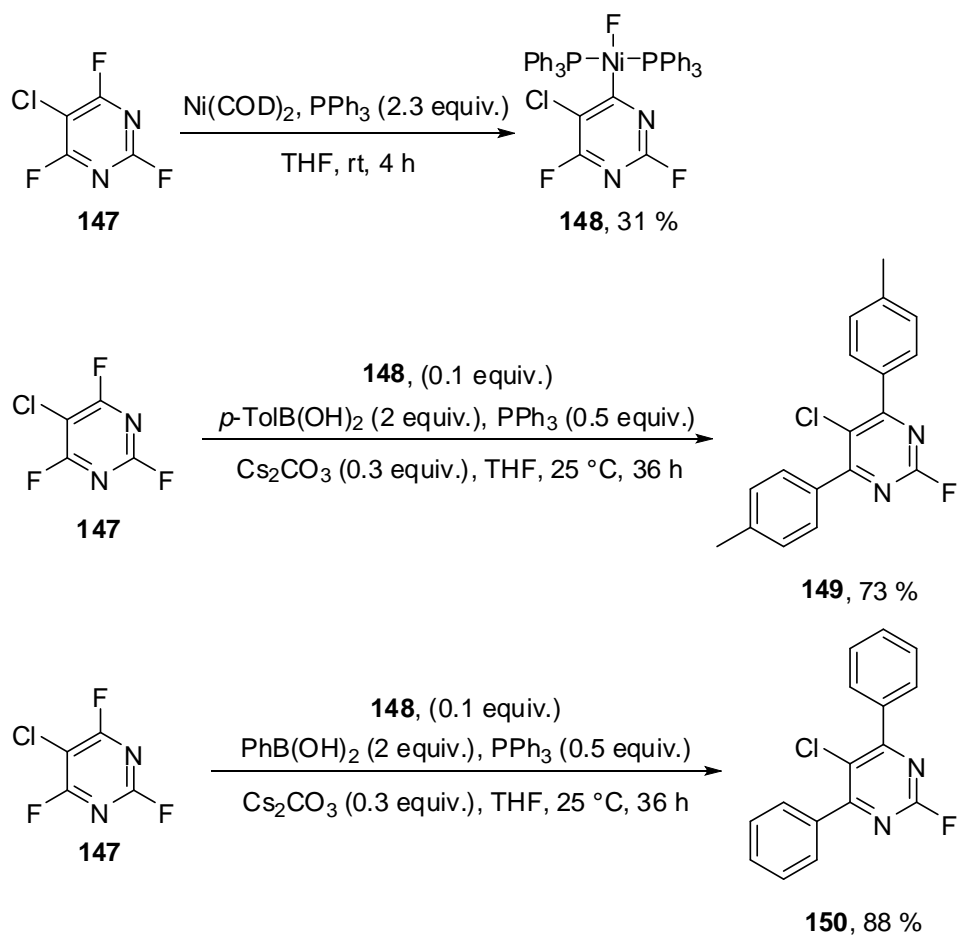

The same year, Robins published a short letter in which a series of Suzuki reactions of 6-fluoropurine nucleosides with nickel–NHC complexes were demonstrated in good yield [Scheme 41].⁹⁵

Scheme 41. Representative Suzuki reaction of a 4-fluoropurine derivative (**151**) under the conditions of Robins

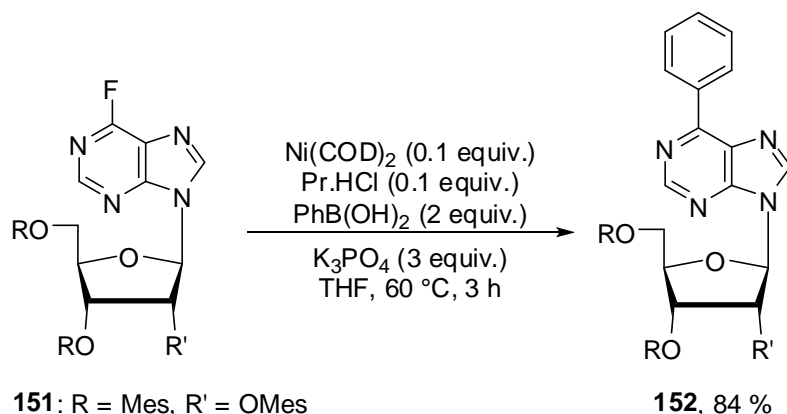

Arguably the most successful development in C–F bond activation chemistry was presented in 2006 by Radius whereby a highly reactive nickel(0)–NHC complex was used for Suzuki reactions of octafluorotoluene (**156**) and decafluorobiphenyl (**158**) with several arylboronic acid derivatives in moderate yield.⁹⁶ The catalyst (**155**) was pre-synthesised by reacting a stoichiometric quantity of $\text{Ni}(\text{COD})_2$ with 1,3-diisopropylimidazol-2-ylidene (**153**) [Scheme 42].⁹⁷

Scheme 42. Catalyst synthesis and representative Suzuki-coupling reactions of octafluorotoluene (**156**) and decafluorobiphenyl (**158**)

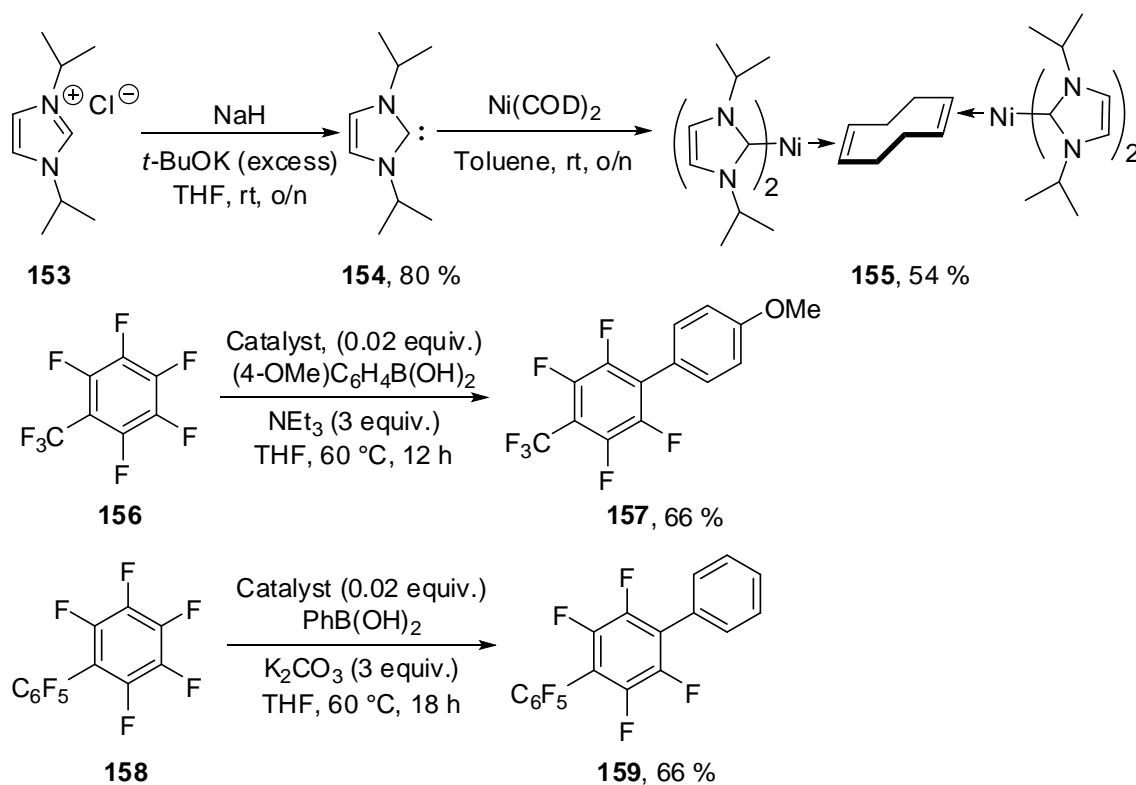

These nickel(0)-catalysed cross-coupling reactions of **153** and **158** represent the only successful examples of a Suzuki reaction of a perfluorinated substrate and conclude this review on nickel-catalysed cross-coupling reactions of C–F bonds.

1.5 Summary

Highly fluorinated aromatic molecules are widely used in liquid crystal display applications due to their ability to interact strongly with the applied electric field used in the cell switching process and due to their excellent voltage holding properties. Polyfluorinated aromatic systems may be accessed by nucleophilic aromatic substitution reactions of highly fluorinated benzene derivatives, in which nucleophilic attack usually occurs preferentially at the C–F bond activated by the greatest number of *ortho* and *meta* ring fluorine substituents. The reactivity profiles of hexafluorobenzene and pentafluorobenzene are well developed, whilst reactions of less fluorinated system are rarer, although similar regioselectivity arguments apply. The presence of nucleophile-directing or strongly electron-donating groups on the fluorinated aromatic ring can have a profound effect on the outcome of a typical S_NAr reaction and care must be taken to choose an appropriate solvent to maximise or minimise any additional nucleophile-electrophile interactions.

An alternative method for the synthesis of polyfluoroaromatic systems is by metal-catalysed C–F bond activation and a discussion of this chemistry has been presented, with a particular focus on palladium and nickel mediated processes. It is noteworthy that several additional examples concerning catalytic C–F activation reactions involving other metal species have been reported, although palladium and nickel processes are much more common.⁹⁸⁻¹⁰⁴ Stoichiometric C–F activation has been omitted to maintain the brevity of this document although a recent review article by Uneyama provides an excellent summary of this field.⁶⁸

The majority of metal-catalysed C–F bond activation processes concern reactions of monofluorinated aromatic systems to afford non-fluorinated products and examples of corresponding cross-coupling reactions of polyfluoroaromatic systems are rare. Further investigations are required to develop the field further so that polyfluorinated aromatic

substrates may be used as electrophilic coupling partners in cross-coupling procedures in a practical manner and on a useful synthetic scale.

1.6 Aims

The focus of this thesis is to improve the response times of commercially available liquid crystal (LC) mixtures so that the moving-image quality of the next generation of LC display devices may be improved. In initial screening procedures, the SONY Corporation discovered that a series of halogenated biphenyl ether derivatives (**160–162**) were particularly effective at improving the response times of commercially available dielectrically negative (–LC) and positive (+LC) type LC mixtures [Figure 6].¹⁰⁵ The rise times of LC mixtures doped with 1–4 weight% of each of the biphenyl ether systems were found to decrease with increasing dopant concentration across a range of operating voltages and temperatures. Corresponding decay times were, in general, found to lengthen slightly with increasing dopant concentration, although the overall result was a net improvement in device response time.

Figure 6. Phase 1: Several promising halogenated biphenyl ether derivatives identified by the SONY Corporation

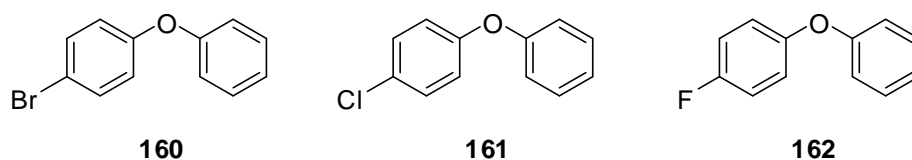

Doping was not observed to impair the off-blackness, voltage-transmittance profile or voltage holding ratio (VHR) of any device, although the nematic-isotropic transition temperatures (T_{NI}) and rotational viscosities (γ_1) of all doped systems were reduced relative to the standard LC host mixtures.

It was proposed that the T_{NI} and γ_1 reductions of each doped mixture were consistent with a system in which the intermolecular interactions between LC molecules of the nematic host were reduced through an increase in their average separation. Indeed, the non-planar structure of the halogenated biphenyl ether derivatives was highlighted as potentially advantageous for increasing the separation between bulk LC molecules and is suggested to be the primary mechanism of operation of these dopants [Figure 7].

Figure 7. Schematic representation of the introduction of a small quantity of fluorinated biphenyl ether dopant into a typical bulk LC system

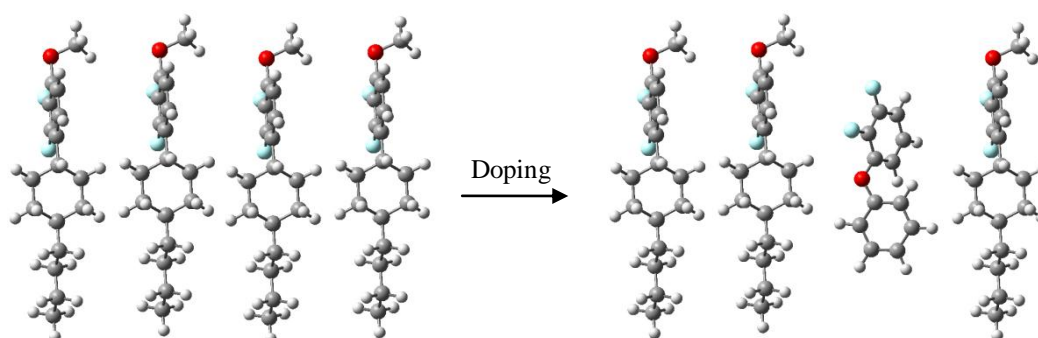

In collaboration with the Durham group, the response times of commercial LC cells doped with each of the halogenated biphenyl ether derivatives (**160–162**) were subsequently compared and 4-fluorobiphenyl ether (**162**) was identified as the most effective dopant of the series.¹⁰⁶ Sterically, ring fluorine may be predicted to be less effective at increasing the average separation between bulk LC molecules than chlorine and bromine and so its electronic properties must offer some additional beneficial effect. The strong dipole moment of fluoroaromatic dopant (**162**) can be envisaged to interact strongly with the electric field applied to the LC cell in the switching process. This is manifested in the exertion of an additional torsional force on the host phase which further improves device rise time. Fluoroaromatic molecules are also expected to have a greater longevity in display applications than other halogenated systems due to the strength of the C–F bond.

It was proposed, therefore, that the incorporation of additional fluorine atoms into the core structure would result in more polar, more effective dopants. The next development of our doping strategy was to study the rise and decay times of a series of trifluorinated biphenyl ether derivatives in both –LC and +LC host systems [Figure 8].

Figure 8. Phase 2: Trifluorinated biphenyl ether derivatives investigated by the SONY-Durham collaboration

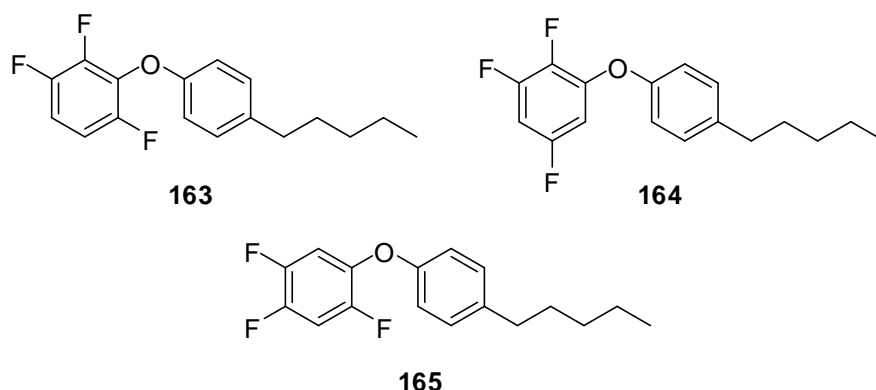

All three dopants (**163–165**) were observed to improve the response times of their commercial LC hosts and the degree of torsional angle between the two aromatic rings was suggested to be a factor in determining the extent to which these chemically-inert spacers could increase the separation between molecules of the LC bulk. Dopant **163** was observed to be the most effective dopant of the series and was calculated to be the most twisted of the three systems studied. In agreement with previous observations regarding the 4-halogenobiphenyl ether derivatives (**160–162**), the VHRs and off-blackness levels of all doped cells were excellent, whilst their respective nematic-isotropic transition temperatures were observed to decrease with increasing doping.

The most recent development in this programme was the synthesis and electro-optical testing of several related polyfluorobiphenyl ether derivatives [Figure 9].¹⁰⁷ In a dielectrically negative LC host system dopants **166–168** were observed to affect a slight reduction in device rise time at the cost of a significant increase in decay time and so did not offer any real improvement in performance. All dopants (**166–170**) offered a slight improvement in device performance for cells fabricated from a dielectrically positive LC host mixture.

Figure 9. Phase 3: Polyfluorinated biphenyl ether derivatives (**166–170**) investigated by the SONY-Durham collaboration

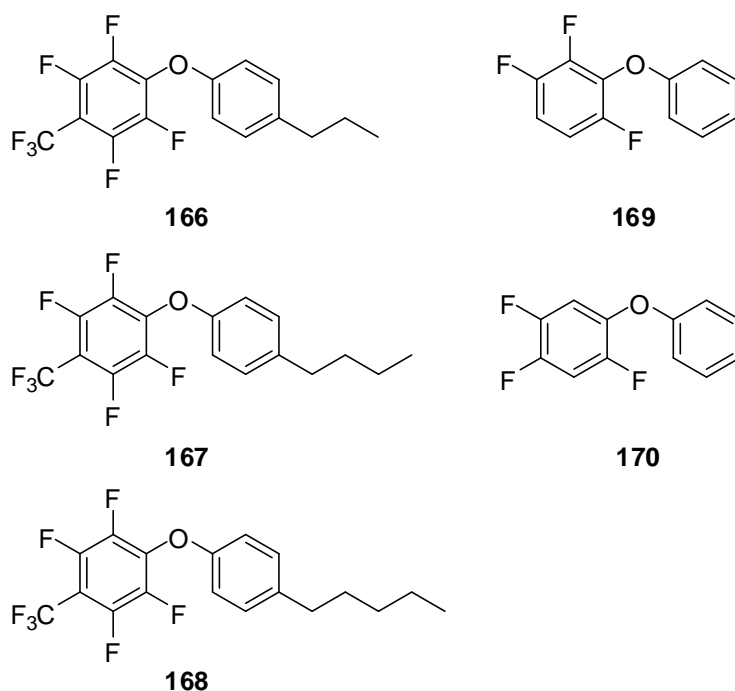

Phase 1 of this research programme was the recognition of the efficacy of polar biaryl ether derivatives at improving the response times of doped commercial LC systems. Phase 2 discovered that similar, highly fluorinated systems are decidedly advantageous and Phase 3 identified several additional fluoroaromatic dopant candidates. The next phase of our doping strategy, which is the focus of this thesis, is to develop the initial screening protocol of the SONY-Durham collaboration into a systematic study concerning how the molecular structures of a range of fluorinated biphenyl ether derivatives affect the performance of doped commercial LC systems.

1.6. References to Chapter 1

- [1] Reinitzer, F. *Monatsh. Chem.* **1888**, 9, 421-441.
- [2] Reinitzer, F. *Liq. Cryst.* **1889**, 5, 7-18.
- [3] Gray, G. W. *Handbook of Liquid Crystals*; Wiley-VCH: Weinheim, 1998; Vol. 1: Fundamentals.
- [4] Hird, M. *Chem. Soc. Rev.* **2007**, 36, 2070-2095.
- [5] Chandrasekhar, S. *Liquid Crystals*; 2 ed.; Cambridge University Press: Cambridge, 1992.
- [6] Naemura, S. In *Physical Properties of Liquid Crystals: Nematics*; Dunmur, D. A., Fukuda, A., Luckhurst, G., Eds.; INSPEC: London, 1999, p 523-591.
- [7] Ohtsuka, T.; Ohnishi, H.; Takatsu, H. In *Physical Properties of Liquid Crystals: Nematics*; Dunmur, D. A., Fukuda, A., Luckhurst, G., Eds.; INSPEC: London, 2000, p 515-522.
- [8] Hird, M. In *Physical Properties of Liquid Crystals: Nematics*; Dunmur, D. A., Fukuda, A., Luckhurst, G., Eds.; INSPEC: London, 1998, p 3-16.
- [9] Schadt, M.; Helfrich, W. *Appl. Phys. Lett.* **1971**, 18, 127-128.
- [10] Kirsch, P.; Bremer, M. *Angew. Chem. Int. Ed.* **2000**, 39, 4216-4235.
- [11] Gooch, C. H.; Tarry, H. A. *J. Phys. D.* **1975**, 8, 1575-1584.
- [12] Keiichi, I.; Takatoh, K.; Akimoto, M.; Miyama, T.; Sakai, Y.; Kobayashi, S.; Saeki, Y.; Hoshi, H.; Kineri, T.; Toshima, N. *Digest of Technical Papers - Society for Information Display International Symposium* **2008**, 39, 595-597.
- [13] Sano, S.; Takatoh, K.; Miyama, T.; Kobayashi, S. *Digest of Technical Papers - Society for Information Display International Symposium* **2006**, 37, 694-696.
- [14] Sano, S.; Miyama, T.; Takatoh, K.; Kobayashi, S. *Proceedings of SPIE-The International Society for Optical Engineering* **2006**, 6135, 613501/1-613501/5.
- [15] Sakai, Y.; Nishida, N.; Shiraki, H.; Shiraishi, Y.; Miyama, T.; Toshima, N.; Kobayashi, S. *Mol. Cryst. Liq. Cryst.* **2005**, 441, 143-152.
- [16] Lee, W.; C.-Y., W.; Shih, Y.-C. *Appl. Phys. Lett.* **2004**, 85, 513-515.
- [17] Reznikov, Y.; Buchnev, O.; Tereshchenko, O.; Reshetnyak, V.; Glushchenko, A.; West, J. *Appl. Phys. Lett.* **2003**, 82, 1917-1919.
- [18] Saito, H. In *Physical Properties of Liquid Crystals: Nematics*; Dunmur, D. A., Fukuda, A., Luckhurst, G., Eds.; INSPEC: London, 1999, p 582-591.
- [19] Chambers, R. D. *Fluorine in Organic Chemistry*; John Wiley & Sons Inc, 1974.
- [20] Banks, R. E. *J. Fluorine Chem.* **1986**, 33, 3-26.
- [21] McBee, E. T.; Lingdren, V. V.; Liggett, W. B. *Ind. Eng. Chem.* **1947**, 39, 378-380.
- [22] Gething, B.; Patrick, C. R.; Stacey, M.; Tatlow, J. C. *Nature* **1959**, 183, 588-589.
- [23] Fowler, R. D.; Burford, W. B.; Hamilton, J. M.; Sweet, R. G.; Weber, C. E.; Kasper, J. S.; Litant, I. In *Preparation Properties and Technology of Fluorine and Organic Fluoro-Compounds*; Slessor, C., Schram, S. R., Eds.; McGraw-Hill: New York, 1951.
- [24] Finger, G. C.; Kruse, C. W. *J. Am. Chem. Soc.* **1956**, 78, 6034-6037.
- [25] Fuller, G. *J. Chem. Soc.* **1965**, 6264-6267.
- [26] Vorozhtsov, N. N.; Platonov, V. E.; Yakobson, G. G. *Bull. Acad. Sci. U.S.S.R.* **1963**, 8, 1524.
- [27] Chambers, R. D.; Hole, M.; Musgrave, W. K. R.; Storey, R. A.; Iddon, B. *J. Chem. Soc. C.* **1966**, 2331-2339.
- [28] Brooke, G. M. *J. Fluorine Chem.* **1997**, 86, 1-76.

- [29] Chambers, R. D.; Martin, P. A.; Sandford, G.; Williams, D. L. H. *J. Fluorine Chem.* **2008**, *129*, 998-1002.
- [30] Wall, L. A.; Pummer, W. J.; Fearn, J. E.; Antonucci, J. M. *J. Res. Nat. Inst. Stand. Technol. A.* **1963**, *67A*, 481-497.
- [31] Harper, R. J.; Soloski, E. J.; Tamborski, C. *J. Org. Chem.* **1964**, *29*, 2385-2389.
- [32] Birchall, J. M.; Haszeldine, R. N. *J. Chem. Soc.* **1959**, 13-17.
- [33] Robson, P.; Stacey, M.; Stephens, R.; Tatlow, J. C. *J. Chem. Soc.* **1960**, 4754-4760.
- [34] Morrison, D. J.; Trefz, T. K.; Piers, W. E.; McDonald, R.; Parvez, M. *J. Org. Chem.* **2005**, *70*, 5309-5312.
- [35] Korenaga, T.; Kosaki, T.; Kawauchi, Y.; Ema, T.; Sakai, T. *J. Fluorine Chem.* **2006**, *127*, 604-609.
- [36] Langille, K. R.; Peach, M. E. *J. Fluorine Chem.* **1972**, *1*, 407-414.
- [37] Brooke, G. M.; Burdon, J.; Stacey, M.; Tatlow, J. C. *J. Chem. Soc.* **1960**, 1768-1771.
- [38] Koppang, R. *J. Fluorine Chem.* **1975**, *5*, 323-333.
- [39] Miller, A. O.; Furin, G. G. *J. Fluorine Chem.* **1987**, *36*, 247-272.
- [40] Callender, D. D.; Coe, P. L.; Tatlow, J. C. *Tetrahedron* **1966**, *22*, 419-432.
- [41] Burdon, J.; Hollyhead, W. B.; Tatlow, J. C. *J. Chem. Soc.* **1965**, 5152-5156.
- [42] Alsop, D. J.; Burdon, J.; Tatlow, J. C. *J. Chem. Soc.* **1962**, 1801-1805.
- [43] Respass, W. L.; Tamborski, C. *J. Organometallic. Chem.* **1970**, *22*, 251-263.
- [44] Chaundhry, M. T.; Stephens, R. *J. Chem. Soc.* **1963**, 4281-4283.
- [45] De pasquale, R. J.; Tamborski, C. *J. Org. Chem.* **1968**, *33*, 1658-1661.
- [46] Allen, G. J.; Burdon, J.; Tatlow, J. C. *J. Chem. Soc.* **1965**, 6329-6336.
- [47] Coe, P. L.; Tatlow, J. C.; Terrell, R. C. *J. Chem. Soc. C.* **1967**, 2626-2628.
- [48] Aroskar, E. V.; Brown, P. J. N.; Plevy, R. G.; Stephens, R. *J. Chem. Soc. C.* **1968**, 1569-1575.
- [49] Kobrina, L. S.; Furin, G. G.; Yakobson, G. G. *Zh. Org. Khim.* **1970**, *6*, 512-520.
- [50] Ivashchuk, O.; Sorokin, V. I. *Tetrahedron* **2009**, *65*, 4652-4658.
- [51] Boros, E. E.; Harfenist, M. *J. Org. Chem.* **1998**, *63*, 10045-10047.
- [52] Dirk, C. W.; Cox, S. D.; Wellman, D. E.; Wudl, F. *J. Org. Chem.* **1985**, *50*, 2395-2397.
- [53] Crowell, T. R.; Peach, M. E. *J. Fluorine Chem.* **1982**, *21*, 469-477.
- [54] Hellberg, J.; Dahlstedt, E.; Pelcman, M. E. *Tetrahedron* **2004**, *60*, 8899-8912.
- [55] Iino, T.; Sasaki, Y.; Bamba, M.; Mitsuya, M.; Ohno, A.; Kamata, K.; Hosaka, H.; Maruki, H.; Futamura, M.; Yoshimoto, R.; Ohyama, S.; Sasaki, K.; Chiba, M.; Ohtake, N.; Nagata, Y.; Eiki, J.-I.; Nishimura, T. *Bio. Med. Chem. Lett.* **2009**, *19*, 5531-5538.
- [56] Orjales, A.; Mosquera, R.; Toledo, A.; Carmen Pumar, M.; García, N.; Cortizo, L.; Labeaga, L.; Innerarity, A. *J. Med. Chem.* **2003**, *46*, 5512-5532.
- [57] Kowalczyk, B. A. *Synthesis* **1997**, *12*, 1411-1414.
- [58] Rodriguez, J. R.; Agejas, J.; Bueno, A. B. *Tet. Lett.* **2006**, *47*, 5661-5663.
- [59] Brown, G. R.; Foubister, A. J.; Roberts, C. A.; Wells, S. L.; Wood, R. *Tet. Lett.* **2001**, *42*, 3917-3919.
- [60] Kim, A.; Powers, J. D.; Toczko, J. F. *J. Org. Chem.* **2006**, *71*, 2170-2172.
- [61] Idoux, J. P.; Madenwald, M. L.; García, B. S.; Chu, D. L.; Gupton, J. T. *J. Org. Chem.* **1985**, *50*, 1876-1878.
- [62] Peng, H.; Kumaravel, G.; Yao, G.; Sha, L.; Wang, J.; Vlijmen, H. V.; Bohnert, T.; Huang, C.; Vu, C. B.; Ensinger, C. L.; Chang, H.; Engber, T. M.; Whalley, E. T.; Petter, R. C. *J. Med. Chem.* **2004**, *47*, 6218-6229.
- [63] Pastor, S. D.; Hessel, E. T. *J. Org. Chem.* **1985**, *50*, 4812-4815.

- [64] West, A. P.; Engen, D. V.; Pascal, R. A. *J. Am. Chem. Soc.* **1989**, *111*, 6846-6847.
- [65] Grushin, V. V.; Alper, H. *Top. Organometallic. Chem.* **1999**, *3*, 193-226.
- [66] Torrens, H. *Coord. Chem. Rev.* **2005**, *249*, 1957-1985.
- [67] Kiplinger, J. L.; Richmond, T. G.; Osterberg, C. E. *Chem. Rev.* **1994**, *94*, 373-431.
- [68] Uneyama, K.; Amii, H. *Chem. Rev.* **2009**, *109*, 2119-2183.
- [69] Widdowson, D. A.; Wilhelm, R. *J. Chem. Soc., Chem. Commun.* **1999**, 2211-2212.
- [70] Wilhelm, R.; Widdowson, D. A. *J. Chem. Soc., Perkin Trans. 1* **2000**, 3808-3813.
- [71] Kim, Y. M.; Yu, S. *J. Am. Chem. Soc.* **2003**, *125*, 1696-1697.
- [72] Widdowson, D. A.; Wilhelm, R. *J. Chem. Soc., Chem. Commun.* **2003**, 578-579.
- [73] Bahmanyar, S.; Borer, B. C.; Kim, Y. M.; Kurtz, D. M.; Yu, S. *Org. Lett.* **2005**, *7*, 1011-1014.
- [74] Mikami, K.; Miyamoto, T.; Manabu, H. *J. Chem. Soc., Chem. Commun.* **2004**, 2082-2083.
- [75] Braun, T.; Izundu, J.; Steffen, A.; Neumann, B.; Stammler, H.-G. *J. Chem. Soc., Dalton Trans.* **2006**, 5118-5123.
- [76] Kiso, Y.; Tamao, K.; Kumada, M. *J. Organometallic. Chem.* **1973**, *50*, C12-C14.
- [77] Dankwardt, J. W. *J. Organometallic. Chem.* **2005**, *690*, 932-938.
- [78] Saeki, Y.; Takashima, Y.; Tamao, K. *Synlett.* **2005**, *11*, 1771-1774.
- [79] Manabe, K.; Ishikawa, S. *Synthesis* **2008**, *16*, 2645-2649.
- [80] Braun, T.; Rothfeld, S.; Schorlemer, V.; Stammler, A.; Stammler, H.-G. *Inorg. Chem. Commun.* **2003**, *6*, 752-755.
- [81] Jasim, N. A.; Perutz, R. N.; Whitwood, A. C.; Braun, T.; Izundu, J.; Neumann, B.; Rothfeld, S.; Stammler, H.-G. *Organometallics* **2004**, *23*, 6140-6149.
- [82] Braun, T.; Schorlemer, V.; Neumann, B.; Stammler, H.-G. *J. Fluorine Chem.* **2006**, *127*, 367-372.
- [83] Ruiz, J. R.; Jiménez-Sanchidrián, C.; Mora, M. *J. Fluorine Chem.* **2006**, *127*, 443-445.
- [84] Böhm, V. P. W.; Gstöttmayr, C. W. K.; Weskamp, T.; Herrmann, W. A. *Angew. Chem. Int. Ed.* **2001**, *40*, 3387-3389.
- [85] Inamoto, K.; Kuroda, J.-I.; Sakamoto, T.; Hiroya, K. *Synthesis* **2007**, *18*, 2853-2861.
- [86] Inamoto, K.; Kuroda, J.-I.; Hiroya, K.; Noda, Y.; Watanabe, M.; Sakamoto, T. *Organometallics* **2006**, *25*, 3095-3098.
- [87] Kuhl, S.; Schneider, R.; Fort, Y. *Adv. Synth. Catal.* **2003**, *345*, 341-344.
- [88] Mongin, F.; Mojovic, L.; Guillamet, B.; Trécourt, F.; Quéguiner, G. *J. Org. Chem.* **2002**, *67*, 8991-8994.
- [89] Ackermann, L.; Born, R.; Spatz, J. H.; Meyer, D. *Angew. Chem. Int. Ed.* **2005**, *44*, 7216-7219.
- [90] Ackermann, L.; Born, R.; Spatz, J. H.; Althammer, A.; Gschrei, C. J. *Pure Appl. Chem.* **2006**, *78*, 209-214.
- [91] Guan, B.-T.; Xiang, S.-K.; Wu, T.; Sun, Z.-P.; Wang, B.-Q.; Zhao, K.-Q.; Shi, Z.-J. *J. Chem. Soc., Chem. Commun.* **2008**, 1437-1439.
- [92] Cronin, L.; Higgitt, C. L.; Karch, R.; Perutz, R. N. *Organometallics* **1997**, *16*, 4920-4928.
- [93] Braun, T.; Perutz, R. N.; Sladek, M. I. *J. Chem. Soc., Chem. Commun.* **2001**, 2254-2255.

- [94] Steffen, A.; Sladek, M. I.; Braun, T.; Neumann, B.; Stammeler, H.-G. *Organometallics* **2005**, *24*, 4057-4064.
- [95] Liu, J.; Robins, M. J. *Org. Lett.* **2005**, *7*, 1149-1151.
- [96] Schaub, T.; Backes, M.; Radius, U. *J. Am. Chem. Soc.* **2006**, *128*, 15964-15965.
- [97] Schaub, T.; Radius, U. *Chem. Eur. J.* **2005**, *11*, 5024-5030.
- [98] Cahoez, G.; Lepifre, F.; Ramiandrasoa, P. *Synthesis* **1999**, *12*, 2138-2144.
- [99] Borah, H. N.; Prajapati, D.; Boruah, R. C. *Synlett.* **2005**, *18*, 2823-2825.
- [100] Guo, H.; Kong, F.; Kanno, K.; He, J.; Nakajima, K.; Takahashi, T. *Organometallics* **2006**, *25*, 2045-2048.
- [101] Yamada, S.; Takahashi, T.; Konno, T.; Ishihara, T. *Chem. Commun.* **2007**, 3679-3681.
- [102] Korn, T. J.; Schade, M. A.; Wirth, S.; Knochel, P. *Org. Lett.* **2006**, *8*, 725-728.
- [103] Wang, T.; Alfonso, B. J.; Love, J. A. *Org. Lett.* **2007**, *9*, 5629-5631.
- [104] Arisawa, M.; Suzuki, T.; Ishikawa, T.; Yamaguchi, M. *J. Am. Chem. Soc.* **2008**, *130*, 12214-12215.
- [105] Kilickiran, P.; Roberts, T.; Hollfelder, N.; Schüller, B.; Masutani, A.; Nelles, G.; Yasuda, A. *J. SID.* **2008**, *16*, 63-70.
- [106] Kilickiran, P.; Masutani, A.; Hollfelder, N.; Nelles, G.; Yasuda, A.; Tadeusiak, A.; Sandford, G. *Digest of Technical Papers - Society for Information Display International Symposium* **2007**, *38*, 999-1002.
- [107] Tadeusiak, A., Durham University, 2008.

Chapter 2

Syntheses of Fluorinated Biphenyl Ether Derivatives

2.1 Introduction

LCD devices have now largely replaced conventional CRT technology due, primarily, to the improved resolution and power consumption of the former. In order to optimise the performance of modern LCD systems, a doping strategy has emerged whereby the host nematic LC phase is blended with small quantities of, approximately, 10-15 additional chemical additives. Nevertheless, the response times of modern LC formulations still need to be improved so that moving-image blurring, which is particularly problematic for fast moving objects on large screens, can be addressed. To this end, the SONY-Durham collaboration identified polyfluorinated biphenyl ether derivatives as potentially very useful dopant systems, which can be mixed with commercial LC systems to improve their respective response times.

2.2 Aims and Approach

As discussed in the introduction, Phase 1 of this research programme was the recognition of the efficacy of polar biaryl ether derivatives at improving the response times of doped commercial LC systems. Phase 2 discovered that similar, highly fluorinated systems are decidedly advantageous and Phase 3 identified several additional fluoroaromatic dopant candidates.

The next phase of our doping strategy, which is the focus of this thesis, was to develop the initial screening protocol of the SONY-Durham collaboration into a systematic study concerning how the molecular structures of a range of fluorinated biphenyl ether derivatives affect the performance of doped commercial LC systems. In particular, further studies into the ‘head-group’ fluorination pattern of each additive were undertaken to ascertain whether or not there is a link between the dipole moment of a dopant and device response time. Additional investigations into how dopant alkylation

alters the performance of an LC mixture were also undertaken to complete the work initiated in Phase 2. In order to achieve these goals, the syntheses of range of polyfluorinated biaryl ether derivatives were targeted [Figure 10].

Figure 10. Phase 4: Target dopant structures

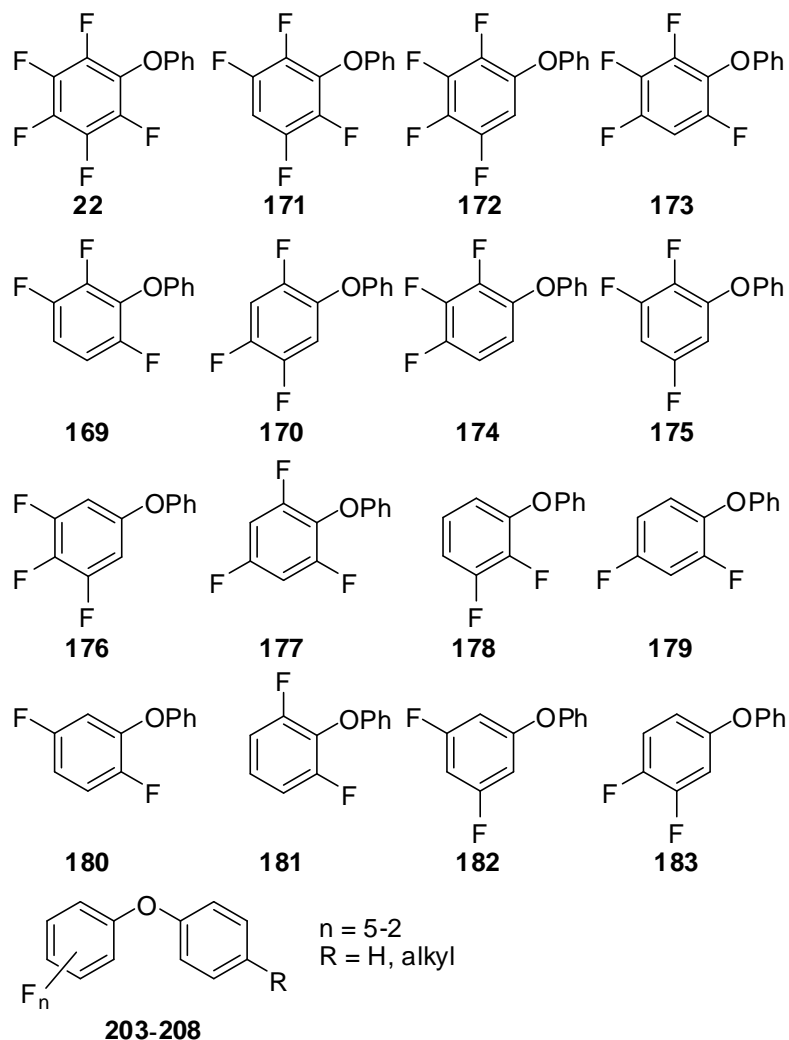

Of these target systems, synthetic routes to polyfluorobiphenyl ether systems **22**, **170**, **171** and **175** have already been described in the literature. Pentafluorophenoxybenzene (**22**) was first synthesised by a nucleophilic aromatic substitution reaction of hexafluorobenzene (**11**) with potassium phenoxide to afford the desired product in moderate yield, together with a small quantity of disubstituted material (**184**).¹ The same group also reported the synthesis of pentafluorophenoxybenzene (**22**) by a copper-mediated oxidative coupling reaction of bromobenzene with potassium pentafluorophenoxide, although the isolated yield of product was significantly reduced [Scheme 43].

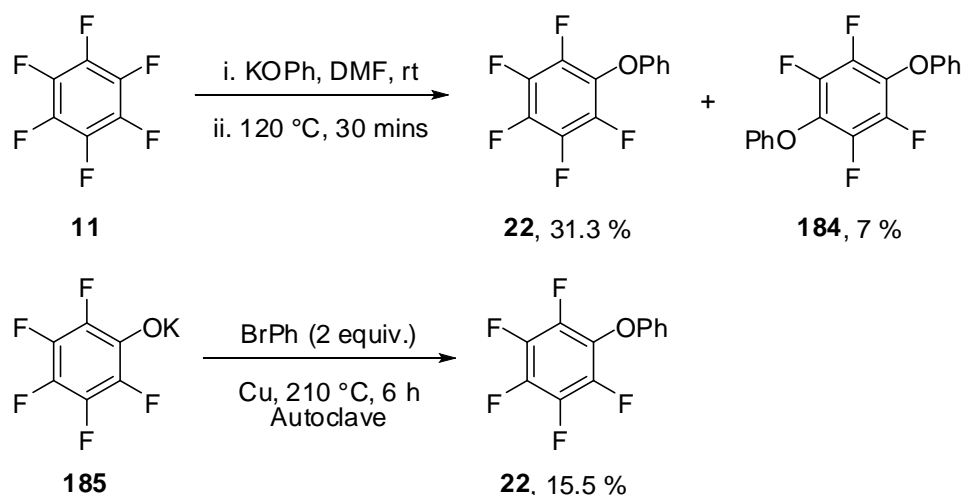
Scheme 43. First documented syntheses of pentafluorophenoxybenzene (**22**)

More recently, pentafluorophenoxybenzene was isolated as a minor product (4%) in the reaction of sodium pentafluorophenoxide with phenylplumbanetriyl triacetate, although this is clearly not a practical route to the desired material.²

1,2,4,5-Tetrafluoro-3-phenoxybenzene (**171**) was synthesised in very low yield by an oxidative coupling reaction of bromopentafluorobenzene (**186**) with phenol, cuprous oxide and a polar aprotic solvent [Scheme 44].³

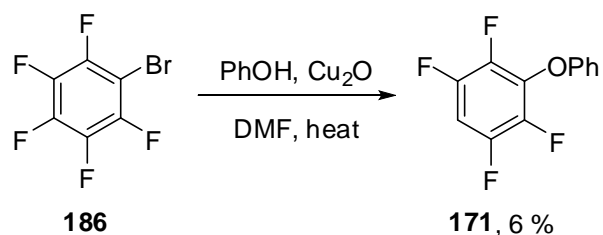
Scheme 44. Synthesis of 1,2,4,5-tetrafluoro-3-phenoxybenzene (**171**)

As part of the Durham/Sony collaboration, the two trifluorobenzene derivatives (**169** and **170**) were synthesised in a two step procedure by nucleophilic aromatic substitution reactions of sodium phenoxide with the corresponding highly activated dibromotetrafluorobenzene system (**187** or **189**) and subsequent hydrodebromination by lithium-halogen exchange [Scheme 45].⁴

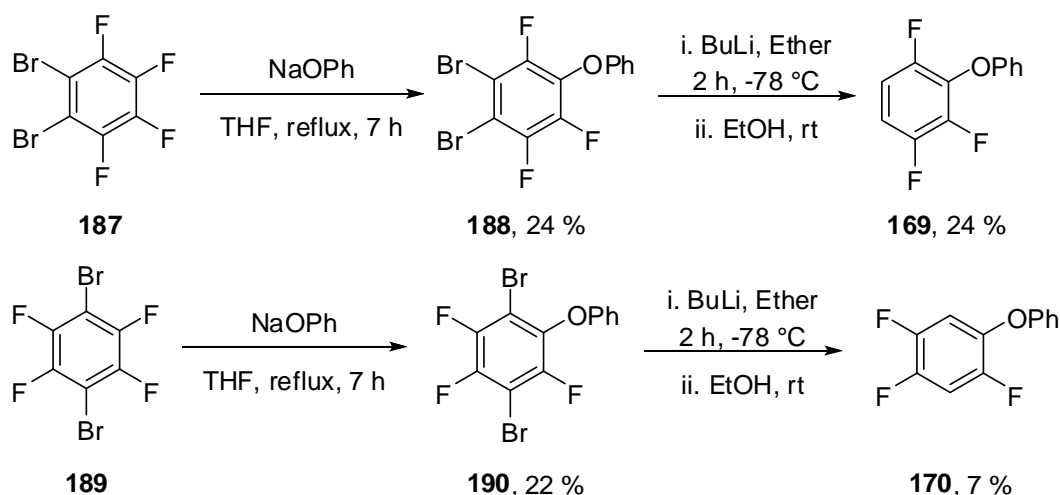
Scheme 45. Syntheses of two trifluorophenoxybenzene derivatives (**169–170**)

Complete consumption of starting material was observed for each of the S_NAr processes, although product purification proved difficult and resulted in low isolated yields of products of **188** and **190**. The hydrodebromination reactions led to complex reaction mixtures and only low quantities of product could be isolated. Indeed, the S_NAr reaction of 1,3-dibromotetrafluorobenzene (**191**) with sodium phenoxide to **192** was successful, although no target product (**175**) was isolated from the hydrodebromination mixture [Scheme 46].

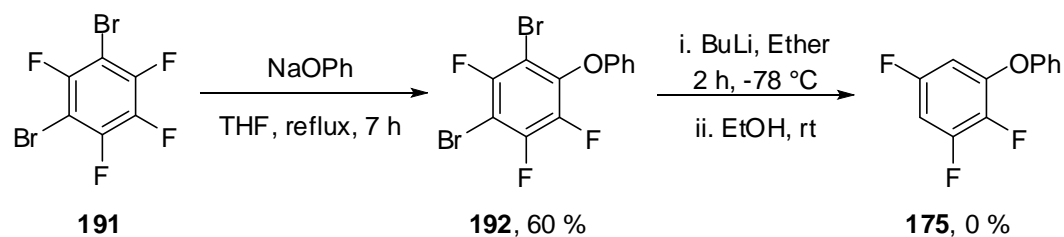
Scheme 46. Reaction of 1,3-dibromotetrafluorobenzene (**191**) with sodium phenoxide

As the documented synthetic routes to the known tetra- and tri-fluorobiphenyl ether derivatives are very low yielding, further optimisation or new methodology is required to improve their syntheses. The remaining tetra-, tri- and di-fluorinated target materials shown in Figure 10 are not currently known and an appropriate synthetic strategy for the preparation of these systems was, therefore, required before electro-optical properties could be explored.

2.3 Synthetic Strategy

Highly fluorinated aromatic systems are reactive towards nucleophilic attack and a wide range of experimental data concerning the regioselectivity and rates of reaction of polyfluoroaromatic derivatives with various nucleophiles has been collected.⁵ The aforementioned synthesis of pentafluorophenoxybenzene by the nucleophilic aromatic substitution reaction of potassium phenoxide with hexafluorobenzene is a potentially useful synthetic route to other highly fluorinated biaryl ether derivatives [Scheme 47].

Scheme 47. Strategy 1: Nucleophilic aromatic substitution methodology for the synthesis of fluorinated biaryl ether derivatives

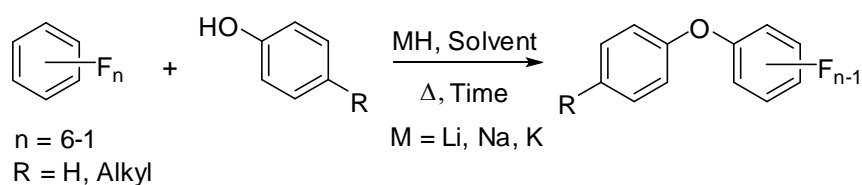

Less fluorinated aromatic systems are expected to be less reactive towards nucleophilic substitution and so other synthetic routes to the corresponding biaryl ether derivatives may be required. One commonly adopted method of improving the electrophilicity of these systems for biaryl ether synthesis is to introduce additional electron withdrawing substituents such as halogeno, cyano, triazenyl, methylcarbonyl and, especially, nitro groups onto the aromatic ring.⁶⁻⁹

In this respect, each of the dibromotetrafluorobenzene systems have been previously identified as suitable substrates towards various phenoxydefluorination reactions with sodium phenoxide. The carbon-bromine bonds in each of the product materials may be removed by lithium-halogen exchange techniques, however, these processes need to be developed further to improve overall product yields [Scheme 48].

Scheme 48. Strategy 2: Two-step S_NAr -hydrodebromination process to access less fluorinated biaryl ethers

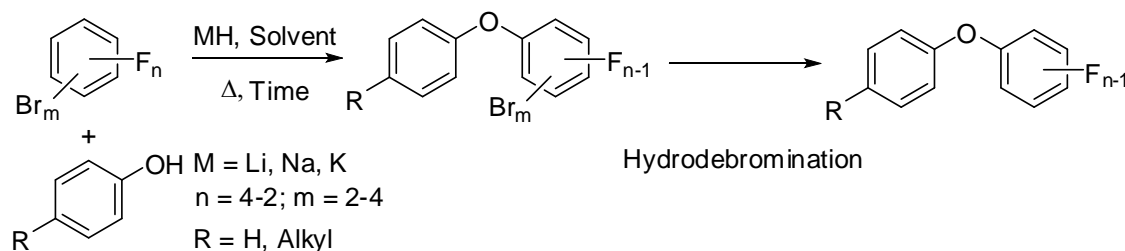

In 2005 Ripin and Vetelino discovered that 2-fluoronitrobenzene (**81**) is sufficiently electrophilic to undergo nucleophilic aromatic substitution reactions with sodium phenoxide under mild conditions [Scheme 49].¹⁰ Indeed, strongly activating nitro groups are particularly attractive substituents for biaryl ether synthesis as they can also be used as chemical handles with which to further derivatise the host system by, for example, conventional reduction-diazotisation-functionalisation processes.

Scheme 49. Reaction of 2-fluoronitrobenzene (**81**) with sodium phenoxide

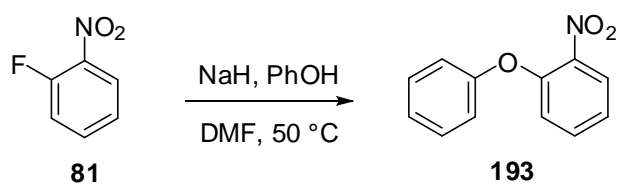

Therefore, we propose a third synthetic strategy to various polyfluoroaromatic systems [Scheme 50]. It will be important to establish whether or not it is best to place additional fluorine substituents on either the nucleophile or the electrophile. The former is likely to have a detrimental effect on the nucleophilicity of the phenol and so reduce the efficiency of the reaction, whereas the use of fluoronitrobenzene derivatives as starting materials may open up problematic regioselectivity issues.

Scheme 50. Strategy 3: Three-step S_NAr -reduction-diazotisation process to access less fluorinated biaryl ethers

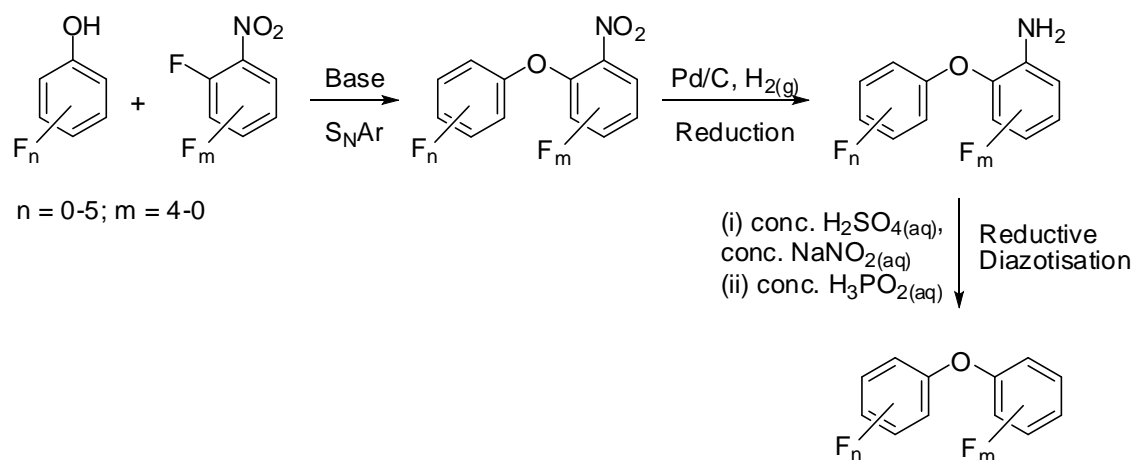

Palladium-catalysed reduction of nitroaromatics to anilines is well documented and reductive diazotisation is traditionally achieved using hypophosphoric acid.¹¹ In general, other common methods of biaryl ether formation include variations of the Ullmann biaryl ether synthesis,¹² the copper-mediated Chan-Lam modification to the Ullmann biaryl ether synthesis¹³ and palladium-catalysed Buchwald-Hartwig type^{14,15} reactions [Scheme 51].

The Ullmann biaryl ether synthesis generally concerns the high temperature oxidative coupling of a phenol derivative to a bromo- or iodo-benzene system and yields of product tend to be moderate to poor. The Chan-Lam modification to the Ullmann biaryl ether synthesis regards the coupling of aryl boronic acids with phenol derivatives and much milder reaction conditions are usually employed for these processes. Buchwald-Hartwig processes are the palladium-catalysed analogues of Ullmann biaryl ether syntheses and involve the use of sterically hindered phosphine ligands to encourage reductive elimination of the ether linkage from the metal centre.

Scheme 51. Examples of recent fluorinated biaryl ether syntheses: (a)¹⁶ Ullmann biaryl ether synthesis; (b)¹⁷ Chan-Lam modification to the Ullmann biaryl ether synthesis; (c)¹⁸ Buchwald-Hartwig cross-coupling reaction.

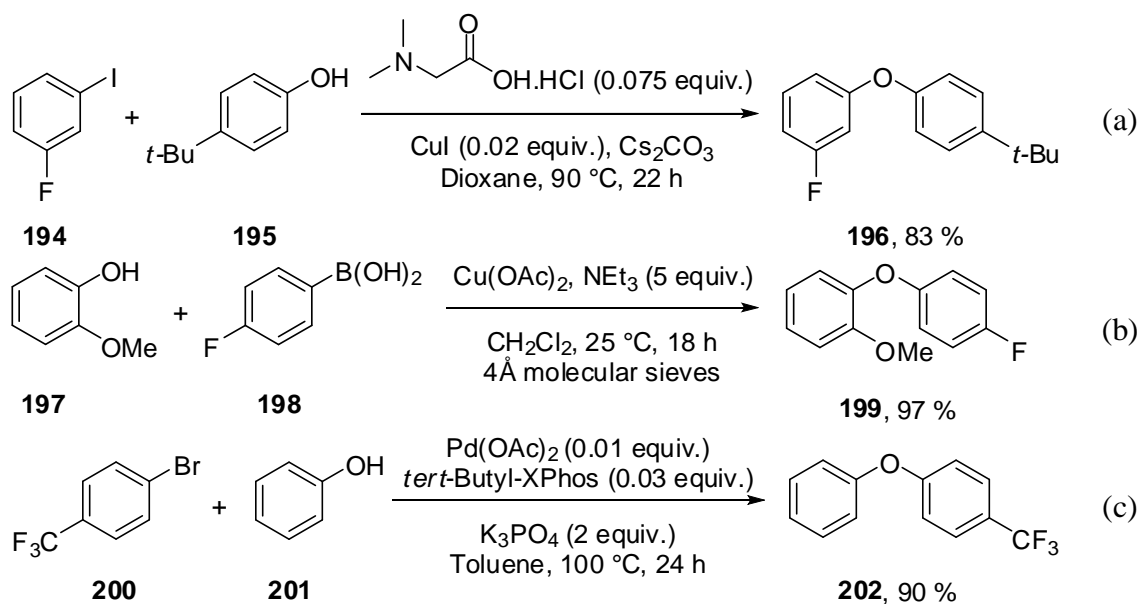

All three methods represent potential routes to the targeted polyfluorinated biaryl ether derivatives and so a fourth and final synthetic strategy to these types of target systems is proposed [Scheme 52].

Scheme 52. Strategy 4: Proposed synthesis of fluorinated biaryl ethers by palladium-catalysed or copper-mediated processes.

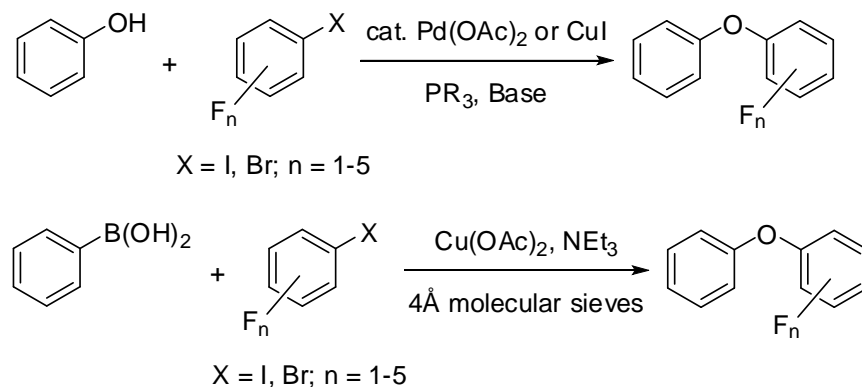

2.4 Results and Discussion

2.4.1 Strategy 1: Dopant Synthesis by Nucleophilic Aromatic Substitution Reactions of Phenoxide Derivatives with Polyfluorobenzene Systems

Nucleophilic aromatic substitution ($S_{\text{N}}\text{Ar}$) reactions have been identified as a useful strategy for the syntheses of polyfluorinated systems and experimental results concerning $S_{\text{N}}\text{Ar}$ reactions of nucleophilic phenoxide derivatives with a range of polyfluorobenzenes are presented and discussed in this section.

2.4.1.1 Reactions of Sodium Phenoxide with Polyfluorobenzene Derivatives

The synthesis of pentafluorophenoxybenzene (**22**) was achieved by the reaction of sodium phenoxide with hexafluorobenzene (**11**) by an adaptation of a literature procedure, whereby solvent acetonitrile was used in preference to DMF [Scheme 53].¹

Scheme 53. Reaction of hexafluorobenzene (**11**) with sodium phenoxide

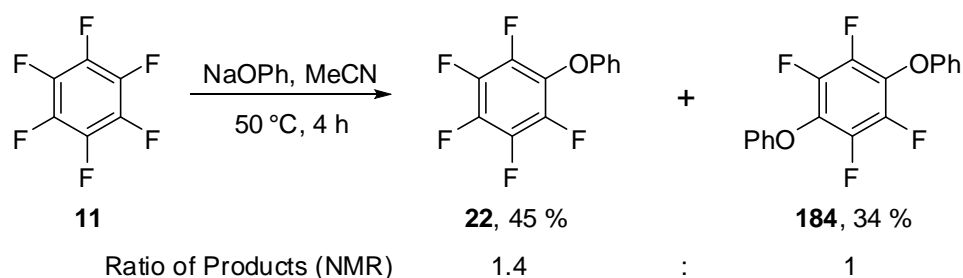

A significant quantity of disubstituted adduct **184** was formed alongside target material **22** and residual hexafluorobenzene (**11**) was observed by ^{19}F NMR spectroscopic analysis of the crude reaction mixture. It is evident that pentafluorophenoxybenzene remains sufficiently electrophilic to react with another equivalent of sodium phenoxide under the reaction conditions to form **184**, in a competing process with the desired phenoxydefluorination of **1**. The structure of **22** is confirmed by the observation of three resonances at -154.4 , -160.4 and -162.6 ppm in the ^{19}F NMR spectrum of the isolated product, which have integrals of 2:1:2, respectively. ^{19}F NMR spectroscopic analysis also confirms the structure of **184** by the observation of a single resonance at -154.8 ppm, which is consistent with literature data.¹

By a similar process, reaction of pentafluorobenzene (**18**) with sodium phenoxide affords only monosubstituted 1,2,4,5-tetrafluoro-3-phenoxybenzene (**171**) in 61 % yield, a significant improvement on the documented oxidative coupling reaction of bromopentafluorobenzene with phenol [Scheme 54].³

Scheme 54. Reaction of pentafluorobenzene (**18**) with sodium phenoxide

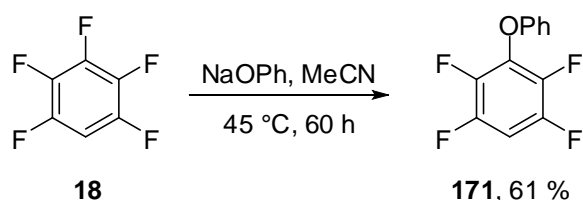

The molecular structure of **171** is confirmed by the observation of two resonances at –139.3 and –154.4 ppm by ¹⁹F NMR spectroscopy. Substitution of any other fluorine atom would result in a product containing four magnetically unique fluorine environments and so give 4 resonances in the corresponding ¹⁹F NMR spectrum.

The three tetrafluorobenzene derivatives (**49**, **52** and **55**) were observed to be markedly less reactive towards nucleophilic substitution than their more fluorinated counterparts (**11** and **18**) because of the reduction in electrophilicity brought about by a lower number of activating ring fluorine substituents. Direct phenoxydefluorination of **49** and **52** was achieved with sodium phenoxide under microwave irradiation to afford trifluorophenoxybenzene derivatives **169** and **175** in moderate yield, whereas no reaction of **55** with sodium phenoxide was observed even after prolonged heating at elevated temperatures [Table 10].

Table 10. Reactions of **49**, **52** and **55** with sodium phenoxide

Fc1ccc(F)cc1
 $\xrightarrow[\mu\text{W}, \Delta]{\text{NaOPh, MeCN}}$
Fc1ccc(Oc2ccccc2)cc1

| Substrate | Product, (Yield / %) |
|---------------|------------------------------------|
| 49 | 169 , (69) ^a |
| 52 | 175 , (60) ^a |
| 55 | 170 , (0) ^b |

Conditions: ^a150 °C, 30 mins; ^b180 °C, 1 h.

Complete conversion of **49** and **52** was observed by ¹⁹F NMR spectroscopy and the reactions were regioselective, although the formation of a significant quantity of tarry material under the forcing reaction conditions meant overall yields of **169** and **175** were slightly reduced. The structures of **169** and **175** can be confirmed by substituent chemical shift (SCS) calculations, under the reliable assumption¹⁹ that the effect of phenoxydefluorination has a consistent additive effect on the ¹⁹F NMR spectroscopic chemical shifts of each remaining fluorine environment.

At the time of writing a complete set of experimental SCS values for the phenoxy substituent had not been determined, however, they may be calculated by considering the chemical shifts of each of the fluorine atoms in biphenyl ether derivatives **22** and **171** compared with hexa- and penta-fluorobenzene, respectively [Figure 11].

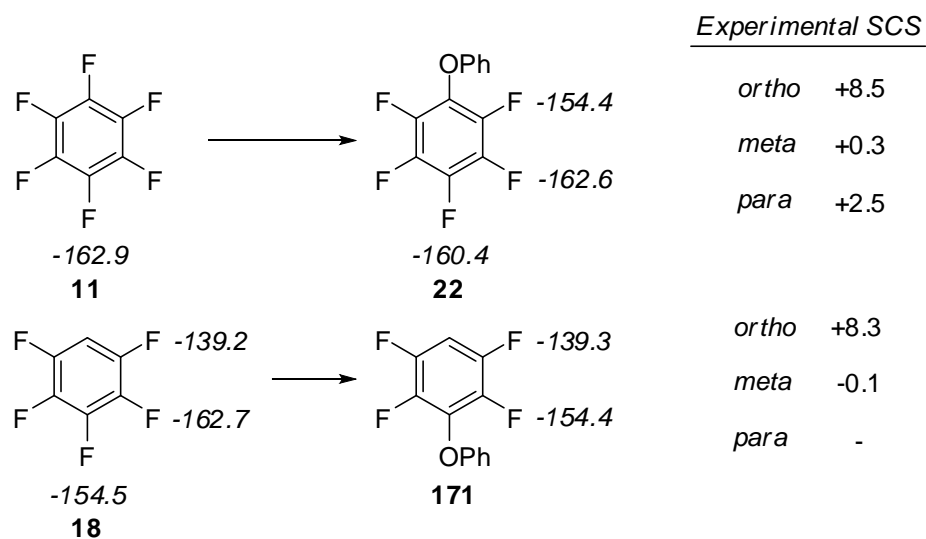
Figure 11. Chemical shifts of hexafluorobenzene (**11**), pentafluorobenzene (**18**), **22** and **171** and calculated substituent chemical shift parameters

On average, and relative to ring fluorine in the same position, a phenoxy substituent will cause the chemical shift of *ortho*, *meta* and *para* fluorine to be located approximately 8.4, 0.1 and 2.5 ppm downfield, respectively. It is possible to apply these calculated SCS values for the phenoxy group to the chemical shifts of each of the tetrafluorobenzene²⁰ derivatives to assign the regiochemistry of each reaction product and to allow each ¹⁹F NMR spectroscopic resonance to be confidently assigned [Figure 12].

Figure 12. Calculated and experimental chemical shifts for trifluorophenoxybenzene derivatives. Experimental data are shown in parentheses.

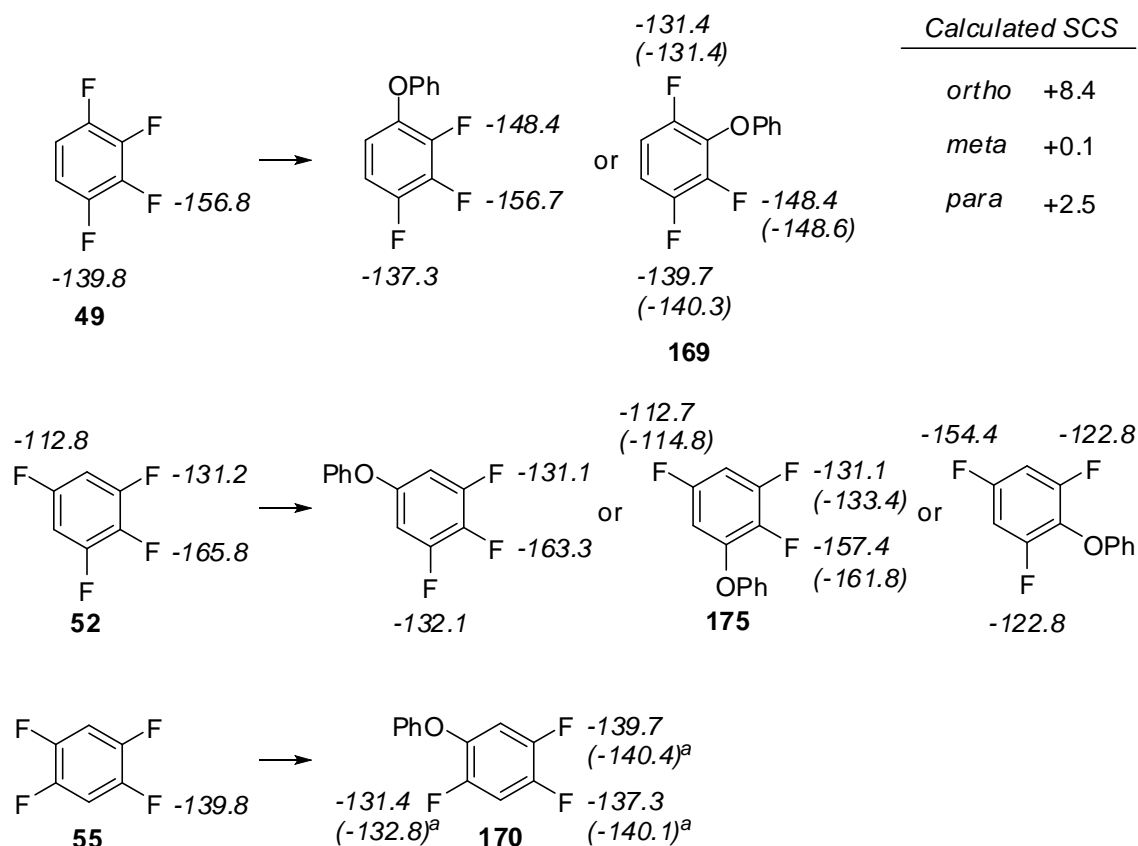

^aAs reported in reference [4]

There is an excellent match between the theoretical and experimental chemical shift values for trifluorinated biphenyl ether derivatives **169**, **175** and **170** and similar SCS analyses will be used in subsequent chapters to assign the spectra of other fluorinated biaryl ether systems.

Although only a handful of examples²¹⁻³¹ of S_NAr reactions of **49**, **52** and **55** have been previously reported, the overall reactivity profile of polyfluoroaromatic systems is well established and, in general, nucleophilic attack is observed to occur preferentially at sites activated by the greatest number of *ortho* and *meta* ring fluorine substituents.³² The preferred sites of phenoxydefluorination of **49**, **52** and **55** can be explained using this model [Figure 13].

Figure 13. Preferred sites of nucleophilic attack of tetrafluorobenzene derivatives **49**, **52** and **55**

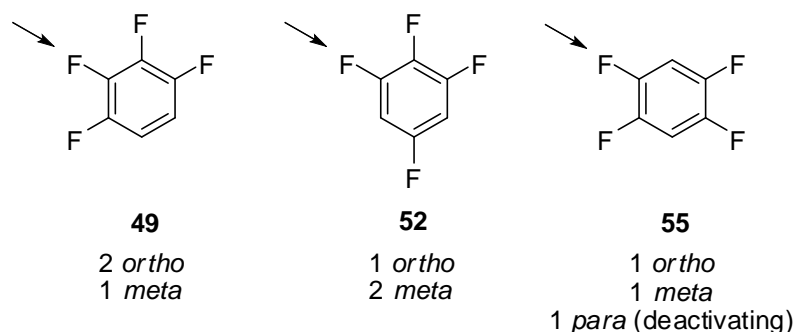

The relatively low reactivity of 1,2,4,5-tetrafluorobenzene (**55**) towards sodium phenoxide can be rationalised by the fact that it is only activated by one *ortho* and one *meta* fluorine atom and is slightly deactivated towards nucleophilic substitution by a *para* fluorine substituent.

Reactions of 1,2,3-trifluorobenzene and 1,3,5-trifluorobenzene with sodium phenoxide were attempted under microwave irradiation although only starting material was detected by ^{19}F NMR spectroscopic analysis of each crude reaction mixture. The poor electrophilicities of these substrates renders them useless for direct functionalisation reactions by $\text{S}_{\text{N}}\text{Ar}$ process by all but the most reactive of nucleophiles.

2.4.1.2 Syntheses of Alkylated Polyfluorobiphenyl Ether Derivatives

To complete the work initiated in Phase 2 of the SONY/Durham collaboration, a number of alkylated polyfluorobiphenyl ether derivatives are required for a thorough electro-optical investigation into how dopant alkylation affects the properties of a doped LC mixture.

Subsequently, two families of alkylated biphenyl ether derivatives (**203–208**) were synthesised by $\text{S}_{\text{N}}\text{Ar}$ reactions of several *para*-alkylated phenoxide nucleophiles with penta- and 1,2,3,4-tetra-fluorobenzene in good to excellent yield using the methodology developed in Section 2.4.1.1 [Table 11].

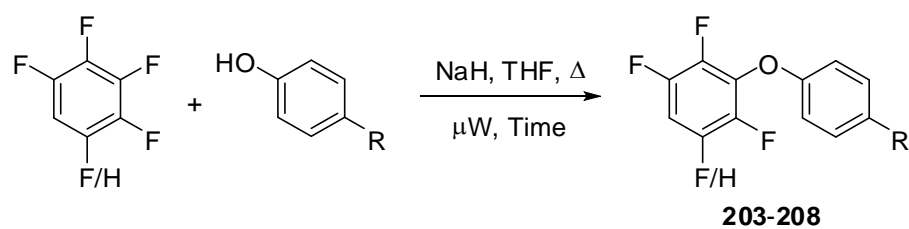
Table 11. Syntheses of 4-*n*-alkylated biphenyl ether derivatives **203–208**

| Electrophile | R | Product, (Yield / %) |
|--------------|--------------------------------|------------------------------------|
| | C ₂ H ₅ | 203 , (94) ^a |
| | C ₅ H ₁₁ | 204 , (90) ^a |
| | C ₇ H ₁₅ | 205 , (82) ^a |
| | C ₂ H ₅ | 206 , (74) ^b |
| | C ₅ H ₁₁ | 207 , (65) ^b |
| | C ₇ H ₁₅ | 208 , (62) ^b |

Conditions: ^a160 °C, 1 h; ^b180 °C, 1 h.

The reactions were carried out in THF, a compatible solvent for the sodium hydride base although, from the results of earlier S_NAr reactions, it appears that acetonitrile is a better solvent for general phenoxydefluorination of polyfluorobenzenes as, in THF,

prolonged heating at elevated temperatures under microwave irradiation is required in order to achieve complete conversion of the starting material to products.

The ^{19}F NMR spectra of all 6 polyfluorinated biaryl ether derivatives **203–206** were observed to be almost identical to those of the corresponding non-alkylated systems **169** and **171**, confirming their respective structures.

2.4.2 Strategy 2: Syntheses of Trifluorophenoxybenzene Derivatives by the Development of a Two-Step $\text{S}_{\text{N}}\text{Ar}$ -Hydrodebromination Protocol

In Phases 2 and 3 of the SONY-Durham research collaboration the highly electrophilic dibromotetrafluorobenzenes were identified as useful substrates from which to synthesise a range of trifluorophenoxybenzene derivatives by a two-step $\text{S}_{\text{N}}\text{Ar}$ -hydrodebromination process.⁴ The practicality of this procedure is, however, limited by the very low isolated yields of target material upon hydrodebromination by lithium-halogen exchange. If the greater electrophilicities of the highly activated dibromotetrafluorobenzene derivatives are to be successfully exploited as part of a $\text{S}_{\text{N}}\text{Ar}$ -hydrodebromination strategy, then a more efficient hydrodebromination protocol is required.

2.4.2.1 Step 1: $\text{S}_{\text{N}}\text{Ar}$ Reactions of Dibromotetrafluorobenzene Systems with Sodium Phenoxide

The first step of this process was to synthesise the dibromotrifluorophenoxybenzene derivatives from the parent dibromotetrafluorobenzene systems, as previously reported.⁴ Reaction of each of the dibromotetrafluorobenzene derivatives (**187**, **189** and **191**) with sodium phenoxide in acetonitrile proceeded as expected, although the moderate isolated yield of product is a reflection of the difficulties encountered in the separation of the desired biaryl ether derivative from some tarry material and small quantities of several unidentified side-products [Table 12].

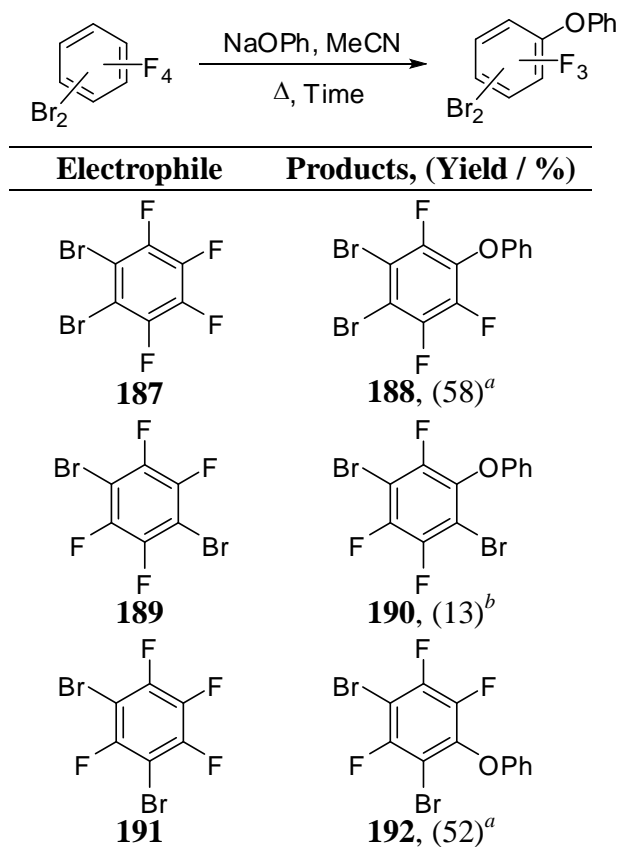
Table 12. Reactions of each of the dibromotetrafluorobenzenes derivatives (**187**, **189** and **191**) with sodium phenoxide

Conditions: ^a50 °C, 18 h; ^b150 °C, μW , 30 mins

The preferred sites of nucleophilic substitution of **187**, **189** and **191** with sodium phenoxide are consistent with the literature precedent⁴ and the structure of **188** has now been confirmed by X-ray crystallography [Figure 14].

Figure 14. X-Ray molecular structure of 1,2-dibromo-3,4,6-trifluoro-5-phenoxybenzene (**188**). ORTEPs set at 50% probability level. Bond lengths (Å): $Br_1-C_1 = 1.871(2)$; $Br_2-C_2 = 1.880(2)$; $C_4-O_1 = 1.365(3)$; $C_7-O_1 = 1.404(3)$. Bond angles ($^\circ$): $C_4-O_1-C_7 = 118.81(17)$; $C_3-C_4-O_1-C_7 = 69.4(3)$.

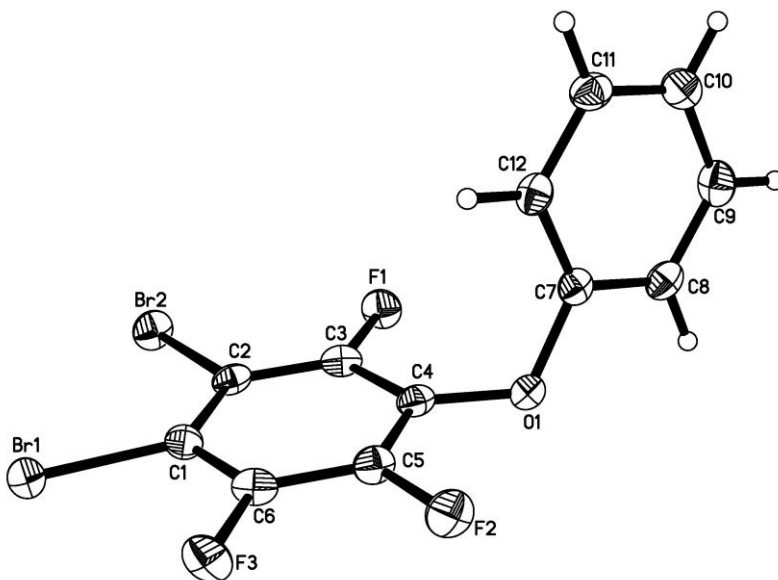

| | |
|----------------------------------------------------|-------------------------------------|
| Temperature/K | 120.15 |
| Crystal system | Monoclinic |
| Space group | $P2_1/c$ |
| $a/\text{Å}$, $b/\text{Å}$, $c/\text{Å}$ | 10.3435(2), 5.80410(10), 19.3488(4) |
| $\alpha/^\circ$, $\beta/^\circ$, $\gamma/^\circ$ | 90.00, 93.271(10), 90.00 |
| Volume/ Å^3 | 1159.71(4) |
| Z | 4 |
| Goodness-of-fit on F^2 | 0.961 |

Reaction of **189** with sodium phenoxide was successful although the isolated yield of biphenyl ether derivative **190** was much poorer than expected. GC–MS and ^{19}F NMR analysis of the crude reaction mixture revealed that the major product of this reaction was actually highly volatile 1,2,4,5-tetrafluoro-3-bromobenzene (**209**) ($m/z = 228$), which is formed in a 3 : 1 ratio relative to target material **190**.

It is likely that **209** is formed by the competing bromophilic attack of sodium phenoxide with **189** to generate an inductively stabilised anionic intermediate which is then either

protonated *in situ* by trace water, or during the aqueous work-up. Indeed, similar processes were documented in reactions of 2,4,6-tribromo-3,5-difluoropyridine with various nucleophiles.³³ Several additional side-products **210–211** were also detected by GC–MS and ¹⁹F NMR spectroscopic analysis and are assigned as systems resulting from further S_NAr or bromophilic attack processes and a schematic diagram of the overall reaction profile can be proposed [Figure 15].

Figure 15. Schematic for the reaction of sodium phenoxide with 1,4-dibromotetrafluorobenzene (**189**).

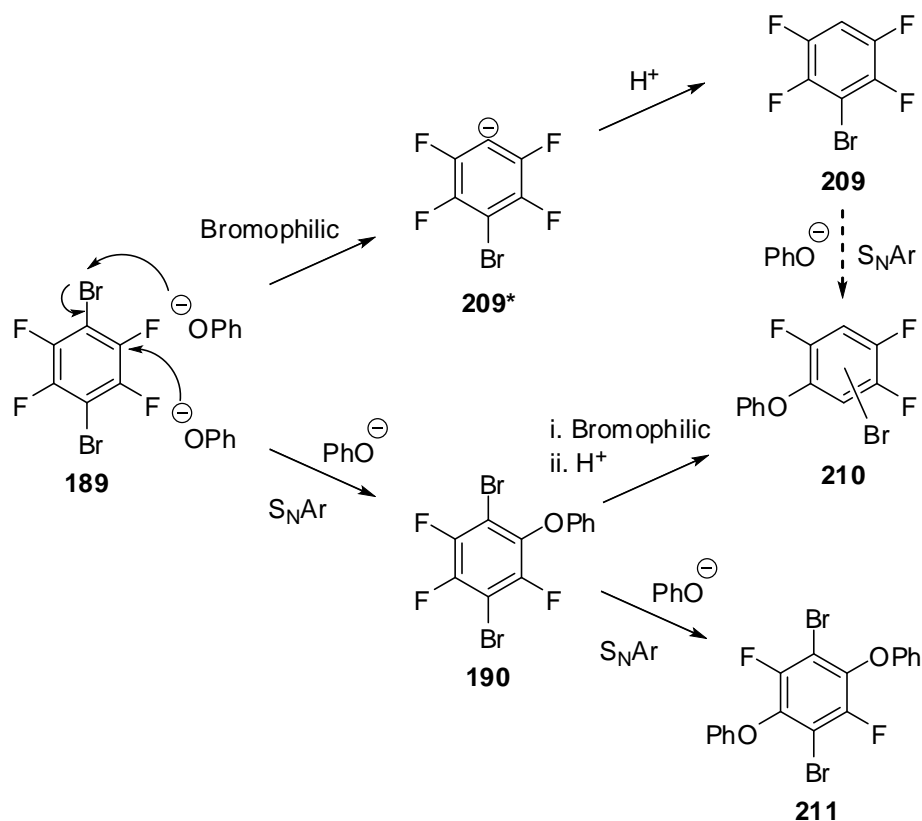

The reaction of pure **190** with sodium phenoxide afforded a mixture of hydrodebrominated adduct **210** and disubstituted **211** [Scheme 55]. ¹⁹F NMR spectroscopic analysis confirmed that complete consumption of **190** was achieved with a single resonance at –121.4 ppm, corresponding to **211**, and three new resonances of equal intensity at –127.8, –132.7 and –136.0 ppm corresponding to **210**, however, it has not been possible to unambiguously assign the structure of **210** and no products were isolated. GC–MS analysis of the crude reaction mixture indicated the presence of two major products, with *m/z* = 302 and 454 atomic mass units, which are consistent with the products **210** and **211**, respectively.

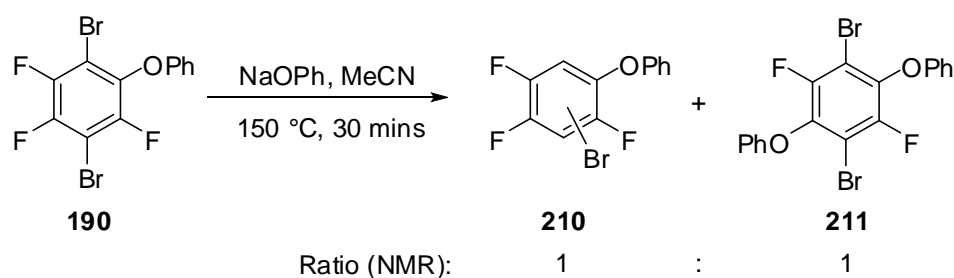
Scheme 55. Reaction of dibromotrifluorophenoxybenzene (**190**) with sodium phenoxide

No direct evidence for the formation of **210** from **209** was obtained, however, the corresponding methoxydefluorination reaction of **209** has been reported under milder conditions than those employed in this procedure.³⁴

2.4.2.2 Step 2: Palladium-catalysed Hydrodebromination Reactions of Dibromotrifluorophenoxybenzene Derivatives

The second part of this synthetic strategy concerns the substitution of aryl bromine atoms hydrogen to access the desired trifluorophenoxybenzene derivatives. Metal-halogen exchange techniques have already been attempted and proved to be inefficient processes which afforded only very low yields of target material and so alternative methodology was required.

Palladium-catalysed hydrodebromination reactions are well documented^{35,36} and, although they generally involve conventional autoclave reactors, recent technological developments in flow-hydrogenation techniques allow for a more controlled hydrogenation protocol. Hydrodebromination of **188**, **190** and **192** was achieved with a *ThalesNano* H-Cube®, whereby a dilute solution (0.01 M) of the substrate in HPLC grade methanol is passed over a heterogeneous catalyst (10 % Pd/C) at a controlled flow rate (1 ml / min), specific temperature (50 °C) and pressure (20 bar) [Table 13]. Hydrogen gas is produced from the electrolysis of high-purity water, which is injected into the flow stream before the substrate reaches the catalyst.

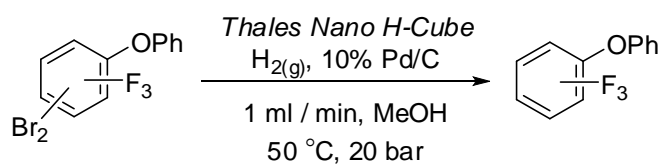
Table 13. Hydrodebromination of biphenyl ether derivatives **188**, **190** and **192**

| Electrophile | Products, (Yield / %) |
|-------------------|-------------------------|
| <p>188</p> | <p>169, (95)</p> |
| <p>190</p> | <p>170, (94)</p> |
| <p>192</p> | <p>175, (87)</p> |

Complete conversion of starting materials was observed by ^{19}F NMR spectroscopic analysis and, after purification by column chromatography, each product displayed two resonances in the aromatic region of their respective ^1H NMR spectra, confirming the successful removal of aryl bromine. Over two synthetic steps, this strategy is as efficient as the direct $\text{S}_{\text{N}}\text{Ar}$ phenoxydefluorination reactions of tetrafluorobenzene derivatives **49** and **52**, although the one-step procedure did not provide a route to 1,2,5-trifluoro-4-phenoxybenzene (**170**). The high isolated yields of **169**, **170** and **175** are a reflection of the high efficiency of this *in-situ* flow hydrogenation methodology with respect to conventional metal-halogen exchange reactions or high pressure autoclave procedures.

2.4.3 Strategy 3: Dopant Synthesis by a Three-Step Directed S_NAr-Reduction-Diazotisation Pathway

Tetrafluorobenzene derivatives have been shown to be poorly activated towards nucleophilic attack by sodium phenoxide and prolonged heating at elevated temperatures were required to synthesise corresponding trifluorophenoxybenzene systems (**169** and **175**). The replacement of aryl hydrogen for activating bromine substituents on the fluoroaromatic ring greatly improved the electrophilicity of the system, although corresponding phenoxydefluorination reactions were only moderately efficient.

The desired difluorophenoxybenzene derivatives may be, theoretically, accessed from parent tribromotrifluorobenzene systems by the two-step S_NAr-hydrodebromination protocol developed in Section 2.4.2, although bromophilic attack processes and tar formation is potentially problematic. To avoid these problems and to establish a synthetic route to all of the targeted difluorophenoxybenzene isomers, the reactions of several fluorinated nitrobenzene derivatives with sodium phenoxide were investigated.

2.4.3.1 Step 1: S_NAr Reactions of Sodium Phenoxide with Fluorinated Nitrobenzene Derivatives

Reaction of sodium phenoxide with trifluoronitrobenzene derivatives **212**, **214** and **216** under microwave irradiation resulted in complete regioselective conversion of starting materials to biaryl ether derivatives **213**, **215** and **217** in good to excellent yields [Table 14].

Table 14. Reactions of trifluoronitrobenzene derivatives **212**, **214** and **216** with sodium phenoxide

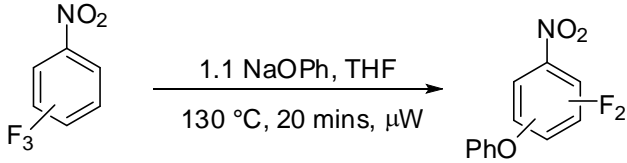
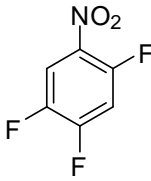
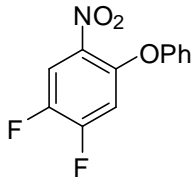
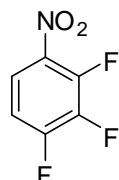
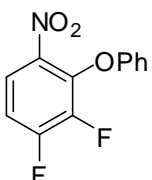
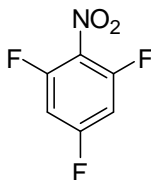
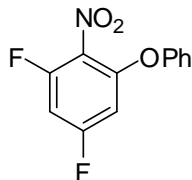
| Substrate | Product, (Yield / %) |
|---------------------------------------------------------------------------------------------------|----------------------------------------------------------------------------------------------------------|
|  | |
|  212 |  213 , (74) |
|  214 |  215 , (62) |
|  216 |  217 , (95) |

The molecular structure of **213** is assigned through the observation of two doublets of doublets at 145.2 ppm ($^1J_{CF} = 250$ Hz, $^2J_{CF} = 14.0$ Hz) and 153.7 ppm ($^1J_{CF} = 260$ Hz, $^2J_{CF} = 13.8$ Hz) by ^{13}C NMR spectroscopy, both of which display characteristic $^1J_{CF}$ and $^2J_{CF}$ coupling constants. The structure of **215** cannot be confidently assigned in the same way as nucleophilic substitution *ortho* or *para* to the nitro group would give rise to two doublets of doublets exhibiting $^1J_{CF}$ and $^2J_{CF}$ coupling constants. The structure of **215** may, however, be confirmed through SCS calculations on the effect of phenoxydefluorination on the known chemical shifts of each of the three starting materials **212**, **214** and **216** [Figure 16].³⁷

Difluorobiphenyl ether derivative **217** must be *ortho* substituted as two fluorine environments are observed by ^{19}F NMR spectroscopy, whereas substitution *para* to the

nitro group would result in the formation of a symmetrical product with only one fluorine signal. Nevertheless, SCS calculations for all three products **213**, **215** and **217** are particularly useful for the assignment of each fluorine substituent to its associated chemical shift.

Figure 16. Calculated ^{19}F NMR chemical shifts of **213**, **215** and **217**. Experimental values are shown in parentheses.

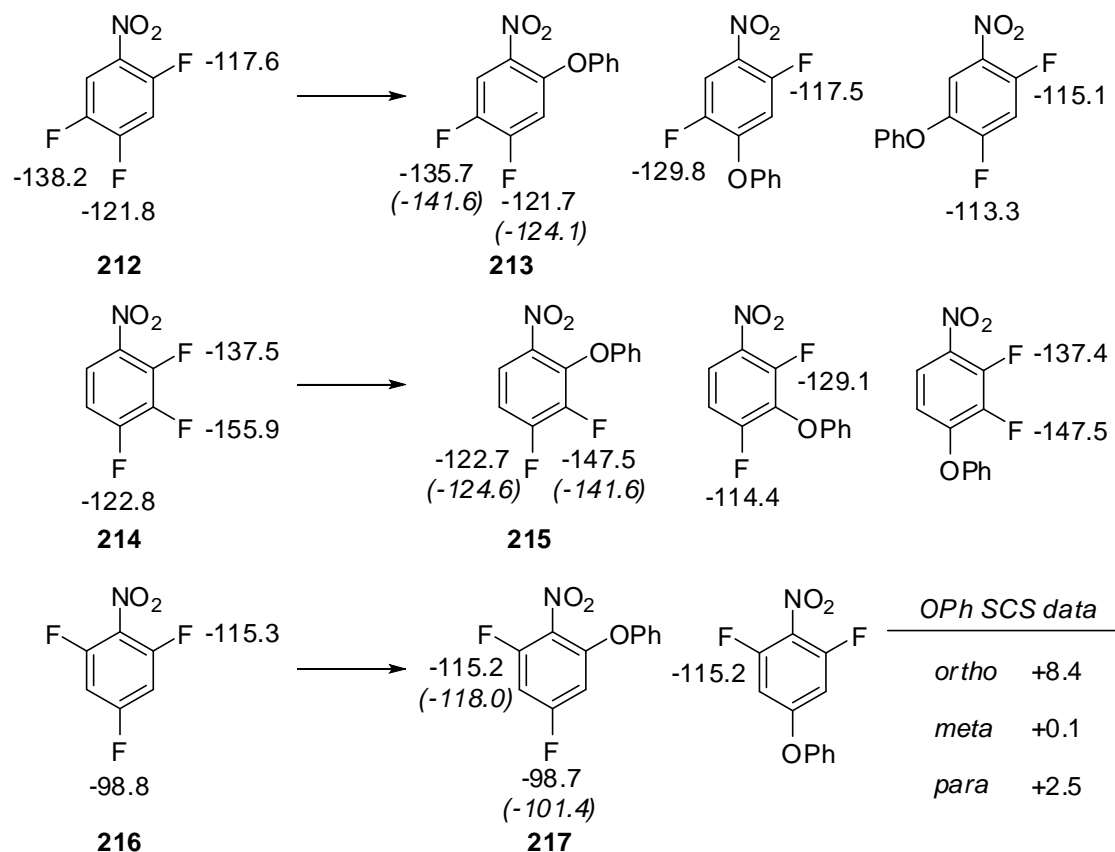

As regioselective *ortho* phenoxydefluorination is observed for all three processes, it is plausible that a significant directing interaction between incoming nucleophile and the pendant nitro group is in operation [Figure 17]. There is some literature precedent for nitro-directed $\text{S}_{\text{N}}\text{Ar}$ reactions of polyfluorinated aromatic substrates; for example, reactions of lithium phenylacetylide with pentafluoronitrobenzene in diethyl ether have been shown to result in exclusive substitution *ortho* to the nitro group.³⁸

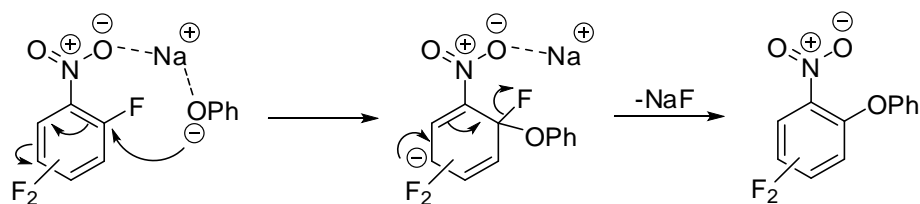
Figure 17. Potential nitro-directed mechanism of S_NAr reactions of sodium phenoxide with fluorinated nitrobenzene derivatives

Corresponding reactions of trifluoronitrobenzene systems **212**, **214** and **216** with two equivalents of sodium phenoxide under microwave irradiation afforded disubstituted derivatives (**218–220**) in moderate yields [Table 15].

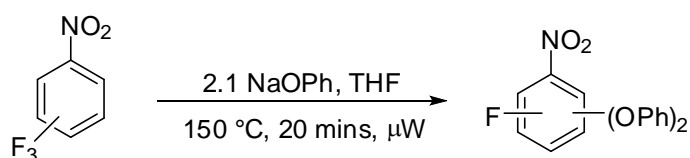
Table 15. Disubstitution reactions of trifluoronitrobenzene systems **212**, **214** and **216** with two equivalents of sodium phenoxide

| Substrate | Product, (Yield / %) |
|----------------|-----------------------|
| 212 | 218 , (68) |
| 214 | 219 , (95) |
| 216 | 220 , (96) |

The molecular structures of **218** and **219** were confirmed by SCS calculations based on the chemical shifts of monosubstituted derivatives **213** and **215**, whilst the structure of **220** is assigned through the observation of a triplet at -103.7 ppm ($^3J_{\text{FH}} = 9.6$ Hz) in the ^{19}F NMR spectrum [Figure 18].

Figure 18. Calculated ^{19}F NMR chemical shifts of **218–219**. Experimental values are shown in parentheses.

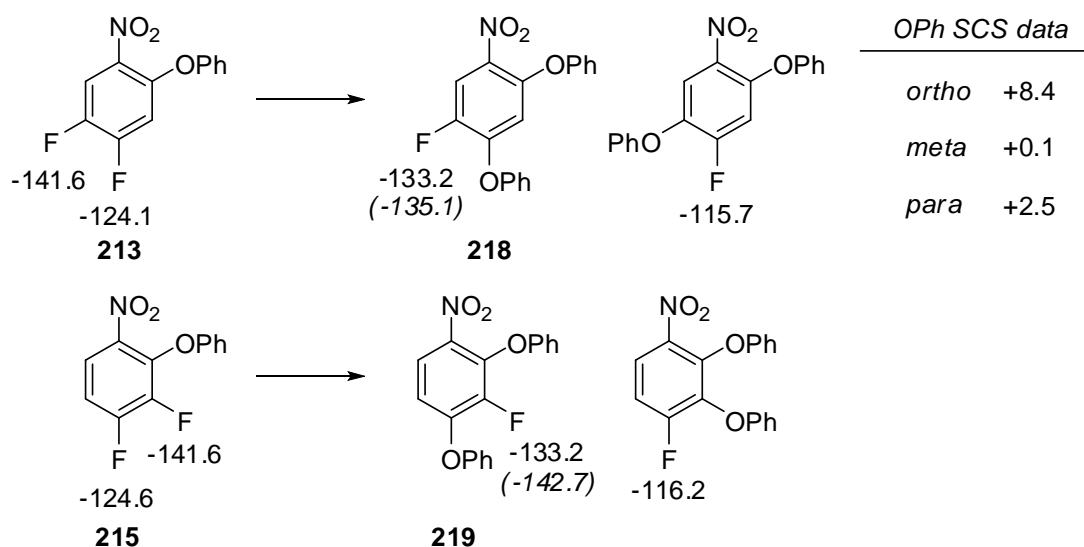

Mechanistically, regioselective phenoxydefluorination of **212**, **214** and **216** *ortho* to the nitro group occurs first, leaving a choice of substitution sites for the second step. The second substitution of **213** and **214** is observed to occur preferentially *para* to the nitro group as this is the site at which the developing negative charge of the Meisenheimer intermediate can be resonance stabilised by the nitro group itself. In disubstitution reactions of **215**, the second equivalent of sodium phenoxide substitutes preferentially *ortho*, rather than *para* to the nitro group and this is likely to be because of strong directing interactions between the nitro group and the approaching nucleophile.

Complete regioselective conversions of starting materials **213**, **214** and **216** were observed under the reaction conditions, although a small quantity of monosubstituted material remained and proved difficult to separate from the desired, disubstituted derivative. Extended heating at elevated temperatures to force the reaction towards completion was not attempted so that the excessive formation of additional tarry material could be avoided.

Reaction of 3,4,5-trifluoronitrobenzene with sodium phenoxide was not attempted and 2,3,5- and 1,3,4-tri-fluoro-2-nitrobenzene were not commercially available at the time of this research. In order to establish whether it is synthetically more efficient to have the fluorine substituents on the nitrobenzene derivative or on the nucleophilic phenoxide species the reactions of 2-fluoronitrobenzene (**81**) with all six isomers of sodium difluorophenoxide were investigated [Table 16].

Table 16. Nucleophilic aromatic substitution reactions of sodium phenoxide derivatives with 2-fluoronitrobenzene (**81**)

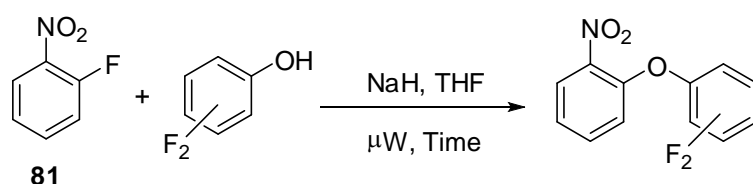

| Nucleophile | Product, (Yield / %) | Nucleophile | Product, (Yield / %) |
|-------------|----------------------|-------------|----------------------|
| | (89) ^a | | (91) ^b |
| | (97) ^a | | (67) ^c |
| | (95) ^b | | (57) ^d |

Conditions: ^a130 °C, 30 mins; ^b150 °C, 20 mins; ^c150 °C, 30 mins; ^d150 °C, 1 h.

Reactions of 2-fluoronitrobenzene (**81**) with sodium phenoxide derivatives **221**, **223**, **225** and **227** afforded corresponding biaryl ether derivatives **222**, **224**, **226** and **228** in excellent yields. Prolonged heating at elevated temperatures was required for the complete conversion of **229** and **231** to products and isolated yields of **230** and **232** were reduced due to the formation of tarry material.

In summary, when attempting the syntheses of nitrated difluorobiaryl ether derivatives, there appears to be no synthetic advantage in placing additional ring fluorine substituents on either the nitro aromatic ring or on the nucleophilic phenoxide species as both processes afford only a single product, in good to excellent yields. The latter method does, however, allow for the complete series of target systems to be synthesised as all six difluorophenol derivatives are commercially available.

2.4.3.2 Step 2: Palladium-Catalysed Reduction Reactions of Nitrobenzene Derivatives to Corresponding Aniline Systems

The second synthetic step of this three step procedure is to transform the fluorinated biaryl ether systems to their respective aniline derivatives by palladium-catalysed hydrogenation techniques. *In situ* flow hydrogenation using a *ThalesNano* H-Cube[®] was selected as the preferred method for these transformations so that the reaction conditions could be precisely controlled and optimised. Reductive hydrogenation of **213**, **215** and **217–220** with a palladium catalyst afforded corresponding aniline derivatives **233–238** in high yields [Table 17].

Milder hydrogenation reactions of **213**, **215** and **217–220** at atmospheric temperature and pressure were also successful, although elevated temperatures have been reported to be effective at prolonging the lifetime of the heterogeneous catalyst,³⁹ whilst a slight back-pressure is often advantageous in the prevention of blockages within the narrow piping of the flow reactor.

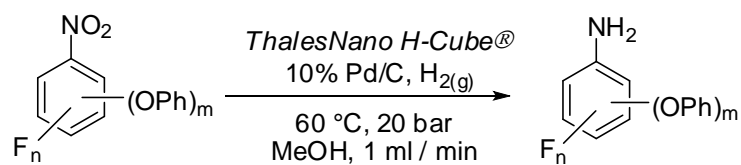
Table 17. Hydrogenation of nitrobiaryl ether derivatives **213**, **215** and **217–220**

n = 1,2; m = 2,1

| Substrate | Product, (Yield / %) | Substrate | Product, (Yield / %) |
|-----------------------------------------------|-----------------------------------------------------|-----------------------------------------------|-----------------------------------------------------|
| <p style="text-align: center;">213</p> | <p style="text-align: center;">233, (77)</p> | <p style="text-align: center;">218</p> | <p style="text-align: center;">236, (67)</p> |
| <p style="text-align: center;">215</p> | <p style="text-align: center;">234, (77)</p> | <p style="text-align: center;">219</p> | <p style="text-align: center;">237, (91)</p> |
| <p style="text-align: center;">217</p> | <p style="text-align: center;">235, (94)</p> | <p style="text-align: center;">220</p> | <p style="text-align: center;">238, (89)</p> |

Reductive hydrogenation reactions of difluoronitrobiaryl ether systems **222**, **224**, **226**, **228**, **230** and **232** to their respective aniline derivatives **239–244** were also successful in good to excellent yields [Table 18].

Table 18. Reductive hydrogenation reactions of difluoronitrobiaryl ether derivatives **222**, **224**, **226**, **228**, **230** and **232**

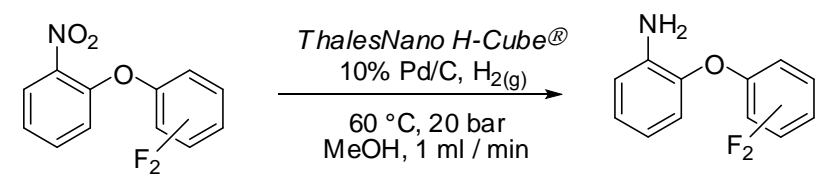
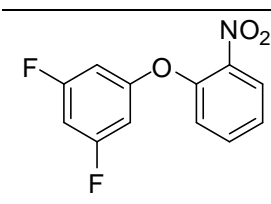
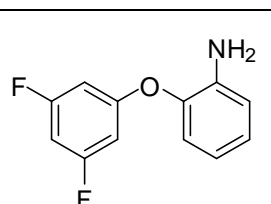
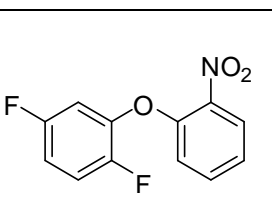
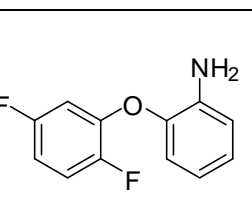
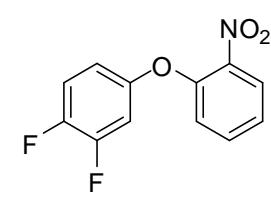
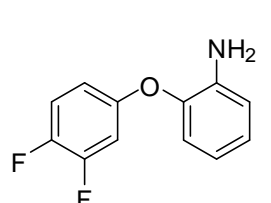
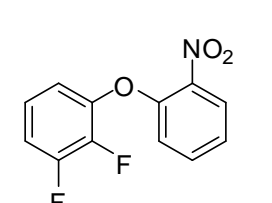
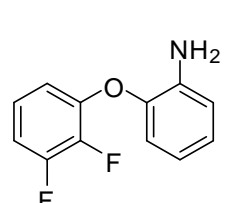
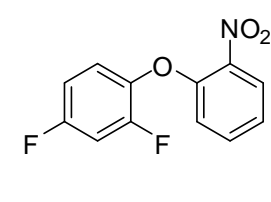
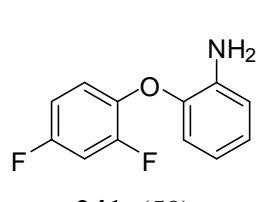
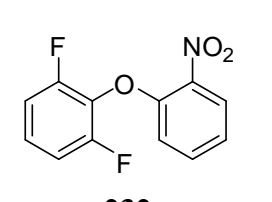
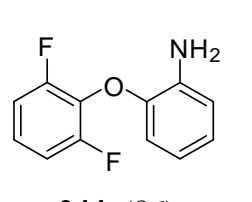
|  | | | |
|---------------------------------------------------------------------------------------------------|----------------------------------------------------------------------------------------------------------|----------------------------------------------------------------------------------------------------|------------------------------------------------------------------------------------------------------------|
| Nucleophile | Product, (Yield / %) | Nucleophile | Product, (Yield / %) |
|  222 |  239 , (92) |  228 |  242 , (89) |
|  224 |  240 , (86) |  230 |  243 , (85) |
|  226 |  241 , (59) |  232 |  244 , (86) |

Complete hydrogenation of starting materials was observed by ^{19}F NMR spectroscopy for all reactions, except in the case of nitrobenzene derivative **226**, which did not reach completion as the activity of the palladium-catalyst expired during the course of the reduction process.

2.4.3.3 Step 3: Reductive Diazotisation Processes

Aniline derivatives may be transformed into a range of functional groups by a variety of well established diazotisation-functionalisation processes.¹¹ The most common method for introducing ring hydrogen into an aromatic system by this route is to add hypophosphoric acid to an acidified solution of the intermediate diazonium salt.⁴⁰

Using similar methodology, the synthesis of 1,3-difluoro-5-phenoxybenzene (**182**) by reductive diazotisation of aniline derivative **235** was attempted [Scheme 56].

Scheme 56. Attempted reductive diazotisation of **235** to biaryl ether derivative **182**

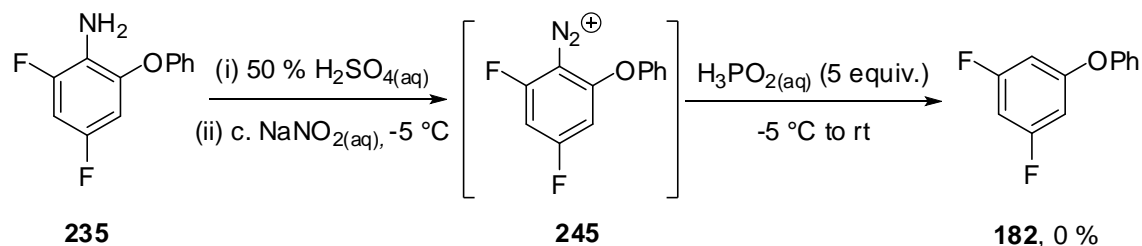

Aniline **235** dissolved readily in 50 % sulfuric acid to give a colourless solution, to which a concentrated aqueous solution of sodium nitrite was carefully added. Starch-iodide paper was used to determine the precise point at which all of **235** had been successfully converted to diazonium salt **245** and the reaction temperature was kept between 0 and $-5\text{ }^{\circ}\text{C}$. The slow evolution of a colourless gas from the reaction mixture was observed throughout this process, before the addition of hypophosphoric acid was attempted.

It appears that diazonium salt **245** is so unstable that reduced temperatures are required so that the addition of hypophosphoric acid may be completed. One plausible mechanism for the decomposition of **245** involves nucleophilic attack of solvent water for either of the aryl fluorine substituents to give new diazonium intermediates and hydrofluoric acid, which may then affect subsequent fluorideazotisation processes.

The reductive diazotisation reaction of **235** was repeated at $-13\text{ }^{\circ}\text{C}$ using an external salt-ice-water bath for cooling and, this time, a rapid effervescence was observed upon the addition of hypophosphoric acid to afford fluorinated biaryl ether derivative **182** in moderate yield [Scheme 57]. No starting material was recovered from the reaction mixture although a significant quantity of tarry material and a number of unidentified side products were produced.

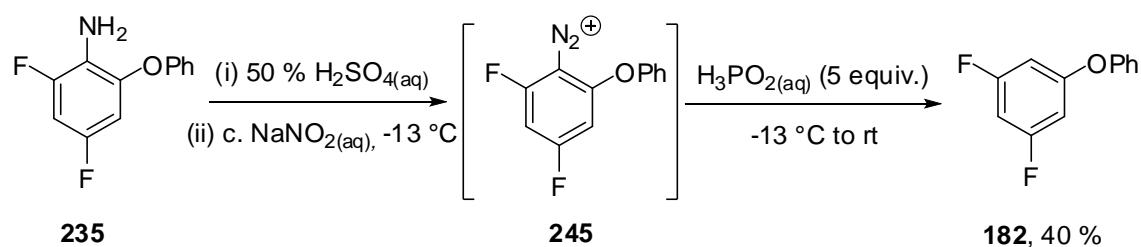
Scheme 57. Attempted reductive diazotisation of **235** to biaryl ether derivative **182**

The lower reaction temperature allows diazonium intermediate **245** to react with the hypophosphoric acid to complete the desired reductive diazotisation procedure. Corresponding hydrodeamination reactions of **233–238** to substituted ether derivatives **178**, **182**, **183** and **236** were also successful in moderate to good yield, although attempted reductive diazotisation of **237** and **238** did not afford any isolable target material [Table 19].

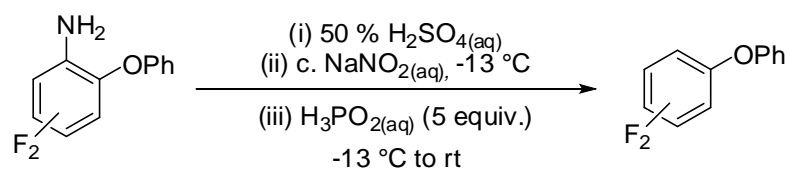
Table 19. Reductive diazotisation reactions of **233–238**

| Substrate | Product, (Yield / %) | Substrate | Product, (Yield / %) |
|-----------|-----------------------|-----------|-----------------------|
| | 183 , (55) | | 236 , (66) |
| | 178 , (70) | | 246 , (0) |
| | 182 , (40) | | 247 , (0) |

237 and **238** were not soluble in the acidic diazotisation solution and it is likely that this was responsible for the poor isolated yields of products **246** and **247**. Increasing the concentration of sulfuric acid to assist with the dissolution of anilines **237** and **238** either resulted in the extensive decomposition of starting material or the production of a complex reaction mixture from which no target material could be isolated.

Corresponding reductive diazotisation reactions of aniline derivatives **239–244** afforded the complete series of difluorinated biaryl ether target compounds **178–183** in moderate to good yields [Table 20].

Table 20. Reductive diazotisation reactions of **239–244**

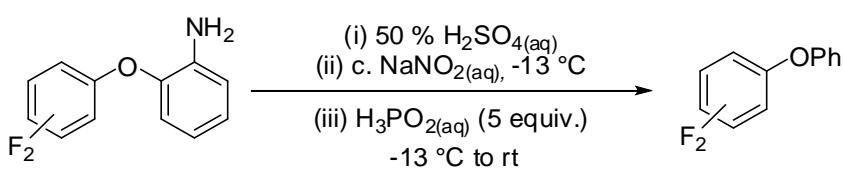

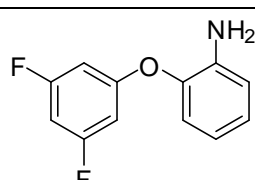
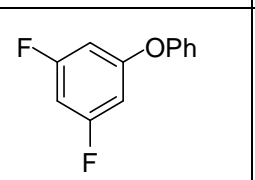
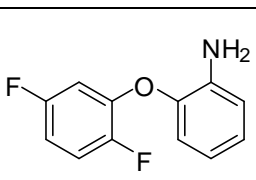
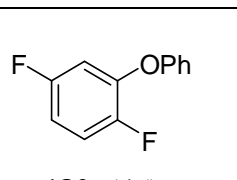
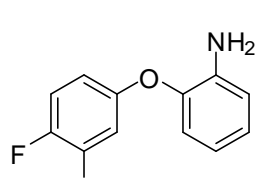
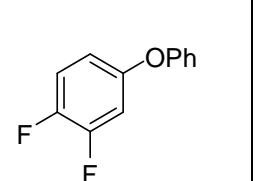
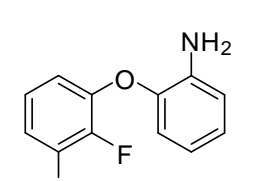
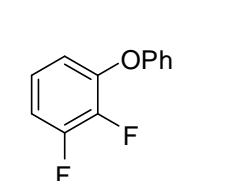
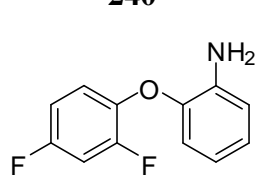
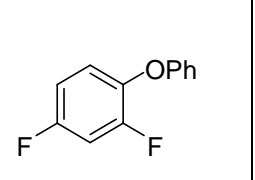
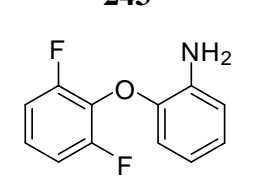
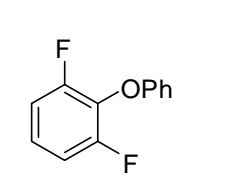
| Substrate | Product, (Yield / %) | Substrate | Product, (Yield / %) |
|---------------------------------------------------------------------------------------------------|----------------------------------------------------------------------------------------------------------|----------------------------------------------------------------------------------------------------|------------------------------------------------------------------------------------------------------------|
|  239 |  182 , (38) |  242 |  180 , (45) |
|  240 |  183 , (51) |  243 |  178 , (67) |
|  241 |  179 , (61) |  244 |  181 , (84) |

The fluorination patterns of **178–183** are expected to be identical to their parent aniline and nitrobenzene derivatives and SCS calculations have been used to assign fluorine atoms with their corresponding ^{19}F NMR spectroscopic chemical shift with confidence.

2.4.4 Strategy 4: Syntheses of Polyfluorinated Biaryl Ether Derivatives by Copper-mediated and Palladium-catalysed Processes

The syntheses of a range of polyfluorinated biphenyl ether derivatives have so far been described in either direct S_NAr phenoxydefluorination reactions of highly fluorinated aromatic systems, by a two-step S_NAr -hydrodebromination procedure from highly activated dibromotetrafluorobenzene derivatives and by a three-step S_NAr -reduction-reductive diazotisation pathway.

This section is concerned with the syntheses of a range of polyfluorinated biaryl ether derivatives in single-step Chan-Lam and Buchwald-Hartwig type coupling processes in an effort to improve overall yields of products. The Ullmann reaction was omitted from this study due to the harsh reaction conditions and low yields usually associated with this methodology.

2.4.4.1 Dopant Synthesis by Chan-Lam Type Procedures

The oxidative coupling reaction of an excess of phenylboronic acid with 3,4-difluorophenol (**223**) in the presence of a stoichiometric quantity of copper(II) acetate and an excess of triethylamine afforded 1,2-difluoro-4-phenoxybenzene (**183**) in low yield [Scheme 58].

Scheme 58. Coupling reaction of 3,4-difluorophenol (**223**) with phenylboronic acid

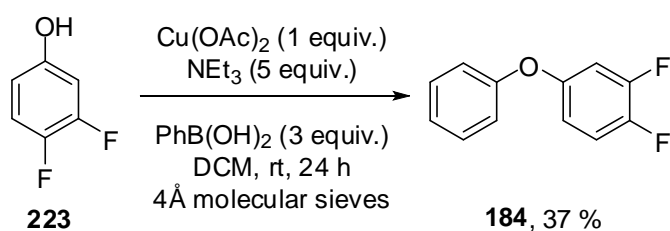

It was difficult to monitor the reaction by ^{19}F NMR spectroscopy or GC-MS due to the slurry-like composition of the crude reaction mixture. TLC analysis also proved ineffectual and so the reaction was worked up after 24 hours of stirring at room temperature. Increasing the reaction time from 24 to 48 hours offered no improvement in product yield. Most of the solid residue was removed by filtration, the starting materials were then separated from the desired organic material by extraction with

aqueous sodium hydroxide solution and DCM and product purification achieved by column chromatography on silica gel. The penultimate extraction proved slightly problematic due to the excessive precipitation of some unknown material which was dispersed between the organic and aqueous phases.

Corresponding reaction of difluorophenol derivatives **221**, **227** and **229** with phenylboronic acid afforded biphenyl ether derivatives **178**, **180** and **182** in very low yield [Table 21].

Table 21. Coupling reaction of **221**, **227** and **229** with phenylboronic acid

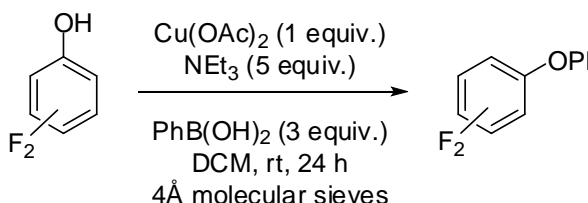
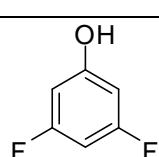
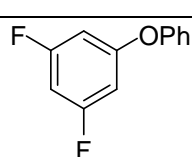
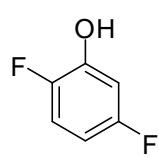
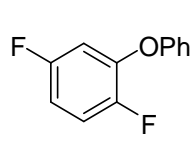
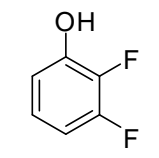
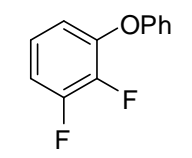
| Substrate | Product, (Yield / %) |
|---------------------------------------------------------------------------------------------------|--------------------------------------------------------------------------------------------------------|
|  | |
|  221 |  182, (3) |
|  227 |  180, (3) |
|  229 |  178, (5) |

Steric hindrance may be responsible for the low reactivity of **227** and **229**, although it is more likely that the electron withdrawing properties of multiple fluorine atoms on the phenol ring is responsible for a significant reduction in its ability to coordinate to the copper centre. No further optimisation was attempted due to the difficulties in monitoring the progress of the reactions.

2.4.4.2 Dopant Synthesis by Buchwald-Hartwig Type Procedures

A significant literature regarding biphenyl ether synthesis by palladium-catalysed Buchwald-Hartwig type processes has developed over the last decade due to, in particular, the development of new, sterically bulky monodentate phosphine ligands which are able to assist with the reductive elimination of the biaryl ether moiety from the palladium catalyst. Indeed, the efficiencies of Buchwald-Hartwig processes are usually highly dependent on the stereoelectronic properties of the ligand and, in a recent publication, *tert*-butyl-XPhos (**248**) was shown to be particularly effective for the coupling of a wide range of species [Figure 19].¹⁸

Figure 19. *tert*-Butyl-XPhos

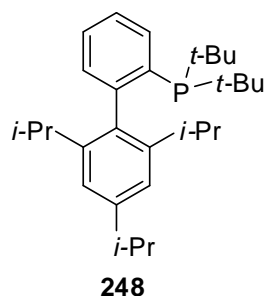

Reaction of sodium 3,4-difluorophenoxide (**249**) with a stoichiometric quantity of bromobenzene in the presence of a catalytic quantity of palladium acetate and *tert*-butyl-XPhos afforded biphenyl ether derivative **183** in a moderate yield [Scheme 59]. Sodium salt **249** was used in preference to 3,4-difluorophenol to assist with the coordination of the oxygen centre to the palladium catalyst by increasing its nucleophilicity.

Scheme 59. Coupling reaction of 3,4-difluorophenoxide (**249**) with bromobenzene

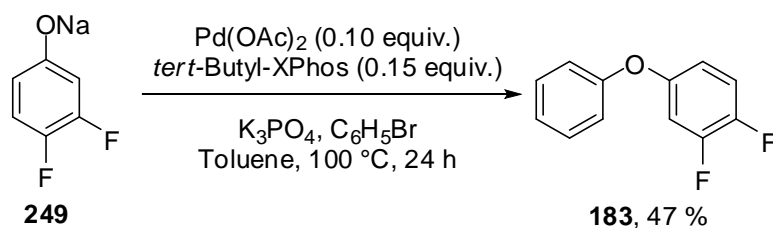

The isolated yield of compound **183** is slightly higher than that obtained by the corresponding Chan-Lam process and product purification was much less problematic.

The reaction of **249** with bromobenzene was also monitored by ^{19}F NMR spectroscopy and it was found that complete consumption of starting material was achieved under the reaction conditions, although the formation of a significant quantity of tarry material and several unidentified side products lead to the reduced yield of desired product.

In a similar process, reaction of sodium 3,5-difluorophenoxide (**250**) with bromobenzene afforded pure biaryl ether derivative **182** in low yield [Scheme 60]. Once again, complete consumption of starting material was achieved under the reaction conditions although several products were formed alongside some tarry material. Nevertheless, this procedure is clearly more appealing than the corresponding Chan-Lam reaction that resulted in the isolation of only 3 % of **182**.

Scheme 60. Coupling reaction of 3,4-difluorophenoxide (**250**) with bromobenzene

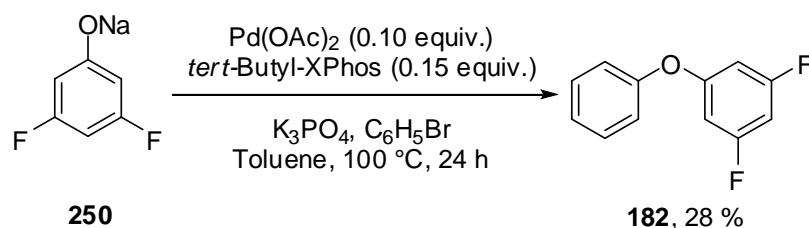

Unfortunately, analogous cross-coupling reactions of *ortho*-fluorinated sodium difluorophenoxide derivatives **251–252** were unsuccessful, presumably because the inductively-stabilised oxy-anion is not sufficiently nucleophilic to coordinate to the palladium centre [Scheme 61]. Steric hindrance is unlikely to be problematic in this instance as there are numerous examples of successful biaryl ether coupling reactions with significantly more bulky substrates.

Scheme 61. Attempted coupling reactions of difluorophenoxide derivatives **251–252** with bromobenzene

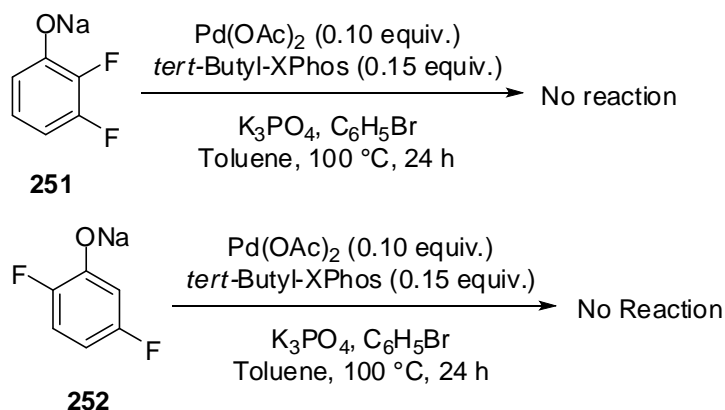

2.5 Conclusions

A single-step $\text{S}_{\text{N}}\text{Ar}$ protocol for the syntheses of a range of polyfluorinated biaryl ether derivatives from highly fluorinated starting materials has been developed. Highly electrophilic hexa- and penta-fluorobenzene are reactive towards sodium phenoxide to afford pentafluorophenoxybenzene and 1,2,4,5-tetrafluorophenoxybenzene, respectively.

1,2,3,4-Tetrafluorobenzene and 1,2,3,5-tetrafluorobenzene are significantly less reactive towards phenoxydefluorination with sodium phenoxide and require elevated temperatures to achieve complete, regioselective substitution in a reasonable period of time. The harsh reaction conditions employed in these processes has a detrimental effect on overall product yield and 1,2,4,5-tetrafluorobenzene and trifluorobenzene systems are not sufficiently electrophilic to react with sodium phenoxide, even after extended heating under elevated temperatures. In addition, several 4-*n*-alkylated tetra- and tri-fluorinated biphenyl ether derivatives were synthesised by $\text{S}_{\text{N}}\text{Ar}$ reactions of various 4-*n*-alkylphenoxide nucleophiles with penta- and 1,2,3,4-tetra-fluorobenzene, respectively.

Secondly, a practical two-step $\text{S}_{\text{N}}\text{Ar}$ -hydrodebromination synthetic procedure to access a series of trifluorinated biaryl ether derivatives from reactions of sodium phenoxide with each of the dibromotetrafluorobenzene derivatives was developed. The key to the success of this procedure is the use of palladium-catalysed *in situ* flow hydrogenation

technology to afford quantitative yields of target material from the parent dibromotrifluorophenoxybenzene system. 1,4-Dibromotetrafluorobenzene is prone to competing bromophilic attack processes due to the inductive stabilisation of the anionic intermediate provided by four ring fluorine substituents, although S_NAr reactions of 1,2- and 1,3-dibromotetrafluorobenzene with sodium phenoxide are significantly more efficient.

Thirdly, a three-step S_NAr -reduction-reductive diazotisation pathway to a range of difluorobiphenyl ether derivatives was described. Regioselective *ortho* phenoxydefluorination was observed in several S_NAr reactions of *ortho*-fluorinated trifluoronitrobenzene derivatives with sodium phenoxide, providing evidence for a strong directing interaction between the incoming nucleophile and the ring nitro group. Alternatively, it is possible to form the necessary biaryl ether linkage from less reactive difluorophenoxide nucleophiles and 2-fluoronitrobenzene in similar yields. There appears to be no advantage to either technique, although the latter procedure allows for synthesis of the complete series of nitrated biaryl ether derivatives.

Quantitative palladium-catalysed nitro group reduction was achieved using *in situ* flow hydrogenation technology and subsequent reductive diazotisation with hypophosphoric acid afforded the corresponding difluorobiaryl ether derivatives in moderate to good yields. This procedure could, in principle, be applied to the syntheses of the remaining 'un-natural' isomers the tri- and tetra-fluorinated biaryl ether derivatives which are otherwise difficult to access due to the high regioselectivity of respective S_NAr processes of penta- and tetra-fluorobenzene systems.

Finally, attempts to synthesise a range of difluorobiphenyl ether derivatives by Chan-Lam and Buchwald-Hartwig type processes were either unsuccessful or low yielding. Chan-Lam reactions proved difficult to monitor and product purification was problematic, whilst corresponding Buchwald-Hartwig processes were only compatible with *meta* and *para* fluorinated substrates. No attempts to develop this methodology further were made due to the success of the three aforementioned strategies.

2.6 References to Chapter 2

- [1] Wall, L. A.; Pummer, W. J.; Fearn, J. E.; Antonucci, J. M. *J. Res. Nat. Inst. Stand. Technol. A.* **1963**, 67A, 481-497.
- [2] Kovotonyuk, V. N.; Kobrina, L. S. *J. Fluorine Chem.* **1993**, 63, 243-252.
- [3] Burdon, J.; Coe, P. L.; Marsh, C. R.; Tatlow, J. C. *J. Chem. Soc., Perkin Trans. 1* **1972**, 763-769.
- [4] Tadeusiak, A., Durham University, 2008.
- [5] Brooke, G. M. *J. Fluorine Chem.* **1997**, 86, 1-76.
- [6] Frlan, R.; Kikelj, D. *Synthesis* **2006**, 14, 2271-2285.
- [7] Li, F.; Wang, Q.; Ding, Z.; Tao, F. *Org. Lett.* **2003**, 5, 2169-2171.
- [8] Cui, S.-L.; Jiang, Z.-Y.; Wang, Y. G. *Synlett.* **2004**, 10, 1829-1831.
- [9] Uргаonkar, S.; Verkade, J. G. *Org. Lett.* **2005**, 7, 3319-3322.
- [10] Ripin, D. H. B.; Vetelino, M. *Synlett.* **2003**, 15, 2353-2353.
- [11] Wade Jr., L. G. *Organic Chemistry*; Pearson Education, Inc.: New Jersey, 2006.
- [12] Ullmann, F. *Chem. Ber.* **1904**, 37, 853-854.
- [13] Chan, D. M. T.; Monaco, K. L.; Wang, R.-P.; Winters, M. P. *Tet. Lett.* **1998**, 39, 2933-2936.
- [14] Mann, G.; Incarvito, C.; Rheingold, R. L.; Hartwig, J. F. *J. Am. Chem. Soc.* **1999**, 121, 3224-3225.
- [15] Aranyos, A.; Old, D. W.; Kiyomori, A.; Wolfe, J. P.; Sadighi, J. P.; Buchwald, S. L. *J. Am. Chem. Soc.* **1999**, 121, 4369-4378.
- [16] Ma, D.; Cai, Q. *Org. Lett.* **2003**, 5, 3799-3802.
- [17] Evans, D. A.; Katz, J. L.; West, J. R. *Tet. Lett.* **1998**, 39, 2937-2940.
- [18] Burgos, C. H.; Barder, T. E.; Huang, X.; Buchwald, S. L. *Angew. Chem. Int. Ed.* **2006**, 45, 4321-4326.
- [19] Mahaffy, C. A. L.; Nanney, J. R. *J. Fluorine Chem.* **1997**, 67, 67-74.
- [20] Berger, S.; Braun, S.; Kalinowski, H.-O. *NMR Spectroscopy of the Non-Metallic Elements*; Wiley: New York, 1997.
- [21] Shtark, A. A.; Chuikova, T. V.; Shteingarts, V. D. *Zh. Org. Khim.* **1984**, 20, 1055-1063.
- [22] Crowell, T. R.; Peach, M. E. *J. Fluorine Chem.* **1982**, 21, 469-477.
- [23] Chambers, R. D.; Sargent, C. R.; Silvester, M. J.; Drakesmith, F. G. *J. Fluorine Chem.* **1980**, 15, 257-262.
- [24] James, J. H.; Peach, M. E.; Williams, C. R. *J. Fluorine Chem.* **1985**, 27, 91-104.
- [25] Feldman, D.; Rabinovitz, M. *Tetrahedron. Lett.* **1989**, 30, 6091-6094.
- [26] Feldman, D.; Segal-Lew, D.; Rabinovitz, M. *J. Org. Chem.* **1991**, 56, 7350-7354.
- [27] Ivashchuk, O.; Sorokin, V. I. *Tetrahedron* **2009**, 65, 4652-4658.
- [28] Chambers, R. D.; Sargent, C. R.; Silvester, M. J. *J. Fluorine Chem.* **1980**, 15, 257-261.
- [29] Hellberg, J.; Dahlstedt, E.; Pelcman, M. E. *Tetrahedron* **2004**, 60, 8899-8912.
- [30] Cheong, C. L.; Wakefield, B. J. *J. Chem. Soc., Perkin Trans. 1* **1988**, 12, 3301-3305.
- [31] Dirk, C. W.; Cox, S. D.; Wellman, D. E.; Wudl, F. *J. Org. Chem.* **1985**, 50, 2395-2397.
- [32] Chambers, R. D.; Close, D.; Williams, D. L. H. *J. Chem. Soc., Perkin Trans. 2* **1980**, 778-780.
- [33] Chambers, R. D. *J. Chem. Soc., Perkin Trans. 1* **1998**, 10, 1705-1713.
- [34] Bolton, R.; Sandall, J. P. B. *J. Chem. Soc., Perkin Trans. 2* **1978**, 137-141.

- [35] Pinder, A. R. *Synthesis* **1980**, 425-453.
- [36] Lunin, V. V.; Lokteva, E. S. *Russ. Chem. Bull.* **1996**, 45, 1519-1534.
- [37] Bolton, R.; Sandall, J. P. B. *J. Chem. Soc., Perkin Trans. 2* **1978**, 141-144.
- [38] Coe, P. L.; Tatlow, J. C.; Terrell, R. C. *J. Chem. Soc. C* **1967**, 2626-2628.
- [39] Knudsen, K. R.; Holden, J.; Lev, S. V.; Ladlow, M. *Adv. Synth. Catal.* **2007**, 349, 535-538.
- [40] Trost, B. M.; Flemming, I. *Comprehensive Organic Synthesis Volume 8: Reduction*; Pergamon: Oxford, 1991.

Chapter 3

Electro–optical Testing of Polyfluorinated Biphenyl Ether Derivatives

3.1 Introduction

Chapter 2 was concerned with the syntheses of a range of polyfluorinated biphenyl ether derivatives, which were previously identified as promising candidate materials for use as dopants in commercial LC mixtures to improve the response times of LCD devices. In reality, these systems were synthesised as part of an iterative feedback strategy whereby decisions regarding the progression of future research were made based on the performance of each series of biphenyl ether dopants. This process may be separated into three independent development phases: (a) initial screening studies; (b) effect of aryl-alkylation on dopant performance; and (c) effect of dopant dipole moment on dopant performance.

This chapter is concerned with the measurement and analysis of the electro-optical (EO) performances of each series of fluorinated biaryl ether derivatives at each phase of the research programme. Details regarding LC fabrication and the various experimental procedures that were used to analyse cell performance are collated in Chapter 5. Chapter 1 contains details of electro-optical properties of interest which were measured in the SONY Materials Science Laboratories in Stuttgart, in collaboration with scientists from SONY.

3.2 Results and Discussion

3.2.1 Phase 1: Initial Screening Studies

The first phase of our research programme was to formulate three new LC mixtures from a commercially available –LC host phase (MLC2038), in order to evaluate the efficacy of the polyfluorinated biaryl ether moiety at improving device rise and decay times [Figure 20].

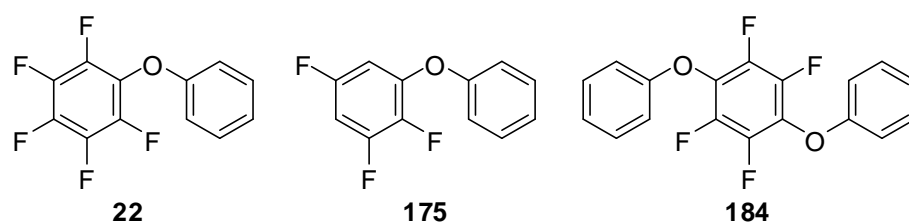
Figure 20. Dopants screened in Phase 1

In this thesis, rise times are plotted against averaged field strength, which corresponds to the applied voltage divided by the thickness of the individual LC cell gap (d), whilst normalised decay times are plotted against the applied voltage. As the rise time of an LC cell is dependent on the applied voltage, any reduction in rise time at a particular voltage (or averaged field strength) represents an improvement in device performance, and is visible as a curve that approaches the origin. Decay times required to switch between fully ‘on’ and ‘off’ do not formally depend on the applied voltage; it is simply a measure of the time taken for the disrupted LC phase to return back to its equilibrium orientation, and improvements in performance are visible as straight lines nearer the x-axis.

It is important to clarify that the LC cell gap plays an important role in determining the rise and decay time for a particular device and so direct comparisons between two cells of different dopant concentration should only be made when they are of similar thickness. To ensure this was possible for our devices, each cell gap was measured by infra-red interferometry, before and after filling, and three cells of similar sizes were selected for each dopant concentration [Equation 10].¹ Where λ_1 and λ_2 are the wavelengths of reflected light at the near and far surfaces, respectively, x is the distance between peaks of these two waves and n is the refractive index of the cell.

$$d = \frac{x\lambda_1\lambda_2}{2n(\lambda_2 - \lambda_1)} \quad (10)$$

The temperature of each cell was kept at 35 °C during the EO measurement procedure as any thermal variations would alter the elasticity and viscosity of the LC mixture. Occasionally, a fabricated device would perform irregularly and data from these systems were necessarily excluded from further analysis.

Initially, 2 and 4 weight% of pentafluorophenoxybenzene (**22**) was used to generate new formulations of commercial –LC host MLC2038. Three LC cells were fabricated from each new LC mixture and the EO response profiles of all devices were measured by optical microscopy and compared to the untouched host phase [Charts 1-2].

Chart 1. Rise times of MLC2038 doped with 2–4 weight% pentafluorophenoxybenzene (**22**)

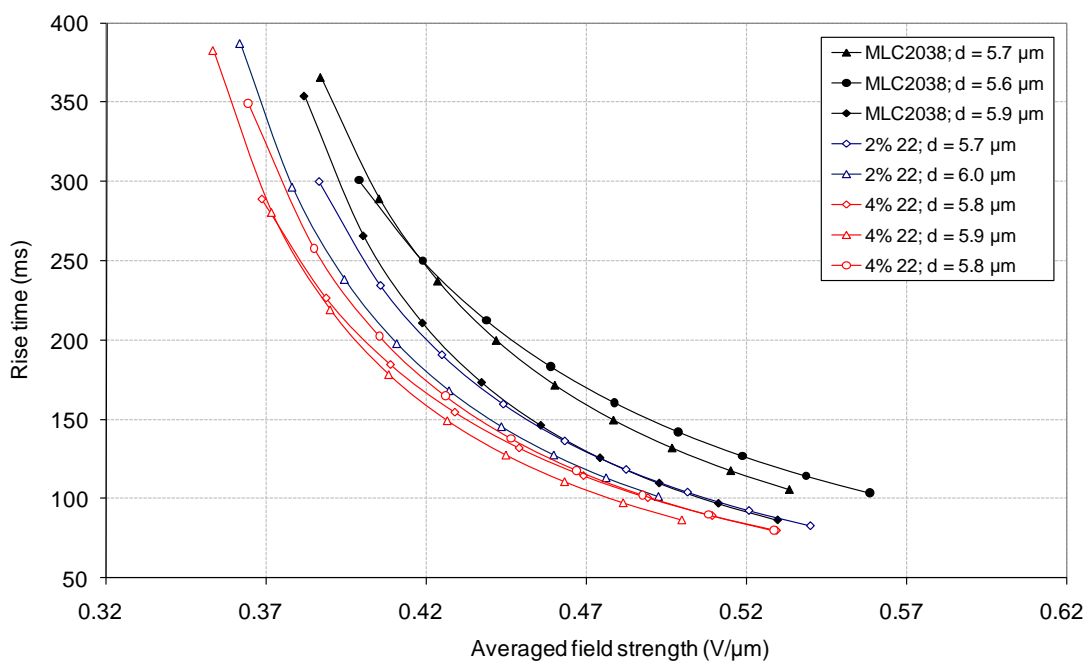

Chart 2. Decay times of MLC2038 doped with 2–4 weight% pentafluorophenoxybenzene (**22**)

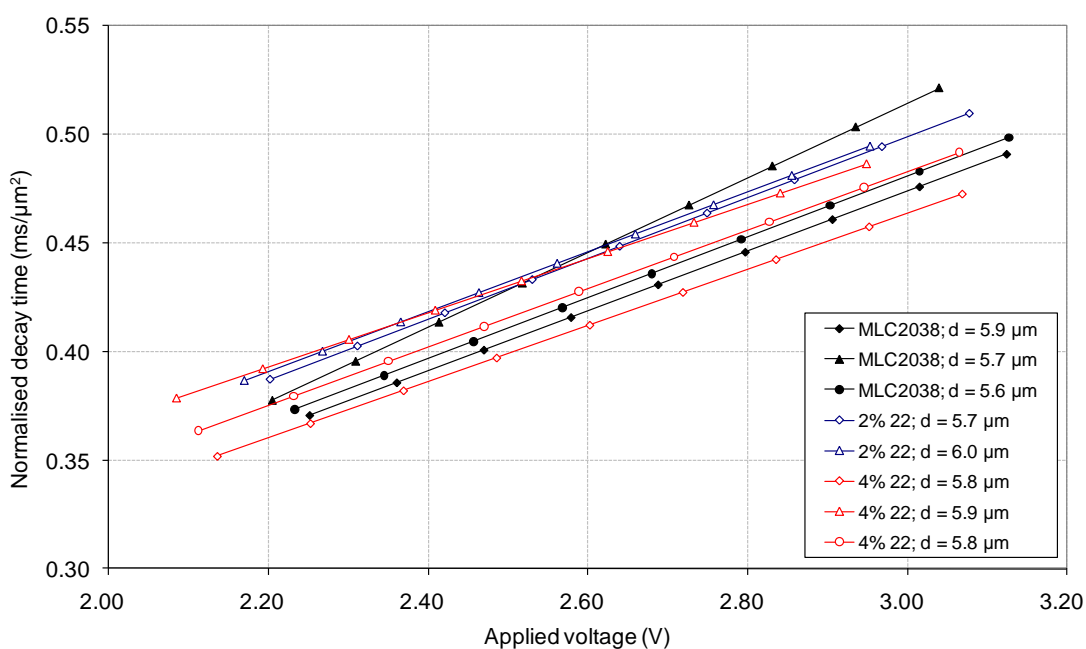
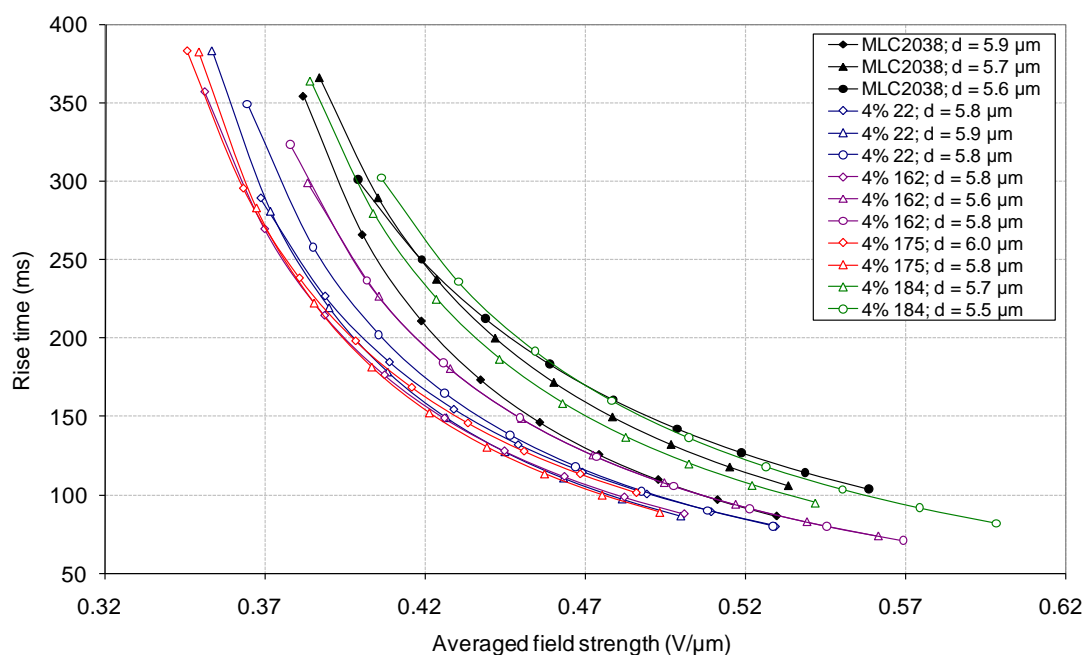

Chart 1 shows that, relative to the commercial host, the introduction of small quantities of pentafluorophenoxybenzene (**22**) gave a significant reduction in device rise time, and that increasing the dopant concentration from 2 to 4 weight% results in further rise time reductions. Chart 2 shows that, at both dopant concentrations, decay times remained relatively unaffected.

It has been proposed that the introduction of small quantities of a biphenyl ether dopant into an LC formulation results in an overall reduction in the rotational viscosity of the system.² Indeed, a reduction in rotational viscosity is expected to shorten both rise and decay times, although the latter is not generally observed as decay times also depend on the elasticity of the system, which is also expected to be reduced upon doping.

Subsequently, the EO response profile of cells fabricated from –LC MLC2038 doped with 2 and 4 weight% of 1,2,5-trifluoro-3-phenoxybenzene (**175**) and 1,2,4,5-tetrafluoro-3,6-diphenoxybenzene (**184**) were studied. 1,2,5-Trifluoro-3-phenoxybenzene (**175**) was observed to be approximately as effective as pentafluorophenoxybenzene (**22**) at reducing device rise times, whilst 1,2,4,5-tetrafluoro-3,6-diphenoxybenzene (**184**) was found to be relatively ineffectual. Individual data for these systems may be found in the electronic appendix (3.1 on CD) which accompanies this thesis; however a chart comparing the relative performance of all three dopants has been included below for clarity [Chart 3]. It is worth commenting that decay times remained relatively unaffected upon doping.

Chart 3. Rise times of MLC2038 doped with 4 weight% pentafluorophenoxybenzene **22**, 4-fluorophenoxybenzene **162**, 1,2,5-trifluoro-3-phenoxybenzene **175** and 1,2,4,5-tetrafluoro-3,6-diphenoxybenzene **184**



4-Fluorophenoxybenzene (**162**), previously identified³ as highly effective at improving the response times of commercial LC formulations, was also included in initial screening procedures as a standard from which to evaluate the performance of each series of dopants. It is clear that polyfluorinated biaryl ether derivatives **22** and **175** were more effective dopants than this monofluorinated benchmark, whereas 1,2,4,5-tetrafluoro-3,6-diphenoxybenzene (**178**) was a very poor dopant. As a result, it was decided that monofluorinated biphenyl ether derivatives and fluorinated 1,4-diphenoxybenzene structures should be excluded from further investigations, and polyfluorinated biphenyl ether derivatives were selected for further study.

3.2.2 Phase 2: Alkylated Polyfluorobiphenyl Ether Derivatives

3.2.2.1 Introduction

As discussed above, Phase 1 of this research strategy identified polyfluorinated biphenyl ether derivatives as effective dopants for the improvement of the response time profile of a commercial –LC system. Phase 1 was also responsible for the omission of

further research into various monofluorinated and disubstituted systems, which only offered small improvements in device performance.

With this in mind, two series of polyfluorinated biaryl ether derivatives bearing terminal alkyl chains of increasing length were synthesised in an attempt to discover new, more effective dopant structures. Two families of dopants bearing different fluoroaryl ‘head’ group fluorination patterns were chosen to ensure any trends were consistent across more than one structural framework [Figure 21].

Figure 21. Dopants screened in Phase 2

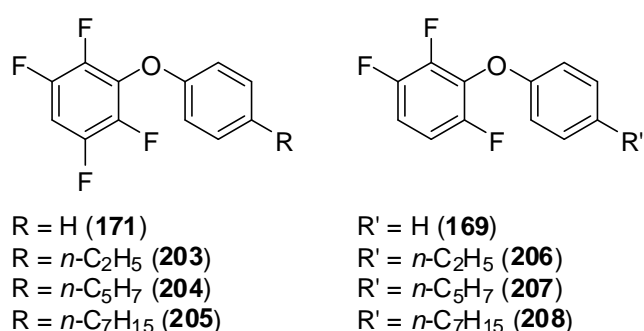

Each fluorinated biphenyl ether derivative was mixed at concentrations of 2 and 4 weight% with commercial –LC host material MLC2038, and at 4 weight% with a +LC host material SY5524. These new –LC and +LC systems were used to fill 5 μm VA and 10 μm TN cells, respectively.

3.2.2.2 Results and Discussion

3.2.2.3 EO Performance of Dopants in –LC Host MLC2038

The introduction of small quantities of both the tri- and tetra-fluorinated series of dopants into the –LC host system effected a significant reduction in device rise time [Charts 4–5]. The decay times of –LC systems mixed with the trifluorinated dopants were increased slightly whilst the introduction of tetrafluorinated dopants generally resulted in an overall reduction in decay time [Appendices 3.2–3.5 on CD].

Nevertheless, the magnitudes of rise time reductions were always much greater than any alterations of the corresponding decay times, so it is possible to assess the impact of

alkyl chain length on the efficacy of both series of dopants in –LC host mixtures by considering solely their respective rise times.

Chart 4. Rise times of MLC2038 doped with 4 weight% each tetrafluorinated dopant 171 and 203–205

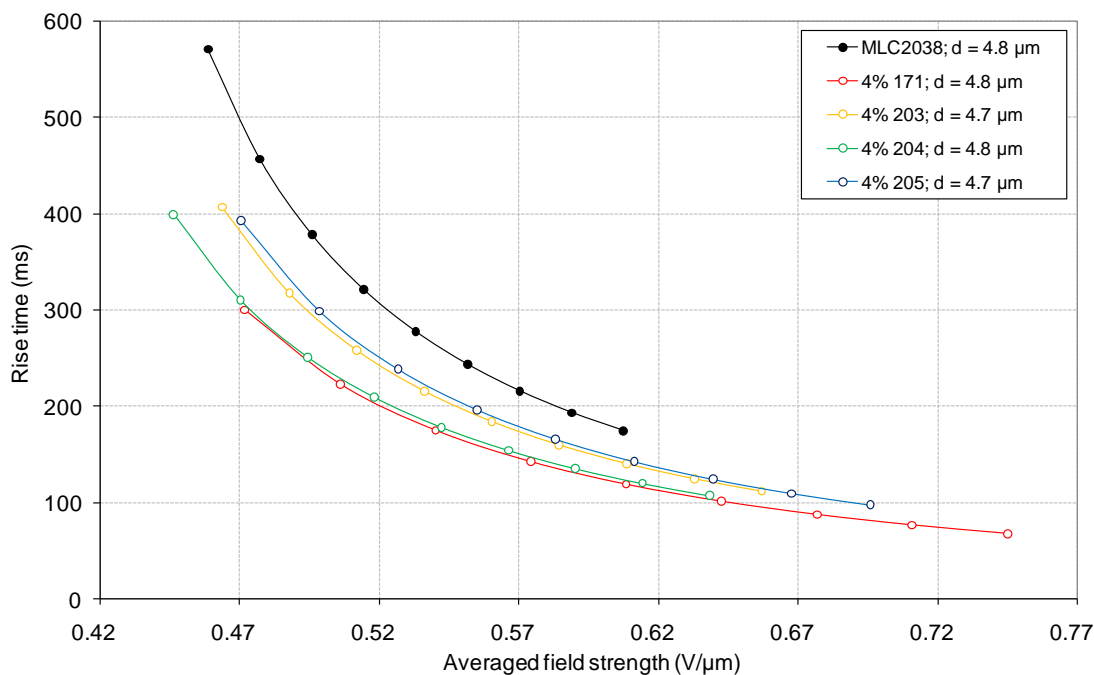
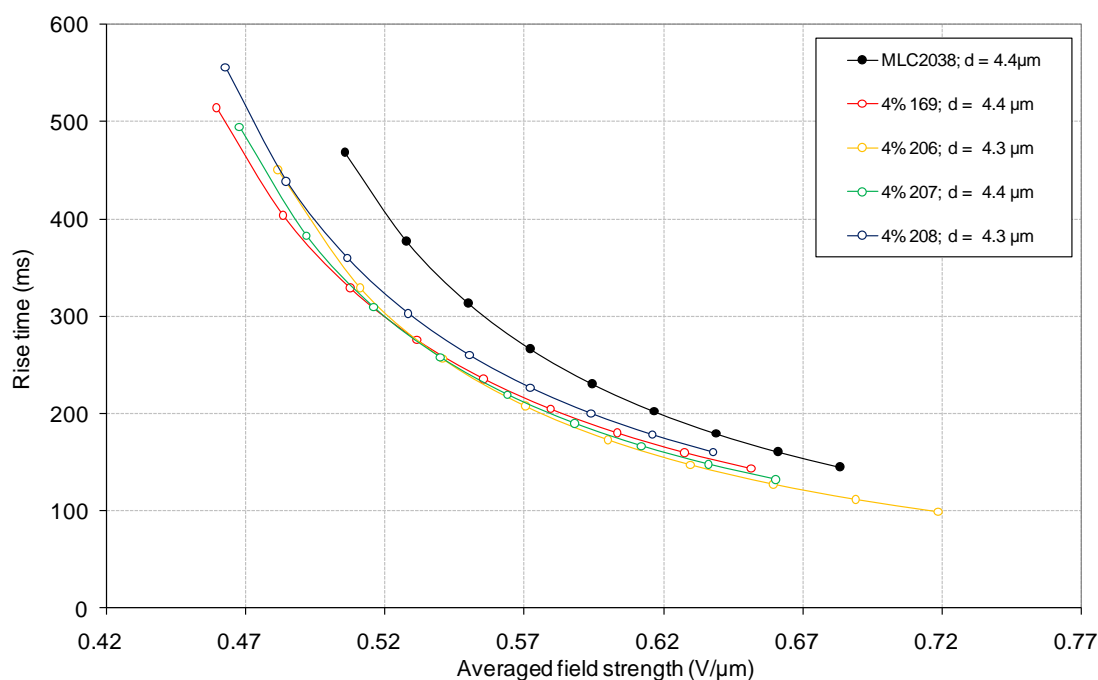

Chart 5. Rise times of MLC2038 cells doped with 4 weight% of each trifluorinated dopant 169 and 206–208



No discernible correlation between alkyl chain length and dopant performance was observed, although it is evident that for both series of dopants, the introduction of an alkyl tail group did not seem to offer any electro-optical advantage over the non-alkylated systems.

In order for a dopant to be a successful candidate for use in display technology it must have an excellent electrical resistivity so that a constant voltage may be maintained between the electrodes of the LC device. To evaluate this property, the voltage holding ratios of each doped cell were measured and found to match those of the commercial LC host systems, thereby permitting the application of these biphenyl ether systems for display applications [Appendices 3.2–3.5 on CD].

Another technological requirement that the newly formulated LC mixtures must meet is that their respective nematic to isotropic transition temperatures must remain greater than the maximum operating temperature of the display device so that LC action is always maintained. Practically, this means that the clearing point of each LC mixture must be at least 70 °C for use in modern display systems. DSC analysis revealed that the introduction of small quantities of each dopant into the –LC host acted to reduce its clearing point [Table 22].

Interestingly, the trifluorinated dopants seem to have a greater impact on the clearing point than the tetrafluorinated systems. We can postulate that the trifluorinated systems are more effective at penetrating the LC host and disrupting stacking interactions between molecules of the nematic bulk. This observation is compatible with the inert-spacer model suggested at the beginning of Chapter 2.

Table 22. DSC analysis of MLC2038 doped with 2–4 weight% of **169**, **171** and **203–208**

| LC System | T_{CR-N} | T_{N-I} | $\Delta T_{N-I} / 1\%$ |
|---------------|------------|-----------|------------------------|
| –LC MLC2038 | -65.3 | 81.5 | - |
| 2% 171 | -65.8 | 75.4 | 3.1 |
| 4% 171 | -66.0 | 72.2 | 2.3 |
| 2% 203 | -67.1 | 74.8 | 3.4 |
| 4% 203 | -66.0 | 71.7 | 2.5 |
| 2% 204 | -65.4 | 75.8 | 2.9 |
| 4% 204 | -66.0 | 72.0 | 2.4 |
| 2% 205 | -66.0 | 74.8 | 3.4 |
| 4% 205 | -66.0 | 72.4 | 2.3 |
| 2% 169 | -65.7 | 75.1 | 3.2 |
| 4% 169 | -66.0 | 69.8 | 2.9 |
| 2% 206 | -65.4 | 74.9 | 3.3 |
| 4% 206 | -66.4 | 68.8 | 3.2 |
| 2% 207 | -66.0 | 74.9 | 3.3 |
| 4% 207 | -66.2 | 68.7 | 3.2 |
| 2% 208 | -65.8 | 75.4 | 3.1 |
| 4% 208 | -66.2 | 68.8 | 3.2 |

As the tetrafluorinated dopants do not cause such a detrimental reduction in the overall T_{NI} , it is possible to introduce greater quantities of these systems into the –LC host than it is for the trifluorinated dopants, which may have a significant impact on device performance. Whilst increased doping was found to be beneficial with respect to improving rise times, corresponding reductions in the clearing point of the LC host suggest that the viscosity and elasticity of the system were detrimentally affected.

To help evaluate whether or not increased doping is advantageous to device performance, it is possible to calculate a figure of merit (FoM), which directly compares overall cell performance, for each new LC formulation. To calculate the FoM for a –LC cell it is useful to employ the methodology of Wu,⁴ who defines an equation which evaluates deviations in the rotational viscosity, bend elastic constant and birefringence of each LC mixture [Equation 11].

$$\text{FoM} = \frac{K_{33}(\Delta n)^2}{\gamma_1} \quad (11)$$

All three parameters were measured for each doped –LC system and the commercial host so that a corresponding FoM could be calculated [Appendix 3.6 on CD]. In each case, the birefringence, elasticity and rotational viscosity of the host phase were reduced with increasing dopant concentration, reinforcing our proposition that the principal mode of action of our fluorinated biphenyl ether derivatives is as inert spacer molecules. A FoM for each cell has been calculated so that their relative performance may be directly compared [Chart 6].

Chart 6. FoM values for MLC2038 doped with 2–4 weight% of 169, 171 and 203–208

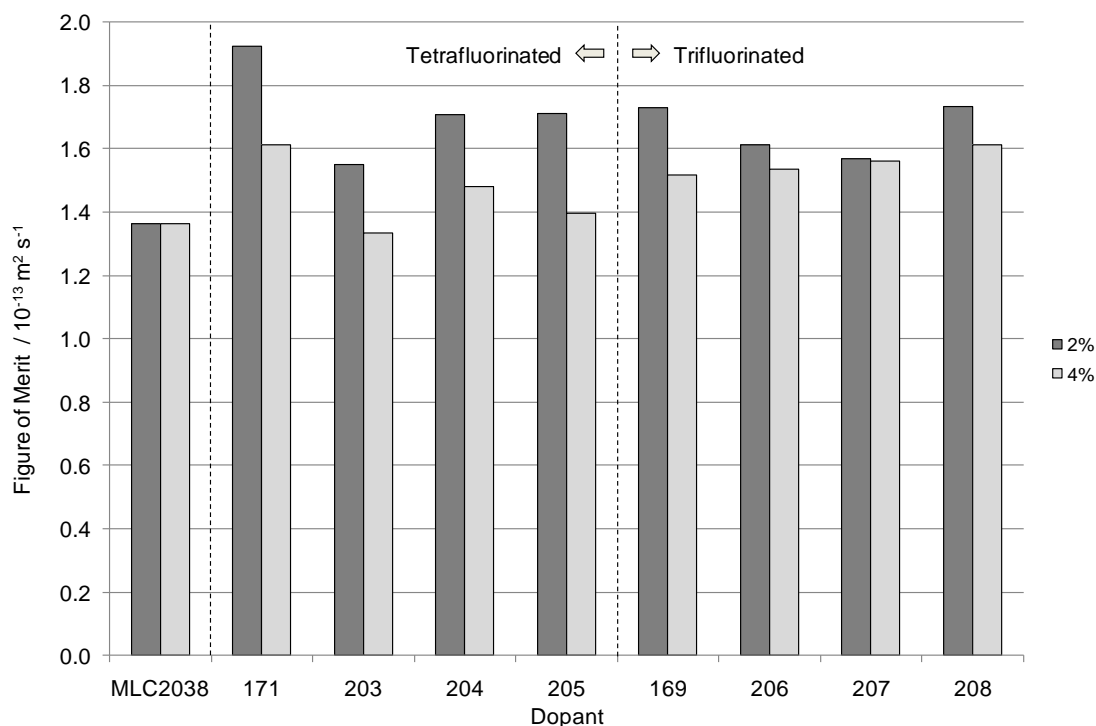

Crucially, doping was found to provoke a more rapid reduction in the rotational viscosity of the LC system with respect to the corresponding bend elastic constant, such that, overall, the FoM for all but one of the doped cells was calculated to be greater than that of the standard –LC host. It was also discovered that doping at a lower concentration of 2 weight% was more beneficial with respect to device performance than doping at higher concentrations. Thus, it is not important that the trifluorinated

series of dopants have such a large impact on the clearing point of the –LC host phase, as only low quantities are required if cell performance is to be optimised.

3.2.2.4 EO Performance of Dopants in +LC Host SY5524

Once again, the introduction of both the tri- and tetrafluorinated series of dopants into the commercial +LC host mixture resulted in a notable reduction in rise time and a slight increase in decay time, although no apparent correlation between alkyl chain length and dopant performance was observed [Charts 7–8].

Chart 7. Rise times of SY5524 doped with 4 weight% each tetrafluorinated dopant **171** and **203–205**

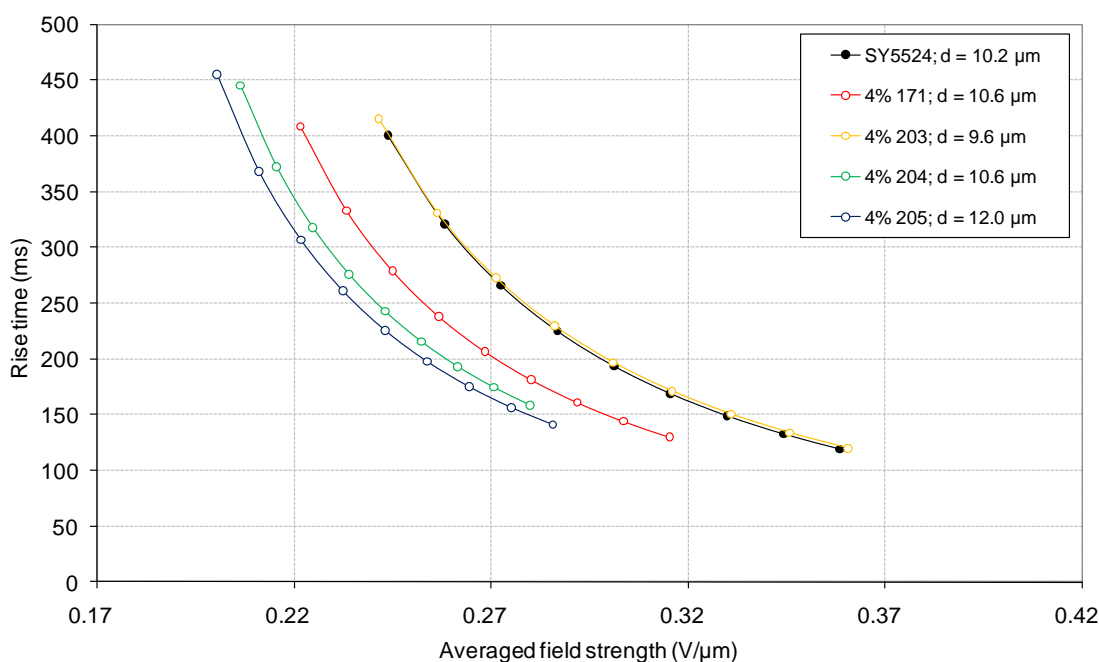
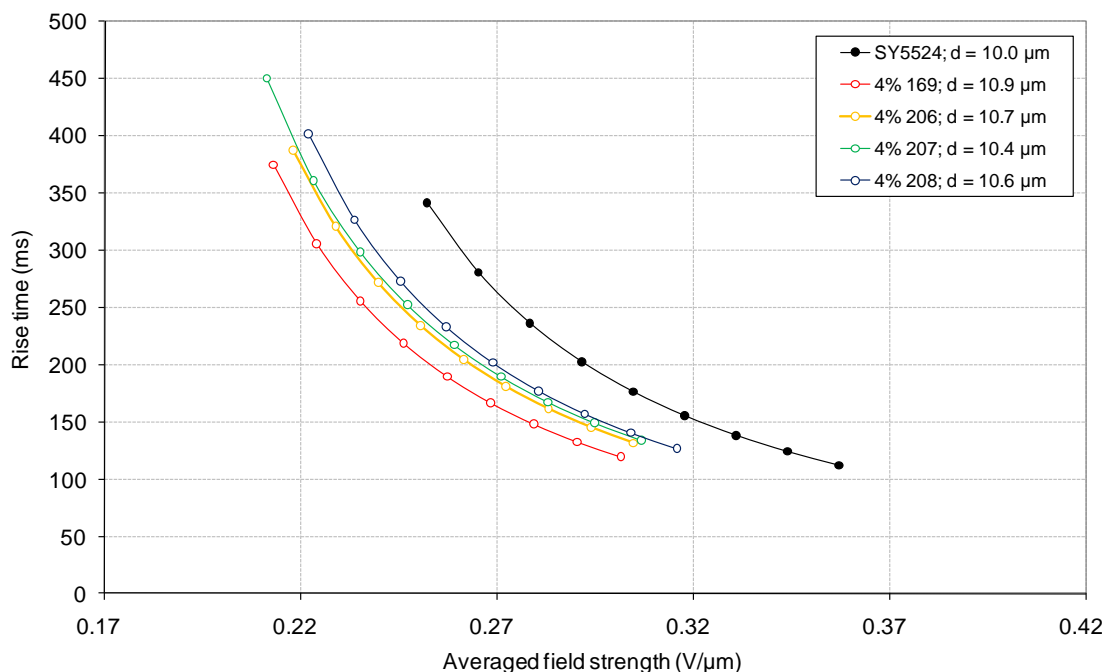

Chart 8. Rise times of SY5524 doped with 4 weight% each trifluorinated dopant **169** and **206–208**

The nematic phase ranges for all doped +LC systems were measured by DSC, and although the percentage reduction in the clearing point per weight percent of added dopant is relatively large, all newly formulated systems have a T_{NI} above the target temperature of 70 °C [Table 23].

Table 23. DSC analysis of SY5524 doped with 2–4 weight% **169**, **171** and **203–208**

| LC System | T_{CR-N} | T_{N-I} | $\Delta T_{NI}/1\%$ |
|---------------|------------|-----------|---------------------|
| SY5524 | -49.7 | 94.4 | - |
| 4% 171 | -56.6 | 83.1 | 2.75 |
| 4% 203 | -58.6 | 81.3 | 3.20 |
| 4% 204 | -58.3 | 80.2 | 3.48 |
| 4% 205 | -57.8 | 81.0 | 3.28 |
| 4% 169 | -56.7 | 83.1 | 2.83 |
| 4% 206 | -58.1 | 80.3 | 3.53 |
| 4% 207 | -57.2 | 82.1 | 3.08 |
| 4% 208 | -57.1 | 80.8 | 3.40 |

Finally, the voltage holding properties of these new formulations were found to be excellent, permitting their use in display technology [Appendices 3.2–3.5 on CD].

3.2.3 Phase 3: Effect of Dopant Dipole Moment on LC Performance

3.2.3.1 Introduction

Phase 2 of this research programme identified that the performance of commercial –LC and +LC systems were significantly improved by blending them with small quantities of trifluorinated and tetrafluorinated biphenyl ether derivatives. Additionally, the incorporation of terminal alkyl tail groups onto the core dopant structure were not found to offer any extra improvement in device performance, so further investigations into dopants of this type were not attempted.

The final phase of our research programme was to establish whether or not these highly polar dopants are able to exert an additional torsional force on the nematic LC matrix to help improve device rise time, or whether they are simply acting as inert spacer groups which simply reduce the rotational viscosity of the host phase. It was proposed, providing the dopants align themselves parallel to the director of the nematic –LC host, that they should also switch with the applied electric field used to turn the cell on and off. This being the case, the dopants with the greatest proportion of their dipole moment perpendicular to their long axis should interact most strongly with the applied electric field, exert the strongest torsional force on the nematic LC bulk and so increase device rise time to the greatest extent.

To provide an insight into this proposition, a series of difluorinated biphenyl ether derivatives **178–183** were synthesised (Chapter 2) as each of these systems bears a different dipole moment yet remain structurally similar [Figure 22].

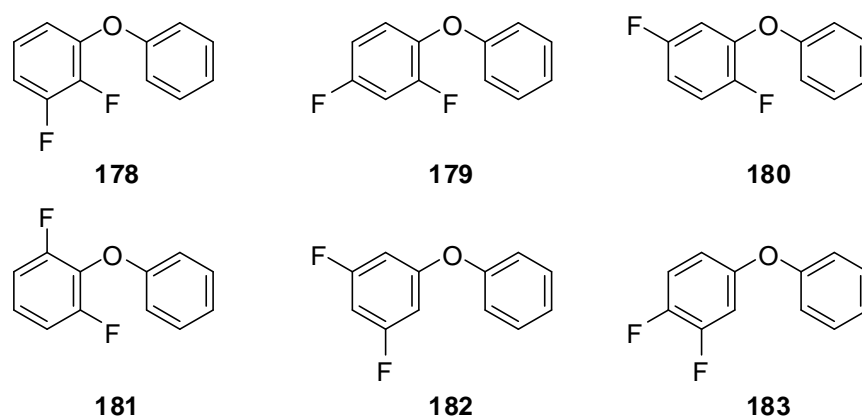
Figure 22. Dopants 178–183 screened in Phase 3

The dipole moment of each dopant was ascertained by molecular structure optimisation procedures with Gaussian 09, using the B3LYP hybrid functional and the 6–311G** basis set. The dipole moment along each of the three Cartesian axes of the molecule, of which the x-axis is defined as the molecular ‘long-axis’, were calculated [Table 24].

Table 24. Calculated dipole moments of dopants 178–183

| Dopant | Dipole Moment / Debye | | | | Negative | Negativity |
|--------|-----------------------|-----|-----|-------|--------------------|------------------------|
| | x | y | z | Total | $\sqrt{y^2 + z^2}$ | $x - \sqrt{y^2 + z^2}$ |
| 178 | 1.6 | 2.7 | 0.3 | 3.1 | 2.7 | –1.1 |
| 179 | 0.2 | 0.4 | 0.9 | 1.0 | 1.0 | –0.7 |
| 180 | 0.8 | 0.9 | 0.3 | 1.2 | 0.9 | –0.1 |
| 181 | 1.2 | 0.9 | 1.2 | 2.0 | 1.5 | –0.3 |
| 182 | 2.1 | 0.4 | 0.2 | 2.1 | 0.4 | 1.7 |
| 183 | 2.6 | 1.1 | 0.2 | 2.9 | 1.1 | 1.5 |

The column labelled ‘negative’ is defined as the total component of the dipole moment perpendicular to the long axis of the molecule and was obtained by calculating the square root of the sum of the squares of the dipole moments along the y and z axes. The column labelled ‘negativity’ is the difference between the dipole moment parallel and perpendicular to the long axis of the dopant and provides an approximation to its dielectric negativity and how strongly it will interact with the applied electric field used to switch the LC cell.

3.2.3.2 Results and Discussion

Each fluorinated biphenyl ether derivative was mixed at concentrations of 2 and 4 weight% with two commercial –LC host systems MLC2038 and LC2, the latter of which has a greater clearing point. The voltage holding ratios of all new formulations were found to match those of the commercially available host phases [Appendices 3.7–3.8 on CD].

3.2.3.3 EO Performance of Dopants in –LC Host MLC2038

In general, the rise times of MLC2038 doped with 2 and 4 weight% of each difluorinated biphenyl ether derivative **178–183** were shorter than those of the untouched commercial host, whilst decay times were slightly lengthened [Charts 9–10].

Chart 9. Rise times of MLC2038 doped with 4 weight% **178–183**

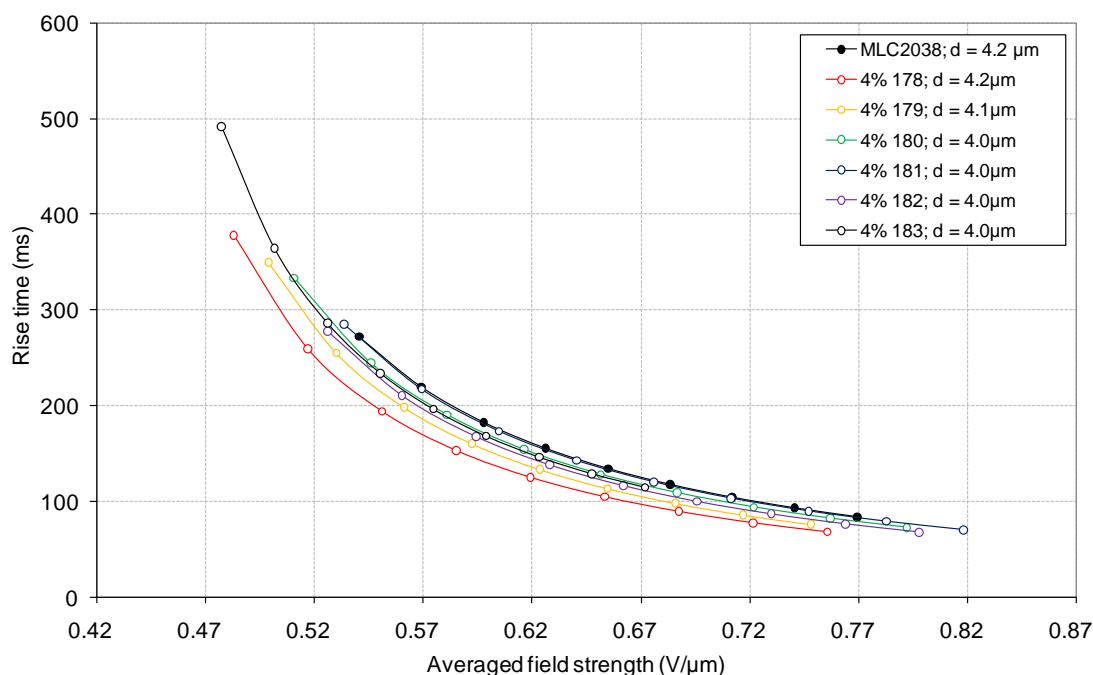
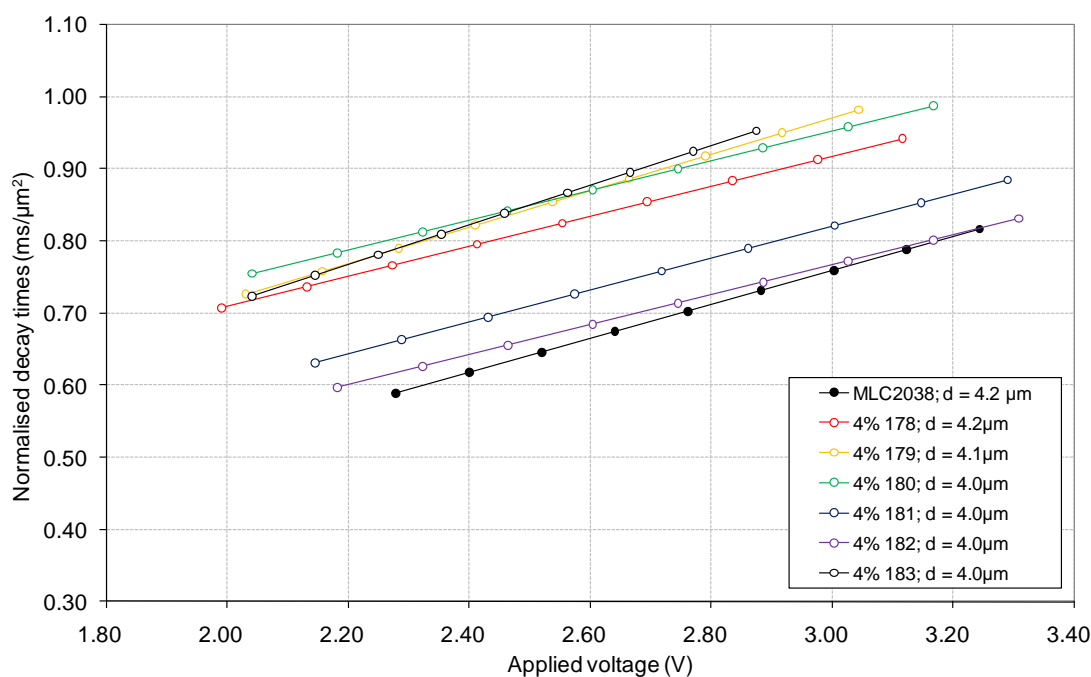

Chart 10. Decay times of MLC2038 doped with 4 weight% 178–183

However, no correlation between the dipole moment of the dopant and the performance of each new LC formulation could be discerned from the EO data obtained, suggesting that there is no significant torsional force exerted by the dopant systems on molecules within the nematic bulk phase. The clearing points of doped systems were evaluated by DSC and were all found to be reduced with respect to that of the host phase [Table 25].

Interestingly, each dopant appears to have a markedly different effect on the clearing point of the host mixture, reflecting a difference in the ability of each dopant to reduce intermolecular interactions between molecules of the nematic bulk. All six molecules have approximately the same flexibilities and sizes, so can be expected to increase the average intermolecular spacing of molecules of the host nematic phase to a similar extent.

Table 25. DSC data for MLC2038 doped with 2 and 4 weight% **178–182**

| LC System | T _{CR-N} / °C | T _{N-I} / °C | ΔT _{NI} / 1% Dopant / °C |
|---------------|------------------------|-----------------------|-----------------------------------|
| MLC2038 | -66.9 | 79.9 | - |
| 2% 178 | -67.5 | 73.8 | 3.05 |
| 4% 178 | -67.8 | 67.4 | 3.19 |
| 2% 179 | -67.5 | 75.7 | 2.13 |
| 4% 179 | -68.1 | 69.6 | 2.59 |
| 2% 180 | -66.8 | 76.7 | 1.60 |
| 4% 180 | -67.6 | 67.9 | 3.00 |
| 2% 181 | -67.1 | 73.4 | 3.30 |
| 4% 181 | -67.0 | 67.8 | 3.03 |
| 2% 182 | -67.5 | 74.3 | 2.83 |
| 4% 182 | -67.7 | 68.9 | 2.75 |
| 2% 183 | -68.0 | 73.3 | 3.33 |
| 4% 183 | -67.8 | 69.1 | 2.71 |

However, there are likely to be additional dopant–host specific interactions, primarily through intermolecular π – π interactions which may act to compound or counteract the increase in average molecular separation. It is, therefore, very difficult to ascertain how best to design a dopant to take advantage of these additional interactions as no information regarding the composition of the host phase is available due to proprietary considerations.

3.2.3.4 EO Performance of Dopants in –LC Host LC2

The rise times of commercial host LC2 doped with each of the difluorinated biphenyl ether systems were found to decrease with increasing doping, although no correlation between dopant structure and rise time could be ascertained. Corresponding decay times were affected in a non-systematic manner [Charts 11–12].

Chart 11. Rise times of LC2 doped with 4 weight% 178–183

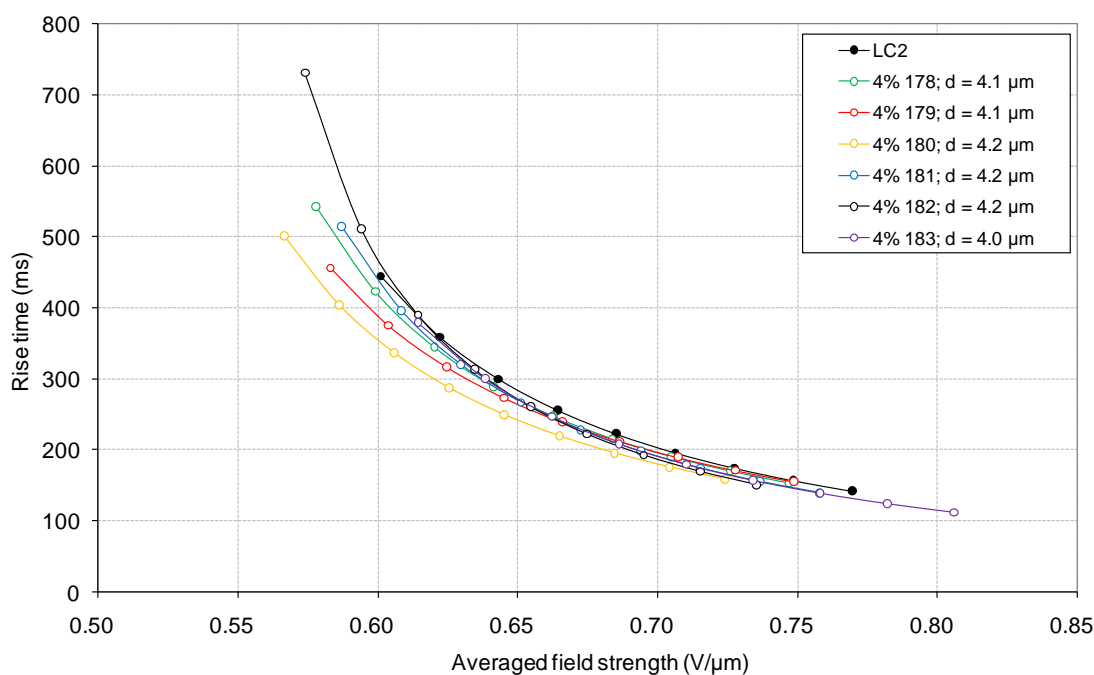
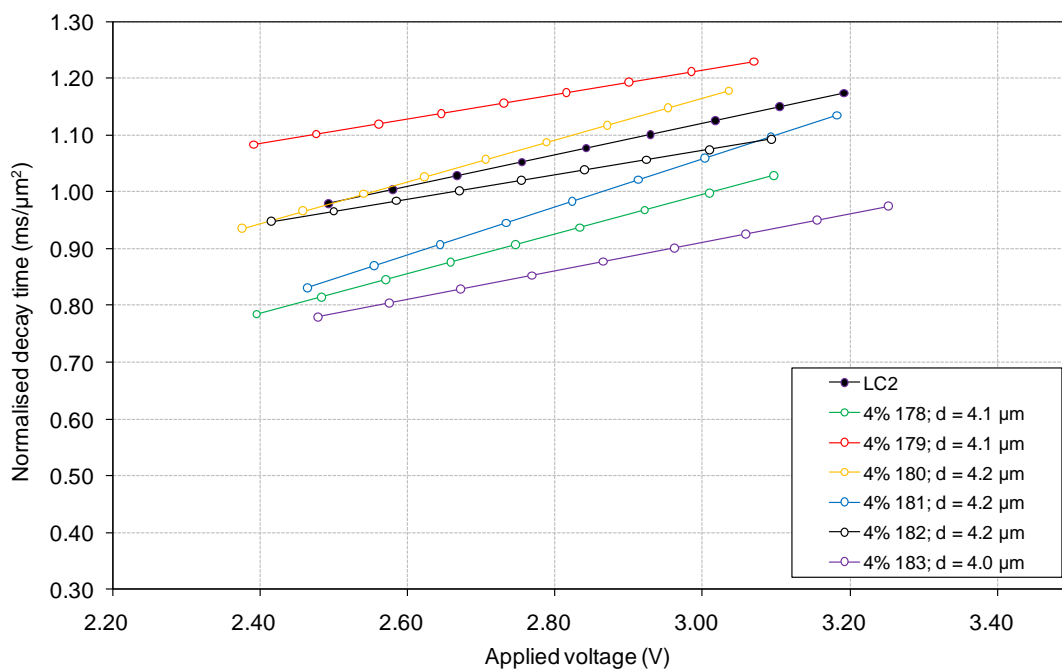

Chart 12. Decay times of LC2 doped with 4 weight% 178–183



As expected, DSC analysis showed that doping effects a reduction in the clearing point of the host phase and that each dopant alters this property to a different extent [Table 26].

Table 26. DSC data for LC2 doped with 2–4 weight% **178–183**

| LC System | T _{CR-N} / °C | T _{N-I} / °C | ΔT _{NI} / 1% Dopant / °C |
|---------------|------------------------|-----------------------|-----------------------------------|
| LC2 | -65.7 | 103.8 | - |
| 2% 178 | -66.8 | 96.7 | 3.55 |
| 4% 178 | -67.8 | 90.2 | 3.40 |
| 2% 179 | -66.6 | 97.7 | 3.05 |
| 4% 179 | -65.4 | 88.4 | 3.85 |
| 2% 180 | -66.2 | 97.2 | 3.30 |
| 4% 180 | -66.5 | 90.5 | 3.33 |
| 2% 181 | -66.5 | 97.1 | 3.35 |
| 4% 181 | -67.7 | 91.7 | 3.03 |
| 2% 182 | -66.2 | 99.9 | 1.93 |
| 4% 182 | -66.9 | 95.4 | 2.10 |
| 2% 183 | -64.4 | 99.5 | 2.15 |
| 4% 183 | -66.8 | 94.1 | 2.43 |

Further characterisation of these new LC formulations was undertaken so that a corresponding FoM could be calculated and direct performance comparisons made.

In order to obtain values for the rotational viscosity of each of the LC systems, which are required for FoM calculations, it was necessary to calculate the dielectric anisotropy of each formulation via a series of capacitance measurements. After collecting these measurements and calculating the corresponding dielectric anisotropy for each newly doped system, it was possible to identify a strong correlation between the calculated ‘negativity’ [Table 24] of each dopant and the overall dielectric anisotropy of the resulting LC mixture [Chart 13].

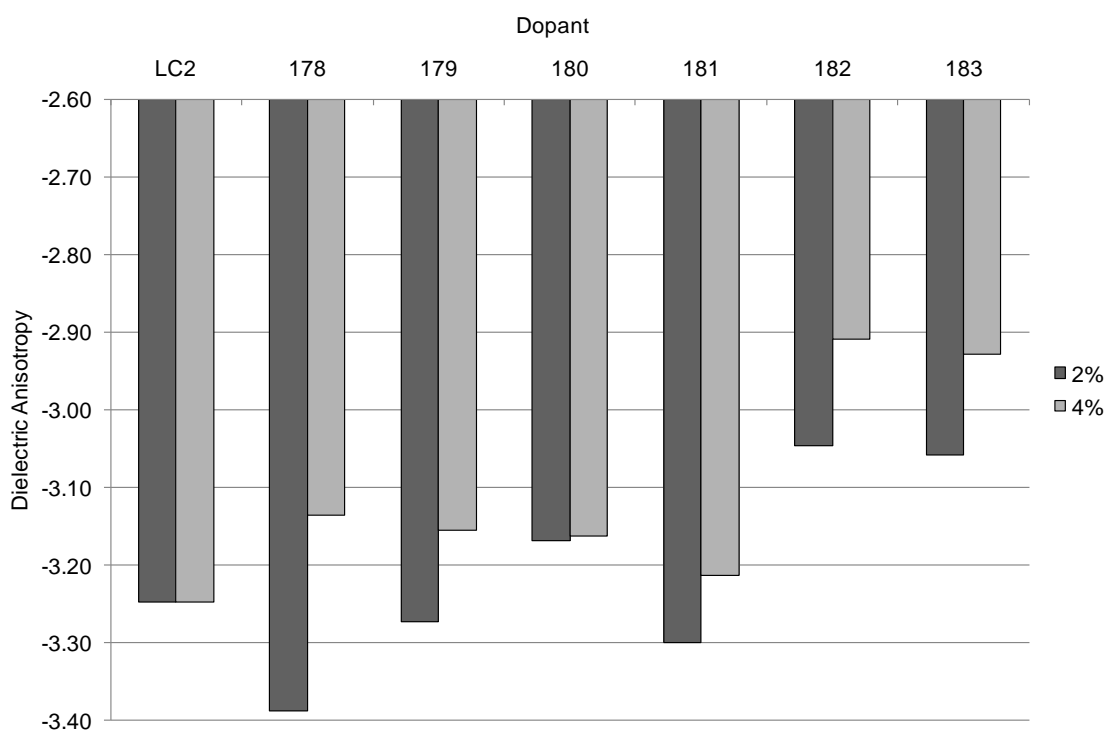
Chart 13. Dielectric anisotropies of LC2 doped with 2–4 weight% of 178–183

At lower doping concentrations, the strongly dielectrically negative difluorobiphenyl ether derivatives act to increase the dielectric anisotropy of the system, whilst the more dielectrically positive dopants have the opposite effect. At higher dopant loadings the anisotropy of the system is greatly reduced and so this correlation is much weaker. These observations suggest that the dopants are indeed aligning themselves parallel to the nematic bulk.

The rotational viscosity of each doped cell was also found to be reduced with respect to the host LC phase and was also observed to be correlated with the calculated dielectric anisotropy of each fluorobiphenyl ether system. No correlation between the rotational viscosity and overall rise time could be identified, although in reality it is highly likely that the performance of each dopant is determined by multiple interactions, of which rotational viscosity is just one important parameter.

Birefringence and elasticity measurements were also collected and both parameters were found to reduce with increasing dopant concentration, although no correlation with dopant structure was apparent [Appendix 3.9 on CD]. These measurements were combined with aforementioned rotational viscosity data to produce a FoM for each new

LC mixture and it was discovered that, in general, the more dielectrically positive dopants (**180**, **182** and **183**) were found to provide new formulations of greater performance than those blended with their more dielectrically negative counterparts (**178**, **179** and **181**) due to the lower rotational viscosities of LC mixtures doped with the former. Specifically, introducing small quantities of dopants **180** and **182** into host LC2 was resulted in the fabrication of LC systems of improved figure of merit and response time and may be considered for use in commercial display applications.

Chart 14. *FoM values for LC2 doped with 2–4 weight% 178–183*

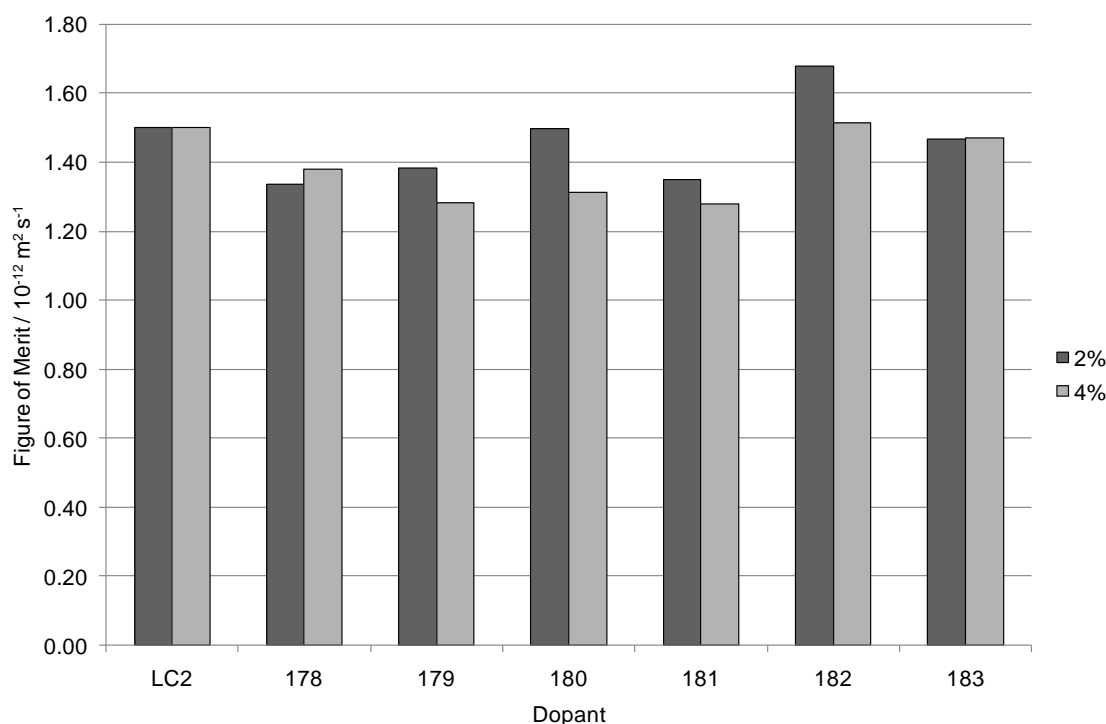

Doping at the higher concentration of 4 weight% should be avoided as this level of doping usually produces systems with lower figure of merits with respect to those formulated with just 2% by weight of the same dopant.

3.3 Conclusions

Phase 1 of this research project identified that pentafluorophenoxybenzene and 1,2,5-trifluoro-3-phenoxybenzene are highly effective dopants for incorporation into commercial host MLC2038 and effect a greater rise time reduction than the standard benchmark dopant, 4-fluorophenoxybenzene. Rise time reductions exhibited by MLC2038 systems doped with 1,2,4,5-Tetrafluoro-3,6-diphenoxybenzene were small in

comparison the reference compound and so diphenoxylated dopants were excluded from further studies.

Phase 2 revealed that 1,2,4,5-tetrafluoro-3-(4-n-alkylphenoxy)benzene and 1,2,4-trifluoro-3-(4-n-alkylphenoxy)benzene dopants were approximately as effective at reducing the rise times of MLC2038 as 1,2,4,5-tetrafluoro-3-phenoxybenzene and 1,2,4-trifluoro-3-phenoxybenzene, respectively. Figure of merit calculations revealed that the overall performance of each doped system was improved relative to commercial host MLC2038. In addition, doping at the lower concentration of 2 weight% was found to provide LC mixtures of higher figure of merits than at the higher concentration of 4 weight%. Importantly, the rotational viscosities of these doped MLC2038 systems were measured to reduce with increasing doping, providing evidence for the proposed inert spacer model originally proposed by SONY.³

Finally, Phase 3 of this project investigated the performance of a series of difluorinated biphenyl ether derivatives as dopants for two dielectrically negative LC host phases, MLC2038 and LC2. In general, the response times of both systems were improved upon doping, although no correlation between dopant structure or dipole moment and response time could be discerned. No comparison between the respective performances of the doped MLC2038 systems blended with these di-fluorinated biphenyl ether derivatives and the tri-, tetra- and penta-fluorinated dopants of Phases 1 and 2 was made.

However, a strong correlation between the orientation of the dipole moment of each difluorinated dopant and the dielectric anisotropy and rotational viscosity of the newly formulated LC2 mixtures suggests that the biphenyl ether systems prefer to align parallel to the long axes of molecules of the nematic bulk. Further characterisation of the doped LC2 systems exposed the expected reductions in rotational viscosities and clearing points, whilst figure of merit calculations revealed that LC2 blends of the most dielectrically positive dopants were of improved performance with respect to the commercially available LC host phase.

To build on the work outlined in this chapter, it would be useful to complete the syntheses of all remaining target materials depicted in Table 10 (Chapter 2) by the

three-step S_NAr-reduction-reductive diazotisation methodology, as employed for the syntheses of the difluorinated biphenyl ether derivatives. It would then be possible to carry out a complete comparison of the effects of dipole moment on the figure of merit of doped commercial systems by comparing experimental data with computational calculations. It would also be useful to investigate polyfluorinated biphenyl ether derivatives bearing fluorine atoms on both aromatic rings, using computational calculations to predict which dopants are likely to provide LC formulations with the highest figure of merits.

3.4 References to Chapter 3

- [1] Bruyneel, F.; De Smet, H.; Vanfleteren, J.; Calster, A. V. *Opt. Eng.* **2000**, *40*, 259-267.
- [2] Kilickiran, P.; Masutani, A.; Hollfelder, N.; Nelles, G.; Yasuda, A.; Tadeusiak, A.; Sandford, G. *Digest of Technical Papers - Society for Information Display International Symposium* **2007**, *38*, 999-1002.
- [3] Kilickiran, P.; Roberts, T.; Hollfelder, N.; Schüller, B.; Masutani, A.; Nelles, G.; Yasuda, A. *J. SID.* **2008**, *16*, 63-70.
- [4] Wu, S.-T.; Wu, C.-S. *Phys. Rev. A.* **1990**, *42*, 2219-2227.

Chapter 4

Palladium-catalysed C–F Bond Activation of Fluoroaromatic Systems

4.1 Introduction

Fluorinated biphenyl derivatives are common component materials of modern LC mixtures due to their high polarity and chemical stability.¹⁻³ It is possible to access fluorobiphenyl systems by S_NAr reactions of highly fluorinated aromatics with standard organometallic reagents^{4,5} or by metal-catalysed cross-coupling processes involving, typically, iodo- or bromo- substituted polyfluorobenzene derivatives [Scheme 62].^{6,7}

Scheme 62. Conventional syntheses of fluorobiphenyl derivatives **19**, **253** and **255**

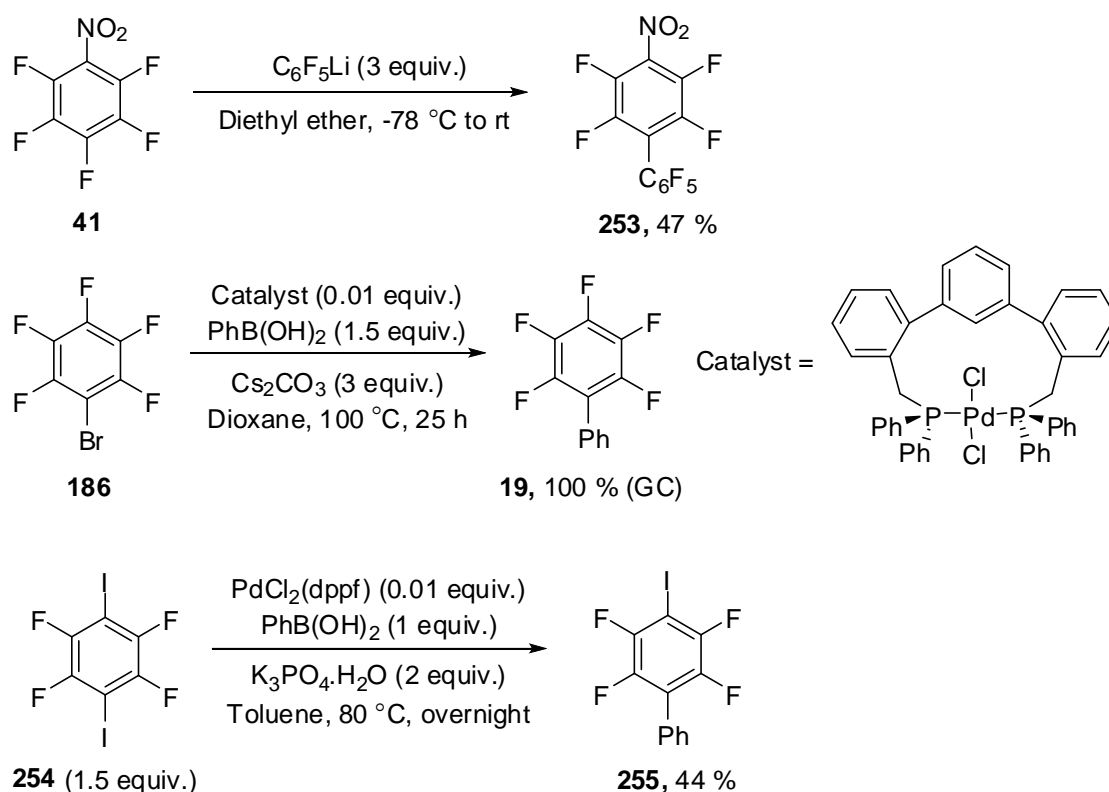

In principle, C–F bonds may also be used as synthetic handles for corresponding metal-catalysed cross-coupling reactions although oxidative addition of the catalyst into the very strong C–F bond is extremely difficult. Only a handful of publications regarding

catalytic C–F bond activation and subsequent functionalisation processes have been produced to date, and the majority of these processes reported tend to involve the use of highly air-sensitive nickel(0) complexes and are concerned with the reactions of monofluorinated aromatic systems to non-fluorinated products, as discussed in Chapter 1. Consequently, the development of reaction conditions that allow the activation of C–F bonds in highly fluorinated aromatic systems by standard, commercially available catalysts that may be used in typical laboratory processes is required.

4.2 Aims and Approach

In 2003 the groups of Kim and Yu⁸ and Widdowson⁹ simultaneously reported several successful palladium-catalysed C–F activation and functionalisation reactions of a number of nitrofluoroaromatic systems under standard Suzuki-Miyaura conditions. The nitro group was highlighted as being particularly advantageous for the oxidative addition of the catalyst into the C–F bond and a directed S_NAr-type mechanism for this step of the catalytic cycle was proposed. Indeed, if the nitro group was removed from the fluoroaromatic ring, or if the *ortho* relationship between the nitro group and fluorine substituents was not present, then no coupling reaction was observed.

As part of a developing research programme concerning C–F bond activation in the Durham Group, it was speculated whether or not highly fluorinated nitrobenzene systems would be compatible substrates for arylation under similar conditions to those reported by Kim and Yu. After some initial optimisation, a successful Suzuki-Miyaura protocol was developed and palladium(0) phosphine complexes were identified as suitable catalytic species for these reactions [Scheme 63].¹⁰

[Scheme 63] Suzuki-Miyaura coupling reaction of pentafluoronitrobenzene (**41**) with phenylboronic acid

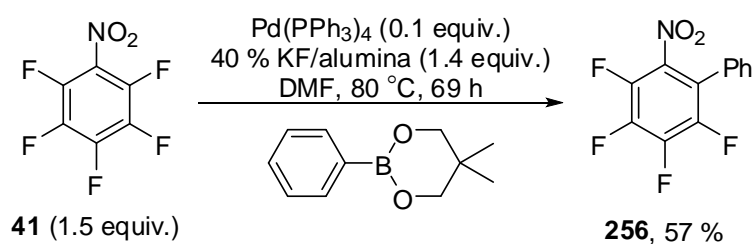

Crucially, the use of fluoride ion as the base, from potassium fluoride or potassium fluoride adsorbed onto the surface of alumina, was necessary to prevent excessive degradation of pentafluoronitrobenzene (**41**) by competing nucleophilic aromatic substitution processes. A catalytic cycle for the coupling reaction was outlined, in which oxidative addition of the palladium catalyst into the C–F bond was proposed as being predominantly nucleophilic in character, in contrast to typical concerted processes of aryl bromides and iodides [Figure 23].

Figure 23. Proposed mechanism of arylation of pentafluoronitrobenzene (**41**)¹⁰

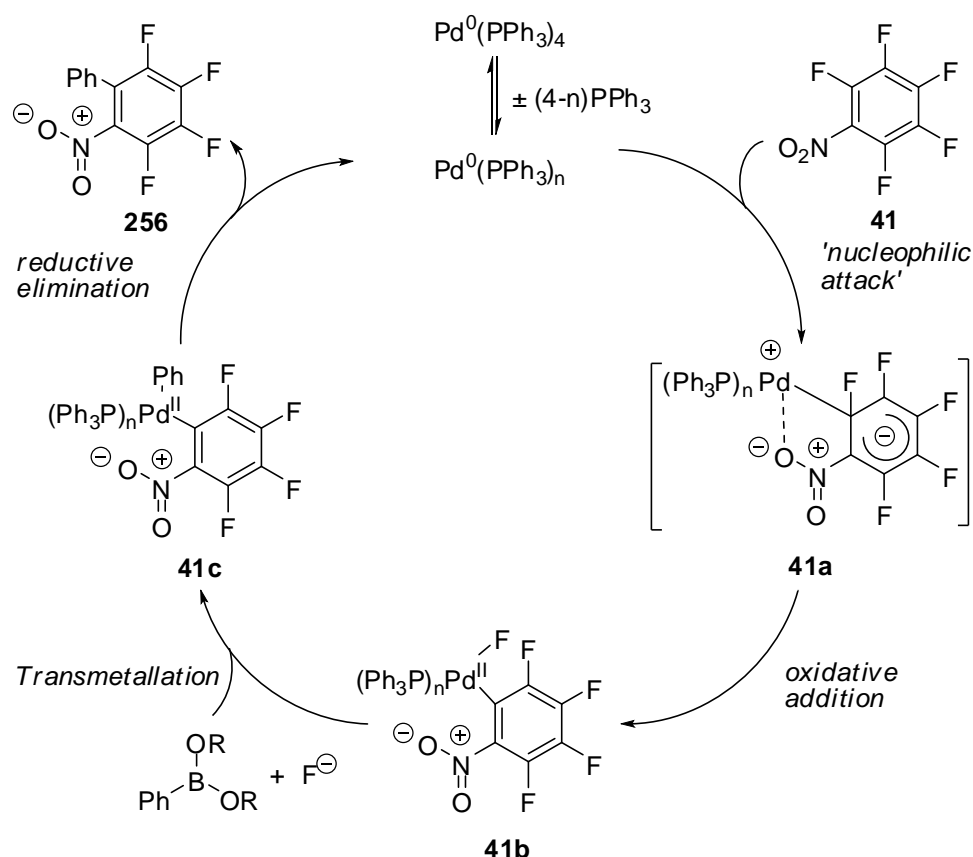

The first step of the catalytic cycle is the nitro-directed nucleophilic attack of the palladium catalyst *ortho* to the nitro group to give, formally, Meisenheimer intermediate **41a**, which regains aromaticity to form oxidative addition adduct **41b**. Transmetalation and reductive elimination occur as usual to afford the cross-coupled biaryl derivative and to regenerate the catalyst.

In initial experiments, several boronic acids and protected ester equivalents bearing electron withdrawing and electron donating substituents were successfully cross-

Chapter 4: Palladium-catalysed C–F Bond Activation of Fluoroaromatic Systems
 coupled with pentafluoronitrobenzene in moderate to good yields. A more thorough optimisation of the reaction conditions was required as optimal solvents, ligands, catalyst loadings and reaction stoichiometry had not been ascertained in order to broaden the scope of this novel C–F activation strategy. To address these issues, palladium-catalysed cross-coupling reactions of a range of substituted polyfluoroaromatic systems will be investigated [Scheme 64].

Scheme 64. Synthetic strategy 1

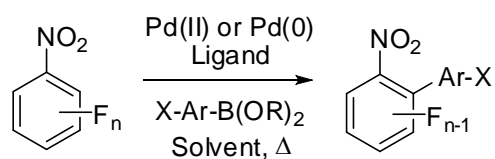

$n = 5-1$; $X = \text{H, EDG, EWG}$
 Ligand = Phosphine, Phosphite, NHC

Once optimised conditions for palladium-catalysed Suzuki-Miyaura reactions of polyfluoronitrobenzene derivatives have been established, corresponding cross-coupling reactions of functionalised pentafluorobenzene and heterocyclic systems bearing activating electron withdrawing substituents will also be studied to explore the scope and limitations of the C–F activation protocol [Scheme 65].

Scheme 65. Synthetic strategy 2

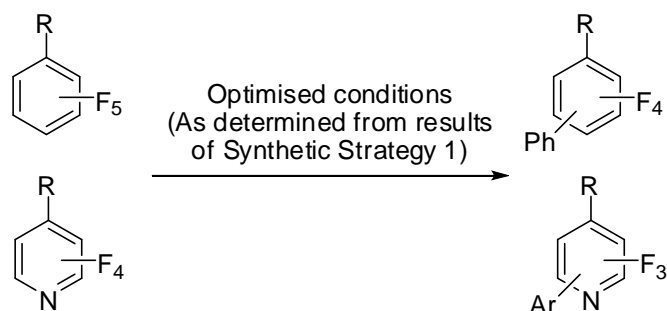

$R = \text{NO}_2, \text{CHO}, \text{CO}_2\text{Me}, \text{CO}_2\text{H}, \text{CO}_2\text{K}, \text{CF}_3, \text{CN}, \text{F}$

4.3 Results and Discussion

4.3.1 Optimisation of the Cross-coupling Procedure

Suzuki-Miyaura cross-coupling reactions of pentafluoronitrobenzene (**41**) with several boronic acids and protected ester equivalents have already been reported by the Durham Group,¹⁰ although a large catalyst loading and excess substrate was required to achieve complete conversion of starting material. In order to develop this methodology further it was necessary to improve the efficiency of the coupling procedure and so a thorough screening of the reaction conditions was undertaken.

Microwave irradiation was employed to allow a number of screening reactions to be performed in a relatively short timeframe and ¹⁹F NMR analysis was used to determine relative conversions of starting material to products. Reaction of phenylboronic acid with pentafluoronitrobenzene (**41**) was selected as the standard experiment for the optimisation process and, in initial procedures, quantitative conversion of **41** was achieved by using only a slight excess of fluoride ion base and phenylboronic acid [Scheme 66].

Scheme 66. Phase 1: Initial optimisation of cross-coupling stoichiometry

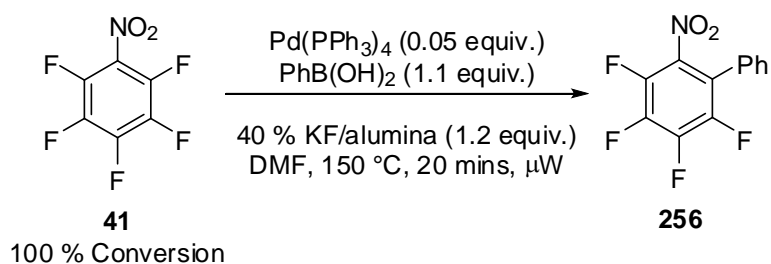

The second phase of the optimisation procedure was to screen a range of aprotic solvents under the conditions outlined in Scheme 66, although the temperature was reduced to 100 °C to prevent the coupling reactions reaching completion so that relative conversions in all solvents could be measured [Table 27].

Highly polar DMF and DMSO were found to afford the greatest yield of biaryl derivative **256** whilst less polar solvents were found to be significantly less effective for the coupling procedures. DMF, rather than DMSO, was selected as the preferred solvent

Chapter 4: Palladium-catalysed C–F Bond Activation of Fluoroaromatic Systems
for further investigations as it is marginally easier to remove during purification processes.

Table 27. Phase 2: Solvent screen

| Solvent | Yield 256 / % ^a | Solvent | Yield 256 / % ^a |
|-------------|----------------------------|---------|----------------------------|
| DMSO | 71 | THF | 48 |
| DMF | 71 | Toluene | 0 |
| MeCN | 41 | NMP | 0 |
| 1,4-Dioxane | 43 | | |

^a¹⁹F NMR Yield

A range of phosphine ligands were screened in Phase 3 of the optimisation procedure and PPh₂Cy and PPh₃ were found to be most effective, although the latter was selected as the preferred ligand due to the commercial availability of Pd(PPh₃)₄ [Table 28].

Table 28. Phase 3: Ligand screen

| Ligand | Yield 256 / % ^a | Ligand | Yield 256 / % ^a |
|---------------------|----------------------------|----------------------------------|----------------------------|
| PPh ₂ Cy | 59 | P(<i>o</i> -tolyl) ₃ | 16 |
| PPh ₃ | 53 | P(OPh) ₃ | Trace |
| PPhCy ₂ | 43 | PCy ₃ | 0 |
| PPh ₂ Me | 27 | PPhMe ₂ | 0 |

^a¹⁹F NMR Yield

Finally, the concentration of Pd(PPh₃)₄ was increased gradually from 0 to 10 mol%, with respect to pentafluoronitrobenzene (**41**), in order to establish the optimal catalyst loading [Table 29].

Table 29. Phase 4: Catalyst loading

| n | Conversion 41 / %^a | n | Conversion 41 / %^a |
|----------|--------------------------------------|----------|--------------------------------------|
| 0 | 0 | 0.039 | 96 |
| 0.001 | 25 | 0.060 | 100 |
| 0.011 | 65 | 0.088 | 100 |
| 0.020 | 83 | 0.098 | 100 |

^a¹⁹F NMR Yield

No reaction was observed in the absence of palladium, confirming the catalytic nature of the arylation process. Complete conversion of starting material was achieved with a catalytic loading between 3.9 and 6.0 mol% relative to pentafluoronitrobenzene (**41**) under the conditions studied.

4.3.2 Palladium-catalysed Suzuki-Miyaura Cross-coupling Reactions of Highly Fluorinated Nitrobenzene Derivatives

4.3.2.1 Cross-coupling Reactions of Pentafluoronitrobenzene

Using our optimised conditions, several coupling reactions of pentafluoronitrobenzene (**41**) with a range of boronic acids and protected boronate esters bearing electron withdrawing and electron donating substituents **257–263** were carried out to afford biaryl derivatives **256** and **264–269** in good yields [Table 30].

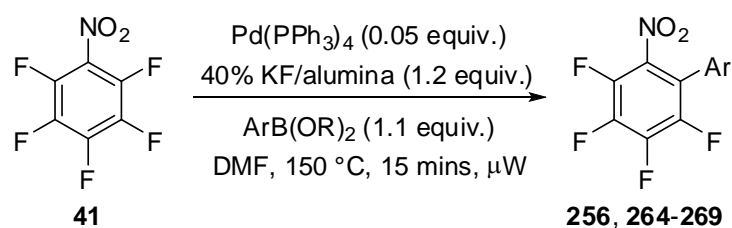
Table 30. Palladium-catalyzed Suzuki reactions of pentafluoronitrobenzene (**41**)

| Boronic Acid or Ester | Product, (Yield / %) | Boronic Acid or Ester | Product, (Yield / %) |
|-----------------------|-----------------------|-----------------------|-----------------------|
| | 256 , (80) | | 267 , (73) |
| | 264 , (56) | | 268 , (70) |
| | 265 , (56) | | 269 , (53) |
| | 266 , (64) | | |

Complete conversion of pentafluoronitrobenzene was achieved in each reaction, although difficulties with product purification resulted in slightly reduced isolated yields of the target biphenyl systems. Regioselective arylation *ortho* to the nitro group was observed for all reactions and the structures of **256** and **267** were confirmed by X-ray crystallography [Figure 24]. The observation of four separate resonances in a 1:1:1:1 ratio in the ^{19}F NMR spectra at very similar chemical shifts for those obtained

spectra of **256** and **267** provide evidence for the structures of the remaining biphenyl derivatives. Attempts to cross-couple pentafluorophenylboronic acid, 2,4,6-trimethylphenylboronic acid 2-nitrophenylboronic acid were unsuccessful, presumably due to the unfavourable steric interactions involved in attaching both ring systems to the palladium catalyst.

Figure 24. X-Ray molecular structures of **256** and **267**. ORTEPs set at 50% probability level. Structure **256** bond lengths (Å): $C_1-N_1 = 1.477(5)$; $C_2-C_7 = 1.485(4)$; $C_6-F_4 = 1.336(4)$; $N_1-O_1 = 1.200(8)$; $N_1-O_2 = 1.220(8)$. Structure **256** bond angles (°): $C_1-C_2-C_7-C_8 = 54.6(5)$; $C_2-C_1-N_1-O_1 = 62.7(6)$; $O_1-N_1-O_2 = 127.2(3)$. Structure **267** bond lengths (Å): $C_1-C_7 = 1.483(2)$; $C_2-N_1 = 1.468(2)$; $C_{10}-C_{13} = 1.484(2)$; $N_1-O_1 = 1.2283(19)$; $N_1-O_2 = 1.2237(19)$. Structure **267** bond angles (°): $C_2-C_1-C_7-C_8 = -129.45(17)$; $C_{11}-C_{10}-C_{13}-C_{14} = 141.60(17)$; $O_1-N_1-O_2 = 124.89(14)$.

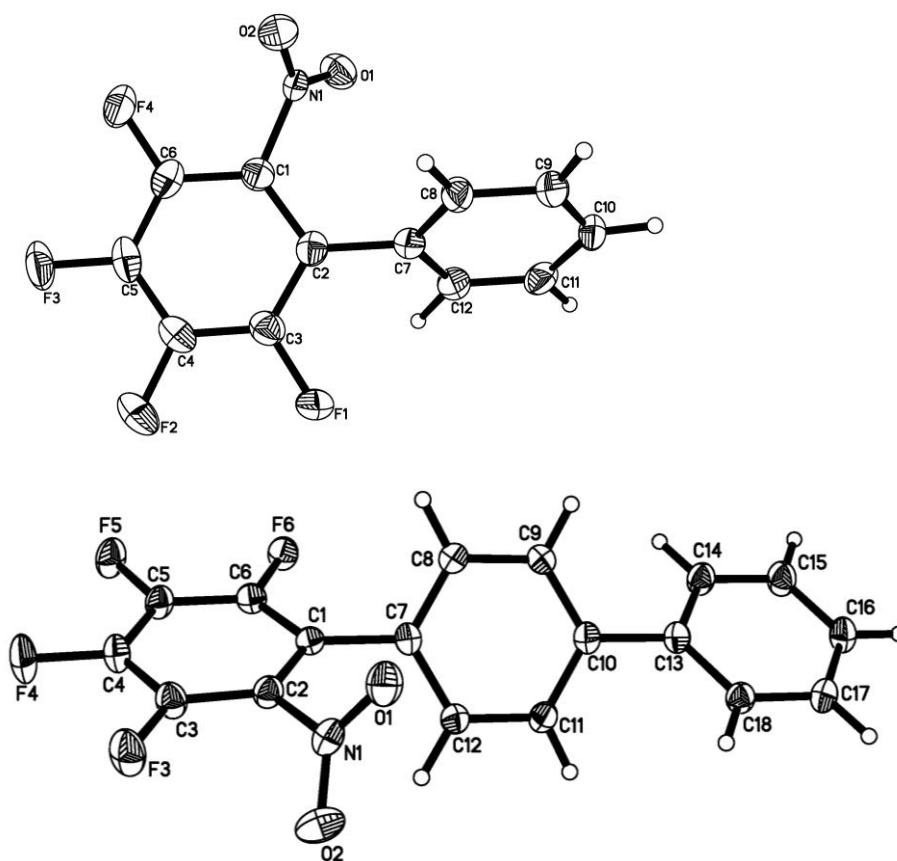

| | 256 | 267 |
|--------------------------------------|--------------------------------------|---------------------------------------|
| Temperature/K | 120(2) | 153(2) |
| Crystal system | Monoclinic | Triclinic |
| Space group | P2 ₁ /n | P-1 |
| a/Å, b/Å, c/Å | 7.6907(5), 11.4847(8), 11.9766(8) | 6.2677(3), 9.9095(5), 12.4290(6) |
| α /°, β /°, γ /° | 90.00, 92.53(2), 90.00 | 82.398(10), 85.577(10), 72.896(10) |
| Volume/Å ³ | 1056.80(12) | 730.74(6) |
| Z | 4 | 2 |
| Goodness-of-fit on F ² | 1.014 | 1.046 |

In addition, oxidative addition intermediate **41b** was synthesised by reaction of a stoichiometric quantity of Pd(PPh₃)₄ with pentafluorobenzene (**41**) in dry, degassed DMF at 80 °C for 8 hours using standard Schlenk-line techniques. Recrystallisation from dry, degassed THF afforded pure **41b**, which was dissolved in *d*₈-toluene and analysed by ¹⁹F NMR spectroscopy. The corresponding spectrum displayed four resonances at –110, –145, –150, and –162 ppm corresponding to the ring-fluorine substituents and a fifth resonance at –311 ppm corresponding to the metal-bound fluorine. Single crystals suitable for X-ray analysis were grown by the slow evaporation of diethyl ether from the purified solid under an argon atmosphere and the resolved structure clearly shows the presence of the C-Pd-F moiety [Figure 25].

Figure 25. X-Ray molecular structure of oxidative addition intermediate **41b**. The nitro group is 50:50 disordered over two positions, although only one structure is shown for clarity. ORTEPs set at 50% probability level. Bond lengths (Å): $C_1-Pd_1 = 1.998(3)$; $C_2-N_1 = 1.454(5)$; $F_1-Pd_1 = 2.0188(16)$; $P_1-Pd_1 = 2.3325(7)$; $P_2-Pd_1 = 2.3270(7)$. Bond angles (°): $C_1-Pd_1-F_1 = 178.52(11)$; $C_1-Pd_1-P_1 = 91.44(8)$; $C_1-Pd_1-P_2 = 90.05(8)$; $F_1-Pd_1-P_1 = 88.90(5)$; $P_1-Pd_1-P_2 = 167.53(3)$.

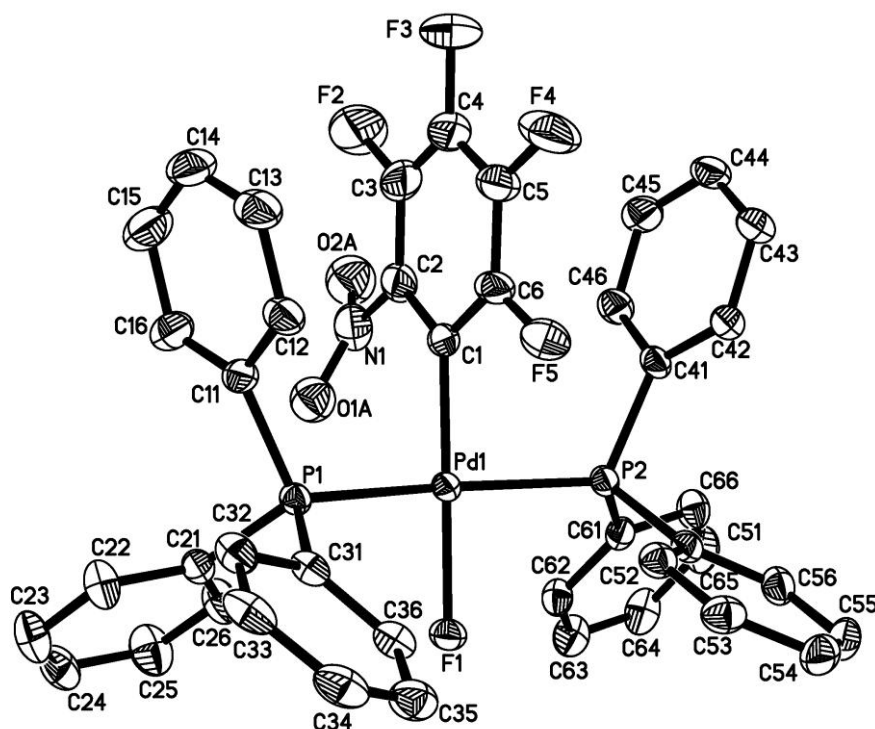

| | |
|----------------------------------------------------|------------------------------------|
| Temperature/K | 120.0 |
| Crystal system | Monoclinic |
| Space group | $P2_1/n$ |
| $a/\text{Å}$, $b/\text{Å}$, $c/\text{Å}$ | 12.9604(4), 13.9264(3), 20.6986(5) |
| $\alpha/^\circ$, $\beta/^\circ$, $\gamma/^\circ$ | 90.00, 105.49(1), 90.00 |
| Volume/Å ³ | 3600.23(16) |
| Z | 4 |
| Goodness-of-fit on F^2 | 1.051 |

4.3.2.2 Cross-coupling Reactions of Tetrafluoronitrobenzene Derivatives

To establish the generality of our coupling protocol to other highly electrophilic systems, similar Suzuki-Miyaura reactions of tetrafluorinated nitrobenzene derivatives **270–272** with 5,5-dimethyl-2-phenyl-1,3,2-dioxaborinane were subsequently investigated [Table 31].

Table 31. Cross-coupling reactions of tetrafluoronitrobenzene derivatives **270–272** with 5,5-dimethyl-2-phenyl-1,3,2-dioxaborinane

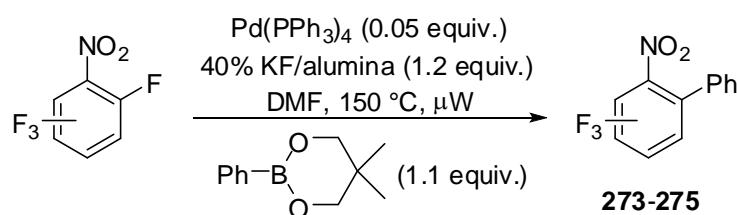

| Substrate | Product, (Yield / %) | Major By-product, (Yield / %) |
|-----------|-----------------------|-------------------------------|
| | 273 , (54) | 276 , (18) |
| | 274 , (27) | 277 , (6) |
| | 275 , (48) | 278 , (6) |

Conditions: ^a30 mins; ^b2 h.

Prolonged heating at elevated temperatures was required to achieve complete conversion of tetrafluorobenzene systems **270–272**, reflecting the reduced electrophilicities of these systems towards nucleophilic aromatic substitution of the

palladium catalyst compared to pentafluoronitrobenzene, and only moderate yields of corresponding biphenyl derivatives **273**–**275** were isolated.

Regioselective *ortho* arylation was observed for all three reactions and the structures of **274** and **275** were confirmed by X-ray crystallography [Figure 26]. The molecular structure of **273** was assigned by the observation of a resonance at 7.2 ppm by ^1H NMR spectroscopy which exhibits two identical $^3J_{\text{HF}}$ coupling constants (9.1 Hz) and two signals in the corresponding ^{19}F NMR spectrum that display a mutual $^3J_{\text{FF}}$ coupling constant (22 Hz). Phenylation at either the 4- or 6-position would result in the observation of just a single $^3J_{\text{HF}}$ coupling constant in the associated ^1H NMR spectrum, whilst phenylation at the 3 position would yield a product whereby all three fluorine substituents are positioned *meta* to one another, so characteristic $^3J_{\text{FF}}$ coupling constants would not be observed.

Figure 26. X-Ray molecular structures of biphenyl derivatives **274** and **275**. ORTEPs set at 50% probability level. Structure **274** bond lengths (Å): $C_1-N_1 = 1.4712(15)$; $C_2-C_7 = 1.4860(14)$; $N_1-O_1 = 1.2244(14)$; $N_2-O_2 = 1.2285(15)$. Structure **274** bond angles ($^\circ$): $C_1-C_2-C_7 = 124.25(10)$; $C_2-C_1-N_1 = 119.77(10)$; $O_1-N_1-O_2 = 124.67(11)$. Structure **275** bond lengths (Å): $C_3-N_1 = 1.4707(14)$; $C_4-C_7 = 1.4861(16)$; $N_1-O_1 = 1.2264(14)$; $N_1-O_2 = 1.2212(13)$. Structure **275** bond angles ($^\circ$): $C_3-C_4-C_7 = 123.22(10)$; $C_4-C_3-N_1 = 120.92(10)$; $O_1-N_1-O_2 = 125.20(10)$.

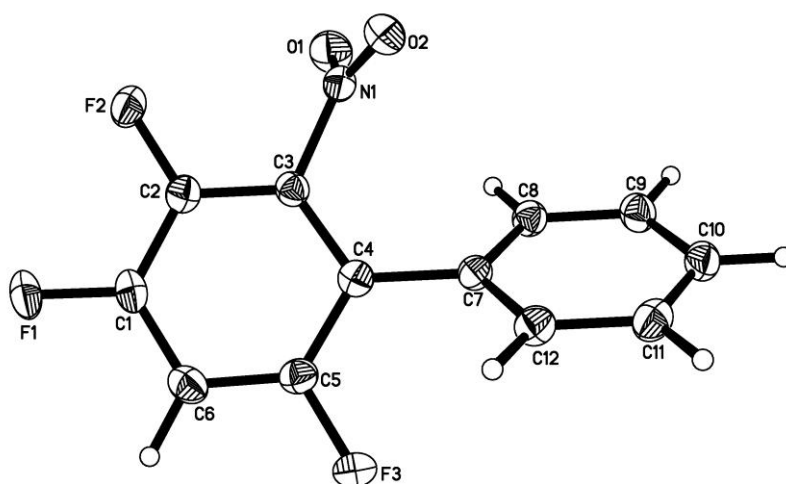

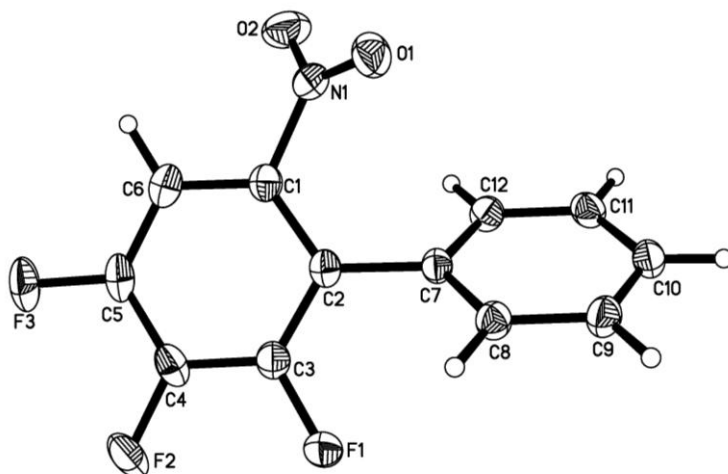

| | 274 | 275 |
|-----------------------------------|--------------------------------------|---------------------------------------|
| Temperature/K | 120(2) | 120(2) |
| Crystal system | Monoclinic | Orthorhombic |
| Space group | P2 ₁ /c | Pbca |
| a/Å, b/Å, c/Å | 12.5365(7), 7.5063(4), 11.0598(6) | 11.6280(2), 12.1588(2), 14.4292(2) |
| α/°, β/°, γ/° | 90.00, 97.89, 90.00 | 90.00, 90.00, 90.00 |
| Volume/Å ³ | 1030.90(10) | 2040.04(6) |
| Z | 4 | 8 |
| Goodness-of-fit on F ² | 1.033 | 1.080 |

Significant quantities of dimethylamino-functionalised trifluoronitrobenzene derivatives **276–278** were also isolated from the reactions of **270–272**, respectively, and ¹⁹F NMR spectroscopic analysis of the crude reaction mixtures revealed the formation of a number of unwanted side-products. Decomposition of DMF to dimethylamine, followed by competing nucleophilic aromatic substitution reactions of the tetrafluoronitrobenzene starting materials **270–272** was believed to be responsible for the formation of **276–278**.

In order to verify the identity of several of the by-products arising from the decomposition of DMF, an excess of dimethylamine was reacted with each of the tetrafluoronitrobenzene systems **270–272** [Table 32].

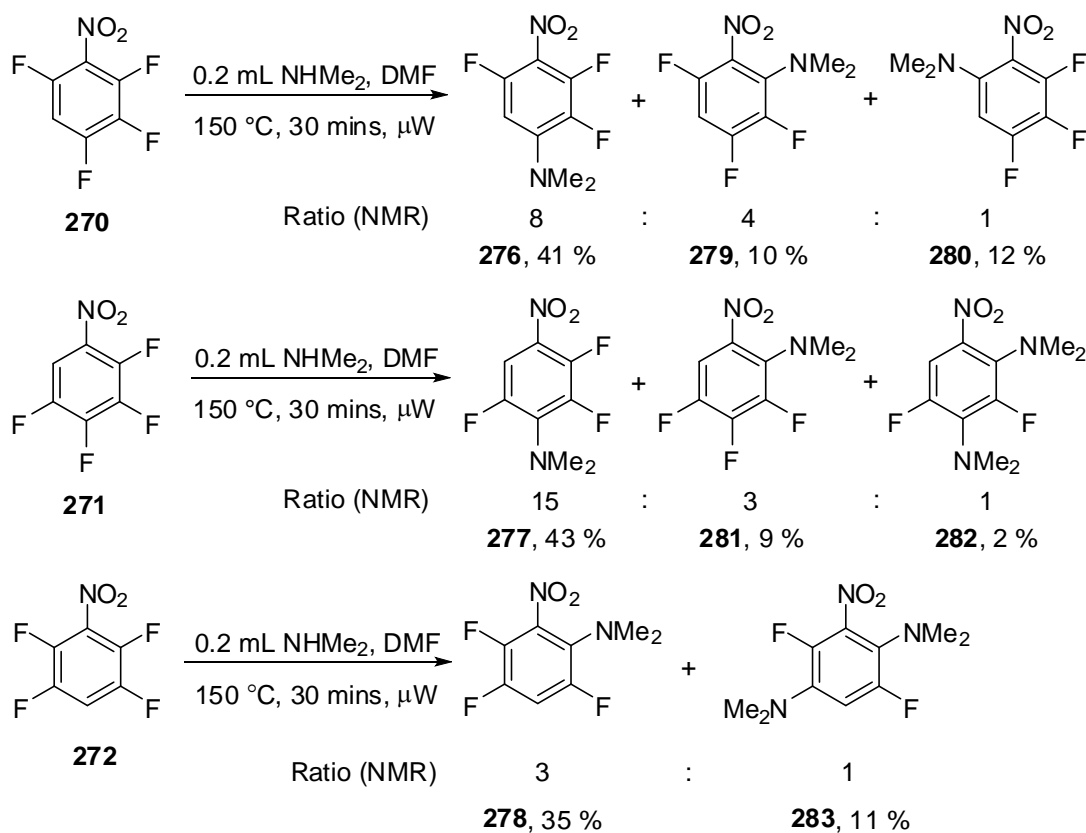
Table 32. *S_NAr* reactions of dimethylamine with tetrafluoronitrobenzene systems **270–****272**

Complete conversion of starting material was achieved under the reaction conditions and a number of dimethylamino- functionalised materials **276–283** were isolated from each reaction mixture by column chromatography. Reaction of **270** with dimethylamine has been documented elsewhere and, although none of the 6-substituted product **280** was reported, our observed ratios of **276** and **279** are consistent with literature data.¹¹ The structures of **272** and **279** were assigned by comparison with available literature data, although **276** was also further characterised by X-ray crystallography [Figure 27]. SCS calculations confirm the structures and ¹⁹F nuclear magnetic resonance assignments of remaining products **277**, **278** and **280–283**.

Figure 27. X-Ray molecular structure of **276**. ORTEPs set at 50% probability level.

Bond lengths (Å): $C_1-N_1 = 1.446(3)$; $C_4-N_2 = 1.353(3)$; $N_1-O_1 = 1.231(3)$; $N_1-O_2 = 1.224(3)$; $N_2-C_7 = 1.465(3)$; $N_2-C_8 = 1.473(3)$. Bond angles (°): $O_1-N_1-O_2 = 122.57(19)$; $C_7-N_2-C_8 = 117.0(2)$.

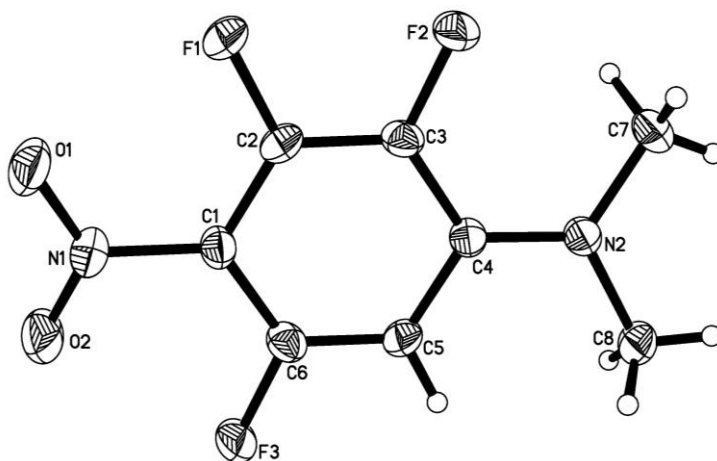

| | |
|----------------------------------------------------|----------------------------------|
| Temperature/K | 120.0 |
| Crystal system | Monoclinic |
| Space group | $P2_1/n$ |
| $a/\text{Å}$, $b/\text{Å}$, $c/\text{Å}$ | 8.0491(4), 9.1029(4), 11.7075(5) |
| $\alpha/^\circ$, $\beta/^\circ$, $\gamma/^\circ$ | 90.00, 94.49(3), 90.00 |
| Volume/Å ³ | 855.17(7) |
| Z | 4 |
| Goodness-of-fit on F^2 | 1.055 |

In addition, each of the tetrafluoronitrobenzene systems **270–272** were heated to 150 °C for 30 minutes in DMF and in the presence of a slight excess of alumina-supported potassium fluoride. A number of products were observed by ¹⁹F NMR spectroscopy and many of these corresponded to the dimethylamino- functionalised derivatives **276–283**, confirming the source of these side-products in the palladium-catalysed reactions described above.

To avoid the problems associated with DMF decomposition, the coupling reactions of the tetrafluorobenzene systems **270–272** with 5,5-dimethyl-2-phenyl-1,3,2-

dioxaborinane were repeated in DMSO, which was found to be equally effective as DMF in initial solvent optimisation studies [Table 33].

Table 33. Cross-coupling reactions of tetrafluoronitrobenzene derivatives **270–272** with 5,5-dimethyl-2-phenyl-1,3,2-dioxaborinane

$\text{Pd(PPh}_3)_4$ (0.05 equiv.)
 $40\% \text{ KF/alumina}$ (1.2 equiv.)
 $\text{DMSO, } 150\text{ }^\circ\text{C, } \mu\text{W}$
 Ph-B (1.1 equiv.)

273-275

| Substrate | Product, (Yield / %) |
|----------------------------|----------------------|
| 270^a | 273, (81) |
| 271^b | 274, (65) |
| 272^b | 275, (54) |

Conditions: ^a30 mins; ^b2 h.

Complete conversion of starting material was achieved under microwave irradiation to afford biaryl derivatives **273–275** in significantly improved yields, although a small quantity of tarry material was also produced and some desired product was lost in the purification procedure. Several methods of product purification were trialled and the most successful process was to avoid organic-aqueous extraction techniques and to first remove all solid material by passing the reaction mixture through silica gel, before separatory flash column chromatography.

Tetrafluorobenzene derivative **270** has two fluorine atoms *ortho* to the nitro group yet arylation occurs exclusively at the 2-position. Under the assumption that oxidative addition of the palladium catalyst into the C–F bond resembles that of a conventional S_NAr type process then the regiochemistry of arylation can be explained by considering the relative activating effects of other ring fluorine substituents [Figure 28].

Figure 28. Possible sites of arylation of 2,3,4,6-tetrafluoronitrobenzene (**270**)

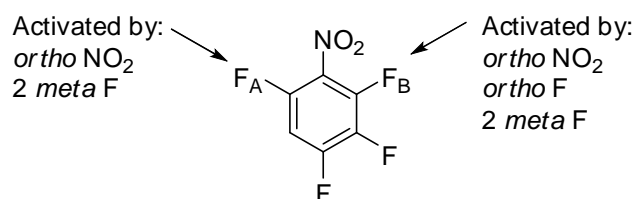

In addition to the electron withdrawing *ortho* nitro group, sites F_A and F_B are further activated towards nucleophilic substitution by the presence of two additional *meta* ring fluorine substituents, which act to stabilise the developing negative charge of the Meisenheimer intermediate. Crucially, site F_B is also activated by an *ortho* fluorine atom which increases the electrophilicity of the carbon atom under attack and so is expected to be the more reactive of the two sites towards nucleophilic aromatic substitution processes. Indeed, regioselective arylation at site F_B was observed in the corresponding cross-coupling procedure, providing additional evidence for the proposed S_NAr -type mechanism.

The relative rates of arylation of tetrafluoronitrobenzene derivatives were assessed by a competition reaction in which 10 mol% of **270–272** and 5 mol% Pd(PPh₃)₄ were dissolved in degassed DMSO (2 ml) and heated to 100 °C, under microwave irradiation, for 30 minutes. Quantitative data was obtained by ¹⁹F NMR analysis of the crude reaction mixture [Table 34].

Table 34. Relative rates of arylation of **270–272**

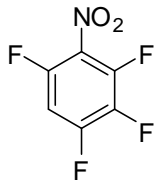
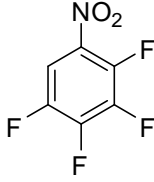
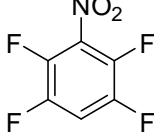
| Substrate | Relative Reactivity ^a | S _N Ar Reactivity ^b |
|-------------------------------------------------------------------------------------------------|----------------------------------|-------------------------------------------|
|  270 | 6.8 | 6.8 |
|  271 | 4.6 | 4.3 |
|  272 | 1.0 | 0.3 |

^aAs measured by ¹⁹F NMR spectroscopic analysis; ^bNormalised literature values for rates of S_NAr methoxydefluorination processes¹²

The relative reactivities of each tetrafluoronitrobenzene substrate (**270–272**) towards palladium-catalysed Suzuki-Miyaura arylation were found to be very similar to those concerning analogous S_NAr reactions of sodium methoxide.¹² This observation provides additional evidence for the nucleophilic character of the coupling procedure.

4.3.2.3 Cross-coupling Reactions of Trifluoronitrobenzene Derivatives

Corresponding cross-coupling reactions of trifluoronitrobenzene derivatives **212**, **214** and **216** required prolonged heating at elevated temperatures and increased catalyst loadings to achieve reasonable conversions of starting material to corresponding biaryl systems **284–286** [Table 35].

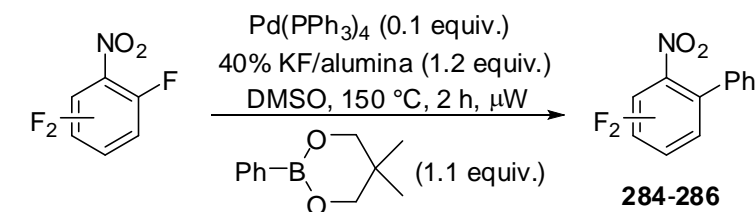
Table 35. Cross-coupling reactions of trifluoronitrobenzene derivatives **212**, **214** and **216**

| Substrate, (Conversion / %) ^a | Product, (Yield / %) |
|------------------------------------------|-----------------------|
| 212 , (40) | 284 , (34) |
| 214 , (85) | 285 , (54) |
| 216 , (100) | 286 , (54) |

^aAs measured by ¹⁹F NMR spectroscopic analysis

Ortho arylation was observed in each case, although the reactions were much less efficient and a number of side products were observed by ¹⁹F NMR spectroscopy. It was not possible to obtain quantitative comparisons of the relative reactivities of each of the three substrates **212**, **214** and **216** towards arylation as the reaction mixtures were too complex, although the reduced conversion of **212** clearly indicates that it is the least reactive electrophilic species of the series.

4.3.2.4 Cross-coupling Reactions of Substituted Pentafluorobenzene Systems

All of the Suzuki-Miyaura processes presented so far concerned palladium-catalysed C–F bond arylation reactions of highly fluorinated nitrobenzene systems and furnished a number of novel *ortho* functionalised biphenyl derivatives. The success of these reactions was proposed to be due to the ability of the nitro group to facilitate the oxidative addition step by directing the palladium catalyst into the adjacent C–F bond. In an attempt to expand the scope of our coupling procedure, a number of Suzuki-Miyaura reactions of substituted pentafluorobenzene derivatives bearing a range of electron withdrawing groups were investigated [Scheme 67].

Scheme 67. Attempted arylation reactions of several substituted pentafluorobenzene derivatives

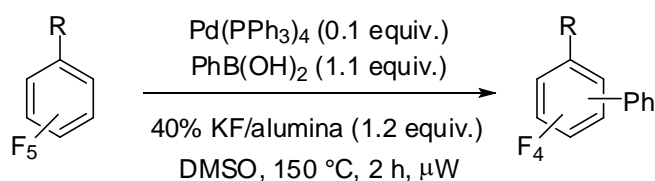

R = F, CF₃, CN, CHO, CO₂Me, CO₂H

Unfortunately, no reaction of any of the substituted pentafluorobenzene derivatives was observed, even after prolonged heating at elevated temperatures, despite the potentially similar directing abilities of the aldehyde, ester and carboxylic acid substituents. It appears that the strong electron withdrawing character of the nitro group, in combination with its ability to exert a strong directing interaction on the palladium catalyst species, is key to the success of the Suzuki reactions. The aldehyde, ester and acid functional groups are not sufficiently electron withdrawing, whereas fluorine, trifluoromethyl and cyano substituents cannot sufficiently interact with an approaching palladium centre.

4.3.3 Heck-type Reactions of Polyfluorinated Nitrobenzene Systems

A key step in the catalytic process for the Suzuki-Miyaura type cross-coupling reactions of phenylboronic acids with highly fluorinated nitrobenzene derivatives is the oxidative

addition of the palladium catalyst into the C–F bond *ortho* to the nitro group. Once this has occurred, the resulting aryl-palladium oxidative addition complex is, theoretically, reactive towards a range of substrates such as, for example, organo-stannanes, organo-zinc reagents, alkynes and alkenes in Stille, Negishi, Sonogashira and Heck type processes, respectively. The highly nucleophilic nature of aryl tin and aryl zinc reagents possibly renders them incompatible for use with highly fluorinated aromatic systems, however, we speculated that alkynes and alkenes may be suitable substrates with which to further develop our C–F bond activation coupling procedure.

Attempted reaction of a mixture of phenyl acetylene, pentafluoronitrobenzene (**41**), KF/alumina, copper(I) iodide and a catalytic quantity of Pd(PPh₃)₄ resulted in the formation of a complex tarry black material, from which no product could be identified [Scheme 68].

Scheme 68. Attempted Sonogashira-type coupling of pentafluoronitrobenzene (**41**) and phenyl acetylene

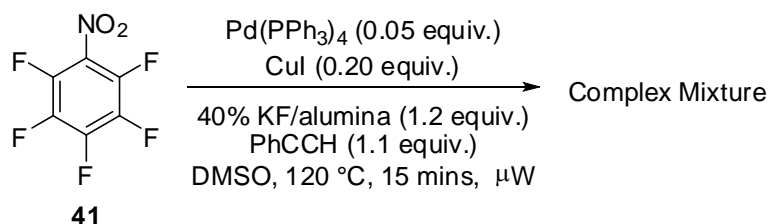

In the Suzuki-Miyaura processes discussed above, the role of the fluoride base is to activate the boronic acid so that transmetallation can take place. In Sonogashira reactions, the role of added base is believed to aid the abstraction the terminal proton from an intermediate copper alkylidene complex, although the precise details of the coupling mechanism are not fully understood. Conversely, in Heck-type reactions of alkynes and alkenes, no base or copper is required although some basic material is commonly added to neutralise the acidic by-product. With this in mind, the reaction of phenyl acetylene with pentafluoronitrobenzene was repeated in the absence of any base or copper(I) iodide and this furnished target material **42** in low yield [Scheme 69].

Scheme 69. Heck-type coupling reaction of phenyl acetylene with pentafluoronitrobenzene (**41**)

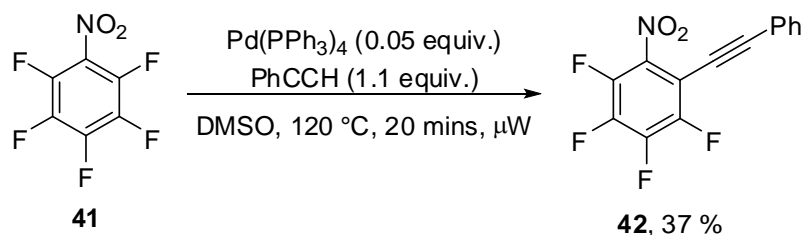

Complete conversion of pentafluoronitrobenzene was achieved under the reaction conditions and only cross-coupled product **42** was observed by ¹⁹F NMR spectroscopic analysis of the crude reaction mixture. Difficulties concerning the decomposition of **42** under atmospheric conditions during the purification procedure resulted in a reduced isolated yield of product. Interestingly, the reaction of lithium phenylacetylide with pentafluoronitrobenzene in diethyl ether was reported to afford exclusively 2-arylated product **42** in good yield and addition of a second equivalent of nucleophile resulted in substitution of the remaining *ortho*, rather than *para* fluorine.¹³

Partially fluorinated aromatic systems such as tetrafluoronitrobenzene are more acidic than deprotonated alkynes such as phenyl acetylide and so S_NAr-type reactions of, for example, pentafluorobenzene with pentafluorophenyl lithium are observed to favour metal-transfer, rather than substitution processes.¹⁴ In our hands, reaction of lithium phenylacetylide with 2,3,4,5-tetrafluoronitrobenzene and 2,3,4,6-tetrafluoronitrobenzene did not afford any S_NAr adduct and, although a small quantity of unidentified material was observed by ¹⁹F NMR spectroscopy, mainly starting material remained. Attempts to trap the proposed reaction intermediate with methyl iodide were unsuccessful, perhaps because of the very low nucleophilicity of the anionic species.

Under our Heck-type cross-coupling protocol, reactions of tetrafluoronitrobenzene derivatives **270** and **271** with a variety of acetylene derivatives **287–289** resulted in complete conversion of starting material to alkynylated products **290–295** in moderate yield [Table 36].

Table 36. Heck-type reactions of tetrafluoronitrobenzene derivatives **270** and **271**

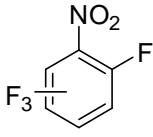
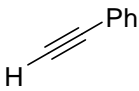
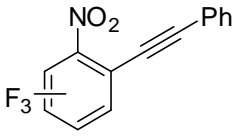
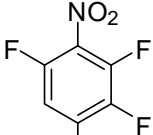
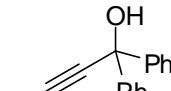
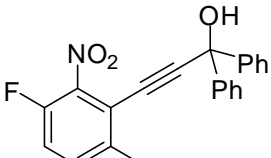
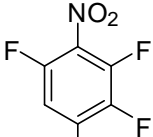
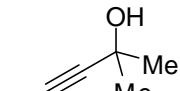
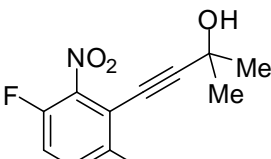
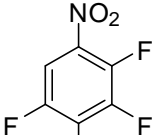
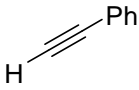
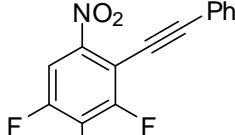
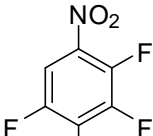
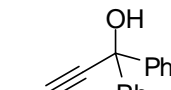
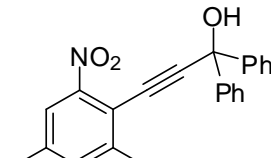
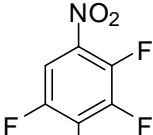
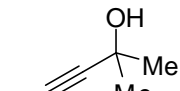
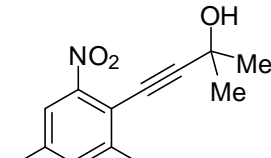
| Substrate | Acetylene Derivative | Product, (Yield / %) |
|---------------------------------------------------------------------------------------------------|---------------------------------------------------------------------------------------------------|-----------------------------------------------------------------------------------------------------------|
|  270 |  287 |  290 , (51) |
|  270 |  288 |  291 , (51) |
|  270 |  289 |  292 , (64) |
|  271 |  287 |  293 , (48) |
|  271 |  288 |  294 , (40) |
|  271 |  289 |  295 , (51) |

¹⁹F NMR spectroscopic analysis of the crude reaction mixtures revealed the coupling processes were highly efficient and only very small quantities of unidentified material was observed, however, difficulties with product purification and decomposition were responsible for the reduced isolated materials of each of the target materials. The regioselectivities of alkylation of tetrafluoronitrobenzene derivatives **270** and **271** were identical to that observed in the corresponding Suzuki-Miyaura reactions and no cross-coupled product was afforded in the absence of palladium catalyst.

The structure of **290** was assigned by the observation of an overlapping doublet of doublet of doublets at 7.1 ppm which displayed two characteristic ³J_{HF} coupling constants (9.2 Hz) by ¹H NMR spectroscopy and by the presence of two fluorine resonances at –126.1 and –134.7 ppm, which were mutually split (³J_{FF} = 21.4 Hz) due to their respective *ortho* relationship. The ¹⁹F NMR spectra of **291** and **292** were very similar to that of **290** and so their structures were assigned accordingly. The structure of **294** was confirmed by X-ray crystallography [Figure 29] and used to assign the structures of **293** and **295** by comparing the very similar chemical shifts of the 3 resonances at approximately –125, –129 and –149 ppm in their corresponding ¹⁹F NMR spectra.

Despite the reduced yields of alkynylated products due to the aforementioned purification and decomposition issues, no further development in this coupling procedure was sought as reactions themselves were highly efficient and highly regioselective.

Figure 29. X-Ray molecular structure of **294**. ORTEPs set at 50% probability level.

Bond lengths (Å): $C_1-C_6 = 1.407(4)$; $C_1-C_7 = 1.428(4)$; $C_7-C_8 = 1.198(4)$; $C_8-C_9 = 1.485(4)$; $C_9-O_3 = 1.429(4)$, $C_9-C_{10} = 1.542(4)$, $C_9-C_{16} = 1.523(4)$; $N_1-O_1 = 1.234(3)$; $N_1-O_2 = 1.218(3)$. Bond angles (°): $C_1-C_7-C_8 = 171.5(3)$; $C_7-C_8-C_9 = 176.1(3)$, $C_8-C_9-O_3 = 109.1(2)$; $C_{10}-C_9-C_{16} = 108.9(2)$; $O_1-N_1-O_2 = 123.4(2)$.

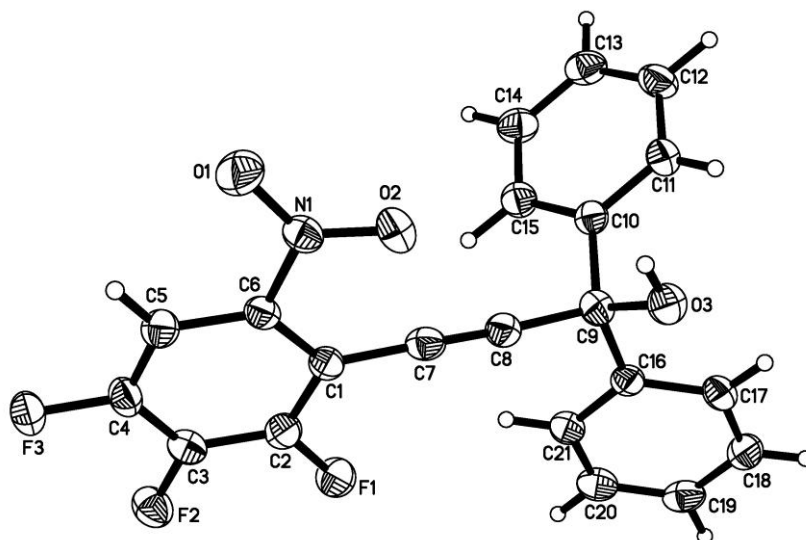

| | |
|------------------------------------------------------|-------------------------------------|
| Temperature/K | 120.0 |
| Crystal system | Monoclinic |
| Space group | $P2_1/n$ |
| $a/\text{Å}$, $b/\text{Å}$, $c/\text{Å}$ | 14.4535(11), 6.2011(5), 19.5369(14) |
| $\alpha/^\circ$, $\beta/^\circ$, $\gamma/^\circ$, | 90.00, 106.778(2), 90.00 |
| Volume/Å ³ | 1676.5(2) |
| Z | 4 |
| Goodness-of-fit on F^2 | 1.003 |

Attempts to couple styrene with pentafluoronitrobenzene under similar reaction conditions did not furnish any detectable product and further investigations into corresponding Heck reactions of sp^2 hybridised substrates with highly fluorinated systems are necessary [Scheme 70].

spectrum of the crude reaction mixture with relevant literature data,¹⁶ although no product was isolated [Scheme 72].

Scheme 72. Attempted cross-coupling reaction of 2,3,5,6-tetrafluoro-4-nitropyridine (**297**)

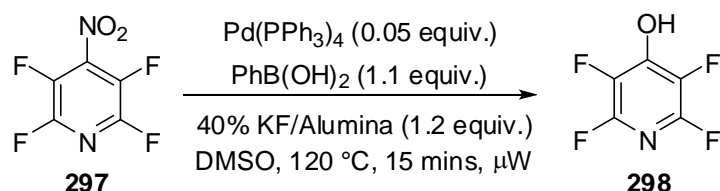

The production of **298** can be explained by a typical S_NAr reaction of highly electrophilic pyridine derivative **297** with trace water, however, dry, degassed DMSO was used and an inert argon atmosphere was maintained throughout the reaction. Nevertheless, it appears as though the highly hygroscopic fluoride base had adsorbed a sufficient quantity of water from the atmosphere that complete hydroxylation of **297** was possible. Indeed, when a solution pyridine derivative **297** in DMSO was heated in the presence of a slight excess of base only, complete conversion to hydroxylated material **298** was also observed.

In conventional Suzuki-Miyaura reactions, the principal role of the base is to coordinate to the boron coupling reagent so that transmetallation of the organo-boron fragment to the palladium catalyst may be readily effected. It was speculated that the employment of alkali-metal boronate salts, which have already been used in several cross-coupling processes as pre-activated equivalents to boronic acids,¹⁷ would circumvent the need to involve hydroscopic fluoride bases in our coupling procedures.

Following a literature procedure,¹⁷ reaction of a concentrated solution of phenylboronic acid (**299**) in toluene with a saturated solution of aqueous sodium hydroxide resulted in the precipitation of sodium phenylboronate (**300**) which was filtered, washed with toluene and isolated in good yield [Scheme 73].

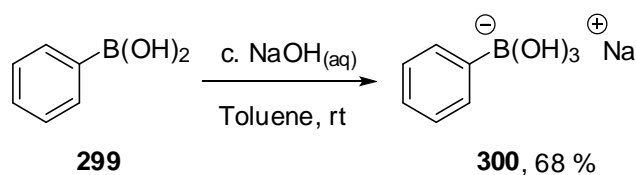
Scheme 73. Synthesis of sodium phenylboronate

Residual toluene was removed *in vacuo* and the solid product was subsequently ground to a fine powder for use in coupling reactions. It was not possible to confirm the purity of the product by NMR analysis as it rapidly dissociates back to phenylboronic acid and sodium hydroxide in D₂O and the ionic nature of the product is not compatible with gas-liquid chromatography techniques. However, the melting point of the isolated product was in excess of 300 °C, significantly higher than that of phenylboronic acid at 216–219 °C, suggesting that the formation of the sodium boronate salt was successful.

Subsequently, reaction of sodium phenylboronate with 2,3,5,6-tetrafluoro-4-nitropyridine (**297**) in DMSO in the presence of a catalytic quantity of Pd(PPh₃)₄ resulted in the complete hydroxylation of **297** to **298**, presumably due to the dissociation of the boronate species back to phenylboronic acid and highly nucleophilic sodium hydroxide [Scheme 74].

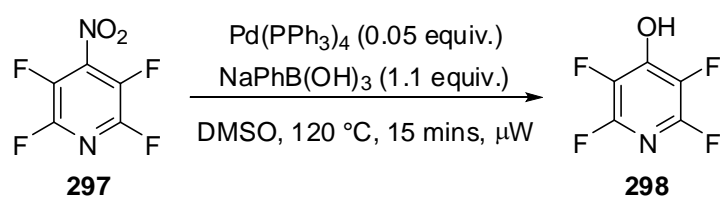
Scheme 74. Attempted arylation of 2,3,5,6-tetrafluoro-4-nitropyridine (**297**) with sodium phenylboronate and Pd(PPh₃)₄ in DMSO

As the synthesis of sodium phenylboronate was performed in toluene, the efficacy of this solvent as a suitable medium for corresponding cross-coupling reactions of **297** was investigated as it was believed that boronate dissociation back to highly insoluble sodium hydroxide would not be favourable [Scheme 75].

Scheme 75. Successful arylation of 2,3,5,6-tetrafluoro-4-nitropyridine (**297**) with sodium phenylboronate and Pd(PPh₃)₄ in toluene

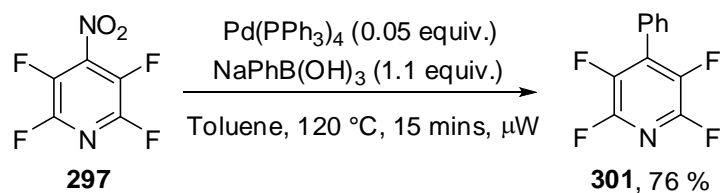

Complete conversion of starting material **297** was observed by ¹⁹F NMR spectroscopy and no hydroxylated material was detected. Interestingly, substitution of the nitro group occurred preferentially and no 3-substituted product arising from C–F activation was observed by either GC–MS or ¹⁹F NMR analysis. The structure of **301** was confirmed by GC–MS analysis (m/z = 227) and from the observation of two resonances of equal intensity at –91.2 and –145.7 ppm in the corresponding ¹⁹F NMR spectrum. No reaction was observed in the absence of palladium, confirming the catalytic nature of this process.

The reactivity profile of 2,3,5,6-tetrafluoro-4-nitropyridine (**297**) towards nucleophilic aromatic substitution processes has been reported and, in general, most products arise from selective nucleophilic attack *ortho* and *para* to ring nitrogen.¹⁸ Substitution at the 3-position is least favoured as this is the least activated site. Consequently, nucleophilic attack of the palladium catalyst into the 4-position of 2,3,5,6-tetrafluoro-4-nitropyridine is lower in energy than for substitution at the 3-position. No arylation *ortho* to ring nitrogen is observed as the pendant nitro group cannot effectively direct the palladium centre into this position.

Unlike for the nitro-substituted pyridine derivative **297**, S_NAr reactions of 2,3,5,6-tetrafluoro-4-(phenylsulfonyl)pyridine occur almost exclusively at the 2-position, leaving the phenylsulfonyl substituent attached to the ring.^{19,20} Thus, to try and affect arylation at the 3-position, the corresponding coupling reaction of 2,3,5,6-tetrafluoro-4-(phenylsulfonyl)pyridine **302** with sodium phenylboronate was attempted, but regioselective arylation *para* to ring nitrogen was once again observed [Scheme 76].

Scheme 76. Cross-coupling reaction of 2,3,5,6-tetrafluoro-4-(phenylsulfonyl)pyridine **302** with sodium phenylboronate

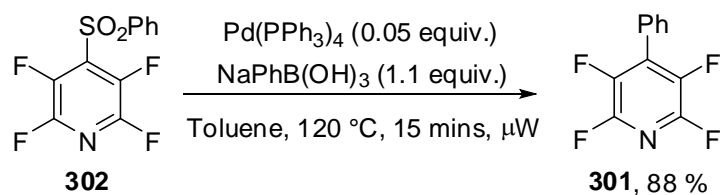

The reaction itself was more efficient than that for nitropyridine derivative **297** and hence a greater yield of product **301** was isolated. Furthermore, corresponding palladium-catalysed cross-coupling reactions of pentafluoropyridine and highly electrophilic 2,3,5,6-tetrafluoro-4-cyanopyridine with sodium phenylboronate in toluene did not afford any arylated material whatsoever.

Despite the fact that C–F activation of a number of substituted polyfluoropyridines derivatives was not achieved, the arylation reactions of 2,3,5,6-tetrafluoro-4-nitropyridine and 2,3,5,6-tetrafluoro-4-(phenylsulfonyl)pyridine are, nonetheless, interesting examples of catalytic C–S and C–N activation processes and so the compatibility of the coupling procedure with other boronate salts **303–305** was studied [Table 37].

Sodium boronate salts **303–305** were synthesised from the parent boronic acid which was first dissolved in diethyl ether at 30 °C and then reacted with a concentrated aqueous solution of sodium hydroxide which was added drop-wise to the reaction vessel. The boronate salt precipitate was then filtered, washed with copious quantities of diethyl ether and thoroughly dried *in vacuo*. The attempted synthesis of sodium 4-dimethylaminophenylboronate by the same process was not successful as the solid precipitate rapidly decomposed to a black paste under atmospheric conditions.

In each case, the corresponding 4-substituted tetrafluoropyridine derivative was formed by replacement of the ring nitro or phenylsulfonyl group for the aromatic coupling partner. Complete conversion of 4-cyanophenylboronate (**305**) was not achieved in either case, presumably as transmetalation of the relatively electron deficient organic fragment to the palladium centre is more difficult than for analogous boronate salts bearing more electron donating ring substituents.

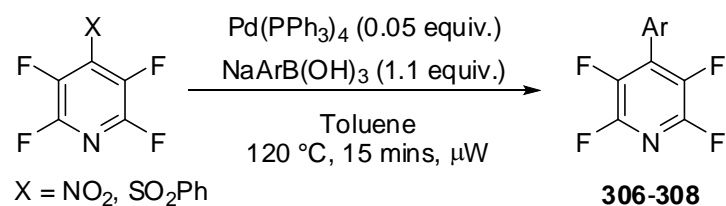
Table 37. Cross-coupling reactions of 2,3,5,6-tetrafluoro-4-nitropyridine (**297**) and 2,3,5,6-tetrafluoro-4-(phenylsulfonyl)pyridine (**302**)

| Substrate | Boronate Salt | Product, (Yield / %) |
|-----------|---------------|------------------------------------|
| | | 306 , (86) |
| | | 307 , (51) |
| | | 308 , (26) ^a |
| | | 306 , (76) |
| | | 307 , (65) |
| | | 308 , (29) ^a |

^a160 °C, 30 mins; Complete consumption of starting material was not achieved

Attempted cross-coupling reactions of pentafluoropyridine, 4-cyano-2,3,5,6-tetrafluoropyridine and 4-methoxyl-2,3,5,6-tetrafluoropyridine were unsuccessful under similar reaction conditions, highlighting the importance of the nitro and phenylsulfonyl moieties.

4.4 Conclusions

Highly fluorinated nitrobenzene systems were shown to be suitable substrates for palladium-catalysed Suzuki-Miyaura and Heck type cross-coupling reactions by C–F bond activation. The electron withdrawing and *ortho*-directing properties of the nitro group is key to the success of these processes as it assists with the proposed S_NAr mechanism for oxidative addition of the palladium catalyst into the adjacent C–F bond.

The use of potassium fluoride adsorbed onto the surface of alumina as the base for the Suzuki-Miyaura processes was found to be advantageous as it prevented decomposition of the highly electrophilic nitrobenzene derivatives by competing S_NAr processes. Additionally, DMSO was found to be a highly effective solvent for less activated systems where degradation of DMF to dimethylamine proved problematic.

Investigations into the regiochemistry and relative rates of arylation of each of the tetrafluoronitrobenzene systems provided further evidence for the S_NAr character of oxidative addition and the aryl-palladium-fluoride intermediate was also synthesised and characterised by NMR spectroscopy and X-ray crystallography, confirming that oxidative addition of the palladium catalyst to the C–F bond is possible.

Corresponding Heck-type reactions of highly fluorinated nitroaromatic systems with a range of substituted alkyne derivatives were found to be highly efficient, although product decomposition and difficulties in the purification procedure resulted in reduced yields of products.

Suzuki-Miyaura cross-coupling reactions of 2,3,5,6-tetrafluoro-4-nitropyridine required the employment of pre-activated boronate salts in order to prevent hydroxylation of the nitro group by water adsorbed by the hygroscopic fluoride base. However, C–N activation was observed in preference to C–F activation and the syntheses of a range of

4-arylated tetrafluoropyridines systems were demonstrated from both 2,3,4,6-tetrafluoro-4-nitropyridine and 2,3,5,6-tetrafluoro-4-phenylsulfonylpyridine.

4.5 References to Chapter 4

- [1] Kirsch, P.; Bremer, M. *Angew. Chem. Int. Ed.* **2000**, *39*, 4216-4235.
- [2] Kirsch, P.; Binder, W.; Hahn, A.; Jährling, K.; Lenges, M.; Lietzau, L.; Maillard, D.; Meyer, V.; Poetsch, E.; Ruhl, A.; Unger, G.; Fröhlich, R. *Eur. J. Org. Chem.* **2008**, 3479-3487.
- [3] Hird, M. In *Physical Properties of Liquid Crystals: Nematics*; Dunmur, D. A., Fukuda, A., Luckhurst, G., Eds.; INSPEC: London, 1998, p 3-16.
- [4] Chaudhry, M. T.; Stephens, R. *J. Chem. Soc.* **1963**, 4281.
- [5] Callender, D. D.; Coe, P. L.; Tatlow, J. C. *Tetrahedron* **1966**, *22*, 419-432.
- [6] Sarwar, M. G.; Dragisic, D.; Salsberg, L. J.; Gouliaras, C.; Taylor, M. S. *J. Am. Chem. Soc.* **2010**, *132*, 1646-1653.
- [7] Smith, R. C.; Bodner, C. R.; Earl, M. J.; Sears, N. C.; Hill, N. E.; Bishop, L. M.; Sizemore, N.; Hehemann, D. T.; Bohn, J. J.; Protasiewicz, J. D. *J. Organometallic. Chem.* **2005**, *690*, 477-481.
- [8] Kim, Y. M.; Yu, S. *J. Am. Chem. Soc.* **2003**, *125*, 1696-1697.
- [9] Widdowson, D. A.; Wilhelm, R. *J. Chem. Soc., Chem. Commun.* **2003**, 578-579.
- [10] Tadeusiak, A., Durham University, 2008.
- [11] Burdon, J.; Fisher, D.; Parsons, I. W.; Tatlow, J. C. *J. Fluorine Chem.* **1981**, *18*, 507-514.
- [12] Bolton, R.; Sandall, J. P. B. *J. Chem. Soc., Perkin Trans. II* **1978**, 141-144.
- [13] Coe, P. L.; Tatlow, J. C.; Terrell, R. C. *J. Chem. Soc. C.* **1967**, 2626-2628.
- [14] Harper, R. J.; Soloski, E. J.; Tamborski, C. *J. Org. Chem.* **1964**, *29*, 2385-2389.
- [15] Chambers, R. D.; Hutchinson, J.; Musgrave, W. K. R. *J. Chem. Soc.* **1965**, 5040-5045.
- [16] Chambers, R. D.; Hutchinson, J.; Musgrave, W. K. R. *J. Chem. Soc.* **1964**, 5634-5640.
- [17] Cammidge, A.; Goddard, V. H. M.; Gopee, H.; Harrison, N. L.; Hughes, D. L.; Schubert, C. J.; Sutton, B. M.; Watts, G. L.; Whitehead, A. J. *J. Org. Chem.* **2006**, *8*, 4071-4074.
- [18] Hargreaves, C. A.; Sandford, G.; Slater, R.; Yufit, D. S.; Howard, J. A. K.; Vong, A. *Tetrahedron* **2007**, *63*, 5204-5211.
- [19] Baron, A.; Sandford, G.; Slater, R.; Yufit, D. S.; Howard, J. A. K.; Vong, A. *J. Org. Chem.* **2005**, *70*, 9377-9381.

- [20] Cartwright, M. W.; Sandford, G.; Bousbaa, J.; Yufit, D. S.; Howard, J. A. K.; Christopher, J. A.; Miller, D. *Tetrahedron* **2007**, *63*, 7027-7035.

Chapter 5

Experimental Section

5.1 General

NMR Spectroscopy: Proton, carbon and fluorine nuclear magnetic resonance spectra (^1H NMR, ^{13}C NMR and ^{19}F NMR) were recorded on a Varian Inova-500 (^1H NMR, 500 MHz; ^{13}C NMR, 126 MHz; ^{19}F NMR, 470 MHz) or a Varian DD-700 (^1H NMR, 700 MHz; ^{13}C NMR, 176 MHz; ^{19}F NMR, 658 MHz) spectrometer with solvent resonance as the internal standard (^1H NMR, CHCl_3 at 7.26 ppm; ^{13}C NMR, CDCl_3 at 77.36 ppm; ^{19}F NMR, CFCl_3 at 0.00 ppm). ^1H , ^{13}C and ^{19}F spectroscopic data are reported as follows: chemical shift, integration, multiplicity (s = singlet, d = doublet, t = triplet, m = multiplet), coupling constants (Hz), and assignment.

Mass Spectrometry: GC-MS analysis was performed on a Trace GC-MS device (Thermo-Finnigan Corporation) operating in electron impact ionisation (EI^+) mode and accurate mass analysis was achieved with a Xevo QToF mass spectrometer (Waters Ltd, UK) equipped with an accurate solids analysis probe (ASAP).

Elemental Analysis: C, H and N analyses were collected with an Exeter Analytical CE-440 Elemental Analyser.

IR: Infra-red spectra were recorded on a Perkin Elmer Spectrum RX1 fitted with an ATR attachment.

X-Ray Analysis: All crystallographic data were recorded with a Rigaku R-Axis SPIDER IP diffractometer equipped with Cryostream (Oxford Cryosystems) low-temperature device at 120 K with graphite-monochromated MoK_{α} -radiation ($\lambda = 0.71073 \text{ \AA}$).

Melting Point Analysis: Melting points were measured with a Gallenkamp apparatus at atmospheric pressure and are uncorrected.

Microwave: All microwave irradiated reactions were heated in a Biotage Initiator™ Sixty microwave using a 0.5–2 mL, 2–5 mL or 10–20 mL microwave vial fitted with a Biotage magnetic follower and sealed with a Reseal™ Septum. The microwave was set to heat to a constant temperature, as specified in the relevant experimental procedure, and each reaction was timed from the point at which the target temperature had been reached. After the reaction time had expired, the microwave vial and its contents were cooled to 45 °C by an external flow of nitrogen gas. Reactions involving solvent DMF, DMSO and NMP were heated to the target temperature using the “very high” irradiation mode. Reactions involving solvent acetonitrile, THF, 1,4-Dioxane were heated using the “high” irradiation mode and those involving solvent toluene were heated using the “normal” irradiation mode.

Chemicals and Solvents: Unless otherwise stated, commercially available reagents were used without purification. Dielectrically negative LC hosts MLC2038 and MJ017252 were purchased from Merck and dielectrically positive LC host SY5524 was purchased from Chisso. An Innovative Technology Inc. Solvent Purification System fitted with a Metrohm 831 Karl Fischer Coulometric Titrator was used to dry MeCN, DMF, THF and toluene whilst anhydrous DMSO and 1,4-dioxane were purchased from Sigma Aldrich. Hexane and DCM were purchased from Fischer and used without further purification. Flash column chromatography was carried out using Fluorochem Silicagel LC60A (40-63 micron).

5.2 Experimental Data to Chapter 2

5.2.3 Strategy 1: Dopant Synthesis by Nucleophilic Aromatic Substitution Reactions of Phenoxide Derivatives with Polyfluorobenzene Systems

1,2,3,4,5-Pentafluoro-6-phenoxybenzene (22) and 1,2,4,5-tetrafluoro-3,6-diphenoxybenzene (184)

Sodium phenoxide (1.010 g, 8.700 mmol) was added to hexafluorobenzene (1.490 g, 8.008 mmol) in anhydrous acetonitrile (100 mL) under an atmosphere of dry argon. The reaction mixture was heated to reflux for 4 h, left to cool, poured on to water (100 mL) and extracted with DCM (3 × 50 mL). The combined extracts were washed with water (100 mL) and dried (MgSO₄). The mixture was filtered and the solvent removed *in vacuo*. Column chromatography using silica gel and hexane as the eluent afforded 1,2,3,4,5-pentafluoro-6-phenoxybenzene (**22**) (0.638 g, 31 %) as a white solid; mp 34–35 °C; Anal. Calcd for C₁₂H₅F₅O: C, 55.38; H, 1.94. Found: C, 55.22; H, 1.94; GC–MS *m/z* (% relative intensity, ion): 260 (79, M⁺), 232 (38), 155 (20), 117 (24), 77 (100), 51 (75), 50 (29), 39 (24); IR (cm⁻¹): 2923, 1592, 1510, 1488, 1315; ¹H NMR (CDCl₃, 500 MHz): δ 6.97 (2H, dd, ³J_{HH} 8.2, H–2'), 7.15 (1H, t, ³J_{HH} 7.8, H–4'), 7.39 (2H, dd, ³J_{HH} 8.2, ³J_{HH} 7.8, H–3'); ¹³C NMR (CDCl₃, 176 MHz): δ 115.6 (s, C–2'), 124.1 (s, C–4'), 129.9 (m, C–4), 130.1 (s, C–3'), 138.4 (dddd, ¹J_{CF} 251, ²J_{CF} 13.9, ²J_{CF} 13.9, ³J_{CF} 5.1, ⁴J_{CF} 3.5, C–2), 139.0 (dtt, ¹J_{CF} 253, ²J_{CF} 14.0, ³J_{CF} 3.9, C–3), 142.4 (dddd, ¹J_{CF} 252, ²J_{CF} 12.3, ³J_{CF} 8.1, ⁴J_{CF} 4.0, C–1), 157.3 (s, C–1'); ¹⁹F NMR (CDCl₃/CFCl₃, 376 MHz): δ –154.4 (2F, m, F–Ar), –160.4 (1F, t, ³J_{FF} 21.7, F–3), –162.6 (2F, m, F–Ar) and 1,2,4,5-tetrafluoro-3,6-diphenoxybenzene (**184**) (0.892 g, 33 %) as a white solid; mp 148–150 °C; Anal. Calcd for C₁₈H₁₀F₄O₂: C, 64.68; H, 3.02. Found: C, 64.78; H, 3.05; GC–MS *m/z* (% relative intensity, ion): 334 (72, M⁺), 213 (11), 77 (100), 51 (51), 50 (11); ¹H NMR (CDCl₃, 500 MHz): δ 7.01 (4H, dd, ³J_{HH} 8.3, H–2'), 7.15 (2H, tt, ³J_{HH} 7.8, ⁴J_{HH} 1.0, H–4'), 7.37 (4H, dd, ³J_{HH} 8.3, ³J_{HH} 7.4, H–3'); ¹³C NMR (CDCl₃, 126 MHz): δ 115.7 (s, C–2'), 124.1 (s, C–4'), 130.1 (s, C–3'), 130.8 (tt, ²J_{CF} 10.3, ³J_{CF} 5.8, C–1), 141.4–143.7 (m, C–F), 157.4 (s, C–1'); ¹⁹F NMR (CDCl₃/CFCl₃, 658 MHz): δ –154.8 (4F, s, F–Ar).

1,2,4,5-Tetrafluoro-3-phenoxybenzene (171)

Sodium phenoxide (1.080 g, 9.303 mmol) was added to pentafluorobenzene (1.421 g, 8.455 mmol) in anhydrous acetonitrile (100 mL) under an atmosphere of dry argon. The reaction mixture was heated to 45 °C for 60 h, left to cool, poured on to water (100 mL) and extracted with DCM (3 × 50 mL). The combined extracts were washed with water (100 mL) and dried (MgSO₄). The mixture was filtered and the solvent removed *in vacuo*. Column chromatography using silica gel and hexane as the eluent afforded 1,2,4,5-tetrafluoro-3-phenoxybenzene (**171**) (1.242 g, 61 %) as a white solid; mp 29–30 °C; Anal. Calcd for C₁₂H₆F₄O: C, 59.50; H, 2.50. Found: C, 59.25; H, 2.48; GC–MS *m/z* (% relative intensity, ion): 242 (77, M⁺), 214 (28), 137 (25), 99 (20), 77 (100), 51 (75), 39 (18); IR (cm⁻¹): 3091, 1588, 1519, 1484; ¹H NMR (CDCl₃, 500 MHz): δ 6.93–7.01 (1H, m, H–6), 6.94 (2H, d, ³J_{HH} 7.3, H–2'), 7.12 (1H, t, ³J_{HH} 7.5, H–4'), 7.34 (2H, dd, ³J_{HH} 7.5, ³J_{HH} 7.3, H–3'); ¹³C NMR (CDCl₃, 126 MHz): δ 102.1 (t, ²J_{CF} 22.8, C–6), 115.8 (s, C–2'), 123.4 (s, C–4'), 130.1 (s, C–3'), 134.5 (tt, ²J_{CF} 13.0, ³J_{CF} 4.0, C–3), 141.8 (dddd, ¹J_{CF} 250, ²J_{CF} 14.5, ³J_{CF} 4.7, ⁴J_{CF} 2.3, C–Ar), 146.7 (dddd, ¹J_{CF} 248, ²J_{CF} 12.1, ³J_{CF} 12.1, ⁴J_{CF} 3.9, C–Ar), 157.4 (s, C–1'); ¹⁹F NMR (CDCl₃/CFCl₃, 188 MHz): δ –139.3 (2F, ddd, ³J_{FF} 21.6; ³J_{FH} 9.9, ⁵J_{FF} 9.9, F–1), –154.4 (2F, ddd, ³J_{FF} 21.6; ⁴J_{FH} 6.9, ⁵J_{FF} 9.9, F–2).

1,2,4-Trifluoro-3-phenoxybenzene (169)

Sodium phenoxide (0.500 g, 4.307 mmol) was added to 1,2,3,4-tetrafluorobenzene (0.585 g, 3.898 mmol) in anhydrous acetonitrile (15 mL) under an atmosphere of dry argon. The reaction mixture was heated to 150 °C for 30 mins under microwave irradiation, left to cool, poured on to water (100 mL) and extracted with DCM (3 × 50 mL). The combined organic extracts were washed with water (100 mL) and dried (MgSO₄). The mixture was filtered and volatile components removed *in vacuo*. Column chromatography using silica gel and hexane as the eluent afforded 1,2,4-trifluoro-3-phenoxybenzene (**169**) (0.598 g, 69 %) as a colourless liquid; Anal. Calcd for C₁₂H₇F₃O: C, 64.29; H, 3.15. Found: C, 63.99; H, 3.03; GC–MS *m/z* (% relative intensity, ion): 224 (74, M⁺), 196 (33), 77 (100), 51 (36); IR (cm⁻¹): 3082, 1591, 1502, 1483, 1323; ¹H NMR (CDCl₃, 500 MHz): δ 6.96 (1H, dddd, ³J_{HH} 9.5, ³J_{HF} 9.5, ⁴J_{HF} 4.6, ⁵J_{HF} 2.3, H–5), 6.99 (2H, d, ³J_{HH} 8.0, H–2'), 7.03 (1H, dddd, ³J_{HH} 9.5, ³J_{HF} 9.5, ⁴J_{HF} 8.0, ⁴J_{HF} 4.6, H–6), 7.12 (1H, tt, ³J_{HH} 7.5, ⁴J_{HH} 1.0, H–4'), 7.35 (2H, m, H–3'); ¹³C NMR

(CDCl₃, 126 MHz): δ 111.1 (ddd, $^2J_{CF}$ 20.9, $^3J_{CF}$ 8.2, $^4J_{CF}$ 4.1, C-5), 112.5 (dd, $^2J_{CF}$ 19.2, $^3J_{CF}$ 8.7, C-6), 115.6 (s, C-2'), 123.6 (s, C-4'), 130.0 (s, C-3'), 133.1 (ddd, $^2J_{CF}$ 10.7, $^2J_{CF}$ 8.2, $^3J_{CF}$ 5.7, C-3), 145.4 (ddd, $^1J_{CF}$ 254, $^2J_{CF}$ 15.1, $^3J_{CF}$ 4.8, C-2), 147.4 (ddd, $^1J_{CF}$ 246, $^2J_{CF}$ 11.0, $^4J_{CF}$ 3.4, C-1), 152.4 (ddd, $^1J_{CF}$ 248, $^3J_{CF}$ 2.5, $^4J_{CF}$ 2.5, C-4), 157.7 (s, C-1'); ^{19}F NMR (CDCl₃/CFCl₃, 376 MHz): δ -131.4 (1F, dddd, $^3J_{FH}$ 9.5, $^4J_{FH}$ 4.6, $^4J_{FF}$ 2.3, $^5J_{FF}$ 13.6, F-4), -140.3 (1F, dddd, $^3J_{FF}$ 20.4, $^3J_{FH}$ 9.5, $^4J_{FH}$ 4.6, $^5J_{FF}$ 13.6, F-1), -148.6 (1F, dddd, $^3J_{FF}$ 20.4, $^4J_{FH}$ 8.0, $^4J_{FF}$ 2.3, $^5J_{FH}$ 2.3, F-2).

1,3,4-Trifluoro-5-phenoxybenzene (175)

Sodium phenoxide (0.503 g, 4.333 mmol) was added to 1,2,3,5-tetrafluorobenzene (0.577 g, 3.845 mmol) in anhydrous acetonitrile (15 mL) under an atmosphere of dry argon. The reaction mixture was heated to 150 °C for 30 mins under microwave irradiation, left to cool, poured on to water (100 mL) and extracted with DCM (3 × 50 mL). The combined organic extracts were washed with water (100 mL) and dried (MgSO₄). The mixture was filtered and volatile components removed *in vacuo*. Column chromatography using silica gel and hexane as the eluent afforded 1,3,4-trifluoro-5-phenoxybenzene (**175**) (0.514 g, 60 %) as a colourless liquid; Anal. Calcd for C₁₂H₇F₃O: C, 64.29; H, 3.15. Found: C, 64.25; H, 3.01; GC-MS *m/z* (% relative intensity, ion): 224 (100, M⁺), 204 (18), 195 (24), 77 (88), 51 (48); ^1H NMR (CDCl₃, 500 MHz): δ 6.48 (1H, dddd, $^3J_{HF}$ 8.9, $^4J_{HF}$ 5.6, $^4J_{HH}$ 3.0, $^5J_{HF}$ 2.4, H-6), 6.69 (1H, dddd, $^3J_{HF}$ 10.1, $^3J_{HF}$ 8.5, $^4J_{HF}$ 5.6, $^4J_{HH}$ 3.0, H-2), 7.06 (2H, dd, $^3J_{HH}$ 8.5, $^4J_{HH}$ 1.0, H-2'), 7.21 (1H, tt, $^3J_{HH}$ 7.5, $^4J_{HH}$ 1.0, H-4'), 7.40 (2H, dd, $^3J_{HH}$ 8.5, $^3J_{HH}$ 7.5, H-3'); ^{13}C NMR (CDCl₃, 126 MHz): δ 100.1 (dd, $^2J_{CF}$ 21.6, $^2J_{CF}$ 27.8, C-2), 103.0 (dd, $^2J_{CF}$ 26.9, $^3J_{CF}$ 3.4, C-6), 119.0 (s, C-2'), 124.9 (s, C-4'), 130.3 (s, C-3'), 139.9 (ddd, $^1J_{CF}$ 247, $^2J_{CF}$ 14.4, $^4J_{CF}$ 5.3, C-4), 147.0 (ddd, $^2J_{CF}$ 12.7, $^3J_{CF}$ 9.8, $^3J_{CF}$ 4.5, C-5), 151.6 (ddd, $^1J_{CF}$ 249, $^2J_{CF}$ 15.0, $^3J_{CF}$ 11.7, C-3), 155.9 (s, C-1'), 157.6 (ddd, $^1J_{CF}$ 245, $^3J_{CF}$ 13.1, $^4J_{CF}$ 3.7, C-1); ^{19}F NMR (CDCl₃/CFCl₃, 188 MHz): δ -114.8 (1F, dddd, $^3J_{FH}$ 8.5, $^3J_{FH}$ 8.9, $^4J_{FF}$ 2.4, $^5J_{FF}$ 11.3, F-1), -133.4 (1F, dddd, $^3J_{FF}$ 20.1, $^3J_{FH}$ 10.1, $^4J_{FF}$ 2.4, $^5J_{FH}$ 2.4, F-3), -161.8 (1F, dddd, $^3J_{FF}$ 20.1, $^4J_{FH}$ 5.6, $^4J_{FH}$ 5.6, $^5J_{FF}$ 11.3, F-4).

1,2,4,5-Tetrafluoro-3-[4-ethyl]phenoxybenzene (203)

60% (w/w) Sodium hydride in mineral oil (0.360 g, 9.000 mmol) was washed with dry hexane (30 mL) under an atmosphere of argon. The hexane/oil solution was removed

using a syringe and dry THF (10 mL) was added to the clean sodium hydride. 4-Ethylphenol (1.000 g, 8.186 mmol) was dissolved in dry THF (5 mL) and carefully added to the sodium hydride solution, with stirring, to produce sodium 4-ethylphenoxide and hydrogen gas. When the evolution of hydrogen gas had stopped the solution was transferred to a 10-20 mL microwave vial, which had been purged three times with argon and fitted with a magnetic stirrer. Pentafluorobenzene (1.376 g, 8.187 mmol) was added to the microwave vial and the reaction was heated to 160 °C for 1 h. The mixture was left to cool, poured on to water (30 mL) and extracted with DCM (3 × 50 mL). The combined extracts were washed with water (50 mL) and dried (MgSO₄). The mixture was filtered and the solvent removed *in vacuo*. Column chromatography using silica gel with hexane as the eluent afforded 1,2,4,5-tetrafluoro-3-[4-ethyl]phenoxybenzene (**203**) (2.082 g, 94 %) as a colourless liquid; Anal. Calcd for C₁₄H₁₀F₄O: C, 62.23; H, 3.73. Found: C, 62.32; H, 3.75; GC-MS *m/z* (% relative intensity, ion): 270 (69, M⁺), 255 (100), 137 (14), 89 (16), 77 (32), 51 (15); IR (cm⁻¹): 2974, 2934, 1641, 1606, 1510, 1483, 1275; ¹H NMR (CDCl₃, 500 MHz): δ 1.25 (3H, t, ³J_{HH} 7.5, -CH₃), 2.65 (2H, q, ³J_{HH} 7.5, -CH₂-), 6.92 (2H, d, ³J_{HH} 8.5, H-3'), 6.96 (1H, tt, ³J_{HF} 10.3, ⁴J_{HF} 7.2, H-6), 7.17 (2H, d, ³J_{HH} 8.5, H-2'); ¹³C NMR (CDCl₃, 126 MHz): δ 15.9 (s, -CH₃), 28.3 (s, -CH₂-), 101.9 (t, ²J_{CF} 23.0, C-6), 115.7 (s, C-2'), 129.3 (s, C-3'), 134.9 (tt, ²J_{CF} 13.2, ³J_{CF} 3.8, C-3), 140.0 (s, C-4'), 141.9 (dddd, ¹J_{CF} 250, ²J_{CF} 14.8, ³J_{CF} 4.7, ⁴J_{CF} 2.5, C-F), 146.7 (dddd, ¹J_{CF} 248, ²J_{CF} 12.3, ³J_{CF} 12.3, ⁴J_{CF} 4.2, C-F), 155.5 (s, C-1'); ¹⁹F NMR (CDCl₃/CFCl₃, 658 MHz): δ -139.4 (2F, ddd, ³J_{FF} 21.2, ³J_{FH} 10.3, ⁵J_{FF} 10.3, F-1), -154.7 (2F, ddd, ³J_{FF} 21.2, ⁴J_{FH} 7.2, ⁵J_{FF} 10.3, F-2).

1,2,4,5-Tetrafluoro-3-[4-n-pentyl]phenoxybenzene (204)

60% (w/w) Sodium hydride in mineral oil (0.310 g, 7.750 mmol) was washed with dry hexane (30 mL) under an atmosphere of argon. The hexane/oil solution was removed using a syringe and dry THF (10 mL) was added to the clean sodium hydride. 4-n-Pentylphenol (1.148 g, 6.990 mmol) was dissolved in dry THF (5 mL) and carefully added to the sodium hydride solution, with stirring, to produce sodium 4-n-pentylphenoxide and hydrogen gas. When the evolution of hydrogen gas had stopped the solution was transferred to a 10-20 mL microwave vial, which had been purged three times with argon and fitted with a magnetic stirrer. Pentafluorobenzene (1.017 g, 6.051 mmol) was added to the microwave vial and the reaction was heated to 160 °C for 1 h. The mixture was left to cool, poured on to water (30 mL) and extracted with DCM

(3 × 50 mL). The combined extracts were washed with water (50 mL) and dried (MgSO₄). The mixture was filtered and the solvent removed *in vacuo*. Column chromatography using silica gel with hexane as the eluent afforded 1,2,4,5-tetrafluoro-3-[4-n-pentyl]phenoxybenzene (**204**) (1.703 g, 90 %) as a colourless liquid; Anal. Calcd for C₁₇H₁₆F₄O: C, 65.38; H, 5.16. Found: C, 65.61; H, 5.16; GC-MS *m/z* (% relative intensity, ion): 312 (85, M⁺), 255 (100), 90 (53), 77 (29), 51 (11). IR (cm⁻¹): 2930, 2859, 1641, 1606, 1511, 1504, 1484, 1275; ¹H NMR (CDCl₃, 500 MHz): δ 0.92 (3H, t, ³J_{HH} 7.0, -CH₃), 1.26–1.39 (4H, m, -CH₂-), 1.56–1.64 (2H, m, H-6'), 2.59 (2H, t, ³J_{HH} 7.5, H-5'), 6.91 (2H, d, ³J_{HH} 8.5, H-3'), 6.97 (1H, tt, ³J_{HF} 9.9, ⁴J_{HF} 7.3, H-6), 7.15 (2H, d, ³J_{HH} 8.5, H-2'); ¹³C NMR (CDCl₃, 126 MHz): δ 14.3 (s, -CH₃), 22.8 (s, -CH₂-), 31.5 (s, C-6'), 31.7 (s, -CH₂-), 35.3 (s, C-5'), 101.9 (t, ²J_{CF} 23.0, C-6), 115.6 (s, C-3'), 129.8 (s, C-2'), 134.8 (tt, ²J_{CF} 13.1, ³J_{CF} 3.8, C-3), 138.7 (s, C-4'), 141.9 (dddd, ¹J_{CF} 251, ²J_{CF} 14.7, ³J_{CF} 4.7, ⁴J_{CF} 2.5, C-F), 146.7 (dddd, ¹J_{CF} 248, ²J_{CF} 12.1, ³J_{CF} 12.1, ⁴J_{CF} 4.2, C-F), 155.5 (s, C-1'); ¹⁹F NMR (CDCl₃/CFCl₃, 470 MHz): δ -139.4 (2F, ddd, ³J_{FF} 21.6, ³J_{FH} 9.9, ⁵J_{FF} 9.8, F-1), -154.6 (2F, ddd, ³J_{FF} 21.6, ⁴J_{FH} 7.3, ⁵J_{FF} 9.8, F-2).

1,2,4,5-Tetrafluoro-3-[4-n-heptyl]phenoxybenzene (205)

60% (w/w) Sodium hydride in mineral oil (0.257 g, 6.425 mmol) was washed with dry hexane (30 mL) under an atmosphere of argon. The hexane/oil solution was removed using a syringe and dry THF (10 mL) was added to the clean sodium hydride. 4-n-Heptylphenol (1.002 g, 5.207 mmol) was dissolved in dry THF (5 mL) and carefully added to the sodium hydride solution, with stirring, to produce sodium 4-n-heptylphenoxide and hydrogen gas. When the evolution of hydrogen gas had stopped the solution was transferred to a 10-20 mL microwave vial, which had been purged three times with argon and fitted with a magnetic stirrer. Pentafluorobenzene (0.965 g, 5.742 mmol) was added to the microwave vial and the reaction was heated to 160 °C for 1 h. The mixture was left to cool, poured on to water (30 mL) and extracted with DCM (3 × 50 mL). The combined extracts were washed with water (50 mL) and dried (MgSO₄). The mixture was filtered and the solvent removed *in vacuo*. Column chromatography using silica gel with hexane as the eluent afforded 1,2,4,5-tetrafluoro-3-[4-n-heptyl]phenoxybenzene (**205**) (1.452 g, 82 %) as a colourless liquid; Anal. Calcd for C₁₉H₂₀F₄O: C, 67.05; H, 5.92. Found: C, 67.20; H, 5.97; GC-MS *m/z* (% relative intensity, ion): 340 (2, M⁺), 256 (8), 255 (100), 206 (12), 89 (22), 78 (25), 43

(67), 29 (40); IR (cm^{-1}): 2927, 2856, 1641, 1606, 1519, 1505, 1484, 1275; ^1H NMR (CDCl_3 , 500 MHz): δ 0.91 (3H, t, $^3J_{\text{HH}}$ 7.0, $-\text{CH}_3$), 1.24–1.40 (8H, m, $-\text{CH}_2-$), 1.56–1.66 (2H, m, H-6'), 2.60 (2H, t, $^3J_{\text{HH}} = 7.0$, H-5'), 6.91 (2H, d, $^3J_{\text{HH}}$ 8.5, H-3'), 6.96 (1H, tt, $^3J_{\text{HF}}$ 10.3, $^4J_{\text{HF}}$ 7.0, H-6), 7.16 (2H, d, $^3J_{\text{HH}}$ 8.5, H-2'); ^{13}C NMR (CDCl_3 , 126 MHz): δ 14.3 (s, $-\text{CH}_3$), 22.9 (s, $-\text{CH}_2-$), 29.4 (s, $-\text{CH}_2-$), 29.4 (s, $-\text{CH}_2-$), 31.8 (s, C-6'), 32.1 (s, $-\text{CH}_2-$), 35.4 (s, C-5'), 101.9 (t, $^2J_{\text{CF}}$ 23.0, C-6), 115.6 (s, C-2'), 129.8 (s, C-3'), 134.9 (tt, $^2J_{\text{CF}}$ 12.6, $^3J_{\text{CF}}$ 3.8, C-3), 138.7 (s, C-4'), 141.9 (dddd, $^1J_{\text{CF}}$ 251, $^2J_{\text{CF}}$ 14.5, $^3J_{\text{CF}}$ 5.0, $^4J_{\text{CF}}$ 2.5, C-F), 146.7 (dddd, $^1J_{\text{CF}}$ 248, $^2J_{\text{CF}}$ 12.2, $^3J_{\text{CF}}$ 12.2, $^4J_{\text{CF}}$ 4.2, C-F), 155.5 (s, C-1'); ^{19}F NMR ($\text{CDCl}_3/\text{CFCl}_3$, 658 MHz): δ -139.5 (2F, ddd, $^3J_{\text{FF}}$ 21.6, $^3J_{\text{FH}}$ 10.3, $^5J_{\text{FF}}$ 10.3, F-1), -154.7 (2F, ddd, $^3J_{\text{FF}}$ 21.6, $^4J_{\text{FH}}$ 7.0, $^5J_{\text{FF}}$ 10.3, F-2).

1,2,4-Trifluoro-3-[4-ethyl]phenoxybenzene (206)

60% (w/w) Sodium hydride in mineral oil (0.360 g, 9.000 mmol) was washed with dry hexane (30 mL) under an atmosphere of argon. The hexane/oil solution was removed using a syringe and dry THF (10 mL) was added to the clean sodium hydride. 4-Ethylphenol (1.000 g, 8.186 mmol) was dissolved in dry THF (5 mL) and carefully added to the sodium hydride solution, with stirring, to produce sodium 4-ethylphenoxide and hydrogen gas. When the evolution of hydrogen gas had stopped the solution was transferred to a 10-20 mL microwave vial, which had been purged three times with argon and fitted with a magnetic stirrer. 1,2,3,4-Tetrafluorobenzene (0.887 g, 5.910 mmol) was added to the microwave vial and the reaction was heated to 180 °C for 1 h. The mixture was left to cool, poured on to water (30 mL) and extracted with DCM (3 \times 50 mL). The combined extracts were washed with water (50 mL) and dried (MgSO_4). The mixture was filtered and the solvent removed *in vacuo*. Column chromatography using silica gel with hexane as the eluent afforded 1,2,4-trifluoro-3-[4-ethyl]phenoxybenzene (**206**) (1.102 g, 74 %) as a colourless liquid; Anal. Calcd for $\text{C}_{14}\text{H}_{11}\text{F}_3\text{O}$: C, 66.66; H, 4.40. Found: C, 66.74; H, 4.39; GC-MS *m/z* (% relative intensity, ion): 252 (11, M^+), 237 (42), 119 (100), 90 (68), 77 (76), 51 (61); IR (cm^{-1}): 2967, 1606, 1501, 1485, 1322; ^1H NMR (CDCl_3 , 700 MHz): δ 1.22 (3H, t, $^3J_{\text{HH}}$ 7.7, $-\text{CH}_3$), 2.61 (2H, q, $^3J_{\text{HH}}$ 7.7, $-\text{CH}_2-$), 6.82 (2H, d, $^3J_{\text{HH}}$ 8.7, H-2'), 6.93 (1H, dddd, $^3J_{\text{HH}}$ 9.4, $^3J_{\text{HF}}$ 9.3, $^4J_{\text{HF}}$ 4.4, $^5J_{\text{HF}}$ 2.4, H-5), 6.99 (1H, dddd, $^3J_{\text{HH}}$ 9.4, $^3J_{\text{HF}}$ 9.4, $^4J_{\text{HF}}$ 8.0, $^4J_{\text{HF}}$ 4.6, H-6), 7.13 (2H, d, $^3J_{\text{HH}}$ 8.7, H-3'); ^{13}C NMR (CDCl_3 , 176 MHz): δ 15.6 (s, $-\text{CH}_3$), 28.0 (s, $-\text{CH}_2-$), 110.7 (ddd, $^2J_{\text{CF}}$ 21.0, $^3J_{\text{CF}}$ 7.7, $^4J_{\text{CF}}$ 4.1, C-5), 112.0 (dd, $^2J_{\text{CF}}$ 19.4, $^3J_{\text{CF}}$

8.5, C-6), 115.2 (s, C-2'), 128.9 (s, C-3'), 133.108–133.325 (m, C-3), 139.2 (s, C-4'), 145.1 (dddd, $^1J_{CF}$ 254, $^2J_{CF}$ 14.8, $^3J_{CF}$ 4.6, C-2), 147.8 (dddd, $^1J_{CF}$ 246, $^2J_{CF}$ 10.9, $^4J_{CF}$ 3.6, C-1), 152.2 (ddd, $^1J_{CF}$ 248, $^3J_{CF}$ 2.8, $^4J_{CF}$ 2.8, C-4), 155.5 (s, C-1'); ^{19}F NMR (CDCl₃/CFCl₃, 658 MHz): δ -131.1 (1F, dddd, $^3J_{FH}$ 9.3, $^4J_{FH}$ 4.6, $^4J_{FF}$ 2.3, $^5J_{FF}$ 13.6, F-4), -140.0 (1F, dddd, $^3J_{FF}$ 20.4, $^3J_{FH}$ 9.4, $^4J_{FH}$ 4.4, $^5J_{FF}$ 13.6, F-1), -148.2 (1F, dddd, $^3J_{FF}$ 20.4, $^4J_{FH}$ 8.0, $^4J_{FF}$ 2.3, $^5J_{FH}$ 2.4, F-2).

1,2,4-Trifluoro-3-[4-n-pentyl]phenoxybenzene (207)

60% (w/w) Sodium hydride in mineral oil (0.310 g, 7.750 mmol) was washed with dry hexane (30 mL) under an atmosphere of argon. The hexane/oil solution was removed using a syringe and dry THF (10 mL) was added to the clean sodium hydride. 4-n-pentylphenol (1.209 g, 7.361 mmol) was dissolved in dry THF (5 mL) and carefully added to the sodium hydride solution, with stirring, to produce sodium 4-n-pentylphenoxide and hydrogen gas. When the evolution of hydrogen gas had stopped the solution was transferred to a 10-20 mL microwave vial, which had been purged three times with argon and fitted with a magnetic stirrer. 1,2,3,4-Tetrafluorobenzene (0.931 g, 6.204 mmol) was added to the microwave vial and the reaction was heated to 180 °C for 1 h. The mixture was left to cool, poured on to water (30 mL) and extracted with DCM (3 × 50 mL). The combined extracts were washed with water (50 mL) and dried (MgSO₄). The mixture was filtered and the solvent removed *in vacuo*. Column chromatography using silica gel with hexane as the eluent afforded 1,2,4-trifluoro-3-[4-n-pentyl]phenoxybenzene (**207**) (1.184 g, 65 %) as a colourless liquid; Anal. Calcd for C₁₇H₁₇F₃O: C, 69.38; H, 5.82. Found: C, 69.49; H, 5.87; GC-MS *m/z* (% relative intensity, ion): 294 (6, M⁺), 238 (8), 237 (100), 89 (30), 78 (24), 41 (56), 29 (43); IR (cm⁻¹): 2930, 2858, 1606, 1501, 1485, 1323; 1H NMR (CDCl₃, 700 MHz): δ 0.89 (3H, t, $^3J_{HH}$ 7.0, -CH₃), 1.28–1.37 (4H, m, -CH₂-), 1.58 (2H, tt, $^3J_{HH}$ 7.7, $^3J_{HH}$ 7.7, H-6'), 2.56 (2H, t, $^3J_{HH}$ 7.7, H-5'), 6.86 (2H, d, $^3J_{HH}$ 8.7, H-2'), 6.93 (1H, dddd, $^3J_{HH}$ 9.4, $^3J_{HF}$ 9.4, $^4J_{HF}$ 4.5, $^5J_{HF}$ 2.4, H-5), 6.99 (1H, dddd, $^3J_{HH}$ 9.4, $^3J_{HF}$ 9.4, $^4J_{HF}$ 8.1, $^4J_{HF}$ 4.4, H-6), 7.10 (2H, d, $^3J_{HH}$ 8.7, H-3'); ^{13}C NMR (CDCl₃, 176 MHz): δ 14.2 (s, -CH₃), 22.7 (s, -CH₂-), 31.5 (s, C-6'), 31.7 (s, -CH₂-), 35.3 (s, C-5'), 111.0 (ddd, $^2J_{CF}$ 20.8, $^3J_{CF}$ 7.8, $^4J_{CF}$ 4.1, C-5), 112.2 (dd, $^2J_{CF}$ 19.4, $^3J_{CF}$ 8.6, C-6), 115.4 (s, C-2'), 129.7 (s, C-3'), 133.5 (dd, $^2J_{CF}$ 14.5, $^2J_{CF}$ 14.5, C-3), 138.1 (s, C-4'), 145.4 (dddd, $^1J_{CF}$ 253, $^2J_{CF}$ 15.0, $^3J_{CF}$ 4.8, C-2), 148.1 (dddd, $^1J_{CF}$ 247, $^2J_{CF}$ 10.9, $^4J_{CF}$ 3.3, C-1), 152.5 (ddd, $^1J_{CF}$ 248, $^3J_{CF}$ 3.2, $^4J_{CF}$

3.2, C-4), 153.8 (s, C-1'); ^{19}F NMR ($\text{CDCl}_3/\text{CFCl}_3$, 658 MHz): δ -131.5 (1F, dddd, $^3J_{\text{FH}}$ 9.4, $^4J_{\text{FH}}$ 4.4, $^4J_{\text{FF}}$ 2.3, $^5J_{\text{FF}}$ 13.5, F-4), -140.5 (1F, dddd, $^3J_{\text{FF}}$ 20.4, $^3J_{\text{FH}}$ 9.4, $^4J_{\text{FH}}$ 4.5, $^5J_{\text{FF}}$ 13.5, F-1), -148.7 (1F, dddd, $^3J_{\text{FF}}$ 20.4, $^4J_{\text{FH}}$ 8.1, $^4J_{\text{FF}}$ 2.3, $^5J_{\text{FH}}$ 2.4, F-2).

1,2,4-Trifluoro-3-[4-n-heptyl]phenoxybenzene (208)

60% (w/w) Sodium hydride in mineral oil (0.229 g, 5.725 mmol) was washed with dry hexane (30 mL) under an atmosphere of argon. The hexane/oil solution was removed using a syringe and dry THF (10 mL) was added to the clean sodium hydride. 4-n-Heptylphenol (1.000 g, 5.200 mmol) was dissolved in dry THF (5 mL) and carefully added to the sodium hydride solution, with stirring, to produce sodium 4-n-heptylphenoxide and hydrogen gas. When the evolution of hydrogen gas had stopped the solution was transferred to a 10-20 mL microwave vial, which had been purged three times with argon and fitted with a magnetic stirrer. 1,2,3,4-Tetrafluorobenzene (0.888 g, 5.917 mmol) was added to the microwave vial and the reaction was heated to 180 °C for 1 h. The mixture was left to cool, poured on to water (30 mL) and extracted with DCM (3 × 50 mL). The combined extracts were washed with water (50 mL) and dried (MgSO_4). The mixture was filtered and the solvent removed *in vacuo*. Column chromatography using silica gel with hexane as the eluent afforded 1,2,4-trifluoro-3-[4-n-heptyl]phenoxybenzene (**208**) (1.040 g, 62 %) as a colourless liquid; Anal. Calcd for $\text{C}_{19}\text{H}_{21}\text{F}_3\text{O}$: C, 70.79; H, 6.57. Found: C, 70.88; H, 6.53; GC-MS *m/z* (% relative intensity, ion): 322 (8, M^+), 237 (100), 90 (13), 43 (38), 41 (44), 29 (26); IR (cm^{-1}): 2927, 2856, 1606, 1502, 1486, 1323, 1259; ^1H NMR (CDCl_3 , 500 MHz): δ 0.87 (3H, t, $^3J_{\text{HH}}$ 7.0, - CH_3), 1.22-1.36 (8H, m, - CH_2 -), 1.55-1.63 (2H, m, H-6'), 2.57 (2H, t, $^3J_{\text{HH}}$ 7.6, H-5'), 6.87 (2H, d, $^3J_{\text{HH}}$ 8.5, H-2'), 6.94 (1H, dddd, $^3J_{\text{HH}}$ 9.3, $^3J_{\text{HF}}$ 8.7, $^4J_{\text{HF}}$ 4.5, $^5J_{\text{HF}}$ 2.4, H-5), 7.00 (1H, dddd, $^3J_{\text{HH}}$ 9.3, $^3J_{\text{HF}}$ 9.2, $^4J_{\text{HF}}$ 8.5, $^4J_{\text{HF}}$ 4.7, H-6), 7.11 (2H, d, $^3J_{\text{HH}}$ 8.5, H-3'); ^{13}C NMR (CDCl_3 , 126 MHz): δ 14.3 (s, - CH_3), 22.9 (s, - CH_2 -), 29.4 (s, - CH_2 -), 29.5 (s, - CH_2 -), 31.8 (s, C-6'), 32.1 (s, - CH_2 -), 35.4 (s, C-5'), 111.0 (ddd, $^2J_{\text{CF}}$ 20.9, $^3J_{\text{CF}}$ 7.7, $^4J_{\text{CF}}$ 4.1, C-5), 112.2 (dd, $^2J_{\text{CF}}$ 19.4, $^3J_{\text{CF}}$ 8.5, C-6), 115.4 (s, C-2'), 129.7 (s, C-3'), 133.5 (ddd, $^2J_{\text{CF}}$ 16.5, $^2J_{\text{CF}}$ 11.9, $^3J_{\text{CF}}$ 2.6, C-3), 138.2 (s, C-4'), 145.4 (dddd, $^1J_{\text{CF}}$ 254, $^2J_{\text{CF}}$ 15.0, $^3J_{\text{CF}}$ 4.9, C-2), 148.0 (dddd, $^1J_{\text{CF}}$ 246, $^2J_{\text{CF}}$ 11.0, $^4J_{\text{CF}}$ 3.6, C-1), 152.4 (ddd, $^1J_{\text{CF}}$ 248, $^3J_{\text{CF}}$ 2.8, $^4J_{\text{CF}}$ 2.8, C-4), 155.7 (s, C-1'); ^{19}F NMR ($\text{CDCl}_3/\text{CFCl}_3$, 658 MHz): δ -130.0 (1F, dddd, $^3J_{\text{FH}}$ 8.7, $^4J_{\text{FH}}$ 4.7, $^4J_{\text{FF}}$ 2.4, $^5J_{\text{FF}}$ 14.1, F-4), -140.1 (1F,

dddd, $^3J_{\text{FF}}$ 20.5, $^3J_{\text{FH}}$ 9.2, $^4J_{\text{FH}}$ 4.5, $^5J_{\text{FF}}$ 14.1, F-1), -148.2 (1F, dddd, $^3J_{\text{FF}}$ 20.5, $^4J_{\text{FH}}$ 8.5, $^4J_{\text{FF}}$ 2.4, $^5J_{\text{FH}}$ 2.4, F-2).

5.2.4 Strategy 2: Synthesis of Trifluorophenoxybenzene Derivatives by the Development of a Two-Step $\text{S}_{\text{N}}\text{Ar}$ -Hydrodebromination Protocol

5.2.4.1 Step 1: $\text{S}_{\text{N}}\text{Ar}$ Reactions of Dibromotetrafluorobenzene Derivatives with Sodium Phenoxide

1,2-Dibromo-3,4,6-trifluoro-5-phenoxybenzene (188)

Sodium phenoxide (0.669 g, 5.763 mmol) was added to 1,2-dibromotetrafluorobenzene (1.612 g, 5.236 mmol) in anhydrous acetonitrile (160 mL) under an atmosphere of dry argon and heated to reflux for 15 h. The mixture was left to cool, volatile components were removed *in vacuo* and the crude organic products extracted with water (100 mL) and DCM (3 × 50 mL). The combined extracts were washed with water (100 mL) and dried (MgSO_4). The mixture was filtered and the solvent removed *in vacuo*. Column chromatography using silica gel with hexane as the eluent afforded 1,2-dibromo-3,4,6-trifluoro-5-phenoxybenzene (**188**) (1.164 g, 58 %) as a white solid; mp 69–70 °C; Anal. Calcd for $\text{C}_{12}\text{H}_5\text{Br}_2\text{F}_3\text{O}$: C, 37.73; H, 1.32. Found: C, 37.86; H, 1.36; GC-MS m/z (% relative intensity, ion): 384 (10, M^+), 382 (18, M^+), 380 (9, M^+), 222 (12), 77 (100), 51 (48); IR (cm^{-1}): 1588, 1477, 1451, 1263, 1203; ^1H NMR (CDCl_3 , 500 MHz): δ 6.95 (2H, d, $^3J_{\text{HH}}$ 8.5, H-2'), 7.13 (1H, tt, $^3J_{\text{HH}}$ 7.5, $^4J_{\text{HH}}$ 1.0, H-4'), 7.34 (2H, dd, $^3J_{\text{HH}}$ 8.5, $^3J_{\text{HH}}$ 7.5, H-3'); ^{13}C NMR (CDCl_3 , 126 MHz): δ 109.0 (dd, $^2J_{\text{CF}}$ 22.5, $^3J_{\text{CF}}$ 4.8, C-Ar), 110.0 (d, $^2J_{\text{CF}}$ 20.6, C-Ar), 115.8 (s, C-2'), 124.1 (s, C-4'), 130.1 (s, C-3'), 133.0 (ddd, $^2J_{\text{CF}}$ 17.6, $^2J_{\text{CF}}$ 12.6, $^4J_{\text{CF}}$ 2.5, C-5), 144.8 (ddd, $^1J_{\text{CF}}$ 257, $^2J_{\text{CF}}$ 16.1, J_{CF} 4.6, C-F), 146.4 (ddd, $^1J_{\text{CF}}$ 249, $^2J_{\text{CF}}$ 12.7, J_{CF} 4.4, C-F), 150.5 (dt, $^1J_{\text{CF}}$ 250.3, $^3J_{\text{CF}}$ 3.5, 6-C), 157.2 (s, C-1'); ^{19}F NMR ($\text{CDCl}_3/\text{CFCl}_3$, 376 MHz): δ -116.8 (1F, dd, $^4J_{\text{FF}}$ 3.0, $^5J_{\text{FF}}$ 9.0, F-6), -125.5 (1F, dd, $^3J_{\text{FF}}$ 21.5, $^5J_{\text{FF}}$ 9.0, F-3), -146.2 (1F, d, $^3J_{\text{FF}}$ 21.5, $^4J_{\text{FF}}$ 3.0, F-4).

1,3-Dibromo-2,4,5-trifluoro-6-phenoxybenzene (190)

Sodium phenoxide (0.669 g, 5.763 mmol) was added to 1,3-dibromotetrafluorobenzene (1.612 g, 5.236 mmol) in anhydrous acetonitrile (160 mL) under an atmosphere of dry argon and heated to reflux for 15 h. The mixture was left to cool, volatile components were removed *in vacuo* and the crude organic products extracted with water (100 mL)

and DCM (3 × 50 mL). The combined extracts were washed with water (100 mL) and dried (MgSO₄). The mixture was filtered and the solvent removed *in vacuo*. Column chromatography on silica gel with hexane as the eluent afforded 1,3-dibromo-2,4,5-trifluoro-6-phenoxybenzene (**190**) (1.031 g, 52 %) as a white solid; mp 74–75 °C; Anal. Calcd for C₁₂H₅Br₂F₃O: C, 37.73; H, 1.32. Found: C, 37.84; H, 1.34; GC–MS *m/z* (% relative intensity, ion): 384 (48, M⁺), 382 (64, M⁺), 380 (53, M⁺), 222 (100), 193 (48), 174 (34), 117 (39), 111 (51), 77 (67), 51 (42); IR (cm⁻¹): 1587, 1488, 1465, 1437; ¹H NMR (CDCl₃, 500 MHz): δ 6.91 (2H, d, ³J_{HH} 8.0, H–2'), 7.13 (1H, t, ³J_{HH} 7.5, H–4'), 7.34 (2H, t, ³J_{HH} 8.0, H–3'); ¹³C NMR (CDCl₃, 126 MHz): δ 96.2 (dd, ²J_{CF} 27.8, ²J_{CF} 22.1, C–3), 102.2 (dd, ²J_{CF} 25.1, ³J_{CF} 4.7, C–1), 115.6 (s, C–2'), 123.9 (s, C–4'), 134.0 (s, C–3'), 141.8 (dt, ²J_{CF} 11.9, ³J_{CF} 3.5, C–6), 142.4 (ddd, ¹J_{CF} 256, ²J_{CF} 15.2, J_{CF} 4.9, C–F), 148.7 (ddd, ¹J_{CF} 251, ²J_{CF} 13.1, J_{CF} 5.5, C–F), 153.2 (ddd, ¹J_{CF} 245, ³J_{CF} 4.3, ⁴J_{CF} 4.3, C–2), 156.8 (s, C–1'); ¹⁹F NMR (CDCl₃/CFCl₃, 188 MHz): δ –101.5 (1F, d, ⁵J_{FF} 9.0, F–2), –121.9 (1F, dd, ³J_{FF} 21.5, ⁵J_{FF} 9.0, F–5), –126.3 (1F, d, ³J_{FF} 21.5, F–4).

1,4-Dibromo-2,3,5-trifluoro-6-phenoxybenzene (192)

Sodium phenoxide (3.331 g, 28.692 mmol) was added to 1,4-dibromotetrafluorobenzene (8.116 g, 26.362 mmol) in anhydrous acetonitrile (160 mL) under an atmosphere of dry argon and heated to reflux for 15 h. The mixture was left to cool, volatile components were removed *in vacuo* and the crude organic products extracted with water (100 mL) and DCM (3 × 50 mL). The combined extracts were washed with water (100 mL) and dried (MgSO₄). The mixture was filtered and the solvent removed *in vacuo*. Column chromatography using silica gel with hexane as the eluent afforded 1,4-dibromo-2,3,5-trifluoro-6-phenoxybenzene (**192**) (1.321 g, 13 %) as a white solid; mp 109–111 °C; Anal. Calcd for C₁₂H₅Br₂F₃O: C, 37.73; H, 1.32. Found: C, 37.66; H, 1.32; GC–MS *m/z* (% relative intensity, ion): 384 (47, M⁺), 382 (61, M⁺), 380 (51, M⁺), 222 (98), 193 (52), 174 (46), 150 (24), 117 (40), 111 (44), 77 (100), 50 (78); IR (cm⁻¹): 2164, 1589, 1545, 1438, 1387; ¹H NMR (CDCl₃, 700 MHz): δ 6.87 (2H, d, ³J_{HH} 8.7, H–2'), 7.10 (1H, t, ³J_{HH} 7.3, H–4'), 7.32 (2H, dd, ³J_{HH} 8.7, ³J_{HH} 7.3, H–3'); ¹³C NMR (CDCl₃, 126 MHz): δ 99.5 (ddd, ²J_{CF} 23.8, ²J_{CF} 22.1, ³J_{CF} 1.5, C–4), 107.2 (ddd, ²J_{CF} 20.1, ³J_{CF} 1.9, ³J_{CF} 1.9, C–1), 115.4 (s, C–2'), 123.7 (s, C–4'), 130.1 (s, C–3'), 138.0 (ddd, ²J_{CF} 16.7, ³J_{CF} 4.9, ⁴J_{CF} 1.4, C–6), 145.8 (ddd, ¹J_{CF} 250, ²J_{CF} 15.3, J_{CF} 4.8, C–F), 146.2 (ddd, ¹J_{CF} 251, ²J_{CF} 15.8, J_{CF} 3.9, C–F), 150.2 (ddd, ¹J_{CF} 251, ³J_{CF} 3.4, ⁴J_{CF}

3.4, C-5), 157.0 (s, C-1'); ^{19}F NMR ($\text{CDCl}_3/\text{CFCl}_3$, 376 MHz): δ -121.9 (1F, d, $^5J_{\text{FF}}$ 9.4, F-5), -129.7 (1F, d, $^3J_{\text{FF}}$ 23.1, F-3), -130.3 (1F, dd, $^3J_{\text{FF}}$ 23.1, $^5J_{\text{FF}}$ 9.4, F-2).

5.2.4.2 Step 2: Hydrodebromination Reactions of Dibromotrifluorophenoxybenzene Derivatives

1,2,4-Trifluoro-3-phenoxybenzene (169)

1,2-Dibromo-3,4,6-trifluoro-5-phenoxybenzene (3.001 g, 7.857 mmol) was added to HPLC grade methanol (786 mL) and hydrogenated in a *ThalesNano H-CubeTM* continuous-flow reactor (10% Pd/C, 60 °C, 20 bar, 1 mL min⁻¹) until complete consumption of the reactant solution was achieved. The solvent was removed *in vacuo* and column chromatography using silica gel using hexane as the eluent afforded 1,2,4-trifluoro-3-phenoxybenzene (**169**) (1.681 g, 95 %) as a colourless liquid, as characterised from the preceding reaction of 1,2,3,4-tetrafluorobenzene with sodium phenoxide.

1,2,4-Trifluoro-5-phenoxybenzene (170)

1,4-Dibromo-2,3,5-trifluoro-6-phenoxybenzene (1.724 g, 4.513 mmol) was added to HPLC grade methanol (451 mL) and hydrogenated in a *ThalesNano H-CubeTM* continuous-flow reactor (10% Pd/C, 60 °C, 20 bar, 1 mL min⁻¹) until complete consumption of the reactant solution was achieved. The solvent was removed *in vacuo* and column chromatography using silica gel with hexane as the eluent afforded 1,3,4-trifluoro-5-phenoxybenzene (**170**) (0.954 g, 94 %) as a colourless liquid; Anal. Calcd for $\text{C}_{12}\text{H}_7\text{F}_3\text{O}$: C, 64.29; H, 3.15. Found: C, 64.24; H, 3.16; GC-MS m/z (% relative intensity, ion): 224 (100, M^+), 196 (46), 77 (88), 51 (68); ^1H NMR (CDCl_3 , 500 MHz): δ 6.95 (1H, ddd, $^3J_{\text{HF}}$ 10.8, $^4J_{\text{HF}}$ 7.8, $^4J_{\text{HF}}$ 7.4, H-6), 7.01 (2H, d, $^3J_{\text{HH}}$ 8.5, H-2'), 7.09 (1H, ddd, $^3J_{\text{HF}}$ 10.0, $^3J_{\text{HF}}$ 9.9, $^4J_{\text{HF}}$ 7.5, H-3), 7.16 (1H, tt, $^3J_{\text{HH}}$ 7.5, $^4J_{\text{HH}}$ 1.0, H-4'), 7.38 (2H, dd, $^3J_{\text{HH}}$ 8.5, $^3J_{\text{HH}}$ 7.5, H-3'); ^{13}C NMR (CDCl_3 , 126 MHz): δ 106.8 (dd, $^2J_{\text{CF}}$ 22.5, $^2J_{\text{CF}}$ 22.3, C-3), 110.5 (d, $^2J_{\text{CF}}$ 21.0, C-6), 117.7 (s, C-2'), 124.1 (s, C-4'), 130.2 (s, C-3'), 140.1 (ddd, $^2J_{\text{CF}}$ 13.1, $^3J_{\text{CF}}$ 8.2, $^4J_{\text{CF}}$ 3.8, C-5), 146.1 (ddd, $^1J_{\text{CF}}$ 250.9, $^2J_{\text{CF}}$ 18.1, $^3J_{\text{CF}}$ 9.3, C-2), 146.6 (ddd, $^1J_{\text{CF}}$ 255, $^2J_{\text{CF}}$ 21.3, $^3J_{\text{CF}}$ 13.4, C-1), 149.8 (ddd, $^1J_{\text{CF}}$ 248, $^3J_{\text{CF}}$ 9.1, $^4J_{\text{CF}}$ 3.3, C-4), 157.0 (s, C-1'); ^{19}F NMR ($\text{CDCl}_3/\text{CFCl}_3$, 470 MHz): δ -132.8 (1F, ddd, $^3J_{\text{FH}}$ 10.0, $^4J_{\text{FH}}$ 7.4, $^5J_{\text{FF}}$ 13.6, F-4), -140.1 (1F, ddd, $^3J_{\text{FF}}$ 21.8, $^3J_{\text{FH}}$ 9.9, $^4J_{\text{FH}}$ 7.8, F-2), -140.4 (1F, dddd, $^3J_{\text{FF}}$ 21.8, $^3J_{\text{FH}}$ 10.8, $^4J_{\text{FH}}$ 7.5, $^5J_{\text{FF}}$ 13.6, F-1).

1,2,5-Trifluoro-3-phenoxybenzene (175)

1,3-Dibromo-2,4,5-trifluoro-6-phenoxybenzene (0.503 g, 1.317 mmol) was added to HPLC grade methanol (132 mL) and hydrogenated in a *ThalesNano H-CubeTM* continuous-flow reactor (10% Pd/C, 60 °C, 20 bar, 1 mL min⁻¹) until complete consumption of the reactant solution was achieved. The solvent was removed *in vacuo* and column chromatography on silica gel using hexane as the eluent afforded 1,2,5-trifluoro-3-phenoxybenzene (**175**) (0.257 g, 87 %) as a colourless liquid, as characterised from the preceding reaction of 1,2,3,5-tetrafluorobenzene with sodium phenoxide.

5.2.5 Strategy 3: Dopant Synthesis by a Three-Step Directed S_NAr-Reduction-Diazotisation Pathway**5.2.5.1 Step 1: S_NAr Reactions of Sodium Phenoxide with Fluorinated Nitrobenzene Derivatives****1,2-Difluoro-4-nitro-5-phenoxybenzene (213)**

60% (w/w) Sodium hydride in mineral oil (0.218 g, 5.450 mmol) was charged to a 10–20 mL microwave vial fitted with a magnetic stirrer bar and sealed. The vial was kept under a positive pressure of argon, which was allowed to leave the vessel through an exit needle inserted into the lid of the vial. Dry hexane (5 mL) was injected into the microwave vial and the contents were stirred for 15 minutes to wash the mineral oil from the sodium hydride. The contents were allowed to settle and the hexane/oil solution was removed using a syringe. Dry THF (5 mL) was added to the reaction vessel, followed by the slow addition of a solution of phenol (0.482 g, 5.121 mmol) in dry THF (10 mL) and allowed to stir for 15 minutes. 2,4,5-Trifluoronitrobenzene (0.678 g, 3.829 mmol) was injected into the vial and the exit needle removed. The reaction mixture was heated to 130 °C for 20 minutes under microwave irradiation, left to cool, volatile components were removed *in vacuo* and the crude organic products extracted with water (100 mL) and DCM (3 × 50 mL). The combined extracts were washed with water (100 mL) and dried (MgSO₄). The mixture was filtered and the solvent removed *in vacuo*. Column chromatography using silica gel with hexane and DCM (7:3) as the eluent afforded 1,2-difluoro-4-nitro-5-phenoxybenzene (**213**) (0.715 g, 74 %) as a yellow solid; mp 56–58 °C; Anal. Calcd for C₁₂H₇F₂NO₃: C, 57.38; H, 2.81; N, 5.58.

Found: C, 57.39; H, 2.62; N, 5.64; GC-MS m/z (% relative intensity, ion): 251 (32, M^+), 234 (57), 158 (95), 93 (76), 77 (70), 65 (100), 51 (92); IR (cm^{-1}): 3072, 1595, 1529, 1482, 1343, 1285; ^1H NMR (CDCl_3 , 700 MHz): δ 6.82 (1H, dd, $^3J_{\text{HF}}$ 10.8, $^4J_{\text{HF}}$ 6.7, H-6), 7.06 (2H, d, $^3J_{\text{HH}}$ 8.0, H-2'), 7.25 (1H, t, $^3J_{\text{HH}}$ 7.5, H-4'), 7.43 (2H, dd, $^3J_{\text{HH}}$ 8.0, $^3J_{\text{HH}}$ 7.5, H-3'), 7.93 (1H, dd, $^3J_{\text{HF}}$ 9.3, $^4J_{\text{HF}}$ 8.1, H-3); ^{13}C NMR (176 MHz, CDCl_3): δ 109.5 (d, $^2J_{\text{CF}}$ 21.7, C-6), 115.4 (dd, $^2J_{\text{CF}}$ 22.6, $^3J_{\text{CF}}$ 2.6, C-3), 119.7 (s, C-2'), 125.7 (s, C-4'), 130.7 (s, C-3'), 136.2–136.3 (m, C-4), 145.2 (dd, $^1J_{\text{CF}}$ 250, $^2J_{\text{CF}}$ 14.0, C-F), 148.8 (dd, $^3J_{\text{CF}}$ 8.6, $^4J_{\text{CF}}$ 2.8, C-5), 153.7 (dd, $^1J_{\text{CF}}$ 260, $^2J_{\text{CF}}$ 13.8, C-F), 155.3 (s, C-1'); ^{19}F NMR (658 MHz, $\text{CDCl}_3/\text{CFCl}_3$): δ -124.1 (1F, ddd, $^3J_{\text{FF}}$ 22.1, $^3J_{\text{FH}}$ 10.8, $^4J_{\text{FH}}$ 8.1, F-1), -141.2 (1F, ddd, $^3J_{\text{FF}}$ 22.1, $^3J_{\text{FH}}$ 9.3, $^4J_{\text{FH}}$ 6.7, F-2).

1,2-Difluoro-4-nitro-3-phenoxybenzene (215)

60% (w/w) Sodium hydride in mineral oil (0.250 g, 6.250 mmol) was charged to a 10–20 mL microwave vial fitted with a magnetic stirrer bar and sealed. The vial was kept under a positive pressure of argon, which was allowed to leave the vessel through an exit needle inserted into the lid of the vial. Dry hexane (5 mL) was injected into the microwave vial and the contents were stirred for 15 minutes to wash the mineral oil from the sodium hydride. The contents were allowed to settle and the hexane/oil solution was removed using a syringe. Dry THF (5 mL) was added to the reaction vessel, followed by the slow addition of a solution of phenol (0.478 g, 5.079 mmol) in dry THF (10 mL) and allowed to stir for 15 minutes. 2,3,4-Trifluoronitrobenzene (1.033 g, 5.833 mmol) was injected into the vial and the exit needle removed. The reaction mixture was heated to 130 °C for 20 minutes under microwave irradiation, left to cool, volatile components were removed *in vacuo* and the crude organic products extracted with water (100 mL) and DCM (3 \times 50 mL). The combined extracts were washed with water (100 mL) and dried (MgSO_4). The mixture was filtered and the solvent removed *in vacuo*. Column chromatography using silica gel with hexane and DCM (7:3) as the eluent afforded 1,2-difluoro-4-nitro-3-phenoxybenzene (**215**) (0.911 g, 62 %) as a yellow liquid; Anal. Calcd for $\text{C}_{12}\text{H}_7\text{F}_2\text{NO}_3$: C, 57.38; H, 2.81; N, 5.58. Found: C, 57.53; H, 2.87; N, 5.78; GC-MS m/z (% relative intensity, ion): 251 (29, M^+), 234 (38), 93 (98), 77 (60), 65 (100), 51 (83); IR (cm^{-1}): 3094, 1591, 1535, 1488, 1463, 1349, 1293; ^1H NMR (500 MHz, CDCl_3): δ 6.95 (2H, d, $^3J_{\text{HH}}$ 8.6, H-2'), 7.13 (1H, t, $^3J_{\text{HH}}$ 7.4, H-4'), 7.20 (1H, ddd, $^3J_{\text{HH}}$ 9.3, $^3J_{\text{HF}}$ 8.8, $^4J_{\text{HF}}$ 7.1, H-6), 7.34 (2H, dd, $^3J_{\text{HH}}$ 8.6, $^3J_{\text{HH}}$ 7.4,

H-3'), 7.87 (1H, ddd, $^3J_{\text{HH}}$ 9.3, $^4J_{\text{HF}}$ 5.1, $^5J_{\text{HF}}$ 2.1, H-5); ^{13}C NMR (126 MHz, CDCl_3): δ 113.3 (d, $^2J_{\text{CF}}$ 19.3, C-6), 115.7 (s, C-2'), 121.0 (dd, $^3J_{\text{CF}}$ 8.9, $^4J_{\text{CF}}$ 4.2, C-5), 124.0 (s, C-4'), 130.1 (s, C-3'), 139.8 (dd, $^2J_{\text{CF}}$ 12.2, $^3J_{\text{CF}}$ 3.2, C-3), 140.5 (m, 4-C), 145.3 (dd, $^1J_{\text{CF}}$ 258, $^2J_{\text{CF}}$ 14.3, C-F), 154.5 (dd, $^1J_{\text{CF}}$ 260, $^2J_{\text{CF}}$ 11.0, C-F), 157.3 (s, C-1'); ^{19}F NMR (658 MHz, $\text{CFCl}_3/\text{CDCl}_3$): δ -124.6 (1F, ddd, $^3J_{\text{FF}}$ 19.7, $^3J_{\text{FH}}$ 8.8, $^4J_{\text{FH}}$ 5.1, F-1), -145.7 (1F, ddd, $^3J_{\text{FF}}$ 19.7, $^4J_{\text{FH}}$ 7.1, $^5J_{\text{FH}}$ 2.1, F-2).

1,5-Difluoro-2-nitro-3-phenoxybenzene (217)

60% (w/w) Sodium hydride in mineral oil (0.255 g, 6.375 mmol) was charged to a 10–20 mL microwave vial fitted with a magnetic stirrer bar and sealed. The vial was kept under a positive pressure of argon, which was allowed to leave the vessel through an exit needle inserted into the lid of the vial. Dry hexane (5 mL) was injected into the microwave vial and the contents were stirred for 15 minutes to wash the mineral oil from the sodium hydride. The contents were allowed to settle and the hexane/oil solution was removed using a syringe. Dry THF (5 mL) was added to the reaction vessel, followed by the slow addition of a solution of phenol (0.587 g, 6.237 mmol) in dry THF (10 mL) and allowed to stir for 15 minutes. 2,4,6-Trifluoronitrobenzene (1.007 g, 5.689 mmol) was injected into the vial and the exit needle removed. The reaction mixture was heated to 130 °C for 20 minutes under microwave irradiation, left to cool, volatile components were removed *in vacuo* and the crude organic products extracted with water (100 mL) and DCM (3 × 50 mL). The combined extracts were washed with water (100 mL) and dried (MgSO_4). The mixture was filtered and the solvent removed *in vacuo*. Column chromatography using silica gel with hexane and toluene (7:3) as the eluent afforded 1,5-difluoro-2-nitro-3-phenoxybenzene (**217**) (1.358 g, 95 %) as a yellow liquid; Anal. Calcd for $\text{C}_{12}\text{H}_7\text{F}_2\text{NO}_3$: C, 57.38; H, 2.81; N, 5.58. Found: C, 57.41; H, 2.85; N, 5.80; GC-MS m/z (% relative intensity, ion): 251 (41, M^+), 234 (50), 157 (90), 93 (82), 64 (100), 51 (74); IR (cm^{-1}): 3098, 1625, 1604, 1587, 1537, 1488, 1445, 1345, 1199; ^1H NMR (700 MHz, CDCl_3): δ 6.39 (1H, ddd, $^3J_{\text{HF}}$ 9.7, $^3J_{\text{HH}}$ 9.7, $^4J_{\text{HH}}$ 2.3, H-6), 6.68 (1H, ddd, $^3J_{\text{HF}}$ 9.6, $^5J_{\text{HF}}$ 8.7, $^4J_{\text{HH}}$ 2.3, H-4), 7.12 (2H, dd, $^3J_{\text{HH}}$ 8.7, $^4J_{\text{HH}}$ 1.1, H-2'), 7.29 (1H, tt, $^3J_{\text{HH}}$ 7.5, $^4J_{\text{HH}}$ 1.1, H-4'), 7.44 (2H, dd, $^3J_{\text{HH}}$ 8.7, $^3J_{\text{HH}}$ 7.5, H-3'); ^{13}C NMR (176 MHz, CDCl_3): δ 99.3 (dd, $^2J_{\text{CF}}$ 23.4, $^2J_{\text{CF}}$ 27.4, C-6), 101.5 (dd, $^2J_{\text{CF}}$ 27.1, $^4J_{\text{CF}}$ 3.5, C-4), 120.6 (s, C-2'), 126.4 (s, C-4'), 129.2–129.3 (m, C-2), 130.7 (s, C-3'), 153.1 (dd, $^3J_{\text{CF}}$ 12.9, $^3J_{\text{CF}}$ 4.2, C-3), 154.2 (s, C-1'), 155.8 (dd, $^1J_{\text{CF}}$ 259, $^3J_{\text{CF}}$ 15.6,

C–F), 163.6 (dd, $^1J_{CF}$ 255, $^3J_{CF}$ 14.2, C–F); ^{19}F NMR (658 MHz, $CFCl_3/CDCl_3$): δ –101.4 (1F, ddd, $^3J_{FH}$ 9.7, $^5J_{FH}$ 8.7, $^4J_{FF}$ 1.8, F–1), –118.0 (1F, ddd, $^3J_{FH}$ 9.7, $^3J_{FH}$ 9.6, $^4J_{FF}$ 1.8, F–5).

4-Fluoro-1,3-diphenoxy-6-nitrobenzene (218)

60% (w/w) Sodium hydride in mineral oil (0.361 g, 9.025 mmol) was charged to a 10–20 mL microwave vial fitted with a magnetic stirrer bar and sealed. The vial was kept under a positive pressure of argon, which was allowed to leave the vessel through an exit needle inserted into the lid of the vial. Dry hexane (5 mL) was injected into the microwave vial and the contents were stirred for 15 minutes to wash the mineral oil from the sodium hydride. The contents were allowed to settle and the hexane/oil solution was removed using a syringe. Dry THF (5 mL) was added to the reaction vessel, followed by the slow addition of a solution of phenol (0.749 g, 7.959 mmol) in dry THF (10 mL) and allowed to stir for 15 minutes. 2,4,5-Trifluoronitrobenzene (0.749 g, 4.230 mmol) was injected into the vial and the exit needle removed. The reaction mixture was heated to 130 °C for 20 minutes under microwave irradiation, left to cool, volatile components were removed *in vacuo* and the crude organic products extracted with water (100 mL) and DCM (3 × 50 mL). The combined extracts were washed with water (100 mL) and dried ($MgSO_4$). The mixture was filtered and the solvent removed *in vacuo*. Recrystallisation from hexane afforded 4-fluoro-1,3-diphenoxy-6-nitrobenzene (**218**) (0.933 g, 68 %) as a yellow solid; mp 88–89 °C; Anal. Calcd for $C_{18}H_{12}FNO_4$: C, 66.46; H, 3.72; N, 4.31. Found: C, 66.52; H, 3.77; N, 4.31; GC–MS *m/z* (% relative intensity, ion): 325 (30, M^+), 202 (90), 158 (100), 77 (85); IR (cm^{-1}): 1521, 1339; 1H NMR (500 MHz, $CDCl_3$): δ 6.57 (1H, d, $^4J_{HF}$ 7.1, H–2), 6.93 (2H, d, $^3J_{HH}$ 8.7, H–Ar), 7.02 (2H, d, $^3J_{HH}$ 8.7, H–Ar), 7.12 (1H, t, $^3J_{HH}$ 7.5, H–Ar), 7.18 (1H, t, $^3J_{HH}$ 7.5, H–Ar), 7.32 (2H, dd, $^3J_{HH}$ 7.5, $^3J_{HH}$ 8.7, H–Ar), 7.36 (2H, dd, $^3J_{HH}$ 7.5, $^3J_{HH}$ 8.7, H–Ar), 7.97 (1H, d, $^3J_{HF}$ 10.0, H–5); ^{13}C NMR (126 MHz, $CDCl_3$): δ 111.8 (d, $^3J_{CF}$ 1.3, C–2), 115.0 (d, $^2J_{CF}$ 23.8, C–5), 118.3 (s, C–Ar), 119.2 (s, C–Ar), 124.6 (s, C–Ar), 125.6 (s, C–Ar), 130.3 (s, C–Ar), 130.5 (s, C–Ar), 135.3 (d, $^3J_{CF}$ 5.5, C–6), 148.2 (d, $^4J_{CF}$ 2.9, C–1), 148.2 (d, $^1J_{CF}$ 250, C–4), 150.7 (d, $^2J_{CF}$ 12.2, C–3), 154.9 (s, C–Ar), 156.2 (s, C–Ar); ^{19}F NMR (658 MHz, $CDCl_3/CFCl_3$): δ –135.1 (1F, dd, $^3J_{FH}$ 10.0, $^4J_{FH}$ 7.1, F–4).

2-Fluoro-1,3-diphenoxy-4-nitrobenzene (219)

60% (w/w) Sodium hydride in mineral oil (0.493 g, 12.325 mmol) was charged to a 10–20 mL microwave vial fitted with a magnetic stirrer bar and sealed. The vial was kept under a positive pressure of argon, which was allowed to leave the vessel through an exit needle inserted into the lid of the vial. Dry hexane (5 mL) was injected into the microwave vial and the contents were stirred for 15 minutes to wash the mineral oil from the sodium hydride. The contents were allowed to settle and the hexane/oil solution was removed using a syringe. Dry THF (5 mL) was added to the reaction vessel, followed by the slow addition of a solution of phenol (1.241 g, 13.187 mmol) in dry THF (10 mL) and allowed to stir for 15 minutes. 2,3,4-Trifluoronitrobenzene (1.028 g, 5.805 mmol) was injected into the vial and the exit needle removed. The reaction mixture was heated to 130 °C for 20 minutes under microwave irradiation, left to cool, volatile components were removed *in vacuo* and the crude organic products extracted with water (100 mL) and DCM (3 × 50 mL). The combined extracts were washed with water (100 mL) and dried (MgSO₄). The mixture was filtered and the solvent removed *in vacuo*. Column chromatography using silica gel with hexane and DCM (7:3) as the eluent afforded 2-fluoro-1,3-diphenoxy-4-nitrobenzene (**219**) (1.802 g, 95 %) as a yellow solid; mp 66–68 °C; Anal. Calcd for C₁₈H₁₂FNO₄: C, 66.46; H, 3.72; N, 4.31. Found: C, 66.39; H, 3.74; N, 4.35; GC–MS *m/z* (% relative intensity, ion): 325 (44, M⁺), 202 (99), 187 (100), 77 (82); IR (cm⁻¹): 1525, 1348; ¹H NMR (500 MHz, CDCl₃): δ 6.82 (1H, dd, ³J_{HH} 9.4, ⁴J_{HF} 7.3, H–6), 6.98 (2H, d, ³J_{HH} 8.3, H–Ar), 7.09–7.14 (3H, m, H–Ar), 7.27 (1H, t, ³J_{HH} 7.5, H–Ar), 7.34 (2H, dd, ³J_{HH} 7.5, ³J_{HH} 8.6, H–Ar), 7.44 (2H, dd, ³J_{HH} 7.6, ³J_{HH} 8.4, H–Ar), 7.82 (1H, dd, ³J_{HH} 9.4, ⁵J_{HF} 2.2, H–5); ¹³C NMR (126 MHz, CDCl₃): δ 113.6 (s, C–5), 115.6 (s, C–Ar), 119.9 (s, C–Ar), 121.2 (d, ³J_{CF} 4.1, C–6), 123.7 (s, C–Ar), 125.8 (s, C–Ar), 130.0 (s, C–Ar), 130.6 (s, C–Ar), 138.61 (s, C–4), 139.5 (d, ²J_{CF} 13.0, C–Ar), 147.3 (d, ¹J_{CF} 256, C–2), 151.5 (d, ²J_{CF} 9.3, C–Ar), 154.7 (s, C–Ar), 157.6 (s, C–Ar); ¹⁹F NMR (658 MHz, CDCl₃/CFCl₃): δ –142.7 (1F, d, ⁴J_{FH} 7.3, F–2).

5-Fluoro-1,3-diphenoxy-2-nitrobenzene (220)

60% (w/w) Sodium hydride in mineral oil (0.520 g, 13.000 mmol) was charged to a 10–20 mL microwave vial fitted with a magnetic stirrer bar and sealed. The vial was kept under a positive pressure of argon, which was allowed to leave the vessel through an exit

needle inserted into the lid of the vial. Dry hexane (5 mL) was injected into the microwave vial and the contents were stirred for 15 minutes to wash the mineral oil from the sodium hydride. The contents were allowed to settle and the hexane/oil solution was removed using a syringe. Dry THF (5 mL) was added to the reaction vessel, followed by the slow addition of a solution of phenol (1.314 g, 13.962 mmol) in dry THF (10 mL) and allowed to stir for 15 minutes. 2,4,6-Trifluoronitrobenzene (1.006 g, 5.681 mmol) was injected into the vial and the exit needle removed. The reaction mixture was heated to 130 °C for 20 minutes under microwave irradiation, left to cool, volatile components were removed *in vacuo* and the crude organic products extracted with water (100 mL) and DCM (3 × 50 mL). The combined extracts were washed with water (100 mL) and dried (MgSO₄). The mixture was filtered and the solvent removed *in vacuo*. Recrystallisation from hexane afforded 5-Fluoro-1,3-diphenoxy-2-nitrobenzene (**220**) (1.770 g, 96 %) as a yellow solid; mp 140–142 °C; Anal. Calcd for C₁₈H₁₂FNO₄: C, 66.46; H, 3.72; N, 4.31. Found: C, 66.57; H, 3.77; N, 4.38; GC–MS *m/z* (% relative intensity, ion): 325 (41, M⁺), 202 (62), 187 (100), 77 (82); IR (cm⁻¹): 1531, 1343; ¹H NMR (500 MHz, CDCl₃): δ 6.24 (2H, d, ³J_{HF} 9.6, H-4), 7.14 (4H, dd, ³J_{HH} 8.6, ⁴J_{HH} 1.0, H-2'), 7.27 (2H, t, ³J_{HH} 7.4, H-4'), 7.43 (4H, dd, ³J_{HH} 7.4, ³J_{HH} 8.6, H-3'); ¹³C NMR (126 MHz, CDCl₃): δ 99.3 (d, ²J_{CF} 27.6, C-4), 120.6 (s, C-2'), 126.1 (s, C-4'), 130.5 (s, C-3'), 131.5–131.6 (m, C-2), 152.5 (d, ³J_{CF} 13.1, C-1), 154.6 (s, C-1'), 163.4 (d, ¹J_{CF} 252, C-5); ¹⁹F NMR (658 MHz, CDCl₃/CFC₃): δ -103.7 (1F, t, ³J_{FH} 9.6, F-5).

1,3-Difluoro-5-(2-nitrophenoxy)benzene (222)

60% (w/w) Sodium hydride (0.272 g, 6.800 mmol) was charged to a 10–20 mL microwave vial that was sealed and subsequently evacuated under high vacuum and back-filled with argon three times to create an inert atmosphere. Dry THF (10 mL) was added to the vial, which was pierced with an exit needle and under a positive pressure of argon, followed by the drop-wise addition of a solution of 3,5-difluorophenol (0.850 g, 6.534 mmol) in dry THF (5 mL). After the evolution of hydrogen gas had stopped, 2-fluoronitrobenzene (0.853 g, 6.045 mmol) was added to the reaction vessel and the contents heated under microwave irradiation (130 °C, 30 mins) with stirring. The vial and its contents were cooled, poured on to water (100 mL) and extracted with DCM (3

× 50 mL). The combined extracts were washed with water (100 mL) and dried (MgSO₄). The mixture was filtered and volatile components removed *in vacuo*. Product purification by column chromatography using silica gel with hexane as the eluent afforded 1,3-difluoro-5-(2-nitrophenoxy)benzene (**222**) (1.350 g, 89 %) as a yellow liquid; Anal. Calcd for C₁₂H₇F₂NO₃: C, 57.38; H, 2.81; N, 5.58. Found: C, 57.43; H, 2.82; N, 5.57; GC-MS *m/z* (% relative intensity, ion): 251 (27, M⁺), 204 (21), 175 (26), 151(45), 122 (100), 78 (56); IR (cm⁻¹): 3098, 1625, 1598, 1526, 1463, 1348; ¹H NMR (700 MHz, CDCl₃): δ 6.52 (2H, dd, ³J_{HF} 7.9, ⁴J_{HH} 2.2, H-4), 6.60 (1H, tt, ³J_{HF} 8.9, ⁴J_{HH} 2.2, H-2), 7.18 (1H, dd, ³J_{HH} 8.2, ⁴J_{HH} 1.2, H-6'), 7.35 (1H, ddd, ³J_{HH} 8.2, ³J_{HH} 7.6, ⁴J_{HH} = 1.2, H-4'), 7.63 (1H, ddd, ³J_{HH} 8.2, ³J_{HH} 7.6, ⁴J_{HH} = 1.6, H-5'), 8.01 (1H, dd, ³J_{HH} 8.2, ⁴J_{HH} 1.6, H-3'); ¹³C NMR (176 MHz, CDCl₃): δ 99.8 (t, ²J_{CF} 25.7, C-2), 101.9 (dd, ²J_{CF} 22.1, ⁴J_{CF} 7.6, C-4), 122.9 (s, C-6'), 125.5 (s, C-4'), 126.3 (s, C-3'), 134.9 (s, C-5'), 142.3 (s, C-2'), 148.6 (s, C-1'), 158.7 (t, ³J_{CF} 13.5, C-5), 163.8 (dd, ¹J_{CF} 249, ³J_{CF} 15.1, C-1); ¹⁹F NMR (658 MHz, CDCl₃/CFCl₃): δ -108.1 (2F, dd, ³J_{FH} 8.9, ³J_{FH} 7.9, F-1).

1,2-Difluoro-4-(2-nitrophenoxy)benzene (224)

60% (w/w) Sodium hydride (0.273 g, 6.825 mmol) was charged to a 10–20 mL microwave vial that was sealed and subsequently evacuated under high vacuum and back-filled with argon three times to create an inert atmosphere. Dry THF (10 mL) was added to the vial, which was pierced with an exit needle and under a positive pressure of argon, followed by the drop-wise addition of a solution of 2,3-difluorophenol (0.860 g, 6.611 mmol) in dry THF (5 mL). After the evolution of hydrogen gas had stopped, 2-fluoronitrobenzene (0.843 g, 5.974 mmol) was added to the reaction vessel and the contents heated under microwave irradiation (150 °C, 30 mins) with stirring. The vial and its contents were cooled, poured on to water (100 mL) and extracted with DCM (3 × 50 mL). The combined extracts were washed with water (100 mL) and dried (MgSO₄). The mixture was filtered and volatile components removed *in vacuo*. Product purification by column chromatography using silica gel with hexane as the eluent afforded 1,2-difluoro-4-(2-nitrophenoxy)benzene (**224**) (1.456 g, 97 %) as a yellow liquid; Anal. Calcd for C₁₂H₇F₂NO₃: C, 57.38; H, 2.81; N, 5.58. Found: C, 57.39; H, 2.82; N, 5.60; GC-MS *m/z* (% relative intensity, ion): 251 (7, M⁺), 151 (34), 122 (78), 101 (56), 78 (99), 63 (100); IR (cm⁻¹): 3086, 1601, 1526, 1506, 1477, 1438, 1347, 1303,

1248; ^1H NMR (500 MHz, CDCl_3): δ 6.77 (1H, m, H-5), 6.89 (1H, ddd, $^3J_{\text{HF}}$ 10.8, $^3J_{\text{HF}}$ 6.5, $^4J_{\text{HH}}$ 2.9, H-3), 7.05 (1H, dd, $^3J_{\text{HH}}$ 8.3, $^4J_{\text{HH}}$ 1.2, H-6'), 7.16 (1H, ddd, $^3J_{\text{HH}}$ 9.0, $^3J_{\text{HF}}$ 9.0, $^4J_{\text{HF}}$ 9.0, H-6), 7.27 (1H, ddd, $^3J_{\text{HH}}$ 8.2, $^3J_{\text{HH}}$ 7.5, $^4J_{\text{HH}}$ 1.2, H-4'), 7.56 (1H, ddd, $^3J_{\text{HH}}$ 8.3, $^3J_{\text{HH}}$ 7.5, $^4J_{\text{HH}}$ 1.7, H-5'), 7.97 (1H, dd, $^3J_{\text{HH}}$ 8.2, $^4J_{\text{HH}}$ 1.7, H-3'); ^{13}C NMR (176 MHz, CDCl_3): δ 108.9 (d, $^2J_{\text{CF}}$ 20.3, C-3), 114.7 (dd, $^3J_{\text{CF}}$ 6.2, $^4J_{\text{CF}}$ 3.8, C-5), 118.1 (dd, $^2J_{\text{CF}}$ 18.9, $^3J_{\text{CF}}$ 1.4, C-6), 121.9 (s, C-6'), 124.4 (s, C-4'), 126.2 (s, C-3'), 134.6 (s, C-5'), 141.7 (s, C-2'), 147.5 (dd, $^1J_{\text{CF}}$ 245, $^2J_{\text{CF}}$ 12.6, C-F), 150.0 (s, C-1'), 150.9 (dd, $^1J_{\text{CF}}$ 251, $^2J_{\text{CF}}$ 14.1, C-F); ^{19}F NMR (658 MHz, $\text{CDCl}_3/\text{CFC}_3$): δ -134.9 - -135.1 (1F, m, F-2), -143.2 - -143.3 (1F, m, F-1).

2,4-Difluoro-1-(2-nitrophenoxy)benzene (226)

60% (w/w) Sodium hydride (0.267 g, 6.675 mmol) was charged to a 10–20 mL microwave vial that was sealed and subsequently evacuated under high vacuum and back-filled with argon three times to create an inert atmosphere. Dry THF (10 mL) was added to the vial, which was pierced with an exit needle and under a positive pressure of argon, followed by the drop-wise addition of a solution of 2,4-difluorophenol (0.855 g, 6.572 mmol) in dry THF (5 mL). After the evolution of hydrogen gas had stopped, 2-fluoronitrobenzene (0.855 g, 6.059 mmol) was added to the reaction vessel and the contents heated under microwave irradiation (150 °C, 30 mins) with stirring. The vial and its contents were cooled, poured on to water (100 mL) and extracted with DCM (3 \times 50 mL). The combined extracts were washed with water (100 mL) and dried (MgSO_4). The mixture was filtered and volatile components removed *in vacuo*. Product purification by column chromatography using silica gel with hexane as the eluent afforded 2,4-difluoro-1-(2-nitrophenoxy)benzene (**226**) (1.441 g, 95 %) as a yellow liquid; Anal. Calcd for $\text{C}_{12}\text{H}_7\text{F}_2\text{NO}_3$: C, 57.38; H, 2.81; N, 5.58. Found: C, 55.26; H, 2.80; N, 5.54; GC-MS m/z (% relative intensity, ion): 251 (40, M^+), 204 (25), 122 (100), 101 (70), 63 (70); IR (cm^{-1}): 3086, 1603, 1525, 1502, 1477, 1435, 1347, 1303, 1249; ^1H NMR (700 MHz, CDCl_3): δ 6.88 (1H, d, $^3J_{\text{HH}}$ 8.4, H-6'), 6.89–6.92 (1H, m, H-5), 6.98 (1H, ddd, $^3J_{\text{HF}}$ 10.3, $^3J_{\text{HF}}$ 8.1, $^4J_{\text{HH}}$ 2.6, H-3), 7.14 (1H, ddd, $^3J_{\text{HH}}$ 8.9, $^3J_{\text{HF}}$ 8.9, $^4J_{\text{HF}}$ 5.4, H-6), 7.19 (1H, dd, $^3J_{\text{HH}}$ 8.0, $^3J_{\text{HH}}$ 8.0, H-4'), 7.49 (1H, ddd, $^3J_{\text{HH}}$ 8.4, $^3J_{\text{HH}}$ 8.0, $^4J_{\text{HH}}$ 1.5, H-5'), 7.96 (1H, dd, $^3J_{\text{HH}}$ 8.0, $^4J_{\text{HH}}$ 1.8, H-3'); ^{13}C NMR (176 MHz, CDCl_3): δ 106.0 (dd, $^2J_{\text{CF}}$ 27.0, $^2J_{\text{CF}}$ 22.7, C-3), 112.1 (dd, $^2J_{\text{CF}}$ 23.1, $^4J_{\text{CF}}$ 3.9, C-5), 118.1 (s, C-6'), 123.3 (dd, $^3J_{\text{CF}}$ 9.8, $^3J_{\text{CF}}$ 1.2, C-6), 123.4 (s, C-4'), 126.2 (s, C-3'),

134.5 (s, C-5'), 138.7 (d, $^2J_{CF}$ 11.7, C-1), 140.5 (s, C-2'), 150.9 (s, C-1'), 154.3 (dd, $^1J_{CF}$ 253, $^3J_{CF}$ 12.3, C-F), 159.8 (dd, $^1J_{CF}$ 248, $^3J_{CF}$ 10.2, C-F); ^{19}F NMR (658 MHz, $CDCl_3/CFCl_3$): δ -113.4 - -113.4 (1F, m, F-4), -125.2 - -125.3 (1F, m, F-2).

1,4-Difluoro-2-(2-nitrophenoxy)benzene (228)

60% (w/w) Sodium hydride (0.272 g, 6.800 mmol) was charged to a 10–20 mL microwave vial that was sealed and subsequently evacuated under high vacuum and back-filled with argon three times to create an inert atmosphere. Dry THF (10 mL) was added to the vial, which was pierced with an exit needle and under a positive pressure of argon, followed by the drop-wise addition of a solution of 2,5-difluorophenol (0.870 g, 6.688 mmol) in dry THF (5 mL). After the evolution of hydrogen gas had stopped, 2-fluoronitrobenzene (0.840 g, 5.953 mmol) was added to the reaction vessel and the contents heated under microwave irradiation (130 °C, 30 mins) with stirring. The vial and its contents were cooled, poured on to water (100 mL) and extracted with DCM (3 \times 50 mL). The combined extracts were washed with water (100 mL) and dried ($MgSO_4$). The mixture was filtered and volatile components removed *in vacuo*. Product purification by column chromatography using silica gel with a mixture of hexane and DCM (9:1) as the eluent afforded 1,4-difluoro-2-(2-nitrophenoxy)benzene (**228**) (1.354 g, 91 %) as a yellow liquid; Anal. Calcd for $C_{12}H_7F_2NO_3$: C, 57.38; H, 2.81; N, 5.58. Found: C, 57.11; H, 2.80; N, 5.60; GC-MS m/z (% relative intensity, ion): 251 (36, M^+), 151 (56), 122 (100), 78 (66), 63 (69); IR (cm^{-1}): 3084, 1599, 1526, 1502, 1479, 1429, 1346; 1H NMR (700 MHz, $CDCl_3$): δ 6.77–6.81 (1H, m, H-3), 6.84–6.88 (1H, m, H-Ar), 6.97 (1H, d, $^3J_{HH}$ 8.4, H-6'), 7.13 (1H, ddd, $^3J_{HF}$ 9.5, $^3J_{HH}$ 9.3, $^4J_{HF}$ 5.0, H-Ar), 7.22 (1H, dd, $^3J_{HH}$ 8.0, $^3J_{HH}$ 7.6, H-4'), 7.51 (1H, ddd, $^3J_{HH}$ 8.4, $^3J_{HH}$ 7.6, $^4J_{HH}$ 1.8, H-5'), 7.95 (1H, ddd, $^3J_{HH}$ 8.0, $^4J_{HH}$ 1.8, H-3'); ^{13}C NMR (176 MHz, $CDCl_3$): δ 109.1 (d, $^2J_{CF}$ 26.7, C-3), 112.3 (dd, $^2J_{CF}$ 23.8, $^3J_{CF}$ 6.9, C-Ar), 117.9 (dd, $^2J_{CF}$ 20.6, $^3J_{CF}$ 9.7, C-Ar), 119.7 (s, C-6'), 124.3 (s, C-4'), 126.2 (s, C-3'), 134.7 (s, C-5'), 141.0 (s, C-2'), 143.5 (dd, $^2J_{CF}$ 13.9, $^3J_{CF}$ 10.8, C-2), 149.8 (s, C-1'), 150.3 (dd, $^1J_{CF}$ 246, $^4J_{CF}$ 2.7, C-F), 158.7 (d, $^1J_{CF}$ 245, C-F); ^{19}F NMR (658 MHz, $CDCl_3/CFCl_3$): δ -115.9 - -116.0 (1F, m, F-4), -136.4 - -136.5 (1F, m, F-1).

1,2-Difluoro-3-(2-nitrophenoxy)benzene (230)

60% (w/w) Sodium hydride (0.260 g, 6.500 mmol) was charged to a 10–20 mL microwave vial that was sealed and subsequently evacuated under high vacuum and back-filled with argon three times to create an inert atmosphere. Dry THF (10 mL) was added to the vial, which was pierced with an exit needle and under a positive pressure of argon, followed by the drop-wise addition of a solution of 2,3-difluorophenol (0.855 g, 6.572 mmol) in dry THF (5 mL). After the evolution of hydrogen gas had stopped, 2-fluoronitrobenzene (0.848 g, 6.010 mmol) was added to the reaction vessel and the contents heated under microwave irradiation (150 °C, 30 mins) with stirring. The vial and its contents were cooled, poured on to water (100 mL) and extracted with DCM (3 × 50 mL). The combined extracts were washed with water (100 mL) and dried (MgSO₄). The mixture was filtered and volatile components removed *in vacuo*. Product purification by column chromatography using silica gel with a mixture of hexane and DCM (9:1) as the eluent afforded 1,2-difluoro-3-(2-nitrophenoxy)benzene (**230**) (1.007 g, 67 %) as a yellow liquid; Anal. Calcd for C₁₂H₇F₂NO₃: C, 57.38; H, 2.81; N, 5.58. Found: C, 57.30; H, 2.81; N, 5.57; GC–MS *m/z* (% relative intensity, ion): 251 (34, M⁺), 175 (22), 151 (46), 122 (100), 78 (58), 63 (65); IR (cm⁻¹): 3098, 1600, 1586, 1499, 1473, 1343; ¹H NMR (700 MHz, CDCl₃): δ 6.87 (1H, dddd, ³J_{HH} 8.6, ⁴J_{HF} 6.7, ⁴J_{HH} 2.1, ⁵J_{HF} 2.1, H-4), 7.02 (1H, d, ³J_{HH} 8.4, H-6'), 7.01–7.10 (3H, m, H-Ar), 7.27 (1H, ddd, ³J_{HH} 8.2, ³J_{HH} 7.5, ⁴J_{HH} 1.3, H-4'), 7.56 (1H, ddd, ³J_{HH} 8.4, ³J_{HH} 7.5, ⁴J_{HH} 1.7, H-5'), 8.02 (1H, dd, ³J_{HH} 8.2, ⁴J_{HH} 1.7, H-3'); ¹³C NMR (176 MHz, CDCl₃): δ 113.8 (d, ²J_{CF} 17.4, C-6), 116.5 (d, ³J_{CF} 3.4, C-4), 119.6 (s, C-6'), 124.1 (dd, ³J_{CF} 8.2, ⁴J_{CF} 5.1, C-5), 124.2 (s, C-4'), 126.3 (s, C-3'), 134.6 (s, C-5'), 141.0 (s, C-2'), 143.2 (dd, ¹J_{CF} 253, ²J_{CF} 14.3, C-F), 144.6 (dd, ²J_{CF} 8.9, ³J_{CF} 2.2, C-3), 150.1 (s, C-1'), 152.0 (dd, ¹J_{CF} 250, ²J_{CF} 10.3, C-F); ¹⁹F NMR (658 MHz, CDCl₃/CFCl₃): δ -135.5 (1F, dddd, ³J_{FF} 20.1, ³J_{FH} 9.6, ⁴J_{FH} 5.8, ⁵J_{FH} 2.1, 1-F), -154.7 (1F, dddd, ³J_{FF} 20.1, ⁴J_{FH} 6.7, ⁴J_{FH} 6.5, ⁵J_{FH} 2.1, 2-F).

1,3-Difluoro-2-(2-nitrophenoxy)benzene (232)

60% (w/w) Sodium hydride (0.264 g, 6.600 mmol) was charged to a 10–20 mL microwave vial that was sealed and subsequently evacuated under high vacuum and back-filled with argon three times to create an inert atmosphere. Dry THF (10 mL) was added to the vial, which was pierced with an exit needle and under a positive pressure of argon, followed by the drop-wise addition of a solution of 1,3-difluorophenol (0.855 g,

6.572 mmol) in dry THF (5 mL). After the evolution of hydrogen gas had stopped, 2-fluoronitrobenzene (0.836 g, 5.925 mmol) was added to the reaction vessel and the contents heated under microwave irradiation (150 °C, 1 h) with stirring. The vial and its contents were cooled, poured on to water (100 mL) and extracted with DCM (3 × 50 mL). The combined extracts were washed with water (100 mL) and dried (MgSO₄). The mixture was filtered and volatile components removed *in vacuo*. Product purification by column chromatography using silica gel with a mixture of hexane and DCM (9:1) as the eluent afforded 1,3-difluoro-2-(2-nitrophenoxy)benzene (**232**) (0.845 g, 57 %) as a yellow liquid; Anal. Calcd for C₁₂H₇F₂NO₃: C, 57.38; H, 2.81; N, 5.58. Found: C, 57.20; H, 2.82; N, 5.63; GC-MS *m/z* (% relative intensity, ion): 251 (18, M⁺), 151 (47), 122 (100), 78 (62), 63 (59); IR (cm⁻¹): 3016, 1601, 1588, 1523, 1495, 1475, 1343; ¹H NMR (700 MHz, CDCl₃): δ 6.84 (1H, dd, ³J_{HH} 8.4, ⁴J_{HH} 1.0, H-6'), 7.04 (2H, dd, ³J_{HH} 8.5, ³J_{HF} 7.9, H-4), 7.18 (1H, ddd, ³J_{HH} 8.3, ³J_{HH} 7.3, ⁴J_{HH} 1.0, H-4'), 7.22 (1H, tt, ³J_{HH} 8.5, ⁴J_{HF} 5.9, H-5), 7.48 (1H, ddd, ³J_{HH} 8.4, ³J_{HH} 7.3, ⁴J_{HH} 1.8, H-5'), 7.99 (1H, dd, ³J_{HH} 8.3, ⁴J_{HH} 1.8, H-3'); ¹³C NMR (176 MHz, CDCl₃): δ 113.0 (dd, ²J_{CF} 18.1, ⁴J_{CF} 4.0, C-4), 116.4 (s, C-6'), 123.2 (s, C-4'), 126.3 (s, C-3'), 126.4 (t, ³J_{CF} 9.0, C-5), 130.6 (t, ²J_{CF} 15.1, C-2), 134.5 (s, C-5'), 139.8 (s, C-2'), 150.9 (s, C-1'), 155.9 (dd, ¹J_{CF} 253, ³J_{CF} 3.8, C-1); ¹⁹F NMR (658 MHz, CDCl₃/CFCl₃): δ -126.7 (2F, ddd, ³J_{FH} 7.9, ⁴J_{FH} 5.9, ⁵J_{FH} 1.0, F-1).

5.2.5.2 Step 2: Palladium-catalysed Reduction Reactions of Nitrobenzene Derivatives to Corresponding Aniline Systems

4,5-Difluoro-2-phenoxyaniline (233)

A solution of 1,2-difluoro-4-nitro-5-phenoxybenzene (0.650 g, 2.588 mmol) in HPLC grade methanol (259 mL) was reduced using a *ThalesNano* H-Cube® fitted with a 10% Pd/C CatCart® catalyst at a flow rate of 1 mL min⁻¹, a temperature of 60 °C and a pressure of 20 bar. Once complete consumption of the reagent solution was achieved, solvent methanol was removed *in vacuo*, and the residual reaction mixture was extracted with DCM (3 × 50 mL) and water (100 mL). The combined extracts were washed with water (100 mL) and dried (MgSO₄). The mixture was filtered and volatile components removed *in vacuo*. Product purification by column chromatography on silica gel using a mixture of hexane and DCM (1:1) as the eluent afforded 4,5-difluoro-2-phenoxyaniline (**233**) (0.442 g, 77 %) as a viscous colourless liquid; Anal. Calcd for

$C_{12}H_9NF_2O$: C, 65.16; H, 4.01; N, 6.33. Found: C, 65.04; H, 4.11; N, 6.31; GC-MS m/z (% relative intensity, ion): 221 (100, M^+), 144 (74), 116 (66), 77 (34), 51 (41); IR (cm^{-1}): 3463, 3370, 3072, 1587, 1516, 1491, 1438, 1227, 1211, 1167; 1H NMR (700 MHz, $CDCl_3$): δ 3.84 (2H, br s, NH_2), 6.63 (1H, ddd, $^3J_{HF}$ 11.3, $^4J_{HF}$ 7.6, $^5J_{HH}$ 1.6, H-Ar), 6.72 (1H, ddd, $^3J_{HF}$ 10.6, $^4J_{HF}$ 8.0, $^5J_{HH}$ 1.6, H-Ar), 6.96 (2H, dd, $^3J_{HH}$ 8.6, $^4J_{HH}$ 1.1, H-2'), 7.10 (1H, tt, $^3J_{HH}$ 7.4, $^1J_{HH}$ 1.1, H-4'), 7.33 (2H, dd, $^3J_{HH}$ 8.6, $^3J_{HH}$ 7.4, H-3'); ^{13}C NMR (176 MHz, $CDCl_3$): δ 104.6 (d, $^2J_{CF}$ 21.7, C-Ar), 109.6 (d, $^2J_{CF}$ 20.3, C-Ar), 117.4 (s, C-2'), 123.6 (s, C-4'), 130.2 (s, C-3'), 135.2–135.3 (m, C-Ar), 138.3–138.4 (m, C-Ar), 142.8 (dd, $^1J_{CF}$ 240, $^2J_{CF}$ 14.0, C-F), 147.4 (dd, $^1J_{CF}$ 243, $^2J_{CF}$ 12.9, C-F), 157.2 (s, C-1'); ^{19}F NMR (658 MHz, $CDCl_3/CFCl_3$): δ -143.1 (1F, ddd, $^3J_{FF}$ 22.3, $^3J_{FH}$ 11.3, $^4J_{FH}$ 7.6, F-C), -149.4 (1F, ddd, $^3J_{FF}$ 22.3, $^3J_{FH}$ 10.6, $^4J_{FH}$ 8.0, F-C).

3,4-Difluoro-2-phenoxyaniline (234)

A solution of 1,2-difluoro-4-nitro-3-phenoxybenzene (0.900 g, 3.583 mmol) in HPLC grade methanol (358 mL) was reduced using a *ThalesNano* H-Cube® fitted with a 10% Pd/C CatCart® catalyst at a flow rate of 1 mL min^{-1} , a temperature of 60 °C and a pressure of 20 bar. Once complete consumption of the reagent solution was achieved, solvent methanol was removed *in vacuo*, and the residual reaction mixture was extracted with DCM (3 \times 50 mL) and water (100 mL). The combined extracts were washed with water (100 mL) and dried ($MgSO_4$). The mixture was filtered and volatile components removed *in vacuo*. Product purification by column chromatography on silica gel using a mixture of hexane and DCM (1:1) as the eluent afforded 3,4-difluoro-2-phenoxyaniline (**234**) (0.610 g, 77 %) as a colourless liquid; Anal. Calcd for $C_{12}H_9NF_2O$: C, 65.16; H, 4.01; N, 6.33. Found: C, 64.92; H, 4.08; N, 6.17; GC-MS m/z (% relative intensity, ion): 221 (100, M^+), 204 (58), 144 (69), 116 (69), 77 (61), 51 (67); IR (cm^{-1}): 3472, 3380, 3058, 1589, 1505, 1483, 1264, 1231, 1199; 1H NMR (700 MHz, $CDCl_3$): δ 3.71 (2H, br s, NH_2), 6.50 (1H, ddd, $^3J_{HH}$ 9.1, $^4J_{HF}$ 4.7, $^5J_{HF}$ 2.3, H-5), 6.88 (1H, ddd, $^3J_{HH}$ 9.1, $^3J_{HF}$ 9.5, $^4J_{HF}$ 8.2, H-6), 6.95 (2H, d, $^3J_{HH}$ 8.1, H-2'), 7.07 (1H, tt, $^3J_{HH}$ 7.4, $^4J_{HH}$ 1.0, H-4'), 7.31 (2H, dd, $^3J_{HH}$ 8.1, $^3J_{HH}$ 7.4, H-3'); ^{13}C NMR (176 MHz, $CDCl_3$): δ 109.7 (dd, $^3J_{CF}$ 6.7, $^4J_{CF}$ 3.4, C-6), 113.4 (d, $^2J_{CF}$ 18.0, 5-C), 115.2 (s, C-2'), 123.1 (s, C-4'), 130.1 (s, C-3'), 130.7 (d, $^2J_{CF}$ 11.9, C-2), 137.5–137.6 (m, C-1), 144.4 (dd, $^1J_{CF}$ 239, $^2J_{CF}$ 11.0, C-F), 145.0 (dd, $^1J_{CF}$ 249, $^2J_{CF}$ 14.5, C-F), 157.3 (s, C-1'); ^{19}F

NMR (658 MHz, CDCl₃/CFC₃): δ -149.8 - -148.9 (1F, m, 1 or F-C), -152.3 - 152.4 (1F, m, 1 or F-C).

2,4-Difluoro-6-phenoxyaniline (235)

A solution of 1,5-difluoro-2-nitro-3-phenoxybenzene (0.802 g, 3.193 mmol) in HPLC grade methanol (319 mL) was reduced using a *ThalesNano* H-Cube® fitted with a 10% Pd/C CatCart® catalyst at a flow rate of 1 mL min⁻¹, a temperature of 60 °C and a pressure of 20 bar. Once complete consumption of the reagent solution was achieved, solvent methanol was removed *in vacuo*, and the residual reaction mixture was extracted with DCM (3 × 50 mL) and water (100 mL). The combined extracts were washed with water (100 mL) and dried (MgSO₄). The mixture was filtered and volatile components removed *in vacuo*. Product purification by column chromatography on silica gel using a mixture of hexane and DCM (1:1) as the eluent afforded 2,4-difluoro-6-phenoxyaniline (**235**) (0.661 g, 94 %) as a colourless liquid; Anal. Calcd for C₁₂H₉NF₂O: C, 65.16; H, 4.01; N, 6.33. Found: C, 64.98; H, 4.10; N, 6.32; GC-MS *m/z* (% relative intensity, ion): 221 (100, M⁺), 144 (46), 116 (77), 77 (62), 51 (66); IR (cm⁻¹): 3472, 3380, 3080, 1588, 1507, 1488, 1449, 1207; ¹H NMR (700 MHz, CDCl₃): δ 3.68 (2H, br s, NH₂), 6.38–6.41 (1H, m, H-3), 6.60–6.64 (1H, m, H-5), 7.03 (2H, d, ³J_{HH} 8.6, H-2'), 7.15 (1H, tt, ³J_{HH} 7.4, ⁴J_{HH} 1.1, H-4'), 7.37 (2H, dd, ³J_{HH} 8.6, ³J_{HH} 7.4, H-3'); ¹³C NMR (176 MHz, CDCl₃): δ 99.3 (dd, ²J_{CF} 26.6, ²J_{CF} 23.5, C-3), 102.3 (dd, ²J_{CF} 25.5, ⁴J_{CF} 2.2, C-5), 118.6 (s, C-2'), 123.5–123.8 (m, C-1), 124.2 (s, C-4'), 130.2 (s, C-3'), 145.3 (dd, ³J_{CF} 11.7, ³J_{CF} 9.0, C-6), 151.8 (dd, ¹J_{CF} 240, ³J_{CF} 14.4, 1 or C-F), 154.5 (dd, ¹J_{CF} 238, ³J_{CF} 14.5, C-F), 156.3 (s, C-1'); ¹⁹F NMR (658 MHz, CDCl₃/CFC₃): δ -124.2 - -124.3 (1F, m, F-C), -130.9 - -131.0 (1F, m, F-C).

5-Fluoro-2,4-diphenoxyaniline (236)

A solution of 4-fluoro-1,3-diphenoxy-6-nitrobenzene (0.754 g, 2.318 mmol) in HPLC grade methanol (232 mL) was reduced using a *ThalesNano* H-Cube® fitted with a 10% Pd/C CatCart® catalyst at a flow rate of 1 mL min⁻¹, a temperature of 60 °C and a pressure of 20 bar. Once complete consumption of the reagent solution was achieved, solvent methanol was removed *in vacuo*, and the residual reaction mixture was extracted with DCM (3 × 50 mL) and water (100 mL). The combined extracts were washed with water (100 mL) and dried (MgSO₄). The mixture was filtered and volatile

components removed *in vacuo*. Product purification by column chromatography on silica gel using a mixture of hexane and DCM (2:1) as the eluent afforded 3-fluoro-2,4-diphenoxyaniline (**236**) (0.459 g, 67 %) as a viscous colourless liquid; HRMS–ASAP m/z : $[M + H]^+$ calcd for $C_{18}H_{15}NFO_2$ 296.10813; found, 296.10833; GC–MS m/z (% relative intensity, ion): 295 (100, M^+), 218 (84), 77 (74), 51 (42); IR (cm^{-1}): 3464, 3382, 3052, 1631, 1589, 1509, 1485, 1432, 1206; 1H NMR (500 MHz, $CDCl_3$): δ 4.06 (2H, br s, NH_2), 6.68 (1H, d, $^3J_{HF}$ 11.3, H–6), 6.72 (1H, d, $^4J_{HF}$ 7.7, H–3), 6.91 (2H, d, $^3J_{HH}$ 8.5, H–Ar), 6.94–6.98 (2H, m, H–Ar), 7.01 (1H, t, $^3J_{HH}$ 7.4, H–Ar), 7.06 (1H, t, $^3J_{HH}$ 7.4, H–Ar), 7.27 (2H, dd, $^3J_{HH}$ 7.5, $^3J_{HH}$ 8.5, H–Ar), 7.31 (2H, dd, $^3J_{HH}$ 7.5, $^3J_{HH}$ 8.5, H–Ar); ^{13}C NMR (126 MHz, $CDCl_3$): δ 104.7 (d, $^2J_{CF}$ 23.2, C–6), 115.4 (d, $^3J_{CF}$ 2.4, C–3), 116.1 (s, C–Ar), 117.2 (s, C–Ar), 122.6 (s, C–Ar), 123.3 (s, C–Ar), 129.8 (s, C–Ar), 130.1 (s, C–Ar), 134.1 (d, $^2J_{CF}$ 13.7, C–4), 136.2 (d, $^3J_{CF}$ 9.5, C–1), 139.0 (d, $^5J_{CF}$ 2.7, C–2), 152.0 (d, $^1J_{CF}$ 244, C–5), 157.3 (s, C–Ar), 158.6 (s, C–Ar); ^{19}F NMR (658 MHz, $CDCl_3/CFCl_3$): δ –134.7 (1F, dd, $^3J_{FH} = 11.3$, $^4J_{FH} = 7.7$, F–5).

3-Fluoro-2,4-diphenoxyaniline (237)

A solution of 2-fluoro-1,3-diphenoxy-4-nitrobenzene (0.920 g, 2.828 mmol) in HPLC grade methanol (283 mL) was reduced using a *ThalesNano* H-Cube® fitted with a 10% Pd/C CatCart® catalyst at a flow rate of 1 mL min^{-1} , a temperature of 60 °C and a pressure of 20 bar. Once complete consumption of the reagent solution was achieved, solvent methanol was removed *in vacuo*, and the residual reaction mixture was extracted with DCM (3 × 50 mL) and water (100 mL). The combined extracts were washed with water (100 mL) and dried ($MgSO_4$). The mixture was filtered and volatile components removed *in vacuo*. Product purification by column chromatography on silica gel using a mixture of hexane and DCM (2:1) as the eluent afforded 3-fluoro-2,4-diphenoxyaniline (**237**) (0.759 g, 91 %) as a white solid; mp 94–95 °C; HRMS–ASAP m/z : $[M + H]^+$ calcd for $C_{18}H_{15}NFO_2$ 296.10813; found, 296.10833; GC–MS m/z (% relative intensity, ion): 295 (100, M^+), 218 (86), 77 (90), 51 (58); IR (cm^{-1}): 3480, 3380, 3044, 1636, 1588, 1503, 1484, 1341, 1264; 1H NMR (700 MHz, $CDCl_3$): δ 4.00 (2H, br s, NH_2), 6.58 (1H, dd, $^3J_{HH}$ 8.8, $^5J_{HF}$ 2.0, H–6), 6.85 (1H, dd, $^3J_{HH}$ 8.8, $^4J_{HF}$ 8.1, H–5), 6.93–6.95 (2H, m, H–Ar), 6.96–6.98 (2H, m, H–Ar), 7.01–7.06 (2H, m, H–Ar), 7.27–7.32 (4H, m, H–Ar); ^{13}C NMR (176 MHz, $CDCl_3$): δ 110.7 (d, $^4J_{CF}$ 3.7, C–6), 115.2 (s, C–Ar), 116.4 (s, C–Ar), 119.6 (d, $^3J_{CF}$ 1.6, C–5), 122.7 (s, C–Ar), 123.0 (s, C–Ar),

129.8 (s, C–Ar), 130.0 (s, C–Ar), 131.0 (d, $^2J_{CF}$ 12.7, C–Ar), 135.9 (d, $^2J_{CF}$ 10.4, C–Ar), 138.0 (s, C–1), 149.1 (d, $^1J_{CF}$ 251, C–3), 157.4 (s, C–Ar), 158.7 (s, C–Ar); ^{19}F NMR (658 MHz, $CDCl_3/CFCl_3$): δ –144.5 (1F, dd, $^4J_{FH} = 8.1$, $^5J_{FH} = 2.0$, F–3).

4-Fluoro-2,6-diphenoxyaniline (238)

A solution of 5-fluoro-1,3-diphenoxy-2-nitrobenzene (0.623 g, 1.915 mmol) in HPLC grade methanol (192 mL) was reduced using a *ThalesNano* H-Cube® fitted with a 10% Pd/C CatCart® catalyst at a flow rate of 1 mL min⁻¹, a temperature of 60 °C and a pressure of 20 bar. Once complete consumption of the reagent solution was achieved, solvent methanol was removed *in vacuo*, and the residual reaction mixture was extracted with DCM (3 × 50 mL) and water (100 mL). The combined extracts were washed with water (100 mL) and dried ($MgSO_4$). The mixture was filtered and volatile components removed *in vacuo*. Product purification by column chromatography on silica gel using a mixture of hexane and DCM (1:1) as the eluent afforded 4-fluoro-2,6-diphenoxyaniline (**238**) (0.501 g, 89 %) as a viscous colourless liquid; HRMS–ASAP *m/z*: $[M + H]^+$ calcd for $C_{18}H_{15}NFO_2$ 296.10813; found, 296.10831; GC–MS *m/z* (% relative intensity, ion): 295 (100, M^+), 77 (69), 51 (46); IR (cm⁻¹): 3464, 3376, 3058, 1617, 1586, 1498, 1486, 1440, 1205; 1H NMR (700 MHz, $CDCl_3$): δ 4.00 (2H, br s, NH_2), 6.39 (2H, d, $^3J_{HF}$ 9.4, H–3), 7.06 (4H, dd, $^3J_{HH}$ 8.6, $^4J_{HH}$ 1.0, H–2'), 7.14 (2H, tt, $^3J_{HH}$ 7.4, $^4J_{HH}$ 1.0, H–4'), 7.37 (4H, dd, $^3J_{HH}$ 7.4, $^3J_{HH}$ 8.6, H–3'); ^{13}C NMR (176 MHz, $CDCl_3$): δ 102.0 (d, $^2J_{CF}$ 25.7, C–3), 118.5 (s, C–2'), 124.0 (s, C–4'), 126.6 (s, C–1), 130.2 (s, C–3'), 145.1 (d, $^3J_{CF}$ 11.8, C–2), 155.2 (d, $^1J_{CF}$ 238, C–4), 156.6 (s, C–1'); ^{19}F NMR (658 MHz, $CDCl_3/CFCl_3$): δ –123.8 – –124.1 (1F, m, F–4).

2-(3,5-Difluorophenoxy)aniline (239)

A solution of 1,3-difluoro-5-(2-nitrophenoxy)benzene (1.350 g, 5.374 mmol) in HPLC grade methanol (0.01 M) was reduced using a *ThalesNano* H-Cube® fitted with a 10% Pd/C CatCart® catalyst at a flow rate of 1 mL min⁻¹, a temperature of 60 °C and a pressure of 20 bar. Once complete consumption of the reagent solution was achieved, solvent methanol was removed *in vacuo*, and the residual reaction mixture was extracted with DCM (3 × 50 mL) and water (100 mL). The combined extracts were washed with water (100 mL) and dried ($MgSO_4$). The mixture was filtered and volatile components removed *in vacuo*. Product purification by column chromatography on

silica gel using hexane as the eluent afforded 2-(3,5-difluorophenoxy)aniline (**239**) (1.092 g, 92 %) as a viscous colourless liquid; Anal. Calcd for $C_{12}H_9F_2NO$: C, 65.16; H, 4.10; N, 6.33. Found: C, 65.09; H, 3.98; N, 6.09; GC-MS m/z (% relative intensity, ion): 221 (100, M^+), 204 (62), 108 (42), 80 (86), 63 (33); IR (cm^{-1}): 3472, 3376, 3100, 1615, 1599, 1499, 1463, 1305; 1H NMR (700 MHz, $CDCl_3$): δ 3.75 (2H, br s, NH_2), 6.45–6.52 (3H, m, H-Ar), 6.77 (1H, ddd, $^3J_{HH}$ 8.0, $^3J_{HH}$ 7.3, $^4J_{HH}$ 1.5, H-4), 6.85 (1H, dd, $^3J_{HH}$ 8.0, $^4J_{HH}$ 1.5, H-6), 6.94 (1H, dd, $^3J_{HH}$ 8.0, $^4J_{HH}$ 1.4, H-3), 7.06 (1H, ddd, $^3J_{HH}$ 8.0, $^3J_{HH}$ 7.3, $^4J_{HH}$ 1.4, H-5); ^{13}C NMR (176 MHz, $CDCl_3$): δ 98.2 (t, $^2J_{CF}$ 25.9, C-4'), 100.4 (dd, $^2J_{CF}$ 22.9, $^4J_{CF}$ 6.9, C-2'), 117.1 (s, C-6), 119.2 (s, C-4), 121.6 (s, C-3), 126.5 (s, C-5), 139.2 (s, C-Ar), 141.5 (s, C-Ar), 160.0 (t, $^3J_{CF}$ 13.3, C-1'), 163.8 (dd, $^1J_{CF}$ 247, $^3J_{CF}$ 15.4, C-3'); ^{19}F NMR (658 MHz, $CDCl_3/CFCl_3$): δ -109.1 (2F, dd, $^3J_{FH}$ 9.2, $^3J_{FH}$ 8.7, F-3').

2-(3,4-Difluorophenoxy)aniline (240)

A solution of 1,2-difluoro-4-(2-nitrophenoxy)benzene (1.456 g, 5.797 mmol) in HPLC grade methanol (0.01 M) was reduced using a *ThalesNano* H-Cube® fitted with a 10% Pd/C CatCart® catalyst at a flow rate of 1 mL min^{-1} , a temperature of 60 °C and a pressure of 20 bar. Once complete consumption of the reagent solution was achieved, solvent methanol was removed *in vacuo*, and the residual reaction mixture was extracted with DCM (3 \times 50 mL) and water (100 mL). The combined extracts were washed with water (100 mL) and dried ($MgSO_4$). The mixture was filtered and volatile components removed *in vacuo*. Product purification by column chromatography on silica gel using hexane as the eluent afforded 2-(2,5-difluorophenoxy)aniline (**240**) (1.106 g, 86 %) as a viscous colourless liquid; Anal. Calcd for $C_{12}H_9F_2NO$: C, 65.16; H, 4.10; N, 6.33. Found: C, 65.08; H, 4.07; N, 6.10; GC-MS m/z (% relative intensity, ion): 221 (21, M^+), 113 (71), 80 (100), 63 (53); IR (cm^{-1}): 3472, 3386, 3062, 1617, 1497, 1459, 1438, 1307; 1H NMR (700 MHz, $CDCl_3$): δ 3.78 (2H, br s, NH_2), 6.67–6.71 (1H, m, H-6'), 6.74 (1H, ddd, $^3J_{HH}$ 8.0, $^3J_{HH}$ 7.6, $^4J_{HH}$ 1.5, H-Ar), 6.79 (1H, ddd, $^3J_{HF}$ 11.5, $^4J_{HF}$ 6.6, $^5J_{HH}$ 3.0, H-Ar), 6.84 (1H, dd, $^3J_{HH}$ 8.0, $^4J_{HH}$ 1.5, H-Ar), 6.87 (1H, dd, $^3J_{HH}$ 8.0, $^4J_{HH}$ 1.5, H-Ar), 7.02 (1H, ddd, $^3J_{HH}$ 8.0, $^3J_{HH}$ 7.6, $^4J_{HH}$ 1.4, H-Ar), 7.08 (1H, ddd, $^3J_{HH}$ 9.0, $^3J_{HF}$ 9.0, $^4J_{HF}$ 9.0, H-Ar); ^{13}C NMR (176 MHz, $CDCl_3$): δ 106.8 (d, $^2J_{CF}$ 20.4, C-Ar), 112.6 (dd, $^3J_{CF}$ 5.9, $^4J_{CF}$ 3.6, C-6'), 116.9 (s, C-Ar), 117.7 (dd, $^2J_{CF}$ 18.7, $^3J_{CF}$ 1.5, C-Ar), 119.2 (s, C-Ar), 120.6 (s, C-Ar), 125.8 (s, C-Ar), 138.9 (s, C-Ar),

142.8 (s, C–Ar), 146.4 (dd, $^1J_{CF}$ 242, $^2J_{CF}$ 12.4, C–F), 150.8 (dd, $^1J_{CF}$ 249, $^2J_{CF}$ 14.0, C–F), 153.9 (dd, $^3J_{CF}$ 8.2, $^4J_{CF}$ 2.5, C–1'); ^{19}F NMR (658 MHz, $CDCl_3/CFCl_3$): δ –135.1 – –135.3 (1F, m, F–3'), –146.2 – –146.3 (1F, m, F–4').

2-(2,4-Difluorophenoxy)aniline (241)

A solution of 2,4-difluoro-1-(2-nitrophenoxy)benzene (1.537 g, 6.119 mmol) in HPLC grade methanol (0.01 M) was reduced using a *ThalesNano* H-Cube® fitted with a 10% Pd/C CatCart® catalyst at a flow rate of 1 mL min⁻¹, a temperature of 60 °C and a pressure of 20 bar. Once complete consumption of the reagent solution was achieved, solvent methanol was removed *in vacuo*, and the residual reaction mixture was extracted with DCM (3 × 50 mL) and water (100 mL). The combined extracts were washed with water (100 mL) and dried ($MgSO_4$). The mixture was filtered and volatile components removed *in vacuo*. Product purification by column chromatography on silica gel using a mixture of hexane and DCM (1:4) as the eluent afforded 2-(2,5-difluorophenoxy)aniline (**241**) (0.801 g, 59 %) as a viscous colourless liquid; Anal. Calcd for $C_{12}H_9F_2NO$: C, 65.16; H, 4.10; N, 6.33. Found: C, 65.02; H, 4.05; N, 6.19; GC–MS m/z (% relative intensity, ion): 221 (93, M^+), 201 (42), 108 (63), 80 (100), 65 (55); IR (cm⁻¹): 3476, 3376, 3072, 1618, 1496, 1459, 1435, 1299; 1H NMR (700 MHz, $CDCl_3$): δ 3.88 (2H, br s, NH_2), 6.67–6.70 (1H, m, H–Ar), 6.71–6.74 (1H, m, H–Ar), 6.87–6.84 (2H, m, H–Ar), 6.93–6.99 (3H, m, H–Ar); ^{13}C NMR (176 MHz, $CDCl_3$): δ 105.6 (dd, $^2J_{CF}$ 26.8, $^2J_{CF}$ 22.0, C–3'), 111.3 (dd, $^2J_{CF}$ 22.8, $^4J_{CF}$ 4.0, C–5'), 116.7 (s, C–Ar), 117.8 (s, C–Ar), 118.9 (s, C–Ar), 121.1 (dd, $^3J_{CF}$ 9.6, $^3J_{CF}$ 2.1, C–6'), 124.8 (s, C–Ar), 137.9 (s, C–Ar), 140.8–140.9 (m, C–1'), 144.2 (s, C–Ar), 153.8 (dd, $^1J_{CF}$ 251, $^3J_{CF}$ 12.4, C–F), 158.5 (dd, $^1J_{CF}$ 245, $^3J_{CF}$ 10.2, C–F); ^{19}F NMR (658 MHz, $CDCl_3/CFCl_3$): δ –116.7 – –116.8 (1F, m, F–4'), –127.9 – –128.0 (1F, m, F–2').

2-(2,5-Difluorophenoxy)aniline (242)

A solution of 1,4-difluoro-2-(2-nitrophenoxy)benzene (1.254 g, 4.992 mmol) in HPLC grade methanol (0.01 M) was reduced using a *ThalesNano* H-Cube® fitted with a 10% Pd/C CatCart® catalyst at a flow rate of 1 mL min⁻¹, a temperature of 60 °C and a pressure of 20 bar. Once complete consumption of the reagent solution was achieved, solvent methanol was removed *in vacuo*, and the residual reaction mixture was extracted with DCM (3 × 50 mL) and water (100 mL). The combined extracts were

washed with water (100 mL) and dried (MgSO_4). The mixture was filtered and volatile components removed *in vacuo*. Product purification by column chromatography on silica gel using hexane as the eluent afforded 2-(2,5-difluorophenoxy)aniline (**242**) (0.985 g, 89 %) as a viscous colourless liquid; Anal. Calcd for $\text{C}_{12}\text{H}_9\text{F}_2\text{NO}$: C, 65.16; H, 4.10; N, 6.33. Found: C, 65.19; H, 4.09; N, 6.32; GC-MS m/z (% relative intensity, ion): 221 (100, M^+), 201 (49), 108 (66), 80 (90), 65 (42); IR (cm^{-1}): 3472, 3381, 3066, 1619, 1497, 1459, 1429, 1298, 1245; ^1H NMR (700 MHz, CDCl_3): δ 3.84 (2H, br s, NH_2), 6.63 (1H, ddd, $^3J_{\text{HF}}$ 9.5, $^4J_{\text{HF}}$ 6.6, $^4J_{\text{HH}}$ 3.1, H-6'), 6.70–6.75 (1H, m, H-4'), 6.74 (1H, ddd, $^3J_{\text{HH}}$ 7.9, $^3J_{\text{HH}}$ 7.8, $^4J_{\text{HH}}$ 1.5, H-5), 6.84 (1H, dd, $^3J_{\text{HH}}$ 7.9, $^4J_{\text{HH}}$ 1.5, H-3), 6.87 (1H, dd, $^3J_{\text{HH}}$ 7.9, $^4J_{\text{HH}}$ 1.2, H-6), 7.02 (1H, ddd, $^3J_{\text{HH}}$ 7.9, $^3J_{\text{HH}}$ 7.8, $^4J_{\text{HH}}$ 1.2, H-4), 7.12 (1H, ddd, $^3J_{\text{HF}}$ 10.2, $^3J_{\text{HH}}$ 9.1, $^4J_{\text{HF}}$ 5.1, H-3'); ^{13}C NMR (176 MHz, CDCl_3): δ 106.6 (d, $^2J_{\text{CF}}$ 27.4, C-6'), 109.7 (dd, $^2J_{\text{CF}}$ 24.0, $^3J_{\text{CF}}$ 6.8, C-4'), 117.0 (s, C-3), 117.2 (dd, $^2J_{\text{CF}}$ 20.6, $^3J_{\text{CF}}$ 9.9, C-3'), 119.1 (s, C-5), 119.7 (s, C-6), 125.8 (s, C-4), 138.6 (s, C-Ar), 142.6 (s, C-Ar), 145.8 (dd, $^2J_{\text{CF}}$ 12.9, $^3J_{\text{CF}}$ 10.5, C-1'), 149.8 (dd, $^1J_{\text{CF}}$ 243, $^4J_{\text{CF}}$ 3.0, C-F), 158.8 (dd, $^1J_{\text{CF}}$ 244, $^4J_{\text{CF}}$ 2.4, C-F); ^{19}F NMR (658 MHz, $\text{CDCl}_3/\text{CFCl}_3$): δ -116.7 - -116.8 (1F, m, F-4), -139.3 - -139.4 (1F, m, F-1).

2-(2,3-Difluorophenoxy)aniline (243)

A solution of 1,2-difluoro-3-(2-nitrophenoxy)benzene (0.967 g, 3.850 mmol) in HPLC grade methanol (0.01 M) was reduced using a *ThalesNano* H-Cube® fitted with a 10% Pd/C CatCart® catalyst at a flow rate of 1 mL min^{-1} , a temperature of $60 \text{ }^\circ\text{C}$ and a pressure of 20 bar. Once complete consumption of the reagent solution was achieved, solvent methanol was removed *in vacuo*, and the residual reaction mixture was extracted with DCM ($3 \times 50 \text{ mL}$) and water (100 mL). The combined extracts were washed with water (100 mL) and dried (MgSO_4). The mixture was filtered and volatile components removed *in vacuo*. Product purification by column chromatography on silica gel using hexane as the eluent afforded 2-(2,3-difluorophenoxy)aniline (**243**) (0.725 g, 85 %) as a viscous colourless liquid; Anal. Calcd for $\text{C}_{12}\text{H}_9\text{F}_2\text{NO}$: C, 65.16; H, 4.10; N, 6.33. Found: C, 65.20; H, 4.10; N, 6.28; GC-MS m/z (% relative intensity, ion): 221 (72, M^+), 201 (21), 108 (61), 80 (100), 65 (42); IR (cm^{-1}): 3476, 3380, 1619, 1498, 1473, 1292; ^1H NMR (700 MHz, CDCl_3): δ 3.78 (2H, br s, NH_2), 6.69 (1H, dddd, $^3J_{\text{HH}}$ 8.5, $^4J_{\text{HF}}$ 7.0, $^4J_{\text{HH}}$ 1.6, $^5J_{\text{HF}}$ 1.7, H-6'), 6.72 (1H, ddd, $^3J_{\text{HH}}$ 7.7, $^3J_{\text{HH}}$ 7.6, $^4J_{\text{HH}}$ 1.5, H-4), 6.82–6.86 (2H, m, H-Ar), 6.90 (1H, dddd, $^3J_{\text{HF}}$ 10.1, $^3J_{\text{HH}}$ 8.4, $^4J_{\text{HF}}$ 6.8, $^4J_{\text{HH}}$ 1.6,

H-4'), 6.96 (1H, dddd, $^3J_{\text{HH}}$ 8.5, $^3J_{\text{HH}}$ 8.4, $^4J_{\text{HH}}$ 5.8, $^5J_{\text{HF}}$ 2.2, H-5'), 7.01 (1H, ddd, $^3J_{\text{HH}}$ 7.8, $^3J_{\text{HH}}$ 7.7, $^4J_{\text{HH}}$ 1.4, H-5), ^{13}C NMR (176 MHz, CDCl_3): δ 111.5 (d, $^2J_{\text{CF}}$ 17.5, C-4'), 114.2 (d, $^3J_{\text{CF}}$ 2.7, C-6'), 116.9 (s, C-6), 119.0 (s, C-4), 119.4 (s, C-3), 123.6 (dd, $^3J_{\text{CF}}$ 8.4, $^4J_{\text{CF}}$ 5.1, C-5'), 125.6 (s, C-5), 138.5 (s, C-1), 142.5 (dd, $^1J_{\text{CF}}$ 250, $^2J_{\text{CF}}$ 14.6, C-F), 143.1 (s, C-2), 146.7 (dd, $^2J_{\text{CF}}$ 8.6, $^3J_{\text{CF}}$ 2.8, C-1'), 151.9 (dd, $^1J_{\text{CF}}$ 248, $^2J_{\text{CF}}$ 10.6, C-F); ^{19}F NMR (658 MHz, $\text{CDCl}_3/\text{CFCl}_3$): δ -135.2 (1F, dddd, $^3J_{\text{FF}}$ 20.9, $^3J_{\text{FH}}$ 10.1, $^4J_{\text{FH}}$ 5.8, $^5J_{\text{FH}}$ 1.7, F-3'), -146.2 (1F, dddd, $^3J_{\text{FF}}$ 20.9, $^4J_{\text{FH}}$ 7.5, $^4J_{\text{FH}}$ 6.8, $^5J_{\text{FH}}$ 2.2, F-2').

2-(2,6-Difluorophenoxy)aniline (244)

A solution of 1,3-difluoro-2-(2-nitrophenoxy)benzene (0.801 g, 3.189 mmol) in HPLC grade methanol (0.01 M) was reduced using a *ThalesNano* H-Cube® fitted with a 10% Pd/C CatCart® catalyst at a flow rate of 1 mL min⁻¹, a temperature of 60 °C and a pressure of 20 bar. Once complete consumption of the reagent solution was achieved, solvent methanol was removed *in vacuo*, and the residual reaction mixture was extracted with DCM (3 × 50 mL) and water (100 mL). The combined extracts were washed with water (100 mL) and dried (MgSO_4). The mixture was filtered and volatile components removed *in vacuo*. Product purification by column chromatography on silica gel using hexane as the eluent afforded 2-(2,6-difluorophenoxy)aniline (**244**) (0.608 g, 86 %) as a viscous colourless liquid; Anal. Calcd for $\text{C}_{12}\text{H}_9\text{F}_2\text{NO}$: C, 65.16; H, 4.10; N, 6.33. Found: C, 65.15; H, 4.10; N, 6.25; GC-MS *m/z* (% relative intensity, ion): 221 (91, M^+), 201 (36), 108 (82), 78 (100), 65 (50); IR (cm^{-1}): 3468, 3388, 1619, 1593, 1494, 1475, 1294, 1222; ^1H NMR (700 MHz, CDCl_3): δ 3.99 (2H, br s, NH_2), 6.56 (1H, dd, $^3J_{\text{HH}}$ 8.2, $^4J_{\text{HH}}$ 1.2, H-6), 6.62 (1H, ddd, $^3J_{\text{HH}}$ 8.2, $^3J_{\text{HH}}$ 7.5, $^4J_{\text{HH}}$ 1.6, H-5), 6.81 (1H, dd, $^3J_{\text{HH}}$ 7.8, $^4J_{\text{HH}}$ 1.6, H-3), 6.90 (1H, ddd, $^3J_{\text{HH}}$ 7.8, $^3J_{\text{HH}}$ 7.5, $^4J_{\text{HF}}$ 1.2, H-4), 7.01 (2H, ddm, $^3J_{\text{HH}}$ 8.2, $^3J_{\text{HF}}$ 8.1, H-3'), 7.14 (1H, tt, $^3J_{\text{HH}}$ 8.2, $^4J_{\text{HF}}$ 6.0, H-4'); ^{13}C NMR (176 MHz, CDCl_3): δ 112.7 (dd, $^2J_{\text{CF}}$ 18.2, $^4J_{\text{CF}}$ 4.2, C-3'), 114.0 (s, C-6), 116.5 (s, C-3), 118.5 (s, C-5), 123.9 (s, C-4), 125.2 (t, $^3J_{\text{CF}}$ 9.1, C-4'), 131.9 (t, $^2J_{\text{CF}}$ 15.1, C-1'), 136.5 (s, C-Ar), 145.8 (s, C-Ar), 156.6 (dd, $^1J_{\text{CF}}$ 251, $^3J_{\text{CF}}$ 4.4, C-2'); ^{19}F NMR (658 MHz, $\text{CDCl}_3/\text{CFCl}_3$): δ -127.4 (2F, ddd, $^3J_{\text{FH}}$ 8.1, $^4J_{\text{FH}}$ 6.0, $^5J_{\text{FH}}$ 1.2, F-2').

5.2.5.3 Step 3: Reductive Diazotisation Processes

1,2-Difluoro-3-phenoxybenzene (178)

Method A: 2-(2,3-Difluorophenoxy)aniline (0.200 g, 0.904 mmol) was dissolved in an aqueous solution of 50% sulfuric acid (15 mL) and cooled to $-13\text{ }^{\circ}\text{C}$ by immersion of the reaction vessel in an external ice–water–NaCl bath. Sodium nitrite (0.380 g, 5.508 mmol) was dissolved in water (1 mL), cooled to $5\text{ }^{\circ}\text{C}$ with an external ice–water bath and added very slowly to the acidic aniline solution, maintaining an overall temperature of lower than $-10\text{ }^{\circ}\text{C}$. Once the addition of sodium nitrite was complete, the reaction was allowed to stir for 5 minutes, after which time an aqueous solution of 50% hypophosphoric acid (1 mL) was added to the reaction vessel with vigorous stirring. The reaction was allowed to warm to room temperature and the evolution of nitrogen gas was observed. The reaction mixture was neutralised with a solution of aqueous sodium hydroxide and extracted with DCM ($3 \times 50\text{ mL}$). The combined extracts were washed with water (100 mL) and dried (MgSO_4), filtered and volatile components were removed *in vacuo*. Product purification by column chromatography using silica gel and hexane as the eluent afforded 1,2-difluoro-3-phenoxybenzene (**178**) (0.130 g, 70 %) as a colourless liquid; Anal. Calcd for $\text{C}_{12}\text{H}_8\text{F}_2\text{O}$: C, 69.90; H, 3.91. Found: C, 69.98; H, 4.01; GC–MS m/z (% relative intensity, ion): 206 (47, M^+), 205 (M^+ , 10), 177 (36), 77 (100), 51 (28); IR (cm^{-1}): 3060, 1621, 1589, 1489, 1473, 1297; ^1H NMR (700 MHz, CDCl_3): δ 6.79 (1H, dddd, $^3J_{\text{HH}}$ 8.6, $^4J_{\text{HF}}$ 6.7, $^4J_{\text{HH}}$ 1.7, $^5J_{\text{HF}}$ 1.8, H–4), 6.95 (1H, dddd, $^3J_{\text{HF}}$ 9.8, $^3J_{\text{HH}}$ 8.6, $^4J_{\text{HF}}$ 6.6, $^4J_{\text{HH}}$ 1.7, H–6), 7.01 (2H, dd, $^3J_{\text{HH}}$ 8.6, $^4J_{\text{HH}}$ 1.0, H–2'), 7.00–7.05 (1H, m H–5), 7.14 (1H, tt, $^3J_{\text{HH}}$ 7.5, $^4J_{\text{HH}}$ 1.0, H–4'), 7.35 (2H, dd, $^3J_{\text{HH}}$ 8.6, $^3J_{\text{HH}}$ 7.5, H–3'); ^{13}C NMR (176 MHz, CDCl_3): δ 112.3 (d, $^2J_{\text{CF}}$ 17.4, C–6), 116.4 (d, $^3J_{\text{CF}}$ 3.2, C–4), 118.1 (s, C–2'), 123.7 (dd, $^3J_{\text{CF}}$ 8.4, $^4J_{\text{CF}}$ 5.1, C–5), 124.0 (s, C–4'), 130.1 (s, C–3'), 143.4 (dd, $^1J_{\text{CF}}$ 251, $^2J_{\text{CF}}$ 14.2, C–F), 146.1 (dd, $^2J_{\text{CF}}$ 8.6, $^3J_{\text{CF}}$ 2.7, C–3), 152.0 (dd, $^1J_{\text{CF}}$ 249, $^2J_{\text{CF}}$ 10.5, C–F), 156.9 (s, C–1'); ^{19}F NMR (658 MHz, $\text{CDCl}_3/\text{CFCl}_3$): δ -136.6 (1F, dddd, $^3J_{\text{FF}}$ 20.0, $^3J_{\text{FH}}$ 9.8, $^4J_{\text{FH}}$ 5.8, $^5J_{\text{FH}}$ 1.8, F–1), -156.0 (1F, dddd, $^3J_{\text{FF}}$ 20.0, $^4J_{\text{FH}}$ 6.7, $^4J_{\text{FH}}$ 6.6, $^5J_{\text{FH}}$ 1.9, F–2); Method B: Reductive diazotisation of 2-(2,3-difluorophenoxy)aniline (**178**) (0.714 g, 3.228 mmol) by the same procedure afforded 1,2-difluoro-3-phenoxybenzene (0.445 g, 67 %).

1,3-Difluoro-5-phenoxybenzene (182)

Method A: 2-(3,5-Difluorophenoxy)aniline (0.280 g, 1.266 mmol) was dissolved in an aqueous solution of 50 % sulfuric acid (15 mL) and cooled to $-13\text{ }^{\circ}\text{C}$ by immersion of the reaction vessel in an external ice–water–NaCl bath. Sodium nitrite (0.115 g, 1.667 mmol) was dissolved in water (1 mL), cooled to $5\text{ }^{\circ}\text{C}$ with an external ice–water bath and added very slowly to the acidic aniline solution, maintaining an overall temperature of lower than $-10\text{ }^{\circ}\text{C}$. Once the addition of sodium nitrite was complete, the reaction was allowed to stir for 5 minutes, after which time an aqueous solution of 50 % hypophosphoric acid (1 mL) was added to the reaction vessel with vigorous stirring. The reaction was allowed to warm to room temperature and the evolution of nitrogen gas was observed. The reaction mixture was neutralised with a solution of aqueous sodium hydroxide and extracted with DCM ($3 \times 50\text{ mL}$). The combined extracts were washed with water (100 mL) and dried (MgSO_4), filtered and volatile components were removed *in vacuo*. Product purification by column chromatography using silica gel and hexane as the eluent afforded 1,3-difluoro-5-phenoxybenzene (**182**) (0.105 g, 40 %) as a colourless liquid; Anal. Calcd for $\text{C}_{12}\text{H}_8\text{F}_2\text{O}$: C, 69.90; H, 3.91. Found: C, 69.95; H, 3.94; GC–MS m/z (% relative intensity, ion): 206 (65, M^+), 177 (38), 101 (36), 77 (100), 51 (33); ^1H NMR (700 MHz, CDCl_3): δ 6.49 (2H, dd, $^3J_{\text{HF}}$ 8.5, $^4J_{\text{HH}}$ 2.2, H–4), 6.52 (1H, tt, $^3J_{\text{HF}}$ 9.0, $^4J_{\text{HH}}$ 2.2, H–2), 7.06 (2H, dd, $^3J_{\text{HH}}$ 8.6, $^4J_{\text{HH}}$ 1.1, H–2'), 7.21 (1H, tt, $^3J_{\text{HH}}$ 7.4, $^4J_{\text{HH}}$ 1.1, H–4'), 7.40 (2H, dd, $^3J_{\text{HH}}$ 8.6, $^3J_{\text{HH}}$ 7.4, H–3'); ^{13}C NMR (176 MHz, CDCl_3): δ 98.5 (t, $^2J_{\text{CF}}$ 25.8, C–2), 101.6 (dd, $^2J_{\text{CF}}$ 22.0, $^4J_{\text{CF}}$ 7.1, C–4), 120.4 (s, C–2'), 125.1 (s, C–4'), 130.3 (s, C–3'), 155.3 (s, C–1'), 160.2 (t, $^3J_{\text{CF}}$ 13.5, C–5), 163.8 (dd, $^1J_{\text{CF}}$ 248, $^3J_{\text{CF}}$ 15.4, C–1); ^{19}F NMR (658 MHz, $\text{CDCl}_3/\text{CFCl}_3$): δ -108.9 - -109.0 (2F, m, F–1); Method B: Reductive diazotisation of 2-(3,5-difluorophenoxy)aniline (0.740 g, 3.345 mmol) by the same procedure afforded 1,3-difluoro-5-phenoxybenzene (**182**) (0.264 g, 38 %).

1,2-Difluoro-4-phenoxybenzene (183)

Method A: 2-(3,4-difluorophenoxy)aniline (0.226 g, 1.022 mmol) was dissolved in an aqueous solution of 50% sulfuric acid (15 mL) and cooled to $-13\text{ }^{\circ}\text{C}$ by immersion of the reaction vessel in an external ice–water–NaCl bath. Sodium nitrite (0.102 g, 1.478 mmol) was dissolved in water (1 mL), cooled to $5\text{ }^{\circ}\text{C}$ with an external ice–water bath and added very slowly to the acidic aniline solution, maintaining an overall temperature

of lower than $-10\text{ }^{\circ}\text{C}$. Once the addition of sodium nitrite was complete, the reaction was allowed to stir for 5 minutes, after which time an aqueous solution of 50% hypophosphoric acid (1 mL) was added to the reaction vessel with vigorous stirring. The reaction was allowed to warm to room temperature and the evolution of nitrogen gas was observed. The reaction mixture was neutralised with a solution of aqueous sodium hydroxide and extracted with DCM ($3 \times 50\text{ mL}$). The combined extracts were washed with water (100 mL) and dried (MgSO_4), filtered and volatile components were removed *in vacuo*. Product purification by column chromatography using silica gel and hexane as the eluent afforded 1,2-difluoro-4-phenoxybenzene (**183**) (0.115 g, 55 %) as a colourless liquid; Anal. Calcd for $\text{C}_{12}\text{H}_8\text{F}_2\text{O}$: C, 69.90; H, 3.91. Found: C, 70.02; H, 4.02; GC-MS m/z (% relative intensity, ion): 206 (72, M^+), 177 (58), 101 (31), 77 (100), 51 (43); IR (cm^{-1}): 3066, 1591, 1509, 1489, 1307, 1249; ^1H NMR (700 MHz, CDCl_3): δ 6.73 (1H, dddd, $^3J_{\text{HH}}$ 8.9, $^4J_{\text{HF}}$ 3.3, $^4J_{\text{HH}}$ 3.0, $^5J_{\text{HF}}$ 1.9, H-5), 6.83 (1H, ddd, $^3J_{\text{HF}}$ 11.4, $^4J_{\text{HF}}$ 6.7, $^4J_{\text{HH}}$ 3.0, H-3), 6.98–7.03 (2H, m, H-3'), 7.11 (1H, ddd, $^3J_{\text{HF}}$ 9.0, $^3J_{\text{HH}}$ 8.9, $^4J_{\text{HF}}$ 9.0, H-6), 6.13–7.17 (1H, m, H-4'), 7.34–7.39 (2H, m, H-2'); ^{13}C NMR (176 MHz, CDCl_3): δ 108.5 (dd, $^2J_{\text{CF}}$ 19.9, C-3), 114.5 (dd, $^3J_{\text{CF}}$ 6.0, $^4J_{\text{CF}}$ 3.6, C-5), 117.7 (dd, $^2J_{\text{CF}}$ 18.7, $^3J_{\text{CF}}$ 1.5, C-6), 119.2 (s, C-2'), 124.2 (s, C-4'), 130.2 (s, C-3'), 146.8 (dd, $^1J_{\text{CF}}$ 243, $^2J_{\text{CF}}$ 12.8, C-F), 150.8 (dd, $^1J_{\text{CF}}$ 249, $^2J_{\text{CF}}$ 14.0, C-F), 158.8 (dd, $^3J_{\text{CF}}$ 8.3, $^4J_{\text{CF}}$ 2.7, C-4), 157.9 (s, C-1'); ^{19}F NMR (658 MHz, $\text{CDCl}_3/\text{CFCl}_3$): δ -135.0 - -135.2 (1F, m, F-2), -145.3 - -145.4 (1F, m, F-1); Method B: Reductive diazotisation of 2-(3,4-difluorophenoxy)aniline (**183**) (0.714 g, 3.223 mmol) by the same procedure afforded 1,2-difluoro-4-phenoxybenzene (0.340 g, 51 %).

4-Fluoro-1,3-diphenoxybenzene (236)

5-Fluoro-2,4-diphenoxyaniline (0.400 g, 1.355 mmol) was mixed with an aqueous solution of 30% sulfuric acid (30 mL) with stirring and cooled to below $5\text{ }^{\circ}\text{C}$ using an external ice-water bath. A small quantity of white precipitate was formed and did not dissolve upon further stirring. Sodium nitrite (0.170 g, 2.464 mmol) was added directly to the flask, with vigorous stirring and the solution turned yellow. After 15 minutes, an aqueous solution of 50% hypophosphoric acid (0.67 mL) was added to the solution dropwise in order to maintain a temperature below $5\text{ }^{\circ}\text{C}$ and stirred for 30 minutes, after which the temperature was increased to $50\text{ }^{\circ}\text{C}$ for 1 hour. The solution was poured onto ice, neutralised with an aqueous solution of sodium hydroxide, extracted with DCM (3

× 50 mL), dried (MgSO₄), filtered and volatile components removed *in vacuo*. Purification by column chromatography using silica gel with a mixture of toluene and hexane (1:1) as the eluent afforded pure 4-fluoro-1,3-diphenoxybenzene (**236**) (0.251 g, 66 %) as a white solid, mp 57–59 °C; Anal. Calcd for C₁₈H₁₃FO₂: C, 77.13; H, 4.67. Found: C, 77.25; H, 4.76; GC–MS *m/z* (% relative intensity, ion): 280 (100, M⁺), 186 (20), 159 (56), 77 (89), 51 (72); IR (cm⁻¹): 3075, 1593, 1529, 1481, 1343, 1285, 1281; ¹H NMR (700 MHz, CDCl₃): δ 6.71–6.76 (2H, m, H–Ar), 6.98 (2H, d, ³J_{HH} 8.5, H–Ar), 7.01 (2H, d, ³J_{HH} 8.3, H–Ar), 7.08–7.11 (2H, m, H–Ar), 7.13 (1H, dd, ³J_{HH} 9.4, ³J_{HF} 9.4, H–5), 7.33 (4H, m, H–Ar); ¹³C NMR (176 MHz, CDCl₃): δ 112.7 (s, C–Ar), 114.7 (d, ³J_{CF} 6.7, C–Ar), 117.6 (d, ²J_{CF} 20.1, C–5), 117.8 (s, C–Ar), 118.8 (s, C–Ar), 123.5 (s, C–Ar), 123.4 (s, C–Ar), 130.0 (s, C–Ar), 130.1 (s, C–Ar), 144.8 (d, ²J_{CF} 13.4, C–3), 150.6 (d, ¹J_{CF} 244, C–4), 153.6 (s, C–Ar), 157.1 (s, C–Ar), 157.3 (s, C–Ar); ¹⁹F NMR (658 MHz, CDCl₃/CFCl₃): δ –138.1 – –138.2 (1F, m, F–4).

2,4-Difluoro-1-phenoxybenzene (179)

2-(2,4-Difluorophenoxy)aniline (0.750 g, 3.391 mmol) was dissolved in an aqueous solution of 50% sulfuric acid (15 mL) and cooled to –10 °C by immersion of the reaction vessel in an external ice–water–NaCl bath. Sodium nitrite (0.381 g, 5.522 mmol) was dissolved in water (1 mL), cooled to 5 °C with an external ice–water bath and added very slowly to the acidic aniline solution, maintaining an overall temperature of lower than –5 °C. Once the addition of sodium nitrite was complete, the reaction was allowed to stir for 5 minutes, after which time an aqueous solution of 50% hypophosphoric acid (1 mL) was added to the reaction vessel with vigorous stirring. The reaction was allowed to warm to room temperature and the evolution of nitrogen gas was observed. The reaction mixture was neutralised with a solution of aqueous sodium hydroxide and extracted with DCM (3 × 50 mL). The combined extracts were washed with water (100 mL) and dried (MgSO₄), filtered and volatile components were removed *in vacuo*. Product purification by column chromatography using silica gel and hexane as the eluent afforded 2,4-difluoro-1-phenoxybenzene (**179**) (0.426 g, 61 %) as a colourless liquid; Anal. Calcd for C₁₂H₈F₂O: C, 69.90; H, 3.91. Found: C, 69.92; H, 3.93; GC–MS *m/z* (% relative intensity, ion): 206 (97, M⁺), 177 (100), 101 (35), 77 (86), 51 (46); IR (cm⁻¹): 3070, 1590, 1503, 1487, 1433, 1302; ¹H NMR (700 MHz, CDCl₃): δ 6.86 (1H, dddd, ³J_{HF} 9.0, ⁴J_{HF} 7.6, ⁴J_{HH} 3.0, ⁵J_{HH} 1.8, H–3), 6.93–6.98 (3H, m, H–Ar),

7.07 (1H, ddd, $^3J_{\text{HF}}$ 9.0, $^4J_{\text{HF}}$ 9.0, $^4J_{\text{HF}}$ 5.5, H-6), 7.09 (1H, tt, $^3J_{\text{HH}}$ 7.4, $^4J_{\text{HH}}$ 1.0, H-4'), 7.37 (2H, dd, $^3J_{\text{HH}}$ 8.7, $^3J_{\text{HH}}$ 7.4, H-3'); ^{13}C NMR (176 MHz, CDCl_3): δ 105.7 (dd, $^2J_{\text{CF}}$ 26.8, $^2J_{\text{CF}}$ 22.1, C-3), 111.6 (dd, $^2J_{\text{CF}}$ 22.8, $^4J_{\text{CF}}$ 3.9, C-5), 117.0 (s, C-2'), 123.1 (dd, $^3J_{\text{CF}}$ 9.7, $^3J_{\text{CF}}$ 2.3, C-6), 123.3 (s, C-4'), 130.0 (s, C-3'), 140.1 (dd, $^2J_{\text{CF}}$ 11.7, $^4J_{\text{CF}}$ 3.9, C-1), 154.6 (dd, $^1J_{\text{CF}}$ 250, $^3J_{\text{CF}}$ 12.3, C-F), 157.8 (s, C-1'), 158.8 (dd, $^1J_{\text{CF}}$ 246, $^3J_{\text{CF}}$ 10.3, C-F); ^{19}F NMR (658 MHz, $\text{CDCl}_3/\text{CFCl}_3$): δ -115.0 - -115.1 (1F, m, F-4), -125.6 - -125.7 (1F, m, F-2).

1,4-Difluoro-2-phenoxybenzene (180)

2-(2,5-Difluorophenoxy)aniline (0.975 g, 4.408 mmol) was dissolved in an aqueous solution of 50% sulfuric acid (15 mL) and cooled to $-10\text{ }^\circ\text{C}$ by immersion of the reaction vessel in an external ice-water-NaCl bath. Sodium nitrite (0.456 g, 6.609 mmol) was dissolved in water (1 mL), cooled to $5\text{ }^\circ\text{C}$ with an external ice-water bath and added very slowly to the acidic aniline solution, maintaining an overall temperature of lower than $-5\text{ }^\circ\text{C}$. Once the addition of sodium nitrite was complete, the reaction was allowed to stir for 5 minutes, after which time an aqueous solution of 50% hypophosphoric acid (1 mL) was added to the reaction vessel with vigorous stirring. The reaction was allowed to warm to room temperature and the evolution of nitrogen gas was observed. The reaction mixture was neutralised with a solution of aqueous sodium hydroxide and extracted with DCM ($3 \times 50\text{ mL}$). The combined extracts were washed with water (100 mL) and dried (MgSO_4), filtered and volatile components were removed *in vacuo*. Product purification by column chromatography using silica gel and hexane as the eluent afforded 1,4-difluoro-2-phenoxybenzene (**180**) (0.410 g, 45 %) as a colourless liquid; Anal. Calcd for $\text{C}_{12}\text{H}_8\text{F}_2\text{O}$: C, 69.90; H, 3.91. Found: C, 69.69; H, 3.93; GC-MS m/z (% relative intensity, ion): 206 (38, M^+), 178 (46), 101 (20), 77 (100), 51 (25); IR (cm^{-1}): 3074, 1624, 1589, 1502, 1488, 1429, 1299, 1245; ^1H NMR (700 MHz, CDCl_3): δ 6.73 (1H, ddd, $^3J_{\text{HF}}$ 9.3, $^4J_{\text{HF}}$ 6.5, $^4J_{\text{HH}}$ 3.2, H-3), 6.78 (1H, dddd, $^3J_{\text{HF}}$ 9.1, $^3J_{\text{HH}}$ 7.6, $^4J_{\text{HF}}$ 3.2, $^4J_{\text{HH}}$ 3.2, H-5), 7.03 (2H, dd, $^3J_{\text{HH}}$ 8.7, $^4J_{\text{HH}}$ 1.0, H-2'), 7.10-7.16 (1H, m, H-6), 7.15 (1H, tt, $^3J_{\text{HH}}$ 7.5, $^4J_{\text{HH}}$ 1.0, H-4'), 7.37 (2H, dd, $^3J_{\text{HH}}$ 8.7, $^3J_{\text{HH}}$ 7.5, H-3'); ^{13}C NMR (176 MHz, CDCl_3): δ 108.6 (dd, $^2J_{\text{CF}}$ 26.6, $^3J_{\text{CF}}$ 1.3, C-3), 110.6 (dd, $^2J_{\text{CF}}$ 23.9, $^3J_{\text{CF}}$ 7.0, C-5), 117.5 (dd, $^2J_{\text{CF}}$ 20.8, $^3J_{\text{CF}}$ 9.9, C-6), 118.4 (s, C-2'), 124.2 (s, C-4'), 130.2 (s, C-3'), 145.2 (dd, $^2J_{\text{CF}}$ 13.3, $^3J_{\text{CF}}$ 10.8, C-2), 150.6 (dd, $^1J_{\text{CF}}$ 244, $^4J_{\text{CF}}$

3.5, C–F), 156.6 (s, C–1'), 158.8 (dd, $^1J_{CF}$ 244, $^4J_{CF}$ 2.6, C–F); ^{19}F NMR (658 MHz, $CDCl_3/CFC_3$): δ –116.8 – –116.7 (1F, m, F–4), –139.6 – –137.4 (1F, m, F–1).

1,3-Difluoro-2-phenoxybenzene (181)

2-(2,6-Difluorophenoxy)aniline (0.608 g, 2.749 mmol) was dissolved in an aqueous solution of 50% sulfuric acid (15 mL) and cooled to -10 °C by immersion of the reaction vessel in an external ice–water–NaCl bath. Sodium nitrite (0.350 g, 5.073 mmol) was dissolved in water (1 mL), cooled to 5 °C with an external ice–water bath and added very slowly to the acidic aniline solution, maintaining an overall temperature of lower than -5 °C. Once the addition of sodium nitrite was complete, the reaction was allowed to stir for 5 minutes, after which time an aqueous solution of 50% hypophosphoric acid (1 mL) was added to the reaction vessel with vigorous stirring. The reaction was allowed to warm to room temperature and the evolution of nitrogen gas was observed. The reaction mixture was neutralised with a solution of aqueous sodium hydroxide and extracted with DCM (3×50 mL). The combined extracts were washed with water (100 mL) and dried ($MgSO_4$), filtered and volatile components were removed *in vacuo*. Product purification by column chromatography using silica gel and hexane as the eluent afforded 1,3-difluoro-2-phenoxybenzene (**181**) (0.477 g, 84 %) as a colourless liquid; Anal. Calcd for $C_{12}H_8F_2O$: C, 69.90; H, 3.91. Found: C, 69.91; H, 4.01; GC–MS m/z (% relative intensity, ion): 206 (54, M^+), 178 (46), 101 (20), 77 (100), 51 (25); IR (cm^{-1}): 3056, 1590, 1402, 1475, 1297, 1227; 1H NMR (700 MHz, $CDCl_3$): δ 6.95 (2H, dd, $^3J_{HH}$ 8.5, $^4J_{HH}$ 1.0, H–2'), 7.01 (2H, dd, $^3J_{HH}$ 8.4, $^3J_{HF}$ 7.6, H–4), 7.07 (1H, tt, $^3J_{HH}$ 7.6, $^4J_{HH}$ 1.0, H–4'), 7.15 (1H, tt, $^3J_{HH}$ 8.4, $^4J_{HF}$ 5.8, H–5), 7.31 (2H, dd, $^3J_{HH}$ 8.5, $^3J_{HH}$ 7.6, H–3'); ^{13}C NMR (176 MHz, $CDCl_3$): δ 112.8 (dd, $^2J_{CF}$ 17.5, $^4J_{CF}$ 4.9, C–4), 115.4 (s, C–2'), 123.1 (s, C–4'), 125.3 (t, $^3J_{CF}$ 9.1, C–5), 129.8 (s, C–3'), 131.7 (t, $^2J_{CF}$ 15.0, C–2), 154.6 (dd, $^1J_{CF}$ 251, $^3J_{CF}$ 4.5, C–1), 158.0 (s, C–1'); ^{19}F NMR (658 MHz, $CDCl_3/CFC_3$): δ –126.9 (2F, dd, $^3J_{FH}$ 7.6, $^4J_{FH}$ 5.8, F–1).

5.2.6 Strategy 4: Syntheses of Polyfluorinated Biaryl Ether Derivatives by Copper-Mediated and Palladium-Catalysed Processes

5.2.6.1 Dopant Synthesis by Chan-Lam Type Procedures

1,2-Difluoro-3-phenoxybenzene (178)

2,3-Difluorophenol (0.692 g, 5.319 mmol), phenylboronic acid (1.534 g, 12.581 mmol), copper(II) acetate (1.109 g, 6.106 mmol) and a small quantity of freshly ground 4Å molecular sieves were charged to a round bottomed flask, which was purged with argon to create an inert atmosphere. Dry DCM (20 mL) and triethylamine (2.59 g, 25.67 mmol) were added to the reaction vessel and the reaction mixture was stirred at room temperature for 24 h. The crude reaction mixture was subsequently filtered through a silica plug with DCM as the eluent to remove residual particulate material. The organic washings were poured onto an aqueous solution (0.1 M) of sodium hydroxide (100 mL) and extracted with DCM (3 × 100 mL). The organic washings were combined, washed with water (200 mL), dried (MgSO₄) and filtered. Volatile components was removed *in vacuo* and purification by column chromatography using hexane as the eluent afforded 1,2-difluoro-3-phenoxybenzene (**178**) (0.053 g, 5 %) as characterised previously in the reductive diazotisation reaction of 3,4-difluoro-2-phenoxyaniline.

1,4-Difluoro-2-phenoxybenzene (180)

2,5-Difluorophenol (0.678 g, 5.212 mmol), phenylboronic acid (1.557 g, 12.770 mmol), copper(II) acetate (1.307 g, 7.196 mmol) and a small quantity of freshly ground 4Å molecular sieves were charged to a round bottomed flask, which was purged with argon to create an inert atmosphere. Dry DCM (20 mL) and triethylamine (2.60 g, 25.67 mmol) were added to the reaction vessel and the reaction mixture was stirred at room temperature for 24 h. The crude reaction mixture was subsequently filtered through a silica plug with DCM as the eluent to remove residual particulate material. The organic washings were poured onto an aqueous solution (0.1 M) of sodium hydroxide (100 mL) and extracted with DCM (3 × 100 mL). The organic washings were combined, washed with water (200 mL), dried (MgSO₄) and filtered. Volatile components was removed *in vacuo* and purification by column chromatography using hexane as the eluent afforded 1,4-difluoro-2-phenoxybenzene (**180**) (0.034 g, 3 %) as characterised previously in the reductive diazotisation reaction of 2-(2,5-difluorophenoxy)aniline.

1,3-Difluoro-5-phenoxybenzene (182)

3,5-Difluorophenol (0.692 g, 5.319 mmol), phenylboronic acid (1.531 g, 12.556 mmol), copper(II) acetate (1.120 g, 6.166 mmol) and a small quantity of freshly ground 4Å molecular sieves were charged to a round bottomed flask, which was purged with argon to create an inert atmosphere. Dry DCM (20 mL) and triethylamine (2.59 g, 25.63 mmol) were added to the reaction vessel and the reaction mixture was stirred at room temperature for 24 h. The crude reaction mixture was subsequently filtered through a silica plug with DCM as the eluent to remove residual particulate material. The organic washings were poured onto an aqueous solution (0.1 M) of sodium hydroxide (100 mL) and extracted with DCM (3 × 100 mL). The organic washings were combined, washed with water (200 mL), dried (MgSO₄) and filtered. Volatile components was removed *in vacuo* and purification by column chromatography using hexane as the eluent afforded 1,3-difluoro-5-phenoxybenzene (**182**) (0.036 g, 3 %) as characterised previously in the reductive diazotisation reaction of 2,4-difluoro-6-phenoxyaniline.

1,2-Difluoro-4-phenoxybenzene (184)

3,4-Difluorophenol (0.435 g, 3.344 mmol), phenylboronic acid (1.504 g, 12.335 mmol), copper(II) acetate (0.802 g, 4.415 mmol) and a small quantity of freshly ground 4Å molecular sieves were charged to a round bottomed flask, which was purged with argon to create an inert atmosphere. Dry DCM (20 mL) and triethylamine (2.08 g, 20.57 mmol) were added to the reaction vessel and the reaction mixture was stirred at room temperature for 24 h. The crude reaction mixture was subsequently filtered through a silica plug with DCM as the eluent to remove residual particulate material. The organic washings were poured onto an aqueous solution (0.1 M) of sodium hydroxide (100 mL) and extracted with DCM (3 × 100 mL). The organic washings were combined, washed with water (200 mL), dried (MgSO₄) and filtered. Volatile components was removed *in vacuo* and purification by column chromatography using hexane as the eluent afforded 1,2-difluoro-4-phenoxybenzene (**184**) (0.258 g, 37 %) as characterised previously from the reductive diazotisation reaction of 4,5-difluoro-2-phenoxyaniline.

5.2.6.2 Dopant Synthesis by Buchwald-Hartwig Type Procedures

1,3-Difluoro-5-phenoxybenzene (182)

60% (w/w) Sodium hydride in mineral oil (0.331 g, 8.275 mmol) was charged to a round bottomed flask which was purged with argon to create a dry atmosphere. The sodium hydride was washed with dry hexane (3×5 mL) to remove excess mineral oil. Excess hexane was removed using a syringe and dry THF (10 mL) was added to the reaction vessel, followed by the careful addition of a solution of 3,5-difluorophenol (1.052 g, 8.087 mmol) in dry THF (10 mL). After 15 minutes of vigorous stirring at room temperature all volatile components were removed *in vacuo* and the residual sodium 3,5-difluorophenolate was dried *in vacuo*. Palladium acetate (0.149 g, 0.664 mmol), *tert*-Butyl XPhos (0.404 g, 0.951 mmol), potassium phosphate (1.629 g, 7.674 mmol) and 3,5-difluorophenolate (1.229 g, 8.082 mmol) were charged to round bottom flask (25 mL) which was subsequently evacuated and back-filled with argon three times to create an inert atmosphere. Dry, degassed toluene (20 mL) and bromobenzene (1.150 g, 7.324 mmol) were added to the reaction vessel which was heated to 100 °C for 24 h, after which time the contents of the flask were cooled, poured onto water (50 mL) and extracted with DCM (3×50 mL). Purification by column chromatography using silica gel with a mixture of hexane and DCM (9:1) as the eluent afford pure 1,3-difluoro-5-phenoxybenzene (**182**) (0.421 g, 28 %) as characterised previously in the reductive diazotisation reaction of 2,4-difluoro-6-phenoxyaniline.

1,2-Difluoro-4-phenoxybenzene (183)

60% (w/w) Sodium hydride in mineral oil (0.330 g, 8.250 mmol) was charged to a round bottomed flask which was purged with argon to create a dry atmosphere. The sodium hydride was washed with dry hexane (3×5 mL) to remove excess mineral oil. Excess hexane was removed using a syringe and dry THF (10 mL) was added to the reaction vessel, followed by the careful addition of a solution of 3,4-difluorophenol (1.133g, 8.709 mmol) in dry THF (10 mL). After 15 minutes of vigorous stirring at room temperature all volatile components were removed *in vacuo* and the residual sodium 3,4-difluorophenolate was dried *in vacuo*. Palladium acetate (0.143 g, 0.637 mmol), *tert*-Butyl XPhos (0.450 g, 1.060 mmol), potassium phosphate (1.639 g, 7.721 mmol) and sodium 3,4-difluorophenolate (1.324 g, 8.706 mmol) were charged to round bottom flask (25 mL) which was subsequently evacuated and back-filled with argon three times to create an inert atmosphere. Dry, degassed toluene (20 mL) and

bromobenzene (0.945 g, 6.019 mmol) were added to the reaction vessel which was heated to 100 °C for 24 h, after which time the contents of the flask were cooled, poured onto water (50 mL) and extracted with DCM (3 × 50 mL). Purification by column chromatography using silica gel with a mixture of hexane and DCM (9:1) as the eluent afford pure 1,2-difluoro-4-phenoxybenzene (**183**) (0.584 g, 47 %) as characterised previously in the reductive diazotisation reaction of 4,5-difluoro-2-phenoxyaniline.

5.3 Experimental Data to Chapter 3

5.3.1 LC Cell Fabrication

To establish the individual performance of the fluorinated biaryl ether derivatives as LC dopants, 2–4 weight % of each substrate was mixed with a commercially available –LC and/or +LC mixture, stirred at 60 °C for one hour, allowed to cool to room temperature and left under vacuum overnight to remove any residual air bubbles. The –LC mixtures were then used to fill, by capillary action, 5 µm vertically aligned (VA) cells whilst the doped +LC mixtures were used to fill 10 µm twisted nematic (TN) cells. Both VA and TN test cells comprising of indium tin oxide (ITO) coated glass substrates and a rubbed polyimide alignment layer were purchased from EHC.

The filled doped cells were annealed in an oven for 90 minutes by heating to a temperature approximately 10 °C above their respective clearing points which, upon slow cooling over a period of several h, allowed each system to reach a homogeneous nematic state. After cooling was complete, the edges of the cells were sealed and electrical wires attached to the anode and cathode of each cell with glue. Conductive silver paint was used to ensure a good contact between the cells' electrodes and output electrical wires and, finally, the faces of all cells were cleaned with optical wipes and analytical reagent grade ethanol.

5.3.2 Rise and Decay Time Measurements

Response and transmittance measurement profiles were recorded at 35 °C using an optical microscope and proprietorial Sony-MSL LC-drive software whereby the rise and decay times of each cell were determined across a range of applied voltages (0–5 V). In each case, three measurements were made for each concentration of dopant to ensure reproducibility of results and that cells of similar cell gap thicknesses could be

compared directly. Reliable results were achieved by fabricating all devices using the same host mixtures, dopant samples and batches of manufactured LC cells.

5.3.3 Rotational Viscosity and Dielectric Anisotropy Measurements

Quantitative rotational viscosity information was collected for the same doped –LC mixtures as prepared for the EO measurements by filling 20 μm VA and 30 μm anti-parallel (AP) polyimide coated cells by the aforementioned method. Rotational viscosity measurements were carried out at 35 °C with an LC material characterization system (Toyo LCM–2) following an adaptation of a literature protocol.¹ In this measurement the γ_1 values are calculated from the response of the electric current measured by applying a square wave to the samples, followed by a mathematical fitting of the experimental data to the theoretical model [Equation 12].

$$\gamma_1 = \frac{A(\varepsilon_0 \Delta\varepsilon)^2}{2I_p} \left(\frac{V}{d} \right)^3 \quad (12)$$

Thus, the rotational viscosity of an LC device depends on the LC plate area, A , cell gap, d , the peak applied current, I_p , and the dielectric anisotropy, $\Delta\varepsilon$, of the host mixture. The first three of these parameters are known quantities; however the dielectric anisotropy of each LC system must be determined before rotational viscosity information can be obtained. This was achieved by measuring the capacitance of the empty and filled 30 μm AP and 20 μm VA LC cells, to yield values for C_{\perp} and C_{\parallel} respectively, which were then be used to calculate $\Delta\varepsilon$ [Equations 13–15)].²

$$\Delta\varepsilon = \varepsilon_{\parallel} - \varepsilon_{\perp} \quad (13)$$

$$\varepsilon_{\parallel} = \frac{C_{\parallel} A}{\varepsilon_0 d} \quad (14)$$

$$\varepsilon_{\perp} = \frac{C_{\perp} A}{\varepsilon_0 d} \quad (15)$$

Technical data³ concerning –LC mixture MLC2038 state that the host material has a rotational viscosity of 179 mPa.s at 20 °C, in good agreement with our value of 139

mPa.s, which is expected to be slightly smaller as our data was collected at the elevated temperature of 35 °C. Indeed, Merck also report $\Delta\varepsilon = -5.0$ at 20 °C for the -LC mixture, consistent with our measurement of $\Delta\varepsilon = -4.0$ at 35 °C.

5.3.4 Clearing Temperature and Voltage Holding Ratio Measurements

In order for a dopant to be a successful candidate for use in modern LC displays the newly doped LC system must remain nematic across the operating temperature range of the device and not ‘leak’ electrical charge when the cell is switched on. The introduction of a guest species into a host LC system can be expected to reduce the overall clearing temperature and it is important that this T_{NI} reduction is not sufficiently large that it lies below, or close to the operating temperature of the display device. In this respect it is necessary that any new LC compositions have a clearing temperature above 70 °C and this property has been measured for all systems by DSC (Netzsch, DSC-204).

In order to evaluate the problem of charge ‘leakage’, it is necessary to measure the voltage holding ratio (VHR) of all doped LC mixtures. This was achieved using the 5 μm VA cells which we had prepared for the EO measurements and a Toyo LCM-2 measurement device operating at a constant temperature of 50 °C. All of the fluorinated biphenyl ether derivative systems tested were found to have excellent voltage holding properties. Data concerning the clearing temperatures and VHRs of all doped cells is collated in the electronic appendix (CD) of this thesis.

5.3.5 Elasticity and Birefringence Measurements

The splay (K_{11}) and bend (K_{33}) elastic constants of each mixture were measured with a Toyo EC-1 device and birefringence measurements were collected by optical polarimetry using an ABBE refractometer (DR-M4/1550) at 35 °C. Both the elastic constants and birefringence values were found to decrease with increasing doping and this data is collated in the electronic appendix to maintain the brevity of this document.

5.4 Experimental Data to Chapter 4

5.4.1 Palladium-catalysed Suzuki-Miyaura Cross-coupling Reactions of Highly Fluorinated Nitrobenzene Derivatives

5.4.1.1 Cross-coupling Reactions of Pentafluoronitrobenzene

2,3,4,5-Tetrafluoro-6-nitrobiphenyl (256)

5,5-Dimethyl-2-phenyl-1,3,2-dioxaborinane (0.268 g, 1.410 mmol), 40% KF/alumina (0.223 g, 1.535 mmol) and Pd(PPh₃)₄ (0.015 g, 0.013 mmol) were charged to a 2–5 mL microwave vial that was sealed, evacuated under high vacuum and back-filled with argon three times to create an inert atmosphere. Dry, degassed DMF (2 mL) and pentafluoronitrobenzene (0.251 g, 1.178 mmol) were added to the vial using a syringe and the reaction vessel was heated to 150 °C for 20 min under microwave irradiation. The vial was cooled and its contents filtered through a silica pad using DCM as the eluent to separate inorganic and particulate material from the reaction mixture. Volatile components were removed *in vacuo* and the product purified by column chromatography on silica gel using hexanes and DCM (4:1) as the eluent. Subsequent recrystallisation from hexanes afforded 2,3,4,5-tetrafluoro-6-nitrobiphenyl (**256**) (0.256 g, 80 %) as an off-white solid; mp 70-71 °C; Anal. Calcd for C₁₂H₅F₄NO₂: C, 53.15; H, 1.86; N, 5.17. Found: C, 53.20; H, 1.89; N, 5.17; GC-MS *m/z* (% relative intensity, ion): 271 (8, M⁺), 243 (65), 224 (73), 187 (100), 175 (30), 51 (14), 30 (13); FT-IR (cm⁻¹): 1546, 1365; ¹H NMR (700 MHz, CDCl₃): δ 7.31–7.34 (2H, m, H-2'), 7.46–7.52 (3H, m, H-Ar), ¹³C NMR (126 MHz, CDCl₃): δ 121.2 (ddd, ²J_{CF} 18.9, ³J_{CF} 4.3, ³J_{CF} 1.1, C-1), 127.0 (s, C-1'), 129.3 (s, C-2'), 129.5 (s, C-Ar), 130.5 (s, C-Ar), 135.5–135.9 (m, C-6), 141.2 (dddd, ¹J_{CF} 259, ²J_{CF} 14.7, ²J_{CF} 13.5, ³J_{CF} 3.4, C-F), 141.1 (dddd, ¹J_{CF} 260, ²J_{CF} 11.6, ³J_{CF} 4.8, ⁴J_{CF} 2.7, C-F), 142.9 (dddd, ¹J_{CF} 261, ²J_{CF} 17.5, ²J_{CF} 12.3, ³J_{CF} 3.2, C-F), 143.9 (dddd, ¹J_{CF} 253, ²J_{CF} 11.0, ³J_{CF} 3.8, ⁴J_{CF} 1.8, C-F); ¹⁹F NMR (658 MHz, CDCl₃/CFCl₃): δ -138.2 (1F, ddd, ³J_{FF} 22.4, ⁴J_{FF} 3.5, ⁵J_{FF} 10.7, F-2), -147.8 (1F, ddd, ³J_{FF} 21.2, ⁴J_{FF} 5.1, ⁵J_{FF} 10.7, F-5), -150.0 (1F, ddd, ³J_{FF} 22.4, ³J_{FF} 20.7, ⁴J_{FF} 5.1, F-3), -152.9 (1F, ddd, ³J_{FF} 21.2, ³J_{FF} 20.7, ⁴J_{FF} 3.5, F-4).

2,3,4,5-Tetrafluoro-4'-methyl-6-nitrobiphenyl (264)

5,5-Dimethyl-2-*p*-tolyl-1,3,2-dioxaborinane (0.466 g, 2.283 mmol), 40% KF/alumina (0.444 g, 3.057 mmol) and Pd(PPh₃)₄ (0.054 g, 0.047 mmol) were charged to a 2–5 mL microwave vial that was sealed, evacuated under high vacuum and back-filled with argon three times to create an inert atmosphere. Dry, degassed DMF (2 mL) and pentafluoronitrobenzene (0.505 g, 2.370 mmol) were added to the vial using a syringe and the reaction vessel was heated to 150 °C for 20 min under microwave irradiation. The vial was cooled and its contents filtered through a silica pad using DCM as the eluent to separate inorganic and particulate material from the reaction mixture. Volatile components were removed *in vacuo* and the product purified by column chromatography on silica gel using hexanes and DCM (4:1) as the eluent. Subsequent recrystallisation from hexanes afforded 2,3,4,5-tetrafluoro-4'-methyl-6-nitrobiphenyl (**264**) (0.364 g, 56 %) as an off-white solid; mp 59–61 °C; Anal. Calcd for C₁₃H₇F₄NO₂: C, 54.75; H, 2.47; N, 4.91. Found: C, 54.83; H, 2.50; N, 4.88; GC–MS *m/z* (% relative intensity, ion): 285 (57, M⁺), 240 (88), 219 (100), 187 (79), 77 (44), 51 (17), 39 (23); FT-IR (cm⁻¹): 1538, 1357; ¹H NMR (700 MHz, CDCl₃): δ 2.41 (3H, s, –CH₃), 7.21 (2H, d, ³J_{HH} 7.9, H–Ar), 7.29 (2H, d, ³J_{HH} 7.9, H–Ar); ¹³C NMR (176 MHz, CDCl₃): 21.7 (s, –CH₃), 121.3 (dd, ²J_{CF} 18.8, ³J_{CF} 4.0, C–1), 124.0 (s, C–Ar), 129.2 (s, C–Ar), 130.2 (s, C–Ar), 133.2 (s, C–Ar), 135.6–135.9 (m, 6-C), 140.77 (s, 1' or 4'-C), 140.2 (dddd, ¹J_{CF} 258, ²J_{CF} 14.7, ²J_{CF} 13.5, ³J_{CF} 3.4, C–F), 141.0 (dddd, ¹J_{CF} 260, ²J_{CF} 13.3, ³J_{CF} 4.8, ⁴J_{CF} 2.7, C–F), 142.8 (dddd, ¹J_{CF} 261, ²J_{CF} 17.5, ²J_{CF} 12.2, ³J_{CF} 3.2, C–F), 144.9 (dddd, ¹J_{CF} 251, ²J_{CF} 10.8, ³J_{CF} 3.7, ⁴J_{CF} 1.7, C–F); ¹⁹F NMR (658 MHz, CDCl₃/CFCl₃): δ –138.3 (1F, ddd, ³J_{FF} 22.5, ⁴J_{FF} 3.2, ⁵J_{FF} 10.7, F–2), –148.1 (1F, ddd, ³J_{FF} 21.3, ⁴J_{FF} 5.0, ⁵J_{FF} 10.7, F–5), –150.2 (1F, ddd, ³J_{FF} 22.5, ³J_{FF} 20.8, ⁴J_{FF} 5.0, F–3), –153.3 (1F, ddd, ³J_{FF} 21.3, ³J_{FF} 20.8, ⁴J_{FF} 3.2, F–4).

2,3,4,5-Tetrafluoro-6-nitrobiphenyl-4'-carbonitrile (259)

4-Cyanophenylboronic acid (0.417 g, 2.838 mmol), 40% KF/alumina (0.442 g, 3.043 mmol) and Pd(PPh₃)₄ (0.057 g, 0.049 mmol) were charged to a 2–5 mL microwave vial that was sealed, evacuated under high vacuum and back-filled with argon three times to create an inert atmosphere. Dry, degassed DMF (2 mL) and pentafluoronitrobenzene (0.552 g, 2.591 mmol) were added to the vial using a syringe and the reaction vessel was heated to 150 °C for 20 min under microwave irradiation. The vial was cooled and

its contents filtered through a silica pad using DCM as the eluent to separate inorganic and particulate material from the reaction mixture. Volatile components were removed *in vacuo* and the product purified by column chromatography on silica gel using hexanes and DCM (4:1) as the eluent. Subsequent recrystallisation from hexanes afforded 2,3,4,5-tetrafluoro-6-nitrobiphenyl-4'-carbonitrile (**259**) (0.432 g, 56 %) as a white solid; mp 93–94 °C; Anal. Calcd for C₁₃H₄F₄N₂O₂: C, 52.72; H, 1.36; N, 9.46. Found: C, 52.76; H, 1.43; N, 9.49; GC–MS *m/z* (% relative intensity, ion): 296 (46, M⁺), 268 (86), 249 (95), 200 (100), 75 (26), 51 (14), 30 (31); FT-IR (cm⁻¹): 1544, 1355; ¹H NMR (700 MHz, CDCl₃): δ 7.46 (2H, d, ³J_{HH} 8.3, H–Ar), 7.99 (2H, d, ³J_{HH} 8.3, H–Ar); ¹³C NMR (126 MHz, CDCl₃): 114.8 (s, C–4'), 118.0 (s, –CN), 119.3 (dd, ²J_{CF} 18.4, ³J_{CF} 4.4, C–1), 130.3 (s, C–Ar), 131.7 (s, C–1'), 133.2 (s, C–Ar), 135.1–135.6 (m, C–6), 140.1 (dddd, ¹J_{CF} 261, ²J_{CF} 14.6, ²J_{CF} 13.4, ³J_{CF} 3.3, C–F), 141.5 (dddd, ¹J_{CF} 262, ²J_{CF} 13.3, ³J_{CF} 4.5, ⁴J_{CF} 2.4, C–F), 141.7 (dddd, ¹J_{CF} 263, ²J_{CF} 17.3, ²J_{CF} 12.3, ³J_{CF} 3.2, C–F), 144.8 (dddd, ¹J_{CF} 266, ²J_{CF} 11.5, ³J_{CF} 3.6, ⁴J_{CF} 1.6, C–F); ¹⁹F NMR (658 MHz, CDCl₃/CFCl₃): δ –137.5 (1F, ddd, ³J_{FF} 22.1, ⁴J_{FF} 4.3, ⁵J_{FF} 10.6, F–2), –146.0 (1F, ddd, ³J_{FF} 21.3, ⁴J_{FF} 6.0, ⁵J_{FF} 10.6, F–5), –148.2 (1F, ddd, ³J_{FF} 22.1, ³J_{FF} 20.8, ⁴J_{FF} 6.0, F–3), –150.2 (1F, ddd, ³J_{FF} 21.3, ³J_{FF} 20.8, ⁴J_{FF} 4.3, F–4).

2,3,4,5-Tetrafluoro-*N,N*-dimethyl-6-nitrobiphenyl-4'-amine (266)

4-(*N,N*-Dimethylamino)phenylboronic acid (0.394 g, 2.388 mmol), 40% KF/alumina (0.445 g, 3.064 mmol) and Pd(PPh₃)₄ (0.055 g, 0.048 mmol) were charged to a 2–5 mL microwave vial that was sealed, evacuated under high vacuum and back-filled with argon three times to create an inert atmosphere. Dry, degassed DMF (2 mL) and pentafluoronitrobenzene (0.432 g, 2.028 mmol) were added to the vial using a syringe and the reaction vessel was heated to 150 °C for 20 min under microwave irradiation. The vial was cooled and its contents filtered through a silica pad using DCM as the eluent to separate inorganic and particulate material from the reaction mixture. Volatile components were removed *in vacuo* and the product purified by column chromatography on silica gel using hexanes and DCM (4:1) as the eluent. Subsequent recrystallisation from hexanes afforded 2,3,4,5-tetrafluoro-*N,N*-dimethyl-6-nitrobiphenyl-4'-amine (**266**) (0.405 g, 64 %) as an orange solid; mp 128–129 °C; Anal. Calcd for C₁₄H₁₀F₄N₂O₂: C, 53.51; H, 3.21; N, 8.91. Found: C, 53.66; H, 3.25; N, 9.08; GC–MS *m/z* (% relative intensity, ion): 314 (100, M⁺), 268 (24), 252 (19), 238

(28), 224 (42), 42 (22); FT-IR (cm^{-1}): 1549, 1363; ^1H NMR (700 MHz, CDCl_3): δ 3.01 (6H, s, 5'-H), 6.74 (2H, d, $^3J_{\text{HH}}$ 8.8, 3'-H), 7.17 (2H, d, $^3J_{\text{HH}}$ 8.8, 2'-H); ^{13}C NMR (126 MHz, CDCl_3): 40.4 (s, $-\text{CH}_3$), 112.4 (s, C-3'), 113.4 (s C-1'), 121.7 (ddd, $^2J_{\text{CF}}$ 18.3, $^3J_{\text{CF}}$ 4.2, $^3J_{\text{CF}}$ 0.9, C-1), 130.1 (s, C-2'), 135.4–135.8 (m, C-6), 139.4 (dddd, $^1J_{\text{CF}}$ 257, $^2J_{\text{CF}}$ 14.5, $^2J_{\text{CF}}$ 13.6, $^3J_{\text{CF}}$ 2.6, C-F), 141.0 (dddd, $^1J_{\text{CF}}$ 259, $^2J_{\text{CF}}$ 13.5, $^3J_{\text{CF}}$ 5.0, $^4J_{\text{CF}}$ 3.0, C-F), 142.8 (dddd, $^1J_{\text{CF}}$ 260, $^2J_{\text{CF}}$ 17.7, $^2J_{\text{CF}}$ 12.2, $^3J_{\text{CF}}$ 3.2, C-F), 143.0 (dddd, $^1J_{\text{CF}}$ 246, $^2J_{\text{CF}}$ 13.3, $^3J_{\text{CF}}$ 5.0, $^4J_{\text{CF}}$ 3.0, C-F), 151.5 (s, C-4'); ^{19}F NMR (658 MHz, $\text{CDCl}_3/\text{CFCl}_3$): δ -139.3 (1F, ddd, $^3J_{\text{FF}}$ 23.0, $^4J_{\text{FF}}$ 2.3, $^5J_{\text{FF}}$ 10.6, F-2), -148.9 (1F, ddd, $^3J_{\text{FF}}$ 21.4, $^4J_{\text{FF}}$ 4.5, $^5J_{\text{FF}}$ 10.6, F-5), -151.1 (1F, ddd, $^3J_{\text{FF}}$ 23.0, $^3J_{\text{FF}}$ 20.8, $^4J_{\text{FF}}$ 4.5, F-3), -155.3 (1F, ddd, $^3J_{\text{FF}}$ 20.8, $^3J_{\text{FF}}$ 21.4, $^4J_{\text{FF}}$ 2.3, F-4).

2,3,4,5-Tetrafluoro-6-nitro[1,1':4'1''-terphenyl] (267)

4-Biphenylboronic acid (0.542, 2.737 mmol), 40% KF/alumina (0.443 g, 3.050 mmol) and $\text{Pd}(\text{PPh}_3)_4$ (0.057 g, 0.049 mmol) were charged to a 2–5 mL microwave vial that was sealed, evacuated under high vacuum and back-filled with argon three times to create an inert atmosphere. Dry, degassed DMF (2 mL) and pentafluoronitrobenzene (0.497 g, 2.333 mmol) were added to the vial using a syringe and the reaction vessel was heated to 150 °C for 20 min under microwave irradiation. The vial was cooled and its contents filtered through a silica pad using DCM as the eluent to separate inorganic and particulate material from the reaction mixture. Volatile components were removed *in vacuo* and the product purified by column chromatography on silica gel using hexanes and DCM (4:1) as the eluent. Subsequent recrystallisation from hexanes afforded 2,3,4,5-tetrafluoro-6-nitro[1,1':4'1''-terphenyl] (**267**) (0.552 g, 73 %) as a white solid; mp 149–150 °C; Anal. Calcd for $\text{C}_{18}\text{H}_9\text{F}_4\text{NO}_2$: C, 62.26; H, 2.61; N, 4.03. Found: C, 62.32; H, 2.63; N, 4.02; GC-MS m/z (% relative intensity, ion): 337 (18, M^+), 302 (48), 280 (63), 115 (46), 77 (29), 51 (13); FT-IR (cm^{-1}): 1550, 1364; ^1H NMR (700 MHz, CDCl_3): δ 7.38–7.42 (3H, m, H-Ar'), 7.48 (2H, dd, $^3J_{\text{HH}}$ 7.7, $^3J_{\text{HH}}$ 7.7, H-3''), 7.62 (2H, d, $^3J_{\text{HH}}$ 8.3, H-Ar), 7.70 (2H, d, $^3J_{\text{HH}}$ 8.3, H-Ar); ^{13}C NMR (126 MHz, CDCl_3): 120.9 (ddd, $^2J_{\text{CF}}$ 18.8, $^3J_{\text{CF}}$ 4.4, $^3J_{\text{CF}}$ 1.1, C-1), 125.7 (s, C-Ar), 127.5 (s, C-Ar), 128.2 (s, C-Ar), 128.4 (s, C-Ar), 129.3 (s, C-3''), 129.8 (s, C-Ar), 135.6–135.8 (m, C-6), 140.1 (s, C-1'), 140.3 (dddd, $^1J_{\text{CF}}$ 259, $^2J_{\text{CF}}$ 14.6, $^2J_{\text{CF}}$ 13.4, $^4J_{\text{CF}}$ 3.4, C-F), 141.1 (dddd, $^1J_{\text{CF}}$ 260, $^2J_{\text{CF}}$ 13.4, $^3J_{\text{CF}}$ 5.0, $^4J_{\text{CF}}$ 2.7, C-F), 142.9 (dddd, $^1J_{\text{CF}}$ 261, $^2J_{\text{CF}}$ 17.4, $^2J_{\text{CF}}$ 12.2, $^3J_{\text{CF}}$ 3.2, C-F), 143.4 (s, C-Ar), 145.0 (dddd, $^1J_{\text{CF}}$ 250, $^2J_{\text{CF}}$ 10.9, $^3J_{\text{CF}}$ 3.9, $^4J_{\text{CF}}$ 1.9, C-

F); ^{19}F NMR (658 MHz, $\text{CDCl}_3/\text{CFCl}_3$): δ -138.1 (1F, ddd, $^3J_{\text{FF}}$ 22.5, $^4J_{\text{FF}}$ 3.3, $^5J_{\text{FF}}$ 10.7, F-2), -147.7 (1F, ddd, $^3J_{\text{FF}}$ 21.3, $^4J_{\text{FF}}$ 5.1, $^5J_{\text{FF}}$ 10.7, F-5), -149.8 (1F, ddd, $^3J_{\text{FF}}$ 22.5, $^3J_{\text{FF}}$ 21.0, $^4J_{\text{FF}}$ 3.3, F-3), -152.8 (1F, ddd, $^3J_{\text{FF}}$ 21.0, $^3J_{\text{FF}}$ 21.3, $^4J_{\text{FF}}$ 5.1, F-4).

2,3,4,5-Tetrafluoro-3',6-dinitrophenyl (268)

3-Nitrophenylboronic acid (0.471 g, 2.822 mmol), 40% KF/alumina (0.446 g, 3.071 mmol) and $\text{Pd}(\text{PPh}_3)_4$ (0.053 g, 0.049 mmol) were charged to a 2–5 mL microwave vial that was sealed, evacuated under high vacuum and back-filled with argon three times to create an inert atmosphere. Dry, degassed DMF (2 mL) and pentafluoronitrobenzene (0.498 g, 2.337 mmol) were added to the vial using a syringe and the reaction vessel was heated to 150 °C for 20 min under microwave irradiation. The vial was cooled and its contents filtered through a silica pad using DCM as the eluent to separate inorganic and particulate material from the reaction mixture. Volatile components were removed *in vacuo* and the product purified by column chromatography on silica gel using hexanes and DCM (4:1) as the eluent. Subsequent recrystallisation from hexanes afforded 2,3,4,5-tetrafluoro-3',6-dinitrophenyl (**268**) (0.518, 70 %) as a yellow solid; mp 70-71 °C; Anal. Calcd for $\text{C}_{12}\text{H}_4\text{F}_4\text{N}_2\text{O}_4$: C, 45.59; H, 1.28; N, 8.86. Found: C, 45.55; H, 1.30; N, 8.71; GC-MS m/z (% relative intensity, ion): 316 (29, M^+), 228 (99), 211 (100), 193 (92), 79 (27), 51 (24), 30 (37); FT-IR (cm^{-1}): 1550, 1351; ^1H NMR (700 MHz, CDCl_3): δ 7.65 (1H, d, $^3J_{\text{HH}}$ 8.0, H-6'), 7.71 (1H, dd, $^3J_{\text{HH}}$ 8.0, $^3J_{\text{HH}}$ 8.0, H-5'), 8.24–8.25 (1H, m, H-2'), 8.38 (1H, ddd, $^3J_{\text{HH}}$ 8.0, $^4J_{\text{HH}}$ 2.2, $^4J_{\text{HH}}$ 1.1, H-4'); ^{13}C NMR (176 MHz, CDCl_3): δ 118.8 (dd, $^2J_{\text{CF}}$ 18.3, $^3J_{\text{CF}}$ 3.9, C-1), 124.8 (s, C-2'), 125.4 (s, C-4'), 128.7 (s, C-1'), 130.8 (s, C-5'), 135.3 (s, C-6'), 135.4–135.6 (m, C-6), 141.2 (dddd, $^1J_{\text{CF}}$ 262, $^2J_{\text{CF}}$ 14.7, $^2J_{\text{CF}}$ 14.5, $^3J_{\text{CF}}$ 3.4, C-F), 141.6 (dddd, $^1J_{\text{CF}}$ 268, $^2J_{\text{CF}}$ 13.4, $^3J_{\text{CF}}$ 4.7, $^4J_{\text{CF}}$ 2.5, C-F), 143.1 (dddd, $^1J_{\text{CF}}$ 266, $^2J_{\text{CF}}$ 17.0, $^2J_{\text{CF}}$ 12.3, $^4J_{\text{CF}}$ 3.0, C-F), 145.0 (ddm, $^1J_{\text{CF}}$ 253, $^2J_{\text{CF}}$ 11.8, C-F), 148.8 (s, C-3'); ^{19}F NMR (658 MHz, $\text{CDCl}_3/\text{CFCl}_3$): δ -137.2 (1F, ddd, $^3J_{\text{FF}}$ 22.1, $^4J_{\text{FF}}$ 4.4, $^5J_{\text{FF}}$ 10.6, F-2), -145.9 (1F, ddd, $^3J_{\text{FF}}$ 21.3, $^4J_{\text{FF}}$ 6.1, $^5J_{\text{FF}}$ 10.6, F-5), -148.1 (1F, ddd, $^3J_{\text{FF}}$ 22.1, $^3J_{\text{FF}}$ 20.8, $^4J_{\text{FF}}$ 6.1, F-3), -150.0 (1F, ddd, $^3J_{\text{FF}}$ 21.3, $^3J_{\text{FF}}$ 20.8, $^4J_{\text{FF}}$ 4.4, F-4).

2,3,3',4,5,5'-Hexafluoro-6-nitrobiphenyl (269)

2-(3,5-Difluorophenyl)-5,5-dimethyl-1,3,2-dioxaborinane (0.500 g, 2.212 mmol), 40% KF/alumina (0.314 g, 2.162 mmol) and $\text{Pd}(\text{PPh}_3)_4$ (0.038 g, 0.033 mmol) were charged to a 2–5 mL microwave vial that was sealed, evacuated under high vacuum and back-

filled with argon three times to create an inert atmosphere. Dry, degassed DMF (2 mL) and pentafluoronitrobenzene (0.358 g, 1.680 mmol) were added to the vial using a syringe and the reaction vessel was heated to 150 °C for 20 min under microwave irradiation. The vial was cooled and its contents filtered through a silica pad using DCM as the eluent to separate inorganic and particulate material from the reaction mixture. Volatile components were removed *in vacuo* and the product purified by column chromatography on silica gel using a mixture of hexane and DCM (4:1) as the eluent. Subsequent recrystallisation from hexanes afforded 2,3,3',4,5,5'-hexafluoro-6-nitrobiphenyl (**269**) (0.274, 53 %) as a white solid; mp 78-80 °C; Anal. Calcd for C₁₂H₃F₆NO₂: C, 46.92; H, 0.98; N, 4.56. Found: C, 47.08; H, 1.06; N, 4.63; GC-MS *m/z* (% relative intensity, ion): 316 (35, M⁺), 279 (47), 260 (66), 242 (100), 211 (77), 205 (44); FT-IR (cm⁻¹): 1552, 1362; ¹H NMR (500 MHz, CDCl₃): δ 6.85–6.91 (2H, m, H-2'), 6.97 (1H, tt, ³J_{FH} 8.8, ⁴J_{HH} 2.3, H-4'); ¹³C NMR (126 MHz, CDCl₃): 106.3 (t, ²J_{CF} 24.9, C-4'), 112.7–113.1 (m, C-2'), 118.5–118.9 (m, C-1), 129.5 (t, ³J_{CF} 10.5, C-1'), 135.2–135.6 (m, C-6), 140.9 (dddd, ¹J_{CF} 256, ²J_{CF} 14.6, ²J_{CF} 13.2, ³J_{CF} 3.4, C-F), 141.2 (dddd, ¹J_{CF} 262, ²J_{CF} 13.4, ³J_{CF} 4.7, ⁴J_{CF} 2.7, C-F), 142.6 (dddd, ¹J_{CF} 248, ²J_{CF} 17.4, ²J_{CF} 12.4, ³J_{CF} 3.3, C-F), 147.7 (dddd, ¹J_{CF} 253, ²J_{CF} 11.4, ³J_{CF} 3.9, ⁴J_{CF} 2.2, C-F), 163.3 (dd, ¹J_{CF} 252, ³J_{CF} 12.9, C-3'); ¹⁹F NMR (470 MHz, CDCl₃/CFCl₃): δ -107.5 - -108.0 (2F, m, F-3'), -137.4 (1F, ddd, ³J_{FF} 22.1, ⁴J_{FF} 4.4, ⁵J_{FF} 10.7, F-2), -146.4 (1F, ddd, ³J_{FF} 21.0, ⁴J_{FF} 5.8, ⁵J_{FF} 10.7, F-5), -148.5 (1F, ddd, ³J_{FF} 22.1, ³J_{FF} 20.7, ⁴J_{FF} 5.8, F-3), -153.3 (1F, ddd, ³J_{FF} 21.0, ³J_{FF} 20.7, ⁴J_{FF} 4.4, F-4).

Synthesis of Pd(F)(C₆F₄NO₂)(PPh₃)₂ (41b)

Pd(PPh₃)₄ (0.988 g, 0.855 mmol) was charged to a two-neck 50 mL round bottomed flask fitted with a suba-seal, that was subsequently evacuated under high vacuum and back-filled with argon three times to create an inert atmosphere. Subsequently, dry, degassed DMF (30 mL) and pentafluoronitrobenzene (0.198 g, 0.929 mmol) were injected into the reaction vessel. The solution was heated, with stirring, to 60 °C for 8 h and allowed to cool. Volatile components were removed *in vacuo* and the remaining solids were washed with three portions of dry, degassed hexane and the washings were discarded. The remaining solid material was recrystallised from dry, degassed THF and transferred to a glove box. Product **41b** was isolated as an off-white solid *via* filtration and single crystals of analytical quality were grown *via* the slow evaporation of dry, degassed diethyl ether at room temperature; ¹H NMR (400 MHz; C₇D₈): δ 7.40–7.48

(12H, m, H–Ar), 7.48–7.54 (6H, m, H–Ar), 7.57–7.65 (12H, m, H–Ar); ^{19}F NMR (188 MHz; C_7D_8): δ –109.7 – –110.1 (1F, m, F–Ar), –144.8 – –145.1 (1F, m, F–Ar), –150.1 – –150.5 (1F, m, F–Ar), –161.7 – –161.9 (1F, m, F–Ar), –310.5 – –311.0 (1F, m, F–Pd); ^{31}P NMR (81 MHz; C_7D_8): δ 19.3–19.7 (m, – PPh_3).

5.4.1.2 Cross-coupling Reactions of Tetrafluoronitrobenzene Derivatives

2,3,5-Trifluoro-6-nitrobiphenyl (273)

Method A: 5,5-Dimethyl-2-phenyl-1,3,2-dioxaborinane (0.285 g, 1.500 mmol), 40% KF/alumina (0.244 g, 1.680 mmol) and $\text{Pd}(\text{PPh}_3)_4$ (0.075 g, 0.065 mmol) were charged to a 2–5 mL microwave vial, that was sealed and evacuated under high vacuum and back-filled with argon three times to create an inert atmosphere. Dry, degassed DMF (3 mL) and 2,3,4,6-tetrafluoronitrobenzene (0.274 g, 1.405 mmol) were added to the vial using a syringe and the reaction vessel was heated to 150 °C for 15 h. The vial was cooled and its contents filtered through a silica pad with DCM as the eluent to remove inorganic and particulate material. Volatile components were removed *in vacuo* and the product purified by column chromatography using silica gel with a mixture of hexane and DCM (4:1) as the eluent to afford 2,3,5-trifluoro-6-nitrobiphenyl (**273**) (0.191 g, 54 %) as a yellow solid; mp 46–47 °C; Anal. Calcd for $\text{C}_{12}\text{H}_6\text{F}_3\text{NO}_2$: C, 56.93; H, 2.39; N, 5.33. Found: C, 57.13; H, 2.44; N, 5.42; GC–MS *m/z* (% relative intensity, ion): 253 (10, M^+), 225 (82), 169 (100), 51 (23), 30 (19); FT-IR (cm^{-1}): 1538, 1361; ^1H NMR (500 MHz, CDCl_3): δ 7.17 (1H, ddd, $^3J_{\text{HF}}$ 9.1, $^3J_{\text{HF}}$ 9.1, $^4J_{\text{HF}}$ 6.5, H–4), 7.33–7.37 (2H, m, H–Ar), 7.45–7.52 (3H, m, H–Ar); ^{13}C NMR (126 MHz, CDCl_3): δ 106.0 (dd, $^2J_{\text{CF}}$ 24.6, $^2J_{\text{CF}}$ 22.6, C–4), 127.0 (dd, $^2J_{\text{CF}}$ 18.5, $^3J_{\text{CF}}$ 1.5, C–1), 127.8 (s, C–Ar), 129.1 (s, C–Ar), 129.3 (s, C–Ar), 130.3 (s, C–Ar), 135.7–136.1 (m, C–6), 144.3 (ddd, $^1J_{\text{CF}}$ 250, $^2J_{\text{CF}}$ 13.4, $^4J_{\text{CF}}$ 4.1, C–2), 149.8 (ddd, $^1J_{\text{CF}}$ 258, $^3J_{\text{CF}}$ 11.0, $^4J_{\text{CF}}$ 4.05, C–5), 151.7 (ddd, $^1J_{\text{CF}}$ 259, $^2J_{\text{CF}}$ 15.2, $^3J_{\text{CF}}$ 11.7, C–3); ^{19}F NMR (658 MHz, $\text{CDCl}_3/\text{CFCl}_3$): δ –124.6 (1F, ddd, $^3J_{\text{FH}}$ 9.1, $^4J_{\text{FF}}$ 5.2, $^5J_{\text{FF}}$ 14.2, F–5), –126.9 (1F, ddd, $^3J_{\text{FF}}$ 22.2, $^3J_{\text{FH}}$ 9.1, $^4J_{\text{FF}}$ 5.2, F–3), –141.3 (1F, ddd, $^3J_{\text{FF}}$ 22.2, $^4J_{\text{FH}}$ 6.5, $^5J_{\text{FF}}$ 14.2, F–2) and 2,3,5-trifluoro-*N,N*-dimethyl-4-nitroaniline (**276**) (0.056 g, 18 %) as a yellow solid; mp 92–93 °C; Anal. Calcd for $\text{C}_8\text{H}_7\text{F}_3\text{N}_2\text{O}_2$: C, 43.65; H, 3.20; N, 12.72. Found: C, 43.77; H, 3.31; N, 12.52; GC–MS *m/z* (% relative intensity, ion): 220 (100, M^+), 190 (73), 173 (80), 144 (32), 42 (31); FT-IR (cm^{-1}): 1624, 1563, 1506, 1453, 1305, 1243; ^1H NMR (700 MHz, CDCl_3): δ 3.10 (6H, d, $^5J_{\text{HF}}$ 2.4, – CH_3), 6.68 (1H, ddd, $^3J_{\text{HF}}$ 13.7, $^4J_{\text{HF}}$ 7.3, $^5J_{\text{HF}}$ 1.7, H–6); ^{13}C NMR

(176 MHz, CDCl₃): δ 42.4 (d, $^4J_{CF}$ 6.6, -CH₃), 97.2 (ddd, $^2J_{CF}$ 26.6, $^3J_{CF}$ 3.2, $^4J_{CF}$ 1.9, C-6), 119.29–119.30 (m, C-4), 137.1 (ddd, $^1J_{CF}$ 245, $^2J_{CF}$ 14.7, $^4J_{CF}$ 2.9, C-2), 144.0 (ddd, $^2J_{CF}$ 12.4, $^3J_{CF}$ 6.0, $^3J_{CF}$ 4.2, 1 C-2), 146.5 (ddd, $^1J_{CF}$ 260, $^2J_{CF}$ 16.4, $^3J_{CF}$ 4.7, C-3), 152.3 (ddd, $^1J_{CF}$ 257, $^3J_{CF}$ 3.3, $^4J_{CF}$ 2.5, C-5); ^{19}F NMR (658 MHz; CDCl₃/CFCl₃): δ -121.6 (1F, ddd, $^3J_{FH}$ 13.7, $^4J_{FF}$ 4.5, $^5J_{FF}$ 8.9, F-5), -141.1 (1F, ddd, $^3J_{FF}$ 18.2, $^4J_{FF}$ 4.5, $^5J_{FH}$ 1.7, F-3), -155.2 - -115.2 (1F, m, 2-F). Method B: Corresponding reaction of 2,3,4,6-tetrafluoronitrobenzene (0.262 g, 1.341 mmol) with 5,5-dimethyl-2-phenyl-1,3,2-dioxaborinane (0.296 g, 1.558 mmol) in dry, degassed DMSO (3 mL) at 150 °C for 30 minutes afforded 2,3,5-trifluoro-6-nitrobiphenyl (**273**) (0.174 g, 81 %) as characterised above (Method A).

2,3,4-Trifluoro-6-nitrobiphenyl (274)

Method A: 5,5-Dimethyl-2-phenyl-1,3,2-dioxaborinane (0.243 g, 1.279 mmol), 40% KF/alumina (0.295 g, 2.031 mmol) and Pd(PPh₃)₄ (0.084 g, 0.073 mmol) were charged to a 2–5 mL microwave vial, that was sealed and evacuated under high vacuum and back-filled with argon three times to create an inert atmosphere. Dry, degassed DMF (3 mL) and 2,3,4,5-tetrafluoronitrobenzene (0.243 g, 1.246 mmol) were added to the vial using a syringe and the reaction vessel was heated to 150 °C for 15 h. The vial was cooled and its contents filtered through a silica pad with DCM as the eluent to remove inorganic and particulate material. Volatile components were removed *in vacuo* and the product purified by column chromatography using silica gel with a mixture of hexane and DCM (4:1) as the eluent to afford 2,3,4-trifluoro-6-nitrobiphenyl (**274**) (0.085 g, 27 %) as a yellow solid; mp 104–106 °C; Anal. Calcd for C₁₂H₆F₃NO₂: C, 56.93; H, 2.39; N, 5.33. Found: C, 56.67; H, 2.43; N, 5.58; GC-MS *m/z* (% relative intensity, ion): 253 (3, M⁺), 225 (22), 169 (44), 51 (31), 30 (100); FT-IR (cm⁻¹): 1530, 1359; 1H NMR (400 MHz, CDCl₃): δ 7.26–7.29 (2H, m, H-Ar), 7.46–7.49 (3H, m, H-Ar), 7.68 (1H, ddd, $^3J_{HF}$ 9.0, $^4J_{HF}$ 6.6, $^5J_{HF}$ 2.3, H-5); ^{13}C NMR (176 MHz, CDCl₃): δ 109.5 (dd, $^2J_{CF}$ 22.0, $^3J_{CF}$ 3.9, C-5), 123.9 (dd, $^2J_{CF}$ 17.7, $^3J_{CF}$ 4.3, C-1), 128.8 (s, C-Ar), 129.1 (s, C-Ar), 129.1 (s, C-Ar), 129.7 (s, C-Ar), 143.2 (ddd, $^1J_{CF}$ 262, $^2J_{CF}$ 16.5, $^2J_{CF}$ 14.9, C-3), 144.0–144.2 (m, C-6), 149.3 (ddd, $^1J_{CF}$ 253, $^2J_{CF}$ 10.8, $^3J_{CF}$ 3.7, C-F), 149.7 (ddd, $^1J_{CF}$ 255, $^2J_{CF}$ 10.9, $^3J_{CF}$ 4.2, C-F); ^{19}F NMR (658 MHz, CDCl₃/CFCl₃): δ -130.1 (1F, dd, $^3J_{FF}$ 21.4, $^4J_{FF}$ 7.7, F-2), -131.1 (1F, ddd, $^3J_{FF}$ 20.9, $^3J_{FH}$ 9.0, $^4J_{FF}$ 7.7, F-4), -150.1 (1F, ddd, $^3J_{FF}$ 21.5, $^3J_{FF}$ 21.3, $^4J_{FH}$ 6.6, F-3) and 2,3,6-trifluoro-*N,N*-dimethyl-4-nitroaniline

(**277**) (0.017 g, 6 %) as a yellow solid; mp 71-72 °C; HRMS–ASAP (m/z): ($M + H^+$) calcd for $C_8H_8N_2O_2F_3$ 221.0538; found 221.0534; GC–MS m/z (% relative intensity, ion): 220 (100, M^+), 219 (M^+ , 30), 173 (93), 158 (62), 42 (33); FT-IR (cm^{-1}): 1613, 1590, 1509, 1460, 1313, 1223; 1H NMR (700 MHz, $CDCl_3$): δ 3.11 (6H, t, $^5J_{HF}$ 2.9, – CH_3), 7.63 (1H, ddd, $^3J_{HF}$ 13.0, $^4J_{HF}$ 6.9, $^5J_{HF}$ 2.0, H–5); ^{13}C NMR (176 MHz, $CDCl_3$): δ 42.92(t, $^4J_{CF}$ 5.4, – CH_3), 108.5 (ddd, $^2J_{CF}$ 28.3, $^3J_{CF}$ 2.4, $^4J_{CF}$ 2.4, C–5), 127.1–127.2 (m, C–4), 136.8 (ddd, $^2J_{CF}$ 12.4, $^2J_{CF}$ 9.1, $^3J_{CF}$ 1.6, C–1), 143.6 (ddd, $^1J_{CF}$ 249, $^2J_{CF}$ 14.7, $^3J_{CF}$ 8.4, C–2), 144.3 (ddd, $^1J_{CF}$ 264, $^2J_{CF}$ 15.5, $^4J_{CF}$ 2.1, C–3), 148.6 (dd, $^1J_{CF}$ 245, $^3J_{CF}$ 7.1, C–6); ^{19}F NMR (658 MHz; $CDCl_3/CFCl_3$): δ –125.4 - –125.5 (1F, m, F–Ar), –144.3 (1F, ddd, $^3J_{FF}$ 18.4, $^4J_{FH}$ 6.9, $^5J_{FF}$ 9.7, F–3), –145.1 - –145.2 (1F, m, F–Ar). Method B: Corresponding reaction of 2,3,4,5-tetrafluoronitrobenzene (0.255 g, 1.307 mmol) with 5,5-dimethyl-2-phenyl-1,3,2-dioxaborinane (0.300 g, 1.579 mmol) in dry, degassed DMSO (3 mL) at 150 °C for 2 h afforded 2,3,4-trifluoro-6-nitrobiphenyl (**274**) (0.216 g, 65 %) as characterised above (Method A).

2,4,5-Trifluoro-6-nitrobiphenyl (275)

Method A: 5,5-Dimethyl-2-phenyl-1,3,2-dioxaborinane (0.227 g, 1.194 mmol), 40% KF/alumina (0.175 g, 1.205 mmol) and $Pd(PPh_3)_4$ (0.059 g, 0.051 mmol) were charged to a 2–5 mL microwave vial, that was sealed and evacuated under high vacuum and back-filled with argon three times to create an inert atmosphere. Dry, degassed DMF (3 mL) and 2,3,5,6-tetrafluoronitrobenzene (0.153 g, 0.784 mmol) were added to the vial using a syringe and the reaction vessel was heated to 150 °C for 15 h. The vial was cooled and its contents filtered through a silica pad with DCM as the eluent to remove inorganic and particulate material. Volatile components were removed *in vacuo* and the product purified by column chromatography using silica gel with a mixture of hexane and DCM (4:1) as the eluent to afford 2,4,5-trifluoro-6-nitrobiphenyl (**275**) (0.095 g, 48 %) as a yellow solid; mp 73–74 °C; Anal. Calcd for $C_{12}H_6F_3NO_2$: C, 56.93; H, 2.39; N, 5.33. Found: C, 56.84; H, 2.44; N, 5.50; GC–MS m/z (% relative intensity, ion): 253 (53, M^+), 224 (100), 169 (81), 51 (21), 30 (18); FT-IR (cm^{-1}): 1543, 1359; 1H NMR (500 MHz, $CDCl_3$): δ 7.23 (1H, ddd, $^3J_{HF}$ 9.6, $^3J_{HF}$ 8.6, $^4J_{HF}$ 6.5, H–3), 7.30–7.34 (2H, m, H–Ar), 7.44–7.49 (3H, m, H–Ar); ^{13}C NMR (126 MHz, $CDCl_3$): δ 108.3 (dd, $^2J_{CF}$ 20.7, $^2J_{CF}$ 28.9, C–3), 120.5 (ddd, $^2J_{CF}$ 22.7, $^3J_{CF}$ 4.8, $^4J_{CF}$ 2.1, C–1), 127.8 (s, C–Ar), 129.2 (s, C–Ar), 129.4 (s, C–Ar), 130.0 (s, C–Ar), 140.1 (ddd, $^1J_{CF}$ 258, $^2J_{CF}$ 16.1, $^4J_{CF}$

4.9, C-5), 140.7–141.0 (m, C-6), 149.6 (ddd, $^1J_{CF}$ 256, $^2J_{CF}$ 12.6, $^3J_{CF}$ 12.6, C-4), 154.6 (ddd, $^1J_{CF}$ 250, $^3J_{CF}$ 9.8, $^4J_{CF}$ 3.3, C-2); ^{19}F NMR (658 MHz, $CDCl_3/CFCl_3$): δ -113.9 (1F, ddd, $^3J_{FH}$ 8.6, $^4J_{FF}$ 4.0, $^5J_{FF}$ 13.6, F-2), -130.7 (1F, ddd, $^3J_{FF}$ 21.8, $^3J_{FH}$ 9.6, $^4J_{FF}$ 4.0, F-4), -151.3 (1F, ddd, $^3J_{FF}$ 21.7, $^4J_{FH}$ 6.5, $^5J_{FF}$ 13.5, F-5) and 3,4,6-trifluoro-*N,N*-dimethyl-2-nitroaniline (**278**) as a yellow liquid (0.011 g, 6 %); HRMS-ASAP (m/z): ($M + H^+$) calcd for $C_8H_8N_2O_2F_3$ 221.0538; found 221.0537; GC-MS m/z (% relative intensity, ion): 220 (53, M^+), 203 (46), 159 (100), 145 (75), 42 (41); FT-IR (cm^{-1}): 3016, 2950, 2886, 2806, 1543, 1503, 1449, 1381; 1H NMR (700 MHz, $CDCl_3$): δ 2.80 (6H, d, $^5J_{HF}$ 1.6, -CH₃), 7.08 (1H, ddd, $^3J_{HF}$ 11.0, $^3J_{HF}$ 9.9, $^4J_{HF}$ 7.3, H-5); ^{13}C NMR (176 MHz, $CDCl_3$): δ 43.6 (d, $^4J_{CF}$ 3.3, -CH₃), 108.0 (dd, $^2J_{CF}$ 26.3, $^3J_{CF}$ 21.3, C-5), 131.3 (dd, $^2J_{CF}$ 16.2, $^3J_{CF}$ 4.6, C-1), 139.3–139.4 (m, C-2), 139.6 (ddd, $^1J_{CF}$ 257, $^2J_{CF}$ 16.4, $^4J_{CF}$ 4.5, C-3), 146.4 (ddd, $^1J_{CF}$ 252, $^2J_{CF}$ 12.5, $^3J_{CF}$ 12.5, C-4), 155.7 (ddd, $^1J_{CF}$ 253, $^3J_{CF}$ 9.3, $^4J_{CF}$ 2.9, C-6); ^{19}F NMR (658 MHz; $CDCl_3/CFCl_3$): δ -119.6 - -119.7 (1F, m, F-6), -136.7 (1F, ddd, $^3J_{FF}$ 22.4, $^3J_{FH}$ 9.9, $^4J_{FF}$ 1.6, F-4), -151.0 (1F, ddd, $^3J_{FF}$ 22.4, $^4J_{FH}$ 7.3, $^5J_{FH}$ 12.4, F-3). Method B: Corresponding reaction of 2,3,5,6-tetrafluoronitrobenzene (0.268 g, 1.374 mmol) with 5,5-dimethyl-2-phenyl-1,3,2-dioxaborinane (0.268 g, 1.410 mmol) in dry, degassed DMSO (3 mL) at 150 °C for 2 h afforded 2,4,5-trifluoro-6-nitrobiphenyl (**275**) (0.189 g, 54 %) as characterised above (Method A).

Reaction of 2,3,4,6-tetrafluoronitrobenzene with dimethylamine

A 0.5-2 mL microwave vial was sealed and purged with argon to create an inert atmosphere. Dry DMF (1.5 mL) was added to the reaction vessel using a syringe, followed by dimethylamine (0.2 mL, 8.4 mmol) and 2,3,4,6-tetrafluoronitrobenzene (0.245 g, 1.256 mmol). The reaction mixture was heated to 150 °C for 30 minutes under microwave irradiation. The mixture was left to cool, poured on to water (100 mL) and extracted with dichloromethane (3 × 50 mL). The combined extracts were washed with water (100 mL) and dried ($MgSO_4$). The mixture was filtered, the solvent removed *in vacuo* and the product purified by column chromatography on silica gel using hexane and DCM (7:3) as the eluent. Subsequent recrystallisation from hexane afforded 2,3,5-trifluoro-*N,N*-dimethyl-4-nitroaniline (**276**) (0.113 g, 41%) as a yellow solid, as characterised (above) as a by-product of the cross-coupling reaction of 2,3,4,6-tetrafluoronitrobenzene with 5,5-dimethyl-2-phenyl-1,3,2-dioxaborinane, 2,3,5-trifluoro-*N,N*-dimethyl-6-nitroaniline (**279**) (0.028g, 10%) as a yellow liquid; HRMS-

ASAP (m/z): ($M + H^+$) calcd for $C_8H_8N_2O_2F_3$ 221.0538; found 221.0524; GC-MS m/z (% relative intensity, ion): 220 (11, M^+), 158 (31), 145 (100), 42 (32); 1H NMR (700 MHz, $CDCl_3$): δ 2.89 (6H, d, $^5J_{HF}$ 2.1, $-CH_3$), 6.68 (1H, ddd, $^3J_{HF}$ 9.4, $^3J_{HF}$ 9.4, $^4J_{HF}$ 6.1, H-4); ^{13}C NMR (176 MHz, $CDCl_3$): δ 42.7 (d, $^4J_{CF}$ 4.3, $-CH_3$), 98.6 (dd, $^2J_{CF}$ 24.5, $^2J_{CF}$ 24.5, C-4), 132.0–132.1 (m, C-6), 137.3 (dt, $^2J_{CF}$ 11.4, $^3J_{CF}$ 3.1, C-1), 143.2 (ddd, $^1J_{CF}$ 247, $^2J_{CF}$ 13.1, J_{CF} 4.6, C-F), 150.7 (ddd, $^1J_{CF}$ 256, $^2J_{CF}$ 14.0, J_{CF} 3.8, C-F), 152.1 (ddd, $^1J_{CF}$ 256, $^2J_{CF}$ 14.0, J_{CF} 14.0, C-F); ^{19}F NMR (658 MHz; $CDCl_3/CFCl_3$): δ -127.2 (1F, ddd, $^3J_{FH}$ 9.4, $^4J_{FF}$ 4.7, $^5J_{FF}$ 11.2, F-5), -129.0 (1F, ddd, $^3J_{FF}$ 19.8, $^3J_{FH}$ 9.4, $^4J_{FF}$ 4.7, F-3), -149.8 - -149.8 (1F, m, F-2) and 3,4,5-trifluoro-*N,N*-dimethyl-2-nitroaniline (**280**) (0.032 g, 12%) as a yellow solid; mp 51–52 °C; HRMS-ASAP (m/z): ($M + H^+$) calcd for $C_8H_8N_2O_2F_3$ 221.0538; found 221.0527; GC-MS m/z (% relative intensity, ion): 220 (23, M^+), 203 (25), 173 (30), 158 (53), 145 (100), 42 (38); 1H NMR (700 MHz, $CDCl_3$): δ 2.86 (6H, s, $-CH_3$), 6.54 (1H, ddd, $^3J_{HF}$ 12.7, $^4J_{HF}$ 6.3, $^5J_{HF}$ 2.3, H-6); ^{13}C NMR (176 MHz, $CDCl_3$): δ 42.3 (s, $-CH_3$), 100.7–100.8 (m, C-6), 127.8–128.0 (m, C-2), 132.8 (ddd, $^1J_{CF}$ 248, $^2J_{CF}$ 16.2, $^2J_{CF}$ 16.2, C-4), 142.0 (ddd, $^3J_{CF}$ 10.4, $^3J_{CF}$ 10.4, $^4J_{CF}$ 2.2, C-1), 146.3 (ddd, $^1J_{CF}$ 259, $^2J_{CF}$ 15.5, $^3J_{CF}$ 2.1, C-F), 152.7 (ddd, $^1J_{CF}$ 254, $^2J_{CF}$ 10.4, $^3J_{CF}$ 5.6, C-F); ^{19}F NMR (658 MHz; $CDCl_3$; $CFCl_3$): δ -128.0 (1F, ddd, $^3J_{FF}$ 22.4, $^3J_{FH}$ 12.7, $^4J_{FF}$ 10.0, F-5), -141.7 (1F, ddd, $^3J_{FF}$ 21.7, $^4J_{FF}$ 10.0, $^5J_{FH}$ 2.3, F-3), -170.8 (1F, ddd, $^3J_{FF}$ 22.4, $^3J_{FF}$ 21.7, $^4J_{FH}$ 6.3, F-4).

Reaction of 2,3,4,5-tetrafluoronitrobenzene with dimethylamine

A 0.5-2 mL microwave vial was sealed and purged with argon to create an inert atmosphere. Dry DMF (1.5 mL) was added to the reaction vessel using a syringe, followed by dimethylamine (0.2 mL, 8.4 mmol) and 2,3,4,5-tetrafluoronitrobenzene (0.261 g, 1.338 mmol). The reaction mixture was heated to 150 °C for 30 minutes under microwave irradiation. The mixture was left to cool, poured on to water (100 mL) and extracted with dichloromethane (3×50 mL). The combined extracts were washed with water (100 mL) and dried ($MgSO_4$). The mixture was filtered, the solvent removed *in vacuo* and the product purified by column chromatography on silica gel using hexane and DCM (7:3) as the eluent. Subsequent recrystallisation from hexane afforded 2,3,6-trifluoro-*N,N*-dimethyl-4-nitroaniline (**277**) (0.126 g, 43%) as a yellow solid, as characterised (above) as a by-product of the cross-coupling reaction of 2,3,4,5-tetrafluoronitrobenzene with 5,5-dimethyl-2-phenyl-1,3,2-dioxaborinane, 2,3,4-

trifluoro-*N,N*-dimethyl-6-nitroaniline (**281**) (0.025 g, 9%) as a yellow liquid; HRMS–ASAP (m/z): ($M + H^+$) calcd for $C_8H_8N_2O_2F_3$ 221.0538; found 221.0530; GC–MS m/z (% relative intensity, ion): 220 (10, M^+), 158 (43), 145 (100), 42 (33); 1H NMR (700 MHz, $CDCl_3$): δ 2.86 (6H, d, $^5J_{HF}$ 1.7, $-CH_3$), 7.42 (1H, ddd, $^3J_{HF}$ 9.7, $^4J_{HF}$ 7.7, $^5J_{HF}$ 2.3, H–5); ^{13}C NMR (176 MHz, $CDCl_3$): δ 42.8 (d, $^4J_{CF}$ 3.8, $-CH_3$), 108.4 (ddd, $^2J_{CF}$ 22.1, $^3J_{CF}$ 3.4, C–5), 134.1 (dd, $^2J_{CF}$ 10.8, $^3J_{CF}$ 3.5, C–1), 139.3–139.4 (m, C–6), 143.3 (ddd, $^1J_{CF}$ 260, $^2J_{CF}$ 16.2, $^2J_{CF}$ 15.2, C–3), 145.0 (dd, $^1J_{CF}$ 248, $^2J_{CF}$ 11.7, C–F), 148.3 (dd, $^1J_{CF}$ 251, $^3J_{CF}$ 14.5, C–F); ^{19}F NMR (658 MHz; $CDCl_3/CFCl_3$): δ –139.1 (1F, ddm, $^3J_{FF}$ 18.7, $^4J_{FF}$ 3.7, $^5J_{FH}$ 1.7, F–2), –140.5 (1F, ddd, $^3J_{FF}$ 21.9, $^3J_{FH}$ 9.7, $^4J_{FF}$ 3.7, F–4), –150.6 (1F, ddd, $^3J_{FF}$ 21.9, $^3J_{FF}$ 18.7, $^4J_{FH}$ 7.7, F–3) and 2,4-difluoro- N^1,N^1,N^3,N^3 -tetramethyl-6-nitrobenzene-1,3-diamine (**282**) (0.007 g, 2%) as a yellow solid; mp 65–67 °C; HRMS–ASAP (m/z): ($M + H^+$) calcd for $C_{10}H_{14}N_3O_2F_2$ 246.1054; found 246.1041; GC–MS m/z (% relative intensity, ion): 245 (23, M^+), 228 (100), 170 (68), 85 (58), 42 (72); 1H NMR (700 MHz, $CDCl_3$): δ 2.82 (6H, d, $^5J_{HF}$ 1.5, $-CH_3$), 2.99 (6H, dd, $^5J_{HF}$ 2.4, $^5J_{HF}$ 2.4, $-CH_3$), 7.34 (1H, dd, $^3J_{HF}$ 12.4, $^5J_{HF}$ 1.9, H–5); ^{13}C NMR (176 MHz, $CDCl_3$): δ 42.9 (d, $^4J_{CF}$ 1.8, $-CH_3$), 43.1 (dd, $^4J_{CF}$ 4.6, $^4J_{CF}$ 4.6, $-CH_3$), 108.9 (dd, $^2J_{CF}$ 26.6, $^4J_{CF}$ 2.9, C–5), 134.3 (dd, $^2J_{CF}$ 14.0, $^4J_{CF}$ 2.9, C–1), 134.9 (dd, $^2J_{CF}$ 12.7, $^2J_{CF}$ 12.7, C–3), 136.3–136.5 (m, C–6), 150.4 (dd, $^1J_{CF}$ 245, $^3J_{CF}$ 8.2, C–F), 152.6 (dd, $^1J_{CF}$ 246, $^3J_{CF}$ 8.0, C–F); ^{19}F NMR (658 MHz; $CDCl_3/CFCl_3$): δ –127.4 – –127.4 (1F, m, F–Ar), –128.0 – –128.1 (1F, m, F–Ar).

Reaction of 2,3,5,6-tetrafluoronitrobenzene with dimethylamine

A 0.5–2 mL microwave vial was sealed and purged with argon to create an inert atmosphere. Dry DMF (1.5 mL) was added to the reaction vessel using a syringe, followed by dimethylamine (0.2 mL, 8.4 mmol) and 2,3,5,6-tetrafluoronitrobenzene (0.250 g, 1.282 mmol). The reaction mixture was heated to 150 °C for 30 minutes under microwave irradiation. The mixture was left to cool, poured on to water (100 mL) and extracted with dichloromethane (3×50 mL). The combined extracts were washed with water (100 mL) and dried ($MgSO_4$). The mixture was filtered, the solvent removed *in vacuo* and the product purified by column chromatography on silica gel using hexane and DCM (7:3) as the eluent. Subsequent recrystallisation from hexane afforded 3,4,6-trifluoro-*N,N*-dimethyl-2-nitroaniline (**278**) (0.099 g, 35%) as a yellow liquid, as characterised previously as characterised (above) as a by-product of the cross-coupling

reaction of 2,3,5,6-tetrafluoronitrobenzene with 5,5-dimethyl-2-phenyl-1,3,2-dioxaborinane, and 2,5-difluoro- N^1,N^1,N^4,N^4 -tetramethyl-3-nitrobenzene-1,4-diamine (0.033 g, 11 %) (**283**) as a yellow liquid; HRMS–ASAP (m/z): ($M + H^+$) calcd for $C_{10}H_{14}N_3F_2O_2$ 246.1049; found 246.1052; GC–MS m/z (% relative intensity, ion): 245 (66, M^+), 184 (100), 183 (86), 99 (16), 42 (17); FT-IR (cm^{-1}): 2946, 2876, 2800, 1544, 1510, 1446, 1338; 1H NMR (700 MHz, $CDCl_3$): δ 2.75 (6H, d, $^5J_{HF}$ 1.5, $-CH_3$), 2.89 (6H, d, $^5J_{HF}$ 1.3, $-CH_3$), 6.59 (1H, dd, $^3J_{HF}$ 13.8, $^4J_{HF}$ 8.3, H–6); ^{13}C NMR (176 MHz, $CDCl_3$): δ 42.6 (d, $^4J_{CF}$ 4.8, $-CH_3$), 44.4 (d, $^4J_{CF}$ 3.1, $-CH_3$), 106.3 (dd, $^2J_{CF}$ 25.5, $^3J_{CF}$ 4.8, C–6), 124.8 (d, $^2J_{CF}$ 17.5, C–4), 139.1 (dd, $^2J_{CF}$ 9.8, $^3J_{CF}$ 8.4, C–1), 140.9–141.0 (m, C–3), 141.2 (dd, $^1J_{CF}$ 251, $^4J_{CF}$ 3.0, C–F), 157.5 (dd, $^1J_{CF}$ 249, $^4J_{CF}$ 2.2, C–F); ^{19}F NMR (658 MHz; $CDCl_3/CFCl_3$): δ -122.2 - -122.3 (1F, m, F–Ar), -140.6 - -140.6 (1F, m, F–Ar).

5.3.1.3 Cross-coupling Reactions of Trifluoronitrobenzene Derivatives

2,3-Difluoro-6-nitrobiphenyl (284)

5,5-Dimethyl-2-phenyl-1,3,2-dioxaborinane (0.309 g, 1.630 mmol), 40% KF/alumina (0.395 g, 2.720 mmol) and $Pd(PPh_3)_4$ (0.167 g, 0.145 mmol) were charged to a 2–5 mL microwave vial that was sealed and evacuated under high vacuum and back-filled with argon three times to create an inert atmosphere. Dry, degassed DMSO (3 mL) and 2,3,4-trifluoronitrobenzene (0.241 g, 1.361 mmol) were added to the vial using a syringe and the reaction vessel was heated to 150 °C for 2 h. The vial was cooled and its contents filtered through a silica pad with DCM as the eluent to remove inorganic and particulate material. Volatile components were removed *in vacuo* and the product purified by column chromatography using silica gel with a mixture of hexane and DCM (4:1) as the eluent to afford 2,3-difluoro-6-nitrobiphenyl (**284**) (0.174 g, 54 %) as a yellow solid; mp 81–83 °C; Anal. Calcd for $C_{12}H_7F_2NO_2$: C, 61.28; H, 3.00; N, 5.96. Found: C, 61.30; H, 3.04; N, 5.96; GC–MS m/z (% relative intensity, ion): 235 (7, M^+), 207 (53), 188 (65), 151 (100), 51 (34); FT-IR (cm^{-1}): 1530, 1350; 1H NMR (700 MHz, $CDCl_3$): δ 7.28–7.35 (3H, m, H–Ar), 7.45–7.50 (3H, m, H–Ar), 7.76 (1H, ddd, $^3J_{HH}$ 9.1, $^4J_{HF}$ 4.4, $^5J_{HF}$ 2.1, H–5); ^{13}C NMR (126 MHz, $CDCl_3$): δ 116.5 (d, $^2J_{CF}$ 19.3, C–4), 120.8 (dd, $^3J_{CF}$ 8.0, $^4J_{CF}$ 4.4, C–5), 128.1 (d, $^2J_{CF}$ 18.2, 1-C), 128.9 (s, C–Ar), 129.0 (s, C–Ar), 129.5 (s, C–Ar), 129.5 (s, C–Ar), 145.6–145.7 (m, C–6), 148.2 (ddd, $^1J_{CF}$ 252, $^2J_{CF}$

13.6, C–F), 153.4 (ddd, $^1J_{CF}$ 259, $^2J_{CF}$ 14.1, C–F); ^{19}F NMR (658 MHz, $CDCl_3/CFCl_3$): δ –128.1 (1F, ddd, $^3J_{FF}$ 21.5, $^3J_{FH}$ 8.8, $^4J_{FH}$ 4.4, F–3), –134.9 (1F, ddd, $^3J_{FF}$ 21.5, $^4J_{FH}$ 7.3, $^5J_{FH}$ 2.1, F–2).

3,4-Difluoro-6-nitrobiphenyl (285)

5,5-Dimethyl-2-phenyl-1,3,2-dioxaborinane (0.313 g, 1.647 mmol), 40% KF/alumina (0.386 g, 2.658 mmol) and $Pd(PPh_3)_4$ (0.167 g, 0.145 mmol) were charged to a 2–5 mL microwave vial that was sealed and evacuated under high vacuum and back-filled with argon three times to create an inert atmosphere. Dry, degassed DMSO (3 mL) and 2,4,5-trifluoronitrobenzene (0.253 g, 1.429 mmol) were added to the vial using a syringe and the reaction vessel was heated to 150 °C for 2 h. The vial was cooled and its contents filtered through a silica pad with DCM as the eluent to remove inorganic and particulate material. Volatile components were removed *in vacuo* and the product purified by column chromatography using silica gel with a mixture of hexane and DCM (4:1) as the eluent to afford 3,4-difluoro-6-nitrobiphenyl (**285**) (0.115 g, 34 %) as a yellow solid; mp 54–56 °C; Anal. Calcd for $C_{12}H_7F_2NO_2$: C, 61.28; H, 3.00; N, 5.96. Found: C, 61.39; H, 3.19; N, 5.53; GC–MS m/z (% relative intensity, ion): 235 (2, M^+), 207 (28), 188 (51), 151 (68), 30 (100); FT-IR (cm^{-1}): 1527, 1355; 1H NMR (400 MHz, $CDCl_3$): δ 7.26–7.32 (3H, m, Ar-H), 7.43–7.48 (3H, m, Ar-H), 7.82 (1H, dd, $^3J_{HF}$ 9.4, $^4J_{HF}$ 7.1, 2 or H–5); ^{13}C NMR (126 MHz, $CDCl_3$): δ 114.8 (dd, $^2J_{CF}$ 21.8, $^3J_{CF}$ 2.0, C–Ar), 120.8 (d, $^2J_{CF}$ 19.1, C–Ar), 128.0 (s, C–Ar), 129.1 (s, C–Ar), 129.1 (s, C–Ar), 134.7–134.9 (m, C–Ar), 136.0 (s, C–Ar), 144.3–144.5 (m, C–Ar), 149.0 (dd, $^1J_{CF}$ 254, $^2J_{CF}$ 13.8, C–F), 152.4 (dd, $^1J_{CF}$ 259, $^2J_{CF}$ 12.6, C–F); ^{19}F NMR (658 MHz, $CDCl_3/CFCl_3$): δ –129.2 (1F, ddd, $^3J_{FF}$ 21.4, $^3J_{FH}$ 9.4, $^4J_{FH}$ 7.7, F–Ar), –136.3 (1F, ddd, $^3J_{FF}$ 21.4, $^3J_{FH}$ 10.1, $^4J_{FH}$ 7.1, F–Ar).

3,5-Difluoro-6-nitrobiphenyl (286)

5,5-Dimethyl-2-phenyl-1,3,2-dioxaborinane (0.322 g, 1.694 mmol), 40% KF/alumina (0.402 g, 2.768 mmol) and $Pd(PPh_3)_4$ (0.162 g, 0.140 mmol) were charged to a 2–5 mL microwave vial that was sealed and evacuated under high vacuum and back-filled with argon three times to create an inert atmosphere. Dry, degassed DMSO (3 mL) and 2,4,6-trifluoronitrobenzene (0.242 g, 1.367 mmol) were added to the vial using a syringe and the reaction vessel was heated to 150 °C for 2 h. The vial was cooled and its contents

filtered through a silica pad with DCM as the eluent to remove inorganic and particulate material. Volatile components were removed *in vacuo* and the product purified by column chromatography using silica gel with a mixture of hexane and DCM (4:1) as the eluent to afford 3,5-difluoro-6-nitrobiphenyl (**286**) (0.173 g, 54 %) as a yellow solid; mp 52–53 °C; Anal. Calcd for C₁₂H₇F₂NO₂: C, 61.28; H, 3.00; N, 5.96. Found: C, 61.27; H, 3.01; N, 5.90; GC–MS *m/z* (% relative intensity, ion): 235 (18, M⁺), 207 (76), 188 (99), 151 (100), 51 (16); FT-IR (cm⁻¹): 1530, 1350; ¹H NMR (700 MHz, CDCl₃): δ 6.98–7.02 (2H, m, H–Ar), 7.34–7.37 (3H, m, H–Ar), 7.43–7.47 (2H, m, H–Ar); ¹³C NMR (176 MHz, CDCl₃): δ 105.5 (dd, ²J_{CF} 23.1, ²J_{CF} 26.8, C–4), 113.9 (dd, ²J_{CF} 23.4, ⁴J_{CF} 3.6, C–2), 127.9 (s, C–Ar), 129.4 (s, C–Ar), 129.8 (s, C–Ar), 134.7 (s, C–Ar), 136.1–136.4 (m, C–Ar), 139.0 (d, ³J_{CF} 10.1, C–Ar), 154.9 (dd, ¹J_{CF} 260, ³J_{CF} 13.5, C–F), 162.8 (dd, ¹J_{CF} 256, ³J_{CF} 12.1, C–F); ¹⁹F NMR (658 MHz, CDCl₃/CFCl₃): δ –103.7 – –103.8 (1F, m, F–Ar), –118.9 – –119.0 (1F, m, F–Ar).

5.4.1.4 Heck-type Reactions of Polyfluorinated Nitrobenzene Systems

1,2,3,4-Tetrafluoro-5-nitro-6-(phenylethynyl)benzene (42)

Pd(PPh₃)₄ (0.102 g, 0.088 mmol) was charged to a 0.5–2.0 mL microwave vial that was sealed and purged with argon to create an inert atmosphere. Dry, degassed DMSO (1.9 mL), phenyl acetylene (0.132 g, 1.292 mmol) and pentafluoronitrobenzene (0.250 g, 1.173 mmol) were added in sequence to the vial which was then heated to 120 °C for 20 minutes under microwave irradiation. The reaction mixture was cooled and filtered through an alumina plug with DCM as the eluent to remove inorganic and particulate material. The organic washings were concentrated *in vacuo*, poured onto water (100 mL) and extracted with DCM (3 × 100 mL). The organic fractions were combined, washed with water (100 mL) and dried (MgSO₄). Volatile components were removed *in vacuo* and the desired product was purified by column chromatography using silica gel and with a mixture of hexane and DCM (1:9) as the eluent. Recrystallisation from hexane afforded 1,2,3,4-tetrafluoro-5-nitro-6-(phenylethynyl)benzene (**42**) (0.127 g, 37 %) as a yellow solid; mp 111–112 °C; HRMS–ASAP (*m/z*): (M⁺) calcd for C₁₄H₆NF₃O₂ 295.0256; found 295.0252; ¹H NMR (700 MHz; CDCl₃): δ 7.38–7.41 (2H, m, H–Ar), 7.43–7.46 (1H, m, H–Ar), 7.55–7.58 (2H, m, H–Ar); ¹³C NMR (126 MHz; CDCl₃): δ 73.9–74.0 (m, –C≡C–), 104.4–104.5 (m, –C≡C–), 105.5 (dd, ²J_{CF} 18.7, ³J_{CF} 1.9, C–6), 121.1 (s, C–Ar), 129.0 (s, C–Ar), 130.7 (s, C–Ar), 132.5 (s, C–Ar), 136.6–136.9 (m, C–

5), 139.9–141.7 (m, C–F), 140.8–142.4 (m, C–F), 142.2–143.9 (m, C–F), 147.1–148.7 (m, C–F); ^{19}F NMR (658 MHz; $\text{CDCl}_3/\text{CFCl}_3$): δ –132.0 (1F, ddd, $^3J_{\text{FF}}$ 21.3, $^4J_{\text{FF}}$ 3.8, $^5J_{\text{FF}}$ 9.8, F–Ar), –145.6 (1F, ddd, $^3J_{\text{FF}}$ 21.5, $^6J_{\text{FF}}$ 6.2, $^5J_{\text{FF}}$ 9.8, F–Ar), –149.1 (1F, ddd, $^3J_{\text{FF}}$ 21.3, $^3J_{\text{FF}}$ 21.0, $^4J_{\text{FF}}$ 6.2, F–Ar). –150.9 (1F, ddd, $^3J_{\text{FF}}$ 21.5, $^3J_{\text{FF}}$ 21.0, $^4J_{\text{FF}}$ 3.8, F–Ar).

1,2,5-Trifluoro-4-nitro-3-(phenylethynyl)benzene (290)

$\text{Pd}(\text{PPh}_3)_4$ (0.076 g, 0.066 mmol) was charged to a 0.5–2.0 mL microwave vial that was sealed and purged with argon to create an inert atmosphere. Dry, degassed DMSO (1.9 mL), phenyl acetylene (0.127 g, 1.243 mmol) and 2,3,4,6-tetrafluoronitrobenzene (0.253 g, 1.297 mmol) were added in sequence to the vial which was then heated to 120 °C for 20 minutes under microwave irradiation. The reaction mixture was cooled and filtered through an alumina plug with DCM as the eluent to remove inorganic and particulate material. The organic washings were concentrated *in vacuo*, poured onto water (100 mL) and extracted with DCM (3 × 100 mL). The organic fractions were combined, washed with water (100 mL) and dried (MgSO_4). Volatile components were removed *in vacuo* and the desired product was purified by column chromatography using silica gel and with a mixture of hexane and DCM (9:1) as the eluent. Recrystallisation from hexane afforded 1,2,5-trifluoro-4-nitro-3-(phenylethynyl)benzene (**290**) (0.151 g, 44 %) as a yellow solid; mp 123–124 °C; HRMS–ASAP (m/z): (M^-) calcd for $\text{C}_{14}\text{H}_6\text{NF}_3\text{O}_2$ 277.0351; found 277.0345; GC–MS m/z (% relative intensity, ion): 277 (1, M^+), 260 (22), 230 (18), 105 (100), 77 (66), 51 (8); ^1H NMR (700 MHz; CDCl_3): δ 7.12 (1H, ddd, $^3J_{\text{HF}}$ 9.2, $^3J_{\text{HF}}$ 9.2, $^4J_{\text{HF}}$ 6.3, H–6), 7.38–7.42 (2H, m, H–Ar), 7.43–7.46 (1H, m, H–Ar), 7.57–7.59 (2H, m, H–Ar); ^{13}C NMR (126 MHz; CDCl_3): δ 75.2–75.3 (m, $-\text{C}\equiv\text{C}-$), 104.8–104.9 (m, $-\text{C}\equiv\text{C}-$), 106.7 (dd, $^2J_{\text{CF}}$ 25.4, $^2J_{\text{CF}}$ 22.4, C–6), 111.0 (d, $^2J_{\text{CF}}$ 16.7, C–3), 121.1 (s, C–Ar), 128.8 (s, C–Ar), 130.5 (s, C–Ar), 132.5 (s, C–Ar), 136.7–137.0 (m, C–4), 147.5 (ddd, $^1J_{\text{CF}}$ 256, $^2J_{\text{CF}}$ 14.3, $^4J_{\text{CF}}$ 4.1, C–2), 150.3 (ddd, $^1J_{\text{CF}}$ 261, $^3J_{\text{CF}}$ 11.6, $^4J_{\text{CF}}$ 4.0, C–5), 151.7 (ddd, $^1J_{\text{CF}}$ 259, $^2J_{\text{CF}}$ 13.9, $^3J_{\text{CF}}$ 12.3, C–1); ^{19}F NMR (658 MHz; $\text{CDCl}_3/\text{CFCl}_3$): δ –122.2 (1F, ddd, $^3J_{\text{FH}}$ 9.2, $^4J_{\text{FF}}$ 6.4, $^5J_{\text{FF}}$ 13.0, F–5), –126.1 (1F, ddd, $^3J_{\text{FF}}$ 21.4, $^3J_{\text{FH}}$ 9.2, $^4J_{\text{FF}}$ 6.4, F–1), –134.7 (1F, ddd, $^3J_{\text{FF}}$ 21.4, $^4J_{\text{FH}}$ 6.3, $^5J_{\text{FF}}$ 13.0, F–2).

1,1-Diphenyl-3-(2,3,5-trifluoro-6-nitrophenyl)prop-2-yn-1-ol (291)

Pd(PPh₃)₄ (0.076 g, 0.066 mmol) was charged to a 0.5–2.0 mL microwave vial that was sealed and purged with argon to create an inert atmosphere. Dry, degassed DMSO (1.9 mL), 1,1-diphenylprop-2-yn-1-ol (0.297 g, 1.426 mmol) and 2,3,4,6-tetrafluoronitrobenzene (0.254 g, 1.302 mmol) were added in sequence to the vial which was then heated to 120 °C for 20 minutes under microwave irradiation. The reaction mixture was cooled and filtered through an alumina plug with DCM as the eluent to remove inorganic and particulate material. The organic washings were concentrated *in vacuo*, poured onto water (100 mL) and extracted with DCM (3 × 100 mL). The organic fractions were combined, washed with water (100 mL) and dried (MgSO₄). Volatile components were removed *in vacuo* and the desired product was purified by column chromatography using silica gel and with a mixture of hexane and DCM (1:9) as the eluent. Recrystallisation from hexane afforded 1,1-diphenyl-3-(2,3,5-trifluoro-6-nitrophenyl)prop-2-yn-1-ol (**291**) (0.255 g, 50 %) as a viscous yellow liquid; HRMS–ASAP (*m/z*): (M⁺) calcd for C₂₁H₁₂NF₃NO₃ 383.0753; found 383.0769; ¹H NMR (700 MHz; CDCl₃): δ 3.04 (1H, s, –OH), 7.13 (1H, ddd, ³J_{HF} 9.2, ³J_{HF} 9.2, ⁴J_{HF} 6.4, H–Ar), 7.29–7.32 (2H, m, H–Ar), 7.35–7.38 (4H, m, H–Ar), 7.59–7.62 (4H, m, H–Ar); ¹³C NMR (126 MHz; CDCl₃): δ 73.0–73.1 (m, –C≡C–), 75.4 (s, C–OH), 107.4–107.5 (m, –C≡C–), 107.4 (dd, ²J_{CF} 25.4, ²J_{CF} 22.4, C–6), 110.1 (ddd, ²J_{CF} 18.2, ³J_{CF} 3.1, ³J_{CF} 1.1, C–3), 126.2 (s, C–Ar), 128.5 (s, C–Ar), 128.8 (s, C–Ar), 136.6–136.8 (m, C–4), 143.6 (s, C–Ar), 147.9 (ddd, ¹J_{CF} 256, ²J_{CF} 14.3, ⁴J_{CF} 4.0, C–2), 150.4 (ddd, ¹J_{CF} 260, ³J_{CF} 11.4, ⁴J_{CF} 4.0, C–5), 151.9 (ddd, ¹J_{CF} 261, ²J_{CF} 14.2, ³J_{CF} 12.5, C–1); ¹⁹F NMR (658 MHz; CDCl₃/CFCl₃): δ –121.5 (1F, ddd, ³J_{FF} 9.2, ⁴J_{FF} 6.6, ⁵J_{FF} 13.1, 5-F), –125.4 (1F, ddd, ³J_{FF} 21.4, ³J_{FF} 9.2, ⁴J_{FF} 6.6, 1-F), –133.8 (1F, ddd, ³J_{FF} 21.4, ⁴J_{FF} 6.4, ⁵J_{FF} 13.1, 2-F).

2-Methyl-4-(2,3,5-trifluoro-6-nitrophenyl)but-3-yn-2-ol (292)

Pd(PPh₃)₄ (0.078 g, 0.067 mmol) was charged to a 0.5–2.0 mL microwave vial that was sealed and purged with argon to create an inert atmosphere. Dry, degassed DMSO (1.9 mL), 1,1-dimethylprop-2-yn-1-ol (0.115 g, 1.367 mmol) and 2,3,4,6-tetrafluoronitrobenzene (0.254 g, 1.302 mmol) were added in sequence to the vial which was then heated to 120 °C for 20 minutes under microwave irradiation. The reaction mixture was cooled and filtered through an alumina plug with DCM as the eluent to

remove inorganic and particulate material. The organic washings were concentrated *in vacuo*, poured onto water (100 mL) and extracted with DCM (3 × 100 mL). The organic fractions were combined, washed with water (100 mL) and dried (MgSO₄). Volatile components were removed *in vacuo* and the desired product was purified by column chromatography using silica gel and with a mixture of hexane and DCM (1:9) as the eluent. Recrystallisation from hexane afforded 2-methyl-4-(2,3,5-trifluoro-6-nitrophenyl)but-3-yn-2-ol (**292**) (0.219 g, 58 %) as a yellow solid which decomposed upon heating; HRMS–ASAP (*m/z*): (M⁻) calcd for C₁₁H₈NF₃O₃ 259.0456; found 259.0459; ¹H NMR (700 MHz; CDCl₃): δ 1.61 (6H, s, –CH₃), 2.63 (1H, s, –OH), 7.12 (1H, ddd, ³J_{HF} 9.2, ³J_{HF} 9.2, ⁴J_{HF} 6.4, H–Ar); ¹³C NMR (126 MHz; CDCl₃): δ 30.9 (s, –CH₃), 66.0 (s, C–OH), 68.4–68.5 (m, –C≡C–), 107.1 (dd, ²J_{CF} 25.3, ²J_{CF} 22.5, C–4), 109.5–109.6 (m, –C≡C–), 110.2 (ddd, ²J_{CF} 18.3, ³J_{CF} 3.3, ³J_{CF} 1.5, C–1), 136.9–137.2 (m, C–6), 147.6 (ddd, ¹J_{CF} 256, ²J_{CF} 14.2, ⁴J_{CF} 4.0, C–2), 150.2 (ddd, ¹J_{CF} 259, ³J_{CF} 11.5, ⁴J_{CF} 4.0, C–5), 151.8 (ddd, ¹J_{CF} 259, ²J_{CF} 13.9, ³J_{CF} 12.2, C–3); ¹⁹F NMR (658 MHz; CDCl₃/CFCl₃): δ –122.2 (1F, ddd, ³J_{FF} 9.1, ⁴J_{FF} 6.4, ⁵J_{FF} 13.1, F–5), –126.0 (1F, ddd, ³J_{FF} 21.3, ³J_{FF} 9.2, ⁴J_{FF} 6.4, F–1), –134.7 (1F, ddd, ³J_{FF} 21.3, ⁴J_{FF} 6.3, ⁵J_{FF} 13.1, F–2).

1,2,3-Trifluoro-5-nitro-4-(phenylethynyl)benzene (293)

Pd(PPh₃)₄ (0.074 g, 0.064 mmol) was charged to a 0.5–2.0 mL microwave vial that was sealed and purged with argon to create an inert atmosphere. Dry, degassed DMSO (1.9 mL), phenyl acetylene (0.154 g, 1.508 mmol) and 2,3,4,5-tetrafluoronitrobenzene (0.255 g, 1.307 mmol) were added in sequence to the vial which was then heated to 120 °C for 20 minutes under microwave irradiation. The reaction mixture was cooled and filtered through an alumina plug with DCM as the eluent to remove inorganic and particulate material. The organic washings were concentrated *in vacuo*, poured onto water (100 mL) and extracted with DCM (3 × 100 mL). The organic fractions were combined, washed with water (100 mL) and dried (MgSO₄). Volatile components were removed *in vacuo* and the desired product was purified by column chromatography using silica gel and with a mixture of hexane and DCM (9:1) as the eluent. Recrystallisation from hexane afforded 1,2,3-trifluoro-5-nitro-4-(phenylethynyl)benzene (**293**) (0.176 g, 48 %) as a yellow solid; mp 79–80 °C; HRMS–ASAP (*m/z*): (M⁻) calcd for C₁₄H₆NF₃O₂ 277.0351; found 277.0355; GC–MS *m/z* (% relative intensity, ion): 277

(7, M⁺), 260 (38), 230 (21), 105 (100), 77 (62), 51 (6); ¹H NMR (700 MHz; CDCl₃): δ 7.39–7.46 (3H, m, H–Ar), 7.45–7.62 (2H, m, H–Ar), 7.88 (1H, ddd, ³J_{HF} 9.4, ⁴J_{HF} 6.8, ⁵J_{HF} 2.1, H–6); ¹³C NMR (126 MHz; CDCl₃): δ 76.2–76.3 (m, –C≡C–), 104.5–104.6 (m, –C≡C–), 108.0 (dd, ²J_{CF} 17.5, ³J_{CF} 3.9, C–4), 110.2 (dd, ²J_{CF} 22.7, ³J_{CF} 3.6, C–6), 121.8 (s, C–Ar), 128.8 (s, C–Ar), 130.3 (s, C–Ar), 132.5 (s, C–Ar), 143.8 (ddd, ¹J_{CF} 263, ²J_{CF} 15.5, ²J_{CF} 15.5, C–2), 144.4–144.5 (m, C–5), 149.5 (ddd, ¹J_{CF} 258, ²J_{CF} 11.3, ³J_{CF} 3.8, C–Ar), 152.4 (ddd, ¹J_{CF} 258, ²J_{CF} 11.2, ³J_{CF} 3.5, C–Ar); ¹⁹F NMR (658 MHz; CDCl₃/CFCl₃): δ –125.0 (1F, ddd, ³J_{FF} 20.6, ⁴J_{FF} 8.1, ⁵J_{FF} 2.1, F–3), –129.4 (1F, ddd, ³J_{FF} 20.8, ³J_{FF} 9.4, ⁵J_{FF} 8.5, F–1), –149.4 (1F, ddd, ³J_{FF} 20.8, ³J_{FF} 20.6, ⁴J_{FF} 6.8, F–2).

1,1-Diphenyl-3-(2,3,4-trifluoro-6-nitrophenyl)prop-2-yn-1-ol (294)

Pd(PPh₃)₄ (0.076 g, 0.066 mmol) was charged to a 0.5–2.0 mL microwave vial that was sealed and purged with argon to create an inert atmosphere. Dry, degassed DMSO (1.9 mL), 1,1-diphenylprop-2-yn-1-ol (0.294 g, 1.412 mmol) and 2,3,4,5-tetrafluoronitrobenzene (0.254 g, 1.302 mmol) were added in sequence to the vial which was then heated to 120 °C for 20 minutes under microwave irradiation. The reaction mixture was cooled and filtered through an alumina plug with DCM as the eluent to remove inorganic and particulate material. The organic washings were concentrated *in vacuo*, poured onto water (100 mL) and extracted with DCM (3 × 100 mL). The organic fractions were combined, washed with water (100 mL) and dried (MgSO₄). Volatile components were removed *in vacuo* and the desired product was purified by column chromatography using silica gel and with a mixture of hexane and DCM (1:9) as the eluent. Recrystallisation from hexane afforded 1,1-diphenyl-3-(2,3,4-trifluoro-6-nitrophenyl)prop-2-yn-1-ol (**294**) (0.202 g, 40 %) as a yellow solid; mp 88–89 °C; Anal. Calcd for C₂₁H₁₂F₃NO₃: C, 65.80; H, 3.16; N, 3.65. Found: C, 65.90; H, 3.21; N, 3.69; GC–MS *m/z* (% relative intensity, ion): 383 (0.5, M⁺), 350 (10), 182 (9), 105 (100), 77 (30), 51 (3); ¹H NMR (700 MHz; CDCl₃): δ 3.01 (1H, s, –OH), 7.30 (2H, t, ³J_{HH} 7.3, H–Ar), 7.37 (4H, dd, ³J_{HH} 7.3, ³J_{HH} 7.3, H–Ar), 7.61 (4H, d, ³J_{HH} 7.3, H–Ar), 7.86–7.91 (1H, m, H–5); ¹³C NMR (126 MHz; CDCl₃): δ 74.1–74.2 (m, –C≡C–), 75.5 (s, C–OH), 106.9–107.1 (m, C–1), 107.1–107.2 (m, –C≡C–), 110.1 (dd, ²J_{CF} 22.6, ³J_{CF} 3.5, C–5), 126.3 (s, C–Ar), 128.4 (s, C–Ar), 128.8 (s, C–Ar), 143.8 (ddd, ¹J_{CF} 264, ²J_{CF} 15.3, ²J_{CF} 15.3, C–3), 143.9 (s, C–Ar), 144.2–144.4 (m, C–6), 149.9 (ddd, ¹J_{CF} 258, ²J_{CF} 11.2, ³J_{CF} 3.8, C–F), 152.9 (ddd, ¹J_{CF} 258, ²J_{CF} 10.5, ³J_{CF} 3.2, C–F); ¹⁹F NMR (658 MHz; CDCl₃;

CFCl₃): δ -124.3 (1F, dd, ³J_{FF} 20.7, ⁴J_{FF} 8.6, F-2), -128.2 (1F, ddd, ³J_{FF} 20.7, ³J_{FH} 8.5, ⁴J_{FF} 8.6, F-4), -148.8 (1F, ddd, ³J_{FF} 20.7, ³J_{FF} 20.7, ⁴J_{FH} 6.7, F-3).

2-Methyl-4-(2,3,4-trifluoro-6-nitrophenyl)but-3-yn-2-ol (295)

Pd(PPh₃)₄ (0.074 g, 0.064 mmol) was charged to a 0.5–2.0 mL microwave vial that was sealed and purged with argon to create an inert atmosphere. Dry, degassed DMSO (1.9 mL), 1,1-dimethylprop-2-yn-1-ol (0.122 g, 1.450 mmol) and 2,3,4,5-tetrafluoronitrobenzene (0.249 g, 1.276 mmol) were added in sequence to the vial which was then heated to 120 °C for 20 minutes under microwave irradiation. The reaction mixture was cooled and filtered through an alumina plug with DCM as the eluent to remove inorganic and particulate material. The organic washings were concentrated *in vacuo*, poured onto water (100 mL) and extracted with DCM (3 × 100 mL). The organic fractions were combined, washed with water (100 mL) and dried (MgSO₄). Volatile components were removed *in vacuo* and the desired product was purified by column chromatography using silica gel and with a mixture of hexane and DCM (1:9) as the eluent. Recrystallisation from hexane afforded 2-methyl-4-(2,3,4-trifluoro-6-nitrophenyl)but-3-yn-2-ol (**295**) (0.246 g, 69 %) as a yellow solid which decomposed upon heating; Anal. Calcd for C₁₁H₈F₃NO₃: C, 50.98; H, 3.11; N, 5.40. Found: C, 51.15; H, 3.15; N, 5.73; ES⁺-MS *m/z* (% relative intensity, ion): 282 (100, [M + Na]⁺), 220 (30), 189 (18), 79 (34); ¹H NMR (700 MHz; CDCl₃): δ 1.65 (6H, s, -CH₃), 2.34 (1H, s, -OH), 7.80–7.85 (1H, m, H-Ar); ¹³C NMR (126 MHz; CDCl₃): δ 31.1 (s, -CH₃), 66.1 (s, C-OH), 69.2–69.3 (m, -C≡C-), 107.2 (dd, ²J_{CF} 17.2, ³J_{CF} 4.3, C-1), 109.2–109.3 (m, -C≡C-), 110.2 (dd, ²J_{CF} 22.6, ³J_{CF} 3.5, C-5), 143.7 (dt, ¹J_{CF} 263, ²J_{CF} 15.4, C-3), 144.6–144.8 (m, C-6), 149.9 (ddd, ¹J_{CF} 258, ²J_{CF} 11.1, ³J_{CF} 3.8, C-F), 152.9 (ddd, ¹J_{CF} 258, ²J_{CF} 11.3, ³J_{CF} 3.6, C-F); ¹⁹F NMR (658 MHz; CDCl₃/CFCl₃): δ -125.1 (1F, dd, ³J_{FF} 20.4, ⁴J_{FF} 8.6, F-2), -129.0 (1F, ddd, ³J_{FF} 20.6, ³J_{FH} 8.9, ⁴J_{FF} 8.6, F-4), -149.3 (1F, ddd, ³J_{FF} 20.6, ³J_{FF} 20.4, ⁴J_{FH} 6.7, F-3).

2.3.5.6-Tetrafluoro-4-phenylpyridine (301)

A concentrated aqueous solution of sodium hydroxide was added drop-wise to a saturated solution of phenylboronic acid (0.812 g, 6.660 mmol) in toluene until the precipitation of sodium trihydroxy(phenyl)borate was complete. The precipitate was isolated by filtration, washed with copious quantities of toluene, ground to a fine

powder and thoroughly dried *in vacuo*. The residual white solid (0.675 g, 63 %) had a melting point in excess of 350 °C and was taken to the next synthetic step without further purification. Method A: Pd(PPh₃)₄ (0.061 g, 0.053 mmol) and crude sodium trihydroxy(phenyl)borate (0.185 g, 1.142 mmol) were charged to a 2–5 mL microwave vial that was sealed, evacuated and back-filled with argon to create an inert atmosphere. Dry, degassed toluene (4 mL) and then 2,3,5,6-tetrafluoro-4-nitropyridine (0.197 g, 1.005 mmol) were added in sequence to the microwave vial using a syringe and the reaction vessel was then heated to 120 °C for 15 minutes under microwave irradiation. The reaction mixture was cooled and filtered through a silica plug with DCM as the eluent to remove inorganic and particulate material. Volatile components were removed *in vacuo* and column chromatography using silica gel and hexane as the eluent afforded 2,3,5,6-tetrafluoro-4-phenylpyridine (**301**) (0.173 g, 76 %) as a white solid; mp 103–104 °C; GC–MS *m/z* (% relative intensity, ion): 227 (100, M⁺), 207 (34), 188 (28), 51 (15); ¹H NMR (400 MHz; CDCl₃): δ 7.50–7.58 (5H, m, H–Ar); ¹³C NMR (176 MHz; CDCl₃): δ 126.2 (s, C–Ar), 129.2 (s, C–Ar), 130.0 (t, ³J_{CF} 2.3, C–1'), 130.8 (s, C–Ar), 133.6–133.8 (m, C–4), 138.6–140.3 (m, C–F), 143.5–145.1 (m, C–F); ¹⁹F NMR (658 MHz; CDCl₃/CFCl₃): δ –91.2 (2F, ddd, ³J_{FF} 29.2, ⁵J_{FF} 29.2, ⁴J_{FF} 13.8, F–2), –145.7 (1F, ddd, ³J_{FF} 29.2, ⁵J_{FF} 29.2, ⁴J_{FF} 13.8, F–3). Method B: Reaction of 2,3,5,6-tetrafluoro-4-(phenylsulfonyl)pyridine (0.301 g, 1.034 mmol), Pd(PPh₃)₄ (0.061 g, 0.053 mmol) and sodium trihydroxy(phenyl)borate (0.187 g, 1.155 mmol) in dry, degassed toluene (4 mL) afforded 2,3,5,6-tetrafluoro-4-phenylpyridine (**301**) (0.206 g, 88 %) as characterised above (Method A).

2,3,5,6-Tetrafluoro-4-*p*-tolylpyridine (306)

A concentrated aqueous solution of sodium hydroxide was added drop-wise to a saturated solution of *p*-tolylboronic acid (0.581 g, 4.273 mmol) in toluene until the precipitation of sodium trihydroxy(*p*-tolyl)borate was complete. The precipitate was isolated by filtration, washed with copious quantities of toluene, ground to a fine powder and thoroughly dried *in vacuo*. The residual white solid (0.512 g, 68 %) had a melting point in excess of 350 °C and was taken to the next synthetic step without further purification. Method A: Pd(PPh₃)₄ (0.059 g, 0.051 mmol) and crude sodium trihydroxy(*p*-tolyl)borate (0.195 g, 1.108 mmol) were charged to a 2–5 mL microwave vial that was sealed, evacuated and back-filled with argon to create an inert atmosphere.

Dry, degassed toluene (4 mL) and then 2,3,5,6-tetrafluoro-4-nitropyridine (0.199 g, 1.015 mmol) were added in sequence to the microwave vial using a syringe and the reaction vessel was then heated to 120 °C for 15 minutes under microwave irradiation. The reaction mixture was cooled and filtered through a silica plug with DCM as the eluent to remove inorganic and particulate material. Volatile components were removed *in vacuo* and column chromatography using silica gel and hexane as the eluent afforded 2,3,5,6-tetrafluoro-4-*p*-tolylpyridine (**306**) (0.211 g, 86 %) as a white solid; mp 105–106 °C; GC–MS *m/z* (% relative intensity, ion): 241 (100, M⁺), 220 (86), 202 (24), 91 (47); ¹H NMR (400 MHz; CDCl₃): δ 2.45 (3H, s, –CH₃), 7.33–7.37 (2H, m, H–Ar), 7.41–7.45 (2H, m, H–Ar); ¹³C NMR (176 MHz; CDCl₃): δ 21.7 (s, –CH₃), 123.2 (s, C–Ar), 129.8 (s, C–Ar), 129.9 (s, C–Ar), 133.6–133.9 (m, C–4), 138.3–140.7 (m, C–F), 142.1 (s, C–Ar), 143.0–145.5 (m, C–F); ¹⁹F NMR (658 MHz; CDCl₃/CFC₃): δ –91.6 (2F, ddd, ³J_{FF} 29.3, ⁵J_{FF} 29.3, ⁴J_{FF} 13.9, F–2), –145.9 (1F, ddd, ³J_{FF} 29.3, ⁵J_{FF} 29.3, ⁴J_{FF} 13.9, F–3). Method B: Reaction of 2,3,5,6-tetrafluoro-4-(phenylsulfonyl)pyridine (0.297 g, 1.020 mmol), Pd(PPh₃)₄ (0.062 g, 0.054 mmol) and sodium trihydroxy(*p*-tolyl)borate (0.202 g, 1.148 mmol) in dry, degassed toluene (4 mL) afforded 2,3,5,6-tetrafluoro-4-*p*-tolylpyridine (**306**) (0.187 g, 76 %) as characterised above (Method A).

2,3,5,6-Tetrafluoro-4-(4'-propoxybiphenyl-4-yl)pyridine (307)

A concentrated aqueous solution of sodium hydroxide was added drop-wise to a saturated solution of 4'-propoxybiphenyl-4-ylboronic acid (1.507 g, 5.884 mmol) in toluene and diethyl ether until the precipitation of sodium trihydroxy(4'-propoxybiphenyl-4-yl)borate was complete. The precipitate was isolated by filtration, washed with copious quantities of toluene, ground to a fine powder and thoroughly dried *in vacuo*. The residual white solid (1.034 g, 59 %) had a melting point in excess of 350 °C and was taken to the next synthetic step without further purification. Method A: Pd(PPh₃)₄ (0.062 g, 0.054 mmol) and crude sodium trihydroxy(4'-propoxybiphenyl-4-yl)borate (0.199 g, 0.672 mmol) were charged to a 2–5 mL microwave vial that was sealed, evacuated and back-filled with argon to create an inert atmosphere. Dry, degassed toluene (4 mL) and then 2,3,5,6-tetrafluoro-4-nitropyridine (0.109 g, 0.556 mmol) were added in sequence to the microwave vial using a syringe and the reaction vessel was then heated to 120 °C for 15 minutes under microwave irradiation. The reaction mixture was cooled and filtered through a silica plug with DCM as the eluent to

remove inorganic and particulate material. Volatile components were removed *in vacuo* and column chromatography using silica gel and hexane as the eluent afforded 2,3,5,6-tetrafluoro-4-(4'-propoxybiphenyl-4-yl)pyridine (**307**) (0.102 g, 51 %) as a yellow solid; mp 178–179 °C; GC–MS m/z (% relative intensity, ion): 361 (57, M^+), 319 (100), 290 (13), 270 (13); ^1H NMR (400 MHz; CDCl_3): δ 1.07 (3H, t, $^3J_{\text{HH}}$ 7.4, $-\text{CH}_3$), 1.79–1.90 (2H, m, $-\text{CH}_2-$), 3.99 (2H, t, $^3J_{\text{HH}}$ 6.6, $-\text{CH}_2-$), 6.98–7.03 (2H, m, H–Ar), 7.56–7.62 (4H, m, H–Ar), 7.70–7.74 (2H, m, H–Ar); ^{13}C NMR (176 MHz; CDCl_3): δ 10.8 (s, $-\text{CH}_3$), 22.9 (s, $-\text{CH}_2-$), 69.9 (s, $-\text{CH}_2-$), 115.3 (s, C–Ar), 124.2 (s, C–Ar), 127.3 (s, C–Ar), 128.5 (s, C–Ar), 130.5 (t, $^3J_{\text{CF}}$ 2.4, C–1'), 132.2 (s, C–Ar), 133.3–133.6 (m, C–4), 138.7–140.4 (m, C–F), 143.4 (s, C–Ar), 143.5–145.1 (m, C–F), 159.7 (s, C–Ar); ^{19}F NMR (658 MHz; $\text{CDCl}_3/\text{CFCl}_3$): δ –91.4 (2F, ddd, $^3J_{\text{FF}}$ 26.1, $^5J_{\text{FF}}$ 26.1, $^4J_{\text{FF}}$ 10.6, F–2), –145.7 (1F, ddd, $^3J_{\text{FF}}$ 26.1, $^5J_{\text{FF}}$ 26.1, $^4J_{\text{FF}}$ 10.6, F–3). Method B: Reaction of 2,3,5,6-tetrafluoro-4-(phenylsulfonyl)pyridine (0.181 g, 0.622 mmol), $\text{Pd}(\text{PPh}_3)_4$ (0.037 g, 0.032 mmol) and sodium trihydroxy(4'-propoxybiphenyl-4-yl)borate (0.203 g, 0.686 mmol) in dry, degassed toluene (4 mL) afforded 2,3,5,6-tetrafluoro-4-(4'-propoxybiphenyl-4-yl)pyridine (**307**) (0.146 g, 65 %) as characterised above (Method A).

4-(Perfluoropyridin-4-yl)benzonitrile (308)

A concentrated aqueous solution of sodium hydroxide was added drop-wise to a saturated solution of 4-cyanophenylboronic acid (0.740 g, 5.036 mmol) in toluene and diethyl ether until the precipitation of sodium (4-cyanophenyl)trihydroxyborate was complete. The precipitate was isolated by filtration, washed with copious quantities of toluene, ground to a fine powder and thoroughly dried *in vacuo*. The residual white solid (0.619 g, 66 %) had a melting point in excess of 350 °C and was taken to the next synthetic step without further purification. Method A: $\text{Pd}(\text{PPh}_3)_4$ (0.063 g, 0.055 mmol) and crude sodium (4-cyanophenyl)trihydroxyborate (0.202 g, 1.081 mmol) were charged to a 2–5 mL microwave vial that was sealed, evacuated and back-filled with argon to create an inert atmosphere. Dry, degassed toluene (4 mL) and then 2,3,5,6-tetrafluoro-4-nitropyridine (0.297 g, 1.515 mmol) were added in sequence to the microwave vial using a syringe and the reaction vessel was then heated to 120 °C for 15 minutes under microwave irradiation. The reaction mixture was cooled and filtered through a silica plug with DCM as the eluent to remove inorganic and particulate

material. Volatile components were removed *in vacuo* and column chromatography using silica gel and hexane as the eluent afforded 4-(perfluoropyridin-4-yl)benzotrile (**308**) (0.071 g, 26 %) as a white solid; mp 101–102 °C; GC–MS *m/z* (% relative intensity, ion): 252 (100, M⁺), 232 (17), 207 (11), 183 (10); ¹H NMR (400 MHz; CDCl₃): δ 7.64–7.69 (2H, m, H–Ar), 7.84–7.88 (2H, m, H–Ar); ¹³C NMR (176 MHz; CDCl₃): δ 114.9 (s, –CN), 118.0 (s, C–Ar), 130.5 (s, C–Ar), 130.8 (t, ³J_{CF} 2.4, C–1'), 131.4–131.7 (m, C–4), 132.9 (s, C–Ar), 138.0–140.5 (m, C–F), 143.1–145.4 (m, C–F); ¹⁹F NMR (658 MHz; CDCl₃/CFCl₃): δ –89.6 (2F, ddd, ³J_{FF} 28.8, ⁵J_{FF} 28.8, ⁴J_{FF} 13.6, F–2), –144.9 (1F, ddd, ³J_{FF} 28.8, ⁵J_{FF} 28.8, ⁴J_{FF} 13.6, F–3). Method B: Reaction of 2,3,5,6-tetrafluoro-4-(phenylsulfonyl)pyridine (0.297 g, 1.020 mmol), Pd(PPh₃)₄ (0.063 g, 0.055 mmol) and sodium (4-cyanophenyl)trihydroxyborate (0.202 g, 1.375 mmol) in dry, degassed toluene (4 mL) afforded 4-(perfluoropyridin-4-yl)benzotrile (**308**) (0.074 g, 29 %) as characterised above (Method A).

5.5 References to Chapter 5

- [1] Iwata, Y.; Naito, H.; Inoue, M.; Ichinose, H.; Klasen-Memmer, M.; Tarumi, K. *Thin Solid Films* **2008**, *517*, 1421-1423.
- [2] Yeh, P.; Gu, G. *Optics of Liquid Crystal Displays*; Wiley: New York, 1999.
- [3] Merck In *Merck Technical Datasheet*.