

## Durham E-Theses

---

*The effect of changes in plasma membrane lipid composition on the heat sensitivity of Hepatoma tissue culture cells and selected plasma membrane enzymes*

Shabirali Ladha

### How to cite:

---

Ladha, Shabirali (1990) The effect of changes in plasma membrane lipid composition on the heat sensitivity of Hepatoma tissue culture cells and selected plasma membrane enzymes. Doctoral thesis, Durham University.

### Use policy

---

The full-text may be used and/or reproduced, and given to third parties in any format or medium, without prior permission or charge, for personal research or study, educational, or not-for-profit purposes provided that:

- a full bibliographic reference is made to the original source
- a <https://etheses.durham.ac.uk/id/eprint/6197/> is made to the metadata record in Durham E-Theses
- the full-text is not changed in any way

The full-text must not be sold in any format or medium without the formal permission of the copyright holders.

Please consult the [full Durham E-Theses policy](#) for further details.

The copyright of this thesis rests with the author.  
No quotation from it should be published without  
his prior written consent and information derived  
from it should be acknowledged.

**The effect of changes in plasma membrane lipid  
composition on the heat sensitivity of Hepatoma  
Tissue Culture cells and selected plasma  
membrane enzymes**

by

**Shabirali Ladha**  
(B.Sc. Bath)

**A Thesis submitted in candidature for  
the degree of  
Doctor of Philosophy**

**Department of Biological Sciences**

**The University of Durham**  
(Hatfield College)  
**1990**



28 AUG 1991

**To My Parents**

**Copyright © 1990 by Shabirali Ladha**

**The copyright of this thesis rests with the author. No quotation from it should be published without Shabirali Ladha's prior written consent and information derived from it should be acknowledged.**

## Abstract

Hepatoma Tissue Culture (HTC) cells grown in the presence of  $60\mu\text{M}$  arachidonic acid for 24, 36 and 48 hours became progressively more thermosensitive than control cells. However, this difference in thermal sensitivity was only detectable with the clonogenic assay and not with the colorimetric assay. Attempts were also made to manipulate cellular cholesterol levels. Firstly, some cells were incubated with phosphatidylcholine liposomes to deplete the plasma membrane of cholesterol. Secondly, another group of cells were treated with 25 hydroxycholesterol, an inhibitor of cholesterol synthesis, to lower cholesterol levels. Finally, a third group of cells were supplemented with cholesterol hemisuccinate, a hydrophilic ester of cholesterol. The first two approaches did not enhance the thermal sensitivity of HTC cells. Supplementation with cholesterol hemisuccinate, which was predicted to partition in to the plasma membrane and reduce membrane fluidity, resulted in increased thermal sensitivity of the cells. Thus, the thermal sensitivity of HTC cells could be enhanced by supplementation with either arachidonate or cholesterol hemisuccinate.

A rapid plasma membrane isolation procedure was developed which generated plasma membranes in relatively high yield and purity. The plasma membrane-enriched fraction was also assayed for contaminating intracellular membranes by determining marker enzyme activities associated with these membranes. Using this method, plasma membranes were prepared from HTC cells grown in  $60\mu\text{M}$  arachidonic acid for 36 hours and from cells grown in normal medium. Analysis of the plasma membrane showed that the arachidonic acid content of the phospholipid fatty acyl groups had been significantly increased in cells grown in the presence of this fatty acid. There was no change in the cholesterol/phospholipid molar ratio or cholesterol concentration relative to amount of protein in the plasma membranes from the two cell populations. The measurement of fluidity using DPH fluorescence polarisation revealed that the increase in the arachidonic acid content of the plasma membrane phospholipid acyl groups was associated with enhanced plasma membrane fluidity when compared to control plasma membranes. This increase in plasma membrane fluidity correlated with the enhanced thermal sensitivity of the cells grown in arachidonic acid-containing medium when compared to cells grown in normal medium. Furthermore, the thermal sensitivity of  $\text{Na}^+$ ,  $\text{K}^+$ -ATPase and alkaline phosphodiesterase I were assessed in plasma membranes derived from arachidonic acid-supplemented and control cells. The enhanced fluidity of plasma membranes derived from arachidonate-supplemented cells also correlated with increased thermosensitivity of alkaline phosphodiesterase I.

## Acknowledgements

I would like to express my thanks to the North of England Cancer Research Campaign for providing financial support for the work undertaken in this thesis and to Professor K. Bowler for providing research facilities in the Department of Biological Sciences. Furthermore, I am very grateful to Professor K. Bowler and Dr. R. Manning for their helpful supervision and critical reading of the manuscript.

I am indebted to the following people for their technical support: Miss J. Chambers for expert and invaluable assistance particularly in cell culture work; Mr T. Gibbons for general technical assistance; Mrs. C. Richardson for electron microscope work and D. Hutchinson for photography.

I would also like to thank Dr. A. R. Cossins of Liverpool University for the use of the fluorescence polarisation equipment and Dr. A. H. Seheult of Durham University for guidance in the statistical treatment of some of the data presented in this thesis. In addition, I would also like to thank the staff of the computer centre for their guidance in the use of the computing facilities especially the following software: T<sub>E</sub>X typesetting, GIMMS graphical and SPSSx statistical packages.

I would like to thank A. Sabokbar, M. Lee, K. Kingston, K. Fogg, C. Cummings, P. Harriman, S. Boyes, P. Milton and P. Aitchison for their encouragement and 'morale boosting meals' throughout the preparation of this thesis. However, my greatest appreciation has to go to A. Sabokbar and M. Lee for their generosity and kindness. In particular, I would like to thank A. Sabokbar for her excellent typing of the references and M. Lee for sending me printed output while computing this thesis from a remote work station. May we all have many more 'morale boosting meals' together.

Finally, I would also like to thank Dr. D. Clark and P. Wilde at the Institute of Food Research for their help in showing me how to compute this thesis at Durham from a remote work station at Norwich.

# Contents

---

<b>Abstract</b> . . . . .	i
<b>Acknowledgements</b> . . . . .	ii
<b>Contents</b> . . . . .	iii
<b>List of Figures</b> . . . . .	viii
<b>List of Tables</b> . . . . .	xii
<b>List of Plates</b> . . . . .	xiv
<b>Glossary</b> . . . . .	xv
<b>Materials</b> . . . . .	xvii
<b>1 General Introduction</b> . . . . .	1
<b>2 Characterization of the culture system and related methods</b>	18
2.1 Introduction . . . . .	18
2.2 Materials and Methods . . . . .	24
2.2.1 Aseptic procedures . . . . .	24
2.2.2 Washing and sterilization of equipment and reagents . . . . .	24
2.2.3 Incubators used for culture of cells . . . . .	24
2.2.4 Pipetting of media and solutions in flasks or 24-well plates . . . . .	24
2.2.5 Growth media and conditions . . . . .	25
2.2.6 Harvesting and subculture of HTC cells . . . . .	25
2.2.7 Estimation of cell number and viability by haemocytometer . . . . .	26
2.2.8 Estimation of cell number by Model D Industrial Coulter Counter . . . . .	27

2.2.9	Determination of cell size distribution using a micrometer . . .	27
2.2.10	Determination of cell size distribution using the Coulter Counter . . . . .	27
2.2.11	Cryopreservation of cells . . . . .	28
2.2.12	Establishing cultures from frozen cells . . . . .	28
2.2.13	Clonogenic assay . . . . .	28
2.2.14	Culture of HTC cells in 24-well plates . . . . .	29
2.2.15	Colorimetric method for the estimation of cell number in plates . . . . .	29
2.2.16	Cholesterol assay . . . . .	30
2.2.17	Preparation of lipid depleted serum . . . . .	30
2.2.18	Assay of total free fatty acids in serum . . . . .	30
2.3	Results . . . . .	32
2.4	Discussion . . . . .	53

### **3 Effect of changes in membrane lipid on thermal sensitivity**

<b>of HTC cells . . . . .</b>	<b>59</b>	
3.1	Introduction . . . . .	59
3.2	Materials and Methods . . . . .	72
3.2.1	pH measurement of culture media during heat treatment . . .	72
3.2.2	Time course of cell adherence to tissue culture flasks . . . . .	72
3.2.3	Supplementation of newborn bovine serum with free fatty acids . . . . .	73
3.2.4	Photography of the 'lipid droplets' formed after supplementation . . . . .	74

3.2.5	The clonogenic assay of cell survival after hyperthermic treatment . . . . .	74
3.2.6	The colorimetric assay of cell survival after hyperthermic treatment . . . . .	75
3.2.7	Preparation of liposomes . . . . .	76
3.2.8	Labelling of cells with [7(n)- <sup>3</sup> H]-cholesterol . . . . .	76
3.2.9	Clonogenic assay of cell thermosensitivity following liposome treatment . . . . .	78
3.2.10	Colorimetric assay of cell thermosensitivity following liposome treatment . . . . .	78
3.2.11	Inhibition of growth with 25-hydroxycholesterol . . . . .	79
3.2.12	25-Hydroxycholesterol treatment of cells followed by exposure to heat . . . . .	79
3.2.13	Cholesterol hemisuccinate treatment of cells followed by exposure to heat . . . . .	80
3.3	Results . . . . .	82
3.4	Discussion . . . . .	121

#### **4 Purification and characterization of plasma membranes**

	<b>from control and arachidonate-supplemented HTC cells . . . . .</b>	<b>138</b>
4.1	Introduction . . . . .	138
4.2	Methods . . . . .	156
4.2.1	Isolation of plasma membranes . . . . .	156
4.2.2	Assay of Na <sup>+</sup> , K <sup>+</sup> -ATPase (EC 3.6.1.3) and Mg <sup>2+</sup> -ATPase (EC 3.6.1.4) . . . . .	158
4.2.3	Assay of Alkaline phosphodiesterase I (EC 3.1.4.1) . . . . .	159

4.2.4	Assay of N-acetyl $\beta$ -glucosaminidase (EC 3.2.1.30)	159
4.2.5	Assay of NADPH cytochrome c reductase (EC 1.6.2.3)	160
4.2.6	Assay of Succinate dehydrogenase (EC 1.3.99.1)	161
4.2.7	Assay of Adenylate cyclase (EC 4.6.1.1)	161
4.2.8	Protein estimation	161
4.2.9	Lipid extraction procedure	162
4.2.10	Assay of phospholipid	162
4.2.11	Assay of unesterified Cholesterol	164
4.2.12	Isolation of serum free fatty acids and total membrane phospholipid	164
4.2.13	Preparation of fatty acid methyl esters	165
4.2.14	Gas-liquid chromatography of fatty acid methyl esters	166
4.2.15	Fluorescence polarization measurements	167
4.3	Results	172
4.3.1	Enzyme activities	172
4.3.2	Plasma membrane purification	175
4.3.3	Lipid analysis	177
4.4	Discussion	197

## 5 Thermostability of selected plasma membrane-bound

<b>enzymes</b>	212	
5.1	Introduction	212
5.2	Materials and Methods	223
5.2.1	Exposure of cells to hyperthermic temperatures	223
5.2.2	Harvesting and homogenisation of heat treated cells	223
5.2.3	Cell size analysis	224

5.2.4	Viability assay . . . . .	224
5.2.5	Enzyme assays . . . . .	224
5.2.6	Assay of adenylate cyclase (EC 4.6.1.1) . . . . .	225
5.2.7	Purification of plasma membranes . . . . .	228
5.2.8	Thermal inactivation of plasma membrane-associated enzymes . . . . .	228
5.2.9	Isothermal inactivation of alkaline phosphodiesterase I . . . . .	229
5.3	Results . . . . .	230
5.4	Discussion . . . . .	250
<b>6</b>	<b>General Discussion . . . . .</b>	<b>262</b>
	<b>References . . . . .</b>	<b>280</b>

## LIST OF FIGURES

2.1	Cell size distribution of HTC cells determined via a micrometer . . . . .	38
2.2	Cell size distribution of HTC cells determined via Coulter Counter . . . . .	39
2.3	A comparison of cryopreservation methods . . . . .	41
2.4	Growth characteristics of HTC cells grown in 25cm <sup>2</sup> flasks . . . . .	42
2.5	Plating efficiency of HTC cells . . . . .	43
2.6	Growth characteristics of HTC cells in LDS media . . . . .	45
2.7	Effect of exposure of HTC cells to LDS medium during expo- nential cell growth . . . . .	46
2.8	Absorption spectrum of the formazan product generated from MTT by HTC cells in culture . . . . .	47
2.9	Determination of optimal MTT concentration for colorimetric assay . . . . .	48
2.10	Optimal incubation time for MTT assay . . . . .	49
2.11	Relationship between cell number and absorbance in MTT colorimetric assay . . . . .	51
2.12	Growth characteristics of cells in 24-well plates as determined by the MTT assay . . . . .	52
3.1	Time course of HTC cell attachment to 25cm <sup>2</sup> tissue culture treated flasks . . . . .	95

3.2	The effect of attachment time on the heat sensitivity of HTC cells . . . . .	96
3.3	The effect of fungizone in culture media on the heat sensitivity of HTC cells . . . . .	97
3.4	The calculation of heat survival parameters $D_q$ and $D_0$ . . . . .	98
3.5	Heat-dose response curves for HTC cells in 25cm <sup>2</sup> flasks using the clonogenic assay of cell survival . . . . .	99
3.6	Heat-dose response curves for HTC cells cultured in 24-well plates, using the colorimetric assay of cell survival . . . . .	100
3.7	Growth characteristics of HTC cells in the presence of supplemental palmitate . . . . .	103
3.8	Growth characteristics of HTC cells in the presence of supplemental arachidonate . . . . .	104
3.9	The effect of arachidonate supplementation on the thermosensitivity of HTC cells at 43 <sup>0</sup> C . . . . .	106
3.10	The effect of 60 $\mu$ M arachidonate supplementation for 36 hours on the thermosensitivity of HTC cells grown in 24-well plates . . . . .	108
3.11	The effect of 80 $\mu$ M arachidonate supplementation on the thermosensitivity of HTC cells grown in 24-well plates . . . . .	110
3.12	Removal of [7(n)- <sup>3</sup> H]-cholesterol from HTC cells by liposomes . . . . .	112
3.13	The effect of exposure to liposomes on the thermosensitivity of HTC cells assessed by the clonogenic assay . . . . .	113
3.14	The effect of 24 hour exposure to 25-hydroxycholesterol on the growth of HTC cells . . . . .	116
3.15	The effect of 48 hour exposure to 25-hydroxycholesterol on the growth of HTC cells . . . . .	117
3.16	The effect 25-hydroxycholesterol on the thermosensitivity of HTC cells . . . . .	118
3.17	The effect of cholesterol hemisuccinate treatment on the thermosensitivity of HTC cells . . . . .	120

4.1 Schematic representation of major pathways for incorporation and turnover of long chain fatty acids in mammalian cells . . . . .	153
4.2 Major pathways for desaturation and elongation of the polyunsaturated fatty acids in mammalian cells . . . . .	155
4.3 Plasma membrane purification scheme . . . . .	171
4.4 Na <sup>+</sup> , K <sup>+</sup> -ATPase and Mg <sup>2+</sup> -ATPase activities with respect to time and protein . . . . .	180
4.5 Effect of Zn <sup>2+</sup> concentration on alkaline phosphodiesterase I activity . . . . .	181
4.6 Effect of incubation time and protein concentration on the activity of alkaline phosphodiesterase I . . . . .	182
4.7 Succinate dehydrogenase activity with respect to protein concentration . . . . .	183
4.8 Effect of protein concentration on NADPH cytochrome c reductase activity . . . . .	184
4.9 Effect of assay time and protein concentration on the activity of N-acetyl $\beta$ D-glucosaminidase . . . . .	185
4.10 Effect of incubation time and enzyme concentration on the activity of adenylate cyclase from HTC cells . . . . .	186
4.11 The relationship between log <sub>10</sub> relative retention time (RRT) and carbon chain length of saturated and unsaturated FAME standards . . . . .	190
4.12 Fatty acid chain length of HTC cell plasma membrane phospholipids . . . . .	193
4.13 Fatty acid unsaturation of plasma membrane phospholipids from control and arachidonate-supplemented HTC cells . . . . .	194
4.14 Steady state fluorescence polarisation of DPH in plasma membranes from control and arachidonic acid-supplemented HTC cells . . . . .	196

5.1	Diagrammatic representation of adenylate cyclase . . . . .	222
5.2	HTC cell size distribution after heat treatment . . . . .	236
5.3	Cell viability after heat treatment . . . . .	237
5.4	Effect of incubation time and enzyme concentration on the activity of adenylate cyclase from rat liver and HTC cells . . . . .	238
5.5	The response to some agonists of rat liver and HTC cell adeny- late cyclase . . . . .	239
5.6	Effect of varying the concentration of isoproterenol, GTP, GTP in the presence of 100 $\mu$ M isoproterenol or GTP $\gamma$ S on adenylate cyclase activity in HTC cell homogenates . . . . .	240
5.7	Effect of varying concentrations of forskolin alone or GTP $\gamma$ S in the presence of 100 $\mu$ M forskolin on adenylate cyclase activity in HTC cell homogenate . . . . .	241
5.8	The activity of adenylate cyclase in cell homogenates after hy- perthermic treatment of HTC cells . . . . .	242
5.9	The activity of Na <sup>+</sup> , K <sup>+</sup> -ATPase in cell homogenates after hyperthermic treatment of HTC cells . . . . .	243
5.10	The activity of Mg <sup>2+</sup> -ATPase in cell homogenates after hy- perthermic treatment of HTC cells . . . . .	244
5.11	The activity of alkaline phosphodiesterase I in cell ho- mogenates after hyperthermic treatment of HTC cells . . . . .	245
5.12	Thermal inactivation of Na <sup>+</sup> , K <sup>+</sup> -ATPase in purified control and arachidonic acid supplemented plasma membranes . . . . .	246
5.13	Thermal inactivation of alkaline phosphodiesterase I in con- trol and arachidonic acid supplemented plasma membranes . . . . .	247
5.14	Kinetics of the isothermal inactivation of alkaline phosphodi- esterase I in purified plasma membranes . . . . .	248

## LIST OF TABLES

2.1	Some landmarks in the development of tissue and cell culture . . . . .	23
2.2	Comparison of cell counts obtained via haemocytometer and Coulter Counter . . . . .	40
2.3	Cholesterol and free fatty acid concentration of lipid depleted serum . . . . .	44
2.4	Absorbance Stability of the formazan product generated from MTT by HTC cells . . . . .	50
3.1	The effect of heating at 43 <sup>0</sup> C on the pH of growth medium . . . . .	94
3.2	The heat survival parameters calculated from figures 3.5 and 3.6 . . . . .	101
3.3	The incorporation of supplemental fatty acid into newborn bovine serum . . . . .	102
3.4	The comparison of heat survival parameters calculated from figure 3.9 for control and supplemented cells . . . . .	107
3.5	The comparison of heat survival parameters calculated from figure 3.10 for control and supplemented cells . . . . .	109
3.6	The comparison of heat survival parameters calculated from figure 3.11 for control and arachidonate-supplemented cells . . . . .	111
3.7	The comparison of heat survival parameters calculated from figure 3.13 for control and liposome treated cells . . . . .	114
3.8	The effect of exposure to liposomes on the thermosensitivity of HTC cells assessed by the colorimetric assay . . . . .	115

3.9	The comparison of heat survival parameters calculated from figure 3.16 for control and 25-hydroxycholesterol treated cells . . . . .	119
4.1	Summary of fatty acid nomenclature . . . . .	154
4.2	Enzyme activities and cholesterol content of plasma membranes isolated from control and arachidonic acid supplemented HTC cells . . . . .	187
4.3	Microsomal, mitochondrial and lysosomal contamination of purified HTC cell plasma membranes . . . . .	189
4.4	Free fatty acid profile of newborn bovine serum (NBS), 16:0- and 20:4-supplemented NBS . . . . .	191
4.5	Fatty acid profile of total phospholipid extracted from HTC cell plasma membrane isolated from control and 20:4-supplemented cells . . . . .	192
4.6	Cholesterol/phospholipid molar ratio, oleic acid/PUFA ratio and the unsaturation index of control and arachidonic acid supplemented HTC cell plasma membranes . . . . .	195
4.7	Plasma membrane purification obtained by other workers . . . . .	211
5.1	The kinetic parameters describing the thermal decay of alkaline phosphodiesterase I . . . . .	249
5.2	Adenylate cyclase activity obtained by other workers . . . . .	261

## LIST OF PLATES

3.1	The accumulation of 'lipid droplets' in HTC cells exposed to 80 $\mu$ M arachidonate supplement . . . . .	105
4.1	Scanning electron micrographs of HTC cells grown on micro- carrier beads . . . . .	170

## Glossary

AMP	Adenosine 5'-monophosphate
ATP	Adenosine 5'-triphosphate
BHT	Butylated hydroxytoluene
BSA	Bovine serum albumin
Cyclic AMP	Adenosine 3'5'-cyclic phosphate
CHO	Chinese hamster ovary
DMSO	Dimethyl sulphoxide
DPH	1,6-Diphenyl-1,3,5-hexatriene
DTT	Dithiothreitol
EDTA	Ethylenediamine tetra-acetic acid
EGTA	Ethylene glycol tetra-acetic acid
ESR	Electron spin resonance
FAME	Fatty acid methyl esters
FBS	Foetal bovine serum
FFA	Free fatty acid
GLC	Gas liquid chromatography
GDP	Guanosine 5'-diphosphate
GPPNHP	Guanosine 5' - [ $\beta$ , $\gamma$ -imido] triphosphate
GTP	Guanosine 5'-triphosphate
GTP $\gamma$ S	guanosine 5' - [ $\gamma$ -thio] triphosphate

Hepes	N-2-Hydroxyethylpiperazine- <i>N'</i> -2-ethanesulphonic acid
HTC	Hepatoma tissue culture
IBMX	3-Isobutyl-1-methyl-xanthine
LDS	Lipid depleted serum
MTT	3-(4,5-dimethylthiazol-2-yl)-2, 5-diphenyl tetrazoliumbromide
NAD	Nicotinamide adenine dinucleotide
NADH	Nicotinamide adenine dinucleotide (reduced form)
NADPH	Nicotinamide adenine dinucleotide phosphate (reduced form)
NBS	Newborn bovine serum
NMR	Nuclear magnetic resonance
PUFA	Polyunsaturated fatty acid
$r_{av}$	Average radius of rotation
RRT	Relative retention time
SF-free	Serum free and Fungizone free
TCA	Trichloroacetic acid
TLC	Thin layer chromatography
UTP	Uridine 5'-triphosphate

## Materials

All reagents were of analytical grade unless stated otherwise.

*Aldrich Chemical Co. Ltd., Gillingham, Dorset.*

Isopropyl ether

*Alltech/Applied Science, Carnforth, Lancashire.*

10% Alltech CS-5, on a chromasorb WAW support (100-120 mesh)

GLC fatty acid methyl ester standards (12 : 0 – 24 : 0)

*Amersham International plc, Amersham, Buckinghamshire.*

[8-<sup>3</sup>H] Adenosine 3'5'-cyclic phosphate ammonium salt

[7(n)-<sup>3</sup>H]-cholesterol

*BDH Ltd., Poole, Dorset.*

Acetic acid (glacial)

Ammonium molybdate

Butan-1-ol

Chloroform

Choloxidate No. 1 kit

Cupric sulphate

Diethyl ether

Heptane

Hydrochloric acid

Light petroleum (b.p. 40-60°C)

Orthophosphoric acid

Potassium chloride

Sulphuric acid

Triton X-100

Zinc dibenzylthiocarbamate (laboratory reagent)

*B.O.C. Ltd., Vigo Lane, Birtley, Co. Durham.*

Nitrogen

Air

Hydrogen

*Coulter Electronic Ltd., Luton, Bedfordshire.*

Isoton II

*Fisons Scientific Apparatus, Loughborough, Leicestershire.*

Imidazole

Methanol

*Flow Laboratories Ltd., Rickmansworth, Hertfordshire.*

$Ca^{2+}$ -,  $Mg^{2+}$ -free PBS

Eagles Minimum Essential Medium

Fungizone (amphotericin B solution)

L-Glutamine

NBS

Non-essential amino acids

Penicillin

Sodium bicarbonate (7.5% solution)

Streptomycin

Tylosin

Trypsin 2.5% (*w/v*)

*James Burrough (FAD) Ltd., Witham, Essex.*

Absolute alcohol

*JJ (Chromatography) Ltd., King's Lynn, Norfolk.*

Glass g.l.c. columns, 2*m* long, 2*mm* internal diameter, 6*mm* external diameter

*Pharmacia (GB) Ltd., Milton Keynes, Buckinghamshire.*

Cytodex 2

Percoll

All other reagents were obtained from *Sigma Chemical Co., Poole, Dorset.*

# Chapter I

## General Introduction

The use of elevated temperatures (hyperthermia) to treat cancer can be traced to initial observations by astute and creative clinicians. Apparent spontaneous remissions of cancer were noted following prolonged intense fevers due to a variety of infections. Busch (1866) noted that a facial sarcoma showed complete regression after two attacks of erysipelas associated with high fever. This led Coley (1893) to devise a hyperthermia treatment which involved deliberate production of fever by administering a preparation containing bacterial pyrogenic toxins. The toxin injected produced a pyrexia of  $40^{\circ}\text{C}$  for 4-6 hours, and resulted in a number of dramatic responses in patients with inoperable and advanced malignant disease. After these crude beginnings, where whole body temperature was raised uncontrollably, improvements in technology have made it possible to raise not only whole body temperature but also the temperature within the specific area of the tumour to defined values (Law and Pettigrew, 1986; Bolomsjo, 1986). The treatment temperatures, for therapeutic purposes, are generally in the range  $42^{\circ}\text{C}$  -  $45^{\circ}\text{C}$  corresponding to elevations in temperature of between  $5^{\circ}\text{C}$  -  $8^{\circ}\text{C}$ . The objective of this temperature rise is the treatment of tumours either directly, by inducing irreversible biological damage, or indirectly by potentiating the effect of other well established treatment regimes such as surgery, radiotherapy or chemotherapy (Herman *et al.*, 1988).

The relative thermal sensitivity of cancer and normal cells is an important factor when considering this form of therapy. It is evident that if the tumour



cells are more heat sensitive than the normal cells heat treatment will result in preferential killing of tumour cells. However, the evidence to support enhanced thermal sensitivity of tumour cells over normal counterparts is contradictory. In several studies it has been suggested that cancer cells are damaged more easily by elevated temperatures than are normal cells, both *in vitro* and *in vivo* (Westermarck, 1927; Auersperg, 1966; Chen and Heidelberger, 1969; Levine and Robbins, 1970; and Giovanella *et al.*, 1976). However, as pointed out by Bhuyan (1979), the value of studies conducted by Auersperg (1966) and Levine and Robbins (1970) was limited since the comparisons were carried out between cells of differing origins.

The comparison of the heat sensitivities of 'normal' liver cells with those obtained from a closely associated hepatoma by Harisiadas *et al.* (1975) showed that the hepatoma cells were slightly more resistant to heat than normal cells. The observed greater thermal sensitivity of solid tumours over normal tissues is now thought to be due to the altered physiology of the solid tumour. For example, most normal tissues when faced with a heat challenge react by increasing blood flow which serves to dissipate the heat. However, these normal physiological responses are often different or totally lacking in the neovasculature of tumours which permits the differential heating of tumours growing within normal tissue (Stewart, 1988). Furthermore, the extracellular milieu in parts of most solid tumours has been shown to be characterised by nutrient depletion (Thomlinson and Gray, 1955), low pH (Wike-Hooley *et al.*, 1984) and chronic hypoxia (Vaupel, 1979), largely as a result of an inadequate vascular supply (Otte, 1988). These conditions have been shown to have a marked influence on the thermosensitivity of mammalian cells in culture (Gerweck, 1988).

The extensive use of cell culture technology in the study of thermal sensi-

tivity of cells has greatly facilitated the understanding of the factors involved in heat-induced cell death. This is because the physiological and physicochemical environment of the cell can be controlled and therefore altered with respect to one variable. However, it has to be noted that after hyperthermic treatment *in vivo* the changes in the immune response and regional blood flow responses will contribute to the overall effect of heat on the tumour cells (Hahn, 1982).

Increased thermal sensitivity due to decreased pH of the culture medium has been demonstrated in at least 10 cell lines (Gerweck, 1988). To assess the significance in tumour tissue of this pH sensitizing effect observed *in vitro*, the range of the pH values over which this effect manifests itself must be considered. Gerweck (1977), using Chinese hamster ovary cells, showed that the variation of extracellular pH between 7.6 and 7.1 did not significantly affect thermal sensitivity; however, thermal sensitivity increased significantly as the medium pH decreased below 7.1. Thus the pH range observed in tumour tissue, i.e. pH 6.6 to 7.0 (Gerweck, 1977) suggests that extracellular pH could play a significant role in determining *in vivo* thermal sensitivity. However, it is not known if a change in extracellular pH only is necessary for the pH sensitizing effect. In general, most studies have shown that when extracellular pH decreases below approximately 7.0, the intracellular pH also decreases approximately 0.5 to 1.0 units per extracellular pH unit (Roos and Boron, 1981). However, Gonzalez-Mendez *et al.* (1982a) reported that a decrease in extracellular pH from 7.5 to approximately 6.2 was virtually without effect on the internal pH of HA-1 cells. It has to be noted that HA-1 cells are sensitized to heat by less pronounced extracellular pH decreases (Li *et al.*, 1980), suggesting extracellular pH alone appears important in thermal sensitization. Therefore, whether increased thermal sensitization, due to a decrease in extracellular pH, involves a

change in intracellular pH remains unresolved. Several studies have compared the response of cultured cells to hyperthermia under normoxic and hypoxic conditions (Kim *et al.*, 1975; Bass *et al.*, 1978; Gerweck *et al.*, 1979). Although varying results have been obtained, in general under hypoxic conditions cells are equally or more sensitive to hyperthermia when compared to normoxic conditions. Similarly, it has been shown by Kim *et al.* (1980) and Gerweck *et al.* (1984) that thermal sensitivity of cultured cells is markedly increased when cells are exposed to reduced levels of both glucose and oxygen. These results suggest that variations in the microenvironment of normal and tumour tissue could play an important part in the differential heat sensitivity of many solid tumours over normal tissue.

The clonogenic assay (Puck *et al.*, 1955) has been used extensively in the measurement of the heat-induced cell death *in vitro*. In this assay, cells are seeded at known density in culture medium, subsequently they are exposed to hyperthermic treatment for a defined time period before being returned to culture at the normal growth temperature. Surviving cells replicate to form colonies which can be counted, so the assay measures the reproductive ability of cells after heat treatment. Using this assay, cell survival curves, produced by plotting the logarithm of the surviving fraction against time of heat treatment, are usually characterised by an initial shoulder with the shape becoming log-linear after longer exposure times. This has been shown to occur in many cell types including V-79 cells, HA-1 cells (Li *et al.*, 1982) and Chinese hamster ovary cells (Westra and Dewey, 1971). Hahn (1982) has suggested that the shoulder region on heat survival curves implies an ability of the cells to sustain sublethal damage.

The phenomenon of thermotolerance also alters the shape of the survival curves. Survival curves which show the occurrence of thermotolerance are char-

acterised by the initial shoulder region followed by the log-linear region, the gradient of which becomes lower at longer exposure times. This resistance to heat killing (thermotolerance) at long exposure times has been demonstrated to occur in Chinese hamster ovary cells heat treated between 41.5<sup>0</sup>C and 42.5<sup>0</sup>C (Dewey *et al.*, 1977). However, the onset of thermotolerance is not a characteristic of all cell lines (Henle and Roti Roti, 1988). The induction of thermotolerance can be achieved by two methods. The first method which has been described above involves prolonged heating at temperatures below 43<sup>0</sup>C. The second method involves the exposure of cells to hyperthermic temperatures (41<sup>0</sup>C to 46<sup>0</sup>C ) for short periods followed by a period of recovery of the cells at physiological temperatures. Subsequent treatment of these cells at lethal temperatures is characterised by an increase in thermal resistance (Nielsen and Overgaard, 1979), which is due to the development of thermotolerance during the recovery phase at physiological temperatures. The molecular basis for this thermotolerance is not understood, but there are a number of reports suggesting that heat treatment causes the synthesis of a specific set of proteins (stress or heat shock proteins) which may be related to the development of thermotolerance (Carper *et al.*, 1987).

To compare successfully the heat sensitivities of different cells, they must be grown and heat treated under the same culture conditions. Raaphorst *et al.* (1979) demonstrated that thermal sensitivity can vary enormously between specific cell lines, derived from different species, when cells were grown and heat treated under the same culture conditions. Rofstad and Brustad (1984) also showed that even cell lines derived from the same tissue (human melanoma xenografts) can span a range of heat sensitivities. The data indicate that it is not possible to predict the heat sensitivities of cell lines based on their tissue of origin.

The lack in understanding of the fundamental mechanisms of thermally-induced killing has hindered progress in defining the response of cells to heat in terms of 'thermal dose'. Once the process leading to thermal death has been identified, it may be possible to elucidate the thermodynamic mechanisms involved (Sapareto, 1988). Radiation treatment, in comparison to heat treatment, is relatively simple to describe since the energy deposited relates directly to the resulting response. However, the situation with hyperthermia is rather different since the biological response is primarily dependent on the time at an elevated temperature and not on the energy deposited (Hahn, 1982). In practice when applying hyperthermia in clinical treatments factors such as the time taken to reach the desired temperature within the tumour; variation in temperature within the tumour; and the thermal history of the cells will determine the overall response of the cells to heat (Field 1987a, b). Consequently, there is no acceptable unit of 'thermal dose' which can be used to quantify a therapeutic thermal treatment.

The models put forward to describe heat-induced cell death follow a hierarchical pattern i.e. primary lesion leads to secondary and tertiary lesions and ultimately cell death (Jung, 1986; Bowler, 1987). The major difference between the model of Jung (1986) and Bowler (1987) is that Jung suggested that heat produces nonlethal lesions which are converted into lethal lesions with time to bring about cell death, whereas Bowler proposed heat produces primary lesions which may or may not be, or become, irreversible that cause a wide range of secondary effects which become irreversible with time leading to cell death.

These models raise the question of the identity of the primary lesion sites which ultimately lead to cell death. The all pervasive influence of heat has led many workers to implicate a variety of cellular components as targets in the mechanism

of heat-induced death.

Lysosomes were the earliest targets implicated in heat-induced cell death because these organelles are involved in cell lysis. Hyperthermia could cause the rupture of lysosomes resulting in the release of lysosomal enzymes, thereby inducing the breakdown of the cell. Evidence to support increased lysosomal enzyme activity after hyperthermia has been obtained (Overgaard and Poulsen, 1977; Hume and Field, 1977). However, agents such as trypan blue, retinol and hydrocortisone which are known to enhance the susceptibility of lysosomal membranes to damage did not affect cell killing by heat (Hofer *et al.*, 1979). This argues against the involvement of lysosomes in heat-induced cell death. In addition, since lysosomes are involved in the destruction of dead cells many of the above considerations could well be a consequence of rather than a cause of heat damage.

Heat-induced damage to mitochondrial membranes has also been suggested to be another primary lesion site. Wheatley *et al.*, (1989) reported that marked changes in the ultrastructure of HeLa S<sub>3</sub> cell mitochondria, which appeared early during hyperthermia treatment, correlated well with the loss of viability and metabolic functioning found after treatment. Similar results have been obtained by other workers (Welch and Suham, 1985; Borrelli *et al.*, 1986). However, Heine *et al.*, (1971) working with HeLa S<sub>3</sub> cells found no significant changes in the mitochondria of cells heat treated for several hours at 45<sup>0</sup>C. Heat-induced damage to mitochondrial membranes should result in measurable changes in cellular respiration rates. However, the data concerning both respiration and glycolysis are quite contradictory. Strom *et al.*, (1977) reported that glycolysis was unaffected in extracts of cells from tumours (rat hepatomas, human melanomas and osteosarcomas) heat treated at temperatures up to 44<sup>0</sup>C. However, Dickson and

Suzanger (1976) found that heat treatment at temperatures as low as 42.5<sup>0</sup>C was sufficient to inhibit glycolysis. Depletion of ATP levels has also been implicated in thermal sensitization of cells (Laval and Michel, 1982). However, more recent work by Calderwood (1987) suggests that a general role for energy status in cellular responses to heat is unlikely. This conclusion is based on experiments using HA-1 fibroblasts, where over 99% of the cells are killed by 45<sup>0</sup>C heat before a decrease is observed in two parameters of energy status. These parameters are the degree of phosphorylation of the ATP-ADP-AMP system (adenylate energy charge) and the phosphorylation potential ( $[\text{ATP}]/[\text{ADP}] \times [\text{P}_i]$ ). Although these *in vitro* studies indicate a lack of correlation between energy status of cells and cell killing the thermal responses of tissues *in vivo* may differ.

Investigations measuring the influence of heat at the organelle level e.g lysosomes and mitochondria, as mentioned above, raise the question of the identity of the macromolecules, damaged by heat, which lead to the malfunction of cellular processes. Proteins are a likely candidate in the involvement in hyperthermic cell death. Johnson (1974) noted that the activation enthalpy for cell killing is similar to that observed for protein denaturation. This suggests the involvement of protein denaturation in heat-induced cell killing. Agents that are known to interact with protein also influence heat-induced cell killing. Kapp and Hahn (1979) showed that when Chinese hamster ovary cells were incubated in the presence of sulphhydryl-rich compounds, which destabilize proteins, the cells became very heat sensitive. In contrast, deuterium oxide and glycerol, both of which are thought to stabilize proteins, protect cells against heat damage (Fisher *et al.*, 1982). Recent investigations by Lepock and collaborators (Lepock *et al.*, 1983, 1988, 1989) have demonstrated that membrane protein denaturation is caused by hyperthermic

temperatures, indicating its important role in hyperthermia-induced cell killing. In addition, several studies have shown that protein synthesis is almost completely inhibited by exposure of cells to 43<sup>0</sup>C or higher temperatures (Henle and Leeper, 1979). However, these studies have also shown that during the subsequent recovery phase at 37<sup>0</sup>C after heat treatment protein synthesis resumes, which suggests that inhibition of protein synthesis is reversible, and therefore is unlikely to be a primary cause of cell killing.

The nucleus, and the macromolecules contained within it, have been shown to be influenced by heat. DNA itself is not thought to be directly damaged by heat treatment since the melting temperature of DNA *in vitro* is approximately 87<sup>0</sup>C. However, the synthesis of DNA is reduced after exposure of cells to heat but this inhibition is reversed when cells are returned to physiological temperatures. The involvement of chromosomes in heat death was demonstrated by Dewey *et al.* (1971) who showed that the number of chromosomal aberrations induced by heat correlated with cell death. Similarly, Tomasovic *et al.*, (1978) observed that after hyperthermia the amount of nonhistone protein associated with DNA increased. In addition, the amount of protein associated with nuclear structures was thought to be related to the extent of cell killing by hyperthermia (Roti Roti and Winward, 1980). However, a complete correlation was not observed in recent studies (Kampinga *et al.*, 1987). To resolve these differences, a thorough investigation into the relationship of increased nuclear protein content induced by hyperthermia to killing of HeLa S<sub>3</sub> cells has been carried out recently (Kampinga *et al.*, 1989). The conclusion reached from this investigation suggested that not only the absolute increment in nuclear protein mass must be taken into account but also the duration of the binding. The parameter 'excess nuclear protein hours', which includes both

the amount of the excess nuclear protein mass and the duration of its association with the nucleus, was calculated up to 5 hours post-hyperthermia. A good correlation was found between this parameter and heat-killing. However, as discussed by Kampinga *et al.* (1989) the increase in nuclear protein content is likely to be a consequence of the primary action of heat at the plasma membrane level.

Cells undergoing division (mitosis) go through several stages collectively known as the cell cycle. The stages which follow sequentially during the cycle are G<sub>1</sub> phase (growth phase 1), S phase (synthesis phase), G<sub>2</sub> phase (growth phase 2) and M phase (cell division). After cell division the cycle resumes again at the G<sub>1</sub> phase. When the division of cells is synchronised the heat sensitivity of the cells in the different phases of the cell cycle can be determined. This type of investigation has been performed on many cell types including HeLa cells (Read *et al.*, 1984), Chinese hamster ovary cells (Fox *et al.*, 1985; Mackey and Dewey, 1988) and V-79 cells (ter Haar, 1986). These studies revealed that cells in S phase are more heat sensitive than cells in the other stages of the cell cycle. Hyperthermia-induced chromosomal aberrations correlate with the decrease in survival of S phase cells but not of G<sub>1</sub> cells (Dewey *et al.*, 1971). A recent investigation into thermal sensitivity of Chinese hamster ovary cells with different shapes (Yasui and Fink, 1990) revealed the importance of the cell cycle in determining heat sensitivity of cells in culture. They found that rounded Chinese hamster ovary cells from suspension cultures were more resistant to heat killing than flattened Chinese hamster ovary cells from monolayer culture. The possible reason put forward for this difference was that rounded cells had a lower percentage of cells in the S phase of the cell cycle (40% versus 52%) than the flattened cells.

Hyperthermia leads to alterations in the organization of various components

of the cytoskeleton (Albert *et al.*, 1983). The severity and type of alteration depends on the temperature, length of treatment and on the cell type examined. The evidence so far indicates that heat induces direct alterations in cytoskeletal components by interfering with their ability to self-assemble. A system, linked with the cytoskeletal organisation which is also affected by hyperthermia, is the calmodulin (CaM)-regulated system that partially mediates the action of  $\text{Ca}^{2+}$  (Evans and Tomasovic, 1989). The activated calcium-calmodulin complex is involved in many  $\text{Ca}^{2+}$  dependent systems, like  $\text{Ca}^{2+}$ -ATPase activation and cytoskeletal organization (Cheung, 1980; Means and Dedman, 1980). Calmodulin antagonists have been demonstrated to potentiate heat killing (Evans and Tomasovic, 1989) and also prevent hyperthermia-induced cytoskeletal alterations (Wiegant *et al.*, 1985). The possible sequence of events put forward by Wiegant *et al.* (1985) which may be responsible for the effects of the calmodulin antagonists are as follows; during heat shock the level of intracellular  $\text{Ca}^{2+}$  is elevated and binds to CaM, which then becomes activated. CaCaM subsequently binds to a cytoskeletal-associated protein after which depolymerization of the cytoskeletal microtubule occurs. The binding of the CaCaM to the microtubule-associated protein is prevented by CaM-antagonists thereby stopping heat-induced cytoskeletal alteration. Therefore, the conclusion obtained from this study is that heat-induced killing is potentiated by CaM-antagonists concomitant with prevention of cytoskeletal alterations. Heat also modifies the mechanisms (centrosomes) involved in the overall *in vivo* control of the assembly of the cytoskeleton. However, the exact mechanism of heat-induced alterations in cytoskeletal organisation is yet to be elucidated. The importance of cytoskeletal damage in heat-induced cell death can be stressed if one assumes that the cytoskeleton provides structural continuity between the nucleus and the plasma membrane. It is therefore tempting to postulate that hyperthermia-induced dis-

ruption of the cytoskeleton will lead to the collapse of the cytoskeleton towards the nucleus, and thereby play a major role in the heat-induced increase in nuclear protein content (Roti Roti and Laszlo, 1988) . The exact role and importance of cytoskeletal damage in causing cell death still needs to be clarified.

To understand the influence of heat on membranes it is necessary to consider the structure of biological membranes. A modification of the fluid-mosaic model proposed by Singer and Nicholson (1972) has been widely accepted as the model for biological membranes. The model, as presently interpreted, shows that the phospholipid molecules form an asymmetric bilayer which also contains integral and peripheral proteins and cholesterol. The hydrophilic polar head groups of the phospholipids are oriented towards the outer surfaces of the bilayer, whilst the hydrocarbon tails are found in the interior. Phospholipids in artificial bilayers undergo phase changes at a temperature (phase transition temperature) determined by the composition of the bilayer. Below this 'phase transition temperature' the lipids are in a solid 'gel phase' whilst above this temperature lipid bilayers enter a more fluid, 'liquid crystalline phase'. In mammalian cell membranes phase changes are masked by the presence of cholesterol and proteins. Cholesterol acts as a buffer of fluidity, stiffening the membrane at temperatures above the phase transition and fluidising it below that temperature. The presence of proteins in the plasma membranes leads to non-uniformity in the viscosity of lipids. In general, it is also accepted that the greater the unsaturation of the plasma membrane phospholipid fatty acyl groups the lower the phase transition temperature. That is, the membrane tends to be more fluid at physiological temperatures as the unsaturation levels of membrane phospholipid fatty acyl groups increase. The phospholipid molecules in the membrane are composed of several different

classes e.g. phosphatidylcholine, phosphatidylethanolamine, phosphatidylinositol, phosphatidylserine and sphingomyelin. The head groups associated with these molecules are another factor determining the overall membrane fluidity. In particular, the primary amine headgroup of phosphatidylethanolamine has the ability to form hydrogen bonds with an adjacent phosphate group. Hence the relative proportions of phosphatidylethanolamine to other classes of phospholipid in the membrane will influence membrane fluidity (Hirata and Axelrod, 1980). The ratio commonly used to quantify the influence of phosphatidylethanolamine on membrane fluidity is the relative amount of phosphatidylethanolamine compared to phosphatidylcholine in the membrane. Another phospholipid, sphingomyelin, also influences membrane fluidity and in general rigidifies the lipid bilayer. Changes in membrane fluidity, due to changes in sphingomyelin content, can also be presented in terms of changes in phosphatidylcholine to sphingomyelin mole ratio (Borochoy *et al.*, 1977).

Lee and Chapman (1987) have reported that a change in temperature has two effects on membrane lipids. Firstly, an increase in temperature will result in kinetic energy causing an increase in the molecular motion of the membrane lipids. Secondly, an increase in temperature may well cause a change in the phase of the lipids from a more ordered gel phase to a less ordered gel phase to a less ordered liquid crystalline phase. The overall effect will be a progressive increase in fluidity, i.e. a decrease in order of the lipid molecules.

The effect of this increase in disorder will influence membrane proteins. Cossins *et al.* (1981) have suggested that the anisotropic hydrophobic core of the membrane forms a relatively hindered, viscous environment for enzyme functioning and that, as a consequence, membrane bound enzymes may well possess relatively loose

tertiary structures to enable molecular flexibility that is vital for catalysis. An increase in temperature that leads to an increase in fluidity would therefore provide a less hindered environment for the membrane proteins, and could result in the proteins adopting configurations that are inactivating. This could be particularly important in the plasma membrane, which separates the intracellular milieu from the extracellular environment, because ion transport, cell recognition, receptor mediated processes, signal transduction and diffusion processes have all been shown to be influenced by heat treatment. There is considerable evidence to support the idea that the plasma membrane plays a major role in heat-induced cell killing. Morphological evidence (Schrek *et al.*, 1980) clearly shows heat-induced damage to the plasma membrane (Bass *et al.*, 1982) and plasma membrane perturbants, including local anaesthetics and aliphatic alcohols, all act synergistically to induce cell death (Yatvin, 1977; Li and Hahn, 1978).

The mechanism by which these agents are thought to bring about the enhancement of cell death by heat is that they increase membrane fluidity. The disruptive effect of these perturbants on the plasma membrane coupled with the fluidising and denaturing effect of heat may bring about the synergistic effect. Another way to increase membrane fluidity is by modifying the fatty acyl composition of the phospholipids in the plasma membrane. This can be achieved by varying the fatty acid composition of the media surrounding the cells (Geyer, 1967), an approach used in several investigations into the role of membrane composition in heat-induced cell killing. This approach of changing membrane composition has shown that an increase in plasma membrane fluidity, associated with an increase in unsaturated fatty acids content of membrane lipids, correlates with heat-induced cell death. Supportive evidence for this has also been shown in micro-organisms (Sinensky,

1974) and ectothermal animals (Cossins and Sinensky, 1984; Hazel, 1984) which respond to changes in environmental temperatures by altering the degree of saturation of the fatty acyl chains of their cellular membrane phospholipids. Decreasing the growth temperature of ectothermal organisms results in an increase in the degree of unsaturation of membrane phospholipids and in membrane fluidity, whilst an increase in growth temperature results in a more saturated membrane lipid composition and decreased membrane fluidity. This phenomenon, termed 'homeoviscous adaptation' by Sinensky (1974), in which cells regulate membrane fluidity (order) in a compensatory fashion, highlights the functional importance of membrane lipid fluidity to cells. Implicit in this strategy is that there is an optimal range of membrane fluidity for normal cell function (Bowler, 1987; Yatvin *et al.*, 1987). This change in membrane fluidity brought about by homeoviscous adaptation may be expected to bring about a parallel change in the thermal sensitivity of the cell i.e. increase in fluidity may increase thermal sensitivity and vice versa. However, it has been noted by Lepock *et al.* (1981) that there was a lack of correlation between hyperthermic cell killing and membrane fluidity. They concluded that a correlation exists between membrane protein denaturation and hyperthermic cell killing (Massicotte-Nolan *et al.*, 1981; Lepock *et al.*, 1983).

The level of cholesterol in the plasma membrane forms another mechanism by which membrane fluidity is maintained. Above the phase transition temperature cholesterol acts as a membrane stabilizer (Sabine, 1983). Therefore, the higher the plasma membrane cholesterol content the lower the plasma membrane fluidity. This implies, according to the hypothesis put forward earlier linking fluidity and hyperthermia, that higher cholesterol levels in the membrane should decrease the sensitivity of the cells to heat. This hypothesis was first tested by Cress and

Gerner (1980) who found a positive correlation between heat sensitivity and the cholesterol levels in the cells when expressed on the basis of cellular protein. However, comparable investigations that have since been performed by other groups have failed to confirm this finding (Anderson *et al.*, 1985; Konings and Ruifrok 1985). It has to be noted that very little work has been carried out investigating the effect of direct manipulation of membrane cholesterol on heat sensitivity.

The work produced over the past few years has contributed greatly to our understanding of the effect of heat on cells. Through these studies it has been shown that hyperthermia has a significant effect on the structure and function of the plasma membrane. It is possible that some of these effects are primary, while others may be secondary in the induction of cell death. The immediate consequences of these membrane effects could play a triggering role in the constellation of other pleiotropic cellular changes induced by hyperthermia, such as cytoskeletal and nuclear alterations. Recently, a scheme put forward by Roti Roti and Laszlo (1988) shows that plasma membranes may play a primary role in heat-induced cell death and the possible consequences of plasma membrane damage. The scheme consists of five steps which show the sequential damage to cellular structures provoked by heat: (1) disruption of critical plasma membrane structure(s), presumably the plasma membrane-cytoskeleton attachment points; (2) collapse of the cytoskeleton towards the nucleus; (3) absorption of protein onto the nuclear matrix; (4) disruption of nuclear functions involving DNA supercoiling changes; (5) damage to critical nuclear structures, possibly DNA and/or structures involving DNA.

The main aim of the work undertaken in this thesis was to clarify further the significance of plasma membrane lipid composition and membrane fluidity in heat-induced cell death. To this end, Hepatoma Tissue Culture (HTC) cells,

maintained in culture, were modified by growing the cells in the presence of media supplemented with arachidonic acid. The heat sensitivities of control and arachidonate-supplemented cells were measured and correlated with changes of fluidity and composition that occurred in the plasma membrane. To further elucidate the molecular mechanism of heat-induced cell death the effect of hyperthermia on the thermal stability of plasma membrane-bound enzymes ( $\text{Na}^+$ ,  $\text{K}^+$ -ATPase, alkaline phosphodiesterase I) brought about by arachidonic acid supplementation was studied. In addition, the cholesterol levels were also directly manipulated and correlated with any changes in heat sensitivity.

Burns and Spector (1987) suggested that fatty acid modification in tumour cells can be of therapeutic benefit as an adjunct to other treatment modalities. It is therefore hoped that this investigation will contribute to our understanding of heat-induced cell death and hence offer possible methods for its potentiation. The long term aim is clearly to develop a procedure which renders cancer cells more sensitive to heat thereby making hyperthermia a more useful method for the treatment of cancer.

## Chapter II

### Characterization of the culture system and related methods

#### 2.1 Introduction

The sophisticated techniques of tissue culture originate from early *in vitro* studies on tissue fragments or explants. The successful explantation of the medullary plate of chick embryo by Roux (1885) was followed by many other studies (Arnold, 1887; Jolly, 1903; Beebe and Ewing, 1906) showing that tissues and cells could survive *in vitro*. However, the demonstration of continuation of normal function *in vitro* by Harrison (1907) marked the major step forward in tissue culture. Harrison (1907) explanted pieces of tissue from the medullary tube region of frog embryos into clots of frog lymph. When kept in aseptic conditions, the fragments survived for some weeks and axones grew out from the cells. These early successes were quickly followed by a number of advances which led to the present day culture of continuous cell lines. The major landmarks in cell culture are listed in table 2.1.

The many facets involved with tissue culture, media requirements, antibiotics to control contamination, equipment and techniques to maintain cell cultures have already been extensively reviewed by many workers (Paul, 1975; Jakoby and Pastan, 1979; Freshney, 1987). Therefore, only the subjects pertinent to the comprehension of data in this chapter will be dealt with.

Antibiotics in culture systems must be used with care due to the potential cytotoxic effects of these antimicrobial agents. However, in long term cell experiments the use of antibiotics is relied upon as a prophylactic measure for the growth

of cells in order to ensure that cells are maintained in a healthy state. It must be noted that polyene antibiotics, such as fungizone and nystatin must be used with caution. As will be discussed in chapter 3, fungizone is known to interact with heat to enhance cell death (Hahn *et al.*, 1977)

Cryopreservation is also necessary to maintain valuable stock cultures. The main reasons for reliance on cryopreservation are to guard against loss of cultures due to mishandling, contamination and to ensure that original seed culture stock is available for use, if the cell line changes its characteristics after many subcultures. Due to the inherent instability of culture lines, fresh stock cultures were started after every ten subcultures in the present study. Cryoprotectants, such as DMSO and glycerol, are used routinely in cryopreservation solutions to enhance successful freezing.

Although contamination and instability of cell lines are disadvantages in cell culture, they can largely be controlled and are outweighed by the advantages of use of cell culture systems in experiments (Freshney, 1987). The precise control of cellular environment, in terms of pH, temperature, osmotic pressure, O<sub>2</sub> and CO<sub>2</sub> tension, is a major advantage in the use of cell culture. However, in view of the requirement for serum in most culture media, the chemical composition of the extracellular fluid cannot always be defined precisely (Hohn *et al.*, 1975). A further advantage of cell lines in culture is that they represent a homogeneous population of a single cell type, so that experiments are relatively more reproducible than with tissue samples which invariably contain more than one cell type.

When considering whether to use the *in vitro* or *in vivo* approach to an experiment it must be realised that mechanisms of action at the cellular level can be

investigated rapidly and economically with the *in vitro* method. The main advantage of the *in vitro* model is that the cellular environment can be controlled and therefore, the effect of one variable on the system determined more precisely. This is not true for the *in vivo* model where the cellular environment (pH, nutrients, oxygen tension, blood supply) will change with the physiological state of the animal (Samulski *et al.*, 1984). However, once the potential of the cellular treatment is evaluated in the *in vitro* model the natural progression to the more expensive *in vivo* methods must be sought. Only if the results of the *in vitro* method can be demonstrated *in vivo* can the validity of the experimental approach be ratified.

The HTC (hepatoma tissue culture) cell line established from the ascites form of the rat hepatoma, Morris 7288C (Thompson *et al.*, 1966) was employed in the present study. The original hepatoma was dissected from the liver of a male rat of the inbred Buffalo strain that had been fed the carcinogen, N,N'-2-7-fluorenylenebis-2,2,2-trifluoroacetamide. It was subsequently converted to the ascites form and carried serially as such. The HTC cell line was isolated from the ascites fluid of tumour-bearing rats and has been maintained in cell culture for over 20 years.

This cell line has been used in investigations of a number of cellular functions (see Thompson *et al.*, 1979), and forms a good candidate for the present study due to relevant background investigations already performed with it. Schamhart *et al.* (1984), for example, has investigated HTC cell survival and morphology following heat treatment (see chapter 3). The lipid metabolism of these cells has been investigated (see chapter 5). Wood and Falch (1973), for example, determined the phospholipid class and fatty acid compositions of phosphoglycerides from HTC cells grown on media containing varying levels of serum lipids.

The uptake and metabolism of a number of fatty acids in HTC cells has also been extensively studied (Alaniz *et al.*, 1975, 1976, 1982, 1984; Wiegand and Wood, 1975; Gasper *et al.*, 1975, 1977; and Marra *et al.*, 1984). In addition to these studies on lipid metabolism, Lopez-Saura *et al.* (1978) and Sauvage *et al.* (1981) have also purified and characterized the plasma membrane of HTC cells.

As mentioned earlier, the growth of cells in defined media is difficult due to the requirement for serum. HTC cells have been adapted by Richter *et al.* (1972) to grow in a serum-free medium called improved minimal essential medium, zinc option (IMEM-ZO). This was clearly desirable in the present study to ensure defined conditions. However, in our hands, the cell line could not be cultured in IMEM-ZO. Nonetheless, methods were sought to grow HTC cells in presence of reduced lipid levels, facilitating the manipulation of lipids of HTC cells.

HTC cells can be propagated attached to a substrate (monolayer culture) or unattached (suspension culture). The monolayer form of culture was used in this project. Typically, the growth of cells in monolayer culture has three stages (McAteer and Douglas, 1979): freshly seeded cells will experience a period during which there is no cell division (lag phase); the cells then enter log phase of growth in which cell number increases exponentially; and, finally, the stationary phase when culture conditions cannot support cell division. There are many factors that will influence the length of these stages of growth, including cell type, the media composition (Richter *et al.*, 1972; Porro *et al.*, 1986), seeding density, pH, oxygen tension (Richter *et al.*, 1972), surface area available for growth and the way in which cells are harvested (Puck *et al.*, 1955).

The aim of the current chapter is to identify and characterize conditions for

the growth and storage of HTC cells using standard tissue culture techniques. In addition, assays to measure cell survival are also characterized.

**Table 2.1 — Some landmarks in the development of tissue and cell culture**

- 
- 1885 Roux** showed that embryonic chick cells could be maintained alive in a saline solution outside the animal body
- 1907 Harrison** cultivated amphibian spinal cord in a lymph clot, thereby demonstrating that axons are produced as extensions of single nerve cells
- 1910 Rous** induced a tumour by using a filtered extract of chicken tumour cells, later shown to contain an RNA virus (Rous sarcoma virus)
- 1913 Carrel** showed that cells could grow for long periods in culture provided they were fed regularly under aseptic conditions
- 1948 Earle** and colleagues isolated single cells of L cell line and showed that they formed clones of cells in tissue culture
- 1952 Gey** and colleagues established a continuous line of cells derived from human cervical carcinoma, which later became the well-known HeLa cell line
- 1954 Levi-Montalcini** and associates showed that nerve growth factor (NGF) stimulated the growth of axons in tissue culture
- 1955 Eagle** made the first systematic investigation of the essential nutritional requirements of cells in culture and found that animal cells could propagate in a defined mixture of small molecules supplemented with a small proportion of serum proteins
- 1956 Puck** and associates selected mutants with altered growth requirements from cultures of HeLa cells
- 1958 Temin and Rubin** developed a quantitative assay for the infection of chick cells in culture by purified Rous sarcoma virus. In the following decade, the characteristics of this and other types of viral transformation were established by **Stoker, Dulbecco, Green**, and other virologists
- 1961 Hayflick and Moorhead** showed that human fibroblasts die after a finite number of divisions
- 1964 Littlefield** introduced HAT medium for the selective growth of somatic cell hybrids. Together with the technique of cell fusion, this made somatic-cell genetics accessible
- 1964 Kato and Takeuchi** obtained a complete carrot plant from a single carrot root cell in tissue culture
- 1965 Ham** introduced a defined, serum-free medium able to support the clonal growth of certain mammalian cells
- 1965 Harris and Watkins** produced the first heterocaryons of mammalian cells by the virus-induced fusion of human and mouse cells
- 1968 Augusti-Tocco and Sato** adapted a mouse nerve cell tumour (neuroblastoma) to tissue culture and isolated clones that were electrically excitable and that extended nerve processes. A number of other differentiated cell lines were isolated at about this time, including skeletal-muscle and liver cell lines
- 1975 Kohler and Milstein** produced the first monoclonal antibody secreting hybridoma cell lines
- 1976 Sato** and associates published the first of a series of papers showing that different cell lines require different mixture of hormones and growth factors to grow in serum-free medium
- 

Table adapted from 'Molecular Biology of The Cell', (1989), by Alberts, B., Bray, D., Lewis, J., Raff, M., Roberts, K., and Watson, J., D., Second edition, p64

## **2.2 Materials and Methods**

### **2.2.1 Aseptic procedures**

All procedures which required the maintenance of sterile HTC cell cultures and preparation of sterile reagents were carried out inside a laminar flow hood, using standard aseptic techniques.

### **2.2.2 Washing and sterilization of equipment and reagents**

All glassware was soaked in in a solution of Linbro Scientific 7X detergent then washed thoroughly with tap water and finally rinsed 3 times with glass double distilled water. The bottles were oven dried and sterilized by autoclaving. Filter holders were washed as described above, assembled with 0.22 $\mu$ m filters wrapped in aluminium foil before sterilization by autoclaving. The efficiency of the autoclave was monitored using thermolog strips. All media and solutions to be sterilized were passed through a sterile 0.22 $\mu$ m filter into a sterile vessel within the laminar flow hood.

### **2.2.3 Incubators used for culture of cells**

The HTC cells were maintained in a Heraeus copper lined incubator set at 37<sup>0</sup>C with humidified atmosphere of air/CO<sub>2</sub> (19:1, v/v).

### **2.2.4 Pipetting of media and solutions in flasks or 24-well plates**

In general, pipetting of solutions into flasks was carried out such that the liquid was directed at the side opposite the attached monolayer. However, with 24-well plates, solutions were pipetted down the walls of the well, not directly onto the attached monolayer. These precautions were necessary in order to prevent

disruption of monolayers.

### 2.2.5 Growth media and conditions

The cells were grown in Eagles minimum essential medium (containing Earle's salts and non-essential amino acids) which was supplemented with 10% (v/v) newborn bovine serum (NBS), 200i.u/ml penicillin, 200 $\mu$ g/ml streptomycin, 10 $\mu$ g/ml tylosin, 2.5 $\mu$ g/ml fungizone and buffered at pH 7.4 (growth medium). The cultures were maintained in a humidified incubator at 37<sup>0</sup>C in an air/CO<sub>2</sub> (19:1, v/v) atmosphere.

The cells were grown as monolayers in plastic culture vessels (flasks) with 0.4ml growth medium per 1cm<sup>2</sup> of growth area. In general, flasks with a growth area of 25cm<sup>2</sup> (25cm<sup>2</sup> flask) or 175cm<sup>2</sup> (175cm<sup>2</sup> flask) were used for culture. The growth medium was replaced the day after the culture was seeded and every 2 to 3 days thereafter. Cell growth was monitored by visual inspection via an Olympus CK inverted light microscope. When the cultures were approximately 70% confluent (coverage of surface area by monolayer) the cells were subcultured into new flasks.

### 2.2.6 Harvesting and subculture of HTC cells

The growth medium in the flasks was discarded and the attached monolayer washed twice with Ca<sup>2+</sup>-and Mg<sup>2+</sup>-free phosphate-buffered saline . The monolayer was then detached by using either Ca<sup>2+</sup>-and Mg<sup>2+</sup>-free phosphate-buffered saline containing 0.25% (w/v) trypsin and 0.2% (w/v) EDTA (trypsin-EDTA solution) or 2mM EDTA in Ca<sup>2+</sup>-and Mg<sup>2+</sup>-free phosphate-buffered saline (EDTA solution).

When using the trypsin-EDTA solution, 0.04ml of solution per 1cm<sup>2</sup> of growth area was pipetted into the flask and allowed to cover the cells for approximately

0.5 minutes. The excess solution was then poured off and the monolayers kept at room temperature for approximately 6 minutes. However, when using the EDTA solution, 0.12ml of solution per  $1\text{cm}^2$  of growth area was added to the flasks, which were then placed in an incubator at  $37^{\circ}\text{C}$  for 3 to 5 minutes. When, with both methods, the cells started to round up and detach from the flask surface, an appropriate amount of growth medium was added to terminate the detachment process and to resuspend the cells. The suspension was transferred to a sterile plastic universal tube and centrifuged at  $200g$  ( $r_{av}=11\text{cm}$ ) at  $20^{\circ}\text{C}$  for 6 minutes, to sediment the cells. The supernatant was discarded and the cell pellet resuspended in a known volume (1 to 3ml) of growth medium and the cells fully disaggregated by 2 to 3 aspirations of the entire cell suspension, by a syringe fitted with a no. 25 guage hypodermic needle. The cells were then counted either by haemocytometer or Coulter Counter, before being used for experiments or seeding fresh flasks (subculture).

### **2.2.7 Estimation of cell number and viability by haemocytometer**

After harvesting and resuspending the cell pellet as described in section 2.2.6, a small aliquot of the disaggregated cell suspension was suitably diluted with a trypan blue solution (0.6% (w/v) trypan blue in  $\text{Ca}^{2+}$ -and  $\text{Mg}^{2+}$ -free phosphate-buffered saline ) such that, when the suspension was introduced into the counting chamber of the haemocytometer, approximately 50 to 100 cells were observed over each of the 9 large squares of the graticule. As viable cells exclude trypan blue, to obtain the number of viable cells present only unstained cells were counted. However, to obtain total cell number both stained and unstained cells were counted. Hence, to obtain the percentage viability of a particular cell suspension the equation below was used:

$$\text{Percent viability} = \frac{\text{viable count}}{\text{total count}} \times 100$$

A minimum of two counts were performed on each cell sample.

### **2.2.8 Estimation of cell number by Model D Industrial Coulter Counter**

After harvesting and resuspending the cell pellet as described in section 2.2.6, a small aliquot of the disaggregated cell suspension was suitably diluted with Isoton II solution and counted together with blanks on the Coulter Counter. The blanks were prepared by diluting growth medium with Isoton II solution to the same extent as the cell suspension. The Coulter Counter was set with aperture at 8, threshold at 20 and current at 0.017amps.

### **2.2.9 Determination of cell size distribution using a micrometer.**

Exponentially growing HTC cells were harvested (using EDTA solution) and the cell pellet resuspended in growth medium. A small aliquot was diluted with Isoton II solution before the cell diameters were measured using a Watson-Barnet micrometer with a calibrated eye piece on a Zeiss light microscope.

### **2.2.10 Determination of cell size distribution using the Coulter Counter**

Exponentially growing HTC cells were harvested using EDTA solution and the cell pellet resuspended in growth medium. A small aliquot was diluted with Isoton II solution and counted. The cell size distribution was obtained by determining the cell counts at a number of different aperture, threshold and current settings, as recommended in the Coulter Counter manual. As the settings govern the size of particle to be counted it is possible to determine the number of cells counted

in that size 'window' and hence the cell size distribution. A background count, using growth medium diluted with Isoton II solution to the same extent as the cell suspension, was also performed at all the different settings used.

### **2.2.11 Cryopreservation of cells**

Subconfluent cells from a total growth area of 350cm<sup>2</sup> were harvested and the cell pellet resuspended in 10ml of freezing medium which consisted of foetal bovine serum/glycerol (92:8, v/v). Aliquots of the cell suspension were placed into plastic bio-freeze vials, sealed tightly and frozen at -80<sup>0</sup>C for 4 to 15 hours. The vials were then stored in liquid nitrogen for up to 26 months.

### **2.2.12 Establishing cultures from frozen cells**

Vials of frozen cells were recovered from liquid nitrogen store and thawed quickly by incubation in a water bath at 37<sup>0</sup>C. The cells were then transferred to 10ml of growth medium in a 25cm<sup>2</sup> culture flask and placed in an humidified incubator at 37<sup>0</sup>C with an air/CO<sub>2</sub> (19:1, v/v) atmosphere. The medium was changed the next day but cells were not used in experiments until they had been subcultured at least once.

### **2.2.13 Clonogenic assay**

The clonogenic assay, first developed by Puck (1955), was used to determine cell survival in culture flasks. The cells were harvested and their number estimated before seeding 200 cells in a 25cm<sup>2</sup> flask containing 10ml of growth medium. The growth medium was changed the next day and every 2 to 3 days thereafter. The colonies were allowed to develop for 9 to 10 days. The culture medium was then discarded and the colonies were fixed in 10ml of phosphate-buffered saline

(PBS)/methanol (1:3, v/v) for 10 to 15 minutes. The fixative was discarded and the colonies were stained with 5ml of 0.6% (w/v) trypan blue in PBS for 10 to 15 minutes. The stain solution was discarded and the visible cell colonies, with greater than 50 cells (Von Hoff *et al.*, 1986), were counted.

#### **2.2.14 Culture of HTC cells in 24-well plates**

Plastic tissue culture plates containing 24-wells, each with an area of 1.76cm<sup>2</sup> were employed in this method of culture. Cells harvested from flasks were used to seed each well with up to 5000 cells in 1ml of growth medium. The medium was changed the day after seeding and every 2 to 3 days thereafter.

#### **2.2.15 Colorimetric method for the estimation of cell number in plates**

The method for estimating cell number in 24-well plates was based on the procedure first developed by Mosmann (1983) and later modified by Denizot and Lang (1986).

Stock solutions of MTT were prepared at 5mg/ml in 20mM HEPES, pH 7.4 then passed through a 0.22µm filter into a sterile container and stored in the dark at 4°C. This solution was diluted prior to use with an equal volume of double strength phenol red-free, serum-free, fungizone-free growth medium (MTT medium).

The growth medium from the wells was discarded by inverting the plates to remove most of the liquid and blotting to drain out any residual media. Then 200µl of the MTT medium was added to each well and the plates incubated at 37°C in humidified atmosphere of air/CO<sub>2</sub> (19:1, v/v) for 4 hours. After this period, 1ml of DMSO was added to each well and mixed thoroughly to dissolve the dark blue formazan crystals. Two 100µl samples were transferred from each well to a 96-well

plate then the absorbance was measured on a Titertek Multiscan MCC/340 plate reader using a test wavelength of 540nm and a reference wavelength of 690nm (Denizot and Lang, 1986)

#### **2.2.16 Cholesterol assay**

Cholesterol levels in serum and delipidized serum were estimated using BDH Chloxidate No. 1 kit. To 10 $\mu$ l of sample, standard or blanks was added 1ml of reconstituted buffered enzyme solution, pre-warmed to 37<sup>0</sup>C , and the tubes incubated for 10 minutes in a waterbath at 37<sup>0</sup>C. The absorbance of the reaction mixture was then measured against distilled water at 500nm on a Pye Unicam SP8-100 spectrophotometer, in plastic cuvettes with 1cm path length.

#### **2.2.17 Preparation of lipid depleted serum**

Serum was delipidized by the method of Cham and Knowles (1976). To one volume of serum was added 2 volumes of butanol/diisopropylether (1:1.5, v/v) and the tubes were mixed on a suspension rotator set at 33rpm for 30 minutes. The resultant emulsion was centrifuged at 2000rpm for 4 minutes at room temperature. The supernatant was carefully recovered, freeze dried and stored desiccated at -20<sup>0</sup>C.

#### **2.2.18 Assay of total free fatty acids in serum**

A modification of the method described by Antonis (1965) was used to assay free fatty acids in serum. This method is based on the production of the copper salts of the fatty acids in chloroform followed by estimation of the copper content of the organic phase by reaction with zinc dibenzylthiocarbamate. Silicic acid (1.2  $\pm$  0.1g), activated at 110<sup>0</sup>C for 1 hour prior to use, was slurried with 7.5ml diisopropyl ether in screw cap vials. The ether had been passed through a

column of activated alumina just before use to remove peroxides. Serum (0.3ml) was added and vortex mixed for 1.5 minutes. The silicic acid adsorbant removed phospholipids, which can be a source of interference, without affecting the levels of free fatty acids. The silicic acid in the mixture was allowed to precipitate at unit gravity for 15 minutes. The ether supernatant (4.5ml) was then removed and transferred to glass centrifuge tubes which had previously been siliconized using dimethyldichlorosilane (0.5%,v/v) in heptane. The ether was evaporated to dryness under a stream of nitrogen and the lipid redissolved in 5ml of chloroform. Copper reagent (2.5ml), consisting of 3.8% (w/v) copper sulphate, pentahydrate, 0.45M-triethanolamine and 0.05M-acetic acid, was added and vortex mixed with the lipid extracts for 45 seconds. Each tube was then centrifuged at low speed for 10 minutes at room temperature and care was taken to remove all of the excess upper aqueous copper phase by aspiration with a pasteur pipette. A 3ml aliquot of the chloroform extract was placed into a clean tube and the colour was developed by addition of 0.5ml of zinc dibenzylthiocarbamate (0.3%, w/v) in chloroform. After 15 minutes at room temperature the absorbance of each reaction mixture was measured at 440nm in quartz cuvettes. Standard curves over the range 0–0.6 $\mu$ mole fatty acid were constructed using 12mM-palmitic acid dissolved in chloroform.

## 2.3 Results

The cell size distribution estimated by micrometer (figure 2.1) gives a mean cell diameter of  $19.2\mu\text{m}$  with a standard deviation of  $5.48\mu\text{m}$ . A logarithmic probability plot of the data was linear, indicating that the data was normally distributed. A theoretical normal distribution with the same mean and standard deviation is also represented on the graph to show the expected distribution. The observed and the expected cell size distributions follow closely, indicating that the cell size is normally distributed. Similarly, the cell size distribution determined by Coulter Counter (figure 2.2) gives a mean cell diameter of  $18.3\mu\text{m}$  with a standard deviation of  $6.29\mu\text{m}$ . A logarithmic probability plot of the data was linear indicating that the data was normally distributed. The same analysis as for the data shown in figure 2.1 was carried out, which indicated again that the observed and expected results follow a normal distribution.

As the Coulter Counter counts all particles present in the cell suspension it was necessary to ensure that the counts obtained at the set size would reflect cell number. Hence a comparison was carried out between cell number determined by haemocytometer and Coulter Counter (table 2.2). It is evident that counts obtained at a minimum diameter of  $13.5\mu\text{m}$  (setting on Coulter Counter of  $A=8$ ,  $I=0.017$ ,  $T=20$ ) correlate with those obtained via haemocytometer.

To ensure that stock HTC cultures were frozen, such that cell viability was maintained when the cultures were thawed, the ability of four different cryopreservation media to maintain viability was evaluated. To this end, viable stock HTC cultures were frozen in the four cryopreservation media and upon thawing the cell viability was assessed (figure 2.3). It was found that the best mixtures for

cryopreservation are those containing serum and either glycerol or DMSO as the cryoprotectant. However, where cells that are to be frozen show the possibility of gene activation and differentiation, it is thought to be advisable (Ashwood-Smith, 1985) to avoid the use of DMSO. This is because a number of workers (Rudland *et al.*, 1982; Higgins *et al.*, 1983) have demonstrated gene activation effects of DMSO in a variety of cellular systems. Therefore, the cryopreservation medium containing foetal bovine serum and glycerol (92:8, v/v) was used in all future cryopreservation procedures. This is in keeping with the methods discussed by Thompson (1979).

For future experiments, where HTC cells grown in 25cm<sup>2</sup> flasks were required in the exponential phase of growth, it was necessary to determine the growth characteristics of HTC cells. Figure 2.4 shows the growth characteristics of HTC cells at several seeding densities. At low seeding density the initial lag phase is considerably longer when compared to high seeding densities. This could reflect the possibility that at low seeding densities some growth factor is not produced in large enough quantities to initiate rapid cell growth. In 25cm<sup>2</sup> flasks seeded at  $2.6125 \times 10^5$ ,  $3.0 \times 10^5$  and  $5.5675 \times 10^5$  cells, the cultures enter exponential growth on approximately day 2. Exponential growth occurs with a doubling time of approximately 20-26 hours until day 6. After this period the cultures enter stationary phase, which is probably because most of the available growth area in the flask is covered by the monolayer. In all subsequent experiments, cultures were initiated at a density of  $3.0 \times 10^5$  cells per 25cm<sup>2</sup> growth area and harvested for use during the exponential phase of growth (day 4 or 5).

To estimate cell survival via the clonogenic assay it is essential that the relationship between cells seeded and colonies formed is predictable. As shown in

figure 2.5, the number of colonies formed was found to be proportional to the number of cells seeded into the flask.

For future experiments, in which HTC cells were to be grown in the presence of exogenous fatty acids or cholesterol, it was considered desirable to grow the cells in medium in which the serum lipids had been depleted, in order to facilitate preferential uptake and utilisation of the added lipids. To develop a suitable growth medium containing reduced lipid levels, lipid depleted serum (LDS) was prepared. As shown in table 2.3, the cholesterol and free fatty acid concentration of serum were reduced in serum delipidated by the method of Cham and Knowles (1976). However, to ensure that it could be used in subsequent experiments, it was necessary to determine the plating efficiency of HTC cells in growth medium in which the serum had been replaced with LDS (LDS medium). When compared to normal growth medium, the use of LDS medium had no significant effect on plating efficiency of HTC cells (table 2.3). However, note in the legend to table 2.3 that the cells were only kept in LDS medium for 24 hours and thereafter in normal growth medium. This reflects the protocols that are to be followed in subsequent experiments involving the manipulation of the lipid environment of the cell i.e. exposure to LDS media for only the duration of the treatment to be investigated, thus minimising the potential harmful effects of lipid depletion. However, in order to manipulate the free fatty acid composition of the cell in LDS medium, cells must be able grow in this medium for longer periods. As shown in figure 2.6, LDS medium could not support sustained growth. However, growth for a short period (48 hours) would be sufficient to bring about changes in the fatty acid composition of the cell. Figure 2.7 shows that once the cultures had been initiated and allowed to start exponential growth in normal growth medium, subsequent trans-

fer of these cultures to LDS medium sustained exponential growth for a further 24 hours. After this period growth stopped. When these cultures were returned to normal growth medium after 48 hours in LDS medium exponential growth was resumed.

In order to assess cell survival following hyperthermia, two assays for cell survival were developed in the present study. The colorimetric assay is based on the cleavage of the tetrazolium salt, MTT, (3-(4,5-dimethylthiazol-2-yl)-2, 5-diphenyltetrazolium bromide) into a blue coloured product (formazan), by the mitochondrial enzyme succinate dehydrogenase (Slater *et al.*, 1963). This conversion only takes place in living cells and the amount of formazan produced is reported to be proportional to the number of cells present (Green *et al.*, 1984; Denizot and Lang, 1986). However, the optimal conditions for the assay have to be determined for every cell line as suggested by Carmichael *et al.*, (1987) and Mosmann (1983) and in this study this has been carried out for the HTC cell line.

To ensure that the recommended wavelengths (Denizot and Lang, 1986) at which the absorption is measured were suitable for use with the assay medium used in this study, the absorption spectra of MTT and the formazan product were determined. The absorption spectrum of the formazan product shows that an absorption maximum occurs at 540nm (figure 2.8, treatment 1). In contrast, the MTT substrate shows no significant light absorption at 540nm, so this was selected as the test wavelength. The absorption maximum at 360nm (off scale) represents unconverted MTT present in the final solubilized formazan solution, in keeping with the findings of Denizot and Lang (1986).

Having determined the optimal wavelength for the colorimetric assay, it was

necessary to find the optimal concentration of MTT and the time to which cells are exposed to MTT, in order to give a maximal response. Figure 2.9 shows that the optimal MTT concentration lies between 2 and 3mg/ml. At MTT concentrations below 2mg/ml there was insufficient MTT to elicit maximal response and above 3mg/ml it is possible that cytotoxic effects of high MTT concentration caused a decline in response. In all subsequent assays, 2.5mg/ml MTT was used. The optimal time required for MTT to be catalysed to formazan is shown in figure 2.10. It can be seen that the absorbance rises very quickly, reaching a maximum after 2 hours. After this the absorbance drops slightly and is stable from 3 hours to 5 hours incubation time. Consequently, in all subsequent assays, plates were processed between 3 and 5 hours incubation with 2.5mg/ml MTT.

After solubilization of the formazan product it is essential that the intensity of the colour generated does not deteriorate before it is measured. Table 2.4 shows that the absorbance values obtained in the final solubilized formazan solution are stable for at least 50 minutes at room temperature. As the plates were read within 20 minutes of solubilization of the formazan crystals there was no problem associated with the deterioration of the colour intensity.

The colorimetric assay provides an estimate of the cell viability simply in terms of the absorbance of formazan generated by the cells. To convert absorbance values to cell number it is necessary to determine the relationship between cell number and absorbance. Figure 2.11 shows that a linear relationship exists between cell number, in the range  $0.0-3.0 \times 10^5$  cells/well, and the absorbance at 540nm. The experiment was carried out 12 hours after cells were seeded into flasks. This allowed sufficient time for cell attachment to the substratum, but insufficient time to permit cell replication during the initial lag phase. The linear response obtained

here is similar to that presented by Denizot and Lang (1986) for EL4 and LB3 cell lines.

For future experiments, where HTC cells were required in exponential growth in 24-well plates, it was necessary to determine the the growth characteristics of HTC cells in 24-well plate culture. The growth characteristics of HTC cells were determined at several seeding densities (figure 2.12), using the colorimetric assay, optimised for HTC cells, and cell number was estimated from figure 2.11. The growth characteristics of HTC cells were determined in 24-well plates are similar to those determined in 25cm<sup>2</sup> flasks (figure 2.4), where cell number was estimated using the Coulter Counter. The characteristic lag, exponential and stationary phases of growth are present with a similar doubling time to that determined in 25cm<sup>2</sup> flasks.

**Figure 2.1 — Cell size distribution of HTC cells determined via a micrometer**

The figure represents size distribution of exponentially growing HTC cells as determined by the method described in Materials and Methods.

The solid line represents a normal distribution with mean and standard deviation of the cell sample calculated using the equation below.

$$y = \frac{1}{\sqrt{2\pi}\sigma} e^{-\frac{(x-\mu)^2}{2\sigma^2}}$$

Standard deviation( $\sigma$ )= $5.48\mu\text{m}$  and mean cell diameter( $\mu$ )= $19.24\mu\text{m}$

Sample size(n)=100

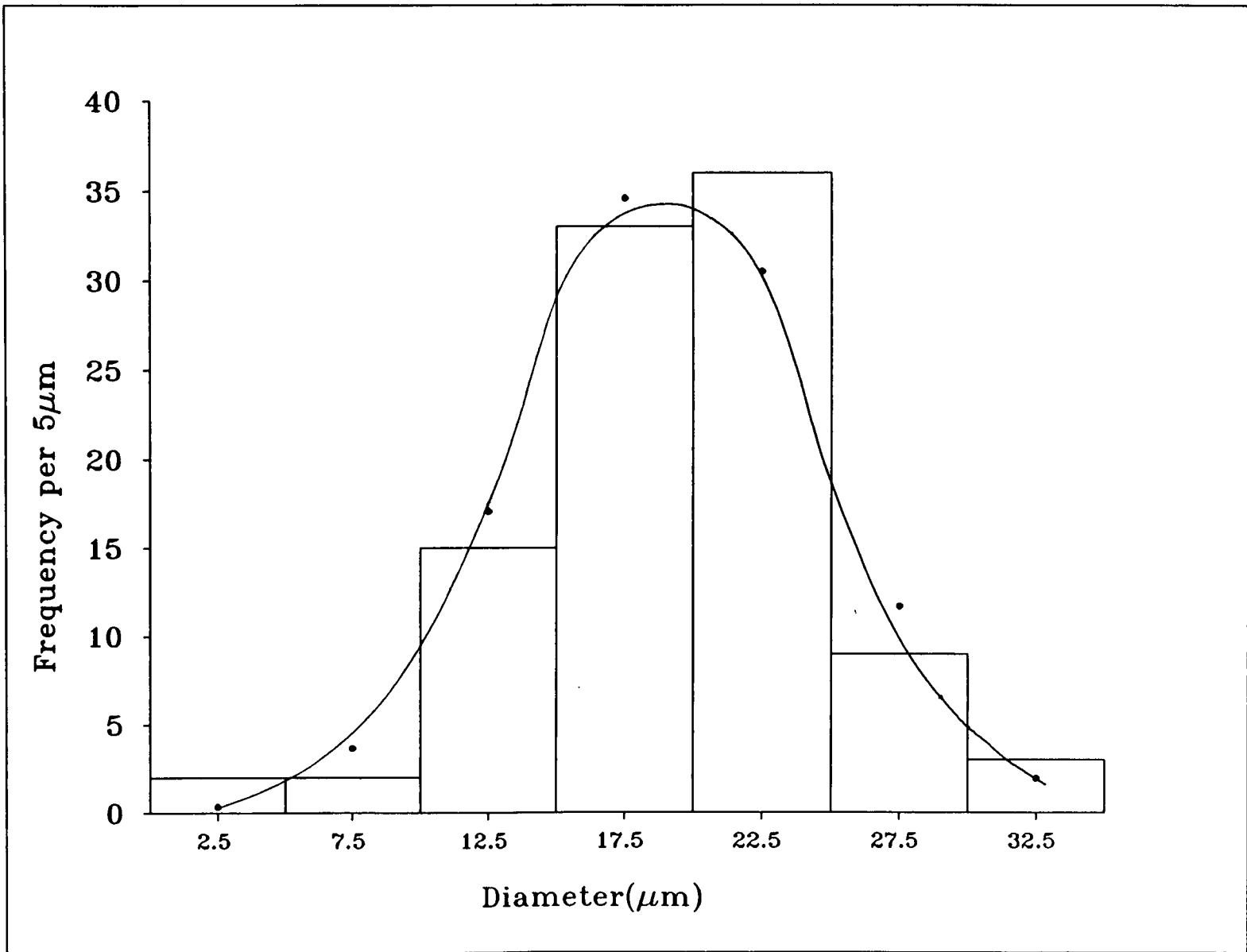

**Figure 2.2 — Cell size distribution of HTC cells determined via Coulter Counter**

Exponentially growing HTC cells were harvested and the cell size distribution determined by the method described in Materials and Methods.

The solid line represents a normal distribution with mean and standard deviation of the cell sample calculated using the equation below.

$$y = \frac{1}{\sqrt{2\pi}\sigma} e^{-\frac{(x-\mu)^2}{2\sigma^2}}$$

Standard deviation( $\sigma$ )= $6.29\mu\text{m}$  and mean cell diameter( $\mu$ )= $18.33\mu\text{m}$

Sample size( $n$ )= $14989$

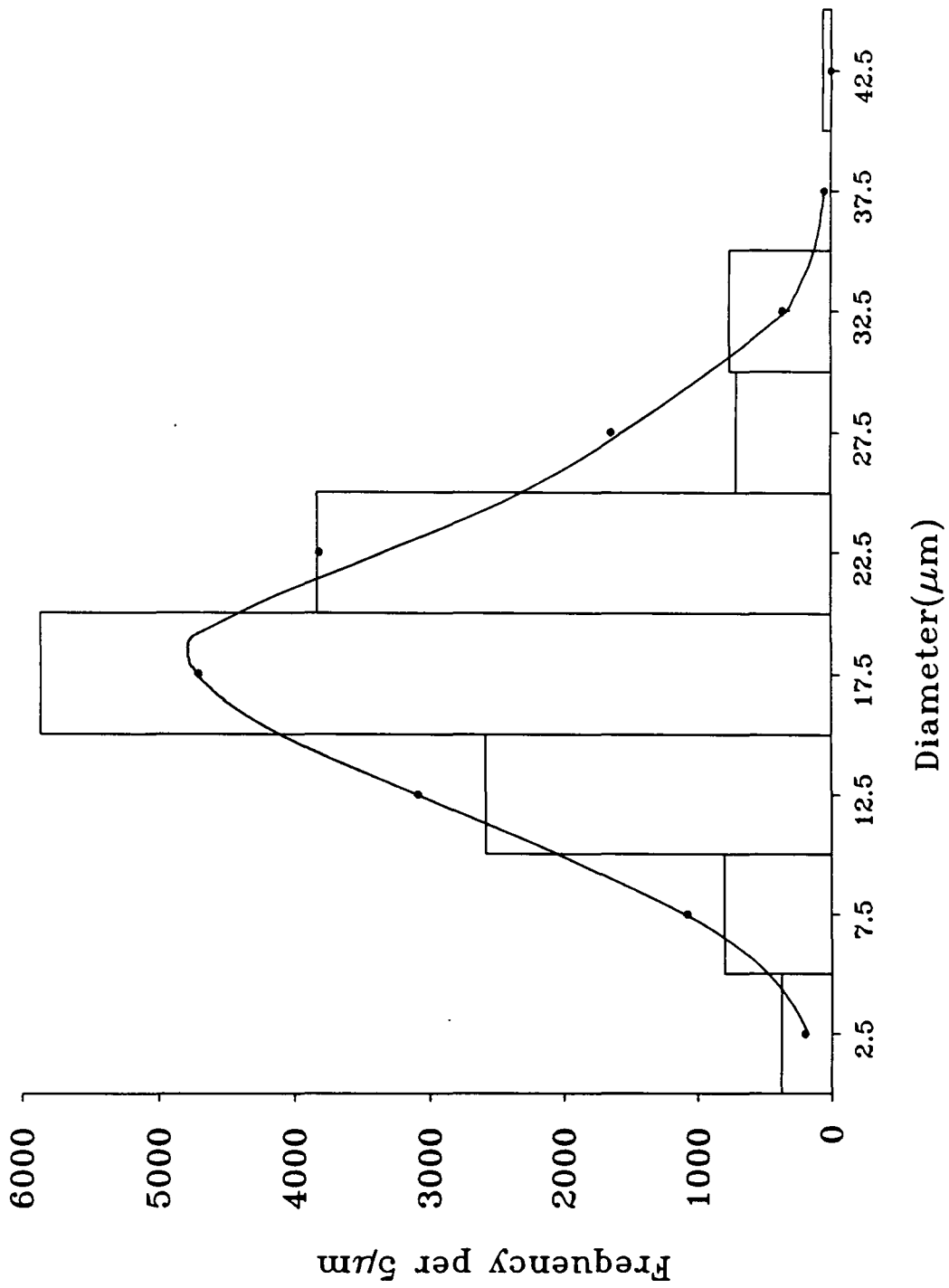

**Table 2.2 — Comparison of cell counts obtained via haemocytometer and Coulter Counter**

Three 25cm<sup>2</sup> flasks were harvested and cells disaggregated as described in Materials and Methods. The cell number of the suspension was then determined using a haemocytometer and by using a Coulter Counter set to count particles of a variety of diameters.

Cell concentration obtained by haemocytometer =  $1.79 \times 10^6$  cells/ml

Minimum diameter counted( $\mu\text{m}$ )	Coulter count $\times 10^6$ cells/ml
7.0	2.77
8.8	2.64
11.1	2.54
13.9	1.76
17.4	0.42
21.9	0.035
27.4	0.004
34.1	0.0004

The cell concentration obtained by counting particles with a minimum diameter of  $13.9\mu\text{m}$  compares best with value obtained by haemocytometer.

**Figure 2.3 — A comparison of cryopreservation methods**

Exponentially growing HTC cells were harvested and preserved in a variety of freezing media. The freezing process was performed as described in Materials and Methods. Frozen cells were thawed after one week and cell viability determined as described in Materials and Methods.

Key to graph	
Freezing media	recipe
1	FBS/DMSO (92:8, v/v)
2	NBS/DMSO (92:8, v/v)
3	FBS/glycerol (92:8, v/v)
4	Growth medium/glycerol (92:8, v/v)

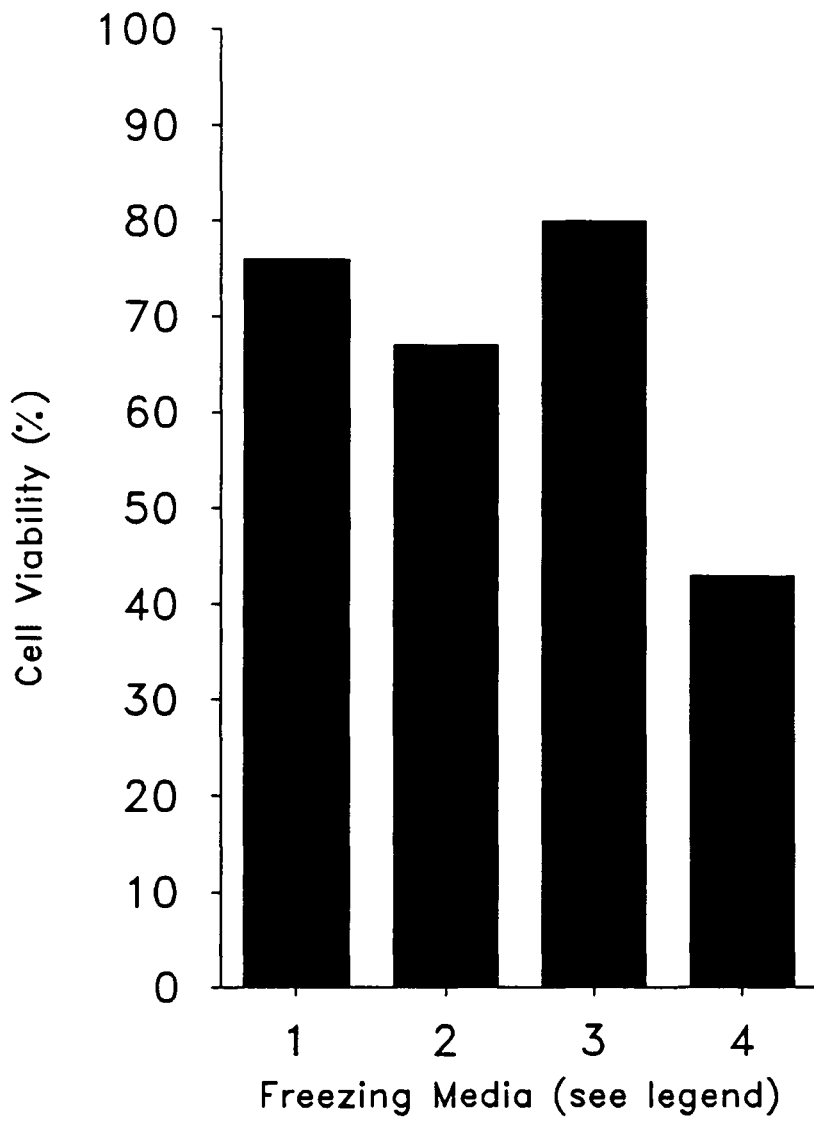

**Figure 2.4 — Growth characteristics of HTC cells grown in 25cm<sup>2</sup> flasks**

Exponentially growing HTC cells were harvested and the cell number determined as using a Coulter Counter, as described in Materials and Methods. Varying number of cells were then seeded into a number of 25cm<sup>2</sup> flasks each containing 10ml of growth medium. The cultures were maintained as described in Materials and Methods. Every 24 hours 2 cultures were harvested and the total cell number per flask determined.

Key to graph		Doubling time (hours)
Seeding density cells/flask	Symbol on graph	
12500	•	nd
52250	○	23.2
261250	×	22.8
300000	◇	19.9
556750	△	25.7

nd=cannot be determined

The doubling time represents the time taken for cell number to double during exponential growth. The following equation was used to calculate doubling time:

$$\text{doubling time} = \frac{t_2 - t_1}{3.32(\log N_{t_2} - \log N_{t_1})}$$

where

$t_2 > t_1$ ,  $t_2$  = time at point 2,  $t_1$  = time at point 1

$N_{t_2}$  = cell number at  $t_2$ ,  $N_{t_1}$  = cell number at  $t_1$

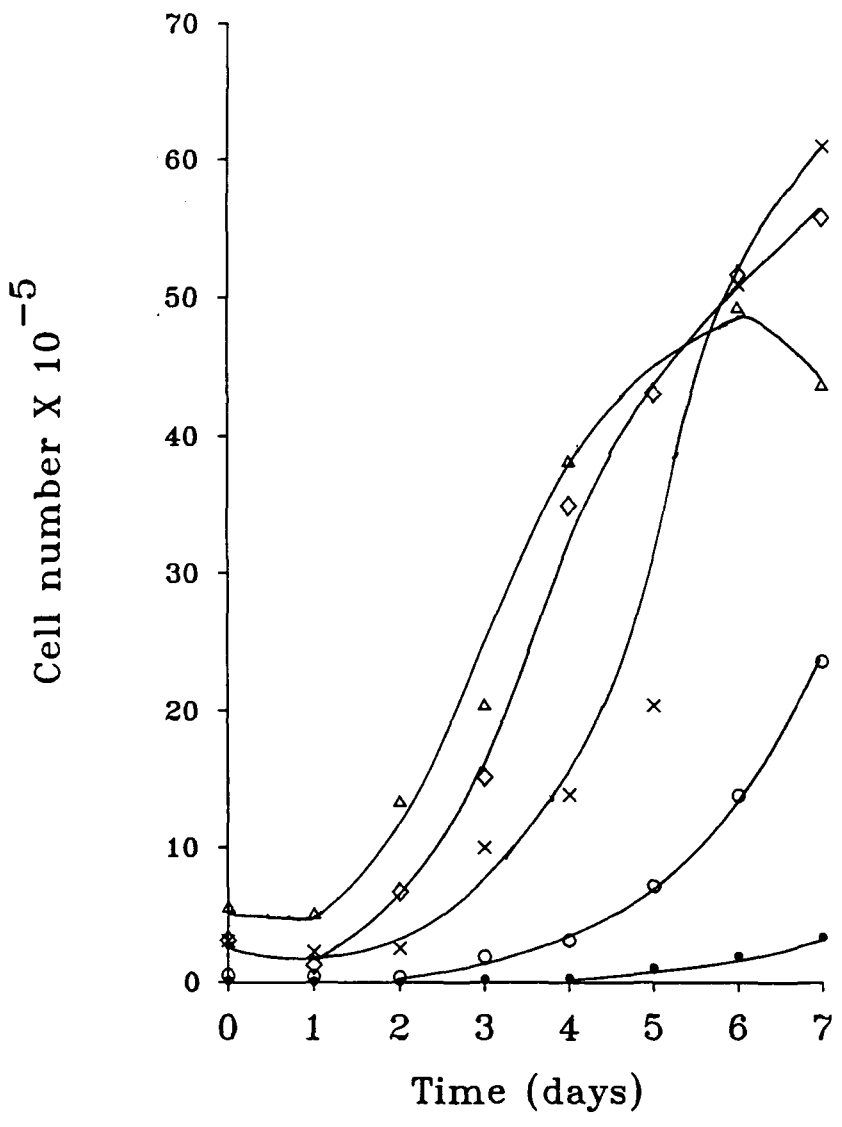

### Figure 2.5 — Plating efficiency of HTC cells

Varying numbers of HTC cells were seeded into 25cm<sup>2</sup> flasks each containing 10ml of growth medium. The flasks were then treated as described in Materials and Methods. Briefly, exponentially growing HTC cell monolayers were harvested and their number estimated before seeding 200 cells in a 25cm<sup>2</sup> flask containing 10ml of growth medium. The growth medium was changed the next day and every 2 to 3 days thereafter. The colonies were allowed to develop for 9 to 10 days. The culture medium was then discarded and the colonies were fixed in 10ml of phosphate-buffered saline (PBS)/methanol (1:3, v/v) for 10 to 15 minutes. The fixative was discarded and the colonies were stained with 5ml of 0.6% (w/v) trypan blue in PBS for 10 to 15 minutes. The stain solution was discarded and the visible cell colonies were counted. Each point on the graph represents the average value obtained from duplicate determinations.

$$\text{Plating efficiency}(\Delta) = \frac{\text{number of colonies formed}(\bullet)}{\text{number of cells seeded}} \times 100$$

Best fit regression lines were fitted to the data using the straight line equation:

$$y=mx + c$$

values of c (intercept on y axis), m (gradient) and r (correlation coefficient) are given below, and represent mean values  $\pm$  SEM.

Parameters of best fit	value
m	0.4659 $\pm$ 0.0287
c	4.0400 $\pm$ 7.404
r	0.9639

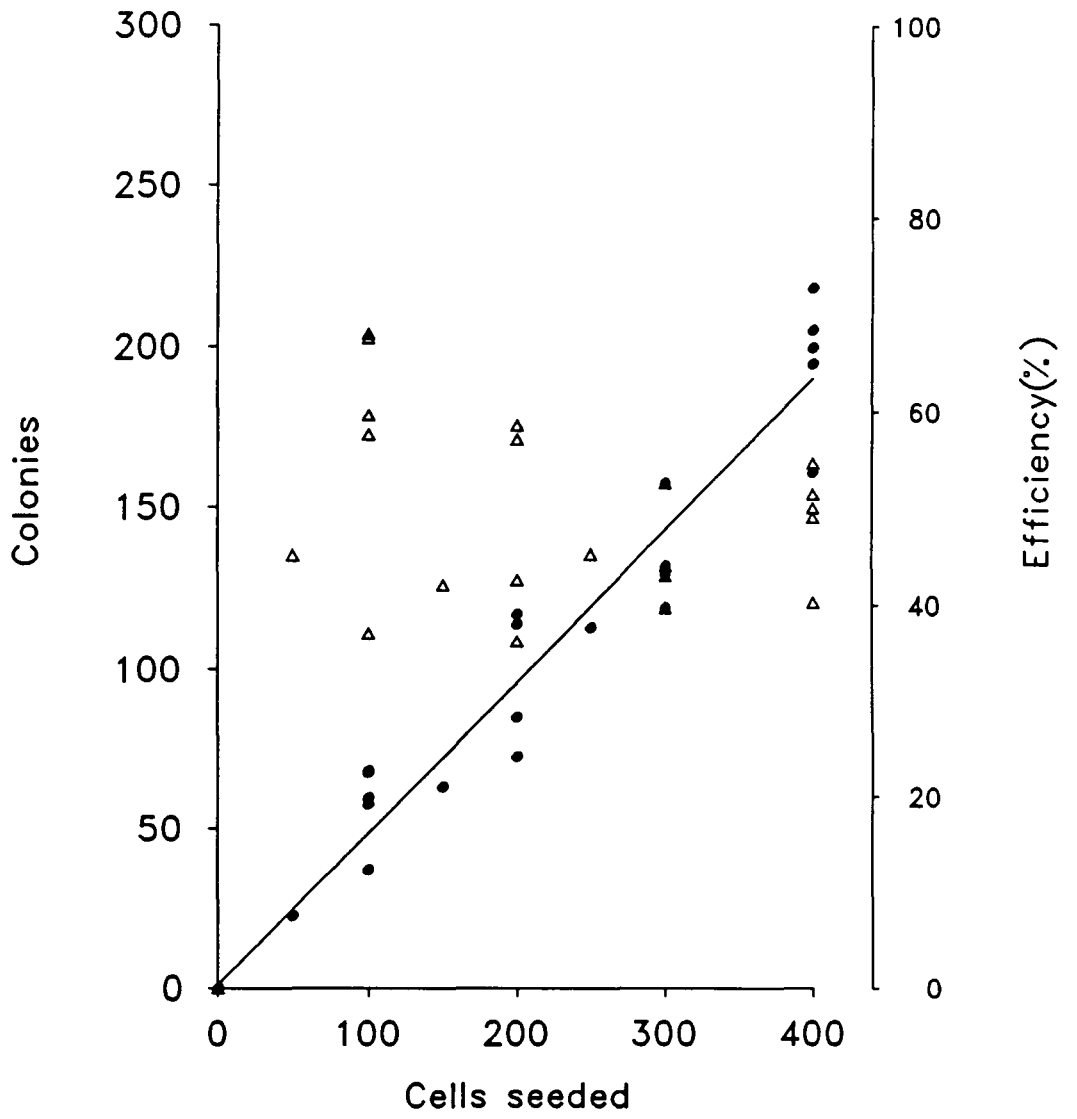

**Table 2.3 — Cholesterol and free fatty acid concentration of lipid depleted serum**

Lipid depleted serum (LDS) was prepared and the cholesterol and free fatty acid concentration determined. To determine plating efficiency, HTC cells were harvested and 200 cells seeded in 25cm<sup>2</sup> flasks containing 10ml of normal growth medium or 10ml of growth medium in which the serum had been replaced by LDS. After 24 hours the medium in both sets of flasks was replaced with normal growth medium. The medium was then changed every 2–3 days and on day 9 the colonies were fixed, stained and counted as described in Materials and Methods.

parameter	NBS	LDS	Reduction(%)
Free fatty acid(mM)	0.684 ±0.081	0.233 ±0.024	66.02
Cholesterol(mM)	1.433 ±0.134	0.0815 ±0.010	94.32
Plating efficiency(%)	71.8 ±8.035	66.8 ±3.728	6.96

Number of determinations=4

Figures represent mean value ± SEM. The plating efficiency in NBS medium (normal growth medium) is not significantly different from that in LDS medium. ( $p \geq 0.05$ ).

## Figure 2.6 — Growth characteristics of HTC cells in LDS media

Exponentially growing HTC cells were seeded into 25cm<sup>2</sup> flasks at an inoculation density of  $3.0 \times 10^5$  cells/flask. The cells were maintained in growth medium lacking serum but containing LDS(●), or cells were cultured in normal growth medium(o). The two cultures from each growth condition were harvested every 24 hours and the total cell number per flask determined using a Coulter Counter as described in Materials and Methods.

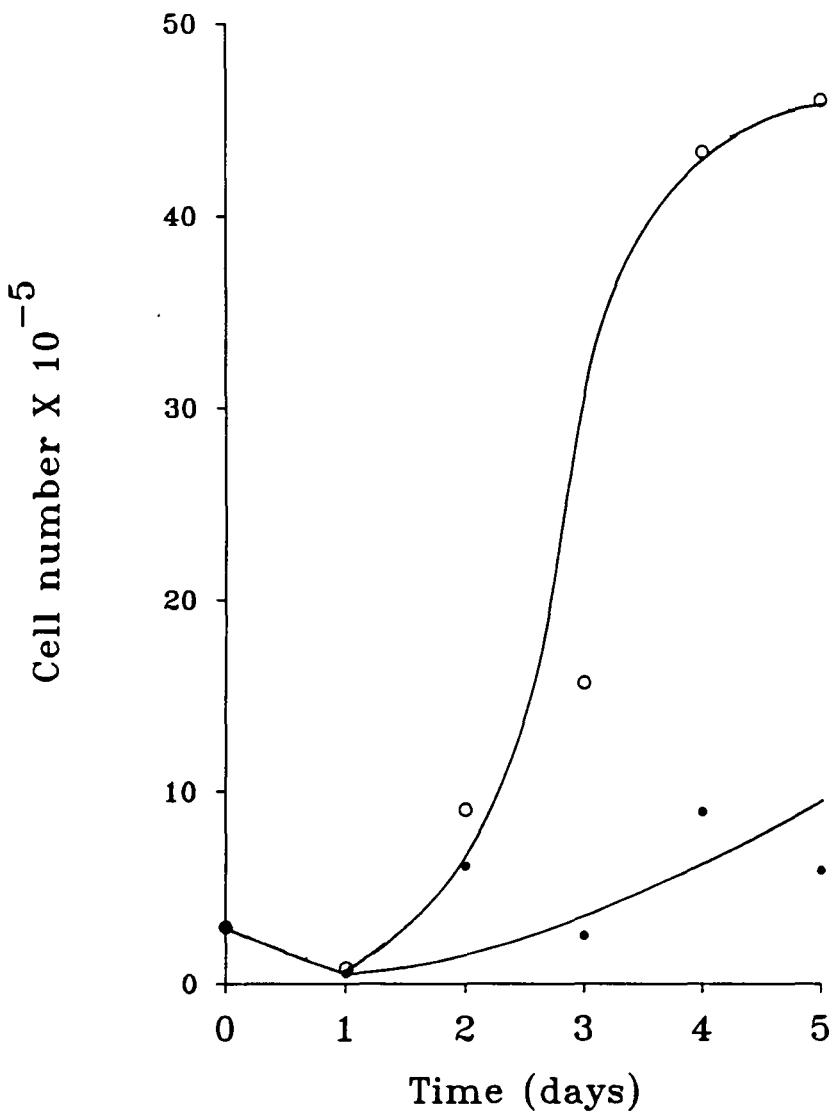

**Figure 2.7 — Effect of exposure of HTC cells to LDS medium during exponential cell growth**

Exponentially growing HTC cells were seeded into 25cm<sup>2</sup> flasks at an inoculation density of  $3.0 \times 10^5$  cells/flask. The cultures were maintained in normal growth medium for the first 3 days of growth. On day 3 the cells were exposed to growth medium lacking serum but containing LDS(●), or the cells were maintained in normal growth medium(o). After 48 hours the medium was replaced in all cultures with normal growth medium. The two cultures were harvested from each growth condition every 24 hours and the total cell number per flask determined using a Coulter Counter as described in Materials and Methods.

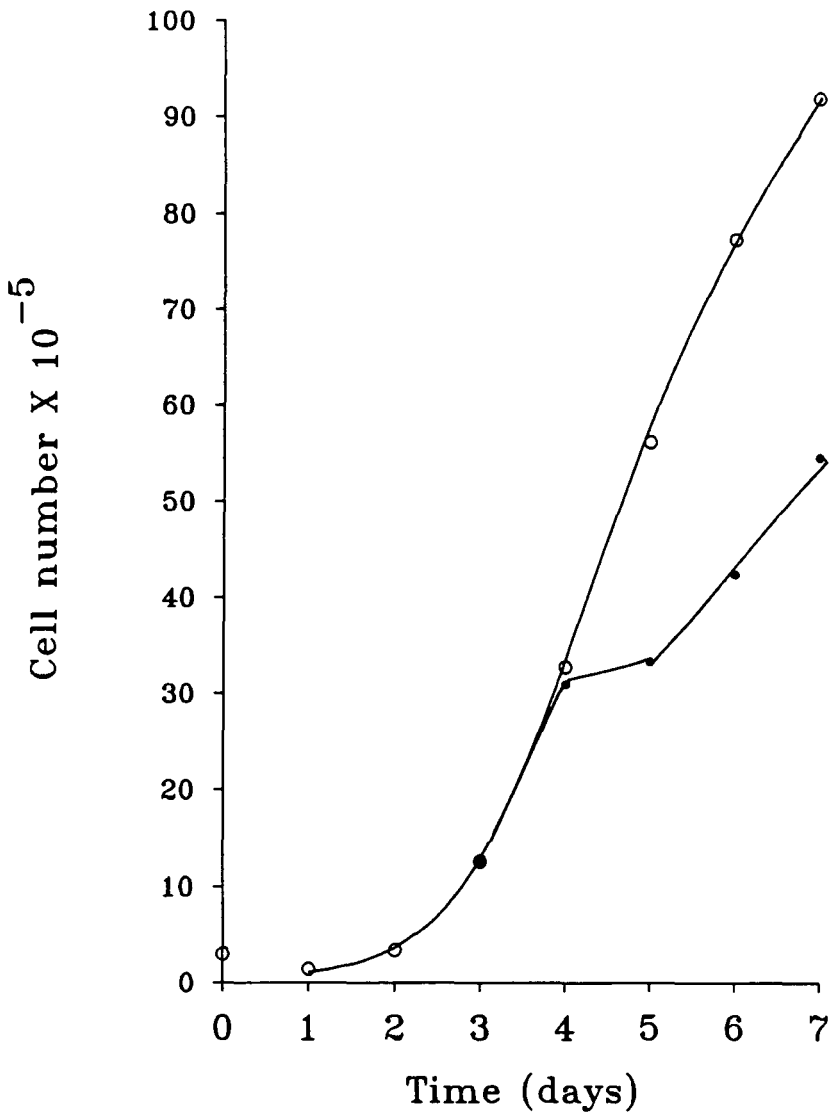

**Figure 2.8 — Absorption spectrum of the formazan product generated from MTT by HTC cells in culture**

24-well plates were set up containing  $3 \times 10^5$  cells per well or growth medium alone and maintained as described in Materials and Methods. After 24 hours the cells were treated as follows.

The growth medium was removed as described in Materials and Methods prior to MTT incubation.

Treatment 1(●): Cells exposed to  $200\mu\text{l}$  of phenol red-free, serum-free and fungizone-free growth medium containing  $2.5\text{mg/ml}$  MTT (MTT medium).

Treatment 2(o): Cells exposed to  $200\mu\text{l}$  of phenol red-free, serum-free and fungizone-free growth medium.

Treatment 3(x): Wells containing no cells were exposed to  $200\mu\text{l}$  of phenol red-free, serum-free and fungizone-free growth medium containing  $2.5\text{mg/ml}$  MTT (MTT medium).

The plates were incubated for 4 hours at  $37^{\circ}\text{C}$  and then  $1\text{ml}$  of DMSO was added to each well as described in Materials and Methods. The spectra were determined by taking  $1\text{ml}$  samples from well and scanning through wavelengths on a Pye Unicam SP8-100 spectrophotometer.

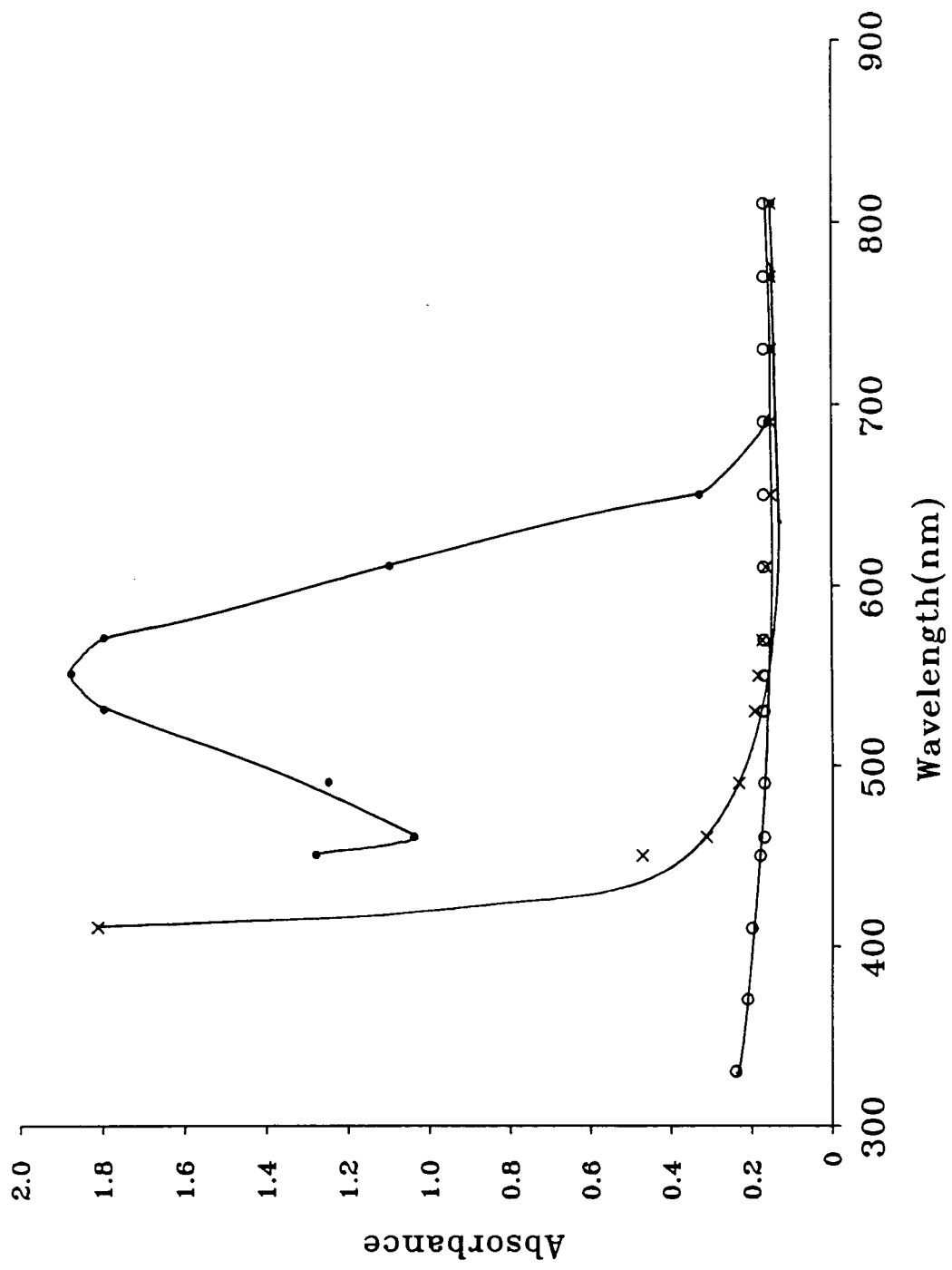

**Figure 2.9 — Determination of optimal MTT concentration for colorimetric assay**

Exponentially growing HTC cells were harvested and seeded into 24-well plates at a concentration of  $1.0 \times 10^5$  cells /well. The medium was changed after 24 hours. After a total of 36 hours the cells in the wells were exposed to 200  $\mu$ l of MTT medium (containing 0.5–4mg/ml MTT) for 4 hours at 37<sup>0</sup>C and processed as described in Materials and Methods.

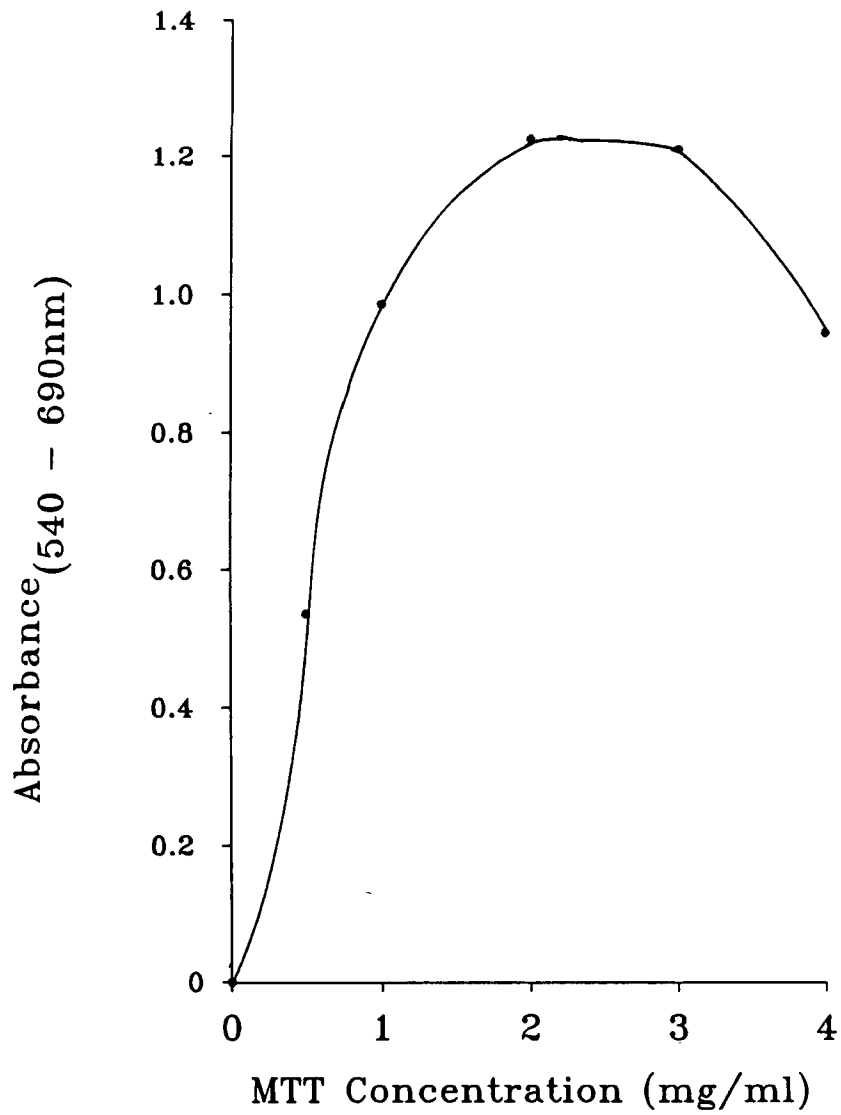

### **Figure 2.10 — Optimal incubation time for MTT assay**

Exponentially growing HTC cells were harvested and seeded at a density of  $5.0 \times 10^4$  cells per well in 1ml of growth medium. After 24 hours the medium was changed. After a total of 36 hours plates were exposed to MTT medium, incubated for varying periods at  $37^{\circ}\text{C}$  in a humidified atmosphere of air/ $\text{CO}_2$  (19:1, v/v), then treated as described in Materials and Methods.

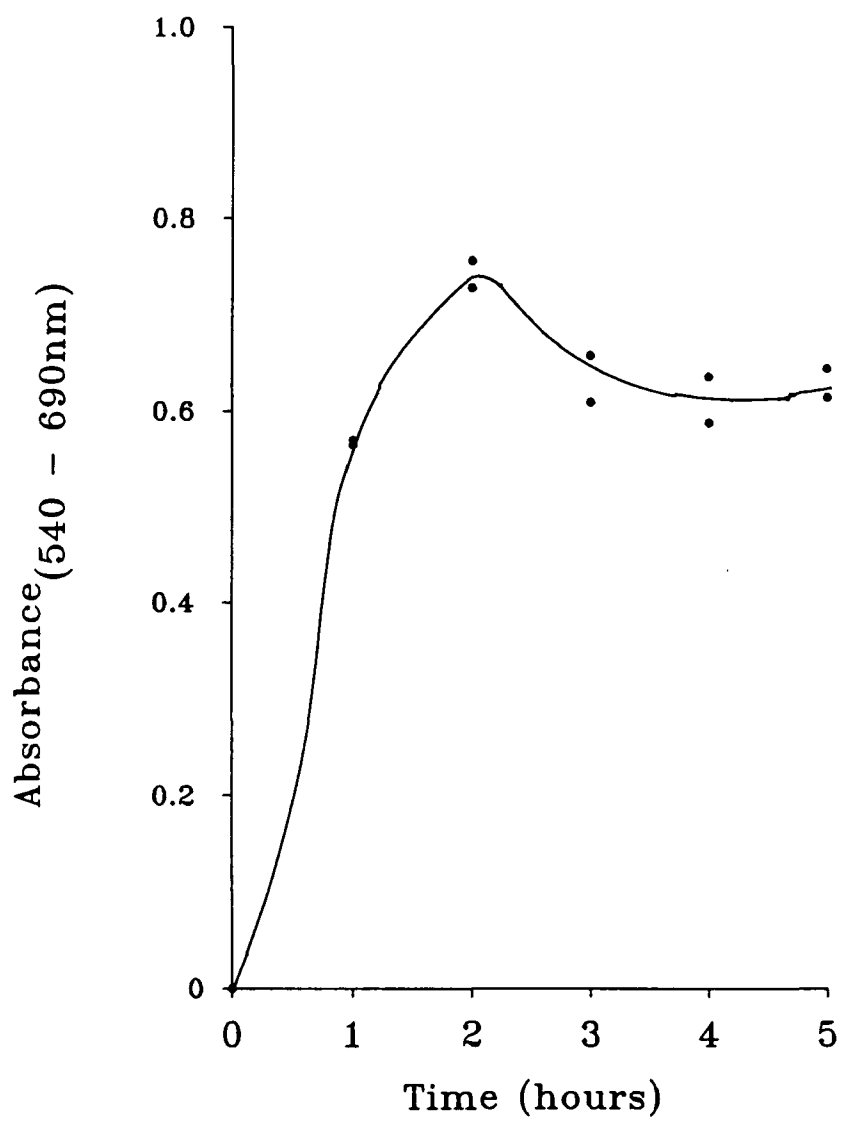

**Table 2.4 — Absorbance Stability of the formazan product generated from MTT by HTC cells**

Exponentially growing cells were harvested and seeded at a density of  $1.0 \times 10^5$  cells per well in 24-well plates. After 24 hours the plates were exposed to MTT medium as described in Materials and Methods. After solubilization of the formazan crystals,  $100\mu\text{l}$  aliquots were withdrawn from the wells at various time periods and absorbance determined. The plates were kept at room temperature.

The table represents the percentage change in absorbance relative to the absorbance obtained immediately after solubilization of the formazan crystals.

Time (minutes)	Absorbance 540nm -690nm	Percentage change
0	0.4159 $\pm 0.0011$	0.0
10	0.4163 $\pm 0.0013$	0.096
20	0.4189 $\pm 0.0035$	0.72
30	0.4146 $\pm 0.0014$	0.31
40	0.4269 $\pm 0.0088$	2.64
50	0.4224 $\pm 0.0035$	1.56

number of determinations=3

Data in table represents mean value  $\pm$  SEM

**Figure 2.11 — Relationship between cell number and absorbance in MTT colorimetric assay**

Exponentially growing HTC cells were harvested, counted and seeded into 24-well plates at different densities ( $0-3.0 \times 10^5$  cells in 1ml of growth medium). The cells were allowed to attach and after 12 hours plates were exposed to MTT medium at  $37^{\circ}\text{C}$  for 4 hours as described in Materials and Methods.

Best fit regression lines were fitted to the data using the straight line equation:

$$y=mx + c$$

Values of c (intercept on y axis), m (gradient) and r (correlation coefficient) are given below.

Parameters of best fit	value
m	$3.76387 \times 10^{-6}$ $\pm 1.0762 \times 10^{-7}$
c	0.04682 $\pm 0.01186$
r	0.9767

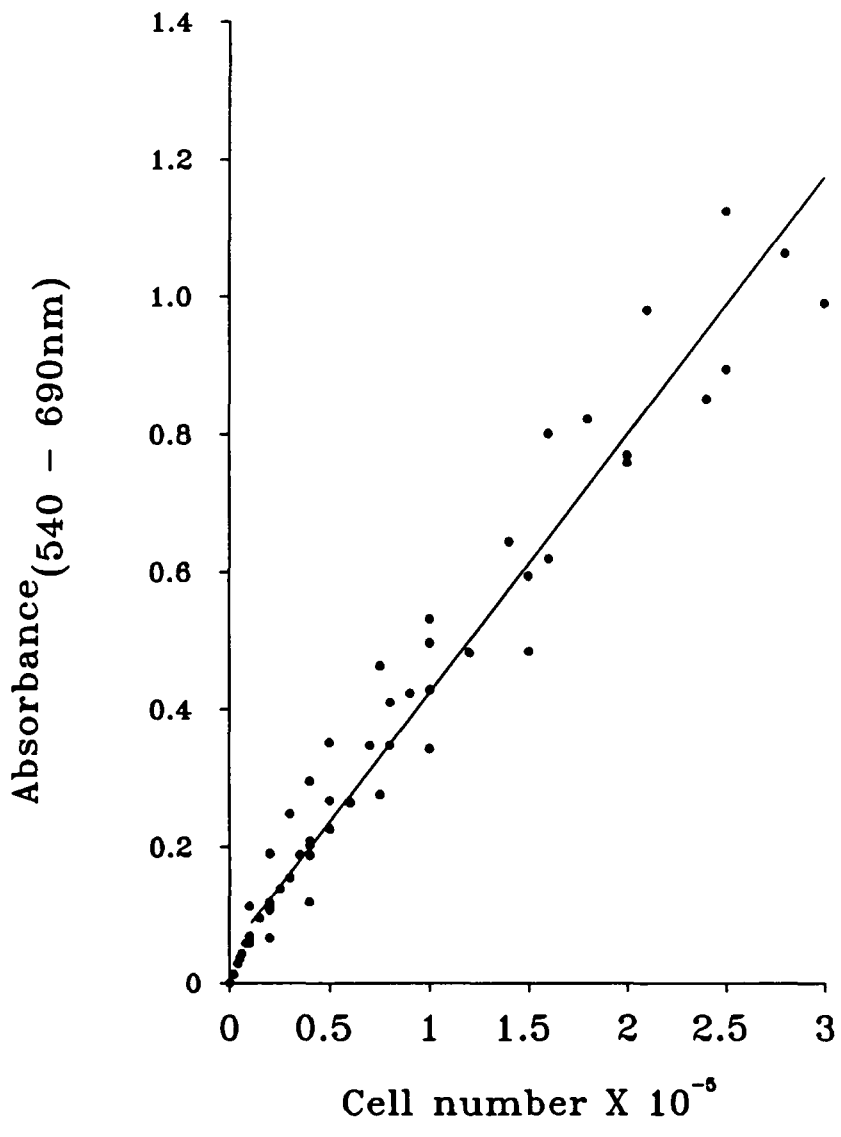

**Figure 2.12 — Growth characteristics of cells in 24-well plates as determined by the MTT assay**

On day 0 varying number of cells ( $4.0\text{--}8.0 \times 10^3$  cells/well) were seeded into 24-well plates in a total of 1ml growth medium. The medium in the wells was changed on day 1 and every 2 days thereafter. Every 24 hours cell number in the wells of one plate was estimated using the MTT assay as described in Materials and Methods.

Figure 2.12a shows the absorbance value obtained and in figure 2.12b these absorbance values have been converted to cell number using the relationship shown in figure 2.11 and plotted against time.

Each point represents the mean value derived from 4 replicate wells.

Key to graph		Doubling time (hours)
Seeding density cells/well	Symbol on graph	
4000	•	24.8
5000	◦	26.1
6000	×	24.6
7000	◊	19.9
8000	△	21.5

The doubling time represents the time taken for cell number to double during exponential growth. The following equation was used to calculate doubling time:

$$\text{doubling time} = \frac{t_2 - t_1}{3.32(\log N_{t_2} - \log N_{t_1})}$$

where

$t_2 > t_1$ ,  $t_2$  = time at point 2,  $t_1$  = time at point 1

$N_{t_2}$  = cell number at  $t_2$ ,  $N_{t_1}$  = cell number at  $t_1$

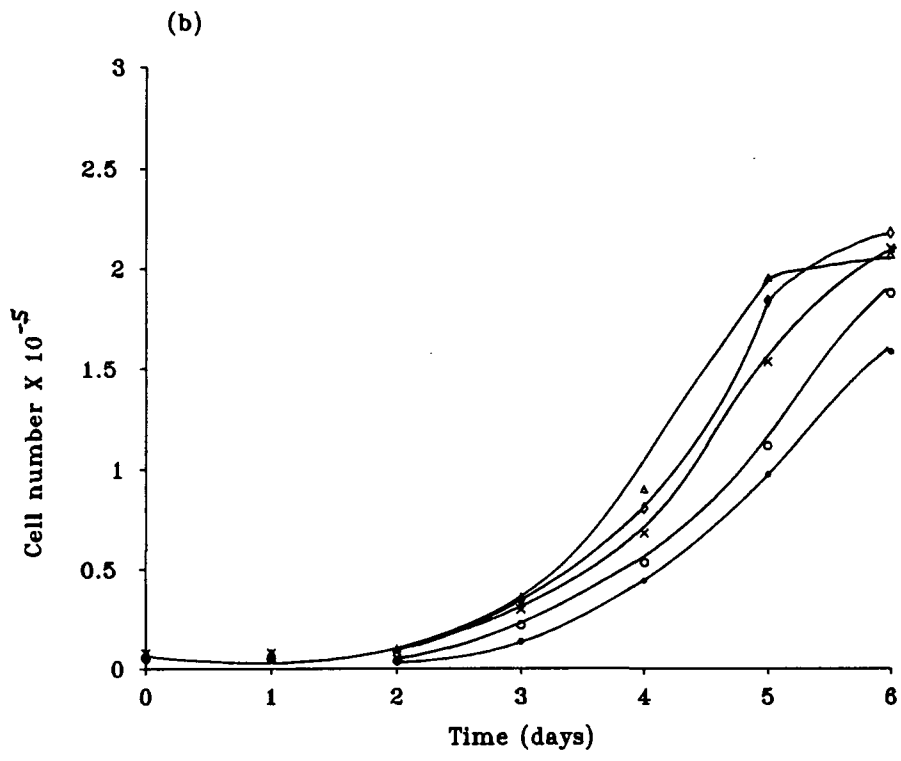
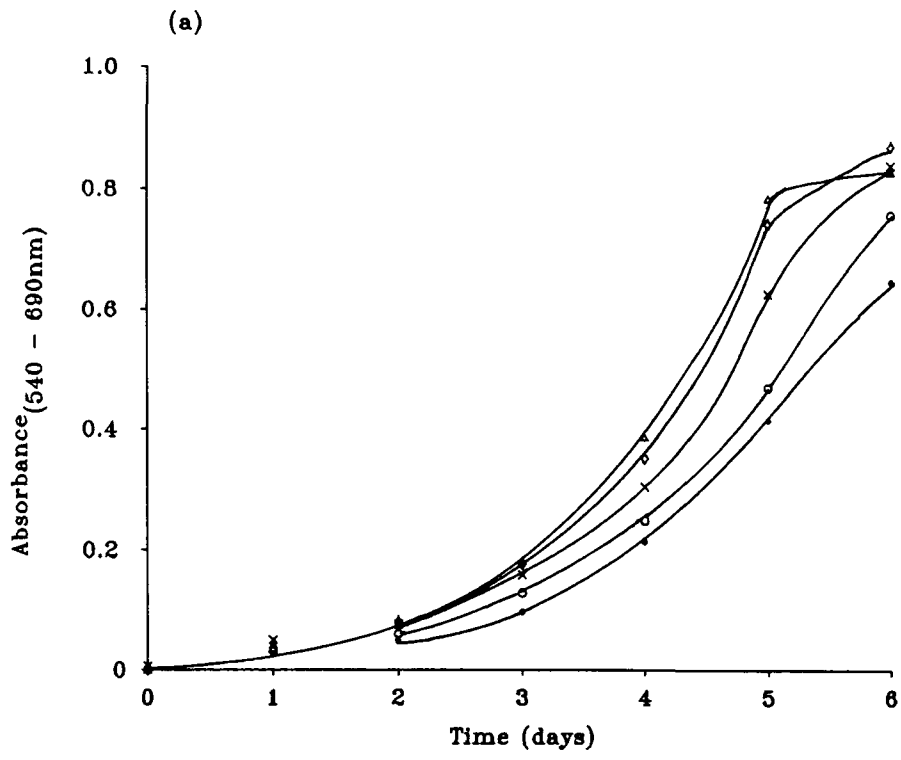

## 2.4 Discussion

The growth characteristics obtained in this study for HTC cells compare favourably with those obtained by Thompson *et al.*, (1966) for HTC cells. The doubling time of 20 to 26 hours obtained in this study is comparable to those obtained by Thompson *et al.* (1966) and Schamhart *et al.* (1984). The plating efficiency of HTC cells varied from 40 to 60% in the present study, while Thompson *et al.* (1966) reported figures of 50 to 100%. Some variation is to be expected since plating efficiency will depend on prior history of the cells i.e. age, culture conditions, harvesting process and the care taken during subculture.

The manipulation of the lipid composition of HTC cells would be improved if the cells could be grown in medium containing low levels of lipids. This is because the methods used to manipulate lipid composition, with respect to fatty acids, involve adding the desired free fatty acid to the growth medium. The cells grown in this medium preferentially take up the added free fatty acid because it is present in a plentiful supply. Therefore, this favours the incorporation of the added free fatty acid into cellular lipids (e.g. phospholipids and triacylglycerols). Normal growth medium contains serum which is an exogenous source of lipid (including free fatty acids and cholesterol) for the cells. If the free fatty acid content can be reduced in the serum component of the growth medium it would greatly favour the uptake of the added free fatty acids. In this study, although, growth medium containing lipid-depleted serum prepared in this study allowed the attachment of cells which remained viable, exposure of HTC cells to LDS media for 48 hours during exponential growth caused a cessation of growth (stationary phase). Exponential growth could be restarted by returning the cells to culture in normal growth media. This shows that a factor or factors needed to sustain growth were either lacking or

inactive in LDS. As the LDS growth medium could not support sustained growth it was of limited use in the free fatty acid supplementation procedure of chapter 3. This is because the methodology used in chapter 3 involves growing cells in medium containing supplemental free fatty acids for upto 72 hours, so that the cells would take up the added free fatty acid and assimilate it into phospholipids. For this to occur efficiently the cells must be able to grow rapidly. Therefore the use of LDS growth medium, in which cell growth cannot be maintained for long periods, is undesirable for fatty acid supplementation studies. However, there are advantages for use of LDS in relatively short term cholesterol depletion experiments of chapter 3, the main advantage being that due to the low cholesterol levels of LDS, the depletion of cholesterol from the cell can be facilitated in LDS media whilst cell viability is maintained.

The colorimetric assay of cell viability first developed by Mosmann (1983) has been modified and adapted to improve its performance. Preliminary experiments using Mosmann's procedure resulted in the precipitation of serum proteins and slow solubilization of the formazan in the solvent used by Mosmann. These problems have been noted and discussed by Denizot and Lang (1986), Alley *et al.* (1986) and Alley *et al.* (1988). Therefore the method of Denizot and Lang (1986) was essentially used in the present study. Denizot and Lang (1986) adapted the method of Mosmann (1983) such that serum and phenol red were omitted from the incubation medium, thus avoiding any interference from these substances. However, in order to assess heat-induced cell death (chapter 3) it was necessary to scale-up the assay from 96-well to larger volumes in 24-well plates. This was in order to avoid the problem of evaporation when using small volumes; furthermore 24-well plates were found to have better thermal characteristics. Additionally, the centrifugation

step in the procedure of Denizot and Lang (1986) had to be omitted as no plate centrifuge was available. Consequently, the flicking and blotting step to remove unconverted MTT resulted in loss of formazan. This problem was overcome by omitting the flicking and blotting step and adding the formazan solubilizing solvent directly to the well containing the MTT incubation medium. Therefore, the absorbance measurements were carried out in the presence of unconverted MTT. The absorption spectrum of MTT alone shows that it does not interfere with the absorption peak of formazan. The formazan solubilizing solvent used by Denizot and Lang (1986) was propanol but, as demonstrated by Alley *et al.* (1988), DMSO was the most suitable solvent for the formazan product generated from MTT by HTC cells in culture and therefore used in the assay adopted in this study. Due to these changes optimal parameters for the assay had to be redetermined.

The absorbance value in the MTT assay was linear with respect to cell number up to  $3.0 \times 10^5$  cells/well. Beyond this point the response with cell number deviated from linearity and approached a plateau, a fact observed by Carmichael *et al.*, (1987). Therefore, it is essential that the absorbance value must not exceed 0.9 units to obtain an accurate assessment of cell number. Also optimal conditions were elucidated for the HTC cell line, in terms of both seeding density and assay duration, because it is important that, after heat treatment, sufficient time is allowed for any cell death to occur in heat treated cells and that the faster-growing control cells are still in exponential growth at the time the assay is processed. This is because serious errors in the interpretation of data can result if control cells are allowed to reach stationary phase. For example, LD<sub>50</sub> is defined as 50% reduction in absorbance compared to controls values, so if control cells are allowed to reach stationary phase but experimental cells continue to grow

following depletion of their number by heat treatment, the LD<sub>50</sub> for treatment will be overestimated. Likewise, with treated cells, time should be given for any cell death to occur and/or mitochondrial damage to occur, leading to loss of ability to convert MTT to formazan. The growth curves carried out in 24-well plates show that a seeding density of  $5.0 \times 10^3$  cells/well ensures that growth is still in exponential phase after 6 days. Therefore a seeding density of  $4.0\text{--}5.0 \times 10^3$  HTC cells/well and assay duration of 5–6 days in 24-well plates were optimal under the present conditions.

The two methods for cell survival, characterised in this chapter are the clonogenic and colorimetric assays. Although both assays determine cell viability, they rely on different endpoints of cell death to determine survival. The clonogenic assay will determine the ability of the cell to divide and form a colony whereas the colorimetric assay will detect the ability of the cell to catalyse conversion of MTT to formazan. Therefore, by definition, the clonogenic assay will determine reproductive cell death whereas the MTT assay will measure metabolic death. The relative advantages and disadvantages of the two assays of cell viability must be considered with respect to the intended work on hyperthermic cell death. The clonogenic assay has been favoured in determining heat-induced cell death as the assay has been established since 1955 (Puck *et al.*, 1955) and is relatively simple, involving the detection of cell clones derived by replication of each viable cell. However, the colorimetric assay has been developed relatively recently (Mosmann, 1983) and has not been used in determining heat-induced cell death. In practice, estimating heat-induced cell death by the clonogenic assay involves harvesting the monolayer culture and reseeding a known number of cells (200 cells) into a 25cm<sup>2</sup> flask, containing 10ml of growth medium. The cells are allowed to attach and

recover from the harvesting process. The attached cells in the flask are then heat treated and returned to normal culture conditions. Survival is estimated by allowing the colonies to form for 10 days, before they are fixed, stained and counted. However, with the colorimetric assay the cell monolayers grown in 24-well plates, containing 1.0ml of growth medium per well, are heat treated in the plates without the need for harvesting and reseeded. After heat treatment the cultures are returned to normal culture conditions. The cells are allowed to grow for a further 3 days and survival is estimated by the ability of the cells to convert MTT to formazan. Therefore, from the procedures outlined above for the two assays to determine cell viability, it can be seen that the clonogenic assay is more time consuming and involves harsher treatment of cells prior to heat treatment (harvesting) compared to the colorimetric assay. Furthermore, a greater number of replicate experiments and treatments can be economically carried out using the colorimetric assay i.e. essentially an experiment carried out in a 24-well plate is equivalent to the same experiment carried out in twenty four 25cm<sup>2</sup> flasks. However, although experiments can be carried out rapidly and economically with the colorimetric assay, the endpoint determined in the clonogenic assay (i.e. reproductive death) is more valid when considering *in vivo* treatments of cancer. For the use of hyperthermia in the treatment of tumours *in vivo* to be successful it must render the tumour cells reproductively dead. However, the endpoint determined using the colorimetric assay is metabolic death. Although the lack of ability to convert MTT may be regarded as metabolic 'death', it is possible that in some cells this ability may be simply impaired temporarily by the heat treatment, thereby giving a falsely high measure of cell death. If functional mitochondria could be regenerated the cells may recover and replicate. Therefore, the choice of which assay to use for cell survival will depend on the nature of the information sought

by the investigator. Both assays are valid in that they detect the consequences of cell damage but they will not necessarily give identical results, since they do not measure the same parameter.

The present chapter has characterised the conditions necessary for successful culture of HTC cells and describes the general methods to be used in this study.

## Chapter III

### Effect of changes in membrane lipid on thermal sensitivity of HTC cells

#### 3.1 Introduction

Studies *in vivo* and *in vitro* have shown the considerable potential of hyperthermia (treatment at 42<sup>0</sup>C -45<sup>0</sup>C ) in cancer therapy, and the cytotoxic effect of heat on both normal and tumour cells has led many investigators to study the underlying mechanisms of cellular heat death. However, although there is a considerable wealth of information on the effects of hyperthermia on tumour and normal tissues (including differential thermal sensitivities) the molecular mechanisms of heat-induced cell death are not understood. The elucidation of the mechanisms underlying heat death is difficult because heat has an all-pervasive effect and so all cellular molecules will experience the thermal perturbation. This has led, at one time or another, to all major cellular structures being suggested as critical targets in heat injury (Roti Roti, 1982). The possibility that heat injury manifests itself in different ways in different cell types may also contribute to this diversity. A further complication suggested by Jung (1986) and Bowler (1987) is that of separating primary heat-induced damage from the secondary consequences of that damage. For example it has been suggested that heat may cause a breakdown in active transport of cations, leading to net influx of calcium (primary lesion). The elevated levels of cell calcium are suggested to cause deleterious changes in mitochondria, swelling of golgi apparatus, activation of nucleases, lipases and proteases causing

damage to chromosomes, membranes and the cytoskeleton (secondary damage). At some point the accumulation of this damage will be irreversible and lead to cell death. Therefore, it is pertinent to determine the sites of primary damage which ultimately lead to cell death, as these hold the key to the mechanism of the malfunction which leads to heat death.

Hyperthermia-induced alterations in the plasma membrane have been suggested to play a major, if not primary, role in the cellular effects of hyperthermia. The evidence to support this hypothesis comes from a number of approaches. Morphological studies have shown that heat causes the destruction of the plasma membrane (Fajardo *et al.*, 1980; Schrek *et al.*, 1980; Kingston, 1989), the loss of microvilli (Mulcahy *et al.*, 1981) and the formation of blebs (Bass *et al.*, 1982). The formation of blebs has also been shown to correlate with cell killing (Bass *et al.*, 1982; Borrelli *et al.*, 1986).

When cells are cultured above or below the normal temperature at which they are grown, they respond to offset, or compensate for, the direct effects of the temperature change. One important response is the preservation of membrane order by virtue of adaptive changes in lipid saturation, a response which has been termed 'homeoviscous adaptation' (Sinensky, 1974). Studies on homeoviscous adaptation form another body of evidence which support the hypothesis that membrane structure, and its physical state, can respond to changes in environmental temperature. For example, mycoplasma (Huang *et al.*, 1974), bacteria (Sinensky, 1974), protozoa (Martin and Thompson, 1978), yeast (Arthur and Watson, 1976) higher plants (Simon, 1974) and animal cells (Johnston and Roots, 1964; Cossins *et al.*, 1977; Hazel, 1979) have all been shown to respond to changes in environmental temperature by altering the degree of saturation of the fatty acyl chains of their membrane phos-

pholipids or indeed the cholesterol levels of the membrane (Anderson *et al.*, 1981). The physiological importance of this response lies in the adaptive regulation of membrane function, which depends upon the influence of lipid order upon membrane function (Cossins *et al.*, 1987). This particular aspect of the study, that is the effect of changes in membrane order on membrane proteins/processes is discussed further in chapter 5. Anderson *et al.*, (1981) have shown that the growth of Chinese hamster ovary cells above 37<sup>0</sup>C led to these cells having increased resistance or tolerance to 43<sup>0</sup>C heat treatment, whereas cells grown at 32<sup>0</sup>C were sensitized to heat. It is possible that these changes in thermal sensitivity are due to the effect of change in membrane fluidity (caused by change in membrane lipid composition) on membrane mediated processes.

Further support for the hypothesis that plasma membrane damage may be an important facet of heat death is that several agents known to act at the membrane interact with heat to alter the thermosensitivity of mammalian cells (Yatvin *et al.*, 1987). Local anaesthetics and aliphatic alcohols are molecules that are thought to partition into the lipid matrix, disrupting lipid order (Seeman, 1972). The action of local anaesthetics on cells in culture shows that they act synergistically with heat in cell killing (Yatvin *et al.*, 1982b; Konings, 1985). *In vivo* models (tumour bearing mice) have also shown that local anaesthetics potentiate the action of heat on cell killing (Yatvin *et al.*, 1979; Hidvegi *et al.*, 1980; Barker, 1985). Aliphatic alcohols also have a potentiating effect on hyperthermic cell killing (Li and Hahn, 1978). Li *et al.* (1980) showed that the cell killing response obtained by ethanol is similar to heat. They concluded that the same 'critical' targets are affected by ethanol and heat. However, Massicotte-Nolan *et al.*, (1981) found that the effect of a series of monohydric alcohols on membrane fluidity did not corre-

late well with their sensitization of cells to heat. Similarly, Lepock *et al.* (1981), using butylated hydroxytoluene to fluidize membranes of V-79 cells, failed to show increased heat sensitivity. These discrepancies may arise because 'fluidity' is a poorly defined term and the different probes used to determine fluidity may be measuring different parameters (see chapter 4 and Lepock, 1982). Furthermore, Yatvin *et al.* (1982a) have questioned whether changes in fluidity caused by butylated hydroxytoluene are the same as those induced by diet or growth temperature manipulation. Minton *et al.* (1980) reported an interesting observation that high pressure inhibits hyperthermic cell killing. One possible explanation for this is that pressure counteracts the increase in membrane fluidity caused by high temperatures. However, Minton *et al.* (1980) also suggested the possibility that other sites could be involved in the inhibition of hyperthermic cell killing by high pressure. For example, the impairment of soluble enzyme activity by heat has also been shown to be pressure-reversible.

Dietary manipulation of the fatty acid composition of the cell membranes has also been used to alter membrane fluidity. This approach has yielded useful evidence to elucidate the relationship between membrane lipid composition and thermosensitivity. The fatty acid auxotroph *Escherichia coli* K1060 requires unsaturated fatty acids for growth and by varying the unsaturated fatty acids in the growth medium, membrane composition can be markedly altered. Using this approach, Yatvin (1977) demonstrated that *E. coli* K1060 cells enriched with linolenic acid (18:3) were more sensitive to heat killing than the same cell type enriched with oleic acid (18:1).

Similarly, dietary manipulation has been used with mammalian cells to alter membrane lipid composition. It has been shown that mammalian cells appear to

have a large capacity to incorporate and accumulate unsaturated fatty acids added to the growth media (Rosenthal, 1987). These fatty acids are incorporated into membrane phospholipids and any excess fatty acids are stored as triacylglycerols, which accumulate in cytoplasmic lipid droplets (Geyer, 1967). However, with saturated fatty acids the cytotoxic effects of elevated concentration in the growth media (Urade and Kito, 1982) hinders the study of their effects on membrane lipid structure. The reasons for this effect could be because saturated fatty acids have a much higher melting point than unsaturated fatty acids. The uptake and accumulation of saturated fatty acids could therefore result in the formation of damaging crystalline neutral lipids (Goto *et al.*, 1986) or increased saturation of membrane phospholipids with a resultant increase in membrane order to a level which does not permit cell growth (Doi *et al.*, 1978).

Free fatty acid supplementation (addition of free fatty acid to growth media) was first carried out with LM cells which can grow in serum-free medium. Williams *et al.* (1974), using LM cells, produced large differences in the fatty acid composition of total cell phospholipids by adding a combination of dl-desthiobiotin, to inhibit fatty acid synthesis in the cells, together with various fatty acid esters of Tween. Glaser *et al.* (1974) supplemented LM cells, grown in a serum free medium, with linoleic acid bound to albumin, and found that the linoleic acid content of total phospholipid increased from undetectable amounts in control cells to 37% of phospholipid fatty acyl groups in supplemented cells. Similarly, Horwitz *et al.* (1974), produced phospholipid fatty acyl modification in 3T3 cells by growing them in a culture medium containing lipid-depleted serum, supplemented with specific fatty acids. As demonstrated in chapter 2 for HTC cells, many diploid cells cannot be grown in adequate numbers in either a serum-free medium or a medium that

contains lipid-depleted serum. However, Spector *et al.* (1979), using human skin fibroblasts demonstrated that it is not essential to remove the serum lipids from the culture medium. Extensive modifications of the fibroblast fatty acyl composition were produced by simply adding specific fatty acids to the usual growth medium containing 10% foetal bovine serum. Under these conditions, cultures continue to grow normally and large quantities of lipid-modified fibroblasts can be produced, facilitating studies such as plasma membrane purification (see chapter 4) which require large amounts of starting material.

Spector and Yorek (1985) have demonstrated that the extent of membrane lipid modification depends on the time of exposure to the supplemental fatty acid and its concentration in the culture medium. Using Y79 retinoblastoma cells supplemented with docosahexaenoic acid (22:6) for up to 72 hours, it was found that the largest change in phospholipid fatty acyl composition occurred during the first 48 hours. Furthermore, in 72-hour exposure to fatty acid supplement, the maximum enrichment with docosahexaenoic was produced with a supplemental fatty acid concentration of less than  $40\mu\text{M}$ .

The consequences of the lipid compositional changes, obtained via dietary supplementation, on the thermal sensitivity of tumour cells have been investigated both *in vivo* and *in vitro*. For example, when mice, bearing tumour cells (L1210 murine leukemia and Ehrlich ascites), were fed on diets modified by incorporating saturated or unsaturated fatty acids, the *in vitro* thermosensitivity of the tumour cells was greater for cells derived from mice fed a high unsaturated fatty acid diet when compared to those from mice fed a high saturated fatty acid diet (Burns and Spector, 1987). Also, the survival of mice receiving heated cells was longer when they received ascites cells from the diet enriched with unsaturated fatty acids (Hid-

vegi *et al.*, 1980). In a morphological study, Mulcahy *et al.* (1981) reported that the pattern of heat damage was greater in P388 cells from animals receiving an unsaturated fatty acid diet. The same conclusions have been reached with studies using solid transplantable mammary adenocarcinomas grown in the medial aspect of the hind legs of mice. The sensitivity of these tumours to local hyperthermia (43.5°C for 1 hour) was increased by feeding mice a diet enriched in linoleic acid (Yatvin *et al.*, 1983a).

Guffy *et al.*, (1982) showed that growing L1210 leukemia cells in media supplemented with highly polyunsaturated fatty acid (docosahexaenoic acid) led to increased thermosensitivity when compared to control cells, whereas decreased thermosensitivity was observed when cells were supplemented with a more saturated fatty acid (oleic acid) when compared to control cells. These changes were accompanied by increased cell membrane 'fluidity' for cells supplemented with docosahexaenoic acid compared to unsupplemented cells, whereas for cells supplemented with oleic acid, reduced membrane 'fluidity' was reduced as compared with unsupplemented cells. This finding was confirmed by Konings (1985) and Konings and Ruifrok (1985) using mouse fibroblast LM cells grown in media supplemented with arachidonic acid. The polyunsaturated fatty acid content of the membrane phospholipids from these cells was increased from 7 to 40% which correlated with increased plasma membrane fluidity and increased thermosensitivity of the LM cells.

These studies suggest that dietary supplementation with unsaturated fatty acids *in vivo* and *in vitro* increases the thermal sensitivity of tumour cells, and this may be associated with an increase in membrane fluidity. This has led to the hypothesis that membrane 'fluidity' might be a major factor contributing to heat-

induced cell death. However, this hypothesis has been challenged by a number of investigations (Lepock *et al.*, 1981; Massicotte-Nolan *et al.*, 1981; Lepock, 1982; Lepock *et al.*, 1983, 1988, 1989) which suggest that membrane protein denaturation rather than membrane lipid fluidity is the major factor leading to hyperthermic cell death (see chapter 5).

Another determinant of membrane fluidity, cholesterol (Yeagle, 1985), can also be manipulated to probe the effects of changes in membrane fluidity on thermosensitivity of cells. Mammalian cell membranes all contain cholesterol, but the distribution of the cholesterol among the membranes of a cell is not uniform. Lange and Ramos (1983) showed that in fibroblasts, Chinese hamster ovary cells and rat hepatocytes 80-90% of the total cell cholesterol was located in the cell plasma membrane. Thus, plasma membranes are rich in cholesterol, whereas mitochondrial membranes possess little cholesterol, and endoplasmic reticulum possesses even less. This disproportionate distribution among the membranes has been demonstrated to occur in cardiac muscle (Severs and Simons, 1983), liver tissue (De Wolf *et al.*, 1977) and adrenal tissue (Conneely *et al.*, 1983). Among cells of different types, the amount of cholesterol within the plasma membranes varies considerably. However, each cell maintains its own optimal membrane lipid composition, especially the amount of cholesterol relative to the more polar lipids, including phospholipids and glyco-lipids.

The interaction of cholesterol with the phospholipid in biological membranes is not completely understood. The phosphoacylglycerols of biological membranes normally contain one saturated fatty acyl chain, usually at the *sn-1* position, and one fatty acyl chain at the *sn-2* position which has at least one unsaturated *cis* double bond. This asymmetry of acyl chain structure is thought to accommodate

the cholesterol molecule within the membrane lipid bilayer (Cooper and Strauss, 1984). The interaction of cholesterol with phosphoacylglycerols causes a degree of immobility to be imposed on the acyl carbon atoms nearest the glycerol moiety of the phosphoacylglycerols. However, near the centre of the bilayer the acyl chains are less influenced by the cholesterol, thus having considerable motional freedom (Oldfield *et al.*, 1978). Recently, it has been shown in pure phospholipid-water systems that cholesterol also interacts with the acyl chains near the centre of the bilayer (Singer and Finegold, 1990). One of the consequences of such interactions can be seen by the effect of cholesterol on the phase transition of pure phospholipid-water systems. The normal endothermic gel to liquid crystalline phase transition observed upon heating of pure phospholipid-water systems is reduced or absent when cholesterol is added (Mabrey *et al.*, 1977). This is consistent with the effect of cholesterol of increasing the disorder of phospholipid hydrocarbon chains below the phase transition temperature and of increasing their order above this temperature (Harrison and Lunt, 1980). In most mammalian cell culture systems the growth temperature of 37<sup>0</sup>C is used, which is above the phase transition temperature for most mammalian cell membranes. This makes the ordering effect of cholesterol on biological membranes more dominant under physiological conditions. During such phase transitions it has been suggested there exists cholesterol- rich and cholesterol-poor regions within the membrane (Schroeder, 1984).

It has been hypothesised that cells maintain an optimum level of cholesterol in membranes (Sabine 1983). This is thought to maintain an optimal membrane environment for membrane function. That is, there is an optimum level of membrane cholesterol at which functional activity is maximal, above or below this level activity declines. This hypothesis holds true for several membrane-bound systems,

in particular the microsomal enzyme cerebroside sulfotransferase, transmembrane ATP/ADP exchange and glucose transport.

The cholesterol/phospholipid mole ratio of membranes is used as the index to determine the influence of cholesterol on the membrane. A low cholesterol/phospholipid ratio implies a low cholesterol level relative to phospholipid and therefore a low ordering effect of cholesterol on the membrane. The opposite is true for a high cholesterol/phospholipid ratio. The involvement of cholesterol in influencing the thermosensitivity of mammalian cells has been supported by evidence from a number of investigations. Gonzalez-Mendez *et al.* (1982b) reported that Chinese hamster ovary fibroblasts grown at 32<sup>0</sup>C , 37<sup>0</sup>C , 39<sup>0</sup>C or 41<sup>0</sup>C show a progressive increase in thermal resistance to exposure at 43<sup>0</sup>C. Growth temperatures above 37<sup>0</sup>C caused an increase in membrane cholesterol content, and in membrane order, that correlated with the increase in thermal resistance. Anderson *et al.* (1981) showed that cholesterol was involved in homeoviscous adaptations. These workers showed that Chinese hamster ovary cells grown below 37<sup>0</sup>C were sensitized to a 43<sup>0</sup>C heat treatment, whereas cells grown above 37<sup>0</sup>C displayed increased resistance or tolerance to 43<sup>0</sup>C heat treatment. Furthermore, in all experiments with stationary phase cells, the cholesterol/phospholipid molar ratio increased with increasing growth temperature which correlated with reduction in membrane fluidity. However, these correlations were less clear with exponentially growing cells.

Direct comparison of the amounts of cellular membrane components of seven different cell lines and their thermosensitivities (Cress and Gerner, 1980; Cress *et al.*, 1982) has shown that cell cholesterol content correlates well with cell thermal sensitivity. In particular, it was demonstrated that cell lines high

in cholesterol and phospholipid relative to protein content were more resistant to heat treatment at 43<sup>0</sup>C. However, the cholesterol/phospholipid molar ratios did not display a linear correlation with sensitivity to 43<sup>0</sup>C - induced cell killing. These studies suggest that cholesterol content relative to protein is a useful index to predict thermal sensitivity of cell lines. However, Raaphorst *et al.* (1985) using seven different cell lines from transformed C3H 10T $\frac{1}{2}$  mouse embryo cells showed no correlation between heat sensitivity and membrane lipid composition. The same conclusion was reached by Konings and Ruifrok (1985), using 3 cell lines (Ehrlich ascites, mouse fibroblast LM cells and HeLa S<sub>3</sub>), who did not find any correlation between cholesterol and phospholipid content and heat sensitivity of the cell lines. Anderson *et al.*, (1985) reported that several indices of membrane composition of nine different cell lines correlated with sensitivity of the cells to heat treatment at 44<sup>0</sup>C. They described positive correlations of heat sensitivity with the cellular content of cholesterol, phospholipid and protein, and with the cholesterol/protein ratio and phospholipid/protein ratio. However, cholesterol/phospholipid molar ratios did not correlate with heat sensitivity. In the data analysed by these workers, the inclusion of 3 very heat sensitive lymphoid cell lines was judged by these workers to distort the results. When data from these cell lines was omitted, the evaluation of the data from the remaining six cell lines only showed a positive correlation between heat sensitivity and cellular cholesterol and protein content.

It can be seen that the approach of correlating heat sensitivity of cell lines to membrane cholesterol has led to contradictory results. However, very little work has been attempted at altering membrane cholesterol of a cell line and assessing the change in heat sensitivity. In this study two approaches were used to lower membrane cholesterol. Liposomes have been demonstrated to be useful

in removing cholesterol from mammalian cells in culture (Rothblat *et al.*, 1986; Phillips *et al.*, 1987) and therefore formed the basis of the first method to lower membrane cholesterol. The second approach involved the inhibition of cholesterol synthesis. Most mammalian cells have the ability to regulate the cholesterol levels in the cell. The key enzyme involved in the *de novo* biosynthesis of cellular cholesterol is 3-hydroxy-3-methylglutaryl coenzyme A reductase (HMG-CoA reductase). This enzyme is subject to several types of control by a variety of regulators, most prominent of which is negative feedback by the availability of cholesterol (Brown and Goldstein, 1980). These controls have been shown to exist in HTC cells by Kirsten and Watson (1974). These workers showed that HTC cells maintained in medium which contained lipoprotein-poor serum (low cholesterol content) have a steady state rate of cholesterol synthesis which is 3- to 4-fold greater than cells grown in medium containing unfractionated dialyzed serum (high cholesterol content). This increase also correlated with a similar change in the catalytic activity of HMG-CoA reductase. The suppression of HMG-CoA reductase activity by the potent inhibitor, 25-hydroxycholesterol (Kandutsch and Chen, 1977) therefore forms the basis of reducing cellular cholesterol.

There are many consequences of changing membrane cholesterol levels via liposomes (Cooper and Strauss, 1984) or by blocking cholesterol synthesis (Kandutsch *et al.*, 1978). However, the most significant with respect to this study is the lowering of membrane order which follows the removal of membrane cholesterol.

The hypothesis that decreased membrane order results in increased heat sensitivity implies that an increase in membrane order will result in a decrease in heat sensitivity. The first two approaches outlined above will help assess the effect of lowering membrane order on heat sensitivity. To investigate the effect of

increased order on heat sensitivity, cholesterol hemisuccinate was administered to HTC cells in culture medium in an attempt to rigidify membranes prior to heating. This hydrophilic ester of cholesterol has proved useful in many studies investigating the effects of membrane rigidification (Traill and Wick, 1984; Shinitzky *et al.*, 1979; Skornick *et al.*, 1981; Muller and Shinitzky, 1981; Deliconstantinos, 1987; Shinitzky *et al.*, 1980). However, the most pertinent investigation with respect to the current study was carried out by Yatvin *et al.* (1983b). These workers demonstrated that the heat sensitivity of P-388 ascites tumour cell and V-79 Chinese hamster lung fibroblasts was not changed after rigidification of the membrane by cholesterol hemisuccinate.

The plasma membrane is a prime candidate for heat damage, but many of the previous investigations linking thermal sensitivity of tumour cells to changes in the fatty acid composition and fluidity of membranes have examined changes in mixed membranes derived from cells (Guffy *et al.*, 1982; Gonzalez-Mendez *et al.*, 1982b; Raaphorst *et al.*, 1985), thus possibly obscuring the importance of changes specific to the plasma membrane.

In this study, HTC cells supplemented with fatty acids were examined for changes in their thermal sensitivity, and the results are reported in the present chapter. In later chapters, these changes are related to changes in the lipid composition and fluidity of purified plasma membranes, and the thermal sensitivity of key membrane-bound enzymes. This approach was adopted in the hope that it would define more precisely the relationship between lipid composition and fluidity of the plasma membrane, thermal sensitivity of tumour cells and their membrane-associated proteins. In addition, the change in heat sensitivity of HTC cells after exposure to liposomes, 25-hydroxycholesterol or cholesterol hemisuccinate was also investigated.

## **3.2 Materials and Methods**

### **3.2.1 pH measurement of culture media during heat treatment**

A flask of 25cm<sup>2</sup> growth area, containing 10ml of growth medium lacking fungizone, was placed in an humidified incubator at 37<sup>0</sup>C with an air/CO<sub>2</sub> (19:1, v/v) atmosphere for 3 hours. After this period a calibrated pH probe attached to a portable pH meter was sealed into the flask such that the pH of the medium could be measured continuously. The flask was immersed in a water bath at 37<sup>0</sup>C and the pH was monitored. After 10 minutes the flask was transferred to a water bath set at 43.5<sup>0</sup>C and the pH monitored with time.

However, to measure pH of media inside 24-well plates it was necessary to adopt a different procedure as the pH probe could not be sealed into a well. The 24-well plates with 1ml of growth medium per well, containing 10mM HEPES, pH 7.4 but lacking fungizone, were placed in an incubator at 37<sup>0</sup>C for 3 hours. After this period the pH of media inside control wells was measured and plates sealed before immersion in a water bath at 37<sup>0</sup>C. After thermoequilibration at 37<sup>0</sup>C the plates were rapidly transferred to a water bath set at 1.5<sup>0</sup>C higher than the required temperature for 5 minutes, before final transfer to a water bath at the desired hyperthermic temperature. This protocol mimics that used in hyperthermic treatment of HTC cells (section 3.2.6). Plates were retrieved at various timed intervals, and the pH of the media inside the wells determined using micro pH electrode (from Russel electrodes).

### **3.2.2 Time course of cell adherence to tissue culture flasks**

HTC cells ( $3 \times 10^5$ ) were seeded into 25cm<sup>2</sup> culture flasks containing 10ml of

growth medium. The flasks were placed in an incubator at 37<sup>0</sup>C for various time periods. At each time point flasks were harvested and the number of cells attached determined using a Coulter Counter as described in chapter 2.

### 3.2.3 Supplementation of newborn bovine serum with free fatty acids

To 100 $\mu$ moles of sodium palmitate was added 3ml of distilled water, and the mixture was warmed to 70<sup>0</sup>C. However, with arachidonic acid 3ml of 0.05M NaOH was added to 100 $\mu$ moles of the free fatty acid (FFA) and the mixture warmed to 37<sup>0</sup>C with gentle shaking. This represents a 50% molar excess of NaOH over fatty acid which is sufficient to solubilize the fatty acid, but insufficient to change pH of the serum and culture medium substantially. When the fatty acids had solubilized, 45ml of newborn bovine serum (NBS), prewarmed to 40<sup>0</sup>C , was added rapidly such that the free fatty acids remained in solution. The solution was allowed to cool to room temperature before adding NBS to make the volume 50ml. This constitutes a 2mM palmitate or arachidonate supplement in NBS ( 94% by volume) and will be referred to as the FFA-NBS solution. The supplemented sera were sterilized by passage through a 0.22 $\mu$ m filter and divided into aliquots in 2ml glass ampoules. The ampoules were then sealed under an atmosphere of N<sub>2</sub> , wrapped in silver foil and stored at -20<sup>0</sup>C.

In order to prepare a growth medium containing the supplement, an appropriate amount of the 2mM FFA-NBS solution was added to the medium such that the final desired serum concentration remained unchanged. This medium was used to replace the normal medium in experiments to expose cells to fatty acid supplement.

### **3.2.4 Photography of the 'lipid droplets' formed after supplementation**

Cells ( $5 \times 10^3$  per well) were seeded in 1ml of growth medium into 24-well plates, which had glass coverslips in each well. The medium was replaced the following day. On the second day after seeding the cells were exposed to  $80\mu\text{M}$  arachidonate-supplemented growth medium for 36 hours. The accumulation of cytoplasmic lipid droplets in cells on coverslips was photographed using an inverted Nikon Diaphot microscope with differential contrast Nomarsky optics.

### **3.2.5 The clonogenic assay of cell survival after hyperthermic treatment**

Cells ( $3 \times 10^5$ ) were seeded into 10ml of growth medium in a  $25\text{cm}^2$  flask on day 0 and incubated at  $37^\circ\text{C}$  in an humidified atmosphere of air/ $\text{CO}_2$  (19:1, v/v) then the medium was changed in the flasks on day 1 and on day 3. In supplementation studies, normal growth medium was replaced by medium containing various concentrations of free fatty acid supplement on either day 2, day 3 or day 4 depending on the period of supplementation required. In all cases, cells were harvested on day 5 by exposure to 2mM EDTA in phosphate-buffered saline. Two hundred control cells or fatty acid-supplemented cells were then seeded into 10ml of normal growth medium lacking fungizone (Hahn *et al.*, 1977) in  $25\text{cm}^2$  flask and cells were allowed to attach to flasks at  $37^\circ\text{C}$  for 3 hours in an humidified atmosphere of air/ $\text{CO}_2$  (19:1, v/v). The flasks were sealed and thermoequilibrated in a water bath at  $37^\circ\text{C}$  before rapid transfer to a water bath at the hyperthermic temperature ( $\pm 0.1^\circ\text{C}$ ). The temperature of the growth medium was monitored continuously inside the flasks by a thermocouple inserted into a 'dummy' flask containing growth medium only, which was heated under the same conditions as the experimental flasks. Equilibration to the higher temperature was complete within 5 minutes

and this thermal lag period was included in the total heating time. After heating, the unsealed flasks were returned to culture at 37<sup>0</sup>C. The following day (day 6) the medium was replaced with normal growth medium (containing fungizone) and changed on day 9. On day 10 the cells were fixed, stained in Trypan Blue and the colonies counted as described in chapter 2.

### **3.2.6 The colorimetric assay of cell survival after hyperthermic treatment**

Cells ( $5 \times 10^3$ ) were seeded into 1ml of growth medium in each well of a 24-well plate on day 0. The plates were then placed in an incubator at 37<sup>0</sup>C with a humidified atmosphere of air/CO<sub>2</sub> (19:1, v/v). In studies not requiring supplementation, the medium was changed on day 1. However, in experiments requiring supplementation, the medium was replaced by growth medium containing supplemental free fatty acid for the appropriate time before heat treatment. In both cases, on day 3 the control or fatty acid-supplemented growth medium was replaced with normal growth medium containing 10mM HEPES, pH 7.4, but lacking fungizone. The plates were then placed in an incubator at 37<sup>0</sup>C with a humidified atmosphere of air/CO<sub>2</sub> (19:1, v/v) for 20 minutes. The plates were sealed and thermoequilibrated at 37<sup>0</sup>C before rapid transfer to a water bath set 1.5<sup>0</sup>C higher than the required hyperthermic temperature for 5 minutes, before final transfer to a water bath at the desired hyperthermic temperature ( $\pm 0.1^0$ C). This protocol reduced the thermal lag time to approximately that determined for flasks. The temperature of the medium was monitored continuously via a thermocouple inserted into medium within a well of a 24-well plate, which was heated under the same conditions as the experimental plates. After heating, unsealed plates were returned to culture at 37<sup>0</sup>C. The following day (day 4) the medium was replaced with normal growth medium (containing fungizone) and surviving cells were estimated on day 6 by

their ability to convert MTT to formazan as described in chapter 2, section 2.2.15.

### 3.2.7 Preparation of liposomes

A solution of egg phosphatidylcholine(10mg) in chloroform was evaporated to dryness under N<sub>2</sub>. Distilled water (2ml) was added to the dry phosphatidylcholine and left for several hours at room temperature. After this period the mixture was vortex mixed vigorously and sonicated to clarity (2 to 3 minutes) under N<sub>2</sub> at 4<sup>0</sup>C (Rothblat *et al.*, 1986) with a MSE Soniprep 150 set at 15 microns amplitude (half maximal power). This liposome solution was then incorporated into growth medium (10ml) lacking serum and fungizone. This constitutes a 1mg/ml phosphatidylcholine liposome solution.

### 3.2.8 Labelling of cells with [7(n)-<sup>3</sup>H]-cholesterol

To [7(n)-<sup>3</sup>H]-cholesterol(5 $\mu$ Ci), dissolved in toluene, was added 80 $\mu$ g of egg phosphatidylcholine dissolved in hexane and the mixture evaporated to dryness under N<sub>2</sub>. The dried lipids were redissolved in 5 $\mu$ l of ethanol before adding to 10ml of growth medium prepared with 5% (v/v) heat-inactivated newborn bovine serum (labelling medium). The heat inactivation of serum was necessary in order to inhibit lecithin cholesterol acyl transferase(LCAT) which, in the active form, will convert [7(n)-<sup>3</sup>H]-cholesterol into [<sup>3</sup>H]-cholesteryl esters and hence reduce efficiency of cellular labelling. The inactivation of the enzyme was carried out by heating the newborn bovine serum (NBS) at 56<sup>0</sup>C for 30 minutes (see Rothblat *et al.*, 1986).

The labelling medium was then sterilized by filtration through a filter with a pore size of 0.22 $\mu$ m and incubated at 37<sup>0</sup>C for 3 to 6 hours prior to use.

HTC cells (3 x 10<sup>5</sup>) were seeded into 25cm<sup>2</sup> flasks containing 10ml of growth

medium on day 0 and placed in an incubator at 37<sup>0</sup>C with a humidified atmosphere of air/CO<sub>2</sub> (19:1). Blank flasks without cells but containing 10ml of growth medium were also set up and treated the same as flasks containing cells. The medium was changed the next day (day 1). On day 4 the growth medium was discarded and the monolayers together with blank flasks were washed once with 10ml Ca<sup>2+</sup>-and Mg<sup>2+</sup>-free phosphate-buffered saline. Then 10ml of labelling medium was added and the flasks returned to culture for 2 days at 37<sup>0</sup>C. After this period the labelling medium was discarded and the cells, together with blank flasks, were washed twice with Ca<sup>2+</sup>-and Mg<sup>2+</sup>-free phosphate-buffered saline before adding 10ml of growth medium lacking serum and fungizone but containing 8mg/ml lipid depleted serum (LDS media). The monolayers of cells together with blank flasks were then returned to culture for a further 24 hours at 37<sup>0</sup>C. The LDS media was then discarded and the flasks washed once with 10ml of Ca<sup>2+</sup>-and Mg<sup>2+</sup>-free phosphate-buffered saline before adding 10ml of liposome solution or LDS media or growth media lacking serum and fungizone. The flasks were then incubated at 37<sup>0</sup>C. Duplicate samples (0.1ml) of the media surrounding the cells and media inside the blank flasks were taken at various time intervals. To the samples, was added 10ml of Fluorosol scintillant/digestant and the radioactivity present determined using a Packard 300 CD liquid scintillation counter. At the end of the experiments the monolayer was harvested with 2mM EDTA solution as described in chapter 2 and the cells resuspended in Ca<sup>2+</sup>-and Mg<sup>2+</sup>-free phosphate-buffered saline. After transferring the cell suspension to a 20ml universal bottle the flasks were washed once with Ca<sup>2+</sup>-and Mg<sup>2+</sup>-free phosphate-buffered saline and the washings pooled with the cell suspension. The cells were recovered by centrifugation at 200 x g ( $r_{av}$  11cm) for 6 minutes at 20<sup>0</sup>C. The cell pellet was resuspended in a minimum volume of Ca<sup>2+</sup>-and Mg<sup>2+</sup>-free phosphate-buffered saline, quantita-

tively transferred to 10ml of Fluorosol scintillant/digestant and mixed thoroughly before measurement of the radioactivity in the cell sample.

### **3.2.9 Clonogenic assay of cell thermosensitivity following liposome treatment**

HTC cells ( $3 \times 10^5$ ) were seeded into 10ml of growth medium in a 25cm<sup>2</sup> flask on day 0. The medium was changed on day 2 and day 4. The growth medium was discarded on day 5 and the exponentially growing cells were washed with growth medium lacking fungizone and serum. The washed monolayers were either exposed to 10ml of liposome solution (liposome treated cells) or 10ml of serum-free and fungizone-free growth medium (control cells) for 3 hours at 37<sup>0</sup>C in an humidified atmosphere of air/CO<sub>2</sub> (19:1, v/v). The cells were then harvested by exposure to 2mM EDTA solution (chapter 2 section 2.2.6) and 200 cells seeded into 10ml of LDS media. The flasks were sealed immediately and heated at 43<sup>0</sup>C as described earlier in this chapter (section 3.2.5), allowing no time for attachment to substratum before heating. The day after heating (day 6) the medium was replaced with 10ml of growth medium and changed every 2 to 3 days. The cell colonies which formed were fixed, stained and counted on day 16 after initiating the culture (10 days after heating) as described in chapter 2, section 2.2.13.

### **3.2.10 Colorimetric assay of cell thermosensitivity following liposome treatment**

HTC cells ( $3 \times 10^3$ ) were seeded into 1ml of growth medium in each well of 24-well plates on day 0. The medium was changed after 24 hours. On day 3 the cells were washed with 1ml of serum-free and fungizone-free growth medium. The washed monolayers were either exposed to 1ml of liposome solution (liposome treated cells) or 1ml of serum-free and fungizone-free growth medium (control cells) for 3 hours at 37<sup>0</sup>C in an humidified atmosphere of air/CO<sub>2</sub> (19:1, v/v). After this

period the cell monolayers were washed once with 1ml of serum-free and fungizone-free growth medium before addition of 1ml of growth medium lacking serum and fungizone but containing 10mM Hepes, pH 7.4 (heating medium). The plates were sealed and heated immediately as described earlier in this chapter (section 3.2.5). After heating, the plates were unsealed and another 1ml of growth medium added to wells already containing 1ml of heating medium. The next day (day 4) the medium was replaced with 1ml of growth medium and changed every 2 to 3 days thereafter. Cell survival was assayed on day 7 by the colorimetric method described in chapter 2, section 2.2.15.

### **3.2.11 Inhibition of growth with 25-hydroxycholesterol**

HTC cells ( $4 \times 10^3$ ) were seeded into 1ml of growth medium in each well of 24-well plates on day 0. The growth medium was changed on day 1 and on day 2 it was replaced with 1ml of serum-free and fungizone-free growth medium containing 25-hydroxycholesterol (concentrations of 25-hydroxycholesterol used in the experiments are given in the figure legends). Plates were returned to culture at 37<sup>0</sup>C for 24 or 48 hours then the medium was removed and replaced with 1ml of growth medium. The cells were allowed to grow for a further 3 to 4 days with a media change every 2 days. Sufficient plates were set up to allow assay of cell number by the colorimetric method described in chapter 2 (section 2.2.15) for every day of culture.

### **3.2.12 25-Hydroxycholesterol treatment of cells followed by exposure to heat**

HTC cells ( $4 \times 10^3$ ) were seeded into 1ml of growth medium in each well of 24-well plates on day 0. The growth medium was changed on day 1 and on day 2 it was replaced with 1ml of serum-free and fungizone-free growth medium

containing 25-hydroxycholesterol (concentrations of 25-hydroxycholesterol used in the experiments are given in the figure legends). Plates were returned to culture at 37<sup>0</sup>C then, after 24 hours, the medium was removed and replaced with 1ml growth medium lacking serum and fungizone but containing 10mM Hepes, pH 7.4 (heating medium). The plates were sealed and heat treated as described earlier in this chapter (section 3.2.6). The plates were unsealed after heat treatment and 1ml of growth medium added to the wells already containing 1ml of heating medium. The plates were then returned to culture at 37<sup>0</sup>C for 24 hours before replacing the medium with 1ml of growth medium which was then changed every 2 to 3 days thereafter. Cell survival was assayed on day 7 by the colorimetric method described in chapter 2, section 2.2.15.

### **3.2.13 Cholesterol hemisuccinate treatment of cells followed by exposure to heat**

HTC cells ( $5 \times 10^3$ ) were seeded into 1ml of growth medium in each well of 24-well plates on day 0. The growth medium was changed on day 1, then on day 3 the the medium was removed and monolayers washed once with Ca<sup>2+</sup>-and Mg<sup>2+</sup>-free phosphate-buffered saline. The cell monolayers were then exposed to cholesterol hemisuccinate or ethanol (vehicle for cholesterol hemisuccinate) for 3 hours at 37<sup>0</sup>C (concentrations of cholesterol hemisuccinate used in the experiments are given in the figure legends) in 1ml of Ca<sup>2+</sup>-and Mg<sup>2+</sup>-free phosphate-buffered saline containing 1mg/ml  $\alpha$ -D-glucose (PBS solution). After this period the PBS solution was carefully removed and replaced with 1ml of growth medium lacking serum and fungizone but containing 10mM Hepes, pH 7.4 (heating medium). The plates were sealed and heated as described earlier in this chapter, section 3.2.6. The plates were then unsealed and 1ml of growth medium added to the wells already containing 1ml of heating medium. The medium was replaced on day 4 with 1ml of growth

medium and changed every 2 to 3 days thereafter. Cell survival was assayed on day 7 by the colorimetric method described in chapter 2, section 2.2.15.

### 3.3 Results

Prior to determining the effect of heat on HTC cell survival, it was necessary to monitor the pH stability of the growth medium during heating, to optimise conditions for cell attachment to flasks, and to determine the influence of fungizone in the medium on the thermal sensitivity of the cells. Table 3.1 shows that the pH of the medium at 37<sup>0</sup>C in 25cm<sup>2</sup> flasks was 7.32 whereas in the plates it was slightly more alkaline at 7.39. However, in neither case did the pH alter significantly during 210 minutes at 43<sup>0</sup>C. In the 24-well plates the volume of medium was 1ml per well and it was necessary to include an additional buffer, 10mM HEPES, during the heating process as this small volume of medium, without HEPES buffer, tended to become more alkaline with time.

In the heating procedures, where cell survival was determined using the clonogenic assay, the protocol involved harvesting the cell monolayers after a particular experimental treatment (e.g. free fatty acid supplementation), seeding the cells into fresh flasks and then heat treating the cells. As the thermal sensitivity of attached and unattached cells is different, it was necessary to determine the optimal time required for the harvested cells to reattach when seeded into fresh flasks prior to heat treatment. To achieve this aim, HTC cell monolayers were harvested and seeded into fresh flasks. At timed intervals the number of cells attached to the flask surface was determined. The results (figure 3.1) show that maximal attachment to tissue culture treated surface (flask) is obtained after 2 hours. The influence of attachment time on cell survival following heating at 43<sup>0</sup>C for 45 minutes is shown in figure 3.2. When no time was allowed for cells to recover from harvesting and attach to flask the cell survival was low compared with cells allowed to attach for greater than 1 hour. In all subsequent heating experiments, where cell

survival was determined using the clonogenic assay, cells were allowed to recover from harvesting and attach for a period of 3 hours prior to exposure to heat.

Hahn *et al.* (1977) have shown that when HA1 cells were heated in the presence of fungizone, which was present at concentrations normally used in routine tissue culture, the thermosensitivity of the cells was enhanced. In the present study fungizone was used in routine culture of HTC cells at a concentration of 2.5 $\mu$ g/ml which has been shown to enhance thermal sensitivity of HA1 cells when heated in fungizone containing media. The use of fungizone in routine culture of HTC cells was necessary to avoid fungal contamination. However, for short periods of culture it was possible to maintain cells in absence of fungizone without contamination. Therefore, during the heating period it was possible to omit the fungizone and thereby avoid the possible interaction of fungizone with heat in cell killing. However, it was necessary to determine the influence of any residual fungizone, left over from the routine culture of cells in fungizone containing media, on the thermal sensitivity of HTC cells. This would involve growing HTC cells in fungizone-containing media, heating them in fungizone-free media and then returning the cells to fungizone-containing media 24 hours post heat. Therefore, control HTC cell cultures were maintained in fungizone-free conditions throughout the experiment whereas in the experimental HTC cell cultures the fungizone was only omitted during the heating period. The results (figure 3.3) show that the omission of fungizone during the heating protocol does not alter the thermosensitivity of HTC cells under the present conditions. Therefore, there is no influence of any residual fungizone, left over from the routine culture of HTC cells, on the thermosensitivity of these cells.

*In vitro* hyperthermic studies, where cell survival is determined using the clono-

genic assay, show survival curves that are similar to those obtained by ionising radiation (Wolters and Konings, 1984). Such curves are characterized by an initial shoulder followed by a phase of logarithmic cell killing. The parameters  $D_0$  and  $D_q$  are used to analyse such responses (see figure 3.4). In hyperthermic inactivation studies,  $D_0$  describes the linear portion of the curve and is the reciprocal of the slope, i.e. the duration in minutes at a particular temperature needed to reduce the survival to  $1/e$  (i.e. 37%) of the initial value (Bhuyan, 1979). Therefore, the lower the  $D_0$  value the greater is the heat sensitivity of the cells.  $D_q$ , which is often referred to as the 'quasithreshold dose', is used to describe the duration of the shoulder. This is obtained by back extrapolating the linear part of the curve to the 100% survival level (Harris *et al.*, 1977). The  $D_q$  value indicates the ability of cells to repair the effects of heat damage. The higher the  $D_q$  value the greater the ability of cells to repair the effects of heat damage.

In experiments where the clonogenic assay was used to assess cell death, the time required to kill 90% of cells ( $LD_{90}$ ) has been used as an index of cytotoxicity since this value occurs on the linear portion of the survival curves and reflects the effect of both the shoulder region and the slope of the curve (Bhuyan, 1979). However, in experiments where cell death was assessed using the colorimetric assay, the time required to kill 50% of cells ( $LD_{50}$ ) has been used as the index of cytotoxicity. This is because a wider range of temperatures was investigated and 90% cell kill was not achieved at lower temperatures. Furthermore, the  $LD_{50}$  values occur in the first linear region of the 3-phase survival curves, obtained with the colorimetric assay.

Having established that pH, residual fungizone and optimal cell attachment time did not interfere with the effect of heat on HTC cell survival, it was now

necessary to determine the response of HTC cells to hyperthermic temperatures as this would aid in the selection of a suitable temperature at which to perform future studies. The procedure used to determine the response of HTC cells to hyperthermic temperatures depended on which assay was used to determine cell survival. Where cell survival was determined using the clonogenic assay, HTC cell monolayers were harvested and 200 cells seeded into fresh flasks, then allowed to attach for 3 hours prior to heat treatment at a variety of temperatures. The cells were then returned to culture at 37<sup>0</sup>C and the cell survival determined after 10 days using the clonogenic assay. Where cell survival was determined using the colorimetric assay, HTC cell monolayers growing in 24-well plates were heat treated at a variety of temperatures. The cells were then returned to culture at 37<sup>0</sup>C and the cell survival determined after 3 days using the colorimetric assay. Figures 3.5 and 3.6 show the hyperthermic survival curves generated from HTC cells over a range of temperatures from 42.5<sup>0</sup>C to 45<sup>0</sup>C , based on results obtained with the clonogenic and colorimetric assay, respectively. As mentioned in chapter 2, these two assays measure different survival parameters. In the clonogenic assay, reproductive ability is measured at 9 days after heating. However, in the colorimetric assay, survival was measured by assessing the cells ability to cleave MTT at 3 days after heating. Since this reaction takes place in living cells utilising the mitochondrial enzyme succinate dehydrogenase, it is thought to reflect the metabolic status of the cell. Therefore, it is not surprising that, as different cell properties are being measured, substantially different heat dose-response curves are produced by the two assays. Although the duration of the shoulder ( $D_q$ ) and the  $D_0$  value in both the assays show similar trends, in that they decrease with increasing temperature, they are quantitatively different (table 3.2). The  $D_q$  values of 50.1, 36.7 and 27.6 minutes obtained at 43.5<sup>0</sup>C , 44<sup>0</sup>C and 45<sup>0</sup>C , respectively, with the clonogenic assay were

higher than the corresponding values of 11.25, 7.5 and 7.5 minutes obtained by the colorimetric assay. The  $D_0$  values of 40.2, 27.6 and 5.8 minutes obtained at 43.5<sup>0</sup>C , 44<sup>0</sup>C and 45<sup>0</sup>C , respectively, with the clonogenic assay were much lower than the corresponding values of 87.2, 51.4 and 31.1 minutes obtained with the colorimetric assay (table 3.2). In addition, the survival curves at 42.5<sup>0</sup>C , 43.0<sup>0</sup>C , 43.5<sup>0</sup>C , 44<sup>0</sup>C and 45<sup>0</sup>C produced by the colorimetric assay have 3 phases unlike the two phases observed with the corresponding curves generated by the clonogenic assay. The initial shoulder phase is followed by a linear phase in both assay systems. However, at longer exposure times to these temperatures, the curves generated via the colorimetric assay exhibit a third phase, involving a change in slope indicating enhanced cell survival when compared to the curves generated via the clonogenic assay.

Having characterized the heat dose-response curves of HTC cells, a suitable method for presenting the supplemental fatty acid to the cells was sought. This was necessary in order to ensure that, in the planned free fatty acid supplementation studies, the cells would take up the supplemental free fatty acid and incorporate it into membrane phospholipids. The direct introduction of free fatty acid into the growth media via the serum component proved a quick and efficient means of supplying fatty acids to cells. Table 3.3 shows the efficiency with which the palmitate and arachidonate were introduced into newborn bovine serum by the procedure given in Materials and Methods, section 3.2.3. The data shows that all the palmitate and arachidonate introduced into newborn bovine serum remains in solution. Using this technique, HTC cells were exposed to supplemental free fatty acid. However, it was necessary to select a concentration of supplemental free fatty acid which did not reduce the growth of HTC cells. To this end, HTC

cells were cultured in normal growth medium for 2 days after initiating the culture and thereafter, the medium was replaced with growth medium supplemented with various concentrations of palmitate (figure 3.7) or arachidonate (figure 3.8) for a further 2 days. The control cultures were maintained in normal growth medium during the experiment. The growth of the cells was monitored by determining cell number on each day of the experiment. This approach, of exposing HTC cells to free fatty acid supplement, was used as it mimics the procedure that will be used in future studies, where exponentially growing cells will be exposed to supplemental free fatty acid for up to 48 hours prior to determining the heat sensitivities of control and supplemented cells. The results show that HTC cells can be grown in up to  $20\mu\text{M}$  palmitate but at a concentration of  $40\mu\text{M}$  it was inhibitory to cell growth (figure 3.7). Exposure to  $40\mu\text{M}$  supplemental palmitate for the first 24 hours did not result in a drastic reduction in growth, but after 48 hours the inhibitory effects were quite marked. Due to these adverse effects of supplemental palmitate it was not utilised in subsequent hyperthermic studies. Although cell growth could be maintained for supplemental palmitate concentrations of up to  $20\mu\text{M}$ , these were deemed to be too low for substantial alteration of the pattern of phospholipid acyl groups. Therefore, the efforts of the study were concentrated on supplementation with arachidonate, which was found to have no inhibitory effect on HTC cell growth at concentrations up to  $80\mu\text{M}$  (figure 3.8) for exposure periods of up to 48 hours. Exposure of HTC cells to  $80\mu\text{M}$  arachidonate supplement for 36 hours resulted in the formation of cytoplasmic 'lipid droplets' which were visible under the light microscope (plate 3.1).

Having established that HTC cells could be grown in arachidonate supplement it was now possible to select a suitable concentration of the free fatty acid,

which did not inhibit growth, and proceed with the investigation into the effects of free fatty acid supplementation on heat sensitivity of HTC cells. A concentration of  $60\mu\text{M}$  arachidonate was selected for these studies as this was deemed to be sufficient to bring about a change in the pattern of the phospholipid acyl groups without reducing the growth of HTC cells. However, although a suitable concentration of arachidonate could be selected for these studies, it was also necessary to select a suitable hyperthermic temperature. In subsequent studies with fatty acid-supplemented cells the temperature of  $43^{\circ}\text{C}$  was chosen for hyperthermic treatment since it was estimated to give a reasonable rate of cell kill for the experimental time course that was planned. Hence, HTC cells were grown in the presence or absence of  $60\mu\text{M}$  arachidonate supplement for 24, 36 or 48 hours prior to harvesting and seeding 200 cells into  $25\text{cm}^2$  culture flasks containing fresh medium lacking supplement (growth medium without fungizone). The control and supplemented cells were then heat treated at  $43^{\circ}\text{C}$ . The cells were then returned to culture at  $37^{\circ}\text{C}$  and cell survival estimated after 10 days using the clonogenic assay. The results (figure 3.9) show that when cell survival was estimated using the clonogenic assay, supplementation with  $60\mu\text{M}$  arachidonate for 24, 36 and 48 hours resulted in progressively greater thermosensitivity (figure 3.9a, b and c respectively). Table 3.4 shows the various survival parameters determined from these survival curves (figure 3.9). All the heat survival parameters  $D_q$ ,  $D_0$ ,  $LD_{90}$  and  $LD_{50}$  are lower for arachidonate supplemented cells when compared to control cells for all three supplementation periods (table 3.4). The decrease in the value of the survival parameters between the supplemented and control cells increases with the supplementation period. For example the decrease in the  $LD_{90}$  value due to supplementation for 24, 36 and 48 hours was 14.1, 29.7 and 44.8 minutes, respectively. The decrease in the  $LD_{90}$  values after 36 and 48 hours supplementation was statis-

tically significant ( $p < 0.05$ ). In addition the decrease in the LD50 value after 48 hours supplementation (27.7 minutes) was also statistically significant ( $p < 0.05$ ). It has to be noted that in figure 3.9c (48 hours supplementation) no cell survival was detected in supplemented cells when heated at  $43^{\circ}\text{C}$  for greater than 150 minutes whereas survival was detected in control cells. Zero cell survival cannot be represented on a logarithmic scale. Having established with the clonogenic assay that supplementation with  $60\mu\text{M}$  arachidonate for 36 hours causes an increase in heat sensitivity of HTC cells at  $43^{\circ}\text{C}$ , the same conditions were used to assess the change in heat sensitivity upon supplementation with the colorimetric assay. Therefore, HTC cell monolayers in 24-well plates were grown in the presence of  $60\mu\text{M}$  arachidonate supplement for 36 hours prior to heat treatment at  $43^{\circ}\text{C}$  in fresh medium without supplement (growth medium lacking fungizone but containing 10mM Hepes). The cells were then returned to culture at  $37^{\circ}\text{C}$  and cell survival estimated after 3 days using the colorimetric assay. The results (figure 3.10 and table 3.5) show that supplementation under these conditions produced no change in heat sensitivity of HTC cells when compared to control cells. The reason that there is no change in heat sensitivity could be because  $60\mu\text{M}$  arachidonate supplement is not sufficient to enhance thermal sensitivity in cells grown as monolayers in 24-well plates and that the temperature selected for heat treatment was not optimal. To test this possibility the concentration of the supplement was increased to  $80\mu\text{M}$  and the cells exposed to this concentration for 36 hours prior to heating at a variety of temperatures in fresh medium without supplement (growth medium lacking fungizone but containing 10mM Hepes). Again the cells were then returned to culture at  $37^{\circ}\text{C}$  and cell survival estimated after 3 days using the colorimetric assay. The survival parameters obtained from this experiment (figure 3.11) are shown in table 3.6 which indicate that supplementation under these conditions

produced no change in heat sensitivity of HTC cells compared to control cells. Strangely, the significant increase in thermal sensitivity seen when the clonogenic assay is used to measure survival at 43<sup>0</sup>C of control cells and cells supplemented with arachidonate was not observed when the colorimetric assay was used.

Following these fatty acid supplementation studies, several methods were used to change the plasma membrane cholesterol content of HTC cells in an effort to determine whether this might affect thermal sensitivity of the cells. The first method involved exposing HTC cells to liposomes which have been shown to remove cholesterol from the cell (Rothblat *et al.*, 1986). To ensure that the liposomes prepared in this study did actually remove cholesterol from the cells, HTC cells were prelabelled with [7(n)-<sup>3</sup>H]-cholesterol to introduce radioactive cholesterol into the plasma membrane. The cells were then exposed to liposomes and the transfer of [7(n)-<sup>3</sup>H]-cholesterol from the cells to the liposomes was monitored. The results (figure 3.12) demonstrate that egg phosphatidylcholine liposomes (1mg phosphatidylcholine/ml) prepared by the method used in this study clearly facilitated the rapid removal of [7(n)-<sup>3</sup>H]-cholesterol from prelabelled HTC cells. The phosphatidylcholine liposomes caused approximately 60% of the label to be removed from prelabelled HTC cells over a 6 hour period, whereas both LDS medium and growth medium lacking serum and fungizone caused approximately 20% of the label to be removed over the same time period (figure 3.12).

Having established that the liposomes facilitate the removal of cholesterol from HTC cells the effect of liposome treatment on thermal sensitivity of the cells was determined. Monolayers were exposed to liposomes (1mg phosphatidylcholine/ml) for 3 hours, harvested to remove the liposomes, then seeded into flasks and then heated at 43<sup>0</sup>C for up to 100 minutes. The cells were returned to culture at 37<sup>0</sup>C

and viability assessed after 10 days using the clonogenic assay. The results (figure 3.13 and table 3.7) demonstrate that this liposome treatment did not alter the thermosensitivity of these cells when compared to cells not treated with liposomes. The effects of the removal of cholesterol from HTC cells by liposomes on the thermosensitivity of the cells was also screened using the colorimetric assay. HTC cell monolayers in 24-well plates were exposed to liposomes (1mg phosphatidylcholine/ml) for 3 hours, washed to remove the liposomes and heated at 43<sup>0</sup>C for 50 minutes. The cells were returned to culture at 37<sup>0</sup>C and cell viability assessed after 3 days using the colorimetric assay. These results (table 3.8) also indicate no change in heat sensitivity as a result of liposome treatment.

The second method utilised to lower membrane cholesterol was to inhibit the synthesis of cholesterol using 25-hydroxycholesterol. The inhibition of cholesterol synthesis has been shown to lower membrane cholesterol and inhibit cell growth (Kandutsch and Chen, 1977). Therefore, it was necessary to select a concentration of 25-hydroxycholesterol which would not irreversibly inhibit cell growth and so allow the subsequent hyperthermic studies to be carried out. To this end, the effect of 25-hydroxycholesterol on the growth of HTC cells was characterized. Two days after initiating the cultures, HTC cell monolayers were exposed to 25-hydroxycholesterol for 24 or 48 hours. After exposure to the inhibitor, it was removed and the cultures returned to normal culture conditions. The results (figure 3.14 and figure 3.15) show that exposure of HTC cells to 25-hydroxycholesterol inhibited growth in a dose-dependent manner. Exposure to 1, 2, 4 or 6 $\mu$ g/ml 25-hydroxycholesterol for 24 hours (figure 3.14) reduced subsequent growth of HTC cells. However, it must be noted that growth was much slower for the first three days post treatment compared to the rapid growth followed on the fourth day post

treatment. The ethanol present in control cultures did not alter growth characteristics of HTC cells represented in figures 3.14 and 3.15. Exposure to 1, 2, 4 or 6 $\mu$ g/ml 25-hydroxycholesterol for 48 hours (figure 3.15) substantially reduced subsequent growth. During the exposure period, cultures exposed to 1, 2 or 4 $\mu$ g/ml 25-hydroxycholesterol showed comparable growth to control cultures. However, at a concentration of 6 $\mu$ g/ml, 25-hydroxycholesterol reduces growth during the exposure period when compared to control cultures. At all the concentrations tested growth was inhibited after exposure to 25-hydroxycholesterol for 48 hours. Cultures exposed to 1 $\mu$ g/ml 25-hydroxycholesterol for 48 hours show slight recovery from the growth inhibition 3 days post treatment (figure 3.15).

Having determined the concentrations and exposure periods which make the growth inhibitory effects of 25-hydroxycholesterol reversible, the effect of 25-hydroxycholesterol treatment on the thermal sensitivity of HTC cells was determined. Monolayers were exposed to 0.0623, 0.125, 0,250 1.0 or 2.0 $\mu$ g/ml of 25-hydroxycholesterol for 24 hours, washed to remove 25-hydroxycholesterol and then heated at 43<sup>0</sup>C. The cells were then returned to culture at 37<sup>0</sup>C and viability was assessed after 3 days using the colorimetric assay. The results (figure 3.16 and table 3.9) indicated that exposure of HTC cells to 0.0623, 0.125, 0,250 1.0 and 2.0 $\mu$ g/ml of 25-hydroxycholesterol as described above (figures 3.16a, b, c, d and e respectively) did not change the heat sensitivity of HTC cells when compared to control cells. However, there are indications that the control cells may be marginally more thermosensitive than the cells treated with higher doses of 25-hydroxycholesterol (figure 3.16d and e). This observation must be considered in context with the inhibition of growth, over the duration of experiment, due to 25-hydroxycholesterol alone (see the legend to figure 3.16). At the higher concen-

tration a dramatic reduction in cell growth is observed by 25-hydroxycholesterol alone, reducing the number of cells that can be heat treated to only 15%. i.e. before heat treatment, 70–80% of the cells were killed by 25-hydroxycholesterol alone. Therefore, at the higher concentrations of 25-hydroxycholesterol, the effects of 25-hydroxycholesterol on the sensitization of HTC cells to heat could be masked by the large kill obtained by inhibitor alone.

The third method used to change the cholesterol content of the plasma membrane involved using cholesterol hemisuccinate. Cholesterol hemisuccinate is a hydrophilic ester of cholesterol which is thought to enter the plasma membrane and thereby increase membrane order (Yatvin *et al.*, 1983b). To test the effects of cholesterol hemisuccinate on the thermal sensitivity of HTC cells, monolayers were exposed to 50 or 100  $\mu\text{g}/\text{ml}$  of cholesterol hemisuccinate (in order to introduce cholesterol hemisuccinate into the plasma membrane) for 3 hours, washed to remove the excess cholesterol hemisuccinate and then heated at 43<sup>0</sup>C for 25 or 50 minutes. The cells were then returned to culture at 37<sup>0</sup>C and viability was assessed after 3 days using the colorimetric assay. The results (figure 3.17a and b) indicated that HTC cell survival was reduced by cholesterol hemisuccinate treatment when compared to control cells, for both the 25 and 50 minute heating periods (figure 3.17a and b respectively). Furthermore, the increase in thermosensitivity is greater when cells are exposed to 100  $\mu\text{g}/\text{ml}$  than those exposed to 50  $\mu\text{g}/\text{ml}$  cholesterol hemisuccinate prior to heat treatment.

**Table 3.1 — The effect of heating at 43<sup>0</sup>C on the pH of growth medium**

The procedure to determine pH in 10ml of medium inside a 25cm<sup>2</sup> culture flask and 1ml of medium inside a 24-well plate is described in Materials and Methods. The effect of the heating procedure on the pH of media is shown in the table below.

Time at 43 <sup>0</sup> C (min)	pH	
	25cm <sup>2</sup> flask	24-well plate
0	7.32	7.39
3	7.33	7.39
4	7.33	7.39
5	7.33	7.39
10	7.33	7.39
15	7.33	7.39
20	7.33	7.39
25	7.33	7.39
30	7.33	7.39
45	7.33	7.39
60	7.33	7.39
75	7.33	7.39
90	7.33	7.39
105	7.34	7.39
120	7.34	7.39
180	7.34	7.39
210	7.34	7.39

**Figure 3.1 — Time course of HTC cell attachment to 25cm<sup>2</sup> tissue culture treated flasks**

Cells ( $3 \times 10^5$ ) were seeded into 25cm<sup>2</sup> culture flasks containing 10ml of growth medium. The flasks were placed in an incubator at 37<sup>0</sup>C containing an humidified atmosphere of air/CO<sub>2</sub> (19:1, v/v) for various time periods. At each time point flasks were harvested using 2mM EDTA in phosphate-buffered saline and the number of cells attached determined by Coulter Counter as described in chapter 2, section 2.2.8.

Data from three experiments are presented on the graph. Each data point on the graph represents the average of duplicates.

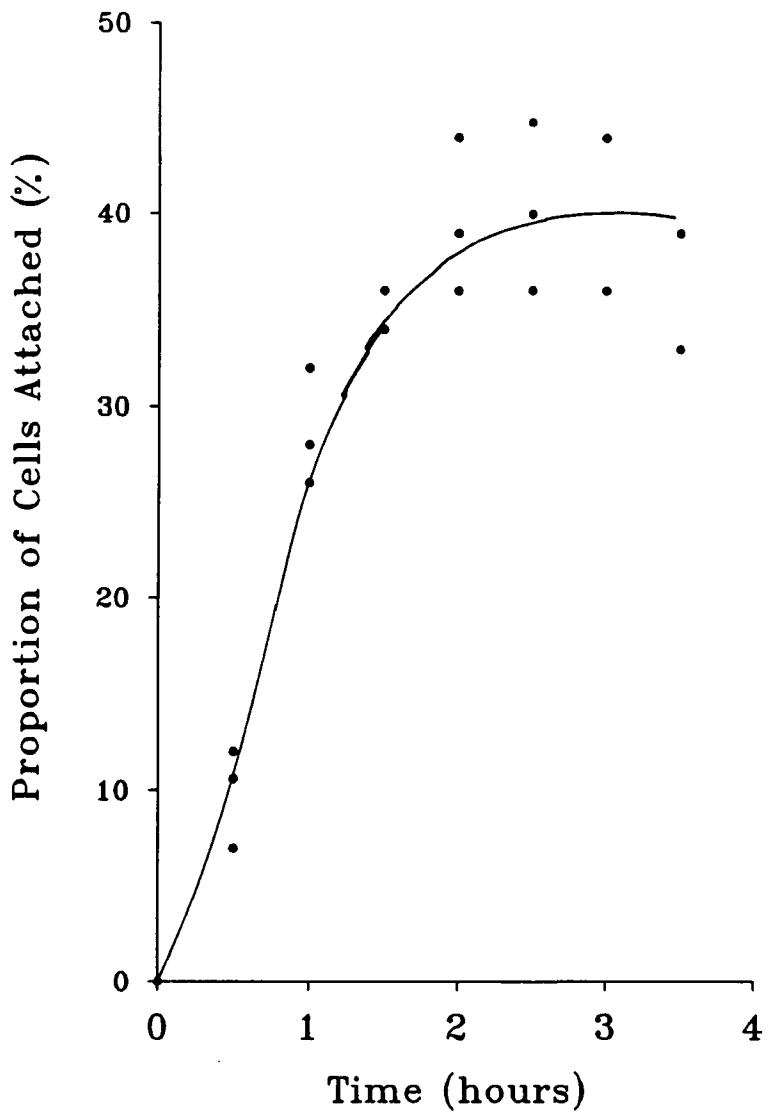

**Figure 3.2 — The effect of attachment time on the heat sensitivity of HTC cells**

HTC cells were cultured in normal growth medium. When growing exponentially the cultures were harvested, counted and 200 cells seeded in to 10ml of normal growth medium lacking fungizone in each 25cm<sup>2</sup> control and experimental flask. The cells were allowed to attach for 0, 1, 2, and 3 hours at 37<sup>0</sup>C in an humidified atmosphere of air/CO<sub>2</sub>(19.1,v/v), prior to heating the experimental flasks at 43<sup>0</sup>C and control flasks at 37<sup>0</sup>C for 45 minutes. After heating the flasks were returned to culture at 37<sup>0</sup>C. The cell survival was estimated after 10 days using the clonogenic assay. The procedure for heating and determining survival is described in Materials and Methods.

Each data point on the graph represents the average of duplicate determinations.

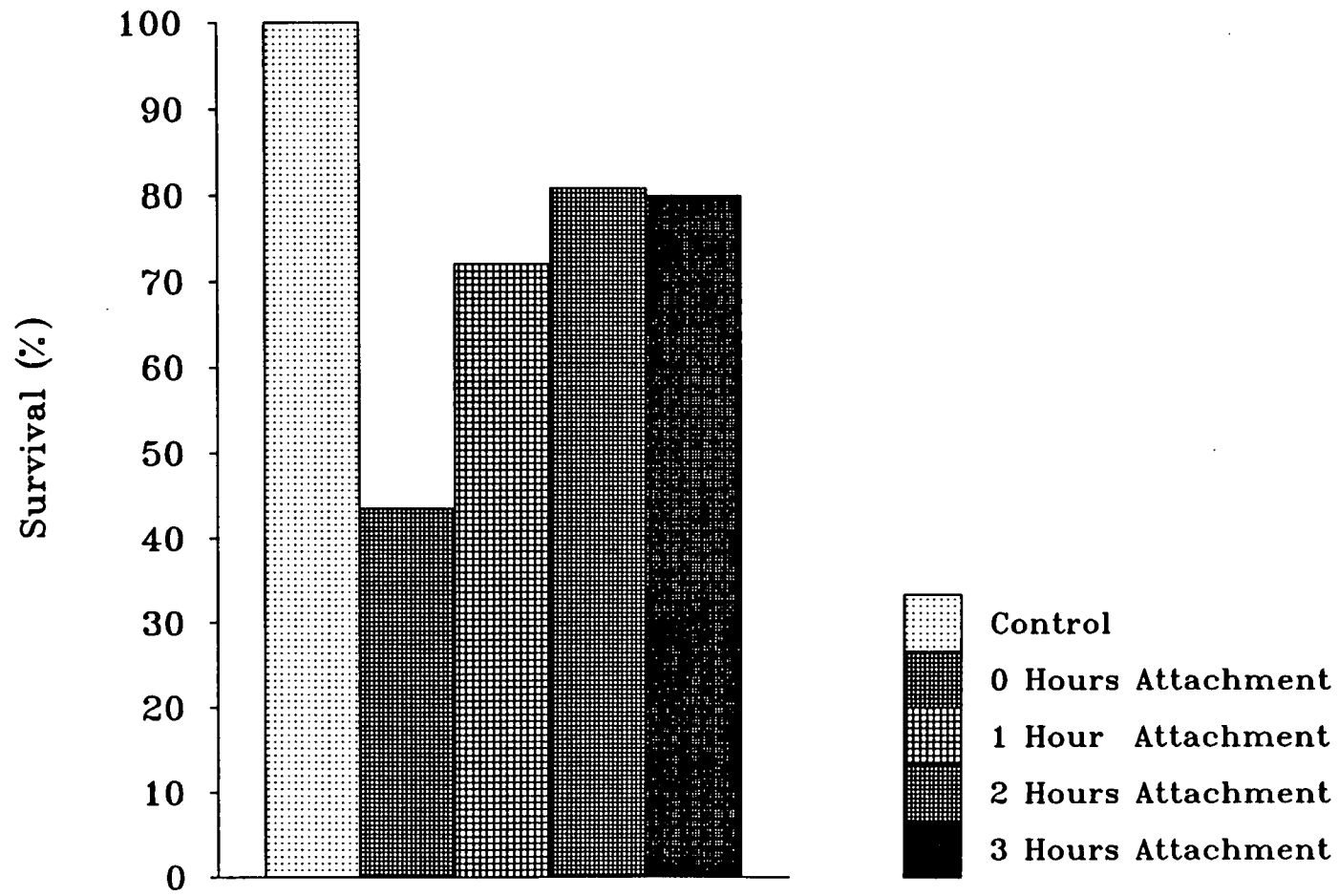

**Figure 3.3 — The effect of fungizone in culture media on the heat sensitivity of HTC cells**

The thermal sensitivity of the cells was determined as described in Materials and Methods. Two sets of HTC cell cultures were set up. In one set of cultures, on day zero,  $3 \times 10^5$  cells were seeded into 10ml of fungizone-free growth medium (●) in a 25cm<sup>2</sup> flask and in the other set of cultures they were seeded into 10ml of normal growth medium which contained 2.5μg/ml fungizone (○). The cultures were then incubated at 37<sup>0</sup>C in an humidified atmosphere of air/CO<sub>2</sub> (19:1, v/v), and the medium was changed in the flasks on day 1 and on day 3. In both sets of cultures the cell monolayers were harvested on day 5 by exposure to 2mM EDTA in phosphate-buffered saline and two hundred cells were then seeded into 10ml of fungizone-free growth medium in 25cm<sup>2</sup> flask and cells were allowed to attach to flasks at 37<sup>0</sup>C for 3 hours in an humidified atmosphere of air/CO<sub>2</sub> (19:1, v/v). The flasks were sealed and thermoequilibrated in a water bath at 37<sup>0</sup>C before rapid transfer to a water bath at the hyperthermic temperature ( $\pm 0.1^0$ C). After heating, the unsealed flasks were returned to culture at 37<sup>0</sup>C. The following day the medium was replaced with normal growth medium (containing fungizone) in flasks containing heated cells derived from monolayers that were grown in normal growth media. In flasks containing heated cells derived from monolayers that were grown in fungizone-free growth media the medium was replaced with fungizone-free growth media. The colonies were allowed to form for 10 days, fixed, stained and counted as described in chapter 2, section 2.2.13. In summary, in one set of heating experiments the cells were maintained in the absence of fungizone (●) throughout the culture, heating and subsequent survival estimation and in the other set the cells were cultured in fungizone containing growth media, heated in growth media lacking fungizone and after 24 hours post heat maintained in fungizone containing growth media (○).

Each data point on the graph represents the average of duplicate determinations.

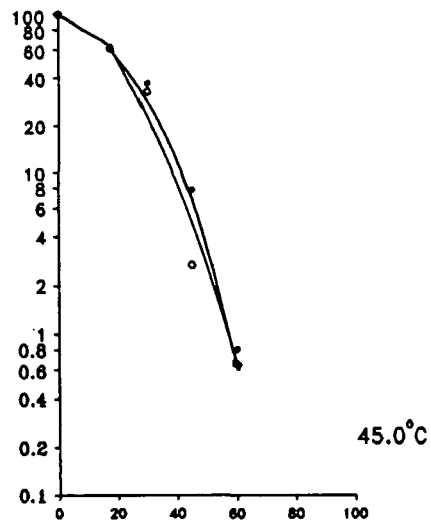
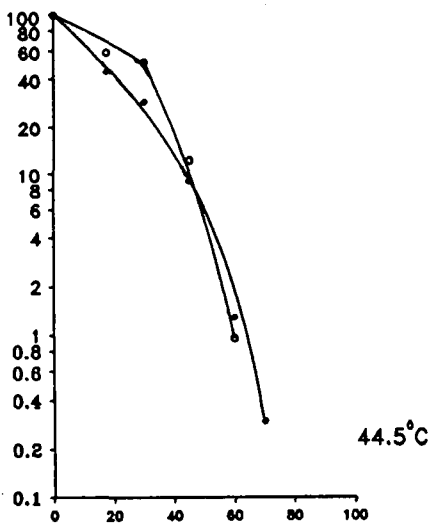
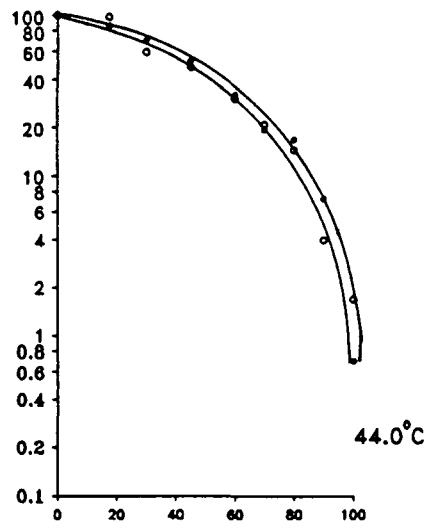
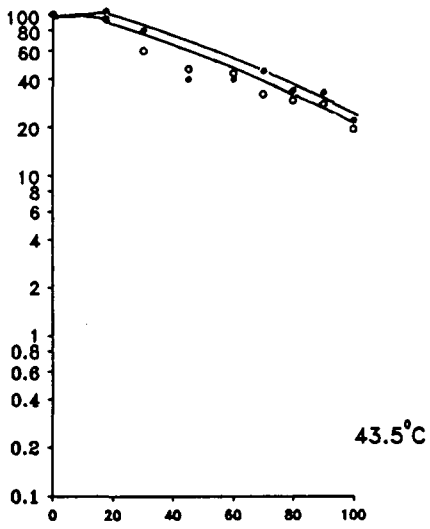
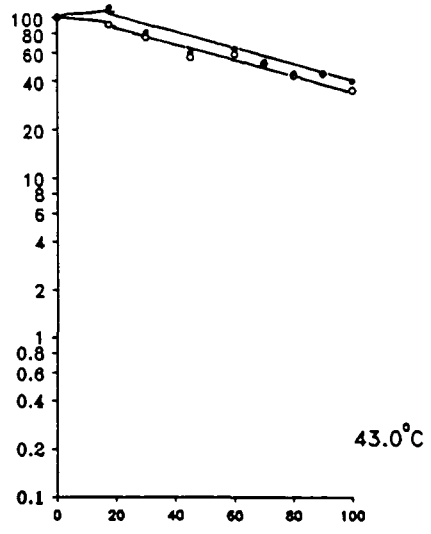
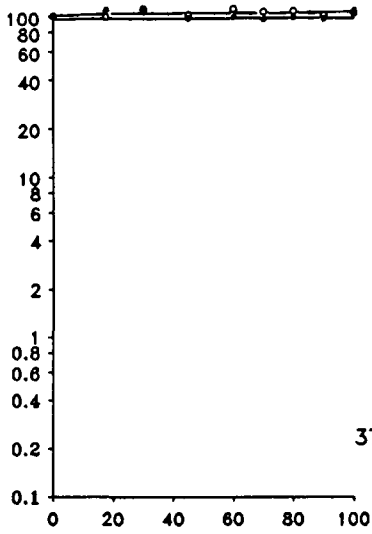

Survival (%)

Time of heating (minutes)

**Figure 3.4 — The calculation of heat survival parameters  $D_q$  and  $D_0$**

The figures shows how the heat survival parameters  $D_q$  and  $D_0$  are determined from a typical survival curve.

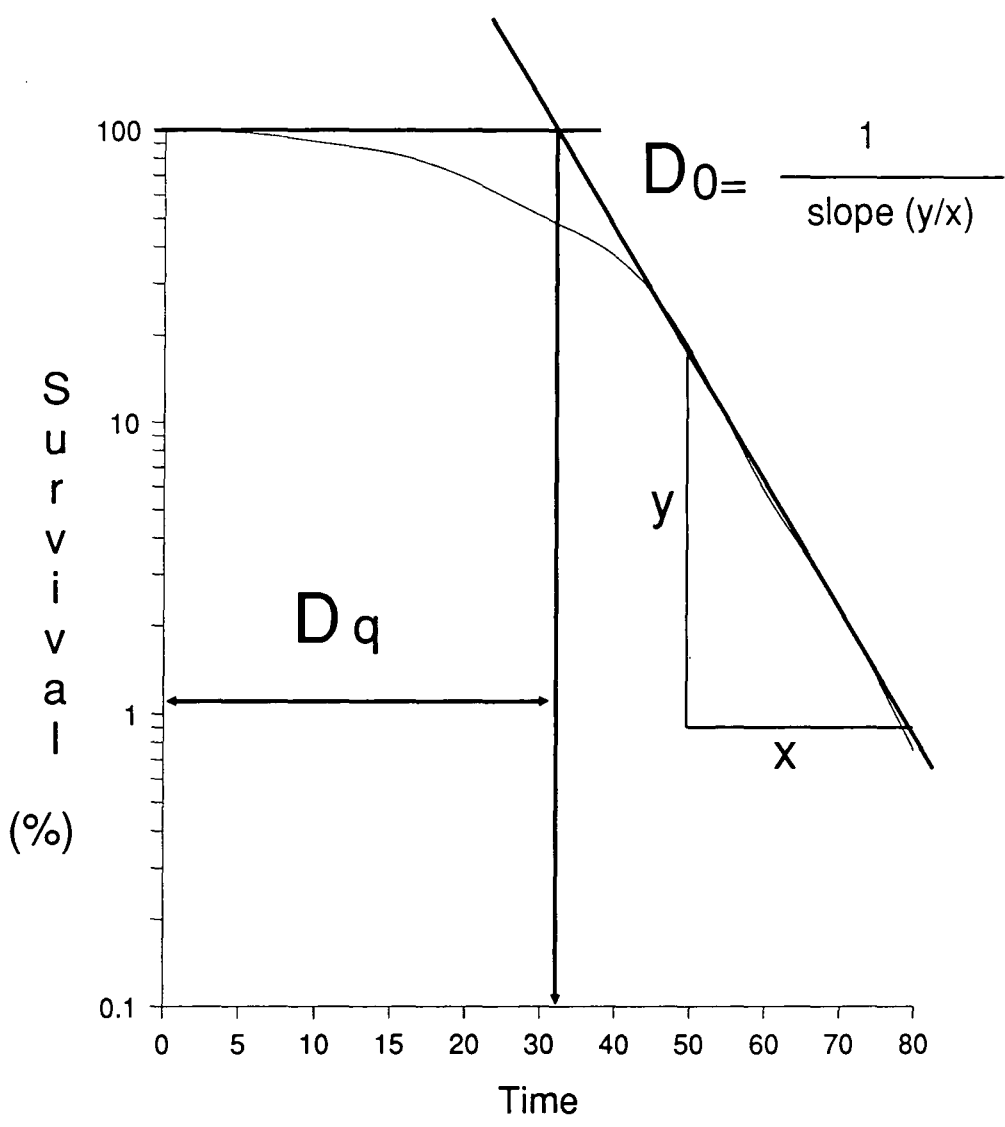

**Figure 3.5 — Heat-dose response curves for HTC cells in 25cm<sup>2</sup> flasks using the clonogenic assay of cell survival**

The cells were prepared, heated and survival estimated as described in Materials and Methods. In brief, exponentially growing cells were harvested and 200 cells seeded in to 25cm<sup>2</sup> flasks containing 10ml of growth medium lacking fungizone. After 3 hours in a 37<sup>0</sup>C incubator containing humidified atmosphere of air/CO<sub>2</sub> (19:1, v/v) the cells were heated at the temperatures indicated in the table below. The cells were returned to 37<sup>0</sup>C and colonies were allowed to form for 10 days. The colonies were then fixed, stained and counted as described in chapter 2, section 2.2.13.

The mean values obtained from three experiments are presented on the graph. Each experiment was carried out in duplicate.

Regression lines have been fitted to the second phase of the survival curves.

Key to Graph	
Temperature (°C )	symbol
37.0	●
42.5	○
43.0	×
43.5	◇
44.0	△
45.0	*

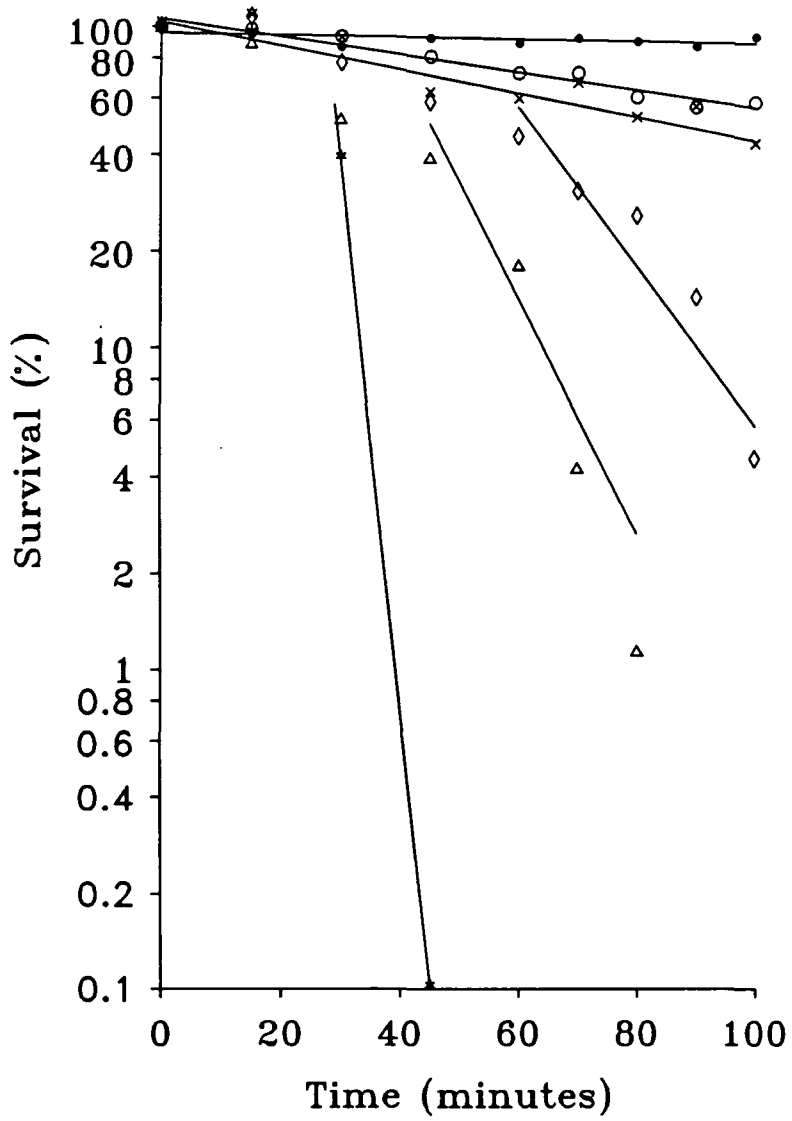

**Figure 3.6 — Heat-dose response curves for HTC cells cultured in 24-well plates, using the colorimetric assay of cell survival**

The procedure used in this experiment is given in Materials and Methods. The cells in 24-well plates were heated at the temperatures indicated in the table below. The cells in the plates were then returned to 37°C culture and the next day the medium was changed. The cells were allowed to grow for 3 days before the number of surviving cells was estimated using the colorimetric assay.

The mean values obtained from three experiments are presented on the graph. Each experiment was carried out in duplicate.

Regression lines have been fitted to the second phase of the survival curves.

Key to Graph	
Temperature (°C )	symbol
37.0	•
42.5	○
43.0	×
43.5	◇
44.0	△
45.0	*

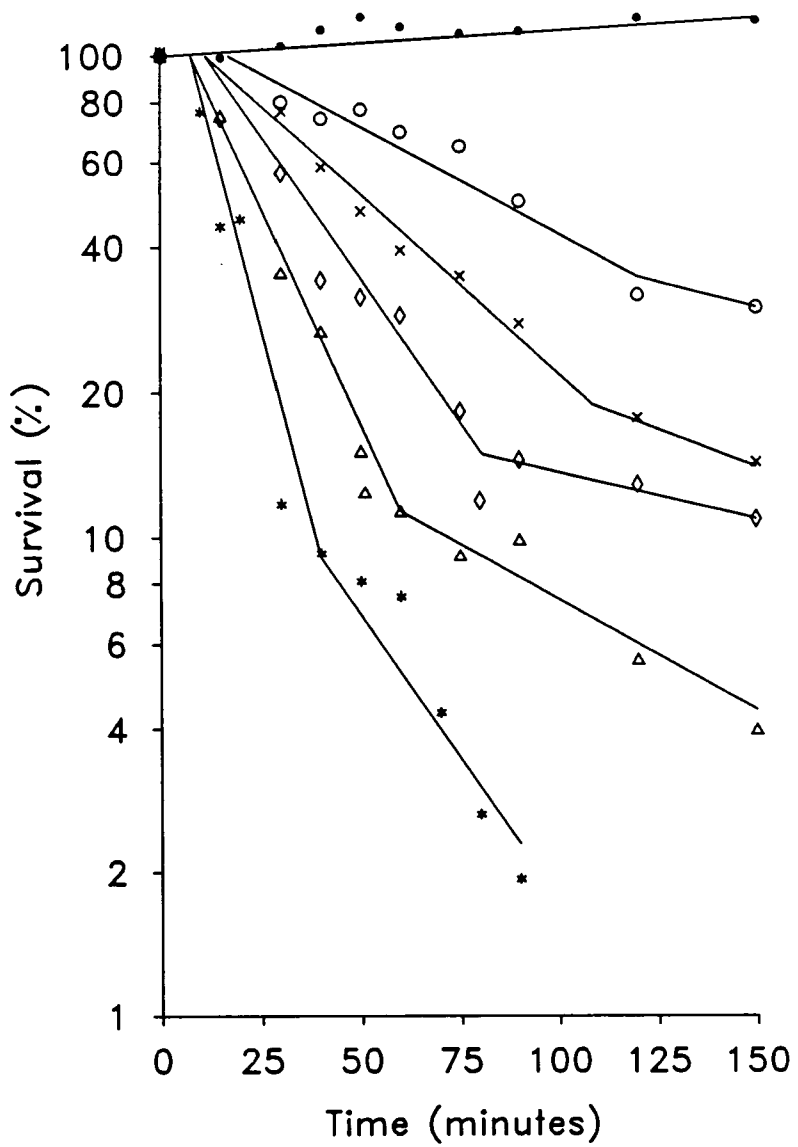

**Table 3.2 — The heat survival parameters calculated from figures 3.5 and 3.6**

$D_q$ ,  $D_0$  and  $LD_{90}$  or  $LD_{50}$  determined from the heat dose response curves (figures 3.5 and 3.6) are given in the table below. The cells were heat treated at 42.5, 43.0, 43.5, 44.0, and 45.0<sup>0</sup>C and the surviving cells estimated using the clonogenic (figure 3.5) or colorimetric assay (figure 3.6). Regression lines were then fitted to the second phase of the survival curves and the heat survival parameters determined from this line.

Heat Survival Parameter	Clonogenic Assay Temperature (°C )					Colorimetric Assay Temperature (°C )				
	42.5	43.0	43.5	44.0	45.0	42.5	43.0	43.5	44.0	45.0
$D_q$ (min)	nd	nd	50.1 ±6.02	36.7 ±6.5	27.6 ±0.12	16.9 ±5.21	11.25 ±3.22	11.25 ±4.5	7.5 ±3.12	7.5 ±2.44
$D_0$ (min)	nd	nd	40.2 ±5.79	27.6 ±9.7	5.8 ±0.06	211.8 ±16.5	137.0 ±17.56	87.2 ±5.65	51.4 ±2.12	31.1 ±4.54
$LD_{50}$ (min)	nd	86.5 ±7.89	67.2 ±4.13	45.0 ±15.43	29.3 ±0.11	81.6 ±1.23	51.6 ±5.25	35.6 ±3.45	23.4 ±2.38	16.9 ±2.54
$LD_{90}$ (min)	nd	nd	90.3 ±3.18	64.3 ±5.73	33.4 ±0.08	nd	nd	nd	nd	nd

nd=not possible to determine

Data in the table represent Estimate ± standard error



**Table 3.3 — The incorporation of supplemental fatty acid into newborn bovine serum**

The free fatty acid was incorporated in newborn bovine serum as described in Materials and Methods. The appropriate amount of free fatty acid was solubilized in 3ml of water (sodium palmitate) or 3ml of 0.05M NaOH (for arachidonic acid). Serum was added to the the solubilized free fatty acid and the solution mixed. The supplemented sera were sterilised by filtering through 0.22 $\mu$ m filter and divided in to aliquots in 2ml glass ampoules. The ampoules were then sealed under an atmosphere of N<sub>2</sub> , wrapped in aluminium foil and stored at -20<sup>0</sup>C. The free fatty acid concentration was determined as described in chapter 2 under Materials and Methods.

Supplemental free fatty acid	Batch number	Theoretical concentration (mM)	Concentration obtained (mM)	Percent solubilized
Palmitate	1	2.0	2.0	100
	2	2.076	2.01	97
Arachidonic acid	1	2.0	2.0	100
	2	2.312	2.25	97

**Figure 3.7 — Growth characteristics of HTC cells in the presence of supplemental palmitate**

Exponentially growing HTC cells ( $3.0 \times 10^5$ ) were seeded in  $25\text{cm}^2$  flasks containing 10ml of growth medium. The cells were maintained in a humidified incubator at  $37^\circ\text{C}$  with an humidified air/ $\text{CO}_2$ (19.1,v/v) atmosphere. After 24 hours the growth medium was changed and after 48 hours the medium was replaced with that containing supplemental palmitate. Every 24 hours the cultures were harvested and total cell number determined using a Coulter Counter as described in chapter 2, section 2.2.8.

The mean values obtained from two experiments are presented on the graph. Each experiment was carried out in duplicate.

Key to Graph		Cell Number ( $\times 10^5$ ) presented on graph	
Palmitate Supplement ( $\mu\text{M}$ )	symbol	day 3	day 4
0.0	•	16.12 $\pm 1.25$	28.18 $\pm 0.9$
5.0	◦	13.15 $\pm 0.44$	24.41 $\pm 2.33$
10	×	16.78 $\pm 3.12$	26.86 $\pm 1.82$
15.0	◊	16.81 $\pm 1.56$	23.64 $\pm 0.59$
20.0	△	15.99 $\pm 2.38$	22.38 $\pm 1.85$
40.0	*	13.13 $\pm 1.27$	8.19 $\pm 2.62$

Data in table represents mean value  $\pm$  standard deviation

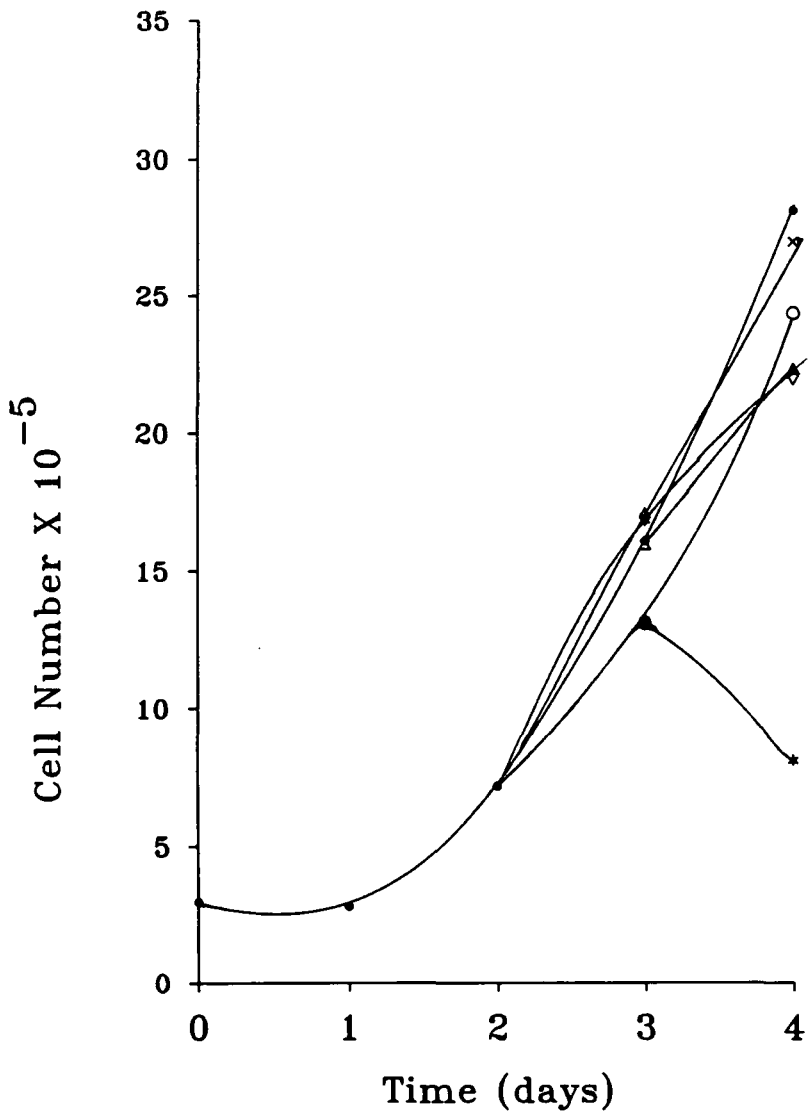

**Figure 3.8 — Growth characteristics of HTC cells in the presence of supplemental arachidonate**

Exponentially growing HTC cells ( $3.0 \times 10^5$ ) were seeded in  $25\text{cm}^2$  flasks containing 10ml of growth medium. The cells were maintained in a humidified incubator at  $37^\circ\text{C}$  with an air/ $\text{CO}_2$ (19:1,v/v) atmosphere. After 24 hours the growth medium was changed and after 48-hours the medium was replaced with that containing supplemental arachidonate. Every 24 hours the cultures were harvested and total cell number determined using a Coulter Counter as described in chapter 2 under section 2.2.8.

The mean values obtained from two experiments are presented on the graph. Each experiment was carried out in duplicate.

Key to Graph		Cell Number ( $\times 10^5$ ) presented on graph	
Arachidonate Supplement ( $\mu\text{M}$ )	symbol	day 3	day 4
0.0	●	17.12 $\pm 2.25$	27.18 $\pm 1.90$
20.0	○	16.93 $\pm 1.06$	21.09 $\pm 3.81$
40.0	×	18.07 $\pm 0.46$	28.63 $\pm 2.07$
60.0	◇	19.68 $\pm 0.95$	28.10 $\pm 2.57$
80.0	△	16.38 $\pm 0.48$	22.36 $\pm 1.17$

Data in the table represents mean value  $\pm$  standard deviation

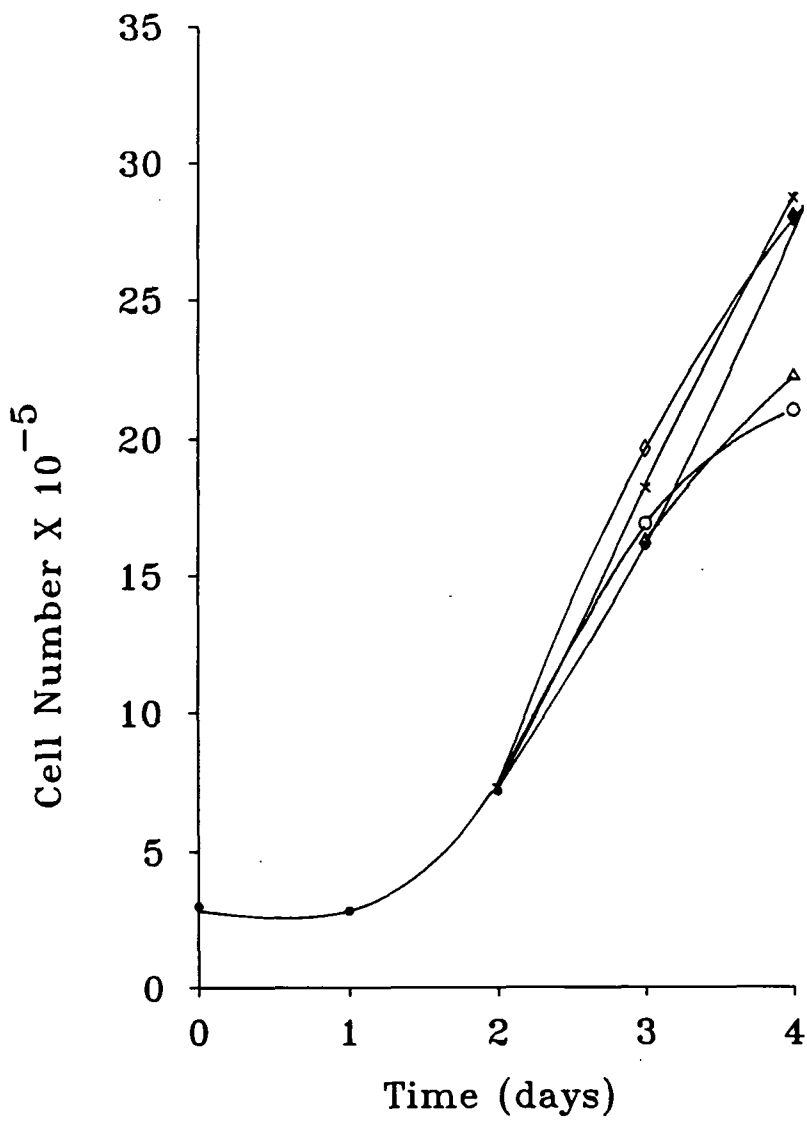

**Plate 3.1 — The accumulation of 'lipid droplets' in HTC cells exposed to 80 $\mu$ M arachidonate supplement**

The cells were prepared as described in Materials and Methods. The cells growing on glass coverslips were either maintained in normal growth medium (plate 3.1a) or in 80 $\mu$ M arachidonate supplemented growth medium for 36 hours (plate 3.1b). The cells on the coverslips were then photographed (x 40 magnification).

a



b



**Figure 3.9 — The effect of arachidonate supplementation on the thermosensitivity of HTC cells at 43<sup>0</sup>C**

The cells were prepared, heat treated and survival estimated by the clonogenic assay as described in Materials and Methods. In brief, exponentially growing control (o, solid line) and arachidonate-supplemented (●, dashed line) cells were harvested. Two hundred cells were seeded into 25cm<sup>2</sup> flasks containing 10ml of growth medium lacking fungizone. After 3 hours in a 37<sup>0</sup>C incubator containing an atmosphere of air/CO<sub>2</sub> (19:1, v/v) the cells were heated at 43<sup>0</sup>C. The cells were returned to 37<sup>0</sup>C and colonies were allowed to form for 10 days. The colonies were then counted as described in chapter 2 under section 2.2.13.

Figure 3.9(a) represents heat sensitivity of control cells (o, solid line) and those grown in 60μM arachidonate-supplemented (●, dashed line) growth media for 24 hours prior to heat treatment.

Figure 3.9(b) represents heat sensitivity of control cells (o, solid line) and those grown in 60μM arachidonate-supplemented (●, dashed line) growth media for 36 hours prior to heat treatment.

Figure 3.9(c) represents heat sensitivity of control cells (o, solid line) and those grown in 60μM arachidonate-supplemented (●, dashed line) growth media for 48 hours prior to heat treatment.

The data values obtained from four experiments are presented on the graph. Each point on the graph represents a value from a single determination.

Regression lines have been fitted to the second phase of the survival curves.

(a) 24 hours

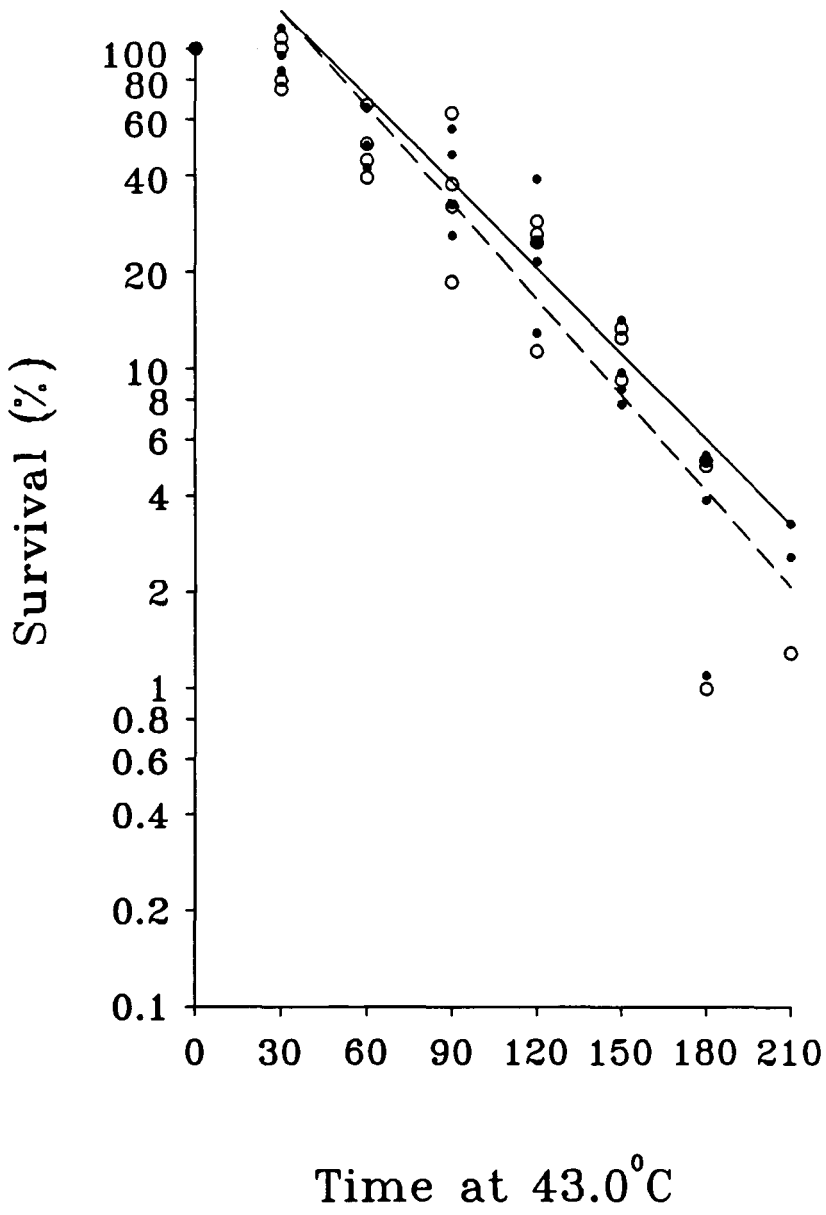

(b) 36 hours

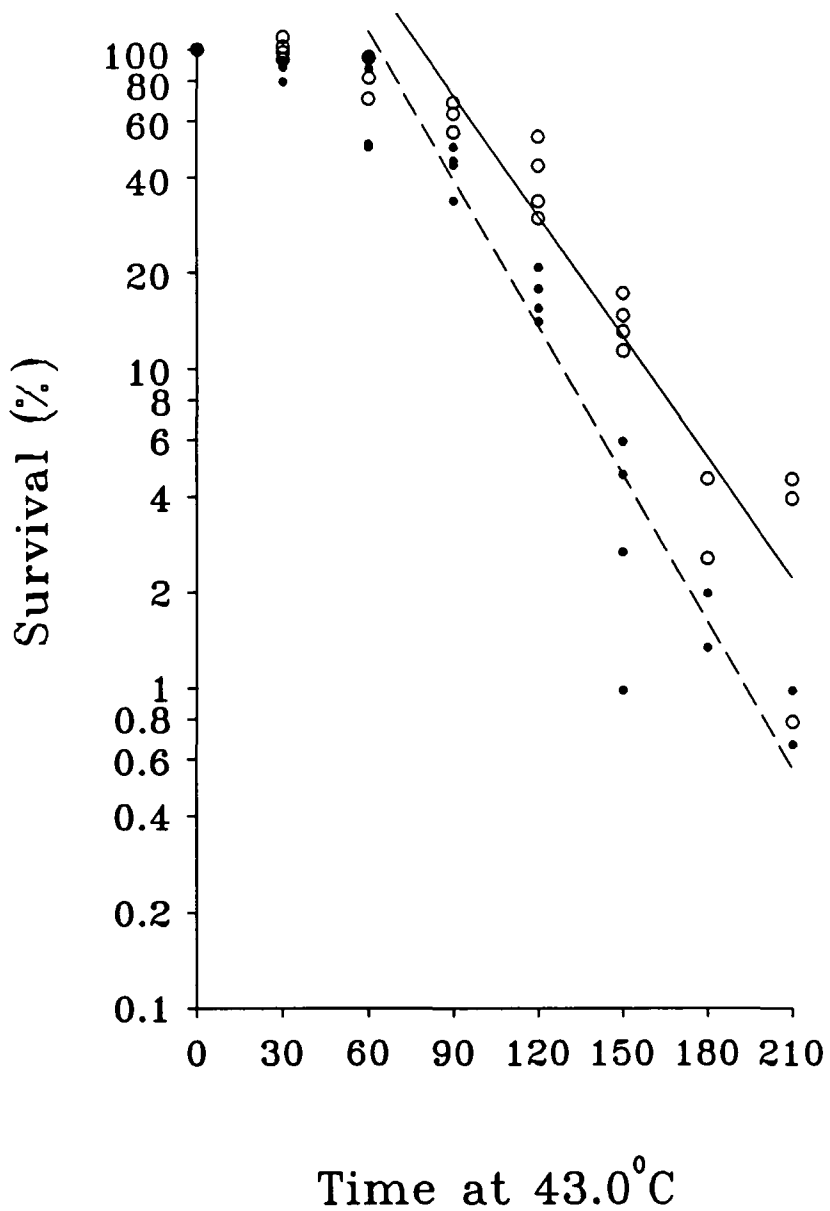

(c) 48 hours

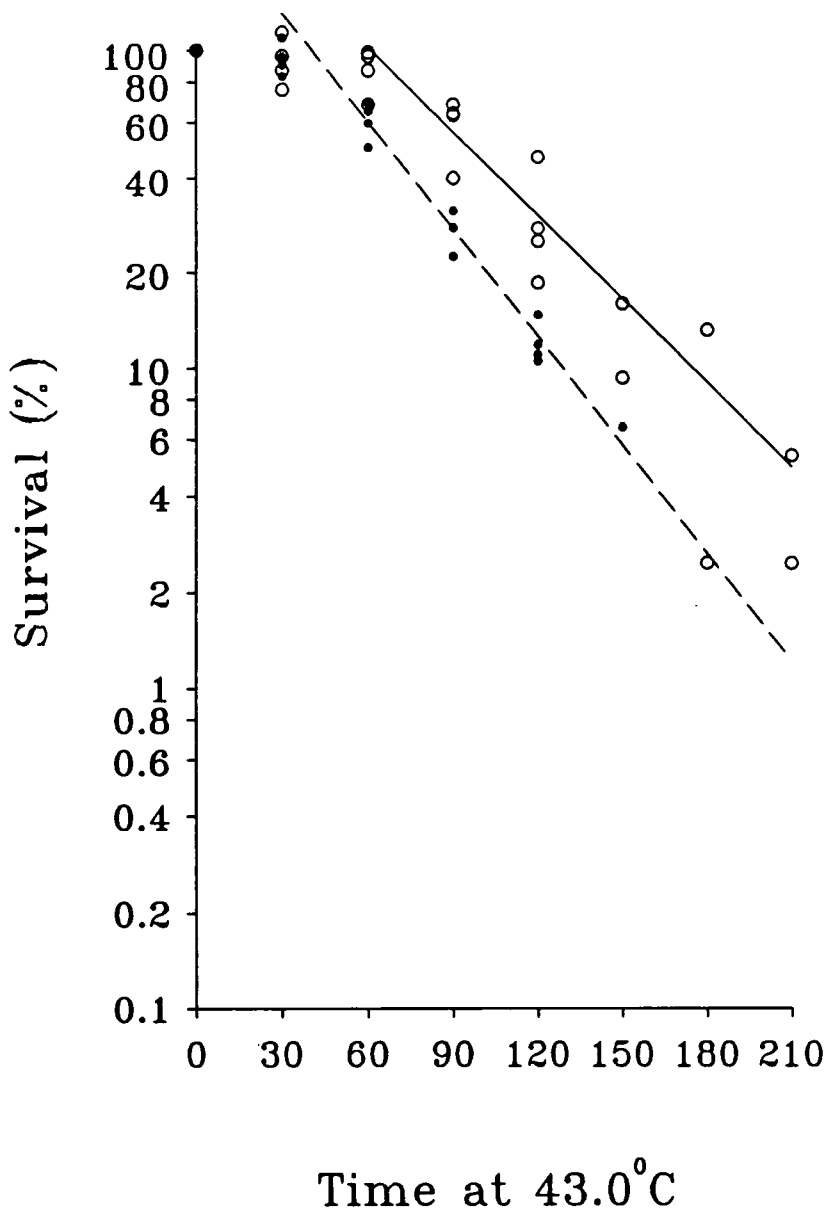

**Table 3.4 — The comparison of heat survival parameters calculated from figure 3.9 for control and supplemented cells**

The  $D_q$ ,  $D_0$  and  $LD_{90}$  values determined from figure 3.9 for control and arachidonate supplemented cells are compared in the table below. The cells were grown in arachidonate supplemented growth media for 24, 36 and 48 hours prior to heat treatment at  $43^{\circ}\text{C}$  in  $25\text{cm}^2$  flasks. The control cells were maintained in normal growth medium prior to heat treatment. Survival was estimated using the clonogenic assay. Regression lines were then fitted to the second phase of the survival curves and the heat survival parameters determined from this line.

Heat Survival Parameter	Period of Growth prior to heat treatment					
	24 hours		36 hours		48 hours	
	Control	Supplemented	Control	Supplemented	Control	Supplemented
$D_q$ (min)	42.5 $\pm 10.29$	42.2 $\pm 8.91$	78.9 $\pm 7.11$	63.7 $\pm 7.70$	60.9 $\pm 6.31$	40.4 $\pm 3.30$
$D_0$ (min)	104.3 $\pm 9.0$	90.5 $\pm 8.05$	79.6 $\pm 6.55$	64.9 $\pm 5.30$	113.3 $\pm 6.78$	88.9 $\pm 4.64$
$LD_{50}$ (min)	73.9 $\pm 7.55$	69.4 $\pm 6.59$	102.9 $\pm 5.38$	83.4 $\pm 6.18$	94.9 $\pm 4.75$	67.3 <sup>†</sup> $\pm 2.12$
$LD_{90}$ (min)	146.6 $\pm 5.34$	132.7 $\pm 4.63$	158.5 $\pm 4.15$	128.8 <sup>†</sup> $\pm 3.70$	174.2 $\pm 4.67$	129.4 <sup>†</sup> $\pm 2.42$

Data in the table represent Estimate  $\pm$  standard error

<sup>†</sup> Found to be significantly different ( $p < 0.05$ ) from the corresponding control value, with the Students t-test

**Figure 3.10 — The effect of 60 $\mu$ M arachidonate supplementation for 36 hours on the thermosensitivity of HTC cells grown in 24-well plates**

The procedure is as described in Materials and Methods. Cell cultures were exposed to 60 $\mu$ M supplemental arachidonate (●, dashed line) for 36 hours or maintained in normal growth medium (○, solid line) prior to heating at 43<sup>0</sup>C. The cell survival was measured using the colorimetric assay described in chapter 2, section 2.2.15.

The data values presented on the graph represent average of quadruplicates obtained from two separate experiments.

Regression lines have been fitted to the second phase of the survival curves.

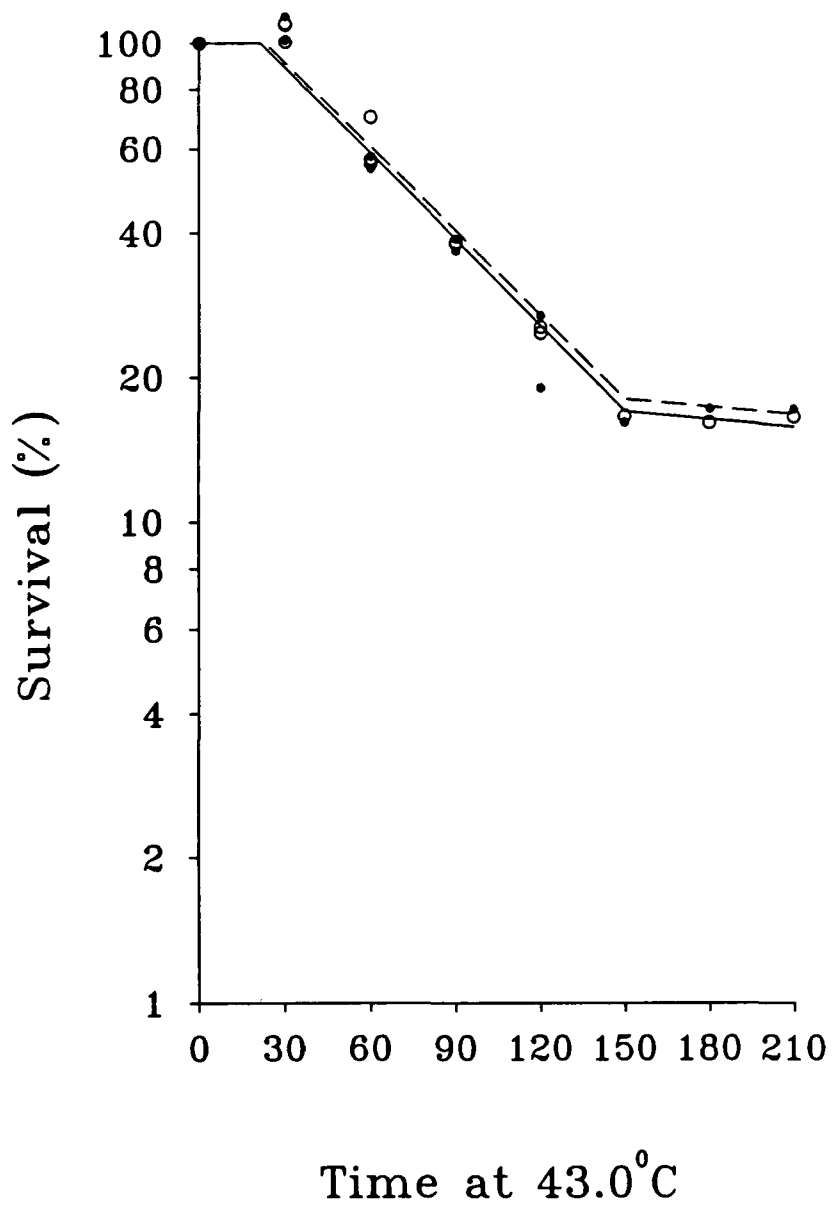

**Table 3.5 — The comparison of heat survival parameters calculated from figure 3.10 for control and supplemented cells**

The  $D_q$ ,  $D_0$  and  $LD_{50}$  values determined from figure 3.10 for control and arachidonate-supplemented cells are compared in the table below. The cells were grown in arachidonate supplemented growth medium for 36 hours prior to heat treatment at 43°C in 24-well plates. The control cells were maintained in normal growth media prior to heat treatment. Survival was estimated using the colorimetric assay. Regression lines were then fitted to the second phase of the survival curves and the heat survival parameters determined from this line.

Heat Survival Parameter	Treatment	
	Control	Supplemented
$D_q$ (min)	21.4 ±5.54	23.0 ±4.81
$D_0$ (min)	167.6 ±12.1	171.1 ±11.1
$LD_{50}$ (min)	71.0 ±3.60	74.7 ±3.17

No significant differences were found between the heat survival parameters obtained for control and supplemented cells. Statistical analyses were carried with the Students t-test.

**Figure 3.11 — The effect of 80 $\mu$ M arachidonate supplementation on the thermosensitivity of HTC cells grown in 24-well plates**

The procedure is described in Materials and Methods. Cell cultures were exposed to 80 $\mu$ M supplemental arachidonate ( $\bullet$ , dashed line) for 36 hours or maintained in normal growth medium ( $\circ$ , solid line) prior to heating at the temperatures indicated on the graphs. The survival was measured using the colorimetric assay described in chapter 2, section 2.2.15.

The data values presented on figures 3.11a, b, d, e and f represent average of quadruplicates obtained from two separate experiments. On figure 3.11c the average of quadruplicates obtained from three separate experiments are presented.

Regression lines have been fitted to the second phase of the survival curves.

(a) 37.0°C

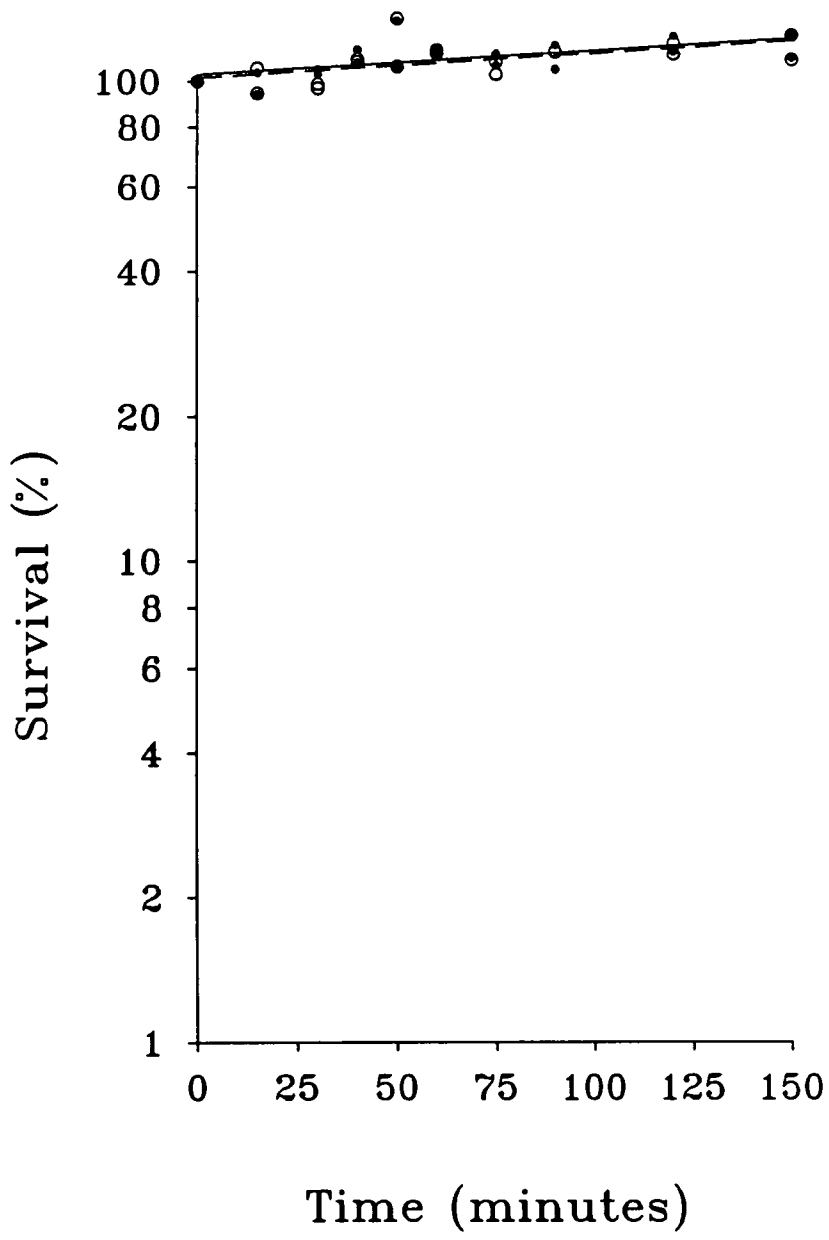

(b) 42.5°C

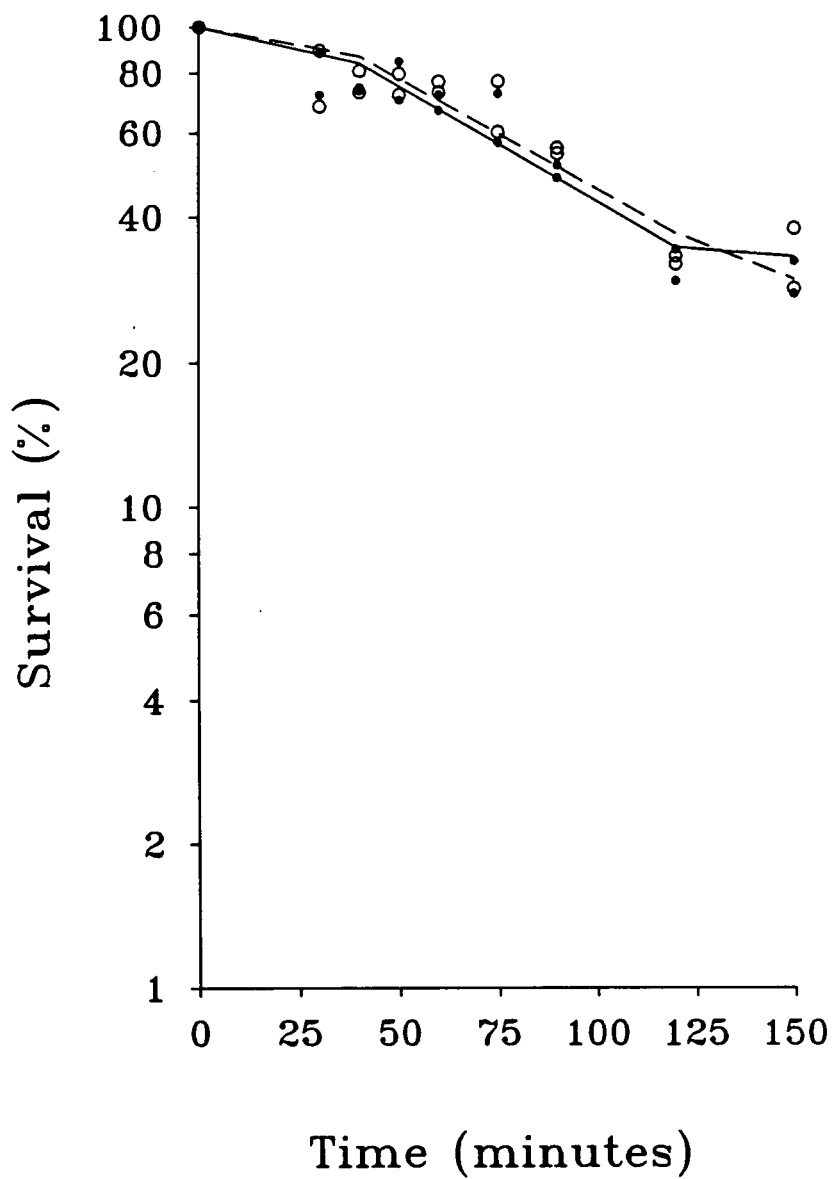

(c) 43.0°C

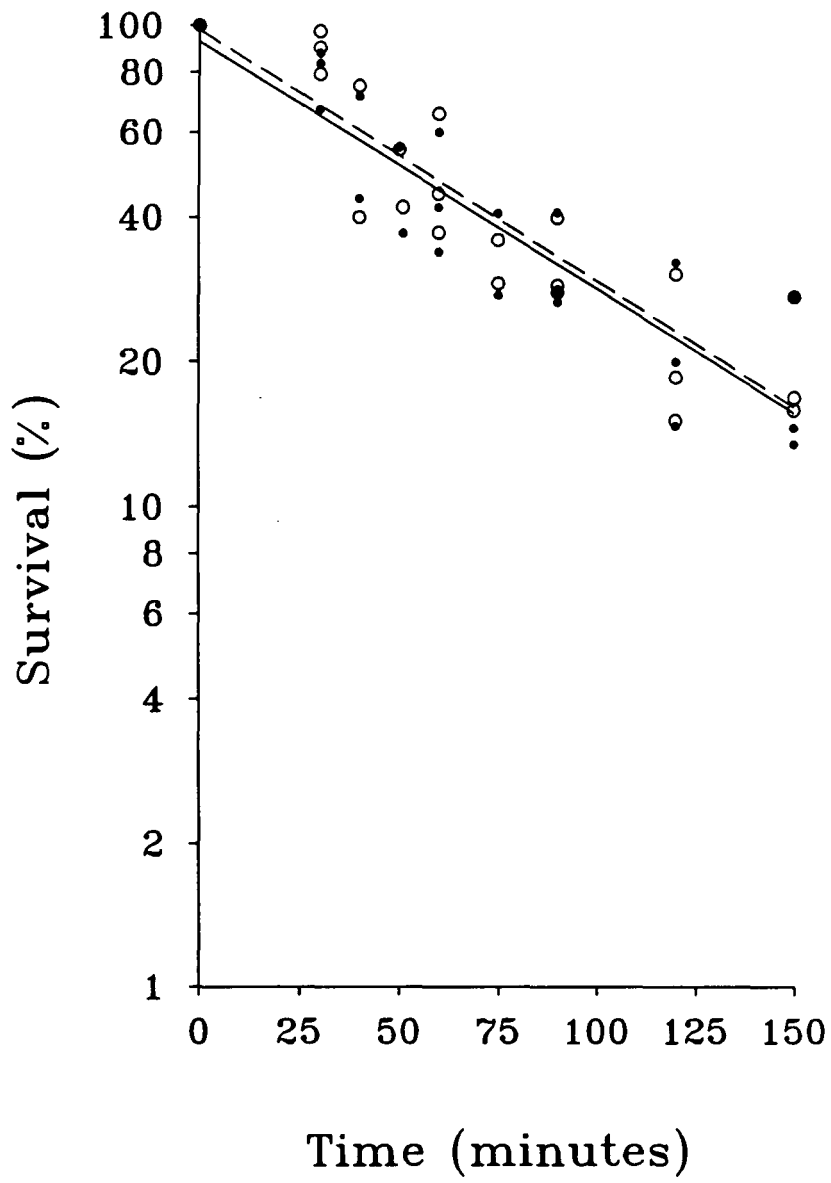

(d) 43.5°C

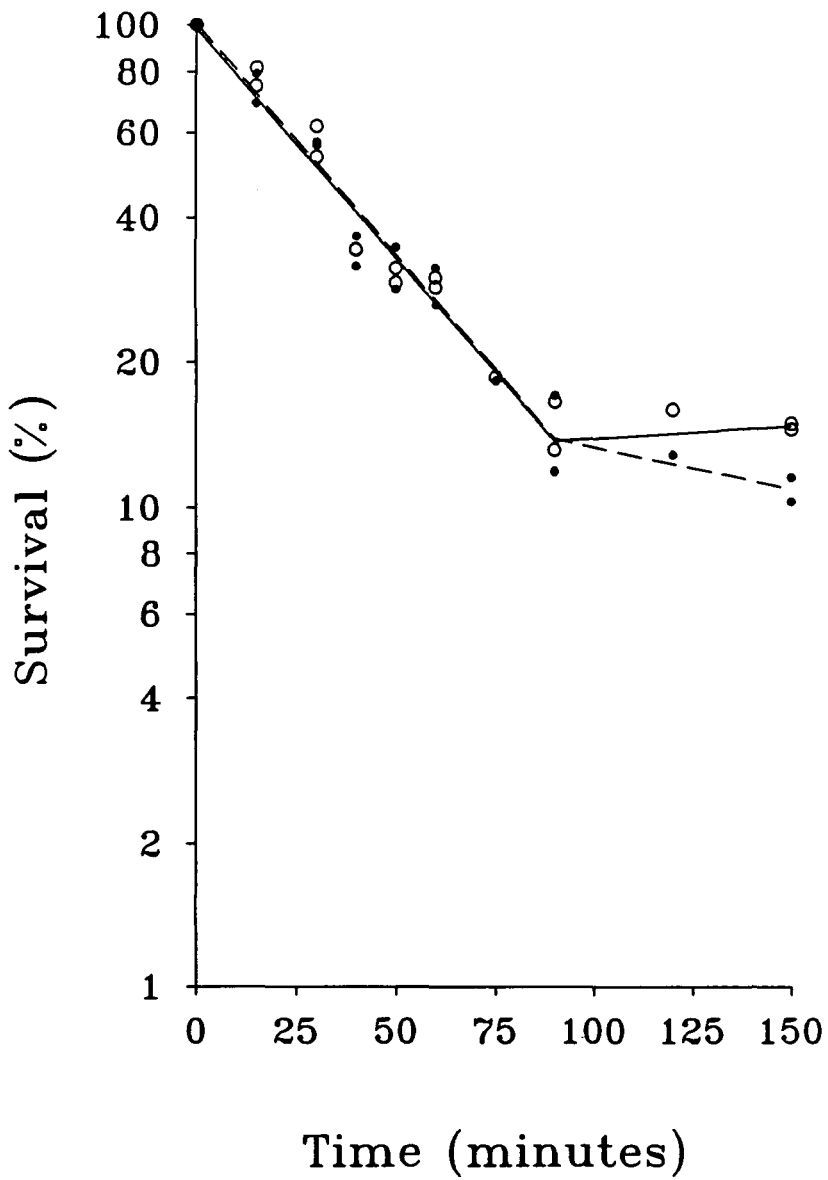

(e) 44.0°C

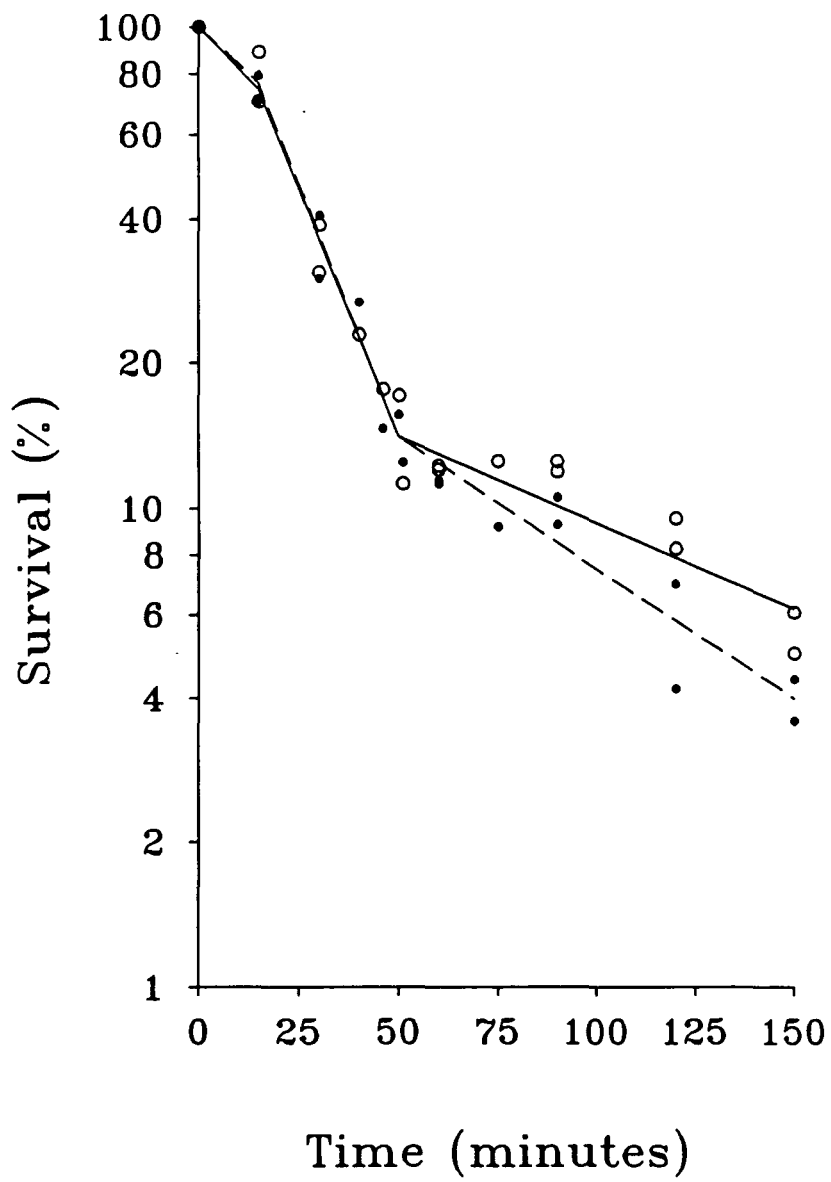

(f) 45.0°C

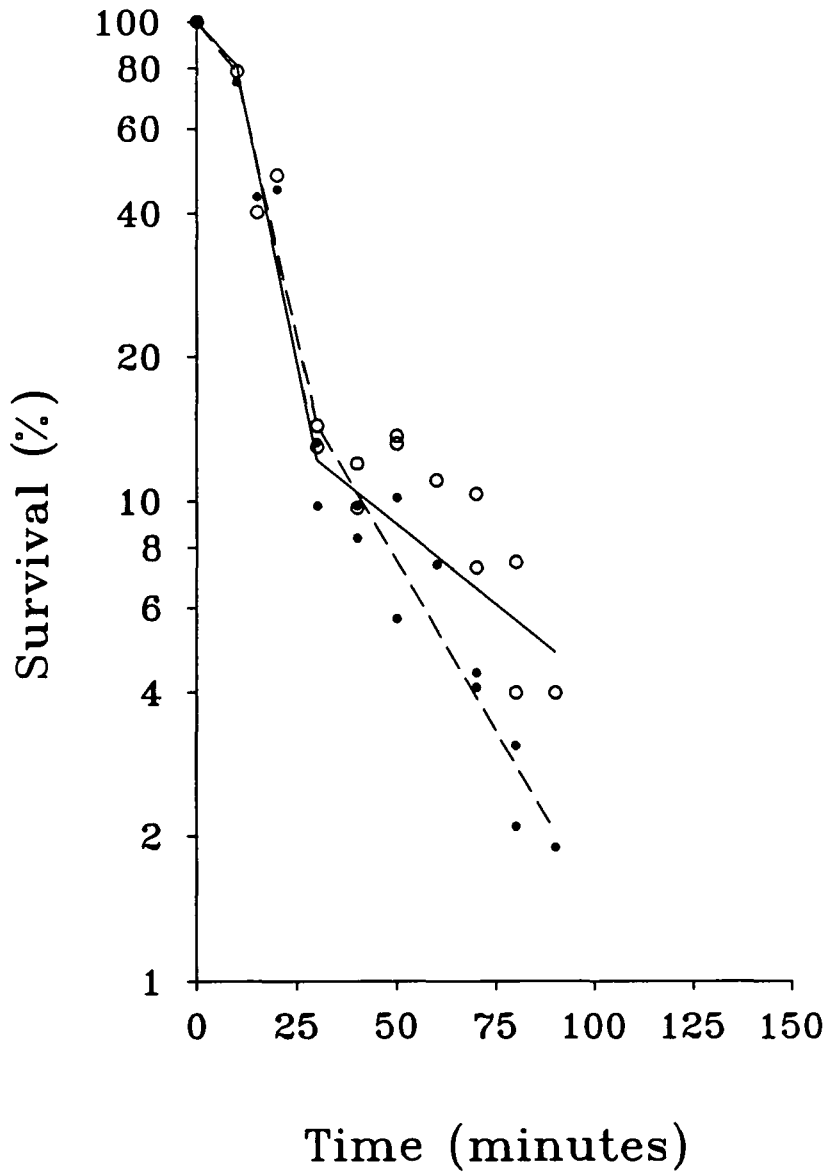

**Table 3.6 — The comparison of heat survival parameters calculated from figure 3.11 for control and arachidonate-supplemented cells**

The  $D_q$ ,  $D_0$  and  $LD_{50}$  values determined from figure 3.11 for control and arachidonate-supplemented cells (labelled as treated in table) are compared in the table below. The cells were grown in arachidonate-supplemented growth medium for 36 hours prior to heat treatment at 42.5, 43.0, 43.5, 44.0 or 45.0<sup>0</sup>C. The control cells were maintained in normal growth medium prior to heat treatment. Survival was estimated using the colorimetric assay. Regression lines were then fitted to the second phase of the survival curves and the heat survival parameters determined from this line.

Heat Survival Parameter	Treatment Temperature ( <sup>0</sup> C)									
	42.5		43.0		43.5		44.0		45.0	
	Control	Treated	Control	Treated	Control	Treated	Control	Treated	Control	Treated
$D_q$ (min)	24.2 ±6.55	26.7 ±6.92	nd	nd	nd	0.3 ±3.77	8.8 ±2.28	9.5 ±2.36	7.8 ±2.37	7.1 ±2.75
$D_0$ (min)	209.3 ±21.71	217.9 ±24.30	195.1 ±18.95	192.1 ±18.62	105.9 ±7.98	105.1 ±6.86	48.5 ±3.66	47.6 ±3.78	24.3 ±3.48	27.2 ±4.30
$LD_{50}$ (min)	87.4 ±3.63	92.5 ±4.36	52.3 ±6.16	56.4 ±5.87	31.1 ±2.45	32.0 ±2.05	23.4 ±1.38	23.9 ±1.43	15.1 ±1.52	15.3 ±1.62

nd=not possible to determine

Data in the table represent Estimate ± standard error

No significant differences were found between the heat survival parameters obtained for control and supplemented cells. Statistical analyses were carried with the Students t-test.

**Figure 3.12 — Removal of [7(n)-<sup>3</sup>H]-cholesterol from HTC cells by liposomes**

The procedure used in this experiment is described in detail under Materials and Methods. In brief, HTC cells labelled with [7(n)-<sup>3</sup>H]-cholesterol were exposed to liposome solution (●), growth medium lacking serum and fungizone but containing lipid depleted serum (○) or growth medium lacking serum and fungizone (×). Duplicate samples (0.1ml) of the media surrounding the cells were taken at hourly intervals and the radioactivity determined. The percent depletion axis represents the portion of the radioactivity present in media relative to that present in the cell monolayer at time zero.

Each point on the graph represents the average of duplicate measurements. Data from two separate experiments are presented for depletion conditions involving liposome solution (●) and lipid depleted serum (○); for experiments with growth medium lacking serum and fungizone (×) data from three separate determinations are presented on the graph.

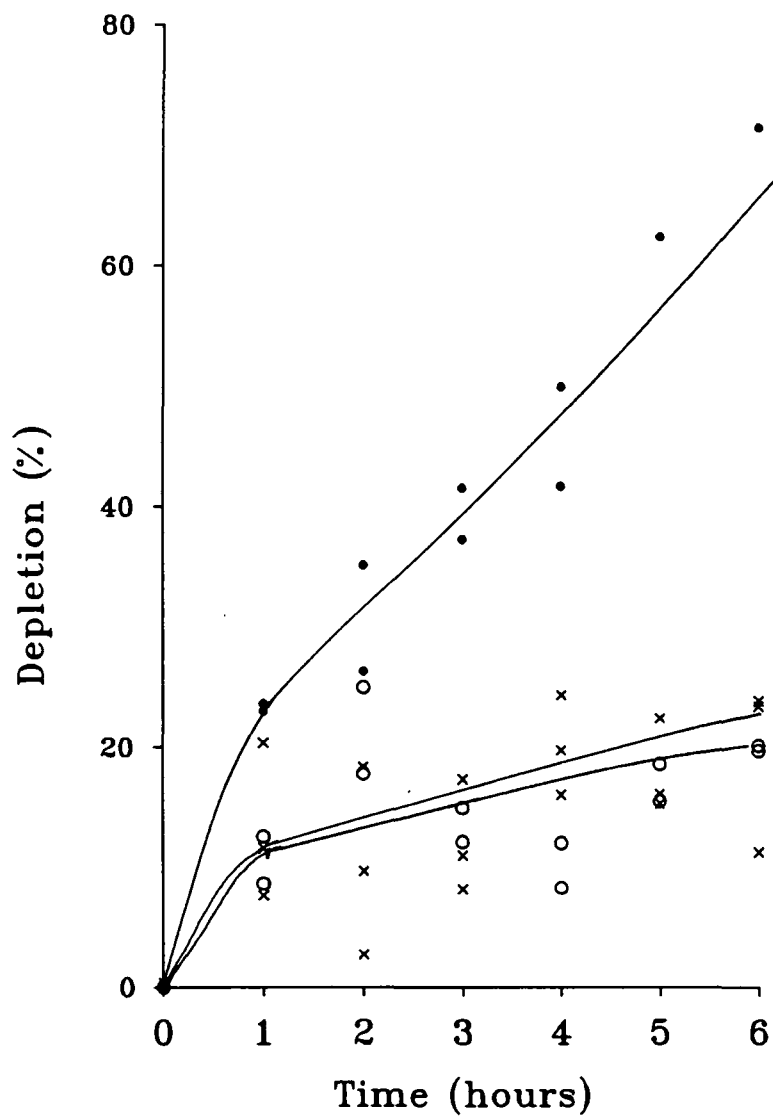
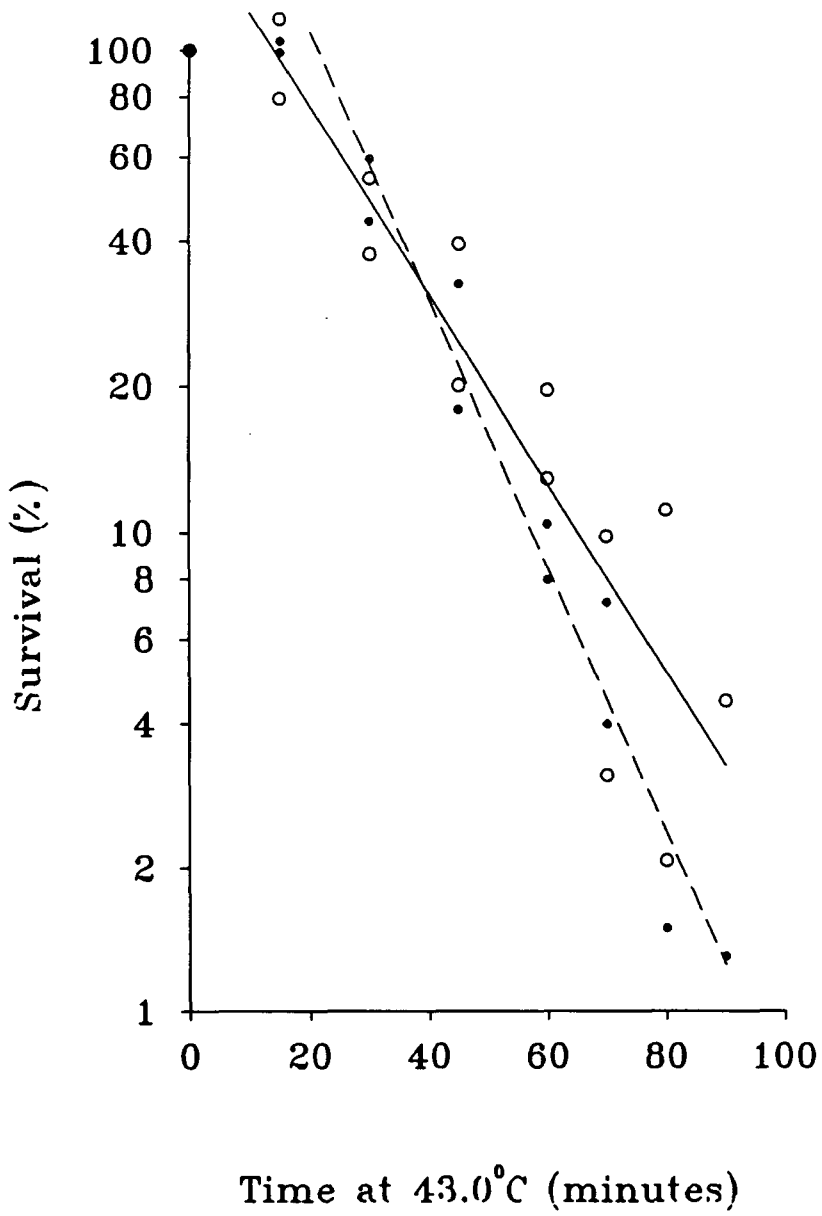

**Figure 3.13 — The effect of exposure to liposomes on the thermosensitivity of HTC cells assessed by the clonogenic assay**

The procedure is described in detail under Materials and Methods. In brief, exponentially growing HTC cells were exposed to liposome solution (●, dashed line) or serum-free and fungizone-free growth media (○, solid line) for 3 hours at 37<sup>0</sup>C. The cultures were harvested and 200 cells seeded into flasks containing LDS media. The cells were then heated at 43<sup>0</sup>C for up to 100 minutes. The flasks were then returned to normal culture conditions and the next day the media was replaced with growth medium. The colonies were allowed form, then fixed, stained and counted.

The data points on the graph represent the average of duplicate determinations from two separate experiments.

Regression lines have been fitted to the second phase of the survival curves.



**Table 3.7 — The comparison of heat survival parameters calculated from figure 3.13 for control and liposome treated cells**

The  $D_q$ ,  $D_0$ ,  $LD_{50}$  and  $LD_{90}$  determined from figure 3.13 for control and liposome treated cells are compared in the table below. The cells were exposed to liposome solution for 3 hours prior to heat treatment at  $43^{\circ}\text{C}$  in  $25\text{cm}^2$  flasks. The control cells were maintained in serum-free and fungizone-free growth media for 3 hours prior to heat treatment. Survival was estimated using the clonogenic assay. Regression lines were then fitted to the second phase of the survival curves and the heat survival parameters determined from this line.

Heat Survival Parameter	Treatment	
	Control	Liposome
$D_q$ (min)	12.4 $\pm 7.96$	19.4 $\pm 2.82$
$D_0$ (min)	52.8 $\pm 7.52$	37.7 $\pm 2.73$
$LD_{50}$ (min)	28.4 $\pm 5.79$	30.9 $\pm 2.19$
$LD_{90}$ (min)	65.2 $\pm 3.90$	57.1 $\pm 1.52$

Data in the table represent Estimate  $\pm$  standard error

No significant differences were found between the heat survival parameters obtained for control and liposome treated cells. Statistical analyses were carried with the Students t-test.

**Table 3.8 — The effect of exposure to liposomes on the thermosensitivity of HTC cells assessed by the colorimetric assay**

The procedure is described in detail under Materials and Methods. In brief, cells growing in 24-well plates were exposed to liposome solution or serum-free and fungizone-free growth media (SF-free growth media) for 3 hours at 37<sup>0</sup>C. The monolayers were then washed with SF-free growth medium before addition of 1ml of growth medium lacking serum and fungizone but containing 10mM HEPES, pH 7.4 (heating medium). The plates were then heated at 43<sup>0</sup>C for 50 minutes after which the cultures were returned to 37<sup>0</sup>C. The next day the medium was replaced with growth medium and the cells allowed to grow. Cell survival was assessed by the colorimetric assay.

Treatment	Survival (%)
Control	61.85 ± 3.88
Liposome	64.00 ± 5.57

The data in the table represents the mean of four separate determinations ± the standard error.

**Figure 3.14 — The effect of 24 hour exposure to 25-hydroxycholesterol on the growth of HTC cells**

The procedure is described in Materials and Methods. On day 2 of culture the cells were exposed to various amounts of 25-hydroxycholesterol or the appropriate amount ( $\leq 0.02\%$ , v/v) of ethanol (the vehicle used for 25-hydroxycholesterol) in control cultures. After 24 hours treatment with 25-hydroxycholesterol in serum-free and fungizone-free growth medium the cells were returned to normal growth medium. The growth of the cells was followed by assessing cell number by the colorimetric assay.

The data presented on the graph represents the mean of two separate determination carried out in duplicate.

Key to Graph	
25-Hydroxycholesterol concentration ( $\mu\text{g/ml}$ )	Symbol on graph
0.0	•
1.0	○
2.0	×
4.0	◇
6.0	△

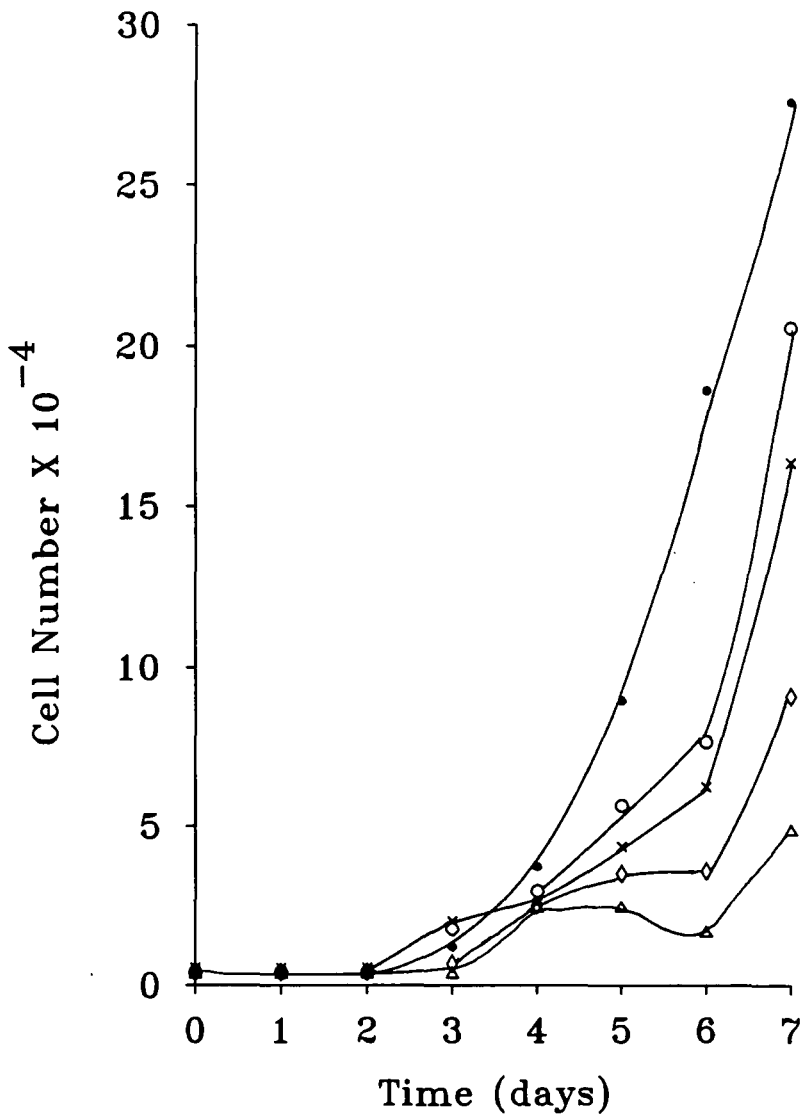

**Figure 3.15 — The effect of 48 hour exposure to 25-hydroxycholesterol on the growth of HTC cells**

The procedure is described in Materials and Methods. On day 2 of culture the cells were exposed to various amounts of 25-hydroxycholesterol or the appropriate amount ( $\leq 0.02\%$ , v/v) of ethanol (the vehicle used for 25-hydroxycholesterol) in control cultures. After 48 hours treatment with 25-hydroxycholesterol in serum-free and fungizone-free growth medium the cells were returned to normal growth medium. The growth of the cells was followed by assessing cell number by the colorimetric assay. The data presented on the graph represents the mean of two separate determination carried out in duplicate.

Key to Graph	
25-Hydroxycholesterol concentration ( $\mu\text{g/ml}$ )	Symbol on graph
0.0	•
1.0	○
2.0	×
4.0	◇
6.0	△

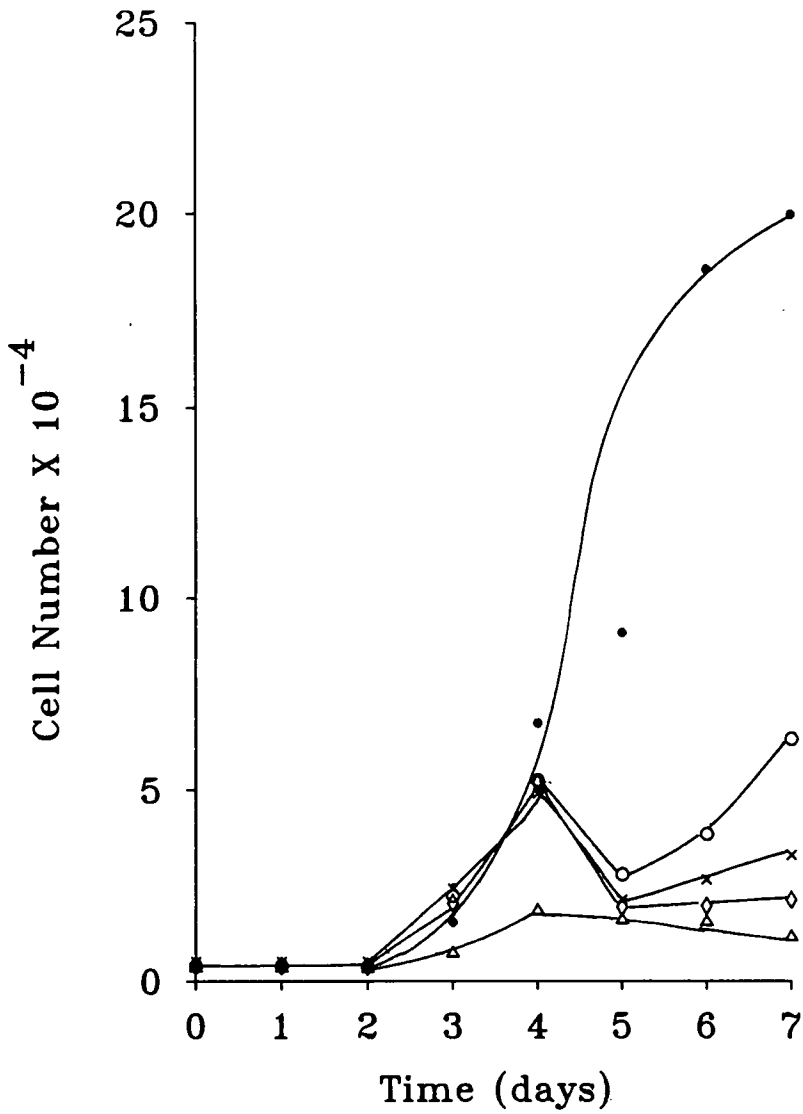

**Figure 3.16 — The effect 25-hydroxycholesterol on the thermosensitivity of HTC cells**

The procedure is described in Materials and Methods. HTC cell cultures grown in 24-well plates were exposed to 25-hydroxycholesterol (●, dashed line) or appropriate amount ( $\leq 0.02\%$ , v/v) of ethanol (○, solid line), the solvent used to solubilize 25-hydroxycholesterol, for 24 hours. The medium was then replaced with growth medium lacking serum and fungizone but containing 10mM Hepes, pH 7.4. The cultures were heat treated at 43<sup>0</sup>C for various time intervals. The plates were unsealed and 1ml of normal growth medium added to the cultures before returning to 37<sup>0</sup>C culture. The cells were allowed to grow and survival was assessed by the colorimetric assay. The concentration of 25-hydroxycholesterol used in each experiment is given on the appropriate graphs.

The data values presented on figures 3.16a and b represent average of quadruplicates obtained from three and four separate experiments respectively. In figure 3.16c, d and e the average of quadruplicates obtained from a single experiment is presented.

Regression lines have been fitted to the second phase of the survival curves.

The inhibition of growth, relative to control cells, due the 25-hydroxycholesterol alone is given in the table below.

25-Hydroxycholesterol concentration ( $\mu\text{g}/\text{ml}$ )	Inhibition of Growth by 25-Hydroxycholesterol alone (%)
0.0625	33.00 $\pm$ 4.73
0.125	43.67 $\pm$ 2.82
0.250	55.25 $\pm$ 1.15
1.000	76.16 $\pm$ 1.05
2.000	83.70 $\pm$ 1.30

Data values in the table represent mean values from four separate determinations  $\pm$  the standard error.

(a) 0.0625 $\mu\text{g/ml}$

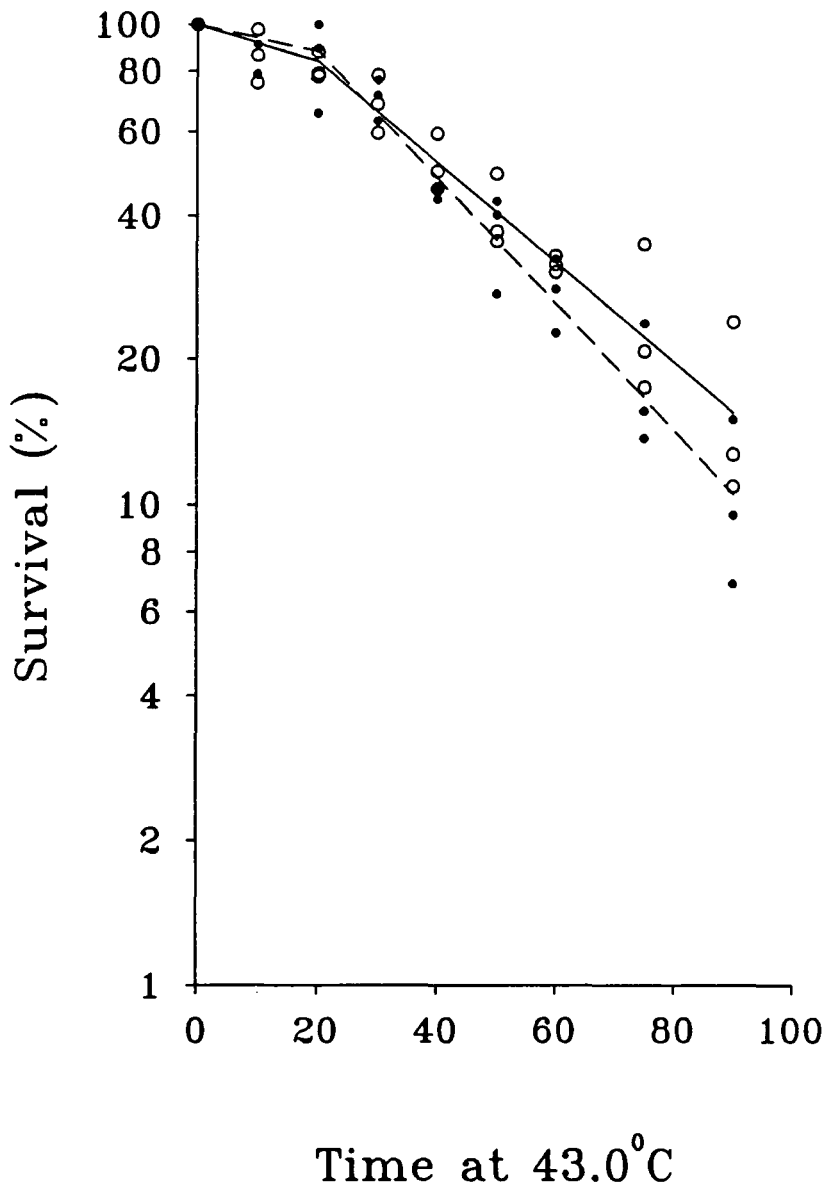

(b) 0.125 $\mu$ g/ml

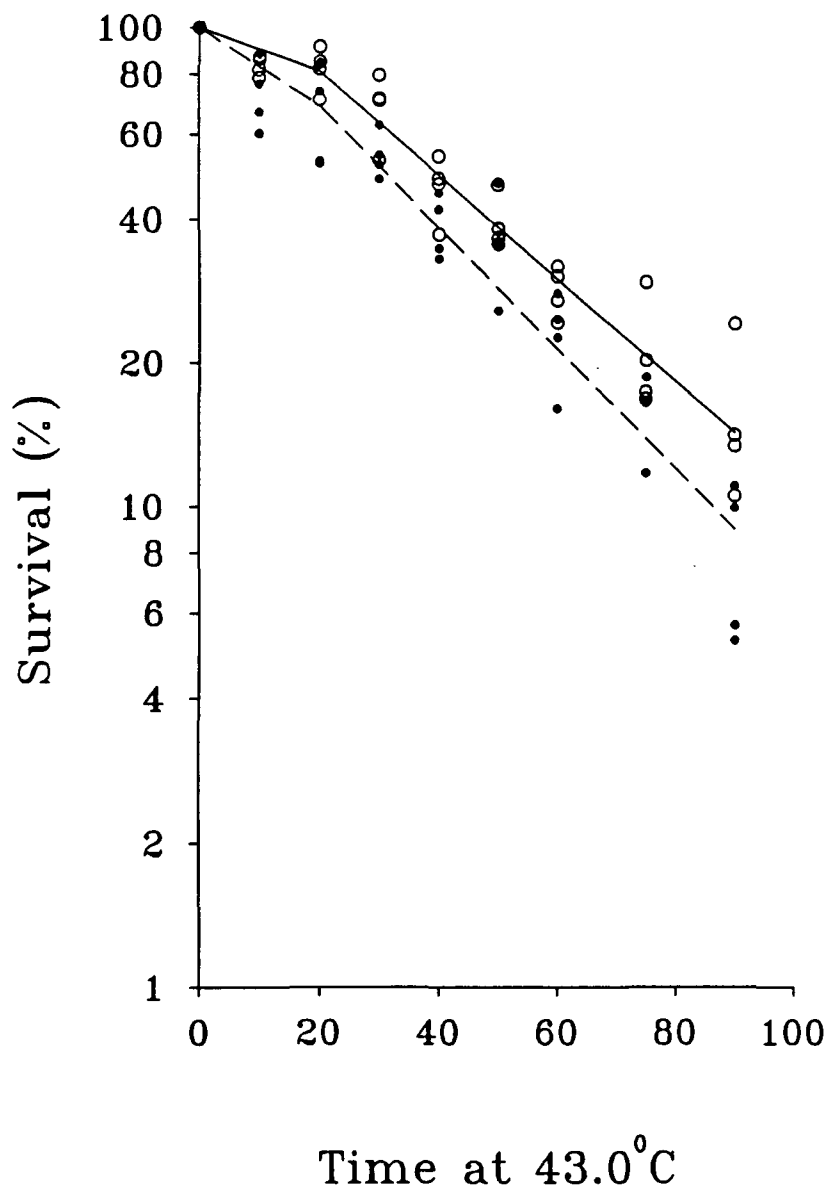

(c) 0.250 $\mu$ g/ml

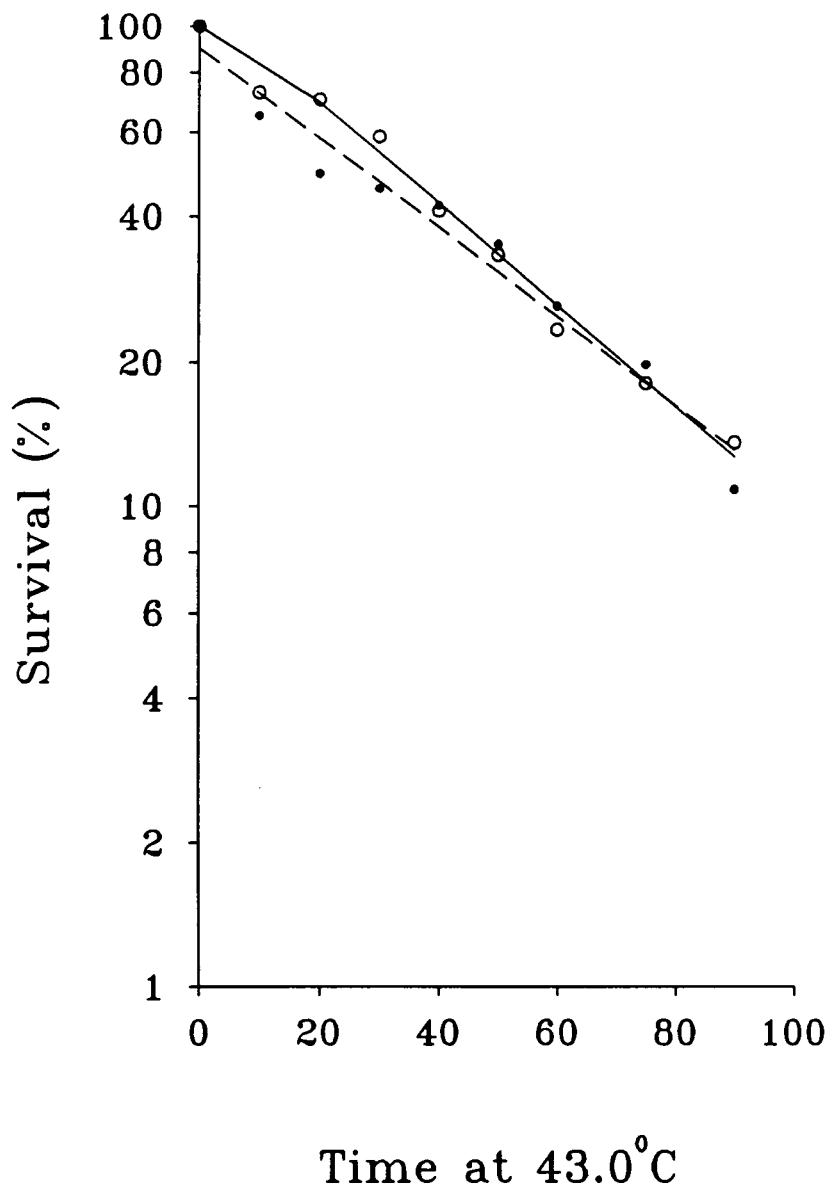

(d) 1.0  $\mu\text{g/ml}$

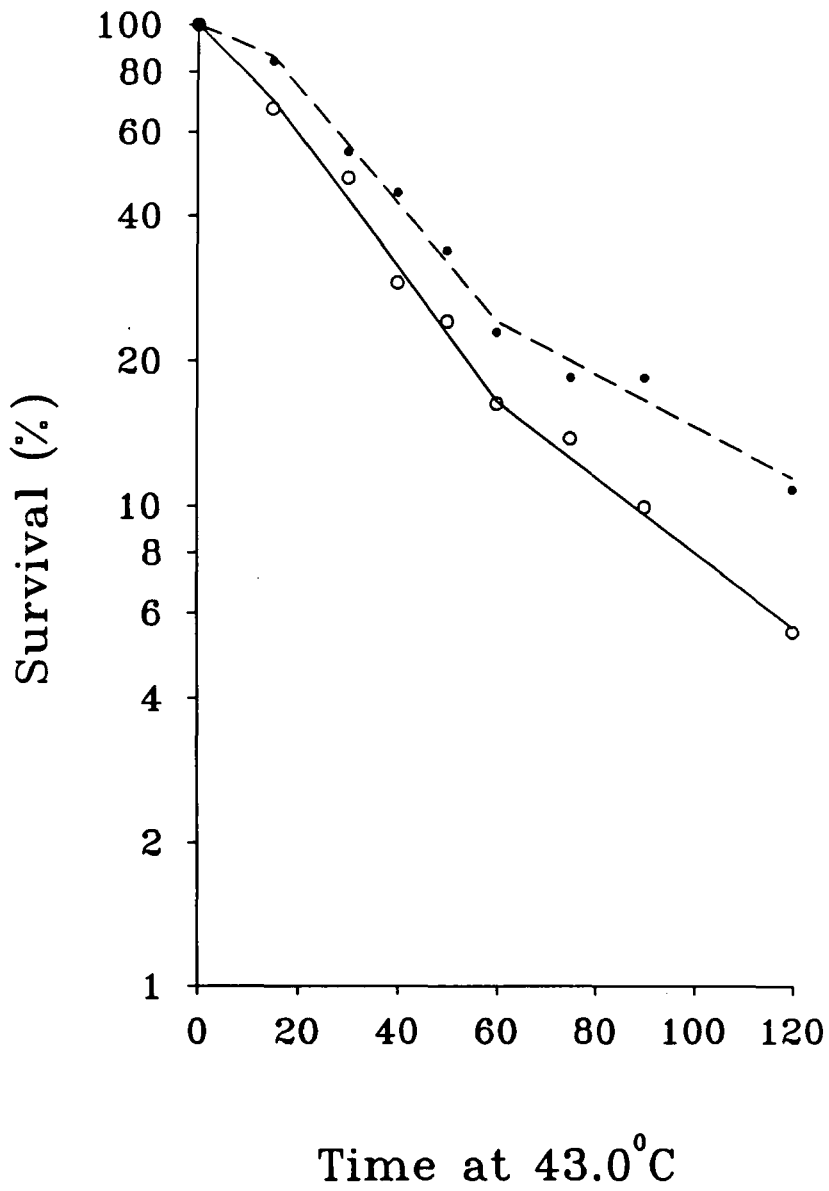

(e) 2.0 $\mu$ g/ml

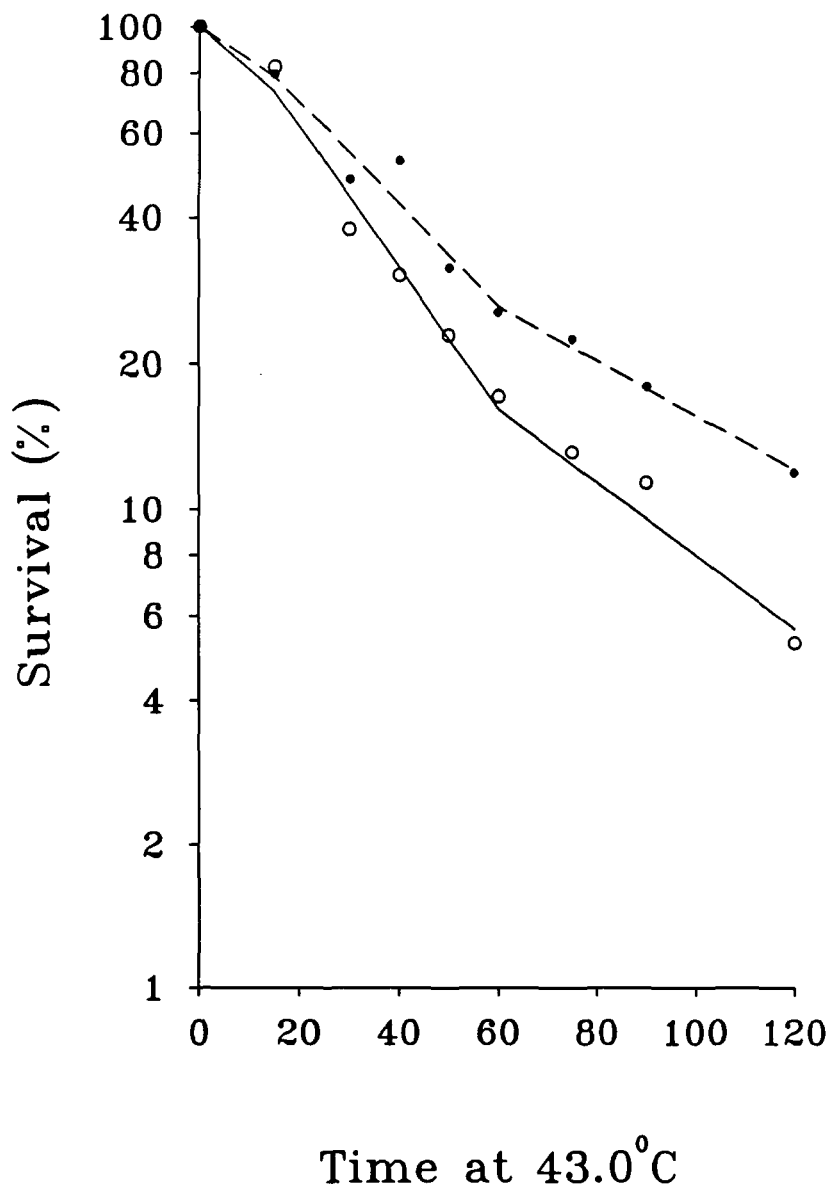

**Table 3.9 — The comparison of heat survival parameters calculated from figure 3.16 for control and 25-hydroxycholesterol treated cells**

The  $D_q$ ,  $D_0$  and  $LD_{50}$  values determined from figure 3.16 for control and 25-hydroxycholesterol treated cells are compared in the table below. The cells were exposed to 25-hydroxycholesterol for 24 hours at the concentrations given in the table below prior to heat treatment at  $43.0^{\circ}\text{C}$ . The control cells were exposed to the appropriate amount of ethanol ( $\leq 0.02\%$ , v/v) prior to heat treatment. Survival was estimated using the colorimetric assay. Regression lines were then fitted to the second phase of the survival curves and the heat survival parameters determined from this line.

Heat Survival Parameter	25-Hydroxycholesterol Concentration ( $\mu\text{g/ml}$ )									
	0.0625		0.0125		0.250		1.000		2.000	
	Control	Treated	Control	Treated	Control	Treated	Control	Treated	Control	Treated
$D_q$ (min)	12.8 $\pm 3.63$	15.9 $\pm 2.80$	11.6 $\pm 2.90$	7.1 $\pm 2.99$	4.9 $\pm 2.72$	nd nd	3.9 $\pm 2.90$	9.8 $\pm 1.86$	5.9 $\pm 3.90$	5.1 $\pm 6.36$
$D_0$ (min)	95.6 $\pm 6.80$	76.0 $\pm 4.59$	93.0 $\pm 5.25$	79.4 $\pm 4.40$	95.3 $\pm 4.87$	108.8 $\pm 11.7$	71.8 $\pm 5.35$	81.7 $\pm 4.54$	68.5 $\pm 7.04$	94.6 $\pm 14.8$
$LD_{50}$ (min)	41.7 $\pm 2.01$	38.9 $\pm 1.74$	39.7 $\pm 1.63$	31.1 $\pm 1.89$	33.7 $\pm 1.52$	27.3 $\pm 3.89$	25.6 $\pm 1.56$	34.4 $\pm 0.91$	26.5 $\pm 2.50$	33.7 $\pm 2.81$

nd=not possible to determine

Data in the table represent Estimate  $\pm$  standard error

No significant differences were found between the heat survival parameters obtained for control and supplemented cells. Statistical analyses were carried with the Students t-test.

**Figure 3.17 — The effect of cholesterol hemisuccinate treatment on the thermosensitivity of HTC cells**

The experiment was performed as described in Materials and Methods. Briefly, HTC cell cultures, grown in 24-well plates, were exposed to cholesterol hemisuccinate or the appropriate amount ( $\leq 0.05\%$ , v/v) of ethanol (the solvent for cholesterol hemisuccinate) for 3 hours at  $37^{\circ}\text{C}$ . Cholesterol hemisuccinate or ethanol were then removed and growth medium lacking serum and fungizone but containing 10mM Hepes, pH 7.4 added to the wells. The plates were sealed and heat treated at  $43^{\circ}\text{C}$  for 25 (figure 3.17a) or 50 (figure 3.17b) minutes. The plates were then unsealed, 1ml of normal growth medium added to the wells and then returned to  $37^{\circ}\text{C}$  culture. The cells were allowed to grow and survival was assessed by the colorimetric assay.

The mean values from four separate experiments  $\pm$  standard error are presented in the histogram.

Significant enhancement ( $p < 0.05$ ) of heat death was obtained compared to control cells when HTC cells were treated under the following conditions: treatment with  $100\mu\text{g}/\text{ml}$  cholesterol hemisuccinate for 3 hours prior to heating at  $43^{\circ}\text{C}$  for 25 minutes; and treatment with 50 and  $100\mu\text{g}/\text{ml}$  cholesterol hemisuccinate prior to heating at  $43^{\circ}\text{C}$  for 50 minutes. Statistical analyses was carried with the Students t-test.

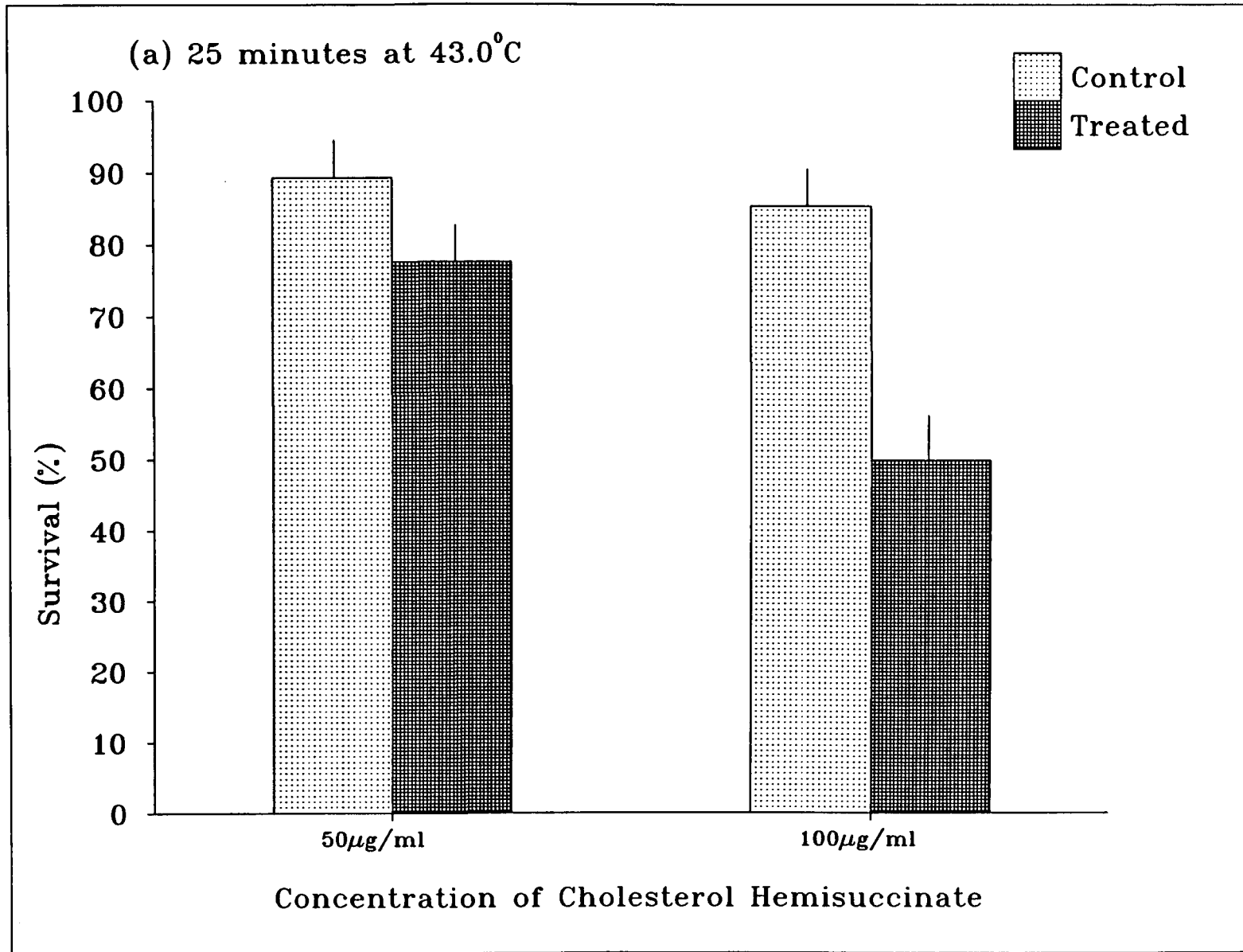

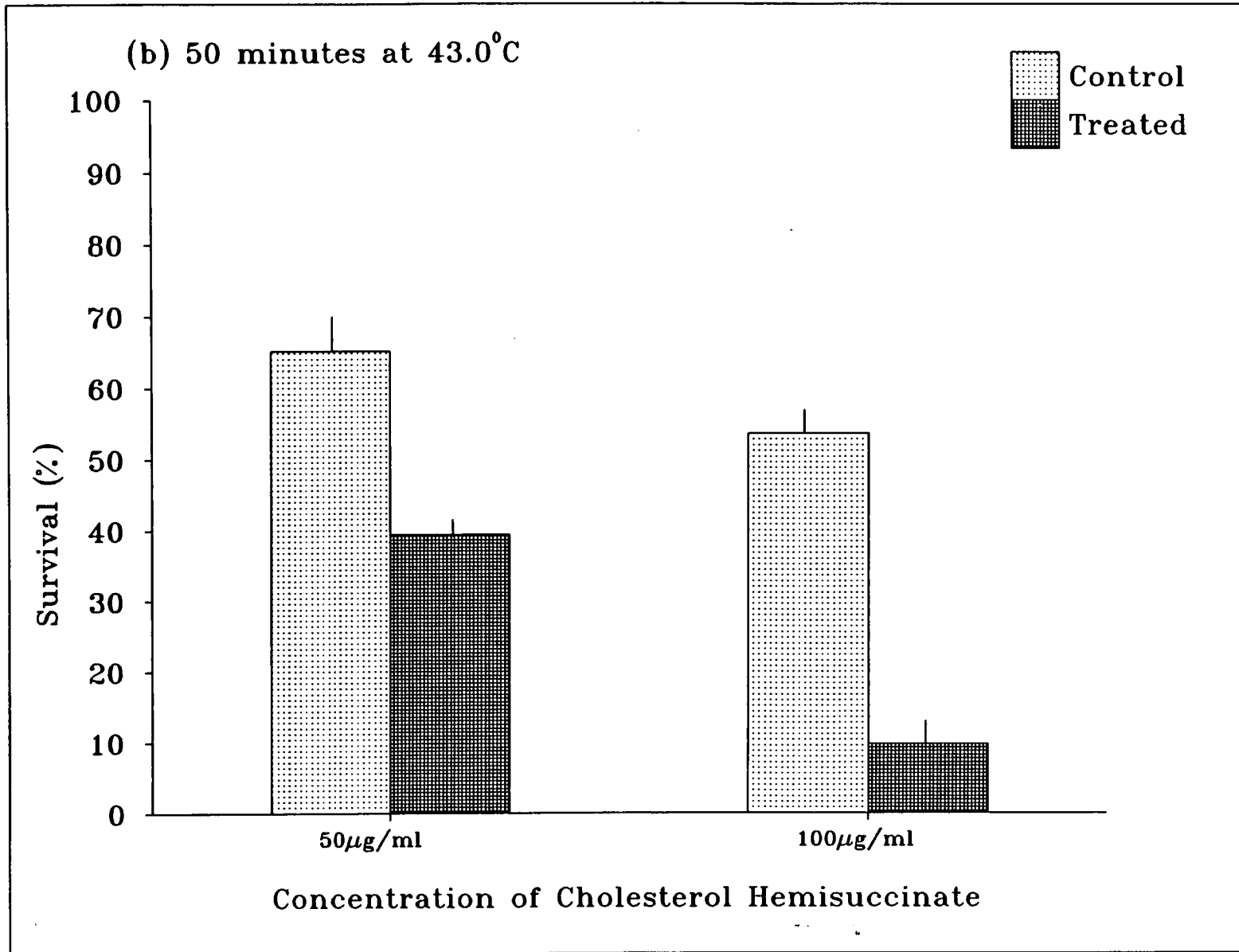

### 3.4 Discussion

A large number of hyperthermic studies have employed the clonogenic assay to assess cell survival. The mammalian cell lines, Chinese hamster ovary, V79 (Gerweck, 1977; Sapareto *et al.*, 1978), murine L1210 leukemia (Guffy *et al.*, 1982), murine lymphoma (Cresswell *et al.*, 1980), mouse fibroblast LM cells (Konings, 1985), Reuber H35 and HTC (Schamhart *et al.*, 1984) are some which have been studied with respect to their response to heat. When the data are plotted as thermal survival curves, most studies show the characteristic shoulder region followed by a linear exponential portion (Figure 3.4). However, to carry out quantitative comparisons of the  $D_q$ ,  $D_0$ ,  $LD_{90}$  and  $LD_{50}$  parameters between different studies, they must have been carried out under identical conditions (Hahn, 1982). This is because differences in cell culture conditions between laboratories (serum, pH, oxygen and carbon dioxide tension) all affect the heat response of the cell. For example, Schamhart *et al.* (1984) using HTC cells obtained a  $D_0$  value of approximately 30 minutes at  $43^{\circ}\text{C}$ . In this study, at the same temperature, a  $D_0$  value of approximately 100 minutes was obtained for HTC cells and this difference could be due to the different sera used, as newborn bovine serum (10%, v/v) was employed in the present study whereas Schamhart *et al.*, (1984) used a mixture of foetal calf serum (5%, v/v) and newborn calf serum (10%, v/v). Alternatively, other differences in culture conditions, or changes in the HTC cells over the intervening years between the two studies, could account for the difference in  $D_0$  values. However, although absolute comparisons cannot be made, changes in the heat sensitivity parameters due to a treatment under identical conditions can be compared.

The reasons for the existence of the shoulder region in the survival curves are not clear, although several workers have suggested that the size of the shoulder

region reflects the cells' ability to sustain sublethal damage (Hahn, 1982). In other words, cells with a high  $D_q$  value show greater ability to repair the effects of heat damage compared to cells with a low  $D_q$ . Consequently, the lower survival seen with the colorimetric assay (figure 3.6), compared with the clonogenic assay (figure 3.5), after short exposure times to heat may be due to the difference in the time allowed for recovery from heat damage before assay (i.e. 3 days in the colorimetric assay and 10 days in the clonogenic assay). For example, if mitochondrial function is temporarily impaired at 3 days after heating, this could account for the short  $D_q$  values and apparent low cell survival after short periods of heating, determined by the colorimetric assay (figure 3.6). However, if such cells subsequently recover, and retain reproductive competence, this would explain the relatively longer  $D_q$  values and higher cell survival after short periods of heating, estimated by the clonogenic assay at 10 days after heating (figure 3.5).

After heat treatment of HTC cells, when cell survival was estimated using the colorimetric assay (figure 3.6) a 3-phase survival curve was obtained, whereas when the clonogenic assay (figure 3.5) was used to estimate cell survival, a 2-phase survival curve was obtained. To account for the triphasic nature of the survival curves obtained by the colorimetric assay (figure 3.6) compared to the biphasic nature of the survival curves obtained by the clonogenic assay (figure 3.5), the modes of cell death must be considered. Vidair and Dewey, (1988) have demonstrated the existence of 'rapid' and 'slow' modes of cell death post heat. The 'rapid' mode of cell death which predominated during the first few days post heating, was characterized by cell detachment and inhibited rates of protein, RNA and DNA synthesis. A 'slow' mode of death became evident after the cells had fully recovered from the heat-induced inhibition of macromolecular synthesis and cell detachment

had ceased. During these investigations it was demonstrated that some cells, post heat, remain attached but have a diminished colony forming ability. Therefore, cells which are metabolically active yet reproductively incompetent, post heat, will not be detected by the clonogenic assay. After long exposure times to heat, the higher cell survival detected by the colorimetric assay (figure 3.6), as compared to the clonogenic assay (figure 3.5), may reflect the presence of cells which cannot divide yet retain the metabolic ability to cleave MTT to formazan.

The obvious solution to this problem would be to leave the 24-well plates for a longer period post heat before assay. However, as discussed in chapter 2, the control cells will reach confluency rapidly and enter the stationary phase of growth, while the viable heat-treated cells will still be in exponential growth. This may lead to errors in assessing cell survival.

The effects of supplemental fatty acids on growth of a number of cell lines has been investigated by Spector *et al.* (1979). Using human skin fibroblasts, they showed that palmitic, linolenic or arachidonic acid reduced growth rate whilst oleate or linoleate did not effect the growth rate. Doi *et al.* (1978), using mouse fibroblast LM cells, showed that supplementation with 100 $\mu$ M saturated fatty acids of longer than 15 carbons caused profound inhibition of cell growth, whilst linoleic and arachidonic acid had no effect. Doi *et al.* (1978) also found a good correlation between the unsaturated fatty acid content of membrane phospholipids and cell growth. When incorporated saturated fatty acids reduced the percentage of unsaturated fatty acids in the membrane phospholipids to less than 50%, severe inhibition of cell growth was found. Urade and Kito (1982) using Chinese Hamster V79-R cells showed a concentration-dependent inhibition of growth by palmitate. Similarly, severe inhibition of HTC cell growth was obtained when cells were grown

in the presence of  $40\mu\text{M}$  palmitate in the present study.

Mammalian cells grown in culture media which contain serum usually contain a small number of microscopically visible cytoplasmic lipid droplets (Moscowitz, 1967). The exposure of cells to supplemental fatty acids is accompanied by an increase in the formation of these cytoplasmic lipid droplets (Rosenthal, 1981). This was shown to occur with the present cell line (plate 3.1) and there may be a possibility that this might influence heat sensitivity of HTC cells.

An increase in the thermosensitivity ( $\text{LD}_{90}$  values) of HTC cells after supplementation with  $60\mu\text{M}$  arachidonate for 36–48 hours was detected when cell survival was measured by reproductive competence at 10 days after heating, using the clonogenic assay (figure 3.9). However, no change in the thermosensitivity of the cells was detected after supplementation with  $60\mu\text{M}$  or  $80\mu\text{M}$  arachidonate for 36 hours, when cell survival was measured by metabolic ability to cleave MTT at 3 days after heating, using the colorimetric assay (figure 3.10 and 3.11). If supplementation with arachidonic acid predisposes cells to be more easily rendered reproductively incompetent when challenged with heat, yet they remain metabolically active, this could account for the observed results. However, when cell survival was estimated using the colorimetric assay, it appears that supplementation with  $80\mu\text{M}$  arachidonate for 36 hours may increase the thermosensitivity of the cells, when heated at  $44^{\circ}\text{C}$  (figure 3.11e) or  $45^{\circ}\text{C}$  (figure 3.11f) for greater than 50 minutes. Therefore, this observed enhancement of thermosensitivity appears in the third phase of the cell survival curves. As the  $\text{LD}_{50}$  and  $\text{LD}_{90}$  values occur in the second phase of the survival curves, these indices cannot be used to quantify the change in heat sensitivity due to arachidonate supplementation in the third phase of the survival curves. However, if the time required to reduce cell survival to 95% is used as the

cytotoxic index ( $LD_{95}$ ), because it occurs in the third phase of the survival curves, then the enhancement of thermosensitivity can be quantified. Regression lines fitted to the data show that, at  $44^{\circ}\text{C}$  and  $45^{\circ}\text{C}$ , the  $LD_{95}$  value is reduced by 42.0 and 26.5 minutes, respectively, in response to supplementation with  $60\mu\text{M}$  arachidonate for 36 hours. However, this reduction in thermal sensitivity was found not to be significant when analysed with the Students t-test.

In summary, therefore, supplementation of HTC cells with  $60\mu\text{M}$  arachidonate for 36–48 hours caused a significant increase in thermal sensitivity of the cells at  $43^{\circ}\text{C}$ , as determined from  $LD_{50}$  and  $LD_{90}$  values derived from the clonogenic assay. In contrast, use of the colorimetric assay showed that supplementation with  $60\text{--}80\mu\text{M}$  arachidonate for 36 hours caused no significant difference in thermal sensitivity of the cells at  $43^{\circ}\text{C}$ , when assessed by using  $LD_{50}$  and  $LD_{90}$  values. However, when cells supplemented with  $80\mu\text{M}$  arachidonate for 36 hours were exposed to higher temperatures ( $44\text{--}45^{\circ}\text{C}$ ), the  $LD_{95}$  values derived from the colorimetric assay suggested that supplementation caused a slight increase in thermal sensitivity, but the difference was not statistically significant.

Enhanced thermosensitivity due supplementation unsaturated fatty acid has also been demonstrated by Guffy *et al.* (1982), using the clonogenic assay for detecting survival. They showed that L1210 Murine Leukemia cells grown in  $40\mu\text{M}$  docosahexaenoic acid (22:6) for 10 days prior to heat treatment at  $42^{\circ}\text{C}$  were more heat sensitive when compared to control cells. A reduction in  $LD_{90}$  of 24 minutes was obtained. Similarly, Konings and Ruifrok, (1985), they showed that LM mouse fibroblast cells grown in  $100\mu\text{M}$  arachidonic acid (20:4) for 24 hours prior to heat treatment at  $43.5^{\circ}\text{C}$  were more heat sensitive when compared to control cells. A reduction in  $LD_{90}$  of 12 minutes was obtained. In the present study, a reduction

in LD<sub>90</sub> of 29.7 minutes was obtained compared to control cells, when HTC cells were grown in 60 μM arachidonic acid for 36 hours prior to heat treatment at 43°C. So the enhancement of thermal sensitivity caused by supplementation with unsaturated fatty acid was similar to that reported by other workers. In order to clarify whether this enhanced thermal sensitivity of cells was related to plasma membrane structure, it was necessary to purify plasma membranes from HTC cells then analyse any changes in lipid composition and membrane order in response to supplementation with arachidonate. This work is reported in chapter 4.

Liposomes have been utilized by many workers (see Rothblat *et al.*, 1986) to study the rates of cholesterol transfer both between donor and acceptor liposomes or between cells and liposomes. A great deal of the work has focused on the composition of the liposomes and the effect of this composition on the rate of cholesterol transfer (Phillips *et al.*, 1987).

There are two popular models for the transfer of cholesterol from the membrane to the liposome (see Phillips *et al.*, 1987). The first model involves the formation of a transient complex which results from the collision of liposomes with the cell membrane (transient collision complex model). This implies close approach of the liposomes to the membrane such that direct transfer of lipid occurs between the liposome/cell membrane bilayers or indeed transfer of lipid occurs by partial fusion of liposomes with the cell membrane. The second model (monomer diffusion transfer model) involves the initial desorption of the lipid from the membrane into the aqueous phase followed by rapid sequestration by the liposome. The experimental evidence strongly favours the monomer diffusion transfer model for the movement of lipid between the cell membrane and the liposomes (see Phillips *et al.*, 1987). In the monomer diffusion transfer model, the rate limiting step is thought to be the

desorption of the monomer from the membrane into the aqueous phase. The efficiency of this step will depend on the solubility of the lipid monomer in the aqueous phase. For example, due to the higher solubility of cholesterol in water relative to long chain phospholipid in the same solvent, the exchange of cholesterol between membranes is much faster than that of long-chain phospholipids. Therefore, in the experimental protocols where liposomes are utilised to remove cholesterol from cellular membranes there is a potential, not only for relatively rapid exchange of cholesterol, but also for a slower exchange of phospholipid species of liposomes with those of the cell membrane. It has to be noted that for rapid unidirectional flux of cholesterol from cells to liposomes, the phospholipid liposomes must be in a large excess relative to the cells (Rothblat and Phillips, 1982).

In the present study, exposure of HTC cells to egg phosphatidylcholine liposomes for 3 hours caused a substantial increase in cholesterol efflux (figure 3.12), but had little effect on the subsequent thermal sensitivity of HTC cells (figure 3.13). The lack of enhancement of HTC cell thermosensitivity by the exposure to liposomes prior to heat treatment raises the question of why there was no substantial effect. In this study, the chemical amounts of cholesterol in HTC cells were not measured before and after exposure to liposomes due to a lack time and of resources. Therefore, there is a possibility that the observed efflux of [7(n)-<sup>3</sup>H]-cholesterol from prelabelled HTC cells by egg phosphatidylcholine liposomes did not reflect a change in cellular free cholesterol. However, the experimental protocol adopted in this study was reviewed by Rothblat *et al.* (1986), who suggested that growth of cells in labelled cholesterol for 1-4 days is sufficient to ensure equilibrium labelling of cellular pools of cholesterol. The HTC cells used in this study were grown in [7(n)-<sup>3</sup>H]-cholesterol for 2 days, a period which has been shown by

Rothblat and Phillips (1982) to be adequate for two hepatoma cell lines to ensure that the changes in labelled cholesterol parallel changes in cellular free cholesterol. Direct measurement of the chemical amount of cholesterol has shown that short exposure (6 hours) of cells to liposomes facilitates the removal of cellular cholesterol (Rothblat and Phillips, 1982). Baldassare *et al.*, (1979) have also demonstrated that a relatively short 2 hour incubation of LM-cells with liposomes led to a decrease in the plasma membrane cholesterol content from 30 to 21 mole percent. Therefore, it is unlikely that the lack of sensitisation to heat by prior liposome treatment in the present study was due to the liposomes failing to decrease the cholesterol levels in the cell membrane. However, there is a possibility that compensatory changes in membrane structure counteracted the decrease in membrane cholesterol levels induced by liposomes. These compensatory changes could occur via three pathways and may have negated any changes in heat sensitisation likely to occur in response to cholesterol depletion. Firstly, there is a potential for the exchange of phospholipid species between the cell membrane and the liposomes. Therefore, if such phospholipid exchange resulted in the introduction of more phospholipids with saturated acyl chain moieties in the membrane, then the disordering effect of depleting cholesterol in the membrane may have been offset by an ordering effect of more saturated acyl chains in the membrane. Therefore, there may be no net change in the membrane order. However, this is not probable as the exchange of phospholipid species is much slower than that of cholesterol (McLean and Phillips, 1981), so during the 3 hour exposure of cells to liposomes the extent of phospholipid exchange would be expected to be low compared to the removal of cholesterol. Secondly, the change in membrane order when cholesterol is depleted by liposomes could have been compensated for by *de novo* biosynthesis of phospholipid and incorporation into the membrane of molecular species containing more

saturated acyl chains (Baldassare and Silbert, 1979). This is again not likely, as the time scale over which compensatory changes tend to occur via *de novo* biosynthesis are large and therefore unlikely to occur during the 3 hour cholesterol-depletion period. For example, Baldassare *et al.* (1979) have shown that 2 hour incubation of LM-cells with liposomes led to a decrease in the plasma membrane cholesterol content from 30 to 21 mole percent, with no change in fatty acid or phospholipid composition. The third pathway for compensating for cholesterol loss from the membrane by liposomes involves replacement of cholesterol via *de novo* biosynthesis. However, the 3 hour cholesterol-depletion period was chosen specially to avoid this problem. As shown by Kirsten and Watson (1974), when HTC cells are transferred from growth medium containing normal levels of cholesterol to medium containing low levels of cholesterol, the activity of HMG-CoA reductase begins to rise after a lag period of 1 to 3 hours. The activity of this enzyme reaches a new maximum in the low cholesterol environment after 9 to 12 hours. Therefore, in the experimental procedure used in this study, when the cells were depleted of cholesterol by liposomes for 3 hours in media which contains no exogenous cholesterol, the replacement of the lost cholesterol by *de novo* biosynthesis within the 3 hour depletion period would be expected to be minimal.

To consider the most likely reason why there was no sensitisation to heat by prior liposome treatment the data presented in figure 3.13 and figure 3.9 must be compared. Although the survival parameters ( $D_0$ ,  $D_q$ ,  $LD_{50}$  and  $LD_{90}$ ) indicated no substantial difference in heat sensitivity between liposome-treated and control cells (figure 3.9), the control cells are more thermosensitive at  $43^{\circ}\text{C}$  than control cells heat treated at the same temperature in figure 3.9. The  $LD_{90}$  at  $43^{\circ}\text{C}$  for control cells obtained in figure 3.9 was  $> 140$  minutes whereas in figure 3.13 it

is 65.2 minutes. This difference probably arises from differences in the treatment of the cells prior to heating. In figure 3.9, cells growing in serum-containing media were harvested and 200 cells/flask were allowed to attach in serum-containing medium for 3 hours before heat treatment. In experiments where cholesterol content of HTC cell membranes was to be altered, experiments were designed to avoid the cholesterol present in serum, in order to help remove cholesterol from the plasma membrane (Fielding and Fielding, 1985). This was achieved by omitting serum or by using lipid depleted serum (chapter 2) in the treatment media. Consequently, the cells were exposed to serum-free and fungizone-free growth media (with and without liposomes) for 3 hours prior to harvesting and heat treating 200 cells/flask in LDS growth media without allowing the cells to attach to flasks. No attachment time was permitted because of the potential for the replacement of cholesterol in the membrane by *de novo* cholesterol biosynthesis. As demonstrated in chapter 2, HTC cells are more heat sensitive when no time for attachment was allowed compared to HTC cells allowed to attach to flasks. Therefore, factors such as attachment time, exposure to serum-free media and heating in LDS growth media may all contribute to the increased heat sensitivity, assessed by the clonogenic assay, observed in experiments shown in figure 3.13 compared to those shown in figure 3.9. This could mean that the control cells are rendered more thermosensitive by the procedure used, when assessing cell survival by the clonogenic assay, and any attempt to further enhance thermosensitivity by removing membrane cholesterol may not be successful. To compensate for this increase in thermosensitivity due to the procedure used it may have been better to heat treat cells at a lower temperature (42.5°C) for longer time periods.

To verify that cholesterol is being removed from the HTC cell plasma mem-

brane, further experiments must be carried out in order to assess the effect of liposomes at the membrane level. This could involve exposing cells to liposomes for various lengths of time followed by isolating the plasma membranes. Then lipid analysis and fluidity measurements of purified plasma membranes, as outlined in chapter 4, would show any consequent change in the cholesterol level and order of the plasma membrane. Although liposomes form one method for removing cholesterol from cell membranes, other methods which involve more complex lipid assemblies (Rothblat *et al.*, 1986) have been used. A potent fluidizing lipid mixture, containing neutral lipids, phosphatidylcholine, and phosphatidylethanolamine, has been shown to operate by extracting cholesterol from the membrane of erythrocytes and lymphocytes (Lyte and Shinitzky, 1985). However, with rat brain synaptic membranes an appreciable incorporation of phosphatidylcholine from the lipid mixture into the synaptic membranes was observed. Despite the fact that the precise mechanism of this lipid mixture in fluidizing membranes may vary between different cell types, it could form a useful method in further experiments to assess if increased membrane fluidity correlates with enhanced thermosensitivity.

Use of the colorimetric assay has the advantage that harvesting cells after liposome (or other) treatment and subsequent reattachment before heating is not necessary. Therefore, with the colorimetric assay, cells can remain attached to the substratum throughout the entire experimental procedure, during which they can be exposed to cholesterol-modifying treatments followed by heating. This is particularly beneficial when dealing with cells that have been treated with 25-hydroxycholesterol or cholesterol hemisuccinate where the treated cells may be fragile. These cells could be easily damaged during the harvesting process and may take a long time to reattach. Therefore, only the colorimetric assay was used

to assess the effects of 25-hydroxycholesterol and cholesterol hemisuccinate on the thermal sensitivity of HTC cells.

25-Hydroxycholesterol has been shown to retard growth in L-cells, primary cultures of foetal liver and hepatoma cells (Kandutsch and Chen 1977); and smooth muscle and endothelial cells (Cox *et al.*, 1988). Similarly, in the present study, the growth of HTC cells was also strongly inhibited by this agent at concentrations used by Kandutsch and Chen (1977). Kandutsch and Chen (1977) found that after exposure of L cells to 1 or 2  $\mu\text{g}/\text{ml}$  25-hydroxycholesterol for 1 or 2 days, cell growth ceases. Lipid analyses of the plasma membranes isolated from cells treated with 1  $\mu\text{g}/\text{ml}$  25-hydroxycholesterol for 36 hours showed that the sterol/phospholipid molar ratio was lower when compared to cells not treated with the inhibitor (reduced from 0.40 to 0.21). Membrane fluidity and thermal sensitivity of the cells were not measured, but there is a possibility that a lower sterol/phospholipid molar ratio after 25-hydroxycholesterol treatment may lead to increased fluidity and increased thermosensitivity. To investigate the interaction of the effects of 25-hydroxycholesterol and heat on HTC cell survival, the dose of 25-hydroxycholesterol must be carefully selected. This is to ensure that, after 25-hydroxycholesterol treatment, a sufficient number of cells remain to allow accurate assessment of the cytotoxic effects of heat treatment. Therefore, a concentration of 25-hydroxycholesterol must be chosen that is sufficiently high to achieve appreciable inhibition of HMG-CoA reductase, but is low enough to permit survival of a substantial number of cells. Exposure of HTC cells to between 1  $\mu\text{g}/\text{ml}$  and 6  $\mu\text{g}/\text{ml}$  of 25-hydroxycholesterol for 48 hours inhibited growth to a point from which the cells barely recovered. However, exposure to between 1  $\mu\text{g}/\text{ml}$  and 4  $\mu\text{g}/\text{ml}$  of 25-hydroxycholesterol for 24 hours inhibited cell growth to a point from which the

cells could recover and continue to grow. Therefore, in experiments where the interaction of the effects of 25-hydroxycholesterol with heat treatment was being investigated, the cells were exposed to  $\leq 2\mu\text{g/ml}$  of 25-hydroxycholesterol for 24 hours prior to heating.

Treatment with 25-hydroxycholesterol (0.0625 to  $2\mu\text{g/ml}$ ) for 24 hours prior to heating at  $43^{\circ}\text{C}$  did not enhance the thermosensitivity of HTC cells (figures 3.16a to e inclusive). The cytotoxic effects of 25-hydroxycholesterol and heat were additive, suggesting that these two agents bring about their effects by independent mechanisms. However, 25-hydroxycholesterol is reported to inhibit HMG-CoA reductase and, as a result, cholesterol levels in the membrane would be expected to decrease, thus increasing membrane fluidity. Increased membrane fluidity is thought to increase thermosensitivity of the cells. There is at least one possibility why increased thermosensitivity was not obtained by prior treatment with 25-hydroxycholesterol in the present study. As the plasma membrane cholesterol and fluidity measurements were not performed, it is possible that 25-hydroxycholesterol did not inhibit HMG-CoA reductase and lower membrane cholesterol in HTC cells, but cell growth inhibition may be due to effects other than inhibition of HMG-CoA reductase. To test this possibility, further experiments need to be carried out to assess the change in plasma membrane cholesterol levels caused by exposure to 25-hydroxycholesterol. This could be carried out by exposing cells to 25-hydroxycholesterol, followed by isolation of the plasma membranes. Lipid analysis and fluidity measurements of the membranes would show the correlation between 25-hydroxycholesterol treatment, cholesterol levels and membrane fluidity of HTC cell plasma membranes.

The discussion this far has concentrated on protocols designed to increase HTC

cell membrane fluidity by removing cholesterol present in the membrane or by increasing the unsaturation level of the acyl groups of the membrane phospholipids. To investigate the effect of lowering the membrane fluidity on the heat sensitivity of HTC cells, cholesterol hemisuccinate was used. This agent partitions into the membrane and increases membrane order. Hence, HTC cells were incubated with up to 100 $\mu$ g/ml cholesterol hemisuccinate prior to heat treatment for 25 minutes or 50 minutes at 43<sup>0</sup>C. The results show that cholesteryl hemisuccinate-modified cells are more sensitive to cell killing by heat (figures 3.17a and 3.17b). Incubation of cells with cholesterol hemisuccinate has been shown to reduce membrane fluidity (Yatvin, 1983b). In order to confirm that a similar decrease in membrane fluidity was achieved in the present study, it would be necessary to isolate plasma membranes from cells exposed to cholesterol hemisuccinate and measure their fluidity.

The enhanced heat sensitivity of cholesteryl hemisuccinate-modified cells contradicts the hypothesis that increased membrane fluidity leads to greater heat sensitivity, while decreased membrane fluidity reduces heat sensitivity. Therefore, the data obtained here provides evidence for the hypothesis that cells maintain an optimal membrane fluidity for growth and any deviation from this may result in enhanced sensitivity to heat. However, this data must be considered in context with the study performed by Yatvin *et al.* (1983b). These workers exposed P-388 tumour cells and V-79 cells to 100 $\mu$ g/ml of cholesterol hemisuccinate for 30 minutes prior to heat treatment for 60 minutes at 43<sup>0</sup>C. Heat sensitivity of P-388 tumour cells was assessed by injecting heated cells (modified or unmodified) into CDF<sub>1</sub> mice and measuring the time taken for the mice to die from the effects of P-388 tumour cells. Therefore, the greater the heat sensitivity of the P-388 tumour cells the longer the mice will survive. Using this assay of heat sensitiv-

ity, cholesterol hemisuccinate treatment enhanced the sensitivity of P-388 tumour cells to heat when compared to untreated cells. However, with the V-79 cells, where cell survival was assessed using the clonogenic assay, there was no difference in thermal sensitivity of cholesteryl hemisuccinate-modified and unmodified cells. In both cell types plasma membrane fluidity, measured using DPH fluorescence polarisation, was decreased in cholesteryl hemisuccinate-modified compared to unmodified cells. Yatvin *et al.* (1983b) also found that treatment with cholesterol hemisuccinate alone resulted in a substantial increase in the proportion of P-388 tumour cells which took up trypan blue, but not in V-79 cells. This suggests that membrane integrity of P-388 tumour cells is altered by addition of cholesterol hemisuccinate. When the results were corrected for these 'dead' cells, the difference in killing between control and cholesteryl hemisuccinate-modified P-388 tumour cells was no longer seen. In the present study, as the colorimetric assay was used to estimate cell survival, cell death caused by cholesterol hemisuccinate alone was accounted for in the control experiments. Therefore, the increase in heat sensitivity observed in this study is real and not apparent. The possible reasons why this enhancement in thermal sensitivity is observed might be explained in terms of membrane function and the cholesterol content of membranes. Sabine (1983) proposed the hypothesis that the relationship between the level of cholesterol in cellular or sub-cellular membrane and the activity of any membrane function affected by cholesterol is ogival in nature, i.e. there is an optimum level of membrane cholesterol at which functional activity is maximal, and above or below this level activity declines. Therefore, incubation of HTC cells with cholesterol hemisuccinate may lead to a membrane environment which is not optimal for membrane function. This may be one reason why cholesteryl hemisuccinate-modified HTC cells are more thermosensitive when compared to unmodified cells.

In summary, the colorimetric and clonogenic assays (characterized in chapter 2) were used in this chapter to estimate cell survival. The optimal conditions for heat treating cells were defined and the response of HTC cells to hyperthermic temperatures was characterized using both assays of cell survival. Having determined the response of HTC cells to heat, various methods were used to alter the membrane lipid composition and the effects of these changes on the heat sensitivity of HTC cells were assessed. There were three methods used which were expected to lower membrane order as a result of a change in the membrane lipid composition: firstly the cells were grown in arachidonic acid in order to increase the unsaturation level of the membrane phospholipid acyl groups; secondly, cells were exposed to liposomes to remove cholesterol from the plasma membrane; and finally, the synthesis of cholesterol was inhibited using 25-hydroxycholesterol, again in order lower membrane cholesterol. The first method was the only one that produced a significant increase in the thermosensitivity of HTC cells compared to control cells, when the clonogenic assay was used to estimate cell survival. There was one method used which was expected to increase membrane order as result of a change in membrane lipid composition: this method involved incubating HTC cells with cholesterol hemisuccinate, a hydrophilic ester, of cholesterol which has been shown to increase membrane order. This approach also significantly increased the thermosensitivity of HTC cells compared to control cells, when the colorimetric assay was used to assay cell survival. Thus, the thermal sensitivity of HTC cells could be enhanced by supplementation with either arachidonate or cholesterol hemisuccinate. In order to clarify whether this enhanced thermal sensitivity was related to changes in plasma membrane structure, it was decided to grow HTC cells in quantity, in order to purify plasma membranes from control and lipid supplemented cells, and to analyse changes in the lipid composition and order of these membranes. Ideally,

this should have been carried out for cells supplemented with arachidonate and for cells supplemented with cholesterol hemisuccinate. However, the cells supplemented with cholesterol hemisuccinate proved to be rather fragile, making them difficult to manipulate, so this together with lack of time and resources, led to the use of cholesterol hemisuccinate being abandoned for this work. Consequently, the work to be reported in the next chapter concentrated on the purification and analysis of plasma membranes derived from HTC cells grown in the presence and absence of arachidonate.

## Chapter IV

### Purification and characterization of plasma membranes from control and arachidonate-supplemented HTC cells

#### 4.1 Introduction

To investigate the effect of lipid supplementation on the structure and properties of the plasma membrane and associated enzymes it is necessary to isolate the plasma membrane.

The foundation of the present day schemes of subcellular fractionation was established by Claude (1946a, 1946b). The techniques for the isolation of plasma membrane have developed since then (de Duve, 1971), and in general depend on the material from which the plasma membranes are to be isolated (Evans, 1982). Erythrocytes, for example, have been the favoured material for membrane studies because the relatively simple ultrastructure allows the easy removal of the cell contents (Dodge *et al.*, 1963) leaving almost unchanged plasma membranes (Nicolson, 1973; Hanahan and Ekholm, 1974). However, isolation of plasma membrane is more difficult from cells with a complex ultrastructure since the cell has to be disrupted (Evans, 1978) and the organelle to be separated from the rest of the cellular debris (Evans, 1982). Plasma membranes, from cells with a complex ultrastructure, were first isolated with some success by Neville (1960) and, since then, plasma membranes have been isolated by many workers from a great variety of tissues (Fleischer and Packer, 1974). The methods developed and perfected in the classical subcellular fractionation of tissues such as liver (Fleischer and Kerv-

ina, 1974) have been adopted and adapted for the isolation of plasma membrane from cultured cells (Lopez-Saura *et al.*, 1978). The main advantage in isolating membranes from cells in culture rather than the freshly extracted tissue is that the cultured cells are composed of a single cell type and therefore will result in the isolation of a homogeneous population of plasma membranes.

In general, subcellular fractionation has two major steps: the homogenisation of the cells; and the subsequent separation of the organelles.

The ideal method of homogenisation should result in the release of all the organelles in suspension as individual elements (Howell *et al.*, 1989). The major drawback to successful fractionation of cells is the difficulty of producing such an ideal homogenate, and the methods used for tissues such as liver often have to be adapted before use with cultured cells. This may be explained by the differential organisation of the cytoskeleton in cultured cells as compared to the corresponding tissue (Franke *et al.*, 1979; Franke *et al.*, 1981), which results in the cytoplasm from cultured cells maintaining some degree of organisation after homogenisation. Organelles can remain associated with the cytoskeletal elements, surrounding the nucleus, and become entrapped in 'clumps' of cytoplasm which readily sediment. As much as 50% of the components of the homogenate may be pelleted along with the nucleus during the initial centrifugation step (Devaney and Howell, 1985). The additional problem of homogenisation of cultured cells, is the application of enough force to rupture the cell but not the nuclei. The nuclei are often large in relation to the cytoplasm and nuclear disruption leads to the formation of a gel which hinders further fractionation of the plasma membrane (Evans, 1982).

Due to the variation of ultrastructure between cell lines there are no stan-

standard homogenisation conditions for cells, consequently these must be optimised for the cell line to be investigated (Howell *et al.*, 1989). In order to achieve this, growth and experimental conditions of the cells must be standardised to obtain reproducible homogenates. For example, cells which have been growing for several days in a confluent state are more difficult to process due to the establishment of a complex network of cytoplasmic filaments (Franke *et al.*, 1981). Also, experimental conditions to which the cells have been subjected prior to homogenisation influences the force required to break the cell. For example, cells brought in to suspension from monolayer growth are more difficult to disrupt than cells scraped from the flask and utilised (Howell *et al.*, 1989).

The ideal homogenisation medium should maintain the structural integrity of the particulate organelles. To this end, isotonic conditions at neutral pH are preferred. However, some cells are very difficult to disrupt in isotonic media and hence are subjected to hypotonic conditions to facilitate disruption at low shear forces. Different homogenisation conditions for HTC cells have been investigated by Sauvage *et al.*, (1981). The procedures carried out were: hypotonic treatment followed by either mild or vigorous homogenisation; stabilization of membranes with  $Zn^{2+}$  and Tween 80 followed by vigorous homogenisation; and homogenisation in 0.25M sucrose/3mM imidazole buffer, pH 7.4. The method to be used for a particular investigation must be dependent on the objectives of the study. For example, if membrane fluidity and enzymes are to be examined, membrane perturbants such as Tween 80 have to be avoided. Homogenisation in isotonic conditions were used in the present study (Manning *et al.*, 1989) in order to preserve membrane and enzyme properties which was the subject of the present investigation.

Having obtained the ideal homogenate, the next step is to separate the partic-

ular groups of membranes and to obtain finally a homogeneous population. The most common separations are those based on centrifugation procedures, but free flow electrophoresis, gel exclusion and affinity chromatography have also been applied to isolate different membrane types (Evans, 1982).

During centrifugation the suspension is subjected to a high artificial gravitational field causing the particles to migrate to the bottom of the centrifuge tube and form a compact pellet. The rate at which individual particles move is determined largely by their size, though shape and density also contribute (Harrison and Lunt, 1980).

Using a combination of increasing gravitational field (g force) and time, it is possible to obtain a series of fractions from the homogenate, each fraction being enriched in particular membrane types (de Duve *et al.*, 1955). After this initial isolation using differential centrifugation it is usual to purify further the isolate using iso-pycnic separation in which particles are centrifuged through a density gradient (Hinton and Dobrota, 1976). The particles migrate to a point along the gradient which matches their own density. Sucrose is widely used to form such gradients but alternatives such as ficoll and percoll have also been used.

The purification of the membranes isolated is determined by measuring the enrichment of markers. A marker has been defined as a cell constituent naturally occurring (enzymes, proteins, RNA, DNA, lipid ) or imposed (iodination, radioactive ligand and antibodies) that is mainly found in one subcellular organelle or in a particular geographical region of that organelle and is retained when that organelle is removed from the normal positional relationships in the intact cell (Morre *et al.*, 1979).

In this study, to obtain the large number of cells required for the isolation of milligram quantities of plasma membranes it was necessary to grow cells in bulk. To achieve this for anchorage-dependent HTC cells, microcarrier bead technology developed by Van Wezel (1967) was employed. The system is based around the attachment and growth of cells on specially designed beads, kept in suspension by gentle stirring. This method of culture clearly lends itself to the production of membranes by the method of Gotlib (1982). The basic principle of this method involves the lysis of cells on the beads followed by washing away the contaminating intracellular contents. The plasma membranes remain attached to the beads and are then removed by washing in a borate buffer. This method of purification was attempted in the present study, but the conditions required in the preparation are harsh (lysis carried out at pH 8.0 and membrane recovery from beads at pH 9.8) and this resulted in the loss of marker enzyme activity.

Using the conventional isolation techniques, membranes have been isolated from many cell types in culture including fibroblasts (Tulkens *et al.*, 1974), HeLa cells (Boone *et al.*, 1969), lymphoid cells of mouse (Koizumi *et al.*, 1981), L1210 leukemia cells, (Tsai *et al.*, 1975) and HTC cells (Lopez-Saura *et al.*, 1978).

These methods rely on homogenisation, partial purification by differential centrifugation, followed by iso-pycnic centrifugation using sucrose to generate the gradients. Recently, however, membranes have been purified from solid tissue or cultured cells using discontinuous or self-forming continuous Percoll gradients (Amende and Donlon, 1985; Chakravarthy *et al.*, 1985; Loten and Redshaw-Loten, 1986; Payrastre *et al.*, 1988). These methods, which can quickly generate relatively pure membranes in high yield, formed the basis of the procedures adopted in this study (Manning *et al.*, 1989).

The purification of the isolated plasma membranes was monitored by the enrichment of marker enzyme activities. However, when using 'abnormal' tumour cells the distribution and activities of some classical markers are different from the corresponding 'normal cells'. Analytical fractionation carried out on HTC cells (Lopez-Saura *et al.*, 1978; Sauvage *et al.*, 1981) has revealed that this cell line does not possess a typical 5' nucleotidase (plasma membrane marker) or glucose 6-phosphatase (endoplasmic reticulum marker) and no alkaline phosphatase (plasma membrane marker) or NAD(P) nucleotidase (plasma membrane marker). The adenylate cyclase system, a marker for plasma membranes, is present but in low amounts (Makman, 1971). Therefore, the best marker for plasma membranes is  $\text{Na}^+ \text{K}^+$  ATPase (Evans, 1982), which is present in this cell line (Karin and Cook, 1986) and this enzyme, together with alkaline phosphodiesterase I was used routinely to assess the purity of the plasma membrane fraction. To ascertain the contamination of the plasma membrane enriched fraction by other membrane types, marker enzymes for lysosomes (N-acetyl  $\beta$  glucosaminidase), mitochondria (succinate dehydrogenase) and endoplasmic reticulum (NADPH cytochrome c reductase) were also assayed.

Work reported in chapter 3 suggested that the thermal sensitivity of HTC cells was not affected by treatment with liposomes or 25-hydroxycholesterol, but could be enhanced by supplementation with arachidonic acid or cholesteryl hemisuccinate. The aim of the work reported in the present chapter was to study any changes in plasma membrane structure and fluidity associated with this enhanced thermal sensitivity. However, during supplementation with cholesteryl hemisuccinate, both control and supplemented cells appeared rather fragile, perhaps due to their exposure to  $\text{Ca}^{2+}$ - and  $\text{Mg}^{2+}$ -free phosphate-buffered saline, so it was consid-

ered unlikely that this treatment would generate sufficient cells to permit plasma membranes characterisation. Consequently, the study was limited to the effect of arachidonic acid supplementation on plasma membrane lipid composition and fluidity.

The major analysis to be carried out on the purified plasma membranes from cells grown in normal media and that supplemented with arachidonic acid was to determine phospholipid fatty acid composition. This approach of altering fatty acid composition has been used by several workers and its effects on many functions of the cell and its membrane related processes have been extensively reviewed (Spector *et al.*, 1981; Stubbs and Smith, 1984; Spector and Yorek, 1985; Rosenthal, 1987). The basic principles of the process of supplementation will therefore be outlined.

The fatty acyl chains of the phospholipids are primarily responsible for conferring the hydrophobic nature of the membrane bilayer which provides cellular and subcellular compartmentalization. The composition of this hydrophobic fatty acyl core depends on environmental conditions, especially the fatty acids available in the growth media for cells in culture. When a free fatty acid nutrient source is available to the cell, *de novo* synthesis is suppressed and fatty acids in the growth media are preferentially incorporated into phospholipids and neutral lipids. This has been demonstrated in HTC cells by Alaniz *et al.* (1975), Wiegand and Wood (1975) and Wood and Falch (1973). The processes involved are schematically presented in figure 4.1. The main facet of the scheme to note is the selective incorporation of arachidonic acid. Chern and Kinsella (1983) examined the concurrent release and reacylation of fatty acids by rat kidney cells. They found that, whereas palmitic, stearic, oleic and linoleic acids competed with each

other for reacylation, arachidonic acid was selectively reincorporated and reacylated. Human skin fibroblasts and bovine aortic endothelial cells have been shown to selectively incorporate arachidonic acid from exogenous fatty acid mixtures. The enzyme arachidonoyl-CoA synthetase is present in a variety of cultured cells including fibroblasts, smooth muscle and endothelial cells but its activity is low or absent in adipocytes and hepatocytes (Laposata *et al.*, 1985). Therefore, selective incorporation of arachidonic acid from physiological fatty acid mixtures may be a common occurrence in cultured cells including HTC cells, but not in all differentiated cells.

The fatty acid nomenclature used in this thesis is summarised in table 4.1. To indicate that a fatty acid has  $n$  carbon atoms with  $x$  double bonds, the shorthand  $n:x$  will be used. Hence oleic acid will be denoted as 18:1. In the following introduction on desaturases the position of the double bond will be assigned by the Delta ( $\Delta$ ) nomenclature. Hence a  $\Delta^9$  denotes a double bond between carbons 9 and 10 relative to the carboxyl carbon of the acyl chains. To designate an individual fatty acid within a family of structurally related fatty acids, the (n-) nomenclature will be used. Thus, 20:4(n-6) indicates that the double bond closest to the methyl end is in the  $\Delta^6$  position, that is, since  $n=20$  and  $n - 6=14$ , it is 6 carbons from the methyl end. This also defines the position of other double bonds in the molecule, since they occur at intervals of 3 carbon atoms, being methylene-interrupted. The *cis* configuration is assumed for all double bonds. Although the fatty acid notation is useful in describing individual fatty acids mentioned in the introduction, the methods used in the analysis of plasma membrane phospholipid fatty acids do not distinguish between positional isomers. Hence in the results and their discussion the notation  $n:x$  ( $n$ =number of carbon atoms and  $x$ =number of

double bonds) will be employed.

The major pathways for desaturation and elongation of the fatty acids in mammalian cells are presented schematically in figure 4.2. These pathways have been studied in HTC cells and have revealed the presence of  $\Delta^9$ ,  $\Delta^6$ ,  $\Delta^5$  and  $\Delta^4$  desaturases. However, the  $\Delta^6$  desaturase activity is high for the substrate  $\alpha$ -linolenate (n-3 family) but low for linoleate (n-6 family). Hence conversion of 18:2(n-6) to 20:4(n-6) is low. Wiegand and Wood (1975) have also shown the synthesis of 18:1(n-7) in HTC cells. It is clear from the work cited above that HTC cells possess the enzymes to perform the conversions shown in figure 4.2.

The characteristics of fatty acids have been reviewed by Stubbs and Smith (1984) and important aspects will be highlighted in context with the present study. Below the phase transition temperature phospholipids containing only fully saturated acyl chains adopt a configuration in which the acyl chain carbons are in extended all-trans conformation. The introduction of even a single double bond is sufficient to exert a profound influence on the physical properties. The potential influence of double bonds can be gauged from the melting points of unesterified fatty acids. The melting points are dependent on the position of the double bond, and the nearer the double bonds to the centre of the chain, the lower the melting point. In some cases the position of the double bond may be a more important influence on melting point than the actual number of double bonds. Thus the melting point ( $-10^{\circ}\text{C}$ ) of  $18:3\Delta^{9,12,15}$  is not markedly different from that of  $18:2\Delta^{9,12}$  but is  $28^{\circ}\text{C}$  lower than that of  $18:2\Delta^{12,15}$ . Similarly, Barton and Gunstone (1975), using phosphatidylcholine synthesised from the complete series of octadecenoic acids, showed that phosphatidylcholine species containing fatty acids with double bonds near the centre of the acyl chain have the lowest phase transition temperature.

The relative importance of the introduction of one or more double bonds has been shown by Coolbear *et al.* (1983). They showed that the insertion of the first double bond into di-18:0-phosphatidylcholine (yielding 18:0/18:1-phosphatidylcholine) lowers the phase transition temperature by nearly 50<sup>0</sup>C and two double bonds (18:0/18:2-phosphatidylcholine) lowers it by a further 22<sup>0</sup>C ; three or four double bonds (18:0/18:3-phosphatidylcholine or 18:0/20:4-phosphatidylcholine) bring about no further decrease and infact cause a slight increase in the phase transition temperature. Hence the introduction of each successive double bond has less effect. Chapman, (1982) have shown a marked decrease in the order of the fatty acyl chains as phospholipids entered the liquid crystalline phase. The term 'order' as applied to fatty acyl chains implies a restriction on mobility and forms the basis for the interpretation of certain aspects of membrane fluidity which will be described later in this section. As pointed out by Barton and Gunstone (1975), a double bond within a fatty acyl group of a membrane phospholipid 'destroys the cooperativity of the lattice interactions across its plane of the bilayer'. Besides lowering the phase transition temperature it also has considerable effects on the motional properties of the hydrocarbon chains. The effect of changes in fatty acid composition in model membranes are relatively simple to ascertain when compared to the complexity of biological membranes. A significant feature of phospholipids occurring in biological membranes is the non-random distribution of saturated and unsaturated fatty acids between the *sn-1* and *sn-2* positions. The unsaturated fatty acid is predominantly found at the *sn-2* position. This clearly leads to heterogeneity within phospholipid classes with respect to fatty acids present in *sn-1* and *sn-2* position, which will influence the physical properties of the phospholipid.

Changes in the phospholipid fatty acid composition will clearly influence mem-

brane properties. In relation to membrane order, an increase in the proportion of unsaturated fatty acids and, therefore, an increase in the disruptive influence of the double bond in the membrane phospholipid should lead to decreased order. A good chemical marker for the measurement of this change is the unsaturation index. This gives a better indication of the change that has been achieved than does the change in the level of the particular fatty acid used for substitution because it relates to the average number of double bonds per molecule. However, membrane order and fatty acid unsaturation cannot be related in such a simple direct manner when considering biological membranes. Components directly affecting the physical properties of the phospholipid acyl chains in biological membranes are the degree of unsaturation and of chain length but the behaviour of the acyl chains is also influenced by other components of the membrane such as cholesterol, proteins and phospholipid head groups. The interactions of phospholipid head groups, particularly phosphatidylethanolamine, are known to restrict movement of acyl chains (see Stubbs and Smith, 1984). This was verified by Gilmore *et al.*, (1979a, b) who found that growth of LM cells in ethanolamine-supplemented media caused an increase in plasma membrane phosphatidylethanolamine and a reduction in phosphatidylcholines. This change in plasma membrane head group composition correlated with an increase in membrane order measured by fluorescence polarisation using 1,6-diphenyl-1,3,5-hexatriene as the probe. However, the supplementation procedure also caused an increase in plasma membrane sphingomyelin and phosphatidylethanolamine, the former of which is also known to stabilize membranes (Borochoy *et al.*, 1977). The molecular interactions of cholesterol with phospholipids have been discussed in chapter 3 and it is sufficient to mention here that cholesterol increases the efficiency of packing of phospholipids above the phase transition temperature. Therefore, the higher the cholesterol to phospholipid mo-

lar ratio, the more ordered the membrane at physiological temperatures. Also, the presence in most phospholipids of an unsaturated acyl chain containing at least one *cis* double bond in the *sn-2* position helps accommodate the sterol molecule in the bilayer.

The influence of membrane proteins on the motions of the acyl chain are difficult to assess but it is likely that proteins will interact with lipids that are in close proximity and not exert a general effect on all the membrane lipids (see chapter 5).

There are now a number of different techniques available to investigate the physical state of the phospholipid fatty acyl chains which make up the hydrophobic core of the membrane. These include electron spin resonance (ESR), nuclear magnetic resonance (NMR), and various fluorescence polarization techniques of which steady state fluorescence polarization is the most popular (Lee, 1982). These techniques have been reviewed recently and their relative merits in determining membrane 'fluidity' discussed in some detail (Stubbs, 1983). Although all these approaches are said to measure 'fluidity', this is at best an ill-defined term, as the techniques mentioned above often measure very different physical interactions (Stubbs and Smith, 1984). Membrane 'fluidity', as suggested by Stubbs and Smith (1984), has been defined in the present study as referring to the physical state of the fatty acyl chains of the membrane bilayer. This definition could describe either the range or rate of motion of the acyl chains. The information obtained by the techniques mentioned above may therefore consist of either a rate or range component or even both. The major portion of the information obtained from steady state fluorescence polarization, the technique used in the current study, is from the 'range' of the lipid motion. Therefore, the technique principally monitors lipid order or packing (Pottel *et al.*, 1983).

The principle of steady state fluorescence polarization is the insertion of a hydrophobic fluorescent dye deep into the core of the membrane bilayer. The dye molecules are introduced into the lipid matrix of the membrane and, when excited by polarized light, they emit fluorescence that is polarized parallel to the excitation light. The extent of movement during the nanoseconds of the excited state determines the proportion of light which is depolarized on fluorescence. In the most extreme case (which would not occur in the constraining structure of the membrane bilayer) all the light will be depolarized.

The most commonly used probe molecule is 1,6-diphenyl-1,3,5-hexatriene (DPH), which has a number of advantages over other fluorescent probes. For example, it only fluoresces when it is in the hydrophobic core of the membrane, and not in the surrounding aqueous environment; it has a high extinction coefficient and an absorption maximum at 355nm, well removed from tryptophan fluorescence. One disadvantage is that it undergoes photo-isomerization, and so exposure to excitation light should only occur just before a measurement is to be taken (Lee, 1982).

It has now been shown that lipid domains of varying order exist within many plasma membranes (Schroeder, 1983). The polarization value obtained from such membranes will be a weighted average of these different regions, and will not reflect the state of any given region in the membrane. Therefore, the main use of this technique is in determining any bulk changes in the hydrophobic core of membranes.

The monitoring of membrane fluidity after alteration of fatty acyl composition by culture of cells in fatty acid supplemented media, has been carried out by many

workers in intact cells or crude membrane preparations but relatively few have investigated purified plasma membrane preparations. However, several investigations have shown that the examination of whole cells by ESR and fluorescent probes can yield misleading results if there is lipid accumulation in the cytoplasm, which is the case for the cells used in this study (see chapter 3). For example, supplementation of lymphocytes with linoleate gave a large decrease in the fluorescence polarization of DPH-labelled intact cells which was found to be due entirely to DPH located in triacylglycerol droplets in the cytoplasm (Stubbs, 1980). Hence, to avoid such artifacts, isolation of membranes is necessary. However, fluidity measurements on crude membrane preparations will produce information which will be an average of all the membrane types present. This clearly will not reflect plasma membrane fluidity, as the extent to which other subcellular membranes are modified by supplemental fatty acids may vary (Burns *et al.*, 1988) and the homeostatic mechanisms that maintain 'optimal fluidity' may act differentially between membrane types. For example, Storch and Schachter (1984) altered the fatty acid composition of liver membranes by starving albino male rats for 2 days; then feeding chow ad libitum for 2 days; starving again for 2 days; and finally refeeding with a fat-free diet for 1 day. They found that this increased the proportion of monoenoic and polyenoic acyl chains in the phospholipids, but lowered the cholesterol/phospholipid molar\_ratio, of liver plasma membranes isolated from these rats compared those isolated from rats fed the normal chow diet. This change resulted in a significant increase in lipid fluidity of the plasma membranes as assessed by steady state fluorescence polarization of DPH, 12-(-9 anthroyloxy) stearate and the intramolecular excimer fluorescence of 1,3-di(1-pyrenyl)propane. However, the dietary regimen used also increased the proportion of monoenoic acyl chains in the phospholipid of microsomal membranes, but with a compensatory decrease in the proportion

of polyenoic acids, and there was no change in the cholesterol/phospholipid molar ratio of microsomal membranes. Correspondingly, the lipid fluidity of microsomal membranes remained almost unchanged. This clearly states the case for the need to purify plasma membranes in order to safely evaluate the changes in fluidity after modification of phospholipid acyl group composition.

The activities of various membrane-bound enzymes may be altered by changes in the fatty acid composition of the membrane. The changes in activities of membrane-bound enzymes associated with fatty acid modification have been reviewed (Stubbs and Smith, 1984; Spector and Yorek, 1985). The precise mechanism by which fatty acid modifications affect the activity of these enzymes is not clear but positive correlation with unsaturation have been shown for *A. Laidlawii* Mg<sup>2+</sup>-ATPase, and in mammalian systems in studies showing differences in the activity of Mg<sup>2+</sup>-ATPase when reconstituted with various lipids. The situation is further complicated by the fact that the activities of Mg<sup>2+</sup>-ATPase and Ca<sup>2+</sup>-ATPase are sensitive to chain length of the membrane phospholipid. *In vivo* dietary modification studies have also shown that enzyme activity can be modulated by changes in the fatty acid composition of membrane phospholipids. The changes in the lipid environment of the enzyme could also bring about subtle changes in the kinetics ( $V_{max}$ ,  $K_m$ ) of the enzyme catalysed reaction.

There are two aims of the current chapter: firstly, to develop a method to obtain plasma membranes in relatively high yield and purity from HTC cells grown in arachidonic acid-supplemented and normal culture media; secondly, to analyse the phospholipid acyl chain composition of the plasma membranes and relate it to plasma membrane fluidity.

**Figure 4.1 — Schematic representation of major pathways for incorporation and turnover of long chain fatty acids in mammalian cells**

Modified from Rosenthal (1987). The scheme depicts two enzymes which convert free fatty acids to their corresponding CoA esters: acyl-CoA synthetase which activates all long chain fatty acids, and arachidonoyl-CoA synthetase, which is specific for arachidonic acid and a few structurally similar long chain polyunsaturated fatty acids. It should be noted that the cellular phospholipids are heterogeneous with respect to polar head groups and fatty acid composition. Remodelling of phospholipids with consequent modification of their fatty acyl composition can be accomplished either through phospholipase-catalysed deacylation and subsequent reacylation as catalysed by acyl transferases, or by the action of transacylases which catalyze the direct, CoA-independent transfer of acyl groups between phospholipids.

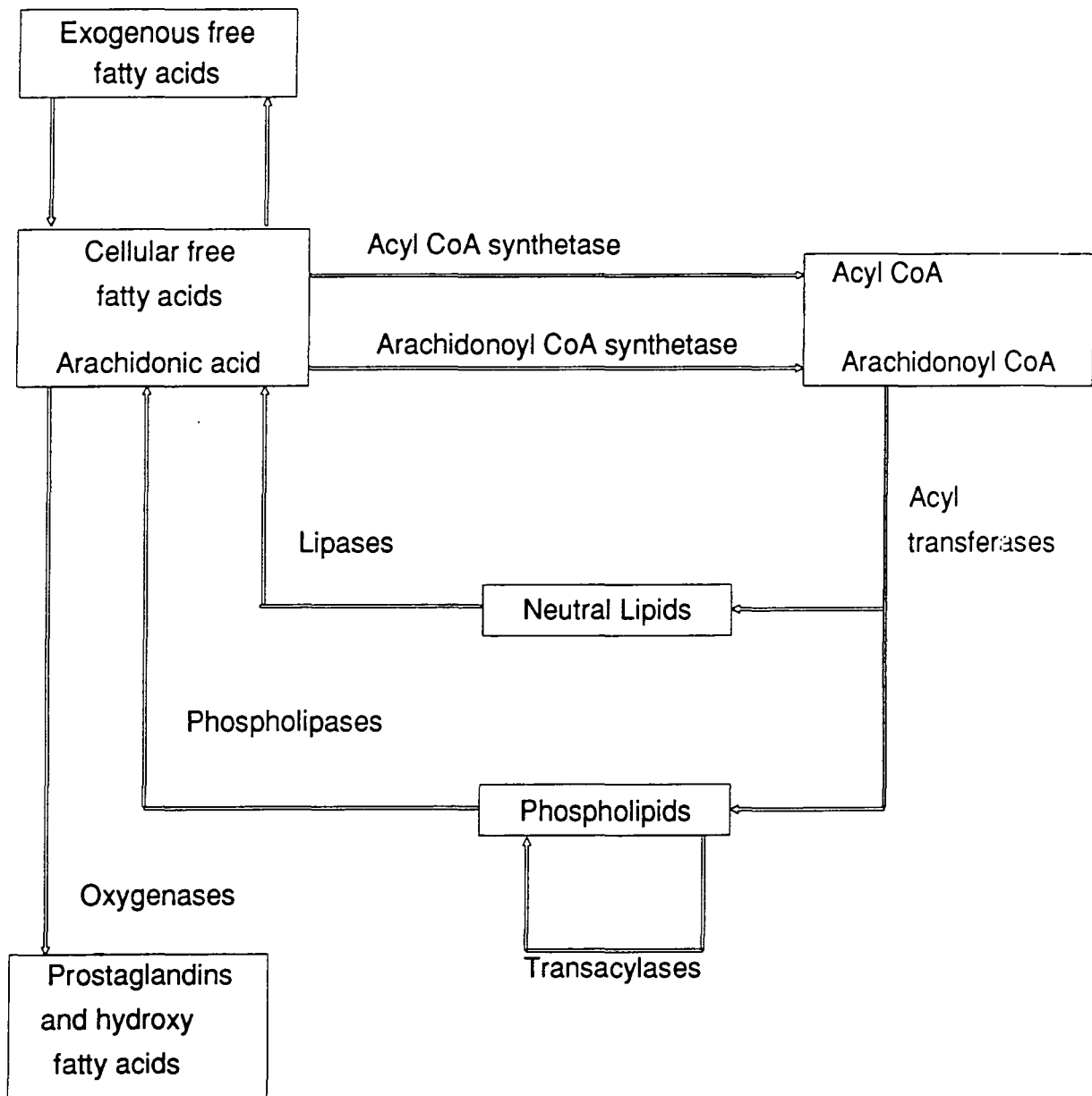
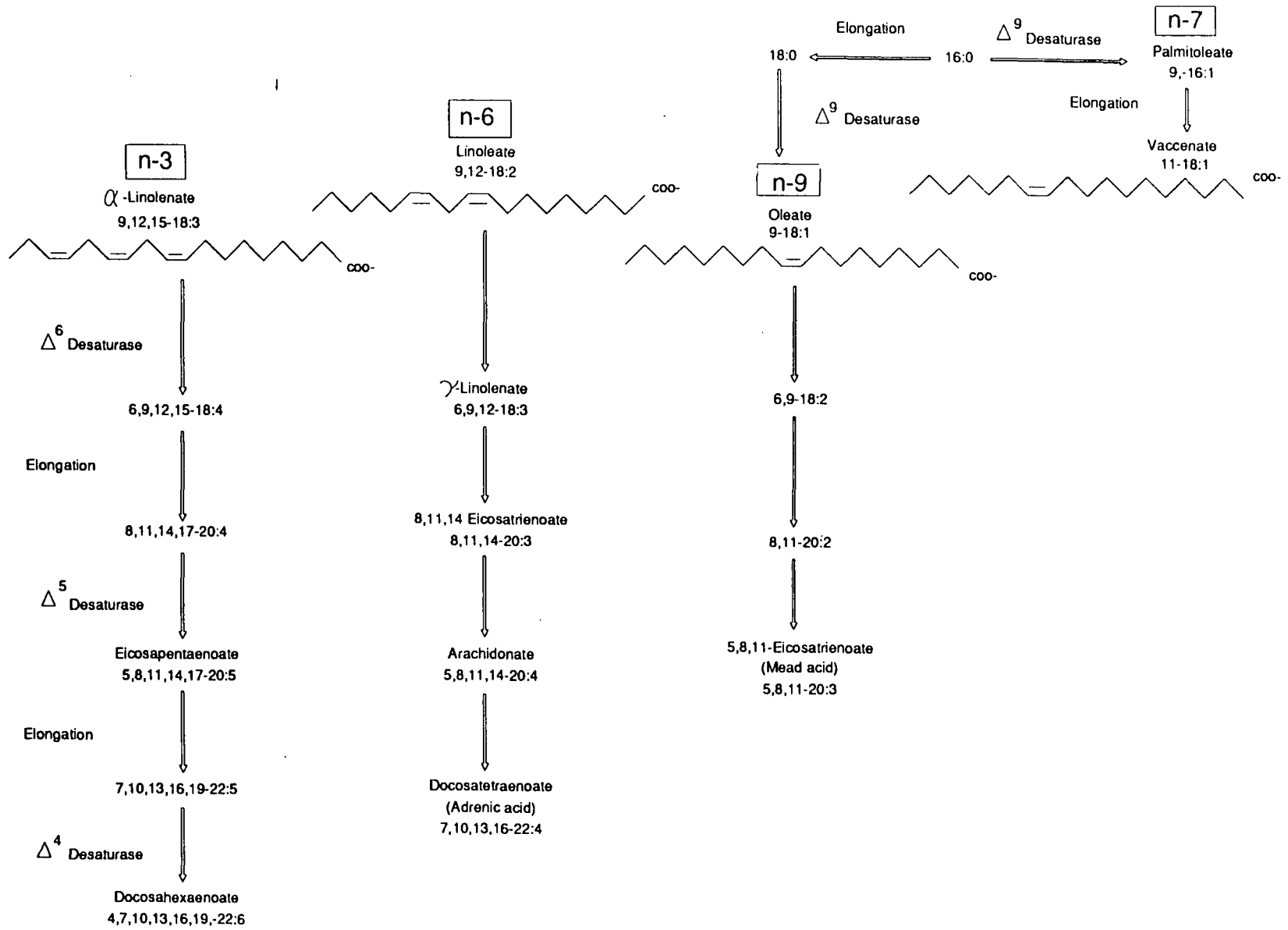

**Table 4.1 — Summary of fatty acid nomenclature**

Common name	Systematic name	Abbreviation	Bond positions
Palmitic acid	n-hexadecanoic acid	16:0	
Palmitoleic acid	n-9-hexadecenoic acid	16:1(n-7)	$\Delta^9$
	n-6-hexadecenoic acid	16:1(n-10)	$\Delta^6$
Stearic acid	n-Octadecanoic acid	18:0	
Oleic acid	n-9-Octadecenoic acid	18:1(n-9)	$\Delta^9$
Vaccenic acid	n-11-Octadecenoic acid	18:1(n-7)	$\Delta^{11}$
Petroselenic acid	n-6-Octadecenoic acid	18:1(n-12)	$\Delta^6$
Linoleic acid	n-9,12-Octadecadienoic acid	18:2(n-6)	$\Delta^{9,12}$
$\alpha$ -Linolenic acid	n-9,12,15-Octadecadienoic acid	18:3(n-3)	$\Delta^{9,12,15}$
$\gamma$ -Linolenic acid	n-6,9,12-Octadecadienoic acid	18:3(n-6)	$\Delta^{6,9,12}$
Arachidic acid	n-eicosanoic acid	20:0	
Gadoleic acid	n-9-eicosanoic acid	20:1(n-11)	$\Delta^9$
Gondoic acid	n-11-eicosanoic acid	20:1(n-9)	$\Delta^{11}$
Dihomo- $\gamma$ -linolenic acid	n-8,11,14-eicosatrienoic acid	20:3(n-6)	$\Delta^{8,11,14}$
Mead acid	n-5,8,11-eicosatrienoic acid	20:3(n-9)	$\Delta^{5,8,11}$
Arachidonic acid	n-5,8,11,14-eicosatetraenoic acid	20:4(n-6)	$\Delta^{5,8,11,14}$
Timnodonic acid	n-5,8,11,14,17-eicosapentaenoic acid	20:5(n-3)	$\Delta^{5,8,11,14,17}$
Behenic acid	n-docosanoic acid	22:0	
Cetoleic acid	n-11-docosenoic acid	22:1(n-11)	$\Delta^{11}$
Erucic acid	n-13-docosenoic acid	22:1(n-9)	$\Delta^{13}$
Adrenic acid	n-7,10,13,16-docosatetraenoic acid	22:4(n-6)	$\Delta^{7,10,13,16}$
Docosapentaenoic acid	n-4,7,10,13,16-docosapentaenoic acid	22:5(n-6)	$\Delta^{4,7,10,13,16}$
Clupanodonic acid	n-7,10,13,16,19-docosapentaenoic acid	22:5(n-3)	$\Delta^{7,10,13,16,19}$
Cervonic acid	n-4,7,10,13,16,19-docosahexaenoic acid	22:6(n-3)	$\Delta^{4,7,10,13,16,19}$
Lignoceric acid	n-tetracosanoic acid	24:0	
Nervonic acid	n-15-tetracosenoic acid	24:1(n-9)	$\Delta^{15}$

**Figure 4.2 — Major pathways for desaturation and elongation of the polyunsaturated fatty acids in mammalian cells**

Adapted from Rosenthal (1987)



## 4.2 Methods

### 4.2.1 Isolation of plasma membranes

The scale up of cell production, to facilitate the isolation of milligram quantities of plasma membranes was achieved by microcarrier cell culture technology. The cells were grown in monolayer on microcarrier beads (plate 4.1), maintained in suspension by the microcarrier stirring mechanism. The glass culture vessels (Techne flasks, 1 litre capacity) were maintained at 37<sup>0</sup>C (±0.1<sup>0</sup>C) by a water bath positioned over the stirrer. The culture of HTC cells on microcarrier beads was developed from the methods given in the book entitled 'Microcarrier Culture: Principles and Methods' (published by Pharmacia Fine Chemicals). The procedure used was as follows: 1.5g of dry cytodex 2 microcarrier beads per Techne flask were hydrated in 75ml of Ca<sup>2+</sup>-and Mg<sup>2+</sup>-free phosphate-buffered saline (PBS) for a minimum of three hours at room temperature. The supernatant was decanted and the microcarrier beads washed twice with 50ml of fresh Ca<sup>2+</sup>-and Mg<sup>2+</sup>-free phosphate-buffered saline.

The microcarrier beads were sterilised by autoclaving at 120<sup>0</sup>C and 15psi for 20 minutes. After cooling, the supernatant was discarded and the beads rinsed once with 50ml of warm growth medium, then suspended in 150ml of growth medium at 37<sup>0</sup>C and transferred to a siliconised sterile Techne flask. The flask was placed in an humidified air/CO<sub>2</sub> (19:1 v/v) incubator at 37<sup>0</sup>C for 15 to 30 minutes such that the medium inside the flask would warm to 37<sup>0</sup>C and equilibrate with the air/CO<sub>2</sub> atmosphere(gassing procedure).

Cells from conventional flask culture were harvested and 40 x 10<sup>6</sup> cells inoculated into each Techne flask, which was gassed a further 10 minutes, sealed and

transferred to the 37<sup>0</sup>C bath of the microcarrier stirrer system. Continuous stirring was commenced at 20rpm for 3 hours. After this time a further 100ml of growth medium was added and the flasks were gassed again for 10 to 15 minutes. The Techne flasks were then returned to the stirrer system and stirring was increased to 30rpm. On the following day the microcarrier culture volume was made up to 500ml with growth medium and gassed for 15 minutes, then returned to culture on the stirrer system at 37<sup>0</sup>C.

The cells were allowed to grow on the microcarrier beads for five to six days before use in the plasma membrane isolation. On each day the cells were gassed for 15 to 30 minutes and 100ml of the supernatant was replaced with fresh growth medium. The growth of the cells was estimated daily by examining, under an Olympus CK inverted light microscope, the cell coverage of a sample of microcarrier beads.

The culture medium was decanted and the beads were washed three times with 10mM Tris-HCl, pH 7.4, containing 150mM NaCl at 4<sup>0</sup>C. The cells were detached by incubation of the beads in the same buffer containing 2mM EDTA, with continuous stirring at 37<sup>0</sup>C for 15 minutes. Cell detachment was facilitated by repeated aspiration of the suspension with a 50ml syringe during the last 3 minutes of this incubation. Beads were allowed to settle, then the supernatant was filtered through nylon mesh (80µmetre pore size) and retained. The cell detachment procedure was repeated twice more and the supernatants combined.

Plasma membranes were isolated by a modification of the method of Loten and Redshaw-Loten (1986). Approximately  $8 \times 10^8$  cells were isolated by centrifugation of the supernatants, then homogenised in 12ml of ice-cold 0.25M Sucrose containing

10mM Tris-HCl, pH 7.4 (ST buffer), using 30 up-and-down strokes of the tight-fitting (A) pestle of an all glass Dounce homogeniser. After centrifugation at 250g for 6 minutes at 4<sup>0</sup>C the supernatant was retained and the cell pellet was homogenised and centrifuged twice more, then the supernatants were combined and centrifuged at 15,000g ( $r_{av}$ =8.26cm) for 20 minutes at 4<sup>0</sup>C. The supernatant was discarded and the pellet was then washed by gently resuspending it in 35ml of ST-buffer using 3 to 4 up-and-down strokes of the loose-fitting pestle (B) of a Dounce homogeniser, then repeating the spin at 15,000g. The supernatant was discarded and the pellet was resuspended in ST buffer, then made up to 56ml with this buffer. After adding 7ml of Percoll, 0.84ml of 100mM CaCl<sub>2</sub> and 1ml of 2M Sucrose, the mixture was centrifuged at 45,000g ( $r_{av}$ =12.3cm) for 30 minutes at 4<sup>0</sup>C (Loten and Redshaw-Loten, 1986). The discrete band, enriched with plasma membranes, near the top of the gradient was collected, diluted to 40ml with ST buffer then membranes were collected by centrifugation at 100,00g ( $r_{av}$ =7.7cm) for 30 minutes at 4<sup>0</sup>C. See figure 4.3 for the purification scheme.

Purity and recovery of the plasma membranes was assessed by measuring activities of marker enzymes.

#### 4.2.2 Assay of Na<sup>+</sup>, K<sup>+</sup>-ATPase (EC 3.6.1.3) and Mg<sup>2+</sup>-ATPase (EC 3.6.1.4)

The assay was carried out at 37<sup>0</sup>C in a final volume of 1ml. The activity was determined by measuring the ouabain-inhibitable enzyme release of inorganic phosphate from ATP. The following reaction conditions were used (final concentrations): 10mM K<sup>+</sup>; 3mM Mg<sup>2+</sup>; 100mM Na<sup>+</sup>; 20mM imidazole buffer, pH 7.2; 3mM ATP (sodium free); with and without 1mM ouabain. The activity determined in the presence of ouabain was attributed to Mg<sup>2+</sup>-ATPase. After preincu-

bation of this reaction media the assay was started by the addition of membrane suspension. The reaction was stopped, after 15 minutes, by the addition of 2ml of freshly prepared ice cold chromogenic reagent containing 22.5%(v/v) H<sub>2</sub>SO<sub>4</sub>, 0.5% (w/v) ammonium molybdate and 0.5% (w/v) lubrol. The tubes were mixed and allow 10 minutes at room temperature for the colour to develop. The reagent reacts quantitatively with released inorganic phosphate, forming a coloured complex which was read at 390nm (Atkinson *et al.*, 1973). A standard curve covering the range 0 to 1.2 $\mu$ moles of inorganic phosphorus was constructed using Na<sub>2</sub>HPO<sub>4</sub>.

#### **4.2.3 Assay of Alkaline phosphodiesterase I (EC 3.1.4.1)**

The enzyme activity was determined by the method based on that of Beaufay *et al.* (1974). The reaction mixture contained the following (final concentration): 100mM MgCl<sub>2</sub>; 4mM zinc acetate; 1mM *p*-nitrophenyl-thymidine 5'-phosphate; and 50mM glycine-NaOH buffer, pH 10.2. After preincubation at 37<sup>0</sup>C, the reaction was started by adding 0.15ml of membrane suspension pretreated with 0.1%(v/v) triton X100 on ice for 10 minutes. The final assay volume was 0.75ml. After 30 minutes incubation at 37<sup>0</sup>C the reaction was terminated by the addition of 0.75ml of 0.2M NaOH and the tubes placed on ice. The tubes were centrifuged at 900g for 5 minutes at 4<sup>0</sup>C. The supernatant was carefully pipetted into a cuvette and the absorbance measured at 400nm. The concentration of the *p*-nitrophenol produced was determined using its molar extinction coefficient of 18300 at 400nm.

#### **4.2.4 Assay of N-acetyl $\beta$ -glucosaminidase (EC 3.2.1.30)**

The enzyme assay was based on the method of Sellinger *et al.* (1960). The assay contained the following (final concentration): 0.1M sodium citrate buffer, pH 4.0; 0.1%(v/v) triton X 100; and 6mM *p*-nitrophenyl-2-acetamido 2-deoxy- $\beta$ -D-

glucopyranoside. After preincubation at 37<sup>0</sup>C the reaction was started by addition of 0.1ml of membranes which had been pretreated with 0.1%(v/v) triton X100 on ice for 10 minutes. The final assay volume was 1ml. After a further 30 minutes at 37<sup>0</sup>C, the reaction was stopped by addition of 0.1ml 10% (w/v) TCA, mixed on a vortex mixer and placed on ice. The mixture was centrifuged at 13,000rpm for 10 minutes at room temperature. To 0.8ml of the supernatant was added 0.3ml of 0.5M NaOH and 0.5ml of 0.25M glycine-NaOH buffer, pH 10.0, to shift the pH of the solution such that the colour of the  $\rho$ -nitrophenol produced would develop. The intensity of the resultant colour was determined at 400nm on a Pye Unicam SP8-100 spectrophotometer using water as a blank. The concentration of  $\rho$ -nitrophenol was calculated using its molar extinction coefficient of 18300 at 400nm.

#### 4.2.5 Assay of NADPH cytochrome c reductase (EC 1.6.2.3)

This assay was based on the method described by Tsai *et al.* (1975). The assay was performed at 37<sup>0</sup>C by measuring the rate of reduction of cytochrome c in a final assay volume of 1.15ml. The membrane suspension was treated with 0.1%(v/v) triton X100 for 10 minutes, on ice, prior to assay. The final composition of the assay was as follows: 78.3mM sodium phosphate buffer, pH 7.4; 0.087% (w/v) cytochrome c; 0.087mM NADPH; and 1%(w/v) triton X100. The membrane suspension was added to duplicate cuvettes containing the phosphate buffer, cytochrome c and triton X100. The reaction was initiated by the addition of NADPH in one cuvette, in the other the same volume of distilled water was added and this acted as a blank. The cuvettes were read immediately against each other and the rate of increase of absorbance of the cytochrome c was measured in a Pye Unicam SP8-100 dual-beam spectrophotometer at 550nm. The initial rate

of cytochrome c reduction was determined from its molar extinction coefficient of 29705 at 550nm.

#### **4.2.6 Assay of Succinate dehydrogenase (EC 1.3.99.1)**

Succinate dehydrogenase activity was determined using the method of Tsai *et al.* (1975). The assay was performed at 37°C in a final volume of 0.875ml containing: 13.7mM sodium phosphate buffer, pH 7.0; 0.057% (w/v) cytochrome c; 0.057% (w/v) BSA; 2.29mM KCN; and 11.43mM succinate. The membrane suspension was added to duplicate cuvettes containing the phosphate buffer, BSA and cytochrome c. The cuvettes were thoroughly mixed and read against each other to form a zero value. When a stable line was achieved, KCN was added to the reference cuvette, and the same volume of KCN containing succinate, was added to the other. The rate of increase in absorbance of cytochrome c at 550nm was measured immediately and followed for several minutes in a dual-beam SP8-100 spectrophotometer. The initial rate of cytochrome c reduction was determined from its molar extinction coefficient of 29705 at 550nm.

#### **4.2.7 Assay of Adenylate cyclase (EC 4.6.1.1)**

Adenylate cyclase was assayed as described in chapter 5, section 5.2.6.

#### **4.2.8 Protein estimation**

Protein was estimated using the method of Bradford (1976). To 100 $\mu$ l of suitably diluted standard BSA solutions and unknown samples was added 10 $\mu$ l of 1.1M NaOH and the mixture was left leave for 10 minutes at room temperature. After this period, 1ml of diluted dye reagent was added and left for 10 minutes at room temperature before measuring the absorbance of the solutions at 595nm.

The dye reagent was prepared by dissolving 100mg of Coomassie blue (G form) in 50ml of 95% (w/v) ethanol. The resultant solution was filtered (through Whatman number 1 filter paper) and 100ml of 85% (w/v) orthophosphoric acid was added to the filtrate, which was then made up to 1000ml with distilled water. This formed the concentrated dye reagent, of which 1 vol. was diluted with 3 vol. of distilled water before use in the assay. A standard curve from 0 to 20 $\mu$ g of BSA was constructed and used to estimate the protein in the test samples.

#### 4.2.9 Lipid extraction procedure

Lipids were extracted from serum, supplemented serum and membrane samples by the rapid method described by Bligh and Dyer (1959). One volume of sample (serum samples were diluted 1.5-fold) was mixed thoroughly with 3.75 volumes of chloroform/methanol (1:2,v/v) and left for 10 minutes at room temperature. Subsequent additions of 1.25 volumes chloroform and 1.25 volumes distilled water were each followed by thorough mixing and, following low-speed centrifugation, the bottom phase was removed and used for lipid assay procedures and thin-layer chromatography. In the production of these lipid extracts all organic solvents contained 0.005% (w/v) BHT.

#### 4.2.10 Assay of phospholipid

Phospholipid estimations were carried out by a variation of the method of Raheja *et al.* (1973), described below.

The following reagents were prepared:

Reagent A: 8g of ammonium molybdate was dissolved in 60ml of distilled water.

Reagent B: 5ml of redistilled mercury was added to a mixture of 20ml of concentrated HCl and 40ml of reagent A. The mixture was stirred on a magnetic stirrer for 45 minutes and filtered. A red-brown filtrate was formed.

The subsequent operations were carried out carefully, with stirring in an ice bath, to prevent denaturation of the reagents by boiling. This was done in a fume cupboard.

Reagent C: To 20ml of reagent A was added 100ml of concentrated H<sub>2</sub>SO<sub>4</sub> to produce reagent C.

The final chromogenic reagent was prepared by very carefully adding reagent C, with stirring, to reagent B, forming a dark green solution. If the solution turned dark blue, the reagents had been denatured during preparation. To the dark green solution (25 vol.) was added methanol (45 vol.) followed by chloroform (5 vol.) and finally distilled water (20 vol.). The resultant green chromogenic reagent was stored at 0-4°C and had a shelf-life in excess of 6 months.

The phospholipid assay was performed as follows. Aliquots of lipid extract, in duplicate, were evaporated to dryness under a stream of nitrogen in thick-walled glass tubes. Duplicate blank and standard assays were included. Chloroform (0.4ml) and chromogenic reagent (0.2ml) were added and the contents mixed. Each tube was heated in a boiling water bath for exactly 3 minutes, then cooled and 1.5ml of chloroform added. The contents were mixed thoroughly and centrifuged at low speed for 5 minutes at room temperature. The absorbance of the lower layer was measured at 716nm. A standard curve was prepared using dipalmitoyl phosphatidylcholine dissolved in chloroform, covering the range 0-0.3μmoles lipid phosphorus.

#### **4.2.11 Assay of unesterified Cholesterol**

Unesterified cholesterol was enzymatically assayed using the BDH Choloxidate No.1 kit. In this method cholesterol esters are hydrolysed by a cholesterol ester hydrolase of broad specificity to produce free cholesterol. This is simultaneously oxidised by the cholesterol oxidase to produce hydrogen peroxide which is determined by a peroxidase linked chromogen system of phenol/4-aminophenazone. Therefore, to determine the unesterified cholesterol concentration only, the cholesterol ester hydrolase was omitted from the reconstituted buffered enzyme solution. The assay was designed for use with blood serum, and so was adapted to deal with membrane derived cholesterol as described by Johnson, (1979).

Appropriate volumes of lipid extract or cholesterol standards were placed in clean conical glass tubes and evaporated to dryness under a stream of nitrogen. The lipids were redissolved in 20 $\mu$ l of isopropanol. After preincubation for 5 minutes at 37<sup>0</sup>C, 0.2ml of the reconstituted buffered enzyme solution was added and the tubes incubated for 10 minutes at 37<sup>0</sup>C. The intensity of the pink colour which formed was measured at 500nm on a Pye Unicam SP8-100 spectrophotometer, in glass cuvettes with 5mm path length.

#### **4.2.12 Isolation of serum free fatty acids and total membrane phospholipid**

Thin-layer chromatography (TLC) was used to isolate the free fatty acid component in the lipid extracts of serum and the phospholipid component in lipid extracts of plasma membranes. To achieve, this TLC plates were prepared as follows. A slurry of silica gel 60 H (0.5mm thick) was applied to clean glass plates (20cm x 20cm). Plates were air dried and then activated in an oven at 100 to 110<sup>0</sup>C for at least one hour prior to use. Lipid extracts from membrane and serum

samples were evaporated to dryness under nitrogen, dissolved in a small volume of chloroform, and aliquots (40 - 50  $\mu$ l) applied as 2cm streaks to activated plates of silica gel 60 H. Lipid standards were run on the same plates. All solvent systems contained 0.005% (w/v) BHT, to minimise oxidation of lipids.

Thin-layer chromatographic separation of free fatty acids from other neutral lipids in serum was carried out using a solvent system of light petroleum (b.p. 40<sup>0</sup> - 60<sup>0</sup>C)/diethyl ether/acetic acid (60:40:1, by vol.). Oleic acid was used as the standard.

Separation of total membrane-associated phospholipid was carried as described below. The plates were first developed in chloroform and, after drying, developed in the same direction in a second solvent system containing methanol/chloroform (9:1, v/v). Sphingomyelin and phosphatidylcholine were run as standards.

After development and drying, standards were visualised by exposure of the appropriate portion of each plate to iodine vapour. Silica gel was scraped off the non-exposed portions of the plates from those areas corresponding to the position of the standards. Scraped plates were later fully exposed to iodine vapour to check that the correct areas had been scraped. The scrapings were collected into small bijou bottles and methyl esters of the fatty acids prepared for gas liquid chromatography (GLC) analysis.

#### **4.2.13 Preparation of fatty acid methyl esters**

Fatty acid methyl esters were prepared by a modification of the method of Morrison and Smith (1964). For phospholipid and free fatty acid samples, sufficient boron trifluoride (14%, w/v) in methanol (approx. 0.3ml) was added to the bijou

bottles to wet the silica gel samples. The bijoux bottles were then flushed with nitrogen, sealed tightly with screw caps containing inert 'tuf-bond' teflon seals and heated at 100<sup>0</sup>C for 15 minutes. After cooling, the bottles were opened and 1ml of n-hexane was added and mixed thoroughly with the sample in order to extract the fatty acid methyl esters. The silica gel was allowed to settle before collecting the top hexane layer and removing any residual silica gel by filtering each extract through glass wool-plugged pasteur pipettes. The extraction was repeated once and all the filtrates were combined in a glass ampoule then evaporated to dryness under a stream of nitrogen. The 'neck' of the ampoule was then sealed in a hot flame, such that the samples were stored under an atmosphere of nitrogen. The ampoules were then covered with aluminium foil and stored in the dark at -20<sup>0</sup>C overnight. When the samples were required the ampoules were opened and the dried methyl esters redissolved in an appropriate volume (10–15 $\mu$ l) of n-hexane before injecting an aliquot onto the GLC column.

#### **4.2.14 Gas-liquid chromatography of fatty acid methyl esters**

Separation of fatty acid methyl esters was carried out using a Shimadzu GC-9A Series gas chromatograph. The glass columns used were 2.0m long with a 2.0mm internal diameter and 6.0mm external diameter and were obtained from JJ (Chromatography) Ltd., King's Lynn. They were packed with a cyano-silicone stationary phase, 10% Alltech CS-5, on a chromasorb WAW 100 - 120 mesh support. Nitrogen was used as the carrier gas and the resolved components were detected by a flame ionisation combustion system (hydrogen/air). The detector was connected to a Trilab 2 computing integrator with graphics, supplied by Trivector Scientific Ltd., which calculated the area of each individual peak and the percentage contribution of each peak to the total peak area. Since peak area is directly related to the

mass of the resolved component, the percentage area contribution represented the percentage mass contribution of individual fatty acids to the total fatty acid mass.

The following parameters were employed on the GLC to resolve fatty acid methyl esters, using a temperature program. Samples were injected onto the column via an injection port (at 260<sup>0</sup>C ), and the column was maintained at 210<sup>0</sup>C for 10 minutes before increasing the temperature at 4<sup>0</sup>C /minute for the next 10 minutes. At the end of this period, the column was maintained at 250<sup>0</sup>C for 5 minutes. The carrier gas flow rate was maintained at 59ml/minute throughout the procedure. Peaks were identified by comparison of their relative retention times (relative to 16:0 and 18:0) with those of the following authentic fatty acid methyl ester standards; 12:0, 14:0, 14:1, 16:0, 16:1, 18:0, 18:1, 18:2, 18:3, 20:0, 20:1, 20:2, 20:3, 20:4, 22:0, 22:4, 22:6, 24:0.

#### **4.2.15 Fluorescence polarization measurements**

The fluorescence probe 1,6-diphenyl-1,3,5-hexatriene (DPH) was first introduced into plasma membranes. The purified HTC cell plasma membranes were added to 2.4ml of 0.1M phosphate buffer, pH 7.7, in a quartz 10mm fluorescence cuvette, to give an optical density of 0.1 units at 500nm, on a dual beam Cecil spectrophotometer. The DPH probe was introduced into the membranes as follows: 2 $\mu$ l of a 2mM solution of DPH, in glass-distilled tetrahydrofuran, was added into the cuvette with rapid mixing. The cuvette was then incubated for 15 minutes at 37<sup>0</sup>C. Cuvettes were then cooled to about 4<sup>0</sup>C before the start of a temperature program between 4 to 50<sup>0</sup>C. Several cuvettes could be taken through any given run so that different membrane samples had their fluorescence polarization measurements determined under exactly the same conditions. Cuvettes, when read,

were placed in a thermostatically controlled chamber: the remaining cuvettes were maintained at about the same temperature, using a separate chamber. This system was maintained at the required temperature ( $\pm 0.1^{\circ}\text{C}$ ) with a Julabo thermostated circulator; cuvette temperature was measured with a calibrated thermistor. The thermostated cuvette chamber was constructed to include provision for gassing of the cuvette surface with dry nitrogen gas at sub-ambient temperatures, to prevent condensation in a humid atmosphere.

Steady state polarization of DPH fluorescence was measured with an analogue T-format fluorimeter (Applied Photophysic Ltd.), mounted on a  $\frac{1}{4}$  inch aluminium optical bench. The excitation wavelength was 360nm and the excitation path was filtered with a Corning 7-54 broad bandpass filter and the emission path with a Corning 3-73 sharp-out filter. The photomultiplier voltage was smoothed by continuously averaging the polarization ratio using a BBC microcomputer (model B, Acorn Computers Ltd., Cambridge), connected to an Acorn 12-bit analogue-to-digital converter. The computer was programmed to provide an average of 256 individual conversions which were themselves continuously averaged until a stable value to 3 decimal places was obtained.

Polarization of fluorescence ( $p$ ) was calculated from the following equation:

$$p = \frac{I_{\parallel} - I_{\perp}}{I_{\parallel} + I_{\perp}}$$

where  $I_{\parallel}$  and  $I_{\perp}$  are the intensities of fluorescent light detected through polarizers orientated parallel and perpendicular, respectively, to the excitation light.

In practice the ratio of  $I_{\parallel}$  to  $I_{\perp}$  was determined and this was inserted into the

following equation:

$$p = \frac{(I_{\parallel}/I_{\perp}) - 1}{(I_{\parallel}/I_{\perp}) + 1}$$

**Plate 4.1 — Scanning electron micrographs of HTC cells grown on microcarrier beads**

HTC cells were cultured on cytodex 2 microcarrier beads in a Techne flask as described in Materials and Methods. The method of Karnovsky (1965) was used to fix HTC cells growing on beads before taking the scanning electron micrographs.

Plate a: black bar represents  $4\mu\text{m}$

Plate b: black bar represents  $10\mu\text{m}$

Plate c: black bar represents  $100\mu\text{m}$

a

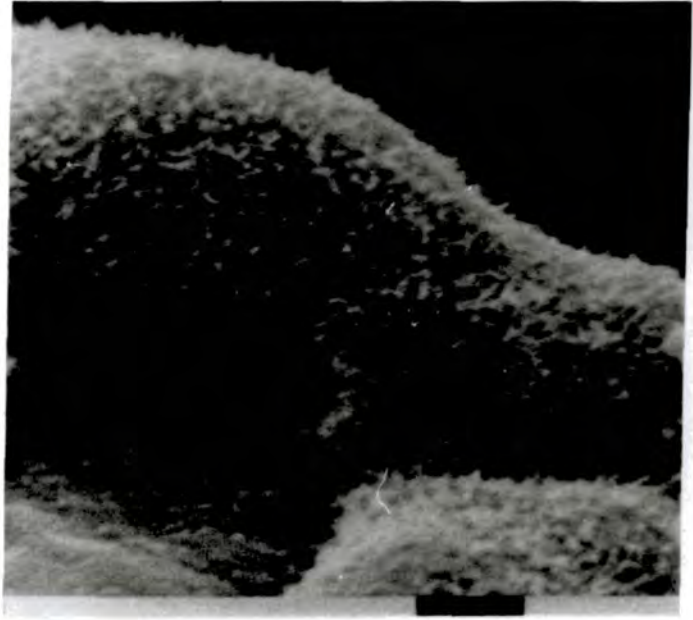

b



c

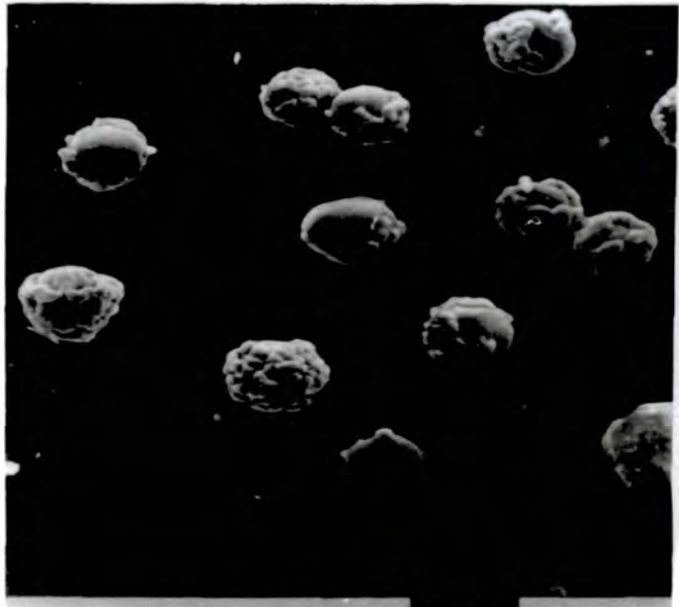

**Figure 4.3 — Plasma membrane purification scheme**

## Purification scheme for HTC cell plasma membrane

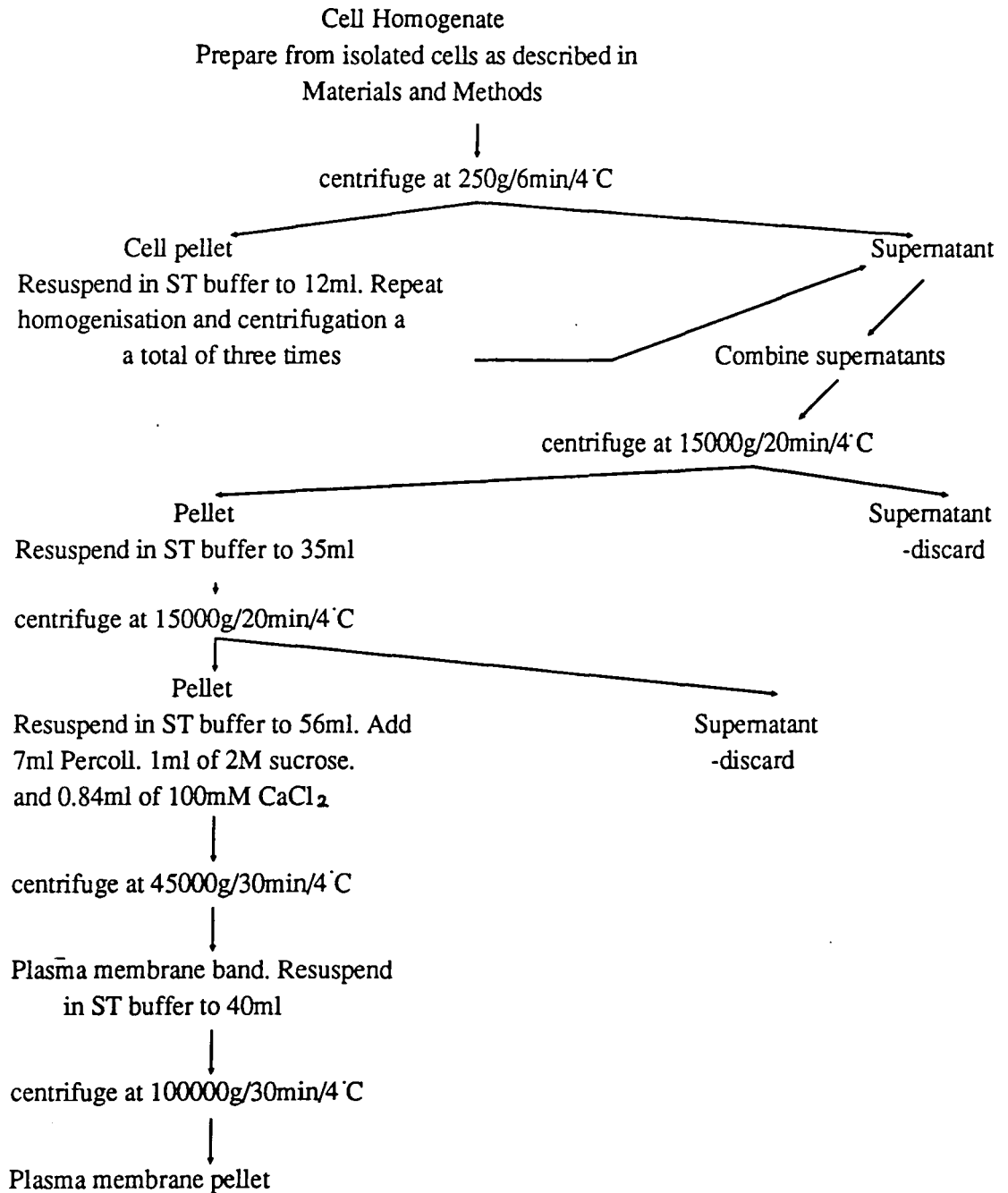

## 4.3 Results

### 4.3.1 Enzyme activities

The measurement of marker enzyme activities entails the establishment of enzyme reaction conditions where the activity determined is directly proportional to the amount of enzyme present. In order to achieve this goal, the linearity of the enzyme activity response with respect to time and protein was investigated.

#### *Na<sup>+</sup>, K<sup>+</sup>-ATPase and Mg<sup>2+</sup>-ATPase activities*

The amount of phosphate liberated from ATP by Na<sup>+</sup>, K<sup>+</sup>-ATPase was linear with respect to incubation time in homogenates and purified membranes for up to 45 minutes. However, the amount of inorganic phosphate liberated from ATP by Mg<sup>2+</sup>-ATPase rapidly deviated from linearity with time in both homogenates and purified membranes (figure 4.4a, b).

The activity of both enzymes was linear with respect to protein in crude homogenates and purified membranes for up to 90 $\mu$ g and 14 $\mu$ g of protein, respectively (figure 4.4c, d). This cell line contains approximately 5 times more Mg<sup>2+</sup>-ATPase than Na<sup>+</sup>, K<sup>+</sup>-ATPase activity (figure 4.4c).

In further assays of these enzymes, an incubation time of 15 minutes was selected and a protein concentration which resulted in a measurable activity on the linear portion of the response.

#### *Alkaline phosphodiesterase I activity*

Alkaline phosphodiesterase I requires Zn<sup>2+</sup> ions for full activity. In the present study, the activity increased with increasing Zn<sup>2+</sup> concentration and reached max-

imal stimulation at 4mM  $Zn^{2+}$ . Above 4mM  $Zn^{2+}$  the amount of  $\rho$ -nitrophenol liberated from the substrate decreased rapidly with increasing  $Zn^{2+}$  concentration (figure 4.5). In all further assays 4mM  $Zn^{2+}$  was included in the reaction medium.

The amount of product generated increased linearly with time in both untreated and triton X100-treated homogenates for up to 60 minutes (figure 4.6a). Similarly, the rate of product formation in both untreated and triton x100-treated homogenates was linear with respect to protein content, up to 28 $\mu$ g protein (figure 4.6b). Triton X100 enhanced the specific activity from 0.09 $\mu$ m/min/mg protein in untreated to 0.13 $\mu$ m/min/mg protein in detergent-treated homogenates. This constitutes a 47% rise in activity. Consequently, triton X100 treatment was included in the assay procedure.

In further assays of this enzyme an incubation time of 30 minutes was selected and a protein concentration which resulted in a measurable activity on the linear portion of the response.

#### *Succinate dehydrogenase activity*

The rate of cytochrome c reduction by this enzyme in HTC cell homogenate was linear with respect to protein from 0 to 100 $\mu$ g of protein (figure 4.7). In all further assays the initial rate of reaction was determined at a protein concentration below 100 $\mu$ g to ensure the enzyme activity was proportional to protein concentration.

#### *NADPH:Cytochrome c reductase activity*

Triton X100 did not enhance the activity of this enzyme. However, it was observed that when triton X100 was present in the assay the length of time over which the trace was linear on the chart recorder, was increased. Hence triton X100

was included in all further assays. The rate of cytochrome c reduction by this enzyme in HTC cell homogenate was linear with respect to protein from 0 to 200 $\mu$ g protein (figure 4.8) and in a protein concentration within this range was used in all subsequent assays.

#### *N-Acetyl $\beta$ D-glucosaminidase activity*

The increase in activity of this enzyme in HTC cell homogenate was linear with respect to time (figure 4.9a) and protein (figure 4.9b) for 40 minutes and 12 $\mu$ g protein respectively. In the absence or presence of triton X100 the same specific activity was obtained. However, even without an enhancement of activity, triton X100 was included in the assay to ensure any potential latent activity was exposed.

#### *Adenylate cyclase activity*

Due to the extremely low basal activities of HTC cell adenylate cyclase (0 - 0.5 pmoles/min/mg protein, see chapter 5), a potent activator of adenylate cyclase, forskolin, was included in the assay in order to obtain a measurable activity. The production of cyclic AMP by the forskolin-stimulated adenylate cyclase of HTC cell homogenate was linear with respect to time (figure 4.10a) from 0 to 10 minutes and protein, from 0 to 200 $\mu$ g protein (figure 4.10b).

In summary, the assay conditions necessary to ensure the marker enzyme activity was proportional to the amount of enzyme present were established. These assay conditions were then used in assessing the activity of marker enzymes in membrane fractions, in order to determine the purity and recovery of the plasma membrane.

### 4.3.2 Plasma membrane purification

In order to investigate the effect of supplementation with arachidonic acid on the phospholipid structure, fluidity and enzyme activity of HTC cell plasma membranes, the membranes were purified as described in Materials and Methods (section 4.2.1). As shown in chapter 3, supplementation with 20:4 for 36 hours and 48 hours significantly enhanced the thermosensitivity of HTC cells. Although a greater enhancement in thermosensitivity was obtained with 48 hours supplementation period the 36 hours supplementation period was used prior to plasma membrane purification. This is because with supplementation periods of greater than 36 hours there is a potential of compensatory mechanisms counteracting the effects of supplementation, at the plasma membrane level (Konings, 1985).

Purity and recovery of the plasma membranes was assessed by measuring  $\text{Na}^+$ ,  $\text{K}^+$ -ATPase, alkaline phosphodiesterase I and cholesterol as markers.

Data for  $\text{Na}^+$ ,  $\text{K}^+$ -ATPase show that plasma membranes from cells grown in normal media were recovered in high yield (29.44%) and were purified 16-fold (table 4.2a). Data for the same enzyme for plasma membranes isolated from cells grown in media supplemented with  $60\mu\text{M}$  arachidonic acid for 36 hours show that a similar yield (32.44%) and purification (20-fold) was obtained (table 4.2b). In contrast, data for alkaline phosphodiesterase I and cholesterol suggest lower values for purification (approximately 7-fold) and recovery (approximately 12% yield) of the plasma membranes from both unsupplemented and supplemented cells. The reasons for this discrepancy could be that cholesterol and alkaline phosphodiesterase I (Draye *et al.*, 1987) are found in intracellular membranes and hence are not ideal plasma membrane markers. However, similar results to the  $\text{Na}^+$ ,  $\text{K}^+$ -ATPase data

are obtained with forskolin-stimulated adenylate cyclase activity which is purified approximately 12-fold, with a recovery of 23% in control plasma membranes.

Mg<sup>2+</sup>-ATPase, an enzyme that is not exclusively associated with the plasma membranes (Kinne-Saffran and Kinne, 1980), co-purified to a similar extent to alkaline phosphodiesterase I and cholesterol, with yields of 12% and purification of approximately 7-fold in both types of membranes. The ratio of activities of Mg<sup>2+</sup>-ATPase to Na<sup>+</sup>, K<sup>+</sup>-ATPase decreases from 4.3 to 1.9 during purification of normal membranes, and from 3.2 to 1.2 during purification of arachidonate supplemented membranes. This comprises a reduction in the ratio of 55.8% and 62.5% for normal and supplemented membranes, respectively. This clearly indicates selective removal of a major portion of the Mg<sup>2+</sup>-ATPase activity not associated with plasma membrane-bound Na<sup>+</sup>, K<sup>+</sup>-ATPase activity.

In this plasma membrane fraction, contamination with mitochondria, lysosomes and endoplasmic reticulum was low when assessed by measuring succinate dehydrogenase (recovery 0.74%, purification 0.42-fold) N-acetyl  $\beta$  D-glucosaminidase (recovery 0.55%, purification 0.98-fold) and NADPH cytochrome c reductase (recovery 2.78%, purification 1.72-fold) respectively (table 4.3).

In this study there was no significant difference in the degree of purification of plasma membranes from control cells and arachidonate-supplemented cells, when assessed by examining the purification of Na<sup>+</sup>, K<sup>+</sup>-ATPase, alkaline phosphodiesterase I, Mg<sup>2+</sup>-ATPase and cholesterol as markers. Similarly, there was no significant difference in the recovery of plasma membranes from the two cell populations, using the same criteria.

For two plasma membrane markers, namely Na<sup>+</sup>, K<sup>+</sup>-ATPase and alkaline

phosphodiesterase I, there was no significant difference in their specific activity in the homogenate of control cells when compared to the homogenate of arachidonate-supplemented cells. Similarly, for the same markers there was no significant difference in their specific activity in the purified plasma membranes from control cells compared to the plasma membranes purified from arachidonate-supplemented cells.

However,  $Mg^{2+}$ -ATPase did show significantly lower ( $p < 0.05$ ) specific activities in homogenates from supplemented cells compared to homogenates from control cells. This difference was not observed in purified plasma membranes. This could be because the  $Mg^{2+}$ -ATPase activity determined in homogenates is an average of the  $Mg^{2+}$ -ATPase from all intracellular sources, but in the purified membranes  $Mg^{2+}$ -ATPase predominantly associated with plasma membranes is measured as described above. This suggests that the effect of arachidonic acid supplementation on lowering the specific activity of  $Mg^{2+}$ -ATPase is greatest on its intracellular source(s).

#### 4.3.3 Lipid analysis

The separation of a standard mixture of methyl esters of free fatty acids (FAME standards) showed that the relative retention times are dependent on the carbon chain length and degree of unsaturation. Figure 4.11 shows the direct proportionality of  $\log_{10}$  relative retention time with carbon chain length for both saturated (figure 4.11a) and unsaturated (figure 4.11b) free fatty acids.

Analysis of newborn bovine serum showed that it contained predominantly 16:0, 18:0 and 18:1 (table 4.4). The other free fatty acids, 14:0, 16:1, 18:2, 18:3, 20:0, 20:1, 20:4, 22:0 and 22:1 are present in minor proportions and together constitute 44.3% of the total free fatty acids. Upon incorporation of the supplemental

free fatty acid into serum the free fatty acid profile of the sera was considerably altered. When  $60\mu\text{M}$  arachidonic acid (20:4) was added to serum it was found to comprise 76.15% of the total free fatty acid, making it the predominant free fatty acid present. The statistically significant ( $p < 0.05$ ) rise in 20:4 caused a statistically significant reduction ( $p < 0.05$ ) in the proportion of 16:0, 18:0, 18:1, 18:2 and 18:3. Similarly, a statistically significant rise ( $p < 0.05$ ) in 16:0 after addition of  $60\mu\text{M}$  16:0 to newborn bovine serum caused a significant decrease ( $p < 0.05$ ) in 18:0, 18:1 18:2 and 18:3.

The most abundant fatty acids in plasma membrane phospholipid isolated from cells grown in unsupplemented media were 16:0, 18:0 and 18:1 (table 4.5). The rest of the fatty acids in plasma membrane phospholipids represent only 15.22% of the total. The plasma membranes isolated from HTC cells grown in medium supplemented with  $60\mu\text{M}$  20:4 for 36 hours, showed a significant rise ( $p < 0.05$ ) in 20:4 with a corresponding statistically significant decrease ( $p < 0.05$ ) in 18:1, 18:2 and 18:3. The largest decrease occurred in 18:1, which was reduced from 39.5% to 24.5% of the fatty acids of plasma membrane phospholipids.

Further analysis based on carbon chain length (figure 4.12) shows that proportion of fatty acids containing 18-carbon atoms are exclusively reduced ( $p < 0.05$ ) from 58.8% to 40.2%, with a corresponding rise ( $p < 0.05$ ) in 20-carbon chain fatty acids, in plasma membrane phospholipid after supplementation with 20:4. The 16 and 22-carbon chains are not significantly altered by supplementation of HTC cells with 20:4.

Examination of the phospholipid fatty acids based on the number of olefinic bonds (figure 4.13) shows a significant rise ( $p < 0.05$ ) in fatty acids containing 4

olefinic bonds as a result of arachidonate supplementation, with a corresponding decrease in mono, di and tri unsaturated fatty acids, the largest decrease from 48.4% to 29.3% being in the proportion of monounsaturates present plasma membrane phospholipids. The saturated fatty acids of plasma membrane phospholipids remained statistically unaltered by supplementation.

The cholesterol to protein ratio, and the cholesterol to phospholipid ratio remained unchanged in arachidonic acid supplemented plasma membranes when compared to normal unsupplemented plasma membranes (table 4.6). These chemical parameters suggest little change in plasma membrane order. However, the unsaturation index which gives an indication of the number of double bonds present in the fatty acids derived from membrane phospholipid, increased significantly ( $p < 0.05$ ) suggesting an increase in fluidity. Similarly, an increase in fluidity is also suggested by the significant reduction ( $p < 0.05$ ) in the oleic acid/polyunsaturated fatty acid ratio (table 4.6). The decrease in membrane order suggested by the unsaturation index and the oleic acid/polyunsaturated fatty acid ratio were substantiated by direct measurement of the plasma membrane fluidity using fluorescence polarisation. Figure 4.14 shows the decrease in membrane order detected by fluorescence polarisation in plasma membranes isolated from cells grown in 20:4 supplemented media when compared to those isolated from cells grown in unsupplemented media. Supplementation of HTC cells with  $60\mu\text{M}$  arachidonic acid for 36 hours prior to plasma membrane isolation served to shift the curve by  $6-8^{\circ}\text{C}$  along the temperature axis. The fact that there is no statistical difference in the slope of the lines generated suggests that the effect of fatty acid supplementation on membrane order does not alter across the range of temperatures measured.

**Figure 4.4 — Na<sup>+</sup>, K<sup>+</sup>-ATPase and Mg<sup>2+</sup>-ATPase activities with respect to time and protein**

The enzymes were assayed as described in Materials and Methods for various time periods (figure a and b) or for 15 minutes with increasing amount of protein (figure c and d). Na<sup>+</sup>, K<sup>+</sup>-ATPase(●) and Mg<sup>2+</sup>-ATPase (○) activities with respect to time for homogenate and plasma membrane preparation are shown in figures a and b respectively. Figures c and d represent the Na<sup>+</sup>, K<sup>+</sup>-ATPase(●) and Mg<sup>2+</sup>-ATPase (○) activities with respect to protein for homogenate and plasma membrane respectively.

Specific activities determined from figure c are given below.

Specific activity $\mu\text{mole}/\text{min}/\text{mg}$ protein	
Na <sup>+</sup> , K <sup>+</sup> -ATPase	Mg <sup>2+</sup> -ATPase
0.04126	0.2182
$\pm 0.00182$	$\pm 0.00176$

Data values in the table represent the mean value  $\pm$  SEM of four determinations.

The mean values obtained from two separate experiments are presented on the graph. Each experiment was carried out in duplicate. In figures a and b curves have been drawn by eye, to the Mg<sup>2+</sup>-ATPase data. Linear regression lines have been fitted to the rest of the data for which the correlation coefficients are given in the table below.

Figure	Enzyme	Correlation coefficient (r)
Figure a	Mg <sup>2+</sup> -ATPase	0.820
	Na <sup>+</sup> , K <sup>+</sup> -ATPase	0.993
Figure b	Mg <sup>2+</sup> -ATPase	0.720
	Na <sup>+</sup> , K <sup>+</sup> -ATPase	0.999
Figure c	Mg <sup>2+</sup> -ATPase	0.999
	Na <sup>+</sup> , K <sup>+</sup> -ATPase	0.993
Figure d	Mg <sup>2+</sup> -ATPase	0.973
	Na <sup>+</sup> , K <sup>+</sup> -ATPase	0.996

(a) Homogenate

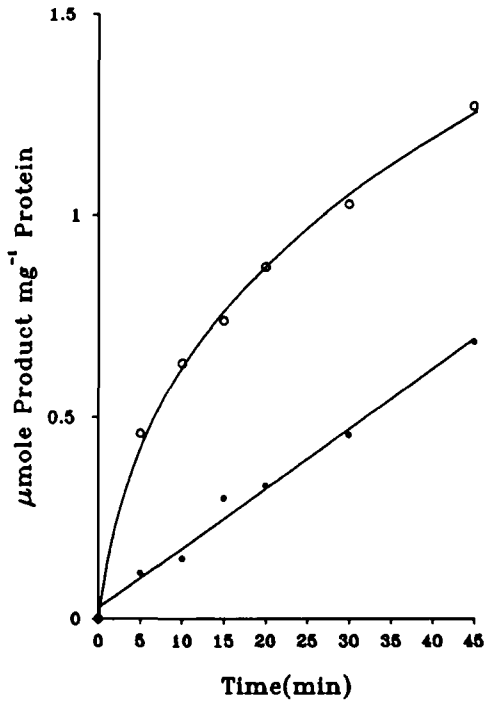

(b) Plasma membrane

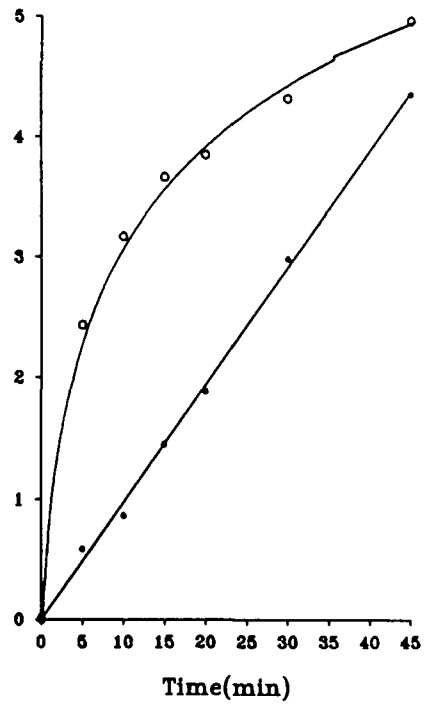

(c) Homogenate

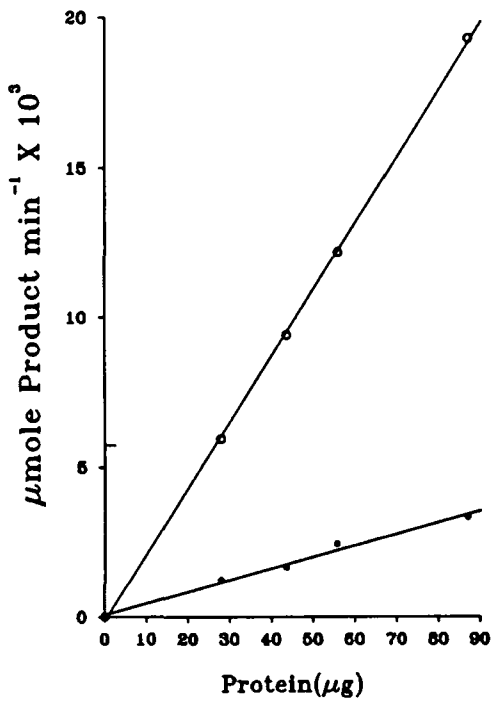

(d) Plasma membrane

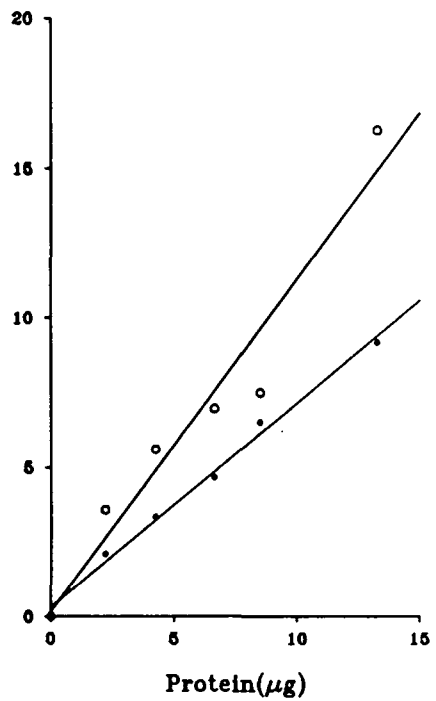

**Figure 4.5 — Effect of  $Zn^{2+}$  concentration on alkaline phosphodiesterase I activity**

The figure represents the change in specific activity of alkaline phosphodiesterase I in homogenate( $\circ$ ) and plasma membrane( $\bullet$ ) preparations with increasing  $Zn^{2+}$  concentration. The assay was performed as described in Materials and Methods with the appropriate concentration of zinc acetate incorporated into the incubation mixture.

Data from three experiments with plasma membranes and one experiment with cell homogenate are presented on the graph. Each data point represents the mean value of duplicate determinations. The curves have been fitted by eye.

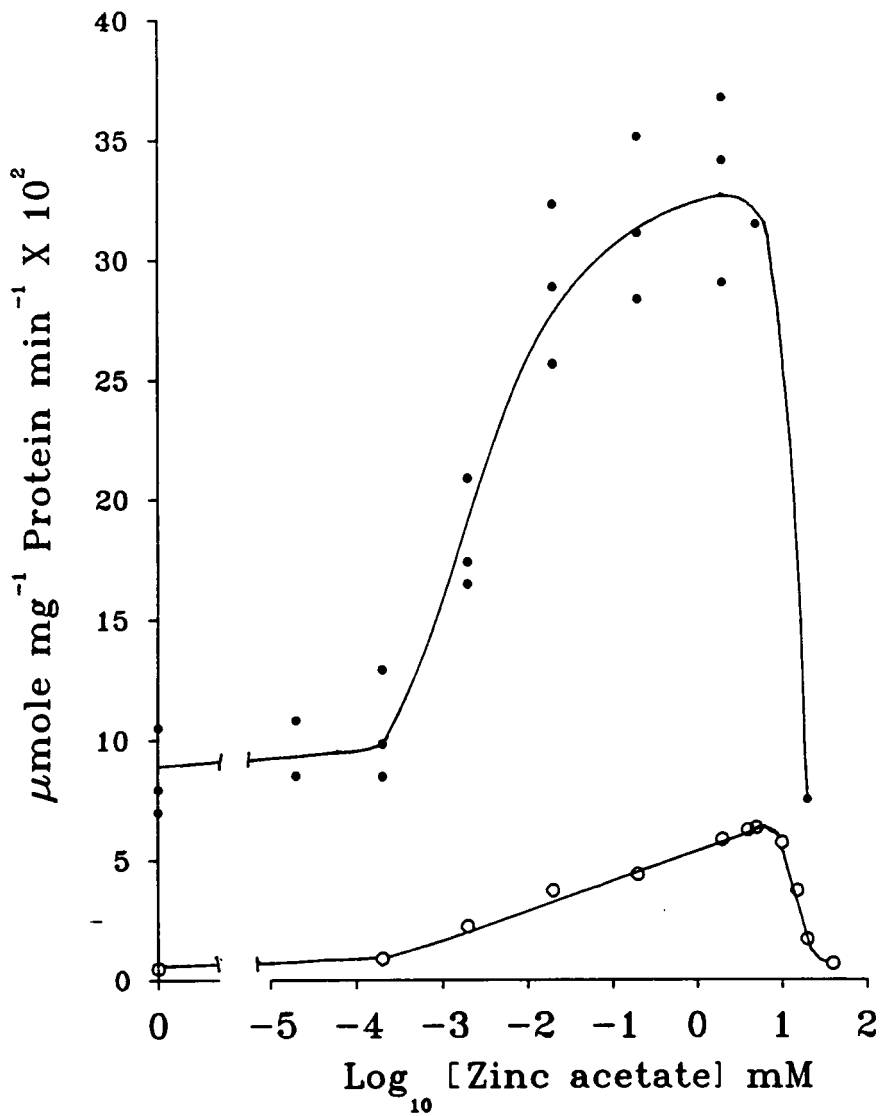

**Figure 4.6 — Effect of incubation time and protein concentration on the activity of alkaline phosphodiesterase I**

The enzyme assay was performed on homogenates of HTC cells as described in Materials and Methods. Figure a shows the enzyme activity with respect to time for homogenates pretreated (○) or not pretreated (●) with 0.1%(v/v) triton X100. All other assay components remained unchanged. Figure b shows the enzyme activity with increasing protein concentration for homogenates pretreated (○) or not pretreated (●) with 0.1%(v/v) triton X100. All other assay components remained unchanged.

The specific activities obtained from figures a and b are given below:

Specific activity $\mu\text{mole}/\text{min}/\text{mg}$ protein		
Without triton pretreatment	With triton pretreatment	Percent activation
0.09033 $\pm 0.00216$	0.1336 $\pm 0.00301$	47.90

Data values in the table represent the mean value  $\pm$  SEM of thirteen determinations.

The mean values obtained from two separate experiments are presented on figure a and on figure b data values from two separate experiments are presented. Each experiment was carried out in duplicate. In figures a and b linear regression lines have been fitted to the data for which the correlation coefficients are given in the table below.

Figure	Triton X100 (% v/v)	Correlation coefficient (r)
Figure a	0.0	0.997
	0.1	0.999
Figure b	0.0	0.995
	0.1	0.997

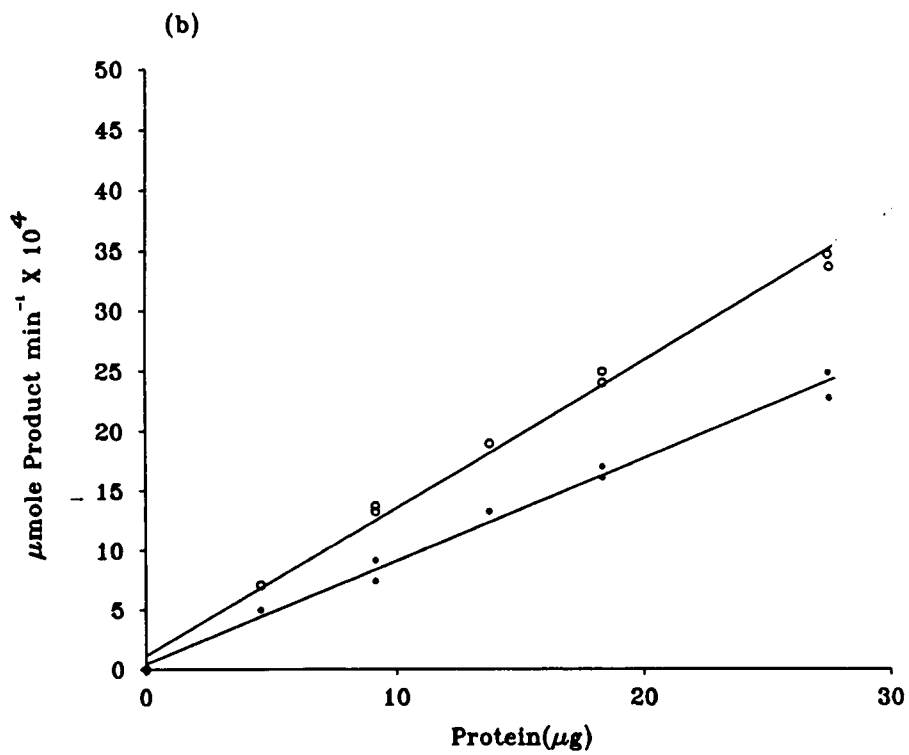
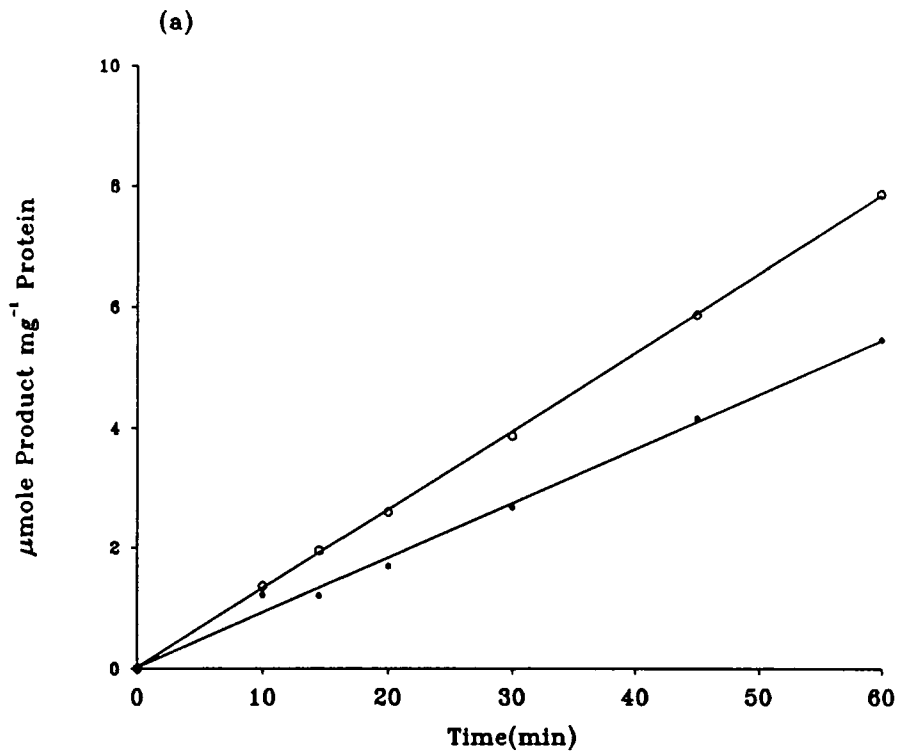

**Figure 4.7 — Succinate dehydrogenase activity with respect to protein concentration**

The assay was carried out on HTC cell homogenates as described in Materials and Methods. Increasing amounts of protein were incorporated into the assay and the activity measured continuously in a Pye-Unicam SP8-100 spectrophotometer set at 550nm.

Data values from two separate experiments are presented on the graph. Each experiment was carried out in duplicate. Linear regression line has been fitted to the data for which the correlation coefficients ( $r$ ) is 0.966.

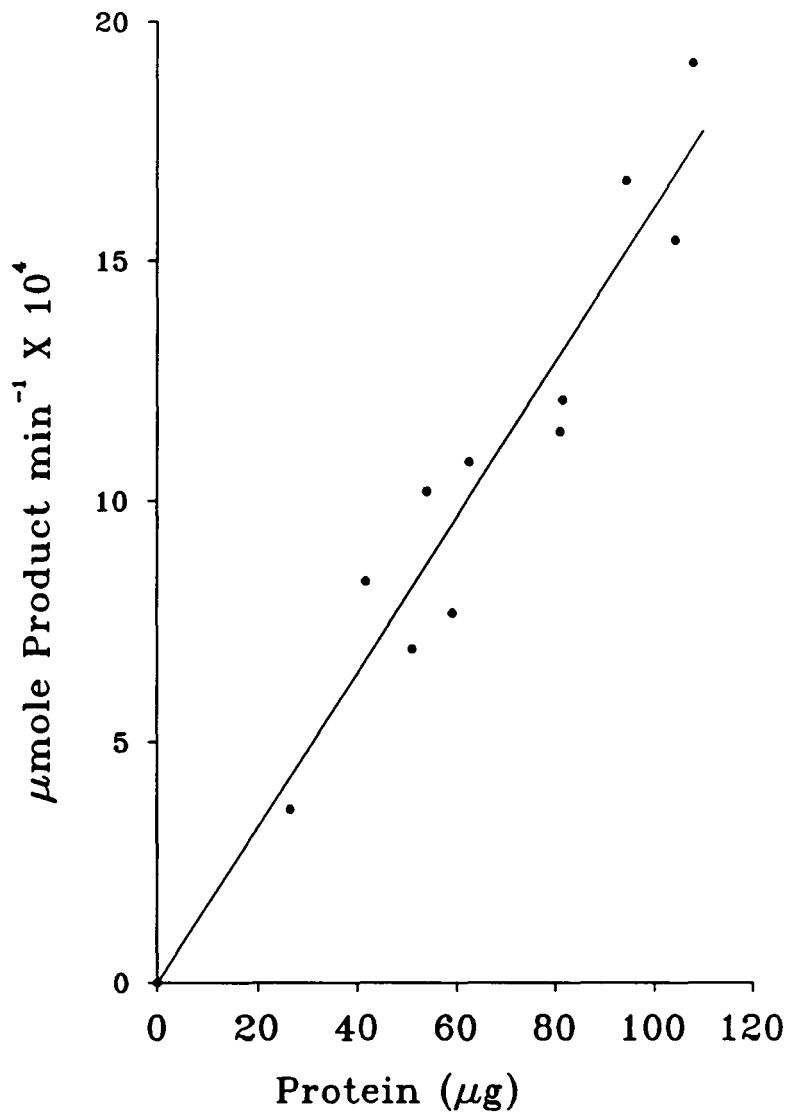

**Figure 4.8 — Effect of protein concentration on NADPH cytochrome c reductase activity**

The assay was carried out on HTC cell homogenates as described in Materials and Methods. Increasing amounts of protein were incorporated into the assay and initial rate of reaction was determined in a spectrophotometer set at 550nm. The specific activity figures given below show the lack of stimulation by 0.1%(v/v) triton X100.

Specific activity $\mu\text{mole}/\text{min}/\text{mg}$ protein	
With triton X-100	Without triton X-100
0.0087669	0.0087589
$\pm 0.0003145$	$\pm 0.008414$
n=17	n=4

n denotes the number of determinations and the data values in the table represent the mean value  $\pm$  SEM.

Data values from three separate experiments are presented on the graph. Each experiment was carried out in duplicate. Linear regression line has been fitted to the data for which the correlation coefficients (r) is 0.937.

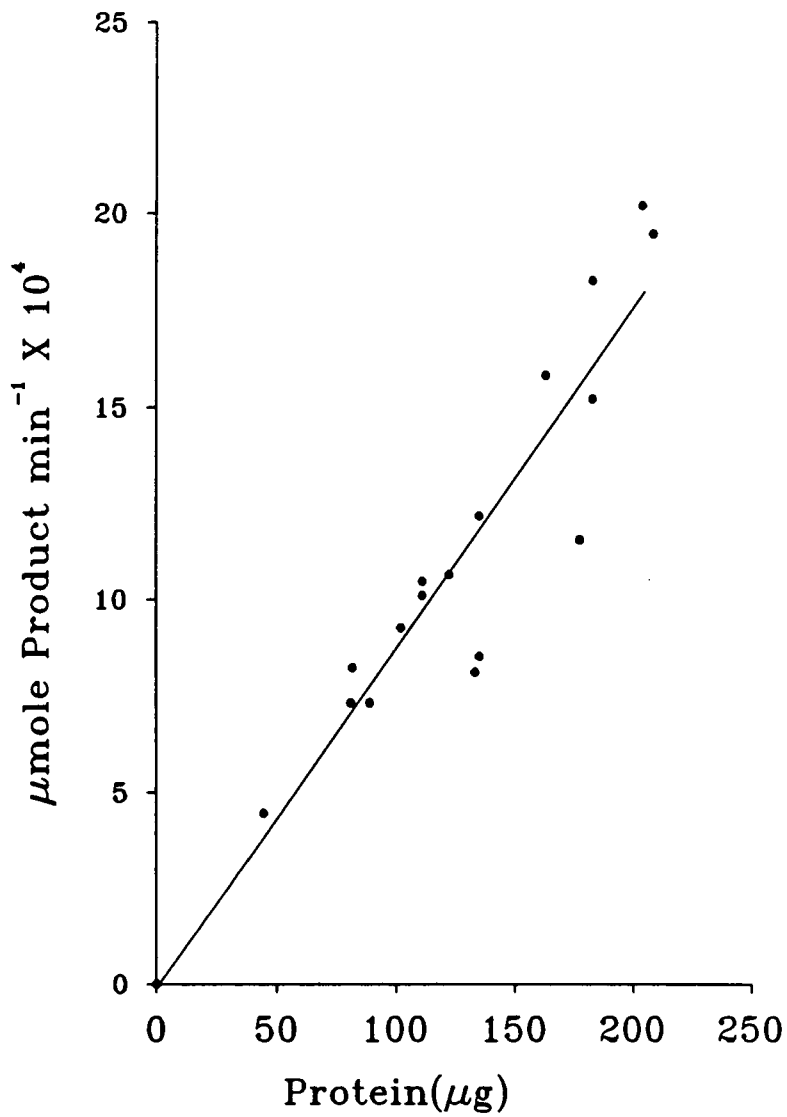

**Figure 4.9 — Effect of assay time and protein concentration on the activity of N-acetyl  $\beta$  D-glucosaminidase**

Portions of HTC cell homogenates were assayed for enzyme activity as described in Materials and Methods. Figure a shows the effect of varying the time of incubation at a constant enzyme concentration in the presence of 0.1%(v/v) triton X-100. Figure b shows the effect of varying the enzyme concentration on enzyme activity, assayed at a constant incubation time (30 minutes) in the presence of 0.1%(v/v) triton X-100. The effect of omitting triton X-100 on the activity of the enzyme is shown in the table below.

Specific activity $\mu\text{mole}/\text{min}/\text{mg}$ protein	
Without triton	With triton
0.3996	0.3912
$\pm 0.00643$	$\pm 0.00643$

Data values in the table represent the mean value  $\pm$  SEM of thirteen determinations.

The data values obtained from two separate experiments are presented on figure a and the on figure b data values from three separate experiments are presented. Each experiment was carried out in duplicate. In figures a and b linear regression lines have been fitted to the data for which the correlation coefficients are given in the table below.

Figure	Correlation coefficient (r)
Figure a	0.994
Figure b	0.998

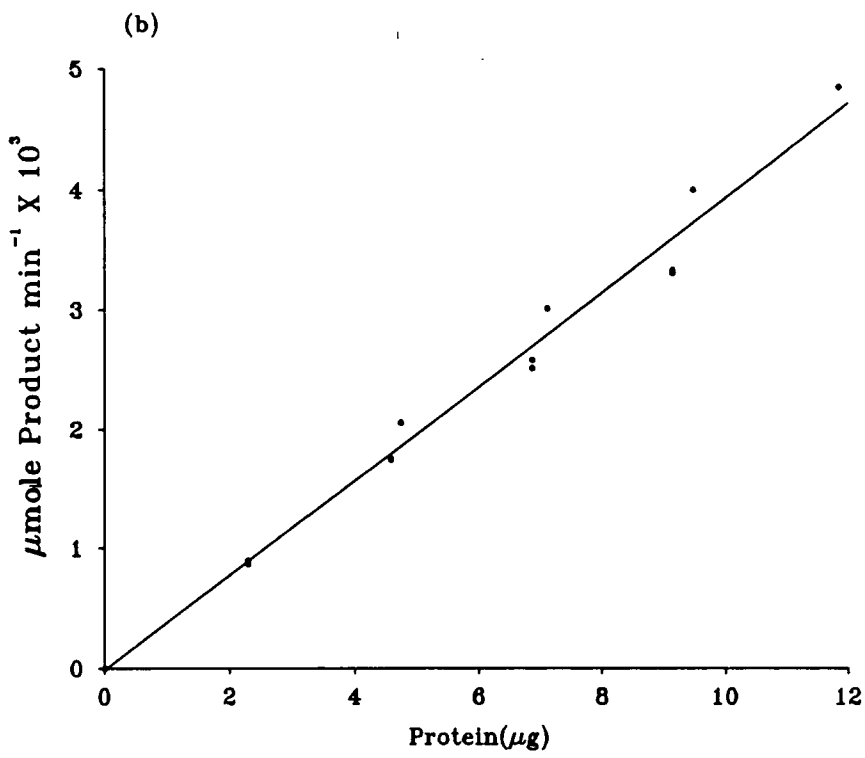
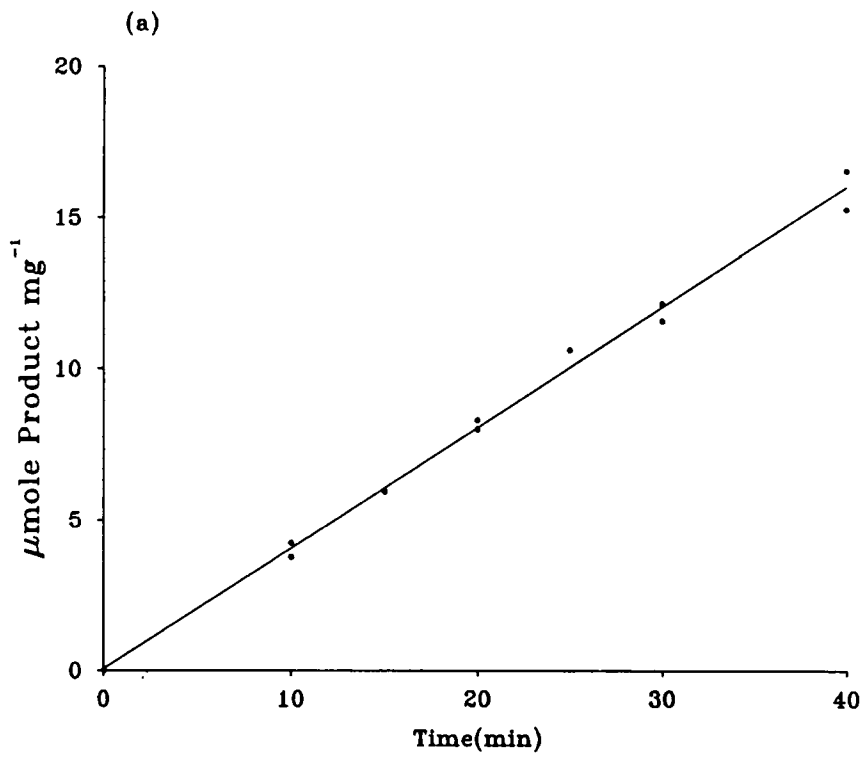

**Figure 4.10 — Effect of incubation time and enzyme concentration on the activity of adenylate cyclase from HTC cells**

Figure a and b represent the forskolin-stimulated activity of adenylate cyclase in HTC cell homogenate with respect to time and protein concentration, respectively. The reaction mixture (see chapter 5 under Materials and Methods) containing  $100\mu\text{M}$  forskolin was preincubated at  $37^{\circ}\text{C}$  for 5 minutes prior to addition of HTC cell homogenate. In figure a the reaction was started with the addition of  $100\mu\text{g}$  homogenate protein and the reaction was terminated at the time intervals indicated. In figure b, different amounts of HTC cell homogenate protein were incubated with the reaction mixture containing  $100\mu\text{M}$  forskolin for 8 minutes at  $37^{\circ}\text{C}$  before terminating the reaction. Reaction mixture containing forskolin also contained 0.1%(v/v) DMSO, the vehicle for forskolin.

In all assays after termination of the reaction the cyclic AMP content was determined as described in chapter 5 under Materials and Methods.

The data values obtained from two separate experiments are presented on the graphs. Each experiment was carried out in duplicate. In figures a and b linear regression lines have been fitted to the data for which the correlation coefficients are given in the table below.

Figure	Correlation coefficient (r)
Figure a	0.993
Figure b	0.991

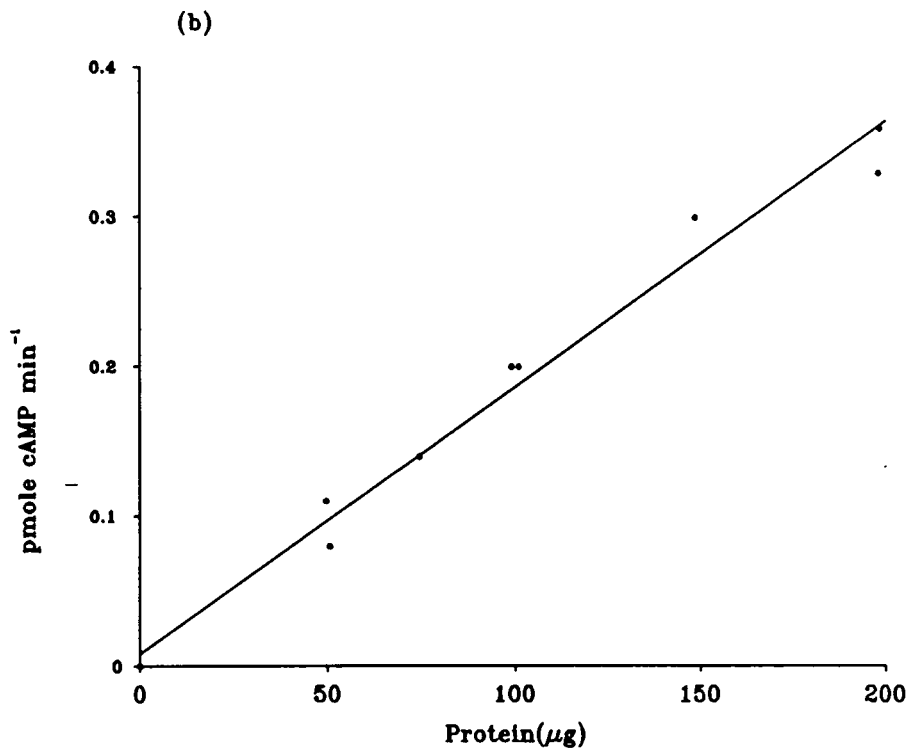
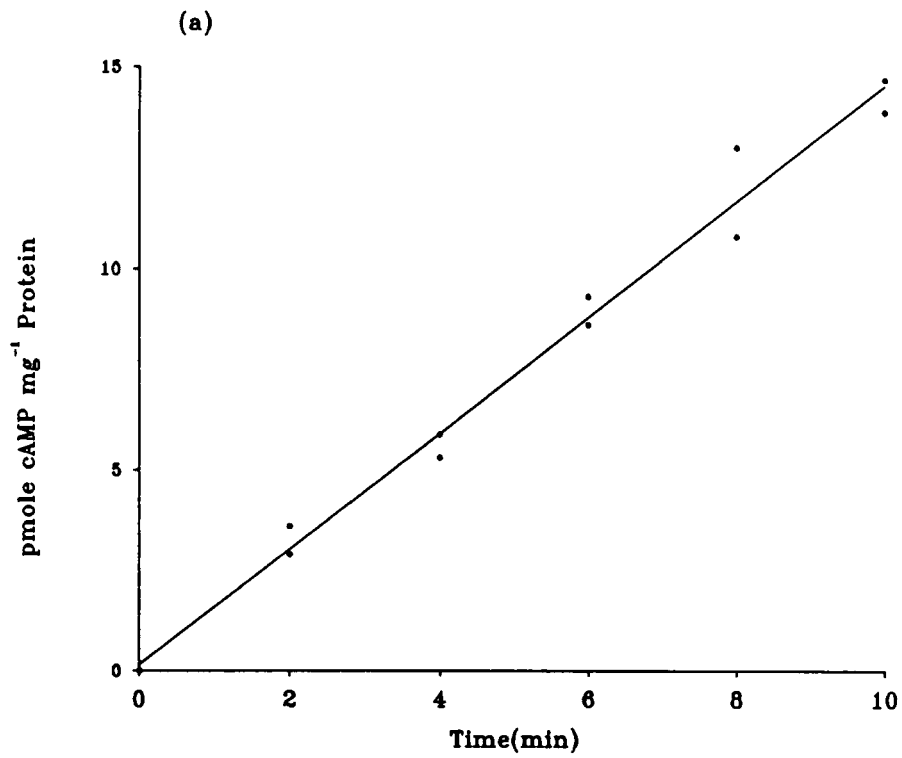

**Table 4.2 — Enzyme activities and cholesterol content of plasma membranes isolated from control and arachidonic acid supplemented HTC cells**

Table a and b show the purification of plasma membranes isolated from control and arachidonic acid supplemented HTC cells respectively by the procedure described in Materials and Methods (section 4.2.1). Supplemented cells were exposed to 60  $\mu$ M arachidonic acid for 36 hours prior to plasma membrane isolation. Specific activity of membrane markers is expressed as  $\mu$ mole of substrate converted per minute per mg of protein for enzymes and  $\mu$ mole per mg of protein for cholesterol. The purification of plasma membrane is indicated by enrichment of Na<sup>+</sup>, K<sup>+</sup>-ATPase, alkaline phosphodiesterase I, adenylate cyclase and cholesterol. (Cholesterol and enzyme assays were carried out as described in Materials and Methods). Results are expressed as mean value  $\pm$  SEM.

*(a) Control plasma membranes*

Membrane Marker	Number of	Specific Activity		Purification	Recovery
	preparations	Homogenate	Final pellet	(fold)	( % )
Na <sup>+</sup> K <sup>+</sup> ATPase	10	0.038 $\pm$ 0.0026	0.612 $\pm$ 0.0630	16.11 $\pm$ 1.331	29.44 $\pm$ 2.988
Mg <sup>2+</sup> -ATPase	10	0.167 <sup>†</sup> $\pm$ 0.0147	1.1650 $\pm$ 0.1225	6.976 $\pm$ 0.419	12.93 $\pm$ 0.840
Alkaline Phosphodiesterase I	10	0.047 $\pm$ 0.0045	0.290 $\pm$ 0.0380	6.170 $\pm$ 0.4322	10.78 $\pm$ 0.6027
Cholesterol	7	0.0290 $\pm$ 0.0029	0.2170 $\pm$ 0.0181	7.483 $\pm$ 0.5144	14.22 $\pm$ 1.362
Adenylate Cyclase (forskolin stimulated)	1	2.28	26.9	11.8	22.5

(b) Plasma membranes from 20:4 supplemented HTC cells

Membrane Marker	Number of	Specific Activity		Purification	Recovery
	preparations	Homogenate	Final pellet	(fold)	( % )
Na <sup>+</sup> K <sup>+</sup> ATPase	4	0.030 ±0.0015	0.599 ±0.0814	19.97 ±2.772	32.62 ±4.334
Mg <sup>2+</sup> -ATPase	4	0.097 <sup>†</sup> ±0.0112	0.727 ±0.119	7.495 ±0.438	12.00 ± 0.309
Alkaline Phosphodiesterase I	4	0.031 ±0.0043	0.223 ±0.0278	7.194 ±0.8117	12.03 ± 0.7928
Cholesterol	3	0.028 ±0.0012	0.219 ±0.0624	7.821 ±1.9390	12.35 ±1.879

The recovery data was transformed using arcsine (to ensure the percentage values were normally distributed) and then analysed statistically. The specific activities (both in homogenate and final pellet), purification, and recovery data in table a (control plasma membranes) were compared statistically with corresponding values in table b (20:4 supplemented membranes). Statistical analyses was carried with the Students t-test. The only significant difference found, was between the specific activity of Mg<sup>2+</sup>-ATPase in homogenates of control and 20:4 supplemented cells. The specific activity (†) of Mg<sup>2+</sup>-ATPase was significantly lower ( $p < 0.05$ ) in 20:4 supplemented cell homogenates when compared with that from control cell homogenates.

**Table 4.3 — Microsomal, mitochondrial and lysosomal contamination of purified HTC cell plasma membranes**

The extent of contamination of the plasma membrane fraction by mitochondrial, lysosomal and endoplasmic reticulum membranes is shown in the table below. The level of contamination from these three sources is indicated by the enrichment of the marker enzymes, succinate dehydrogenase (mitochondria), N-acetyl  $\beta$  D-glucosaminidase (lysosomes) and NADPH cytochrome c reductase (endoplasmic reticulum). Specific activity of membrane marker enzymes is expressed as  $\mu$ mole of substrate converted per minute per mg of protein

Membrane Marker	Number of preparations	Specific Activity		Purification (fold)	Recovery ( % )
		Homogenate	Final pellet		
Succinate Dehydrogenase	2	0.00795 $\pm 0.00009$	0.00336 $\pm 0.00056$	0.42 $\pm 0.0643$	0.74 $\pm 0.06$
N-Acetyl $\beta$ -glucosaminidase	2	0.3664 $\pm 0.0477$	0.3581 $\pm 0.0879$	0.98 $\pm 0.132$	1.55 $\pm 0.19$
NADPH-cytochrome c reductase	2	0.0195 $\pm 0.00223$	0.0336 $\pm 0.0025$	1.72 $\pm 0.33$	2.78 $\pm 0.13$

Data values in the table represent mean values  $\pm$  SEM.

**Figure 4.11 — The relationship between  $\log_{10}$  relative retention time (RRT) and carbon chain length of saturated and unsaturated FAME standards**

The analysis was carried out as described in Materials and Methods. Retention times obtained from GLC for saturated FAME standards are represented in figure a relative to the retention time of 16:0( $\circ$ ) and 18:0( $\bullet$ ). Similarly, in figure b retention times of monosaturated FAME standards are represented relative to the retention times of 16:0( $\circ$ ) and 18:0( $\bullet$ ).

The mean values obtained from ten separate experiments are presented on the graph. In figures a and b linear regression lines have been fitted to the data for which the correlation coefficients are given in the table below.

Figure	Retention time relative to:	Correlation coefficient (r)
Figure a	16:0	0.999
	18:0	0.999
Figure b	16:0	0.998
	18:0	0.998

(a)

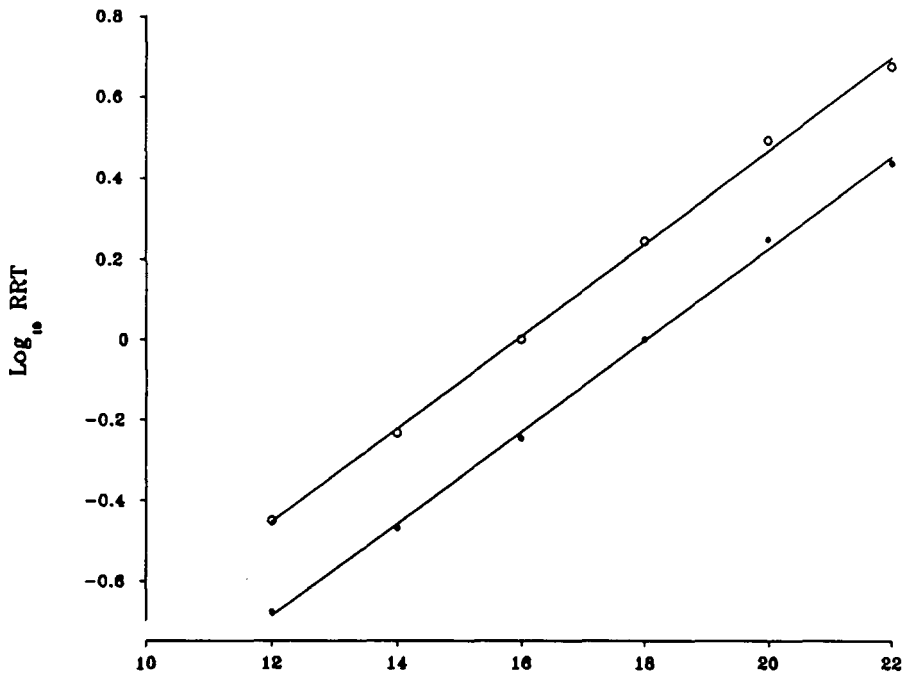

(b)

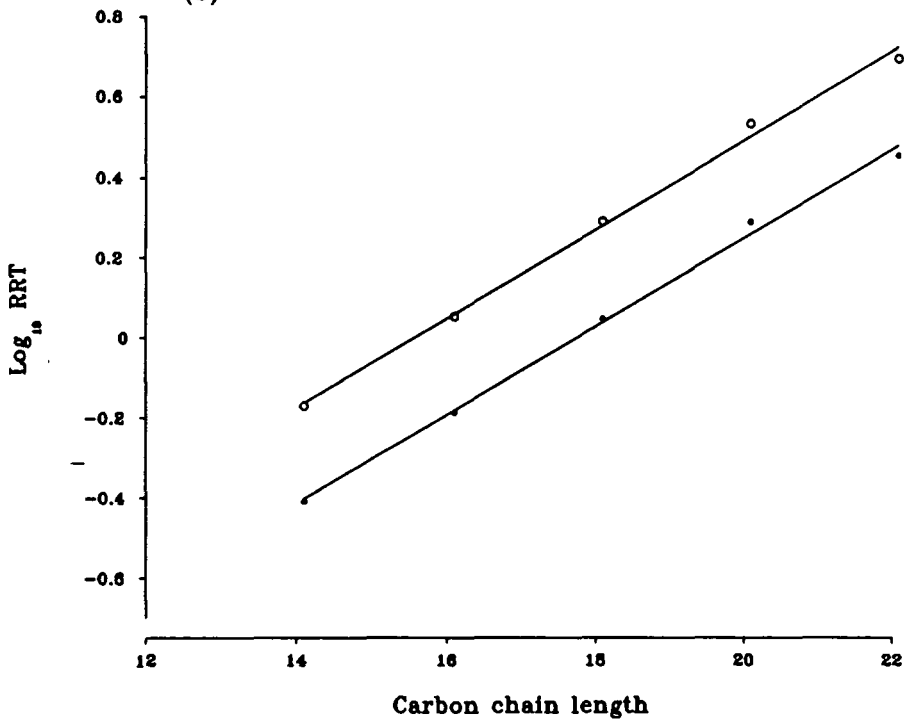

**Table 4.4 — Free fatty acid profile of newborn bovine serum (NBS), 16:0- and 20:4-supplemented NBS**

Analysis procedure was as described in Materials and Methods. Briefly, lipid extracted from NBS and NBS supplemented with 60 $\mu$ M 16:0 or 20:4 were separated on TLC and the free fatty acid fraction isolated. Methyl esters prepared from the isolated free fatty acids were separated by GLC. The peaks were identified by comparison with relative retention times of FAME standards.

Free fatty acid	Serum		
	Control	20:4 supplemented	16:0 supplemented
14:0	0.501 $\pm$ 0.293	0.146 $\pm$ 0.049	0.343 $\pm$ 0.190
16:0	26.582 $\pm$ 1.074	6.999 $\pm$ 1.351 <sup>†</sup>	80.041 $\pm$ 0.884 <sup>†</sup>
16:1	3.350 $\pm$ 1.955	0.458 $\pm$ 0.287	none detected
18:0	20.365 $\pm$ 1.751	5.961 $\pm$ 1.588 <sup>†</sup>	7.942 $\pm$ 0.708 <sup>†</sup>
18:1	35.343 $\pm$ 2.954	8.231 $\pm$ 0.734 <sup>†</sup>	9.233 $\pm$ 0.238 <sup>†</sup>
18:2	4.513 $\pm$ 0.698	1.681 $\pm$ 0.584 <sup>†</sup>	1.765 $\pm$ 0.188 <sup>†</sup>
18:3	1.423 $\pm$ 0.178	0.178 $\pm$ 0.103 <sup>†</sup>	0.157 $\pm$ 0.073 <sup>†</sup>
20:0	3.281 $\pm$ 1.738	0.178 $\pm$ 0.104	0.298 $\pm$ 0.168
20:1	2.525 $\pm$ 1.397	none detected	0.082 $\pm$ 0.057
20:4	0.002 $\pm$ 0.000	76.151 $\pm$ 3.666 <sup>†</sup>	none detected
22:0	0.155 $\pm$ 0.155	none detected	none detected
22:1	1.961 $\pm$ 1.259	none detected	0.056 $\pm$ 0.056

The data was transformed using arcsine (to ensure the percentage values were normally distributed) and then analysed statistically. Data values in table refer to percentage (w/w) free fatty acid composition of serum and represent mean value  $\pm$  SEM of four determinations. Students t-test was used to compare data from supplemented sera with those from control serum.

<sup>†</sup> significantly higher ( $p < 0.05$ ) then the value obtained for control serum.

<sup>‡</sup> significantly lower ( $p < 0.05$ ) then the value obtained for control serum.

**Table 4.5 — Fatty acid profile of total phospholipid extracted from HTC cell plasma membrane isolated from control and 20:4-supplemented cells**

Plasma membranes were isolated from control HTC cells and those grown in 60 $\mu$ M 20:4 for 36 hours as described in Materials and Methods and legend of table 4.3. The lipids were extracted from the purified plasma membranes and phospholipid fraction purified on TLC as described in Materials and Methods. Methyl esters of the fatty acid moiety of the isolated plasma membrane phospholipids were prepared and analysed as described in Materials and Methods.

Fatty acid	Plasma membrane type	
	Control	20:4 supplemented
16:0	31.049 $\pm$ 1.745	30.608 $\pm$ 1.687
16:1	7.963 $\pm$ 1.368	4.540 $\pm$ 1.618
18:0	14.265 $\pm$ 0.855	13.443 $\pm$ 0.854
18:1	39.466 $\pm$ 1.018	24.499 $\pm$ 0.748 <sup>†</sup>
18:2	4.426 $\pm$ 0.309	2.276 $\pm$ 0.274 <sup>‡</sup>
18:3	0.694 $\pm$ 0.205	0.017 $\pm$ 0.013 <sup>‡</sup>
20:0	0.559 $\pm$ 0.304	0.234 $\pm$ 0.112
20:1	0.962 $\pm$ 0.408	0.277 $\pm$ 0.160
20:4	0.005 $\pm$ 0.005	24.303 $\pm$ 1.769 <sup>†</sup>
22:0	0.158 $\pm$ 0.108	none detected
22:1	none detected	none detected

The data was transformed using arcsine (to ensure the percentage values were normally distributed) and then analysed statistically. Data values in table refer to percentage (w/w) fatty acid composition of plasma membrane phospholipids, and represent mean value  $\pm$  SEM of four determinations. Students t-test was used to compare data from 20:4 supplemented plasma membranes with those from control plasma membranes.

<sup>†</sup> significantly higher ( $p < 0.05$ ) than the value obtained for control plasma membranes.

<sup>‡</sup> significantly lower ( $p < 0.05$ ) than the value obtained for control plasma membranes.

**Figure 4.12 — Fatty acid chain length of HTC cell plasma membrane phospholipids**

The figure shows the proportions of fatty acid, grouped according to chain length, present in plasma membrane phospholipids derived from control and arachidonic acid-supplemented HTC cells that were treated as described in legend of table 4.5. This figure has been constructed from data shown in table 4.5.

The data was transformed using arcsine (to ensure the percentage values were normally distributed) and then analysed statistically. Students t-test was used to compare data from 20:4 supplemented plasma membranes with those from control plasma membranes.

Supplementation with 20:4 resulted in a significant rise ( $p < 0.05$ ) in fatty acids (derived from plasma membrane phospholipid) containing 20 carbons and a significant decrease ( $p < 0.05$ ) in 18 carbon fatty acids when compared to the corresponding data from control.

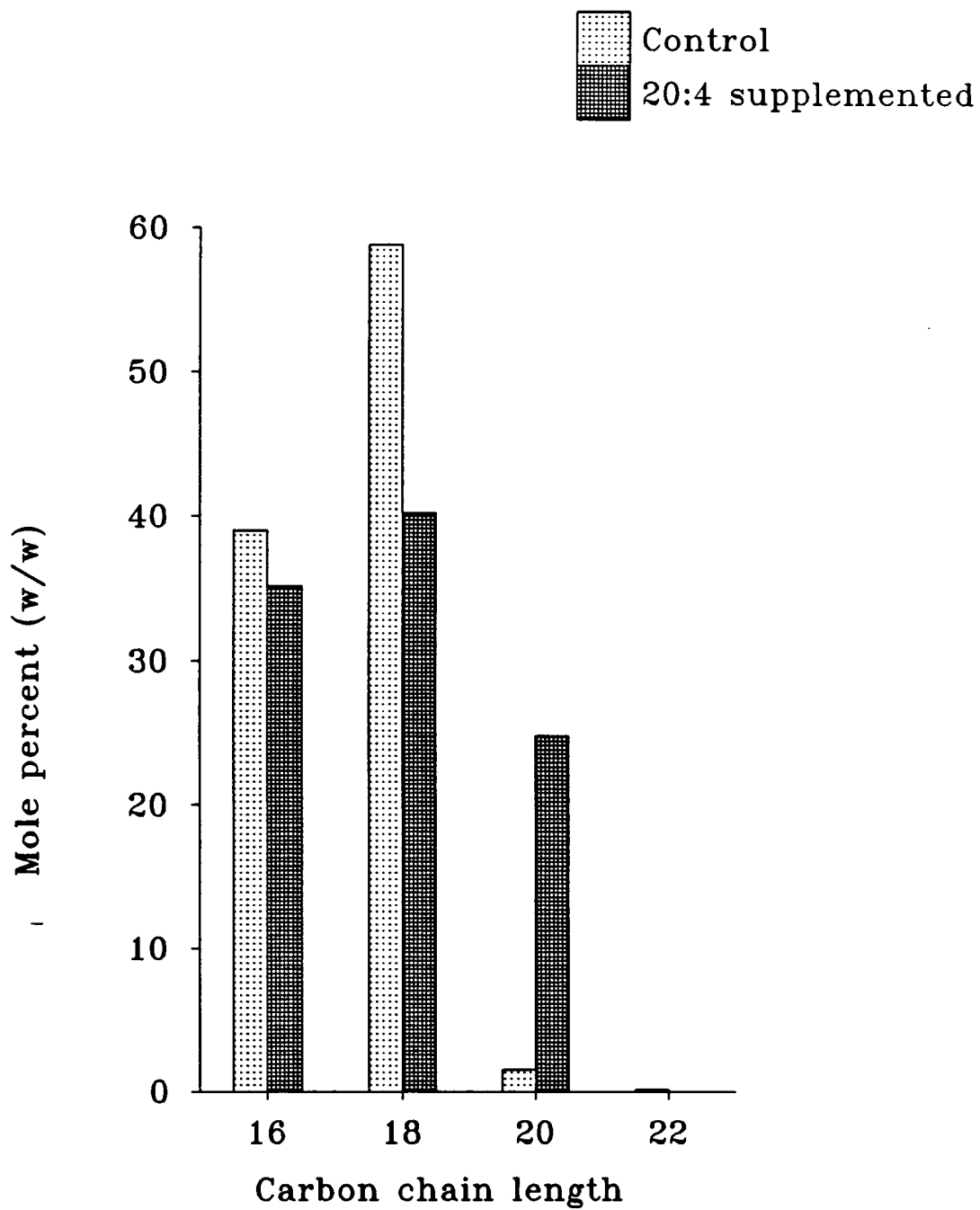
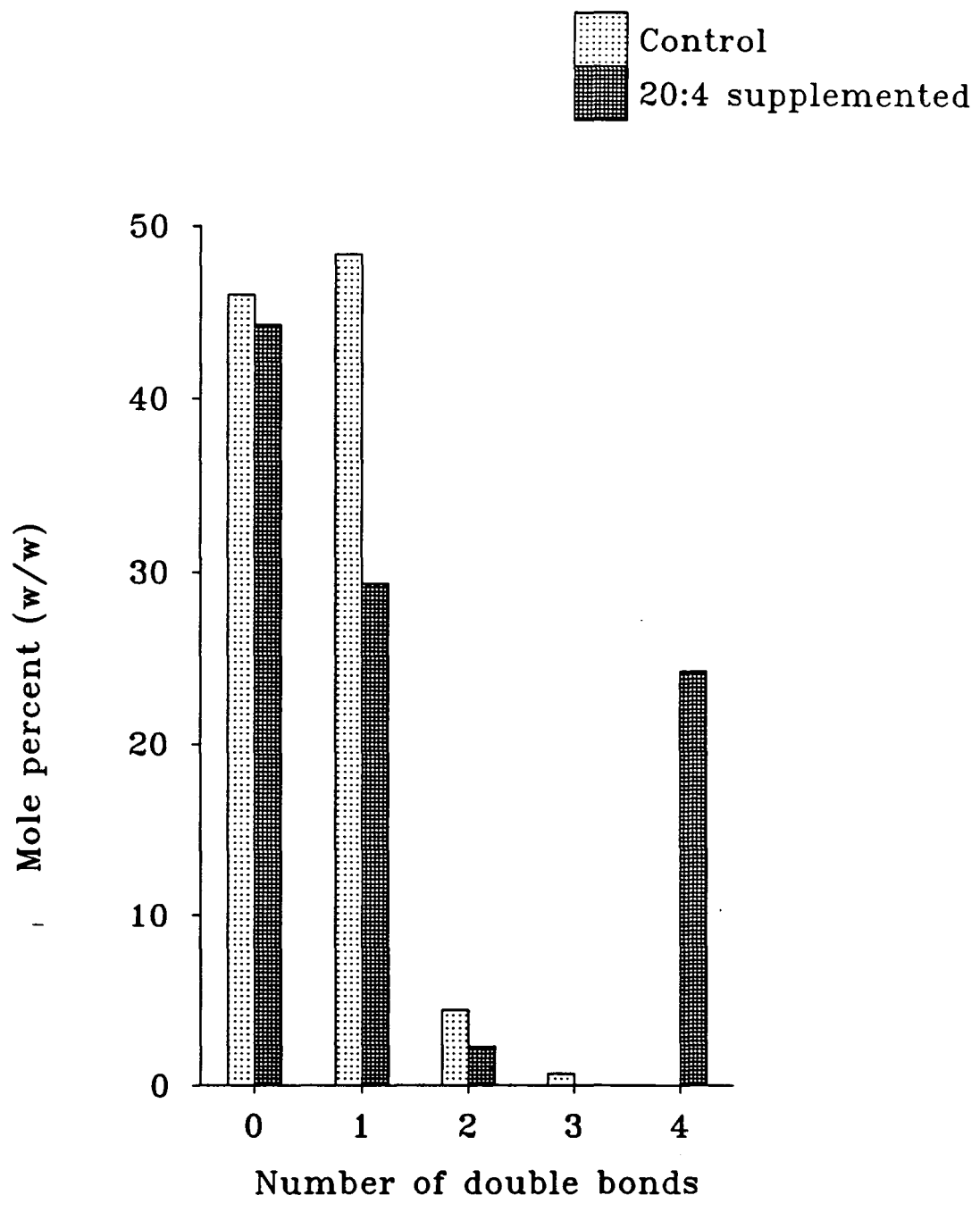

**Figure 4.13 — Fatty acid unsaturation of plasma membrane phospholipids from control and arachidonate-supplemented HTC cells**

The figure shows the proportion of fatty acids bearing olefinic (unsaturated) bonds in plasma membrane phospholipids derived from control and arachidonic acid- supplemented HTC cells as described in the legend of table 4.5. This figure has been constructed from data shown in table 4.5.

The data was transformed using arcsine (to ensure the percentage values were normally distributed) and then analysed statistically. Students t-test was used to compare data from 20:4 supplemented plasma membranes with those from control plasma membranes.

Supplementation with 20:4 resulted in a significant rise ( $p < 0.05$ ), in fatty acids (derived from plasma membrane phospholipid) containing 4 olefinic bonds with a significant decrease ( $p < 0.05$ ) in mono, di and tri unsaturated fatty acids when compared with the corresponding data from control plasma membranes.



**Table 4.6 — Cholesterol/phospholipid molar ratio, oleic acid/PUFA ratio and the unsaturation index of control and arachidonic acid supplemented HTC cell plasma membranes**

Plasma membranes were isolated as described in Materials and Methods from control cells and cells supplemented with 60 $\mu$ M arachidonic acid for 36 hours. Cholesterol, phospholipid and protein assays were performed as described in Materials and Methods. Oleic acid/PUFA ratio and unsaturation index were calculated from table 4.5.

Parameter	Plasma membrane type	
	Control	20:4 supplemented
Cholesterol/protein ratio	0.217 $\pm$ 0.018	0.219 $\pm$ 0.062
Number of determinations	7	3
Cholesterol/phospholipid ratio	0.438 $\pm$ 0.031	0.440 $\pm$ 0.065
Number of determinations	7	3
Phospholipid/protein ratio	0.496 $\pm$ 0.024	0.480 $\pm$ 0.066
Number of determinations	7	3
Oleic acid/PUFA ratio	7.700 $\pm$ 0.783	0.921 $\pm$ 0.060 <sup>†</sup>
Number of determinations	4	4
Unsaturation index	59.34 $\pm$ 2.171	131.1 $\pm$ 5.023 <sup>†</sup>
Number of determinations	4	4

Data values in the table represent the mean value  $\pm$  SEM. Students t-test was used to compare data from 20:4 supplemented plasma membranes with those from control plasma membranes.

In order to calculate the unsaturation index the proportion of each fatty acid in an analysis is multiplied by the number of double bonds contained in that fatty acid and the values thus obtained are summed over all the fatty acids present.

<sup>†</sup> significantly higher ( $p < 0.05$ ) than the value obtained for control plasma membranes.

<sup>‡</sup> significantly lower ( $p < 0.05$ ) than the value obtained for control plasma membranes.

**Figure 4.14 — Steady state fluorescence polarisation of DPH in plasma membranes from control and arachidonic acid-supplemented HTC cells**

Plasma membranes were purified as described in Materials and Methods from control cells and from supplemented cells that had been exposed to  $60\mu\text{M}$  arachidonic acid for 36 hours. The figure shows the effect of temperature on the polarisation of DPH in control (●) and arachidonic acid supplemented (○) plasma membrane preparations. The plot is derived from two separate plasma membrane preparations.

Best fit regression lines were fitted to the data using the straight line equation:

$$y=mx + c$$

Values of  $c$ (intercept on  $y$  axis),  $m$ (gradient) and  $r$ (correlation coefficient) are given below.

Parameters of best fit	Control plasma membranes	20:4 supplemented plasma membranes
$m$	-0.00404 $\pm 0.00004$	-0.00418 $\pm 0.00008$
$c$	0.3931 $\pm 0.00090$	0.3641 $\pm 0.00215$
$r$	-0.9944	-0.9707

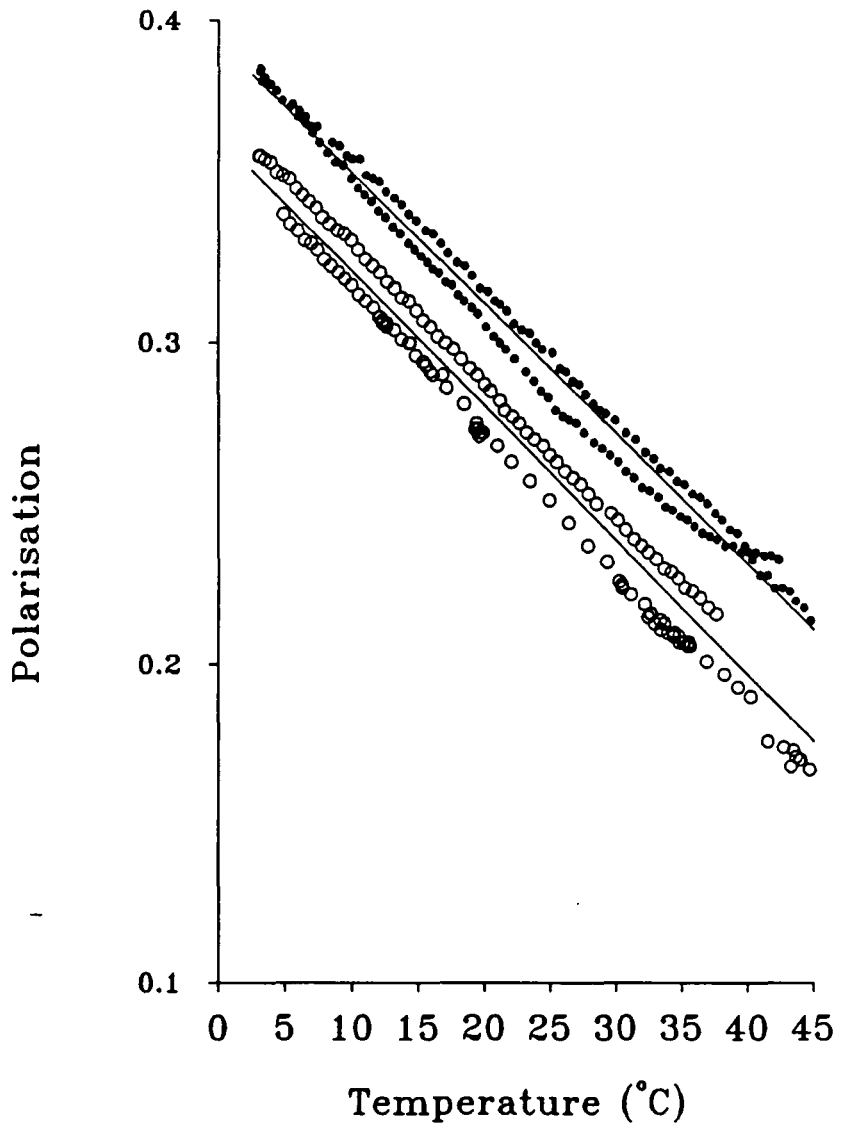

## 4.4 Discussion

The activities of alkaline phosphodiesterase I, NADPH cytochrome c reductase, succinate dehydrogenase and N-acetyl  $\beta$  D-glucosaminidase all followed linear kinetics with increasing time and protein concentration in agreement with Lopez-Saura *et al.*, (1978). Three additional enzymes  $Mg^{2+}$ -ATPase,  $Na^+$ ,  $K^+$ -ATPase and adenylate cyclase were also investigated and the latter two showed linear responses with respect to protein and time. However  $Mg^{2+}$ -ATPase only showed linear kinetics with respect to protein but not time.

The requirement for metal ions by alkaline phosphodiesterase I has been reported by Nakabayashi and Ikezawa (1986) who found that  $Ca^{2+}$ , and to greater extent  $Mg^{2+}$ , stimulates the enzyme. Beaufay *et al.* (1974) tested a variety of other divalent ions and showed that  $Zn^{2+}$  was the most potent activator of the rat liver enzyme. Lopez-Saura *et al.* (1978) showed that the enzyme of HTC cells was also stimulated by 2mM  $Zn^{2+}$ . Similarly, in this study the maximal activation of the enzyme was obtained at  $Zn^{2+}$  concentration of 4mM, above which rapid loss of activation was obtained. The role the metal ion plays in the catalysis is not clear and the potential mechanisms of action are listed below.

- 1) Required at the active site (similar to carboxypeptidase)
- 2) Substrate- $Zn^{2+}$  complex required for effective catalysis

The unmasking of 30% of the alkaline phosphodiesterase I activity by triton X100 has been shown by Lopez-Saura *et al.* (1978). The reason given for this observation is that this ectoenzyme is also present in substantial amounts within the cell, on endoplasmic reticulum, lysosomes or endocytic vesicles. The homogenisation procedure employed does not release the enzyme from the intra-

cellular compartments, but solubilization of the membranes by triton X100 results in the exposure of this enzyme.

The lack of effect of triton X100 on N-acetyl  $\beta$  D-glucosaminidase activity may indicate that the lysosomes were damaged in the homogenisation step and all the N-acetyl  $\beta$  D-glucosaminidase activity was released.

The loss in activity with time observed with  $Mg^{2+}$ -ATPase is a property common to  $Mg^{2+}$ -ATPase from liver (Emmelot and Bos, 1966) and mitochondria (Kielley and Kielley, 1953). This effect has been attributed to inhibition by the product, ADP, of the enzyme during catalysis (Kielley and Kielley, 1953).

The non-linear response of  $Mg^{2+}$ -ATPase with incubation time also raises the problem of meaningful interpretation of the results. If it is assumed that inhibition properties of the enzyme remain constant after purification then for a given assay time the activity is directly proportional to the amount of enzyme present. Therefore, the relative purification and recovery data can be reliably determined, although one cannot compare the absolute activities at different reaction times. However, since the enzyme is present in a variety of cell membranes, it was not an important marker enzyme in this study, so these problems were not important.

The data presented in table 4.7 shows the plasma membrane purification obtained by other workers. The method used by Lopez Saura *et al.* (1978) generates plasma membranes in very high yield (45.6%) but with low purity (3.1-fold). The procedure used by Tweto *et al.* (1976) obtained a purification of 11.7-fold but with a poor recovery (1.2%). Sauvage *et al.* (1981) using HTC cells isolated a plasma membrane fraction enriched in alkaline phosphodiesterase I by 21-fold with a yield of 22.8% . However, digitonin treatment was used to resolve the membranes. This

procedure is undesirable in the present study as the work involves measurement of the physical state of the HTC plasma membranes. Thus these methods were not suitable for the present work and the purpose of the procedure developed was to isolate, rapidly, a plasma membrane enriched fraction in high relative purity and yield without the use of membrane perturbants. To this end, the method used by Loten and Redshaw-Loten (1986) to purify plasma membrane from liver was adapted for purification of plasma membrane from HTC cells. The plasma membrane fraction produced via this method meets these requirements, thereby facilitating the studies on the structure and function of HTC cell plasma membranes. The markers used to assess plasma membrane recovery and purity were  $\text{Na}^+$ ,  $\text{K}^+$ -ATPase activity, adenylate cyclase activity, alkaline phosphodiesterase I activity and cholesterol content. The best markers for plasma membranes are the  $\text{Na}^+$ ,  $\text{K}^+$ -ATPase and adenylate cyclase, because these enzymes are solely located in the plasma membrane. However, the adenylate cyclase activity present in HTC cells was extremely low and only detectable after forskolin stimulation (see chapter 5). The alkaline phosphodiesterase I and cholesterol are not ideal plasma membrane markers as these are also found in intracellular membranes. These differences in the plasma membrane markers may account for the lower purification and recovery of plasma membrane obtained when using alkaline phosphodiesterase I and cholesterol as markers, compared with using  $\text{Na}^+$ ,  $\text{K}^+$ -ATPase and adenylate cyclase as markers. The contamination of plasma membrane fraction by lysosomal, endoplasmic reticulum and mitochondrial membranes was low. The purification and recovery for the markers of these intracellular membranes in the plasma membrane fraction compare favourably (see table 4.7) with those obtained by Sauvage *et al.* (1981) for the same cell line. However, digitonin was used by these workers to obtain a plasma membrane fraction with low contamination from intracellular membranes.

Lopez-Saura *et al.* (1978) also isolated a plasma membrane fraction from HTC cells which was greatly contaminated with intracellular membranes (see table 4.7). Tweto *et al.* (1976) isolated a plasma membrane fraction from HTC cells which was free from endoplasmic reticulum membrane contamination and only slightly contaminated with mitochondrial membranes (see table 4.7). Contamination of the plasma membrane fraction with lysosomal membranes was not assessed by these workers.

The majority of the studies investigating the effect of supplemental fatty acid have been at the cellular level, and this work has been reviewed extensively (Spector *et al.*, 1981; Stubbs and Smith, 1984; Spector and Yorek, 1985; Rosenthal, 1987). However, relatively few investigations have dealt with the effect of fatty acid supplementation on purified subcellular membranes. As the analyses carried out in this study are on purified plasma membranes, comparisons will be made to other investigations dealing with isolated plasma membrane and only pertinent studies carried out on whole cells will be considered.

When serum, a source of free fatty acids, is present in culture medium suppression of *de novo* fatty acid synthesis takes place which favours the uptake and incorporation of fatty acids present in the culture medium (Spector and Yorek, 1985). This is reflected in the similarity between the fatty acid profiles of normal newborn bovine serum (Table 4.4) and the plasma membrane phospholipid isolated from HTC cells grown in the culture medium containing newborn bovine serum (Table 4.5). This observation is in agreement with those reported by Geyer *et al.*, (1962) and Wood (1973). The large proportion of 18:1 in the plasma membrane fatty acids of HTC cells correlates with the findings of Alaniz *et al.* (1984), working on the whole cell fatty acid composition of HTC cells

grown in Swim's 77 medium containing calf serum. This high level of 18:1 is one of the most frequently reported abnormalities in lipids of neoplasms when compared to lipids of normal cells (Ruggieri and Fallani, 1973; Wood *et al.*, 1974; Van Blitterswijk, 1984). The low 20:4 content in plasma membrane fatty acids of HTC cells also correlates with the low cellular 20:4 content obtained by Alaniz *et al.* (1984). This may arise from an impairment of the ability to synthesize 20:4 from linoleic acid due to a low  $\Delta^6$  desaturase activity for 18:2  $\Delta^{9,12}$  (linoleic acid). In control cells, the direct incorporation of 20:4 from the growth medium will also be small due to the low levels of 20:4 in newborn bovine serum. When the newborn serum free fatty acid profile was substantially altered by supplementation with 20:4 (Table 4.4), the cells grown in the 20:4 enriched environment incorporated the 20:4 into the fatty acids of plasma membrane phospholipids. The proportion of 20:4 in the fatty acids of plasma membrane phospholipid increased (Table 4.5) from 0.005 to 24.3% of the fatty acid content. The mechanism by which this occurs could be via both *de novo* synthesis of phospholipid and through the deacylation/reacylation pathway. The relative contribution of these two routes to the incorporation of 20:4 cannot be determined from the present study and is known to depend on cell type and experimental conditions. The incorporation of 20:4 resulted in a substantial reduction in 18:1 in plasma membrane phospholipids. This could be due to competition by a relatively large load of 20:4 as compared to 18:1 available for incorporation and the selective incorporation of 20:4 via arachidonoyl CoA synthetase. This will favour remodelling of acyl groups towards 20:4. The replacement of 18:1 in cellular lipids caused by supplementation with polyunsaturated fatty acid is a common feature observed by many other workers analysing plasma membrane fatty acids (Spector and Burns, 1987; King and Spector, 1978). Alaniz *et al.* (1984), using HTC cells, showed that when 40  $\mu$ M 20:4 was added to

the culture medium the cellular proportion of 20:4 in total lipids increased from 4.6% to 13.2% of the fatty acid content while 18:1 was decreased from 39.1% to 30.8% of the fatty acid content.

Although the supplementation procedure used in this study caused an increase in the level of 20:4 in plasma membrane phospholipid acyl groups, this was at the expense of other unsaturated fatty acids. The proportion of saturated fatty acids remained constant in plasma membrane phospholipid acyl groups, which is in keeping with the findings of Stubbs and Smith (1984). This implies that the saturated fatty acids found in the *sn-1* position of the phospholipid remain unaltered while the unsaturated fatty acids predominantly found in the *sn-2* position are substituted by the supplemental unsaturated acids.

There are two main approaches to altering fatty acid composition of cell membranes: feeding tumour bearing animals diets of different fatty acid composition (*in vivo* modification); and the growth of cells in culture media containing the supplemental fatty acid (*in vitro* modification). Using the first approach of *in vivo* modification, Burns and Spector (1987) showed that fatty acid composition of plasma membranes isolated from L1210 cells grown in mice was altered in favour of the fatty acids present in the diet. That is, L1210 cells grown in mice fed the basal diet supplemented with 16% coconut oil (saturated fats) had a greater proportion of saturated acyl chains in the plasma membrane phospholipids from these cells. Conversely, L1210 cells grown in mice fed the basal diet supplemented with 16% sunflower seed oil (polyunsaturated fat) had a greater proportion of unsaturated acyl chains in the plasma membrane phospholipids from these cells. Furthermore, in agreement with data obtained in the present study, there was no change in the phospholipid or cholesterol content due to the change in fatty acyl groups of the

phospholipids in the plasma membranes. In addition, another determinant of fluidity, the proportion of different phospholipid head groups, which was not analysed in the present study also remained unaltered. However, fluidity measurements, as determined by ESR using 12-nitroxystearate and 5-nitroxystearate, showed a decrease in membrane order in plasma membranes isolated from L1210 cells grown in mice fed the diet supplemented with polyunsaturated fat when compared to plasma membranes isolated from cells grown in mice fed the diet supplemented with saturated fat. Therefore, these changes in plasma membrane order can be attributed to a change in fatty acyl groups of the plasma membrane phospholipid. Although dietary studies in animals yield useful information on gross fatty acid compositional changes in tumours, the method does not permit a precise evaluation of a specific fatty acid substitution that is possible with *in vitro* modification. However, there are a number of factors that need to be taken into account when comparing data obtained by other workers using *in vitro* modification methodology. For example, the extent of modification of the plasma membrane phospholipid acyl chains will depend on the concentration of the supplemental fatty acid in the culture media and the time of supplementation. The concentration presented to the cell must be high enough to ensure incorporation into the phospholipids, but low enough to avoid the potential cytotoxic effects of high levels of supplemental fatty acid in the culture media. This optimisation of the concentration of supplemental fatty acid to be used was carried out in the present study and has been presented in chapter 3.

The uptake of the fatty acid is dependent on the form in which the supplemental fatty acid is presented to the cell i.e. whether included in culture media with serum, or bound to albumin (Fleischer *et al.*, 1986) and then incorporated

into serum-free media. In the former approach, used in this investigation, the supplemental fatty acid predominates in the culture medium, but is accompanied by a spectrum of other free fatty acids present in the serum component of the culture medium. However, in the latter approach, using serum-free media (chemically defined media), the supplemental fatty acid is the only source of fatty acid and, therefore, makes the interpretation of results simpler, as the undefined constituents of serum are omitted. As discussed in chapter 2, this approach was not possible in the present study as the HTC cells would not grow in chemically defined media.

The lipid metabolism of the cell, which is dependent on culture conditions, will direct the assimilation of fatty acid into a variety of lipids. The possible fates of fatty acids supplied to the cell have been summarised in the general schemes presented in figures 4.1 and 4.2. The conversion of the supplemental fatty acid to another fatty acid may also influence the composition of acyl groups of membrane phospholipids. For example, when LM cells were grown in  $100\mu\text{M}$  20:4 for 24 hours there was an increase in the proportion of 20:4 from 2.0% to 18.3%, as well as an increase in 22:4 from 0% to 12.7% in the acyl groups of cellular phospholipids. Hence, the cells converted 20:4 to 22:4, which was also incorporated into the fatty acids of cellular phospholipids (Wolters and Konings, 1982).

The time for which the cells are exposed to the supplemental fatty acid (supplementation time) will influence the extent of fatty acid incorporation into phospholipid. Supplementation times of 3 hours have been shown to be sufficient to alter plasma membrane fluidity of Ehrlich ascites (King and Spector, 1978). They isolated plasma membranes (10-fold pure as judged by  $\text{Na}^+$ ,  $\text{K}^+$ -ATPase activity) after supplementing with the appropriate fatty acid at a concentration of 1.67mM in defined media for 3 hours. The fatty acids of the plasma membrane phospho-

lipids from these cells were enriched with the supplemental fatty acid with no change in the cellular phospholipid composition, phospholipid/cholesterol molar ratio, cell number, DNA, protein and phospholipid content. These results indicated that the changes in fatty acyl composition resulted from a modification or replacement of plasma membrane phospholipid, not from cell growth or division. However, the short term incubation of 3 hours results in less extensive changes than those that can be attained with long term cultures. As discussed by Konings and Ruifrok (1985) if the supplementation time is too long (>36 hours), compensatory mechanisms will gradually eliminate the differences produced in membrane fluidity. Hence supplementation times must be chosen with care to optimise effects of fatty acyl modification of plasma membrane phospholipid.

The purity of the isolated membranes is rarely quoted in the literature when fatty acid profiles of purified plasma membrane phospholipids are presented. This is important, as it gives an indication of the contamination of the plasma membrane fraction by membranes from subcellular organelles. As clearly demonstrated by Burns *et al.* (1988), subcellular membranes are altered to a different extent when the cells are presented with a supplemental fatty acid. Their data indicated that when L1210 cells were supplemented with 22:6, the proportion (mole %) of 22:6 in phospholipid from nuclear, mitochondrial, plasma membrane and microsomal fractions was 26.2% ,40.8% ,30.3% , and 17.4% of the total fatty acid content of each fraction respectively. Therefore, changes in phospholipid fatty acid composition determined in crude preparations cannot be attributed mostly to plasma membrane phospholipids. This problem was discussed by Burns *et al.* (1988) when analysing data from the investigations of Hyman and Spector (1982). They isolated a microsomal fraction from human Y79 retinoblastoma cells grown in culture

media supplemented with fatty acid (18:1 or 18:3 or 20:4 or 22:6) but this microsomal fraction contained both endoplasmic reticulum and plasma membranes. Hence, the change in the phospholipid fatty acid composition determined was an average, dependent on the relative proportions of each type of membrane present. When the Y79 cells were supplemented with 30 $\mu$ M arachidonic acid for 72 hours, the arachidonate content of microsomal membranes increased by 8.2% of the total fatty acid. This increase resulted in a corresponding decrease in 18:1 but an increase in the level of 22:5 and 16:0. Wolters and Konings (1982), using mouse fibroblast LM cells, showed that when these cells were exposed to 100 $\mu$ M 20:4 bound to BSA in serum-free medium for 24 hours, the proportion of 20:4 in cellular phospholipids rose from 2% to 18.3% of the fatty acid content. However, supplemental 20:4 was also converted to 22:4, the proportion of which increased in the cellular phospholipid from 0% to 12.7% of the fatty acid content. Plasma membranes isolated from these cells (Wolters and Konings, 1984) by the method of Maeda *et al.* (1980) showed an increase in the proportion of polyunsaturated fatty acids of plasma membrane phospholipids from 6.8% to 44.3% of fatty acid content. Correspondingly, an increase in plasma membrane fluidity measured by fluorescence polarisation of DPH at room temperature was also obtained, which is in general agreement with the trends obtained in this study.

The measurement of membrane fluidity using a variety of probes has been reviewed by Stubbs and Smith (1984). DPH, the probe used in this study, does not reveal subtle information such as the motion of the acyl chains at different depths in the membrane or the conformational disorder associated with chain isomerization. The assessment of these subtle changes should be the subject of further investigation with NMR techniques or other fluorescent probes.

However, the increase in the proportion of 20:4 and decrease in 18:1 in the fatty acids of plasma membrane phospholipids obtained in the present study correlated with a decrease in the DPH polarisation at all temperatures from 2–45<sup>0</sup>C. This indicates an increase in membrane fluidity. However, the DPH polarisation data does not show the dramatic change in fluidity associated with the phase transition from the gel state to the liquid crystalline state. The lack of a distinct phase transition point may be due to the presence of cholesterol in the plasma membrane which is known to diminish a sharp transition point (see chapter 3). The more likely explanation for this observation was put forward by Gilmore *et al.* (1979a), who found that LM cell membranes did not give any indication of a sharp phase transition or discrete region of a lateral phase separation in the temperature range studied (5–40<sup>0</sup>C), using DPH to monitor membrane order. This was also found in earlier studies by Barenholz *et al.* (1976) and Esko *et al.* (1977). The most likely interpretation of the data is that there is a continuous change in the motion of DPH and the fatty acid chains in this temperature range. Further analysis of individual phospholipid classes shows that their phase transition temperatures are practically all below 0<sup>0</sup>C (except sphingomyelin, a minor membrane component; Gilmore *et al.*, 1979b).

The existence of membrane domains could also influence the detection of a distinct change in the DPH polarisation expected during phase transition e.g. below the phase transition temperature the membrane could consist of gel state domains, and hyperfluid domains (lipid phase separation). As DPH partitions into both domains the relative contributions of each type of domain to the overall fluidity of the membrane will influence the detection of a phase transition point. The resolution of the membrane order present in domains would be of interest and could be

possible if probes were designed to partition exclusively into particular domains.

In the present study the increase in plasma membrane fluidity, observed by DPH polarisation measurements, is thought to be due primarily to the change in fatty acid composition of membrane phospholipids after supplementation with 20:4. Other membrane parameters such as the phospholipid/cholesterol molar ratio, the cholesterol content relative to protein and the phospholipid content relative to protein remained unaltered after 20:4 supplementation. As the phospholipid content did not change, in agreement with the findings of Spector *et al.* (1979), the fatty acid compositional change occurred in a fixed amount of total phospholipid. However, phospholipid head group analysis was not carried out and the ratio of phosphatidylcholine to phosphatidylethanolamine, which is another index of fluidity, may have altered. Although this analysis was not performed it has been shown by previous investigators that fatty acid modifications such as those carried out in this study cause no change in phospholipid head groups (King and Spector, 1978; Robert *et al.*, 1978; Mahoney *et al.*, 1980). Hence, it is likely that the change in fatty acid composition of plasma membrane phospholipid is responsible for the higher membrane fluidity in the present study. This is quite feasible, as the 20:4 primarily replaced 18:1 in the plasma membranes isolated from cells grown in 20:4-supplemented growth media. Although 20 carbon chains (mostly 20:4) replaced 18 carbon chains, the effective chain length is reduced by the double bonds which determine the structural configuration adopted by the 20:4 acyl chains. The conformed configuration adopted by 20:4 will decrease order and packing within the lipid bilayer. This will reduce the magnitude of van der Waals interactions with surrounding acyl chains, thus increasing fluidity. Phospholipids containing such highly unsaturated fatty acyl chains are also unlikely to associate with cholesterol,

and may thus create extremely fluid domains leading to decreased DPH polarisation. The incorporation of 20:4 into plasma membrane phospholipid at the expense of 18:1 will have the obvious consequence of the introduction of double bonds in the C1-C9 region of the fatty acyl core. As the acyl chain in membrane phospholipids has been found to exhibit a higher degree of order in the region between C1-C9 than in the region more distal from the head group, the introduction of double bonds in this region will result in lowering the degree of order associated with this part of the fatty acyl core. This will result in lowering the membrane fluidity.

The increase in membrane fluidity by both *in vivo* and *in vitro* fatty acid modification of membrane phospholipid has been demonstrated by many workers (See Stubbs and Smith, 1984). Furthermore, Cossins and Prosser (1978) in their study of synaptic membranes from a variety of animal species, have shown that membrane fluidity is principally influenced by the fatty acid composition of the phospholipid. They found a very good correlation between fluorescence polarisation and the ratio of saturated to unsaturated fatty acids. Similarly, Castuma and Brenner (1983), who isolated liver microsomes from guinea pigs fed fat-free diets, showed that such microsomal membranes were less fluid and this correlated with an increase in the proportion of saturated fatty acids of the microsomal membrane-phospholipids. York *et al.* (1982), using genetically obese (*ob/ob*) mice, isolated plasma membranes and subcellular membranes from a variety of tissues. Compared to lean mice, the *ob/ob* mice membranes showed a lower DPH polarisation (increased fluidity) in all cases except red blood cells. Lipid analysis of the adipocyte plasma membrane indicated that the change in membrane fluidity was entirely due to a change in fatty acid composition of the membrane phospholipids. An increase in the proportion of 22:6 from 13.8 to 20.7% and a decrease in the pro-

portion of 18:2 from 21.7 to 10.6% of the fatty acid content of plasma membrane phosphatidylethanolamine was the major compositional change. The studies cited above clearly show that the fatty acid composition of membrane phospholipids play a major role in determining membrane fluidity.

There are many possible consequences of increased membrane fluidity in relation to hyperthermia. As pointed out by Bowler *et al.* (1982), decreased order of plasma membranes makes them more fluid, and therefore more permeable at any given temperature, as compared with normal plasma membrane. Lepock (1982) suggested that membranes undergo irreversible structural transitions after mild hyperthermia (41-44<sup>0</sup>C ) and these are probably due to denaturation of membrane proteins, leading to the impairment of cell function. Recently, Konings (1988) also suggested that membrane-bound proteins are the primary target molecules in hyperthermic cell killing. Thus the importance of the decreased membrane order of 20:4-supplemented plasma membrane in the heat sensitivity of HTC cells may be fully realized when considering how this factor affects membrane protein thermostability. Therefore, it seems crucial to investigate the effect of heat on the stability of key membrane bound enzymes in 20:4-supplemented and control plasma membrane (Konings, 1988). This is the aim of the work presented in the next chapter.

Table 4.7 — Plasma membrane purification obtained by other workers

Cell source	Plasma membranes		Endoplasmic Reticulum		Lysosomes		Mitochondria		Density gradient	Homogenisation method	Reference
	P	R	P	R	P	R	P	R			
HTC cells	11.7 <sup>a</sup>	1.2	0 <sup>b</sup>	0			0.3 <sup>d</sup>	1.5	Sucrose (discontinuous)	Dounce homogeniser	Tweto <i>et al.</i> , 1976
HTC cells	3.10 <sup>j</sup> 3.17 <sup>h</sup>	45.6 46.7	3.65 <sup>e</sup>	53.7	0.96 <sup>c</sup> 0.83 <sup>i</sup>	14.1 12.2	0.27 <sup>i</sup> 0.17 <sup>d</sup>	3.90 2.50	Sucrose (continuous)	Dounce homogeniser	Lopez-Saura <i>et al.</i> , 1978
HTC cells	21.0 <sup>j</sup>	22.8	1.09 <sup>e</sup>	1.2	2.73 <sup>c</sup> 1.81 <sup>i</sup>	3.0 2.0	0.27 <sup>g</sup>	0.3	Sucrose (continuous)	Dounce homogeniser	Sauvage <i>et al.</i> , 1981
Hepatoma 7288ctc	8.10 <sup>f</sup> 10.8 <sup>m</sup> 0.60 <sup>a</sup>		1.4 <sup>k</sup>				0 <sup>g</sup>	0	Sucrose (discontinuous)	Dounce homogeniser	Wood <i>et al.</i> , 1986
Rat liver	14.5 <sup>f</sup> 2.40 <sup>m</sup> 5.80 <sup>a</sup>		6.0 <sup>k</sup>				0 <sup>g</sup>	0	Sucrose (discontinuous)	Dounce homogeniser	Wood <i>et al.</i> , 1986
Rat liver	29.8 <sup>a</sup> 26.6 <sup>j</sup> 32.3 <sup>l</sup>	24.0 17.0 24.0	0.57 <sup>b</sup> 0.19 <sup>e</sup>	0.3 0.1			0 <sup>d</sup>	0	Percoll (continuous)	Dounce homogeniser	Loten and Redshaw-Loten, 1986

P=purification (fold) and R=recovery (%), relative to the initial homogenate

These purification parameters were calculated from assay of the specific activities of the following marker enzymes, denoted by superscript letters in the table: a=5'-nucleotidase, b=glucose-6-phosphatase, c=acid phosphatase, d=succinate dehydrogenase, e=NADPH cytochrome-c reductase, f=Na<sup>+</sup>, K<sup>+</sup>-ATPase, g=cytochrome-c oxidase, h=cholesterol, i=N-acetyl β D-glucosaminidase, j=alkaline phosphodiesterase I, k=NADH cytochrome-c reductase, l=adenylate cyclase (fluoride stimulated), m=Mg<sup>2+</sup>-ATPase

## Chapter V

### Thermostability of selected plasma membrane-bound enzymes

#### 5.1 Introduction

Biological membranes consist mainly of phospholipids, cholesterol and proteins. The proteins which are situated in the lipid bilayer interact with various components of the membrane in order to function effectively. These interactions may be with lipids of the membrane, and with submembranous peripheral and cytoskeletal proteins. The interaction of the proteins with the lipid component of the membrane is pertinent to this study and will be discussed further.

Membrane proteins have a short-range ordering effect on the lipids of the membrane. There usually exists around many membrane-bound proteins a shell of phospholipids. The composition of this shell of phospholipids is difficult to determine in the membrane, but reconstitution experiments have shown that membrane-bound enzymes express different levels of activity depending on the lipid composition of the model membranes into which these enzyme molecules are inserted. In the case of  $\text{Na}^+$ ,  $\text{K}^+$ -ATPase, it was shown that membrane bilayers comprising dioleoyl phosphatidylcholine yielded an enzyme with higher activity than those comprising dimyristoyl phosphatidylcholine, dipalmitoyl phosphatidylcholine, or distearoyl phosphatidylcholine (Anderle and Mendelson, 1986). It is therefore not surprising that the activities of many membrane enzymes are related to the physical state of the bilayer (Hesketh *et al.*, 1976), which in turn is related to the composition

of the membrane. Thus, lipid-protein interactions in biological membranes are important in sealing integral proteins into the bilayer, while maintaining the permeability barrier, and in controlling the conformation of integral proteins in the lipid bilayer.

Heat treatment of cells will bring about changes in the physical state of the membrane and probably alter the lipid-protein interactions. The influence of such heat-induced changes on the structure and function of membrane proteins has led to these events being implicated in hyperthermic cell death. Bowler *et al.* (1973) suggested that cellular heat injury may well result from the thermal sensitivity of membrane lipoproteins. This conclusion was based on *in vitro* thermal inactivation studies of 3 enzymes from crayfish muscle membrane:  $Mg^{2+}$ -ATPase;  $Na^+$ ,  $K^+$ -ATPase and  $Ca^{2+}$ -ATPase. These enzymes were found to be thermolabile in the range of temperatures lethal to the whole organism. In addition, pyruvate kinase, a soluble enzyme from muscle, was found to be much more thermostable than the membrane-associated enzymes. Similarly, Lepock *et al.* (1983) have shown that hyperthermic death of V79 cells correlated with irreversible transitions in membrane proteins. Using both intrinsic protein fluorescence, and energy transfer from membrane protein to the lipid soluble fluorescent probe, *trans*-paranaric acid, they found that membrane proteins underwent irreversible transitions above  $40^{\circ}C$ .

The plasma membrane-mediated transport of  $Ca^{2+}$  via the  $Ca^{2+}$ -ATPase and the co-transport of  $Na^+$  and  $K^+$  via the  $Na^+$ ,  $K^+$ -ATPase are well characterised, and so it is not surprising these enzymes, and their associated ion fluxes, have been used to probe the protein perturbing effects of high temperature. The  $Na^+$ ,  $K^+$ -ATPase activity of HeLa cells has been demonstrated to be rapidly inactivated by exposure to  $45^{\circ}C$  for 10 minutes (Burdon and Cutmore 1982; Burdon *et al.*, 1984),

but this activity was partially restored by subsequent incubation at 37<sup>0</sup>C. However, Ruifrok *et al.* (1986) found no reduction in the Na<sup>+</sup>, K<sup>+</sup>-ATPase activity of mouse lung fibroblasts and HeLa S<sub>3</sub> cells after heat treatment at 44<sup>0</sup>C for 40 minutes.

The changes in the ion fluxes across the plasma membrane during heat treatment have been demonstrated by many workers. Boonstra *et al.* (1984) found that incubation of hepatoma H35 cells at 42<sup>0</sup>C for up to 30 minutes increased Rb<sup>+</sup> (potassium tracer) influx through the Na<sup>+</sup>, K<sup>+</sup>-ATPase, which returned to normal levels after subsequent incubation at 37<sup>0</sup>C. Stevenson *et al.* (1983) demonstrated an increased K<sup>+</sup> transport in Chinese hamster ovary cells at 42<sup>0</sup>C, associated with the Na<sup>+</sup>, K<sup>+</sup>-ATPase. Bates and Mackillop (1985) showed that, in Chinese hamster ovary cells, ouabain-sensitive Rb<sup>+</sup> influx increased with temperature between 31<sup>0</sup>C and 45<sup>0</sup>C, and only above 45<sup>0</sup>C did an irreversible inhibition of Rb<sup>+</sup> influx occur. Similarly, Ruifrok *et al.* (1986) showed enhanced influx of Rb<sup>+</sup> in mouse lung fibroblasts during incubation at 44<sup>0</sup>C. However, when treated cells were returned to 37<sup>0</sup>C the enhanced activity was returned to control levels. Therefore, heat treatment did not cause irreversible damage to the K<sup>+</sup>-pumping activity of Na<sup>+</sup>, K<sup>+</sup>-ATPase at 44<sup>0</sup>C.

Anderson and Hahn (1985) carried out an investigation into the effect of hyperthermia on three separate activities of Na<sup>+</sup>, K<sup>+</sup>-ATPase, namely ATP hydrolysis, K<sup>+</sup> uptake, and binding of the specific inhibitor, ouabain. Their studies concluded that heating Chinese hamster ovary cells at 45<sup>0</sup>C inhibited ouabain-binding and Rb<sup>+</sup> uptake to the same extent, but ATPase activity was more resistant. Although the effect of heat on Na<sup>+</sup>, K<sup>+</sup>-ATPase has been investigated in detail, other membrane bound processes have also been studied. Na<sup>+</sup>-dependent amino acid transport is reversibly inactivated in a number of cell lines by hyperthermic treatment

(Lin *et al.*, 1978; Kwock *et al.*, 1978; Kwock *et al.*, 1985). Kwock *et al.* (1985) found that there was a 30% increase in DTNB-sulfhydryl group titration of surface proteins and this was associated with a reduction in Na<sup>+</sup>-dependent amino acid uptake. This suggests that hyperthermic treatment caused, or permitted, a rearrangement to occur in membrane protein conformation. The facilitated entry of glucose into Chinese hamster ovary cells has also been shown to be impaired at hyperthermic temperatures above 45<sup>0</sup>C (Le Cavalier and Mackillop, 1985).

Membrane receptors have also been shown to be altered after heat treatment. The affinity of the receptor for epidermal growth factor was reduced after heating rat fibroblasts for 30 minutes at 45<sup>0</sup>C (Magun, 1981). Calderwood and Hahn (1983) showed that the insulin receptor of Ha-1 cells was heat sensitive when treated at temperatures from 43<sup>0</sup>C to 45<sup>0</sup>C but, in contrast to the epidermal growth factor data, the affinity was not affected and the number of receptors was reduced. Hyperthermia also inhibits the binding of monoclonal antibodies to histocompatibility antigens on the surface of murine lymphoma cells in suspension culture. This inhibition also appears to result from reduction of receptor number (Mehdi *et al.*, 1984).

The investigations discussed so far show that heat affects the structure and function of membrane proteins, but how are the effects of heat on membrane proteins altered when their lipid environment is changed? Thermal acclimation, mentioned in chapter 3, involves maintaining cells or animals at temperatures above or below the normal growth temperatures. The cells or animals adapt to these changes by adjusting the membrane lipid composition, thereby altering membrane order to suit the acclimation temperature. However, acclimation of crayfish to 8<sup>0</sup>C or 25<sup>0</sup>C caused no change in the heat sensitivity of muscle plasma membrane

$\text{Na}^+$ ,  $\text{K}^+$ -ATPase and  $\text{Mg}^{2+}$ -ATPase nor the sarcoplasmic reticulum  $\text{Ca}^{2+}$ -ATPase (Bowler *et al.*, 1973; Cossins and Bowler 1976). In contrast, Cossins *et al.* (1981) demonstrated a clear resistance acclimation effect on the thermal sensitivity of goldfish synaptic membrane  $\text{Na}^+$ ,  $\text{K}^+$ -ATPase. The enzyme from 28<sup>0</sup>C -acclimated fish was thermally more resistant than that from 7<sup>0</sup>C -acclimated fish when the synaptic membranes were heated between 40<sup>0</sup>C to 52<sup>0</sup>C. The thermal stability of synaptic membrane acetylcholine-esterase in goldfish was similarly dependent upon acclimation temperature, and this correlated with the fact that warm acclimation caused an increase in the membrane order of the lipids. This evidence argues for the case that the more ordered the membrane, the more thermostable are the membrane proteins. However, Le Cavalier and Mackillop (1985) showed that whilst thermal adaptation of Chinese hamster ovary cells at 40<sup>0</sup>C increased survival at 43<sup>0</sup>C and 45<sup>0</sup>C, no difference in the thermostability of the transport of glucose was observed.

Barker (1985) working with the  $\text{Mg}^{2+}$ -ATPase enzyme from rat liver and two transplantable rat tumours (MC7 and D23) found that the  $\text{Mg}^{2+}$ -ATPase from the tumour was far more thermolabile than the same enzyme from liver. The plasma membrane lipid order, as measured by DPH fluorescence polarisation, correlated with the thermal sensitivity of the three enzymes: the less ordered (more fluid) the membrane lipid, the greater the sensitivity of this membrane-bound enzyme to heat.

Direct modification of the composition model membranes has also shown that thermostability of reconstituted membrane proteins is related to the order of the membrane. Cheng *et al.* (1987) demonstrated that when  $\text{Ca}^{2+}$ -ATPase from muscle sarcoplasmic reticulum was reconstituted into lipid mixtures containing differ-

ent proportions of cholesterol, the rate of thermal inactivation of  $\text{Ca}^{2+}$  uptake activity was lowest in lipid mixtures containing high levels of cholesterol. This implies that the more ordered the membrane (high cholesterol), the more thermostable the enzyme. However, it should be noted that although the  $\text{Ca}^{2+}$  uptake activity was thermolabile at hyperthermic temperatures, the ATP hydrolysis activity of  $\text{Ca}^{2+}$ -ATPase was more heat resistant. This is consistent with the findings of Anderson and Hahn (1985) for  $\text{Na}^+$ ,  $\text{K}^+$ -ATPase already mentioned earlier in this introduction. The data from Cheng *et al.* (1987) also demonstrated, using circular dichroism to monitor conformational change, that the  $\text{Ca}^{2+}$  uptake inactivation appears to be due to a direct denaturation of protein by heat and the protective effect of cholesterol on thermal inactivation of membrane proteins is probably due to increasing the denaturation temperature of protein domains embedded in the bilayer.

The enzyme responsible for generating cyclic AMP in the cell is adenylate cyclase which is present in the plasma membrane of the cell. Investigations into the mechanism, control and structure of this enzyme have shown it to be a complex regulatory system, the general features of which have been shown to apply to most tissues and species studied (Gilman, 1984). The basic structure of the adenylate cyclase functional unit consists of three plasma membrane-bound proteins: a hormone receptor, a guanine nucleotide binding protein and the catalytic subunit (Rodbell, 1980). Although only one type of catalytic subunit is known, it can operate in combination with one of several receptors and two or more guanine nucleotide-binding proteins. Therefore, the adenylate cyclase system is a good candidate for investigations into the effects of heat on interactions of the protein components within the plasma membrane.

There are many specific, high affinity receptors for a variety of hormones that act via adenylate cyclase. The receptors can be divided into two major groups: those that are concerned with transmitting the signal of stimulatory agents e.g.  $\beta$ -adrenergic and glucagon receptors; and those that are concerned with transmitting the signal of inhibitory agents e.g.  $\alpha_2$ -adrenergic, adenosine and prostaglandin receptors (Lefkowitz, *et al.*, 1983).

The guanine nucleotide-binding proteins function to control the activity of the catalytic subunit which converts ATP to cyclic AMP in the presence of  $Mg^{2+}$ . The guanine nucleotide-binding proteins (G-proteins) which affect adenylate cyclase are also divided into two groups (Hilderbrandt *et al.*, 1983), the stimulatory guanine nucleotide-binding proteins ( $G_s$ ) which mediate the stimulatory response (Northup *et al.*, 1980) and the inhibitory guanine nucleotide-binding proteins ( $G_i$ ) which mediate the inhibitory response (Bockoch *et al.*, 1983). The G-proteins ( $G_s$  and  $G_i$ ) consist of three different subunits,  $\alpha$ ,  $\beta$  and  $\gamma$ , and the  $G_\alpha$  can bind GDP or GTP.

The sites involved in the binding of nucleotide on the  $G_\alpha$  subunit are absolutely specific for guanine nucleotides; they will not bind adenosine 5'-triphosphate (ATP) or cytidine 5'-triphosphate (CTP). However, the  $G_s$  proteins require smaller concentrations of guanine nucleotide to activate them than the  $G_i$  proteins. i.e. the affinity of  $G_s$  for guanine nucleotides is higher than that of  $G_i$  (Cooper, 1983).

The guanine nucleotide-binding proteins also act as nucleoside triphosphatases (GTPases) hydrolysing bound guanosine 5'-triphosphate (GTP) to guanosine 5'-diphosphate (GDP) (Cassel and Selinger, 1976). In the resting state i.e. the non-hormonally activated condition, the GDP remains bound to the  $G_\alpha$  subunit (Cassel

and Selinger, 1978) as depicted in figure 5.1, showing the various components of the adenylate cyclase system.

The proposed mechanism of how these proteins cooperate in initiating and regulating the production of cyclic AMP has been summarised by Casperson and Bourne, (1987). The guanine nucleotide-binding proteins are active when GTP is bound, and inactive when GDP occupies the nucleotide binding site. On binding a stimulatory ligand, e.g. adrenaline, glucagon or high affinity  $\beta$ -adrenergic analogues such as L-isoproterenol, the hormone receptor is thought to undergo a conformational change which allows it to interact with the inactive  $G_s$  protein, bearing GDP bound to the  $\alpha$  subunit. This interaction stimulates the release of GDP and binding of GTP to this subunit, causing dissociation of the inhibitory  $\beta\gamma$  complex from the active  $\alpha$  subunit-GTP complex. The latter then interacts with the catalytic subunit and increases its enzymic activity. Thus, the adenylate cyclase system is 'turned on'. The activated  $G_s$  returns to its resting state when the GTP is hydrolysed to GDP and phosphate by the GTPase activity of the G-proteins. This 'turns off' the adenylate cyclase system, which returns to its former resting state in order to re-start the cycle of activation. In the resting state, slow exchange of bound GDP for cytosolic GTP occurs, resulting in low basal activity of adenylate cyclase.

However, in investigations in vitro, GTP analogues such as guanosine 5' - [ $\beta$ ,  $\gamma$ -imido] triphosphate (GPPNHP) and guanosine 5' - [ $\gamma$ -thio] triphosphate (GTP $\gamma$ S) which contain stable imido and thio bonds, respectively, cannot be hydrolysed by the action of the GTPase. Hence, when either of these analogues binds to the  $\alpha$  subunit of  $G_s$  it remains permanently activated and so adenylate cyclase remains 'turned on' (Pfeuffer and Helmreich, 1975).

The inhibitory response of  $\alpha_2$ -adrenergic agonists, adenosine, prostaglandins, somatostatin and high affinity analogues such as (-)-N-[(R)-1-methyl-2-phenylethyl]-adenosine (PIA) occurs in a similar manner to that of the stimulatory response described above but involves the appropriate inhibitory receptors and the  $G_i$ -proteins (Jakobs *et al.*, 1979). The mechanisms involved here are less well known than the stimulatory response but the end result is a reduction of the adenylate cyclase activity.

It will be evident from the above that there is a common requirement for both the stimulatory and inhibitory responses: both are absolutely dependent on guanine nucleotides.

Forskolin, 7- $\beta$ -acetoxy-8, 13-epoxy-1, 6 $\beta$ , 9 $\alpha$ -trihydroxy-labd-14-3n-11-one, a diterpene produced by the plant *Coleus forskolii*, is one of the most potent activators of adenylate cyclase in both intact cell and membrane preparations (Seamon and Daly, 1983). It acts by directly activating the catalytic subunit of adenylate cyclase without involving  $G_s$  and  $G_i$  proteins. Hence this compound is very useful in detecting and investigating the adenylate cyclase system. An example of the use of forskolin is in detecting inhibitory effects of  $G_i$ . Forskolin is used to activate the adenylate cyclase so that stimulatory agonist and  $G_s$  effects have a negligible influence on the activity. However inhibition via the  $G_i$ -protein will cause an easily detectable decrease in the forskolin-stimulated activity (Fain *et al.*, 1984).

There are conflicting reports in the literature as to the presence of a functional adenylate cyclase in HTC cells. Granner *et al.*, (1968) could not find significant basal or stimulated adenylate cyclase activity, but Makman (1971) showed that the enzyme was present and responsive to L-epinephrine and glucagon. HTC cells

grown as tumours (hepatoma 7288-C) have also been shown to be responsive to glucagon (Allen *et al.*, 1971). Hence, characterisation of the properties of adenylate cyclase in HTC cells grown in this laboratory was necessary before further analysis of the individual components of the adenylate cyclase system.

In chapters 3 and 4 it was demonstrated that supplementation with arachidonic acid increases both the heat sensitivity of HTC cells and the plasma membrane fluidity. The enhanced thermosensitivity could be due to a decrease in the thermostability of membrane-bound proteins as a consequence of the more fluid lipid environment within the membrane of supplemented cells. This could lead to enhanced thermal denaturation of plasma membrane-bound enzymes, transport proteins and signal transduction systems in arachidonate-supplemented cells compared to control cells. Thermal disruption of such key processes in the plasma membrane may lead to cell death. In order to investigate the relationship between membrane fluidity and the thermostability of membrane proteins, the effect of arachidonate supplementation on the thermal sensitivity of two plasma membrane enzymes ( $\text{Na}^+$ ,  $\text{K}^+$ -ATPase and alkaline phosphodiesterase I) was investigated, and the results are reported in this chapter. In addition, preliminary characterisation of adenylate cyclase was carried out, to estimate its potential for thermostability studies of a complex enzyme system that requires multiple subunit interactions within the membrane in order to express activity.

**Figure 5.1 — Diagrammatic representation of adenylate cyclase**

The figure shows the adenylate cyclase system and the its response to stimulatory agent.

$R_s$ =receptor for stimulatory agent

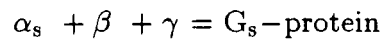

An inhibitory ligand would operate in a similar manner, through its receptor, but the  $\alpha_i$  subunit of the  $G_i$ -protein inhibits cyclic AMP production.

Diagrammatic representation of the adenylate cyclase system

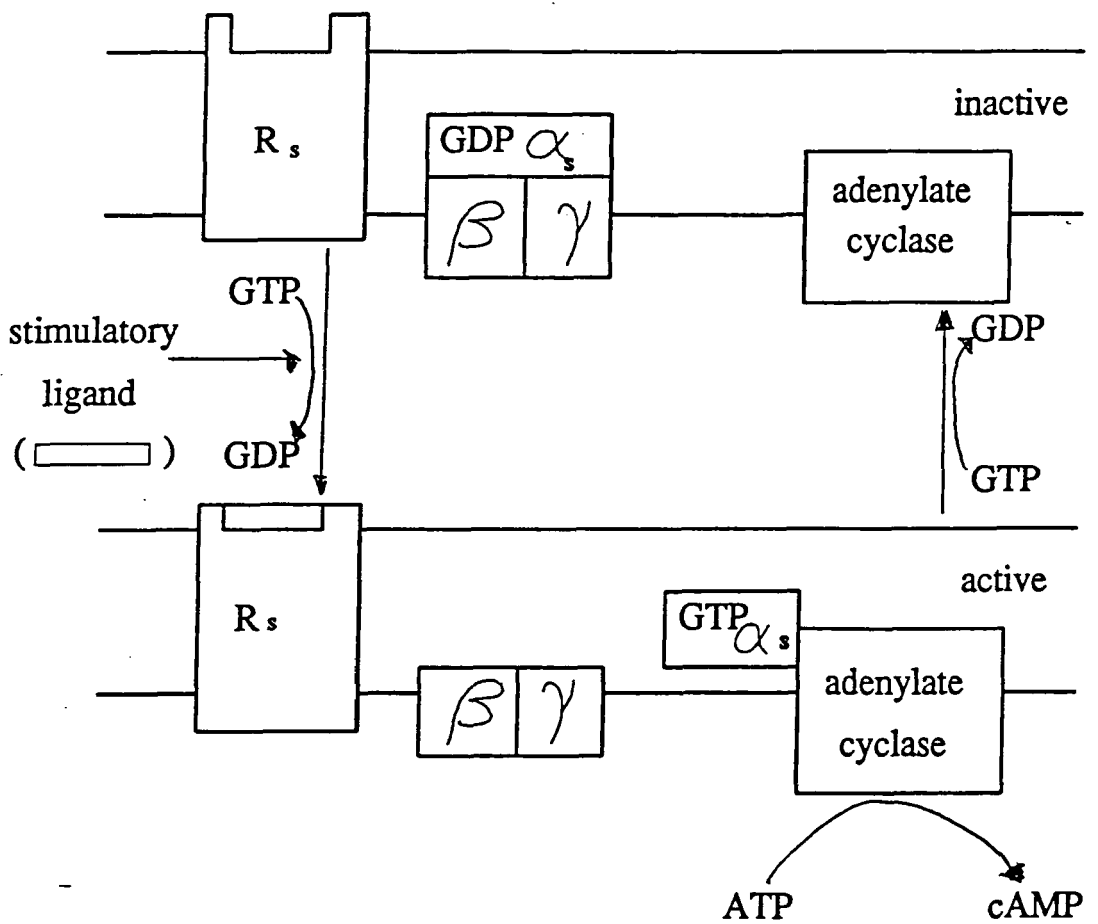

## 5.2 Materials and Methods

### 5.2.1 Exposure of cells to hyperthermic temperatures

HTC cells ( $3 \times 10^5$ ) were seeded into 10ml of growth medium in a 25cm<sup>2</sup> flask and incubated at 37°C in an atmosphere of air/CO<sub>2</sub> (19:1, v/v). The medium was changed the next day and then every 2 to 3 days thereafter. On day 5 the medium was replaced with 10ml of growth medium lacking fungizone and flasks heat treated as described in chapter 3, section 3.2.5.

### 5.2.2 Harvesting and homogenisation of heat treated cells

After heating, the cell monolayers were harvested by scraping them with a rubber policeman into the 10ml of medium already in the flask. The cell suspensions were centrifuged at 200g ( $r_{av}=11\text{cm}$ ) for 6 minutes at room temperature. The supernatant was discarded and the cell pellet was washed by resuspension in 0.25M sucrose, buffered with 10mM Tris-HCl to pH 7.4 (ST-buffer), followed by centrifugation at 200g ( $r_{av}=11\text{cm}$ ) for 6 minutes to sediment the cells. The cell pellet was resuspended in 1ml of ST-buffer and aspirated through a 25-gauge hypodermic needle fitted to a syringe. A further 9ml of ST-buffer was added to the disaggregated cells before taking 1.5ml of the suspension for determination of cell size distribution and viability. The remaining cell suspension was centrifuged at 200g ( $r_{av}=11\text{cm}$ ) for 6 minutes to sediment the cells, then the cell pellet was resuspended in 0.5ml ice-cold ST-buffer and the cells were homogenised by 12 up-and-down strokes in a Potter-Elvehjem homogeniser (1ml size) with a motor-driven teflon pestle at setting 6. The homogenising tube was kept ice cold throughout the procedure. The suspension formed was centrifuged at 200g for 5 minutes at 4°C. The supernatant from this centrifugation was used in the assay of Mg<sup>2+</sup>-ATPase,

alkaline phosphodiesterase I and Na<sup>+</sup>, K<sup>+</sup>-ATPase.

### 5.2.3 Cell size analysis

The cell size distribution of the cells in the cell suspensions prepared as described in section 5.2.2 from control and heated HTC cell monolayers was determined as described in chapter 2, section 2.2.10.

### 5.2.4 Viability assay

The viability of the cells in the cell suspensions prepared as described in section 5.2.2 from control and heated HTC cell monolayers was determined. The cells were counted using the Coulter Counter, then control and heat-treated cells were diluted to the same cell density with growth medium lacking phenol red, serum and fungizone. The diluted cell suspension (100 $\mu$ l), containing a fixed number of cells greater than  $1 \times 10^6$  but less than  $5 \times 10^6$  /ml, was pipetted into wells in a 24 well plate. To this was added 100 $\mu$ l of growth medium lacking phenol red, serum and fungizone but containing 5mg/ml MTT, buffered with 20mM Hepes to pH 7.4. The plates were placed in an incubator at 37<sup>0</sup>C in an atmosphere of air/CO<sub>2</sub> for 4 hours. After this period, 1ml of DMSO was added and mixed thoroughly to dissolve the dark blue crystals. Two 100 $\mu$ l aliquots were transferred from each well to a 96-well plate and the absorbance of the solution measured on a Titertek Multiskan MCC/340 plate reader using a test wavelength of 540nm and a reference wavelength of 690nm.

### 5.2.5 Enzyme assays

Na<sup>+</sup>, K<sup>+</sup>-ATPase, alkaline phosphodiesterase I and Mg<sup>2+</sup>-ATPase activities were measured as described in chapter 4, section 4.2.

### 5.2.6 Assay of adenylate cyclase (EC 4.6.1.1)

#### *Preparation of HTC cell homogenate*

HTC cells grown as monolayers in 25cm<sup>2</sup> flasks were harvested by scraping them with a rubber policeman in to the 10ml of growth medium already in the flask. The cell suspensions were centrifuged at 200g for 6 minutes at room temperature. The supernatant was discarded and the cell pellet was washed by resuspension in 0.25M sucrose buffered with 10mM Tris-HCl to pH 7.4, followed by centrifugation at 200g for 6 minutes at room temperature to recover the cells. This washing procedure was repeated once. The final washed cell pellet was resuspended in 0.5ml of ice-cold buffer containing 6mM MgCl<sub>2</sub>, 2mM EGTA, 0.5mM DTT and 25mM Tris-HCl, pH 7.4 (MEDT-buffer). The cells were homogenised by 12 up-and-down strokes in a Potter-Elvehjem homogeniser (1ml size) with a motor-driven teflon pestle at setting 6. The homogenising tube was kept ice cold throughout the procedure. The suspension formed was centrifuged at 200g for 5 minutes at 4<sup>0</sup>C. The supernatant from this centrifugation was used in the assay.

#### *Preparation of rat liver homogenate*

Rats were killed by cervical dislocation and the liver dissected. The liver was chopped up into small pieces and washed with ice cold MEDT-buffer. The pieces were transferred to a Potter-Elvehjem homogeniser (50ml size) containing ice cold 20ml MEDT-buffer and homogenised by 10 up and down strokes at setting 4 with a motor-driven teflon pestle. The suspension was diluted to 50ml with MEDT-buffer and centrifuged at 200g for 10 minutes at 4<sup>0</sup>C. The supernatant was retained for assay.

### *Incubations*

Adenylate cyclase activity of the membrane preparation was determined in a final volume of 50 $\mu$ l. The reaction mixture used for this determination consisted of 25mM Tris (pH adjusted to 7.4 at room temp. with HCl), 6mM MgCl<sub>2</sub>, 2mM EGTA, 0.5mM IBMX, 1mM ATP, 1mg/ml BSA, and an ATP regenerating system composed of 7mM phosphocreatine and 30units/ml creatine kinase. After 5 minutes preincubation at 37<sup>0</sup>C , the reaction was started by addition of 10 $\mu$ l membrane suspension and the mixture incubated for a further 8 minutes at 37<sup>0</sup>C. The reaction was terminated by the addition of 50 $\mu$ l of buffer, consisting of 50mM Tris-HCl and 12mM EDTA pH 7.4, and heating the reaction tube in a boiling water bath for 15 seconds, before dropping it into liquid nitrogen. The frozen reaction mixture could be stored overnight at -20<sup>0</sup>C before determination of the cyclic AMP content.

### *Measurement of cyclic AMP content*

The cyclic AMP generated by the adenylate cyclase, or added in standards and recovery experiments, was determined by a procedure first described by Gilman (1970) and later modified by Tovey *et al.* (1974), based on the competition between <sup>3</sup>H-labelled cyclic AMP and non radioactive cyclic AMP for binding to a high-affinity cyclic AMP -binding protein.

The final composition of the assay was 0.015 $\mu$ Ci <sup>3</sup>H-cyclic AMP , 37.5mM Tris-HCl pH 7.0 at 25<sup>0</sup>C , 3mM EDTA, 20 $\mu$ g/ml 3'5'-cyclic AMP -dependent protein kinase and 0.025% (w/v) BSA in a final volume of 200 $\mu$ l.

The reaction mixtures containing cyclic AMP were thawed, centrifuged at 10000g<sub>av</sub> for 2 minutes and an aliquot of the supernatant was taken and mixed

with the  $^3\text{H}$ -cyclic AMP, Tris-HCl and EDTA. A mixture of the protein kinase and BSA was added to initiate the binding of the cyclic AMP. The tube contents were mixed on a Vortex mixer for 5 seconds and left in an ice bath for 2 to 5 hours at which time equilibrium binding had been achieved. After this period, a  $100\mu\text{l}$  aliquot of the charcoal reagent composed of 2.6% (w/v) charcoal suspended in 50mM Tris-HCl and 4mM EDTA, pH 7.0 at  $25^{\circ}\text{C}$ , was added with mixing to adsorb unbound cyclic nucleotide. The mixture was centrifuged for 2 minutes at  $10000g_{\text{av}}$  to sediment the charcoal and a portion ( $200\mu\text{l}$ ) of the supernatant was taken for liquid scintillation counting to determine radioactivity complexed with the binding protein. The amount of [ $^3\text{H}$ ]-cyclic AMP complexed with the binding protein was an inverse function of the amount of unlabelled cyclic AMP present in the assay. It was necessary to quantitate this relationship by reference to a set of calibration standards.

#### *Standardisation of cyclic AMP binding*

The standard binding curve was prepared by substituting known amounts of cyclic AMP for the supernatant in the binding assay. Final standard concentrations were 0, 20, 40, 80 and 160nM cyclic AMP. These were not incubated for 8 minutes at  $37^{\circ}\text{C}$ ; otherwise they were treated in exactly the same way as for the incubations involving membrane preparations.

#### *Blanks*

To determine the cyclic AMP already present in the membrane preparation itself, sample blanks were carried out. These were prepared and treated as for the normal adenylate cyclase assay but in a reaction mixture which lacked ATP. The final concentration of all other constituents remained unaltered.

### *Recovery of cyclic AMP*

Experiments designed to measure the recovery of cyclic AMP were routinely performed in reaction mixtures lacking ATP but incorporating 40nM cyclic AMP. The final concentration of the other constituents remained unchanged and the mixtures were incubated with membrane preparation and treated as normal.

### *Calculation and expression of results*

The following ratio was determined:

$$\frac{\text{counts obtained without unlabelled cyclic AMP (C}_0\text{)}}{\text{counts obtained with unlabelled cyclic AMP (C}_x\text{)}}$$

This ratio was plotted versus the amount of cyclic AMP present in the standards ( $x=0,1,2,4,8$  pmole) to obtain a standard curve so that cyclic AMP in test samples can be obtained, by interpolation, using the  $\frac{C_0}{C_x}$  values of the unknowns.

## **5.2.7 Purification of plasma membranes**

Isolation of plasma membranes was carried out as described in chapter 4, section 4.2.1.

## **5.2.8 Thermal inactivation of plasma membrane-associated enzymes**

### *gradient inactivation*

The thermal inactivation was carried out in clean plastic test tubes which were thermo-equilibrated at the study temperature ( $\pm 0.1^\circ\text{C}$ ) in a 'Forbes bar'. This apparatus maintains a temperature gradient between two defined temperatures. To these tubes, 0.6ml of a suitably diluted (diluted with ST-buffer) purified membrane

preparation was quickly added and after 10 minutes the thermal inactivation was quenched by quickly cooling the tubes to 4<sup>0</sup>C by immersing in an ice bath. The inactivation of enzyme in purified plasma membrane preparations from both control and supplemented cells was carried out in parallel. Then the residual Na<sup>+</sup>, K<sup>+</sup>-ATPase activity and alkaline phosphodiesterase I activity was assayed as described in chapter 4, section 4.2.2 and 4.2.3, respectively.

### **5.2.9 Isothermal inactivation of alkaline phosphodiesterase I**

In order to subject the enzyme to an inactivation temperature of 64<sup>0</sup>C ( $\pm 0.1^0$ C) instantaneously, an appropriate volume of plasma membrane suspension equilibrated at 37<sup>0</sup>C for 5 minutes was diluted into an appropriate volume of ST-buffer, thermoequilibrated at a higher temperature than 64<sup>0</sup>C in a glass test tube. The volumes were chosen such that, upon mixing, the inactivation temperature of 64<sup>0</sup>C was attained instantly, and the glass test tube was immediately placed in a water bath maintained at 64<sup>0</sup>C ( $\pm 0.1^0$ C). The inactivation of enzyme in purified plasma membrane from both control and supplemented cells was carried out in parallel. Aliquots of 200 $\mu$ l were withdrawn from the test tubes at various times during the hyperthermic incubation and placed on ice to quench the inactivation process. The enzyme activity was then assayed as described in chapter 4, section 4.2.3.

### 5.3 Results

The viability assay carried out in this chapter involved harvesting control and heat treated HTC cell monolayers and then estimating the number of cells using the Coulter Counter. The cell suspensions from control and heat treated cells were then diluted to the same cell density and the number of viable cells were assessed using the colorimetric assay. The percent reduction in viability due to heat treatment was determined relative to the viability measured for control cells. As the Coulter Counter determines the cell number by counting cells above a certain preset cell size threshold, any change in the cell size distribution due to heat treatment would result in errors in estimating cell number of cell suspensions from heat treated monolayers compared to those from control monolayers. This would give rise to errors in estimating the percent reduction in viability due heat treatment, because this parameter is determined relative to the viability of control cells. Therefore, cell size distribution of control and heat treated cells was determined. Heat treatment at 43<sup>0</sup>C to 45<sup>0</sup>C did not significantly alter cell size distribution of HTC cells (figure 5.2). The mean sizes and standard deviations of control and heat-treated cells are given in the legend to figure 5.2, which shows the similarity of the distributions.

The viability data presented in figure 5.3 is essentially the same as that presented in chapter 3. However, it was repeated at this stage in order to correlate with thermal sensitivity of plasma membrane-bound enzymes derived from these cells. As expected, heat treatment lowered the viability of the HTC cells. At 43<sup>0</sup>C , viability decreased progressively with treatment time (figure 5.3a). At 45<sup>0</sup>C , viability decreased rapidly for the first 30 minutes and thereafter reached a minimum of approximately 30% (figure 5.3b). The reduction in viability was greater at 45<sup>0</sup>C compared to 43<sup>0</sup>C for a 60 minute exposure time.

The adenylate cyclase system of HTC cells used in this study was characterised in order to assess its potential for thermostability studies. The activities associated with the various subunits of the system were probed with appropriate agents. However, it was necessary to carry out preliminary experiments using adenylate cyclase from rat liver, which is known to contain measurable basal activities of this enzyme. This was to ensure that the adenylate cyclase assay was working. The basal activity of adenylate cyclase in rat liver homogenate was linear with respect to time from 0 to 10 minutes (figure 5.4a) and protein concentration from 0 to 200 $\mu$ g protein (figure 5.4c) respectively.

Due to the extremely low basal activities of HTC cell adenylate cyclase (0 - 0.5 pmoles/min/mg protein, see chapter 4), a potent activator of adenylate cyclase, forskolin, was included in the assay in order to obtain a measurable activity. The production of cyclic AMP by the forskolin-stimulated adenylate cyclase of HTC cell homogenate was linear with respect to time (figure 5.4b) from 0 to 10 minutes and protein, from 0 to 175 $\mu$ g protein (figure 5.4d).

Adenylate cyclase in rat liver homogenate was not stimulated markedly by either 10 $\mu$ M GTP or isoproterenol alone (figure 5.5a). However, when added together, 10 $\mu$ M GTP and isoproterenol caused a doubling of basal activity. DMSO (0.1%, v/v), the vehicle used for forskolin, did not alter basal activity and 100 $\mu$ M forskolin caused a 10-fold stimulation of adenylate cyclase activity (figure 5.5a).

The activities determined for HTC cell homogenate in the presence of isoproterenol, GTP were extremely low and could not be measured reliably. HTC cell adenylate cyclase was not stimulated markedly by GTP, isoproterenol or when both GTP and isoproterenol were used together (figure 5.5b). DMSO (0.1%, v/v) again

did not change basal activity. However, forskolin caused a 30-fold stimulation of basal activity and this activation was not altered greatly when GTP or isoproterenol alone, or both agonists together, were present in the assay (figure 5.5b).

The 30-fold greater basal activity and 20-fold greater forskolin-stimulated activity of adenylate cyclase in liver homogenate compared to HTC cell homogenate indicate a much reduced level of adenylate cyclase activity in these hepatoma cells.

The dose response for isoproterenol (figure 5.6a) or GTP (figure 5.6b) or GTP in the presence of  $100\mu\text{M}$  isoproterenol (figure 5.6c) showed that the low basal activity of HTC cell adenylate cyclase was not enhanced to reliably detectable levels by these agonists across a concentration range of  $10^{-7}$  to  $10^{-4}$  M. GTP $\gamma$ S, a non-hydrolysable analogue of GTP, also had no effect over the same concentration range (figure 5.6d). The adenylate cyclase activity of HTC cell homogenate increased in a concentration dependent manner in response to forskolin (figure 5.7a) and the forskolin stimulated activity was not changed by GTP $\gamma$ S over a concentration range of  $10^{-7}$  to  $10^{-4}$  M (figure 5.7b).

The characterisation of the HTC cell adenylate cyclase revealed that the only activity that could be measured with confidence was the forskolin-stimulated activity. Therefore, the thermostability of the forskolin-stimulated activity was assessed. The homogenates prepared from heat treated cell monolayers showed that heat treatment at  $43^{\circ}\text{C}$  for up to 180 minutes or  $45^{\circ}\text{C}$  for up to 120 minutes produced no substantial change in the activity of forskolin-stimulated adenylate cyclase (figure 5.8).

Similarly, homogenates prepared from heat treated cell monolayers showed that heat treatment at  $43^{\circ}\text{C}$  for up to 180 minutes or  $45^{\circ}\text{C}$  for up to 120 minutes also produced no substantial change in the activity of  $\text{Na}^+$ ,  $\text{K}^+$ -ATPase (figure 5.9) and

Mg<sup>2+</sup>-ATPase (figure 5.10). However, it has to be noted that for the Mg<sup>2+</sup>-ATPase data there was a consistent decline in activity with time when heat treated at 45<sup>0</sup>C, but there was insufficient data to test if this decline was significant.

However, alkaline phosphodiesterase I activity in homogenates prepared from monolayers heat treated at 43<sup>0</sup>C showed the activity to be stable for 120 minutes treatment but thereafter the activity increased and rose approximately 20% above control values at 180 minutes treatment (figure 5.11a). The rise in activity was even more dramatic in homogenates prepared from monolayers heat treated at 45<sup>0</sup>C. The activity of alkaline phosphodiesterase I in these preparations increased with treatment time and rose to values which are approximately 100% above control values after 120 minutes treatment at 45<sup>0</sup>C (figure 5.11b). When cells were exposed to the hyperthermic temperature for 60 minutes, no increase in alkaline phosphodiesterase I activity was observed at 43<sup>0</sup>C to 44<sup>0</sup>C, but substantial elevation of enzyme activity was apparent at 45<sup>0</sup>C (figure 5.11c).

Following the preliminary experiments on the thermal sensitivity of plasma membrane-bound enzymes shown in figures 5.8 to 5.11, it was decided to investigate the effect of supplementation of HTC cells with arachidonic acid on the thermal sensitivity of two of these enzymes, using more extreme hyperthermic temperatures, in order to reveal whether changes in membrane lipid composition influence thermostability of membrane enzymes. Na<sup>+</sup>, K<sup>+</sup>-ATPase was chosen because it is a good example of an integral membrane protein, known to be specifically associated with the plasma membranes, and its kinetics of thermal inactivation in plasma membranes from control cells and from arachidonate-supplemented cells were investigated by treating the membranes at 37<sup>0</sup>C to 57<sup>0</sup>C for 10 minutes prior to assay. Using this technique, the thermal sensitivity of Na<sup>+</sup>, K<sup>+</sup>-ATPase in control plasma

membranes was not different from that present in plasma membranes isolated from HTC cells grown in  $60\mu\text{M}$  arachidonic acid supplement for 36 hours (figure 5.12). In both types of plasma membrane preparations the activity was reduced to 50% of control values after exposure to approximately  $54^{\circ}\text{C}$  for 10 minutes.

The second enzyme chosen for further investigation was alkaline phosphodiesterase I. Plasma membranes were purified from control cells and from cells supplemented with  $60\mu\text{M}$  arachidonic acid for 36 hours, then exposed to a range of temperatures from  $37^{\circ}\text{C}$  to  $73^{\circ}\text{C}$  in a Forbes bar for 10 minutes, and residual alkaline phosphodiesterase I activity was measured. The results (figure 5.13) show that the thermal sensitivity of the enzyme from the two cell populations was similar and that slight activation occurred up to  $52^{\circ}\text{C}$ . However, above this temperature a rapid decline in activity was noted and, in both plasma membrane preparations, the activity was reduced to 50% of control values after exposure to  $64^{\circ}\text{C}$  for 10 minutes.

The inactivation studies shown in figures 5.12 and 5.13, which were carried out at increasing temperatures for a fixed period of time, did not detect any substantial differences in the thermostability of either  $\text{Na}^+$ ,  $\text{K}^+$ -ATPase or alkaline phosphodiesterase I from the two membrane sources. However, isothermal inactivation studies offer a more sensitive means of studying the effect of supplementation on the thermal sensitivity of membrane enzyme activity. The small quantities of purified plasma membrane material available limited such studies to one membrane enzyme. The enzyme alkaline phosphodiesterase I was selected as opposed to  $\text{Na}^+$ ,  $\text{K}^+$ -ATPase for the study, as this required less purified plasma membranes than the corresponding analysis of  $\text{Na}^+$ ,  $\text{K}^+$ -ATPase activity. The isothermal inactivation of alkaline phosphodiesterase I in plasma membranes from control cells and from cells grown in  $60\mu\text{M}$  arachidonic acid supplement for 36 hours displays a curvilinear time-course,

with a linear rate of inactivation at times greater than 10 minutes (figure 5.14). It is thought that this represents a sequential decay of a thermolabile species of the enzyme into a more thermostable species.

e.g.



Where  $K_1$  and  $K_2$  are the first order decay constants with  $K_1 \geq K_2$ .

The slope of the final decay process defines  $K_2$ , whilst the decay constant  $K_1$  for the thermolabile species can be derived by calculation as shown in the legend to figure 5.14. The kinetic parameters given in table 5.1 show that  $K_2$  values obtained are very similar for the enzyme from plasma membranes of control cells and those supplemented with arachidonic acid. However, the  $K_1$  value for the enzyme from plasma membranes of arachidonic acid-supplemented cells is higher than that from control cells. This translates into a shorter half life for the thermolabile species of the enzyme from arachidonate-supplemented plasma membranes than that from control membranes. This indicates that growth of HTC cells in  $60\mu\text{M}$  arachidonic acid supplement for 36 hours reduces the thermostability of alkaline phosphodiesterase I when compared to the enzyme from control cells.

**Figure 5.2 — HTC cell size distribution after heat treatment**

HTC cell monolayers were heat treated for 60 minutes and cell size determined as described in Materials and Methods.

Figures a, b and c show the size distribution of cells after heat treatment (○) at 43<sup>0</sup>C , 44<sup>0</sup>C and 45<sup>0</sup>C respectively compared to 37<sup>0</sup>C control cells (●). The average cell size and standard deviation of the cell size distribution are given below.

Temperature (°C )	Average cell size (μm)	Standard deviation (μm)
37.0	17.39	6.52
43.0	15.93	6.01
44.0	17.65	7.13
45.0	19.93	5.05

The cell size distribution was determined three times after heating at each temperature for 60 minutes. The data was analysed using a Students t-test. Using this test, comparison of the distributions obtained after heating at 43.0, 44.0 and 45.0<sup>0</sup>C with that obtained at 37.0<sup>0</sup>C showed that there was no change ( $p > 0.05$ ) in the cell size distribution.

(a) 43.0°C for 60 minutes

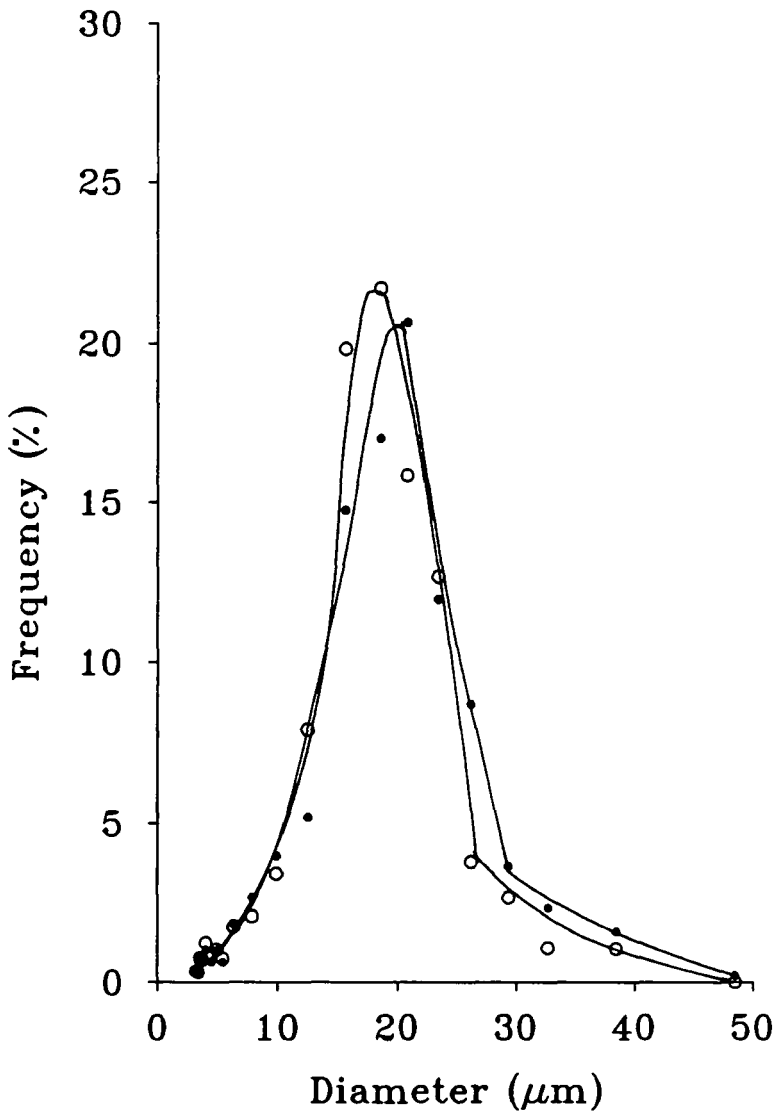

(b) 44.0°C for 60 minutes

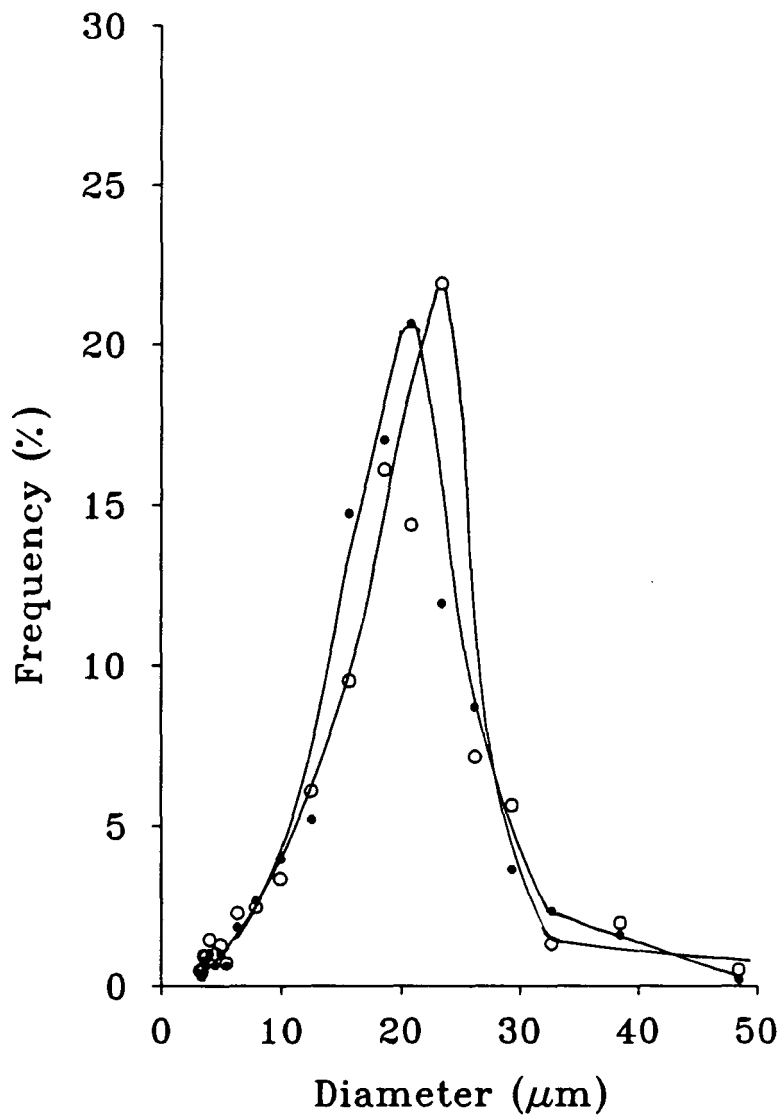

(c) 45.0°C for 60 minutes

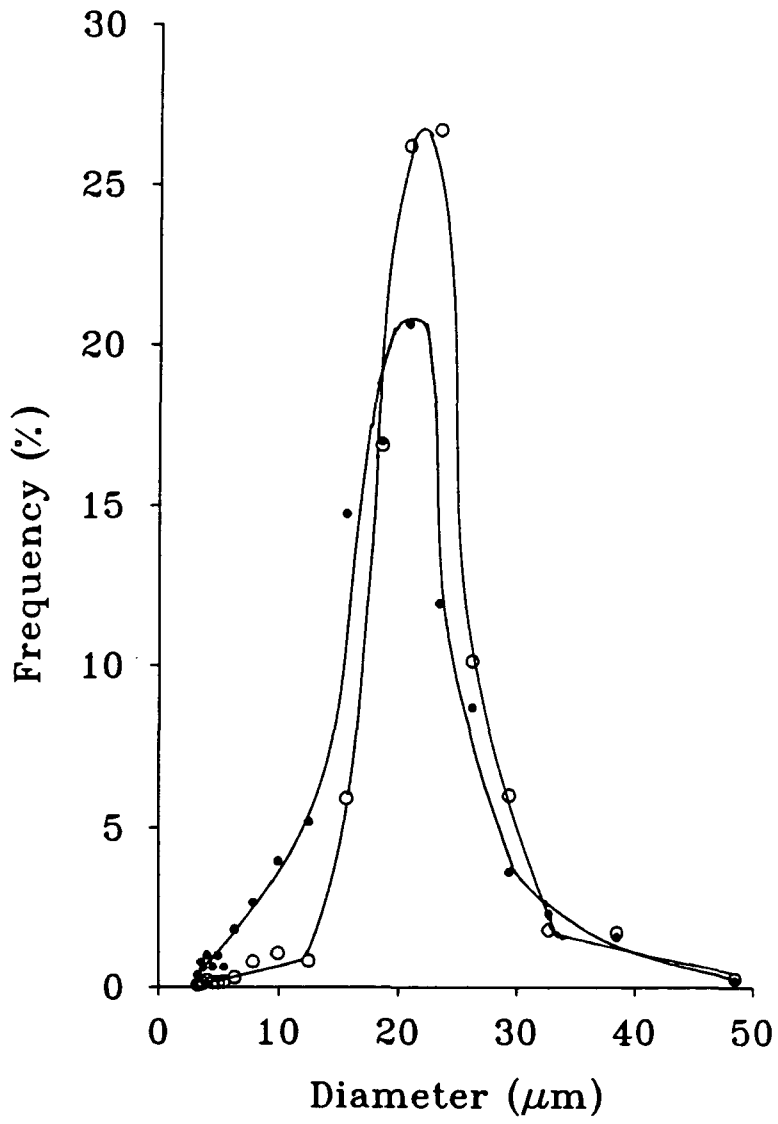

### Figure 5.3 — Cell viability after heat treatment

HTC cell monolayers were heat treated returned to 37<sup>0</sup>C then the viability determined by the colorimetric assay as described in Materials and Methods. The data in the graphs are presented as percent viable cells in heat treated cells relative to viable cells in control cells maintained at 37<sup>0</sup>C.

Figures a and b show the reduction in viability of cells when heat treated at 43<sup>0</sup>C and 45<sup>0</sup>C , respectively, for various periods of time.

Each data point on the graph represents the average of duplicate determinations.

(a) 43.0°C

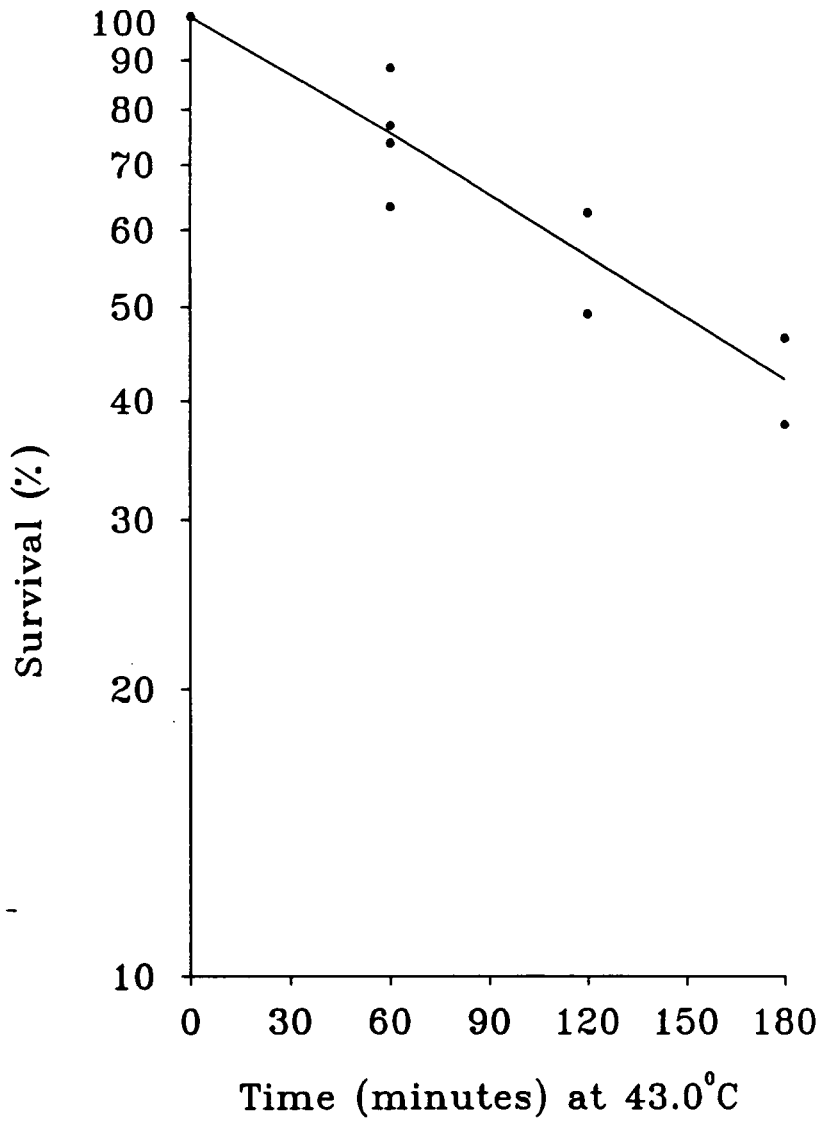

(b) 45.0°C

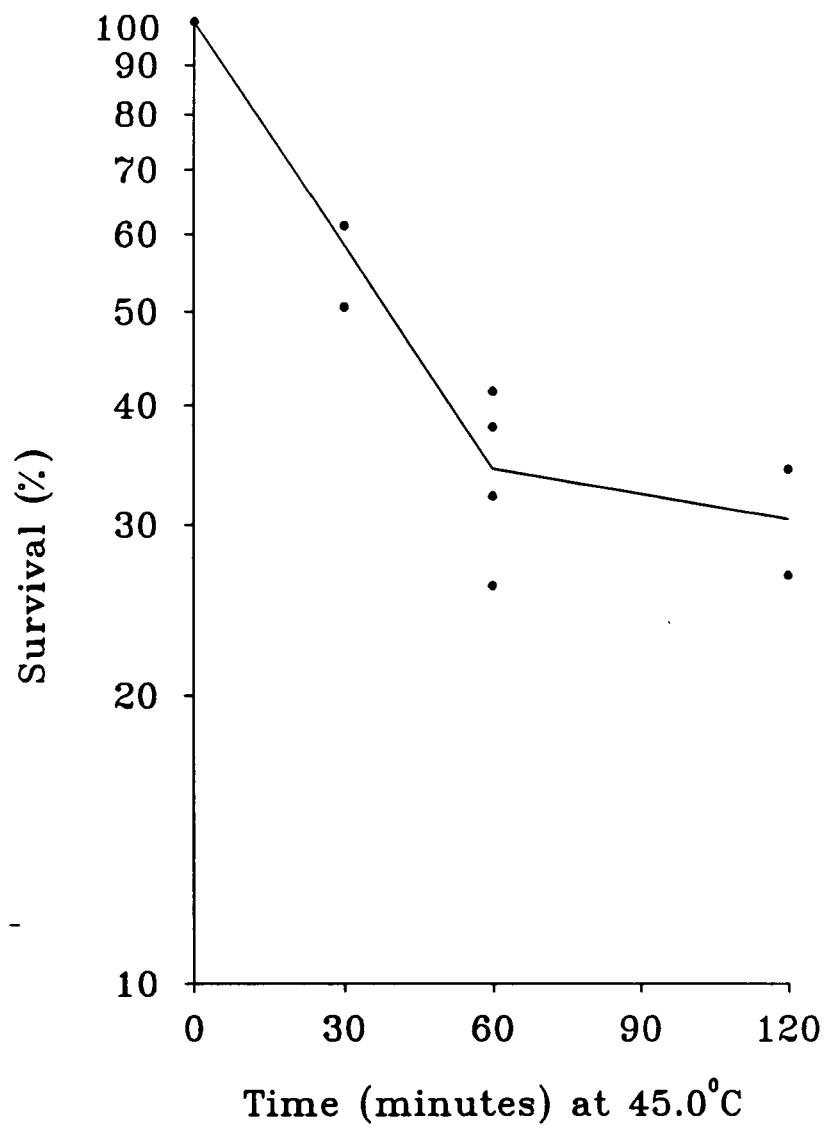

**Figure 5.4 — Effect of incubation time and enzyme concentration on the activity of adenylate cyclase from rat liver and HTC cells**

Figure a and c represent the activity of liver adenylate cyclase with respect to time and protein concentration. The reaction mixture (see Materials and Methods) was preincubated at 37<sup>0</sup>C for 5 minutes prior to addition of rat liver homogenate. In figure a the the reaction was started with the addition of 100μg of homogenate protein and the reaction was terminated at the time intervals indicated. In figure c different amounts of rat liver homogenate protein were incubated with the reaction mixture for 8 minutes at 37<sup>0</sup>C before terminating the reaction.

Figure b and d represent the forskolin-stimulated activity of HTC cell adenylate cyclase with respect to time and protein concentration. The reaction mixture (see under Materials and Methods) containing 100μM forskolin was preincubated at 37<sup>0</sup>C for 5 minutes prior to addition of HTC cell homogenate. In figure a the the reaction was started with the addition of 100μg of homogenate protein and the reaction was terminated at the time intervals indicated. In figure b, different amounts of HTC cell homogenate protein were incubated with the reaction mixture containing 100μM forskolin for 8 minutes at 37<sup>0</sup>C before terminating the reaction. Reaction mixture containing forskolin also contained 0.1%(v/v) DMSO, the vehicle for forskolin.

In all assays after termination of the reaction the cyclic AMP content was determined.

The data in figures b and d have already been presented in chapter 4 figure 4.10 and are included in this figure for comparison with rat liver adenylate cyclase activity. The data presented in figures b and d are the mean values of the data presented in figures 4.10a and b respectively.

The data presented in figures a and c represent the mean values obtained from two separate determinations carried out in duplicate.

(a) Liver

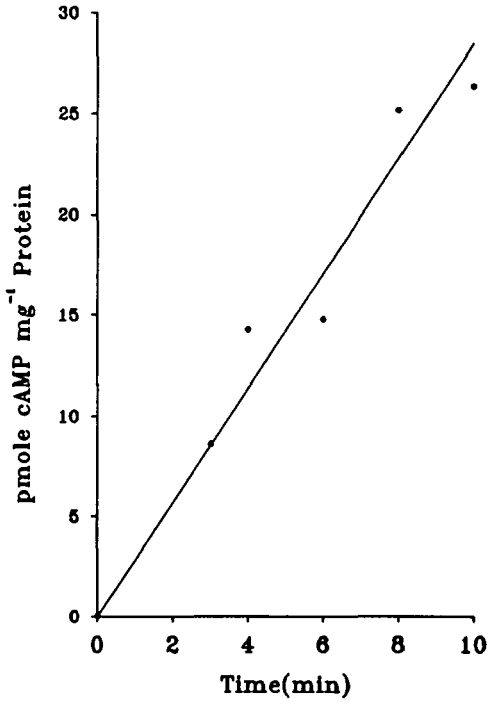

(b) HTC

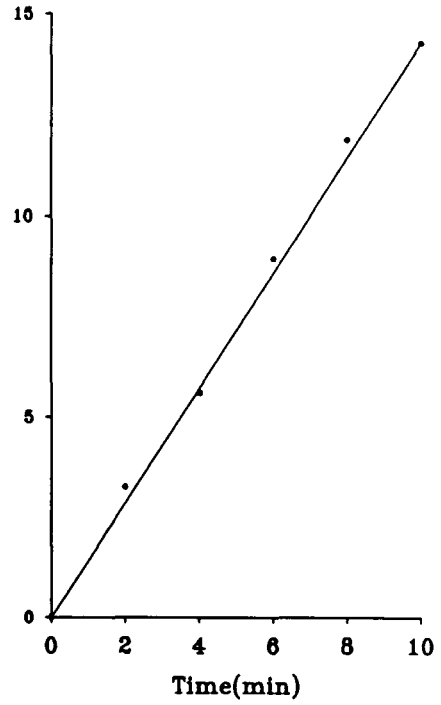

(c) Liver

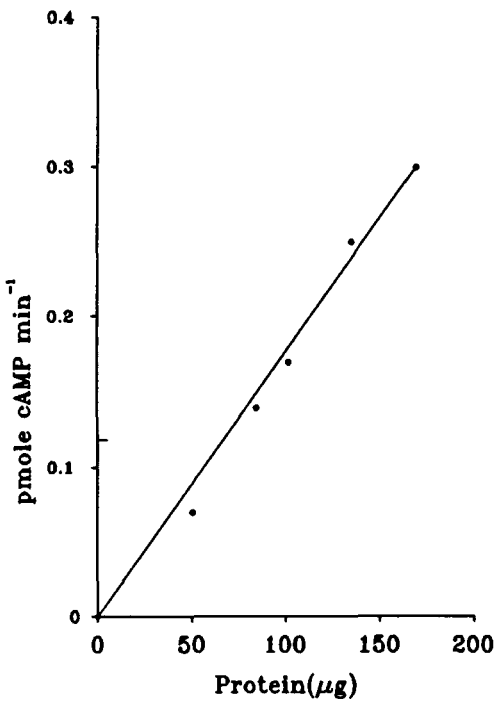

(d) HTC

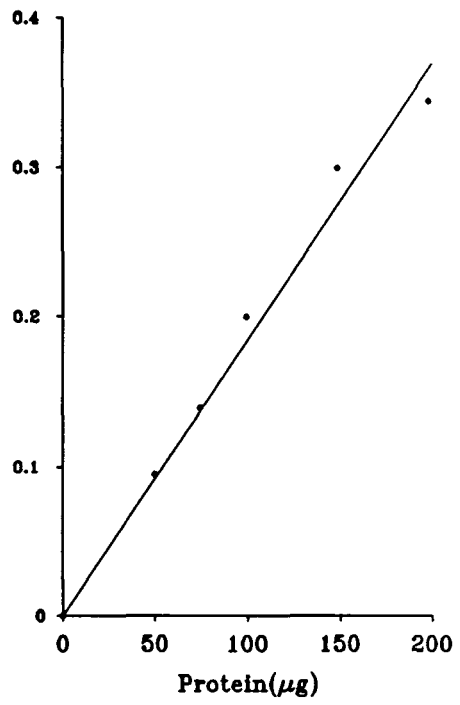

**Figure 5.5 — The response to some agonists of rat liver and HTC cell adenylate cyclase**

Assay conditions were as described in Materials and Methods. Rat liver homogenate (figure a) and HTC cell homogenate (figure b) were incubated in reaction media containing various combinations (given in table below) of the agonists for 8 minutes at 37°C. The reaction was stopped and the cyclic AMP content determined.

Assays utilising forskolin also contained 0.1% (v/v) DMSO.

Assay condition	Figure a	Figure b
1	Basal	Basal
2	0.1% v/v DMSO	0.1% v/v DMSO
3	10 $\mu$ M GTP	10 $\mu$ M GTP
4	10 $\mu$ M Isoproterenol	10 $\mu$ M Isoproterenol
5	10 $\mu$ M Isoproterenol + 10 $\mu$ M GTP	10 $\mu$ M Isoproterenol + 10 $\mu$ M GTP
6	100 $\mu$ M Forskolin	100 $\mu$ M Forskolin
7		10 $\mu$ M GTP + 100 $\mu$ M Forskolin + 10 $\mu$ M Isoproterenol
8		10 $\mu$ M GTP + 100 $\mu$ M Forskolin
9		10 $\mu$ M Isoproterenol + 100 $\mu$ M Forskolin

The mean values  $\pm$  standard error of two separate determinations are presented on the graph. Each determination was carried out in duplicate

(a) Liver

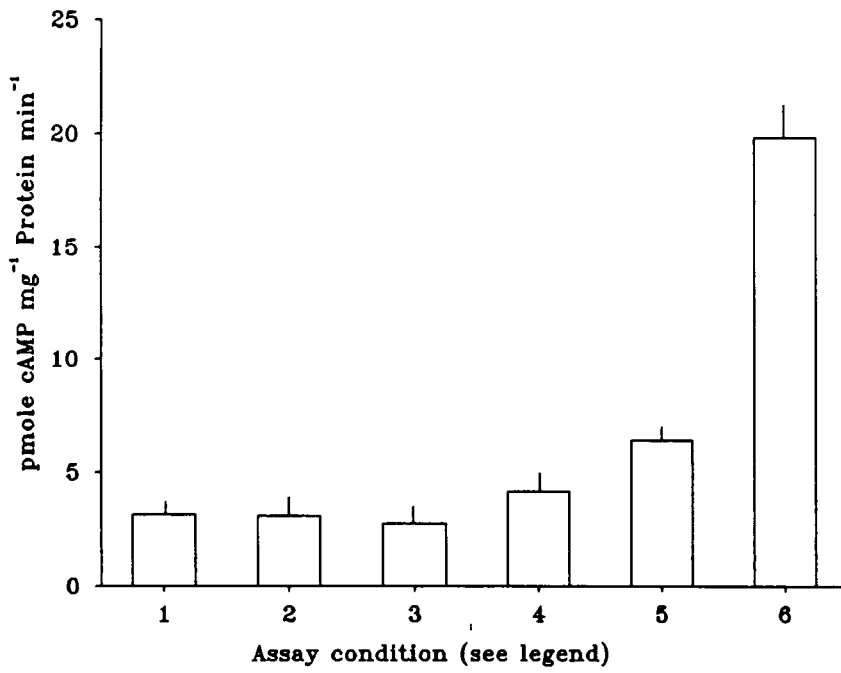

(b) HTC

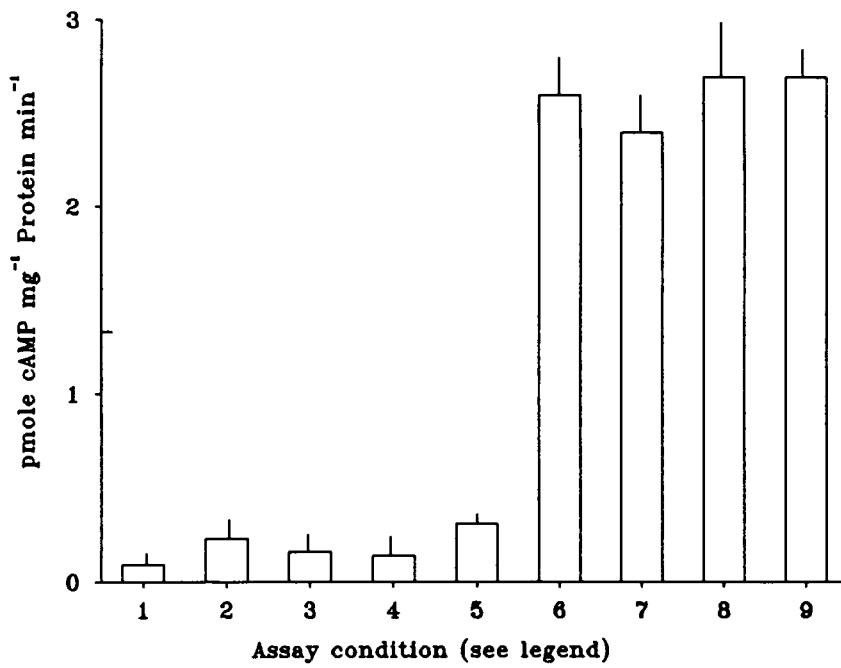

**Figure 5.6 — Effect of varying the concentration of isoproterenol, GTP, GTP in the presence of 100 $\mu$ M isoproterenol or GTP $\gamma$ S on adenylate cyclase activity in HTC cell homogenates**

Assay conditions were as described in Materials and Methods. HTC cell homogenate (100 $\mu$ g protein) was incubated for 8 minutes with reaction media containing various concentration of isoproterenol (figure a), GTP (figure b), GTP in the presence of 100 $\mu$ M isoproterenol (figure c) or GTP $\gamma$ S (figure d). The reaction was terminated and the cyclic AMP content was determined as described in Materials and Methods.

The mean values of two separate determinations are presented on the graph. Each determination was carried out in duplicate

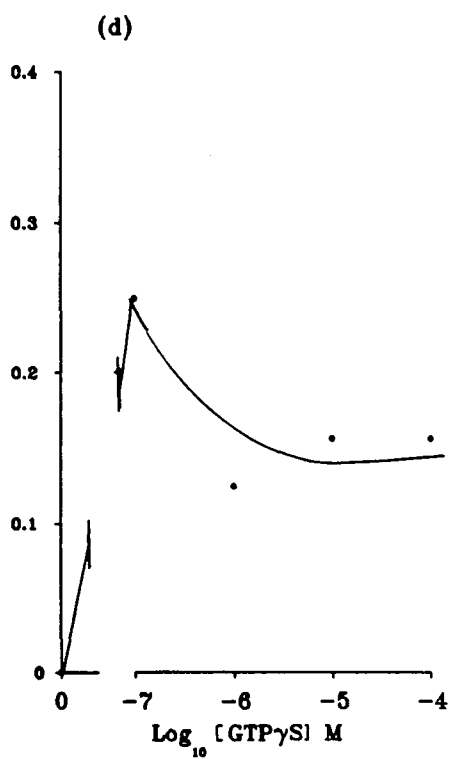
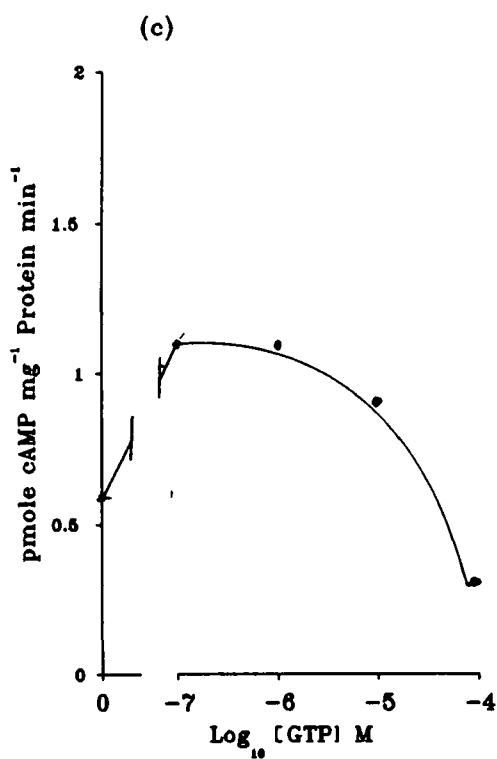
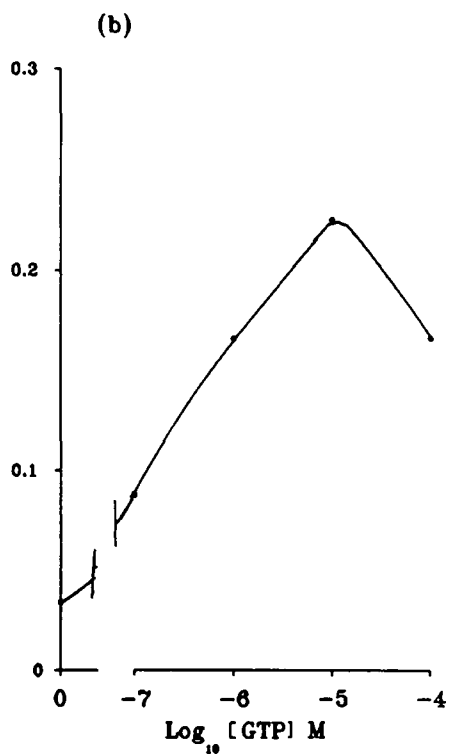
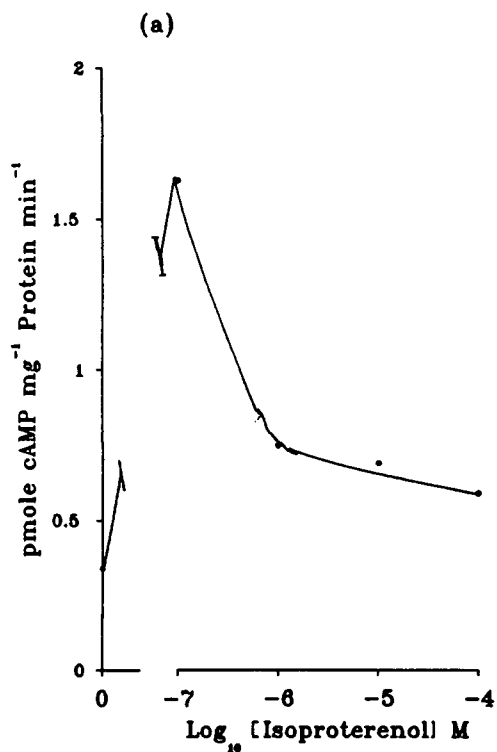

**Figure 5.7 — Effect of varying concentrations of forskolin alone or GTP $\gamma$ S in the presence of 100 $\mu$ M forskolin on adenylate cyclase activity in HTC cell homogenate**

Assay conditions were as described in Materials and Methods. HTC cell homogenate (100 $\mu$ g protein) was incubated for 8 minutes with a mixture containing various concentrations of forskolin alone (figure a) or GTP $\gamma$ S in the presence of 100 $\mu$ M forskolin (figure b). The reaction was terminated and the cyclic AMP content was determined as described in Materials and Methods.

Each data point on the graphs represent the mean values from duplicate determinations. Figure b shows data obtained from two separate experiments.

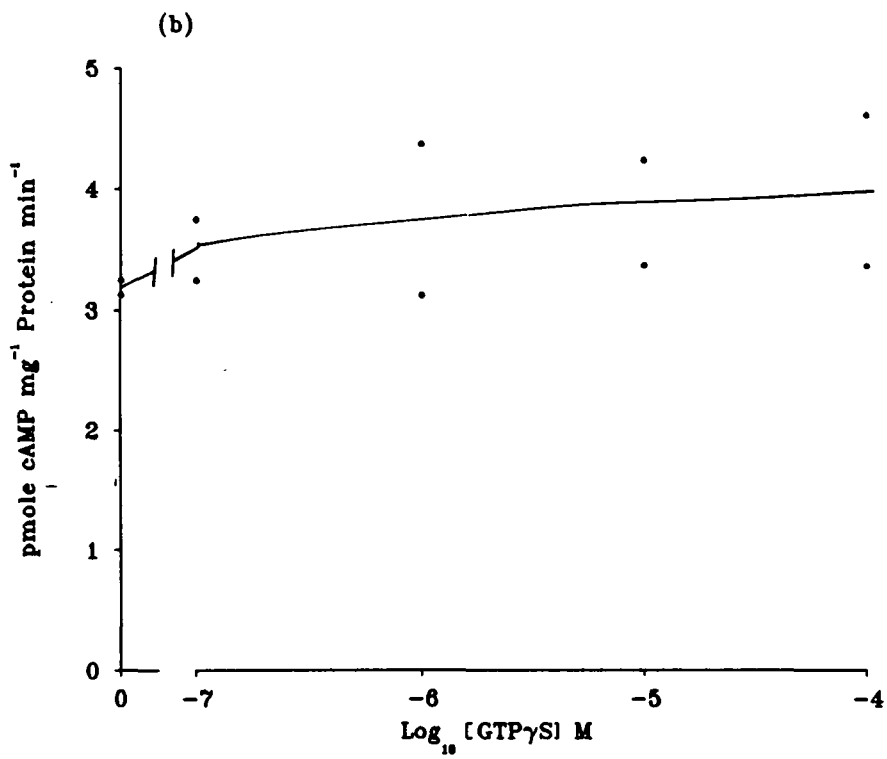
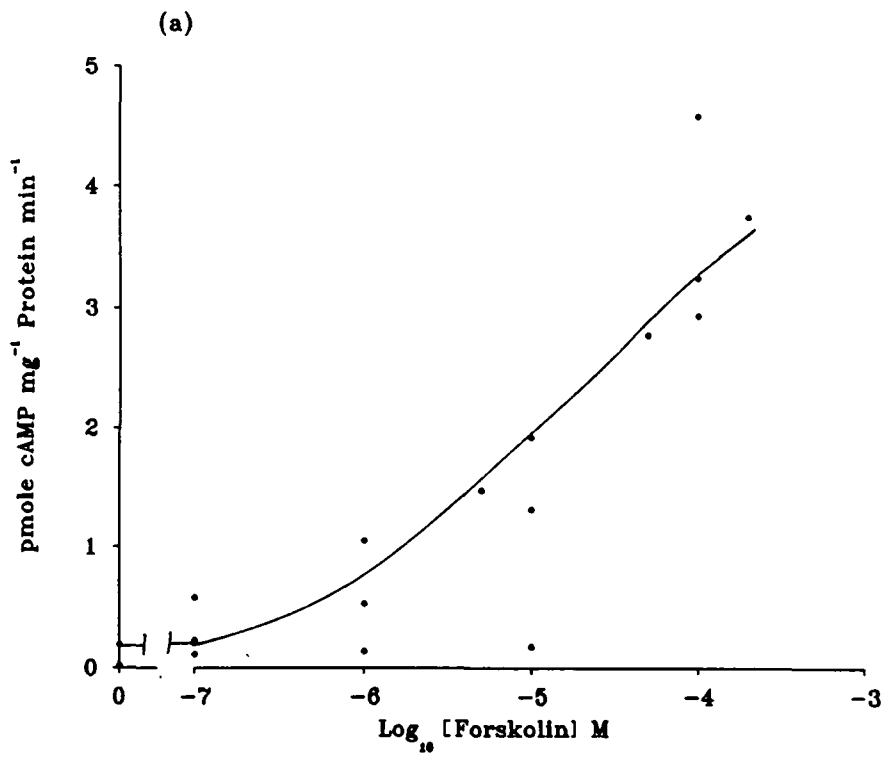

**Figure 5.8 — The activity of adenylate cyclase in cell homogenates after hyperthermic treatment of HTC cells**

HTC cell monolayers were heat treated at 43<sup>0</sup>C or 45<sup>0</sup>C for various times, then the forskolin-stimulated adenylate cyclase activity in cell homogenates was determined at 37<sup>0</sup>C as described in Materials and Methods. The data in the graphs are presented as percent activity present in cell homogenates of heat treated cells relative to unheated control cell homogenates.

Figures a and b represent the adenylate cyclase activity in cell homogenates prepared from cell monolayers heat treated at 43<sup>0</sup>C and 45<sup>0</sup>C , respectively, for various periods of time.

Figure c shows the adenylate cyclase activity in cell homogenates prepared from cell monolayers heat treated for 60 minutes at the specified temperatures. The data for 43<sup>0</sup>C and 45<sup>0</sup>C temperature points were obtained from figures a and b respectively.

Each data point on the graph represents the average of duplicate determinations.

(a) 43.0°C

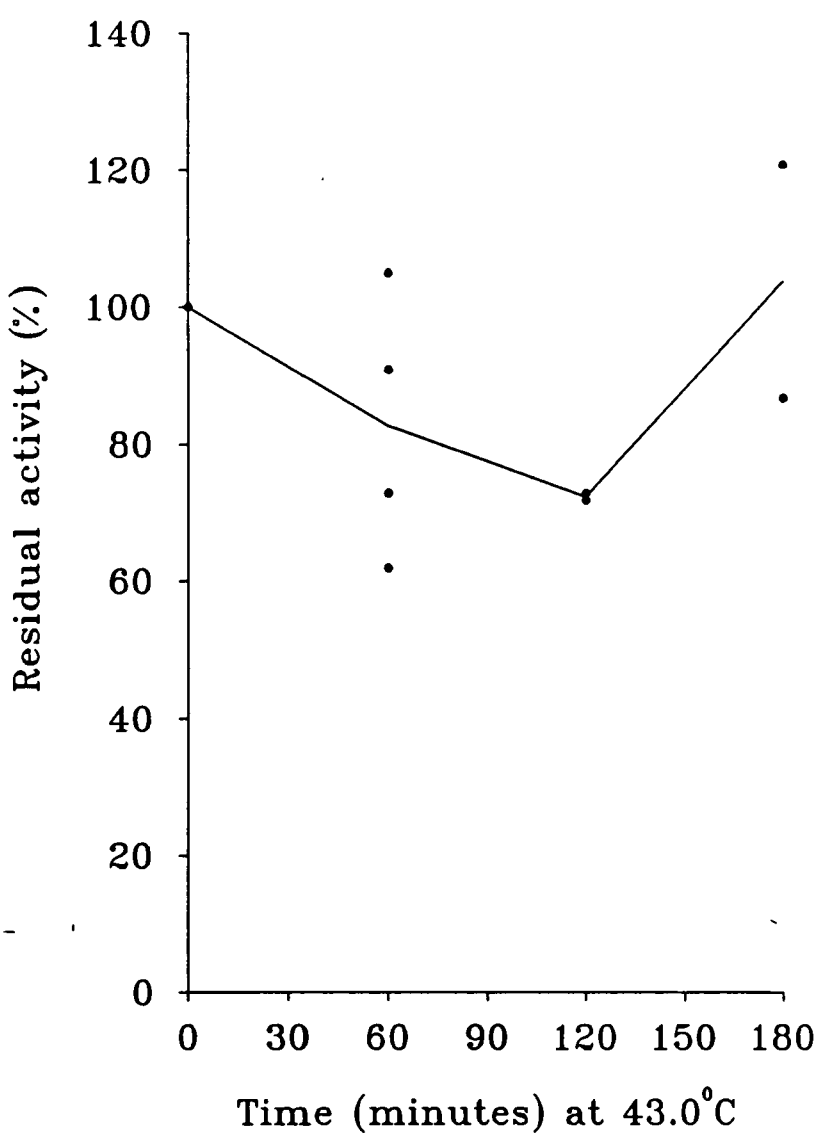

(b) 45.0°C

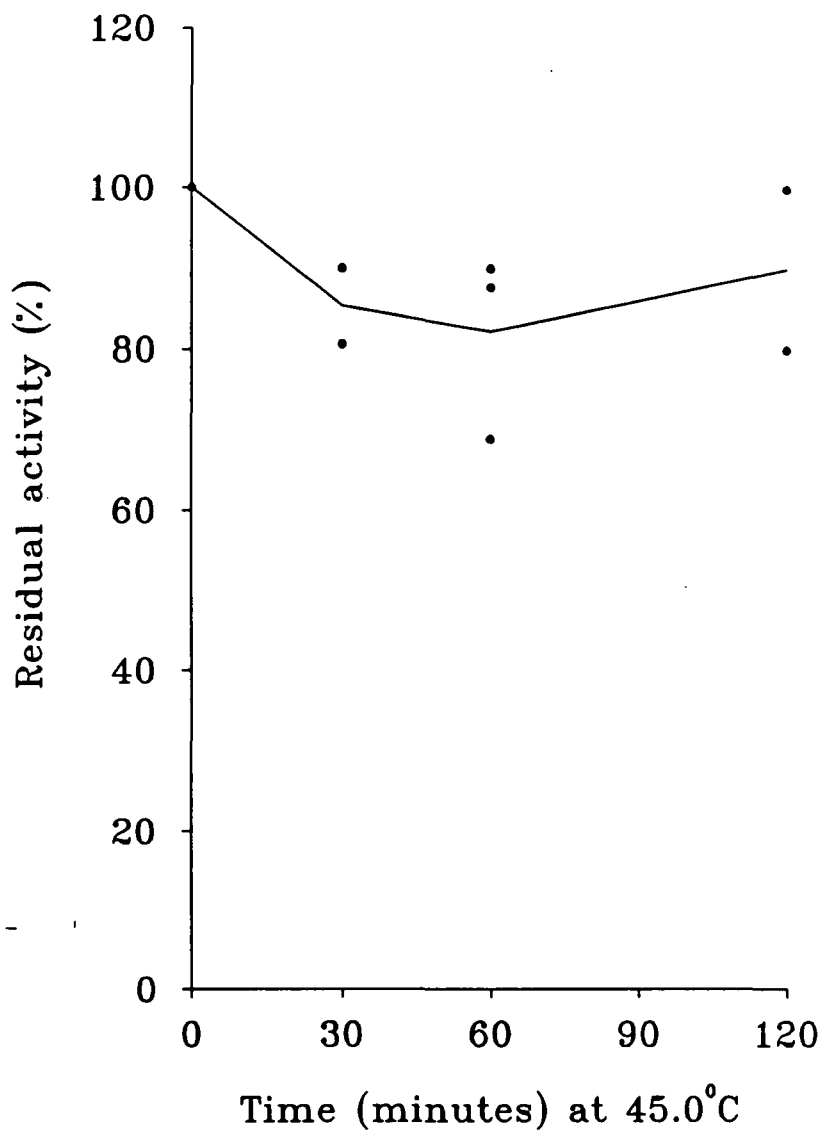

(c) 60 minutes exposure at constant temperature

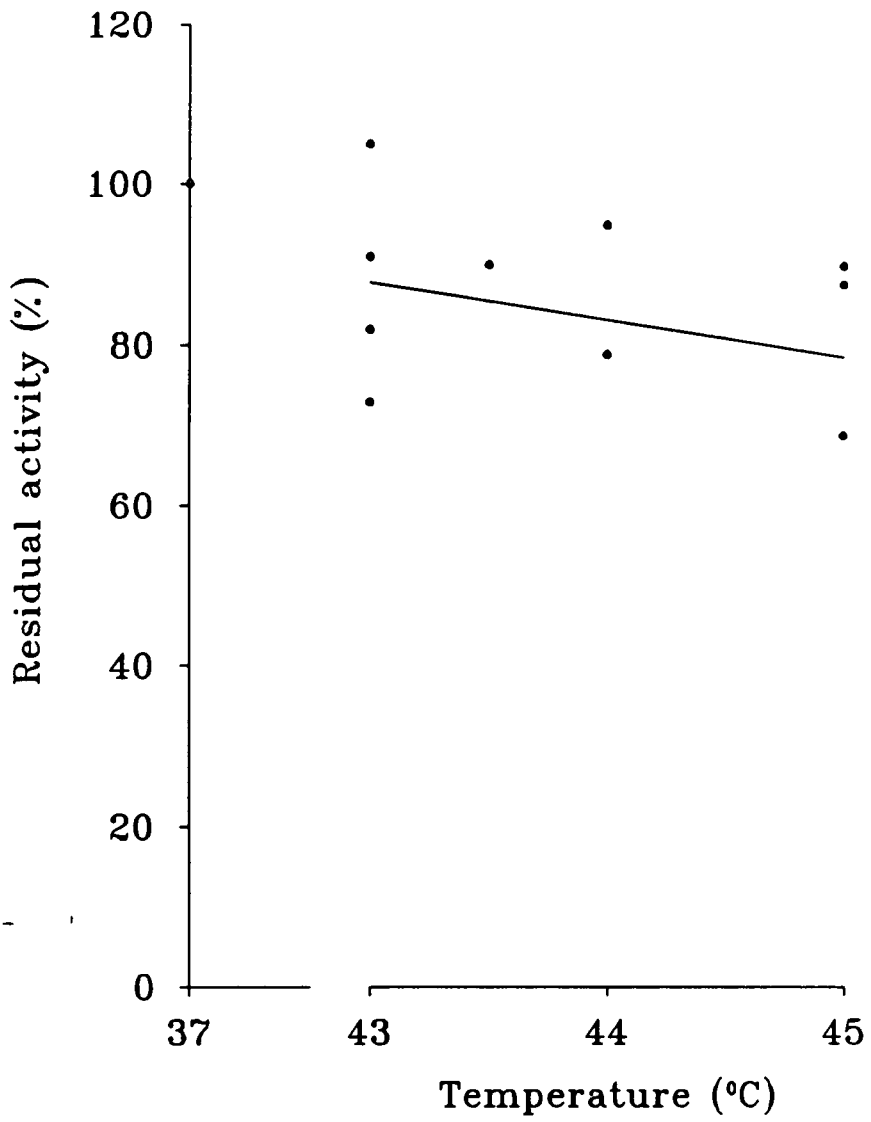

**Figure 5.9 — The activity of Na<sup>+</sup>, K<sup>+</sup>-ATPase in cell homogenates after hyperthermic treatment of HTC cells**

HTC cell monolayers were heat treated at 43<sup>0</sup>C or 45<sup>0</sup>C for various times, then Na<sup>+</sup>, K<sup>+</sup>-ATPase activity in cell homogenates was determined at 37<sup>0</sup>C as described in Materials and Methods. The data in the graphs are presented as percent activity present in cell homogenates of heat treated cells relative to cell homogenates from control cells maintained at 37<sup>0</sup>C.

Figures a and b represent the Na<sup>+</sup>, K<sup>+</sup>-ATPase activity in cell homogenates prepared from cell monolayers heat treated at 43<sup>0</sup>C and 45<sup>0</sup>C , respectively, for various periods of time.

Figure c shows the Na<sup>+</sup>, K<sup>+</sup>-ATPase activity in cell homogenates prepared from cell monolayers heat treated for 60 minutes at the specified temperatures. The data for 43<sup>0</sup>C and 45<sup>0</sup>C temperature points were obtained from figures a and b respectively.

Each data point on the graph represents the average of duplicate determinations.

(a) 43.0°C

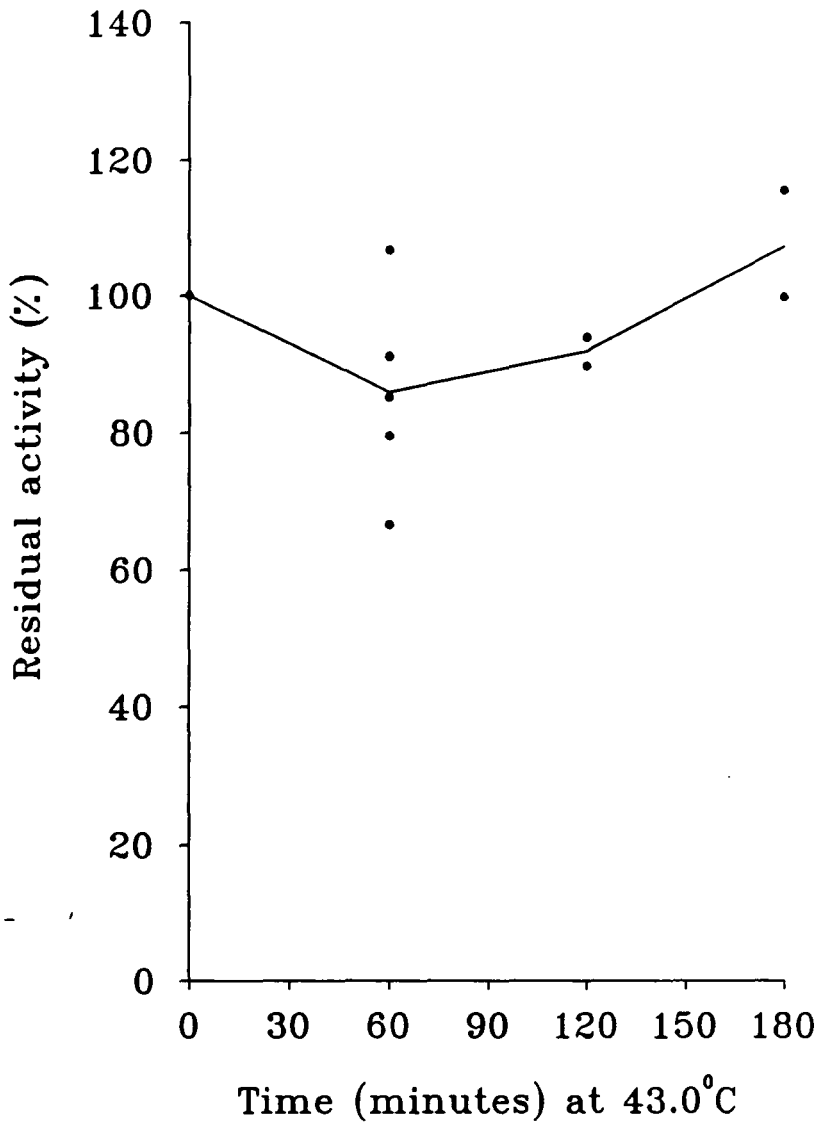

(b) 45.0°C

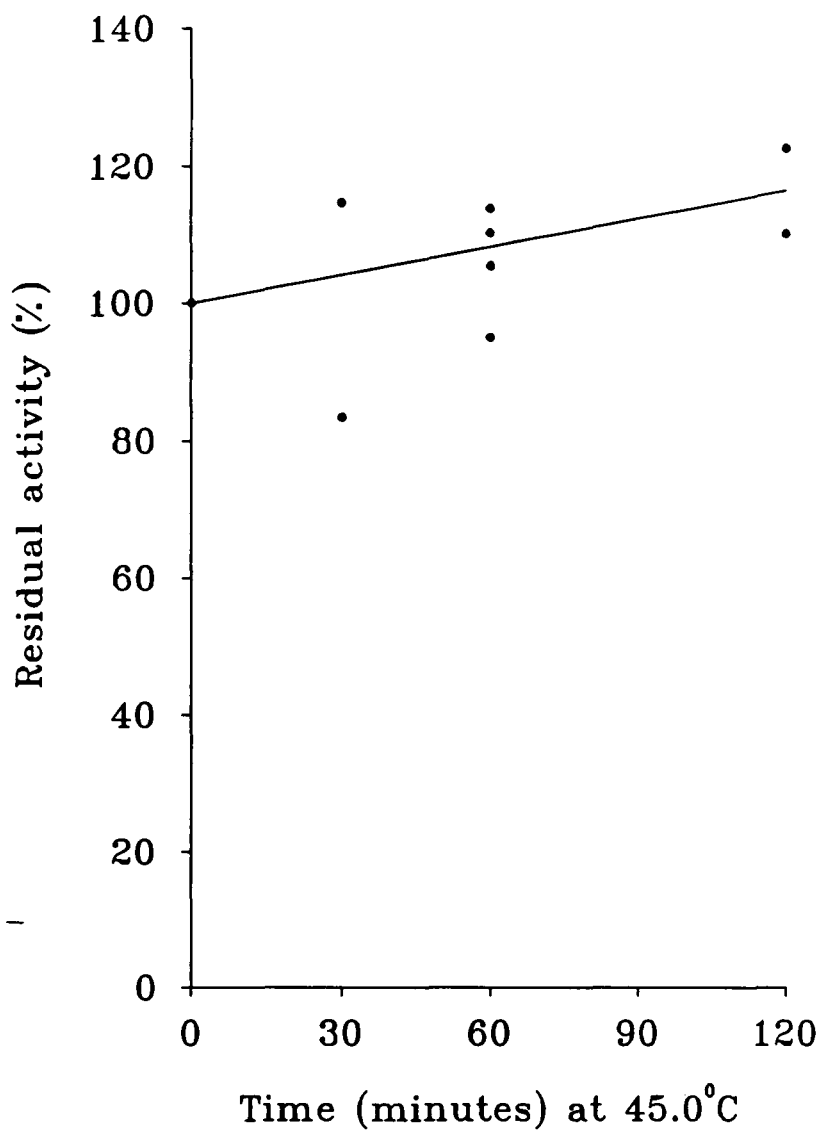

(c) 60 minutes exposure at constant temperature

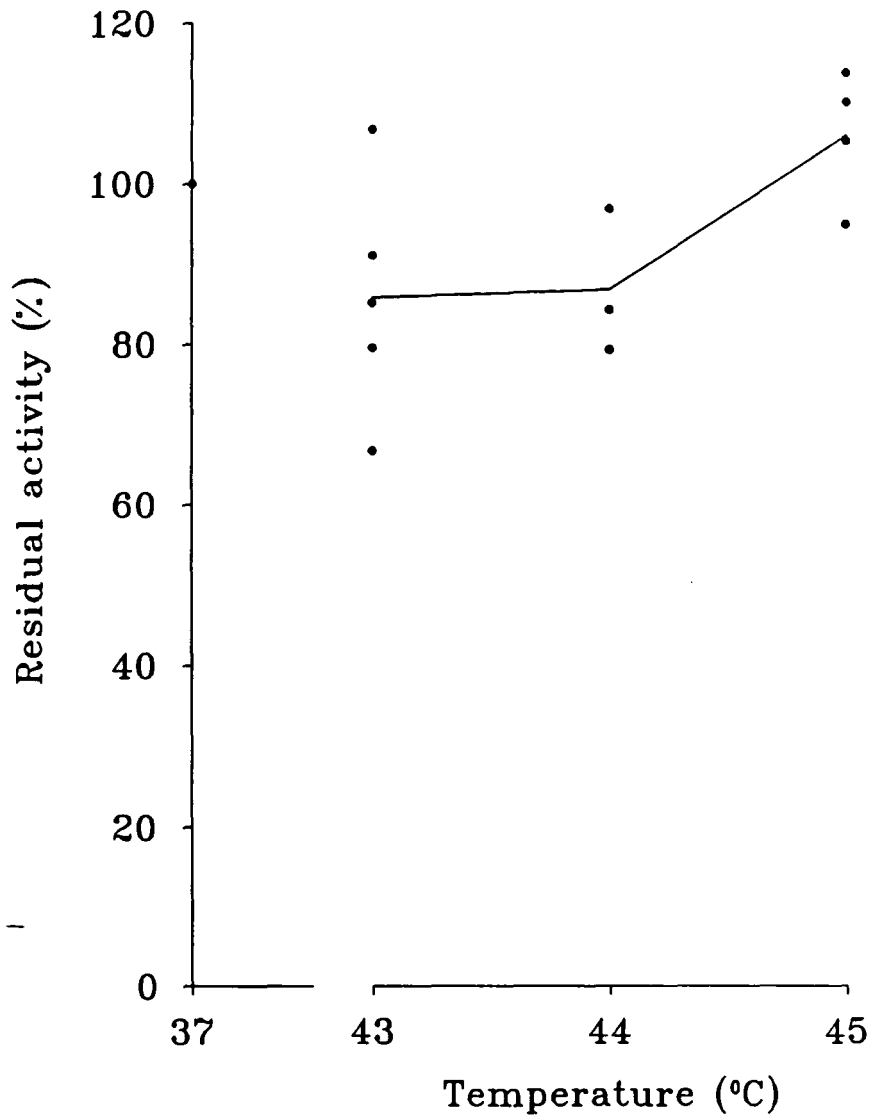

**Figure 5.10 — The activity of  $Mg^{2+}$ -ATPase in cell homogenates after hyperthermic treatment of HTC cells**

HTC cell monolayers were heat treated at  $43^{\circ}C$  or  $45^{\circ}C$  for various times, then the  $Mg^{2+}$ -ATPase activity in cell homogenates was determined at  $37^{\circ}C$  as described in Materials and Methods. The data in the graphs are presented as percent activity present in cell homogenates of heat treated cells relative to unheated control cell homogenates.

Figures a and b represent the  $Mg^{2+}$ -ATPase activity in cell homogenates prepared from cell monolayers heat treated at  $43^{\circ}C$  and  $45^{\circ}C$ , respectively, for various periods of time.

Figure c shows the  $Mg^{2+}$ -ATPase activity in cell homogenates prepared from cell monolayers heat treated for 60 minutes at the specified temperatures. The data for  $43^{\circ}C$  and  $45^{\circ}C$  temperature points were obtained from figures a and b respectively.

Each data point on the graph represents the average of duplicate determinations.

(a) 43.0°C

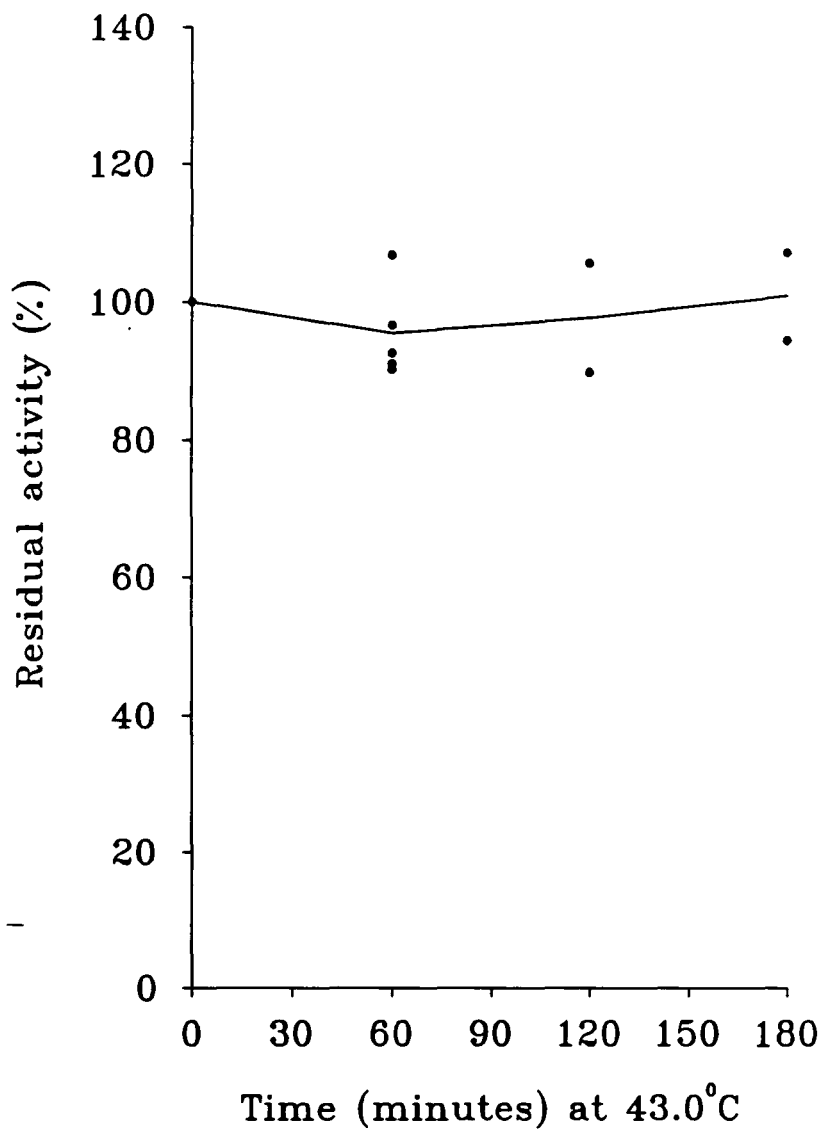

(b) 45.0°C

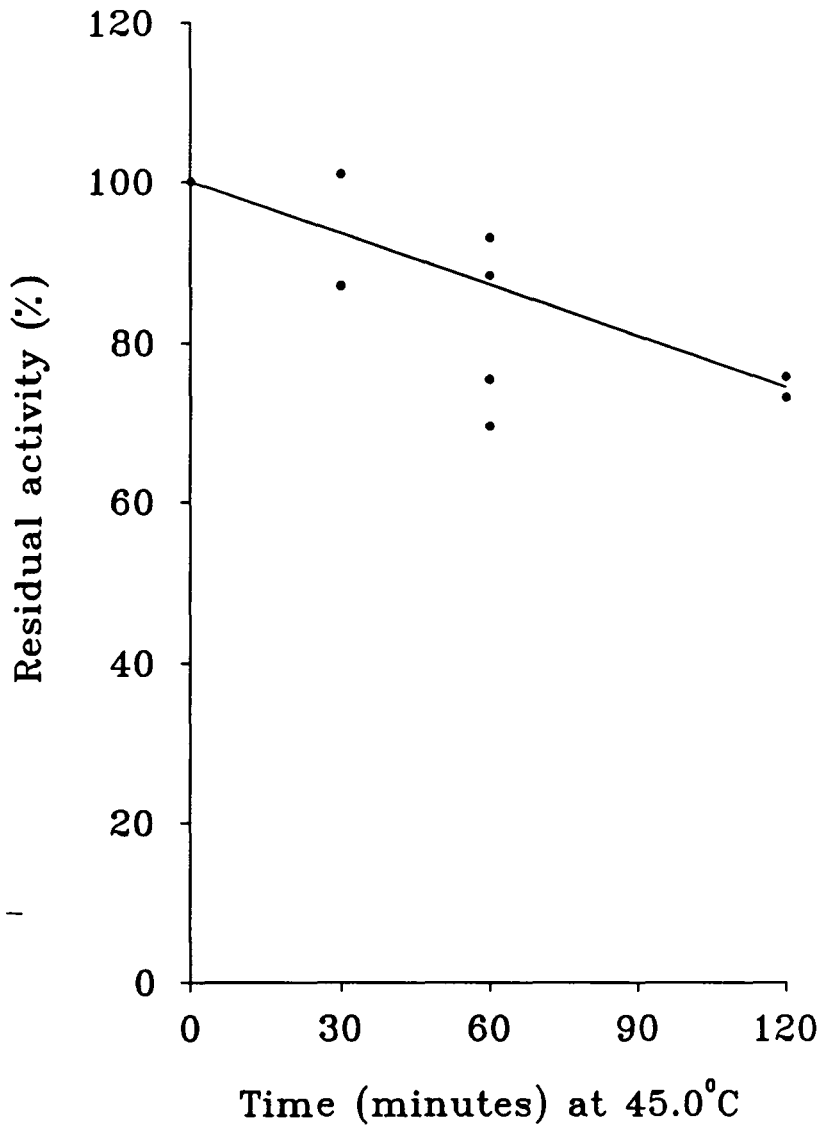

(c) 60 minutes exposure at constant temperature

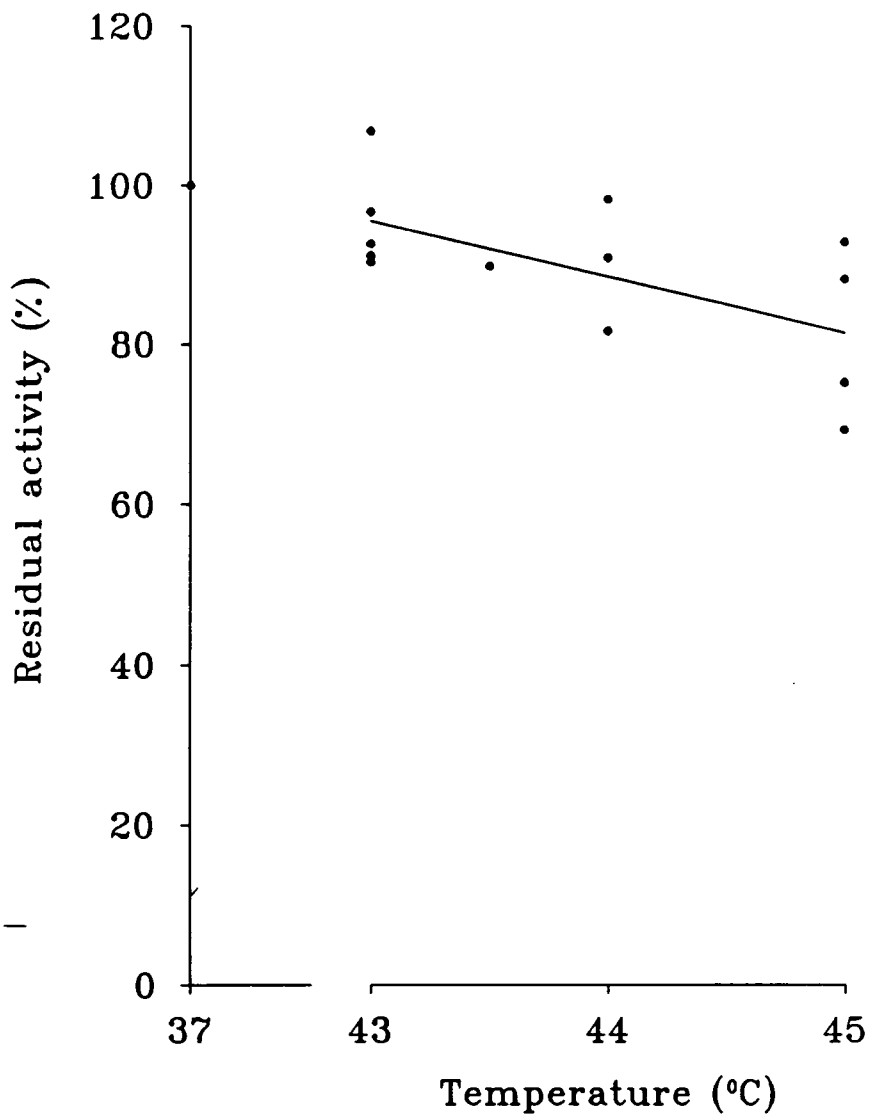

**Figure 5.11 — The activity of alkaline phosphodiesterase I in cell homogenates after hyperthermic treatment of HTC cells**

HTC cell monolayers were heat treated at 43<sup>0</sup>C or 45<sup>0</sup>C for various times, then the alkaline phosphodiesterase I activity in cell homogenates was determined at 37<sup>0</sup>C as described in Materials and Methods. The data in the graphs are presented as percent activity present in cell homogenates of heat treated cells relative to unheated control cell homogenates.

Figure a and b represent the alkaline phosphodiesterase I activity in cell homogenates prepared from cell monolayers heat treated at 43<sup>0</sup>C and 45<sup>0</sup>C , respectively, for various periods of time.

Figure c shows the alkaline phosphodiesterase I activity in cell homogenates prepared from cell monolayers heat treated for 60 minutes at the specified temperatures. The data for 43<sup>0</sup>C and 45<sup>0</sup>C temperature points were obtained from figures a and b respectively.

Each data point on the graph represents the average of duplicate determinations.

(a) 43.0°C

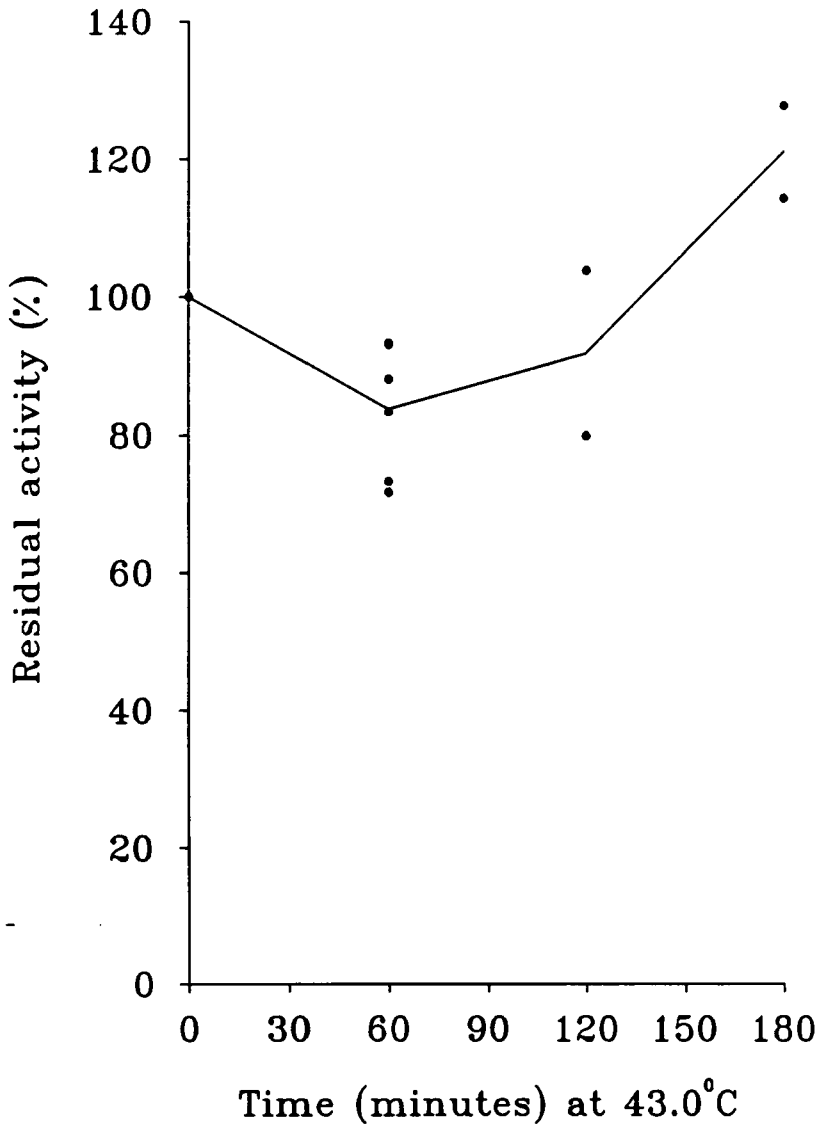

(b) 45.0°C

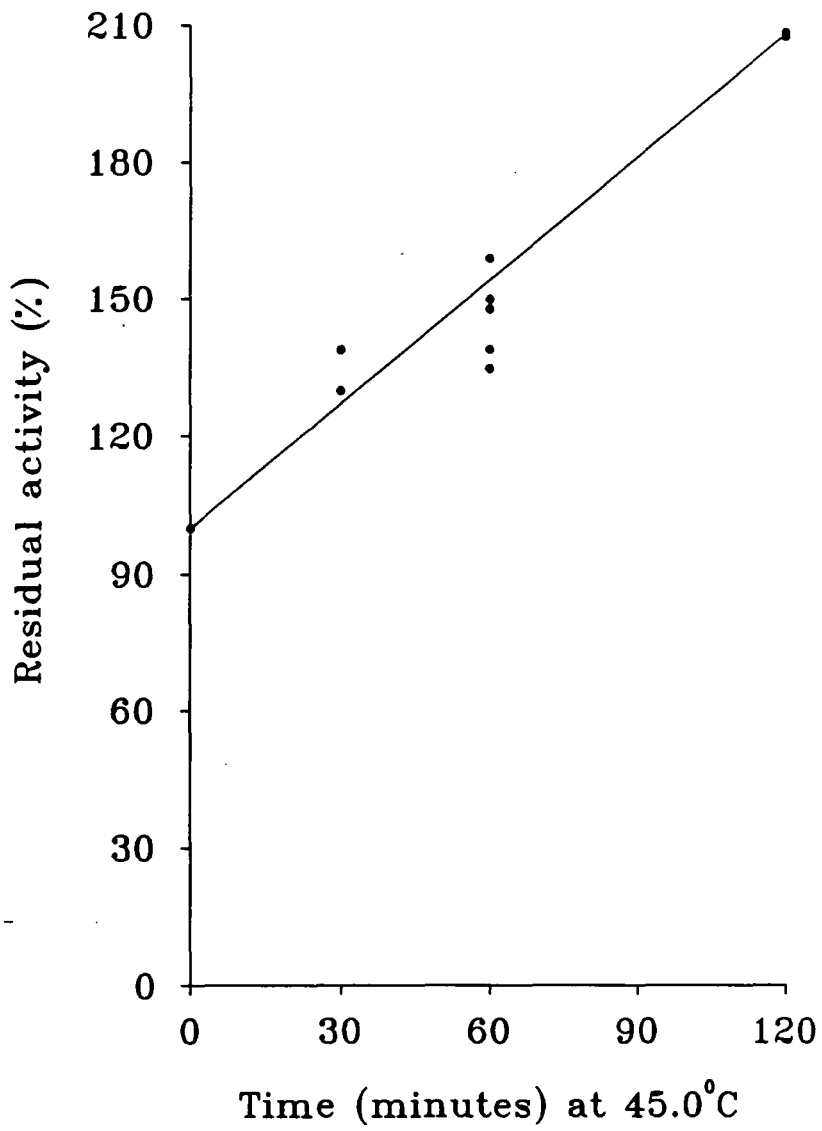

(c) 60 minutes exposure at constant temperature

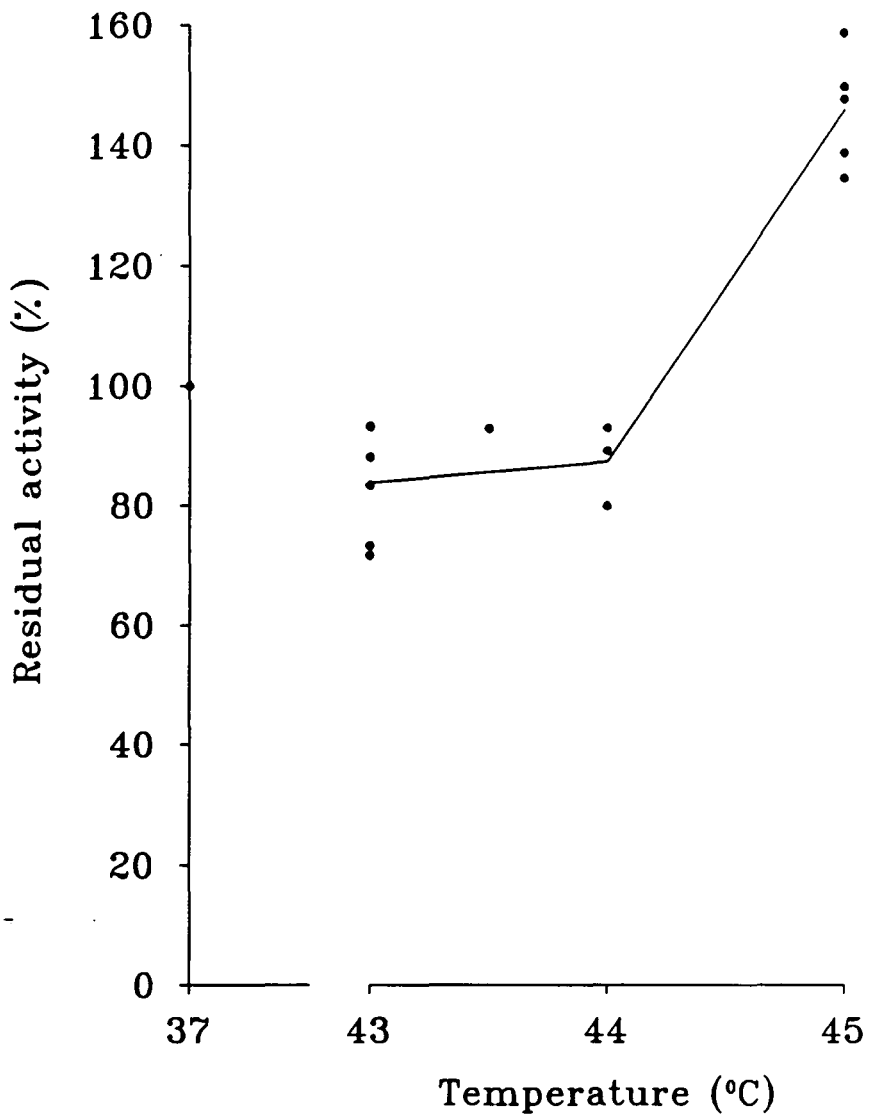

**Figure 5.12 — Thermal inactivation of Na<sup>+</sup>, K<sup>+</sup>-ATPase in purified control and arachidonic acid supplemented plasma membranes**

Plasma membranes purified from HTC cells grown in normal growth media (●) and growth media supplemented with 60μM arachidonic acid (○) for 36 hours were heat treated at 37<sup>0</sup>C to 57<sup>0</sup>C in a Forbes bar for 10 minutes as described in Materials and Methods. The residual Na<sup>+</sup>, K<sup>+</sup>-ATPase activity present after heat treatment was determined at 37<sup>0</sup>C. The activity in the figure is presented as percent activity remaining in heat treated plasma membranes relative to 37<sup>0</sup>C treated plasma membranes.

Each data point on the graph represents the average of duplicate determinations.

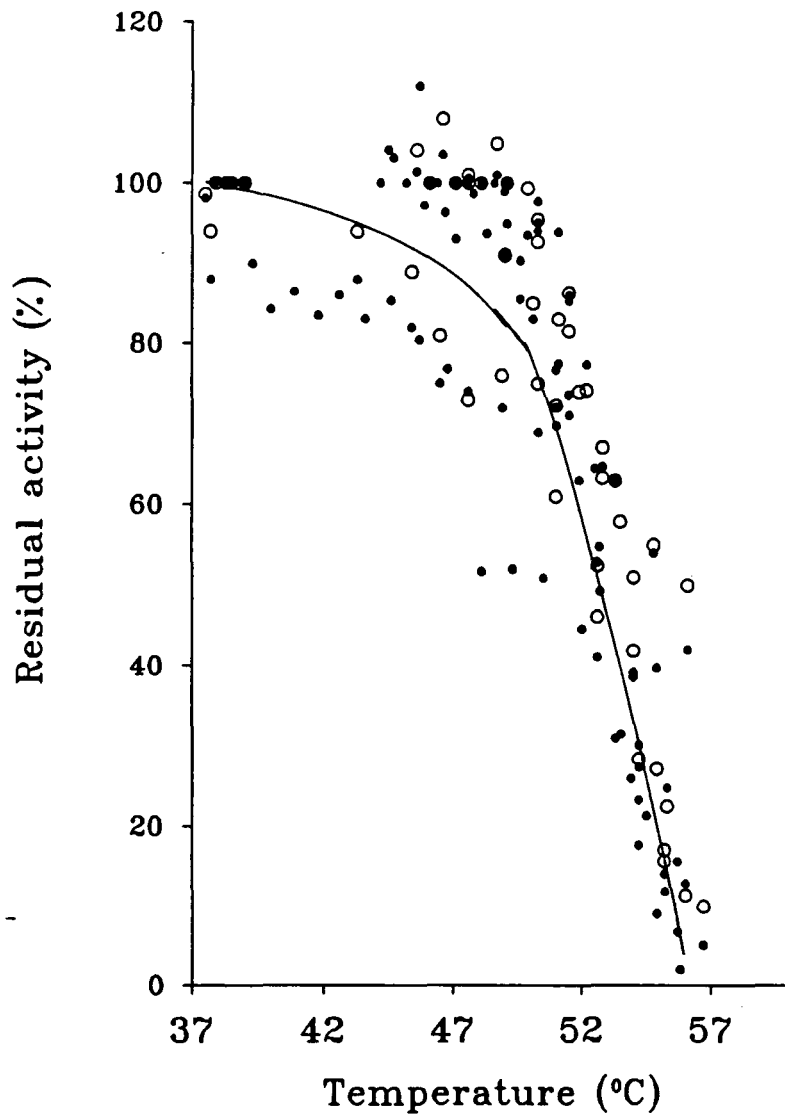

**Figure 5.13 — Thermal inactivation of alkaline phosphodiesterase I in control and arachidonic acid supplemented plasma membranes**

Plasma membranes purified from HTC cells grown in normal growth media (●) and growth media supplemented with 60 $\mu$ M arachidonic acid (○) for 36 hours were heat treated at 37<sup>0</sup>C to 73<sup>0</sup>C for 10 minutes in a Forbes bar as described in Materials and Methods. The residual alkaline phosphodiesterase I activity present after heat treatment was determined at 37<sup>0</sup>C. The activity in the figure is presented as percent activity remaining in heat treated plasma membranes relative to 37<sup>0</sup>C treated plasma membranes.

Each data point on the graph represents the average of duplicate determinations.

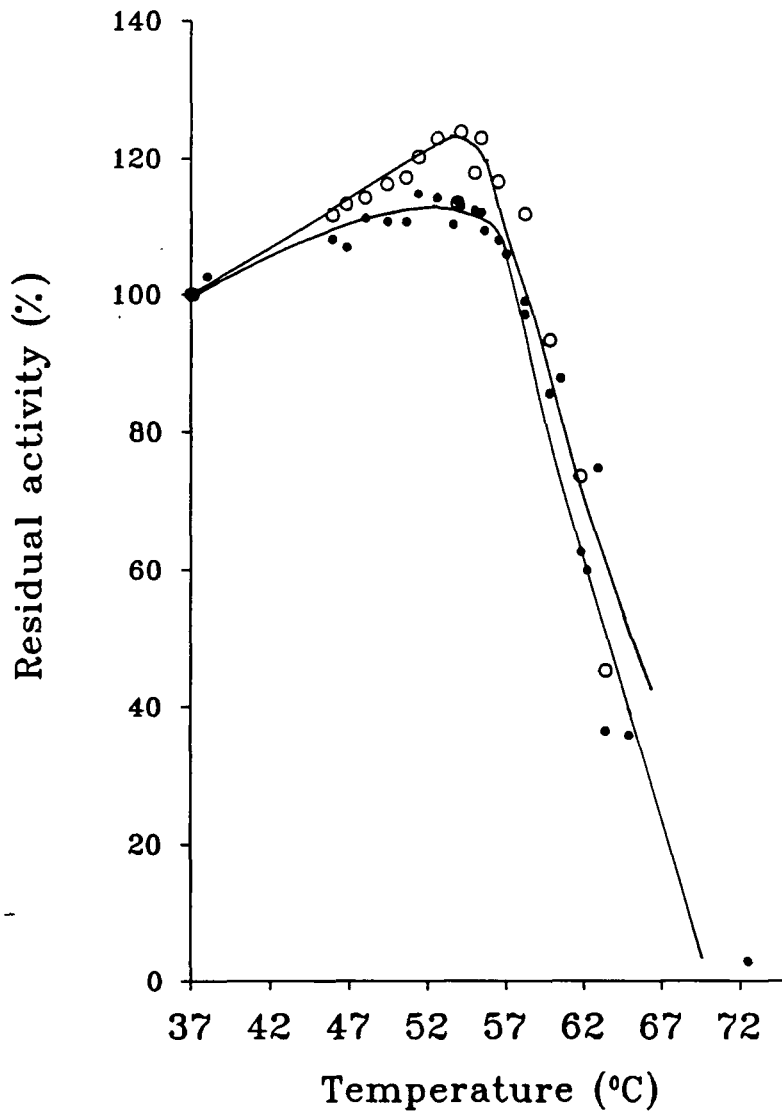

**Figure 5.14 — Kinetics of the isothermal inactivation of alkaline phosphodiesterase I in purified plasma membranes**

Plasma membranes purified from HTC cells grown in normal growth medium (●) and growth media supplemented with 60 $\mu$ M arachidonic acid (○) for 36 hours were heat treated at 64<sup>0</sup>C for up to 60 minutes as described in Materials and Methods. The alkaline phosphodiesterase I activity present after heat treatment was determined at 37<sup>0</sup>C. The observed decay of enzyme activities from control plasma membranes (●) and arachidonic acid supplemented plasma membranes (○) are presented (figure a). From figure a the gradient of the curve at time points greater than 10 minutes represents  $K_2$  and therefore the decay of the thermostable species. The intercept of the extrapolated decay of the 'thermostable' species on the enzyme activity axis represents  $x$  in the equation given below:

$$Z = \text{Ln} ((\text{total activity}) - e^x \cdot e^{-k_2 t})$$

where  $t$  represents time

From this equation activity ( $Z$ ) of the 'thermolabile' species is calculated.

The plot of  $\text{Ln}(Z)$  versus time (figure b) gives a line, the gradient of which represents constant  $K_1$  and therefore the decay of the 'thermolabile' species of enzyme.

Each data point on the graph represents the average of duplicate determinations.

(a) Isothermal inactivation

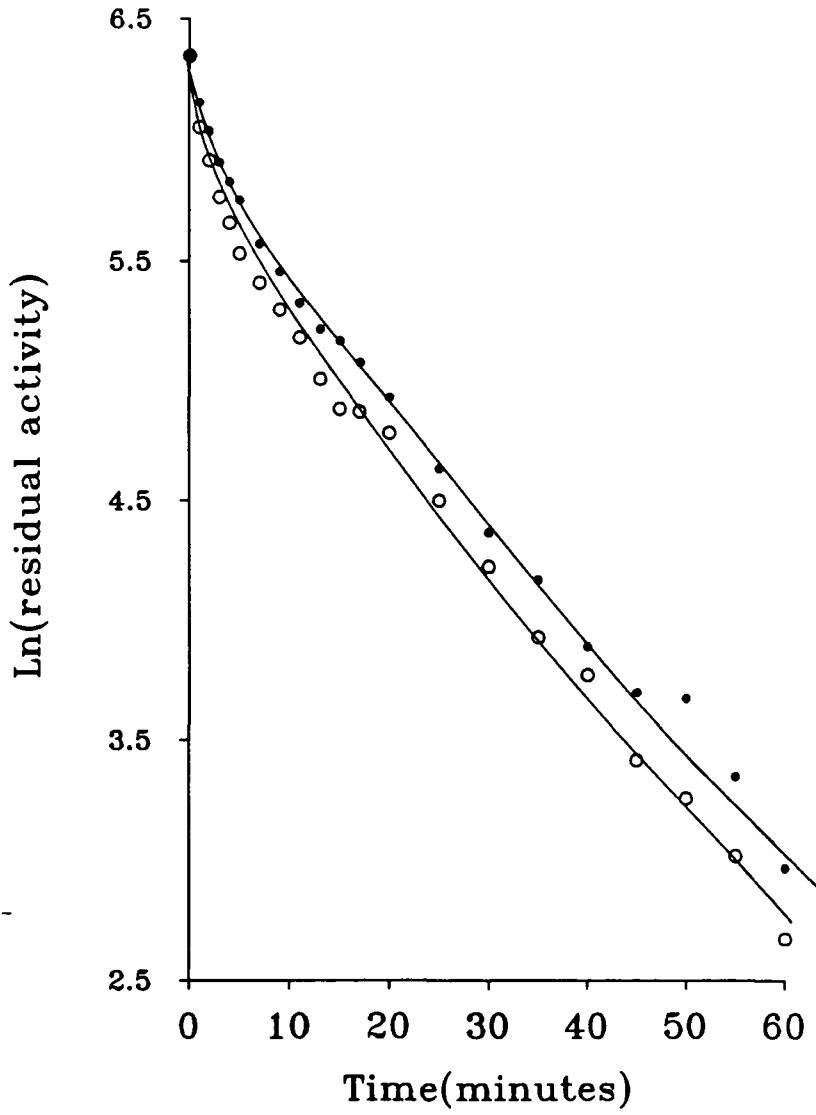

(b)  $K_1$  determination

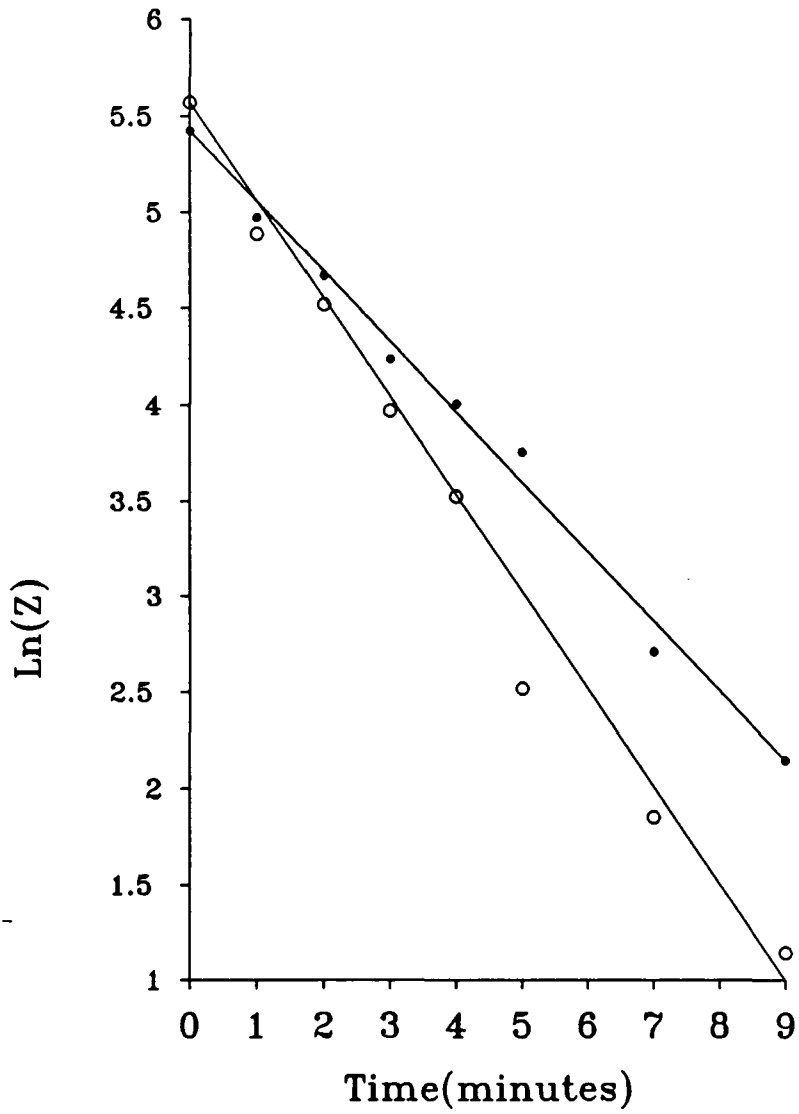

**Table 5.1 — The kinetic parameters describing the thermal decay of alkaline phosphodiesterase I**

The data in this table are obtained from figure 5.14. The table compares the  $K_1$ ,  $K_2$  and half lives of alkaline phosphodiesterase I from three separate control and arachidonic acid supplemented plasma membrane preparations.

Constant	Plasma membrane source	
	Control cells	Arachidonate supplemented cells
$K_1$	0.3452 $\pm 0.015$	0.4732 $\pm 0.037$
Half life (min) for thermolabile species	2.013 $\pm 0.094$	1.479 <sup>†</sup> $\pm 0.112$
$K_2$	0.0450 $\pm 0.0015$	0.0465 $\pm 0.0021$
Half life (min) for thermostable species	15.43 $\pm 0.532$	14.98 $\pm 0.692$

Data in the table represent mean values  $\pm$  standard error

<sup>†</sup>Found to be significantly different ( $p < 0.05$ ) from control values with the Paired t-test

## 5.4 Discussion

There have been several different approaches used to investigate the effects of heat on membrane-bound proteins. These approaches exploit various properties of membrane-bound proteins, the majority of which rely on enzymes with associated activities some of which transport molecules across the membrane. The various approaches that have been used are listed and discussed below.

*The first approach:* Direct measurement of changes in protein conformation.

Lepock *et al.* (1983) demonstrated in Chinese hamster lung cells an irreversible transition in protein structure or rearrangement above 40°C in both mitochondrial and plasma membranes. This was done by measurement of intrinsic protein fluorescence and energy transfer from protein fluorophore to *trans*-paranaric acid. Lepock *et al.* (1988) using differential scanning calorimetry have demonstrated irreversible transitions primarily representing protein denaturation, when Chinese hamster lung V79 cells were heated from 49.5°C to 98.9°C. Similar investigations into the relationship of hyperthermia-induced haemolysis of human erythrocytes to the thermal denaturation of membrane protein revealed that the major protein that was denatured was spectrin (Lepock *et al.*, 1989).

*The second approach:* Purifying the membrane-bound protein and reconstituting into defined lipid bilayers. The protein, in this defined environment, is then subjected to heat treatment.

Using this approach, Fischer and Williams (1982) measured the thermal decay rates of rhodopsin in detergent systems containing specific phospholipid species. Their series of experiments demonstrated that the structure of fatty acid chains are as important as the headgroup structure in determining the stabilization abil-

ity of a phospholipid. The ability of phospholipids to stabilize the chromophoric site of rhodopsin increases with saturated fatty acid chain length up to 16 carbons long. Thermal denaturation measurements involving phospholipids with 18 carbon fatty acids showed that denaturation was greater in phospholipids containing 18:0 when compared to those containing 18:1. The introduction of a double bond in the acyl groups of the phospholipid helps in allowing the rhodopsin to adopt a stable conformation.

Cheng *et al.* (1987), using  $\text{Ca}^{2+}$ -ATPase reconstituted into proteoliposomes, showed that the rate of thermal inactivation of calcium uptake activity of the reconstituted vesicles with a cholesterol/phospholipid ratio of 0.3 was lower than those with a cholesterol/phospholipid ratio of 0.1 in the temperature range  $43^{\circ}\text{C}$  to  $47^{\circ}\text{C}$ . This suggests that cholesterol protects against denaturation of proteins and therefore the higher the membrane order the greater the thermostability of membrane proteins.

*The third approach:* Heating whole cells and measuring changes in the properties of membrane-bound proteins at the elevated temperatures.

This approach has been used by many workers (Stevenson *et al.*, 1983; Boonstra *et al.*, 1984; Bates and Mackillop, 1985; Ruifrok *et al.*, 1986) and they have demonstrated that  $\text{K}^{+}$  influx is increased at hyperthermic temperatures. In addition, Le Cavalier and Mackillop (1985) have also shown that facilitated transport of glucose is increased at temperatures up to  $45^{\circ}\text{C}$ , but above this temperature glucose transport into the cells is reduced. Bates and Mackillop (1985) have also demonstrated that Chinese hamster ovary cells when adapted to  $40^{\circ}\text{C}$  showed a higher membrane viscosity when compared to control cells. The  $\text{Rb}^{+}$  influx through

the Na<sup>+</sup>, K<sup>+</sup>-ATPase in both types of cells increased steadily when the cells were heated at temperatures between 31 to 46<sup>0</sup>C then decreased rapidly between 46<sup>0</sup>C and 50<sup>0</sup>C. Although membrane viscosity in thermally adapted cells was greater than in control cells the kinetics of Rb<sup>+</sup> influx through Na<sup>+</sup>, K<sup>+</sup>-ATPase was the same in both types of cells. This suggests that membrane viscosity does not influence the thermostability of K<sup>+</sup> transport through the Na<sup>+</sup>, K<sup>+</sup>-ATPase.

*The fourth approach:* Heating whole cells and then measuring transport activities in intact cells at 37<sup>0</sup>C or homogenising the cells and measuring enzyme activities in whole cell homogenates and/or membranes isolated from these cells at physiological temperatures.

Using this approach, Kwock *et al.*, (1985) heated Molt-4 and RPMI 1788 cells at hyperthermic temperatures (39-43<sup>0</sup>C ) for 1 or 2 hours. After this treatment the transport of amino acids into the cell via the Na<sup>+</sup>-dependent amino acid transport protein was measured at 37<sup>0</sup>C. It was found that the transport of amino acids was impaired after heating but gradually recovered with time when the cells were returned to normal culture conditions after heating. Burdon *et al.* (1982; 1984), Anderson and Hahn (1985), and Ruifrok *et al.* (1986) have all investigated the effect of hyperthermic temperatures on the ATP hydrolyzing activity of Na<sup>+</sup>, K<sup>+</sup>-ATPase. The approach used involved heating cells, homogenising them and then measuring the Na<sup>+</sup>, K<sup>+</sup>-ATPase activity at 37<sup>0</sup>C. This approach clearly measures irreversible changes in the activity of the enzyme. Burdon *et al.* (1982; 1984), and Anderson and Hahn (1985) found that the ATP hydrolyzing activity was reduced by hyperthermic treatment. In contrast, Ruifrok *et al.* (1986) found no reduction in ATP hydrolyzing activity of Na<sup>+</sup>, K<sup>+</sup>-ATPase in keeping with the findings of the present study. Ruifrok *et al.* (1986) also measured ouabain-sensitive ATPase activity

in crude membrane preparations of mouse LM fibroblasts at 37°C after treatment of cells at 44°C. Again no reduction in enzyme activity was detected. In addition Ruifrok *et al.* (1986) showed that there was no correlation between heat induced cell death of mouse LM fibroblasts and the effects of heat on the ATP hydrolyzing capacity of Na<sup>+</sup>, K<sup>+</sup>-ATPase, in keeping with the findings of this study.

In the present study, prior to the determination of the thermal stability of HTC adenylate cyclase the enzyme was characterised in order to ascertain whether the adenylate cyclase system of these cells contained the various subunits, which make up the enzyme, in an active form. This would enable the thermal stability of each component of the system to be determined.

The characterisation of the liver adenylate cyclase system in the present study was not exhaustive, as the purpose of this work was to ensure that the low activities obtained with HTC adenylate cyclase were not due to a flaw in the assay procedure. The 15-fold stimulation obtained by forskolin indicates that the adenylate cyclase is present in an active form in the liver homogenate preparation used in this assay. The data show that there was no stimulation relative to basal activity by GTP, which is contradictory to that obtained by other workers (Salomon *et al.*, 1975). However, it must be borne in mind that the crude preparation used in the study probably contains endogenous agonists, including GTP. This is supported by a slight stimulation obtained by isoproterenol alone. Hence the activity designated as basal is not agonist-free basal activity of liver cells. The synergistic activation by isoproterenol when GTP is also added clearly indicates that a coupled adenylate cyclase system is present.

The low HTC adenylate cyclase activity relative to the activity in liver is in

agreement with the findings of Granner *et al.*, (1968) and Makman (1971). In general, it has been noted that malignant tissue contains lower adenylate cyclase activity than its non-malignant counterpart.

The HTC cell adenylate cyclase system was stimulated by forskolin, an agonist known to interact directly with the catalytic subunit, thereby indicating the presence of a catalytic subunit. Therefore, when the thermal stability of forskolin-stimulated adenylate cyclase was measured (figure 5.8) the thermal stability of the catalytic subunit was being determined. The data indicated that heat treatment of HTC cell monolayers at 43<sup>0</sup>C to 45<sup>0</sup>C for up to 180 minutes caused no substantial change in the forskolin-stimulated activity of adenylate cyclase (figure 5.8) in homogenates prepared from heat treated monolayers. However, the failure of GTP and isoproterenol to stimulate the adenylate cyclase suggests that the catalytic subunit is not coupled to G-proteins and to  $\beta$ -adrenergic receptors via the G-proteins. These findings are substantiated by the corresponding lack of effect with GTP $\gamma$ S which is a non hydrolysable analogue of GTP. In an effort to probe for a putative G<sub>i</sub> system, a GTP $\gamma$ S dose-response curve with a highly stimulated adenylate cyclase was carried out. If the G<sub>i</sub> was active, the chronically stimulated cyclase activity would be attenuated by GTP $\gamma$ S at the higher concentrations of GTP $\gamma$ S used in the experiment. However, no such response was observed (figure 5.7b), suggesting no coupling between G<sub>i</sub> and the catalytic subunit. The results do not show a coupled adenylate cyclase system, and the possibility that the G-proteins and  $\beta$ -receptors are not present cannot be excluded. If, for example, G-proteins or both G-proteins and  $\beta$ -adrenergic receptors were lacking, similar results to an uncoupled adenylate cyclase would be obtained. This raises the possibility that  $\beta$ -adrenergic receptors may be present but G-proteins lacking or uncoupled, and hence isoproterenol will

not stimulate the adenylate cyclase. A situation where one of the components of the adenylate cyclase system is missing has been demonstrated by Mourelle and Rojkind (1984) in Morris hepatoma 7800. They showed that this cell line lacked glucagon receptors but contained intact regulatory and catalytic subunits.

The lack of response of the adenylate cyclase system to glucagon has been reported by Granner *et al.*, (1968) using a membrane preparation from HTC cells and by Allen *et al.*, (1971) using a homogenate preparation from the hepatoma 7288-C. However, Allen *et al.*, (1971) did show a response with NaF which was not obtained by experiments carried out by Granner *et al.*, (1968). Furthermore, Allen *et al.*, (1971) concluded that the growth rate of cells in culture was inversely correlated to the glucagon response. Makman (1971) reported that HTC cells grown in suspension did not express a detectable adenylate cyclase. However, in monolayer culture they produced a detectable adenylate cyclase which responded to  $\beta$ -adrenergic agents. Makman (1971) suggested that the low response to hormones was due to a defective or reduced number of catalytic subunits. The differences in results compared to the present study may be due to conditions of culture and changes in the characteristics of HTC cells through many years of culture leading to an altered adenylate cyclase system.

Table 5.2 shows the adenylate cyclase activities obtained by other workers using HTC cells and other tissues as a source of enzyme. The response of HTC cells to a number of agonists is non-existent or low when compared to other cell lines. This could be due to a defective adenylate cyclase system, low expression of the intact system or a high turnover of all or some of the proteins that constitute a functional adenylate cyclase.

In the present study, the heat treatment procedures for cell monolayers used in this chapter were the same as those used in chapter 3, where survival of cells was measured in response to heat treatment. Therefore, the procedure adopted in this chapter, where cell monolayers were heat treated then cooled to room temperature before determining the enzyme activities in homogenates prepared from the cells, measures thermally-induced changes in the enzyme activity under conditions previously shown to produce measurable cell death. Any transient changes in the enzyme activity during the heating period will not be detected. When cell monolayers are heated the permanent changes that may arise in the enzyme activity could be due to thermal denaturation and/or modification of the enzyme protein by intracellular mechanisms, which could include protein phosphorylation/dephosphorylation. Heat treatment of HTC cell monolayers at 43<sup>0</sup>C to 45<sup>0</sup>C for up to 180 minutes clearly reduced cell viability in a heat dose dependent manner (figure 5.3). However, this reduction in viability did not correlate with a substantial change in cell size (figure 5.2) or in the activity of forskolin-stimulated adenylate cyclase (figure 5.8) or Na<sup>+</sup>, K<sup>+</sup>-ATPase (figure 5.9), or Mg<sup>2+</sup>-ATPase (figure 5.10) in homogenates prepared from heat treated monolayers. This may reflect that thermal inactivation of these proteins may not be critical in causing heat-induced cell death.

The activity of alkaline phosphodiesterase I in homogenates from HTC cells treated at 43<sup>0</sup>C to 45<sup>0</sup>C for up to 180 minutes increased with heat dose. This is unusual as it is generally accepted that heat denatures proteins and therefore reduces the activity. The activation of the enzyme at the hyperthermic temperatures could be due to thermally-induced conformational changes in the protein which generates a more active species. However, the neutralisation of possible inhibitory components by heat treatment cannot be eliminated. In addition this ecto-enzyme is anchored in

the membrane via linkage to phosphatidylinositol (Nakabayashi and Ikezawa, 1986). Therefore, there is a possibility that heat induced changes in the plasma membrane (e.g. increase in membrane fluidity), may allow the enzyme to adopt a more active configuration.

Hepatocyte alkaline phosphodiesterase I has been shown (Bischoff *et al.*, 1975) to have a broad specificity for hydrolysing many nucleotides (ATP, UTP and NAD). In addition, it has also been shown to be not only located on the outer surface of the plasma membrane but also in the endoplasmic reticulum (Bischoff *et al.*, 1975). Therefore, one possible consequence of enhanced activity is the rapid hydrolysis of intracellular nucleotides as well as extracellular nucleotides. The precise mechanism by which activity is enhanced and the consequences of the increase in activity on cell survival should form the basis for further experiments.

*The fifth approach:* Isolating membranes and then heating the membrane-associated enzyme. The residual enzyme activity remaining is then determined at physiological temperatures.

This approach has mainly been used to investigate the effects of a change in membrane order on the thermostability of membrane-bound enzymes. Membrane-associated enzymes are often found to be influenced by the fluidity (order) of membrane lipids (Kimmelberg, 1977). Part of the reason for this influence stems from the anisotropic hydrophobic core of the membrane which forms a viscous, relatively hindered environment for enzyme functioning (Cossins *et al.*, 1981). Since enzymes require molecular flexibility for catalytic purposes it is probable that such an environment will cause enzymes to adopt relatively loose tertiary structures which in turn are likely to be susceptible to perturbation. Any increase in membrane

fluidity caused, for example, by supplementation procedure and/or hyperthermic temperatures is likely to produce a less hindered environment for the proteins. This less ordered environment in turn is likely to permit a greater range of conformational movement which could lead to the membrane proteins more rapidly adopting inactivating configurations.

Cossins and Bowler (1976) isolated sarcoplasmic reticulum vesicles from crayfish acclimated at 4°C or 25°C. This protocol, as explained in chapter 3, results in membranes from the low temperature acclimated animals being less ordered than the high temperature acclimated animals. The influence of this change in membrane order on the thermostability of Ca<sup>2+</sup>-ATPase was negligible. Similar experiments with crayfish showed that plasma membrane Na<sup>+</sup>, K<sup>+</sup>-ATPase and Mg<sup>2+</sup>-ATPase thermostability remained unaltered. However, Cossins *et al.*, (1981) found that the acetylcholine-esterase and Na<sup>+</sup>, K<sup>+</sup>-ATPase from goldfish brain synaptic membranes were more thermolabile in membranes from 7°C acclimated animals compared to those acclimated at 28°C.

In the above experiments, temperature gradient inactivation was used to assess the thermostability of the enzymes. i.e. the enzyme preparation was heat treated at different temperatures for a fixed time period before measuring the residual activity at physiological temperatures. A variation on this procedure is to measure the rate of inactivation of the enzyme activity. This is achieved by heating the enzyme at a constant temperature for different time periods and then measuring the residual activity of the enzyme at physiological temperatures (isothermal inactivation).

Further analysis, using isothermal inactivation, showed that the acetylcholine-esterase and Na<sup>+</sup>, K<sup>+</sup>-ATPase from goldfish brain synaptic membranes were again

more thermolabile in membranes from 7<sup>0</sup>C acclimated animals compared to those acclimated at 28<sup>0</sup>C (Bowler, 1987). The kinetic analysis carried out by Bowler (1987) was the same as that carried out in this study for alkaline phosphodiesterase I. i.e. K<sub>1</sub> values were calculated for the thermolabile species and it was found that the half life for the thermolabile species of the enzymes from the 7<sup>0</sup>C acclimated animals was shorter than for the thermolabile species of the enzymes from 28<sup>0</sup>C acclimated animals. In keeping with the findings of the present study the increase in thermosensitivity of the enzymes was accompanied by a lower membrane order in brain synaptic vesicles from 7<sup>0</sup>C acclimated animals compared to those from 28<sup>0</sup>C acclimated animals (Cossins *et al.*, 1981). Also, the lowered membrane order correlates well with the earlier report by Cossins *et al.* (1977) that warm acclimation caused the incorporation of more saturated fatty acids into membrane phospholipids.

In the current study, a 36 hour period of supplementation of HTC cells with 60 $\mu$ M arachidonic acid had been found to increase the fluidity (decrease the order) of the plasma membrane derived from these cells (see chapter 4, figure 4.14). As this change may be expected to influence membrane-bound enzyme activity, the effect of arachidonate supplementation on the thermal sensitivity of Na<sup>+</sup>, K<sup>+</sup>-ATPase and alkaline phosphodiesterase I activity was investigated. Plasma membranes were isolated from control cells and from cells supplemented with 60 $\mu$ M arachidonate for 36 hours, then membranes were heated at 37<sup>0</sup>C to 57<sup>0</sup>C for 10 minutes before measurement of residual Na<sup>+</sup>, K<sup>+</sup>-ATPase activity. The results from this temperature gradient technique (figure 5.12) revealed no substantial difference in the thermal sensitivity of this enzyme from the two cell populations. Similarly, no substantial difference in the thermal sensitivity of alkaline phosphodiesterase I from the two cell populations was revealed after isolated plasma membranes were treated for 10 min-

utes over a temperature gradient from 37<sup>0</sup>C to 73<sup>0</sup>C (figure 5.13). However, studies of the kinetics of isothermal inactivation of alkaline phosphodiesterase I at 64<sup>0</sup>C (figure 5.14) suggested that an initial thermolabile species of the enzyme present in plasma membrane from arachidonate-supplemented cells was more sensitive to thermal inactivation compared to the same enzyme in plasma membrane from control cells.

It is clear from these results that isothermal inactivation represents a more sensitive method than inactivation using a temperature gradient, in detecting changes in the thermal sensitivity of alkaline phosphodiesterase I after arachidonate supplementation of HTC cells. Similar isothermal inactivation methods should be used to study the thermal sensitivity of other plasma membrane-bound enzymes, (e.g. Na<sup>+</sup>, K<sup>+</sup>-ATPase, adenylate cyclase, Mg<sup>2+</sup>-ATPase) after arachidonate supplementation, but this was precluded in the present study by lack of time and lack of sufficient quantities of purified plasma membranes. However, this work should form the basis of future investigations in this area.

**Table 5.2 — Adenylate cyclase activity obtained by other workers**

The table below shows the basal and agonist stimulated adenylate cyclase activities (pmole/min/mg protein) obtained by other workers. The concentration of the agonist are given in parenthesis.

Agonists	Workers								
	Granner <i>et al.</i> , 1968	Makman 1971		Allen <i>et al.</i> , 1971		Ladha <i>et al.</i> , 1985	Trier <i>et al.</i> , 1988		This work
None (basal)	0.84	0.6	7.5	2.3	1.33	13	36.0 <sup>a</sup> 25.7 <sup>b</sup>	6.50 <sup>a</sup> 10.5 <sup>b</sup>	0.09
l-Epinephrine (16 $\mu$ M)	2.9	38.3							
Glucagon (0.2mM) and GTP(20 $\mu$ M)	2.35	27.0							
Prostaglandin E <sub>1</sub> (1 $\mu$ g/ml)	2.0	10.25							
Sodium fluoride	1.12 (10mM)	1.0 (8mM)	141 (8mM)	21.7 (100mM)	6.5 (100mM)		96.0 <sup>a</sup> (10mM)	15.8 <sup>a</sup> (10mM)	
Glucagon	1.04 (10 $\mu$ g/ml)			6.6 (10 <sup>-6</sup> M)	1.83 (10 <sup>-6</sup> M)				
Dexamethasone (10 $\mu$ M)	0.42								
Forskolin (100 $\mu$ M)						152	190 <sup>b</sup>	60.8 <sup>b</sup>	2.7
Assay temp.	30 <sup>0</sup> C	30 <sup>0</sup> C	30 <sup>0</sup> C	37 <sup>0</sup> C	37 <sup>0</sup> C	37 <sup>0</sup> C	37 <sup>0</sup> C	37 <sup>0</sup> C	37 <sup>0</sup> C
Source of adenylate cyclase	HTC cell membrane particles	HTC cell lysate	HeLa cell lysate	Rat liver homog.	Hepatoma 7288-C homog.	Rat mammary microsomal membranes	RIN-A2 cell membranes	Rat islets of langerhans membranes	HTC cell lysate

(temp.=temperature homog.=homogenate)

## Chapter VI

### General Discussion

The effect of hyperthermia on cells has been the subject of a considerable number of investigations over many years, but the renewed recent interest in this field has arisen largely in order to define conditions which may be clinically useful in the treatment of cancer (Urano and Douple, 1988). Whilst the application of heat in human illness has been recorded from early civilisations (Hand, 1987) the recent resurgence of interest can be related to such reports as those by Giovanella *et al.*, (1976). These workers observed that tumour cells were more thermosensitive than the normal cells, which clearly suggested a use for hyperthermia in the treatment of cancer. The treatment temperatures, for therapeutic purposes, are generally in the range  $42^{\circ}\text{C}$  to  $45^{\circ}\text{C}$ . However, the time required at the elevated temperature, to kill the tumour cells, will depend on the treatment temperature selected. For example, the thermal dose can be increased by either a longer time at a particular temperature or by a higher temperature or both. This means that to kill tumour cells at  $42^{\circ}\text{C}$ , they must be exposed to this temperature for several hours whereas only minutes are required at  $45^{\circ}\text{C}$ .

In many instances, however, the differences in the sensitivity of normal and tumour cells to heat is relatively small, which makes difficult therapeutic measures based on the thermosensitivity of cancer cells. Fortunately, it seems possible to increase such differential sensitivity by combining local hyperthermia with chemotherapeutic agents and radiation therapy (Herman *et al.*, 1988). However, if

the causes of heat-induced cell death can be understood then the potential arises to manipulate and potentiate the deleterious effects of heat on tumour cells. This will help in developing better protocols for the hyperthermic treatment of cancer. To this end, a great deal of effort has been directed to determine the molecular mechanism of heat-induced death. However, due to the all-pervasive influence of heat it has been difficult to determine an exact mechanism as virtually all structures within the cell are potentially subject to perturbation in heat-induced cell death (Roti Roti and Laszlo, 1988). These structures include DNA, proteins, membranes and the cytoskeleton (see General Introduction).

In order to identify mechanisms from the plethora of events that follow heat treatment of cells, models for heat-induced cell death have been put forward (Jung, 1986; Bowler, 1987). These models suggest that heat-induced cell death follows a hierarchical pattern i.e. primary lesion leads to secondary lesions which in turn give rise to tertiary lesions and ultimately cell death (see General Introduction). This raises the question of the identity of the primary lesion site(s) which initiate the cascade of events which ultimately lead to cell death. The investigations into the effects of hyperthermic temperatures on cells has led to the general consensus (Bowler, 1987; Konings, 1988) that the plasma membrane may be the primary site of heat damage. The evidence for this has been presented in chapter 3 and will be critically examined here.

Membranes are likely targets for heat-induced damage because of their intrinsic properties. Membranes consist of lipid molecules which form a fluid matrix in which proteins are dispersed. Lee and Chapman (1987) reported that a change in temperature has two effects on membrane lipid. First, in response to a gradual increase in temperature, the molecular motion of the lipids increases as a conse-

quence of the increase in kinetic energy. This is thought to cause the progressive increase in membrane fluidity, as a result of decreased order of lipids, which occurs as the temperature increases. The second effect that a change in temperature might cause is a change in the physical state of the membrane lipids from gel to liquid-crystalline state, which occurs at the transition temperature. Below this transition temperature the fatty acyl chains of the phospholipids are packed in an ordered form (gel state) and as the temperature increases, 'melting' occurs because of the thermally-induced flexing of the acyl chains. Above the transition temperature the bulk of the lipids are liquid-crystalline and this state is considered to be essential for function and lateral mobility of integral membrane proteins (Stubbs, 1983).

Homeoviscous adaptation has been shown to occur in microorganisms (Sinensky, 1974), poikilothermic animals (Hazel and Prosser, 1974; Cossins and Sinensky, 1984) and mammalian cells in culture (Anderson *et al.*, 1981). During this process the organisms respond to a change in environmental temperature by altering the degree of saturation of their membrane lipids. Cold acclimation results in an increase in unsaturation of the fatty acyl chains of membrane phospholipid whereas warm acclimation results in more saturated fatty acyl chains in membrane phospholipids (Cossins *et al.*, 1977). This idea, that organisms change the lipid composition of their cell membranes to compensate for direct effects of temperature on membrane physical properties, was an important step in appreciating that temperature has a powerful modulating influence on membrane structure. However, in experiments where thermal acclimation method was used, the change in membrane order was not always accompanied by a change in heat sensitivity of plasma membrane  $\text{Na}^+$ ,  $\text{K}^+$ -ATPase and  $\text{Mg}^{2+}$ -ATPase nor the sacroplasmic

reticulum  $\text{Ca}^{2+}$ -ATPase (Bowler *et al.*, 1973; Cossins and Bowler 1976). In contrast, Cossins *et al.* (1981) demonstrated a clear resistance acclimation effect on the thermal sensitivity of goldfish synaptic membrane  $\text{Na}^+$ ,  $\text{K}^+$ -ATPase. The enzyme from  $28^{\circ}\text{C}$  -acclimated fish was more thermally resistant than that from  $7^{\circ}\text{C}$  -acclimated fish when the synaptic membranes were heated between  $40^{\circ}\text{C}$  to  $52^{\circ}\text{C}$ . The thermal stability of synaptic membrane acetylcholine-esterase in goldfish was similarly dependent upon acclimation temperature, and this correlated with the fact that warm acclimation caused an increase in the membrane order of the lipids. This evidence argues for the case that the more ordered the membrane, the more thermostable are the membrane proteins. Anderson *et al.*, (1981) have shown that the growth of Chinese hamster ovary cells above  $37^{\circ}\text{C}$  led to these cells having increased resistance or tolerance to  $43^{\circ}\text{C}$  heat treatment, whereas cells grown at  $32^{\circ}\text{C}$  were sensitized to heat. It is possible that these changes in thermal sensitivity are due to the effect of change in membrane fluidity (caused by change in membrane lipid composition) on membrane mediated processes.

Evidence which suggests that the plasma membrane is damaged during heat treatment of cells comes from electron microscopy. Evidence from this technique gives a qualitative measure of plasma membrane integrity and it has been shown that the plasma membrane is disrupted after heat treatment. However, the possibility of introducing artefacts during the preparation of samples for electron microscopy must be considered when interpreting data from this technique. For example, fixing and staining cells that have already been subjected to the stress of heating may be sufficient to bring about further changes in the structure of the plasma membrane. However, Bass *et al.* (1982) carried out experiments using living Chinese hamster ovary cells, which formed plasma membrane blebs during

the heating procedure. Thus supporting the suggestion that the plasma membrane is damaged by heat treatment.

Membrane perturbants have been shown to affect heat-induced cell death. Many investigators using the local anaesthetics and aliphatic alcohols as membrane perturbants have shown that these agents act synergistically with hyperthermic cell killing (Yatvin, 1977; Li and Hahn, 1978). Therefore these studies are often cited as evidence that the plasma membrane is the primary target in heat killing of cells. Such interpretations are problematical, for it is unlikely that the actions of these agents are confined to the plasma membrane. For example, exposure of HeLa cells to aliphatic alcohols or procaine alone causes an increase in protein associated with the nucleus (Li *et al.*, 1980). However, these workers concluded that the protein accumulation in the nucleus was a secondary event, as procaine and aliphatic alcohols are exerting their effects at the plasma membrane. The problems of interpreting the effects of aliphatic alcohols and local anaesthetics in potentiating heat sensitivity of cells is the lack of understanding of the site(s) and mode of action these agents. There is evidence to show that these molecules do partition into the membrane, particularly in the liquid-crystalline phase (Shinitzky, 1984). Considerable evidence shows that these agents increase membrane fluidity. It is therefore tempting to speculate that their potentiating action with heat is an additive effect on fluidity. However, Massicotte-Nolan *et al.*, (1981) have questioned the assumption that the enhancement of heat sensitivity is a lipid mediated effect. They found that the fluidizing effect of a series of monohydric alcohols did not correlate well with their sensitization of cells to heat. They considered their evidence supported more strongly an effect on membrane proteins, in agreement with other recent findings (Chan and Wang 1984). The mechanism of potentiation

of heat damage by aliphatic alcohols and local anaesthetics remains unresolved, and action on both membrane order and membrane proteins should be considered likely.

Another approach used to probe the importance of membranes in heat-induced cell death is to relate alterations in the membrane lipid composition to any associated change in heat sensitivity. This approach has been used by many investigators (see chapter 3) and was also used in this study. For example, the growth of L1210 leukemia cells in media supplemented with a polyunsaturated fatty acid (docosahexaenoic acid) led to increased thermosensitivity when compared to control cells, whereas when the medium was supplemented with a more saturated fatty acid (oleic acid) the experimental cells were less heat sensitive than control cells. These changes were accompanied by increased cell membrane 'fluidity' for cells supplemented with docosahexaenoic acid compared to unsupplemented cells, whereas for cells supplemented with oleic acid, membrane 'fluidity' was reduced as compared with unsupplemented cells (Guffy *et al.*, 1982). This finding was confirmed by Konings (1985) and Konings and Ruifrok (1985) using mouse fibroblast LM cells grown in media supplemented with arachidonic acid. The polyunsaturated fatty acid content of the membrane phospholipids from these cells was increased from 7 to 40% which correlated with increased plasma membrane fluidity and increased thermosensitivity of the LM cells.

These studies suggest that dietary supplementation with unsaturated fatty acids *in vivo* and *in vitro* increases the thermal sensitivity of tumour cells, and this may be associated with an increase in membrane fluidity. This supports the hypothesis that membrane 'fluidity' might be a major factor contributing to heat-induced cell death.

From the work cited above, the effects of hyperthermia on membranes may be due to thermally-induced alterations of either membrane lipids or membrane-bound proteins or both. However, it is likely that the membrane lipid matrix in which these proteins are embedded could influence the thermal stability of these proteins. For example, Cossins *et al.* (1981) suggested that the anisotropic hydrophobic core of the membrane forms a relatively hindered, viscous environment for enzyme functioning and that, as a consequence, enzymes may well possess relatively loose tertiary structures to enable molecular flexibility that is vital for catalysis. An increase in membrane fluidity will, therefore, provide a less hindered environment for the proteins which under heat stress, may have an enhanced tendency to adopt configurations that are inactivating. The opposite would be true if membrane fluidity is reduced.

This hypothesis implies that the degree of membrane fluidity has an important role in determining the thermal sensitivity of membrane proteins, and that this is a key feature in hyperthermic cell death. However, there have been investigations where membrane fluidity has been altered with no change in heat sensitivity of the cells. For example, Massicotte-Nolan *et al.* (1981) showed that the fluidizing effect of a series of monohydric alcohols did not correlate well with their sensitization of cells to heat. Similarly, Lepock *et al.* (1981) found that butylated hydroxytoluene fluidized membrane lipids of V79 cells but did not affect the inactivation rate of cells at 42.6<sup>0</sup>C, and even decreased it at 43.6<sup>0</sup>C. This could be explained if the data is considered in terms of recent models for the arrangement of proteins in the lipid matrix. It has been shown that membrane-bound enzymes interact with specific lipids within the membrane, which bind and form a 'tight' annulus around the protein (East and Lee, 1982; Anderle and Mendelson, 1986). This annulus of

lipid creates a microdomain around the protein which is separate from the bulk lipid domain of the membrane. If it is assumed that key membrane-bound enzymes are involved in heat-induced cell death and that they are surrounded by microdomains of lipids then a change in the biophysical properties of the bulk lipid may not alter the biophysical properties of the key microdomains. This in turn would not alter the thermal stability of the protein according to the hypothesis of Cossins *et al.*, (1981). If the above assumption is correct, this could lead to results where changes in membrane fluidity are obtained without changes in thermal sensitivity of cells. Furthermore, butylated hydroxytoluene, a known antioxidant, may not be an ideal choice as a membrane perturbant because it may have multiple effects on membranes, by increasing membrane fluidity but reducing peroxidative damage to membrane lipids. It is not clear to what extent thermal sensitivity of cells would be affected by these conflicting properties of this agent (Leyko and Bartosz, 1986). Yatvin *et al.* (1982a) also suggested that comparing increased membrane 'fluidity' induced by butylated hydroxytoluene with that induced by other agents such as diet, growth temperature, or hyperthermia is not a valid functional comparison.

Although the precise mechanism of hyperthermic cell death, is not clear, the inactivation of membrane proteins will have the potential to instigate cell death. For example, animal cells contain a high concentration of intracellular potassium and low concentration of intracellular sodium and calcium ions. These concentrations are maintained by active transport through specialised membrane-bound transport proteins in order to control the intracellular ionic environment such that optimal conditions are maintained for cellular functions. An impairment of the control of permeability at hyperthermic temperatures would allow the leakage of potassium

from, and sodium and calcium into, the cells and thereby disrupt the intracellular ionic balance. This may lead to a disruption of cellular functions and, ultimately, cell death. The effect of heat treatment on the activities of membrane-bound proteins has already been presented in chapter 5 and it must be noted that the evidence for a correlation between heat-induced perturbation of enzyme activity and heat-induced cell death is equivocal. The work reported for calcium suggests that cells accumulate this ion during hyperthermia (Stevenson *et al.*, 1986), but whether the rise in cell calcium is involved in cell killing is unclear. However, changes in the intracellular concentration of this important secondary messenger may set into motion a cascade of events which could disrupt cellular metabolism and bring about cell death.

However the above mentioned studies have not led to an unequivocal role of the plasma membrane in heat-induced cell death. Therefore, the basis of this investigation was to clarify further the involvement of the plasma membrane in hyperthermic cell killing. One of the major criticisms (Bowler, 1987) of the many investigations into the role of the plasma membrane in hyperthermic cell killing is that the so-called plasma membrane fraction isolated in many studies (Guffy *et al.*, 1982; Gonzalez-Mendez *et al.*, 1982b; Raaphorst *et al.*, 1985) has been very poorly purified and characterised. In particular, those studies in which protein, cholesterol and phospholipid assays have been carried out using whole cell extracts are especially difficult to interpret in terms of plasma membrane composition. One of the major reasons why plasma membranes were not extensively purified and characterized in many of these studies is due to the fact that large scale culture of cells is required in order to generate sufficient plasma membranes in a highly purified form to carry out the necessary analysis. An attempt was made in the present

study to overcome these problems.

In chapter 2, the growth characteristics of HTC cells were evaluated on a small scale in order to optimise cell growth and to establish suitable growth conditions for later hyperthermic studies. The characterisation of the cell culture system also involved the establishment of standard conditions for the clonogenic and colorimetric assays which were to form the basis of the measurement of cell survival described in chapter 3.

In chapter 3, the heat sensitivity of HTC cells was determined using both the clonogenic and colorimetric assays (Kingston *et al.*, 1989). These experiments were performed to characterise the response of HTC cells to heat, so that a suitable hyperthermic temperature could be chosen to carry out lipid modification studies. The growth characteristics of the cells in various concentrations of supplemental fatty acid were also determined to ensure that no adverse effects on the cells were occurring due to the presence of the fatty acid. Having selected a suitable temperature for heat treatment and a suitable concentration of supplemental arachidonic acid, experiments were performed to change the fatty acid composition of the plasma membrane lipids and to measure any subsequent change in heat sensitivity of the cell. HTC cells grown in the presence of 60 $\mu$ M arachidonic acid for 24, 36 and 48 hours became progressively more thermosensitive than control cells. However, this difference in thermal sensitivity was only detectable with the clonogenic assay (Ladha *et al.*, 1989) and not with the colorimetric assay. Having established the greater thermal sensitivity of cells grown in arachidonic acid supplement over those grown in normal media, the changes in the plasma membrane lipid composition and lipid order were investigated. Although the effects of supplementation were investigated at the plasma membrane level, it must be real-

ized that other changes within the cell caused by free fatty acid supplementation may enhance cell death. For example, altered prostaglandin synthesis due to increased availability of the arachidonic acid precursor (Denning *et al.*, 1982). These changes in metabolism should be investigated in future studies and correlated with heat-induced cell death.

In chapter 3, attempts were also made to manipulate cellular cholesterol levels. Firstly, some cells were incubated with phosphatidylcholine liposomes to deplete the plasma membrane of cholesterol: Secondly, another group of cells were treated with 25 hydroxycholesterol, an inhibitor of cholesterol synthesis, to lower cholesterol levels: Finally, a third group of cells were supplemented with cholesterol hemisuccinate, a hydrophilic ester of cholesterol. The first two approaches did not enhance the thermal sensitivity of HTC cells. It was thought that incubation of cells with liposomes or 25 hydroxycholesterol may lower membrane fluidity and, therefore, enhance thermosensitivity in keeping with the hypothesis. However, the changes in the plasma membrane content of cholesterol following these treatments were not investigated and therefore any alteration in plasma membrane cannot be correlated with heat sensitivity. This should be the basis of further investigation. Paradoxically, supplementation with cholesterol hemisuccinate, which was predicted to partition in to the plasma membrane and reduce membrane fluidity, resulted in increased thermal sensitivity of the cells. This clearly argues against the hypothesis put forward linking thermal sensitivity and membrane fluidity, but it must be emphasized that any changes in plasma membrane cholesterol level or membrane fluidity, as a result of this treatment, were not investigated. It would be of great interest in further investigations to correlate changes in thermal sensitivity of cells with the changes in plasma membrane fluidity induced by supplementation

with cholesterol hemisuccinate and to study its effect on the thermal stability of membrane proteins. If it is assumed that, in this investigation, plasma membrane fluidity was decreased by cholesterol hemisuccinate then the question to be asked is why is thermal sensitivity increased? An explanation for this event has been presented in chapter 3 but will be reiterated here in the context with of discussion. The data obtained for cholesterol hemisuccinate in this study must be considered in context with the study performed by Yatvin *et al.* (1983b). These workers exposed P-388 tumour cells and V-79 cells to 100 $\mu$ g/ml of cholesterol hemisuccinate for 30 minutes prior to heat treatment for 60 minutes at 43<sup>0</sup>C. Heat sensitivity of P-388 tumour cells was assessed by injecting heated cells (modified or unmodified) into CDF<sub>1</sub> mice and measuring the time taken for the mice to die from the effects of P-388 tumour cells. Therefore, the greater the heat sensitivity of the P-388 tumour cells the longer the mice will survive. Using this assay of heat sensitivity, cholesterol hemisuccinate treatment enhanced the sensitivity of P-388 tumour cells to heat when compared to untreated cells. However, with the V-79 cells, where cell survival was assessed using the clonogenic assay, there was no difference in thermal sensitivity of cholesteryl hemisuccinate-modified and unmodified cells. In both cell types plasma membrane fluidity, measured using DPH fluorescence polarisation, was decreased in cholesteryl hemisuccinate-modified compared to unmodified cells. Yatvin *et al.* (1983b) also found that treatment with cholesterol hemisuccinate alone resulted in a substantial increase in the proportion of P-388 tumour cells which took up trypan blue, but not in V-79 cells. This suggests that membrane integrity of P-388 tumour cells is altered by addition of cholesterol hemisuccinate. When the results were corrected for these 'dead' cells, the difference in killing between control and cholesteryl hemisuccinate-modified P-388 tumour cells was no longer seen. In the present study, as the colorimetric assay was

used to estimate cell survival, cell death caused by cholesterol hemisuccinate alone was accounted for in the control experiments. Therefore, the increase in heat sensitivity observed in this study is real and not apparent. The possible reasons why this enhancement in thermal sensitivity is observed might be explained in terms of membrane function and the cholesterol content of membranes. Sabine (1983) proposed the hypothesis that the relationship between the level of cholesterol in cellular or sub-cellular membrane and the activity of any membrane function affected by cholesterol is ogival in nature, i.e. there is an optimum level of membrane cholesterol at which functional activity is maximal, and above or below this level activity declines. Therefore, incubation of HTC cells with cholesterol hemisuccinate may lead to a membrane environment which is not optimal for membrane function. This may be one reason why cholesteryl hemisuccinate-modified HTC cells are more thermosensitive when compared to unmodified cells. As shown by Deliconstatinos *et al.* (1987), when normal lymphocytes were treated with cholesterol hemisuccinate, membrane fluidity decreased but the activity of the ecto-ATPase increased dramatically. Such changes brought about by membrane rigidification could make cells more prone to death by heat. The elucidation of the mechanism by which cholesterol hemisuccinate sensitises cells to heat should form the basis of further investigation.

Thus, the thermal sensitivity of HTC cells could be enhanced by supplementation with either arachidonate or cholesterol hemisuccinate. In order to clarify whether this enhanced thermal sensitivity was related to changes in plasma membrane structure, it was decided to grow HTC cells in quantity, in order to purify plasma membranes from control and lipid supplemented cells, and to analyse changes in the lipid composition and order of these membranes. Ideally, this should

have been carried out for cells supplemented with arachidonate and for cells supplemented with cholesterol hemisuccinate. However, the cells supplemented with cholesterol hemisuccinate proved to be rather fragile, making them difficult to manipulate, so this together with lack of time and resources, led to the use of cholesterol hemisuccinate being abandoned for this work. Consequently, the subsequent work, reported chapter 4 concentrated on the purification and analysis of plasma membranes derived from HTC cells grown in the presence and absence of arachidonate.

In chapter 4 the culture of the HTC cells was scaled up for plasma membrane preparation. The scale up process involved, the growth of cells on microcarrier beads to substantially increase the growth area, thereby generating enough cells to prepare plasma membranes. A rapid plasma membrane isolation procedure was developed which generated plasma membranes in relatively high yield and purity (Manning *et al.*, 1989). The plasma membrane-enriched fraction was also assayed for contaminating intracellular membranes by determining marker enzyme activities associated with these membranes. Using this method, plasma membranes were prepared from HTC cells grown in  $60\mu\text{M}$  arachidonic acid for 36 hours and from cells grown in normal medium. Analysis of the plasma membrane showed that the arachidonic acid content of the phospholipid fatty acyl groups had been significantly increased in cells grown in the presence of this fatty acid. There was no change in the cholesterol/phospholipid molar ratio or cholesterol concentration relative to amount of protein in the plasma membranes from the two cell populations. The measurement of fluidity using DPH fluorescence polarisation revealed that the increase in the arachidonic acid content of the plasma membrane phospholipid acyl groups was associated with enhanced plasma membrane fluidity when

compared to control plasma membranes. The information obtained by the measurement of plasma membrane fluidity using steady state fluorescence polarisation must be interpreted in terms changes in the structure of the plasma membrane. There are now a number of different techniques available to investigate the physical state of the phospholipid fatty acyl chains which make up the hydrophobic core of the membrane. These include electron spin resonance (ESR), nuclear magnetic resonance (NMR), and various fluorescence polarization techniques of which steady state fluorescence polarization is the most popular (Lee, 1982). These techniques have been reviewed recently and their relative merits in determining membrane 'fluidity' discussed in some detail (Stubbs, 1983). Although all these approaches are said to measure 'fluidity', this is at best an ill-defined term, as the techniques mentioned above often measure very different physical interactions (Stubbs and Smith, 1984). Membrane 'fluidity', as suggested by Stubbs and Smith (1984), has been defined in the present study as referring to the physical state of the fatty acyl chains of the membrane bilayer. This definition could describe either the range or rate of motion of the acyl chains. The information obtained by the techniques mentioned above may therefore consist of either a rate or range component or even both. The major portion of the information obtained from steady state fluorescence polarization, the technique used in the current study, is from the 'range' of the lipid motion. Therefore, the technique principally monitors lipid order or packing (Pottel *et al.*, 1983). Consequently, lipid order or packing was reduced when the arachidonic acid content in the plasma membrane phospholipid acyl groups was increased when compared to control plasma membranes. This correlated with the enhanced thermal sensitivity of the cells grown in arachidonic acid-containing medium when compared to cells grown in normal medium. Furthermore, the thermal sensitivity of Na<sup>+</sup>, K<sup>+</sup>-ATPase and alkaline phosphodiesterase I were assessed

in plasma membranes derived from arachidonic acid-supplemented and control cells (see chapter 5). The enhanced fluidity of plasma membranes derived from arachidonate-supplemented cells also correlated with increased thermosensitivity of alkaline phosphodiesterase I. The significance of these results is clear, in that the increase in membrane fluidity caused by arachidonate supplementation could predispose some membrane proteins to be inactivated more quickly by heat treatment, in keeping with the ideas of Cossins *et al.*, (1981). However, it must be stressed here that the temperatures required to inactivate alkaline phosphodiesterase I were well above hyperthermic temperatures which induce cell killing. Therefore, the significance of this data in terms of heat-induced cell death is not clear. However, Cheng *et al.* (1987), using  $\text{Ca}^{2+}$ -ATPase reconstituted into proteoliposomes, showed that the rate of thermal inactivation of calcium uptake activity of the reconstituted vesicles with a cholesterol/phospholipid ratio of 0.3 was lower than those with a cholesterol/phospholipid ratio of 0.1 in the temperature range  $43^{\circ}\text{C}$  to  $47^{\circ}\text{C}$ . This suggests that cholesterol protects against denaturation of proteins and therefore the higher the membrane order the greater the thermostability of membrane proteins.

Preliminary studies of the thermostability of a variety of membrane-bound enzymes after exposure to hyperthermic temperatures were also carried out. The thermal stability of the plasma membrane-bound enzymes adenylate cyclase, alkaline phosphodiesterase I,  $\text{Na}^{+}$ ,  $\text{K}^{+}$ -ATPase and  $\text{Mg}^{2+}$ -ATPase were determined by heating cell monolayers at hyperthermic temperatures followed by measurement of the enzyme activities in cell homogenates at  $37^{\circ}\text{C}$ . The enzymes adenylate cyclase,  $\text{Na}^{+}$ ,  $\text{K}^{+}$ -ATPase and  $\text{Mg}^{2+}$ -ATPase were not substantially affected by temperatures investigated. However, the most striking feature of this investigation was

the activation of alkaline phosphodiesterase I caused by hyperthermic treatment of HTC cells. The activity at 45<sup>0</sup>C increased with treatment time, which correlated with a decrease in cell viability. The significance of this result is that the mechanism by which heat induces cell death may not be dependent on inactivating membrane proteins. The thermal activation of plasma membrane enzymes could also have catastrophic effects on the normal function of the cell. In particular, activation of enzymes such as adenylate cyclase and phospholipase C which are involved in secondary messenger production could have profound effects on the metabolism of the cell. In this study the regulatory properties of HTC adenylate cyclase were investigated, but the enzyme activity was extremely low and only detectable by the addition of the potent activator forskolin. This enzyme is responsible for generating the secondary messenger cyclic AMP in the cell and is present in the plasma membrane of the cell. Investigations into the mechanism, control and structure of this enzyme have shown it to be a complex regulatory system, the general features of which have been shown to apply to most tissues and species studied (Gilman,1984). The basic structure of the adenylate cyclase functional unit consists of three plasma membrane-bound proteins: a hormone receptor, a guanine nucleotide binding protein and the catalytic subunit (Rodbell, 1980). Although only one type of catalytic subunit is known, it can operate in combination with one of several receptors and two or more guanine nucleotide-binding proteins. Therefore, the multicomponent adenylate cyclase system is a good candidate for investigations into the effects of heat on interactions of the protein components within the plasma membrane. It would be of great interest to correlate heat-induced changes in the interactions of the adenylate cyclase system with hyperthermic cell killing.

In summary, this investigation is the first attempt to correlate the following three parameters; cellular thermosensitivity, plasma membrane composition/fluidity and the thermostability of plasma membrane enzymes. The results obtained may indicate an involvement of plasma membranes in heat-induced cell death.

## References

ALANIZ, M. J. T. de., PONZ, G. & BRENNER, R. R. (1975) Biosynthesis of unsaturated fatty acids in cultured minimal deviation hepatoma 7288C cells, *Acta Physiol. Latinoam.* **25** 1-11.

ALANIZ, M. J. T. de., GOMEZ DUMM, I. N. T. de. & BRENNER, R. R. (1976) The action of insulin and dibutyryl cyclic AMP on the biosynthesis of polyunsaturated acids of  $\alpha$ -linoleic acid family in HTC cells, *Mol. Cell. Biochem.* **12** 3-8.

ALANIZ, M. J. T. de., GOMEZ DUMM, I. N. T. de. & BRENNER, R. R. (1982) Effect of different carbon sources on  $\Delta 5$  desaturation activity of HTC cells, *Mol. Cell. Biochem.* **48** 15-18.

ALANIZ, M. J. T. de., GOMEZ DUMM, I. N. T. de. & BRENNER, R. R. (1984) Effect of fatty acids of  $w6$  series on the biosynthesis of arachidonic acid in HTC cells, *Mol. Cell. Biochem.* **64** 31-37.

ALBERTS, B., BRAY, D., LEWIS, J., RAFF, M., ROBERTS, K. & WATSON, J. D. (1983) *Molecular Biology of the Cell*, Garland publishing, New York.

ALLEN, D.O., MUNSHOWER, J., MORRIS, H.P. & WEBER, G. (1971). Regulation of adenyl cyclase in hepatomas of different growth rates. *Cancer Res.* **31** 557-560.

ALLEY, M. C., SCUDIERO, D. A., MONKS, A., CZERWINSKI, M.J., SHOEMAKER, R. H. & BOYD, M. R. (1986) Validation of an automated microculture tetrazolium assay (MTA) to assess growth and drug sensitivity of human tumour cell lines, *Proc. Am. Assoc. Cancer Res* **27** 389.

ALLEY, M. C., SCUDIERO, D. A., MONKS, A., HURSEY, M. L., CZERWINSKI, M. J., FINE, D. L., ABBOTT, B., MAYO, J. G., SHOEMAKER, R. H. & BOYD, M. R. (1988) Feasibility of drug screening with panels of human tumour cell lines using a microculture tetrazolium assay, *Cancer Res.* **48** 586-604.

AMENDE, L. M. & DONLON, M. A. (1985) Isolation of cellular membranes from rat mast cells, *Biochim. Biophys. Acta* **812** 713-720.

ANDERLE, G. & MENDELSON, R. (1986). Fourier-transform infra red studies of  $\text{Ca}^{2+}$ -ATPase/phospholipid interaction: Survey of lipid classes, *Biochem.* **125** 2174-2179.

- ANDERSON, R. L., MINTON, K. W., LI, G. C. & HAHN, G. M. (1981) Temperature induced homeoviscous adaptation of Chinese hamster ovary cells, *Biochim. Biophys. Acta* **641** 334-348.
- ANDERSON, R. L., LUNEC, J. & CRESSWELL, S. R. (1985) Cholesterol content and heat sensitivity of nine mammalian cell lines, *Int. J. Hyperthermia* **1** 337-347.
- ANDERSON, R.L. & HAHN, G.M. (1985). Differential effects of hyperthermia on the Na<sup>+</sup>, K<sup>+</sup>-ATPase of Chinese hamster ovary cells, *Radiat. Res.* **102** 314-323.
- ANTONIS, A. (1965) Semi-automated method for the colorimetric determination of plasma free fatty acids, *J. Lipid Res.* **6** 307-312.
- ARNOLD, J. (1887). Ueber theilungsvorgange an den wanderzellen ihre progressiven und retrogressiven metamorphosen, *Arch. Mikr. Anat.* **30** 205.
- ARTHUR, H. & WATSON, K. (1976). Thermal adaptation in yeast: Growth temperatures, membrane lipid, and cytochrome composition of psychrophilic, mesophilic and thermophilic yeasts, *J. Bacteriol.* **128** 56-68.
- ASHWOOD-SMITH, M. J. (1985) Genetic damage is not produced by normal cryopreservation procedures involving either glycerol or DMSO. A cautionary note, however, on possible effects of DMSO, *Cryobiology* **22** 427-433.
- ATKINSON, A., GATENBY, A. D. & LOWE, A. G. (1973) The determination of inorganic orthophosphate in biological systems, *Biochim. Biophys. Acta* **320** 195-204.
- AUERSPERG, N. (1966) Differential heat sensitivity of cells in tissue culture, *Nature* **209** 415-416.
- BALDASSARE, J.J. & SILBERT, D.F. (1979) Membrane phospholipid metabolism in response to sterol depletion. *J. Biol. Chem.* **254** 10078-10083.
- BALDASSARE, J.J., SAITO, Y. & SILBERT, D.F. (1979) Effects of sterol depletion on LM cells sterol mutants. *J. Biol. Chem.* **254** 1108-1113.
- BARENHOLZ, Y., MOORE, N.F. & WAGNER, R.R. (1976) Enveloped viruses as model membrane systems: microviscosity of vesicular stomatitis and host cell membranes, *Biochem.* **15** 3563.
- BARKER, C. J. (1985) A study of the potential use of membrane perturbants in enhancing the hyperthermic treatment of cancer, Ph.D. Thesis, Durham University.
- BARTON, P.G. & GUNSTONE, F.D. (1975) Hydrocarbon chain packing and molecular motion in phospholipid bilayers formed from unsaturated lecithins, *J. Biol. Chem.* **250** 4470-4476.
- BASS, H., MOORE, J. A. & COAKLEY, W. T. (1978) Lethality in mammalian cells due to hyperthermia under oxic and hypoxic conditions, *Int. J. Radiat. Biol.* **33** 57-62.

- BASS, H., COAKLEY, W. T., MOORE, J. L. & TILLEY, D. (1982) Hyperthermia induced changes in the morphology of CHO-K<sub>1</sub> and their refractive inclusions, *J. Therm. Bio.* **7** 231-242.
- BATES, D. A. & MACKILLOP, W. J. (1985) The effect of hyperthermia on the sodium-potassium pump in Chinese hamster ovary cells, *Radiat. Res.* **103** 441-451.
- BEUFAY, H., AMAR-COSTESECC, A., FEYTMANS, E., THINES - SEMPOUX, D., WIBO, M., ROBBI, M. & BERTHET, J. (1974) Analytical study of microsomes and isolated subcellular membranes from rat liver I. Biochemical methods, *J. Cell Biol.* **61** 188-200.
- BEEBE, S.P. & EWING, J. (1906) A study of the biology of tumor cells, *Brit. Med. J.* **2** 1559.
- BHUYAN, B. H. (1979) Kinetics of cell kill by hyperthermia, *Cancer Res.* **39** 2277-2284.
- BISCHOFF, E., TRAN-THI, T.A. & DECKER, K.F.A. (1975) Nucleotide pyrophosphatase of rat liver, *Eur. J. Biochem.* **51** 353-361.
- BLIGH, E. G. & DYER, W. J. (1959) A rapid method of total lipid extraction and purification, *Can. J. Biochem. Physiol.* **37** 911-917.
- BOCKOCH, G.M., KATADA, T., NORTHUP, J.K., HEWLETT, E.L. & GILMAN, A.G. (1983) identification of the predominant substrate for ADP-ribosylation by islet-activating protein, *J. Biol. Chem.* **258** 2072-2075.
- BOLMSJO, M. (1986) Commercially available equipment for hyperthermia, In *Hyperthermia*, eds. Watmough, D.J. & Ross, W.M., Blackie & Son Limited, pp224-242.
- BOONE, C. W., FORD, L. E., BOND, H. E., STUART, D. C. & LORENZ, D. (1969) Isolation of plasma membrane fragments from HeLa cells, *J. Cell Biol.* **41** 378-392.
- BOONSTRA, J., SCHAMHART, D. H. J., De LAAT, S. W. & Van WIJK, R. (1984) Analysis of K<sup>+</sup> and Na<sup>+</sup> transport and intracellular contents during and after heat shock and their role in protein synthesis in rat hepatoma cells, *Cancer Res.* **44** 955-960.
- BOROCHOV, H., ZAHLER, P., WELBRANDT, W. & SHINITZKY, M. (1977) The effect of phosphatidylcholine to sphingomyelin mole ratio on the dynamic properties of sheep erythrocytes membrane, *Biochim. Biophys. Acta* **470** 382-388.
- BORRELLI, M. J., WONG, R. S. L. & DEWEY, W. C. (1986) A direct correlation between hyperthermia induced membrane blebbing and survival in synchronous G<sub>1</sub> CHO cells, *J. Cell Physiol.* **126** 181-190.
- BOWLER, K., DUNCAN, D. J., GLADWELL, R. T. & DAVIDSON, T. F. (1973) Cellular heat injury, *Comp. Biochem. Physiol.* **45** 441-449.

- BOWLER, K., LAUDIEN, H. & LAUDIEN, I. (1982) Cellular heat injury. Workshop on mechanisms of thermal regulation, *J. Therm. Bio.* **8** 426-430.
- BOWLER, K. (1987) Cellular heat injury: are membranes involved? In *Temperature and Animal Cells*, SEB symposium XLI, eds. Bowler, K. & Fuller, B. J., Cambridge: The Company of Biologists Ltd.
- BRADFORD, M. M. (1976) A rapid and sensitive method for the quantitation of microgram quantities of protein utilising the principle of protein-dye binding, *Analyt. Biochem.* **72** 248-254.
- BROWN, M.S. & GOLDSTEIN, J.L. (1980) Multivalent feedback regulation of HMG-CoA reductase, a control mechanism coordinating isoprenoid synthesis and cell growth, *J. Lipid Res.* **21** 505.
- BURDON, R. & CUTMORE, C. M. M. (1982) Human heat shock gene expression and the modulation of plasma membrane  $\text{Na}^+$ ,  $\text{K}^+$ -ATPase activity, *FEBS Lett.* **140** 45-48.
- BURDON, R. KERR, S. M., CUTMORE, C. M. M., MUNRO, J. & GILL, V. (1984) Hyperthermia,  $\text{Na}^+$ ,  $\text{K}^+$ -ATPase and lactic acid production in some human tumour cells, *Br. J. Cancer* **49** 437-445.
- BURNS, C.P. & SPECTOR, A.A. (1987) Membrane fatty acid modification in tumor cells: A potential therapeutic adjunct, *Lipids* **22** 178-184.
- BURNS, C.P., NORTH, J.A., MOSSMAN, C.J. & INGRAHAM, L.M. (1988) Modification of the fatty acid composition of L1210 Leukemia subcellular organelles, *Lipids* **23** 615-618.
- BUSCH, W. (1866) Über den einfluss welchen leftigere erysiplen zuweilen auf organisierte Neubildungen ausuben, *Verh. Natur. Preuss Rhein Westphal.* **23** 28-30.
- CALDERWOOD, S.K. & HAHN, G.M. (1983) Thermal sensitivity and resistance of insulin-receptor binding, *Biochim. Biophys. Acta* **756** 1-8.
- CALDERWOOD, S. K. (1987) Role of energy in cellular responses to heat, in *Temperature and Animal Cells*, SEB symposium XLI, eds. Bowler, K. & Fuller, B. J., Cambridge, the Company of Biologists Ltd.
- CARMICHAEL, J., DeGRAFF, W. G., GAZDAR, A. F., MINNA, J. D. & MITCHELL, J. B. (1987) Evaluation of a tetrazolium-based semiautomated colorimetric assay: assessment of chemosensitivity testing, *Cancer Res.* **47** 936-942.
- CARPER, S., W., DUFFY, J., J. & GERNER, E., W. (1987) Heat shock proteins in thermotolerance and other cellular processes, *Cancer Res.* **47** 5249-5255.
- CASPERSON, G.F. & BOURNE, H.R. (1987) Biochemical and molecular genetic analysis of hormone-sensitive adenylyl cyclase, *Ann. Rev. Pharm. Toxicol.* **27** 371-384.

- CASSEL, D. & SELINGER, Z. (1976) Catecholamine-stimulated GTPase activity in turkey erythrocyte membranes, *Biochim. Biophys. Acta* **452** 538-551.
- CASSEL, D. & SELINGER, Z. (1978) Mechanism of adenylate cyclase activation through the  $\beta$ -adrenergic receptor: Catecholamine-induced displacement of bound GDP by GTP, *Proc. Natn. Acad. Sci. (USA)* **75** 4155-4159.
- CASTUMA, C.E. & BRENNER, R.R. (1983) Effect of fatty acid deficiency on microsomal membrane fluidity and cooperativity of the UDP-glucuronyltransferase, *Biochim. Biophys. Acta* **729** 9-16.
- CHAKRAVARTHY, B. R., SPENCE, M. W., CLARKE, J. T. R. & COOK, H. W. (1985) Rapid isolation of neuroblastoma plasma membranes on Percoll gradients. Characterisation and lipid composition, *Biochim. Biophys. Acta* **812** 223-233.
- CHAM, B. E. & KNOWLES, B. R. (1976) A solvent system for delipidation of plasma or serum without protein precipitation, *J. Lipid Res.* **17** 176-181.
- CHAN, D. S. & WANG, H. H. (1984) Local anesthetics can interact electrostatically with membrane proteins, *Biochim. Biophys. Acta* **77** 55-64
- CHAPMAN, D. (1982) *Biological membranes*, ed. Chapman, D., Academic Press, New York, Volume 4, 179-229.
- CHEN, T.T. & HEIDELBERGER (1969) Quantitative studies on the malignant transformation of mouse prostate cells by carcinogenic hydrocarbons *in vitro*, *Int. J. Cancer* **4** 166-178.
- CHENG, K.-H., HUI, S. W. & LEPOCK, J. R. (1987) Protection of the membrane calcium adenosine triphosphate by cholesterol from thermal inactivation, *Cancer Res.* **47** 1255-1262.
- CHERN, T.C. & KINSELLA, J.E. (1983) Concurrent release and reacylation of fatty acids by rat kidney cells. Selective incorporation of arachidonic acid, *Biochim. Biophys. Acta* **750** 7-17.
- CHEUNG, W.Y. (1980) Calmodulin plays pivotal role in cellular regulation, *Science* **207** 19.
- CLAUDE, A. (1946a) Fractionation of mammalian liver cells by differential centrifugation, *J. Exp. Med.* **84** 51.
- CLAUDE, A. (1946b) Fractionation of mammalian liver cells by differential centrifugation, *J. Exp. Med.* **84** 61.
- COLEY, W. (1893) The treatment of malignant tumours by repeated inoculations of erysipelas: with a report of ten original cases, *Am. J. Med. Sci.* **105** 487-511.
- CONNELLY, O.M., GREENE, J.M., HEADON, D.R., HSIAO, J. & UNGAR, F. (1983) Distribution of membrane cholesterol of adrenal cortical cells after corticotropin stimulation, *Biochem. J.* **214** 561-567.

- COOLBEAR, K.P., BERDE, C.B. & KEOUGH, K.M.W. (1983) Gel to liquid-crystalline phase transitions of aqueous dispersions of polyunsaturated mixed-acid phosphatidylcholines, *Biochem.* **22** 1466-1473.
- COOPER, D.M.F. (1983) Receptor-mediated stimulation and inhibition of adenylate cyclase, *Current topics in membranes and transport* **18** 67-83
- COOPER, R.A. & STRAUSS, J.F. (1984) Regulation of cell membrane cholesterol. In *Physiology of membrane fluidity*, ed. Shinitzky, M., CRC Press, Volume 1, 73-97.
- COSSINS, A. R. & BOWLER K. (1976) Changes in muscle lipid composition and resistance adaptation to temperature in the freshwater crayfish, *Austropotamobius pallipes*, *Lipids* **11** 307-316.
- COSSINS, A. R., FRIEDLANDER, M. J. & PROSSER, C. L. (1977) Correlations between behavioural temperature adaptations of goldfish and the viscosity and fatty acid composition of their synaptic membranes, *J. Comp. Physiol.* **120** 109-121.
- COSSINS, A. R. & PROSSER, C. L. (1978) Evolutionary adaptation of membranes to temperature, *Proc. Natn. Acad. Sci. (USA)* **75** 2040-2043.
- COSSINS, A. R., BOWLER, K. & PROSSER, C. L. (1981) Homeoviscous adaptation and its effect upon membrane-bound proteins, *J. Therm. Bio.* **6** 183-187.
- COSSINS, A. R. & SINENSKY, M. (1984) Adaptation of membranes to temperature, pressure and exogeneous lipids, in *Physiology of Membrane Fluidity*, Vol. II, ed. Shinitzky, M., Boca Raton, USA CRC Press, pp1-20.
- COSSINS, A. R., BEHAN, M., JONES, G. & BOWLER, K. (1987) Lipid-protein interactions in the adaptive regulation of membrane function, *Bioch. Soc. T.* **15** 77-81.
- COX, D.C., COMAI, K. & GOLDSTEIN, A.L. (1988) Effects of cholesterol and 25-hydroxycholesterol on smooth muscle cell and endothelial cell growth, *Lipids* **23** 85-88.
- CRESS, A. E. & GERNER, E. W. (1980) Cholesterol levels inversely reflect the thermal sensitivity of mammalian cells in culture, *Nature* **283** 610-617.
- CRESS, A. E., CULVER, P. S., MOON, T. E. & GERNER, E. W. (1982) Correlation between amounts of cellular membrane components and sensitivity to hyperthermia in a variety of mammalian cell lines in culture, *Cancer Res.* **42** 1716-1721.
- CRESSWELL, S., LUNEC, J., LEDDA, J. & CRAMP, W.A. (1980) The response of murine lymphoma cells L5178YS and R- to heat at 44<sup>0</sup>C, *Cell Biol. Int. Rep.* **4** 1065-1073.
- de DUVE, C., PRESSMAN, B. C., GIANETTO, R., WATTIAUX, R. & APPELMANS, F. (1955) Tissue fractionation studies: Intracellular distribution patterns of enzymes in rat liver tissue, *Biochem. J.* **60** 604-617.

de DUVE, C. (1971) Tissue fractionation past and present *J. Cell Biol.* **50** 20D-55D

DELICONSTANTINOS, G., DAFFLER, S. & KRUEGER, G.R.F. (1987) Cholesterol modulation of membrane fluidity and Ecto-nucleotide triphosphatase activity in human normal and CLL lymphocytes, *Anticancer Res.* **7** 347-352.

DENIZOT, F. & LANG, R. (1986) Rapid colorimetric assay for cell growth and survival. Modifications to the tetrazolium dye procedure giving improved sensitivity and reliability, *J. Immunol. Methods* **89** 271-277.

DENNING, G. M., FIGARD, P. H. & SPECTOR, A. A. (1982) Effect of fatty acid modification on prostaglandin production by cultured 3T3 cells, *J. Lipid Res.* **23** 584-596.

DEVANEY, E. & HOWELL, K. E. (1985) Immuno-isolation of a plasma membrane fraction from the Fao cell, *EMBO. J.* **4** 3123-3130

DEWEY, W.C. WESTRA, A., MILLER, H.H. & NAGASAWA, H. (1971) Heat-induced lethality and chromosomal damage in synchronized Chinese hamster cells treated with 5-bromodeoxyuridine, *Int. J. Radiat. Biol.* **20** 505-520.

DEWEY, W. C., HOPWOOD, L. E., SAPARETO, S. A. & GERWECK, L. E. (1977) Cellular responses to combinations of hyperthermia and radiation, *Radiol.* **123** 463-474.

De WOLF, M.J.S., HILDERSON, N.J.J. & DIERCK, W.H.S. (1977) In *Methodological surveys in Biochemistry*, ed. Reid, E., Elsevier, Amsterdam, Volume 6, 251-257.

DICKSON, J. A. & SUZANGER, M. (1976) A predictive *in vitro* assay for the sensitivity of human solid tumours to hyperthermia (42°C) and its value in patient management, *Clin. Oncol.* **2** 141-155.

DODGE, J. T., MITCHELL, C. & HANAHAN, D. J. (1963) The preparation and chemical characterisation of haemoglobin free ghosts of human erythrocytes, *Arch. Biochem. Biophys.* **100** 119.

DOI, O., DOI, F., SCHROEDER, F., ALBERTS, A. W. & VAGELOS, P. R. (1978) Manipulation of fatty acid composition of membrane plasma and its effects on cell growth in mouse LM cells, *Biochim. Biophys. Acta* **509** 239-250.

DRAYE, J. P., COURTOY, P. J., QUINTART, J. & BAUDHUIN, P. (1987) Relations between plasma membrane and lysosomal membrane. 2. Quantitative evaluation of plasma membrane marker enzymes in the lysosomes, *Eur. J. Biochem.* **170** 405-411.

EAST, J. M. & LEE, A. G. (1982) Lipid selectivity of the calcium and magnesium ion dependent adenosinetriphosphatase, studied with fluorescence quenching by brominated phospholipid, *Biochem.* **21** 4144-4151.

EMMELOT, P. & BOS, C. J. (1966) Studies on plasma membranes III.  $Mg^{2+}$ -ATPase,  $(Na^+ - K^+ - Mg^{2+})$ -ATPase and 5'nucleotidase activity of plasma membranes isolated from rat liver, *Biochim. Biophys. Acta* **120** 369-382.

ESKO, J.D., GILMORE, J.R. & GLASER, M. (1977) Use of a fluorescent probe to determine the viscosity of LM cell membranes with altered phospholipid composition, *Biochem.* **16** 1881-1890.

EVANS, W. H. (1978) Preparation and characterisation of mammalian plasma membranes. Elsevier/North-Holland, Amsterdam.

EVANS, W. H. (1982) Subcellular membranes and isolated organelles: preparative techniques and criteria for purity, In: *Techniques in Lipid and Membrane Biochemistry*, Elsevier scientific publishers, North-Holland, **B407a** pp1-46.

EVANS, D.P. & TOMASOVIC, S.P. (1989) The effect of calmodulin antagonists on hyperthermic cell killing and the development of thermotolerance, *Int. J. Hyperthermia* **5** 563-578.

FAIN, N.J., GARCIA-SAINZ, A.J., MILLS, I. & O'DONNELL, C.S. (1984) Activation of lipolysis and cyclic AMP accumulation in rabbit adipocytes by isoproterenol in the presence of forskolin or pertusis toxin, *Biochim. Biophys. Acta* **798** 382-389.

FAJARDO, L. F., EGBERT, B., MARMOR, J. & HAHN, G. M. (1980) Effects of hyperthermia in a malignant tumour, *Cancer* **45** 613-623.

FERGUSON, K. A., GLASER, M., BAYER, W. H. & VAGELOS, P. R. (1975) Alteration of fatty acid composition of LM cells by lipid supplementation and temperature, *Biochem.* **14** 146-151.

FIELD, S. B. (1987a) Studies relevant to a means of quantifying the effects of hyperthermia, *Int. J. Hyperthermia* **3** 291-296.

FIELD, S. B. (1987b) Hyperthermia in the treatment of cancer, *Phys. Med. Biol.* **32** 789-811.

FIELDING, C.J. & FIELDING, P.E. (1985) Metabolism of cholesterol and lipoproteins. In *Biochemistry of lipids and membranes* eds. Vance, D.E. and Vance, J.E. The Benjamin/ Cummings publishing company, Inc., p416.

FISCHER, T.H. & WILLIAMS, T.P. (1982) The effects of phospholipid structure on the thermal stability of Rhodospin, *Biochim. Biophys. Acta* **707** 203-279.

FISHER, G. A., LI, G. C. & HAHN, G. M. (1982) Modification of the thermal response by  $D_2O$ . I. Cell survival and the temperature shift, *Radiat. Res.* **92** 530-540.

FLEISCHER, A.B., SHURMANTINE, W.O., LUXON, B.A. & FORKER, E.L. (1986) Palmitate uptake by hepatocyte monolayers. Effect of albumin binding, *J. Clin. Invest.* **77** 964-970.

- FLEISCHER, S. & KERVINA, M. (1974) Subcellular fractionation of rat liver, *Methods Enzymol.* **XXXI** 6-41
- FLEISCHER, S. & PACKER, L. (1974) Biomembranes part A, *Methods Enzymol.* **XXXI** 1
- FOX, M.H., READ, R.A. & BEDFORD, J.S. (1985) The cell cycle dependence of thermotolerance. III. HeLa cells heated at 45<sup>0</sup>C , *Radiat. Res.* **104** 429-442.
- FRANKE, W. W., SCHMID, E., KARTENBECK, J., MAYER, D., HACKER, H.-J., BANNASH, P., OSBORN, M., WEBER, K., DENK, H., WANSON, J.-C. & DROCHMANS, P. (1979) Characterisation of the intermediate-sized filaments in liver cells by immunofluorescence and electron microscopy, *Biol. Cellulaire* **34** 99-110.
- FRANKE, W. W., MAYER, D., SCHMID, E., DENK, H. & BORENFREUND, E. (1981) Differences of expression of cytoskeletal proteins in cultured rat hepatocytes and hepatoma cells, *Exp. Cell Res.* **134** 345-365
- FRESHNEY, R.I. (1987) Culture of animal cells; A manual of basic techniques. Alan R. LISS, Inc., New York, second edition.
- GASPAR, G., ALANIZ, M. J. T. de. & BRENNER, R. R. (1975) Uptake and metabolism of exogenous Eicosa-8,11,14-trienoic acid in minimal deviation hepatoma 7288C cells, *Lipids* **10** 726-731.
- GASPAR, G., ALANIZ, M. J. T. de. & BRENNER, R. R. (1977) Incorporation and metabolism of stearic, oleic, linoleic and  $\alpha$ -linoleic acids in minimal deviation hepatoma 7288C cells, *Mol. Cell. Biochem.* **16** 197-203.
- GERWECK, L. E. (1977) Modification of cell lethality at elevated temperatures: the pH effect, *Radiat. Res.* **70** 224-235.
- GERWECK, L. E., NYGAARD, T. G. & BURLETT, M. (1979) Response of cells to hyperthermia under acute and chronic hypoxic conditions, *Cancer Res.* **39** 966-972.
- GERWECK, L. E., DAHLBERG, W. C., EPSTEIN, L. & SHIMM, D. S. (1984) Influence of nutrient and energy deprivation on cellular response to single and fractionated heat treatments, *Radiat. Res.* **99** 573-581.
- GERWECK, L. E. (1988) Modifiers of thermal effects: environmental factors. In: *Hyperthermia and oncology. I. Thermal effects on cells and tissues.* eds. Urano, M. & Douple, E., Utrecht, VNU Scientific publishers, pp83-98.
- GEYER, R. P., BENNET, A. & ROHR, A. (1962) Fatty acids of the triglycerides and phospholipids of HeLa cells and strain L fibroblasts, *J. Lipid Res.* **3** 80-83.
- GEYER, R. P. (1967) *Lipid metabolism in tissue culture cells*, eds. Rothblat, G. H. & Kritchevsky, Y. D., Wistar Institute Press, Philadelphia, pp33-44.
- GILMAN, A. G. (1970) A protein binding assay for adenosine 3'5'-cyclic monophosphate, *Proc. Natn. Acad. Sci. (USA)* **67** 305-312.

GILMAN, A.G. (1984) Guanine nucleotide-binding regulatory proteins and dual control of adenylate cyclase, *J. Clin. Invest.* **73** 1-4.

GILMORE, R., COHN, N. & GLASER, M. (1979a) Fluidity of LM cell membranes with modified lipid compositions as determined with 1,6-diphenyl-1,3,5-hexatriene, *Biochem.* **18** 1042-1049.

GILMORE, R. COHN, N. & GLASER, M. (1979b) Rotational relaxation times of 1,6-diphenyl-1,3,5-hexatriene in phospholipid polar head group and fatty acid composition, *Biochem.* **18** 1050-1056.

GIOVANELLA, B. C., STEHLIN, J. S. & MORGAN, A. C. (1976) Selective lethal effect of supranormal temperatures on human neoplastic cells, *Cancer Res.* **36** 3944-3950.

GLASER, M., FERGUSON, K. A. & VAGELOS, P. R. (1974) Manipulation of the phospholipid composition of tissue culture cells, *Proc. Natn. Acad. Sci. (USA)* **71** 4072-4076.

GONZALEZ-MENDEZ, R., WEMMER, D., ITAH, D., WADE-JARDETZKI, N. & JARDETZKI, J. (1982a) Continuous flow NMR culture system for mammalian cells, *Biochim. Biophys. Acta* **720** 274-280.

GONZALEZ-MENDEZ, R., MINTON, K. W. & HAHN, G. M. (1982b) Lack of correlation between membrane lipid composition and thermotolerance in Chinese hamster ovary cells, *Biochim. Biophys. Acta* **692** 168-170.

GOTLIB, L. J. (1982) Isolation of cell plasma membranes on microcarrier culture beads, *Biochim. Biophys. Acta* **685** 21-26.

GOTO, I., KOBAYASHI, T., ANTOKU, Y., TOBIMATSU, S. & KUROIWA, Y. (1986) Adrenoleukodystrophy and variants: Clinical, neurophysiological and biochemical studies in patients and family members, *J. Neurol. Sci.* **72** 103-112.

GRANNER, D.J., CHASE, L.R., AURBACH, G.D. & TOMKINS, G.M. (1968) Tyrosine Aminotransferases: Enzyme induction independent of adenosine 3',5'-monophosphate, *Science* **162** 1018-1020.

GREEN, L. M., READE, J. L. & WARE, C. F. (1984) Rapid colorimetric assay for cell viability: application to the quantitation of cytotoxic and growth inhibitory lymphokines, *J. Immunol. Methods* **70** 257-268.

GUFFY, M. M., ROSENBERGER, J. A., SIMON, I. & BURNS, C. P. (1982) Effect of cellular fatty acid alteration on hyperthermic sensitivity in cultured L1210 mouse leukemia cells, *Cancer Res.* **42** 3625-3630.

HANAHAH, D. J. & EKHOLM J. E. (1974) The preparation of red cell ghosts (membranes), *Methods Enzymol.* **XXXI** 168-180

HAND, J. W. (1987) Hyperthermia: Challenging applications of physics in cancer therapy, *Phys. Bull.* **38** 111-113.

- HAHN, G. M., LI, G. C. & SHIU, E. (1977) Interaction of amphotericin B and 43°C hyperthermia, *Cancer Res.* **37** 761-764.
- HAHN, G. M. (1982) *Hyperthermia and Cancer*, Plenum, New York.
- HARISIADIS, L., HALL, E. J., KRAIJEVIC, U. & BOREK, C. (1975) Hyperthermia: biological studies at the cellular level, *Radiol.* **117** 447-452.
- HARRIS, J. R., MURTHY, A. K. & BELLI, J. A. (1977) Repair following combined X-ray and heat at 41°C in plateau-phase mammalian cells, *Cancer Res.* **37** 3374.
- HARRISON, R.G. (1907) Observations on the living developing nerve fibre, *Proc. Soc. Exp. Biol. (N.Y.)* **4** 140.
- HARRISON, R. & LUNT, G.G. (1980) *Biological membranes*. Second edition, Blackie, Glasgow, London.
- HAZEL, J. R. & PROSSER, C. L. (1974) Molecular mechanisms of temperature compensation in poikilotherms, *Ann. R. Physl.* **54** 620-677.
- HAZEL, J. R. (1979) Influence of thermal acclimation on membrane lipid composition of rainbow trout liver, *Am. J. Physiol.* **236** R91-101.
- HAZEL, J. R. (1984) Effects of temperature on the structure and metabolism of cell membranes of fish, *Am. J. Physiol.* **246** R460-470.
- HEINE, U., SEVERAK, L., KONDRATICK, J. & BONAR, R. A. (1971) The behaviour of HeLa S<sub>3</sub> cells under the influence of supranormal temperatures, *J. Ultrastruc. Res.* **34** 375-396.
- HENLE, K. J. & LEEPER, D. B. (1979) Effects of hyperthermia (45°C) on macromolecular synthesis in Chinese hamster ovary cells, *Cancer Res.* **39** 2665-2674.
- HENLE, K. J. & ROTI ROTI, J. L. (1988) Response of cultured mammalian cells to hyperthermia. In: *Hyperthermia and oncology. I. Thermal effects on cells and tissues*. eds. Urano, M. & Douple, E., Utrecht, VNU Scientific publishers, pp57-82.
- HERMAN, T.S., TEICHER, B.A., JOCHELSON, M., CLARK, J., SVENSSON, G. & COLEMAN, C.N. (1988) Rationale for use of local hyperthermia with radiation therapy and selected anticancer drugs in locally advanced human malignancies, *Int. J. Hyperthermia* **4** 143-158.
- HESKETH, T.R., SMITH, G.A., HOUSLAY, M.D., MCGILL, K.A., BIRDSALL, N.J.M., METCALFE, J.C. & WARREN, G.B. (1976) Annular lipids determine the ATPase activity of a calcium transport protein complexed with dipalmitoyllecithin, *Biochem.* **15** 4145-4151.
- HIDVÉGI, E. J., YATVIN, M. B., DENNIS, W. H. & HIDVÉGI, E. (1980) Effect of altered membrane lipid composition and procaine on hyperthermic killing of ascites tumour cells, *Oncology* **37** 360-363.

- HIGGINS, P. J., DARZYNKIEWICZ, Z. & MELAMED, M. R. (1983) Secretion of albumin and alpha-foetoprotein by DMSO-stimulated hepatocellular carcinoma cells, *Br. J. Cancer* **48** 485-493.
- HILDEBRAND, J.D., SEKURA, R.D., CORDINA, J., IYENGAR, R., MANCLARK, C.R., & BIRNBAUMER, L. (1983) Stimulation and inhibition of adenylyl cyclases mediated by distinct regulatory proteins, *Nature* **302** 706-709.
- HIRATA, F. & AXELROD, J. (1980) Phospholipid methylation and biological signal transmission, *Science* **209** 1082.
- HINTON, R. AND DOBROTA, M. (1976) Density gradient centrifugation. Laboratory techniques in biochemistry and molecular biology, eds., Work, T. S. and Work, E., Elsevier/North-Holland Biomedical Press, Amsterdam
- HOFER, K. G., BRIZZARD, B. & HOFER, M. G. (1979) Effect of lysosome modification on the heat potentiation of radiation damage and direct heat death of BP-8 sarcoma cells, *Eur. J. Cancer* **15** 1449-1457.
- HONN, K. V., SINGLEY, J. A. & CHAVIN, W. (1975) Fetal bovine serum: a multivariate standard (38805), *Proc. Soc. Exp. Biol. Med.* **149** 344-347.
- HORWITZ, A. F., HATTEN, M. E. & BURGER, M. M. (1974) Membrane fatty acid replacements and their effect on growth and lectin-induced agglutinability, *Proc. Natn. Acad. Sci. (USA)* **71** 3115-3119.
- HOWELL, K. E., DEVANEY, E & GRUENBERG, J. (1989) Subcellular fractionation of tissue culture cells, *Trends Biochem. Sci.* **14** 44-47
- HUANG, L. LORCH, S.K., SMITH, G.G. & HAUG, A. (1974) Control of membrane lipid fluidity in *Acholesplasma Laidlawii*, *FEBS Lett.* **43** 1-5.
- HUME, S. P. & FIELD, S. B. (1977) Acid phosphatase activity following hyperthermia of mouse spleen and its implication in heat potentiation of X-ray damage, *Radiat. Res.* **72** 145-153.
- HYMAN, B. T. & SPECTOR, A. A. (1981) Accumulation of  $n-3$  polyunsaturated fatty acids by cultured human Y79 retinoblastoma cells, *J. Neurochem.* **37** 60-69.
- JAKOBS, K.H., WILHELM, S. & JOHNSON, R.A. (1979) Regulation of platelet adenylyl cyclase by adenosine, *Biochim. Biophys. Acta* **583** 409-421.
- JAKOBY, W.B. & PUSTAN, I.H. (1979) *Cell culture methods in enzymology*, Academic press, New York, Vol LVIII.
- JOHNSON, H.A. (1974) On the thermodynamics of cell injury: some insights into the molecular mechanism, *Am. J. Pathol.* **75** 13-25.
- JOHNSON, S. M. (1979) A new specific cholesterol assay gives reduced cholesterol/phospholipid molar ratios in cell membranes, *Analyt. Biochem.* **95** 344-350.
- JOHNSTON, P. V. & ROOTS, B. I. (1964) Brain lipid fatty acids and temperature acclimation, *Comp. Biochem. Physiol.* **11** 303-309.

- JOLLY, J. (1903) Surla duree de la vie et de la multiplication des cellules animals en dehors de l'organisme, *C.R. Soc. Biol. (Paris)* **55** 1266.
- JUNG, H. (1986) A generalised concept for cell killing by heat, *Radiat. Res.* **106** 56-72.
- KAMPINGA, H.H., LUPPES, J.G. & KONINGS, A.W.T. (1987) Heat-induced nuclear protein binding and its relation to thermal cytotoxicity, *Int. J. Hyperthermia* **3** 459-465.
- KAMPINGA, H.H., TURKLE-UYGUR, N., ROTI ROTI, J.L. & KONINGS, A.W.T. (1989) The relationship of increased nuclear protein content induced by hyperthermia to killing of HeLa S<sub>3</sub> cells, *Radiation Research* **117** 511-522.
- KANDUTSCH, A.A. & CHEN, H.W. (1977) Consequences of blocked steol synthesis in cultured cells, *J. Biol. Chem.* **252** 409-415.
- KANDUTSCH, A.A., CHEN, H.W. & HEINIGER, H.J. (1978) Biological activity of some oxygenated sterols, *Science* **201** 498-501.
- KAPP, D. S. & HAHN, G. M. (1979) Thermosensitisation by sulfhydryl compounds of exponentially growing Chinese hamster cells, *Cancer Res.* **39** 4630-4635.
- KARIN, N. J. & COOK, J. S. (1986) Turnover of the catalytic subunit of Na<sup>+</sup>, K<sup>+</sup>-ATPase in HTC cells, *J. Biol. Chem.* **261** 10422-10428
- KARNOVSKY, M. J. (1965) A formaldehyde-glutaraldehyde fixative of high osmolality for use in electron microscopy, *J. Cell Biol.* **27** 137A.
- KIELLEY, W.W. & KIELLEY, R.K. (1953) A specific adenosinetriphosphatase of liver mitochondria, *J. Biol. Chem.* **200** 213.
- KIM, S. H., KIM, J. H. & HAHN, E. W. (1975) Enhanced killing of hypoxic tumour cells by hyperthermia, *Br. J. Radiol.* **48** 872-874.
- KIM, S. H., KIM, J. H., HAHN, E. W. & ENSIGN, N. A. (1980) Selective killing of glucose and oxygen-deprived HeLa cells by hyperthermia, *Cancer Res.* **40** 3459-3462.
- KIMELBERG, H. K. (1977) The influence of membrane fluidity on the activity of membrane bound enzymes, *Cell Surf. Rev.* **3** 205-293.
- KING, M. E. & SPECTOR, A. A. (1978) Effect of specific fatty acyl enrichments on membrane physical properties detected with a spin label probe, *J. Biol. Chem.* **253** 6493-6501.
- KINGSTON, C.A. (1989) The effect of modulating membrane lipid composition on the thermal sensitivity of tumour cells in culture. Ph.D. Thesis, University of Durham.
- KINGSTON, C. A., LADHA, S., MANNING, R. & BOWLER, K. (1989) Hyperthermic cell death of HTC cells in culture: a comparison of assays, *Bioch. Soc. T.* **17** 531-532.

- KINNE-SAFFRAN, E. & KINNE, R. (1980) Further studies on the potential role of anion-stimulation  $Mg^{2+}$ -ATPase in rat proximal tubule proton transport, *Current topics in membranes and transport* **13** 337-341.
- KIRSTEN, E.S. & WATSON, J.A. (1974) Regulation of 3-hydroxy-3-methylglutaryl coenzyme-A reductase in hepatoma tissue culture cells by serum lipoproteins, *J. Biol. Chem.* **249** 6104-6109.
- KOIZUMI, K., SHIMIZU, S., KOIZUMI, K. T., NISHIDA, K., SATO, C., OTA, K. & YAMAWAKA, N. (1981) Rapid isolation and lipid characterisation of plasma membranes from normal and malignant lymphoid cells of mouse, *Biochim. Biophys. Acta* **649** 393-403.
- KONINGS, A. W. T. (1985) Development of thermotolerance in mouse fibroblast LM cells with modified membranes and after procaine treatment, *Cancer Res.* **45** 2016-2019.
- KONINGS, A. W. T. & RUIFROK, A. C. C. (1985) Role of membrane lipids and membrane fluidity in thermosensitivity and thermotolerance of mammalian cells, *Radiat. Res.* **102** 86-98.
- KONINGS, A.W.T. (1988) Membranes as targets for hyperthermic cell killing *Cancer Research* **209** 9-20.
- KWOCK, L., LIN, P.-S., HEFTER, K. & WALLACH, D. F. H. (1978) Impairment of  $Na^{+}$ -dependent amino acid transport in cultured human T-cell line by hyperthermia and irradiation, *Cancer Res.* **38** 83-87.
- KWOCK, L., LIN, P.S. & HEFTER, K. (1985) A comparison of the effects of hyperthermia on cell growth in human T and B lymphoid cells: Relationship to alterations in plasma membrane transport properties, *Radiat. Res.* **101** 197-206.
- LADHA, S., WEST, D.W. & CLEGG, R.A. (1985) Cyclic AMP production in rat mammary gland: Adenylate cyclase activity associated with microsomal membranes, *Bioch. Soc. T.* **13** 866-867.
- LADHA, S., KINGSTON, C. A., BOWLER, K. & MANNING, R. (1989) Effect of fatty acid supplementation on the thermal sensitivity of HTC cells in culture, *Bioch. Soc. T.* **17** 530-531.
- LANGÉ, Y. & RAMOS, B.V. (1983) Analysis of the distribution of cholesterol in the intact cell, *J. Biol. Chem.* **258** 15130-15134.
- LAPOSATA, M., REICH, E.L. & MAJERUS, P.W. (1985) Arachidonoyl-CoA synthetase. Separation from nonspecific acyl-CoA synthetase and distribution in various cells and tissues, *J. Biol. Chem.* **260** 11016-11020.
- LAW, H.T. & PETTIGREW, R.T. (1986) Whole-body and regional hyperthermia by direct heating. In: *Hyperthermia*, eds. WATMOUGH, D.J. & ROSS, W.M., Blackie & Son Limited, pp180-201.
- LAVAL, F. & MICHEL, S. (1982) Enhancement of hyperthermia-induced cytotoxicity upon ATP deprivation, *Cancer Lett.* **15** 61-65.

- Le CAVAIER, D. & MACKILLOP, W.J. (1985) The effect on hyperthermia on glucose transport in normal and thermotolerant Chinese hamster ovary cells, *Cancer Lett.* **29** 223-231.
- LEE, A. G. (1982) Membrane studies using fluorescence spectroscopy. In: *Techniques in the Life Sciences, Lipid and Membrane Biochemistry*, Elsevier scientific publishers, Ireland, *New. Pythol.* **B422** pp1-49.
- LEE, D. C. & CHAPMAN, D. (1987) The effects of temperature on biological membranes and their models. In: *Temperature and Animal Cells*, S.E.B. symposium XLI, eds. Bowler, K. & Fuller, B. J., Cambridge: The Company of Biologists Ltd.
- LEFKOWITZ, R.J. STADEL, J.M. & CARON, M.G. (1983) Adenylate cyclase-coupled beta-adrenergic receptors: structure and mechanisms of activation and desensitization, *Ann. Rev. Biochem.* **52** 159-186.
- LEPOCK, J. R., MASSICOTTE-NOLAN, P., RULE, G. S. & KRUVU, J. (1981) — Lack of correlation between hyperthermic cell killing, thermotolerance and membrane lipid fluidity, *Radiat. Res.* **87** 300-313.
- LEPOCK, J. R. (1982) Involvement of membranes in cellular responses to hyperthermia, *Radiat. Res.* **92** 433-438.
- LEPOCK, J. R., CHENG, K.-H., AL-QYSI, H. & KRUVU, J. (1983) Thermotropic lipid and protein transitions in Chinese hamster lung cell membranes: relationship to hyperthermic cell killing, *Can. J. Biochem.* **61** 421-427.
- LEPOCK, J. R., FREY, H. E., RODAHL, A. M. & KRUVU, J. (1988) Thermal analysis of CHL V79 cells using differential scanning calorimetry: implications for hyperthermic cell killing and the heat shock response, *J. Cell Physiol.* **137** 14-24.
- LEPOCK, J. R., FREY, H. E., BAYNE, H. & MARKUS, J. (1989) Relationship of hyperthermia-induced hemolysis of human erythrocytes to the thermal denaturation of membrane proteins, *Biochim. Biophys. Acta* **980** 191-201.
- LEVINE, E. M. & ROBBINS, E. B. (1970) Differential temperature sensitivity of normal and cancer cells in culture, *J. Cell Physiol.* **76** 373-379.
- LEYKO, W. & BARTOSZ, G. (1986) Review: membrane effects of ionizing radiation and hyperthermia, *Int. J. Radiat. Biol.* **49** 743-770.
- LI, G. C. & HAHN, G. M. (1978) Ethanol-induced tolerance to heat and adriamycin, *Nature* **274** 699-701.
- LI, G. C., SHIU, E. C. & HAHN, G. M. (1980) Similarities in cellular inactivation by hyperthermia or by ethanol, *Radiat. Res.* **82** 257-268.
- LI, G.L.; CAMERON, R.B.; SAPARETO, S.A. & HAHN, G.M. (1982) Reinterpretation of Arrhenius analysis of cell inactivation by heat, *Natl. Cancer. Inst. Monograph* **61** 111-113.

- LIN, P. S., KWOCK, L., HEFTER, K. & WALLACH, D. F. H. (1978) Modification of rat thymocyte membrane properties by hyperthermia and ionising radiation, *Int. J. Radiat. Biol.* **33** 371-382.
- LOPEZ-SAURA, P., TROUET, A. & TULKENS, P. (1978) Analytical fractionation of cultured hepatoma cells (HTC cells), *Biochim. Biophys. Acta* **543** 430-449.
- LOTEN, E. G. & REDSHAW-LOTEN, J. C. (1986) Preparation of rat liver plasma membranes in a high yield, *Analyt. Biochem.* **154** 183-185.
- LYTE, M. & SHINITZKY, M. (1985) A special lipid mixture for membrane fluidization, *Biochim. Biophys. Acta* **812** 133-138.
- MABREY, S., MATEO, P. L. & STURTEVANT, J. M. (1977) Differential scanning calorimetry of lecithin-cholesterol mixtures, *Biophys. J.* **17** 82a.
- MACKEY, M.A. & DEWEY, W.C. (1988) Time-temperature analysis of cell killing of synchronous G1 and S phase Chinese hamster cells *in vitro*, *Radiat. Res.* **113** 318-333.
- MAEDA, M., DOI, O., & AKAMATSU, Y. (1980) Behavior of vesicular stomatitis virus glycoprotein in mouse LM cells with modified membrane phospholipids, *Biochim. Biophys. Acta* **597** 552
- MAGUN, B.E. (1981) Inhibition and recovery of macromolecules synthesis, membrane transport and lysosomal function following exposure of cultured cells to hyperthermia, *Radiat. Res.* **87** 657-669.
- MAHONEY, E.M., SCOTT, W.A., LANDBERGER, F.R., HAMILL, A.L. & COHN, Z.A. (1980) Influence of fatty acyl substitution on the composition and function of macrophage membranes, *J. Biol. Chem.* **255** 4910-4917.
- MAKMAN, M. H. (1971) Conditions leading to enhanced response to glucagon, epinephrine or prostaglandins by adenylate cyclase of normal and malignant cultured cells, *Proc. Natn. Acad. Sci. (USA)* **68** 2127-2130.
- MANNING, R., CHAMBERS, J., LADHA, S., KINGSTON, C. A. & BOWLER, K. (1989) Rapid purification of plasma membranes in high yield from HTC cells, *Bioch. Soc. T.* **17** 670-671.
- MARRA, C. A., ALANIZ, M. J. T. de. & BRENNER, R. R. (1984) Uptake and metabolism of eicosa-8,11,14-trienoic acid in normal hepatocytes and HTC cells, *Mol. Cell. Biochem.* **65** 143-152.
- MARTIN, C. E. & THOMPSON, G. A. Jnr. (1978) Use of fluorescence polarisation to monitor intracellular membrane changes during temperature acclimation. Correlation with lipid compositional and ultrastructural changes, *Biochem.* **17** 3581-3586.
- MASSICOTTE-NOLAN, P., GLOFCHESKI, D. J., KRUVU, J. & LEPOCK, J. R. (1981) Relationship between hyperthermic cell killing and protein denaturation by alcohols, *Radiat. Res.* **87** 284-299.

- McATEER, J. A. & DOUGLAS, W. H. J. (1979) Monolayer culture techniques, *Cell culture, section 1: Basic methods in enzymology*, eds. Jakoby, W. B. & Pastan, I. H. Vol. LVIII pp132-140.
- McLEAN, L.R. & PHILLIPS, M.C. (1981) Mechanism of cholesterol and phosphatidylcholine exchange or transfer between unilamellar vesicles, *Biochem.* **20** 2893-2900.
- MEANS, A.R. & DEDMAN, J.R. (1980) Calmodulin; an intracellular calcium receptor, *Nature* **285** 73.
- MEHDI, S.Q., RECKTENWALD, D.J., SMITH, L.M., LI, G.C., ARMOUR, E.P. & HAHN, G.M. (1984) Effect of hyperthermia on murine cell surface histocompatibility antigens, *Cancer Res.* **44** 3394-3397.
- MINTON, K.W., STEVENSON, M.A., KENDIG, J. & HAHN, G.M. (1980) Pressure inhibits thermal killing of Chinese Hamster ovary fibroblasts, *Nature* **285** 482-483.
- MORRÉ, D.J., CLINE, G.B., COLEMAN, R., EVANS, W.H., GLAUMANN, H., HEADON, D.R., REID, E., SIEBERT, G. & WIENELL, C.C. (1979) Markers for membranous cell components, *Eur. J. Cell Biol.* **20** 195-199.
- MORRISON, W.R. SMITH, L.M. (1964) Preparation of fatty acid methyl esters and dimethyl acetals from lipids with boron fluoride-methanol, *J. Lipid. Res.* **5** 600-608.
- MOSCOWITZ, M. S. (1967) *Lipid metabolism in tissue culture cells*, eds. Rothblat, G. H. & Kritchevsky, Y. D., Wistar Institute Press, Philadelphia, pp49-62.
- MOSMANN, T. (1983) Rapid colorimetric assay for cellular growth and survival: application to proliferation and cytotoxicity assays, *J. Immunol. Methods* **65** 55-63.
- MOURELLE, M. & ROJKIND, M. (1984) Lack of glucagon receptors in Morris Hepatoma 7800, *Hepatology* **4** 515-519.
- MULCAHY, R. T., GOULD, M. N., HIDVERGI, E., ELSON, C. E. & YATVIN, M. B. (1981) Hyperthermia and surface morphology of P388 ascites tumour cells: effects on membrane modifications, *Int. J. Radiat. Biol.* **39** 95-106.
- MULLER, C.P. & SHINITZKY, M. (1981) Passive shedding of erythrocyte antigens induced by membrane rigidification, *Exp. Cell Res.* **136** 53-62.
- NAKABAYASHI, T. & IKEZAWA, H. (1986) Alkaline phosphodiesterase I release from eucaryotic plasma membranes by phosphatidyl-inositol-specific phospholipase C. II. the release from brush border membranes of porcine intestine, *Toxicon* **24** 975-984.
- NEVILLE, D. M. (1960) The isolation of a cell membrane fraction from rat liver, *J. Biophys. Biochem. Cytol.* **8** 413-422.

- NICOLSON, G. L. (1973) Anionic sites of human erythrocyte membranes I. Effects of trypsin, phospholipase c, and pH on the topography of bound positively charged colloidal particles, *J. Cell Biol.* **57** 373-387
- NIELSEN, O. S. & OVERGAARD, J. (1979) Effect of extra-cellular pH on thermo-tolerance and recovery of hyperthermic damage in vitro *Cancer Res.* **39** 2772-2778.
- NORTHUP, J.K., STERNWIS, P.C., SMIGEL, M.D., SCHLEIFER, L.S., ROSS, E.M. & GILMAN, A.G. (1980) Purification of the regulatory component of adenylate cyclase, *Proc. Natn. Acad. Sci. (USA)* **77** 6516-6520.
- OLDFIELD, E., MEADOWS, M., RICE, D. & JACOBS, R. (1978) Spectroscopic studies of specifically deuterium labeled membrane systems. Nuclear magnetic resonance investigation of the effects of cholesterol in model systems, *Biochem.* **17** 2727-2740.
- OTTE, J. (1988) Hyperthermia in cancer therapy, *Eur. J. Pediatr.* **147** 560-569.
- OVERGAARD, J. & POULSON, H. S. (1977) Effect of hyperthermia and environmental acidity on the proteolytic activity in murine ascites tumour cells, *J. Natl. Cancer Inst.* **58** 1159-1161.
- PAUL, J. (1975) *Cell and tissue culture*, Churchill Livingstone, fifth edition.
- PAYRASTRE, B., PLANTAVID, M., ETIEVAN, C., RIBBES, G., CARRATERO, C., CHAP, H. & DOUSTE-BLAZY, L. (1988) Characterisation of plasma membranes from A431 cells, isolated by self generating Percoll gradient: a rapid isolation procedure to obtain plasma membranes with functional epidermal growth factor receptors, *Biochim. Biophys. Acta* **939** 355-365.
- PFEUFFER, T. & HELMREICH, E.J.M. (1975) Activation of pigeon erythrocyte membrane adenylate cyclase by guanylnucleotide analogues and separation of a nucleotide binding protein, *J. Biol. Chem.* **250** 867-876.
- PHARMACIA FINE CHEMICALS A. B. (1981) Microcarrier cell culture: principles and methods, *Technical booklet series*, Uppsala, Sweden.
- PHILLIPS, M.C., JOHNSON, W.J. & ROTHBLAT, G.H. (1987) Mechanisms and consequences of cellular cholesterol exchange and transfer, *Biochim. Biophys. Acta* **906** 223-276.
- PORRO, G., TAGLIABUE, E., MENARD, S. & COLNAGHI, M. I. (1986) Influence of in vitro culture conditions on tumour cell differentiation, *Tumori* **72** 15-20.
- POTTEL, H., Van DER MEER, W. & HERREMAN, W. (1983) Correlation between the order parameter and steady-state fluorescence anisotropy of 1,6-diphenyl-1,3,5-hexatriene and an evaluation of membrane fluidity, *Biochim. Biophys. Acta* **730** 181-186.
- PUCK, T. T., MARCUS, P. I. & CIECIURA, S. J. (1955) Clonal growth of mammalian cells in vitro. Growth characteristics of colonies from single HeLa cells with and without a 'feeder' layer, *J. Exp. Med.* **103** 273-284.

- RAAPHORST, G. P., ROMANO, S. L., MITCHELL, J. B., BEDFORD, J. S. & DEWEY, W. C. (1979) Intrinsic differences in heat and/or X-ray sensitivity of seven mammalian cell lines cultured and treated under identical conditions, *Cancer Res.* **39** 369-401.
- RAAPHORST, G. P., VADASZ, J. A., AZZAM, E. I., SARGENT, M. D., BORSA, J. & EINSPENNER, M. (1985) Comparison of heat and/or radiation sensitivity and membrane composition of seven X-ray-transformed *C3H 10T $\frac{1}{2}$*  cell lines and normal *C3H 10 $\frac{1}{2}$*  cells, *Cancer Res.* **45** 5452-5456.
- RAHEJA, R. K., KAUR, C., SINGH, A. & BHATIA, I. S. (1973) New colorimetric method for the quantitative estimation of phospholipids without acid digestion, *J. Lipid Res.* **14** 695-697.
- READ, R.A., FOX, M.H. & BEDFORD, J.S. (1984) The cell cycle dependence of thermotolerance. II. CHO cells heated at 45<sup>0</sup>C, *Radiat. Res.* **98** 491-505.
- RICHTER, A., SANFORD, K. K. & EVANS, V. J. (1972) Influence of oxygen and culture media on plating efficiency of some mammalian tissue cells, *J. Natl. Cancer Inst.* **49** 1705-1712.
- ROBERT, J., REBEL, G. & MANDEL, P. (1978) Utilization of polyunsaturated fatty acid supplements by cultured neuroblastoma cells, *J. Neurochem.* **30** 543-548.
- RODBELL, M. (1980) The role of hormone receptors and GTP-regulatory proteins in membrane transduction, *Nature* **284** 17-22.
- ROFSTAD, E. K. & BRUSTAD, T. (1984) Response to heat treatment (42.5°C) in vivo and in vitro of five human melanoma xenografts, *Br. J. Radiol.* **57** 1023-1032.
- ROOS, A. & BORON, W.F. (1981) Intracellular pH, *Physiol. Rev.* **6** 296-434.
- ROSENTHAL, M.D. (1981) Accumulation of neutral lipids by human skin fibroblasts: Differential effects of saturated and unsaturated fatty acids, *Lipids* **16** 173-183.
- ROSENTHAL, M. D. (1987) Fatty acid metabolism of isolated mammalian cells, *Prog. Lipid Res.* **26** 87-124.
- ROTHBLAT, G.H. & PHILLIPS, M.C. (1982) Mechanisms of cholesterol efflux from cells, *J. Biol. Chem.* **257** 4775-4782.
- ROTHBLAT, G.H., BAMBERGER, M. & PHILLIPS, M.C. (1986) Reverse cholesterol transport, *Methods in Enzymology* **129** 628-644.
- ROTI ROTI, J. L. & WINWARD, R. T. (1980) Factors affecting the heat induced increase in protein content of chromatin, *Radiat. Res.* **81** 138-144.
- ROTI ROTI, J. L. (1982) Heat induced cell death and radiosensitisation: Molecular mechanics, *Natl. Cancer Inst. Monogr.* **61** 3-10.

- ROTI ROTI, T.J. & LASZLO, A. (1988) The effect of hyperthermia on cellular macromolecules. In: *Hyperthermia and oncology. I. Thermal effects on cells and tissues*. eds. Urano, M. & Douple, E., Utrecht, VNU Scientific publishers pp13-56.
- ROUX, W. (1885) Beitrage zur entwicklungsmechanik des embryo, *Z. Biol.* **21** 411.
- RUDLAND, P. S., TWISTON-DAVIES, A. & WARBURTON, M. J. (1982) Prostaglandin-induced differentiation or DMSO-induced differentiation: reduction of the neoplastic potential rat mammary tumour stem-cell line, *J. Natl. Cancer Inst.* **69** 1083-1093.
- RUGGIERI, S. & FALLANI, A. (1973) In: *Tumor Lipids: Biochemistry and metabolism* eds. WOOD, R., Am. Oil Chemists' Society Champaign, p89.
- RUIFROK, A.C.C., KANON, B. & KONINGS, A.W.T. (1986) Na<sup>+</sup>, K<sup>+</sup>-ATPase activity in mouse lung fibroblasts and HeLa S<sub>3</sub> cells during and after hyperthermia, *Int. J. Hyperthermia* **2** 51-59.
- SABINE, J. R. (1983) Membrane homeostasis: is there an optimal level of membrane cholesterol? *Biosci. Rep.* **3** 337-344.
- SAMULSKI, T. V., LEE, E. R. & HAHN, G. M. (1984) Hyperthermia as a clinical treatment modality, *Cancer Treat. Rep.* **68** 309-316.
- SALMON, Y., LIN, M.C., LONDOS, C., RENDELL, M. & RODELL, M. (1975) The hepatic adenylate cyclase system. Evidence for transition states and structural requirement for guanine nucleotide activation, *J. Biol. Chem.* **250** 4239-4245.
- SAPARETO, S. A., HOPWOOD, L. E., DEWEY, W. C., RAJU, M. R. & GRAY, J. W. (1978) Effects of hyperthermia on survival and progression of Chinese hamster ovary cells, *Cancer Res.* **38** 393-400.
- SAPARETO, S.A. (1988) Practical concepts of thermal dose. In: *Hyperthermia and oncology. I. Thermal effects on cells and tissues*. eds. Urano, M. & Douple, E., Utrecht, VNU Scientific publishers, pp13-56.
- SAUVAGE, P., LOPEZ-SAURA, P., LEROY-HOUYET, M. A., TULKENS, P. & TROUET, A. (1981) Analytical characterisation and purification of plasma membrane from cultured hepatoma cells (HTC cells), *Biochim. Biophys. Acta* **644** 41-52.
- SCHAMHART, D. H. J., BERENDSEN, W., Van RIJN, J. & Van WIJK, R. (1984) Comparative studies of heat sensitivity of several rat hepatoma cell lines and hepatocytes in primary culture, *Cancer Res.* **44** 4507-4516.
- SCHREK, R., CHANDRA, S., MOLNAR, Z. & STEFANI, S. S. (1980) Two types of interphase death of lymphocytes exposed to temperatures of 37-45°C, *Radiat. Res.* **82** 162-170.
- SCHROEDER, F. (1983) Lipid domains in plasma membranes from rat liver, *Eur. J. Biochem.* **132** 509-516.

- SCHROEDER, F. (1984) Fluorescent sterols: Probe molecules of membrane structure and function, *Prog. Lipid Res.* **23** 97-113.
- SEAMON, K.B. & DALY, J.W. (1983) Forskolin, cyclic AMP and cellular physiology, *Trends. Pharm. Sci.* **4** 120-123.
- SEEMAN, P. (1972) The membrane actions of anaesthetics and tranquilisers, *Pharmacol. Rev.* **24** 583-633.
- SELLINGER, O. Z., BEAUFAY, H., JAQUES, P., DOYEN, A. & De DUVE, C. (1960) Intracellular distribution and properties of  $\beta$ -N-acetylglucosaminidase and  $\beta$ -galactosidase in rat liver, *Biochem. J.* **74** 450-456.
- SEVERS, N.J. & SIMONS, H.L. (1983) Failure of filipin to detect cholesterol-rich domains in smooth muscle plasma membranes, *Nature* **303** 635-636.
- SHINITZKY, M., SKORNICK, Y. & HARAN-GHERA, N. (1979) Effective tumour immunization induced by cells of elevated membrane-lipid microviscosity, *Proc. Natn. Acad. Sci. (USA)* **76** 5313-5316.
- SHINITZKY, M., BOROCHOV, H. & WILBRANDT, W. (1980) Lipid fluidity as a physiological regulator of membrane transport and enzyme activities. In: *Membrane Transport in Erythrocytes*, eds. Lassen, U.V., Ussing, H.N. & Wieth, J.O., Munksgaard, Copenhagen Symposium 14, pp91-107.
- SHINITZKY, M. (1984) in *Physiology of membrane fluidity*, Vol. 1, CRC Press, Florida, pp99-129.
- SIMON, E. W. (1974) Phospholipids and plant membrane permeability, *New. Pythol.* **73** 377-420.
- SINENSKY, M. (1974) Homeoviscous adaptation - A homeostatic process that regulates the viscosity of membrane lipids in *Escherichia Coli*, *Proc. Natn. Acad. Sci. (USA)* **71** 522-525.
- SINGER, S. J. & NICHOLSON, G. L. (1972) The fluid mosaic model of the structure of cell membranes, *Science* **175** 720-731.
- SINGER, M.A. & FINEGOLD, L. (1990) Cholesterol interacts with all of the lipid bilayer membranes, *Biophys. J.* **57** 153-156.
- SKORNICK, Y., DANCIGER, E., ROZIN, R.R. & SHINITZKY, M. (1981) Positive skin tests with autologous tumour cells of increased membrane viscosity, *Cancer Immunol. Immunother.* **11** 93-96.
- SLATER, T. F., SAWYER, B., & STRAULI, U. (1963) Studies on succinate-tetrazolium reductase systems. III. Points of coupling of four different tetrazolium salts, *Biochim. Biophys. Acta* **77** 383-393.
- SPECTOR, A. A., KISER, R. E., DENNING, G. M., KOH, S.-W. & DeBAULT, L. E. (1979) Modification of the fatty acid composition of cultured human fibroblasts, *J. Lipid Res.* **20** 536-547.

- SPECTOR, A.A., MATHUR, S.N., KADUCE, T.L. & HYMAN, B.T. (1981) Lipid nutrition and metabolism of cultured mammalian cells, *Prog. Lipid Res.* **19** 155-186.
- SPECTOR, A. A. & YOREK, M. A. (1985) Membrane lipid composition and cellular function, *J. Lipid Res.* **26** 1015-1035.
- SPECTOR, A.A. BURNS, C.P. (1987) Biological and therapeutic potential of membrane lipid modification in tumors, *Cancer Research* **47** 4529-4537.
- STEVENSON, A., GALEY, W. R. & TOBEY, R. A. (1983) Hyperthermia-induced increase in potassium transport in Chinese hamster cells, *J. Cell Physiol.* **115** 75-86.
- STEVENSON, M. A., CALDERWOOD, S. K. & HAHN, G. M. (1986) Rapid increases in inositol triphosphate and intracellular calcium after heat shock, *Biochem. Biophys. Res. Commun.* **137** 826-833.
- STEWART, J. R. (1988) Prospects for hyperthermia in cancer therapy. In: *Hyperthermia and oncology. I. Thermal effects on cells and tissues.* eds. Urano, M. & Douple, E., Utrecht, VNU Scientific publishers, pp1-12.
- STORCH, J. & SCHACHTER, D. (1984) Dietary induction of acyl chain desaturates alters the lipid composition and fluidity of rat hepatocyte plasma membranes, *Biochem.* **23** 1165-1170.
- STROM, R., CRIFO, C., ROSSI-FANELLI, A. & MONDOVI, B. (1977) Biochemical aspects of heat sensitivity of tumour cells, in *Selective Heat Sensitivity of Cancer Cells*, eds. Rossi-Fanelli, A., Cavaliere, R., Mondovi, B. & Morricca, G., Springer Verlag, Berlin Heidelberg New York, pp7-35.
- STUBBS, C. D., TSANG, W. M., BELIN, J., SMITH, A. D. & JOHNSON, S. M. (1980) Incubation of exogeneous fatty acids with lymphocytes. Changes in fatty acid composition and effects on the rotational relaxation time of 1,6-diphenyl-1,3,5-hexatriene, *Biochem.* **19** 2756-2762.
- STUBBS, C. D. (1983) Membrane fluidity: structure and dynamics of membrane lipids, in *Essays in Biochemistry*, eds. Campbell, P. N. & Marshall, R. D., London Academic Press, Vol. **19** pp1-39.
- STUBBS, C. D. & SMITH, A. D. (1984) The modification of mammalian membrane polyunsaturated fatty acid composition in relation to membrane fluidity and function, *Biochim. Biophys. Acta* **779** 89-137.
- TER HAAR, G. (1986) Effects of increased temperature on cells, on membranes and on tissues, in *Hyperthermia*, eds. Watmough, D. J. & Ross, W. M., Blackie & son Ltd., pp14-41.
- THOMLINSON, R.H. & GRAY, L.H. (1955) The histological structure of some human lung cancers and possible implications for radiotherapy, *Br. J. Cancer* **9** 539-549.

- THOMPSON, B. E., TOMKINS, G. M. & CURRAN, J. F. (1966) Induction of tyrosine and  $\alpha$ -ketoglutarate transamininase by steroid hormones in a newly established tissue culture cell line, *Proc. Natn. Acad. Sci. (USA)* **56** 296-303.
- THOMPSON, B. E. (1979) Liver cells (HTC): In: *Cell Culture Methods in Enzymology* **LVIII** 544-522.
- TOMASOVIC, S. P., TURNER, G. N. & DEWEY, W. C. (1978) Effect of hyperthermia on nonhistone proteins isolated with DNA, *Radiat. Res.* **73** 535-552.
- TOVEY, K. C., OLDHAM, K. G. & WHELAN, J. A. M. (1974) A simple direct assay for cyclic AMP in plasma and other biological samples using an improved competitive protein binding technique, *Clin. Chim. Acta* **56** 221-234.
- TRAILL, K.N. & WICK, G. (1984) Lipids and lymphocytes function, *Immunology Today* **5** 70-76.
- TRIER, J.K., KUHN, M. & AMMON, H.P.T. (1988) Adenylate cyclase in membrane fractions of RIN-A22-cells: Studies with forskolin, NaF, GppNHp and NEM, *Cell Biochemistry and function* **6** 131-135.
- TSAI, C.-M., CHEN, K. U. & CANELLAKIS, E. S. (1975) Isolation and characterisation of the plasma membrane of L-1210 cells. Iodination as a marker for the plasma membrane, *Biochim. Biophys. Acta* **401** 196-212.
- TULKENS, P., BEAUFAY, H. & TROUET, A. (1974) Analytical fractionation of homogenates from cultured rat embryo fibroblasts, *J. Cell Biol.* **63** 383-401.
- TWETO, J., FRIEDMAN, E. & DOYLE, D. (1976) Proteins of the hepatoma tissue culture cell plasma membrane, *J. Supramol. Struct.* **4** 141-159.
- URADE, R. & KITO, M. (1982) Perturbation of lipid metabolism by palmitic acid in Chinese hamster V79-R cells, *J. Biochem.* **91** 1639-1649.
- URANO, M. & DOUPLE, E. (1988) *Hyperthermia and oncology. I. Thermal effects on cells and tissues.* eds. Urano, M. & Douple, E., Utrecht, VNU Scientific publishers.
- Van BLITTEERSWIJK (1984) Alterations in lipid fluidity in the plasma membrane of tumor cells. In: *Physiology of membrane fluidity: Vol II*, CRC Press, Florida, p53-83.
- Van WEZEL, A. L. (1967) Growth of cell strains and primary cells on microcarriers in homogenous culture, *Nature* **216** 64-65.
- VAUPEL, P. (1979) Oxygen supply to malignant tumours. In: *Tumour Blood Circulation: Angiogenesis, Vascular Morphology and Blood Flow of Experimental and Human Tumours*, ed. Peterson, H. I., Boca Raton, Florida, CRC press, pp143-168.
- VIDAIR, C. A. & DEWEY, W. C. (1988) Two distinct modes of hyperthermic cell death, *Radiat. Res.* **116** 157-171.

Von HOFF, D. D., FORSETH, B. J., HUONG, M., BUCHOK, J. B. & LATHAN, B. (1986) Improved plating efficiencies for human tumours closed in capillary tubes versus petri dishes, *Cancer Res.* **46** 4012-4017.

WELCH, W. J. & SUHAN, J. P. (1985) Morphological study of the mammalian stress response: characterisation of changes in the cytoplasmic organelles, cytoskeleton, and nucleoli, and appearance of intranuclear Actin filaments in rat fibroblasts after heat-shock treatment, *J. Cell Biol.* **101** 1198-1211.

WESTERMARK, N. (1927) The effect of heat upon rat tumours, *Skand. Arch. Physiol.* **52** 257-322.

WESTRA, A. & DEWEY, W. C. (1971) Variation in sensitivity to heat shock during the cell cycle of Chinese hamster cells in vitro, *Int. J. Radiat. Biol.* **19** 467-477.

WHEATLEY, D. N., KERR, C. & GREGORY, D. W. (1989) Heat induced damage to HeLa S<sub>3</sub> cells: correlation of viability, permeability, osmosensitivity, phase-contrast light-, scanning electron- and transmission electron-microscopical findings, *Int. J. Hyperthermia* **5** 145-162.

WIEGAND, R.D. & WOOD, R. (1975) Lipids of cultured hepatoma cells: VI. Glycerolipid and monoenoic fatty acid biosynthesis in minimal deviation hepatoma 7288c, *Lipids* **10** 194-201.

WIEGANT, F. A. C., TUYL, M. & LINNEMANNS, W. A. M. (1985) Calmodulin inhibitors potentiate hyperthermic cell killing, *Int. J. Hyperthermia* **1** 157-169.

WIKE-HOOLEY, J. L., HAVEMAN, J. & REINHOLD, H. S. (1984) The relevance of tumour pH to the treatment of malignant disease, *Radiother. Oncol.* **2** 343-366.

WILLIAMS, R. E., WISNIESKI, B. J., RITTENHOUSE, H. G. & FOX, C. F. (1974) Utilisation of fatty acid supplements by cultured cells, *Biochem.* **13** 1969-1977.

WOLTERS, H. & KONINGS, A.W. (1982) Radiation effects on membranes. III. The effect of x-irradiation on survival of mammalian cells substituted by polyunsaturated fatty acids, *Radiation Research* **92** 474-482.

WOLTERS, H. & KONINGS, A. W. T. (1984) Radiosensitivity of normal and polyunsaturated fatty acid supplemented fibroblasts after depletion of glutathione, *Int. J. Radiat. Biol.* **46** 161-168.

WOOD, R. (1973) Lipids of cultured hepatoma cells: 1. Effect of serum lipid levels on cell and media lipids, *Lipids* **8** 690-701.

WOOD, R. & FALCH, J. (1973) Lipids of cultured hepatoma cells: II. Effect of media lipids on cellular phospholipids, *Lipids* **8** 702-710.

WOOD, R., FALCH, J. & WIEGAND, R. D. (1974) Lipids of cultured hepatoma cells: V. Distribution of isomeric monoene fatty acids in individual lipid classes, *Lipids* **9** 987-992.

- WOOD, R., UPRETI, G. C. & DeANTUENO, R. S. (1986) A comparison of lipids from liver and hepatoma subcellular membranes, *Lipids* **21** 292
- YASUI, L.S. & FINK, T.J. (1990) Thermal sensitivity of CHO cells with different shapes, *Int. J. Hyperthermia* **6** 67-65.
- YATVIN, M. B. (1977) The influence of membrane lipid composition and procaine in hyperthermic death of cells, *Int. J. Radiat. Biol.* **32** 513-521.
- YATVIN, M. B., CLIFTON, K. H. & DENNIS, W. H. (1979) Hyperthermia and local anaesthetics: potentiation of survival of tumour-bearing mice, *Science* **205** 195-196.
- YATVIN, M. B., CREE, T. C., ELSON, C. E., GIPP, J. J., TEGMO, P. M. & VORPAHL, J. W. (1982a) Probing the relationship of membrane 'fluidity' to heat killing of cells, *Radiat. Res.* **89** 644-646.
- YATVIN, M. B., GIPP, J. J., RUSY, B. F. & DENNIS, W. H. (1982b) Correlation of bacterial hyperthermic survival with anaesthetic potency, *Int. J. Radiat. Biol.* **42** 141-149.
- YATVIN, M. B., ABUIRMEILEH, N. M., VORPAHL, J. W. & ELSON, C. E. (1983a) Biological optimisation of hyperthermia: modification of tumour membrane lipids, *Eur. J. Cancer Clin. Oncol.* **19** 657-663.
- YATVIN, M.B., VORPAHL, J.W., GOULD, M.N. & LYTE, M. (1983b) The effects of membrane modification and hyperthermia of survival of P-388 and V-79 cells, *Eur. J. Cancer Clin. Oncol.* **19** 1247-1253.
- YATVIN, M. B., DENNIS, W. H., ELEGBEDE, J. A. & ELSON, C. E. (1987) Sensitivity of tumour cells to heat and ways of modifying the response, in *Temperature and Animal Cells*, S.E.B. symposium XLI, eds. Bowler, K. & Fuller, B. J., Cambridge: The Company of Biologists Ltd.
- YEAGLE, P.L. (1985) Cholesterol and the cell membrane, *Biochim. Biophys. Acta* **882** 267-287.
- YORK, D.A., HYSLOP, P.A. & FRENCH, R. (1982) Fluorescence polarisation and composition of membranes in genetic obesity, *Biochim. Biophys. Acta* **106** 1478-1483.

