

## Durham E-Theses

---

### *Solid state NMR of acid anhydride/hydroxyl crosslinking systems*

Anita Findlay

#### How to cite:

---

Findlay, Anita (1991) Solid state NMR of acid anhydride/hydroxyl crosslinking systems. Doctoral thesis, Durham University.

#### Use policy

---

The full-text may be used and/or reproduced, and given to third parties in any format or medium, without prior permission or charge, for personal research or study, educational, or not-for-profit purposes provided that:

- a full bibliographic reference is made to the original source
- a <https://etheses.durham.ac.uk/id/eprint/6177/> is made to the metadata record in Durham E-Theses
- the full-text is not changed in any way

The full-text must not be sold in any format or medium without the formal permission of the copyright holders.

Please consult the [full Durham E-Theses policy](#) for further details.

Solid state NMR of Acid anhydride/hydroxyl crosslinking  
systems

by

Anita Findlay

A thesis submitted in partial fulfilment  
of the requirements for the degree of  
Doctor of Philosophy

Department of Chemistry  
The University of Durham  
1991

The copyright of this thesis rests with the author.  
No quotation from it should be published without  
his prior written consent and information derived  
from it should be acknowledged.



21 APR 1992

To my Parents

The research in this thesis has been carried out at the Department of Chemistry of the University of Durham between October 1987 and September 1990. It is the original work of the Author unless stated otherwise. None of this work has been submitted for any other degree.

The copyright of this thesis rests with the Author. No quotation from it may be published without her prior written consent, and information derived from it should be acknowledged.

## Acknowledgements

There are a number of people I wish to mention who have contributed either directly or indirectly to the work in this thesis.

First, I would like to express my gratitude to Professor Robin Harris for his supervision and encouragement throughout the last three years.

I would also like to convey my appreciation to Courtaulds Coatings for their support of my work, especially to Dr. A. Port and Dr. A. Marrion for many helpful discussions and suggestions, and without whose assistance much of this work would not have been possible.

I would like to mention other members of the group, both past and present who contributed towards this thesis. My thanks go to Alan for useful discussions, and to David and Nicola for the VXR300 spectra. Amongst my friends, I wish to especially mention Matthew Leach and Xiao Ping for their friendship and for the many enjoyable times we had together.

Lastly, I would like to thank Michael for his encouragement throughout the past three years, and for his patience and understanding whilst this thesis was being written.

## Abstract

This thesis is concerned with the study by solid-state NMR of the polymers formed by acid anhydride/hydroxyl cross-linking systems. The polymers studied in this thesis are based on a copolymer containing either itaconic or maleic anhydride which cross-links with a polyester tipped with triethanolamine.

The mobility of the polyester chains in the cross-linked films is probed by solid-state NMR, and the kinetics of the cure between acid anhydride/hydroxyl systems is discussed.

The degradation of the cross-linked films is studied by  $^{13}\text{C}$  solid-state NMR. The films are shown to undergo hydrolysis when subjected to their exposure environment.

The theory behind transient nuclear Overhauser effects in the solid state is discussed, and comparisons are made between the theoretical simulations and the experimental data for the cross-linked films.

Lastly, a solid-state heteronuclear NOESY experiment is presented for a  $^{13}\text{C}_2$ -enriched acid anhydride/hydroxyl cross-linked film.

# Table of contents

Contents	Page
Chapter One	
Introduction	
1.1 Introduction	1
Chapter Two	
Industrial cross-linked coatings and polymer networks	
2.1 Introduction	5
2.2 Industrial Coatings	5
2.2.1 Coating composition	5
2.2.2 Reasons for interest in	
Cross-linking coating system	7
2.3 Cross-linking resins	7
2.3.1 Polyester resins	8
2.3.2 Acrylic resins	8
2.4 Classification of polymerisation reactions	9
2.4.1 Step-growth polymerisations	9
2.4.1.1 Condensation Reactions	11
2.4.1.2 Addition Reactions	11
2.4.2 Chain-growth polymerisations	11
2.4.2.1 Initiation	12
2.4.2.2 Propagation	12
2.4.2.3 Termination	12

2.4.3	Non-linear polymerisations	13
2.5	Polymer network formation	13
2.5.1	Cure and cure mechanism	13
2.5.2	The gel point	15
2.5.3	Cross-linking	17
2.6	The molecular network	17
2.6.1	Importance of cross-linking	17
2.6.2	Elastic properties of networks	18
2.7	Why study networks by NMR	19

### Chapter Three

#### Theory

3.1	General theory	21
3.2	The classical case	21
3.3	Population of the spin states	23
3.4	Relaxation	24
3.5	The Bloch equations	25
3.6	The rotating frame of reference	26
3.6.1	Case 1	28
3.6.2	Case 2	28
3.6.3	Relaxation in the rotating frame of reference	28
3.7	Spin diffusion	29

3.8	The quantum mechanical approach	30
3.8.1	The external Hamiltonian $\mathcal{H}_{\text{ext}}$	31
3.8.1.1	Zeeman Hamiltonian	31
3.8.1.2	Radiofrequency Hamiltonian	31
3.8.2	The internal Hamiltonian $\mathcal{H}_{\text{int}}$	32
3.8.2.1	The principal axis system	32
3.8.2.2	The shielding Hamiltonian	34
3.8.2.3	The indirect spin-spin coupling Hamiltonian	35
3.8.2.4	The dipole-dipole interaction	35
3.9	Relaxation	37
3.9.1	The effect of molecular motion on relaxation	37
3.10	The nuclear Overhauser effect	39
3.10.1	The nuclear Overhauser effect and molecular motion	40
3.11	Selective averaging techniques	42
3.11.1	Magic angle spinning	44
3.11.2	High power dipolar decoupling	45
3.12	Spin temperature	46
3.13	Cross-polarisation	48
3.13.1	Cross-polarisation dynamics	51
3.13.2	Spin-temperature inversion	54
3.13.3	Flip-back	55

## Chapter Four

### Experimental

4.1	Instrumentation	56
4.1.1	Bruker CXP200 NMR spectrometer	56
4.1.2	Other spectrometers utilised	56
4.1.3	The probes	57
4.2	Experimental	58
4.2.1	Shimming the magnet	58
4.2.2	Setting the proton $90^\circ$ pulse	58
4.2.3	Setting the angle	58
4.2.4	$^{13}\text{C}$ referencing	59
4.2.5	$^{13}\text{C}$ matching for CP	59
4.2.6	Setting $^{13}\text{C}$ $90^\circ$ pulse for single pulse	59
4.3	Pulse sequences	60
4.3.1	Single-pulse-excitation	60
4.3.2	INV1H	60
4.3.3	Cross-polarisation	61
4.3.4	Non-quaternary suppression	61
4.3.5	T1CP	62
4.4	Fitting of variable contact time measurements	63
4.5	Cross-linking chemistry	64
4.5.1	Courtaulds coatings cross-linking chemistry	65

4.6	Synthesis of the polymers	66
4.6.1	Synthesis of the itaconic anhydride copolymer	66
4.6.2	Synthesis of the maleic anhydride copolymer	67
4.6.3	Synthesis of the polyester	67
4.6.4	Characterisation of the polyester	68
4.6.4.1	Determination of the acid value	68
4.6.5	Tipping of the polyester	69
4.6.6	Characterisation of tipped polyester	70
4.6.6.1	Determination of the solids content	70
4.6.6.2	Determination of the amine equivalent weight	70
4.6.7	Preparation of the polymeric films	70
4.6.8	Synthesis of the polyester with <sup>13</sup> C enrichment	71
4.6.8.1	The trial run	71
4.6.8.2	Tipping of the polyester	72
4.6.8.3	Characterisation of the polyester	72
4.6.8.4	The enrichment	72
4.6.8.5	Characterisation	73

## Chapter Five

### Spectral assignment and kinetics

5.1	Spectral assignment of the polymeric films	74
5.1.1	Assignment of the itaconic anhydride copolymer	74
5.1.2	Assignment of the polyester	75
5.1.3	Assignment of the itaconic anhydride film	75
5.1.4	Assignment of the maleic anhydride copolymer	76
5.1.5	Assignment of the maleic anhydride film	76
5.2	Polyester carbons of differing mobilities	77
5.2.1	Measurement of the shorter carbon $T_1$ component	79
5.2.2	Measurement of the longer $T_1^{\text{II}}$ component	82
5.2.3	Origins of the two component $T_1^{\text{II}}$	84
5.3	Variable temperature studies	85
5.3.1	Cross-polarisation	85
5.3.1.1	The maleic anhydride film	86
5.3.1.2	The itaconic anhydride film	87
5.3.1.3	Discussion	88
5.3.2	Single-pulse-excitation	89

5.4	Kinetics of the cure of the polymeric films	91
5.5	Model studies of the cross-linking reaction	96
5.5.1	Reaction between succinic anhydride and N,N dimethyl ethanolamine	96
5.5.2	Reaction between succinic anhydride and 4-(2-hydroxyethyl) morpholine	98
Chapter Six		
Degradation of acid anhydride/hydroxyl cross-linked systems		
6.1	Introduction	100
6.2	General aspects of polymer deterioration	100
6.3	The exposure environment	101
6.4	Hydrolytic degradation	102
6.5	Acid anhydride/hydroxyl degradation studies	103
6.6	Possible sites of degradation in acid anhydride/hydroxyl systems	106
6.6.1	Model A: Cleavage only occurs at positions 1 and 2	106
6.6.2	Model B: Cleavage occurs at all three positions	107

6.7	Characterisation and analysis of the sol product	107
6.7.1	GPC	107
6.7.2	NMR	107
6.7.3	HP liquid chromatography	108
6.8	Conclusions	108
6.9	The degradation of the maleic anhydride film	109
6.10	The degradation of the itaconic anhydride film	115
6.11	Conclusions from solid-state NMR study	119
6.12	The anchimeric effect	119

## Chapter Seven

### Solid-state nuclear Overhauser effects in cross-linked polymers

7.1	Introduction	122
7.2	The nuclear Overhauser effect	124
7.2.1	Definition	124
7.3	Techniques for the measurements of NOE's	126
7.3.1	Solution-state NOE: The gated-decoupling method	126
7.3.2	Solid-state NOE	127
7.4	Effects of inadequate pulse delays	129
7.5	Transient Overhauser effects	130

7.5	Transient Overhauser effects	130
7.6	The single-pulse-excitation experiment	132
7.6.1	Stage 1	132
7.6.2	Stage 2	133
7.7	A second transient experiment: INV1H	137
7.7.1	Calculation of $I_z$	138

## Chapter Eight

### Solid-state heteronuclear NOESY

8.1	Molecular motion	141
8.2	Assignment of $^{13}\text{C}$ -enriched polyester	142
8.3	Measurement of solid-state NOEF	142
8.4	Solid-state NOE	143
8.5	The solid-state NOESY experiment	144

## Chapter Nine

### Conclusions

9.1	Conclusions	148
-----	-------------	-----

References	152-159
------------	---------

## Appendices

### A Computer programs

SPE $^{13}\text{C}$ intensity simulation: SPEPLT	I
SPE $^1\text{H}$ intensity simulation: INVER	II

INV1H  $^{13}\text{C}$  intensity simulation: INV1H

III

B Lectures, colloquia and seminars

Lectures between 1/8/87 and 31/7/90

IV–XI

# CHAPTER 1

## Introduction

### 1.1 Introduction

Polymers play a very important role in life today. They may be found in a wide range of applications from industrial situations through to domestic appliances. In systems where polymers are used, the polymers usually occur as solids or as highly viscous liquids. It is therefore of great interest to apply a suitable technique to the study of polymers in these states of matter. Solid-state NMR provides such a technique. The chemical shifts are sensitive to chemical structure: Thus NMR may be used for the structural determination of polymers. NMR is a technique which is also sensitive to motion: Therefore the mobility of polymers may be assessed by NMR. High-resolution, solid-state NMR, via both chemical shifts and relaxation times, provides a direct link between polymer physical properties and the details of molecular structure. Thus solid-state NMR may provide information of a similar quality to that obtained via mechanical loss and dielectric relaxation methods.

The polymers studied in this thesis are based on a copolymer of styrene, methyl methacrylate and either itaconic or maleic anhydride which cross-links with a polyester tipped with triethanolamine. The cross-linked film which results is intended for use as a yacht paint. The cross-linked film must therefore possess certain properties such as good adhesion and resistance to hydrolysis.



This thesis describes the application of high-resolution solid-state NMR techniques to the study of acid anhydride/hydroxyl cross-linking systems. Solid-state NMR is a very versatile technique which has many applications in the study of polymers. NMR offers the ability to study insoluble materials in their natural environment: Thus the degradation of the polymer films may be studied directly by solid-state NMR. NMR can also provide information about the mobilities of the two components of the cross-linked films from measurements of nuclear Overhauser enhancements and relaxation times. A short description of the contents of each chapter is presented below.

A brief overview of protective coatings and network polymers is given in Chapter Two. The chapter covers the composition and uses of industrial coatings, the classification of polymerisation reactions, as well as polymer network formation and cross-linking.

Chapter Three describes the theory and principles behind the NMR experiment. The aim of this chapter is to provide the background knowledge of NMR necessary to follow the experimental results covered in chapters Five to Eight.

Details of the spectrometer hardware, software and other equipment are given in Chapter Four. The pulse sequences used in this thesis are also discussed, and descriptions of the synthesis of the polymers used in the research are given.

Chapters Five, Six, Seven and Eight cover the experimental results and conclusions drawn. In Chapter Five assignments of the cross-polarisation spectra of the polymers are made. The polymers are

probed for regions of differing mobility using discriminating techniques and variable temperature, variable contact time experiments. A new experiment is presented which can be used to determine carbon  $T_1$  values which are less than one second. Lastly, a study of the kinetics of the cure between acid anhydride/hydroxyl systems is discussed.

The potential application of the acid anhydride/hydroxyl cross-linked film is as a yacht paint. Chapter Six is concerned with the performance of the films when subjected to their expected exposure environment. The films are shown to undergo hydrolysis, and therefore fail to meet the requirements of a yacht paint.

Transient nuclear Overhauser effects (NOE) are a well-known phenomenon in the solution-state. However, a detailed study of transient NOE in the solid-state does not appear to have been made previously. Chapter Seven covers the theory behind such effects in the solid-state, and comparisons are made between the theoretical simulations and the experimental data for the cross-linked films. A new pulse program is presented in this chapter which determines the nuclear Overhauser enhancement factor in the solid-state using a saturation chain of pulses at the proton frequency to achieve build-up of the NOE.

Chapter Eight takes the theme of the nuclear Overhauser effect in the solid-state one step further. In Chapter Eight the first solid-state heteronuclear NOESY experiment is presented for a  $^{13}\text{C}$ -enriched acid anhydride/hydroxyl cross-linked film. The 2-dimensional heteronuclear NOESY experiment is a well-known technique in solution-state NMR. However, the use of such an experiment for structural correlation in the

solid-state does not appear to have been made.

Finally, Chapter Nine summarises the general conclusions made from the work in this thesis, and suggestions for further research are made.

## CHAPTER 2

### Industrial cross-linked coatings and polymer networks

#### 2.1 Introduction

The various paints currently on the market may be classified into two main categories: a) decorative paints and b) industrial protective coatings. The paints belonging to the two groups differ mainly in end applications and property requirements. Decorative paints are used mainly for interior and exterior house paints, whereas industrial paints are used for marine coatings, coatings for metal containers, wood and aircraft finishes, to name but a few.

The property requirements of the two categories of paints differ greatly. Decorative paints need to be fast drying, to have good adhesion to old paints and have a good appearance. In addition to this, exterior paints must possess outdoor durability properties. On the other hand, the main criteria for industrial coatings are mechanical properties, chemical resistance, adhesion, flexibility and corrosion and impact resistance properties. In this chapter only industrial coatings are considered.

#### 2.2 Industrial coatings

##### 2.2.1 Coating composition

The category consisting of industrial paints can be subdivided into atmospheric temperature-curing and heat-curing (stoving) systems. We

shall limit our discussion to atmospheric temperature-curing systems only. The large number of resins and curing agents available makes it possible to obtain coatings with a wide spectrum of properties. Rigid or flexible castings may be combined with outstanding adhesion, mechanical strength, and electrical insulation coupled with stability in widely differing environments. This range of behaviour can be extended even further by the incorporation of fillers, extenders, flexibilisers, plasticisers etc. into the basic resin mixture before curing. A paint consists of a polymeric binder plus pigments, extenders, solvent mixture and other materials where necessary.<sup>1</sup>

a). The binder is often a polyfunctional resin or high molecular weight polymer which reacts, either with itself or with another polymer, to form a cross-linked polymer network. The binder gives the film many of its protective properties such as its resistance to chemicals and abrasion as well as other properties of adhesion, flexibility and durability.

b). Pigments are used to colour the film and give it opacity. They may also enhance some of the properties of the coating, for example durability, adhesion and toughness. Sometimes pigments such as barium chromate may also be incorporated into the film to enhance the anti-corrosive properties of the coating.

c). Extenders are often incorporated into a paint system. Extenders are sometimes used to replace some of the pigments, thus making the manufacture of the paint more economical.

d). Solvents are added to the paint to facilitate the handling and mixing with materials. They are used to lower the viscosity of the paint,

making the application of the paint easier.

### 2.2.2 Reasons for interest in cross-linking coating systems

The curing mechanism and the type of binder system selected for each paint system vary depending on the end application and the property requirements of the paint. The curing mechanism is independent of the state in which the binder exists, whether in solution, dispersion, emulsion or as a solid. From a properties point of view, resins which are used as paint binders should have as high a molecular weight as possible. However, the use of very high molecular weight resins in paint formulations is restricted by both the polymerisation techniques used for polymer synthesis and the solution viscosities necessary for paint-application.

In order to overcome the problems associated with the molecular weight of resins, a method is used in which low molecular weight resins containing functional groups as binders are cross-linked in situ. The cross-linking may involve either intra- or inter-molecular bond formation. In order for inter-molecular cross-linking to take place, it is customary to add a different type of external cross-linking agent to the system. Curing catalysts are also often added to the system, either to lower the reaction temperature or to speed up the curing rate or both.

### 2.3 Cross-linking resins

In this thesis, the reaction of acid anhydride/hydroxyl cross-linking systems is considered specifically. For this reason only polyester resins and

acrylic resins are discussed in this chapter.

### 2.3.1 Polyester resins

Polyesters belong to a general category of resins obtained by reacting together a suitable polybasic acid with a suitable polyhydric alcohol.<sup>2</sup> The functional groups which are generally used to bring about *in situ* curing are carboxyl, hydroxyl or unsaturated groups in the resins. Polyesters almost inevitably contain hydroxyl and/or carbonyl end groups according to formulation and manufacture, and such groups can very conveniently be used for cross-linking. A hydroxylated polyester resin is often used in industrial paints. This type of resin is discussed in more detail later in this chapter.

Resins generally used to cure and modify the properties of polyester cross-linkers include amino resins, phenolic resins, polyisocyanates, epoxy resins, silicone resins, vinyl and acrylic resins with suitable functionality. The latter is also covered in more detail later in this chapter.

### 2.3.2 Acrylic resins

Acrylic resin is a term generally applied to the polymers and copolymers of methacrylic and acrylic acid derivatives.<sup>2</sup> The copolymers of one or more of these esters with non-acrylic monomers such as styrene, butadiene or vinyl acetate are also often referred to as acrylic resins. The main properties of an acrylic resin are: outstanding outdoor durability, good flexibility and toughness, resistance to chemicals such as acids, alkalis and water and minimum pigment reactivity.

The work in this thesis is concerned with the cross-linking between an acrylic resin of itaconic or maleic anhydride, styrene and methyl methacrylate and a triethanolamine tipped polyester resin of adipic acid, butane 1,4 diol and ethylene glycol. Figure 2.1 shows the cross-linking reaction between the itaconic anhydride resin and the triethanolamine tipped polyester resin. The product is a three-dimensional network of acrylic resin molecules cross-linked via ester linkages to the polyester chains.

## 2.4 Classification of polymerisation reactions

The formation of a polymer from monomer or monomers is traditionally divided into two broad reaction classes: step growth and chain growth. The distinction between these two processes can be made on mechanistic grounds as they exhibit quite dissimilar reaction kinetics which lead to different distributions of species as a function of the extent of reaction, and, depending on the detailed mechanism, the molecular weight distributions of the polymers formed. With both the step and chain mechanism, the polymerisation processes can be based on either one or two types of propagation reaction: condensation or addition<sup>3,4</sup> (i.e. with or without elimination of various by-products, respectively).

### 2.4.1 Step-growth polymerisations

Step-growth polymerisations<sup>5</sup> proceed via a step-by-step succession of elementary reactions between reactive sites, which are usually functional groups, but may also be ions or complexes. Each independent step causes

the disappearance of two co-reacting centres and creates a new linking unit between a pair of molecules. In order to obtain high polymers, the reactants must be at least difunctional; monofunctional ones act as chain stoppers.

The features of step-growth processes from a general point of view have been described by Lenz<sup>3</sup> and Sakolov.<sup>6</sup>

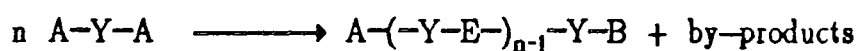
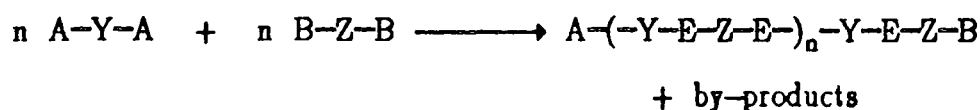

Each reaction step causes the disappearance of two reaction sites A and B, and converts them into a linking unit E. Two reactive sites remain at the end of any growing molecule, irrespective of its size. Throughout the reaction, the polymerisation process has the characteristics of a statistical combination of fragments. In the initial stages of the reaction dimer formation will be largely predominant; in subsequent stages trimers, tetramers and so on will be preferentially produced. Molecular weight distributions follow this random scheme. The increase in molecular weight becomes increasingly rapid as conversion increases, but the reaction rate becomes lower owing to the increasing difficulty of assembling fewer, larger fragments. In order to get the highest molecular weights there is a need for equimolecularity of reactive sites as close as possible to the theoretical value.

#### 2.4.1.1 Condensation reactions

An example of a step-growth condensation polymerisation reaction is the formation of a polyester from a dicarboxylic acid and a diol.

#### 2.4.1.2 Addition reactions

An example of a reaction which proceeds via a step-growth addition mechanism is the cross-linking between an acrylic resin and a hydroxyl-amine tipped polyester as shown in figure 2.1.

#### 2.4.2 Chain-growth polymerisations

Addition polymerisations are known to take place via a chain reaction<sup>6</sup> which is a self-sustaining molecular reaction maintained by the fact that the product of one stage initiates a further reaction step which in turn regenerates more product capable of causing further reactions. The polymerisation thus involves a large number of identical and successive events, initiated by some triggering mechanism, which eventually lead to the production of long chain-like molecules.

For a successful polymerisation, the chain reaction must be started by first providing a suitable active centre capable of reacting with the monomers present and in doing so regenerate the active centre during each addition step, thereby allowing the reaction to continue. Addition polymerisation can be regulated by the controlled production of initiating active centres which only regenerate themselves singly at each step and are susceptible to deactivation in a variety of ways. Thus an addition

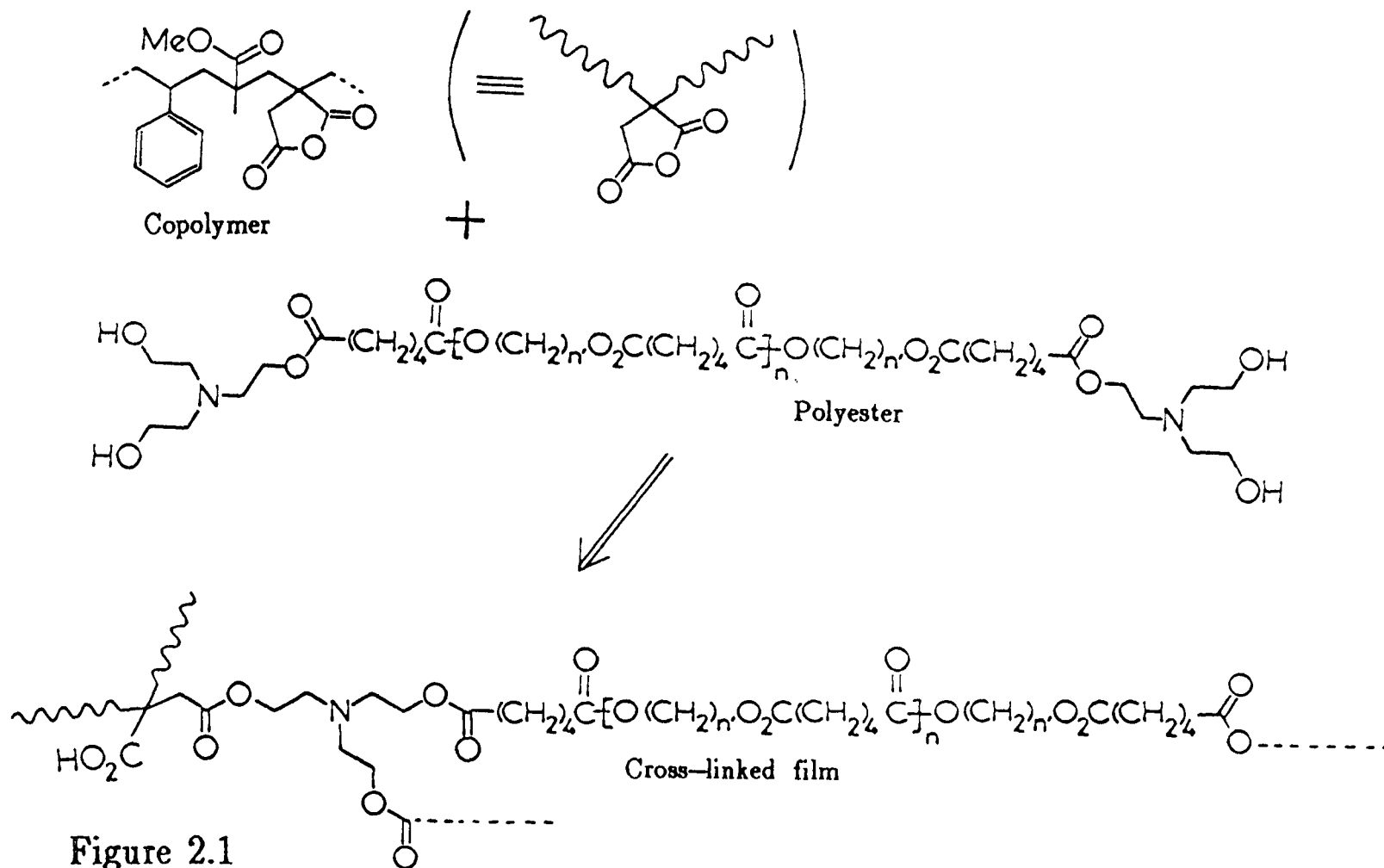

Figure 2.1

The cross-linking reaction between a random copolymer of itaconic anhydride, styrene and methyl methacrylate, and a polyester tipped with triethanolamine. The itaconic anhydride ring-opens during the reaction to form a half-ester cross-link.

polymerisation has three clearly defined reaction stages: i) initiation of the reaction ii) propagation and chain-growth by means of a chain reaction, and iii) termination of the growing chain.

#### 2.4.2.1 Initiation

The active centre which initiates and propagates the chain can be either a free radical, an ion or a radical ion. The free radical is perhaps the most commonly used type of initiator and is produced by decomposition of a suitable material either thermally or by irradiation. In general the active species is produced by homolytic fission of a  $\sigma$  bond to produce two free radicals.

#### 2.4.2.2 Propagation

Once initiation has taken place, growth of the polymer chain is effected by the repetitive addition of a monomer to the active centre with regeneration of that centre. Although the lifetime of an individual radical centre is short, the propagation steps occur many times in rapid succession to build a polymer chain comprising  $10^2$  to  $10^5$  monomer units before termination takes place.

#### 2.4.2.3 Termination

In free-radical-initiated polymerisations, chain termination occurs by reaction with other free radicals in the system, or abstraction of a moiety, usually H', from a molecule to produce a new radical. The

growing chain can be terminated by interaction with initiator fragments, but a more likely process is the bimolecular reaction between two active chains. This can occur either by combination or disproportionation.

An example of a chain addition polymerisation is the reaction between styrene, itaconic anhydride and methyl methacrylate to form an acrylic resin.

### 2.4.3 Non-linear polymerisations

When a difunctional monomer is polymerised, the product consists of linear polymer chains. Linear polymers remain soluble in suitable solvents, regardless of the extent of reaction. Non-linear condensation polymers, on the other hand, are not restricted to growth in only two directions.

When polymers have a functionality of three or more, the polymer molecules grow in three dimensions rather than one dimension as for difunctional monomers.<sup>7</sup> This results in branching and ultimately in the formation of polymer networks. Polymer networks are discussed more fully in the following section.

## 2.5 Polymer network formation

### 2.5.1 Cure and cure mechanism

In order to achieve the required mechanical and resistance properties required in most of their applications, low molecular weight

acrylic resins need to be converted by means of cross-linking reactions into a three dimensional infusible network held together by covalent bonds. In acid anhydride acrylic resin technology, this conversion from a liquid into a tough cross-linked polymer is called curing, and is achieved by the addition of a curing agent. Curing agents in general fall broadly into two types: catalytic and polyfunctional. We consider only polyfunctional curing agents here. Cross-linking between the resin molecules is achieved through the anhydride groups of the acrylic resin and the hydroxyl groups of the polyester curing agent, leading to the formation of a three-dimensional network composed of acrylic resin units cross-linked via the polyester curing agent. The cure reactions are exothermic and the rates of reaction are increased by increases in temperature.

The acid anhydride acrylic resin reacts with the polyester curing agent at room temperature. Thus the mixing of the resin and curing agent is a point of no return; cure begins and proceeds at a rate determined by reactivity, concentration and temperature. The mixture of resin has a finite pot life beyond which the viscosity of the system has so increased as to render the materials unusable. It will subsequently gel when viscosity becomes infinite and ultimately reach a satisfactory level of cure.

To obtain a three-dimensional meshed network on curing, the functionality of the resin and curing agent combination must accord with Kienle's principle that one component must have an average functionality greater than two and the other a functionality not less than two, their

sum therefore not being less than five. In practice, the functionality of groups can depend upon the particular set of reaction conditions being considered. Thus although the anhydride group is regarded as having a functionality of two, only one of these is involved when it reacts with the hydroxyl group of the polyester, the acid group not entering into any significant reaction under these conditions. This is illustrated in figure 2.2.

Also the total environment of the acid anhydride group has a great influence on the curing process. Steric factors can play an overriding part in determining the ease with which cross-linking can take place.

### 2.5.2 The gel point

Among the physical characteristics of non-linear condensation polymerisations, the occurrence of a gel point<sup>8</sup> is of foremost significance. Before the reaction starts, the polymer mixture consists of a fluid of low molecular weight molecules. As the reaction proceeds, larger and larger molecules are formed. Eventually a stage is reached where an infinitely large molecule extends throughout the volume of the sample. This is known as the gel point.<sup>4</sup> At the gel point, which occurs at a well-defined stage in the course of the polymerisation, the polymer transforms suddenly from a viscous liquid to an elastic gel. Prior to the gel point, all of the polymer is soluble in suitable solvents, however beyond the gel point, the polymer is not entirely soluble in solvents.

The gel point occurs at a particular extent of reaction, independent of temperature or solvent. Gelation also occurs before all of the monomer has reacted to form one infinite molecule. This indicates that there are

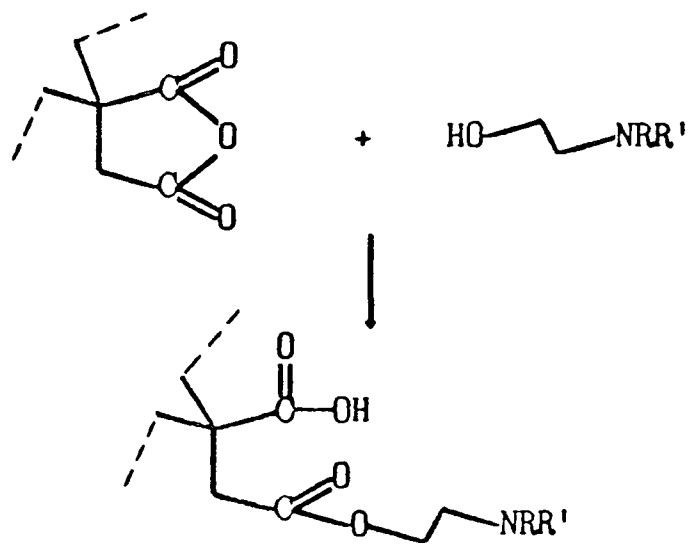

Figure 2.2

A diagram to show the cross-link formation between an acid anhydride resin and an hydroxy-amine tipped polyester resin.

other molecules of varying size distributed throughout the gel. These other molecules are known as the sol fraction, and may be extracted by solvent.

Carothers<sup>9</sup> work on step-growth condensation polymerisation reactions lead him to derive an expression to relate the extent of reaction of functional groups,  $P$ , to the degree of polymerisation of the polymer produced,  $\overline{DP}_n$ , and to the functionality of the monomer,  $f$ .

$$P = \frac{2}{f} - \frac{2}{\overline{DP}_n \cdot f} \quad (2.1)$$

It was assumed in the derivation of equation 2.1 that only intermolecular reaction takes place. As the network becomes infinitely large, the  $\overline{DP}_n$  approaches an infinite value, and thus  $\frac{2}{\overline{DP}_n \cdot f} \rightarrow 0$ .

By substituting this in equation 2.1, Carothers was able to predict a value of the extent of reaction at the gel point,  $P_c$ .

$$P_c = \frac{2}{f} \quad (2.2)$$

Carothers stated that this value of  $P$  was the maximum value for gelation to occur. Flory<sup>10</sup> later showed that the  $\overline{DP}_n$  is not infinite at the gel point, and some modifications were made to the theory of Carothers by both Flory<sup>10,11</sup> and Stockmayer.<sup>12</sup>

### 2.5.3 Cross-linking

The changes in polymer structure during cross-linking of long polymer chains are indicated schematically in figure 2.3. Regardless of the chemical method employed, the formation of cross-linkages consists of the joining together of pairs of structural units belonging to different molecules. Each pair of units participating in the formation of a cross-linkage will be selected at random; it is required merely that the partners be in suitable proximity at the instant of formation of the linkage. From a chemical point of view, cross-linkages are scattered throughout the bulk of the polymer at random points where pairs of polymer units were properly situated with respect to each other before gelation.

## 2.6 The molecular network

### 2.6.1 Importance of cross-linking

Both the curing rate and the degree of cross-linking influence the final properties of paint films.<sup>5</sup> The curing rate affects the rate of surface and through drying of the coating, while increasing the degree of cross-linking increases the modulus (stiffness and surface hardness) and the mechanical properties of the films. The glass-transition temperature of a film also increases as the degree of cross-linking is increased.

## 2.6.2 Elastic properties of networks

In order to obtain a more precise understanding of the properties of a network, consideration must be given to the way in which the molecules are arranged in relation to one another and to the forces by which they are held together. For a network to possess elastic properties there are three main criteria which must be satisfied:<sup>13</sup>

- i) The network must contain long-chain units which possess freely rotating links
- ii) The forces between the molecules as segments must be weak, as in a liquid
- iii) The molecules must be joined together or 'cross-linked' at certain points along their lengths.

The first of these criteria is self-explanatory and need not be discussed any further. The second is essential if the molecules are to have the freedom of motion and the ability to change their conformations necessary for the network to possess elastic properties. The materials of which networks are composed are of such a chemical nature that the forces between their molecules are of the same order of magnitude as the forces between the molecules of an ordinary liquid. In a liquid the inter-molecular forces are not too strong, and individual molecules possess sufficient kinetic energy to break away from neighbouring molecules and form other attachments. It is this repeated breaking away of individual molecules which gives the liquid its fluidity. For a material to possess elastic properties, it must have the same kind of loose structure which enables the molecules to rearrange themselves.

Although the forces between the molecules of a network are sufficiently weak for them to be able to move freely with respect to one another, like the molecules of a liquid, the network is in fact a solid rather than a liquid. It is the presence of cross-links at certain points along the length of the molecules which causes the network to be a solid. Owing to the great length of the chains, quite a small number of cross-linkages is sufficient to ensure that each molecule is connected to at least two other molecules so that the whole assembly of chains becomes one single structure as shown in figure 2.3.

These cross-linkages do not interfere appreciably with the local freedom of motion of the molecules with respect to neighbouring chains, but they do eliminate the possibility of bulk slippage of one molecule past another, which is the necessary condition for flow to take place. Network polymers exhibit no viscoelastic flow even up to the point of decomposition. The combination of the second and third criteria thus enables the two opposing requirements to be satisfied; the requirement of freedom of local molecular motion and the requirement of suppression of flow, and hence to combine in a single material certain of the properties of both the liquid and solid states.

## 2.7 Why study networks by NMR ?

Network polymers have many unique characteristics. Depending on the degree of cross-linking, they tend to be virtually insoluble in all solvents. For this reason solid-state NMR is an excellent tool for the study of cross-linked networks. Cross-linking reactions start from the

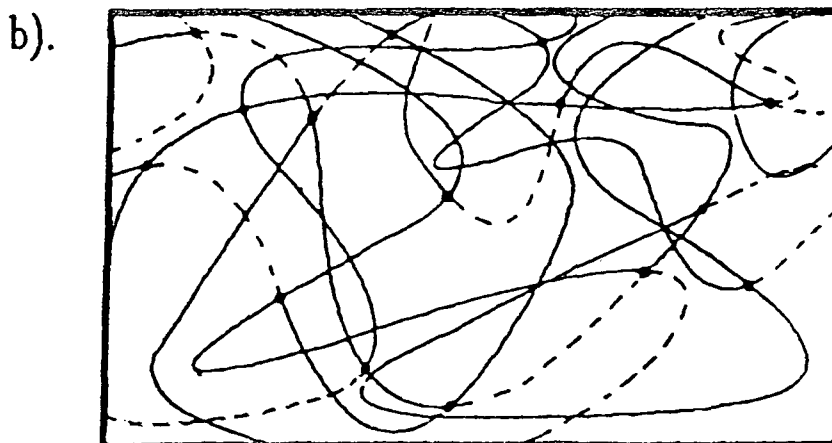
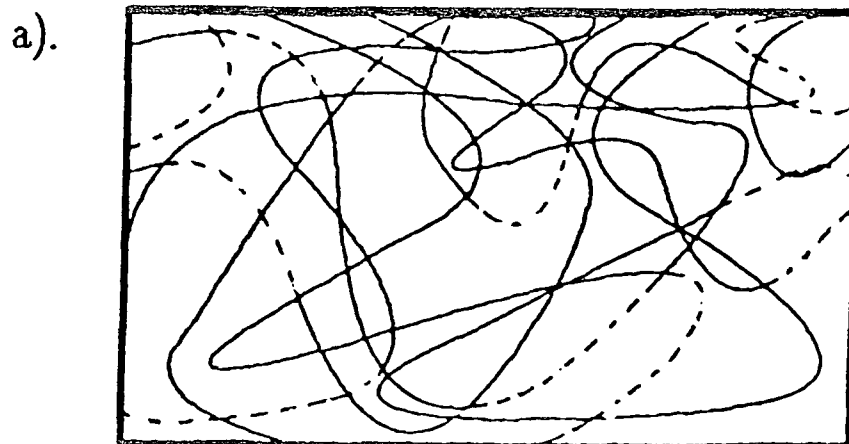

● = cross-link

### Figure 2.3

a). An entangled network of copolymer and polyester chains immediately after mixing.

b). The same network at a later time in the cure. The cross-links form where two suitable reactive centres find themselves placed near enough to each other in space.

solution state and proceed through to the solid state. Since nuclear magnetic resonance can be applied to both the solution and solid states, it is an ideal technique for the study of such reactions.

# CHAPTER 3

## Theory

### 3.1 General theory

Isotopes with an odd atomic number or an odd atomic mass possess spin angular momentum. The nuclear magnetic moment ( $\mu$ )<sup>1</sup> which arises from the motion of a charged particle, is colinear with the axis of spin and is usually described in terms of the gyromagnetic ratio,<sup>2</sup>  $\gamma$ , where  $I$  is the nuclear spin quantum number.

$$\mu = \gamma \hbar [I(I+1)]^{\frac{1}{2}} \quad (3.1)$$

Throughout this thesis, only nuclei with spin  $I = \frac{1}{2}$  are discussed. Therefore, the theory in this chapter will concentrate only on the spin  $I = \frac{1}{2}$  case.

### 3.2 The classical case<sup>3</sup>

Consider the case when a nucleus of spin  $I = \frac{1}{2}$  is placed in a static magnetic field ( $B_0$ ). A torque is exerted upon the magnetic moment by the magnetic field which causes it to precess about  $B_0$  with a precession frequency ( $\omega$ ).

$$\omega = -\gamma B_0 \quad (3.2)$$

The motion of the magnetic moment is expressed by equation 3.3.

$$\frac{d\bar{\mu}}{dt} = \gamma\bar{\mu} \times \bar{B}_0 \quad (3.3)$$

Defining the static magnetic field  $B_0$  to be along the  $z$  axis in the laboratory frame of reference, the magnetic moment,  $\mu$ , may be resolved into three components,  $\mu_x$ ,  $\mu_y$  and  $\mu_z$ .

In a static field,  $B_0$ , the component of the magnetic moment in the direction of the field is constant. However the two components perpendicular to the magnetic field,  $\mu_x$  and  $\mu_y$ , oscillate so that the magnitude of the transverse component remains constant.

i.e. 
$$\mu_x^2(t) + \mu_y^2(t) = \mu_x^2(0) + \mu_y^2(0) \quad (3.4)$$

The net result corresponds to a rotation of the direction of  $\mu$  in a cone with the axis along  $B_0$ . Such a motion is known as Larmor precession. The angular velocity of the precession is given by  $\omega_1 = -\gamma B_0$ , and thus the Larmor frequency,  $\omega_0$  is

$$\omega_0 = -\gamma B_0 \quad (3.5)$$

So far only the motion of individual nuclear magnetic moments has been considered. A typical macroscopic sample will contain an ensemble of many such magnetic moments, which will be distributed at random around the precessional cone.

The total magnetic moment or magnetisation  $M$  of the sample is the resultant of the individual magnetic moments  $\mu$

$$M = \sum_i \mu_i \quad (3.6)$$

The effects of the individual magnetic fields upon each other are negligible compared to  $B_0$ . Therefore, as the individual magnetic moments are identical, the equation of motion for the net magnetic moment is

$$\frac{dM}{dt} = \sum_i \frac{d\mu_i}{dt} = \sum_i +\gamma_i \bar{\mu}_i \times \bar{B}_0 = \gamma \bar{M} \times \bar{B}_0 \quad (3.7)$$

Equation 3.7 holds provided that all the magnetic moments started at time zero with identical positions. However, in any one sample, there will be a random distribution of initial orientations, and therefore a random orientation of the  $x$  and  $y$  components of the individual magnetic moments. The net result is that the sum of the  $x$  and  $y$  components of the magnetic moments average to zero. Thus the only observable magnetic moment is the  $z$  component, which lies along the direction of the field  $B_0$ .

### 3.3 Population of the spin states

For a spin  $I = \frac{1}{2}$  nucleus with a positive gyromagnetic ratio, the two possible orientations of the nuclear spin define a high ( $\beta$ ) and a low ( $\alpha$ ) energy state.

When the system is at thermal equilibrium, the spins will be distributed among the two energy levels according to the Boltzmann law. Thus, for spin  $I = \frac{1}{2}$  nuclei, the ratio of nuclei in the upper energy level ( $n_\beta$ ) to the number in the lower level ( $n_\alpha$ ) as a function of absolute temperature is given by

$$\frac{n_\beta}{n_\alpha} = \exp\left[\frac{-\gamma h B_0}{kT}\right] \quad (3.8)$$

where  $k$  is the Boltzmann constant, and  $\frac{\Delta E}{kT} \ll 1$

At ordinary temperatures the populations of the spin states are almost equal, with  $n_\alpha$  slightly more populated than  $n_\beta$ . Therefore net absorption can occur at the resonance condition which will produce a corresponding signal.

### 3.4 Relaxation

The excitation and detection of a signal will affect the equilibrium Boltzmann populations of the spin states. Just as excitation transfers population from the lower to the higher energy level, so there is an opposing phenomenon which tries to re-establish thermal equilibrium by transferring population from the higher energy level to the lower. This phenomenon is known as relaxation.

Two types of relaxation describe the re-establishment of thermal equilibrium

- a). Spin-lattice or longitudinal relaxation is characterised by a time constant  $T_1$ . This governs the return to equilibrium along the  $z$  axis after some perturbation.
- b). Spin-spin or transverse relaxation is characterised by a time constant  $T_2$ . Spin-spin relaxation is the relaxation of the  $M_x$  and  $M_y$  components of the magnetisation in the  $xy$  plane.

### 3.5 The Bloch equations

One of the most convenient treatments of the magnetic resonance phenomenon is that described by Bloch. His classical approach was to use a vector model and treat the assembly of nuclear spins in macroscopic terms.

The magnetisation  $M$  may be resolved into three components along the  $x$ ,  $y$  and  $z$  axes. Bloch derived the combined relaxation/equation of motion with first order kinetics<sup>4</sup> so that

$$\frac{dM}{dt} = \gamma M \times B_0 - \frac{M_x}{T_2} - \frac{M_y}{T_2} - \frac{(M_z - M_{eq})}{T_1} \quad (3.9)$$

The  $z$  component of the Bloch equation was modified by Solomon<sup>5</sup> for the case of coupled C-H spins.

$$\frac{d\langle I_z \rangle}{dt} = -\frac{1}{T_1^{II}} [\langle I_z \rangle - I_0] - \frac{1}{T_1^{IS}} [\langle S_z \rangle - S_0] \quad (3.10a)$$

$$\frac{d\langle S_z \rangle}{dt} = -\frac{1}{T_1^{SS}} [\langle S_z \rangle - S_0] - \frac{1}{T_1^{IS}} [\langle I_z \rangle - I_0] \quad (3.10b)$$

These modified Bloch equations are known as the Solomon equations.

Although it is not possible to give an analytical solution to this set of differential equations, they may be solved under various limiting conditions. This is demonstrated in chapter 7.

### 3.6 The rotating frame of reference

Up until now all our descriptions of the NMR experiment have used a set of cartesian coordinates which are fixed with respect to the laboratory. Within this frame we have seen that the nuclei precess about the  $B_0$  field at the Larmor frequency. Now let us consider a new set of cartesian axes ( $x'$ ,  $y'$  and  $z'$ ) which rotate about the static magnetic field,  $B_0$  at  $\omega = 2\pi\nu$ .<sup>6</sup>

$$x' = x\cos 2\pi\nu t + y\sin 2\pi\nu t \quad (3.11a)$$

$$y' = -x\sin 2\pi\nu t + y\cos 2\pi\nu t \quad (3.11b)$$

$$z' = z \quad (3.11c)$$

The mathematics of the system becomes substantially simpler when the axes are transformed from the laboratory frame into the rotating frame of reference.

In the rotating frame of reference the nuclei precess about the effective field,  $B_{\text{eff}}$  (illustrated in figure 3.1)

where

$$B_{\text{eff}} = \left[ \left[ B_0 - \frac{\omega}{\gamma} \right]^2 + B_1^2 \right]^{\frac{1}{2}} \quad (3.12)$$

The resonance condition occurs when  $\omega = \omega_0$ .

In equation 3.12, when  $\omega = \omega_0$  then

$$B_0 - \frac{\omega}{\gamma} = 0 \quad (3.13)$$

$$\text{and } B_{\text{eff}} = B_1$$

The effective field,  $B_{\text{eff}}$  now lies in the  $x'$  direction along  $B_1$ . The magnetisation,  $M$ , precesses about  $B_1$  in a circle in the  $y'z$  plane at a rate  $-\gamma B_1$ .

Let us now consider the effect of an RF pulse applied at a frequency  $\omega_0$  and in the direction of the  $x$  axis in the rotating frame. When the field is first turned on the magnetisation precesses from the  $z$  axis through an angle  $\theta$  in the  $y'z$  plane.

$$\theta = \gamma B_1 t \quad (3.14)$$

where  $t$  is the length of time the RF pulse is turned on (see figure 3.2). It is this property of rotating the magnetisation that is utilised in pulsed NMR experiments.

There are two angles of particular interest which are worth our consideration.

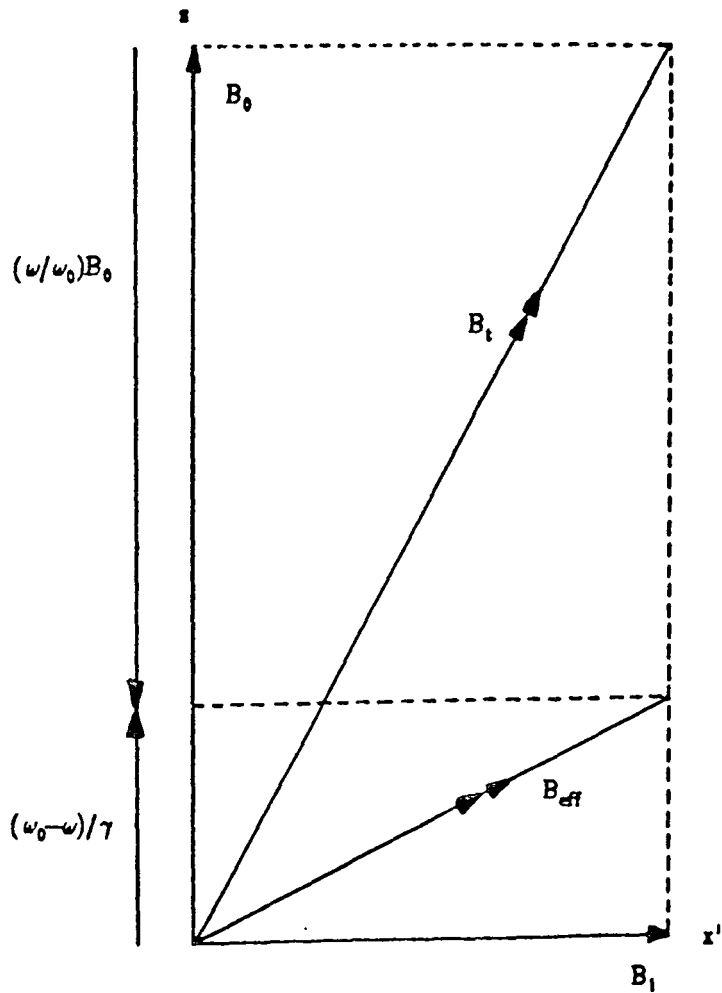

Figure 3.1

The magnetic fields in the rotating frame of reference. The magnitude of the rotating field ( $B_1$ ) is exaggerated with respect to  $B_0$ , the static field.

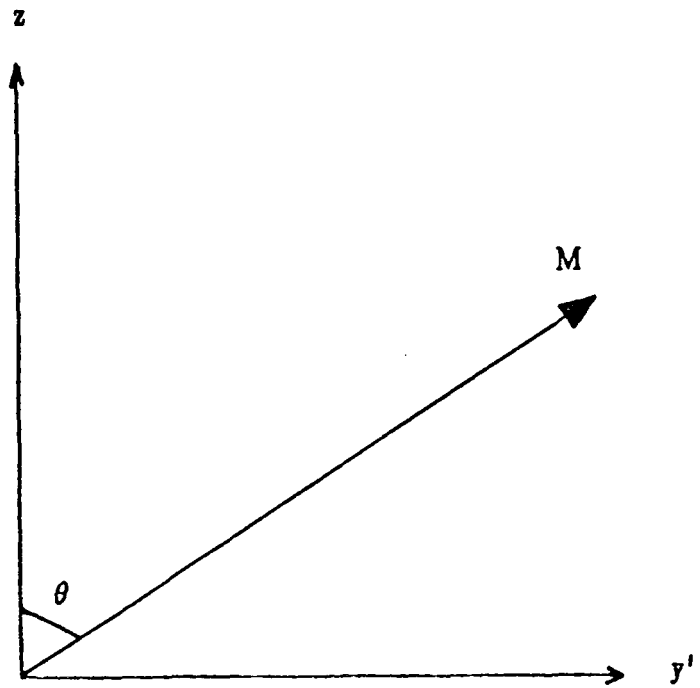

Figure 3.2

Precession of the magnetisation  $M$  occurs in the  $y'z$  plane after the  $B_1$  field is turned on.  $\theta$ , the angle through which precession occurs, is equal to  $\gamma B_1 t$ , where  $t$  is the length of time for which the  $B_1$  field is turned on.

### 3.6.1 Case 1

When  $\theta = \pi$  the magnetisation is flipped into the  $-z$  direction. A  $180^\circ$  or  $\pi$  pulse may be seen schematically as the inversion of the  $\alpha$  and the  $\beta$  states, thus inverting the magnetisation. Following the pulse, the Boltzmann equilibrium situation is restored by relaxation. A  $180^\circ$  (or  $\pi$ ) pulse is succeeded by purely spin-lattice relaxation as in equation 3.15.

$$M_z(t) - M_0 = [M_z(0) - M_0] \exp(-t/T_1) \quad (3.15)$$

### 3.6.2 Case 2

When  $\theta = \frac{\pi}{2}$  the magnetisation is flipped into the  $x'y'$  plane along the  $y'$  direction. The  $90^\circ$  pulse causes phase coherence of the spins. Following a  $90^\circ$  (or  $\frac{\pi}{2}$ ) pulse, two types of relaxation occur; spin-lattice relaxation and transverse relaxation. Spin-lattice relaxation is given by equation 3.15, whereas transverse relaxation, which governs the rate at which the spins dephase in the rotating frame of reference is given by

$$M_y(t) = M_y(0) \exp(-t/T_2) \quad (3.16)$$

### 3.6.3 Relaxation in the rotating frame of reference

As has been discussed in section 3.6.2, a  $90^\circ$  pulse is followed by transverse relaxation. However if the radiofrequency field is not switched off following the pulse, but is phase-adjusted by  $90^\circ$ , as shown in figure

3.3, a different situation is obtained. In this case the magnetisation is aligned with the RF field, which is the only effective field in the rotating frame of reference when on resonance. The magnetisation does not precess in the rotating frame, and is said to be spin-locked. But the magnetisation is much greater than can be maintained by  $B_1$ , since it was developed in  $B_0$ , which is several orders of magnitude larger than  $B_1$ . Consequently the  $M_y$  magnetisation will decay with time to its equilibrium value  $(B_1/B_0)M_0$  at a rate governed by the exponential time constant  $T_{1\rho}$ .

$$M_y(\tau) = M_0 \exp(-\tau/T_{1\rho}) \quad (3.17)$$

### 3.7 Spin diffusion

Spin diffusion is not an actual molecular diffusion, but is the transport of spin energy within the system by mutual, energy-conserving spin flips. Consider two adjacent protons in a solid coupled by the dipolar interaction. If the two protons have antiparallel magnetic moments, it is an entropy-favourable process for both of them to change orientations simultaneously or 'flip', again yielding an antiparallel pair, but with moments reversed. Such flips can occur rapidly among neighbouring coupled protons in a solid, and serve to distribute excess energy or magnetisation among all the coupled spins. The process, like any diffusion process, is driven by a concentration gradient, in this case the spatial gradient in the magnetisation. It is spin diffusion that ensures that the  $^1\text{H}$  linewidth is homogeneous. However, spin diffusion between dilute spins

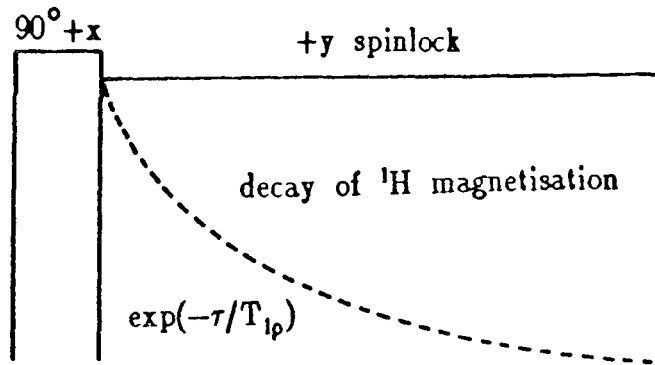

Figure 3.3

The decay of  $M_y$ , the magnetisation in the  $y$  direction, to its equilibrium value occurs at a rate characterised by the exponential time constant  $T_{1\rho}$ .

such as  $^{13}\text{C}$  is slow. This means that whereas a single value of  $T_1$  will be obtained for all protons in a solid sample unless there is substantial heterogeneity (domain sizes  $>$  hundreds of Angstroms),  $^{13}\text{C}$  nuclei in a homogeneous sample will have separate values of  $T_1$ . Such differences between  $^1\text{H}$  and  $^{13}\text{C}$  also correlate with the lack of resolution in proton spectra.

### 3.8 The quantum mechanical approach<sup>3,7</sup>

In order to fully understand the behaviour of spins in pulsed NMR experiments, it is necessary to consider the quantum mechanical approach.

Spin interactions can be described quantum mechanically in terms of the appropriate Hamiltonians. The total Hamiltonian,  $\mathcal{H}$ , which completely describes the spin interactions of a system is given by

$$\mathcal{H} = \mathcal{H}_{\text{int}} + \mathcal{H}_{\text{ext}} \quad (3.18)$$

$$\mathcal{H}_{\text{ext}} = \mathcal{H}_z + \mathcal{H}_{\text{RF}} \quad (3.18a)$$

$$\mathcal{H}_{\text{int}} = \mathcal{H}_{\text{H}} + \mathcal{H}_{\text{SS}} + \mathcal{H}_{\text{IS}} + \mathcal{H}_{\text{S}} + \mathcal{H}_{\text{J}} + \mathcal{H}_{\text{SR}} + \mathcal{H}_{\text{Q}} \quad (3.18b)$$

$\mathcal{H}_{\text{ext}}$  is the external hamiltonian. The name arises from the fact that the terms in  $\mathcal{H}_{\text{ext}}$  depend on external parameters which are controlled by the experiment.

$\mathcal{H}_{\text{int}}$  is the internal hamiltonian.  $\mathcal{H}_{\text{int}}$  comprises of terms which depend upon the sample, and therefore it is these terms in the Hamiltonian which provide information of chemical interest.

### 3.8.1 The external Hamiltonian $\mathcal{H}_{\text{ext}}$

The external Hamiltonian,  $\mathcal{H}_{\text{ext}}$ , consists of the sum of the zeeman and radiofrequency terms.

#### 3.8.1.1 Zeeman Hamiltonian $\mathcal{H}_z$

The zeeman term describes the interaction between the nuclear spins and the magnetic field,  $B_0$ .

For a single nuclear spin,

$$\mathcal{H}_z = \hbar \gamma B_0 \hat{I}_{z1} \quad (3.19)$$

$$= -\hbar \nu_0 \hat{I}_{z1} \quad (3.19a)$$

For an ensemble of nuclear spins, equation 3.19a may be modified to

$$\mathcal{H}_z = -\hbar \sum_i \nu_0^i I_{z1i} \quad (3.20)$$

where  $I_{z1i}$  is the  $i^{\text{th}}$  nuclear spin with Larmor frequency  $\nu_0^i$ .

#### 3.8.1.2 Radiofrequency Hamiltonian $\mathcal{H}_{\text{RF}}$

The radiofrequency term,  $\mathcal{H}_{\text{RF}}$ , of the external Hamiltonian describes the interaction between the spins and the perturbing radiofrequency field.

The perturbing radiofrequency field (RF) is applied perpendicular to the static magnetic field  $B_0$ , and is aligned parallel to the  $x$  axis by convention.

$$\mathcal{H}_{RF} = \hbar\gamma I_x B_1 \cos(\omega t + \phi) \quad (3.21)$$

where  $\omega$  and  $\phi$  are the frequency and phase respectively of the perturbing field.

### 3.8.2 The internal Hamiltonian

$$\mathcal{H}_{int} = \mathcal{H}_D + \mathcal{H}_S + \mathcal{H}_{SR} + \mathcal{H}_Q + \mathcal{H}_J \quad (3.22)$$

The internal Hamiltonian consists of the sum of the dipolar ( $\mathcal{H}_D$ ), J-coupling ( $\mathcal{H}_J$ ), spin-rotation ( $\mathcal{H}_{SR}$ ), shielding ( $\mathcal{H}_S$ ) and quadrupolar ( $\mathcal{H}_Q$ ) Hamiltonian terms. The spin-rotation and the quadrupolar Hamiltonian terms are not relevant to the work presented in this thesis, and for this reason are omitted.

#### 3.8.2.1 The principal axis system

The above spin interactions may be written in compact form using second-rank tensors. Any Hamiltonian involving spin interactions may be expressed in the form

$$\mathcal{H}_\lambda = K^\lambda I^\lambda R^\lambda Y^\lambda \quad (3.23)$$

$R^\lambda$  is a second-rank cartesian tensor (3x3 matrix),  $I^\lambda$  and  $Y^\lambda$  are vectors, and  $K^\lambda$  is a typical constant for each interaction mechanism.

All the tensors are molecular properties, and for this reason are

best described in a molecule-fixed axis system. The cartesian tensor consists of 9 components. A sensible choice of molecule-fixed axes (say XYZ) puts a tensor into a diagonal form.

$$\begin{bmatrix} R_{xx} & R_{xy} & R_{xz} \\ R_{yx} & R_{yy} & R_{yz} \\ R_{zx} & R_{zy} & R_{zz} \end{bmatrix} \longrightarrow \begin{bmatrix} R_{xx} & 0 & 0 \\ 0 & R_{yy} & 0 \\ 0 & 0 & R_{zz} \end{bmatrix} \quad (2.24)$$

This choice of axes is called the principal axis system (PAS), and the diagonal elements  $R_{xx}$ ,  $R_{yy}$  and  $R_{zz}$  are known as the principal components of the tensor  $R$ .

The principal axes are usually defined so that:

$$|R_{zz} - \frac{1}{3}\text{Tr}R| \geq |R_{xx} - \frac{1}{3}\text{Tr}R| \geq |R_{yy} - \frac{1}{3}\text{Tr}R| \quad (3.25)$$

where 
$$\text{Tr}R = R_{xx} + R_{yy} + R_{zz} \quad (3.25a)$$

Each tensor  $R$  may be divided into the sum of the isotropic,  $R_{\text{iso}}$ , antisymmetric  $R_{\text{asym}}$  and symmetric,  $R_{\text{sym}}$  parts.

These are given by

$$\begin{aligned} R_{\text{iso}} &= \frac{1}{3}\text{Tr}R \\ &= \frac{1}{3}(R_{xx} + R_{yy} + R_{zz}) \end{aligned} \quad (3.26a)$$

$$\text{anisotropy } \Delta R = R_{zz} - \frac{1}{2}(R_{xx} + R_{yy}) \quad (3.26b)$$

$$\text{asymmetry } \eta = \frac{(R_{yy} - R_{xx})}{R_{zz} - R_{\text{iso}}} \quad (3.26c)$$

where  $0 \leq \eta \leq 1$

If the tensor is axially symmetric (i.e.  $R_{zz} = R_{\parallel}$  and  $R_{xx} = R_{yy} = R_{\perp}$ )

Table 3.1

Values of  $K^\lambda$ ,  $R^\lambda$  and  $Y^\lambda$  for the interactions.

$h^\lambda$	$K^\lambda$	$R^\lambda$	$Y^\lambda$	units	Interaction
$h^\lambda_S$	1	$\sigma$	$B_0$	None	Shielding Tensor
$h^\lambda_J$	$2\pi$	J	S	Hz	Indirect Coupling Tensor
$h^\lambda_D$	$\frac{\mu_0 \gamma_i \gamma_j \hbar}{4\pi r_{ij}^3}$	D	S	None	Dipolar Tensor
$h^\lambda_{SR}$	$2\pi$	C	J	None	Spin Rotation Tensor

then  $\eta = 0$ .

$$R \text{ (PAS)} = \begin{bmatrix} R_{xx} & R_{xy} & R_{xz} \\ R_{yx} & R_{yy} & R_{yz} \\ R_{zx} & R_{zy} & R_{zz} \end{bmatrix} = R_{\text{iso}} + \delta \begin{bmatrix} -\frac{1}{2}(1+\eta) & 0 & 0 \\ 0 & -\frac{1}{2}(1-\eta) & 0 \\ 0 & 0 & 1 \end{bmatrix} \quad (3.27)$$

The values of  $K^\lambda$ ,  $R^\lambda$  and  $Y^\lambda$  for the various interactions are listed in table 3.1.

### 3.8.2.2 The shielding Hamiltonian $\mathcal{H}_S$

The shielding Hamiltonian describes the coupling between a spin  $I$  and the static magnetic field  $B_0$

$$\mathcal{H}_S = \hbar \sum_i \gamma^i \hat{I}^i \cdot \sigma^i B_0 \quad (3.28)$$

where  $\sigma$  is the shielding tensor in the principle axis system.

$$\sigma = \begin{bmatrix} \sigma_{xx} & 0 & 0 \\ 0 & \sigma_{yy} & 0 \\ 0 & 0 & \sigma_{zz} \end{bmatrix} \quad (3.29)$$

$\mathcal{H}_S$  may be expanded as

$$\mathcal{H}_S = \hbar \gamma I_z \left[ \sigma_{\text{iso}} + \bar{\sigma} \begin{bmatrix} -\frac{1}{2}(1+\eta) & 0 & 0 \\ 0 & -\frac{1}{2}(1-\eta) & 0 \\ 0 & 0 & 1 \end{bmatrix} \right] B_0 \quad (3.30)$$

where  $\sigma_{\text{iso}} = \frac{1}{3} \text{Tr} \sigma$

### 3.8.2.3 The indirect spin-spin coupling interaction $\mathcal{H}_J$

The indirect spin-spin coupling Hamiltonian  $\mathcal{H}_J$  describes the coupling between two nuclei (i,k) via their associated electron spins.

$$\mathcal{H}_J = h \sum_{i < k} \hat{\mathbf{I}}_i \cdot \mathbf{J}_{ik} \cdot \hat{\mathbf{I}}_k \quad (3.31)$$

The magnitude of the indirect spin-spin coupling is small compared to the dipolar coupling and therefore is not discussed further in this thesis.

### 3.8.2.4 The dipole-dipole interaction $\mathcal{H}_D$

Classically, the energy of interaction between two magnetic point dipoles,  $\mu_I$  and  $\mu_S$ , is given by

$$U = \left[ \frac{\mu_I \cdot \mu_S}{r_{IS}^3} - \frac{3(\mu_I \cdot \mathbf{r}')(\mu_S \cdot \mathbf{r}')}{r_{IS}^5} \right] \frac{\mu_0}{4\pi} \quad (3.32)$$

where  $r_{IS}$  is the internuclear distance, and  $\mathbf{r}'$  is the internuclear vector common to the dipoles.

The appropriate quantum mechanical expression equation 3.33 is obtained by substituting the expression for the magnetic moment  $\mu = \gamma \mathbf{I}$  into equation 3.32.

$$\mathcal{H}_D = \hbar \gamma_I \gamma_S \left[ \frac{\hat{\mathbf{I}}_I \cdot \hat{\mathbf{I}}_S}{r_{IS}^3} - \frac{3(\hat{\mathbf{I}}_I \cdot \mathbf{r}')(\hat{\mathbf{I}}_S \cdot \mathbf{r}')}{r_{IS}^5} \right] \frac{\mu_0}{4\pi} \quad (3.33)$$

The dipolar Hamiltonian may be written in tensor form

$$\mathcal{H}_D = K^\lambda \underline{I}_I \underline{D} \underline{I}_S \quad (3.34)$$

where  $\underline{D}$  is the dipole tensor.

The tensor  $\underline{D}$  is not diagonal if the orientation of the internuclear vector,  $\underline{r}'$ , is given relative to the  $x$ ,  $y$ ,  $z$  axes of the laboratory frame of reference.

However if the principal axis system is used, where  $r$  is parallel to the  $z$  axis, then the tensor  $\underline{D}$  is diagonalised.

i.e

$$\mathcal{H}_D = \left[ \frac{\mu_0}{4\pi} \right] \frac{\gamma_I \gamma_S \hbar^2}{r_{IS}^3} \begin{bmatrix} I_{Ix} & I_{Iy} & I_{Iz} \end{bmatrix} \begin{bmatrix} 1 & 0 & 0 \\ 0 & 1 & 0 \\ 0 & 0 & -2 \end{bmatrix} \begin{bmatrix} I_{Sx} \\ I_{Sy} \\ I_{Sz} \end{bmatrix} \quad (3.35)$$

It is possible to describe the dipolar interaction in terms of polar coordinates, which define the orientation of the principal axis system to the laboratory frame of reference. The common factor  $\frac{\hbar}{2\pi} \left[ \frac{\mu_0}{4\pi} \right] r_{IS}^{-3} \gamma_I \gamma_S$  (in frequency units) is known as the dipolar coupling constant. Polar angles  $\theta$  and  $\phi$  may be used to describe the position of the internuclear vector  $\underline{r}'$  in the laboratory frame of reference.

The dipolar Hamiltonian may be expanded into the dipolar alphabet, and may be expressed as

$$H_D = \frac{\mu_0}{4\pi} \frac{\gamma_I \gamma_S \hbar}{r_{IS}^3} \left[ A + B + C + D + E + F \right] \quad (3.36)$$

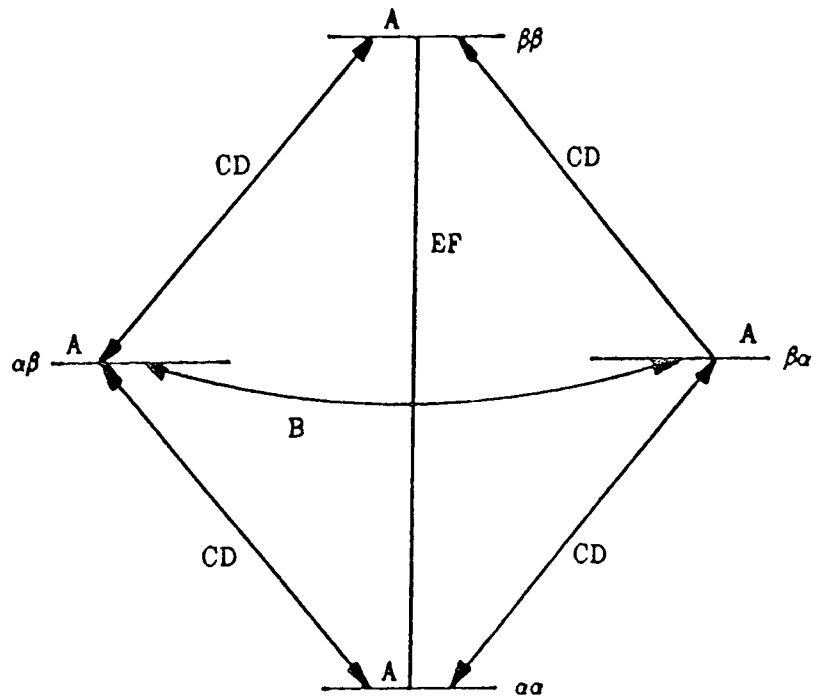

Figure 3.4

States joined by the terms A to F in the alphabet expansion.

where

$$A = (1-3\cos^2\theta)I_{Iz}I_{Sz} \quad (3.36a)$$

$$B = -\frac{1}{4}(1-3\cos^2\theta) [I_{I+} \cdot I_{S-} + I_{I-} \cdot I_{S+}] \quad (3.36b)$$

$$C = -\frac{3}{2}\sin\theta\cos\theta\exp(-i\phi) [I_{Iz} \cdot I_{S+} + I_{I+} \cdot I_{Sz}] \quad (3.36c)$$

$$D = -\frac{3}{2}\sin\theta\cos\theta\exp(+i\phi) [I_{Iz} \cdot I_{S-} + I_{I-} \cdot I_{Sz}] \quad (3.36d)$$

$$E = -\frac{3}{4}\sin^2\theta\exp(-2i\phi) [I_{I+} \cdot I_{S+}] \quad (3.36e)$$

$$F = -\frac{3}{4}\sin^2\theta\exp(2i\phi) [I_{I-} \cdot I_{S-}] \quad (3.36f)$$

Each of the terms A to F contains a spin factor and a geometrical factor<sup>8</sup>. The effects of these spin and geometrical factors may be appreciated separately. Term B simultaneously flips one spin down and one spin up, that is to say term B links the  $\alpha\beta$  and  $\beta\alpha$  states only. The terms C and D each flip one spin only, and the terms E and F flip both spins up or both spins down. The states joined by the terms A to F are shown in figure 3.4.

### 3.9 Relaxation

In order for relaxation to take place, it is necessary that local fields fluctuating at the appropriate frequency are present in order to bring about transitions between the various energy levels. These fluctuating local fields originate from the various interactions already mentioned in section 3.8 and from molecular motion.<sup>6</sup>

#### 3.9.1 The effect of molecular motion on relaxation

One of the most important properties of NMR is its sensitivity to

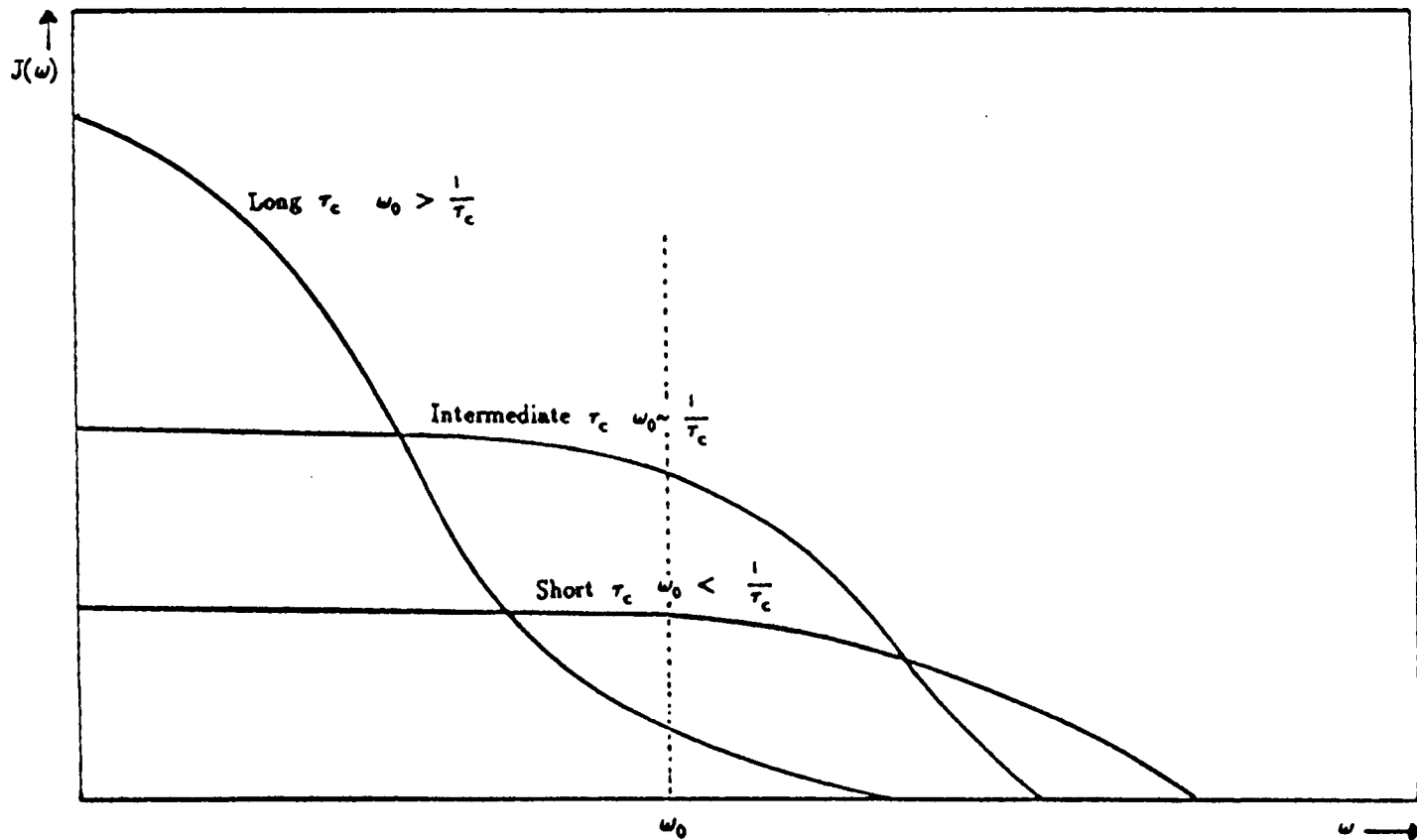

**Figure 3.5**

A plot which illustrates the change in the spectral density as a function of frequency for fast, intermediate and slow molecular motion.

the types of molecular motion. The power available from the fluctuations in the local fields at the relevant transition frequency,  $\omega$ , may be expressed in terms of the spectral density  $J(\omega)$ . If  $J(\omega)$  is known, then it is possible to work out the magnitude of the fluctuating fields at the Larmor frequency, which is what is required to study relaxation processes.<sup>2</sup>

A useful property in describing random molecular motion is that of a correlation time,  $\tau_c$ . Roughly  $\tau_c$  is the average time for a molecule to rotate by one radian. Figure 3.5 shows a plot of spectral density as a function of frequency.

It is informative to look at the shape of the plot. There is a flat portion, and then a sudden drop at  $\omega\tau_c \sim 1$ . The flat portion occurs when  $\omega^2\tau_c^2 \ll 1$ . This is known as the extreme narrowing condition. If  $\tau_c$  is short, then the molecular motion is distributed over a wide range, and all motional frequencies within that range have an equally probable chance of occurring. If  $\tau_c$  is long, then low motional frequencies have a higher chance of happening while high frequency has an almost zero probability.

The expression for  $J(\omega)$  is

$$J(\omega) = \frac{2\tau_c}{(1+\omega^2\tau_c^2)} \quad (3.37)$$

The expression predicts a maximum in  $T_1^{-1}$  (a minimum in  $T_1$ ) as a function of  $\tau_c$ . This is shown in figure 3.6. Figure 3.6 shows the dependence of  $T_1$ ,  $T_2$  and  $T_{1\rho}$  on the correlation time  $\tau_c$ .<sup>9</sup> The  $T_1$  minimum occurs when the sudden drop in  $J(\omega)$  as a function of  $\log(\omega)$

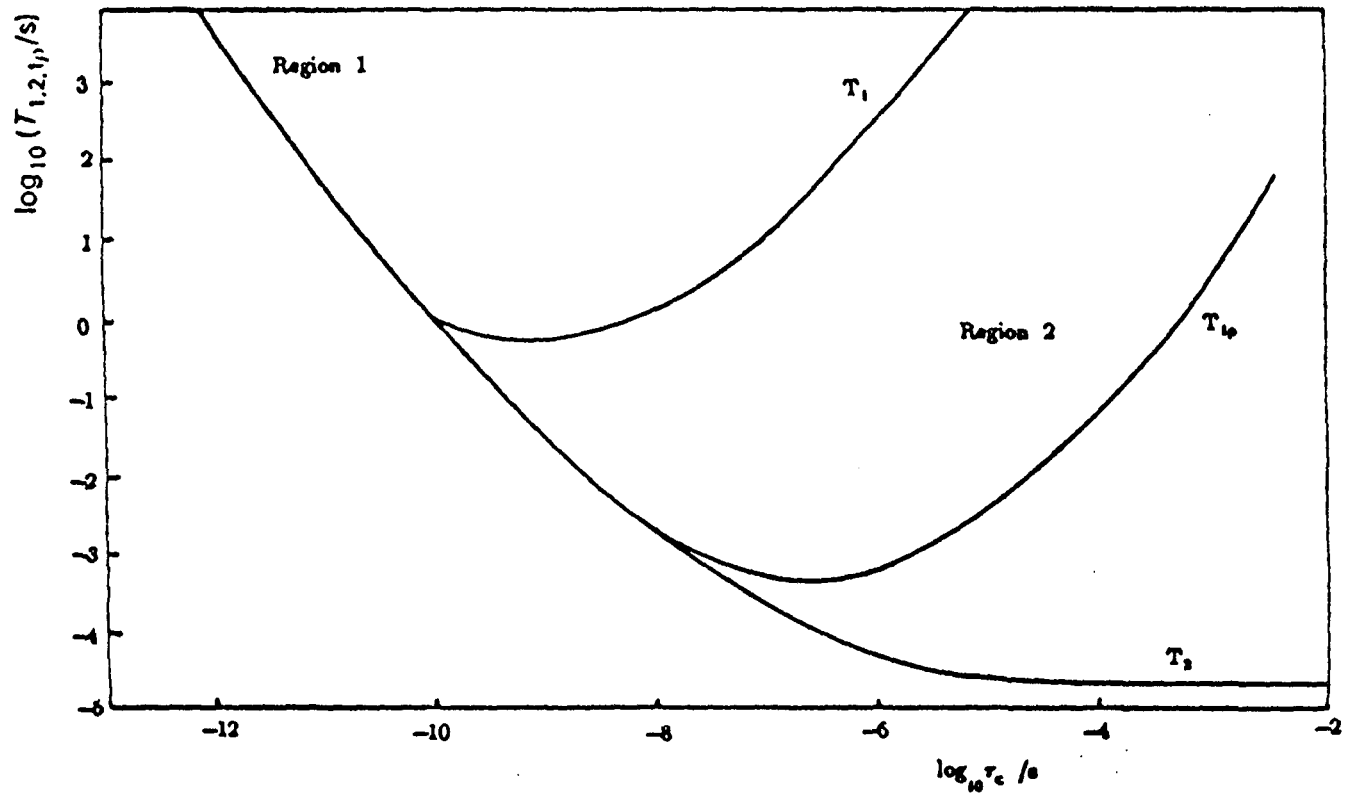

Figure 3.6

The effect of correlation time on  $T_1$ ,  $T_{1p}$  and  $T_2$  for an isolated CH vector rotating isotropically in a field of 63kG. The bond length,  $r_{CH}$  is 1.09 Å.

corresponds to the resonance frequency, i.e. when  $\tau_c = \omega_0^{-1}$ .

For very short values of the correlation time, the molecule undergoes rapid isotropic molecular motion which causes averaging of the anisotropic interactions to such an extent that  $T_1 = T_{1\rho} = T_2$ . This is the extreme narrowing limit. As  $\tau_c$  decreases the anisotropic interactions are averaged to an even greater extent. This leads to an increase in  $T_1$ ,  $T_{1\rho}$  and  $T_2$  (region 1 in fig 3.6).

As the correlation time is increased, the  $T_1$  passes through a minimum value as already described. As  $\tau_c$  is increased even further, the degree to which the isotropic interactions are averaged decreases. This causes the amplitudes of the local fields produced by the anisotropic interactions to increase, but the fields fluctuate at a slower rate. The overall result is that there are fewer local fields which fluctuate at an appropriate frequency to introduce transitions between the  $\beta$  and  $\alpha$  energy states in either the laboratory or the rotating frame of reference. This results in an increase in  $T_1$  as  $\tau_c$  increases (region 2, figure 3.6).  $T_2$  is governed by spin-spin flip-flop transitions. These transitions are energy-conserving, and therefore  $T_2$  decreases as  $\tau_c$  increases.

### 3.10 The nuclear Overhauser effect

Solid-state single pulse  $^{13}\text{C}$  spectra are obtained routinely under conditions of dipolar decoupling. Saturation of the proton energy levels results in a non-Boltzmann distribution of the  $^{13}\text{C}$  spins in their own energy levels. This phenomenon, known as the nuclear Overhauser enhancement (NOE) depends on the extent to which C-H dipolar

relaxation is the operative mechanism.

The NOE may be calculated from the ratio of the intensities of the decoupled resonance without saturation ( $I_{ns}$ ) to the decoupled resonance with saturation ( $I_s$ ).

$$\text{NOE} = \frac{I_s}{I_{ns}} = 1 + \eta \quad (3.38)$$

where  $\eta$  is the nuclear Overhauser enhancement factor (NOEF).

In the extreme narrowing case,  $\eta$  may be expressed by

$$\eta = \frac{\gamma_H}{2\gamma_S} \frac{(T_1^D)^{-1}}{(T_1^D)^{-1} + (T_1^0)^{-1}} \quad (3.39)$$

where  $T_1^D$  is the longitudinal relaxation time for the dipolar mechanism, and  $T_1^0$  is the longitudinal relaxation time for other relaxation mechanisms.

The maximum value for the NOEF for carbon is 2.99 under extreme narrowing conditions to 1.15 for  $\omega^2\tau_c^2 \gg 1$ .

### 3.10.1 The nuclear Overhauser effect and molecular motion

For bulk polymers above  $T_g$ , the magnetic resonance parameters that primarily relate to molecular dynamics are the spin-relaxation times  $T_1$  and the nuclear overhauser enhancement (NOE). Spin-lattice processes are sensitive to motions at or near the nuclear Larmor frequencies,

typically 5–500 MHz. There are several mechanisms that contribute to the spin relaxation of  $^{13}\text{C}$  nuclei. The  $^{13}\text{C}$  dipolar relaxation mechanism is the most useful to analyse molecular rotational motions in polymers. Other mechanisms may be ignored as their contributions to relaxation are usually small.

The NOE depends on motions near the Larmor frequency, but in a manner different from that of  $T_1$ <sup>10</sup>. For a carbon that is fully relaxed by the C–H dipolar mechanism, up to a threefold enhancement of intensity can be obtained.

It can be shown that the  $^{13}\text{C}$   $T_1$  and NOE are given by

$$\frac{1}{T_1} = \frac{1}{10} \gamma_C^2 \gamma_H^2 \hbar^2 \sum_i r_i^{-6} [f(\omega_H - \omega_C) + 3f(\omega_C) + 6f(\omega_H + \omega_C)] \quad (3.40)$$

$$\text{NOE} = 1 + (\gamma_H/\gamma_C) \frac{[6f(\omega_H + \omega_C) - f(\omega_H - \omega_C)]}{[f(\omega_H - \omega_C) + 3f(\omega_C) + 6f(\omega_H + \omega_C)]} \quad (3.41)$$

where  $\omega_C$  and  $\omega_H$  are the carbon and proton resonance frequencies respectively and  $r_i$  is the distance between the  $^{13}\text{C}$  nucleus of interest and the  $i$ th relaxing proton.

The spectral density functions  $f(\omega_i)$  are the Fourier transforms of the autocorrelation functions of second-order spherical harmonics. They describe the power available at angular frequency  $\omega_i$  from the fluctuating interaction. The form of  $f(\omega_i)$  depends on the model used to describe the molecular motion. The simplest model available is that of isotropic rotational diffusion. In this case the  $f(\omega)$  have the form

Figure 3.7

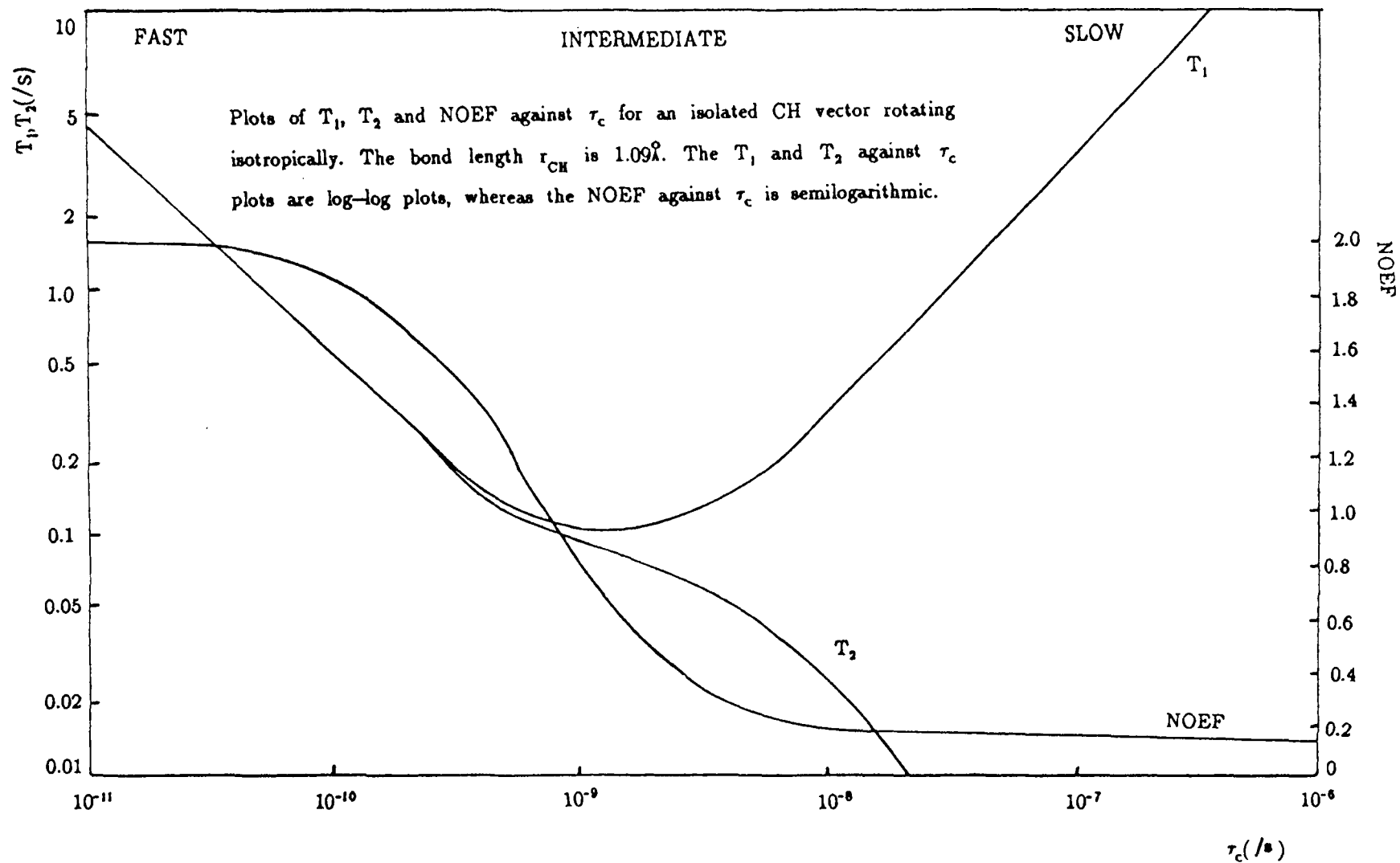

$$f(\omega) = \tau_c(1 + \omega^2 \tau_c^2) \quad (3.42)$$

where  $\tau_c$  is the rotational correlation time.

Figure 3.7 shows the behaviour of  $T_1$  and the NOE as a function of correlation time for a C-H vector rotating isotropically. A given value of  $T_1$  corresponds to two values of the correlation time, except at the minimum. These correspond to the so-called 'fast' and 'slow' solutions for  $T_1$ , depending on the value of  $T_c$ . The NOE decreases monotonically with increasing  $\tau_c$ . Since for slower motion the dipolar mechanism becomes less efficient, the NOE decreases as illustrated in figure 3.7. When  $\tau_c$  is small, as is the case in the extreme narrowing region, the NOE = 3. As  $\tau_c$  increases, the value of the NOE decreases.

For high molecular weight polymer chains in bulk, overall reorientation does not occur. The predominant motional feature is segmental mobility, either of the backbone or of the side chains. Thus the  $T_1$  and NOE parameters of such polymers do not adhere to the simple isotropic model outlined here. Often more complicated models for segmental motion involving several or a distribution of correlation times are invoked. An important feature of these distributions is the inclusion of longer correlation times to account for the reduced NOE's observed in polymers.

### 3.11 Selective averaging techniques

In solution state NMR, high resolution NMR spectra are obtained. Rapid isotropic molecular tumbling averages the geometric factor

$(3\cos^2\theta-1)$  to zero, and hence the anisotropic spin interactions discussed in section 3.8 are averaged out. However, in solids, the molecules are generally held rather rigidly. The anisotropic spin interactions are not averaged out by molecular motion, and so contribute to the linewidth in the NMR spectra. These interactions lead to very broad lines in the solid state which obscure valuable high-resolution information. There are two types of broadening which contribute to the linewidth in the solid state.

- a). Homogeneous broadening arises from the dipolar interactions between abundant spins, where each spin is coupled to every other spin. All nuclei in the sample give rise to the entire line, which is broad because of spin-relaxation or spin-diffusion effects.
- b). Inhomogeneous broadening of lineshapes arises from the dipolar interactions between abundant and rare spins and shielding anisotropy. The resonance frequency for a particular spin depends on the orientation of the principal axis system with respect to the magnetic field  $B_0$ . In a powder, all orientations of PAS with respect to  $B_0$  are possible. Therefore the lineshape results from the summation of many individual lines tending towards a gaussian shape.

In order to obtain 'solution-state' type spectra in the solid state, the interactions discussed in section 3.8 must be averaged to zero.

Several techniques have been developed which selectively average these interactions. This results in line-narrowing, and hence high resolution spectra may be obtained for solids.

### 3.11.1 Magic angle spinning

It is possible to reduce the effect of the direct dipolar interactions and the shielding anisotropy in solids using a technique called magic angle spinning (MAS). Manipulation of the spin interactions can be achieved by rotating the sample at a rate  $\omega_r$  about an axis which is tilted by an angle  $\theta$  with respect to the magnetic field  $B_0$ . This technique simulates the isotropic molecular tumbling found in liquids.

Inspection of the dipolar Hamiltonian  $\mathcal{H}_D$  and the shielding Hamiltonian  $\mathcal{H}_S$  (equations 3.33 and 3.28 respectively) shows that there exists the option of averaging the spatial term to zero. Both these Hamiltonians contain the common term  $(1-3\cos^2\theta)$ . The angle  $\theta$  describes the orientation of the principal axis system of those interactions with respect to  $B_0$ .

Rotation of the sample at an angle  $\beta$  which is fixed relative to  $B_0$  causes orientation dependent interactions to have a time dependence<sup>11</sup>. As long as the rate of sample rotation is greater than the static linewidth, the average angle of  $\theta$  is such that

$$\langle 3\cos^2\theta - 1 \rangle = \frac{1}{2}(3\cos^2\beta - 1)(3\cos^2\aleph - 1) \quad (3.43)$$

The parameter  $\aleph$  is fixed for a rigid solid, and it takes all possible values for a powder sample. The term  $\frac{1}{2}(3\cos^2\beta - 1)$  acts as a scaling factor on a dipolar powder pattern. The angle  $\beta$  is at the control of the experimentalist. The case of most interest is that when  $\beta = 54^\circ 44'$ . At

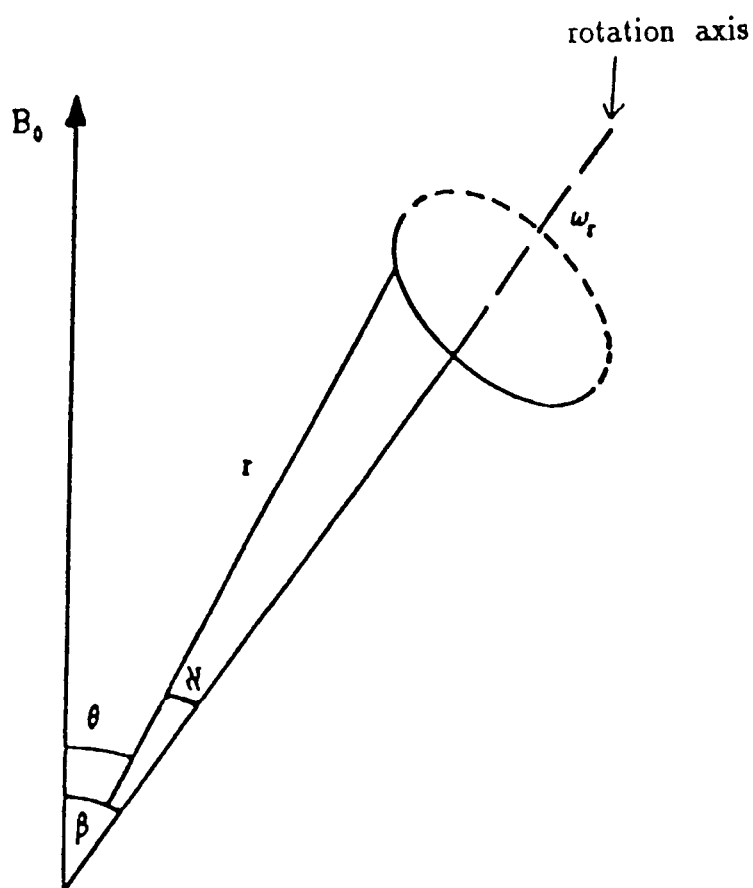

Figure 3.8

Magic-angle spinning. The sample is rotated at an angle  $\beta$  with respect to  $B_0$  at a rate  $\omega_r$ .  $r$  is the internuclear vector.

this angle the term  $(3\cos^2\beta-1) = 0$ , and therefore the term  $(3\cos^2\theta-1)=0$ . This is the spatial term in the dipolar Hamiltonian. Hence, just as for isotropic tumbling, the dipolar interaction is averaged to zero. This eliminates dipolar broadening, thus giving high resolution spectra.

Any solid-state interaction that displays the  $(3\cos^2\theta-1)$  dependence can be removed, in principle, by MAS. The special requirements are different for homogeneous and inhomogeneous interactions, however. In the homogeneous case, as for H-H dipolar interactions in a solid,  $\omega_r$  must exceed the full strength of the interaction for complete narrowing to take place. However, some narrowing may be accomplished by using slower spinning speeds. For inhomogeneous interactions such as the chemical shift anisotropy, MAS at less than the full width of the interaction yields a relatively narrow centre band and a spectrum of side bands separated by the spinning frequency.

### 3.11.2 High Power dipolar decoupling

As a result of the dipolar interactions with protons, the  $^{13}\text{C}$  NMR linewidth in an organic solid is of the order of 20 KHz. The fine structure associated with the various chemically shifted resonances occurs over a range much less than this. Therefore, in order for high-resolution NMR spectra to be obtained in the solid state, it is necessary to remove the effects of this dipolar interaction. The dipolar interactions are often so large that they cannot be averaged completely by MAS. Dipolar decoupling averages  $I_z S_z$ , the spin part of  $\mathcal{H}_{IS}$  rather than the spatial part. The  $^{13}\text{C}$  magnetic moments experience the  $z$  component of the local

field from the proton moments. If this local field can be averaged to zero, the  $^{13}\text{C}$  spin sees zero net field from the protons, and the effect of heteronuclear dipolar coupling is removed.

In a typical  $^{13}\text{C}$  solid state experiment, RF radiation of sufficient power applied at the proton frequency forces the proton spins to precess rapidly. This averages the effective field from  $^1\text{H}$  that is seen by the  $^{13}\text{C}$  nucleus. For the averaging to be effective, the dipolar irradiation must be powerful enough to average  $\mathcal{H}_{\text{IS}}$ , the C-H dipolar coupling.

Dipolar decoupling is analogous to the proton decoupling normally done in  $^{13}\text{C}$  NMR of liquids to remove  $^{13}\text{C}$  spin-spin (scalar) couplings. For solids, decoupling fields at least an order of magnitude larger than those used in the solution state are necessary to reduce the much stronger dipolar coupling.

### 3.12 Spin temperature

In a static magnetic field  $B_0$  the  $^1\text{H}$  spins populate their set of zeeman levels separated by  $\Delta E = \gamma \hbar B_0$  according to the Boltzmann distribution.

$$\frac{n_u}{n_l} = \exp\left[-\frac{\Delta E}{kT_s}\right] \quad (3.44)$$

where  $T_s$  is the temperature of the spin system, and  $n_u$  and  $n_l$  are the populations of the upper and lower energy states respectively.

A schematic diagram of the carbon and proton spin systems in a typical polymer is illustrated in figure 3.9.

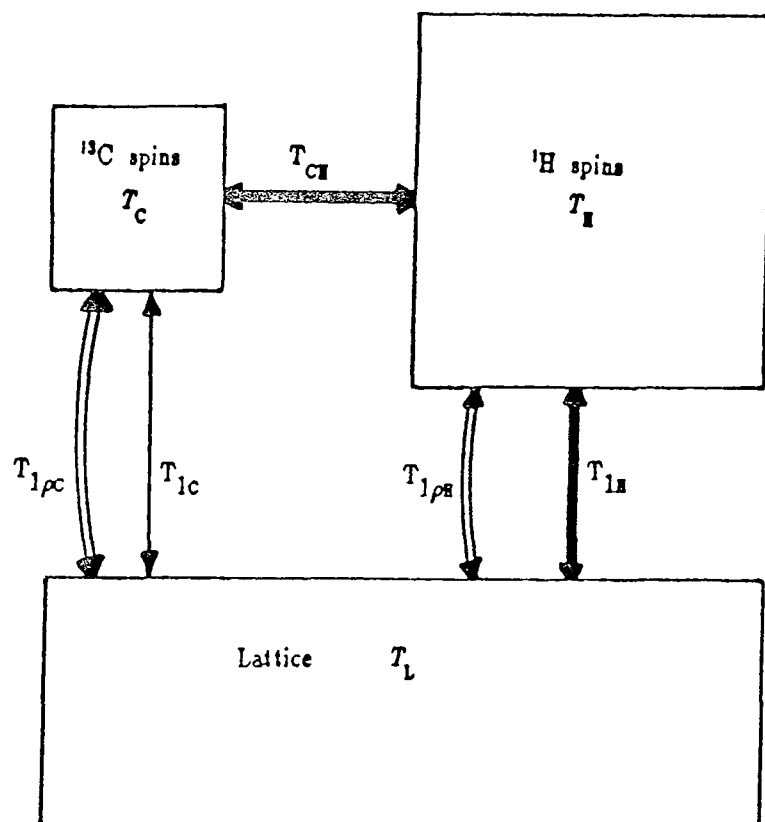

Figure 3.9

A schematic diagram to illustrate the carbon and proton spin systems in a typical polymer. The  $T$  indicate spin temperatures, the  $T$  indicate the relaxation processes which occur between the carbons, protons and the lattice.

From equation 3.44 it may be seen that a larger polarisation (greater population difference) corresponds to a lower spin temperature. Via spin diffusion the proton spin system equilibrates at a single  $T_S$  in a very short time, and may be considered as an isolated spin reservoir.

After a much longer time the proton system equilibrates with the surroundings (the lattice), and  $T_S$  equals  $T_L$ , the lattice temperature.

The proton magnetisation may be expressed by the Curie law.

$$M_H = \frac{C_H B_0}{T_L} \quad (3.45)$$

where

$$C_H = \frac{N_H \gamma_H^2 \hbar^2}{4k} \quad (3.46)$$

The carbon spins also equilibrate among their levels in the same manner. The carbon levels have only about  $\frac{1}{4}$  the separation of the proton levels at the same temperature because  $\gamma_H \sim 4\gamma_C$ . Because of the different relaxation processes involved and the larger internuclear distances, the equilibrium times for the  $^{13}\text{C}$  spin reservoir are longer than for the protons. The fact that the separation of the carbon levels is greatly different from the separation of the proton levels (i.e. the nuclei have greatly different resonance frequencies) means that these two sets of nuclei cannot undergo mutual energy-conserving spin flips efficiently, and are therefore isolated from each other. This enables them to possess different relaxation times.

### 3.13 Cross-polarisation

A common problem that is encountered when attempting to obtain high-resolution NMR spectra of solids is the low sensitivity of the nucleus under observation. The sensitivity of a particular nucleus is dependent upon several factors:

- 1). The natural abundance of the isotope
- 2). The size of the magnetic moment which results from the interaction of the nuclear magnetic moment with the static field  $B_0$
- 3). The length of the spin-lattice relaxation times (relative to the proton  $T_1$  values).

The last factor limits the rate at which experiments may be repeated, and therefore reduces the sensitivity. The sensitivity may be enhanced by using the cross-polarisation (CP) technique. The pulse sequence used in the cross-polarisation experiment is shown in figure 3.10.

As has already been stated in the last section, the equilibrium magnetisation for the abundant proton spins is given by

$$M_H = \frac{C_H B_0}{T_L} \quad (3.47)$$

This proton magnetisation is tipped to lie along the  $y$  axis in the rotating frame of reference by a  $90^\circ +x$  pulse applied at the proton frequency. This magnetisation is then spin-locked along the  $y$  axis by a field  $B_{1H}$  applied along the  $y$  axis at the proton frequency. The proton

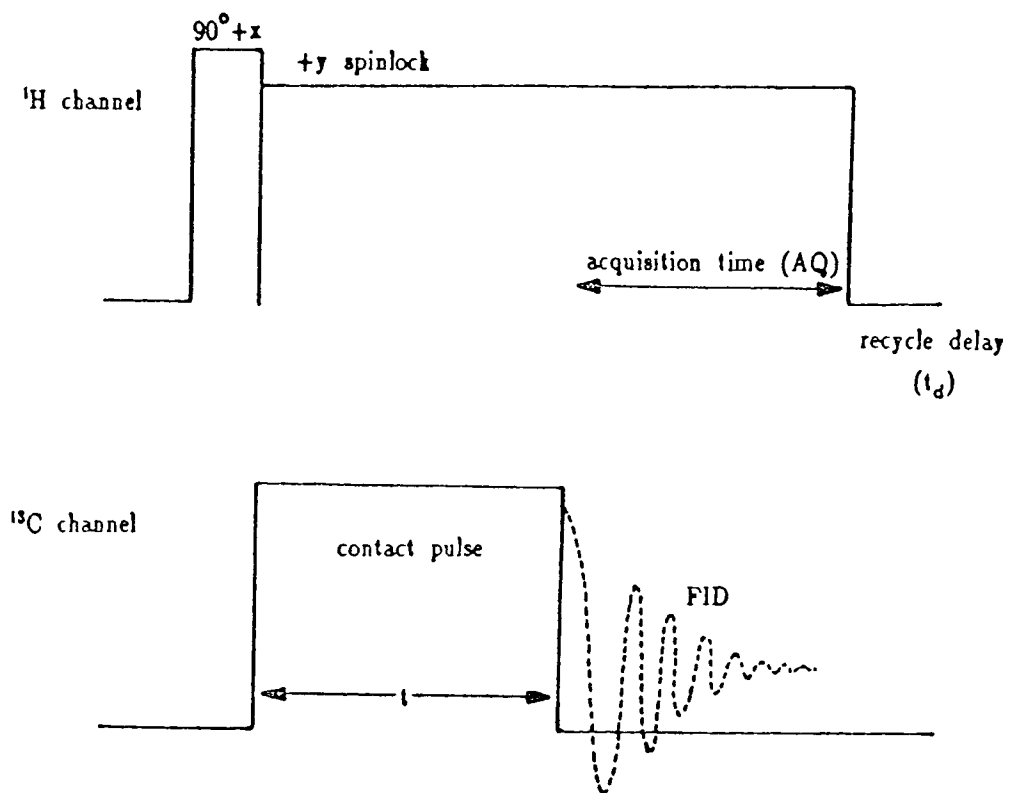

Figure 3.10

The cross-polarisation pulse sequence.

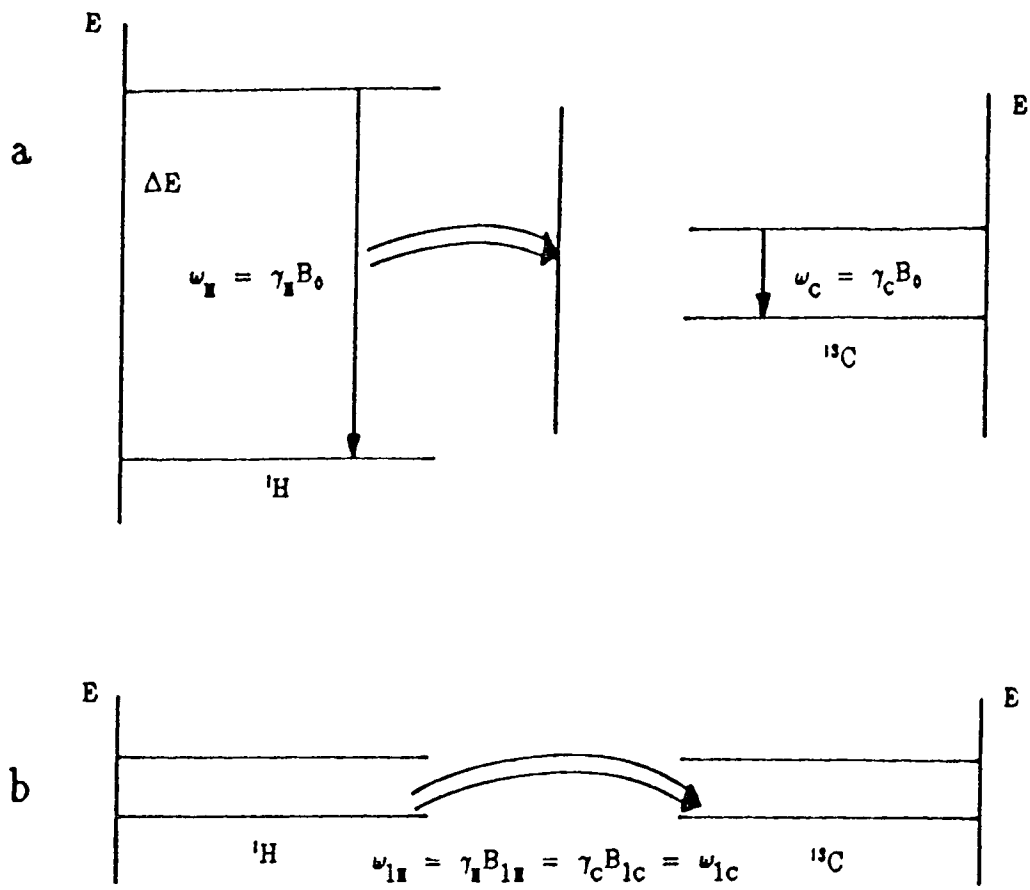

Figure 3.11

A schematic diagram to illustrate the cross-polarisation process.

In figure a). The proton levels have four times the separation of the carbon levels. This makes transfer from proton to carbon an unfavourable process.

In figure b). The Hartmann-Hahn condition is satisfied and both  $^1\text{H}$  and  $^{13}\text{C}$  spin systems are in frames rotating at the same rate. Energy transfer can now take place.

magnetisation is no longer at thermal equilibrium. At this stage

$$M_H = \frac{C_H B_0}{T_L} = \frac{C_H B_{1H}}{T_H} \quad (3.48)$$

From the above equation, it may be deduced that

$$T_H = \frac{B_{1H}}{B_0} T_L \quad (3.49)$$

$B_{1H}$  is much less than  $B_0$ , therefore  $T_H \ll T_L$ . Thus the effect of the spin-locking field  $B_{1H}$  is to effectively cool the spins. This was brought about not by an actual lowering of temperature, but by a lowering of the effective field seen by the protons.

The cross-polarisation process occurs when the smaller, hotter  $^{13}\text{C}$  reservoir is brought into contact with the larger, cooler  $^1\text{H}$  reservoir. This is accomplished by irradiating the carbons with an RF field  $B_{1C}$  of a strength such that the Hartmann-Hahn condition is satisfied:

$$\gamma_H B_{1H} = \gamma_C B_{1C} \quad (3.50)$$

When this condition is met the original proton and carbon levels which did not match, are brought to lower matching levels. This is illustrated in figure 3.11. The energy-conserving spin flips can now occur between the carbon and the proton spins instead of just within the individual reservoirs. The rotating frames of both the carbon and proton

spins precess at the same rate and with equal energies.

At this point, before transfer of magnetisation, the carbon magnetisation in the  $xy$  plane of the rotating frame is considered to be zero, and the carbon is said to have an infinite spin temperature.

$$T_C = \infty \quad (3.51)$$

During the transfer of magnetisation, the larger, cooler proton reservoir cools the carbon reservoir; that is, a carbon signal is created along  $B_{1C}$ . The spin energy is redistributed between the two spin systems to give a common spin temperature  $T_M$ .

Assuming energy conservation in the rotating frame

$$\frac{C_H B_{1H}^2}{I_H} + \frac{C_C B_{1C}^2}{I_C} = \frac{1}{I_M} [ C_H B_{1H}^2 + C_C B_{1C}^2 ] \quad (3.52)$$

But  $T_C = \infty$ ,

So

$$\frac{I_H}{I_M} = \frac{1}{1 + \epsilon \alpha^2} \quad (3.53)$$

where

$$\epsilon = \frac{N_C}{N_H} \quad (3.54)$$

and

$$\alpha = \frac{\gamma_C B_{1C}}{\gamma_H B_{1H}} \quad (3.55)$$

Following cross-polarisation, the carbon magnetisation is

$$M_C = \frac{M_C(0) B_{1C} T_L}{B_0 T_H} \quad (3.56)$$

Therefore,

$$M_C = \frac{\gamma_H}{\gamma_C} \frac{\alpha M_C(0)}{1 + \epsilon \alpha^2} \quad (3.56a)$$

Since  $\gamma_H/\gamma_C > 1$ , the intensity of the carbon magnetisation has been enhanced.  $M_C(0)$  is the intensity of the carbon spin magnetisation observed in a single pulse experiment.

### 3.13.1 Cross-polarisation dynamics<sup>12</sup>

The description of the cross-polarisation experiment in the last section omitted the effects of the various types of relaxation on the observed carbon intensity at a particular contact time.

During the cross-polarisation experiment, the abundant proton spins undergo three types of relaxation.

1. During the cross-polarisation experiment, a  $90^\circ +x$  proton pulse transfers S spin magnetisation to the y axis in the rotating frame of reference. When  $T_2^*$  for the S spins is comparable to the duration of the  $90^\circ$  pulse, spin-spin relaxation can occur during this period, which results in a reduction in the amount of S spin magnetisation which is transferred.
2. Immediately after the S spin magnetisation is spin-locked, the magnetisation decays at a rate characterised by the exponential time constant  $T_{1\rho}^S$ .
3. As a consequence of cross-relaxation with the carbon spins,

there is a loss of proton magnetisation. The rate at which cross-polarisation occurs is characterised by the exponential time constant  $T_{IS}$ .

The rare carbon spins (I) undergo two types of relaxation during the cross-polarisation experiment.

1. Loss of carbon magnetisation occurs as a result of relaxation in the rotating frame of reference. The rate of decay is characterised by the exponential time constant  $T_{I\rho}^I$ .
2. Whilst the proton spins are spin-locked, the I spin magnetisation grows as a consequence of cross-relaxation with the proton spins. The rate at which the growth of magnetisation occurs is characterised by the exponential time constant  $T_{IS}$ .

The following section assumes that  $T_2^* \ll$  the  $90^\circ$  pulse length, and that  $\frac{1}{T_{I\rho}^I} \approx 0$ .

If energy conservation in the rotating frame of reference is invoked, it may be written

$$\frac{d\beta_I}{dt} + \epsilon\alpha^2 \frac{d\beta_S}{dt} = 0 \quad (3.57)$$

where  $\beta_I$  is the inverse spin temperature of spins I, and  $\beta_S$  is the inverse spin temperature of spins S.

The variation of the inverse spin temperature with contact time for both the I and S spins is given by

$$\frac{d\beta_I}{dt} = -\frac{1}{T_{IS}} [\beta_I - \beta_S] \quad (3.58a)$$

$$\frac{d\beta_S}{dt} = -\frac{\epsilon\alpha^2[\beta_S - \beta_I]}{T_{IS}} - \frac{\beta_S}{T_{I\rho}^S} \quad (3.58b)$$

These coupled differential equations are straightforwardly solved under the initial conditions:

$$\beta_I(0) = 0 \quad \text{and} \quad \beta_S(0) = \beta_{S_0}$$

The solution for  $\beta_I(t)$  is

$$\beta_I(t) = \beta_{S_0} \frac{1}{a_+ - a_-} \left[ \exp(-a_- t/T_{IS}) - \exp(-a_+ t/T_{IS}) \right] \quad (3.59)$$

where

$$a_{\pm} = \frac{1}{2} \left[ 1 + \epsilon\alpha^2 + \frac{T_{IS}}{T_{I\rho}^S} \right] \left[ 1 \pm \left[ 1 - \frac{4T_{IS}/T_{I\rho}^S}{1 + \epsilon\alpha^2 + T_{IS}/T_{I\rho}^S} \right]^{\frac{1}{2}} \right] \quad (3.60)$$

The variation of carbon magnetisation  $M_I(t)$  with contact time is

$$\frac{M_I(t)}{M_{I_0}} \propto \frac{\gamma_I}{\gamma_S} \frac{\beta_I(t)}{\beta_{S_0}} \quad (3.61)$$

After the carbon magnetisation has been developed, the spin-locking of the proton spins is continued. This decouples the proton spins from the carbon spins, allowing observation of the carbon spins during the

acquisition period. Since the carbon spin magnetisation is derived from the proton spins, the recycle delay between pulses is governed by the  $T_1$  of the proton spins, and not the carbon spins. Proton  $T_1$  values are usually considerably shorter than carbon  $T_1$  values, therefore the delay between pulses is substantially reduced, and hence the experiment time is shortened.

The cross-polarisation experiment described so far is the "single-contact" cross-polarisation experiment. This is the pulse sequence which has been used in this thesis.

Two modifications have been made to this pulse sequence. They are known as spin-temperature inversion and flip-back.

### 3.13.2 Spin-temperature inversion<sup>13</sup>

Cross-polarisation experiments are susceptible to two different artifacts. These arise as a result of the long radiofrequency pulse on the proton channel. The first type of artifact arises from phase irregularities, or glitches. These result in some of the carbon spin magnetisation present at the start of the experiment being rotated by the glitch, and thus being spin-locked along the RF field. This carbon magnetisation is indistinguishable from the carbon magnetisation derived by cross-polarisation. The second artifact originates from transients generated by eddy currents in the aluminium probe housing. The characteristics of the pulse solely determine these artifacts, which may be removed by spin-temperature inversion.

### 3.13.3 Flip-back<sup>14</sup>

The second modified cross-polarisation experiment is called the flip-back experiment. It is designed to improve the efficiency with which spectra are acquired using cross-polarisation. In the ordinary single-contact experiment, the signal-to-noise is dependent upon the recycle delay during which the repolarisation of the spins occurs.

$$S/N \propto n^{1/2}(1 - B) \quad (3.62)$$

where  $n$  = number of transients acquired

$$\text{and where } B = \exp \left[ -\frac{RD}{T_1^S} \right] \quad (3.63)$$

and  $RD$  = recycle delay.

when  $T_1^S > T_{1\rho}^S > AQ$  (the acquisition time), then repolarisation of the proton spins may be effected by rotating the proton spin magnetisation so that it is aligned along the direction of  $B_0$  following acquisition. This improves the efficiency of the experiment.

In the flip-back experiment,

$$S/N \propto \frac{n^{1/2}(1 - B)}{(1 - AB)} \quad (3.64)$$

$$\text{where } A = \exp \left[ -\frac{AQ}{T_{1\rho}^S} \right] \quad (3.65)$$

## CHAPTER 4

### Experimental

#### 4.1 Instrumentation

##### 4.1.1 Bruker CXP200 NMR spectrometer

A Bruker CXP200 NMR spectrometer was used to acquire the majority of the solid-state spectra shown in this thesis. The spectrometer is equipped with an Oxford Instruments superconducting wide-bore (89.5 mm) solenoid magnet with an operating field of 4.7 Tesla. At this field the resonance frequencies of  $^1\text{H}$  and  $^{13}\text{C}$  are 200.13 MHz and 50.323 MHz respectively.

The CXP is a dual-channel spectrometer which is capable of simultaneous irradiation of both low and high frequency nuclei. The lower frequency channel can irradiate between 4 and 95 MHz, and the higher frequency channel can operate at either 200.13 MHz ( $^1\text{H}$ ) or 188 MHz ( $^{19}\text{F}$ ). For the research described in the following chapters, the high frequency channel is only used at the proton frequency. The NMR properties of the proton and carbon nuclei are listed in Table 4.1. The details of the spectrometer construction are well-known and a description may be found in reference one<sup>1</sup>.

##### 4.1.2 Other spectrometers utilised

Some of the work described in this thesis was obtained on a Varian VXR300 spectrometer equipped with a 7.1 Tesla narrow-bore

magnet. The operating frequencies are 75.431 MHz for carbon and 299.949 MHz for protons respectively.

The solution-state work described in this thesis was obtained using a Bruker AC-250 spectrometer equipped with a 5.9 Tesla narrow-bore magnet. The system was field/frequency locked by the  $^2\text{H}$  resonance of deuterated DMSO.

Some proton work was carried out on a purpose-built static spectrometer operating at 60 MHz for protons. The spectrometer is equipped with an electromagnet, and is only suitable for static samples

#### 4.1.3 The probes

During the course of this work two probes were routinely used on the CXP200 spectrometer. The two wide-bore (84.5 mm) broad-band, dual-channel, high-resolution commercial double-bearing probes covered a frequency range of 20-90 MHz. The double-bearing system allows samples in cylindrical-shaped zirconia rotors to be rotated at the magic angle, at rates between 100 Hz - 5 KHz, however the rotor had to be packed fully and homogeneously to obtain stable spinning rates.

The probe used for the VXR300 spectrometer was a narrow-bore double-bearing probe designed by Doty. The samples were packed in zirconia rotors for sample spinning.

The solution-state studies were made using a broad-band 10mm VSP probe.

Table 4.1

NMR properties of nuclei studied.

Isotope	% natural abundance	$\gamma/10^7 \text{radT}^{-1}\text{s}^{-1}$	NMR $\nu/\text{MHz}$ at 4.7 T	Sensitivity rel to $^1\text{H}$
$^1\text{H}$	99.99	26.75	200.13	1.000
$^{13}\text{C}$	1.11	6.73	50.32	$1.76 \times 10^{-4}$

## 4.2 Experimental

### 4.2.1 Shimming the magnet

The homogeneity of the magnetic field is required to be maximised in order to obtain a good lineshape and narrow linewidths for signals. For the CXP200, the homogeneity of the field is maximised by adjusting the positions of the shim coils to minimise the linewidth of the proton signal observed from silicone gum. A recycle time of 3 seconds was used to acquire spectra. The linewidth at half-height of the silicone gum signal was typically between 6–10 Hz. The signal occurs at 0.2 ppm with respect to tetramethylsilane (TMS).

### 4.2.2 Setting the proton $90^\circ$ pulse

In order to obtain a  $90^\circ$  proton pulse, the proton FID from silicone gum is first set on resonance. A  $180^\circ$  proton pulse is obtained by adjusting the gain until a null signal is observed after the pulse. To obtain the  $90^\circ$  proton pulse, the pulse duration is halved.  $90^\circ$  pulse durations of 4  $\mu$ s were typically used for the double-bearing probe. This corresponds to a decoupling frequency of 62.5 kHz.

### 4.2.3 Setting the angle

In order to minimise the effects of dipolar coupling, it is necessary to adjust the angle at which the rotor spins to the magic angle ( $54^\circ 44'$ ). This is achieved by maximising the sharpness of rotational echoes observed in the  $^{127}\text{I}$  spectrum of potassium iodide. The nucleus  $^{127}\text{I}$  has a

spin  $5/2$ , and has a resonance frequency of 40.047 MHz on the CXP200 spectrometer. The sidebands observed arise from the spinning modulation of the first-order quadrupolar interaction resulting from imperfections in the crystal lattice. This technique is accurate to within  $\pm 0.1^\circ$  of the magic angle.

#### 4.2.4 $^{13}\text{C}$ referencing

The  $^{13}\text{C}$  chemical shifts were obtained using adamantane as a reference. Adamantane exhibits shifts at 38.5 ppm and 29.5 ppm with respect to TMS for the CH and  $\text{CH}_2$  carbons respectively.

#### 4.2.5 $^{13}\text{C}$ matching for CP

The  $^{13}\text{C}$   $90^\circ$  pulse duration was established by adjustment of the gain setting on the low frequency amplifier until the Hartmann-Hahn matching condition was obtained, and the observed cross-polarisation signal maximised.

#### 4.2.6 Setting $^{13}\text{C}$ $90^\circ$ pulse for single pulse

For single pulse experiments, the  $90^\circ$  carbon pulse is set in a similar way to the  $90^\circ$  proton pulse. The gain on the low frequency amplifier is adjusted until a null signal is observed from adamantane. The pulse duration is then halved to obtain a  $90^\circ$  carbon pulse.

### 4.3 Pulse sequences

A number of pulse sequences have been used during the course of the work outlined in this thesis. The more common pulse sequences used are described in the following sections, whereas the new pulse sequences devised are described in more depth later in the thesis.

#### 4.3.1 Single pulse excitation (SPE)

The single pulse excitation pulse sequence with high-power proton decoupling is shown in figure 4.1a. High-power proton decoupling is necessary when there are strong C-H dipolar interactions present such as in the case of polymers. The  $\pi/2$  carbon pulse gives maximum signal provided the recycle delay is adequate for relaxation. Any inaccuracies in the pulse duration lead to a signal lower than the maximum. The intensities obtained are quantitative provided the recycle time is of sufficient length to allow the nuclei to relax back to equilibrium. The single pulse excitation experiment is of particular use when observing carbons which do not have long spin-lattice relaxation times. It is possible to discriminate between carbons in polymers which differ in mobility, and therefore differ in the length of the carbon  $T_1$ 's.

#### 4.3.2 INV1H

The INV1H pulse sequence is shown in figure 4.1b. The pulse sequence is used in the study of the transient nuclear Overhauser effect. At the start of the sequence there is a proton  $180^\circ$  inversion pulse. The

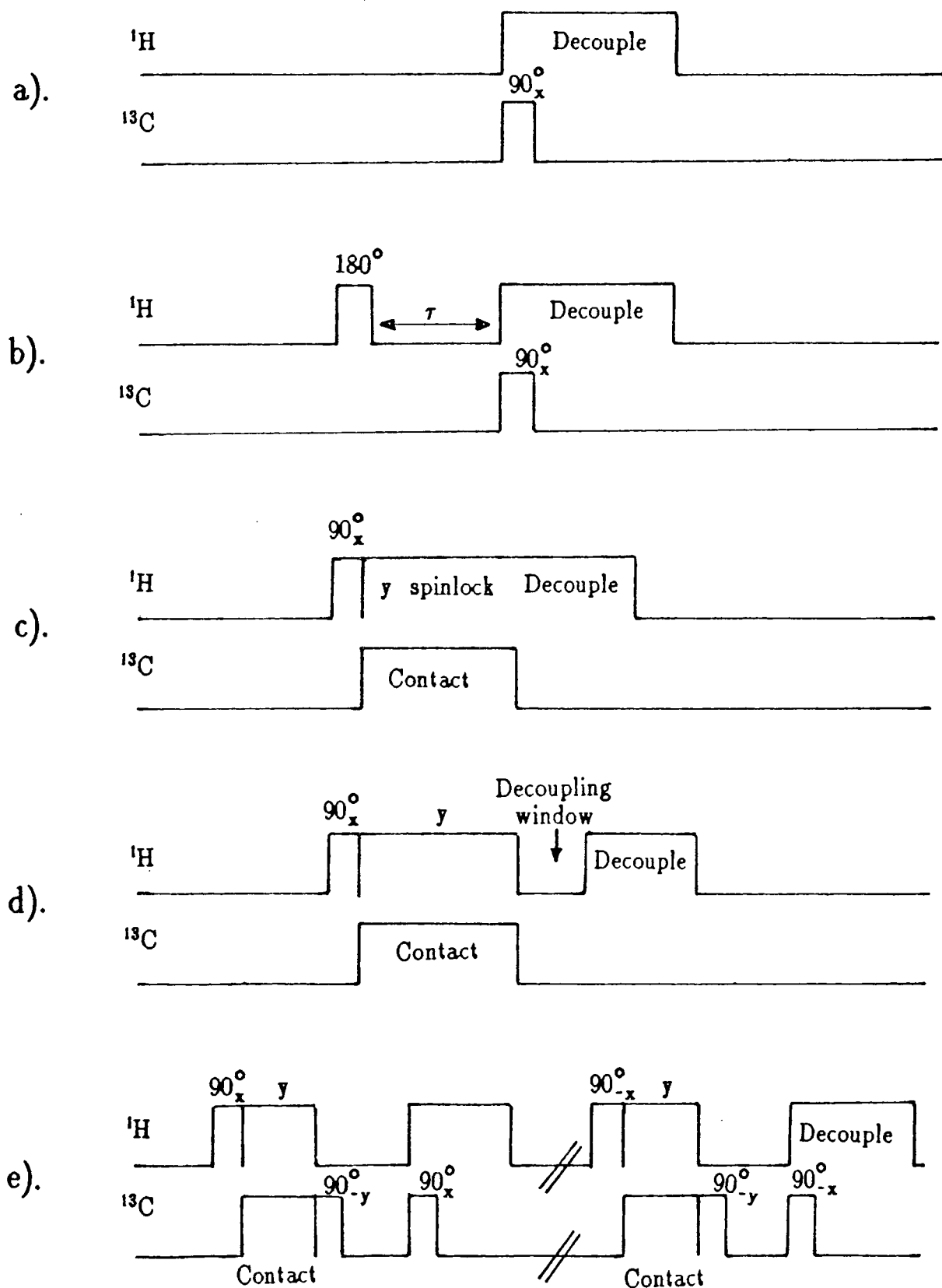

Figure 4.1

- a). The pulse sequence for the Single-pulse-excitation experiment.
- b). The pulse sequence for the INV1H experiment.
- c). The pulse sequence for the Cross-polarisation experiment.
- d). The pulse sequence for the NQS experiment.
- e). The pulse sequence for the TICP experiment.

protons are allowed to begin to relax back to equilibrium in delay time  $\tau$ . The carbon signal is monitored as a function of  $\tau$ , and thus the effect of the dipolar cross-relaxation between the protons and the carbons can be observed. During the acquisition time high-power proton decoupling is applied to average the strong C-H dipolar interactions to zero.

### 4.3.3 Cross-polarisation<sup>2</sup>

Often spins which are spatially or isotropically dilute have long  $T_1$  values, whereas the abundant proton spins have  $T_1$  values which are generally shorter than the  $T_1$  values of the dilute spins. The cross-polarisation pulse sequence is shown in figure 4.1c. In this sequence the carbon signal is generated from the abundant spins. A  $\pi/2$  proton pulse generates proton magnetisation. This is followed by a  $\pi/2$  phase shift of the RF which spin-locks the proton magnetisation. The  $^{13}\text{C}$  contact pulse is switched on immediately following the phase shift. If the Hartmann-Hahn condition is satisfied then transfer of polarisation takes place from the abundant proton spins to the dilute carbon spins. The dynamics of the cross-polarisation experiment have already been described in Chapter Three.

### 4.3.4 Non-quaternary suppression (NQS)<sup>3</sup>

The pulse sequence for the non-quaternary suppression pulse sequence is shown in figure 4.1d. The NQS pulse sequence differs from that of the cross-polarisation experiment only by the insertion of a window in the proton decoupling before acquisition of the FID. The

duration of this window is typically 40  $\mu$ s. Protonated carbons have strong C-H interactions, and therefore give broad bands. This results in a rapid decay of transverse magnetisation, so that at the end of the decoupling window there is little signal left in the FID from such carbons. On the other hand, quaternary carbons give relatively narrow bands, so there is little decay of magnetisation during the decoupling window. This leaves a substantial signal from quaternary carbons during the carbon acquisition period.

#### 4.3.5 T1CP<sup>4</sup>

The pulse sequence shown in figure 4.1e shows the experiment devised by Torchia for the measurement of the  $T_1$  of dilute spins using cross-polarisation. The experiment consists of two similar but not identical pulse sequences. In the first pulse sequence, transverse carbon magnetisation is generated by CP. This magnetisation is then transferred to the z axis. This longitudinal magnetisation decays exponentially from an initial value  $M_{CP}(0)$  to an equilibrium value  $M$  in a time characterised by the time constant  $T_1$ . This magnetisation is then detected. The second sequence differs from the first in that the proton spin temperature is inverted by a phase shift of  $\pi$ , giving rise to proton enhanced carbon signal of opposite sign to that obtained by the first sequence. Subtraction of the second sequence from the signal generated by the first sequence gives a signal equal to  $M_{CP}(0)\exp(-t/T_1)$ .

#### 4.4 Fitting of variable contact time measurements

A program has been written on the mainframe computer which fits the data obtained from variable contact time measurements. The variation in the signal observed for the carbon spins with contact time in cross-polarisation experiments was fitted to equation 4.1.

$$M_I(t) = \frac{M_I(0)\gamma_S}{\gamma_I(1-\lambda)}\exp(-t/T_{1\rho}) - \frac{M_I(0)\gamma_S}{\gamma_I(1-\lambda)}\exp(-t/T_{IS}) \quad (4.1)$$

where  $\lambda = T_{IS}/T_{1\rho}$ .

Equation 4.1 assumes single-exponential  $T_{1\rho}$  behaviour for the peak in question.

The intensity of a particular carbon peak, and its corresponding contact time is read into the program for all the values of the contact time. The program notes the contact time at which the maximum signal intensity is observed ( $t_{opt}$ ). A least squares fit on the data is then carried out, from which values of  $T_{1\rho}$  and  $T_{IS}$  are determined. The least squares fit is done in two parts. Firstly the regime where the contact time  $t$  is greater than  $t_{opt}$  is fitted to a plot of  $\ln(M_I(t))$  against  $t$  to give a value for  $T_{1\rho}$ . Then, in the regime  $t < t_{opt}$ ,  $T_{IS}$  is obtained from the slope of  $\log M$  against time. The full theoretical curve is then plotted out, and an estimate of how well the parameters  $T_{IS}$  and  $T_{1\rho}$  fit the curve is made by determining the sum of the squares of the error.

The variable contact time experiment may be used as a discriminating technique. The  $^1\text{H}$   $T_{1\rho}$  values, and therefore the slopes of the plots, need not necessarily be the same in any one sample. It is possible for a sample to have more than one proton  $T_{1\rho}$  value. This is usually an indication that either there is incomplete spin diffusion, or

that there is more than one proton reservoir in the system as can occur in heterogeneous systems. Variable contact measurements may also be used to obtain quantitative information about a sample. Comparison between two peaks at any individual contact time will not normally provide quantitative intensities. However, if a range of contact times are used, extrapolation back to zero contact time will result in quantitative intensity measurements.

#### 4.5 Cross-linking chemistry

A surface coating may undergo a transition from a liquid or a solution to a film after application. One technique of achieving such films is to use coatings which undergo chemistry to form intractable films. The chemistry may be chain extension, polymerisation, or cross-linking between two polymers.

Many coatings are stoved at temperatures between  $120^{\circ}$ – $250^{\circ}$ C to form cross-links between the prepolymers. However there are many cases when such temperature conditions are impractical. For example, when the substrate is very large, such as a ship, coatings which require stoving are unsuitable.

For such cases as these, it is necessary to find an alternative surface coating which will cross-link at ambient temperatures. This is much more difficult. The functional groups of the prepolymers must be much more reactive than for stoving systems. Also ambient temperature and humidity vary according to the weather. Possibly the most successful ambient curing reactions are those undergone by two-pack systems

consisting of two components, each with reactive functional groups. The two components are mixed together. The coating has a finite time or 'pot life' within which it must be applied to the substrate.

One of the earliest types of ambient curing reactions was devised by Bayer during which an isocyanate functional curing agent reacts with an hydroxyl functional polymer forming a urethane linkage. Variations of this curing reaction were also used to form surface coatings with excellent mechanical properties. The one major drawback of chemistry based on these systems is the toxicity of the isocyanates. A substitute reaction of improved toxicity and similar mechanical properties would be extremely desirable.

Various reactions have been proposed for the formation of films with good mechanical properties at ambient temperatures.

#### 4.5.1 Courtaulds Coatings cross-linking chemistry

Courtaulds have devised a cross-linking reaction which cures at ambient temperature. The reaction between an acid anhydride and an alcohol readily occurs at ambient temperature forming the half-ester (figure 4.2). It was found that polymers of either itaconic anhydride or maleic anhydride were the most suitable for this type of reaction<sup>5</sup>. The polymer used is a copolymer of styrene, methyl methacrylate and either itaconic or maleic anhydride. The styrene is included as it has a noticeable moderating effect on the cross-linking reaction. Methyl methacrylate is required in order that the copolymer is compatible with the curing polyester.

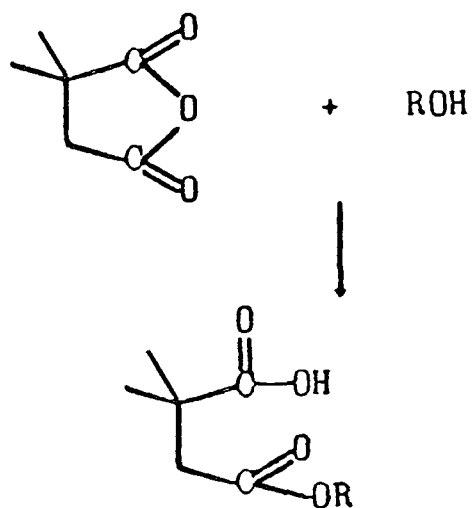

Figure 4.2

The reaction between an acid anhydride and an alcohol readily occurs at ambient temperature forming the half-ester.

Table 4.2

Monomers for the synthesis of the itaconic anhydride copolymer

monomer	% by weight
Itaconic anhydride	20
Styrene	65
Methyl methacrylate	15
Butyl acetate	+100
Vazo 67	+5

the curing polyester.

The curing polyester is formed from adipic acid and a 50/50 mixture of butane-1,4-diol and ethylene glycol. The polyester is tipped with triethanolamine. It has been found that primary alcohols react faster with acid anhydrides than secondary alcohols under the same conditions. It is also known that nitrogenous bases (e.g. tertiary amines) are effective catalysts for the cross-linking reaction. The tertiary amines, however, must be present in similar molar quantities as the reactants in order for the amine to have a noticeable catalytic effect on the rate of reaction. Courtaulds chemistry has incorporated the amine into the polyester chain orientated  $\beta$  to the reactive hydroxyl tip. An amine placed in such a position renders the hydroxyl tip highly reactive. A mechanism for the catalytic effect of amine positioned  $\beta$  to the hydroxyl tip has been suggested by Courtaulds. The mechanism is shown in figure 4.3<sup>6</sup>. It has been suggested that the enhanced reactivity of  $\beta$ -hydroxyamines may be explained in terms of 5-membered cyclic intermediates for nucleophilic catalysts (figure 4.4a) or general base catalysts (figure 4.4b).

## 4.6 Synthesis of the polymers<sup>7,8</sup>

### 4.6.1 Synthesis of itaconic anhydride copolymer

The recipe of the ingredients for the synthesis of the itaconic anhydride copolymer is listed in table 4.2. The percentage weight of the individual reactants is given as well as the mass of each reactant required to make up a standard-sized batch of copolymer. The itaconic anhydride was dissolved in some of the butyl acetate (340g). The itaconic

### Table 4.3

Percentage weight and mass of monomers to make 1000g of polyester.

monomer	Molar ratio	Mass/g
Adipic acid	2.52	707.6
Ethylene glycol	1.00	119.3
Butane 1,4 diol	1.00	173.1

Figure 4.3

A general base mechanism has been proposed for the reaction between the triethanolamine-tipped polyester and the acid anhydride.

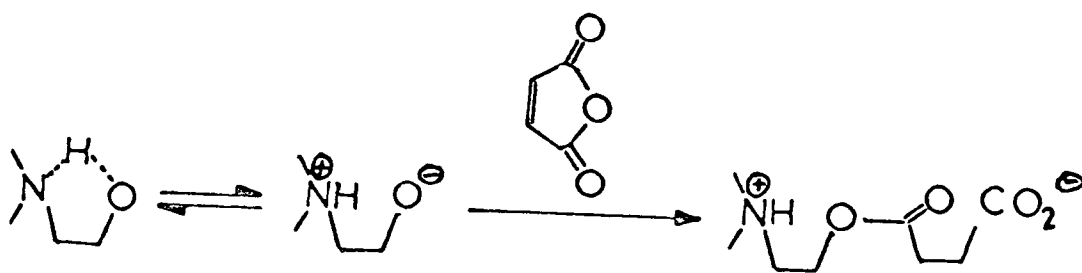

## Figure 4.4

It is thought that the enhanced reactivity of  $\beta$ -hydroxyamines may be explained in terms of 5-membered cyclic intermediates for a). nucleophilic catalysts or b). general base catalysts.

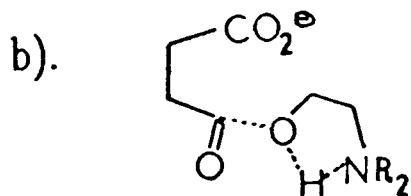
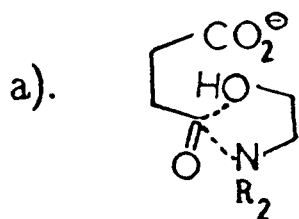

anhydride/butyl acetate solution was then filtered. 80g of the butyl acetate was charged into the reaction vessel. The styrene, methyl methacrylate and the initiator were dissolved in the remainder of the itaconic anhydride/butyl acetate solution. This mixture was then added dropwise to the reaction flask over a period of four hours with continual heating and stirring. The reaction was carried out under nitrogen. The average molecular weight of the itaconic anhydride film was 8000.

#### 4.6.2 Synthesis of the maleic anhydride copolymer

The maleic anhydride copolymer was made in a similar way to the itaconic anhydride copolymer, with the itaconic anhydride replaced by an equivalent mass of maleic anhydride. The synthesis of the maleic anhydride copolymer was carried out according to the method described in the last section. The average molecular weight of the maleic anhydride film was 8000.

#### 4.6.3 Synthesis of the polyester

Table 4.3 lists the percentage weight and the mass of the reactants required to make approximately 1000g of polyester. The quantities of monomers were such that the polymer formed was acid-tipped, and the alcohol component was a 50/50 mixture of ethylene glycol and butane-1,4-diol. The adipic acid, ethylene glycol and butane-1,4-diol were placed together in a reaction flask. The reaction was carried out under nitrogen, and the water was removed by the use of a dean and stark

trap. The reaction took place at a temperature between 160–190°C over a period of two days with continual heating and stirring. Towards the end of the reaction the temperature of the flask was raised by 20°C to drive off the excess water. A small quantity of xylene was added beforehand to prevent decomposition of the polyester. During the reaction, glycol loss was monitored by measuring the refractive index of the water collected by the dean and stark trap, and extra glycol was added to make up for glycol lost during water extraction. The average molecular weight of the polyester was 1000.

#### 4.6.4 Characterisation of the polyester

The polyester was characterised by solution–state  $^{13}\text{C}$  and  $^1\text{H}$  NMR and IR.

##### 4.6.4.1 Determination of the acid value

The acid value is a measure of how many of the polyester chains are acid–tipped. The higher the acid value, the greater is the number of polyester chains with acid end groups.

The amount of polyester used is dependent upon the expected acid value of the sample. Table 4.4 lists the weight of polymer required depending on the expected acid value.

The monomers used to form the polyester were reacted together with a ratio such that the polyester would be acid–tipped. Therefore the expected acid value is  $>50$ . Hence 1g of polyester was accurately weighed into a conical flask. This sample was then dissolved in 50ml of acid

## Table 4.4

Weight of polymer required for the determination of the acid value.

Expected acid value	Weight of resin/g
<10	5
10-50	5-3
>50	1

value solvent. This solvent is a 3:1 v:v mixture of xylene:butanol containing phenolphthalein indicator (0.1g/litre). This mixture is titrated with 0.1M methanolic KOH until the end point is reached, when a faint pink colour is sustained for more than 10 seconds. The titration is repeated several times, and an average titre taken. A blank titration is also performed on the acid value solvent which may have an inherent acid value.

The acid value (AV) is calculated from equation 4.2.

$$AV = \frac{(A-B) \times M \times 56.1}{W} \quad (4.2)$$

where W = weight of sample (g)

A = volume (ml) of 0.1M methanolic KOH used to titrate sample

B = volume (ml) of 0.1M methanolic KOH used to titrate blank

M = molarity of methanolic KOH.

The acid value of the polyester is in the region of 130.

The acid equivalent weight (AEW) is calculated by equation 4.3.

$$AEW = \frac{1000 \times W}{(A-B) \times M} \quad (4.3)$$

$$AEW = \frac{56100}{AV}$$

The AEW of the polyester is usually in the region of 420.

As the polyester is acid-tipped on both ends, the acid equivalent weight must be doubled.

#### 4.6.5 Tipping of the polyester

The final stage in the formation of the polyester resin is to tip the ends with triethanolamine. The molecular weight of triethanolamine is 149.2. Therefore 149.2g of triethanolamine is equivalent to AEWg of

untipped polyester. To tip Zg of polyester, it is necessary to react the polyester with  $(149.2 \times Z)/AVg$  of triethanolamine.

Untipped polyester was added to an equivalent weight of triethanolamine in a reaction flask together with an equal amount of xylene. The system was refluxed under nitrogen for 2–3 hours. After the reaction was completed, most of the xylene was taken off under vacuum.

#### 4.6.6 Characterisation of tipped polyester

The tipped polyester was characterised by IR, GPC, and  $^1H$  and  $^{13}C$  solution–state NMR.

##### 4.6.6.1 Determination of the solids content

The ratio of tipped polyester:xylene was determined by weighing out accurately 1g of the tipped polyester. This sample was then placed in an oven, and the solvent allowed to evaporate. The sample was then reweighed. The percentage solid content of the tipped polyester was calculated by:

$$\% \text{ solid content} = \frac{\text{Mass of the sample after evaporation}}{\text{Mass of the sample before evaporation}} \times 100 \quad (4.4)$$

This is repeated several times, and an average taken.

The solid content of the copolymers is usually in the region of 53%.

##### 4.6.6.2 Determination of the amine equivalent weight

1g of tipped polyester was dissolved in 50ml of acetic acid. This was titrated against 0.1M  $HClO_4$ . The titration was repeated several

times, and an average titre taken.

The amine equivalent weight was calculated from equation 4.5.

$$\text{Amine equivalent weight} = \frac{1000 \times \text{Mass}}{0.1 \times \text{titre}} \quad (4.5)$$

#### 4.6.7 Preparation of the polymeric films

The polymeric films were prepared by mixing together stoichiometric amounts of either itaconic or maleic anhydride copolymer and the triethanolamine-tipped polyester in a 1:1 ratio of equivalent weights. The film was drawn evenly on a PTFE sheet and allowed to cure at room temperature for two weeks. For the solid-state NMR experiments, the film was powdered under liquid nitrogen, and then stored in a sample jar until required. Throughout this thesis, the film made with the itaconic anhydride copolymer will be referred to as itaconic anhydride film, and similarly the film made with the maleic anhydride copolymer will be referred to as maleic anhydride film.

#### 4.6.8 Synthesis of polyester with $^{13}\text{C}$ enrichment

Polyester was made on a small scale with 90%  $^{13}\text{C}_2$ -enriched ethylene glycol. 1.9g of the enriched ethylene glycol was purchased from MSD Isotopes. Before making the enriched polyester, trial runs were carried out using scaled-down proportions of monomer.

##### 4.6.8.1 The trial run

The amount of monomers required to react with 1.9g of ethylene glycol is shown in table 4.5. The monomers were placed together in a

Table 4.5

Mass of monomers required to form the polyester from 1.9g of  $^{13}\text{C}_2$ -enriched ethylene glycol.

Monomer	weight/g
Adipic acid	11.27
Butane 1,4 diol	2.76
Ethylene glycol	1.90

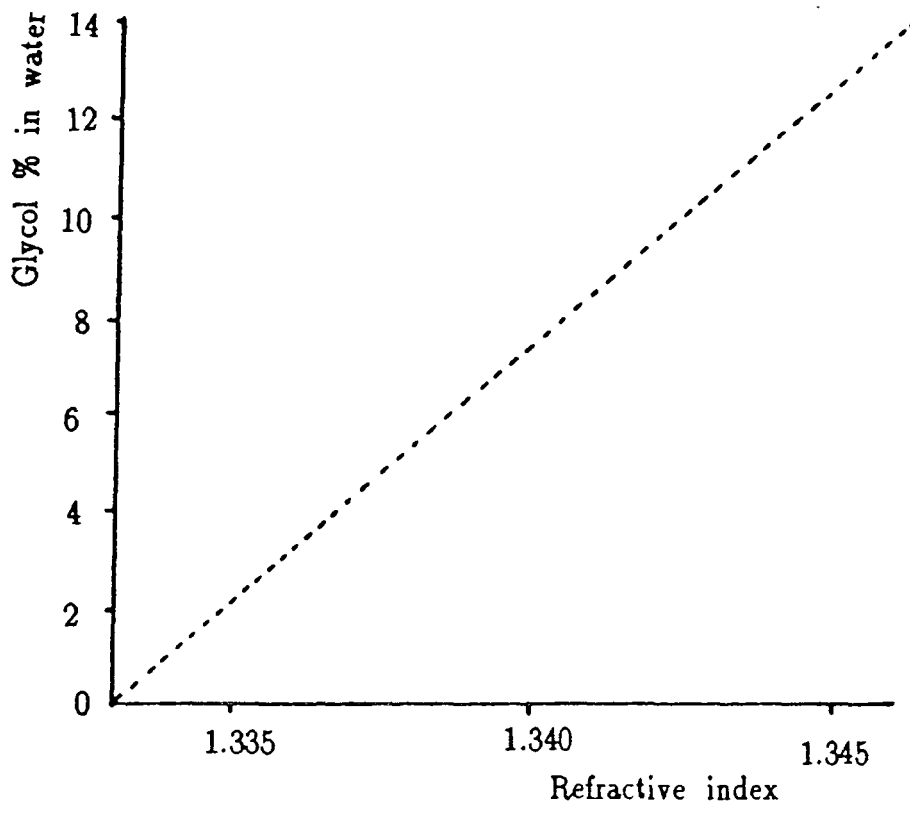

**Figure 4.5**

The determination of ethylene glycol content of distillate water using refractive index.

50ml flask. A small dean and stark trap was fitted, and the monomers were stirred and heated at 170°C for two days. The dean and stark trap was designed so that only water could collect at this temperature; the temperature in the flask was insufficient for ethylene glycol to be collected by the dean and stark trap. This would prevent expensive loss of ethylene glycol when enriching. The water collected by the dean and stark trap was monitored for glycol content by refractive index measurements. The refractive index of the water was measured at 1.34, which corresponds to 1% ethylene glycol content (figure 4.5). This loss was minimal. The polyester product was characterised by GPC, IR and <sup>13</sup>C and <sup>1</sup>H solution-state NMR.

#### 4.6.8.2 Tipping of the polyester

A trial run of the final stage of the polyester formation was carried out on a similar scale. 4.76g of triethanolamine was added to 13.3g of polyester. An equivalent weight of xylene was added, and the mixture was refluxed at 160°C for 2–3 hours. After the reaction was completed, the flask was allowed to cool, and the xylene extracted under vacuum.

#### 4.6.8.3 Characterisation of the polyester

The product was characterised by GPC, IR and <sup>13</sup>C and <sup>1</sup>H solution-state NMR. The product was found to be identical to the tipped polyester made using the standard bulk method as described in section

Figure 4.6

The  $^{13}\text{C}$  solution-state spectrum of  $^{13}\text{C}_2$ -enriched polyester. The recycle delay was 3 seconds, the acquisition time 1.2 seconds and 256 transients were acquired.

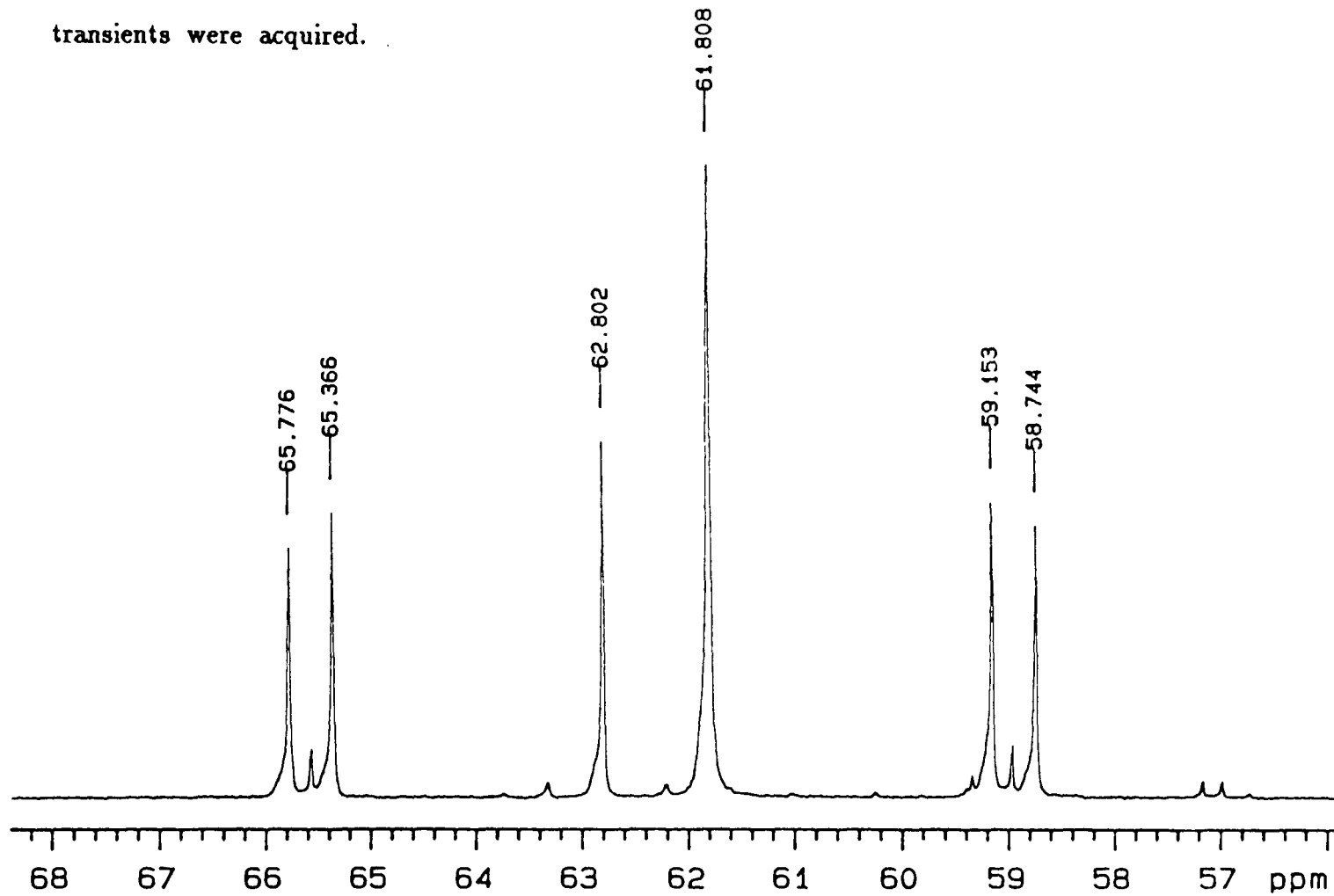

4.6.8.1. Both stages of this synthesis were each repeated several times to ensure that the enrichment would produce polyester.

#### 4.6.8.4 The enrichment

1.9g of 90%  $^{13}\text{C}_2$ -enriched ethylene glycol, 2.76g of butane 1,4 diol and 11.27g of adipic acid were placed in a 50ml flask. The method used to make the enriched polyester follows that described for the trial run exactly.

#### 4.6.8.5 Characterisation

The refractive index of the water was measured to be 1.34. this corresponds to 1% loss of enriched ethylene glycol during the synthesis. The enriched tipped polyester was checked by solution-state  $^{13}\text{C}$  NMR. The solution-state  $^{13}\text{C}$  spectrum obtained is shown in figure 4.6. The peak due to the expected product is present at 62.8ppm. The assignments of the other peaks can be, found in Chapter Eight.

## CHAPTER 5

### Spectral assignment and kinetics

#### 5.1 Spectral assignment of the polymeric films

The solid-state  $^{13}\text{C}$  cross-polarisation NMR spectra of both the maleic anhydride film and the itaconic anhydride film are complex. Figure 5.3a shows the CP spectrum of the itaconic anhydride film. With so many overlapping and obscured peaks, assignment of the spectra is not a straight-forward task. In order to fully assign the spectra, it is necessary to simplify the spectra as much as possible using discriminating techniques such as non-quaternary suppression (NQS)<sup>1</sup> and single pulse excitation (SPE) pulse sequences.

##### 5.1.1 Assignment of the itaconic anhydride copolymer

The  $^{13}\text{C}$  cross-polarisation spectrum of the itaconic anhydride copolymer is shown in figure 5.1a, together with the structure of the copolymer. The spectrum would be greatly simplified if the peaks due to the quaternary carbons could be identified and assigned. One method of achieving this is by using the non-quaternary suppression pulse sequence. Figure 5.1b shows the NQS spectrum of the itaconic anhydride copolymer with assignments. The assignments were made by searches for similar compounds in the  $^{13}\text{C}$  NMR database at Daresbury and by comparing the solution-state shifts for similar carbons in a  $^{13}\text{C}$  NMR databook<sup>2</sup>. By comparing the NQS spectrum with the CP spectrum of the itaconic

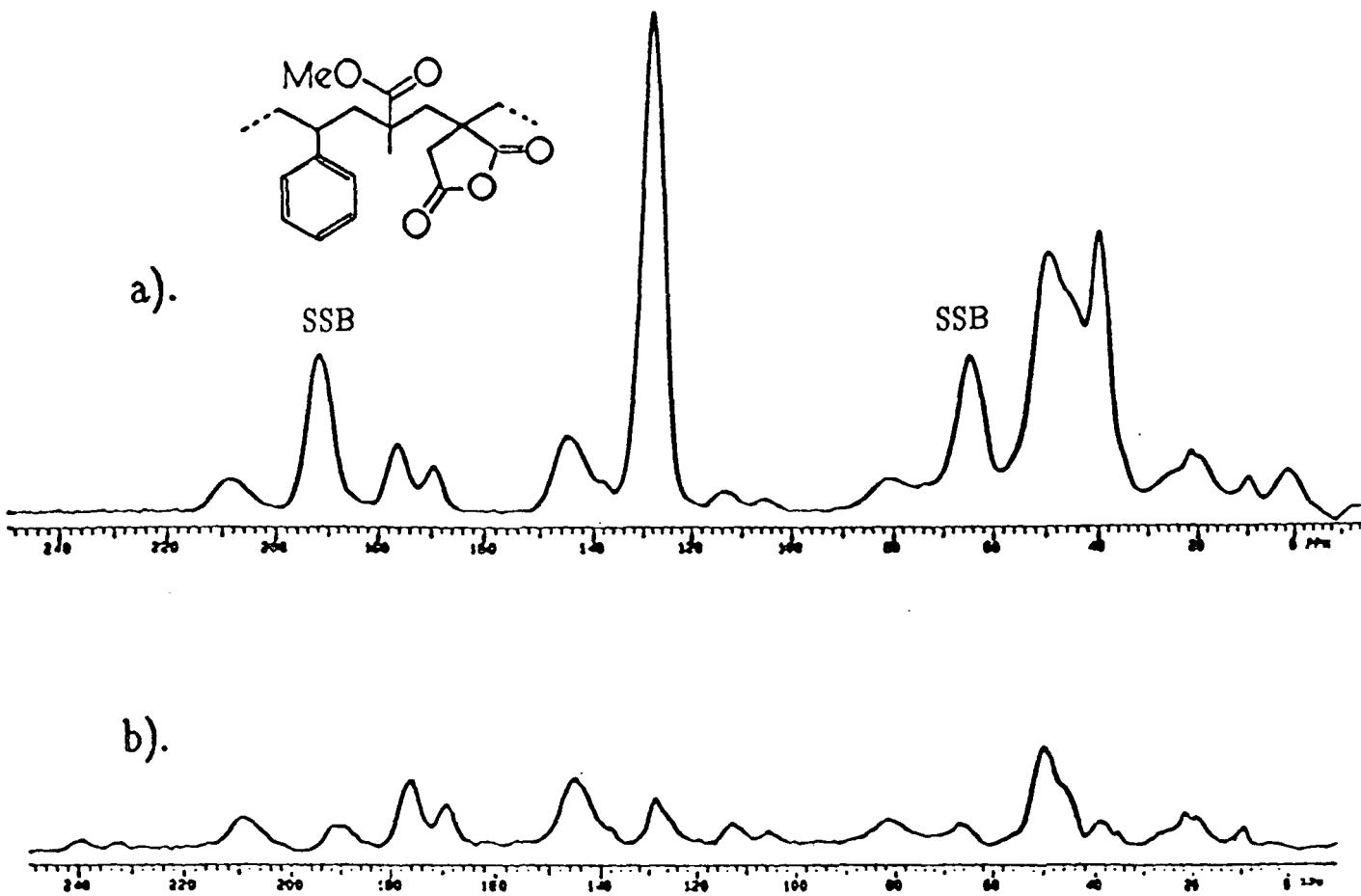

Figure 5.1

a). The  $^{13}\text{C}$  cross-polarisation spectrum of the itaconic anhydride copolymer.

b). The NQS  $^{13}\text{C}$  spectrum of the itaconic anhydride copolymer. A decoupling window of  $40\ \mu\text{s}$  was used.

parameters

contact time = 1.5 ms

NT = 1000

Recycle delay = 6 seconds

Acquisition time = 26 ms.

## Table 5.1

Assignment of the peaks in the itaconic anhydride copolymer spectrum.

Peak/ppm	Assignment
176	C=O of MMA
169.5	C=O of itaconic anhydride
144.8	Aromatic quaternary carbon of styrene
128.3	Aromatic C-H of styrene
49.6	CH <sub>3</sub> O of MMA
49	Quaternary carbon of itaconic anhydride
45	Quaternary carbon of MMA
40-45	CH backbone carbons
41.5	CH of polystyrene
40.1	CH <sub>2</sub> 'backbone' of copolymer
19.8	CH <sub>3</sub> of MMA

## Table 5.2

Assignment of the peaks in the polyester spectrum.

Peak/ppm	Assignment
173	C=O in ester
64	O=C-O-CH <sub>2</sub>
34	O-C(=O)-CH <sub>2</sub>
25	CH <sub>2</sub> 'backbone'



anhydride copolymer, it is possible to assign the remaining carbons in the itaconic anhydride copolymer. A full assignment of the itaconic anhydride copolymer is shown in Table 5.1.

### 5.1.2 Assignment of the polyester

The solution-state  $^{13}\text{C}$  spectrum of the polyester tipped with triethanolamine is shown in figure 5.2 together with the structure of the polyester. The assignments were made on the basis of predicted chemical shifts in the  $^{13}\text{C}$  NMR chemical shift data handbook.<sup>2</sup> An assignment of the peaks in the spectrum is shown in Table 5.2.

### 5.1.3 Assignment of the itaconic anhydride film

The  $^{13}\text{C}$  cross-polarisation spectrum of the itaconic anhydride copolymer is shown together with the  $^{13}\text{C}$  cross-polarisation spectrum of the itaconic anhydride film in figures 5.3a and 5.3b respectively. There are four main extra peaks at 25, 34, 64 and 173 ppm in the  $^{13}\text{C}$  CP spectrum of the itaconic anhydride film which were not present in the  $^{13}\text{C}$  CP spectrum of the itaconic anhydride copolymer. These peaks are due to the polyester component of the film. The assignments were made by looking-up the predicted chemical shift in the  $^{13}\text{C}$  NMR chemical shift handbook,<sup>2</sup> and comparing this predicted chemical shift with the four peaks observed. The chemical shifts and assignments of the peaks in the  $^{13}\text{C}$  CP spectrum of the itaconic anhydride film are listed in Table 5.3.

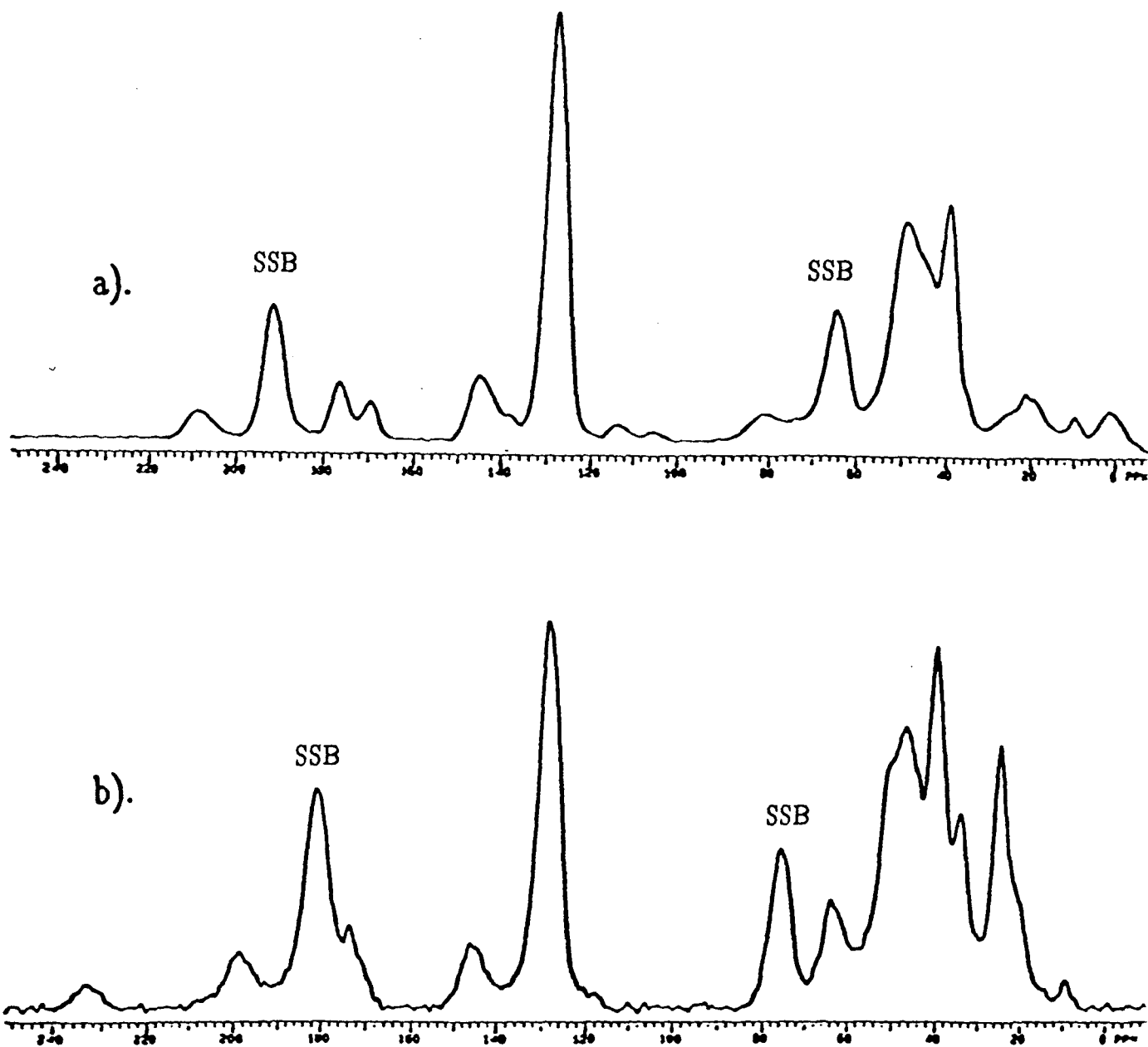

**Figure 5.3**

- a). The  $^{13}\text{C}$  CP spectrum of the itaconic anhydride copolymer.
- b). The  $^{13}\text{C}$  CP spectrum of the itaconic anhydride film.

Parameters

Contact time = 1.5 ms

NT = 1000

Recycle delay = 6 seconds

Acquisition time = 26 ms.

### Table 5.3

Assignment of the peaks in the itaconic anhydride film spectrum.

Peak/ppm	Assignment
173.5	C=O of MMA, cross-link, and polyester
144.8	Aromatic quaternary carbon of styrene
128.3	Aromatic C-H of styrene
63	O=C-O-CH <sub>2</sub> in polyester chain
49.6	CH <sub>3</sub> O of MMA
45	Quaternary carbon of MMA
40-45	CH backbone carbons
41.5	CH of polystyrene
40.1	CH <sub>2</sub> 'backbone' of copolymer
33.5	O-C(=O)-CH <sub>2</sub> in polyester chain
25	CH <sub>2</sub> 'backbone' of polyester
19.8	CH <sub>3</sub> of MMA

## Table 5.4

Assignment of the peaks in the maleic anhydride copolymer spectrum.

Peak/ppm	Assignment
173	C=O composite peak of MMA and maleic anhydride
143	Aromatic quaternary carbon of styrene
128.4	Aromatic C-H of styrene
51.1	CH <sub>3</sub> O of MMA
45.3	Quaternary carbon of MMA
40-45	CH backbone carbons
41.5	CH of polystyrene
40.9	CH <sub>2</sub> 'backbone' of copolymer
19.7	CH <sub>3</sub> of MMA

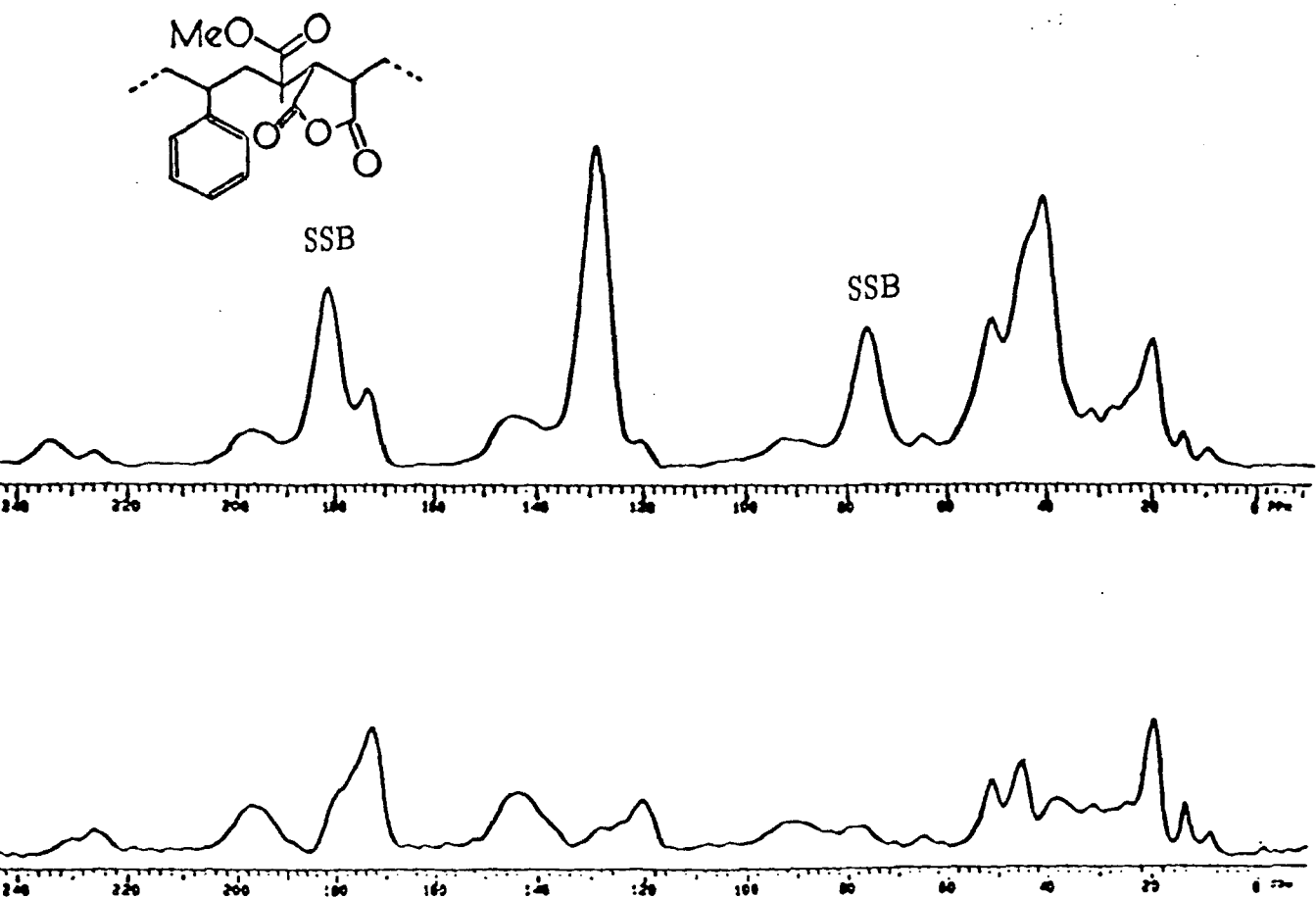

Figure 5.4

a). The  $^{13}\text{C}$  cross-polarisation spectrum of the maleic anhydride copolymer.

b). The NQS  $^{13}\text{C}$  spectrum of the maleic anhydride copolymer. A decoupling window of  $40\ \mu\text{s}$  was used.

parameters

contact time = 1.5 ms

NT = 1000

Recycle delay = 6 seconds

Acquisition time = 26 ms.

#### 5.1.4 Assignment of the maleic anhydride copolymer

The assignments of the peaks in the CP spectrum of the maleic anhydride copolymer were made in a similar way to those in the itaconic anhydride copolymer. Figure 5.4 shows the NQS spectrum of the maleic anhydride copolymer together with the CP spectrum of the same sample. The NQS spectrum shows peaks arising from quaternary carbons only. The assignments shown were made on the basis of the predictions of the chemical shifts of the quaternary carbons from the  $^{13}\text{C}$  NMR chemical shift databook.<sup>2</sup> Comparison between the NQS spectrum and the CP spectrum of the maleic anhydride copolymer allows the non-quaternary peaks in the maleic anhydride copolymer to be assigned using the  $^{13}\text{C}$  chemical shift databook. The full assignment of the maleic anhydride copolymer is shown in Table 5.4.

#### 5.1.5 Assignment of the maleic anhydride film

The  $^{13}\text{C}$  cross-polarisation spectrum of the maleic anhydride copolymer is shown together with the  $^{13}\text{C}$  cross-polarisation spectrum of the maleic anhydride film in figure 5.5. In the same manner as for the itaconic anhydride film, comparison between these two spectra shows that there are four main additional peaks in the CP spectrum of the maleic anhydride film. These peaks at 25, 34, 64 and 173 ppm are assigned to the polyester regions of the maleic anhydride film. A full assignment of the peaks in the  $^{13}\text{C}$  CP spectrum of the maleic anhydride film is shown in Table 5.5.

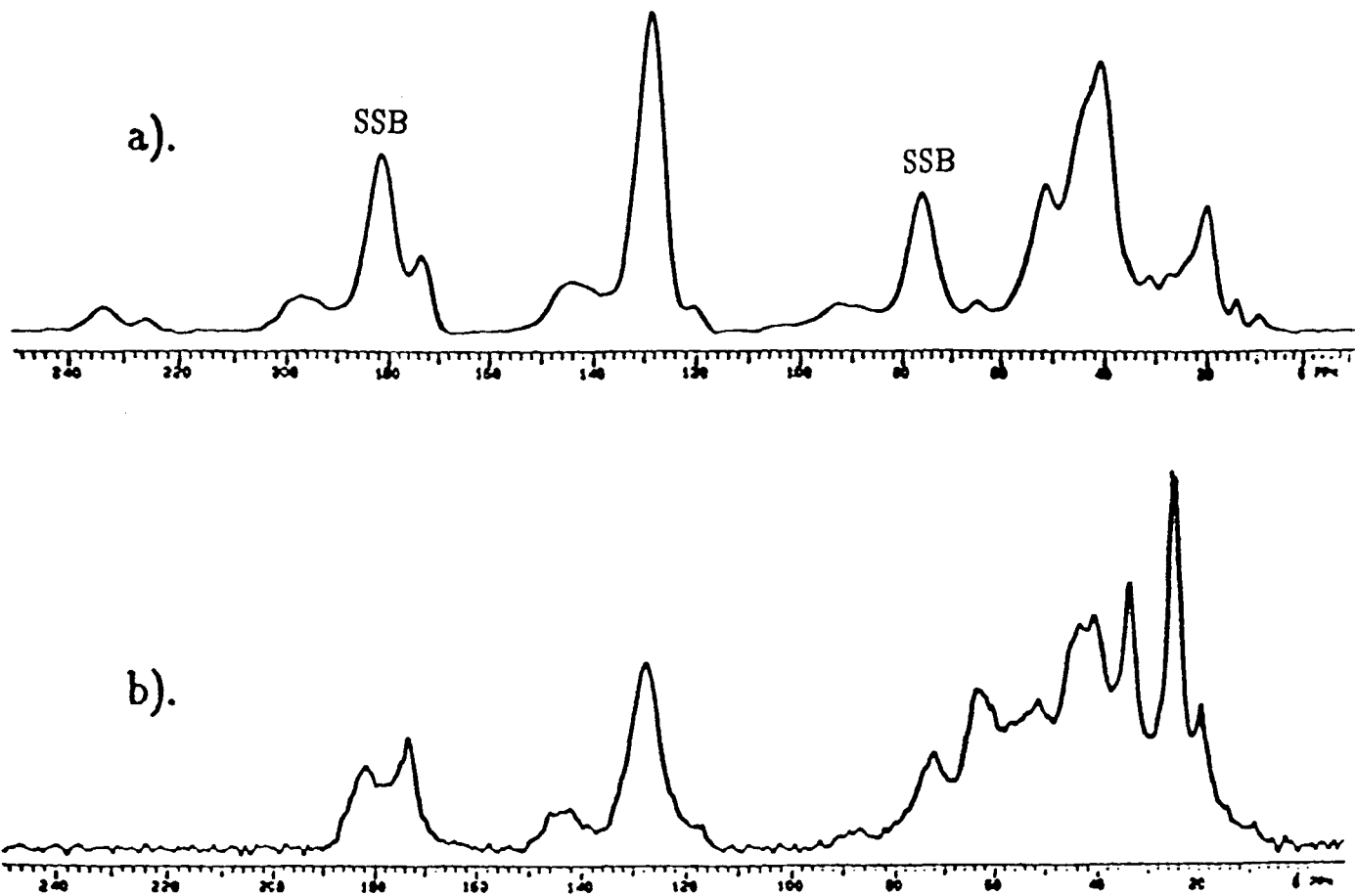

Figure 5.5

- a). The  $^{13}\text{C}$  CP spectrum of the maleic anhydride copolymer.  
 b). The  $^{13}\text{C}$  CP spectrum of the maleic anhydride film.

Parameters

Contact time = 1.5 ms

NT = 1000

Recycle delay = 6 seconds

Acquisition time = 26 ms.

## Table 5.5

Assignment of the peaks in the maleic anhydride film spectrum.

Peak/ppm	Assignment
173.5	C=O of MMA, cross-link, and polyester
143	Aromatic quaternary carbon of styrene
127.8	Aromatic C-H of styrene
63.1	O=C-O-CH <sub>2</sub> in polyester chain
51.3	CH <sub>3</sub> O of MMA
45	Quaternary carbon of MMA
40-45	CH backbone carbons
41.5	CH of polystyrene
40.8	CH <sub>2</sub> 'backbone' of copolymer
33.8	O-C(=O)-CH <sub>2</sub> in polyester chain
24.9	CH <sub>2</sub> 'backbone' of polyester
19.6	CH <sub>3</sub> of MMA

## 5.2 Polyester carbons of differing mobilities

The spectra of polymers will consist of a superposition of subspectra from carbons of different mobilities which may be in similar chemical environments and hence have overlapping resonances. It is of great interest to be able to discriminate between these mobilities and to be able to obtain spectra of carbons with different mobilities separately. To obtain spectra of the more mobile carbons, a simple  $90^\circ$  ( $^{13}\text{C}$ ) repetitive (single-pulse-excitation) pulse sequence with high-power decoupling can be used. This experiment will discriminate in favour of carbons with short  $T_1(^{13}\text{C})$  if the repetition rate of the pulses is reasonably high. The pulse sequence for the single-pulse-excitation (SPE) experiment is shown in figure 5.6. The shorter the recycle delay,  $t_d$ , the more mobile are the carbons observed in the corresponding spectrum. A set of SPE spectra were acquired for the itaconic anhydride film. The recycle delay was varied between 0.05 and 10 seconds. Four of the spectra acquired with recycle times of 0.05, 0.2, 0.5 and 10 seconds are shown in figure 5.7a-d. Figure 5.7a with a recycle time of 0.05 seconds shows four peaks at 19, 25, 34 and 64 ppm. The peaks at 25, 34 and 64 ppm originate from the polyester chains in the film, and the peak at 19 ppm originates from the  $\text{CH}_2$  in the copolymer chains. In general, the shorter the recycle time, the more mobile are the carbons shown in the spectrum. Thus the polyester chains in the film are much more mobile than the copolymer chains. As the recycle time is increased, peaks due to the more rigid copolymer chains begin to appear in the spectra. The apparent decrease in intensity of the peaks at 19, 25, 34 and 64 ppm

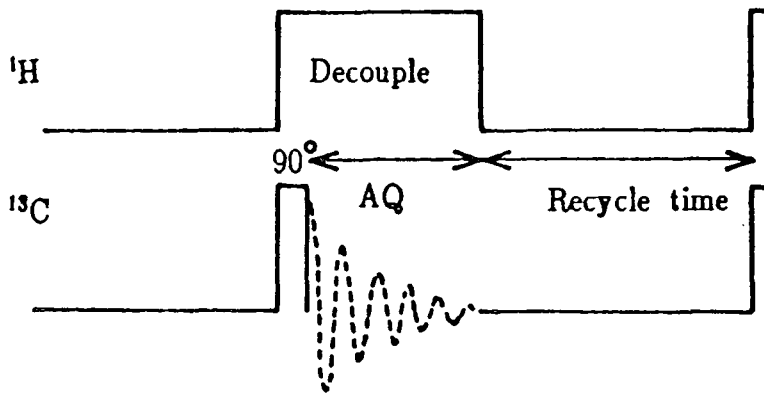

Figure 5.6

The pulse sequence for the single-pulse-excitation experiment.

between 0.5 and 10 seconds was thought to have arisen from transient nuclear Overhauser effects.<sup>3</sup> This suggestion is shown to be correct in Chapter Seven. Figure 5.8a-d shows similar SPE spectra of the maleic anhydride film for recycle times of 0.5, 0.75, 1.5 and 2 seconds. The peaks at 25, 34 and 64 ppm decrease substantially as the recycle time is increased. Again, this was thought to arise from transient nuclear Overhauser effects. The carbonyl peak of the polyester at 173 ppm increases as the recycle time increases. The carbonyl does not have any attached protons, thus the C-H interactions between the carbonyl and its neighbouring protons are a little weaker than for the carbons with protons directly bonded to them. Hence the carbonyl carbon, even though it is mobile, does not show transient nuclear Overhauser effects. One point of particular interest in figure 5.8 is that the peak at 64 ppm with a recycle time of 0.5 seconds shows fine structure, which is subsequently lost as the recycle time is increased. The fine structure of the peak at 64 ppm shows two peaks resolved at 62.1 ppm and 63.3 ppm. These peaks originate from the CH<sub>2</sub> in the alcohol component of the polyester next to the ester linkage in the polyester chain. The ethylene glycol component gives rise to the peak at 62.1 ppm, and the butane-1,4 diol component gives rise to the peak at 63.3 ppm. One possible explanation for this loss of structure is that there are two types of polyester present in the film, one slightly more mobile than the other. This would result in a two component carbon T<sub>1</sub> for the polyester peaks: a shorter T<sub>1</sub> component arising from the more mobile polyester chains, and a longer T<sub>1</sub>

**Figure 5.7**

Single-pulse-excitation spectra of the itaconic anhydride film obtained with a recycle time of a). 0.05 seconds b). 0.2 seconds c). 0.5 seconds and d). 10 seconds.

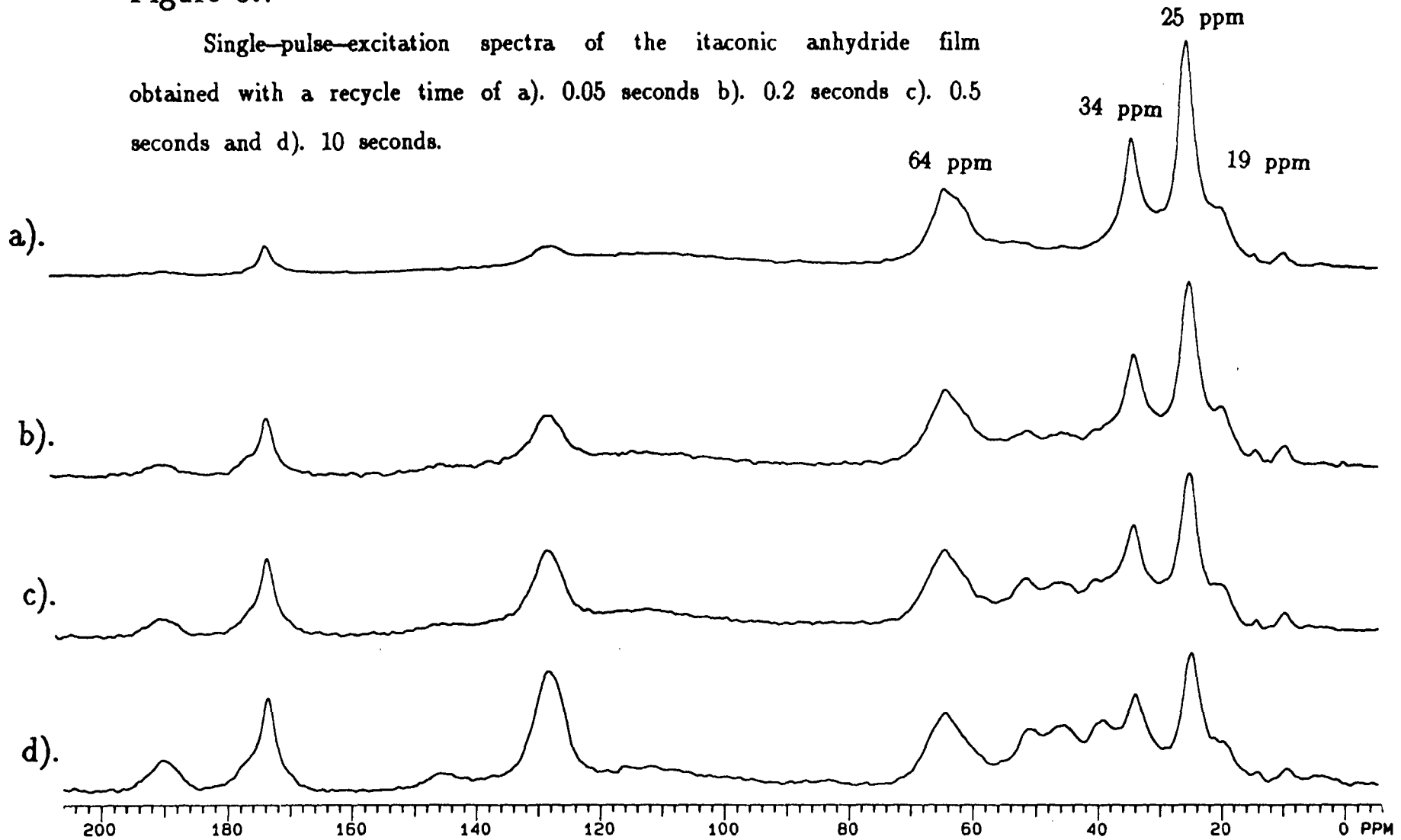

Parameters: NT = 1000  
AQ = 20 ms

Ethylene glycol component

Butane 1,4 diol component

$\text{OCH}_2\text{CH}_2\text{O}$

$\text{OCH}_2\text{CH}_2\text{CH}_2\text{CH}_2\text{O}$

Figure 5.8

Single-pulse-excitation spectra of the maleic anhydride film obtained with a recycle time of a). 0.5 seconds b). 0.75 seconds c). 1.5 seconds and d). 2 seconds.

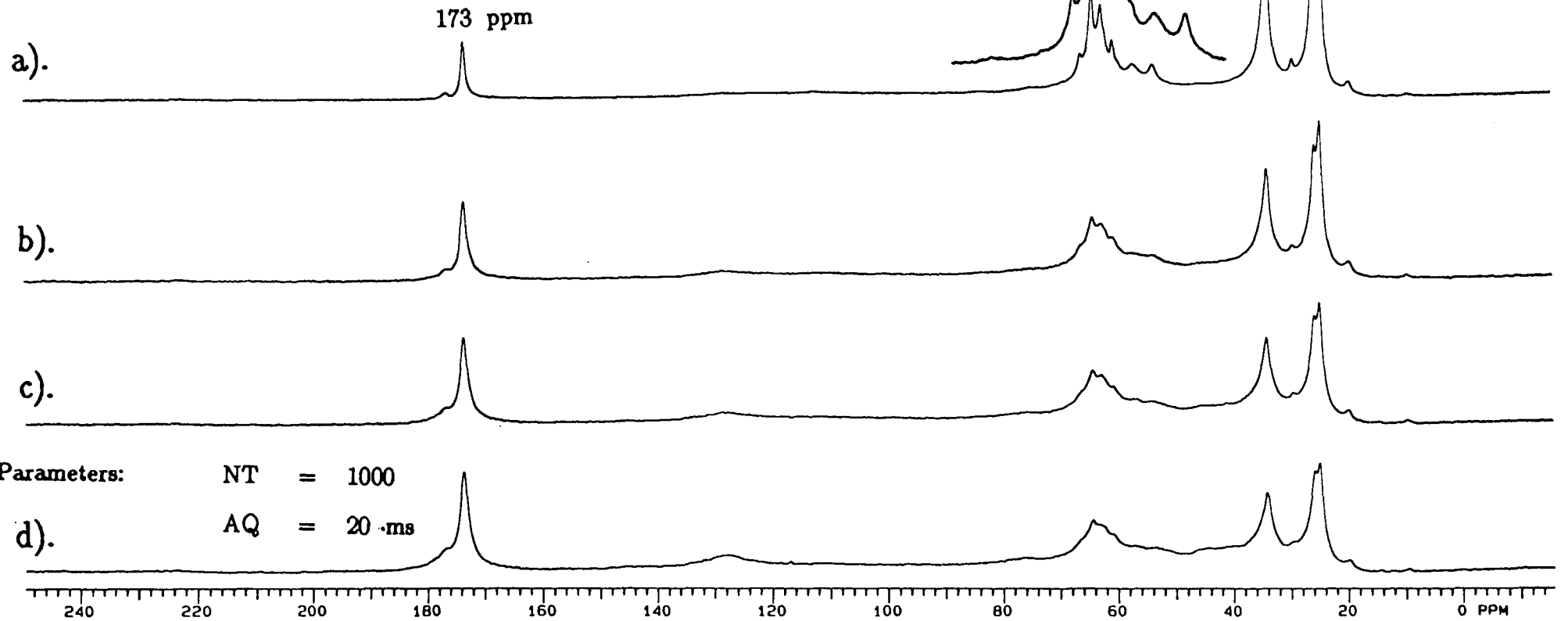

component arising from the less mobile polyester chains. It is not easy to distinguish a two component carbon  $T_1$  from a single component carbon  $T_1$  using conventional techniques to measure the  $T_1$ . This is because usually only a few datapoints are obtained for each peak on account of the large amount of time which a  $^{13}\text{C}$   $T_1$  experiment takes. It is totally impractical to obtain enough datapoints to distinguish between a two component or a one component carbon  $T_1$  via the inversion recovery method. Another well-known method of measuring carbon  $T_1$ 's is by using the method proposed by Torchia<sup>4</sup> involving cross-polarisation. However this method is suitable for more rigid carbons because of the cross-polarisation stage in the pulse sequence.

#### 5.2.1 Measurement of the shorter carbon $T_1$ component

A new pulse sequence has been devised which specifically measures short carbon  $T_1$ 's. The pulse sequence for the measurement of short spin-lattice relaxation times for  $^{13}\text{C}$  in solid polymers is presented in figure 5.9. The usual way to measure the carbon spin-lattice relaxation times in a sample in the solid-state is by using the inversion recovery pulse sequence. However in some cases it is not feasible to use this method. For example, when spectra are complex with overlapping peaks from carbons with short and long relaxation times, the inversion-recovery method will produce complicated recovery curves because of the requirement for a long recycle delay to allow full recovery between successive  $180^\circ$  pulses. The MOST pulse sequence was devised to measure the carbon  $T_1$ 's of the mobile chains in a solid polymer. The mobile

Figure 5.9

MOST: The pulse sequence for the measurement of short carbon  $T_1$  values.

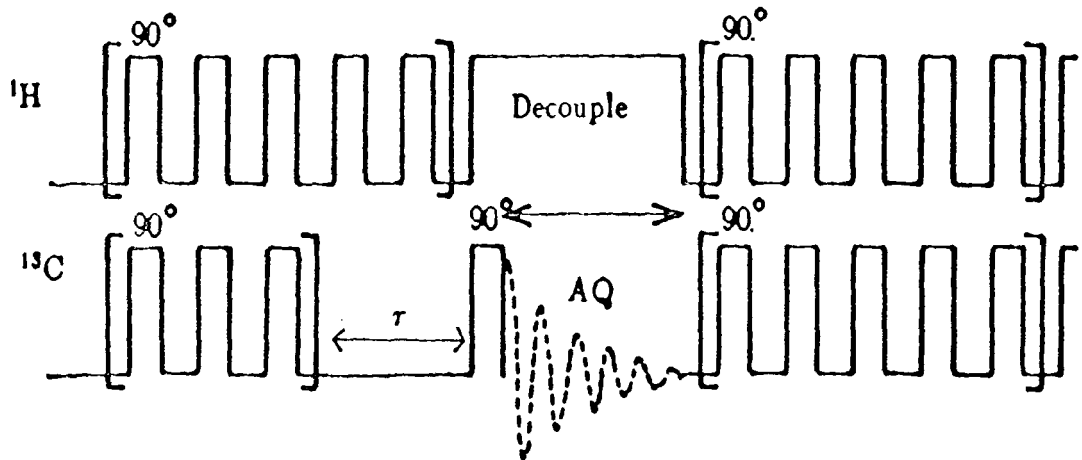

polymer chains of such a system tend to have short carbon  $T_1$ 's, but more rigid polymer chains (with longer carbon  $T_1$ 's) give peaks in the same part of the spectrum as the mobile carbons.

An  $I=\frac{1}{2}$  spin is saturated when the populations of the two energy levels are equal. This situation occurs when the magnetisation is placed in the  $xy$  plane. Therefore a succession of  $90^\circ$  pulses at the proton frequency during the recycle delay saturates the proton spins. A similar saturation chain applied at the carbon frequency saturates the carbon spins. In practice  $5 \mu\text{s}$   $90^\circ$  proton and carbon pulses were applied alternately every 1ms during the saturation chain. During the recovery time,  $\tau$ , only the proton saturation pulses are continued.

The aim of the pulse sequence is to monitor the recovery of the carbon signal from saturation whilst the proton spins remain saturated. One effect of saturating the proton spins is to increase the carbon signal by the nuclear Overhauser enhancement factor. The saturation-recovery method for determining  $T_1$  for solutions is not generally applicable to the solid-state because of the risk that a large duty-cycle of high-power decoupling may damage the probe. The maximum  $^1\text{H}$  duty-cycle used in the following experiments is 0.007, though obviously there is also  $^{13}\text{C}$  irradiation to consider.

Solomon<sup>5</sup> derived equations through consideration of the population changes to describe the behaviour of macroscopic magnetisation with time. Consider a pair of coupled spins  $^{13}\text{C} \equiv I = \frac{1}{2}$  and  $^1\text{H} \equiv S = \frac{1}{2}$ . These obey the coupled equations:

$$\frac{d\langle I_z \rangle}{dt} = -\frac{1}{T_1^{II}} \left[ \langle I_z \rangle - I_0 \right] - \frac{1}{T_1^{IS}} \left[ \langle S_z \rangle - S_0 \right] \quad (5.1a)$$

$$\frac{d\langle S_z \rangle}{dt} = -\frac{1}{T_1^{SI}} \left[ \langle I_z \rangle - I_0 \right] - \frac{1}{T_1^{SS}} \left[ \langle S_z \rangle - S_0 \right] \quad (5.1b)$$

where

$1/T_1^{SS}$  is the total direct relaxation rate of the protons

$1/T_1^{II}$  is the total direct relaxation rate of the carbons

$1/T_1^{IS}$  is the cross-relaxation rate,

and  $I_0$ ,  $S_0$  are the Boltzmann equilibrium values of  $I_z$ ,  $S_z$  respectively.

The intensity of the carbon magnetisation,  $\langle I_z \rangle$ , at any instant in a single-pulse experiment may be calculated by solving the above linear simultaneous differential equations under the appropriate boundary conditions.

These boundary conditions are:

$$\langle I_z \rangle(0) = 0 \quad (5.2a)$$

$$\langle S_z \rangle(0) = \langle S_z \rangle(\tau) = 0 \quad (5.2b)$$

This results in expression 5.3 for the intensity of the carbon signal at the end of the delay period  $\tau$ .

$$\langle I_z \rangle_\tau = \left[ \frac{S_0 T_1^{II}}{T_1^{IS}} + I_0 \right] \left[ 1 - \exp(-\tau/T_1^{II}) \right] \quad (5.3)$$

Figure 5.10 shows the growth from saturation of the polyester carbons in the itaconic anhydride film with  $\tau$  values ranging between 0.05 and 8 seconds (infinity measurement). By fitting the experimentally measured carbon intensities to equation 5.3, it is possible to obtain values for the carbon spin-lattice relaxation time,  $T_1^{II}$ . The fitted intensities are

Table 5.6

Short carbon  $T_1$  values of the polyester chains in the itaconic anhydride film.

Peak/ppm	Assignment	Short $T_1(^{13}\text{C})/\text{secs}$
64	$\text{O}=\text{C}-\text{O}-\text{CH}_2$	0.36
34	$\text{O}-\text{C}(=\text{O})-\text{CH}_2$	0.29
25	$\text{CH}_2$ 'backbone'	0.28
19	$\text{CH}_3$ of MMA	0.29

Table 5.7

Short carbon  $T_1$  values of the polyester chains in the maleic anhydride film.

Peak/ppm	Assignment	Short $T_1(^{13}\text{C})/\text{secs}$
64	$\text{O}=\text{C}-\text{O}-\text{CH}_2$	0.31
34	$\text{O}-\text{C}(=\text{O})-\text{CH}_2$	0.33
25	$\text{CH}_2$ 'backbone'	0.26
19	$\text{CH}_3$ of MMA	0.57

Parameters: NT = 1000  
AQ = 20 ms  
Recycle delay = 5 seconds

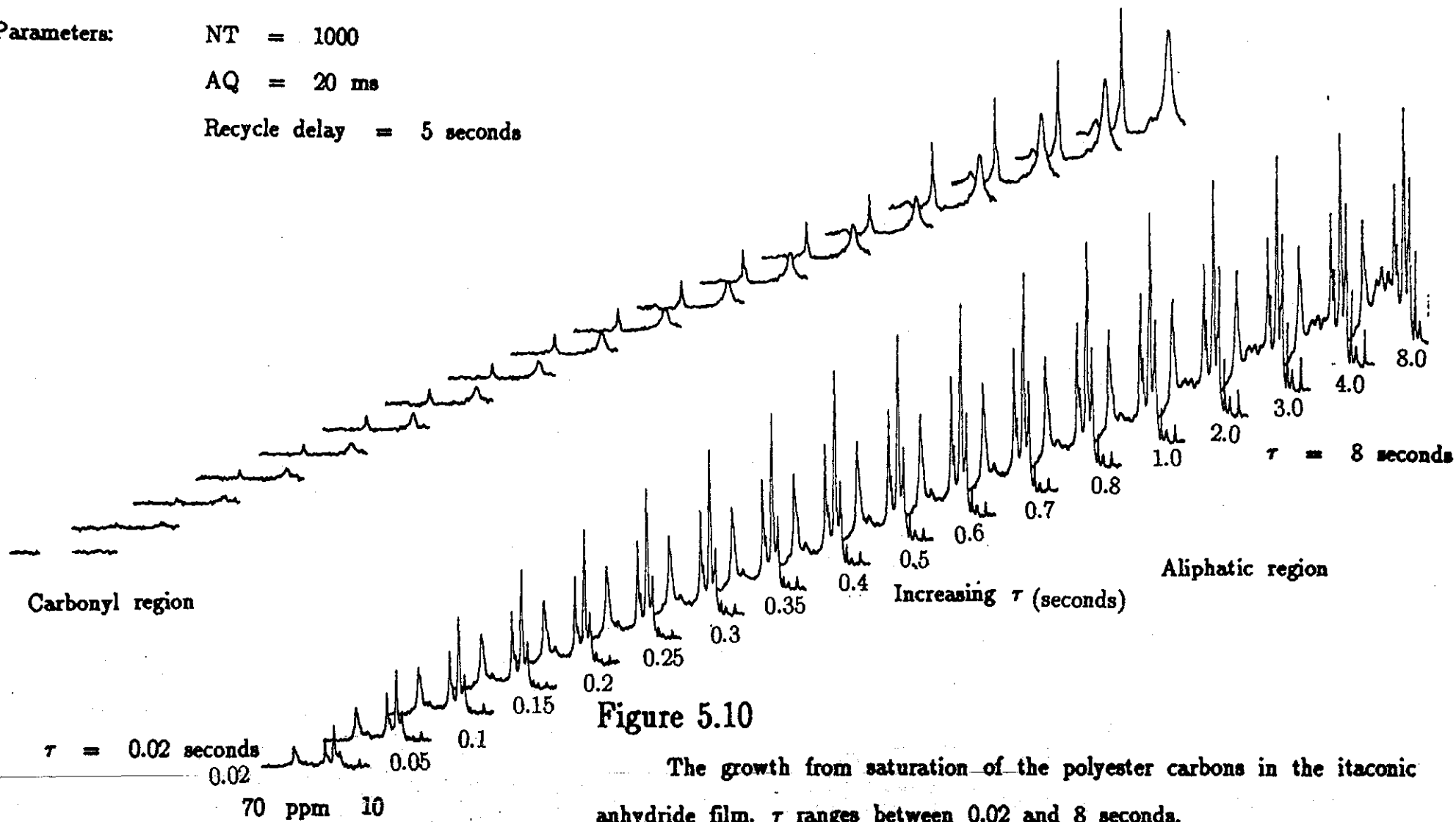

Figure 5.10

The growth from saturation of the polyester carbons in the itaconic anhydride film.  $\tau$  ranges between 0.02 and 8 seconds.

Figure 5.11

The fitted MOST carbon intensities for the itaconic anhydride film.

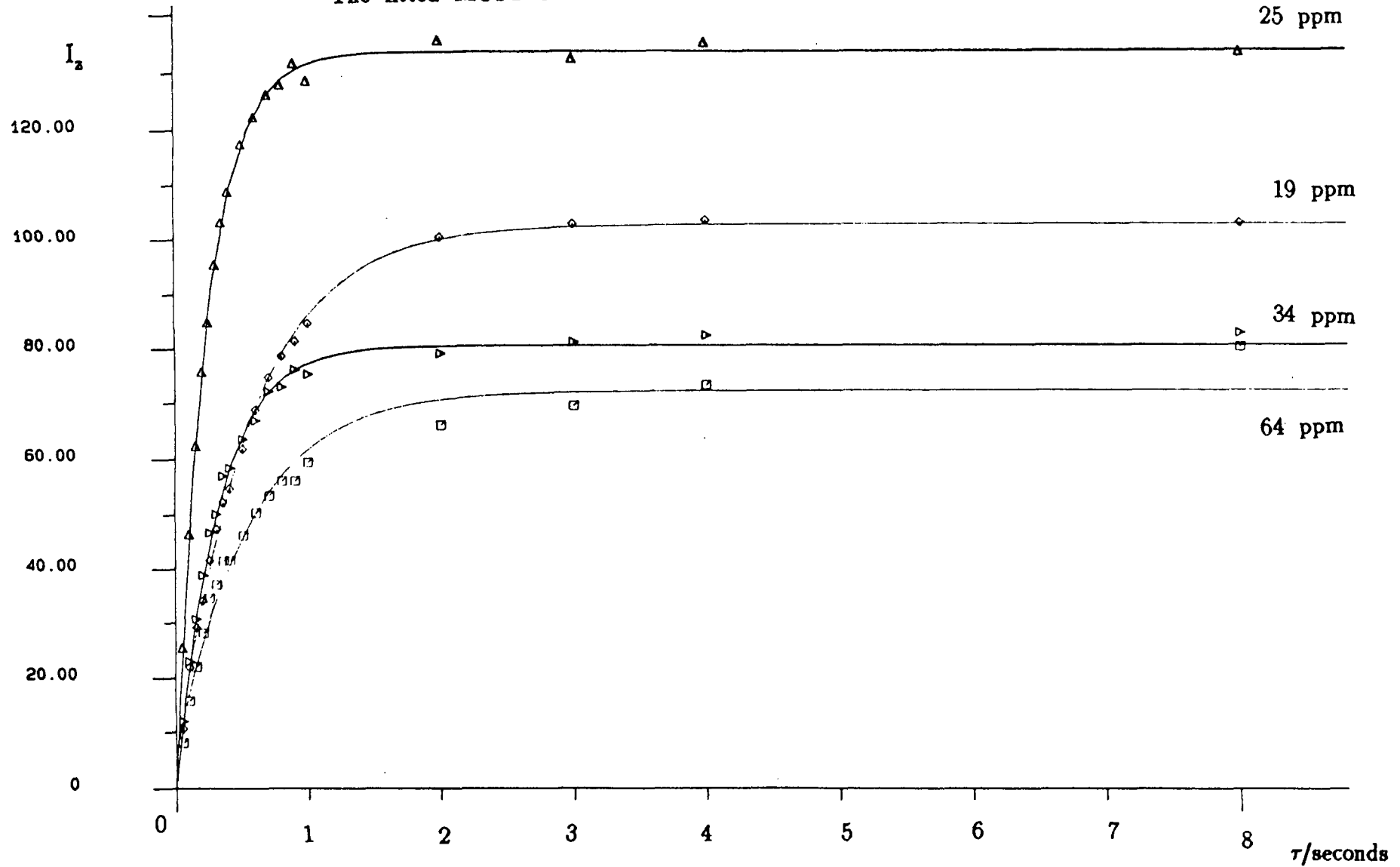

Figure 5.12

The growth from saturation of the polyester carbons in the maleic anhydride film.  $\tau$  ranges between 0.02 and 8 seconds.

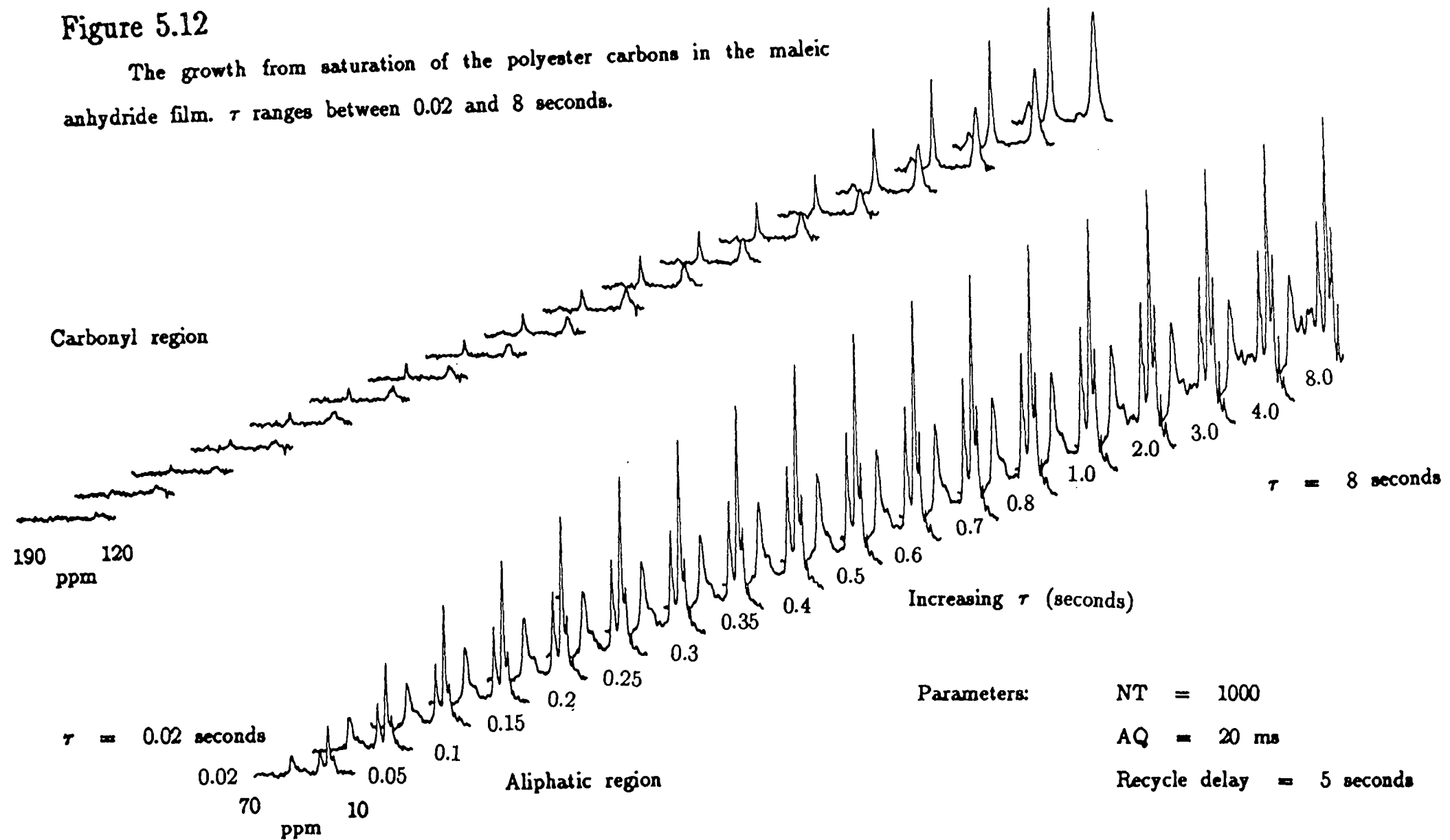
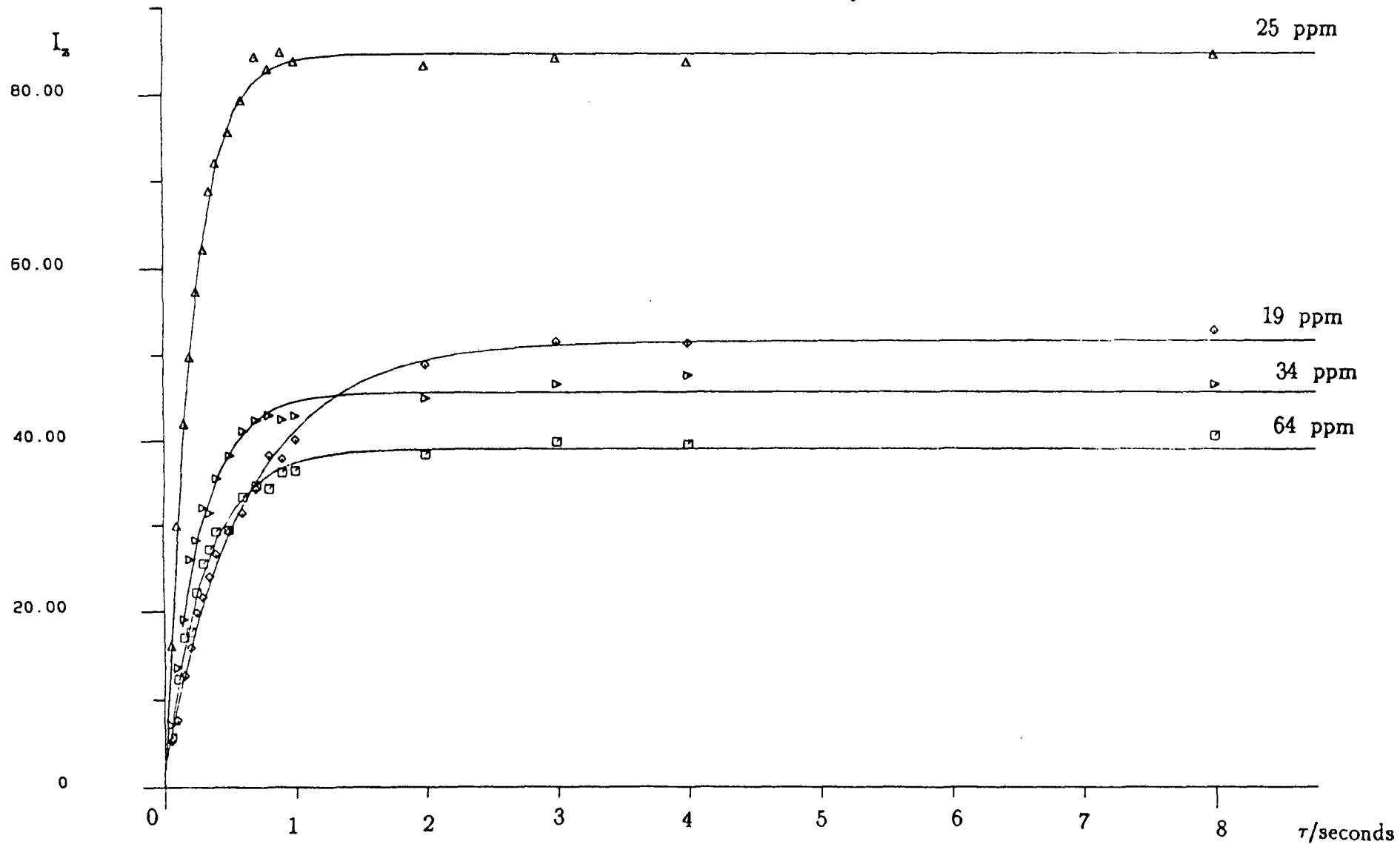

Figure 5.13

The fitted MOST carbon intensities for the maleic anhydride film.



shown in figure 5.11, and the corresponding short component of the carbon  $T_1$  values for the more mobile polyester chains in the itaconic anhydride film are shown in Table 5.6.

Figure 5.12 shows the growth from saturation of the polyester carbons in the maleic anhydride film with  $\tau$  values ranging between 0.05 and 8 seconds. Figure 5.13 shows the fitted intensities of the spectra, and Table 5.7 lists the corresponding short component of the carbon  $T_1$  values for the more mobile polyester chains in the maleic anhydride film.

In principle, each peak has a contribution from more rigid polyester chains of the sample as well as the more mobile polyester chains which have the short  $^{13}\text{C}$   $T_1$  values. However, the longer component of the carbon  $T_1$ 's was expected to be at least an order of magnitude larger than the short component of the carbon  $T_1$ 's, and thus any error in the intensity at short  $\tau$  is small.

### 5.2.2 Measurement of the longer $T_1^{\text{II}}$ component

The carbon peaks arising from more rigid polyester chains are observable by the cross-polarisation technique. Cross-polarisation works best for rigid, protonated carbons. Thus the longer component of the carbon  $T_1$  may be measured using cross-polarisation without complications arising from the contribution to the  $T_1$  of the short component. The pulse sequence for the measurement of carbon  $T_1$  values via cross-polarisation from the proton spins is shown in figure 5.14. The T1CP experiment, as the pulse sequence is known, was originally proposed

Figure 5.14

The TICP pulse sequence.

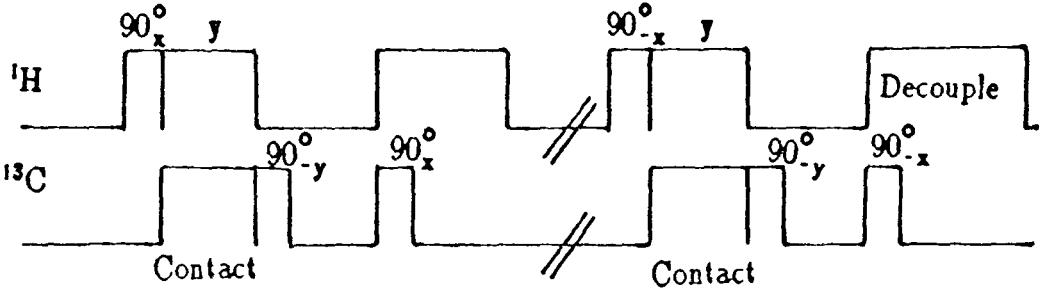

Figure 5.15

The fit of the carbon intensities from the T1CP experiment obtained for the itaconic anhydride film.

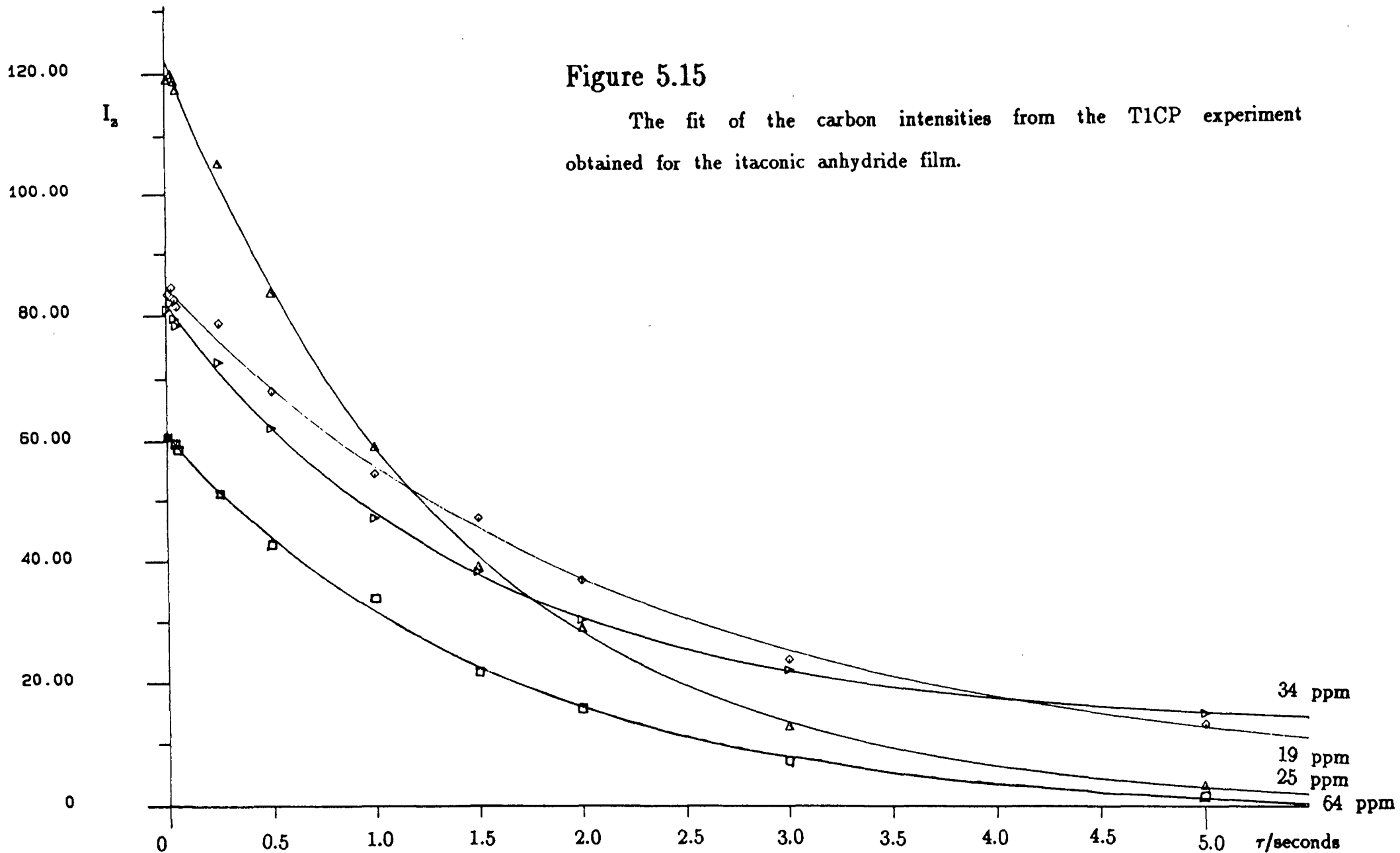
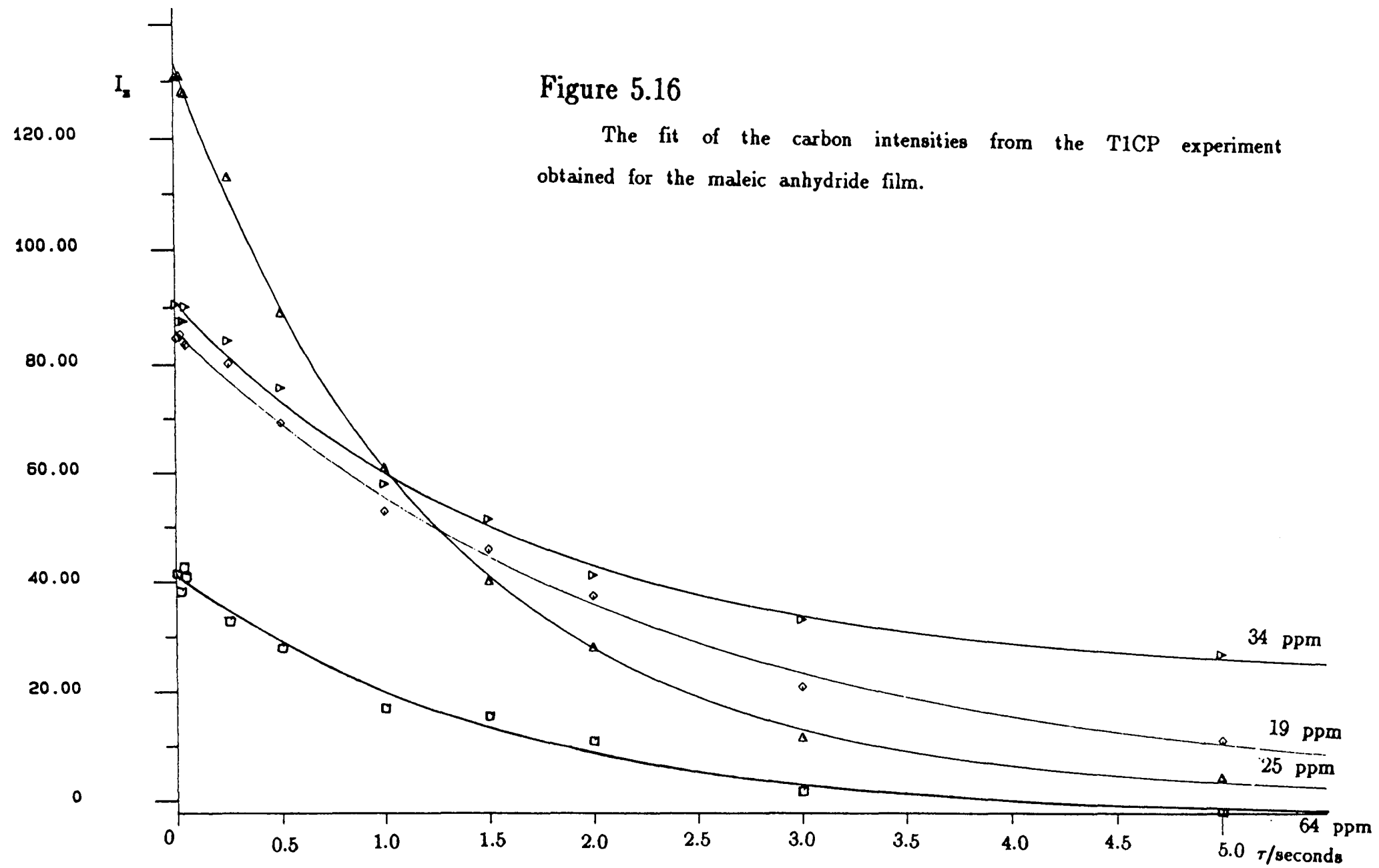

Figure 5.16

The fit of the carbon intensities from the T1CP experiment obtained for the maleic anhydride film.



### Table 5.8

Long carbon  $T_1$  values of the polyester chains in the itaconic anhydride film.

Peak/ppm	Assignment	Long $T_1(^{13}\text{C})/\text{secs}$
64	$\text{O}=\text{C}-\text{O}-\text{CH}_2$	1.22
34	$\text{O}-\text{C}(=\text{O})-\text{CH}_2$	3.32
25	$\text{CH}_2$ 'backbone'	1.22
19	$\text{CH}_3$ of MMA	2.92

## Table 5.9

Long carbon  $T_1$  values of the polyester chains in the maleic anhydride film.

Peak/ppm	Assignment	Long $T_1(^{13}\text{C})/\text{secs}$
64	$\text{O}=\text{C}-\text{O}-\text{CH}_2$	0.83
34	$\text{O}-\text{C}(=\text{O})-\text{CH}_2$	3.87
25	$\text{CH}_2$ 'backbone'	1.53
19	$\text{CH}_3$ of MMA	2.55

by Torchia.<sup>4</sup> The T1CP experiment consists of two pulse sequences. In the first sequence, a  $B_{1H}$  resonant field is applied to the proton spins, which causes the proton magnetisation to rotate until it lies along the  $+y$  direction in the rotating frame of reference, and is then spin-locked along this direction. A  $B_{1C}$  field is then applied to the carbon spins, and the carbon magnetisation is then derived along the  $+x$  axis. The proton spin-locking field is then switched off, and the carbon magnetisation is rotated from the  $x$  axis to the  $z$  axis by the  $B_{1C}$  field which has been phase-shifted to the  $-y$  direction. In the absence of the  $B_1$  field, the carbon magnetisation decays exponentially from its initial value  $M_{CP}(0)$  to its equilibrium value  $M(0)$  with time  $\tau$ . After the delay time  $\tau$ , the remaining carbon magnetisation is measured from the intensity of the peaks in the spectrum obtained from the Fourier Transform of the resultant FID acquired.

The second part of the pulse sequence has spin-temperature inversion, thus inverting the sign of the proton-enhanced carbon signal compared to that obtained in the first pulse sequence. The carbon magnetisation is then rotated into the  $-z$  direction, and then recovers from an initial value of  $-M_{CP}(0)$  to an equilibrium value of  $M(0)$  with time  $\tau$ . By subtracting one from the other, the change in the carbon intensity with delay  $\tau$  may be described by equation 5.4.

$$M(\tau) = 2M_{CP}(0)\exp(-\tau/T_1^H) \quad (5.4)$$

There are several advantages of using the T1CP experiment rather than the inversion-recovery pulse sequence to measure the longer component of the carbon  $T_1$  values in the polyester chains in the films.

- 1). It is only necessary to leave a recycle delay of  $5 \times T_1(^1\text{H})$  between experiments instead of  $5 \times T_1(^{13}\text{C})$
- 2). The carbon signal is enhanced by cross-polarisation
- 3). Spectral artifacts are suppressed by spin-temperature inversion.

The T1CP experiment was used to measure the longer component of the carbon  $T_1$  of the films which arises from the more rigid polyester chains in the films. The experimental plot used to determine the  $T_1$  values of the less mobile polyester chains in the itaconic anhydride film is shown in figure 5.15. The long components of the  $T_1$  values of the carbons in polyester chains are shown in Table 5.8 together with the assignments of the relevant peaks. A similar experimental plot is shown in figure 5.16 for the maleic anhydride film. the long  $T_1$  components of the  $T_1$  values of the polyester chains in the maleic anhydride film are shown in Table 5.9.

### 5.2.3 Origins of the two component $T_1^{\text{II}}$

It appears from the  $^{13}\text{C}$   $T_1$  measurements that there are two distinct types of polyester chains in the cross-linked films, one more mobile than the other. In order to understand how this might arise, it is necessary to consider the cross-linking chemistry between the two components of the films. In the cross-linking reaction the acid anhydride in the copolymer reacts with the triethanolamine tip of the polyester, ring-opening to form an ester cross-link as shown in figure 5.17a. The

Figure 5.17

Origins of the two component carbon T<sub>1</sub>.

a). The acid anhydride in the copolymer reacts with the triethanolamine tip of the polyester, ring-opening to form an ester cross-link.

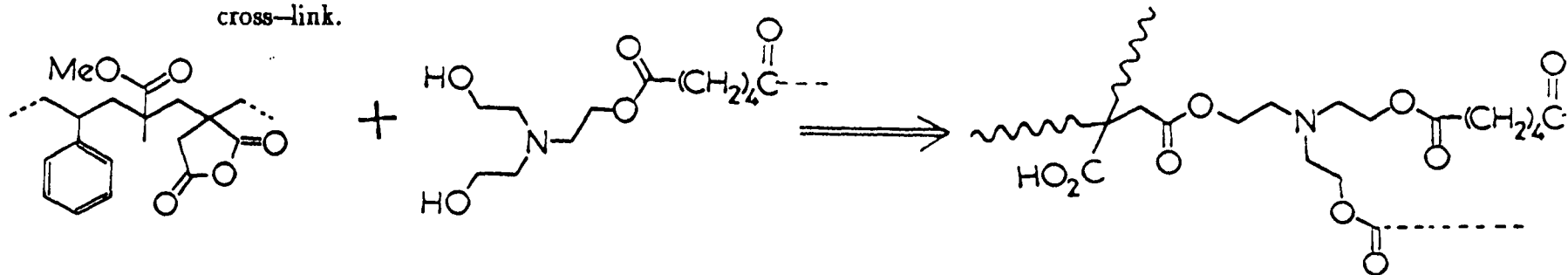
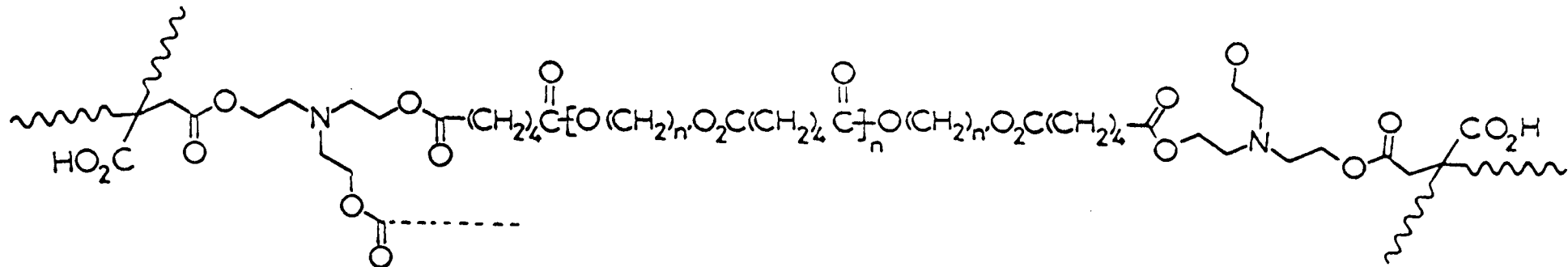
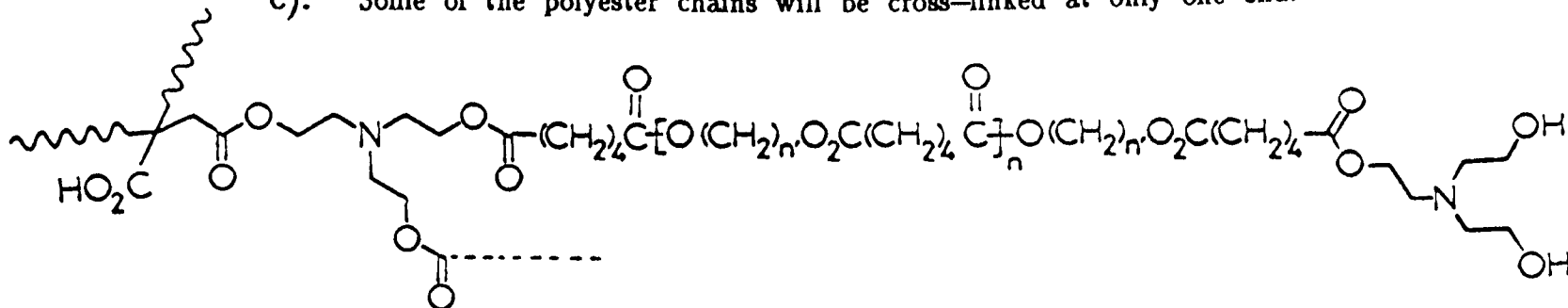

Figure 5.17

b). Some of the polyester chains will be cross-linked at both ends.



c). Some of the polyester chains will be cross-linked at only one end.



d). There will be some polyester chains which are not cross-linked at all.

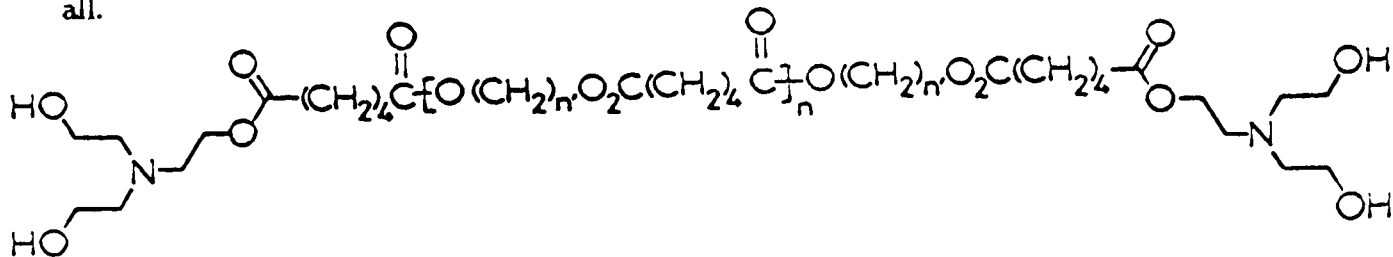

tip of the polyester can only react with the acid anhydride to form a cross-link if they are both close enough to each other in space. In a typical cross-linking system the polymer chains are entangled. There will be some acid anhydride groups which will be inaccessible to the polyester chains, and similarly, there will be some tips of the polyester chains which are not near enough to an acid anhydride group to react. Thus, some of the polyester chains will be cross-linked at both ends, as illustrated in figure 5.17b, and some of the polyester chains will be cross-linked at only one end, with the other end free, as shown in figure 5.17c. There may also be some polyester chains which are not cross-linked at all (figure 5.17d). There will be a difference in the mobility between these three polyester chains, the polyester chains shown in figure 5.17d being the more mobile. It could be this difference in mobility of the polyester chain depending on how the polyester is cross-linked which gives rise to a two-component carbon  $T_1$  value.

### 5.3 Variable temperature studies

#### 5.3.1 Cross-polarisation

In the last section it was seen that the polymer films contain polyester chains which differ in mobility. The polyester chains with a short  $^{13}\text{C}$   $T_1$  were found to be much more mobile than the copolymer chains. This difference in mobility was detected using the SPE pulse sequence. It would be of interest if differences in mobility between polyester chains and copolymer chains could also be detected using cross-polarisation techniques. Cross-polarisation works best when a carbon

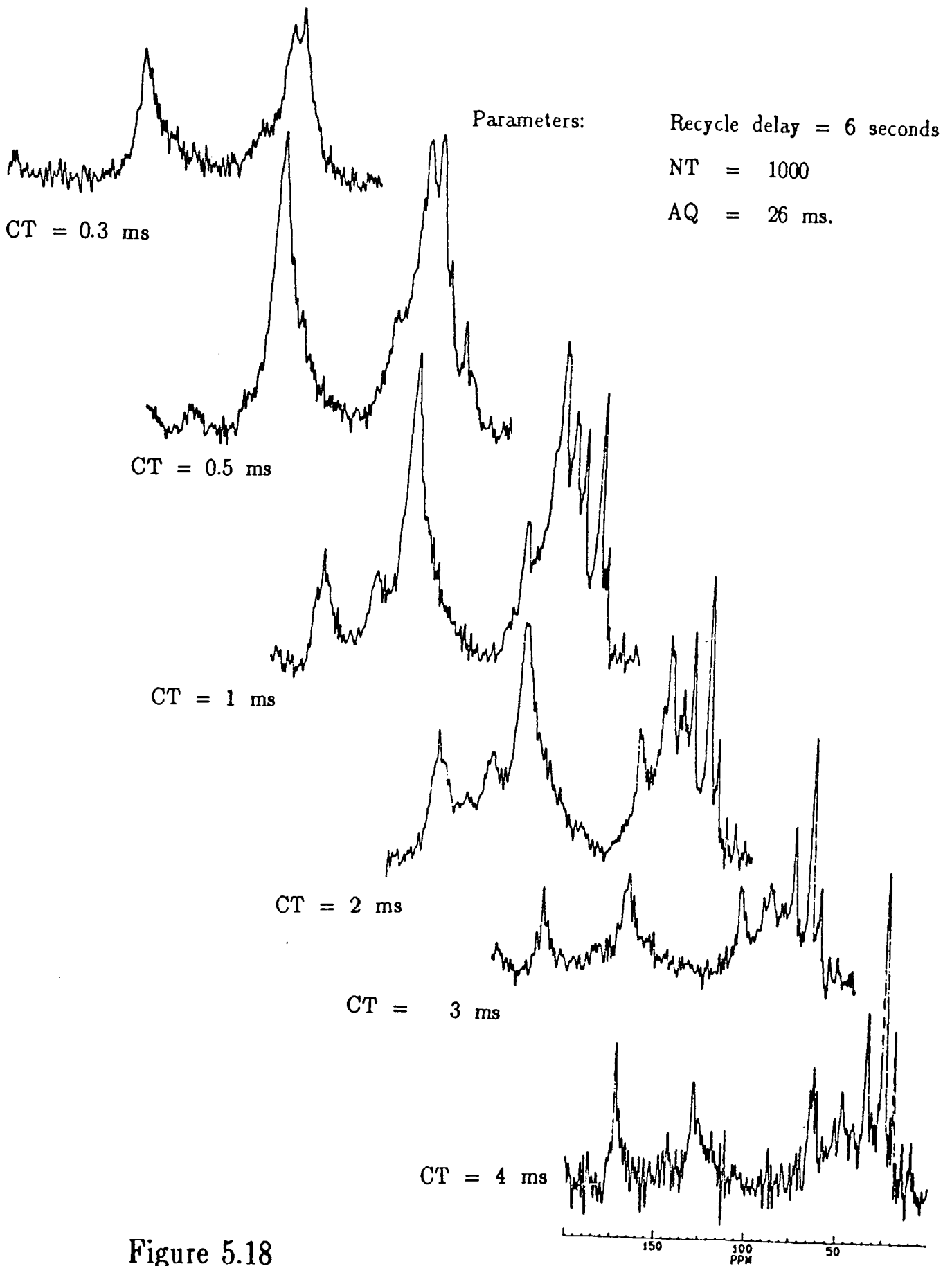

Figure 5.18

Variable contact time spectra of the maleic anhydride film at 60°C for a range of contact times.

is rigid, especially when that carbon is protonated. Variable contact time measurements were made for the itaconic and the maleic anhydride films both at room temperature (25°C) and at higher temperatures. The variable contact time experiment leads to values of  $T_{IS}$  and the  $T_{1\rho}$  of the protons which cross-polarised the carbon in question.

### 5.3.1.1 The maleic anhydride film

Variable contact time measurements were obtained for the maleic anhydride film at room temperature (25°C), 60°C and 80°C. Figure 5.18 shows variable contact time spectra of the maleic anhydride film at 60°C for a range of contact times. Plots of peak intensity against contact time at room temperature (25°C), 60°C and 80°C are shown in figures 5.19 to 5.21 for the peaks at 25 ppm and 40 ppm. The assignments of these peaks and the values of  $T_{IS}$  and  $T_{1\rho}$  obtained from these plots at room temperature (25°C), 60° and 80°C are shown in table 5.10. At room temperature (25°C) both copolymer and polyester peaks were present in the spectra at all values of the contact time. However, as the temperature was raised, spectra at short contact times were dominated by peaks due to the copolymer only, and spectra at long contact times were dominated by peaks due to the polyester only. The signal to noise of the cross-polarisation spectra becomes worse as the temperature is raised. This is because the overall mobility of the films increases as the temperature increases, and therefore CP efficiency decreases. It can be seen that at room temperature (25°C), the  $T_{1\rho}$  and the  $T_{IS}$  values of the polyester peaks are identical within experimental error to those of the copolymer peaks. Therefore at room temperature (25°C) the copolymer and the

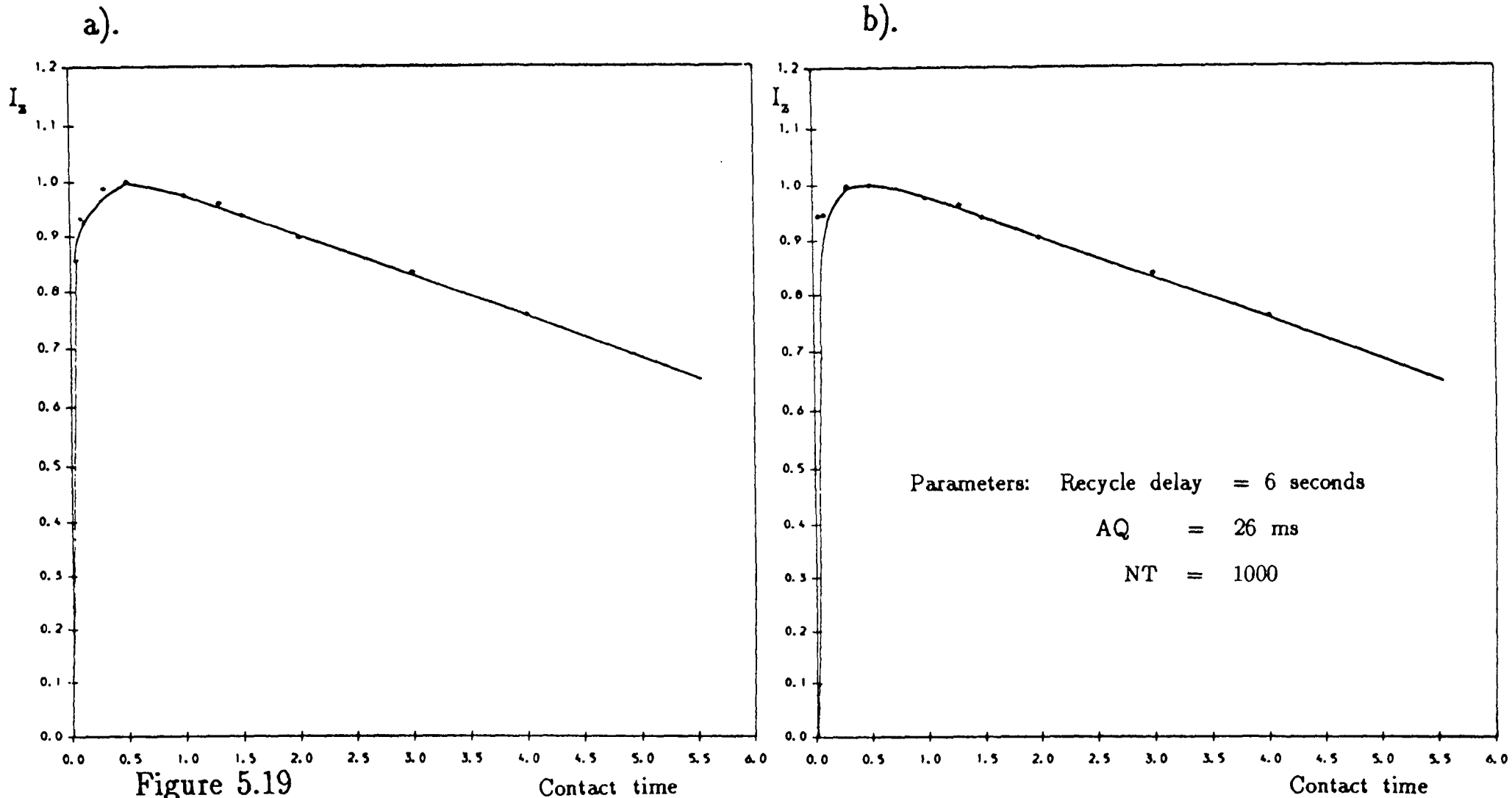

Figure 5.19

- a). Plot of peak intensity against contact time at room temperature for the polyester peak at 25 ppm in the maleic anhydride film.
- b). Plot of peak intensity against contact time at room temperature for the copolymer peak at 40 ppm in the maleic anhydride film.

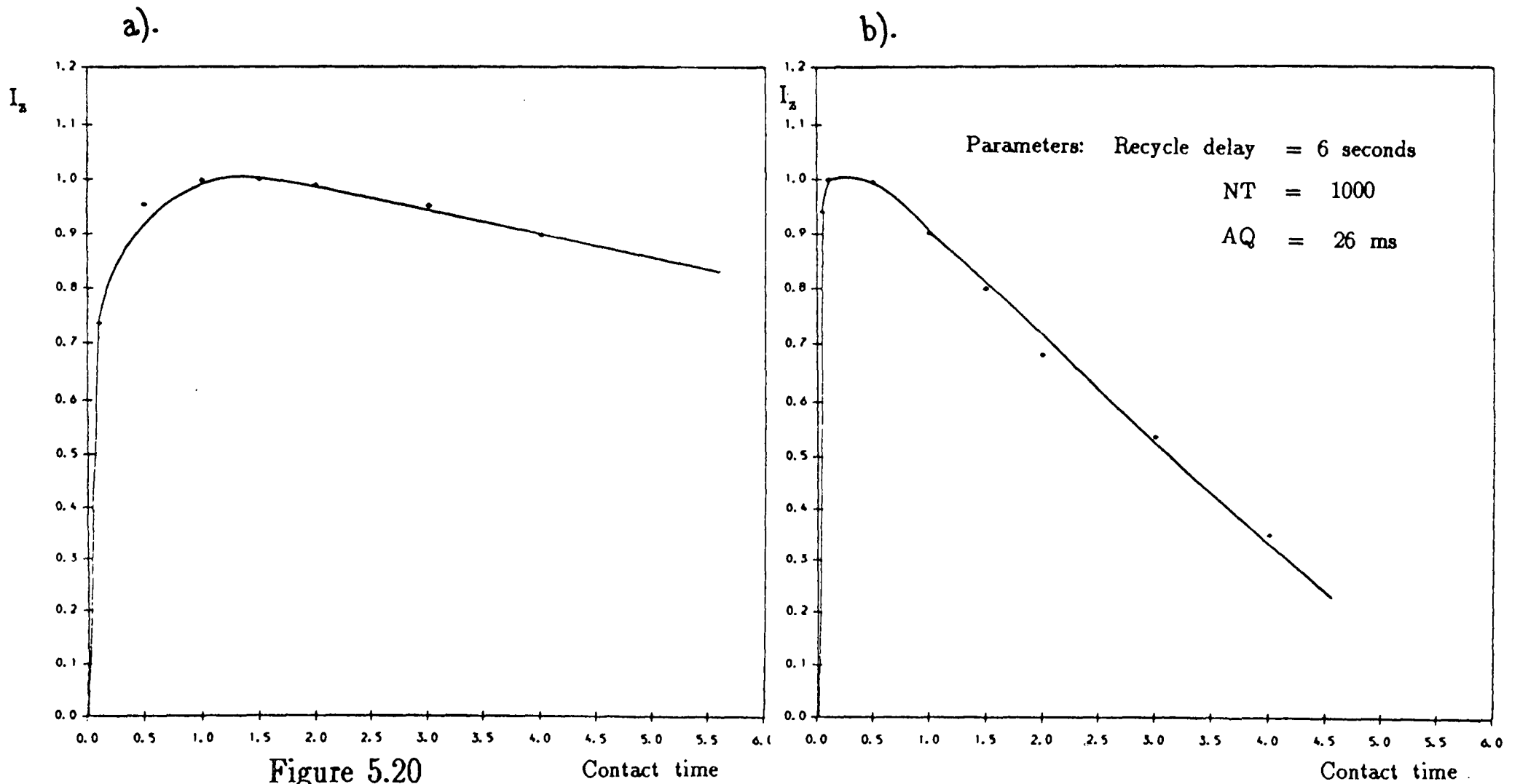

Figure 5.20

a). Plot of peak intensity against contact time at  $60^\circ\text{C}$  for the polyester peak at 25 ppm in the maleic anhydride film.

b). Plot of peak intensity against contact time at  $60^\circ\text{C}$  for the copolymer peak at 40 ppm in the maleic anhydride film.

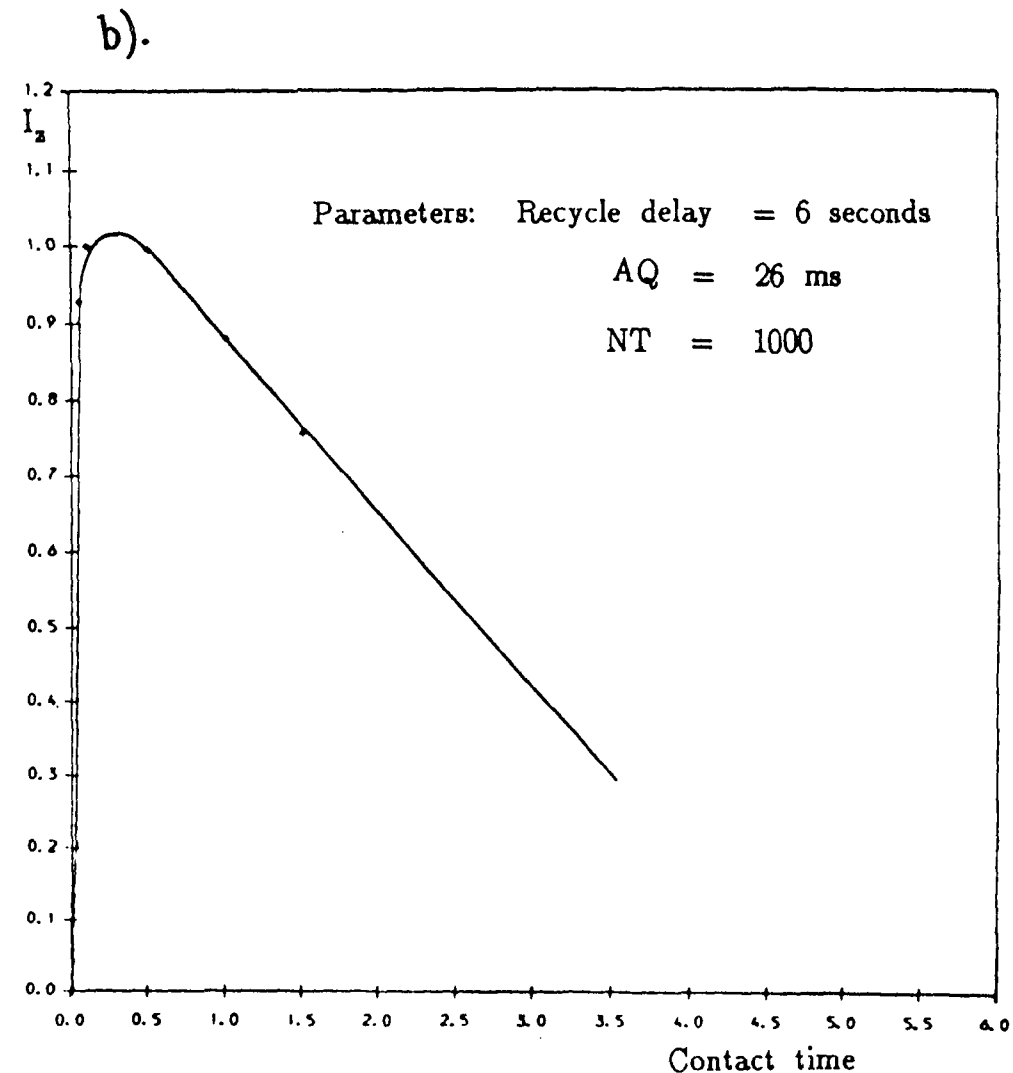
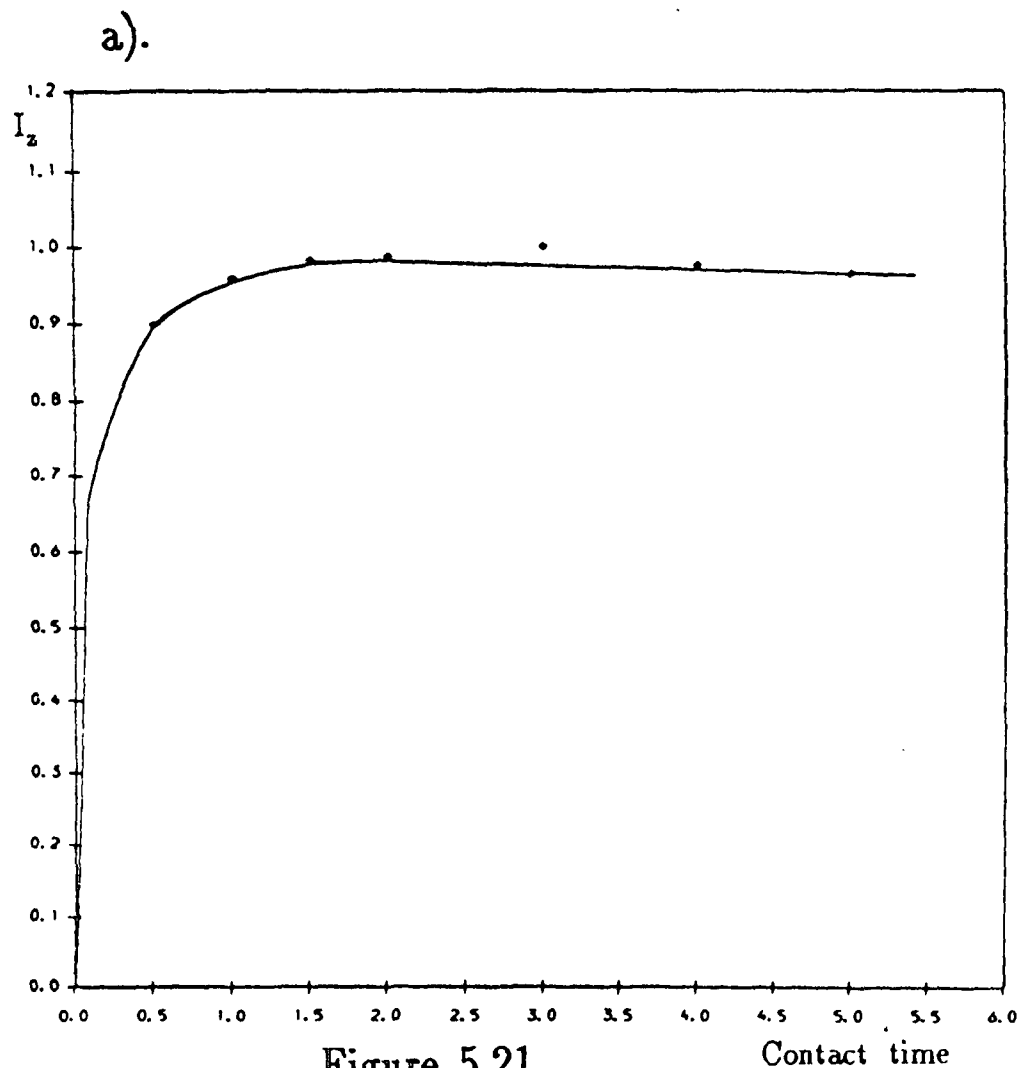

Figure 5.21

a). Plot of peak intensity against contact time at 80°C for the polyester peak at 25 ppm in the maleic anhydride film.

b). Plot of peak intensity against contact time at 80°C for the copolymer peak at 40 ppm in the maleic anhydride film.

Table 5.10

Values of  $T_{lp}$  and  $T_{IS}$  obtained from Variable contact time measurements for the maleic anhydride film at room temperature, 60°C and 80°C.

Temperature/°C	Peak/ppm	$T_{IS}/ms$	$T_{lp}/ms$
RT	25	0.063	9.676
RT	40	0.054	10.07
60	25	0.084	12.346
60	40	0.031	2.706
80	25	0.110	57.519
80	40	0.015	1.430

polyester peaks in the film are not distinguishable by cross-polarisation. However, at temperatures of 60°C and 80°C, both the  $T_{IS}$  and the  $T_{Ip}$  of the copolymer peaks are different from those of the polyester peaks. It is interesting to note the general trend of the relaxation times. As the temperature is increased,  $T_{IS}$  and  $T_{Ip}$  of the copolymer peaks decrease but the  $T_{IS}$  and  $T_{Ip}$  of the polyester peaks increase.

At room temperature (25°C), the relaxation times of the copolymer and the polyester peaks are too similar to make it possible to distinguish between copolymer and polyester peaks using either cross-polarisation variable contact or delayed contact techniques. However, as the temperature is raised, the relaxation characteristics of the copolymer and the polyester peaks become different. It becomes possible to distinguish between copolymer and polyester peaks using CP techniques.

### 5.3.1.2 The itaconic anhydride film

Variable contact measurements were made on the itaconic anhydride film at room temperature (25°C), 60°C and 80°C. Plots of peak intensity against contact time at room temperature (25°C), 60°C and 80°C are shown in figures 5.22 to 5.24 for the peaks at 25 ppm and 40 ppm. The assignments of these peaks and the values of  $T_{IS}$  and  $T_{Ip}$  obtained from these plots at room temperature (25°C), 60°C and 80°C are listed in table 5.11. Again, as the temperature is increased,  $T_{IS}$  of the copolymer peaks decrease while the  $T_{IS}$  of the polyester peaks increase. Separate copolymer and polyester peaks cannot be distinguished by cross-polarisation techniques at room temperature (25°C). This is because at 25°C the relaxation times  $T_{Ip}$  and  $T_{IS}$  of the polyester and the

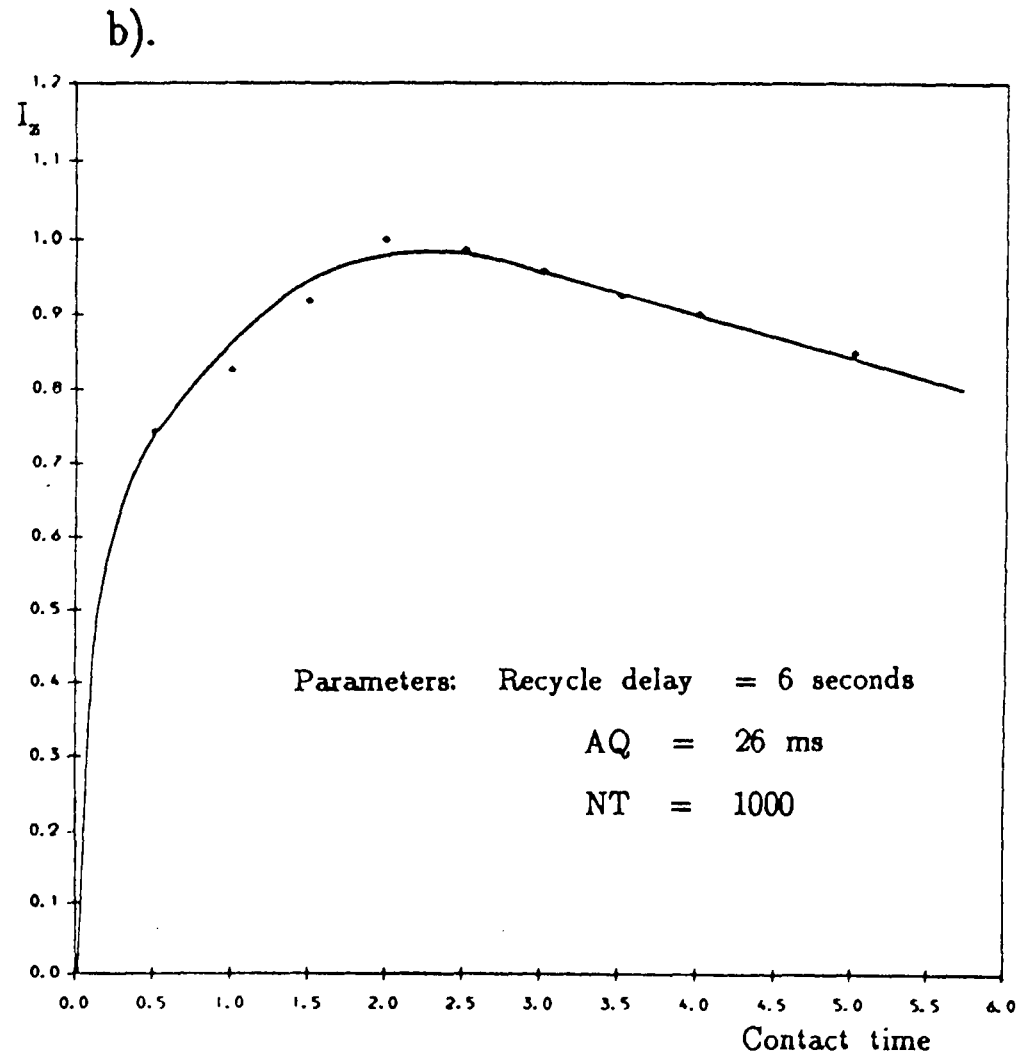
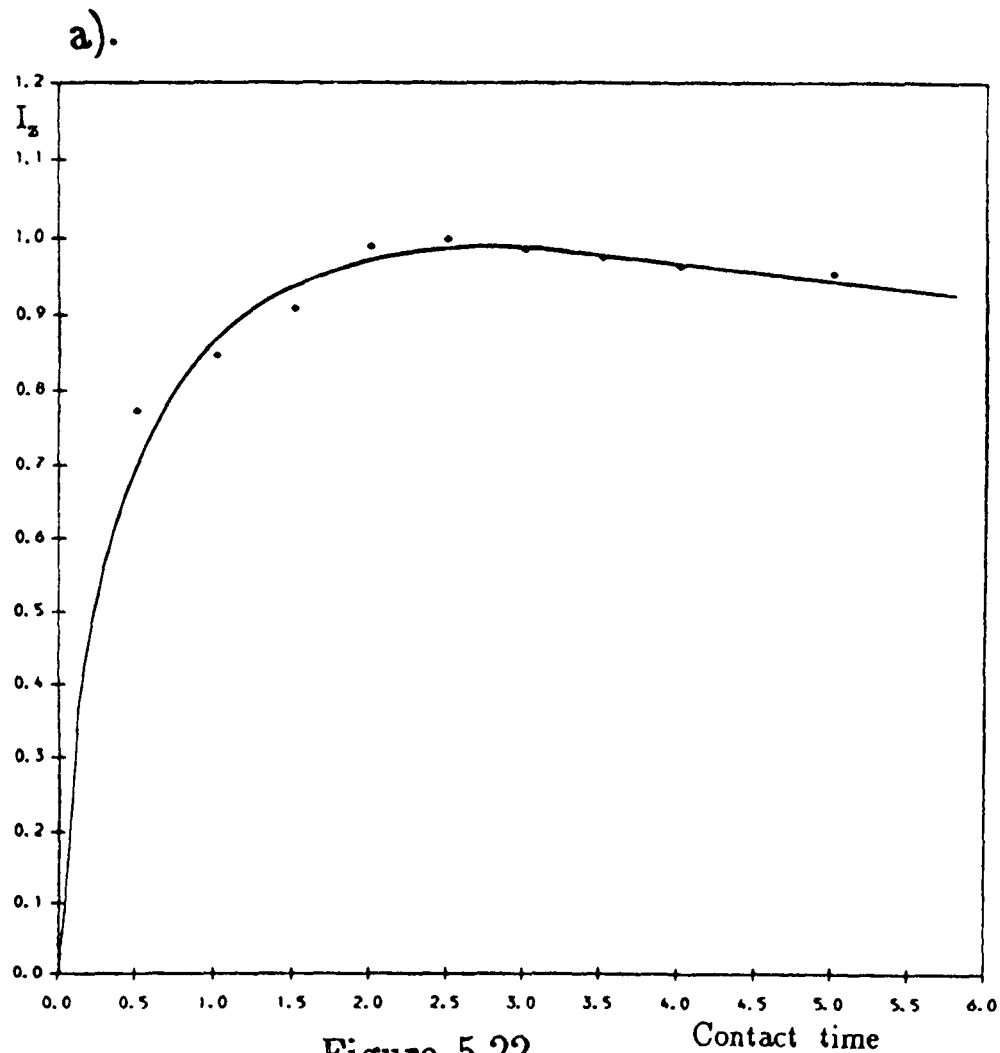

Figure 5.22

- a). Plot of peak intensity against contact time at room temperature for the polyester peak at 25 ppm in the itaconic anhydride film.
- b). Plot of peak intensity against contact time at room temperature for the copolymer peak at 40 ppm in the itaconic anhydride film.

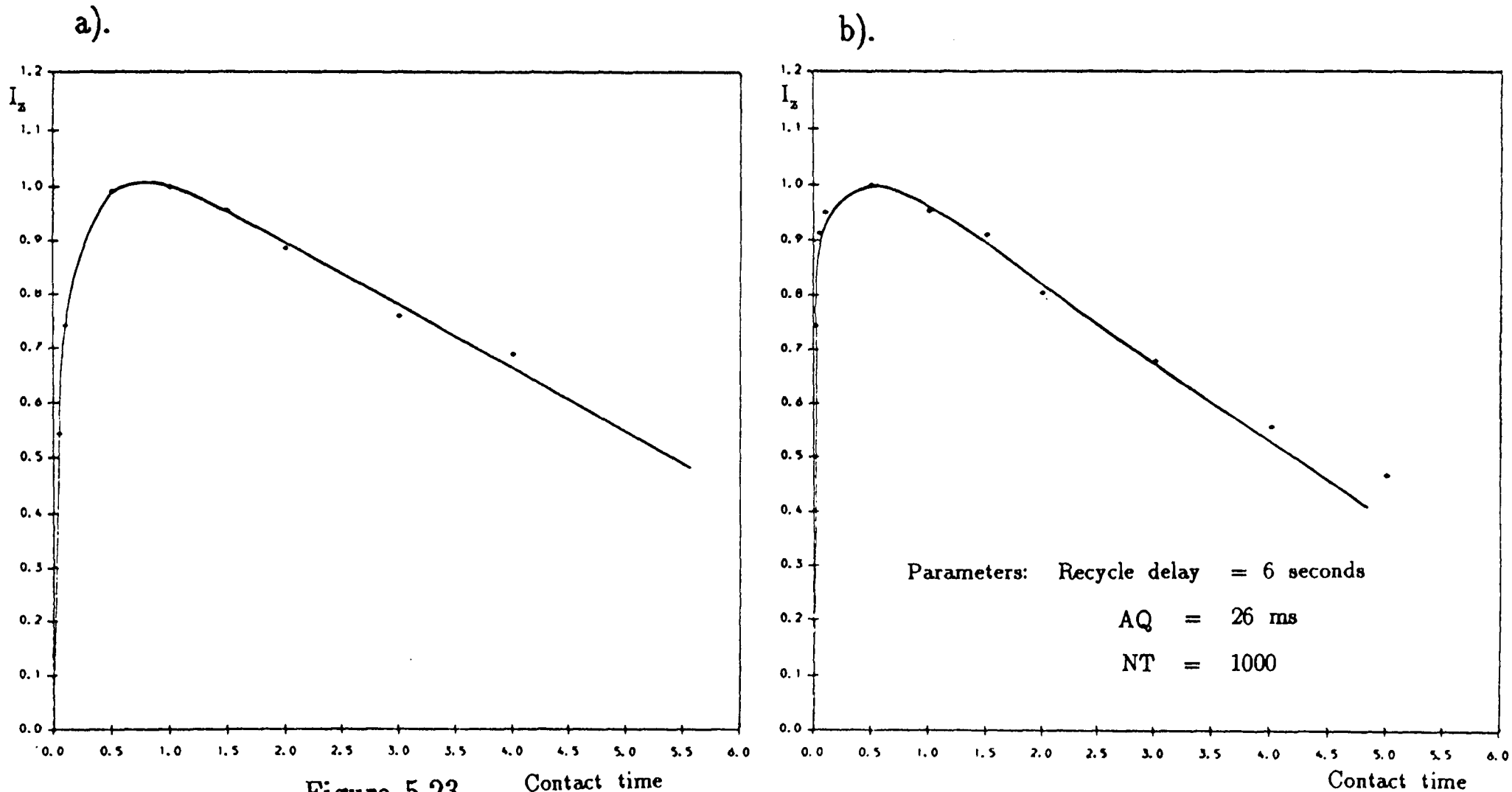

Figure 5.23

a). Plot of peak intensity against contact time at  $60^{\circ}\text{C}$  for the polyester peak at 25 ppm in the itaconic anhydride film.

b). Plot of peak intensity against contact time at  $60^{\circ}\text{C}$  for the copolymer peak at 40 ppm in the itaconic anhydride film.

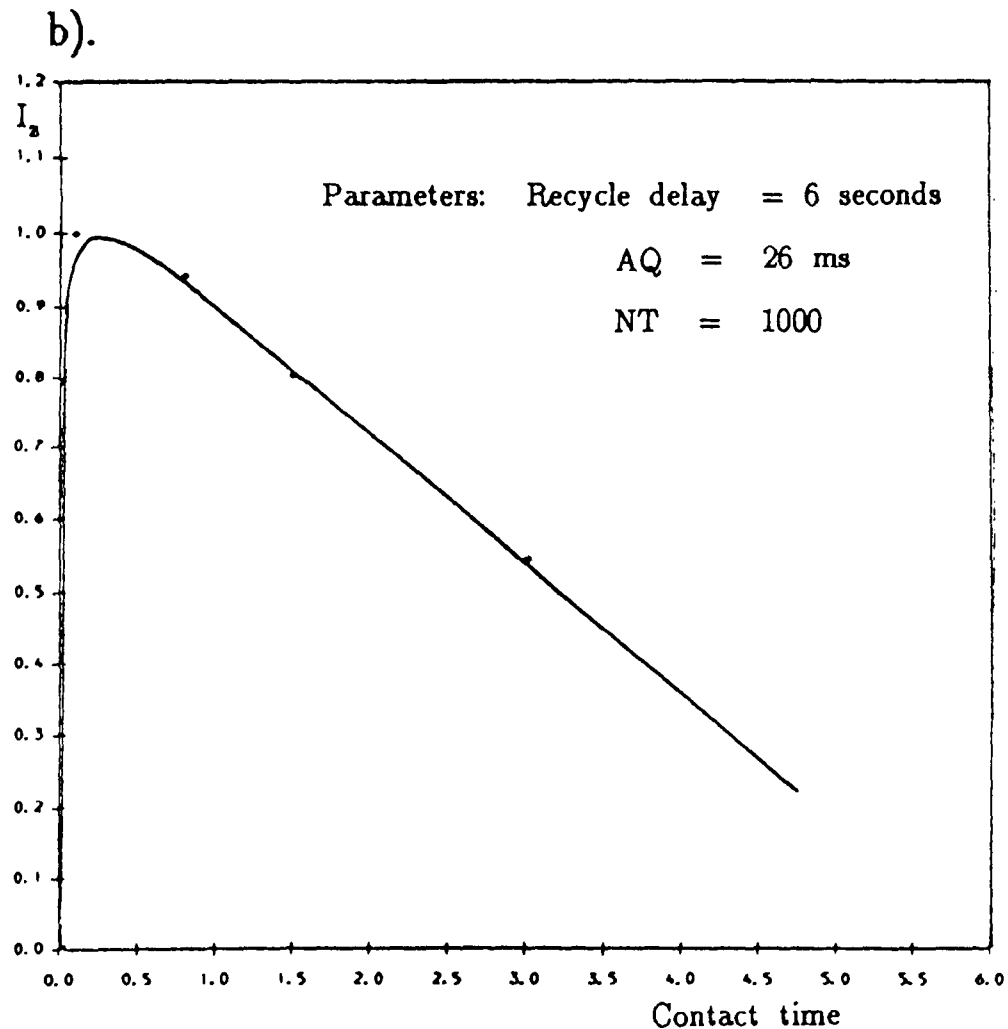
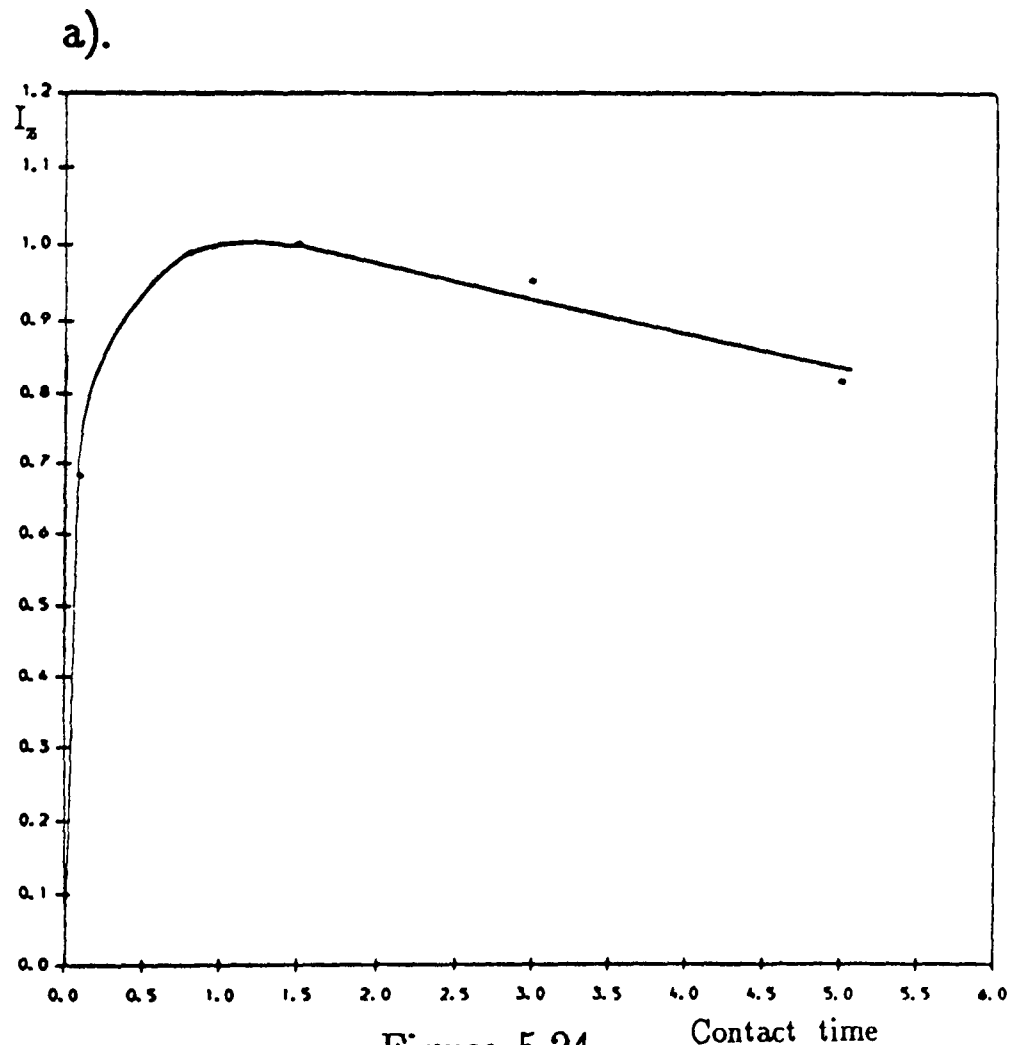

Figure 5.24

a). Plot of peak intensity against contact time at 80°C for the polyester peak at 25 ppm in the itaconic anhydride film.

b). Plot of peak intensity against contact time at 80°C for the copolymer peak at 40 ppm in the itaconic anhydride film.

Table 5.11

Values of  $T_{ip}$  and  $T_{is}$  obtained from Variable contact time measurements for the itaconic anhydride film at room temperature, 60°C and 80°C.

Temperature/°C	Peak/ppm	$T_{is}/ms$	$T_{ip}/ms$
RT	25	0.063	9.676
RT	40	0.054	8.493
60	25	0.152	3.399
60	40	0.021	3.395
80	25	0.190	7.198
80	40	0.014	1.799

copolymer peaks are too similar to distinguish between the two types of peaks. However, at higher temperatures the relaxation times  $T_{1s}$  and  $T_{1p}$  of the copolymer and the polyester peaks become sufficiently dissimilar to allow the two components to be observed separately.

### 5.3.1.3 Discussion

It is not an easy matter to decide on the reason why it is possible to distinguish between copolymer and polyester peaks at higher temperature, but not at 25°C. There are two possible explanations for this.

Firstly, it is known that carbons in the polyester chains have a two-component carbon  $T_1$  arising from the difference in mobility of the various types of cross-linked polyester chains in the polymer films. If the carbon  $T_1$  of the polyester chains are two-component, then it is very likely that the  $T_{1s}$  values of the polyester peaks will be complex, and not single-component. The theory used here assumes that both  $T_{1s}$  and  $T_{1p}$  are single-component. Thus the separation of the spectrum for the film at higher temperatures into copolymer peaks only at short contact times and into polyester peaks only at longer contact times may be an apparent effect.

The second, and perhaps the more probable, explanation of why the copolymer and polyester peaks may be observed separately at higher temperatures is that there may be a genuine phase separation of copolymer and polyester regions. It is possible that after mixing there may still be regions of high polyester density and regions of high copolymer density in the films. At room temperature (25°C), the

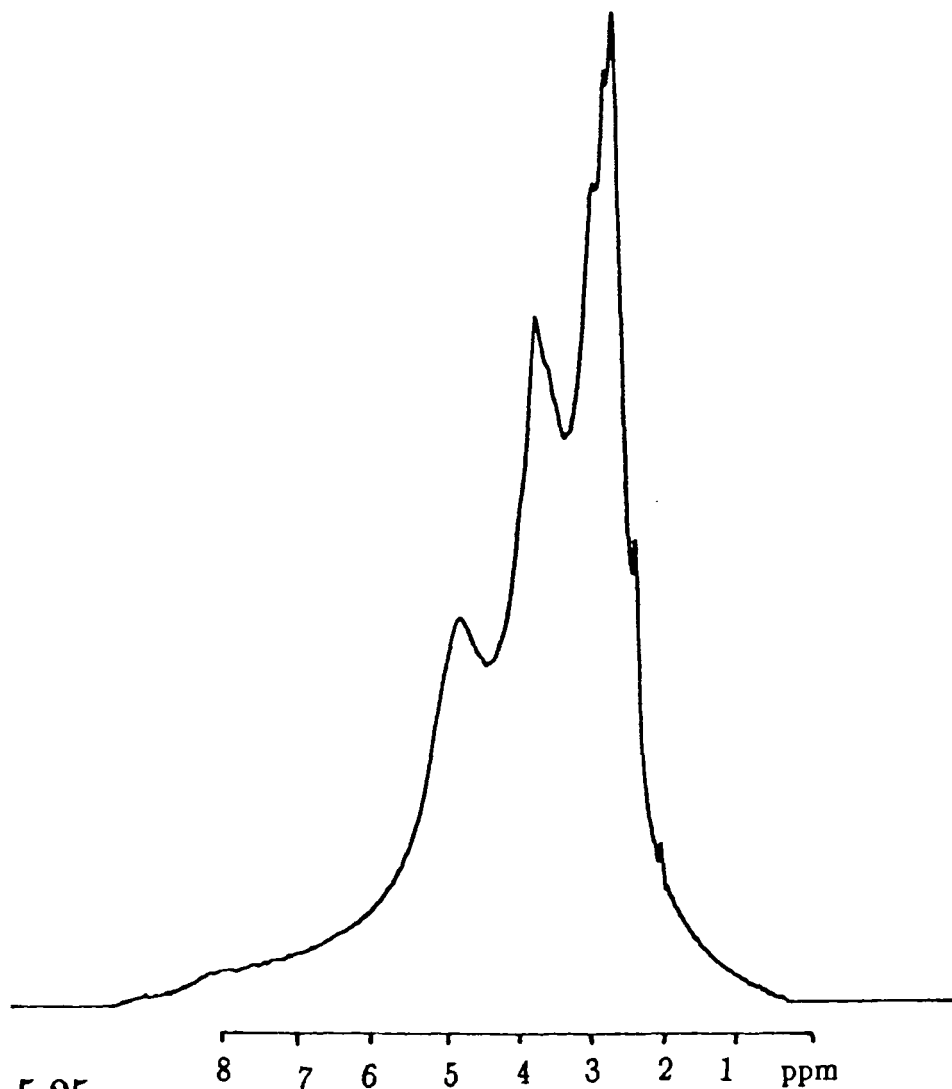

Figure 5.25

The proton single-pulse spectrum of the  $^{13}\text{C}_2$ -enriched itaconic anhydride film obtained at 363 K.

Parameters:

NT = 32

AQ = 128 ms

Recycle time = 5 seconds

single-pulse proton spectrum of the film is a single broad band. This homogeneous lineshape indicates efficient spin diffusion over the whole film at room temperature. However, at higher temperatures the single-pulse proton spectrum shows partial resolution. The single-pulse proton spectrum of the itaconic anhydride film at 90°C is shown in figure 5.25. The partial resolution in the proton spectrum at higher temperatures may inhibit spin diffusion, thus allowing separate copolymer and polyester parts of the film to be resolved at higher temperature.

### 5.3.2 Single-pulse-excitation

Single-pulse spectra at recycle times of 1, 3 and 5 seconds have been obtained for both the itaconic anhydride and the maleic anhydride films at room temperature (25°C) and 80°C. The single-pulse spectra of the itaconic anhydride film at room temperature (25°C) and 80°C are shown in figures 5.26 and 5.27 respectively, and the single-pulse spectra of the maleic anhydride film at room temperature (25°C) and 80°C are shown in figures 5.28 and 5.29 respectively. There are some interesting points to note about the spectra obtained at 80°C. Firstly the linewidths of the spectra at 80°C are about 100 Hz less than the linewidths at room temperature (25°C). This is because the dispersion of the chemical shifts is averaged to a greater extent by molecular motion at higher temperatures. Secondly, the transient nuclear Overhauser effect observed is larger at higher temperature. This is as predicted: The nuclear Overhauser enhancement factor increases with increased mobility. In the spectra at 80°C with a recycle delay of 5 seconds (figures 5.27 and 5.29) peaks arising from the copolymer regions are of much lower intensity than the

Figure 5.26

Single-pulse spectra of the itaconic anhydride film at room temperature.

Parameters: AQ = 20 ms  
NT = 3000

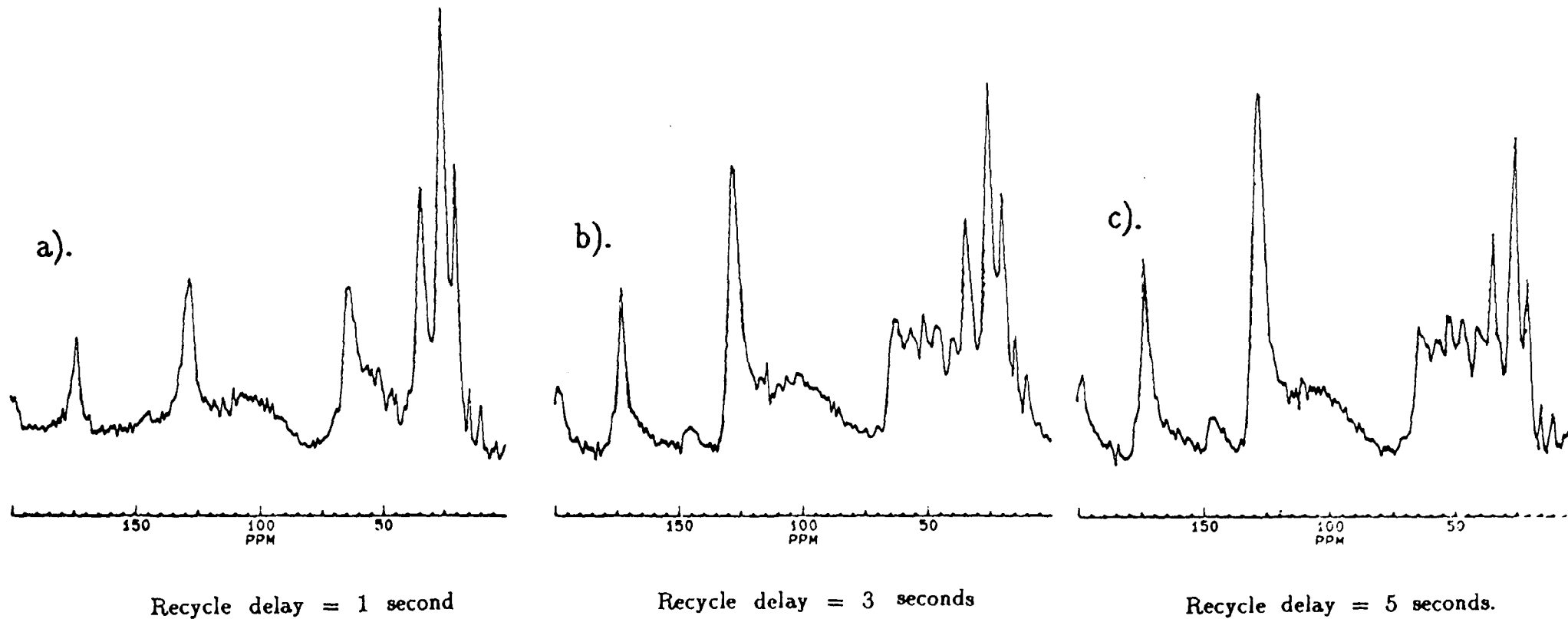
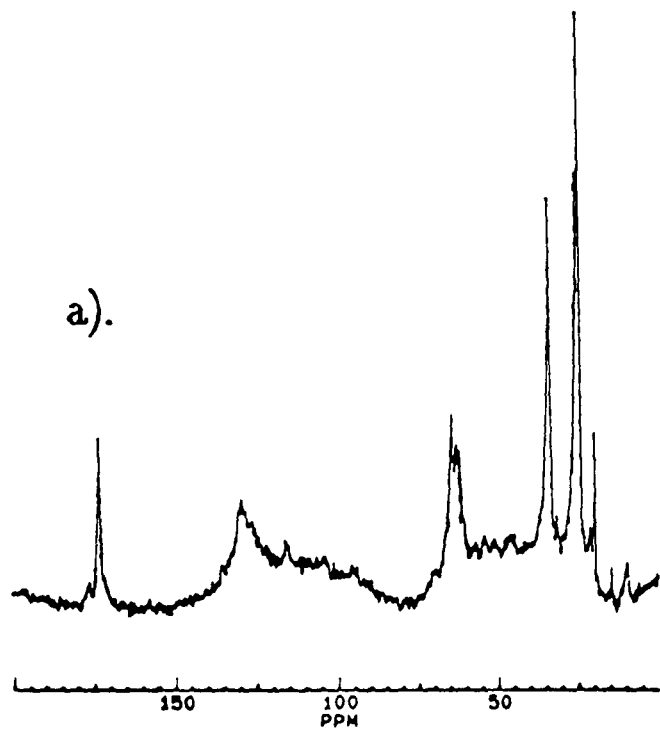

Figure 5.27

Single-pulse spectra of the itaconic anhydride film at 80°C.

Parameters:      AQ = 20 ms  
                     NT = 3000



Recycle delay = 1 second

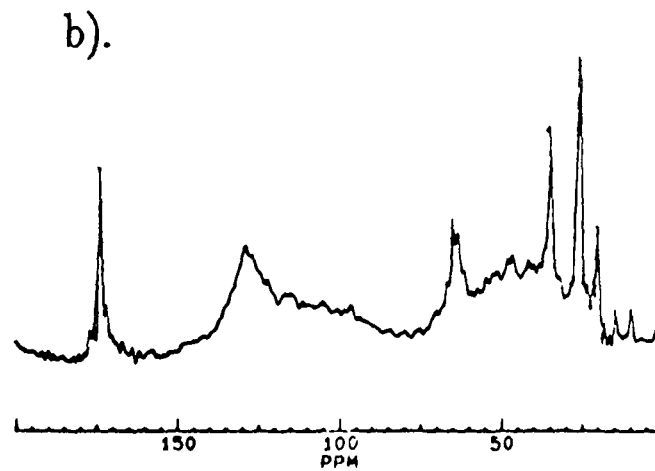

Recycle delay = 3 seconds

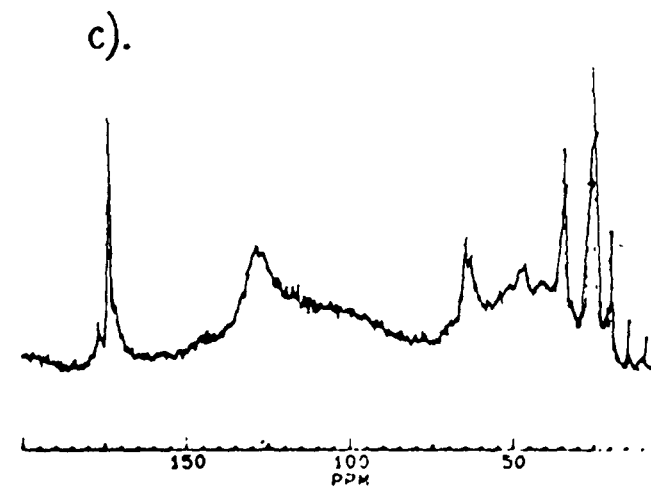

Recycle delay = 5 seconds.

Figure 5.28

Single-pulse spectra of the maleic anhydride film at room temperature.

Parameters: AQ = 20 ms  
NT = 3000

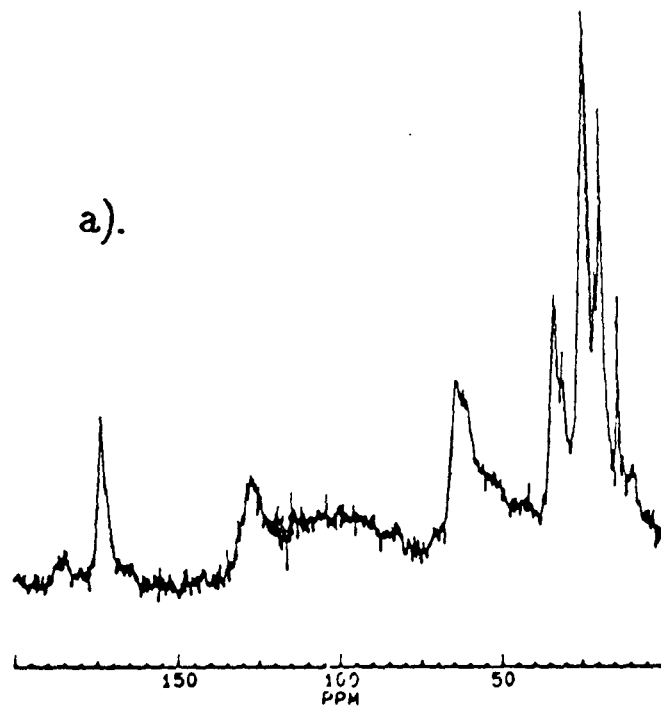

Recycle delay = 1 second

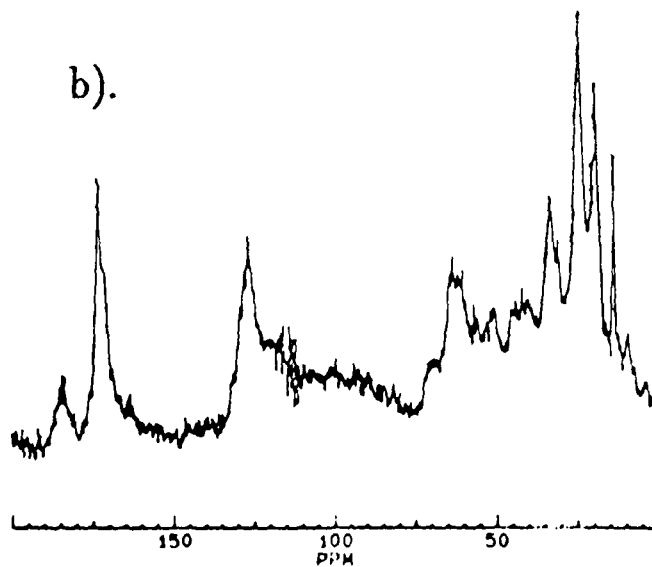

Recycle delay = 3 seconds

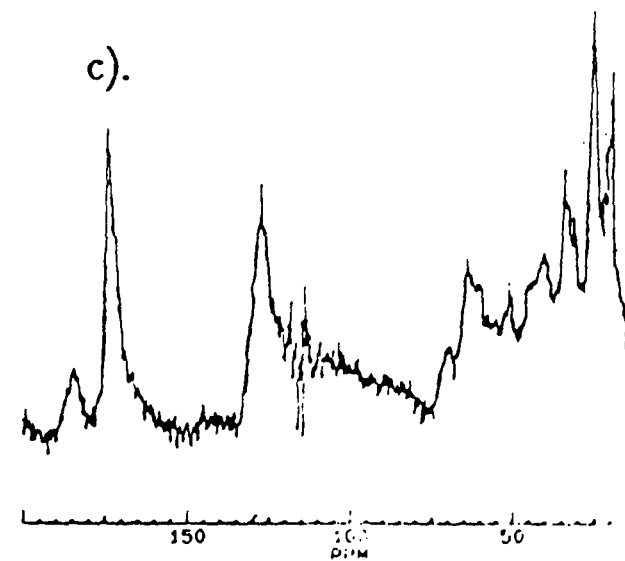

Recycle delay = 5 seconds.

Figure 5.29

Single-pulse spectra of the maleic anhydride film at 80°C.

Parameters: AQ = 20 ms  
NT = 3000

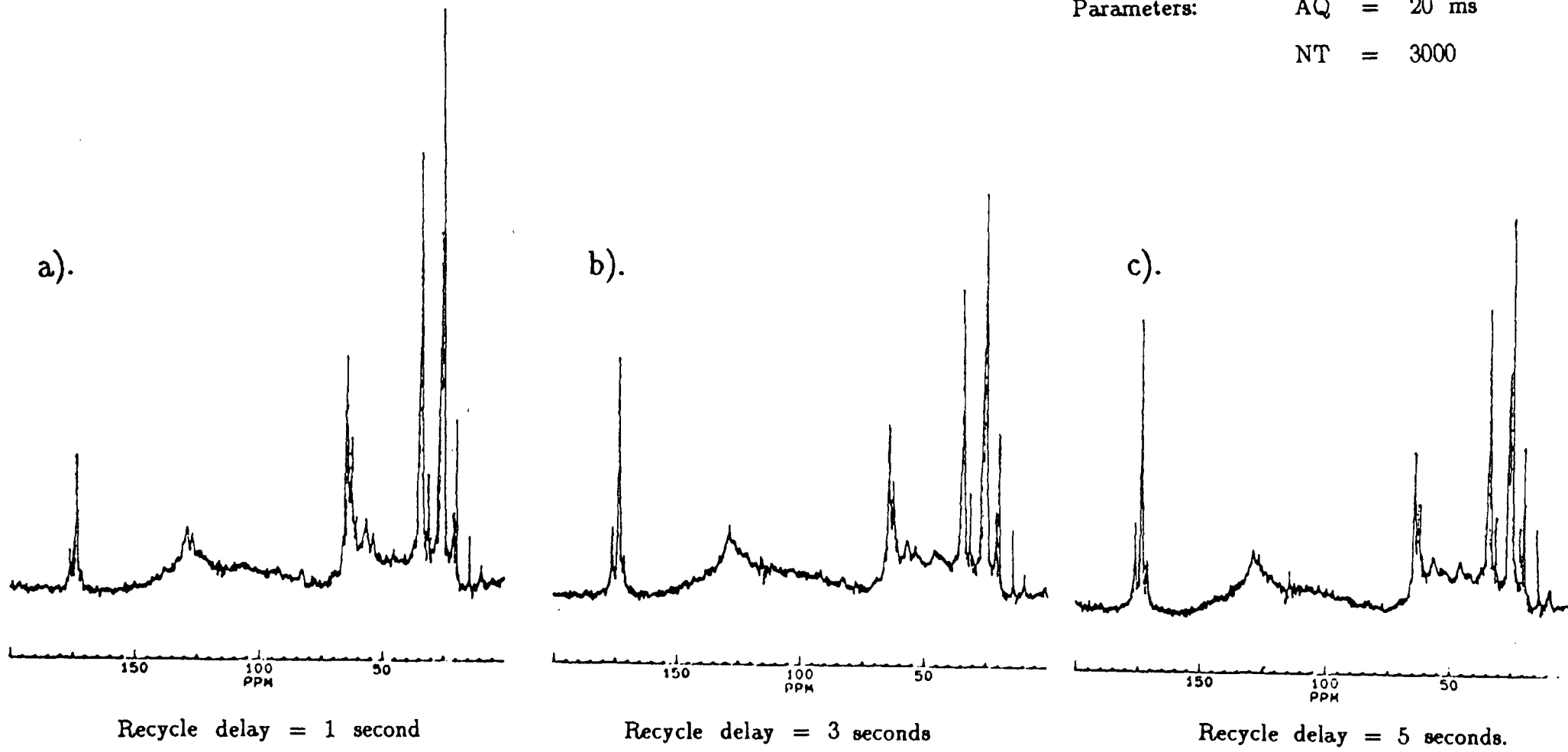

same peaks in the room temperature (25°C) spectra with a recycle time of 5 seconds (figures 5.26 and 5.28). This indicates that the carbon  $T_1$  values of the copolymer peaks increase with temperature. Figure 5.30 compares the 5 second recycle time spectrum at 80°C with the 5 second recycle time room temperature (25°C) SPE spectrum of the itaconic anhydride film. Figure 5.31 shows similar spectra for the maleic anhydride film. At 80°C the peaks have narrowed sufficiently to allow the carbonyl peak at 173 ppm to be resolved into three sharp lines and the  $\text{CH}_2$  peak at 64 ppm to be resolved into two sharp lines. The carbonyl peak is split into three lines at 172.8, 173.3 and 175 ppm. The large peak at 173.3 ppm is known to arise from the carbonyl carbons in the polyester backbone, but the origin of the two smaller peaks at 172.8 and 175 ppm is a little less obvious. The two peaks are thought to originate from two different situations. The peak at 175 ppm probably arises from the carbonyl at the end of the polyester chain before the triethanolamine tip (figure 5.32a). Although the acid and the alcohols used to form the polyester were reacted together in such proportions so as to form an acid-tipped polyester, it is inevitable that some of the polyester will be formed with an alcohol tip. It is believed that the peak at 172.8 ppm originates from the carbonyl next to a terminal ethylene glycol unit (figure 5.32b). Although it is also possible that butane 1,4 diol could be the terminal unit, the chemical shift of the carbonyl next to this unit is too close to that of the carbonyl in the backbone of the polyester to be distinguished.

The broad peak at 64 ppm in the room temperature spectra is narrowed considerably in the spectra at 80°C. Two peaks are resolved at 62.1 ppm and 63.3 ppm. These peaks originate from the  $\text{CH}_2$  in the

Figure 5.30

A comparison between the 5 second recycle delay SPE spectrum at room temperature and the 5 second recycle delay SPE spectrum at 80°C for the itaconic anhydride film.

Parameters: AQ = 20 ms  
NT = 3000

a).  
room temperature.

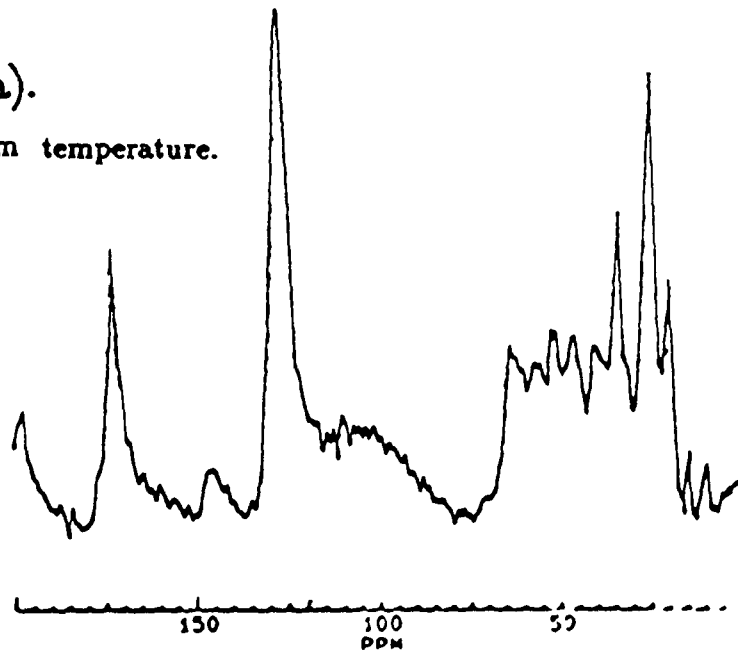

Recycle delay = 5 seconds

b). 80°C.

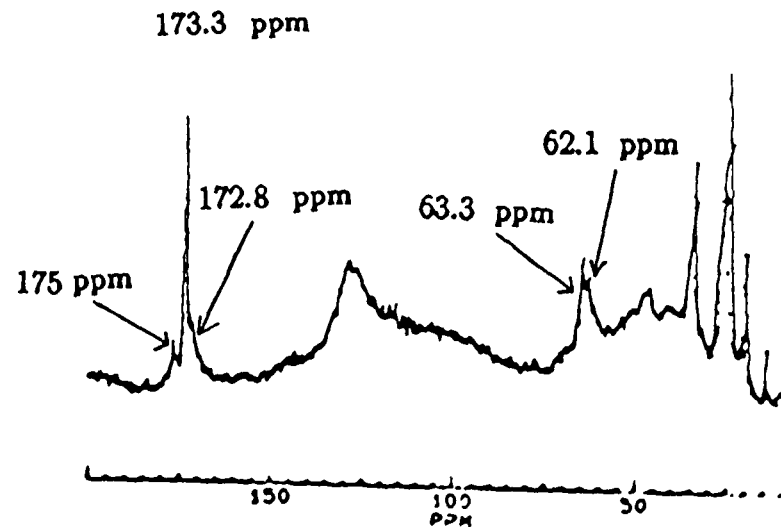

Recycle delay = 5 seconds

Figure 5.31

A comparison between the 5 second recycle delay SPE spectrum at room temperature and the 5 second recycle delay SPE spectrum at 80°C for the maleic anhydride film.

Parameters: AQ = 20 ms  
NT = 3000

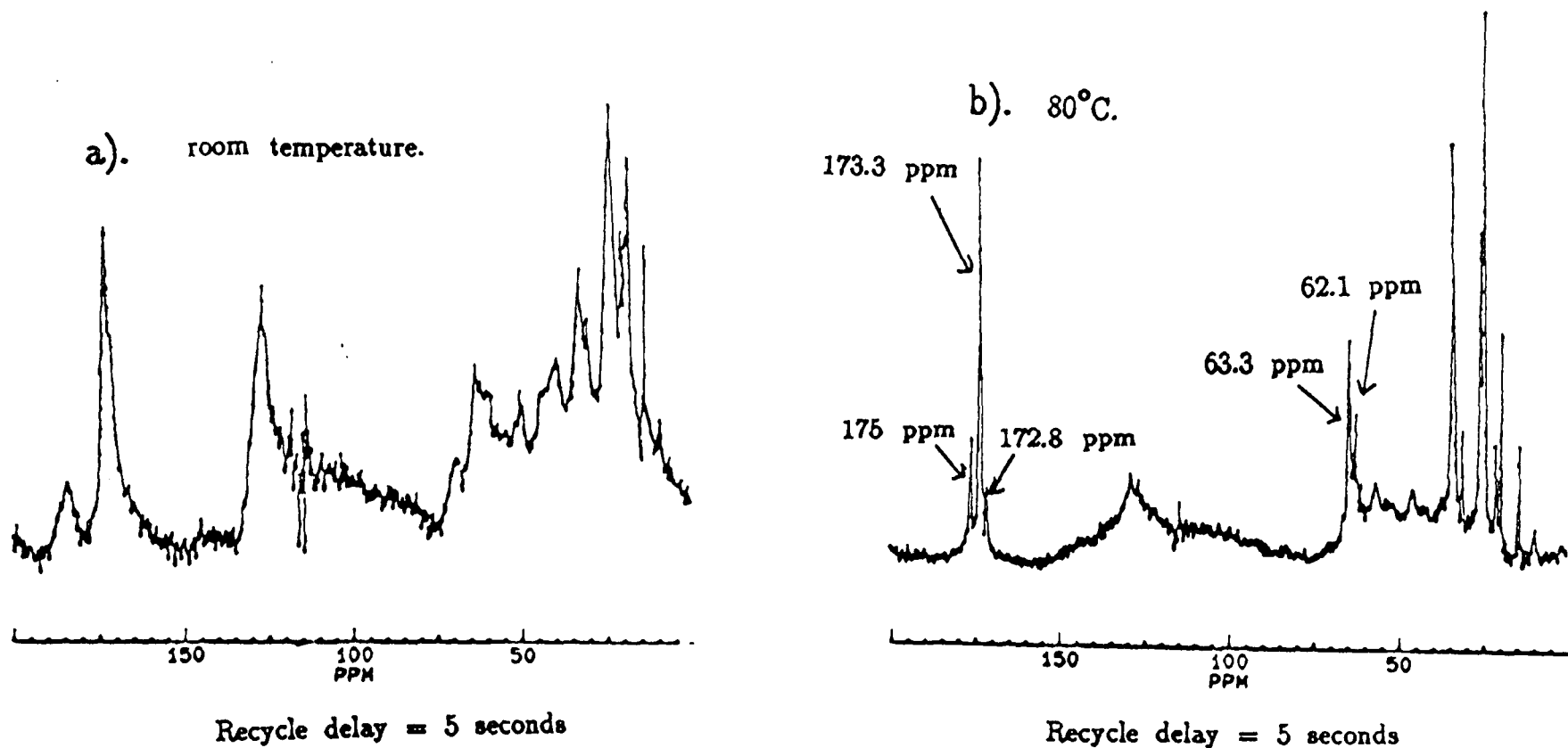
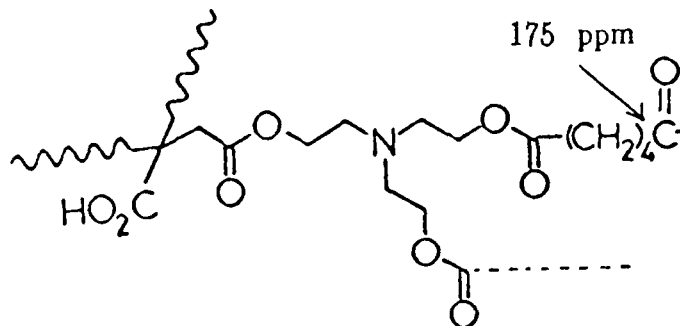
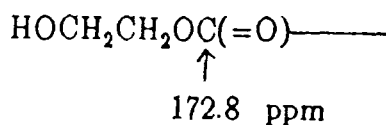

Figure 5.32

a). The peak at 175 ppm arises from the carbonyl at the end of the polyester chain before the triethanolamine tip.



b). The peak at 172.8 ppm originates from the carbonyl next to a terminal ethylene glycol unit.



c). The peaks at 62.1 ppm and 63.3 ppm arise from the  $\text{CH}_2$  in the alcohol component next to the ester linkage.

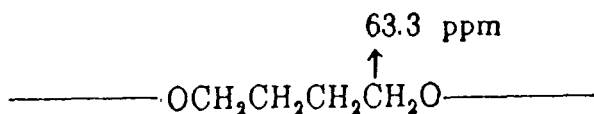
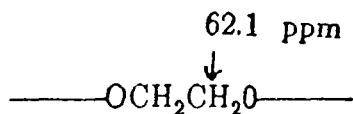

alcohol component next to the ester linkage as shown in figure 5.32c. The ethylene glycol component gives rise to the peak at 62.1 ppm, and the butane 1,4 diol component gives rise to the peak at 63.3 ppm.

#### 5.4 Kinetics of the cure of the polymeric films<sup>6,7</sup>

It would be of great interest if the curing process between the acrylic copolymer and the triethanolamine-tipped polyester could be probed by solid-state NMR techniques. Unfortunately the cure is not very easy to follow by <sup>13</sup>C CP MAS techniques. The only regions of the spectra which changes during cure are the resonances arising from the formation of the cross-links. Due to a combination of the low intensity of the cross-link peaks and the broad resonances of other peaks, any changes in the intensity of old peaks and growth of new peaks are obscured by other resonances. Another method of monitoring the cure, therefore, had to be found.

It is predicted that as the cure progresses, the proton relaxation characteristics will change. It is well-known that the proton relaxation times change with both temperature and mobility. Initially, when the copolymer and the polyester are first mixed, both components are relatively mobile liquids. As the cure proceeds up until the gel point, the mixture becomes less and less liquid-like until at the gel point, a single three-dimensional network is formed. From then onwards, the film becomes less and less mobile as more cross-links are formed. The cure of the itaconic anhydride copolymer with the triethanolamine-tipped polyester was monitored by the proton spin-lattice relaxation times as a function of curing time. Stoichiometric amounts of itaconic anhydride copolymer

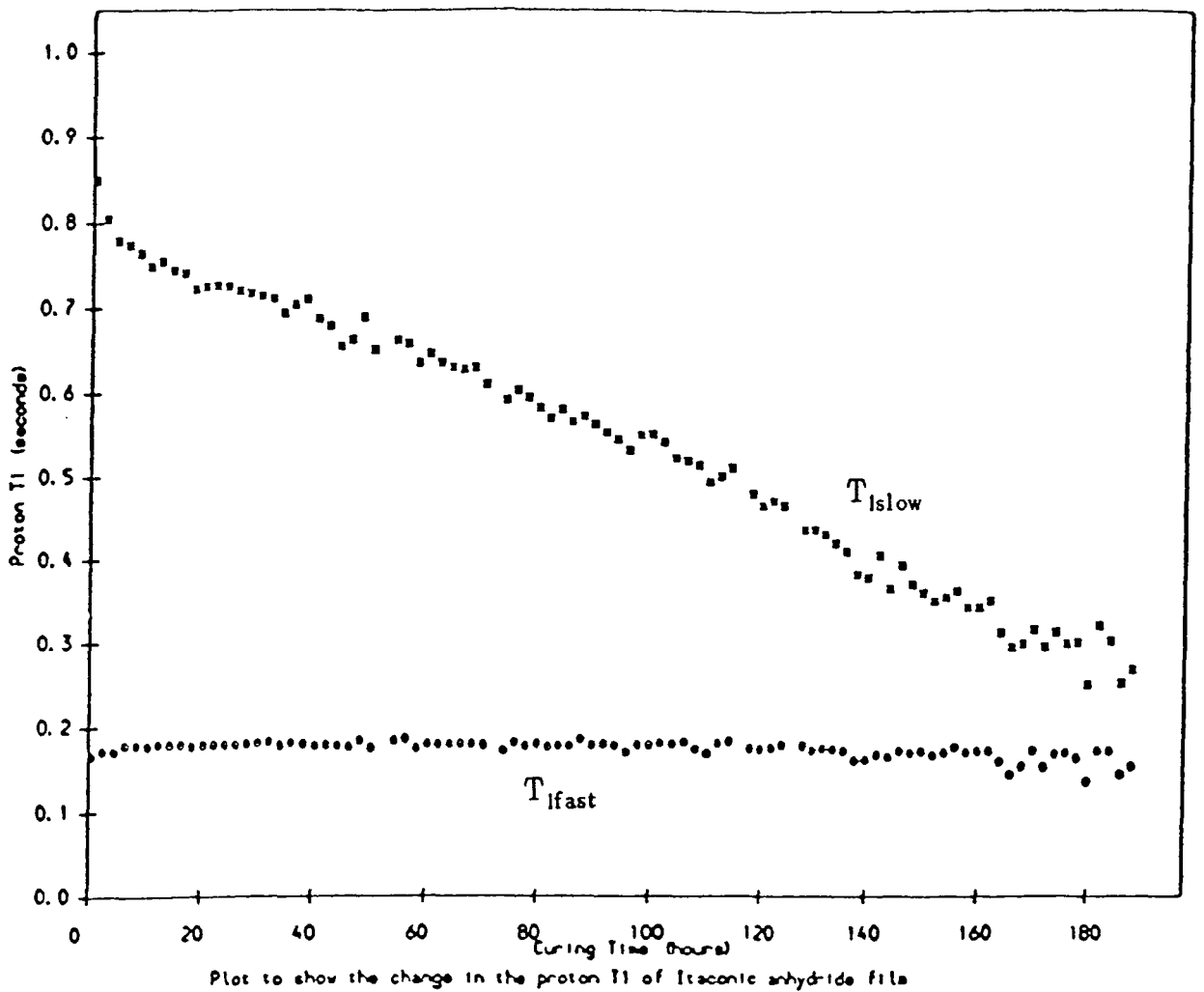

Figure 5.33

Plot to show the change in proton T<sub>1</sub> with curing time for the itaconic anhydride film. The recovery of the protons was biexponential, the two components of the proton T<sub>1</sub> were labelled T<sub>ifast</sub> and T<sub>ismow</sub> as shown in the figure.

and polyester were mixed thoroughly and placed in an NMR tube. Proton  $T_1$  measurements were made using the inversion recovery pulse sequence at hourly intervals over a period of one week using a purpose-built proton/fluorine spectrometer operating at 60 MHz for protons. The plot of proton  $T_1$  as a function of curing time is shown in figure 5.33. This study of the kinetics of the cure was carried out in a different situation to usual paint cure. The itaconic anhydride film network in this experiment was cured in the confined space of an NMR tube rather than in the usual environment of a thin cast film. One of the main differences between these two environments is the rate of loss of solvent. In a thin cast film solvent evaporation takes place much more rapidly than in a bulk network. The slow escape of solvent in the case of the bulk causes the cure to occur at a slower rate than for the cure of a thin film. The important factor in the rate of cure is the surface area:volume ratio. The larger this ratio, the faster the cure takes place. Therefore, not all the conclusions drawn from this experiment may be applicable to the kinetics of the cure of the itaconic anhydride network when cast as a film. There are several points of interest worth noting. The cure initially has a 2 component proton  $T_1$  which gradually become closer together until finally, at the end of the cure, the two components are only separated by a factor of two and are therefore indistinguishable from each other. After seven days the cure is practically over; any changes in the proton  $T_1$  are within the experimental error after this time. The copolymer before mixing has a proton  $T_1$  of 0.85 seconds, and the polyester has a proton  $T_1$  of 0.18 seconds. These times are close to the initial values of the proton  $T_1$  after mixing, which suggests that the longer component of the proton  $T_1$  arises from the copolymer in the network, and the shorter

component of the proton  $T_1$  arises from the polyester in the network. It would appear that during the cure separate copolymer and polyester parts of the network can be resolved until approximately 140 hours into the cure when the two components become too close to be resolved. During the cure only the longer component of the proton  $T_1$  changes significantly. It was expected that both components of the proton  $T_1$  would change as cross-linking occurred. It is not at all clear why only the component arising from the copolymer parts of the network should change as the cure proceeds. It is possible that this is due to the effect of spin diffusion on the measured proton spin-lattice relaxation times. Another possibility is that there may be more than two components, but the components are too close together so that an average  $T_1(^1\text{H})$  is observed. During the cure the solvents evaporate. This loss of solvent is constrained to some extent by the conditions of the reaction. The solvent escapes from the system at a slower rate when the network is formed in bulk than when it is cast as a film. This loss of solvent will have an effect on the proton  $T_1$  observed. The proton  $T_1$  of butyl acetate, the comonomer solvent, was found to be 0.28 seconds at 60 MHz. This is close to the fast relaxing component of the proton  $T_1$ , although the proton  $T_1$  for the solvent in the cross-linking medium is not necessarily the same as for the neat liquid. The fast relaxing component is apparently constant during the cure. This is a surprising observation as it would seem more logical if the fast relaxing component changed as solvent loss took place. However the fact that there is no apparent change in the value of the  $T_1$  for the fast relaxing component during the cure may indicate that a balance is observed between the effects of solvent loss and curing.

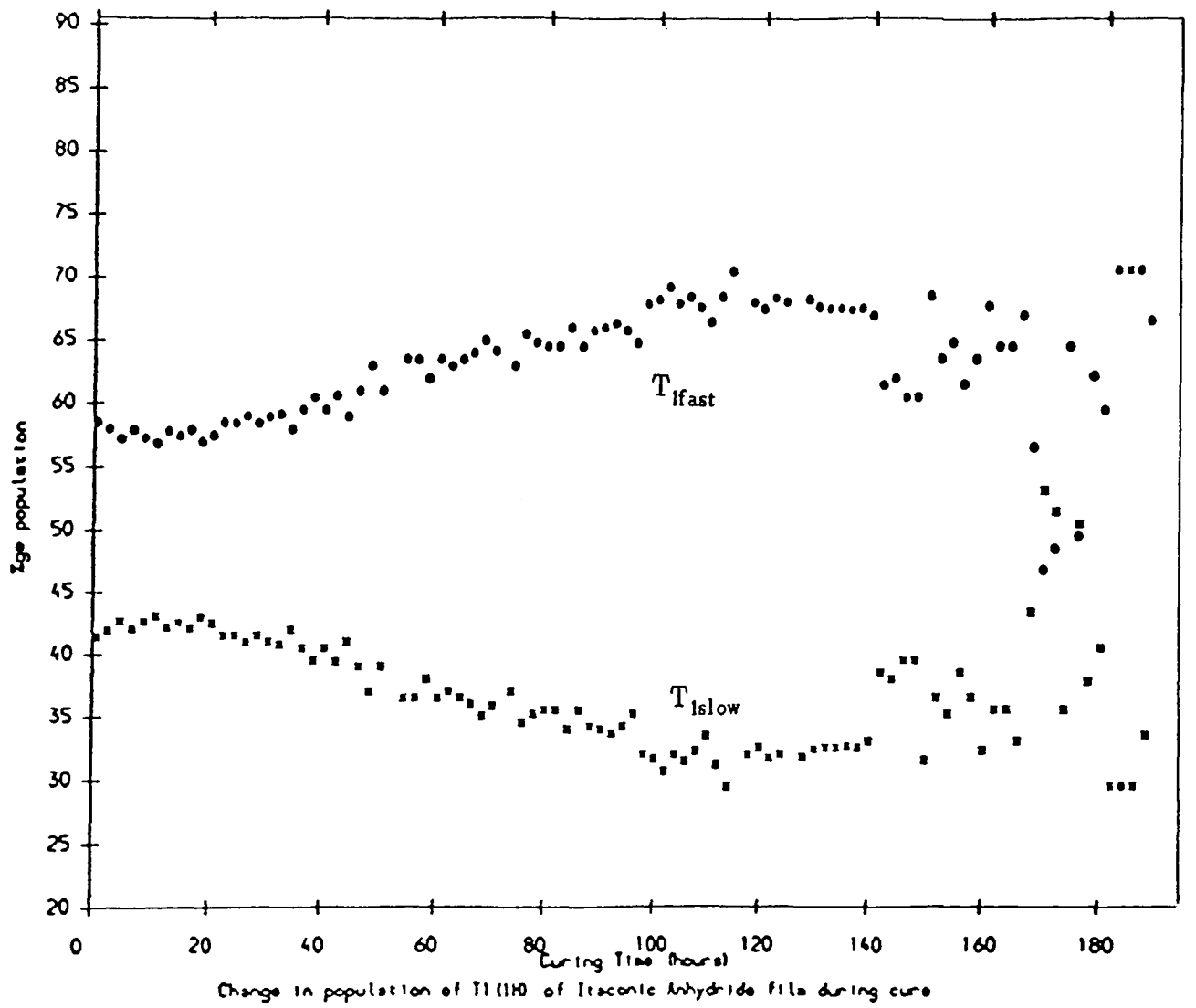

Figure 5.34

Plot to show the change in the populations of the two components with curing time for the itaconic anhydride film.

In order to clarify the effect of this loss of solvent on the proton  $T_1$  observed during the cure, there are a number of possible experiments which could be carried out. If the loss of solvent from the polyester alone was monitored as a function of time by its proton  $T_1$  value, then a direct comparison could be made between the proton  $T_1$  of the polyester with time under conditions of loss of solvent but no cure, and the proton  $T_1$  of the polyester component with time under conditions of loss of solvent and cure. Similar comparisons could be made for the copolymer component by monitoring the proton  $T_1$  as a function of time for the copolymer as solvent evaporation takes place, and comparing this with the proton  $T_1$  values observed for the copolymer component as the polymer system cures. A third experiment which would complement the last two suggested experiments is to monitor the proton  $T_1$  as a function of time as the system cures in a sealed NMR tube. The sealed NMR tube would prevent loss of solvent during the cure, allowing a direct comparison between the cure observed with loss of solvent (figure 5.33) and the cure observed with no solvent loss.

It is interesting to determine on which side of the  $T_1$  minimum the cure lies. As the cure proceeds, the network becomes more and more rigid. The proton  $T_1$  decreases as the cure time increases. Therefore, an initial deduction would be that the cure lies to the left of the main  $T_1$  minimum in the more mobile regime. However, on closer inspection, the more mobile polyester chains give the faster relaxing  $T_1(^1\text{H})$  component, and the more rigid copolymer chains give the slower relaxing  $T_1(^1\text{H})$  component. This would suggest that the cure actually lies to the right of the main  $T_1$  minimum in the rigid regime. However, the proton  $T_1$  values decrease as the cure proceeds, indicating that the cure occurs to the left

of a local minimum in the rigid regime.

The populations of these two components during the cure are shown in figure 5.34. The shorter  $T_1$  component has the higher population, and the longer  $T_1$  component has the lower population. Both the polyester and the copolymer are liquids before the cure takes place, and therefore initially neither component has any spin diffusion. Therefore, at curing time  $t=0$ , the populations should have their intrinsic values. As the cure proceeds, there is an apparent increase in the population of the fast relaxing component and an apparent decrease in the population of the slow relaxing component. The populations no longer have their intrinsic values, but are altered by the effect of spin diffusion. At a curing time of 140 hours to 190 hours almost total averaging is seen in the populations. It is in this part of the plot in figure 5.33 where the two components of the  $T_1(^1H)$  are so close that they are within the experimental error of each other. Assuming that the two components of the  $T_1$  arise from two distinct regions in the film, say A and B, then it is possible to state a few points about the relative sizes of the diffusion coefficients and the intrinsic  $T_1$  values.

Using a one-dimensional two lamellar model it is possible to give some idea of the behaviour of the copolymer and polyester regions. Let the copolymer domains be called region A, and the polyester domains be region B. If  $L_A$  is half the lamellar thickness of region A and  $D_A$  is the spin diffusion coefficient of region A, then the time taken for magnetisation to diffuse out of a region is directly proportional to  $L_A^2/D_A$ . The relaxation of region A will be dominated by the intrinsic relaxation time of region A,  $T_A$  when  $L_A^2/D_A T_A \gg 1$ . However when  $L_A^2/D_A T_A < 1$  then the relaxation in region A is dominated by spin diffusion to the faster

relaxing region B. It is unlikely that the parameters  $D_A$ ,  $T_A$ ,  $D_B$  and  $T_B$  remain constant during the cure. As the cure proceeds it can be expected that the spin diffusion coefficients and the intrinsic relaxation times will change. One prediction which is probably true is that the actual sizes of the regions  $L_A$  and  $L_B$  do not change appreciably after the gel point.

It is not possible from this data to gain a clearer indication of what is happening to the parameters  $D_A$ ,  $D_B$  and  $T_A$ ,  $T_B$  during the cure. There are an infinite number of solutions to explain the observed results. To summarise the conclusions drawn:

- 1). The cure is practically complete after one week
- 2). The values of the proton  $T_1$  components are affected by spin diffusion during the cure
- 3). The domain sizes  $L_A$  and  $L_B$  of the polyester and the copolymer regions are unlikely to change appreciably after the gel point
- 4). The two  $T_1$  components cannot be resolved at the end of the cure
- 5). The initial  $T_1$  values at cure time  $t=0$  are probably the intrinsic values at that stage
- 6). The faster relaxing polyester  $T_1$  component has the higher population
- 7).  $D_A$ ,  $D_B$ ,  $T_A$  and  $T_B$  change during the cure.

### 5.5 Model studies of the cross-linking reaction

Because of the low intensity of the peaks arising from the cross-links and because of the complexity of the CP spectra obscuring

such peaks, it is not easy to study the curing process by  $^{13}\text{C}$  CP NMR. The cross-linking reaction was studied using model compounds to simplify the spectra obtained. The copolymer was replaced by succinic anhydride, and the polyester replaced by various alcohol compounds. The aim was to observe the model cross-link formation, and to attempt to identify any intermediate and final compounds formed. The intention was to obtain an idea of the rates and mechanism of reaction.

#### 5.5.1 Reaction between succinic anhydride and N,N dimethyl ethanolamine?

Excess N,N dimethyl ethanolamine was added to a 10mm NMR tube containing succinic anhydride dissolved in deuterated DMSO. The exothermic reaction was immediate, and by the time the first  $^{13}\text{C}$  NMR spectrum was acquired, the reaction was complete. The reaction between succinic anhydride and N,N dimethyl ethanolamine was too fast to monitor the rate of reaction by NMR. Figure 5.35 shows the carbonyl region of the spectra obtained at 1, 3 and 5 minutes after the mixing of the reactants. The small peak at 176.8 ppm corresponds to unreacted carbonyl in succinic anhydride. The two large peaks belong to the carbonyls in the product. In the spectrum at three minutes two extra small peaks appear which subsequently disappear. The origin of these two peaks will be discussed a little later. Figure 5.36 shows the same three spectra, but this time the region between 35 to 60 ppm is shown. The assignments of the various peaks are shown on the diagram. Again, in the second spectrum 5 extra small peaks appear (indicated with arrows). These peaks disappear before the time reaches 5 minutes since the start of the reaction. Figure 5.37 again shows the same spectra, but this time

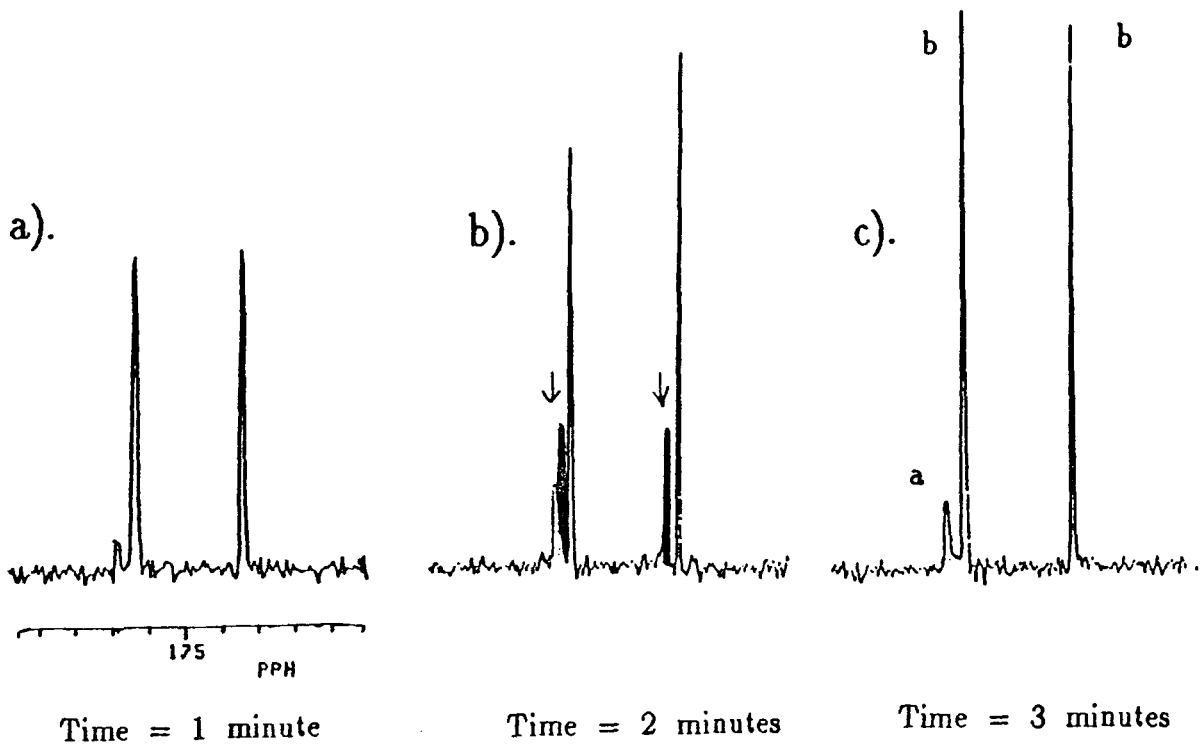

Figure 5.35

The carbonyl region of the spectra obtained at 1, 3 and 5 minutes after the mixing of succinic anhydride and N,N dimethyl ethanolamine.

Parameters

Recycle delay = 3 seconds

AQ = 0.2 seconds

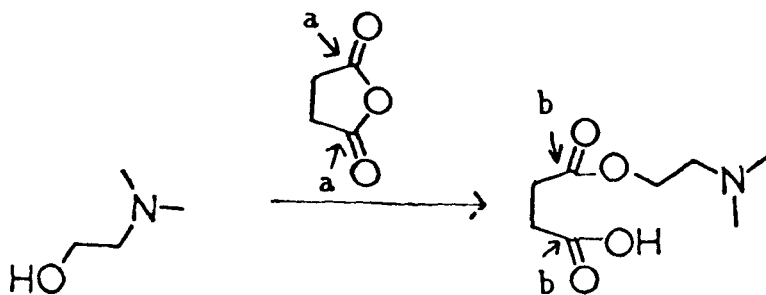
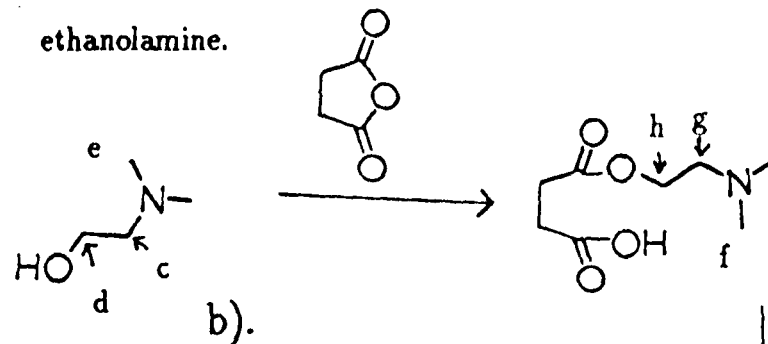

Figure 5.36

The region of the spectra between 35 and 60 ppm obtained at 1, 3 and 5 minutes after the mixing of succinic anhydride and N,N dimethyl ethanolamine.



Parameters

Recycle delay = 3 seconds

AQ = 0.2 seconds

a).

b).

c).

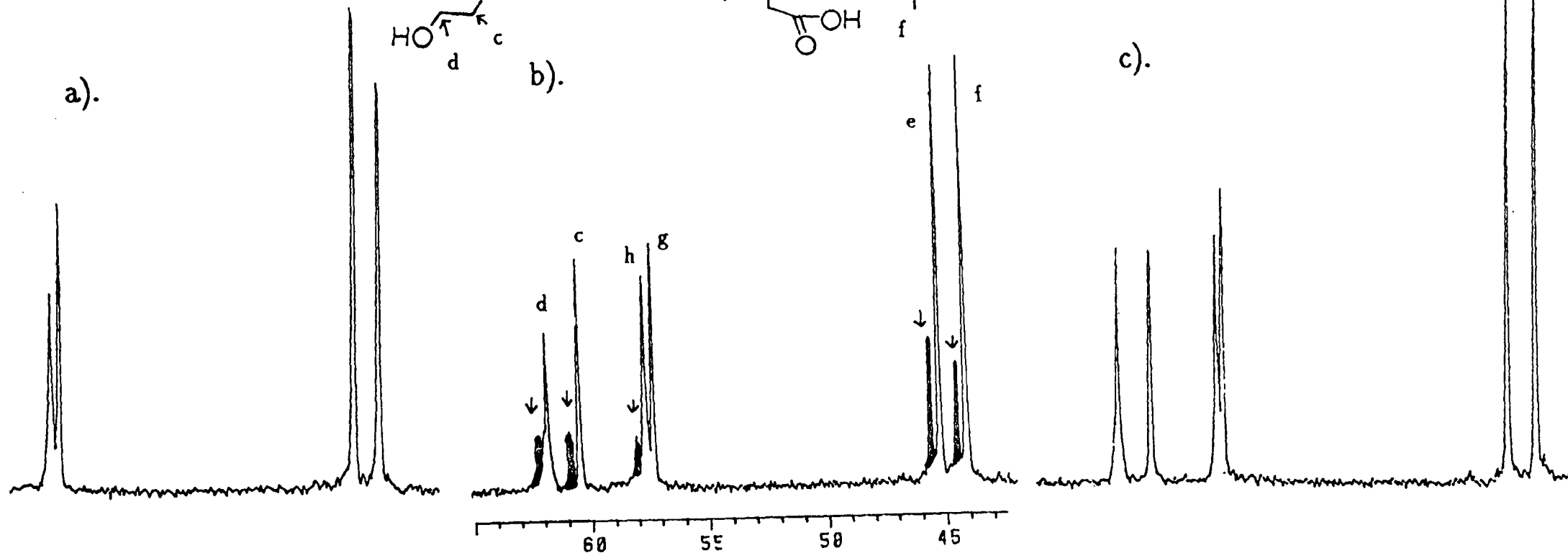

Time = 1 minute

Time = 2 minutes

Time = 3 minutes

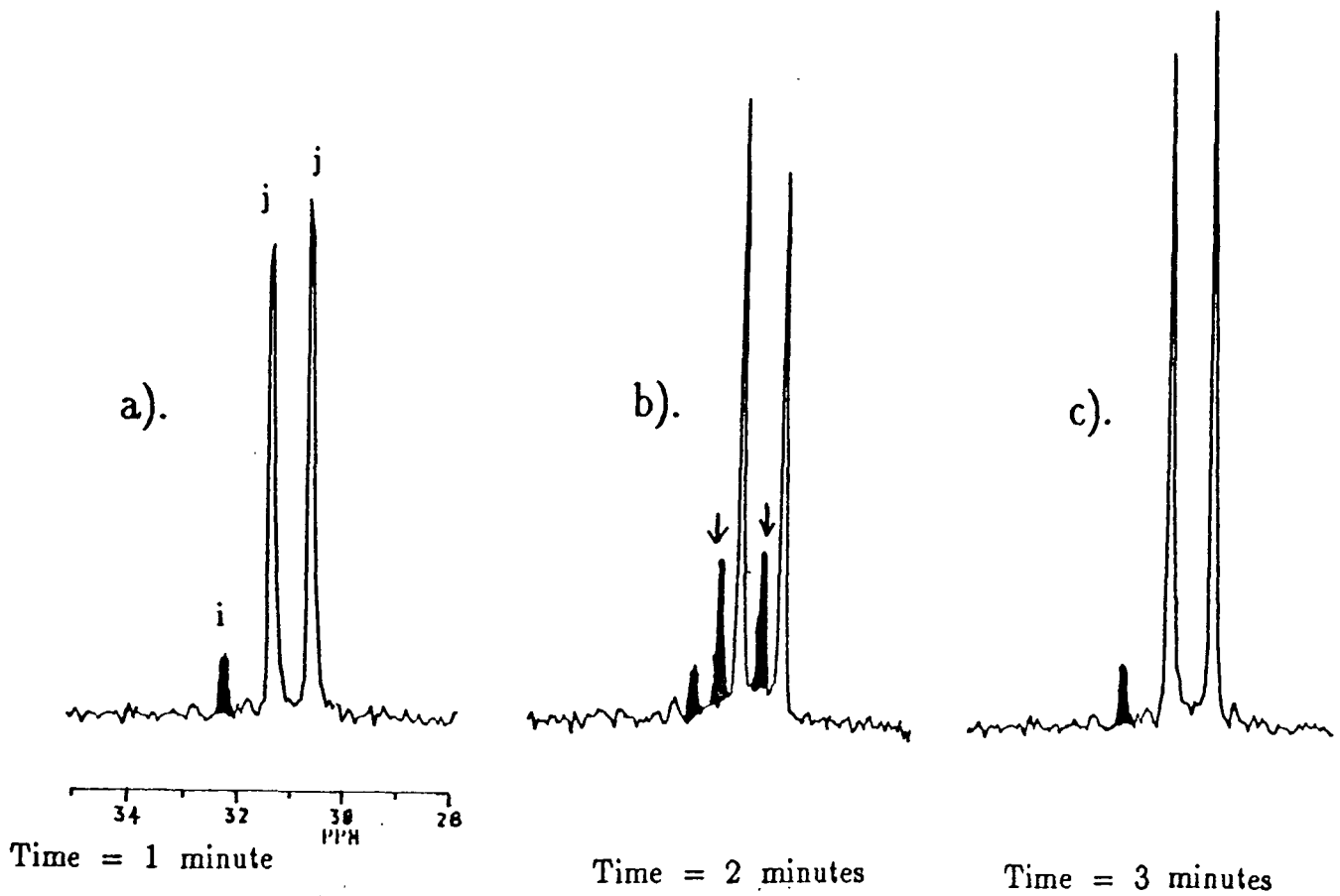

Figure 5.37

The region of the spectra between 28 and 34 ppm obtained at 1, 3 and 5 minutes after the mixing of succinic anhydride and N,N dimethyl ethanolamine.

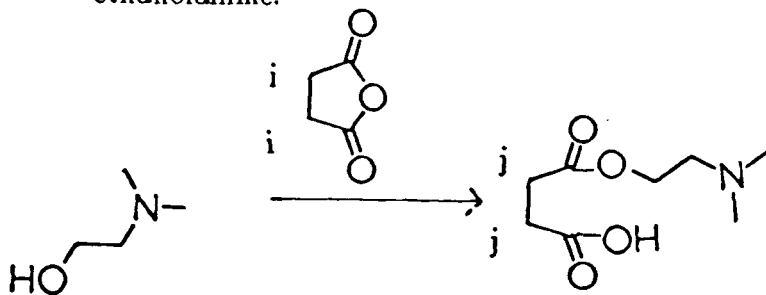

Figure 5.38

a). The salt formed from the reaction between succinic anhydride and N,N dimethyl ethanolamine.

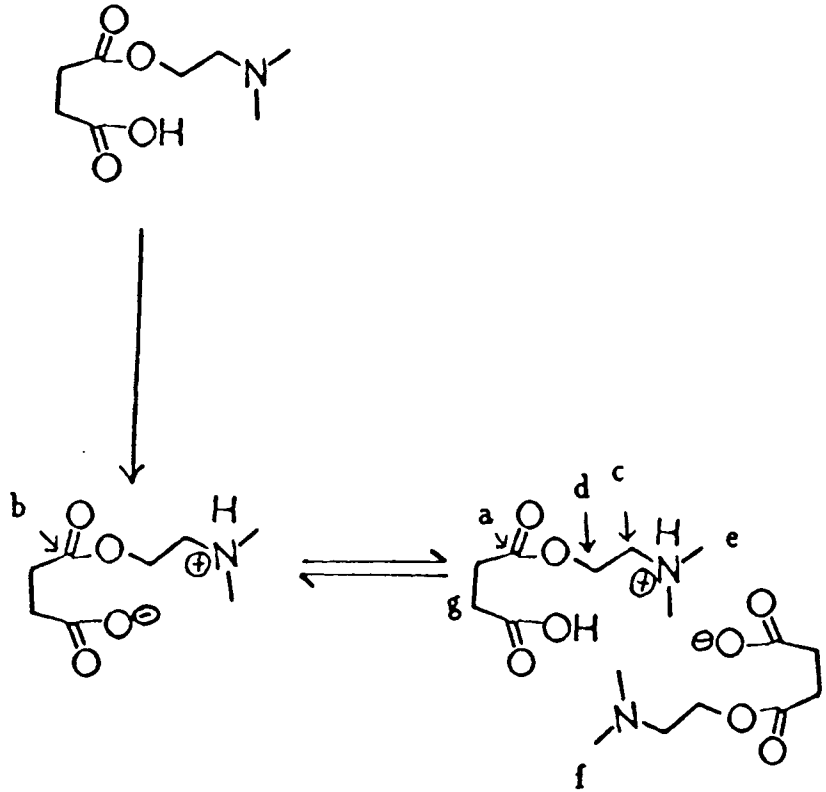
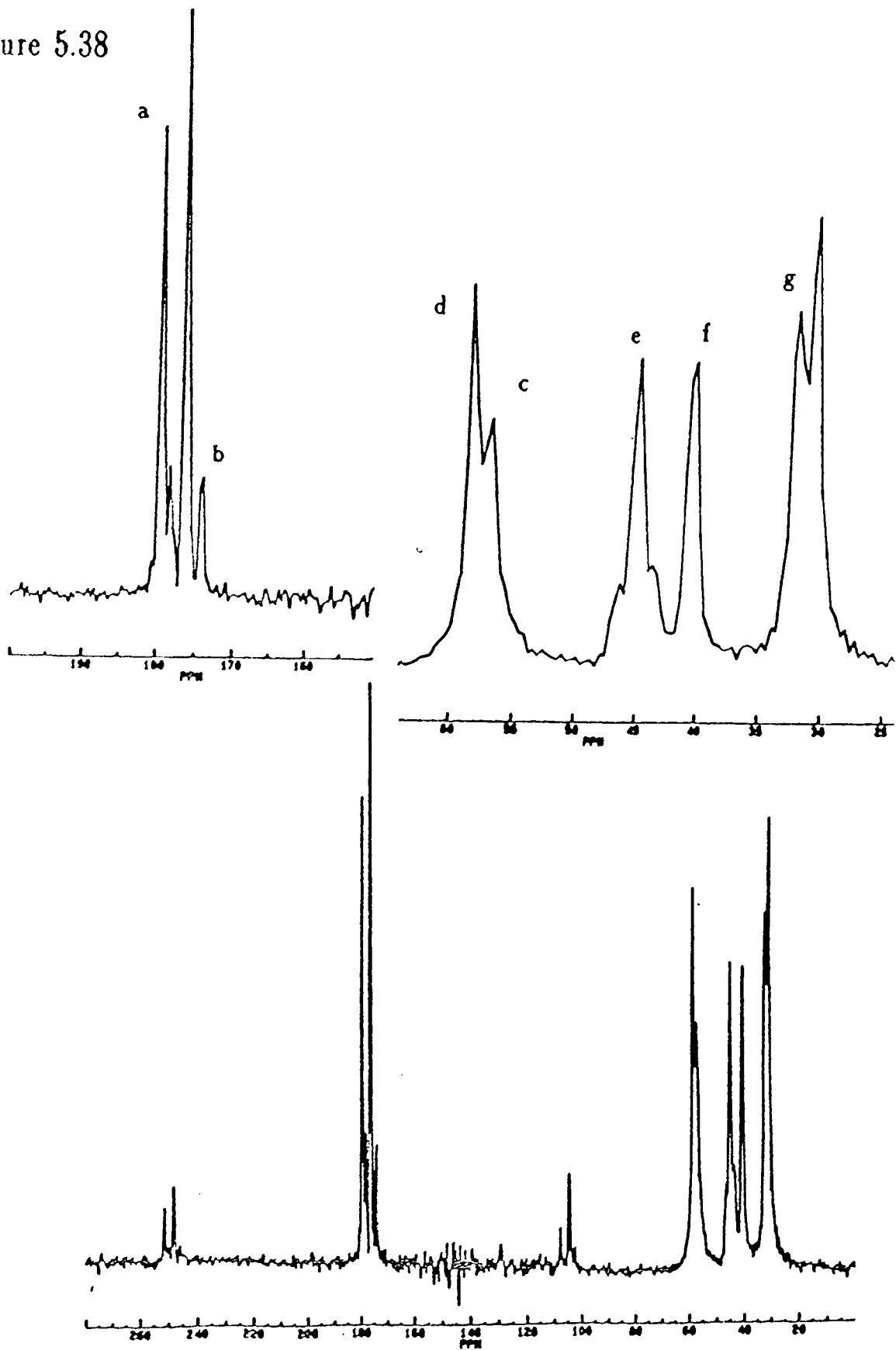

Figure 5.38



b). The  $^{13}\text{C}$  CP NMR spectrum of the isolated salt.

in the region 28 to 34 ppm. The assignments are shown in the figure. Again two extra peaks are seen in the spectrum at 3 minutes since the start of the reaction. In the spectrum acquired at three minutes after the start of the reaction there is a second species formed, which subsequently disappears. It is thought that this species is the salt of the product, as shown in figure 5.38a. When the reaction is repeated but this time using acetone as the solvent, a large amount of salt precipitates out of solution. This salt has been isolated, and studied by  $^{13}\text{C}$  cross-polarisation NMR. The  $^{13}\text{C}$  CP NMR spectrum of the isolated salt is shown in figure 5.38b. There are two salt species present. The assignments are shown in the figure. Acetone is a less polar solvent than DMSO, thus the more polar salt species are less soluble in acetone.

#### 5.5.2 Reaction between succinic anhydride and 4-(2-hydroxyethyl) morpholine

The reaction between succinic anhydride and 4-(2-hydroxyethyl) morpholine was studied in a similar way to the reaction between succinic anhydride and N,N dimethyl ethanolamine. Excess 4-(2-hydroxyethyl) morpholine was added at time zero to a solution of succinic anhydride dissolved in deuterated DMSO and the mixture was allowed to react in an NMR tube. The reaction was monitored by solution-state  $^{13}\text{C}$  NMR.

The spectra in the region 170 to 175 ppm are shown together with assignments in figure 5.39. The loss of succinic anhydride as the reaction proceeds can clearly be seen. Several points of interest may be made. The time taken for the reaction to reach completion is much longer than for the reaction between succinic anhydride and N,N dimethyl ethanolamine.

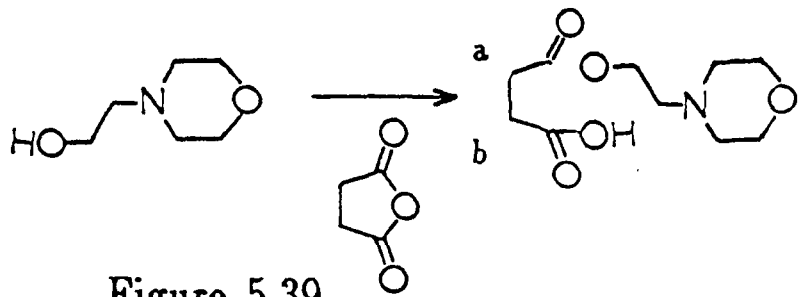

Parameters

Recycle delay = 3 seconds

AQ = 0.2 seconds

Figure 5.39

The carbonyl region of the spectra obtained after the mixing of succinic anhydride and 4-(2-hydroxyethyl) morpholine.

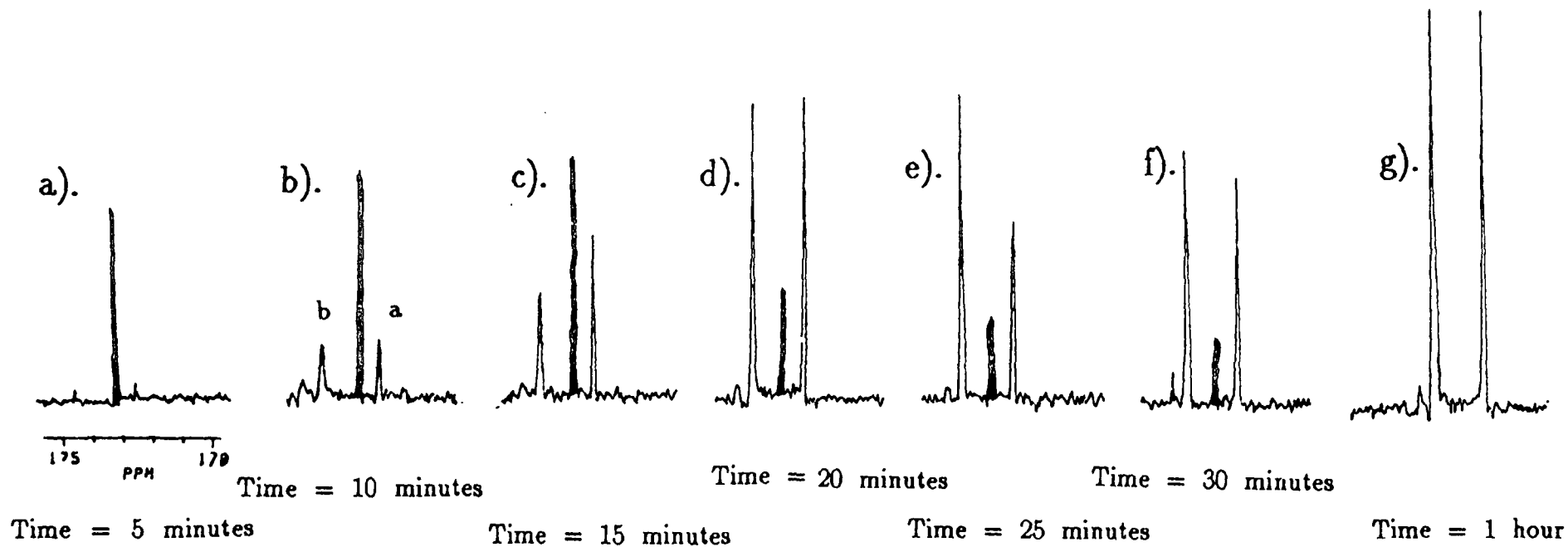

This is because the 4-(2-hydroxyethyl) morpholine is more sterically hindered than N,N dimethyl ethanolamine. 4-(2-hydroxyethyl) morpholine is also less basic than N,N dimethyl ethanolamine, causing the former to be less reactive with an anhydride. No evidence was found of the formation of salts as in the case of N,N dimethyl ethanolamine and succinic anhydride in either DMSO or acetone.

Overall the cross-linking reaction becomes much slower the less basic the amine and the more hindered the amine. Salt formation has been shown to take place in the reaction between succinic anhydride and N,N dimethyl ethanolamine, and conclusive evidence that the salt has two different structures has been shown.

Although such reactions are very simple compared to the cross-linking reaction between an acid anhydride copolymer and a triethanolamine-tipped polyester, the general trends shown by such reactions give an indication of what occurs in the cross-linking reaction between the two polymers.

## CHAPTER 6

### Degradation of acid anhydride/hydroxyl cross-linked systems.

#### 6.1 Introduction

Both natural and synthetic polymers deteriorate as a result of conditions encountered during exposure. The changes in composition and structure lead to the degeneration of useful properties and, ultimately, to failure of the polymer. The cracking of rubber, the yellowing of cotton fabrics and the embrittlement of plastics are typical examples of polymer deterioration. These and similar changes occur under a wide variety of conditions, generally described as the exposure environment.

#### 6.2 General aspects of polymer deterioration

Polymers vary widely in their vulnerability to deterioration when exposed to the same environment. These variations in stability are caused primarily by differences in chemical structure, but they also result from trace impurities in the polymer. Partially degraded molecules are a common impurity in polymers, and these modified molecules often initiate deterioration. Stability is also dependent on the physical structure or morphology of the polymer.

### 6.3 The exposure environment<sup>1</sup>

Both chemical reactants and energy sources contribute to the deterioration of polymeric materials. Although a wide variety of chemical reactants in the environment is responsible for polymer deterioration, oxygen is probably the most important. Most polymers react with oxygen under extreme conditions at combustion temperatures, and many oxidise extensively at much lower temperatures. Water ranks next to oxygen in importance as a chemical reactant in the exposure environment. Although its effect is most evident in the hydrolysis of condensation polymers, certain addition polymers are also vulnerable, and hydrolysis of side groups, for example, ester groups can adversely affect important properties. Hydrolysis of polymers is often catalysed by traces of acids or bases. This chapter is concerned with the hydrolysis of both the itaconic anhydride film and the maleic anhydride film.

For completeness, other methods of degradation are mentioned briefly. The absorption of several types of energy by polymers initiates or accelerates those chemical reactions responsible for deterioration. Various forms of radiation and mechanical stress contribute to polymer failure. Acceleration of deterioration by heat is a general phenomenon responsible for the degradation of polymers both in the presence and absence of chemical reactants. Ultraviolet radiation initiates the deterioration of many polymers, and mechanical stress also contributes to failure.

Long-term aging is the most important period of exposure. During this period the polymer is exposed to conditions of actual use. Deterioration is usually slow and can escape detection for long periods of



time. When visible effects become apparent, many polymers may already have failed for the application intended.

#### 6.4 Hydrolytic degradation<sup>2</sup>

Moisture can have a deleterious effect on some types of polymer. Hydrolysis is a very important deteriorative process in modern polymer technology as many commercial materials incorporate hydrolysable linkages. These materials include polyesters, polyurethanes and polycarbonates. In each of these groups the hydrolysable group is almost invariably part of the main chain structure. Hence hydrolysis results in chain scission, leading to a rapid decrease in molecular weight and consequent rapid deterioration in the mechanical properties such as the tensile strength.

Polymers are much more resistant to hydrolysis than might be predicted from the behaviour of low molecular weight model compounds. This is not due to the inherent difference in stability of the hydrolysable linkages but to the fact that attack by the water is usually confined to the surface because of the hydrophobic nature of most organic polymers, and because of the subsequent low rate of diffusion of aqueous solutions into the polymer bulk. In the overall weathering process in many polymers there is no doubt that both the humidity and the presence of liquid water often play a significant role. It is usually difficult however to disentangle the effects of a large number of degradation mechanisms at work in typical outdoor exposures where the effects of sunlight and oxygen are paramount. There are some situations, however, in which there is no doubt that hydrolysis is the most important mechanism.

### 6.5 Acid anhydride/hydroxyl degradation studies<sup>3</sup>

The acid anhydride/hydroxyl cross-linked systems are intended for use as coatings for yachts. The cross-linked coatings must therefore be durable against various kinds of weathering. Throughout its lifetime, the coating must retain its colour and glossy appearance, be resistant to peeling and cracking, as well as maintain its physical and mechanical properties such as its strength and adhesion. The potential environment of a yacht paint is in humid, wet conditions such as are found in the mediterranean. In order to predict the durability of the acid anhydride/hydroxyl cross-linked systems under these conditions, accelerated tests were carried out on the films by Courtaulds Coatings. Although accelerated tests are not conclusive evidence for the prediction of the weathering of a coating in its intended environment, they are generally recognised as useful in so far as they indicate how the coating is likely to behave in long-term natural exposure tests. High humidity was identified as the most aggressive environment for the films. A series of experiments were carried out by Courtaulds Coatings to study the effect of high humidity on the films.

The films were prepared by mixing together stoichiometric amounts of the component polymer solutions. The mixture was degassed under vacuum. The films were drawn onto PTFE sheets to produce dry films between 150–200 $\mu$ m thick. The samples were cured for 24 hours in a dust-free environment at ambient temperature and humidity. The films were then exposed to an environment of 30% relative humidity at 25°C

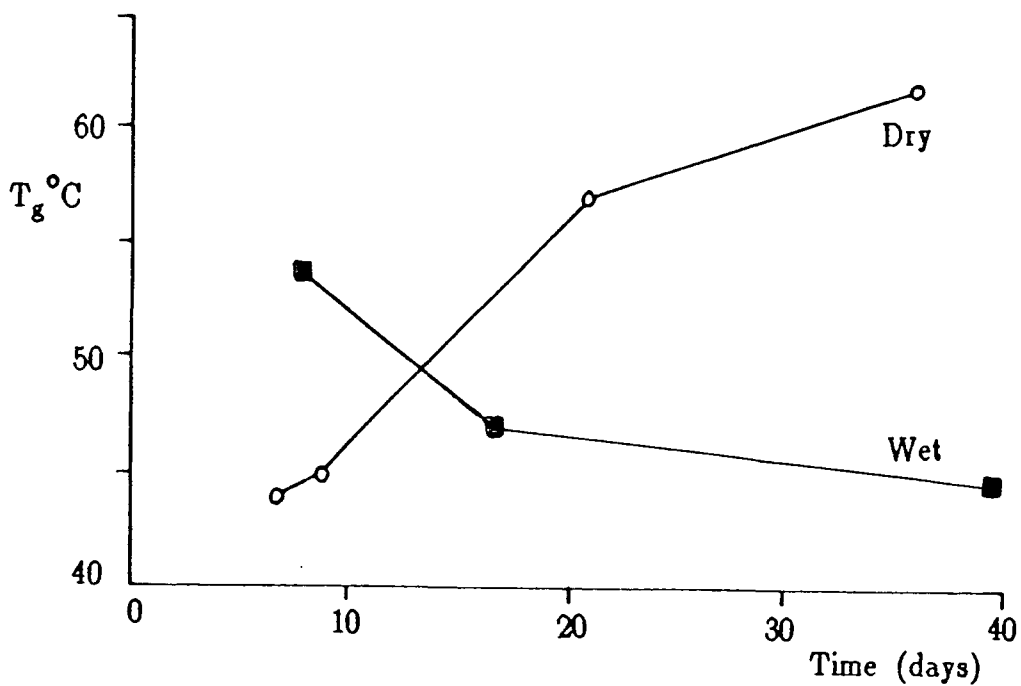

Figure 6.1

A comparison between the  $T_g$  of itaconic anhydride film which was subjected to 35°C/100% relative humidity and the  $T_g$  of itaconic anhydride film which was subjected to dry conditions only. Reproduced with permission from Courtaulds Coatings.

for 6 days, and the cure was allowed to continue. The cured films were placed in an environmental cabinet at 35°C and a relative humidity of 100%. These conditions attempted to simulate the environment which a yacht paint could be expected to be exposed to. The samples were removed at intervals to monitor the progress of the degradation. Both the itaconic and the maleic anhydride films showed evidence of irreversible degradation. The  $T_g$  of the itaconic anhydride film at 35°C/100% relative humidity was monitored as the degradation progressed, and was compared to the  $T_g$  of the sample of the same age, but which had not been exposed to the wet conditions. The results can be seen in figure 6.1. The clear film became white and opaque as degradation occurred, and a progressive lowering of the  $T_g$  was observed compared to the itaconic anhydride film which had undergone similar ageing in dry conditions.

Another method of monitoring the extent to which degradation has occurred is by measurement of the increasing sol fraction. The sol fraction is obtained by weighing a strip of degraded film of size 25×10×0.2mm. The strip was soaked in excess butan-2-one solvent for 5-6 hours. The solvent was then discarded, and the film soaked further in fresh solvent. The strip of film was then dried overnight at a slightly elevated temperature, and then reweighed. The ratio

$$\frac{\text{Weight of extracted material}}{\text{Weight of insoluble network polymer}}$$

is the sol:gel ratio.

The sol fraction increased as the age of the itaconic and maleic anhydride films kept at 35°C/100% relative humidity increased. The increasing sol fraction shows that hydrolysis of the network is taking

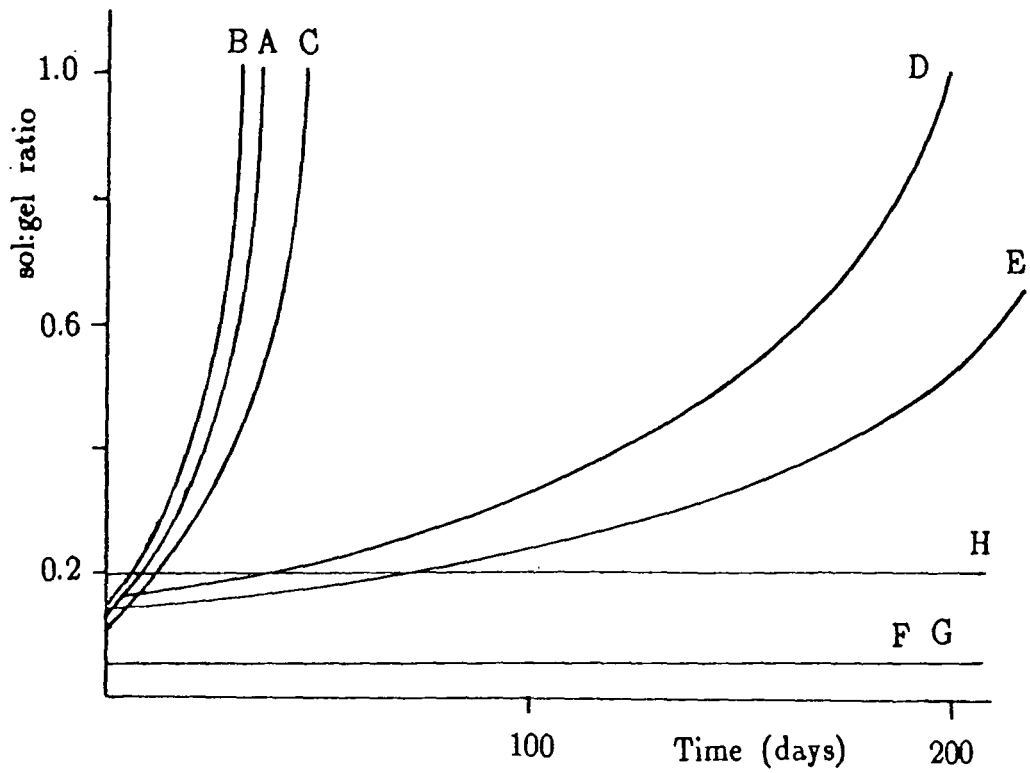

Figure 6.2

Sol/gel against age data for the itaconic anhydride films of the resins A to H. Reproduced with permission from Courtaulds Coatings.

## Table 6.1

Resins A to H used as cross-linkers in figure 6.2

### Key

A	Adipic polyester hydroxyamine
B	Adipic polyester hydroxyamine, 50% extended with triethanolamine
C	Azelaic polyester hydroxyamine
D	Cycloaliphatic polyester hydroxyamine
E	Hydrocarbon hydroxyamine
F,G	Aliphatic and aromatic linear polyesters cured with aliphatic triisocyanates
H	Proprietary system based on maleic copolymer and acrylic polyol.

Resins A to E are used to cross-link the itaconic anhydride copolymer.

place, and hence the measurement of the increasing sol fraction is a powerful technique for assessing the hydrolytic stability of the films. The degradation of a range of films was studied by the sol:gel method. The copolymer of itaconic anhydride, styrene and methyl methacrylate was cross-linked with a range of resins (A-H in table 6.1) where resin A is the most susceptible to water attack, and resin H the least. Figure 6.2 shows the sol/gel against age data for all of the itaconic anhydride films of the resins A to H. It can clearly be seen that the less hygroscopic the cross-linker resin, the less is the extent of degradation.

Although these data on hydrolytic ageing cannot identify the sites of degradation, a general trend in the rates of degradation may clearly be seen. The three cross-linkers A,B and C which have ester linkages along the main chain degrade at a much faster rate than cross-linkers D and E which have only hydrocarbons along the main chain. The itaconic anhydride films formed with cross-linkers H, F and G are not seen to degrade at all under conditions of 35°C and 100% relative humidity. All five resins A to E have a triethanolamine extension at the cross-link which is a possible cleavage site, whereas resins F, G and H are based on triisocyanates (F, G) and an acrylic polyol which do not have a triethanolamine cleavage site either at the cross-link or along the polymer chain.

Although these suggestions explain the observed relative rates of the various resins, the hydrolytic ageing data do not supply any concrete evidence to identify the actual sites of degradation. This was attempted through spectroscopic means.

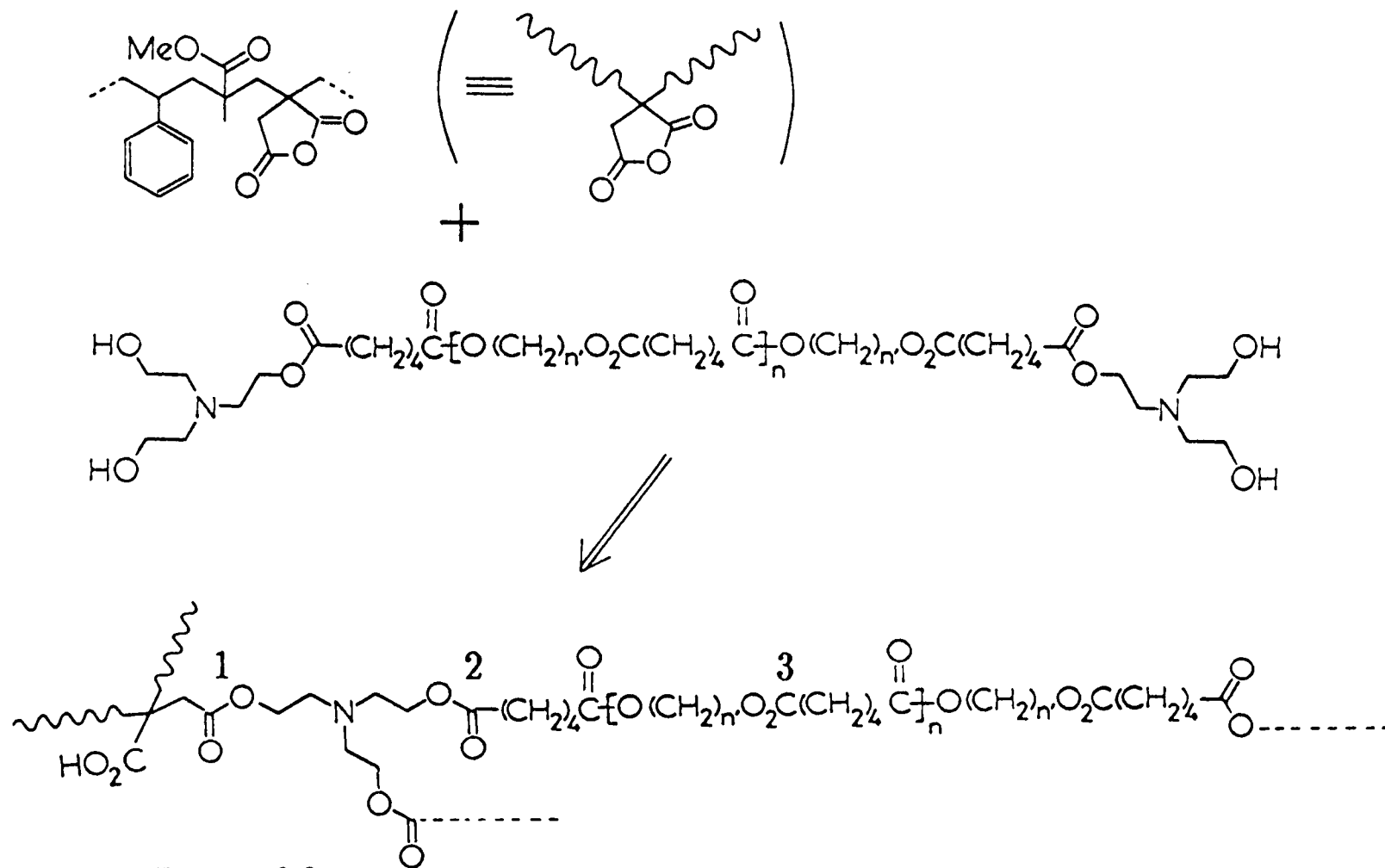

Figure 6.3

Possible sites of degradation in acid anhydride/hydroxyl systems.

## 6.6 Possible sites of degradation in acid anhydride/hydroxyl systems

Figure 6.3 shows the general structure of the itaconic anhydride film. There are three possible sites for hydrolysis to occur:

1. at the half-ester cross-link
2. at the ester linking the triethanolamine to the polyester backbone
3. at an ester linkage in the polyester backbone

Cleavage at position 1. would result in amine attached to the polyester unit, whereas cleavage at position 2. would leave amine-functional acrylic and acid-tipped polyester. Failure at position 3. would lead to polyester fragments.

There are two degradation models to consider.

### 6.6.1 Model A: cleavage only occurs at positions 1. and 2.

If cleavage were only to occur at the cross-links, it is reasonable to predict that scission of a few linkages would initially release polyester fragments of network only. As the degradation proceeds, scission takes place at more and more bonds. Therefore as hydrolysis continues, fragments containing copolymer as well as polyester are released. As even more cleavages take place, the fragments of copolymer and polyester break down into smaller fragments, until eventually the network is completely reverted back to molecules resembling the network precursors.

### 6.5.2 Model B: Cleavage occurs at all three positions

If cleavage were to occur along the backbone of the polyester chain as well as at the cross-link sites, then the prediction is that initially only polyester fragments of network will be released, with copolymer being released as the degradation proceeds for the same reason as in model A. If a scission occurs at position 3 in figure 6.3, then the ester linkage in the polyester chain which is next to the cleavage is more susceptible to attack than other ester linkages along the chain. This is known as the anchimeric effect, and is discussed in more detail later in the chapter. The net result towards the end of degradation will be that the network will contain intact copolymer chains together with fragmented polyester chains.

## 6.7 Characterisation and analysis of the sol product<sup>4</sup>

### 6.7.1 GPC

Sol extracts of the itaconic anhydride film with ageing periods ranging from just cured to 115 days showed progressive increases in apparent peak molecular weight as the age of the film increases. However the fragments expected from polyester cleavage are low molecular weight and highly functional. Such samples are at the limits of the range of the GPC apparatus, thus the results may only be treated as a guide.

### 6.7.2 NMR

Both <sup>1</sup>H and <sup>13</sup>C spectra of the sol fractions were obtained by

Courtaulds Coatings using a Bruker WP80 FTNMR spectrometer operating at 80MHz for protons and 20MHz for carbon. The spectra contained residues of both the acrylic and the polyester. However both the spectral resolution and the signal to noise were poor. The results were inconclusive; it was unclear if the polyester present was intact or in fragments.

### 6.7.3 HP liquid chromatography

Two major broad peaks were observed by HPLC. The first peak, and therefore the less polar of the two, is assigned to the polyester component in the sol. The second peak, which is more polar, contained acrylic. It could not be concluded, however, that the second peak did not contain some polyester residues.

## 6.8 Conclusions

From the evidence it is unclear exactly how the film degrades. The itaconic anhydride film samples are hydrolytically unstable resulting in the breakdown of either the polyester-triethanolamine linkage or the acrylic-triethanolamine cross-link, or both. No definite evidence from the sol fractions has been found which concludes beyond doubt that the ester linkages along the polyester backbone either do or do not hydrolyse. Although no precursor fragments of the polyester have been directly observed in the sol fractions, it is possible that these fragments could have been washed out of the film samples during the ageing process in the environmental cabinet. In order to complete the study of the

## Table 6.2

Assignment of the peaks in the maleic anhydride film spectrum.

Peak/ppm	Assignment
173.5	C=O of MMA, cross-link, and polyester
143	Aromatic quaternary carbon of styrene
127.8	Aromatic C-H of styrene
63.1	O=C-O-CH <sub>2</sub> in polyester chain
51.3	CH <sub>3</sub> O of MMA
45	Quaternary carbon of MMA
40-45	CH backbone carbons
41.5	CH of polystyrene
40.8	CH <sub>2</sub> 'backbone' of copolymer
33.8	O-C(=O)-CH <sub>2</sub> in polyester chain
24.9	CH <sub>2</sub> 'backbone' of polyester
19.6	CH <sub>3</sub> of MMA

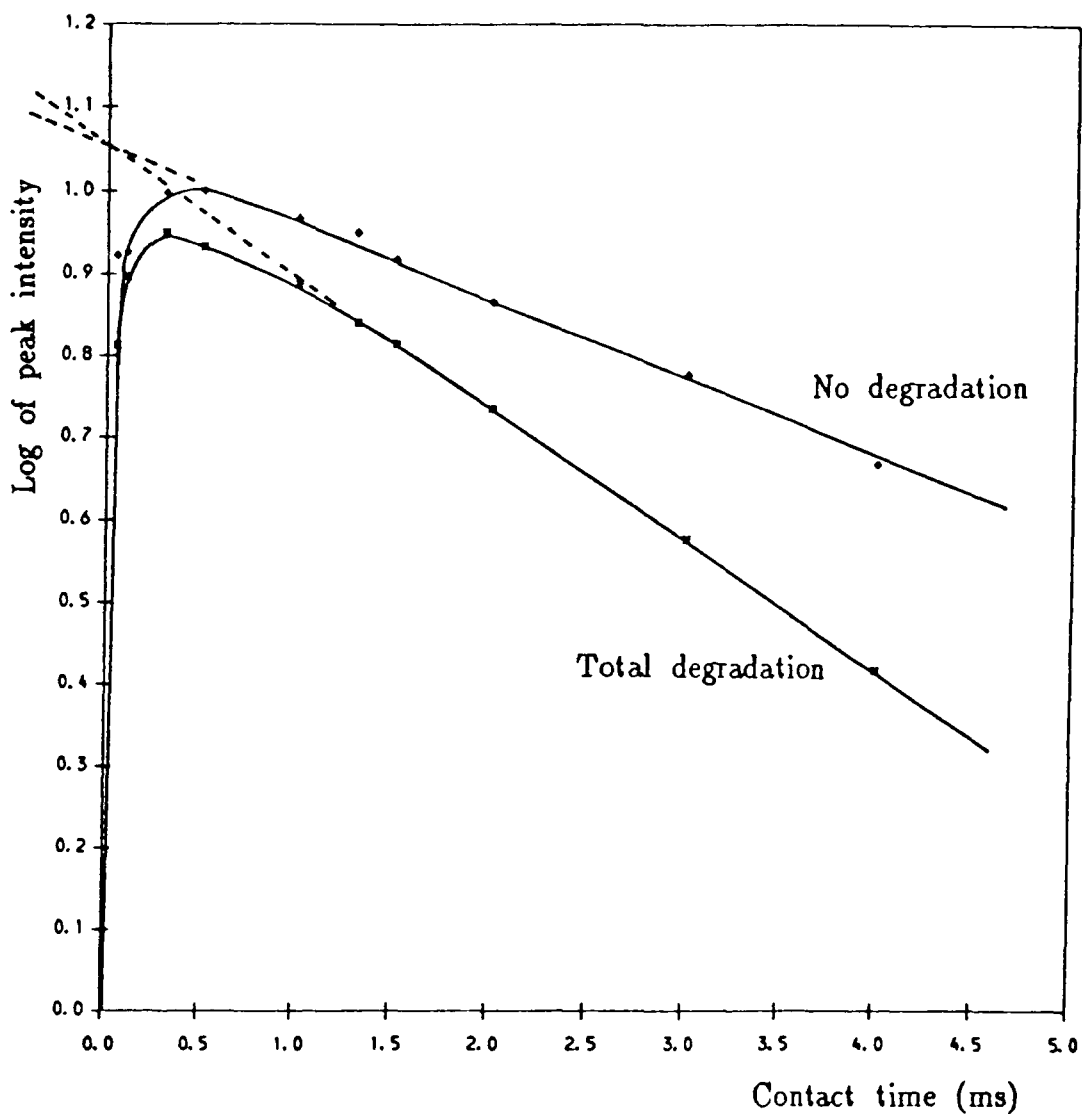

Figure 6.4

Plot of the log of the peak intensity against contact time for the copolymer peak at 40 ppm in the maleic anhydride film. The maleic anhydride film with no degradation is compared to the film with total degradation for contact times between 0.05 and 4 ms. The recycle delay was 6 seconds, the acquisition time was 26 ms and 1000 transients were acquired for each experiment.

degradation, the solid parts of the films were studied using solid-state  $^{13}\text{C}$  MAS NMR. The intention was to study the solid fraction of the degraded films in order to clarify whether or not hydrolysis was occurring at the ester linkages along the polyester chains. The degradation of both the itaconic anhydride film and the maleic anhydride film was studied by solid-state NMR. Samples of the maleic anhydride film were prepared at four different stages of the degradation: no degradation (i.e. 1 week cure), 2 weeks degradation, 4 weeks degradation and total degradation (3 months degradation).

#### 6.9 The degradation of the maleic anhydride film

During the curing reaction between the maleic anhydride, styrene and methyl methacrylate copolymer with the triethanolamine tipped polyester, the system converts from a liquid into a solid. Hence, if this process is reversed by hydrolysis, it is expected that the films would become less rigid as degradation progresses.

As the film degrades, any change in the absolute intensity of a particular peak may indicate a change in the chemical structure of the carbons which give rise to the peak. In order to study the change in intensity of the various carbons as the film degrades, variable contact time cross-polarisation experiments were carried out on the films at various stages in the degradation process.

Figure 6.4 shows the variable contact time intensities of the peak at 40 ppm (the  $\text{CH}_2$  backbone of the copolymer). The assignments of the peaks for the maleic anhydride film are shown in table 6.2. The maleic

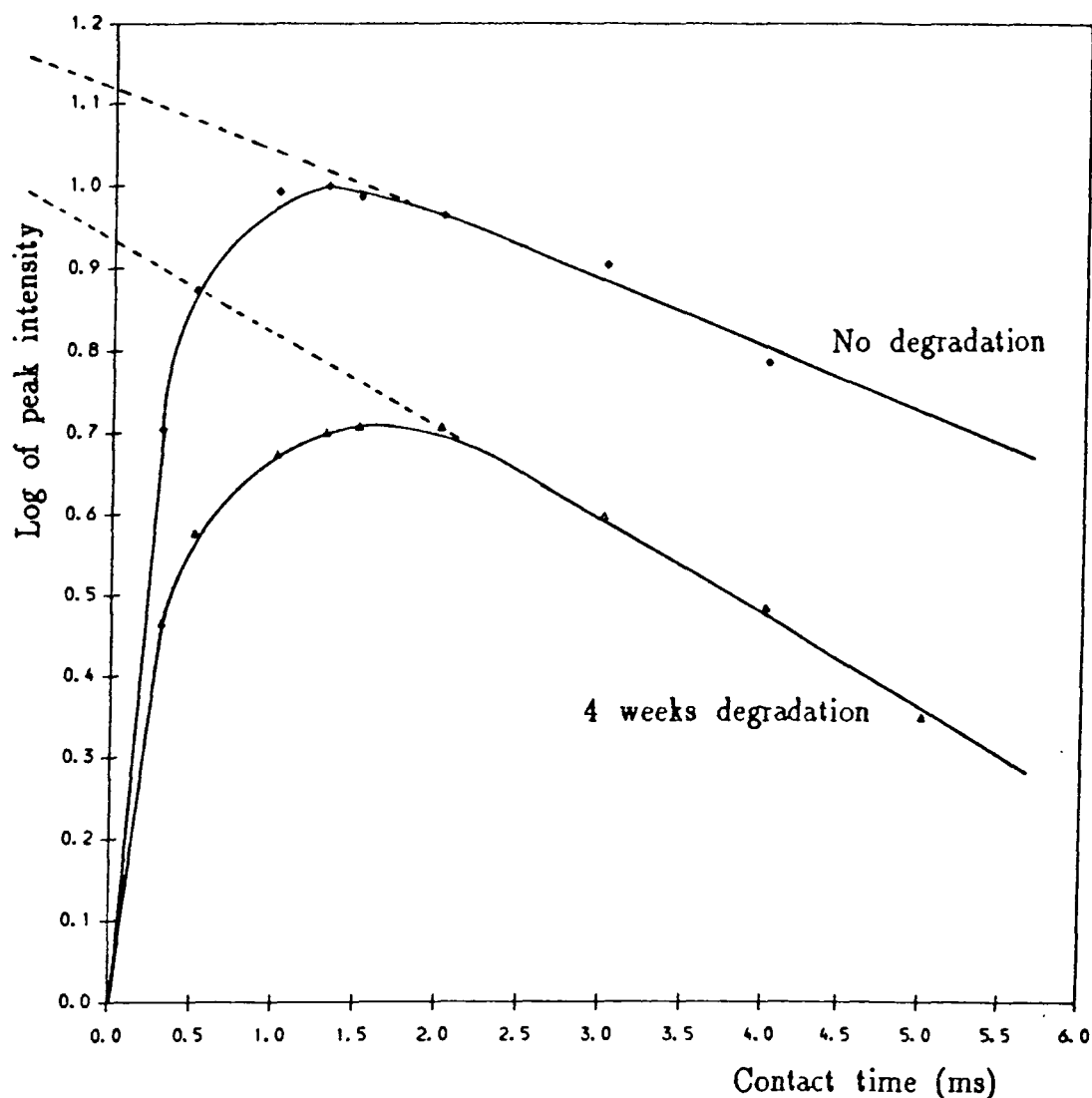
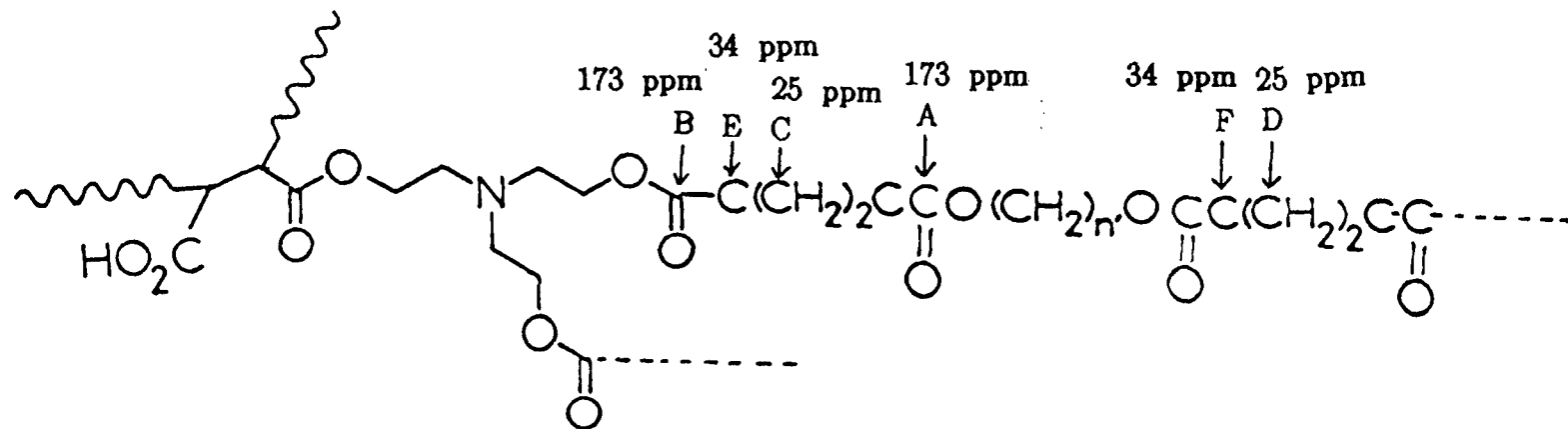

**Figure 6.5**

Plot of the log of the peak intensity against contact time for the polyester peak at 173 ppm in the maleic anhydride film. The maleic anhydride film with no degradation is compared to the film with 4 weeks degradation for contact times between 0.3 and 5 ms. The recycle delay was 6 seconds, the acquisition time was 26 ms and 1000 transients were acquired for each experiment.

Figure 6.6

Types of carbons in the polyester chain.



anhydride film with no degradation is compared to the film with total degradation for contact times between 0.05 and 4 ms. Extrapolating back to the intensity axis, it is found that the film without degradation and the film with total degradation both intercept the  $y$  axis at the same point. From this it may be concluded that the copolymer backbone remains intact during the degradation of the polymer film. Hence any degradation in the maleic anhydride film must be taking place either at the cross-links or along the polyester chain, or both.

A similar plot is shown in figure 6.5 for the peak at 173 ppm (the carbonyls in the polyester chain). Figure 6.5 compares the intensities of the maleic anhydride film with no degradation to the maleic anhydride film with 4 weeks degradation. A decrease in the intensity of 16% is seen for the film with 4 weeks degradation. There are two possible sites of degradation for the carbonyls in the polyester chain: the carbonyl at the ester linkages along the polyester chain (type A figure 6.6) and the carbonyl at the end of the polyester chain before the triethanolamine (type B figure 6.6). Assuming that only type B carbonyls cleave, and assuming that all such carbonyls cleave during the degradation, the maximum decrease in the intensity of the peak at 173 ppm may be calculated as 23%. Since this theoretical decrease in intensity is more than the experimental loss in intensity of the peak at 173 ppm, it is not possible to conclude from this whether only type B carbonyls are cleaved, or whether type A carbonyls are also hydrolysed. However, what it is possible to deduce is that some acid groups formed during the degradation of carbonyl groups type B give rise to a carbonyl peak at

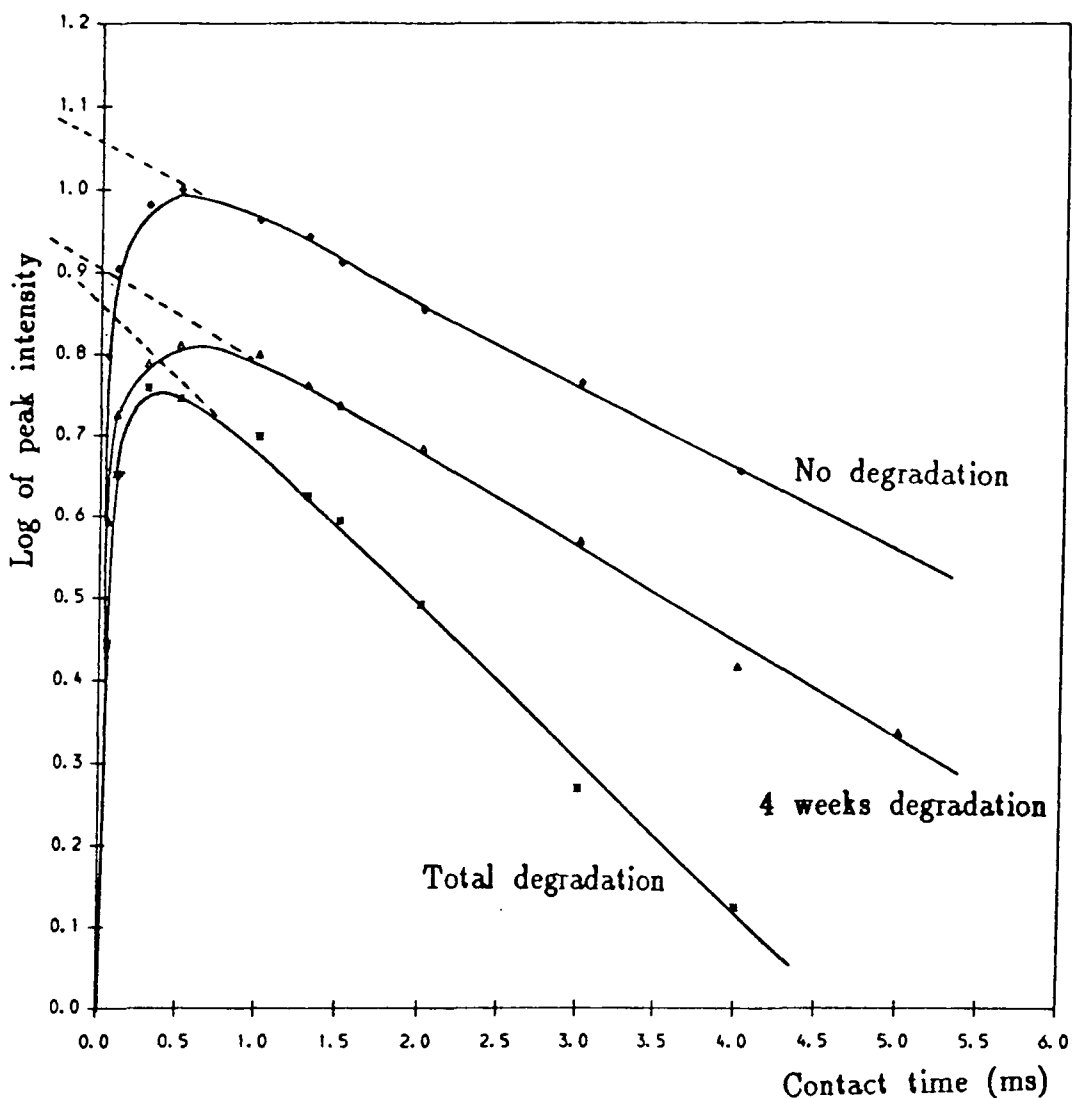

**Figure 6.7**

Plot of the log of the peak intensity against contact time for the polyester peak at 25 ppm in the maleic anhydride film. The maleic anhydride film with no degradation is compared to the film with 4 weeks degradation and with total degradation for contact times between 0.05 and 5 ms. The recycle delay was 6 seconds, the acquisition time was 26 ms and 1000 transients were acquired for each experiment.

Table 6.3

Values of  $T_{IS}$  and  $T_{Ip}$  for the maleic anhydride film.

$T_{Ip}$	Peak			
	25 ppm	34 ppm	40 ppm	173 ppm
Degradation	25 ppm	34 ppm	40 ppm	173 ppm
No deg.	9.67	8.92	10.07	11.29
2 weeks deg.	18.89	—	17.73	17.67
4 weeks deg.	10.98	9.51	12.81	9.85
Total deg.	4.54	—	6.422	5.81

$T_{IS}$	Peak			
	25 ppm	34 ppm	40 ppm	173 ppm
Degradation	25 ppm	34 ppm	40 ppm	173 ppm
No deg.	0.063	0.056	0.054	0.425
2 weeks deg.	0.074	—	0.065	0.499
4 weeks deg.	0.060	0.057	0.054	0.443
Total deg.	0.078	—	0.057	0.402

Table 6.4

Assignment of the peaks in the itaconic anhydride film spectrum.

Peak/ppm	Assignment
173.5	C=O of MMA, cross-link, and polyester
144.8	Aromatic quaternary carbon of styrene
128.3	Aromatic C-H of styrene
63	O=C-O-CH <sub>2</sub> in polyester chain
49.6	CH <sub>3</sub> O of MMA
45	Quaternary carbon of MMA
40-45	CH backbone carbons
41.5	CH of polystyrene
40.1	CH <sub>2</sub> 'backbone' of copolymer
33.5	O-C(=O)-CH <sub>2</sub> in polyester chain
25	CH <sub>2</sub> 'backbone' of polyester
19.8	CH <sub>3</sub> of MMA

177 ppm.

Figure 6.7 shows the variable contact time intensities of the peak at 25 ppm (the CH<sub>2</sub> backbone of the polyester). The plot compares the relative intensities of the 25 ppm peak of the films with no degradation, with 4 weeks degradation and with total degradation. Extrapolating back to the intensity axis as before, it can be seen that as the degradation progresses, the absolute intensity of the 25 ppm peak decreases consistently. There is a loss in intensity of 14% between the film with 4 weeks degradation and the film with no degradation, and a loss in intensity of 18% between the film with total degradation and the film with no degradation. It is of interest to determine whether this loss in intensity may be attributed to cleavage at the cross-link only (figure 6.6 position C), or whether there is a contribution to the decrease in intensity from cleavage at the ester positions along the chain (figure 6.6 position D). Calculations of the chemical shift have shown that degradation either at the cross-link or at the ester linkages along the polyester chain does not alter the chemical shift of the peak from 25 ppm. Therefore, any degradation which takes place either at the cross-link or at the ester linkage along the polyester chain should not result in a decrease in the absolute intensity of the fully degraded film compared to the film with no degradation. An explanation of why an 18% decrease in the absolute intensity is observed may be obtained through consideration of the effect on the overall intensity of the 25 ppm peak if the polyester chain were to degrade. If some or all of the ester linkages along the polyester chain are hydrolysed, then the polyester chain

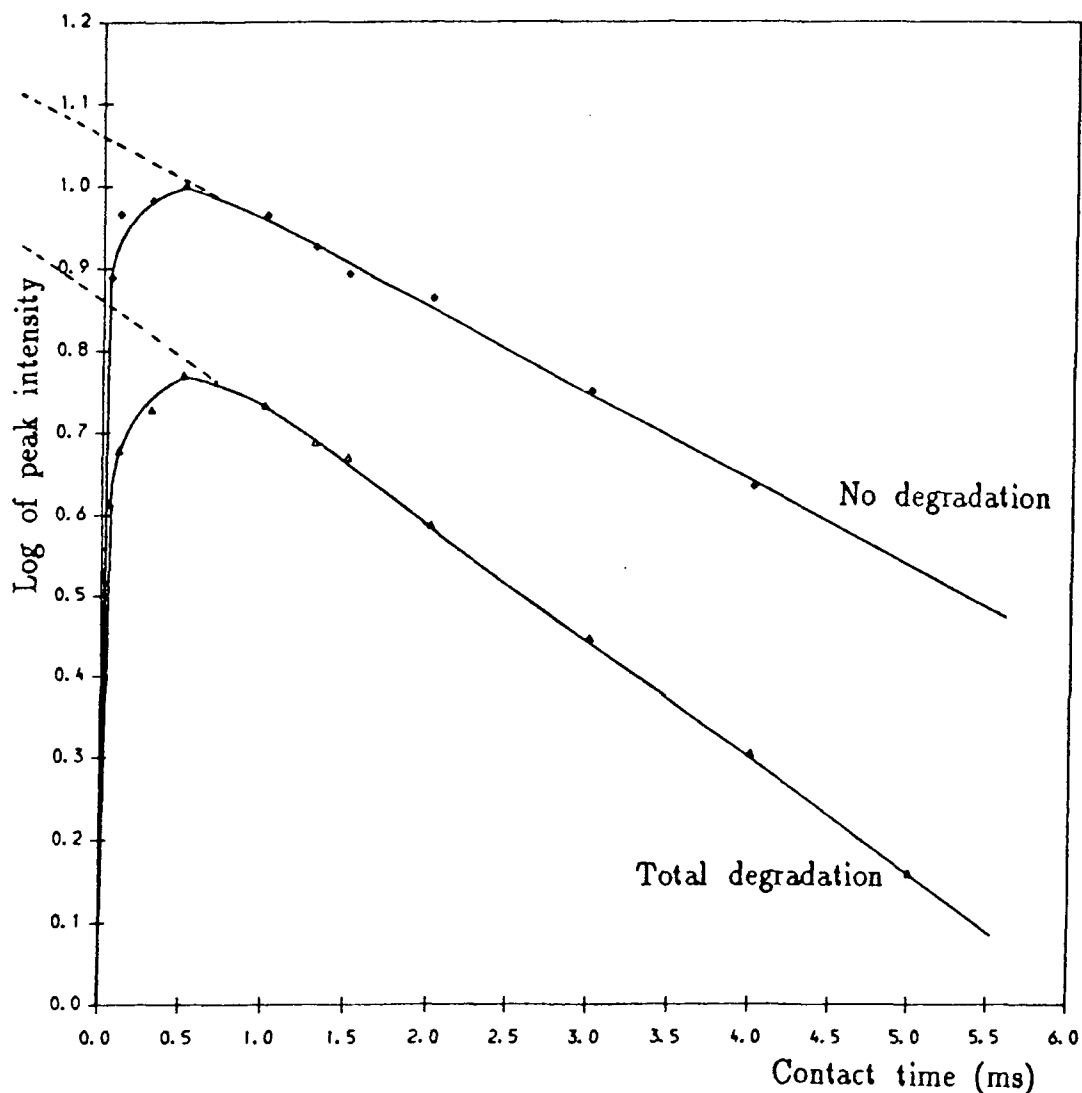

Figure 6.8

Plot of the log of the peak intensity against contact time for the polyester peak at 34 ppm in the maleic anhydride film. The maleic anhydride film with no degradation is compared to the film with total degradation for contact times between 0.05 and 5 ms. The recycle delay was 6 seconds, the acquisition time was 26 ms and 1000 transients were acquired for each experiment.

will break up into smaller fragments. The conditions in the environmental cabinet in which the maleic anhydride films were degraded were 35°C and 100% relative humidity. These conditions of continually dripping water wash any small fragments out of the film. Thus, when the absolute intensity of the totally degraded film is measured, a decrease in the absolute intensity of the 25 ppm peak is found. Therefore the decrease of 18% between the film with no degradation and the film with total degradation is partially due to the degradation of the ester linkages along the polyester chain.

The variable contact time intensities of the peak at 34 ppm ( $\text{CH}_2$  next to the carbonyl) are shown in figure 6.8. The intensities of the maleic anhydride film with no degradation are compared with the maleic anhydride film with total degradation. Extrapolating back to the intensity axis, there is a loss in intensity of 18% between the film with no degradation and the film with total degradation. As in the case of the peak at 25 ppm, calculations of the chemical shifts have shown that degradation at either position E near the cross-link or position F along the polyester chain (see figure 6.6) does not alter the chemical shift of the 34 ppm peak. Therefore, for the same reason as in the case of the 25 ppm peak, the 18% loss in intensity must be due to degradation at the ester linkages along the polyester chain (position F figure 6.6).

Table 6.3 lists the values of  $T_{1S}$  and  $T_{1\rho}$  obtained from the variable contact time plots (figures 6.4-5 and 6.7-8). Variable contact time measurements were also obtained for a maleic anhydride film with 2 weeks degradation, the values of  $T_{1S}$  and  $T_{1\rho}$  of which are listed in table

6.3. It can be seen that the sample with 2 weeks degradation gave anomalous results which could not be explained. It is thought that the sample was at fault. However the experiment would have to be repeated to prove this. The anomalous plot of the maleic anhydride film with 2 weeks degradation has been omitted from figures 6.4-5 and 6.7-8 for this reason. However, because the maleic anhydride film with 2 weeks degradation has been left out of these plots, the conclusion that the ester linkage in the polyester backbone also cleaves during degradation must be treated with caution.

In order to obtain an understanding of the chemistry of the degradation process, spectra of the maleic anhydride film with no degradation are compared to spectra of the maleic anhydride film with total degradation. Figure 6.9a and b shows the carbonyl region of the  $^{13}\text{C}$  CP MAS spectra of the maleic anhydride film with no degradation and with total degradation respectively. Figure 6.9a is dominated by the peak at 173 ppm. This is explained by the variable contact time measurements (figure 6.5). There is a new peak in figure 6.9b at 177 ppm. This corresponds to a carbonyl in the polyester chain which has been hydrolysed to a carboxylic acid as illustrated in figure 6.9c. The increase in intensity in figure 6.9b at about 180 ppm is attributed to the formation of more free carboxylic groups at the cross-link in the degraded sample compared to the maleic anhydride film with no degradation.

Figure 6.10a and b show the same spectra as figures 6.9, but this time the aliphatic region between 15 and 70 ppm is illustrated. The

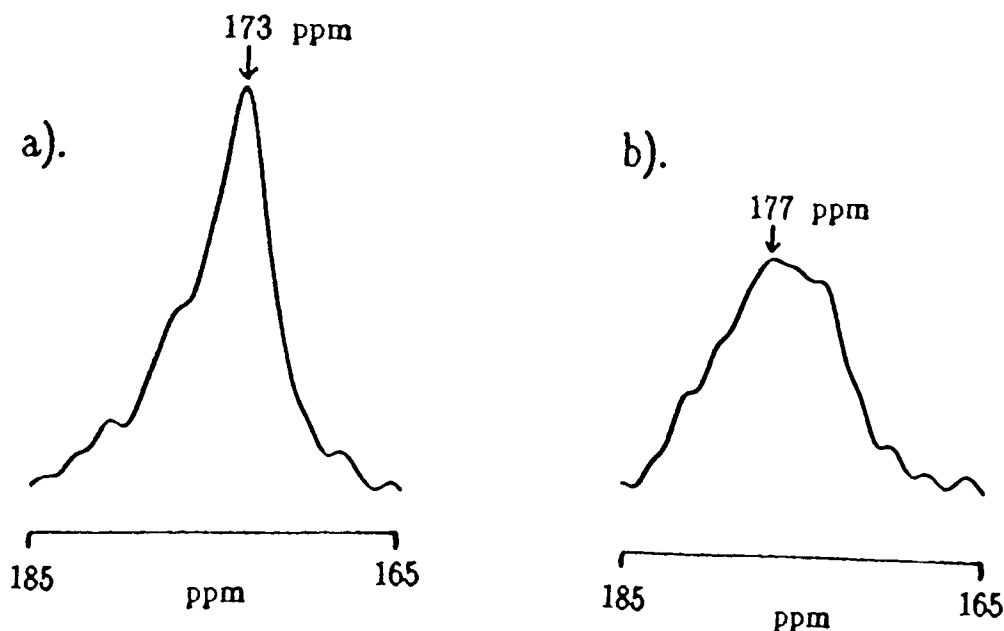

Figure 6.9

a). The carbonyl region of the  $^{13}\text{C}$  cross-polarisation spectrum of the maleic anhydride film with no degradation.

b). The carbonyl region of the  $^{13}\text{C}$  cross-polarisation spectrum of the maleic anhydride film with total degradation.

Recycle delay = 6 seconds

contact time = 1.5 ms

acquisition time = 26 ms

no. of transients = 1000

c).

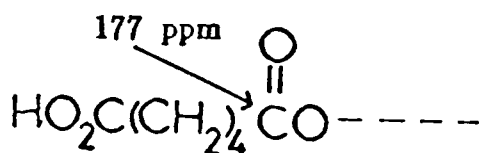
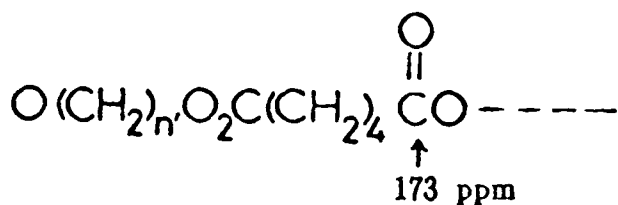

c). The new peak at 177 ppm corresponds to a carbonyl in the polyester chain which has been hydrolysed.

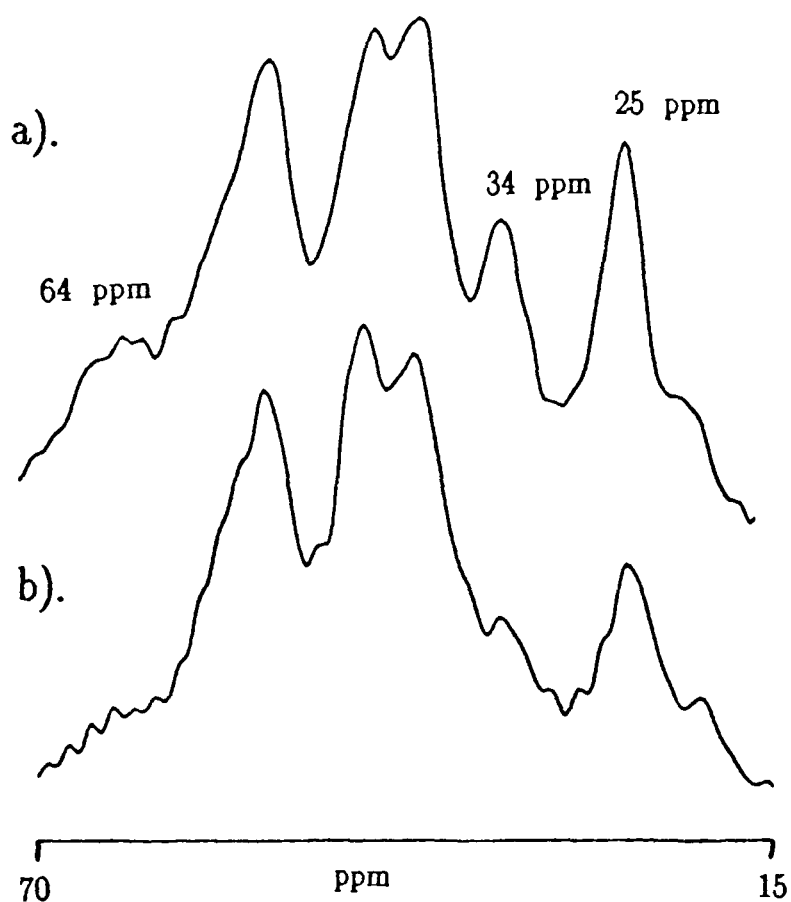

Figure 6.10

- a). The aliphatic region of the  $^{13}\text{C}$  cross-polarisation spectrum of the maleic anhydride film with no degradation.
- b). The aliphatic region of the  $^{13}\text{C}$  cross-polarisation spectrum of the maleic anhydride film with total degradation.

Recycle delay = 6 seconds  
 contact time = 1.5 ms  
 acquisition time = 26 ms  
 no. of transients = 1000

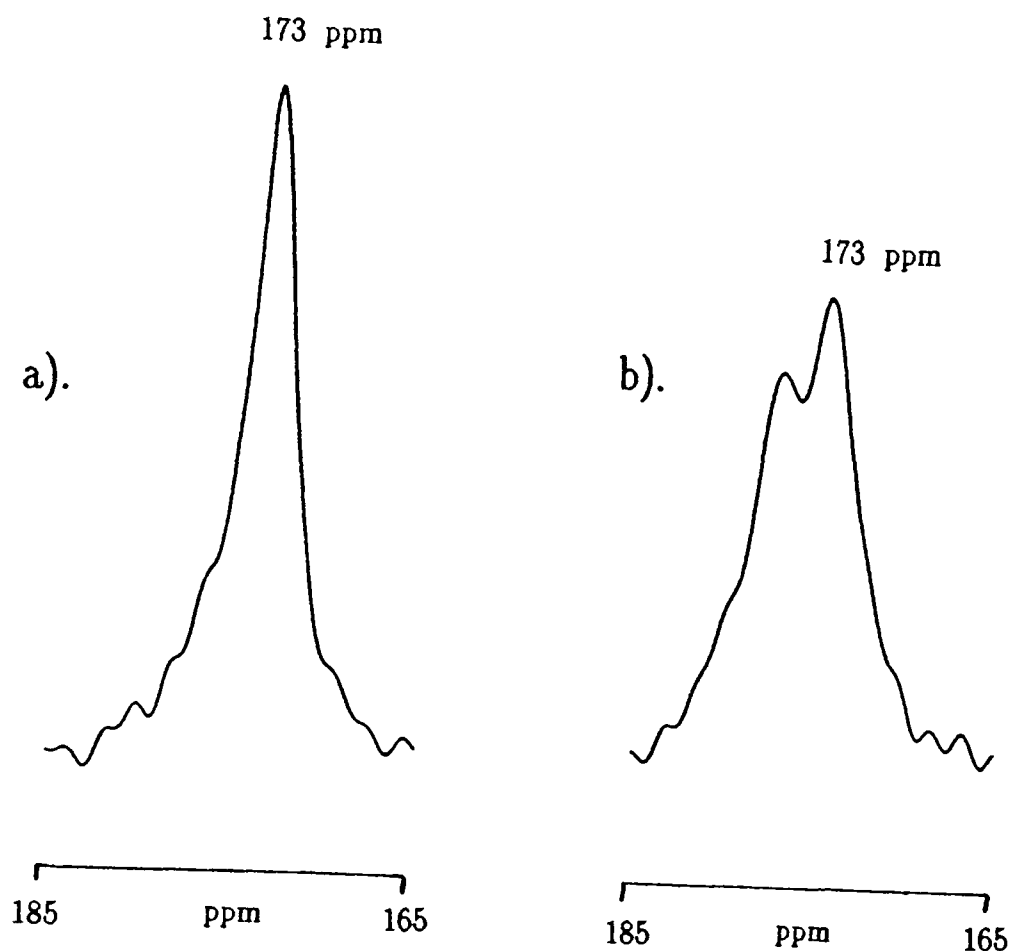

Figure 6.11

- a). The carbonyl region of the  $^{13}\text{C}$  single-pulse spectrum of the maleic anhydride film with no degradation.
- b). The carbonyl region of the  $^{13}\text{C}$  single-pulse spectrum of the maleic anhydride film with total degradation.

Recycle delay = 7 seconds  
 acquisition time = 26 ms  
 no. of transients = 3000

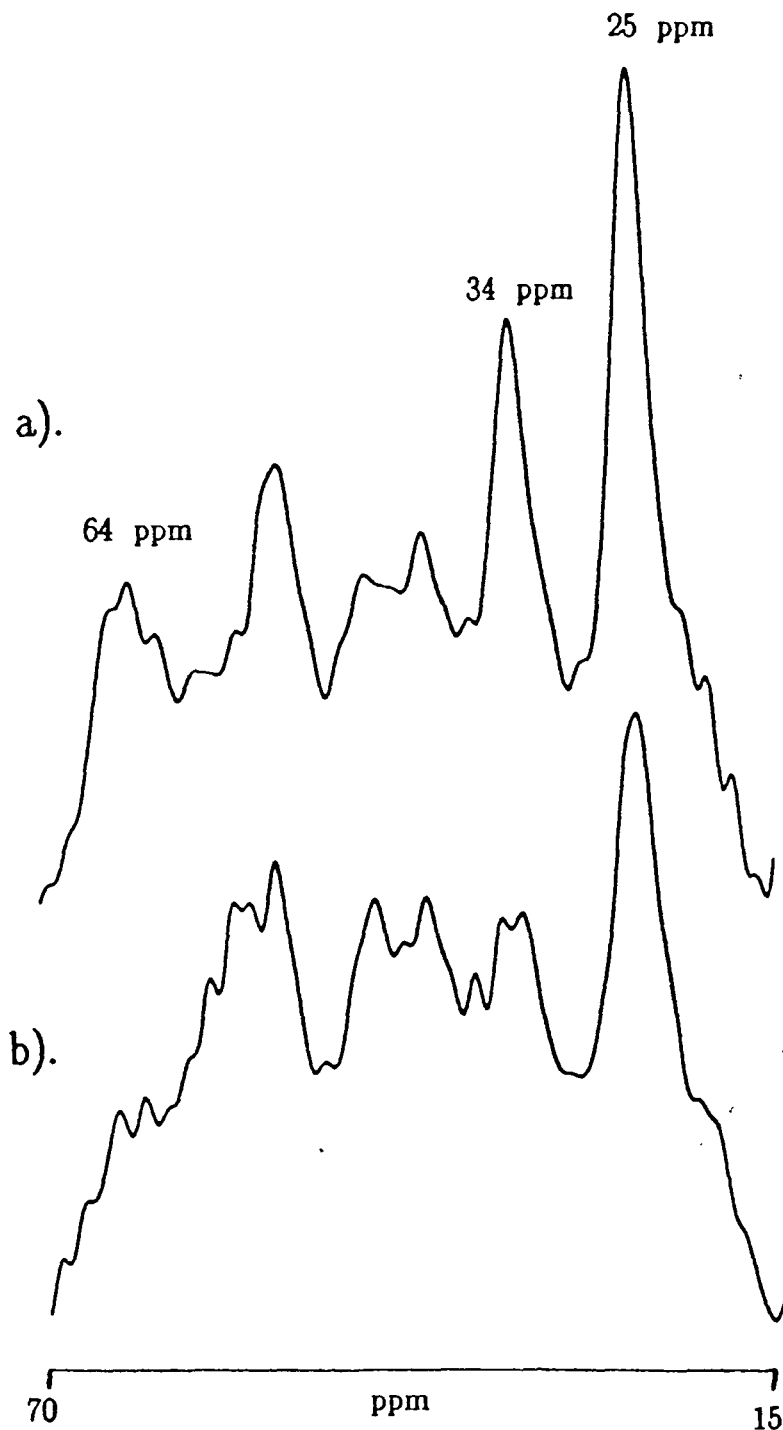

Figure 6.12

a). The aliphatic region of the  $^{13}\text{C}$  single-pulse spectrum of the maleic anhydride film with no degradation.

b). The aliphatic region of the  $^{13}\text{C}$  single-pulse spectrum of the maleic anhydride film with total degradation.

Recycle delay = 7 seconds

acquisition time = 26 ms

no. of transients = 3000

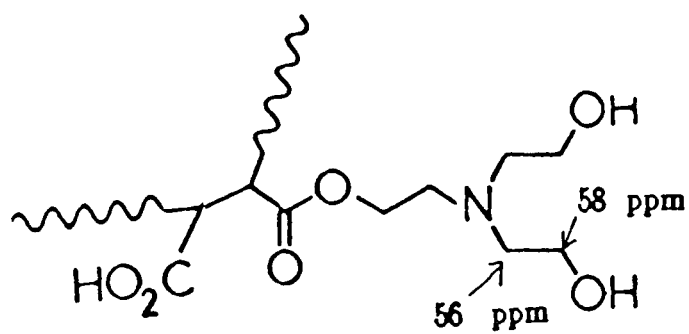

Figure 6.13

Predicted chemical shifts of the triethanolamine tip of the polyester.

peaks at 25 ppm and 34 ppm show a marked decrease in intensity in the fully degraded film compared to the maleic anhydride film with no degradation. Again, this is explained by the variable contact time measurements (figures 6.7 and 6.8).

Whereas the CP experiment enhances signals from the more rigid carbons, the single pulse experiment discriminates in favour of the more mobile carbons. The shorter the recycle time used, the more mobile is the region observed in the spectrum. Figure 6.11 shows the carbonyl regions of the single pulse spectra of the maleic anhydride film with no degradation (figure a), and the maleic anhydride film with total degradation (figure b). Figure 6.11a is dominated by the carbonyl peak of the polyester chain at 173 ppm. The intensity of the carbonyl at 173 ppm is greatly reduced in the case of the totally degraded film (figure 6.11b). This is direct evidence that the polyester chain hydrolyses. Again a shift is seen to higher ppm (179–181 ppm) in the totally degraded sample (figure 6.11b) compared to figure 6.11a, the film with no degradation. This is attributed to the formation of carboxylic acid groups in the film.

Figures 6.12a and b show the aliphatic regions (between 15 and 70 ppm) of the single pulse spectra of the maleic anhydride films with no degradation and with total degradation. There is a significant loss in intensity in the polyester peaks at 25, 34 and 64 ppm, the assignments of which are shown in Table 6.2. A decrease in the polyester resonances shows that degradation has taken place along the polyester chain.

There is one region of the spectrum of the totally degraded maleic

anhydride film (figure 6.12b) between 55–59 ppm where there is a significant increase in intensity. It is thought that this arises from the formation of free triethanolamine tips as the cross-links degrade. The two carbons of the triethanolamine tip have predicted chemical shifts of 56 ppm and 58 ppm as shown in figure 6.13. This is evidence that there is cleavage of the triethanolamine–polyester and/or the triethanolamine–copolymer ester linkages during hydrolysis, releasing free triethanolamine tipped fragments of polyester and copolymer with triethanolamine attached.

#### 6.10 The degradation of the itaconic anhydride film

A study of the degradation similar to that of the maleic anhydride film has been made. In this work only two samples were studied: a sample of itaconic anhydride film with no degradation and a sample of itaconic anhydride film with total degradation (3 months degradation).

As in the case of the maleic anhydride film, variable contact time CP measurements were obtained for the itaconic anhydride films both with and without degradation. Figure 6.14 shows the variable contact time plot of the peak at 40 ppm (the  $\text{CH}_2$  backbone of the copolymer) for the itaconic anhydride film with no degradation and with total degradation. The assignments of the peaks for the itaconic anhydride film are shown in Table 6.4. Extrapolating back to the intensity axis it can be seen that both the films with no degradation and with total degradation have the same absolute intensity. From this it may be concluded that the copolymer does not degrade.

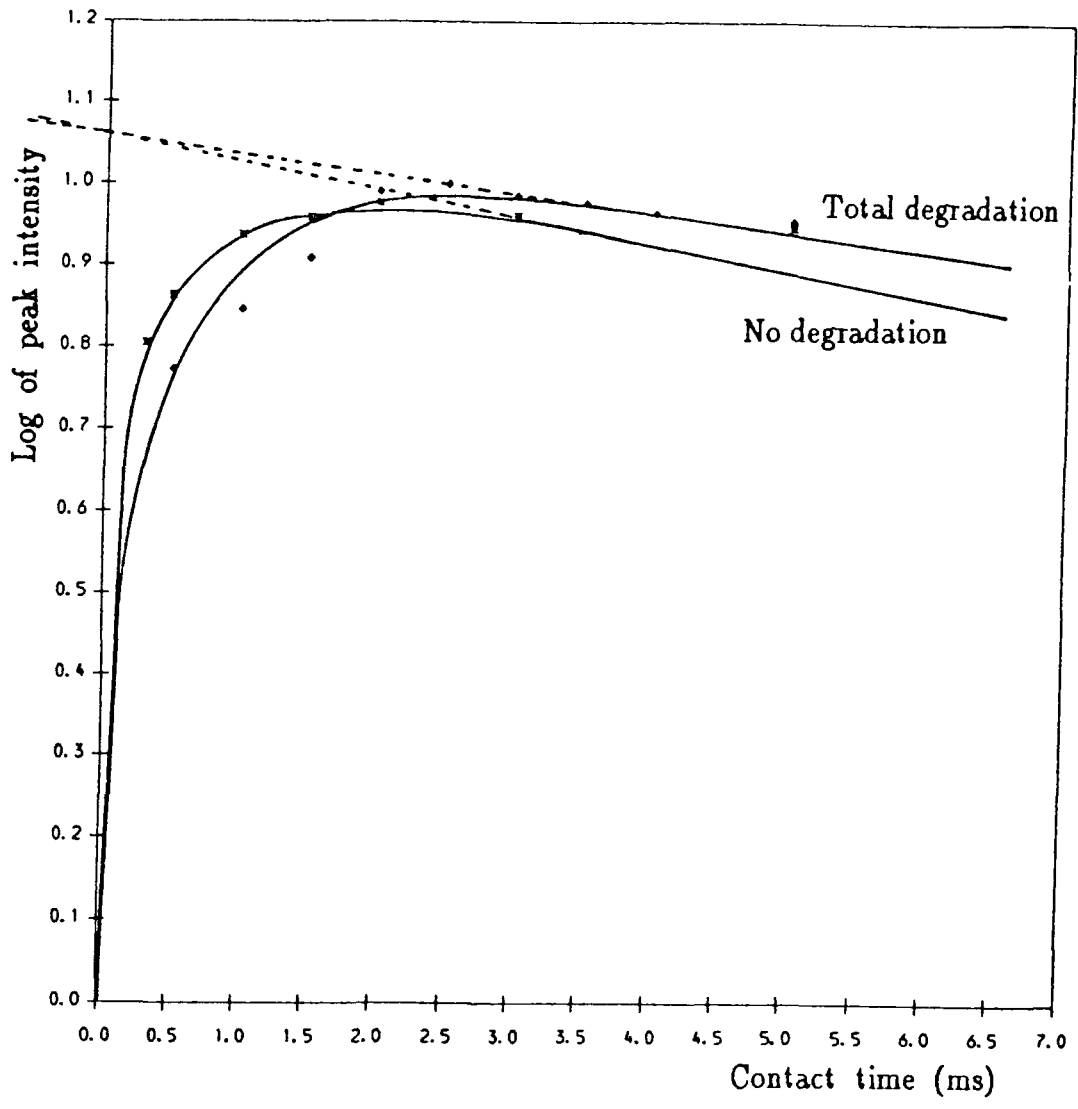
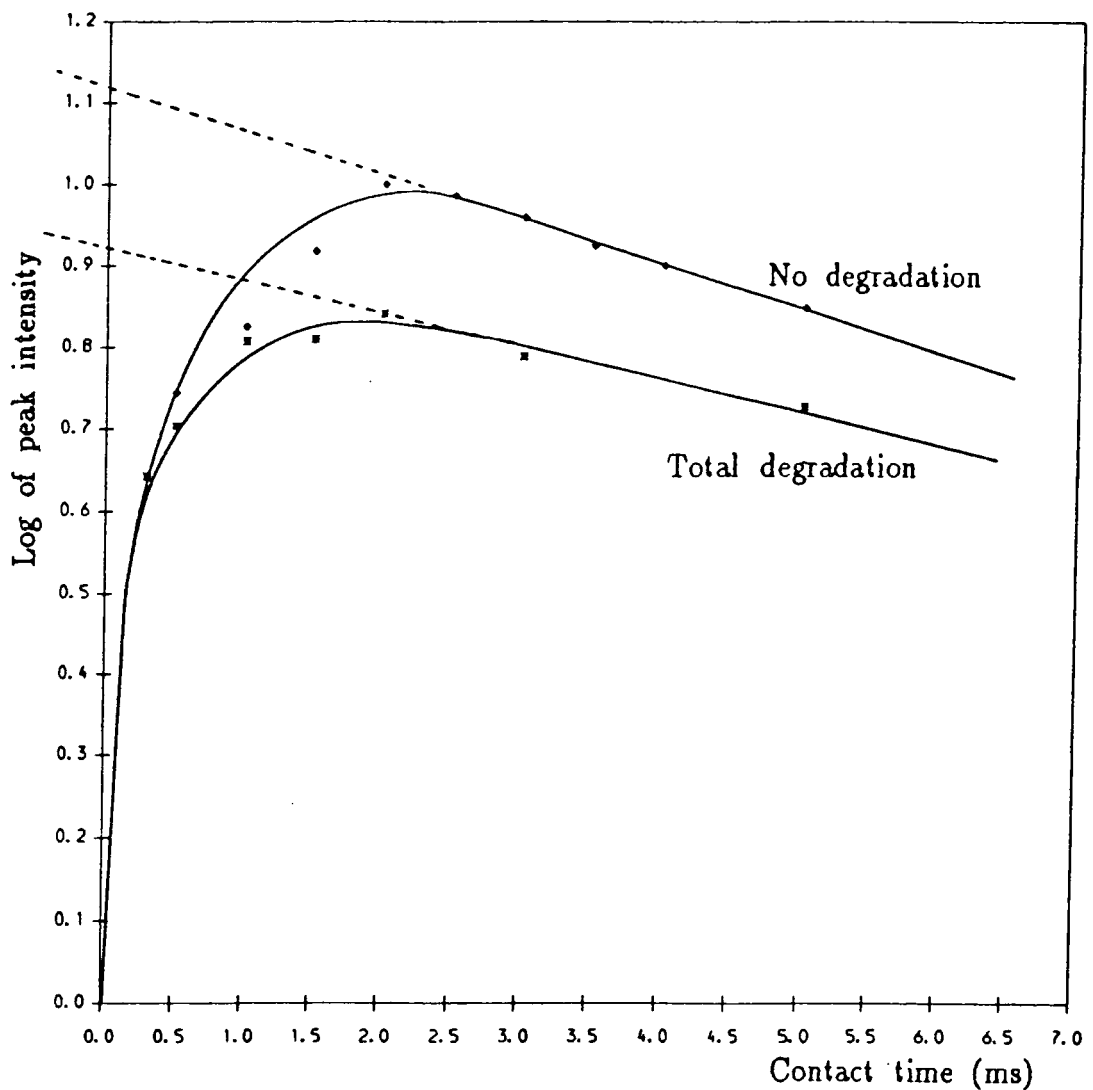

Figure 6.14

Plot of the log of the peak intensity against contact time for the copolymer peak at 40 ppm in the itaconic anhydride film. The itaconic anhydride film with no degradation is compared to the film with total degradation for contact times between 0.05 and 5 ms. The recycle delay was 6 seconds, the acquisition time was 26 ms and 1000 transients were acquired for each experiment.



**Figure 6.15**

Plot of the log of the peak intensity against contact time for the polyester peak at 25 ppm in the itaconic anhydride film. The itaconic anhydride film with no degradation is compared to the film with total degradation for contact times between 0.3 and 5 ms. The recycle delay was 6 seconds, the acquisition time was 26 ms and 1000 transients were acquired for each experiment.

Table 6.5

Values of  $T_{IS}$  and  $T_{Ip}$  for the itaconic anhydride film.

$T_{Ip}$	Peaks	
	25 ppm	40 ppm
Degradation	25 ppm	40 ppm
No deg.	9.68	8.49
Total deg.	25.73	40.66

$T_{IS}$	Peaks	
	25 ppm	40 ppm
Degradation	25 ppm	40 ppm
No deg.	0.063	0.054
Total deg.	0.393	0.364

A similar plot of the peak at 25 ppm (the CH<sub>2</sub> backbone of the polyester) for the itaconic anhydride film with no degradation and the itaconic anhydride film with total degradation is shown in figure 6.15. Extrapolating back to the intensity axis it can be seen that there is a loss in the intensity of the 25 ppm peak of 18% between the film with no degradation and the film with total degradation. As in the case of the maleic anhydride film, calculations of the chemical shifts have shown that degradation at either the cross-link or at the ester linkages along the polyester chain does not alter the chemical shift of the peak from 25 ppm, and hence the degradation of the itaconic anhydride film should not result in a loss of intensity of the peak at 25 ppm. This loss may be explained if hydrolysis were to take place along the polyester chain as well as at the cross-linkages. Some polyester chains hydrolyse into fragments which are washed out of the film in the environmental cabinet. Table 6.5 lists the values of T<sub>IS</sub> and T<sub>IP</sub> obtained from the variable contact time plots (figures 6.14–6.15).

The chemical changes which take place during degradation of the itaconic anhydride film may be understood by comparing the spectra of the itaconic anhydride film with no degradation to the spectra of the film with total degradation.

Figure 6.16a and b show the carbonyl region of the carbon CP MAS spectra of the itaconic anhydride film with no degradation and total degradation respectively. The spectrum of the film with no degradation is dominated by the peak at 173 ppm (the carbonyls in the polyester chain). But figure 6.16b, the spectrum of the itaconic anhydride film with

total degradation, shows a decrease in the intensity of the peak at 173 ppm. As has been discussed for the maleic anhydride film, this decrease could arise from either the degradation of the cross-link only, or the degradation of both the cross-linkages and the ester linkages in the polyester chain. In figure 6.16b there is an increase in the intensity of peaks to a higher ppm. This is attributed to the formation of more free carboxylic acid groups in the totally degraded sample compared to the itaconic anhydride film with no degradation.

Figures 6.17a and b illustrates the aliphatic regions of the same spectra as in figure 6.16a and b. The aliphatic region between 10 and 70 ppm is shown of the  $^{13}\text{C}$  CP spectra of the itaconic anhydride film with no degradation (figure a) and the itaconic anhydride film with total degradation (figure b). The polyester peaks at 25 ppm and 34 ppm in figure b, the assignments of which are shown in Table 6.4, show a marked decrease in intensity relative to the copolymer peaks in the spectrum b, compared to the same two peaks in the case with no degradation (figure a). Again this indicates that degradation is taking place either at the cross-links or both at the cross-links and at the ester positions along the polyester chain.

The single pulse excitation experiment discriminates in favour of the mobile carbons. Single pulse spectra of the itaconic anhydride film with no degradation and with total degradation were obtained with a recycle time of 7 seconds. At this recycle time the polyester peaks have reached equilibrium, and therefore the intensities of the polyester peaks in the single pulse spectra of the films with no degradation and total

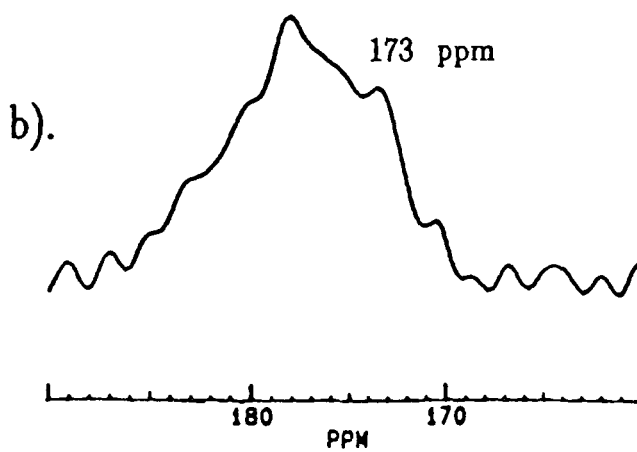
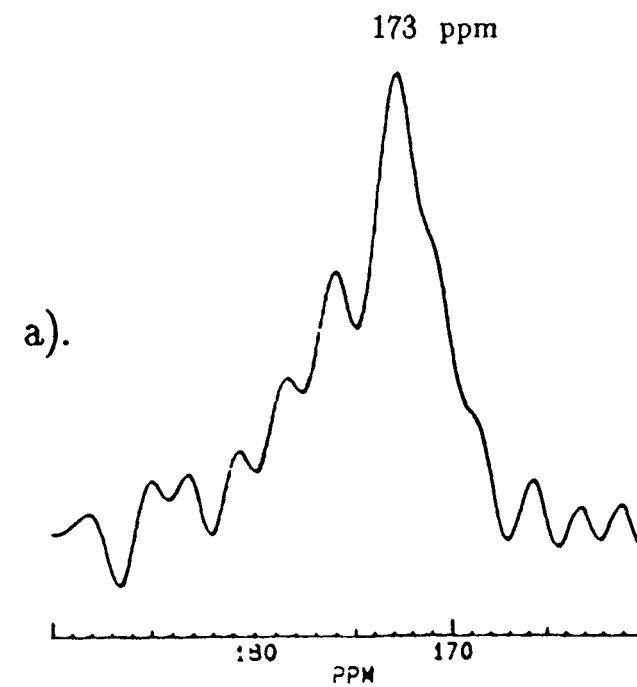

Figure 6.16

a). The carbonyl region of the  $^{13}\text{C}$  cross-polarisation spectrum of the itaconic anhydride film with no degradation.

b). The carbonyl region of the  $^{13}\text{C}$  cross-polarisation spectrum of the itaconic anhydride film with total degradation.

Recycle delay = 6 seconds

contact time = 1.5 ms

acquisition time = 26 ms

no. of transients = 1000

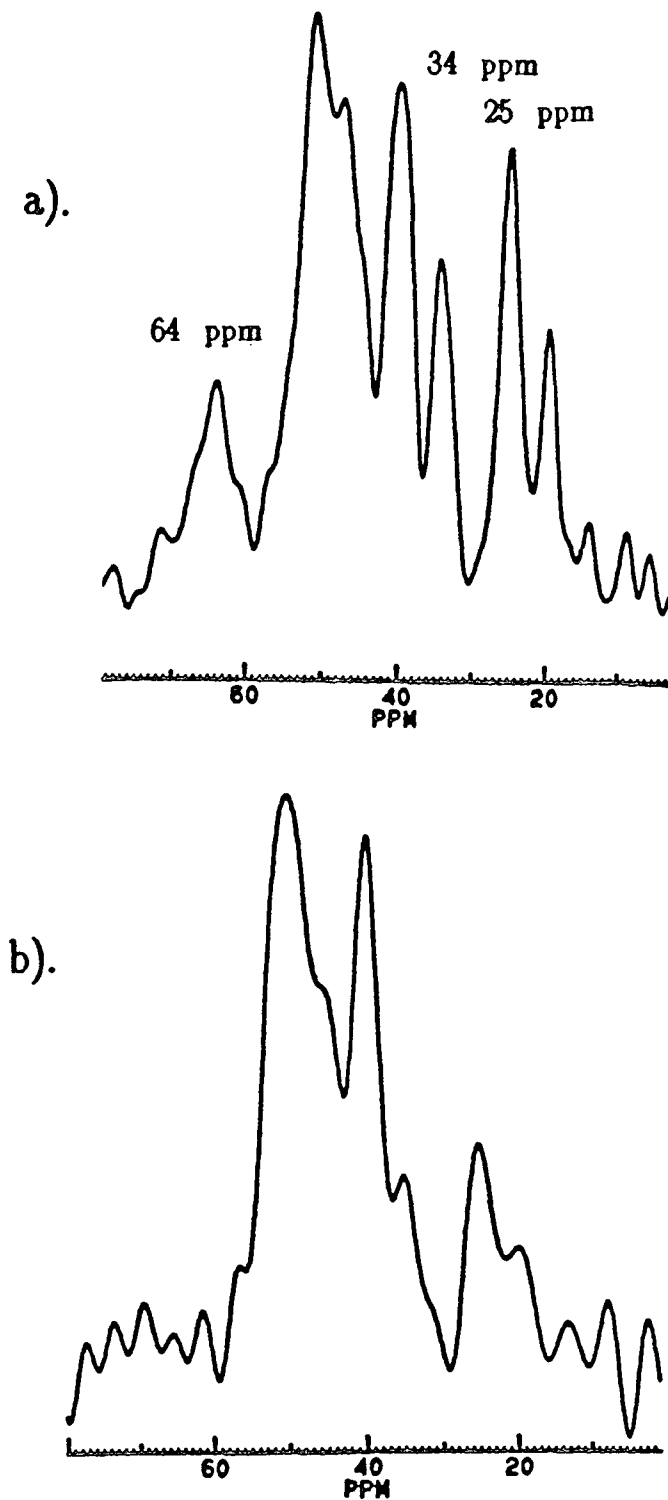

Figure 6.17

- a). The aliphatic region of the  $^{13}\text{C}$  cross-polarisation spectrum of the itaconic anhydride film with no degradation.
- b). The aliphatic region of the  $^{13}\text{C}$  cross-polarisation spectrum of the itaconic anhydride film with total degradation.

Recycle delay = 6 seconds  
 contact time = 1.5 ms  
 acquisition time = 26 ms  
 no. of transients = 1000

degradation may be compared quantitatively. Figures 6.18a and b show the carbonyl regions of the single pulse excitation spectra of the non-degraded sample and the totally degraded sample respectively. The carbonyl peak (173 ppm) is greatly reduced in intensity in the film with total degradation compared to the film with no degradation. It is not possible to conclude from this peak alone whether the degradation is taking place only at the cross-link positions, or whether the ester linkages along the polyester chain are also hydrolysed to cause this reduction in the peak at 173 ppm. In figure 6.18b there is a shift to higher ppm (179–181 ppm) compared to figure 6.18a, which is attributed to the formation of free carboxylic acid groups during the degradation of the itaconic anhydride film. There is intensity in the region of 171 ppm in figure 6.18a. This is the predicted position of the peak due to the ester of itaconic anhydride in the cross-link. This intensity is not present in the spectrum of the totally degraded film (figure b), possibly indicating cleavage of the cross-link (see figure 6.18c).

The aliphatic regions (10–70 ppm) of the same single pulse spectra are shown in figure 6.19a and b. There is a significant loss in intensity in the polyester peaks at 25, 34 and 64 ppm. The assignment of the peaks are shown in Table 6.4. Calculations show that there is no change in chemical shift between the non-degraded carbons giving rise to the peaks at these positions, and the same carbons when they are degraded. Thus, any loss in intensity of these peaks must be due to the hydrolysis of the polyester chain, where some of the small fragments formed are washed out of the film while it is degrading in the environmental

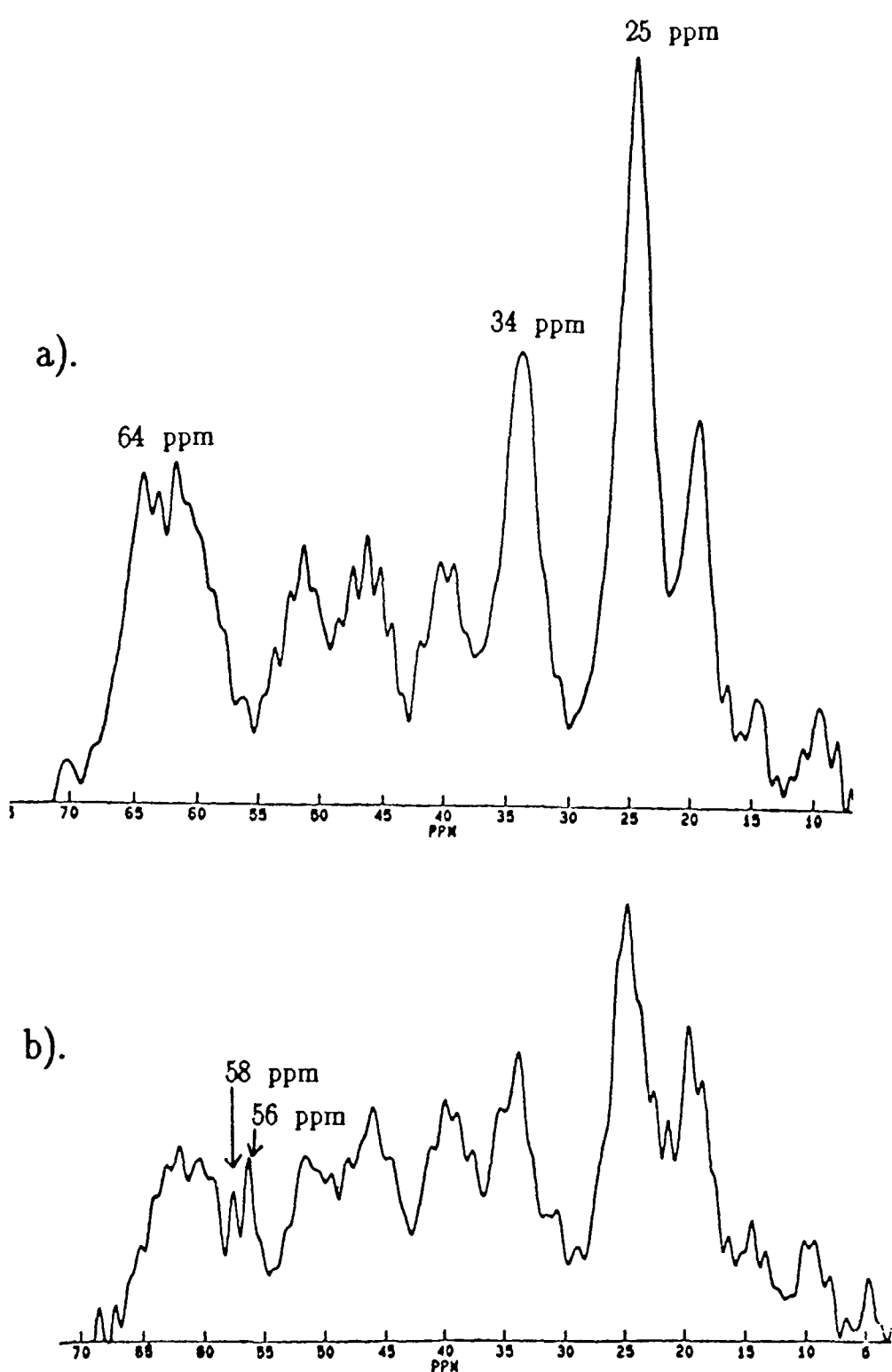

Figure 6.19

- a). The aliphatic region of the  $^{13}\text{C}$  single-pulse spectrum of the itaconic anhydride film with no degradation.
- b). The aliphatic region of the  $^{13}\text{C}$  single-pulse spectrum of the itaconic anhydride film with total degradation.

Recycle delay = 7 seconds

acquisition time = 26 ms

no. of transients = 3000

cabinet. There is one region between 55 ppm and 59 ppm in which the intensity increases notably in the fully degraded case (figure 6.19b) compared to the film with no degradation (figure a). One possibility is that this intensity arises from the triethanolamine tip after cleavage has taken place at the cross-link. It is probable that there is cleavage of the triethanolamine-polyester and triethanolamine-copolymer ester linkages during hydrolysis, releasing copolymer with triethanolamine attached and triethanolamine tipped fragments of polyester (figure 6.19c).

### 6.11 Conclusions from solid-state NMR study

From solid-state  $^{13}\text{C}$  MAS NMR there is conclusive evidence that cleavage occurs in all three positions predicted in figure 6.3. The acrylic copolymer does not degrade, but merely unzips from the polyester. There is, however, cleavage at some of the ester linkages along the polyester chain. Variable contact time measurements show that the polyester chains undergo 18% degradation of the ester linkages along the backbone of the polyester chains. Not all the cross-links are cleaved. There is concrete evidence that some of the polyester remains intact and cross-linked, even in films which are considered to be totally degraded.

### 6.12 The anchimeric effect<sup>5</sup>

The anchimeric effect is the most likely cause of the breakdown of the polyester backbone during the degradation studies. The anchimeric effect is the intramolecular catalytic action on a particular site by a neighbouring group or atom on the same molecule.

In ester hydrolysis, a hydroxyl or carboxylate ion situated on the same molecule and close to the ester group promotes attack by the nucleophile, water. This provides more pressure on the alcohol to be released, and so results in an accelerated rate of hydrolysis. The effect only operates strongly over short distances. As the separation between assisting group and reaction site increases, the rate of hydrolysis decreases rapidly.

Equations representing the anchimeric effect are shown in figure 6.20.

There are two important parameters which directly affect how good a resistance a polyester has to hydrolysis.

1. The steric factor. The more sterically-hindered the polyester, the greater is its resistance to hydrolysis.
2. The anchimeric effect. For a polyester to have a good resistance to hydrolysis, the diol and diacid precursors must contain at least four linear carbons between the functional groups.

Both ethylene glycol and butane 1,4 diol, when incorporated in a polyester, have a poor resistance to hydrolysis due to the anchimeric effect. Increasing the number of linear carbon atoms between the diol components of the polyester should go some way towards stabilising the films from hydrolysis attack. However, hydrolysis would still take place at the cross-link positions. It is believed that the nitrogen atom positioned  $\beta$  to the cross-link atom aids the hydrolysis of the cross-link by the reversal of the mechanism by which it catalyses the formation of the



cross-link. From the degradation studies undertaken, it is clear that the polyester component of the two-pack film system needs to be completely modified. The polyester should be replaced by a long chain without any hydrolysable linkage along the backbone, and the ester cross-link replaced by some linkage which is more resistant to water attack.

## CHAPTER 7

### Solid-state nuclear Overhauser effects in cross-linked polymers

#### 7.1 Introduction

Carbon 13 NMR spectroscopy can be used to investigate molecular conformation and molecular motion<sup>1</sup>. Those NMR parameters, from which information about the motion of molecules in the solution state may be obtained (i.e. spin-lattice relaxation times and nuclear Overhauser enhancements), may also be acquired for solids from dipolar-decoupled <sup>13</sup>C NMR spectra<sup>2</sup>. In this chapter we concentrate on the nuclear Overhauser effect, and the prediction of the behaviour of the carbon spins when subjected to various pulse sequences.

Irradiation at the proton frequency in solid state <sup>13</sup>C MAS NMR spectroscopy allows the observation of carbon resonances without effect from (<sup>13</sup>C,<sup>1</sup>H) dipolar couplings. However the <sup>13</sup>C equilibrium magnetisation is changed from a Boltzmann distribution by the interaction of the <sup>1</sup>H and <sup>13</sup>C dipoles when the proton resonances are saturated with a radiofrequency field<sup>3</sup>. This results in the nuclear Overhauser effect (NOE).

Although the nuclear Overhauser effect is very commonly observed and discussed for solutions, it is rarely reported in the case of solids. Most spectra of solids are obtained using cross-polarisation so that the question of a NOE does not arise. However, in some cases where the solid is very mobile, simple MAS spectra without cross-polarisation can

be obtained which may have nuclear Overhauser enhancements. The nuclear Overhauser effect in the solid state does not appear to have been discussed in detail.

Equations describing the behaviour of macroscopic magnetisation have been derived by Solomon through consideration of population changes<sup>3</sup>. Abragam has also described a related theory in density matrix notation<sup>4</sup>. The treatment used by Solomon is the more easily understood, hence Solomon's theory has been used here in the study of transient Overhauser effects in the solid state.

Consider an ensemble of  $N$  spins,  $I \equiv {}^{13}\text{C} = \frac{1}{2}$  and  $S \equiv \text{H} = \frac{1}{2}$

Four eigenstates of the spins can be defined by the following relations:

$$\begin{aligned} \hat{I}_z |\alpha\rangle &= +\frac{1}{2} |\alpha\rangle & \hat{S}_z |\alpha\rangle &= +\frac{1}{2} |\alpha\rangle \\ \hat{I}_z |\beta\rangle &= -\frac{1}{2} |\beta\rangle & \hat{S}_z |\beta\rangle &= -\frac{1}{2} |\beta\rangle \end{aligned}$$

Hence, the unperturbed eigenstates for C-H spin pairs are  $|\alpha\rangle|\alpha\rangle$ ,  $|\beta\rangle|\alpha\rangle$ ,  $|\alpha\rangle|\beta\rangle$  and  $|\beta\rangle|\beta\rangle$ . These eigenstates have occupation numbers  $N_{\alpha\alpha}$ ,  $N_{\beta\alpha}$ ,  $N_{\alpha\beta}$  and  $N_{\beta\beta}$  respectively.

When these coupled spins are placed in a magnetic field of intensity  $B_0$ , the energy levels are split as shown in figure 7.1.

If an RF field with a frequency equal to the Larmor frequency of the proton spins is applied to these spins, transitions will be induced between the energy levels. The number of transitions, say  $\alpha\alpha \rightarrow \beta\beta$  will be proportional to  $N_{\alpha\alpha}$ , the population of the  $\alpha\alpha$  state; the number of transitions  $\beta\alpha \rightarrow \beta\beta$  will similarly be proportional to  $N_{\beta\alpha}$ , the population of the  $\beta\alpha$  state. Initially the lower energy level will have a larger population so that the number of upward transitions will exceed the number of

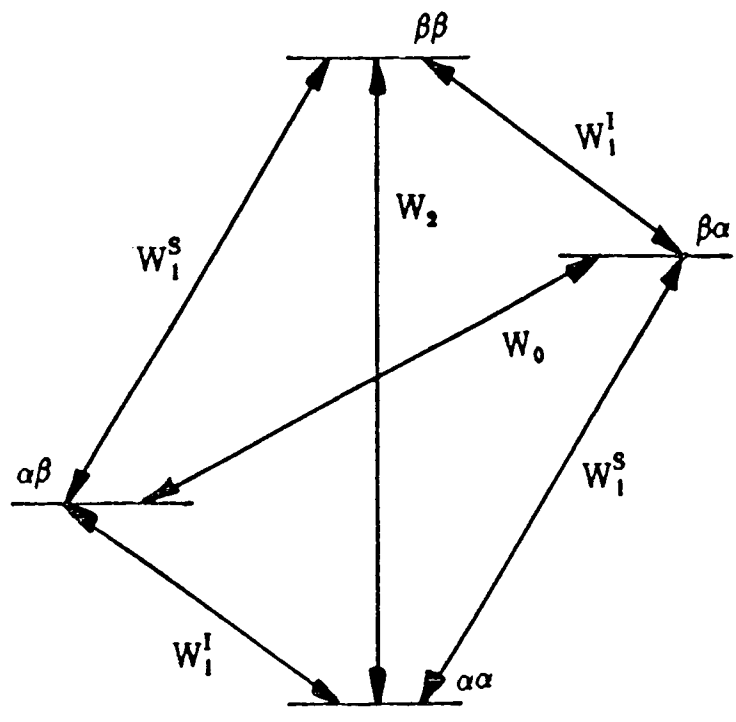

Figure 7.1

The energy level diagram for a coupled C-H spin system placed in a magnetic field.

downward transitions. If the RF field is strong, this process results in saturation. When the energy levels are saturated, the populations of the two energy levels become equal, and the absorption of RF energy will cease. A mechanism exists for these populations to return to equilibrium. The mechanism by which nuclear spins return to equilibrium is called spin-lattice relaxation. A quantity  $W$  may be defined as the probability per unit time that a transition will occur between any two states due to spin relaxation.

The description of the spin-lattice relaxation in figure 7.1 requires four transition probabilities:

$W_1^I$  The single quantum transition probability that spin I will go from  $\alpha$  to  $\beta$  (or  $\beta$  to  $\alpha$ ) while the state of spin S remains unchanged.

$W_1^S$  The single quantum transition probability for spin S when the state of spin I remains unchanged.

$W_2$  The two quantum transition probability for the two spins to relax simultaneously in the same direction, i.e.  $\alpha\alpha \rightarrow \beta\beta$  or  $\beta\beta \rightarrow \alpha\alpha$ .

$W_0$  The zero quantum transition probability for a mutual spin flip,  $\alpha\beta \rightarrow \beta\alpha$  or  $\beta\alpha \rightarrow \alpha\beta$ .

## 7.2 The nuclear Overhauser effect

### 7.2.1 Definition

The nuclear Overhauser enhancement is the fractional change in the integrated NMR absorption intensity of a nuclear spin when the NMR absorption of another spin is saturated<sup>5</sup>. The spins may be either chemically-shifted homonuclear or heteronuclear spins. In the solid-state,

only heteronuclear Overhauser effects are possible due to spin diffusion between proton spins. In order to understand how the nuclear Overhauser effect arises, it is necessary to consider the population changes which occur when a spin is saturated. Figure 7.2 (a-c) shows schematically how the populations of the I-S coupled spin systems change when the S spins are saturated.

Figure 7.2a shows the population levels (not the energy levels) of the coupled I-S spin system at equilibrium. Let the excess population of levels 2 and 3 at equilibrium be  $\delta-\Delta$  and  $-\delta+\Delta$  respectively. The excess population of level 1 will be  $-\delta-\Delta$ , and the population of level 4 will be  $\delta+\Delta$ .

The NMR resonance of spin S will consist of two transitions, 1-2 and 3-4, both of the same frequency. Likewise the resonance of spin I will have two components, the 1-3 and 2-4 transitions.

Figure 7.2b shows how the populations of these four levels change when the S spins are saturated. If a strong RF field is applied at the resonance frequency of the S spins, then the S spins will become saturated. The result is that the energy levels become equally populated. i.e.  $P_1=P_2$  and  $P_3=P_4$ .

There is a limiting condition on these population levels that the total number of spins must remain unchanged. These population changes do not result in any change in the I spin resonance absorption energy. Thus at the stage shown in figure 7.2b there is no enhancement of the carbon signal.

Figure 7.2c shows how the spin-lattice transition probabilities W

Figure 7.2

A Population level diagram to show the nuclear Overhauser effect.

Excess populations

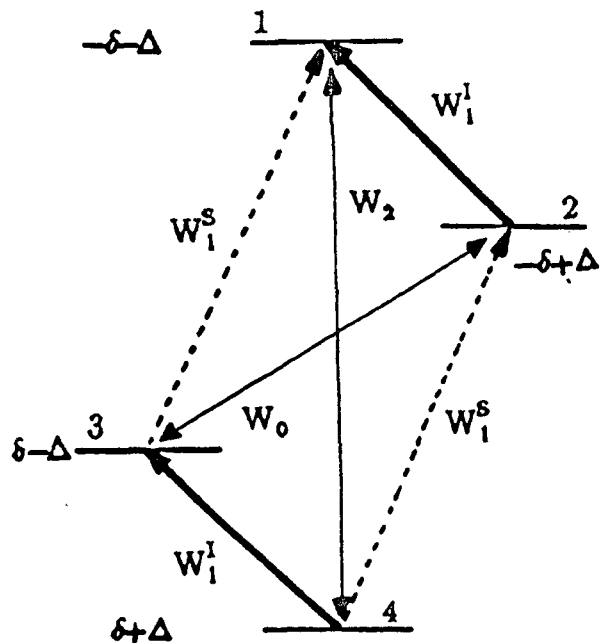

a). Equilibrium situation

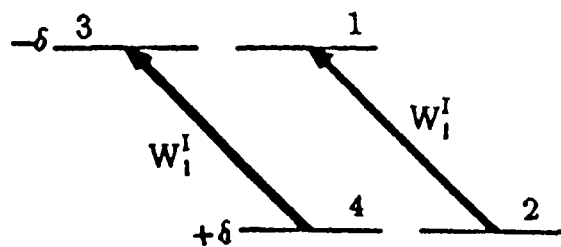

b). After saturation of the protons.

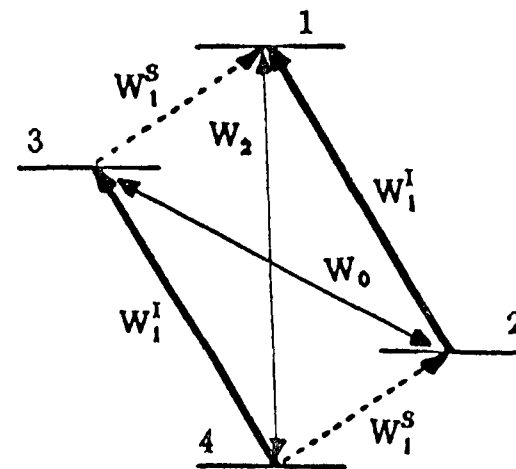

c).  $W_0$  and  $W_2$  attempt to restore equilibrium.

$W_2$ —simultaneous jump of  $^1\text{H}$  and  $^{13}\text{C}$  spins.

↑ =  $^1\text{H}$   
 ↑ =  $^{13}\text{C}$

### Figure 7.3

Pulse sequence for the measurement of the heteronuclear NOE enhancement in the solution state.

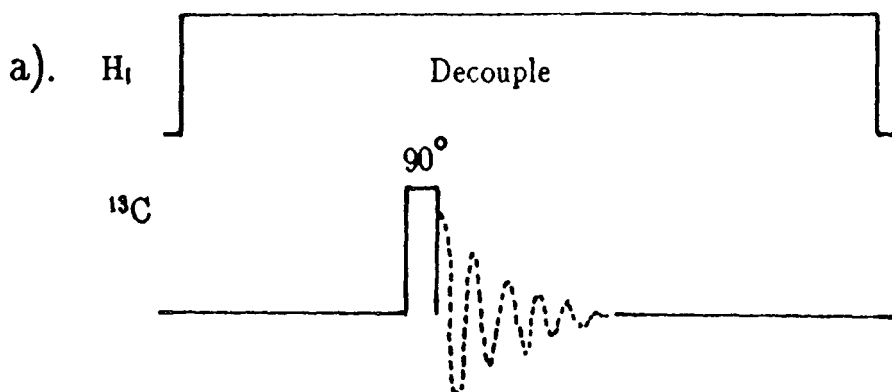

a). Pulse sequence to obtain  $^{13}C$  spectrum with NOE.

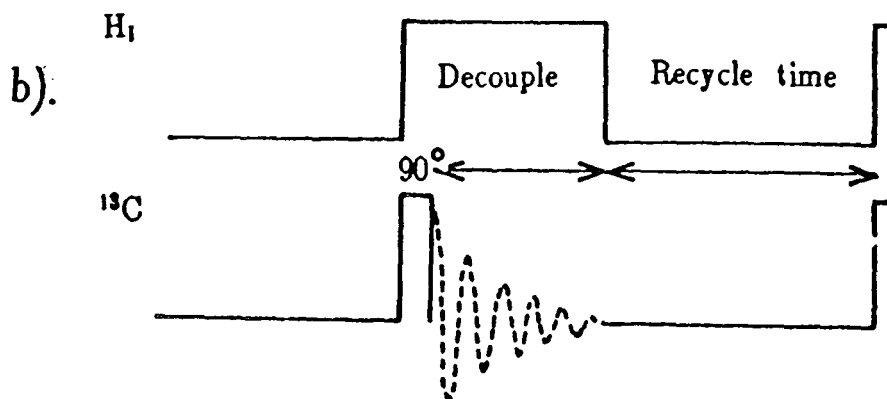

b). Pulse sequence to obtain  $^{13}C$  spectrum without NOE.

must be taken into account to explain the nuclear Overhauser effect. Figure 7.2b is not an equilibrium situation. The population difference  $P_4 - P_1$  in figure 7.2b is less than the equilibrium value  $P_4^0 - P_1^0 = 2\delta + 2\Delta$ . The effect of  $W_2$  will be to attempt to re-establish equilibrium by increasing  $P_4$  and decreasing  $P_1$ . Therefore the effect of  $W_2$  is to increase the intensity of the I spin resonance. The effect of  $W_0$  will be to increase  $P_2$  and decrease  $P_3$  to attempt to restore equilibrium.  $W_0$  has an overall effect of decreasing the intensity of the NMR resonance of spin I. In reality all the transition probabilities are simultaneously effective, and the resulting enhancement of spin I arises from a compromise between transition probabilities  $W_2$  and  $W_0$ . The amount by which the carbon signal is increased is an important value in NMR spectroscopy. The ways in which the nuclear Overhauser enhancement factors are measured are described in the following section.

### 7.3 Techniques for the measurement of NOE's

#### 7.3.1 Solution-state NOE: The gated-decoupling method

In order to measure a heteronuclear NOE enhancement it is required to saturate the S spins whilst observing the I spins; and then compare the intensities obtained with their equilibrium values. This is done very simply by integrating resonances with and without a period of presaturation.

In order to obtain a decoupled  $^{13}\text{C}$  spectrum with the NOE it is necessary to saturate the proton resonances during the delay period between pulses. In the solution state this is easily done by leaving the

proton decoupler on continuously throughout the experiment. The pulse sequence is shown in figure 7.3a. Figure 7.3b shows the pulse sequence used to obtain a decoupled spectrum without the NOE in the solution state. The recycle delay,  $t_d$ , must be long enough to allow the carbon spins to reach their equilibrium value.  $T_d$  must usually be at least 9 times the longest carbon  $T_1$ . The NOE enhancement factors (NOEF) are readily obtained by comparing the intensities of peaks between spectra with and without the NOE.

### 7.3.2 Solid-state NOE

In the case of solids, it is not feasible to leave the proton decoupler on for long periods of time since the decoupling power necessary for work on solids is an order of magnitude larger than that of the solution case. The duty cycle of pulse experiments must be kept low. A new pulse sequence has been devised which overcomes this problem. The new pulse sequence to obtain a decoupled solid-state spectrum with NOE is shown in figure 7.4a. A spin  $I=\frac{1}{2}$  case is saturated when the populations of the two energy levels are equal. This situation occurs when the magnetisation is tilted into the  $xy$  plane. Therefore a succession of  $90^\circ$  pulses at the proton frequency during the recycle delay saturates the proton spins. The new pulse sequence (figure 7.4a) consists of such a saturation chain of  $90^\circ$  pulses at the proton frequency followed by carbon observation. A  $5 \mu\text{s}$   $90^\circ$  proton pulse was applied every 1ms during the saturation chain.

A spectrum without the NOE may be obtained using the pulse

Figure 7.4

Pulse sequence for the measurement of the heteronuclear NOE enhancement in the solid state.

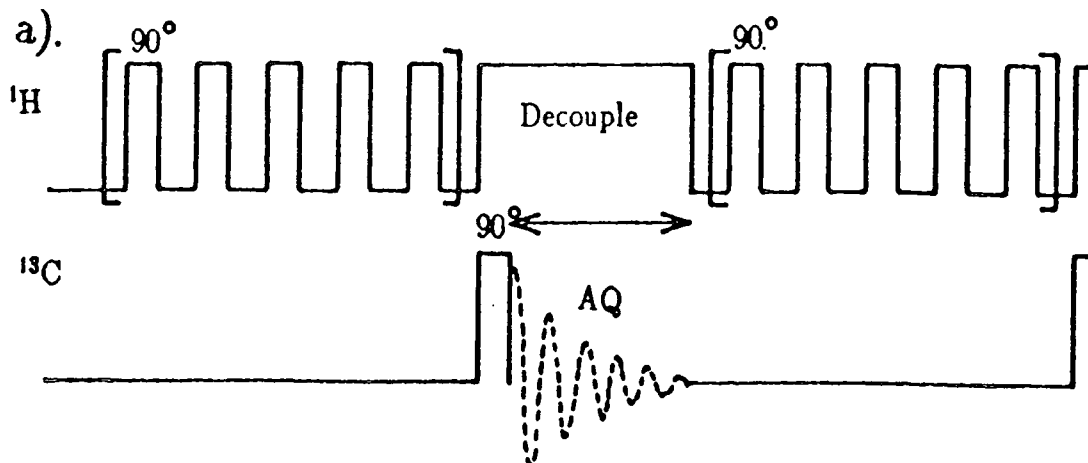

a). Pulse sequence to obtain  $^{13}\text{C}$  spectrum with NOE.

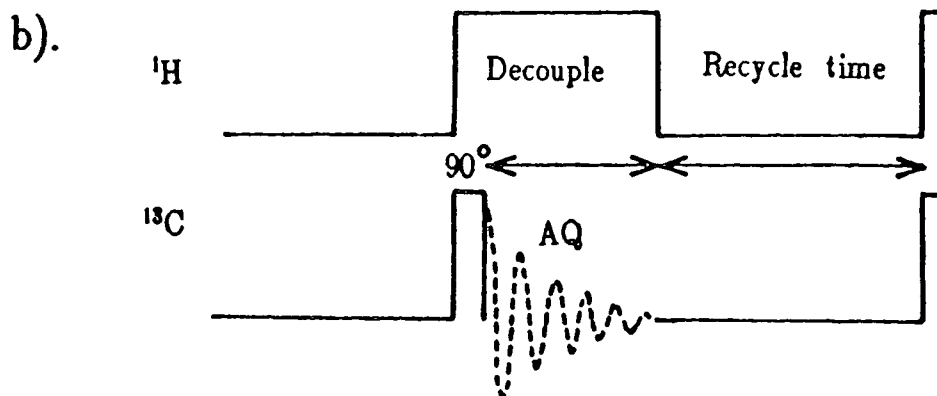

b). Pulse sequence to obtain  $^{13}\text{C}$  spectrum without NOE.

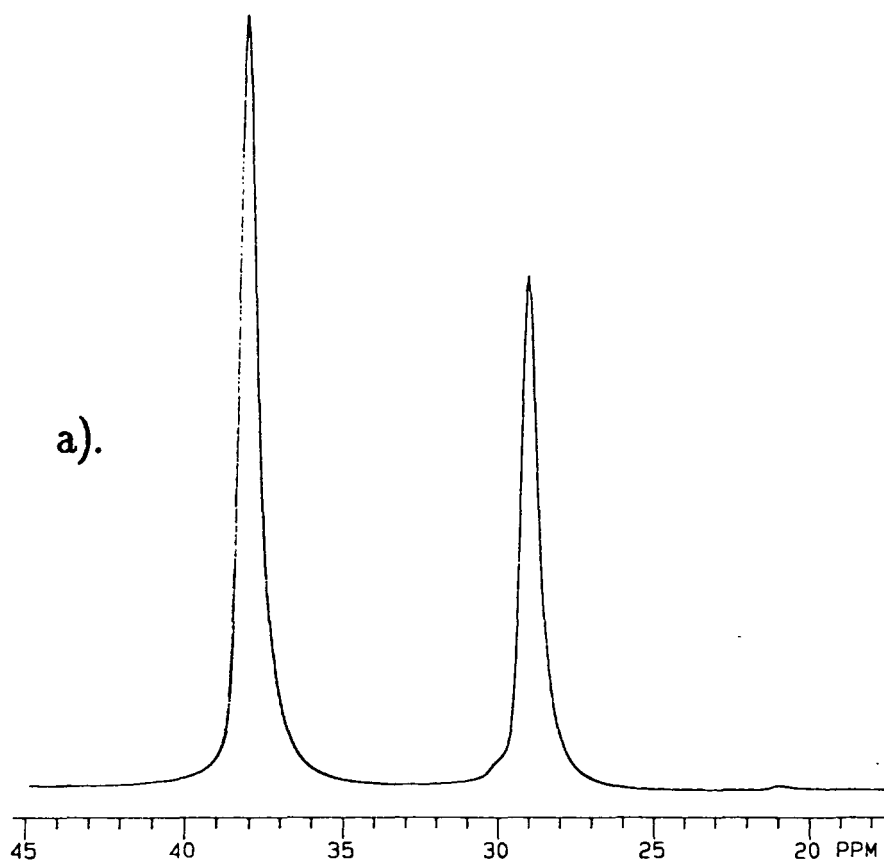
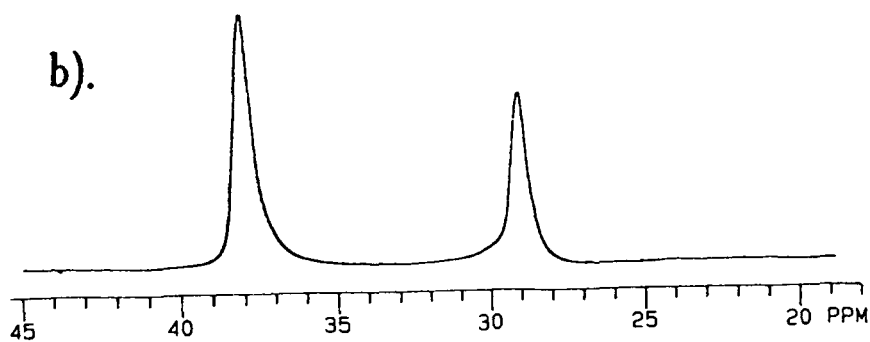

Figure 7.5

a). Solid-state decoupled  $^{13}\text{C}$  spectrum of adamantane with NOE



b). Solid-state decoupled spectrum of adamantane without NOE.

Recycle time = 30 seconds

Acquisition time = 99 ms

no. of transients = 16

program shown in figure 7.4b (the gated-decoupler method), as for solution-state studies. However for solids a high-power decoupler is used. Provided the recycle delay is long enough, turning off the decoupler during the delay allows the nuclei to relax to an equilibrium Boltzmann distribution at the time of the observation pulse. Again, the recycle delay should normally be about nine times the longest  $T_1$ .

The ratio of peak intensities in the spectrum with NOE to those in the spectrum obtained using the gated decoupler method gives the NOE enhancement factors. Ideally a pulse program which interleaves between the pulse programs in figures 7.4a and 7.4b may be used. This would minimise possible errors due to sample heating.

The pulse sequences in figures 7.4a and 7.4b were tested on adamantane. Figure 7.5a shows the solid state decoupled spectrum of adamantane with NOE, and figure 7.5b shows the decoupled spectrum of adamantane without NOE. Comparison between the intensities of the peaks in each spectrum gives  $\eta$ , the NOE factor. These are tabulated and compared with the solution state values in Table 7.1. It can be seen that there is a very good agreement between the  $\eta$  values measured in the solid state using the new pulse sequence, and in the solution state by conventional methods. The relaxation in adamantane is dominated by the dipolar mechanism, hence the nuclear Overhauser enhancement factor is the theoretical maximum for each peak within the experimental error. Spins whose relaxation is not dominated by the dipolar mechanism have reduced values of the NOEF.

The pulse sequences in figures 7.4a and 7.4b have been applied on

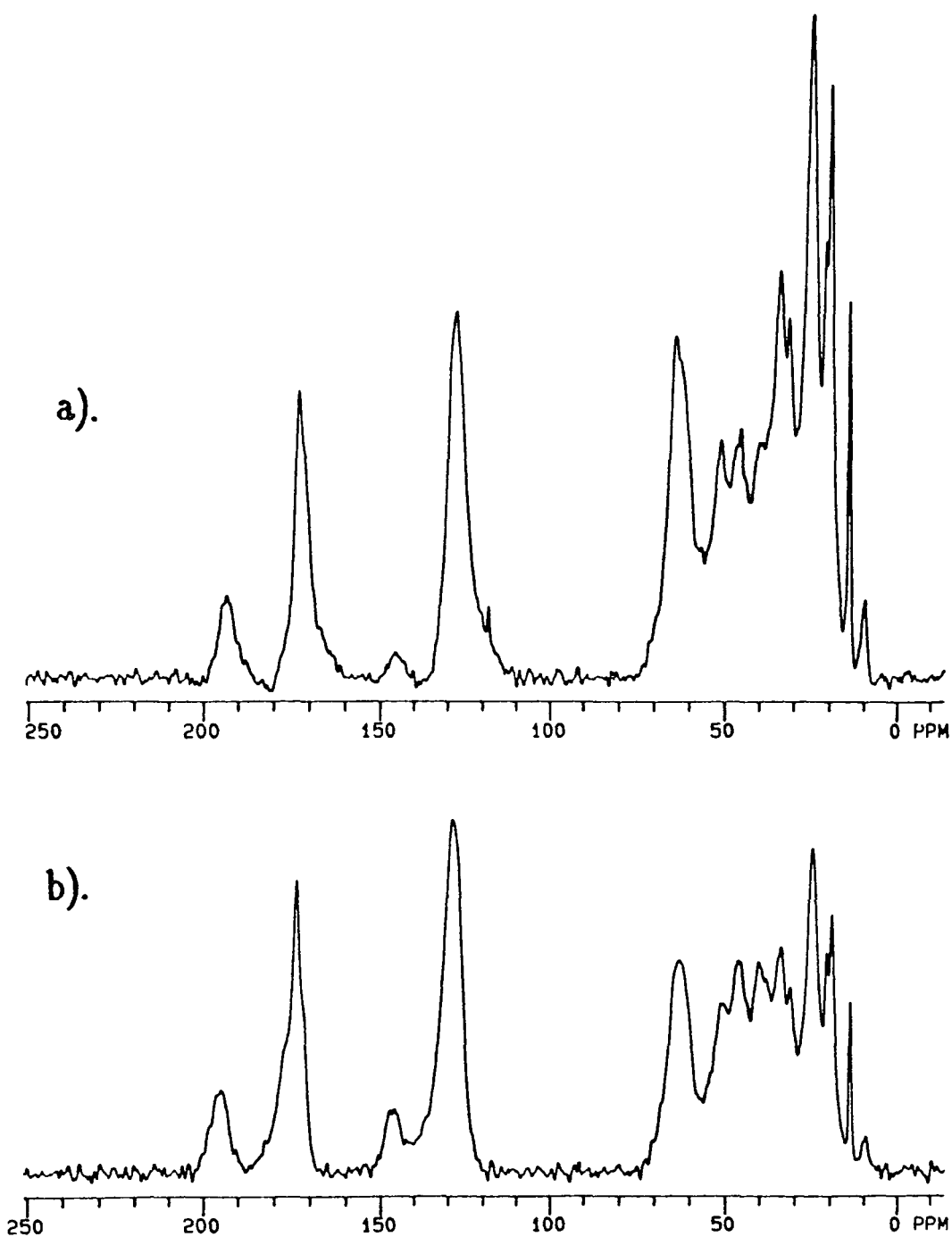

**Figure 7.6**

a). Solid-state decoupled  $^{13}\text{C}$  spectrum of the itaconic anhydride film with NOE.

b). Solid-state decoupled  $^{13}\text{C}$  spectrum of the itaconic anhydride film without NOE.

Recycle time = 7 seconds

Acquisition time = 26 ms

no. of transients = 1000

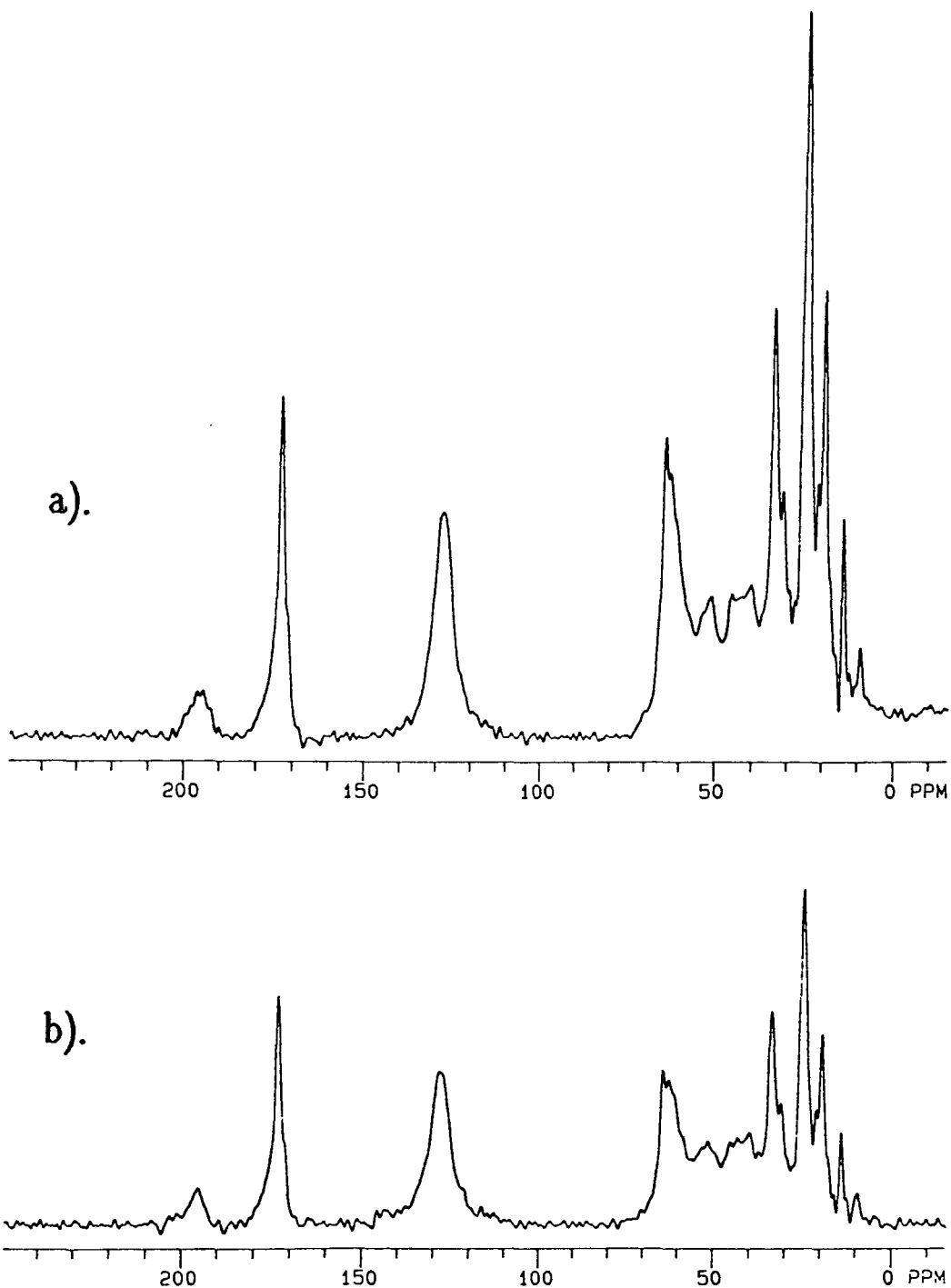

**Figure 7.7**

a). Solid-state decoupled  $^{13}\text{C}$  spectrum of the maleic anhydride film with NOE.

b). Solid-state decoupled  $^{13}\text{C}$  spectrum of the maleic anhydride film without NOE.

Recycle time = 7 seconds

Acquisition time = 26 ms

no. of transients = 1000

Table 7.1

The NOE factors for adamantane in both the solution and solid states.

	Adamantane NOE	
	Peak 29.4 ppm	Peak 38.4 ppm
Solution	1.970	1.979
Solid	1.874	1.859

Table 7.2

Nuclear Overhauser enhancements for the itaconic anhydride film.

Peak/ppm	$\eta$	Assignment
19	1.14	CH <sub>3</sub> of MMA
25	1.24	CH <sub>2</sub> 'backbone'
34	1.06	O-C(=O)-CH <sub>2</sub>
64	0.86	O=C-OCH <sub>2</sub>

Table 7.3

Nuclear Overhauser enhancements for the maleic anhydride film.

Peak/ppm	$\eta$	Assignment
19	1.21	CH <sub>3</sub> of MMA
25	1.36	CH <sub>2</sub> 'backbone'
34	0.97	O-C(=O)-CH <sub>2</sub>
64	0.82	O=C-OCH <sub>2</sub>

both the itaconic anhydride film and the maleic anhydride film. The spectra with and without the NOE for the itaconic anhydride film are shown in figures 7.6a and 7.6b respectively, and similar spectra for the maleic anhydride film are shown in figure 7.7a and 7.7b. Values of  $\eta$  for peaks which show the Overhauser enhancement are shown in Tables 7.2 and 7.3 for the itaconic anhydride and the maleic anhydride films respectively.

In the solution state, each carbon is coupled to a proton or protons either directly bonded to it or in its immediate environment. Thus the nuclear Overhauser enhancement factor has been used to obtain information about C-H bond lengths and structure.

However, in the solid state, the  $^1\text{H}$ - $^1\text{H}$  dipolar interactions are very strong. Each proton spin is strongly coupled to other proton spins. The protons usually have a single  $T_1$  value due to spin diffusion. A carbon spin is coupled very strongly to its attached protons. These protons are also strongly coupled to other protons nearby. The result is that a carbon spin in the solid-state is strongly coupled to nearby protons, and is coupled to a lesser extent to the more distant protons. This makes the steady-state NOE values less specific in the solid-state. It is therefore generally not possible to use solid-state nuclear Overhauser enhancements to obtain C-H bondlengths and structural information.

#### 7.4 Effects of inadequate pulse delays<sup>6,7</sup>

As has been described in the last section, a spectrum without the NOE may be obtained using the pulse sequence shown in figure 7.4b (the

gated decoupler method) as for solution state studies. Provided the recycle delay  $t_d$  is long enough, turning off the decoupler during the delay allows the nuclei to relax to an equilibrium Boltzmann distribution at the time of the observation pulse<sup>6,8</sup>. However, if the recycle delay is reduced, and the nuclei are not allowed to reach thermal equilibrium, then the value of the nuclear Overhauser enhancement factor is affected<sup>6</sup>.

Figure 7.8 compares a plot of intensities of the peak at 25 ppm for the itaconic anhydride film obtained with NOE by varying the saturation time using the pulse sequence in figure 7.4a with a plot of intensities of the peak at 25 ppm obtained with transient Overhauser effects by varying the recycle time using the SPE pulse sequence (figure 7.4b). Comparison between these two intensities for each recycle time gives a plot of NOE against recycle time for the peak at 25ppm, as shown in figure 7.9. If an inadequate pulse delay is used in the SPE pulse sequence (figure 7.4b) then a reduced value of the nuclear Overhauser enhancement is observed. It is of the greatest importance, therefore, when measuring NOE enhancements that the recycle delay is long enough to allow the nuclei to return to thermal equilibrium.

### 7.5 Transient Overhauser effects

In transient NMR experiments, the populations of the spin states are disturbed from their equilibrium or steady-state values and the decay of the system to a new steady-state is observed<sup>6,9</sup>. The perturbation may be effected by two main methods.

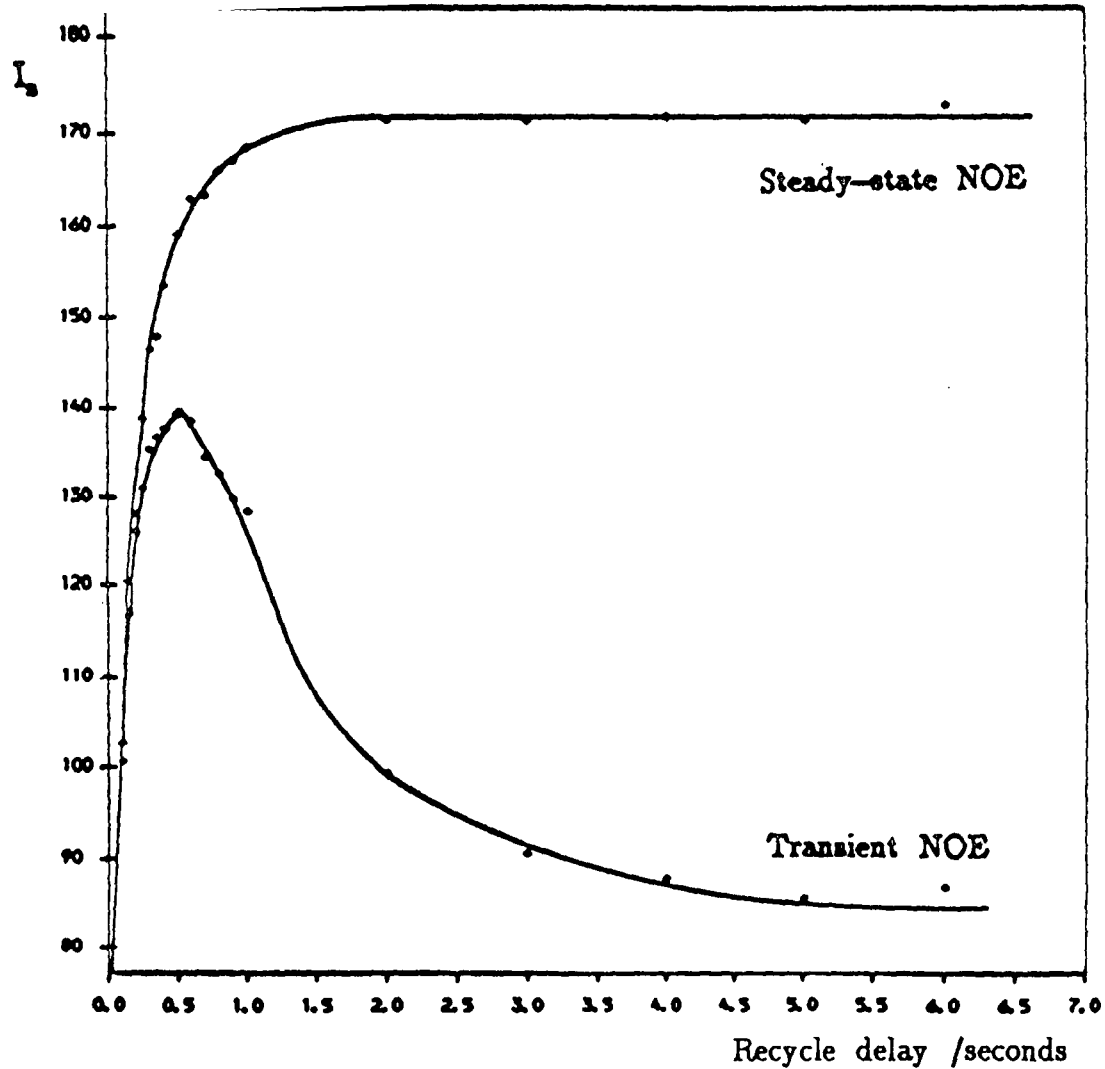

Figure 7.8

A comparison of the intensities of the peak at 25 ppm for the itaconic anhydride film obtained a). with steady-state NOE and b). with transient nuclear Overhauser effects.

AQ = 26 ms

NT = 1000

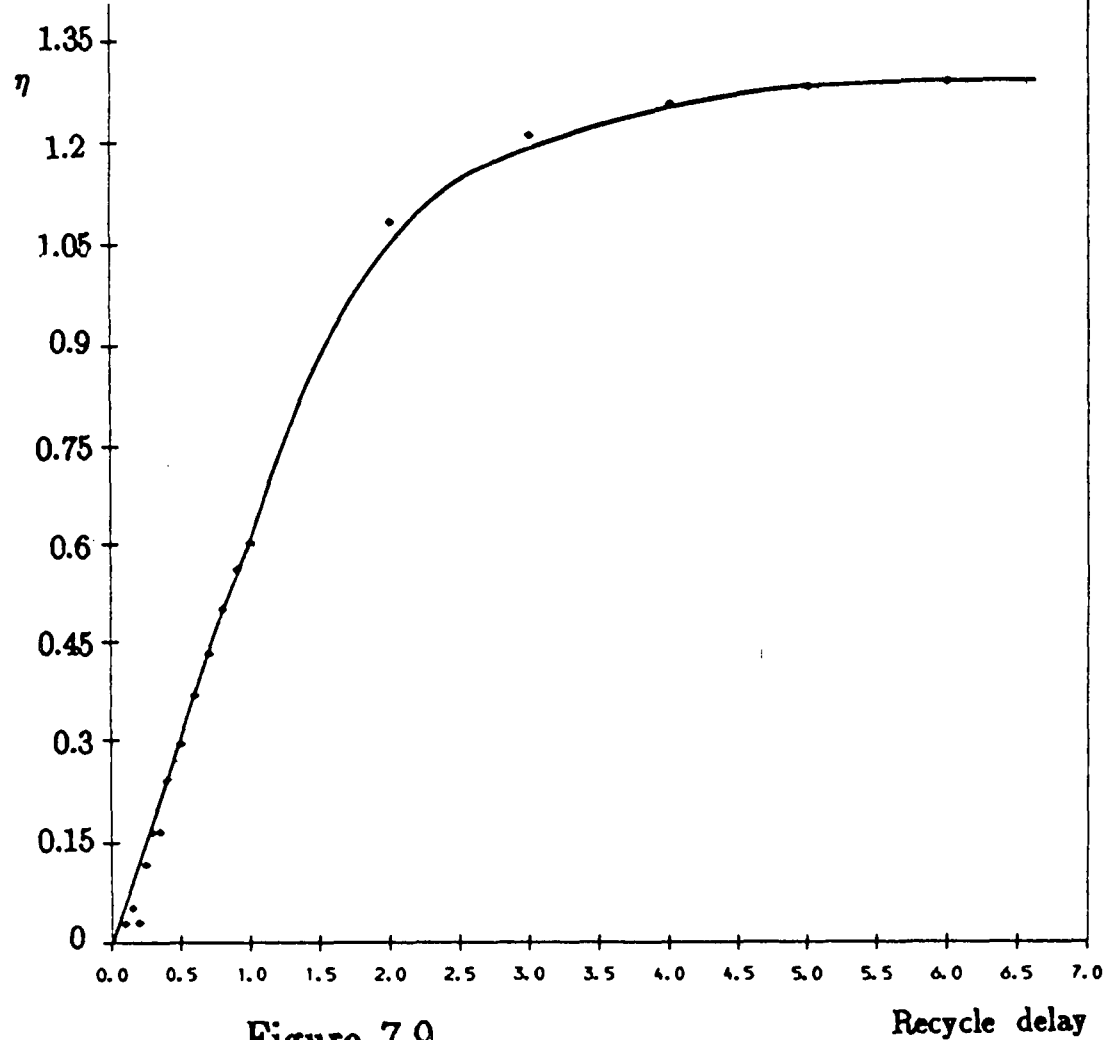

Figure 7.9

The apparent nuclear Overhauser enhancement factor obtained for the peak at 25 ppm for the itaconic anhydride film when inadequate recycle delays are used.

AQ = 26 ms

NT = 1000

1. by applying a strong RF field at the resonance frequency of one of the spins
2. by removing a saturating field from a spin

The behaviour of a spin system under the various possible treatments is the subject of the rest of this chapter.

Consider a two spin system  $I \equiv {}^{13}\text{C} = \frac{1}{2}$  and  $S \equiv {}^1\text{H} = \frac{1}{2}$ . It is assumed that the only mutual interaction is the (I,S) dipole-dipole interaction, but relaxation of both nuclei by other mechanisms is not excluded.

The relaxation of the C-H coupled spin system has been described by Solomon<sup>3</sup> by a pair of simultaneous differential equations.

$$\frac{d}{dt} (\langle I_z \rangle - I_0) = - (\langle I_z \rangle - I_0)/T_1^{II} - (\langle S_z \rangle - S_0)/T_1^{IS} \quad (7.1a)$$

$$\frac{d}{dt} (\langle S_z \rangle - S_0) = - (\langle I_z \rangle - I_0)/T_1^{IS} - (\langle S_z \rangle - S_0)/T_1^{SS} \quad (7.1b)$$

The general solution is of the form

$$\langle I_z \rangle = I_0 + C_1 \exp(-\lambda_1 t) + C_2 \exp(-\lambda_2 t) \quad (7.2a)$$

$$\langle S_z \rangle = S_0 + (\lambda_1 - 1/T_1^{II}) C_1 T_1^{IS} \exp(-\lambda_1 t) + (\lambda_2 - 1/T_1^{II}) C_2 T_1^{IS} \exp(-\lambda_2 t) \quad (7.2b)$$

where  $C_1$  and  $C_2$  are constants, and  $\lambda_1$  and  $\lambda_2$  are roots of the characteristic equation.

$$\lambda = \frac{1}{2T_1^{II}} \left[ (x+1) \pm \left[ (x-1)^2 + 4 \left[ \frac{\eta\gamma_I}{\gamma_S} \right]^2 \right]^{\frac{1}{2}} \right] \quad (7.3)$$

$$\text{where } x = \frac{T_1^{II}}{T_1^{SS}} \quad (7.4)$$

Both  $T_1^{II}$  and  $T_1^{SS}$  are easily measured.  $T_1^{II}$  is simply the carbon  $T_1$  value, and similarly,  $T_1^{SS}$  is the proton  $T_1$  value.  $T_1^{IS}$ , the cross-relaxation rate, may be expressed in terms of the NOEF,  $\eta$  by

$$T_1^{IS} = \frac{T_1^{II}}{\eta} \left[ \frac{\gamma_I}{\gamma_S} \right] \quad (7.5)$$

In order to obtain values for the constants  $C_1$  and  $C_2$ , the equations must be solved under specific limiting conditions which depend upon the pulse sequence applied to the spins.

Two transient experiments are covered in this thesis.

## 7.6 The single pulse excitation experiment<sup>9</sup>

The pulse sequence for the single pulse excitation (SPE) experiment is shown in figure 7.10. In order to obtain an expression for the carbon magnetisation at any instance in the recycle delay, the calculation must be split into two stages.

### 7.6.1 Stage 1

Stage one calculates the growth of  $I_x$  between  $t=0$  and  $t=t_{aq}$ , the end of the acquisition time. A  $90^\circ$  pulse is applied to spin I, followed by an acquisition period  $t_{aq}$  during which the spins are decoupled. If an infinitely powerful RF is assumed, then the initial conditions of the spins at time  $t=0$  are

$$\langle I_x \rangle(0)=0 \quad (7.6a)$$

and 
$$\langle S_x \rangle(0)=0 \quad (7.6b)$$

The proton spins are kept saturated between times  $t=0$  and  $t=t_{aq}$ , thus we have another limiting condition; that the S magnetisation is zero throughout stage 1.

$$\text{i.e. } \langle S_x \rangle(0)=\langle S_x \rangle(t)=0 \quad (7.6c)$$

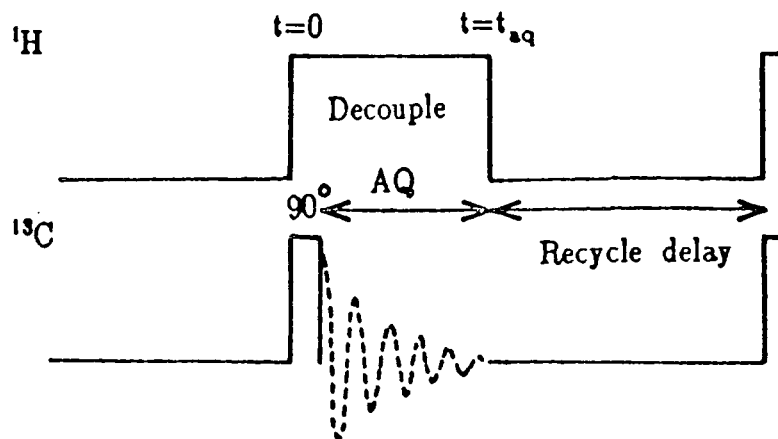

Figure 7.10

The pulse sequence for the single-pulse-excitation experiment.

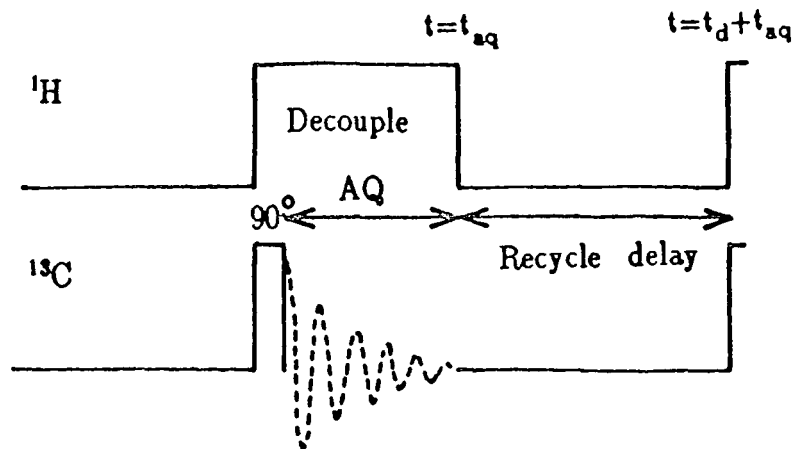

Figure 7.11

The pulse sequence for the single-pulse-excitation experiment. The second stage of the calculation considers the development of  $I_x$  between  $t=t_{aq}$  and  $t=t_d+t_{aq}$ .

Substituting these conditions into equations 7.2a and 7.2b leads to values for the constants  $C_1$  and  $C_2$ , and hence an expression for the carbon intensity at the end of the acquisition time.

$$\langle I_z \rangle(t_{aq}) = \left[ \frac{S_0 T_1^{II}}{T_1^{IS}} + I_0 \right] \left[ 1 - \exp \left[ - \frac{t_{aq}}{T_1^{II}} \right] \right] \quad (7.7)$$

### 7.6.2 Stage 2

Stage 2 of the calculation considers the development of the carbon magnetisation between time  $t=t_{aq}$  and the end of the recycle time  $t=t_d+t_{aq}$  as shown in figure 7.11.

The following calculation considers the time dependence of  $\langle I_z \rangle$  after releasing  $\langle S_z \rangle$  from saturation.

$$\text{The initial conditions are now } \langle S_z \rangle(t_{aq})=0 \quad (7.8a)$$

$$\text{and } \langle I_z \rangle(t_{aq}) = \left[ \frac{S_0 T_1^{II}}{T_1^{IS}} + I_0 \right] \left[ 1 - \exp \left[ - \frac{t_{aq}}{T_1^{II}} \right] \right] \quad (7.8b)$$

The expectation value of the carbon magnetisation at the end of the recycle delay,  $\langle I_z \rangle(t_{aq}+t_d)$ , will be given by the solution of the Solomon equations under these boundary conditions.

As before, expressions for the constants  $C_1$  and  $C_2$  are found, and these constants are then substituted in equation 7.2a to yield:

$$\frac{\langle I_z \rangle(t_{aq}+t_d) - I_0}{I_0} = A$$

where

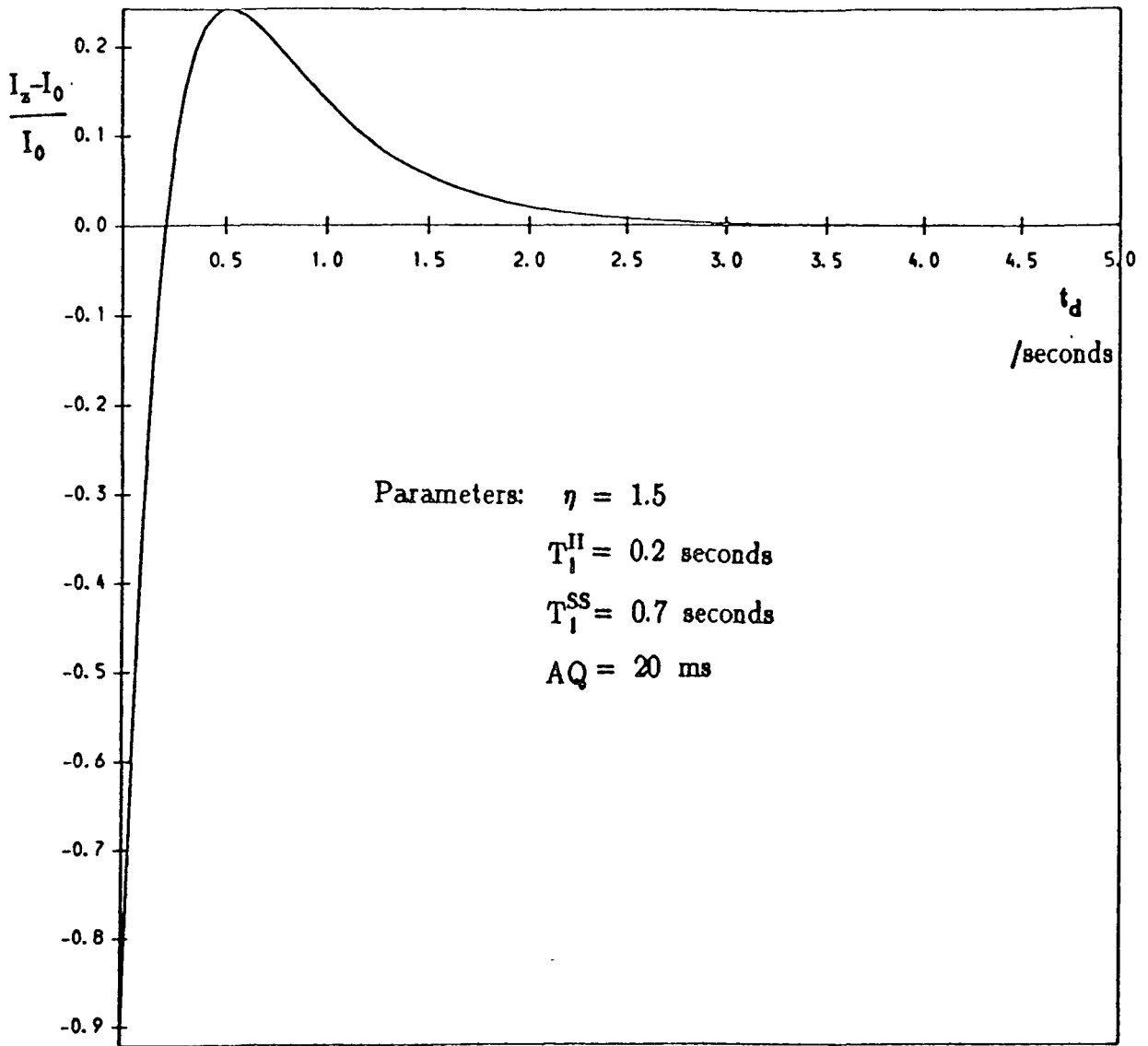

Figure 7.12a

A typical simulation of the carbon intensity observed during the recycle delay in the single-pulse experiment.

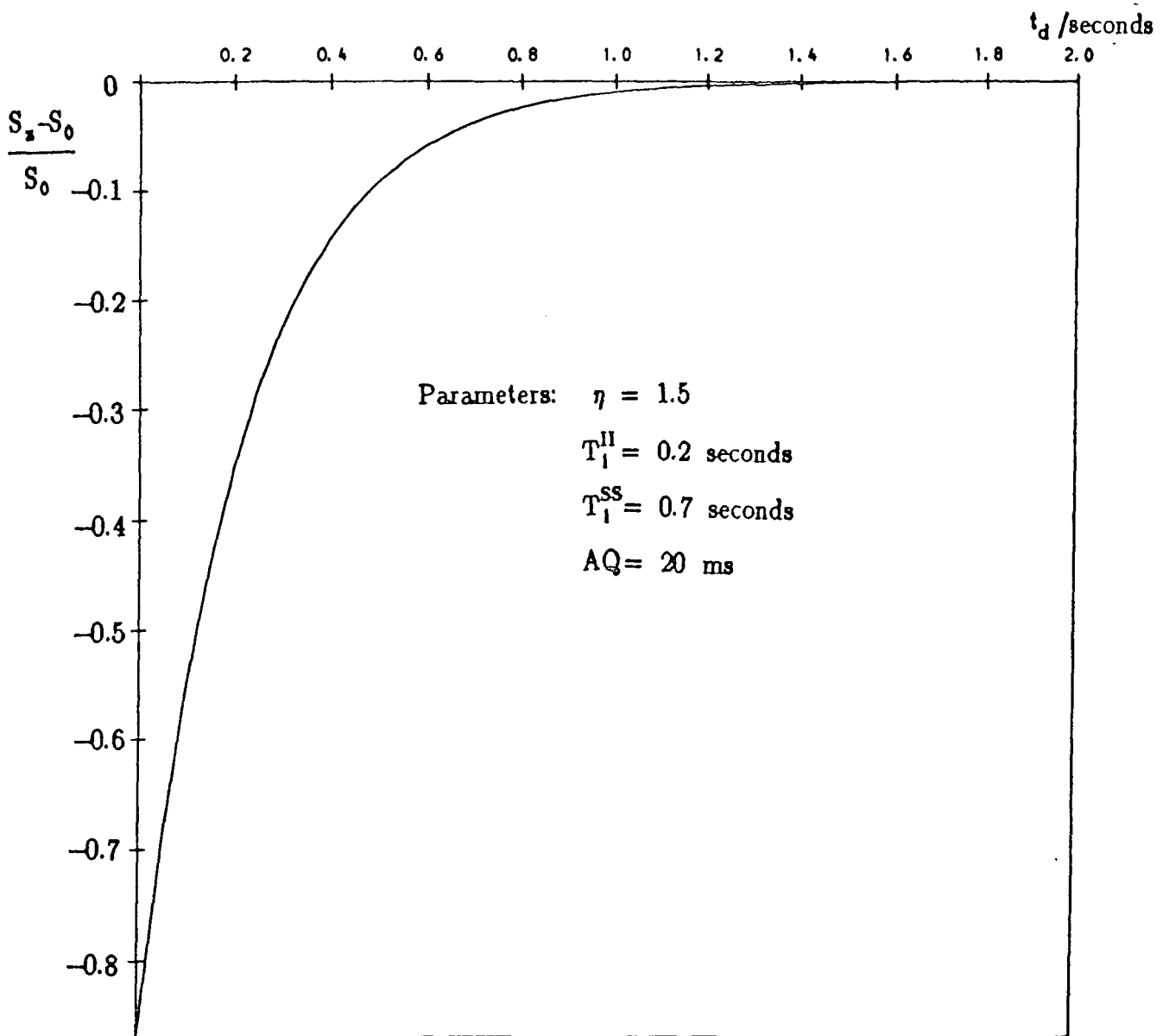
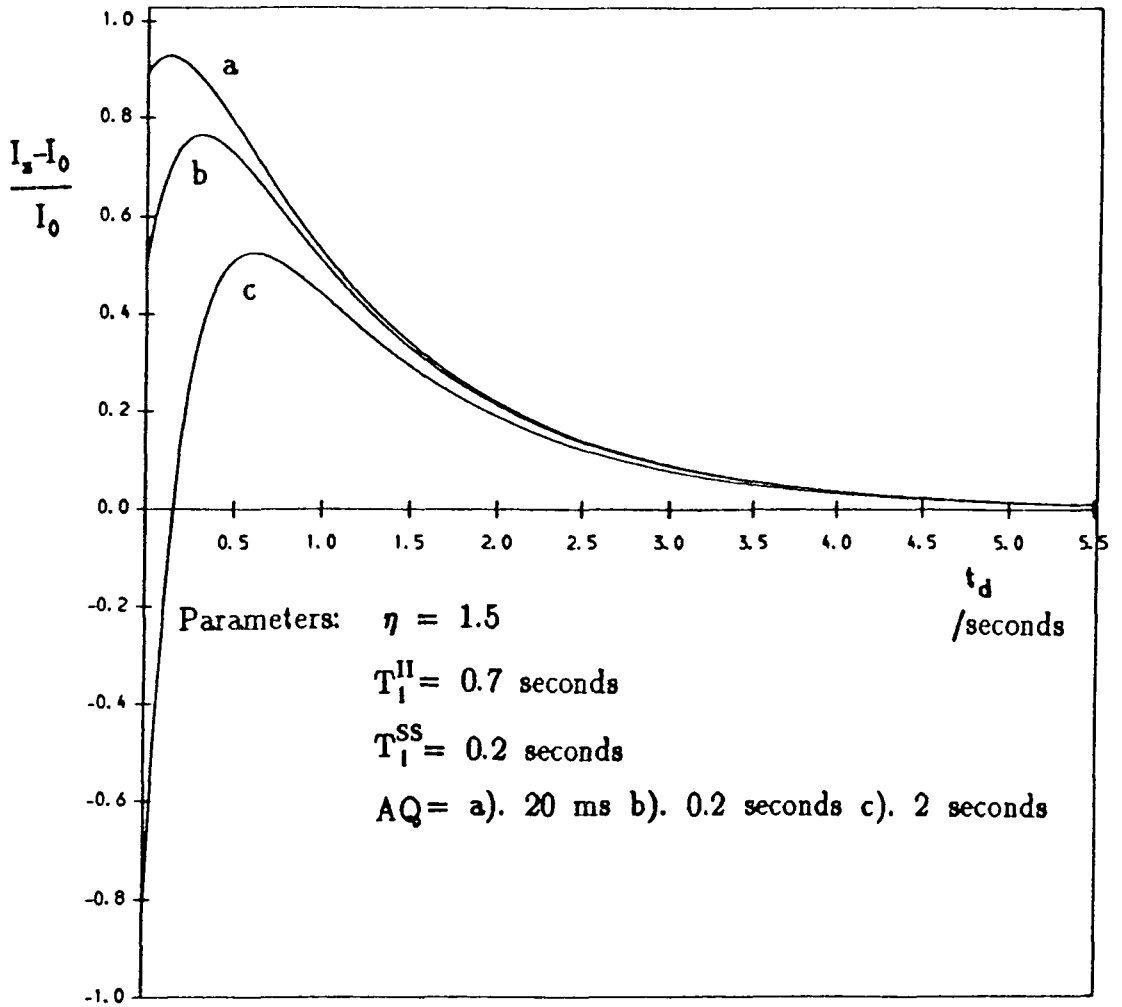

Figure 7.12b

A typical simulation of the proton intensity during the recycle delay in the single-pulse experiment.



**Figure 7.13**

A simulation to illustrate how varying the acquisition time alters the observed carbon magnetisation.

$$A = \frac{\exp(-t_{\text{aq}}/T_1^{\text{II}}) \left[ (\eta+1) \left[ (\lambda_1 T_1^{\text{II}} - 1) \exp(-\lambda_2 t_d) - (\lambda_2 T_1^{\text{II}} - 1) \exp(-\lambda_1 t_d) \right] \right]}{T_1^{\text{II}} (\lambda_2 - \lambda_1)} + \frac{\eta (\lambda_2 \exp(-\lambda_1 t_d) - \lambda_1 \exp(-\lambda_2 t_d))}{(\lambda_2 - \lambda_1)} \quad (7.9)$$

$$\text{where } \lambda_1, \lambda_2 = \frac{1}{2T_1^{\text{II}}} \left[ x+1 \pm \left[ (x-1)^2 + 4 \left[ \frac{\eta \gamma_1}{\gamma_s} \right]^2 \right]^{\frac{1}{2}} \right] \quad (7.10)$$

$$\text{and } x = \frac{T_1^{\text{II}}}{T_1^{\text{SS}}} \quad (7.10a)$$

The pulse sequence is then repeated.

A simulation program has been written using equation 7.9 to predict the behaviour of the carbon intensity during the recycle delay. The computer program can be found in Appendix A. Figure 7.12a shows a typical simulation of the carbon intensity using realistic parameter values for the variables. Figure 7.12b shows a theoretical simulation of how the proton magnetisation varies under the same conditions. From equation 7.9 it can be seen that several parameters affect the carbon intensity at a particular point in the recycle delay. One of these is  $t_{\text{aq}}$ , the duration of the high-power decoupling, which effects the build-up of the NOE<sup>10</sup>. Therefore the acquisition time is an experimental parameter which must be taken into account in order to obtain a correct simulation of the carbon intensity. Figure 7.13 demonstrates how varying the acquisition time alters the observed carbon magnetisation.

Once the carbon magnetisation during the recycle delay is predicted theoretically, it is necessary to compare the theory with experiment. Signal from the first few transients of the experiment is rejected to

Figure 7.14

The single-pulse-excitation spectra obtained for the itaconic anhydride film. The recycle delay ranged between 0.02 and 5 seconds. The acquisition time was 20 ms, and 1000 transients were acquired for each spectrum.

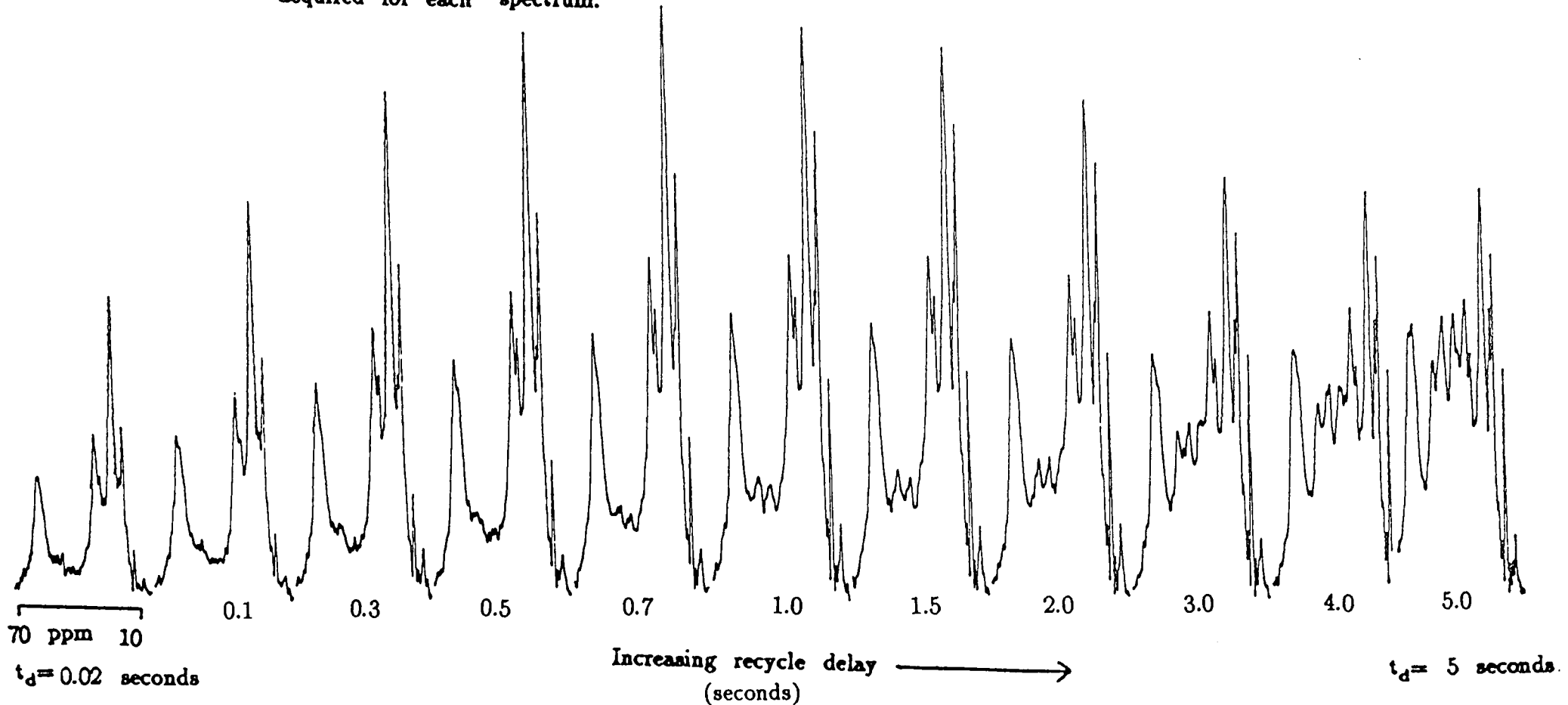

enable a steady-state situation to occur before the data is acquired. The signal accumulated is proportional to the macroscopic magnetisation  $M_z^I$ , and hence to the expectation value of the carbon intensity  $\langle I_z \rangle (t_{aq} + t_d)$ .

$$\frac{M_z^I}{M_0} = \frac{\langle I_z \rangle (t_{aq} + t_d)}{I_0} \quad (7.11)$$

The SPE experiment was repeated several times on the itaconic anhydride film, each time with a different recycle delay ( $t_d$ ). The signal intensities of the spectra obtained after Fourier transformation of the FIDs represent the magnetisations at the time of the  $90^\circ$   $^{13}\text{C}$  pulse. Therefore it is possible to trace the time development of the magnetisation (i.e. the transient NOE) by varying the recycle delay of the gated decoupler experiment. In this way the growth of the carbon magnetisation towards equilibrium was monitored. The SPE spectra obtained for the itaconic anhydride film are shown in figure 7.14. In general, the lower the recycle time, the more mobile are the peaks which are observed in the spectrum. Thus only polyester peaks are apparent in the spectra with low recycle time.

Simulations have been made of the carbon intensity for each of the four peaks at 19, 25, 34 and 64ppm which show transient nuclear Overhauser effects. These simulations are compared to the experimental intensities in figures 7.15–18 for the itaconic anhydride film. The assignments of the peaks and their relevant parameters are shown in Table 7.4. The Overhauser enhancement,  $\eta$ , was measured using the saturation method described in section 7.3.2 (figure 7.4a).  $T_1^{\text{II}}$ , the carbon  $T_1$  was measured using the MOST pulse sequence as described in chapter

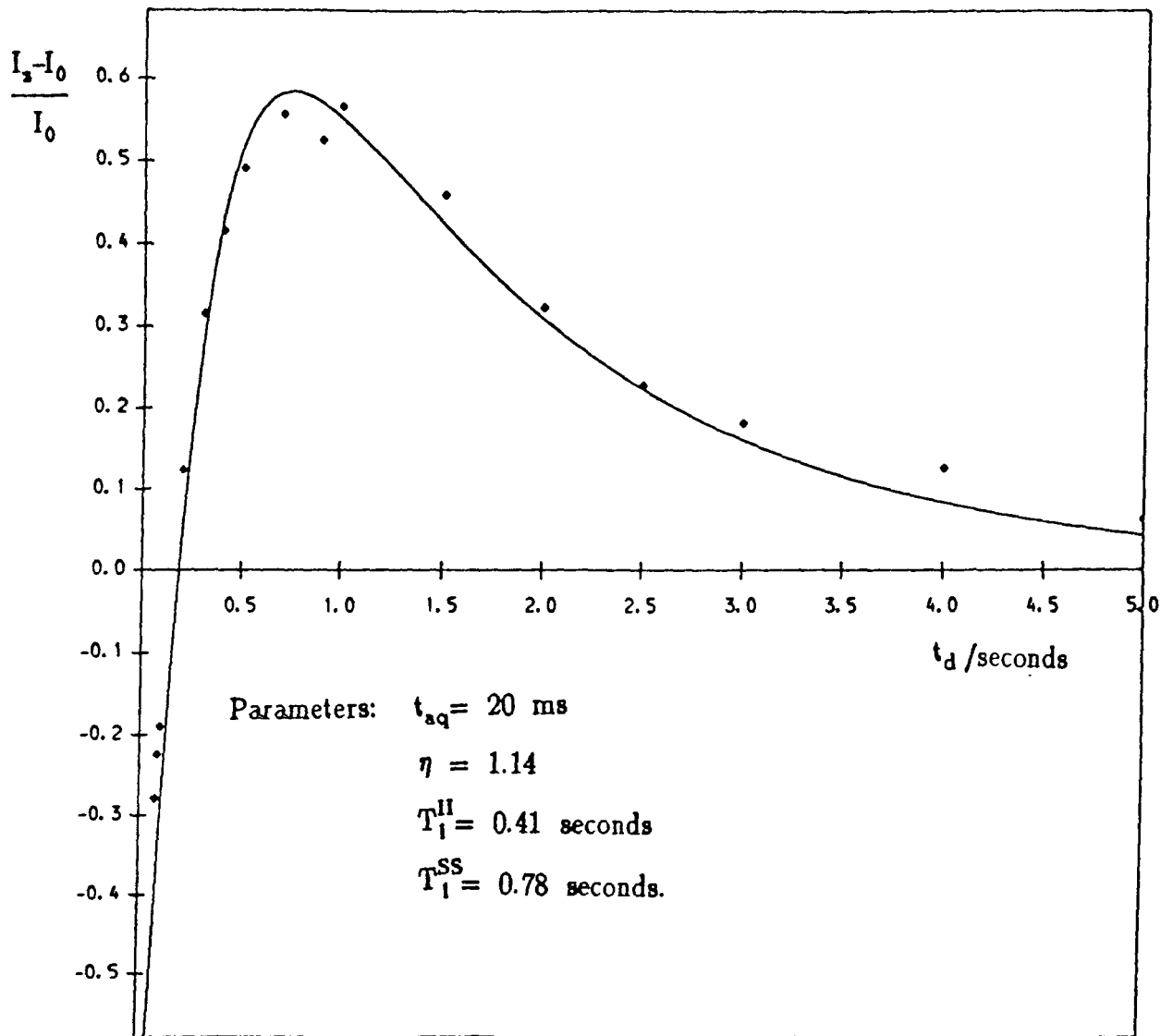

**Figure 7.15**

A comparison between the theoretical SPE simulation and the experimental intensities for the peak at 19 ppm in the itaconic anhydride film.

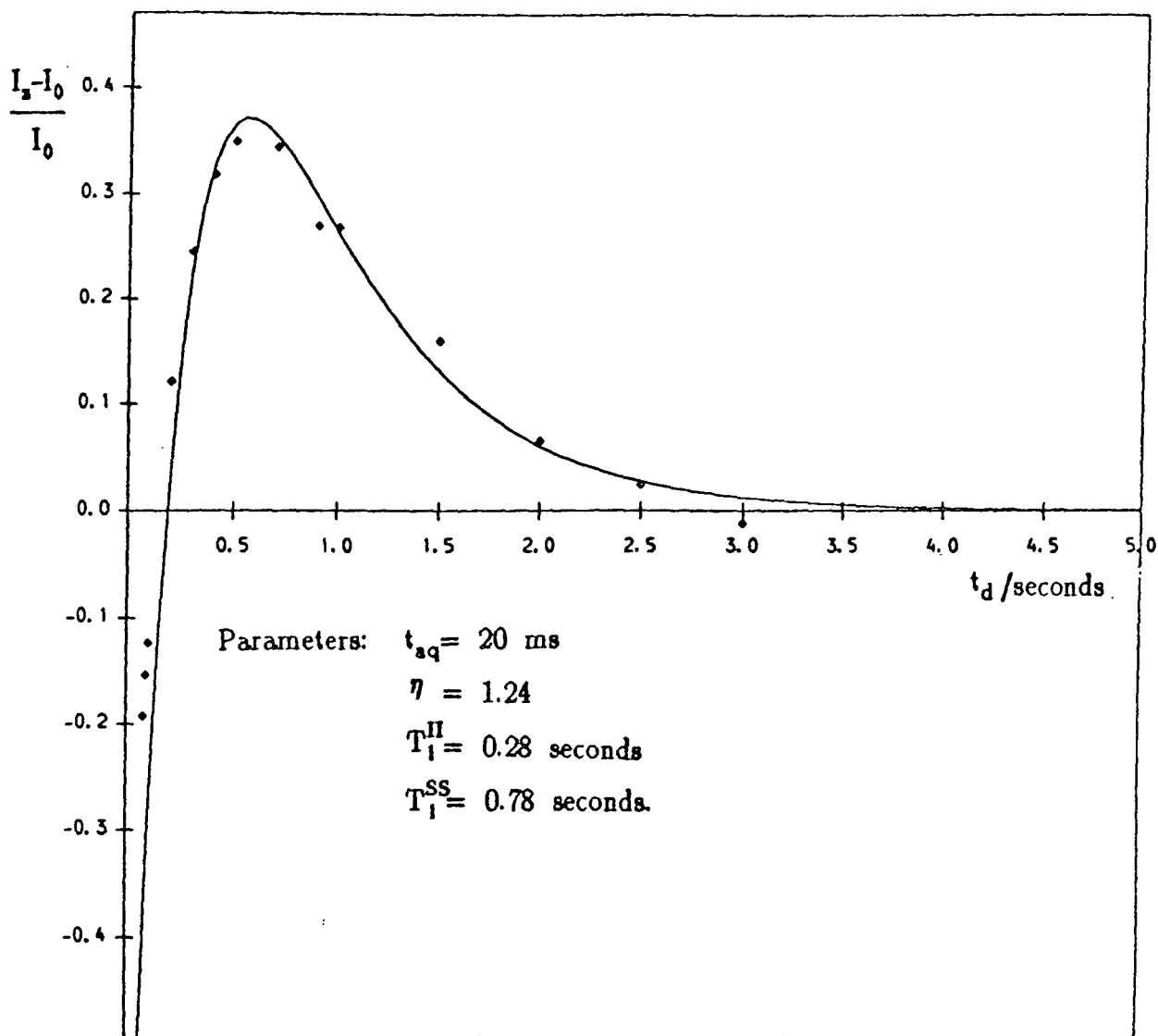

**Figure 7.16**

A comparison between the theoretical SPE simulation and the experimental intensities for the peak at 25 ppm in the itaconic anhydride film.

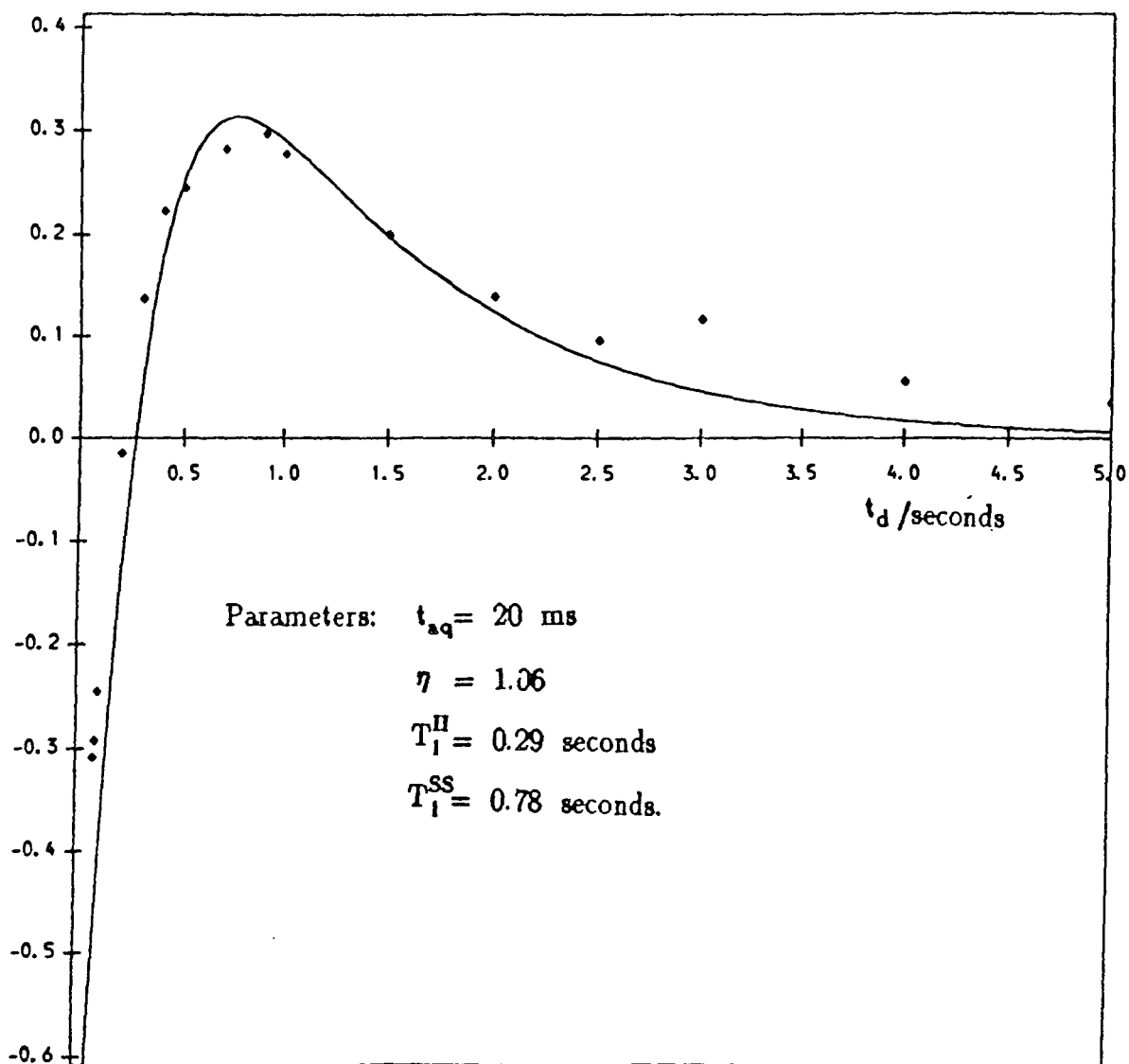

**Figure 7.17**

A comparison between the theoretical SPE simulation and the experimental intensities for the peak at 34 ppm in the itaconic anhydride film.

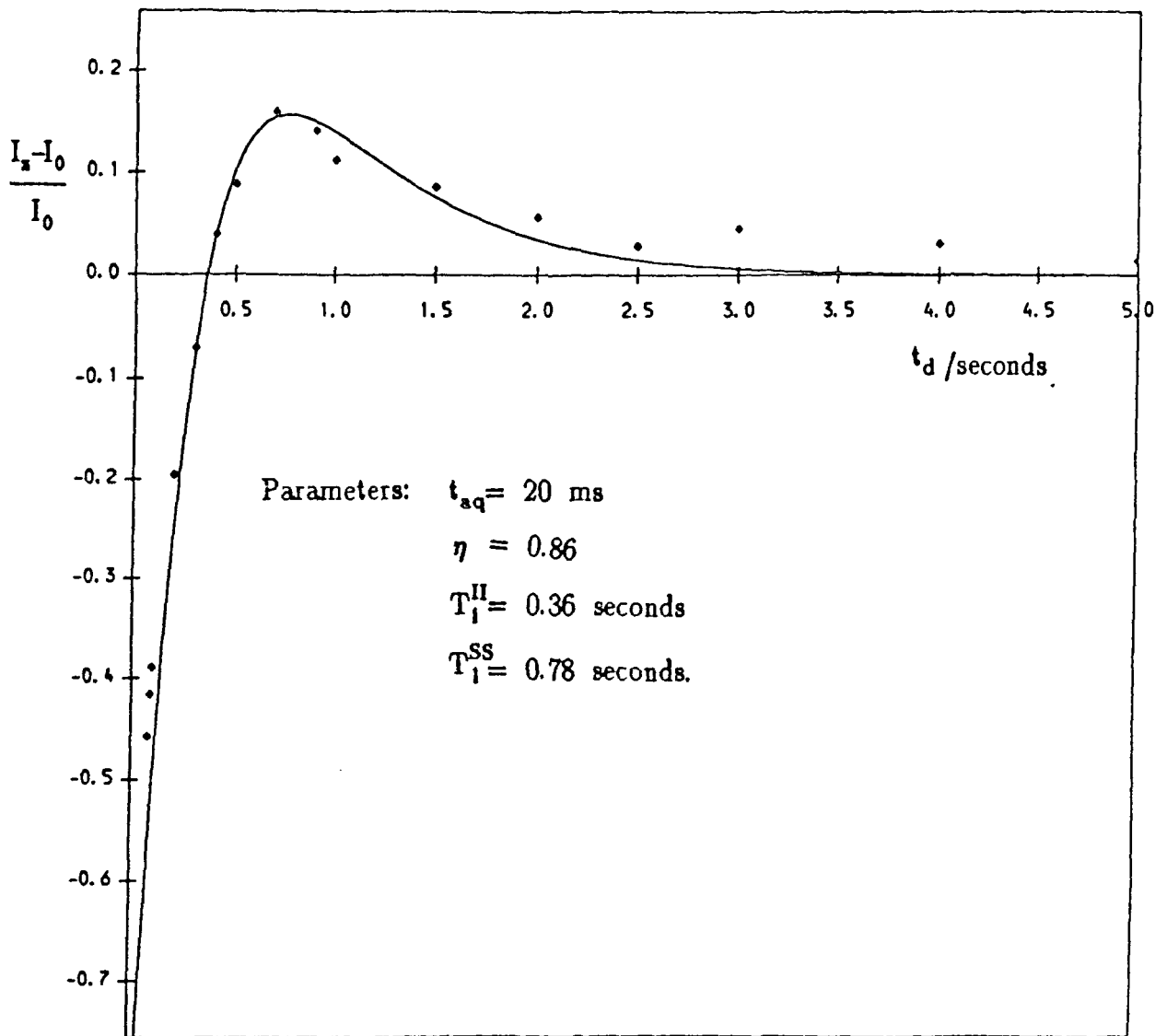

Figure 7.18

A comparison between the theoretical SPE simulation and the experimental intensities for the peak at 64 ppm in the itaconic anhydride film.

## Table 7.4

Parameters for the simulation of the SPE carbon intensity of the itaconic anhydride film.

Peak/ppm	$\eta$	$T_1^H$ /seconds	Assignment
19	1.14	0.41	CH <sub>3</sub> of MMA
25	1.24	0.28	CH <sub>2</sub> 'backbone'
34	1.06	0.29	O-C(=O)-CH <sub>2</sub>
64	0.86	0.36	O=C-OCH <sub>2</sub>

## Table 7.5

Parameters for the simulation of the SPE carbon intensity of the maleic anhydride film.

Peak/ppm	$\eta$	$T_1^H$ /seconds	Assignment
19	1.21	0.32	CH <sub>3</sub> of MMA
25	1.24	0.23	CH <sub>2</sub> 'backbone'
34	1.06	0.29	O-C(=O)-CH <sub>2</sub>
64	0.86	0.34	O=C-OCH <sub>2</sub>

Five.  $T_1^{SS}$ , the proton  $T_1$ , assumed to be single exponential, was measured by the saturation recovery method.  $T_1^{II}$  is also assumed to be single exponential. As discussed in chapter Five, the carbon  $T_1$ 's of the polyester peaks have two components, the shorter component arising from the carbons of the more mobile polyester, either uncross-linked, or cross-linked at only one end of the polyester chain, and the longer component arising from the carbons of the more rigid polyester cross-linked at both ends of the polyester chain. The more mobile a particular carbon atom, the more likely it is to show NOE effects. The assumption was made that only the more mobile carbons in the polyester chain contributed to the observed transient Overhauser effects. Therefore only the short component of the carbon  $T_1$  has been taken into account in the simulations (Figures 7.15–18). Initially the simulations are an excellent fit to the experimental data. However at longer recycle times (4 seconds onwards), the measured experimental carbon intensity is greater than the theoretical prediction. At short recycle times ( $< 3$  seconds) the longer  $^{13}\text{C}$   $T_1$  component has a negligible effect on the measured carbon intensity. However, as the recycle time is increased, the longer component of the carbon  $T_1$  has a larger contribution to the measured carbon intensity. The effect of the longer  $^{13}\text{C}$   $T_1$  component has been neglected in the theoretical simulations, hence, at longer recycle times, the theoretical simulation deviates from the experimental data.

The single pulse excitation experiments were also repeated on the maleic anhydride film, again each time with a different recycle delay. The SPE spectra are shown in figure 7.19. Figures 7.20–23 show the four

Figure 7.19

The single-pulse-excitation spectra obtained for the maleic anhydride film. The recycle delay ranged between 0.02 and 5 seconds. The acquisition time was 20 ms, and 1000 transients were acquired for each spectrum.

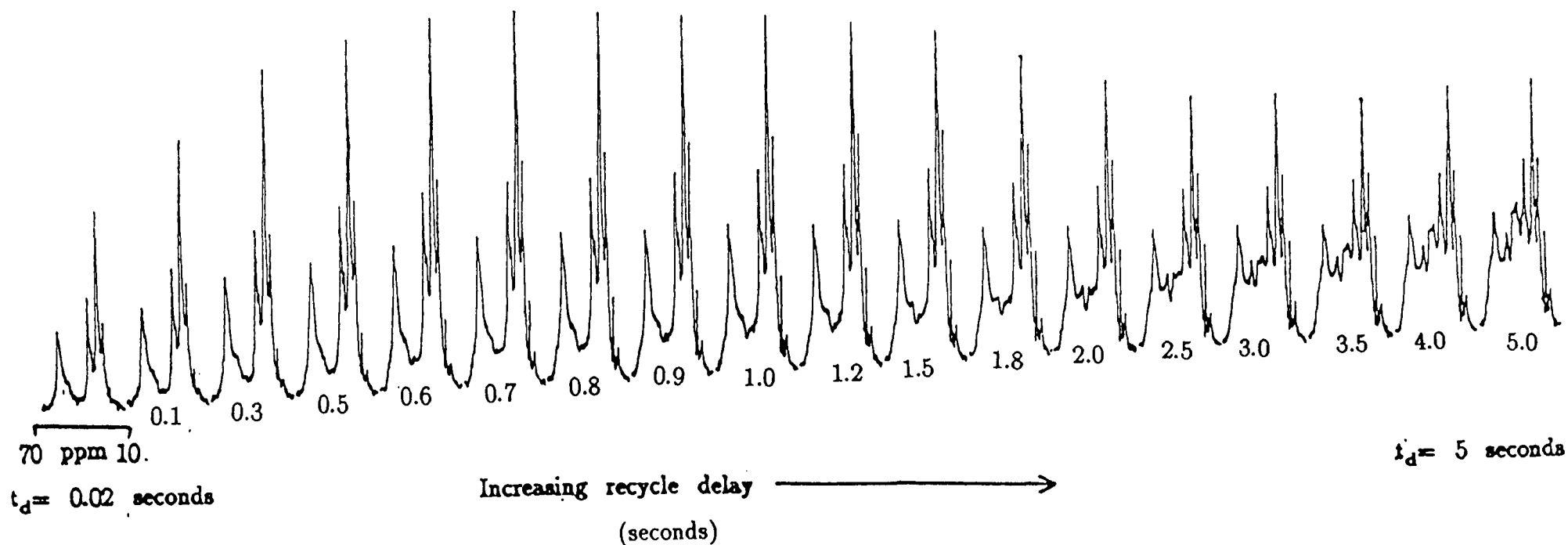

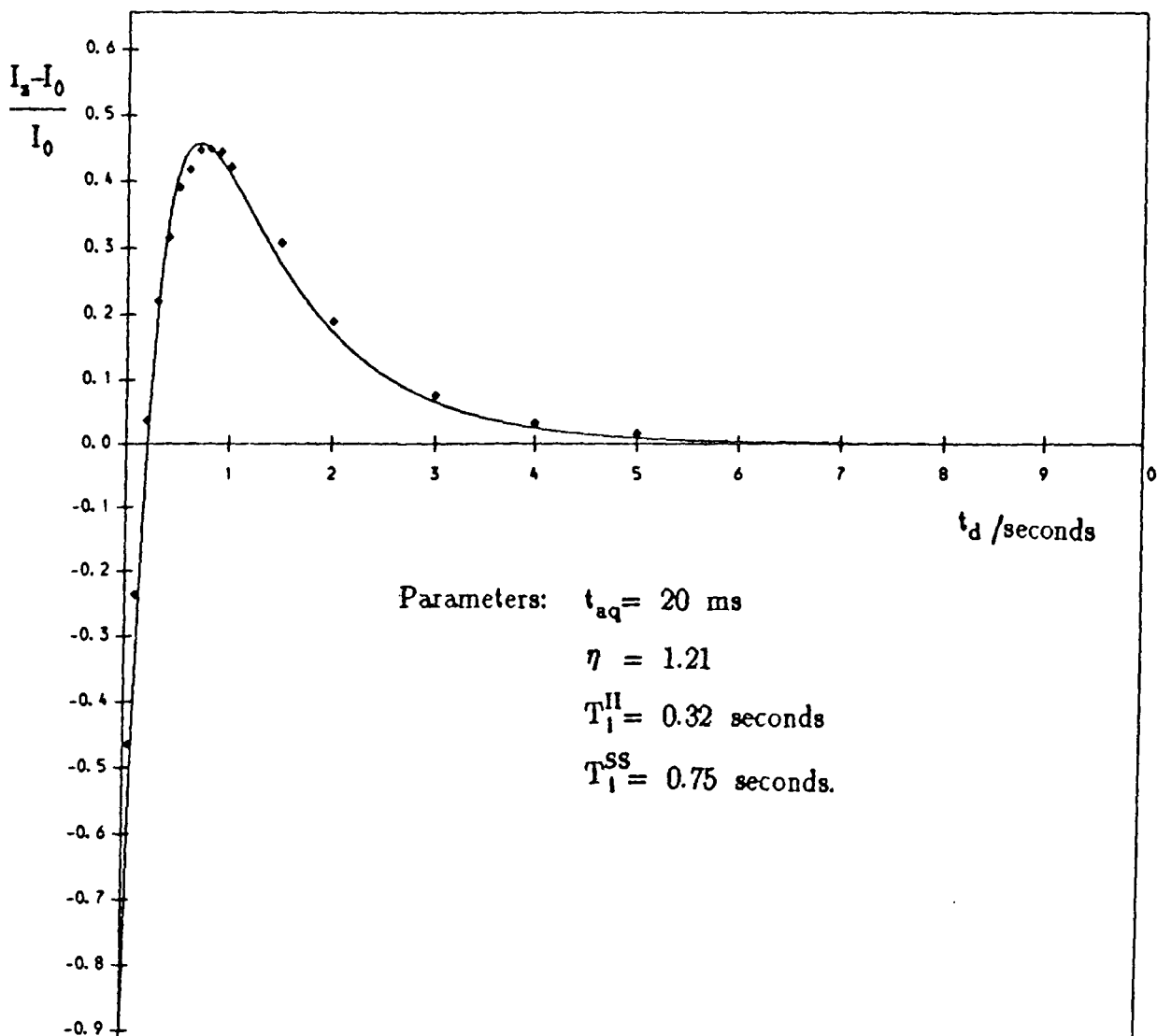
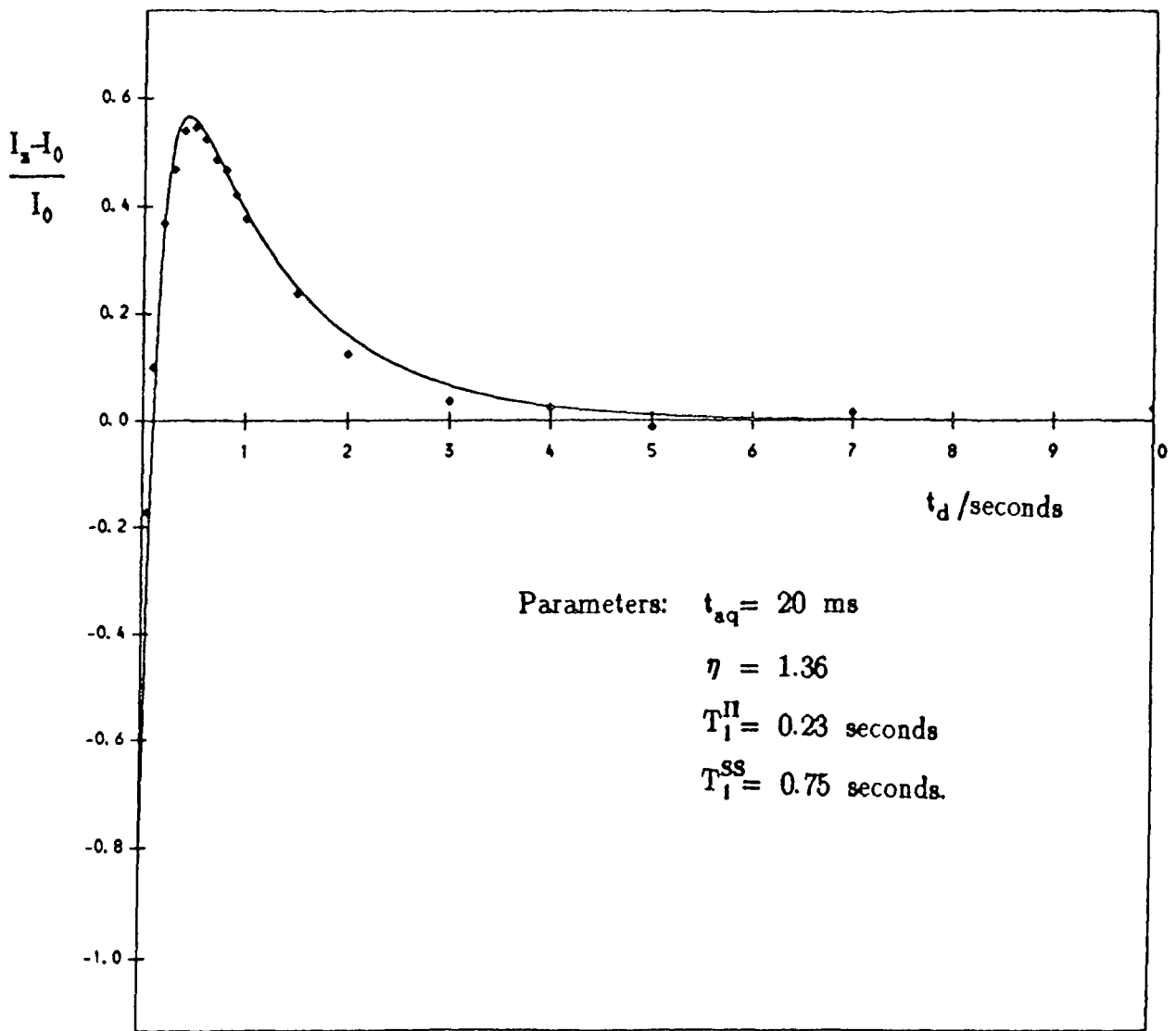

Figure 7.20

A comparison between the theoretical SPE simulation and the experimental intensities for the peak at 19 ppm in the maleic anhydride film.



**Figure 7.21**

A comparison between the theoretical SPE simulation and the experimental intensities for the peak at 25 ppm in the maleic anhydride film.

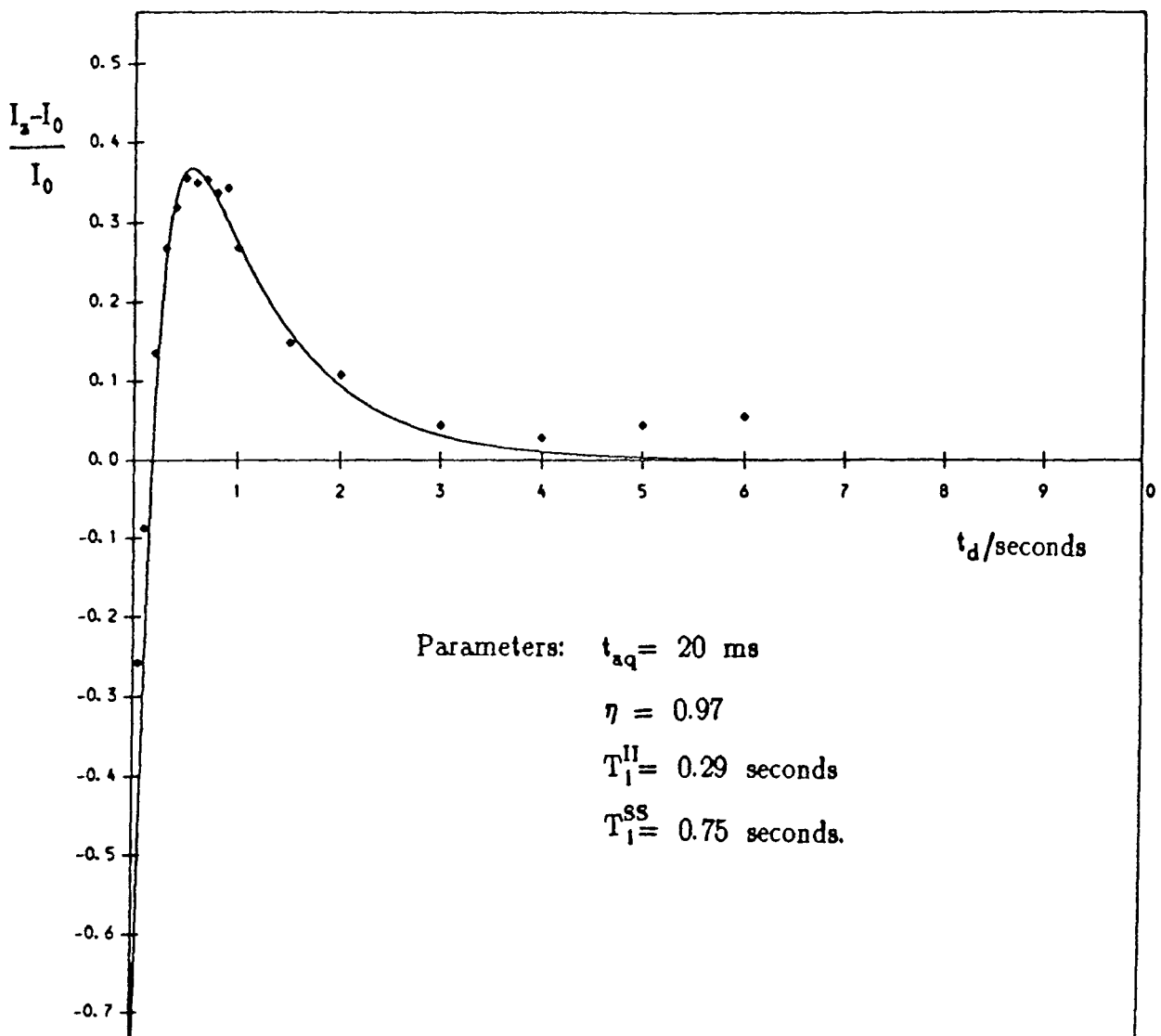

**Figure 7.22**

A comparison between the theoretical SPE simulation and the experimental intensities for the peak at 34 ppm in the maleic anhydride film.

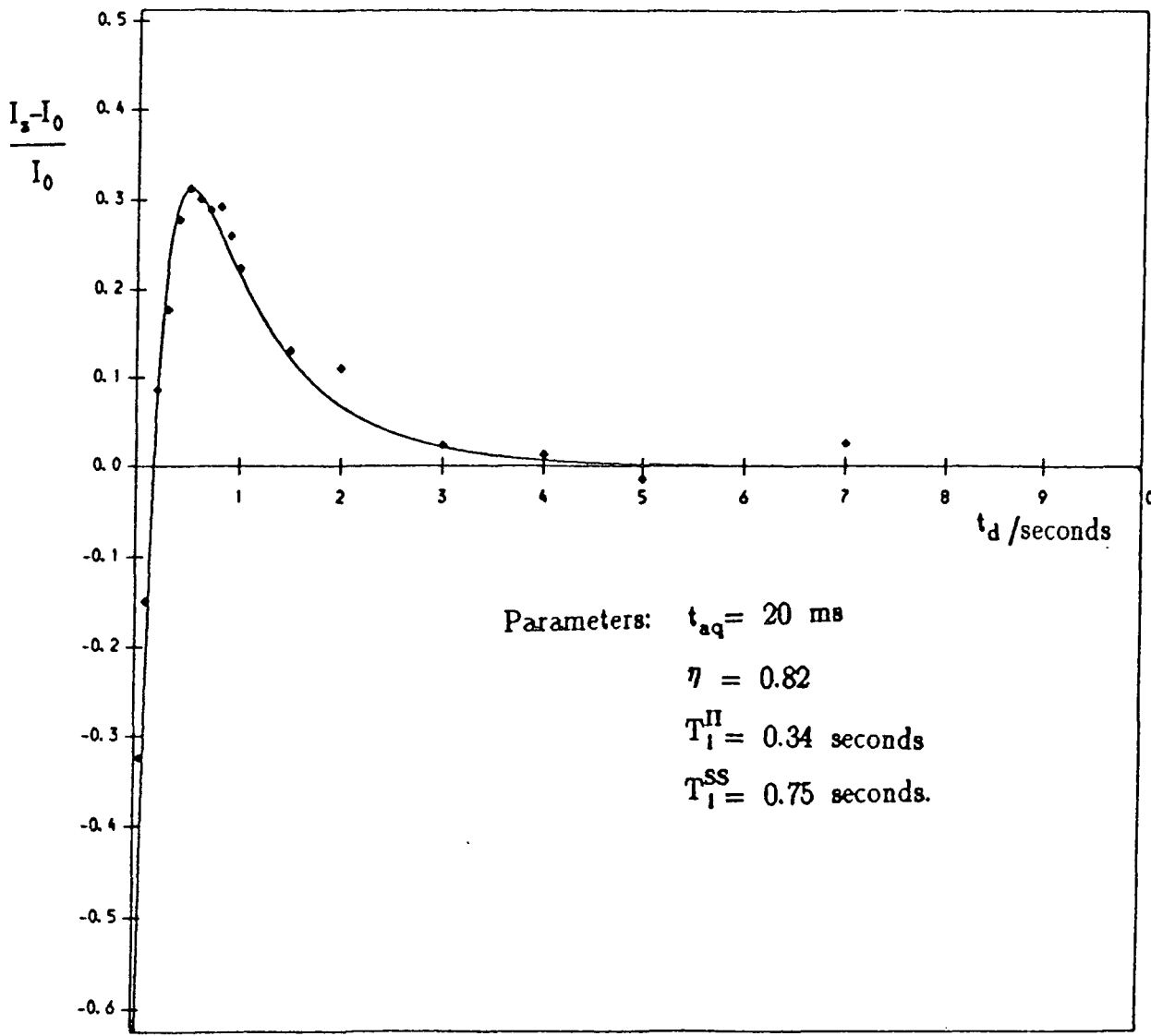

Figure 7.23

A comparison between the theoretical SPE simulation and the experimental intensities for the peak at 64 ppm in the maleic anhydride film.

peaks in the maleic anhydride film spectra with nuclear Overhauser enhancements. The assignments of the peaks and the relevant parameters are shown in Table 7.5.

From figs 7.15–18 and 7.20–23 it may be seen that the simulations produce an excellent fit to the experimental spectra in spite of the fact that many complexities (such as anisotropy of the relevant motion and the direct effects of spin diffusion) have been ignored.

The practical conclusion from the gated–decoupler MAS experiment in the solid–state without cross–polarisation is that for mobile systems, in order to measure correct resonance intensities, the proton decoupler must be gated off for a long time. Spectra obtained at shorter recycle times will not yield correct relative intensities between carbons in any one spectrum since the NOE will vary from one carbon to another. Thus care must be taken when using the gated–decoupler experiment for quantitative measurements.

### 7.7 A second transient experiment: INV1H<sup>9</sup>

The pulse sequence for the INV1H experiment is shown in figure 7.24. The experiment consists of a  $180^\circ$  pulse at the proton frequency followed by a delay  $\tau$  during which the proton spin systems are allowed to evolve. The intensity of the carbon magnetisation during the delay  $\tau$  is monitored by a carbon  $90^\circ$  read pulse followed by carbon acquisition and dipolar decoupling. A recycle delay of at least  $5 \times T_1^H$  is used to allow full recovery to the Boltzmann distributions.

An expression for the carbon magnetisation at any instance during

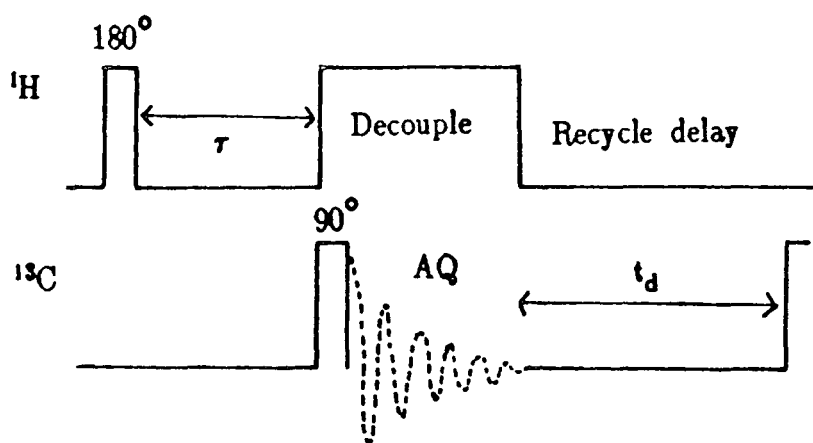

Figure 7.24

The pulse sequence for the INV1H experiment.

the delay  $\tau$  may be obtained in a similar way as for the SPE transient experiment. However the calculation for the INV1H experiment has only one step.

### 7.7.1 Calculation of $I_x$

The aim of the experiment is to monitor the time dependence of the carbon spins after the inversion of the proton magnetisation. The only part of the pulse sequence which needs to be considered theoretically is from the  $180^\circ$  proton pulse until the end of the delay  $\tau$ . (Figure 7.24)

If  $t=0$  is immediately after the  $180^\circ$  proton pulse, then the initial conditions of the spins at time  $t=0$  are

$$\langle I_x \rangle(0) = +I_0 \quad (7.12a)$$

$$\text{and} \quad \langle S_x \rangle(0) = -S_0 \quad (7.12b)$$

Substituting these conditions into equations 7.2a and 7.2b leads to values for the constants  $C_1$  and  $C_2$ , and hence an expression for the carbon intensity at the end of the delay period  $\tau$ .

$$\frac{\langle I_x \rangle_\tau - I_0}{I_0} = \frac{2T_1^{II}}{\tau(\lambda_2 - \lambda_1)} \left[ \exp(-\lambda_1\tau) - \exp(-\lambda_2\tau) \right] \quad (7.13)$$

As in the previous SPE experiment, the theoretical simulation is compared to experimental data. The INV1H experiment was repeated several times on a sample of itaconic anhydride film, each time varying the value of the delay  $\tau$ . The recycle delay is kept constant at 5s throughout the experiments. All three of the mobile polyester peaks and the  $\text{CH}_3$  copolymer peak reach equilibrium by 5 seconds. The spectra obtained for the itaconic anhydride film are shown in figure 7.25. As

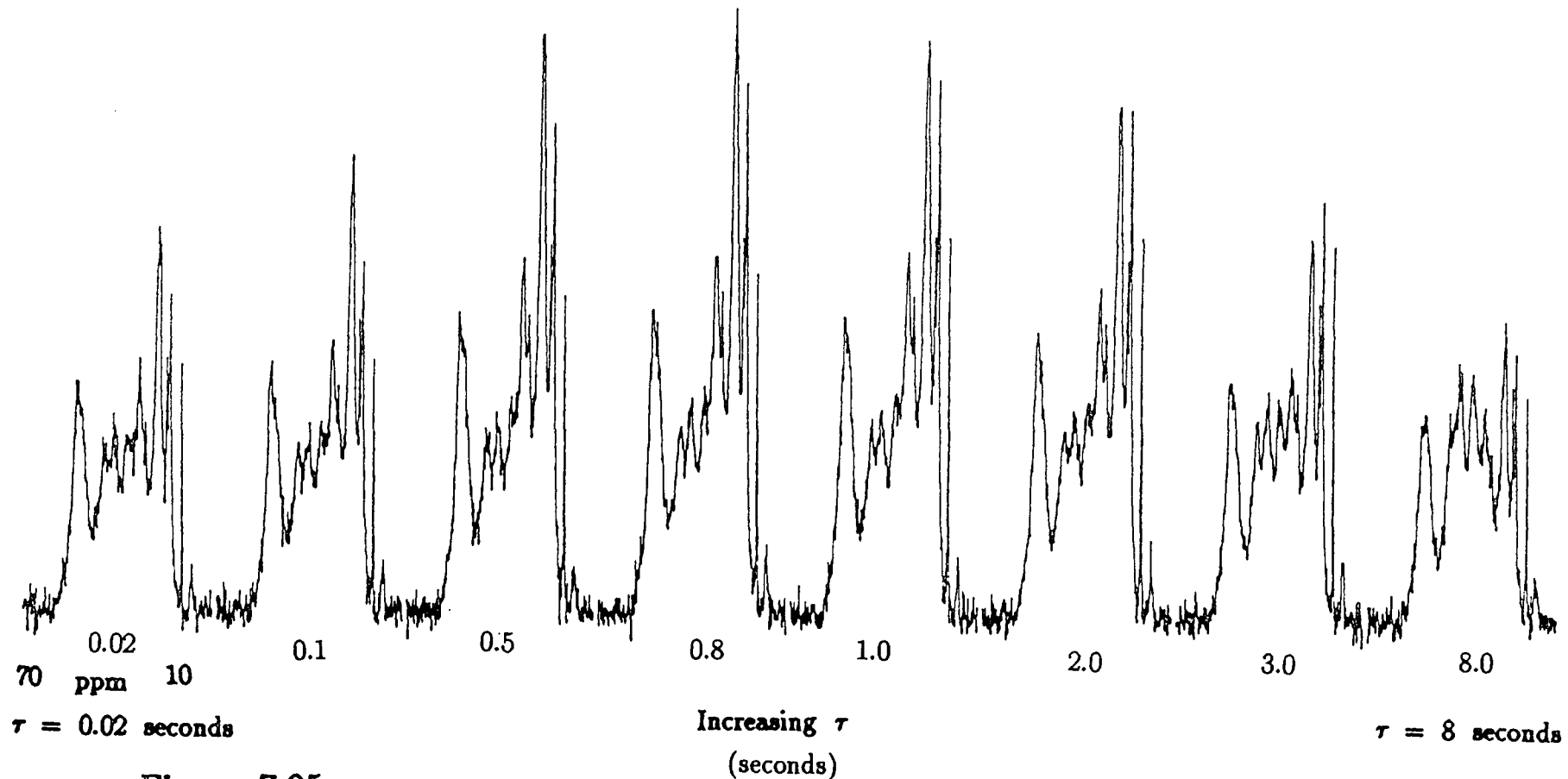
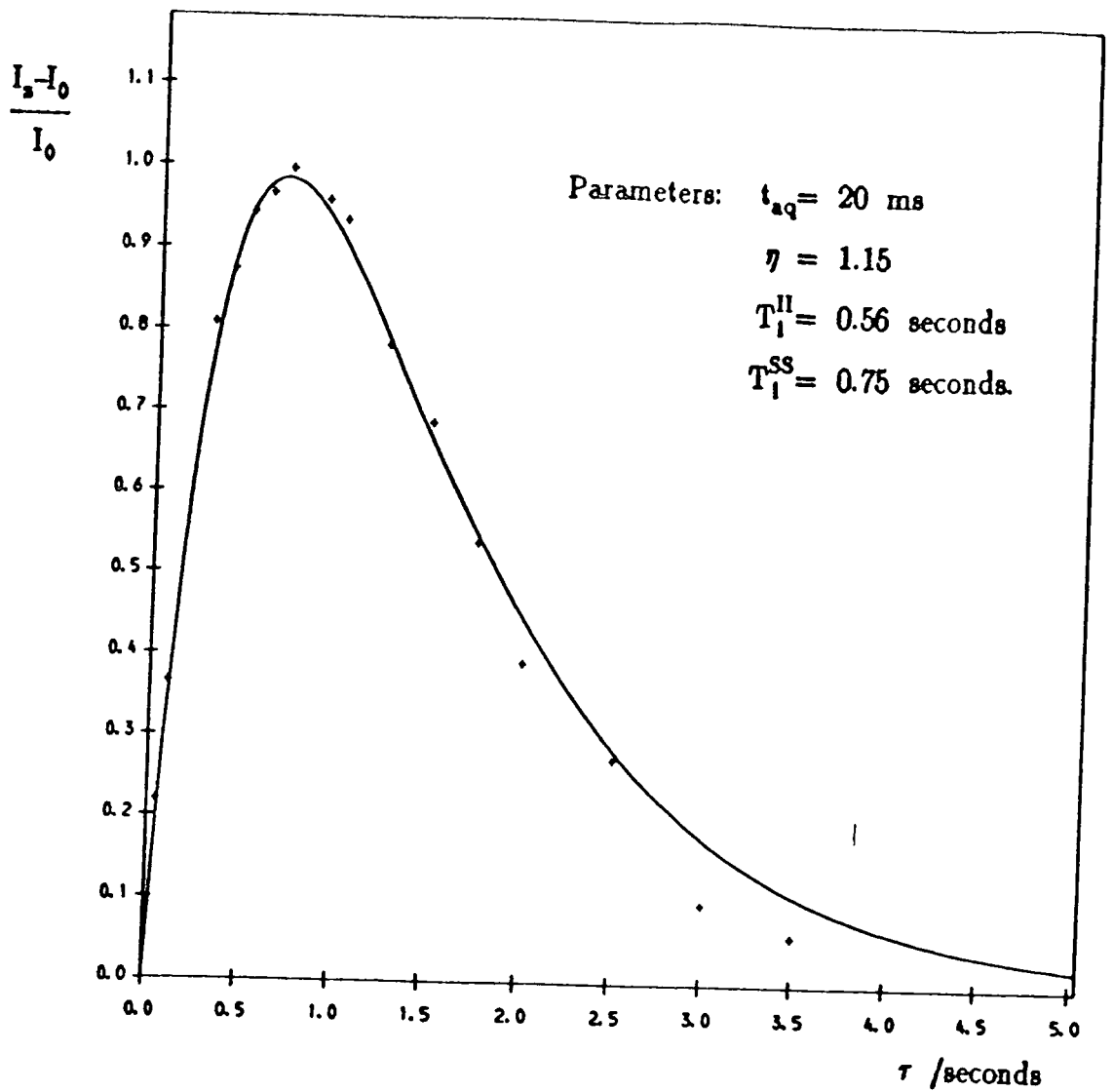

Figure 7.25

The  $^1\text{H}$  NMR spectra obtained for the itaconic anhydride film. The delay  $\tau$  ranged between 0.02 and 8 seconds. The acquisition time was 20 ms, and 1000 transients were acquired for each spectrum.



**Figure 7.26**

A comparison between the theoretical INV1H simulation and the experimental intensities for the peak at 19 ppm in the itaconic anhydride film.

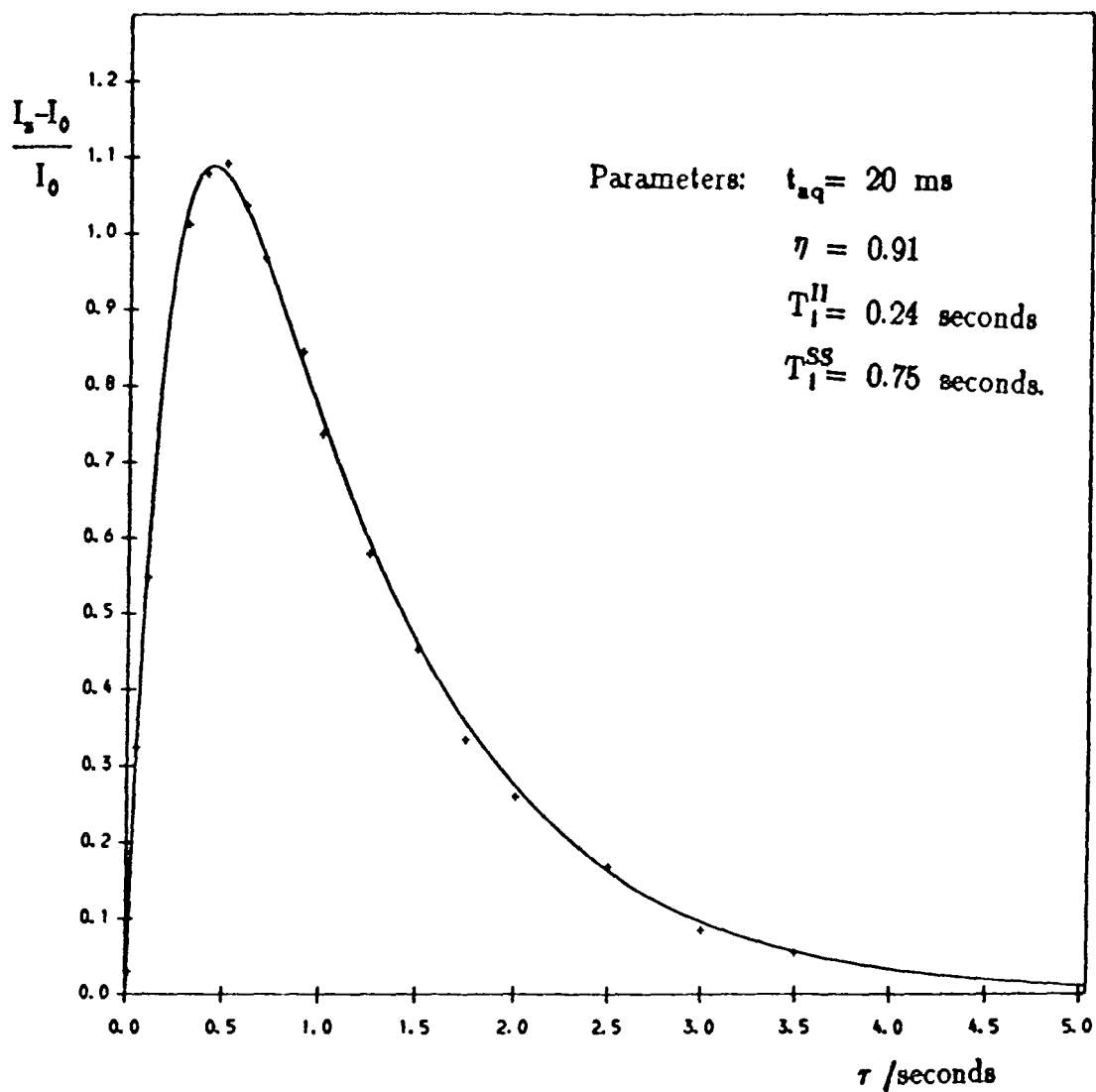

**Figure 7.27**

A comparison between the theoretical INV1H simulation and the experimental intensities for the peak at 25 ppm in the itaconic anhydride film.

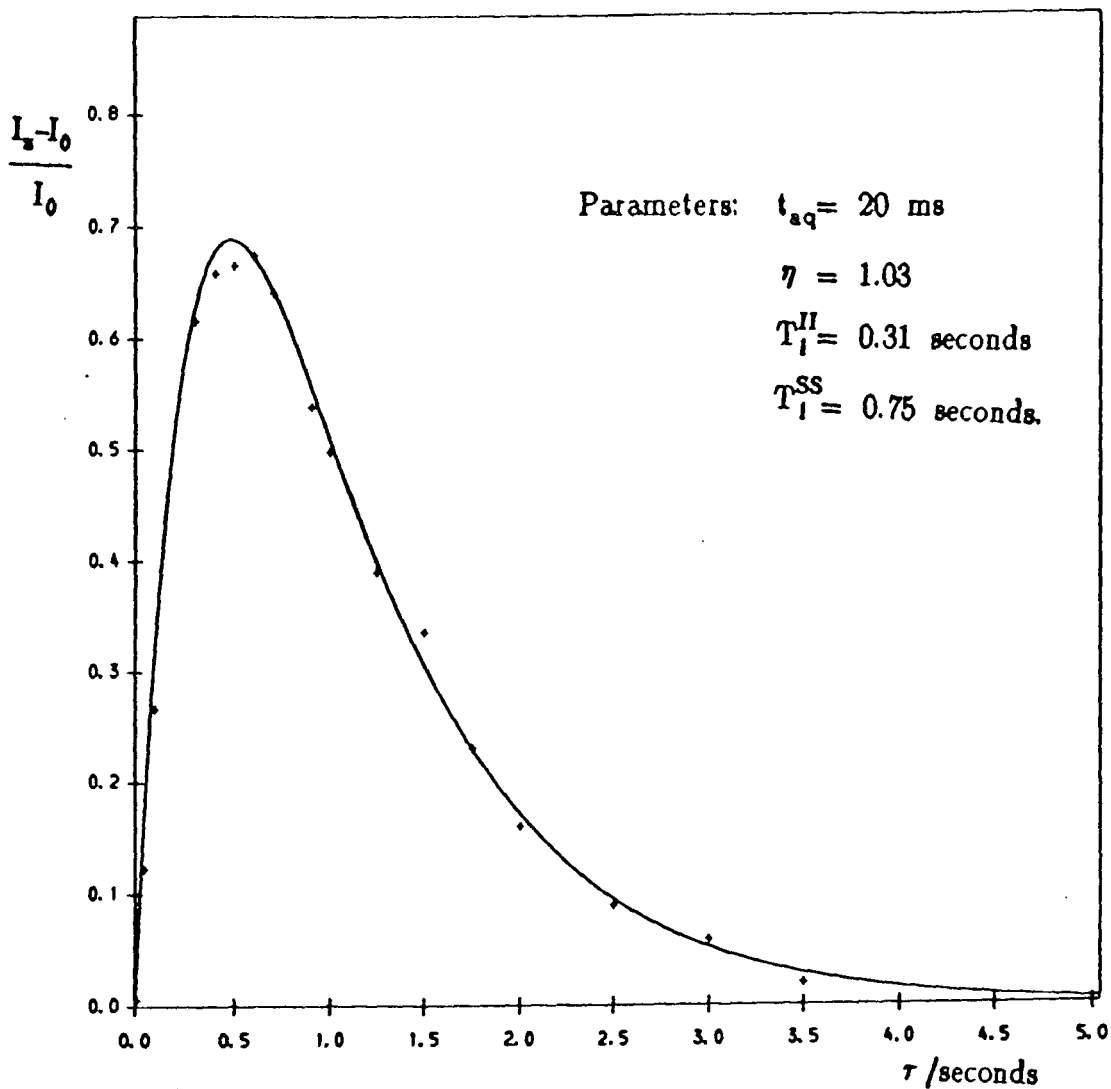

**Figure 7.28**

A comparison between the theoretical INV1H simulation and the experimental intensities for the peak at 34 ppm in the itaconic anhydride film.

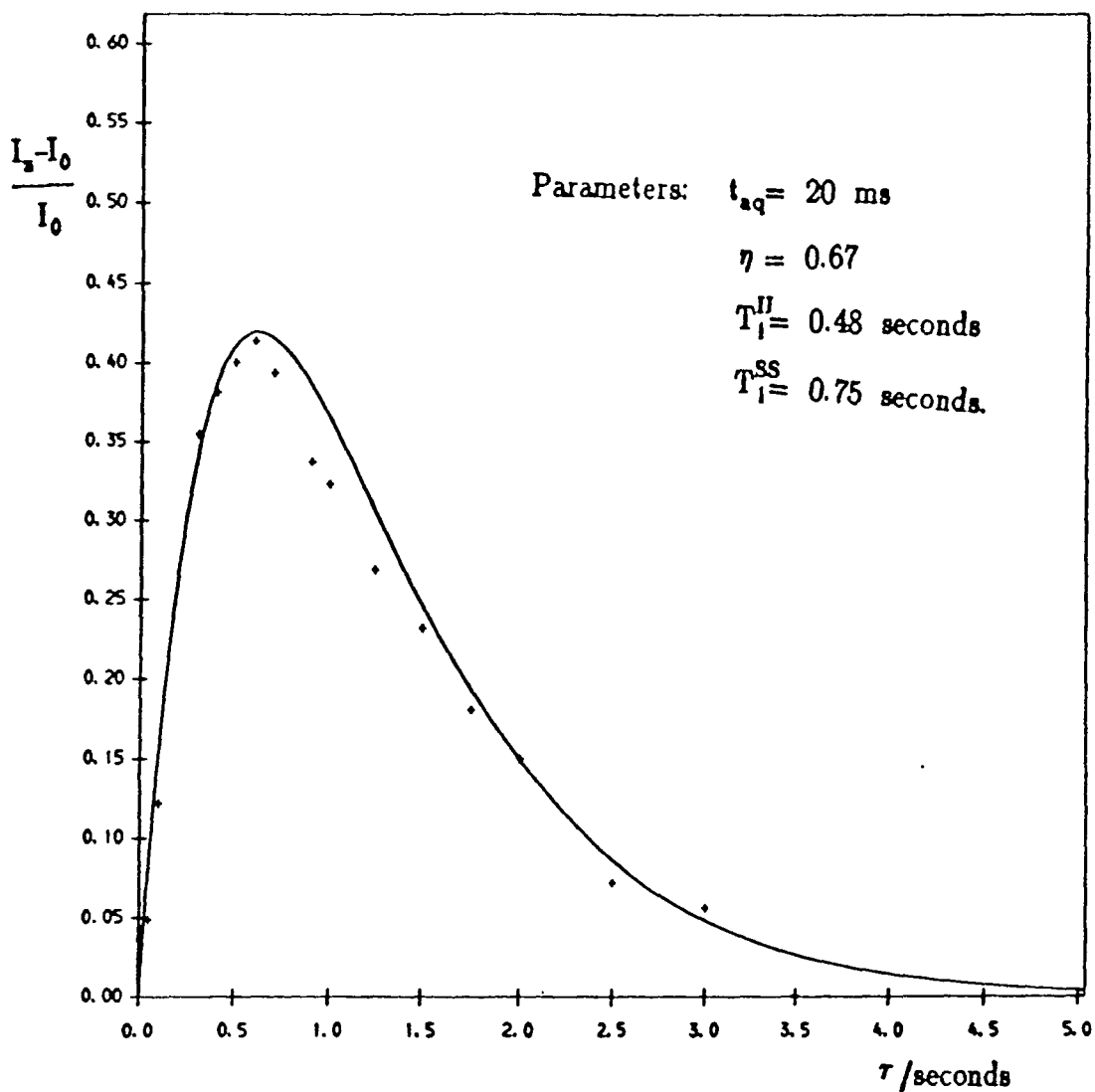
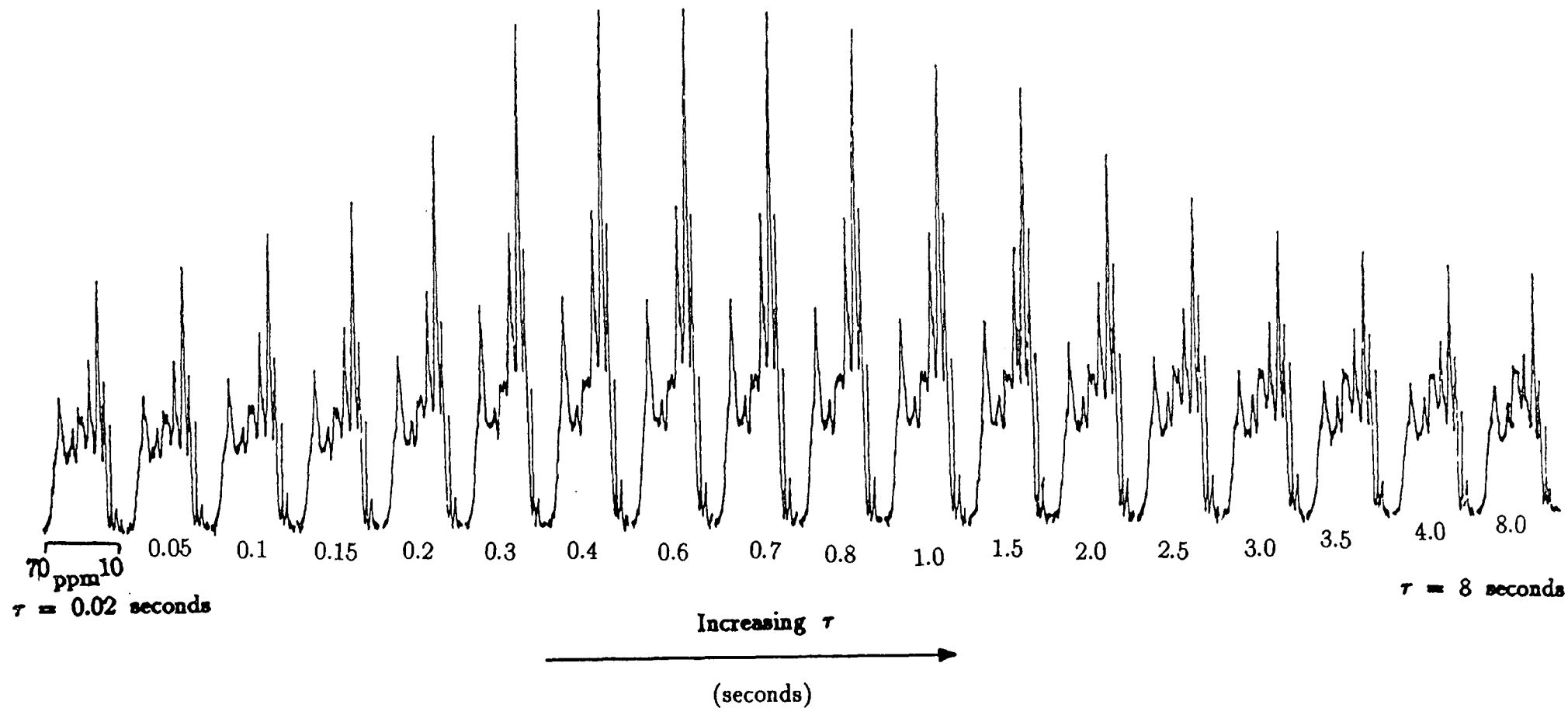

Figure 7.29

A comparison between the theoretical INV1H simulation and the experimental intensities for the peak at 64 ppm in the itaconic anhydride film.

Figure 7.30

The INV1H spectra obtained for the maleic anhydride film. The delay  $\tau$  ranged between 0.02 and 8 seconds. The acquisition time was 20 ms, and 1000 transients were acquired for each spectrum.



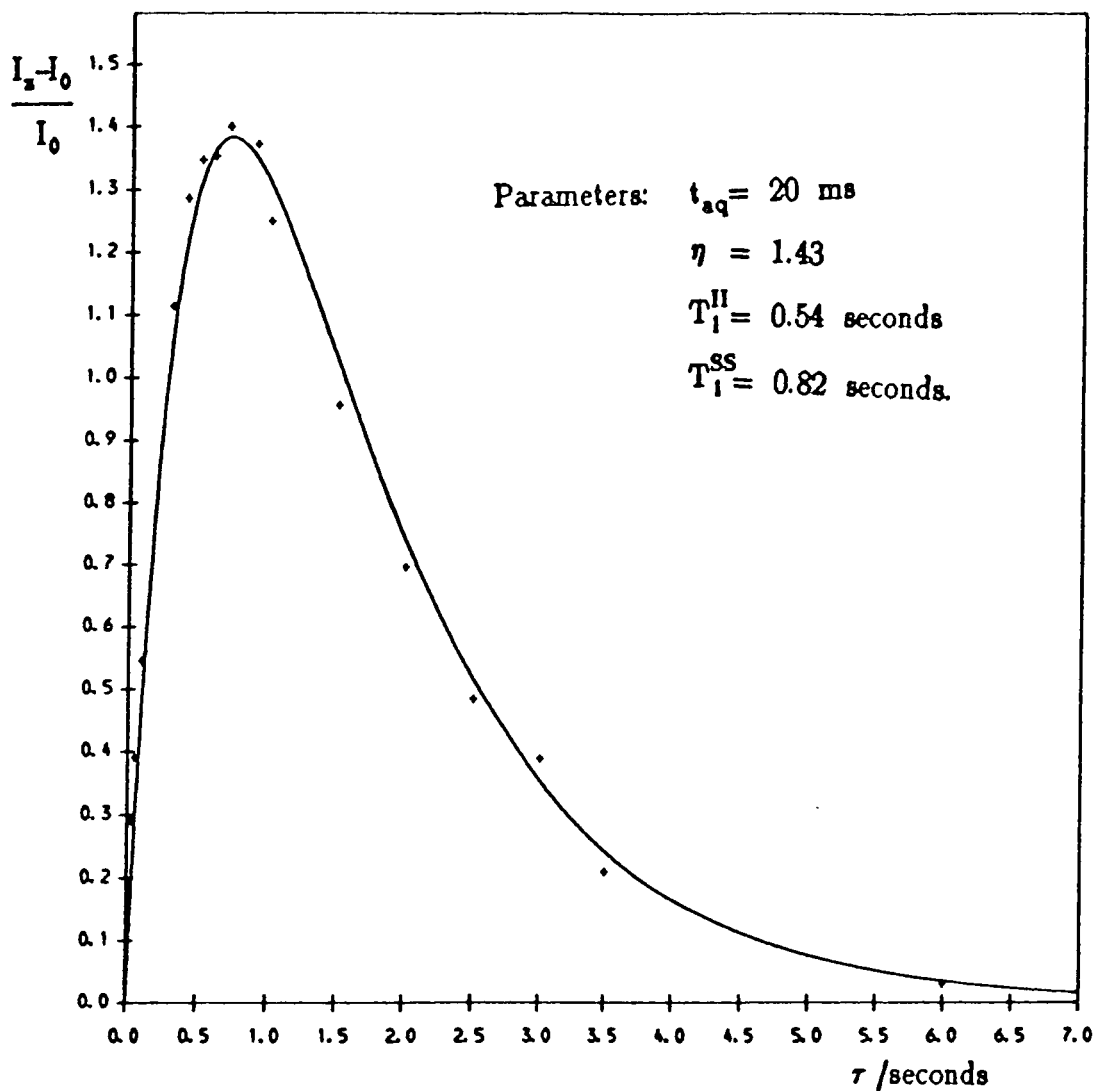

**Figure 7.31**

A comparison between the theoretical INV1H simulation and the experimental intensities for the peak at 19 ppm in the maleic anhydride film.

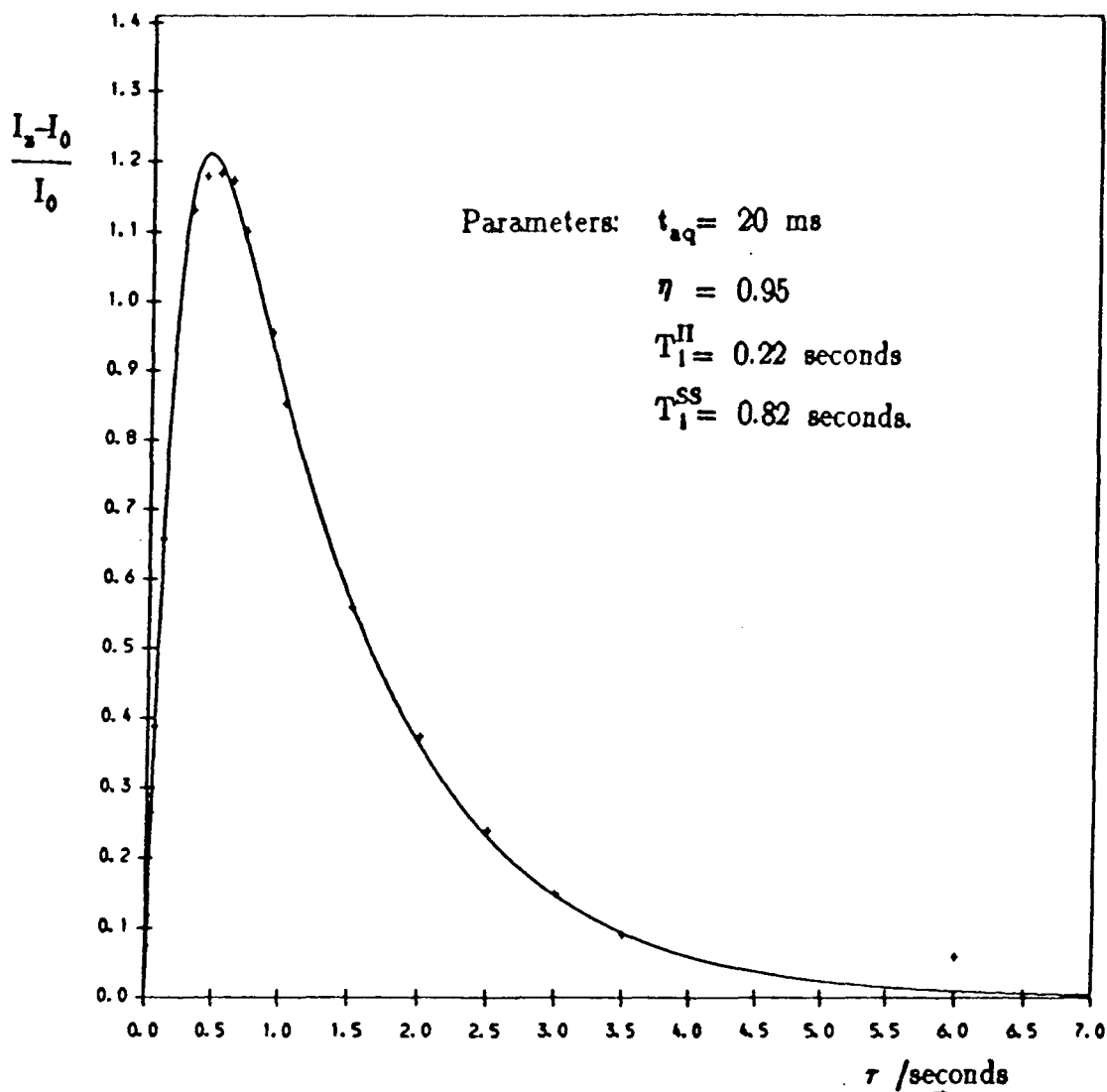

**Figure 7.32**

A comparison between the theoretical INV1H simulation and the experimental intensities for the peak at 25 ppm in the maleic anhydride film.

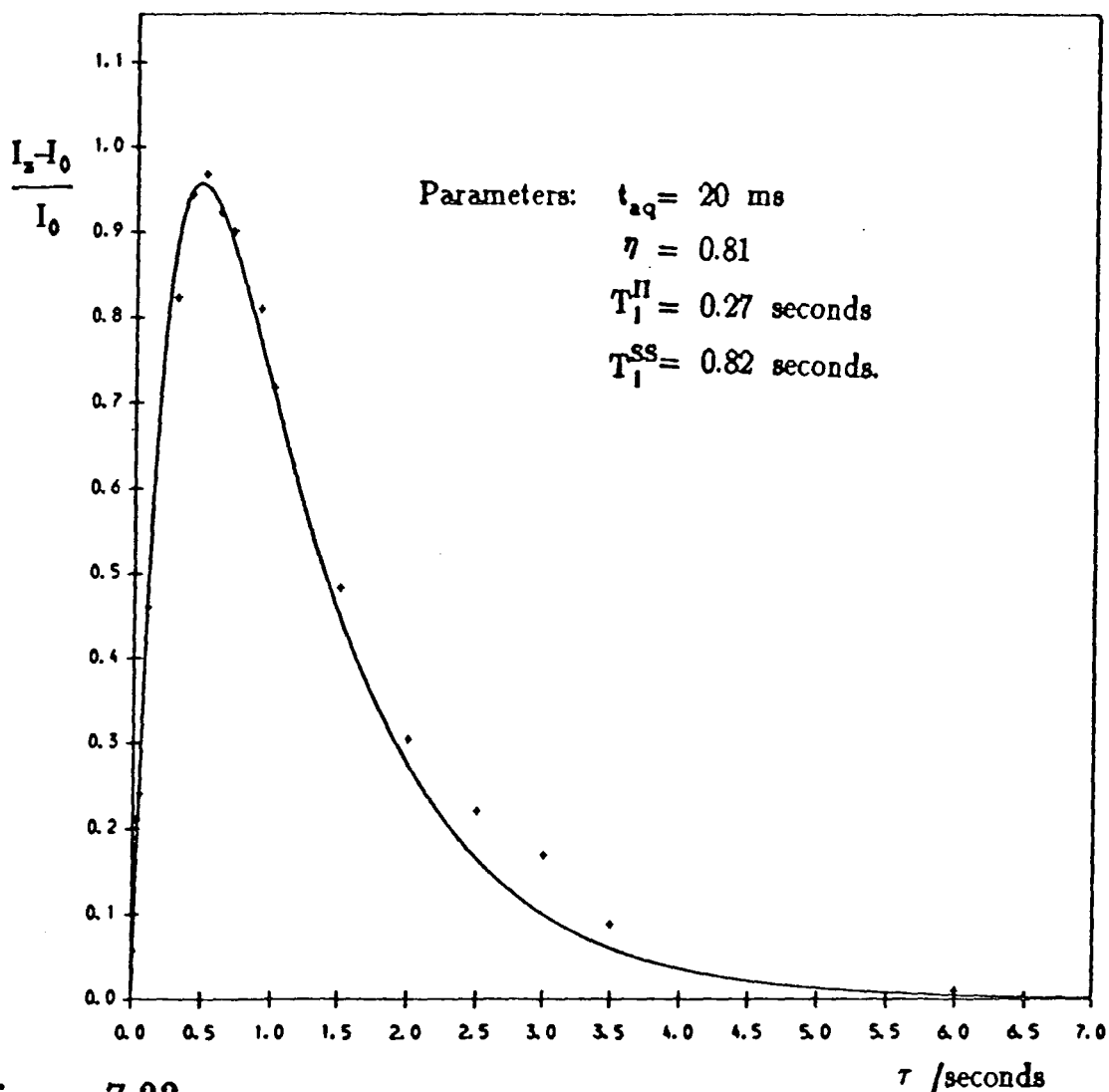

Figure 7.33

A comparison between the theoretical INV1H simulation and the experimental intensities for the peak at 34 ppm in the maleic anhydride film.

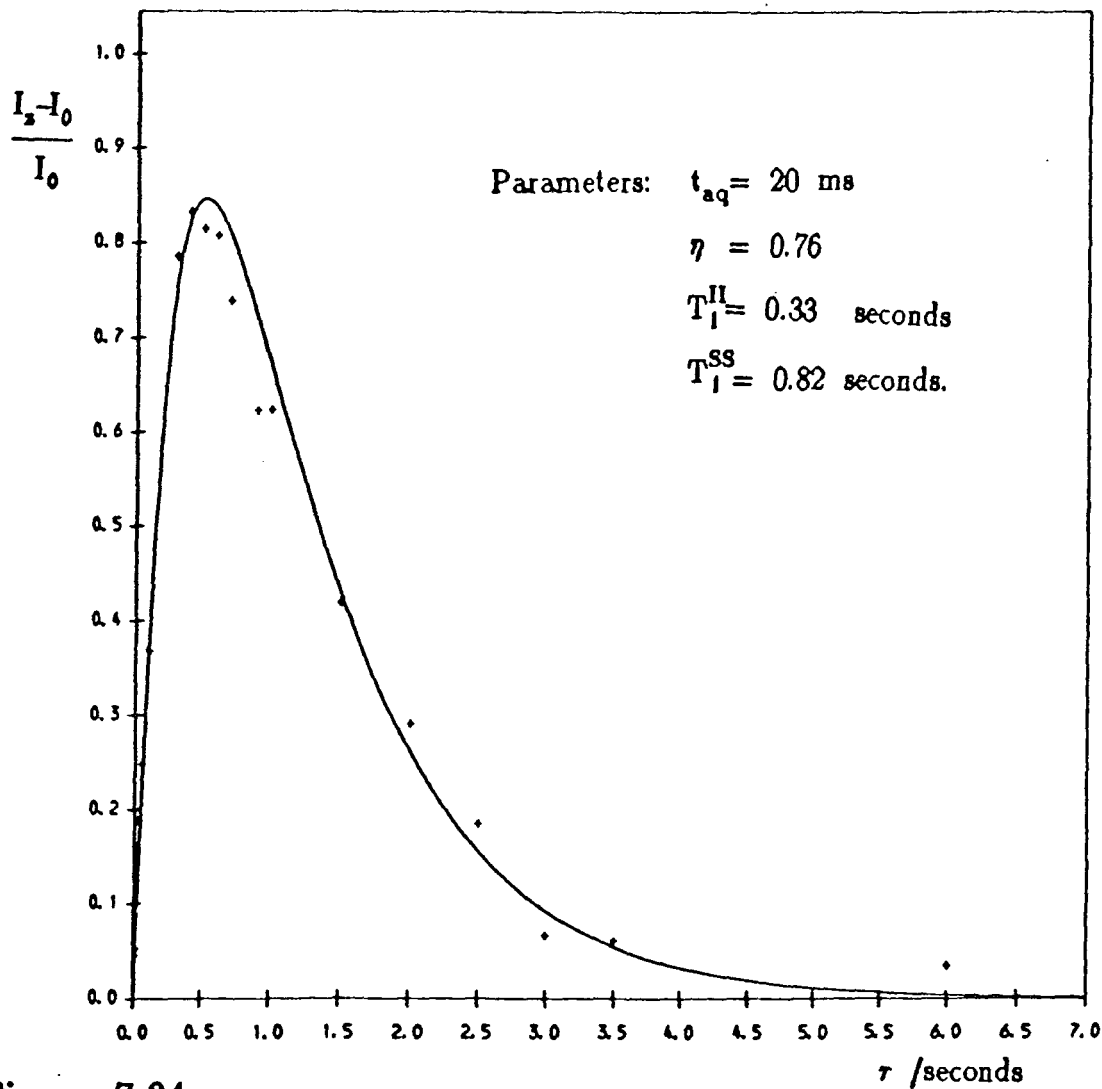

Figure 7.34

A comparison between the theoretical INV1H simulation and the experimental intensities for the peak at 64 ppm in the maleic anhydride film.

before, plots of the theoretical simulation compared to the experimental data are shown in figures 7.26–29. Similar spectra and plots are shown for the maleic anhydride film in figure 7.30 and figures 7.31–34 respectively. The values of  $\eta$ ,  $T_1^{\text{H}}$  and  $T_1^{\text{SS}}$  were measured in the same way as for the SPE experiment. Again  $T_1^{\text{H}}$ , the carbon  $T_1$ , is two-component. However in this experiment the longer  $^{13}\text{C}$   $T_1$  component does not have such a noticeable effect on the measured  $^{13}\text{C}$  intensities at longer  $\tau$  delays. This is because the carbon signal does not start from the saturation situation but from equilibrium. Thus any effect on the carbon magnetisation due to the long  $^{13}\text{C}$  component is negligible.

The systems studied are unusual in that some of the carbon  $T_1$  values in question are smaller than the proton  $T_1$  value,  $T_1^{\text{SS}}$ . The proton  $T_1$  value is increased by the averaging effect of spin diffusion, while the carbon  $T_1$  values are small due to the mobility of the polyester chains and the lack of spin diffusion because of the low natural abundance of  $^{13}\text{C}$ . In order to observe transient nuclear Overhauser effects in the solid state it is necessary that there are carbons in mobile positions. In general, the more mobile a carbon, the shorter is its  $T_1$  value. The NOE decay occurs as soon as the dipolar decoupling is removed. The strength of the transient Overhauser effect is dependent upon competition between the decay of the NOE and the growth of signal due to the carbon  $T_1$ . If  $T_1^{\text{H}}$  is long, then the NOE will decay before enough signal is present, and no transient NOE effects will be observed. (Figure 7.35a). However if  $T_1$  is short, then the carbon signal due to the  $T_1$  will have grown significantly before the NOE starts to decay, and transient NOE effects

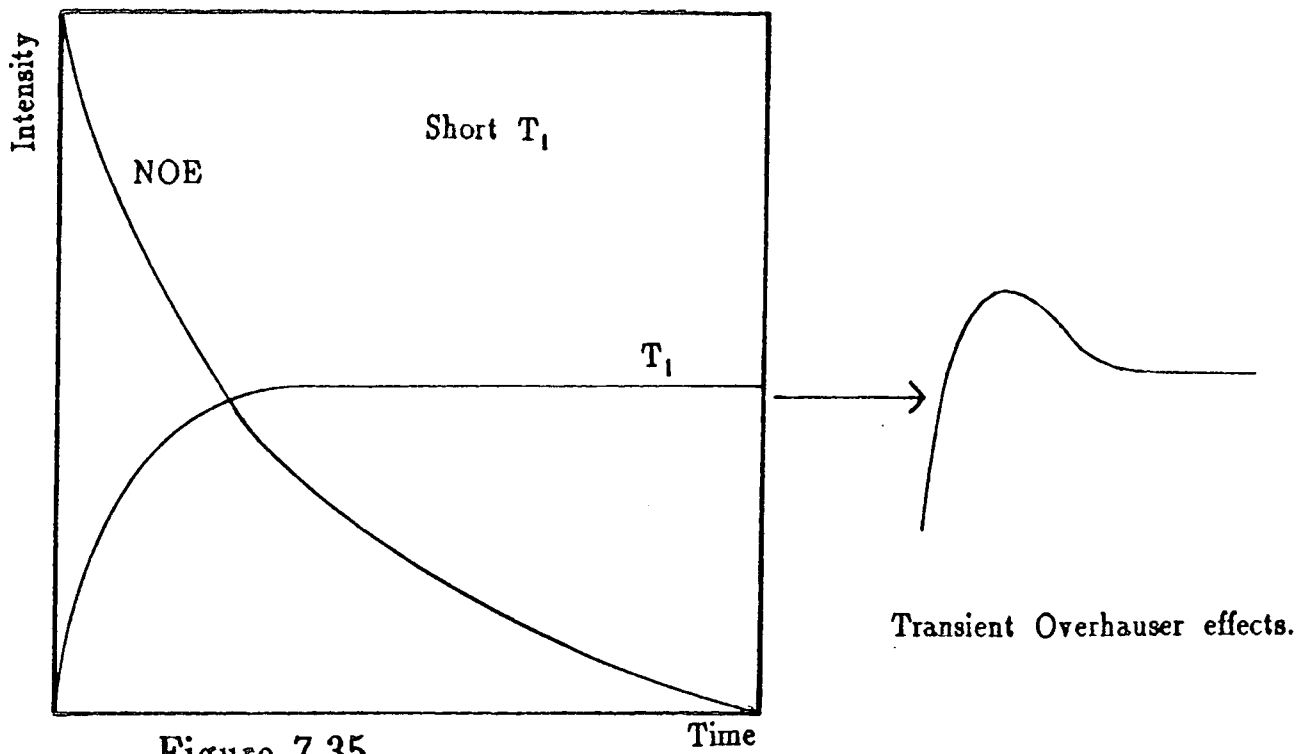
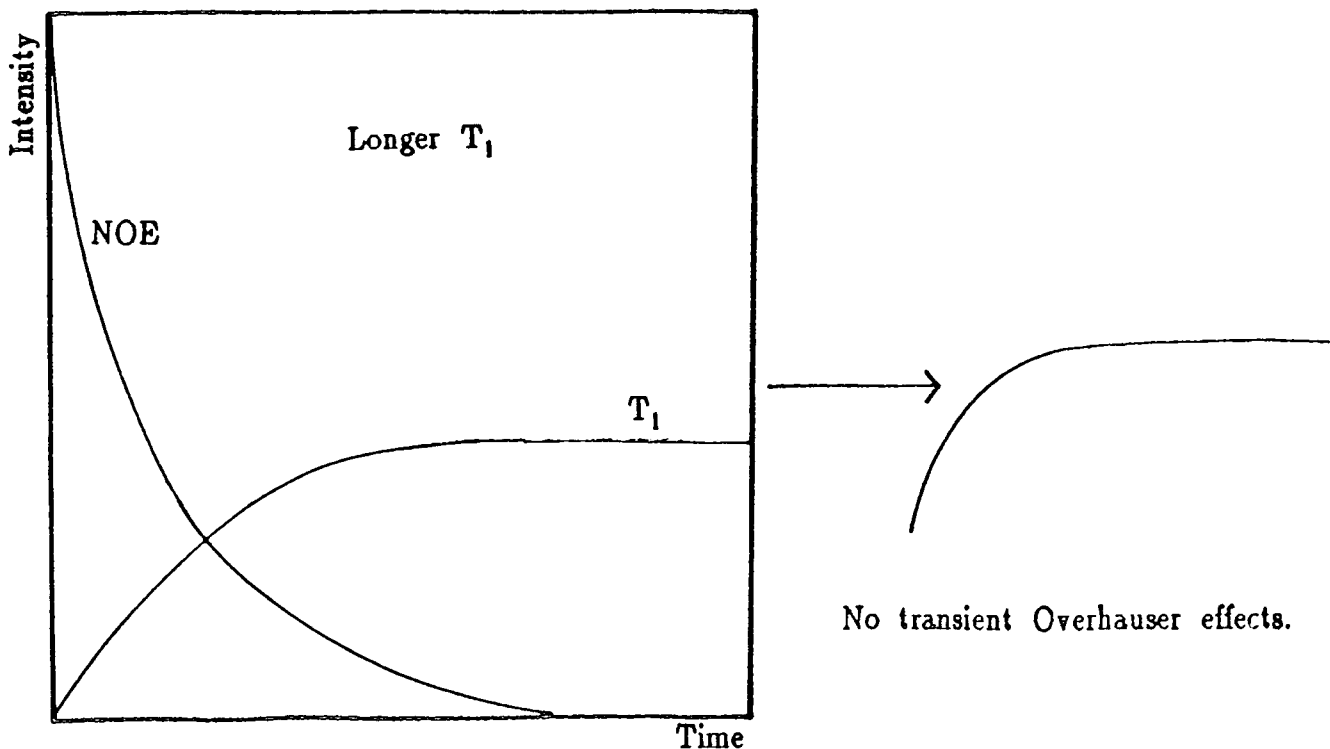

Figure 7.35

The strength of the transient Overhauser effect is dependent upon competition between the decay of the NOE and the growth of signal due to the carbon  $T_1$ .

a). If  $T_1$  is short, then signal is present before the NOE fully decays. Hence transient nuclear Overhauser effects will be observed.



b). If  $T_1$  is longer, then the NOE will decay before enough signal is present. Thus no transient Overhauser effects will be observed.

will be observed (figure 7.35b).

The treatment of carbon spins in this chapter is also applicable to other nuclei, independent of the sign of the Overhauser enhancement. In principle, nuclei such as  $^{29}\text{Si}$  should show negative transient Overhauser effects. However no suitable sample which contains silicon has been found as yet. The  $^{29}\text{Si}$   $T_1$  values of the silicon compounds tested to date have been too long for transient NOE effects to be present.

## CHAPTER 8

### Solid-state heteronuclear NOESY

#### 8.1 Molecular motion

One of the most important properties of the NMR method is its sensitivity to the various types of molecular motions. Both the relaxation processes  $T_1$  and  $T_2$  occur by the interaction of the nuclear spin system with fluctuating local magnetic fields. These fields are generated, for example, by other spins in the system, and their fluctuations are governed by the motion of the molecules or molecular fragments. If the locally induced magnetic fields have components at the appropriate Larmor frequency, they can interact and cause spin relaxation. The larger such a component, the quicker relaxation can occur. The power available from the fluctuations in the local fields at a particular frequency ( $\omega$ ) can be expressed in terms of the spectral density  $J(\omega)$ .

$$J(\omega) = \int_{-\infty}^{+\infty} G(\tau) \exp(-i\omega\tau) d\tau \quad (8.1)$$

where  $G(\tau)$  is the autocorrelation function.

Molecular motion may be divided into two types: isotropic and anisotropic. Isotropic motions are described by a one-parameter correlation function which averages the interactions to zero. The motion is considered anisotropic when its correlation function splits into at least two different time scales and can be described by at least two characteristic times.

Various models such as the Hall-Helfand,<sup>1</sup> Viovy-Monnerie<sup>2</sup> and

Figure 8.1

The  $^{13}\text{C}$  solution-state spectrum of  $^{13}\text{C}_2$ -enriched polyester. The recycle delay was 3 seconds, the acquisition time 1.2 seconds and 256 transients were acquired.

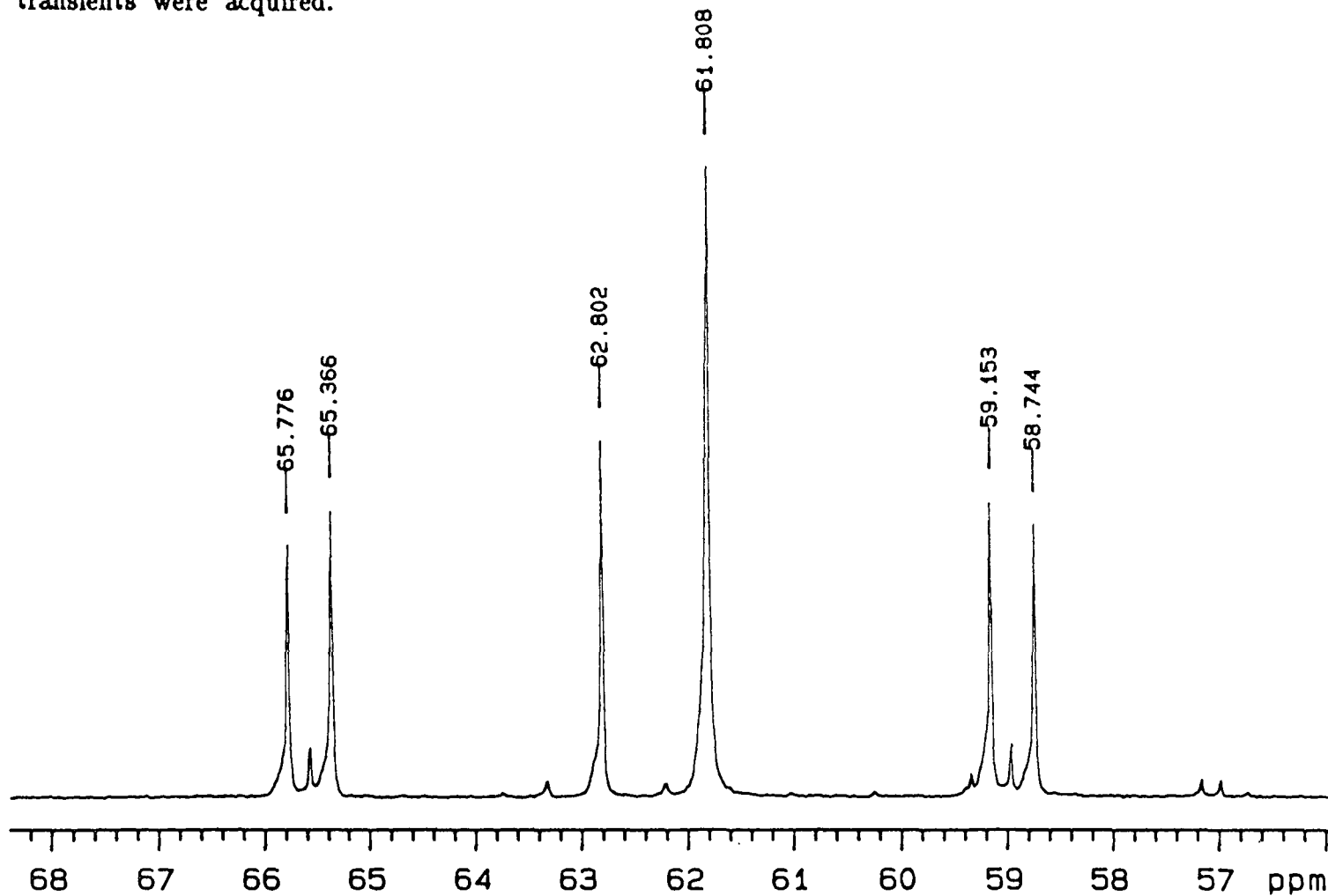

## Figure 8.2

The assignments of the peaks in the spectrum shown in figure 8.1

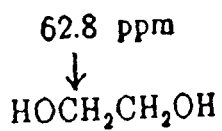
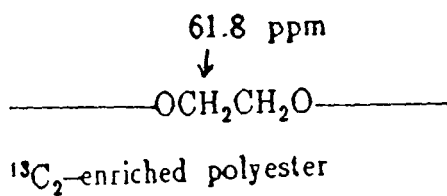
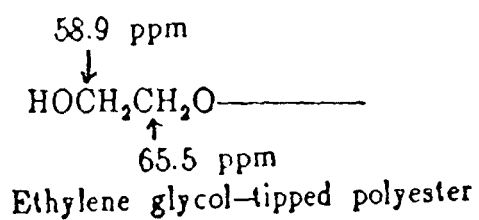

Free ethylene glycol

Jones–Stockmayer<sup>3</sup> models have been proposed to describe the motion observed in bulk polymers. Originally the intention in the present work was to measure  $^{13}\text{C}$   $T_1$  values and NOE enhancement factors for the itaconic anhydride film, which was  $^{13}\text{C}$ –enriched at the ethylene glycol position, at different temperatures, and then to compare these data to those obtained using the models in an attempt to describe the motion undergone by the polyester chain in the itaconic anhydride film.

## 8.2 Assignment of $^{13}\text{C}$ –enriched polyester

The synthesis of the itaconic anhydride film enriched with  $^{13}\text{C}_2$  at the ethylene glycol positions in the polyester chain is described in detail in Chapter Four. The solution–state spectrum of the  $^{13}\text{C}$ –enriched polyester after tipping with triethanolamine, but before the cross–linking with a copolymer is shown in figure 8.1. There appear to be two approximately equivalent  $^{13}\text{C}$  carbons and two coupled  $^{13}\text{C}$  carbons with different environments. The peak at 61.8 ppm is due to the enriched ethylene glycol incorporated in an approximately symmetrical position in the polyester chain. The pair of doublets originate from polyester chains with ethylene glycol tips. The assignments of the peaks are shown in figure 8.2. It is believed that the peak at 62.8 ppm arises from unreacted free ethylene glycol.<sup>4</sup> The assignments were made by comparing the carbon shifts observed with the shifts predicted from the  $^{13}\text{C}$  NMR Chemical Shift Handbook.<sup>5</sup>

Figure 8.3

Single-pulse-excitation spectra of the  $^{13}\text{C}_2$ -enriched itaconic anhydride film between 300 K and 355 K without nuclear Overhauser effects.

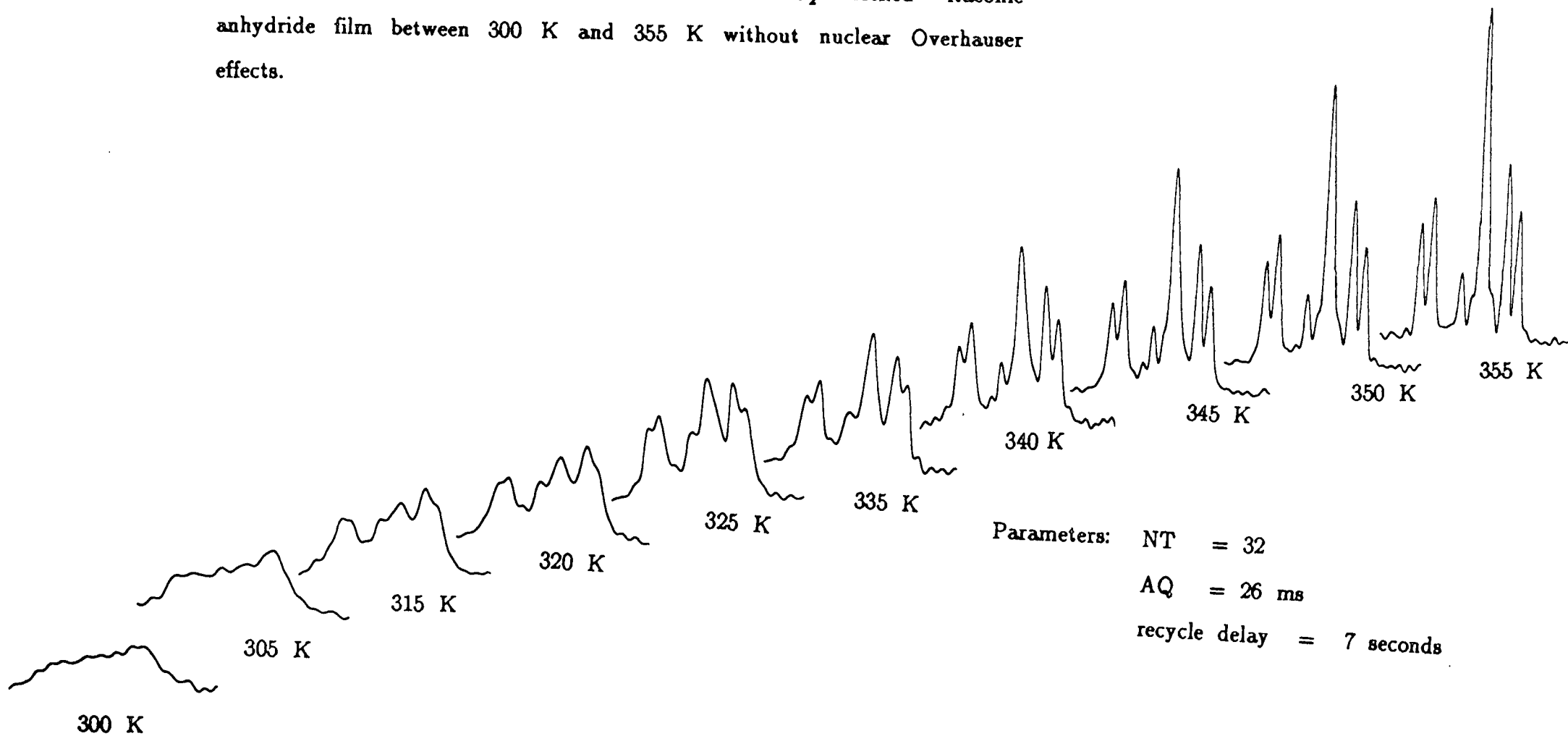
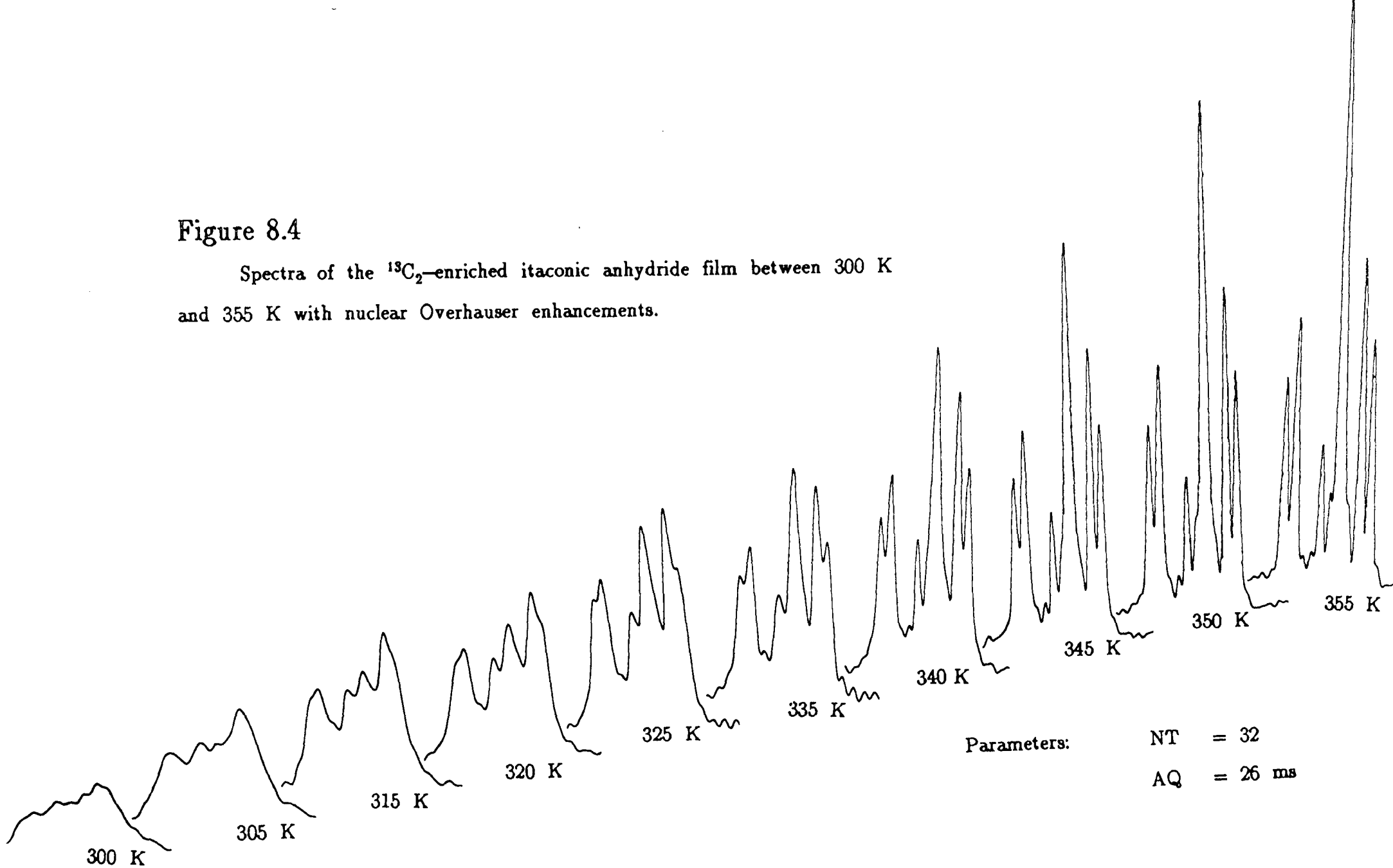

Figure 8.4

Spectra of the  $^{13}\text{C}_2$ -enriched itaconic anhydride film between 300 K and 355 K with nuclear Overhauser enhancements.



### 8.3 Measurements of solid-state NOEF

Solid-state spectra were obtained for the  $^{13}\text{C}$ -enriched itaconic anhydride film both without and with the nuclear Overhauser enhancement for temperatures between 300 K and 355 K. These spectra are shown in figures 8.3 and 8.4 respectively. Unfortunately, at temperatures between 300 and 345K the carbon peaks were not sufficiently resolved to allow measurement of the NOEF for the peaks. The temperature range over which the NOEF measurements could be obtained was too narrow to attempt to use any of the models to describe the motion of the ethylene glycol units in the polyester chain. For similar reasons it was also not possible to obtain  $^{13}\text{C}$   $T_1$  measurements over a wide-enough range to describe the motion of the polyester chains in the itaconic anhydride film.

### 8.4 Solid-state NOE

Fundamentals of the theory of the nuclear Overhauser effect were established in 1955 by Solomon.<sup>6</sup> Since that time an increasing number of chemical applications have appeared in the literature, and studies of spin-lattice relaxation<sup>7</sup> and NOE<sup>8,9,10</sup> have proved to be direct and powerful methods of structure elucidation in the solution-state. The work presented in this thesis has attempted to take the concept of the nuclear Overhauser effect one stage further into the solid-state.

The one-dimensional NOE experiments described in Chapter Seven suffer from one major drawback. Spin diffusion between the protons in the polymer film is efficient. Therefore, calculations of the C-H bond

Figure 8.5

The two-dimensional NOESY pulse sequence.

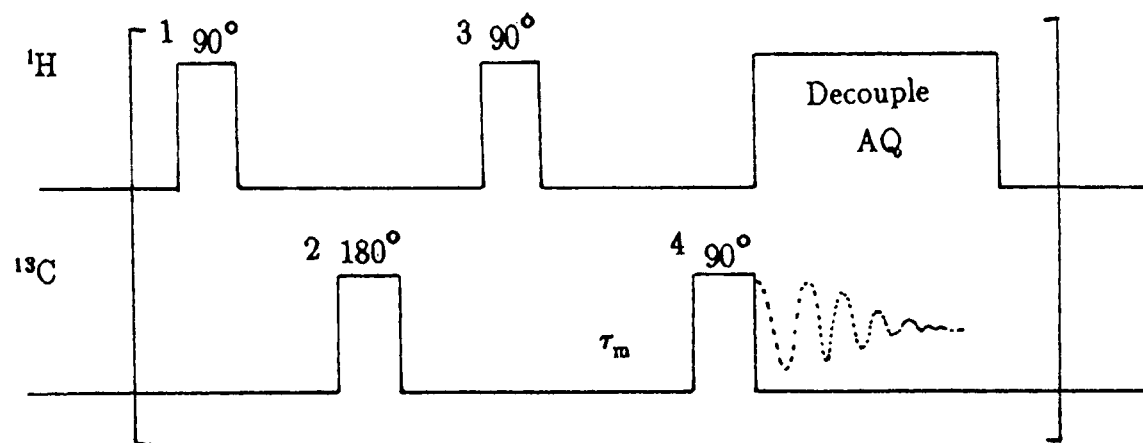

1	X	Y	-X	-Y	-X	-Y	X	Y	X	Y	-X	-Y	-X	-Y	X	Y
2	Y															
3	X	Y	-X	-Y	X	Y	-X	-Y	Y	-X	-Y	X	Y	-X	-Y	X
4	X															
RLS	X	X	X	X	-X	-X	-X	-X	Y	Y	Y	Y	-Y	-Y	-Y	-Y

length from the one-dimensional NOE experiments would not yield an accurate answer. In order to obtain structural information in the solid-state, the strong  $^1\text{H}$ - $^1\text{H}$  dipolar interactions must be suppressed. This can be achieved either by the use of multiple pulse sequences or by raising the temperature. The remainder of this chapter is concerned with the study of the heteronuclear NOESY experiment in the solid-state. The advantages of the two-dimensional technique are apparent in the study of macromolecules where spin diffusion is efficient, making the conventional steady-state NOE less specific.<sup>11</sup> The heteronuclear NOESY experiment has been applied extensively in the solution-state. However due to the nature of the experiment, applications of the heteronuclear NOESY experiment are limited in the solid-state.

### 8.5 The solid-state NOESY experiment

The two-dimensional heteronuclear NOE experiment (NOESY) pulse sequence is shown in figure 8.5.<sup>12,13,14</sup> The sequence involves three successive  $90^\circ$   $^1\text{H}$  pulses. The first  $90^\circ$   $^1\text{H}$  pulse creates transverse magnetisation. During the evolution period,  $t_1$ , the various magnetisation components precess with their characteristic precession frequency in the  $xy$  plane and are frequency-labelled. A  $180^\circ$  carbon pulse is applied in the middle of the evolution period  $t_1$  to remove scalar and dipolar interactions between  $^1\text{H}$  and  $^{13}\text{C}$  nuclei. Thus, at the end of the  $t_1$  period the  $^1\text{H}$  spins are only frequency-labelled. After the second proton  $90^\circ$  pulse, cross-relaxation leads to incoherent magnetisation transfer during the mixing time  $\tau_m$ . The signal is recorded after the mixing time as a

function of  $t_2$ . A recycle time of at least  $5 \times T_1$  is required to enable the system to reach equilibrium before each sequence. A two-dimensional Fourier transformation of the data matrix  $S(t_1, t_2)$  then produces the desired frequency-domain spectrum. The appearance of a cross-peak at frequencies  $\omega_1$  and  $\omega_2$  in the 2D spectrum indicates that a cross-relaxation process during the mixing period has transferred magnetisation components of frequency  $\omega_1$  to a transition of frequency  $\omega_2$ . The pulse sequence used, together with phases of the pulses and the receiver are shown in Figure 8.5. This phase cycling eliminates artifacts and axial peaks, and it ensures the quadrature detection in the  $F_1$  dimension.

Before applying the NOESY pulse sequence to the itaconic anhydride film with  $^{13}\text{C}_2$  enrichment at the ethylene glycol position, the proton spectrum of the sample had to be obtained to determine the extent to which the  $^1\text{H}$ - $^1\text{H}$  dipolar interactions were averaged. As illustrated in section 8.3, the resolution of the single-pulse carbon spectrum is poor below 345K. The chosen temperature for the solid-state NOESY experiment was 363K. Proton single-pulse and CRAMPS spectra were acquired at a temperature of 363K in order to assess the extent of averaging of the  $^1\text{H}$ - $^1\text{H}$  dipolar interactions. The proton single-pulse spectrum obtained is shown in figure 8.6. It is clear that the  $^1\text{H}$ - $^1\text{H}$  dipolar interactions are sufficiently averaged by molecular motion that some fine structure is visible. The CRAMPS spectrum obtained did not yield any better resolution. It was therefore deemed unnecessary to apply homonuclear decoupling techniques during the  $t_1$  delay, or to synchronise

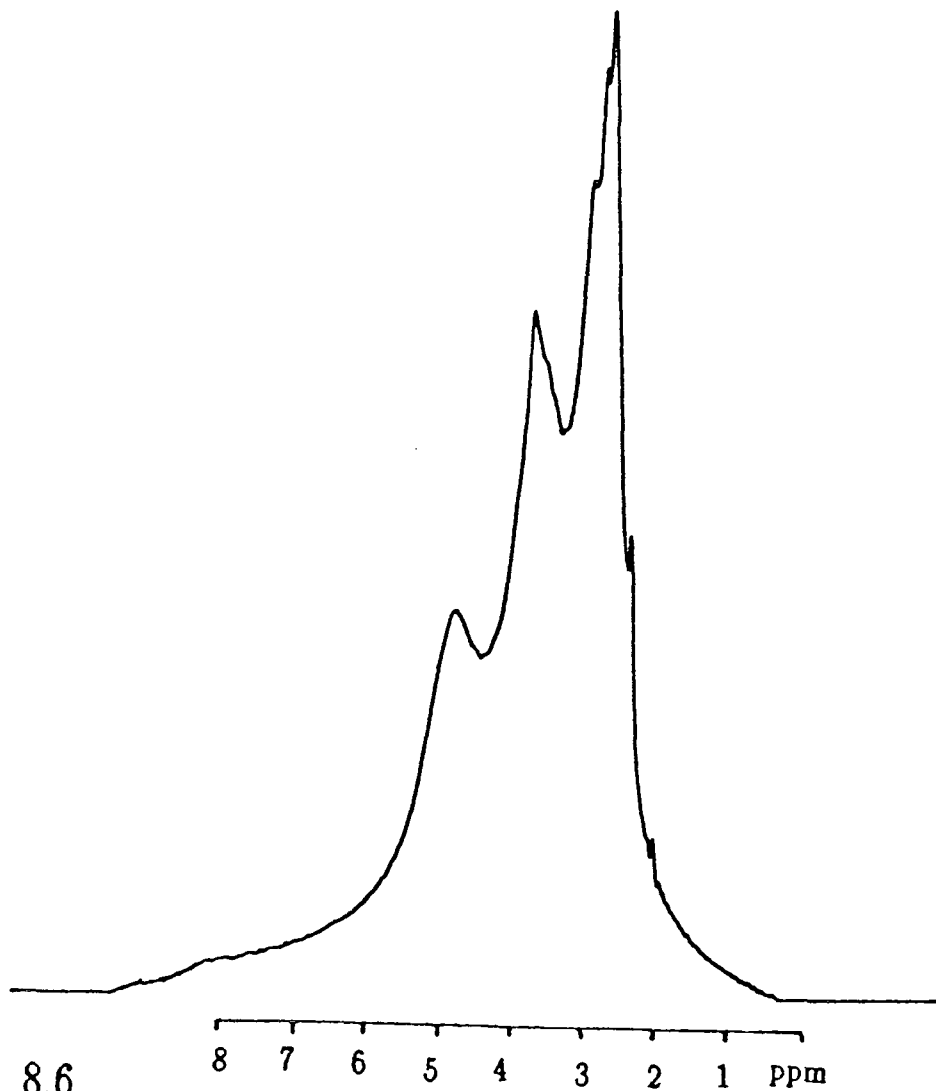

Figure 8.6

The proton single-pulse spectrum of the  $^{13}\text{C}_2$ -enriched itaconic anhydride film obtained at 363 K.

Parameters:

NT = 32

AQ = 128 ms

Recycle time = 5 seconds

the rotor rotation during delays  $t_1$  and  $\tau_m$ .

The solid-state NOESY spectrum obtained is shown in figure 8.7. and the cross-sections of the proton spectra at each of the carbon peaks are shown in figure 8.8. The main advantage of the 2D NOESY experiment over the 1D NOE experiments is that it can clearly be seen between which protons and carbons cross-relaxation takes place. The proton projection shows only protons which undergo cross-relaxation to the  $^{13}\text{C}$ -enriched carbons. The doublet at 58.7 and 59.1 ppm arises from the  $\text{CH}_2$  next to the OH group in the polyester chains which are tipped with an ethylene glycol unit. The cross-section of the proton spectrum at this  $^{13}\text{C}$  doublet shows two main proton peaks at 4.31 and 3.88 ppm as well as other smaller peaks. The peak at 3.88 ppm corresponds to the protons on the  $\text{CH}_2$  next to the OH group, and the proton peak at 4.31 ppm corresponds to the protons on the adjacent  $\text{CH}_2$  group. The other smaller proton peaks arise from cross-relaxation between the carbon and the other protons in the polyester chain. The doublet at 65.7 and 65.3 ppm corresponds to the  $\text{CH}_2$  group positioned  $\beta$  to the OH in the terminal ethylene glycol unit. The cross-sections of the proton spectra again show two main peaks at 4.31 and 3.88 ppm as well as other smaller proton peaks. The assignments of these proton peaks is already given. Therefore, both types of protons in the terminal ethylene glycol unit have cross-relaxation to both carbons, causing nuclear Overhauser enhancement of these carbons. The carbon peak at 61.8 ppm arises from ethylene glycol which has been incorporated in the polyester chain in an approximately symmetrical position between two adipic acid groups. The

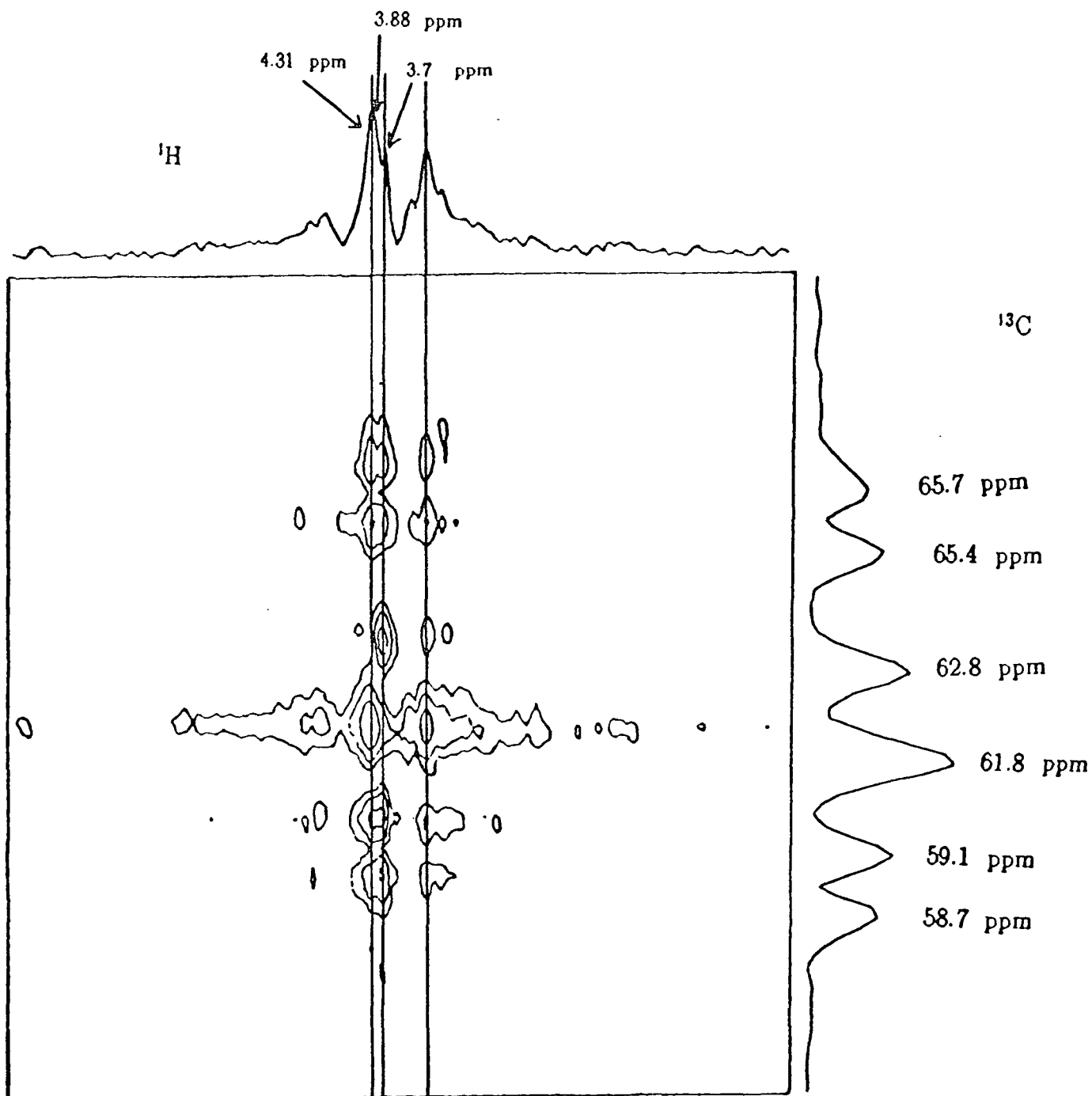

Figure 8.7

The solid-state NOESY spectrum of  $^{13}\text{C}_2$ -enriched itaconic anhydride film.

Parameters: AQ = 128 ms  
 $t_1$  = 64  $\mu\text{s}$   
 Recycle delay = 2 seconds  
 NT = 500  
 $\tau_m$  = 0.3 seconds

Figure 8.8

Cross-sections of the proton spectra in the NOESY spectrum of  $^{13}\text{C}_2$ -enriched itaconic anhydride film.

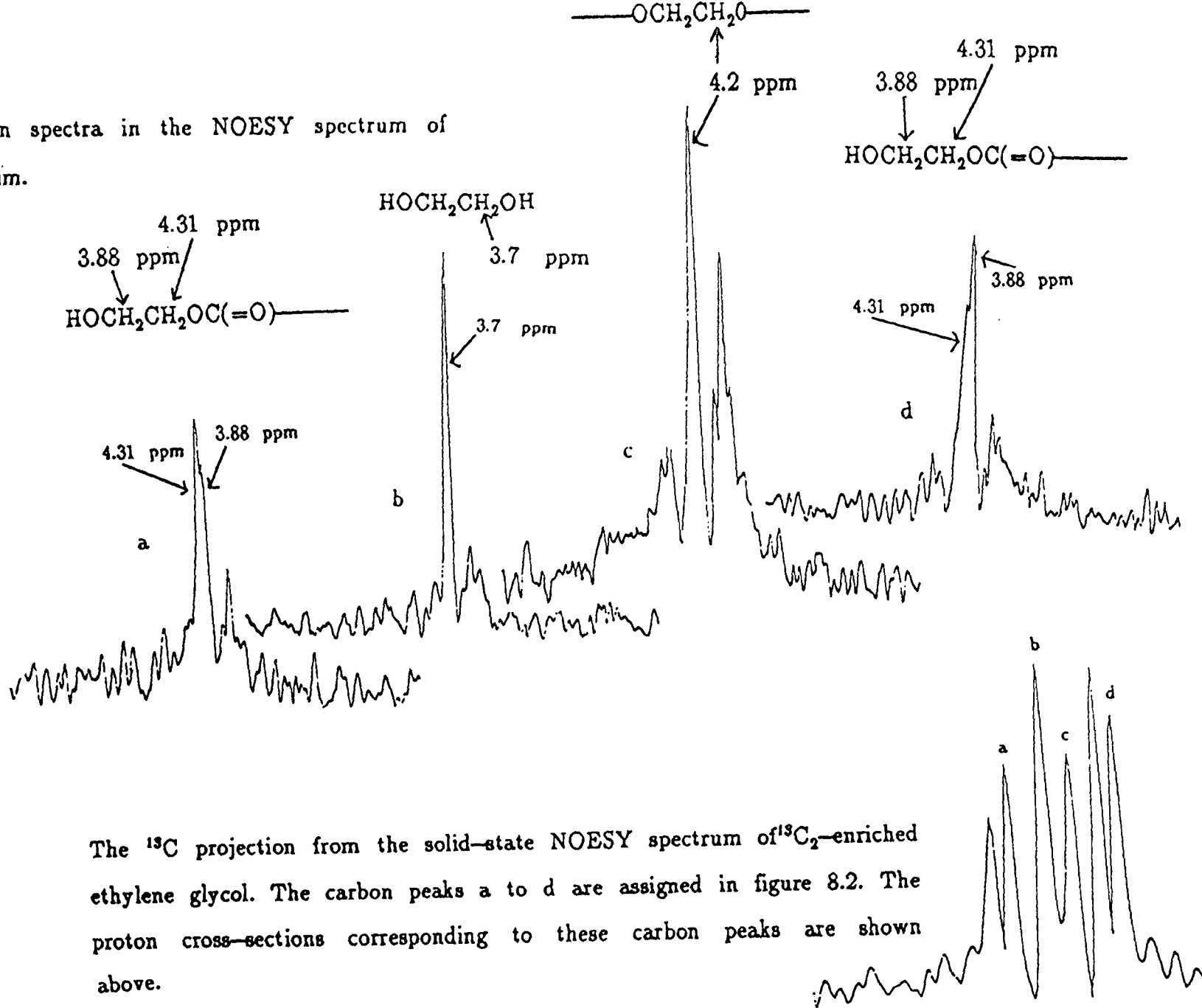

The  $^{13}\text{C}$  projection from the solid-state NOESY spectrum of  $^{13}\text{C}_2$ -enriched ethylene glycol. The carbon peaks a to d are assigned in figure 8.2. The proton cross-sections corresponding to these carbon peaks are shown above.

corresponding proton spectrum for this peak shows that all the protons in the polyester chain undergo cross-relaxation to the carbon at 61.8 ppm, with the strongest cross-relaxation arising from the protons which are directly bonded to the carbons. In the solid state, the  $^1\text{H}$ - $^1\text{H}$  dipolar interactions are very strong. Each proton spin is strongly coupled to other proton spins nearby. The protons usually have a single  $T_1$  value due to spin diffusion. The result is that a carbon spin in the solid state is strongly coupled to nearby protons, and is coupled to a lesser extent to the more distant protons. It is therefore not a surprising observation that the enriched ethylene glycol carbons, when incorporated in the polyester chain, are coupled by varying extents to all the protons in the polyester chain. The peak at 62.8 ppm is believed to arise from free unreacted ethylene glycol in the system.<sup>4</sup> The corresponding proton spectrum contains a peak at 3.7 ppm which is consistent with the chemical shift of the protons in ethylene glycol.

The heteronuclear NOESY experiment in the solid-state is unlikely to be able to produce the extent of information and applications which arise from the NOESY experiment in the solution-state. This is because of the problem of obtaining good resolution in the proton spectrum. There are several criteria which must be met before a sample is suitable for the solid-state heteronuclear NOESY experiment.

1. The sample must have suitable nuclei which possess a short  $T_1$
2. The proton spectrum must have reasonable resolution either from molecular motion or by the use of CRAMPS
3. The sample must have good signal-to-noise. This often means that enrichment is necessary.

## CHAPTER 9

### Conclusions

#### 9.1 Conclusions

In this thesis a number of  $^{13}\text{C}$  solid-state NMR techniques have been demonstrated which yield information concerning the structure and the variation in the regional mobilities of the cross-linked films. The work in this thesis has relied on two main pulse sequences: the cross-polarisation experiment and the single-pulse-excitation experiment. The theoretical aspects of the cross-polarisation experiment have been discussed in Chapter Three.

In Chapter Five, peaks in the spectra of the copolymers and the cross-linked films used in this thesis are assigned. The films were found to contain polyester chains of two different mobilities. The two mobilities were distinguishable on account of the fact that the polyester carbons had a two-component carbon  $T_1$ . A new pulse sequence (MOST) was presented which can be used to measure the carbon  $T_1$ 's of the mobile polyester chains specifically. It was proposed that the more rigid polyester chains with the longer carbon  $T_1$  were polyester chains which are cross-linked at both ends, thus having a restricted mobility, and that the more mobile polyester chains were polyester chains which were cross-linked at only one end, or totally uncross-linked. The carbon  $T_1$  of the rigid polyester chains could be distinguished from those of the mobile polyester chains by using the T1CP pulse sequence. The cross-polarisation

technique works best for rigid protonated carbons, and therefore the carbon  $T_1$  values of the rigid polyester chains may be specifically measured by the T1CP pulse sequence.

At room temperature the cross-polarisation relaxation characteristics of the copolymer and the polyester peaks are too similar to be distinguished by variable contact time measurements. However, variable temperature studies have shown that at 80°C the cross-polarisation relaxation characteristics of the copolymer and polyester peaks are sufficiently dissimilar from each other to allow CP spectra of the copolymer and the polyester parts of the film to be observed separately.

The kinetics of the cross-linking reaction between the itaconic anhydride copolymer and the triethanolamine tipped polyester was studied by monitoring the proton  $T_1$  as a function of curing time. It was found that the reaction was mainly over by 180 hours into the cure. Spin diffusion was found to have an effect on the populations. To complement this data it would be interesting to make a similar study which monitors the proton  $T_{1\rho}$  as a function of curing time.

Chapter Six was concerned with the hydrolytic stability of the films. The final application of the cross-linked films was to be as a paint for yachts. Therefore it is of the utmost importance that the cross-linked films are stable in wet environments. It was shown that the cross-linked films degraded in wet conditions. Failure was pin-pointed at the cross-link sites and at some of the ester cross-links along the polyester chain. Breakdown of ester linkages along the polyester chain was believed to take place via the anchimeric effect. Further research is

necessary to find a suitable cross-linker which does not have hydrolysable bonds along the backbone chain, and which does not form cross-links which are susceptible to attack by water.

In Chapter Seven the first published work on the transient nuclear Overhauser effect in the solid-state was presented. The theory behind the transient NOE was discussed for both the single pulse experiment and the INV1H pulse sequence. Comparison between the theoretical simulation and the experimental data shows that the theory is a good model for the cross-linked films. It would be of interest to apply this theory to another nucleus which shows a negative Overhauser enhancement, for example  $^{29}\text{Si}$ . However it is not easy to find suitable samples for solid-state transient NOE measurements. As yet no suitable  $^{29}\text{Si}$  solid-state sample has been found. The  $^{29}\text{Si}$   $T_1$  values have always been too long for transient NOE effects to be present.

Finally, in Chapter Eight the results of the first solid-state heteronuclear NOESY experiment are presented. The 2D experiment was obtained using a sample of itaconic anhydride film which was  $^{13}\text{C}$ -enriched at the ethylene glycol position. The experiment showed that individual types of proton could be pin-pointed as providing cross-relaxation to a particular type of carbon. By using such an experiment it should be possible to obtain solid-state structural correlation for carbons and protons between which relaxation occurs.

To summarise, solid-state NMR has proved to be a powerful tool which may be used to gain a new insight into the structure and mobility of cross-linked polymers. Solid-state NMR was able to provide valuable

information on the degradation of the cross-linked films which was not provided by any of the other techniques used in the analysis. Lastly, transient nuclear Overhauser effects in the solid-state have been observed. The theory behind such effects was established, and simulations of the model gave excellent agreement with experiment. A solid-state heteronuclear NOESY experiment has been achieved, thus opening the doors for structural determination in the solid-state via the nuclear Overhauser effect.

## REFERENCES

## CHAPTER 2

1. Potter W.G., "Epoxide Resins", Butterworth & Co Ltd., London (1970).
2. "Comprehensive polymer science", 6 ch.6 Pergamon Press plc, Oxford (1989).
3. Lenz R.W., "Organic Chemistry of Synthetic High Polymers", Wiley-Interscience (1967).
4. Flory P.J., "Principles of Polymer Chemistry", Cornell University Press (1953).
5. "Introduction to Polymer Science and Technology", Wiley-Interscience (1977).
6. Sakolov L.B., "Synthesis of Polymers by Polycondensation", Israel Program for scientific Translations, Jerusalem ch.1 (1968).
7. Carothers W.H., Chem. Revs., 8 353 (1931).
8. "Comprehensive Polymer Science", 3 ch.8., Pergamon Press plc, Oxford (1989).
9. Carothers W.H., Trans. Farad. Soc., 32 39 (1936).
10. Flory P.J., J. Am. Chem. Soc., 63 3083 (1941).
11. Flory P.J., Chem. Revs., 39 137 (1946).
12. Stockmayer W.H., J. Chem Phys. 11 45 (1943).
13. "Comprehensive Polymer Science", 2 ch.9, Pergamon Press plc, Oxford (1989).

## CHAPTER 3

1. Stern O., Gerlach W., *Ann. Physik* 74 673 (1924).
2. Shaw D., "Fourier Transform NMR Spectroscopy", Elsevier, Amsterdam, (2nd edition) (1984).
3. Gerstein B.C., Dybowski C.R., "Transient Techniques in NMR of Solids", Academic Press Inc., (1985).
4. Abragam A., "The Principles of Nuclear Magnetism", Clarendon, Oxford (1961).
5. Solomon I., *Phys. Rev.*, 99 559 (1955).
6. Harris R.K., "Nuclear Magnetic resonance Spectroscopy", Longman Scientific and Technical, (1986).
7. Haeberlen U., "High Resolution NMR in Solids. Selective Averaging", Academic Press, New York, (1976).
8. Slichter C.P., "Principles of Magnetic Resonance", Springer-Verlag, (1978).
9. Komoroski R.A., "High Resolution NMR Spectroscopy of Synthetic Polymers in Bulk", VCH publishers Inc., Florida, (1986).
10. Fedotov V.D., Schneider H., "Structure and Dynamics of Bulk Polymers by NMR Methods", Springer-Verlag (1989).
11. Andrew E.R., Farnell L.F., Firth M., Gledhill T.D., *J. Magn. Reson.*, 1 27 (1969).
12. Diehl P., Fluck E., Kosfeld R., "High Resolution Spectroscopy in Solids", Springer-Verlag (1976).
13. Stejskal E.O., Schaefer J., *J. Magn. Reson.*, 18 560 (1975).

14. Tangenfeldt J., Haeberlen U., *J. Magn. Reson.*, 36 453 (1979).

## CHAPTER 4

1. Bruker Spectrospin Ltd., "Pulse NMR Spectrometer CXP user's manual."
2. Pines A., Gibby M.G., Waugh J.S., *J. Chem. Phys* 59 569 (1973).
3. Opella S.J., Frey D.M.H., *J.A.C.S.* 101 5855 (1979).
4. Torchia D.A., *J. Magn. Reson.* 30 613 (1978).
5. European Patent no. 0048128 (1984).
6. Decroix J.C., Bouvier J.M., Roussel R., Nicco A., Brunceau E.M., *J. Polymer Sci. Symposium* 52 299 (1975).
7. European Patent no. 0048120 (1984).
8. European Patent no. 0259172 (1987).

## CHAPTER 5

1. Opella S.J., Frey D.M.H., *J. Am Chem. Soc.*, 101 5855 (1979).
2. Bremser W., Franke B., Wagner H., "Chemical Shift ranges in Carbon-13 NMR Spectroscopy", Verlag Chemie Weinheim (1982).
3. Noggle J.H., Schirmer R.E., "The Nuclear Overhauser Effect", Academic Press, New York (1971).
4. Torchia D.A., *J. Magn. Reson.*, 30 613 (1978).
5. Solomon I., *Phys. Rev.*, 99 559 (1955).
6. Larsen D.W., Strange J.M., *J. Polym. Sci. Phys. Ed.*, 11 65 (1973).
7. Larsen D.W., Strange J.M., *J. Polym. Sci. Phys. Ed.*, 11 449 (1973).

## CHAPTER 6

1. "Polymer Stabilization", Ed. Hawkins W.L., Wiley-Interscience New York (1972).
2. "Polymer Stabilisation and Degradation", Ed. Klemchuk P.P., ACS Symposium Series 280, A.C.S. Publishers, Washington d.c. (1985).
3. Marrion A.R., Port A.B., "New Chemistry and Technology in the Development o Isocyanate-free Paint Systems", RSC Congress Belfast, (April 1990). In Press.
4. Courtaulds Coatings Internal Report.
5. Turpin E.T., J. Paint Technology, 47 40 (1975).

## CHAPTER 7

1. Komoroski A., Peat I.R., Levy G.C., "Topics in Carbon-13 NMR Spectroscopy" 2 Ed. G.C. Levy, Wiley, New York (1976).
2. Torchia D.A., Vanderhart D.L., "Topics in Carbon-13 NMR Spectroscopy" 3 Ed. G.C. Levy, Wiley, New York (1979).
3. Solomon I., Phys. Rev. **99** 559 (1955).
4. Abragam A., "The Principles of Nuclear Magnetism", O.U.P. London (1961).
5. Kuhlmann K., Grant D.M., Harris R.K., J. Chem. Phys. **52** 3439 (1970).
6. Opella S.J., Nelson D.J., Jardotzky O., J. Chem Phys. **64** 2533 (1976).
7. Jelinski L.W., Sullivan C.E., Torchia D.A., J. Magn. Reson. **41** 133 (1980).
8. Harris R.K., Newman R.H., J. Magn. Reson. **24** 449 (1976).
9. Noggle J.H., Schirmer R.E., "The Nuclear Overhauser Effect", Academic Press, New York. (1971).
10. Lyerla J.R., Levy G.C., "Topics in Carbon-13 NMR Spectroscopy" 1 G.C. Levy Ed., Wiley New York (1974).

## CHAPTER 8

1. Hall C.K., Helfand E., J. Chem. Phys. 77 3275 (1982).
2. Viovy J.L., Monnerie L., Brochon J.C., Macromolecules 16 1845 (1983).
3. Jones A.A., Stockmayer W.H., J. Polym. Sci. Phys. Ed. 15 847 (1975).
4. Breitmaier E., Haas G., Voelter W., "Atlas of Carbon-13 NMR Data", Heyden, Rheine (1979).
5. Bremser W., Franke B., Wagner H., "Chemical Shift ranges in Carbon-13 NMR Spectroscopy", Verlag Chemie Weinheim (1982).
6. Solomon I., Phys. Rev. 99 559 (1955).
7. Vold R.L., Waugh J.S., Klein M.P., Phelps D.E., J. Chem. Phys. 48 3831 (1968).
8. Kuhlmann K.F., Grant D.M., J. Am. Chem. Soc. 90 7355 (1968).
9. Kuhlmann K.F., Grant D.M., Harris R.K., J. Chem. Phys. 52 3439 (1970).
10. Noggle J.H., Schirmer R.E., "The Nuclear Overhauser Effect", Academic Press, New York (1971).
11. Kumar A., Wagner G., Ernst R.R., Wüthrich K., J. Am. Chem. Soc. 103 3654 (1981).
12. Rinaldi P.L., J. Am. Chem. Soc. 105 5167 (1983).
13. Yu C., Levy G.C., J. Am. Chem. Soc. 105 6994 (1983).
14. Yu C., Levy G.C., J. Am. Chem. Soc. 106 6533 (1984).



# APPENDIX A

## COMPUTER PROGRAMS

SPEPLT: A program to simulate the carbon intensity in the single-pulse-excitation experiment.

```

PROGRAM SPEPLT
REAL IZ(6000,20), T(6000), IZMIN, IZMAX, LAMBD1, LAMBD2
REAL TOBS(20), IZOBS(20), IZOMAX
READ (5,*) TACO, DTAC, NAC, T111, T1SS, ETA, GAMMAI, GAMMAS, TD1,
1  TSTEP
X = T111 / T1SS
A = (X - 1) ** 2
B = ((GAMMAI*ETA)/GAMMAS) ** 2
C = X + 1 + SQRT(A + 4*B)
D = X + 1 - SQRT(A + 4*B)
LAMBD1 = C / (2*T111)
LAMBD2 = D / (2*T111)
ALPHA = (LAMBD2 - LAMBD1) * T111
ALPHA1 = (1 + ETA) / (ALPHA)
TAC = TACO
IZMIN = 1.E6
IZMAX = -1.E6
DO 40 KK = 1, NAC
  ALPHA2 = (EXP(-TAC/T111)*ALPHA1)
  DO 10 I = 1, 6000
    TD = (I - 1) * TSTEP
    T(I) = TD
    POWER1 = EXP(-LAMBD1*TD)
    POWER2 = EXP(-LAMBD2*TD)
    A1 = (LAMBD1*T111 - 1.0) * POWER2
    A2 = (LAMBD2*T111 - 1.0) * POWER1
    B1 = LAMBD2 * POWER1 - LAMBD1 * POWER2
    IZ(I, KK) = (ALPHA2*(A1 - A2)) + ((ETA*B1)/(LAMBD2 - LAMBD1))
    IND = I
    IF (TD .GE. TD1) GO TO 20
10  CONTINUE
20  CONTINUE
    DO 30 I = 1, IND
      IF (IZ(I, KK) .LT. IZMIN) IZMIN = IZ(I, KK)
      IF (IZ(I, KK) .GT. IZMAX) IZMAX = IZ(I, KK)
30  CONTINUE
    TAC = TAC + DTAC
40  CONTINUE
  READ (7,*) NOBS
  DO 50 I = 1, NOBS
    READ (7,*) TOBS(I), IZOBS(I)
50  CONTINUE
  DO 60 I = 1, NOBS
    IZOBS(I) = (IZOBS(I) - IZOBS(NOBS)) / IZOBS(NOBS)
    IF (IZOBS(I) .GT. IZMAX) IZMAX = IZOBS(I)
60  CONTINUE
  IF (IZMAX .NE. 0) IZMIN = -1
  IZMAX = IZMAX+0.1
  CALL PAPER(1)
  CALL PSPACE(0.1, 0.9, 0.1, 0.9)
  CALL MAP(0.0, T(IND), IZMIN, IZMAX)
  CALL BORDER
  CALL AXES
  DO 70 KK = 1, NAC
    CALL PTJOIN(T, IZ(1, KK), 1, IND, 0)
    CALL PTPLT(TOBS, IZOBS, 1, NOBS, 252)
70  CONTINUE
  CALL GREND
END

```

INVER: A program to simulate the proton intensity in the single-pulse-excitation experiment.

```
PROGRAM INVER
REAL IZ(5000), T(5000), IZMIN, IZMAX, LAMBD1, LAMBD2, INT(18), TIME(18)
REAL IINF
READ(5, *) T111, T1SS, ETA, GAMMAI, GAMMAS, TAU1, TSTEP, IINF
      DO 50 I = 1, 18
            READ(7, *) INT(I), TIME(I)
50      CONTINUE
            CONTINUE
WRITE(6, *) TIME(10), INT(10)
      DO 60 I = 1, 18
            INT(I) = (INT(I) - IINF)/IINF
60      CONTINUE
X = T111 / T1SS
A = (X-1)**2
B = ((ETA * GAMMAI) / GAMMAS)**2
C = X+1 + SQRT(A + 4*B)
D = X+1 - SQRT(A + 4*B)
LAMBD1 = C / (2*T111)
LAMBD2 = D / (2*T111)
ALPHA = (2 * ETA) / T111
ALPHA1 = ALPHA / (LAMBD2-LAMBD1)
IZMIN = 1.E6
IZMAX = -1.E6
      DO 100 I = 1, 1000
            TAU = (I-1) * TSTEP
            T(I) = TAU
            POWER1 = EXP(-LAMBD1*TAU)
            POWER2 = EXP(-LAMBD2*TAU)
            IZ(I) = ALPHA1 * (POWER1 - POWER2)
            IND = I
            IF (TAU .GE. TAU1) GO TO 200
100     CONTINUE
200     CONTINUE
            DO 300 I = 1, IND
                    IF (IZ(I) .LT. IZMIN) IZMIN = IZ(I)
                    IF (IZ(I) .GT. IZMAX) IZMAX = IZ(I)
300     CONTINUE
IZMAX = IZMAX + 0.2
CALL PAPER(1)
CALL PSPACE(0.1, 0.9, 0.1, 0.9)
CALL MAP(0.0, T(IND), IZMIN, IZMAX)
CALL BORDER
CALL AXES
      CALL PTJOIN(T, IZ(1), 1, IND, 0)
CALL PTPLOT(TIME, INT, 1, 18, 232)
CALL GREND
END
```

INV1H: A program to simulate the carbon intensity in the INV1H experiment.

```
PROGRAM INV1H
REAL SZ(5000), T(5000), SZMIN, SZMAX, LAMBD1, LAMBD2
READ(5, *) T11I, T1SS, ETA, GAMMAI, GAMMAS, TAU1, TSTEP
X = T11I / T1SS
A = (X-1)**2
B = ((ETA * GAMMAI) / GAMMAS)**2
C = X+1 + SQRT(A + 4*B)
D = X+1 - SQRT(A + 4*B)
LAMBD1 = C / (2*T11I)
LAMBD2 = D / (2*T11I)
ALPHA = 2 / (LAMBD2-LAMBD1)
ALPHA1 = (LAMBD1-(1/T11I))
ALPHA2 = (LAMBD2-(1/T11I))
SZMIN = 1.E6
SZMAX = -1.E6
      DO 100 I = 1, 5000
            TAU = (I-1) * TSTEP
            T(I) = TAU
            POWER1 = EXP(-LAMBD1*TAU)
            POWER2 = EXP(-LAMBD2*TAU)
            SZ(I) = (ALPHA1 * POWER1) - (ALPHA2 * POWER2)
            SZ(I) = ALPHA * SZ(I)
            IND = I
            IF (TAU .GE. TAU1) GO TO 200
100      CONTINUE
200      CONTINUE
            DO 300 I = 1, IND
            IF (SZ(I) .LT. SZMIN) SZMIN = SZ(I)
            IF (SZ(I) .GT. SZMAX) SZMAX = SZ(I)
300      CONTINUE
SZMAX = 0
CALL PAPER(1)
CALL PSPACE(0.1,0.9,0.1,0.9)
CALL MAP(0.0, T(IND), SZMIN, SZMAX)
CALL BORDER
CALL ANNOTP(1,0)
CALL AXES
      CALL PTJOIN(T, SZ(1), 1, IND, 0)
CALL GREND
END
```

APPENDIX B

LECTURES, COLLOQUIA AND SEMINARS  
BETWEEN 1/8/87 AND 31/7/90.

UNIVERSITY OF DURHAM

Board of Studies in Chemistry

COLLOQUIA, LECTURES AND SEMINARS GIVEN BY INVITED SPEAKERS  
1ST AUGUST 1987 to 31st JULY 1988

<u>BIRCHALL</u> , Prof. D. (I.C.I. Advanced Materials) Environmental Chemistry of Aluminium	25th April 1988
<u>BORER</u> , Dr. K. (University of Durham Industrial Research Labs.) The Brighton Bomb - A Forensic Science View	18th February 1988
<u>BOSSONS</u> , L. (Durham Chemistry Teachers' Centre) GCSE Practical Assessment	16th March 1988
<u>BUTLER</u> , Dr. A.R. (University of St. Andrews) Chinese Alchemy	5th November 1987
<u>CAIRNS-SMITH</u> , Dr. A. (Glasgow University) Clay Minerals and the Origin of Life	28th January 1988
<u>DAVIDSON</u> , Dr. J. (Herriot-Watt University) Metal Promoted Oligomerisation Reactions of Alkynes	November 1987
<u>GRADUATE CHEMISTS</u> (Northeast Polytechnics and Universities) R.S.C. Graduate Symposium	19th April 1988
<u>GRAHAM</u> , Prof. W.A.G. (University of Alberta, Canada) Rhodium and Iridium Complexes in the Activation of Carbon-Hydrogen Bonds	3rd March 1988
<u>GRAY</u> , Prof. G.W. (University of Hull) Liquid Crystals and their Applications	22nd October 1987
<u>HARTSHORN</u> , Prof. M.P. (University of Canterbury, New Zealand) Aspects of Ipso-Nitration	7th April 1988
<u>HOWARD</u> , Dr. J. (I.C.I. Wilton) Chemistry of Non-Equilibrium Processes	3rd December 1987
<u>JONES</u> , Dr. M.E. (Durham Chemistry Teachers' Centre) GCSE Chemistry Post-mortem	29th June 1988
<u>JONES</u> , Dr. M.E. (Durham Chemistry Teachers' Centre) GCE Chemistry A Level Post-mortem	6th July 1988
<u>KOCH</u> , Prof. H.F. (Ithaca College, U.S.A.) Does the E2 Mechanism Occur in Solution?	7th March 1988
<u>LACEY</u> , Mr. (Durham Chemistry Teachers' Centre) Double Award Science	9th February 1988

<u>LUDMAN</u> , Dr. C.J. (Durham University) Explosives	10th December 1987
<u>McDONALD</u> , Dr. W.A. (I.C.I. Wilton) Liquid Crystal Polymers	11th May 1988
<u>MAJORAL</u> , Prof. J.-P. (Université Paul Sabatier) Stabilisation by Complexation of Short-Lived Phosphorus Species	8th June 1988
<u>MAPLETOFT</u> , Mrs. M. (Durham Chemistry Teachers' Centre) Salters' Chemistry	4th November 1987
<u>NIETO DE CASTRO</u> , Prof. C.A. (University of Lisbon and Imperial College) Transport Properties of Non-Polar Fluids	18th April 1988
<u>OLAH</u> , Prof. G.A. (University of Southern California) New Aspects of Hydrocarbon Chemistry	29th June, 1988
<u>PALMER</u> , Dr. F. (University of Nottingham) Luminescence (Demonstration Lecture)	21st January 1988
<u>PINES</u> , Prof. A. (University of California, Berkeley, U.S.A.) Some Magnetic Moments	28th April 1988
<u>RICHARDSON</u> , Dr. R. (University of Bristol) X-Ray Diffraction from Spread Monolayers	27th April 1988
<u>ROBERTS</u> , Mrs. E. (SATRO Officer for Sunderland) Talk - Durham Chemistry Teachers' Centre - "Links Between Industry and Schools"	13th April 1988
<u>ROBINSON</u> , Dr. J.A. (University of Southampton) Aspects of Antibiotic Biosynthesis	27th April 1988
<u>ROSE</u> van Mrs. S. (Geological Museum) Chemistry of Volcanoes	29th October 1987
<u>SAMMES</u> , Prof. P.G. (Smith, Kline and French) Chemical Aspects of Drug Development	19th December 1987
<u>SEEBACH</u> , Prof. D. (E.T.H. Zurich) From Synthetic Methods to Mechanistic Insight	12th November 1987
<u>SODEAU</u> , Dr. J. (University of East Anglia) Durham Chemistry Teachers' Centre Lecture: "Spray Cans, Smog and Society"	11th May 1988
<u>SWART</u> , Mr. R.M. (I.C.I.) The Interaction of Chemicals with Lipid Bilayers	16th December 1987
<u>TURNER</u> , Prof. J.J. (University of Nottingham) Catching Organometallic Intermediates	11th February 1988
<u>UNDERHILL</u> , Prof. A. (University of Bangor) Molecular Electronics	25th February 1988
<u>WILLIAMS</u> , Dr. D.H. (University of Cambridge) Molecular Recognition	26th November 1987
<u>WINTER</u> , Dr. M.J. (University of Sheffield) Pyrotechnics (Demonstration Lecture)	15th October 1987

UNIVERSITY OF DURHAM

Board of Studies in Chemistry

COLLOQUIA, LECTURES AND SEMINARS GIVEN BY INVITED SPEAKERS  
1ST AUGUST 1988 to 31st JULY 1989

- ASHMAN, Mr. A. (Durham Chemistry Teachers' Centre) 3rd May, 1989  
The Chemical Aspects of the National Curriculum
- AVEYARD, Dr. R. (University of Hull) 15th March, 1989  
Surfactants at your Surface
- AYLETT, Prof. B.J. (Queen Mary College, London) 16th February, 1989  
Silicon-Based Chips:- The Chemist's Contribution
- BALDWIN, Prof. J.E. (Oxford University) 9th February, 1989  
Recent Advances in the Bioorganic Chemistry of  
Penicillin Biosynthesis
- BALDWIN & WALKER, Drs. R.R. & R.W. (Hull University) 24th November, 1988  
Combustion: Some Burning Problems
- BOLLEN, Mr. F. (Durham Chemistry Teachers' Centre) 18th October, 1988  
Lecture about the use of SATIS in the classroom
- BUTLER, Dr. A.R. (St. Andrews University) 15th February, 1989  
Cancer in Linxiam: The Chemical Dimension
- CADOGAN, Prof. J.I.G. (British Petroleum) 10th November, 1988  
From Pure Science to Profit
- CASEY, Dr. M. (University of Salford) 20th April, 1989  
Sulphoxides in Stereoselective Synthesis
- CRESSEY & WATERS, Mr. D. & T. (Durham Chemistry Teachers' Centre) 1st February, 1989  
GCSE Chemistry 1988: "A Coroner's Report"
- CRICH, Dr. D. (University College London) 27th April, 1989  
Some Novel Uses of Free Radicals in Organic  
Synthesis
- DINGWALL, Dr. J. (Ciba Geigy) 18th October, 1988  
Phosphorus-containing Amino Acids: Biologically  
Active Natural and Unnatural Products
- ERRINGTON, Dr. R.J. (University of Newcastle-upon-Tyne) 1st March, 1989  
Polymetalate Assembly in Organic Solvents
- FREY, Dr. J. (Southampton University) 11th May, 1989  
Spectroscopy of the Reaction Path: Photodissociation  
Raman Spectra of NOCl
- GRADUATE CHEMISTS, (Polytechs and Universities in North East England) 12th April, 1989  
R.S.C. Symposium for presentation of papers by  
postgraduate students

<u>HALL</u> , Prof. L.D. (Addenbrooke's Hospital, Cambridge) NMR - A Window to the Human Body	2nd February, 1989
<u>HARDGROVE</u> , Dr. G. (St. Olaf College, U.S.A.) Polymers in the Physical Chemistry Laboratory	December, 1988
<u>HARWOOD</u> , Dr. L. (Oxford University) Synthetic Approaches to Phorbols Via Intramolecular Furan Diels-Alder Reactions: Chemistry under Pressure	25th January, 1988
<u>JÄGER</u> , Dr. C. (Friedrich-Schiller University GDR) NMR Investigations of Fast Ion Conductors of the NASICON Type	9th December, 1988
<u>JENNINGS</u> , Prof. R.R. (Warwick University) Chemistry of the Masses	26th January, 1989
<u>JOHNSON</u> , Dr. B.F.G. (Cambridge University) The Binary Carbonyls	23rd February, 1989
<u>JONES</u> , Dr. M.E. (Durham Chemistry Teachers' Centre) Discussion Session on the National Curriculum	14th June, 1989
<u>JONES</u> , Dr. M.E. (Durham Chemistry Teachers' Centre) GCSE and A Level Chemistry 1989	28th June, 1989
<u>LUDMAN</u> , Dr. C.J. (Durham University) The Energetics of Explosives	18th October, 1988
<u>MACDOUGALL</u> , Dr. G. (Edinburgh University) Vibrational Spectroscopy of Model Catalytic Systems	22nd February, 1989
<u>MARKO</u> , Dr. I. (Sheffield University) Catalytic Asymmetric Osmylation of Olefins	9th March, 1989
<u>McLAUCHLAN</u> , Dr. K.A. (University of Oxford) The Effect of Magnetic Fields on Chemical Reactions	16th November, 1988
<u>MOODY</u> , Dr. C.J. (Imperial College) Reactive Intermediates in Heterocyclic Synthesis	17th May, 1989
<u>MORTIMER</u> , Dr. C. (Durham Chemistry Teachers' Centre) The Hindenberg Disaster - an Excuse for Some Experiments	14th December, 1988
<u>NICHOLLS</u> , Dr. D. (Durham Chemistry Teachers' Centre) Demo. "Liquid Air"	11th July, 1989
<u>PAETZOLD</u> , Prof. P. (Aachen) Iminoboranes $\text{XB}\equiv\text{NR}$ : Inorganic Acetylenes?	23rd May, 1989
<u>PAGE</u> , Dr. P.C.B. (University of Liverpool) Stereocontrol of Organic Reactions Using 1,3-dithiane- 1-oxides	3rd May, 1989

- POLA, Prof. J. (Czechoslovak Academy of Sciences) 15th June, 1989  
Carbon Dioxide Laser Induced Chemical Reactions -  
New Pathways in Gas-Phase Chemistry
- REES, Prof. C.W. (Imperial College London) 27th October, 1988  
Some Very Heterocyclic Compounds
- REVELL, Mr. P. (Durham Chemistry Teachers' Centre) 14th March, 1989  
Implementing Broad and Balanced Science 11-16
- SCHMUTZLER, Prof. R. (Technische Universitat Braunschweig) 6th October, 1988  
Fluorophosphines Revisited - New Contributions to an  
Old Theme
- SCHROCK, Prof. R.R. (M.I.T.) 13th February, 1989  
Recent Advances in Living Metathesis
- SINGH, Dr. G. (Teesside Polytechnic) 9th November, 1988  
Towards Third Generation Anti-Leukaemics
- SNAITH, Dr. R. (Cambridge University) 1st December, 1988  
Egyptian Mummies: What, Where, Why and How?
- STIBER, Dr. R. (Czechoslovak Academy of Sciences) 16th May, 1989  
Recent Developments in the Chemistry of Intermediate-  
Sited Carboranes
- VON RAGUE SCHLEYER, Prof. P. (Universitat Erlangen Nurnberg) 21st October, 1988  
The Fruitful Interplay Between Computational and  
Experimental Chemistry
- WELLS, Prof. F.B. (Hull University) 10th May, 1989  
Catalyst Characterisation and Activity

UNIVERSITY OF DURHAM

Board of Studies in Chemistry

COLLOQUIA, LECTURES AND SEMINARS GIVEN BY INVITED SPEAKERS  
1ST AUGUST 1989 TO 31ST JULY 1990

- ASHMAN, Mr. A. (Durham Chemistry Teachers' Centre) 11th October, 1989  
The National Curriculum - an update
- BADYAL, Dr. J.P.S. (Durham University) 1st November, 1989  
Breakthroughs in Heterogeneous Catalysis
- BECHER, Dr. J. (Odense University) 13th November, 1989  
Synthesis of New Macrocylic Systems using  
Heterocyclic Building Blocks
- BERCAW, Prof. J.E. (California Institute of Technology) 10th November, 1989  
Synthetic and Mechanistic Approaches to  
Ziegler-natta Polymerization of Olefins
- BLEASDALE, Dr. C. (Newcastle University) 21st February, 1990  
The Mode of Action of some Anti-tumour Agents
- BOLLEN, Mr. F. (Formerly Science Advisor, Newcastle LEA) 27th March, 1990  
Whats's New in Satis, 16-19
- BOWMAN, Prof. J.M. (Emory University) 23rd March, 1990  
Fitting Experiment with Theory in Ar-OH
- BUTLER, Dr. A. (St. Andrews University) 7th December, 1989  
The Discovery of Penicillin: Facts and Fancies
- CAMPBELL, Mr. W.A. (Durham Chemistry Teachers' Centre) 12th September, 1989  
Industrial catalysis - some ideas for the  
National Curriculum
- CHADWICK, Dr. P. (Dept. of Physics, Durham University) 24th January, 1990  
Recent Theories of the Universe (with Reference  
to National Curriculum Attainment Target 16)
- CHEETHAM, Dr. A.K. (Oxford University) 8th March, 1990  
Chemistry of Zeolite Cages
- CLARK, Prof. D.T. (ICI Wilton) 22nd February, 1990  
Spatially Resolved Chemistry (using Natures's  
Paradigm in the Advanced Materials Arena)
- COLE-HAMILTON, Prof. D.J. (St. Andrews University) 29th November, 1989  
New Polymers from Homogeneous Catalysis

<u>CROMBIE</u> , Prof. L. (Nottingham University) The Chemistry of Cannabis and Khat	15th February, 1990
<u>DYER</u> , Dr. U. (Glaxo) Synthesis and Conformation of C-Glycosides	31st January, 1990
<u>FLORIANI</u> , Prof. C. (University of Lausanne, Switzerland) Molecular Aggregates - A Bridge between homogeneous and Heterogeneous Systems	25th October, 1989
<u>GERMAN</u> , Prof. L.S. (USSR Academy of Sciences - Moscow) New Syntheses in Fluoroaliphatic Chemistry: Recent Advances in the Chemistry of Fluorinated Oxiranes	9th July, 1990
<u>GRAHAM</u> , Dr. D. (B.P. Reserch Centre) How Proteins Absorb to Interfaces	4th December, 1989
<u>GREENWOOD</u> , Prof. N.N. (University of Leeds) Novel Cluster Geometries in Metalloborane Chemistry	9th November, 1989
<u>HOLLOWAY</u> , Prof. J.H. (University of Leicester) Noble Gas Chemistry	1st February, 1990
<u>HUGHES</u> , Dr. M.N. (King's College, London) A Bug's Eye View of the Periodic Table	30th November, 1989
<u>HUISGEN</u> , Prof. R. (Universität München) Recent Mechanistic Studies of [2+2] Additions	15th December, 1989
<u>IDDON</u> , Dr. B. (Univeristy of Salford) Schools' Christmas Lecture - The Magic of Chemistry	15th December, 1989
<u>JONES</u> , Dr. M.E. (Durham Chemistry Teachers' Centre) The Chemistry A Level 1990	3rd July, 1990
<u>JONES</u> , Dr. M.E. (Durham Chemistry Teachers' Centre) GCSE and Dual Award Science as a starting point for A level Chemistry - how suitable are they?	21st November 1989
<u>JOHNSON</u> , Dr. G.A.L. (Durham Chemistry Teachers' Centre) Some aspects of local Geology in the National Science Curriculum (attainment target 9)	8th February, 1990
<u>KLINOWSKI</u> , Dr. J. (Cambridge University) Solid State NMR Studies of Zeolite Catalysts	13th December 1989
<u>LANCASTER</u> , Rev. R. (Kimbolton Fireworks) Fireworks - Principles and Practice	8th February, 1990
<u>LUNAZZI</u> , Prof. L. (University of Bologna) Application of Dynamic NMR to the Study of Conformational Enantiomerism	12th February, 1990
<u>PALMER</u> , Dr. F. (Nottingham University) Thunder and Lightning	17th October, 1989

- PARKER, Dr. D. (Durham University) 16th November, 1989  
 Macrocycles, Drugs and Rock 'n' roll
- PERUTZ, Dr. R.N. (York University) 24th January, 1990  
 Plotting the Course of C-H Activations with  
 Organometallics
- PLATONOV, Prof. V.E. (USSR Academy of Sciences -  
 Novosibirsk) 9th July, 1990  
 Polyfluoroindanes: Synthesis and Transformation
- POWELL, Dr. R.L. (ICI) 6th December, 1989  
 The Development of CFC Replacements
- POWIS, Dr. I. (Nottingham University) 21st March, 1990  
 Spinning off in a huff: Photodissociation of  
 Methyl Iodide
- RICHARDS, Mr. C. (Health and Safety Executive,  
 Newcastle) 28th February, 1990  
 Safety in School Science Laboratories and COSHH
- ROZHKOVA, Prof. I.N. (USSR Academy of Sciences -  
 Moscow) 9th July, 1990  
 Reactivity of Perfluoroalkyl Bromides
- STODDART, Dr. J.F. (Sheffield University) 1st March, 1990  
 Molecular Lego
- SUTTON, Prof. D. (Simon Fraser University,  
 Vancouver B.C.) 14th February, 1990  
 Synthesis and Applications of Dinitrogen and Diazo  
 Compounds of Rhenium and Iridium
- THOMAS, Dr. R.K. (Oxford University) 28th February, 1990  
 Neutron Reflectometry from Surfaces
- THOMPSON, Dr. D.P. (Newcastle University) 7th February, 1990  
 The role of Nitrogen in Extending Silicate  
 Crystal Chemistry

