

Durham E-Theses

Infinite Dimensional Symmetries of Self-Dual Yang-Mills Theories.

ADAM BARTHOLOMEW WARDLOW

How to cite:

WARDLOW, ADAM BARTHOLOMEW (2011) Infinite Dimensional Symmetries of Self-Dual Yang-Mills Theories. Doctoral thesis, Durham University.

Use policy

The full-text may be used and/or reproduced, and given to third parties in any format or medium, without prior permission or charge, for personal research or study, educational, or not-for-profit purposes provided that:

- a full bibliographic reference is made to the original source
- a <https://etheses.durham.ac.uk/id/eprint/590/> is made to the metadata record in Durham E-Theses
- the full-text is not changed in any way

The full-text must not be sold in any format or medium without the formal permission of the copyright holders.

Please consult the [full Durham E-Theses policy](#) for further details.

Infinite Dimensional Symmetries of Self-Dual Yang-Mills Theories

Adam Bartholomew Wardlow

University College, Durham

A Thesis presented for the degree of
Doctor of Philosophy



Centre for Particle Theory (CPT)
Department of Mathematical Sciences
University of Durham
England

January 2011

Dedicated to
my teacher, Paul Mansfield.

Infinite Dimensional Symmetries of Self-Dual Yang-Mills Theories

Adam Wardlow

Submitted for the degree of Doctor of Philosophy
January 2011

Abstract

We construct infinite dimensional symmetries of the Chalmers-Siegel action describing the self-dual sector of non-supersymmetric Yang-Mills. The symmetries are derived by virtue of a canonical transformation between the Yang-Mills fields and new fields that map the Chalmers-Siegel action to a free theory which has been used to construct a Lagrangian approach to the MHV rules. We describe the symmetries of the free theory in a quite general way which are an infinite dimensional algebra in the group algebra of isometries.

We dimensionally reduce the symmetries of the action to write down symmetries of the Hitchin system and further, we extend the construction to the $N = 4$ supersymmetric, self-dual theory.

We review recent developments in the approach to calculating $N=4$ Yang-Mills scattering amplitudes using symmetry arguments. Super-conformal symmetry and the recently discovered dual super-conformal symmetry have been shown to be related as a Yangian algebra and moreover, anomalous terms appearing in their action on amplitudes lead to deformations of the generators which gives rise to recursive relationships between amplitudes.

Declaration

The work in this thesis is based on research carried out at the Centre for Particle Theory (CPT), Department of Mathematical Sciences, University of Durham, England. No part of this thesis has been submitted elsewhere for any other degree or qualification and it is all my own work unless referenced to the contrary in the text.

Copyright © 2011 by Adam Wardlow.

“The copyright of this thesis rests with the author. No quotations from it should be published without the author’s prior written consent and information derived from it should be acknowledged”.

Acknowledgements

It is an honour to thank my Ph.D. supervisor, Prof. Paul Mansfield for his instruction, advice and support and thanks is given to the STFC for a four year studentship. I wish to express my appreciation for the administrative support of the Department of Mathematical Sciences, the Graduate School and my college, University College. I also wish to thank M. Imran for creating the L^AT_EX template which I have used to typeset this thesis and thanks to JHEP for supplying the L^AT_EX code for a symbol used throughout.

I wish to thank my good friends Linus, Chris, Max, Jugglin' John (*et-al*) for putting up with my incessant worrying. Thanks to Carol, the landlady at the local 'Ale-house', The Colpitts Hotel, for her kindness and for serving up a much needed beer and pork pie after endless hours struggling with intractable problems.

But foremost, I am grateful to my father, André Wardlow, for his consistent efforts to keep me focused, my mother, Angela Shaw, for her support and my step-mother, grandmother and family.

Contents

Abstract	iii
Declaration	iv
Acknowledgements	v
1 Introduction and Outline	1
2 Yangian Symmetry of N=4 SYM Scattering Amplitudes as an Infinite Dimensional Algebra	6
2.1 Super-Conformal Symmetry of Amplitudes	8
2.2 Dual Super-Conformal Symmetry of Amplitudes and the Yangian	11
2.3 Deformed Yangian Symmetry	13
2.3.1 The Holomorphic Anomaly	13
2.3.2 Generators That Change the Number of Legs	14
2.4 Chapter Summary	18
3 Symmetries of Free Field Theories	21
3.1 Introduction	21
3.2 Symmetries Produced by Displacements for a Complex Free Scalar Field	22
3.3 Symmetries Generated by Lorentz Transformations	26
3.4 Symmetries Generated by Isometries on Curved Space-times	33
3.4.1 Anti de-Sitter Space	37
3.5 General Case	40
3.6 Lie Algebra	43

3.6.1	Infinite Dimensional Kac-Moody and Loop Algebras	45
3.6.2	Conjugacy Classes of G and the Dimension of \mathfrak{g}	47
3.6.3	Triangle Sub-group of $SO(3)$	49
3.6.4	Tetrahedral Sub-Group of $SO(3)$	51
3.6.5	Dihedral Sub-Groups of $SO(3)$	54
3.7	Chapter Summary	57
4	Infinite Dimensional Symmetries of Self-Dual Yang-Mills	58
4.1	Review of the Lagrangian Formulation of MHV Rules	59
4.2	Transformation of A and \bar{A}	64
4.2.1	Transformation of A for the Isometry that Preserves Γ and Υ	66
4.2.2	Transformation of \bar{A} for the Isometry that Preserves Γ and Υ	69
4.2.3	Most General Transformation Using the Full Lorentz Group .	72
4.3	Chapter Summary	79
5	Infinite Dimensional Symmetries of Self-Dual N=4 Super Yang-Mills	81
5.1	Light Cone N=4 SYM	82
5.1.1	MHV Rules Lagrangian for N=4 SYM	84
5.2	Symmetries in Free Supersymmetric Theories	89
5.2.1	Transformations of N=1 Chiral Free SUSY	89
5.2.2	Transformation of the Free N=4 Multiplet	90
5.3	Transformation that Leaves the N=4 SYM Action Invariant	92
5.4	Chapter Summary	100
6	Symmetries of the Hitchin System	103
6.1	Chapter Introduction	103
6.2	The Hitchin system	104
6.3	The Self-Dual Equations	106
6.4	Symmetries of the 2D Euclidean Self-Dual Equations on the plane	109
6.5	Chapter Summary	112
7	Conclusions	113

Appendix	116
A Commutators of the Tetrahedral Group Algebra	116
B Detailed Calculations from Chapter 4	119
B.1 Order by Order Calculation of δA	119
B.2 Order by Order Calculation of $\delta \bar{A}$	124
C Detailed Calculations from Chapter 5	129
C.1 Order by Order Calculation of $\Delta \Phi$ up to Quartic Terms	129

List of Figures

2.1	Action of Generators on an n -point, l -loop Amplitude	15
2.2	Recursive Action of Generators on the Tree-Level Amplitudes	18
2.3	Super-Conformal Dilation Generator $D_{2 \rightarrow 2}$	19
3.1	Root Space of $su(3)$	54
4.1	Transformation, δA	68
4.2	Transformation, $\delta \bar{A}$	72
4.3	Expressions for δA and $\delta \bar{A}$ for the Full Lorentz Group	73
4.4	Change in the Self-Dual Action, δS	74
4.5	Change in the Free Part of the Action δS_F	75
4.6	Change in the Free Part of the Action δS_F	76
4.7	Change in the Interacting Part of the Action δS_I	77
4.8	Change in the Interacting Part of the Action δS_I	78
5.1	Transformation, $\Delta \Phi$	94
5.2	Change in the Self-Dual Action ΔS	96
5.3	Change of Φ , $\Delta \Phi$	96
5.4	Change in the free part of the self-dual action ΔS_F	98
5.5	Change in the Free Part of the Self-Dual Action ΔS_F	99
5.6	Change in the Interacting Part of the Self-Dual Action ΔS_I	100
5.7	Change in the Interacting Part of the Self-Dual Action ΔS_I	101
5.8	Change in the Component Field ΔA	101

List of Tables

3.1	Cayley Table of the Triangle Group	50
3.2	Cayley Table of Tetrahedral Group	52
A.1	Cayley Table of Tetrahedral Group	118

Chapter 1

Introduction and Outline

The well known Feynman approach to calculating scattering amplitudes, (see, for example, [1] for reviews), in quantum field theory has been hugely successful. However, the complexity of calculations grows quickly in relation to the number of particles and in high loop order. Even at tree-level, a 10-point gluon scattering amplitude with 2 negative helicity gluons (known as the MHV amplitude) has over 10^7 diagrams which we must evaluate, for example, [2–4]. The observation that tree-level gluon scattering amplitudes localise on simple curves in twistor space [5] led to the proposal of a new set of rules for calculating such amplitudes [5–8] with drastically reduced complexity. (See also [9] for a review of Penrose’s Twistor space.) For instance, the n -point MHV amplitude takes a particularly simple form known as the Parke-Taylor amplitude, [10]. It was observed later that any tree-level N^m MHV amplitude with $m + 2$ negative helicity gluons can be written in terms of amplitudes of fewer points knitted together by a Feynman propagator, leading to the BCFW recursion relations: see [11,12]. Beyond the pure Yang-Mills setting, the four dimensional, maximally supersymmetric $N = 4$ theory, [13,14], is proving to be a useful tool to study gauge theory amplitudes because of its high degree of symmetry. The extension of these recursion relations to planar $N = 4$ supersymmetry was discussed in the papers [15,16].

The $N = 4$ scattering amplitudes in the planar limit are expected to be invariant under super-conformal transformations, [5]. The symmetry is known to survive even in the presence of UV divergences but the dimensional regularisation applied

at loop-level for IR divergences breaks the special conformal symmetry since conformal symmetry is only manifest in $d = 4$ dimensions, [20]. This might suggest that at loop-level the super-conformal symmetry is masked or broken altogether, [21], but the situation is even worse than this. Even at tree-level, the super-conformal symmetry is broken when particles become collinear. It was recently observed that when written in dual-space, scattering amplitudes are invariant under a new set of symmetries, namely the dual super-conformal symmetry, [16] (Also see [22–25]). Beisert (*et-al*) [21] argue that the existence of this new set of symmetries suggests that super-conformal symmetry is not beyond repair and they propose correction terms added to the generators which may change the number of legs of the amplitude. The dual super-conformal symmetry is related to the ordinary super-conformal symmetry as the quantized version of a loop algebra, the Yangian algebra [26]. The original super-conformal generators are the level zero Yangian generators and the dual generators have been shown recently to be related to the level one Yangian generators in the infinite ‘tower’ of Yangian generators, [27]. The Yangian generators annihilate the amplitude but extending the work in [21], the authors of [28] calculate deformations of the Yangian generators to account for anomalous terms, thus constraining amplitudes at 1-loop order (also see [29]). In §(2) we review this recent work as an example of how infinite dimensional symmetries are important as regards integrability in the hope that $N = 4$ super Yang-Mills in 4 dimensions might be our first integrable quantum field theory.

The MHV rules were proven initially using twistor methods, [12]. A method of deriving the rules in the Lagrangian formalism was considered in [30] and [31], using a non-local canonical transformation that maps the self-dual part of the action in light-cone coordinates to the action of a free theory. Since free theories have a high degree of symmetry we expect the self-dual part of the Yang-Mills action to exhibit the same degrees of symmetry. A field that undergoes a transformation $\phi(x) \rightarrow \phi(x) + \Delta\phi(x)$ has generators

$$M_i = \int d^d x \Delta_i \phi(x) \frac{\delta}{\delta \phi(x)} \quad (1.1)$$

as discussed in [32] and [33]. As is easy to understand, a free-theory with Euler-Lagrange equation $\Omega(x) \phi(x) = 0$ has a symmetry if the operator, Ω transforms

covariantly when $x \rightarrow x_G$, because if $\Omega(x_G) = A\Omega(x)$, then $0 = \Omega(x_G)\phi(x_G) = A\Omega(x)\phi(x_G)$, so $\phi(x_G)$ is a new solution. Taking the transformation G close to the identity gives the change in the field, $\delta\phi(x) = \phi(x_G) - \phi(x)$ which can be used to construct the usual Noether currents and conserved charges. However, because the Euler-Lagrange equation is linear we can also construct a new solution as $\phi(x) + \varepsilon\phi(x_G)$, with G a finite transformation. The change in the field is then $\delta\phi(x) = \varepsilon\phi(x_G)$, ergo we have $\Delta\phi(x) = \varepsilon\phi(x_G)$ from Dolan's work, [32] and (1.1). This leads to higher derivative conserved currents such as the 'zilch' of the electromagnetic field discovered in the 60s by Lipkin [34].

In §(3) we construct infinite dimensional symmetries of the simple Klein-Gordon field on Minkowski space when $x \rightarrow x_G$ is a translation and calculate the Noether current. Further generalizations are made to include the case when $x \rightarrow x_G$ is a Lorentz transformation and then to the case of the Klein Gordon field on curved backgrounds where we also consider the field on the Anti de-Sitter background as an example. A final generalization is made to the Lagrangian $\mathcal{L} = \tilde{\Phi}\Omega\Phi$ where Φ is some arbitrary space-time object and Ω is an operator. Such a procedure creates an uncountable set of symmetries but we may consider transformations created from discrete sub-groups of the isometry group, $x \rightarrow x_G$. Commutators between transformations $\delta_i\varphi = \varepsilon_i\varphi(x_{G_i})$ and $\delta_j\varphi = \varepsilon_j\varphi(x_{G_j})$ where G_i and G_j are members of the isometry group G are shown to satisfy the closure property for a Lie algebra and the Jacobi identity. Further, the conjugacy classes of the isometry group are shown to be related to the trivial centre of the Lie algebra. By considering discrete sub-groups of $SO(3)$ combined with discrete time translations we show how to create a loop algebra that is related to the aforementioned Yangian algebra, [35, 36], whose zero-mode sub-algebra we consider for several examples of discrete crystallographic sub-groups of $SO(3)$.

The Yang-Mills action is split into two parts; the Chalmers-Siegel action, [37] describing the self-dual part of the action plus the rest. The canonical transformation, which is a power series solution to a functional differential equation, maps the Chalmers-Siegel action to the free theory whose symmetries we calculate in §(3). The rest of the action encompasses the interaction terms and care must be taken

that the transformation does not introduce any extra terms that survive the LSZ procedure which is addressed in [31]. In §(4) we review the work in [30] and [31] where the authors derive the form of the canonical transformation, its conjugate and inverse. Remarkably, when written in terms of independent momenta the coefficients in the expansion reduce to very simple expressions. We may use the canonical transformation to write the symmetry of the Yang-Mills fields in terms of the symmetries of the free fields and then use the inverse transformation to write the symmetry in terms of the original variables order by order in powers of the fields. Again, by writing in terms of independent momenta, the coefficients in the series reduce to simple expressions which can be written in terms of the coefficients of the canonical transformation itself. We first perform our procedure for the one parameter subgroup of isometries in $(2, 2)$ space that leave the coefficients in the series unchanged. We then guess a more general expression where the isometries are members of the full Lorentz group of physical $(1, 3)$ space and prove this leaves the Chalmers-Siegel action invariant. Further, we show that the symmetries that we calculate satisfy the same algebra as the free theory from which they were constructed.

The extension of the MHV rules and recursion relations for calculating scattering amplitudes to $N = 4$ super Yang-Mills has been given in the literature, for example [19]. In particular, the Lagrangian formulation of the $N = 4$ super Yang-Mills MHV rules was recently discussed by Feng and Huang, [38]. Given the power series expansion for the transformation of the component gluon fields derived in [30] and [31], they conjectured the form of the power series in terms of $N = 4$ superfields and then proved it leaves the Chalmers-Siegel action invariant. In §(5) we extend our consideration of the symmetries of free field theories to the $N = 1$ chiral super multiplet and further, to the free $N = 4$ multiplet. Then by analogy with the procedure we discuss in §(4) we use the transformation to write the symmetry of the Yang-Mills superfield in terms of the transformation of the free superfield. We derive the inverse of the transformation given in [38] to write the symmetry of the Yang-Mills field in terms of the original variables. It is possible to then calculate the transformations of the component fields and we give an example.

Two dimensional field theories are generally integrable and have high degrees

of symmetry. In 4 dimensions, the existence of infinite local symmetries renders the theory as non-interacting. Should the symmetries of the self-dual action that we derive in §(4) and §(5) survive the full theory our ‘get out clause’ is that the symmetries we calculate are non-local. To conclude this thesis, we describe a 2d self-dual theory in our final chapter, §(6), called the Hitchin system, [39]. We impose translational invariance of the 4d theory over 2 of the dimensions to write down the self-dual equation in 2 dimensions and use our result of §(4) to calculate non-local symmetries of this system.

Chapter 2

Yangian Symmetry of N=4 SYM Scattering Amplitudes as an Infinite Dimensional Algebra

We review current developments in the subject that show how infinite dimensional symmetries have been used to constrain amplitudes, most prominently by authors such as Heslop, Plefka, Beisert, Drummond (*et-al*) in the papers [21, 28] and [29]. The N=4 Super Yang-Mills scattering amplitudes have long been expected to be invariant under generators of a super-conformal symmetry [5], at least at tree-level; although there is a technicality relating to the holomorphic anomaly [21]. These generators are written in terms of $\lambda_i, \tilde{\lambda}_i$ and η_i and include translations, Lorentz transformations, dilations, SUSY generators and special conformal transformations. An n -point tree-level amplitude is given by the simple expression

$$A_n = \frac{\delta^4(P)\delta^8(Q)}{\langle 12 \rangle \langle 23 \rangle \cdots \langle n1 \rangle} \mathcal{P}(\lambda, \tilde{\lambda}, \eta) \quad (2.1)$$

as written down in [19] using the spinor-helicity formalism (see [4] for details) where λ_j are two-spinors satisfying

$$\lambda_j \tilde{\lambda}_j = (p_t)_j 1 + \sigma \cdot \mathbf{p}_j$$

with $\sigma = (\sigma^1, \sigma^2, \sigma^3)$ being the Pauli matrices and (p_t, \mathbf{p}) being the momenta of the on-shell gluons and the bracket $\langle i, j \rangle = \langle \lambda_i, \lambda_j \rangle = \lambda_i^\alpha \lambda_{j\alpha}$. The delta functions

impose momentum and ‘super momentum’ conservation with

$$P^{\alpha\dot{\alpha}} = \sum_{i=1}^n \lambda_i^\alpha \lambda_i^{\dot{\alpha}}, \quad Q^{\alpha A} = \sum_{i=1}^n \lambda_i^\alpha \eta_i^A.$$

The factor \mathcal{P} is a polynomial in η of degree $4m$ corresponding to N^m MHV amplitudes and clearly the MHV amplitudes correspond to the constant term $\mathcal{P}_0 = 1$.

It has been shown by Drummond (*et-al*) in [22] (also see [15]) that there exists further symmetries of the amplitudes which manifest themselves when the amplitude is written in terms of dual-space coordinates. Referred to as the ‘dual super-conformal symmetries’, the generators which are written in terms of $\lambda_i, \tilde{\lambda}_i, \eta_i, x_i$ and θ_i , where x and θ are suitably defined, annihilate the amplitude subject to certain constraints defining a surface on the dual-space.

It has proven interesting to consider commutators of the conventional super-conformal symmetry with the dual super-conformal symmetry [27]. To do this, one must write the dual generators in terms of $\lambda, \tilde{\lambda}$ and η by a simple change of variables and ultimately show that the dual generators are intimately related to level one Yangian generators, [26]. A Yangian algebra is an associative Hopf algebra (See for example [40]). As discussed in [27], take for instance generators of an algebra J_a which satisfy the mixed commutator relations

$$[J_a, J_b\} = f_{ab}{}^c J_c.$$

Now Beisert (*et-al*), in [28] write the level one Yangian generator as

$$\hat{J}_a = f_a{}^{bc} \sum_{i < j} (J_b)_i (J_c)_j$$

which satisfies

$$[\hat{J}_a, J_b\} = f_{ab}{}^c \hat{J}_c$$

and also satisfies the Serre relations, [27] and [26], given by,

$$\begin{aligned} & [\hat{J}_a, [\hat{J}_b, J_c\}\} + (-1)^{|a|(|b|+|c|)} [\hat{J}_b, [\hat{J}_c, J_a\}\} + (-1)^{|c|(|a|+|b|)} [\hat{J}_c, [\hat{J}_a, J_b\}\} \\ & = h(-1)^{|r||m|+|t||n|} \{J_l, J_m, J_n\} f_{ar}{}^l f_{bs}{}^m f_{ct}{}^n f^{rst} \end{aligned}$$

where the mixed commutator of operators O_1 and O_2 is defined as

$$[O_1, O_2\} = O_1 O_2 - (-1)^{|O_1||O_2|} O_2 O_1$$

with $|O|$ being the Grassmanian order of the operator O and the bracket $[O_1, O_2, O_3]$ is the graded symmetrizer.

Now even at tree-level when particles are collinear the symmetries are broken by the holomorphic anomaly which we shall discuss, and at loop-level they are broken by the conformal anomaly. In two excellent papers, [21] and [28], they use this fact to write ‘deformed’ symmetry generators to correct the anomaly and this leads to expressions relating, for example, n -point amplitudes to $n - 1$ point amplitudes or 1-loop amplitudes to tree-level amplitudes. A further paper by Heslop (*et al*), [29], writes an n -point amplitude as a linear combination of box functions and uses the conformal anomaly equation arising from the generator of special dual super-conformal transformations, which we shall write down later, to constrain the coefficients of this linear combination.

2.1 Super-Conformal Symmetry of Amplitudes

It is convenient to compute scattering amplitudes of the superfield

$$\begin{aligned} \Phi(x, \eta, \bar{\eta}) = & \frac{1}{\hat{\partial}} A(y) + \frac{i}{\hat{\partial}} \eta^A \lambda_A(y) + i \frac{1}{\sqrt{2}} \eta^A \eta^B \bar{C}_{AB}(y) \\ & + \frac{\sqrt{2}}{3!} \eta^A \eta^B \eta^C \epsilon_{ABCD} \bar{\lambda}^D(y) + \frac{1}{12} \eta^A \eta^B \eta^C \eta^D \epsilon_{ABCD} \hat{\partial} \bar{A}(y) \end{aligned}$$

where the Grassman variables, η , carry helicity 1/2 and so one can calculate amplitudes for scattering of the desired particles by choosing the relevant term in the expansion of η . The amplitude is a function of the spinor-helicity coordinates $A_n(\lambda_1, \tilde{\lambda}_1, \eta_1, \dots, \lambda_n, \tilde{\lambda}_n, \eta_n)$ as given by (2.1). The representation of the generators given in [27] on the k th leg of an amplitude is as follows,

$$\begin{aligned} p_i^{\alpha\dot{\alpha}} &= \lambda_i^\alpha \tilde{\lambda}_i^{\dot{\alpha}} & k_{i\alpha\dot{\alpha}} &= \partial_{i\alpha} \partial_{i\dot{\alpha}} \\ \bar{m}_{i\dot{\alpha}\dot{\beta}} &= \tilde{\lambda}_{i(\dot{\alpha}} \partial_{i\dot{\beta})} & m_{i\alpha\beta} &= \lambda_{i(\alpha} \partial_{i\beta)} \\ d_i &= \frac{1}{2} \lambda_i^\alpha \partial_{i\alpha} + \frac{1}{2} \tilde{\lambda}_i^{\dot{\alpha}} \partial_{i\dot{\alpha}} + 1 & r_{iB}^A &= -\eta_i^A \partial_{iB} + \frac{1}{4} \delta_B^A \eta_i^C \partial_{iC} \\ q_i^{\alpha A} &= \lambda_i^\alpha \eta_i^A & \bar{q}_{iA}^{\dot{\alpha}} &= \tilde{\lambda}_i^{\dot{\alpha}} \partial_{iA} \\ s_{i\alpha A} &= \partial_{i\alpha} \partial_{iA} & \bar{s}_{i\dot{\alpha}}^A &= \eta_i^A \partial_{i\dot{\alpha}} \\ c_i &= 1 + \frac{1}{2} \lambda_i^\alpha \partial_{i\alpha} - \frac{1}{2} \tilde{\lambda}_i^{\dot{\alpha}} \partial_{i\dot{\alpha}} - \frac{1}{2} \eta_i^A \partial_{iA} \end{aligned} \tag{2.2}$$

where c is the central charge that extends $psu(2, 2|4)$ to $su(2, 2|4)$, related to the total helicity h_i by $c = \sum_{i=1}^n (1 - h_i)$ with $h_i A_n = A_n$ since the helicity of the multiplet Φ_i is one. The algebra can be further extended to $u(2, 2|4)$ by including a hypercharge b but this generator is not a symmetry of the amplitude. The amplitude is invariant under the action of the generators J_a , viz

$$J_a A_n = 0$$

where J is given by summing over the generators acting on individual legs, in what is the standard tensor product form.

$$J_a = \sum_{i=1}^n J_{i,a}$$

with $J_{i,a}$ being the above generators acting on the i th leg.

Convincing oneself of the invariance of the super amplitudes under these transformations is a matter of a few prototype calculations. The simplest is $p^{\alpha\dot{\alpha}}$ where

$$p^{\alpha\dot{\alpha}} A_n = \sum_{i=1}^n (\lambda^\alpha \tilde{\lambda}^{\dot{\alpha}}) \frac{\delta^4(P) \delta^8(Q)}{\langle 12 \rangle \langle 23 \rangle \cdots \langle n1 \rangle} \mathcal{P} = 0$$

simply using the fact the sum is zero given momentum conservation. Similarly for $q^{\alpha A}$. Naively we may also show, for example, that $\bar{s}_{\dot{\alpha}}^A$ annihilates the MHV part of the amplitude using the calculation presented in [21] thus

$$\bar{s}_{\dot{\alpha}}^A \delta^4(P) = \sum_{i=1}^n \eta_i^A \partial_{i\dot{\alpha}} \delta^4(P) = \sum_{i=1}^n \eta_i^A \lambda_i^\beta \frac{\partial \delta^4(P)}{\partial P^{\beta\dot{\alpha}}} = Q^{\beta B} \frac{\partial \delta^4(P)}{\partial P^{\beta\dot{\alpha}}} \quad (2.3)$$

since in $(2, 2)$ signature space-time the denominator does not depend on $\tilde{\lambda}$ and so $\bar{s}_{\dot{\alpha}}^A$ only acts on the delta function $\delta^4(P)$. By virtue of the delta function $\delta^8(Q)$ the above expression is zero as required. However, in physical $(1, 3)$ space-time λ and $\tilde{\lambda}$ are related by conjugation and as discussed in [21], this breaks the invariance. We shall see how the authors resolve this later as their method leads to an interesting result. We can show that $s_{\alpha A}$ annihilates the $\overline{\text{MHV}}$ amplitude, given by

$$A_n^{\overline{\text{MHV}}} = \int \prod_{i=1}^n (d^4 \bar{\eta}_i \exp(\eta_i^B \bar{\eta}_{iB})) \frac{\delta^4(P) \delta^8 \left(\sum_{j=1}^n \tilde{\lambda}_j^{\dot{\alpha}} \bar{\eta}_{jB} \right)}{[12][23] \cdots [n1]}$$

where the bracket $[\cdot, \cdot]$ is $[\tilde{\lambda}_i, \tilde{\lambda}_j] = \tilde{\lambda}_{i,\dot{\alpha}} \tilde{\lambda}_j^{\dot{\alpha}}$. The action of $s_{\alpha A} = \sum_k \partial_{k\alpha} \partial_{kA}$ brings a factor of $\bar{\eta}_k$ down from the exponential when performing the η_{kA} derivative and the

$\lambda_{i\alpha}$ derivative acts only on $\delta^4(P)$ thus

$$s_{\alpha A} A_n^{\overline{MHV}} = \int \left(\sum_{k=1}^n \tilde{\lambda}_k^{\dot{\beta}} \bar{\eta}_{kA} \right) \prod_{i=1}^n (d^4 \bar{\eta}_i \exp(\eta_i^B \bar{\eta}_{iB})) \frac{\delta^8 \left(\sum_{j=1}^n \tilde{\lambda}_j^{\dot{\alpha}} \bar{\eta}_{jB} \right)}{[12][23] \cdots [n1]} \frac{\partial \delta^4(P)}{\partial P^{\alpha \dot{\beta}}}$$

which reduces to zero by virtue of the delta function $\delta^8 \left(\sum_{j=1}^n \tilde{\lambda}_j^{\dot{\alpha}} \bar{\eta}_{jB} \right)$.

For completeness, we write commutation relations of the $su(2, 2|4)$ super-conformal algebra which are also written down in [27]. The commutators of a generator l with the generators of Lorentz transformations, m and \bar{m} and internal rotations r are, [21]

$$\begin{aligned} [m^\alpha{}_\beta, l_\gamma] &= -\delta_\gamma^\alpha l_\beta + \frac{1}{2} \delta_\beta^\alpha l_\gamma, & [m^\alpha{}_\beta, l^\gamma] &= \delta_\beta^\gamma l^\alpha - \frac{1}{2} \delta_\beta^\alpha l^\gamma \\ [\bar{m}^{\dot{\alpha}}{}_{\dot{\beta}}, l_{\dot{\gamma}}] &= -\delta_{\dot{\gamma}}^{\dot{\alpha}} l_{\dot{\beta}} + \frac{1}{2} \delta_{\dot{\beta}}^{\dot{\alpha}} l_{\dot{\gamma}}, & [\bar{m}^{\dot{\alpha}}{}_{\dot{\beta}}, l^{\dot{\gamma}}] &= \delta_{\dot{\beta}}^{\dot{\gamma}} l^{\dot{\alpha}} - \frac{1}{2} \delta_{\dot{\beta}}^{\dot{\alpha}} l^{\dot{\gamma}} \\ [r^A{}_B, l_C] &= -\delta_C^A l_B + \frac{1}{4} \delta_B^A l_C, & [r^A{}_B, l^C] &= \delta_B^C l^A - \frac{1}{4} \delta_B^A l^C. \end{aligned}$$

The dilation generator, d and the central charge generator c act on generator l , thus

$$[d, l] = \dim(l)l, \quad [c, l] = \text{hyp}(l)l$$

where $\dim(l)$ and $\text{hyp}(l)$ are the dimensions and hypercharges of the generators, given by

$$\begin{aligned} \dim(p) = 1, & \quad \dim(q) = \dim(\bar{q}) = \frac{1}{2}, & \quad \dim(s) = \dim(\bar{s}) = -\frac{1}{2} \\ \dim(k) = -1, & \quad \text{hyp}(q) = \text{hyp}(\bar{s}) = \frac{1}{2}, & \quad \text{hyp}(\bar{q}) = \text{hyp}(s) = -\frac{1}{2} \end{aligned}$$

and all others are zero, [27]. The rest of the non-zero commutators are,

$$\begin{aligned} \{q_{\alpha A}, \bar{q}_{\dot{\alpha}}^B\} &= \delta_A^B p_{\alpha \dot{\alpha}}, & \{s_\alpha^A, \bar{s}_{\dot{\alpha} B}\} &= \delta_B^A k_{\alpha \dot{\alpha}} \\ [p_{\alpha \dot{\alpha}}, s^{\beta A}] &= \delta_\alpha^\beta \bar{q}_{\dot{\alpha}}^A, & [k_{\alpha \dot{\alpha}}, q_A^\beta] &= \delta_\alpha^\beta \bar{s}_{\dot{\alpha} A} \\ [p_{\alpha \dot{\alpha}}, \bar{s}_A^{\dot{\beta}}] &= \delta_\alpha^{\dot{\beta}} q_{\alpha A}, & [k_{\alpha \dot{\alpha}}, \bar{q}^{\dot{\beta} A}] &= \delta_\alpha^{\dot{\beta}} s_\alpha^A \\ [k_{\alpha \dot{\alpha}}, p^{\beta \dot{\beta}}] &= \delta_\alpha^\beta \delta_{\dot{\alpha}}^{\dot{\beta}} d + m_\alpha^\beta \delta_{\dot{\alpha}}^{\dot{\beta}} + \bar{m}_{\dot{\alpha}}^{\dot{\beta}} \delta_\alpha^\beta \\ \{q_A^\alpha, s_\beta^B\} &= m_\beta^\alpha \delta_A^B + \delta_\beta^\alpha r_A^B + \frac{1}{2} \delta_\beta^\alpha \delta_A^B (d + c) \\ \{\bar{q}^{\dot{\alpha} A}, \bar{s}_{\dot{\beta} B}\} &= \bar{m}_{\dot{\beta}}^{\dot{\alpha}} \delta_B^A - \delta_{\dot{\beta}}^{\dot{\alpha}} r_B^A + \frac{1}{2} \delta_{\dot{\beta}}^{\dot{\alpha}} \delta_B^A (d - c) \end{aligned}$$

also written down in [27].

2.2 Dual Super-Conformal Symmetry of Amplitudes and the Yangian

Earlier, we wrote down the level one Yangian generator as

$$\hat{J}_a = f_a^{bc} \sum_{i < j} (J_b)_i (J_c)_j \quad (2.4)$$

satisfying

$$[\hat{J}_a, J_b] = f_{ab}^c \hat{J}_c. \quad (2.5)$$

and the Serre relation written down earlier and in [27]. In the paper [27], the authors prove the level one generators annihilate the amplitude and discuss how they are related to recently discovered ‘dual super-conformal symmetry’, [22]. The authors discuss how these symmetries become manifest in the dual-space coordinates $(\lambda_i, \tilde{\lambda}_i, \eta_i, x_i, \theta_i)$ with x and θ defined thus,

$$(x_i - x_{i+1})_{\alpha\dot{\alpha}} = \lambda_{i\alpha} \tilde{\lambda}_{i\dot{\alpha}} = p_{i\alpha\dot{\alpha}} \quad (\theta_i - \theta_{i+1})_\alpha^A = \lambda_{i\alpha} \eta_i^A. \quad (2.6)$$

It would seem natural to impose the identification $(x_{n+1}, \theta_{n+1}) = (x_1, \theta_1)$. However, as explained in the literature referred to herein, it turns out to be more convenient to act on the amplitude as a distribution rather than a loop by introducing an extra point $(x_{n+1}, \theta_{n+1}) \neq (x_1, \theta_1)$. Then, the delta functions $\delta^4(P)$ and $\delta^8(Q)$ appearing in the amplitude reimpose the loop because $\delta^4(P) = \delta^4(x_1 - x_{n+1})$ and $\delta^8(Q) = \delta^8(\theta_1 - \theta_{n+1})$. In the papers [22] and [27], the expression for the generator of special dual super-conformal transformations on the space (x, θ) is given as

$$K^{\alpha\dot{\alpha}} = \sum_{i=1}^n \left[x_i^{\alpha\dot{\beta}} x_i^{\dot{\alpha}\beta} \frac{\partial}{\partial x_i^{\beta\dot{\beta}}} + x_i^{\dot{\alpha}\beta} \theta_i^{\alpha B} \frac{\partial}{\partial \theta_i^{\beta B}} \right]$$

and this is written in terms of the whole space by adding terms so that the action of the generator preserves the surface defined by (2.6). The procedure followed in [27] is to add terms thus,

$$K^{\alpha\dot{\alpha}} = - \sum_{i=1}^n \left[x_i^{\alpha\dot{\beta}} x_i^{\dot{\alpha}\beta} \frac{\partial}{\partial x_i^{\beta\dot{\beta}}} + x_i^{\dot{\alpha}\beta} \theta_i^{\alpha B} \frac{\partial}{\partial \theta_i^{\beta B}} \right] + \text{the rest.}$$

Now the action of this new K on the amplitude A_n gives rise to conformal weights, as explained in their paper thus

$$K^{\alpha\dot{\alpha}} A_n = \sum_i^n x_i^{\alpha\dot{\alpha}} A_n$$

so the generator

$$\tilde{K}^{\alpha\dot{\alpha}} = K^{\alpha\dot{\alpha}} + \sum_{i=1}^n x_i^{\alpha\dot{\alpha}}$$

annihilates the tree-level amplitudes. Then by using (2.6) to eliminate x_i and θ_i

$$x_i^{\alpha\dot{\alpha}} = x_1^{\alpha\dot{\alpha}} - \sum_{i>j} \lambda_j^\alpha \tilde{\lambda}_j^{\dot{\alpha}}, \quad \theta_i^{\alpha A} = \theta_1^{\alpha A} - \sum_{i>j} \lambda_j^\alpha \eta_j^A$$

for $2 \leq i \leq n+1$, the authors write \tilde{K} purely in terms of $(\lambda_i, \tilde{\lambda}_i, \eta_i)$ as

$$K^{\alpha\dot{\alpha}} = - \sum_{i=1}^n \left[\sum_{j=1}^{i-1} \lambda_j^\beta \tilde{\lambda}_j^{\dot{\alpha}} \lambda_i^\alpha \frac{\partial}{\partial \lambda_i^\beta} + \sum_{j=1}^i \lambda_j^\alpha \tilde{\lambda}_j^{\dot{\beta}} \tilde{\lambda}_i^{\dot{\alpha}} \frac{\partial}{\partial \tilde{\lambda}_i^{\dot{\beta}}} + \sum_{j=1}^i \tilde{\lambda}_i^{\dot{\alpha}} \lambda_j^\alpha \eta_j^B \frac{\partial}{\partial \eta_i^B} + \sum_{j=1}^{i-1} \lambda_j^\alpha \tilde{\lambda}_j^{\dot{\alpha}} \right]$$

and similarly for the generator S they write,

$$S_\alpha^A = - \sum_{i=1}^n \left[\sum_{j=1}^{i-1} \lambda_j^\gamma \eta_j^A \lambda_{i\alpha} \frac{\partial}{\partial \lambda_i^\gamma} + \sum_{j=1}^i \lambda_{j\alpha} \tilde{\lambda}_j^{\dot{\beta}} \eta_i^A \frac{\partial}{\partial \tilde{\lambda}_i^{\dot{\beta}}} - \sum_{j=1}^i \lambda_{i\alpha} \eta_j^B \eta_i^A \frac{\partial}{\partial \eta_i^B} + \sum_{j=1}^{i-1} \lambda_{j\alpha} \eta_j^A \right]$$

which both annihilate the amplitude. The remaining dual generators are simply calculated using the commutation relations.

Since these generators are now written in terms of $(\lambda_i, \tilde{\lambda}_i, \eta_i)$ we can consider commutators between conventional and dual super-conformal generators. We know that the level one generators (2.4) satisfy (2.5) so it suffices to show how the dual super-conformal generators are related to the conventional generators by (2.5). In [27], they make the observation that $f_a{}^{cb}$ has the property

$$f_a{}^{cb} = -(-1)^{|b||c|} f_a{}^{bc}$$

using (2.4). They emulate this symmetry property in their expression for S' by adding the term ΔS which annihilates the amplitude by itself by virtue of the conventional symmetry generators

$$\Delta S_\alpha^A = \frac{1}{2} \left[-q_\gamma^A m_\alpha^\gamma + q_\alpha^A \frac{1}{2} d_\lambda + n q_\alpha^A + p_\alpha^{\dot{\beta}} \bar{s}_{\dot{\beta}}^A + q_\alpha^B r_B^A - q_\alpha^A \frac{1}{4} d_\eta \right]$$

where $d_\lambda = \sum_i \lambda_i^\beta \frac{\partial}{\partial \lambda_i^\beta}$ and $d_\eta = \sum_i \eta_i^B \frac{\partial}{\partial \eta_i^B}$ are referred to in the paper as counting operators. Their calculation reveals the following

$$\begin{aligned} S'_\alpha{}^A + \Delta S_\alpha^A &= \frac{1}{2} \sum_{i \geq j} \left[m_{i\alpha}^\gamma q_{j\gamma}^A - \frac{1}{2} (d_i + c_i) q_{j\alpha}^A + p_{i\alpha}^{\dot{\beta}} \bar{s}_{j\dot{\beta}}^A + q_{i\alpha}^B r_{jB}^A - (i \leftrightarrow j) \right] \\ &\quad + \sum_{i=1}^n q_{i\alpha}^A c_i - \frac{1}{2} q_\alpha^A \end{aligned}$$

The left hand side annihilates the amplitude and the last term on the right hand side annihilates the amplitude by itself therefore the operator

$$q_\alpha^{(1)A} = \sum_{i \geq j} \left[m_{i\alpha}^\gamma q_{j\gamma}^A - \frac{1}{2}(d_i + c_i)q_{j\alpha}^A + p_{i\alpha}^{\dot{\beta}} \bar{s}_{j\dot{\beta}}^A + q_{i\alpha}^B r_{jB}^A - (i \leftrightarrow j) \right]$$

is a symmetry of the amplitude and as they show in their paper exactly corresponds to the level one Yangian (2.4) not just by using consistency arguments but also by directly calculating (2.4).

One could continue this procedure ad-infinitum to obtain an infinite ‘tower’ of Yangian generators. However, even just the level zero and level one generators have been shown in the recent papers, [21] and [28] to be useful in constraining amplitudes at tree-level and at 1-loop level.

2.3 Deformed Yangian Symmetry

2.3.1 The Holomorphic Anomaly

In the previous section we reviewed the discussion in [21] of the generator \bar{s} given by

$$\bar{s}_{i\dot{\alpha}}^A = \eta_i^A \partial_{i\dot{\alpha}}$$

on the tree-level amplitude, (2.1). In that argument, the authors make the assumption that the denominator of (2.1) depends on λ and not on $\tilde{\lambda}$ in $(2, 2)$ signature space-time. In physical space-time however they make the observation that λ and $\tilde{\lambda}$ are related by conjugation and the action of \bar{s} on A_n is subject to the holomorphic anomaly. The anomaly arises by defining the complex measure $d^2z = dx dy$ and

$$\int d^2z \delta^2(z) = 1$$

and then using Green’s theorem

$$\int_{\mathcal{R}} d^2z \frac{\partial}{\partial \bar{z}} \frac{1}{z} = \int_{\partial \mathcal{R}} dz \frac{1}{z}$$

to show that

$$\frac{\partial}{\partial \bar{z}} \frac{1}{z} = \pi \delta^2(z).$$

Then Beisert (*et-al*) [21] explain that this gives rise to extra terms in the action of \bar{s} on A_n , since

$$\frac{\partial}{\partial \tilde{\lambda}^{\dot{\alpha}}} \frac{1}{\langle \lambda, \mu \rangle} = \pi \delta^2(\langle \lambda, \mu \rangle) \varepsilon_{\dot{\alpha}\dot{\beta}} \tilde{\mu}^{\dot{\beta}}.$$

In physical (1,3) space-time the action of the generator \bar{s} on A_n is given in that paper as

$$\begin{aligned} \bar{s}_{\dot{\alpha}}^A A_n &= \sum_{k=1}^n \eta_k^A \frac{\partial}{\partial \tilde{\lambda}^{\dot{\alpha}}} \frac{\delta^4(P) \delta^8(Q)}{\langle 12 \rangle \cdots \langle k-1, k \rangle \langle k, k+1 \rangle \cdots \langle n1 \rangle} \\ &= -\pi \sum_{k=1}^n \varepsilon_{\dot{\alpha}\dot{\beta}} \left(\tilde{\lambda}_{k-1}^{\dot{\beta}} \eta_k^A - \tilde{\lambda}_k^{\dot{\beta}} \eta_{k-1}^A \right) \frac{\delta^2(\langle \lambda_{k-1} \lambda_k \rangle) \delta^4(P) \delta^8(Q)}{\langle 12 \rangle \cdots \langle k-1, k \rangle^0 \cdots \langle n1 \rangle}, \end{aligned}$$

clearly not annihilating the amplitude as it does so simply in (2,2) space-time.

2.3.2 Generators That Change the Number of Legs

Beisert (*et-al*), [21], consider generators that deform the number of legs acting on the sum of l -loop, n -point amplitudes, $A_n^{(l)}$ in powers of the coupling constant, g ,

$$\mathcal{A}(g) = \sum_{n=4}^{\infty} \sum_{l=0}^{\infty} g^{n-2+2l} A_n^{(l)}$$

They write the generators of the symmetries as the series

$$J_a(g) = \sum_{m,n=1}^{\infty} \sum_{l=0}^{\infty} g^{2l+m+n-2} (J_{m,n}^{(l)})_a$$

where m is the number of incoming legs and n is the number of outgoing legs. The generators also contain loops, labelled l . The free generator J_0 is defined to be $J_{1,1}^0$ and takes one leg of the amplitude to one leg and contains no loops. The action of generators on the amplitude can create extra loops by taking two legs from an $n+1$ leg amplitude into one leg of an n point amplitude. (See fig(2.1) and see the original figure in [21].) The action of the deformed generators on this amplitude is written in [21] as,

$$\begin{aligned} J_{1,1}^{(0)} A_n^{(l)} + J_{1,2}^{(0)} A_{n-1} + J_{2,1}^{(0)} A_{n+1}^{(l-1)} + J_{1,1}^{(1)} A_n^{(l-1)} + J_{1,3}^{(0)} A_{n-2}^{(l)} \\ + J_{2,2}^{(0)} A_n^{(l-1)} + J_{3,1}^{(0)} A_{n+2}^{(l-2)} + \cdots = 0 \end{aligned}$$

and with this expression in mind it is possible to not only write tree-level n -point amplitudes in terms of $n-1$ point amplitudes but also write l -loop amplitudes

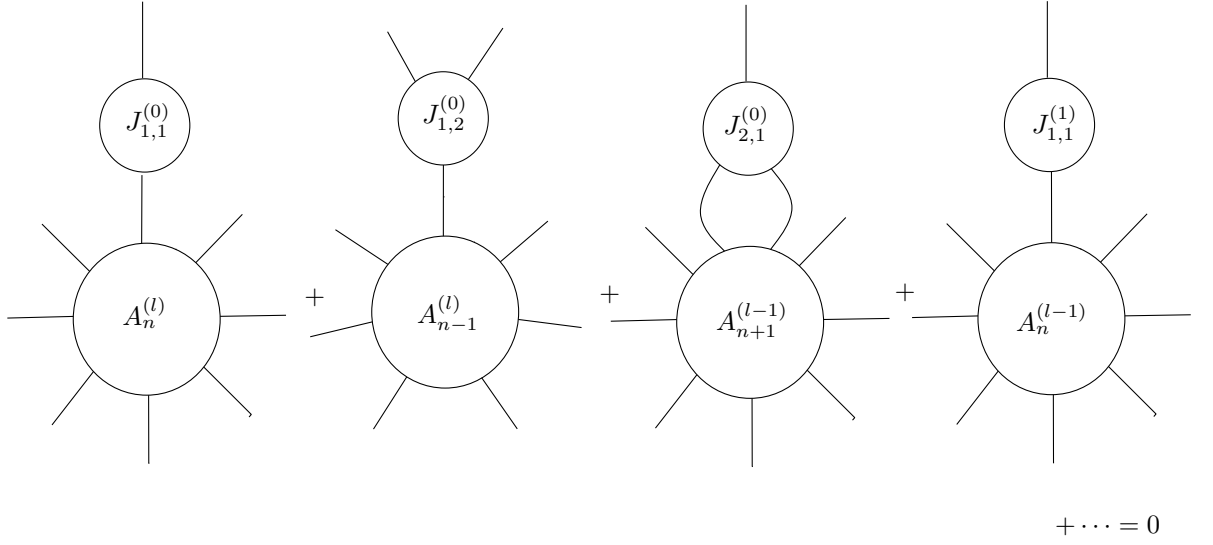
 Figure 2.1: Action of Generators on an n -point, l -loop Amplitude

in terms of amplitudes that are lower order in the loop expansion as done in the paper [28].

For now, let us review how the holomorphic anomaly is used in [21] to constrain tree-level amplitudes. The authors write the amplitude and the generator \bar{s} in a functional formalism. They write,

$$\mathcal{A}_n(J) = \sum \int d^{4|4}\Lambda_1 \cdots d^{4|4}\Lambda_n \frac{1}{n} \text{Tr}(J(\Lambda_1) \cdots J(\Lambda_n)) \mathcal{A}_n(\Lambda_1 \cdots \Lambda_n)$$

and

$$(\bar{s}_0)_\alpha^A = - \int d^{4|4}\Lambda \text{Tr}(\eta^A \partial_{\dot{\alpha}} J(\Lambda) \frac{\delta}{\delta J(\Lambda)})$$

for a generating functional J and where $\Lambda = (\lambda^\alpha, \tilde{\lambda}^{\dot{\alpha}}, \eta^A)$ and $d^{4|4}\Lambda = d^4\lambda d^4\eta$. A calculation reveals the action of \bar{s}_0 on \mathcal{A}_n using the expression for the holomorphic anomaly as

$$(\bar{s}_0)_\alpha^A \mathcal{A}_n[J] = -\pi \int \prod_{k=2}^{n-1} d^{4|4}\Lambda_k \text{Tr}([J(\Lambda_n), J(\Lambda_1)] \cdots J(\Lambda_{n-1})) \varepsilon_{\dot{\alpha}\dot{\gamma}} \tilde{\lambda}_n^{\dot{\gamma}} \eta_1^A \times \\ \times \frac{\delta^2(\langle n1 \rangle) \delta^4(P) \delta^8(Q)}{\langle 12 \rangle \cdots \langle n-1, n \rangle}.$$

After some careful variable changes under the integrals and after evaluating the

various Jacobians and one integral (see [21] for details) this expression can be written

$$(\bar{s}_0)_{\dot{\alpha}}^A \mathcal{A}_n = -2\pi^2 \int \prod_{k=2}^{n-1} d^{4|4} \Lambda_k d^{4|4} \dot{\Lambda}_1 d^4 \dot{\eta} d\alpha \varepsilon_{\dot{\alpha}\dot{c}} \tilde{\lambda}_n^{\dot{c}} \eta_1^A \times \\ \times \text{Tr}([\check{J}(\Lambda_n), J(\Lambda_1)] \cdots J(\Lambda_{n-1})) \frac{\delta^4(P) \delta^8(Q)}{\langle \dot{1} 2 \rangle \cdots \langle n \dot{1} \rangle}$$

where they make the variable transformation

$$\lambda_n = \dot{\lambda}_1 \sin \alpha, \quad \eta_n = (\dot{\eta}_1 \sin \alpha + \dot{\eta} \cos \alpha) \\ \lambda_1 = \dot{\lambda}_1 \cos \alpha + z \dot{\lambda}, \quad \eta_1 = \dot{\eta}_1 \cos \alpha - \dot{\eta} \sin \alpha$$

and

$$\check{J}(\Lambda) = \frac{1}{2\pi} \int_0^{2\pi} d\varphi e^{i2\varphi} J(e^{i\varphi} \Lambda).$$

The term \check{J} arises by noting that the amplitudes are homogeneous under phase shifts of the arguments, that is $A(\Lambda_1, \dots, e^{i\varphi} \Lambda_k, \dots, \Lambda_n) = e^{-2i\varphi} A(\Lambda_1, \dots, \Lambda_n)$.

The authors observe that this is equivalent to writing

$$(s_0)_{\dot{\alpha}}^A \mathcal{A}_n^{MHV} = (S_+)_{\dot{\alpha}}^A \mathcal{A}_{n-1}^{MHV}$$

where (\bar{s}_+) is given by

$$(\bar{s}_+)_{\dot{\alpha}}^A = 2\pi^2 \int d^{4|4} \Lambda d\eta d\alpha \varepsilon_{\dot{\alpha}\dot{c}} \tilde{\lambda}_1^{\dot{c}} \eta_2^A \text{Tr}([\check{J}(\Lambda_1), J(\Lambda_2)] \frac{\delta}{\delta J(\Lambda)})$$

after the further redefinition

$$\lambda_1 = \lambda \sin \alpha, \quad \eta_1 = \eta \sin \alpha + \dot{\eta} \cos \alpha \\ \lambda_2 = \lambda \cos \alpha, \quad \eta_2 = \eta \cos \alpha + \dot{\eta} \sin \alpha.$$

The conclusion Beisert (*et-al*) arrive at is that the n -point tree-level amplitude is written in terms of the $n-1$ point amplitude using the the generator \bar{s}_+ which alters the number of legs on \mathcal{A}_{n-1} . By considering the $\overline{\text{MHV}}$ amplitude acted upon by the generator $s_{\alpha A}$ defined in (2.2) they further conclude that the holomorphic anomaly gives rise to non-zero terms which are corrected by deriving the correction to the generator as

$$(s_-)_{\alpha A} = -2\pi^2 \int d^{4|4} \Lambda d\alpha d^4 \dot{\eta} \varepsilon_{\alpha c} \lambda_1^c \text{Tr}([\hat{J}(\Lambda_1), \partial_{2,A} J(\Lambda_2)] \frac{\delta}{\delta J(\Lambda)})$$

using a similar procedure to that we have just reviewed whose action gives

$$(s_0)_{\alpha A} \overline{\mathcal{A}}_n^{MHV} + (s_-)_{\alpha A} \overline{\mathcal{A}}_{n-1}^{MHV} = 0.$$

To summarise, we have the two deformed generators, s and \bar{s} given by

$$s_{\alpha A} = (s_0)_{\alpha A} + (s_-)_{\alpha A}, \quad (\bar{s})_{\dot{\alpha}}^A = (\bar{s}_0)_{\dot{\alpha}}^A + (\bar{s}_+)_{\dot{\alpha}}^A \quad (2.7)$$

where s_- and \bar{s}_+ have been given in [21] and reviewed here. Now Beisert (*et al*) calculate the commutators of the super-conformal generators with the deformed generators. They conclude that the deformed generators satisfy the super-conformal algebra and that no other generators acquire quantum corrections except $k_{\alpha\dot{\alpha}}$ which is defined in (2.2). The deformation that k receives is

$$k = k_0 + k_+ + k_- + k_{+-} \quad (2.8)$$

where their derived expressions for the corrections are

$$\begin{aligned} (k_+)_{\alpha\dot{\alpha}} &= -2\pi^2 \int d^{4|4} \Lambda \, d^4 \tilde{\eta} \, d\alpha \, \varepsilon_{\dot{\alpha}b} \tilde{\lambda}_1^b \text{Tr}[\hat{J}(\Lambda_1), \partial_{2,\alpha} J(\Lambda_2)] \frac{\delta}{\delta J(\Lambda)} \\ (k_-)_{\alpha\dot{\alpha}} &= -2\pi^2 \int d^{4|4} \Lambda \, d^4 \tilde{\eta} \, d\alpha \, \delta^4(\tilde{\eta}) \, \varepsilon_{\alpha b} \lambda_1^b \text{Tr}[\hat{J}(\Lambda_1), \partial_{2,\dot{\alpha}} J(\Lambda_2)] \frac{\delta}{\delta J(\Lambda)} \\ (k_{+-})_{\alpha\dot{\alpha}} &= -4\pi^4 \int d^{4|4} \Lambda \, d^4 \tilde{\eta} \, d\alpha \, d\dot{\alpha} \, \cos(\alpha) \text{Tr}[\varepsilon_{\alpha d} \lambda_1^d \hat{J}(\Lambda_1), [\varepsilon_{\dot{\alpha}c} \tilde{\lambda}_2^c \hat{J}(\Lambda_2), J(\Lambda_3)]] \frac{\delta}{\delta J(\Lambda)}. \end{aligned}$$

In their paper they show that the deformed generators s , \bar{s} and k , complete with the other super-conformal generators, satisfy the super-conformal algebra.

Their expressions for the deformed generators are derived by considering their action on MHV and $\overline{\text{MHV}}$ amplitudes. Later in the paper, [21], they use the BCFW recursion relations to show that the expressions for the deformed generators (2.7) and (2.8) generalize to a general n -point amplitude given by

$$A_n = \sum_{k=2}^{k=n-2} A_{n,k}$$

where $A_{n,k}$ is an n -point amplitude with k negative helicities and $k - 2$ positive helicities. Then $k = 2$ corresponds to the MHV rules, $k = 3$ corresponds to NMHV and so on. The action of k on $A_{n,k}$ is then,

$$k A_{n,k} = k_0 A_{n,k} + k_+ A_{n-1,k} + k_- A_{n-1,k-1} + k_{+-} A_{n-2,k-1} = 0.$$

They argue that the deformed generators give rise to recursive diagrams such as fig (2.2) where the collinear singularities arising from the holomorphic anomaly seen by the free generator k_0 are corrected by k_+ , k_- or k_{+-} . In that way, they use symmetry arguments to constrain tree-level amplitudes.

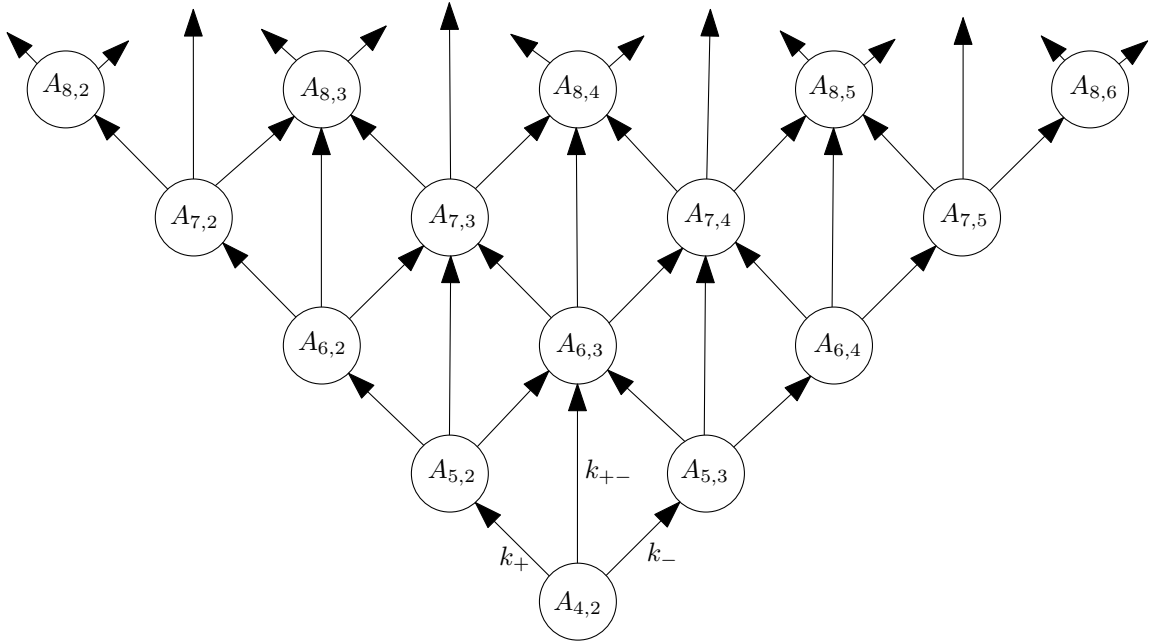
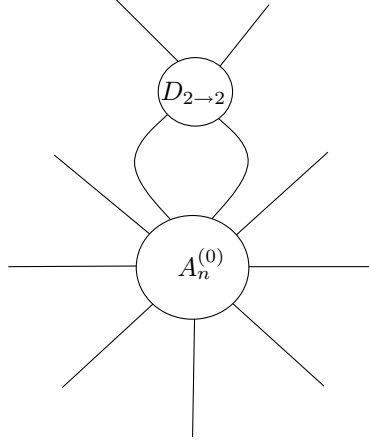

Figure 2.2: Recursive Action of Generators on the Tree-Level Amplitudes

2.4 Chapter Summary

We have reviewed the recent work presented in the papers [27], [21] and [28]. We began by writing down the generators of the super-conformal algebra and gave some example calculations of their action on tree-level MHV and $\overline{\text{MHV}}$ amplitudes. We wrote down the generators of the algebra. Further, we discussed that it has recently been observed that scattering amplitudes exhibit higher symmetries (see [22]) referred to as the dual super-conformal symmetry which manifests itself in dual-space coordinates. It was then reviewed how the dual super-conformal symmetry is related to the level one Yangian symmetry generators (see [27]) and the commutators of the level one generators with the level zero, super-conformal generators were written down along with the Serre relations.

Figure 2.3: Super-Conformal Dilation Generator $D_{2 \rightarrow 2}$

The authors of [21] claim that the super-conformal symmetry is broken in $(1, 3)$ space, even at tree-level by collinearities and the holomorphic anomaly. We discussed their calculations which led to some of the generators acquiring quantum corrections. It was shown in their paper that this leads to a recursive relationship between n -point amplitudes and $n - 1$ point amplitudes.

It is interesting to consider what quantum corrections the level one Yangian generators receive. This has recently been addressed in the very detailed paper, [28]. The authors write down the known result for the action of the dual super-conformal generator K on the 1-loop amplitude in terms of the tree-level amplitude arising from the conformal anomaly and taking care with collinearities in the loop, [20, 41]. They then write the dual super-conformal generator acting on the 1-loop amplitude in terms of the level zero Yangian generators, alias the ordinary super-conformal generators, and the level one Yangian generator \hat{P} and compare the expressions to find a deformed generator

$$(\hat{P}^{(1)})^{\alpha\dot{\alpha}} = - \left[\sum_{1 \leq j < i \leq n} \left(P_j^{\alpha\dot{\alpha}}(D_{2 \rightarrow 2})_i - P_i^{\alpha\dot{\alpha}}(D_{2 \rightarrow 2})_{j-1} \right) + (P_i^{\alpha\dot{\alpha}} - P_{i+1}^{\alpha\dot{\alpha}})(D_{2 \rightarrow 2})_i \right]$$

where $D_{2 \rightarrow 2}$ is a generator which they calculate that maps two legs of an n -point tree-level amplitude onto two outward legs thus creating a loop, fig (2.3). The action of the deformed Yangian generator $\hat{P}^{(1)}$ on the tree-level amplitude is thus

$$(\hat{P}^{(1)})A_n^{(0)} = \hat{P}^{(0)}A_n^{(1)}$$

demonstrating a recursive relationship between tree-level and 1-loop amplitudes by virtue of the deformed level one Yangian generator. It is believed by those working on these particularly interesting ideas, which we have briefly reviewed, that the infinite tower of Yangian generators which we alluded to earlier may help to constrain amplitudes at higher loop level, or ultimately to all loops.

Chapter 3

Symmetries of Free Field Theories

3.1 Introduction

We shall illustrate the extended symmetries of free theories with the example of complex scalar fields φ and $\tilde{\varphi}$ with action

$$\begin{aligned} S &= \int d^d x \sqrt{-g} (g^{\mu\nu} \partial_\mu \tilde{\varphi} \partial_\nu \varphi + m^2 \tilde{\varphi} \varphi) \\ &= \int d^d x \sqrt{-g} (-g^{\mu\nu} \tilde{\varphi} \partial_\mu \partial_\nu \varphi + m^2 \tilde{\varphi} \varphi) \\ &= \int d^d x \sqrt{-g} \tilde{\varphi} \Omega \varphi \end{aligned} \tag{3.1}$$

where Ω is an operator given by $\Omega = -\eta^{\mu\nu} \partial_\mu \partial_\nu + m^2$. Consider the transformation $\varphi \rightarrow \varphi + \delta\varphi$ and $\tilde{\varphi} \rightarrow \tilde{\varphi} + \delta\tilde{\varphi}$ with $\delta\varphi$ and $\delta\tilde{\varphi}$ given by

$$\delta\varphi(x) = \varepsilon\varphi(x_G), \quad \delta\tilde{\varphi}(x) = -\varepsilon\tilde{\varphi}(x_{G^{-1}})$$

resulting from the finite isometry $x \rightarrow x_G$. Now the change in the action is

$$\delta S = \varepsilon \int d^d x \sqrt{-g(x)} \tilde{\varphi}(x) \Omega(x) \varphi(x_G) - \varepsilon \int d^d x \sqrt{-g(x)} \tilde{\varphi}(x_{G^{-1}}) \Omega(x) \varphi(x). \tag{3.2}$$

We are free to apply the isometry $x \rightarrow x_G$ to the second integral. By writing $y = x_{G^{-1}}$ and realising that the following is true

$$\sqrt{-g(x)} d^d x = \sqrt{-\dot{g}(y)} d^d y$$

then (3.2) becomes

$$\delta S = \varepsilon \int d^d x \sqrt{-g(x)} \tilde{\varphi}(x) \Omega(x) \varphi(x_G) - \varepsilon \int d^d y \sqrt{-\dot{g}(y)} \tilde{\varphi}(y) \Omega(y_G) \varphi(y_G).$$

Since Ω is an index-less scalar operator we have $\Omega(y_G) = \dot{\Omega}(y)$ and we get

$$\delta S = \varepsilon \int d^d x \sqrt{-g(x)} \tilde{\varphi}(x) \Omega(x) \varphi(x_G) - \varepsilon \int d^d y \sqrt{-\dot{g}(y)} \tilde{\varphi}(y) \dot{\Omega}(y) \varphi(y_G),$$

and since $x \rightarrow x_G$ is an isometry we have $\dot{g} = g$ and $\dot{\Omega} = \Omega$ hence we arrive at the conclusion that $\delta S = 0$.

3.2 Symmetries Produced by Displacements for a Complex Free Scalar Field

We consider symmetries generated as above where $x \rightarrow x_G$ is a displacement. This approach differs from the approach taken by Fairlie [42] and the method will allow us to generalize our approach to more general diffeomorphisms of objects on arbitrary backgrounds. The displacements form a Lie group with elements j by $x \rightarrow x + a_j$ where the a_j are finite, constant vectors and the ε_j are infinitesimal. We write¹

$$\delta_\varepsilon \varphi(x) = \sum_j \varepsilon_j \exp(a_j \cdot \partial) \varphi(x) \quad (3.3)$$

$$\delta_\varepsilon \tilde{\varphi}(x) = - \sum_j \varepsilon_j \exp(-a_j \cdot \partial) \tilde{\varphi}(x) \quad (3.4)$$

which can be Taylor expanded in powers of a^λ

$$\delta_\varepsilon \varphi(x) = \sum_j \varepsilon_j \left\{ \varphi(x) + \frac{a_j^{\lambda_1} \partial_{\lambda_1} \varphi(x)}{1!} + \frac{a_j^{\lambda_1} a_j^{\lambda_2} \partial_{\lambda_1} \partial_{\lambda_2} \varphi(x)}{2!} + \dots \right\} \quad (3.5)$$

$$\delta_\varepsilon \tilde{\varphi}(x) = \sum_j \varepsilon_j \left\{ -\tilde{\varphi}(x) + \frac{a_j^{\lambda_1} \partial_{\lambda_1} \tilde{\varphi}(x)}{1!} - \frac{a_j^{\lambda_1} a_j^{\lambda_2} \partial_{\lambda_1} \partial_{\lambda_2} \tilde{\varphi}(x)}{2!} + \dots \right\} \quad (3.6)$$

thus generating an infinite number of symmetries since the whole object is a symmetry hence the individual linearly independent terms must be a symmetry. Dropping the summation over j for the moment to reduce notation, our transformations are then given by the expressions

$$\delta_{(n)} \varphi(x) = \varepsilon a^{\lambda_1} \dots a^{\lambda_n} \partial_{\lambda_1} \dots \partial_{\lambda_n} \varphi(x)$$

$$\delta_{(n)} \tilde{\varphi}(x) = (-1)^{n+1} \varepsilon a^{\lambda_1} \dots a^{\lambda_n} \partial_{\lambda_1} \dots \partial_{\lambda_n} \tilde{\varphi}(x).$$

¹The index j is not a space time index.

Given that these linearly independent transformations are symmetries of the action then it is possible by Noether's theorem to construct conserved currents for general n by

$$J_{(n)}^\mu = \frac{\partial \mathcal{L}}{\partial \partial_\mu \varphi} \delta_{(n)} \varphi + \frac{\partial \mathcal{L}}{\partial \partial_\mu \tilde{\varphi}} \delta_{(n)} \tilde{\varphi} - K_{(n)}^\mu \quad (3.7)$$

with $\delta_{(n)}$ as defined and $K_{(n)}^\mu$ is to be determined. We assume a zero mass term for simplicity and consider single group elements j . By calculating an expression for $K_{(n)}^\mu$ for $n = 1, n = 2, n = 3, \dots$ derivatives in turn, it is possible to deduce an expression for $K_{(n)}^\mu$ by following the pattern and then proving it explicitly by checking that the divergence of eqn (3.7) is zero as required by the condition that $J_{(n)}^\mu$ is a conserved current.

Terms that are first order in a

First calculate $K_{(n)}^\mu$ for terms that are first order in a^λ in (3.5) and (3.6); we have

$$\begin{aligned} \delta_{(1)} \varphi &= \varepsilon a^{\lambda_1} \partial_{\lambda_1} \varphi \\ \delta_{(1)} \tilde{\varphi} &= \varepsilon a^{\lambda_1} \partial_{\lambda_1} \tilde{\varphi}. \end{aligned}$$

Under the transformation the massless Lagrange density changes by

$$\begin{aligned} \delta_{(1)} \mathcal{L} &= \eta^{\mu\nu} \partial_\mu \delta_{(1)} \tilde{\varphi} \partial_\nu \varphi + \eta^{\mu\nu} \partial_\mu \tilde{\varphi} \partial_\nu \delta_{(1)} \varphi \\ &= \varepsilon \eta^{\mu\nu} a^{\lambda_1} \partial_\mu \partial_{\lambda_1} \tilde{\varphi} \partial_\nu \varphi + \varepsilon \eta^{\mu\nu} a^{\lambda_1} \partial_\mu \tilde{\varphi} \partial_\nu \partial_{\lambda_1} \varphi \\ &= \varepsilon \partial_{\lambda_1} (\eta^{\mu\nu} a^{\lambda_1} \partial_\mu \tilde{\varphi} \partial_\nu \varphi) \end{aligned}$$

giving,

$$K_{(1)}^\mu = \eta^{\lambda_1 \lambda_2} a^{\lambda_2} \partial_{\lambda_1} \tilde{\varphi} \partial_{\lambda_2} \varphi \quad (3.8)$$

by the swapping of dummy indices giving free index μ .

Terms that are second order in a

The change in the field variables is

$$\begin{aligned} \delta_{(2)} \varphi &= \varepsilon a^{\lambda_1} a^{\lambda_2} \partial_{\lambda_1} \partial_{\lambda_2} \varphi \\ \delta_{(2)} \tilde{\varphi} &= -\varepsilon a^{\lambda_1} a^{\lambda_2} \partial_{\lambda_1} \partial_{\lambda_2} \tilde{\varphi}. \end{aligned}$$

Then the change in the Lagrangian is

$$\begin{aligned}
 \delta_{(2)}\mathcal{L} &= \eta^{\mu\nu}\partial_\mu(\delta_{(2)}\tilde{\varphi})\partial_\nu\varphi + \eta^{\mu\nu}\partial_\mu\tilde{\varphi}\partial_\nu(\delta_{(2)}\varphi) \\
 &= -\varepsilon\eta^{\mu\nu}\partial_\mu(a^{\lambda_1}a^{\lambda_2}\partial_{\lambda_1}\partial_{\lambda_2}\tilde{\varphi})\partial_\nu\varphi + \varepsilon\eta^{\mu\nu}\partial_\mu\tilde{\varphi}\partial_\nu(a^{\lambda_1}a^{\lambda_2}\partial_{\lambda_1}\partial_{\lambda_2}\varphi) \\
 &= -\varepsilon\eta^{\mu\nu}a^{\lambda_1}a^{\lambda_2}\partial_{\lambda_1}(\partial_\mu\partial_{\lambda_2}\tilde{\varphi}\partial_\nu\varphi) + \varepsilon\eta^{\mu\nu}a^{\lambda_1}a^{\lambda_2}\partial_\mu\partial_{\lambda_2}\tilde{\varphi}\partial_{\lambda_1}\partial_\nu\varphi \\
 &\quad - \varepsilon\eta^{\mu\nu}a^{\lambda_1}a^{\lambda_2}\partial_\mu\partial_{\lambda_1}\tilde{\varphi}\partial_{\lambda_2}\partial_\nu\varphi + \varepsilon\eta^{\mu\nu}a^{\lambda_1}a^{\lambda_2}\partial_{\lambda_1}(\partial_\mu\tilde{\varphi}\partial_{\lambda_2}\partial_\nu\varphi).
 \end{aligned}$$

The second and third terms cancel by symmetry of the λ_i , leaving

$$\delta_{(2)}\mathcal{L} = \varepsilon\eta^{\mu\nu}a^{\lambda_1}a^{\lambda_2}\partial_{\lambda_1}(\partial_\mu\tilde{\varphi}\partial_\nu\partial_{\lambda_2}\varphi - \partial_\mu\partial_{\lambda_2}\tilde{\varphi}\partial_\nu\varphi).$$

Rearranging indices gives our final expression for $K_{(2)}^\mu$,

$$K_{(2)}^\mu = \eta^{\lambda_1\lambda_3}a^\mu a^{\lambda_2}(\partial_{\lambda_1}\tilde{\varphi}\partial_{\lambda_3}\partial_{\lambda_2}\varphi - \partial_{\lambda_1}\partial_{\lambda_2}\tilde{\varphi}\partial_{\lambda_3}\varphi). \quad (3.9)$$

Terms that are third order in a

An expression for $K_{(n)}^\mu$ for terms that are higher order in a can be found similarly by taking out ∂_{λ_1} . Following the same procedure gives

$$\begin{aligned}
 \delta_{(3)}\mathcal{L} &= \eta^{\mu\nu}a^{\lambda_1}a^{\lambda_2}a^{\lambda_3}\partial_\mu\partial_{\lambda_1}\partial_{\lambda_2}\partial_{\lambda_3}\tilde{\varphi}\partial_\nu\varphi + \eta^{\mu\nu}a^{\lambda_1}a^{\lambda_2}a^{\lambda_3}\partial_\mu\tilde{\varphi}\partial_{\lambda_1}\partial_{\lambda_2}\partial_{\lambda_3}\partial_\nu\varphi \\
 &= \eta^{\mu\nu}a^{\lambda_1}a^{\lambda_2}a^{\lambda_3}\partial_{\lambda_1}(\partial_\mu\partial_{\lambda_2}\partial_{\lambda_3}\tilde{\varphi}\partial_\nu\varphi + \partial_\mu\tilde{\varphi}\partial_{\lambda_2}\partial_{\lambda_3}\partial_\nu\varphi) \\
 &\quad - \eta^{\mu\nu}a^{\lambda_1}a^{\lambda_2}a^{\lambda_3}(\partial_\mu\partial_{\lambda_2}\partial_{\lambda_3}\tilde{\varphi}\partial_{\lambda_1}\partial_\nu\varphi + \partial_\mu\partial_{\lambda_1}\tilde{\varphi}\partial_{\lambda_2}\partial_{\lambda_3}\partial_\nu\varphi) \\
 &= \eta^{\mu\nu}a^{\lambda_1}a^{\lambda_2}a^{\lambda_3}\partial_{\lambda_1}(\partial_\mu\partial_{\lambda_2}\partial_{\lambda_3}\tilde{\varphi}\partial_\nu\varphi + \partial_\mu\tilde{\varphi}\partial_{\lambda_2}\partial_{\lambda_3}\partial_\nu\varphi) \\
 &\quad - \eta^{\mu\nu}a^{\lambda_1}a^{\lambda_2}a^{\lambda_3}\partial_{\lambda_2}(\partial_\mu\partial_{\lambda_3}\tilde{\varphi}\partial_{\lambda_1}\partial_\nu\varphi) \\
 &\quad + \eta^{\mu\nu}a^{\lambda_1}a^{\lambda_2}a^{\lambda_3}(\partial_\mu\partial_{\lambda_3}\tilde{\varphi}\partial_{\lambda_1}\partial_{\lambda_2}\partial_\nu\varphi) \\
 &\quad - \eta^{\mu\nu}a^{\lambda_1}a^{\lambda_2}a^{\lambda_3}(\partial_\mu\partial_{\lambda_1}\tilde{\varphi}\partial_{\lambda_2}\partial_{\lambda_3}\partial_\nu\varphi) \\
 &= \eta^{\mu\nu}a^{\lambda_1}a^{\lambda_2}a^{\lambda_3}\partial_{\lambda_1}(\partial_\mu\partial_{\lambda_2}\partial_{\lambda_3}\tilde{\varphi}\partial_\nu\varphi + \partial_\mu\tilde{\varphi}\partial_{\lambda_2}\partial_{\lambda_3}\partial_\nu\varphi - \partial_\mu\partial_{\lambda_3}\tilde{\varphi}\partial_{\lambda_2}\partial_\nu\varphi)
 \end{aligned}$$

giving as an expression for $K_{(3)}^\mu$ by the manipulation of dummy indices,

$$K_{(3)}^\mu = \eta^{\lambda_1 \lambda_4} a^\mu a^{\lambda_2} a^{\lambda_3} (\partial_{\lambda_1} \partial_{\lambda_2} \partial_{\lambda_3} \tilde{\varphi} \partial_{\lambda_4} \varphi - \partial_{\lambda_1} \partial_{\lambda_2} \tilde{\varphi} \partial_{\lambda_3} \partial_{\lambda_4} \varphi + \partial_{\lambda_1} \tilde{\varphi} \partial_{\lambda_2} \partial_{\lambda_3} \partial_{\lambda_4} \varphi)$$

for third order terms.

It is possible to see a pattern emerging. For terms that are n^{th} order in a^λ the first term is made of n derivatives acting on φ , each contracted with an a^λ and one derivative acting on $\tilde{\varphi}$, contracted with the metric. Subsequent terms are made by commuting one derivative at a time to act on the $\tilde{\varphi}$, each time picking up a minus sign until the last term when there are n derivatives acting on $\tilde{\varphi}$, each contracted with an a^λ and one derivative acting on φ , contracted with the metric. We can now give a general expression for $K_{(n)}^\mu$,

$$\begin{aligned} K_{(n)}^\mu = & \eta^{\lambda_1 \lambda_{n+1}} a^\mu a^{\lambda_2} \dots a^{\lambda_n} \partial_{\lambda_1} \tilde{\varphi} \partial_{\lambda_2} \dots \partial_{\lambda_{n+1}} \varphi & (3.10) \\ & - \eta^{\lambda_1 \lambda_{n+1}} a^\mu a^{\lambda_2} \dots a^{\lambda_n} \partial_{\lambda_1} \partial_{\lambda_2} \tilde{\varphi} \partial_{\lambda_3} \dots \partial_{\lambda_{n+1}} \varphi + \dots \\ & \dots + (-1)^n \eta^{\lambda_1 \lambda_{n+1}} a^\mu a^{\lambda_2} \dots a^{\lambda_n} \partial_{\lambda_1} \dots \partial_{\lambda_{n-1}} \tilde{\varphi} \partial_{\lambda_n} \partial_{\lambda_{n+1}} \varphi \\ & + (-1)^{n+1} \eta^{\lambda_1 \lambda_{n+1}} a^\mu a^{\lambda_2} \dots a^{\lambda_n} \partial_{\lambda_1} \dots \partial_{\lambda_n} \tilde{\varphi} \partial_{\lambda_{n+1}} \varphi. \end{aligned}$$

Differentiating this expression with respect to the free index μ one gets back $\delta_{(n)} \mathcal{L}$, the proof of which is simple. We now calculate eqn (3.7) using this expression.

$$\begin{aligned} J_{(n)}^\mu = & \eta^{\mu\nu} a^{\lambda_1} \dots a^{\lambda_n} \partial_\nu \tilde{\varphi} \partial_{\lambda_1} \dots \partial_{\lambda_n} \varphi + (-1)^{n+1} \eta^{\mu\nu} a^{\lambda_1} \dots a^{\lambda_n} \partial_\nu \varphi \partial_{\lambda_1} \dots \partial_{\lambda_n} \tilde{\varphi} \\ & - \eta^{\lambda_1 \lambda_{n+1}} a^\mu a^{\lambda_2} \dots a^{\lambda_n} \partial_{\lambda_1} \tilde{\varphi} \partial_{\lambda_2} \dots \partial_{\lambda_{n+1}} \varphi \\ & + \eta^{\lambda_1 \lambda_{n+1}} a^\mu a^{\lambda_2} \dots a^{\lambda_n} \partial_{\lambda_1} \partial_{\lambda_2} \tilde{\varphi} \partial_{\lambda_3} \dots \partial_{\lambda_{n+1}} \varphi - \dots \\ & \dots - (-1)^n \eta^{\lambda_1 \lambda_{n+1}} a^\mu a^{\lambda_2} \dots a^{\lambda_n} \partial_{\lambda_1} \dots \partial_{\lambda_{n-1}} \tilde{\varphi} \partial_{\lambda_n} \partial_{\lambda_{n+1}} \varphi \\ & - (-1)^{n+1} \eta^{\lambda_1 \lambda_{n+1}} a^\mu a^{\lambda_2} \dots a^{\lambda_n} \partial_{\lambda_1} \dots \partial_{\lambda_n} \tilde{\varphi} \partial_{\lambda_{n+1}} \varphi & (3.11) \end{aligned}$$

where the first line is $\frac{\partial \mathcal{L}}{\partial \partial_\mu \varphi} \delta_{(n)} \varphi + \frac{\partial \mathcal{L}}{\partial \partial_\mu \tilde{\varphi}} \delta_{(n)} \tilde{\varphi}$ from (3.7) and the remaining terms are the expression for $-K_{(n)}^\mu$. Calculating the divergence of this expression gives zero, as required.

Now generalizing to the massive case is simple by adding extra terms to $K_{(n)}^\mu$ and the proof is similar to before except most of the extra $K_{(n)}^\mu$ terms will cancel each

other when differentiated and the two remaining terms will cancel by the equations of motion. We have

$$\begin{aligned}
 J^\mu = & \eta^{\mu\nu} a^{\lambda_1} \dots a^{\lambda_n} \partial_\nu \tilde{\varphi} \partial_{\lambda_1} \dots \partial_{\lambda_n} \varphi + (-1)^{n+1} \eta^{\mu\nu} a^{\lambda_1} a^{\lambda_n} \partial_\nu \varphi \partial_{\lambda_1} \dots \partial_{\lambda_n} \tilde{\varphi} \\
 & - \eta^{\lambda_1 \lambda_{n+1}} a^\mu a^{\lambda_2} \dots a^{\lambda_n} \partial_{\lambda_1} \tilde{\varphi} \partial_{\lambda_2} \dots \partial_{\lambda_{n+1}} \varphi \\
 & + \eta^{\lambda_1 \lambda_{n+1}} a^\mu a^{\lambda_2} \dots a^{\lambda_n} \partial_{\lambda_1} \partial_{\lambda_2} \tilde{\varphi} \partial_{\lambda_3} \dots \partial_{\lambda_{n+1}} \varphi - \dots \\
 & \dots - (-1)^n \eta^{\lambda_1 \lambda_{n+1}} a^\mu a^{\lambda_2} \dots a^{\lambda_n} \partial_{\lambda_1} \dots \partial_{\lambda_{n-1}} \tilde{\varphi} \partial_{\lambda_n} \partial_{\lambda_{n+1}} \varphi \\
 & - (-1)^{n+1} \eta^{\lambda_1 \lambda_{n+1}} a^\mu a^{\lambda_2} \dots a^{\lambda_n} \partial_{\lambda_1} \dots \partial_{\lambda_n} \tilde{\varphi} \partial_{\lambda_{n+1}} \varphi \\
 & - m^2 a^\mu a^{\lambda_2} \dots a^{\lambda_n} \tilde{\varphi} \partial_{\lambda_2} \dots \partial_{\lambda_n} \varphi \\
 & + m^2 a^\mu a^{\lambda_2} \dots a^{\lambda_n} \partial_{\lambda_2} \tilde{\varphi} \partial_{\lambda_3} \dots \partial_{\lambda_n} \varphi - \dots \\
 & \dots - (-1)^n m^2 a^\mu a^{\lambda_2} \dots a^{\lambda_n} \partial_{\lambda_2} \dots \partial_{\lambda_{n-1}} \tilde{\varphi} \partial_{\lambda_n} \varphi \\
 & - (-1)^{n+1} m^2 a^\mu a^{\lambda_2} \dots a^{\lambda_n} \partial_{\lambda_2} \dots \partial_{\lambda_n} \tilde{\varphi} \varphi. \tag{3.12}
 \end{aligned}$$

Finally, the current generated by the transformation (3.3) and (3.4) would be the double sum over the currents (3.12), $J_{(n)}^\mu$ for the nth derivative and group elements j .

$$J^\mu = \sum_{j,n} \varepsilon_j \frac{J_{(n)}^\mu}{n!}.$$

3.3 Symmetries Generated by Lorentz Transformations

In flat 3+1 space-time, the isometries are elements of the Poincaré group, that is the 6 elements of the Lorentz group and the 4 displacements. For the former we have

$$x^\mu \rightarrow (x^\mu)_G = \Lambda^\mu_\nu x^\nu.$$

In the infinitesimal case where $\Lambda^\mu{}_\nu$ is close to the identity matrix one can write the field transformations as

$$\begin{aligned}\varphi(x^\mu) &\rightarrow \varphi(\delta^\mu{}_\nu x^\nu + \varepsilon a^\mu{}_\nu x^\nu) \\ \tilde{\varphi}(x^\mu) &\rightarrow \tilde{\varphi}(\delta^\mu{}_\nu x^\nu - \varepsilon a^\mu{}_\nu x^\nu)\end{aligned}$$

where $a^\mu{}_\nu$ are the components of an anti-symmetric matrix since we require the metric to transform thus,

$$\begin{aligned}\eta^{\mu\nu} &= \Lambda^\mu{}_\rho \Lambda^\nu{}_\sigma \eta^{\rho\sigma} \\ &= (\delta^\mu{}_\rho + \varepsilon a^\mu{}_\rho) (\delta^\nu{}_\sigma + \varepsilon a^\nu{}_\sigma) \eta^{\rho\sigma} \\ &\implies a^{\mu\nu} = -a^{\nu\mu}\end{aligned}$$

under infinitesimal Lorentz transformations. We may consider building a finite isometry out of repeated infinitesimal isometries generated by infinitesimal Killing vectors of the space-time $X(\sigma_x(t))$ where $\sigma_x(t)$ are flows generated by the isometry and t is a parameter [43]. In an infinitesimal case

$$\begin{aligned}\varphi(x_G) &= (1 + \varepsilon X^\mu \partial_\mu + \dots) \varphi(x) \\ &= \varphi(x) + \varepsilon L(x) \varphi(x) + \dots\end{aligned}$$

where $L\varphi$ is given by $X^\mu(x) \partial_\mu \varphi(x) = a^\mu{}_\nu x^\nu \partial_\mu \varphi$ and is the Lie derivative of φ in the direction of the Killing vector $X(x)$, see [43]. Repeated application of such infinitesimal isometries gives

$$\begin{aligned}\varphi(x_G) &= \lim_{N \rightarrow \infty} \left(1 + \frac{L(\sigma_x(t_N))}{N}\right) \left(1 + \frac{L(\sigma_x(t_{N-1}))}{N}\right) \times \dots \\ &\quad \dots \times \left(1 + \frac{L(\sigma_x(t_0))}{N}\right) \varphi(x) \\ &= T \exp \left\{ \int_0^t dt L(\sigma_x(\dot{t})) \right\} \varphi(x)\end{aligned}$$

where T is the time ordering operator. We know that

$$\dot{\varphi}(x) = \varphi(x) + \varepsilon \varphi(x_G) = \varphi(x) + \varepsilon T \exp \left\{ \int_0^t dt L(\sigma_x(\dot{t})) \right\} \varphi(x)$$

is a symmetry, where $\sigma_x(0) = x$ and $\sigma_x(t) = x_G$. We must be careful in our definition of $L(\sigma_x(t_i)) = X^{\mu_i}(\sigma_x(t_i)) \dot{\partial}_{\mu_i}$. The partial derivative is the derivative with respect

to $y = \sigma_x(t_i)$ which is

$$\dot{\partial}_{\mu_i} = \frac{\partial x^\nu(y(t_i))}{\partial y^{\mu_i}} \partial_\nu \quad (3.13)$$

which we can absorb in to X^μ by defining

$$\dot{X}^\mu(x) = \frac{\partial x^\mu}{\partial y^\nu} X^\nu(y) \quad (3.14)$$

which gives us the advantage that all the partial derivatives are with respect to x rather than $y(t_i) = \sigma_x(t_i)$. The usual product rule will apply when we move derivatives through terms without worrying about which variable we should differentiate with respect to.

Since all terms in a Taylor expansion of the ordered exponentials are linearly independent, each term must itself be a symmetry, so the action must be invariant under the infinitesimal change in the field

$$\delta_{(n)}\varphi(x) = \varepsilon \int_0^t dt_1 \int_0^{t_1} dt_2 \dots \int_0^{t_{n-1}} dt_n L(t_1) \dots L(t_n) \varphi(x) \quad (3.15)$$

for $n = 0 \dots \infty$. For the conjugate field, the path ordering is reversed and we have

$$\delta_{(n)}\tilde{\varphi}(x) = (-1)^{n+1} \varepsilon \int_0^t dt_1 \int_0^{t_1} dt_2 \dots \int_0^{t_{n-1}} dt_n L(t_n) \dots L(t_1) \tilde{\varphi}(x). \quad (3.16)$$

We shall show that the change in the Lagrangian is given by a divergence by considering the change order by order as follows.

First order terms

The change in the field variables is given by

$$\begin{aligned} \delta_{(1)}\varphi &= \varepsilon \int_0^t dt_1 a^{\lambda_1}_{\sigma_1}(t_1) x^{\sigma_1} \partial_{\lambda_1} \varphi \\ \delta_{(1)}\tilde{\varphi} &= \varepsilon \int_0^t dt_1 a^{\lambda_1}_{\sigma_1}(t_1) x^{\sigma_1} \partial_{\lambda_1} \tilde{\varphi} \end{aligned}$$

using (3.15) and (3.16) where

$$y^{\sigma_1} = \frac{\partial y^{\sigma_1}}{\partial x^{\lambda_1}} x^{\lambda_1}$$

is the Lorentz transformation parameterised by t and

$$a^{\lambda_1}_{\sigma_1}(t_1) = \frac{\partial x^{\lambda_1}}{\partial y^\kappa} \frac{\partial y^\rho}{\partial x^{\sigma_1}} a^\kappa_\rho$$

is the Lorentz transformation of a^κ_ρ which depends on t_1 and is traceless. The change in the Lagrange density is

$$\delta_{(1)}\mathcal{L} = \varepsilon \int_0^t dt_1 \left\{ \eta^{\mu\nu} a^{\lambda_1}_{\sigma_1}(t_1) \partial_\mu (x^{\sigma_1} \partial_{\lambda_1} \tilde{\varphi}) \partial_\nu \varphi + \eta^{\mu\nu} a^{\lambda_1}_{\sigma_1}(t_1) \partial_\mu \tilde{\varphi} \partial_\nu (x^{\sigma_1} \partial_{\lambda_1} \varphi) \right\}.$$

Performing the ∂_μ and ∂_ν derivatives and noting that $\partial_\mu x^\sigma = \delta_\mu^\sigma$ gives

$$\delta_{(1)}\mathcal{L} = \varepsilon \int_0^t dt_1 \left\{ \eta^{\mu\nu} a^{\lambda_1}_{\sigma_1}(t_1) \delta_\mu^{\sigma_1} \partial_{\lambda_1} \tilde{\varphi} \partial_\nu \varphi + \eta^{\mu\nu} a^{\lambda_1}_{\sigma_1}(t_1) x^{\sigma_1} \partial_\mu \partial_{\lambda_1} \tilde{\varphi} \partial_\nu \varphi + \eta^{\mu\nu} a^{\lambda_1}_{\sigma_1}(t_1) \delta_\nu^{\sigma_1} \partial_\mu \tilde{\varphi} \partial_{\lambda_1} \varphi + \eta^{\mu\nu} a^{\lambda_1}_{\sigma_1}(t_1) x^{\sigma_1} \partial_\mu \tilde{\varphi} \partial_\nu \partial_{\lambda_1} \varphi \right\}.$$

We now take out the ∂_{λ_1} derivatives and perform the contraction of the δ_ν^σ with the $a^\lambda_\sigma(t_1)$

$$\delta_{(1)}\mathcal{L} = \varepsilon \int_0^t dt_1 \left\{ \partial_{\lambda_1} (\eta^{\mu\nu} a^{\lambda_1}_{\sigma_1}(t_1) x^{\sigma_1} \partial_\mu \tilde{\varphi} \partial_\nu \varphi) - \eta^{\mu\nu} a^{\lambda_1}_{\lambda_1}(t_1) \partial_\mu \tilde{\varphi} \partial_\nu \varphi - \eta^{\mu\nu} a^{\lambda_1}_{\sigma_1}(t_1) x^{\sigma_1} \partial_\mu \tilde{\varphi} \partial_\nu \partial_{\lambda_1} \varphi + \eta^{\mu\nu} a^{\lambda_1}_\mu(t_1) \partial_{\lambda_1} \tilde{\varphi} \partial_\nu \varphi + \eta^{\mu\nu} a^{\lambda_1}_\nu(t_1) \partial_\mu \tilde{\varphi} \partial_{\lambda_1} \varphi + \eta^{\mu\nu} a^{\lambda_1}_{\sigma_1}(t_1) x^{\sigma_1} \partial_\mu \tilde{\varphi} \partial_\nu \partial_{\lambda_1} \varphi \right\}.$$

The second term is zero since $a^\mu_\nu(t_1)$ is traceless, the third and sixth terms cancel with each other and the fourth and the fifth terms cancel using the anti-symmetry of a^μ_ν and the symmetry of the metric, leaving only the first term giving our expression for $K_{(1)}^\mu$, after rearranging indices

$$K_{(1)}^\mu = \int_0^t dt_1 \eta^{\lambda_1 \lambda_2} a^\mu_{\sigma_1}(t_1) x^{\sigma_1} \partial_{\lambda_1} \tilde{\varphi} \partial_{\lambda_2} \varphi.$$

Second order terms

The change in the field variables is given by

$$\delta_{(2)}\varphi = \varepsilon \int_0^t dt_1 \int_0^{t_1} dt_2 a^{\lambda_2}_{\sigma_2}(t_1) a^{\lambda_1}_{\sigma_1}(t_2) x^{\sigma_1} \partial_{\lambda_1} (x^{\sigma_2} \partial_{\lambda_2} \varphi)$$

$$\delta_{(2)}\tilde{\varphi} = -\varepsilon \int_0^t dt_1 \int_0^{t_1} dt_2 a^{\lambda_2}_{\sigma_2}(t_2) a^{\lambda_1}_{\sigma_1}(t_1) x^{\sigma_1} \partial_{\lambda_1} (x^{\sigma_2} \partial_{\lambda_2} \tilde{\varphi}).$$

The change in the Lagrange density is now

$$\delta_{(2)}\mathcal{L} = \varepsilon \int_0^t dt_1 \int_0^{t_1} dt_2 \left\{ \eta^{\mu\nu} a^{\lambda_1}_{\sigma_1}(t_1) a^{\lambda_2}_{\sigma_2}(t_2) \partial_\nu \tilde{\varphi} \partial_\mu (x^{\sigma_1} \partial_{\lambda_1} (x^{\sigma_2} \partial_{\lambda_2} \varphi)) - \eta^{\mu\nu} a^{\lambda_1}_{\sigma_1}(t_2) a^{\lambda_2}_{\sigma_2}(t_1) \partial_\nu \varphi \partial_\mu (x^{\sigma_1} \partial_{\lambda_1} (x^{\sigma_2} \partial_{\lambda_2} \tilde{\varphi})) \right\}.$$

Performing all the derivatives and making the same observations as for first order terms, one gets

$$\begin{aligned} \delta_{(2)}\mathcal{L} = \varepsilon \int_0^t dt_1 \int_0^{t_1} dt_2 \left\{ \eta^{\mu\nu} a_{\sigma_1}^{\lambda_1}(t_1) a_{\sigma_2}^{\lambda_2}(t_2) \{ \partial_\nu \tilde{\varphi} \delta_\mu^{\sigma_1} x^{\sigma_2} \partial_{\lambda_1} \partial_{\lambda_2} \varphi + \partial_\nu \tilde{\varphi} x^{\sigma_1} \delta_\mu^{\sigma_2} \partial_{\lambda_1} \partial_{\lambda_2} \varphi \right. \\ + \partial_\nu \tilde{\varphi} x^{\sigma_1} x^{\sigma_2} \partial_\mu \partial_{\lambda_1} \partial_{\lambda_2} \varphi \\ + \partial_\nu \tilde{\varphi} \delta_\mu^{\sigma_1} \delta_{\lambda_1}^{\sigma_2} \partial_{\lambda_2} \varphi + \partial_\nu \tilde{\varphi} x^{\sigma_1} \delta_{\lambda_1}^{\sigma_2} \partial_\mu \partial_{\lambda_2} \varphi \} \\ - \eta^{\mu\nu} a_{\sigma_1}^{\lambda_1}(t_2) a_{\sigma_2}^{\lambda_2}(t_1) \{ \partial_\nu \varphi \delta_\mu^{\sigma_1} x^{\sigma_2} \partial_{\lambda_1} \partial_{\lambda_2} \tilde{\varphi} + \partial_\nu \varphi x^{\sigma_1} \delta_\mu^{\sigma_2} \partial_{\lambda_1} \partial_{\lambda_2} \tilde{\varphi} \\ + \partial_\nu \varphi x^{\sigma_1} x^{\sigma_2} \partial_\mu \partial_{\lambda_1} \partial_{\lambda_2} \tilde{\varphi} \\ + \partial_\nu \varphi \delta_\mu^{\sigma_1} \delta_{\lambda_1}^{\sigma_2} \partial_{\lambda_2} \tilde{\varphi} + \partial_\nu \varphi x^{\sigma_1} \delta_{\lambda_1}^{\sigma_2} \partial_\mu \partial_{\lambda_2} \tilde{\varphi} \} \Big\}. \end{aligned}$$

The 4th term and the 9th term cancel by anti-symmetry leaving a final expression for $\delta_{(2)}\mathcal{L}$

$$\begin{aligned} \delta_{(2)}\mathcal{L} = \varepsilon \int_0^t dt_1 \int_0^{t_1} dt_2 \left\{ \eta^{\mu\nu} a_{\sigma_1}^{\lambda_1}(t_1) a_{\sigma_2}^{\lambda_2}(t_2) \{ \partial_\nu \tilde{\varphi} \delta_\mu^{\sigma_1} x^{\sigma_2} \partial_{\lambda_1} \partial_{\lambda_2} \varphi + \partial_\nu \tilde{\varphi} x^{\sigma_1} \delta_\mu^{\sigma_2} \partial_{\lambda_1} \partial_{\lambda_2} \varphi \right. \\ + \partial_\nu \tilde{\varphi} x^{\sigma_1} x^{\sigma_2} \partial_\mu \partial_{\lambda_1} \partial_{\lambda_2} \varphi + \partial_\nu \tilde{\varphi} x^{\sigma_1} \delta_{\lambda_1}^{\sigma_2} \partial_\mu \partial_{\lambda_2} \varphi \} \\ - \eta^{\mu\nu} a_{\sigma_1}^{\lambda_1}(t_2) a_{\sigma_2}^{\lambda_2}(t_1) \{ \partial_\nu \varphi \delta_\mu^{\sigma_1} x^{\sigma_2} \partial_{\lambda_1} \partial_{\lambda_2} \tilde{\varphi} + \partial_\nu \varphi x^{\sigma_1} \delta_\mu^{\sigma_2} \partial_{\lambda_1} \partial_{\lambda_2} \tilde{\varphi} \\ + \partial_\nu \varphi x^{\sigma_1} x^{\sigma_2} \partial_\mu \partial_{\lambda_1} \partial_{\lambda_2} \tilde{\varphi} + \partial_\nu \varphi x^{\sigma_1} \delta_{\lambda_1}^{\sigma_2} \partial_\mu \partial_{\lambda_2} \tilde{\varphi} \} \Big\}. \quad (3.17) \end{aligned}$$

Now take a guess at the expression for $K_{(2)}^\mu$ by analogy with the treatment used for displacements.

$$\begin{aligned} K_{(2)}^\mu = \int_0^t dt_1 \int_0^{t_1} dt_2 \left\{ \eta^{\lambda_1 \nu} a_{\sigma_1}^\mu(t_1) a_{\sigma_2}^{\lambda_2}(t_2) (\partial_{\lambda_1} \tilde{\varphi} x^{\sigma_1} \partial_\nu (x^{\sigma_2} \partial_{\lambda_2} \varphi)) \right. \\ \left. - \eta^{\lambda_1 \nu} a_{\sigma_1}^\mu(t_2) a_{\sigma_2}^{\lambda_2}(t_1) (\partial_\nu \varphi x^{\sigma_1} \partial_{\lambda_1} (x^{\sigma_2} \partial_{\lambda_2} \tilde{\varphi})) \right\} \end{aligned}$$

where we have replaced the derivatives ∂_{λ_i} in the corresponding expression for displacements (3.9) with $x^{\sigma_i} \partial_{\lambda_i}$ and maintained the order of terms. Now

$$\begin{aligned} \partial_\mu K_{(2)}^\mu = \int_0^t dt_1 \int_0^{t_1} dt_2 \left\{ \eta^{\lambda_1 \nu} a_{\sigma_1}^\mu(t_1) a_{\sigma_2}^{\lambda_2}(t_2) \{ \partial_{\lambda_1} \partial_\mu \tilde{\varphi} x^{\sigma_1} x^{\sigma_2} \partial_\nu \partial_{\lambda_2} \varphi + \partial_{\lambda_1} \tilde{\varphi} x^{\sigma_1} \delta_\mu^{\sigma_2} \partial_\nu \partial_{\lambda_2} \varphi \right. \\ + \partial_{\lambda_1} \tilde{\varphi} x^{\sigma_1} x^{\sigma_2} \partial_\mu \partial_\nu \partial_{\lambda_2} \varphi \\ + \partial_{\lambda_1} \partial_\mu \tilde{\varphi} x^{\sigma_1} \delta_\nu^{\sigma_2} \partial_{\lambda_2} \varphi + \partial_{\lambda_1} \tilde{\varphi} x^{\sigma_1} \delta_\nu^{\sigma_2} \partial_\mu \partial_{\lambda_2} \varphi \} \\ - \eta^{\lambda_1 \nu} a_{\sigma_1}^\mu(t_2) a_{\sigma_2}^{\lambda_2}(t_1) \{ x^{\sigma_1} \delta_\mu^{\sigma_2} \partial_{\lambda_1} \partial_{\lambda_2} \tilde{\varphi} \partial_\nu \varphi + x^{\sigma_1} x^{\sigma_2} \partial_{\lambda_1} \partial_\mu \partial_{\lambda_2} \tilde{\varphi} \partial_\nu \varphi \\ + x^{\sigma_1} x^{\sigma_2} \partial_{\lambda_1} \partial_{\lambda_2} \tilde{\varphi} \partial_\nu \partial_\mu \varphi \\ + x^{\sigma_1} \delta_{\lambda_1}^{\sigma_2} \partial_\mu \partial_{\lambda_2} \tilde{\varphi} \partial_\nu \varphi - x^{\sigma_1} \delta_{\lambda_1}^{\sigma_2} \partial_{\lambda_2} \tilde{\varphi} \partial_\mu \partial_\nu \varphi \} \Big\}. \end{aligned}$$

The first and eighth terms cancel leaving

$$\begin{aligned} \partial_\mu K_{(2)}^\mu = & \int_0^t dt_1 \int_0^t dt_2 \left\{ \eta^{\lambda_1 \nu} a_{\sigma_1}^\mu(t_1) a_{\sigma_2}^{\lambda_2}(t_2) \left\{ \partial_{\lambda_1} \tilde{\varphi} x^{\sigma_1} \delta_{\mu}^{\sigma_2} \partial_\nu \partial_{\lambda_2} \varphi + \partial_{\lambda_1} \tilde{\varphi} x^{\sigma_1} x^{\sigma_2} \partial_\mu \partial_\nu \partial_{\lambda_2} \varphi \right. \right. \\ & + \partial_{\lambda_1} \partial_\mu \tilde{\varphi} x^{\sigma_1} \delta_{\nu}^{\sigma_2} \partial_{\lambda_2} \varphi + \partial_{\lambda_1} \tilde{\varphi} x^{\sigma_1} \delta_{\nu}^{\sigma_2} \partial_\mu \partial_{\lambda_2} \varphi \left. \right\} \\ & - \eta^{\lambda_1 \nu} a_{\sigma_1}^\mu(t_2) a_{\sigma_2}^{\lambda_2}(t_1) \left\{ x^{\sigma_1} \delta_{\mu}^{\sigma_2} \partial_{\lambda_1} \partial_{\lambda_2} \tilde{\varphi} \partial_\nu \varphi + x^{\sigma_1} x^{\sigma_2} \partial_{\lambda_1} \partial_\mu \partial_{\lambda_2} \tilde{\varphi} \partial_\nu \varphi \right. \\ & \left. \left. + x^{\sigma_1} \delta_{\lambda_1}^{\sigma_2} \partial_\mu \partial_{\lambda_2} \tilde{\varphi} \partial_\nu \varphi - x^{\sigma_1} \delta_{\lambda_1}^{\sigma_2} \partial_{\lambda_2} \tilde{\varphi} \partial_\mu \partial_\nu \varphi \right\} \right\} \end{aligned}$$

and this expression coincides with (3.17). Subtracting one from the other, careful inspection shows some terms cancel trivially when swapping dummy indices and the rest of the terms cancel by virtue of the anti-symmetry of $a^{\mu\nu}$.

General order terms

Using the same guess work as for second order terms we can deduce what the general expression for $K_{(n)}^\mu$ will be by replacing the derivatives ∂_{λ_i} in the expression for displacements (3.10) with $x^{\sigma_i} \partial_{\lambda_i}$ and maintain the order of terms. With the operator L , that we defined as

$$L(t_i) = a_{\sigma}^\mu(t_i) x^{\sigma} \partial_\mu$$

the action of $L(t_i)$ on an ordinary partial derivative gives

$$L(t_i) \partial_\nu = a_{\sigma}^\mu(t_i) x^{\sigma} \partial_\mu \partial_\nu = \partial_\nu L(t_i) - a_{\nu}^\mu(t_i) \partial_\mu. \quad (3.18)$$

Now we claim that $K_{(n)}^\mu$ can be written

$$\begin{aligned} K_{(n)}^\mu = & \int_0^t dt_1 \cdots \int_0^{t_{n-1}} dt_n \left\{ \eta^{\lambda_1 \lambda_2} a_{\rho}^\mu(t_1) x^{\rho} \partial_{\lambda_1} \tilde{\varphi} \partial_{\lambda_2} L(t_2) \cdots L(t_n) \varphi \right. \\ & - \eta^{\lambda_1 \lambda_2} a_{\rho}^\mu(t_2) x^{\rho} \partial_{\lambda_1} L(t_1) \tilde{\varphi} \partial_{\lambda_2} L(t_3) \cdots L(t_n) \varphi + \cdots \\ & \left. \cdots + (-1)^n \eta^{\lambda_1 \lambda_2} a_{\rho}^\mu(t_{n-1}) x^{\rho} \partial_{\lambda_1} L(t_{n-2}) \cdots L(t_1) \tilde{\varphi} \partial_{\lambda_2} L(t_n) \varphi + \right. \\ & \left. + (-1)^{n+1} \eta^{\lambda_1 \lambda_2} a_{\rho}^\mu(t_n) x^{\rho} \partial_{\lambda_1} L(t_{n-1}) \cdots L(t_1) \tilde{\varphi} \partial_{\lambda_2} \varphi \right\}. \end{aligned}$$

Now let us prove $\partial_\mu K_{(n)}^\mu = \delta_{(n)} \mathcal{L}$. Take the i th term in the series,

$$\int_0^t dt_1 \int_0^t dt_2 (-1)^{i+1} \eta^{\lambda_1 \lambda_2} a_{\rho}^\mu(t_i) x^{\rho} \partial_{\lambda_1} L(t_{i-1}) \cdots L(t_1) \tilde{\varphi} \partial_{\lambda_2} L(t_{i+1}) \cdots L(t_n) \varphi$$

and take the divergence to arrive at

$$\int_0^t dt_1 \int_0^{t_1} dt_2 (-1)^{i+1} \left\{ \eta^{\lambda_1 \lambda_2} L(t_i) \partial_{\lambda_1} L(t_{i-1}) \cdots L(t_1) \tilde{\varphi} \partial_{\lambda_2} L(t_{i+1}) \cdots L(t_n) \varphi \right. \\ \left. \eta^{\lambda_1 \lambda_2} \partial_{\lambda_1} L(t_{i-1}) \cdots L(t_1) \tilde{\varphi} L(t_i) \partial_{\lambda_2} L(t_{i+1}) \cdots L(t_n) \varphi \right\}.$$

The derivatives $L(t_i)$ can be simultaneously commuted past the partials ∂_{λ_1} and ∂_{λ_2} using (3.18) because extra terms cancel due to anti-symmetry of $a^{\mu\nu}(t_i)$. Writing out all terms in the series sequentially there is massive cancellation leaving only,

$$\partial_\mu K_{(n)}^\mu = \int_0^t dt_1 \int_0^{t_1} dt_2 \left\{ \eta^{\lambda_1 \lambda_2} \partial_{\lambda_1} \tilde{\varphi} \partial_{\lambda_2} L(t_1) \cdots L(t_2) \varphi \right. \\ \left. + (-1)^{n+1} \eta^{\lambda_1 \lambda_2} \partial_{\lambda_1} L(t_n) \cdots L(t_1) \tilde{\varphi} \partial_{\lambda_2} \varphi \right\} \\ = \delta_{(n)} \mathcal{L}$$

as required.

Given this expression for $K_{(n)}^\mu$, the Noether current is

$$J_{(n)}^\mu = \int_0^t dt_1 \cdots \int_0^{t_{n-1}} dt_n \left\{ \eta^{\mu\rho} \partial_\rho \tilde{\varphi} L(t_1) \cdots L(t_n) \varphi \right. \\ + (-1)^{n+1} \eta^{\mu\rho} L(t_n) \cdots L(t_1) \tilde{\varphi} \partial_\rho \varphi \\ - \eta^{\lambda\rho} a^\mu{}_\sigma(t_1) x^\sigma \partial_\lambda \tilde{\varphi} \partial_\rho L(t_2) \cdots L(t_{n-1}) \varphi \\ + \eta^{\lambda\rho} a^\mu{}_\sigma(t_2) x^\sigma \partial_\lambda L(t_1) \tilde{\varphi} \partial_\rho L(t_3) \cdots L(t_{n-1}) \varphi - \cdots \\ \cdots - (-1)^n \eta^{\lambda\rho} a^\mu{}_\sigma(t_{n-1}) x^\sigma \partial_\lambda L(t_{n-2}) \cdots L(t_1) \tilde{\varphi} \partial_\rho L(t_n) \varphi \\ \left. - (-1)^{n+1} \eta^{\lambda\rho} a^\mu{}_\sigma(t_n) x^{\sigma_1} \partial_\lambda L(t_{n-1}) \cdots L(t_1) \tilde{\varphi} \partial_\rho \varphi \right\}.$$

Here the first two terms are the terms $\frac{\partial \mathcal{L}}{\partial \partial_\mu \varphi} \delta_{(n)} \varphi + \frac{\partial \mathcal{L}}{\partial \partial_\mu \tilde{\varphi}} \delta_{(n)} \tilde{\varphi}$ from eqn (3.7) and the remaining terms are $-K_{(n)}^\mu$. Calculating $\partial_\mu J_{(n)}^\mu$ we get zero, after invoking the equations of motion, as we would hope.

Now considering the massive case is easy, by analogy with our treatment of

displacements we have

$$\begin{aligned}
 J_{(n)}^\mu = & \int_0^t dt_1 \cdots \int_0^{t_{n-1}} dt_n \left\{ \eta^{\mu\rho} \partial_\rho \tilde{\varphi} L(t_1) \cdots L(t_n) \varphi \right. \\
 & + (-1)^{n+1} \eta^{\mu\rho} L(t_n) \cdots L(t_1) \tilde{\varphi} \partial_\rho \varphi \\
 & - \eta^{\lambda\rho} a^\mu{}_\sigma(t_1) x^\sigma \partial_\lambda \tilde{\varphi} \partial_\rho L(t_2) \cdots L(t_n) \varphi - m^2 a^\mu{}_\sigma(t_1) x^\sigma \tilde{\varphi} L(t_2) \cdots L(t_n) \varphi \\
 & + \eta^{\lambda\rho} a^\mu{}_\sigma(t_2) x^\sigma \partial_\lambda L(t_1) \tilde{\varphi} \partial_\rho L(t_3) \cdots L(t_n) \varphi + m^2 a^\mu{}_\sigma(t_2) x^\sigma L(t_1) \tilde{\varphi} L(t_3) \cdots L(t_n) \varphi \\
 & \vdots \\
 & - (-1)^n \eta^{\lambda\rho} a^\mu{}_\sigma(t_{n-1}) x^\sigma \partial_\lambda L(t_{n-2}) \cdots L(t_1) \tilde{\varphi} \partial_\rho L(t_n) \varphi \\
 & \quad - (-1)^n m^2 a^\mu{}_\sigma(t_{n-1}) x^\sigma L(t_{n-2}) \cdots L(t_1) \tilde{\varphi} L(t_n) \varphi \\
 & - (-1)^{n+1} \eta^{\lambda\rho} a^\mu{}_\sigma(t_n) x^{\sigma_1} \partial_\lambda L(t_{n-1}) \cdots L(t_1) \tilde{\varphi} \partial_\rho \varphi \\
 & \quad \left. - (-1)^{n+1} m^2 a^\mu{}_\sigma(t_n) x^\sigma L(t_{n-1}) \cdots L(t_1) \tilde{\varphi} \varphi \right\}. \quad (3.19)
 \end{aligned}$$

Given that the equations of motion will be

$$\begin{aligned}
 \eta^{\mu\nu} \partial_\mu \partial_\nu \varphi &= m^2 \varphi \\
 \eta^{\mu\nu} \partial_\mu \partial_\nu \tilde{\varphi} &= m^2 \tilde{\varphi}
 \end{aligned}$$

one can show the divergence of (3.19) is zero by carefully canceling terms.

3.4 Symmetries Generated by Isometries on Curved Space-times

The massless Lagrangian density in curved space-times is written as

$$\mathcal{L} = \sqrt{g} g^{\mu\nu} \partial_\mu \tilde{\varphi}(x) \partial_\nu \varphi(x).$$

Under the diffeomorphism $x \rightarrow x_G$ the field variables transform thus

$$\begin{aligned}
 \varphi(x) &\rightarrow \varphi(x_G) \\
 \tilde{\varphi}(x) &\rightarrow \tilde{\varphi}(x_G).
 \end{aligned}$$

The metric $g_{\mu\nu}$ is invariant under a transformation if

$$\dot{g}_{\mu\nu}(y) = g_{\mu\nu}(y) \quad \forall y.$$

Then, given that $g_{\mu\nu}$ transforms as a covariant tensor, under $x \rightarrow x_G$ the metric is invariant if

$$g_{\mu\nu}(x) = \frac{\partial \hat{x}^\lambda}{\partial x^\mu} \frac{\partial \hat{x}^\sigma}{\partial x^\nu} g_{\lambda\sigma}(\hat{x}).$$

Initially consider the infinitesimal transformation $x^\mu \rightarrow \hat{x}^\mu = x^\mu + \epsilon X^\mu(x)$ where X^μ is a vector field defined on the manifold. Then it is known that the condition for the metric to be invariant is for it to satisfy Killing's equation, [44].

$$L_X g_{\mu\nu} = \nabla_\nu X_\mu + \nabla_\mu X_\nu = 0 \tag{3.20}$$

where L_X is the Lie derivative of $g^{\mu\nu}$ with respect to X , given by

$$L_X g_{\mu\nu} = X^\sigma \partial_\sigma g_{\mu\nu} + g_{\mu\sigma} \partial_\nu X^\sigma + g_{\nu\sigma} \partial_\mu X^\sigma.$$

From this, an infinitesimal isometry is generated by a Killing vector $X^\mu(x)$ satisfying $L_X g_{\mu\nu} = 0$. The infinitesimal change in the field variables generated by the isometry is

$$\begin{aligned} \varphi &\rightarrow \varphi + \epsilon X^\mu \partial_\mu \varphi \\ \tilde{\varphi} &\rightarrow \tilde{\varphi} - \epsilon X^\mu \partial_\mu \tilde{\varphi}. \end{aligned}$$

It is possible to generate finite transformations by analogy with the treatment of displacements and Lorentz transformations in flat space-times by taking exponentials. One must be careful however due to the dependence on x^μ of the Killing vectors as we are now in curved space-times. Consider a Killing vector field on the manifold, M . This field generates a congruence of curves on M whose tangent vectors are the Killing vectors themselves.

$$X^\mu(\sigma_x(t)) = \frac{d\sigma_x(t)^\mu}{dt}$$

where X^μ are the tangent Killing vectors, σ_x^μ are the trajectories and t is a parameter. Existence and uniqueness theorems guarantee a solution on a finite bounded interval of $t \in \mathbb{R}$. Given a Killing vector at a point $\sigma_x^\mu(0)$, we evaluate the field at $\varphi(\sigma_x(0))$ and then consider moving along the trajectory σ_x^μ by a finite amount t so that we have

$$\begin{aligned} \varphi(x_G) = \varphi(\sigma_x(t)) = \varphi(x) &+ \int_0^t dt_1 X^{\lambda_1}(\sigma_x(t_1)) \dot{\partial}_{\lambda_1} \varphi(x) \\ &+ \int_0^t dt_1 \int_0^{t_1} dt_2 X^{\lambda_1}(\sigma_x(t_1)) \dot{\partial}_{\lambda_1} \left(X^{\lambda_2}(\sigma_x(t_2)) \dot{\partial}_{\lambda_2} \varphi(x) \right) + \dots \end{aligned}$$

where ∂_{λ_i} is

$$\frac{\partial}{\partial y^{\lambda_i}} = \frac{\partial x^{\sigma_i}}{\partial y^{\lambda_i}} \frac{\partial}{\partial x^{\sigma_i}}$$

for $y = \sigma_x(t)$. This expansion can be written as the time ordered exponential

$$\varphi(x_G) = T \exp \left\{ \int_0^t dt \dot{X}^\lambda(\sigma_x(t)) \partial_\lambda \right\} \varphi(x)$$

as per previous sections, where

$$\dot{X}^\lambda = \frac{\partial x^\lambda}{\partial y^\sigma} X^\sigma(y)$$

and the partial derivative is with respect to x and not $y = \sigma_x(t_i)$. Again, we expect each term in the time ordered expansion of the exponential is a linearly independent symmetry of the action. For the symmetry transformations $\delta\varphi = \varepsilon\varphi(x_G)$ and $\delta\tilde{\varphi} = -\varepsilon\tilde{\varphi}(x_{G^{-1}})$ we can say that each of the transformations

$$\begin{aligned} \delta_{(n)}\varphi(x) &= \varepsilon \int_0^t dt_1 \int_0^{t_1} dt_2 \dots \int_0^{t_{n-1}} dt_n L(t_1) \dots L(t_n) \varphi(x) \\ \delta_{(n)}\tilde{\varphi}(x) &= (-1)^{n+1} \varepsilon \int_0^t dt_1 \int_0^{t_1} dt_2 \dots \int_0^{t_{n-1}} dt_n L(t_n) \dots L(t_1) \tilde{\varphi}(x) \end{aligned}$$

are symmetries where

$$L(t_i) = \dot{X}^\lambda(x) \frac{\partial}{\partial x^\lambda}.$$

To nth order, the change in the Lagrange density is

$$\begin{aligned} \delta_{(n)}\mathcal{L} &= \varepsilon \int_0^t dt_1 \dots \int_0^{t_{n-1}} dt_n \left\{ \sqrt{g} g^{\mu\nu} \partial_\mu \tilde{\varphi} \partial_\nu L(t_1) \dots L(t_n) \varphi \right. \\ &\quad \left. + (-1)^{n+1} \sqrt{g} g^{\mu\nu} \partial_\mu L(t_n) \dots L(t_1) \tilde{\varphi} \partial_\nu \varphi \right\} \end{aligned}$$

and we claim that $\partial_\mu K_{(n)}^\mu = \delta_{(n)}\mathcal{L}$ where

$$\begin{aligned} K_{(n)}^\mu &= \int_0^t dt_1 \dots \int_0^{t_{n-1}} dt_n \left\{ \sqrt{g} g^{\lambda\sigma} \dot{X}^\mu \partial_\lambda \tilde{\varphi} \partial_\sigma L(t_2) \dots L(t_n) \varphi \right. \\ &\quad \left. - \sqrt{g} g^{\lambda\sigma} \dot{X}^\mu \partial_\lambda L(t_1) \tilde{\varphi} \partial_\sigma L(t_3) \dots L(t_n) \varphi \right. \\ &\quad \left. + (-1)^n \sqrt{g} g^{\lambda\sigma} \dot{X}^\mu \partial_\lambda L(t_{n-2}) \dots L(t_1) \tilde{\varphi} \partial_\sigma L(t_n) \varphi \right. \\ &\quad \left. + (-1)^{n+1} \sqrt{g} g^{\lambda\sigma} \dot{X}^\mu \partial_\lambda L(t_{n-1}) \dots L(t_1) \tilde{\varphi} \partial_\sigma \varphi \right\}. \end{aligned}$$

It only remains to prove that this expression satisfies $\delta_{(n)}\mathcal{L} = \partial_\mu K_{(n)}^\mu$ which follows in exactly the same manner as that in §(3.3). We take the i th term in the series

$$\int_0^t dt_1 \cdots \int_0^{t_{n-1}} dt_n (-1)^{i+1} \sqrt{g} g^{\lambda\sigma} \dot{X}^\mu \partial_\lambda L(t_{i-1}) \cdots L(t_1) \tilde{\varphi} \partial_\sigma L(t_{i+1}) \cdots L(t_n) \varphi$$

and take the divergence thus,

$$\int_0^t dt_1 \cdots \int_0^{t_{n-1}} dt_n (-1)^{i+1} \sqrt{g} \nabla_\mu \{ g^{\lambda\sigma} \dot{X}^\mu \partial_\lambda L(t_{i-1}) \cdots L(t_1) \tilde{\varphi} \partial_\sigma L(t_{i+1}) \cdots L(t_n) \varphi \}$$

since \sqrt{g} is a tensor density. Now $\nabla_\mu \dot{X}^\mu = 0$ since $\dot{X}^\mu(x)$ is a Killing vector field and so the above term becomes

$$\int_0^t dt_1 \cdots \int_0^{t_{n-1}} dt_n (-1)^{i+1} \sqrt{g} L(t_i) \{ g^{\lambda\sigma} \partial_\lambda L(t_{i-1}) \cdots L(t_1) \tilde{\varphi} \partial_\sigma L(t_{i+1}) \cdots L(t_n) \varphi \}.$$

Using the product rule on the Lie derivative $L(t_i)$ and given that the Lie derivative acting on the metric gives zero we have

$$\begin{aligned} \int_0^t dt_1 \cdots \int_0^{t_{n-1}} dt_n (-1)^{i+1} \sqrt{g} g^{\lambda\sigma} L(t_i) \partial_\lambda L(t_{i-1}) \cdots L(t_1) \tilde{\varphi} \partial_\sigma L(t_{i+1}) \cdots L(t_n) \varphi \\ + (-1)^{i+1} \sqrt{g} g^{\lambda\sigma} \partial_\lambda L(t_{i-1}) \cdots L(t_1) \tilde{\varphi} L(t_i) \partial_\sigma L(t_{i+1}) \cdots L(t_n) \varphi. \end{aligned}$$

By using the Killing equation and the fact that

$$L(t_i) \partial_\nu = \partial_\nu L(t_i) - (\nabla_\nu \dot{X}^\mu) \partial_\mu$$

when acting on scalars, the Lie derivative $L(t_i)$ commutes through the partials ∂_λ and ∂_σ . Calculating the divergence of all terms in the series proves the result after cancellations.

Finally we can trivially write an expression for the conserved Noether current using Noether's theorem. We will have

$$\begin{aligned} J^\mu = \int_0^t dt_1 \cdots \int_0^{t_{n-1}} dt_n \left\{ \sqrt{g} g^{\mu\sigma} \partial_\sigma \tilde{\varphi} L(t_1) \cdots L(t_n) \varphi + (-1)^{n+1} \sqrt{g} g^{\mu\sigma} L(t_n) \cdots L(t_1) \tilde{\varphi} \partial_\sigma \varphi \right. \\ - \sqrt{g} g^{\lambda\sigma} \dot{X}^\mu \partial_\lambda \tilde{\varphi} \partial_\sigma L(t_2) \cdots L(t_n) \varphi \\ + \sqrt{g} g^{\lambda\sigma} \dot{X}^\mu \partial_\lambda L(t_1) \tilde{\varphi} \partial_\sigma L(t_3) \cdots L(t_n) \varphi \\ - (-1)^n \sqrt{g} g^{\lambda\sigma} \dot{X}^\mu \partial_\lambda L(t_{n-2}) \cdots L(t_1) \tilde{\varphi} \partial_\sigma L(t_n) \varphi \\ \left. - (-1)^{n+1} \sqrt{g} g^{\lambda\sigma} \dot{X}^\mu \partial_\lambda L(t_{n-1}) \cdots L(t_1) \tilde{\varphi} \partial_\sigma \varphi \right\} \end{aligned}$$

where the first line is $\frac{\partial \mathcal{L}}{\partial \partial_\mu \varphi} \delta_{(n)} \varphi + \frac{\partial \mathcal{L}}{\partial \partial_\mu \tilde{\varphi}} \delta_{(n)} \tilde{\varphi}$ and the remaining terms are $-K_{(n)}^\mu$. One can check that the covariant divergence of this expression is zero by noting that the massless equation of motion will be

$$\sqrt{g} g^{\mu\nu} \nabla_\mu \nabla_\nu \varphi = 0$$

and similarly for $\tilde{\varphi}$.

3.4.1 Anti de-Sitter Space

Begin by writing an infinitesimal distance on AdS_{p+2} , defined by one of its many forms of metric, as

$$ds^2 = -(1+r^2)d\tau^2 + \frac{1}{(1+r^2)}dr^2 + r^2 d\Omega_p^2$$

with AdS_{p+2} embedded on the space $R^{3,p}$, the Ω_p are angles and the time-like boundary of AdS is at $r \rightarrow \infty$. The metric is

$$g_{\mu\nu} = \text{diag} \left(-(1+r^2), \frac{1}{1+r^2}, r^2 \right)_{\mu\nu}$$

and the Jacobian factor $\sqrt{-g}$, where g is the metric determinant, is given by

$$\sqrt{-g} = r^p$$

because, roughly speaking, there are p angles in AdS_{p+2} . The inverse metric is

$$g^{\mu\nu} = \text{diag} \left(-\frac{1}{1+r^2}, (1+r^2), \frac{1}{r^2} \right)^{\mu\nu}$$

and trivially the Lagrangian is

$$\mathcal{L} = \sqrt{-g} (g^{\mu\nu} \partial_\mu \tilde{\varphi} \partial_\nu \varphi + m^2 \tilde{\varphi} \varphi).$$

We now consider the behaviour of the equations of motion in the limit of large r for reasons we discuss later. The Euler-Lagrange equations for the field $\varphi(\tau, r, \Omega_p)$ are

$$(\nabla_\mu \nabla^\mu - m^2) \varphi = 0.$$

Using the symmetries, the solution is separable into a radial part, a time part and the angular part, which are the spherical harmonic functions $Y_l(\Omega)$,

$$\varphi = \varphi(r) e^{i\omega\tau} Y_l(\Omega_p).$$

Now, the equation of motion is²

$$\frac{1}{1+r^2} \left[-\omega^2 \varphi - \frac{l(l+2)(1+r^2)\varphi}{r^2} + \frac{(1+r^2)\partial_r (r^p(1+r^2)\partial_r \varphi)}{r^p} \right] - m^2 \varphi = 0,$$

for φ and similarly for the conjugate field. Here l labels the modes of the spherical harmonic functions. For the behaviour of the solution at large r , we arrive at

$$\frac{1}{r^{p-2}} \partial_r (r^{p+2} \partial_r \varphi) - m^2 r^2 = 0. \quad (3.21)$$

At the boundary, we write an ansatz for the fields up to multiplication by a complex number

$$\varphi(r) \approx r^{-\lambda}, \quad (3.22)$$

and substitute into eqn (3.21). We note that in the above expression λ is real: see [45], page 45. Then eqn (3.22) is a solution if λ satisfies the condition

$$\lambda = \frac{p+1}{2} \pm \sqrt{\left(\frac{(p+1)^2}{4} + m^2\right)} \quad (3.23)$$

which is known as the Breitenlohner-Freedman bound. Now we make the observation that non-tachyonic modes satisfy

$$-\frac{(p+1)^2}{4} \leq m^2.$$

We hope that when calculating the expression for $K_{(n)}^\mu$ we reproduce a consistent condition on p and m in order to ensure $K_{(n)}^\mu$ vanishes sufficiently quickly on the boundary, resulting in an invariant Lagrangian and Noether currents.

Our expression for $K_{(n)}^\mu$ on a general manifold was

$$\begin{aligned} K_{(n)}^\mu = & \int_0^t dt_1 \cdots \int_0^{t_{n-1}} dt_n \left\{ \sqrt{g} g^{\lambda\sigma} \dot{X}^\mu \partial_\lambda \tilde{\varphi} \partial_\sigma L(t_2) \cdots L(t_n) \varphi \right. \\ & - \sqrt{g} g^{\lambda\sigma} \dot{X}^\mu \partial_\lambda L(t_1) \tilde{\varphi} \partial_\sigma L(t_3) \cdots L(t_n) \varphi \\ & + (-1)^n \sqrt{g} g^{\lambda\sigma} \dot{X}^\mu \partial_\lambda L(t_{n-2}) \cdots L(t_1) \tilde{\varphi} \partial_\sigma L(t_n) \varphi \\ & \left. + (-1)^{n+1} \sqrt{g} g^{\lambda\sigma} \dot{X}^\mu \partial_\lambda L(t_{n-1}) \cdots L(t_1) \tilde{\varphi} \partial_\sigma \varphi \right\} \end{aligned}$$

²We can write $\nabla_\mu \nabla^\mu = \frac{1}{\sqrt{g}} \partial_\mu (\sqrt{g} g^{\mu\nu} \partial_\nu)$

where X^μ is the Killing vector field of the manifold. These are translations in time, τ , and rotations of S_p . We begin by grouping the τ and Ω_p dependence into a field χ and separate out the r dependence viz,

$$\varphi = \varphi(r)\chi(\tau, \Omega_p).$$

We substitute \sqrt{g} and $g^{\mu\nu}$, and $K_{(n)}^\mu$ becomes

$$\begin{aligned} K_{(n)}^\mu = \int_0^t dt_1 \cdots \int_0^{t_{n-1}} dt_n \left\{ \right. & - \dot{X}^\mu r^p \frac{1}{1+r^2} \partial_\tau \tilde{\chi} \partial_\tau (L(t_2) \cdots L(n)\chi) \tilde{\varphi}(r) \varphi(r) \\ & + \dot{X}^\mu r^p (1+r^2) \partial_r \tilde{\varphi}(r) \partial_r \varphi(r) \tilde{\chi}(L(t_2) \cdots L(n)\chi) \\ & + \dot{X}^\mu r^p \frac{1}{r^2} \partial_{\Omega_p} \tilde{\chi} \partial_{\Omega_p} (L(t_2) \cdots L(n)\chi) \tilde{\varphi}(r) \varphi(r) \\ & \left. + m^2 \dot{X}^\mu r^p \tilde{\varphi}(r) \varphi(r) \tilde{\chi}(L(t_2) \cdots L(n)\chi) - \cdots \right\} \end{aligned}$$

because $L = X^\mu \partial_\mu$ does not act on r since r is not a Killing vector and $X^r = 0$. At large r , $K_{(n)}^\mu$ reduces to

$$\begin{aligned} K_{(n)}^\mu = \int_0^t dt_1 \cdots \int_0^{t_{n-1}} dt_n \dot{X}^\mu r^{p-2\lambda-2} \times & \\ \times \left(- \partial_\tau \tilde{\chi} \partial_\tau (L(t_2) \cdots L(n)\chi) + \tilde{\chi}(L(t_2) \cdots L(n)\chi) \lambda^2 r^2 \right. & \\ \left. + \partial_{\Omega_p} \tilde{\chi} \partial_{\Omega_p} (L(t_2) \cdots L(n)\chi) + r^2 m^2 \tilde{\chi}(L(t_2) \cdots L(n)\chi) + \cdots \right) & \end{aligned} \quad (3.24)$$

after substituting the large r solution to the field equations $\varphi \approx r^{-\lambda}$. Now we need to arrange for λ to kill $K_{(n)}^\mu$ sufficiently quickly at $r \rightarrow \infty$. The second and fourth terms are the highest power in r , so it is sufficient to consider the condition that these terms vanish sufficiently quickly at large r . The condition for the isometries to generate symmetries is

$$\int \partial_\mu K_{(n)}^\mu dx^{p+2} = \int_\tau d\tau \int_{\Omega_p} d\Omega_p \int_r \partial_\mu K_{(n)}^\mu dr = 0.$$

Using the divergence theorem

$$\int_V dx^{p+2} \partial_\mu K^\mu = \int_{\delta V} dx^{p+1} n_\mu K_{(n)}^\mu |_\infty = 0$$

where n_μ is a unit vector normal to the boundary and thus we wish $K_{(n)}^\mu$ to vanish at the boundary. Bringing the boundary at infinity to a finite distance by writing

$$r = \tan \theta$$

then close to the boundary we have

$$r = \tan\left(\frac{\pi}{2} - \epsilon\right) \approx \frac{1}{\epsilon}$$

for $\epsilon \rightarrow 0$. Substituting this into (3.24) we get

$$\begin{aligned} K_{(n)}^\mu &= \int_0^t dt_1 \cdots \int_0^{t_{n-1}} dt_n \dot{X}^\mu \times \\ &\quad \times \left(-\epsilon^{2\lambda-p+2} \partial_\tau \tilde{\chi} \partial_\tau (L(t_2) \cdots L(t_n) \chi) + \lambda^2 \epsilon^{2\lambda-p} \tilde{\chi} (L(t_2) \cdots L(t_n) \chi) + \right. \\ &\quad \left. + \epsilon^{2\lambda-p+2} \partial_{\Omega_p} \tilde{\chi} \partial_{\Omega_p} (L(t_2) \cdots L(t_n) \chi) + m^2 \epsilon^{2\lambda-p} \tilde{\chi} (L(t_2) \cdots L(t_n) \chi) + \cdots \right) \end{aligned}$$

At the boundary, for which $\epsilon = 0$, $K_{(n)}^\mu$ vanishes as we require, provided we take the positive solution for λ that is always normalisable, for which

$$2\lambda - p \geq 1$$

from (3.23) and that non-tachyonic modes satisfy $(p+1)^2 + 4m^2 \geq 0$.

3.5 General Case

It is not difficult to generalize this argument to other space-time objects by writing the action as

$$S = \int d^4x \sqrt{-g(x)} \tilde{\Phi}_i(x) \Omega^i_j(x) \Phi^j(x) \quad (3.25)$$

where Ω is some operator and the transformation as

$$\begin{aligned} \delta\Phi(x) &= \varepsilon T \exp \left\{ \int_0^t dt L(\sigma_x(\dot{t})) \right\} \Phi(x) \\ &= \Phi(x) + \int_0^t dt_1 L(\sigma_x(t_1)) \Phi(x) + \int_0^t dt_1 \int_0^{t_1} dt_2 L(\sigma_x(t_1)) L(\sigma_x(t_2)) \Phi(x) + \cdots \\ \\ \delta\tilde{\Phi}(x) &= -\varepsilon T \exp \left\{ \int_0^{-t} dt L(\sigma_x(\dot{-t})) \right\} \tilde{\Phi}(x) \\ &= -\tilde{\Phi}(x) + \int_0^t dt_1 L(\sigma_x(t_1)) \tilde{\Phi}(x) - \int_0^t dt_1 \int_0^{t_1} dt_2 L(\sigma_x(t_2)) L(\sigma_x(t_1)) \tilde{\Phi}(x) + \cdots \end{aligned} \quad (3.26)$$

where the operator L is some generalization to the normal Lie derivative of the field. To understand this result let us begin by writing the field transformations as follows

$$\begin{aligned}\delta\Phi^i &= \varepsilon (\delta^i_j + \epsilon S^i_j(x)) \Phi^j(x - \epsilon X) = \varepsilon (\Phi^i(x) - \epsilon L\Phi^i(x)) \\ \delta\tilde{\Phi}_i &= -\varepsilon \tilde{\Phi}_j(x + \epsilon X) (\delta^j_i + \epsilon S^j_i(x)) = -\varepsilon (\tilde{\Phi}_i(x) + \epsilon L\tilde{\Phi}_i(x))\end{aligned}$$

for an infinitesimal isometry with Killing vector X , given by $x^\mu \rightarrow x^\mu + \epsilon X^\mu$ and generated by the Lie derivatives L ,

$$\begin{aligned}L\Phi^i &= X^\mu \partial_\mu \Phi^i - S^i_j \Phi^j \\ L\tilde{\Phi}_i &= X^\mu \partial_\mu \tilde{\Phi}_i + \tilde{\Phi}_j S^j_i.\end{aligned}$$

Then the change in the action is

$$\begin{aligned}\delta S &= \varepsilon \int d^d x \sqrt{-g(x)} \tilde{\Phi}_i(x) \Omega^i_j(x) (\delta^j_k + \epsilon S^j_k(x)) \Phi^k(x - \epsilon X) \\ &\quad - \varepsilon \int d^d x \sqrt{-g(x)} \tilde{\Phi}_i(x + \epsilon X) (\delta^i_j + \epsilon S^i_j(x)) \Omega^j_k(x) \Phi^k(x).\end{aligned}\quad (3.27)$$

Now perform the following change of variables in the second integral

$$x \rightarrow x - \epsilon X$$

and then the second integral becomes

$$-\varepsilon \int d^d x \sqrt{g(x)} \tilde{\Phi}_i(x) (\delta^i_j + \epsilon S^i_j(x)) \Omega^j_k(x - \epsilon X) \Phi^k(x - \epsilon X)$$

since $d^d \hat{x} \sqrt{-g(\hat{x})} = d^d x \sqrt{-g(x)}$ for an isometry. Then insert the identity between Ω and Φ

$$\begin{aligned}-\varepsilon \int d^d x \sqrt{-g(x)} \tilde{\Phi}_i(x) (\delta^i_j + \epsilon S^i_j(x)) \Omega^j_k(x - \epsilon X) \times \\ \times (\delta^k_l - \epsilon S^k_l(x)) (\delta^l_m + \epsilon S^l_m(x)) \Phi^m(x - \epsilon X)\end{aligned}$$

and define

$$\dot{\Omega}^i_l(x) = (\delta^i_j + \epsilon S^i_j(x)) \Omega^j_k(x - \epsilon X) (\delta^k_l - \epsilon S^k_l(x))$$

and since the transformation is an isometry with $\dot{\Omega} = \Omega$ then the second integral in (3.27) becomes

$$\begin{aligned}-\varepsilon \int d^d x \sqrt{-g(x)} \tilde{\Phi}_i(x) (\delta^i_j + \epsilon S^i_j(x)) \Omega^j_k(x - \epsilon X) \Phi^k(x - \epsilon X) \\ = -\varepsilon \int d^d x \sqrt{-g(x)} \tilde{\Phi}_i(x) \Omega^i_j(x) (\delta^j_k + \epsilon S^j_k(x)) \Phi^k(x - \epsilon X)\end{aligned}\quad (3.28)$$

which cancels with the first integral giving $\delta S = 0$ as we required. Repeated infinitesimal transformations viz,

$$\begin{aligned} & \lim_{N \rightarrow \infty} \left(1 + \frac{L(\sigma_x(t_N))}{N} \right) \left(1 + \frac{L(\sigma_x(t_{N-1}))}{N} \right) \times \dots \\ & \dots \times \left(1 + \frac{L(\sigma_x(t_0))}{N} \right) \varphi(x) \\ & = T \exp \left\{ \int_0^t dt L(\sigma_x(\dot{t})) \right\} \varphi(x) \end{aligned}$$

will give us the finite version of (3.28) as

$$\begin{aligned} & \varepsilon \int d^d x \sqrt{-g(x)} \tilde{\Phi}_i(x) \left(T \exp \left\{ \int_0^t dt L(\sigma_x(\dot{t})) \right\} \Omega^i_j(x) \Phi^j(x) \right) \\ & = \varepsilon \int d^d x \sqrt{-g(x)} \tilde{\Phi}_i(x) \Omega^i_j(x) \left(T \exp \left\{ \int_0^t dt L(\sigma_x(\dot{t})) \right\} \Phi^j(x) \right). \end{aligned}$$

Expanding out the time ordered exponentials we get the following result,

$$[L(\sigma_x(\dot{t})), \Omega(x)] = 0 \quad (3.29)$$

which we will use presently.

Let us guess the form of the order-by-order expression for $K_{(n)}^\mu$. We shall write,

$$\begin{aligned} K_{(n)}^\mu &= \int_0^t dt_1 \dots \int_0^{t_{n-1}} dt_n \left(\sqrt{-g} \dot{X}^\mu \tilde{\Phi} \Omega L(t_2) \dots L(t_n) \Phi \right. \\ & \quad \left. - \sqrt{-g} \dot{X}^\mu L(t_1) \tilde{\Phi} \Omega L(t_3) \dots L(t_n) \Phi + \dots \right. \\ & \quad \left. + \dots (-1)^n \sqrt{-g} \dot{X}^\mu L(t_{n-2}) \dots L(t_1) \tilde{\Phi} \Omega L(t_n) \Phi \right. \\ & \quad \left. + (-1)^{n+1} \sqrt{-g} \dot{X}^\mu L(t_{n-1}) \dots L(t_1) \tilde{\Phi} \Omega \Phi \right) \end{aligned} \quad (3.30)$$

where

$$\dot{X}^\mu(x) = \frac{\partial x^\mu}{\partial y^\nu} X^\nu(y)$$

for $y = \sigma_x(t_i)$. Now let us calculate $\partial_\mu K_{(n)}^\mu$ as per previous sections of this chapter.

Take the i th term in the above expression,

$$\int_0^t dt_1 \dots \int_0^{t_{n-1}} dt_n (-1)^i \sqrt{-g} \dot{X}^\mu L(t_{i-1}) \dots L(t_1) \tilde{\Phi} \Omega L(t_{i+1}) \dots L(t_n) \Phi$$

and take the divergence. We have the basic result that for a tensor density

$$\partial_\mu \sqrt{-g} X^\nu = \sqrt{-g} \nabla_\mu X^\nu$$

and that $\nabla_\mu X^\mu = 0$ since X^μ is Killing and thus, for the i th term in the expansion (3.30), we have

$$\int_0^t dt_1 \cdots \int_0^{t_{n-1}} dt_n (-1)^n \sqrt{-g} L(t_i) \left\{ L(t_{i-1}) \cdots L(t_1) \tilde{\Phi} \Omega L(t_{i+1}) \cdots L(t_n) \Phi \right\}$$

where $L(t_i)$ is the Lie derivative acting on the scalar quantity, given by $L = \dot{X}^{\lambda_i}(\sigma_x(t_i)) \partial_{\lambda_i}$. The derivative obeys the usual product rule and by using (3.29) we get

$$\begin{aligned} & \int_0^t dt_1 \cdots \int_0^{t_{n-1}} dt_n (-1)^i \sqrt{-g} L(t_i) L(t_{i-1}) \cdots L(t_1) \tilde{\Phi} \Omega L(t_{i+1}) \cdots L(t_n) \Phi \\ & + \int_0^t dt_1 \cdots \int_0^{t_{n-1}} dt_n (-1)^i \sqrt{-g} L(t_{i-1}) \cdots L(t_1) \tilde{\Phi} \Omega L(t_i) L(t_{i+1}) \cdots L(t_n) \Phi. \end{aligned}$$

Then there is cancellation amongst the terms in the divergence of (3.30) leaving only

$$\begin{aligned} \partial_\mu K_{(n)}^\mu &= \int_0^t dt_1 \cdots \int_0^{t_{n-1}} dt_n \sqrt{-g} \tilde{\Phi} \Omega L(t_1) \cdots L(t_n) \Phi \\ &+ \int_0^t dt_1 \cdots \int_0^{t_{n-1}} dt_n (-1)^n \sqrt{-g} L(t_n) \cdots L(t_1) \tilde{\Phi} \Omega \Phi \\ &= \delta_{(n)} \mathcal{L} \end{aligned}$$

as required.

3.6 Lie Algebra

Let $\varphi(x)$ be a free scalar field and $x \rightarrow x_{G_i}$ be a member of the isometry group G

$$x \rightarrow x_{G_i} = \Lambda_i x + a$$

where Λ is the matrix generator of Lorentz boosts and rotations and a is a displacement vector. Then as we have seen, a change in the free field $\delta\varphi(x)$ given by

$$\delta_i \varphi(x) = \varepsilon_i \varphi(x_{G_i}) \tag{3.31}$$

is a symmetry of the action, (3.1). More generally however, it is obvious that linear combinations of (3.31),

$$\delta_i \varphi(x) = \sum_i \varepsilon_i \varphi(x_{G_i})$$

are also symmetries of (3.1) with $\varepsilon \in \mathbb{C}$ and the sum being over a discrete sub-group of G for simplicity rather than an integral over the full continuous group. These objects $\delta\varphi(x)$ clearly satisfy the elementary vector space axioms. Two consecutive transformations δ_1 and δ_2 are given by

$$\delta_1\delta_2\varphi(x) = \sum_i \sum_j \varepsilon_i^1 \varepsilon_j^2 \varphi(x_{G_i G_j}) = \sum_i \sum_j \varepsilon_i^1 \varepsilon_j^2 \varphi(C_{ij}^k x_{G_k})$$

with a sum over the index k and with $C_{ij}^k = 1$ for one combination of i, j and k and zero otherwise. In that sense the C_{ij}^k s are a group multiplication table (or Cayley table) for the discrete sub-group with

$$G_i G_j = C_{ij}^k G_k. \quad (3.32)$$

and so C_{ij}^k has only one non-vanishing term in the implied sum over k . Moreover, C_{ij}^k can also be taken outside thus,

$$\delta_1\delta_2\varphi(x) = \sum_i \sum_j \varepsilon_i^1 \varepsilon_j^2 \varphi(x_{G_i G_j}) = \sum_i \sum_j \varepsilon_i^1 \varepsilon_j^2 C_{ij}^k \varphi(x_{G_k})$$

and the commutator is given by

$$[\delta_1, \delta_2] \varphi(x) = \sum_i \sum_j \varepsilon_i^1 \varepsilon_j^2 (C_{ij}^k - C_{ji}^k) \varphi(x_{G_k}) = \sum_i \sum_j \varepsilon_i^1 \varepsilon_j^2 f_{ij}^k \delta_k \varphi(x), \quad (3.33)$$

hence satisfying a closure relation. With the transformations $\delta\varphi(x)$ defined this way, the commutators also satisfy the Jacobi identity as follows. Writing out the commutators, we arrive at

$$\begin{aligned} & [[\delta_1, \delta_2], \delta_3] + [[\delta_2, \delta_3], \delta_1] + [[\delta_3, \delta_1], \delta_2] \varphi(x) = \\ & \sum_i \sum_j \sum_k \varepsilon_i^1 \varepsilon_j^2 \varepsilon_k^3 (f_{ij}^l f_{lk}^m + f_{jk}^l f_{li}^m + f_{ki}^l f_{lj}^m) \varphi(x_{G_m}) \end{aligned}$$

then writing in terms of C_{ij}^k

$$\begin{aligned} & [[\delta_1, \delta_2], \delta_3] + [[\delta_2, \delta_3], \delta_1] + [[\delta_3, \delta_1], \delta_2] \varphi(x) = \\ & = \sum_i \sum_j \sum_k \varepsilon_i^1 \varepsilon_j^2 \varepsilon_k^3 \left(C_{ij}^l C_{lk}^m - C_{ij}^l C_{kl}^m - C_{ji}^l C_{lk}^m + C_{ji}^l C_{kl}^m \right. \\ & \quad + C_{jk}^l C_{li}^m - C_{jk}^l C_{il}^m - C_{kj}^l C_{li}^m + C_{kj}^l C_{il}^m \\ & \quad \left. + C_{ki}^l C_{lj}^m - C_{ki}^l C_{jl}^m - C_{ik}^l C_{lj}^m + C_{ik}^l C_{jl}^m \right) \varphi(x_{G_m}) = 0, \end{aligned}$$

by using the associativity property $(G_i G_j) G_k = G_i (G_j G_k)$ of the group multiplication and eqn (3.32). Since the objects δ_i form a vector space, and satisfy commutator closure relations and the Jacobi identity, they are a Lie algebra g over the field \mathbb{C} . Since G has an infinite number of elements the Lie algebra g not only has an infinite number of generators, they are also uncountable due to G being a continuous group. However, there exists an infinite number of discrete sub-groups of G such as the dihedral sub-groups of $SO(3)$ which can be used to form discrete infinite dimensional Lie algebras using the above argument. Algebras constructed in this way are called ‘group algebras’. (See [46] for a full discussion on this subject)

3.6.1 Infinite Dimensional Kac-Moody and Loop Algebras

All the finite dimensional simple Lie algebras (and more generally the semi-simple Lie algebras) are well understood and classified by their root spaces and Dynkin diagrams. There are the 4 infinite series; A, B, C and D together with the exceptional Lie algebras; E, F and G. See for example [47]. In particular these classes of Lie algebra possess no non-trivial extensions and have commutation relations

$$[M_i, M_j] = f_{ij}{}^k M_k$$

where $f_{ij}{}^k$ completely define the algebra. On the other hand, as explained in [40, 48], we are far away from classifying completely the infinite dimensional Lie algebras. However, the Kac-Moody type 1 affine algebra, [48], is associated with a finite dimensional semi-simple algebra g given by the formal expression

$$g \otimes C[t, t^{-1}] \oplus C_z$$

where $C[t, t^{-1}]$ is a map from the circle S_1 to g and C_z is the central extension. The commutation relations are

$$\begin{aligned} [M_i^m, M_j^n] &= f_{ij}{}^k M_k^{m+n} - m\delta^{m,-n}\delta_{ij}K \\ [M_i^m, K] &= 0 \end{aligned} \tag{3.34}$$

with $m, n = -\infty \cdots \infty$. The term $m\delta^{m,-n}\delta_{ij}K$ is referred to as the central extension. These affine algebras are amongst the infinite dimensional Lie algebras that

have been classified straightforwardly from the classification of the semi-simple Lie algebras. In fact their Dynkin diagrams are slight modifications of those of the semi-simple algebras: see for example [40]. We note that the central extension vanishes for $m, n \geq 0$ and this object is known as the half Kac-Moody algebra. In the case where $K = 0$ then the second relation is trivially satisfied and the algebra simply becomes

$$[M_i^m, M_j^n] = f_{ij}{}^k M_k^{m+n}$$

and we can write a representation of the generators as

$$M_i^m = M_i \otimes t^m \quad m = -\infty \cdots \infty \quad (3.35)$$

where M_i is a generator of the semi-simple Lie algebra \mathfrak{g} . This is referred to as the loop algebra of the semi-simple Lie algebra \mathfrak{g} and are the structures we will consider here. It is worth noting that (3.35) is not a representation of (3.34) for $K \neq 0$. Also, when $m = n = 0$, we have what is referred to as the zero-mode sub-algebra \mathfrak{g}_0 .

Let us consider discrete sub-groups of the Poincaré group. We shall restrict ourselves to the case of discrete rotations and discrete time dilations thus,

$$(t, \mathbf{x}) \rightarrow (\dot{t}, \dot{\mathbf{x}}) = (t + am, R_i \mathbf{x})$$

where $m = -\infty, \cdots, \infty$ are integers and the R_i are elements of discrete sub-groups of $SO(3)$. Then two consecutive transformations gives

$$(t, \mathbf{x}) \rightarrow (\dot{t}, \dot{\mathbf{x}}) = (t + a(m + n), R_i R_j \mathbf{x}) = (t + a(m + n), R_k \mathbf{x})$$

thus giving us the closure property. Then by similar arguments to those we gave in equation (3.33), if we define

$$\delta_i^m \varphi(t, \mathbf{x}) = \varepsilon_i \varphi(t + ma, R_i \mathbf{x})$$

then we arrive at the loop algebra

$$[\delta_i^m, \delta_j^n] \varphi(t, \mathbf{x}) = f_{ij}{}^k \delta_k^{m+n} \varphi(t, \mathbf{x})$$

with $f_{ij}{}^k = C_{ij}{}^k - C_{ji}{}^k$ and as before the expression also satisfies the Jacobi identity. This loop algebra has a representation given by (3.35) and we shall now give examples of the generators M_i for the various discrete sub-groups of $SO(3)$ to classify the

algebra g . It suffices to consider the zero-mode sub-algebra g_0 to classify g since g_0 and g are clearly isomorphic,

$$[\delta_i^0, \delta_j^0] \varphi(t, \mathbf{x}) = f_{ij}^k \delta_k^0 \varphi(t, \mathbf{x})$$

and so we shall perform changes of basis for g_0 .

3.6.2 Conjugacy Classes of G and the Dimension of \mathfrak{g}

Clearly the dimension of the zero-mode algebra g_0 is given by

$$\text{Dim}(g) = |G|$$

where $|G|$ is the order of the $SO(3)$ sub-group. In the obvious choice of basis, we have $n = |G|$ generators of g_0 ,

$$\delta_1 \varphi(x), \delta_2 \varphi(x), \dots, \delta_n \varphi(x). \quad (3.36)$$

A Lie algebra can be decomposed into the direct sum of a non-Abelian algebra \bar{g} and possibly a trivial Abelian algebra $\mathcal{C}(g)$ (See [49], page 135 and also [40]) referred to as the centre, as follows

$$g_0 = \bar{g} \oplus \mathcal{C}(g). \quad (3.37)$$

Furthermore, the group elements G are distributed amongst conjugacy classes which are subsets of G with mutually conjugate elements [46].

It turns out that the dimension of $\mathcal{C}(g_0)$ equals the number of conjugacy classes of the group G and this is a well known theorem in the subject of group algebras. We shall give a proof that pertains to our application. (For an alternative proof in the more general setting of group algebras, see [46].) Let us consider a conjugacy class C_1 of G containing r elements say,

$$C_1 = \{a_1, a_2, \dots, a_r\}$$

and any other element of the group G , say h . Now,

$$\delta_{a_i} \delta_h \varphi(x) = \varepsilon_{a_i} \varepsilon_h \varphi(x_{a_i h})$$

and by using the defining relationship between mutually conjugate elements in a conjugacy class that $h^{-1}ah = b$ this equals

$$\delta_{a_i} \delta_h \varphi(x) = \varepsilon_a \varepsilon_h \varphi(x_{hb_i})$$

where b_i is also an element (possibly identical to a_i) of C_1 . Also, for any a_i and a_j with $a_i \neq a_j$ we have $b_i \neq b_j$ by the mutually conjugate property of the conjugacy class. It is possible to construct a generator $\bar{\delta}$ by summing over the elements in C_1 ,

$$\bar{\delta} \varphi(x) = \varepsilon_a \varphi(x_{a_1}) + \varepsilon_a \varphi(x_{a_2}) + \cdots + \varepsilon_a \varphi(x_{a_r}) \quad (3.38)$$

so

$$\bar{\delta} \delta_h \varphi(x) = \varepsilon_a \varepsilon_h \sum_r \varphi(x_{a_r h}) = \varepsilon_a \varepsilon_h \sum_r \varphi(x_{hb_r}).$$

Now since r runs over all elements in the conjugacy class C_1 , the right hand sum can be written as

$$\varepsilon_a \varepsilon_h \sum_r \varphi(x_{hb_r}) = \varepsilon_a \varepsilon_h \sum_s \varphi(x_{ha_s}) = \delta_h \bar{\delta} \varphi(x)$$

giving

$$[\bar{\delta}, \delta_h] = 0.$$

Now if there are m conjugacy classes C_1, \dots, C_m , this implies that the number of Abelian generators is bigger than or equal to m . Equality is proved by assuming we have found m linearly independent Abelian generators given by (3.38), $\bar{\delta}_q$ and then constructing an $(m+1)$ th Abelian generator, $\bar{\delta}_{m+1}$, as follows,

$$\bar{\delta}_{m+1} \varphi(x) = \varepsilon_a \sum_{a_r \in C_1} \lambda_{r1} \varphi(x_{a_{r1}}) + \varepsilon_a \sum_{a_r \in C_2} \lambda_{r2} \varphi(x_{a_{r2}}) + \cdots$$

where the sum over r is the sum over the r elements a_{rq} contained within the conjugacy class C_q and λ_{rq} is the coefficient of the the r th generator in the q th conjugacy class. Then if we take the commutator $[\bar{\delta}_{m+1}, \delta_h]$, it must be zero for all δ_h so take the q th term in the above sum of $\bar{\delta}_{m+1} \delta_h$

$$\varepsilon_a \varepsilon_h \sum_{a_r \in C_q} \lambda_{rq} \varphi(x_{a_{rq} h}) = \varepsilon_a \varepsilon_h \sum_r \lambda_{rq} \varphi(x_{hb_{rq}})$$

by again using the expression $h^{-1}ah = b$. The a_{rq} are all distinct elements so it follows that the b_{rq} are also distinct by the mutual orthogonality property of

elements in the conjugacy class. Now relabel the elements b_{rq} as follows, which we can do because we are summing over all elements a (or alternatively b) in C_q

$$\bar{\delta}_{m+1}\delta_h\varphi(x) = \cdots + \varepsilon_a\varepsilon_h \sum_r \lambda_{rq}\varphi(x_{ha_{\hat{r}q}}) + \cdots \quad (3.39)$$

and we require,

$$\bar{\delta}_{m+1}\delta_h\varphi(x) = \cdots + \varepsilon_a\varepsilon_h \sum_r \lambda_{\hat{r}q}\varphi(x_{ha_{r\hat{q}}}) + \cdots = \cdots + \varepsilon_a\varepsilon_h \sum_r \lambda_{rq}\varphi(x_{ha_{r\hat{q}}}) + \cdots = \delta_h\bar{\delta}_{m+1}$$

which is satisfied only if $\lambda_{\hat{r}q} = \lambda_{rq}$ for all r and \hat{r} because the a_{rq} are all distinct linearly independent elements. So we have

$$\lambda_{1q} = \lambda_{2q} = \cdots = \lambda_{rq}$$

for all conjugacy classes C_q , hence $\bar{\delta}_{m+1}$ is in fact a linear combination of $\bar{\delta}_1, \dots, \bar{\delta}_m$. Hence, if the n elements of G are distributed amongst m conjugacy classes there are exactly m Abelian generators of $\mathcal{C}(g_0)$ and the dimension of \bar{g} from eqn (3.37) is $n - m$.

3.6.3 Triangle Sub-group of $SO(3)$

Consider rotations of a prism with one of its corners located at the origin and whose opposite face is perpendicular to the z -axis: see [50]. The matrices corresponding to the rotations of this prism are given by

$$\begin{aligned} \mathbb{I} &= \begin{pmatrix} 1 & 0 & 0 \\ 0 & 1 & 0 \\ 0 & 0 & 1 \end{pmatrix}, \quad R_1 = \begin{pmatrix} -1 & 0 & 0 \\ 0 & 1 & 0 \\ 0 & 0 & 1 \end{pmatrix}, \quad R_2 = \begin{pmatrix} 1/2 & -\sqrt{3}/2 & 0 \\ -\sqrt{3}/2 & -1/2 & 0 \\ 0 & 0 & -1 \end{pmatrix}, \\ R_3 &= \begin{pmatrix} 1/2 & \sqrt{3}/2 & 0 \\ \sqrt{3}/2 & -1/2 & 0 \\ 0 & 0 & -1 \end{pmatrix}, \quad R_4 = \begin{pmatrix} -1/2 & -\sqrt{3}/2 & 0 \\ \sqrt{3}/2 & -1/2 & 0 \\ 0 & 0 & 1 \end{pmatrix}, \\ R_5 &= \begin{pmatrix} -1/2 & \sqrt{3}/2 & 0 \\ \sqrt{3}/2 & -1/2 & 0 \\ 0 & 0 & 1 \end{pmatrix} \end{aligned}$$

Table 3.1: Cayley Table of the Triangle Group

	\mathbb{I}	R_1	R_2	R_3	R_4	R_5
\mathbb{I}	\mathbb{I}	R_1	R_2	R_3	R_4	R_5
R_1	R_1	\mathbb{I}	R_5	R_4	R_3	R_2
R_2	R_2	R_4	\mathbb{I}	R_5	R_1	R_3
R_3	R_3	R_5	R_4	\mathbb{I}	R_2	R_1
R_4	R_4	R_2	R_3	R_1	R_5	\mathbb{I}
R_5	R_5	R_3	R_1	R_2	\mathbb{I}	R_4

which can be easily checked that their determinants are all +1 and all close under multiplication thus the Cayley table is readily calculated, table (3.1). The conjugacy classes are

$$C_1 = \{\mathbb{I}\}, \quad C_2 = \{R_1, R_2, R_3\}, \quad C_3 = \{R_4, R_5\} \quad (3.40)$$

and then by the discussion of §(3.6.2) the generators

$$Z_1 = \varepsilon\varphi(\mathbb{I}\mathbf{x})$$

$$Z_2 = \varepsilon\varphi(R_1\mathbf{x}) + \varepsilon\varphi(R_2\mathbf{x}) + \varepsilon\varphi(R_3\mathbf{x})$$

$$Z_3 = \varepsilon\varphi(R_4\mathbf{x}) + \varepsilon\varphi(R_5\mathbf{x})$$

commute with everything and can also not appear on the right hand side of the commutators and thus form the trivial centre of g_0 . In the following basis we have

$$M_1\varphi = \varepsilon\frac{i}{\sqrt{3}}(\varphi(R_1\mathbf{x}) - \varphi(R_2\mathbf{x}))$$

$$M_2\varphi = \varepsilon\frac{i}{3}(\varphi(R_1\mathbf{x}) - 2\varphi(R_3\mathbf{x}) + \varphi(R_2\mathbf{x}))$$

$$M_3\varphi = \varepsilon\frac{1}{\sqrt{3}}(\varphi(R_5\mathbf{x}) - \varphi(R_4\mathbf{x})).$$

We can calculate the commutators

$$[M_1, M_2]\varphi = -2M_3\varphi$$

$$[M_2, M_3]\varphi = -2M_1\varphi$$

$$[M_3, M_1]\varphi = -2M_2\varphi$$

which is

$$[M_i, M_j]\varphi = -2\varepsilon_{ijk}M_k\varphi$$

where ε_{ijk} is the completely anti-symmetric symbol, so this algebra is in fact $su(2)$.

3.6.4 Tetrahedral Sub-Group of $SO(3)$

Now let us consider the algebra formed from the discrete group of rotations of a tetrahedron. See [50] for a description of the tetrahedral group but it is sufficient for us to write down the matrix representation of the group here. We have

$$\begin{aligned} \mathbb{I} &= \begin{pmatrix} 1 & 0 & 0 \\ 0 & 1 & 0 \\ 0 & 0 & 1 \end{pmatrix}, R_1 = \begin{pmatrix} 1 & 0 & 0 \\ 0 & -1 & 0 \\ 0 & 0 & -1 \end{pmatrix}, R_2 = \begin{pmatrix} -1 & 0 & 0 \\ 0 & 1 & 0 \\ 0 & 0 & -1 \end{pmatrix}, \\ R_3 &= \begin{pmatrix} -1 & 0 & 0 \\ 0 & -1 & 0 \\ 0 & 0 & 1 \end{pmatrix}, R_4 = \begin{pmatrix} 0 & 0 & 1 \\ 1 & 0 & 0 \\ 0 & 1 & 0 \end{pmatrix}, R_5 = \begin{pmatrix} 0 & -1 & 0 \\ 0 & 0 & 1 \\ -1 & 0 & 0 \end{pmatrix}, \\ R_6 &= \begin{pmatrix} 0 & -1 & 0 \\ 0 & 0 & -1 \\ 1 & 0 & 0 \end{pmatrix}, R_7 = \begin{pmatrix} 0 & 0 & 1 \\ 1 & 0 & 0 \\ 0 & -1 & 0 \end{pmatrix}, R_8 = \begin{pmatrix} 0 & -1 & 0 \\ 0 & 0 & 1 \\ -1 & 0 & 0 \end{pmatrix}, \\ R_9 &= \begin{pmatrix} 0 & 0 & -1 \\ -1 & 0 & 0 \\ 0 & 1 & 0 \end{pmatrix}, R_{10} = \begin{pmatrix} 0 & 0 & -1 \\ 1 & 0 & 0 \\ 0 & -1 & 0 \end{pmatrix}, R_{11} = \begin{pmatrix} 0 & 1 & 0 \\ 0 & 0 & -1 \\ -1 & 0 & 0 \end{pmatrix} \end{aligned} \quad (3.41)$$

and the multiplication table can easily be calculated using computer algebra or by hand, table (3.2). The conjugacy classes of the tetrahedral group are, [50],

$$C_1 = \{\mathbb{I}\}, C_2 = \{R_1, R_2, R_3\}, C_3 = \{R_4, R_7, R_9, R_{10}\}, C_4 = \{R_5, R_6, R_8, R_{11}\}$$

so as before the action of the generators

$$Z_1\varphi(\mathbf{x}) = \varepsilon\varphi(\mathbf{x})$$

$$Z_2\varphi(\mathbf{x}) = \varepsilon\varphi(R_1\mathbf{x}) + \varepsilon\varphi(R_2\mathbf{x}) + \varepsilon\varphi(R_3\mathbf{x})$$

$$Z_3\varphi(\mathbf{x}) = \varepsilon\varphi(R_4\mathbf{x}) + \varepsilon\varphi(R_7\mathbf{x}) + \varepsilon\varphi(R_9\mathbf{x}) + \varepsilon\varphi(R_{10}\mathbf{x})$$

$$Z_4\varphi(\mathbf{x}) = \varepsilon\varphi(R_5\mathbf{x}) + \varepsilon\varphi(R_6\mathbf{x}) + \varepsilon\varphi(R_8\mathbf{x}) + \varepsilon\varphi(R_{11}\mathbf{x})$$

Table 3.2: Cayley Table of Tetrahedral Group

	\mathbb{I}	R_1	R_2	R_3	R_4	R_5	R_6	R_7	R_8	R_9	R_{10}	R_{11}
\mathbb{I}	\mathbb{I}	R_1	R_2	R_3	R_4	R_5	R_6	R_7	R_8	R_9	R_{10}	R_{11}
R_1	R_1	\mathbb{I}	R_3	R_2	R_{10}	R_6	R_5	R_9	R_{11}	R_7	R_4	R_8
R_2	R_2	R_3	\mathbb{I}	R_1	R_7	R_8	R_{11}	R_4	R_5	R_{10}	R_9	R_6
R_3	R_3	R_2	R_1	\mathbb{I}	R_9	R_{11}	R_8	R_{10}	R_6	R_4	R_7	R_5
R_4	R_4	R_7	R_9	R_{10}	R_8	R_3	R_1	R_6	\mathbb{I}	R_{11}	R_5	R_2
R_5	R_5	R_{11}	R_6	R_8	R_2	R_9	R_4	R_3	R_7	\mathbb{I}	R_1	R_{10}
R_6	R_6	R_8	R_5	R_{11}	R_3	R_7	R_{10}	R_2	R_9	R_1	\mathbb{I}	R_4
R_7	R_7	R_4	R_{10}	R_9	R_5	R_1	R_3	R_{11}	R_2	R_6	R_8	\mathbb{I}
R_8	R_8	R_6	R_{11}	R_5	\mathbb{I}	R_{10}	R_7	R_1	R_4	R_2	R_3	R_9
R_9	R_9	R_{10}	R_4	R_7	R_6	\mathbb{I}	R_2	R_8	R_3	R_5	R_{11}	R_1
R_{10}	R_{10}	R_9	R_7	R_4	R_{11}	R_2	\mathbb{I}	R_5	R_1	R_8	R_6	R_3
R_{11}	R_{11}	R_5	R_8	R_6	R_1	R_4	R_9	\mathbb{I}	R_{10}	R_3	R_2	R_7

commute with everything. If we define generators of the algebra to be

$$\delta_i \varphi = \varepsilon \varphi(R_i \mathbf{x})$$

then only differences of members of the algebra can appear on the right hand side of the commutator, for example

$$[\delta_8, \delta_5] \varphi = \delta_{10} \varphi - \delta_7 \varphi.$$

An exhaustive list of all the commutators is given in appendix (A) and one can use computer algebra to find a linearly independent set of them. For example, by writing

$$\begin{aligned} L_1 &= \delta_{10} - \delta_7, & L_2 &= \delta_6 - \delta_{11}, & L_3 &= \delta_5 - \delta_8, & L_4 &= \delta_9 - \delta_4 \\ L_5 &= \delta_7 - \delta_9, & L_6 &= \delta_8 - \delta_6, & L_7 &= \delta_3 - \delta_2, & L_8 &= \delta_1 - \delta_3 \end{aligned} \quad (3.42)$$

the L_i together with the Z_i form a basis for the algebra and what is more the set of L_i above is closed under commutation and forms a sub-algebra \bar{g} . We write down all

the commutators $[L_i, L_j]$ in appendix (A) and proceed to use the well known Cartan-Weyl procedure to make another change of basis to write down the commutators in a canonical way. In the standard Cartan-Weyl procedure we simultaneously solve the eigen-problems

$$[\overline{H}, E_\alpha] = \alpha E_\alpha. \quad (3.43)$$

The eigenvalues α are referred to as the roots and the set of roots Φ is called the root space. Using the Jacobi identity and consistency arguments (see [40]) the rest of the commutators are given by

$$[E_\alpha, E_\beta] = e_{\alpha,\beta} E_{\alpha+\beta} \quad (3.44)$$

for some numbers $e_{\alpha,\beta}$ if $\alpha + \beta \in \Phi$ is also a root and

$$[E_\alpha, E_\beta] = 0 \quad (3.45)$$

if $\alpha + \beta \neq 0$ and $\alpha + \beta \notin \Phi$. Further, we have

$$[E_\alpha, E_{-\alpha}] = \sum_i \tilde{\alpha}_i H_i. \quad (3.46)$$

One begins by observing that the generators L_7 and L_8 with $[L_7, L_8] = 0$ are a maximally commuting set referred to as the Cartan sub-algebra. We make the redefinition

$$H_1 = \frac{1}{4}(L_8 + L_7), \quad H_2 = \frac{1}{4\sqrt{3}}(L_8 - L_7)$$

and the following change of basis

$$\begin{aligned} E_\alpha &= \frac{1}{4}(L_2 + L_3), & E_{-\alpha} &= \frac{1}{4}(L_1 + L_4) \\ E_\beta &= -\frac{1}{2}\left(L_6 + \frac{L_2}{2} + \frac{L_3}{2}\right), & E_{-\beta} &= \frac{1}{2}\left(L_5 + \frac{L_1}{2} + \frac{L_4}{2}\right) \\ E_\gamma &= \frac{1}{4}(L_1 - L_4), & E_{-\gamma} &= \frac{1}{4}(L_2 - L_3) \end{aligned}$$

satisfies (3.43) with

$$\begin{aligned} [\overline{H}, E_{\pm\alpha}] &= \pm(1, 0)E_{\pm\alpha} \\ [\overline{H}, E_{\pm\beta}] &= \pm\frac{1}{2}(-1, \sqrt{3})E_{\pm\beta} \\ [\overline{H}, E_{\pm\gamma}] &= \pm\frac{1}{2}(1, \sqrt{3})E_{\pm\gamma} \end{aligned}$$

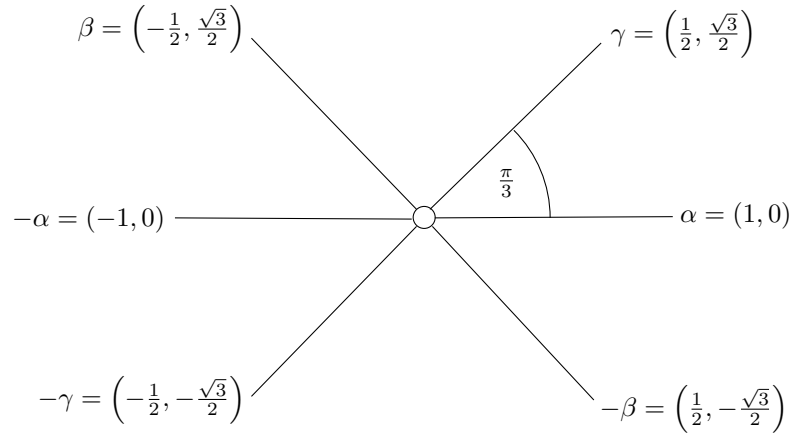
Figure 3.1: Root Space of $su(3)$

where $\bar{H} = (H_1, H_2)$, giving us the typical $su(3)$ root space diagram fig (3.1). The other non zero commutators are then

$$\begin{aligned}
 [E_{\pm\alpha}, E_{\pm\beta}] &= \pm E_{\pm\gamma}, & [E_{\pm\alpha}, E_{\mp\gamma}] &= \mp E_{\mp\beta} \\
 [E_{\pm\beta}, E_{\mp\gamma}] &= \pm E_{\mp\alpha}, & [E_{\alpha}, E_{-\alpha}] &= 2H_1 \\
 [E_{\beta}, E_{-\beta}] &= -H_1 + \sqrt{3}H_2, & [E_{\gamma}, E_{-\gamma}] &= H_1 + \sqrt{3}H_2
 \end{aligned}$$

which the reader may wish to check satisfy (3.44), (3.45) and (3.46). The root space Φ uniquely defines the algebra as $g_0 = su(3) \oplus \mathcal{C}_Z(4)$.

3.6.5 Dihedral Sub-Groups of $SO(3)$

Consider rotations of an n -sided prism about an axis, z with rotation matrix G representing a self congruent rotation of angle $2\pi/n$. The full set of self congruent rotations about the axis, z , forms the cyclic groups C_n with presentation

$$C_n = \langle r : r^n = \mathbb{I} \rangle$$

with group action $r^i r^j = r^{i+j} \text{ mod } (n)$. It is obvious the group algebra $g(C_n)$ is Abelian, so we don't consider it. However, the cyclic group C_n composed with n , C_2 rotations about axes perpendicular to z and orthogonal to the faces of the prisms forms the full rotation group of an n -sided prism and has abstract group $D_{2n} = C_n \otimes C_2$ called the dihedral group and has presentation

$$D_{2n} = \langle r, s : r^n = \mathbb{I}, s^2 = \mathbb{I}, s^{-1}rs = r^{-1} \rangle$$

and can be shown to have $m < 2n$ conjugacy classes and so $g(D_{2n})$ has a $2n - m$ dimensional non-Abelian part by [33, 46]. The conjugacy classes for n odd and n even are different. They are given by the following

$$\begin{aligned} \text{odd} : & \{\mathbb{I}\}, \{r^{\pm 1}\}, \{r^{\pm 2}\} \dots \{r^{\pm(n-1)/2}\}, \{r^i s : 0 \leq i \leq n-1\} \\ \text{even} : & \{\mathbb{I}\}, \{r^{\pm 1}\}, \{r^{\pm 2}\} \dots \{r^{\pm(n/2-1)}\}, \{r^{n/2}\}, \{r^{2i} s : 0 \leq i \leq n/2-1\}, \\ & \{r^{2i+1} s : 0 \leq i \leq n/2-1\} \end{aligned}$$

giving the following for the number of conjugacy classes, m in the group D_{2n}

$$\begin{aligned} m &= \frac{n-1}{2} + 2 : n \text{ odd} \\ m &= \frac{n}{2} + 3 : n \text{ even} \end{aligned}$$

Since $m = \text{Dim}(\mathcal{C}(g_0))$, the dimension of the non-Abelian part of g_0 which is $p = 2n - m$ for even n is given by

$$p = 2n - m = \frac{3n}{2} - 3$$

and for odd n , we have

$$p = 2n - m = \frac{3n-3}{2}.$$

Notice that the dimension of the non-Abelian sub-algebra p is surprisingly a multiple of 3, so it follows that classifying this algebra completely in terms of the four classifications of the infinite simple Lie algebras, A_r , B_r , C_r and D_r is not possible, rather a sum over simple Lie algebras, possibly $su(2)$ which has dimension 3. (See any text book on Lie algebra, for example [40].)

Consider the dihedral groups with even n . Begin by writing the action of the generators on the fields φ as follows,

$$\begin{aligned} \delta_i \varphi &= \varepsilon \varphi(r^i \mathbf{x}) & -\frac{n}{2} + 1 \leq i \leq \frac{n}{2} \\ \bar{\delta}_i \varphi &= \varepsilon \varphi(r^i s \mathbf{x}) & 0 \leq i \leq n-1 \end{aligned}$$

with the identifications

$$\begin{aligned} \delta_{n/2} &= \delta_{-n/2} \\ \bar{\delta}_n &= \bar{\delta}_0 \end{aligned}$$

arising from the modular behaviour of the group action. The actions of the generators which commute with everything to form $\mathcal{C}(g)$ are

$$\begin{aligned} Z_1^i \varphi &= \varepsilon \varphi(r^i \mathbf{x}) + \varepsilon \varphi(r^{-i} \mathbf{x}) & 1 \leq i \leq \frac{n}{2} \\ Z_2 \varphi &= \varepsilon \varphi(r s \mathbf{x}) + \varepsilon \varphi(r^3 s \mathbf{x}) + \cdots + \varepsilon \varphi(r^{n-1} s \mathbf{x}) \\ Z_3 \varphi &= \varepsilon \varphi(s \mathbf{x}) + \varepsilon \varphi(r^2 s \mathbf{x}) + \cdots + \varepsilon \varphi(r^{n-2} s \mathbf{x}). \end{aligned}$$

It is easy to show this by calculating the commutators of the Z_1^i , and the Z_2 and Z_3 with all the δ_i and $\bar{\delta}_i$. Now, by calculating the commutators of the δ_i and $\bar{\delta}_i$ with each other, with careful observation and picking out the linearly independent terms on the right hand side of the commutators we can deduce that the following generators form a closed algebra,

$$\begin{aligned} M_i \varphi &= \varepsilon \varphi(r^i \mathbf{x}) - \varepsilon \varphi(r^{-i} \mathbf{x}) & 1 \leq i \leq \frac{n}{2} - 1 \\ \bar{M}_i &= \varepsilon \varphi(r^i s \mathbf{x}) - \varepsilon \varphi(r^{i+2} s \mathbf{x}) & 0 \leq i \leq n - 3 \end{aligned} \quad (3.47)$$

with commutators

$$\begin{aligned} [M_i, M_j] &= 0 \\ [M_i, \bar{M}_j] &= 2\bar{M}_{j+i} - 2\bar{M}_{j-i} \\ [\bar{M}_i, \bar{M}_j] &= 2M_{i-j} - M_{i-j+2} - M_{i-j-2} \end{aligned}$$

and with the identifications

$$\begin{aligned} \bar{M}_n &= \bar{M}_0 \\ \bar{M}_{n+1} &= \bar{M}_1 \end{aligned}$$

due to the modular nature of the indices attached to δ and $\bar{\delta}$. Further, linear independence of the generators requires

$$\begin{aligned} \bar{M}_{n-2} &= -\bar{M}_0 - M_2 - \cdots - \bar{M}_{n-4} \\ \bar{M}_{n-1} &= -\bar{M}_1 - M_3 - \cdots - \bar{M}_{n-3} \end{aligned}$$

which can be seen from the definition of M and \bar{M} , (3.47) and the summations $M_0 + M_2 + \cdots + M_{n-2} = 0$ and $M_1 + M_3 + \cdots + M_{n-1} = 0$. The reader may wish to check this for the simple $n = 4$ and $n = 6$ cases.

3.7 Chapter Summary

We have derived an expression, $\delta\Phi$ and $\delta\tilde{\Phi}$ for a transformation $\Phi \rightarrow \tilde{\Phi} = \Phi + \delta\Phi$ which leaves the free action (3.25) invariant given by the time ordered exponential of an operator (3.26) where Φ is some arbitrary space time object. The operator is the generator of isometries $x \rightarrow x_G$ on the space-time. We began this procedure by considering the free Klein-Gordon action for complex scalar fields (3.1) and wrote down expressions, (3.3) and (3.4), for $\delta\varphi$ and $\delta\tilde{\varphi}$ in terms of the field variables evaluated at x_G where $x \rightarrow x_G$ are displacements. By Taylor expanding we calculated, order by order, the boundary terms $K_{(n)}^\mu$ with $\partial_\mu K_{(n)}^\mu = \delta_{(n)}\mathcal{L}$ and calculated the Noether currents. It was remarked upon that our approach generates higher order conserved symmetries than those discussed in [42] like those discussed in [34].

This was then extended to the case where $x \rightarrow x_G$ is a Lorentz transformation of (1,3) signature space-time by considering repeated applications of infinitesimal isometries resulting in a path ordered exponential of an operator L acting on the complex scalar field. Again, we calculated boundary terms, order by order, and simply read off the expression for the Noether current. By analogy, the approach was extended further to complex scalars on curved backgrounds, guessing the form of $K_{(n)}^\mu$ and taking the order by order divergence to show $\partial_\mu K_{(n)}^\mu = \delta_{(n)}\mathcal{L}$. We gave a concrete example by considering anti de-Sitter backgrounds. Our aforementioned general result was derived in a similar vein.

Finally, we considered the Lie algebra of transformations $\varphi \rightarrow \varphi + \delta_i\varphi$ for $\delta_i\varphi = \varepsilon_i\varphi(x_{G_i})$ where $x \rightarrow x_{G_i}$ are elements of a discrete sub-group of isometries. We showed that the generators satisfied the Jacobi identity and further, that the sum over all the generators of the algebra whose action $\delta_i\varphi(x) = \varepsilon_i\varphi(x_{G_i})$ for G_i that are elements of conjugacy classes of the group formed Abelian elements of the algebra. We considered how infinite dimensional loop algebras could be constructed by considering discrete sub-groups of rotations composed with time translations and we gave three examples of zero-mode sub-algebras constructed from the triangle group, the tetrahedral group and the dihedral groups. The ‘group algebras’ of the triangle and tetrahedral groups, respectively, were shown to be $su(2)$ and $su(3)$.

Chapter 4

Infinite Dimensional Symmetries of Self-Dual Yang-Mills

We discussed in our introduction §(1) that tree-level gluon scattering amplitudes localise on simple curves in twistor space [5] and this led to the proposal of a new set of rules for calculating such amplitudes [6]. These provided an efficient alternative to conventional Feynman rules. Initially they were proven using non-Lagrangian methods [11], but they may be derived by applying a non-local canonical transformation to light-cone Yang-Mills theory [51], [30]. This action can be split into a part, the Chalmers-Siegel action, [37], that describes self-dual gauge theory and the rest. By itself the self-dual theory has the bizarre property of yielding an S-matrix that is trivial at tree-level whilst having non-linear Euler-Lagrange equations, and non-trivial scattering amplitudes at one-loop, [52]. The canonical transformation maps the Chalmers-Siegel part of the Lagrangian to a free theory, so that the rest of the Lagrangian furnishes interaction terms. This canonical transformation provides a new approach to the self-dual sector of gauge theories. We will use it to construct new non-local symmetries of the self-dual Lagrangian, thereby extending the programme of [32] off-shell, (see also [53], [54] and [55]).

The free theory with fields B and \bar{B} has equation of motion $0 = \Omega(x)B(x) = \Omega(x_G)B(x_G) = \Omega(x)B(x_G)$ where $x \rightarrow x_G$ is a finite isometry and then $B(x_G)$ is another solution since it is trivial to show that, for Ω as defined later, $\Omega(x_G) = \Omega(x)$. By the linearity of the free equation of motion $B(x) + \varepsilon B(x_G)$ is a new solution where

$\delta B(x) = \varepsilon B(x_G)$ is the change in the field by our considerations of §(3) which we may use to construct the Noether currents.

Since the canonical transformation maps the Chalmers-Siegel action to a free theory we can in principle construct the symmetries of this action for self-dual Yang-Mills from those of the free theory by inverting the transformation back to the original variables. This leads to quite cumbersome expressions, so to produce a compact result we begin by examining just the first few orders (in powers of the fields) of the transformations $A \rightarrow A + \delta A$ and $\bar{A} \rightarrow \bar{A} + \delta \bar{A}$ and guess a more concise general expression for δA given by

$$\delta A_1 = -\varepsilon \sum_{n=2}^{\infty} \sum_{i=2}^n \sum_{j=i}^n \int_{2 \dots n} \frac{\hat{1}}{\hat{q}} \Gamma(q^G, i^G, \dots, j^G) \Gamma(q, j+1, \dots, n, 1, \dots, i-1) \times \\ \times A_{\bar{2}} \dots A_{\bar{i}^G} \dots A_{\bar{j}^G} \dots A_{\bar{n}}$$

and expanded diagrammatically in fig (4.3), which also includes the expansion for $\delta \bar{A}$. We then prove that this guess is correct by showing that it leaves the Chalmers-Siegel action invariant.

4.1 Review of the Lagrangian Formulation of MHV Rules

In recent years, an alternative approach to the usual Feynman diagram expansion of Yang-Mills theory has been suggested at tree level, [5], and to low order in the loop expansion. The Feynman approach is well understood but the complexity of the calculations grows very quickly. In many cases scattering amplitudes are much simpler than their constituent Feynman diagrams. For example the Parke-Taylor amplitude [10] for a tree-level process in which the greatest number of gluon helicities changes is written in terms of the reduced amplitude

$$A = g^{n-2} \frac{\langle \lambda_r, \lambda_s \rangle^4}{\prod_{j=1}^n \langle \lambda_j, \lambda_{j+1} \rangle}$$

where g is the coupling constant and r and s label the gluons with positive and negative helicity respectively. The λ_j are two spinors satisfying

$$\lambda_j \tilde{\lambda}_j = (p_t)_j 1 + \sigma \cdot \mathbf{p}_j$$

with $\sigma = (\sigma^1, \sigma^2, \sigma^3)$ being the Pauli matrices and (p_t, \mathbf{p}) being the momenta of the on-shell gluons. The bracket $\langle \ , \ \rangle$ is $\langle \lambda_j, \lambda_k \rangle = \lambda_j^T i \sigma^2 \lambda_k$. Then, the full tree-level amplitude is a sum over colour ordered amplitudes, σ :

$$\mathcal{A}_n = \sum_{\sigma} \text{Tr} (T^{R_{\sigma(1)}} \dots T^{R_{\sigma(n)}}) i(2\pi)^4 \delta^4(p_1 + \dots + p_n) A_n^{\sigma}.$$

These amplitudes (suitably continued off-shell) become the interaction vertices of the CSW approach to Yang-Mills [6] and [5]. These MHV rules were proven outside the Lagrangian formalism, indirectly from the BCFW recursion [12] and using twistor methods. (See [56] through to [63].) An alternative, Lagrangian approach was taken in [51] and [30] which describe a canonical transformation taking the standard Yang-Mills action into one generating the MHV rules. See also [64] and [65]. We shall now give a brief review.

The Yang-Mills action in coordinates (t, x^1, x^2, x^3) is

$$S = \frac{1}{2g^2} \int dt dx^1 dx^2 dx^3 \text{Tr} (F^{\mu\nu} F_{\mu\nu})$$

where the trace is taken over the generators of the gauge group T^R , and

$$\begin{aligned} F_{\mu\nu} &= [D_{\mu}, D_{\nu}] & D_{\mu} &= \partial_{\mu} + A_{\mu} \\ A_{\mu} &= A_{\mu}^R T^R & [T^R, T^S] &= f^{RS P} T^P \\ \text{Tr}(T^R T^S) &= -\frac{\delta^{RS}}{2}. \end{aligned}$$

We will use light-front co-ordinates $x^0 = t - x^3$, $x^{\bar{0}} = t + x^3$, $z = x^1 + ix^2$ and $\bar{z} = x^1 - ix^2$. By imposing the gauge condition $A_{\bar{0}} = 0$, and integrating out the non-dynamical field A_0 we arrive at the transformed action

$$S = \frac{4}{g^2} \int dx^0 \{ L^{-+} + L^{++-} + L^{--+} + L^{---+} \} \quad (4.1)$$

where the L 's are the terms in the Lagrangian, which is defined on the light front surface as an integral over constant x^0 surfaces. The decorations on the L 's label the

helicity content and we observe that the term L^{+-} is unwanted since it contains only one negative helicity, whereas we need two negative helicities in the MHV formalism. Further, the terms $L^{++\dots++--}$ are missing. On the quantization surface, it is worth noting that the fields have the same x^0 dependence so we don't have to explicitly write this and we use the notation $(x^{\bar{0}}, z, \bar{z}) = \mathbf{x}$ on the quantization surface. Explicitly, the L 's are given by [30]

$$\begin{aligned} L^{+-}[A] &= \frac{4}{g^2} \text{Tr} \int_{\Sigma} d^3 \mathbf{x} \bar{A} (\partial_0 \partial_{\bar{0}} - \partial_z \partial_{\bar{z}}) A \\ L^{++-}[A] &= \frac{4}{g^2} \text{Tr} \int_{\Sigma} d^3 \mathbf{x} (-\partial_{\bar{z}} \partial_{\bar{0}}^{-1} A) [A, \partial_{\bar{0}} \bar{A}] \\ L^{--+}[A] &= \frac{4}{g^2} \text{Tr} \int_{\Sigma} d^3 \mathbf{x} [\bar{A}, \partial_{\bar{0}} A] (-\partial_z \partial_{\bar{0}}^{-1} \bar{A}) \\ L^{---+}[A] &= \frac{4}{g^2} \text{Tr} \int_{\Sigma} d^3 \mathbf{x} (- [[\bar{A}, \partial_{\bar{0}} A] \partial_{\bar{0}}^{-2} [A, \partial_{\bar{0}} \bar{A}]]). \end{aligned}$$

To remove the unwanted term L^{+-} and generate the missing terms we define a change of variables $A, \bar{A} \rightarrow B, \bar{B}$ so that

$$L^{+-}[A, \bar{A}] + L^{++-}[A, \bar{A}] = L^{+-}[B, \bar{B}]. \quad (4.2)$$

B is a functional of A only on the quantization surface, $B = B[A]$, and

$$\partial_{\bar{0}} \bar{A}(\mathbf{y}) = \int_{\Sigma} d^3 \mathbf{x} \frac{\delta B(\mathbf{x})}{\delta A(\mathbf{y})} \partial_{\bar{0}} \bar{B}(\mathbf{x}) \quad (4.3)$$

where Σ refers to the quantization surface. It transpires that not only does this remove the unwanted vertex, it also generates the missing MHV vertices. The LHS of eqn (4.2) is known as the Chalmers-Siegel action on the light cone and its Euler-Lagrange equations give the self-dual Yang-Mills equations.

By substituting (4.3) into (4.2) and noting that terms involving $\partial_{\bar{0}} A$ and $\partial_{\bar{0}} B$ are automatically equal, [30], we arrive at the defining expression relating A and B . This is given by the following functional differential equation, (suppressing the x^0 dependence for brevity),

$$\int_{\Sigma} d^3 \mathbf{y} [D_z, \partial_{\bar{z}} \partial_{\bar{0}}^{-1} A](\mathbf{y}) \frac{\delta B(\mathbf{x})}{\delta A(\mathbf{y})} = \omega(\mathbf{x}) B(\mathbf{x}) \quad (4.4)$$

where we use the same notation to that in [31] in which $\omega(p) = p_z p_{\bar{z}} / p_{\bar{0}}$. Using this expression, one can calculate B in terms of A , and its inverse A in terms of B . In

momentum space, (4.4) can be written

$$\omega_1 A_1 - i \int_{23} [A_2, \zeta_3 A_3] (2\pi)^3 \delta^4(p_1 - p_2 - p_3) = \int_p \omega(p) B(p) \frac{\delta A(p_1)}{\delta B(p)} \quad (4.5)$$

where $\zeta(p) = p_{\bar{z}}/p_{\bar{0}}$. The group generators are absorbed into the fields, we introduce the notation $A_s = A(p_s)$, $A_{\bar{s}} = A(-p_s)$ and we introduce the shorthand notation

$$\int_{1\dots n} = \int \frac{d^4 p_1}{(2\pi)^4} \cdots \frac{d^4 p_n}{(2\pi)^4}.$$

Ettle and Morris define the above notation as integrals over the quantization surfaces since there is no need to Fourier transform the x^0 dependence. Here however, we shall be applying a linear transformation involving all the space-time coordinates, so it makes sense to Fourier transform the x^0 dependence, which does not affect the calculations in [31]. We also introduce the notation $((p_0)_n, (p_{\bar{0}})_n, (p_z)_n, (p_{\bar{z}})_n) = (\tilde{n}, \hat{n}, \tilde{\bar{n}}, \hat{\bar{n}})$ for the n -th particle and the following brackets, their meanings described in [31]

$$\begin{aligned} \{p_1, p_2\} &= \hat{1}\bar{2} - \hat{2}\bar{1} \\ (p_1, p_2) &= \hat{1}\tilde{2} - \hat{2}\tilde{1}. \end{aligned}$$

The relation (4.5) has power series solutions of the form

$$A_1 = \sum_{n=2}^{\infty} \int_{2\dots n} \Upsilon(1\dots n) B_{\bar{2}} \cdots B_{\bar{n}} \quad (4.6)$$

using the shorthand notation, and dropping the momentum conserving delta functions and factors of 2π (as we shall do throughout the majority of this thesis). Similarly, its inverse is given by the power series

$$B_1 = \sum_{n=2}^{\infty} \int_{2\dots n} \Gamma(1\dots n) A_{\bar{2}} \cdots A_{\bar{n}}. \quad (4.7)$$

We solve for Γ and Υ by putting these expressions into (4.5) thereby extracting a recursion relation. When expressed in terms of their independent momenta, $\Upsilon(1, \dots, n)$ and $\Gamma(1, \dots, n)$ take the following particularly simple form

$$\Upsilon(1, \dots, n) = (-i)^n \frac{\hat{1}}{(2, 3)} \frac{\hat{3}}{(3, 4)} \cdots \frac{\widehat{n-1}}{(n-1, n)} \quad (4.8)$$

and also

$$\Gamma(1, \dots, n) = -(i)^n \frac{\hat{1}}{(1, 2)} \frac{\hat{1}}{(1, 2 + 3)} \cdots \frac{\hat{1}}{(1, 2 + \dots + (n-1))}. \quad (4.9)$$

We should pay attention to the fact that these coefficients are independent of p_0 and $p_{\bar{z}}$ when expressed in this way.

In addition, we can express \bar{A} as a power series in \bar{B} viz

$$\bar{A}_{\bar{1}} = \sum_{n=2}^{\infty} \sum_{k=2}^n \int_{2 \dots n} \frac{\hat{k}}{\hat{1}} \Xi^k(\bar{1}2 \dots n) B_{\bar{2}} \cdots \bar{B}_{\bar{k}} \cdots B_{\bar{n}} \quad (4.10)$$

where the coefficients are given by

$$\Xi^k(\bar{1}2 \dots n) = -\frac{\hat{k}}{\hat{1}} \Upsilon(\bar{1}2 \dots n). \quad (4.11)$$

Note we use a different convention for the indices attached to Ξ . In the paper [31], the left hand side of the above reads Ξ^{k-1} .

Ettle and Morris [31] do not calculate the inverse of (4.10) but the calculation is similar to the one they describe in some respects. We begin by writing an ansatz for the inverse of (4.10)

$$\bar{B}_{\bar{1}} = \sum_{n=2}^{\infty} \sum_{k=2}^n \int_{2 \dots n} \frac{\hat{k}}{\hat{1}} \Theta^k(\bar{1}2 \dots n) A_{\bar{2}} \cdots \bar{A}_{\bar{k}} \cdots A_{\bar{n}}. \quad (4.12)$$

Later, we will calculate $\delta \bar{A}$ and write a transformation of the field $\bar{A} \rightarrow \bar{A} + \delta \bar{A}$ to the first three orders in powers of the fields A and \bar{A} . As discussed already, we will then guess a more general result to all orders and prove that it leaves the Chalmers-Siegel action invariant so it is only necessary to calculate the coefficients of the first five terms in (4.12) to use in the explicit calculations of the first three orders in A and \bar{A} in the expression for $\delta \bar{A}$. We differentiate (4.7) with respect to x^0 , which in momentum space gives

$$\check{1}B_{\bar{1}} = \sum_{n=2}^{\infty} \sum_{k=2}^n \int_{2 \dots n} \check{k} \Gamma(\bar{1}2 \dots n) A_{\bar{2}} \cdots A_{\bar{k}} \cdots A_{\bar{n}} \quad (4.13)$$

and then use

$$\text{Tr} \int_1 \check{1}A_1 \hat{1} \bar{A}_{\bar{1}} = \text{Tr} \int_1 \check{1}B_1 \hat{1} \bar{B}_{\bar{1}} \quad (4.14)$$

to extract a recurrence relation for $\Theta^k(12 \dots n)$ to the first few order in Θ . By substituting eqn (4.13) and eqn (4.12) into the invariant quantity (4.14) and considering momentum conservation we can easily extract the first five expressions for Θ ,

$$\begin{aligned}
\Theta^2(123) &= -\Gamma(231), \\
\Theta^3(123) &= -\Gamma(312), \\
\Theta^2(1234) &= -\Gamma(2+3, 4, 1) \Theta^2(1+4, 2, 3) - \Gamma(2341), \\
\Theta^3(1234) &= -\Gamma(3+4, 1, 2) \Theta^2(1+2, 3, 4) - \Gamma(2+3, 4, 1) \Theta^3(1+4, 2, 3) - \Gamma(3412), \\
\Theta^4(1234) &= -\Gamma(3+4, 1, 2) \Theta^3(1+2, 3, 4) - \Gamma(4123). \tag{4.15}
\end{aligned}$$

When written in terms of their independent momenta they reduce to the simple expressions

$$\begin{aligned}
\Theta^2(123) &= -\Gamma(231), & \Theta^3(123) &= -\Gamma(312), \\
\Theta^2(1234) &= -\frac{\hat{2}}{\hat{1}}\Gamma(1234), & \Theta^3(1234) &= -\frac{\hat{3}}{\hat{1}}\Gamma(1234), \\
\Theta^4(1234) &= -\frac{\hat{4}}{\hat{1}}\Gamma(1234). \tag{4.16}
\end{aligned}$$

4.2 Transformation of A and \bar{A}

We shall calculate expressions that leave the the Chalmers-Siegel action $L^{+-}[A] + L^{++-}[A]$ invariant under the transformation $A \rightarrow \hat{A} = A + \delta A$. The operators appearing in the denominators of L^{+-} , L^{++-} and L^{+---} are most simply expressed in momentum space. After performing a Fourier transformation on (4.2) we have the following expression absorbing the interaction term on the left hand side into the kinetic term on the right, thus

$$\begin{aligned}
\text{Tr} \int_1 \{ \bar{p}_1 \tilde{p}_1 - \hat{p}_1 \check{p}_1 \} \bar{A}_1 A_1 - i \text{Tr} \int_{123} \hat{p}_1 (\zeta_3 - \zeta_2) \bar{A}_1 A_2 A_3 (2\pi)^4 \delta^4(p_1 + p_2 + p_3) \\
= \text{Tr} \int_1 \{ \bar{p}_1 \tilde{p}_1 - \hat{p}_1 \check{p}_1 \} \bar{B}_1 B_1 \tag{4.17}
\end{aligned}$$

where $\zeta_p = \bar{p}/\hat{p}$. In configuration space the isometry is $x \rightarrow x_G = \Lambda x$. Now, Lorentz transformations commute with the Fourier transform, i.e under the isometry

$x \rightarrow x_G = \Lambda x$ we have $B^G(p) = B(p_G) = B(\Lambda p)$. We write the change in the B fields as follows

$$\begin{aligned}\delta B(p) &= \varepsilon B(p_G) \\ \delta \bar{B}(p) &= -\varepsilon \bar{B}(p_{G^{-1}}).\end{aligned}$$

We shall consider the finite isometries in momentum space primarily, however it is instructive to consider the infinitesimal transformations that preserve the quantity $\bar{p}\tilde{p} - \hat{p}\check{p}$ and the finite case will follow. We have

$$(\check{p}', \hat{p}', \tilde{p}', \bar{p}') = (\check{p}, \hat{p}, \tilde{p}, \bar{p}) + \varepsilon v_i.$$

In the light-cone coordinates, we have $\tilde{p} = p_1 + ip_2$ and $\bar{p} = p_1 - ip_2$ where p_1 and p_2 are real, thus \tilde{p} and \bar{p} are complex conjugates of each other in $(1, 3)$ space. Therefore there is no isometry where \tilde{p} is transformed and \bar{p} is left unaltered or vice-versa in physical $(1, 3)$ space-time. However, by making p_2 pure imaginary \tilde{p} and \bar{p} are real and independent coordinates in $(2, 2)$ space-time. Then a basis for the infinitesimal isometries of $(2, 2)$ space-time, v_i is

$$\begin{aligned}v_1 &= (\bar{p}, 0, \hat{p}, 0), \quad v_2 = (0, 0, -\tilde{p}, \bar{p}), \quad v_3 = (\tilde{p}, 0, 0, \check{p}), \\ v_4 &= (0, \tilde{p}, 0, \check{p}), \quad v_5 = (0, \bar{p}, \tilde{p}, 0), \quad v_6 = (-\check{p}, \hat{p}, 0, 0).\end{aligned}$$

where $\check{p}, \hat{p}, \tilde{p}$ and \bar{p} are all real. It is simple to substitute these into $\bar{p}'\tilde{p}' - \hat{p}'\check{p}'$ and retrieve $\bar{p}\tilde{p} - \hat{p}\check{p}$ hence showing they have the desired isometry property. By writing the infinitesimal isometries in configuration space, and then Fourier transforming them, we discover that isometries which preserve the quantization surface $\dot{x}^0 = x^0$ also preserve \hat{p} in momentum space. Hence the first three isometries above preserve the constant x^0 surfaces. It is also convenient to notice that $(\check{p}', \hat{p}', \tilde{p}', \bar{p}') = (\check{p}, \hat{p}, \tilde{p}, \bar{p}) + \varepsilon v_3$ only alters \tilde{p} and \bar{p} , and leaves \hat{p} and \check{p} unchanged. Since the coefficients, Γ and Υ depend only on \hat{p} and \tilde{p} as mentioned earlier, this will simplify the problem for that one parameter subgroup of isometries. The properties of each of these transformations will be preserved in the finite case also and we shall use this to our advantage by considering only the Γ and Υ preserving transformation

for the moment but generalizing to the other five transformations will turn out to be fairly straight forward.

4.2.1 Transformation of A for the Isometry that Preserves Γ and Υ

Begin with the expression for A in terms of B , derived in [31] and stated earlier,

$$A_1 = \sum_{n=2}^{\infty} \int_{2 \dots n} \Upsilon(1 \dots n) B_{\bar{2}} \cdots B_{\bar{n}}.$$

The expression for δA in terms of B is

$$\begin{aligned} \delta A_1 &= \sum_{n=2}^{\infty} \sum_{i=2}^n \int_{2 \dots n} \Upsilon(1 \dots n) B_{\bar{2}} \cdots \delta B_{\bar{i}} \cdots B_{\bar{n}} \\ &= \varepsilon \sum_{n=2}^{\infty} \sum_{i=2}^n \int_{2 \dots n} \Upsilon(1 \dots n) B_{\bar{2}} \cdots B_{\bar{i}G} \cdots B_{\bar{n}} \end{aligned} \quad (4.18)$$

where $B_{\bar{i}G}$ is shorthand for $B(-p_{iG})$. To the first four orders, this is

$$\begin{aligned} \delta A_1 &= \varepsilon B_{1G} + \varepsilon \int_{23} \Upsilon(123) \{B_{\bar{2}G} B_{\bar{3}} + B_{\bar{2}} B_{\bar{3}G}\} \\ &\quad + \varepsilon \int_{234} \Upsilon(1234) \{B_{\bar{2}G} B_{\bar{3}} B_{\bar{4}} + B_{\bar{2}} B_{\bar{3}G} B_{\bar{4}} + B_{\bar{2}} B_{\bar{3}} B_{\bar{4}G}\} \\ &\quad + \varepsilon \int_{2345} \Upsilon(12345) \{B_{\bar{2}G} B_{\bar{3}} B_{\bar{4}} B_{\bar{5}} + B_{\bar{2}} B_{\bar{3}G} B_{\bar{4}} B_{\bar{5}} + B_{\bar{2}} B_{\bar{3}} B_{\bar{4}G} B_{\bar{5}} + B_{\bar{2}} B_{\bar{3}} B_{\bar{4}} B_{\bar{5}G}\} \\ &\quad + \cdots \end{aligned} \quad (4.19)$$

Temporarily re-instating the delta functions, we can now substitute the inverse expression B in terms of A given by

$$B_1 = \sum_{n=2}^{\infty} \int_{2 \dots n} \Gamma(1 \dots n) A_{\bar{2}} \cdots A_{\bar{n}} (2\pi)^4 \delta^4(p_1 + \cdots + p_n).$$

There is the added complication that we are evaluating $B(p)$ at $B(p_G)$ but this is dealt with using the property of the delta function that $\delta^4(\Lambda p_1 + \cdots + \Lambda p_n) = \delta^4(p_1 + \cdots + p_n)$. B_{1G} is given by

$$B_{1G} = \sum_{n=2}^{\infty} \int_{2 \dots n} \Gamma(1_G, 2, \dots, n) A_{\bar{2}} \cdots A_{\bar{n}} (2\pi)^4 \delta^4(p_1^G + \cdots + p_n)$$

and we can change variables under the integrals using the isometry $p \rightarrow p_G$ to get the following expression. It is an isometry so the Jacobian of the transformation is 1,

$$B_{1G} = \sum_{n=2}^{\infty} \int_{2 \cdots n} \Gamma(1_G, 2_G, \dots, n_G) A_{\bar{2}G} \cdots A_{\bar{n}G} (2\pi)^4 \delta^4(p_1^G + \cdots + p_n^G)$$

which is

$$B_{1G} = \sum_{n=2}^{\infty} \int_{2 \cdots n} \Gamma(1_G, 2_G, \dots, n_G) A_{\bar{2}G} \cdots A_{\bar{n}G} (2\pi)^4 \delta^4(p_1 + \cdots + p_n)$$

using the stated property of the delta function. Further, seeing as for the moment we are considering the one transformation that leaves Γ and Υ invariant we have

$$B_{1G} = \sum_{n=2}^{\infty} \int_{2 \cdots n} \Gamma(1, 2, \dots, n) A_{\bar{2}G} \cdots A_{\bar{n}G} (2\pi)^4 \delta^4(p_1 + \cdots + p_n).$$

Performing the substitution into (4.19) and working up to fourth order only for now, taking care with delta functions, maintaining the order of the A fields and labelling the momentum arguments we get a somewhat nasty looking expression which is included in appendix (B.1). When like terms are collected and their coefficients calculated in terms of independent momenta the expression simplifies into something more tangible. We shall collect terms order by order. First order is trivial, we get $\delta A = \varepsilon A_{1G} + \cdots$. The next two orders in A are given below and the more cumbersome fourth order result is included in appendix by (B.1.2).

Second Order

$$\delta A_1 = \varepsilon A_{1G} + \varepsilon i \int_{23} \left\{ \frac{\hat{1} A_{\bar{2}G} A_{\bar{3}G}}{(23)} - \frac{\hat{1} A_{\bar{2}G} A_{\bar{3}}}{(23)} - \frac{\hat{1} A_{\bar{2}} A_{\bar{3}G}}{(23)} \right\} + \cdots$$

Third Order

$$\cdots + \varepsilon \int_{234} \left\{ \frac{\hat{1}\hat{q} A_{\bar{2}G} A_{\bar{3}G} A_{\bar{4}G}}{(q, 2)(q, 2+3)} + \frac{\hat{1}\hat{q} A_{\bar{2}G} A_{\bar{3}G} A_{\bar{4}}}{(q, 2)(q, 4)} + \frac{\hat{1}\hat{q} A_{\bar{2}} A_{\bar{3}G} A_{\bar{4}G}}{(q, 3)(q, 1)} \right. \\ \left. + \frac{\hat{1}\hat{q} A_{\bar{2}G} A_{\bar{3}} A_{\bar{4}}}{(q, 3)(q, 3+4)} + \frac{\hat{1}\hat{q} A_{\bar{2}} A_{\bar{3}G} A_{\bar{4}}}{(q, 4)(q, 4+1)} + \frac{\hat{1}\hat{q} A_{\bar{2}} A_{\bar{3}} A_{\bar{4}G}}{(q, 1)(q, 1+2)} \right\} + \cdots$$

where for any term with $A_{\bar{2}} \cdots A_{\bar{i}G} \cdots A_{\bar{j}G} \cdots A_{\bar{n}}$, q is defined to be $q = p_i + \cdots + p_j$.

We may now be tempted to hypothesize the full expression. We write

$$\delta A_1 = -\varepsilon \sum_{n=2}^{\infty} \sum_{i=2}^n \sum_{j=i}^n \int_{2 \cdots n} \frac{\hat{1}}{\hat{q}} \Gamma(q, i, \cdots, j) \Gamma(q, j+1, \cdots, n, 1, \cdots, i-1) \times$$

$$\times A_{\bar{2}} \cdots A_{\bar{i}G} \cdots A_{\bar{j}G} \cdots A_{\bar{n}} \quad (4.20)$$

where Γ is given by (4.9) and $q = p_i + \cdots + p_j$ as before. Notice this is a cyclic insertion of the momentum arguments into the product of the Γ s. It is a simple matter to check that this expression does indeed generate the first, second, third and fourth order terms. A diagrammatic representation of this expression is extremely beneficial where we attach A fields to the external legs of a momentum flow diagram whose momenta flow out of the two vertices Γ connected by an internal line with momentum q and summing over all diagrams, fig (4.1), where the vertices labelled

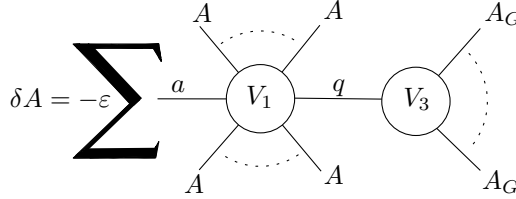

Figure 4.1: Transformation, δA

V_1 and V_3 are expressed in terms of k , q and Γ which we are forcing to be invariant at the moment and are given explicitly by

$$V_1 = \frac{\hat{a}}{\hat{q}} \Gamma \quad V_3 = \Gamma.$$

It is reasonable to expect the transformations of the field A satisfy the same algebra and in fact this is easy to prove. From eqn (4.18) we have

$$\delta_j A_1 = \sum_{n=2}^{\infty} \sum_{q=2}^n \int_{2 \cdots n} \Upsilon(1 \cdots n) B_{\bar{2}} \cdots \delta_j B_{\bar{q}} \cdots B_{\bar{n}}.$$

Two consecutive transformations are given by

$$\delta_i \delta_j A_1 = \sum_{n=2}^{\infty} \sum_{p=2}^n \sum_{q=2}^n \int_{2 \cdots n} \Upsilon(1 \cdots n) B_{\bar{2}} \cdots \delta_i B_{\bar{p}} \cdots \delta_j B_{\bar{q}} \cdots B_{\bar{n}}$$

and the commutator is

$$[\delta_i, \delta_j] A_1 = \sum_{n=2}^{\infty} \sum_{p=2}^n \sum_{q=2}^n \int_{2 \cdots n} \left(\Upsilon(1 \cdots n) B_{\bar{2}} \cdots \delta_i B_{\bar{p}} \cdots \delta_j B_{\bar{q}} \cdots B_{\bar{n}} - \right. \\ \left. - \Upsilon(1 \cdots n) B_{\bar{2}} \cdots \delta_j B_{\bar{p}} \cdots \delta_i B_{\bar{q}} \cdots B_{\bar{n}} \right).$$

After summing over p and q , all terms are zero except those for which $p = q$, leaving only

$$[\delta_i, \delta_j] A_1 = \sum_{n=2}^{\infty} \sum_{p=2}^n \int_{2 \cdots n} \Upsilon(1 \cdots n) (B_{\bar{2}} \cdots \delta_i \delta_j B_{\bar{p}} \cdots B_{\bar{n}} - B_{\bar{2}} \cdots \delta_j \delta_i B_{\bar{p}} \cdots B_{\bar{n}}) = \\ = \sum_{n=2}^{\infty} \sum_{p=2}^n \int_{2 \cdots n} \Upsilon(1 \cdots n) (B_{\bar{2}} \cdots B_{\bar{p}^{G_{ji}}} \cdots B_{\bar{n}} - B_{\bar{2}} \cdots B_{\bar{p}^{G_{ij}}} \cdots B_{\bar{n}}) = \\ = (C_{ij}^k - C_{ji}^k) \sum_{n=2}^{\infty} \sum_{p=2}^n \int_{2 \cdots n} \Upsilon(1 \cdots n) B_{\bar{2}} \cdots B_{\bar{p}^{G_k}} \cdots B_{\bar{n}} = \\ = (C_{ij}^k - C_{ji}^k) \delta_k A_1$$

which has the same structure constants $f_{ij}^k = (C_{ij}^k - C_{ji}^k)$ as the commutators in the free theory, eqn (3.33), thus identifying the algebra unambiguously with that of the free theory, §(3.6). It makes sense therefore to study the algebra of the transformations given by eqn (4.20) in the free theory knowing that the algebra in the less trivial self-dual Yang-Mills setting will be the same.

4.2.2 Transformation of \bar{A} for the Isometry that Preserves Γ and Υ

The expression for the change in the conjugate field is not dissimilar, although the expansion is significantly more detailed. The change in the free B field is defined as

$$\delta \bar{B}(p) = -\varepsilon \bar{B}(p_{G^{-1}}).$$

Let us consider the change in \bar{A} in terms of B .

$$\delta \bar{A}_1 = \delta \bar{B}_1 - \int_{23} \left\{ \frac{\hat{2}}{\hat{1}} \Xi^2(123) \delta \bar{B}_2 B_3 - \frac{\hat{2}}{\hat{1}} \Xi^2(123) \bar{B}_2 \delta B_3 - \right. \\ \left. - \frac{\hat{3}}{\hat{1}} \Xi^3(123) \delta B_2 \bar{B}_3 - \frac{\hat{3}}{\hat{1}} \Xi^3(123) B_2 \delta \bar{B}_3 \right\} - \dots$$

Now substitute the change in the B fields, $\delta B_p = \varepsilon B_{p^{G-1}}$ and $\delta \bar{B} = -\varepsilon \bar{B}_{p^{G-1}}$;

$$\begin{aligned}
\delta \bar{A}_1 = & -\varepsilon \bar{B}_{1^{G-1}} + \\
& + \varepsilon \int_{23} \left\{ \frac{\hat{2}}{\hat{1}} \Xi^2(123) \bar{B}_{2^{G-1}} B_{\bar{3}} - \frac{\hat{2}}{\hat{1}} \Xi^2(123) \bar{B}_2 B_{\bar{3}^G} - \right. \\
& \quad \left. - \frac{\hat{3}}{\hat{1}} \Xi^3(123) B_{\bar{2}^G} \bar{B}_{\bar{3}} + \varepsilon \int_{23} \frac{\hat{3}}{\hat{1}} \Xi^3(123) B_{\bar{2}} \bar{B}_{\bar{3}^{G-1}} \right\} \\
& + \varepsilon \int_{234} \left\{ \frac{\hat{2}}{\hat{1}} \Xi^2(1234) \bar{B}_{2^{G-1}} B_{\bar{3}} B_{\bar{4}} - \frac{\hat{2}}{\hat{1}} \Xi^2(1234) \bar{B}_2 B_{\bar{3}^G} B_{\bar{4}} - \frac{\hat{2}}{\hat{1}} \Xi^2(1234) \bar{B}_{\bar{2}} B_{\bar{3}} B_{\bar{4}^G} \right. \\
& \quad - \frac{\hat{3}}{\hat{1}} \Xi^3(1234) B_{\bar{2}^G} \bar{B}_{\bar{3}} B_{\bar{4}} + \frac{\hat{3}}{\hat{1}} \Xi^3(1234) B_{\bar{2}} \bar{B}_{\bar{3}^{G-1}} B_{\bar{4}} - \frac{\hat{3}}{\hat{1}} \Xi^3(1234) B_{\bar{2}} \bar{B}_{\bar{3}} B_{\bar{4}^G} \\
& \quad \left. - \frac{\hat{4}}{\hat{1}} \Xi^4(1234) B_{\bar{2}^G} B_{\bar{3}} \bar{B}_{\bar{4}} - \frac{\hat{4}}{\hat{1}} \Xi^4(1234) B_{\bar{2}} B_{\bar{3}^G} \bar{B}_{\bar{4}} + \frac{\hat{4}}{\hat{1}} \Xi^4(1234) B_{\bar{2}} B_{\bar{3}} \bar{B}_{\bar{4}^{G-1}} \right\} + \dots
\end{aligned}$$

to third order. In a similar fashion to the previous calculation, we substitute the inverse expressions, $B[A]$ and $\bar{B}[A, \bar{A}]$ which is given by the expansion in appendix (B.2). Again, we shall collect terms order by order and we shall see that we have already done most of the work when calculating the coefficients earlier. First order is again trivial, we get $\delta \bar{A}_1 = -\varepsilon \bar{A}_{1^{G-1}} + \dots$. At second order we can pick out the terms and express Ξ and Θ in terms of independent momenta, no extra calculation is required and the result is given below. The third order result is given in the appendix by eqn (B.2.3).

Second Order

$$\begin{aligned}
\delta \bar{A}_1 = & -\varepsilon \bar{A}_{1^{G-1}} - \varepsilon \int_{23} i \left\{ \frac{\hat{2}}{\hat{1}} \frac{\hat{2}}{(31)} \bar{A}_{2^{G-1}} A_{\bar{3}^{G-1}} - \frac{\hat{3}}{\hat{1}} \frac{\hat{3}}{(12)} A_{2^{G-1}} \bar{A}_{\bar{3}^{G-1}} \right. \\
& \quad + \frac{\hat{2}}{\hat{1}} \frac{\hat{2}}{(31)} \bar{A}_{2^{G-1}} A_{\bar{3}} - \frac{\hat{2}}{\hat{1}} \frac{\hat{2}}{(31)} \bar{A}_{\bar{2}} A_{\bar{3}^G} \\
& \quad \left. - \frac{\hat{3}}{\hat{1}} \frac{\hat{3}}{(12)} A_{\bar{2}^G} \bar{A}_{\bar{3}} + \frac{\hat{3}}{\hat{1}} \frac{\hat{3}}{(12)} A_{\bar{2}} \bar{A}_{\bar{3}^{G-1}} \right\} + \dots
\end{aligned}$$

We hypothesize the full expression is

$$\begin{aligned}
\delta\bar{A}_1 = & -\varepsilon \sum_{n=2}^{\infty} \sum_{k=2}^n \sum_{i=2}^{k-1} \sum_{j=i}^{k-1} \int_{2\dots n} \frac{\hat{k}^2}{\hat{1}\hat{q}} \Gamma(q, i, \dots, j) \Gamma(q, j+1, \dots, n, 1, \dots, i-1) \times \\
& \times A_{\bar{2}} \cdots A_{\bar{i}G} \cdots A_{\bar{j}G} \cdots \bar{A}_{\bar{k}} \cdots A_{\bar{n}} \\
& +\varepsilon \sum_{n=2}^{\infty} \sum_{k=2}^n \sum_{i=2}^k \sum_{j=k}^n \int_{2\dots n} \frac{\hat{k}^2}{\hat{1}\hat{q}} \Gamma(q, i, \dots, j) \Gamma(q, j+1, \dots, n, 1, \dots, i-1) \times \\
& \times A_{\bar{2}} \cdots A_{\bar{i}G-1} \cdots \bar{A}_{\bar{k}G-1} \cdots A_{\bar{j}G-1} \cdots A_{\bar{n}} \\
& -\varepsilon \sum_{n=2}^{\infty} \sum_{k=2}^n \sum_{i=k+1}^n \sum_{j=i}^n \int_{2\dots n} \frac{\hat{k}^2}{\hat{1}\hat{q}} \Gamma(q, i, \dots, j) \Gamma(q, j+1, \dots, n, 1, \dots, i-1) \times \\
& \times A_{\bar{2}} \cdots \bar{A}_{\bar{k}} \cdots A_{\bar{i}G} \cdots A_{\bar{j}G} \cdots A_{\bar{n}}.
\end{aligned} \tag{4.21}$$

It is possible to verify that this expression reproduces first, second and third order terms and again, encoding the expression in a diagrammatic fashion is beneficial, fig (4.2). We have a series of similar diagrams to fig (4.1) but with cyclic permutations of the \bar{A} field over diagrams in the series. Notice also, the distribution of A_G and A_{G-1} legs in relation to the position of the conjugate field. The transformed legs all flow out of the right hand vertex in each diagram. If the conjugate field is attached to the right hand vertex, then all fields attached to the right hand vertex are transformed as A_{G-1} . If the conjugate field is not connected to the right hand vertex but rather the left vertex, then the fields attached to it are transformed as A_G . The symbol k labels the position of the conjugate field and a labels the position of the ‘in-coming’ leg of the diagram. The vertices, V_2 , V_4 and V_5 are given by

$$V_2 = \frac{\hat{a}\hat{k}^2}{\hat{q}\hat{a}^2}\Gamma \quad V_4 = \frac{\hat{q}}{\hat{a}}\Gamma \quad V_5 = \frac{\hat{k}^2}{\hat{q}^2}\Gamma.$$

We now have a conjecture for δA and $\delta\bar{A}$ for the transformation which leaves \check{p} and \tilde{p} unchanged. We shall not prove this now but instead we shall hypothesize the most general case by considering the remaining five Lorentz transformations using results thus far and prove that they leave the Chalmers-Siegel action invariant.

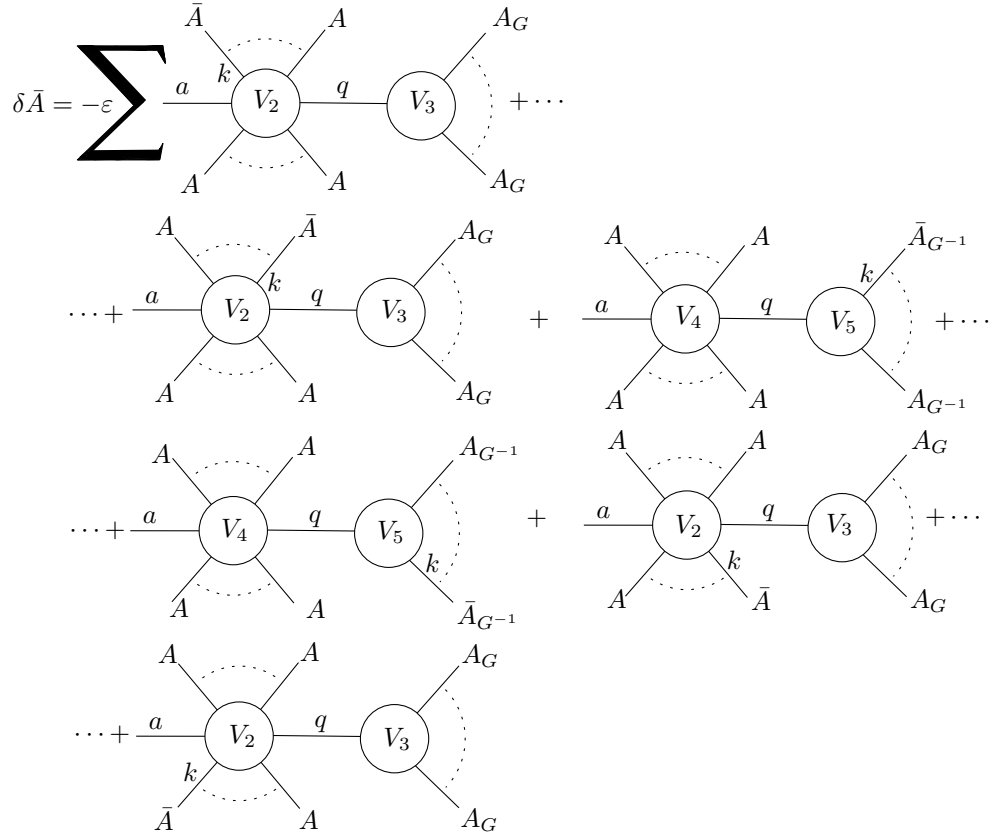
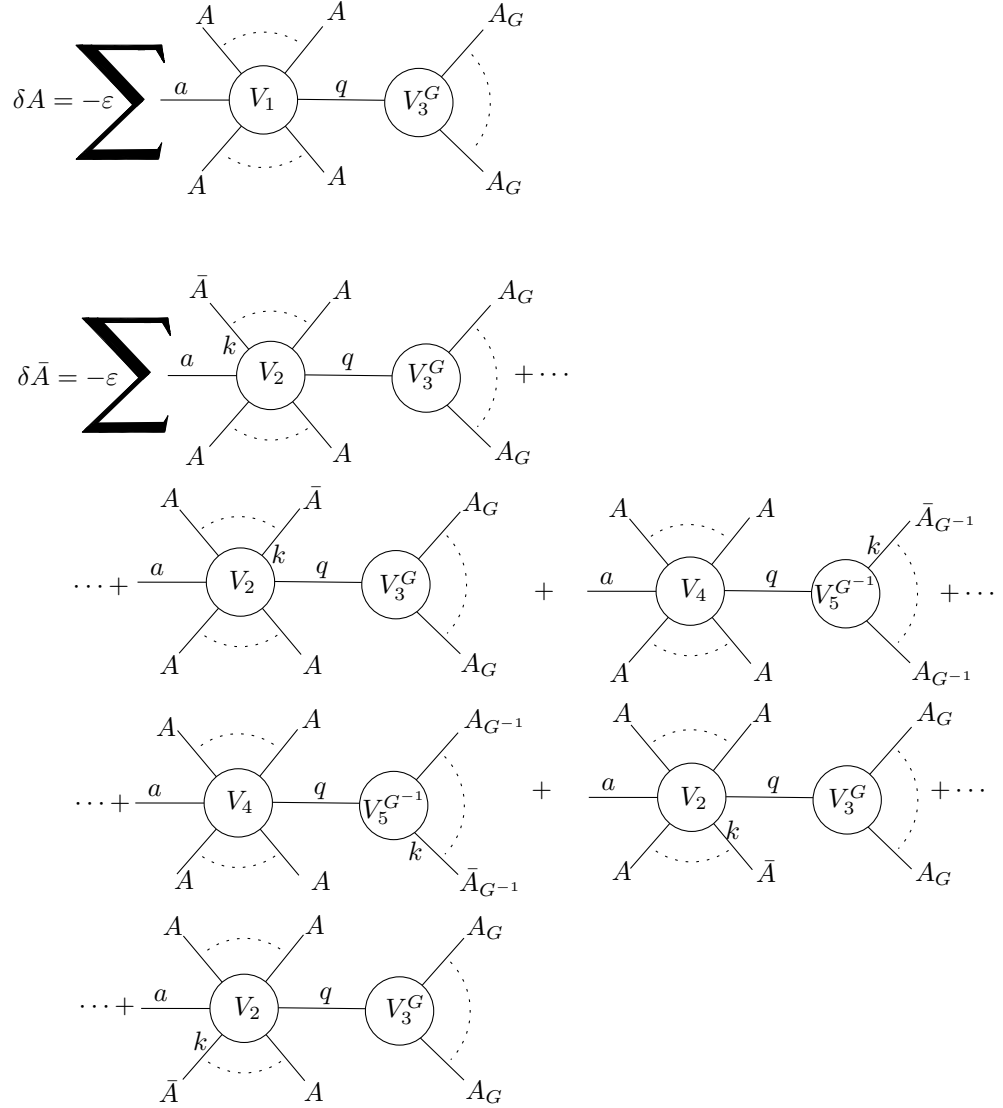

 Figure 4.2: Transformation, $\delta\bar{A}$

4.2.3 Most General Transformation Using the Full Lorentz Group

Up to now we have considered the one isometry that leaves the coefficients Γ and Υ invariant, namely

$$(\tilde{p}', \hat{p}', \tilde{p}', \bar{p}') = (\tilde{p}, \hat{p}, \tilde{p}, \bar{p}) + \epsilon (\tilde{p}, 0, 0, \tilde{p}).$$

Generally of course, Γ is not invariant under the six parameter independent Lorentz transformations. In the case of the isometries that preserve the quantization surface (surfaces of constant x_0 or equivalently constant \hat{p}), the prefactors $\hat{1}/\hat{q}$ and $\hat{k}^2/\hat{1}\hat{q}$ appearing in (4.20) and (4.21) respectively are invariant but more generally these also transform under the full Lorentz group. Writing the vertex factors in the diagrams as we have done in fig (4.1) and fig (4.2) it strongly suggests the form of the most general expressions as fig (4.3), with transformed expressions in the appropriate vertices. The proof of these invariances is obtained by substituting them into the

Figure 4.3: Expressions for δA and $\delta \bar{A}$ for the Full Lorentz Group

change in action, (4.17). In fact, in what follows we need not assume the momenta are real and we need not make any allusion to the explicit form of the isometries and so our hypothesized expressions will be shown to leave the action invariant in physical $(1, 3)$ space. Algebraically, performing the variation of the action gives us.

$$\begin{aligned}
\delta S = & \text{Tr} \int_1 \{ \bar{p}_1 \tilde{p}_1 - \hat{p}_1 \check{p}_1 \} (\delta \bar{A}_1) A_1 + \text{Tr} \int_1 \{ \bar{p}_1 \tilde{p}_1 - \hat{p}_1 \check{p}_1 \} \bar{A}_1 (\delta A_1) \\
& - i \text{Tr} \int_{123} \hat{p}_1 (\zeta_3 - \zeta_2) (\delta \bar{A}_1) A_2 A_3 - i \text{Tr} \int_{123} \hat{p}_1 (\zeta_3 - \zeta_2) \bar{A}_1 (\delta A_2) A_3 \\
& - i \text{Tr} \int_{123} \hat{p}_1 (\zeta_3 - \zeta_2) \bar{A}_1 A_2 (\delta A_3). \quad (4.22)
\end{aligned}$$

It will be easier to separate out the free and interacting parts of the action and consider their diagrams separately, i.e $\delta S = \delta S_F + \delta S_I$. Each piece reduces to a simpler algebraic expression by considering their diagrammatic expansions, and taken together they will sum to zero. Diagrammatically, the free action S_F is a sum over two, two point vertices and the interacting part is a sum over three point vertices as shown in fig (4.4), where $\Omega = \{\bar{p}_1\tilde{p}_1 - \hat{p}_1\check{p}_1\}$. Recall that Ω is invariant under

$$\begin{aligned} \delta S_F &= \bar{A} \text{---} \textcircled{\Omega} \text{---} \delta A + A \text{---} \textcircled{\Omega} \text{---} \delta \bar{A} \\ \delta S_I &= \begin{array}{c} \bar{A} \\ \diagdown \\ \textcircled{I_1} \\ \diagup \\ A \end{array} \text{---} \delta A + \begin{array}{c} A \\ \diagdown \\ \textcircled{I_2} \\ \diagup \\ \bar{A} \end{array} \text{---} \delta A + \begin{array}{c} A \\ \diagdown \\ \textcircled{I_3} \\ \diagup \\ A \end{array} \text{---} \delta \bar{A} \end{aligned}$$

Figure 4.4: Change in the Self-Dual Action, δS

isometries $x \rightarrow x_G$ whereas the expression I appearing in fig (4.4) is not invariant. The sum over all diagrams for δS_F is relatively straight forward. We have fig (4.5) where again, the symbol k labels the leg to which the conjugate field is attached and we are free to label the momentum of this leg, p_1 . Now we can apply the isometry $x \rightarrow x_G$ to diagrams containing A_{G-1} , fig (4.6). Notice the cyclic permutation of the \bar{A} field which is equivalent to a cyclic permutation of the two point vertex, Ω . Algebraically then, these diagrams reduce to the following expression, involving a product of Γ s and sum over k of $\Omega(k)$ arising from cyclically permuting the Ω vertex over the out going legs of the V and V^G vertices,

$$\delta S_F = \varepsilon \sum_{n=2}^{\infty} \sum_{i=2}^n \sum_{j=i}^n \int_{1 \dots n} X_{i,j}(1, \dots, n) \bar{A}_1 \cdots A_{i^G} \cdots A_{j^G} \cdots A_{\bar{n}}$$

where the coefficient $X_{i,j}$ is given by

$$\begin{aligned} X_{i,j}(1, \dots, n) &= \\ &= -\frac{\hat{1}^2}{\hat{q}^2} \left(\frac{\hat{q}}{\hat{1}} \Omega_1 + \cdots + \frac{\hat{q}}{\widehat{i-1}} \Omega_{i-1} + \frac{\hat{q}^G}{\hat{i}^G} \Omega_i^G + \cdots + \frac{\hat{q}^G}{\hat{j}^G} \Omega_j^G + \frac{\hat{q}}{\hat{j+1}} \Omega_{j+1} + \cdots + \frac{\hat{q}}{\hat{n}} \Omega_n \right) \times \\ &\quad \times \Gamma(q^G, i^G, \dots, j^G) \Gamma(q, j+1, \dots, i-1). \end{aligned}$$

The interacting part is similar except for the cyclic permutation of a three point vertex around the V vertices as opposed to the two point vertex. We attach the

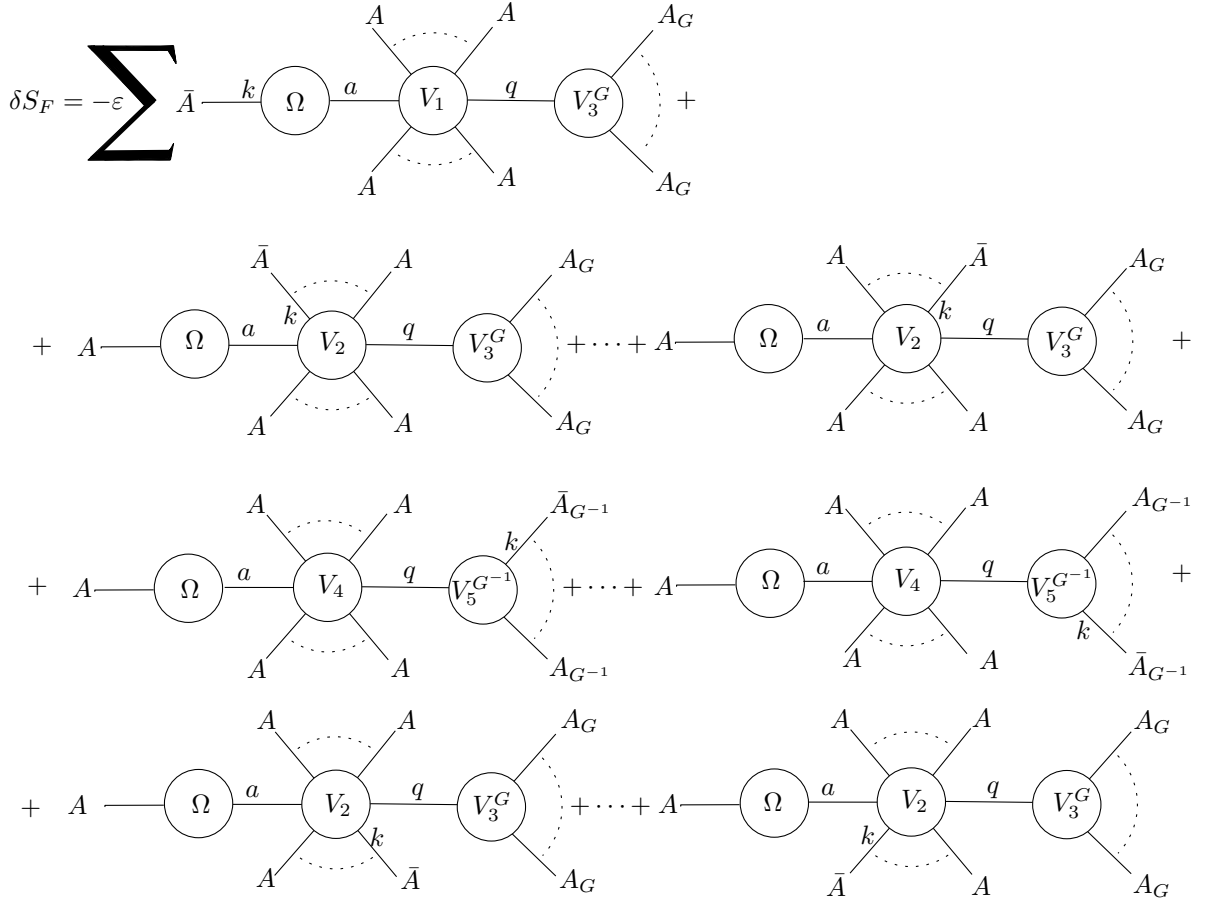
Figure 4.5: Change in the Free Part of the Action δS_F

diagrams δA and $\delta \bar{A}$ from fig (4.3) respectively to δS_I as shown in fig (4.7), where k , again, labels the conjugate field which we are free to label as momentum p_1 and a labels the leg to which the vertex I is attached. We proceed to reverse the isometry from the appropriate diagrams, fig (4.8). If the leg k has momentum p_1 , these diagrams are interpreted as a cyclic permutation of the three point vertex, I . Adding cyclic contributions together gives.

$$\delta S_I = \varepsilon \sum_{n=2}^{\infty} \sum_{i=2}^n \sum_{j=i}^n \int_{1 \dots n} Y_{i,j}(1, \dots, n) \bar{A}_1 \cdots A_{\bar{j}G} \cdots A_{jG} A_{\bar{n}}$$

with the coefficient $Y_{i,j}$ given by

$$Y_{i,j}(1, \dots, n) = -i \frac{\hat{1}^2}{i \hat{q}^2} \left(\sum_{k=i}^{j-1} \frac{\{k^G, (k+1)^G\}}{\hat{k}^G \widehat{k+1}^G} (q^G, P_{i,k}^G) + \sum_{k=j+1}^{i-2} \frac{\{k, k+1\}}{\hat{k} \widehat{k+1}} (q, P_{i,k}) \right) \times \\ \times \Gamma(q^G, i^G, \dots, j^G) \Gamma(q, j+1, \dots, i-1).$$

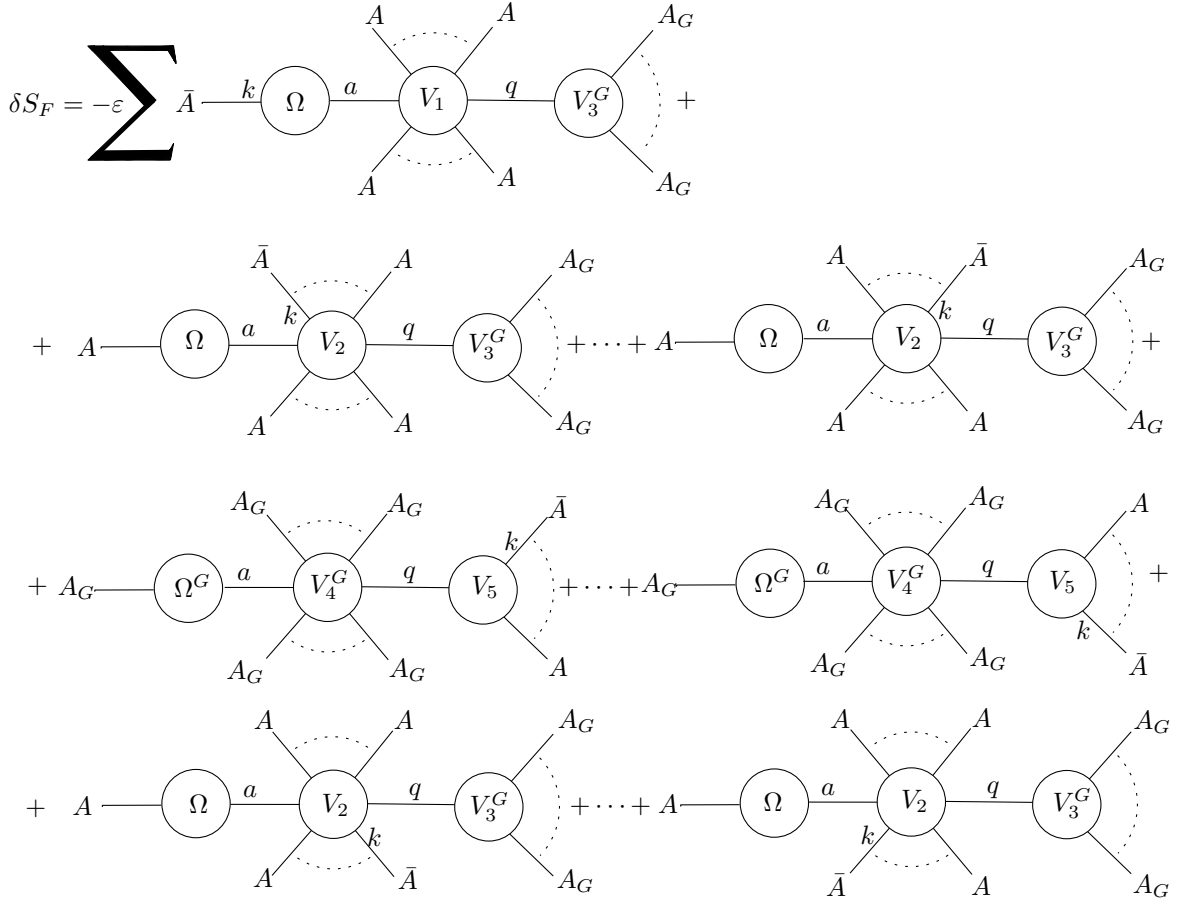
Figure 4.6: Change in the Free Part of the Action δS_F

The notation, $P_{i,k}$ means $P_{i,k} = p_i + \dots + p_k$. Expanding out the summations in the brackets, either explicitly or by comparison with equation (3.6) in [31], they reduce to

$$\sum_{k=i}^{j-1} \frac{\{k, k+1\}}{\widehat{k}k+1} (q, P_{i,k}) = -\hat{q}(\omega_{-q} + \omega_i + \dots + \omega_j)$$

with $q = p_i + \dots + p_j = -p_{j+1} - \dots - p_n - p_1 + \dots - p_{i-1}$ and $\omega_p = \bar{p}\tilde{p}/\hat{p}$. So we have

$$Y_{i,j} = \frac{\hat{1}^2}{\hat{q}^2} \left(\hat{q}^G \left\{ \omega_{-q}^G + \omega_i^G + \dots + \omega_j^G \right\} + \hat{q} \left\{ \omega_q + \omega_{j+1} + \dots + \omega_{i-1} \right\} \right) \times \\ \times \Gamma(q^G, i^G, \dots, j^G) \Gamma(q, j+1, \dots, i-1).$$

Now since $-q + p_i + \dots + p_j = 0$ and $q + p_{j+1} + \dots + p_n + p_1 + \dots + p_{i-1} = 0$ we can subtract these from each of the brackets $\omega_{-q} + p_i + \dots + p_j$ as follows

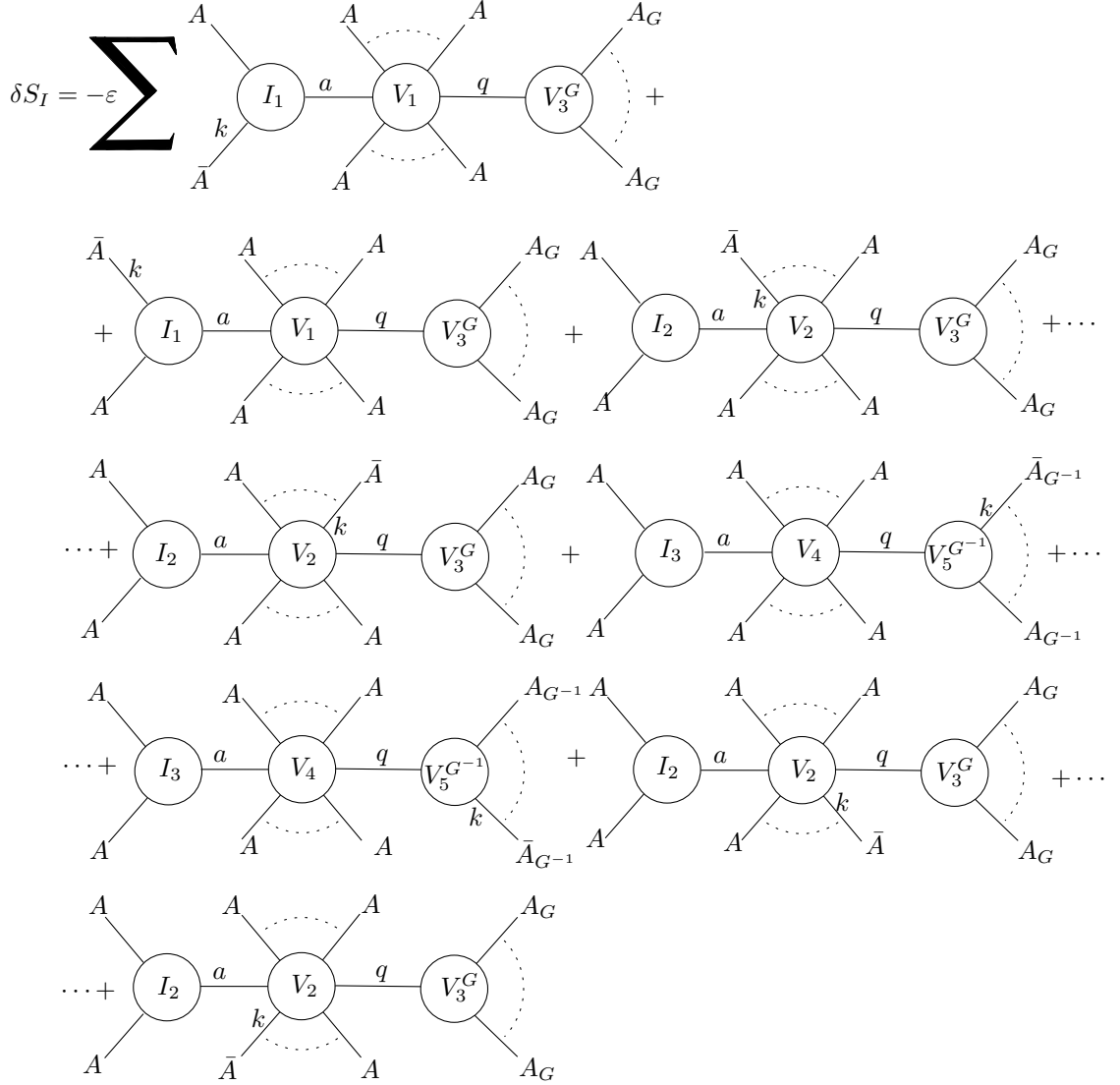
 Figure 4.7: Change in the Interacting Part of the Action δS_I

$$\begin{aligned}
 Y_{i,j} = & \frac{\hat{1}^2}{\hat{q}^2} \left(\hat{q}^G \left\{ \omega_{-q}^G - \widetilde{-q}^G + \omega_i^G - \check{i}^G + \cdots + \omega_j^G - \check{j}^G \right\} + \right. \\
 & \left. + \hat{q} \left\{ \omega_q - \check{q} + \omega_{j+1} - \widetilde{j+1} + \cdots + \omega_{i-1} - \widetilde{i-1} \right\} \right) \times \\
 & \times \Gamma(q^G, i^G, \dots, j^G) \Gamma(q, j+1, \dots, i-1)
 \end{aligned}$$

and then take out a factor of $1/\hat{p}$ from each term $\omega_p - \check{p}$ as follows

$$\begin{aligned}
 Y_{i,j} = & \frac{\hat{1}^2}{\hat{q}^2} \left(\frac{\hat{q}^G}{\hat{q}^G} \Omega_q^G + \frac{\hat{q}^G}{\hat{i}^G} \Omega_i^G + \cdots + \frac{\hat{q}^G}{\hat{j}^G} \Omega_j^G - \frac{\hat{q}}{\hat{q}} \Omega_{-q} + \frac{\hat{q}}{\hat{j}+1} \Omega_{j+1} + \cdots + \frac{\hat{q}}{\hat{i}-1} \Omega_{i-1} \right) \times \\
 & \times \Gamma(q^G, i^G, \dots, j^G) \Gamma(q, j+1, \dots, i-1).
 \end{aligned}$$

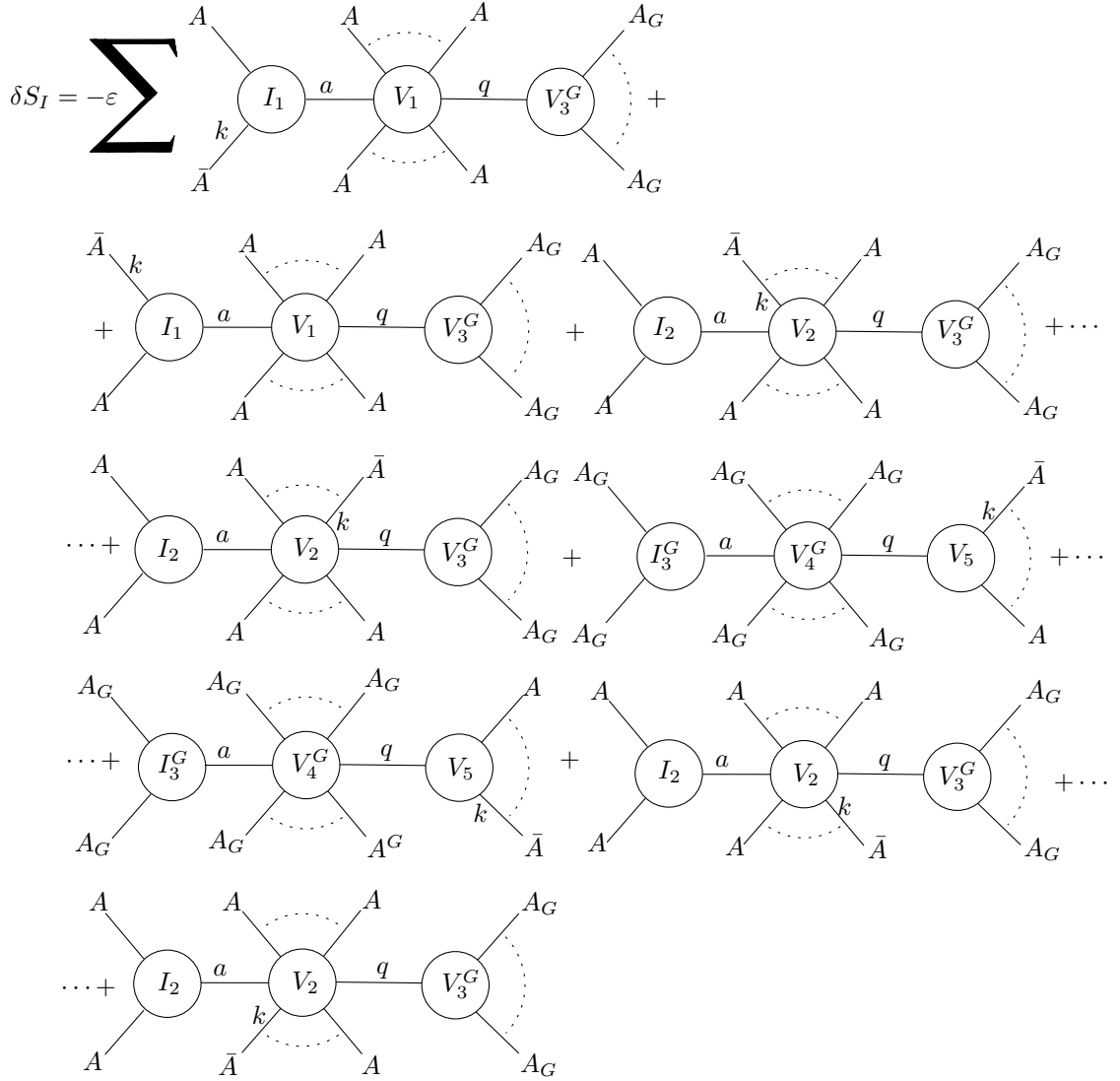
Figure 4.8: Change in the Interacting Part of the Action δS_I

Terms in Ω_q and Ω_{-q} cancel, using the fact that $\Omega^G = \Omega$. So we arrive at

$$Y_{i,j} = \frac{\hat{1}^2}{\hat{q}^2} \left(\frac{\hat{q}}{\hat{1}} \Omega_1 + \cdots + \frac{\hat{q}}{\hat{i}-1} \Omega_{i-1} + \frac{\hat{q}^G}{\hat{i}^G} \Omega_i^G + \cdots + \frac{\hat{q}^G}{\hat{j}^G} \Omega_j^G + \frac{\hat{q}}{\hat{j}+1} \Omega_{j+1} + \cdots + \frac{\hat{q}}{\hat{n}} \Omega_n \right) \times \\ \times \Gamma(q^G, i^G, \dots, j^G) \Gamma(q, j+1, \dots, i-1) \\ = -X_{i,j}$$

and so coefficients of linearly independent, like terms in $\bar{A}_1 \cdots A_{\bar{i}G} \cdots A_{jG} \cdots A_{\bar{n}}$ in δS_F and δS_I sum to zero, $X_{i,j} + Y_{i,j} = 0$ and the result follows

$$\delta S = \delta S_F + \delta S_I = 0$$

thus not only proving that the expressions (4.20) and (4.21) and their associated momentum flow diagrams are indeed symmetries of the Chalmers-Siegel action but also the most general transformations in fig (4.3) are also symmetries of the action (4.17).

4.3 Chapter Summary

The Chalmers-Siegel action which describes self-dual Yang-Mills theory can be mapped to a free theory by a canonical transformation arising from the construction of a Lagrangian formalism of the MHV rules. Free theories have a high degree of symmetry. In addition to the well known symmetries induced by infinitesimal isometries there are those in which infinitesimal changes in the fields are related to finite isometries which we have reviewed briefly. The Lie algebra of these transformations is built out of the group algebra of the isometries, and this can be used to decompose the Lie algebra into a direct sum of its Abelian and non-Abelian parts. By studying the canonical transformation we found the corresponding symmetries of the self-dual Yang-Mills theory, and showed that these satisfy the same Lie algebra as in the free theory. We might expect that these results are generalizable to the supersymmetric case and in particular to $N = 4$ super Yang-Mills on the light cone which we will discuss in §(5). It will also be interesting to see which (if any) of these symmetries survive the full Yang-Mills theory on the light-cone, given by eqn (4.1). We expect only a subset of the transformations to survive. Further, by considering the dihedral subgroups $D(2n)$ of $SO(3)$ and counting the number of Abelian generators, we find that the number of non-Abelian generators increases in multiples of 3 with increasing n . We expect to find that the algebra constructed in this way using the dihedral groups is going to be a sum of $su(2)$ algebras.

Throughout this chapter we have restricted ourselves to studying the isometries of the Lorentz group. Extending the result to include displacements is somewhat more trivial and a phase factor appears in the expressions using the fundamental property of Fourier transforms that

$$\phi(x + a) \xrightarrow{FT} e^{ipa} \tilde{\phi}(p).$$

For example under a pure translation $x \rightarrow x + a$, following the same procedure to the one we have given throughout, we would get

$$\delta A_1 = -\varepsilon \sum_{n=2}^{\infty} \sum_{i=2}^n \sum_{j=i}^n \int_{2 \dots n} \frac{\hat{1}}{\hat{q}} \Gamma(q, i, \dots, j) \Gamma(q, j+1, \dots, n, 1 \dots, i-1) \times \\ \times \exp \{i(p_{\mu}^i + \dots + p_{\mu}^j) a^{\mu}\} A_{\bar{2}} \dots A_{\bar{n}}$$

neglecting various factors of 2π . A similar expression would hold for the transformation of the conjugate field $\overline{\delta A}$ with the exponential factors appearing in each term of the sum.

Chapter 5

Infinite Dimensional Symmetries of Self-Dual N=4 Super Yang-Mills

The normal Feynman approach to calculating n -gluon tree-level scattering amplitudes is well understood but the complexity of calculations grows quickly with n making the method inefficient and prohibitive. It was recently observed that such gluon amplitudes localise on simple curves in twistor space [5] and this led to a new set of rules for calculating them [6]. This approach provides an alternative to the Feynman rules with drastically reduced complexity, for example the Parke-Taylor amplitude for tree-level scattering of $n - 2$ positive helicity gluons and 2 negative is remarkably simple [10]. The new set of rules was initially proven outside the Lagrangian formalism using the BCFW recursion relation [12] and using twistor methods, (See [56] through to [63]). More recently they have been derived in the non-supersymmetric theory by applying a non-local canonical transformation to the Yang-Mills action on the light-cone [30, 51]. The action is split into the Chalmers-Siegel action describing the self-dual sector [37] plus the rest and the canonical transformation maps the self-dual part of the action to a free action. The transformation was also studied in more detail in [31].

The superspace version of the MHV rules and recursion relations to find all tree-level supersymmetric amplitudes were also derived initially in the twistor language,

[15, 16] but Feng and Huang, [38] then extended the procedure in [30, 31] to the supersymmetric case by defining a field transformation between the Yang-Mills fields and a new field which maps the self-dual part of the action to a free theory, thus deriving a Lagrangian formulation of the $N = 4$ MHV rules.

In §(4) we used the non-SUSY version of this field redefinition to create infinite dimensional, non-local symmetries of the self-dual non-supersymmetric theory. We used the simple fact that a free theory with Euler-Lagrange equation $\Omega(x)\phi(x) = 0$ has a symmetry if $\Omega(x^G) = \Omega(x)$ where $x \rightarrow x^G$ is a finite isometry of the space-time. Then since $0 = \Omega(x^G)\phi(x^G) = \Omega(x)\phi(x^G)$, we see that $\phi(x^G)$ is a new solution. Because of the linearity of the free Euler-Lagrange equation we can construct a new solution as $\phi(x) + \varepsilon\phi(x^G)$. This was said to lead to higher order conserved currents such as the ‘Zilch’ of the electromagnetic field [34] and those calculated in [42].

In this chapter we shall extend this and construct symmetries of the $N = 4$ self-dual SYM action by using the supersymmetric canonical transformation of [38] to map the self-dual action to the free theory and then writing the symmetry in terms of the free fields. We derive an expression for the inverse transformation and use it to write the expression in terms of the original variables. We examine the first 4 orders in powers of the fields and then hypothesize the general result. We then prove the above expression leaves the action invariant and conclude by showing how we can extract expressions for the transformations of the component fields.

5.1 Light Cone N=4 SYM

We shall review the construction of the $N = 4$ supersymmetric Yang-Mills action on the light cone. For a more detailed treatment see [38, 66]. Let us start by considering the action in 10 dimensions, which is given by

$$S = \int d^{10}x \left\{ \frac{1}{4} F_a^{\mu\nu} F_{\mu\nu a} + \frac{1}{2} i \bar{\psi}^a \Gamma^\mu D_\mu \psi^a \right\} \quad (5.1)$$

for $\mu, \nu = 0, \dots, 9$ and where Γ is a generalization of the Dirac gamma matrices to 10 dimensions. The spinor degrees of freedom satisfy the Weyl and Majorana conditions and $F_{\mu\nu}^a$ is given by

$$F_{\mu\nu}^a = \partial_\mu A_\nu^a - \partial_\nu A_\mu^a + g f^{abc} A_\mu^b A_\nu^c.$$

As stated in [66] it is straightforward to show that the action (5.1) is invariant under the supersymmetry transformations

$$\delta A_\mu = \bar{\xi} \Gamma_\mu \psi \qquad \delta \psi = -\frac{1}{2} F_{\mu\nu} \Gamma^{\mu\nu} \xi.$$

It is known however that consecutive supersymmetry transformations of this form do not close to form an algebra off-shell. To make this algebra close requires the introduction of auxiliary fields, however as explained in [66] it is not known how to do this. Take for example the commutator of transformations of the spinor field

$$(\delta_{\xi_2} \delta_{\xi_1} - \delta_{\xi_1} \delta_{\xi_2}) \psi = (\bar{\xi}_2 \Gamma^\mu \xi_1) D_\mu \psi - \frac{1}{2} (\bar{\xi}_2 \Gamma^\mu \xi_1) \Gamma_\mu \Gamma^\nu D_\nu \psi \quad (5.2)$$

which, by using the field equation $\Gamma^\mu D_\mu \psi = 0$, closes to

$$(\delta_{\xi_2} \delta_{\xi_1} - \delta_{\xi_1} \delta_{\xi_2}) \psi = (\bar{\xi}_2 \Gamma^\mu \xi_1) D_\mu \psi.$$

It is still possible to retain half the SUSY on-shell at this stage by transforming to a frame in which only \hat{p} is non vanishing. As explained in the papers [38, 66], if we now split the spinor as follows

$$\psi = -\frac{1}{2} (\hat{\Gamma} \check{\Gamma} + \check{\Gamma} \hat{\Gamma}) \psi = \hat{\psi} + \check{\psi}$$

where $\hat{\Gamma} = 1/\sqrt{2} (\Gamma^0 + \Gamma^1)$ and $\check{\Gamma} = 1/\sqrt{2} (\Gamma^0 - \Gamma^1)$ then (5.2) now closes with on-shell degrees of freedom A_\perp and $\check{\psi}$ leaving only the $SO(8)$ sub-group of the original Lorentz group manifest [38]. Now (L.Brink *et al*) [66] dimensionally reduce this to four dimensions which breaks the $SO(8)$ invariance

$$SO(8) \rightarrow SO(6) \otimes SO(2) \sim SU(4) \otimes U(1) \quad (5.3)$$

leaving the 4 dimensional SUSY algebra

$$\{\bar{q}^A, q_B\} = -i\sqrt{2} \delta_B^A \hat{\partial} \quad (5.4)$$

where A and B are $SU(4)$ indices $A, B = 1, 2, 3, 4$. A supersymmetry transformation on superspace $(\hat{x}, \check{x}, \tilde{x}, \bar{x}; \theta, \bar{\theta})$ generates the following change in coordinates

$$(\hat{x}, \check{x}, \tilde{x}, \bar{x}; \theta, \bar{\theta}) \rightarrow \left(\hat{x} + \frac{i}{\sqrt{2}} \xi^A \bar{\theta}_A - \frac{i}{\sqrt{2}} \theta^A \bar{\xi}_A, \check{x}, \tilde{x}, \bar{x}; \theta + \xi, \bar{\theta} - \bar{\xi} \right)$$

where θ are Grassman variables. The transformations give rise to the following SUSY generators and covariant derivatives, d and \bar{d}

$$\begin{aligned} q_A &= \frac{\partial}{\partial\theta^A} + \frac{i}{\sqrt{2}}\bar{\theta}_A\hat{\partial} & \bar{q}^A &= -\frac{\partial}{\partial\theta_A} - \frac{i}{\sqrt{2}}\theta^A\hat{\partial} \\ d_A &= \frac{\partial}{\partial\theta^A} - \frac{i}{\sqrt{2}}\bar{\theta}_A\hat{\partial} & \bar{d}^A &= -\frac{\partial}{\partial\theta_A} + \frac{i}{\sqrt{2}}\theta^A\hat{\partial} \end{aligned} \quad (5.5)$$

and it is easily verified that q and \bar{q} do indeed satisfy the SUSY algebra given in [66] and in (5.4). A chiral superfield is defined by imposing the constraint

$$\bar{d}_A\Phi = 0 \quad (5.6)$$

and further, the N=4 SUSY multiplet is CPT self conjugate and so we impose a second ‘reality’ constraint in the same way that was discussed in [66],

$$\bar{\Phi} = \frac{\epsilon^{ABCD}}{48\hat{\partial}^2}d_Ad_Bd_Cd_D\Phi. \quad (5.7)$$

A superfield satisfying both (5.6) and (5.7) is written

$$\begin{aligned} \Phi(x, \theta, \bar{\theta}) &= \frac{1}{\hat{\partial}}A(y) + \frac{i}{\hat{\partial}}\theta^A\lambda_A(y) + i\frac{1}{\sqrt{2}}\theta^A\theta^B\bar{C}_{AB}(y) \\ &+ \frac{\sqrt{2}}{3!}\theta^A\theta^B\theta^C\epsilon_{ABCD}\bar{\lambda}^D(y) + \frac{1}{12}\theta^A\theta^B\theta^C\theta^D\epsilon_{ABCD}\hat{\partial}\bar{A}(y) \end{aligned} \quad (5.8)$$

where $y = \left(\hat{x} - \frac{i}{\sqrt{2}}\theta^A\bar{\theta}_A, \tilde{x}, \tilde{x}, \bar{x}\right)$ is known as the chiral basis in which (5.6) is trivially satisfied and the fields A, λ and C are the gauge fields, fermions and scalars respectively. (See [67], page (30)). In terms of this superfield the N=4 super Yang-Mills action on the light cone in 4 dimensions is

$$\begin{aligned} S &= \int d^4x d^4\theta d^4\bar{\theta} \left\{ \bar{\Phi}^a \frac{\hat{\partial}\hat{\partial} - \tilde{\partial}\tilde{\partial}}{\hat{\partial}^2} \Phi^a + \frac{2}{3}g f^{abc} \left[\frac{1}{\hat{\partial}}\bar{\Phi}^a\Phi^b\tilde{\partial}\Phi^c + \text{complex conjugate} \right] \right. \\ &\quad \left. - \frac{g^2}{2} f^{abc} f^{ade} \left[\frac{1}{\hat{\partial}} \left(\Phi^b\hat{\partial}\Phi^c \right) \frac{1}{\hat{\partial}} \left(\bar{\Phi}^d\hat{\partial}\bar{\Phi}^e \right) + \frac{1}{2}\Phi^b\bar{\Phi}^c\Phi^d\bar{\Phi}^e \right] \right\} \end{aligned} \quad (5.9)$$

as given in [66] and [38]. It is straightforward to express this in component form which agrees with the expression in [66], (Equation (3.13) in their paper).

5.1.1 MHV Rules Lagrangian for N=4 SYM

Let us examine the helicity content of the action by considering each part. We write

$$S = S^{-+} + S^{-++} + S^{--+} + S^{----}$$

with

$$S^{-+} = \text{Tr} \int d^4x d^4\theta d^4\bar{\theta} \left\{ \bar{\Phi} \frac{\hat{\partial}\check{\partial} - \check{\partial}\bar{\partial}}{\hat{\partial}^2} \Phi \right\}$$

$$S^{-++} = \text{Tr} \int d^4x d^4\theta d^4\bar{\theta} \left\{ \frac{2}{3} g f^{abc} \frac{1}{\hat{\partial}} \bar{\Phi}^a \Phi^b \bar{\partial} \Phi^c \right\}$$

and so on for S^{--+} and S^{---+} . In the MHV rules (Maximal helicity violating amplitude) an n point amplitude consists of 2 negative helicities and $n-2$ positive helicities (see [6, 10, 58]). In parallel with papers by Mansfield, and Eittle and Morris [30, 31], the part of the action S_{-++} clearly does not satisfy this requirement and further, terms with more than two positive helicities are missing from the full action (5.9).

We can express (5.9) in the chiral basis y by expressing the action in terms of Φ only using (5.7) at the expense of introducing covariant derivatives in to the action. One will get a kinetic term, a cubic term with 4 covariant derivatives and a further two terms with 8 covariant derivatives, as explained in [38]. Chalmers and Siegel [37] show that terms which contain only four covariant derivatives, i.e. $S^{-+} + S^{-++}$ express the self-dual sector in terms of the Chalmers-Siegel action. Classically, self-dual Yang-Mills is free so we wish to transform the self-dual sector $S^{-+} + S^{-++}$ into a free action by a canonical change of fields $\Phi[\chi]$. This procedure absorbs the unwanted term S^{-++} into a free action, and it turns out the change of field variables generates all the missing terms S^{---+} . By that argument, Feng and Huang give us the Chalmers-Siegel action describing the self-dual sector as

$$S_{SD} = \text{Tr} \int d^4x d^4\theta \left\{ \Phi \left(\hat{\partial}\check{\partial} - \check{\partial}\bar{\partial} \right) \Phi + \frac{2}{3} \hat{\partial}\Phi [\Phi, \bar{\partial}\Phi] \right\}$$

$$= \text{Tr} \int d^4x d^4\theta \left\{ \chi \left(\hat{\partial}\check{\partial} - \check{\partial}\bar{\partial} \right) \chi \right\}$$
(5.10)

where the free superfield χ is written as

$$\chi(y, \theta) = \frac{1}{\hat{\partial}} B(y) + \frac{i}{\hat{\partial}} \theta^A \rho_A(y) + i \frac{1}{\sqrt{2}} \theta^A \theta^B \bar{D}_{AB}(y)$$

$$+ \frac{\sqrt{2}}{3!} \theta^A \theta^B \theta^C \epsilon_{ABCD} \bar{\rho}^D(y) + \frac{1}{12} \theta^A \theta^B \theta^C \theta^D \epsilon_{ABCD} \hat{\partial} \bar{B}(y)$$
(5.11)

in the chiral basis with B and \bar{B} the gauge fields, ρ and $\bar{\rho}$ are fermions and D_{AB} is a four by four anti-symmetric matrix of real scalars (thus having six independent

scalar fields). The field transformation derived in [38] satisfies the equation

$$\mathrm{Tr} \int d^4x d^4\theta \left\{ -\Phi \tilde{\partial} \bar{\partial} \Phi + \frac{2}{3} \hat{\partial} \Phi [\Phi, \bar{\partial} \Phi] \right\} = \mathrm{Tr} \int d^4x d^4\theta \left\{ -\chi \tilde{\partial} \bar{\partial} \chi \right\} \quad (5.12)$$

arising from (5.10) and the condition that Φ and χ have the same \tilde{x} dependence (See [30]). Further, we apply the additional constraint

$$\mathrm{Tr} \int d^4x d^4\theta \Phi \hat{\partial} \tilde{\partial} \Phi = \mathrm{Tr} \int d^4x d^4\theta \chi \hat{\partial} \tilde{\partial} \chi \quad (5.13)$$

as discussed in Feng and Huang, [38]. They calculate the transformation $\Phi[\chi]$ in their paper but not the inverse transformation which we shall also need. We shall state their result here and calculate the inverse for ourselves using their procedure. Their field redefinition reads

$$\Phi_1 = \chi_1 + \sum_{n=3}^{\infty} \int_{2 \cdots n} C(12 \cdots n) \chi_{\bar{2}} \chi_{\bar{3}} \cdots \chi_{\bar{n}} \quad (5.14)$$

where we use the abbreviations $\Phi_i = \Phi(p_i)$ and $\Phi_{\bar{i}} = \Phi(-p_i)$ as we shall do throughout this paper and we drop the momentum conserving delta function $\delta^4(p_1 + p_2 + \cdots + p_n)$.

In the above we use the notation

$$\int_{1 \cdots n} = \int \frac{d^4 p_1}{(2\pi)^4} \cdots \frac{d^4 p_n}{(2\pi)^4}.$$

The kernel C is given by

$$C(12 \cdots n) = (-1)^n \frac{\hat{2} \hat{3}^2 \hat{4}^2 \cdots \widehat{n-2}^2 \widehat{n-1}^2 \hat{n}}{(2, 3) (3, 4) \cdots (n-1, n)} \quad (5.15)$$

where the bracket $(,)$ is given by $(i, j) = \hat{i} \tilde{j} - \tilde{i} \hat{j}$. Now let us calculate the inverse field redefinition $\chi[\Phi]$ for ourselves. We guess the form of the expansion as

$$\chi_1 = \Phi_1 + \sum_{n=3}^{\infty} \int_{2 \cdots n} D(12 \cdots n) \Phi_{\bar{2}} \Phi_{\bar{3}} \cdots \Phi_{\bar{n}}. \quad (5.16)$$

Under the field redefinition and the product of superfields, the A fields do not mix with any of the other fields in the multiplet as they are zeroth order in the expansion of θ in the superfield. We can simply read off the field transformation for the A and B fields.

$$\frac{B_1}{i\hat{p}_1} = \frac{A_1}{i\hat{p}_1} - \sum_{n=3}^{\infty} \int_{2 \cdots n} D(12 \cdots n) \frac{A_{\bar{2}}}{i\hat{p}_2} \frac{A_{\bar{3}}}{i\hat{p}_3} \cdots \frac{A_{\bar{n}}}{i\hat{p}_n}.$$

We will compare this to the transformation that is in the literature, namely the papers [30], [31] and §(4). We have

$$B_1 = A_1 - \sum_{n=3}^{\infty} \int_{2 \dots n} (i)^n \frac{\hat{1}}{(1, 2)} \frac{\hat{1}}{(1, 2 + 3)} \cdots \frac{\hat{1}}{(1, 2 + \cdots + (n - 1))} A_{\bar{2}} A_{\bar{3}} \cdots A_{\bar{n}}$$

giving our expression for $D(12 \cdots n)$ as the following

$$D(12 \cdots n) = -(-1)^n \frac{\hat{1}^{n-3} \hat{2} \hat{3} \cdots \hat{n}}{(1, 2) (1, 2 + 3) \cdots (1, 2 + 3 + \cdots + (n - 1))} \quad (5.17)$$

We can prove this expression by substituting it into (5.12), writing down a recursion relation for the coefficients D and showing they satisfy this recursion relation as follows. Given the canonical transformation condition proved in [38], namely

$$\hat{\partial} \Phi = \int d^4 y \frac{\delta \chi(y)}{\delta \Phi(x)} \hat{\partial} \chi(y),$$

we substitute this in to (5.12), transform into momentum space and rearrange to arrive at a relation between fields χ and Φ given by

$$\begin{aligned} \int_{p_1} \omega(p_1) \Phi(p_1) \frac{\delta \chi(p)}{\delta \Phi(p_1)} + \int_{p_1 p_2 p_3} \frac{[\hat{p}_2 \Phi(p_2), \bar{p}_3 \Phi(p_3)]}{\hat{p}_1} \delta(p_1 - p_2 - p_3) \frac{\delta \chi(p)}{\delta \Phi(p_1)} = \\ = \omega(p) \chi(p) \end{aligned}$$

where $\omega(p) = \bar{p} \tilde{p} / \hat{p}$. Then we take the ansatz for the field redefinition (5.16) and proceed by substituting this into the above expression to extract the recurrence relation

$$D^n(1 \cdots n) = \frac{1}{\omega_1 + \omega_2 + \cdots + \omega_n} \sum_{k=2}^{n-1} \{k+1, k\} D^{n-1}(1, 2, \dots, k-1, k+(k+1), k+2, \dots, n)$$

and then substituting (5.17) on the right hand side and taking a factor of $D^n(12 \cdots n)$ outside the sum we get

$$-\frac{D^n(1 \cdots n)}{\hat{1}(\omega_1 + \cdots + \omega_n)} \sum_{k=2}^{\infty} \frac{\{k, k+1\}}{\widehat{k \bar{k} + 1}} (1, p_{2,k})$$

with $\{i, j\} = \hat{i} \bar{j} - \bar{i} \hat{j}$. The expression under the sum then reduces to $-\hat{1}(\omega_1 + \cdots + \omega_n)$ thus proving the result.

As an aside, we can use the inverse field redefinition to calculate the field redefinition $\bar{B}[A, \bar{A}]$, an expression missing from [30], [31] and §(4). We calculate the component of (5.16) (which is now proven) that is fourth order in θ and find

$$\bar{B}_{\bar{1}} = \sum_{n=2}^{\infty} \sum_{k=2}^n \int_{2 \dots n} \frac{\hat{k}}{\hat{1}} \Theta^k(12 \cdots n) A_{\bar{2}} \cdots \bar{A}_{\bar{k}} \cdots A_{\bar{n}}$$

where

$$\Theta^k(1 \cdots n) = -\frac{\hat{k}}{\hat{1}} \Gamma(1 \cdots n).$$

A further point to note about (5.16) is that since each term in the expansion is linearly independent, and since χ is a superfield satisfying the constraints (5.6) and (5.7) then it makes sense that each term in the expansion also satisfies these constraints and is therefore a superfield which has the same form as the free field χ and the SYM field Φ . So if we write the field redefinition as

$$\chi(1) = \Psi^0(1) + \Psi^1(1) + \Psi^2(1) + \cdots$$

and so on, with $\Psi^0 = \Phi$ and defining

$$\Psi^{n-2} = \int_{2 \cdots n} D(12 \cdots n) \Phi_2 \Phi_3 \cdots \Phi_{\bar{n}} \quad (5.18)$$

as the individual terms in the field redefinition, then the Ψ^{n-2} trivially satisfies the constraint (5.6) since χ can be written in the chiral basis in which it contains no $\bar{\theta}$.

We can then write the conjugate of Ψ as the following

$$\bar{\chi}(1) = \bar{\Psi}^0(1) + \bar{\Psi}^1(1) + \bar{\Psi}^2(1) + \cdots$$

then since χ satisfies (5.7) we write

$$\begin{aligned} \bar{\chi}(1) &= \frac{\epsilon^{ABCD} d_A d_B d_C d_D}{48 \cdot \hat{1}^2} \{ \Psi^0(1) + \Psi^1(1) + \Psi^2(1) + \cdots \} \\ &= \frac{\epsilon^{ABCD} d_A d_B d_C d_D}{48 \cdot \hat{1}^2} \Psi^0(1) + \frac{\epsilon^{ABCD} d_A d_B d_C d_D}{48 \cdot \hat{1}^2} \Psi^1(1) + \frac{\epsilon^{ABCD} d_A d_B d_C d_D}{48 \cdot \hat{1}^2} \Psi^2(1) + \cdots \end{aligned}$$

Since all the terms Ψ^{n-2} are linearly independent, we have

$$\begin{aligned} \bar{\Psi}^0 &= \bar{\Phi} = \frac{\epsilon^{ABCD} d_A d_B d_C d_D}{48 \cdot \hat{1}^2} \Phi \\ \bar{\Psi}^1 &= \frac{\epsilon^{ABCD} d_A d_B d_C d_D}{48 \cdot \hat{1}^2} \Psi^1 \\ \bar{\Psi}^2 &= \frac{\epsilon^{ABCD} d_A d_B d_C d_D}{48 \cdot \hat{1}^2} \Psi^2 \\ &\vdots \end{aligned}$$

and so on, thus showing that all the Ψ^{n-2} individually satisfy both the constraints and that they have the same form as (5.8)

$$\begin{aligned} \Psi(y, \theta) &= \frac{1}{\hat{\partial}} \underline{A}(y) + \frac{i}{\hat{\partial}} \theta^A \underline{\lambda}_A(y) + i \frac{1}{\sqrt{2}} \theta^A \theta^B \bar{C}_{AB}(y) \\ &\quad + \frac{\sqrt{2}}{3!} \theta^A \theta^B \theta^C \epsilon_{ABCD} \bar{\lambda}^D(y) + \frac{1}{12} \theta^A \theta^B \theta^C \theta^D \epsilon_{ABCD} \hat{\partial} \bar{A}(y) \end{aligned} \quad (5.19)$$

where the underscores attached to the component fields are present to distinguish them from the fields present in (5.8) and depend on some multiples of the fields in (5.8) and we have dropped the superscripts on Ψ .¹ For example,

$$\begin{aligned} \underline{A}_1 &= \int_{2\dots n} \frac{-(i)^n \hat{1}^{n-1}}{(1,2)(1,2+3)\cdots(1,2+\cdots+(n-1))} A_{\underline{2}} \cdots A_{\underline{n}} \\ (\underline{\lambda}_A)_1 &= \sum_{k=2}^n \int_{2\dots n} \frac{-(i)^n \hat{1}^{n-1}}{(1,2)(1,2+3)\cdots(1,2+\cdots+(n-1))} A_{\underline{2}} \cdots (\lambda_A)_{\bar{k}} \cdots A_{\underline{n}} \\ &\vdots \end{aligned}$$

and so on for \underline{C} , $\underline{\bar{\lambda}}$ and $\underline{\bar{A}}$. This is a result we need to use later.

5.2 Symmetries in Free Supersymmetric Theories

5.2.1 Transformations of N=1 Chiral Free SUSY

As a precursor to studying symmetries of the N=4 Super Yang-Mills multiplet, let us study a simpler theory with action

$$S = \int d^4x \left\{ \eta^{\mu\nu} \partial_\mu \tilde{\varphi} \partial_\nu \varphi + \tilde{\psi} i \gamma^\mu \partial_\mu \psi \right\}.$$

Clearly this will be invariant under the component SUSY transformations, for example see [67]. If $x \rightarrow x^G$ is a member of the isometry group of the space-time then the action is invariant under

$$\begin{aligned} \delta\varphi(x) &= \varepsilon \tilde{\lambda} \psi(x_G), & \delta\tilde{\varphi}(x) &= \varepsilon \tilde{\psi}(x_{G^{-1}}) \lambda \\ \delta\psi(x) &= -i \gamma^\mu \partial_\mu \varphi(x_G) \lambda, & \delta\tilde{\psi}(x) &= \tilde{\lambda} i \gamma^\mu \partial_\mu \tilde{\varphi}(x_{G^{-1}}) \end{aligned}$$

where λ is a constant spinor and the γ^μ are the Dirac gamma matrices. This is simple to prove, we have

$$\begin{aligned} \delta S &= \int d^4x \left\{ \eta^{\mu\nu} \partial_\mu \tilde{\varphi}(x) \partial_\nu (\tilde{\lambda} \psi(x_G)) + \eta^{\mu\nu} \partial_\mu (\tilde{\psi}(x_{G^{-1}}) \lambda) \partial_\nu \varphi(x) \right. \\ &\quad \left. + \tilde{\psi}(x) i \gamma^\mu \partial_\mu (-i \gamma^\nu \partial_\nu \varphi(x_G) \lambda) + (\tilde{\lambda} i \gamma^\nu \partial_\nu \tilde{\varphi}(x_{G^{-1}})) i \gamma^\mu \partial_\mu \psi(x) \right\}. \end{aligned}$$

¹It is actually a basic fact that products of superfields are also superfields, but as our field Ψ as defined by (5.18) consists of fields multiplied together at different points and knitted together with a non-local kernel and integrated over, the situation is not as simple, but as we have discussed it still holds.

Multiplying out terms and then taking ∂_ν out of the third term as a total derivative, we get

$$\begin{aligned} \delta S = \int d^4x \left\{ \eta^{\mu\nu} \tilde{\lambda} \partial_\mu \tilde{\varphi}(x) \partial_\nu \psi(x_G) - \frac{1}{2} \tilde{\lambda} \partial_\mu \tilde{\varphi}(x_{G^{-1}}) \{ \gamma^\mu, \gamma^\nu \} \partial_\nu \psi(x) \right. \\ \left. + \eta^{\mu\nu} \partial_\mu \tilde{\psi}(x_{G^{-1}}) \partial_\nu \varphi(x) \lambda - \frac{1}{2} \partial_\mu \tilde{\psi}(x) \{ \gamma^\mu, \gamma^\nu \} \partial_\nu \varphi(x_G) \lambda \right\}. \end{aligned}$$

Applying the isometry $x \rightarrow x^G$ in the second and third terms and using the Dirac algebra

$$\eta^{\mu\nu} = \frac{1}{2} \{ \gamma^\mu, \gamma^\nu \}$$

we get $\delta S = 0$.

5.2.2 Transformation of the Free N=4 Multiplet

The free action on the RHS of (5.10) was written as

$$S = \text{Tr} \int d^4x d^4\theta \chi(x, \theta) \Omega(x) \chi(x, \theta) \quad (5.20)$$

where $\Omega(x) = \hat{\partial} \check{\partial} - \check{\partial} \bar{\partial}$ and the change in this action is

$$\delta S = 2 \text{Tr} \int d^4x d^4\theta \chi(x, \theta) \Omega(x) \delta \chi(x, \theta)$$

where the superfield $\chi(x, \theta)$ is given by (5.11). The expression for $\delta \chi$ is

$$\begin{aligned} \delta \chi(y, \theta) = \frac{1}{\hat{\partial}} \delta B(y) + \frac{i}{\hat{\partial}} \theta^A \delta \rho_A(y) + i \frac{1}{\sqrt{2}} \theta^A \theta^B \delta \bar{D}_{AB}(y) \\ + \frac{\sqrt{2}}{3!} \theta^A \theta^B \theta^C \epsilon_{ABCD} \delta \bar{\rho}^D(y) + \frac{1}{12} \theta^A \theta^B \theta^C \theta^D \epsilon_{ABCD} \hat{\partial} \delta \bar{B}(y) \end{aligned}$$

where $\delta A, \delta \rho, \delta C, \delta \bar{\rho}$ and $\delta \bar{B}$ are to be determined. In component form the free action (5.20) is easily expanded out to give

$$S = \text{Tr} \int d^4x \left\{ \bar{B}(x) \Omega(x) B(x) + \frac{1}{4} \bar{D}_{AB}(x) \Omega(x) D^{AB}(x) + \frac{i}{\sqrt{2}} \bar{\rho}^A(x) \frac{\Omega(x)}{\hat{\partial}} \rho_A(x) \right\}. \quad (5.21)$$

In the paper [66] they give the supersymmetry transformations of the component fields, $B(x)$, $\rho_A(x)$ and $D_{AB}(x)$. The transformations of their conjugates can easily be calculated directly from eqns (3.15), (3.16) and (3.17) in their paper, or using the super-symmetry generators q^A and \bar{q}_A given in (5.5). These transformations on

their own do indeed leave the free action invariant but we can go further than that. We can write the transformations as

$$\begin{aligned}
\delta B &= \varepsilon \xi^A \rho_A(x^G) \\
\delta \rho_A &= \varepsilon \sqrt{2} \hat{\partial} \bar{D}_{AB}(x^G) \xi^B + \varepsilon \sqrt{2} \bar{\xi}_A \hat{\partial} B(x^G) \\
\delta D^{AB} &= -i\varepsilon \left(\xi^A \bar{\rho}^B(x^{G^{-1}}) - \xi^B \bar{\rho}^A(x^{G^{-1}}) + \varepsilon^{ABCD} \rho_C(x^G) \bar{\xi}_D \right) \\
\delta \bar{D}_{AB} &= -i\varepsilon \left(\rho_A(x^G) \bar{\xi}_B - \rho_B(x^G) \bar{\xi}_A + \varepsilon_{ABCD} \xi^C \bar{\rho}^D(x^{G^{-1}}) \right) \\
\delta \bar{\rho}^A &= \varepsilon \sqrt{2} \bar{\xi}_B \hat{\partial} D^{BA}(x^{G^{-1}}) + \varepsilon \sqrt{2} \xi^A \hat{\partial} \bar{B}(x^{G^{-1}}) \\
\delta \bar{B} &= -i\varepsilon \bar{\rho}^A(x^{G^{-1}}) \bar{\xi}_A,
\end{aligned} \tag{5.22}$$

where ξ^A are finite Grassman numbers carrying $SU(4)$ indices. It is simple to check that the transformations $B \rightarrow B + \delta B, \rho \rightarrow \rho + \delta \rho, \dots$ with the δ s as given above leave the free action (5.21) invariant using the fact $x \rightarrow x^G$ is an isometry, which implies $\Omega(x^G) = \Omega(x)$ and further that the Jacobian of the transformation is unity. However defining the transformations in component form in this manner leads to complications. The terms at the front of the superfield (5.11), B and ρ , are defined to transform under the isometry $x \rightarrow x_G$ whereas those at the end of the superfield, namely $\bar{\rho}$ and \bar{A} , transform under the inverse of the isometry, $x \rightarrow x_{G^{-1}}$. This presents a problem in constructing a superfield formulation of these transformations. It is solved by noticing that we can interchange x^G and $x^{G^{-1}}$ in (5.22) and this will also be a symmetry of the action since we can write $H = G^{-1}$ and do the same calculation. Further, since both these are symmetries, we can add them together to also form a symmetry of the action thus,

$$\begin{aligned}
\delta B &= \varepsilon \xi^A \rho_A(x^G) + \varepsilon \xi^A \rho_A(x^{G^{-1}}) \\
&\vdots \\
\delta \bar{B} &= -i\varepsilon \bar{\rho}^A(x^{G^{-1}}) \bar{\xi}_A - i\varepsilon \bar{\rho}^A(x^G) \bar{\xi}_A
\end{aligned} \tag{5.23}$$

and then this can be written as the sum of two transformed superfields, one with arguments x^G in the component fields and the other with arguments $x^{G^{-1}}$, so roughly speaking

$$\delta \chi = \varepsilon \chi^G(x) + \varepsilon \chi^{G^{-1}}(x) \tag{5.24}$$

with

$$\begin{aligned} \chi^G = & \frac{i\xi^A \rho(x^G)}{\hat{\partial}} + \dots \\ & - \frac{i}{12} \epsilon^{ABCD} \theta_A \theta_B \theta_C \theta_D \hat{\partial} \bar{\rho}^E(x^G) \bar{\xi}_E \end{aligned} \quad (5.25)$$

and similarly for $\chi^{G^{-1}}$. The above is simply the SUSY transformed field with the arguments of the component fields being x^G (or $x^{G^{-1}}$) instead of x .

5.3 Transformation that Leaves the N=4 SYM Action Invariant

In the previous chapter, we calculate symmetries of the non-supersymmetric Chalmers-Siegel action. Given the gauge fields A and \bar{A} we use the field redefinition $A[B]$ mapping the Chalmers-Siegel action to that of the free theory to calculate an expression for δA in terms of the free field δB order by order in B . The inverse expression $B[A]$ is then substituted to arrive at an order by order expansion of δA in terms of the A field itself to non-trivial order in perturbation theory. We then guess the expression for δA to all orders in perturbation theory and prove that the change in the action is indeed zero. The expression we arrive at for δA is

$$\begin{aligned} \delta A_1 = -\varepsilon \sum_{n=2}^{\infty} \sum_{i=2}^n \sum_{j=i}^n \int_{2 \dots n} \frac{\hat{1}}{\hat{q}} \Gamma(q^G, i^G, \dots, j^G) \Gamma(q, j+1, \dots, n, 1, \dots, i-1) \times \\ \times A_2 \dots A_{i^G} \dots A_{j^G} \dots A_{\bar{n}} \end{aligned}$$

where Γ is given by

$$\Gamma(1 \dots n) = -(i)^n \frac{\hat{1}}{(1, 2)} \frac{\hat{1}}{(1, 2+3)} \dots \frac{\hat{1}}{(1, 2+\dots(n-1))}.$$

We shall extend this to the supersymmetric Chalmers-Siegel action describing the self-dual sector of $N = 4$ supersymmetric Yang-Mills on the light-cone (5.10) by following the same procedure described in §(4) for $\Delta\Phi$ using (5.14) and (5.16), and the discussion in §(5.2). We shall guess the expression to all orders in perturbation theory by comparison with (4.20) and substitute this back into the self-dual part of the action (5.10) to prove it does indeed leave the action invariant.

Start with our expression for the field redefinition $\Phi[\chi]$ from (5.14). The change in Φ is then written

$$\Delta\Phi_1 = \sum_{n=2}^{\infty} \sum_{i=2}^n \int_{2\dots n} C(12\dots n) \chi_{\bar{2}} \cdots \delta\chi_{\bar{i}} \cdots \chi_{\bar{n}}$$

where $\delta\chi$ is the transformation of the free field as defined by (5.24). We use a capital Delta to represent the change in Φ to distinguish it from the change in the free field $\delta\chi$. Now as discussed, each term in the series expansion is itself a superfield of the form (5.8) and

$$\delta\chi_1 = \sum_{n=2}^{\infty} \int_{2\dots n} \delta \left\{ D(12\dots n) \Phi_{\bar{2}} \cdots \Phi_{\bar{n}} \right\}.$$

We shall expand order by order and collect terms. We have

$$\begin{aligned} \Delta\Phi_1 = & \varepsilon \delta\chi_1 + \varepsilon \int_{23} C(123) \{ \delta\chi_{\bar{2}}\chi_{\bar{3}} + \chi_{\bar{2}}\delta\chi_{\bar{3}} \} \\ & + \varepsilon \int_{234} C(1234) \{ \delta\chi_{\bar{2}}\chi_{\bar{3}}\chi_{\bar{4}} + \chi_{\bar{2}}\delta\chi_{\bar{3}}\chi_{\bar{4}} + \chi_{\bar{2}}\chi_{\bar{3}}\delta\chi_{\bar{4}} \} \\ & + \varepsilon \int_{2345} C(12345) \{ \delta\chi_{\bar{2}}\chi_{\bar{3}}\chi_{\bar{4}}\chi_{\bar{5}} + \chi_{\bar{2}}\delta\chi_{\bar{3}}\chi_{\bar{4}}\chi_{\bar{5}} + \\ & \qquad \qquad \qquad + \chi_{\bar{2}}\chi_{\bar{3}}\delta\chi_{\bar{4}}\chi_{\bar{5}} + \chi_{\bar{2}}\chi_{\bar{3}}\chi_{\bar{4}}\delta\chi_{\bar{5}} \} \\ & + \dots \end{aligned} \tag{5.26}$$

Now, as per §(4) we substitute the inverse expression (5.16) into the above to get the extremely cumbersome expression given by (C.1.1). Recall that we wrote down the inverse of (5.14) as (5.16). Collecting like terms and writing their coefficients in terms of their independent momenta the expression reduces nicely. We shall write it out order by order here, where the argument in the kernels labeled with a $(-)$ is taken to be minus the sum of the remaining arguments. First order is simply $\Delta\Phi = \delta\Phi + \dots$.

Second Order

$$\dots - \varepsilon \int_{23} \left\{ \frac{\hat{q}}{1} \delta \{ D(-23) \Phi_{\bar{2}} \Phi_{\bar{3}} \} + \frac{\hat{q}}{1} \delta \Phi_{\bar{2}} D(-31) \Phi_{\bar{3}} + \frac{\hat{q}}{1} D(-12) \Phi_{\bar{2}} \delta \Phi_{\bar{3}} \right\}. \tag{5.27}$$

Third Order

$$\begin{aligned}
 \dots - \varepsilon \int_{234} \left\{ \frac{\hat{q}}{1} \delta \{ D(-234) \Phi_2 \Phi_3 \Phi_4 \} + \frac{\hat{q}}{1} \delta \{ D(-23) \Phi_2 \Phi_3 \} D(-41) \Phi_4 \right. \\
 \left. + \frac{\hat{q}}{1} D(-12) \Phi_2 \delta \{ D(-34) \Phi_3 \Phi_4 \} + \frac{\hat{q}}{1} \delta \Phi_2 D(-341) \Phi_3 \Phi_4 \right. \\
 \left. \frac{\hat{q}}{1} \Phi_2 \delta \Phi_3 D(-412) \Phi_4 + \frac{\hat{q}}{1} D(-123) \Phi_2 \Phi_3 \delta \Phi_4 \right\}. \quad (5.28)
 \end{aligned}$$

The fourth order expression is written down in appendix (C), eqn (C.1.2). Note that in the above, for each term containing $\delta \{ D(-, i, \dots, j) \Phi(i) \dots \Phi(j) \}$, we define q to be $q = p_i + \dots + p_j$. As was done in §(4) we now hypothesize a generalization to the expression given in that chapter, (4.20). We write

$$\begin{aligned}
 \Delta \Phi_1 = -\varepsilon \sum_{n=2}^{\infty} \sum_{i=2}^n \sum_{j=i}^n \int_{2 \dots n} \frac{\hat{q}}{1} \Phi_2 \dots \Phi_{i-1} \delta \{ D(-, i, \dots, j) \Phi_i \dots \Phi_j \} \times \\
 \times D(-, j+1, \dots, n, 1, \dots, i-1) \Phi_{j+1} \dots \Phi_n. \quad (5.29)
 \end{aligned}$$

It is now simply a matter of proving that this expression leaves the Chalmers-Siegel action of self-dual Yang-Mills (5.10) invariant which is a similar calculation to that in §(4). Because of the CPT self conjugacy property of the N=4 SYM multiplet, then the ensuing calculation is in fact easier than that given in the pure Yang-Mills setting of §(4) as $\Delta \bar{\Phi}$ is eliminated from the self-dual part of the action. Figure

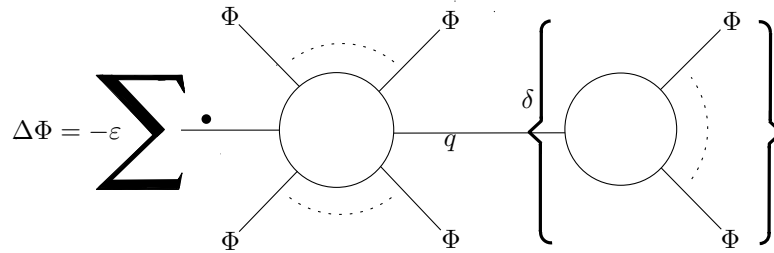
 Figure 5.1: Transformation, $\Delta \Phi$

(5.1) is a diagrammatic expression of (5.29) with the dotted leg representing the argument not integrated over, i.e. p_1 . In §(4), the transformation of the free fields was written as $\delta B(p) = \varepsilon B(p_G)$ and in the expression for δA we wrote something of the form $A_2 \dots A_{i-1} A_i^G \dots A_j^G A_{j+1} \dots A_n$. Here the situation is more complicated

and an operation is performed on the group of fields enclosed in the parentheses that mixes up fermionic and bosonic degrees of freedom. The summation here means to sum over all n , the total number of legs, and all i and j with $2 \leq i \leq j \leq n$. As we shall see later, there is no conceptual difficulty in calculating the transformations of each of the component fields.

First however, let us now consider how to prove that the transformation $\Phi \rightarrow \check{\Phi} = \Phi + \Delta\Phi$ does indeed leave the action (5.10) invariant. The change in the action is

$$\begin{aligned} \Delta S_{SD} = & 2\text{Tr} \int d^4p d^4\theta \quad \Phi(p)\Omega(p)\Delta\Phi(-p) + \\ & + \frac{2}{3}\text{Tr} \int_{123} d^4\theta \quad \hat{p}_1 \{ \bar{p}_3 - \bar{p}_2 \} \Delta\Phi(-1)\Phi(-2)\Phi(-3) \\ & + \frac{2}{3}\text{Tr} \int_{123} d^4\theta \quad \hat{p}_1 \{ \bar{p}_3 - \bar{p}_2 \} \Phi(-1)\Delta\Phi(-2)\Phi(-3) \\ & + \frac{2}{3}\text{Tr} \int_{123} d^4\theta \quad \hat{p}_1 \{ \bar{p}_3 - \bar{p}_2 \} \Phi(-1)\Phi(-2)\Delta\Phi(-3) \end{aligned}$$

with $\Omega(p) = \hat{p}\check{p} - \check{p}\bar{p}$ as before, after transforming into momentum space and stripping off δ functions and various factors of 2π . Using momentum conservation and the cyclical property of the trace, (recall that the fields contain the generators of the gauge group), and relabeling arguments the change in the action easily reduces to

$$\begin{aligned} \Delta S_{SD} = & 2\text{Tr} \int d^4p d^4\theta \quad \Phi(p)\Omega(p)\Delta\Phi(-p) + \\ & - 2\text{Tr} \int_{12} d^4\theta \quad \{ p_1, p_2 \} \Delta\Phi(1+2)\Phi(-1)\Phi(-2) \end{aligned}$$

where the bracket $\{ , \}$ is defined as $\{ p_i, p_j \} = \hat{p}_i \bar{p}_j - \bar{p}_i \hat{p}_j$. We shall separate the calculation into two distinct parts, ΔS_F , the free part and ΔS_I , the interaction. The diagrams for these are given in fig (5.2), clearly the free part is just a two point vertex with Ω as the vertex factor which as we recall is invariant under the isometry $x \rightarrow x^G$ and the interacting part is a 3 point vertex with I given by $\{ k, k+1 \}$. The vertex factor I is clearly not invariant under $x \rightarrow x^G$. For each part we shall collect all possible diagrams and extract algebraic expressions from them for ΔS_F , the free part, and ΔS_I and show that $\Delta S_{SD} = \Delta S_F - \Delta S_I = 0$. As discussed earlier, the expression enclosed in the brackets

$$\Psi_q = \int_{i \dots j} D(q, i, \dots, j) \Phi_i \dots \Phi_j$$

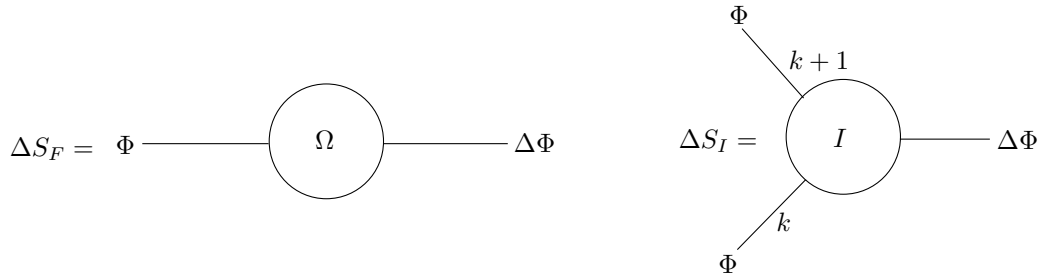

Figure 5.2: Change in the Self-Dual Action ΔS

is itself a superfield with argument q satisfying (5.6) and (5.7) and the solutions to the constraints are expressed in (5.19). The transformation (5.24) is applied to the superfield enclosed in the brackets with component fields \underline{A} , $\underline{\lambda}$, \underline{C} , $\bar{\underline{\lambda}}$ and $\bar{\underline{A}}$. This is represented as a diagram in fig (5.3). We will proceed by drawing all the possible

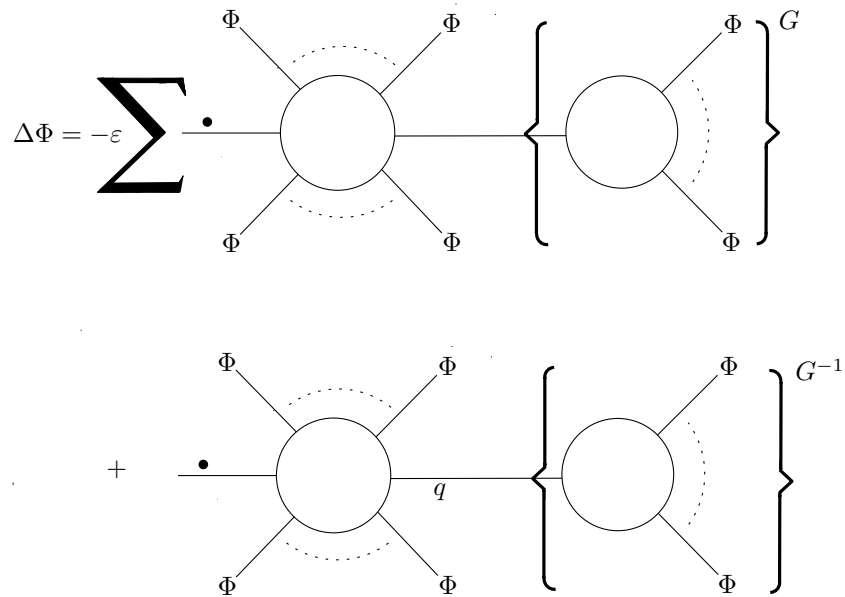

Figure 5.3: Change of Φ , $\Delta\Phi$

diagrams that make up ΔS_F , fig (5.4). Now the expression in brackets satisfies the

constraints, and so does the part outside the brackets. We write

$$\begin{aligned} \Delta S_F = -\varepsilon \sum_{n=2}^{\infty} \sum_{i=2}^n \sum_{j=i}^n \text{Tr} \int_{12\dots n} \frac{\hat{q}}{\hat{1}} \Omega(1) \Phi_{\bar{1}} \Phi_{\bar{2}} \cdots \Phi_{\bar{i-1}} \{D(-, i, \dots, j) \Phi_{\bar{i}} \cdots \Phi_{\bar{j}}\}^G \times \\ \times D(-, j+1, \dots, n, 1, \dots, i-1) \Phi_{\bar{j+1}} \cdots \Phi_{\bar{n}} \\ + G \rightarrow G^{-1}. \end{aligned}$$

Next we can use the cyclicity of the trace and relabel arguments as follows

$$\begin{aligned} \Delta S_F = -\varepsilon \sum_{n=2}^{\infty} \sum_{j=1}^{n-1} \sum_{k=j+1}^n \text{Tr} \int_{12\dots n} \frac{\hat{q}}{\hat{k}} \Omega(k) \{D(-, 1, \dots, j) \Phi_{\bar{1}} \cdots \Phi_{\bar{j}}\}^G \times \\ \times D(-, j+1, \dots, n) \Phi_{\bar{j+1}} \cdots \Phi_{\bar{n}} \\ + G \rightarrow G^{-1} \end{aligned}$$

and then define

$$\begin{aligned} \Psi &= \int_{1\dots j} D(q, 1, \dots, j) \Phi_{\bar{1}} \cdots \Phi_{\bar{j}} \\ \Theta &= \int_{j+1\dots n} \frac{\hat{q}\Omega(k)}{\hat{k}} D(q, j+1, \dots, n) \Phi_{\bar{j+1}} \cdots \Phi_{\bar{n}}. \end{aligned}$$

Both of these have the form (5.18) and as we proved in §(5.1.1) satisfy the constraints (5.6) and (5.7) and the solution to these constraints are of the form (5.19) with a similar expression for Θ . By writing in component form it is possible to show that

$$\Delta S_F = \text{Tr} \int_q \Psi^{G^{-1}}(q) \Theta(q) = -\text{Tr} \int_q \Psi(q) \Theta^G(q).$$

by utilizing the integral over θ which picks out the θ^4 component. Therefore, fig (5.4) becomes fig (5.5) and there is a summation over cyclic rotations of the vertex Ω around the diagram. The diagram of fig (5.5) becomes the following expression where a factor of $\{D\Phi \cdots \Phi\}^G D\Phi \cdots \Phi$ can be taken out of a cyclic clockwise sum over rotations of Ω with the momentum of the first leg enclosed in brackets being p_1 ,

$$\begin{aligned} \Delta S_F = -\varepsilon \sum_{n=2}^{\infty} \sum_{j=1}^{n-1} \text{Tr} \int_{1\dots n} X(1, j) \{D(-, 1, \dots, j) \Phi_{\bar{1}} \cdots \Phi_{\bar{j}}\}^G \times \\ \times D(-, j+1, \dots, n) \Phi_{\bar{j+1}} \cdots \Phi_{\bar{n}} \end{aligned}$$

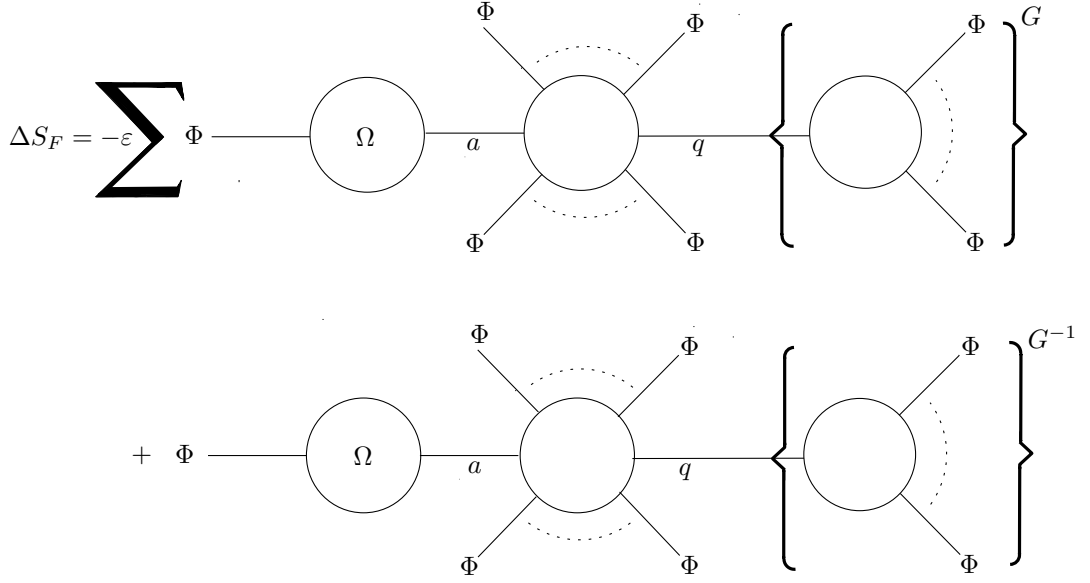
 Figure 5.4: Change in the free part of the self-dual action ΔS_F

where the coefficient $X_{1,j}$ is given by

$$X(1, j) = \frac{\hat{q}^G}{\hat{1}^G} \Omega_1^G + \cdots + \frac{\hat{q}^G}{\hat{j}^G} \Omega_j^G + \frac{\hat{q}}{\hat{j}+1} \Omega_{j+1} + \cdots + \frac{\hat{q}}{\hat{n}} \Omega_n.$$

Moving on to the cubic part of the action, ΔS_I , we have a sum over cyclic rotations of a three point vertex with factor I around all possible diagrams, as given in fig (5.6). We can then undo the transformation in the second diagram as before to arrive at fig (5.7). Similarly then, rotating the vertex I clockwise around the diagram and with the first leg enclosed in the brackets has momentum p_1 , we have

$$\Delta S_I = -\varepsilon \sum_{n=2}^{\infty} \sum_{j=1}^{n-1} \text{Tr} \int_{1 \cdots n} Y(1, j) \{D(-, 1, \dots, j) \Phi_{\bar{1}} \cdots \Phi_{\bar{j}}\}^G \times \\ \times D(-, j+1, \dots, n) \Phi_{\bar{j+1}} \cdots \Phi_{\bar{n}}$$

with

$$Y(1, j) = - \sum_{k=1}^{j-1} \frac{\{\hat{k}^G, (k+1)^G\}}{k^G, \widehat{k+1}^G} (q^G, p_{1,k}^G) - \sum_{k=j+1}^{n-1} \frac{\{k, k+1\}}{\widehat{k} \widehat{k+1}} (q, p_{j+1,k}). \quad (5.30)$$

The left hand sum should be interpreted as zero when $j = 1$ and the right hand sum

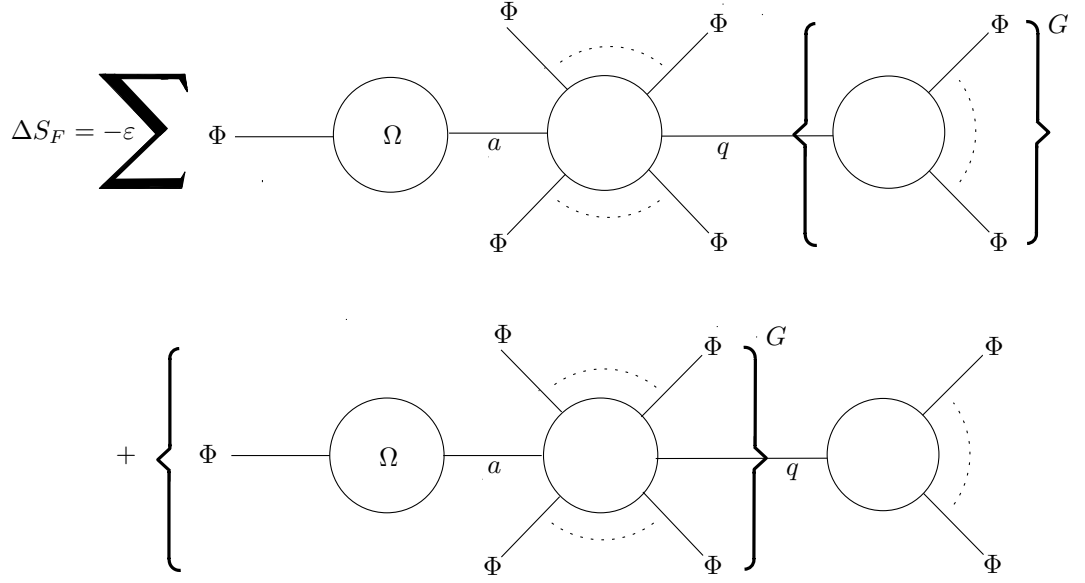
Figure 5.5: Change in the Free Part of the Self-Dual Action ΔS_F

should be interpreted as zero when $j = n - 2$. When expanded out, the summations reduce to

$$\sum_{k=i}^{j-1} \frac{\{k, k+1\}}{\widehat{k}k+1} (q, P_{i,k}) = -\hat{q}(\omega_{-q} + \omega_i + \cdots + \omega_j)$$

where $\omega_p = \bar{p}\tilde{p}/\hat{p}$. Evaluating the sums in (5.30) we get

$$Y_{1,j} = \left(\hat{q}^G \left\{ \omega_{-q}^G + \omega_1^G + \cdots + \omega_j^G \right\} + \hat{q} \left\{ \omega_q + \omega_{j+1} + \cdots + \omega_n \right\} \right).$$

Now, $-q + p_1 + \cdots + p_j = 0$ and $-p_{j+1} - \cdots - p_n = 0$ and we subtract these from each of the above brackets to arrive at

$$Y_{1,j} = \hat{q}^G \left\{ \omega_{-q}^G - \widetilde{-q}^G + \omega_1^G - \check{1}^G + \cdots + \omega_j^G - \check{j}^G \right\} + \hat{q} \left\{ \omega_q - \check{q} + \omega_{j+1} - \widetilde{j+1} + \cdots + \omega_n - \check{n} \right\}$$

and then take out a factor of $1/\hat{p}$ from each term $\omega_p - \check{p}$ as follows

$$Y_{1,j} = \frac{\hat{q}^G}{\hat{q}^G} \Omega_q^G + \frac{\hat{q}^G}{\hat{1}^G} \Omega_1^G + \cdots + \frac{\hat{q}^G}{\hat{j}^G} \Omega_j^G - \frac{\hat{q}^G}{\hat{q}} \Omega_{-q} + \frac{\hat{q}}{\widehat{j+1}} \Omega_{j+1} + \cdots + \frac{\hat{q}}{\hat{n}} \Omega_n.$$

Terms in Ω_q and Ω_{-q} cancel since $\Omega^G = \Omega$. We arrive at

$$Y_{1,j} = \frac{\hat{q}^G}{\hat{1}^G} \Omega_1^G + \cdots + \frac{\hat{q}^G}{\hat{j}^G} \Omega_j^G + \frac{\hat{q}^G}{\widehat{j+1}} \Omega_{j+1} + \cdots + \frac{\hat{q}}{\hat{n}} \Omega_n = X_{i,j}$$

and since all terms in the summation over j and n are linearly independent and sum to zero, we arrive at the result, $\Delta S = \Delta S_F - \Delta S_I = 0$ as required.

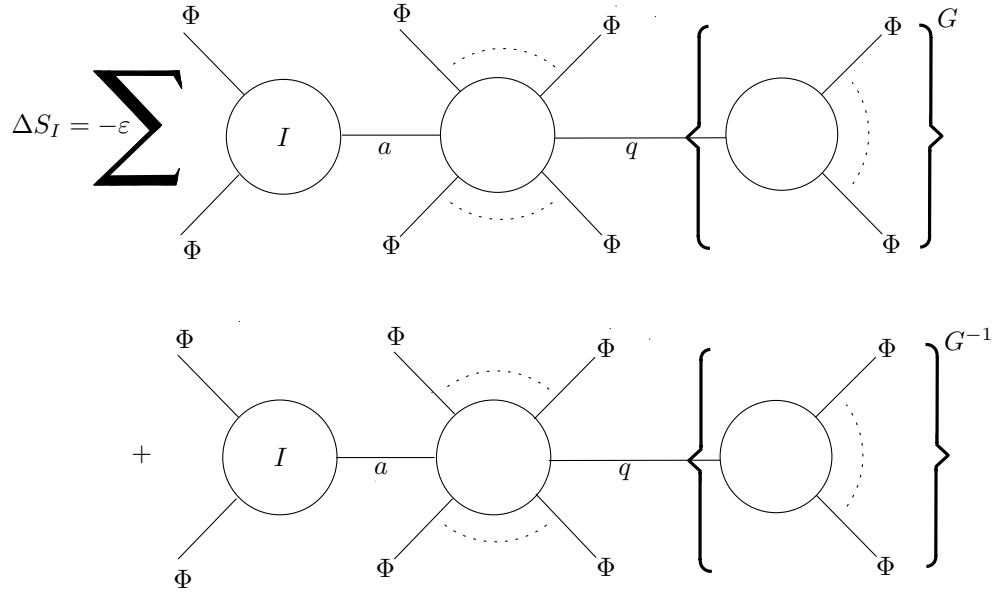

Figure 5.6: Change in the Interacting Part of the Self-Dual Action ΔS_I

Since we now have calculated an expression for $\Delta\Phi$ and proved it, we can in principle calculate the expressions for the transformations of the component fields. For example, let us pick out the zeroth order θ component of ΔS . We will have diagrams of the form fig (5.8) or algebraically

$$\delta A_1 = -\varepsilon \sum_{n=2}^{\infty} \sum_{k=2}^n \sum_{i=2}^k \sum_{j=k}^n \int_{2\dots n} \frac{\hat{1}}{\hat{q}} \Gamma(q, i, \dots, j) \Gamma(q, j+1, \dots, n, 1, \dots, i-1) \times$$

$$\times A_{\bar{2}} \cdots A_{\bar{i}G} \cdots \xi^A \lambda_{A\bar{k}G} \cdots A_{\bar{j}G} \cdots A_{\bar{n}}$$

$$+G \rightarrow G^{-1}.$$

Similarly, one could calculate more complicated expressions for the rest of the component fields.

5.4 Chapter Summary

We began by reviewing the formulation of N=4 super Yang-Mills theory on the light-cone [38] and writing the action in terms of superfields Φ and $\bar{\Phi}$, (5.9). The CPT self conjugacy property of the fields was used to express the action in terms of Φ only, at the expense of introducing covariant derivatives in the action. The self-dual part however contains only 4 covariant derivatives giving us the Chalmers-

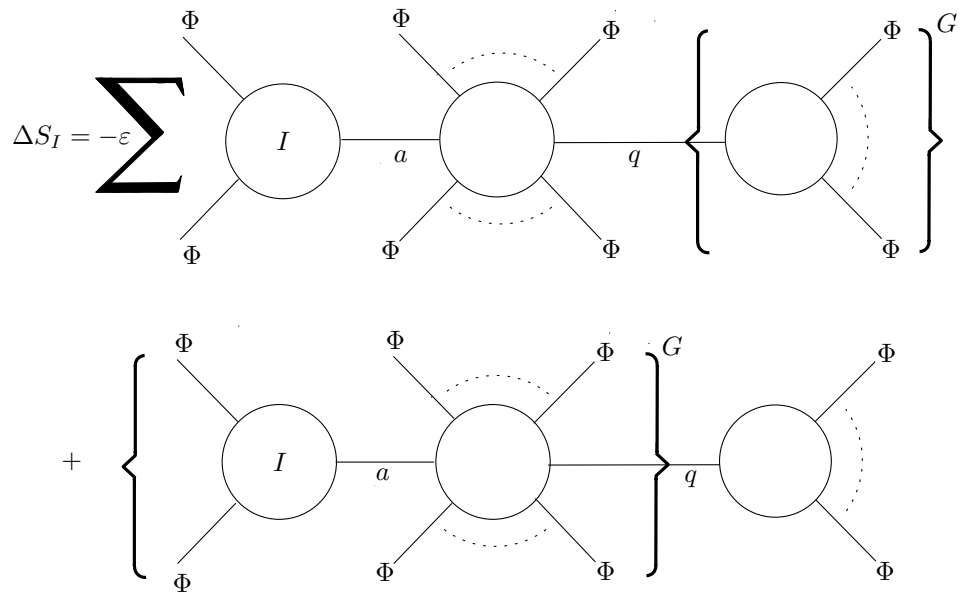

Figure 5.7: Change in the Interacting Part of the Self-Dual Action ΔS_I

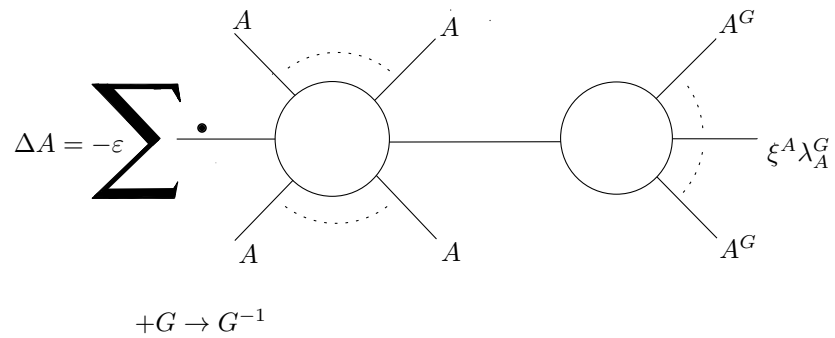

Figure 5.8: Change in the Component Field ΔA

Siegel action [37] which is free classically. The full action contains the wrong helicity content for consistency with the MHV rules so we define a canonical transformation from the self-dual sector to a free theory with field variables χ and we write down the result given in [38] for the expression $\Phi[\chi]$, (5.14). Further, we calculate the inverse of this field redefinition by writing down an ansatz for $\chi[\Phi]$ and substituting it into a recursion relation to prove it.

It was briefly discussed how to construct symmetries in $N = 1$ chiral supersymmetry using isometries $x \rightarrow x^G$. This helped us to see how to construct symmetries of a free $N = 4$ SUSY theory with action (5.20). We proceeded to calculate a field

transformation order by order (up to fourth order in the field variables) by writing $\Delta\Phi$ in terms of the free fields χ , whose transformation we knew, and then substituted the inverse field redefinition to write $\Delta\Phi$ in terms of the original variables. We used these results to guess an expression to all orders in perturbation theory and this was proved by substituting it back into the self-dual action (5.10) to show $\Delta S_{SD} = 0$ thus proving our final result (5.29). We concluded by showing how, in principle, we can use our result to calculate the component field transformations, and gave an example of the simplest calculations by writing down ΔA in terms of A and λ .

Chapter 6

Symmetries of the Hitchin System

6.1 Chapter Introduction

The self-dual Yang-Mills action written in four dimensions has physically relevant solutions and in particular in Euclidean space the solutions are referred to as instantons. Starting with the Euclidean equations in \mathbb{R}^4 they may be dimensionally reduced by demanding that solutions are invariant under translations of two of the coordinates, [39]. The solutions of the dimensionally reduced equations, called Hitchin's equations, have the property that they may be defined over a Riemann surface using analytic maps and are conformally invariant, and they have found applications in the field of integrability amongst others; see for example [68, 69] and [70] (Also see [71–76] for previous discussions on symmetries of the self-dual system). We review the procedure taken by Hitchin in [39].

We have seen in previous chapters how to construct infinite symmetries of the self-dual equations in $(1, 3)$ space using (complex) light-cone coordinates, $x_o = t - x_3$, $x_{\bar{o}} = t + x_3$, $z = x_1 + ix_2$, $\bar{z} = x_1 - ix_2$ for t , x_1 , x_2 and x_3 real. In particular, we mentioned in §(4) that by making x_2 imaginary, the light-cone system became a set of real coordinates and our arguments extended to $(2, 2)$ space-time where A_z and $A_{\bar{z}}$ are not related by complex conjugation. By writing the Euclidean Cartesian coordinates (τ, x_1, x_2, x_3) in terms of two complex coordinates, $z = x_1 + ix_2$ and $u = x_3 + i\tau$ we write the Hitchin equations by assuming that the fields do not depend on the imaginary parts of the new coordinates, x_2 and τ where we assume

an anti-hermitian representation of the Lie algebra valued fields with $A_{\bar{u}}^* = -A_u =$ and $A_z^* = -A_{\bar{z}}$. In the case where x_2 and τ are pure imaginary then we arrive at the same dimensionally reduced equations but now the fields are no longer related by complex conjugation and on the plane we may impose the gauge $A_{\bar{u}} = 0$. Since the symmetry, (4.20) with real momenta is a symmetry of the 4d action in (2, 2) space (using the light-cone gauge) where fields are not related by conjugation it is necessarily a symmetry of the equation of motion. By dimensionally reducing the expression, we write down an expression for the symmetry of the 2d equation of motion.

6.2 The Hitchin system

We shall review the derivation of the Hitchin equations in \mathbb{R}^4 with Euclidean signature, first discussed in [39]. We shall consider the space-time with coordinates (x_0, x_1, x_2, x_3) endowed with the metric

$$g_{\mu\nu} = \begin{pmatrix} 1 & 0 & 0 & 0 \\ 0 & 1 & 0 & 0 \\ 0 & 0 & 1 & 0 \\ 0 & 0 & 0 & 1 \end{pmatrix}_{\mu\nu}.$$

Hitchin considers the Lie-algebra valued curvature two form

$$F(A) = \sum_{\mu < \nu} F_{\mu\nu} dx^\mu \wedge dx^\nu$$

which can also be written as $F(A) = dA + A^2$ where A is the connection over the G-bundle

$$A = A_0 dx^0 + A_1 dx^1 + A_2 dx^2 + A_3 dx^3.$$

In the above we also have

$$F_{\mu\nu} = [D_\mu, D_\nu]$$

where the covariant derivative D_μ is defined as $\partial_\mu + A_\mu$. The factor of i that normally appears in the expression for the gauge covariant derivative is absorbed into the fields

A_μ and so we stipulate an anti-hermitian representation of the Lie algebra valued fields with $A^* = -A$. Given the self-duality condition,

$$F_{\mu\nu} = \frac{1}{2}\sqrt{g}\varepsilon_{\mu\nu\lambda\rho}F^{\lambda\rho},$$

in this basis, lowering indices as required with the above Euclidean metric in Cartesian form, the self-dual equations are

$$F_{01} = F_{23}$$

$$F_{02} = F_{31}$$

$$F_{03} = F_{12}.$$

Hitchin, [39], then assumes that the functions A_μ are independent of two of the coordinates. We shall assume that the A_μ are functions of x_0 and x_1 only so that the connection becomes

$$A = A_0 dx^0 + A_1 dx^1$$

and we relabel the fields A_2 and A_3 as

$$A_2 = \phi_1, \quad A_3 = \phi_2$$

which are referred to as auxiliary fields, or Higgs fields, in [39]. The equations of motion, which are similar to those in [39], over $(x_0, x_1) \in \mathbb{R}^2$ are then

$$F_{01} = [D_0, D_1] = [\phi_1, \phi_2] = F_{23}$$

$$F_{02} = [D_0, \phi_1] = [\phi_2, D_1] = F_{31}$$

$$F_{03} = [D_0, \phi_2] = [D_1, \phi_1] = F_{12}.$$

Then by introducing the complex Higgs field $\phi = \phi_1 - i\phi_2$ these become

$$F = \frac{1}{2}i[\phi, \phi^*]$$

$$0 = [D_0 + D_1, \phi]$$

and further, Hitchin, [39] writes

$$\Phi = \frac{1}{2}\phi dz$$

$$\Phi^* = \frac{1}{2}\phi^* d\bar{z}$$

where $z = x^0 + ix^1$ and the equations become

$$\begin{aligned} F &= -[\Phi, \Phi^*] \\ d_A'' \Phi &= F \wedge \Phi = 0 \end{aligned}$$

in basis independent form.

Note that in [39], Hitchin dimensionally reduces the self-dual equations in \mathbb{R}^4 with Euclidean signature in Cartesian coordinates, which we have briefly reviewed. We move on to derive the equations in different coordinates.

6.3 The Self-Dual Equations

We have seen the derivation of the Hitchin equations in Cartesian coordinates. The approach in the papers [30], [31] and §(4) is to write the self-dual action and its symmetries in $(1, 3)$ light-cone momentum space coordinates, $\check{p} = p_t - p_3$, $\hat{p} = p_t + p_3$, $\tilde{p} = p_1 + ip_2$ and $\bar{p} = p_1 - ip_2$ where \tilde{p} and \bar{p} are related by complex conjugation. However, we discussed in §(4) that we can make p_2 pure imaginary thereby making all $(\check{p}, \hat{p}, \tilde{p}, \bar{p})$ real. Then the arguments written down in §(4) extend to $(2, 2)$ space. In fact we used this to derive our results to begin with.

With that in mind, we derive the self-dual equations that are dimensionally reduced from Euclidean space-time in a new coordinate system. We define complex coordinates $(\tau, x_1, x_2, x_3)^\mu$ of Euclidean space

$$\begin{aligned} u &= x_3 + i\tau, & z &= x_1 + ix_2 \\ \bar{u} &= x_3 - i\tau, & \bar{z} &= x_1 - ix_2 \end{aligned} \tag{6.1}$$

with

$$ds^2 = dud\bar{u} + dzd\bar{z} = d\tau^2 + dx_1^2 + dx_2^2 + dx_3^2$$

In these coordinates, the metric is

$$g_{\mu\nu} = \begin{pmatrix} 0 & 1/2 & 0 & 0 \\ 1/2 & 0 & 0 & 0 \\ 0 & 0 & 0 & 1/2 \\ 0 & 0 & 1/2 & 0 \end{pmatrix}_{\mu\nu}.$$

Given the usual Yang-Mills field strength tensor

$$F_{\mu\nu} = \partial_\mu A_\nu - \partial_\nu A_\mu + [A_\mu, A_\nu]$$

the Hodge dual $F_{\mu\nu}^*$ is written

$$F_{\mu\nu}^* = \frac{1}{2}\sqrt{g}\varepsilon_{\mu\nu\lambda\rho}F^{\lambda\rho}$$

where the usual definitions apply

$$\begin{aligned} F_{\mu\nu} &= [D_\mu, D_\nu] & D_\mu &= \partial_\mu + A_\mu \\ A_\mu &= A_\mu^R T^R & [T^R, T^S] &= f^{RSP} T^P \\ \text{Tr}(T^R T^S) &= -\frac{\delta^{RS}}{2}. \end{aligned}$$

In the above, g is the metric determinant which has the value $g = 1/16$, the T^A are the anti-hermitian generators of the gauge group and $\varepsilon_{\mu\nu\lambda\rho}$ is the totally antisymmetric symbol where we define

$$\varepsilon_{u\bar{u}z\bar{z}} = +1.$$

The self-dual equations are obtained by setting F equal to its dual tensor F^* as follows

$$F_{\mu\nu}^* = F_{\mu\nu} = \frac{1}{2}\sqrt{g}\varepsilon_{\mu\nu\lambda\rho}F^{\lambda\rho}$$

and using the metric to raise and lower indices as required, the self-dual equations in these coordinates are given by

$$F_{u\bar{u}} = -F_{z\bar{z}}$$

$$F_{uz} = 0$$

$$F_{\bar{u}\bar{z}} = 0.$$

Using the definition of the field strength tensor these equations are, explicitly,

$$\begin{aligned} \partial_u A_z - \partial_z A_u + [A_u, A_z] &= 0 \\ \partial_{\bar{u}} A_{\bar{z}} - \partial_{\bar{z}} A_{\bar{u}} + [A_{\bar{u}}, A_{\bar{z}}] &= 0 \\ \partial_u A_{\bar{u}} - \partial_{\bar{u}} A_u + [A_u, A_{\bar{u}}] &= -\partial_z A_{\bar{z}} + \partial_{\bar{z}} A_z - [A_z, A_{\bar{z}}] \end{aligned} \quad (6.2)$$

where the fields are related by conjugation with $A_{\bar{u}}^* = -A_u$ and $A_{\bar{z}}^* = -A_z$ because of the anti-hermitian generators. Following Hitchin's procedure, we assume that the fields are independent of the coordinates x_2 and τ , and the auxiliary (Higgs) fields are $\phi_1 = A_2$ and $\phi_2 = A_\tau$. Then we have

$$\begin{aligned}\partial_\tau A_\mu &= \partial_u A_\mu - \partial_{\bar{u}} A_\mu = 0 \\ \partial_{x_2} A_\mu &= \partial_{\bar{z}} A_\mu - \partial_z A_\mu = 0.\end{aligned}\tag{6.3}$$

for all the field components, A_μ . The Hitchin equations in this coordinate system, (6.2) are then

$$\partial_u A_z - \partial_z A_u + [A_u, A_z] = 0\tag{6.4}$$

$$\partial_u A_{\bar{z}} - \partial_z A_{\bar{u}} + [A_{\bar{u}}, A_{\bar{z}}] = 0\tag{6.5}$$

$$\partial_u A_{\bar{u}} - \partial_u A_u + [A_u, A_{\bar{u}}] = -\partial_z A_{\bar{z}} + \partial_z A_z - [A_z, A_{\bar{z}}]\tag{6.6}$$

with, [39],

$$\begin{aligned}\phi_1 &= \frac{i}{2}(A_{\bar{z}} - A_z) \\ \phi_2 &= \frac{i}{2}(A_{\bar{u}} - A_u)\end{aligned}$$

and the connection

$$\begin{aligned}A_1 &= \frac{1}{2}(A_{\bar{z}} + A_z) \\ A_2 &= \frac{1}{2}(A_{\bar{u}} + A_u).\end{aligned}$$

Now in [30, 31] and §(4) we set the gauge condition $A_{\bar{o}} = 0$ which we are free to do because $A_{\bar{o}}$ and A_o are independent. Here, we have $A_{\bar{u}}^* = -A_u$ and cannot stipulate this gauge. Similarly, $A_{\bar{z}}$ and A_z are not independent. So now we consider the problem in (2, 2) space by writing $x_2 = iy$ and $\tau = it$, with t and y real. Then the coordinates (6.1) are all real and independent with $x_o = -u$, and $\partial_u = -\partial_o$ and ∂_z are derivatives with respect to real coordinates. Further, $A_{\bar{u}} = A_{\bar{o}}$ and $A_u = -A_o$ with $A_{\bar{u}} \neq -A_u$ and $A_{\bar{z}} \neq -A_z$, thus the fields are no longer related by complex conjugation.

In an appropriate domain we can make the gauge choice $A_{\bar{u}} = 0$ and then by (6.5) we can set $A_{\bar{z}} = 0 \neq -A_z^*$. Then using (6.6) we can write

$$A_u = -\frac{\partial_z}{\partial_u} A_z$$

and substitute into (6.4) to arrive at

$$\left(\partial_u + \frac{\partial_z^2}{\partial_u}\right) A_z - \left[\frac{\partial_z}{\partial_u} A_z, A_z\right] = 0 \quad (6.7)$$

or, to make a simplification by defining $\psi = \partial_u A_z$, we can write

$$(\partial_u^2 + \partial_z^2) \psi - [\partial_z \psi, \partial_u \psi] = 0. \quad (6.8)$$

6.4 Symmetries of the 2D Euclidean Self-Dual Equations on the plane

In §(4) we constructed infinite dimensional symmetries of the self-dual action in (1, 3) space but by assuming real momenta then the results are valid in (2, 2) space. The procedure was extended to the $N = 4$ supersymmetric theory in §(5). The non-supersymmetric self-dual action on the light cone is

$$S = \frac{4}{g^2} \text{Tr} \int d^4 x \bar{A} (\partial_0 \partial_{\bar{0}} - \partial_z \partial_{\bar{z}}) A + \frac{4}{g^2} \text{Tr} \int d^4 x (-\partial_{\bar{z}} \partial_{\bar{0}}^{-1} A) [A, \partial_{\bar{0}} \bar{A}] \quad (6.9)$$

where, for notational convenience in what follows, we define $A_z = A$ and $A_{\bar{z}} = \bar{A}$. Note also that $\partial_o = -\partial_u$ since in §(4), $x_0 = t - x_3$ whereas here $u = x_3 + i\tau = x_3 - t$ for $t = i\tau$ which will give $\partial_z \partial_{\bar{z}} - \partial_o \partial_{\bar{o}} = \partial_z \partial_{\bar{z}} + \partial_u \partial_{\bar{u}}$ on the left hand side. We also define the notation, $((p_u)_n, (p_{\bar{u}})_n, (p_z)_n, (p_{\bar{z}})_n) = (\tilde{n}, \hat{n}, \tilde{n}, \bar{n})$ and $\zeta_p = \bar{p}/\hat{p}$, and also

$$\int_{1 \dots n} = \int \frac{d^4 p_1}{(2\pi)^4} \dots \frac{d^4 p_n}{(2\pi)^4}.$$

Writing the action in momentum space, bearing in mind $u = -x_o$, we have

$$\begin{aligned} \text{Tr} \int_1 \{\bar{p}_1 \tilde{p}_1 + \hat{p}_1 \check{p}_1\} \bar{A}_1 A_1 - i \text{Tr} \int_{123} \hat{p}_1 (\zeta_3 - \zeta_2) \bar{A}_1 A_2 A_3 (2\pi)^4 \delta(p_1 + p_2 + p_3) \\ = \text{Tr} \int_1 \{\bar{p}_1 \tilde{p}_1 + \hat{p}_1 \check{p}_1\} \bar{B}_1 B_1 \end{aligned}$$

and we perform the transformation $A \rightarrow A' = A + \varepsilon \delta A$ and $\bar{A} \rightarrow \bar{A}' = \bar{A} + \varepsilon \delta \bar{A}$ with

$$\begin{aligned} \delta A_1 = -\varepsilon \sum_{n=2}^{\infty} \sum_{i=2}^n \sum_{j=i}^n \int_{2 \dots n} \frac{\hat{1}}{\hat{q}} \Gamma(q^G, i^G, \dots, j^G) \Gamma(q, j+1, \dots, n, 1 \dots, i-1) \times \\ \times A_2 \dots A_{\bar{j}G} \dots A_{jG} \dots A_{\bar{n}} \end{aligned} \quad (6.10)$$

and

$$\begin{aligned}
 \delta \bar{A}_1 = & -\varepsilon \sum_{n=2}^{\infty} \sum_{k=2}^n \sum_{i=2}^{k-1} \sum_{j=i}^{k-1} \int_{2 \cdots n} \frac{\hat{k}^2}{\hat{1} \hat{q}} \Gamma(q^G, i^G, \dots, j^G) \Gamma(q, j+1, \dots, n, 1, \dots, i-1) \times \\
 & \times A_{\bar{2}} \cdots A_{\bar{i}G} \cdots A_{\bar{j}G} \cdots \bar{A}_{\bar{k}} \cdots A_{\bar{n}} \\
 + \varepsilon \sum_{n=2}^{\infty} \sum_{k=2}^n \sum_{i=2}^k \sum_{j=k}^n \int_{2 \cdots n} \frac{\hat{q} (\hat{k}^{G-1})^2}{\hat{1} (\hat{q}^{G-1})^2} \Gamma(q^{G-1}, i^{G-1}, \dots, j^{G-1}) \Gamma(q, j+1, \dots, n, 1, \dots, i-1) \times \\
 & \times A_{\bar{2}} \cdots A_{\bar{i}G-1} \cdots \bar{A}_{\bar{k}G-1} \cdots A_{\bar{j}G-1} \cdots A_{\bar{n}} \\
 - \varepsilon \sum_{n=2}^{\infty} \sum_{k=2}^n \sum_{i=k+1}^n \sum_{j=i}^n \int_{2 \cdots n} \frac{\hat{k}^2}{\hat{1} \hat{q}} \Gamma(q^G, i^G, \dots, j^G) \Gamma(q, j+1, \dots, n, 1, \dots, i-1) \times \\
 & \times A_{\bar{2}} \cdots \bar{A}_{\bar{k}} \cdots A_{\bar{i}G} \cdots A_{\bar{j}G} \cdots A_{\bar{n}}.
 \end{aligned}$$

where $\Gamma(12 \cdots n)$ was first written in [31] as

$$\Gamma(1, \dots, n) = -(i)^n \frac{\hat{1}}{(1, 2)} \frac{\hat{1}}{(1, 2+3)} \cdots \frac{\hat{1}}{(1, 2+\dots+(n-1))}.$$

The bracket (i, j) is defined as $(i, j) = (\hat{i}\hat{j} - \tilde{i}\tilde{j})$. The invariance of the action under these transformations is proven in §(4). Given that they are symmetries of the action, that is sufficient for us to be able to infer that they are indeed symmetries of the equation of motion which we derived earlier (6.7). We could have also derived this equation using the action (6.9).

Here, we are concerned with finding symmetries of the dimensionally reduced equation (6.8) where, as before, we have defined $A_z = A = \partial_o \psi$,

$$(\partial_u^2 + \partial_z^2) \psi - [\partial_z \psi, \partial_u \psi] = 0. \tag{6.11}$$

which in momentum space is

$$(\tilde{1}^2 + \tilde{1}^2) \psi_1 - \int d^2 p_1 d^2 p_2 (2, 3) \psi_2 \psi_3 \delta^2(p_1 + p_2 + p_3).$$

where $d^2 p = d\tilde{p} d\tilde{p}$

By writing $A_p = -i\hat{p}\psi_p$ the expression for δA , (4.20), becomes

$$\begin{aligned}
 \delta \psi_1 = & -\varepsilon \sum_{n=2}^{\infty} \sum_{i=2}^n \sum_{j=i}^n \int_{2 \cdots n} \frac{\hat{q}}{\hat{1}} D(q^G, i^G, \dots, j^G) D(q, j+1, \dots, n, 1, \dots, i-1) \times \\
 & \times \psi_{\bar{2}} \cdots \psi_{\bar{i}G} \cdots \psi_{\bar{j}G} \cdots \psi_{\bar{n}} \delta^4 \left(\sum_m p_m \right)
 \end{aligned} \tag{6.12}$$

where $D(1, 2, \dots, n)$ is given by

$$D(12 \dots n) = -(-1)^n \frac{\hat{1}^{n-3} \hat{2} \hat{3} \dots \hat{n}}{(1, 2)(1, 2+3) \dots (1, 2+3+\dots+(n-1))} \quad (6.13)$$

in momentum space. The $\psi(p_\tau, p_1, p_2, p_3)$ are the Fourier transform of $\psi(\tau, x_1, x_2, x_3)$,

$$\psi(p_\tau, p_1, p_2, p_3) = \int \frac{d^4 x}{(2\pi)^4} e^{ip_\mu x^\mu} \psi(\tau, x_1, x_2, x_3).$$

Since we assume that ψ depends only on x_1 and x_3 , we have

$$\begin{aligned} \psi(p_\tau, p_1, p_2, p_3) &= \int \frac{dx^2}{2\pi} e^{ip_2 x^2} \int \frac{d\tau}{2\pi} e^{ip_\tau \tau} \int \frac{d^2 x}{(2\pi)^2} e^{ip_1 x^1 + ip_3 x^3} \psi(x_1, x_3) \\ &= \delta(p_2) \delta(p_\tau) \psi'(p_1, p_3) \\ &= \delta(\hat{p} - \check{p}) \delta(\tilde{p} - \bar{p}) \psi'(\check{p}, \bar{p}). \end{aligned}$$

Substitute this into (6.12) and evaluate the integrals over \hat{p}_i and \bar{p}_i for $i = 2, \dots, n$ and we have

$$\begin{aligned} \delta\psi_1 &= -\varepsilon \sum_{n=2}^{\infty} \sum_{i=2}^n \sum_{j=i}^n \int_{2 \dots n} \frac{\hat{q}}{\hat{1}} D(q^G, i^G, \dots, j^G) D(q, j+1, \dots, n, 1, \dots, i-1) \times \\ &\quad \times \psi'_2 \dots \psi'_{i^G} \dots \psi'_{j^G} \dots \psi'_n \delta^2 \left(\sum_m p_m \right) \delta(\hat{p}_1 - \check{p}_1) \delta(\tilde{p}_1 - \bar{p}_1) \end{aligned}$$

where now

$$\int_{1 \dots n} = \int \frac{d^2 p_1}{(2\pi)^2} \dots \frac{d^2 p_n}{(2\pi)^2}$$

and the kernels, D , (6.13) are written in terms of \check{p} and \bar{p} using $\check{p} = \hat{p}$ and $\bar{p} = \tilde{p}$.

Then write the inverse Fourier transform, $\delta\psi(\tau, x_1, x_2, x_3)$, of $\delta\psi(p_1)$,

$$\delta\psi(x) = \int d^4 p_1 e^{-i(p_\mu)_1 x^\mu} \delta\psi(p_1)$$

and evaluating the integrals over \hat{p}_1 and \bar{p}_1 the final expression is

$$\begin{aligned} \delta\psi'_1 &= -\varepsilon \sum_{n=2}^{\infty} \sum_{i=2}^n \sum_{j=i}^n \int_{2 \dots n} \frac{\hat{q}}{\hat{1}} D(q^G, i^G, \dots, j^G) D(q, j+1, \dots, n, 1, \dots, i-1) \times \\ &\quad \times \psi'_2 \dots \psi'_{i^G} \dots \psi'_{j^G} \dots \psi'_n \delta^2 \left(\sum_m p_m \right) \end{aligned}$$

and the isometry $x \rightarrow x^G$ is simply a rotation of the plane about angle t , viz

$$\begin{aligned} u^{Gt} &= \cos(t)u + \sin(t)z \\ z^{Gt} &= -\sin(t)u + \cos(t)z. \end{aligned}$$

Given two transformations, δ_{t_1} and δ_{t_2} and the argument in §(4), the commutator of the transformations is

$$[\delta_{t_1}, \delta_{t_2}] \psi = 0$$

and the infinite set of transformations clearly forms an Abelian algebra.

6.5 Chapter Summary

We reviewed the derivation of Hitchin's equations on Euclidean space and re-wrote them in terms of two complex coordinates. By transforming to $(2, 2)$ space we were able to impose a light-cone gauge condition by virtue of the fact that $A_u^* \neq -A_u$ in this space which enabled us to write the dimensionally reduced equations of motion in the same gauge as we used throughout §(4). By comparing the results of §(4) we wrote down the symmetry of the 2d self-dual equation on the plane.

In the introduction to this chapter we alluded to the fact that the solutions to the Hitchin equations may be defined over Riemann surfaces using analytic maps. It would be interesting to consider how we might extend our approach to find symmetries of the self-dual equations on such surfaces, for example Riemann spheres or Tori.

Chapter 7

Conclusions

The CSW approach to calculating QCD scattering amplitudes discussed in the literature, [5–7] and [8], has been used to good effect in drastically reducing the complexity of calculations that would otherwise have been prohibitive in the Feynman approach. This is the case, not only at tree-level, but to higher loop orders also. In particular, we have reviewed the especially simple form of the MHV amplitude, [10]. When the Yang-Mills action is written in the light-cone gauge the kinetic term and a second term that has the wrong helicity content to be an MHV term are grouped together in to what is referred to as the Chalmers-Siegel action describing the self-dual part, [37], which is mapped to a free theory. This map generates the MHV Lagrangian, [30, 31].

The map is a canonical, non-local transformation expressing the Yang-Mills fields in terms of free fields. In §(4) we have used it to construct infinite dimensional, non-local symmetries of the self-dual part of the action by virtue of the high degree of symmetry of the free theory to which it is mapped. The method for constructing symmetries of the free theory has been discussed in a quite general way in §(3) and the associated Noether currents were calculated. In particular we discussed the symmetry transformations $\varphi(x) \rightarrow \varphi(x) + \varepsilon\varphi(x_G)$ on flat space-time where x_G is an element of the Poincaré group. This was then used to construct the symmetries of the Yang-Mills fields which we showed left the self-dual action invariant. Further, consecutive symmetry transformations of the free theory thus described were shown to form a non-trivial Lie algebra and we proved that the symmetry transformation

of the Yang-Mills fields satisfied the same algebra, as we would expect. It is therefore beneficial to consider the classification of the algebra in the free theory. We considered the discrete sub-groups of $SO(3)$ and showed that the Abelian centre of the algebra is directly related to the conjugacy classes of the group. In the case where $x \rightarrow x_G$ was an element of the well known triangle group we calculated the zero-mode algebra $g = su(2) + \mathcal{C}_Z(3)$ where the elements of \mathcal{C}_Z commute with everything. In the case where $x \rightarrow x_G$ is an element of the tetrahedral sub-group the algebra is $g = su(3) + \mathcal{C}_Z(4)$. We wrote down commutation relations for the case where $x \rightarrow x_G$ is a member of one of the infinite number of dihedral groups and the number of non-Abelian generators increases in multiples of 3 with increasing n . We expect to find that the algebra constructed in this way using the dihedral groups is going to be a sum of $su(2)$ algebras although this remains conjecture. We briefly discussed the symmetry transformation of the Yang-Mills fields in the case where $x \rightarrow x_G$ is a displacement and in momentum space this simply corresponds to multiplication by Fourier modes. By combining the $SO(3)$ rotations with discrete time translations, $t \rightarrow t + na$ where n is some non-negative integer then we create a loop algebra. Commutation relations between generators of the algebra for which $n = 0$ correspond to the respective algebras we calculated ($su(2)$ and $su(3)$ for the triangle and tetrahedral groups respectively) and are the zero-mode sub algebras.

The extension of the new methods for calculating QCD amplitudes to $N = 4$ superspace, [15–18] and [19], led to the need to construct a similar Lagrangian formalism for the MHV rules in superspace. Feng and Huang, [38], write down the super-space Lagrangian in the light-cone gauge in a similar fashion to the authors of [30] and [31]. The CPT self conjugacy property of the $N = 4$ superfield introduces covariant derivatives in to the action, but the self-dual part of the action contains no SUSY covariant derivative. They conjecture an ansatz for a map which maps the self-dual part of the action to a free theory in a similar vein to the authors of [30] and [31] in terms of the Yang-Mills superfields, a free superfield and unknown coefficients to be determined. By expanding out the expression and considering only the gluon fields, their ansatz is compared to the known transformation for the gluon fields derived in [30] and [31] to determine the coefficients in the series. In §(5)

we review their procedure and we also calculate the inverse of their transformation which we need. Not surprisingly, since the self-dual part of the action contains no covariant derivatives, the conjugate field is eliminated which reduces our work load. Owing to the high degree of symmetry in the $N = 4$ theory, this is in contrast to the pure Yang-Mills setting where the expression for the conjugate field were markedly more complicated. We proceeded to calculate symmetries of the free $N = 4$ theory and wrote the symmetry transformations of the Yang-Mills fields in terms of the free fields. Substituting our expression for the inverse field redefinition we got an order by order expression for the symmetry in terms of the original Yang-Mills field and guessed a more concise result to all orders as we did in §(4). The proof that this leaves the self-dual part of the action invariant follows in an almost identical manner to §(4).

We have not discussed the algebra of the symmetries of self-dual $N = 4$ Yang-Mills. However, in principle, we could construct an algebra in exactly the same way as we did in the pure Yang-Mills setting. Perhaps the most interesting question arising from our work is the possibility that a subset of these symmetries survives the full action. In which case, we might hope that the quantized version of the loop algebra, the infinite Yangian algebra, may be helpful in regards integrability in a similar way to the literature review we gave in §(2). In this very interesting field, amplitudes are constrained by deformed level-zero and level-one Yangian generators which are related to the super-conformal and dual super-conformal symmetries of scattering amplitudes.

We concluded with a brief discussion on how to write down symmetries of the Hitchin system. We began by reviewing Hitchin's equations, [39] and continued by writing them in a specific coordinate system. By assuming $(2, 2)$ space-time signature we wrote down the symmetry of the 2d equations of motion by using the results we have derived previously.

Appendix A

Commutators of the Tetrahedral Group Algebra

We list the commutators of the tetrahedral group algebra discussed in §(3.6.4). Writing,

$$\delta_i \varphi(\mathbf{x}) = \varepsilon_i \varphi(R_i \mathbf{x})$$

where the matrices are given by (3.41) we write the linearly independent set of generators, L_i as

$$\begin{aligned} L_1 &= \delta_{10} - \delta_7, & L_2 &= \delta_6 - \delta_{11}, & L_3 &= \delta_5 - \delta_8, & L_4 &= \delta_9 - \delta_4 \\ L_5 &= \delta_7 - \delta_9, & L_6 &= \delta_8 - \delta_6, & L_7 &= \delta_3 - \delta_2, & L_8 &= \delta_1 - \delta_3. \end{aligned}$$

The commutators $[L_i, L_j]$ are now calculated using the Cayley table, (3.2). We list all the commutators,

$$\begin{aligned} [L_1, L_2] &= -2L_7, & [L_1, L_3] &= -2L_7 - 4L_8, & [L_1, L_4] &= 4L_6 + 2L_2 + 2L_3, \\ [L_1, L_5] &= L_3 - L_2 - 2L_6, & [L_1, L_6] &= 2L_8 + 2L_7, & [L_1, L_7] &= 2L_1, \\ [L_1, L_8] &= 3L_3 - L_1, \end{aligned}$$

$$\begin{aligned} [L_2, L_3] &= 4L_5 + 2L_4 + 2L_1, & [L_2, L_4] &= 4L_8 + 2L_7, & [L_2, L_5] &= -2L_8 - 2L_7, \\ [L_2, L_6] &= L_4 - 2L_5 - L_1, & [L_2, L_7] &= -2L_2, & [L_2, L_8] &= -3L_3 + L_2, \end{aligned}$$

$$\begin{aligned}
 [L_3, L_4] &= 2L_7, & [L_3, L_5] &= -2L_7 - 2L_8, & [L_3, L_6] &= 2L_5 + L_4 - L_1, \\
 [L_3, L_7] &= -2L_3, & [L_3, L_8] &= -3L_2 + L_3,
 \end{aligned}$$

$$\begin{aligned}
 [L_4, L_5] &= 2L_6 + L_3 - L_2, & [L_4, L_6] &= 2L_7 + 2L_8, & [L_4, L_7] &= 2L_4, \\
 [L_4, L_8] &= 3L_1 - L_4,
 \end{aligned}$$

$$[L_5, L_6] = -4L_7 - 2L_8, \quad [L_5, L_7] = -3L_1 - 3L_4 - 4L_5, \quad [L_5, L_8] = 2L_5$$

$$[L_6, L_7] = 3L_3 + 3L_2 + 4L_6, \quad [L_6, L_8] = -2L_6, \quad [L_7, L_8] = 0.$$

Let us do a prototype calculation as an example and take the commutator $[L_1, L_3]$.

We have

$$\begin{aligned}
 L_1 L_3 \varphi(\mathbf{x}) &= L_1 (\varphi(R_5 \mathbf{x}) - \varphi(R_8 \mathbf{x})) \\
 &= \varphi(R_{10} R_5 \mathbf{x}) - \varphi(R_7 R_5 \mathbf{x}) - \varphi(R_{10} R_8 \mathbf{x}) + \varphi(R_7 R_8 \mathbf{x}).
 \end{aligned}$$

Using the Cayley table given below, we have

$$\begin{aligned}
 L_1 L_3 \varphi(\mathbf{x}) &= \varphi(R_2 \mathbf{x}) - \varphi(R_1 \mathbf{x}) - \varphi(R_1 \mathbf{x}) + \varphi(R_2 \mathbf{x}) \\
 &= 2\varphi(R_2 \mathbf{x}) - 2\varphi(R_1 \mathbf{x})
 \end{aligned}$$

Similarly,

$$L_3 L_1 = 2\varphi(R_1 \mathbf{x}) - 2\varphi(R_3 \mathbf{x})$$

and thus,

$$\begin{aligned}
 [L_1, L_3] \varphi(\mathbf{x}) &= 2\varphi(R_2 \mathbf{x}) + 2\varphi(R_3 \mathbf{x}) - 4\varphi(R_1 \mathbf{x}) \\
 &= -2L_7 \varphi - 4L_8 \varphi
 \end{aligned}$$

as expected. Further, the generators

$$Z_2 = \delta_1 + \delta_2 + \delta_3$$

$$Z_3 = \delta_4 + \delta_7 + \delta_9 + \delta_{10}$$

$$Z_4 = \delta_5 + \delta_6 + \delta_8 + \delta_{11}$$

commute with all the generators L_i and with each other and they may not appear on the right hand side of the commutators between L_1, \dots, L_8 . We write down the Cayley table again here for the convenience of the reader who may wish to check these calculations.

Table A.1: Cayley Table of Tetrahedral Group

	I	R_1	R_2	R_3	R_4	R_5	R_6	R_7	R_8	R_9	R_{10}	R_{11}
I	I	R_1	R_2	R_3	R_4	R_5	R_6	R_7	R_8	R_9	R_{10}	R_{11}
R_1	R_1	I	R_3	R_2	R_{10}	R_6	R_5	R_9	R_{11}	R_7	R_4	R_8
R_2	R_2	R_3	I	R_1	R_7	R_8	R_{11}	R_4	R_5	R_{10}	R_9	R_6
R_3	R_3	R_2	R_1	I	R_9	R_{11}	R_8	R_{10}	R_6	R_4	R_7	R_5
R_4	R_4	R_7	R_9	R_{10}	R_8	R_3	R_1	R_6	I	R_{11}	R_5	R_2
R_5	R_5	R_{11}	R_6	R_8	R_2	R_9	R_4	R_3	R_7	I	R_1	R_{10}
R_6	R_6	R_8	R_5	R_{11}	R_3	R_7	R_{10}	R_2	R_9	R_1	I	R_4
R_7	R_7	R_4	R_{10}	R_9	R_5	R_1	R_3	R_{11}	R_2	R_6	R_8	I
R_8	R_8	R_6	R_{11}	R_5	I	R_{10}	R_7	R_1	R_4	R_2	R_3	R_9
R_9	R_9	R_{10}	R_4	R_7	R_6	I	R_2	R_8	R_3	R_5	R_{11}	R_1
R_{10}	R_{10}	R_9	R_7	R_4	R_{11}	R_2	I	R_5	R_1	R_8	R_6	R_3
R_{11}	R_{11}	R_5	R_8	R_6	R_1	R_4	R_9	I	R_{10}	R_3	R_2	R_7

Appendix B

Detailed Calculations from Chapter 4

B.1 Order by Order Calculation of δA

Expanding δA in terms of B as per (4.18) and substituting $B[A]$ up to fourth order, we arrive at the following expression

$$\begin{aligned}\delta A_{\bar{1}} = \varepsilon A_{\bar{1}G} &+ \int_{23} \Gamma(123) A_{\bar{2}G} A_{\bar{3}G} + \int_{234} \Gamma(1234) A_{\bar{2}G} A_{\bar{3}G} A_{\bar{4}G} \\ &+ \int_{2345} \Gamma(12345) A_{\bar{2}G} A_{\bar{3}G} A_{\bar{4}G} A_{\bar{5}G} \\ &+ \varepsilon \int_{23} \Upsilon(123) \left(A_{\bar{2}G} + \int_{45} \Gamma(\bar{2}45) A_{\bar{4}G} A_{\bar{5}G} + \int_{456} \Gamma(\bar{2}456) A_{\bar{4}G} A_{\bar{5}G} A_{\bar{6}G} \right) \times \\ &\quad \times \left(A_{\bar{3}} + \int_{78} \Gamma(\bar{3}78) A_{\bar{7}} A_{\bar{8}} + \int_{789} \Gamma(\bar{3}789) A_{\bar{7}} A_{\bar{8}} A_{\bar{9}} \right) \\ &+ \varepsilon \int_{23} \Upsilon(123) \left(A_{\bar{2}} + \int_{45} \Gamma(\bar{2}45) A_{\bar{4}} A_{\bar{5}} + \int_{456} \Gamma(\bar{2}456) A_{\bar{4}} A_{\bar{5}} A_{\bar{6}} \right) \times \\ &\quad \times \left(A_{\bar{3}G} + \int_{78} \Gamma(\bar{3}78) A_{\bar{7}G} A_{\bar{8}G} + \int_{789} \Gamma(\bar{3}789) A_{\bar{7}G} A_{\bar{8}G} A_{\bar{9}G} \right) \\ &+ \varepsilon \int_{234} \Upsilon(1234) \left(A_{\bar{2}G} + \int_{56} \Gamma(\bar{2}56) A_{\bar{5}G} A_{\bar{6}G} \right) \left(A_{\bar{3}} + \int_{78} \Gamma(\bar{3}78) A_{\bar{7}} A_{\bar{8}} \right) \times \\ &\quad \times \left(A_{\bar{4}} + \int_{9\ 10} \Gamma(\bar{4}9\ 10) A_{\bar{9}} A_{\bar{10}} \right)\end{aligned}$$

$$\begin{aligned}
& + \varepsilon \int_{234} \Upsilon(1234) \left(A_{\bar{2}} + \int_{56} \Gamma(\bar{2}56) A_{\bar{5}} A_{\bar{6}} \right) \left(A_{\bar{3}G} + \int_{78} \Gamma(\bar{3}78) A_{\bar{7}G} A_{\bar{8}G} \right) \times \\
& \quad \times \left(A_{\bar{4}} + \int_{9\ 10} \Gamma(\bar{4}9\ 10) A_{\bar{9}} A_{\bar{10}} \right) \\
& + \varepsilon \int_{234} \Upsilon(1234) \left(A_{\bar{2}} + \int_{56} \Gamma(\bar{2}56) A_{\bar{5}} A_{\bar{6}} \right) \left(A_{\bar{3}} + \int_{78} \Gamma(\bar{3}78) A_{\bar{7}} A_{\bar{8}} \right) \times \\
& \quad \times \left(A_{\bar{4}G} + \int_{9\ 10} \Gamma(\bar{4}9\ 10) A_{\bar{9}G} A_{\bar{10}G} \right) \\
& + \varepsilon \int_{2345} \Upsilon(12345) A_{\bar{2}G} A_{\bar{3}} A_{\bar{4}} A_{\bar{5}} + \varepsilon \int_{2345} \Upsilon(12345) A_{\bar{2}} A_{\bar{3}G} A_{\bar{4}} A_{\bar{5}} \\
& + \varepsilon \int_{2345} \Upsilon(12345) A_{\bar{2}} A_{\bar{3}} A_{\bar{4}G} A_{\bar{5}} + \varepsilon \int_{2345} \Upsilon(12345) A_{\bar{2}} A_{\bar{3}} A_{\bar{4}} A_{\bar{5}G}.
\end{aligned}$$

Despite looking horrendous, when like terms are collected and their coefficients calculated the expression simplifies into something more tangible. We shall collect terms order by order. The reader may wish to study an example to lower orders first, say cubic terms to become used to the calculations. First order is trivial, we get $\delta A = \varepsilon A_{1G} + \dots$.

Second order isn't much more difficult, we simply find the terms that are quadratic in the A fields when expanding out the brackets. We get

$$\delta A_1 = \varepsilon A_{1G} + \varepsilon \int_{23} \{ \Gamma(123) A_{\bar{2}G} A_{\bar{3}G} + \Upsilon(123) A_{\bar{2}G} A_{\bar{3}} + \Upsilon(123) A_{\bar{2}} A_{\bar{3}G} \} + \dots$$

Further, when Γ and Υ are expressed in terms of their independent momenta the expression is

$$\delta A_1 = \varepsilon A_{1G} + \varepsilon \int_{23} \left\{ i \frac{\hat{1}}{(23)} A_{\bar{2}G} A_{\bar{3}G} - i \frac{\hat{1}}{(23)} A_{\bar{2}G} A_{\bar{3}} - i \frac{\hat{1}}{(23)} A_{\bar{2}} A_{\bar{3}G} \right\} + \dots$$

Third order gets more tricky. Taking the third order terms out of the expansion, we get

$$\begin{aligned}
\cdots & + \varepsilon \int_{234} \Gamma(1234) A_{\bar{2}G} A_{\bar{3}G} A_{\bar{4}G} + \\
& + \varepsilon \int_{2378} \Upsilon(123) \Gamma(\bar{3}78) A_{\bar{2}G} A_{\bar{7}} A_{\bar{8}} + \varepsilon \int_{2345} \Upsilon(123) \Gamma(\bar{2}45) A_{\bar{4}G} A_{\bar{5}G} A_{\bar{3}} \\
& + \varepsilon \int_{2378} \Upsilon(123) \Gamma(\bar{3}78) A_{\bar{2}} A_{\bar{7}G} A_{\bar{8}G} + \varepsilon \int_{2345} \Upsilon(123) \Gamma(\bar{2}45) A_{\bar{4}} A_{\bar{5}} A_{\bar{3}G} \\
& + \varepsilon \int_{234} \Upsilon(1234) A_{\bar{2}G} A_{\bar{3}} A_{\bar{4}} + \varepsilon \int_{234} \Upsilon(1234) A_{\bar{2}} A_{\bar{3}G} A_{\bar{4}}
\end{aligned}$$

$$+ \varepsilon \int_{234} \Upsilon(1234) A_{\bar{2}} A_{\bar{3}} A_{\bar{4}G} + \dots$$

Now we carefully change variables of integration, maintaining the order of the fields since they contain group matrices, and collect terms,

$$\begin{aligned} \dots + \varepsilon \int_{234} \left\{ \Gamma(1234) A_{\bar{2}G} A_{\bar{3}G} A_{\bar{4}G} + \Upsilon(154) \Gamma(\bar{5}23) A_{\bar{2}G} A_{\bar{3}G} A_{\bar{4}} + \Upsilon(125) \Gamma(\bar{5}34) A_{\bar{2}} A_{\bar{3}G} A_{\bar{4}G} + \right. \\ \left. + \{ \Upsilon(125) \Gamma(\bar{5}34) + \Upsilon(1234) \} A_{\bar{2}G} A_{\bar{3}} A_{\bar{4}} + \{ \Upsilon(154) \Gamma(\bar{5}23) + \Upsilon(1234) \} A_{\bar{2}} A_{\bar{3}} A_{\bar{4}G} + \right. \\ \left. + \Upsilon(1234) A_{\bar{2}} A_{\bar{3}G} A_{\bar{4}} \right\} + \dots \end{aligned}$$

where p_5 is minus the sum of the remaining arguments in the coefficient. For example, in the second term, $p_5 = -p_1 - p_4 = +p_2 + p_3$. Remarkably, when expressed in terms of their independent momenta they reduce to simpler expressions, in particular the fourth and fifth terms whose coefficients are $\{ \Upsilon(125) \Gamma(\bar{5}34) + \Upsilon(1234) \}$ and $\{ \Upsilon(154) \Gamma(\bar{5}23) + \Upsilon(1234) \}$ respectively reduce nicely. For example, take the fourth coefficient bearing in mind momentum conservation, $1 + 2 + 3 + 4 = 0$,

$$\Upsilon(125) \Gamma(\bar{5}34) + \Upsilon(1234) = \left(-i \frac{\hat{1}}{(25)} \right) \left(i \frac{\hat{5}}{(34)} \right) + \frac{\hat{1}}{(23)} \frac{\hat{3}}{(34)}$$

taking out a factor $\hat{1}/(34)$ gives

$$\frac{\hat{1}}{(34)} \left(\frac{\hat{1} + \hat{2}}{(12)} + \frac{\hat{3}}{(23)} \right)$$

then putting the expression in brackets under a common denominator and expanding out terms on the numerator

$$\frac{\hat{1}}{(34)} \left(\frac{\hat{1}\hat{2}\hat{3} + \hat{2}\hat{2}\hat{3} - \hat{2}\hat{2}\hat{3} - \hat{3}\hat{1}\hat{2}}{(12)(23)} \right)$$

giving

$$\frac{\hat{1}\hat{2}}{(12)(23)} = \frac{\hat{1}\hat{2}}{(23)(2, 3 + 4)}.$$

Expressing the coefficients in this way and using momentum conservation to express the denominators in a certain way, the third order expression is

$$\begin{aligned} \dots + \varepsilon \int_{234} \left\{ \frac{\hat{1}\hat{q}}{(q, 2)(q, 2 + 3)} + \frac{\hat{1}\hat{q}}{(q, 2)(q, 4)} + \frac{\hat{1}\hat{q}}{(q, 3)(q, 1)} \right. \\ \left. + \frac{\hat{1}\hat{q}}{(q, 3)(q, 3 + 4)} + \frac{\hat{1}\hat{q}}{(q, 4)(q, 4 + 1)} + \frac{\hat{1}\hat{q}}{(q, 1)(q, 1 + 2)} \right\} + \dots \end{aligned}$$

where for any term with $A_{\bar{2}} \cdots A_{\bar{i}G} \cdots A_{\bar{j}G} \cdots A_{\bar{n}}$, q is defined to be $q = p_i + \cdots + p_j$. Given these expressions it is tempting to substitute $q = p_i + \cdots + p_j$ and simplify the coefficients further. However, we write the terms like this deliberately because as we shall see fourth order terms follow a similar pattern which would not otherwise be visible.

We can collect together terms that are quartic in A within the confines of an A4 page too. Doing so, and carefully relabeling variables of integration, we arrive at

$$\begin{aligned}
& \cdots + \varepsilon \int_{2345} \left\{ \Gamma(12345) A_{\bar{2}G} A_{\bar{3}G} A_{\bar{4}G} A_{\bar{5}G} + \right. \\
& \quad + \Upsilon(165) \Gamma(\bar{6}234) A_{\bar{2}G} A_{\bar{3}G} A_{\bar{4}G} A_{\bar{5}} + \Upsilon(126) \Gamma(\bar{6}345) A_{\bar{2}} A_{\bar{3}G} A_{\bar{4}G} A_{\bar{5}G} + \\
& \quad + \{ \Upsilon(167) \Gamma(\bar{6}23) \Gamma(\bar{7}45) + \Upsilon(1645) \Gamma(\bar{6}23) \} A_{\bar{2}G} A_{\bar{3}G} A_{\bar{4}} A_{\bar{5}} + \\
& \quad + \Upsilon(1265) \Gamma(\bar{6}34) A_{\bar{2}} A_{\bar{3}G} A_{\bar{4}G} A_{\bar{5}} + \\
& \quad + \{ \Upsilon(167) \Gamma(\bar{6}23) \Gamma(\bar{7}45) + \Upsilon(1236) \Gamma(\bar{6}45) \} A_{\bar{2}} A_{\bar{3}} A_{\bar{4}G} A_{\bar{5}G} + \\
& \quad + \{ \Upsilon(126) \Gamma(\bar{6}345) + \Upsilon(1236) \Gamma(\bar{6}45) + \Upsilon(1265) \Gamma(\bar{6}34) + \Upsilon(12345) \} A_{\bar{2}G} A_{\bar{3}} A_{\bar{4}} A_{\bar{5}} + \\
& \quad + \{ \Upsilon(1236) \Gamma(\bar{6}45) + \Upsilon(12345) \} A_{\bar{2}} A_{\bar{3}G} A_{\bar{4}} A_{\bar{5}} + \\
& \quad + \{ \Upsilon(1645) \Gamma(\bar{6}23) + \Upsilon(12345) \} A_{\bar{2}} A_{\bar{3}} A_{\bar{4}G} A_{\bar{5}} + \\
& \quad + \{ \Upsilon(165) \Upsilon(\bar{6}234) + \Upsilon(1265) \Gamma(\bar{6}34) + \Upsilon(1645) \Gamma(\bar{6}23) + \Upsilon(12345) \} A_{\bar{2}} A_{\bar{3}} A_{\bar{4}} A_{\bar{5}G} \left. \right\} \\
& \quad + \cdots .
\end{aligned} \tag{B.1.1}$$

The above expression simplifies in a similar way to earlier. We shall state the result first, and give an example of one of the calculations. The others are similar, the

most complicated ones can be checked on a computer algebra package. We have

$$\begin{aligned} \dots + \varepsilon \int_{2345} i \left\{ \frac{\hat{1}\hat{q}^2 A_{2G} A_{3G} A_{4G} A_{5G}}{(q, 2)(q, 2+3)(q, 2+3+4)} A_{2G} + \frac{\hat{1}\hat{q}^2 A_{2G} A_{3G} A_{4G} A_5}{(q, 2)(q, 2+3)(q, 5)} + \right. \\ + \frac{\hat{1}\hat{q}^2 A_2 A_{3G} A_{4G} A_{5G}}{(q, 3)(q, 3+4)(q, 1)} + \frac{\hat{1}\hat{q}^2 A_{2G} A_{3G} A_4 A_5}{(q, 2)(q, 4)(q, 4+5)} + \\ + \frac{\hat{1}\hat{q}^2 A_2 A_{3G} A_{4G} A_5}{(q, 3)(q, 5)(q, 5+1)} + \frac{\hat{1}\hat{q}^2 A_2 A_3 A_{4G} A_{5G}}{(q, 4)(q, 1)(q, 1+2)} \\ + \frac{\hat{1}\hat{q}^2 A_{2G} A_3 A_4 A_5}{(q, 3)(q, 3+4)(q, 3+4+5)} + \frac{\hat{1}\hat{q}^2 A_2 A_{3G} A_4 A_5}{(q, 4)(q, 4+5)(q, 4+5+1)} + \\ \left. + \frac{\hat{1}\hat{q}^2 A_2 A_3 A_{4G} A_5}{(q, 5)(q, 5+1)(q, 5+1+2)} + \frac{\hat{1}\hat{q}^2 A_2 A_3 A_4 A_{5G}}{(q, 1)(q, 1+2)(q, 1+2+3)} \right\} + \dots \end{aligned} \quad (\text{B.1.2})$$

As an example, let us take the fourth term

$$\Upsilon(167)\Gamma(\bar{6}23)\Gamma(\bar{7}45) + \Upsilon(1645)\Gamma(\bar{6}23) = i \frac{\hat{1}(\hat{2} + \hat{3})}{(23)(45)} \left\{ \frac{\hat{4} + \hat{5}}{(2+3, 4+5)} - \frac{\hat{4}}{(2+3, 4)} \right\},$$

upon expressing the coefficients Γ and Υ explicitly in terms of their independent momenta and taking out a factor $i \frac{\hat{1}(\hat{2} + \hat{3})}{(23)(45)}$. Further, we substitute $p_4 + p_5 = -p_1 - p_2 - p_3$ and take out a factor of -1

$$= -i \frac{\hat{1}(\hat{2} + \hat{3})}{(23)(45)} \left\{ \frac{\hat{1} + \hat{2} + \hat{3}}{(2+3, 4+5)} + \frac{\hat{4}}{(2+3, 4)} \right\}.$$

Let us call $q = 2 + 3$, and put the term in brackets under a common denominator i.e.,

$$= -i \frac{\hat{1}\hat{q}}{(23)(45)} \left(\frac{(\hat{1} + \hat{q})(q, 4) + \hat{4}(1, q)}{(1, q)(q, 4)} \right).$$

Now expand the numerator, two terms cancel, then a factor of \hat{q} can be taken outside the bracket giving

$$= -i \frac{\hat{1}\hat{q}^2}{(23)(45)(1, q)(q, 4)} (1 + q, 4) = -i \frac{\hat{1}(\hat{2} + \hat{3})^2}{(23)(1, 2+3)(2+3, 4)}.$$

Then using momentum conservation, we get the simplified coefficient

$$\Upsilon(167)\Gamma(\bar{6}23)\Gamma(\bar{7}45) + \Upsilon(1645)\Gamma(\bar{6}23) = i \frac{\hat{1}\hat{q}^2}{(q, 2)(q, 4)(q, 4+5)}$$

where $q = p_2 + p_3$. Calculation of the other terms is equally as simple.

B.2 Order by Order Calculation of $\delta\bar{A}$

We expand $\delta\bar{A}$ in terms of the free field B , \bar{B} , δB and $\delta\bar{B}$ and as per (4.21). Working to third order only. In a similar fashion to the calculation of appendix (B.1), we substitute the inverse expressions, $B[A]$ and $\bar{B}[A, \bar{A}]$ which is given by the expansion

$$\begin{aligned} \bar{B}_1 = \bar{A}_1 + \int_{23} \left\{ \frac{\hat{2}}{\hat{1}} \Theta^2(\bar{1}23) \bar{A}_2 A_3 + \frac{\hat{3}}{\hat{1}} \Theta^3(\bar{1}23) A_2 \bar{A}_3 + \right. \\ \left. + \frac{\hat{2}}{\hat{1}} \Theta^2(\bar{1}234) \bar{A}_2 A_3 A_4 + \frac{\hat{3}}{\hat{1}} \Theta^3(\bar{1}234) A_2 \bar{A}_3 A_4 + \frac{\hat{4}}{\hat{1}} \Theta^4(\bar{1}234) A_2 A_3 \bar{A}_4 \right\} + \dots \end{aligned}$$

Performing this substitution, maintaining third order terms only, we arrive at

$$\begin{aligned} \delta\bar{A}_1 = & -\varepsilon \bar{A}_{1G-1} + \varepsilon \int_{23} \frac{\hat{2}}{\hat{1}} \Theta^2(123) \bar{A}_{2G-1} A_{3G-1} + \varepsilon \int_{23} \frac{\hat{3}}{\hat{1}} \Theta^3(123) A_{2G-1} \bar{A}_{3G-1} + \\ & + \varepsilon \int_{234} \frac{\hat{4}}{\hat{1}} \Theta^4(1234) \bar{A}_{2G-1} A_{3G-1} A_{4G-1} + \varepsilon \int_{234} \frac{\hat{3}}{\hat{1}} \Theta^3(1234) A_{2G-1} \bar{A}_{3G-1} A_{4G-1} \\ & + \varepsilon \int_{234} \frac{\hat{2}}{\hat{1}} \Theta^2(1234) \bar{A}_{2G-1} A_{3G-1} A_{4G-1} \\ & + \varepsilon \int_{23} \frac{\hat{2}}{\hat{1}} \Xi^2(123) \left(\bar{A}_{2G-1} + \int_{45} \frac{\hat{4}}{\hat{2}} \Theta^2(\bar{2}45) \bar{A}_{4G-1} A_{5G-1} + \int_{45} \frac{\hat{5}}{\hat{2}} \Theta^3(\bar{2}45) A_{4G-1} \bar{A}_{5G-1} \right) \times \\ & \quad \times \left(A_3 + \int_{67} \Gamma(\bar{3}67) A_6 A_7 \right) \\ & - \varepsilon \int_{23} \frac{\hat{2}}{\hat{1}} \Xi^2(123) \left(\bar{A}_2 + \int_{45} \frac{\hat{4}}{\hat{2}} \Theta^2(\bar{2}45) \bar{A}_4 A_5 + \int_{45} \frac{\hat{5}}{\hat{2}} \Theta^3(\bar{2}45) A_4 \bar{A}_5 \right) \times \\ & \quad \times \left(A_{3G} + \int_{67} \Gamma(\bar{3}67) A_6 A_7 \right) \\ & - \varepsilon \int_{23} \frac{\hat{3}}{\hat{1}} \Xi^3(123) \left(A_{2G} + \int_{45} \Gamma(\bar{2}45) A_4 A_5 \right) \times \\ & \quad \times \left(\bar{A}_3 + \int_{67} \frac{\hat{6}}{\hat{3}} \Theta^2(\bar{3}67) \bar{A}_6 A_7 + \int_{67} \frac{\hat{7}}{\hat{3}} \Theta^3(\bar{3}67) A_6 \bar{A}_7 \right) \\ & + \varepsilon \int_{23} \frac{\hat{3}}{\hat{1}} \Theta^3(123) \left(A_2 + \int_{45} \Gamma(\bar{2}45) A_4 A_5 \right) \times \\ & \quad \times \left(\bar{A}_{3G-1} + \int_{67} \frac{\hat{6}}{\hat{3}} \Xi^2(\bar{3}67) \bar{A}_{6G-1} A_{7G-1} + \int_{67} \frac{\hat{7}}{\hat{3}} \Xi^3(\bar{3}67) \bar{A}_{6G-1} A_{7G-1} \right) \\ & + \varepsilon \int_{234} \frac{\hat{2}}{\hat{1}} \Xi^2(1234) \bar{A}_{2G-1} A_3 A_4 - \varepsilon \int_{234} \frac{\hat{2}}{\hat{1}} \Xi^2(1234) \bar{A}_2 A_{3G} A_4 - \varepsilon \int_{234} \frac{\hat{2}}{\hat{1}} \Xi^2(1234) \bar{A}_2 A_3 A_{4G} \end{aligned}$$

$$\begin{aligned}
& - \varepsilon \int_{234} \frac{\hat{3}}{\hat{1}} \Xi^3(1234) A_{2G} \bar{A}_3 A_4 + \varepsilon \int_{234} \frac{\hat{3}}{\hat{1}} \Xi^3(1234) A_2 \bar{A}_{3G-1} A_4 - \varepsilon \int_{234} \frac{\hat{3}}{\hat{1}} \Xi^3(1234) A_2 \bar{A}_3 A_{4G} \\
& - \varepsilon \int_{234} \frac{\hat{4}}{\hat{1}} \Xi^4(1234) A_{2G} A_3 \bar{A}_4 - \varepsilon \int_{234} \frac{\hat{4}}{\hat{1}} \Xi^4(1234) A_2 A_3 G \bar{A}_4 + \varepsilon \int_{234} \frac{\hat{4}}{\hat{1}} \Xi^4(1234) A_2 A_3 \bar{A}_{4G-1} \\
& + \dots
\end{aligned}$$

Again, we shall collect terms order by order we shall see that we have already done most of the work already when calculating the coefficients in appendix (B.1). First order is again trivial, we get $\delta\bar{A}_1 = -\varepsilon\bar{A}_{1G-1} + \dots$. At second order we can pick out the terms and express Ξ and Θ in terms of independent momenta, no extra calculation is required.

$$\begin{aligned}
\delta\bar{A}_1 = -\varepsilon\bar{A}_{1G-1} + \varepsilon \int_{23} \left\{ \frac{\hat{2}}{\hat{1}} \Theta^2(123) \bar{A}_{2G-1} A_{3G-1} + \frac{\hat{3}}{\hat{1}} \Theta^3(123) A_{2G-1} \bar{A}_{3G-1} \right. \\
+ \frac{\hat{2}}{\hat{1}} \Xi^2(123) \bar{A}_{2G-1} A_3 - \frac{\hat{2}}{\hat{1}} \Xi^2(123) \bar{A}_2 A_{3G} \\
\left. - \frac{\hat{3}}{\hat{1}} \Xi^3(123) A_{2G} \bar{A}_3 + \frac{\hat{3}}{\hat{1}} \Xi^3(123) A_2 \bar{A}_{3G-1} \right\} + \dots
\end{aligned}$$

As per [31] we have

$$\begin{aligned}
\Xi^2(123) &= -\Upsilon(231) = i \frac{\hat{2}}{(31)} \\
\Xi^3(123) &= -\Upsilon(312) = i \frac{\hat{3}}{(12)}
\end{aligned}$$

and we can deduce for ourselves

$$\begin{aligned}
\Theta^2(123) &= -\Gamma(231) = -i \frac{\hat{2}}{(31)} \\
\Theta^3(123) &= -\Gamma(312) = -i \frac{\hat{3}}{(12)}
\end{aligned}$$

so to second order we find

$$\begin{aligned}
\delta\bar{A}_1 = -\varepsilon\bar{A}_{1G-1} - \varepsilon \int_{23} i \left\{ \frac{\hat{2}}{\hat{1}} \frac{\hat{2}}{(31)} \bar{A}_{2G-1} A_{3G-1} - \frac{\hat{3}}{\hat{1}} \frac{\hat{3}}{(12)} A_{2G-1} \bar{A}_{3G-1} \right. \\
+ \frac{\hat{2}}{\hat{1}} \frac{\hat{2}}{(31)} \bar{A}_{2G-1} A_3 - \frac{\hat{2}}{\hat{1}} \frac{\hat{2}}{(31)} \bar{A}_2 A_{3G} \\
\left. - \frac{\hat{3}}{\hat{1}} \frac{\hat{3}}{(12)} A_{2G} \bar{A}_3 + \frac{\hat{3}}{\hat{1}} \frac{\hat{3}}{(12)} A_2 \bar{A}_{3G-1} \right\} + \dots
\end{aligned}$$

Finally to third order, careful inspection of the expansion will produce the following, where we have carefully relabelled variables,

$$\begin{aligned}
\cdots &+ \varepsilon \int_{234} \left\{ \frac{\hat{2}}{\hat{1}} \Theta^2(1234) \bar{A}_{2G-1} A_{3G-1} A_{4G-1} + \frac{\hat{3}}{\hat{1}} \Theta^3(1234) A_{2G-1} \bar{A}_{3G-1} A_{4G-1} \right. \\
&+ \frac{\hat{4}}{\hat{1}} \Theta^4(1234) A_{2G-1} A_{3G-1} \bar{A}_{4G-1} \\
&+ \frac{\hat{2}}{\hat{1}} \Xi^2(125) \Gamma(\bar{5}34) \bar{A}_{2G-1} A_{\bar{3}} A_{\bar{4}} + \frac{\hat{5}}{\hat{1}} \Xi^2(154) \frac{\hat{2}}{\hat{5}} \Theta^2(\bar{5}23) \bar{A}_{2G-1} A_{3G-1} A_{\bar{4}} \\
&+ \frac{\hat{5}}{\hat{1}} \Xi^2(154) \frac{\hat{3}}{\hat{5}} \Theta^3(\bar{5}23) A_{2G-1} \bar{A}_{3G-1} A_{\bar{4}} \\
&- \frac{\hat{2}}{\hat{1}} \Xi^2(125) \Gamma(\bar{5}34) \bar{A}_{\bar{2}} A_{3G} A_{\bar{4}G} - \frac{\hat{5}}{\hat{1}} \Xi^2(154) \frac{\hat{2}}{\hat{5}} \Theta^1(\bar{5}23) \bar{A}_{\bar{2}} A_{\bar{3}} A_{\bar{4}G} \\
&- \frac{\hat{5}}{\hat{1}} \Xi^2(154) \frac{\hat{3}}{\hat{5}} \Theta^3(\bar{5}23) A_{\bar{2}} \bar{A}_{\bar{3}} A_{\bar{4}G} \\
&- \frac{\hat{5}}{\hat{1}} \Xi^3(125) \frac{\hat{3}}{\hat{5}} \Theta^2(\bar{5}34) A_{2G} \bar{A}_{\bar{3}} A_{\bar{4}} - \frac{\hat{5}}{\hat{1}} \Xi^3(125) \frac{\hat{4}}{\hat{5}} \Theta^3(\bar{5}34) A_{2G} A_{\bar{3}} \bar{A}_{\bar{4}} \\
&- \frac{\hat{3}}{\hat{1}} \Xi^3(154) \Gamma(\bar{5}23) A_{2G} A_{3G} \bar{A}_{\bar{4}} \\
&+ \frac{\hat{5}}{\hat{1}} \Xi^3(125) \frac{\hat{3}}{\hat{5}} \Theta^2(\bar{5}34) A_{\bar{2}} \bar{A}_{3G-1} A_{\bar{4}G-1} + \frac{\hat{5}}{\hat{1}} \Xi^3(125) \frac{\hat{4}}{\hat{5}} \Theta^3(\bar{5}34) A_{\bar{2}} A_{3G-1} \bar{A}_{\bar{4}G-1} \\
&+ \frac{\hat{4}}{\hat{1}} \Xi^3(154) \Gamma(\bar{5}23) A_{\bar{2}} A_{\bar{3}} \bar{A}_{\bar{4}G-1} \\
&+ \frac{\hat{2}}{\hat{1}} \Xi^2(1234) \bar{A}_{2G-1} A_{\bar{3}} A_{\bar{4}} - \frac{\hat{2}}{\hat{1}} \Xi^2(1234) \bar{A}_{\bar{2}} A_{3G} A_{\bar{4}} - \frac{\hat{2}}{\hat{1}} \Xi^2(1234) \bar{A}_{\bar{2}} A_{\bar{3}} A_{\bar{4}G} \\
&- \frac{\hat{3}}{\hat{1}} \Xi^3(1234) A_{2G} \bar{A}_{\bar{3}} A_{\bar{4}} + \frac{\hat{3}}{\hat{1}} \Xi^3(1234) A_{\bar{2}} \bar{A}_{3G-1} A_{\bar{4}} - \frac{\hat{3}}{\hat{1}} \Xi^3(1234) A_{\bar{2}} \bar{A}_{\bar{3}} A_{\bar{4}G} \\
&- \left. \frac{\hat{4}}{\hat{1}} \Xi^4(1234) A_{2G} A_{\bar{3}} \bar{A}_{\bar{4}} - \frac{\hat{4}}{\hat{1}} \Xi^4(1234) A_{\bar{2}} A_{3G} \bar{A}_{\bar{4}} + \frac{\hat{4}}{\hat{1}} \Xi^4(1234) A_{\bar{2}} A_{\bar{3}} \bar{A}_{\bar{4}G-1} \right\} + \cdots .
\end{aligned}$$

We shall persevere and collect terms and use relations (4.16) and (4.11),

$$\begin{aligned}
\cdots \varepsilon \int_{234} \left\{ - \left(\frac{\hat{2}}{\hat{1}} \right)^2 \Gamma(1234) \bar{A}_{2G-1} A_{3G-1} A_{4G-1} - \left(\frac{\hat{3}}{\hat{1}} \right)^2 \Gamma(1234) A_{2G-1} \bar{A}_{3G-1} A_{4G-1} \right. \\
- \left(\frac{\hat{4}}{\hat{1}} \right)^2 \Gamma(1234) A_{2G-1} A_{3G-1} \bar{A}_{4G-1} - \left(\frac{\hat{2}}{\hat{1}} \right)^2 \Upsilon(154) \Gamma(\bar{5}23) \bar{A}_{2G-1} A_{3G-1} A_{\bar{4}} \\
- \left(\frac{\hat{3}}{\hat{1}} \right)^2 \Upsilon(154) \Gamma(\bar{5}23) A_{2G-1} \bar{A}_{3G-1} A_{\bar{4}} + \left(\frac{\hat{4}}{\hat{1}} \right)^2 \Upsilon(154) \Gamma(\bar{5}23) A_{2G} A_{3G} \bar{A}_{\bar{4}} \\
\left. \right\}
\end{aligned}$$

$$\begin{aligned}
& + \left(\frac{\hat{2}}{\hat{1}}\right)^2 \Upsilon(125)\Gamma(\bar{5}34)\bar{A}_2 A_{\bar{3}G} A_{\bar{4}G} - \left(\frac{\hat{3}}{\hat{1}}\right)^2 \Upsilon(125)\Gamma(\bar{5}34)A_2 \bar{A}_{\bar{3}G-1} A_{\bar{4}G-1} \\
& - \left(\frac{\hat{4}}{\hat{1}}\right)^2 \Upsilon(125)\Gamma(\bar{5}34)A_2 A_{\bar{3}G-1} \bar{A}_{\bar{4}G-1} + \left(\frac{\hat{2}}{\hat{1}}\right)^2 \Upsilon(1234)\bar{A}_2 A_{\bar{3}G} A_{\bar{4}} \\
& - \left(\frac{\hat{3}}{\hat{1}}\right)^2 \Upsilon(1234)A_2 \bar{A}_{\bar{3}G-1} A_{\bar{4}} + \left(\frac{\hat{4}}{\hat{1}}\right)^2 \Upsilon(1234)A_2 A_{\bar{3}G} \bar{A}_{\bar{4}} \\
& - \left(\frac{\hat{2}}{\hat{1}}\right)^2 \{\Upsilon(125)\Gamma(\bar{5}34) + \Upsilon(1234)\} \bar{A}_{\bar{2}G-1} A_{\bar{3}} A_{\bar{4}} \\
& + \left(\frac{\hat{3}}{\hat{1}}\right)^2 \{\Upsilon(125)\Gamma(\bar{5}34) + \Upsilon(1234)\} A_{\bar{2}G} \bar{A}_{\bar{3}} A_{\bar{4}} \\
& + \left(\frac{\hat{4}}{\hat{1}}\right)^2 \{\Upsilon(125)\Gamma(\bar{5}34) + \Upsilon(1234)\} A_{\bar{2}G} A_{\bar{3}} \bar{A}_{\bar{4}} \\
& + \left(\frac{\hat{2}}{\hat{1}}\right)^2 \{\Upsilon(154)\Gamma(\bar{5}23) + \Upsilon(1234)\} \bar{A}_2 A_{\bar{3}} A_{\bar{4}G} \\
& + \left(\frac{\hat{3}}{\hat{1}}\right)^2 \{\Upsilon(154)\Gamma(\bar{5}23) + \Upsilon(1234)\} A_2 \bar{A}_{\bar{3}} A_{\bar{4}G} \\
& - \left(\frac{\hat{4}}{\hat{1}}\right)^2 \{\Upsilon(154)\Gamma(\bar{5}23) + \Upsilon(1234)\} A_2 A_{\bar{3}} \bar{A}_{\bar{4}G-1} \Big\} + \dots
\end{aligned}$$

Fortunately, now, we have already calculated the above expressions enclosed in parentheses in Γ and Υ in the previous calculation of δA in appendix (B.1) so we do not need to do these again. We can reach the result

$$\begin{aligned}
\cdots \varepsilon \int_{234} \Big\{ & - \left(\frac{\hat{2}}{\hat{1}}\right)^2 \frac{\hat{1}\hat{q}\bar{A}_{\bar{2}G-1} A_{\bar{3}G-1} A_{\bar{4}G-1}}{(q,2)(q,2+3)} - \left(\frac{\hat{3}}{\hat{1}}\right)^2 \frac{\hat{1}\hat{q}A_{\bar{2}G-1} \bar{A}_{\bar{3}G-1} A_{\bar{4}G-1}}{(q,2)(q,2+3)} - \\
& - \left(\frac{\hat{4}}{\hat{1}}\right)^2 \frac{\hat{1}\hat{q}A_{\bar{2}G-1} A_{\bar{3}G-1} \bar{A}_{\bar{4}G-1}}{(q,2)(q,2+3)} - \left(\frac{\hat{2}}{\hat{1}}\right)^2 \frac{\hat{1}\hat{q}\bar{A}_{\bar{2}G-1} A_{\bar{3}G-1} A_{\bar{4}}}{(q,2)(q,4)} - \\
& - \left(\frac{\hat{3}}{\hat{1}}\right)^2 \frac{\hat{1}\hat{q}A_{\bar{2}G-1} \bar{A}_{\bar{3}G-1} A_{\bar{4}}}{(q,2)(q,4)} + \left(\frac{\hat{4}}{\hat{1}}\right)^2 \frac{\hat{1}\hat{q}A_{\bar{2}G} A_{\bar{3}G} \bar{A}_{\bar{4}}}{(q,2)(q,4)} + \\
& + \left(\frac{\hat{2}}{\hat{1}}\right)^2 \frac{\hat{1}\hat{q}\bar{A}_2 A_{\bar{3}G} A_{\bar{4}G}}{(q,3)(q,1)} - \left(\frac{\hat{3}}{\hat{1}}\right)^2 \frac{\hat{1}\hat{2}A_2 \bar{A}_{\bar{3}G-1} A_{\bar{4}G-1}}{(q,3)(q,1)} - \\
& - \left(\frac{\hat{4}}{\hat{1}}\right)^2 \frac{\hat{1}\hat{q}A_2 A_{\bar{3}G-1} \bar{A}_{\bar{4}G-1}}{(q,3)(q,1)} + \left(\frac{\hat{2}}{\hat{1}}\right)^2 \frac{\hat{1}\hat{q}\bar{A}_2 A_{\bar{3}G} A_{\bar{4}}}{(q,4)(q,4+1)} -
\end{aligned}$$

$$\begin{aligned}
& - \left(\frac{\hat{3}}{\hat{1}} \right)^2 \frac{\hat{1}\hat{q}A_2\bar{A}_{3G-1}A_4}{(q,4)(q,4+1)} + \left(\frac{\hat{4}}{\hat{1}} \right)^2 \frac{\hat{1}\hat{q}A_2A_3\bar{A}_4}{(q,4)(q,4+1)} - \\
& - \left(\frac{\hat{2}}{\hat{1}} \right)^2 \frac{\hat{1}\hat{q}\bar{A}_{2G-1}A_3A_4}{(q,3)(q,3+4)} + \left(\frac{\hat{3}}{\hat{1}} \right)^2 \frac{\hat{1}\hat{q}A_{2G}\bar{A}_3A_4}{(q,3)(q,3+4)} - \\
& + \left(\frac{\hat{4}}{\hat{1}} \right)^2 \frac{\hat{1}\hat{q}A_{2G}A_3\bar{A}_4}{(q,3)(q,3+4)} + \left(\frac{\hat{2}}{\hat{1}} \right)^2 \frac{\hat{1}\hat{q}\bar{A}_2A_3A_{4G}}{(q,1)(q,1+2)} + \\
& + \left. \left(\frac{\hat{3}}{\hat{1}} \right)^2 \frac{\hat{1}\hat{q}A_2\bar{A}_3A_{4G}}{(q,1)(q,1+2)} - \left(\frac{\hat{4}}{\hat{1}} \right)^2 \frac{\hat{1}\hat{q}A_2A_3\bar{A}_{4G-1}}{(q,1)(q,1+2)} \right\} + \dots .
\end{aligned}
\tag{B.2.3}$$

Appendix C

Detailed Calculations from Chapter 5

C.1 Order by Order Calculation of $\Delta\Phi$ up to Quartic Terms

In §(5.3) we wrote down $\Delta\Phi$ in terms of the free field χ , (5.26). Carefully substituting the inverse field redefinition, (5.16) being careful to label the arguments correctly and maintain the order of the fields, we arrive at

$$\begin{aligned}\delta\Phi_1 = & \varepsilon\delta\Phi_1 + \varepsilon \int_{23} \delta \{D(123)\Phi_2\Phi_3\} + \varepsilon \int_{234} \delta \{D(1234)\Phi_2\Phi_3\Phi_4\} \\ & + \varepsilon \int_{23} \delta \{D(12345)\Phi_2\Phi_3\Phi_4\Phi_5\} \\ & + \varepsilon \int_{23} C(123) \left(\delta\Phi_2 + \int_{45} \delta \{D(-245)\Phi_4\Phi_5\} + \int_{456} \delta \{D(-2456)\Phi_4\Phi_5\Phi_6\} \right) \times \\ & \quad \times \left(\Phi_3 + \int_{78} D(-378)\Phi_7\Phi_8 + \int_{789} D(-3789)\Phi_7\Phi_8\Phi_9 \right) \\ & + \varepsilon \int_{23} C(123) \left(\Phi_2 + \int_{45} D(-245)\Phi_4\Phi_5 + \int_{456} D(-2456)\Phi_4\Phi_5\Phi_6 \right) \times \\ & \quad \times \left(\delta\Phi_3 + \int_{78} \delta \{D(-378)\Phi_7\Phi_8\} + \int_{789} \delta \{D(-3789)\Phi_7\Phi_8\Phi_9\} \right)\end{aligned}$$

$$\begin{aligned}
& + \varepsilon \int_{234} C(1234) \left(\delta\Phi_{\bar{2}} + \int_{56} \delta \{D(-256)\Phi_{\bar{5}}\Phi_{\bar{6}}\} \right) \times \\
& \quad \times \left(\Phi_{\bar{3}} + \int_{78} D(-378)\Phi_{\bar{7}}\Phi_{\bar{8}} \right) \left(\Phi_{\bar{4}} + \int_{9\ 10} D(-49\ 10)\Phi_{\bar{9}}\Phi_{\bar{10}} \right) \\
& + \varepsilon \int_{234} C(1234) \left(\Phi_{\bar{2}} + \int_{56} D(-256)\Phi_{\bar{5}}\Phi_{\bar{6}} \right) \times \\
& \quad \times \left(\delta\Phi_{\bar{3}} + \int_{78} \delta \{D(-378)\Phi_{\bar{7}}\Phi_{\bar{8}}\} \right) \left(\Phi_{\bar{4}} + \int_{9\ 10} D(-49\ 10)\Phi_{\bar{9}}\Phi_{\bar{10}} \right) \\
& + \varepsilon \int_{234} C(1234) \left(\Phi_{\bar{2}} + \int_{56} D(-256)\Phi_{\bar{5}}\Phi_{\bar{6}} \right) \times \\
& \quad \times \left(\Phi_{\bar{3}} + \int_{78} D(-378)\Phi_{\bar{7}}\Phi_{\bar{8}} \right) \left(\delta\Phi_{\bar{4}} + \int_{9\ 10} \delta \{D(-49\ 10)\Phi_{\bar{9}}\Phi_{\bar{10}}\} \right) \\
& + \varepsilon \int_{2345} C(12345)\delta\Phi_{\bar{2}}\Phi_{\bar{3}}\Phi_{\bar{4}}\Phi_{\bar{5}} + \varepsilon \int_{2345} C(12345)\Phi_{\bar{2}}\delta\Phi_{\bar{3}}\Phi_{\bar{4}}\Phi_{\bar{5}} \\
& + \varepsilon \int_{2345} C(12345)\Phi_{\bar{2}}\Phi_{\bar{3}}\delta\Phi_{\bar{4}}\Phi_{\bar{5}} + \varepsilon \int_{2345} C(12345)\Phi_{\bar{2}}\Phi_{\bar{3}}\Phi_{\bar{4}}\delta\Phi_{\bar{5}}. \quad (\text{C.1.1})
\end{aligned}$$

This is a somewhat cumbersome expression but we proceed by collecting like terms.

First order is simply $\Delta\Phi_1 = \varepsilon\delta\Phi_1 + \dots$. Second order gives us

$$\dots + \varepsilon \int_{23} \left(\delta \{D(123)\Phi_{\bar{2}}\Phi_{\bar{3}}\} + \delta\Phi_{\bar{2}}C(123)\Phi_{\bar{3}} + C(123)\Phi_{\bar{2}}\delta\Phi_{\bar{3}} \right) + \dots$$

and further, when the coefficients C and D are written explicitly in terms of their arguments, rearranged and momentum conservation used this becomes (5.27),

$$\dots - \varepsilon \int_{23} \left\{ \frac{\hat{q}}{\hat{1}} \delta \{D(-23)\Phi_{\bar{2}}\Phi_{\bar{3}}\} + \frac{\hat{q}}{\hat{1}} \delta\Phi_{\bar{2}}D(-31)\Phi_{\bar{3}} + \frac{\hat{q}}{\hat{1}} D(-12)\Phi_{\bar{2}}\delta\Phi_{\bar{3}} \right\}.$$

We shall now extract the third order terms, carefully multiplying out the brackets and keeping terms cubic in Φ and then relabeling variables of integration. We arrive

at

$$\begin{aligned} \dots + \varepsilon \int_{234} \left\{ \delta \{D(1234)\Phi_2\Phi_3\Phi_4\} + \right. \\ + C(154)\delta \{D(-523)\Phi_2\Phi_3\} \Phi_4 + C(125)\Phi_2\delta \{D(-534)\Phi_3\Phi_4\} + \\ + \delta\Phi_2 \{C(125)D(-534) + C(1234)\} \Phi_3\Phi_4 + \\ + \{C(154)D(-523) + C(1234)\} \Phi_2\Phi_3\delta\Phi_4 + \\ \left. + C(1234)\Phi_2\delta\Phi_3\Phi_4 \right\} + \dots \end{aligned}$$

and the first argument of the kernels C and D is equal to minus the sum of the remaining arguments. For example, in the second term, $-p_5 = -p_2 - p_3 = p_1 + p_4$. Now write individual terms in terms of the independent momenta using the expressions (5.15) and (5.17) to arrive at our third order expression

$$\begin{aligned} \dots + \varepsilon \int_{234} \left\{ \delta \left\{ \frac{-\hat{5}\hat{2}\hat{3}\hat{4}}{(5,2)(5,2+3)} \Phi_2\Phi_3\Phi_4 \right\} - \frac{\hat{5}\hat{4}}{(5,4)} \delta \left\{ \frac{\hat{2}\hat{3}}{(-5,2)} \Phi_2\Phi_3 \right\} \Phi_4 \right. \\ - \frac{\hat{2}\hat{5}}{(2,5)} \Phi_2 \delta \left\{ \frac{\hat{3}\hat{4}}{(-5,3)} \Phi_3\Phi_4 \right\} + \delta\Phi_2 \frac{\hat{2}\hat{3}\hat{4}}{(2,3)(2,3+4)} \Phi_3\Phi_4 \\ \left. + \Phi_2\delta\Phi_3 \frac{\hat{2}\hat{3}\hat{4}}{(3,4)(3,4+1)} \Phi_4 + \Phi_2\Phi_3\delta\Phi_4 \frac{\hat{2}\hat{3}\hat{4}^2}{(4,1)(4,1+2)} \right\} + \dots \end{aligned}$$

These calculations are almost identical to those performed in appendix (B.1) so the reader may wish to check these calculations by referring to this paper to verify that the final expression is indeed (5.28). The fourth order expression is also calculable without a great deal of effort. By writing the fourth order terms out, and then expressing them in terms of independent momenta in the above manner, we find that the calculations are again similar to those in appendix (B.1) (See the equation (B.1.1)) and so proceed with the calculation in the same manner to find simpler expressions, and then write in terms of the kernel D . We get

$$\begin{aligned}
\cdots - \varepsilon \int_{2345} & \left\{ \frac{\hat{q}}{\hat{1}} \delta \{D(-2345)\Phi_2\Phi_3\Phi_4\Phi_5\} + \frac{\hat{q}}{\hat{1}} \delta \{D(-234)\Phi_2\Phi_3\Phi_4\} D(q51)\Phi_5 \right. \\
& + \frac{\hat{q}}{\hat{1}} \Phi_2 \delta \{D(-345)\Phi_3\Phi_4\Phi_5\} D(-12) + \frac{\hat{q}}{\hat{1}} \delta \{D(-23)\Phi_2\Phi_3\} D(-45)\Phi_4\Phi_5 \\
& + \frac{\hat{q}}{\hat{1}} \Phi_2 \delta \{D(-34)\Phi_3\Phi_4\} D(q51)\Phi_5 + \frac{\hat{q}}{\hat{1}} \Phi_2\Phi_3 \delta \{D(-45)\Phi_4\Phi_5\} \\
& + \frac{\hat{q}}{\hat{1}} \delta \Phi_2 D(-3451)\Phi_3\Phi_4\Phi_5 + \frac{\hat{q}}{\hat{1}} \Phi_2 \delta \Phi_3 D(-4512)\Phi_4\Phi_5 \\
& \left. + \frac{\hat{q}}{\hat{1}} \Phi_2\Phi_3 \delta \Phi_4 D(-5123)\Phi_5 + \frac{\hat{q}}{\hat{1}} D(-1234)\Phi_2\Phi_3\Phi_4 \delta \Phi_5 \right\} + \cdots
\end{aligned} \tag{C.1.2}$$

It is not hard to envisage that this continues to all orders and we can therefore hypothesize a final result to all orders in perturbation theory, given by (5.29)

Bibliography

- [1] M. E. Peskin and D. V. Schroeder, *An Introduction to Quantum Field Theory*. Westview Press, Princeton, New Jersey, 1st ed., 1995.
- [2] F. A. Cachazo, *Mhv diagrams and tree amplitudes of gluons*, *PoS jhw2004* (2004) 015. 7 p.
- [3] L. J. Dixon, *Calculating scattering amplitudes efficiently*, [hep-ph/9601359](#).
- [4] M. L. Mangano and S. J. Parke, *Multi-Parton Amplitudes in Gauge Theories*, *Phys. Rept.* **200** (1991) 301–367, [[hep-th/0509223](#)].
- [5] E. Witten, *Perturbative gauge theory as a string theory in twistor space*, *Commun. Math. Phys.* **252** (2004) 189–258, [[hep-th/0312171](#)].
- [6] F. Cachazo, P. Svrcek, and E. Witten, *MHV vertices and tree amplitudes in gauge theory*, *JHEP* **09** (2004) 006, [[hep-th/0403047](#)].
- [7] L. Mason and D. Skinner, *Scattering Amplitudes and BCFW Recursion in Twistor Space*, [arXiv:0903.2083](#).
- [8] N. Arkani-Hamed, F. Cachazo, C. Cheung, and J. Kaplan, *The S-Matrix in Twistor Space*, *JHEP* **03** (2010) 110, [[arXiv:0903.2110](#)].
- [9] R. Penrose, *Twistor Algebra*, *J. Math. Phys* **08** (1967) 345.
- [10] S. J. Parke and T. R. Taylor, *An Amplitude for n Gluon Scattering*, *Phys. Rev. Lett.* **56** (1986) 2459.
- [11] R. Britto, F. Cachazo, and B. Feng, *New Recursion Relations for Tree Amplitudes of Gluons*, *Nucl. Phys.* **B715** (2005) 499–522, [[hep-th/0412308](#)].

- [12] R. Britto, F. Cachazo, B. Feng, and E. Witten, *Direct proof of tree-level recursion relation in yang-mills theory*, *Physical Review Letters* **94** (2005) 181602.
- [13] L. Brink, H. Schwarz, and J. Scherk, *Supersymmetric Yang-Mills Theories*, *Nucl. Phys B* **121** (1977) 77.
- [14] F. Gliozzi, J. Scherk, and D. I. Olive, *Supersymmetry, Supergravity And The Dual Spinor Model*, *Nucl. Phys B* **121** (1977) 253.
- [15] A. Brandhuber, P. Heslop, and G. Travaglini, *A note on dual superconformal symmetry of the $N=4$ super Yang-Mills S -matrix*, *Phys. Rev.* **D78** (2008) 125005, [arXiv:0807.4097].
- [16] N. Arkani-Hamed, F. Cachazo, and J. Kaplan, *What is the Simplest Quantum Field Theory?*, arXiv:0808.1446.
- [17] H. Elvang, D. Z. Freedman, and M. Kiermaier, *Recursion Relations, Generating Functions, and Unitarity Sums in $N=4$ SYM Theory*, *JHEP* **04** (2009) 009, [arXiv:0808.1720].
- [18] M. Bianchi, H. Elvang, and D. Z. Freedman, *Generating Tree Amplitudes in $N=4$ SYM and $N = 8$ SG*, *JHEP* **09** (2008) 063, [arXiv:0805.0757].
- [19] J. M. Drummond and J. M. Henn, *All tree-level amplitudes in $N=4$ SYM*, *JHEP* **04** (2009) 018, [arXiv:0808.2475].
- [20] A. Brandhuber, P. Heslop, and G. Travaglini, *Proof of the Dual Conformal Anomaly of One-Loop Amplitudes in $N=4$ SYM*, *JHEP* **10** (2009) 063, [arXiv:0906.3552].
- [21] T. Bargheer, N. Beisert, W. Galleas, F. Loebbert, and T. McLoughlin, *Extracting $N=4$ Superconformal Symmetry*, *JHEP* **11** (2009) 056, [arXiv:0905.3738].

- [22] J. M. Drummond, J. Henn, G. P. Korchemsky, and E. Sokatchev, *Dual superconformal symmetry of scattering amplitudes in $N=4$ super-Yang-Mills theory*, *Nucl. Phys.* **B828** (2010) 317–374, [[arXiv:0807.1095](#)].
- [23] N. Beisert, *On Yangian Symmetry in Planar $N=4$ SYM*, [arXiv:1004.5423](#).
- [24] N. Beisert, *T-Duality, Dual Conformal Symmetry and Integrability for Strings on $AdS_5 \times S^5$* , *Fortschr. Phys.* **57** (2009) 329–337, [[arXiv:0903.0609](#)].
- [25] N. Beisert, R. Ricci, A. A. Tseytlin, and M. Wolf, *Dual Superconformal Symmetry from $AdS_5 \times S^5$ Superstring Integrability*, *Phys. Rev.* **D78** (2008) 126004, [[arXiv:0807.3228](#)].
- [26] D. Bernard, 2, *An Introduction to Yangian Symmetries*, *Int. J. Mod. Phys.* **B7** (1993) 3517–3530, [[hep-th/9211133](#)].
- [27] J. M. Drummond, J. M. Henn, and J. Plefka, *Yangian symmetry of scattering amplitudes in $N=4$ super Yang-Mills theory*, *JHEP* **05** (2009) 046, [[arXiv:0902.2987](#)].
- [28] N. Beisert, J. Henn, T. McLoughlin, and J. Plefka, *One-Loop Superconformal and Yangian Symmetries of Scattering Amplitudes in $N=4$ Super Yang-Mills*, *JHEP* **04** (2010) 085, [[arXiv:1002.1733](#)].
- [29] A. Brandhuber, P. Heslop, and G. Travaglini, *One-Loop Amplitudes in $N=4$ Super Yang-Mills and Anomalous Dual Conformal Symmetry*, *JHEP* **08** (2009) 095, [[arXiv:0905.4377](#)].
- [30] P. Mansfield, *The lagrangian origin of $m\bar{h}v$ rules*, *JHEP* **0603** (2006) 037.
- [31] J. H. Eittle and T. R. Morris, *Structure of the $m\bar{h}v$ -rules lagrangian*, *JHEP* **0608** (2006) 003.
- [32] L. Dolan, *Kac-Moody algebras and exact solvability in hadronic physics*, *physrep* **109** (July, 1984) 1–94.
- [33] R. Gilmore, *Lie Groups, Lie algebras and Some of Their Applications*. Wiley, New York, US, 1st ed., 1974.

- [34] D.M.Lipkin, *Existence of a new conservation law in electro-magnetic theory*, *J.Math. Phys* **5** 696–700.
- [35] I. Bena, J. Polchinski, and R. Roiban, *Hidden symmetries of the AdS(5) x S(5) superstring*, *Phys. Rev.* **D69** (2004) 046002, [hep-th/0305116].
- [36] L. Dolan, C. R. Nappi, and E. Witten, *A relation between approaches to integrability in superconformal Yang-Mills theory*, *JHEP* **10** (2003) 017, [hep-th/0308089].
- [37] G. Chalmers and W. Siegel, *The self-dual sector of QCD amplitudes*, *Phys. Rev.* **D54** (1996) 7628–7633, [hep-th/9606061].
- [38] H. Feng and Y. tin Huang, *Mhv lagrangian for n=4 super yang-mills*, *JHEP* **0904** (2009) 047.
- [39] N.J.Hitchin, *The Self-Duality Equations on a Riemann Surface*, *Proc. London Math. Soc* **55** (1986) 59–126.
- [40] J. Fuchs, *Affine Lie Algebras and Quantum Groups*. Cambridge University Press, Cambridge UK, 1st ed., 1992.
- [41] N. Beisert, *The complete one-loop dilatation operator of N = 4 super Yang-Mills theory*, *Nucl. Phys.* **B676** (2004) 3–42, [hep-th/0307015].
- [42] D.B.Fairlie, *Conservation laws and invariance principles*, *Il Nuovo Cimento, Serie X* **vol 37** 897–904.
- [43] M.Nakahara, *Geometry, Topology and Physics*. IOP publishing, Bristol UK, 1st ed., 1990.
- [44] R. d’Inverno, *Introducing Einstein’s Relativity*. Oxford University Press, Oxford, UK, 1st ed., 1992.
- [45] O. Aharony, S. S. Gubser, J. M. Maldacena, H. Ooguri, and Y. Oz, *Large N field theories, string theory and gravity*, *Phys. Rept.* **323** (2000) 183–386, [hep-th/9905111].

- [46] G. James and M. Liebeck, *Representations and Characters of Groups*. Cambridge University Press, Cambridge, UK, 1st ed., 1993.
- [47] K. Erdman and M. J. Wildon, *Introduction to Lie Algebras*. Springer, London, UK, 1st ed., 2006.
- [48] V. G. Kac, *Infinite dimensional Lie algebras*. Cambridge University Press, Cambridge, England, 3rd ed., 1990.
- [49] R. Gilmore, *Lie Groups, Physics and Geometry An Introduction for Physicists, Engineers and Chemists*. Cambridge University Press, New York, US, 1st ed., 2008.
- [50] R. M. Muradyan, *On Discrete Subgroups of the Three-Dimensional Rotation Group*, *Theoretical and Mathematical Physics* **46** (1981) 219–227.
- [51] A. Gorsky and A. Rosly, *From Yang-Mills Lagrangian to MHV diagrams*, *JHEP* **01** (2006) 101, [[hep-th/0510111](#)].
- [52] W. Bardeen, *Self-Dual Yang-Mills Theory, Integrability and Multiparton Amplitudes*, *Prog. Theor. Phys. suppl.* **123** (1996) 1.
- [53] C. Adam, J. Sanchez-Guillen, and A. Wereszczynski, *Infinitely many conservation laws in self-dual Yang–Mills theory*, *JHEP* **0809** (2008) [[hep-th/0804.4418](#)].
- [54] A. D. Popov and M. Wolf, *Hidden symmetries and integrable hierarchy of the $N = 4$ supersymmetric Yang-Mills equations*, *Commun. Math. Phys.* **275** (2007) 685–708, [[hep-th/0608225](#)].
- [55] M. Wolf, *On hidden symmetries of a super gauge theory and twistor string theory*, *JHEP* **02** (2005) 018, [[hep-th/0412163](#)].
- [56] R. Boels, L. Mason, and D. Skinner, *Supersymmetric gauge theories in twistor space*, *JHEP0702* **014** (2007).
- [57] L. J. Mason and D. Skinner, *An ambitwistor yang-mills lagrangian*, *Physics Letters B* **636** (2006) 60.

- [58] R. Boels, L. Mason, and D. Skinner, *From twistor actions to mhw diagrams*, *Physics Letters B* **648** (2007) 90.
- [59] R. Boels, *A quantization of twistor yang-mills theory through the background field method*, *Physical Review D* **76** (2007) 105027.
- [60] R. Boels, C. Schwinn, and S. Weinzierl, *Recent developments for multi-leg qcd amplitudes with massive particles*, 2007.
- [61] R. Boels and C. Schwinn, *Deriving csw rules for massive scalar legs and pure yang-mills loops*, *JHEP0807* **007** (2008).
- [62] R. Boels and C. Schwinn, *Csw rules for massive matter legs and glue loops*, *Nuclear Physics B - Proceedings Supplements* **183** (2008) 137.
- [63] W. Jiang, *Aspects of Yang-Mills theory in twistor space*. D.Phil in mathematics, Oriel College, Oxford, Mathematical, Physical and Life Sciences Division - Mathematical Institute, 2008.
- [64] J. H. Eittle, C.-H. Fu, J. P. Fudger, P. R. W. Mansfield, and T. R. Morris, *S-matrix equivalence theorem evasion and dimensional regularisation with the canonical mhw lagrangian*, *JHEP0705* **011** (2007).
- [65] C.-H. Fu, J. Fudger, P. R. W. Mansfield, T. R. Morris, and Z. Xiao, *S-matrix equivalence restored*, [arXiv:0902.1906](https://arxiv.org/abs/0902.1906).
- [66] L. Brink, J. H. Schwarz, and J. Scherk, *Supersymmetric Yang-Mills Theories*, *Nucl. Phys.* **B121** (1977) 77.
- [67] J. Wess and J. Bagger, *Supersymmetry and Supergravity*. Princeton University Press, Princeton, New Jersey, 1st ed., 1983.
- [68] M. A. C. Kneipp, *Hitchin's equations and integrability of BPS $Z(N)$ strings in Yang-Mills theories*, *JHEP* **11** (2008) 049, [[arXiv:0801.0720](https://arxiv.org/abs/0801.0720)].
- [69] M. Bochiocchio, *Solving loop equations by Hitchin systems via holography in large- N QCD(4)*, *JHEP* **06** (2003) 026, [[hep-th/0305088](https://arxiv.org/abs/hep-th/0305088)].

-
- [70] R. A. Mosna and M. Jardim, *Nonsingular solutions of Hitchin's equations for noncompact gauge groups*, *Nonlinearity* **20** (2007) 1893.
- [71] T. A. Ivanova and A. D. Popov, *Selfdual Yang-Mills fields and Nahm's equations*, *Lett. Math. Phys.* **23** (1991) 29–34.
- [72] L. Dolan, *A new symmetry group of real self-dual Yang-Mills theory*, *Phys. Lett. B* **113** (1982) 387–390.
- [73] L.-L. Chau, G. Mo-Lin, and W. Yong-Shi, *Kac-moody algebra in the self-dual yang-mills equation*, *Phys. Rev. D* **25** (Feb, 1982) 1086–1094.
- [74] A. Popov and C. Preitschopf, *Extended conformal symmetries of the self-dual yang-mills equations*, *Phys. Lett B* **374** (1996) 71–79.
- [75] A. D. Popov, *Self-dual Yang-Mills: Symmetries and moduli space*, *Rev. Math. Phys.* **11** (1999) 1091–1149, [[hep-th/9803183](#)].
- [76] T. A. Ivanova and O. Lechtenfeld, *Hidden symmetries of the open $N = 2$ string*, *Int. J. Mod. Phys.* **A16** (2001) 303–329, [[hep-th/0007049](#)].