

Durham E-Theses

Multi Agent Systems for the Active Management of Electrical Distribution Networks

PAVLOS TRICHAKIS

How to cite:

TRICHAKIS, PAVLOS (2009) Multi Agent Systems for the Active Management of Electrical Distribution Networks. Doctoral thesis, Durham University.

Use policy

The full-text may be used and/or reproduced, and given to third parties in any format or medium, without prior permission or charge, for personal research or study, educational, or not-for-profit purposes provided that:

- a full bibliographic reference is made to the original source
- a <https://etheses.durham.ac.uk/id/eprint/57/> is made to the metadata record in Durham E-Theses
- the full-text is not changed in any way

The full-text must not be sold in any format or medium without the formal permission of the copyright holders.

Please consult the [full Durham E-Theses policy](#) for further details.

Multi Agent Systems for the Active Management of Electrical Distribution Networks

Pavlos Trichakis

School of Engineering
Durham University

A thesis submitted in partial fulfilment of the requirements of the Council of the
University of Durham for the Degree of Doctor of Philosophy (PhD)

2009

Multi Agent Systems for the Active Management of Electrical Distribution Networks

Pavlos Trichakis

Abstract

This Thesis presents an investigation on the technical impacts caused by the steady-state operation of Small-Scale Embedded Generators (SSEGs) and also introduces the Small Scale Energy Zone (SSEZ) concept which aims to remove the technical barriers associated with SSEGs through intelligent coordination of large numbers of customer-owned SSEGs, energy storage units and controllable loads. This approach represents a move away from the conventional passive, “fit-and-forget” philosophy under which the majority of Low Voltage (LV) distribution networks are currently operated and towards a higher degree of network operational management.

The employment of a distributed management and control approach for an SSEZ, realised through the Multi Agent Systems (MAS) technology, is proposed due to the advantages that can potentially be realised in the areas of: (i) scalability and openness, (ii) reliability and resilience and (iii) communications efficiency. A FIPA-compliant MAS-based control approach is designed, developed and evaluated based on the specific SSEZ control requirements. The MAS is composed of three types of agents: direct control agents, indirect control agents and utility agents, exchanging information through the employment of a common ontology. In addition, a relational database management system is also designed and developed in order to be coupled with the developed MAS for data management purposes.

Acknowledgements

I would like to thank my supervisor, Prof. Phil Taylor, for his continuous support and guidance during my time at Durham. I would also like to thank Dr. Graham Coates and Mr. Richard Hair for providing their technical expertise and E.ON UK Power Technology for financing this project. Moreover, special thanks to the members of the Board of Examiners, Prof. Nikos Hatziargyriou from the National Technical University of Athens and Prof. Peter Tavner from Durham University, for agreeing to review my work and for finding it worthwhile. Finally, heartfelt thanks to my family for their moral and spiritual support during these three years.

Declaration

I hereby declare that this thesis is a record of work undertaken by myself, that it has not been the subject of any previous application for a degree, and that all sources of information have been duly acknowledged.

© Copyright 2009, Pavlos Trichakis

Copyright of this thesis rests with the author. No quotation from it should be published without prior written consent and information derived from it should be acknowledged.

CONTENTS

LIST OF FIGURES	X
------------------------------	----------

LIST OF TABLES	XIV
-----------------------------	------------

LIST OF PUBLICATIONS.....	XVII
----------------------------------	-------------

GLOSSARY OF ABBREVIATIONS.....	XVIII
---------------------------------------	--------------

CHAPTER 1.

INTRODUCTION.....	1
--------------------------	----------

1.1. BACKGROUND.....	4
----------------------	---

1.2. SMALL SCALE ENERGY ZONES	11
-------------------------------------	----

1.3. RESEARCH OBJECTIVES	18
--------------------------------	----

1.4. THESIS OUTLINE	19
---------------------------	----

CHAPTER 2.

DISTRIBUTION NETWORKS CONTROL.....	21
---	-----------

2.1. EXISTING CONTROL APPROACH.....	22
-------------------------------------	----

2.2. PASSIVE NETWORKS	25
-----------------------------	----

2.3. ACTIVE NETWORKS	26
----------------------------	----

2.3.1. RELEVANT WORK	29
----------------------------	----

2.3.2. INFORMATION AND COMMUNICATION TECHNOLOGIES	30
---	----

2.3.3. INTELLIGENT ELECTRONIC DEVICES	34
---	----

2.4.	SSEG CONTROL	35
2.5.	LOAD CONTROL	38
2.6.	ESU CONTROL.....	41
2.7.	CONCLUSIONS.....	43

CHAPTER 3.

MULTI AGENT SYSTEMS	45
3.1. AGENT AND MAS ATTRIBUTES	46
3.2. ARCHITECTURAL STYLES.....	47
3.2.1. INDIVIDUAL AGENT ARCHITECTURES	47
3.2.2. MAS ARCHITECTURES.....	50
3.3. FIPA STANDARDS.....	51
3.3.1. WHY FIPA-COMPLIANCE?.....	53
3.3.2. AGENT PLATFORMS AND DEVELOPMENT KITS.....	54
3.3.3. AGENT INTERACTIONS	55
3.4. MAS APPLICATIONS IN POWER ENGINEERING.....	57
3.5. CONCLUSIONS.....	58

CHAPTER 4.

SSEG TECHNICAL IMPACT STUDIES	60
4.1. TECHNICAL CHALLENGES	61
4.1.1. CUSTOMER VOLTAGE RISE/DROP	61
4.1.2. VOLTAGE REGULATION	66
4.1.3. VOLTAGE UNBALANCE	67
4.1.4. THERMAL LIMITS	69
4.1.5. NETWORK LOSSES	71

4.2.	CASE STUDY NETWORKS	72
4.2.1.	UK GENERIC LV DISTRIBUTION NETWORK	73
4.2.2.	EUROPEAN GENERIC LV DISTRIBUTION NETWORK	74
4.2.3.	UK EXISTING LV DISTRIBUTION NETWORK	75
4.3.	MODELLING APPROACH.....	76
4.4.	SIMULATION RESULTS	78
4.4.1.	CUSTOMER VOLTAGE RISE AND VOLTAGE REGULATION.....	79
4.4.2.	VOLTAGE UNBALANCE	82
4.4.3.	THERMAL LIMITS	85
4.4.4.	NETWORK LOSSES.....	86
4.5.	PROPOSED METHODOLOGY	88
4.5.1.	APPARENT IMPEDANCE	89
4.5.2.	DESCRIPTION OF THE METHODOLOGY	92
4.5.3.	APPLICATION OF THE METHODOLOGY	92
4.5.3.1.	CUSTOMER VOLTAGE RISE	94
4.5.3.2.	VOLTAGE REGULATION	96
4.5.3.3.	VOLTAGE UNBALANCE	97
4.5.3.4.	CABLE THERMAL LIMITS	97
4.5.3.5.	TRANSFORMER THERMAL LIMITS	98
4.5.3.6.	NETWORK LOSSES.....	98
4.5.4.	DISCUSSION	99
4.6.	CONCLUSIONS.....	100

CHAPTER 5.

CONTROL APPROACH SELECTION..... 103

5.1.	CONTROL REQUIREMENTS OF AN SSEZ.....	104
------	--------------------------------------	-----

5.1.1. LOW VOLTAGE DISTRIBUTION NETWORK CONSTRAINTS.....	105
5.1.2. OPERATIONAL GOALS	106
5.2. POTENTIAL CONTROL APPROACH FOR AN SSEZ.....	108
5.2.1. CENTRALISED CONTROL APPROACH	110
5.2.2. DISTRIBUTED CONTROL APPROACH.....	111
5.2.3. WHY MAS FOR THE CONTROL OF AN SSEZ?.....	113
5.3. CONCLUSIONS.....	116

CHAPTER 6.

DESIGN OF THE SSEZ CONTROL SYSTEM..... 118

6.1. CASE STUDY SSEZ.....	119
6.2. TASK DECOMPOSITION	121
6.3. DESCRIPTION OF SYSTEM AGENTS.....	123
6.3.1. DIRECT CONTROL AGENTS	125
6.3.2. INDIRECT CONTROL AGENTS	126
6.3.3. UTILITY AGENTS.....	128
6.3.4. COMMUNICATION LINKS.....	129
6.4. OPERATING STATES OF SYSTEM AGENTS.....	133
6.4.1. NORMAL STATE	134
6.4.2. ALERT STATE.....	136
6.4.3. EMERGENCY STATE	138
6.5. AGENT REASONING.....	139
6.5.1. RULE-BASED REASONING	140
6.5.2. CONFLICT RESOLUTION	142
6.6. AGENT COORDINATION.....	143
6.6.1. ONTOLOGY DESIGN.....	144

6.6.2. AGENT INTERACTIONS	148
6.7. RELATIONAL DATABASE MANAGEMENT SYSTEM	149
6.7.1. ARCHITECTURE OF THE RDBMS	150
6.7.2. FUNCTIONALITY OF THE RDBMS	154
6.7.3. DESIGN OF THE RDBMS	155
6.8. CONCLUSIONS.....	156
CHAPTER 7.	
SSEZ CONTROL SYSTEM SOFTWARE DEVELOPMENT	158
7.1. JAVA AGENT DEVELOPMENT FRAMEWORK - JADE.....	160
7.1.1. WHY JADE ?	162
7.1.2. AGENT SERVICES	163
7.1.3. INTER-AGENT MESSAGING	165
7.1.4. ONTOLOGY.....	166
7.1.5. AGENT REASONING.....	170
7.2. MYSQL.....	172
7.2.1. WHY MYSQL ?	173
7.2.2. DEVELOPING THE RDBMS	175
7.2.3. JAVA DATABASE CONNECTIVITY - JDBC	178
7.3. CONCLUSIONS.....	179
CHAPTER 8.	
EVALUATION OF THE SSEZ CONTROL SYSTEM	180
8.1. POWER SYSTEMS EVALUATION.....	182
8.1.1. CUSTOMER VOLTAGE RISE	185
8.1.2. VOLTAGE REGULATION	195

8.1.3. VOLTAGE UNBALANCE	202
8.1.4. THERMAL LIMITS	209
8.1.5. NETWORK LOSSES.....	216
8.1.6. OPERATIONAL GOALS	219
8.2. SCALABILITY AND OPENNESS	224
8.3. RESILIENCE AND RELIABILITY	226
8.4. COMMUNICATIONS EFFICIENCY	230
8.5. EXPERIMENTAL EVALUATION.....	234
8.6. CONCLUSIONS.....	238
CHAPTER 9.	
CONCLUSIONS AND FURTHER WORK	239
9.1. CONCLUSIONS.....	240
9.2. FURTHER WORK	251
9.2.1. EXTENSION OF THE RESEARCH.....	251
9.2.2. FURTHER EVALUATION	253
REFERENCES.....	254
APPENDIX A	268
APPENDIX B	270
APPENDIX C	278

List of Figures

<u>Figure 1.1:</u> Conventional structure of electrical power systems.....	5
<u>Figure 1.2:</u> Structure of electrical power systems with DG and SSEG present.....	8
<u>Figure 1.3:</u> Coincidence factor curve for a typical LV distribution network.....	12
<u>Figure 1.4:</u> A Small Scale Energy Zone.....	13
<u>Figure 1.5:</u> A Small Scale Energy Zone within a typical LV network – no control...	14
<u>Figure 1.6:</u> An SSEG connected to an infinite bus.....	15
<u>Figure 1.7:</u> Architecture of a centralised Virtual Power Station.....	17
<u>Figure 2.1:</u> A Supervisory Control and Data Acquisition system.....	23
<u>Figure 2.2:</u> Example of an active transmission and distribution system.....	27
<u>Figure 2.3:</u> Typical telecommunication setup in distribution networks.....	31
<u>Figure 2.4:</u> A small-scale wind turbine, PV panel and dCHP installation	36
<u>Figure 2.5:</u> Block diagram showing a typical SSEG installation.....	38
<u>Figure 2.6:</u> Block diagram showing a typical ESU installation.....	38
<u>Figure 3.1:</u> Structure of an agent with a deliberative architecture.....	48
<u>Figure 3.2:</u> The PRS agent architecture.....	48
<u>Figure 3.3:</u> Horizontal, one-pass control vertical and two-pass control vertical layered architectures	49
<u>Figure 3.4:</u> The layered architecture employed by JADE agents	50
<u>Figure 3.5:</u> The FIPA Agent Management Reference Model.....	52
<u>Figure 3.6:</u> The entities that comprise a FIPA-compliant AP.....	53
<u>Figure 3.7:</u> The FIPA Message Transport Reference Model.....	56

<u>Figure 4.1:</u> Single-line diagram of a feeder with a 3-phase load connected.....	63
<u>Figure 4.2:</u> Single-line diagram of a feeder with one 3-phase load and one 3-phase SSEG connected at the end.....	64
<u>Figure 4.3:</u> Single-line diagram of the UK generic LV distribution network.....	73
<u>Figure 4.4:</u> Single-line diagram of the European generic LV distribution network....	74
<u>Figure 4.5:</u> Single-line diagram of the existing UK LV distribution network.....	75
<u>Figure 4.6:</u> Results for %VUF in the UK generic network.....	84
<u>Figure 4.7:</u> Results for network losses in the UK generic network.....	87
<u>Figure 5.1:</u> Centralised control operation for an SSEZ.....	109
<u>Figure 5.2:</u> Distributed control operation for an SSEZ.....	110
<u>Figure 6.1:</u> The design of the SSEZ control system.....	119
<u>Figure 6.2:</u> The case study SSEZ under a passive control approach.....	121
<u>Figure 6.3:</u> Task hierarchy for overcoming the identified LV network constraints..	122
<u>Figure 6.4:</u> Task hierarchy for meeting an identified operational goal.....	123
<u>Figure 6.5:</u> The FIPA-based SSEZ agent platform management model.....	125
<u>Figure 6.6:</u> The MAS-based control approach on the case study SSEZ.....	129
<u>Figure 6.7:</u> Control architecture for connectivity between a JAVA-based generator agent and an inverter-based SSEG.....	131
<u>Figure 6.8:</u> Agent communication links using broadband and the public Internet...	132
<u>Figure 6.9:</u> Flow chart of the proposed MAS-based control system.....	133
<u>Figure 6.10:</u> The ontology for the MAS-based control of an SSEZ	147
<u>Figure 6.11:</u> Message sequence diagram for the voltage unbalance task of a UA....	148
<u>Figure 6.12:</u> The MAS-based approach and RDBMS on the case study SSEZ.....	152

<u>Figure 7.1:</u> SSEZ control system software development.....	160
<u>Figure 7.2:</u> FIPA message structure.....	166
<u>Figure 7.3:</u> The AgentActions and Concepts of the developed ontology.....	169
<u>Figure 7.4:</u> Using the MySQL Administrator in order to provide an overview of the databases running within the developed DBMS.....	178
<u>Figure 8.1:</u> The evaluation process of the developed control system.....	181
<u>Figure 8.2:</u> The case study SSEZ under a passive control approach.....	182
<u>Figure 8.3:</u> Probability of having different proportions of SSEG capacity available for different availabilities.....	185
<u>Figure 8.4:</u> Feeder voltages at different time intervals – no control.....	187
<u>Figure 8.5:</u> Feeder voltages at different time intervals – MAS control.....	192
<u>Figure 8.6:</u> Instantaneous customer voltages showing the dynamic operation of the MAS-based control system.....	194
<u>Figure 8.7:</u> Instantaneous current showing the dynamic operation of the MAS-based control system.....	195
<u>Figure 8.8:</u> Voltage regulation under the devised simulation scenarios.....	201
<u>Figure 8.9:</u> Instantaneous voltage phasors at the remote ends of the case study SSEZ.....	205
<u>Figure 8.10:</u> % VUF under the devised simulation scenarios.....	208
<u>Figure 8.11:</u> Apparent power flow at the PCC under the devised simulation scenarios.....	214
<u>Figure 8.12:</u> Apparent power flow at the PCC – dynamic operation.....	215
<u>Figure 8.13:</u> Instantaneous three phase currents at the SSEZ PCC showing the dynamic operation of the MAS-based control system.....	215

<u>Figure 8.14:</u> The case study SSEZ with direct control agents installed.....	225
<u>Figure 8.15:</u> A JADE platform without and with the main container replication service.....	229
<u>Figure 8.16:</u> View of the Experimental SSEZ at Durham University.....	235
<u>Figure 8.17:</u> Application of an agent-based approach to the Experimental SSEZ....	235
<u>Figure 8.18:</u> Operation of over-voltage agents in the Experimental SSEZ	237
<u>Figure C-1:</u> An example of a TLA accessing a database through the use of JDBC..	282

List of Tables

<u>Table 2.1:</u> Voltage and frequency limits for the protection devices used for SSEGs connected in UK LV distribution networks	37
<u>Table 4.1:</u> Allowable SSEG volumes for the UK and European generic networks for permissible voltage regulation and voltage rise limits.....	82
<u>Table 4.2:</u> Allowable SSEG volumes on one phase of one 400V feeder of the UK and European generic network for voltage unbalance limits.....	85
<u>Table 4.3:</u> Allowable SSEG volumes for the UK and European generic network for cable and transformer thermal limits.....	86
<u>Table 4.4:</u> Network losses for different SSEG penetrations and power factors for the UK generic network under minimum and maximum loading conditions.....	87
<u>Table 4.5:</u> Key factors causing adverse SSEG technical impacts that need to be considered in a methodology for assessing allowable SSEG volumes in a network.....	88-89
<u>Table 4.6:</u> Inherent network characteristics of the case study existing public UK network.....	93
<u>Table 4.7:</u> Allowable SSEG volumes for the case study public UK LV network using the methodology compared to the accurate results produced by simulation.....	99
<u>Table 4.8:</u> Allowable SSEG volumes for the three case study LV networks.....	102
<u>Table 6.1:</u> Required individual agent attributes of the MAS control approach.....	124
<u>Table 6.2:</u> Rules for agent behaviour in the proposed MAS.....	141

<u>Table 7.1:</u> Services offered by system agents within the developed MAS	164
<u>Table 7.2:</u> The different commands exchanged by system agents for action execution within the developed MAS	172
<u>Table 7.3:</u> Database developed in MySQL for a controllable consumer demand that is coupled with the CDA that controls it.....	177
<u>Table 8.1:</u> Limits for the operating parameters of the case study SSEZ	183
<u>Table 8.2:</u> Feeder voltages at different time intervals – no control.....	187
<u>Table 8.3:</u> SSEG power output per customer at which the upper alert state voltage limit of 253V is exceeded on two different feeder locations.....	189
<u>Table 8.4:</u> Feeder voltages at different time intervals – emergency state operation..	193
<u>Table 8.5:</u> Steady-state voltage regulation under the devised simulation scenarios..	198
<u>Table 8.6:</u> SSEG power output per customer for which the % steady-state voltage regulation limits are exceeded in the case study SSEZ.....	199
<u>Table 8.7:</u> Resultant % VUF under the devised simulation scenarios.....	204
<u>Table 8.8:</u> SSEG power output per customer on phase A for which the % steady-state VUF limits are exceeded in the case study SSEZ.....	206
<u>Table 8.9:</u> Current and apparent power flows under the devised simulation scenarios.....	211
<u>Table 8.10:</u> SSEG power output per customer for which the cable “hot-spot” and transformer thermal limits are exceeded in the case study SSEZ.....	212
<u>Table 8.11:</u> Active power losses under the devised simulation scenarios for a SSEG power output per customer of 1kW.....	218
<u>Table 8.12:</u> Active power losses under the devised simulation scenarios for a SSEG power output per customer of 1.5kW.....	219

<u>Table 8.13:</u> Real power flows at the SSEZ PCC with the upstream distribution network under the devised simulation scenarios.....	224
<u>Table 8.14:</u> Communication delays of popular communication media.....	232
<u>Table 8.15:</u> Data rates (bps) of popular communication media.....	232
<u>Table 8.16:</u> Bandwidth requirements and response time requirements for different tasks within the developed control system.....	233
<u>Table A-1:</u> Conductor Cross-Sectional Area (CSA) [mm ²], Length [m], Impedance data [Ω /km] and maximum continuous current carrying capacity I_z per phase conductor [A] for the cables used in the case study UK network.....	268
<u>Table A-2:</u> Apparent resistance ($R_{\text{location}}^{(ap)}$) and reactance ($X_{\text{location}}^{(ap)}$) for the customer locations of the generic UK network, the European generic network and the case study public UK network.....	269
<u>Table B-1:</u> Database coupled to a SSEG unit and the GA that controls it.....	271
<u>Table B-2:</u> Database coupled to a controllable load and the CDA that controls it....	273
<u>Table B-3:</u> Database coupled to an ESU and the ESA that controls it.....	275
<u>Table B-4:</u> Database coupled to the indirect control agents within the SSEZ	277
<u>Table C-1:</u> Behaviour classes provided by JADE.....	278
<u>Table C-2:</u> FIPA ACL message parameters.....	279
<u>Table C-3:</u> FIPA ACL message performatives.....	280

List of Publications

Journal Papers:

- [1] Trichakis P., Taylor P., Hair R., Lyons, P. 'Predicting the technical impacts of high levels of small scale embedded generators on low voltage networks'. IET Renewable Power Generation, 2 (4): p. 249 – 262, December 2008.
- [2] Trichakis P., Taylor P., Coates G., Cipcigan L. 'A distributed control approach for small scale energy zones', Proceedings of the Institution of Mechanical Engineers, Part A, Journal of Power and Energy, 222 (2), p. 137-147, 2008.
- [3] Trichakis P., Taylor P., Lyons P., Hair, R. 'Transforming low voltage networks into small scale energy zones', Proceedings of the Institution of Civil Engineers, Journal of Energy, 162 (1), p. 37-46, February 2008.
- [4] Lyons P. Trichakis P. Taylor P., Coates, G. 'A practical implementation of a distributed control approach for MicroGrids'. Autosoft - Intelligent Automation and Soft Computing Journal, MicroGrids Special Edition, 16 (2), p. 315-330, 2009.

Conference Proceedings:

- [1] Trichakis P., Taylor P., Cipcigan L., Lyons P., Hair R., Ma, T. 'An investigation of voltage unbalance in low voltage distribution networks with high levels of SSEG'. 41st Universities Power Engineering Conference, Newcastle, UK, September 2006.
- [2] Lyons P., Taylor P., Cipcigan L., Trichakis P., Wilson A. 'Small scale energy zones and the impacts of high concentrations of small scale embedded generators', 41st Universities Power Engineering Conference, Newcastle, UK, September 2006.
- [3] Cipcigan L., Taylor P., Trichakis, P. 'The impact of small scale wind generators on LV distribution system voltage'. International Conference on Clean Electrical Power, Capri, Italy, May 2007.
- [4] Trichakis P, Taylor P, Lyons P, Hair R, Coates, G. 'An agent based control approach for Microgrids'. PowerGrid Europe Conference, Milan, Italy, June 2008.
- [5] Taylor P., Jupe S., Trichakis P., Michiorri A., Lyons, P. 'Active MV and LV distribution networks'. CIGRE-NGN Meeting, Paris, France, 2008.

Glossary of Abbreviations

AC – Alternating Current

ACC – Agent Communication Channel

ACL – Agent Communication Language

ADA – Advanced Distribution Automation

ADK – Agent Development Kit

AID – Agent Identifier

AMS – Agent Management System

ANM – Active Network Management

AP – Agent Platform

CCGT - Combined Cycle Gas Turbine

CHP – Combined Heat and Power

CDA – Consumer Demand Agent

CIM – Common Information Model

CSA – Cross Sectional Area

DC – Direct Current

DCS – Distributed Control System

DF – Directory Facilitator

DMS – Distribution Management System

DNO - Distribution Network Operator

DSL – Digital Subscriber Line

DSM – Demand Side Management

EMS – Energy Management System

ESA – Energy Storage Agent

ESM – Energy Storage Management

ESU – Energy Storage Unit

EV – Electric Vehicle

FIPA – Foundation for Intelligent Physical Agents

GA – Generator Agent

GUI – Graphical User Interface

HV – High Voltage

ICT – Information and Communication Technologies

IED – Intelligent Electronic Device

JADE – Java Agent Development Framework

JDBC – Java Database Connectivity

JVM – Java Virtual Machine

KQML – Knowledge Query and Manipulation Language

LAN – Local Area Network

LV – Low Voltage

MAS – Multi Agent System

MTS – Message Transport Service

MV – Medium Voltage

OGA – Operational Goals Agent

OLE – Object Linking and Embedding

OLTC – On Load Tap Changers

OPC – OLE Process Control

PCC – Point of Common Coupling

PHEV – Plug-in Hybrid Electric Vehicles

PLC – Power Line Carrier

PV – Photovoltaic

RES – Renewable Energy Sources

RDBMS – Relational Database Management System

RTU – Remote Terminal Unit

SAS – Substation Automation System

SCADA – System Control And Data Acquisition

SMES - Superconducting Magnetic Energy Storage

SOC – Service Oriented Computing

SQL – Structured Query Language

SSEG - Small Scale Embedded Generation

SSEZ - Small Scale Energy Zone

TCP/IP – Transmission Control Protocol / Internet Protocol

TLA – Thermal Limits Agent

TSO – Transmission System Operator

UA – Unbalance Agent

VPP – Virtual Power Plant

VPS – Virtual Power Station

VRA – Voltage Regulation Agent

VUF – Voltage Unbalance Factor

WAN – Wide Area Network

CHAPTER 1

Introduction

The following Chapter examines the context of this research and its relevance to the challenges and opportunities facing future electrical distribution networks, in particular at the Low Voltage (LV) sections. It will show that there is considerable potential to increase the penetration of Small Scale Embedded Generation (SSEG) in UK LV distribution networks, in light of the current position of the UK's energy supply, as well as in order to meet the Government's ambitious environmental targets. This is due to the substantial investment in new power generation capacity that will be required over the next two decades in order to replace existing power stations and in order to meet the projected increasing electricity demand figures [1].

According to the Updated Energy and Carbon Emissions Projections [2], electricity generation is anticipated to increase at approximately 5% between 2010 (362 TWh) and 2020 (381 TWh), while total final energy consumption is anticipated to increase by about 4% (144.1 Mtoe and 150.1 Mtoe respectively). In addition, it has been

reported that around 20GW of existing power stations may have to close by 2020 [3] as a direct result of the decommissioning of approximately 7GW of existing nuclear power stations, as well as due to the EU Large Combustion Plant Directive [4] which may result in the shut-down of approximately 8.5GW of coal-fired and 2.5GW of oil-fired power stations by the end of 2015.

A diverse energy portfolio is likely to be required in order to reduce the level of dependency on foreign energy imports and thus reduce the risk of high and volatile prices while increasing security of supply. The recent Energy White Paper [1] has signalled that Small Scale Embedded Generators (SSEGs) connected on public LV distribution networks can provide an important contribution to meeting part of the UK's electrical and thermal energy needs. According to a recent study [5], the amount of SSEG installations in the UK could reach as high as 21GW by 2050.

However, a key factor for the financial and technical viability of large-scale SSEG installations is that their integration should be accomplished without costly modification to the electrical distribution system. Hence, existing LV distribution networks need to be operated and/or modified in such a way that the benefits offered by SSEGs can be realised without significant costs for customers and Distribution Network Operators (DNOs). Traditionally, the focus with regards SSEG integration has been on minimising their negative impacts to system operation, however a number of researchers [9-16] have recently attempted to shift focus towards maximising the potential technical, economical and environmental benefits gained from these units.

Before the penetration of SSEGs on existing LV distribution networks is increased and reaches anticipated future projections [5-7], it will be necessary to increase the SSEG volumes that may be accommodated on these networks. Three common solutions are currently employed by DNOs in order to achieve this: (i) through network reinforcement; (ii) by altering static network settings, such as distribution transformer tap positions; or (iii) through the use of some form of Active Network Management (ANM). ANM is being encouraged by a number of researchers [9-16] and the Department of Trade and Industry in particular has recognised the need to “*encourage distribution companies to actively manage electrical distribution networks*” [15]. This is because ANM schemes may allow a higher degree of network operational management to be achieved, which may be required due to the increasing share of DG and SSEG in total electrical energy production.

The research described in this Thesis proposes and evaluates an ANM system for LV distribution networks which aims at dynamically and intelligently managing controllable customer-owned power systems entities (SSEGs, distributed energy storage units and controllable loads) such that they can contribute to system operation. By doing so, it is anticipated that the technical LV distribution network constraints associated with high levels of SSEGs may be overcome. In addition, by grouping these entities into a Small Scale Energy Zone (SSEZ), improved economic and environmental benefits may be realised by increasing the value of SSEGs in the energy market through meeting a set of operational goals.

Having established the background behind the research area under investigation, this Chapter discusses the SSEZ concept, focusing on the potential challenges and benefits

that may be presented by employing this particular LV distribution network paradigm. Finally, the main research objectives and the outline of the Thesis are summarised.

1.1. BACKGROUND

The conventional structure of electrical power systems until now has dictated that electrical energy is predominantly generated in large, centralised power stations such as coal, nuclear and Combined Cycle Gas Turbine (CCGT) plants. In the UK, these stations supply three-phase AC (alternating current) power into a ‘National Grid’ of transmission lines which interconnect generators, switching stations and demand centres. Transmission of electrical energy is hence the bulk, often long-distance, movement of electricity at high voltages (400kV and 275kV in the UK) from generating stations to distribution companies and to a small number of large industrial customers. It has been reported that the UK’s National Grid handled approximately 350TWh of energy in 2007, through more than 7,000 km of transmission lines [1].

Electrical energy distribution refers to the provision of electricity to the majority of customers through lower voltage, more localised networks (from 132kV down to 230/400V). It is the final stage in the delivery of electrical energy to consumers after generation and transmission and is generally considered to include: (i) medium-voltage ($1\text{kV} < V < 50\text{ kV}$) electrical power lines; (ii) electrical substations and pole-mounted power distribution transformers; (iii) low-voltage (less than 1kV) distribution wiring; (iv) protection devices; and (v) electricity meters. Because this part of the system is closest to the majority of customers, its performance and reliability directly impact the service quality that these customers are receiving.

The majority of existing electrical distribution networks were designed and operated based on planned centralised generation, as shown in Figure 1.1. Their role was restricted to unidirectional power flows from large generating stations progressively down the voltage levels until the transferred electrical energy reached the point of utilisation. The emergence of this hierarchical structure was based on technical constraints and geographical and economical considerations, where the main focus was on reliability and quality of supply [8]. Any discrepancies in the system energy balance were immediately dealt with by controlling the electrical power output of the connected generators and these generators also provided most of the ancillary services required by the Transmission System Operators (TSOs). Moreover, interconnected high-voltage transmission networks allow generator reserve requirements to be minimised, the most cost-effective generators to be dispatched at all times and bulk electrical power to be transferred over large distances with relatively low losses [8].

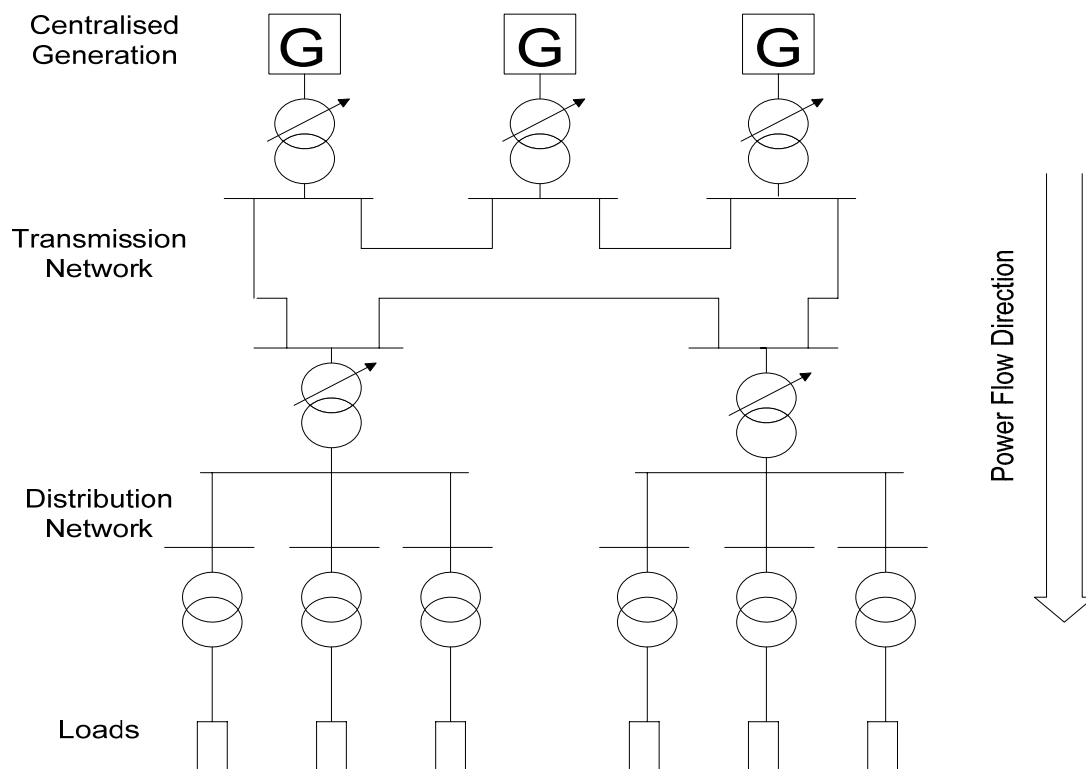

Figure 1.1: Conventional structure of electrical power systems.

In recent years, however, fears over global warming, high oil prices, the decline of indigenous energy supplies and increasing Governmental support have led to a continuous increase in electrical energy generated by generators based on Renewable Energy Sources (RES). Furthermore, the deregulation of the electricity industry in some countries has also played a key role in increasing competition and opening the market to newcomers, and thus allowing more privately owned generators to be connected to public electrical MV or LV distribution networks.

In order to meet the Government's environmental targets for 2020 and 2050 [1], a 20% and a 60% reduction in carbon dioxide emissions compared to 1990 levels have been set for the UK respectively. To ensure that *“energy, the environment and economic growth are properly and sustainably integrated [1]”*, the Government's policy on renewable energy is that by 2020, 20 per cent of the UK electrical energy should be generated using RES [4].

The anticipated increase in electricity generated by RES will require the introduction of Distributed Generation (DG) at various locations on the UK electrical distribution system, i.e. the connection of large numbers of generators of different types and sizes. These may employ a number of different technologies and fuels using synchronous or non-synchronous electrical generators. Most distributed generators are powered either by RES such as wind, solar and hydro, or by combined heat and power (CHP) units using conventional fuels with higher overall energy efficiency than electricity only cycles. Other drivers encouraging DG have been listed in [8] with particular emphasis on commercial considerations, such as (i) ease of finding sites for smaller generators;

(ii) shorter construction times and lower capital costs; and (iii) generation is located closer to demand, which may reduce transmission costs.

In addition to the DG embedded in MV distribution networks at 132kV and below, SSEGs installed at end users' premises at LV levels are gaining significant momentum due to potential advantages regarding reliability, energy efficiency and power quality. According to the recent Energy White Paper [1], current SSEG technologies include small-scale wind turbines, photovoltaic arrays and domestic CHP systems among other small-scale power generating units. According to two recent studies [6-7], SSEGs are seen as an important part of the additional DG that is required to meet the UK Government's environmental targets. The first study has indicated that installed SSEG capacity in the UK could grow to as much as 8GW by 2015 [6], while the second has suggested that SSEG technologies could supply between 30 to 40 per cent of the UK's electricity demands by 2050 and help to reduce household carbon emissions by 15% per annum [7].

These projections are in line with increased Governmental support for SSEGs through the Low Carbon Buildings Program [17] which provides grants for the installation of SSEG technologies. Moreover, the UK Secretary of State for Energy and Climate Change announced in October 2008 that the UK would implement a feed-in tariff by 2010 for small-scale, low-carbon electricity production with an electrical capacity of 5MW or less, in addition to its current renewable energy quota scheme [18].

The share of DG in some countries such as Denmark, Germany and Spain is already significant (in some cases even around 40% [8]), strongly affecting the operation of

the entire electricity network. This is because the current technical planning and operating framework within which electrical distribution networks are managed was not conceived with DGs or SSEGs in mind. Distribution networks were designed and operated based on planned centralised generation and on the assumption that the electrical current always flows from the substations to the end of network feeders. However, the anticipated growth of DGs and SSEGs may reverse the power flows within electrical distribution networks as shown in Figure 1.2. This may result in serious technical impacts relating to power quality, distribution system efficiency and potential equipment overloads that will be explained in detail in Chapter 4.

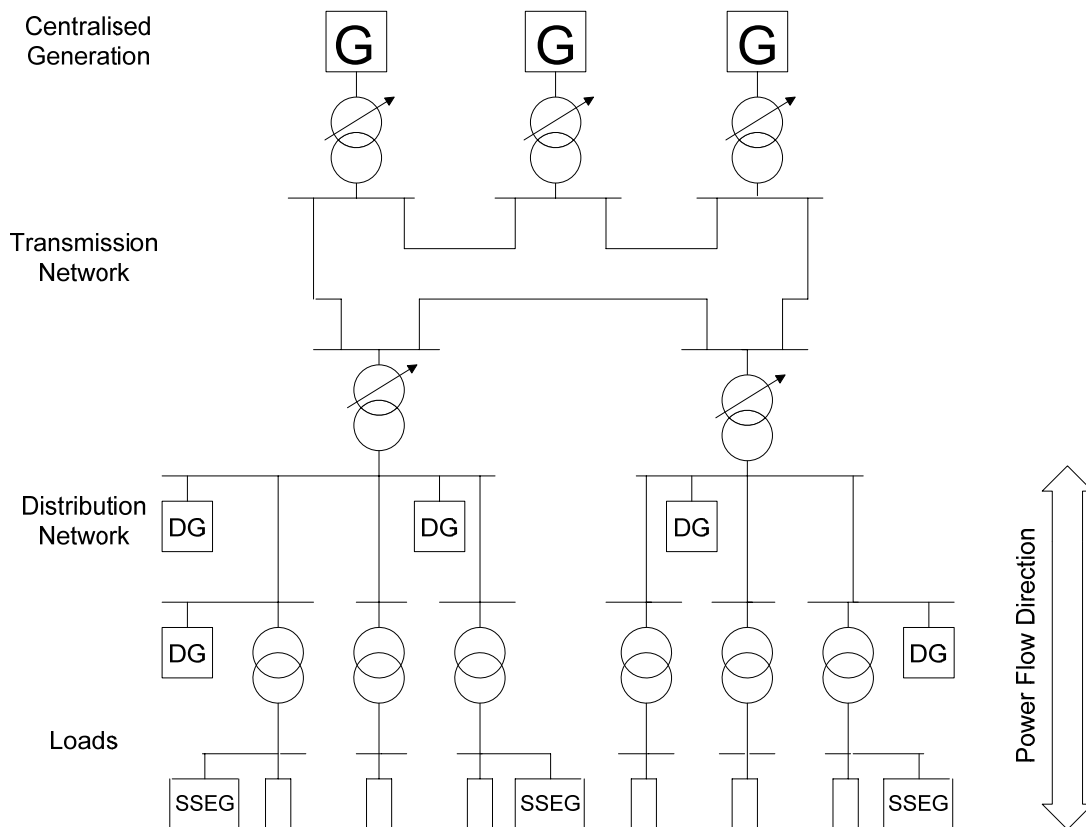

Figure 1.2: Structure of electrical power systems with DG and SSEG present.

Furthermore, the proliferation of intermittent generation (such as generators powered by RES) introduces a higher degree of uncertainty and thus presents challenging

issues regarding power system operation and control. Compared to large centralised generation power plants, DG and SSEG units generally have a lower capacity factor, i.e. a higher ratio of peak to average generation. This is either due to the intermittent nature of their primary energy source or due to operational and economical constraints such as the heat-bound limitations of CHP plants.

If the potential benefits of employing zero or low carbon generators are to be realised, their growth must be accompanied by a phased decommissioning of large centralised plants without resulting in a reduction in security of supply. This will be a challenging task as it will involve replacing large flexible fossil fuelled generators with a large number of small, often less controllable, power generation sources each of whom may have an individual commercial contract for supply. Hence, sufficient reserve margins will be required in order to dynamically manage the balance between generation and demand, with Demand Side Management (DSM) [19-21] and electrical Energy Storage Management (ESM) [22-23] schemes also likely to be employed.

The research described in this Thesis focuses on the integration and growth of SSEGs, which is consumer-driven and not centrally planned, according to the “fit-and-inform” policy specified in Engineering Recommendation G83/1 [24]. Traditionally in the UK, DNOs have viewed SSEGs as unpredictable negative loads producing electrical energy on a localised level and with no standard guidelines on their contribution to system operation. This is done in accordance with Engineering Recommendation P2/5 [25], which is a standard concerned with security of supply in electrical distribution networks. As a result, SSEGs have no option for active communication with the grid operator (DNOs) or the electricity market and are required to instantaneously

disconnect in the event of technical problems arising at the electrical distribution system.

The existing passive or “fit-and-forget” control approach stemming from Engineering Recommendation P2/5 [25] has resulted in the employment of central control systems which rarely extend down to the LV network level due to the vast number of elements that would need to be controlled. For future high SSEG penetration scenarios, this passive control approach would severely limit the SSEG capacity that may be accommodated as will be shown through simulation results in Chapters 4 and 8.

Recently, Engineering Recommendation P2/5 has been replaced by P2/6 [26] which aims to allow DNOs to take account of medium- to large-scale DG when designing their networks in order to utilise this generation as an alternative to network reinforcement and meet the required performance standards. According to the latest report regarding P2/6, however, SSEGs “*would continue to be treated as negative load, and would not be considered to be providing any local system security*” [27].

The research in this Thesis is concerned with a shift from the current passive operating philosophy of LV networks towards a more active approach, as demonstrated by the SSEZ concept [28-33]. By doing so, it is anticipated that the technical LV distribution network constraints associated with high levels of SSEGs may be overcome, as well as the value of SSEGs in the energy market may be increased through meeting a set of operational goals. The SSEZ concept is discussed below in greater detail, focusing on the potential challenges and benefits that may be presented by employing this electrical LV distribution network paradigm.

1.2. SMALL SCALE ENERGY ZONES

The value of SSEGs in modern electricity markets [28] may depend on a number of factors including: (i) the revenue streams that can be achieved through the sale of electricity; (ii) the degree to which SSEGs can reduce the electrical energy purchased from the electric utility; (iii) the degree to which SSEGs can participate in ancillary services markets; (iv) the environmental impact that can be achieved and the degree to which SSEGs can displace fossil fuel based generation plants; and (v) the ability of SSEGs to contribute to the deferral or avoidance of network reinforcement.

In the current UK electricity market, significant limitations exist regarding the ability of individual SSEGs to participate [28-29]. The current market allows for late forecasting of generation output (one hour in advance) but it is expensive to collate this information from large numbers of SSEGs on an ongoing basis. Moreover, their volumes of exported electrical energy are often too small to justify the transaction cost to capture them and small generators have no direct commercial relationship with the National Grid; the information is exchanged via the DNO. Research at Durham University [28-33], however, has suggested that if SSEGs are aggregated and their electrical power outputs are combined, they will be able to trade larger amounts of electrical energy as a group of generators. This could result in SSEG owners being able to negotiate improved contractual terms with supply companies, thereby increasing revenue streams and improving the value of SSEGs in the energy market.

Moreover, intelligent coordination of large numbers of SSEGs coupled with DSM and ESM schemes may allow the overall zone to be viewed by DNOs as predictable and controllable load or generation, depending on the electrical power balance within that

block. Improved predictability and controllability means that these zones may assist DNOs with network operational tasks, such as voltage control, while also providing increased confidence for the phased decommissioning of large centralised power plants. This may therefore translate into significant environmental benefits through zero or low carbon power generation. Research described in [34] has examined how the output from a number of small wind turbines may be aggregated to form a more consistent electrical power output. In addition, research described in [35] has demonstrated that the concept of “load diversity” guarantees that the maximum electrical power demand of a group of customers is always less than the sum of customer-specific peak electrical power demand. Load diversity may be expressed mathematically as the “coincidence factor” (Figure 1.3) or the ratio of the maximum coincident total electrical power demand for a group of customers to the sum of the peak electrical power demand of each customer in that group. It has been shown that as the number of customers on the LV distribution network increases, the coincidence factor is reduced significantly at first (for 1-15 customers) but less significantly for higher number of customers.

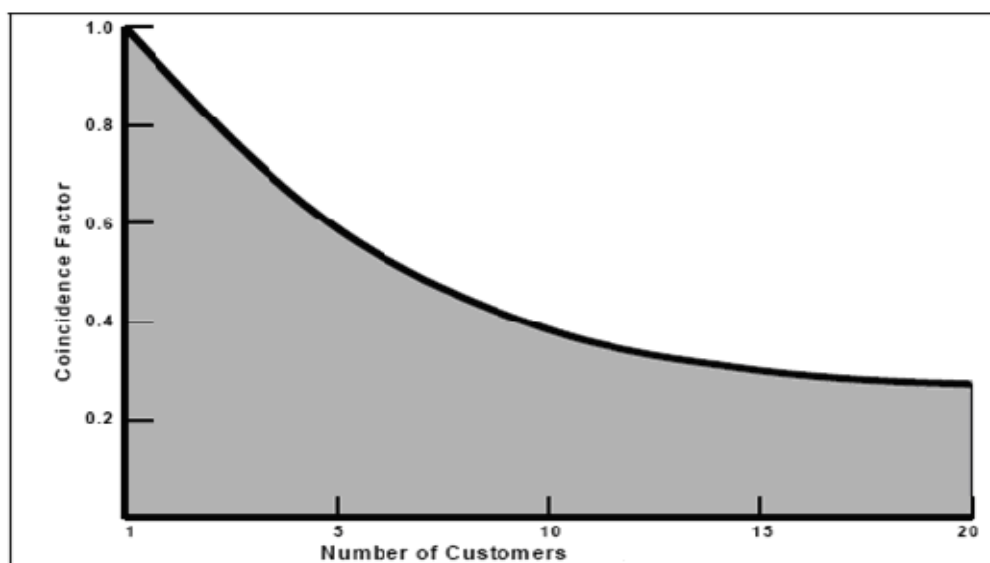

Figure 1.3: Coincidence factor curve for a typical LV distribution network [32]

Based on these two concepts, an SSEZ contains a mixture of customer-owned SSEGs, Energy Storage Units (ESUs) and controllable loads and appears to the upstream electrical distribution network as a controllable entity, as shown in Figure 1.4. It is assumed that all customer-owned power system entities include communication and control interfaces and are addressable by other components using an available common long-range communications medium, such as the Internet or wireless networks. Accurate and safe communications between the customer-owned power system entities, measurement devices installed on the electrical distribution system, and utility control centres would be essential if the SSEZ is to satisfy its specific control requirements, as will be described in Chapter 5.

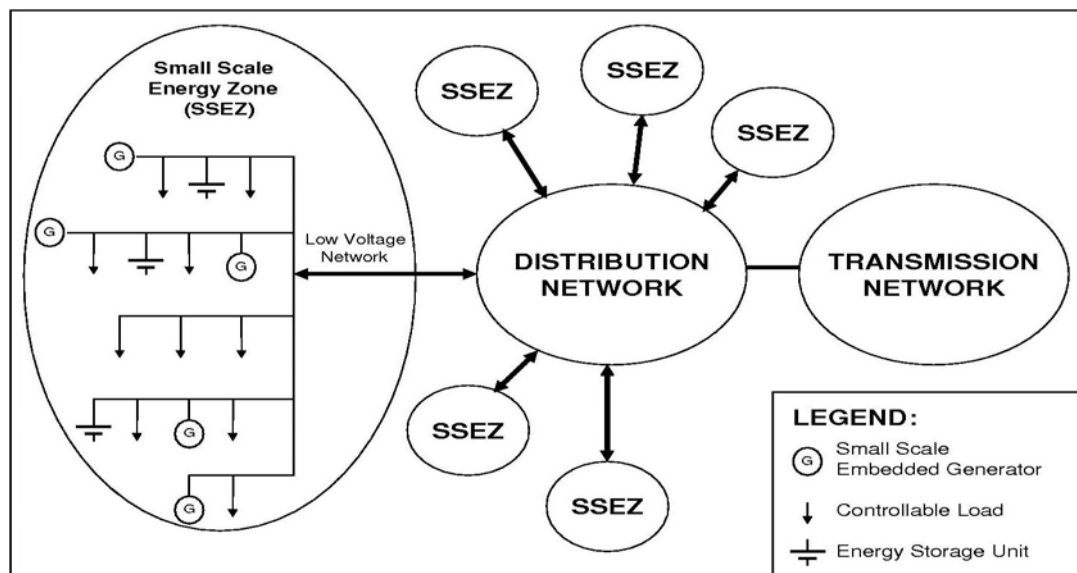

Figure 1.4: A Small Scale Energy Zone.

The SSEZ is a concept similar and complementary to MicroGrids [35-41], but while research on MicroGrids predominantly focuses on alternative future network designs, SSEZs exclusively consider the addition of SSEGs to existing (“legacy”) LV distribution networks. It is anticipated that an SSEZ could exist within a small, dense group of proximate geographic sites, such as for example residential estates or

commercial districts. The customer-owned power system entities comprising the SSEZ would be distributed across the LV distribution network supplying them, with the aim being to coordinate and manage their actions during on-grid system operation (Figure 1.5). Due to the “fit-and-inform” policy [24] governing SSEG growth, however, DNOs will have limited control over selecting the phase of connection and therefore unbalanced system operation must also be considered.

The SSEZ concept presents a number of challenges to the existing distribution control and protection equipment that are installed in public distribution networks. An SSEZ must be operated within existing voltage and frequency statutory limits as defined by [42] for UK and [43] for EU LV distribution networks, while at the same time ensuring that equipment ratings are not exceeded for the distribution transformer(s) and the network lines supplying the SSEZ. Protection equipment will be required at the connection point of each SSEG, ESU, and controllable load, as well as the Point of Common Coupling (PCC) with the distribution network if islanding is considered.

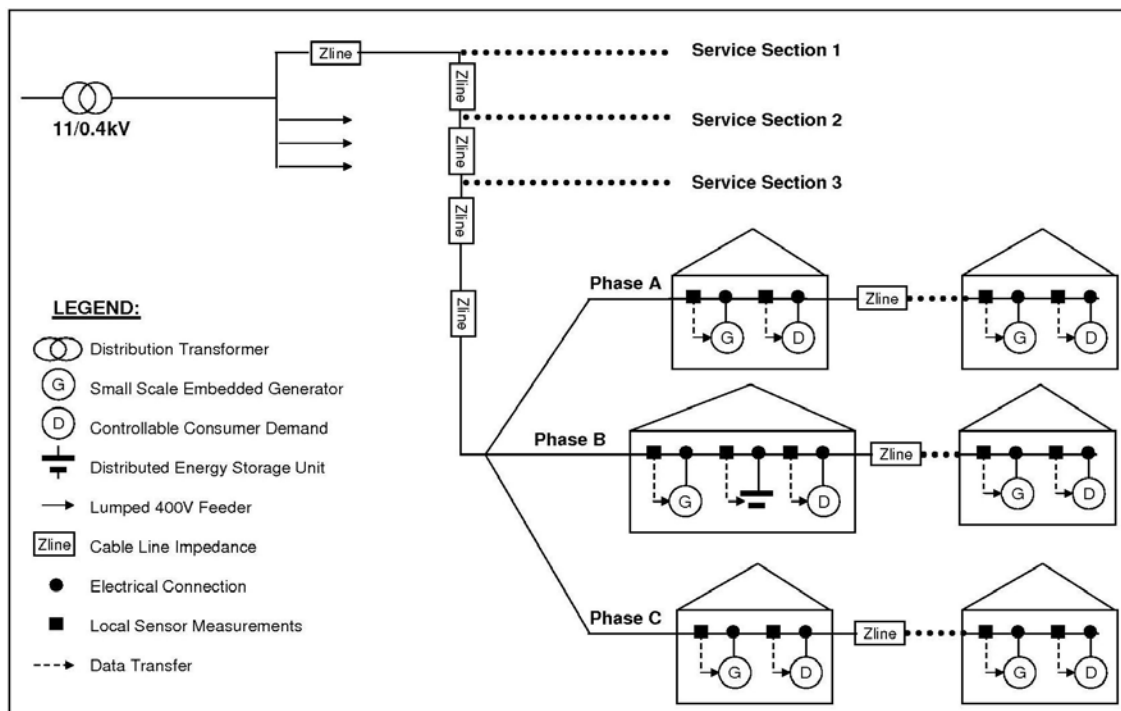

Figure 1.5: A Small Scale Energy Zone within a typical LV network – no control.

The research described in this Thesis considers normal operating conditions, i.e. no faults present, and that the SSEZ is always operating in parallel with the upstream distribution network. Thus, the system is treated as an “infinite bus” whose voltage and frequency can not be altered by an individual SSEG, ESU or customer load (Figure 1.6). The adopted control system aims to ensure that the SSEZ operates within the existing network protection settings. A key aim of the control system is that, even with high levels of SSEG penetration, the generation, load and energy storage within the SSEZ are controlled such that protection devices do not operate and thus customer interruptions are minimised as are generator trips, thus increasing their energy yield.

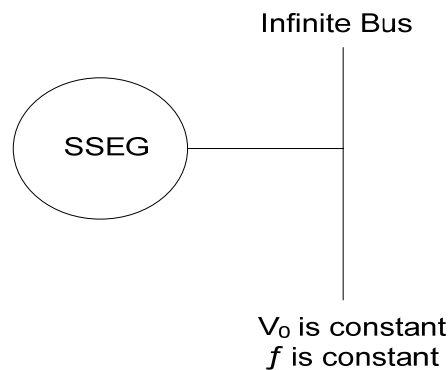

Figure 1.6: An SSEG connected to an infinite bus.

Central to the SSEZ concept are the control and communication architectures to be adopted. These comprise of hardware and software components for receiving and exchanging measurement data and control signals within the SSEZ. The hardware components include the controllable customer-owned power system entities (SSEGs, ESUs and loads), communication and measurement devices, as well as process computers or control units for real-time management and control. The software components may include several programs and protocols for supporting and managing system information within the SSEZ, adopted using an open and standard configuration that is accessible to all customers in the system. In addition, a unified

Relational DataBase Management System (RDBMS) may exist for data management purposes as will be explained in Chapter 6.

Despite years of ongoing research, development and demonstration projects [39-40], it remains unclear what the appropriate architecture for distributed automation systems at the LV feeder level should be. A number of researchers [31, 37, 44-46] propose a distributed management and control hierarchy, in which each piece of feeder equipment has its own intelligence and communicates with other components while still functioning somewhat autonomously. Other researchers [47-49] argue for more centralised management and control schemes where feeder-level devices have little autonomy, with a system central point responsible for decision-making.

The research described in this Thesis proposes the employment of a distributed management and control approach, realised through the Multi-Agent Systems (MAS) technology, due to potential benefits that may be realised in three key areas: (i) scalability and openness; (ii) resilience and reliability; and (iii) communication efficiency. These areas will be shown in Chapter 5 to be particularly important when considering future high SSEG penetration scenarios. MAS are based on distributed artificial intelligence computing, where the main aim is to split a complex problem, such as the control of an SSEZ, into several subtasks and distribute the management of these tasks to intelligent agents. This way, each agent may have only a limited view of the system but the overall MAS can perform system wide control through autonomous and cooperative actions of the agents. General MAS theory and the reasons that make this technology particularly attractive for this control problem are described in greater detail in Chapter 3.

The concept of an SSEZ or a MicroGrid has been extended by a number of researchers [30, 50-53] to the concept of a Virtual Power Station (VPS) or Virtual Power Plant (VPP), which is the highest level of aggregation with regards SSEG. The rationale behind VPS is that while individual SSEGs can displace electrical energy produced by centralised generation, they cannot displace this capacity. A VPS may consist of a number of SSEZs each with different mixes of generation, load and storage. The value assigned to a VPS by a DNO or a supply company is largely determined by its capacity and controllability, with large VPSs having the potential to improve the value of SSEGs in the energy market even further compared to single SSEZs. The most common architecture for a VPS found in the literature is shown in Figure 1.7, which is based on a central dispatching unit that sends control signals based on secure and efficient power system operation (“local network”), as well as the interaction of VPS with the electricity market (“electricity market”).

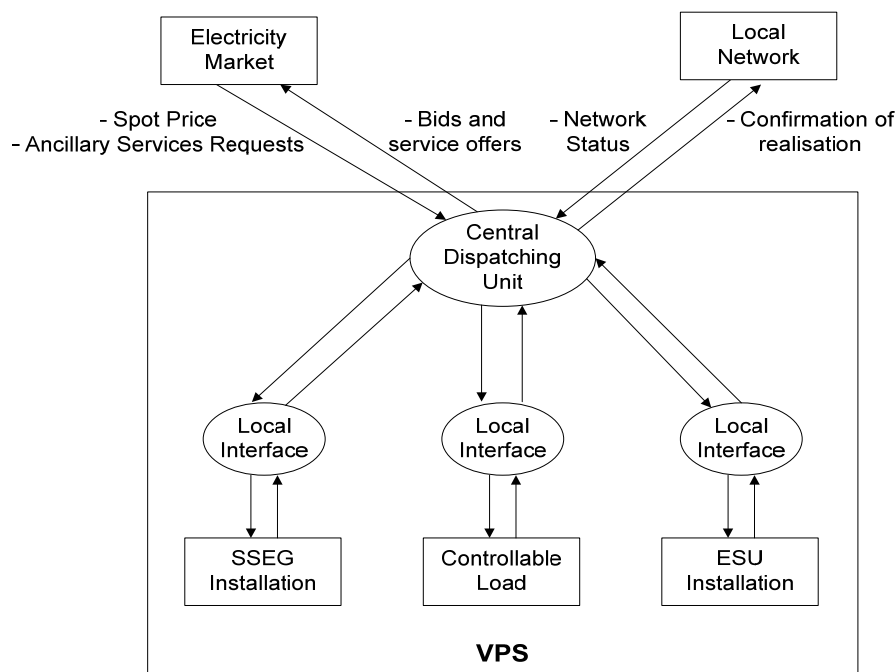

Figure 1.7: Architecture of a centralised Virtual Power Station [50].

1.3. RESEARCH OBJECTIVES

The main objectives of the research described in this Thesis are the following:

1. To evaluate the technical impacts caused by the steady-state operation of SSEGs and to quantify allowable SSEG penetration limits on suitable case study LV distribution networks.
2. To develop a methodology for predicting allowable SSEG volumes on any case study LV distribution network quickly and easily and without the need for developing detailed computer-based models. The methodology should be drawn from an analysis of the key electrical characteristics that determine the response of LV distribution networks to the addition of high SSEG volumes.
3. To identify the key control requirements of an SSEZ, focusing on: (i) overcoming the LV distribution network constraints associated with high SSEG penetrations; and (ii) on meeting a set of operational goals that allow the SSEZ to provide the local DNO with predictable and controllable demand or generation depending on the electrical power balance within the zone.
4. To select and design a suitable management and control approach for an SSEZ based on its specific control requirements. This approach must be based on responsive control, whereby control actions are based on reacting timely and appropriately to changes occurring in the SSEZ environment. The proposed approach must then be implemented using software development tools and evaluated on a case study SSEZ using a suitable power systems simulation package. The aim is to evaluate its performance based on the specific SSEZ control requirements and to identify the main strengths and weaknesses offered by the proposed approach.

1.4. THESIS OUTLINE

The Thesis starts with two Chapters that contain background information on the research area under investigation. Chapter 2 provides an overview of the existing approaches for the management and control of electrical distribution networks. It includes a survey of ongoing research, development and demonstration projects with regards ANM, focusing mainly on the LV customer levels. In addition, Chapter 3 provides an introduction to the theory behind MAS technology and some of its potential application to power engineering.

Chapter 4 is concerned with the technical impacts associated with the steady-state operation of SSEGs on public LV distribution networks. It presents simulation results from PSCAD/EMTDC™ that aim to quantify allowable SSEG penetration limits on three different LV distribution networks: (i) one generic urban UK LV distribution network; (ii) one existing urban UK LV distribution network; and (iii) one generic sub-urban European LV distribution network. The following LV distribution network constraints are considered: (i) customer voltage rise/drop; (ii) voltage regulation; (iii) voltage unbalance; (iv) cable and transformer thermal limits; and (v) network losses. On the basis of these simulation results, a methodology for SSEG impact analysis of LV distribution networks is proposed that may be used to predict the LV distribution network response to the addition of high SSEG volumes.

Chapter 5 describes the specific control requirements of the SSEZ concept, namely: (i) to ensure secure system operation by complying with existing statutory regulations and equipment thermal ratings; and (ii) to meet a set of operational goals associated with providing the local DNO with predictable and controllable demand or

generation, depending on the electrical power balance within the zone. It proposes the employment of a distributed control approach, realised through the MAS technology, over a centralised approach due to the distinct advantages that may be offered in a number of key areas that will be explained.

Chapters 6 and 7 examine the design and development of the proposed MAS and RDBMS which are designed specifically for meeting the SSEZ control requirements. The design and software implementation of the developed types of agents and databases are explained in detail, along with a description of the three operating states of system agents: (i) normal; (ii) alert; and (iii) emergency state. Moreover, the reasoning and communication capabilities of system agents are detailed, with particular emphasis on rule-based agent decision-making and the design and development of a common ontology used by agents to exchange information.

Chapter 8 presents the evaluation of the developed control approach on a case study SSEZ, focusing on its suitability to meet the specific SSEZ control requirements, along with the potential improvements that may be realised in three key areas: (i) scalability and openness; (ii) resilience and reliability; and (iii) communication efficiency. These areas are shown to be particularly important when considering future high SSEG penetration scenarios. In addition to research work performed using simulation tools, an initial experimental investigation of the proposed MAS-based control approach is also presented. Finally, Chapter 9 summarises the research described in this Thesis and indicates a number of potential areas for further work.

CHAPTER 2

Distribution Networks Control

In the UK, there are fourteen electricity regions and in each area a local DNO is responsible for maintaining customer voltages inside the range fixed by national standards [39]. In order to minimise associated costs with system equipment, electrical distribution networks were designed to use most, if not all, of the allowable voltage bandwidth. Customer quality of supply has traditionally been ensured by planning a degree of redundancy and by some centralised ability to switch connection points, although this usually takes place at a relatively low response rate [54]. Voltage profiles in the network are assessed at the planning stage and transformer tap changers (usually with line-drop compensation) are used to accommodate variation in system demand [54-55].

The current policy and regulatory framework of the electricity industry has evolved without much consideration of its impact on the growth of SSEGs, which are still seen as unpredictable negative loads in accordance with Engineering Recommendations

P2/5 [25] and P2/6 [26]. Thus, significant technical, commercial as well as policy and regulatory changes will be required in order to achieve the Government's targeted growth in SSEG. This Chapter presents an overview of the existing control approaches employed by DNOs for the control of electrical distribution networks, as well as the possible technical changes that could facilitate the integration of SSEGs onto existing LV networks. It is, however, outside the scopes of this Thesis to provide a summary of the commercial and policy and regulatory changes that would be required in order for SSEGs to reach their anticipated high projections [4-6]. An overview of these may be found in [69-70].

2.1. EXISTING CONTROL APPROACH

The existing approach in electric utility computer control systems is the employment of three automation technologies: (i) Energy Management Systems (EMS); (ii) Supervisory Control and Data Acquisition (SCADA) systems; and (iii) Substation Automation Systems (SAS). These have been installed in control centres in order to improve overall system reliability and performance and ensure the effective operation of system equipment. A hierarchical structure is employed, with EMS sitting on the top level, SCADA on the middle and the individual SAS of each distribution substation at the lowest level.

SCADA systems employed by DNOs focus on supervising and controlling power plants and HV and MV transmission and distribution networks. They provide information to the EMS on distribution system status, such as substation switch status, substation voltages and line MW, MVAR and current flows, while also allowing for

remote switching of circuits and other equipment. In order to achieve that, SCADA systems collect measurement data from network substations and power plants via a number of Remote Terminal Units (RTUs) and after performing state estimation, load flow and economic dispatch calculations, they send set-points to the connected power plants or to the RTUs for execution by the SAS. SCADA systems are being increasingly used for the control of electrical distribution networks with high DG penetrations, but not down to the LV, 230/400V, end. The operation of a typical SCADA system is shown in Figure 2.1.

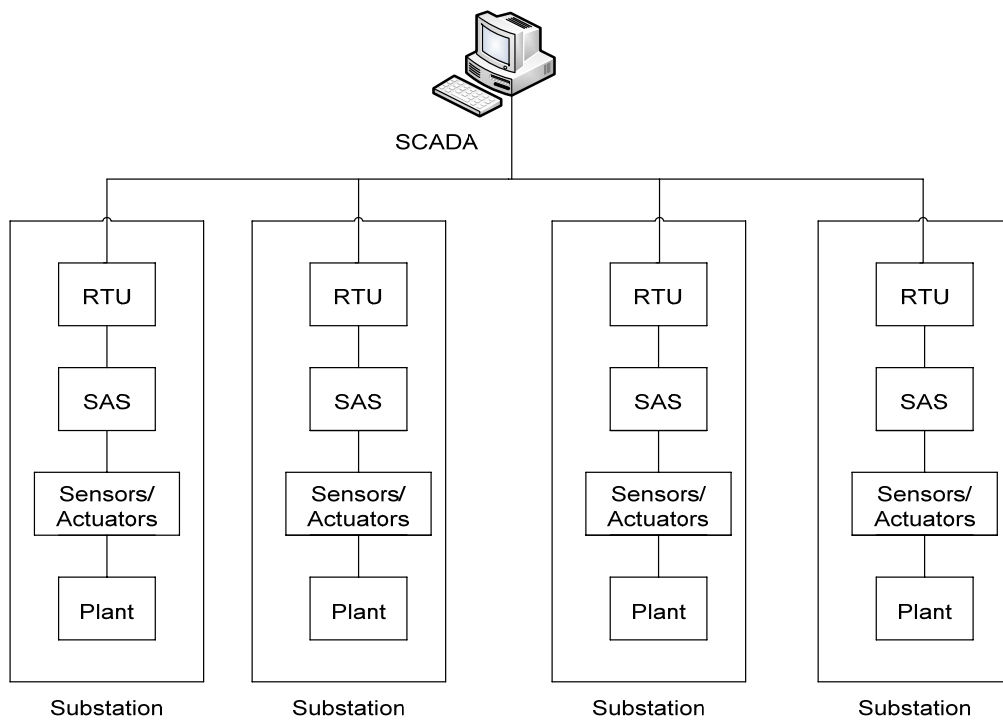

Figure 2.1: A Supervisory Control and Data Acquisition system.

In contrast to MV and HV electrical networks, at the LV customer level very little command, control and data acquisition is typically carried out besides some notable exceptions such as feeder-level capacitor banks controlled by radio signals, or remote meter-reading technologies and Smart-Meters [56]. In the UK for example, despite the significant extension of electrical distribution networks in order to accommodate the

increasing demand that has taken place in the past 50 years, the operation and control of LV networks has remained “*largely unchanged*” [11] and is still based on the passive, “fit-and-forget” philosophy of Engineering Recommendation P2/5 [25].

Computerised control systems, typically operating over power line carriers, telephone-lease lines, fiber optics or radio-based techniques, allow the connected medium- to large-scale DG (>1MW) to operate as dispatchable sources in order to generate power according to system needs [15-16]. For SSEGs and smaller-scale DGs, however, a mechanism for capturing and coordinating large numbers of these units currently does not exist. Nevertheless, it is anticipated that the widespread use of newer technologies such as the Internet or wireless cellular and packet switching data networks could play a part in improving the control and communication capabilities of future LV distribution networks [35-36]. These technologies may either be incorporated into new buildings or retrofitted onto existing ones.

Before the penetration of SSEGs on existing LV distribution networks is increased and reaches anticipated future projections [5-7], it will be necessary to increase the SSEG volumes that may be accommodated on these networks. Three common solutions are employed by DNOs in order to achieve this: (i) through network reinforcement; (ii) by altering static network settings, such as distribution transformer tap positions; or (iii) through the use of some form of Active Network Management (ANM). The first two approaches are also known as “passive”, while the latter is termed “active”. Both approaches are briefly discussed below, highlighting their main advantages and disadvantages.

2.2. PASSIVE NETWORKS

The passive operating philosophy of distribution networks has traditionally led to the over-sizing of distribution network components during the design stage in order to accommodate load growth [56]. In cases where secure system operation could not be maintained with existing network capacities due to increased power flows in the system, network reinforcement measures have commonly been employed by DNOs. An example of network reinforcement is re-conductoring a circuit with cables with higher cross-sectional area. The reduced resistance along that circuit will increase the amount of load that may be accommodated before the supplied voltage drops below statutory limits.

Similarly, network reinforcement could significantly increase allowable SSEG penetration limits by mitigating component thermal issues, power quality issues such as voltage regulation and customer voltage rise, and by reducing network load losses. Although the initial capital expenditure requirements for network reinforcement may in some cases be high, such approaches add incrementality to the network and their interaction with the distribution system is understood and predictable. Hence, potential benefits include robustness and uncomplicated, hence low cost, distribution network operation [57].

Current UK regulatory design practices [58] for LV distribution networks are based on worst case operational conditions, such as maximum loading conditions, and do not take into account any network contribution from SSEGs. This may cause a conflict between the interests of the local DNO and the customers trying to connect their SSEG units. On the one hand, DNOs must design and operate their networks in

order to ensure high power quality and that security of supply is provided. However, on the other hand, customers may prefer the network design and SSEG connection scheme which minimises connection costs, even if this may adversely result in poorer security of the overall system.

Since the growth of SSEGs is consumer-driven and not centrally planned, it is difficult for DNOs to provide an accurate cost comparison between network reinforcement and ANM solutions. In order to overcome the technical challenges associated with the connection and operation of SSEGs, the capital expenditure of upgrading LV distribution equipment may in some cases be less costly than applying active control techniques. However, if SSEGs are to realise their full potential, other issues such as contribution to system operation through the provision of ancillary services, and efficient energy market participation need to be taken into account, which may not be realised by employing passive, network reinforcement practices.

Hence, although network reinforcement practices were considered adequate in the past to accommodate increasing load growth, LV distribution networks in the future are likely to move away from the conventional passive control approach and towards a higher degree of network operational management [11]. ANM is being encouraged by a number of researchers [9-16] and is discussed in the following Section.

2.3. ACTIVE NETWORKS

ANM schemes require the employment of intelligent metering, control and communication systems, where the aim is to improve network performance during

normal and emergency system operation (Figure 2.2). Research [12-13] suggests that this can be achieved through integrated control of (i) real and reactive power demand and generation; (ii) On Load Tap Changers (OLTC) of distribution transformers; (iii) network configuration equipment, such as line reclosers, voltage regulators, switches, capacitor banks etc; (iv) islanding technologies; and (v) protection systems.

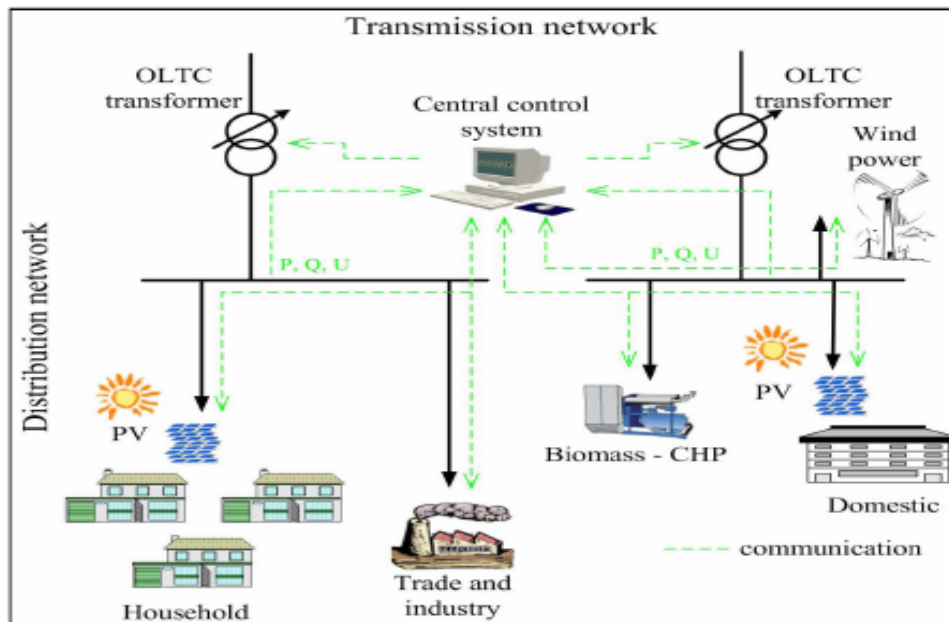

Figure 2.2: Example of an active transmission and distribution system [14].

The integration of ANM techniques on distribution networks is anticipated to take place in three stages: the first stage involves the automation of distribution substations, where automation and communication equipment are in many cases already installed. The second stage is the automation of network feeders and DG at the MV levels of distribution systems. Finally, the last stage involves the integration of LV customer systems, such as SSEGs, ESUs and customer DSM schemes. ANM schemes are seen by many researchers [9-16] as having the potential to maximise DG/SSEG penetrations while minimising related network reinforcement costs.

In order to realise such networks, R&D in several electrical power and distribution automation technologies is required. These technologies may include [59]:

1. A supervisory control system with automated reasoning and data interpretation capabilities that monitors electrical distribution networks in real-time and takes control decisions based on the control requirements of the overall system. Depending on system communications and the location(s) where control decisions are made, a number of hierarchical structures could be employed for the supervisory control system ranging from centralised [47-49] to fully distributed [44-46].
2. Sensors and metering devices at critical points throughout the network for the real-time acquisition and transfer of measurement data to the supervisory controller. In particular, Smart-Meter installations [56] would be required for the separate metering of generation and load.
3. Integrated protection systems that provide timely reaction to network fault conditions, unusual transient behaviour and post-event recovery in order to allow the system to return back to normal operating state.
4. Intelligent power electronics-based devices for network interfacing of SSEGs and DGs to public electrical distribution networks [60-61].
5. Communication links to allow for network reconfigurability in the event of system disturbances or to achieve optimal system performance. Dedicated communications systems may be incorporated into new networks or might be retrofitted onto existing ones using technologies such as power line carriers, wireless networks, or the existing Internet communication infrastructure.
6. Generation and demand forecasting techniques to ensure the overall balance of electricity generation and consumption.

7. Condition monitoring tools and the use of dynamic equipment ratings [62-63] to improve existing network utilisation, thereby enabling higher levels of DG/SSEG to operate without thermal violations.

2.3.1. Relevant Work

The SmartGrid European Technology Platform [64] has recently been introduced in order to “*formulate and promote a vision for the development of European electricity networks looking towards 2020 and beyond*”. Eight major research projects on the ANM of LV distribution networks are currently under development: (i) MicroGrids and More MicroGrids [37]; (ii) FENIX [65]; DER-LAB [66]; INTEGRAL [67]; ADDRESS [68]; SUSPLAN [69]; EU-DEEP [70]; and SOLID-DER [71].

In the UK, the concepts of ANM and improved SSEG integration have recently gained increased attention as evident by the technical focus of the DTI, Ofgem and the Distribution Working Group of the Electricity Network Strategy Group [72]. Two major work programmes are currently under investigation, one entitled “Enabling Active Network Management” [73] and another one entitled “Facilitating Small-Scale Generation” [74] which aim to “*develop the technologies, protocols, tools, processes, techniques and standards that would be needed to ensure that low-carbon compliant power systems could be operated on an active basis to ensure efficient use of investment and an effective contribution from potential market participants.*” A recent report for the DTI [75] has provided a comprehensive review of 105 ANM schemes that have been commissioned in the UK as well as internationally, including projects both at the MV as well as the LV levels of electrical distribution networks. Other UK research activities on ANM of electrical distribution networks are presented in [76].

In North America, the “advanced distribution automation” concept by EPRI (Electric Power Research Institute) envisions future electrical distribution systems as highly automated systems operated via open-architecture communications networks [77]. The “IntelliGrid” initiative [78], for example, attempts to create the technical foundation for a smart power grid that links electricity with communications and computer control to achieve gains in reliability, capacity, and customer services. Moreover, the CERTS (Consortium for Electric Reliability Technology Solutions) Microgrid concept [36] assumes an aggregation of loads and power electronics-based generators operating as a single system providing both power and heat. Similar major demonstration projects have also been undertaken in Japan [41] as well as other countries worldwide [39-40].

2.3.2. Information and Communication Technology

Data communication in electrical distribution networks typically serves two purposes: (i) for data analysis regarding the operating state of the power system; and (ii) for remote use for storing, retrieving and processing data for control and management purposes. This allows Distribution Management Systems (DMSs) to acquire and produce information to be used for distribution automation purposes.

Currently, the majority of communication links used for data acquisition, signalling and control of electrical distribution networks are dedicated connections, typically owned by the system operator. Figure 2.3 shows the telecommunication setup that is usually employed. It involves data signal communications between RTUs such as feeder devices, substation devices and customer devices, the DMS and other automated distribution functions that require data signals for automation and control.

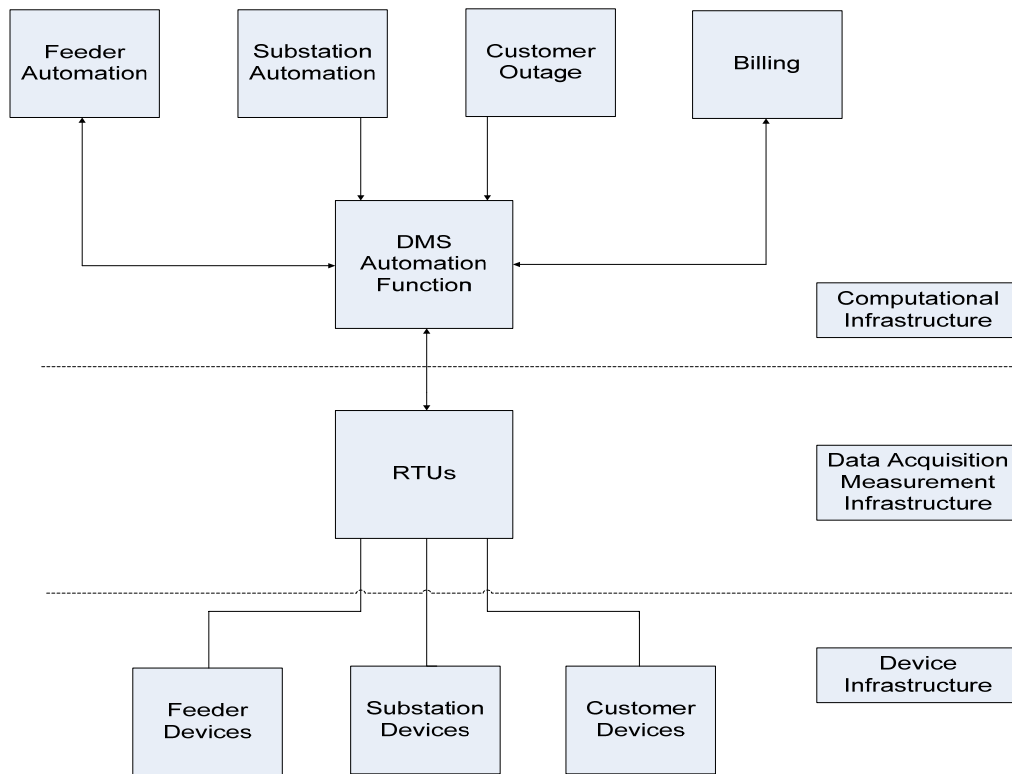

Figure 2.3: Typical telecommunication setup in distribution networks.

The anticipated move towards active LV distribution networks requires the coordinated management of large numbers of power system entities that are connected on these networks. Therefore, the importance of information and communication technologies (ICT) is likely to increase significantly because the control capabilities of these networks will partly depend on the ICT that are employed. At the same time, expanding distribution network services such as real-time monitoring and control as well as improved electricity trading applications are driving the need for increased bandwidth in the electricity industry. Currently, most communication technologies used in electrical power systems are suffering from a lack of efficient, high speed and bandwidth communication media [11]. Present information management systems must therefore be restructured to allow for more and faster information exchange.

Undifferentiated one-way communication links, for example via radio broadcast, is presently the cheapest type of communications available [11]. Within an SSEZ, one-way communication signals could be sent in real-time from a central point in order to transmit real and reactive power set-points or market signals to large numbers of customer-owned power system components (SSEGs, ESUs and loads). However, one-way communications do not permit a differentiated response and therefore do not offer the communication functionality required (Section 1.2).

According to a number of researchers [79-82], Internet and Semantic Web technologies appear as the most cost effective and promising ways to achieve the peer-to-peer communication functionalities required by ANM, such as the management of the connected controllable entities, the management of metering information and the integration of market management. According to [81], "*Internet is the undisputable choice, as it is the biggest virtual network in the world and is accessible to everybody independently of its platform*".

For active LV distribution networks, the aim is to make available across Wide Area Networks (WANs) the measurement data acquired by measurement devices such as sensors, data loggers, power quality analysers, Smart-Meters etc. These data would then be processed by distributed or centralised processors and sent as control signals to the controllable power system entities of the network. WANs use long-distance carriers and may be linked by cable, optical fibres or satellites, but their users typically access the network using modems. In order to satisfy the requirement for wideband communications, the high speed Internet access Digital Subscriber Line (DSL) technology is proposed in [81] with speeds which can vary from 128 kbps up

to several Mbps. This allows data to be accessed independently of location by using cheap, reliable and standard access communication mechanisms and tools. The industry practice based on Transmission Control Protocol/Internet protocol (TCP/IP) for the intercommunication of all installed devices within a distribution network may be employed in order to ensure interoperability [82].

The cost of provision and maintenance of such advanced peer-to-peer communication networks, however, would be decisive towards their potential employment. The potential benefits realised by employing communication at the LV customer levels of electrical distribution networks would only be attractive if their associated costs could be kept as low as possible. Sharing existing communication infrastructure, i.e. residential broadband and the public Internet, could help to achieve that and could also potentially reduce implementation times, but questions regarding reliability and safety would also need to be taken into account.

Moreover, if SSEGs are to reach their anticipated high penetration levels [5-7], they would need both a standard way of interconnecting to the distribution system, as well as a standard way for information exchange. Currently, while significant work has been carried out for the development and adoption of standards for connecting and operating SSEGs on public LV distribution networks (as for example [24] in the UK), considerably less work has been done to promote interoperability with regards information exchange. A recent draft standard proposal entitled “UCA-DER” [83] has aimed to define object models, services and other requirements for the exchange of information with small-scale DG systems, however more work is likely to be needed in order to define a common international standard for SSEG communications.

2.3.3. Intelligent Electronic Devices

Intelligent Electronic Devices (IED) is a broad term for communicating devices used in electrical transmission and distribution systems. IEDs incorporate one or more micro-processors with the capability to send or receive data signals to/from an external source. Typical IEDs include substation host computers, RTUs, programmable logic controllers, communication processors, digital protective relays, sequence of events and fault recorders and automatic system controllers [54].

IEDs perform multiple functions by exchanging digital data. Their primary application is in the digital monitoring and protection of electric system equipment with the transfer of basic, raw data and control commands between IEDs and external systems, such as SCADA systems. Another application is in the acquisition and processing of protection, control and operating data for exchange with system applications and enterprise-wide users, such as large-scale DMSs. The potentially widespread application of IEDs in electrical distribution networks could provide integration and sharing of data through networking and distributed processing.

IEDs of different types may interact with each other and with other levels of distribution SAS. In particular, the “IEC 61850” international standard [84] for substation communications allows the future development of self-configuring SAS. It defines SAS functions related to the protection, control, monitoring and recording of the equipment in the substation. These functions may be embedded within a single IED or may be distributed between multiple devices using communication networks.

Within the SSEZ concept, intelligent devices will be required to provide the hardware environment for the computational and I/O capabilities needed to satisfy the control requirements of the SSEZ. These devices must also be able to communicate with each other and other components within the SSEZ by employing common communication protocols. For reasons that will be explained in Chapter 5, this Thesis proposes the employment of the MAS technology, coupled with various power system measurement devices and a long-range peer-to-peer communications medium as a means of achieving these capabilities. This is because, compared with traditional SCADA or client-server architectures, *“a multiagent system on an IP network provides a greater autonomy to each of the constituent parts of an inherently distributed power system [85]”*. The communication requirements for the control system of an SSEZ will be described in Section 6.3.4 in greater detail.

2.4. SSEG CONTROL

In the United Kingdom, Engineering Recommendation G83/1 [24] defines a Small Scale Embedded Generator (SSEG) as any source of electrical energy rated up to, and including, 16 Ampere per phase, single or multi phase, 230/400 Volts ac. Furthermore, the draft European standard EN 50438 [86] uses the term “micro-generators” to define all sources of electrical energy rated up to, and including: (i) 25 Ampere per phase when the network connection is single phase; or (ii) 16 Ampere per phase when the network connection is three phase. For the purposes of this Thesis, an SSEG and a micro-generator will be treated as interchangeable terms, according to the definition provided by ER G83/1. SSEGs are anticipated to use mainly single-phase

connections and to operate in parallel with public LV distribution networks within domestic or light commercial properties.

In terms of the currently available technologies, SSEGs include domestic Combined Heat and Power (dCHP) units, fuel cells and small RES-based units, such as small-scale wind turbines, photovoltaic (PV) panels and micro-hydro (Figure 2.4). SSEG technologies that generate either DC (wind, PV, fuel cells) or non-power frequency AC (micro-turbines, such as dCHP) may not be directly interfaced to the LV network. DC electricity must be converted to AC at a desired voltage and frequency, or the high frequency AC from the generator is first rectified and then converted to AC.

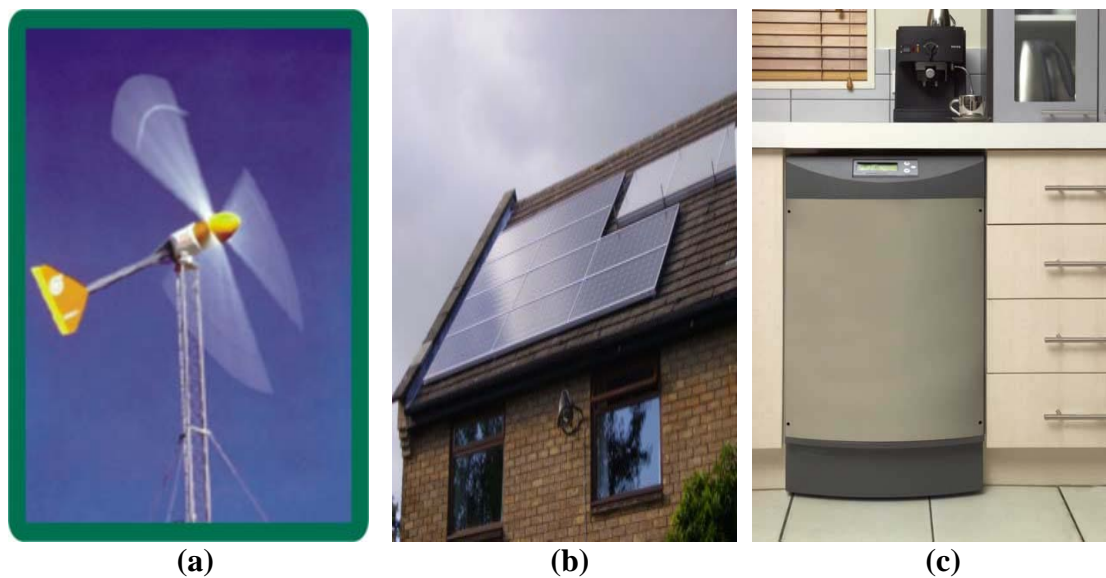

Figure 2.4: A small-scale wind turbine (a); PV panel (b); and dCHP installation (c).

SSEGs are currently treated as non-firm generation, whereby they must operate within the statutory voltage and frequency limits, but are tripped during contingency conditions. In order to ensure that SSEGs do not degrade the safety of the distribution system in the event of system disturbances, interface protections are installed in order to disconnect the SSEG from the LV distribution network. These may either be

incorporated within the SSEG or by separate devices. The voltage and frequency limits after which SSEGs will trip are shown in Table 2.1 for UK LV distribution networks.

Parameter	Trip setting (maximum range)	Trip time (maximum value)
Over Voltage	264V (230V +14.7%)	1.5 seconds
Under Voltage	207V (230V -10%)	1.5 seconds
Over Frequency	50.5Hz (50Hz +1%)	0.5 seconds
Under Frequency	47Hz (50Hz – 6%)	0.5 seconds

Table 2.1: Voltage and frequency limits for the protection devices used for SSEGs connected in UK LV distribution networks [24].

SSEG control within the SSEZ concept assumes that the connected SSEG units are controlled to provide a set of key functions associated with the specific control requirements of the SSEZ. This requires individual SSEG units to be able to regulate their active and reactive power output and thus regulate the voltage at the point of connection to the LV distribution network, as well as to regulate feeder voltages through their coordinated control.

In general, the control concepts and strategies employed for SSEG units largely depend on the interface type of the SSEG with the LV distribution network. SSEGs may either be directly interfaced through rotating electrical machines or through power electronic converters (DC/AC or AC/DC/AC). Both types comprise a primary energy source, which may be a fuel or a RES, the interface medium, a monitoring device for measurement purposes and the switchgear (fuse, circuit breaker) used at the point of coupling to the LV distribution network, as shown in Figure 2.5.

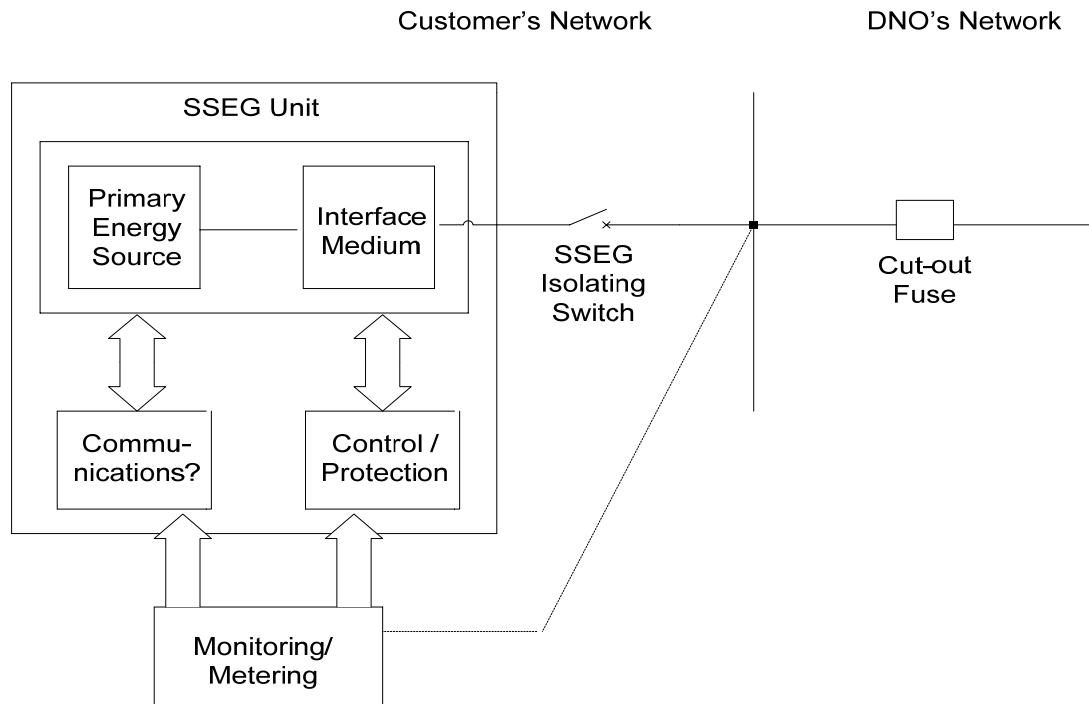

Figure 2.5: Block diagram showing a typical SSEG installation.

In addition, a communications unit may exist to enable the SSEG to exchange electricity transfer information with other distribution system components or the local utility. Currently, the majority of SSEG units are not linked to a communication system which has generally been required for DG installations greater than 1MW in size [35]. In the near future, however, *“most industry observers expect practices to change so that virtually every distributed resource will eventually be linked to a centralised or distributed control system”* [35].

2.5. LOAD CONTROL

Loads or consumption units may include motors, thermostatic loads, electronic loads, air conditioning and refrigeration units, discharge lighting and incandescent lighting [87-88]. Almost all loads consume electric power in a stochastic way that is subject to

seasonal and daily variations and are typically divided into four categories: residential, commercial, light commercial and industrial. Traditionally, customers located at the LV levels of electrical distribution networks have no other obligations except for paying their electricity bills and may extract at any time any amount of power within the safety limitations of their installation. Under such an operation, customer demand response is not required and real-time energy balancing is a responsibility of the system operator.

In general, electrical loads may be divided into the following three broad categories:

1. Critical loads: Load units that are essential in order to maintain production, or for health and safety purposes. Active control or unscheduled shutdown of these loads is highly undesirable. Examples include hospitals, banks, telecommunication sites, military bases, police stations, airports etc.
2. Re-shiftable loads: Load units whose operation may be re-scheduled without significantly affecting customer comfort. The most common examples of re-shiftable loads include washing machines, dryers, dish washers and water heaters.
3. Curtailable loads: Load units that are able to adjust their consumption in a variable manner, for example by various power load control or voltage control techniques, depending on the equipment. Examples include space heating, air-conditioning units and swimming pool pumps [32]. Curtailable loads are dispatchable but to varying degrees depending on the type of load involved.

The term Demand Side Management (DSM) is used to refer to actions which change the electrical demand in an electrical power system. A common definition provided in [89] defines DSM as “*the planning and implementation of those electric utility*

activities designed to influence customer uses of electricity in ways that will produce desired changes in the utility's load shape". In contrast to "supply-side" techniques, which aim to increase the energy supplied to the system by building, connecting and operating new generators, DSM techniques aim to make efficient use of existing energy assets and to defer the need for new resources.

The most common types of DSM found in the literature [19-21] are:

1. Peak Clipping: Peak clipping is generally considered as the reduction of energy consumption at times of peak load by using direct load control.
2. Valley Filling: Valley filling describes the addition of off-peak loads to the electrical demand of the system in order to smooth the load profile and thus decrease customer electricity costs and/or improve overall system efficiency.
3. Load shifting: Load shifting involves shifting loads from on-peak to off-peak periods in order to improve the load factor, and hence the economic efficiency of the utility. This is usually achieved through thermal energy storage, such as space and water heating, but may also include electrical energy storage or other types of customer load shifting.

Because DSM schemes have a direct impact on the customers, they must not deteriorate customer comfort or supply quality to unacceptable levels. Load control may take place automatically or manually and is classified into two main categories:

1. Direct load control: This requires a communication system to transmit the control signals sent by the utility to directly control a customer load. Most of the appliances targeted by utilities for direct load control, such as water and space heaters, air-conditioners and swimming pool pumps, provide a big amount of

thermal inertia and may be switched off for short periods of time with minimal customer impact [19-21]. Within the SSEZ concept, the direct control of re-shiftable and curtailable customer loads by a supervisory controller is considered.

2. Local load control: This allows customers to self-adjust loads in order to limit peak electrical power demand, for example by using timers, demand-activated breakers, thermostats, cogeneration heating, etc.

2.6. ESU CONTROL

In traditional power system operation, electrical energy storage has been provided through the inertia of the connected rotating generators. With the addition of new loads to the system, the initial energy balance has been satisfied by the system's inertia with a slight reduction in system frequency. For distribution networks with high levels of DG and SSEG present, however, the proliferation of intermittent (and often inertia-less) generation will introduce a higher degree of uncertainty and thus present challenging issues regarding power system control and operation.

According to two recent reports [22-23], electrical energy storage systems will become particularly important in order to decouple energy availability and demand and thus increase power quality and system stability. This is because in order to manage the balance between generation and demand under increased uncertainty due to intermittent generation, additional amounts of reserve will be required. This reserve will be supplied by a combination of synchronised reserve, provided by part-loaded generating plants, and standing reserve in the form of storage and/or flexible generation.

A wide range of electrical energy storage technologies [22] exist that could be installed at the LV ends of electrical LV distribution systems. Such technologies may include: (i) lead-acid batteries; (ii) hydrogen fuel cells; (iii) flywheels; (iv) supercapacitors; and (v) Superconducting Magnetic Energy Storage (SMES). Moreover, plug-in hybrid electric vehicles (PHEVs) and electric vehicles (EVs) are receiving considerable interest from vehicle manufacturers and policy makers [90] and could present significant opportunities for electrical ESM in the near future.

In general, ESM may be employed for one of the following purposes [91]:

1. For system regulation purposes whereby energy storage is used for system stabilisation in order to smooth out short-term load fluctuations. This allows the connected SSEGs to operate at a constant, stable power output level without altering the frequency of their generation.
2. ESUs may be used as spinning reserve or back-up energy capacity by providing energy through periods when SSEG units are unavailable.
3. ESUs may allow non-dispatchable SSEG units to operate as dispatchable units by permitting the generating output to vary depending on network conditions.
4. ESUs can provide power in order to avoid or reduce the need for load curtailment when the available system generating capacity from all other sources can not supply the respective total load demand.
5. ESM schemes may be deployed for peak shaving purposes by providing power at times of peak load. This practice is similar to peak clipping for DSM.
6. Finally, ESUs may be used as load levelling by providing storage for the surplus electricity that is generated during off-peak time periods. This would map particularly well with the usage of renewable energy sources that have an intermittent generation capacity output, as for example wind and solar energy.

The installation system for an ESU is shown in Figure 2.6 and may consist of the following components: (i) the ESU device which comprises an energy storage medium for storing electrical energy; (ii) a control and protection system which monitors the level of the energy stored in the energy storage medium and controls the operation of the ESU; (iii) a monitoring device which is responsible for real-time measurement purposes; and (iv) a communications unit that enables the ESU to communicate and exchange data with the local utility or other distribution system components. Similarly to SSEGs, most small-scale ESU installations currently do not include a long-range communications medium but this may change in future actively managed electrical distribution networks.

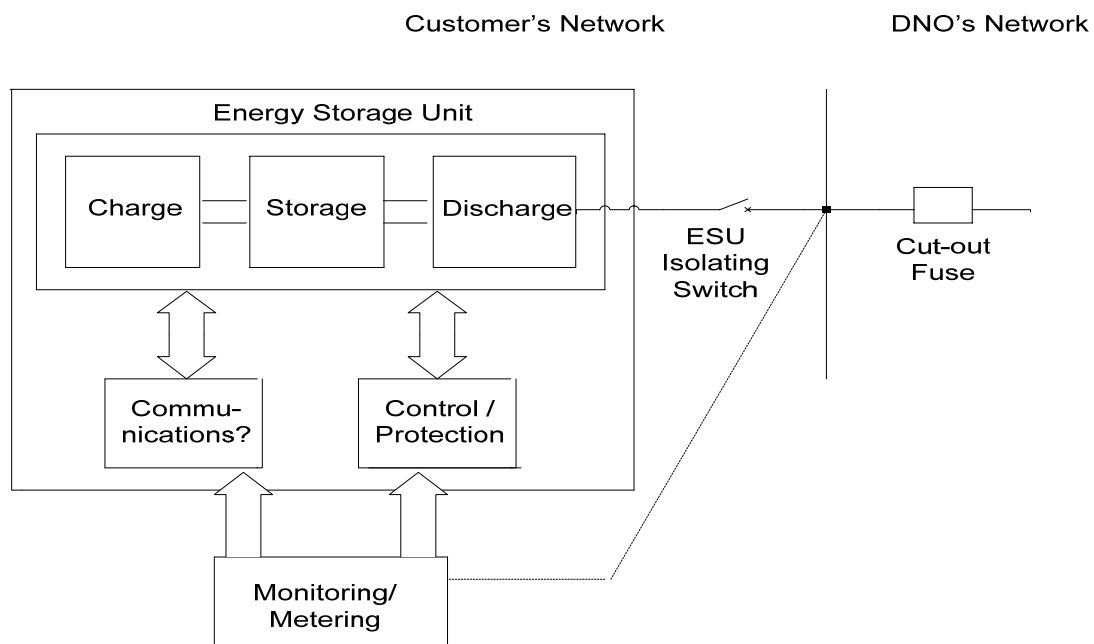

Figure 2.6: Block diagram showing a typical ESU installation.

2.7. CONCLUSIONS

This Chapter presented an overview on the control approaches typically employed in electrical distribution networks. The existing control approach is based on SCADA

systems which supervise and control power plants and electrical transmission networks. In contrast to MV and HV networks, at the LV customer level very little command, control and data acquisition is typically carried out, in accordance with the passive, “fit-and-forget” philosophy of Engineering Recommendation P2/5 [25].

Although passive practices were considered adequate in the past to accommodate load growth, LV networks with high SSEG penetrations are likely to move towards a higher degree of network operational management. This will require the employment of intelligent metering, control and communication systems, where the aim is to improve network performance during normal and emergency system operation. ICT and IEDs will become increasingly important in order to realise such networks

Finally, the main control concepts employed for the management of SSEG units, as well as strategies for DSM and ESM were described. Within the SSEZ concept, the focus is on grid-dependent control strategies, where real and reactive power set-points are provided by a supervisory controller in accordance with overall distribution system operation. The controllability of the SSEGs, ESUs and controllable load units installed within an SSEZ is crucial, as they will determine the capability for active and reactive power control within the zone. In general, units that are capable of regulating their active and reactive power output/input at all times are preferred, because they provide the highest flexibility for active control.

CHAPTER 3

Multi Agent Systems

The theory behind Multi Agent Systems is based on distributed artificial intelligence computing, where the main aim is to split a complex problem into several subtasks and distribute the management of these tasks to individual software entities. This allows system intelligence to be distributed across the system components rather than being concentrated on a single point, which may present significant advantages that will later be described. The popularity of MAS has risen significantly with the continuous increase in Internet and Web computing, which present an environment in which agents can exist and interact with one another.

The terms “agent” and “MAS” are used here according to the standards set by the Foundation for Intelligent Physical Agents (FIPA) and in particular the FIPA Agent Management Reference Model [92] that defines standards for creating, locating, removing and communicating with agents. The advantages offered by designing and developing an MAS to comply with FIPA standards are explained in Section 3.3.1.

3.1. AGENT AND MAS ATTRIBUTES

The simplest definition of an agent [93] has been used to describe a software or hardware entity that is situated in some environment over which it has partial control and particular objectives to achieve. An agent has well-defined boundaries and interfaces and is able to monitor the environment through sensors or data access from other sources and modify it by reacting autonomously to changes that occur in it. It has therefore been argued that, at this level, some simple existing control and protection systems employed at electrical distribution systems such as protection relays could also be classed as “agents” [94].

This simple definition of an “agent” has been extended in order to include the reasoning and communication capabilities of the agent as well. According to this definition, the four key agent attributes found in the literature [95-97] are:

1. **Autonomy:** Agents have a self-starting behaviour and some kind of control over their actions and internal state.
2. **Social Ability:** Agents take part in social activities with other agents (or users) in order to achieve their design objectives.
3. **Reactivity:** Agents interact with their environment and respond in a timely fashion to changes that occur in it.
4. **Pro-activeness:** Agents are able to exhibit goal-directed behaviour by taking the initiative.

Other, more general attributes of agents have been described in [95] and include:

1. **Accuracy:** Agents will always try to do what it is asked of them.
2. **Adaptivity:** Agents are able to learn and improve with experience.

3. Adaptability: Agents are able to respond to changing environmental conditions.
4. Mobility: Agents can move and migrate from one host platform to another.
5. Temporal continuity: Agents are continuously running processes and have persistence of their identity and state over long periods of time.
6. Reliability: Agent can not intentionally pass false information.
7. Inferential capability: Agents can act on abstract task specifications using prior knowledge of general goals.

The term “Multi Agent System” is used to denote the combination of one or more agents capable of exhibiting these attributes within a co-operative system [93]. Hence, from the point of view of system control, an MAS control approach is different to both the centralised and the fully distributed control paradigms [96]. An MAS works in a distributed control regime, where most decision-making occurs locally and autonomously. However, when necessary, an MAS may also require inter-agent communications, which typically occur between agents with common interests.

3.2. ARCHITECTURAL STYLES

A number of architectural styles have been used for the development of MAS. This Section provides an overview both on the micro- (individual agent structure) and the macro-level (agent society and organisational structure) of MAS architectural theory.

3.2.1. Individual Agent Architectures

There are three main types of individual agent architectures currently employed for MAS [93]: (i) deliberative, (ii) reactive and (iii) hybrid agent architectures.

Deliberative architectures contain an explicitly represented, symbolic model of the world and decide on their actions using logical reasoning based on pattern matching and symbolic manipulation as seen in Figure 3.1. Examples of deliberative architectures are IRMA [98] and the Procedural Reasoning System (PRS) [99] that may be seen in Figure 3.2.

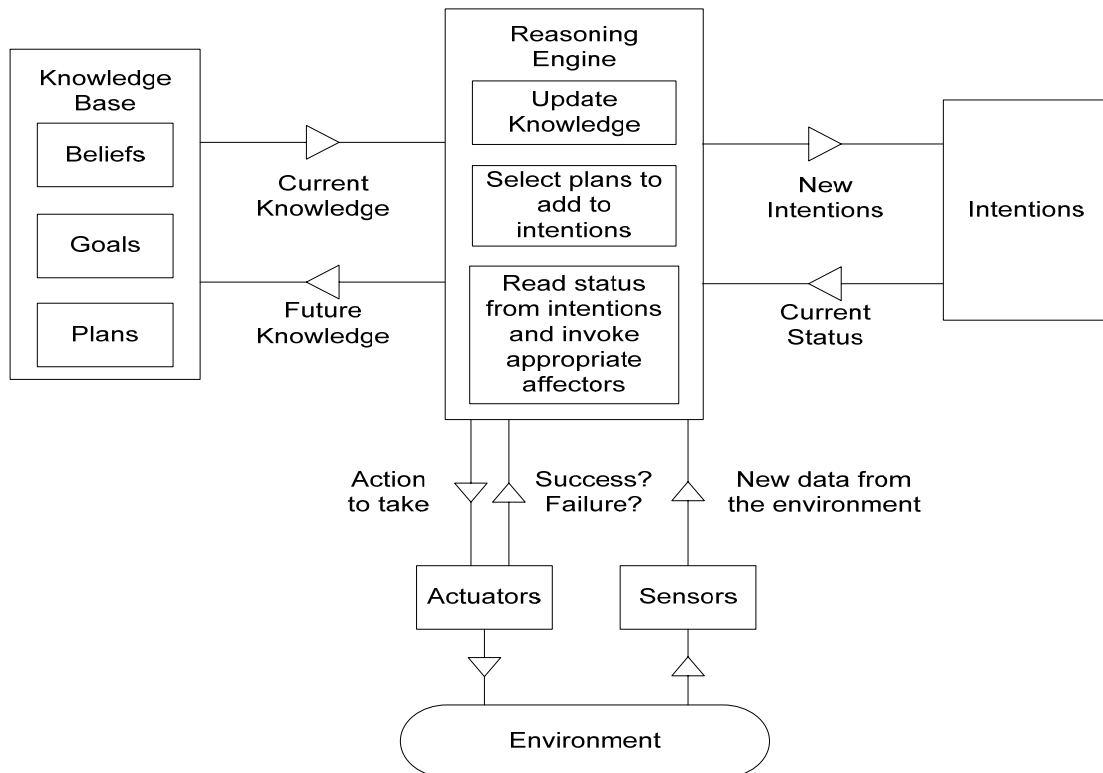

Figure 3.1: Structure of an agent with a deliberative architecture [79].

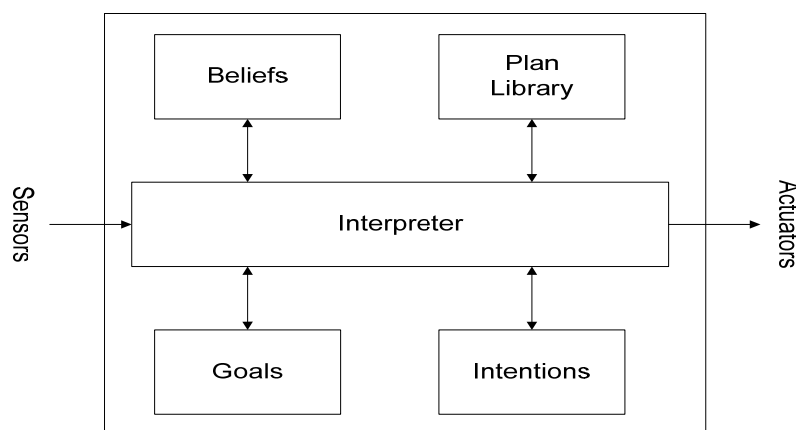

Figure 3.2: The PRS agent architecture [99].

(iii) a functional layer that represents the functional attributes of the agent, i.e. the actions the agent can perform. The layered architecture employed by JADE agents is illustrated in Figure 3.4.

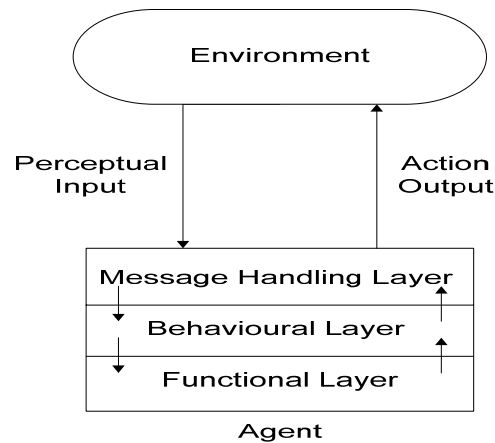

Figure 3.4: The layered architecture employed by JADE agents [151].

In order to select the most fitting agent architecture, the different architectural types must be evaluated based on their suitability to meet the specific design objectives of the MAS. If multiple agent architectures appear to be suitable, research described in [104] has proposed to assess agent architectures based on generic software quality attributes, i.e. non functional requirements describing how well the MAS can accomplish its design objectives. The choice, however, will often also depend on the MAS development kit that is used during the implementation stage.

3.2.2. MAS Architectures

According to the literature [105], four main MAS organisations exist:

1. Hierarchical MAS, in which agents communicate according to a hierarchical organisation. According to [105], the disadvantage of this architectural type is the reduction in autonomy of individual agents, as the lower levels of the MAS

depend on the higher levels. However, this architecture could reduce the required communications as well as individual agent complexity.

2. Flat MAS, where any agent may interact with any other agent in the MAS. These provide the greatest autonomy, but could result in extensive inter-agent communications. Moreover, agents in a flat MAS must either know the agent identifier number of all agents that they need to interact with, or be provided with location mechanisms such as white and yellow pages services.
3. A subsumption MAS is a system in which agents are themselves made up of other agents. In this system, the subsumed agents are completely controlled by the containing agents. According to [105], the fixed structure of a subsumption MAS provides efficiency but restricts the flexibility of the system.
4. A modular MAS is comprised of a number of modules. Each module is typically flat, while inter-module communications are relatively limited..

The choice for the adopted MAS architecture typically depends on two factors: (i) the MAS architectural organisation provided by the MAS development kit that is used; and (ii) the communication and computational requirements of the overall system. If requirements must be kept at minimal levels, hierarchical or subsumption MAS architectures are often employed in order to reduce system complexity. On the contrary, flat MAS are typically used in applications where flexibility, “plug and play” capabilities and significant inter-agent communications are required.

3.3. FIPA STANDARDS

The Foundation for Intelligent Physical Agents (FIPA) [106] is a standards organisation that promotes MAS technologies and the interoperability of its standards

between different MAS implementations. In particular, the FIPA Agent Management Reference model shown in Figure 3.5 defines “*the normative framework within which FIPA agents exist and operate. It establishes the logical reference model for the creation, registration, location, communication, migration and retirement of agents*” [92]. The normative framework includes a set of entities that FIPA-compliant MAS must contain, according to Figure 3.6. These include:

- an agent runtime environment for defining the FIPA notion of agency;
- an Agent Platform (AP) for deploying agents in a physical infrastructure;
- a Directory Facilitator (DF) which provides a yellow pages service for the agents registered on the platform;
- an Agent Management System (AMS) acting as a white pages service for supervisory control over access to the agent platform;
- a Message Transport Service (MTS) for communication between the agents registered on different platforms.

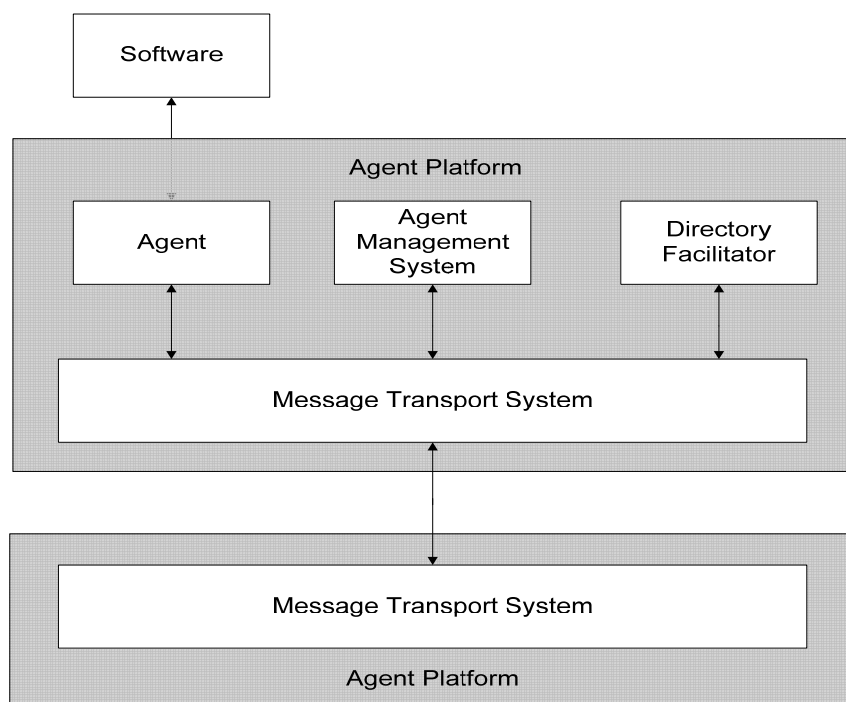

Figure 3.5: The FIPA Agent Management Reference Model [92].

The five entities comprising a FIPA-compliant MAS are explained later in this Chapter in greater detail. Firstly, however, Section 3.3.1 attempts to clarify the potential advantages offered to the developer by complying with FIPA standards.

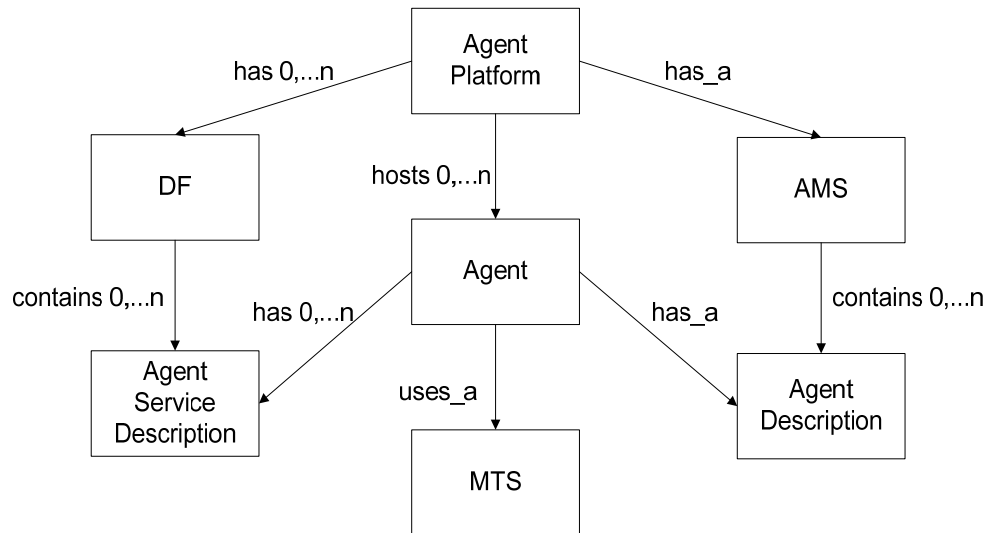

Figure 3.6: The entities that comprise a FIPA-compliant AP.

3.3.1. Why FIPA Compliance?

The development of agents and MAS in general that can interact with each other irrespective of the platform they run on is often a fundamental requirement for on-line industrial applications. For the control of electrical distribution networks, in particular, DNOs are striving for increased integration between previously separate systems in order to improve system performance [94]. Adoption of FIPA standards can provide interoperability to agents that belong to different agent platforms and which may have been developed by different organisations. This way, agents are able to dynamically discover each other and coordinate their actions using a common MTS as will later be described.

Moreover, many MAS have been employed in the past using closed architectures where agents were implemented without the ability for potential changes in the future. Adherence to FIPA specifications may provide an open and scalable architecture where agents can easily be added or removed. This allows additional functionality to be added to the system at any time by replacing existing agents with improved ones. The ability to reconfigure and upgrade the system with minimum complexity is particularly important when considering the fact that MAS could potentially be implemented on different sites under different operating conditions and may need to be upgraded in the future,.

3.3.2. Agent Platforms and Development Kits

A FIPA-compliant AP (Figure 3.5) consists of the machine(s), operating system, system agents and the FIPA agent management components, i.e. the AMS, the DF and the Agent Communication Channel (ACC). The AMS is a mandatory component and offers “white page services” to system agents by providing a directory of AIDs (Agent Identifiers) registered with the MAS platform. The DF is optional and acts as “yellow pages” by keeping a directory of the services offered by system agents. Finally, the ACC provides the MTS for the delivery of FIPA-ACL (FIPA - Agent Communication Language) messages between agents running on the same or different agent platforms.

The implementation of the AP, as well as whether it complies with FIPA specifications or not, greatly depends on the Agent Development Kit (ADK) that is employed. There exist a number of ADKs for the development of fully FIPA-compliant APs. In terms of the most popular publicly available ADKs, these include JADE [102-103], FIPA-OS [107], ZEUS [108] and the Comtec Agent Platform [109].

The most popular commercially available ADKs include the Tryllian ADK [110] and JACK [111]. Finally, popular non FIPA-compliant ADKs include Cougaar [112] and MadKit [113]. A review of available ADKs may be found in [114-115].

3.3.3. Agent Interactions

According to [105], four paradigms for agent interactions exist:

1. Peer to peer communication: messages are sent directly to a specific agent.
2. Broadcast communication: a message is sent to all agents within the MAS.
3. Multicast communication: a message is sent to a specific group of agents.
4. Generative communication: agents generate messages on a blackboard, which can be read by other agents.

Agent-oriented interactions are based on high-level Agent Communication Languages (ACLs) [116], i.e. languages in which agent communicative acts can be expressed. The core of an agent message lies in the content of the ACL. However, in order to allow composition and interpretation of meaningful messages between agents, the following parameters must also be included: (i) message transport protocols; (ii) content languages; and (iii) ontologies. Finally, an MTS must exist to provide a mechanism for the transfer of ACL messages between agents.

The first popular ACL was the Knowledge Query and Manipulation Language (KQML) [117]. In recent years, however, the agent communication standards developed by FIPA [118-119] and FIPA-ACL “*have become the de facto standards used by MAS developers in the computer science community and beyond*” [114-115].

FIPA-ACL is based on speech act theory which states that messages represent actions or communicative acts (“performatives”) [119].

The message transport protocol is used to carry out the physical transfer of messages between two agent communication channels. FIPA specifications [120] describe how message transport protocols may be used to transfer agent messages, however message transport is completely handled by the AP and therefore the MAS developer does not need to understand the details of the message transport protocol employed. The FIPA message transport reference model is shown in Figure 3.7.

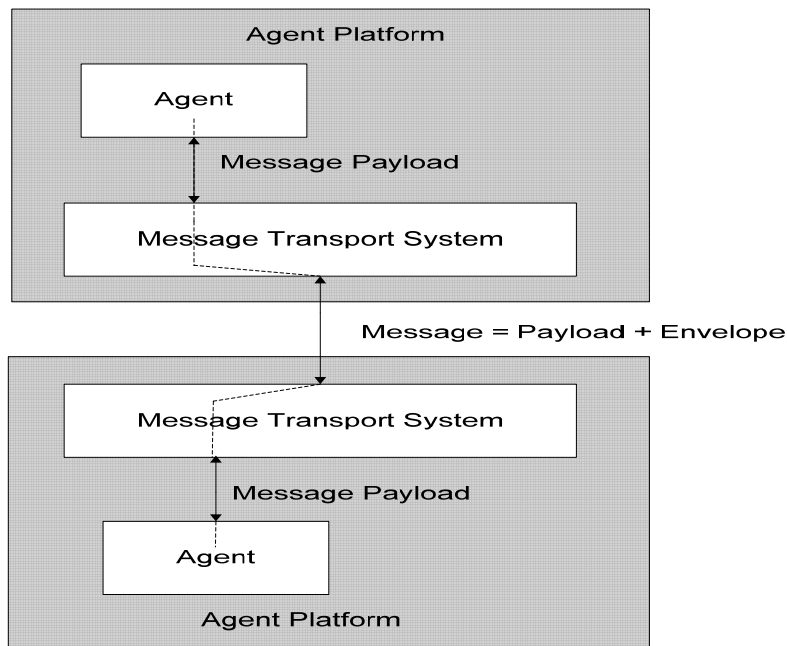

Figure 3.7: The FIPA Message Transport Reference Model [120].

An ontology provides a vocabulary for representing and exchanging knowledge about some topic and a set of relationships for the parameters denoted by that vocabulary. Because the ontology depends on the specific tasks of each domain, a standard ontology for agent messaging does not exist. Hence, it is necessary to design a specialised ontology for any individual MAS application in order to provide an

adequate description of the environment such that it includes all information required by system agents. Finally, the MTS provides the means to send and receive ACL messages between agents. The agents may be local to a single AP or on different APs. On any given platform, the MTS is provided by an ACC, which transfers the messages it receives according to the transport instructions contained in the message.

3.4. MAS APPLICATIONS IN POWER ENGINEERING

The IEEE Power Engineering Society Multi-Agent Systems Working Group [121] has created a Task Force whose aim was to carry out an extensive literature review of the body of work on MAS applied to Power Engineering. Durham University was part of this Task Force and the results may be found in [122]. Four broad fields of MAS applications were identified: (i) distributed control; (ii) modelling and simulation; (iii) state-estimation, monitoring and diagnostics; and (iv) protection. In addition, two recent papers [114-115] have also presented a comprehensive review of the Power Engineering applications for which MAS are being investigated.

For the MAS-based distributed control of power systems, literature suggests that the applications under investigation include ANM [123-124] and in particular the control of MicroGrids [125-128], VPPs [53] or power plants [129], power system restoration [130-132] and control of shipboard electrical systems [133-134]. In addition, MAS have also been proposed as a means for DG dispatch for voltage support [135].

The deregulation of the electricity industry in many countries has introduced market systems that are influenced by a much greater number of factors than before. The

distributed nature of MAS may be exploited in order to simulate such complex markets and how they may react to specific operating conditions [136-140]. Specific examples include the simulation of cross-border trading [139] and the simulation of social considerations into market participant models [140]. In addition to electricity market simulation, the use of MAS as a modelling approach has also been proposed for transmission planning [141].

The third common power engineering application area for MAS is data management and interpretation for state estimation, monitoring and/or diagnostic functions. A transformer condition monitoring MAS is described in [142], while [143] details the agent-based management and analysis of SCADA and digital fault recorder data. MAS-based state estimation for electrical distribution networks is proposed in [144], as well as for substation automation in [145-146]. Finally, power system protection is a research area where the possibility of employing MAS technology in place of protection relays and associated equipment has recently been proposed [147-150].

3.5. CONCLUSIONS

This Chapter presented general theory behind the notions of “agency” and “MAS” according to the standards set by the Foundation for Intelligent Physical Agents (FIPA) and in particular the FIPA Agent Management Reference Model [157]. MAS have recently been employed in a variety of applications [93] such as air traffic control, process control, manufacturing, electronic commerce, patient monitoring or computer games, however the research described here focuses on the application of MAS in the Power Engineering industry as described in Section 3.4.

The literature review of the body of work on MAS applied for the distributed control of electrical power systems indicated that the research described in [125-128] and [123] are most closely linked with the research described in this Thesis. The first work is mainly concerned with the optimal participation of MicroGrid components (production, storage and load units) in the market [125-128]. A MAS-based distributed control system is presented in [125] that aims at maximising the overall internal benefits of the MicroGrid components, i.e. to minimise the operational cost of the MicroGrid. The second work proposes the employment of MAS technology with AuRA-NMS [123], an autonomous regional ANM system. AuRA-NMS aims to integrate different network management tasks, such as voltage control, power flow management and network restoration, and is proposed as a means of offering a flexible ANM system for MV distribution networks with high levels of DG.

The objectives of the MAS described in this Thesis differ from the two above-mentioned pieces of research. This is because within the SSEZ concept, MAS technology is proposed as a means of delivering the control approach that satisfies the specific SSEZ control requirements, namely to: (i) overcome the LV distribution network constraints associated with high penetrations of SSEG; and (ii) to meet specific SSEZ operational goals depending on operating network conditions. Crucial to the functionality of the developed MAS are the reasoning and communication capabilities implemented inside each agent within the MAS, as well as the employment of a common ontology for sharing knowledge. These must be designed and developed specifically for the SSEZ environment and as a result, they differ from previous research as will be explained in Chapters 6 and 7.

CHAPTER 4

SSEG Technical Impact Studies

There is a growing need to investigate the technical impacts that the anticipated high penetrations of SSEGs may cause to the operation of LV distribution networks. SSEG technical impact studies must therefore be performed using suitable case study networks in order to evaluate the effects of SSEGs and quantify allowable SSEG penetration limits. This Chapter details the development of simulation models in the power systems simulation package PSCAD™/ EMTDC™ [151] for three different LV distribution networks: a generic UK LV distribution network, a generic European LV distribution network and an existing UK LV distribution network. Moreover, a methodology for predicting the technical impacts of SSEGs without the need for developing detailed computer-based models is proposed. This methodology is drawn from an analysis of the key electrical characteristics that determine the response of LV networks to the addition of SSEGs, focusing on the following technical constraints: (i) customer voltage rise/drop; (ii) voltage regulation; (iii) voltage unbalance; (iv) cable and transformer thermal limits; and (v) network losses.

4.1. TECHNICAL CHALLENGES

There are a number of technical challenges that need to be considered with respect to the connection and operation of SSEGs on LV distribution networks. The introduction of SSEGs will affect the operation of the distribution system both at the LV, as well as the MV levels through distribution transformers. Engineering Recommendation G83/1 [24] recommends a two-stage procedure to facilitate the connection of SSEGs on LV distribution networks. A “Stage 1 Connection” consists of a single SSEG installation and this generally has a negligible impact on the operation of the LV distribution network. Hence, there is no need for the DNO to either carry out a network study or to perform any work on the network. A “Stage 2 Connection” consists of multiple SSEG installations in a close geographical region. In such cases, the DNO is advised to assess the technical impacts of the proposed connections on the operation of the LV distribution network and to specify conditions for connection.

A recent report [152] concluded that “*the operation of SSEGs connected to the LV network can cause statutory voltage limits to be exceeded, recommended voltage unbalance levels to be exceeded and reverse real and reactive power to flow*”. These technical challenges, along with network losses and other power quality issues have been well documented in a number of recent publications [153–159] and are explained here in greater detail.

4.1.1. Customer Voltage Rise/Drop

DNOs have an obligation to supply their customers at a steady-state voltage within the specified limits of 230V +10/-6% for LV distribution networks in the UK [42] and

Europe [43]. Without any SSEGs connected, the steady-state three-phase voltages at intermediate points in the LV distribution network are determined by network impedances and the loads connected. Hence, DNOs have traditionally set steady-state voltages near the top statutory limit at source substations during minimum loading conditions to allow for downstream voltage drop where voltages will approach the bottom limit during maximum loading conditions.

The active power produced by SSEG units, however, will tend to increase the steady-state voltage and, depending on the power factor of the generator, the reactive power produced or absorbed by the SSEG will also have an impact on network voltages. To determine whether the local steady-state voltage at the SSEG connection point has exceeded statutory limits, the generator, load and network characteristics must be considered. In addition, excessive voltage drop (230V -6% for LV networks in the UK [42] and Europe [43]) may also become an issue under maximum loading conditions, when the available generation of the connected SSEGs is low, or when the tap position on a secondary transformer has been changed.

In symmetrical three-phase power system operation (Figure 4.1), the voltage drop $\Delta\bar{V}$ observed on a line segment due to a balanced three-phase load is:

$$\Delta\bar{V} = \left| \bar{V}_s - \bar{V}_r \right| = \left| \bar{I} \left[R_1 + jX_1 \right] \right| = \left| \frac{R_1 P_r + X_1 Q_r - j(X_1 P_r - R_1 Q_r)}{\bar{V}_r} \right| \quad (4.1)$$

where:

\bar{V}_s sending end line-to-line voltage [V]

\bar{V}_r receiving end line-to-line voltage [V]

\bar{I}	phase load current [A]
R_1	positive sequence line resistance [Ω]
X_1	positive sequence line reactance [Ω]
θ	angle between voltage at receiving end and load current [degrees]
S_s, P_s, Q_s	sending end apparent power [VA], real power [W] and reactive power [VAr] respectively
P_L, Q_L	real [W] and reactive [VAr] power input of the load respectively

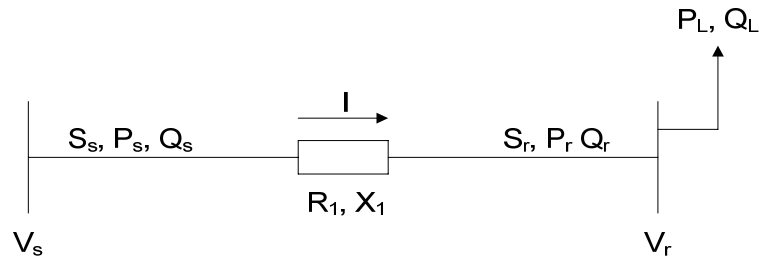

Figure 4.1: Single-line diagram of a feeder with a 3-phase load connected at the end.

For a small power flow, the angle θ is small and the voltage drop can be approximated by:

$$\Delta \bar{V} = \frac{R_1 P_r + X_1 Q_r}{V_r} \quad (4.2)$$

Equation (4.2) may also be used to calculate the voltage rise caused by a three-phase connected SSEG. The voltage rise on a feeder with one SSEG and one load connected at the end (Figure 4.2) is:

$$\Delta \bar{V} = \frac{R_1 P_r + X_1 Q_r}{V_r} = \frac{R_1 (P_G - P_L) + X_1 (Q_G - Q_L)}{V_r} \quad (4.3)$$

where:

P_G, Q_G real [W] and reactive [VAr] power output of the SSEG respectively

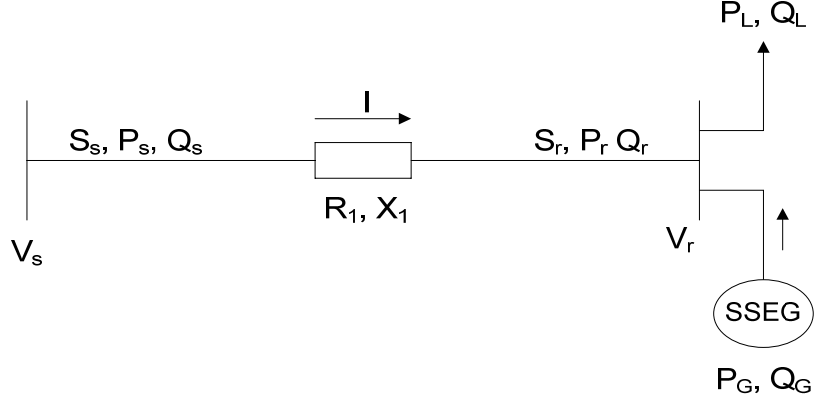

Figure 4.2: Single-line diagram of a feeder with one 3-phase load and one 3-phase SSEG connected at the end.

For unbalanced four-wire LV distribution networks, the voltages due to return currents flowing in the neutral conductor and earth need to be considered in addition to the voltage changes due to the phase currents. The phase-to-ground voltage drop along a line section l of a single-phase conductor in a four-wire system including the effect of self and mutual coupling between the phase and the neutral conductors and the effects of the grounding points may be written according to [160]:

$$\Delta \bar{V}_{AG} = \bar{Z}_{AA} \bar{I}_A + \bar{Z}_{AB} \bar{I}_B + \bar{Z}_{AC} \bar{I}_C + \bar{Z}_{AN} \bar{I}_N \quad (4.4)$$

$$\Delta \bar{V}_{BG} = \bar{Z}_{BA} \bar{I}_A + \bar{Z}_{BB} \bar{I}_B + \bar{Z}_{BC} \bar{I}_C + \bar{Z}_{BN} \bar{I}_N \quad (4.5)$$

$$\Delta \bar{V}_{CG} = \bar{Z}_{CA} \bar{I}_A + \bar{Z}_{CB} \bar{I}_B + \bar{Z}_{CC} \bar{I}_C + \bar{Z}_{CN} \bar{I}_N \quad (4.6)$$

$$\Delta \bar{V}_{NG} = \bar{Z}_{NA} \bar{I}_A + \bar{Z}_{NB} \bar{I}_B + \bar{Z}_{NC} \bar{I}_C + \bar{Z}_{NN} \bar{I}_N \quad (4.7)$$

where:

$\Delta \bar{V}_{AG}$ voltage drop in phase A with reference to ground [Volts]

$\overline{Z_{AA}}$	self-impedance of phase A conductor [Ω]
$\overline{Z_{AB}}$	mutual impedance of phase A and phase B conductor [Ω]
$\overline{Z_{AC}}$	mutual impedance of phase A and phase C conductor [Ω]
$\overline{Z_{AN}}$	mutual impedance of phase A and neutral conductor [Ω]

similarly for phase B, C and for the neutral N.

In order to relate phase voltages with reference to the neutral point of the load, the primary phase voltage drops with respect to neutral can be expressed as follows [160]:

$$\Delta \overline{V}_{AN} = \Delta \overline{V}_{AG} - \Delta \overline{V}_{NG} \quad (4.8)$$

$$\Delta \overline{V}_{AN} = \overline{I}_A (\overline{Z}_{AA} - \overline{Z}_{NA}) + \overline{I}_B (\overline{Z}_{AB} - \overline{Z}_{NB}) + \overline{I}_C (\overline{Z}_{CC} - \overline{Z}_{NC}) + \overline{I}_N (\overline{Z}_{AN} - \overline{Z}_{NN}) \quad (4.9)$$

where:

$\Delta \overline{V}_{AN}$ voltage drop on phase A with respect to neutral [Volts]

According to [160], equation (4.9) may be simplified by ignoring the mutual impedances between the conductors of the network without losing accuracy. The primary phase voltage drops with respect to neutral for phases A, B and C may hence be re-written as:

$$\Delta \overline{V}_{AN} = \overline{I}_A \overline{Z}_{AA} - \overline{I}_N \overline{Z}_{NN} \quad (4.10)$$

$$\Delta \overline{V}_{BN} = \overline{I}_B \overline{Z}_{BB} - \overline{I}_N \overline{Z}_{NN} \quad (4.11)$$

$$\Delta \overline{V}_{CN} = \overline{I}_C \overline{Z}_{CC} - \overline{I}_N \overline{Z}_{NN} \quad (4.12)$$

Equations (4.10) – (4.12) are also applicable to calculate the voltage rise caused by the single-phase connection of an SSEG to an unbalanced four-wire LV distribution network. The voltage rise on the phase of connection is attributable both to phase currents as well as due to return currents flowing in the neutral conductor and earth.

Customer voltage rise is likely to be of concern in rural networks, which are commonly radial networks with feeders covering long distances with relatively low current capacity conductors. In such networks, excessive voltage rise can be initiated by relatively small penetrations of SSEGs due to the high impedance of the conductors and because these feeders are often operated close to the statutory upper voltage limit to counter the relatively large voltage drops over these feeders.

In essentially all LV distribution networks, the impact of any individual SSEG unit on the feeder primary will be almost negligible. However, when the aggregate capacity of many SSEG units reaches a critical threshold, steady-state voltage rise studies must be undertaken in order to ensure that customer voltages are maintained within statutory limits. A useful rule-of-thumb given in [159] states that if the injected current (measured at the primary level) is less than 5% of the feeder loading at the interconnection point and if all customers had satisfactory voltage prior to the addition of the SSEG, then a voltage problem on the primary is unlikely. Only after much above 5% injection would there be reason to worry about potential impacts.

4.1.2. Voltage Regulation

The introduction of SSEGs, in particular for generators based on intermittent RES, is likely to lead to increased voltage variation within the LV distribution system.

Voltage regulation in LV distribution networks is defined as the maximum allowable deviation between the LV busbars of the MV/LV substation and the end of service. Voltage regulation statutory limits differ between countries and DNOs, however in the UK most DNOs allow a maximum of 5-8% voltage regulation [161-163]. During periods of maximum generation and minimum demand, voltage regulation statutory limits may be exceeded due to the voltage rise caused by the power output of the connected SSEGs. Similarly with customer voltage rise, the impact of any individual SSEG unit on the system voltage variation will be almost negligible. However, when the aggregate capacity of many SSEG units reaches a critical threshold, voltage regulation studies must be undertaken to ensure that statutory limits are not exceeded.

4.1.3. Voltage Unbalance

Voltage unbalance in three-phase distribution systems is a condition in which the three-phase voltages differ in amplitude or are displaced from their normal 120 degree phase relationship or both [164]. Mathematically, voltage unbalance can be defined as the maximum deviation from the average of the three-phase voltages, divided by the average of the three-phase voltages and expressed as a percentage [165]. A very common definition is also given by using symmetrical components and is used in Engineering Recommendation P29 [165] and EN 50160 [43] which define the acceptable levels of voltage unbalance in LV distribution networks in the UK and Europe respectively. The percentage voltage unbalance factor (% VUF) is determined by the ratio of the negative- to the positive sequence voltage component and has a design limit of 1.3% in the UK, although short-term deviations (less than 1 minute) may be allowed up to 2%, which is the standard limit used in European networks.

$$\% \text{ VUF} = \frac{V_-}{V_+} \times 100 \quad (4.13)$$

where the negative (V_-) and positive (V_+) sequence components may be computed using the following equation:

$$\begin{bmatrix} V_a \\ V_b \\ V_c \end{bmatrix} = \frac{1}{3} \begin{bmatrix} 1 & 1 & 1 \\ 1 & 1\angle 120^\circ & 1\angle -120^\circ \\ 1 & 1\angle -120^\circ & 1\angle 120^\circ \end{bmatrix} \begin{bmatrix} V_0 \\ V_+ \\ V_- \end{bmatrix} \quad (4.14)$$

where:

$V_a \ V_b \ V_c$ three-phase line or phase voltages [V]

$V_+ \ V_- \ V_0$ positive, negative and zero sequence voltage component [V]

Single-phase loads in LV distribution networks are continually connected to, and disconnected from, the distribution system and are not evenly distributed between the three phases. Additionally, the level of unbalance present in distribution networks also depends on phase-conductor configurations, such as unsymmetrical spacing between phase conductors [165]. Voltage unbalance until now has generally not been of great concern, because the distribution of single-phase customer loads has been centrally planned by DNOs by allocating them equally across the three phases.

The single-phase nature of SSEGs, however, along with the fact that their growth is consumer-driven and not centrally planned may result in additional unbalanced currents and voltages [210]. In addition to generation unbalance, load behaviour is also likely to change significantly in the future adding further complexity to the inherent symmetry of distribution systems [154]. Unbalanced voltages can result in adverse effects on power system equipment and on the electrical network, which is

intensified by the fact that a small unbalance in the phase voltages can cause a disproportionately large unbalance in the phase currents [165].

4.1.4. Thermal Limits

Transformers and network lines, such as overhead lines and underground cables, have a thermal rating determined by the maximum current carrying capacity of that component. If a component is loaded above its thermal rating for an extended period of time, it will overheat which could then lead to permanent damage, or even to a dangerous event such as a fire or explosion [164]. Hence, protection systems are employed to ensure the safety of humans and network equipment. The different types of thermal ratings that could be quoted by DNOs are:

1. Continuous ratings, which indicate 100% rated current for 100% of the time.
2. Cyclic ratings, which are based on a specific load-shape, load-duration etc.
3. Seasonal ratings, which are based on a seasonal variation.

The presence of SSEGs will alter current flows in the LV distribution network and the extent of the effect of SSEG output current on the thermal rating of the network will mainly depend on the interaction between demand and generation. With a suitable choice of site and connection scheme, SSEGs could have a beneficial effect, with no increase in the currents circulating in the network and even some significant reductions. For high SSEG penetration scenarios, however, the operation of SSEGs may cause an increase in the overall current flowing in the network, bringing system components closer to their thermal limits. Since the majority of LV distribution networks have a radial topology, the line sections that will be affected the most by the change in power flows are those in which SSEGs are connected.

- **Cable Thermal Limits**

The current flowing in an overhead line I_{OHL} can be defined [167]:

$$I_{OHL} = \sqrt{\frac{Q_C + Q_R - Q_S}{R}} \quad (4.15)$$

where:

Q_C heat exchange by convection per length, dependant on air temperature, conductor temperature, wind speed and wind direction [W/m]

Q_R heat exchange by radiation, dependant on air and conductor temperature [W/m]

Q_S solar heat gain, dependant on solar radiation [W/m]

R conductor resistance, dependant on conductor temperature [Ω/m]

In underground cables it is also necessary to consider the heat production by eddy currents in the metal sheets and internal thermal resistances of the cable [168]. The current flowing in an underground cable is thus defined by:

$$I_{UC} = \sqrt{\frac{\Delta\theta - W_d \left[\frac{1}{2} T_1 + n(T_2 + T_3 + T_4) \right]}{R \left[T_1 + n(1 + \lambda_1) T_2 + n(1 + \lambda_1 + \lambda_2)(T_3 + T_4) \right]}} \quad (4.16)$$

where:

$\Delta\theta$ conductor temperature rise above the ambient temperature [K]

W_d dielectric loss for the insulation surrounding the conductor [W/m]

$T_{1,2,3}$ thermal resistances of the different insulations [mK/W]

T_4 external thermal resistance [mK/W]

n number of load-carrying conductors in the cable

$\lambda_{1,2}$ ratio of losses in the metal sheaths to total losses in the cable

- **Distribution Transformer Thermal Limits**

Distribution transformers are referred to in terms of operating voltage and nominal kVA rating. Their kVA rating indicates the amount of apparent power that can be transferred between their two sets of terminals. At low demand and high SSEG penetration scenarios, it is possible that the power output of the connected SSEGs in the network may exceed local demand. This would cause the surplus power to be fed into the higher voltage system (11kV or 20kV) through distribution transformers, which in extreme cases might exceed their nominal ratings [169]. Secondary distribution transformers are usually fitted with off-load tap changers and therefore this rating is symmetrical and does not vary with the direction of the power flow. For transformers fitted with On-Load Tap-Changers (OLTCs), however, reverse power flows may present an even more significant problem as the OLTC mechanism can impose an asymmetrical power flow limit, greatly reducing the transformer's kVA rating when power flows in the reverse direction [169].

4.1.5. Network Losses

When electricity is transported across the transmission and distribution system, a proportion of the electricity is dissipated as heat giving rise to electrical losses. The losses considered here are the load losses, i.e. the losses dependent on the power flows in the system. Since losses are a quadratic function of the current, the largest losses occur during peak loading conditions of the network. For underground cables and overhead lines, the majority of losses are conductor losses due to their impedances. The dielectric losses and sheath losses at voltage levels of distribution networks are

relatively small compared with conductor losses and may be neglected. The connection of SSEGs may reduce the amount of power transferred from remote generation via distribution and transmission networks and hence also reduce system losses. For a feeder with a load and an SSEG, as shown in Figure 4.2, feeder losses P_{losses} may be calculated as:

$$P_{losses} = I^2 R = \frac{(P_G - P_L)^2 + (Q_G - Q_L)^2}{V_f^2} R \quad (4.17)$$

In addition to network lines, distribution transformers are also responsible for losses within distribution systems. Transformers have fixed losses that are the heat losses within the iron core (hysteresis and eddy current losses) and load losses represented by the heat produced by the current flowing through their windings (resistive copper losses). These may be calculated using the short-circuit resistance of the transformer and the output current.

4.2. CASE STUDY NETWORKS

Three different LV distribution networks have been adopted as the case study networks for the purposes of this research. The first case study network represents an urban generic UK radial LV distribution network, as approved by UK DNOs [152]. The second case study network represents a typical European radial sub-urban LV network which has been adopted as a benchmark LV system by CIGRE TF C6.04.02 [170]. Finally, the third case study network represents an existing urban UK radial LV network, operated by E.ON UK Central Networks.

4.2.1. UK Generic LV Distribution Network

The UK generic distribution network contains six 11kV feeders, each supplying eight 11/0.4kV 500kVA ground mounted distribution transformers and 400V substations. Simulation results described here focus on the connection of SSEGs on just one 400V substation of the distribution network, which represents a 1.2km long underground cable LV distribution system serving 384 evenly-distributed customers. Maximum and minimum domestic load figures were taken from Electricity Association sources, which show that, including diversity of demand, the minimum and maximum demand figures of each domestic single-phase load are 0.16kVA and 1.3kVA respectively [152]. The total load is 61.44kW at minimum demand, equal to 12.3% of transformer capacity, and 499.2kW at maximum demand, equal to 99.8% of transformer capacity. More detailed network data may be found in [152].

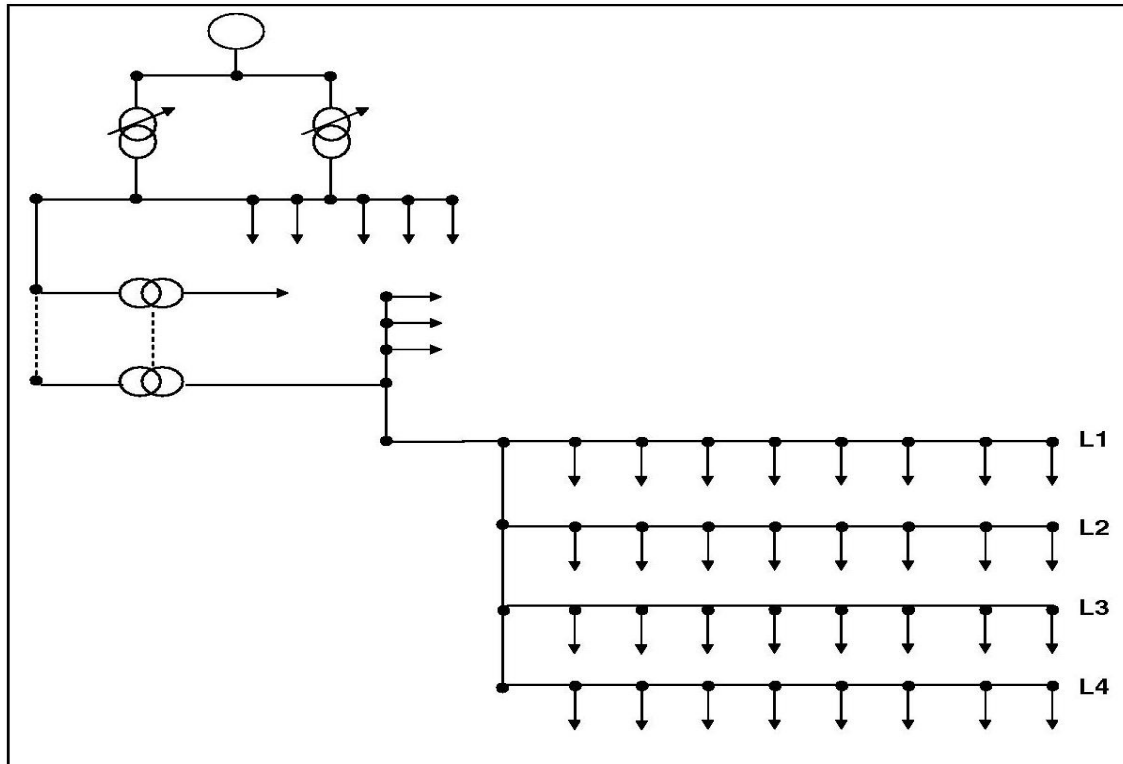

Figure 4.3: Single-line diagram of the UK generic LV distribution network.

4.2.2. European Generic LV Distribution Network

The network comprises a single 20/0.4kV 400kVA distribution transformer and three 400V outgoing feeders: one residential, one industrial and one commercial. The residential feeder is 350m long and supplies 14 single-phase and 12 three-phase connected customers. The industrial feeder is 200m long and supplies a three-phase connected workshop, while the commercial feeder is 330m long and supplies 15 single-phase and 3 three-phase connected customers. Customers are not spread uniformly throughout the network and are connected with different service cables, which are typically 30m long. Load figures based on standardised coincidence factors for residential, industrial and commercial customers were used, as described in [170]. The total maximum demand is 272.1kW, or 68% of transformer capacity, while the total minimum demand is 85.2kW, equal to 21.3% of transformer capacity. Detailed network data may be found in [170].

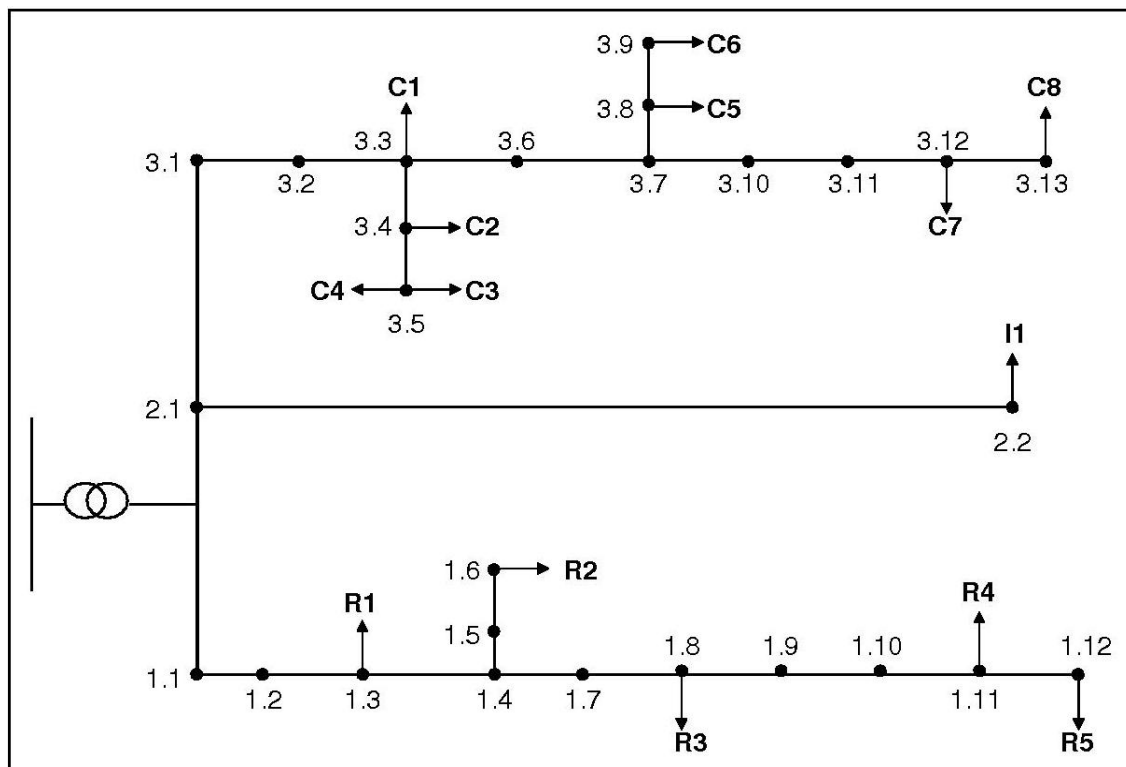

Figure 4.4: Single-line diagram of the European generic LV distribution network

4.2.3. UK Existing LV Distribution Network

The network comprises a single 11/0.4kV 500kVA distribution transformer and four 400V outgoing feeders with a total length of 1,588m. The remote end of the second feeder has an open link point to a feeder from another LV network, which in the event of a fault may be closed. For the purposes of this Thesis, however, the network is assumed to be radial. In total, there are 198 single-phase customers taken from 400V three-phase street mains; each customer is assumed to use a 30m long service cable. The total load (customer loads and public street lighting) is measured at approximately 450kVA during maximum and 75kVA during minimum loading conditions. For the purposes of this Thesis, all demand is attributed to customer loads. Hence, demand per customer equals 0.375kW under minimum and 2.27kW under maximum loading conditions compared to 0.16kW and 1.3kW respectively in the UK generic network. Detailed network data may be found in the Appendix – Table A-1.

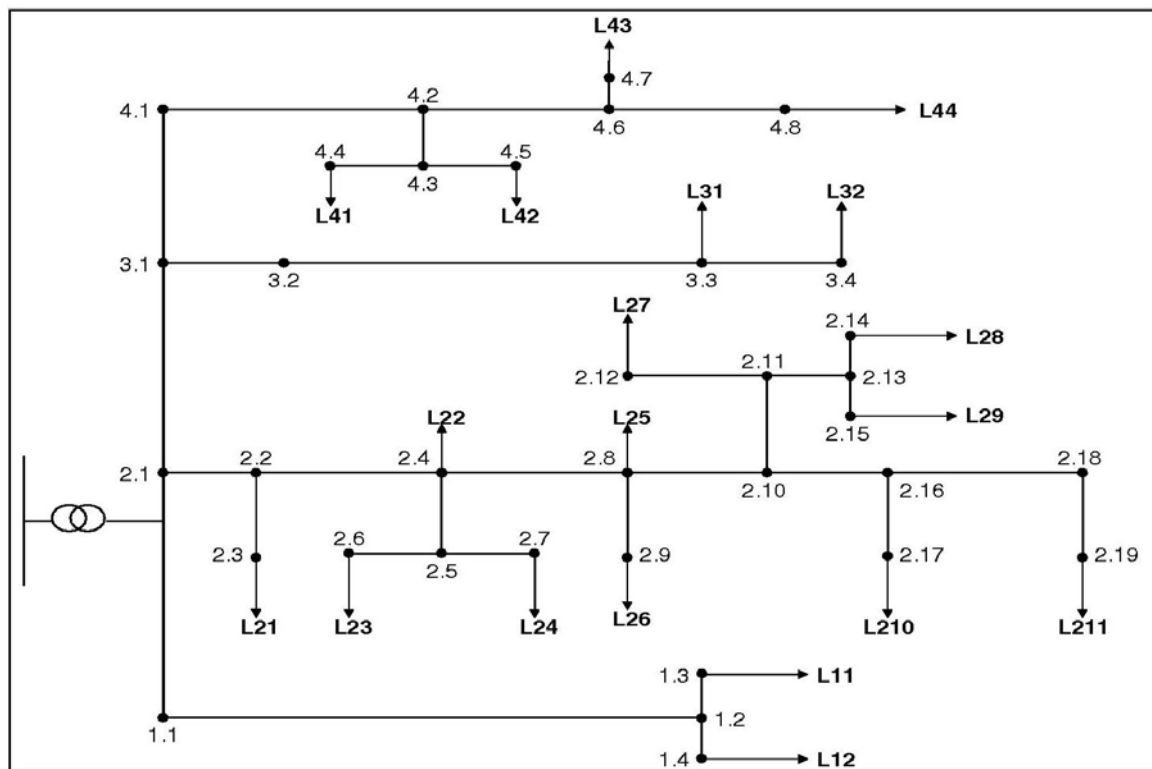

Figure 4.5: Single-line diagram of the existing UK LV distribution network

4.3. MODELLING APPROACH

The LV distribution network models described above were modelled using the power systems simulation package PSCAD™/EMTDC™ [151]. PSCAD™ is the graphical user interface for the EMTDC™ transients' and POWER FLOW simulation engines. The Fortran-based EMTDC™ solution engine represents and solves differential equations (for both electromagnetic and electromechanical systems) in the time domain at a series of discrete intervals (time steps). Hence, PSCAD™ is most suitable for simulating the time domain instantaneous responses of electrical power systems.

Using suitable equivalent models of network components, PSCAD™ is capable of representing and simulating a power distribution system, with neutral wires and system grounding explicitly represented. This makes PSCAD™ a useful tool for the analysis of unbalanced multi-grounded 4 or 5-wire LV distribution systems. All distribution network models described here were modelled as multi-grounded three-phase four-wire systems. The secondary side of the substation transformers are wye connected and are solidly grounded along with the neutral wires. As the neutral is multi-grounded and the LV system is inherently unbalanced, a parallel return path exists through the earth for neutral (zero sequence) current, even in the absence of any fault. Using a reference node, which is normally the ground potential, network solution for an LV line with three phases a, b, c and a neutral conductor n may then be given by the following 4x4 matrix:

$$\begin{bmatrix} V_a \\ V_b \\ V_c \\ V_n \end{bmatrix} = \begin{bmatrix} Z_{aa} & Z_{ab} & Z_{ac} & Z_{an} \\ Z_{ab} & Z_{bb} & Z_{bc} & Z_{bn} \\ Z_{ac} & Z_{bc} & Z_{cc} & Z_{cn} \\ Z_{an} & Z_{bn} & Z_{cn} & Z_{nn} \end{bmatrix} \begin{bmatrix} I_a \\ I_b \\ I_c \\ I_n \end{bmatrix} \quad (4.18)$$

where:

- \bar{V} vector of bus voltages measured from the reference node [V p.u.]
- \bar{I} vector of injection bus currents [A p.u.]
- \bar{Z} bus impedance matrix [Ω p.u.]

SSEGs are modelled as current sources with a fixed power factor that is predetermined and held constant throughout any particular simulation. The use of current sources ensures that the output current is not affected by minor voltage variations. Before each simulation run the power factor of each generator is set by adjusting the phase angle of the generator relative to the phase angle of the supply voltage. For SSEGs in the UK, the SSEG power factor under normal operation at rated power must be within the range of 0.95 lagging to 0.95 leading [24].

Single- and three-phase loads are modelled as constant active and reactive power consumers connected to the distribution network. Static load models are used, which express the characteristics of the loads at any instant of time as functions of voltage magnitude and frequency. The load real power component P and reactive power component Q are considered separately, using the well-known expressions:

$$P = P_0 (V / V_0)^{NP} (1 + K_{PF} \cdot dF) \quad (4.19)$$

$$Q = Q_0 (V / V_0)^{NQ} (1 + K_{QF} \cdot dF) \quad (4.20)$$

where:

- P_0, Q_0 rated real [W] and reactive[VAr] power
- V load voltage [V]
- V_0 rated load voltage [V]

NP, NQ	$dP/dV, dQ/dV$ voltage index for real and reactive power
K_{PF}, K_{QF}	$dP/dF, dQ/dF$ frequency index for real and reactive power

The frequency of the distribution system with or without SSEGs is assumed to remain constant at 50Hz, hence varying the values of NP and NQ determines the type of loads used in the simulation: NP=NQ=0 represents constant power loads, NP=NQ=1 represents constant current loads and NP=NQ=2 represents constant impedance loads. All simulations were carried out using constant power loads.

Primary and distribution transformers are represented by a general series model containing resistances and reactances and are based on the classical modeling approach, where inter-phase coupling is not represented. They are modelled in an ideal mode, as their magnetising current is small compared to normal load current and their magnetising shunt impedance is large, and thus negligible. Distribution lines (overhead lines and underground cables) are also represented by a general series model containing resistances and reactances. Their shunt capacitances are neglected due to the relatively short length of the feeders and the distribution voltage level.

4.4. SIMULATION RESULTS

Five technical impacts were investigated in order to identify the effects of high SSEG volumes on the three networks: (i) customer voltage rise, (ii) voltage regulation, (iii) voltage unbalance, (iv) thermal limits and (v) network losses. Different simulation scenarios were devised, whereby the parameters affecting each impact were varied. The term ‘‘SSEG volume’’ is used to denote the capacity of installed SSEG in the

network. Results described here focus on the particular parts of each network where the impacts of SSEGs are most severe, i.e. the remote ends of the feeders where SSEGs are connected for voltage regulation, voltage rise and voltage unbalance studies and “cable hot spots” for thermal limits.

Original results focus on the UK generic and the EU generic LV distribution networks, while results from the UK existing LV distribution networks are used in order to validate the methodology that is proposed in Section 4.5.

4.4.1. Customer Voltage Rise and Voltage Regulation

Voltage profile studies were undertaken by considering the effect of the following parameters on the level of system voltage change with increasing SSEG penetrations: (i) loading conditions, (ii) SSEG/load power factor, (iii) network impedances, (iv) SSEG network location and (v) SSEG phase location. Allowable SSEG volumes on both networks were then determined considering (i) customer voltage rise statutory limits and (ii) voltage regulation statutory limits, as shown in Table 4.1.

Loading conditions, by influencing the line voltage at SSEG connection point, are important when considering the volumes of SSEGs that can be accepted. For both issues, minimum loading conditions represent the worst-case scenario with regards to the allowable SSEG volume that may be accommodated. For customer voltage rise, this is because under minimum loading conditions the connected network feeders are operating closer to the +10% statutory upper voltage limit compared to maximum loading conditions and hence the effect of increasing SSEG capacity is exaggerated.

For voltage regulation, this is because under maximum loading conditions the voltage drops across network feeders are higher compared to minimum loading conditions, thus allowing a higher bandwidth before voltage regulation limits are exceeded and hence higher SSEG volumes to be connected.

Operating the connected SSEGs or loads at a leading power factor (i.e. importing VARs from the network) has been found to reduce customer voltages, thus alleviating voltage regulation and voltage rise issues. Lagging power factors (i.e. exporting VARs) have been found to have the exact opposite effect. The effect of varying SSEG/load power factors, however, has been found to be less marked for voltage regulation issues, because the voltages at the LV busbars of the substation will also drop/rise according to the SSEG/load power factors and hence deviation will be affected.

Network impedance and voltage rise due to SSEG power output have been found to have a linear relationship, as expected from Equation 4.3. Hence, doubling the impedance of any network will allow only half SSEG capacity to be connected before voltage rise and voltage regulation statutory limits are exceeded, while halving this value has been found to have the exact opposite effect (Table 4.1).

Finally, the non-uniform connection of SSEGs has been examined, firstly by considering the phase location of the connected SSEGs and secondly by considering their network location. The first investigation yielded a useful observation regarding the severe effect unbalanced generation has on network voltages and therefore the SSEG volumes that can be accommodated. Assuming that the neutral and phase

conductors have the same impedance and that the feeder neutral conductor is the only return path, it can be stated that if the generation is greater on one of the three phases of a 4-wire network, the voltage rise observed on this phase is equivalent to that observed when six times the additional balanced generation is connected across the three phases. This is because customers on a 3-phase 4-wire network are connected to the neutral and hence the change in the phase-to-neutral voltage ($\Delta \bar{V}_{AN}$, $\Delta \bar{V}_{BN}$ and $\Delta \bar{V}_{CN}$) will equal the change in the phase-to-ground voltage ($\Delta \bar{V}_{AG}$, $\Delta \bar{V}_{BG}$ and $\Delta \bar{V}_{CG}$) plus the change in the neutral-to-ground voltage ($\Delta \bar{V}_{NG}$).

$$\Delta \bar{V}_{AN} = \Delta \bar{V}_{AG} + \Delta \bar{V}_{NG} \quad (4.21)$$

$$\Delta \bar{V}_{BN} = \Delta \bar{V}_{BG} + \Delta \bar{V}_{NG} \quad (4.22)$$

$$\Delta \bar{V}_{CN} = \Delta \bar{V}_{CG} + \Delta \bar{V}_{NG} \quad (4.23)$$

For the second case (“SSEG clustering”), different SSEG volumes were connected on only one feeder of the UK generic network and on the residential feeder of the European generic network. Allowable SSEG volumes were found to have significantly dropped due to statutory limits being exceeded in the feeders where SSEGs were connected (Table 4.1).

This is because, as expected, localised generation was found to have the greatest impact on customer voltages compared to generation at different network segments. In particular, clustering SSEGs at the remote ends of a network represents the worst-case scenario, since this is the weakest part of the network and hence more prone to customer voltage rise and voltage regulation issues.

	CUSTOMER VOLTAGE RISE		VOLTAGE REGULATION	
	UK	EU	UK	EU
SSEG and load power factor:				
- Unity	185	535	770	325
- 0.95 Lead	380	765	860	425
- 0.95 Lag	123	340	615	255
Double impedance at unity power factor	92	268	385	160
SSEG clustering:				
- One feeder	48	285	185	140
- Remote ends	28	170	122	105

Table 4.1: Allowable SSEG volumes [kW] for the UK and European generic networks for permissible voltage regulation and voltage rise limits.

4.4.2. Voltage Unbalance

For voltage unbalance studies, the impact of connecting different SSEG volumes on only one phase of various parts of the two networks was considered, with the other two phases assuming to contain no SSEGs. The following factors were considered: (i) loading conditions, (ii) SSEG/load power factor, (iii) network impedances, (iv) neutrals and earthing resistances.

For LV distribution networks with uniform demand across the three phases, loading conditions were found to have no influence on the amount of unbalanced SSEG volumes that may be accommodated. It has been found that it is the amount of unbalanced generation connected that will determine whether the %VUF has exceeded statutory limits, independent of loading conditions.

Varying the power factor of the connected SSEGs or loads of the phase of interest was found to have a small significance on the values of %VUF present in both UK and European generic networks. Lagging power factors were found to slightly increase, and leading power factors slightly decrease the values of the %VUF present compared to the unity power factor scenario for reasons explained above (Table 4.2).

Network impedance was found to be an important factor with regards to voltage unbalance, with the difference here compared to balanced studies being that the values of the neutral conductors also have a significant effect. In all the cases, low impedance lines were found to have a positive effect on the values of %VUF present compared to high impedance lines, however impedance and allowable SSEG volumes no longer have a linear relationship. This is because the %VUF does not increase linearly with increasing impedance (Table 4.2). Results linking the % VUF with varying network impedance have shown that when the UK generic network is operating at just below voltage unbalance statutory limits (1.3%), halving the network impedance will reduce the %VUF by 22%. Doubling the network impedance has been found to increase the %VUF present by 65%, while if impedance is then further doubled, the %VUF present has been found to further increase by 88%, as shown in Figure 4.6. The same pattern is observed in the European generic network, where the higher the %VUF present is, the higher it will increase with increasing impedance due to the presence of higher neutral currents (Table 4.2).

As both networks are multi-grounded 4-wire systems, the effects of neutrals and earthing resistances with respect to voltage unbalance were also considered. It was found that the more severe system unbalance is, the larger the neutral currents which

would flow in the neutral conductors. In the UK generic network, if the %VUF was kept within UK statutory limits (1.3%), neutral currents were found to be significantly less than phase currents, approximately one fourth of phase currents. However, for the European generic network, due to a larger %VUF being allowed (2%) and due to unequal system impedances, neutral currents were found in some segments to be equal to phase currents. In general, the magnitude of neutral currents in different segments within each network was found to vary, as feeders are multiple grounded.

Similar studies have shown that if neutral wires were ignored, less than 25kW of unbalanced SSEG penetrations would only be allowed in the UK generic network, significantly less than using a 4-wire system (47.6kW). For the European generic network, this figure would be just 8kW under maximum loading conditions, i.e. just a fifth of using a 4-wire system (39.5kW). Hence, neutral wires clearly are very important in mitigating voltage unbalance issues.

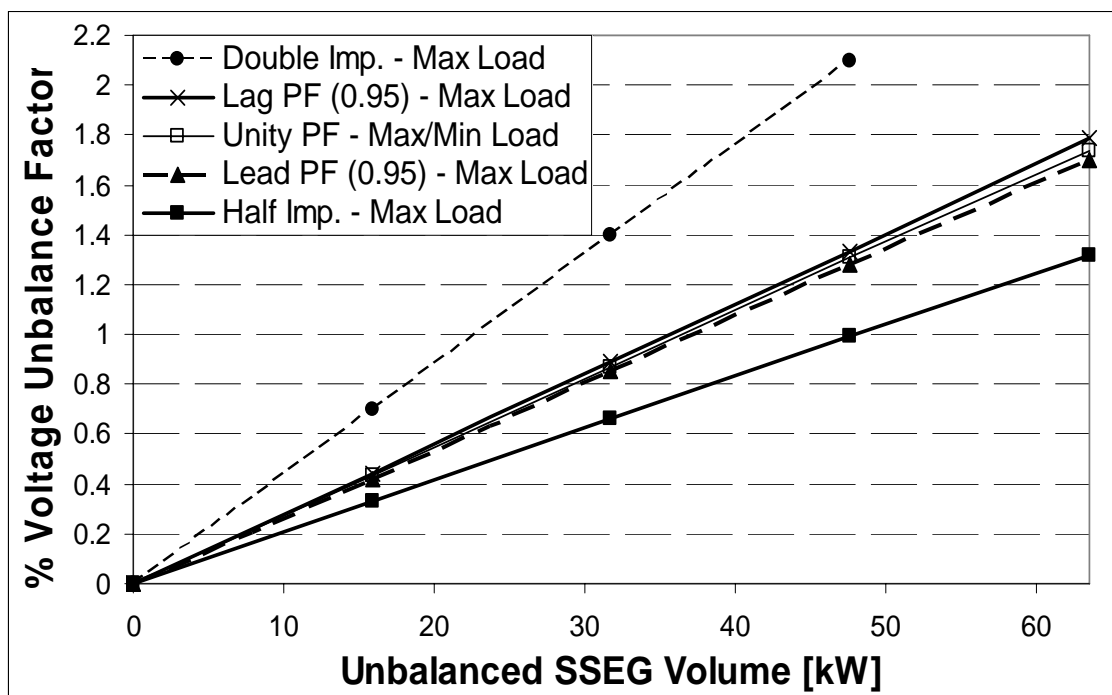

Figure 4.6: Results for %VUF in the UK generic network.

Changing the values for the grounding resistances of the neutral point of the substation transformer and the grounding points along the neutral wire was also considered. Values used varied between 1-3 Ω and 20-40 Ω respectively. These are typical and recommended values taken from [171]. Results showed that variation of the grounding resistances did affect, although not significantly, the neutral currents and neutral voltages, but they were found to have a negligible effect on the value of the %VUF present in the system.

	VOLTAGE UNBALANCE	
	UK	EU
SSEG and load power factor:		
- Unity	47.8	27.0
- 0.95 Lead	49.5	25.6
- 0.95 Lag	46.1	33.5
50% Impedance	61.0	39.4
200% Impedance	29.0	15.1
300% Impedance	20.2	10.2
400% Impedance	15.5	7.6

Table 4.2: Allowable SSEG volumes [kW] on one phase of one 400V feeder of the UK and European generic network for voltage unbalance limits.

4.4.3. Thermal Limits

Both cable and transformer thermal limits were found to depend almost entirely on the interaction between total demand and the power output of the connected SSEGs, and as such, minimum loading conditions represent the worst-case scenario with respect to the SSEG volumes that may be accommodated. The power factor of the connected SSEGs and loads was also considered: for transformer thermal limits, where transformer kVA ratings are taken as reference, the best case scenario has been found to be when load and SSEG power factors equal to unity (i.e. there are no reactive

power flows). For cable thermal limits, where Ampere ratings of the cables are taken as reference, the best case scenario has been found to be when loads and SSEGs are consuming reactive power, i.e. operating at a leading power factor, because network current flows are reduced (Table 4.3).

While localised generation has no effect on transformer thermal limits, it is very important when considering cable thermal limits. Although a network line may be able to operate without its thermal limits being exceeded for a specific SSEG volume distributed uniformly, it may not be able to do this if all of the SSEG units are concentrated in one location and connected to a single feeder (“hot spot”).

	CABLE THERMAL LIMITS		TRANSFORMER THERMAL LIMITS	
	UK	EU	UK	EU
SSEG and load power factor:				
- Unity	1,045	340	610	505
- 0.95 Lead	1,063	357	585	479
- 0.95 Lag	1,010	320	550	452

Table 4.3: Allowable SSEG volumes [kW] for the UK and European generic network for cable and transformer thermal limits.

4.4.4. Network Losses

Loading conditions have a direct effect on network losses: at low penetrations, SSEGs tend to decrease losses, but as the penetration reaches and exceeds local demand, SSEGs tend to increase network losses (Figure 4.7). Reduction or increase in losses has also been observed at higher voltage levels, and these generally follow the same pattern as the losses at the voltage levels where SSEGs are connected. The power factor of the connected SSEGs or loads has been found to be an important factor

contributing to network losses, but only at high SSEG penetration scenarios. Assuming the load power factor is unity, a leading SSEG power factor, although beneficial for voltage rise and voltage regulation issues, will increase network losses compared to a unity SSEG power factor, while a lagging SSEG power factor will also increase network losses, although not as much (Table 4.4). Finally, the effect of varying network impedances with respect to network losses has also been examined, as shown in Figure 4.7 and Table 4.4. As expected from Equation 4.3, network impedance and network losses have been found to have a linear relationship.

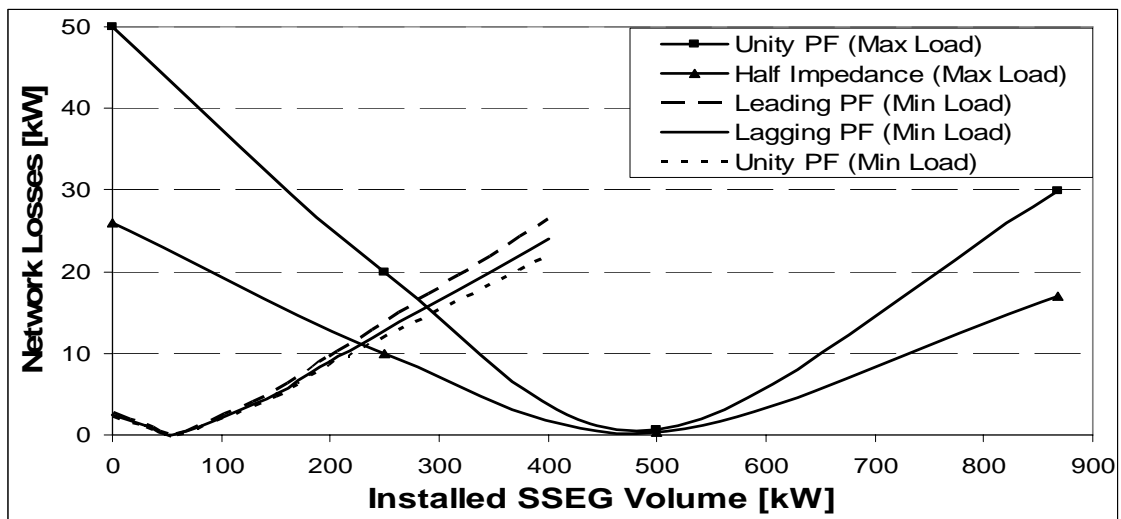

Figure 4.7: Results for network losses in the UK generic network.

	NETWORK LOSSES					
	MINIMUM LOAD			MAXIMUM LOAD		
	$P_G/P_D=0$	$P_G/P_D=0.5$	$P_G/P_D=2$	$P_G/P_D=0$	$P_G/P_D=0.5$	$P_G/P_D=2$
SSEG and load power factor:						
- Unity	3.5	2	3.7	50	24	48
- 0.95 Lead	3.5	2.3	4.1	54	27	52
- 0.95 Lag	3.5	2.1	3.9	53	26	50

Table 4.4: Network losses [in kW] for different SSEG penetrations and power factors for the UK generic network under minimum and maximum loading conditions.

4.5. PROPOSED METHODOLOGY

Using the simulation results described in Section 4.4, a methodology for SSEG impact analysis of LV networks has been developed that may be used to predict a network's response to the addition of high SSEG volumes without the need to carry out a simulation. The methodology makes use of the key factors identified through simulation and simplifies the analysis by comparing the network under study with either the UK or the European generic network, depending on which of the two networks is deemed by the user to be the most similar. This allows approximate allowable SSEG volumes to be predicted on any case study LV network quickly and easily and without the need for developing detailed computer-based models. The key factors that have been identified through simulation as having an effect on the technical impacts of SSEGs under investigation are shown in Table 4.5. This table presents the key factors along with the technical impacts under consideration but also describes the specific circumstances which cause the most severe adverse effects.

	SSEG TECHNICAL IMPACTS		
	Customer Voltage Rise	Voltage Regulation	Voltage Unbalance
Key Factors			
Network symmetry	Asymmetrical	Asymmetrical	Asymmetrical
Network topology	Radial	Radial	Radial
Network length	Long	Long	Long
Distribution substation voltage	High	-	-
Network lines	high R, low X^1 or high R, high X^2	high R, low X^1 or high R, high X^2	high R, low X^1 or high R, high X^2
Distribution transformer	-	-	-
SSEG power factor	Lagging	Lagging	Lagging
SSEG network location	Clustering, Remote end ⁴	Clustering, Remote end ⁴	Clustering, Remote end ⁴
SSEG phase location	Clustering at same phase	Clustering at same phase	Clustering at same phase
Loading conditions	Minimum	Minimum	-

	SSEG TECHNICAL IMPACTS		
	Cable Thermal Limits	Transformer Thermal Limits	Network Losses
Key Factors			
Network symmetry	Asymmetrical	-	-
Network topology	Meshed	-	Meshed
Network length	-	-	Long
Distribution substation voltage	-	-	-
Network lines	Low thermal ratings	-	High impedance
Distribution transformer	-	Low thermal rating	High impedance
SSEG power factor	Non unity ³	Non unity ³	Non unity ³
SSEG network location	Clustering at the same line segment	-	-
SSEG phase location	Clustering at same phase	-	-
Loading conditions	Minimum	Minimum	Light

Table 4.5: Key factors causing adverse SSEG technical impacts that need to be considered in a methodology for assessing allowable SSEG volumes in a network.

¹ assumes leading SSEG/load power factor

² assumes lagging SSEG/load power factor

³ assumes unity power factor loads

⁴ assumes uniform SSEG penetration

4.5.1. Apparent Impedance

In order to produce the methodology, the concept of apparent impedances was developed drawing on work described in [172] where a technique for reducing a radial network into a single line equivalent was developed for the fast computation of load-flow calculations and voltage instability analysis of radial distribution networks. The apparent impedance method presented here differs from the single line equivalent impedance method described in [172] in that it is applied in reverse order as it starts from the point of known network impedances. The methodology derives a value for overall network apparent impedance in three steps.

- Step 1: Determining the apparent impedance at a network location (single customer).
- Step 2: Determining the apparent impedance at a network location (multiple customers).
- Step 3: Determining the overall network apparent impedance (all customers, all locations).

Step 1 determines the apparent impedance for a single customer at a network location by summing the impedances between the substation and the specific customer location. Step 2 determines the apparent impedance at a network location for multiple customers by assuming that all customers are supplied by similar service cables. The apparent impedance, considering all customers connected to that point, will then be the sum of the impedances between the substation and a single customer connection point, multiplied by the total number of customers in that location.

$$Z_{location}^{(ap)} \cong m \cdot Z_{customer}^{(ap)} \quad (4.24)$$

where:

$Z_{location}^{(ap)}$	apparent impedance [Ω] of a network location with customer connections
m	number of customers connected to the location
$Z_{customer}^{(ap)}$	apparent individual customer impedance [Ω]

Step 3 determines the overall network impedance by summing the apparent impedances of all network locations where customers are connected.

$$Z_{net}^{(ap)} = R_{net}^{(ap)} + jX_{net}^{(ap)} = \sum_{i=1}^n Z_{location}^{(ap)} \quad (4.25)$$

where:

$Z_{net}^{(ap)}$	apparent impedance of the network [Ω]
$R_{net}^{(ap)}, X_{net}^{(ap)}$	apparent resistance [Ω] and reactance [Ω] of the network
n	number of network locations with customer connections

Since the maximum allowable SSEG volume that can be accommodated on the two generic networks is known, it is possible to gain a first estimate of the allowable SSEG volume of a different network by comparing their overall network apparent impedances. However to gain a more accurate prediction of the allowable SSEG volume a number of further considerations must be taken into account as shown in Table 4.5. Additionally, the ratio between the number of customers in the selected generic network and the network under study must be taken into account. For uniform SSEG penetration scenarios this may be done by calculating the average single customer apparent impedance for each network.

Using the network line data found in [152] and [170] respectively, the overall network apparent impedance of the UK generic network, for a scenario where every customer has an SSEG connected, is calculated to be $R_{net}^{(ap)} = 24.981 \Omega$ and $X_{net}^{(ap)} = 5.822 \Omega$ for 384 single-phase customers, while the overall network apparent impedance of the European generic network, for the same scenario, is $R_{net}^{(ap)} = 7.9615\Omega$ and $X_{net}^{(ap)} = 1.9665\Omega$ for 16 three-phase and 26 single-phase connected customers (Appendix – Table A-2). These impedances may be used as benchmark overall network apparent impedances when applying the methodology on any case study LV network.

4.5.2. Description of the Methodology

SSEG impact analysis using the methodology on any case study LV network takes place in three main stages: Firstly, the inherent network and load characteristics of the LV network under investigation must be obtained and reviewed, according to Table 4.5. Secondly, the user must consider specific scenarios for the type (i.e. active and reactive power output profile) and phase and network location of the connected SSEGs. Typically this is done through a deterministic analysis of the worst-case conditions for each of the five SSEG impacts, however explicit scenarios may also be devised. Having determined the SSEG penetration scenarios to be considered, the overall network apparent impedance of the selected generic network and the network under study must be calculated for each scenario.

Finally, estimated allowable SSEG volumes may be obtained based on either statutory regulations (voltage regulation, voltage rise, voltage unbalance) or equipment ratings (cable and transformer thermal limits). These may be quantified by considering the allowable excess SSEG power output in the case study network for each SSEG impact in comparison to results obtained from the selected generic network.

4.5.3 Application of the Methodology

In order to validate the proposed methodology, it has been applied on the existing public LV network described in Section 4.2.3 and results obtained have been compared against simulation results. The first step of the methodology is to obtain and review the main characteristics of the network that have been identified as having an impact on the five SSEG technical impacts under consideration. This may be seen in

Table 4.6 which shows that the case study network can be described as *Asymmetrical*, *Radial*, *Medium Length*, with a *High* distribution substation voltage, *Medium* line and transformer resistances and reactances while having *Heavy* loads per customer.

Network symmetry	Due to unbalanced system impedances and the unbalanced distribution of single-phase customers, the network is inherently <i>Asymmetrical</i> .
Network topology	The network has a radial layout, with four feeders being supplied from the LV busbars of the infeeding MV/LV substation. Each feeder supplies a number of branches; customers are connected at various parts of each branch. The remote end of the second feeder has an open link point to a feeder from another LV network, which in the event of a fault may be closed. For the purposes of this Thesis, however, the network under study is assumed to be <i>Radial</i> .
Network length	Excluding the service cables used, the network is 1,588m long, an increased length of 388m compared to the UK generic network. It can be categorised as <i>Medium Length</i> .
Distribution substation voltage	Subsequent to the recent European Voltage Harmonisation, the nominal UK voltage is now 230/400V. Most LV networks, however, have remained unchanged and are still operated to supply 240/415V. For the purposes of this paper, distribution substation voltage is assumed to be approximately 250V, the same as the UK generic network. This can be categorised as being <i>High</i> .
Network lines	The following underground cables are used: 300mm ² (327m), 185mm ² (235m), 120mm ² (498m), 70mm ² (528m). Detailed data are provided in the Appendix. This can be categorised as predominantly <i>Medium R</i> , <i>Medium X</i> .
Distribution transformer	The distribution transformers used are similar to the UK generic network. Detailed data are provided in [152]. This can be categorised as having a <i>medium thermal rating</i> and <i>typical impedance</i> .
Loading conditions	There are 198 single-phase customers taken from 400V three-phase street mains; each customer is assumed to use a 30m long service cable. The total load (customer loads and public street lighting) is measured at around 450kVA during maximum and 75kVA during minimum loading conditions. For the purposes of this work, all demand is attributed to customer load. Demand per customer equals 0.375kW under minimum and 2.27kW under maximum loading conditions compared to 0.16kW and 1.3kW respectively in the UK generic network. This can be categorised as <i>Heavy</i> loading.

Table 4.6: Inherent network characteristics of the case study existing public UK network.

The second step is to consider the type, phase and network location of the connected SSEGs, by examining specific scenarios for SSEG penetrations under measured minimum loading conditions in the network. Different scenarios have been devised, as illustrated in the following section. For simplicity, unity power factors are assumed for the loads and SSEGs connected. It must be noted that the following text takes each technical impact in turn and in isolation, therefore the methodology not only allows SSEG volumes to be predicted but also the order in which they are expected to be encountered.

4.5.3.1 Customer Voltage Rise

Customer voltage rise is anticipated to be the most limiting constraint to the operation of SSEGs in the network. Predicted results using the methodology are as follows:

- **Uniform distribution of SSEGs throughout the network**

The first scenario considers the uniform distribution of SSEGs across all customers of the case study network. The overall network apparent impedance is $R_{net}^{(ap)} = 12.2824 \Omega$ and $X_{net}^{(ap)} = 2.9476 \Omega$ for 198 single-phase customers (Appendix – Table A-2). Average single customer apparent impedance is hence $R_{avg-cust}^{(ap)} = 0.062032 \Omega$ and $X_{avg-cust}^{(ap)} = 0.014887 \Omega$ which is slightly less than $R_{avg-cust}^{(ap)} = 0.06505 \Omega$ and $X_{avg-cust}^{(ap)} = 0.01516 \Omega$ for the UK generic network.

Simulation results have shown that the allowable excess SSEG power output on the UK generic network is 124kW. This is calculated as the difference between the SSEG volume on the network (185kW, Table 4.1) and the total network load P_D (61kW).

Hence, by comparing apparent impedances the estimated allowable excess SSEG power output on the case study network is:

$$P_{excess} = 124kW \times \frac{0.06505\Omega}{0.062032\Omega} = 130kW$$

while the estimated allowable SSEG volume P_G equals $P_G = P_{excess} + P_D = 130kW + (198 \times 0.375kW) = 204kW$ (1.03kW per customer).

- **SSEG feeder clustering**

The second scenario considers the uniform distribution of SSEGs across all customers of the second feeder only. The overall feeder apparent impedance in the case study network is $R_{net}^{(ap)} = 7.341 \Omega$ and $X_{net}^{(ap)} = 1.949 \Omega$ for 107 customers. For the UK generic network, each 400V feeder supplies 96 customers and has an overall feeder apparent impedance equal to $R_{net}^{(ap)} = 6.24525 \Omega$ and $X_{net}^{(ap)} = 1.45548 \Omega$. The allowable excess SSEG power output on one feeder of the UK generic network has been found to equal $P_{excess} = 48kW - (96 \times 0.16kW) = 32.6kW$. The excess SSEG power output that can be accommodated on the second feeder of the case study UK network is then $P_{excess} = 30.9kW$, or alternatively the predicted SSEG volume $P_G = 30.9kW + (107 \times 0.375kW) = 71kW$ (0.66kW per customer). This was subsequently found to be inaccurate, the reasons for this are discussed in Section 4.5.4.

- **SSEG phase clustering**

Non-uniform SSEG distribution across the three phases of the second feeder is considered, by assuming that phase A has double the SSEG capacity of the other two. The estimated allowable balanced SSEG volume for the second feeder was found, using the proposed methodology, to be $P_G = 71kW$, representing a SSEG volume of

23.6kW/phase. Using the observation described in Section 4.1.1, voltage rise statutory limits on phase A would be exceeded if 16kW were connected on phase A and 8kW on phases B and C, i.e. total generation of only 32kW.

4.5.3.2 Voltage Regulation

The same three scenarios were considered with regards to voltage regulation statutory limits and the predicted results are as follows:

- **Uniform distribution of SSEGs throughout the network**

For the case study network, the estimated allowable excess SSEG power output is $P_{\text{excess}} = 744.5\text{kW}$ compared to 710kW in the UK generic network. The predicted allowable SSEG volume on the network is hence $P_G = 744.5\text{kW} + (198 \times 0.375\text{kW}) = 819\text{kW}$ (4.135kW per customer).

- **SSEG feeder clustering**

The estimated allowable excess SSEG power output that can be accommodated on the second feeder of the network is $P_{\text{excess}} = 161.2\text{kW}$ compared to 170kW for a 400V feeder in the UK generic network. The estimated allowable SSEG volume on the feeder is then $P_G = 161.2\text{kW} + (107 \times 0.375\text{kW}) = 201\text{kW}$ (1.9kW per customer).

- **SSEG phase clustering**

Assuming that phase A has double SSEG capacity compared to the other two phases, voltage regulation limits on phase A would be exceeded if 44kW were connected on phase A and 22kW on phases B and C, i.e. a total generation of 88kW.

4.5.3.3 Voltage Unbalance

This scenario considers the voltage unbalance caused by uniform connection of SSEG units on all customers of one phase of the second feeder of the case study network. The average apparent customer resistance of the feeder ($R_{avg-cust}^{(ap)} = 0.0686 \Omega$) is slightly (5%) higher than that of a 400V feeder of the UK generic network ($R_{avg-cust}^{(ap)} = 0.062032 \Omega$). The estimated allowable SSEG volume may then be approximated to be equal to that obtained for the UK generic network (47.8kW per phase). It must be noted however that if the impedances were not comparable this task would be more difficult as the relationship has been shown in Section 4.1.3 to be non linear. Table 4.2 has been produced to help the user in this respect by linking the %VUF present in the network with varying network impedance.

4.5.3.4 Cable Thermal Limits

The worst case scenario in this respect would be the connection of high levels of SSEGs on the second feeder, where one underground cable (section 2.1-2.2 from Figure 4.5) is used to supply a large number of customers. Although the feeder in the case study network consists mainly of 70mm² cables, which have a smaller cross sectional area than the UK generic network (95mm² and 185mm²), all sections of the case study feeder that carry larger loads are designed with 300mm² cables. These have increased cable thermal limits (465A) compared to the 185mm² cables used in the UK generic network (355A) [173].

Considering a uniform SSEG connection, the estimated allowable excess SSEG power output on that feeder is: $P_{excess} = 3 \times V_{line} \times I_{phase} \times \cos\theta = 3 \times 400V \times 465A = 558kW$

compared to approximately $P_{\text{excess}} = 282\text{kW}$ in the UK generic network. This corresponds to an estimated allowable SSEG volume on that feeder of $P_G = 558\text{kW} + (107 \times 0.375\text{kW}) = 600\text{kW}$ (5.59kW per customer), which represents an extreme penetration scenario and hence cable thermal limits are not expected to be the most limiting network constraint to the operation of SSEGs for this particular LV network.

4.5.3.5 Transformer Thermal Limits

When the power flows within the UK generic network are such that the transformer is operating at its thermal limits ($P_{\text{rating}} = 500\text{kVA}$), network losses of $P_{\text{losses}} \approx 50\text{kW}$ (Figure 4.7) were observed. Assuming similar current and power flows, the network losses of the case study UK network under this scenario are:

$$P_{\text{losses}} = 50\text{kW} \times \frac{0.062032\Omega}{0.06505\Omega} = 47.7\text{kW}.$$

Hence, estimated SSEG volumes of $P_G = P_{\text{rating}} + P_D + P_{\text{losses}} = 500\text{kW} + 75\text{kW} + 47.7\text{kW} = 622.7\text{kW}$ (3.1kW per customer) would be required in order to exceed the case study network transformer's thermal limits.

4.5.3.6 Network Losses

Increase in network losses due to the operation of SSEGs is less likely to occur in the network under study compared to the UK generic network. This is because demand per customer for this particular network is approximately double (0.375kW under minimum and 2.27kW under maximum loading conditions) compared to the UK generic network (0.16kW and 1.3kW respectively) and hence the SSEG power output per customer required to exceed local demand will also effectively double.

4.5.4 Discussion

Table 4.7 shows the predicted results produced by the methodology in comparison to the simulated results derived from the PSCAD™ model. It can be seen that there is generally reasonable agreement between the two sets of results in cases of uniform SSEG penetrations throughout the network.

	METHODOLOGY RESULTS	SIMULATION RESULTS
Customer voltage rise	204 71 ¹	204 85 ¹
Voltage regulation	819 201 ¹	819 201 ¹
Voltage unbalance	47.8 ¹ /ph	41 ¹ /ph
Transformer thermal limits	623	625
Cable thermal limits	600 ¹	605 ¹

Table 4.7: Allowable SSEG volumes [kW] for the case study public UK LV network using the methodology compared to the accurate results produced by simulation.

¹ assumes SSEG volume on the second feeder of the network only.

Taking a closer look at these results it can be seen that the methodology predictions are accurate regarding voltage regulation for both uniform and non-uniform distributions of SSEG. This is because this particular technical impact can be assessed adequately by only considering the impedances and power flows between the distribution transformer and the end of each feeder. In the case of customer voltage rise, the methodology is accurate for a uniform distribution of SSEGs where the assumed distribution transformer voltage is accurate. However for SSEGs on only one feeder this assumption is not correct which is reflected in the discrepancy between the methodology results and the simulation results. A full load flow calculation would be required to remove this error completely.

The voltage unbalance predictions are reasonably accurate but not exact as they are based on the assumption that the case study network impedances are exactly the same as those found in the UK generic network. This assumption was made due to the non linear relationship between network impedance and the voltage unbalance in the network. For cases where the impedances are significantly different, Table 4.2 can be used in order to obtain an estimate on the allowable SSEG volumes that may be accommodated.

When considering transformer and cable thermal limits the methodology predictions are again reasonably accurate, the errors are due to errors in losses predictions caused by differences in customer distribution and hence in power flows. However it must be noted that the PSCAD™ simulations used in this research employed fixed loads only, taking diversity into account, and that for an improved assessment of the thermal stresses imposed on cables and transformers dynamic load and generation profiles should be used for extended simulation runs. PSCAD™ is capable of carrying out such simulations and they are described in work carried out at Durham University in [169]. This method was not used in this case as the focus of this work was to quantify allowable SSEG volumes under worst case conditions.

4.6. CONCLUSIONS

The anticipated high penetrations of SSEGs on public LV distribution networks are likely to present DNOs with a number of technical impacts relating to power quality, distribution system efficiency and potential equipment overloads. Impact studies need to be performed using suitable case study networks in order to evaluate the effects of

SSEGs on LV distribution networks and quantify allowable SSEG penetration levels. Four wire PSCAD™ models have been used to analyse one UK generic and one European generic LV distribution network in order to determine their response to the operation of high levels of SSEG. Significant differences between the two networks were observed regarding both the SSEG volumes that may be accommodated (Table 4.8), and the order in which the five constraints were encountered (voltage regulation, voltage rise, voltage unbalance, cable and transformer thermal limits, and network losses). Voltage rise was shown to be the most limiting constraint for the UK generic network and voltage regulation and cable thermal limits were found to be the most limiting constraints for the European generic network.

Based on the simulation results obtained for the two generic networks and the development of an apparent impedance method, a methodology for SSEG impact analysis of LV networks was presented that may be used to predict the network response to the addition of high SSEG volumes for real LV networks without the need for simulation. The proposed methodology was then applied to an existing public UK LV network operated by E.ON UK Central Networks. A four-wire PSCAD™ model of this network was also developed and used to validate the methodology. There was reasonable agreement between the simulation results and the methodology predictions providing confidence that the methodology could in some cases be used instead of detailed modelling. When comparing the results from the UK generic model and the UK LV network operated by E.ON UK Central Networks it became apparent that although the order in which the constraints would be encountered remains the same, the SSEG volumes at which they are encountered are quite different (Table 4.8). This is because of differences between generic and real networks in terms of details such as

the number and location of customers, their consumer demands, length and impedance of lines and distribution substation voltages (Table 4.5).

These differences illustrate that the generic networks are often quite different from real networks and therefore the results of SSEG impact studies carried out on generic networks alone must be treated with caution. This emphasises the need for specific impact studies to be performed by DNOs on their LV networks in order to investigate the technical impacts of SSEGs and to assess SSEG penetration limits within each LV network. If SSEG proliferates as anticipated [4-6], the number of studies required could place a significant burden on DNOs.

The proposed methodology offers a means of managing this, without the need for developing a detailed computer-based model of the network and simulating a range of operating scenarios. The methodology allows approximate SSEG penetration limits on any case study LV network to be predicted quickly and easily, following a step-by-step approach as illustrated in the paper. The strength of the methodology presented here is that although it is based on studies carried out on generic networks it contains adaptation steps designed to ensure it is applicable to real LV networks.

	UK Generic Network	EU Generic Network	UK Existing Network
Customer voltage rise	185	535	204
Voltage regulation	770	325	819
Voltage unbalance	47.8/ph	27/ph	41/ph
Transformer thermal limits	610	505	625
Cable thermal limits	1,045	340	605
Contribution to network losses	80	180	90

Table 4.8: Allowable SSEG volumes [kW] for the three case study LV networks.

CHAPTER 5

Control Approach Selection

Central to the secure and satisfactory operation of the SSEZ are the control and communication architectures to be adopted. Accurate and safe communications between the customer-owned power system entities, measurement devices installed on the distribution system and utility control centres are essential if the SSEZ is to satisfy its specific control requirements, as will be described in Section 5.1. Power system operation is generally divided into two main types: centralised operation where decision-making is based on system wide information, and distributed (or decentralised) operation which is based on local information. Despite years of ongoing research and demonstration projects [39-40], it remains unclear what the appropriate architecture for distributed automation systems at the LV feeder level should be.

Having presented the specific control requirements of an SSEZ, this Chapter attempts to compare centralised and distributed control approaches over their suitability to satisfy these requirements. The employment of a distributed control approach, realised

through the MAS technology, is proposed here due to the significant benefits that may be realised in three key areas: (i) scalability and openness; (ii) resilience and reliability; and (iii) communication efficiency. These areas will be shown to be particularly important when considering future high SSEG penetration scenarios.

5.1. CONTROL REQUIREMENTS OF AN SSEZ

Since SSEZs contain sections of public LV networks, they must be transformed from passive to active entities to facilitate the connection and proliferation of SSEGs. This must be achieved without impairing the ability of DNOs to operate their networks within necessary performance standards [42-43]. The research described here considers normal operating conditions, i.e. no faults present. The control system adopted aims to ensure that the power system operates within the existing network protection settings. A key aim is that, even with high levels of SSEG penetration, it will control the generation, load and energy storage such that protection devices do not operate and thus customer interruptions are minimised as are generator trips.

Aside from the technically-driven goal of ensuring secure system operation (Section 5.1.1.), an SSEZ should also have the ability to provide the local DNO with predictable and controllable demand or generation. In turn, this could lead to increased economic benefits due to group interaction with energy markets and the potential provision of ancillary services to DNOs. Increased economic benefits could facilitate the proliferation of SSEGs and hence offer significant environmental benefits for RES-based SSEGs. Depending on network conditions, five different operational goals for an SSEZ have been identified (Section 5.1.2).

5.1.1. Low Voltage Distribution Network Constraints

In order to overcome steady-state customer voltage rise issues, the control system needs to be able to measure the magnitudes of all single-phase customer voltages. These values should then be compared with the 230V +10/-6% statutory limits defined in [42] for UK and [43] for European LV distribution networks. If the magnitude of a single-phase voltage falls outside the statutory limits, the control system must be able to change the power flows in the SSEZ so that this voltage can return within the statutory limits. This may be achieved by: (i) reducing the power output of SSEGs; (ii) diverting power into ESUs; and/or (iii) increasing the load in the locally affected area. Moreover, importing reactive power could reduce local steady-state voltages hence alleviating excessive voltage rise issues, while exporting reactive power could have the exact opposite effect thus alleviating voltage drop issues.

Overcoming steady-state voltage regulation issues within an SSEZ requires the control system to measure the magnitudes of all single-phase voltages at the remote point of each feeder and compare these values to the single-phase voltages at the LV busbars of the MV/LV distribution transformer supplying the SSEZ. If steady-state voltage deviation falls outside statutory limits, the control system must be able to change the power flows in the SSEZ so that this value can return within desired limits. This may be achieved similarly as with customer voltage rise/drop issues.

With regards to overcoming steady-state voltage unbalance, measurement of the magnitudes and angles of each of the phase voltages at the remote end of the SSEZ's feeders must be processed and compared with the maximum allowable %VUF (1.3% for the UK [166] and 2% for Europe [43]). In the event that voltage unbalance

exceeds this limit, the control system would need to change the single-phase power flows to restore balance to the voltages by manipulating the power output/input of the SSEGs, loads and/or ESUs located on the relevant phase.

Overcoming thermal issues within the SSEZ requires the control system to measure the RMS values of the currents (A) at known ‘hot spots’ within the SSEZ and compare them to the appropriate cable ratings. For reverse power flow issues, the control system must be able to compare apparent power flow (kVA) values to transformer ratings. If values exceed equipment ratings, the control system needs to be able to change the power flows in the network to solve these issues.

Finally, in order to reduce network load losses, the aim of the control system is to minimise reactive power flows within the SSEZ. This requires the control system to measure reactive power flows at SSEZ branches and then change the operating power factors of customer-owned power system entities accordingly. Network load losses may also be reduced by manipulating active power flows within the zone in order to achieve an overall balance, but this type of loss reduction is only considered as an operational goal (“self-sufficiency”) as will later be described.

5.1.2. Operational Goals

Depending on network conditions, five different operational goals for an SSEZ have been identified [31-32]. If local generation is not enough to cover local demand, the goal of an SSEZ could be to not export any power to the distribution network. On the opposite, if local generation exceeds local demand, an SSEZ could aim for zero power import. If there is a good match between local demand and generation an SSEZ could

attempt to operate self-sufficiently, with no power import and no power export from the distribution network. A fourth possible goal could be for the SSEZ to operate as a fixed load by having a constant power import from the distribution network over a period of time. Finally, and in line with the request of the local DNO, the last possible operational goal for an SSEZ could be to provide dispatchable power to the distribution network over a specified time period.

Synoptically, the five identified operational goals are: (i) zero power export, (ii) zero power import, (iii) zero power import and export (self-sufficiency), (iv) constant power import and (v) dispatchable power. All operational goals are concerned with providing predictable and controllable demand/generation to the upstream distribution network and in return for this service the local DNO could compensate the SSEZ for its contribution to network operation. Meeting these goals could increase the value of SSEGs in the energy market and also increase their environmental impact.

As evident from the above, SSEZ operational goals depend on the interaction between the connected demand and generation within the zone. At any time, the power balance for an SSEZ feeder may be calculated according to the following equations:

$$\sum_{i=1}^{n_{feeder}} P_{in}(i) = \sum_{i=1}^{n_{feeder}} P_{out}(i) \quad (5.1)$$

$$\sum_{i=1}^{n_{feeder}} P_G(i) + P_{ESU}(i) + P_D(i) = \sum_{i=1}^{n_{feeder}} P(i) + P_{losses}(i) \quad (5.2)$$

where: $P_G(i)$, $P_{ESU}(i)$ and $P_D(i)$ are the SSEG, ESU and load power input/output at an SSEZ feeder i respectively, $P(i)$ corresponds to the net power injection at the feeder and $P_{losses}(i)$ correspond to the associated load losses. In order to determine the total

amount of regulating power required in an SSEZ, SSEG and ESU power export are regarded as negative loads while load and ESU demand, as well as the curtailed SSEG power output are treated as positive load.

For an SSEZ to meet an operational goal, the control system to be adopted needs to be able to measure the three-phase power flows at the PCC of the SSEZ with the distribution network and then change the power flows within the SSEZ depending on the desired operational goal. This should be done at half-hourly intervals, in accordance with UK and most European electricity market procedures [8-9]. For power dispatch, communication links between the control system and the DNO need to be established to allow the SSEZ to receive a central request from the DNO to specify the required change in power exchange with the distribution network. In line with this central request, the control system will then determine if it is capable of delivering the specified power and will decide how to achieve this.

5.2. POTENTIAL CONTROL APPROACHES FOR AN SSEZ

Two potential control approaches have been identified. The first one would be the extension of traditional centralised control systems from their current operation to cover LV networks as well. This would require the presence of a central controller located at the DNO control room or at the secondary distribution substation level which would receive measurement data from critical [174] or even all nodes within the SSEZ. Using automated reasoning and data interpretation, the controller would process this data and send control commands to all controllable entities within the SSEZ in accordance with the specific control requirements of the zone (Figure 5.1).

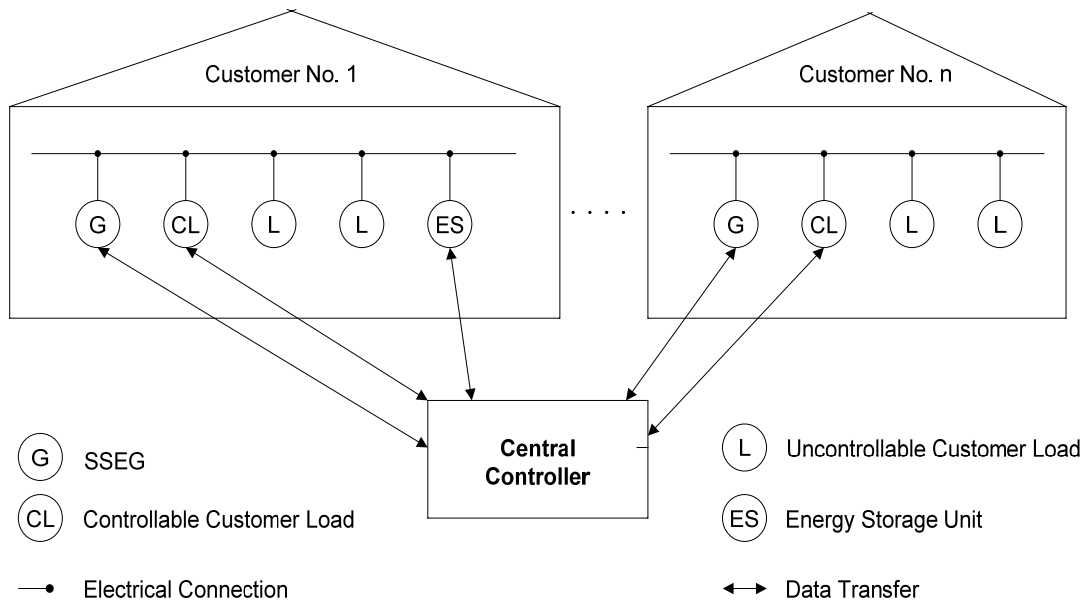

Figure 5.1: Centralised control operation for an SSEZ.

The second potential control solution would be the development of a distributed control approach. Depending on system communications and the locations where control decisions are made, a number of distributed control structures could be used for the control of an SSEZ. For the purposes of this research, the distributed control approach assumes that each controllable customer-owned power system entity within the SSEZ has its own controller with decision-making capabilities. Each controller is able to autonomously react to changing network conditions, but is also capable of interacting with other system controllers when necessary. This may be achieved using a common communications network as shown in Figure 5.2.

Brief descriptions of both potential control approaches will be given in the next Section and they will both be evaluated on their capability to overcome the challenges and realise the opportunities presented with the connection of SSEGs on LV distribution networks.

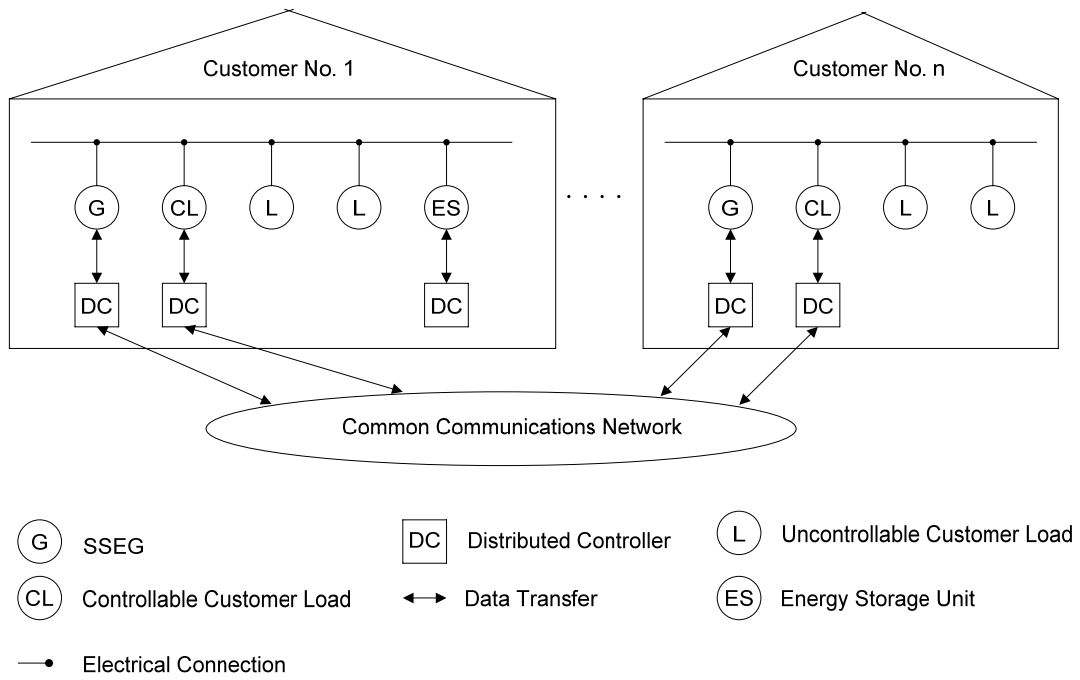

Figure 5.2: Distributed control operation for an SSEZ.

5.2.1. Centralised Control Approach

Existing SCADA systems employed for the control of electrical networks do not provide any information on individual LV customers, as this has little or almost no effect on the running of the system. In particular, the SCADA systems used by UK DNOs are a mixture of 2nd and 3rd generation systems, i.e. technologies dated since the early 1980s and 1990s respectively and were not designed to accommodate DG or SSEG [11]. In general, centralised control is employed where the cost of network infrastructure is high and as a consequence is static or very slow to change. The main advantage of this approach is that it offers full network transparency, allowing optimal control decisions to be made based on the objective functions of the controller.

The potential number of SSEG units and the nature of their incremental connection can complicate their centralised control. With respect to the control of an SSEZ, the most fundamental limitations of using a centralised control system are linked to: (i)

lack of scalability and openness, (ii) lack of resilience and reliability and (iii) lack of efficient communications. Using a centralised control system means that the additional connection of new system components would require re-programming of the central controller, which could prove to be complex and time-consuming, especially taking into account the potential number of customers within an SSEZ. Additionally, a failure of a single component or a software error in the central controller could result in a complete failure of the control system.

Moreover, in centralised control systems all data needs to be periodically collected at a central point and then distributed throughout the system, which places a heavy burden on the communications infrastructure. Finally, SSEG units are anticipated to be owned by different individuals or organisations that are not likely to have hardware and communications systems from the same vendor [12-13]. Communications could therefore prove to be challenging unless global communication standards and protocols are employed.

5.2.2. Distributed Control Approach

According to a number of researchers [31, 37, 44-46], a distributed management and control approach for LV distribution networks could potentially offer advantages over a centralised approach in the areas of: (i) reliability and resilience, (ii) scalability and openness and (iii) communications efficiency. In terms of scalability and openness, the distributed approach offers a means of managing the growth of entities, such as customers, SSEGs, storage devices and network infrastructure within the LV distribution network. This growth is managed through the instantiation of the

corresponding number and type of distributed controllers, often without the need for rewriting software.

Further, these controllers may facilitate a “plug-and-play” capability, which permits new entities to easily participate in system operation. In contrast, a centralised approach would require permission to be granted and software modifications to be made every time a new entity was added to the SSEZ. Given that the consumer-driven growth of SSEGs is dynamic and unforeseen, scalability and openness are important features when considering SSEZs, but also between instances of SSEZs.

With regard to resilience and reliability, properly designed distributed control approaches may present no single point of system failure. Furthermore, in the event of individual failures the system remains operational, however its performance may be degraded. As such, the system is resilient to individual failures, which in turn increases system reliability. Conversely, a centralised system is vulnerable since failure at the point of control could result in the system ceasing to operate. This cease in operation could lead to unsafe operating conditions within the SSEZ, such as exceeding statutory limits and equipment ratings.

Within the distributed approach, communication efficiency gains can be realised through the execution of local autonomous control actions, which reduces the likelihood of communication bottlenecks. For example, when solving a steady state voltage problem, all agent control actions may be performed locally and autonomously by the relevant subset of the agent community. In comparison to a centralised approach, this level of communication is less intensive. Further, this

reduction in communication intensity is achievable for all other control actions undertaken by the distributed controllers within the SSEZ but with varying degrees of localisation and autonomy. A centralised approach would require communication links between all entities participating within the SSEZ and the central point, which is likely to become a communication bottleneck.

According to [114-115], there are two main types of distributed computing that have been used for Power Engineering applications: MAS and Service Oriented Computing (SOC). SOC approaches that have been used for Power Engineering applications are grid computing [226] and web-services [227]. All three technologies offer a means of managing distributed hardware and software resources, however they differ in their specific application areas. Grid computing is “*normally focused on harnessing hardware resources to solve computationally complex problems*” [114], while web-services are “*designed to offer interoperability between software systems, providing the mechanisms for the discovery of those systems and their communication across a network*” [114]. According to the authors, “*it is the co-operative and pro-active nature of agents that set them apart from grid computing and web-services*” [114], and therefore applications where the agent attribute of autonomy (Section 3.1) is required tend to be the cases where MAS are preferred. The following Section attempts to justify the selection of MAS by looking at the characteristics of MAS technology and how they match with the specific control requirements of an SSEZ.

5.2.3. Why MAS for the control of an SSEZ?

As with most computer programming paradigms, a general advice on when to consider the MAS technology tends to be requirement-driven rather than technology-

driven. Thus, the characteristics of the target domain must be examined to check if they match with the characteristics of the domains for which MAS technology has been found suitable. Here, the employment of agent technology for the distributed control of an SSEZ is justified by looking at why the four main agent attributes would be required for this particular control problem:

1. **Autonomy:** Due to the potential number of controllable entities within an SSEZ, the control system is required to operate without extensive need for communications and with minimal human supervision. Furthermore, control of customer-owned power system entities must be based on these components having only a partial representation of the SSEZ. Hence, control decisions must be taken with a degree of autonomy, i.e. self-starting behaviour. Within an MAS, agents are capable of autonomous action by taking the initiative and by changing their behaviour depending on the goals they are aiming to meet. Autonomous agents are not dependant on control calls from other software modules and may be added or removed from the MAS without affecting the ability of the remaining agents to operate.

As an example, an agent is able to identify when operating conditions (i.e. demand versus generation) within the SSEZ allow for a particular operational goal to be met, and behave autonomously by instructing controllable entities within the SSEZ to change their power inputs/outputs accordingly.

2. **Social ability:** Communication between different components is needed to satisfy the SSEZ control requirements as described in Section 5.1. For example, in the event of voltage unbalance statutory limits being exceeded at an SSEZ feeder, an

agent responsible for voltage unbalance needs to communicate with other agents located on each of the three phases of the affected area and change the power flows by increasing or decreasing the generation or demand of the relevant phases in order to restore balance to the SSEZ.

The social ability of agents is more than just an ability to exchange data [93]. Agents are able to negotiate and interact in a cooperative or competitive manner, depending on their particular implementation. This ability is particularly important when considering that power system entities within an SSEZ are owned by different customers which may have different objectives from these units. This research, however, assumes that the overall system goal is always a higher priority compared to individual agent goals (“good citizen” behaviour) as will be explained in Section 6.6.

3. **Reactivity:** The SSEZ concept represents a dynamically changing environment. The adopted control approach must therefore allow flexible response to dynamic changes that occur within the SSEZ environment in order to either overcome an identified LV distribution network constraint or to meet an operational goal. An MAS is able to exhibit such flexibility and adaptability by coordinating the actions of agents with different behaviours and design objectives in order to solve a particular problem. As an example, in order to solve a customer voltage rise problem, system agents could react by issuing control commands to the relevant SSEZ power system entities, such as SSEG power output reduction, ESU charging and/or increasing customer load, in accordance to changes occurring inside the SSEZ environment.

4. Pro-activity: Goal-directed behaviour is needed in order to meet the SSEZ control requirements. Agents operating within an SSEZ are able to demonstrate such behaviour by using the resources available to them, such as: (i) measurement data from monitoring points within the SSEZ; (ii) knowledge with regards existing statutory regulations and distribution equipment ratings; and (iii) in the case of operational goals, the amount of power and time period as specified by the particular operational goal. The required functionality in order to satisfy the control requirements of an SSEZ was described in Section 5.1, however as an example, if a section of LV cable is close to becoming thermally overloaded, an agent could exist that anticipates this situation and exhibits pro-active behaviour by issuing mitigating control commands such as SSEG power output reduction, and/or decreasing the load.

5.3. CONCLUSIONS

Despite years of ongoing research, development and demonstration projects [39-40], it remains unclear what the appropriate architecture for distributed automation systems at the LV feeder level should be. A distributed management and control hierarchy is being proposed by a number of researchers [31, 37, 44-46], while other researchers [47-49] argue for more centralised management and control schemes where LV feeder-level devices have little autonomy.

This Chapter describes the selection of the most suitable control approach for an SSEZ based on the specific SSEZ control requirements, namely to: (i) to overcome the LV distribution network constraints associated with high penetrations of SSEG;

and (ii) meet a set of SSEZ operational goals for the provision of predictable and controllable demand or generation to the upstream distribution network. The employment of a distributed management and control approach, realised through the MAS technology, is proposed here due to the significant benefits that can potentially be realised in three key areas: (i) scalability and openness; (ii) resilience and reliability; and (iii) communication efficiency. This is because of the potential number of SSEG units and the nature of their incremental connection which can complicate their centralised control.

At the same time, however, there are significant challenges arising from the possible employment of such a distributed control approach. The transition from the current centralised to a fully decentralised control approach might be difficult for DNOs to adopt, as a number of regulatory and trust issues could arise. Moreover, decentralised control approaches have limited operating experience compared to centralised approaches. Finally, a significant research challenge arising due to the multi-objective nature of this particular control problem could be the occurrence of conflicts between the actions of individual agents. Conflict resolution techniques must therefore be investigated and their impact on the individual agent and system architecture design must be taken into account.

CHAPTER 6

Design of the SSEZ Control System

This Chapter details the design of the SSEZ control system based on the MAS technology, placing particular emphasis on the reasoning and communication capabilities of system agents. The design of the MAS has been devised to enable diagnosis of system operating conditions and to provide the appropriate control actions to the customer-owned power system entities such that the specific control requirements of the SSEZ are met. This may be achieved through responsive control, whereby control actions are based on reacting timely and appropriately to changes occurring in the SSEZ environment. The MAS presented here is based on the case study network described in Section 6.1 as well as on the structured approach proposed in [228]. It involves firstly defining the requirements and design tasks of the MAS as a whole (Section 6.2) and then specifying the individual agents within the MAS (Section 6.3), their reasoning capabilities (Section 6.5), as well as their interactions and the ontology required to support inter-agent communications (Section 6.6).

In addition to MAS design, this Chapter also describes the design of an SSEZ Relational Database Management System (RDBMS) in Section 6.7. The aim of the RDBMS is to allow measurement data within the SSEZ to be stored and retrieved by the relevant system agents in order to provide information regarding the current status of the SSEZ, thereby enabling analyses of network events and network performance. The design of the SSEZ control system may be seen schematically in Figure 6.1.

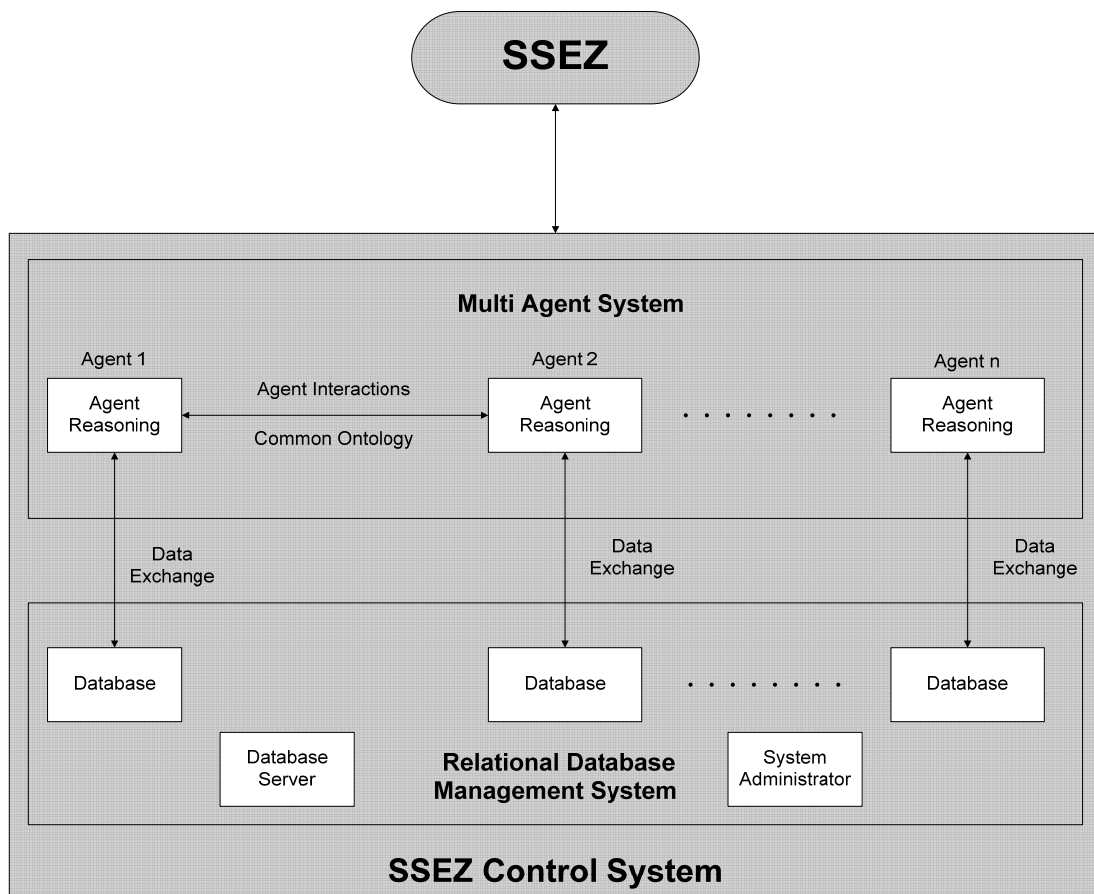

Figure 6.1: The design of the SSEZ control system.

6.1. CASE STUDY SSEZ

For the purposes of this research, the UK generic LV distribution network described in Section 4.2.1 is considered as the case study SSEZ that the MAS design is based on. The design of the MAS must be generic enough to be applicable to any type of LV

distribution network but at the same time the number and type of system agents present will depend on the specific technical characteristics of the SSEZ, such as the type, location and number of SSEGs, ESUs and controllable loads present, the installed measurement and communication devices, network feeders etc.

The case study SSEZ is assumed to contain the typical network protection settings employed in existing LV distribution networks [173] but there are no measurement, control and communication devices present, such as for example IEDs (Section 2.3.3). This is in accordance with the current “fit-and-forget” operating philosophy employed by DNOs for LV distribution networks (Section 2.1). Moreover, each customer is assumed to have installed a single-phase SSEG with a rating of 2.5kW. The rationale for choosing this particular rating per customer corresponds to results from Table 4.8 which illustrate that at this level of SSEG penetration each of the LV network constraints under consideration may be encountered. However, if lower SSEG penetration scenarios were assumed, the number and type of agents that are required to satisfy the SSEZ control requirements could be different as will later be described.

Furthermore, it is also assumed that 10% of the customers have installed an ESU capable of a continuous power input/output of 5kW and that every customer has installed a controllable consumer demand attributing to 1kW. These assumed values are intended to illustrate the role of employing ESM and DSM schemes within the SSEZ. Consequently, the case study SSEZ contains 384 single-phase SSEGs, i.e. 24 single-phase SSEGs in each service section evenly distributed across the three phases, 384 controllable consumer demands and 38 ESUs. The case study SSEZ under a passive control approach is shown in Figure 6.2.

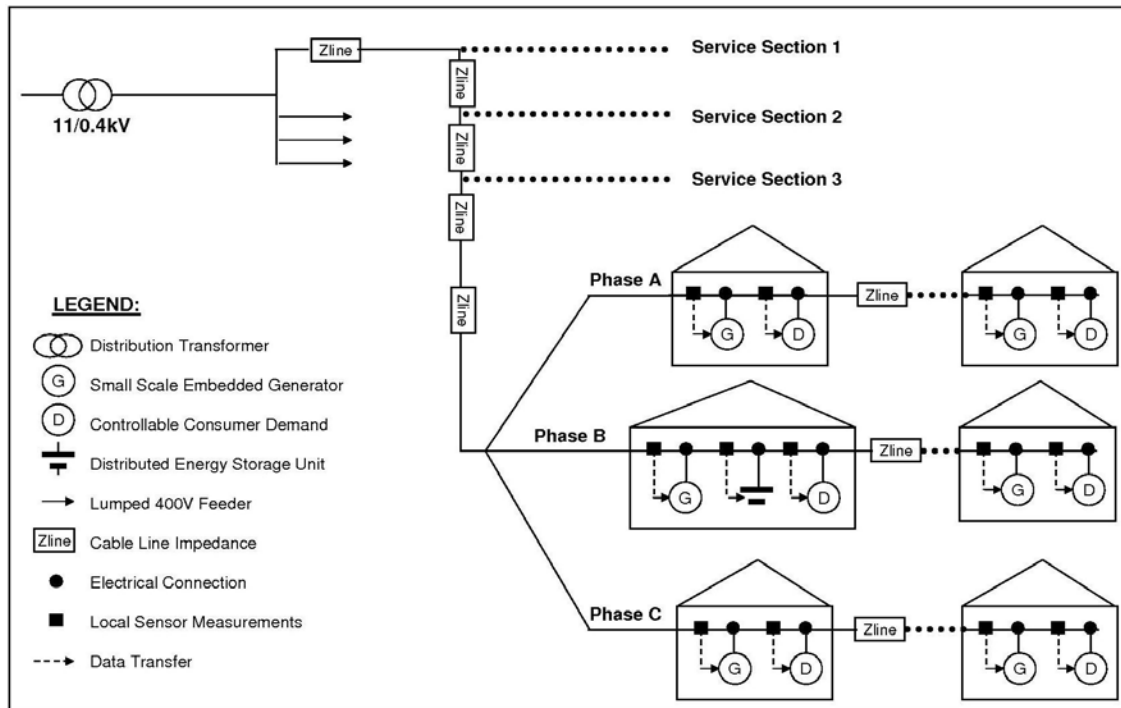

Figure 6.2: The case study SSEZ under a passive control approach.

6.2. TASK DECOMPOSITION

In order to realise the control tasks of the MAS, these tasks must be decomposed into several sub-tasks whose execution may then be assigned to system agents. The task hierarchy for overcoming the LV distribution network constraints under consideration is shown in Figure 6.3, while Figure 6.4 illustrates the task hierarchy for meeting an SSEZ operational goal.

Both involve three main stages: (i) state assessment, where measurement data from specific measurement points within the SSEZ are collected and processed by the relevant agents; (ii) action planning and decomposition, where potential control actions are identified; and (iii) action execution, where control actions are sent to the relevant customer-owned power system entities and are also reviewed.

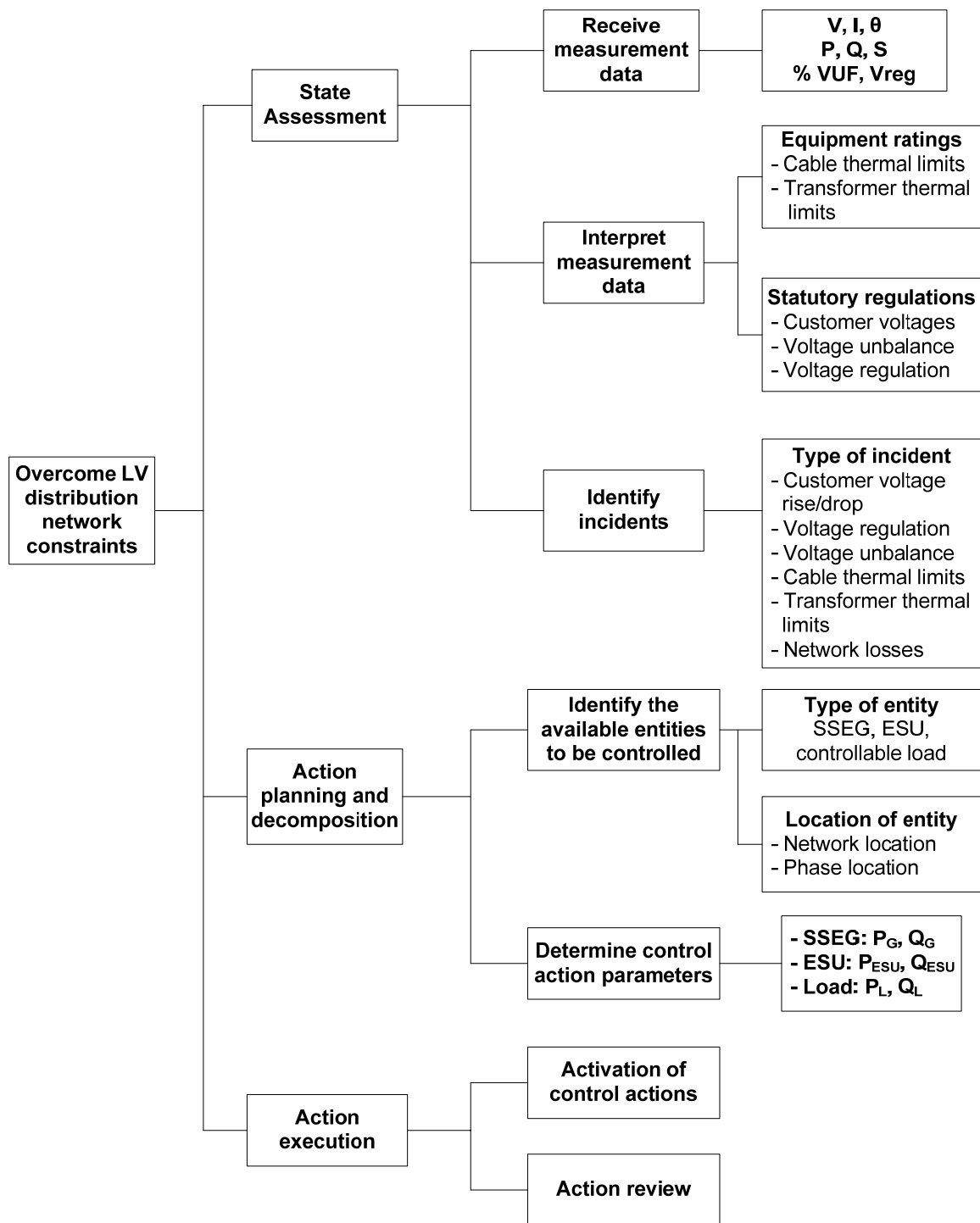

Figure 6.3: Task hierarchy for overcoming the identified LV network constraints.

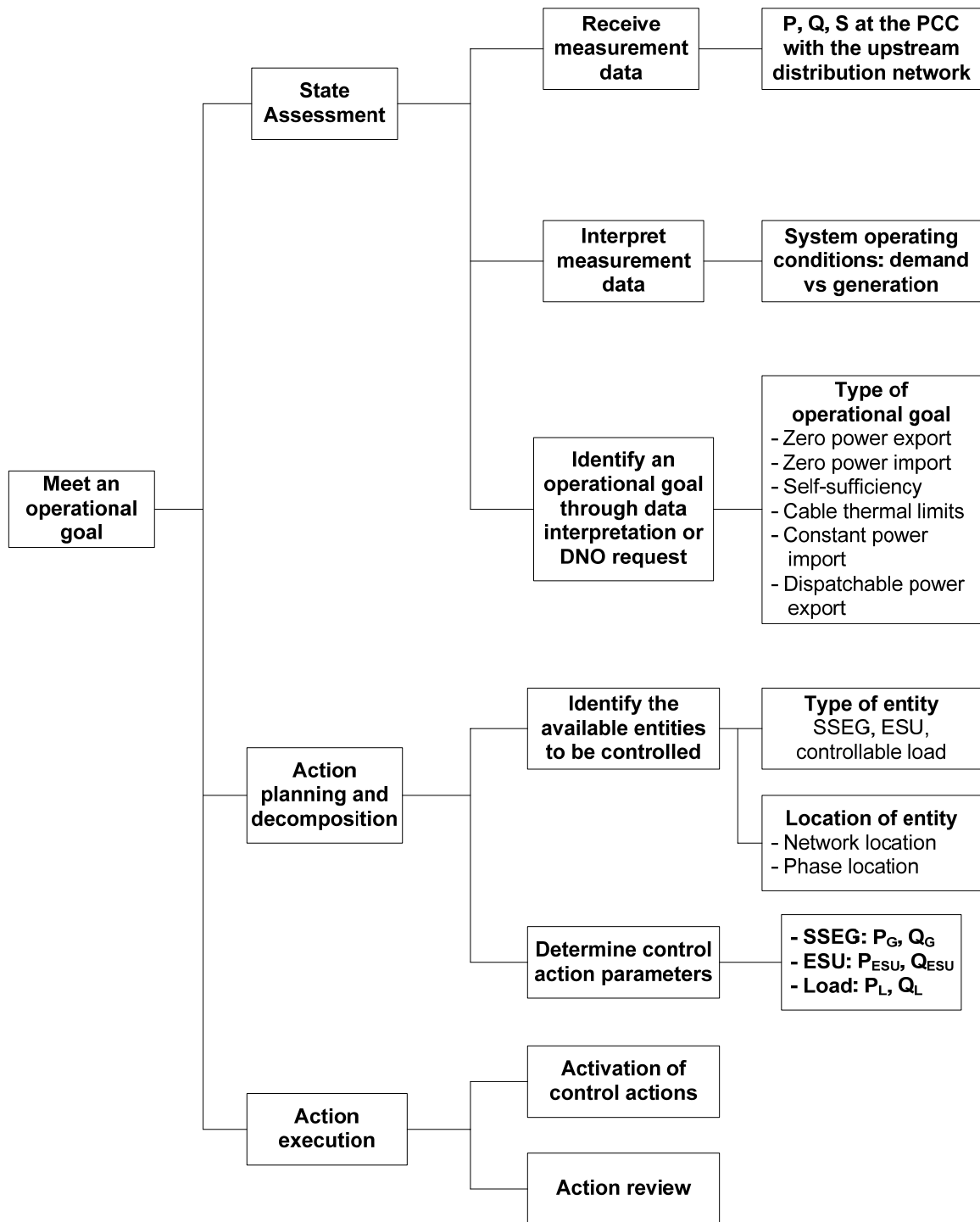

Figure 6.4: Task hierarchy for meeting an identified operational goal.

6.3. DESCRIPTION OF SYSTEM AGENTS

Table 6.1 presents which of the listed attributes the agents operating within the proposed MAS-based control approach need to exhibit such that the LV distribution

constraints can be overcome and the operational goals can be met. From the eleven agent attributes listed in Table 6.1, eight are viewed as essential in order to satisfy the specific control requirements of an SSEZ.

Required Agent Attributes	Customer voltage rise/drop	Voltage regulation	Voltage unbalance	Thermal limits	Network losses	Operational goals
Autonomy	✓	✓	✓	✓	✓	✓
Social Ability		✓	✓	✓		✓
Reactivity	✓	✓	✓	✓	✓	✓
Pro-activeness	✓	✓	✓	✓	✓	✓
Accuracy	✓	✓	✓	✓	✓	✓
Adaptivity						
Adaptability	✓	✓	✓	✓	✓	✓
Mobility						
Temporal Continuity	✓	✓	✓	✓	✓	✓
Reliability	✓	✓	✓	✓	✓	✓
Inferential Capability						

Table 6.1: Required individual agent attributes of the MAS control approach.

Having identified the attributes that system agents need to exhibit, it is now necessary to define the types of agents required to satisfy the specific control requirements of an SSEZ and adhere to the specifications developed by FIPA [92]. There are three types of agents, namely: (i) direct control agents; (ii) indirect control agents; and (iii) utility agents. The agents reside on a particular agent platform, as shown in Figure 6.5, which provides the message transport service in order to allow agents from the same or different agent platforms to communicate.

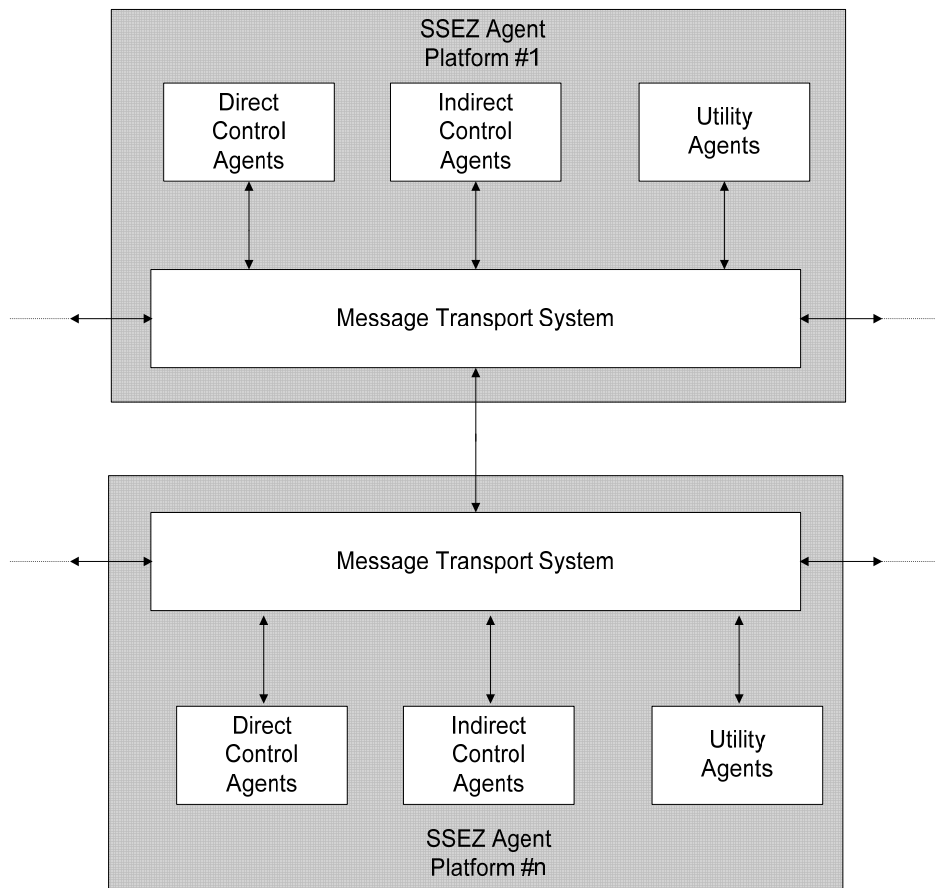

Figure 6.5: The FIPA-based SSEZ agent platform management model.

6.3.1. Direct Control Agents

This type of agent directly controls a customer-owned power system entity (SSEG, ESU or consumer demand) within the SSEZ in order to achieve its design goals.

Given the nature of these goals, there are three categories of direct control agents:

- Generator Agent (GA) ~ an agent that controls the real and reactive power set-points of an SSEG unit.
- Consumer Demand Agent (CDA) ~ an agent that controls the demand of a controllable customer load, which may be either: (i) re-shiftable, (ii) curtailable, or (iii) critical. The first two types constitute the “low priority loads” which ideally are the only load types to be managed. Curtailable loads are dispatchable, but to varying degrees depending on the type of load involved (Section 2.5).

- Energy Storage Agent (ESA) ~ an agent that controls the real and reactive power set-points of an ESU.

Instances of these agents contribute towards overcoming the LV distribution network constraints under consideration and meeting the SSEZ operational goals. Each of these agents uses local measurements at the terminal point of the unit it is controlling in order to make the appropriate control decisions. These agents behave autonomously where possible, however in certain circumstances they respond to requests from indirect control agents as will later be described. The locations of the direct control agents in the case study SSEZ are shown in Figure 6.6. In accordance with the controllable customer-owned power system entities that exist in the network, the case study SSEZ is assumed to contain 384 GAs, 384 CDAs and 38 ESAs.

The implementation of each direct control agent on an actual SSEZ requires a processing unit with a microprocessor that supports the installation of a Java Virtual Machine, where the agent environment of the MAS is then embedded. In addition, a physical and logical connection between every installed customer-owned power system entity and the direct control agent that controls this entity must exist, along with a common long-range communications medium for inter-agent communications.

6.3.2. Indirect Control Agents

This type of agent indirectly controls a power system entity (SSEG, ESU or consumer demand) within the SSEZ in order to achieve its goals. There are four categories of indirect control agents, which are able to influence the actions of direct control agents.

- Thermal Limits Agent (TLA) ~ an agent that indirectly controls the power flow through a cable or transformer.
- Operational Goals Agent (OGA) ~ an agent that indirectly controls the power flow at the interface (PCC) between the SSEZ and the upstream distribution network.
- Unbalance Agent (UA) ~ an agent that indirectly balances the power flow across each of the three phases of an SSEZ feeder.
- Voltage Regulation Agent (VRA) ~ an agent that indirectly controls the voltage variation between the LV busbars of the distribution transformer supplying the SSEZ and the remote ends of the SSEZ.

Each of these agents uses measurement data from strategic points within the SSEZ in order to decide which direct control agents need to be employed in order for the indirect control agent to achieve its design objectives. Measurement data may be provided either from customer-owned power system entities within the SSEZ, or from dedicated measurement devices that need to be installed at specific locations within the SSEZ. The indirect control agents in the case study SSEZ are shown in Figure 6.6.

There exist 4 UAs, each controlling the % VUF at the remote ends of the four 400V SSEZ feeders. The term remote end is used to signify the last customer on each of the three phases of the fourth service sections. The rationale for choosing these locations as the points where UAs monitor voltage unbalance within the SSEZ case study is based on results described in Section 4.4.2 that have identified these points as the worst case locations for voltage unbalance. For similar reasons, 4 VRAs exist that monitor the voltage variation between the LV busbars of the distribution transformer supplying the SSEZ and the remote ends of each of the four 400V SSEZ feeders.

Moreover, 5 TLAs exist that are responsible for protecting cables and transformers from thermal damage. Research described in Section 4.4.3 has identified the location of four cable “hot spots”, i.e. one in each SSEZ feeder. Therefore, there exist 4 TLAs that use measurements from these vulnerable sections of the distribution network such that they can intervene to protect the cable from thermal damage. An additional TLA is employed in order to ensure that reverse power flows through the distribution transformer do not exceed their corresponding kVA ratings. Finally, the MAS also contains 1 OGA occupied with meeting the identified SSEZ operational goals.

6.3.3. Utility Agents

This type of agent performs administrative duties and is in alignment with FIPA specifications [92]. Each agent platform contains two utility agents which facilitate the efficient operation of direct and indirect control agents within the MAS:

- Agent Management System (AMS) ~ a mandatory component of the FIPA specification, which is responsible for offering “white pages” services to other agents by maintaining a directory of registered agents.
- Directory Facilitator (DF) ~ an optional component of the FIPA specification, which provides “yellow pages” services by enabling agents to identify services offered by other agents.

Utility agents are not responsible for any control actions, but their operation is central to the functionality of the MAS because they ensure compliance with FIPA specifications, and also offer “plug and play” capabilities to the system by allowing new agents to automatically register their services and announce them to the other

agents in the system. This provides functionality to the MAS that is not “hard-wired” by the system developer, but is allowed to change as the system runs [114].

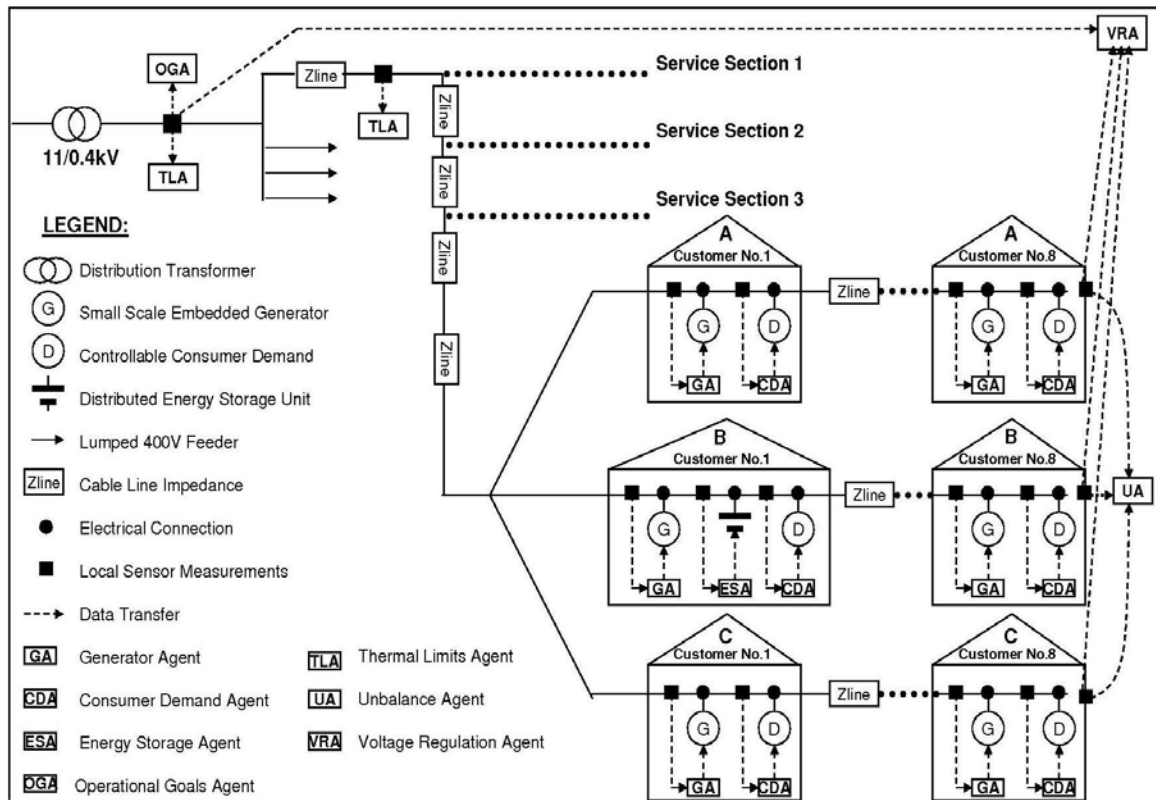

Figure 6.6: The MAS-based control approach on the case study SSEZ.

6.3.4. Communication Links

Data exchanges between agents include the exchange of control commands and measurement data. The number of communication links required depends on the number and type of direct and indirect control agents present. In turn, these depend on:

1. The direct control agents that need to be installed depend exclusively on the number and type of controllable customer-owned power system entities present. The network and phase location of a direct control agent does not have an impact on communication links because direct control agents do not send any control commands to other agents. They do, however, require two-way communication

links with the power system entity they are coupled with in order to receive real-time measurement data and to send back control commands (“action execution”).

2. The number and type of indirect control agents that need to be installed depend on the specific technical characteristics of the SSEZ (such as the number of cable “hot spots”, the number of network feeders for voltage unbalance and voltage regulation etc) but also on the SSEG penetration limits that may be accommodated before each LV distribution network constraint is encountered. If, through simulation studies, these are found to be too high for some network constraints under consideration, then their respective indirect control agent(s) may not be required thereby also minimising the need for installing new dedicated measurement devices.

In addition, network location is important because indirect control agents must only send control commands to direct control agents that can help them to achieve their objectives. For example, a TLA responsible for protecting a specific cable section from thermal damage must only send control signals to the direct control agents that are located in that particular cable “hot spot”.

The required data links for the agents of the case study SSEZ are shown in Figure 6.6 and are also explained in greater detail in Section 6.7.

1. The OGA and the TLA that is responsible for protecting the distribution transformer from thermal damage must be able to send control signals to all direct control agents located within the SSEZ.
2. Each TLA, VRA and UA must have established command links with the direct control agents located on the particular feeder for which they are responsible.

3. Finally, the AMS and the DF are responsible for administrative duties within the MAS and therefore communication links with all direct and indirect control agents are required, in accordance with FIPA specifications [92].

The following points regarding communications are assumed for the case study SSEZ:

1. Agent connectivity: A mechanism must exist for establishing a physical and logical connection between every installed customer-owned power system entity (SSEG, ESU or controllable consumer demand) and the direct control agent that controls this entity. As an example, a JAVA-based “Generator Agent” and an XML-RPC server have been employed in [128] in order to access generator data settings and working parameters from the inverter of the generator as shown in Figure 6.7. The XML-RPC is an Internet standard that encapsulates information under XML (eXtensible Markup Language) and uses HTTP (HyperText Transfer Protocol) as communications protocol.

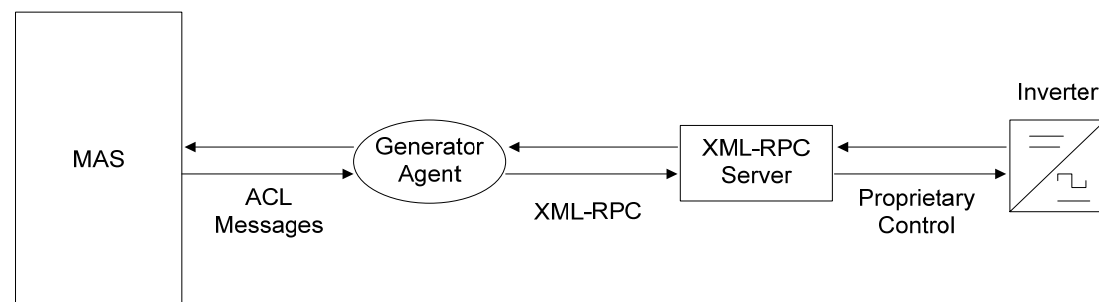

Figure 6.7: Control architecture used in [128] for connectivity between a JAVA-based generator agent and an inverter-based SSEG.

2. Syntactic and semantic interoperability: Understanding of the concepts contained within the data exchanged between system agents, power system entities and measurement devices is critical for the functionality of the control system. A common problem discussed in the literature when employing MAS technologies is

their proprietary nature which could limit communications among devices that do not have hardware and systems from the same vendor [46]. This could be achieved through the use of appropriate protocols and standards in order to achieve systems integration. As an example, OPC (OLE for Process Control where OLE stands for Object Linking and Embedding) server/clients are used in [127] in order to achieve this functionality.

3. Network interoperability: An available long-range communications medium is required for communication purposes. In order to reduce costs and implementation times, existing communication infrastructure such as resi-dential broadband and the public Internet could be used (Figure 6.8) but issues regarding reliability and safety would also need to be taken into account.

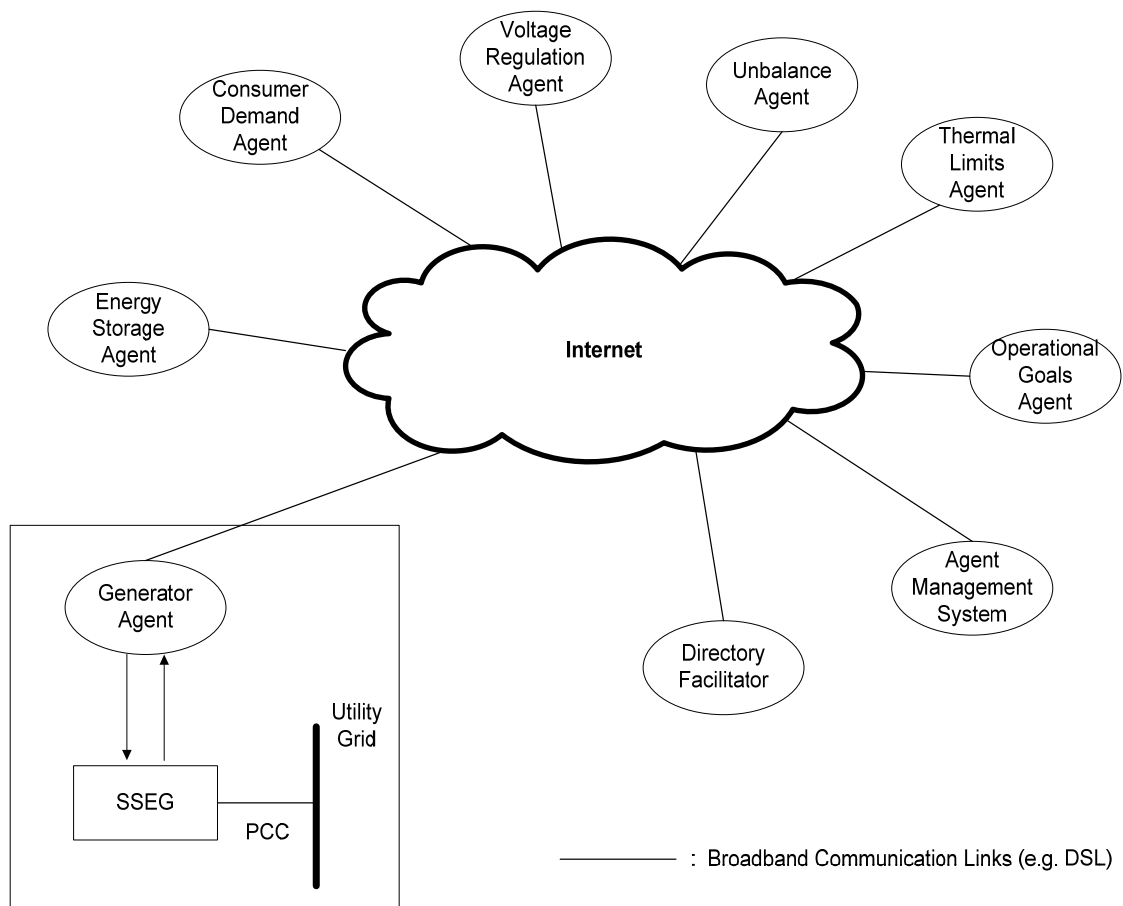

Figure 6.8: Agent communication links using broadband and the public Internet.

6.4. OPERATING STATES OF SYSTEM AGENTS

In order to ensure that the LV distribution network constraints under consideration are overcome, the operation of direct and indirect control agents relies on general power systems control and operation theory described in [175]. Three operating states were identified in order to be implemented inside the functionality of the developed direct and indirect control agents: (i) normal; (ii) alert; and (iii) emergency state, as shown in Figure 6.9. In contrast to evaluating voltage and current profiles or allowable real and reactive power flows, there is not a standard or reference value for network losses in LV distribution networks. Hence, network losses are not taken into account when determining the operating states of system agents.

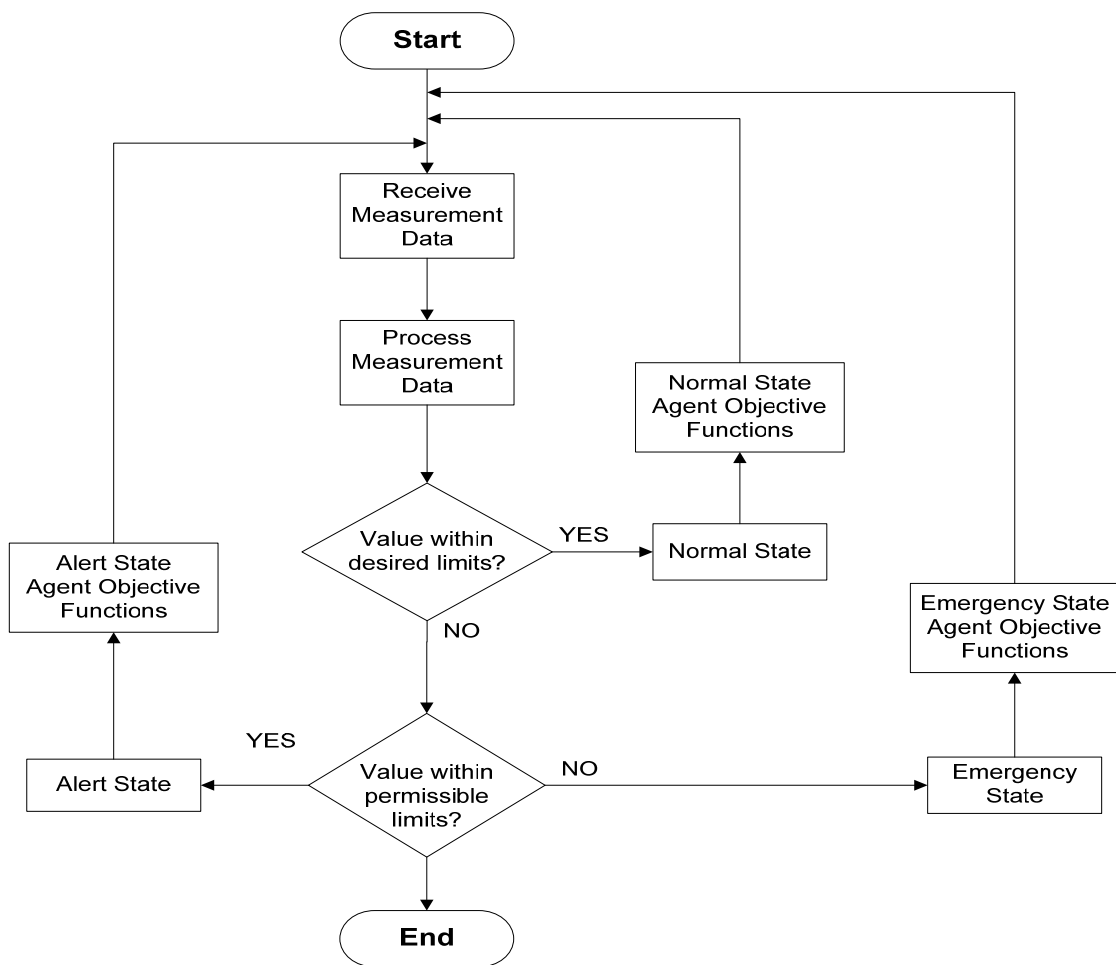

Figure 6.9: Flow chart of the proposed MAS-based control system.

6.4.1. Normal State

If all agents are operating in their normal state, system voltages (for customer voltages V_i , voltage regulation $V_{reg,i}$ and voltage unbalance $\%VUF_i$), currents I_{ij} (for cable thermal limits) and apparent power flows S_k^t (for transformer thermal limits) are located within their desired operating limits.

$$V_i^{\min_desired} \leq V_i \leq V_i^{\max_desired} \quad \text{where: } i = 1, 2, \dots, N_{customers} \quad (6.1)$$

$$V_{reg,i}^{\min_desired} \leq V_{reg,i} \leq V_{reg,i}^{\max_desired} \quad \text{where: } i = 1, 2, \dots, N_{feeders} \quad (6.2)$$

$$\%VUF_i \leq \%VUF_i^{\max_desired} \quad \text{where: } i = 1, 2, \dots, N_{feeders} \quad (6.3)$$

$$|I_{ij}^{line}| \leq |I_{ij,\max_desired}^{line}| \quad \text{where: } i, j = 1, 2, \dots, N_{network_lines} \quad (6.4)$$

$$|S_k^t| = |P_k^t| + j|Q_k^t| \leq |S_{k,\max_desired}^t| \quad \text{where: } i = 1, 2, \dots, N_{transformers} \quad (6.5)$$

The aim of the control system is to provide the individual active (P) and reactive (Q) power set-points for the customer-owned power system components (SSEGs, ESUs, controllable loads) in order to:

1. Maximise the total SSEG active power output (P_G) in the SSEZ:

$$\Delta P_G = \max \left(\sum_{i=1}^{N_G} P_{Gi} \right) \quad (6.6)$$

where P_{Gi} is the active power output of the i -th SSEG and N_G is the number of SSEGs within the SSEZ.

This is achieved by ensuring that SSEGs are operating at their maximum power output and by avoiding unnecessary active generation curtailment.

2. Minimise system losses in the SSEZ branches and the MV/LV windings of the distribution transformer(s).

$$\Delta P_{losses} = \min \left(\sum_{i=1, j=1}^{N_B} R_{ij} I_{ij}^2 + \sum_{k=1}^{N_t} R_t I_t^2 \right) \quad (6.7)$$

where I_{ij} R_{ij} is the current and resistance between branches i and j ; N_B is the number of branches; I_t R_t is the current and resistance of the k -th MV/LV distribution transformer; and N_t is the number of transformers supplying the SSEZ (likely to be 1).

Network loss reduction is achieved through reactive power flow minimisation as described in Section 5.1.1, while reduction in network losses through active power flow minimisation is only considered as an SSEZ operational goal (“self-sufficiency”).

During normal state, SSEGs are operated such that all their available active power is injected into the SSEZ, while their reactive power output is regulated based on local reactive power flow minimisation. This is only considered for cases, however, where the active power output remains unaffected. At the same time, Q injection (lagging power factor) or absorption (leading power factor) can not exceed existing regulation limits (0.95 leading to 0.95 lagging) as defined by [24] in the UK. Finally, the management of loads and ESUs during the normal state is only considered for cases where they can assist the SSEZ in order to meet an operational goal.

An SSEZ only attempts to meet an operational goal if all system agents are operating in their normal state. If one or more system agents move into an alert state while the SSEZ is attempting to meet an operational goal, operation of system agents remains unchanged. If, however, one or more of the indirect control agents within the MAS enter their emergency state, the operational goal must be dropped in order to ensure

secure system operation which is the single most important requirement of the SSEZ. This is achieved by the relevant indirect control agent sending an ACL message to inform the OGA that the operational goal must be cancelled.

6.4.2. Alert State

If one or more of the system parameters (voltages, currents, power flows) that are being monitored in various locations within the SSEZ exceed their desired operating limits, the respective agents are said to be operating under the alert state. The aim of the control system is to provide the individual active (P) and reactive (Q) power set points for customer-owned power system components in order to restore the system back to its normal operating state.

$$V_i^{\min_permissible} \leq V_i \leq V_i^{\min_desired} \text{ or } V_i^{\max_desired} \leq V_i \leq V_i^{\max_permissible},$$

where: $i = 1, 2, \dots, N_{customers}$ (6.8)

$$V_{reg,i}^{\min_permissible} \leq V_{reg,i} \leq V_{reg,i}^{\min_desired} \text{ or } V_{reg,i}^{\max_desired} \leq V_{reg,i} \leq V_{reg,i}^{\max_permissible},$$

where: $i = 1, 2, \dots, N_{feeders}$ (6.9)

$$\%VUF_i^{\max_desired} \leq \%VUF_i \leq \%VUF_i^{\max_permissible} \text{ where: } i = 1, 2, \dots, N_{feeders} \text{ (6.10)}$$

$$|I_{ij,\max_desired}^{line}| \leq |I_{ij}^{line}| \leq |I_{ij,\max_permissible}^{line}| \text{ where: } i, j = 1, 2, \dots, N_{network_lines} \text{ (6.11)}$$

$$|S_{k,\max_desired}^t| \leq |S_k^t| \leq |S_{k,\max_permissible}^t| \text{ where: } i = 1, 2, \dots, N_{transformers} \text{ (6.12)}$$

In the event of exceeding the desired voltage rise or voltage regulation limits, GAs operating under the alert state firstly attempt to regulate the reactive power of their respective SSEGs in order to keep the steady-state voltage at the minimum desired

limit ($V_i^{min_desired}$, $V_{reg}^{min_desired}$) or the maximum desired limit ($V_i^{max_desired}$, $V_{reg}^{max_desired}$). SSEG reactive power support, however, is only considered for cases where the active power output of these units remains unaffected. At the same time, ESAs and CDAs operating under the alert state attempt to increase/reduce the load in the affected area by controlling the power consumption of their respective ESUs and controllable consumer demand. Traditionally, due to the relatively low X/R ratios of LV distribution networks, reactive power support has rarely been employed at the LV customer level [8]. Simulation results for LV distribution networks with high SSEG penetrations (Table 4.1), however, have shown that significantly higher SSEG volumes may be accommodated by changing the operating SSEG power factor from unity to 0.95 leading. Power factor control is considered in order to avoid active generation curtailment and hence maximise the total energy yield of the SSEGs.

For voltage unbalance and cable and transformer thermal limits, simulation results (Tables 4.2 and 4.3) have shown that reactive power control is not a particularly effective mitigation strategy. Therefore, corrective actions are performed only through DSM and ESM schemes. In general, energy storage devices such as batteries and ultra capacitors are considered ideal for short term power requirements (seconds to minutes), but for longer term needs (such as minutes to hours) DSM of non-critical (“low-priority”) loads is preferred as a source or sink of reserve power. Curtailment or disconnection of critical loads is not performed during the alert state because it produces clear inconvenience to SSEZ customers and is therefore only considered during emergency system operation.

6.4.3. Emergency State

The SSEZ is said to be operating under the emergency state if one or more of the system parameters have exceeded their maximum or minimum permissible operating limits, according to either statutory regulations (customer voltage rise/drop, voltage regulation and voltage unbalance) or equipment ratings (cable and transformer thermal limits).

$$V_i \leq V_i^{\min_permissible} \text{ or } V_i^{\max_permissible} \leq V_i \quad i = 1, 2, \dots, N_{customers} \quad (6.13)$$

$$V_{reg,i} \leq V_{reg,i}^{\min_permissible} \text{ or } V_{reg,i}^{\max_permissible} \leq V_{reg,i} \text{ where: } i = 1, 2, \dots, N_{feeders} \quad (6.14)$$

$$\%VUF_i^{\max_permissible} \leq \%VUF_i \text{ where } i = 1, 2, \dots, N_{feeders} \quad (6.15)$$

$$|I_{ij,\max_permissible}^{line}| \leq |I_{ij}^{line}| \text{ where: } i, j = 1, 2, \dots, N_{network_lines} \quad (6.16)$$

$$|S_{k,\max_permissible}^t| \leq |S_k^t| \text{ where: } i = 1, 2, \dots, N_{transformers} \quad (6.17)$$

Under the emergency state, SSEGs are operated in active power regulation mode, whereby they reduce their scheduled active power output in order to bring the system back to the alert state. Active power curtailment, however, has important economic consequences as the SSEG owner loses part of its revenue which will have an impact on the SSEG payback time. If secure system operation can not be achieved due to technical reasons (i.e. due to the SSEG minimum stable power output being reached), disconnection of these units will be necessary. In that case, the MAS-based control system must also ensure that the disconnected SSEGs are brought back to service once normal system operation is resumed.

A number of active power dispatch techniques have been proposed, such as:

1. Conventional reactive power/voltage (Q/V) and active power/frequency (P/f) droops or non-conventional active power/voltage (P/V) and reactive power/frequency (Q/f) droops [176]. These droops are typically implemented in a purely distributed manner, with each SSEG/DG responsible for setting its individual P and Q set-points, and by using a number of voltage source inverters in parallel for redundancy [177].
2. Active power dispatch based on the “Last In First Off” (LIFO) policy [178], where the power output of new DGs/SSEGs in the system is typically constrained in intervals of 33%.
3. Active power dispatch based on proportionality sharing policies that are typically derived from power flow sensitivity factors that relate the changes in distribution system power flows to DG/SSEG nodal power injections [179].
4. Active power dispatch based on optimisation criteria, such as: (i) fuel cost minimisation or profit maximisation; (ii) network losses minimisation; or (iii) emissions minimisation or renewable power generation maximisation [175].

The applicability of different SSEG active power dispatch techniques within the SSEZ concept are discussed in greater detail in Chapter 8.

6.5. AGENT REASONING

FIPA standards govern the basics of agent architecture [92], as well as inter-agent message formats and protocols [120], but they do not specify how agents achieve their reasoning capabilities. For the MAS under consideration, the reasoning capabilities of system agents may be divided into two main categories: (i) reasoning about ACL

messages that agents are receiving from other agents within the MAS; and (ii) reasoning about inputs that agents are receiving directly from the SSEZ environment, i.e. values from the installed measurement devices within the SSEZ. Hence, system agents must be able to reason both about where the input is coming from, as well as about what the input is. The research described in this Thesis is concerned with responsive control, whereby control actions are based on reacting timely and appropriately to changes occurring in the SSEZ environment.

Due to the potential number of direct control agents within the MAS, the processing time and power of the hardware entities where these agents are to be housed must be kept as low as possible, in order to also reduce the associated costs of employing a MAS-based control system. Thus, the reasoning capabilities of system agents must be kept as simple as possible, while at the same time ensuring that the SSEZ remains functional independent of the operating state. Moreover, system agents must be designed to operate with minimal human supervision, i.e. with a high degree of autonomy. This is due to the potential number of controllable entities that may exist within an SSEZ, as well as due to the nature of their incremental connection.

6.5.1. Rule-based Reasoning

Agent decision-making is performed according to the set of rules described in Section 6.4, which are governed by the three agent operating states. The idea behind rule-based reasoning is to represent knowledge of a particular environment in a form called “rules”. A rule consists of “if – then” statements, i.e. several premises and a conclusion; if all the premises are true, then the conclusion is also considered true. The rules for agent behaviour in the proposed MAS are shown in Table 6.2.

Condition	If	Then
Customer over-voltage or under-voltage	Maximum voltage limits exceeded	1. Reactive power support 2. DSM & ESM 3. SSEG active power curtailment 4. SSEG disconnection
	Minimum voltage limits exceeded	1. Reactive power support 2. DSM & ESM 3. Load disconnection
Voltage regulation issues	%VUF exceeded	1. DSM & ESM 2. SSEG active power management 3. SSEG or load disconnection
Cable and transformer thermal limits	Thermal limits exceeded	1. DSM & ESM 2. SSEG active power curtailment 3. SSEG disconnection
Operational goals	An operational goal has been identified	1. DSM & ESM 2. SSEG active power management
Multiple control actions need to be taken simultaneously in the network	Voltage limits and thermal limits exceeded	1. Mitigate against voltage issues. 2. Mitigate against thermal issues.
	Voltage unbalance and voltage rise / regulation limits exceeded	1. Mitigate against voltage rise issues. 2. Mitigate against voltage regulation issues. 3. Mitigate against voltage unbalance issues.
Occurrence of conflicts	Meeting an operational goal and overcoming network constraint(s) simultaneously	1. Mitigate against network constraint(s) 2. Attempt to meet the operational goal

Table 6.2: Rules for agent behaviour in the proposed MAS.

Execution of these decisions is performed through conventional feedback control loops. Action execution is adapted to the process through a continuous state assessment which monitors the difference between measured parameters and their predefined target values. Measurement data and agent control decisions must

therefore be updated in real-time or close to real-time which requires a fast and continuous feed of information to and from the system agents and the measurement devices within the SSEZ, which could present significant research challenges as will be described in Section 9.2.1. Implementation of action execution in the developed MAS is described in greater detail in Section 7.1.6.

6.5.2. Conflict Resolution

Under high SSEG penetration scenarios, customer voltage rise has been found to be the most likely limiting LV distribution network constraint in the case study SSEZ (Table 4.8). In order to ensure that customer voltages are maintained within statutory limits, active management of the connected SSEGs, ESUs and consumer loads will be required. As a result, it is possible that the other network constraints may not be encountered within the system. In the possibility of multiple network constraints being encountered simultaneously, however, or in the possibility of conflicting goals (Table 6.2), agent decision-making is based on the set of rules that is explained below. An example for the former is a case where both voltage rise and cable thermal limits are encountered. The second possibility might arise if a direct control agent receives conflicting messages from different indirect control agents.

In both cases, issues associated with voltage control are given a higher priority compared to thermal limits issues. This is because in most distribution systems, system equipment (cables, lines and transformers) will not be critically damaged if their maximum current rating capacity has been exceeded by a small margin and for a short period of time. Additionally, each equipment manufacturer interprets maximum allowable current ratings slightly differently and DNOs adopt different loading

methodologies as detailed in their organisation specific sections of Engineering Recommendation G81 [180]. Hence, approximate figures are normally used for the maximum carrying capacity of cables, lines and transformers. For voltage control issues, however, common statutory regulations are employed in all UK LV distribution networks and adhering to these regulations is a higher priority for the control system.

In addition, direct control agents always assume that control actions received from an OGA have a lower priority than control actions associated with overcoming a network constraint. This is because secure system operation is the single most important requirement of the proposed SSEZ control system.

6.6. AGENT COORDINATION

The SSEZ control system may be characterised as a collection of decision-making components (“agents”) with limited processing capabilities and where inter-component communications must be kept as low as possible due to the potential number of these components. In a MAS domain with limited resources, i.e. where system agents only have a partial representation of the environment, coordination of agent activity is often necessary in order to satisfy the design goals of the MAS. In general, these goals may be achieved by either [93]:

- Competition, where agents are self-interested and compete for resources.
- Cooperation, where agent coordination is non-antagonistic.

Under the proposed MAS, agent coordination is achieved through cooperation of system agents. The system depends on fairness and on the truthfulness of agents, i.e. individual agents within the MAS do not lie in order to gain benefits compared to other agents. This type of agent behaviour is often termed as “good citizen” behaviour [93] and is suitable for the SSEZ concept where the overall goal is always given a higher priority compared to individual goals.

Having defined all tasks in the system (Section 6.2), as well as the agents that are required to perform these tasks (Section 6.3), agent interactions within the MAS must also be identified. This includes the identification of the sequence of ACL messages required for agent communications, as well as the design of the common ontology used by agents to exchange information.

6.6.1. Ontology Design

Control tasks that involve inter-agent communications require agents that share the same ontology and use a common MTS in order for them to be able to request or provide the transfer of a resource. The MTS, along with the parameters required for inter-agent messaging, depend on the ADK that is employed and is explained in Section 7.1.4 in greater detail. Ontologies, however, depend on the specific tasks of each domain and thus a standard ontology for agent messaging does not exist [94]. It is necessary to design a specialised ontology for any individual MAS application in order to provide an adequate description of the environment such that it includes all concepts that may appear in conversations between system agents. The general requirement when designing an ontology is to keep it as simple as possible, while ensuring that the ontology is complete enough to allow agents to perform their tasks

[181]. This is a challenging task because the same domain can usually be expressed by means of several different sets of concepts and classes by individual MAS developers, i.e. by means of different ontologies.

With the increasing popularity of FIPA-compliant MAS in the power industry (Section 3.4), greater integration between previously separate systems could be realised if the developed MAS were able to interoperate and share information. In order for this to occur, however, agents that belong to different agent communities would have to share the same standards for agent messaging and content grammar (such as FIPA-ACL and FIPA-SL [120]) and also use a common ontology. If they do not use the same ontology, they may be able to engage in conversations but these are unlikely to be productive because they would not be able to discuss about objects (such as for example a generator or an ESU) using the same concepts [94].

According to research described in [94, 114-115], developing a large standardised ontology for power engineering applications would be impractical as it would not be specific enough to cover all possible interactions between agents. As a potential solution, the development of “bilingual agents” [94] was proposed in order to integrate agents that use different ontologies. In addition, FIPA have proposed the employment of “ontology agents” that provide ontology-related services to the MAS, such as maintaining a list of public ontologies and translating expressions between different ontologies [182]. As the number of supported ontologies increases, however, the development of ontology agents becomes more complicated due to the increasing number of mappings and translations that need to be created by the developer.

For this reason, the ontology of the MAS described in this Thesis only includes concepts and classes required by system agents for inter-agent messaging, i.e. whose instances have to be encoded inside the content of exchanged messages. If an agent provides a particular service, it only needs to understand messages related to that service. This supports the development of a distributed system where each agent only handles the required information. A potential limitation of this approach, however, is that any future additions to the ontology would not be understood by existing agents, as it does not provide or deal with the new concepts.

The ontology design process was based on general recommendations from [181] and takes place in three main steps. The first requires the identification of the terms used in order to describe the main domain concepts, such as ‘Generator’, ‘consumerDemand’, ‘energyStorageUnit’, ‘Transformer’ and ‘networkLine’. The next stage is to identify the classes describing these terms, as shown in Figure 6.10. All classes describing a domain concept must be included every time the resources of that concept need to be exchanged. For example, in order to describe a ‘Generator’ the ‘generatorName’, ‘generatorNetworkLocation’, ‘generatorPhaseLocation’, ‘generatorRating’ and ‘generatorType’ must all be specified. Finally, the attributes of each class need to be defined, i.e. the variables that describe each class. These are described in greater detail in Section 7.1.4 where the development of the ontology is explained and discussed.

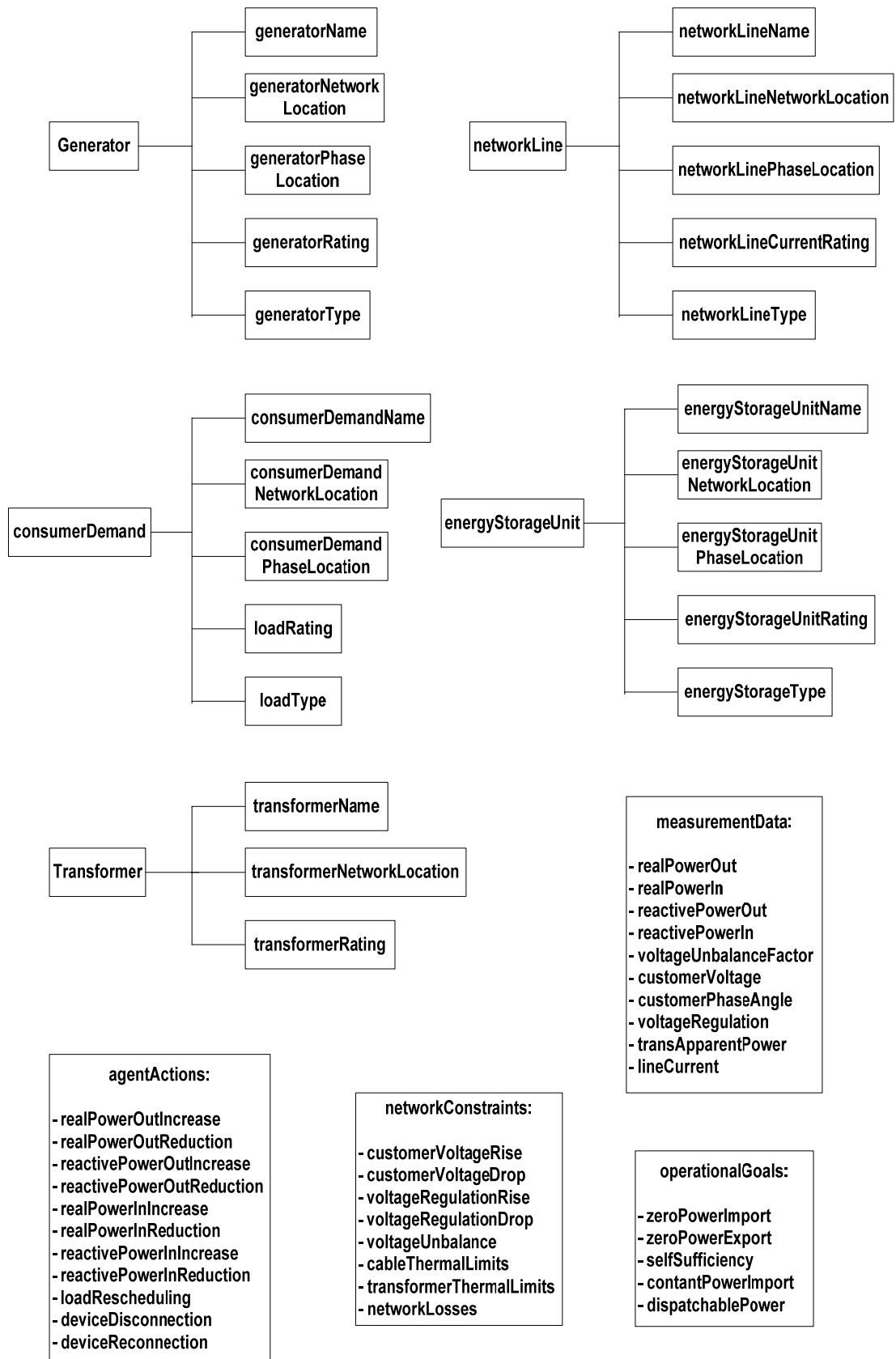

Figure 6.10: The ontology for the MAS-based control of an SSEZ.

6.6.2. Agent Interactions

During the MAS design stage, all agent interaction tasks were identified along with the sequence of agent messages required to perform these tasks. Hence, the ACL message parameters and their contents were determined for all inter-agent messages in order to design the agent message handlers for each task such that they conform to the FIPA interaction protocols [119]. As an example, Figure 6.11 shows the message sequence diagram for the voltage unbalance control task of the UA.

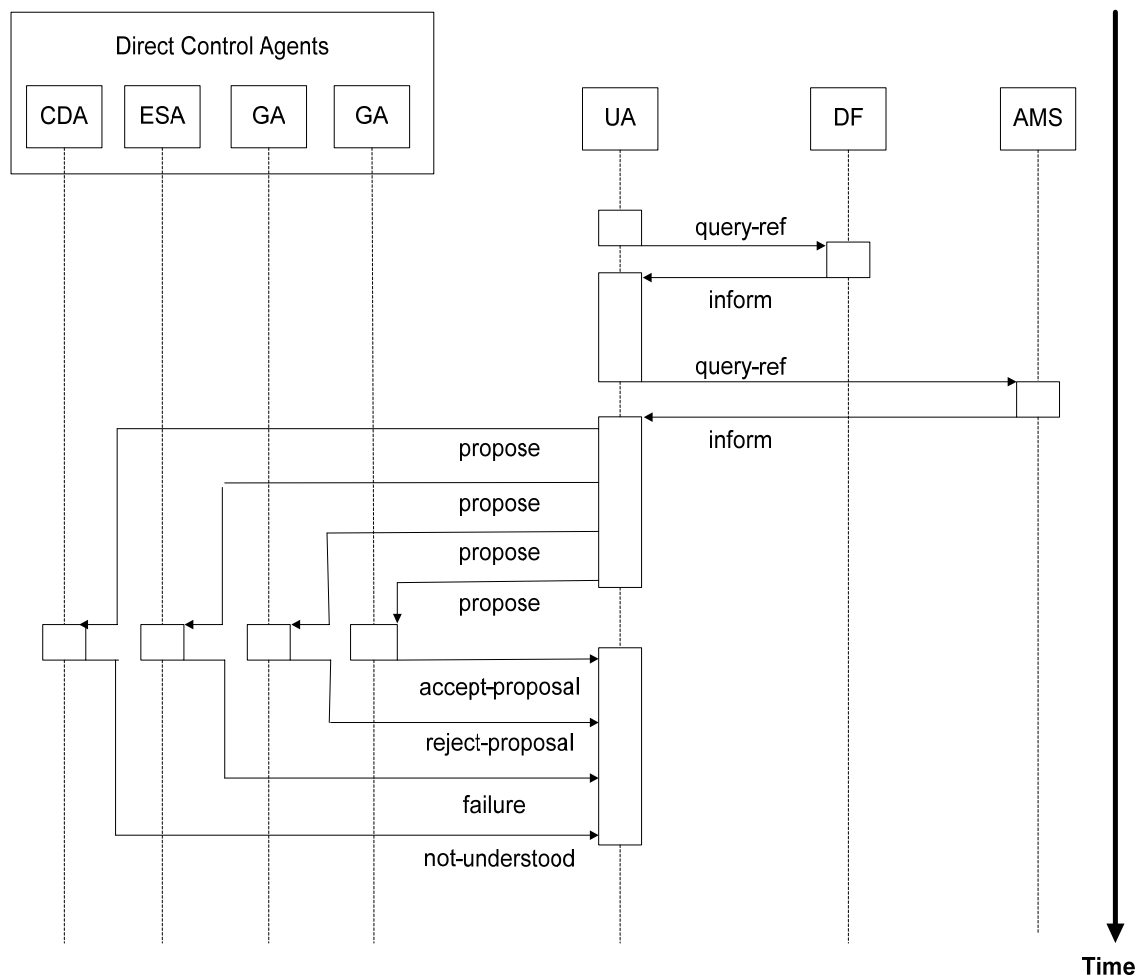

Figure 6.11: Message sequence diagram for the voltage unbalance task of a UA.

Having observed that the %VUF at the remote ends of an SSEZ feeder has exceeded its desired operating limits, the UA firstly sends a “query-ref” message with content

“Voltage_Unbalance” to the DF. The DF acts as a “yellow pages” and replies with an “inform” message to allow the UA to find out which direct control agents located on that particular feeder are able to mitigate this voltage unbalance. The UA then needs to identify the AIDs of these agents by interacting with the AMS. Having established their AIDs, the UA then sends “proposal” messages to these agents in order to: (i) control an SSEG in case of a GA; (ii) control an ESU in case of an ESA; or (iii) control a controllable customer load in case of a CDA.

Depending on their availability, direct control agents respond with an “accept-proposal” or a “reject-proposal” message to inform the UA that the submitted proposal has been accepted or rejected respectively. An agent may also respond with a “reject-proposal” in the event of conflicting goals or if a higher priority control action must firstly be taken, as explained in Section 6.5.2. In the event of a failure (such as a mechanical failure for example or loss of communications between the direct control agent and the entity it controls), or if the message is for whatever reason not understood, the agent responds with a “failure” or “not-understood” message accordingly. The process described above is repeated until the %VUF is brought back to its desired limits and secure system operation is restored.

6.7. RELATIONAL DATABASE MANAGEMENT SYSTEM

Data management within the SSEZ control system is performed through the relational database management system (RDBMS), where the term RDBMS is used to describe the entire application supporting a database, including all server and client components. The RDBMS allows measurement data within the SSEZ to be stored and

retrieved by the relevant system agents in order to provide information regarding the current status of the SSEZ. This may allow system engineers to detect network events and evaluate the performance of the SSEZ.

The inclusion of database agents within an MAS for information management applications and architectures was proposed in [79]. These agents are responsible for providing FIPA ACL-based access to the database and for distributing relevant data to system agents that query the database. The presence of database agents, however, for this particular MAS application would be challenging due to the potential number of databases (and thus database agents) that would exist. Therefore, direct and indirect control agents themselves are responsible for accessing and managing the data they require in order to achieve their design objectives.

Section 6.7.1 describes the architecture of the proposed RDBMS, which consists of the following four types of databases: (i) an indirect control database where data for indirect control agents are stored; (ii) an SSEG database for each SSEG installed within the SSEZ; (iii) an ESU database for each ESU; and (iv) a consumer demand database for each controllable load. The different tasks performed by the RDBMS are explained in Section 6.7.2, while Section 6.7.3 describes the four different database types that exist within the RDBMS in greater detail.

6.7.1. Architecture of the RDBMS

In a typical industrial installation where data management is required, a machine with large amounts of disk space available is allocated as the database server. The RDBMS that supports it is installed on the same machine with a server application that handles

all requests of storing, updating and retrieving information. In addition, a database administrator is responsible for all administrative tasks within the server. The architecture for the RDBMS of an SSEZ is made up of the following databases:

1. The indirect control database where data used by indirect control agents are stored. The indirect control database receives measurement data values from the following measurement devices located at strategic locations within the SSEZ:
 - a. Three-phase voltage measurements at the LV busbars of the distribution substation, to be compared against the three-phase voltages at the remote ends of all SSEZ feeders.
 - b. Three-phase voltage and phase angle measurements at the remote ends of the SSEZ feeders, to be used for calculating voltage unbalance factors.
 - c. Three-phase real and reactive power flows at the PCC of the SSEZ with the distribution network, to be used for: (i) transformer thermal limits; (ii) to identify an operational goal depending on network conditions; and (iii) to ensure that an operational goal has been met.
 - d. Single- or three-phase current flows at known “hot spots” to be used for ensuring that these cable sections have not exceeded their thermal limits.
2. Several distributed databases, in accordance with the number of controllable customer-owned power system entities within the SSEZ. Each distributed database receives measurement data values from the entity it is coupled with and is also sending measurement data to the direct control agent that controls this entity. The following measurement data values must be extracted:
 - a. Customer steady-state voltages, currents and phase angles, in order to ensure that statutory regulations [42] have not been exceeded and to ensure that reactive power flows are minimised thereby reducing network losses.

- b. Real and reactive power inputs/outputs of the controllable customer-owned power system entities, to be used for assessing the operating status of these entities and for their coordinated management and control.

The rationale for designing an RDBMS that also contains an indirect control database instead of one that is based on a purely distributed architecture is that indirect control agents require measurement data from locations where there are no direct control agents installed. The exception is voltage unbalance which could be mitigated using measurement data from existing distributed databases. However, if this data is unavailable, dedicated measurement devices would be required. The required data links for the agents of the case study SSEZ are shown in Figure 6.5 and were discussed in Section 6.5.2. Figure 6.5 can be updated to include the location of the required databases within the case study SSEZ, as seen in Figure 6.12.

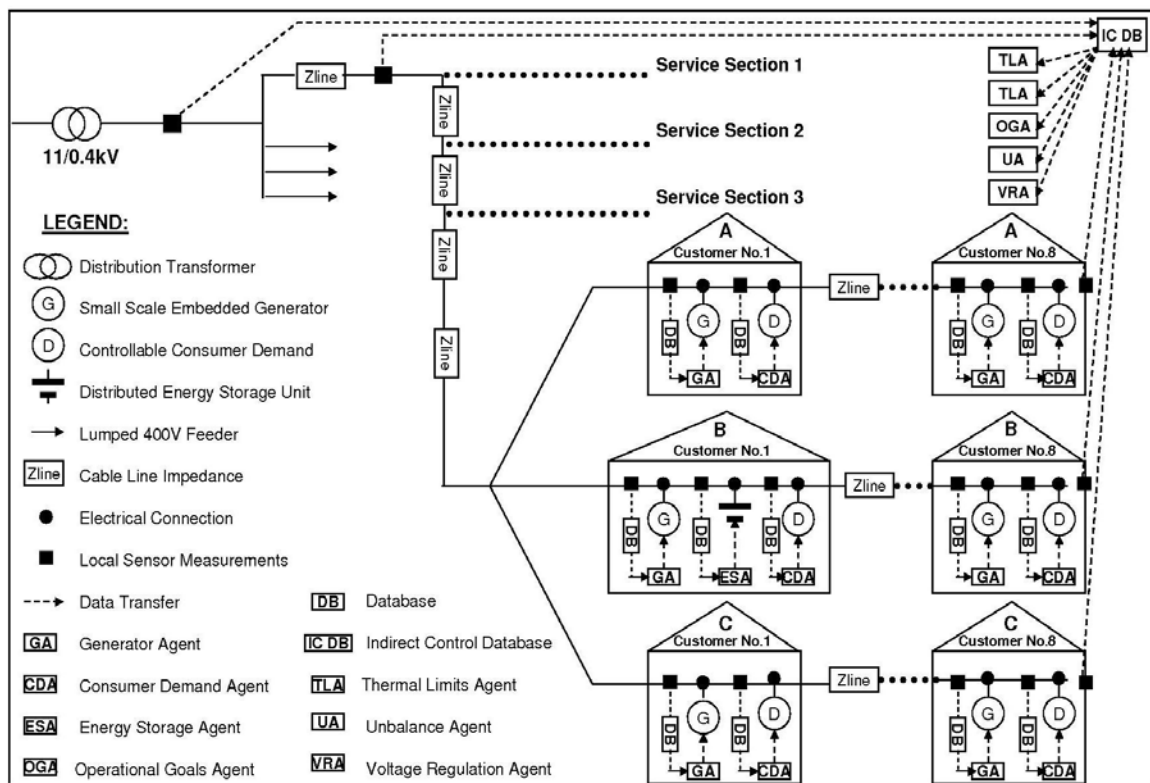

Figure 6.12: The MAS-based control approach and RDBMS on the case study SSEZ.

System agents may be located on the same or different APs, with all inter-agent communications and mechanisms for changing, adding or removing agents completely handled by the AP (Figure 6.4). Similarly, the databases of the RDBMS may be hosted on the same server if a common communications medium is employed. However, it is also possible that these databases are running separately. The advantages and disadvantages of each approach are discussed below:

1. If all databases are hosted on the same server, the machine where the indirect control database is running could be allocated as the database server and could be positioned at the distribution substation level. In addition, the indirect control agents and the utility agents of the MAS could also be running on the same machine. A database administrator (i.e. the SSEZ system operator) would be responsible for administrative tasks within the server and could also keep a record of all distributed databases (and hence all controllable power system entities) that exist within the SSEZ. This could have the additional advantage of allowing direct control agents to know the network and phase location of the power system entity they are controlling. It should be noted, however, that real-time measurement data from the distributed databases are not to be updated in the indirect control database as that would be too heavy on communications due to the potential number of distributed databases that may exist.
2. The second possibility would be for the distributed databases and the indirect control database to be running separately, without data exchange. The indirect control agents and the utility agents could still be running on the same machine as the indirect control database. The database administrator, however, would no longer be able to have a global view of the system and thus keeping a record of all customer-owned entities within the SSEZ would become more challenging.

6.7.2. Functionality of the RDBMS

The RDBMS is running in parallel with the MAS, while a standard interface between agents and their respective databases must exist to allow for data exchange. The following tasks are performed by the RDBMS, which run at different timescales and which involve the transfer of different types of data within the SSEZ:

1. **Data acquisition:** This functionality is similar to traditional SCADA systems employed in power distribution management systems. The RDBMS takes raw measurement data from measurement devices within the SSEZ and translates the data in the correct format to be used by system agents. This is because data management must be performed according to the global ontology employed.
2. **Data storage:** The RDBMS stores measurement data values and all events detected by system agents as historical data. The required measurement data were described in Section 6.7.1, while event detection is associated with the LV network constraints under investigation: (i) customer voltage rise/drop; (ii) voltage regulation; (iii) voltage unbalance; (iv) cable and transformer thermal limits. For reasons explained in Section 6.4, network losses are not considered here.
3. **Data access and management:** In order to minimise data exchange, only relevant data are transferred from the RDBMS to the appropriate system agents. Access to the indirect control database is provided only to indirect control agents who are able to query the database and retrieve appropriate stored data in order to achieve their design objectives. In addition, direct control agents act based on local information only, which is stored in each individual distributed database.
4. **User interaction:** User interaction denotes the ability of the RDBMS to handle queries from users and to retrieve and display associated results. As an example, such queries could be used by system engineers in order to evaluate the

performance of the SSEZ in terms of (i) customer minutes lost; (ii) customer interruptions; and (iii) network losses, similar to traditional distribution network performance evaluation.

6.7.3. Design of the RDBMS

Database design for any application normally takes place in three main stages [183]:

1. Firstly, the data to be stored in each database needs to be determined. This process requires knowledge of the specific SSEZ control requirements in order to extract the necessary information to be used by the direct and indirect control agents.
2. The relationships between the different data elements need to be established in order to determine how these elements are related with each other. For a database that is coupled to a SSEG unit, for example, when the “real power output” of the SSEG remains the same but the “reactive power output” changes, the “operating power factor” needs to change accordingly. However, when both “real power output” and “reactive power output” change, it is not necessarily true that the “operating power factor” will change as well.
3. Having determined the relationships between the different data elements, the required data for each database are then mapped into a table for each database that stores data in rows and columns.

Tables B-1 to B-4 in Appendix B illustrate the four different types of databases that exist within the SSEZ: (i) an SSEG database that is coupled to a SSEG unit and the GA that controls it (Table B-1); (ii) a load database that is coupled to a controllable consumer demand and the CDA that controls it (Table B-2); (iii) an ESU database that is coupled to an ESU and the ESA that controls it (Table B-3); and (iv) an indirect

control database, which receives data from measurement devices within the SSEZ and is coupled to the indirect control agents (Table B-4). These databases comprise all the necessary information and measurement data required by system agents in order to achieve their design objectives. Two types of data are contained:

1. Static data, whose values are fixed and do not change over time.
2. Dynamic data, which are measurement data whose values are dynamically changing.

In addition, some values (marked with * in the Tables below) are not dynamically updated, but may still change during the runtime of the database.

6.8. CONCLUSIONS

This Chapter described the design of the MAS-based control system for an SSEZ, with particular emphasis on the reasoning and communication capabilities of system agents. The design of the MAS was devised to enable diagnosis of system operating conditions (Section 6.4) and to provide the appropriate corrective actions to the customer-owned power system entities (SSEGs, ESUs and controllable loads) such that the specific control requirements of the SSEZ are met.

The reasoning capabilities of system agents were kept as simple as possible, while at the same time ensuring that the SSEZ remains functional independent of the operating state. This was done in order to minimise the required processing time and power of the hardware entities where the agents are to be housed and thus also reduce their associated costs. In addition, system agents were designed to operate with minimal

human supervision due to the potential number of controllable entities that may exist within an SSEZ.

Agent coordination was achieved through cooperation of system agents. The design of the required agent interactions included the identification of the sequence of ACL messages and the design of a common ontology for information and knowledge exchange. Ontology design (Section 6.6.2) only included concepts and classes required by system agents for inter-agent messaging, while the modeling of the identified agent interactions was described in Section 6.6.3.

In addition to MAS design, the design of a Relational Database Management System (RDBMS) for an SSEZ was detailed in Section 6.7. The aim of the RDBMS is to allow measurement data within the SSEZ to be stored and retrieved by the relevant system agents. Four different types of databases were described in Section 6.7.3: (i) an SSEG database that is coupled to a SSEG unit and the GA that controls it; (ii) a load database that is coupled to a controllable consumer demand and the CDA that controls it; (iii) an ESU database that is coupled to an ESU and the ESA that controls it; and (iv) an indirect control database, which receives data from measurement devices within the SSEZ and is coupled to the indirect control agents. Data from these databases allow information to be provided regarding the operating status of the SSEZ, thereby enabling analyses of network events and network performance.

CHAPTER 7

SSEZ Control System Software Development

This Chapter details the software development of the SSEZ control system that comprises of the MAS and the RDBMS that were described in Chapter 6. In order to achieve this, two main software packages were employed: (i) JADE, which is a middleware for the development of fully FIPA-compliant MAS; and (ii) MySQL, which is a software that can deliver fast, multi-threaded, multi-user and robust SQL (Structured Query Language) database servers for RDBMS.

Section 7.1 provides an introduction to JADE and details the main reasons that make it particularly suitable for this application. The different services offered by system agents are described, along with the behaviours and event handling code that were implemented inside each agent. In JADE, agents communicate via asynchronous message passing and the implementation of inter-agent messaging is described in Section 7.1.4. Moreover, the development of a common ontology specific to the

active control of an SSEZ is detailed in Section 7.1.5 using two different pieces of software: Protégé, which is a JAVA-based open-source platform for the development of domain models and knowledge-based applications with ontologies; and the OntologyBeanGenerator plug-in, which is a Protégé Tab widget that generates Java files representing an ontology. Finally, Section 7.1.6 describes the implementation of the designed reasoning capabilities to system agents.

Section 7.2 provides an introduction to MySQL along with the potential benefits that may be realised through its application based on the specific requirements and characteristics of the SSEZ environment. The development of the proposed RDBMS is detailed in Section 7.2.2 and is based on two common tools offered by MySQL: (i) the MySQL command line client tool which allows MySQL client programs to be invoked from the command line; and (ii) the MySQL Administrator which contains a graphical user interface to assist the user in system development. Finally, connectivity between the agents within the MAS and the developed databases is achieved through Java DataBase Connectivity (JDBC), which is the industry standard for interface between applications developed using the Java programming language and a wide range of databases.

A block diagram showing the different software tools that were employed for the development of the SSEZ control system, along with their interfaces, is shown in Figure 7.1.

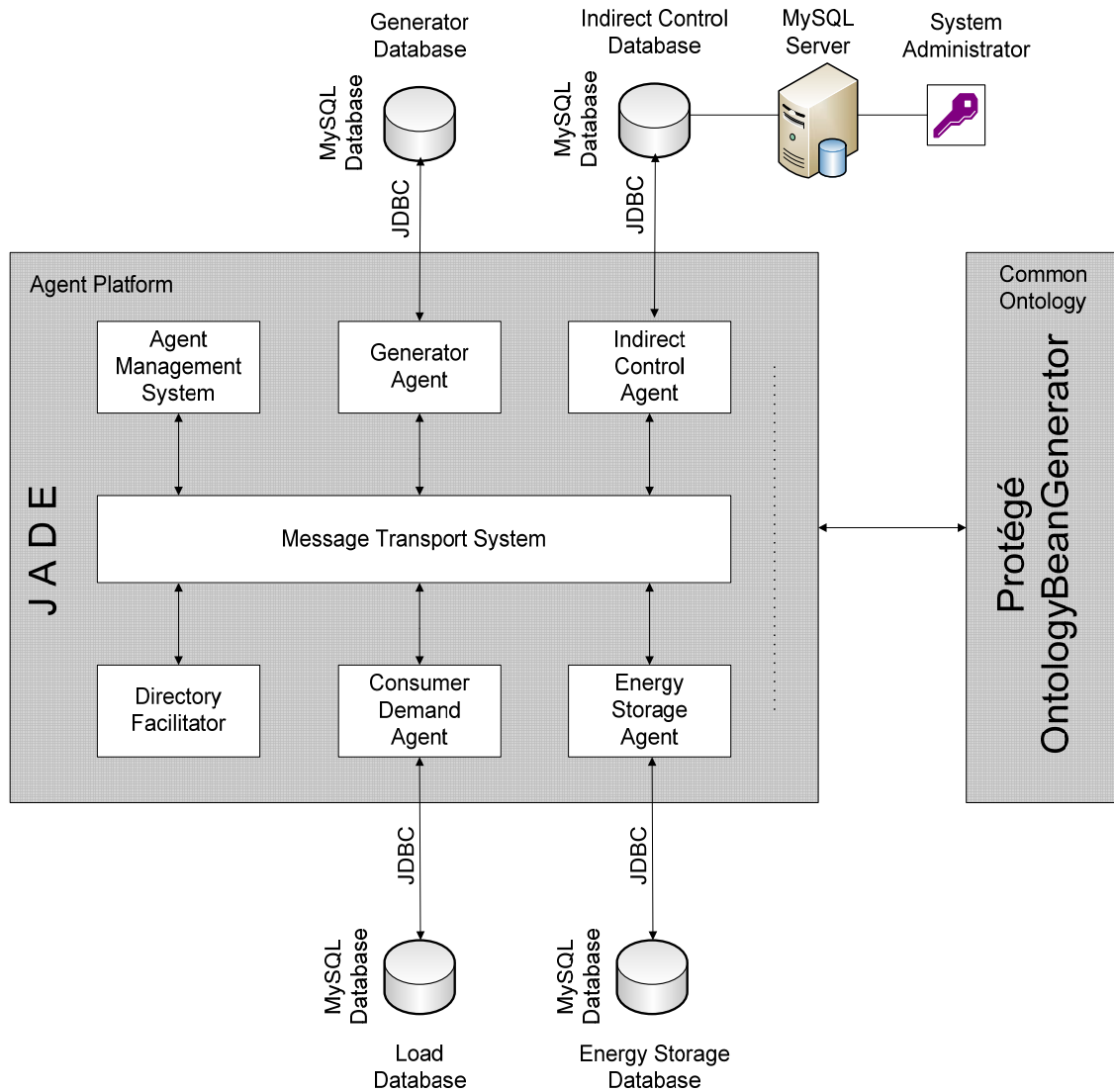

Figure 7.1: SSEZ control system software development.

7.1. JADE – JAVA AGENT DEVELOPMENT FRAMEWORK

JADE is a software framework for the development of fully FIPA-compliant MAS [102-103]. It simplifies MAS implementation through a middleware that complies with FIPA specifications and through a set of graphical tools that supports the debugging and deployment phases. JADE is implemented in Java language and is made of various Java packages, giving MAS developers “*both ready-made pieces of functionality and abstract interfaces for custom, application dependent tasks*” [184].

The JADE Agent Platform complies with FIPA specifications to provide interoperability not only in the platform architectural design (Figure 3.4), but also in the communication infrastructures (Figure 3.5). It includes all mandatory components that manage the agent platform, i.e. the agent communication channel, as well as the AMS and the DF. All agent communications are performed through message passing, where FIPA ACL [119] is the language to represent messages. The AP can be distributed on several hosts. Only one Java application, and therefore only one Java Virtual Machine (JVM), is executed on each host. Each JVM is basically a container of agents that provides a complete run time environment for agent execution and allows several agents to concurrently execute on the same host.

A MAS application using JADE is typically composed by one or several containers running on several distributed machines which may be running under different operating systems. The first container is the main container which maintains a central registry of all others so that agents can discover and interact with each other (Figure 7.4). The overall MAS is then monitored and managed using the JADE remote agent management Graphical User Interface (GUI) [102-103].

Similarly, the MAS for the control of an SSEZ may be composed of one or several run-time containers launched on several hosts within an accessible long-range communication medium, such as for example the Internet. The hardware devices where direct and indirect control agents are running, such as industrial PCs, may each execute one JVM, and their operation would be comparable to the IEDs that are commonly employed for power distribution network control (Section 2.3.3). The hardware devices that are coupled to the customer-owned controllable power system

entities would host the direct control agents controlling these entities, while the hardware devices that are located at the distribution substation level would host the indirect control agents and the utility agents. Depending on the computing and communication resources available, the latter could also be achieved by using only one machine where utility and indirect control agents could be running.

7.1.1. Why JADE?

The reasons that make JADE suitable for industrial applications, and in particular for distributed real-time industrial applications, were described in detail in [94] and [102-103]. According to [94], the four key requirements for selecting an ADK (Agent Development Kit) may be summarised as follows:

1. Robustness: the AP must be able to run indefinitely without memory leaks or crashes, in order to ensure reliability and robustness.
2. Standards support: the AP must provide interoperability with FIPA standards and protocols for reasons explained in Section 4.3.1.
3. Flexibility of agent deployment: the ADK must provide mechanisms for modifying the agents launched at system start-up, as well as for adding/removing agents in order to deal with changing operating conditions.
4. Active developers and community support: a large and active community of users is desirable in the event that developers require support as well as to ensure that the ADK is continuously updated and improved.

JADE was selected because it was found to meet all these requirements:

1. Robustness: A number of demonstration research projects [94, 114-115, 125-128, 142-143] have provided evidence for the reliability and robustness of JADE

agents. In addition, supplementary support tools were designed and developed [185] in order to “*provide the ability to keep agent systems up 24/7 and facilitate the management of what could be thousands of agents*”.

2. Standards support: JADE ensures full FIPA-compliance through a set of system services and utility agents in compliance with FIPA specifications [92]: white-page (AMS) and yellow-page (DF) services, message transport and parsing service and a library of FIPA interaction protocols [118-120].
3. Flexibility of agent deployment: JADE allows the deployment of new agents while the AP is running, which means that agents are able to enter the system without the need to stop and restart the other agents [103]. This may be done either to replace existing agents with improved ones, or to add new agents in order to provide new services and functionalities. Moreover, JADE provides simple mechanisms for distributing agents on different hosts, which in a real-world application may allow some agents to run on-site and some off-site.
4. Active developers and community support: JADE is currently the most widely used ADK [114-115] and is supported by a large and active community of users. This improves and simplifies MAS development by ensuring that support may be readily available, while also ensuring that developers remain up to date with standards, features, and bug fixes.

7.1.2. Agent Services

The functionality and openness of the MAS largely depends on the “white-” and “yellow-page” services offered by the AMS and DF utility agents respectively. Table 7.1 shows a list of the services that were implemented along with a brief description. As it can be seen from the table, direct control agents are responsible for most of the

services because they are responsible for performing the tasks delegated to them by indirect control agents, but they are also responsible for: (i) maintaining steady-state customer voltages within statutory limits; and (ii) minimising reactive power flows within the SSEZ and thereby also reducing network load losses.

Service	Responsible Agents	Description
White_pages	AMS	The AMS maintains a directory of all registered agents within the system.
Yellow_pages	DF	The DF enables system agents to dynamically discover the services offered by other agents in the system.
Voltage_Regulation	VRA, GA, CDA, ESA	The VRA employs the services of the direct control agents in order to mitigate excessive rise or drop in voltage regulation.
Voltage_Unbalance	UA, GA, CDA, ESA	The UA employs the services of the direct control agents in order to control excessive voltage unbalance.
Cable_Thermal_Limits	TLA, GA, CDA, ESA	The TLA employs the services of the direct control agents in order to protect a network line from thermal damage.
Transformer_Thermal_Limits	TLA, GA, CDA, ESA	The TLA employs the services of the direct control agents in order to protect the distribution transformer(s) supplying the SSEZ from thermal damage.
Operational_Goals	OGA, GA, CDA, ESA	The OGA employs the services of the direct control agents in order to meet a specified operational goal.
Direct_Control	GA, ESA, CDA	Under the Direct_Control service, direct control agents are responsible for keeping customer voltages within specific operating limits, and also for minimising active network losses based on power factor correction.

Table 7.1: Services offered by system agents within the developed MAS.

An important point to note is that, as demonstrated through simulation results in Chapter 4, the network and phase location of the customer-owned power system entities to be controlled play an important role in order to overcome the LV distribution network constraints under investigation. Thus, it is crucial that indirect control agents employ the services of the direct control agents that are located on the relevant network line and/or connection phase with respect to the identified LV distribution network constraint. This may be achieved by dividing a particular indirect control service (for example “Voltage_Regulation”) into several sub-services (for example “Voltage_Regulation-1”, “Voltage_Regulation-2”, etc.) and then registering the relevant direct control agents that are able to overcome the identified network constraint. However, this assumes that information with regards the network and phase location of all customer-owned power system entities within the SSEZ is known. Subject to the agreement of the local DNO, this information could be provided through the use of an RDBMS as described in Section 6.7.1.

7.1.3. Inter-agent Messaging

FIPA standards govern the framework within which FIPA agents exist and operate (Section 4.4), but also the formats and protocols [118-120] to be used for inter-agent messaging. In JADE, agents communicate via asynchronous message passing which allows them to carry out tasks without having to wait for messages from other agents. Messages are retrieved from a queue of messages and may be selected by the agent according to the agent’s priority. Messages are providing a transport envelope that comprises the set of parameters detailing, for example, to whom the message is to be sent. The general structure of a FIPA-compliant message is depicted in Figure 7.2.

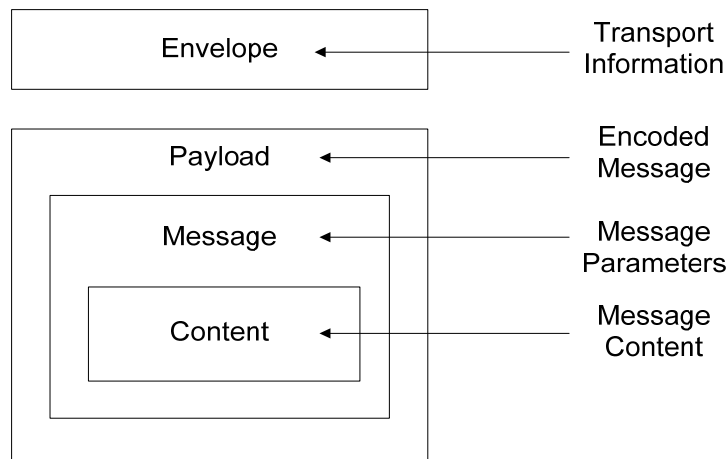

Figure 7.2: FIPA message structure.

The core of inter-agent messaging is the content of the ACL message, which may contain one or more message parameters. A list of all FIPA ACL message parameters is given in Table C-2 in the Appendix. According to [118], the only mandatory parameter in all ACL messages is the performative, although it is expected that most ACL messages will also contain sender, receiver and content parameters. A list of the most commonly used performatives is shown in Table C-3 in the Appendix.

7.1.4. Ontology

JADE allows the creation of application-specific ontologies, independent of the adopted content language. This is because the code that implements the ontology and the code that sends and receives messages do not depend on the adopted content language [103]. JADE provides three ways to implement inter-agent communications:

1. The first and simplest way uses strings to represent the content of agent messages.

This is appropriate when the content of agent messages is atomic data, but not for abstract concepts, objects or structured data.

2. In the second way, Serialised Java objects may be sent directly as the content of agent messages. This is a popular method for local applications where all agents are implemented in Java programming language.
3. The third method requires the definition of the transmitted ontology objects as extension of predefined classes so that JADE can encode and decode messages in a standard FIPA format. This may allow the agents implemented in JADE to be able to interoperate with other agent communities.

The ontology described in Section 6.6.1 was developed according to FIPA specifications [182]. These require the developed ontology to be composed of two parts: (i) a vocabulary that describes all the concepts used by agents; and (ii) the relationships between these concepts must also be specified. As an example, the following scenario may be considered: a UA (e.g. UA-2) attempts to request from a GA (e.g. GA-12) to curtail its active power output in order to restore voltage unbalance in a SSEZ feeder. The content of the message must include the AID of the agent that is requested to perform this task (i.e. GA-12), as well as a descriptor that determines the action to be performed (i.e. “realPowerOutReduction”).

In order to develop an ontology using JADE, the Ontology class predefined in JADE must be extended and the following set of interfaces must be added specific to the application domain: (i) Concepts; (ii) AgentActions; (iii) Predicates; and (iv) AIDs (Agent IDentifiers).

1. Concepts model domain concepts, such as SSEGs, ESUs, loads, transformers and network lines, as seen in Figure 6.10. As an example, an SSEG unit using the developed ontology may be described as follows:

(Generator : generatorName “GA-13” : generatorType: “WindTurbine” :
generatorRating “1.5kW” : generatorNetworkLocation “node_5” :
generatorPhaseLocation “phase_A”)

2. An AgentAction is a special type of concept that indicates actions that can be performed by some agents, e.g.

(realPowerOutReduction (Generator : generatorName “GA-13”))

3. Predicates are expressions that specify concept relationships, and there are two types of predicates: (i) directControlAgent; and (ii) indirectControlAgent, e.g.

(directControlAgent (Generator : generatorName “GA-13”))

4. Finally, AIDs indicate the agents that perform the requested actions.

The designed ontology was implemented using two software tools: (i) Protégé [186], which is a JAVA-based open-source platform for the development of domain models and knowledge-based applications with ontologies; and (ii) the OntologyBeanGenerator plug-in [187], which is a Protégé Tab widget that generates Java files representing an ontology. The OntologyBeanGenerator plug-in uses the BeanOntology class [188] to simplify the ontology development process by allowing the developer to create the ontological classes (“beans”) representing the concepts, agent actions and predicates relevant to the addressed domain and add them to the MAS ontology class by means of the Protégé GUI [186].

Figure 7.3 shows an excerpt of the designed ontology class hierarchy that has been implemented using the Protégé GUI and the OntologyBeanGenerator plug-in. Figure 7.3(a) illustrates the AgentActions in detail, while Figure 7.3(b) details the consumerDemand, energyStorageUnit, Generator, networkLine and Transformer

concepts of the SSEZ ontology. The ontology model of Protégé consists of classes, slots and slot facets. Classes are concepts which correspond to objects, or types of objects, in the domain. In the SSEZ ontology classes include all concepts, agent actions, predicates and AIDs.

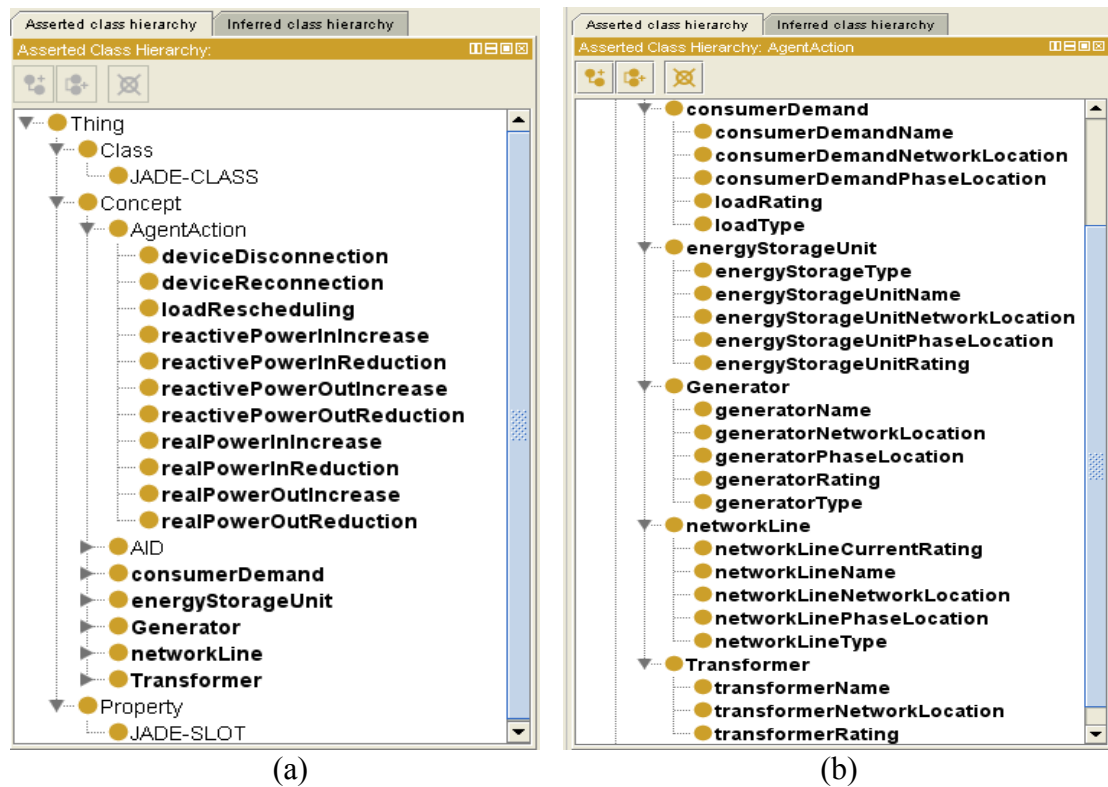

Figure 7.3: The AgentActions (a) and Concepts (b) of the developed ontology.

In addition, classes have attributes and relations between them, such as the name, the type, the rating and the location of a generator. In Protégé, class attributes and relations such as those seen in Figure 7.3(b) are described using slots. Slots have properties, for example generatorRating is a number (i.e. a Float class) which must always have a positive value. Having created the Java files that describe the Concepts, AgentActions, Predicates and AIDs of the SSEZ ontology, these files may then be directly imported into the agents of the developed MAS.

7.1.5. Agent Reasoning

As mentioned in Section 6.5, FIPA standards govern the basics of agent architecture [92], as well as inter-agent message formats and protocols [120], but they do not specify how agents achieve their reasoning capabilities. This is an important characteristic of MAS that distinguishes it from classical distributed control techniques and allows the software written for each agent to encompass its own level of intelligence [96]. The decision-making capabilities of an agent are then determined in accordance with this intelligence.

Under the developed MAS, agent decision-making is performed based on the set of rules for agent behaviour shown in Table 6.2. These rules have been adopted for all direct and indirect control agents using simple “*if-then*” statements. Action execution is adapted to the process through a continuous state assessment which dynamically monitors the difference between the measured parameters for each agent (such as voltages, currents and power flows) and their predefined target values. These target values are based on either statutory regulations (for customer voltages, voltage regulation and voltage unbalance) or equipment ratings (for cable and transformer thermal limits).

Feedback control is achieved using “*while*” statements that continuously test an expression (such as if the measured customer steady-state voltage is higher than the statutory limit of 253V) and executing the expression’s block until the expression evaluates to false (in this case, for example, to curtail the real power output of a connected SSEG). For the purposes of this research, it is assumed that measurement data and agent control decisions are updated in real-time or close to real-time which

would require a fast and continuous feed of information to and from the system agents and the measurement devices within the SSEZ.

The following methods are employed by direct and indirect control agents for the management of the connected SSEGs, ESUs and controllable loads within the SSEZ, as shown in Table 7.2: (i) `realPowerOutReduction`; (ii) `realPowerOutIncrease`; (iii) `reactivePowerOutReduction`; (iv) `reactivePowerOutIncrease`; (v) `realPowerInReduction`; (vi) `realPowerInIncrease`; (vii) `reactivePowerInReduction`; (viii) `reactivePowerInIncrease`; (ix) `loadRescheduling`; (x) `deviceDisconnection`; and (xi) `deviceReconnection`. For reasons explained in Section 6.4, reactive power support is only considered for voltage management and network loss reduction purposes within the SSEZ and is performed by SSEGs and ESUs only.

Moreover, `loadRescheduling`, `deviceDisconnection` and `deviceReconnection` are sent by system agents as single commands and therefore feedback control loops are not employed for their execution. The other nine methods, however, are continuously running when selected until the measured parameter reaches its predefined target value. If this can not be achieved using the originally selected command (for example if reactive power support does not bring the local steady-state voltage back to its desired limits), the subsequent control command will be selected by the agent according to Table 6.2. The implementation of the agent reasoning capabilities, along with the different active and reactive power dispatch techniques that have been investigated, are examined in Chapter 8 in greater detail.

Command	Responsible Agents	Description
realPowerOutReduction	GA, ESA, and all indirect control agents	Reduction in the real power output of a SSEG or ESU.
realPowerOutIncrease	GA, ESA, and all indirect control agents	Increase in the real power output of a SSEG or ESU.
reactivePowerOutReduction	GA, ESA, UA, VRA	Reduction in the reactive power output of a SSEG or ESU.
reactivePowerOutIncrease	GA, ESA, UA, VRA	Increase in the reactive power output of a SSEG or ESU.
realPowerInReduction	CDA, ESA, and all indirect control agents	Reduction in the real power input of a load or ESU.
realPowerInIncrease	CDA, ESA, and all indirect control agents	Increase in the real power input of a load or ESU.
reactivePowerInReduction	GA, ESA, UA, VRA	Reduction in the reactive power input of a SSEG or ESU.
reactivePowerInIncrease	GA, ESA, UA, VRA	Increase in the reactive power input of a SSEG or ESU.
loadRescheduling	CDA and all indirect control agents	Rescheduling the operation of a load for a specified time.
deviceDisconnection	GA, ESA, CDA, UA, TLA, VRA	Disconnection of a SSEG, ESU or load.
deviceReconnection	GA, ESA, CDA, UA, TLA, VRA	Reconnection of a SSEG, ESU or load.

Table 7.2: The different commands exchanged by system agents for action execution within the developed MAS.

7.2. MYSQL

MySQL is one of the most popular open source software available for the development of fast, multi-user and robust SQL-based relational database management systems (RDBMS) [189]. SQL is a standard database programming

language designed for providing access and managing data in RDBMS. The term RDBMS was used in Section 6.7 in order to describe the entire application supporting a database, including all server and client components. A relational model is the basis for any RDBMS and is composed of three main elements: (i) a collection of objects or relations in tabular form, with each table consisting of a set of rows and columns; (ii) relational operators that can manipulate the data in tabular form; and (iii) data integrity methods [183]. MySQL provides all three elements by running as a server that provides multi-user access to a central database or several distributed databases.

MySQL is used as the RDBMS of choice for a wide range of applications, and in particular for Internet applications, because it can provide similar functionalities to those provided by most commercial RDBMSs [190]. MySQL has a rich feature set, as will be described in Section 8.2.1, but is also considered easy to install and administer and requires little maintenance other than adding or modifying user permissions and creating, updating or removing databases [183].

7.2.1. Why MySQL?

Similarly to selecting the most appropriate control approach for an SSEZ (Chapter 5), the choice for the adopted RDBMS should be driven by the specific requirements and characteristics of the SSEZ environment. The feature set of MySQL is described in detail in [190]. A number of the core features offered by MySQL fit particularly well with the requirements and characteristics of the SSEZ environment, in particular:

1. **Scalability:** Because of its modularity and flexibility in configuration, MySQL is employed to systems varying in size from small embedded systems to systems hosting databases with millions of records. This feature of MySQL is important

because the proposed RDBMS will contain both types, with a small distributed database embedded within each controllable power system entity installed by SSEZ customers and one large database containing data regarding the operation of the overall SSEZ.

2. Portability: A MySQL database may run on all popular operating systems such as Unix, Linux, Windows, Solaris, MacOS X etc. This is important because the hardware entities where direct and indirect control agents are running may use different operating systems and thus the operation of system databases should remain unaffected.
3. Speed: MySQL is considered to be one of the fastest RDBMSs currently available [190]. Speed of operation for storing, updating, querying and retrieving data is crucial for the functionality of the developed control system, both in order to overcome the LV distribution networks constraints under consideration as well as to meet an operational goal. However, the overall speed of operation will also depend on: (i) the time it takes for the database to acquire the raw data from the measurement devices within the SSEZ; and also (ii) on the communications between agents and (iii) between agents and the customer-owned power system entities. The first factor will depend on the interface and communications medium between the SSEZ databases and the customer-owned power system entities, the second factor will depend on the MAS development kit and on the communications medium used, while the last factor will depend on the interface and communications medium between the MAS and the customer-owned power system entities.
4. Access from other languages/systems: Due to MySQL's popularity, a number of tools exist for connecting to MySQL from Java, C/C++, Perl, PHP, ODBC and

other languages and systems. Because most MAS development kits are implemented using the Java programming language (Section 4.4.2), MySQL becomes a particularly attractive option due to an application programming interface called Java DataBase Connectivity (JDBC). JDBC provides methods for querying and updating data in a database using Java and is described in greater detail in Section 7.2.2.3.

5. Robustness and security: MySQL is considered to be one of the most robust open source RDBMS available [190]. However, robustness will also depend on the stability of the operating system that the MySQL server is running on, with different implementations of MySQL achieving different degrees of robustness [190]. In addition, system security is crucial in order to prevent unauthorised modification or retrieval of data. MySQL allows the restriction of users' rights from a database based on login name, password and the hostname that users are connected from. This could be particularly important for the DBMS application for an SSEZ, where large numbers of customers will be connected to the system and thus partitioning of responsibilities and capabilities of different users will be necessary.

7.2.2. Developing the RDBMS

The software development of the RDBMS that was described in Section 6.7.3 is detailed here. As mentioned in Section 6.7.3, the proposed RDBMS is made up of four different types of databases: (i) an SSEG database that is coupled to a SSEG unit and the GA that controls it (Table B-1 in the Appendix); (ii) a load database that is coupled to a controllable consumer demand and the CDA that controls it (Table B-2); (iii) an ESU database that is coupled to an ESU and the ESA that controls it (Table B-

3); and (iv) an indirect control database, which receives data from measurement devices within the SSEZ and is coupled to the indirect control agents (Table B-4).

Two different tools provided by MySQL may be deployed: (i) the MySQL command line client tool [191] which allows MySQL client programs to be invoked from the command line; and (ii) the MySQL Administrator [192] which contains a GUI to assist the user when developing the database. Both tools perform similar administrative tasks, such as configuring, monitoring, starting and stopping MySQL servers, managing users and connections and other administrative tasks [190]. However, each tool has its own advantages and disadvantages: the MySQL command line client tool is very fast, but requires large amounts of typing in order to execute queries, to insert, update and retrieve data etc which slows down the overall programming time. At the same time, the MySQL Administrator is more user-friendly and also provides an overview of the settings that are crucial for the performance, reliability, and security of MySQL servers, but may execute slower than the MySQL command line client [190].

Specific examples for the four different types of databases described in Section 6.7.3 have been implemented and interfaced with the relevant agents of the developed MAS using the Java DataBase Connectivity (JDBC) tool as will be described in Section 7.2.3. Table 7.3 illustrates a snapshot of a database that is coupled to a controllable consumer demand and the CDA that controls it.

data_type	value
network_location	feeder_12
phase_location	phase_A
load_type	reshiftable
grid_dep_operation	yes
real_power_rating	3.0kW
current_real_power_input	0.0kW
current_reactive_power_input	0.0kVAr
current_operating_pf	0.0
control_steps	0
minimum_outage_time	40m:00s
maximum_outage_time	70m:00s
lead_time	30s
activation_signal	control
date	10-10-2008
time	22h:56m:00s
start_date	10-10-2008
start_time	23h:00m:00s
duration	60m:00s
lower_normal_state_voltage_limit	225.0V
upper_normal_state_voltage_limit	235.0V
lower_alert_state_voltage_limit	216.2V
upper_alert_state_voltage_limit	253.0V
lower_emergency_state_voltage_limit	207.0V
upper_emergency_state_voltage_limit	264.0V
current_steadystate_voltage	233.5V
current_operating_state	normal
lower_frequency_limit	49.5Hz
upper_frequency_limit	50.5Hz
current_operating_frequency	50.0Hz

Table 7.3: Database developed in MySQL for a controllable consumer demand that is coupled with the CDA that controls it.

Moreover, the MySQL Administrator tool may be used by the system administrator to provide an overview of the databases running within the DBMS, particularly so if the databases that are interfaced to the customer-owned power system entities are also hosted on the same server. As an example, Figure 7.4 shows a list of SSEG databases (“ssegdb”) that have been registered and running on a MySQL server entitled “inputs”. This list may be updated periodically and provides information to the system administrator with regards the addition or removal of SSEGs to the system, as well as their technical characteristics (the “static” data from Table B-1 in the Appendix).

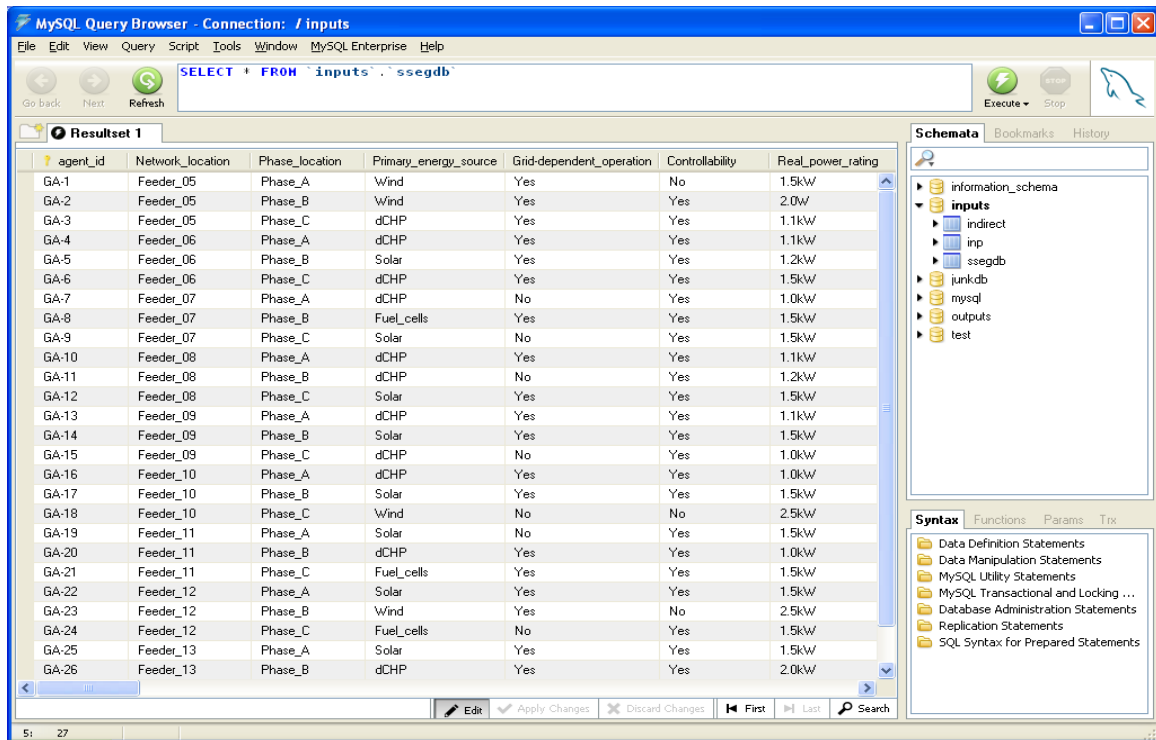

Figure 7.4: Using the MySQL Administrator in order to provide an overview of the databases running within the developed DBMS.

7.2.3 Java DataBase Connectivity - JDBC

Having designed and developed the databases to be used for the RDBMS, the next issue concerns how system agents can have access to these databases. JDBC is the industry standard for interface between applications developed using the Java programming language and a wide range of databases – SQL databases and other tabular data sources, such as spreadsheets or flat files [193]. It allows Java applications to query, update and retrieve data from database servers in a portable way: having installed a driver for a given server engine, JDBC applications may then communicate with any server of that type. The JDBC specifications [194] define the interfaces and classes required for any Java application to interface with an underlying database and they are based on the commands of the SQL programming language.

In order for a Java application to access a database developed using MySQL, a JDBC driver called MySQL Connector/J [195] is typically used. The driver is pure-Java implementation of the MySQL protocol and does not rely on the MySQL client libraries. Figure C-1 in the Appendix illustrates the code for an agent which registers in an input database and then checks the value for the current flow in a line segment. If this value is higher than a particular limit, the agent instructs the relevant GAs to curtail their real power output in order to reduce this current flow.

7.3. CONCLUSIONS

This Chapter described the software development of the SSEZ control system that comprises of the MAS and the RDBMS that have been presented in Chapter 6. JADE [102-103] was used for implementing the MAS for reasons explained in Section 7.1.1. Moreover, the development of a common ontology specific to the active control of an SSEZ is detailed in Section 7.1.5 using two different pieces of software: Protégé [186] and the OntologyBeanGenerator plug-in [187]. The development of the RDBMS is detailed in Section 7.2.2 and is based on two common tools offered by MySQL: (i) the MySQL command line client tool [191] and the MySQL Administrator [192]. Finally, connectivity between the agents within the MAS and the developed databases is achieved through Java DataBase Connectivity (JDBC) [193], which is the industry standard for interface between applications developed using the Java programming language and a wide range of databases.

CHAPTER 8

Evaluation of the SSEZ Control System

The previous two Chapters discussed the design and software development of the proposed MAS-based control system. In this Chapter, various evaluation scenarios are outlined in order to assess the operation of the developed control system on the case study SSEZ. The aim is to evaluate its performance based on the specific SSEZ control requirements (Section 5.1), and to identify the main strengths and weaknesses that are offered by this particular distribution network control paradigm. In addition to the software tools described in Chapter 7, PSCAD/EMTDC is used for modelling the case study SSEZ as described in Section 4.3.

The evaluation process that has been employed is shown in Figure 8.1. Detailed communication issues, such as time delays between inter-agent communications, agent-to-database communications, or between direct control agents and the customer-owned power system entities have not been taken into account when evaluating the functionality of the developed control system. The rationale behind this is that these issues will depend on the specific implementation characteristics of the control system, i.e. on the software and hardware devices as well as the data rate of

the communications medium used, and as such they were considered to be outside the scopes of this Thesis.

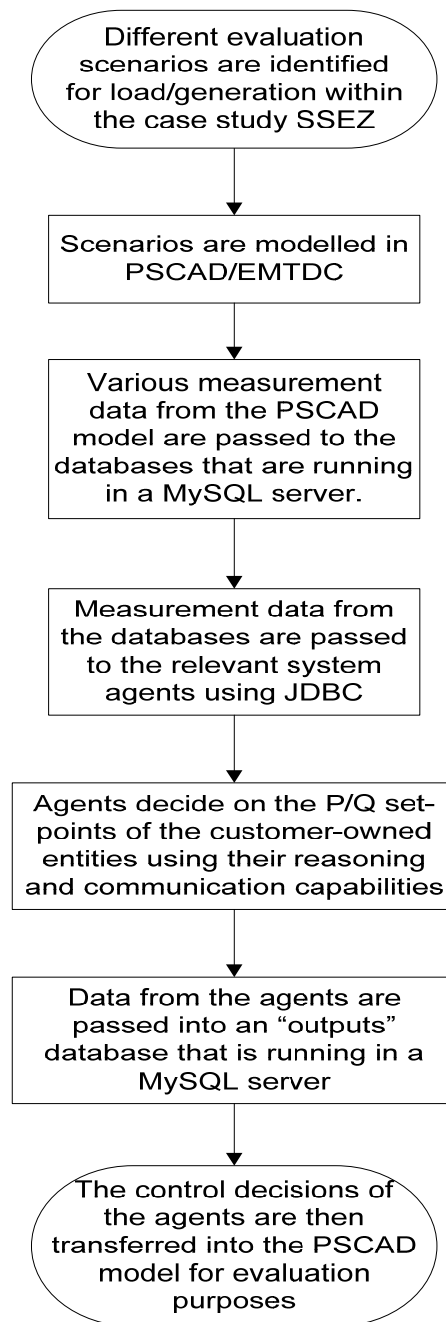

Figure 8.1: The evaluation process of the developed control system.

8.1. POWER SYSTEMS EVALUATION

The case study SSEZ described in Section 6.1 is used for evaluating the functionality of the developed control system. The case study SSEZ under a passive control

approach is shown in Figure 8.2 and is based on the UK generic LV distribution network model presented in Section 4.2.1. Each customer is assumed to have installed a single-phase SSEG with a rating of 2.5kW, a controllable consumer demand attributing to 1kW and it is also assumed that 10% of the customers have installed an ESU capable of a continuous power input/output of 5kW.

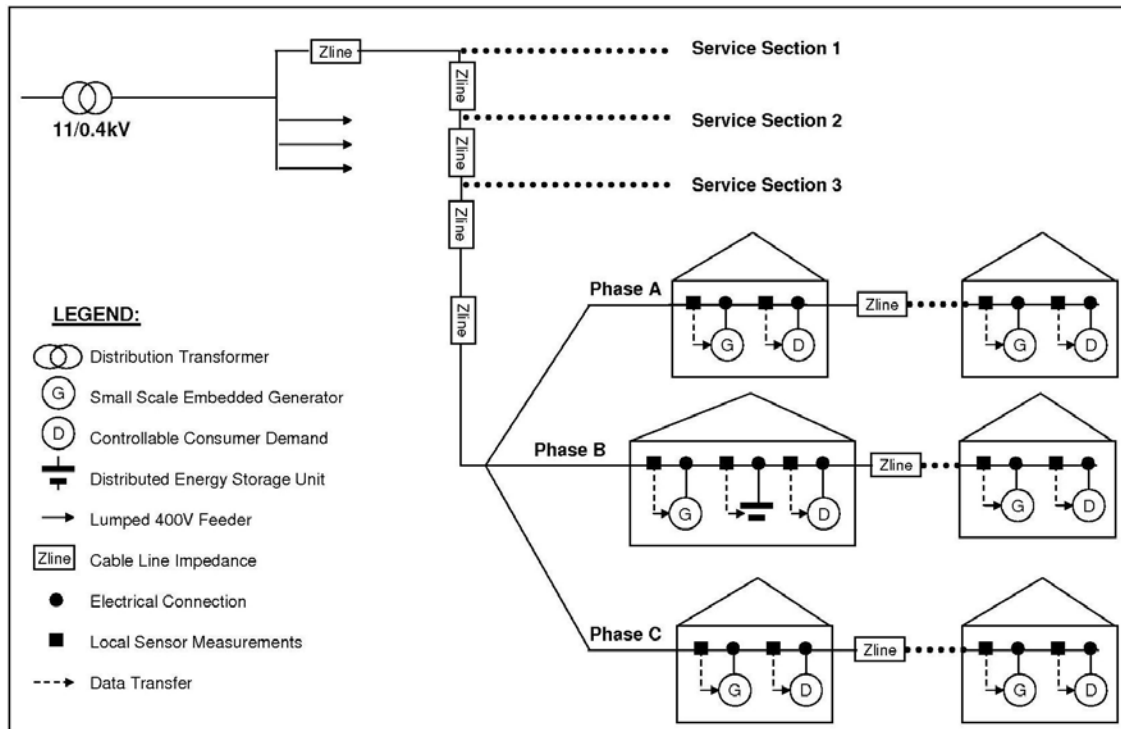

Figure 8.2: The case study SSEZ under a passive control approach.

Table 8.1 illustrates the assumed limits for the operating parameters of the case study SSEZ. Voltage profiles and real and reactive power flows within the SSEZ feeders are a function of the real and reactive power input/output of the installed SSEGs, ESUs and controllable and uncontrollable consumer demands as shown in Equation 5.1.

Customer Voltage Rise	Lower normal state customer voltage limit	220.0 V
	Upper normal state customer voltage limit	250.0 V
	Lower alert state customer voltage limit	216.2 V
	Upper alert state customer voltage limit	253.0 V

	Lower emergency state customer voltage limit	207.0 V
	Upper emergency state customer voltage limit	264.0 V
Cable Thermal Limits	Upper normal state current flow limits	280.0 A
	Upper alert state current flow limits	320.0 A
	Upper emergency state current flow limits	355.0 A
Transformer Limits	Upper normal state apparent power flow limit	420.0 kVA
	Upper alert state apparent power flow limit	460.0 kVA
	Upper emergency state apparent power flow limit	500.0 kVA
Voltage Unbalance	Upper normal state %VUF limit	0.8%
	Upper alert state %VUF limit	1.0%
	Upper emergency state %VUF limit	1.3%
Voltage Regulation	Lower normal state voltage regulation limit	-4.0%
	Upper normal state voltage regulation limit	+4.0%
	Lower alert state voltage regulation limit	-4.5%
	Upper alert state voltage regulation limit	+4.5%
	Lower emergency state voltage regulation limit	-5.0%
	Upper emergency state voltage regulation limit	+5.0%

Table 8.1: Limits for the operating parameters of the case study SSEZ.

In order to implement an appropriate control strategy, it is therefore necessary to determine the capability for active and reactive power control of the customer-owned power system entities within the SSEZ. System agents have access to this information through the relevant SSEZ databases, as described in Section 6.7.3. For the purposes of this research, two assumptions were made with regards the control capabilities and the operation of the installed power system entities within the SSEZ:

1. The installed SSEGs are assumed to be capable of regulating their active and reactive power output at all times during their operation; and

2. A grid-dependent control strategy is assumed for all controllable customer-owned power system entities within the SSEZ. In return, customers are assumed to receive financial rewards for their contribution to distribution system operation.

These assumptions were made in order to increase the capability for active and reactive power control within the overall SSEZ. Coordinated P/Q control is required in the event of system disturbances or when the SSEZ is attempting to meet an operational goal (Section 5.1). The developed control system would be able to operate without these two assumptions, but flexibility for control would be limited and thus system performance would be affected, for example by requiring more SSEG active power output to be curtailed and thus reducing the total SSEG energy yield.

As an example, assuming that there 10 SSEGs operating within an SSEZ, Figure 8.3 shows the probability of having different proportions of SSEG capacity operating under different availabilities [15]. SSEG availabilities are assumed to be independent from each other and that there are no common modes of failure between the installed SSEGs. For example, assuming that the SSEGs are operating at an availability of 0.9, there is a 0.92 probability that 80% of the connected SSEGs are available, 0.73 probability that 90% are available, and 0.35 probability that all SSEGs are available. Using the binomial distribution as in Figure 8.3, the system operator could estimate the proportion of controllable customer-owned entities within the SSEZ. In general, electric-led dCHP units, ESUs and controllable consumer demands would be expected to have high average availabilities, while heat-led dCHP units, PV units and small-scale wind turbines would be expected to have lower average availabilities.

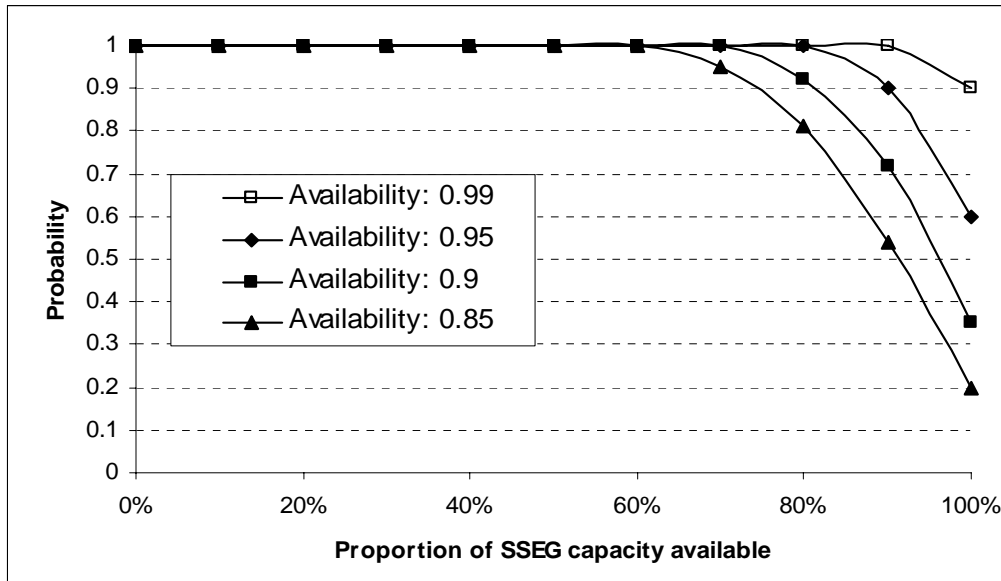

Figure 8.3: Probability of having different proportions of SSEG capacity available for different availabilities.

The following Sections attempt to evaluate the performance of the developed control system to satisfy the specific control requirements of the SSEZ, namely to: (i) overcome the identified LV distribution network constraints (Sections 8.1.1 – 8.1.5); and (ii) meet an SSEZ operational goal (Section 8.1.6). In all cases, agents are responsible for determining the P and Q set-points for all customer-owned power system entities in response to the dynamically changing SSEZ environment.

8.1.1. Customer Voltage Rise

The evaluation scenarios devised here focus on overcoming customer steady-state voltage rise, which is seen by a number of researchers [152-159] as the most likely limiting network constraint to the operation of SSEGs on radial LV networks. The aim of the control system is to ensure that all customer steady-state voltages are located within their statutory limits [42]. Steady state voltage rise can be mitigated by:

(i) importing reactive power in order to reduce the voltage in the locally affected area; (ii) increasing the electrical load through DSM schemes; (iii) diverting power into the installed ESUs through ESM schemes; and (iv) reducing the active power output of the installed SSEGs. These interventions can be performed individually or collectively by system agents, as will later be described.

In order to simulate a customer voltage violation at the branches of the case study SSEZ, an increase in generation and/or a reduction in load can be initiated. Table 8.1 defines the operating voltage limits as: (i) 250V as the upper normal state customer voltage limit; (ii) 253V as the upper alert state customer voltage limit; and (iii) 264V as the upper emergency state customer voltage limit. Figure 8.4 illustrates a minimum load scenario (0.16kW per customer) where there are no agents deployed in the system and each SSEZ customer has installed a SSEG with a rating of 2.5kW. Initially, at time $t = 0 - 0.5\text{sec}$, it is assumed that the connected SSEGs are not producing any power. All voltages are located within their permissible limits, with the highest voltage being at Feeder 1 (249.3V). At time $t = 0.5 - 1\text{sec}$, each SSEG is assumed to operate at 20% of its rated power output (i.e. 0.5kW), while at time $t = 1 - 1.5\text{sec}$ this figure rises to 50% (i.e. 1.25kW), at time $t = 1.5 - 2\text{sec}$ to 75% (i.e. 1.875kW) and at time $t = 2 - 2.5\text{sec}$ to 100% (2.5kW). It can be seen that the steady-state voltage rise limit of 253V is exceeded under a SSEG penetration scenario of approximately 0.55kW per customer, which under a passive control approach would result in SSEG disconnection in order to ensure secure system operation.

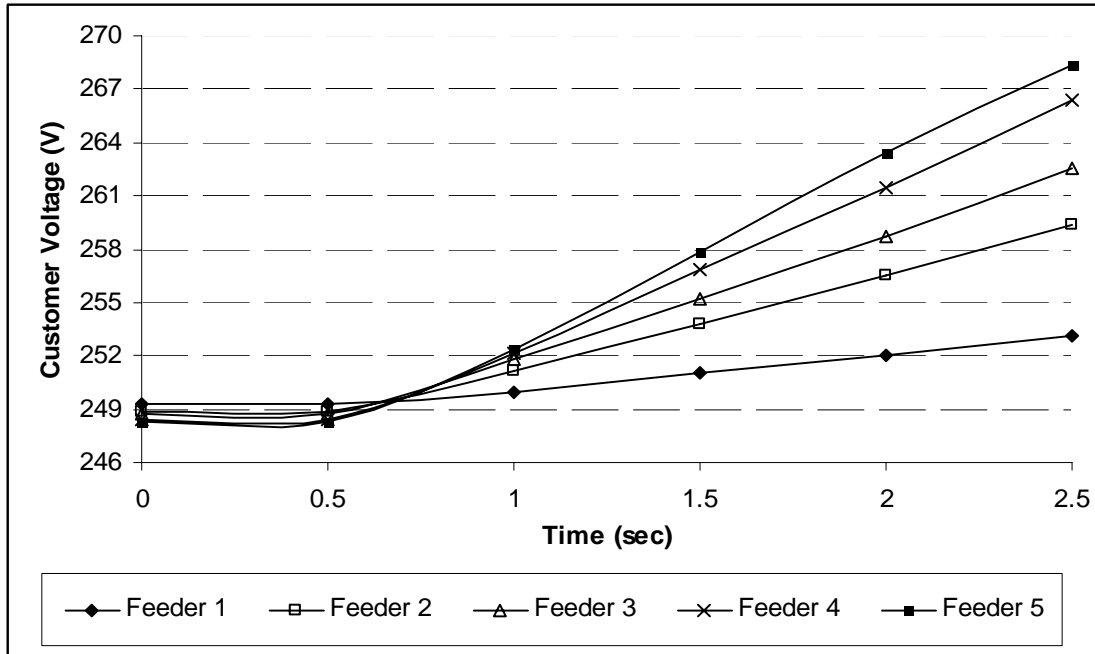

Figure 8.4: Feeder voltages at different time intervals – no control.

Feeder	Voltage @ t = 0-0.5sec	Voltage @ t = 0.5-1sec	Voltage @ t = 1-1.5sec	Voltage @ t = 1.5-2sec	Voltage @ t = 2-2.5sec
1	249.3V	250V	251V	252.0V	253.1V
2	248.9V	251.2V	253.8V	256.5V	259.4V
3	248.7V	251.8V	255.2V	258.7V	262.5V
4	248.4V	252.1V	256.9V	261.5V	266.4V
5	248.3V	252.4V	257.8V	263.4V	268.4V

Table 8.2: Feeder voltages at different time intervals – no control.

The following evaluation scenarios attempt to illustrate the response of the developed MAS-based control system to various operational changes on the case study SSEZ. Assuming minimum loading conditions and a “zero generation” scenario, customer voltages in the case study SSEZ are already high, ranging from 248.3V to 248.9V. This suggests that all direct control agents are operating at their normal state, but also that the upper normal state customer voltage limit of 250V is close to being exceeded. At the remote ends of the network this occurs at a SSEG power output per customer

of approximately 0.3kW, while at a SSEG power output per customer of around 0.45kW all direct control agents are under alert state (assuming a scenario where no corrective actions have been taken in order to reduce this voltage).

All GAs operating under the alert state attempt to regulate the reactive power of their respective SSEGs in order to keep the local steady-state customer voltage below 250V, without at the same time violating power factor regulation limits (0.95 leading to 0.95 lagging). During the alert state, SSEG reactive power control may or may not bring steady-state customer voltages back to their desired limits depending on the total SSEG active power output in the network, as well as on the available DSM and ESM schemes in the zone. Without any DSM or ESM schemes and assuming 0.95 leading SSEG power factors, simulation results have shown that the upper alert state customer voltage limit of 253V is exceeded at the remote ends of the network at a SSEG power output per customer of about 0.65kW, while this figure rises to 1.4kW for all customer voltages in the zone. Employing DSM and ESM schemes, however, may significantly increase these figures as will later be demonstrated.

- GA operation – Alert State:

Under the developed MAS, all GAs that are operating under the alert state instruct their respective SSEG to regulate their power factor towards a 0.95 leading power factor (“reactivePowerInIncrease”), without changing their active power output. This takes place without any agent interactions, with GAs acting based on local voltage measurements only.

- ESA and CDA operation – Alert State:

In addition to the reactive power control actions instructed by the relevant GAs within the developed MAS, ESM and DSM corrective schemes are also performed by the ESAs (“realPowerInIncrease”) and CDAs (“loadRescheduling” or “realPowerInIncrease”) that are operating under the alert state. These schemes are also performed based on local voltage measurements. Assuming that 10% of the customers uniformly distributed within the SSEZ have installed an ESU capable of a continuous power input/output of 5kW and that every customer has installed a controllable consumer demand attributing to 1kW, the SSEG volumes that may be accommodated before exceeding the upper alert state voltage limit have significantly increased as seen in Table 8.3.

Customer Voltage [V]	No control	SSEG reactive power control	ESM	DSM	Proposed MAS
Exceeding 253V - Feeder 5	0.55kW	0.65kW	0.55kW	1.1kW	2.1kW
Exceeding 253V - Feeder 1	1.2kW	1.4kW	1.7kW	2.2kW	2.7kW

Table 8.3: SSEG power output per customer at which the upper alert state voltage limit of 253V is exceeded on two different feeder locations.

Through SSEG reactive power control coupled with ESM and DSM schemes, the developed MAS-based control system may prevent steady-state customer voltages from exceeding 253V until each SSEG is generating a real power output of 2.1kW. This is a significant increase compared to the 0.55kW per customer that may be accommodated under a passive control approach. For higher SSEG penetrations, however, steady-state customer voltages will increase resulting in the direct control

agents located at the remote ends of the SSEZ (Feeder 5) entering the emergency state, as described below.

- GA operation – Emergency State:

Under SSEG penetrations higher than 2.1kW per customer, active power generation curtailment (“realPowerOutReduction”) is necessary in order to ensure secure system operation. The following four schemes were considered for implementation inside the agent reasoning capabilities, as described in Section 6.4.3:

1. Droop-control with no communications.
2. Active power dispatch based on the “Last In First Off” (LIFO) policy.
3. Active power dispatch based on proportionality sharing.
4. Active power dispatch based on optimisation criteria.

When selecting the most appropriate active power dispatch technique for overcoming steady-state customer voltage rise issues, the following two main criteria were taken into account:

1. Performance, i.e. minimising the total SSEG active power output that needs to be curtailed before bringing system voltages back to their desired limits;
2. Communications, i.e. minimising the need for data exchange both in terms of agent negotiations as well as exchanging measurement data.

Active power dispatch based on optimisation criteria was deemed too “communications-heavy” as a global view of the SSEZ would be required before an agent makes a control decision. Meanwhile, LIFO and proportionality sharing would require communications between the utility agents (AMS, DF) and the related direct

control agents every time a customer voltage violation had occurred, which also significantly increases the amount of communications required. On the other hand, however, by using droop control, GAs within the MAS simply need to register their services once and this control approach could result in the following key advantages: (i) optimal performance may be achieved by curtailing generation locally; (ii) the need for communications is minimised; and (iii) the system is open and can easily be expanded [176-177].

Figure 8.5 shows the droop control that has been implemented inside the emergency state of the GAs within the developed MAS. Initially, at time $t = 0 - 0.5\text{sec}$, it is assumed that the real power output of each SSEG is 2.1kW and that all direct control agents are operating under the alert state, with SSEG reactive power control, DSM and ESM schemes responsible for keeping steady-state customer voltages within statutory limits. An additional increase in generation, however, or a reduction in load may cause the steady-state remote-end voltage to exceed 253V and therefore local GAs will enter the emergency state. This is illustrated during time $t = 0.5 - 1\text{sec}$, where it is assumed that the real power output of each SSEG has increased to 2.5kW. As seen from Table 8.4, emergency-state GAs are those located on Feeders 4 and 5 and, according to the adopted droop control, only these SSEGs would have to curtail their real power output in order to bring customer voltages back to desired limits. This occurs at time $t = 1 - 1.5\text{sec}$ where GAs at Feeder 5 reduce their real power output down to 2.2kW, for which the upper steady-state voltage limit of 253V is reached, while for GAs located on Feeder 4 this limit is reached for a real power output of 2.35kW.

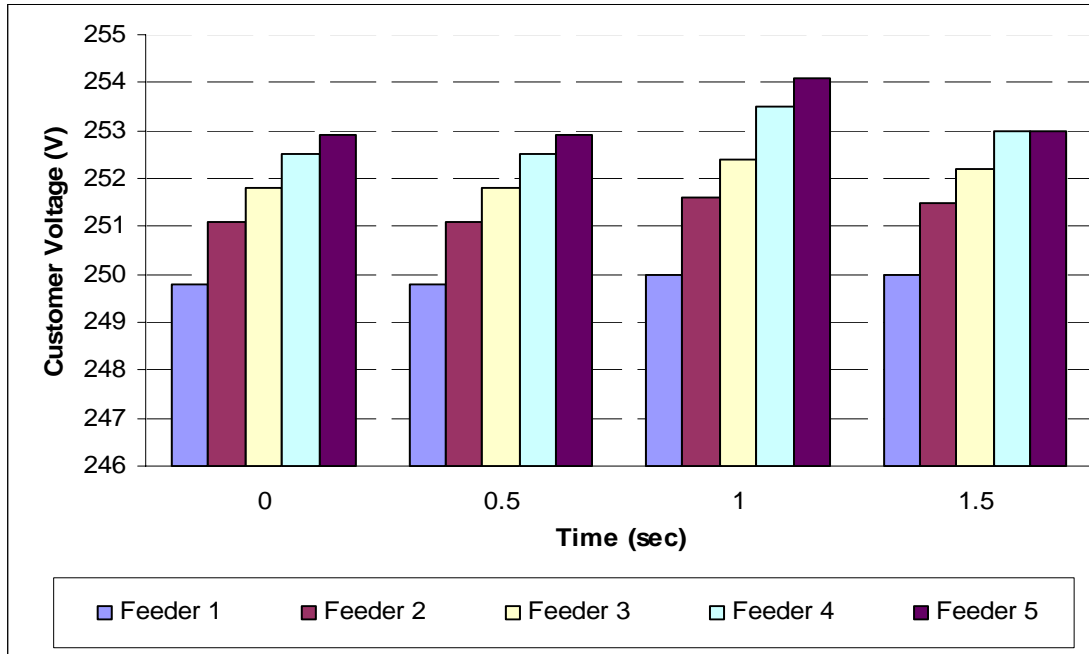

Figure 8.5: Feeder voltages at different time intervals – MAS control.

In total, the amount of SSEG real power that is required to be curtailed in the SSEZ case study using a droop control with no communications is: $(2.5\text{kW} - 2.2\text{kW}) \times 8 + (2.5\text{ kW} - 2.35\text{ kW}) \times 8 = 3.6\text{kW}$. Simulation results have shown that if an egalitarian approach had been implemented, where SSEG units on an SSEZ feeder equally curtailed their real power output in order to overcome steady-state customer voltage rise issues, the total amount of real power that would need to be curtailed would be significantly higher, approximately 12kW. In addition to requiring extensive communications, such an approach could also significantly decrease the total energy yield of these units. Therefore, even though SSEG units located at the remote-ends of the SSEZ feeders are most likely to be penalised assuming uniform SSEG penetration scenarios, total SSEG active power curtailment within the SSEZ is minimised.

- ESA and CDA operation – Emergency State:

The operation of ESAs and CDAs remains unchanged during the emergency state.

Feeder	Voltage [Volts] @ t = 0-0.5sec	Voltage [Volts] @ t = 0.5-1sec	Voltage [Volts] @ t = 1-1.5sec
1	249.8V	250V	250V
2	251.1V	251.6V	251.5V
3	251.8V	252.4V	252.2V
4	252.5V	253.5V	253V
5	252.9V	254.1V	253V

Table 8.4: Feeder voltages at different time intervals – emergency state operation.

A key concern towards the potential employment of the developed control system on an actual SSEZ is that the dynamic fluctuations caused by altering the electrical power input/output of large numbers of power system components must be within existing limits [42] in order to ensure that stability problems are minimised. The aim of this Thesis is to investigate the unbalanced steady-state operation of LV distribution networks and as such a detailed stability analysis of the operation of the developed control system on the case study SSEZ has not been performed. However, PSCAD™ is capable of simulating the time domain instantaneous responses of electrical power systems and hence may be used for analysing the dynamic operation and electromagnetic transients of the case study SSEZ.

An initial investigation indicated that the dynamic operation of the developed control system causes some fluctuations to the SSEZ, but that these fluctuations are within tolerable range as shown in Figures 8.6 and 8.7. This view has been further supported by experimental results on a real power system, the Experimental SSEZ that will be described in Section 8.5. Figure 8.6 illustrates customer voltages at the SSEZ feeders during time $t = 0.995 - 1.03$ sec, where GAs at Feeder 4 and 5 have reduced their real power output down to 2.35kW and 2.2kW respectively in order to bring steady-state customer voltages within statutory limits. It can be seen that the resultant

perturbations to the power system from the operation of the direct control agents are tolerable, both in terms of the magnitude as well as the time period of the fluctuation. As evident from the graphs above, these fluctuations are more pronounced at the feeders where control actions have been taken.

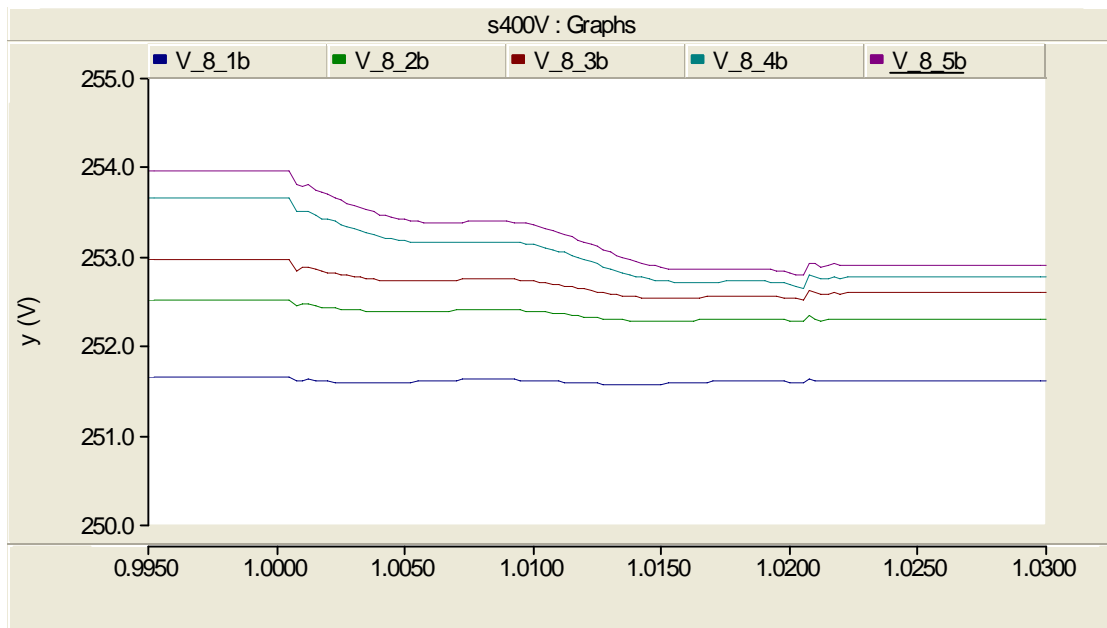

Figure 8.6: Instantaneous customer voltages showing the dynamic operation of the MAS-based control system.

Meanwhile, Figure 8.7 shows the instantaneous current of phase A at the remote ends of the detailed SSEZ feeder. As it can be seen, the current output of the SSEGs located on that feeder has been reduced at time $t = 1.0\text{sec}$, which originally causes some small fluctuations which are then eliminated.

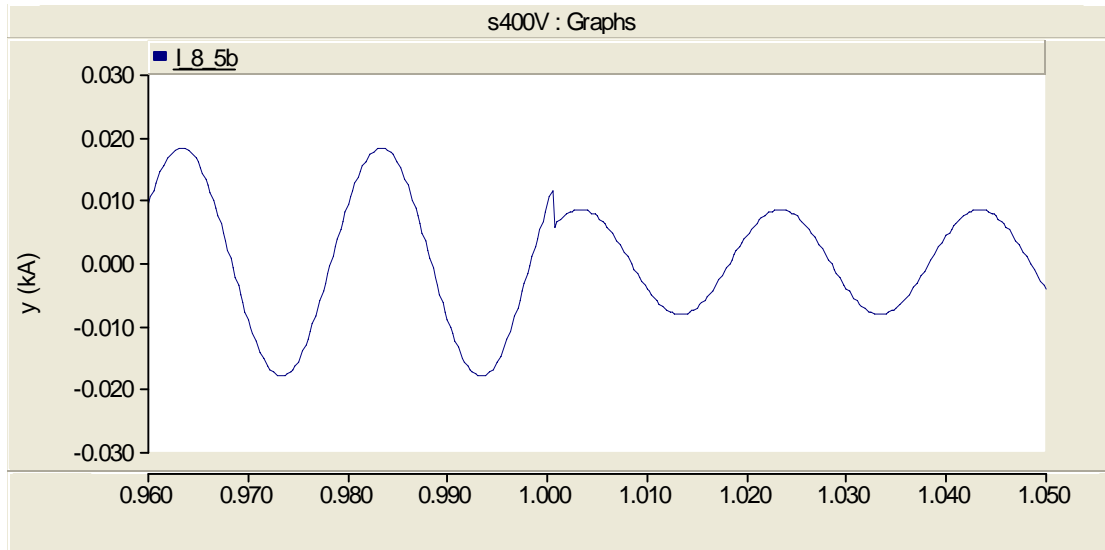

Figure 8.7: Instantaneous current showing the dynamic operation of the MAS-based control system.

8.1.2. Voltage Regulation

The evaluation scenarios devised here focus on overcoming steady-state voltage regulation issues. According to Table 4.1, these are anticipated to require mitigating control actions only after high SSEG penetrations, namely 770kW assuming minimum loading conditions and unity SSEG and load power factors. The aim of the control system is to ensure that the steady-state voltage variation between the LV busbars of the MV/LV distribution transformer supplying the SSEZ and the remote ends of the SSEZ feeders are located within their statutory limits [161-163].

In order to achieve that, the following sequence of actions takes place within the developed MAS:

1. Firstly, a VRA observes that steady-state voltage variation within an SSEZ feeder has exceeded the upper or lower voltage regulation limit. For illustrative purposes, the former is considered here.

2. The VRA sends a “query-ref” message with content “Voltage_regulation” to the DF.
3. The DF replies with an “inform” message to allow the VRA to find out the ID of all direct control agents located on that particular feeder that are able to regulate this voltage deviation.
4. The VRA then sends “proposal” ACL messages to these agents according to their network location:
 - a. For direct control agents located close to the MV/LV distribution substation, the goal is to increase local steady-state voltage.
 - b. For direct control agents located close to the SSEZ end-of-service, the goal is to reduce local steady-state voltage.
5. Depending on their availability, these agents respond with an “accept-proposal” or “reject-proposal” message to inform the VRA that the submitted proposal has been accepted or rejected respectively. In the event of a failure (for example loss of communications between the direct control agent and the entity it controls) or if the message is for whatever reason not understood by the direct control agent, it will respond with a “failure” or “not-understood” message accordingly.
6. Action execution is then performed by direct control agents that have responded with an “accept-proposal” ACL message.
7. This process is repeated until satisfactory system operation is restored.

In the event that the VRA observes that steady-state voltage variation within an SSEZ feeder has exceeded the lower voltage regulation limit, the sequence of actions is similar to the one described above, however the goal here is to: (i) reduce local steady-state voltage for direct control agents located close to the MV/LV distribution

substation; and (ii) increase local steady-state voltage for direct control agents located close to the SSEZ end-of-service.

As evident from above, overcoming voltage regulation issues requires a more coordinated approach compared to customer voltage rise. In order to simulate a violation of the upper voltage regulation limit at an SSEZ feeder, an increase in generation and/or a reduction in load on that feeder can be initiated. Table 8.1 defines the operating voltage regulation limits as: (i) +4% as the upper normal state voltage regulation limit; (ii) +4.5% as the upper alert state voltage regulation limit; and (iii) +5% as the upper emergency state voltage regulation limit.

Table 8.5 illustrates steady-state voltage regulation in the case study SSEZ under a minimum load scenario (0.16kW per customer) where there are no agents deployed in the system and each SSEZ customer has installed a SSEG with a rating of 2.5kW. Initially, at time $t = 0 - 0.5\text{sec}$, it is assumed that the connected SSEGs are not producing any power. As it can be seen, the value for steady-state voltage regulation (-0.43%) is located within normal operating limits. At time $t = 0.5 - 1\text{sec}$, each SSEG is assumed to operate at 20% of its rated power output (i.e. 0.5kW), while at time $t = 1 - 1.5\text{sec}$ this figure rises to 50% (i.e. 1.25kW), at time $t = 1.5 - 2\text{sec}$ to 75% (i.e. 1.875kW) and at time $t = 2 - 2.5\text{sec}$ to 100% (2.5kW). The % steady-state voltage regulation limit of +5% has been found to be exceeded under a SSEG penetration scenario of around 1.9kW per customer, which under a passive control approach would result in SSEG disconnection in order to ensure secure system operation. Meanwhile the % steady-state voltage regulation limits of +4% and +4.5% would be

exceeded under SSEG penetration scenarios of approximately 1.6kW and 1.75kW per customer respectively.

Simulation Time Period [sec]	Steady-State Voltage Regulation [Volts]	Percentage Steady-State Voltage Regulation [%]
t = 0 – 0.5sec	- 1.0V	- 0.43%
t = 0.5 – 1sec	+ 2.4V	+ 1%
t = 1 – 1.5sec	+ 6.8V	+ 2.8%
t = 1.5 – 2sec	+ 11.4V	+ 4.9%
t = 2 – 2.5sec	+ 15.3V	+ 6.4%

Table 8.5: Steady-state voltage regulation under the devised simulation scenarios.

- VRA operation – Alert State:

Under the devised scenarios, the VRA enters the alert state assuming a uniform SSEG penetration of approximately 1.6kW per customer. Having received from the DF the ID of all direct control agents that offer the “Voltage_Regulation” service on that feeder, the VRA sends the following control commands, which are to be executed depending on SSEG/ESU/load availability:

1. For GAs located close to the MV/LV distribution substation: to regulate their power factor to 0.95 lagging (with the message content “reactivePowerOutIncrease”), without changing their active power output.
2. For ESAs and CDAs located close to the MV/LV distribution substation: to reduce demand in the area by exporting active power through ESM (“realPowerOutIncrease”) and by curtailing consumer demands through DSM (“realPowerInReduction”).
3. For GAs located close to the SSEZ end-of-service: to regulate their power factor to 0.95 leading (“reactivePowerInIncrease”), without changing their active power output.

4. For ESAs and CDAs located close to the SSEZ end-of-service: to increase demand in the area by importing active power through ESM (“realPowerInIncrease”) and by instructing consumer demands to switch on through DSM (“loadRescheduling” or “realPowerInIncrease”).

- VRA operation – Emergency State:

Under the devised scenarios, the VRA enters the emergency state assuming a uniform SSEG penetration of approximately 1.75kW per customer under a passive control approach, or 2.45kW per customer under the proposed MAS-based control approach (Table 8.6). Active power curtailment of the connected SSEGs may therefore be necessary in order to ensure secure system operation. Similarly to the alert state, the VRA receives from the DF the ID of all direct control agents that offer the “Voltage_Regulation” service on that feeder, and then dispatches the following control commands:

1. For GAs located close to the MV/LV distribution substation: to increase their active power output by 10% (“realPowerOutIncrease”), for units that are not already exporting their maximum active power output.
2. For GAs located close to the SSEZ end-of-service: to reduce their active power output by 10% (“realPowerOutReduction”).

% Steady-State Voltage Regulation	No Control	SSEG Reactive Power Control	ESM	DSM	Proposed MAS
Exceeding upper alert state (+4.5%)	1.75kW	1.8kW	1.8kW	2.35kW	2.45kW
Exceeding upper emergency state (+5%)	1.9kW	1.95kW	1.95kW	2.5kW	2.6kW

Table 8.6: SSEG power output per customer for which the % steady-state voltage regulation limits are exceeded in the case study SSEZ.

Figure 8.8 shows the steady-state voltage regulation control that has been implemented inside the alert and emergency state of the 4 VRAs within the developed MAS. Initially, at time $t = 0 - 0.5\text{sec}$, it is assumed that the real power output of each SSEG in the case study SSEZ is 1.5kW and that the resultant % steady-state voltage regulation (+3.5%) is located within desired limits (+4%). An increase in generation, however, or a reduction in load may cause the % steady-state voltage variation to exceed +4% and therefore the VRA to enter the alert state. This is illustrated during time $t = 0.5 - 1\text{sec}$, where it is assumed that the real power output of each SSEG has increased to 1.85kW, thus resulting in a % steady-state voltage variation of 4.7%. The time period $t = 1 - 1.5\text{sec}$ illustrates the response of the control system, with the VRA instructing the relevant GAs, ESAs and CDAs to perform corrective actions in order to restore this voltage variation. For the case study SSEZ, these actions result in the % steady-state voltage variation to drop to 3.2%, which is well within the desired operating limit of +4%.

An additional increase in generation or a load reduction may cause the % steady-state voltage variation to exceed +4.5% and therefore cause the VRA to enter the emergency state. Simulation results, however, have shown that under the developed MAS, the VRA would enter the emergency state only after SSEG penetrations of 2.45kW per customer and hence SSEG active power curtailment is not likely to be required. During time $t = 1.5 - 2\text{sec}$ it is assumed that the real power output of each SSEG has instantaneously increased to 2.5kW, thus resulting in a % steady-state voltage variation of 4.8%. The VRA then sends ACL messages to the 24 GAs that are located at the remote ends of that feeder with the content “realPowerOutReduction” and instructs them to reduce current active power output by 10%, i.e. down to 2.25kW

for each SSEG. This results in a % steady-state voltage variation of 4.47%, which is just below the upper alert state limit of 4.5%. If, however, variation continued to exceed statutory limits, additional SSEG active power generation curtailment (in 10% intervals) would have been required.

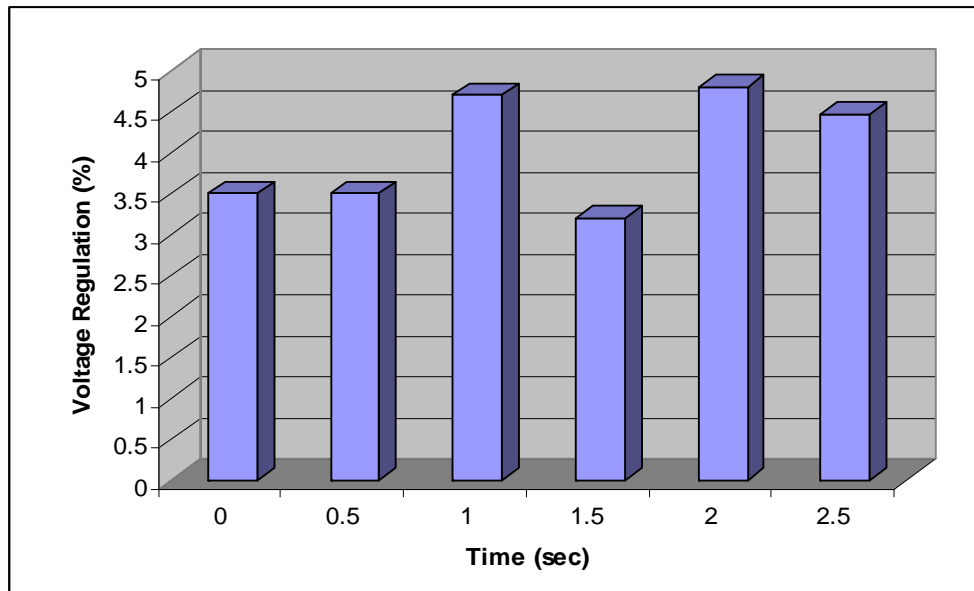

Figure 8.8: Voltage regulation under the devised simulation scenarios.

In total, the amount of real power output that is required to be curtailed within the SSEZ using the proposed control approach is: $(2.5\text{kW} - 2.25\text{kW}) \times 24 = 6\text{kW}$. Simulation results have shown that if a more egalitarian approach had been implemented, where all SSEG units on that feeder equally curtailed their real power output, the total amount of real power that would need to be curtailed would be approximately: $(2.5\text{kW} - 2.35\text{kW}) \times 96 = 14.4\text{kW}$. Hence, although the proposed control approach penalises SSEG units located at the remote-ends of the SSEZ feeders, communication links are kept relatively low, while ensuring that the total SSEG active power curtailment within the SSEZ is minimised.

8.1.3. Voltage Unbalance

The evaluation scenarios devised here focus on overcoming steady-state voltage unbalance which is anticipated to be a likely limiting constraint to the operation of SSEGs for two reasons: the first is the relatively low volumes of unbalanced single-phase generation that may be accommodated before statutory limits are exceeded (Table 4.2); and the second is due to the “fit and inform” policy governing SSEG growth which means that DNOs will have no control over the phase of connection. The aim of the control system is to ensure that steady-state % VUFs of all SSEZ feeders are located within their operating statutory limits [166].

In order to achieve that, the following sequence of actions takes place within the MAS:

1. Firstly, a UA observes that the steady-state % VUF within an SSEZ feeder has exceeded desired or allowable operating limits.
2. The UA sends a “query-ref” message with content “Voltage_unbalance” to the DF.
3. The DF replies with an “inform” message to allow the UA to find out the ID of all direct control agents located at the remote ends of that particular feeder.
4. The UA then sends “proposal” ACL messages to these agents according to their phase location:
 - a. For direct control agents located at the phase with the highest steady-state voltage, the goal is to increase local demand through DSM and ESM schemes and/or reduce local generation.
 - b. For direct control agents located at the phase with the lowest steady-state voltage, the goal is to reduce local demand through DSM and ESM schemes and/or increase local generation.

5. Depending on their availability, these agents respond with an “accept-proposal” or “reject-proposal” message to inform the UA that the submitted proposal has been accepted or rejected respectively. In the event of a failure or if the message is not understood by the direct control agent, it will respond with a “failure” or “not-understood” message accordingly.
6. Action execution is then performed by direct control agents that have responded with an “accept-proposal” ACL message.
7. This process is repeated until satisfactory system operation is restored.

In order to overcome voltage unbalance issues within an SSEZ, the co-ordinated control of entities located on a specific phase of an SSEZ feeder is required. Hence, flexibility for control may be limited compared to a network constraint such as voltage regulation where entities from the overall zone may be asked to contribute. Control flexibility is additionally limited due to the fact that, under the developed UAs, control actions are delegated only to power system entities located at the remote ends of the SSEZ feeders, where the impacts of uniform penetrations of SSEGs are at their most adverse. In the possibility of SSEG clustering, however, additional control strategies would have to be devised in order to employ the services of entities which may not be located at the remote ends of the SSEZ.

In order to simulate a steady-state voltage unbalance violation, an increase in single-phase generation and/or a reduction in single-phase load on an SSEZ feeder can be initiated. Table 8.1 defines the operating steady-state voltage unbalance limits as: (i) 0.8% as the upper normal state voltage unbalance limit; (ii) 1.0% as the upper alert

state voltage unbalance limit; and (iii) 1.3% as the upper emergency state voltage unbalance limit.

Table 8.7 illustrates the resultant % VUF on a feeder of the case study SSEZ under a minimum load scenario (0.16kW per customer) where there are no agents deployed in the system and each customer on that feeder has installed a SSEG with a rating of 2.5kW. Initially, at time $t = 0-0.5\text{sec}$, it is assumed that the connected SSEGs are not exporting any active power, with the resultant steady-state % VUF equalling zero. At time $t = 0.5 - 1\text{sec}$, each SSEG on phase A is assumed to increase its active power output to 20% of its rated power (i.e. 0.5kW), while at time $t = 1 - 1.5\text{sec}$ this figure rises to 50% (i.e. 1.25kW), at time $t = 1.5 - 2\text{sec}$ to 75% (i.e. 1.875kW) and at time $t = 2 - 2.5\text{sec}$ to 100% (i.e. 2.5kW).

If the power output of SSEGs located on phases B and C is assumed to remain constant at 0kW, the % steady-state VUF limit of 1.3% has been found to be exceeded under a SSEG penetration scenario of around 1.5kW for customers on phase A. For passive LV distribution networks, where corrective control actions are not employed for voltage unbalance, high % VUFs may result in adverse effects on power system equipment and on the electrical network as described in Section 4.1.3.

Simulation Time Period [sec]	% Steady-State VUF
$t = 0 - 0.5\text{sec}$	0 %
$t = 0.5 - 1\text{sec}$	0.4 %
$t = 1 - 1.5\text{sec}$	1.1 %
$t = 1.5 - 2\text{sec}$	1.6 %
$t = 2 - 2.5\text{sec}$	2.1 %

Table 8.7: Resultant % VUF under the devised simulation scenarios.

Figure 8.9 shows the three unbalanced phasors V_a , V_b and V_c taken from a typical simulation run in PSCAD™. As it can be seen, unbalance exists not only in the magnitude of the voltages but also in the phase angles as the three phasors are no longer separated by exactly 120° .

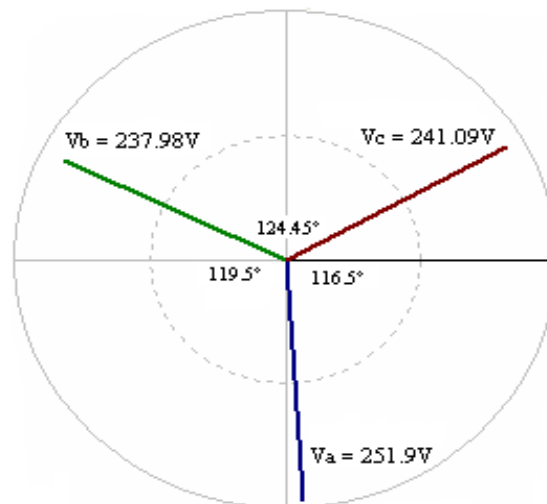

Figure 8.9: Instantaneous voltage phasors at the remote ends of the case study SSEZ.

- UA operation – Alert State:

Under the devised scenarios, the UA enters the alert state assuming an unbalanced single-phase generation of approximately 1.0kW per customer. Having received from the DF the ID of all direct control agents that offer the “Voltage_Unbalance” service on that feeder, the UA dispatches the following control commands, which are to be executed depending on ESU/load availability:

1. For ESAs and CDAs located at the phase with the highest steady-state voltage: to increase demand in the area by importing active power through ESM (“realPowerInIncrease”) and by instructing consumer demands to switch on through DSM (“loadRescheduling” or “realPowerInIncrease”).
2. For ESAs and CDAs located at the phase with the lowest steady-state voltage: to reduce demand in the area by exporting active power through ESM

(“realPowerOutIncrease”) and by curtailing consumer demands through DSM (“realPowerInReduction”).

SSEG reactive power control for voltage unbalance has not been considered, in accordance with simulation results (Table 4.2) that have shown that changing the SSEG power factor has a minor effect on the resultant % VUF.

- VRA operation – Emergency State:

Under the devised scenarios, the UA enters the emergency state assuming an unbalanced single-phase generation of 1.15kW per customer under a passive control approach, or 2.4kW per customer under the proposed MAS-based approach (Table 8.8). Active power curtailment of the connected SSEGs may therefore be necessary in order to ensure secure system operation. Similarly to the alert state, the UA receives from the DF the ID of all direct control agents that offer the “Voltage_Unbalance” service on that feeder, and then dispatches the following control commands:

1. For GAs located at the phase with the highest steady-state voltage: to reduce their active power output by 10% (“realPowerOutReduction”).
2. For GAs located at the phase with the highest steady-state voltage: to increase their active power output by 10% (“realPowerOutIncrease”), for units that are not exporting their maximum active power output.

% Steady-State VUF	No Control	SSEG Reactive Power Control	ESM	DSM	Proposed MAS
Exceeding upper alert state (1.0%)	1.15kW	1.15kW	1.4kW	2.1kW	2.4kW
Exceeding upper emergency state (1.3%)	1.5kW	1.5kW	1.8kW	2.5kW	2.8kW

Table 8.8: SSEG power output per customer on phase A for which the % steady-state VUF limits are exceeded in the case study SSEZ.

Figure 8.10 shows the steady-state voltage unbalance control that has been implemented inside the alert and emergency state of the four UAs within the developed MAS. Initially, at time $t = 0 - 0.5\text{sec}$, a single-phase unbalanced generation of 0.75kW per customer is assumed, which results in a % VUF of 0.6% which is located within desired limits (0.8%). An additional increase in single-phase generation, however, or a demand reduction on that phase may cause the %VUF to exceed 0.8% and therefore the UA to enter the alert state. This is illustrated during time $t = 0.5 - 1\text{sec}$, where it is assumed that the single-phase unbalanced generation per customer has increased to 1.1kW , thus resulting in a steady-state % VUF of 0.95% . The time period $t = 1 - 1.5\text{sec}$ illustrates the response of the control system, with the UA instructing the relevant ESAs and CDAs to increase the load in order to restore this voltage unbalance. For the case study SSEZ, these actions result in the % VUF to drop to 0.7% , which is within the desired operating limit of 0.8% .

An additional increase in single-phase generation, or a demand reduction on that phase may cause the %VUF to exceed 1.0% and therefore cause the UA to enter the emergency state. Simulation results, however, have shown that under the developed MAS, the UA would enter the emergency state only after unbalanced single-phase SSEG penetrations of 2.4kW per customer (Table 8.8) and hence SSEG active power curtailment is not likely to be required. During time $t = 1.5 - 2\text{sec}$ it is assumed that the unbalanced single-phase generation has increased to 2.5kW per customer, thus resulting in a % VUF of approximately 1.1% . The UA then sends ACL messages to the 8 GAs that are located on the phase of interest and at the remote ends of that SSEZ feeder with the content “realPowerOutReduction” and instructs them to reduce current active power output by 10% , i.e. down to 2.25kW for each SSEG. The resultant

steady-state % VUF has been found to remain slightly higher than the upper alert state limit of 1.0% and therefore the UA re-instructs these units to reduce current active power output by 10%, i.e. down to approximately 2kW for each SSEG. This results in a steady-state % VUF of 0.95%, which is just below the upper alert state of 1.0%.

In total, the amount of real power output that is required to be curtailed within the SSEZ using the proposed control approach is: $(2.5\text{kW} - 2.025\text{kW}) \times 8 = 3.8\text{kW}$. Simulation results have shown that if a more egalitarian approach had been implemented, where all SSEG units on the phase of that feeder equally curtailed their real power output, the total amount of real power that would need to be curtailed would be approximately: $(2.5\text{kW} - 2.35\text{kW}) \times 32 = 4.8\text{kW}$. This is a small difference compared to curtailing SSEG units located at the remote-ends of the SSEZ feeders only and therefore a different control strategy could also be effective, where active power reduction intervals are reduced (for example from 10% down to 5%), but the number of GAs controlled by the UA is increased (in this case from 8 to 32).

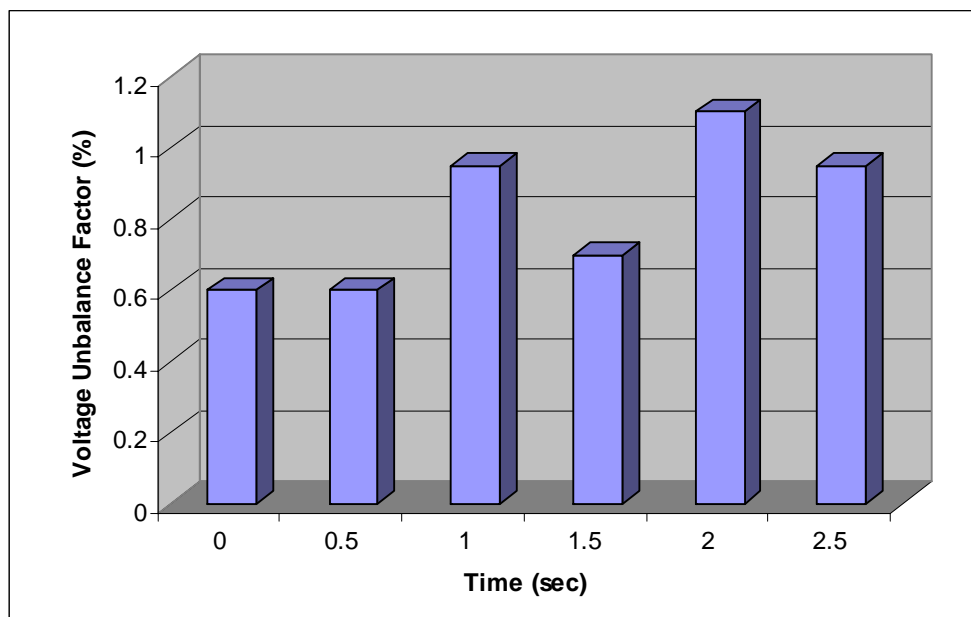

Figure 8.10: % VUF under the devised simulation scenarios.

8.1.4. Thermal Limits

The evaluation scenarios devised here focus on overcoming issues associated with cable and transformer thermal limits. The aim of the control system is to ensure that current flows within SSEZ “hot-spots” and the apparent power flow through the PCC with the upstream distribution network have not exceeded their allowable continuous current (A) or apparent power flow (kVA) ratings. For this particular case study SSEZ, where uniform SSEG penetrations are considered, only three-phase current flows are monitored and controlled within the four “hot-spots” that exist in the zone (Section 6.1). In the event of SSEG clustering on the same phase, however, it may be necessary to monitor single-phase current flows as well by adding single-phase TLA(s) to the system.

The following sequence of actions takes place within the developed MAS in order to overcome cable and transformer thermal overloads:

1. Firstly, a TLA observes that the current flowing through a SSEZ network line or the apparent power flow through the PCC has exceeded desired or allowable operating limits.
2. The TLA sends a “query-ref” message with content “Cable_Thermal_Limits” or “Transformer_Thermal_Limits” respectively to the DF.
3. The DF replies with an “inform” message to allow the TLA to find out the ID of all direct control agents that offer the requested service.
4. The TLA then sends “proposal” ACL messages to these agents in order to increase local demand through DSM and ESM schemes and/or reduce local generation.
5. Depending on their availability, these agents respond with an “accept-proposal” or “reject-proposal” message to inform the TLA that the submitted proposal has been

accepted or rejected respectively. In the event of a failure or if the message is not understood by the direct control agent, it will respond with a “failure” or “not-understood” message accordingly.

6. Action execution is then performed by direct control agents that have responded with an “accept-proposal” ACL message.
7. This process is repeated until satisfactory system operation is restored.

In order to simulate a cable or transformer thermal limit violation, an increase in generation and/or a reduction in load can be initiated. Table 8.1 defines the operating current flow limits for the four known “hot-spots” within the SSEZ as: (i) 280A as the upper normal state current flow limit; (ii) 320A as the upper alert state current flow limit; and (iii) 355A as the upper emergency state current flow limit. Meanwhile, the apparent power flow limits for the distribution transformer supplying the SSEZ are: (i) 420kVA as the upper normal state apparent power flow limit; (ii) 460kVA as the upper alert state apparent power flow limit; and (iii) 500kVA as the upper emergency state apparent power flow limit.

Table 8.9 illustrates the current and apparent power flows within the case study SSEZ under a minimum load scenario (0.16kW per customer) where there are no agents deployed in the system and each customer has installed a SSEG with a rating of 2.5kW. Initially, at time $t = 0 - 0.5\text{sec}$, it is assumed that the connected SSEGs are not exporting any active power, with power flowing from the upstream distribution network to the SSEZ. At time $t = 0.5 - 1\text{sec}$, each SSEG is assumed to increase its active power output to 20% of its rated power (i.e. 0.5kW), while at time $t = 1 - 1.5\text{sec}$

this figure rises to 50% (i.e. 1.25kW), at time $t = 1.5 - 2\text{sec}$ to 75% (i.e. 1.875kW) and at time $t = 2 - 2.5\text{sec}$ to 100% (i.e. 2.5kW).

The emergency state limits of 355A and 500kVA have been found to be exceeded under SSEG penetration scenarios of around 2.7kW and 1.6kW respectively, which under a passive control approach could result in SSEG or even customer load disconnection if the existing SSEZ overcurrent protection devices trip. The following simulation scenarios focus on overcoming transformer thermal limits, which are anticipated to be a more limiting network constraint compared to cable thermal limits.

Simulation Time Period [sec]	Current Flow at SSEZ “hot-spot” [A]	Apparent Power Flow at PCC [kVA]
t = 0 – 0.5sec	23A	60kVA
t = 0.5 – 1sec	48.5A	120kVA
t = 1 – 1.5sec	156A	380kVA
t = 1.5 – 2sec	243A	600kVA
t = 2 – 2.5sec	330A	790kVA

Table 8.9: Current and apparent power flows under the devised simulation scenarios.

- TLA operation – Alert State:

The TLA enters the alert state assuming a uniform SSEG penetration of 1.4kW per customer. Having received from the DF the ID of direct control agents that offer the “Transformer_Thermal_Limits” service, which is likely to be all direct control agents within the SSEZ, the TLA dispatches the following control commands, which are to be executed depending on ESU/load availability:

1. For ESAs: to increase demand in the area by importing active power through ESM (“realPowerInIncrease”).

2. For CDAs: to increase demand in the area by instructing consumer demands to switch on through DSM (“loadRescheduling” or “realPowerInIncrease”).

SSEG reactive power control for reducing apparent power flows at the PCC has not been considered, in accordance with simulation results (Table 4.3) that have found it to have a minor effect on the additional SSEG volumes that may be accommodated.

- TLA operation – Emergency State:

The TLA enters the emergency state assuming a uniform SSEG penetration of 1.5kW per customer under a passive approach, or 3kW per customer under the proposed approach (Table 8.10). SSEG active power curtailment is therefore not anticipated to be required. In general, due to the high SSEG volumes that may be accommodated, cable and transformer thermal violations are not anticipated to present a limiting constraint to the operation of SSEGs in the case study SSEZ, as shown in Table 8.10.

	No Control	ESM	DSM	Proposed MAS
Exceeding upper alert state apparent power flow limit (460kVA)	1.5kW	2kW	2.5kW	3kW
Exceeding upper emergency state apparent power flow limit (500kVA)	1.6kW	2.1kW	2.6kW	3.1kW
Exceeding upper alert state current flow limit (320A)	4.2kW	4.7kW	5.2kW	5.7kW
Exceeding upper emergency state current flow limit (355A)	4.6kW	5.1kW	5.6kW	6.1kW

Table 8.10: SSEG power output per customer for which the cable “hot-spot” and transformer thermal limits are exceeded in the case study SSEZ.

Figure 8.11 shows the transformer thermal overload control that has been implemented inside the alert and emergency state of the TLA within the developed MAS. Initially, at time $t = 0 - 0.5\text{sec}$, it is assumed that the real power output of each

SSEG in the case study SSEZ is 1.2kW and that the apparent power flow at the SSEZ PCC with the upstream distribution network (380kVA) is located within desired limits (420kVA). An increase in generation, however, or a reduction in load may cause this value to exceed 420kVA and therefore cause the TLA to enter the alert state. This is illustrated during time $t = 0.5 - 1\text{sec}$, where it is assumed that the real power output of each SSEG has increased to 1.45kW, thus resulting in the apparent power flow at the SSEZ PCC to increase to 450kVA.

Since all customer-owned power system entities within the SSEZ have an effect on the apparent power flow at the PCC, it is important that the TLA does not overestimate the required mitigating control actions in the event of thermal overloads. Therefore, state estimation is necessary in order to determine the extent of thermal violation, as well as to provide an approximation of the number of customer-owned power system entities that need to be controlled. A simple logic has been implemented inside the alert state of the TLA, which dynamically calculates the difference between apparent power flow at the SSEZ PCC and the upper normal state apparent power flow limit (in this case: $450\text{kVA} - 420\text{kVA} = 30\text{kVA}$) and accordingly instructs ESAs (“realPowerInIncrease”) and CDAs (“loadRescheduling” or “realPowerInIncrease”) to increase the load in the zone. The response of the control system is illustrated during $t = 1 - 1.5\text{sec}$, where the total load in the zone is increased in order to reduce the apparent power flow at the PCC.

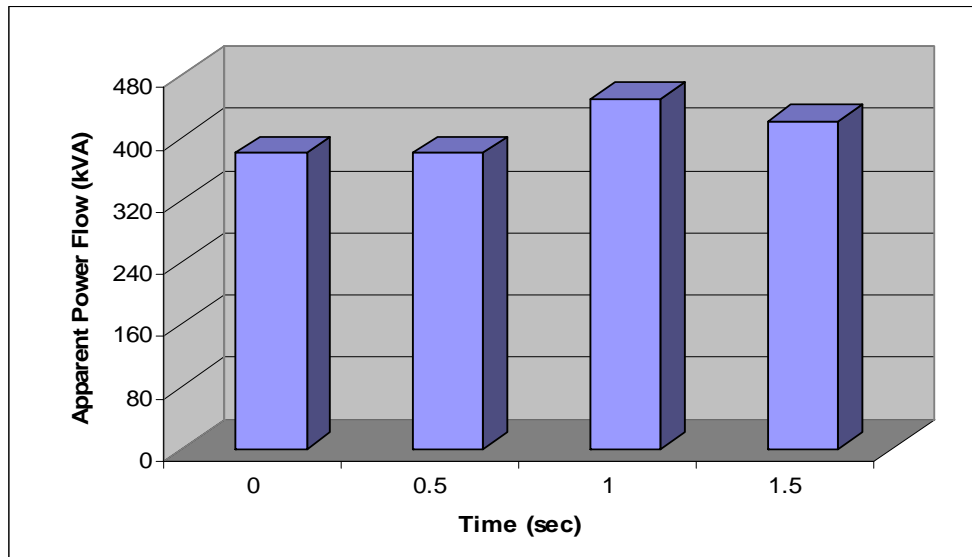

Figure 8.11: Apparent power flow at the PCC under the devised simulation scenarios.

An additional increase in generation or a load reduction may cause the apparent power flow at the SSEZ PCC to exceed 460kVA and therefore cause the TLA to enter the emergency state. Simulation results, however, have shown that under the developed MAS, the TLA would enter the emergency state only after SSEG penetrations of 3kW per customer, which represent extreme SSEG penetration scenarios. Therefore, under the proposed MAS, SSEG active power curtailment will not be required for overcoming cable and transformer thermal overloads on the case study SSEZ.

Finally, due to the large number of power system entities that are likely to be controlled, stability becomes increasingly important in order to overcome cable or transformer thermal overloads. An initial investigation, however, indicated that the resultant fluctuations from the dynamic operation of the control system are within tolerable range. Figure 8.12 illustrates the apparent power flow at the PCC with the upstream distribution network during time $t = 0.5 - 0.6\text{sec}$, where it is assumed that the real power output of each SSEG in the case study SSEZ is increased from 1.2kW

to 1.45kW, thus resulting in the apparent power flow at the SSEZ PCC to increase to 450kVA. The steady-state value is reached after a considerable time period (approximately 0.1sec) due to the large number of components that are controlled.

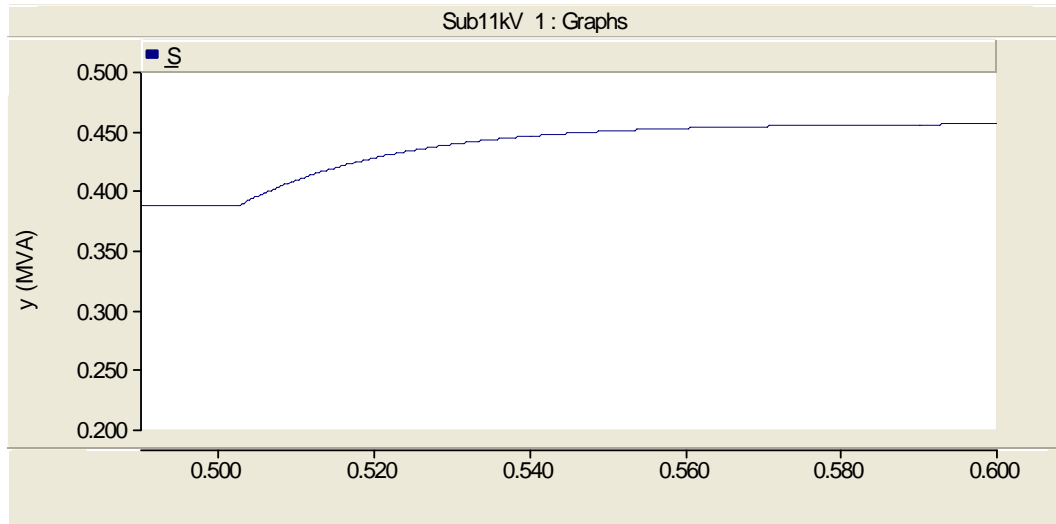

Figure 8.12: Apparent power flow at the PCC – dynamic operation.

Meanwhile, Figure 8.13 shows the instantaneous three phase currents at the SSEZ PCC during the same time period. As it can be seen, the value for each single-phase current has increased from approximately 720A peak to 810A peak, which originally causes some small fluctuations which are then eliminated.

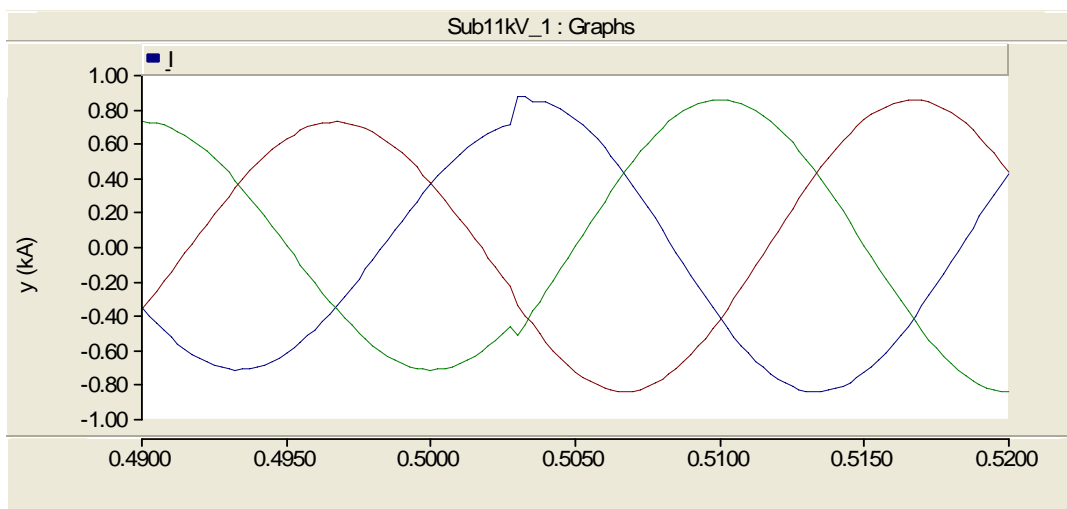

Figure 8.13: Instantaneous three phase currents at the SSEZ PCC showing the dynamic operation of the MAS-based control system.

9.1.5. Network Losses

In order to reduce active power losses within an electrical distribution network, active and reactive power flow reduction may be considered (Equation 4.17). The first is typically achieved by manipulating the total demand and generation within the network in order to achieve an overall balance and thus reduce the associated power flows. The second is typically achieved by means of power factor correction, and is the loss reduction type considered here. For reasons mentioned in Section 6.4, network losses are not taken into account when determining the operating states of system agents. Moreover, power factor correction is only considered during normal operating conditions because secure system operation is the priority for the developed control system.

The developed “Direct_Control” service (Table 7.1) may allow controllable customer-owned entities to perform similar functionalities as traditional power factor correction equipment [196] which automatically regulate the controller’s power factor to the target $\cos\phi$ entered. In the examples devised here, reactive power control for power factor correction has only been considered for the GAs and SSEGs within the SSEZ control system, however it may also be considered for ESAs and CDAs if such controllability is available.

Currently, SSEG units are typically operated at unity power factors in accordance with existing standards that do not provide any guidelines on their contribution to system operation [25-26]. The majority of customer loads in LV distribution networks are consuming reactive power (inductive loads), with typical aggregate power factors of residential or light commercial LV feeders in the range of 0.85 to 0.95 lagging [54-

55]. Therefore, if these customers had SSEGs on their premises, operating these units at lagging power factors (i.e. by exporting VARs) would reduce reactive power flows on network feeders, thereby also reducing active power losses in the network. However, exporting reactive power at SSEG connection points could have important implications for customer voltage rise and voltage regulation that need to be taken into account as described in Sections 8.1.1 and 8.1.2.

The “Direct_Control” service of direct control agents is responsible for reducing reactive power flows within the SSEZ. Similarly to customer voltage control, which also belongs to the “Direct_Control” service (Table 7.1), reactive power flow reduction is based on local measurements only, with no communication signals exchanged by direct control agents within the MAS. The reduction in active power losses that can be achieved from power factor correction on any case study SSEZ will depend mainly on: (i) the real and reactive power profiles of the installed power system entities, along with their network and phase location; and (ii) network line impedances, with greater active power loss reductions expected in LV distribution networks with high-impedance lines.

Tables 8.11 and 8.12 illustrate the active power losses within the case study SSEZ for a range of different load power factors under both minimum (0.16kW per customer) and maximum loading scenarios (1.3kW per customer). Each customer in the SSEZ is assumed to have installed a SSEG with a rating of 1kW (Table 8.11) or 1.5kW (Table 8.12) and in all the cases the operating SSEG power factor are modified such that reactive power flows in the network are reduced.

Load losses are proportional to the current squared, whereas the current is reduced in direct proportion to the power-factor improvement. Therefore, load losses are inversely proportional to the square of the power factor, which suggests that significant reductions in load losses of up to 30% (from 50kW down to 35kW) may be obtained by power factor correction through the co-ordinated control of SSEGs.

In addition to active power loss reduction, power factor correction may relieve the unnecessary transmission of reactive power, resulting in feeder power factors that approach unity. With the anticipated increased penetration of DG and SSEG units on electrical distribution networks, preventing existing networks from reaching their thermal limits will become increasingly important. Even if power factor correction is in most cases unlikely to be able to replace expansion or reinforcement of the grid for large-scale SSEG/DG integration, the additional capacity that could be accommodated may in some cases reduce potential network bottlenecks.

Loading Scenario	No Control	Proposed MAS
Minimum Loading Conditions – Load Power Factor: 0.85 (inductive)	30kW	22kW
Minimum Loading Conditions – Load Power Factor: 0.95 (inductive)	24kW	22kW
Minimum Loading Conditions – Load Power Factor: Unity	22kW	22kW
Maximum Loading Conditions – Load Power Factor: 0.85 (inductive)	12kW	7kW
Maximum Loading Conditions – Load Power Factor: 0.95 (inductive)	9kW	7kW
Maximum Loading Conditions – Load Power Factor: Unity	7kW	7kW

Table 8.11: Active power losses under the devised simulation scenarios for a SSEG power output per customer of 1kW.

Loading Scenario	No Control	Proposed MAS
Minimum Loading Conditions – Load Power Factor: 0.85 (inductive)	50kW	35kW
Minimum Loading Conditions – Load Power Factor: 0.95 (inductive)	41kW	35kW
Minimum Loading Conditions – Load Power Factor: Unity	35kW	35kW
Maximum Loading Conditions – Load Power Factor: 0.85 (inductive)	13kW	8kW
Maximum Loading Conditions – Load Power Factor: 0.95 (inductive)	10kW	8kW
Maximum Loading Conditions – Load Power Factor: Unity	8kW	8kW

Table 8.12: Active power losses under the devised simulation scenarios for a SSEG power output per customer of 1.5kW.

8.1.6. Operational Goals

The evaluation scenarios devised here focus on the case study SSEZ meeting the “zero power export” operational goal (Section 5.1.2) which may be selected for two reasons: (i) the first is due to economic considerations based on the fact that the electrical power used in the zone is commercially more valuable than the electrical power exported to the system; and (ii) the second is due to technical considerations, such as a congested 11kV feeder which dictates that power flows through that feeder must be minimised. For both cases, the aim of the control system is to ensure that the real power flow from the SSEZ to the upstream distribution network is zero.

The following sequence of actions takes place within the developed MAS in order to ensure that the SSEZ meets an operational goal:

1. Firstly, the OGA identifies an operational goal (in this case “zero power import”) either through data interpretation by observing the real power flow at the PCC with the upstream distribution network or through DNO request.

2. The OGA sends a “query-ref” message with content “Operational_Goals” to the DF.
3. The DF replies with an “inform” message to allow the OGA to find out the ID of the direct control agents that offer the requested service. In the case of “Operational_Goals”, it is likely that this service is provided by all direct control agents within the zone.
4. The OGA then sends “proposal” ACL messages to these agents in order to increase local demand through DSM and ESM schemes and/or reduce local generation.
5. Depending on their availability, these agents respond with an “accept-proposal” or “reject-proposal” message to inform the OGA that the submitted proposal has been accepted or rejected respectively. In the event of a failure or if the message is not understood by the direct control agent, it will respond with a “failure” or “not-understood” message accordingly.
6. Action execution is then performed by direct control agents that have responded with an “accept-proposal” ACL message.
7. This process is repeated until the “zero power import” operational goal has been achieved. If, however, one or more of the indirect control agents within the MAS enter their emergency state, the operational goal must be dropped in order to ensure secure system operation. This is achieved using the following two steps: (i) the respective indirect control agent(s) send an “inform” message to the OGA to ensure that the operational goal is dropped; (ii) the OGA then sends a “cancel” message to all direct control agents that had previously responded with “accept-proposal” in order to inform them that their actions are no longer requested.

As previously mentioned, two scenarios are considered for the “zero power export” operational goal within the case study SSEZ: the first one is due to economic considerations, while the second one is due to technical considerations. Minimum loading conditions (0.16kW per customer) are assumed where each customer has installed a SSEG with a rating of 2.5kW. Initially, at time $t = 0 - 0.5\text{sec}$, it is assumed that the connected SSEGs are not exporting any active power, with power flowing from the upstream distribution network to the SSEZ. At time $t = 0.5 - 1\text{sec}$, each SSEG is assumed to increase its active power output to 20% of its rated power (i.e. 0.5kW), while at time $t = 1 - 1.5\text{sec}$ this figure rises to 50% (i.e. 1.25kW), at time $t = 1.5 - 2\text{sec}$ to 75% (i.e. 1.875kW) and at time $t = 2 - 2.5\text{sec}$ to 100% (i.e. 2.5kW). Without any agents connected, the real power flows at the SSEZ PCC with the upstream distribution network under the devised simulation scenarios may be shown in Table 8.13. For the purposes of this research, the associated voltage and thermal violations as described in Sections 8.1.1 – 8.1.5 are ignored. This is done in order to illustrate the operation of the developed OGA.

- OGA operation – Economic Considerations:

Having received from the DF the ID of direct control agents that offer the “Operational_Goals” service, the OGA dispatches the following control commands, which are to be executed depending on ESU/load availability:

1. For ESAs: to increase demand in the area by importing active power through ESM (“realPowerInIncrease”).
2. For CDAs: to increase demand in the area by instructing consumer demands to switch on through DSM (“loadRescheduling” or “realPowerInIncrease”).

Similarly to the developed TLA, a simple logic has been implemented inside the OGA which dynamically calculates the difference between the real power flow from the SSEZ to the upstream distribution network and its desired value $P_{\text{out,desired}}$ (in this case $P_{\text{out,desired}} = 0$) and accordingly instructs ESAs and CDAs to increase the load in the zone. If the difference can not be kept at zero through the application of DSM and ESM schemes, a small export of electrical power to the upstream distribution network is preferable compared to curtailing the active power output of the connected SSEGs.

Hence, the aspiration of the OGA is to ensure that the real power export is zero but depending on the difference between the demand and generation within the zone, as well as the capacity of the DSM and ESM schemes available, this may not be always possible. Under the devised simulation scenarios, zero power export may be achieved during $t = 0 - 1.5\text{sec}$ (Table 8.13), but during $t = 1.5 - 2.5\text{sec}$ the difference between the generation and the demand in the SSEZ is too high to be offset by the available ESM and DSM schemes in the zone. Hence, for commercial reasons, exporting this difference to the upstream distribution network is preferable compared to curtailing the active power output of the connected SSEGs.

- OGA operation – Technical Considerations:

The operation of the OGA here is similar to before, with the OGA instructing ESAs (“realPowerInIncrease”) and CDAs (“loadRescheduling” or “realPowerInIncrease”) to increase electrical demand in the zone in order to balance the connected demand with generation. However, if balance can not be achieved through DSM and ESM schemes, SSEG active power curtailment is necessary in order to ensure that the real power flow export from the SSEZ remains at zero. This is achieved by the OGA

sending ACL messages to the connected GAs with the content “realPowerOutReduction” in order to instruct them to reduce their active power output. Due to active control signals being sent to all GAs within the MAS, the generation curtailment steps must be kept low, assuming that a fast communications medium is available for inter-agent communications. As an example, an active generation curtailment of 2.5% is instructed by the developed OGA, which means that the active power output of the connected SSEGs is down to 1.83kW during $t = 1.5 - 2$ sec and 2.44kW during $t = 2 - 2.5$ sec.

During the time period $t = 1.5 - 2$ sec, the real power flow at the SSEZ PCC has been found to have dropped down to just 4kW and additional SSEG active power curtailment is not instructed by the OGA. During the time period $t = 1.5 - 2$ sec, however, a much higher SSEG active power reduction than 2.5% is required in order to ensure that the “zero power export” operational goal is met. Simulation results have shown that it would require 13 commands from the OGA to instruct GAs to reduce their active power output down to 1.6875kW, which would then cause the real power flow at the SSEZ PCC to drop to as close to zero as possible (14kW).

Such an implementation could therefore be problematic due to the time delays caused by the extensive inter-agent communications required. In practice, however, it would be unlikely that such a high instantaneous difference in generation (i.e. an increase of 190kW according to Table 8.13) would be observed when the SSEZ is attempting to meet an operational goal. Moreover, the amount of inter-agent communications required could also be reduced by increasing the generation curtailment steps.

Simulation Time Period [sec]	Real Power Flow at PCC [kW] – no agents	Real Power Flow at PCC [kW] – OGA (economic)	Real Power Flow at PCC [kW] – OGA (technical)
t = 0 – 0.5sec	+60kW	0kW	0kW
t = 0.5 – 1sec	+120kW	0kW	0kW
t = 1 – 1.5sec	+380kW	0kW	0kW
t = 1.5 – 2sec	+600kW	+24kW	+4kW
t = 2 – 2.5sec	+790kW	+220kW	+14kW

Table 8.13: Real power flows at the SSEZ PCC with the upstream distribution network under the devised simulation scenarios.

8.2. SCALABILITY AND OPENNESS

Given that the consumer-driven growth of SSEGs is dynamic and unforeseen, the control system for an SSEZ must be able to adapt to a changing environment. In addition, due to the potential number of controllable entities that may exist, the entities managed by the control system should be allowed to grow as quickly and easily as possible, i.e. with minimum requirements for modifying the original system. In terms of scalability and openness, a FIPA-compliant MAS approach can offer a means of managing the growth of entities, such as customers, SSEGs, storage devices and network infrastructure within an SSEZ. This can be achieved through the instantiation of the corresponding number and type of direct and indirect control agents that register their services as described in Section 7.1.2. In addition to the new agents to the system, their corresponding databases must also be instantiated.

The use of FIPA agent services offers “plug and play” capabilities to the MAS by allowing new agents to automatically register themselves and announce to other agents the services they provide. Similarly, agents may be removed from the MAS at

all times according to the specific SSEZ environment. This way, it is possible to not only introduce new agents to the system, but also to introduce improved versions of existing agents and therefore provide increased functionality to the overall MAS. Scalability and openness are relevant not only within an SSEZ, but also between instances of SSEZs as for example the VPP concept [50-52].

Simulation results from Chapter 4 identified the order in which the LV distribution network constraints under investigation are likely to be encountered as SSEG penetrations are increased in the case study SSEZ. On the basis of these results, a basic MAS responsible for maintaining customer voltages within statutory limits would most likely be adopted first, as shown in Figure 8.14. This approach would originally comprise of direct control agents (GAs, ESAs and CDAs) only, reducing the need for extensive inter-agent communications, as well as the additional implementation costs of installing indirect control agents to the SSEZ.

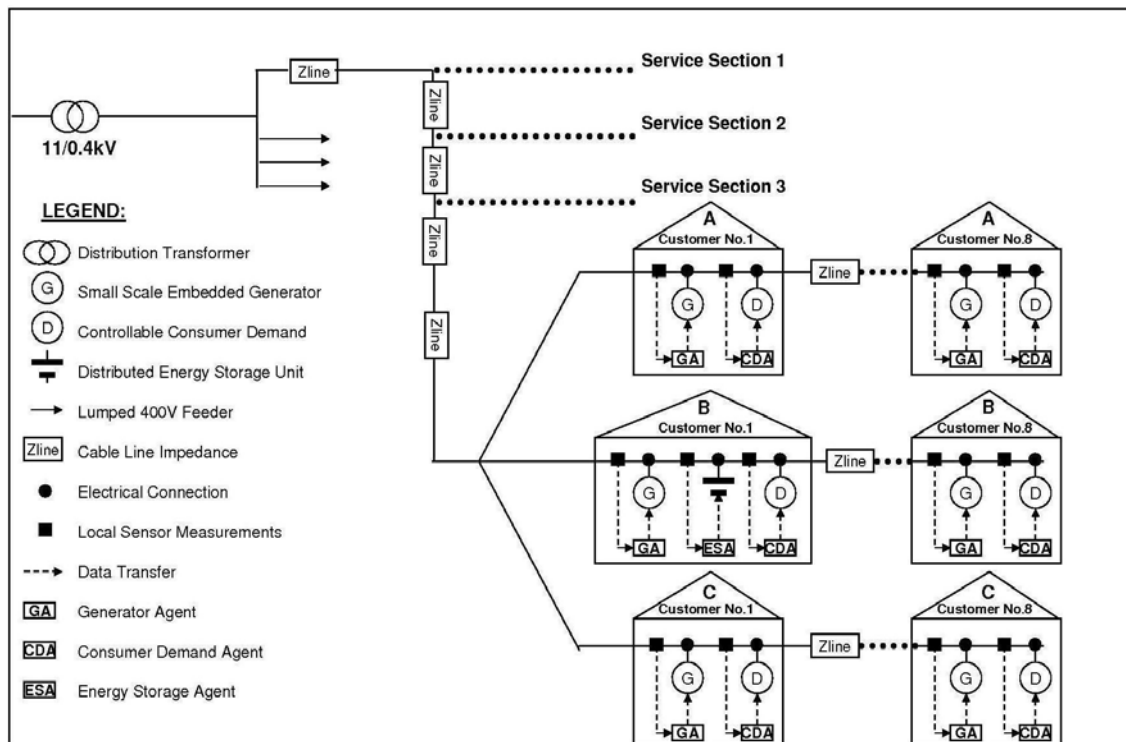

Figure 8.14: The case study SSEZ with direct control agents installed.

If SSEG penetration in the network is increased, or if regulatory reforms take place in the future which allow small-scale generators to provide ancillary services to the local DNO (for example through meeting a set of operational goals), increased functionality will be required by the MAS. The addition of indirect control agents to the system could then provide this functionality and this could take place in the “plug-and-play” manner described in Section 7.1.2. Similarly, introducing improved versions of existing agents is also possible, for example in order to improve their reasoning capabilities as will be described in Section 9.2.1.

8.3. RESILIENCE AND RELIABILITY

In order to evaluate the resilience and reliability of the developed control system, potential failures may be considered with respect to:

1. SSEZ component failure, i.e. the failure of an SSEG, ESU or load to be controlled when instructed by the relevant direct control agent;
2. Measurement and monitoring equipment failure, i.e. the failure of these devices to send measurement data back to system agents, or the provision of erroneous measurements.
3. DBMS failure, which may occur either due to failure in one or more of the databases present in the SSEZ, or due to failure in the management of these databases.
4. MAS failure, i.e. failure of the machine(s), operating system, system agents or the agent platform where the agents run. This includes failure in the control software as well as the hardware platform where the software is deployed.

The research described here only considers DBMS and MAS failure, as the other two types of failure are independent of the selected control approach. It has been argued [93, 97] that MAS technology has the potential of eliminating single points of failure. Although this may be achieved through proper design and implementation, eliminating single points of failure is not guaranteed simply by employing a MAS-based control system. General MAS theory with regards resilience and reliability has been described in detail in [93] and [197]. The following characteristics must generally be taken into account:

1. Individual agent architecture: Agents should be designed and developed with respect to potential internal or external failures.
2. MAS platform: The failure of an agent residing on a particular platform should not affect the agent environment or the other agents within the MAS.
3. Communications: Inter-agents communications must be as reliable as possible. If a message is not delivered, the sender must be notified along with the reason that caused this failure.
4. Social knowledge: Knowledge within the MAS must be dynamically obtained in a reliable and resilient manner.
5. Physical distribution: By physically distributing the agents within an MAS, fault tolerance may be improved in the event of hardware failure, software failure, power failure etc.

During the software design (Chapter 6) and implementation (Chapter 7), the following steps ensured that these five characteristics were taken into account:

1. Individual agent architecture: For direct control agents, communications failure with the indirect control or the utility agents within the MAS, or the individual

failure of other agents in the system may cause their performance to be degraded (for example by not allowing them to respond to control signals sent by indirect control agents), however they remain operational and continue to provide locally the “Direct_Control” service. Indirect control agents, however, rely on direct control agents in order to satisfy their design objectives, and therefore loss of communications is likely to have a more adverse effect to their performance. These agents remain operational in the event of system failures but their ability to effectively provide the services that they offer will depend on the type and severity of failure. Ideally, agent design is performed according to the concept of “graceful degradation” [123], where in the event of failures performance is gracefully degraded, fulfilling as many of the agent design objectives as possible without resulting in failure of the whole system.

2. MAS Platform and Communications: The employment of JADE, one of the most robust MAS development toolkits currently available [102-103] can ensure that both of these points are met. This is one of the main reasons for selecting JADE as the ADK for the implementation of the MAS, as detailed in Section 8.1.1.
3. Social knowledge: The presence of just one DF and one AMS that manage social knowledge within the MAS could present single points of failure within the system. In order to increase redundancy, providing a replication of these agents that would run on a separate container could increase system reliability (Figure 8.15), however this would not protect the system from faults in the code within these agents.
4. Physical distribution: Direct control agents within the MAS are physically distributed, with each agent running on a separate hardware platform. Indirect control agents and utility agents may or may not be physically distributed,

depending on the specific MAS implementation, which in turn will depend on the computing and communications resources available. If the MAS is running on only one container, failure of the Java virtual machine or the operating system on which the container is running could result in failure of the whole system. For this reason, two features of JADE could be employed in order to ensure that the MAS remains fully operational even in the event of a main container failure [103]: (i) the main container replication service, i.e. allowing the main container and the AMS to be replicated in order to keep all replicas fully synchronised and to ensure that another container takes over in the event of failure (Figure 8.15); and (ii) the DF persistence implementation, i.e. allowing the list of services of the DF to be recorded in a relational database, typically using the JDBC interface. In the event of main container failure, a new DF is automatically started on the new main container, which then retrieves this list from the database.

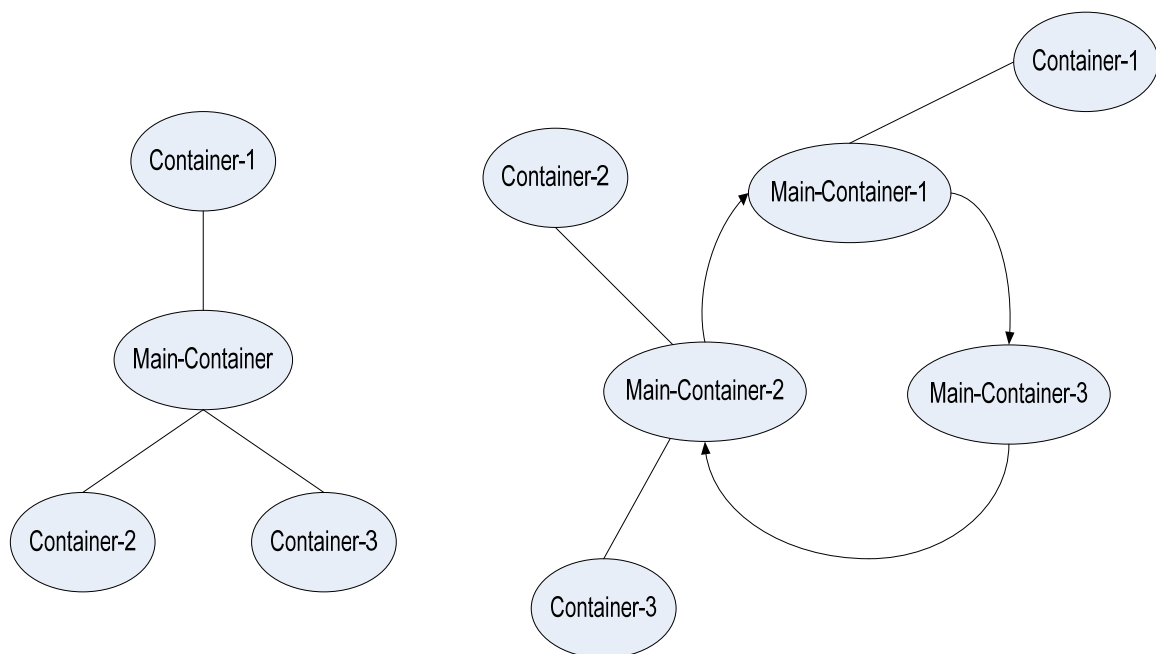

Figure 8.15: A JADE platform without (left) and with (right) the main container replication service.

Failure in the DBMS may occur either due to an individual database failure, or due to failure in the management of these databases, such as a failure in the database server.

1. Failure in an SSEG, ESU or load database will cause the direct control agent that is coupled to this database to lose communication with the power system entity it is controlling and will therefore result in the agent being unable to achieve its primary design objective, namely the “Direct_Control” service. In the absence of a local database, the power system entity may therefore need to be disconnected from the SSEZ in order to protect the equipment from potential damage. Additionally, in the event of such failure, direct control agents could attempt to receive measurement data directly from the power system entity that they are coupled with, if such functionality exists. In all the cases, however, failure in an SSEG, ESU or load database will not bring the system down and customer steady-state voltages within the SSEZ will be kept inside statutory limits as a result of the distributed droop control paradigm described in Section 8.1.1.
2. Failure in the indirect control database or the database server could result in a single point of failure, and therefore increased redundancy is required in order to gain fault tolerance. Since indirect control agents can not achieve their design objectives without receiving measurement data from the indirect control database, contingency plans such as replication or back-up servers should be employed in order to increase system resilience and reliability.

8.4. COMMUNICATIONS EFFICIENCY

The proposed MAS-based approach offers communication efficiency gains compared to traditional centralised approaches through: (i) the execution of local autonomous

control actions; and (ii) by ensuring that only relevant measurement data and control signals are sent for system control purposes. For the management of customer voltages and network losses within the SSEZ, all control actions are performed locally and autonomously by the relevant subset of the agent community, i.e. direct control agents, without the need for any inter-agent communications. Using a centralised approach, the level of communications required would be significantly more intensive, as measurement data would firstly need to be collected at a central point and then control signals would be dispatched to the relevant controllable entities within the SSEZ.

Moreover, through the employment of indirect control agents that monitor strategic locations within the SSEZ, such as cable “hot-spots”, power flows at the PCC and voltage unbalance factors at the remote ends of the SSEZ feeders, the proposed MAS-based control approach ensures that only relevant measurement data and control signals are exchanged. All agents within the developed MAS have a limited view of the system, which is based on the notion that they only receive measurement data that will allow them to achieve their particular design objectives. In addition, inter-agent communications are only performed between the relevant agents as explained in Section 6.3.4. This way, information exchange within the system is minimised, which is an important requirement for the selected control approach due to the potential number of monitoring and control points within the SSEZ. On the contrary, a centralised approach would require communication links between the measurement devices, the controllable power system entities within the SSEZ and the central point of the controller, which could potentially become a communication bottleneck.

Delays and data rates of some of the commonly available media employed in electrical power systems are shown in Tables 8.14 and 8.15 respectively.

Communication medium	Associated delay – One way (milliseconds)
Fiber-optic cables	100 – 150
Digital microwave links	100 – 150
Power line carriers (PLC)	150 – 350
Telephone lines	200 – 300
Satellite link	500 – 700

Table 8.14: Communication delays of popular communication media.

Communication medium	Data rate (bps)
T1	1 Mbps. Effective bandwidth, however, considering network traffic, data collision etc could be as low as 125 kbps
Frame relay	280 kbps
ISDN	140 kbps
56k leased line	565 kbps. Effective bandwidth, however, will be lower than this.
Internet	Effective rate could be as low as 40 kbps, depending on network traffic
Radio frequency	9.6 kbps
Power line carriers (PLC)	1.2 kbps

Table 8.15: Data rates (bps) of popular communication media.

The communication requirements of the SSEZ control system correspond to the different tasks that must be realised in order to control the zone under normal, alert or emergency state. The bandwidth needs for each measurement, control or communication task described in Sections 5.1.1 and 5.1.2 are different and with a required time response that depends on the nature of the task. In all the cases, monitoring of the system is critical for event detection. During alert or emergency state, the bandwidth requirements depend on the duration and disturbance nature of

the event. With the exception of voltage rise/drop and loss reduction, information must be shared between different components as previously described.

Table 8.16 illustrates the bandwidth requirements and the response time requirements for different tasks of the SSEZ control system. In general, issues associated with voltage control require a faster response compared to thermal limits. This is because in most distribution systems, system equipment (cables, lines and transformers) will not be critically damaged if their maximum current rating capacity has been exceeded by a small margin and for a short period of time. For voltage control issues, however, common statutory regulations are employed in all UK LV distribution networks and adhering to these regulations often requires a faster response.

Measurement, control or communication task	Bandwidth requirement	Response time requirement
Transfer of power system data measurements	- Low (for direct control agents) - Medium (for indirect control agents)	Seconds
Inter-agent communications (ACL)	Medium	Seconds
Communication between a direct control agent and a SSEG/ESU/load	Low	Milliseconds to Seconds
Agent-to-database communications (JDBC)	Low	Milliseconds
Control of customer voltages based on local decisions	Low	Milliseconds to Seconds
Control of load losses based on local decisions	Low	Milliseconds to Seconds
Control of an SSEZ thermal “hot-spot” or a distribution transformer	Low/Medium	Seconds to minutes
Control of voltage regulation statutory limits	Low/Medium	Seconds
Control of voltage unbalance statutory limits	Low/Medium	Seconds

Table 8.16: Bandwidth requirements and response time requirements for different tasks within the developed control system.

As it can be seen, the communication requirements for the control system of an SSEZ could be met through the employment of the communication architecture shown in Figure 6.8. This is because the majority of tasks within an SSEZ require a response time in the region of seconds, which can readily be provided by utilising existing peer-to-peer communication infrastructure such as residential broadband and the public Internet (Table 8.15).

8.5. EXPERIMENTAL EVALUATION

In addition to the simulation work described previously, a laboratory-based Experimental SSEZ was developed at Durham University by another PhD student [32, 198-199]. The Experimental SSEZ consists of one load emulator, one wind turbine generator emulator, one PV generation emulator, one dCHP emulator, one ESU and a network connection emulator as shown in Figure 8.16.

Monitoring and control systems were developed using the LabVIEW™ [200] visual programming environment that enable the flexible, real-time measurement of system parameters (voltage, current, frequency etc) and also enable repeatable, controlled testing to be carried out. The aim of the Experimental SSEZ is to highlight the practical issues associated with implementing distributed control techniques on an existing LV distribution network, as well as to observe the actual dynamic responses of power system components such as power electronic converters and electrical machines.



Figure 8.16: View of the Experimental SSEEZ at Durham University.

A simple application of the proposed agent-based approach for voltage control in the Experimental SSEEZ is presented based on work described in [32]. The following agents were implemented in the Experimental SSEEZ using the LabVIEW™ visual programming environment, as shown in Figure 8.17:

- Generator Agents (GAs) ~ one GA controlling the wind turbine generator emulator and one GA controlling the PV generator emulator.
- Consumer Demand Agent (CDA) ~ one CDA controlling the load emulator.
- Energy Storage Agent (ESA) ~ one ESA controlling the ESU emulator.

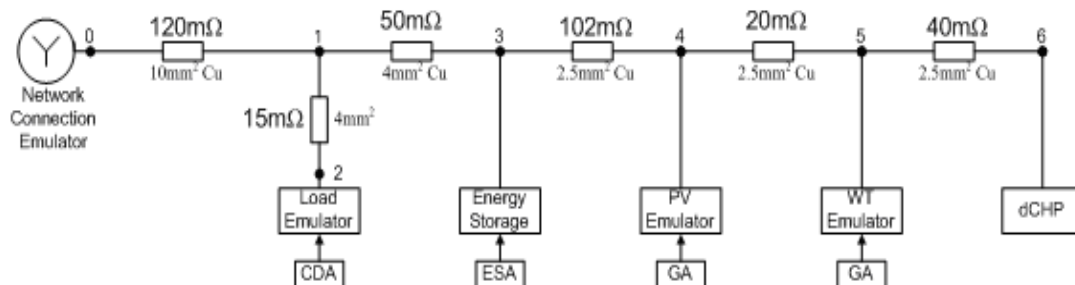

Figure 8.17: Application of an agent-based approach to the Experimental SSEEZ.

Under normal operating conditions, the Experimental SSEZ was operated such that steady-state voltages were maintained within the designated statutory limits. For the purposes of the test, the nominal voltage was defined as 225.5V, while the allowable voltage rise limit was defined as 232V. Initially, the prime mover of the wind turbine generator emulator was instructed to operate at a speed that results in a power output of 0.4kW to the system, the PV generator emulator was instructed to export 1.5kW and the load imports approximately 0.8kW.

At time $t = 230s$ the prime mover of the wind turbine generator emulator was instructed to accelerate to a speed that resulted in the export of 1.2kW to the system. The power import of the load emulator and the power export of the PV generator emulator initially remain constant. At time $t = 320s$ and at 90s intervals thereafter the load is reduced by 0.2kW until the demand is reduced to zero. Figure 8.18(a) illustrates the effect of the operation of the wind turbine generator emulator and the changing load profile on the remote end network voltage, without any agents deployed in the system. It can be seen that the voltage in this case exceeds the defined voltage rise limit of 232V following the increase in wind generation and thereafter the decrease in demand.

Figure 8.18(b) illustrates the operation of the initial Wind Generator Agent (WGA I) and the PV Generator Agent (PVGA I) operating individually to mitigate the steady-state voltage rise. This was achieved through feedback control loops in WGA I and PVGA I instructing the grid interface inverters of the wind turbine and the PV generator emulator respectively to curtail their power outputs until satisfactory system operation is achieved.

Figure 8.18(c) illustrates the operation of WGA I and the PVGA 1 operating at the same time to overcome the steady-state voltage rise. In the trace titled *WGA I & PVGA I (No Comms)* there are no inter-agent communications however in the trace titled *WGA II & PVGA II (Comms)* inter-agent communication is part of the functionality of these agents who work as a team to solve the voltage rise problem.

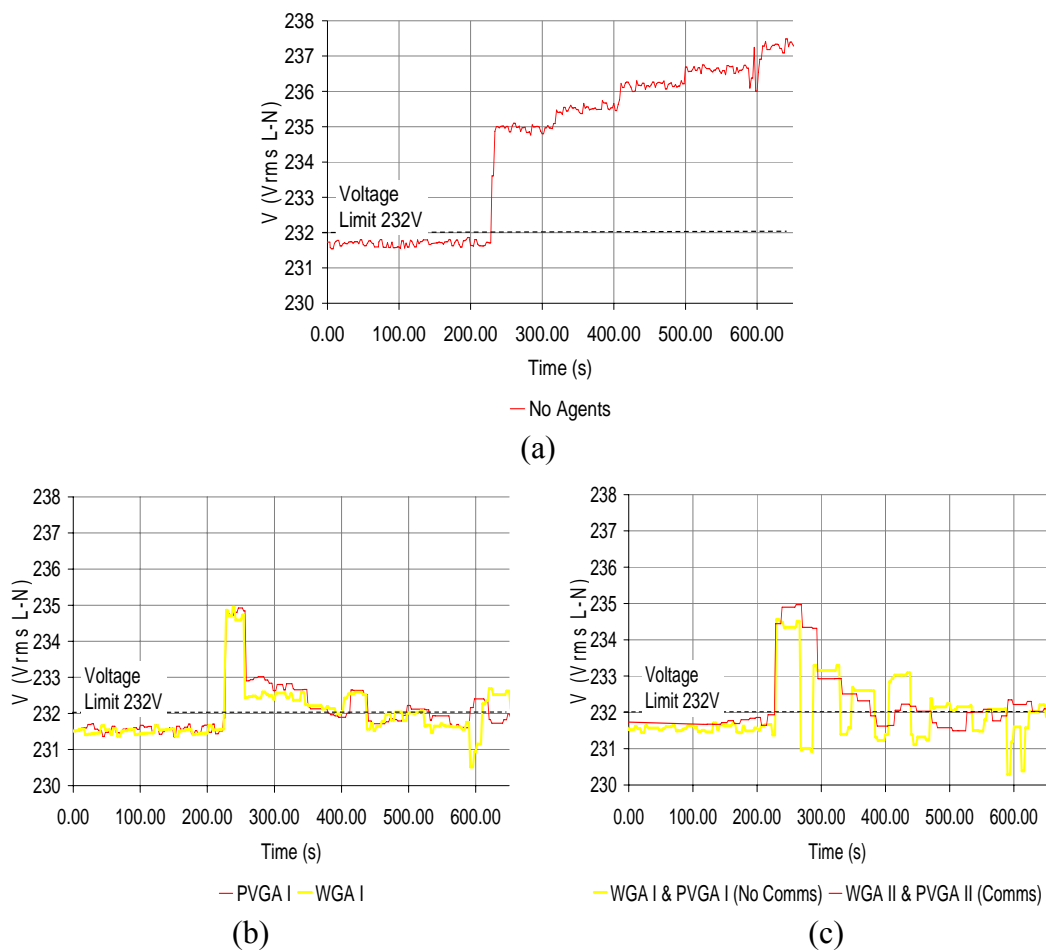

Figure 8.18: Operation of over-voltage agents in the Experimental SSEZ.

The deployment of agents without inter-agent communications was shown in [32] to result in lower energy yields for consumers at the remote end of the radial LV network than if inter-agent communications were implemented among the agents. The overall energy yield from the system, however, is likely to be higher if no inter-agent

communication is implemented. This is due to the fact that if large amounts of generation result in the voltage at the remote end exceeding statutory limits the reduction in generation output is likely to take place near the remote end of the network where the effect of the local controllers will be most pronounced, assuming that the feedback gains are equal. In addition, the extra cost of setting up a communications infrastructure between the agents is also a factor when considering the benefits of implementing inter-agent communications.

8.6. CONCLUSIONS

The principles described in the previous two Chapters were applied to the case study SSEZ model in PSCAD/EMTDC™ with the aim being to evaluate the suitability of the developed control system to provide the functionality required for an SSEZ. Various evaluation scenarios were outlined in order to: (i) overcome the identified LV distribution network constraints (Sections 8.1.1 – 8.1.5); and (ii) meet an operational goal (Section 8.1.6). In all the cases, the developed control system was found to satisfy the specific control requirements of the SSEZ, while at the same time: (i) avoiding unnecessary SSEG active power curtailment; and (ii) reducing active power losses within the SSEZ through reactive power flow minimisation. In addition, the proposed MAS-based control approach could provide significant benefits compared to traditional centralised control techniques in the following three areas: (i) scalability and openness; (ii) resilience and robustness; and (iii) communications efficiency. These findings suggest that MAS technology has the potential of being able to meet the requirements of the electricity industry for the distributed control of electrical distribution networks with high SSEG penetrations.

CHAPTER 9

Conclusions and Further Work

This Thesis presented an investigation on the technical impacts caused by the steady-state operation of Small-Scale Embedded Generators (SSEGs) and also introduced the Small Scale Energy Zone (SSEZ) concept which aims to remove the technical barriers associated with SSEG through intelligent coordination of large numbers of customer-owned SSEGs, energy storage units and controllable loads. In addition, by grouping these entities into a controllable zone, increased economic and environmental benefits may be realised. This approach represents a move away from the conventional passive, “fit-and-forget” philosophy under which the majority of LV networks are currently operated and towards a higher degree of network operational management. The employment of a distributed management and control approach, realised through the Multi Agent Systems (MAS) technology, was proposed due to the advantages that can potentially be realised in the areas of: (i) scalability and openness, (ii) reliability and resilience and (iii) communications efficiency. These areas were shown to be particularly important when considering future high SSEG penetration scenarios.

9.1. CONCLUSIONS

The main conclusions stemming from the research described in this Thesis are presented here. As stated in Section 1.3, the research objectives of this Thesis were:

1. *To evaluate the technical impacts caused by the steady-state operation of SSEGs and to quantify allowable SSEG penetration limits on suitable case study LV distribution networks.*

Three different LV distribution networks were modelled in the power systems simulation package PSCAD™/EMTDC™: (i) one generic urban UK LV distribution network; (ii) one existing urban UK LV distribution network; and (iii) one generic sub-urban European LV distribution network. Simulation results were obtained from the developed models in order to obtain allowable SSEG penetration limits and in order to analyse the key electrical characteristics that determine the response of LV distribution networks to the addition of high SSEG volumes.

Significant differences were observed regarding both the SSEG volumes that may be accommodated on each network and the order in which the five constraints under consideration were encountered (voltage regulation, customer voltage rise, voltage unbalance, cable and transformer thermal limits and network losses). Customer voltage rise was shown to be the most limiting constraint for the UK generic and the UK existing case study network, while voltage regulation and cable thermal limits were found to be the most limiting constraints for the European generic network. In addition, voltage unbalance has been identified as having the potential to cause concern for DNOs in LV networks with high SSEG penetrations. This is both due to the relatively low unbalanced SSEG volumes that may be accommodated before voltage unbalance statutory limits are exceeded, as well as because SSEG growth is

consumer-driven (as governed by the “fit-and-inform” policy) and DNOs in most cases will have limited control over selecting the phase of SSEG connection.

These differences illustrate that generic networks are often quite different from real networks and therefore the results of SSEG impact studies carried out on generic networks alone must be treated with caution. This emphasises the need for specific impact studies to be performed by DNOs on their LV distribution networks in order to investigate the technical impacts of SSEGs and to assess SSEG penetration limits within each LV distribution network. If SSEG proliferates as anticipated [5-7], the number of studies required could place a significant burden on DNOs and therefore a means of managing this might be needed in the future.

2. To develop a methodology for predicting allowable SSEG volumes on any case study LV distribution network quickly and easily and without the need for developing detailed computer-based models.

On the basis of the simulation results obtained from PSCAD™/EMTDC™, an analysis of the key electrical characteristics that determine the response of LV distribution networks to the addition of high SSEG volumes was performed. The key factors that have been identified through simulation as having an effect on the technical impacts of SSEGs under investigation are the following: (i) network symmetry; (ii) network topology; (iii) network length; (iv) distribution substation voltage; (v) network lines; (vi) distribution transformer; (vii) SSEG power factor; (viii) SSEG network location; (ix) SSEG phase location; and (x) loading conditions.

In order to develop a methodology for predicting allowable SSEG penetration limits on any case study LV distribution network, the concept of “overall network apparent impedance” was derived which calculates the value for the overall apparent impedance of any LV distribution network in three steps: (i) by determining the apparent impedance at a network location (single customer); (ii) by determining the apparent impedance at a network location (multiple customers); and (iii) by determining the overall network apparent impedance (all customers, all locations).

The proposed methodology allows SSEG penetration limits to be predicted quickly and easily and without the need for developing detailed computer-based models. These may be quantified by comparing the overall network apparent impedance of the case study LV distribution network to the overall network apparent impedance of the UK or European generic network, depending on which of the two networks is deemed by the user to be the most similar. Estimated allowable SSEG volumes may then be obtained based on either statutory regulations (voltage regulation, voltage rise, voltage unbalance) or equipment ratings (cable and transformer thermal limits) by considering the excess SSEG power output that may be accommodated in the case study network in comparison to results obtained from the selected generic network.

Having developed the proposed methodology, it was then applied on an existing public UK LV distribution network for evaluation purposes. There was reasonable agreement between the results obtained from simulations and the methodology predictions providing confidence that the methodology could in some cases be used instead of detailed modelling. In particular, the strength of the proposed methodology

is that although it is based on studies carried out on generic networks it contains adaptation steps designed to ensure it is applicable to real LV distribution networks.

The methodology predictions were found to be accurate regarding voltage regulation as this impact can be assessed adequately by only considering the impedances and power flows between the distribution transformer and the end of each feeder. In the case of customer voltage rise, the methodology was found to be accurate for uniform distributions of SSEGs where the assumed distribution transformer voltage is accurate. For SSEGs clustered on only one feeder of the case study network, however, this assumption is not correct and this was reflected in the results obtained.

Voltage unbalance predictions were found to be reasonably accurate but not exact as they were based on the assumption that the case study network impedances are exactly the same as those found in the UK generic network. For cases where the impedances are significantly different, the methodology contains an adaptation stage for obtaining an estimate on the allowable SSEG volumes that may be accommodated. In general, however, due to the non linear relationship between network impedances and voltage unbalance, a discrepancy between results from the methodology and simulation results is to be expected.

Finally, for transformer and cable thermal limits, the methodology predictions were also found to be reasonably accurate, with some minor differences observed due to errors in losses predictions caused by differences in customer distribution and hence in power flows. A full load flow calculation would then be required in order to remove this error completely.

3. To identify the key control requirements of an SSEZ.

Since SSEZs contain sections of public LV networks, they must be transformed from passive to active entities to facilitate the integration of SSEGs. The key control requirements of an SSEZ are: (i) to ensure secure system operation by complying with existing statutory regulations and equipment thermal ratings; and (ii) to meet a set of operational goals associated with providing the local DNO with controllable demand or generation, depending on the electrical power balance within the zone.

The following technical constraints were taken into consideration: (i) customer voltage rise; (ii) voltage regulation; (iii) voltage unbalance; (iv) cable and transformer thermal limits; and (v) network losses. In order for the adopted control system to ensure that these constraints are overcome, three main stages are involved: (i) state assessment, where measurement data from specific measurement points within the SSEZ are collected and processed; (ii) action planning and decomposition, where potential control actions are identified; and (iii) action execution, where control actions are sent to customer-owned SSEZ power system entities (SSEGs, ESUs and/or controllable loads) and these actions also reviewed.

Aside from the technically-driven goal of ensuring secure system operation, an SSEZ should also have the ability to provide the local DNO with predictable and controllable demand or generation. In turn, this could lead to increased economic benefits due to group interaction with energy markets and the potential provision of ancillary services to DNOs. Depending on network conditions, five different operational goals for an SSEZ were identified: (i) zero power export, (ii) zero power import, (iii) zero power import and export (self-sufficiency), (iv) constant power

import and (v) dispatchable power. In order for the adopted SSEZ control system to ensure that an operational goal has been met, the same three stages (state assessment, action planning and decomposition and action execution) are employed.

4. *To select and design a suitable control approach based on the specific control requirements of an SSEZ. The proposed approach must then be implemented using software development tools and evaluated on a case study SSEZ using a suitable power systems simulation package.*

Two different control approaches were considered over their suitability to satisfy the specific control requirements of an SSEZ. The first one would be the extension of traditional centralised control systems from their current operation to cover LV distribution networks as well. The second would be the development of a distributed control approach, where control decisions are made with a degree of autonomy. The employment of a distributed control approach, realised through the MAS technology, was proposed due to the advantages that can potentially be realised in the areas of: (i) scalability and openness, (ii) reliability and resilience and (iii) communications efficiency. These areas were shown to be particularly important when considering future high SSEG penetration scenarios.

The MAS for the active control of an SSEZ was implemented using the JADE (Java Agent DEvelopment Framework) agent development toolkit ensuring full FIPA (Foundation for Intelligent Physical Agents) compliance, and comprises of three types of agents: (i) direct control agents, (ii) indirect control agents and (iii) utility agents. The objective of the MAS is to provide a grid-interactive control strategy for all customer-owned controllable components installed within the SSEZ (SSEGs, ESUs

and controllable loads) by determining their real and reactive power set points based on the specific control requirements of the SSEZ. In order to achieve that, three operating states were implemented inside the functionality of the direct and indirect control agents: (i) normal state, where the aim is to maximise the total SSEG active power output and to reduce system load losses by reactive power flow minimisation; (ii) alert state, where the aim is to bring the system back to its normal state by employing DSM and ESM schemes as well as reactive power support for voltage control; and (iii) emergency state, where active power curtailment of SSEGs is necessary in order to ensure secure system operation.

Central to the functionality of the developed MAS are the reasoning and communication capabilities implemented inside each agent, as well as the employment of a common ontology for sharing knowledge. These were designed and developed specifically for meeting the SSEZ control requirements. Protégé and the OntologyBeanGenerator plug-in were employed for the development of the application-specific common ontology. Meanwhile, agent decision-making is performed according to a set of rules based on the three operating states of system agents. The reasoning capabilities of system agents were kept as simple as possible, while at the same time ensuring that the SSEZ remains functional independent of the operating state. This was done in order to minimise the required processing time and power of the hardware entities where the agents are to be housed and thus also reduce the associated costs of employing a MAS-based control system. Finally, agent coordination is achieved through cooperation of system agents, where the overall goal is always a higher priority compared to individual goals (“good citizen” behaviour).

In addition to the proposed MAS, a relational database management system (RDBMS) was designed and implemented using MySQL. The aim of the RDBMS is to allow measurement data within the SSEZ to be stored and retrieved by the relevant system agents in order to provide information regarding the current status of the SSEZ, thereby enabling analyses of network events and network performance. Four types of databases were developed: (i) an indirect control database; (ii) a SSEG database; (iii) an ESU database; and (iv) a load database. These databases comprise all the necessary information and measurement data required by system agents in order to achieve their design objectives. Communications between the developed agents and their respective databases may be achieved using Java DataBase Connectivity (JDBC), which is the industry standard for interface between applications developed using the Java programming language and a wide range of databases. Finally, all data management functions within the SSEZ, i.e. data entry, access, update, storage, retrieval, etc, are performed through the RDBMS.

Having designed and developed the MAS and RDBMS for satisfying the specific control requirements of an SSEZ, various evaluation scenarios were devised in order to assess the operation of the developed control system on a case study SSEZ. In general, the performance of the control system will depend on the capability for active and reactive power control within the overall SSEZ, which will depend on the availability and controllability of the installed customer-owned power system entities (SSEGs, ESUs and controllable loads). In all the cases, however, the developed control system was found to be able to overcome the identified LV distribution network constraints or to meet an SSEZ operational goal. At the same time, benefits compared to a passive control approach can be realised in the following two areas:

1. Maximising the total SSEG active power output in the SSEZ: Currently, SSEGs are treated as non-firm generation, whereby they must operate within statutory voltage and frequency limits and are tripped during contingency conditions. Under the proposed active management scheme, SSEGs are treated as regulated non-firm generation whereby they are subject to power factor adjustment or curtailment of real power output and are only tripped during emergency conditions.

Maximising the total SSEG active power output in the SSEZ was achieved by ensuring that SSEGs were operating at their maximum power output and by avoiding SSEG active power output curtailment. This is because SSEG active power curtailment has important economic consequences as the SSEG owner loses part of its revenue which will have an impact on the SSEG payback time.

2. Reducing active power losses within the SSEZ through reactive power flow minimisation. Power factor correction has only been considered for the GAs within the SSEZ control system, however it may also be considered for ESAs and CDAs if such controllability is available. This operation is in contrast to current typical SSEG operation, where SSEG units are operated at unity power factors because their owners are financially rewarded only for active power output.

Load losses were found to be proportional to the current squared, whereas the current reduced due to SSEG reactive power control was in direct proportion to the power-factor improvement. Therefore, load losses were found to be inversely proportional to the square of the power factor, with significant reductions in load losses observed through adjusting the power factor of the connected SSEGs. Finally, in addition to active power loss reduction, power factor correction was also found to relieve the unnecessary transmission of reactive power, resulting in feeder power factors that approach unity. Hence, the additional capacity that may

be accommodated due to power factor correction may in some cases reduce potential network bottlenecks.

In terms of scalability and openness of the control system, a FIPA-compliant MAS approach was found to offer a flexible means of managing the growth of entities, such as customers, SSEGs, storage devices and network infrastructure within an SSEZ. The use of FIPA agent services ensured “plug-and-play” capabilities to the MAS by allowing new agents to automatically register themselves and announcing to other agents the services they provide. Similarly, agents can be removed from the MAS at all times according to the specific SSEZ environment. This way, it is possible to not only introduce new agents to the system, but also to introduce improved versions of existing agents and therefore provide increased functionality to the overall MAS. At the same time, these changes may occur without any modifications to the basic communication and computing infrastructure and with minimal human supervision.

Regarding resilience and reliability, the presence of just two utility agents that manage social knowledge within the MAS could present single points of failure within the system. In addition, if the MAS was running on only one container, failure of the Java Virtual Machine or the operating system on which the container was running could result in failure of the whole system. For this reason, the employment of the main container replication service and the directory facilitator persistence implementation was proposed as a means of ensuring that the MAS remains fully operational even in the event of a main container failure. Additionally, the individual failure of an indirect control agent may cause agent performance to be degraded (for example by not allowing the agent to respond to control signals sent by an indirect control agent),

however the agent remains operational and continues to provide locally the “Direct_Control” service. Failure of an indirect control agent, however, is likely to have a more adverse effect to agent performance. These agents remain operational in the event of system failures but their ability to effectively provide the services that they offer will depend on the type and severity of failure.

Finally, the proposed MAS-based approach can offer communication efficiency gains compared to traditional centralised approaches through: (i) the execution of local autonomous control actions; and (ii) by ensuring that only relevant measurement data and control signals are sent for system control purposes. All agents within the developed MAS have a limited view of the system, which is based on the notion that they only receive measurement data that will allow them to achieve their particular design objectives. In addition, inter-agent communications are only performed between relevant agents in order to minimise information exchange within the system. In contrast to current practices at the LV customer level, where very little command, control and data acquisition is typically carried out, the communication requirements of the proposed MAS-based control system were found to be significant. An initial investigation, however, showed that these may be met by utilising existing peer-to-peer communication infrastructure, such as for example residential broadband and the public Internet. This is because the majority of measurement, control or communication tasks within an SSEZ require a response time in the region of seconds, which can readily be provided by existing communication media used for Power Engineering applications.

9.2. FURTHER WORK

The research described in this Thesis presents a MAS-based control approach for an SSEZ, but it is recognised that further work in a number of research areas could provide still more benefit. There are two possible directions for the continuation of the work described here. The first would be going deeper and extending some of the topics that were investigated in this Thesis, while the second would be the further evaluation of the MAS-based control approach that was presented.

9.2.1. Extension of the Research

There are a variety of research topics that could be explored as a means of improving the functionality of the developed MAS-based control system. Some specific examples are outlined below, along with the potential benefits that could be realised.

1. Include economic scheduling in agent decision-making: Further value could be added to the SSEZ concept if agent decision-making was also based on economic scheduling, i.e. the participation of direct control agents to the electricity market through interaction with a market operator [125-127]. This operation, however, would also necessitate consideration of agents competing for resources and not just cooperation of agent activity according to the “good citizen” behaviour.
2. Include heat management in agent decision-making: In general, since electrical power is more readily transported than heat, heat production close to the location of heat demand is more common than heat production close to electrical demand. The ability of some types of SSEGs to supply waste heat near the point of utilisation coupled with appropriate control strategies may allow more effective use of waste heat, thereby avoiding extensive thermal distribution networks.

3. Include forecasting techniques: Forecasting techniques may include both demand forecasting, as well as renewable power generation forecasting. As an example, such techniques may be implemented inside the functionality of the MAS as a means of simplifying the identification of a suitable operational goal.
4. Ontology design based on the Common Information Model: The Common Information Model (CIM) [201-202] may be used in any domain where a common representation for an electrical power system is needed, such as for example an SSEZ. However, the CIM is not currently mature enough for adoption within an LV distribution network environment since description for LV distribution network components is not currently present. Hence, additional development of the CIM would be required in order to be able to adopt it for an SSEZ.
5. Improved agent reasoning capabilities: The research described in this Thesis was concerned with responsive control, however pro-active techniques may also be investigated, whereby the location, period and possibility of an LV distribution network constraint to be encountered may be anticipated over a time period. In addition, learning techniques may be incorporated, where agents are able to act based on previous experiences and beliefs. This could allow direct and indirect control agents to store their control actions according to the identified network event and also to be able to determine the most suitable course of action for future events. Finally, a more flexible approach could be adopted in the occurrence of conflicting actions between system agents, where agent priorities change depending on technical, economic, or environmental considerations. For instance, reflection was applied in [94, 123] as a means of allowing an agent to reflect on the knowledge, abilities and goals of other agents and thus provide the appropriate solution from a set of competing actions.

9.2.2. Further Evaluation

The second potential direction for the continuation of the work described in this Thesis would be the further evaluation of the proposed MAS-based control approach.

1. Simulation tools could be employed to investigate the dynamic and transient response of the developed control system. An initial investigation in the dynamic behaviour of the case study SSEZ suggested that the proposed system would not cause significant stability problems. However, additional research is required in order to further support this view and to develop specific control actions for the dynamic behaviour of the direct and indirect control agents within the MAS. In addition, the evaluation scenarios described in this Thesis focused only on one case study SSEZ and only on one operational goal. Further evaluation on different types of case study SSEZs could provide different conclusions with regards the benefits that may be realised by employing MAS technology.
2. An initial experimental investigation of the proposed MAS-based control approach was presented in Section 8.5. However, there are two main limitations with the presented approach: firstly, it is not FIPA-compliant and secondly, it does not include an RDBMS for data management purposes. Hence, a more comprehensive experimental investigation could provide still more benefit towards the evaluation of the MAS-based control approach presented in this Thesis. This could allow detailed communication issues, such as time delays between inter-agent communications, agent-to-database communications or between direct control agents and the customer-owned power system entities, to be taken into account. In addition, the dynamic behaviour of the developed control system could be investigated experimentally in order to determine whether the proposed system would cause stability problems to the operation of the SSEZ.

References

- [1] 'Meeting the energy challenge: A white paper on energy', Department of Trade and Industry, May 2007 - <http://www.berr.gov.uk/files/file39387.pdf/>, last accessed: 2009.
- [2] 'Updated energy and carbon emission projections: The energy white paper', Department for Business Enterprise and Regulatory Reform, February 2008 - <http://www.berr.gov.uk/files/file39580.pdf/>, last accessed: 2009.
- [3] Stephenson P.M. 'An uncertain future for UK electricity?' Power Systems Conference and Exposition, IEEE Power Engineering Society, October 2006, p. 1807–1813.
- [4] 'The limitation of emissions of certain pollutants into the air from large combustion plants', Office Journal of the European Communities, October 2001 - http://eur-lex.europa.eu/LexUriServ/site/en/oj/2001/l_309/l_30920011127en00010021.pdf/, last accessed: 2009.
- [5] 'Capacity mapping and market scenarios for 2010 and 2020', Mott MacDonald, The Carbon Trust and Department of Trade and Industry Renewables Network Impact Study, November 2003.
- [6] 'System integration of additional micro-generation costs and benefits – Final Draft Report', Mott McDonald, June 2004.
- [7] 'Potential for microgeneration - Study and analysis', Energy Saving Trust, November 2005.
- [8] Jenkins N., Allan R., Crossley P., Kirschen D., Strbac G., 'Embedded generation', 2000 Published by: The Institution of Electrical Engineers, ISBN: 0852967748.
- [9] Djapic P., Ramsay C., Pudjianto D., Strbac G., Mutale, J., Jenkins N., Allan R., 'Taking an active approach', IEEE Power and Energy Magazine, 5 (4): p. 68-77, July-Aug. 2007.
- [10] Shafiu A., Bopp T., Chilvers I., Strbac G. 'Active management and protection of distribution networks with distributed generation', IEEE Power Engineering Society General Meeting, June 2004, p. 1098-1103.
- [11] Roberts D.A. 'Network management systems for active distribution networks – A feasibility study', Department of Trade and Industry, October 2004.
- [12] Smart P., Dinning A., Maloyd A, Causebrook A., Cowdry S. 'Accommodating distributed generation', Econect, Department of Trade and Industry, March 2006.
- [13] Strbac G., Jenkins J., Hird M., Djapic P., Nicholson G. 'Integration of operation of embedded generation and distribution networks', Manchester Centre for Electrical Energy, Final Report, May 2002.
- [14] Pfajfar T., Papic I., Bletterie B., Brunner H. 'Improving power quality with coordinated voltage control in networks with dispersed

- generation'. International Conference on Electrical Power Quality and Utilisation, October 2007, p. 1-7.
- [15] Wright A.J., Formby J.R. 'Overcoming barriers to scheduling embedded generation', EA Technology, Department of Trade and Industry, May 2000.
- [16] Collinson A., Dai F., Beddoes A., Crabtree J. 'Solutions for the connection and operation of distributed generation', EA Technology, Department of Trade and Industry, July 2003.
- [17] Low Carbon Building Programme, Department of Business Enterprise and Regulatory Reform - <http://www.lowcarbonbuildings.org.uk/home/>, last accessed: 2009.
- [18] UK set to approve feed-in-tariff for renewables micro-generation - http://www.pv-tech.org/news/_a/uk_set_to_approve_feed_in_tariff_for_renewable_micro_generation/, last accessed: 2009.
- [19] Strbac G. 'Demand side management – Benefits and challenges', Energy Policy, 36 (12), p. 4419-4426, December 2008.
- [20] Crossley D. 'Network-driven DSM', Workshop on the future of demand response, November 2005 - <http://www.efa.com.au/Library/David/Conference%20Papers/2005/TaskXVNetwork-drivenDSM.pdf/>, last accessed: 2009.
- [21] Crossley D. 'Assessment and development of network-driven demand side management measures', International Energy Agency, October 2008 - http://www.ieadsm.org/Files/Tasks/Task%20XV%20-%20Network%20Driven%20DSM/Publications/IEADSMTaskXVResearchReport2_Secondedition.pdf/, last accessed: 2009.
- [22] Swanbarton Limited. 'Status of electrical energy storage systems', Department of Trade and Industry, July 2004.
- [23] Manchester Centre for Electrical Energy. 'The future value of electrical energy storage in the UK with generator intermittency', Department of Trade and Industry, November 2004.
- [24] The Licensed Distribution Network Operators of Great Britain. 'Engineering recommendation G83/1: Recommendations for the connection of small-scale embedded generators (up to 16 A per phase) in parallel with public low-voltage distribution networks', September 2003.
- [25] Electricity Council. 'Engineering Recommendation P2/5: Security of supply', October 1978.
- [26] Energy Network Association. 'Engineering Recommendation P2/5: Security of supply', April 2006.
- [27] Power Planning Associates. 'P2/6 data collection' - <http://www.powerplanning.com/pdfs/dataP26.pdf/>, last accessed: 2009.
- [28] Taylor P., Cipcigan, L. 'Small scale energy zones for the effective participation of SSEGs in energy markets'. FOREN, Bucharest, Romania, 2006.

- [29] Lyons P., Taylor P., Cipcigan L., Trichakis P., Wilson A. ‘Small scale energy zones and the impacts of high concentrations of small scale embedded generators’, 41st Universities Power Engineering Conference, Newcastle, UK, September 2006.
- [30] Cipcigan L., Taylor P. ‘A generic model of a virtual power station consisting of small scale energy zones’. CIRED, Vienna, Austria, May 2007.
- [31] Trichakis P., Taylor P., Coates G., Cipcigan L. ‘A distributed control approach for small scale energy zones’, Proceedings of the Institution of Mechanical Engineers, Part A, Journal of Power and Energy, 222 (2), p. 137-147, 2008.
- [32] Trichakis P., Taylor P., Lyons P., Hair, R. ‘Transforming low voltage networks into small scale energy zones’, Proceedings of the Institution of Civil Engineers, Journal of Energy, 162 (1), p. 37-46, February 2008.
- [33] Taylor P., Jupe S., Trichakis P., Michiorri A., Lyons, P. ‘Active MV and LV distribution networks’. CIGRE-NGN Meeting, Paris, France, 2008.
- [34] Stannard N., Bumby J. R., Taylor P., Cipcigan L. M. ‘AC and DC aggregation effects of small scale wind generators’. Proceedings of the Institution of Engineering and Technology, Renewable Power Generation. 1 (2), p. 123-130, 2007.
- [35] T. Peterson. ‘Distributed renewable energy generation impacts on microgrid operation and reliability’ - <http://mydocs.epri.com/docs/public/000000000001004045.pdf>, last accessed: 2009.
- [36] Meliopoulos A., Yinger R., Eto J. ‘White paper on integration of distributed energy resources - The CERTS microgrid concept’ - <http://certs.lbl.gov/pdf/50829.pdf>, last accessed: 2009.
- [37] MicroGrids and More MicroGrids - <http://www.microgrids.eu/default.php/>, last accessed: 2009.
- [38] Katiraei F., Iravani R., Hatziargyriou N., Dimeas A. ‘Microgrids management’, IEEE Power and Energy Magazine, 5 (4), p. 54-65, July/August 2008.
- [39] Hatziargyriou N., Asano, H., Iravani R., Marnay C. ‘Microgrids – An overview of ongoing research, development and demonstration projects’, IEEE Power and Energy Magazine, 5 (4), p. 78-94, July/August 2008.
- [40] Barnes M., Kondoh J., Asano H., Oyarzabal J., Ventakaramanan G., Lasseter R., Hatziargyriou N., Green, T., ‘Real-world MicroGrids - An overview’, IEEE International Conference on System of Systems Engineering, p. 1-8, April 2007.
- [41] S. Morozumi, ‘Micro-grid demonstration projects in Japan’, Power Conversion Conference, p. 635-642, April 2007.

- [42] Department of Trade and Industry. 'The electricity safety, quality and continuity regulations'. October 2002.
- [43] CENELEC. 'EN50160: Voltage characteristics of electricity supplied by public distribution systems'. November 1999.
- [44] Toyoshima T., Shirai G., Tsukui T., Matsubara M., Fujita G., Chen W., Yokoyama R., Koyanagi K., Funabashi T., 'Autonomous distributed control of micro grid with diesel generator', 41st Universities Power Engineering Conference, Newcastle, UK, September 2006.
- [45] De Brabandere K., Vanthournout K., Driesen J., Deconinck G., Belmans R. 'Control of Microgrids', IEEE Power Engineering Society General Meeting, p. 1-7, June 2007.
- [46] Rahman S., Pipattanasomporn, M., Teklu Y. 'Intelligent distributed autonomous power systems (IDAPS)', IEEE Power Engineering Society Summer Meeting, p. 1-8, June 2007.
- [47] Tsikalakis A. G., Hatziargyriou N. D. 'Centralized control for optimizing microgrids operation', IEEE Transaction on Energy Conversion, 23 (1): p. 241-248., 2008.
- [48] Hatziargyriou N., Tsikalakis A., Dimeas A. 'Centralized and decentralized control of microgrids', International Journal of Distributed Energy Resources, 1 (3): p. 197-212, 2005.
- [49] Celli G., Pilo F., Pisano G., Soma G. G. 'Optimal participation of a microgrid to the energy market with an intelligent EMS', Power Engineering Conference, p. 663-668, December 2005.
- [50] Pudjianto D., Ramsay C., Strbac G.. 'Microgrids and virtual power plants: concepts to support the integration of distributed energy resources', Proceedings of the Institution of Mechanical Engineers, Part A, Journal of Power and Energy, 222 (7), p. 731-741, 2008.
- [51] Gustavsson R. 'Sustainable virtual utilities based on microgrids' - [http://www.iiisci.org/journal/CV\\$/sci/pdfs/Y384MW.pdf/](http://www.iiisci.org/journal/CV$/sci/pdfs/Y384MW.pdf/), last accessed: 2009.
- [52] ENCORP Intelligence. 'Virtual power plants' - <http://www.encorp.com/VPP-TechDataSheet.pdf/>, last accessed: 2009.
- [53] Dimeas A.L., Hatziargyriou, N.D. 'Agent based control of virtual power plants', International Conference on Intelligent Systems Applications to Power Systems, p. 1-6, November 2007.
- [54] Momoh. J. A. 'Electric power distribution, automation, protection and control', 2007 Published by: CRC, ISBN: 0849368359.
- [55] Faulkenberry L. M., Coffey W. 'Electrical power distribution and transmission' 1996 Published by: Prentice Hall, ISBN: 0132499479.
- [56] Department of Energy and Climate Change. 'Smart Meters' - http://decc.gov.uk/en/content/cms/what_we_do/consumers/smart_meters/smart_meters.aspx/, last accessed: 2009.

- [57] Lakervi E., Holmes E. J. 'Electricity distribution network design' 1996
Published by: Institution of Engineering and Technology, ISBN:
0863413099
- [58] The distribution code of licensed distribution operators of Great Britain
- <http://www.dcode.org.uk/>, last accessed: 2009.
- [59] McDonald J. 'Adaptive intelligent power systems – Active distribution
networks', Energy Policy, 36 (12): p. 4346-4351, December 2008.
- [60] Green T. C., Hernandez-Aramburo, C. A. 'The role of power
electronics for future power systems', Future Electricity Technologies
and Systems, 2006 Published by: Cambridge University Press, ISBN:
0521860490, p. 247 – 278.
- [61] Tran-Quoc T., Braun M., Marti J., Kieny C., Hadjsaid N., Bacha
S. 'Using control capabilities of DER to participate in distribution
system operation', IEEE Power Tech, p. 561-566, July 2007.
- [62] Neumann A., Taylor P., Jupe S., Michiorri A., Goode A., Curry D.
Roberts D. 'Dynamic thermal rating and active control for improved
distribution network utilisation' PowerGrid Europe Conference, Milan,
Italy, June 2008.
- [63] Roberts D., Taylor,P., Michiorri, A. 'Dynamic thermal rating for
increasing network capacity and delaying network reinforcements'
CIRED Smart Grids, Frankfurt, Germany, June 2008.
- [64] SmartGrids European technology platform for the electricity networks
of the future - <http://www.smartgrids.eu/>, last accessed: 2009.
- [65] Flexible electricity network to integrate the expected energy evolution
– FENIX - <http://www.fenix-project.org/>, last accessed: 2009.
- [66] Network of DER laboratories and pre-standardisation - DER-LAB -
<http://www.der-lab.net/>, last accessed: 2009.
- [67] Integrated ICT-platform based distributed control in electricity grids –
INTEGRAL - <http://integral-eu.com/>, last accessed: 2009.
- [68] Active distribution networks with full integration of demand and
distributed energy resources – ADDRESS - [http://ec.europa.eu/
research/energy/pdf/gp/gp_events/vienna_28feb07/17_giovanni_valortata_iberdrola_en.pdf/](http://ec.europa.eu/research/energy/pdf/gp/gp_events/vienna_28feb07/17_giovanni_valortata_iberdrola_en.pdf/), last accessed: 2009.
- [69] Planning for sustainability – SUSPLAN - <http://www.susplan.eu/>, last
accessed: 2009.
- [70] European distributed energy partnership - EU-DEEP.
<http://www.eudeep.com/>, last accessed: 2009.
- [71] Large-scale integration of DER into the European electricity market -
SOLID-DER - <http://www.solid-der.org/>, last accessed: 2009.
- [72] The Electricity Networks Strategy Group: Distribution Working Group
- <http://www.ensg.gov.uk/index.php?article=16>, last accessed: 2009.
- [73] Enabling active network management - [http://www.ensg.gov.uk/
index.php?article=22/](http://www.ensg.gov.uk/index.php?article=22/), last accessed: 2009.

- [74] Facilitating small scale embedded generation - <http://www.ensg.gov.uk/index.php?article=23/>, last accessed: 2009.
- [75] Register of active management pilots, trials, research, development and demonstration projects activities - http://www.ensg.gov.uk/assets/anm_deployment_register_-_january_2008_-_final.pdf/, last accessed: 2009.
- [76] Ault G.W., Foote C.E.T., McDonald J.R. 'UK research activities on advanced distribution automation', IEEE Power Engineering Society General Meeting, p. 2616- 2619, June 2005.
- [77] Goodman F., McGranaghan, M. 'EPRI research plan for advanced distribution automation', IEEE Power Engineering Society General Meeting, p. 2620, June 2005.
- [78] IntelliGrid: electric power research institute- <http://intelligrid.epri.com/> last accessed: 2009.
- [79] Buse D. P., Wu Q-H. 'IP Network based multi agent systems for industrial automation' 2006 Published by: Springer, ISBN: 1846286468.
- [80] Matsumoto Y., Yanab S., 'A vision of the electric power system architecture aiming for our new generation', Electrical Engineering in Japan, 150 (1): p. 18-25, October 2004.
- [81] International Energy Agency demand side management programme. Task XVII: Integration of demand side management, distributed generation, renewable energy sources and energy storages - <http://www.ieadsm.org/ViewTask.aspx?ID=16&Task=17&Sort=0/>, last accessed: 2009.
- [82] Nordman M., Lehtonen M. 'A TCP/IP based communication architecture for distribution network operation and control', CIRED Barcelona, Spain, May 2003.
- [83] Electricity Innovation Institute. 'Utility communications architecture - Object models for distributed energy resources - Version for IEC TC57' - http://www.epri-intelligrid.com/intelligrid/docs/Draft_UCA-DER_Object_Models_ver_IEC.pdf/, last accessed: 2009.
- [84] IEC 61850 Communication Networks and Systems in Substations - <http://www.61850.com/>, last accessed: 2009.
- [85] Buse D. P., Sun P., Wu Q. H., Fitch J. 'Agent-based substation automation', IEEE Power and Energy Magazine, 1 (2): p. 50-55, March/April 2003.
- [86] CENELEC. 'EN 50438 Requirements for the connection of micro-generators in parallel with public low-voltage distribution networks', August 2004.
- [87] Department of Business Enterprise and Regulatory Reforms. 'Energy consumption in the United Kingdom' - <http://www.berr.gov.uk/files/file11250.pdf/>, last accessed: 2009.

- [88] Department of Business Enterprise and Regulatory Reforms. 'Energy consumption in the United Kingdom: domestic data tables. 2008 update' - <http://www.berr.gov.uk/files/file47214.xls/>, last accessed: 2009.
- [89] Gellings C.W., Smith W.M., 'Integrating demand-side management into utility planning', *Proceedings of the IEEE*, 77 (6): p. 908 – 918, June 1989.
- [90] Bradley T. H., Frank A. A., 'Design, demonstrations and sustainability impact assessments for plug-in hybrid electric vehicles', *Renewable and Sustainable Energy Reviews*, 13 (1): p. 115, 2009.
- [91] Price A., Thijssen G., Symons P., 'Electricity storage, A solution in network operation?' *Distributech Europe*, Miami Beach, USA, October 2000.
- [92] The Foundation for Intelligent Physical Agents. 'FIPA Agent Management Specification'- <http://www.fipa.org/specs/fipa00023/SC00023K.pdf/>, last accessed: 2009.
- [93] Wooldridge M. 'An introduction to multi agent systems', 2002 Published by: John Wiley & Sons, ASIN: B000QEC8Q4
- [94] Catterson, V. 'Engineering robustness, flexibility, and accuracy into a multi-agent system for transformer condition monitoring', PhD Thesis, University of Strathclyde, UK, December 2006.
- [95] Jennings N. R. 'On agent-based software engineering', *Artificial Intelligence*, 117 (2): p. 277-296, March 2000.
- [96] Jennings N. R., Bussmann S. 'Agent-based control systems', *IEEE Control Systems Magazine*, 23 (3): p. 61 – 74, June 2003.
- [97] Ferber J. 'Multi-agent systems: An introduction to distributed artificial intelligence', 1999 Published by: Addison-Wesley, ISBN: 0201360489
- [98] Bratman M. E., Israel D. J., Pollack M. E. 'Plans and resource-bounded practical reasoning'. *Computational Intelligence*, 4 (4): p. 349-355, 1988.
- [99] Georgeff M., Lansky A. 'Reactive reasoning and planning: an experiment with a mobile robot' 7th National Conference on Artificial Intelligence, p. 677–682, Seattle, USA, 1987.
- [100] Brooks R. A. 'A robust layered control system for a mobile robot', *IEEE Journal of Robotics and Automation*, 2 (1): p. 14–23, March 1986.
- [101] Arkin R. C. 'Integrating behavioral, perceptual, and world knowledge in reactive navigation' *Robotics and Autonomous Systems*, 6: p. 105-122, 1990.
- [102] Java Agent Development Framework – JADE - <http://jade.tilab.com/>, last accessed: 2009.
- [103] Bellifemine F. L., Caire G., Greenwood D. 'Developing multi agent systems with JADE', 2007 Published by: Wiley, ISBN: 0470057475.

- [104] Shehory O., Sturm A. ‘Evaluation of modeling techniques for agent-based systems’, Fifth International Conference on Autonomous Agents, p. 624-631, 2001.
- [105] Shehory O. ‘Software architecture attributes of multi agent systems’, First International Workshop on agent-oriented software engineering, p. 77-90, 2001.
- [106] The Foundation for Intelligent Physical Agents – FIPA - <http://www.fipa.org/>, last accessed: 2009.
- [107] FIPA-OS Agent Toolkit - <http://sourceforge.net/projects/fipa-os/>, last accessed: 2009.
- [108] ZEUS Agent Toolkit - <http://sourceforge.net/projects/zeusagent/>, last accessed: 2009.
- [109] Comtec Agent Platform - www.agentland.com/Download/Intelligent_Agent/500.html/, last accessed: 2009.
- [110] Tryllian Agent Development Kit - <http://www.tryllian.org/>, last accessed: 2009.
- [111] JACK Agent Development Platform - <http://www.agent-software.com.au/>, last accessed: 2009.
- [112] Cougaar Agent Architecture - <http://www.cougaar.org/>, last accessed: 2009.
- [113] MadKit - <http://www.madkit.org/>, last accessed: 2009.
- [114] McArthur S. D. J., Davidson E. M., Catterson V. M., Dimeas A. L., Hatziargyriou N. D., Ponci F., Funabashi T. ‘Multi-agent systems for power engineering applications - Part I: Concepts, approaches, and technical challenges’, IEEE Transactions on Power Systems, 22 (4): p. 1743 – 1752, Nov. 2007.
- [115] McArthur S. D. J., Davidson E. M., Catterson V. M., Dimeas A. L., Hatziargyriou N. D., Ponci F., Funabashi T. ‘Multi-agent systems for power engineering applications - Part II: Technologies, Standards, and Tools for Building Multi-agent Systems’, IEEE Transactions on Power Systems, 22 (4): p. 1753 - 1759, Nov. 2007.
- [116] Labrou Y., Finin T., Peng Y. ‘Agent communication languages: The current landscape’, IEEE Intelligent Systems and their Applications, 14 (2): p. 45-52, March/April 1999.
- [117] Finin T., Labrou Y., Mayfield J. ‘KQML as an agent communication language’ - <http://www.flacp.fujitsulabs.com/~yannis/publications/mitpress96.pdf>, last accessed: 2009.
- [118] The Foundation for Intelligent Physical Agents. ‘FIPA communicative act library specification’ - <http://www.fipa.org/specs/fipa00037/XC00037H.pdf>, last accessed: 2009.
- [119] The Foundation for Intelligent Physical Agents. ‘FIPA ACL message structure specification’ - <http://www.fipa.org/specs/fipa00061/SC00061G.pdf>, last accessed: 2009.

- [120] The Foundation for Intelligent Physical Agents. ‘FIPA Agent Message Transport Service Specification’ - <http://standards.computer.org/fipa/specs/fipa00067/XC00067D.pdf>, last accessed: 2009.
- [121] IEEE Power Engineering Society Multi Agent Systems Task Force - <http://ewh.ieee.org/cmte/pesmastf/>, last accessed: 2009.
- [122] IEEE PES Multi Agent Systems Task Force – Material Database - <http://www.ee.sc.edu/ieeewg/>, last accessed: 2009.
- [123] Davidson E. M., McArthur S. D. J. ‘Exploiting multi-agent system technology within an autonomous regional active network management system’ International Conference on Intelligent Systems Applications to Power Systems, p. 1-6, November 2007.
- [124] Nordman M. M., Lenton M. ‘An agent concept for managing electrical distribution networks’, IEEE Transactions on Power Delivery, 20 (2): p. 696- 703, April 2005.
- [125] Dimeas A. L., Hatziargyriou N. D. ‘Operation of a multiagent system for microgrid control’, IEEE Transactions on Power Systems, 20(3): p. 1447- 1455, August 2005.
- [126] Dimeas A. L., Hatziargyriou N. D. ‘A MAS architecture for microgrids control’, 13th International Conference on Intelligent Systems Application to Power Systems, 2005.
- [127] Dimeas A. L., Hatziargyriou N. D. ‘A multi-agent system for microgrids’, IEEE Power Engineering Society General Meeting, p. 55–58, June 2004.
- [128] Oyarzabal J., Jimeno J., Engler A., Hardt C., Ruela J. ‘Agent based micro grid management system’, International Conference on Future Power Systems, p. 1-6, 2005.
- [129] Heo J. S., Lee K. Y. ‘A multi-agent system-based intelligent control system for a power plant’, IEEE Power Engineering Society General Meeting, pp. 1050-1055, 2005.
- [130] Nagata T., Sasaki H. ‘A multi-agent approach to power system restoration’, IEEE Transactions on Power Systems, 17 (2): p.: 457 - 462, May 2002.
- [131] Solanki J. M., Khushalani S., Schulz N. N. ‘A multi-agent solution to distribution systems restoration’, IEEE Transactions on Power Systems, 22 (3): p. 1026 - 1034, August 2007.
- [132] Huang K., Srivastava S. K., Cartes D. A. ‘Decentralized reconfiguration for power systems using multi agent system’ 1st Annual IEEE Systems Conference, 2007.
- [133] Feliachi A., Schoder K., Ganesh S., Lai H., ‘Distributed control agents approach to energy management in electric shipboard power system’, IEEE Power Engineering Society General Meeting, 2006.
- [134] Maturana F., Staron R., Discenzo F., Carnahan D., Hall K., ‘Agent virtual machine for shipboard automation systems’, Power Engineering Society General Meeting, June 2007.

- [135] Baran M. E., El-Markabi I. M. ‘A multiagent-based dispatching scheme for distributed generators for voltage support on distribution feeders’ IEEE Transactions on Power Systems, 22 (1): p. 52-59, February 2007.
- [136] Widergren S. E., Roop J. M., Guttromson R. T., Huang Z., ‘Simulating the dynamic coupling of market and physical system operations’, IEEE Power Engineering Society General Meeting, p.748 – 753, June 2004.
- [137] Koesrindartoto D., Junjie S., Tesfatsion L., ‘An agent-based computational laboratory for testing the economic reliability of wholesale power market designs’, IEEE Power Engineering Society General Meeting, p. 931 – 936, June 2005.
- [138] Widergren S., Sun J., Tesfatsion L. ‘Market design test environments’, IEEE Power Engineering Society General Meeting, June 2006.
- [139] Wei P., Yan Y., Ni Y., Yen J., and Wu F. F. ‘A decentralized approach for optimal wholesale cross-border trade planning using multi-agent technology’. IEEE Transactions on Power Systems, 16 (4): p. 833-838, November 2001.
- [140] Koritarov V. S. ‘Real-world market representation with agents’. IEEE Power and Energy Magazine, 2 (4): p. 39 - 46, July/August 2004.
- [141] Contreras J., Wu F. F. ‘Coalition formation in transmission expansion planning’, IEEE Transactions on Power Systems, 14 (3): p. 1144-1152, August 1999.
- [142] McArthur S. D. J., Strachan S. M., Jahn G., ‘The design of a multi-agent transformer condition monitoring system’, IEEE Transactions on Power Systems, 19 (4): p. 1845 – 1852, November 2004.
- [143] Davidson E. M., McArthur S. D. J., McDonald J. R., Cumming T., Watt I. ‘Applying multi-agent system technology in practice: Automated management and analysis of SCADA and digital fault recorder data’, IEEE Transactions on Power Systems, 21 (2): p. 559-567, May 2006.
- [144] Nordman M. M., Lentonon M. ‘Distributed agent-based state estimation for electrical distribution networks’, IEEE Transactions on Power Systems, 20 (2): p. 652- 658, May 2005.
- [145] Buse D. P., Sun P., Wu Q. H., Fitch J., ‘Agent-based substation automation’, IEEE Power and Energy Magazine, 1 (2): p. 50 - 55, March/April 2003.
- [146] Baxevanos I. S., Labridis D. P. ‘Implementing Multiagent Systems Technology for Power Distribution Network Control and Protection Management’, IEEE Transactions on Power Delivery, 22 (1), p. 433 - 443, January 2007.
- [147] Park S-J., Lim J-T. ‘Modelling and control of agent-based power protection system using supervisors’, IEE Proceedings in Control Theory and Applications, 153 (1): p. 92-98, January 2006.

- [148] Li S.S., Chan K.K., Zeng W.L., Xiangjun Z., Xianzhong D., “Agent-based self-healing protection system”, IEEE Transactions on Power Delivery, 21 (2): p. 610 – 618, April 2006.
- [149] Coury D.V., Thorp J.S., Hopkinson K.M., Birman K.P. ‘An agent based current differential relay for use with a utility intranet.’ IEEE Transactions on Power Delivery, 17 (1): p. 47 – 53, January 2002.
- [150] Fukui C., Kudo H., Koda J., Yabe K., Tomita Y. ‘A cooperative protection system with an agent model’, IEEE Transactions on Power Delivery, 13 (4), p. 1060 – 1066, October 1998.
- [151] Manitoba HVDC Research Centre - PSCAD/EMTDC - <https://pscad.com/products/pscad/>, last accessed: 2009.
- [152] Ingram S., Probert S., Jackson K. ‘The impact of small scale embedded generation on the operating parameters of distribution networks’, Department of Trade and Industry, 2003.
- [153] Trichakis P., Taylor P., Hair R., Lyons, P. ‘Predicting the technical impacts of high levels of small scale embedded generators on low voltage networks’. IET Renewable Power Generation, 2 (4): p. 249 – 262, December 2008.
- [154] Trichakis P., Taylor P., Cipcigan L., Lyons P., Hair R., Ma, T. ‘An investigation of voltage unbalance in low voltage distribution networks with high levels of SSEG’. 41st Universities Power Engineering Conference, Newcastle, UK, September 2006.
- [155] Cipcigan L., Taylor P., Trichakis, P. ‘The impact of small scale wind generators on LV distribution system voltage’. International Conference on Clean Electrical Power, Capri, Italy, May 2007.
- [156] Lopes J. A., ‘Integration of dispersed generation on distribution networks - impact studies’ IEEE Power Engineering Society Winter Meeting, p. 323–328, 2002.
- [157] Tran Quoc T., Andrieu C. and Hadjsaid N. ‘Technical impacts of small distributed generation units on LV networks’. IEEE PowerTech, Bologna, Italy, p. 2459-2464, 2003.
- [158] Conti S., Raiti S., Tina G., Vagliasindi U. ‘Study of the impact of PV generation on voltage profile in LV distribution networks’. IEEE PowerTech, Porto, Portugal, p. 6 – 10, 2001.
- [159] Barker P. P., de Mello R. W. ‘Determining the impact of distributed generation on power systems: Part 1 – Radial Distribution Systems’, IEEE Power Engineering Society Summer Meeting, p. 1645 – 1656. 2000.
- [160] Galey M. E. ‘Benefits of performing unbalanced voltage calculations’, in IEEE Transactions on Industry Applications, 24 (1), p. 15-24, January/February 1988.
- [161] Framework for design and planning for low voltage housing developments underground network installations and associated, new,

- HV/LV distribution substations - <http://www.scottishpower.com/uploads/ESDD02012Issue2GreenfieldHousing.pdf>, last accessed: 2009.
- [162] Framework for underground networks (and associated HV/LV distribution substations) in EDF Energy's three Distribution Networks (EPN, LPN and SPN) - <http://www.edfenergy.com/attachments/networksg81designplanappdixv-1a.pdf>, last accessed: 2009.
- [163] Western Power Distribution housing development design framework - <http://www.westernpower.co.uk/getdoc/089aedc1-7019-4ad6-bf06-212e7df8e664/WPD-G81---1-Design-Framework-Appendix.aspx/>, last accessed: 2009.
- [164] Dugan R.C., McGranaghan M.F., Beaty H. W, 'Electrical power systems quality'. 1995 Published by: McGraw-Hill Companies, ISBN: 0070180318.
- [165] von Jouanne A., Banerjee B., 'Assessment of Voltage Unbalance', IEEE Transactions on Power Delivery, 16 (4): p. 782-790, October 2001.
- [166] The Electricity Council. 'Engineering recommendation P29: Planning limits for voltage unbalance in the United Kingdom', 1990.
- [167] International Electrotechnical Commission. 'Overhead electrical conductors - calculation methods for stranded bare conductors' May 1995.
- [168] International Electrotechnical Commission. 'Electric cables – calculation of the current rating,' May 2002.
- [169] Cipcigan L. M., Taylor, P. C. 'Investigation of the reverse power flow requirements of high penetrations of small scale embedded generation', IET Renewable Power Generation, 1 (3): p.160 – 166, September 2007.
- [170] Papathanassiou S., Hatziargyriou N., Strunz K. 'A benchmark low voltage microgrid network', CIGRE Symposium, Athens, Greece, April 2005.
- [171] Institute for Electrical and Electronics Engineers. 'IEEE Std. 142-1991: IEEE Recommended Practice for Grounding of Industrial and Commercial Power Systems', May 1991.
- [172] Jasmon G. B., Lee L.H.C.C.: 'Distribution network reduction for voltage stability analysis and load flow calculations', International Journal of Electrical Power Energy Systems, 13 (1): p. 9–13, 1991.
- [173] SIEMENS. 'Switching, protection and distribution in low-voltage networks', 1994 Published by: Wiley-VCH, ISBN: 3895780006.
- [174] Chindris M, Tomoiaga B, Taylor P, Cipcigan L. 'The identification of critical equipment and optimum configuration for electrical substations', 41st Universities Power Engineering Conference, Newcastle, UK, September 2006.
- [175] Kundur, P. 'Power system stability and control', 1994 Published by: McGraw-Hill Professional, ISBN: 007035958X.

- [176] Engler A., Soultanis N., ‘Droop control in LV-grids’ International Conference on Future Power Systems, p. 1-6, November 2005.
- [177] De Brabandere K., Bolsens B., Van den Keybus J., Woyte A., Driesen J., Belmans R. ‘A voltage and frequency droop control method for parallel inverters’, IEEE Transactions on Power Electronics, 22 (4): p. 1107-1115, 2007.
- [178] Ault G. W., Currie R. A. F., McDonald J. R. ‘Active power flow management solutions for maximising DG connection capacity’, IEEE Power Engineering Society General Meeting, p. 5 – 11, 2006.
- [179] Jupe S., Taylor P. ‘Distributed generation output control for network power flow management’. IET Renewable Power Generation, *to appear soon*.
- [180] Electricity Association. ‘Engineering Recommendation G81: Framework for design and planning, materials specification, installation and record for Greenfield low voltage housing estate underground network installations and associated, new, HV/LV distribution substations’, 2004.
- [181] Rehtanz C. ‘Autonomous systems and intelligent agents in power system control and operation’, 2003 Published by: Springer, ISBN: 3540402020.
- [182] The Foundation for Intelligent Physical Agents. ‘FIPA Ontology Service Specification’ - <http://www.fipa.org/specs/fipa00086/XC00086D.pdf/>, last accessed: 2009.
- [183] Teorey T., Lightstone S., Nadeau T., ‘Database modeling & design: logical design’, 2005 Published by: Morgan Kaufman, ISBN: 0126853525.
- [184] JADE Programmer’s guide - <http://sharon.cselt.it/projects/jade/doc/programmersguide.pdf/>, last accessed: 2009.
- [185] Cowan D., Griss M., Kessler R., Remick B., Burg B. ‘A robust environment for agent deployment’ - <http://martin.griss.com/pubs%5Caamas-agentcities.pdf/>, last accessed: 2009.
- [186] The Protégé Ontology Editor and Knowledge Acquisition System - <http://protege.stanford.edu/>, last accessed: 2009.
- [187] The OntologyBeanGenerator plug-in - <http://protege.cim3.net/cgi-bin/wiki.pl?OntologyBeanGenerator/>, last accessed: 2009.
- [188] JADE Tutorial - Creating ontologies by means of the Bean Ontology class - <http://jade.tilab.com/doc/tutorials/BeanOntologyTutorial.pdf/>, last accessed: 2009.
- [189] MySQL – the world’s most popular open source database - <http://www.mysql.com/>, last accessed: 2009.
- [190] MySQL Reference Manual - <http://dev.mysql.com/doc/refman/4.1/en/index.html/>, last accessed: 2009.
- [191] The MySQL Command Line Tool - <http://dev.mysql.com/doc/refman/5.1/en/mysql.html/>, last accessed: 2009.

- [192] MySQL Administrator - <http://dev.mysql.com/doc/administrator/en/index.html/>, last accessed: 2009.
- [193] Java DataBase Connectivity (JDBC) Overview - <http://java.sun.com/products/jdbc/overview.html/>, last accessed: 2009.
- [194] Java DataBase Connectivity (JDBC) Specifications - <http://java.sun.com/products/jdbc/download.html/>, last accessed: 2009.
- [195] MySQL Connector/J - <http://dev.mysql.com/doc/refman/5.0/en/connector-j.html/>, last accessed: 2009.
- [196] Energy efficiency by power factor correction - https://www.zvei.org/index.php?id=87&no_cache=1&tx_ZVEIpubFachverbaende_pi1%5Bdownload%5D=848&type=98, last accessed: 2009.
- [197] Tichy P., Slechta P., Staron R. J., Maturana F. P., Hall K. H. 'Multiagent technology for fault tolerant and flexible control'. IEEE Transactions on Systems, Man and Cybernetics – Part C: Applications and Reviews, 36 (5): p. 700 – 705, September 2006.
- [198] Trichakis P, Taylor P, Lyons P, Hair R, Coates, G. 'An agent based control approach for Microgrids'. PowerGrid Europe Conference, Milan, Italy, June 2008.
- [199] Lyons P. Trichakis P. Taylor P., Coates, G. 'A practical implementation of a distributed control approach for MicroGrids'. Autosoft - Intelligent Automation and Soft Computing Journal, MicroGrids Special Edition, *to appear soon*.
- [200] National Instruments – LabVIEW - <http://www.ni.com/labview/>, last accessed: 2009.
- [201] International Electrotechnical Commission. 'IEC 61970 Energy management system application program interface - Part 301: Common Information Model (CIM) Base', November 2003.
- [202] McMorran A. W. 'An Introduction to IEC 61970-301 & 61968-11: The Common Information Model' - <http://cimphony.org/cimphony/cim-intro.pdf>, last accessed: 2009.

Appendix A

Rec.	Send.	CSA	Length	Rph	Xph	Rn	R ₀	X ₀	I _Z
1.1	1.2	300	78.6	0.1	0.073	0.164	0.593	0.042	465
1.2	1.3	70	36	0.443	0.076	0.443	1.772	0.052	205
1.2	1.4	185	85	0.164	0.074	0.164	0.656	0.05	355
2.1	2.2	300	32	0.1	0.073	0.164	0.593	0.042	465
2.2	2.3	120	73	0.253	0.071	0.253	1.012	0.046	280
2.2	2.4	300	90	0.1	0.073	0.164	0.593	0.042	465
2.4	2.5	70	67	0.443	0.076	0.443	1.772	0.052	205
2.5	2.6	70	24	0.443	0.076	0.443	1.772	0.052	205
2.5	2.7	70	52	0.443	0.076	0.443	1.772	0.052	205
2.4	2.8	300	41	0.1	0.073	0.164	0.593	0.042	465
2.8	2.9	70	93	0.443	0.076	0.443	1.772	0.052	205
2.8	2.10	300	35	0.1	0.073	0.164	0.593	0.042	465
2.10	2.11	120	70	0.253	0.071	0.253	1.012	0.046	280
2.11	2.12	70	53	0.443	0.076	0.443	1.772	0.052	205
2.11	2.13	120	12	0.253	0.071	0.253	1.012	0.046	280
2.13	2.14	70	32	0.443	0.076	0.443	1.772	0.052	205
2.13	2.15	70	41	0.443	0.076	0.443	1.772	0.052	205
2.10	2.16	300	33	0.1	0.073	0.164	0.593	0.042	465
2.16	2.17	120	68	0.253	0.071	0.253	1.012	0.046	280
2.16	2.18	300	17	0.1	0.073	0.164	0.593	0.042	465
2.18	2.19	70	40	0.443	0.076	0.443	1.772	0.052	205
3.1	3.2	185	15	0.164	0.074	0.164	0.656	0.05	355
3.2	3.3	120	80	0.253	0.071	0.253	1.012	0.046	280
3.3	3.4	120	85	0.253	0.071	0.253	1.012	0.046	280
4.1	4.2	185	27	0.164	0.074	0.164	0.656	0.05	355
4.2	4.3	185	82	0.164	0.074	0.164	0.656	0.05	355
4.3	4.4	120	40	0.253	0.071	0.253	1.012	0.046	280
4.3	4.5	120	17	0.253	0.071	0.253	1.012	0.046	280
4.2	4.6	120	26	0.253	0.071	0.253	1.012	0.046	280
4.6	4.7	70	90	0.443	0.076	0.443	1.772	0.052	205
4.6	4.8	120	53	0.253	0.071	0.253	1.012	0.046	280
Public Lighting		25	-	1.18	0.043	0.9	4.72	0.03	100
House Services		35	30	0.851	0.041	0.9	3.404	0.03	120

Table A-1: Conductor Cross-Sectional Area (CSA) [mm²], Length [m], Impedance data [Ω /km] and maximum continuous current carrying capacity I_Z per phase conductor [A] for the cables used in the case study UK network

Location	$R_{location}^{(a)}$	$X_{location}^{(a)}$	Location	$R_{location}^{(a)}$	$X_{location}^{(a)}$	Location	$R_{location}^{(a)}$	$X_{location}^{(a)}$
L1	0.90792	0.16272	C1	0.19566	0.0576	L11	0.74007	0.14556
L2	1.20312	0.29592	C2	0.32976	0.11208	L12	0.56796	0.15909
L3	1.77912	0.43092	C3	0.16896	0.0372	L21	0.56639	0.10499
L4	2.35512	0.56592	C4	0.29898	0.11052	L22	0.45276	0.12163
			C5	0.38976	0.09168	L23	1.0926	0.23873
Feeder	6.24528	1.44558	C6	0.23142	0.05538	L24	0.81402	0.17262
			C7	0.5628	0.2496	L25	0.25098	0.07877
			C8	0.47376	0.21366	L26	0.99635	0.24236
						L27	0.77867	0.22214
			I1	0.1953	0.04899	L28	0.48151	0.14363
						L29	0.50543	0.14773
			R1	0.40356	0.05868	L210	0.79	0.27505
			R2	2.05321	0.39204	L211	0.61245	0.20137
			R3	0.90996	0.20346	L31	0.77168	0.12832
			R4	0.57066	0.07818	L32	1.04603	0.21083
			R5	1.17774	0.25744	L41	0.4804	0.10922
						L42	0.42803	0.09453
						L43	0.45755	0.07148
						L44	0.44951	0.07953
TOTAL	24.9811	5.82192	TOTAL	7.96153	1.96651	TOTAL	12.2824	2.94758

Table A-2: Apparent resistance ($R_{location}^{(ap)}$) and reactance ($X_{location}^{(ap)}$) for the customer locations of the generic UK network, the European generic network and the case study public UK network.

Appendix B

SSEG Database	Data Type	Description
Network location	Static *	The network location of the SSEG, as provided by the system operator (DNO). This value is not updated in the database in real-time, however, it may change in the event of future modifications to the LV distribution network.
Phase location	Static	The phase location of the SSEG, as provided by the system operator (DNO).
Primary energy source	Static	The primary energy source fuelling the SSEG unit. This information could be useful for cases where the aim is to maximise renewable-based generation within the SSEZ. It can either be: (i) renewable based; or (ii) non-renewable based.
Grid-dependent operation	Static *	The option for grid-dependent operation of the SSEG can either be: (i) yes; or (ii) no. This is because some customers may not want to manage their SSEGs in accordance with overall distribution system operation. This value is not updated in real-time, however it may change in the future according to customer aspiration.
Controllability	Static	The option for controllability can either be: (i) yes; or (ii) no. This depends on the capabilities of the SSEG unit for power flow and voltage control, as described in Section 3.4.
Real power rating	Static	The real power rating of the SSEG in kW.
Generator minimum output	Dynamic	The minimum active power output limitation of the SSEG unit in kW.
Generator status	Dynamic	The current operating status of the SSEG. This can be: (i) ON, which means that the SSEG is active; or (ii) OFF, which means the SSEG is inactive.
Real power	Dynamic	The value for the current real power output of the SSEG unit in kW.
Reactive power	Dynamic	The value for the current reactive power input or output of the SSEG unit in kVAr.
Operating power factor	Dynamic	The value for the current operating power factor of the SSEG unit.
Date	Dynamic	The current date, as provided by a timer.
Time	Dynamic	The current time, as provided by a timer.
Lower normal state voltage limit	Static *	The lower normal state operating voltage limit in Volts, as defined by the system operator.
Upper normal state voltage limit	Static *	The upper normal state operating voltage limit in Volts, as defined by the system operator.
Lower alert state voltage limit	Static *	The lower alert state operating voltage limit in Volts, as defined by the system operator.

Upper alert state voltage limit	Static *	The upper alert state operating voltage limit in Volts, as defined by the system operator.
Lower emergency state voltage limit	Static	The lower emergency state operating voltage limit, as defined by statutory regulations. This value may not change and equals 216.2 V.
Upper emergency state voltage limit	Static	The upper emergency state operating voltage limit, as defined by statutory regulations. This value may not change and equals 253 V.
Trip-off undervoltage limit	Static	The trip-off undervoltage operating limit, as defined by statutory regulations. This value may not change and equals 207 V.
Trip-off overvoltage limit	Static	The trip-off overvoltage operating limit, as defined by statutory regulations. This value may not change and equals 264 V.
Current steady-state voltage	Dynamic	The current steady-state voltage of the SSEG unit in Volts.
Current operating state	Dynamic	The current operating state of the SSEG unit. This value may be: (i) normal state, (ii) alert state, or (iii) emergency state.
Lower frequency limit	Static	The lower operating frequency limit, as defined by statutory regulations. This value may not change and equals 49.5 Hz.
Upper frequency limit	Static	The upper operating frequency limit, as defined by statutory regulations. This value may not change and equals 50.5 Hz.
Current operating frequency	Dynamic	The current operating frequency of the SSEG unit in Hz.

Table B-1: Database coupled to a SSEG unit and the GA that controls it.

Load Database	Data Type	Description
Network location	Static *	The network location of the load, as provided by the system operator (DNO). This value is not updated in the database in real-time, however, it may change in the event of future modifications to the LV distribution network.
Phase location	Static	The phase location of the load, as provided by the system operator (DNO).
Load type	Static	The type of controllable load. This value can either be: (i) reshiftable; (ii) curtailable; or (iii) critical.
Grid-dependent operation	Static *	The option for grid-dependent operation of the load can either be: (i) yes; or (ii) no. This value is not updated in real-time, however it may change in the future according to customer aspiration.
Real power rating	Static	The real power rating of the load in kW.
Real power	Dynamic	The value for the current real power consumption of the load in kW.
Reactive power	Dynamic	The value for the current reactive power input of the load in kVAr.
Operating power factor	Dynamic	The value for the current operating power factor of the load.
Control steps	Static	The number of steps for controlling the load. This value can either be: (i) 0 which means the load is either ON or OFF; or (ii) any positive integer, which means that the load is curtailable and can reduce its power consumption.
Minimum outage time	Static	The minimum time that the load can reduce its power consumption, or can be rescheduled.
Maximum outage time	Static	The maximum time that the load can reduce its power consumption, or can be rescheduled.
Lead time	Static	The time needed before the load can reduce its power consumption, or before rescheduling can take effect.
Activation signal	Dynamic	The signal received from the CDA that determines when the load is to be controlled. This value can either be (i) control, which means the load control actions must be activated; or (ii) no_control, which means that the load is not currently actively controlled.
Date	Dynamic	The current date, as provided by a timer.
Time	Dynamic	The current time, as provided by a timer.
Start date of rescheduling	Dynamic	The date when rescheduling is set to take place. This value may or may not be specified by the customer or CDA depending on the load.
Start time of rescheduling	Dynamic	The time when rescheduling is set to take place. Similarly, this value may or may not be specified by the customer or by the CDA.

Duration of rescheduling	Dynamic	The duration that the load is to be active after re-scheduling. This value may or may not be specified by the customer or CDA and must be within minimum/maximum outage time limits.
Lower normal state voltage limit	Static *	The lower normal state operating voltage limit in Volts, as defined by the system operator.
Upper normal state voltage limit	Static *	The upper normal state operating voltage limit in Volts, as defined by the system operator.
Lower alert state voltage limit	Static *	The lower alert state operating voltage limit in Volts, as defined by the system operator.
Upper alert state voltage limit	Static *	The upper alert state operating voltage limit in Volts, as defined by the system operator.
Lower emergency state voltage limit	Static	The lower emergency state operating voltage limit, as defined by statutory regulations. This value may not change and equals 216.2 V.
Upper emergency state voltage limit	Static	The upper emergency state operating voltage limit, as defined by statutory regulations. This value may not change and equals 253 V.
Current steady-state voltage	Dynamic	The current steady-state voltage in Volts.
Current operating state	Dynamic	The current operating state of the load unit. This value may be: (i) normal state, (ii) alert state, or (iii) emergency state.
Lower frequency limit	Static	The lower operating frequency limit, as defined by statutory regulations. This value may not change and equals 49.5 Hz.
Upper frequency limit	Static	The upper operating frequency limit, as defined by statutory regulations. This value may not change and equals 50.5 Hz.
Current operating frequency	Dynamic	The current operating frequency of the load unit in Hz.

Table B-2: Database coupled to a controllable load and the CDA that controls it.

ESU Database	Data Type	Description
Network location	Static *	The network location of the ESU, as provided by the system operator (DNO). This value is not updated in the database in real-time, however, it may change in the event of future modifications to the LV distribution network.
Phase location	Static	The phase location of the ESU, as provided by the system operator (DNO).
ESU technology	Static	The technology used inside the ESU. This can be: (i) lead-acid battery; (ii) fuel cell; (iii) flywheel; (iv) super-capacitor; or (v) other.
Operating time	Static	The operating time of the ESU. This is used by the ESA to identify the type of application that best suits the installed ESU and its value can be: (i) slow; or (ii) fast.
Grid-dependent operation	Static *	The option for grid-dependent operation of the load can either be: (i) yes; or (ii) no. This value is not updated in real-time, however it may change in the future according to customer aspiration.
Real power rating	Static	The real power rating of the ESU in kW.
ESU status	Dynamic	The operating status of the ESU. This can be: (i) ON, which means that the ESU is active; or (ii) OFF, which means that the ESU is inactive.
Real power	Dynamic	The value for the current real power input or output of the ESU in kW.
Reactive power	Dynamic	The value for the current reactive power input or output of the ESU in kVAr.
Operating power factor	Dynamic	The value for the current operating power factor of the ESU.
Date	Dynamic	The current date, as provided by a timer.
Time	Dynamic	The current time, as provided by a timer.
Lower normal state voltage limit	Static *	The lower normal state operating voltage limit in Volts, as defined by the system operator.
Upper normal state voltage limit	Static *	The upper normal state operating voltage limit in Volts, as defined by the system operator.
Lower alert state voltage limit	Static *	The lower alert state operating voltage limit in Volts, as defined by the system operator.
Upper alert state voltage limit	Static *	The upper alert state operating voltage limit in Volts, as defined by the system operator.
Lower emergency state voltage limit	Static	The lower emergency state operating voltage limit, as defined by statutory regulations. This value may not change and equals 216.2 V.
Upper emergency state voltage limit	Static	The upper emergency state operating voltage limit, as defined by statutory regulations. This value may not change and equals 253 V.
Current steady-state voltage	Dynamic	The current steady-state voltage in Volts.
Current operating	Dynamic	The current operating state of the load unit.

state		This value may be: (i) normal state, (ii) alert state, or (iii) emergency state.
Lower frequency limit	Static	The lower operating frequency limit, as defined by statutory regulations. This value may not change and equals 49.5 Hz.
Upper frequency limit	Static	The upper operating frequency limit, as defined by statutory regulations. This value may not change and equals 50.5 Hz.
Current operating frequency	Dynamic	The current operating frequency of the load unit in Hz.

Table B-3: Database coupled to an ESU and the ESA that controls it.

Indirect Control Database	Data Type	Description
Date	Dynamic	The current date, as provided by a timer.
Time	Dynamic	The current time, as provided by a timer.
Current flow at SSEZ “hot spots”.	Dynamic	The values for single- or three-phase current flows at particular cable sections (“hot spots”) that are being monitored within the SSEZ.
Upper normal state current flow limits	Static *	The upper normal state current flow limits, as defined by the system operator for each particular cable “hot spot”. This value is not updated in real-time, but may change according to the system operator.
Upper alert state current flow limits	Static *	The upper alert state current flow limits, as defined by the system operator for each particular cable “hot spot”.
Upper emergency state current flow limits	Static *	The upper emergency state current flow limits, as defined by the maximum permissible current rating of each particular cable “hot spot”.
Trip-off overcurrent limits	Static	The trip-off overcurrent limit at which the existing network protection settings of that particular cable section will operate.
Real power flow at the PCC	Dynamic	The value for the three-phase real power flow in kW at the PCC between the SSEZ and the upstream distribution network.
Reactive power flow at the PCC	Dynamic	The value for the three-phase reactive power flow in kVAr at the PCC between the SSEZ and the upstream distribution network.
Apparent power flow at the PCC	Dynamic	The value for the three-phase apparent power flow in kVA at the PCC between the SSEZ and the upstream distribution network.
Upper normal state apparent power flow limit	Static *	The upper normal state apparent power flow limit from/to the distribution transformer, as defined by the system operator.
Upper alert state apparent power flow limit	Static *	The upper alert state apparent power flow limit from/to the distribution transformer, as defined by the system operator.
Upper emergency state apparent power flow limit	Static	The upper emergency state apparent power flow limit from/to the distribution transformer, as defined by the thermal rating of that particular distribution transformer.
%VUFs at the SSEZ remote ends	Dynamic	The values for the %VUFs at the remote ends of the SSEZ feeders that are being monitored.
Upper normal state %VUF limit	Static *	The upper normal state %VUF limit, as defined by the system operator.
Upper alert state %VUF limit	Static *	The upper alert state %VUF limit, as defined by the system operator.
Upper emergency state %VUF limit	Static	The upper emergency state %VUF limit, as defined by current statutory regulations. This value is 1.3% for UK LV distribution networks

		and 2% for EU LV distribution networks.
Voltage regulation	Dynamic	The values for the percentage voltage deviation between the LV distribution substation voltage and the remote ends of each of the SSEZ feeders that are being monitored.
Lower normal state voltage regulation limit	Static *	The lower normal state voltage regulation limit, as defined by the system operator.
Upper normal state voltage regulation limit	Static *	The upper normal state voltage regulation limit, as defined by the system operator.
Lower alert state voltage regulation limit	Static *	The lower alert state voltage regulation limit, as defined by the system operator.
Upper alert state voltage regulation limit	Static *	The upper alert state voltage regulation limit, as defined by the system operator.
Lower emergency state voltage regulation limit	Static *	The lower emergency state voltage regulation limit. This is also defined by the system operator because common statutory voltage regulation limits for LV distribution networks do not currently exist.
Upper emergency state voltage regulation limit	Static *	The upper emergency state voltage regulation limit, as defined by the system operator.
Selected operational goal	Dynamic	The operational goal that has been selected either by the OGA or through a request from the local DNO. This can either be: (a) “zero_import”; (b) “zero_export”; (c) “self-sufficiency”; (d) “constant_power_import”; (e) “dispatchable power output”; or (f) “none”.
Start date of the selected operational goal	Dynamic	The date when the selected operational goal is set to take place. This is specified either by the OGA or through a request from the local DNO.
Start time of the selected operational goal	Dynamic	The time when the selected operational goal is set to start. This is specified either by the OGA or through a request from the local DNO.
Duration of the selected operational goal	Dynamic	The duration of the selected operational goal. In line with the current electricity market operation, this value is typically 30 minutes.
Amount of real power requested	Dynamic	The amount of real power requested from the local DNO if the “dispatchable_power_output” operational goal has been selected.

Table B-4: Database coupled to the indirect control agents within the SSEZ.

Appendix C

Behaviour	Description
SimpleBehaviour	This class models simple atomic behaviours, and may be extended accordingly by the MAS developer.
OneShotBehaviour	This class models atomic behaviours that must be executed only once and cannot be blocked. Its <i>done ()</i> method always returns <i>true</i> .
WakerBehaviour	This class executes a one-shot user-defined task only once after a given timeout is elapsed.
ReceiverBehaviour	This class triggers when a given type of message is received or a given timeout is elapsed.
CyclicBehaviour	This class stays active as long as its agent is alive and must always be executed. Its <i>done ()</i> method always returns <i>false</i> .
TickerBehaviour	This class implements a cyclic task that must be executed periodically.
CompositeBehaviour	This class models behaviours that are made up by composing a number of children behaviours. The tasks performed by this behaviour are defined inside its children, while the composite behaviour only takes care of children scheduling.
SequentialBehaviour	This class executes its children behaviours one after the other and terminates when all children behaviours have ended.
ParallelBehaviour	This class executes its children behaviours in parallel and terminates when a particular condition on its children behaviours is met. This may be specified to be when all children have ended, n children have ended, or any child.

Table C-1: Behaviour classes provided by JADE

Parameter	Description	Category
Performative	Denotes the type of the communicative act of the ACL message.	Required
Sender	Denotes the identity of the sender of the message.	Participant
Receiver	Denotes the identity of the intended recipients of the message.	Participant
Reply-to	Denotes that subsequent messages are to be directed to the agent named in the reply-to parameter.	Participant
Content	Denotes the content of the message.	Content
Language	Denotes the language in which the content parameter is expressed.	Content Descriptor
Encoding	Denotes the specific encoding of the content language expression.	Content Descriptor
Ontology	Denotes the ontology(s) used to give meaning to the symbols in the content expression.	Content Descriptor
Protocol	Denotes the interaction protocol the sending agent is using with the message.	Conversation Control
Conversation-id	Introduces an expression (a conversation identifier) which is used to identify the ongoing sequence of communicative acts that together form a conversation.	Conversation Control
Reply-with	Introduces an expression that will be used by the responding agent to identify this message.	Conversation Control
In-reply-to	Denotes an expression that references an earlier action to which this message is a reply.	Conversation Control
Reply-by	Denotes a time and/or date expression which indicates the latest time by which the sending agent would like to receive a reply.	Conversation Control

Table C-2: FIPA ACL message parameters.

Performative	Description
Accept-proposal	Accepting a previously submitted proposal to perform an action.
Agree	Agreeing to perform some action, usually in reply to a Request.
Cancel	Informing another agent that an action is no longer intended.
Cfp	Calling for proposals to perform a given action.
Confirm	Informing another agent that a given proposition is true.
Failure	Informing another agent that an action was attempted, but the attempt failed for a given reason
Inform	Informing another agent that a given proposition is true.
Not-Understood	Informing another agent that his action was perceived but not understood; e.g. a message was sent but was not understood by the receiving agent.
Propose	Submitting a proposal to perform a certain action, given certain preconditions.
Query-if	Asking another agent if a given proposition is true or not.
Query-ref	Asking another agent for the object referred to by a referential expression.
Refuse	Refusing to perform a given action, with an explanation for the refusal.
Reject-proposal	Rejecting a previously submitted proposal to perform an action.
Request	Requesting that another agent performs a given action.
Subscribe	Requesting persistent notification for the value of a reference and to notify again when the object identified by the reference changes.

Table C-3: FIPA ACL message performatives.

```

public class TLA extends Agent {

protected void setup() {

    addBehaviour(new TickerBehaviour(this, 15000) {
        protected void onTick() {
            Connection con = null;
            Connection connection = null;
            Statement stmt = null;
            Statement statement = null;
            ResultSet rs = null;

        try {

            //Register the JDBC driver for MySQL.
            Class.forName("com.mysql.jdbc.Driver");

            //Get a connection to the INPUTS database for a
            // user named "root" with the password "password"
            con = DriverManager.getConnection("jdbc:mysql://localhost:3306/inputs",
                "root", "password");

            //Take a value from the "inp" database table for the current flow of a
            //particular line segment and for a particular time
            stmt = con.createStatement ( );
            rs = stmt.executeQuery ("SELECT current_flow FROM inp WHERE
                time = '22:56:00'");

        while (rs.next()) {

            double amps = rs.getDouble(1);

        if (amps < 50) {
            try {
                System.out.println("The current at the line segment of interest is less
                    than 50 A, it is "+amps+" A");
                System.out.println("No generators need to be controlled ");
            }
            }

        else {
            try {
                ACLMessage msg = new ACLMessage (ACLMessage.REQUEST);
                msg.addReceiver(new AID("GA-1", AID.ISLOCALNAME));
                msg.addReceiver(new AID("GA-2", AID.ISLOCALNAME));
                msg.addReceiver(new AID("GA-3", AID.ISLOCALNAME));
                msg.setOntology("SSEZ-control ");
                msg.setContent("realPowerOutReduction ");
            send(msg);
            }
            }
        }
    }
}

```

```

finally {
    System.out.println("Problem! The current at the line segment of interest
        is more than 50 A, it is "+amps+" A");
    System.out.println("The connected generators' real power output must
        be curtailed!");
    }
}
} catch (Exception e) {
    System.err.println("Exception: " + e.getMessage());
} finally {
    try {
        if(rs != null)
            rs.close();
        if(stmt != null)
            stmt.close();
        if(con != null)
            con.close();
    } catch (SQLException e) {
    }
}
}
});
}
}

```

Figure C-1: An example of a TLA accessing a database through the use of JDBC.