

Durham E-Theses

Developmental studies on Malpighian tubule structure and function in Spodoptera Littoralis

Saeed S.R. Al-Ahmadi

How to cite:

Al-Ahmadi, Saeed S.R. (1993) Developmental studies on Malpighian tubule structure and function in Spodoptera Littoralis. Doctoral thesis, Durham University.

Use policy

The full-text may be used and/or reproduced, and given to third parties in any format or medium, without prior permission or charge, for personal research or study, educational, or not-for-profit purposes provided that:

- a full bibliographic reference is made to the original source
- a <https://etheses.durham.ac.uk/id/eprint/5693/> is made to the metadata record in Durham E-Theses
- the full-text is not changed in any way

The full-text must not be sold in any format or medium without the formal permission of the copyright holders.

Please consult the [full Durham E-Theses policy](#) for further details.

**DEVELOPMENTAL STUDIES ON MALPIGHIAN TUBULE STRUCTURE AND
FUNCTION IN *SPODOPTERA LITTORALIS***

By

Saeed S.R. Al-Ahmadi B. Sc., M. Sc.

(King Abdul Aziz University Saudi Arabia)

The copyright of this thesis rests with the author.
No quotation from it should be published without
his prior written consent and information derived
from it should be acknowledged.

Being a thesis submitted for the degree of Doctor of Philosophy of the University of Durham

September, 1993

(Graduate Society)

University of Durham



- 9 DEC 1993

DECLARATION

I hereby declare that the work presented in this thesis is based on research carried out by me, and that this work has not been presented anywhere else for a degree and has not been published before.

Saeed S. R. Al-Ahmadi

DEDICATION

This thesis is dedicated to my parents and also my brothers for their support and encouragement and to my wife and children for their patience

STATEMENT OF COPYRIGHT ©

This copyright of this thesis rests with the author. No quotation from it should be published without his written consent, and information derived from it should be acknowledged

ACKNOWLEDGEMENTS

I would like to thank Dr. John H. Anstee for his tireless help and supervision throughout the course of this work and his guidance in the preparation of this thesis, without which this work would not have been possible.

I gladly and gratefully acknowledge the help and advice I have received from many people during the writing of this work, particularly Prof. Ken Bowler, Dr. Bob Banks, Dr. M.J. Stacey, Z. I. Al-Fifi and Sarah Marshall.

I also thank Mrs. Christine Richardson for her assistance with electron microscopy.

My thanks go to Mr. Paul Loftus and Miss. Gillian Davison for maintaining the insects and also to Mr. Terry Gibbons and all other technical staff for their help in many ways.

I owe my most grateful thanks to my brother Mr. M. S. Al-Ahmadi for his support, help and encouragement throughout the course of this study.

My special thanks go to my wife for her help and motivation throughout my study, and my children for their endless love and patience.

Finally, most thanks go to my father and mother for their continuous and endless support, to whom I owe this investment in time and education.

CONTENTS

Acknowledgements		i
Contents		ii
Abstract		iii
Glossary		vi
Chapter 1	Introduction	1
Chapter 2	Materials and Methods	10
Chapter 3	Morphological and ultrastructural studies	28
	Section (1): Morphological and Histological observation	28
	Section (2): Developmental change in the fine structure of the Malpighian tubules during the last larval, pupal and adult stages	39
	Discussion	51
Chapter 4	The effect of methoprene on the last larval instar of <i>Spodoptera littoralis</i>	63
	Introduction	63
	Materials and methods	66
	Results	67
	Discussion	72
Chapter 5	Characterisation of fluid and ion secretion by Malpighian tubules of <i>Spodoptera littoralis</i>	76
	Section (1): Studies on Malpighian tubules secretion by fifth instar larvae	76
	Section (2): Effect of age on Malpighian tubule fluid production, <i>in vitro</i>	87
	Section (3): Measurement of wet weight and dry weight changes throughout the 4th, 5th, and 6th stadia	89
	Section (4): Cytochemical localization of K⁺-dependent p-nitrophenyl phosphatase activity in the larval Malpighian tubules of <i>Spodoptera littoralis</i>	90
	Discussion	92
Chapter 6	Conclusion	105
References		111

Abstract

A study has been made on Malpighian tubule structure and function in *Spodoptera littoralis*. The concentrations of the main ions present in insect haemolymph were determined and a Ringer solution developed on the basis of this information. *In vitro* preparations of the medial region of the Malpighian tubules were set up to characterise fluid secretion using this 'normal' Ringer solution. Ion substitution experiments, involving varying concentrations of K^+ , Na^+ and Cl^- in the bathing media indicated that K^+ and Cl^- were necessary for normal fluid secretion rates to be maintained. Incubation in media containing high K^+ (and zero Na^+) yielded the maximum rate of fluid secretion *in vitro*, whereas high Na^+ (and zero K^+) resulted in a rate of fluid secretion lower than that of the control. Cl^- substitution with gluconate resulted in reduced rates of fluid secretion.

The agonists, 5-HT (10^{-3} M) and cAMP (10^{-3} M), both effected stimulation of fluid secretion; the maximal observed level of stimulation being 267.4% and 148.7%, respectively. In contrast, synthetic *Manduca sexta* diuretic peptide had no significant effect on the rate of fluid secretion by medial tubules of *Spodoptera*. The effects of known inhibitors of specific ion transport processes (ouabain; furosemide and NEM) on urine secretion was investigated. These three inhibitors inhibited fluid secretion significantly. NEM was the most effective inhibitor used; secretion being totally inhibited at 10^{-5} M NEM. Maximal inhibition with ouabain (1mM) and furosemide (10^{-3} M) was 94.6% and 80.3%, respectively. These results were taken as evidence for Na^+/K^+ ATPase, $Na^+/K^+ / 2Cl^-$ co-transport and a V-type ATPase being involved in the transport of ions across tubule cells.

Cytochemical localization studies showed the presence of Na^+/K^+ ATPase activity on the basal membrane of the proximal but not of the medial tubules. The apparent anomaly between this latter observation and the fact that fluid secretion by medial tubules was inhibited by ouabain is discussed.

A hypothetical model has been constructed to explain ion and fluid secretion by the medial tubules of *Spodoptera littoralis* and its endocrine control.

The rate of fluid secretion *in vitro* was studied at different ages throughout the 4th, 5th, 6th larval stages, the prepupae, the pupae and into adult life. It was shown that the rate of fluid secretion varied throughout development; both within each instar and between stadia. Fluid secretion ceased in the prepupal and pupal stages and started again following eclosion of the adult.

Morphological studies on the relationship between the Malpighian tubules and the alimentary tract were carried out on last instar larvae, prepupae, pupae and adults; six tubules were present in all these stages. Each tubule consisted of several distinct regions; proximal, medial, iliac plexus, rectal leads and a cryptonephridial arrangement (larvae only). Electron microscopical studies on Malpighian tubules of 5th and 6th instar larvae and adults showed that one cell type was present in each region (the cryptonephridium was excluded from the E-M study). However, differences in cellular fine structure were apparent between regions. In the proximal region, the basal membrane foldings created a labyrinth and the apical membrane formed microvilli which were relatively short, loosely packed and contained mitochondria. In the medial and distal regions, which were similar in fine structure, the basal membrane was much infolded and extended further into the cytoplasm than in the proximal tubules. The apical microvilli of the medial region were considerably longer and more densely packed than in the proximal region and the apical surface was folded so that canaliculi were formed.

Ultrastructural studies throughout development of the last larval instar revealed that the basic ultrastructure of the cells of the different regions of Malpighian tubules changed little. The major change seen during development from the last larval stage to the adult was seen in the prepupal Malpighian tubules where the basal membrane foldings became very narrow and the apical microvilli were also very thin and their mitochondria were withdrawn into the cytoplasm. This change in the ultrastructure was

associated with cessation of fluid secretion. The tubule cells in the adult, unlike in the larva, contain numerous clear vacuoles and mineralized concretions. In addition the apical membrane of adult Malpighian tubule cells contained stalks which extend into the tubule lumen. The latter were only seen in larvae following treatment with the juvenile hormone analogue, methoprene.

GLOSSARY

BSA	Bovine serum albumen (Fraction V, Sigma)
cAMP	Cyclic adenosine 3', 5-monophosphate
IP ₃	D-myo-inositol 1,4,5-trisphosphate
HEPES	4-(2-hydroxyethyl)-1-piperazine-ethanesulphonic acid
5-HT	5-hydroxytryptamine
Fig	Figure
mM	Millimolar
(Na ⁺ +K ⁺)-ATPase	Magnesium-dependent, sodium-potassium-stimulated adenosine triphosphatase
SEM	Standard error of mean
J.H	Juvenile Hormone
JHA	Juvenile hormone analogue
M	Molar
DH	Diuretic hormone
E.M.	Electron microscope
NEM	N-ethyl-maleimide
Mas-DH	<i>Manduca sexta</i> diuretic hormone
Wt	Wet weight

CHAPTER 1

INTRODUCTION

Urine formation by the Malpighian tubules of insects has been the subject of numerous studies in the last thirty to forty years (e.g. Ramsay 1953, 1954, 1955, 1956, Berridge 1968, Pilcher 1970, Anstee and Bell 1975, Gee 1975a, 1976a, Maddrell 1969, 1971, 1977, Ryerse 1978). This research has shown that in the majority of insect species studied to date, K^+ transport is the 'prime mover' in fluid secretion. However, there appear to be some exceptions. It was found that the Malpighian tubules of *Rhodnius* and *Glossina* are different. In *Rhodnius*, tubules will secrete Na^+ or K^+ (Maddrell 1969) whereas in *Glossina*, Na^+ is the 'prime mover' (Gee 1975a, 1976a). Berridge and Oschman, (1969) reported that whilst the K^+ concentration in the bathing medium was of prime importance in determining the rate of fluid secretion in *Calliphora*, the secretion of fluid was enhanced when Na^+ was present as well as K^+ . They accordingly proposed a model for ion and fluid movement across *Calliphora* Malpighian tubules in which the primary cells possess an apical electrogenic 'pump' which transports K^+ from the cytoplasm into the lumen. At the basal cell surface, K^+ entry was suggested to involve a coupled Na^+/K^+ exchange 'pump'. In general the presence of an electrogenic K^+ 'pump' in the apical membrane is accepted (Berridge 1967, Berridge and Oschman 1969, Maddrell 1977). Objections were raised about the presence of a Na^+/K^+ pump on the basal membrane. This objection came from some workers who failed to show that fluid secretion by insect Malpighian tubules was inhibited by ouabain, a specific inhibitor of Na^+/K^+ - activated ATPase activity (Berridge 1968, Maddrell 1969, Pilcher 1970, Rafaeli-Bernstein and Mordue 1978). This led Maddrell (1977) to propose an alternative model which might apply to all Malpighian tubules regardless of whether they pump K^+ or Na^+ as the 'prime mover'.

In this model he suggested that K^+ , Na^+ and Cl^- cross the cells basal membrane passively at a rate which was determined by the permeability of the membrane to these ions and the electrochemical gradient across the membrane. Active transport of K^+ and/or Na^+ across the apical membrane was by an electrogenic cation pump, whereas Cl^- moves across the apical membrane passively. It was further proposed that the apical pump showed a higher affinity for Na^+ than K^+ so that if the basal membrane was more permeable to K^+ than Na^+ (e.g. *Carausius*, Pilcher, 1970 and *Rhodnius*, Maddrell, 1971), the former cation would enter the cell more rapidly and be transported into the tubule lumen. In insects where the basal membrane was more permeable to Na^+ these ions would be secreted in preference to K^+ into the lumen. This model is not altogether consistent with the observed facts. Thus it is known that the rate of fluid secretion is enhanced by Na^+ under conditions of low bathing medium K^+ (Berridge, 1968; Maddrell, 1971; Anstee and Bell, 1975; Morgan and Mordue, 1981). This has been taken as evidence for a Na^+/K^+ exchange pump on the basal cell surface and this is supported by reports of ouabain-sensitivity of tubule function by several research groups and the demonstration that a Na^+/K^+ ATPase is present in Malpighian tubules of several species (see reviews by Anstee and Bowler, 1979, 1984; Nicolson, 1993). In addition, the intracellular K^+ concentration is high compared with that of the bathing medium (Gupta *et al.*, 1977; Pivovarova *et al.*, 1993) so that it is difficult to see how adequate K^+ entry into the cell could be achieved passively (Baldrick *et al.*, 1988). Maddrell and Overton, (1988) suggested that the Na^+/K^+-Cl^- cotransporter, was located on the basal membrane and directed the movement of Na^+ , K^+ and Cl^- into the cell. O'Donnell and Maddrell, (1984) proposed that during diuretic hormone or 5-HT-stimulated fluid secretion, a cotransporter mechanism is responsible for these cation and anion movements into the cell. Baldrick, *et al.*, (1988) suggested that the considerable concentration and electrical gradients across the basal membrane might permit some Na^+ entry with Cl^- entry by some electroneutral mechanism, possibly stimulated by extracellular K^+ . The Cl^- entry by electroneutral cotransport with K^+ and

/or Na^+ appears to be feasible on the basis of the effects of some specific inhibitors, such as furosemide, on the electrophysiology of this epithelium (Baldrick, 1987).

More recently, studies have concentrated on the nature of the apical membrane transport processes. Electrophysiological studies (Morgan and Mordue, 1983, O'Donnell and Maddrell, 1984; Baldrick *et al.*, 1988; Fogg *et al.*, 1989; and Pannabecker *et al.*, 1992) showed that an electrogenic 'pump' is required for cation transport from cytoplasm to lumen across the apical plasma membrane of tubule cells. However, the exact nature of this pump has, until recently, been uncertain. The current view is that K^+ (or Na^+) secretion is powered by a vacuolar (V-type)-ATPase which pumps protons from the cytoplasm into the tubule lumen. The resulting proton gradient is believed to energize a K^+ (or Na^+)/ H^+ antiporter which exchanges intracellular K^+ (or Na^+) for luminal H^+ . A similar arrangement is suggested for the K^+ pump of lepidopteran midgut goblet cells and lepidopteran and other insect Malpighian tubules (see Schweickl *et al.*, 1989, Wieczorek *et al.*, 1989, 1991; Klein *et al.*, 1991; Fogg *et al.*, 1991; Wieczorek 1992; Klein, 1992; Moffett and Koch 1992, Maddrell and O'Donnell 1992, see also review by Nicolson 1993). NEM and bafilomycin A_1 are reported to be fairly specific inhibitors of V-type ATPase activity and several researchers have taken inhibition of fluid secretion by these molecules as evidence for this enzyme being involved in ion and fluid secretion by Malpighian tubules (Bertram, *et al.*, 1991, Welens *et al.*, 1992).

The fluid secreted by Malpighian tubules of some species is reported to be slightly hypo-osmotic to the bathing medium (e.g., *Carausius morosus*, Ramsay 1954, *Dysdercus fasciatus*, Berridge 1965) but in the majority of insects it has been found to be slightly hyperosmotic (Berridge 1968, Maddrell 1969, 1977, Anstee *et al.* 1979) with the rate of fluid secretion being inversely proportional to the osmotic concentration of the bathing medium, (Phillips 1981). These observations conform with suggestions that water movement is linked to solute movement by osmosis (Maddrell 1977, 1980). However, the exact mechanism whereby solute-solvent coupling is achieved in near iso-

osmotic secretion remains uncertain. Several of theories have been proposed to account for water movement across epithelia. A significant step was made by Curran and Solomon (1957), when they suggested that intestinal water absorption in rat ileum was a passive process achieved by active transport of solute. This observation led Curran and McIntosh (1962) to propose the double-membrane theory of osmotic coupling. Basically this model consists proposes two membranes in series with a compartment in between (see Fig. 1.1A and legend). Subsequently, this model was modified by Diamond and Bossert (1967, 1968) in an attempt to relate the structural appearance of transporting cells to their function. Their standing osmotic gradient model has received considerable attention and support. A diagrammatic representation of the standing osmotic gradient model can be seen in Figure 1.1 B (i & ii) and is described in the figure legends. This model was originally proposed on the basis of studies on rabbit gallbladder and has since been applied to insect Malpighian tubule fluid secretion (Berridge and Oschman, 1969).

An alternative hypothesis involving electro-osmosis has been suggested by Hill (1975) to explain ion and water transport across epithelia. In electro-osmosis, the transmembrane potential can move water because there is frictional interaction between water and one of the ions in a special pore, which excludes the counter-ion. Maddrell (1977) has discussed how this theory may be applied to insect Malpighian tubules. It is suggested that an electrical potential difference across the apical plasma membrane generated by an electrogenic cation pump would draw Cl^- from the cytoplasm through the membrane. In so doing, the Cl^- would frictionally interact with water molecules and cause them to move out of the cell. This mechanism requires a potential gradient to exist across the plasma membrane and that the apical cell surface is bathed in its own secreted fluids. Maddrell (1977) suggests that the microvillar foldings would serve to create an appropriate unstirred layer to serve this purpose. He also points out that this model and that of Diamond and Bossert referred to above are not exclusive. Water movements might partly result from an osmotic gradient and partly from electro-

Fig. 1.1

(A) Double membrane model

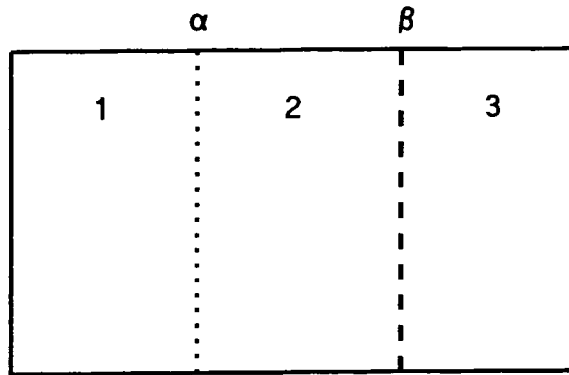

(B) Standing osmotic gradient model

(i) 'forward' facing channel

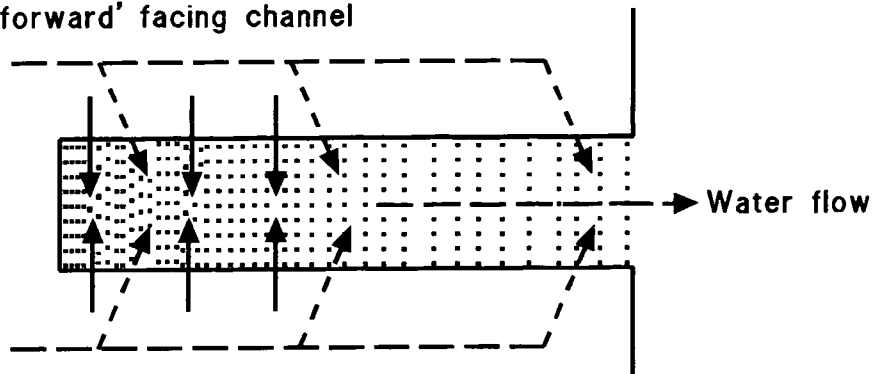

(ii) 'backward' facing channel

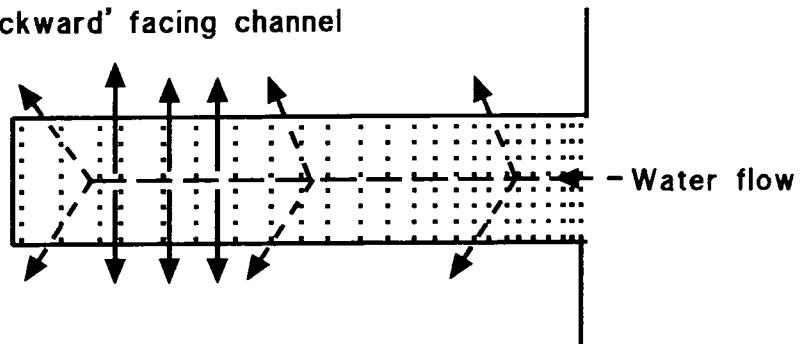

osmotic coupling with passive ion movements. Whatever the true nature of the coupling proves to be, it is generally accepted that water movement is dependent on solute movement and that local osmotic changes involving intra- and extracellular spaces are likely to be important.

Whilst the precise mechanism by which water is transported across the Malpighian tubules remains vague, it has been established that the secretion of fluid is under hormonal control (Phillips 1981, 1982). Diuretic hormones (DH) in insects which stimulate Malpighian tubule and rectal fluid secretion are produced by neurosecretory cells in different species of insect (see review by Maddrell 1981, Phillips, 1982, 1983, Nicolson and Hanrahan, 1986, Wheelock *et al.*, 1988). In some species of insect the hormone is released into the haemolymph *via* the corpora cardiaca after its synthesis in the neurosecretory cells of the brain, for example in *Schistocerca gregaria* (Highnam *et al.*, 1965, Mordue 1969) and in *Carausius morosus* (Pilcher 1970). Whereas in *Rhodnius* and *Corethra* spp. it is synthesised by neurosecretory cells in the mesothoracic ganglion (Maddrell 1963; Gersch 1967, respectively). In *Glossina morsitans* diuretic hormone is present in the thoracic ganglion and released from neurosecretory axon endings in the abdomen (Gee 1975b).

Cyclic AMP is thought to be an intracellular second messenger mediating the action of DH in insect Malpighian tubules. Cyclic AMP was applied on isolated Malpighian tubules of various insects and found to increase fluid secretion (*Rhodnius prolixus* and *Carausius morosus*, Maddrell *et al.*, 1971; *Schistocerca gregaria*, Maddrell and Klunswan, 1973, *Glossina morsitans*, Gee 1976a; *Pieris brassicae*, Nicolson 1976a, 1980; *Locusta migratoria*, Anstee *et al.*, 1980; Donkin, 1981; *Papilio demodocus*, Nicolson and Millar, 1983; *Onymacris plana*, Nicolson and Hanrahan, 1986). Extensive studies have been carried out in an attempt to explain the mode of diuretic hormone action on Malpighian tubules of insects (e.g., in *Rhodnius prolixus*, Maddrell, 1971, 1978; O'Donnell and Maddrell, 1983 in *Locusta migratoria*, Rafaeli *et al.*, 1984; Morgan and Mordue, 1985; Fogg *et al.*, 1991). These studies report

increased intracellular levels of cyclic AMP following stimulation with diuretic hormone or corpora cardiaca extracts with established diuretic activity (see Aston 1975, 1979; Fogg *et al.*, 1990; Nicolson, 1992; 1993). Farmer *et al.*, (1981) reported that cAMP stimulated fluid absorption in the mid-gut of *Rhodnius prolixus*.

5-hydroxytryptamine (5HT or serotonin) has been found to mimic DH action on the Malpighian tubules of some insects. In the present study 5-HT was found to increase the rate of fluid secretion by Malpighian tubules of *Spodoptera littoralis*. This feature of 5-HT has been proposed for other insects such as *Rhodnius prolixus*, *Carausius morosus*, (Maddrell *et al.*, 1971), *Calliphora vicina* (Schwartz and Reynolds, 1979), *Papilla demodocus* (Nicolson and Millar, 1983), *Locusta migratoria* (Morgan and Mordue 1984) and *Aedes aegypti* (Veenstra 1988). Similarly 5-HT stimulated fluid secretion by salivary glands (Berridge and Patel 1968, Berridge and Prince 1972). In some studies it was found that 5-HT is an effective stimulator of fluid secretion, independent of the presence of cAMP, for example in locust Malpighian tubules (Morgan and Mordue 1984). Whereas in some insects 5-HT has no effect on fluid secretion by Malpighian tubules (Maddrell and Klunswan 1973; Dalton and Windmill, 1980). Furthermore, Anstee *et al.*, (1980) and Baldrick (1987) mentioned that 5-HT caused no significant stimulation of secretion by Malpighian tubules of *Locusta migratoria*.

The mechanism by which this hormone regulates fluid secretion by insect Malpighian tubules is still not obvious and little is understood about it. Nevertheless, the receptor mechanisms mediating the action of 5-HT have been determined in the salivary gland of *Calliphora erythrocephala*, (Berridge, 1980, Berridge and Heslop, 1982) and in other epithelial tissues where this hormone acts, (Trimmer, 1985). It is thought that the information carried by the 5-HT molecule is changed into two second messengers, cyclic AMP and Ca^{2+} (Prince and Berridge, 1973). Hence a 5-HT₁ receptor activates the entry of Ca^{2+} and a 5-HT₂ receptor activates adenylate cyclase to generate cAMP (Berridge and Heslop, 1982). The role of the two second messengers

(cAMP & Ca^{2+}), responsible for mediating the action of 5-HT, is to increase ion and fluid secretion (Berridge 1980).

There is a hypothetical model to explain the hormonal control of fluid secretion by the Malpighian tubules of *Locusta migratoria* suggested by Morgan and Mordue (1984). This model suggests the presence of two receptors located on the surface of the tubules, one (R_1) which activates adenylate cyclase activity to increase cAMP and the other (R_2) to trigger a different secondary cellular event which might increase intracellular Ca^{2+} or IP_3 as suggested by Fogg (1990) and Fogg *et al.*, (1992). Similarly, Coast *et al.*, (1991) discussed and cited evidence for the concept that cAMP mediates increases in Na^+ and K^+ transport, while Ca^{2+} mediates increases in Cl^- conductance.

Various studies have been carried out to determine the fine structure of the Malpighian tubules in different species of insects. For example, *Calliphora erythrocephala* (Berridge and Oschman 1969), *Carausius morosus* (Taylor 1971a & b), *Periplaneta americana* (Wall *et al.*, 1975), *Jamaicana flava* (Peacock and Anstee, 1977) and *Locusta migratoria* (Bell and Anstee, 1977; Donkin, 1981; and Fogg, 1990) and in *Calpodes ethlius* (Ryerse, 1979). Some of the authors reported that there are two distinct cell types in some insect Malpighian tubules. For instance Berridge and Oschman (1969), Taylor (1971a & b), Wall *et al.*, (1975), Peacock and Anstee, (1977), Bell and Anstee, (1977), Donkin, (1981) and Fogg, (1990). The 'primary' cells reported by Berridge and Oschman (1969) or as they are sometimes called the 'type 1' cells (Taylor 1971a), are structurally distinct from the so called 'stellate' cells (Berridge and Oschman 1969). The 'type 2' (Taylor 1971b) or 'secondary' cells (Peacock 1975) are less frequently encountered. Whereas the 'primary' cells are distinguished by the presence of a basal membrane which contains invaginations which form the extracellular spaces and the apical membrane which forms microvilli which face the tubule lumen. In contrast the 'secondary' cells are smaller than the 'primary' cells and their basal membrane invaginations are reduced and the apical microvilli are

less dense and shorter (Peacock, 1975; Fogg, 1990), also in the latter the cell cytoplasm is rich in endoplasmic reticulum, Golgi bodies and lysosomes, (see, Berridge and Oschman 1969, Taylor, 1971b). However the function of these cells remains unsure, although some investigators suggest that they may play a role in the absorption of ions and water from the lumen. The association of mitochondria with the basal infoldings and apical microvilli give these cells the characteristics of epithelial secretory tissues. These features of transporting epithelial tissues have been reported in mammalian kidney and gall bladder (see Rhodin, 1958; and Kaye *et al.*, 1966 respectively) as well as in insect Malpighian tubules and salivary glands (see Taylor 1971a, b; Berridge and Oschman 1969; Oschman and Berridge 1970, respectively).

The models which were mentioned previously attempted to explain fluid movement across epithelia by relating fine structure to function (Diamond and Bossert 1968) and included the standing gradient hypothesis of Diamond and Bossert (1968), which was also used to explain fluid flow across the Malpighian tubules of *Calliphora* by Berridge and Oschman (1969).

To date, few ultrastructural studies have been carried out on larval Malpighian tubules and how these change with development; the majority of studies being carried out on adult insects (see Berridge and Oschman, 1969; Taylor 1971a & b, Bell and Anstee, 1977). A notable exception is the study by Ryerse (1979) on Malpighian tubules of larvae and adults of the skipper butterfly, *Calpododes ethlius*. In addition, little is known about how tubule function changes with larval development and metamorphosis, again with the exception of some studies by Ryerse, (1977, 1979) on the Malpighian tubules of *Calpododes ethlius*. Ryerse, (1977) reported that the Malpighian tubules of *Calpododes ethlius* were remodelled at the larval- pupal metamorphosis. Particularly that there was obvious retraction of mitochondria from the apical microvilli and the basal infoldings of tubule cells were reduced. These changes in the structure were accompanied by functional changes. Ryerse, (1978) found marked changes in Malpighian tubules fluid secretion throughout the larval instars.

Fluid secretion ceased when the mitochondria retracted from the microvilli and when the basal membrane infoldings were reduced in the pupal instar, but secretion started when remodelling occurred, Ryerse, (1978, 1979).

The present study was carried out to characterise fluid secretion by the medial tubule region of the Malpighian tubules of the lepidopteran, *Spodoptera littoralis*, and how this was affected by development and metamorphosis. In addition a study was made to determine the morphology and fine structure of the Malpighian tubules and how these change in the last larval stage insects, during metamorphosis and the extent to which such changes were related to tubule function.

CHAPTER 2

MATERIALS AND METHODS

Maintenance of *Spodoptera littoralis*

A population of the armyworm, *Spodoptera littoralis*, was maintained on artificial diets in an insectary at a temperature of $24 \pm 1^\circ\text{C}$ and $40 \pm 10\%$ relative humidity. A constant photoperiod of 14 hours light and 10 hours dark was maintained.

The larvae were kept in sealed transparent plastic 'rearing boxes' measuring 26 cm in length x 16 cm in width x 10 cm in depth. Ventilation was provided by two mesh-covered openings in the lids of the boxes. An abundant supply of food was always present and this was provided fresh each day. Following the last larval stadium, pupae were collected and transferred to plastic containers measuring 17 cm in length x 11 cm in width x 6 cm in depth and with lids. The latter containers were then placed inside cylindrical cages constructed of aluminium and perspex and measuring 40 cm in height and 44 cm in diameter. Cotton wool soaked with adult diet was placed in the cylindrical cages for emerging adult insects to feed on; a plentiful supply of food was present at all times. In addition, the walls of the cylinder were lined with tissue paper to provide a suitable surface on which the adult females could lay their eggs.

The paper liners were removed daily, once egg-laying had begun, and were cut into small circular pieces (*ca.* 2 cm in diameter). The latter were then placed in a 100 ml plastic container with a secure lid and containing a small piece of larval diet. On hatching, the larvae were quickly transferred to the food and it is at this stage that they are placed in the larger 'rearing boxes' described above.

Composition of diets

(i) Composition of the artificial larval diet (J Ratcliffe, Shell International Ltd; personal communication) is shown in Table 2.1. The medium was made up as follows:

The agar was dissolved in approx. 650 ml of distilled water with heating and to this solution was added 350 ml of distilled water containing the remaining ingredients apart from the vitamins and antibiotics. The 1litre of solution was then allowed to cool to below 50°C and the vitamin mix and antibiotics added, with stirring until dissolved. Aliquots of the warm medium were then poured into petri dishes and allowed to set. They were then stored in plastic bags at -20°C until needed.

(ii) Composition of the adult diet is shown in Table 2.2. The various ingredients were mixed and dissolved in 1 litre of distilled water. The diet was stored in a glass bottle in a fridge at approx. 4°C until needed.

Table 2.1. Composition of Larval diet.

Components	Amount
Casein	54.000 g
Sucrose	54.000 g
Bemax	70.000 g
Cellulose	10.000 g
Sorbic acid	1.125 g
Benzoic acid methyl ester	1.750 g
Linseed oil	0.125 g
Agar	38.000 g
Salt mix*	14.400 g
Aureomycin	1.000 g
Ascorbic acid	0.500 g
Ampicillin	0.500 g
Formalin	0.500 ml
Vitamin mix#	14.400 g
Water	1 litre

* Wessons salt (I C N Biochemicals, Cleveland, Ohio)

#Vaderzant Vitamin Supplement for Insects (United States Biochemical Corporation, Cleveland, Ohio).

Table 2.2 Composition of adult diet.

Component	Amount
Sucrose	50.04 g
Yeast	1.01g
Honey	60.00 ml
Methyl-P-hydroxybenzoate	2.00 mg
Vitamin solution#	20.00 ml

#Vaderzant Vitamin Supplement for Insects (United States Biochemical Corporation, Cleveland, Ohio); 2.01 g Vitamin mix dissolved in 200 ml distilled water.

Experimental animals

In developmental studies, it was necessary to accurately age the animals. This was achieved as follows. All insects of the required stadium were removed from stock cages containing post-3rd instar larvae. Thereafter, these cages were checked twice daily, at 10.00 a.m. and 6 p.m. and insects of the required stadium removed and placed in experimental plastic boxes (17 cm long x 11 cm wide x 6 cm deep). In this way it was possible to age newly emerged larvae of the appropriate stadium to within ± 4 hr (insects collected at 6.00 p.m.) or ± 8 hr (insects collected at 10.00 a.m.). In some experiments, aged insects were reared individually in 100 ml round plastic containers (supplied by DRG Plastics, Corby England). In all cases, the experimental larvae were supplied with fresh food daily as described above for the stock populations.

Collection of larval haemolymph

Fifth and 6th instar larvae were used. These were rinsed in deionized water in a petri dish to remove surface debris and then blotted dry on filter-paper. The insects were then restrained by holding the anterior and posterior ends of each larva tightly together between the fore-finger and thumb. This prevented ejection of the gut contents. An incision was made through the dorsal body wall with care being taken not to puncture the alimentary canal and the body fluid which emerged collected in an Eppendorf tube. Slight pressure was applied to increase the expulsion of the haemolymph. The collected haemolymph was 'pooled' and stored frozen at -20°C until required; usually within 2-3 weeks.

The concentrations of sodium, potassium, calcium, magnesium, chloride, phosphate and protein in haemolymph were determined, as was the haemolymph osmotic pressure, using the methods described below.

Collection of secreted 'urine'

Malpighian tubules were dissected from decapitated 5th instar larvae and were set up as described for measurements of fluid secretion. After the initial 10 min. equilibration period the 'urine' droplet was removed and discarded. The 'urine' secreted over the next 20 minutes was dislodged from each tubule using a finely tipped glass rod and 'pooled' on a clean glass coverslip under the liquid paraffin. The 'pooled' droplet of 'urine' was then taken-up in a clean glass Hamilton microsyringe, transferred to a clean plastic petri dish and 1 μl aliquots, collected in microcap capillaries. Then diluted to 2 ml with deionized water in a 3 ml plastic specimen tube.

Determination of Na^+ , K^+ , Ca^{2+} and Mg^{2+} concentration of haemolymph and 'urine'

Samples contain 1 μl of haemolymph or 'urine' diluted to 2 ml in deionized water were analysed by atomic emission (for Na^+ and K^+) and atomic absorption (for Ca^{2+} and Mg^{2+}) spectroscopy to determine ionic concentration, using a Pye Unicam

SP90 spectrophotometer. Emission and absorbance readings were referred to standard calibration curves constructed with known concentrations of NaOH, KOH, CaCl₂ and MgCl₂ (see Figs. 2.1, 2.2, 2.3 and 2.4).

Determination of chloride concentration

Chloride concentration was determined using a potentiometric titration method. 600µl aliquots of larval haemolymph were diluted to 1ml and titrated potentiometrically against N/100 AgNO₃ using silver/silver chloride electrodes in acetone medium. The solution was stirred continuously during the titration using a magnetic stirrer and follower.

Determination of inorganic phosphate

Inorganic phosphate concentration was determined using the method of Atkinson, *et al.* (1973). A standard calibration curve relating concentration of inorganic phosphate to absorbance was produced by using a stock solution of 0.6M Na₂HPO₄, which was serially diluted to give a concentration range of (0-0.6M). 2ml of lubrol/acid molybdate solution (1 volume of 1% lubrol in deionized water: 1 volume of 1% ammonium molybdate in 0.9 M sulphuric acid) were added to 2 ml aliquots of the different phosphate solutions. The mixtures were then left to stand at room temperature for 10 min. when their absorbances were read at 390 nm using an Ultraspec 4050 spectrophotometer.

To determine the inorganic phosphate concentration in the haemolymph, 1µl haemolymph was diluted in 1ml deionized water and 2ml of lubrol/acid molybdate added. The mixture was then treated as above, the absorbance measured and the concentration of inorganic phosphate determined by reference to the standard curve (see Fig. 2.5).

Fig. (2.1)

Calibration curve for sodium hydroxide concentration against % emission, estimated using an S.P. 90 spectrophotometer wavelength at 589 nm.

Ordinate: % emission

Abscissa: $[\text{Na}^+]$ mM

Fig. 2.1

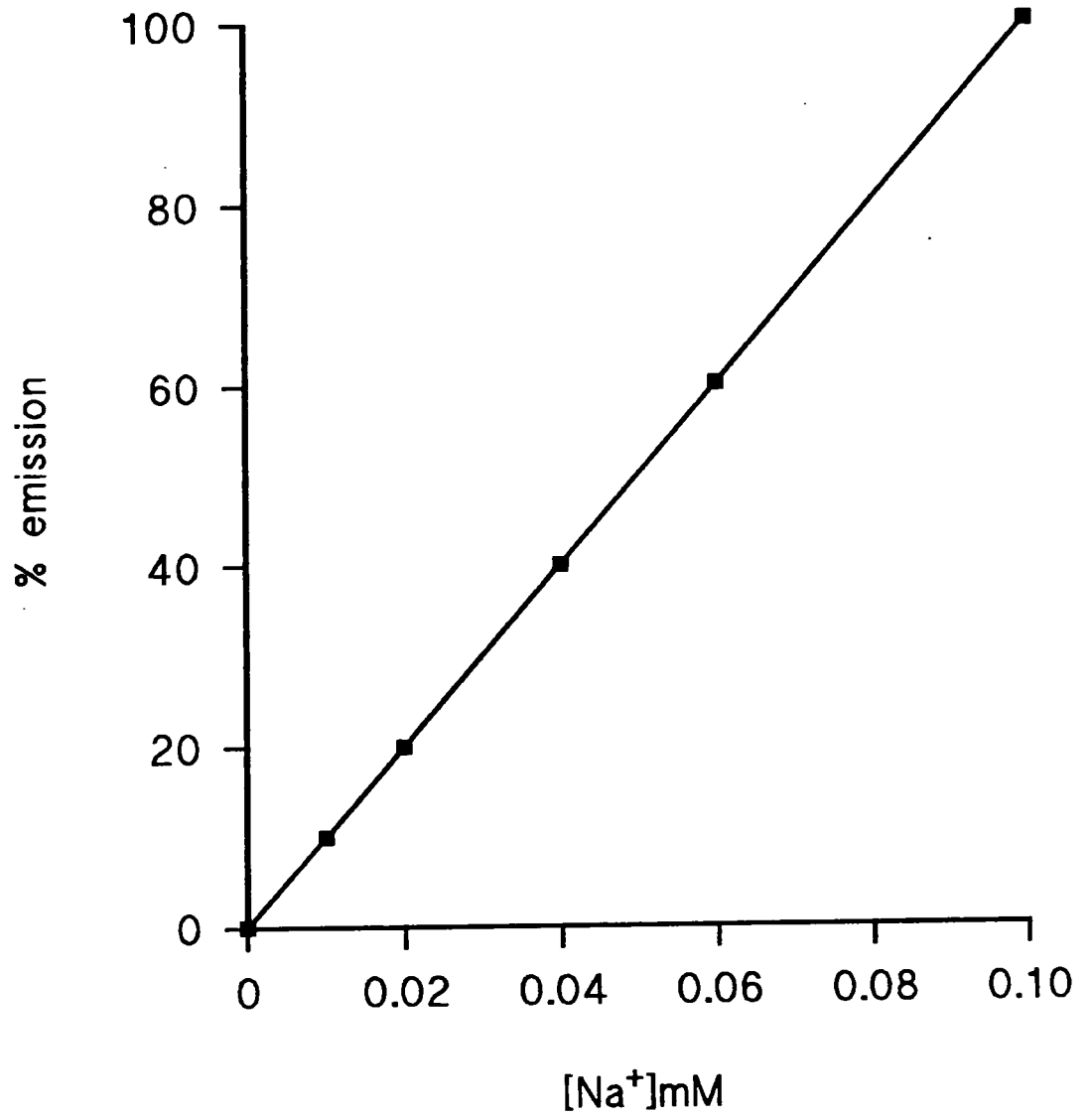

Fig. (2.2)

Calibration curve for potassium hydroxide concentration against % emission, estimated using an S.P. 90 spectrophotometer wavelength at 760 nm.

Ordinate: % emission

Abscissa: $[K^+]$ mM

Fig. 2.2

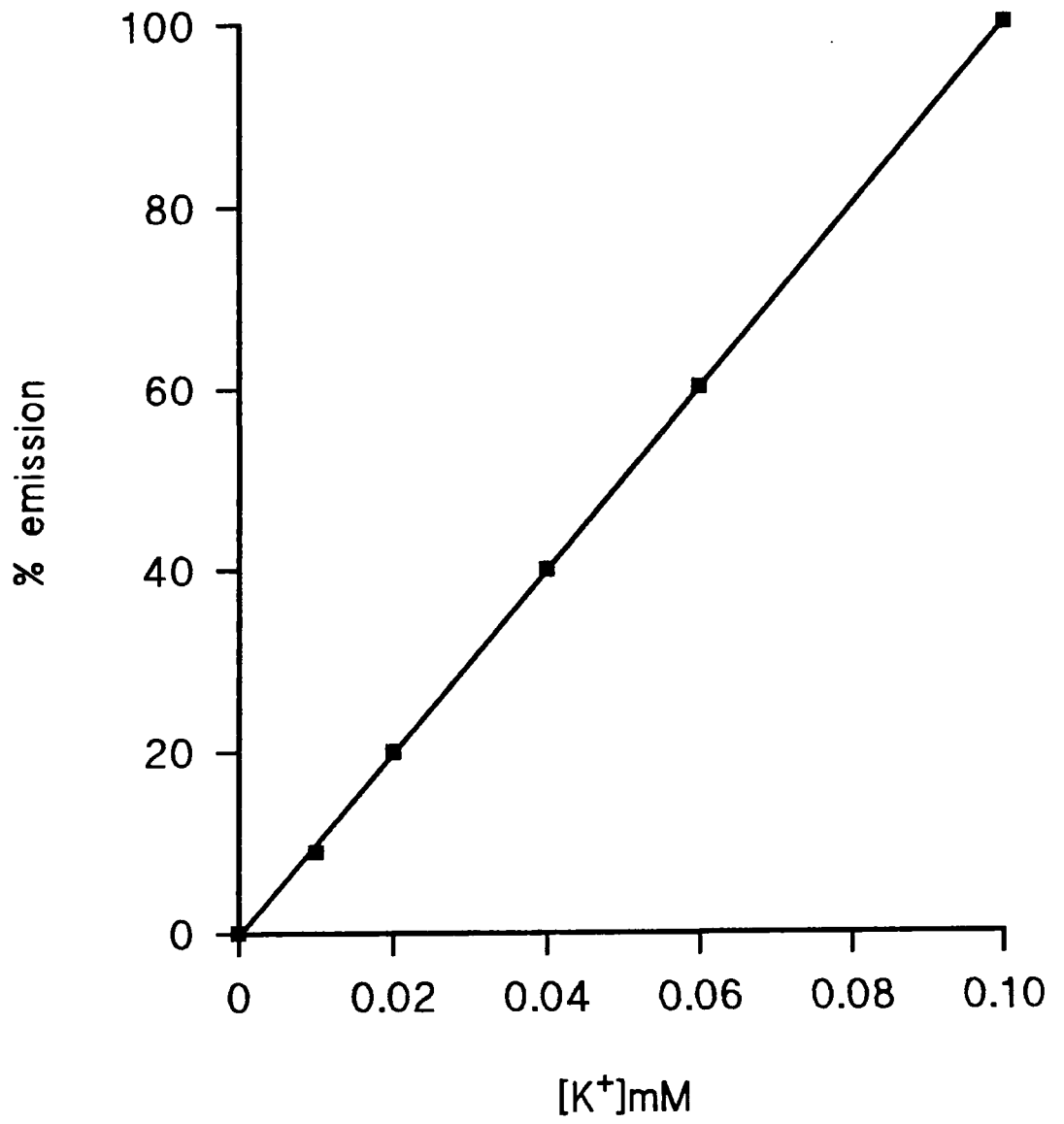

Fig. (2.3)

Calibration curve for calcium chloride concentration against % transmission measurement, using an S.P.90 spectrophotometer.

Ordinate: % transmission

Abscissa: $[\text{Ca}^{2+}]$ mM

Fig. 2.3

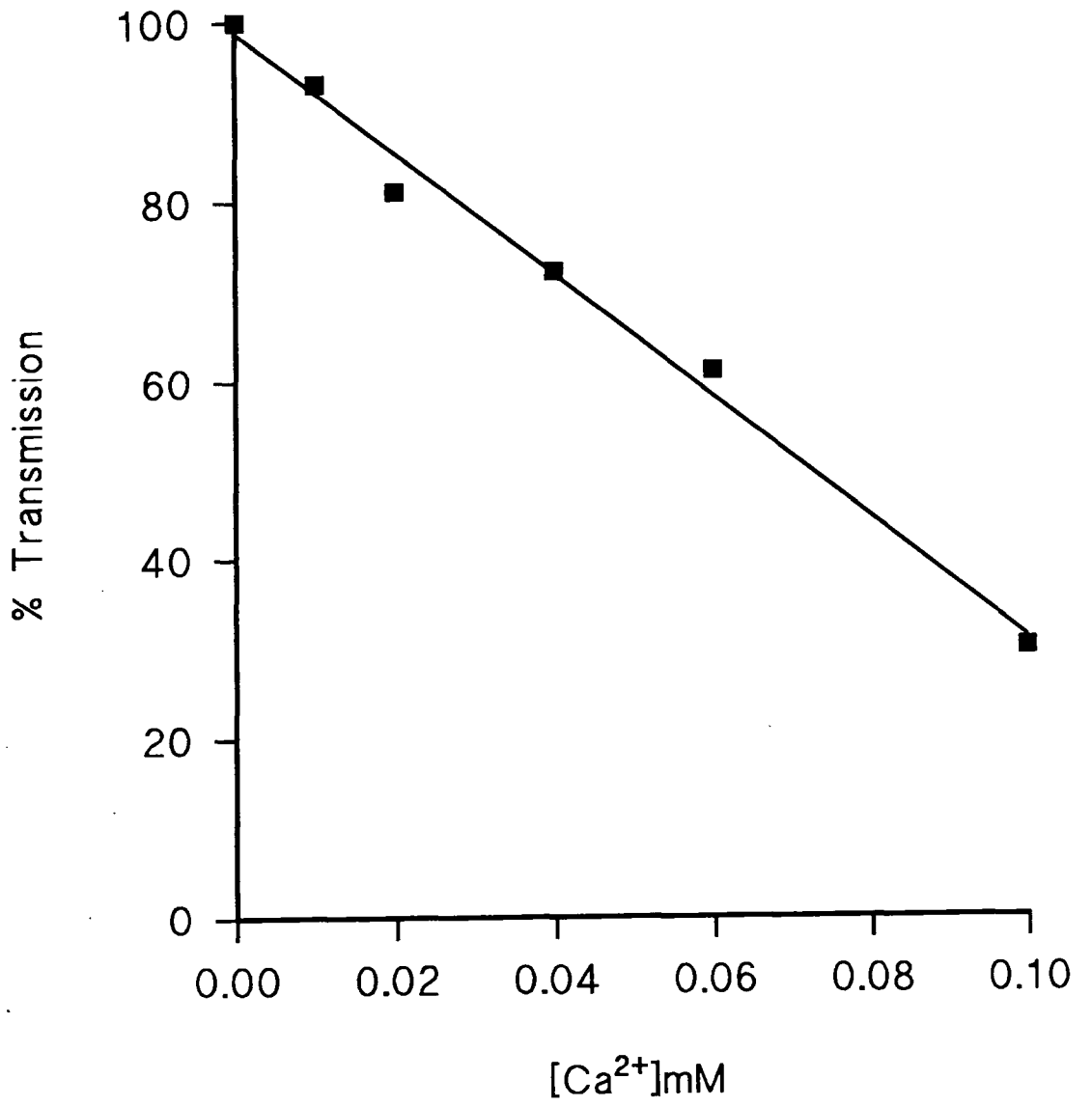

Fig. (2.4)

Calibration curve for magnesium chloride concentration against % transmission measurement, using an S.P. 90 spectrophotometer.

Ordinate: % transmission

Abscissa: $[\text{Mg}^{2+}]$ mM

Fig. 2.4

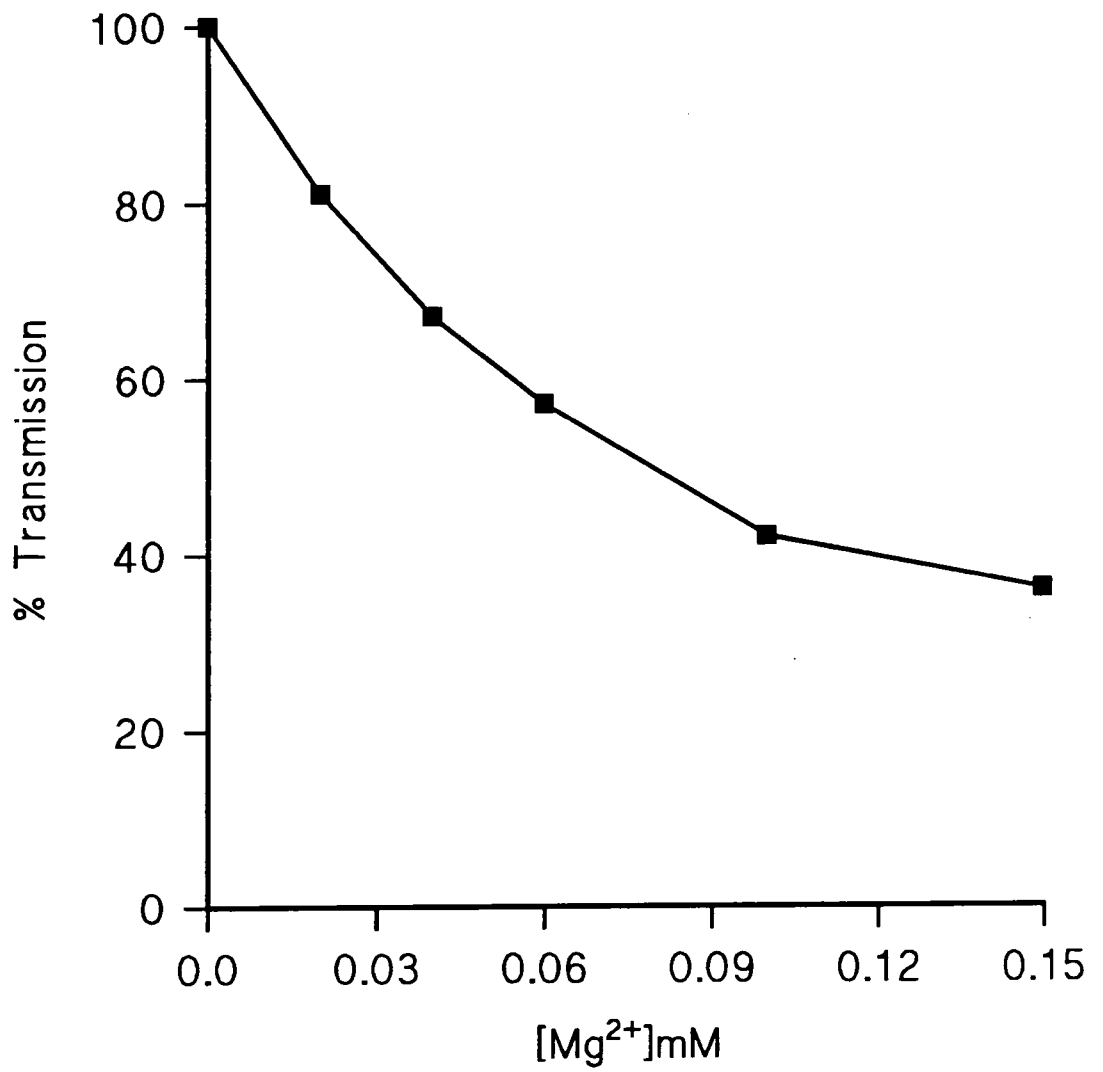

Fig. (2.5)

Standard calibration curve for the determination of inorganic phosphate.

Ordinate: Absorbance at 390nm.

Abscissa: Inorganic phosphate (P_i) in nmoles.

Fig. 2.5

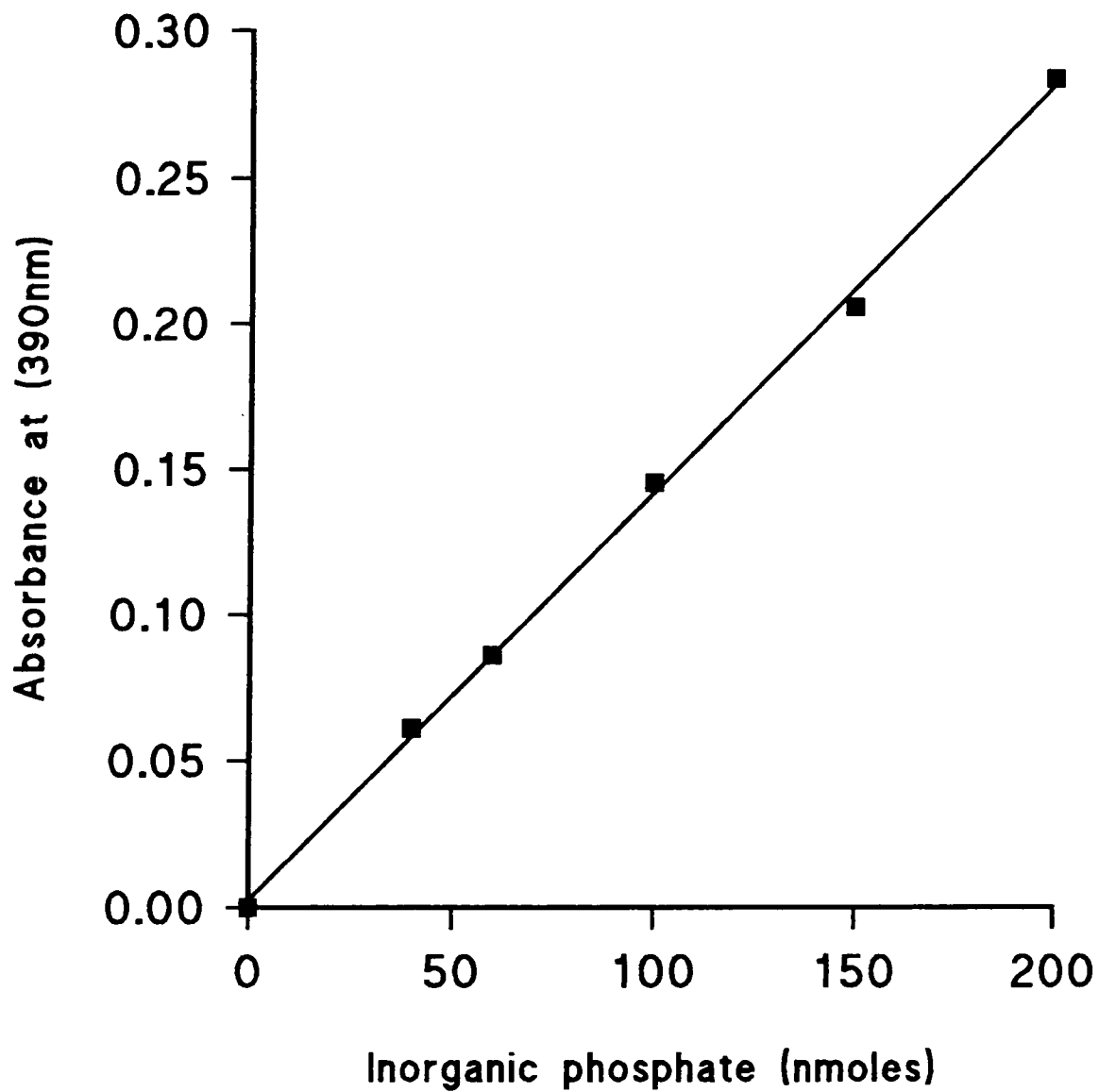

Determination of protein concentration

Protein determinations were made using the Coomassie brilliant blue binding method of Bradford (1976), using bovine serum albumen fraction V (BSA) as standard. The protein reagent was made by dissolving 100mg Coomassie brilliant blue G-250 in 50ml of 95% ethanol. To this was added 100ml of 85% (w/v), orthophosphoric acid. The solution was then diluted to 1 litre with deionized water and stored at 4°C until needed.

Protein determinations were carried out by placing 200 μ l of the sample in a tube to which was added 20 μ l 1.1M NaOH and 2 ml of the above protein reagent. The tubes were then kept for 10min. at room temperature, at which time the absorbance of each solution was read at 595 nm on an LKB Ultraspec 4050 spectrophotometer.

Protein content was determined by reference to a freshly made standard BSA curve relating protein concentration (0-40 μ g BSA/200 μ l) to absorbance of standard solutions which had been treated in the same way as the test samples, as described above (Fig. 2.6).

Fig. (2.6)

Standard calibration curve for determination of protein using bovine serum albumen (BSA) Fraction V as standard (typical example).

Ordinate: Absorbance at 595nm.

Abscissa: protein in μg .

Fig. 2.6

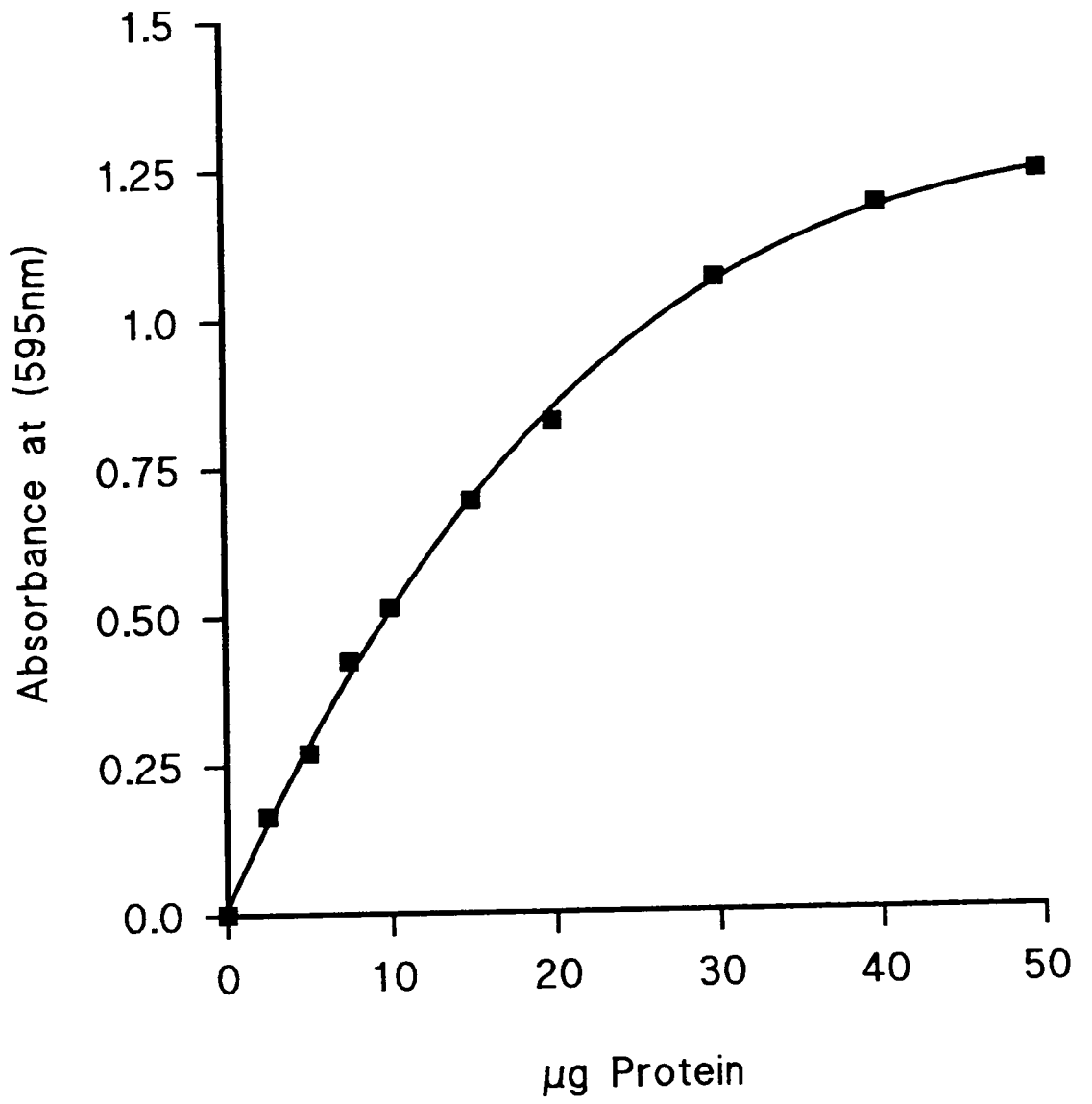

Determination of the major ionic and protein composition of haemolymph from 5th instar larvae

The main cations and anions of haemolymph were determined with a view to constructing a simple physiological saline for subsequent physiological studies. Table 2.3 shows the concentrations of the main ions present. Mg^{2+} was the dominant cation present followed by K^+ , Na^+ and Ca^{2+} . The total concentration of Cl^- and inorganic phosphate was relatively low compared with that of above cations suggesting the presence of some other anionic species. The measured ions account for approximately 37% of the measured osmolarity of haemolymph. The total protein concentration was approx. 17.1 mg/100 μ l. On the basis of this study and that of Thomas and May (1984), the following saline was constructed and in following preliminary studies, was used throughout this investigation.

Table 2.3 Haemolymph composition in larval stage of *Spodoptera littoralis*

Parameter	Haemolymph Mean \pm S.E.M(mM)	n
[Na^+]	19.1 \pm 1.6	20
[K^+]	31.0 \pm 2.2	20
[Ca^{2+}]	6.1 \pm 0.1	5
[Mg^{2+}]	39.6 \pm 1.7	30
[Cl^-]	16.9 \pm 1.1	3
[PO_4^{3-}]	10.2 \pm 0.5	30
[Protein]	17.1 \pm 5.8 (mg/100 μ l)	30
Osmolarity	332.2 \pm 12.4 mosmoles / L	20

Saline (normal Ringer)

A simple physiological saline was constructed based, in part, on the results obtained from analysis of larval haemolymph composition and from data for related lepidoptera (Florkin and Jeuniaux, 1974; Sutcliffe, 1963)). This 'normal' *Spodoptera* Ringer solution had the following composition and was used routinely in all *in vitro* experiments, unless otherwise stated in the text (mM): KHCO_3 , 5; $\text{KH}_2\text{PO}_4 \cdot 2\text{H}_2\text{O}$, 10; NaOH, 10; NaCl, 10; KCl, 15; $\text{CaCl}_2 \cdot 6\text{H}_2\text{O}$, 2; Mg gluconate, 40; glucose, 35; and HEPES (4-(2-hydroxyethyl -) -1-piperazine-ethanesulphonic acid), 30, pH 7.0 (see Table 2.4 A). The latter Table also shows the compositions of various modified Ringer solutions used during the course of this investigation (see Table 2.4 B-H).

Determination of osmotic pressure

The osmotic pressure of samples of blood, urine and bathing media was determined using the cryoscopic method of Ramsay and Brown (1955). Small samples of the appropriate fluids were collected into a 1 μ l microcapillary tube and the ends of the glass tube blocked with liquid paraffin. Each sample was then frozen by immersion in a freezing mixture of 98 % ethanol and solid CO₂, and the melting points determined. The results were converted from $\Delta^{\circ}\text{C}$ to m.osmoles by comparison with a standard curve relating osmotic concentration (m.osmoles) to depression of freezing. The range of osmotic concentrations was produced using NaCl and assuming near complete ionization in aqueous solution (see Fig. 2.7).

Measurement of Malpighian tubule secretion rates

Insects were decapitated under saline and their Malpighian tubules dissected free from the alimentary tract. Following rinsing with 'normal' saline to remove any contamination with blood, individual tubules were transferred quickly to the experimental chamber, immersed in fresh Ringer solution (see Figs.2.8 A and B) and the whole preparation was covered with liquid paraffin. The medial region of the Malpighian tubule was kept in the Ringer bath whilst its proximal and more distal regions were drawn out of the Ringer solution and looped around small glass peg in the liquid paraffin. The Malpighian tubule was then punctured at a point along the length of the proximal region, using a fine tungsten needle. Up to ten Malpighian tubules could be set-up in this way at any one time and fluid secretion from the cut tubule studied

The rate of fluid secretion was determined by measuring the rate of change in diameter of each secreted droplet of 'urine' emerging from the cut, as described elsewhere (Ramsay, 1954; Maddrell, 1969). Once the tubule preparation had been set-up, it was allowed to equilibrate for a 10 min. period before beginning to measure the rate of secretion. At the end of this time, any secreted fluid droplet was removed from

Fig. (2.7)

Calibration curve relating osmotic concentration (m. osmoles) to the Δ °C value obtained using the cryoscopic method of Ramsay and Brown (1955). The range of osmotic concentrations were produced by NaCl solutions.

Ordinate: Osmotic concentration Δ °C.

Abscissa: Osmotic concentration (m.Osmoles).

Fig. 2.7

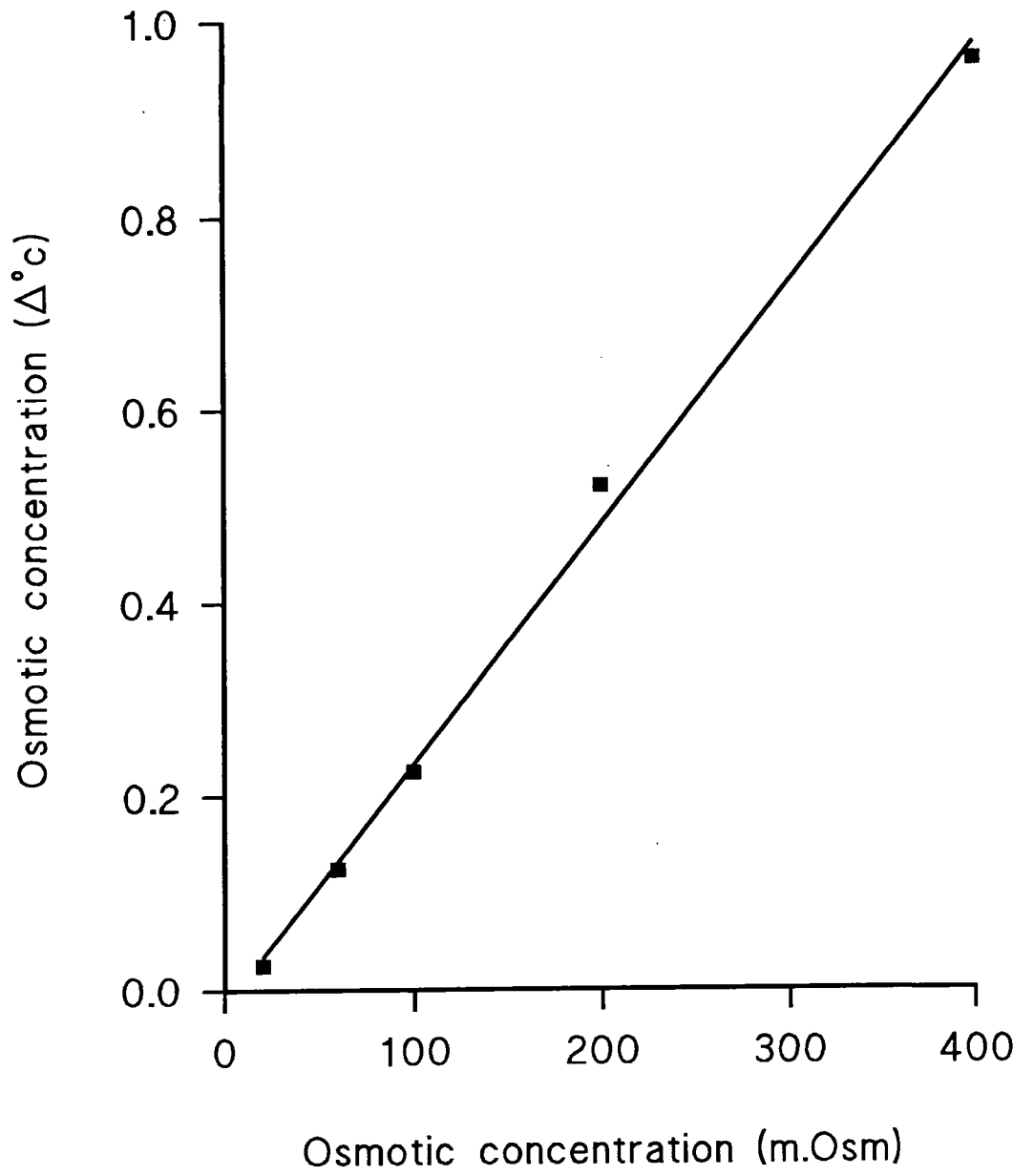

Fig. (2.8)

The experimental arrangement involved in setting up *in vitro* preparation of Malpighian tubules of *Spodoptera littoralis*.

A: Diagrammatic representation of the whole preparation dish.

B: Section through the above preparation dish. The dish has a sylgard base with a cut into it. The trough is filled with Ringer solution in which whole medial tubules are placed. The ends of the Malpighian tubules are looped around small glass pegs and one end is punctured to permit the secreted 'urine' to emerge as a droplet. The entire preparation is covered with liquid paraffin.

Fig. 2.8

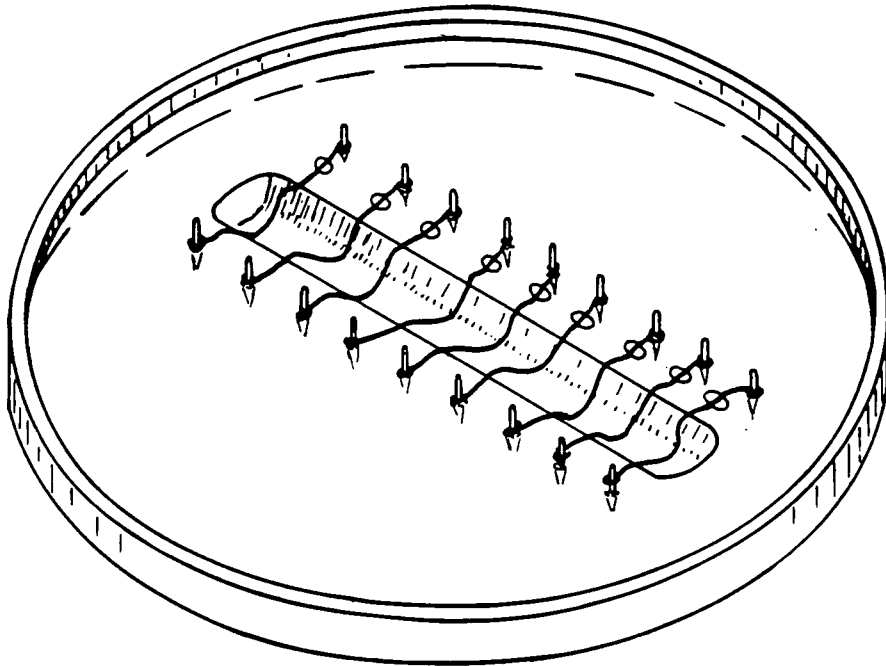

A

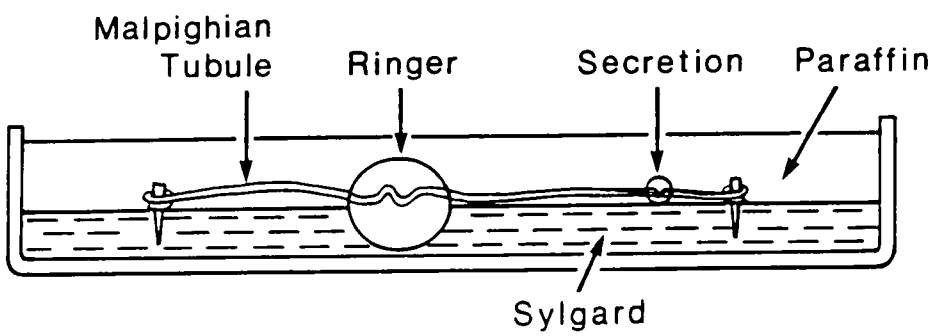

B

the tubule and discarded. Thereafter, the diameter of the new secreted droplet was measured at 5 min. intervals over a period of 20 minutes to give rate 1. The saline bathing the tubule was then changed for a fresh solution of either the same (control) or modified (experimental) composition and after a further equilibration period of 10 min., the secretion rate (rate 2) was determined over a second 20 min. period. Comparison between rate 1 and rate 2 was used to determine the response to a particular treatment wherever possible. In this way, each tubule served as its own control and variation between individual tubules was minimized.

The volume of each droplet was calculated by assuming it to be a sphere, according to the formula $\frac{4\pi r^3}{3}$ (where r is the radius of the droplet) and the rate of fluid secretion expressed as nl/min. In some cases, the length and diameter of the tubule in contact with the bathing medium was measured using an eye-piece graticule and from this data the surface area of tubule in contact with the saline calculated, according to the formula $2\pi r.h$. In such cases, the rates of secretion were expressed as nl/min or nl/min/mm² tubule surface bathed in saline.

The temperature throughout these experiments was maintained at $30 \pm 0.5^\circ\text{C}$ by placing the experimental chamber on a thermostatically controlled hotplate.

Measurement of wet weight, dry weight and percentage water content of insect

The wet weight of individual larvae of *Spodoptera littoralis* was determined as follows. Larvae were killed by decapitation over a 3ml weighing bottle and the gut contents removed from the alimentary tract. The body weight (minus gut contents) was then determined. Each larva was then placed in an oven at 125°C for 24 hours to dry before determining the final dry weight. The percentage water content of the larva was then calculated using the following formula:

$$\text{Percentage water content} = \frac{(\text{Wet wt.} - \text{dry wt.}) \times 100}{\text{Wet Wt.}}$$

Preparation of the larval gut and associated Malpighian tubules for light microscopy

The larvae were killed and the whole guts with associated Malpighian tubules were dissected out and the gut contents removed, as previously described. The tissue was then fixed in Bouin's fixative followed by dehydration using a graded series of ethanol solutions in an Elliot Automatic Tissue processor as follows:

1. 1 hour 70% ethanol
2. 2 x 1 hour in 95% ethanol
3. 2 x 1 hour in absolute ethanol

Following dehydration, the gut tissue was cleared in chloroform and embedded in paraffin wax (melting point 58°C). Serial sections were cut at 10µm on a Specer '820' microtome and mounted on glass slides with albumen. Sections were subsequently dewaxed and stained with Erlich's haematoxylin and eosin using a Shandon Southern 24 Stainer and the following procedure:

1. Paraffin wax was removed from the sections by immersing them in xylene for 5 minutes.
2. Sections were dehydrated for 2 minutes in absolute alcohol, followed by 1 minute in each of 95% alcohol, 70% alcohol and distilled water.
3. Stained for 5 minutes in haematoxylin.
4. Rinsed in distilled water for 30 minutes.
5. Decolourized in alkaline alcohol containing 1% ammonium hydroxide for 30 seconds.
6. Washed in 70% ethanol for 30 seconds.
7. Washed in 95% ethanol for 30 seconds.
8. Counterstained in eosin for 30 seconds.
9. Washed in 95% alcohol for 20 seconds with one change.
10. Washed in absolute alcohol for 45 seconds with one change.

11. Sections were cleared in xylene and then mounted in DePeX mounting medium .

Preparation of Malpighian tubules for electron microscopy

The Malpighian tubules of *Spodoptera littoralis* were dissected out and fixed for 1-1.50 hr. in Karnovsky's fixative (Karnovsky, 1965), which was made up as follows:

Solution (A)

Paraformaldehyde	2.0 g
Distilled water	40 ml
NaOH	2-6 drops

Solution (B)

25 % Gluteraldehyde	10 ml
0.2M Sodium cacodylate buffer (pH7.2)	50 ml

Solution (A) was made up by warming the water and adding the paraformaldehyde. NaOH was then added dropwise until the precipitate dissolved.

Solutions (A) and (B) were kept separately at 0-4 °C until just before use, when they were mixed in the ratio 1:1,. After fixing, the material was post-fixed with 1 % osmium tetroxide in 0.1 M sodium cacodylate buffer (pH 7.2), for 1 hour. It was then dehydrated by passage through an alcohol series:

70 % ethanol	(3 washes of 5 minutes each),
90 % ethanol	(3 washes of 5 minutes each),
Absolute ethanol	(3 washes of 5 minutes each).

Infiltration was carried out as follows: The tissue was transferred to absolute ethanol and propylene oxide mixed in the ratio of 1:1 (3 washes of 10 minutes each), thence into propylene oxide (3 washes of 10 minutes each) followed by propylene oxide/Araldite mixture, in ratio of 1:1 (30 minutes at 45°C), and finally Araldite (30 minutes at 45°C). It was then embedded in fresh Araldite mixture:

Araldite Mixture

10 ml Araldite

10 ml D.D.S.A. (dodecenylsuccinic anhydride)

2 ml Dibutyl Phthalate

1 ml DMP 30 . (2,4,6-tri-(dimethylaminomethyl)phenol,

After embedding the tissue in Araldite, it was kept at 45°C for 12 hours and then at 60°C for 48 hours to allow it to polymerise

Sectioning and staining processes

Sections of the tissue were cut using 'OM U3' ultramicrotome and glass knives. Initially, thick sections were prepared for examination by light microscopy. For electron microscopy, thin sections (gold and/or silver) cut and these were placed on coated 100 mesh copper grids. Prior to examination, the sections were stained for 10 min. in a solution of uranyl acetate followed by staining for 10 min. in lead citrate (Reynolds, 1963). The stained sections were examined in a Philips EM400T electron microscope.

Cytochemical localization of K⁺-dependent p-nitrophenyl phosphatase activity

The larvae were killed and the Malpighian tubules dissected out and fixed in ice-cold (*ca.* 4°C) Karnovsky's fixative, as described above, for 1-1.5 hr. The tubules were then incubated for 60 min., at room temperature, in a standard or modified incubation medium of the following composition (final concentrations):

Standard medium

100 mM Tris-HCl buffer (pH 9.0)

20 mM SrCl₂

10 mM KCl

10 mM MgCl₂

5 mM NPP (p-nitrophenyl phosphate)

In addition to this standard medium, three modified media were used as follows:

- (1) K⁺-free medium: Standard medium in which 10mM KCl was replaced by 10mM choline chloride.
- (2) Modified substrate: Standard medium in which 5mM NPP was replaced by 5mM β-glycerophosphate.
- (3) Ouabain medium: Standard medium containing 10 mM ouabain.

Post-incubation procedure

After incubation the tissues for 1 hour in various modified media, the tissues were rinsed in three changes of 0.1M tris-HCl buffer, pH 9.0, then treated with two 5 minute rinses in 2% Pb(NO₃)₂ as Ernst (1972a, b) mentioned. This step was necessary to convert the precipitated strontium phosphate to lead phosphate for visualisation in the electron microscope. After this step the tissues were rinsed in 0.25 M sucrose to remove any free lead (Ernst, 1972a, b), then rinsed in 0.1 M Tris and cacodylate buffer, pH 7.5, and post-fixed for 30-60 minutes 1% osmium tetroxide in 0.1 M cacodylate buffer, pH 7.5, after that the tissues treated according to the processes of dehydration throughout a series of graded ethanol solutions, as the following:

- (1) 15 min in 70 % ethanol with 3 changes each 5 min
- (2) 15 min in 90 % ethanol with 3 changes each 5 min
- (3) 15 min in absolute ethanol, 3 changes every 5 min
- (4) 30 min in 100 % alcohol / propylene oxide in ratio of 1:1, with 3 changes at each 10 minutes
- (5) 30 min in pure propylene oxide, with 3 changes at every 10 minutes
- (6) 30 min in propylene oxide in ratio of 1:1, in bottles with lids off, at 45°C
- (7) 30 min in pure Araldite in bottles with lids off, at 45°C

Then the tissues were embedded in fresh Araldite followed by polymerization at 45°C overnight. The next day the preparations were moved from 45°C, to 60°C, for further 48 hours. The methods for cutting, staining and examining section was mentioned previously.

Statistical techniques

The statistical methods used in data analysis in the present study were as described by Sokal and Rohlf (1969) and where necessary the statistical tables of Fischer and Yates (1963) were used. Student's t test and paired t test were used to test the significance of differences between experimentals and their controls.

Throughout this study, there was considerable variation in the rates of secretion observed with different individual Malpighian tubules. To overcome the effect this might have when comparing responses to different treatments involving different tubules, an initial rate of secretion was determined for each tubule (rate 1) prior to exposing it to experimental or control treatments when the new rate was determined (rate 2). The rate 2 values were normalised with respect to their initial rate values by calculating rate 2 secretion as a percentage of that observed over the initial measurement period (i.e. rate 2 was expressed as % rate 1).

Chemicals

All chemicals used in these studies were the purest available, and were generally supplied by Sigma Chemical Company Ltd. and British Drug House Chemicals Ltd.. The methoprene used was a gift from Zoecon Corporation, Palo Alto, California.

Glassware

Pyrex glassware was used throughout these experiments. Prior to use, it was cleaned by soaking overnight in 2% solution Quadralene laboratory detergent followed by several rinses in hot tap water and finally in 7 changes of deionized water. Glassware used in ion-free experiments was soaked in 50% nitric acid and then treated as above. The glassware was oven-dried.

Effect of different ouabain concentrations on ion and water transport

Malpighian tubules were set up as described above. The first droplet produced after an initial equilibration period of 10 minutes was discarded. This step created a means of flushing the lumen of any residual urine. Droplets were collected at 5 min intervals over a period of 20 min (rate 1). Tubules were divided into 3 groups and the droplets which came from each group were collected using a glass rod and pooled together under liquid paraffin to ensure a sufficient volume for analysis. Using the same methods droplets were collected from modified Ringer over a second 20 min period (rate 2) after an equilibration time of 25 min. The pooled droplet was collected using a 1 μ l capillary tube. This sample was then diluted in 2 ml deionized water. Samples were analysed by atomic emission spectroscopy to determine the concentrations of Na^+ and K^+ for 10^{-7} to 10^{-3} M ouabain. The same concentrations of ouabain were applied to tubules in order to study its effect on the rate of secretion using the same methods as described below for furosemide.

Effect of Furosemide on the rate of fluid secretion

Fifth instar larvae were used in this experiment. The animals were killed and Malpighian tubules were prepared in the same way as described previously. Rate 1 was measured in normal Ringer, after a 10 minute equilibration period the first droplet was removed and the diameter of the secreted droplet every 5 minutes after was measured over a period of 20 minutes. The normal Ringer was then replaced with fresh modified solution containing furosemide which was dissolved in normal Ringer to produce concentrations from 10^{-7} to 10^{-3} M. This was equilibrated for 25 minutes, after which the initial droplet was removed and discarded. After this droplets were removed at 5 min intervals and the diameter calculated over 20 minutes. The effect of the inhibitor (Rate 2) was expressed as a percentage of Rate 1.

Effect of N-Ethylmaleimide on the rate of fluid secretion

The effect of NEM on the rate of fluid secretion of 5th instar larvae was done by the same methods as outlined above. NEM was applied to Malpighian tubules at values ranging from 10^{-7} to 10^{-5} M.

Effect of developmental changes on the rate of fluid secretion or on the ultrastructure of Malpighian tubules

4th, 5th and 6th stage larvae, prepupae, pupae and adults were aged by previous methods outlined above. Fluid secretion was measured at 5 minute intervals for a period of 30 minutes and results were presented in nl/min/mm² or nl/min⁻¹.

X-ray analysis

Tubules from 5th instar larvae were dissected out and cut into small pieces in a petri-dish containing a few drops of deionized water to allow granules to be released and concentrated in the water (see Krueger *et al.*, 1987). Then using a small pipette they were transferred to a coated 100 mesh grid and dried at room temperature. The grid was then examined by X-ray analysis with a link Qx200 attached to a Philips EM 400 T. Analysis time was 100 s at 100KV. The beam was adjusted to cover the whole of the granule, a number of spectra were collected and the results averaged.

CHAPTER 3

MORPHOLOGICAL AND ULTRASTRUCTURAL STUDIES

Results:

Section (1): Morphological and Histological observation

Malpighian tubules of *Spodoptera littoralis* larvae

The materials and methods which applied in this chapter were as described previously in chapter 2.

The morphology and arrangements of the Malpighian tubules were similar in the different larval stages studied (i.e. 4th, 5th and 6th instars). The larvae of this species possess six Malpighian tubules which are arranged in two groups of three; one group on each side of the alimentary tract. Each group of tubules opens into the gut at the midgut/hindgut junction *via* a short 'ureter' or common vesicle. The relationship between each of the three tubules in a group and the 'ureter' is not the same. Thus, the ventral tubule, tubule 1, opens directly into the 'ureter' whilst tubule 2 and tubule 3, which run more dorsally along the gut, open into a short common duct before joining tubule 1 to form the 'ureter' (Fig. 3.1). Each larval Malpighian tubule can be divided into three regions: proximal, medial and distal. The relationship between these regions and the alimentary tract can be illustrated by reference to studies on sixth stage larva (Fig. 3.1 A). The proximal and medial regions extend alongside the midgut, whereas the distal regions are associated with the hindgut and rectum and consist of an iliac plexus, a short rectal lead and a cryptonephridium. Excluding the cryptonephridium, each tubule was approximately 6-7 cm long. The proximal region extends from the 'ureter' and passes forward over the surface of the midgut for about two-thirds to three-quarters of its length before turning posteriorly as the medial region. The proximal portion of tubule is relatively straight, smooth and transparent whilst the medial region

is distinguishable by its more sinuous appearance. Little difference was noted in the relative lengths of the regions between tubules 1, 2 and 3, although tubule 1 may be slightly longer due to the fact that, unlike tubules 2 and 3, it opens directly into the 'ureter' as referred to above.

The medial and distal regions are similar in appearance apart from the substantial degree of coiling shown by the latter and its close association with the hindgut surface to form an iliac plexus. The segment designated the medial region in this study appears to equate with the so-called yellow region in *Calpodes ethlius* (Ryser, 1979). However, unlike the latter species this region was not coloured differently from the rest of the tubule in *Spodoptera littoralis*. Finally, the tubules become very fine and pass beneath the muscle layers of the rectal wall to form a cryptonephridial arrangement (Fig.3.1A). There were a lot of fine branching tracheoles associated with this distal portion of tubule. Indeed, all six Malpighian tubules are bound to the alimentary canal by fat body, trachea and tracheoles and do not float freely in the haemolymph of the body cavity. These tubules discharge their secreted fluids into the 'ureters' and thence in to the lumen of the gut. The latter is helped by contraction of muscles surrounding each 'ureter' (Fig.3.2G). These contractions cause peristaltic movements of the 'ureter' which could be seen in *in vitro* preparations under the light microscope. Numerous white mineral concretions were present inside the lumina of the tubules and these were seen moving backwards and forwards during contraction of the 'ureters.' If the tubules were punctured the concretions poured out into the bathing medium.

The prepupae

The arrangement and number of Malpighian tubules in prepupae was the same as described above for larvae. As in larvae, the Malpighian tubules of prepupae were divisible into various regions; proximal region, medial region, iliac plexus and rectal leads being recognisable. However, the cryptonephridium, if present, was difficult to

study due to the accumulation of fat body lipids in this region and the large numbers of branching trachea. The main change in the appearance of tubules in prepupae compared with those of larvae was due to the presence of large numbers of mineral concretions within the prepupal tubule lumen. This gave the prepupal tubules a milky look. In addition, the prepupal tubules were more sinuous in appearance than in larvae.

Fig. 3.1B shows the relationship between the Malpighian tubules and the alimentary tract in the prepupae. The arrangement was essentially the same as seen in the larvae except that in the prepupa, the midgut was shorter and the ileum longer and thinner, and the rectum shorter and thinner. A consequence of these changes in the relative sizes of the midgut and the hindgut is that associated with the latter's increase in length, the iliac plexus becomes longer and the medial region shorter in length

The pupae

The detailed morphology of the Malpighian tubules and their relationship to the alimentary tract was extremely difficult to identify in pupae. This was due to the fact that the gut, at this stage, was very thin and very large amounts of lipid were present. Nevertheless, it was clear that the arrangement of the Malpighian tubules was essentially the same as that seen in prepupae, although only the proximal and medial regions of the tubules could be distinguished (Fig. 3.1C).

The adult:

As in the larvae and prepupae, three pairs of Malpighian tubules are present in the adult insects. On each side of the alimentary tract, the three tubules open into the gut *via* a common 'ureter' although this is considerably smaller than in larvae; the 2+1 relationship between the three tubules and the 'ureter' being similar to that seen in larvae and prepupae. In the adult, the midgut was much shorter and the hindgut longer than in larvae and prepupae and the latter was not straight but was sinuous in appearance. Fig. 3.1D shows the arrangement of the tubules with respect to the alimentary tract in the adult. For much of their lengths, the tubules were attached to the gut musculature by

Fig. (3.1)

Diagram to show morphological relations of the alimentary canal and Malpighian tubules of *Spodoptera littoralis*, during the development of last larval instar, prepupa, pupa and adult

A: Last larval instar

B: Prepupa

C: Pupa

D: Adult

a. Anus, c.r. cryptonephridia region, where the tubules pass beneath muscles to form cryptonephridia arrangement as seen in the last larval instar., r.l. rectal lead, i.p. iliac plexus, ur. ureter, p.r. proximal region, m.r. medial region and the rectal caecum in the pupae and adult r.c.

In these diagrams from A-D only one tubule from each pair is drawn, the other three tubules which lie on the other side are not shown.

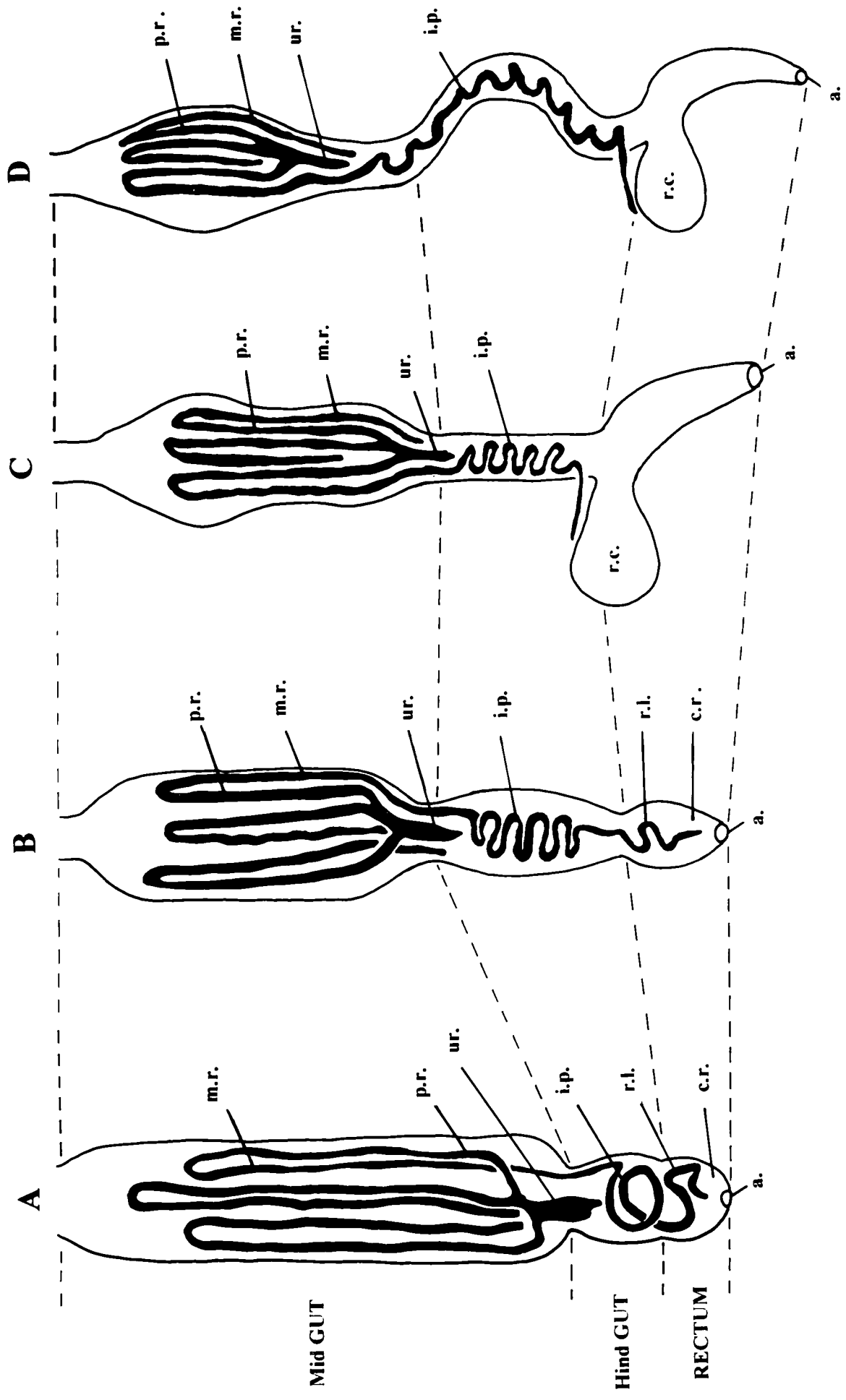

tracheae and the region associated with the hindgut showed considerable folding to form an iliac plexus which terminated as a short blind-ending tubule lying free in the haemolymph. No cryptonephridial arrangement was seen in adults. The fact that the ileum is much longer in the adult insect means that the iliac plexus is similarly more extensive.

The proximal region, which passed anteriorly along the midgut, was fairly straight and 'milky' in appearance due to the presence of mineral concretions in the lumen. The medial region, which runs alongside the midgut, was slightly more folded than the proximal region and there was a gradual reduction in 'miliness' towards the more distal parts of this region. Thus the tubules of the major part of the medial region and the iliac plexus were transparent.

At metamorphosis, changes were observed in the relative lengths of the different regions of the Malpighian tubules compared with divisions of the alimentary tract. Thus, the proximal and medial regions increased in length relative to that of the midgut with the transition from larva to prepupa to adult (Fig. 3.1A-D). In addition the iliac plexus was considerably longer in the adult than in the larval and prepupal stages, reflecting the increase in the length of the ileum with development. This is similar to what was observed in *Calpodes ethlius* (Ryerse, 1979). The common duct was considerably reduced in the prepupal instar making it difficult to obtain sections through this region. However, the Malpighian tubules did maintain the same connections to the common duct and there was no change in the number of Malpighian tubules during metamorphosis.

Histology of the Malpighian tubules and the cryptonephridium in sixth instar larvae

Fig. 3.2 shows a series of light micrographs of transverse sections, cut at various levels, through the alimentary canal of sixth instar larvae of *Spodoptera littoralis*. These sections were used to help in interpreting the anatomical relationships

between the Malpighian tubules and the mid- and hindguts. In addition, they show the histological features of the various regions of the tubules. Fig. 3.2A shows a section through the wall of the rectum. It is noticeable that surrounding the cuticle-lined gut epithelium are numerous sections through the much folded distal ends of the Malpighian tubules enclosed within a fiscal chamber between the epithelial cells and the outer muscle layer. Other tubule sections are located outside this membrane layer. These represent tubules which lie on the surface of the rectum. Thus, in the rectal region, Malpighian tubules not only run over the surface of the gut but also pass beneath the muscle layers to form a cryptonephridial arrangement, as described elsewhere in lepidoptera (Wigglesworth, 1972; Mathur, 1973). The rectum and the chamber are richly supplied with trachea (Fig. 3.2A).

The histological appearance of the tubules inside the fiscal chamber is shown in a high power micrograph (Fig. 3.2B). In transverse section, the tubule lumen appears to be surrounded by numerous cells with a well-developed microvillar border. In places, these cells appear to be pear-shaped in section with their attachment to the basement membrane being by a narrow stalk (Fig. 3.2B). In longitudinal and oblique sections, the elongated and irregular shape of the cell nuclei can be seen. Indeed, these appear to extend for some distance along the tubule suggesting that the cells of this region must be extremely elongated. The exact number of cells surrounding the tubule lumen is difficult to determine precisely; it is estimated that approximately five cells are involved. The basement membrane of these cells is very thick.

The tubules of the iliac plexus and medial regions are shown in section in Fig. 3.2C. A major feature of the cells in these regions was the marked folding of their luminal cell surfaces which possess a very well-developed microvillar border. Indeed, the folding is such that canaliculi lined with microvilli are formed (Fig. 3.2D). In some sections, a 'membrane', possibly representing a glycocalyx, seems to separate the apical cell surface from the tubule lumen (Fig. 3.2D). Nuclei were seen in the cytoplasm adjacent to the canaliculi; i.e. where the cells projected maximally into the lumen. A

Fig. (3.2 A-D)

Light micrographs of transverse sections show the relationship between the alimentary canal and different regions of Malpighian tubules.

A: Section through the rectum wall shows the Malpighian tubules after penetrating the rectal muscles, when they make several folds in the fiscal chamber. Note there are several sections of these inner tubules (IT), which most of the time are associated with tracheae (T). Observe the presence of cryptonephric rectal epithelium (CRE), prenephric membrane (PM) and the detached cuticle of gut lumen (DC).

Scale = 100 μ m

B: Shows high magnification of the fiscal chamber (FC) which is surrounded by the fiscal chamber membrane (FCM) and contains inner tubules (IT) which have obvious nuclei (N) and basement membranes (BM) also observe the presence of the circular muscles (CM) of the rectal wall.

Scale = 50 μ m

C: Section through the hindgut (HG) shows the medial and iliac plexus (MR), (IR) regions respectively and associated tracheae (T). See the lumen of the gut (L) surrounded by inner cuticle (I) which lies on epithelial tissue (E). Circular muscles are present outside the gut.

Scale = 250 μ m

D: High magnification of the medial region of the tubules, this region is surrounded by thick basement membrane (BM). This section shows the characteristics of the region such as the presence of canaliculi (Ca) and well developed microvilli (Mv) which sometimes are separated from the luminal side by the glycocalyx (Gl), also observe the presence of a nucleus (N) and vacuolar aggregates apical to the nuclei (*). Some dense material (DL) can be seen inside the tubule lumen (L).

Scale = 50 μ m

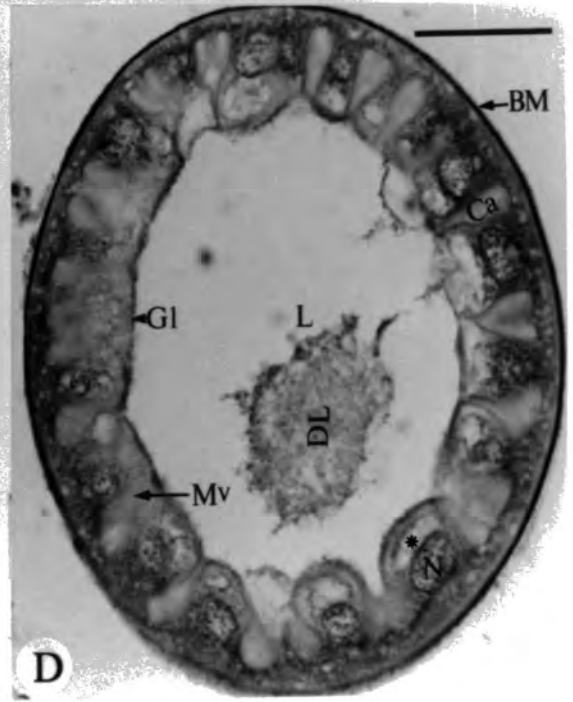
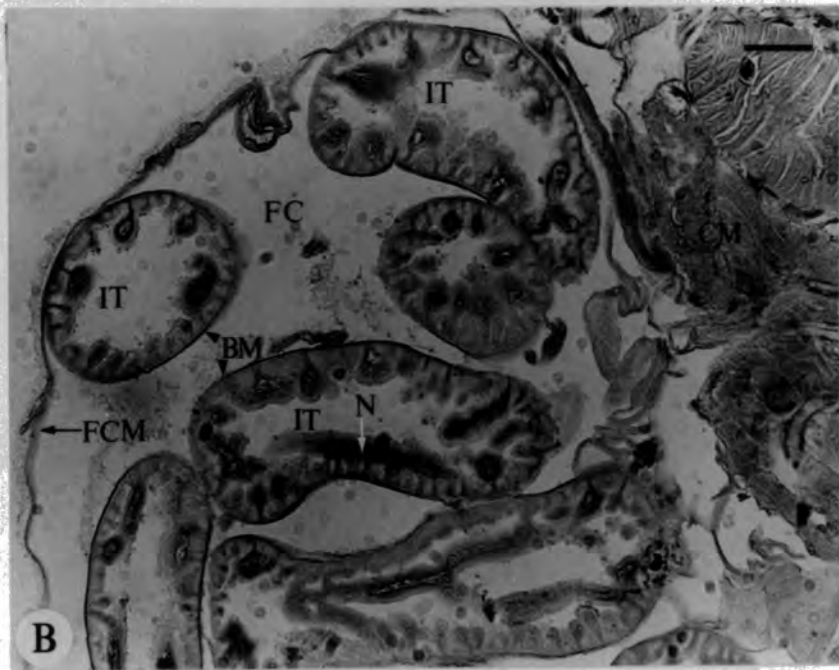
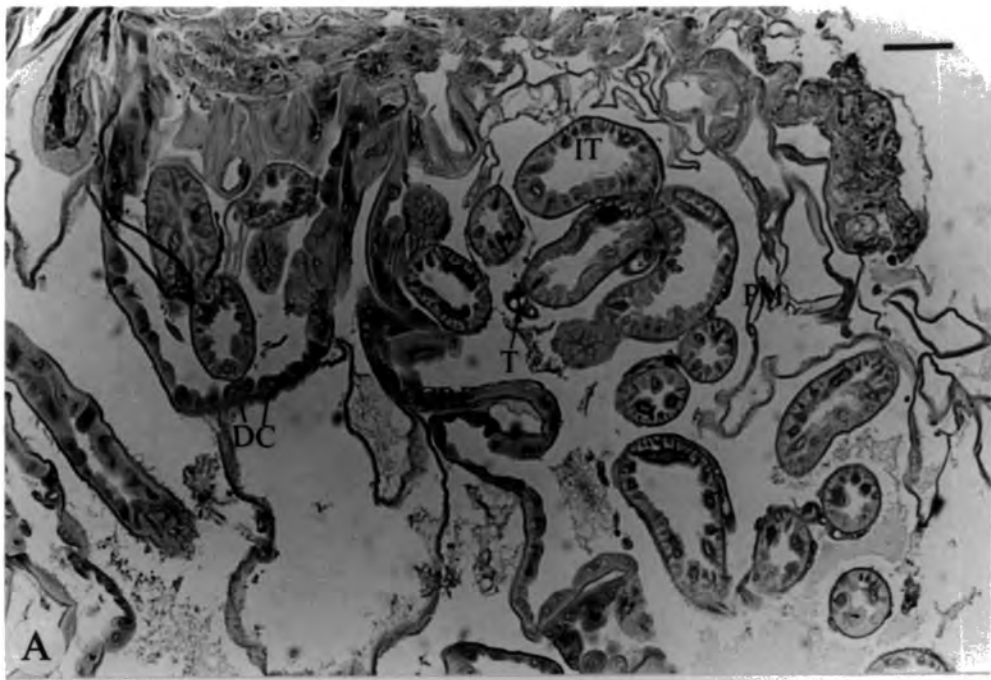

Fig. (3.2 E-G)

E: This section shows the Malpighian tubule regions which are associated with the midgut. The proximal and medial regions (PR) & (MR) can be seen respectively. In these sections note the thick basement membrane (BM) which surrounds these tubules.

Scale = 100 μ m

F: High magnification of the proximal tubule region illustrates the epithelial tissues which contain a nucleus (N). The lumen (L) contains some dense bodies and the thick basal membrane (BM) surrounds the tubule.

Scale = 33 μ m

G: High magnification photograph of the ureter showing the longitudinal muscles (LM) and the circular muscles (CM) which are associated with the ureter. Note the wide lumen (L) which is surrounded by chitinous intima (CI).

Scale = 50 μ m

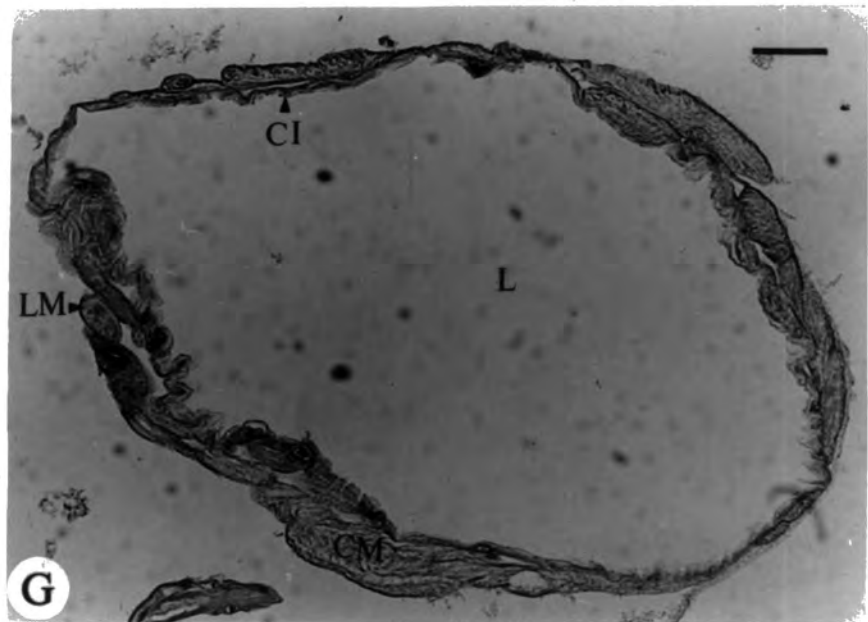
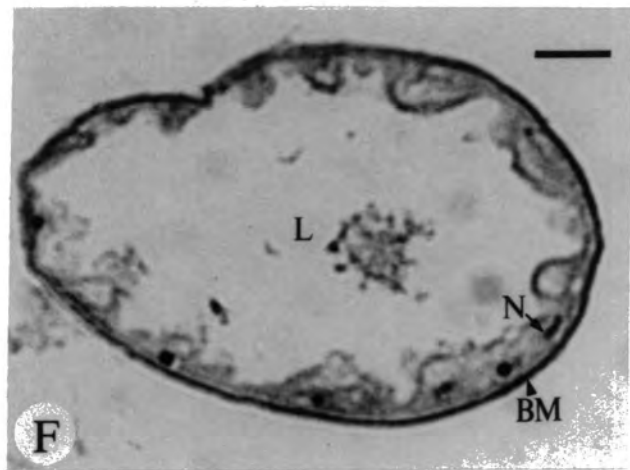
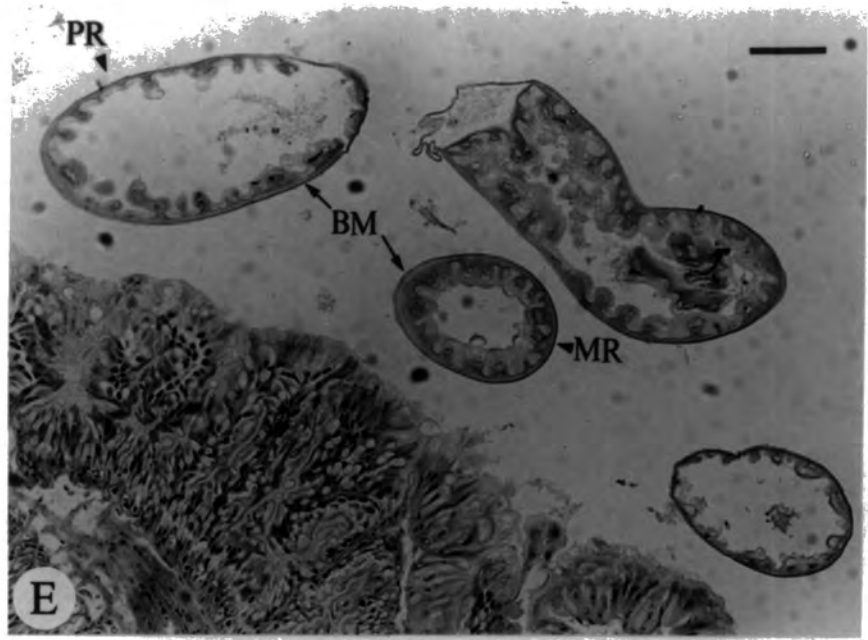

consistent feature of these cells was the presence of vacuolar aggregates apical to the nuclei (Fig. 3.2D). As described for the cryptonephridial tubules above, a thick basement membrane was associated with the basal cell membrane in this region, also.

In the proximal region, the epithelium was considerably thinner than in the more distal regions described above (Fig. 3.2E and F). Once again, the apical cell surfaces were markedly folded although in this region, unlike the iliac plexus and medial regions, no canaliculi were formed. The basal surface of the tubule cells is marked by a well-developed basement membrane.

Sections through the midgut/hindgut junction illustrate the histological features of the 'ureter' or common duct whereby the three tubules open into the gut lumen (Fig. 3.2 G). Unlike the Malpighian tubules, the 'ureters' are provided with a musculature of circular and longitudinal/oblique fibres. The epithelium lining the 'ureter' lumen was extremely thin and further cytological detail was difficult to discern.

The ultrastructure of the Malpighian tubules

Tissue was prepared for electron microscopy as described earlier (see Chapter2). Examination of electron microscopical sections taken at various points along the length of the Malpighian tubules of *Spodoptera littoralis* indicated that, in the proximal, the medial and the distal regions, only one cell type was present.

Proximal region

Fig. 3.3A is an electron micrograph through wall of proximal tubule. The fine structure of the tubule cells can be conveniently described under three sub-headings; basal zone, intermediate zone and apical zone.

(a) Basal zone

This zone is nearest to the body cavity. The basal plasma membrane is considerably infolded and extends for varying distances into the cytoplasm. This creates a labyrinth of interconnecting extracellular spaces in the basal region of the

cells. At various points, this labyrinth is in direct contact with the basement membrane for short distances whereas elsewhere it is separated from the basement membrane by a layer of cytoplasm (Fig.3.3A and B). The overall impression is of an extracellular labyrinth sitting on a thin layer of cytoplasm and basement membrane and suggests that the infolded spaces extend laterally for some distance as well as in the direction of the luminal side of the cell. The extracellular labyrinth of spaces is between 0.8-3.5 μm deep whilst the distance between adjacent cytoplasmic folds and the thickness of the latter is highly variable. In many sections (Figs.3.3A and B) cytoplasmic processes are seen to contain mitochondria, rough endoplasmic reticulum and free ribosomes. The basement membrane has a fine fibrous appearance and is approximately 0.4 μm in thickness.

(b) Intermediate zone :

The intermediate region contains the majority of the cytoplasm and associated organelles. The nucleus is large, roughly oval in shape and measures *ca.* 7.0 μm (small diameter) 17.5 μm (large diameter). It has a well-defined nuclear envelope consisting of an inner and outer membrane. Numerous pores are present in the nuclear envelope and these presumably permit the transfer of information between the nucleus and surrounding cytoplasm (Fig. 3.3A and B). However, the outline of the nucleus is not perfectly regular and the nuclear envelope shows marked infoldings in places (Fig. 3.3A and B). The nucleoplasm contains electron-dense regions of chromatin and a nucleolus was occasionally seen in section. Rough endoplasmic reticulum, Golgi bodies, small vesicles, mitochondria and numerous free ribosomes are present in the cytoplasm. In addition, the cytoplasm contained significant amounts of glycogen; accumulations of glycogen being frequently located near the folds in the nuclear envelope.

Fig. (3.3 A-D).

Electronmicrographs showing sections throughout the proximal region of the Malpighian tubules of *Spodoptera littoralis*.

A: Low power section through the proximal region showing the three main zones of the cell. Basal zone (B) characterised by infolding of the basal membrane as a labyrinth (La), Intermediate zone (I) containing the nucleus (N) and other small organelles such as mitochondria. (A) represents the apical zone which contains microvilli (Mv) packed with mitochondria.

Scale = 5 μ m

B: High power section through the basal and some of the intermediate zone shows the basement membrane (BM), labyrinth (La) and in the cytoplasm some organelles such as, Golgi bodies (G), mitochondria and rough endoplasmic reticulum (RER).

Scale = 0.5 μ m

C: High magnification micrograph of the apical zone. The microvilli (Mv) contain mitochondria (M). Note that the apical cytoplasm also contains numerous mitochondria and some Golgi bodies.

Scale = 0.5 μ m

D: High power transverse section showing a septate desmosome (SD) junction.

Scale = 0.5 μ m

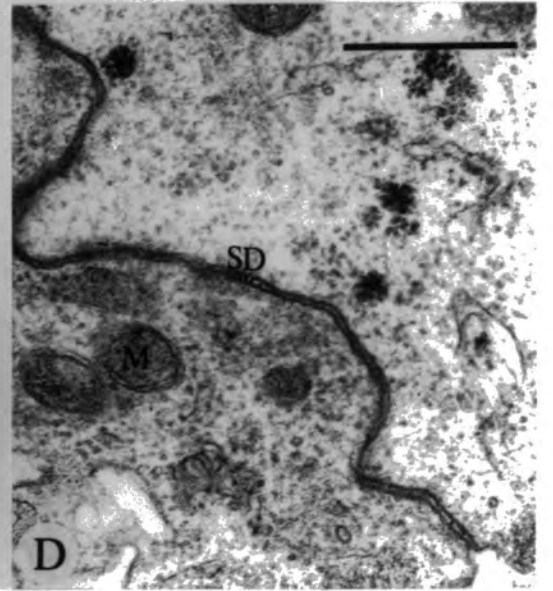
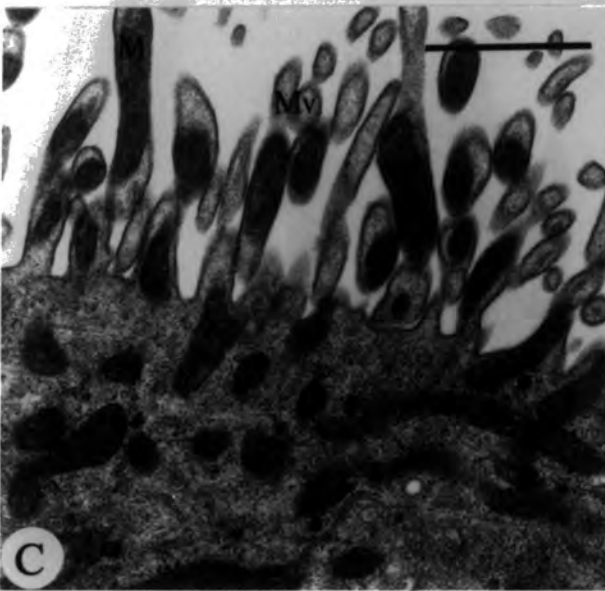
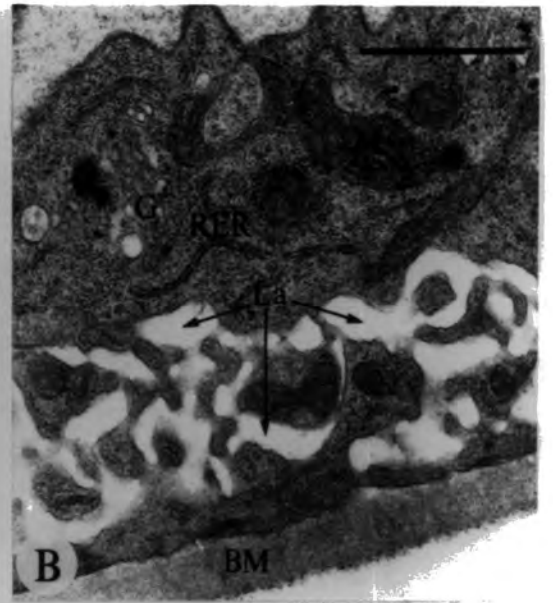
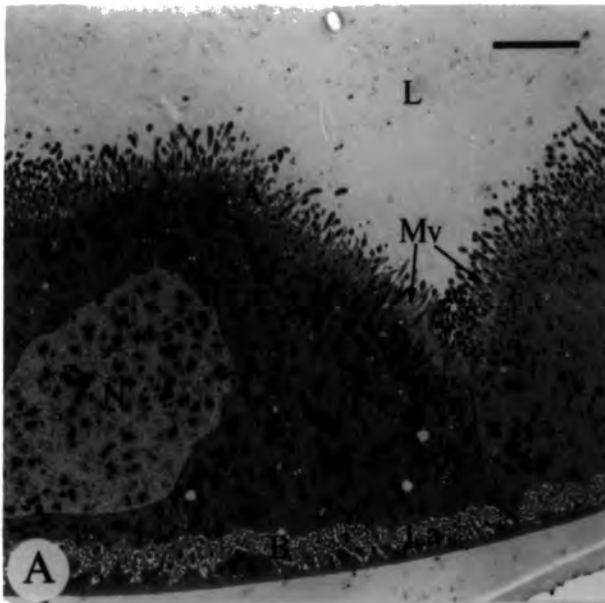

(c) Apical zone

Figs. 3.3A, and C show the apical region of cell from the proximal region. This surface of the cell is distinguished by a brush border of relatively short loosely packed microvilli. In sections, the microvilli are cut in variable profile and seldom along their full length. This suggests that they are not regularly arranged with respect to one another and that they are not at right angles to the apical cell surface. This makes accurate measurement of microvillar length difficult. Nevertheless, it is estimated that these microvilli are approximately 3.4 μm or more in length and up to 0.22 μm in diameter at their widest point. The microvilli are apparently unbranched, finger-shaped and contain mitochondria which were frequently observed extending into them. Small vesicles were occasionally observed at the base of some microvilli.

Adjacent cells were joined to one another laterally by junctions that appear at a high magnification as septate desmosomes. These were largely confined to the apical and basal regions of the cells and appear to be absent from the intermediate region (Fig. 3.3D). Occasional dilations of the intercellular spaces were seen in the apical region. Zonula occludens were occasionally found between cells in the intermediate region. The intercellular membranes of adjacent cells show considerable folding along their length and do not form a straight line from the basal to the apical membrane.

Cells of the Medial and Distal regions

No obvious differences in fine structure were observed between cells of the medial and distal (iliac plexus) regions. Consequently, the description that follows is common to both these parts of the tubules. Once again, it is convenient to divide the cells into three structural regions; basal, intermediate, and apical.

(a) Basal zone

The basement membrane surrounding the basal plasma membrane was approximately 0.4 μm in thickness with a more-or-less homogenous appearance (Fig. 3.4A and B). Hemidesmosomes join the basement membrane to the tips of the

Fig. (3.4 A-C)

Electronmicrographs showing transverse sections through the medial region of *Spodoptera littoralis* Malpighian tubules.

A: Low power transmission electronmicrograph shows the three main zones of the cell. The basal, intermediate and apical zone, (B), (I) and (A) respectively. The basal zone is the region of extracellular channels (EC) and the basement membrane (BM). The intermediate zone is characterised by the presence of a nucleus (N) and also some glycogen (Gl) and vacoules (Va). The apical zone contains microvilli (Mv) packed with mitochondria, and mineral concretions (C) are also present in this zone between the microvilli.

Scale = 5 μ m

B: High power transverse section showing the basal zone of a Malpighian tubule cell. Note the basement membrane (BM) and the extracellular channels (EC), which extend into the cytoplasm. In this cytoplasm there are mitochondria (M) and rough endoplasmic reticulum (RER).

Scale = 1 μ m

C: High power transverse section through the apical zone and cytoplasm. In this zone the microvilli (Mv) contain mitochondria (M). In the cytoplasm multivesicular bodies (MB) and coated vesicles (CV) are present.

Scale = 1 μ m

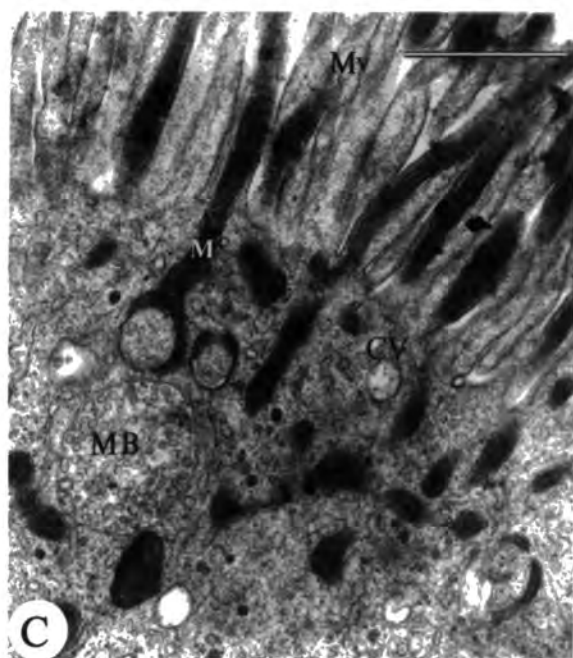
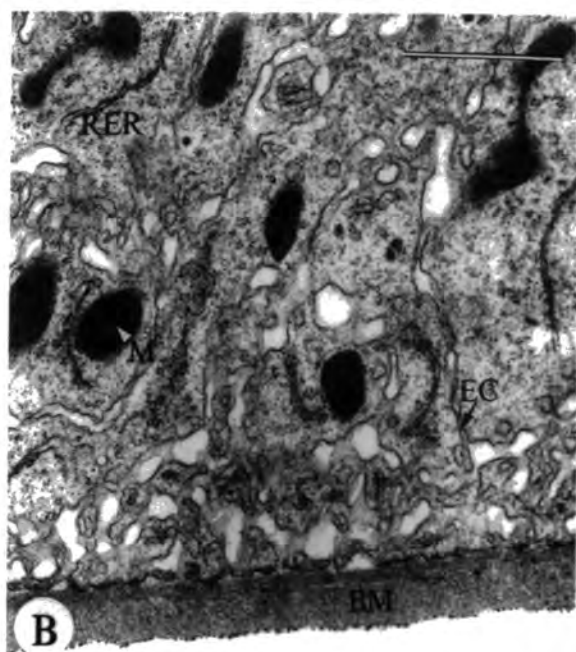
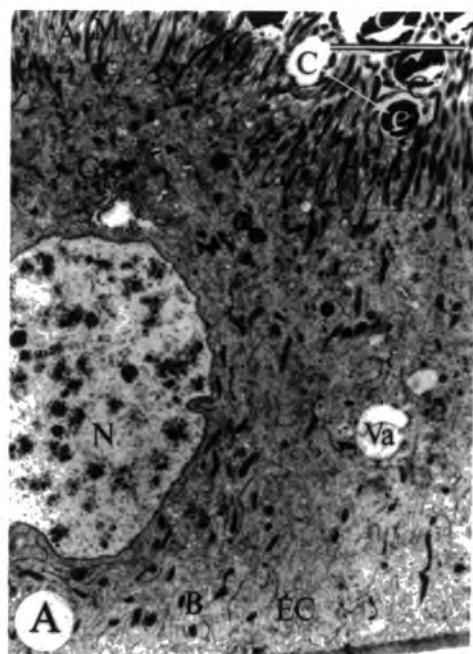

cytoplasmic processes formed by folding of the basal cell membrane which lies beneath it. This is suggested to maintain channel geometry (Ryerse, 1979). The basal cell membrane showed numerous infoldings such that the extracellular spaces formed extended approximately 5-17.3 μm into the cytoplasm and were approximately 0.02-0.22 μm in width. These extracellular channels were arranged perpendicular to the basal cell surface being orientated in the direction of secreted fluid movement from haemolymph to lumen. This arrangement contrasts with the basal labyrinth reported above in cells of the proximal region of the tubules. Numerous mitochondria were found in the cytoplasm between the extracellular channels (Fig. 3.4A and B).

(b) Intermediate zone:

The fine structure of the intermediate region of these cells was similar to that described above for the proximal region. A large irregularly shaped nucleus was present measuring about 5.4x3.2 μm in diameter being somewhat smaller than that found in the proximal region. The cytoplasm contained rough endoplasmic reticulum, a lot of free ribosomes and numerous mitochondria (Fig. 3.4A). However, fewer Golgi bodies were found compared with the cells of the proximal region. Vacuoles of various sizes were present in this zone of cytoplasm and these were often surrounded by concentrations of glycogen granules. In addition, microbodies and peroxisomes ultrastructurally similar to those described by Berridge and Oschman (1969), Wall *et al.* (1975) and Ryerse (1979) were present.

(c) Apical zone

The apical cell surface is characterized by the presence of microvilli (Fig.3.4A,C). The latter are considerably longer and more densely packed than was seen in the cells of the proximal region. Furthermore, as shown in Fig. 3.3.A, here the microvilli are orientated more-or-less perpendicular to the apical cell surface and mitochondria can be seen extending along their lengths. These microvilli were 1.7-4.2 μm long and 0.15-0.22 μm in width and in some places several microvilli were seen to

arise from a common cytoplasmic 'stalk'. In some sections, mitochondria were not visible within all the microvilli (Fig. 3.4A and C). It is not clear whether this is due to the point of sectioning or whether some microvilli do indeed lack mitochondria. Where mitochondria do occur, they appear to project into the microvilli from the apical cytoplasm (Fig. 3.4A and C). Microtubules and/or smooth endoplasmic reticulum were visible in some of the microvilli which lack mitochondria (Fig. 3.4C).

In places, the apical microvilli were pushed apart by concentrically banded luminal concretions (Fig. 3.4A). No such concretions were found in the proximal regions of the tubules. The composition of these near spherical concretions was examined using X-ray probe analysis as described in the Materials and Methods section. Fig. 3.5 shows analytical data obtained using concretions collected from fresh tubules. It can be seen that these concretions contain various elements. Calcium is present in the highest amounts followed by phosphorus whilst potassium and magnesium are present in only small amounts.

The cells of the distal end of the iliac plexus and the rectal leads

Little difference in fine structure was noted between the cells of the iliac plexus tubules immediately proximal to the rectal leads and those of the rectal leads themselves. Fig. 3.6A shows a transverse section through a rectal lead tubule. It is noticeable that the luminal surface of the cells is considerably folded so that in places the apical and basal cell membranes almost meet.

(a) Basal zone

The basement membrane surrounding these cells is similar to that found in the medial region of the tubules, being approximately 5nm wide. The basal cell membrane shows a complicated series of invaginations to create a system of interconnected extracellular channels (Fig. 3.6A). These channels extend some 3 to 20 μm into the cytoplasm and the adjacent cytoplasmic processes contain mitochondria, rough endoplasmic reticulum and numerous small vesicles. As seen in other regions of the

Fig. (3.5)

Typical X-ray spectra analysis of the concretions which were collected from the lumen of fresh tubules, showing the composition of these concretions.

Ordinate: No. of X-ray counts.

Abscissa: X-ray energy (KeV).

Fig. 3.5

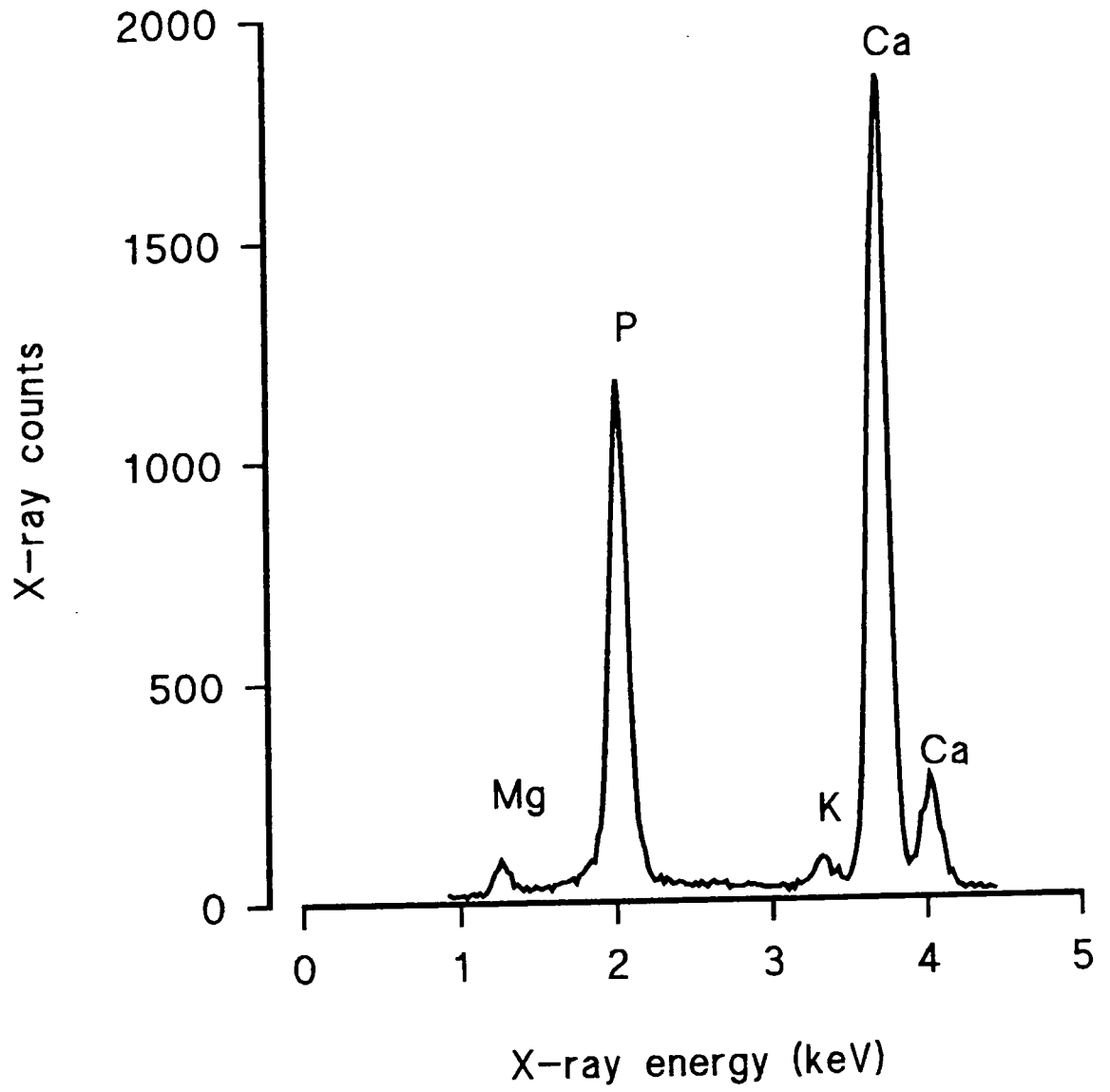

Malpighian tubules, hemidesmosomes join the basement membrane to the basal tips of the cytoplasmic processes. As described above, the apical surface of cells of these tubules is considerably folded with the result that in the 'troughs' the basal infoldings extend two-thirds to three-quarters of the distance from the basement membrane to the base of the microvilli. In contrast, in the region of greatest cell depth these infoldings extend for perhaps one-eighth of this distance (Fig. 3.6A).

(b) Intermediate zone

This zone is poorly represented in the 'troughs' referred to above. Elsewhere, it represents the major part of the cytoplasm and contains the nucleus, which is roughly oval in shape and measures *ca* 3.2 μm (small diameter) by 5.3 μm (large diameter), and numerous organelles, such as mitochondria, rough endoplasmic reticulum, free ribosomes, Golgi bodies, vacuoles and accumulations of glycogen granules. The latter are frequently found in substantial amounts apical to the nucleus (Fig. 3.6A).

(c) Apical zone

Figs. 3.6A and B show that the apical surface of these cells is characterized by a well-developed microvillar border which is deeply folded to form canaliculi, which are lined by microvilli. The latter are closely packed so that microvilli from each side of the fold meet with the result that the canaliculi are more-or-less occluded. Mitochondria can be seen projecting from the cytoplasm of the apical zone into the microvilli. Mineral concretions are found in the lumen of this part of Malpighian tubules (Fig. 3.6A).

Fig. (3.6 A-B)

Electronmicrograph section through rectal lead tubules.

A: Low power micrograph shows the characteristics of this region such as the presence of deep foldings of the microvilli-lined apical membrane which form the canaliculi (Ca). Sometimes the extracellular channel foldings (EC) nearly meet with the apical surface. Like the other regions these cells have a basement membrane (BM) and the cytoplasm contains some organelles such as mitochondria (M), a nucleus (N), rough endoplasmic reticulum (RER) and glycogen (Gl). Mineral concretions (C) are seen in the lumen (L).

Scale = 5 μ m

B: High power section showing the extracellular channels (EC) which extends from the basal membrane almost to the extreme of the apical. Sometimes they almost reach the apical membrane. Region of septate desmosomes (SD) which hold adjacent cells together. The microvilli are very rich in mitochondria as well as in the cells cytoplasm.

Scale = 1 μ m

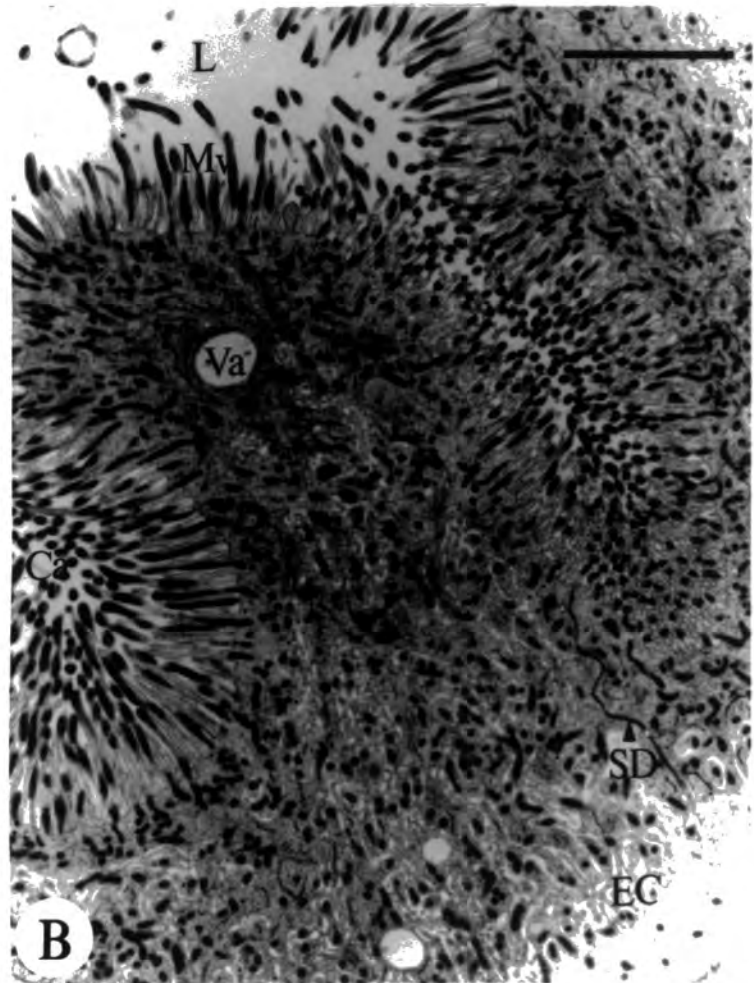
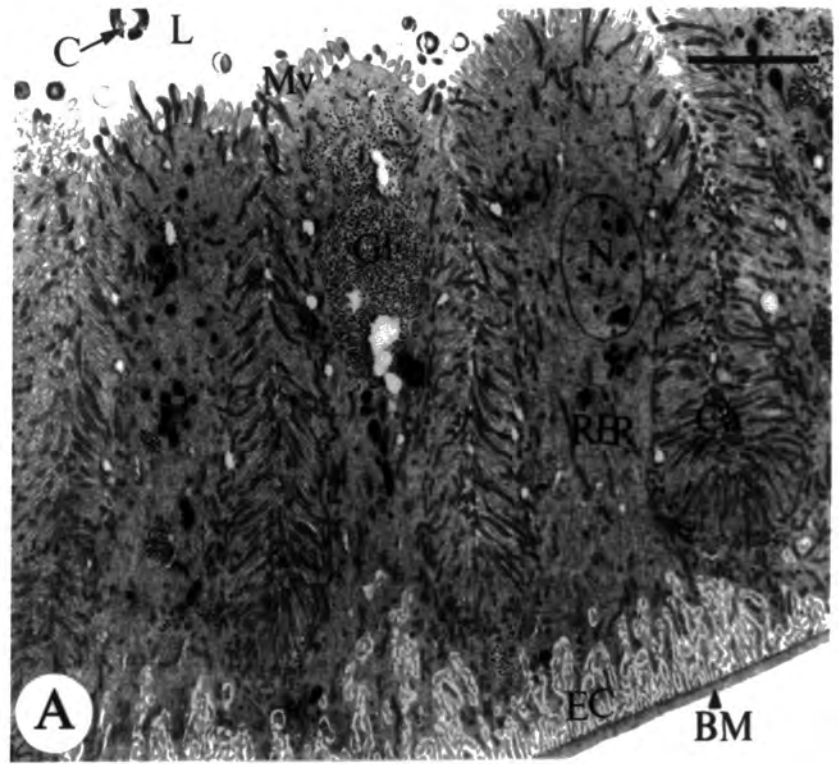

Section (2): Developmental changes in the fine structure of the Malpighian tubules during the last larval, pupal and adult stages

Sixth instar larvae, pupae and adult insects were aged as described previously and their Malpighian tubules dissected out at appropriate times and prepared for electron microscopic studies (see Chapter 2). As mentioned in Section 1 above, the Malpighian tubules of larval *Spodoptera littoralis* consist of various regions. This developmental study will concentrate on changes affecting the proximal, medial and iliac plexus regions. In the adult, as in the larval instar, each Malpighian tubule can be divided into three regions; proximal, medial and distal. These regions are similar to that described in the larval instar but the cryptonephridial region was absent in the adult *Spodoptera*.

The basic ultrastructure of the cells of the different regions of the Malpighian tubules was essentially unchanged throughout the sixth stadium and was similar to that described in Section (1); one cell type being present in each region. Similarly, only one cell type was observed in the adult. Unlike the larval and adult tubules, in the prepupae and pupae the fine structural features of the tubule cells were not readily discernible. Once again the cells can be conveniently described under three subheadings: basal, intermediate and apical cytoplasmic zones. In this Section, descriptions will be confined to the age-dependent changes.

The larvae and prepupae

Proximal region

(a) Basal zone:

The basal zone was studied in sixth instar larvae aged 8, 32, 44, and 80 hours (prepupae) from start of sixth stadium (see Figs. 3.7A, B). In newly moulted larvae (8 hours old), the basement membrane was approximately 0.4 μ m in thickness and was

similar in appearance to that described in Section 1. The basal cell membrane was invaginated to form an extracellular labyrinth of spaces 1.5 - 4.0 μm deep. At 32 hours little change was noted in the basement membrane which was approx. 0.3 μm in thickness and the extracellular labyrinth ranged from 1.0 to 4.2 μm in depth. By 44 hours, the larval basement membrane had increased in thickness to about 0.44 μm , whereas the basal labyrinth was much more varied in depth; spaces extending between 1.7 and 5.8 μm into the cytoplasm. The cytoplasmic processes associated with the basal labyrinth were fewer in number in 8 hour and 32 hour-old insects. In 80 hour-old insects (prepupae) the basement membrane measured 0.6 μm in thickness. The extracellular labyrinth of spaces was similar in extent to that seen at 44 hours, ranging in depth between 1.8-6 μm . Occasional lipid inclusions were seen in this part of the cell and the basal labyrinth was extremely vacuolated in appearance. Thus, some variation in the thickness of the basement membrane and the size of the basal labyrinth was noted with age during the last larval stadium (Figs. 3.7A, B, C and D). In addition, variations in basal mitochondrial density were noted with age; fewer mitochondria being observed in this zone at 32 and 80 hours (see Table 3.1).

(b) Intermediate zone

The composition of the cytoplasm in this region changed little during the course of the sixth stadium; numerous mitochondria, free ribosomes and segments of rough endoplasmic reticulum (RER) were present at all ages studied. The major change in fine structure was observed in the prepupae (at 80 hours) when the cytoplasm contained large numbers of swollen mitochondria and numerous lipid droplets. In addition, myelin bodies and numerous vacuoles were seen; the latter often containing coiled segments of RER (Fig. 3.7D, E). Examination of Table 3.1 indicates that glycogen and Golgi bodies were present at all larval ages but were absent from the prepupae, although more Golgi bodies were seen in newly emerged larvae (8 hours old) than later in the instar. Mineral concretions were absent from the cytoplasm except perhaps for one or two which were present at the prepupal stage. Perhaps the most noticeable change in

cellular fine structure concerned lipid inclusions. These were absent in newly moulted larvae and increased dramatically with age so that as already mentioned they were abundant in the cells of prepupae.

(c) Apical zone

The apical zone of the proximal region of the tubules was characterized by a well-developed microvillar border and this was present throughout the sixth stadium. Mitochondria were present in the microvilli at all ages apart from the prepupae although the numbers present at 44 hours (Fig. 3.7C) were slightly less than at the younger ages. The microvilli in prepupal cells were extremely thin as if the majority of their cytoplasm and mitochondria had been withdrawn into the main compartment of the cell (Fig.3.7E).

Table 3.1 Developmental changes in various cellular components in Malpighian tubule cells of 6th instar larvae.

Distribution of organelles in regions of the Malpighian tubules at different ages (hr.).												
ORGANELLE / ZONE	8			32			44			80 (prepupa)		
	P	M	IP	P	M	IP	P	M	IP	P	M	IP
Mitochondria / basal foldings	++	++	++	+	+	++	++	++	++	+	+	?
Mitochondria / intermediate cytoplasm	++	++	++	++	++	++	++	++	++	+++	+	?
Mitochondria / apical cytoplasm	+++	+++	+++	+++	+++	+++	+++	+++	+++	+	++	?
Multivesicular bodies	+	+	+	-	-	+	+	-	++	+	++	?
Coated Vesicles	+	+	+	+	+	+	-	-	++	+	+	?
Lipid inclusions	-	-	++	+	-	-	+	-	++	+++	+++	?
Mineral concretions / lumen	-	+	++	-	++	++	-	-	++	-	+	?
Golgi bodies	++	++	+	+	+	+	+	++	-	-	-	?
Glycogen	+	+	++	+	-	+	+	+	+++	+	+	?
Vacuoles	+	+	++	-	++	++	+	++	++	-	++	?

- absent, + present, ++ common, +++ abundant, ? not clear
P proximal tubules, M medial tubules, IP iliac plexus tubule.

Fig. (3.7 A-E)

Transmission electronmicrocrographs showing transverse sections through the proximal region of the Malpighian tubules at different ages in the last larval instar of *Spodoptera littoralis*.

A: The proximal region in 8 hour old sixth instar larva.

Scale = 5 μ m

B: The proximal region in 32 hour old sixth instar larva.

Scale = 2 μ m

C: The proximal region in 44 hour old sixth instar larva.

Scale = 2 μ m

D: The proximal region in 80 hour old prepupa. (Basal and cytoplasm zone)

Scale = 2 μ m

E: The proximal region in 80 hour old prepupa. (Apical and cytoplasm zone)

Scale = 2 μ m

Note that the most changes in the ultrastructure of this region are related to development in the prepupa (D, E). The labyrinth (La) changed with age see the difference between (A, B, C and D) in (D) the labyrinth spaces became very narrow and extended further into the cytoplasm and sometimes were vacuolated in appearance also lipid droplets (Li) were seen between these spaces. The cytoplasm at this age also seems to be very thick and contains (Li) and vacoules (Va) and some rough endoplasmic reticulum can be seen, for more details see the text. Basement membrane (BM).

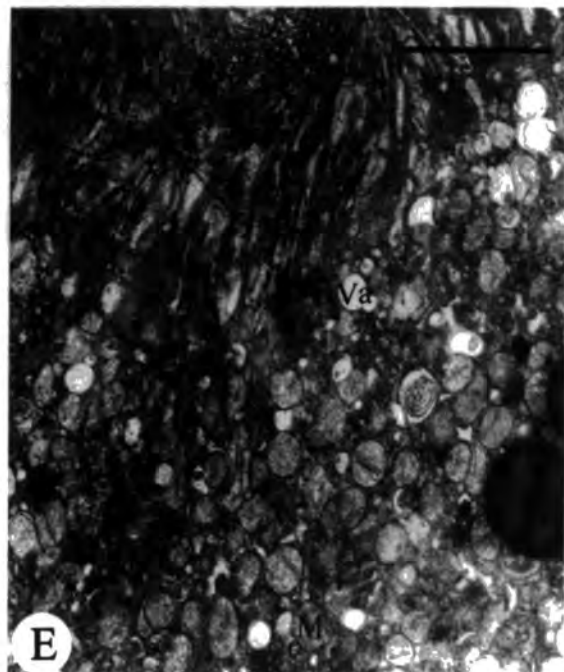
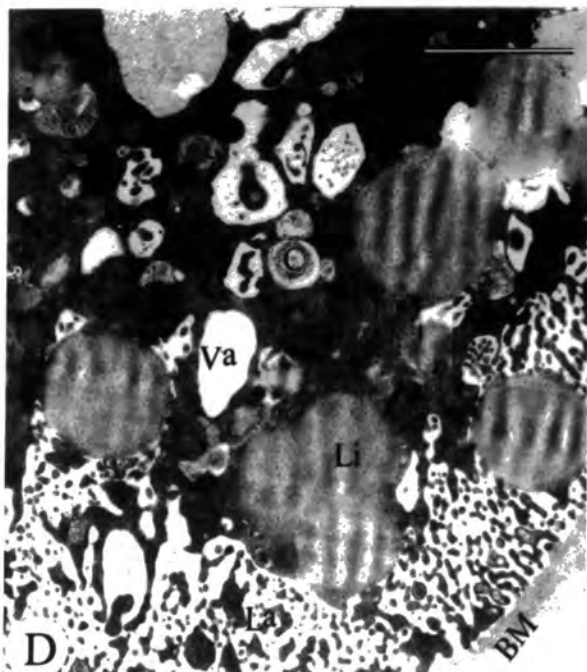
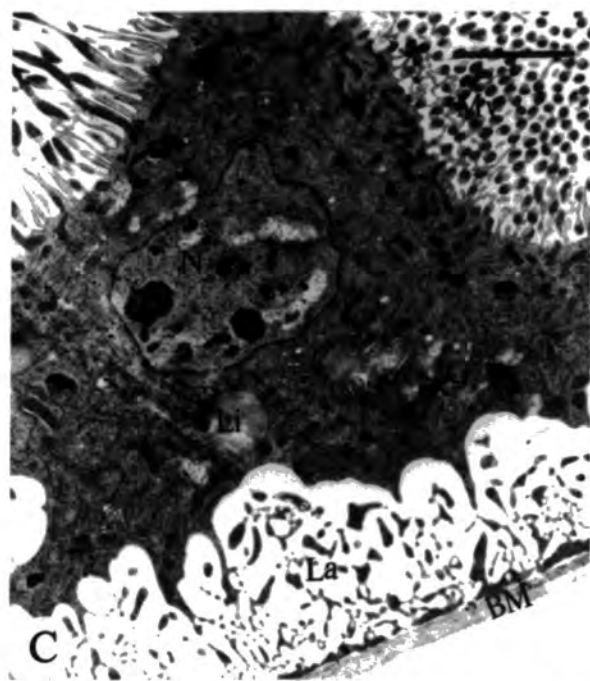
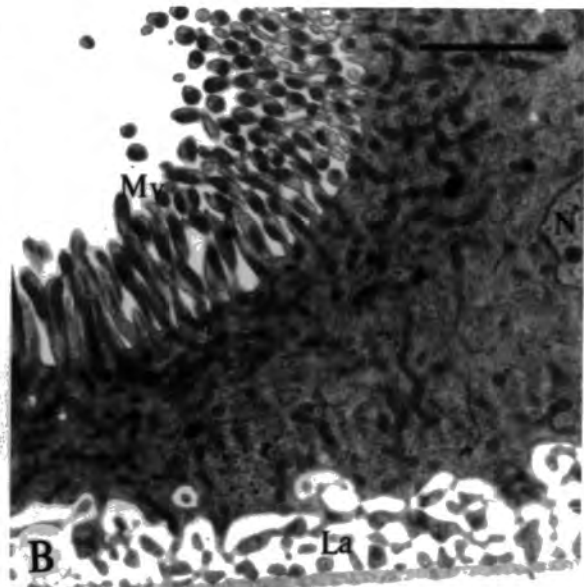
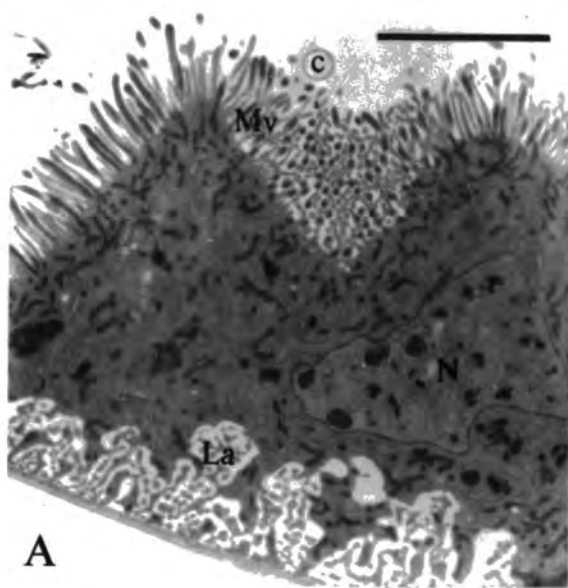

The medial region

(a) Basal zone

As described previously, this zone is characterized by a basement membrane and infoldings of the basal cell membrane. No change in the thickness of the basement membrane was noticed over the period studied; the basement membrane being *ca.* 0.4 μm thick at all ages. In contrast, the basal cell membrane infoldings increased in depth between 8 hr and 32 hr. Thus the maximum depth of the infolded extracellular space changed from 7.0 μm at 8 hrs to 12.5 μm at 32 hr and remained unchanged thereafter up to prepupal formation at 80 hr when the extracellular spaces appeared much dilated. Indeed, in the prepupal stage the spaces were so expanded that the cytoplasmic processes between them became extremely thin and it was impossible to distinguish the presence of the various cytoplasmic organelles such as mitochondria which were seen in the younger stages (Fig. 3.8A, B, C and D). The numbers of mitochondria present in this basal zone, particularly in the cytoplasmic processes, changed with age (Table 3.1); maximal numbers being observed at 8 hr and 44 hr old.

(b) Intermediate zone

The cytoplasm and associated organelles were similar in fine structural appearance to that described in Section 1. A well-developed rough endoplasmic reticulum (RER) was observed in 8 hr old larvae and those aged 32 hrs old. This organelle was less obvious in cells of 44 hr old larvae whereas in prepupae (80 hrs old) the fine structure of this zone was extremely unclear; the dominant feature being numerous lipid inclusions, multivesicular bodies and vacuoles. Vacuoles were present at all larval ages studied and in the prepupae, these often contained cellular organelles possibly suggesting that they are involved in cellular autolysis. Golgi bodies were particularly obvious in 8 hr and 44 hr old larvae although these were less common at

Fig. (3.8 A-D)

Transmission electronmicrographs showing transverse sections through the medial region of the Malpighian tubules at different ages in the last larval instar of *Spodoptera littoralis*.

A: The medial region in 8 hour old sixth instar larva.

Scale = 2 μ m

B: The medial region in 32 hour old sixth instar larva.

Scale = 5 μ m

C: The medial region in 44 hour old sixth instar larva.

Scale = 2 μ m

D: The medial region in 80 hour old prepupa. (Basal and cytoplasm zone)

Scale = 5 μ m

In this region the obvious change seen with age was in the 80 hour old prepupa, where the cytoplasmic processes between the extracellular channels (EC) became extremely thin. The basal region in the prepupa, as well as the cell cytoplasm, contains numerous vacuoles (Va) which sometimes contain unidentified structures (*). Whereas in the younger stages (A-C) most of the small organelles of the cell are obvious such as mitochondria (M), rough endoplasmic reticulum (RER), Golgi bodies (G) and extracellular channels (EC).

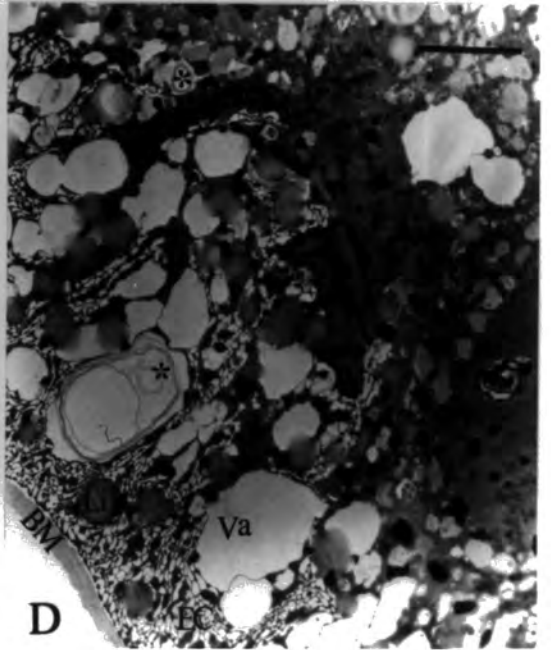
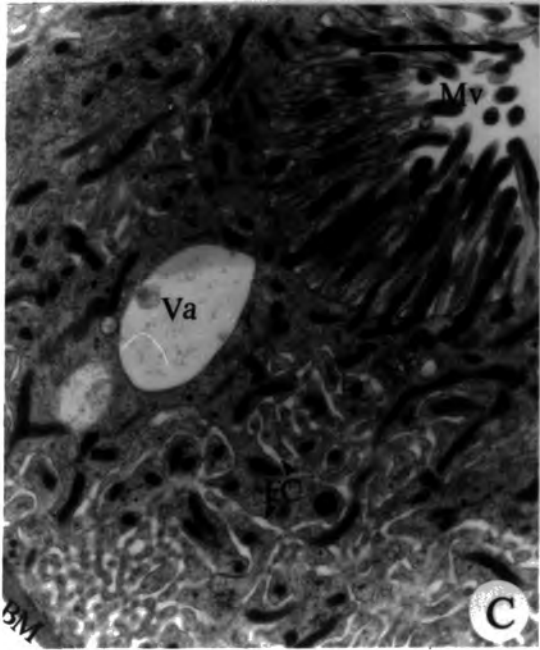
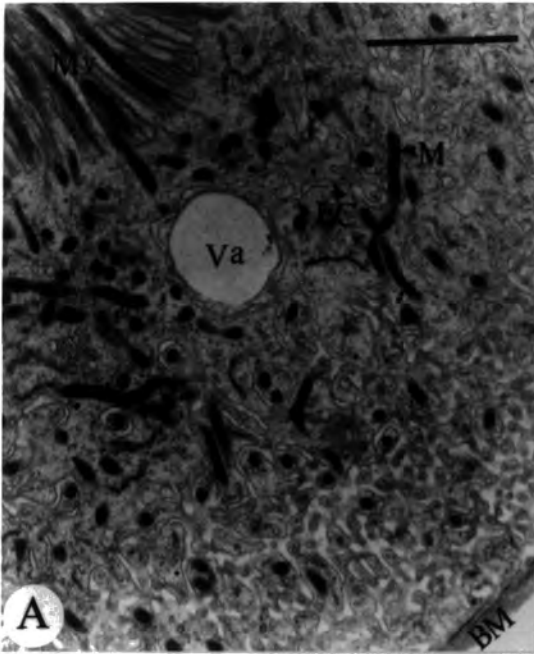

32 hrs and were apparently absent in prepupae. Table 3.1 and Figs. 3.8A, B, C and D show how the fine structure of this part of these cells varied with age.

(c) Apical zone

Fig. 3.8A-D show that throughout the period from 8-44 hrs studied the apical surface is characterized by a well-developed microvillar border with numerous elongated mitochondria being present both within the microvilli and the cytoplasm immediately beneath the microvillar border. The major developmental change noted was in the prepupal stage where the luminal surface was difficult to distinguish. At this stage the lumen appeared occluded with electron dense material and no microvilli or mitochondria were recognisable (Fig. 3.8D). Numerous mineral concretions were seen in the lumen of this region of the Malpighian tubules although these were less common or absent from 44 hr old larvae. No indication of such concretions was observed in the cytoplasm of the cells in this region(see Table 3.1).

Iliac plexus region

As mentioned in Section 1, the apical surface of the cells of this region is deeply folded and this is unchanged with age.

(a) Basal zone

The basement membrane of the newly moulted larvae (8 hours old) was approximately *ca* 0.35 μm in thickness and was similar in appearance to that mentioned in Section 1. The basal cell membrane infoldings extend *ca.* 6.2 μm into the cell cytoplasm and since the apical surface is itself deeply folded, the basal extracellular channels almost extends to the apical cell surface in the apical folds (Figs. 3.9A, B and C). In contrast, the basal infoldings stop well short of the apical surface in the thickest part of the cells (Fig. 3.9C). By 32 hrs, the basement membrane had increased in thickness to *ca.* 0.5 μm . The major change in fine structure in this zone concerns the extent to which the basal infoldings extend into the cytoplasm at the

thickest parts of the folded epithelium. Thus, at 32 hr, in these thicker regions of the epithelium, the basal extracellular spaces extend half to three-quarters of the way across the cell. Little change was noted in the basement membrane in larvae aged 44 hr although the extracellular spaces were considerably more extensive and dilated, the extracellular spaces frequently extending to near the apical cell surface in both troughs and peaks of cell thickness. Numerous mitochondria were seen in the cytoplasmic processes adjacent to the infolded extracellular spaces (Figs. 3.9A, B and C and Table 3.1). It was not possible to investigate the fine structure of this tubule region in prepupae because the accumulation of the mineral concretions in the tubule lumen and cells make sectioning throughout this tissue very difficult if not impossible.

(b) Intermediate zone

A significant intermediate zone of cytoplasm was only found in the thicker parts of the epithelium and was absent from the troughs (Fig. 3.9C). Indeed, apart from the cytoplasm around the nucleus, an intermediate zone was only recognisable at 8 and 32 hr- old larvae. Here it was characterized by a well-developed rough endoplasmic reticulum, relatively few mitochondria, accumulation of glycogen and the presence of occasional vacuoles. Examination of the figures shows the main developmental changes observed. It can be seen that associated with the dramatic increase in the extracellular infoldings referred to above, there was a marked reduction in the size of this zone such that it was hardly recognisable at 44 hr (Fig. 3.9D). Glycogen particles were found at all ages studied although more extensive accumulations were found with increased age (Fig. 3.9D). Numerous mineral concretions were present in the lumen at 8, 32 and 44 hr.

(c) Apical zone

The fine structure of this zone changed little, if at all, over the period studied; a well-developed microvillar border with canaliculi resulting from the deep foldings of the apical cell border was present at all ages studied. Numerous elongate

Fig. (3.9 A-D)

Transmission electronmicrocrographs showing transverse sections through the iliac plexus region of the Malpighian tubules at different ages in the last larval instar of *Spodoptera littoralis*.

(A) shows mineral concretions (C) in the lumen and in the 'troughs' of the canaliculi, whereas (B) shows the presence of more vacuoles in the cell cytoplasm, which may be as a result of the mineral concretion growth cycle.

A: The iliac plexus region in 8 hour old sixth instar larva.

Scale = 5 μ m

B: The iliac plexus region in 8 hour old sixth instar larva.

Scale =5 μ m

C: The iliac plexus region in 32 hour old sixth instar larva.

Scale =5 μ m

D: The iliac plexus region in 44 hour old prepupa . (Basal and cytoplasm zone)

Scale =2 μ m

The presence of canaliculi (Ca) as described previously are a characteristic feature of this region as well as being found in the medial region. Extracellular channels (EC) extend into the cytoplasm (see B & C). The obvious change caused by development is the expansion in the extracellular channel spaces and these are sometimes vacuolated and contain lipid droplets (Li). Accumulation of glycogen (Gy) obviously increased with age (see D).

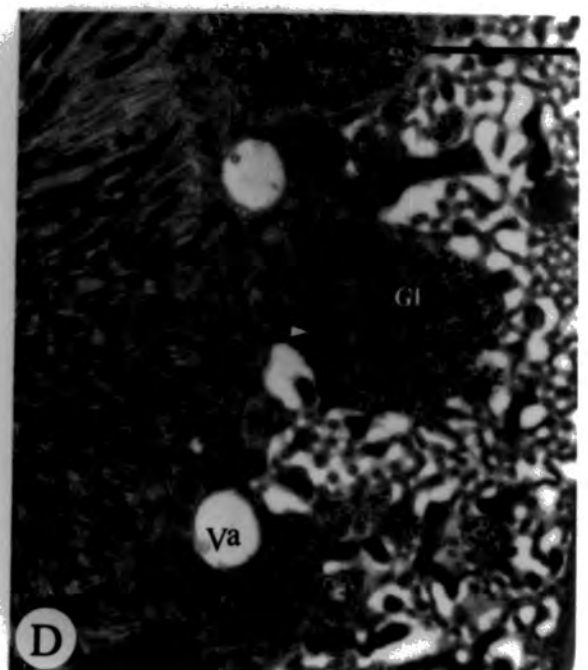
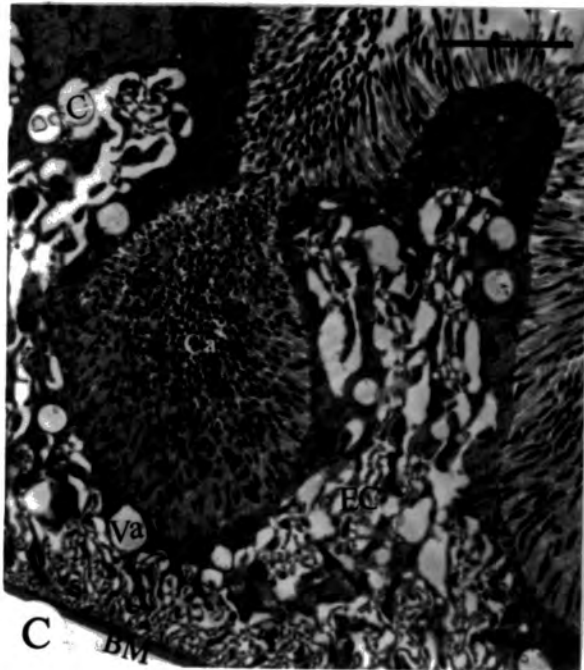
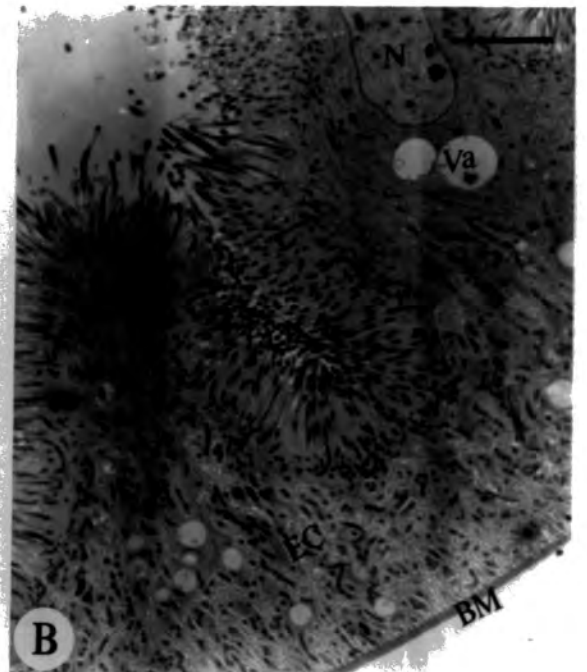
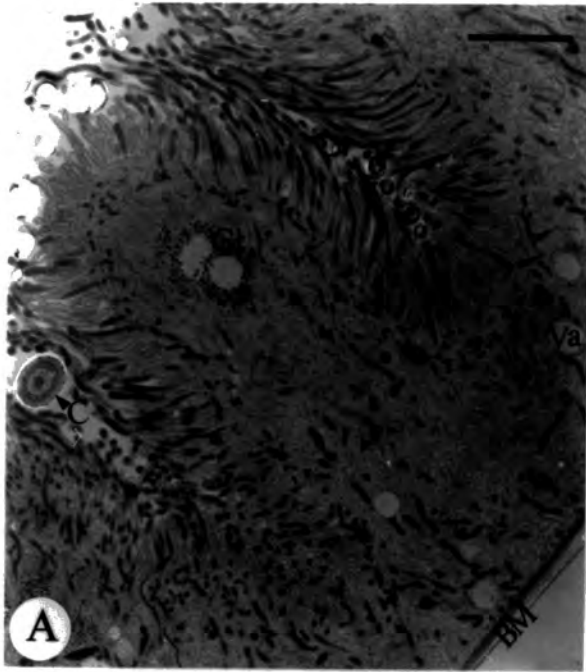

mitochondria were present in the submicrovillar cytoplasm and can be seen extending into the microvilli (Figs. 3.9A, B, C and D). Mineral concretions were apparent in the lumen of tubule, sometimes between the microvilli. These concretions were found in considerable numbers in 8 and 32 hr-old larvae, but were less numerous at 44 hr.

During the development of the larval and adult stage of *Spodoptera littoralis* mitochondria are mainly associated with the microvilli and basal infoldings. However, in the prepupal instar, mitochondria are seen mostly in the cytoplasmic processes (Table 3.1). Wigglesworth and Salpeter, (1962) and Ryerse, (1979) suggested that the mitochondrial distribution in Malpighian tubules indicates "the sites of maximal energy requirement in the cell".

The Malpighian tubules of *Spodoptera littoralis* contain mineral concretions. These were seen occasionally in the cells of the larval and prepupal stages but in the adult they were found at a much higher density. They appear to increase dramatically in number during metamorphosis. These concretions are thought to be storage excretion sites (Maddrell 1971, 1977; Sohal 1974; Sohal *et al.*, 1976, 1977).

Adult Malpighian tubules ultrastructure

The basic cell structure

The basic ultrastructure of the cells of the Malpighian tubules of adult *Spodoptera littoralis* will be discussed along the length of the tubules under the sub-headings of: proximal, medial and distal regions. Developmental changes in cell ultrastructure were observed between larvae and adults. In the cells of each region of the adult, unlike the larva, numerous clear vacuoles and mineralized concretions are found. Also, in the Malpighian tubules of adults, stalk-like projections of the apical membrane of the cells extended into the tubule lumen, and numerous microvilli were projected from such stalks.

The proximal region:

(a) Basal zone

The basement membrane in this region was similar to that described previously for the larval stage being approximately 0.2 μ m thick. The plasma membrane was infolded, extending for varying distances into the cytoplasm (0.7-2 μ m). A well-developed labyrinth of extracellular spaces between the plasma membrane infoldings was present. Mitochondria and mineral concretions were present in the cytoplasm, (Fig. 3.10A).

(b) Intermediate zone

This zone formed the major part of the cytoplasm. Mitochondria, numerous accumulations of vacuoles and mineral concretions were present. The latter frequently obscuring other small organelles in the cytoplasm. The oval nucleus was often surrounded by accumulations of dense mineral concretions, (see Fig. 3.10A;B)

(c) Apical zone

The apical zone is characterized by the presence of closely-packed microvilli. Sometimes, 'vacuolar' spaces were seen between microvilli. These may represent sites of mineral concretions which have been lost during processing of tissue. Mitochondria were mainly found in the cytoplasm near the base of the brush border, although some penetrate into the microvilli, (Fig. 3.10A, B)

The cells of medial and distal regions

No obvious differences in the fine structure were observed between cells of the medial and distal regions.

(a) Basal zone

The basement membrane of this zone was similar in appearance to that of the proximal region, although it was somewhat thicker here (0.5 μ m). Numerous plasma membrane infoldings and extracellular spaces were present and these extended approximately 1.8-3.0 μ m into the cytoplasm. Mitochondria and other cellular organelles, as was described for the proximal region, were present in the cytoplasmic folds, (Fig. 3.10E).

(b) Intermediate zone

This zone was similar in appearance to that of the cells of the proximal region.

(c) Apical zone

The apical zone is characterized by a well-developed microvillar border (Fig. 3.10E). In the apical cytoplasm large numbers of mitochondria are seen and many of these extend into the microvilli. Once again, stalk-like projections bearing microvilli were seen projecting into the lumen. These were not seen in the larvae. Unlike the larvae, no canaliculi were observed. It is possible that they may have been present but obscured by the large numbers of mineral concretions present.

As already described, some morphological differences were noted between larvae and adults. In this study, the fine structure of cells of the different tubular regions, viz. the proximal and middle regions and the iliac plexus, was investigated together with the extent to which variations in ultrastructure occurred with age. Adult tubules were studied at the following times post-eclosion; 8 hrs, 32 hrs and 80 hrs (Figs. 10 A-F). No significant differences in fine structure were observed between cells of the medial region and those of the iliac plexus, nor did their fine structure change significantly over the period studied (8-80 hrs). As in larvae, these cells were characterized by a well-developed microvillar border associated with the apical cell membrane. However, the appearance of the microvilli was somewhat different. Thus, in the adult insects the microvilli were considerably thinner and much more closely

packed together. In addition, the apical cell surface was not as deeply folded as seen in the larval stages. Another feature of the apical cell surface was the presence of large stalk-like cytoplasmic processes between the microvilli, (Fig. 3.10D). In places such processes were extremely large. Sections through adult cells frequently revealed several nuclear profiles suggesting that the nucleus in these cells is elongated and irregular in outline. No well-developed rough endoplasmic reticulum was present although free-ribosomes were abundant. Numerous mitochondria were distributed throughout the cytoplasm with marked concentrations of these organelles being observed in the sub-microvillar cytoplasm and in the cytoplasmic processes associated with the basal membrane infoldings (Fig. 3.10E). There are considerable accumulations of mineral concretions in these cells. Such concretions appear to be near-spherical in shape and show concentric lamellae of varying electron density when cut in section. Each concretion granule is localized within a vacuole; the granule diameter being approx. $0.05\ \mu\text{m}$ and the vacuolar diameter approx $0.07\ \mu\text{m}$. The dimensions of the vacuoles and concretion granules may increase with age. Unlike the proximal tubule cells in larvae, relatively little glycogen was observed in the proximal cells of the adult insect although glycogen deposits were common in the cells of the adult medial region and iliac plexus (Fig. 3.10E). The basal membrane shows marked infoldings creating numerous extracellular spaces which extend into the cytoplasm; these extracellular spaces extend approximately one-quarter to one-third of the distance from the basal cell surface to the bases of the microvilli. A more-or-less homogenous basement membrane layer enclosed the basal cell surface (Fig. 3.10D). Numerous trachea were associated with the basement membrane of cells from the iliac plexus (Fig. 3.10F). These were less apparent in the other regions of the adult tubules.

Table 3.2 Developmental changes in various cellular components in Malpighian tubule cells of the adult *Spodoptera littoralis*

ORGANELLE / ZONE	Distribution of organelles in regions of the Malpighian tubules at different ages (hr.).											
	8			32			80					
	P	M	IP	P	M	IP	P	M	IP			
Mitochondria / basal foldings	+++	+	+	+	+	+	+	+	++			
Mitochondria / intermediate cytoplasm	++	+	+++	++	+	+	++	+	++			
Mitochondria / apical cytoplasm	+++	+++	++	+	++	++	++	++	+++			
Multivesicular bodies	+	+	-	-	-	-	-	+	+			
Coated vesicles	+	+	-	-	-	-	+	+	+			
Lipid inclusions	+	+	+	-	-	-	-	-	+			
Mineral concretion / cytoplasm	+++	+++	+++	+++	+++	+++	+++	+++	+++			
Mineral concretion / lumen	+	+	-	-	-	-	-	-	+			
Golgi bodies	-	+	-	-	-	-	-	-	-			
Glycogen	-	-	-	+	+	-	-	-	-			
Vacuoles	++	++	++	++	+	++	++	+	++			

- absent, + present, ++ common, +++ abundant.
P = proximal tubule M = medial tubules, IP = iliac plexus tubule.

Fig. (3.10 A-F)

Transmission electronmicrographs showing transverse sections through the proximal region of the Malpighian tubules at different regions in the adult instar of *Spodoptera littoralis*.

A: Low power electronmicrograph, the tubule is surrounded by basement membrane (BM), and the basal membrane foldings form a labyrinth (La). The intermediate zone contains cytoplasm, a nucleus (N), mitochondria, vacuoles (Va) and mineral concretions. In the apical region the microvilli (Mv) contain mitochondria, these microvilli extend into the lumen (L) and seem to be thinner than that seen in larval tubules.

Scale = 5 μ m

B: High magnification showing basement membrane, labyrinth (La), vacuoles of mineral concretions (Va), Nucleus (N), and numerous mitochondria are seen in the apical cytoplasm. Note the presence of some vacuoles between the microvilli which maybe created by the concretions.

Scale = 2 μ m

C: An electronmicrograph, showing the basement membrane (BM) and basal membrane foldings forming extracellular channels. In the cytoplasm there is a nucleus (N) and numerous of mineral concretions (C), in the apical microvilli there are some projections of the apical membrane which make this area unclear.

Scale = 5 μ m

D: Section of the same region as above, showing a lot of mineral concretions in the cytoplasm surrounding the nucleus. Note the obvious apical microvilli which contain mitochondria and a numerous number of mitochondria in the apical cytoplasm, and the appearance of stalk-like projections (St) extending into the lumen.

Scale = 5 μ m

E: High power magnification of the apical region of medial tubules contains vacuoles (Va), multivesicular bodies (MB), mitochondria (M), Golgi bodies (G) and microvilli containing mitochondria and having stalk-like projections (St)

Scale = 5 μ m

F: An electronmicrograph through the iliac plexus region, which is similar to the medial region which is described above, it includes the presence of tracheae (T) associated with the basement membrane.

Scale = 5 μ m.

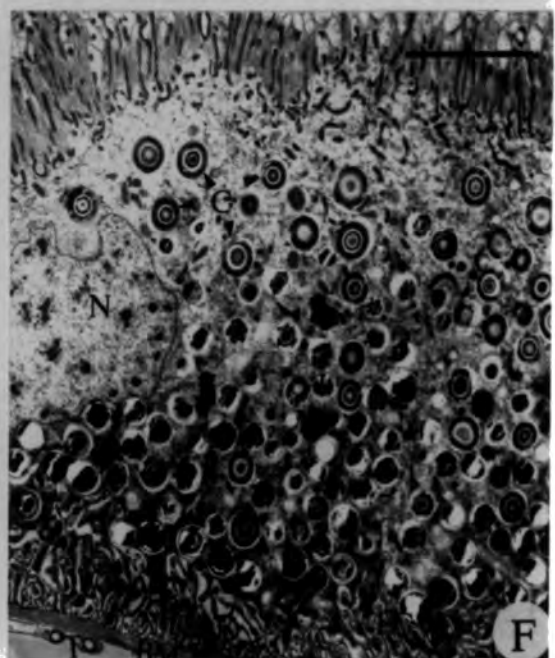
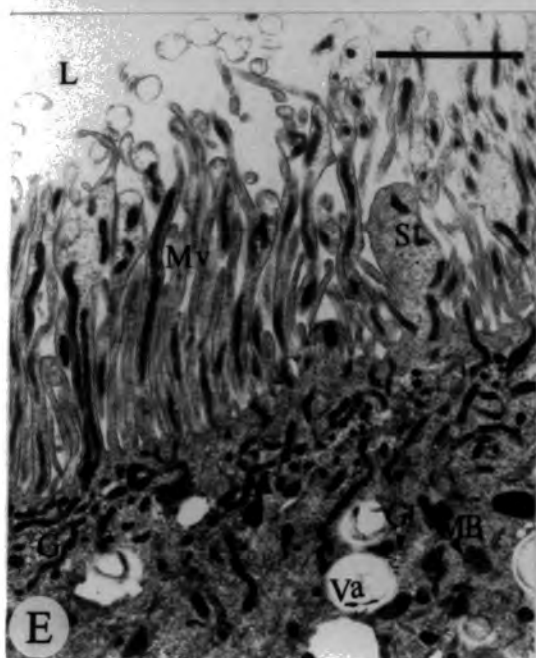
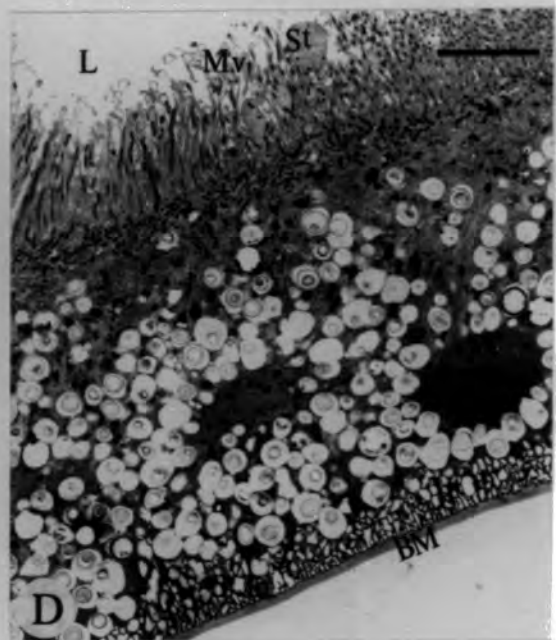
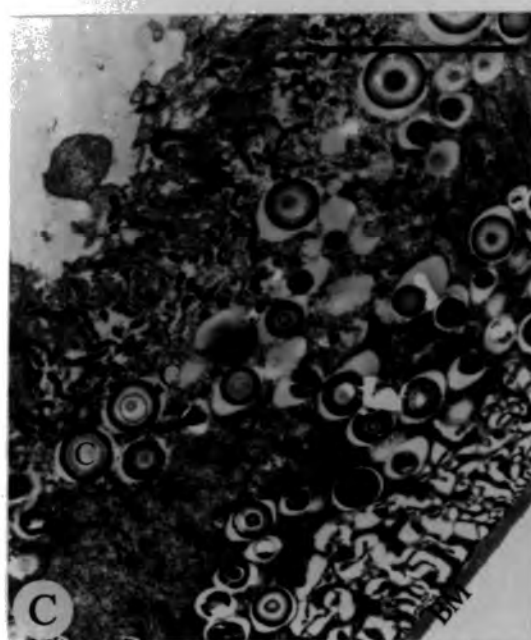
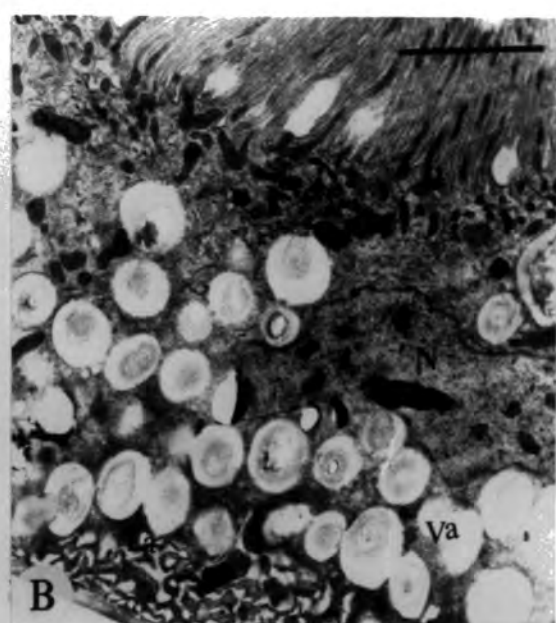
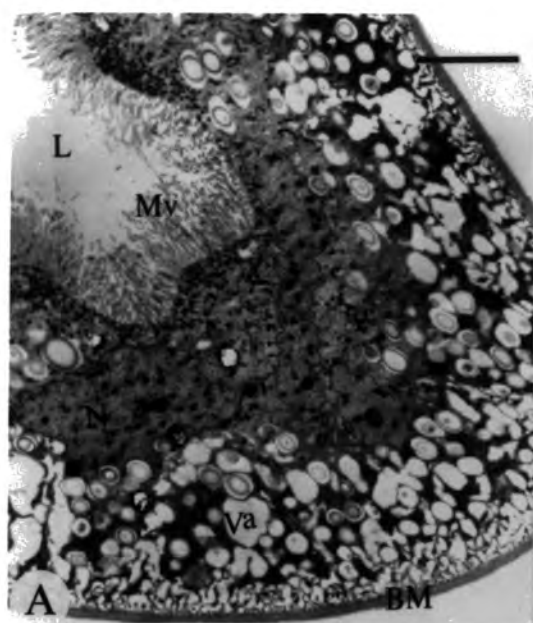

Discussion

The present study revealed that *Spodoptera littoralis*, in common with a number of other lepidopteran insects (e.g. *Vanessa urticae*, Hensen, 1937; *Heliothis zea*, Standlea and Yonke, 1968; *Bombyx mori*, Teiger and Arnott 1972), possesses three pairs of Malpighian tubules at all stages of the life-cycle. Henson (1937) reported that, in larval *Vanessa urticae*, each tubule could be divided into five recognisably distinct regions: a common duct, the tubule proper, an iliac plexus, a rectal lead and a rectal plexus. Except for the term 'rectal plexus' which was renamed the 'cryptonephridial system' by Poll (1939), most authors have adopted this terminology with slight modification (Irvine, 1969; Ramsay, 1976; Ryerse, 1979). However, more recently, Kumar and Srivastava (1981) have argued that this is inappropriate. They reported that in the lemon-butterfly, *Papilio demoleus*, the larval system is composed of three Malpighian tubules basally joined to give rise to a thin-walled sac, the ureter, which opens into an ampulla; the latter being divisible into a duct, which opens into the hindgut, a bladder and a neck. They argued that as the ampulla and ureter are histologically quite different, it is misleading to refer to the entire structure as a common duct. Similarly, they argued that the terms 'tubule proper', 'iliac plexus' and 'rectal plexus' are inappropriate. They concluded that each Malpighian tubule was divisible into proximal (which approximates to the tubule proper of Henson), middle (which approximates to the iliac plexus of Henson), distal and terminal regions; the latter penetrating the rectal wall to form the cryptonephridial system. These regions were reported to have variable histological features and it was suggested that the main excretory part was the middle region with the distal region being involved in the return of water, reabsorbed by the cryptonephridial system, into the haemolymph. The terminology used to describe the Malpighian tubule system in lepidoptera is variable. A number of workers have divided the tubule proper of Henson (proximal tubule of Ryerse, 1979) into distinct regions. For example, white and yellow regions are

described in *Calpododes ethlius* (Ryerse, 1979) and in *Pieris brassicae* (Ramsay, 1976) whereas in *Manduca sexta*, the proximal tubule is that part of the tubule which runs anteriorly along the midgut from the 'common vesicle' to the 2nd or 3rd abdominal segment (a region that approximates to the white region of *Calpododes*), the posteriorly directed part of the 'tubule proper' being described as the 'medial tubule' (Nijhout, 1975). In the latter species, the region associated with the ileum is described as the 'distal tubule' and if there was not already enough confusion in terminology, this region is distinct from the medial region in being yellow in colour. The system of nomenclature adopted in the present study is similar to that used by Ryerse (1979) for *Calpododes ethlius*. However, unlike in this species, the proximal tubules in *Spodoptera littoralis* are not divided into white and yellow regions. In this system the equivalent regions in *Spodoptera* have been referred to as the proximal and medial regions, respectively, using the terminology of Nijhout (1975). Thus the tubules of *Spodoptera littoralis* consist of a proximal tubule running anteriorly along the midgut from the common duct, a medial tubule which runs posteriorly along the midgut to the hindgut where it becomes highly convoluted to form an iliac plexus, a short rectal lead and a cryptonephridial system. As indicated above, cryptonephridial systems have been reported in other lepidopteran larvae; for example in *Papilio demoleus* (Kumar and Srivastava, 1981; Srivastava *et al.*, 1983), in *Pieris brassicae* and *Manduca sexta* (Ramsay, 1976) and in *Hyalophora cecropia* (Judy and Gilbert, 1969). Cryptonephridial systems have also been reported in other insect orders, such as the Coleoptera. In *Tenebrio molitor* the cryptonephridial system has been studied in some detail (Meyran, 1982), and has been reported to function in water recovery from rectum as an adaptation to dry living conditions. However the function of this system in larval lepidoptera may be primarily concerned with ionic regulation as reported by Chapman (1988).

In *Spodoptera littoralis*, one of the three Malpighian tubules opens directly into the muscular coated common duct whilst the other two unite to form a short duct before

joining the common duct. This arrangement is similar to that reported by Henson (1937) for *Vanessa urticae*. In contrast, in *Papilio demoleus*, the Malpighian tubules join basally to give rise to a thin-walled sac or ureter which opens into the alimentary tract via a muscular ampulla (Kumar and Srivastava, 1981). In *Calpodex ethlius* (Ryerse, 1979) a common collecting duct empties via a bladder into the alimentary tract. It is not stated whether the bladder is muscular or not. Ramsay (1976) reported that the white regions of the tubules in *Pieris brassicae* and *Manduca sexta* unite into a small pulsating vesicle from which a very short common duct leads into the gut lumen; an arrangement not too dissimilar from that seen in this study on *Spodoptera*. Whilst the latter author does not state whether the pulsating vesicle is supplied with a musculature, the fact that it pulsates suggests that it is muscular. In *Spodoptera littoralis*, muscles were certainly present (Figure 3.2F) around the common duct, although no muscles were found in association with the tubules of the proximal, medial, iliac plexus, rectal leads and cryptonephridial regions. This absence of musculature associated with the tubules has been reported in other lepidopteran species, for example *Papilio demoleus* (Kumar and Srivastava, 1981).

Light microscopical and ultrastructural studies on sections through the Malpighian tubules of sixth stage *Spodoptera* larvae revealed differences in cellular and epithelial morphology between the proximal region and that of the medial and distal tubule regions. Thus, whilst the cells in all regions exhibited a convoluted apical cell surface, in the medial and distal regions the convolutions of the apical membrane were so marked that canaliculi lined with microvilli were formed. These were not seen in the proximal tubule region. Canaliculi depressions have not been reported previously in lepidopteran Malpighian tubules. However, other researchers have reported histological differences between tubule regions in other lepidopteran species. Kumar and Srivastava (1981) reported two distinct cell sizes in the Malpighian tubules of *Papilio demoleus*. They suggested that the presence of differently sized cells in different regions of the

tubules, with the larger cells in parts of the distal and cryptonephridial regions, might indicate functional regionalization.

Electron microscopical studies on the Malpighian tubules of *Spodoptera littoralis* indicated one cell type in larval and adult insects although as discussed below, there were structural differences between regions. Distinct cellular types have been reported in Malpighian tubules from other insect species (Wigglesworth, 1972). For example, two cell types have been reported in *Calliphora erythrocephala* (Berridge and Oschman, 1969), *Locusta migratoria* (Donkin, 1981; Fogg, 1990), *Jamaicana flava* (Peacock and Anstee, 1977), *Carausius morosus* (Taylor, 1971a, b) and *Periplaneta americana*, (Wall *et al.*, 1975). However in the Malpighian tubules of the housefly, *Musca domestica* (Sohal, 1974) four distinct cellular types have been observed, distributed along the length of the Malpighian tubules.

Berridge and Oschman (1969) suggested distinct functions for the two cell types in *Calliphora*; the Type 1 cells being responsible for the secretion of the primary urine whereas the Type 2 or stellate cells may be involved in the reabsorption of Na^+ from the tubule lumen resulting in the low Na^+ content of the secreted fluid.

Variations in the organisation of the basal plasma membrane was noted in the different regions of the Malpighian tubules of *Spodoptera littoralis*. Thus, a distinct extracellular labyrinth-like space was observed in the basal zone of the proximal region. The extent to which this is a common feature of proximal region cells from lepidopteran larvae is uncertain as this region seems to have been largely ignored in previous fine structural studies. In contrast, in the medial region and the iliac plexus the basal plasma membrane, whilst infolded, did not generate such a dilated system of interconnected extracellular spaces. Instead, the infoldings of the basal cell membrane were more-or-less perpendicular to the basal surface of the tubule and the extracellular spaces narrower. This latter pattern of infoldings is similar to that reported in Malpighian tubule cells of other insect species. For example, the primary cells of the yellow region in *Calpodes ethlius* (Ryerse, 1979), the Type I cells of the Malpighian tubules of adult

blowfly, *Calliphora erythrocephala* (Smith, 1968) and *Locusta migratoria* (Bell and Anstee, 1977). In *Carausius morosus*, the basal infolds extend a considerable distance into the cell cytoplasm and mitochondria are located in the cytoplasm between the infolds (Taylor, 1971b). Mitochondria were similarly located in the cells of the medial region in *Spodoptera*. The infoldings of the basal cell membrane are thought to be important in increasing the surface area of the cells (Smith, 1968). In the last larval stage of *C. ethius*, Ryerse (1979) found that numerous mineral concretions were present in the cytoplasm between the basal membrane infolds. In contrast in *Spodoptera* relatively few mineral concretions were seen in the cytoplasm of these cells.

The intermediate zones of cells of the different regions of the Malpighian tubules of *Spodoptera littoralis* were essentially similar in their ultrastructure. The organelles present included, Golgi bodies, various vacuoles and vesicles, endoplasmic reticulum, a large nucleus and numerous mitochondria. Thus, this zone was similar to that reported in Malpighian tubule cells of a variety of different species of insects (*Calpodes ethlius*: Ryerse, 1979; *Locusta migratoria*: Anstee and Bell, 1977; *Carausius morosus*: Taylor, 1971a,b; *Jamicana flava*: Peacock and Anstee, 1977; *Periplaneta americana*: Wall *et al.*, 1975; *Dichroplus elongatus*: Lange, 1987; *Musca domestica*: Sohal, 1974; *Rhodnius prolixus*: Wigglesworth and Salpeter, 1962; Skaer *et al* 1990; *Drosophila melanogaster*: Eichelberg and Wessing, 1975; *Calliphora erythrocephala*: Berridge and Oschman, 1969; *Anopheles quadrimaculatus*: Bradley and Nayar, 1987).

The apical zones of the Malpighian tubule cells of *Spodoptera littoralis* in common with those of other species studied (e.g. *Calpodes ethlius*, Ryerse, 1979; *Manduca sexta*, Klein *et al*, 1991; *Bombyx mori*, Teigler and Arnott, 1972; *Carausius morosus*, Taylor, 1971a,b; *Rhodnius prolixus*, Wigglesworth and Salpeter, 1961; Bradley, 1983; Maddrell *et al* 1985; Skaer *et al*, 1987; Skaer *et al*, 1990) were characterized by the presence of a brush border, although this varied in depth in the

different regions. Mitochondria were present within the microvilli of larval tubules in all regions studied.

In *Spodoptera*, the cells of the proximal region possessed a well-developed microvillar border and the epithelium in this region was distinguished by invaginations similar to that described in the proximal region of *Papilio demoleus* (Kumar and Srivastava, 1981). Henson (1937) reported that two rows of cells with luminal striated borders formed the wall of the tubule proper in *Vanessa urticae*. Furthermore, he noted that the nucleus was much branched in later stage larvae. Multi-lobed nuclei were, also observed in the cells of the proximal region in the present study.

The cells of the distal and medial regions of tubules from *Spodoptera* were characterized by the presence of microvilli which were considerably longer and more densely packed compared with those seen in the cells of the proximal region. Marked foldings of the apical plasma membrane were observed and the luminal space between the folds was much narrower than that seen in the proximal region. This, together with the increased folding of the basal cell membrane may well reflect functional specialization of these cells. In *Calpodes ethlius*, the cells of the yellow region are known to be involved in ion and fluid secretion (Ryerse, 1977, 1979). The latter region approximates to the medial region in *Spodoptera littoralis*. In addition, in common with other transporting epithelia, numerous mitochondria were seen in association with the basal plasma membrane infoldings and within the microvilli on the apical cell surface.

A number of models have been proposed to explain the interrelationship of structure and function in fluid and solute transport across epithelia. An early model, the double-membrane model, was proposed by Curran and McIntosh (1962). In this model, it is suggested that an osmotic gradient produced by active solute transport from one subcompartment of an epithelium into another could, theoretically, result in a net flow of water across the epithelium.

Diamond and Tormey (1966) showed how this theoretical model could be correlated with ultrastructural features in mammalian gallbladder. Subsequently, Diamond and Bossert (1967; 1978), working on rabbit bladder, went on to propose the standing-gradient hypothesis to explain solute-solvent coupled water transport. The basis of this hypothesis is the active transport of solute into deep, narrow intercellular spaces or deep basolateral infoldings i.e. into channels which are closed at one end and open from the other end. It is suggested that as solute is actively transported out of the cell into these channels an osmotic gradient is established such that the concentration is highest near the closed end, reducing towards the open end where it comes into contact with the bulk of medium bathing that surface of the epithelium. The high osmolarity within these extracellular spaces/channels causes water to be drawn from the cell into the channel and this water together with solute gradually moves out into the bathing medium. The water leaving the cell is replaced by water entering at the opposite cell surface. Thus, the active extrusion of solute at one cell surface, into a narrow intercellular channel, produces a local increase in concentration which, in turn, creates a steady osmotic flow of water from one side of the epithelium to the other.

Berridge and Oschman (1969) suggested that the model of Diamond and Bossert, referred to above and earlier (see Introduction), could be used to explain fluid flow across the Malpighian tubules of *Calliphora*. This hypothesis can be applied to fluid flow into and out of 'forward' and 'backward' facing channels.

The standing-gradient model has been proposed to explain solute-solvent coupling in a variety of vertebrate and invertebrate systems including reptilian kidney (Schmidt-Nielson and Davis, 1968), toad urinary bladder (Davis *et al*, 1974), insect rectum (Berridge and Gupta, 1968) and Malpighian tubules (Berridge and Oschman, 1969; 1972).

In *Spodoptera littoralis*, the fine structure of the cells in the medial and distal regions of larval, prepupal and adult insects showed changes in channel geometry with development similar to those reported by Ryerse (1979) in cells of the yellow region in

Calpodes ethlius. Thus, the basal and apical channels increased in length during the larval period and associated with this *Spodoptera* tubule secretion increased (see Chapter 4), as did that in *Calpodes ethlius* (Ryerse, 1979). Furthermore, the basal channels disappeared and the apical channels shortened when fluid transport was switched off in the prepupa (see Chapter. 3). The basal channels reappeared and the apical channels lengthened, and fluid secretion was re-established in the adult. These observations, that changes in channel geometry in cells of the medial and distal regions are coordinated with secretory activity during development, are consistent with the osmotic gradient models for fluid transport described above.

The cells of the proximal region in *Spodoptera littoralis* resemble the Type II or stellate cells of Malpighian tubules of *Musca domestica* (Sohal, 1974) and *Calliphora erythrocephala* (Berridge and Oschman, 1969) in being characterized by wide labyrinth spaces at the basal cell surface. It is perhaps significant that the Type II cells in these latter insects are thought to be responsible for reabsorption of Na^+ from the luminal medium or from the Type I or primary cells *via* septate desmosomes. Berridge and Oschman (1969) point out that the presence of these shorter and wider basal infoldings is consistent with the geometry which Diamond and Bossert (1967) consider appropriate to produce a hypertonic fluid if the channels were involved in reabsorption. Thus, it is tempting to suggest that in *Spodoptera*, the cells of the proximal region may also be involved in solute reabsorption without returning as much water as was originally secreted by the distal and medial regions. Similarly, in *Rhodnius* tubules the urine becomes hypotonic in the proximal segment when ions are returned to the blood (Ramsay, 1952). Eichelberg and Wessing (1975), reported that the cells of the main part of the Malpighian tubules of *Drosophila melanogaster* serve mainly for resorption whilst the distal tubule segment (initial segment) is thought to be responsible for primary urine production. Other researchers have also suggested functional differences for the different tubule regions in *Lepidoptera*. Patton (1953) suggested that the medial region was responsible for the secretion of solute and water from the haemolymph to

the tubule lumen and that the proximal tubules and the cryptonephridia are responsible for reabsorption. Indeed, it has been suggested that in Lepidoptera the function of the cryptonephridia may be to absorb toxic substances which may be extracted from the hindgut at the same time as water is taken up. Thus, the cryptonephridia are seen as a means of preventing such substances passing into the body cavity (Metalnikov, 1908; referred to in Wigglesworth, 1972). However, Wigglesworth (1972) suggests that the cryptonephridial arrangement may simply be a means of increasing the water absorbing efficiency of the gut wall as is reported in *Tenebrio* (Grimstone *et al.* 1968) whereas Chapman (1988) considers that it may be primarily concerned with ionic regulation.

Kumar and Srivastava (1981) reported considerable amounts of excretory material in the middle region of Malpighian tubules from *Papilio ethlius* and suggested an active secretory role for this region. In the present study, the shape of the cells was similar in all the regions studied, except for some differences in the folding of the apical cell surfaces. The extent of this folding was particularly marked in the medial and distal regions. These folded structures (canaliculi) have been reported in the ampulla of the cockroach, *Periplaneta americana* (Wall *et al.*, 1975). Similar foldings were also mentioned in the ultrastructure of *Calliphora* salivary glands, these amplify the apical surface area of the secretory cells and create extracellular spaces that face the lumen (Oschman and Berridge, 1970).

In the present study, the basal cell surface of the Malpighian tubules was enclosed by a basement membrane of homogeneous appearance and in this feature, it is similar to Malpighian tubule cells of *Bombyx mori* (Teigler and Arnott, 1972). In contrast, Ryerse (1979) reported that the basement membrane of the skipper butterfly, *Calpodis ethlius*, was thick and structurally complex. The basement membrane is structurally varied in different insect species. Thus, in the stick insect, *Carausius morosus*, the tubule basement membrane is a complicated structure, composed of three well defined layers of fibres, that completely ensheathes the outer surface of the tubule (Taylor, 1971b). Similarly, in *Jamaicana flava*, the basement membrane consists of

three layers (Peacock and Anstee, 1977) whereas in the cockroach, *Periplaneta americana*, it consists of an inner granular layer and a fibrillar layer (Wall *et al.*, 1975). In some species, the basal surface of the Malpighian tubules cells are heavily invested with connective tissue and musculature (Wall *et al.*, 1975). However, in *Spodoptera littoralis*, in common with other species of Lepidoptera, Ryerse (1979), no musculature was present. The function of the basement membrane in *Spodoptera* Malpighian tubules is uncertain. Ryerse (1979) reported that the basement membrane of the *Calpodes ethlius* may regulate the movement of ions and molecules into or out of the cell. Taylor (1971a) suggested that the permeability properties of the basement membrane could be important in determining the composition of the fluid transported by the Malpighian tubules of *Carausius morosus*. He further suggested that the main function of the basement membrane was to protect the tubules against distortion by intraluminal pressure created by tubular activity and transtubular transport. In *Spodoptera*, the smaller lumen of the medial region creates a higher intraluminal pressure, hence the basement membrane must be thicker in this region possibly to prevent distortion of cells.

Ryerse (1978) reported that the ability of Malpighian tubules in *Calpodes ethlius* to transport fluid, and the rate of fluid secretion depended on the developmental stage and the physiological state. He found that fluid secretion increased in rate as the larvae fed and grew and that rate was not dependent on a diuretic hormone.

The present study investigated the ultrastructure of the different regions of Malpighian tubules of *Spodoptera littoralis*, throughout the last larval instar, prepupal and adult instars. The basic ultrastructure of the cells was similar for each instar studied. Table 3.1 summarises the main features in terms of cell contents between the instars. In the proximal region in larvae little change was seen, the major change in the fine structure was observed in the prepupal instar (80 hours old), (for more details see Results section 2). During metamorphosis changes in ultrastructure were observed, such as a change in the thickness of the basement membrane, it increased in thickness

with age between the last larval and prepupal instars. Ryerse (1979), reported that the basement membrane thickness remained constant during the last two larval stages of *Calpodes ethlius*. He suggested that the basement membrane is continuously synthesized during larval development, and that wall thickness increases during pharate pupal instars, as a result of this there was a reduction or occlusion of the tubule lumen. The basal membrane foldings were varied in length in the sixth larval stage, and comparing this stage to the prepupal instar, the basal extracellular spaces were extremely vacuolated (in appearance in the latter), this is similar to the case of Malpighian tubules in *Locusta migratoria*, Donkin and Anstee (1980). Ryerse (1977) observed that in the prepupal stage of *Calpodes* the apical microvilli contain numerous mitochondria and the extracellular channels were reduced in length. In addition, during this stage fluid secretion is switched-off. Similarly the same changes are seen in *Spodoptera*. These examples illustrate (as discussed in Chapter 5) that changes in function are related to changes in structure.

The ultrastructure of the Malpighian tubules in adult *Spodoptera littoralis* were similar, in general, to that described previously for the larval instar. However, some differences may emerge as a result of age (see Table 3.2), for instance the basal membrane infoldings become shorter and much narrower when compared to the larval instar. In addition mineral concretions were observed in the cytoplasm between the basal membrane infoldings and also in abundance in the cells cytoplasm. These mineral concretions were seen in all stages of their formation in the different regions of the adult Malpighian tubules. Ryerse (1979) reported that the mineral concretions are present in the larval, pupal and adult instars and that the density increases dramatically with age. For more details see Table 3.1 and 3.2. X-ray analysis of the mineral concretions from fresh larval Malpighian tubule lumens shown in Fig.3.5, illustrates the composition of these concretions. Sohal *et al.*, (1976), found that the Malpighian tubules of *Musca domestica* contain three different types of concretions, some of these concretions were seen inside vacuoles in the present study. They suggest that

concretions may originate from multi-vesicular bodies and lysosomes. Furthermore, Donkin (1981), explained the growth cycle of mineral concretions from the Malpighian tubules of *Locusta migratoria*. Most of the stages that make up the growth cycle were seen in the adult (but not the larval) stage of *Spodoptera*. So it is possible that the same sequence of formation occurs but only in the adult. In the Malpighian tubules of *Periplaneta americana*, Wall *et al.*, (1975) observed the presence of mineral concretions within the nucleus, this was not seen in the present study.

The apical zones in the different regions of *Spodoptera littoralis* Malpighian tubules, throughout metamorphosis, were characterized by a well-developed microvillar border. In some regions, this border, as mentioned previously, was present as canaliculi. These microvilli contain elongate mitochondria. The main developmental change was seen in the prepupal instar where these microvilli became thin and their mitochondria and cytoplasm retracted into the main cytoplasm. The tubule lumens in most regions of the prepupal instar were unrecognizable, because of the presence of electron dense material. This has been mentioned previously in the results. In the adult the microvilli were similar to that described for the larval instar, but in some regions of the adult Malpighian tubules the microvilli seemed to be closer together. The mitochondria in the microvilli varied with age (Table 3.1). Some of these results are similar to that reported in the skipper butterfly *Calpodetes ethlius*, by Ryerse (1979). He found that in the pharate pupal stage the mitochondria retracted into the cytoplasm from the microvilli. The lumen of the Malpighian tubules of this stage was also occluded. He also observed that the density of mineral concretions increased dramatically with age during the metamorphosis of *C. ethlius* and that abundant crystalline inclusions were seen in the pupal instar. Comparatively, in the present study, crystalline inclusions were not seen in any stage of the life cycle, whereas the mineral concretions were observed in both the prepupal and adult stages in all stages of their growth cycle (Tables. 3.1 and 3.2).

CHAPTER 4

THE EFFECT OF METHOPRENE ON THE LAST LARVAL INSTAR OF *SPODOPTERA LITTORALIS*

Introduction

Growth regulation in insects is dependent on several glands, which produce hormones. These hormones are involved in many functions such as control of reproductive processes, moulting and metamorphosis. They include ecdysone and juvenile hormone (see Riddiford 1980, 1985), the first is produced by the prothoracic gland and is responsible for the acceleration of moulting and the latter is produced by the corpora allata and inhibit or prevents metamorphosis (Slàma *et al.*, 1974; Ciemior *et al.*, 1979). Juvenile hormone (JH) was first proposed to have potential as an insect pest control agent when Williams (1956) found that extracts from adult males of *Hyalophora cecropia* moths prevented normal metamorphosis when applied to silkworm pupae. Unfortunately, natural juvenile hormones are too unstable to be used as commercial pesticides because they are rapidly broken down in the environment and by insects. Subsequent studies by Slàma and Williams (1965) indicated that resin from the American Balsam fir tree contained a JH analogue (JHA) which was specific in its activity against the hemipteran bug, *Pyrrhocoris apterus*, and other members of the family Pyrrhocoridae. Since that time, a number of plant-derived compounds with JH-activity have been identified and a number of synthetic juvenile hormone analogues and mimics have been synthesised (see reviews by Staal, 1975; Henrick, 1982 and Slàma, 1985). Methoprene is one synthetic JHA which is used commercially to control a number of insect pest species. This compound is resistant to hydrolysis by insect esterase enzymes (Hammock and Quistad, 1981) is registered with the U.S. Environmental Protection Agency for insecticidal use against floodwater mosquitoes and to control Pharaoh ants, *Monomorium baonis*. Methoprene has also been applied

to raw tobacco to prevent its contamination by storage pest larvae which cause considerable damage e.g. the cigarette beetle, *Lasioderma serricorne* and the tobacco moth, *Ephestia elutella* (Manzelli, 1982). It is also used to increase silk production by larvae of the silkworm, *Bombyx mori* (see Staal, 1975; Henrick, 1982).

Methoprene is relatively safe in terms of human toxicity and environmental damage being effective in minute amounts (Loschiavo, 1976). These features are advantageous for a control agent. Furthermore, since methoprene affects development at an early stage it can slow population growth. Numerous species of Lepidoptera are serious agricultural pests, especially members of the family Noctuidae. In consequence, numerous investigations have been carried out to improve methods of control. Current information concerning the role of endocrines in the control of growth and development of noctuids suggests that this group differs from species such as *Galleria mellonella* or *Bombyx mori* which are considered to be representative of Lepidoptera in general (Sehna *et al.*, 1976). Treatment of noctuid larvae with juvenoids has been reported to be ineffective (El-Ibrashy and Mansour, 1970; Bransby-Williams, 1972) or to require high doses (Benskin and Vinson, 1973). However, Sehna *et al.*, (1976) reported inhibition of egg hatching in *Spodoptera littoralis* and *Mamestra brassicae* following administration of juvenoids at a concentration of 0.01% in acetone solution. In addition, these authors reported inhibition of larval metamorphosis and changes in body colouration following treatment of last instar larvae with various juvenoids.

The mode of action of JH at the molecular level is not clearly understood. Several theories have been proposed. For example, the *status quo* theory (Ilans, 1970) suggests that JH acts on RNA translation by the cell. Williams and Kafatos (1971) have also suggested a theoretical model for the action of JH based on its control over sporulation in *Bacillus subtilis*. They proposed that there are three master regulatory genes controlling specific gene sets (larval, pupal and adult) each of which can only be read by a particular RNA polymerase, one for each gene set. According to this theory, ecdysone activates the different gene sets depending on how much JH is present. In the

larval stage JH act as a co-repressor of both pupal and adult gene sets. Thus, it is suggested that when the JH titre falls, the pupal repressor no longer binds to the pupal master regulatory gene because its binding requires a high JH level and hence the pupal gene set can be read. Similarly, when JH levels fall to zero the adult repressor is removed and adult development is initiated by ecdysone.

An alternative hypothesis to explain JH action was proposed by Kroeger and Lezzi, (1966) and Kroeger, (1968); the ion hypothesis of gene activation. This proposes that JH and ecdysone control gene activity indirectly by controlling the electrolyte milieu of the nuclear sap. Some support for this mode of JH action was claimed on the basis that JH-specific 'puffs' were induced dipteran polytene chromosomes by varying the Na^+/K^+ concentration ratio (Lezzi and Gilbert 1972). Baumann, (1968) reported that in an electrophysiological study on salivary glands of *Galleria mellonella*, JH affected cell membrane permeability. In addition, injection of ouabain into *Tenebrio* pupae resulted in the production of larval-pupal intermediates similar to treatment with JH (Chase, 1970). Since ouabain is known to be a specific inhibitor of Na^+/K^+ -ATPase (the Na^+/K^+ pump of cell membranes (Schatzmann, 1953)) it is suggested that JH may act like ouabain and lead to a decrease in the K^+/Na^+ concentration ratio within the nucleus. However, Fristrom and Kelly (1976) reported that JH increased Na^+/K^+ -ATPase activity in homogenates of imaginal discs of *Drosophila*. Whilst the ion hypothesis of gene activation has been the subject of much scepticism and controversy, the experimental evidence does not rule out the possibility of non-specific effects. There is evidence that JH affects the properties of biological membranes (Gilbert, 1974) and the membrane conductance of artificial membranes to ions (Baumann, 1969).

It has been shown in the present study that there is Na^+/K^+ ATPase which is involved in fluid secretion across the Malpighian tubules of *Spodoptera littoralis*, since this process was inhibited by ouabain as (see Chapter 5). On this basis, it was decided to extend this study on the effects of methoprene on development in *Spodoptera*

littoralis to examine the effects of this JHA on Malpighian tubule fine structure and function.

Materials and methods

Newly moulted ($12\text{h} \pm 12\text{h}$) 6th instar *Spodoptera littoralis* larvae were collected and divided into 6 groups of 10 individual insects; each insect being placed in its own plastic container as described previously (see Chapter 2). The 10 larvae within each group were then treated individually with 5 μl of an ethanolic solution containing either 91 μg , 60 μg , 40 μg , 20 μg or 10 μg of methoprene (experimentals), or an equivalent volume of pure ethanol (controls). The appropriate 5 μl aliquot of ethanol or ethanolic methoprene was topically applied to the dorsal surface of each larval abdomen and thorax. The larvae were then observed daily and their body weight, any colour change and the occurrence of further moults recorded. Wet weight, dry weight and body water content were measured as described in Chapter 2. In studies on the effects of methoprene on Malpighian tubule fine structure, only larvae treated with 91 μg of methoprene and ethanolic controls were used.

Malpighian tubule fluid secretion rates were determined as described in Chapter 2. Initially, the Malpighian tubules were bathed in 'normal' Ringer solution and the rate 1 secretion value determined. The normal Ringer solution was then replaced with normal Ringer containing 5 μg of methoprene per 10 ml (experimentals) or 5 μl of absolute ethanol per 10 ml (controls) and the rate 2 secretion value was measured after an equilibration period of 25 min.

Results

Effect of methoprene on the body weight and the development of the last larval instar

Treatment of newly moulted sixth instar larvae with the different concentrations of methoprene affected normal growth and development compared with the ethanol-treated controls. Thus, topical application of methoprene resulted in an additional larval moult and this was observed at all concentrations of methoprene used. In addition, methoprene-treated larvae continued to grow following the supernumerary moult as indicated by a marked increase in body weight. The results obtained with the different experimental treatments are shown in Figs. 4.1 A-E. It can be seen that in controls, the body weight increased over the first two days of the stadium. Thereafter, it decreased on the third day and remained fairly constant throughout the prepupal and pupal periods with a further small decrease being observed in early adult life. In contrast, methoprene appeared to prevent the marked decrease in weight that preceded formation of the prepupa in controls and the experimental insects moulted to a seventh instar on or near day seven. This ecdysis was accompanied by a small, but not always significant, decrease in body weight (see arrows above Figs.). Thereafter, the experimental larvae showed a dramatic increase in weight (see Fig. 4.1) reaching maximum mean values of 2340, 2559, 2647, 2167 and 1437 mg following treatment with 91, 60, 40, 20 and 10 μg methoprene per insect, respectively. The greatest mean weight was seen in larvae which had been treated with 60 μg methoprene where an increase of about 2.5 times was seen when compared to the control maximum of 1050 mg and the lowest increase (approx. 1.4 times) was seen in larvae treated with 10 μg methoprene. The maximum body weight achieved was maintained for several days before decreasing slowly. Surviving larvae gave rise to non-feeding prepupae at all concentrations of methoprene used. However, these failed to complete their development to pupae and subsequently died. Thus the larval/prepupal stages of the life cycle were considerably extended following treatment with methoprene.

Fig. (4.1 A-E)

Effect of methoprene on body weight in sixth larvae of *Spodoptera littoralis*.

A, B, C and D indicate how body weight varied with age of methoprene-treated larvae given different concentrations (91, 60, 40, 20 and 10 $\mu\text{g}/5\mu\text{l}$ per larva) of methoprene respectively. Control larvae were treated with 5 μl ethanol per larva. Note the presence of an extra moult in all treated larvae where indicated.

Number of experiments for each point = 10.

Error bars = S.E. of mean

Ordinate: Mean body weight (mg)

Abscissa: Days after treatment.

Fig. 4.1 A-C

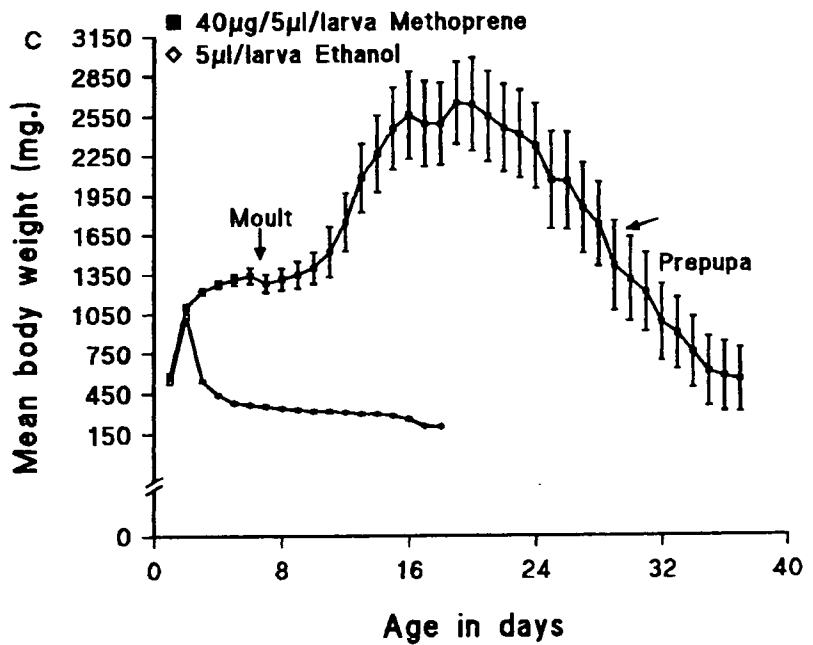
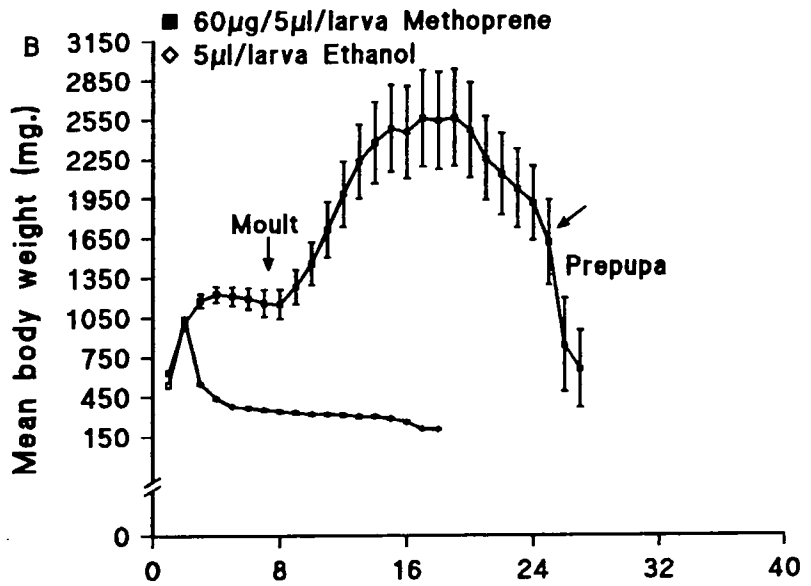
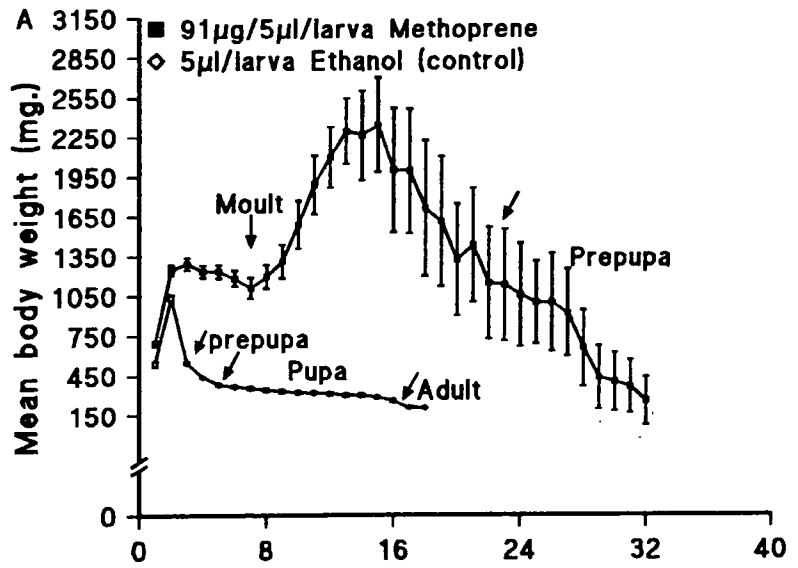
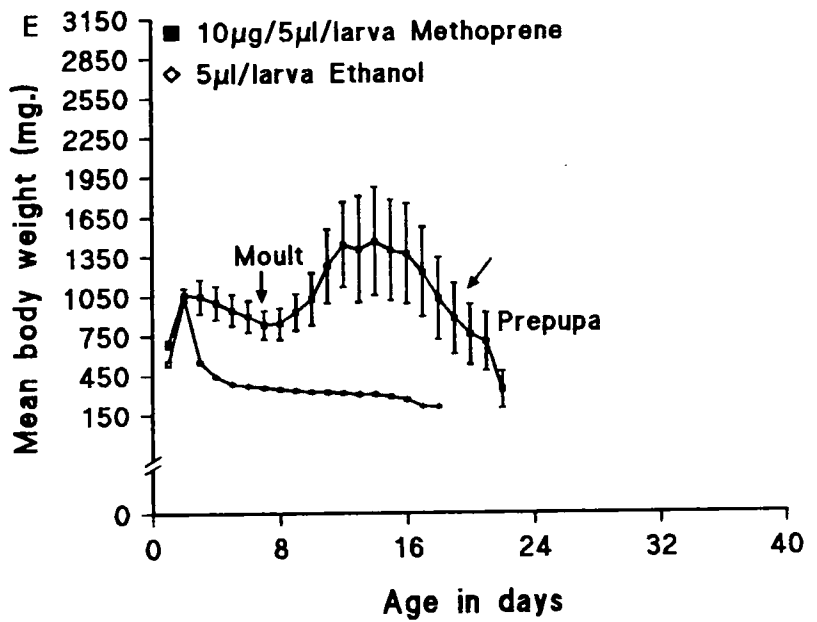
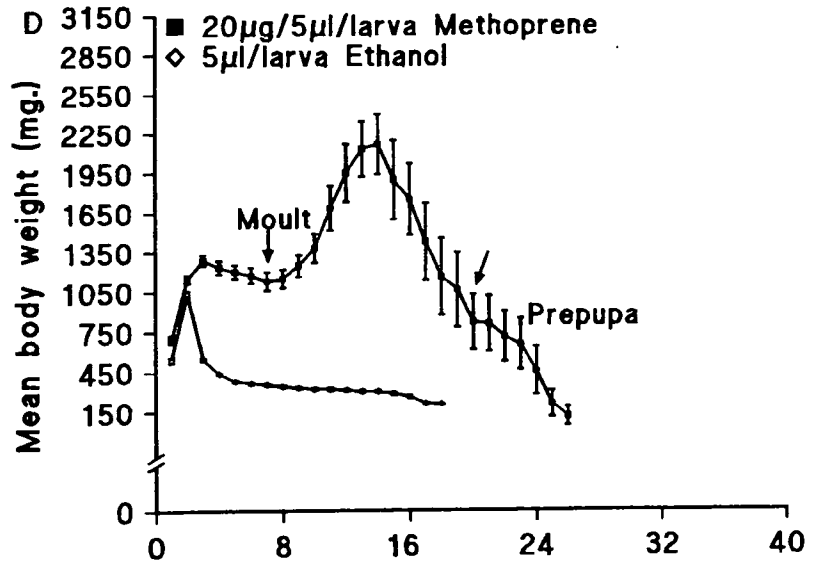

Fig. 4.1 D & E



All control insects completed their development to adults whereas there was a marked increase in mortality in the methoprene-treated insects. Figs. 4.2 (A-E) show the effect of 91 μg , 60 μg , 40 μg , 20 μg and 10 μg methoprene, respectively, on the percentage survival of treated insects. It can be seen that the four highest concentrations had relatively little effect on % survival over the first 15 days compared with insects treated with 10 μg methoprene; the latter showing approximately 30% mortality at this time. However, at all concentrations, apart from 40 μg per insect, the level of mortality was 80-90% or more by day 30. At a dose of 91 μg , the numbers surviving declined rapidly after 15 days with all insects dead by 40 days after treatment (Fig.4.2 A). Similarly, with doses of 40 or 60 μg the numbers surviving decreased slowly at first and then much more rapidly after 28 days from the treatment time so that no insects remained alive after 39 and 35 days, respectively. Death was most rapid at the lowest methoprene concentrations (10 μg and 20 μg per insect) although further studies are necessary to determine whether this observation is statistically significant.

During this study, the supernumerary larvae resulting from methoprene treatment showed a marked colour change compared with controls; the methoprene-treated larvae were yellowish immediately after the extra moult becoming light to dark brown with time. This was in contrast to the near-black colour of the last instar control larvae (Fig. 4.3A-F).

Effect of methoprene on the wet and dry weight and water content

Newly moulted 6th instar larvae were treated with 91 μg methoprene in 5 μl ethanol (experimentals) or 5 μl ethanol alone (controls), as described previously. Thereafter, insects were killed at known times and their wet weights, dry weights and water contents determined as described in Chapter 2. Fig.4.4 A and C show how these parameters varied with age throughout the 6th stadium in control and experimental insects. In controls, the larval wet weight and dry weight increased over the first 2.5 days of the stadium to 1298 ± 30 mg and 187 ± 6 mg, respectively, before falling

Fig. (4.2 A-E)

Effect of methoprene on survival of sixth instar larvae.

A, B, C, D and E show survival data for larvae treated with 91, 60, 40, 20 and 10 $\mu\text{g}/5\mu\text{l}$ per larva methoprene respectively. All controls survived throughout the period studied (i.e. Control survival was 100%).

Ordinate: % Survival.

Abscissa: Days after treatment.

Fig. 4.2 A-C

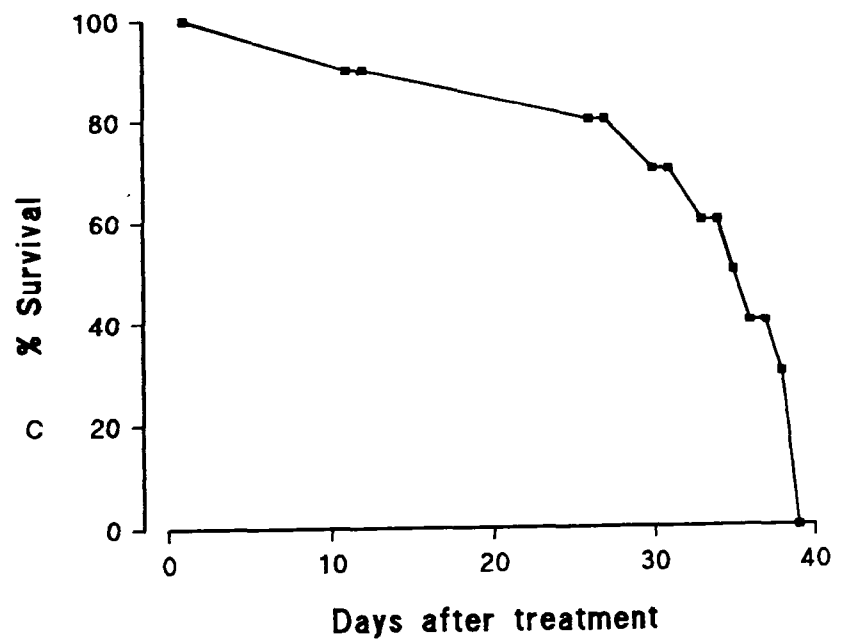
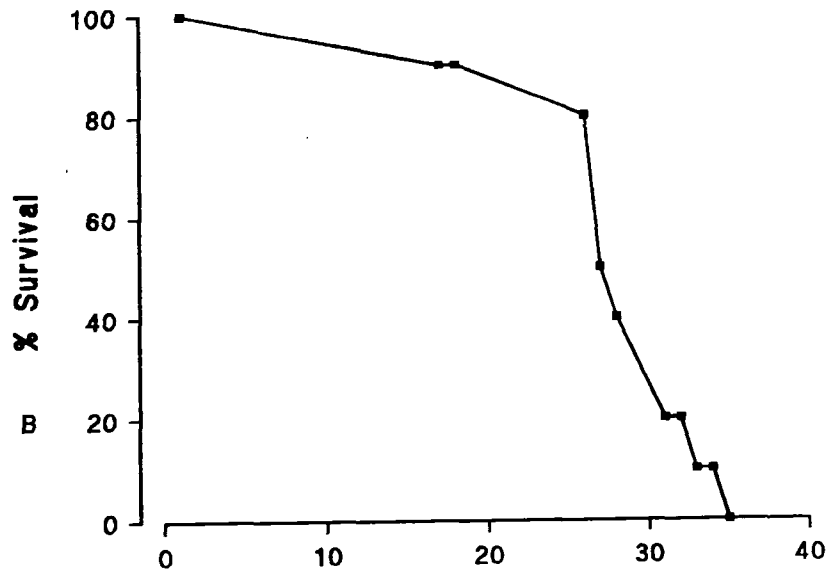
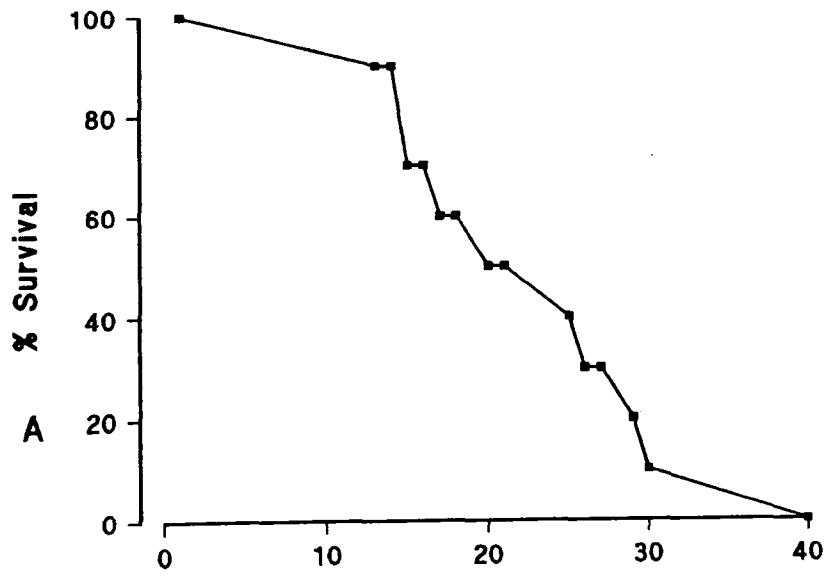

Fig. 4.2 D & E

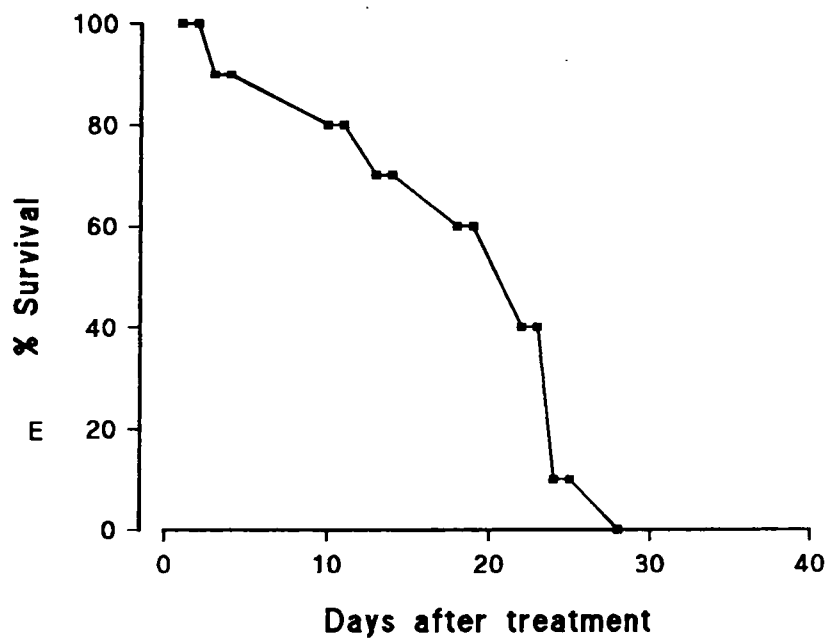
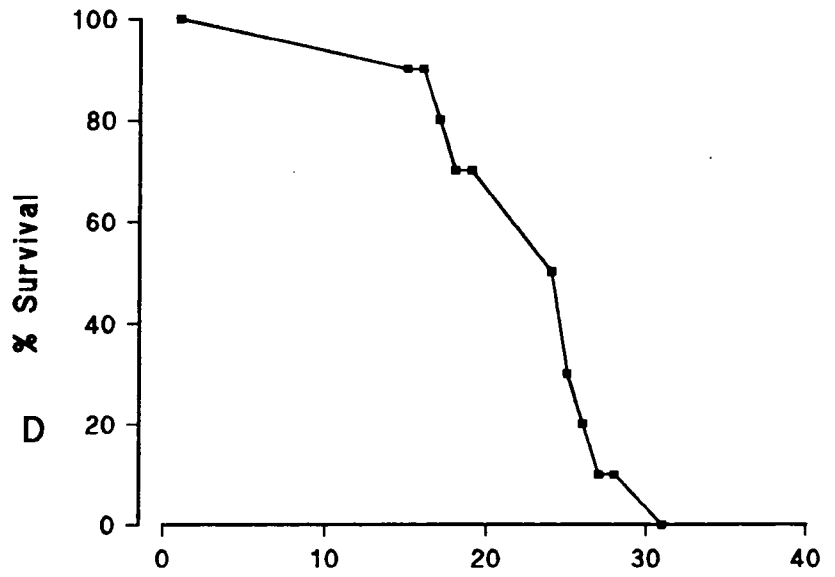

Fig. (4.3 A-F)

Photographs of the last larval instar (sixth) control + methoprene treated larvae.

A: ethanol control sixth instar larvae.

B, C, D, E and F: Supernamary (7th instar) larvae resulting from treated with 91, 60, 40, 20, and 10 μ m of methoprene respectively. Note the different colour and body size of methoprene-treated larvae from the control larvae.

Both the control and experimental larvae are shown at 2 \times life-size.

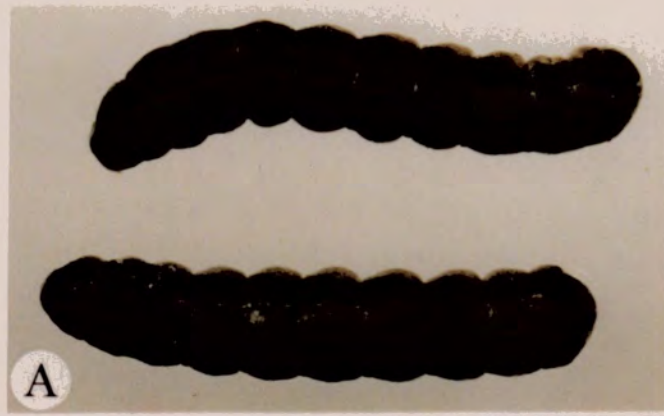

sharply to a wet weight of 571 ± 51 mg and a dry weight of 175 ± 9 mg in the early prepupal stage at about 3.4 days. In the treated larvae, as already mentioned above, the stadium was considerably extended. Data were collected only up to and including day 8 (i.e. approx. twice the length of the control stadium). In contrast to the controls, little increase in wet weight or dry weight was observed in methoprene-treated insects until about day 5 (Fig. 4.4). Thus the wet and dry weights of the experimental larvae remained lower than those of the controls until day 6 or 7. After the fifth day, both weights increased dramatically to give maximum wet and dry weights of 1412 ± 160 mg and 250 ± 20 mg in near 7 day-old larvae. There followed a small decrease in both weights prior to the supernumerary moult. The wet weight maximum for treated larvae was not significantly different from that observed for controls. In contrast, the maximum dry weight recorded for experimentals was 133.7% ($P < 0.05$) of that recorded for controls indicating that the water content of experimentals was lower than that of controls at these different times.

The water content of newly moulted sixth instar larvae was approximately 82% of body weight. This changed little in ethanol-treated controls up to near day 2. Thereafter, it increased to $84.9 \pm 0.3\%$ in 1.7 day-old larvae and to $85.5 \pm 0.34\%$ by day 2.5. The relative water content of the control insects then dropped rapidly to 68.13 ± 1.7 % in early prepupae at 3.4 days. In contrast, the water content of the methoprene-treated larvae remained more-or-less constant over the 8-day period of the study at approx. 82 % apart from a small but non-significant rise to $85.82 \pm 1.11\%$ around day 3.

Fig. (4.4 A-C)

The effect of methoprene on the wet and dry weight and the % of water content of the last larval methoprene-treated insect

A: The wet weight of control and experimental, larvae after treatment. Note the control larvae change to prepupa earlier than the experimentals, whereas the treated larvae show a supernumary moult (see arrow).

Ordinate: Mean wet weight (mg).

Abscissa: Age in days

B: This figure illustrates the dry weight of the control and experiment larvae. Note that the treated larvae have a higher peak in their dry weight than seen in the control. just before the supernumary moult.

Ordinate: Mean dry weight (mg).

Abscissa: Age in days

C: This figure shows how the % body water content, in the control larvae declined sharply. Whereas no significant change was noted in experiments.

Ordinate: Mean % water content

Abscissa: Age in days

Fig. 4.4

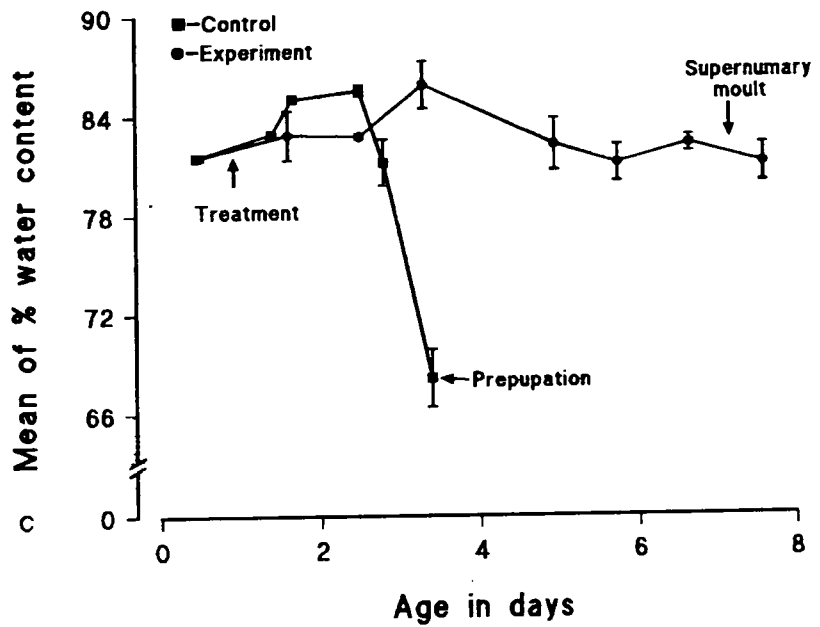
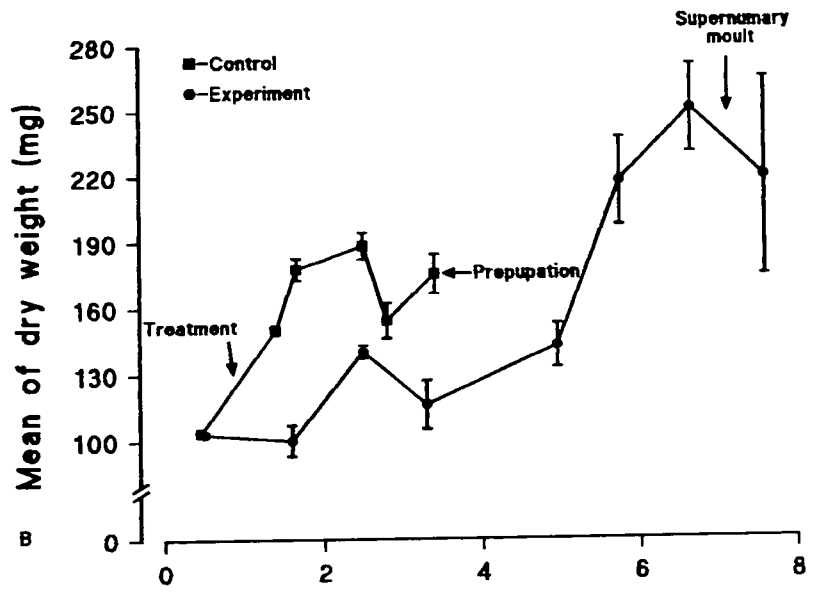
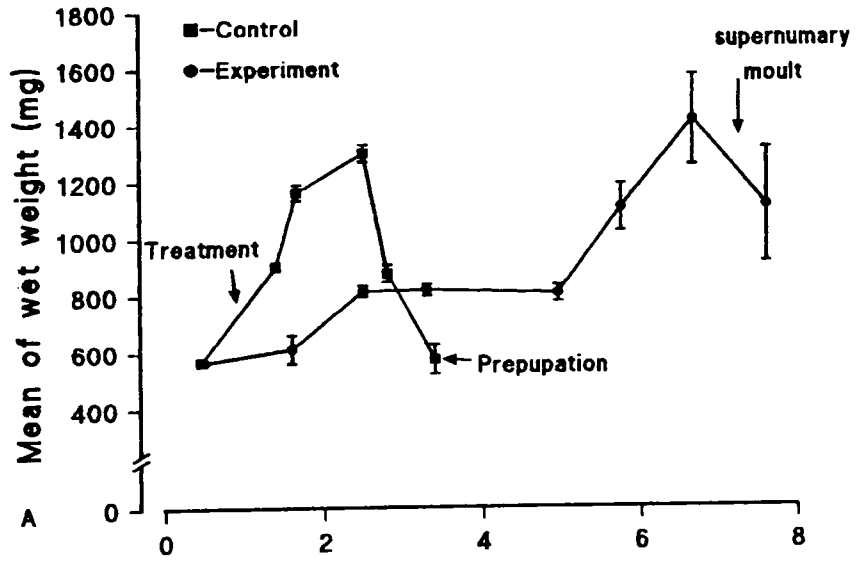

Effect of 91µg methoprene on the rate of fluid secretion *in vitro*

Table 4.1 shows the effects of methoprene on Malpighian tubule fluid secretion *in vitro*. It can be seen that the rate 1 values obtained with control and experimental insects were not significantly different from one another and that whilst the rate 2 values were relatively lower in methoprene-treated insects, the experimental and control data were not significantly different from one another.

Table 5.1 The effect of methoprene on the rate of fluid secretion by Malpighian tubules.

Treatment	n	Mean Rate 1 ± S.E.M. (nl/min ⁻¹)	P	Mean Rate 2 ± S.E.M. (nl/min ⁻¹)	P	Mean Rate 2 as % of Rate 1
Control	10	19.3 ± 2.6	n.s	12.9 ± 1.9	n.s	67.3 ± 4.5
Experimental	10	*12.8 ± 2.9		8.1 ± 2.5		49.7 ± 7.2

* indicates rate 1 measured in the presence of normal Ringer solution.

P values were obtained by comparing respective rate 1 and rate 2 values for control and treated tubules by student 't' test.

Effect of methoprene on the fine structure of Malpighian tubules of 6th instar larvae

The fine structure of Malpighian tubules of 6th stadium larvae of *Spodoptera littoralis* was fully described in Chapter 3. In this study, newly moulted larvae were treated with 91 µg methoprene or ethanol (5 µl/larva) as described previously and subsequently insects were killed at different ages (controls: 2.5 days; experimentals: 7, 8 and 9 days) and their Malpighian tubules dissected out and prepared for electron microscopy, as described in Chapter 2. This study was confined to the proximal and medial regions of the Malpighian tubules.

The fine structure of the cells of the proximal region of larvae at 7 days post-treatment with methoprene (Fig. 4.6 A) was similar to that of the controls aged 2.5 days post-treatment. Indeed, relatively few fine structural differences were noted over the period of this study. The main changes were as follows. By the eighth day after treatment with methoprene, large vacuoles were observed in the cytoplasm (Fig. 4.7 A) that had not been seen in controls (Fig. 4.5 A) or in normal 6th instar larvae (see Chapter 3). In addition, substantial glycogen deposits were observed in the cytoplasm between the basal membrane foldings 9-days post-treatment with methoprene (Fig. 4.8 A). Such deposits were not seen in controls or in normal insects (Chapter 3) although glycogen was observed elsewhere in the cytoplasm in non-methoprene treated insects (Fig. 4.5 A). These increased reserves of glycogen may reflect the fact that the feeding stage has been extended by methoprene with the result that larger stores of this carbohydrate have been accumulated.

In the medial region of the Malpighian tubules, a main feature observed in the cells of the treated larvae was the presence of large cytoplasmic projections extending into the lumen of the tubule (Figs. 4.6 D & 4.7 D). These were seen in methoprene treated insects at all the above treatment ages. No such structures were seen in controls or in normal larvae (see Chapter 3). Indeed, structures of this type were only seen in the medial region of adult Malpighian tubules (see Chapter 3). Numerous small vacuoles, many containing electron dense materials, were also found in the cytoplasm. These were much more common in methoprene-treated insects than in controls and were particularly noticeable in the cytoplasm between the basal infoldings. Once again, this feature was reminiscent of the picture seen with adult tubule cells.

Fig. (4.5 A & B)

Electronmicrographs of control Malpighian tubules from larvae which were treated with ethanol, at day 2.5 of last larval instar.

A: Proximal region showing the basement membrane (BM), extracellular spaces, the labyrinth (La) which has started to become vacuolated because the larvae are about 3/4 of the way through their normal life cycle. The cytoplasm contains glycogen (Gl) and some lipid droplets (Li). The apical region contains microvilli packed with mitochondria which extend into the lumen (L)

Scale = 3 μ m

B: Medial region, note that the extracellular channels (EC) extend deeply into the cell cytoplasm. A nucleus (N) is present in the cytoplasm, which shows a well-developed rough endoplasmic reticulum (RER). Mitochondria (M). The apical zone contains microvilli (Mv) with mitochondria.

Scale = 5 μ m

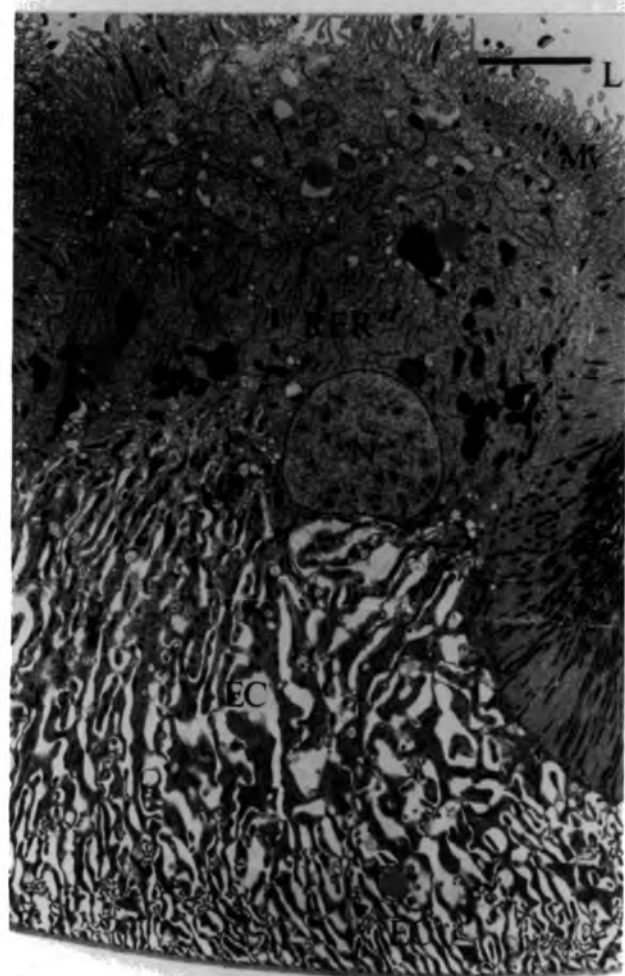
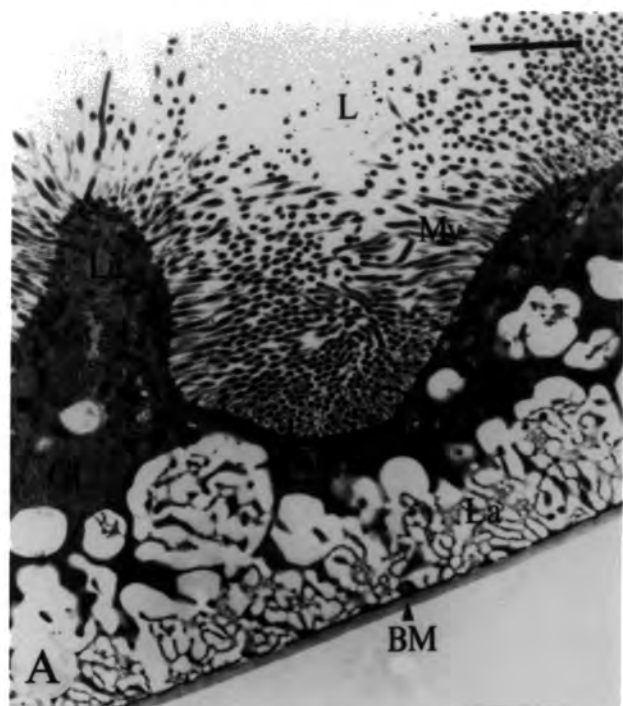

B

Fig. (4.6 A-D)

Electronmicrograph of Malpighian tubules from methoprene-treated larvae on day 7 of the sixth instar.

A: Proximal region showing the extracellular spaces labyrinth (La). Note that the cytoplasm contains rough endoplasmic reticulum (RER), mitochondria (M), Golgi bodies (G) and glycogen (Gl). The apical zone contains microvilli (Mv) with mitochondria. Basement membrane (BM).

Scale = 1 μ m

B: Medial region. Note the extracellular channel spaces (EC). The cytoplasm contains a nucleus (N) and mitochondria. The apical zone contains numerous closely packed microvilli (Mv) (compare with A above).

Scale = 5 μ m

C: High power magnification of the basal zone of the medial region showing the basement membrane, extracellular channels (EC) and the presence of rough endoplasmic reticulum (RER) and a nucleus (N).

Scale = 4 μ m

D: High power magnification of the apical zone of the medial region shows stalk-like projections (St) between the microvilli (Mv).

Scale = 4 μ m

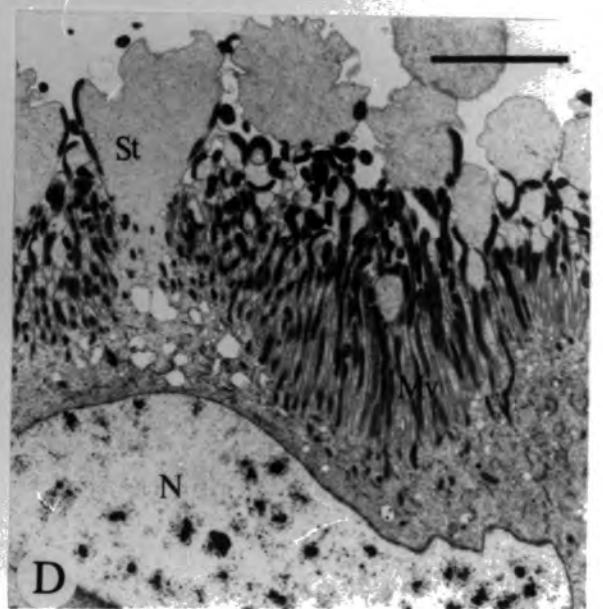
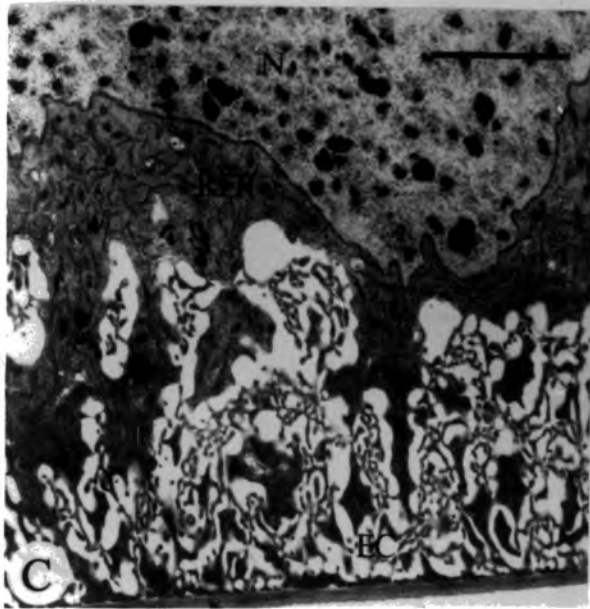
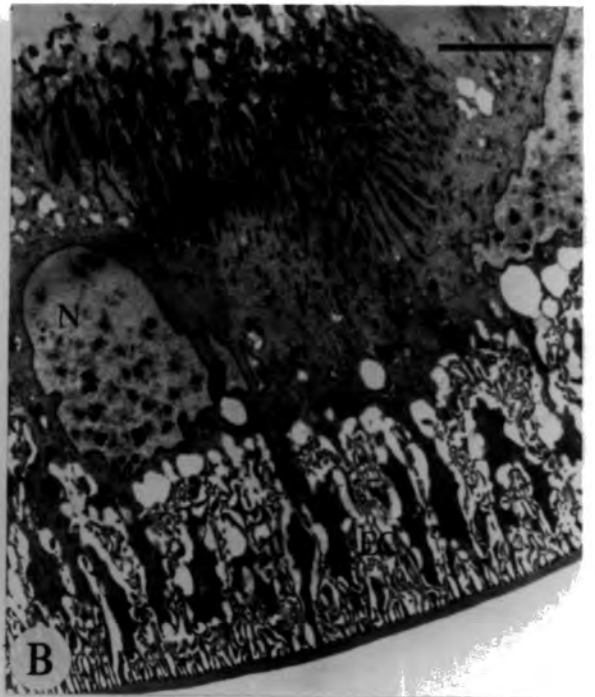
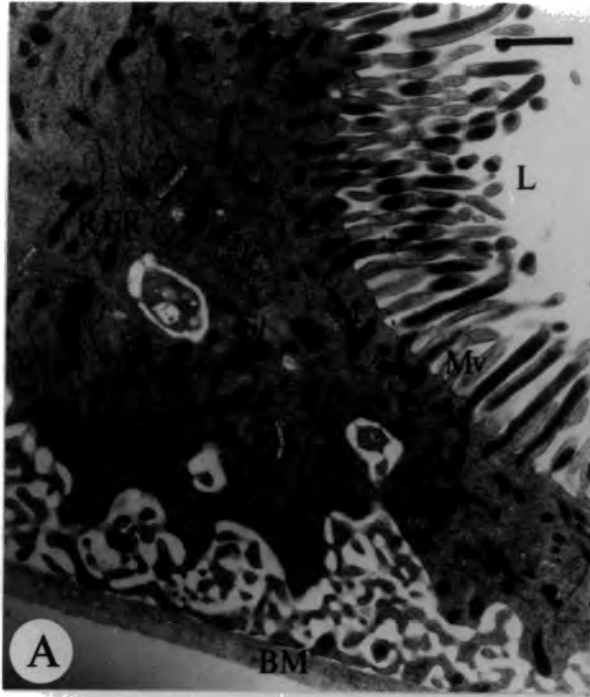

Fig. (4.7 A-E)

Electronmicrograph of Malpighian tubules from methoprene-treated larvae on day 8 of the sixth instar.

A: Low power micrograph through the proximal region showing the basement membrane (BM), basal labyrinth (La), Glycogen (G) in the cytoplasm and the presence of apical microvilli (Mv) extending into the lumen (L).

Scale = 2 μ m

B: Oblique section through the medial region. Note the extracellular channels (EC) and mitochondria in the cytoplasm between them. A number of large vacuoles (Va) appear in the cytoplasm. Observe the presence of numerous mitochondria in the cytoplasm as well as in the microvilli.

Scale = 5 μ m

C: Micrograph of the apical zone of the medial region showing the densely packed microvilli (Mv) containing mitochondria.

Scale = 2 μ m

D: Micrograph of the apical zone of the medial region showing stalk-like projections (St) between the microvilli (Mv). Note also that the mitochondria extend from sub-microvillar cytoplasm into the microvilli. Rough endoplasmic reticulum (RER).

Scale = 4 μ m.

E: Micrograph of the basal zone of the medial region showing the tracheoles (Tr) associated with the basal cell surface. Note the extracellular channels (EC) and the cytoplasm between them containing mitochondria.

Scale = 2 μ m

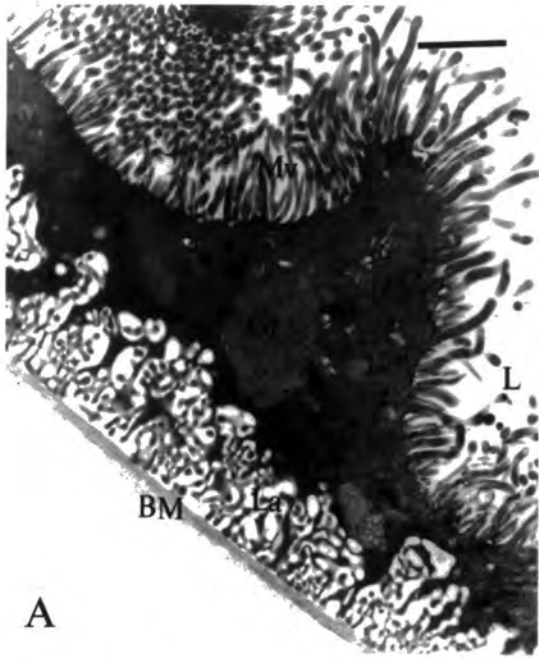

A

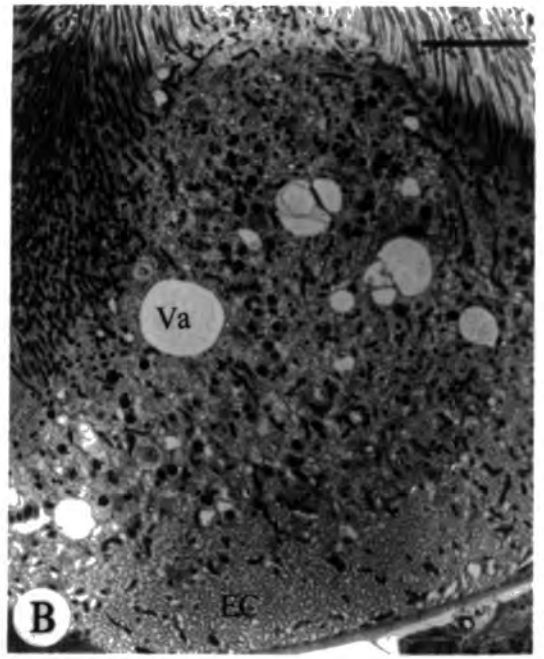

B

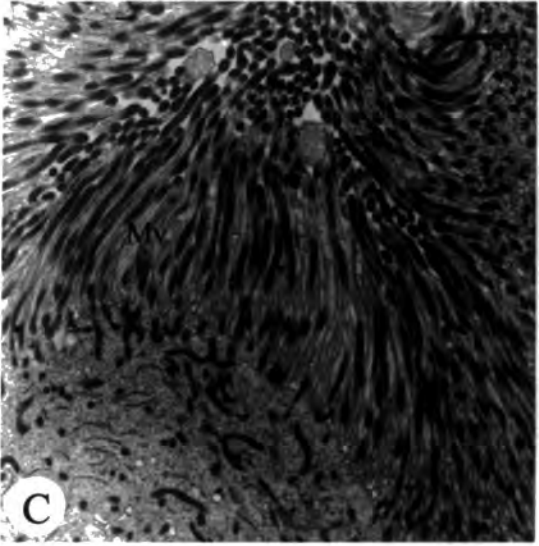

C

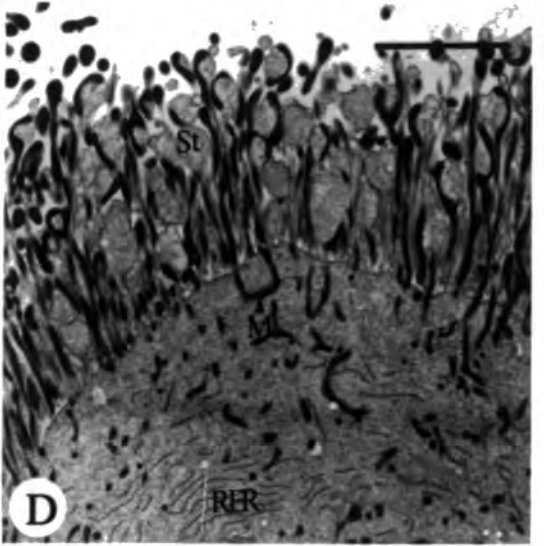

D

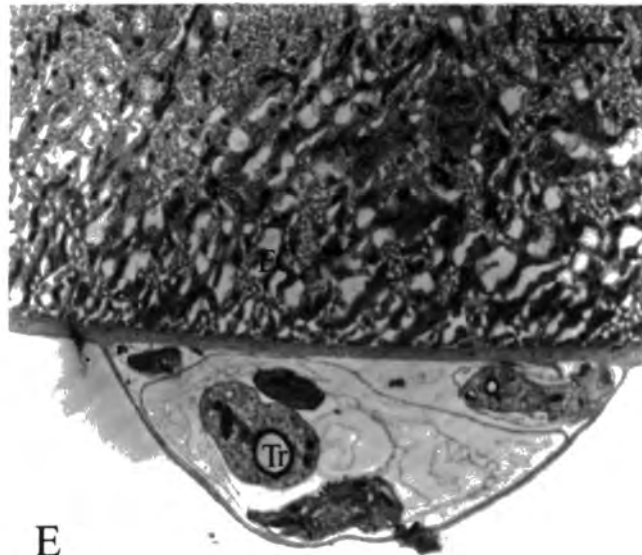

E

Fig. (4.8 A-C)

Electronmicrograph of Malpighian tubules from methoprene-treated larvae on day 9 of the sixth instar.

A: Section through the proximal region. Note that the cytoplasm adjacent to the extracellular spaces (labyrinth) contains a lot of glycogen (G). The basement membrane (BM)

Scale = 5 μ m

B: Micrograph of medial region showing the extensive extracellular channels (EC). Note the presence of mineral concretions (C) in the lumen. The basement membrane (BM)

Scale = 5 μ m

C: High magnification of the basal cellular zone shown in B above. (EC) extracellular channels; (BM) basement membrane.

Scale = 5 μ m

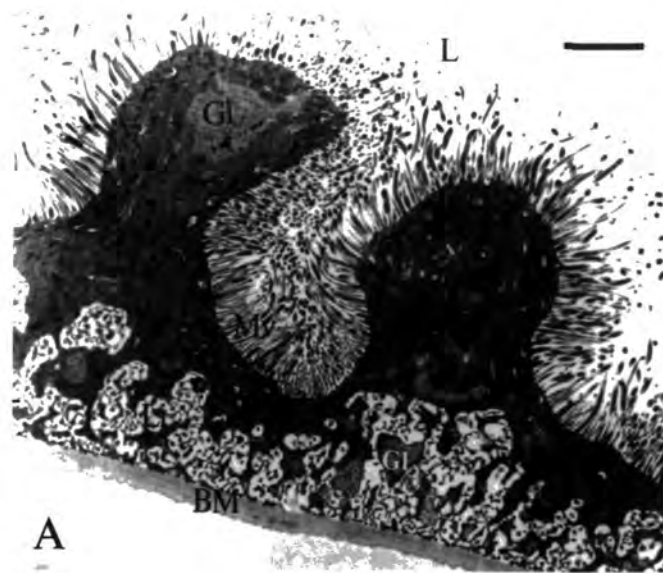

A



B

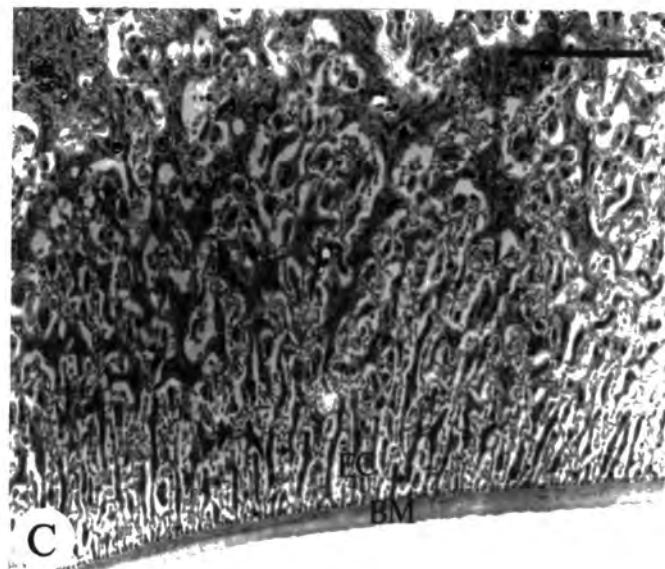

C

Discussion

The general effect of methoprene observed was apparent as a distinct change of colour in treated larvae of *Spodoptera littoralis* following a supernumary moult. Similar effects have been reported elsewhere in various species of lepidoptera e.g. *Autographa gamma*, *Scotia ipsilon*, *Mamestra brassicae* and *Spodoptera littoralis* (Sehnal *et al.*, 1976). In locusts, distinct colourations are reported between two different phases, *viz.* *phase gregaria* and *phase solitaria*. The phase type is influenced by the population density and is hormonally controlled with juvenile hormone playing an important role (Staal, 1961; Girardie and Joly, 1967). In addition to colour differences, there are morphological, developmental and behavioural differences. Cotton and Anstee (1990) reported that methoprene treatment effected a colour change in larval *Locusta* similar to that observed in the change from the gregarious to solitary phase. However, morphometric analysis indicated in other respects there was no phase transformation. Distinct phases have also been reported in some lepidopteran species including members of the genus *Spodoptera*. For example, Foure (1943a, b) noted that under crowded conditions larvae of the armyworm, *Spodoptera exigua*, *Spodoptera exempta* and *Spodoptera abyssinia*, develop a dark colouration whereas under conditions of low population density the larval colour is much paler (see also review by Iwao, 1968). It would appear, therefore, that methoprene is effecting colour changes not dissimilar to those which accompany phase changes in *Spodoptera*, although, as in the case of *Locusta*, this may not reflect a complete phase change.

Perhaps the most dramatic change effected by methoprene treatment was the extension of the larval period of development with an extra larval moult. Thus the larval period was about four times longer than that seen in controls. Associated with this extension of the feeding period of the life-cycle, body weight was considerably increased compared to the controls. These observations are similar to those observed in other species of lepidoptera: *Bombyx mori* (Akai and Kobayashi, 1971), *Hyalophora*

cecropia, (Riddiford, 1972) *Cydia pomonella* (Gelbic and Sehnal, 1973), *Galleria mellonella* (Sehnal and Granger, 1975), *Calpodex ethlius*, (Ryerse, 1980) and *Ephesstia cautella* (Shaaya, 1993). As in the current study, these insects remained in the larval state for a prolonged period and died without reaching the pupal stage. Metamorphosis in holometabolous insects is controlled by ecdysteroid and juvenile hormone titres changing in the last larval stage and the pupa. In the presence of JH, ecdysone stimulates a larval ecdysis. When JH is relatively low, prepupation and pupal moult is initiated and in the absence of JH in the pupa, the adult is developed (see Nijhout and Williams, 1974; Fain and Riddiford, 1975; Schooley et al., 1976; Riddiford, 1980 and Bollenbacher *et al.*, 1981).

In this study, methoprene treatment has clearly acted like natural juvenile hormone in determining that the post-treatment moult (the supernumerary moult) is of a larval type. Sehnal *et al.*, (1976) reported that the role of juvenile hormone in lepidopteran larvae may postpone pupation until the insect reaches a suitable body size or meets favourable environmental conditions. Recently, Jones *et al.*, (1993) reported that in *Trichoplusia ni* a high juvenile hormone titre extended the feeding stage of the final stadium. This is consistent with the findings in the current investigation where very high increments in the body weight of superlarvae were related to a prolonged period of feeding. In the present study the treated larvae underwent an extra moult at all concentrations used and at the end of the prepupal instar all the treated insects failed to change into pupa or reach the adult stage. Similarly, Retnakaran, (1973) found that 1µg/larva of ZR-515 (JHA) applied to the dorsal abdominal area of last larval instar (sixth) *Choristoneura fumiferana* caused moulting into a seventh instar for about 65% of the total treated number and 10% of these went on to moult into eighth instar larvae. All the treated larvae failed to develop into adults. It seems possible, that these and the current observations are explained by JHA preventing those processes which differentiate the structure of the prepupa (Retnakaran, 1973; Shaaya, 1993). Sundaramurthy *et al.*, (1978) reported that the haemolymph of the untreated larval

Spodoptera litura contained fewer protein fractions than that of methoprene-treated insects. These authors related the occurrence of supernumerary moulting to the protein fraction which was missing in the untreated-larvae. They suggested that this protein was present in treated animals only because in controls, it was being used in the pupal transformation process.

In vivo treatment with 91 µg methoprene had little effect on the ultrastructure of cells of the Malpighian tubules of *Spodoptera littoralis*, although, in some profiles, increased accumulations of glycogen were observed (Fig. 4.8A). A number of researchers have reported that methoprene stimulated both food consumption and midgut amylase activity in the larval lepidopteran, *Hyblaea puera* (Muraleedharan and Prabhu, 1981). It is possible, therefore, that the increased glycogen observed in cells of treated *Spodoptera littoralis* may be due to a stimulation of food intake and its digestion, resulting in increased storage. However, Gordon and Burford (1984) reported a substantial decrease in glycogen levels in larvae of *Aedes aegypti* after the application of methoprene. It was noticeable in the current study that numerous vacuoles were present in the tubule cells of treated insects and that many of these contained glycogen granules. Similar vacuoles have been reported in the fat body cells of *Calpodes ethius* where it is suggested that they arise due to the conversion of stored glycogen to soluble sugars during carbohydrate mobilisation (Locke, 1985). The extent to which this is true in Malpighian tubule cells of *Spodoptera* requires further investigation.

Little change in relative water content was observed in methoprene-treated larvae, whereas controls showed a substantial decrease in water content at the onset of prepupa formation. It is likely that these differences relate to the cessation of food and fluid intake by prepupae in the controls, whereas, as already mentioned, feeding is maintained and possibly increased following methoprene application. At the time that the relative water content falls prior to pupation, Malpighian tubule secretion declined and eventually ceased altogether (see Chapter 4). This switching-off of fluid secretion,

together with the cellular remodelling at pupation, is thought to be controlled by 20-hydroxyecdysone which also triggers the development of the adult Malpighian tubules (Ryerse, 1980), at low juvenile hormone levels. Thus methoprene-treatment, by artificially maintaining relatively high 'juvenile hormone' levels, might be expected to maintain the larval state and tubule function. This is consistent with the observation that *in vitro* treatment with methoprene did not significantly affect tubule function compared with controls and that no major fine structural differences were apparent in the electron microscopical study on tubule cells. In contrast, Donkin (1980) reported the juvenile hormone effected significant inhibition of Malpighian tubule fluid secretion in *Locusta*.

CHAPTER 5

CHARACTERISATION OF FLUID AND ION SECRETION BY MALPIGHIAN TUBULES OF *SPODOPTERA LITTORALIS*

Section (1): Studies on Malpighian tubule secretion by fifth instar larvae

The materials and methods applicable to this chapter are described in Chapter 2.

Relationship between the cation composition of bathing medium and that of the secreted 'urine'

Table 5.1 shows the relationship between the concentration of various cations in the secreted 'urine' and that of the bathing medium surrounding Malpighian tubules dissected from 5th instar larvae. It can be seen that the percentage 'Urine'/Blood' ratio is substantially greater than 100 for Na^+ and Ca^{2+} indicating that these cations are being secreted from the bathing medium to the lumen against their concentration gradients. In contrast, the low ratio for Mg^{2+} suggests that this cation is selectively retained. The distribution of K^+ was similar on both sides of the tubule wall. No statistically significant difference in osmolarity was observed between the secreted 'urine' and the bathing medium.

Table 5.1 Comparison of cation concentration of bathing media and fluid secreted by *in vitro* larval tubules of 5th instars *Spodoptera littoralis*.

Parameter	Concentration in "Urine":(mM)	Concentration. in Bathing Medium (mM)	U/B Ratio %	n.
[Na^+]	36.3 \pm 1.9	20	181.5	50
[K^+]	30.5 \pm 1.3	30	101.5	48
[Ca^{2+}]	3.5 \pm 0.8	2	175	14
[Mg^{2+}]	21.0 \pm 0.3	40	52.5	9
Osmolarity	331.7 \pm 16.7 (mosmol l ⁻¹)	346.6 \pm 15.2 (mosmol l ⁻¹)	95.7	6

Data are presented as Mean \pm S.E.M.

n. represents number of independent determinations.

Relationship between concentration of Na^+ and K^+ in the bathing medium and their composition in the secreted 'urine'

A study was carried out to determine the effects of varying Na^+ and K^+ concentrations in the bathing medium on the concentrations of these two cations in the secreted fluid. To this end, the relative Na^+ and K^+ concentrations of bathing media were varied whilst maintaining the total concentration of these two cations at 50mM. This was achieved by mixing Na^+ -free Ringer with K^+ -free Ringer in different proportions (see Materials and Methods Chapter 2). The results obtained are shown in Fig. 5.1 It can be seen that as the relative proportion of Na^+ in the bathing medium was increased so the concentration of Na^+ in the secreted 'urine' increased, until the bathing Na^+ concentration reached 35 mM. No further increase in 'urine' Na^+ concentration was observed when the bathing concentration of this cation was increased further; the 'urine' concentration of Na^+ being maintained at *ca.* 70mM. The maximum concentration of Na^+ in the secreted 'urine' (roughly 80mM) occurred when the bathing medium contained 15mM K^+ and 35mM Na^+ . The accompanying K^+ concentration secreted was only marginally above that of the bathing medium at approximately 18mM. Indeed, little increase in 'urine' K^+ concentration was observed when the K^+ concentration of the bathing medium was increased from 0 to 25 mM. At higher bathing concentrations of K^+ , and therefore lower concentrations of Na^+ , there was some evidence of K^+ secretion being increased. However, even with total replacement of Na^+ by K^+ in the bathing medium the 'urine' K^+ concentration never approached that of Na^+ under reciprocal conditions. In this experiment the total concentration of Na^+ plus K^+ in the secreted 'urine' increased with increasing Na^+ concentration in the bathing medium. It would seem, therefore, that Na^+ is preferentially secreted by Malpighian tubules of *Spodoptera littoralis* compared with K^+

Fig. 5.1

The relationship between the concentration of Na⁺ And K⁺ in the fluid produced by Malpighian tubules of *Spodoptera littoralis* as a function of their concentration in the bathing medium, the vertical lines represent the mean \pm S.E.M.

Ordinate: Concentration in the 'urine' (mM).

Abscissa: Concentration in the bathing medium (mM).

Fig. 5.1

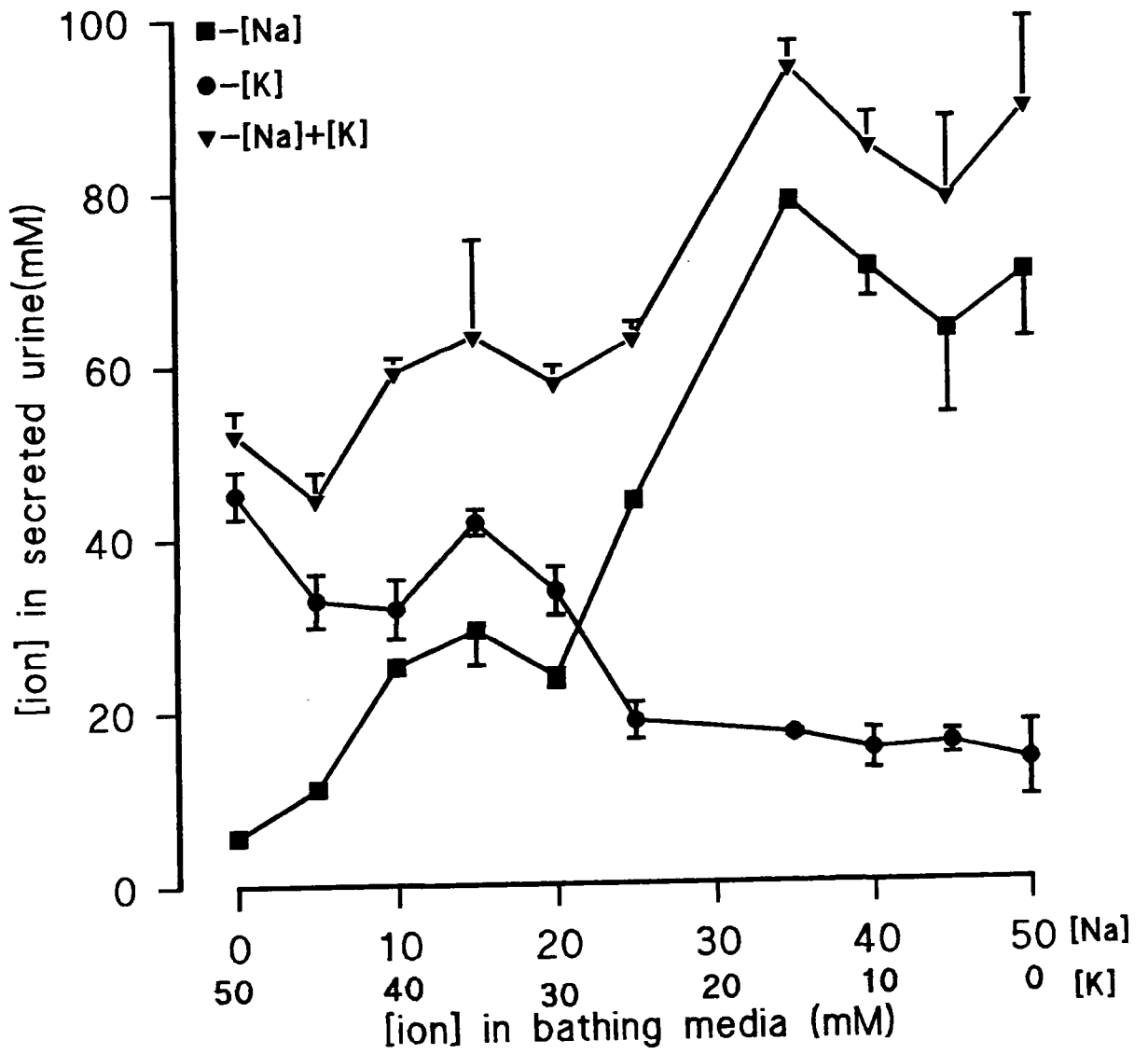

Effect of Na⁺, K⁺ and Cl⁻ concentration on the rate of fluid secretion by Malpighian tubules

The effect of varying the concentrations of Na⁺, K⁺ and Cl⁻ on the rate of fluid secretion was determined as described earlier.

Fig. 5.2 shows representative examples of results obtained with individual isolated Malpighian tubules over two 20 min periods (the first in normal and the second in the experimental bathing saline (Table 2.4). From these results and the data presented in Fig. 5.3 and Table 5.2 it can be seen that the highest normalised rate of fluid secretion was found in tubules bathed in Ringer containing high K⁺ and zero Na⁺; rate 2 being about 133% of rate 1. However, this stimulation of secretion ($P < 0.05$) must be viewed in the context of the controls in which rate 2 was only some 80% of the rate 1 value. Thus the actual level of stimulation is considerably greater than the 33% difference between rate 1 and rate 2; the difference between control and experimental rates being nearer 53%. Exclusion of Na⁺ and Cl⁻ from the high [K⁺] bathing medium resulted in a rate 2 secretion value significantly below that observed in the high [K⁺], Na⁺-free medium containing Cl⁻, although not significantly different from that of rate 2 for controls. However, fluid secretion was slightly, but significantly, lowered compared with controls, when K⁺, K⁺ and Cl⁻, or Cl⁻ (medium C; E and F respectively, (Table 2.4) were excluded from the bathing media. No significant differences in rate 2 secretion values were found between the latter three treatments.

Fig. 5.2 A-F

Typical examples of the effect of various Ringers on fluid secretion by individual Malpighian tubules.

- A. Both rates with 'normal' Ringer (control).
- B. Rate 2 with high $[K^+]$, zero $[Na^+]$.
- C. Rate 2 with high $[K^+]$, zero $[Na^+]$ & Cl^- .
- D. Rate 2 with high $[Na^+]$, zero $[K^+]$.
- E. Rate 2 with high $[Na^+]$, zero $[K^+]$ & Cl^- .
- F. Rate 2 with zero Cl^- .

Ordinate: Volume of fluid produced (nl)

Abscissa: Time in (mins)

Fig. 5.2 A-F

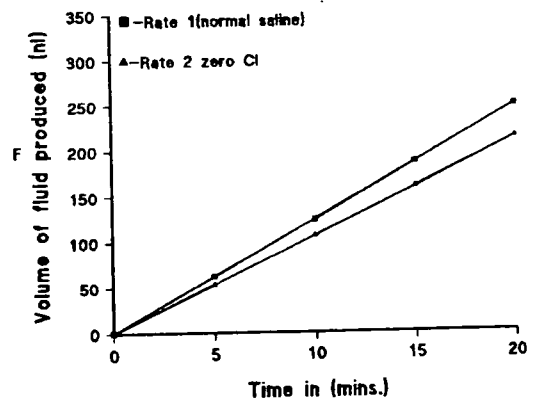
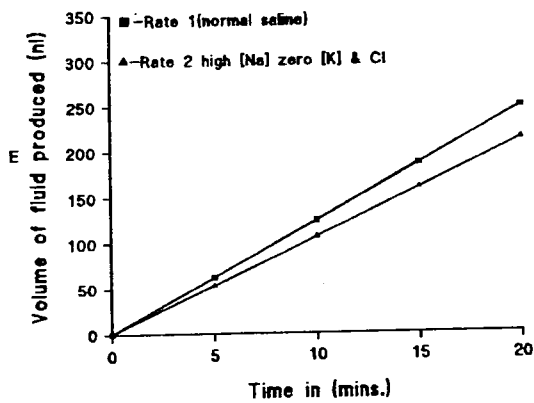
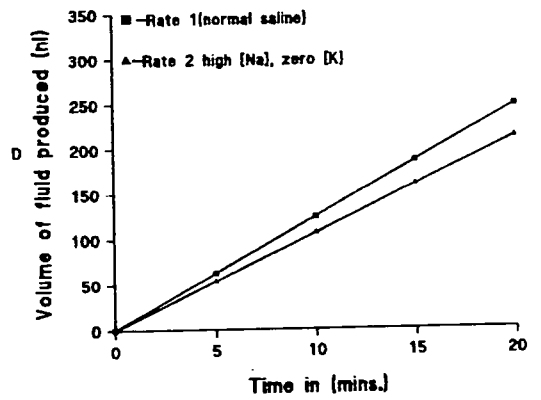
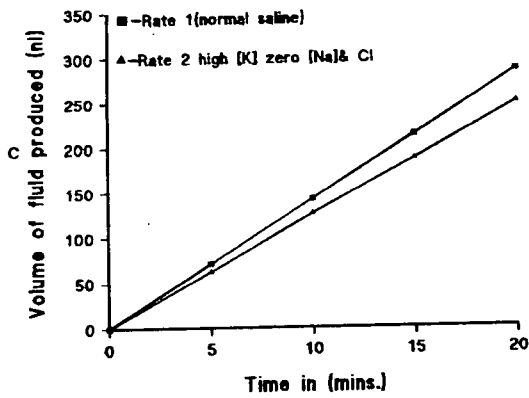
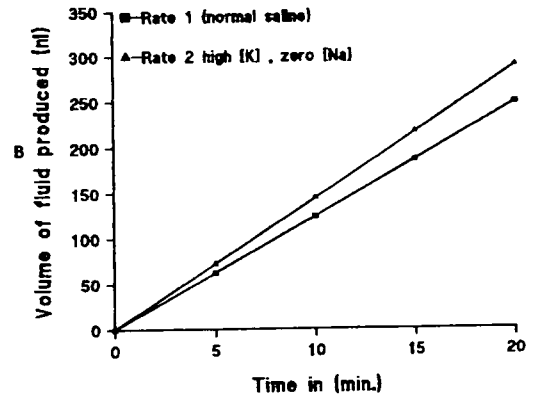
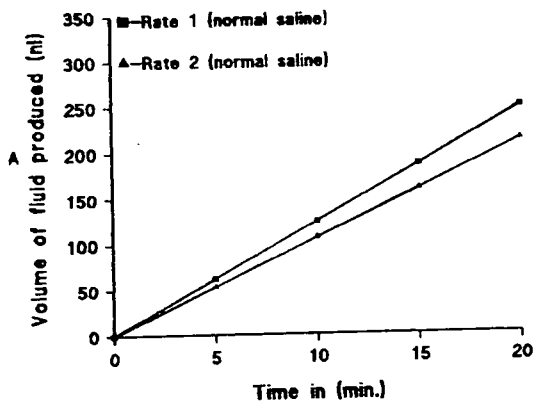

Fig. 5.3

The effect of various Ringers, (see the key) on the rate of fluid secretion.

Ordinate: Ordinate: Rate 2 as % of rate 1.

Fig. 5.3

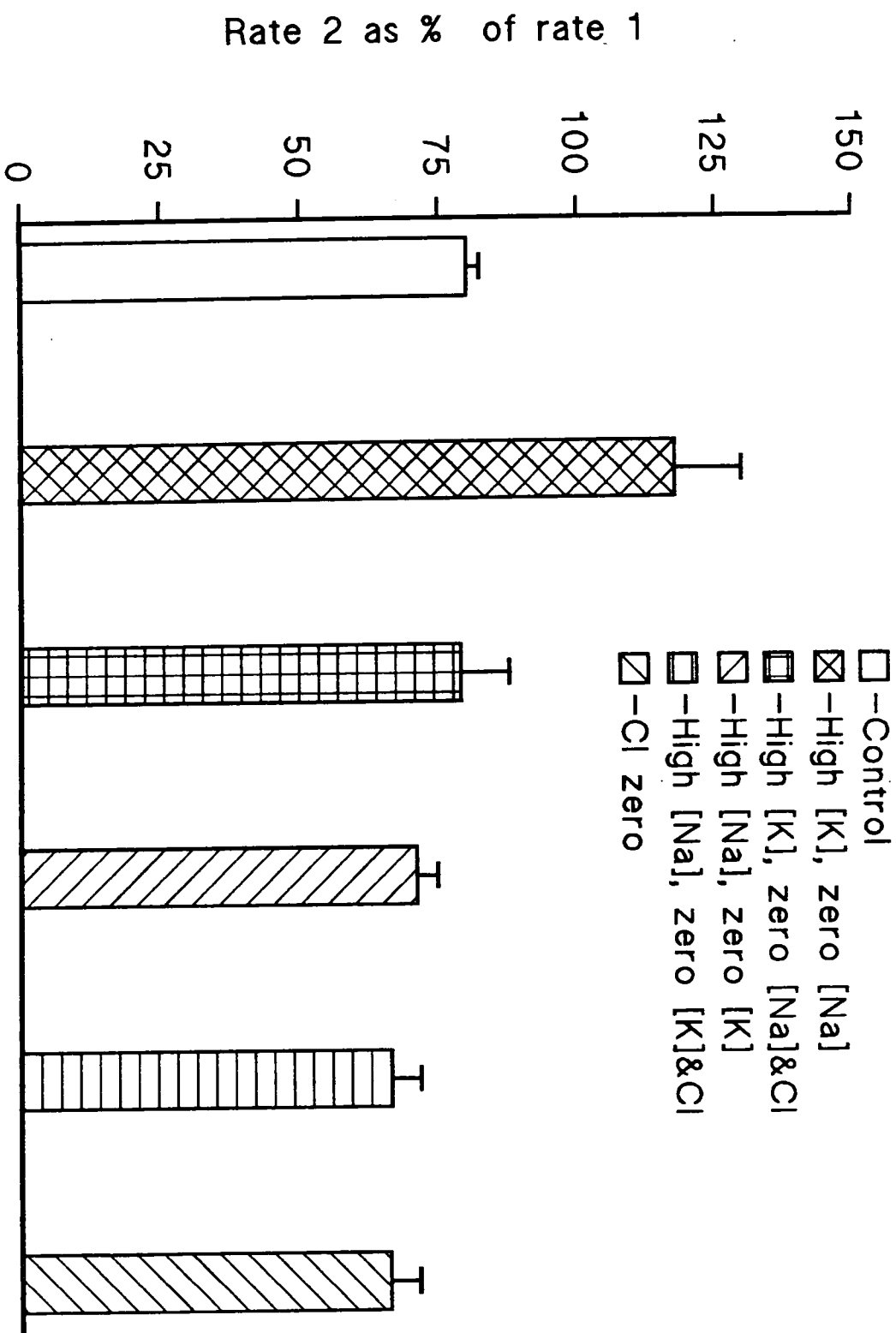

Table 5.2 Effect of various Ringer solutions on the rate of fluid secretion by the Malpighian tubules.

Treatment	n	Mean Rate1 ± S.E.M. (nl/min ⁻¹)	p	Mean Rate2 ± S.E.M. (nl/min ⁻¹)	p	Mean Rate2 as % of Rate1*	P	
Control	20	10.1 ± 1.5	n.s	7.5 ± 1.2	n.s	80.01 ± 2.3	ns	
High [K ⁺], zero [Na ⁺]	18	7.2 ± 1.2		8.4 ± 1.4		133.4 ± 10.4		
High [K ⁺], zero [Na ⁺] & Cl ⁻	19	11.4 ± 1.6		9.8 ± 1.7		77.4 ± 8.4		< 0.05
High [Na ⁺], zero [K ⁺]	20	9.7 ± 1.7		7.2 ± 1.5		70.8 ± 3.7		< 0.05
High [Na ⁺], zero [K ⁺] & Cl ⁻	20	11.3 ± 2.2		7.4 ± 1.4		66.1 ± 5.3		< 0.05
Cl- zero	20	9.5 ± 1.7		6.6 ± 1.2		65.7 ± 5.3		< 0.05

P values were obtained by comparing experimental data and the appropriate (rate 1, rate 2 or normalised) control data by means of a Student's 't' test.

n.s. not significant.

* For each tubule rate 2 was expressed as a percentage of rate 1 and data presented are mean of these individual values.

Effect of dilution of the bathing medium on the rate of fluid secretion by Malpighian tubules.

The experimental design was essentially the same as described previously; rate 1 and rate 2 secretion being determined under control and experimental conditions. The concentration of 'normal' saline was decreased by dilution with deionized water. Fig. 5.4 shows a plot of rate 2 as a percentage of rate 1 secretion against the concentration of the bathing medium. The best fit line ($R=0.95$) through the data shows that as the concentration of the bathing medium was decreased so the rate of fluid secretion was reduced.

Fig. 5.4

The effect of dilution of the bathing medium on the rate of fluid secretion.

Each point is the mean Of 8- 12 measurements \pm SEM.

Ordinate: Rate 2 as % of rate 1.

Abscissa: Conc. of bathing medium (% of 'normal' saline).

Fig. 5.4

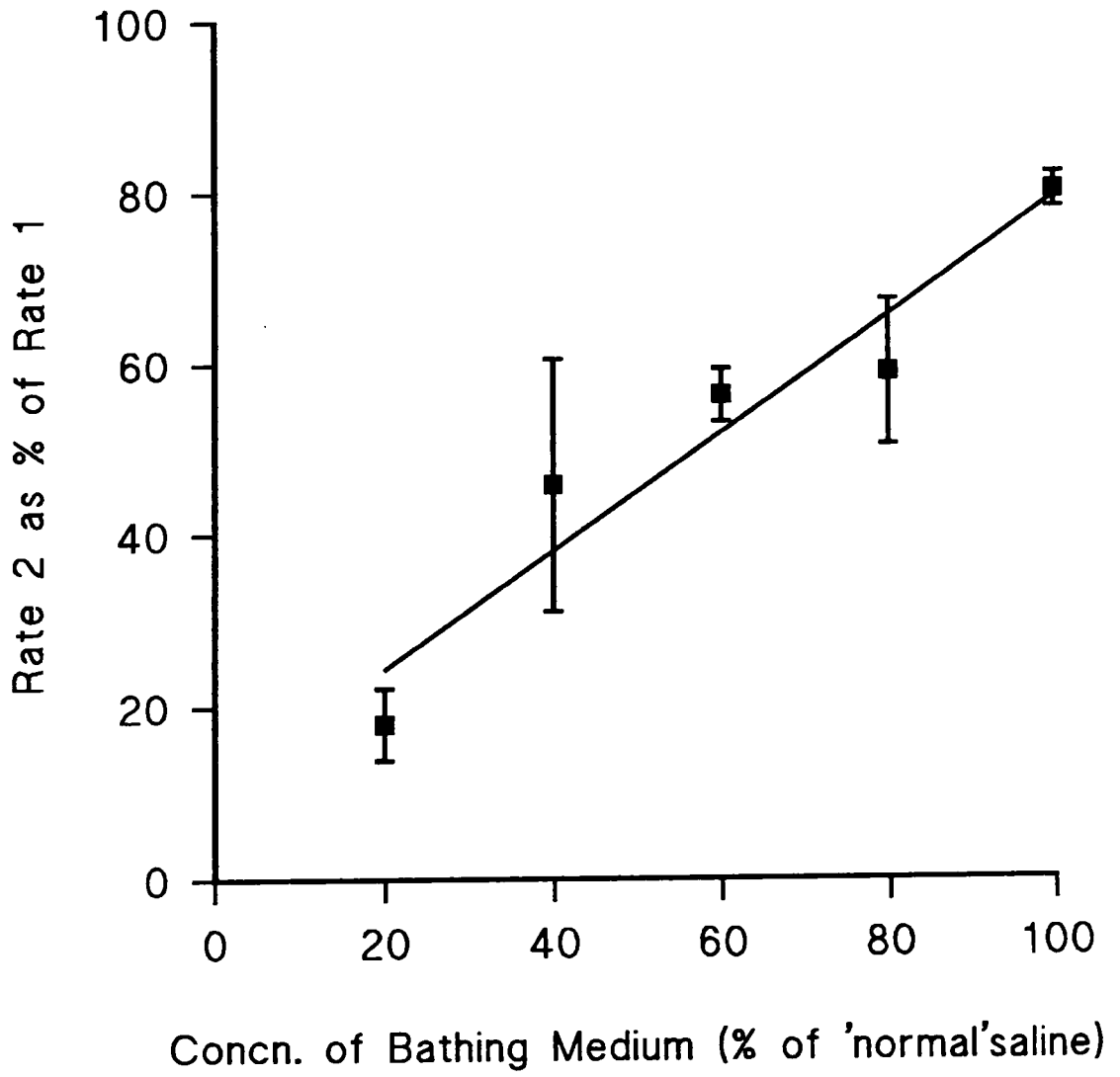

Effect of 5-Hydroxytryptamine (5HT) on fluid secretion by Malpighian tubules

Rate 1 secretion was measured in 'normal' Ringer solution which was then replaced with 'normal' Ringer solution containing 5-HT, at concentrations ranging from 10^{-6} M to 10^{-3} M. Rate 2 secretion was then re-determined following an equilibration period of 15 minutes.

Fig. 4.5 and Table 5.3 shows the effect of different concentrations of 5-HT on the rate of fluid secretion by isolated Malpighian tubules. The rate of fluid secretion increased with the increasing concentration of 5-HT over the range 10^{-5} to 10^{-3} M; maximal secretion rate occurring at 10^{-3} M 5-HT. At the latter concentration, 5-HT stimulated fluid secretion approximately 2.5 fold compared with the normalised control rate 2.

Table 5.3 Effect of 5HT on the rate of fluid secretion by the Malpighian tubules

Treatment	n	Mean Rate1 \pm S.E.M. (nl/min ⁻¹)	p	Mean Rate2 \pm S.E.M. (nl/min ⁻¹)	p	Mean Rate2 as % o Rate1*	P
Control	10	10.4 \pm 2.6	n.s	8.6 \pm 2.3		80.0 \pm 3.5	
5HT (10^{-6} M)	10	9.2 \pm 2.3		6.7 \pm 1.6	n.s	93.9 \pm 10.0	ns
HT (10^{-5} M)	10	9.5 \pm 2.7		9.1 \pm 2.5	<0.02	121.2 \pm 15.3	< 0.02
HT (10^{-4} M)	10	9.5 \pm 2.6		14.0 \pm 2.5	<0.02	188.6 \pm 11.5	< 0.01
HT (10^{-3} M)	10	10.9 \pm 3.2		18.3 \pm 5.4	<0.001	203.9 \pm 23.0	< 0.001

P values were obtained by comparing experimental data and the appropriate (rate 1, rate 2 or normalised) control data by means of a Student's 't' test.

n.s. not significant.

* For each tubule rate 2 was expressed as a percentage of rate 1 and data presented are mean of these individual values.

Fig. 5.5

Effect of 5-HT on the rate of fluid secretion.

Ordinate: Rate 2 as % of rate 1.

Abscissa: Concentration of 5-HT (M), on a Logarithmic scale.

Fig. 5.5

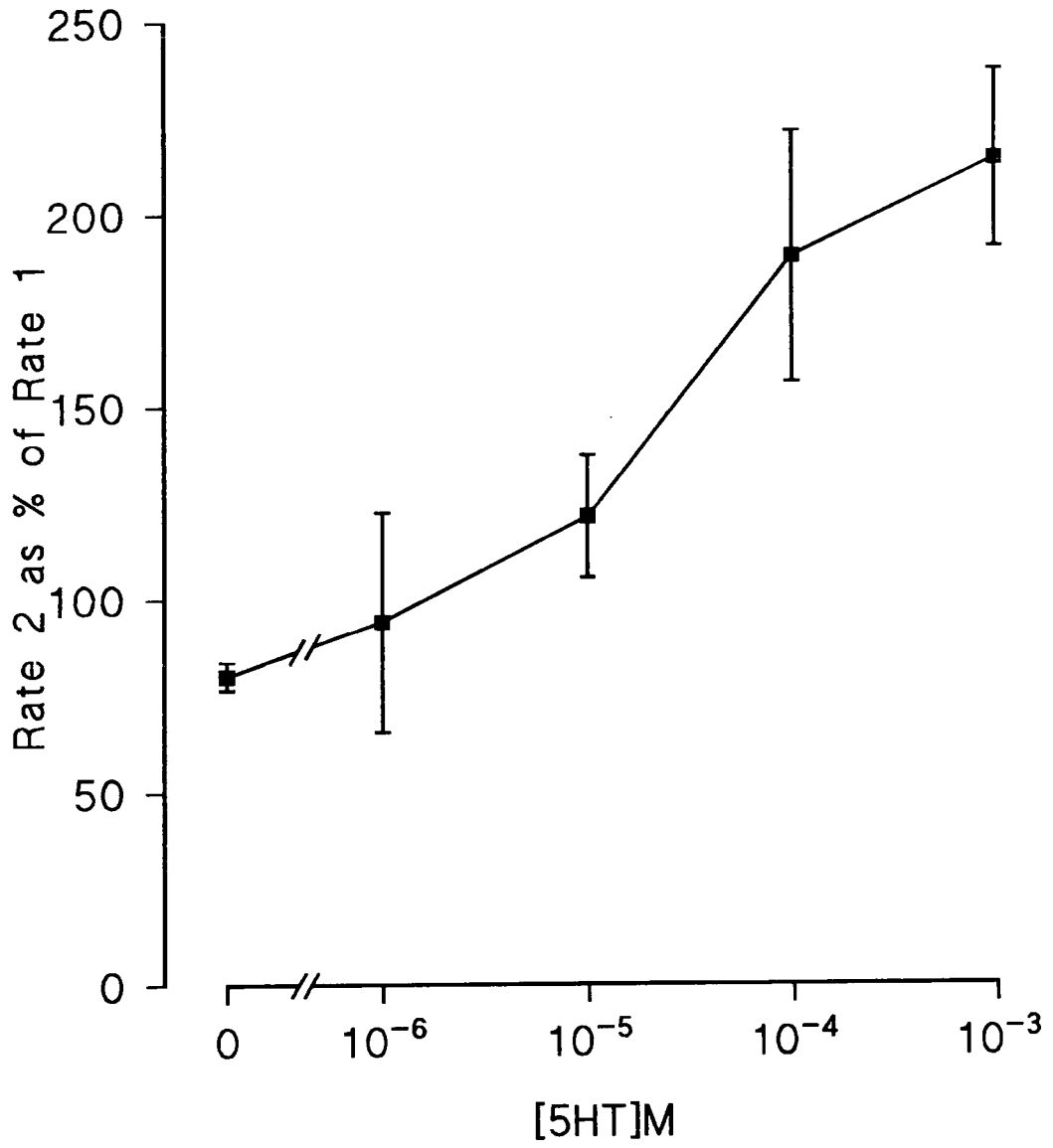

Effect of *Manduca sexta* diuretic hormone (Mas-DH) and cAMP on fluid secretion by Malpighian tubules

Rate 1 secretion was measured in 'normal' Ringer solution which was then replaced with 'normal' Ringer solution containing Mas-DH ($M_r = 4,715$) at concentrations ranging from 10^{-8} M to 10^{-6} M or 1mM dibutyryl cAMP. Rate 2 secretion was then re-determined following an equilibration period of 15 minutes.

Table 5.4 shows effect of the different concentrations of Mas-DH and 1mM cAMP on the rate of fluid secretion by isolated Malpighian tubules. The rate of fluid secretion was not significantly affected by the used doses of the Mas-DH. The normalized percentage secretion rate of experimentals was higher than the control but this was not a statistically significant increase. In contrast, it can be seen that 1mM cAMP significantly increased the rate 2 fluid secretion compared with that of the control ($P < 0.001$).

Table 5.4 Effect of Mas-DH and cAMP on the rate of fluid secretion by the Malpighian tubules.

Treatment	n	Mean Rate 1 ± S.E.M. (nl/min ⁻¹)	p	Mean Rate 2 ± S.E.M. (nl/min ⁻¹)	p	Mean Rate 2 as % of Rate 1*	P
Control	10	28.4 ± 5.1	ns	23.9 ± 4.4	n.s	82.0 ± 5.5	ns
Mas-DH (10^8 M)	10	25.8 ± 4.8		23.9 ± 54.8		93.4 ± 8.9	
Mas-DH (10^{-7} M)	10	25.1 ± 4.1		26.2 ± 5.6		93.9 ± 11.3	
Mas-DH (10^{-6} M)	10	29.3 ± 4.3		28.7 ± 4.4		109.6 ± 16.1	
cAMP (10^{-3} M)	10	17.8 ± 3.4	ns	21.9 ± 4.5	n.s	119.48 ± 6.2	0 < 0.001

P values were obtained by comparing experimental data and the appropriate (rate 1, rate 2 or normalised) control data by means of a Student's 't' test.

n.s. not significant.

* For each tubule rate 2 was expressed as a percentage of rate 1 and data presented are mean of these individual values.

Effect of ouabain on fluid secretion

Rate 1 was measured in 'normal' Ringer solution. For rate 2 the solution was replaced with a modified Ringer solution containing 10^{-7} to 10^{-3} M ouabain. In order to measure rate 2 the tubules were allowed to equilibrate for about 25 minutes, after that the rate was determined as described previously.

The results are shown in Fig. 5.6. and Table 5.5 It can be seen that the rate of fluid secretion was significantly inhibited by ouabain. Comparison of rate 2 secretion values for experimentals with those of controls indicate significant inhibition at 10^{-3} M ouabain only. However, when rate 2 values were normalised to take account of rate 1 variability between tubules, significant inhibition by ouabain was indicated over the range 10^{-6} to 10^{-3} M. Inhibition of fluid secretion was almost complete in the presence of 10^{-3} M ouabain; the activity remaining being only 5.4% of that of control rate 2.

Fig. 5.6

Effect of Ouabain on the rate of fluid secretion.

Ordinate: Rate 2 as % of rate 1.

Abscissa: Concentration of ouabain (M), on a Logarithmic scale.

Fig. 5.6

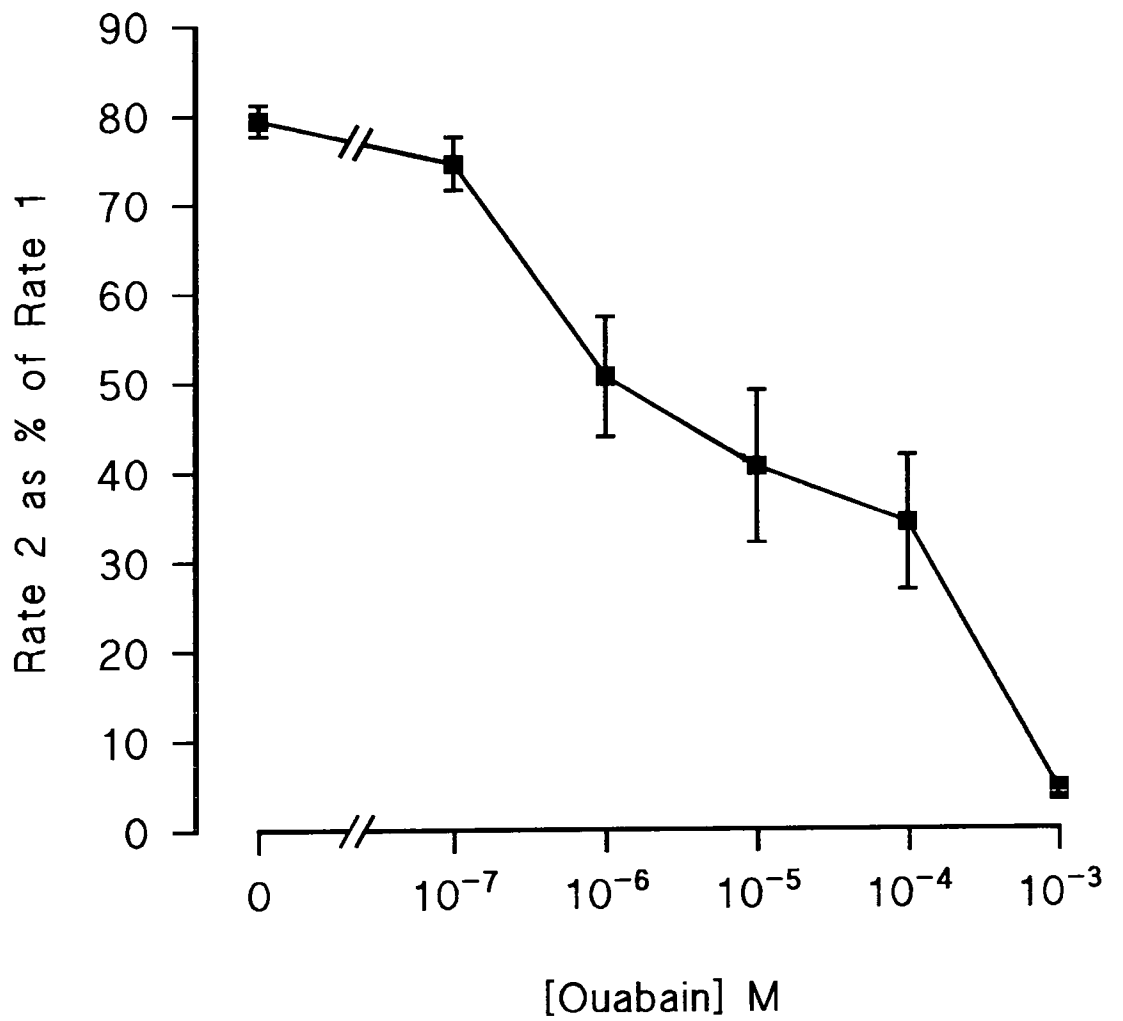

Table 5.5 Effect of ouabain on the rate of fluid secretion by the Malpighian tubules .

Treatment	n	Mean Rate 1 ± S.E.M. (nl/min ⁻¹)	p	Mean Rate 2 ± S.E.M. (nl/min ⁻¹)	p	Mean Rate 2 as % of Rate 1*	P
Control	20	14.3 ± 2.2	n.s	11.7 ± 1.9		79.4 ± 1.8	
Ouabain (10 ⁻⁷)M	20	14.8 ± 2.5		11.6 ± 2.0	n.s	74.4 ± 3.0	ns
Ouabain (10 ⁻⁶)M	20	12.3 ± 2.8		7.8 ± 2.1	n.s	50.5 ± 6.6	< 0.001
Ouabain (10 ⁻⁵)M	20	13.8 ± 3.1		6.9 ± 2.1	n.s	40.5 ± 8.5	< 0.001
Ouabain (10 ⁻⁴)M	20	17.3 ± 3.6		8.9 ± 2.8	n.s	34.2 ± 7.4	< 0.001
Ouabain (10 ⁻³)M	20	13.2 ± 2.2		0.7 ± 0.2	<0.001	4.3 ± 1.1	< 0.001

P values were obtained by comparing experimental data and the appropriate (rate 1, rate 2 or normalised) control data by means of a Student's 't' test.

* For each tubule rate 2 was expressed as a percentage of rate 1 and data presented are mean of these individual values.

Effect of ouabain on the Na⁺ and K⁺ concentration in the 'urine'

Droplets of 'urine' were collected and 'pooled' over each of the two periods of secretion described as for ouabain. The [Na⁺] and [K⁺] in the 'urine' secreted over the rate 1 and rate 2 periods were then analysed by atomic emission spectrophotometry. The methods for collection and analysis were as described in Chapter 2.

Table 5.6 shows [Na⁺]/[K⁺] ratios obtained over the two collection periods for control and experimental conditions. Statistical comparison of ratio 1 and ratio 2 was carried out by means of a paired "t" test (results from F-tests indicating that this was appropriate). It can be seen that ouabain had no significant effect on the [Na⁺]/[K⁺]

ratio in the fluid secreted by the Malpighian tubules over a wide range of bathing medium ouabain concentrations.

Table 5.6 Effect of ouabain on $[Na^+]/[K^+]$ ratio in fluid secreted by Malpighian tubules *in vitro*.

Treatment	n	$[Na^+]/[K^+]$ Ratio \pm S.E		Ratio 2 as % 1	P
		Ratio 1	Ratio 2		
Control	4	1.11 \pm 0.26	1.02 \pm 0.13	92.6	ns
Ouabain 10^{-7} M	3	0.98 \pm 0.08	0.76 \pm 0.19	77.5	ns
Ouabain 10^{-6} M	3	0.78 \pm 0.26	0.79 \pm 0.15	101.3	ns
Ouabain 10^{-5} M	3	0.99 \pm 0.04	0.99 \pm 0.12	100.3	ns
Ouabain 10^{-4} M	3	1.00 \pm 0.01	0.97 \pm 0.10	97.10	ns
Ouabain 10^{-3} M	3	1.03 \pm 0.11	1.27 \pm 0.30	123.3	ns

P. values were obtained by comparing rate 1 and 2 by paired 't' test.

ns. = not significant

In all cases ratio 1 was established in normal Ringer. The ratio 2 was determined in the presence of the ouabain concentration shown.

Effect of furosemide on the rate of fluid secretion.

The same procedures were followed as in subsection 4.6, but this time using different doses of furosemide (10^{-7} to 10^{-3} M). The results, shown in Fig. 5.7 and Table 5.7 indicate that the furosemide has a marked inhibitory effect on fluid production by the Malpighian tubules. The level of inhibition increased with increasing concentrations of furosemide. Thus the rate of fluid secretion was reduced to approximately 41.6% (47.9% for normalised data) compared with the control rate 2 values in the presence of 10^{-6} M furosemide. Maximal inhibition was effected by 10^{-4} M

Fig. 5.7

Effect of furosemide on the rate of fluid secretion.

Ordinate: Rate 2 as % of rate 1.

Abscissa: Concentration of furosimide (M), on a Logarithmic scale.

Fig. 5.7

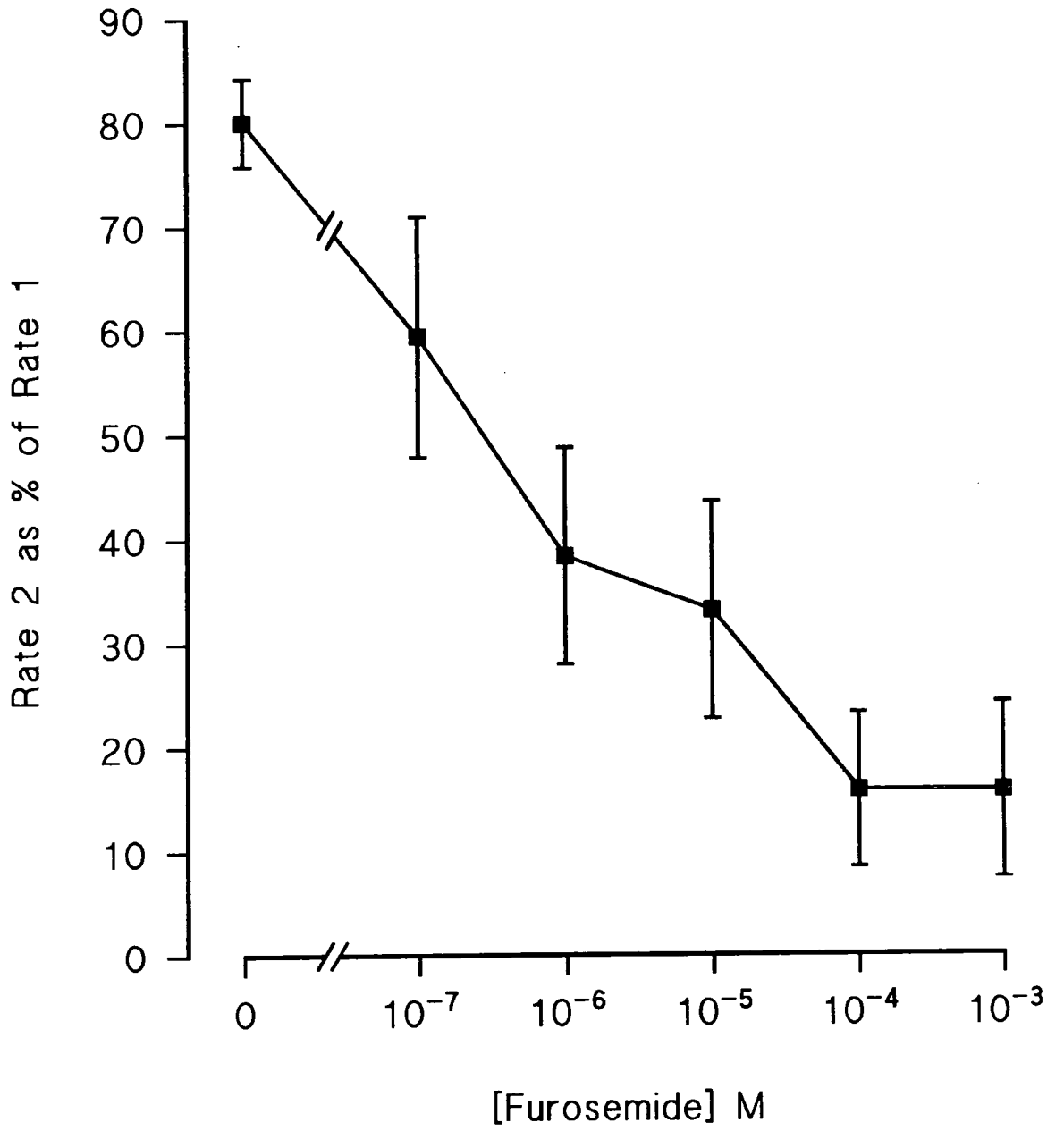

4M furosemide (concentrations higher than this give the same result) when the rate of secretion was reduced to *ca.* 18.6% of the rate 2 value observed in controls.

Table 5.7 Effect of Furosemide on the rate of fluid secretion by the Malpighian tubules

Treatment	n	Mean Rate1 ± S.E.M. (nl/min ⁻¹)	p	Mean Rate2 ± S.E.M. (nl/min ⁻¹)	p	Mean Rate 2 as % of Rate1*	P
Control	10	30.1 ± 5.3		25.2 ± 4.5		80.0 ± 4.2	
Furosemide (10 ⁻⁷)M	10	25.4 ± 5.1	n.s	16.7 ± 4.2	n.s	59.3 ± 11.5	< 0.002
Furosemide 10 ⁻⁶ M	10	27.5 ± 5.1		10.5 ± 3.6	<0.002	38.3 ± 10.4	< 0.001
Furosemide (10 ⁻⁵)M	10	11.0 ± 4.6		4.8 ± 2.4	<0.001	33.1 ± 10.4	< 0.001
Furosemide (10 ⁻⁴)M	10	19.8 ± 5.2		4.7 ± 2.5	<0.001	15.8 ± 7.4	< 0.001
Furosemide (10 ⁻³)M	10	26.0 ± 5.5		4.5 ± 2.4	<0.001	15.8 ± 8.4	< 0.001

P values were obtained by comparing experimental data and the appropriate (rate 1, rate 2 or normalised) control data by means of a Student's 't' test.

* For each tubule rate 2 was expressed as a percentage of rate 1 and data presented are mean of these individual values.

Effect of N-ethylmaleimide (NEM) on the rate of fluid secretion by the Malpighian tubules

The effect of NEM on rate 2 fluid secretion was determined over the concentration range of 10⁻⁷M to 10⁻⁵M, using the methodology described above.

The effects of various NEM concentrations on the rate of urine are shown in Fig. 5.8. and Table 5.8 NEM showed a strong inhibitory effect at all the dosage levels used. It can be seen that NEM effected approximately 50% inhibition of fluid secretion compared with controls at 10⁻⁷M concentration and completely inhibited fluid secretion at a concentration of 10⁻⁵M.

Fig. 5.8

Effect of NEM on the rate of fluid secretion.

Ordinate: Rate 2 as % of rate 1.

Abscissa: Concentration of NEM (M), on a Logarithmic scale.

Fig. 5.8

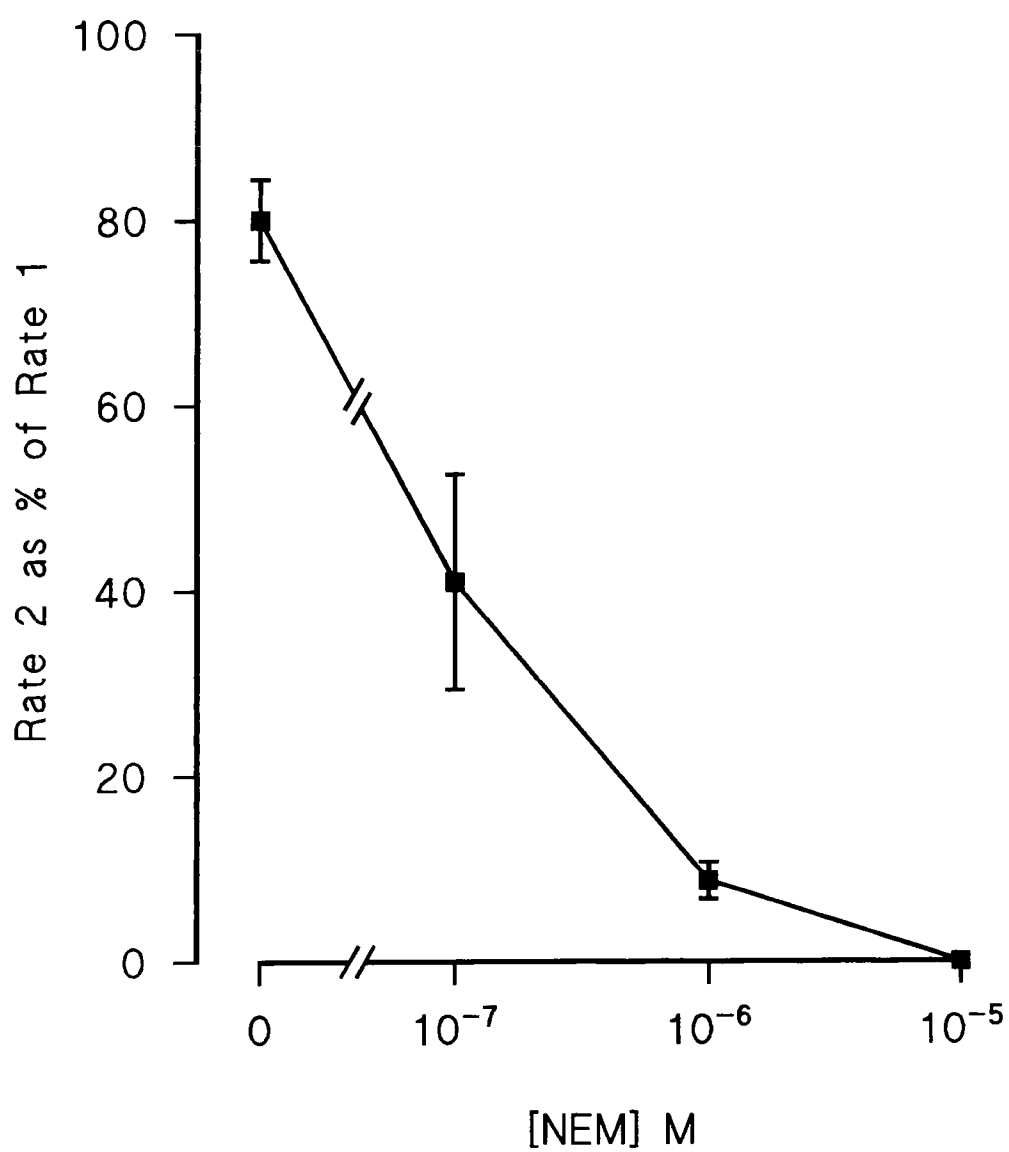

Table 5.8 Effect of NEM on the rate of fluid secretion by the Malpighian tubules

Treatment	n	Mean Rate 1 ± S.E.M. (nl/min ⁻¹)	p	Mean Rate 2 ± S.E.M. (nl/min ⁻¹)	p	Mean Rate 2 as % of Rate 1*	P
Control	10	18.5 ± 4.3	n.s	15.2 ± 4.1		80.0 ± 4.4	
NEM (10 ⁻⁷)M	10	19.8 ± 5.1		10.3 ± 4.3	n.s	40.9 ± 11.6	< 0.002
NEM (10 ⁻⁶)M	10	26.9 ± 4.7		2.8 ± 0.8	<0.01	8.7 ± 10.4	< 0.001
NEM (10 ⁻⁵)M	10	21.0 ± 3.8		0.0 ± 0.0	<0.001	0.0 ± 0.0	<0.001
NEM (10 ⁻⁴)M	10	18.7 ± 4.1		0.0 ± 0.0	<0.001	0.0 ± 0.0	< 0.001

P values were obtained by comparing experimental data and the appropriate (rate 1, rate 2 or normalised) control data by means of a Student's 't' test.
ns. Not significant.

* For each tubule rate 2 was expressed as a percentage of rate 1 and data presented are mean of these individual values.

Section (2): Effect of age on Malpighian tubule fluid production, *in vitro*

The rate of fluid secretion was measured in aged insects from different larval instars (4th, 5th and 6th), prepupae, pupae and adults. The methods of ageing the experimental animals and of measuring fluid secretion were as described previously in Chapter 2.

Fig. 5.9A shows the mean secretion rate, expressed in $\text{nl}\cdot\text{min}^{-1}\cdot\text{mm}^{-2}$, of tubules at different ages throughout the 4th, 5th and 6th larval stadia, and the prepupal stage. It can be seen that at the beginning of the fourth stadium, fluid secretion was slow but increased rapidly with age, reaching a maximum at *ca.* 20 hr. Thereafter, it declined prior to ecdysis to the fifth stadium. Again the rate of fluid secretion increased shortly after the moult reaching a level similar to that observed with fourth instar tubules and then gradually declined until the moult. A similar pattern was observed with tubules from the sixth instar larvae, although the maximal rate of secretion was lower than that observed for the earlier instar tubules. No secretion was measurable in tubules dissected from prepupae or pupae (see Figs. 5.9 and 5.10). Secretion, whilst variable in rate, increased dramatically following adult emergence before falling back to a lower level. The results obtained are shown in Fig. 5.10.

Fig. 5.9B shows the data collected in the above experiments expressed in terms of nl of urine secreted per tubule. min^{-1} . The pattern of change in the rates of secretion was similar to those described above for the different stadia, *viz.* a marked increase in the rate of fluid production following a moult and a decrease in secretion preceding the next ecdysis. However, these data show that the maximum rate of tubule secretion in the fourth instar was lower than in either of the fifth or sixth larval stadia. Thus, in 4th instar larvae, the rate of fluid secretion increased from $3.76 \pm 0.9 \text{ nl}\cdot\text{min}^{-1}$ at 3 hr to a maximum of $19.55 \pm 3.9 \text{ nl}\cdot\text{min}^{-1}$ in 18hr old larvae. In the 5th stadium, the maximum rate of secretion was $48.6 \pm 3.9 \text{ nl}\cdot\text{min}^{-1}$, and this was observed 8 hrs after the moult to the fifth instar. This represents a 248.5% increase in secretion rate compared to the

Fig. 5.9 A, B

The secretion rates from the larval and prepupal developmental stages of *Spodoptera littoralis*. Each point is the mean of 10-20 tubules \pm S.E.M. The dotted arrows represent ecdysis.

A. The Mean secretion rate (nl/min. $^{-1}$.mm $^{-2}$).

B. The total secretion rate (nl/min. $^{-1}$).

Ordinate: Mean secretion rate (nl/min. $^{-1}$ mm $^{-2}$ as in A), or total secretion rate (nl/min. $^{-1}$ as in B).

Abscissa: Insect age (h).

Fig. 5.9

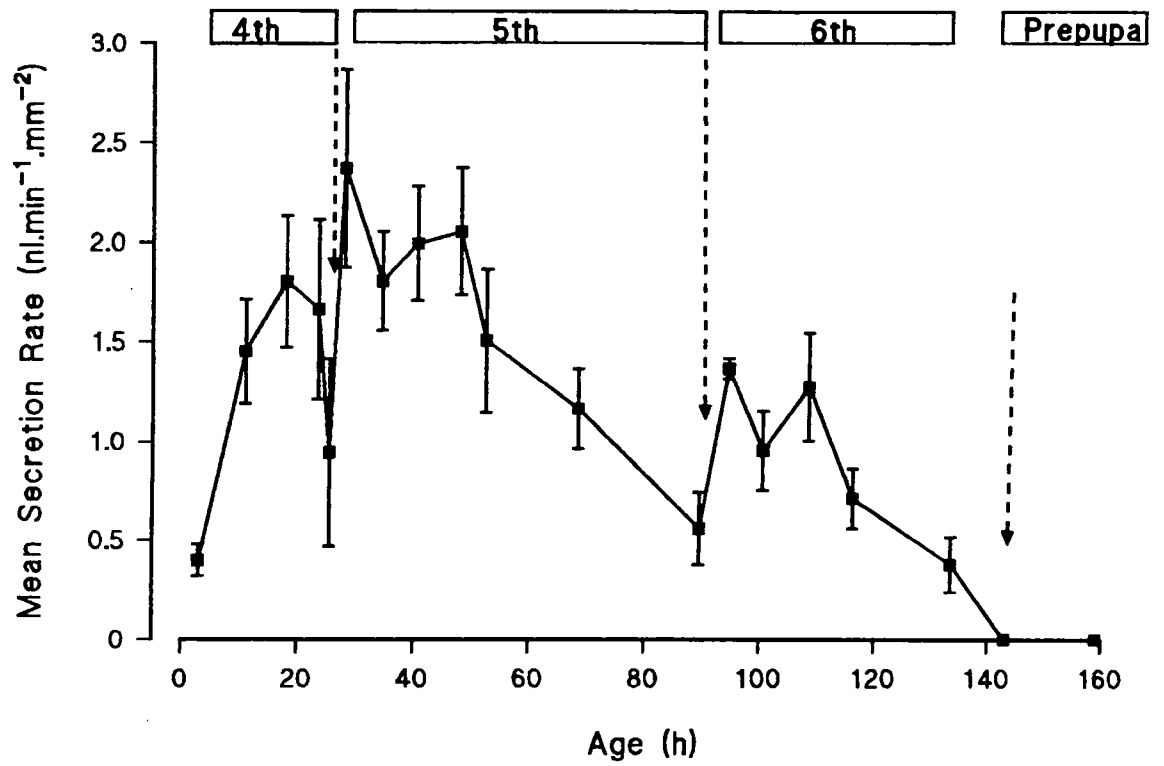

A

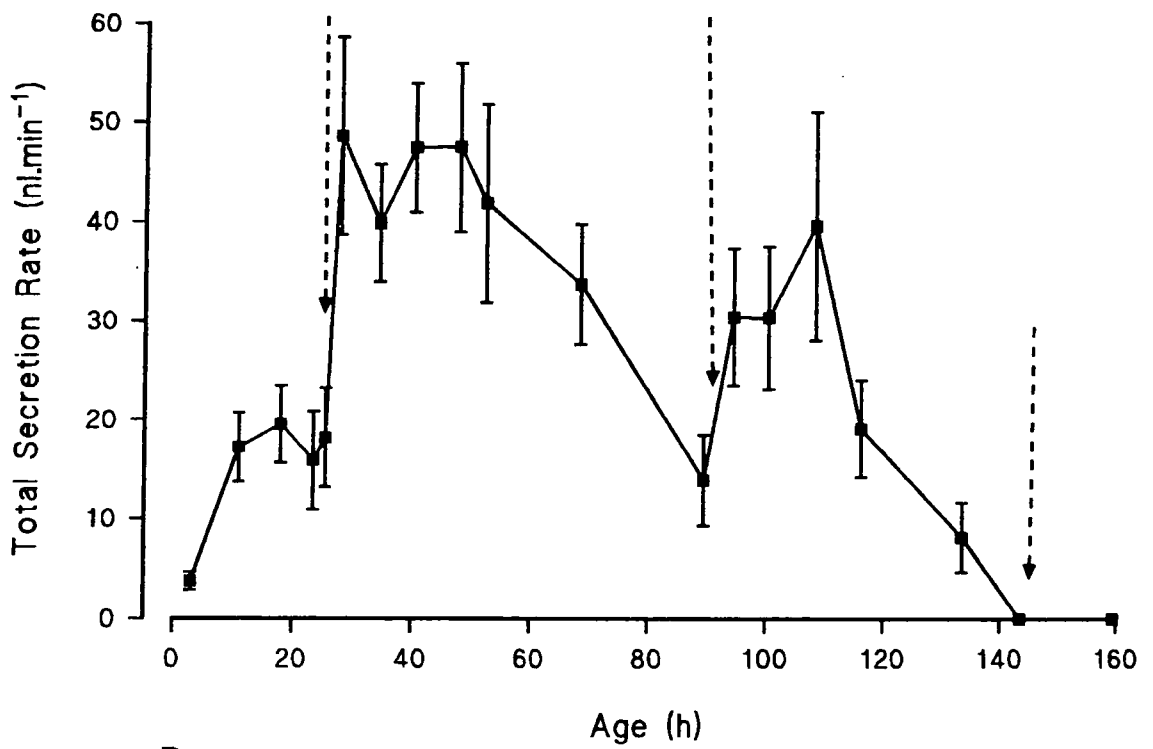

B

Fig. 5.10

The secretion rates from the pupal and adult developmental stages of *Spodoptera*.
Note the cessation of the fluid secretion in pupae.

Ordinate: Mean secretion rate ($\text{nl. min}^{-1}.\text{mm}^{-2}$).

Abscissa: Age (h).

Fig. 5.10

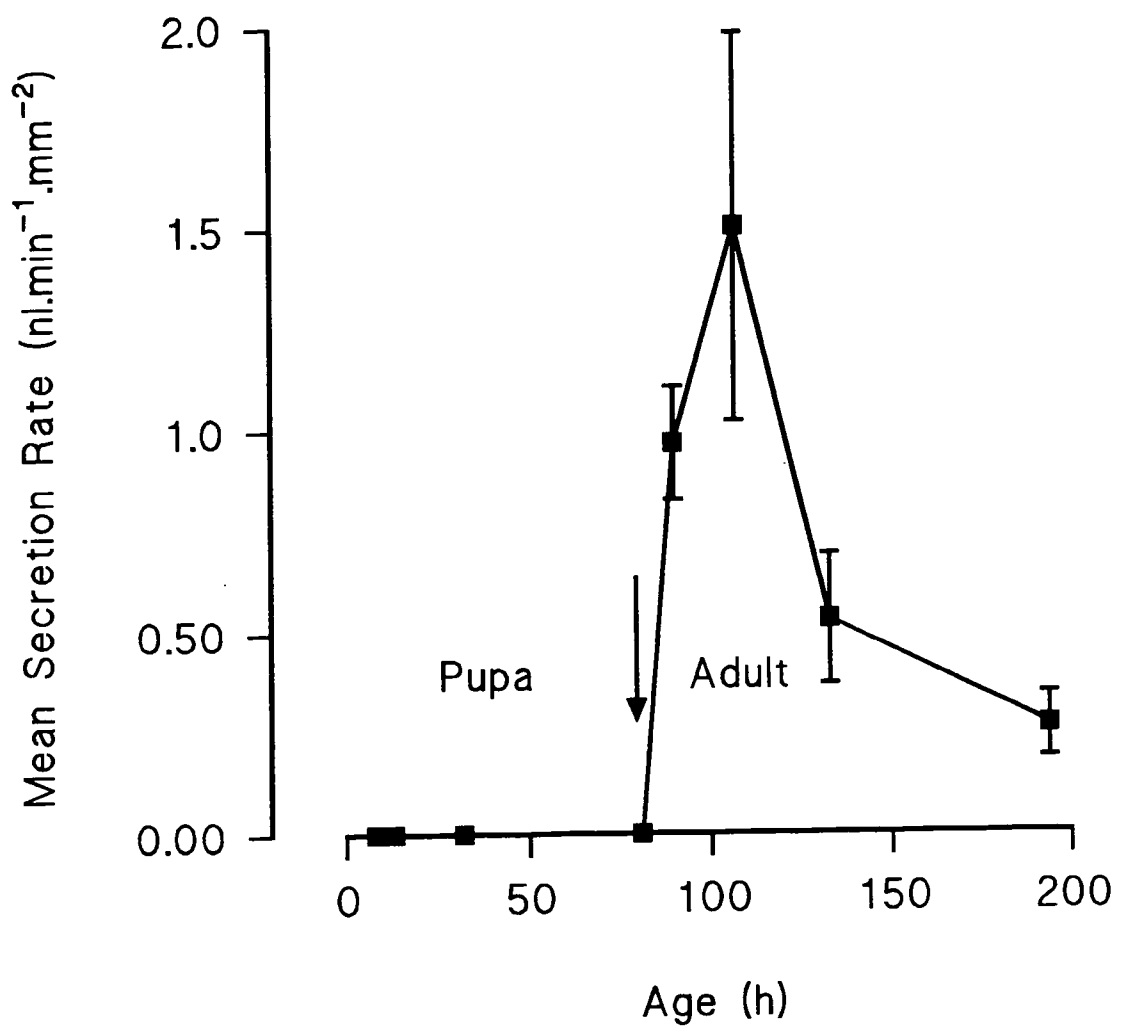

maximum measured in 4th instar larval tubules. Tubules from sixth instar larvae appeared to secrete at a slightly reduced rate compared with those of fifth instar insects; the maximal rate of secretion being $39.6 \pm 11.5 \text{ nl} \cdot \text{min}^{-1}$ at 19.5 hr after the moult to the sixth instar. This represents approx. 81.5% of the maximal rate of secretion measured for 5th instar larval tubules and a near two-fold increase in the maximal rate seen in the 4th instar. However, the rate of fluid secretion showed considerable variation between different tubules and between insects in all stages studied with the result that differences between maximal rates in fifth and sixth instar tubules was not statistically significant.

Section (3): Measurement of wet weight and dry weight changes throughout the 4th , 5th and 6th stadia

Fig. 5.11 illustrates the changes in wet and dry body weight during the 4th, 5th and 6th larval stadia of *Spodoptera littoralis*. Each point on the graph represents the mean of 10 determinations. Fig. 5.11A shows data obtained throughout the 4th larval stadium. It can be seen that there was a substantial increase in mean wet weight between 5 and 10 hr old insects after which the wet weight remained more-or-less stable until the moult. At the beginning of the fifth stadium, the wet weight was significantly higher than in late fourth instar larvae. Following an initial drop in wet weight, the latter increased over the next 30 hr, then decreased prior to a sharp rise and fall which preceded the next ecdysis. During each of these two stadia, mean body dry weight showed a similar pattern of change to that of the wet weight (Figs. 5.11A & B).

Fig. 5.11C shows how mean wet weight and dry weight varied during the last larval instar and in the early prepupal stage. Again the mean wet weight and mean dry weight showed a similar pattern of changes during the stadium. There was a marked peak mid-instar and a later one which preceded the prepupal stage. The fall in the latter peak continued, albeit at a slower rate in the prepupae.

The results presented in Figs. 5.12A- C show the changes in the percentage water content throughout the different stages referred to above. It can be seen that in newly moulted 4th instar larvae about 85.5% of the body weight is due to water. The relative water content remained more-or-less at this level throughout the stadium apart from small but non-significant decreases to ca. 84% at 6 hr and just before the moult. Similarly, the fluctuations in relative water content seen in the fifth and sixth instar larvae were not statistically significant. However, in all three larval instars there was a noticeable drop in mean percentage water content in the early part of the stadium and immediately prior to the moult. The latter may be related to preparation for the moult to the next instar. A marked decline ($P < 0.001$) in mean water content was observed in prepupae.(Fig. 5.11C).

Fig. 5.11 A-C

The developmental changes in wet and dry weight.

A. Wet and dry weight in 4th instar.

B. Wet and dry weight in 5th instar.

C. Wet and dry weight in 6th instar.

Ordinate 1: Mean insect wet weight (mg).

Ordinate 2: Mean insect dry weight (mg).

Abscissa: Insect age (h)

Fig. 5.11 A-C

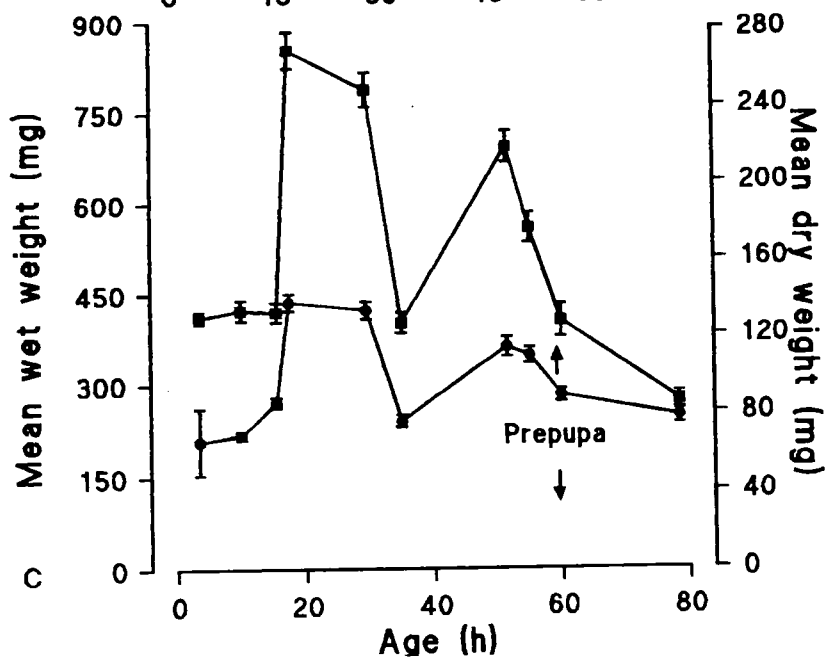
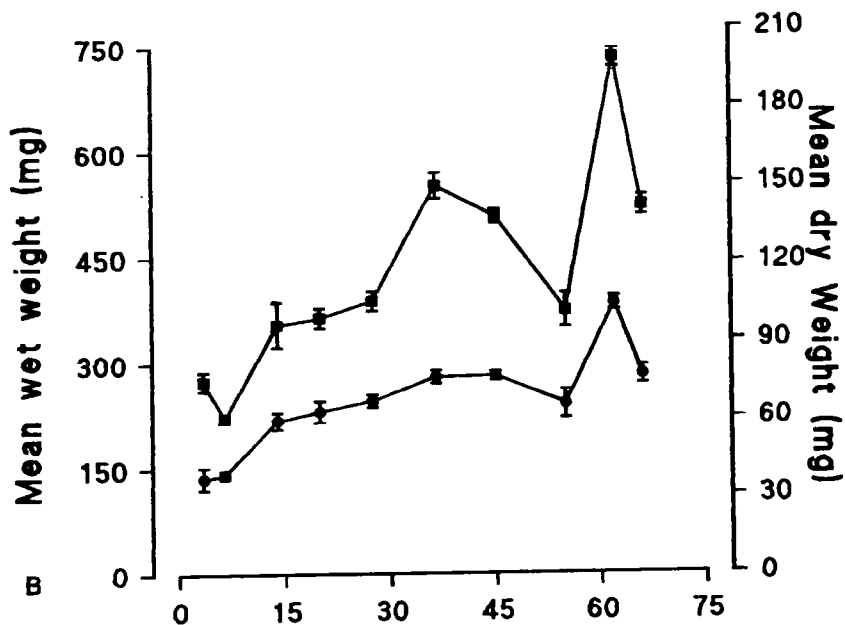
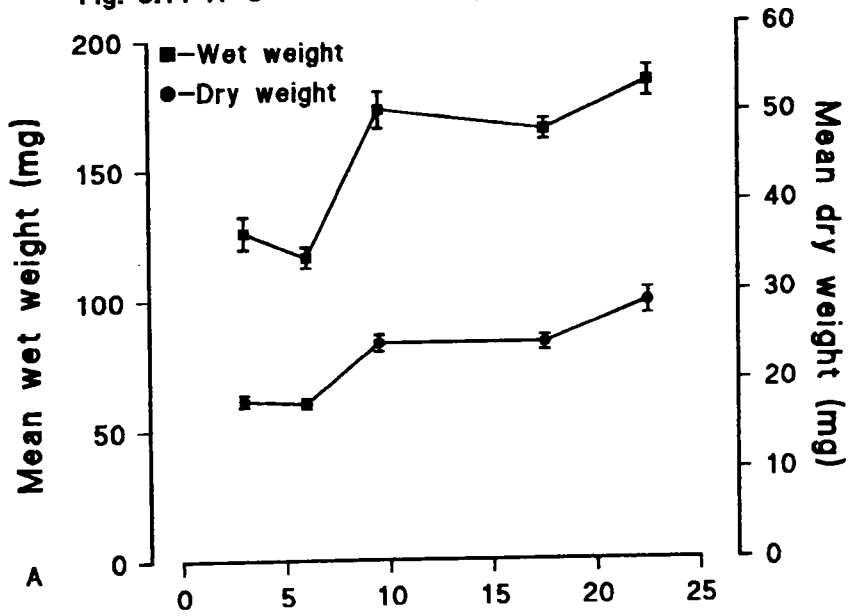

Fig. 5.12 A- C

The changes in relative water content throughout the larval instars.

A. Percentage of water content in 4th instar.

B. Percentage of water content in 5th instar.

C. Percentage of water content in 6th instar.

Ordinate: Mean percentage of water content.

Abscissa: Insect age (h).

Fig 5.12

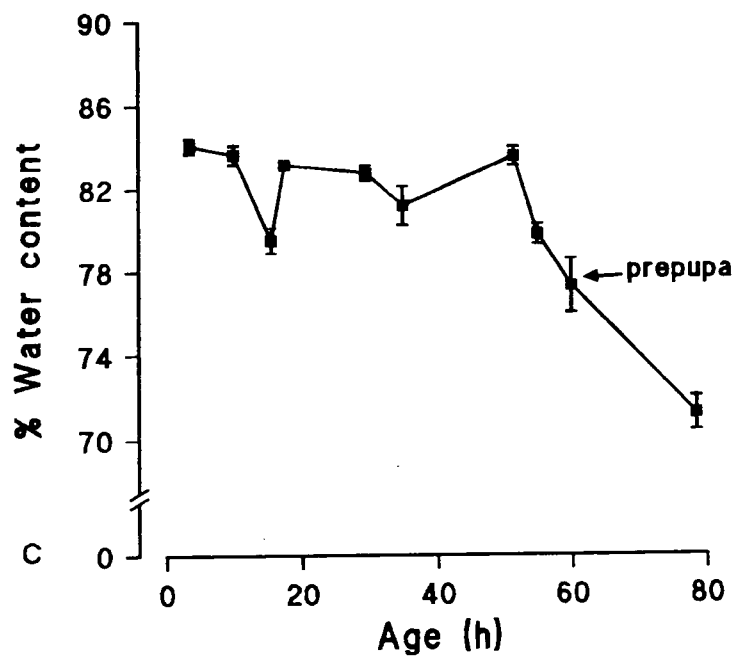
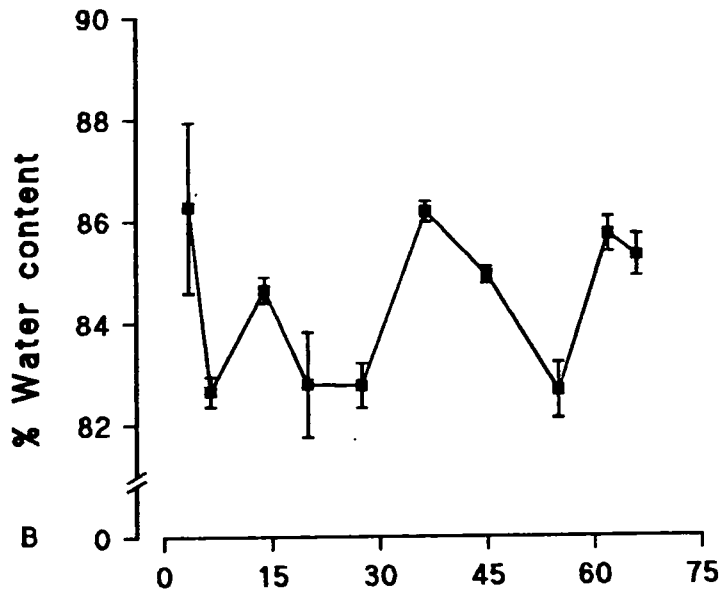
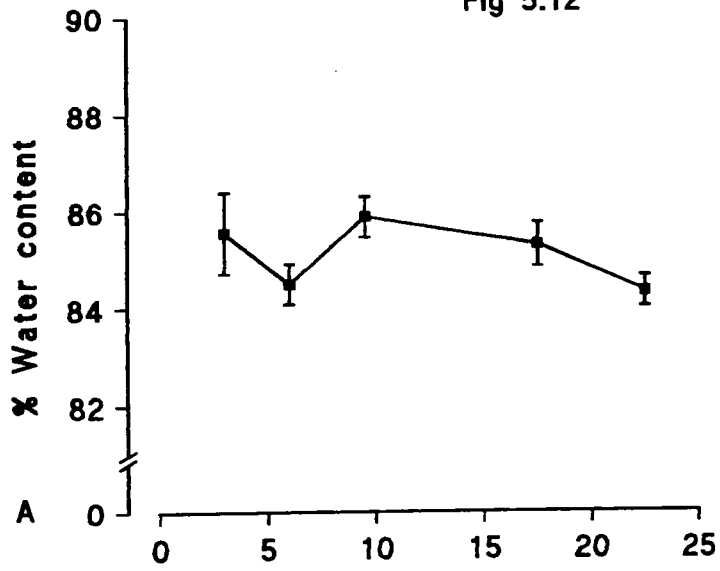

Section (4): Cytochemical localization of K^+ -dependent p-nitrophenyl phosphatase activity in the larval Malpighian tubules of *Spodoptera littoralis*

The structure of the cells of the Malpighian tubules of *Spodoptera littoralis*, in both proximal and distal regions, are as described previously in chapter 3.

Cytochemical localization of NNPase using the standard incubation medium

Fig(5.13A) shows the distribution of reaction product in cells of the proximal region of *Spodoptera littoralis* Malpighian tubules. It can be seen that substantial amounts of precipitated reaction product was located along the basal membrane infoldings (Fig 5.13A). In contrast, little or no reaction product was seen elsewhere apart from small amounts which were occasionally observed on the outer side of the microvillar membrane and in the sub-microvillar region of the main cytoplasm. The lumen of this region contained no reaction product.

The medial region of the Malpighian tubules was treated with the same incubation medium, (Figs. 5.13 B-D). Unlike, the cells of the proximal region, no reaction product was seen in association with the basal membrane infoldings, nor was it evident in the main cytoplasm of the cell. However, considerable deposits of reaction product were seen around the microvilli (see Fig. 5.13 C, D). This was especially noticeable in microvilli within the canaliculi (Fig. 5.13E).

Effect of replacing potassium chloride by choline chloride

The effect of replacing K^+ with choline, in the incubation medium, on reaction product production and localisation in cells of the proximal and medial tubular regions is shown in Fig.(5. 14A) and (5.14B; C; D) respectively. Reaction product was completely absent from the both the basal and apical membranes in cells of the proximal region (Fig. 5.14A). In fact, no reaction product was detected anywhere in the cells of this region, under these conditions of incubation.

In the medial region, there was a marked reduction in the amount of deposit observed around the microvilli (Fig. 5.14B) when compared with the controls which had been incubated in the standard medium. As with controls, deposits were completely absent from the basal zone (Fig.5.14C; D).

Effect of substrate substitution

Substitution of p-nitrophenyl phosphate (NPP) with the non-specific phosphatase substrate, β -glycerophosphate (Ernst, 1972b, 1975) was carried out to permit the localisation of alkaline phosphatase activity; an enzyme which should utilize both NPP and β -glycerophosphate as substrates. The effects of this substrate substitution on reaction product distribution in cells of the proximal and medial regions are shown in (Fig. 5.15A; B). and (Fig. 5.15C; D) respectively. Examination of Fig. 5.15A-B) shows the absence of reaction deposits in the basal zone of the proximal region. As in controls, there were only small amounts of reaction deposit around the microvilli (Fig. 5.15C; D).

In the medial region, reaction product was absent from the basal plasma membrane infoldings, although it was clearly present in association with the apical microvilli (see Fig. 5.15 C; D).

Effect of ouabain

The inclusion of 10mM of ouabain in the standard incubation medium resulted in the complete absence of reaction product deposition in association with the infoldings of the basal cell membrane of cells in the proximal region (Fig. 5.16A). However, a few fine deposits were seen around the apical microvilli. In the distal region (Fig. 5.16B) deposits were observed around the microvilli, although none were seen in the basal zone of cytoplasm.

Fig. (5.13 A-E)

Electronmicrograph of Malpighian tubules when they were incubated in the standard incubation media.

A: Proximal region showing substantial amount of precipitated product associated with membrane of labyrinth (La) (see arrows) little or none was associated with the apical microvilli (Mv). Note the lumen (L) of tubule also has no precipitates.

Scale = 1 μ m.

B: High power magnification of the basal zone of the proximal region showing precipitated product in the labyrinth (arrows). Note the main part of the cytoplasm is almost free from precipitates. The basement membrane (BM) is free from precipitate.

Scale = 1 μ m

C: Section through the medial region showing the presence of reaction product around the microvilli (Mv) (see arrows). Elsewhere deposits were absent.

Scale = 2 μ m

D: Section through the medial region showing considerable amounts of reaction product in association with microvilli (see arrows).

Scale = 2 μ m

E: Section through the medial region showing considerable amounts of precipitated reaction product in the microvilli of the canaliculi (Ca), (see arrows).

Scale = 5 μ m

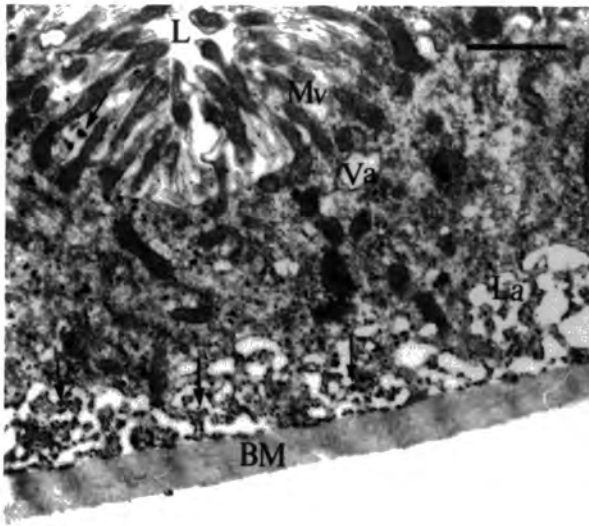

A

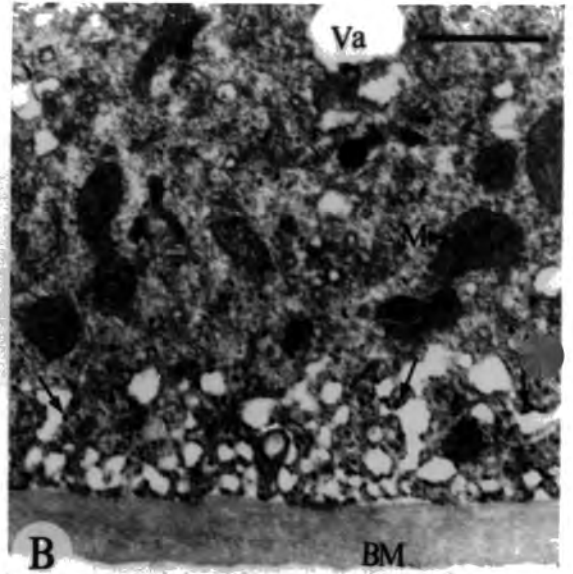

B

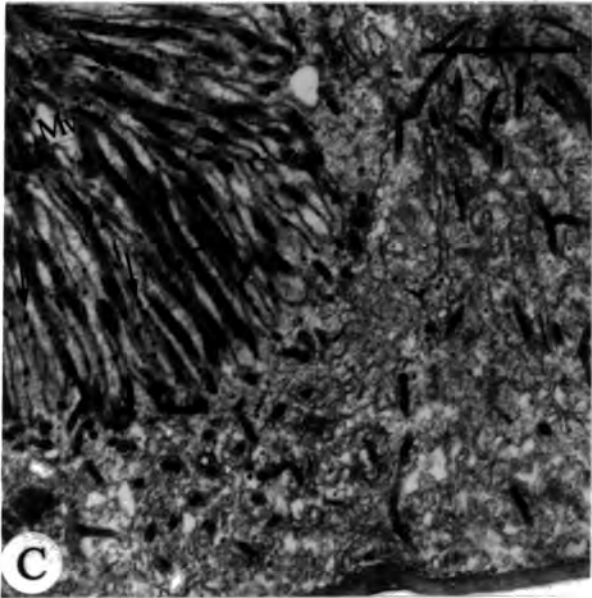

C

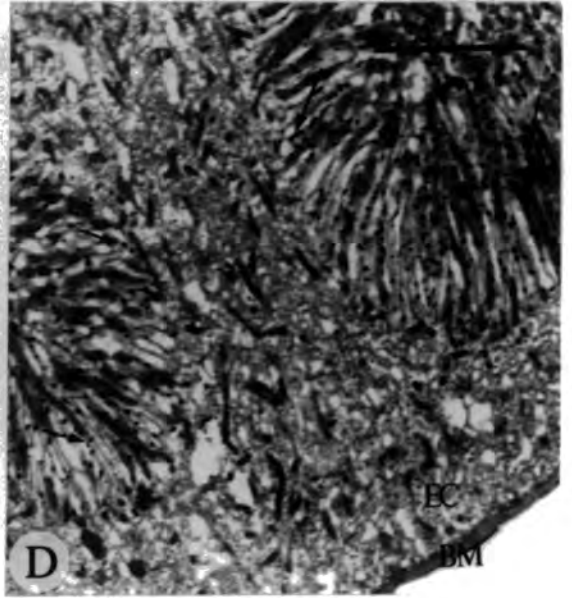

D

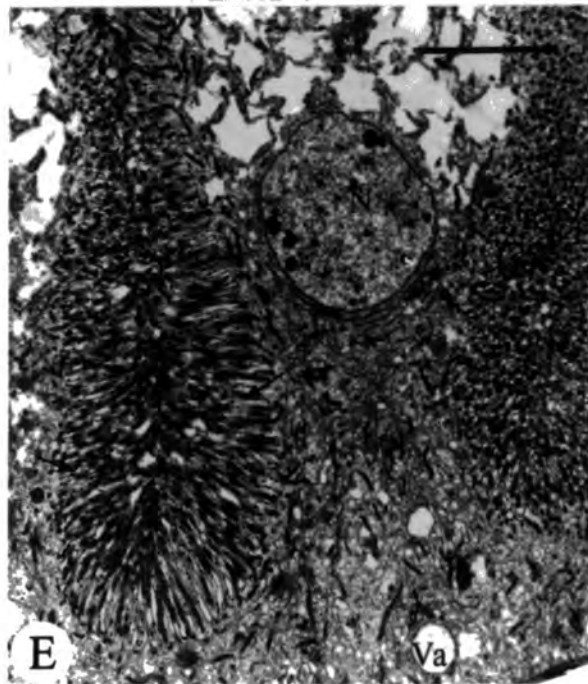

E

Fig. (5.14 A-d)

Electronmicrograph of Malpighian tubules following incubation in media in which choline chloride substituted for KCl.

A: Electronmicrograph of the proximal region showing the total absence of the reaction product deposits from the labyrinth (La). (compare with control Fig. 5.13 A; B),

Scale = 2 μ m

B: Electronmicrograph of the medial region showing reduced reaction product deposit in the apical zone between the microvilli (see arrows) (compare with that seen in the control Fig. 5.13C; D).

Scale = 0.5 μ m

C: Electronmicrograph of the medial region showing reduced reaction product deposits in the canaliculi (Ca) (compare with that seen in the control Fig. 5.13E).

Scale = 2 μ m

D: Electronmicrograph of the medial region showing that reaction product is totally absent from the extracellular channels (EC) of the basal membrane.

Scale = 2 μ m

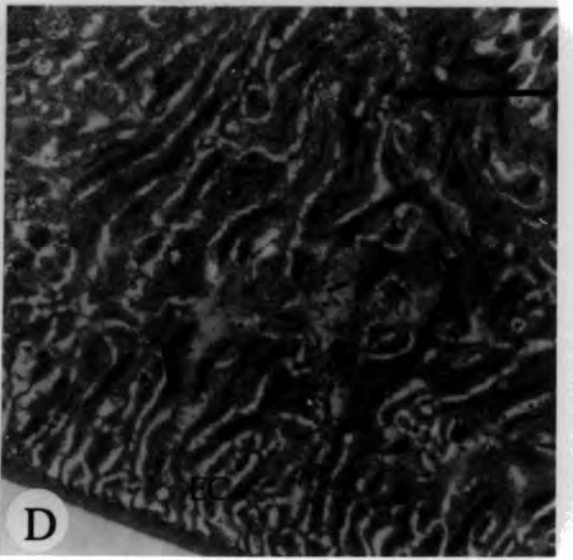
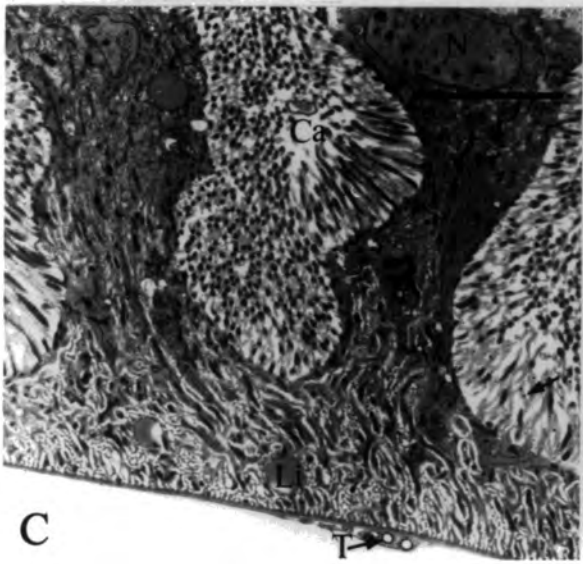
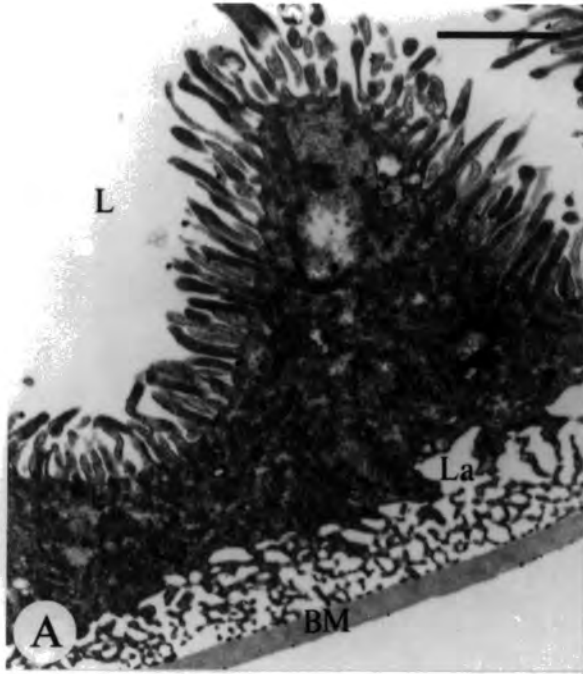

Fig. (5.15 A-d)

Electronmicrographs showing results obtained when the Malpighian tubules were incubated in the standard incubation media, in which the substrate p-nitrophenyl phosphate (NPP) was replaced by β -glycerophosphate.

A: Electronmicrograph of proximal region shows a total absence of reaction product in the basal cell membrane foldings of the labyrinth (La) (compare with control Fig. 5.13A; B). Also very little reaction product was seen in the apical zone between the microvilli (Mv) (see arrows).

Scale = 2 μ m

B: Electronmicrograph of the proximal region showing that the basement membrane (BM); labyrinth and the cytoplasm are free of reaction product.

Scale = 2 μ m

C: Electronmicrograph of the medial region showing that the basement membrane; the extracellular channels (EC) and the cytoplasm are free from reaction product. Only few deposits of reaction product were seen in the apical zone between the microvilli and in the microvilli of the canaliculi (Ca) (see arrows).

Scale = 5 μ m

D: High power magnification for the basal zone of the medial region confirming a total absence of reaction product as described above.

Scale = 2 μ m

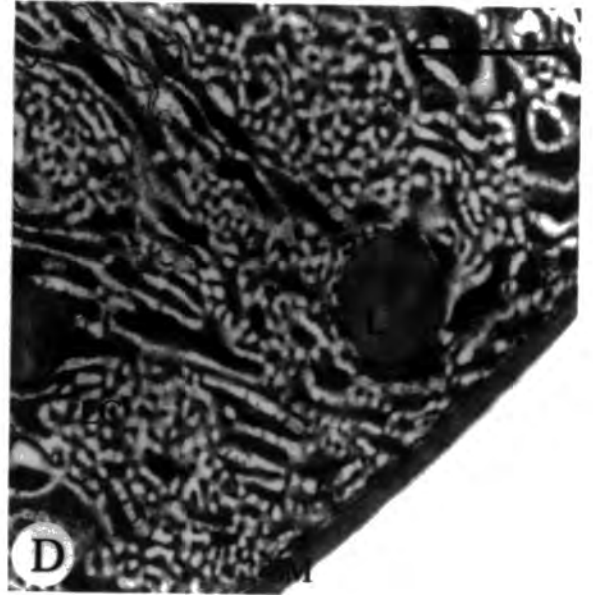
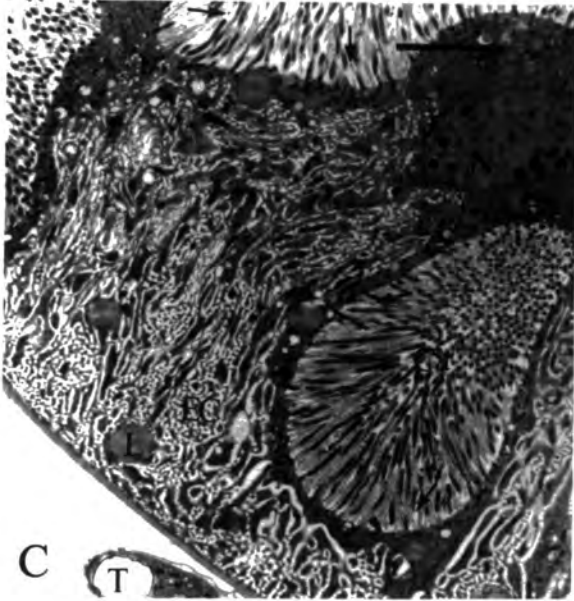
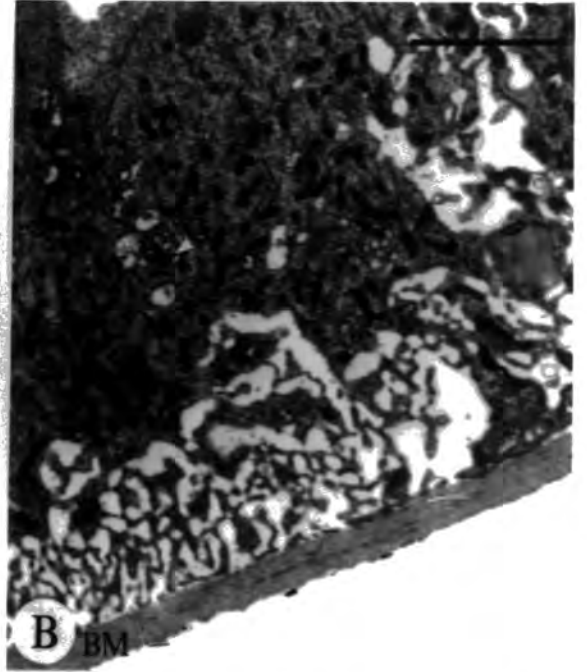

Fig. (5.16 A and B)

Electron micrographs showing results obtained when the Malpighian tubules were incubated in the standard incubation media containing 10 mM ouabain.

A: Electronmicrograph of the proximal region showing that the basement membrane (BM); labyrinth (La) and the cytoplasm are free of reaction product (compare with the control Fig. 5.13 A and B). Small amounts of reaction product were seen in the apical zone (see arrows).

Scale = 2 μ m

B: Electronmicrograph of medial region showing a near total absence of reaction product. Only a few spots of reaction product can be seen in the apical zone between the microvilli (see arrows).

Scale = 5 μ m

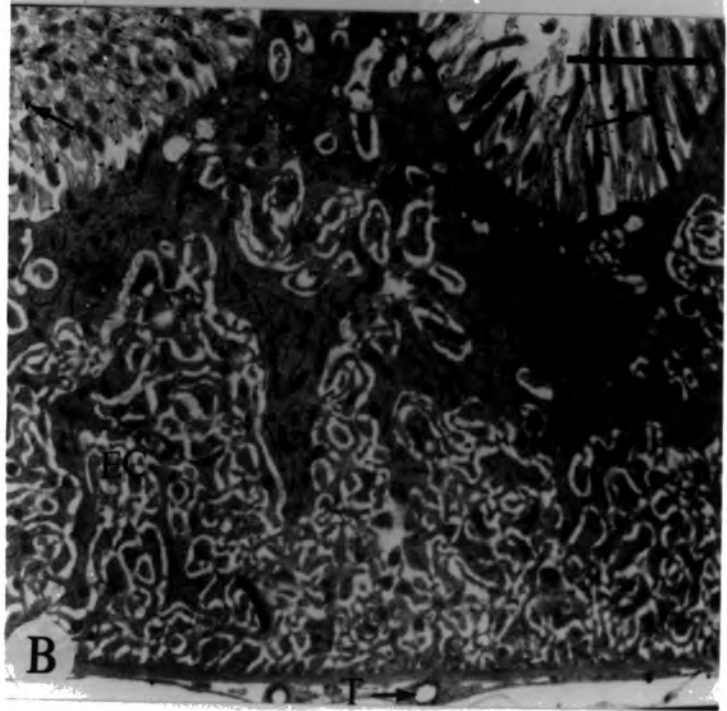
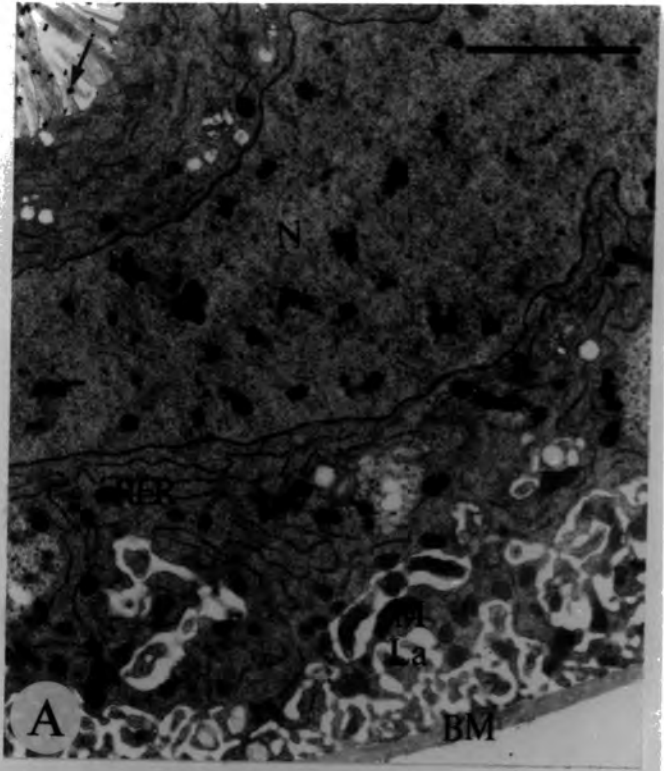

Discussion

Table 5.9 compares the haemolymph composition of *Spodoptera littoralis* with that of other lepidopteran species which have been studied. It can be seen that the results obtained in the current investigation indicate that the haemolymph composition of this species is similar to that of the other lepidopterans. For example, the concentrations of Na⁺ and K⁺ are very similar to those found in *Spodoptera exigua* (Cohen and Patana, 1982) and *Lymantria dispar* (Pannabecker, *et al.*, 1992). Similarly, the levels of Mg²⁺ and Ca²⁺ resemble those reported in *Spodoptera exigua* (Cohen and Patana, 1982) and *Heliothis virescens* (Bindokas and Adams, 1988). The amount of Cl⁻ present agrees closely with the value reported in *Lymantria dispar* (Pannabecker, *et al.*, 1992). In addition, the protein content and osmolarity compare very closely to that seen in *Lymantria dispar*.

Table (5.9) Composition of haemolymph from the larvae of *Spodoptera littoralis* and other lepidoptera larvae.

Species	Cations (mM)				Anions (mM)		Protein (mg/100µl)	Osmolarity (mosmol l ⁻¹)	Reference
	Na	K	Mg	Ca	Cl	PO4			
<i>Spodoptera littoralis</i>	19.1	31.0	39.6	6.1	16.9	10.2	17.1	332.2	Present study
<i>Spodoptea exigua</i>	16	36	37	4	32	38	26	292	Cohen & Patana (1982)
<i>Prodenia eridania</i>	22	40	7	9	34	6	10	-	Babers (1938)
<i>Heliothis virescens</i>	15	39	28	6	31	35	-	341	Bindokas & Adamas (1988)
<i>Heliothis zea</i>	28	38	61	3	26	-	-	338	Racioppi & Dahlman (1980)
<i>Lymantria dispar</i>	5	29	26	7	15	6	18	313	Pannabecker <i>et al.</i> (1992)

On the basis of the current studies on haemolymph composition, a physiological saline solution was produced which enabled fluid secretion to be studied *in vitro*, using isolated, individual Malpighian tubules.

In common with the Malpighian tubules of various other insect species which have been studied (*Calpodes ethlius*, Ryerse, 1978; *Calliphora erythrocephala*, Berridge, 1966), those of *Spodoptera littoralis* continued to secrete fluid at a near constant rate over approximately 1 hr, *in vitro*. This was taken as clear evidence that the saline used was appropriate for use in physiological studies. Furthermore, Malpighian tubules of *Spodoptera littoralis* secrete fluid *in vitro* without the need for an agonist to be added to the bathing medium; the maximum rate of fluid secretion being 47.5 ± 8.5 nl/min ($n=20$) for tubules from 5th instar larvae studied under 'normal' conditions. This compares favourably with maximal rates of secretion (31 nl/min) reported for tubules from 5th instar *Calpodes ethlius* (Ryerse, 1978) and is somewhat greater than that reported for adult instar *Pieris brassicae* where the stimulated secretion rate was about 15nl/min (Nicolson, 1976b); two of the few lepidopterans to have been studied. In the tsetse fly, *Glossina morsitans*, Gee, (1976b) reported that the maximum rate of fluid secretion was approximately 20nl/min in the presence of cAMP. Much lower rates have been reported in other species. For example, Malpighian tubules of *Locusta migratoria* (Anstee et al., 1978; Anstee et al., 1979; Donkin, 1981) and *Schistocerca gregaria* (Maddrell and Klunswan, 1973) are reported to secrete fluid at rates of approx. 2-4 nl/min. In *Rhodnius prolixus* the secretion rate for unstimulated tubules was 0.95 ± 0.05 nl/min⁻¹ (Maddrell and Overton, 1988), although this increases dramatically in the presence of 5-HT and cAMP (Maddrell et al., 1971). Similarly, Nicolson, (1992) reported that in *Tenebrio molitor*, Malpighian tubules secrete at about 4nl/min, but the rate increases to 25nl/min in the presence of corpora cardiaca homogenates. In the present study the maximal non-stimulated rate of fluid secretion was higher than that reported in the above insects. Nevertheless, fluid secretion by the

Malpighian tubules of *Spodoptera littoralis* was also stimulated by the addition of 5-hydroxytryptamine to the bathing medium. In addition to *Rhodnius* (referred to above), similar responses to 5-HT have been reported elsewhere for Malpighian tubules of a number of different insect species. These include the butterfly, *Papilio demodocus* (Nicolson and Millar, 1983), *Locusta migratoria* (Morgan and Mordue, 1984), *Calliphora vicina* (Schwartz and Reynolds, 1979), *Aedes aegypti* (Veenstra, 1988) and *Carausius morosus* (Maddrell, *et al*, 1971).

The fluid secretion by Malpighian tubules is known to be hormonally controlled in a number of insect species (e.g *Rhodnius prolixus*, Maddrell (1964); *Dysdercus fasciatus*, Berridge and Oberlader, (1966); *Schistocerca gregaria*, Mordue (1969) and *Glossina morsitans*, Gee (1975b) and numerous diuretic peptides have been identified which stimulate tubule fluid secretion. Such agonists are believed to operate *via* a second messenger system involving cAMP and/or IP₃ and Ca²⁺. A number of researchers have demonstrated changes in intracellular second messenger levels following corpora cardiaca extract treatment of Malpighian tubules (Aston 1975, 1979; Nicolson and Isaacson, 1987; Fogg *et al.*, 1990; Barrett and Orchard, 1990; Rafaeli, 1990; Marshall *et al*, 1993 and Lehmberg *et al*, 1993). In some insects, such as *Rhodnius*, *Locusta* and *Carausius*, the action of diuretic hormone is reportedly mimicked by 5HT (Maddrell, 1969,1971; Morgan and Mordue, 1984). However, some researchers have failed to demonstrate that 5-HT has a significant stimulatory effect on fluid secretion by Malpighian tubules in some insects e.g *Schistocerca gregaria* (Maddrell and Klunswan, 1973), *Locusta migratoria* (Morgan and Mordue, 1984); Anstee *et al.*, 1980). More recently, Maddrell *et al.* (1991) have suggested that 5-HT is in fact a true insect hormone in *Rhodnius*.

Insect diuretic peptide hormones are reported to stimulate the rate of fluid secretion by insect Malpighian tubules and to effect an increase in intracellular cAMP levels in various insect species (Kay *et al.*, 1991; Lehmberg *et al.*, 1991 and Audsley *et al*, 1993). One such peptide hormone is that isolated from pharate adult whole head

extracts of *Manduca sexta*. This hormone has recently been sequenced and synthesised and is called *Manduca sexta* diuretic hormone (Mas-DH) (see Kataoka *et al.*, 1989). However, this hormone had no significant effect on the rate of fluid secretion by Malpighian tubules of larval *Spodoptera littoralis* over a wide range of concentrations, in the present study. Similar results were reported in isolated Malpighian tubules of *Manduca sexta* by Kataoka *et al.*, (1989) and Troetschler and Kramer (1992). Moreover, they also failed to demonstrate any significant effect in increasing the cAMP level in adult and pharate adult *Manduca sexta*. Audsley *et al.*, (1993) demonstrated that Mas-DH increased the rate of fluid secretion by adult Malpighian tubules of *Manduca sexta*. However, they failed to show that this hormone stimulated fluid secretion by the Malpighian tubules in larvae. This would seem to suggest that there may be a change in the hormone receptor site associated with metamorphosis in *Manduca sexta*. Whether this is also the case in *Spodoptera littoralis* is unknown as no study on the effects of Mas-DH on adult tubules of the latter species was carried out.

The mode of action of 5-HT at the cellular level has been much studied using *Calliphora* salivary glands (Berridge, 1970; Oschman and Berridge, 1970; Berridge and Prince; 1972; Berridge and Heslop, 1982). It is suggested that as in other transporting epithelia, fluid secretion is linked to solute transport (see Introduction for description of proposed ion transport model). The secretory processes are thought to be controlled by 5-HT activating two different second messenger systems (cAMP and IP₃/calcium). Two distinct types of 5-HT receptor are reported to be present on the basal cell membrane; a 5-HT₁ receptor which activates the cAMP system and a 5-HT₂ receptor which stimulates the Ca²⁺-phosphoinositide cascade (Berridge 1981; 1984). Thus it is suggested that stimulation with 5-HT effects an increase in intracellular cAMP and Ca²⁺, which in turn results in activation of the apical potassium transport pump and increased chloride permeability, respectively. In the present study, 5-HT stimulated the rate of fluid secretion by the medial region of Malpighian tubules of larval *Spodoptera littoralis*. It is tempting to suggest, therefore, that a similar mechanism may be

operating here. This would be consistent with studies on the effects of diuretic agents on other insect tubules. Thus, as mentioned above, diuretic hormones or endocrine gland extracts have been shown to stimulate increased intracellular levels of cAMP (e.g. in *Rhodnius*, Aston, 1975; and in *Locusta*, Fogg *et al.*, 1990) and IP₃ (in *Locusta*, Fogg *et al.*, 1990). However, further studies are necessary before it can be concluded that diuretic hormones operate in this way in *Spodoptera* with certainty.

It is generally accepted that fluid secretion by insect Malpighian tubules is iso-osmotic or slightly hyperosmotic to the bathing medium (Taylor, 1971a; Marshall *et al.*, 1993). Thus, the 'urine' secreted by Malpighian tubules of *Spodoptera*, which was slightly hyper-osmotic to the bathing medium (see Table 5.1), is, in this respect, like that produced in numerous other species (e.g. *Calliphora*, Berridge, 1968; *Locusta*, Anstee *et al.*, 1979; *Rhodnius*, Maddrell, 1969; and *Glossina morsitans*, Gee, 1975a; *Pieris brassicae* Nicholson, 1976a). In contrast, tubules of some other species have been reported to secrete a 'urine' which is slightly hypo-osmotic to the bathing medium (e.g. *Carausius morosus*, Ramsey, 1954; and *Dysdercus fasciatus*, Berridge, 1965). Taylor (1971a, b) discussed hypotonic urine secretion in insects and pointed out that whilst hyperosmotic secretion by Malpighian tubules presented no conceptual difficulty, hypo-osmotic secretion is more difficult to explain. He suggested that the production of hypo-osmotic fluid may be explained as a result of reabsorptive processes along the tubule and this view is supported by Bradley (1985).

The rate of fluid secretion by the Malpighian tubules of *Spodoptera littoralis* was affected by the osmotic concentration of the bathing medium; decreasing as the osmolarity of the medium was reduced from 'normal'. This is in contrast to results obtained with other species. For example, in *Calliphora* (Berridge, 1968), *Rhodnius* (Maddrell, 1969), and *Locusta* (Anstee *et al.*, 1979) the rate of fluid secretion was rapid in Ringer solutions of low osmolarity and slow in high osmotic concentration bathing media. However, it was reported, in *Locusta* that this was only true provided sufficient ions were available. It would seem, therefore, that the current observations on

Spodoptera littoralis may be explained by dilution of the media resulting in levels of K^+ and/or Na^+ which are too low to sustain 'normal' solute transport and water movements across the tubule wall.

In common with studies carried out on Malpighian tubules from other insects (e.g. *Locusta migratoria*, Anstee and Bell, 1975; Morgan and Mordue, 1981; *Calliphora erythrocephala*, Berridge, 1968; *Carausius morosus*, Pilcher, 1970; *Pieris brassicae*, Nicholson, 1976a) high concentrations of K^+ , in the bathing medium increased the rate of fluid secretion *in vitro*, suggesting that, as in the above species, K^+ transport may be the 'prime mover' in generating fluid secretion. As in *Calliphora* (Berridge, 1968), maximal rates of secretion were recorded when K^+ completely replaced Na^+ in the bathing medium. In *Spodoptera littoralis*, this effect was dependent on the presence of Cl^- , so that in the absence of the latter anion secretion under high $[K^+]$ conditions was not significantly different from the control rate. Other researchers have also reported that Cl^- is essential for the maintenance of maximal fluid secretion in other species (e.g. *Locusta*, Morgan and Mordue, 1981). In *Calliphora* fluid secretion was stopped by replacing Cl^- with SO_4^{2-} in the bathing medium (Berridge, 1969). In the present study, secretion was significantly reduced in the absence of K^+ and Cl^- , and although the rates of secretion were seldom less than 82% of the control rate, Na^+ is clearly an inadequate replacement for K^+ in maintaining maximal fluid secretion. Indeed, the rate of fluid secretion was not significantly different from the control under Na^+ -free conditions. This contrasts with the findings of Morgan and Mordue (1981) who reported that K^+ , Na^+ and Cl^- were essential to both basal and stimulated secretion in *Locusta migratoria*. Similarly, in *Musca domestica*, secretion is stated to be critically dependent upon the presence of Na^+ and K^+ with Na^+ being necessary for normal secretion; K^+ alone permitting only a low rate of secretion (Dalton and Windmill, 1980).

The effect of varying the relative concentrations of Na^+ and K^+ in the bathing medium on the concentration of these ions secreted in the 'urine' was somewhat

different from that reported in other species. In *Spodoptera littoralis*, the concentrations of Na^+ and K^+ in the secreted 'urine' were similar to those present in the bathing medium when the latter was the standard Ringer solution. However, increasing Na^+ concentration (at the expense of K^+) above this level resulted in a substantial increase in urine $[\text{Na}^+]$ (and a decrease in urine $[\text{K}^+]$). This dramatic increase in urine $[\text{Na}^+]$ was not matched by an equivalent decrease in urine $[\text{K}^+]$ so that urine $[\text{Na}^+ + \text{K}^+]$ was greater in bathing media containing 25 - 50mM Na^+ (and 25 - 0 mM K^+) than in bathing media containing 0 - 25 mM Na^+ (and 50 - 25 mM K^+). This would seem to indicate increased Na^+ transport across the epithelium at above 'normal' $[\text{Na}^+]_o$ whereas $[\text{K}^+]$ in the urine was seldom greater than that of the bathing medium above 15 mM $[\text{K}^+]_o$. In contrast to these findings, in *Locusta migratoria* (Anstee, *et al*, 1979); *Pieris brassicae* (Nicolson, 1976), *Calliphora erythrocephala* (Berridge, 1968), *Rhodnius* (Maddrell, 1969), *Musca domestica* (Dalton and Windmill, 1980), $[\text{Na}^+ + \text{K}^+]$ in secreted fluid was fairly constant over a wide range of reciprocal cation ratios in bathing media. It would appear, therefore, that in *Spodoptera*, the tubules are more effective in removing excess Na^+ than in dealing with increased bathing medium K^+ concentrations. This is despite the fact that K^+ transport appears to be the 'prime mover' in generating fluid secretion. If the latter is true, then reduced levels of K^+ in the bathing media would reduce fluid secretion and provided that Na^+ secretion is maintained (or possibly increased at elevated $[\text{Na}^+]_o$) a marked increase in the 'urine' concentration of Na^+ would be expected. Further investigation, using ion flux studies would help clarify this. It is tempting to suggest that in this insect the Malpighian tubules may play an important role in the regulation of Na^+ concentration in haemolymph, with K^+ being dealt with by some extra-renal route. Nicolson (1976a) reported that the Na^+ concentration of fluid secreted by tubules of the butterfly, *Pieris brassicae* was higher than that of the medium under K^+ -free bathing conditions. Cioffi, (1979,1984), Harvey and Zerahn, (1969); Thomas and May, (1984) and Dow and O'Donnell (1990) have shown that the goblet cells of lepidopteran midgut secrete

K^+ into the goblet cavities and thence to the gut lumen from the blood side. Other species have been reported to secrete significant Na^+ concentrations across the Malpighian tubules. In *Glossina morsitans* (Gee, 1976a), Na^+ is secreted in preference to K^+ and appears to be the 'prime mover' for fluid secretion. However, as indicated earlier, this is the opposite to other insects which have the ability to secrete potassium against its chemical gradient (e.g. *Pieris brassicae*, Nicolson, 1976a; *Calliphora*, Berridge, 1968; *Rhodnius*, Maddrell, 1969; *Musca domestica*, Dalton and Windmill, 1979; and *Locusta migratoria*, Anstee *et al.*, 1979).

The rate of fluid secretion by Malpighian tubules of *Spodoptera littoralis* was inhibited by the cardiac glycoside, ouabain; a specific inhibitor of $(Na^+ + K^+)$ -ATPase (Anstee and Bowler 1984). The rate of secretion decreased as the concentration of ouabain surrounding the tubules was increased; maximal inhibition being *ca* 94.6% at $10^{-3}M$. These findings are similar to those reported by Anstee and Bell (1975); Anstee *et al.*, (1979, 1980); see also review by Anstee and Bowler (1984). They showed that ouabain inhibited the rate of fluid secretion by the Malpighian tubules of *Locusta migratoria*. Also Atzbacher *et al.*, (1974) found that the rate of excretion of the two dyes, azocarmine and indigocarmine was significantly reduced in presence of ouabain. For some time the effect of ouabain on insect epithelial tissues was in dispute and in consequence the presence of Na^+/K^+ -ATPase in insect Malpighian tubules was disputed (see review by Anstee and Bowler, 1979, 1984). However, it is now generally accepted that this enzyme is indeed present in insects and Anstee *et al.* (1986) have suggested that the activity of this basolateral membrane ATPase is adequate to account for significant K^+ uptake in *Locusta*. More recently, Maddrell and Overton, (1988) have reported that Malpighian tubules of *Rhodnius* are sensitive to ouabain at concentrations greater than $2 \times 10^{-7} \text{ mol.l}^{-1}$ indicating that there is a Na^+/K^+ -ATPase involved in tubule function in this insect. Nevertheless, Nicolson and Millar, (1983) reported that ouabain had no effect on the rate of fluid secretion by Malpighian tubules of another lepidopteran, *Papilio demodocus*. Numerous studies suggest that little or no

Na^+/K^+ ATPase is present in lepidopteran midgut (Jungreis and Vaughan, 1977; Harvey *et al.*, 1983; Zeiske, 1992). Indeed, Jungreis and Vaughan, (1977) reported that caterpillar midgut definitely lacked this enzyme and that alkali metal transport across the larval midgut must occur via energy dependent mechanisms not involving a ouabain-sensitive Na^+/K^+ ATPase. The present study indicates that a Na^+/K^+ ATPase is present in *Spodoptera littoralis* Malpighian tubules and that its normal functioning is essential for fluid secretion.

Despite the effect of ouabain on fluid secretion by *Spodoptera* tubules, it did not have any significant effect on the $[\text{Na}^+]/[\text{K}^+]$ ratio in the secreted 'urine', at any concentration studied (see Table 5.6). In contrast, in *Locusta*, treatment with 1 mM ouabain significantly increased the urine $[\text{Na}^+]/[\text{K}^+]$ ratio and inhibited fluid secretion (Anstee *et al.*, 1980). However, in the 'urine' of pill millipede, *Glomeris marginata* (Farquharson, 1974), ouabain was found to have no effect on the concentration of Na^+ and K^+ although it did inhibit fluid secretion; a result comparable with that observed here.

The lack of clear evidence for K^+ -activated, ouabain-sensitive p-nitrophenylphosphatase (i.e. Na^+/K^+ ATPase) in medial tubule cells was surprising given the ouabain-sensitivity of fluid secretion observed in the physiological studies. Indeed, no reaction product was observed in the basolateral regions of these cells. One possible explanation is that the fixation and incubation conditions used in the cytochemical procedure may have inhibited the ATPase activity. Ernst (1972a) reported that paraformaldehyde fixation preserved a large proportion of the K^+ -activated NPPase activity in avian salt gland. However, Komnick and Achenbach (1979) and Fogg *et al.* (1992) have questioned the validity of this technique having demonstrated substantial inhibition of activity associated with the preparative procedures. Fogg *et al.* (1992) conclude that the cytochemical procedure of Ernst (1972b) does not permit the positive demonstration of Na^+/K^+ ATPase activity in Malpighian tubules of *Locusta* and that the technique is probably only suitable where a tissue is very rich in this

transport enzyme so that sufficient activity remains unhibited after the histochemical procedure.

In contrast, to the absence of specific reaction product in medial tubule cells, there was evidence of K^+ -activated, ouabain-sensitive NPPase in cells of the proximal region of Malpighian tubules of *Spodoptera*. The strontium-capture technique of Ernst (1972a,b) showed the deposition of electron dense reaction product in association with the basal plasma membrane infoldings and that this was dependent on the presence of K^+ in the incubation medium and inhibited by ouabain. Furthermore, no reaction product was observed in this region in controls in which p-nitophenylphosphate (NPP) substrate was replaced with B-glycerophosphate; the former but not the latter being a substrate which is hydrolysed by the (Na^+K^+) -ATPase (Fujita *et al.*, 1966; Ernst, 1972a,b; Fogg *et al.*, 1992). This would suggest that the (Na^+K^+) -ATPase activity is localised in association with the basal plasma membrane of the proximal tubule cells. It would also imply, if the explanation offered for the lack of specific reaction product in the medial tubule cells is correct, that there is greater basolateral membrane Na^+/K^+ ATPase activity in the proximal tubule cells than in those of the distal region. Hence, sufficient activity would be retained after processing to permit cytochemical localisation to be achieved.

In this study, little if any K^+ -activated, ouabain-sensitive NPPase specific reaction product was observed at the apical microvillar surface in either the distal or the proximal tubule regions. This is consistent with reports that the (Na^+K^+) -ATPase is normally associated with the basolateral membranes of cells (Fogg *et al.*, 1992; Ernst, 1972b; Karnaky *et al.*, 1976; Peacock, 1976 and Greenwald *et al.*, 1984). The reaction product that was observed in the apical region was unaffected by ouabain or substrate, supporting the suggestion by Fogg *et al.*, (1992) that such activity is due to non-specific alkaline phosphatase. If this interpretation is correct, then there must be more alkaline phosphatase activity associated with the microvilli of distal tubule cells than those of the proximal region. However, the exact nature of this activity warrants further study as



the results suggest that deposition of alkaline phosphatase reaction product was K^+ -sensitive being significantly reduced when choline replaced K^+ in the incubation medium.

The rate of fluid secretion by the Malpighian tubules of *Spodoptera littoralis* was also inhibited by furosemide. Furosemide is a known inhibitor of Na^+ coupled Cl^- transport in various epithelia (Frizzell et al, 1979; Hanrahan and Phillips, 1983; Palfrey and Rao, 1983; Welsh, 1983). In the present study $10^{-4}M$ furosemide caused a highly significant reduction in the fluid secretion ($P < 0.001$) by Malpighian tubules of *Spodoptera*. Similar results have been reported with Malpighian tubules from other species. For example, O'Donnell and Maddrell (1984) observed inhibition of fluid secretion in *Rhodnius* tubules by using $10^{-4}M$ furosemide. They suggested that a co-transport process was responsible for Na^+ and Cl^- entry into the cells across the basal plasma membrane. Similarly, in *Locusta*, Baldrick et al, (1988) reported that the effects of furosemide indicated that chloride might cross the basal plasma membrane into the cell by means of a co-transport mechanism. Thus the observed effect of furosemide on tubules of *Spodoptera* suggest that a Na^+/Cl^- or $Na^+/K^+/2Cl^-$ cotransport process is involved in fluid and ion secretion in this insect also and that this cotransport process is probably associated with the basal cell surface.

Recent studies (Schweickl et al., 1989; Wieczorek et al, 1989; Zeiske, 1992) have suggested that a vacuolar or V-type ATPase may be responsible for ion transport across the apical cell surface of insect Malpighian tubules. Such vacuolar ATPases have been observed in the membranes of eukaryotic cells (Forgac 1989) and in the apical plasma membrane of goblet cells of *Manduca sexta* (Zheng, et al., 1992; Novak, et al., (1992). NEM and bafilomycin A_1 are reported to be a fairly selective inhibitors of V-type ATPase activity. Forgac (1989) reported that such ATPases are sensitive to NEM at 1-2 μM concentrations. Torres-Zamorano et al., (1992) reported that the plasma membrane V-type H^+ -pump of bovine corneal epithelium was completely inhibited by 10 μM NEM. Similarly, Bertram et al, (1991) have shown that bafilomycin A_1 inhibits

this ATPase. It was particularly interesting, therefore, that fluid secretion by tubules of *Spodoptera littoralis* was found to be completely inhibited by 10^{-5} M NEM suggesting that a V-type ATPase was involved in tubule function. Other workers have also reported that a V-type ATPase is centrally involved in the formation of fluid secretion by insect Malpighian tubules (Maddrell and O'Donnell 1992). This suggestion is based on reports showing that the rate of fluid secretion by Malpighian tubules is inhibited by bafilomycin A₁ and NEM (e.g. in *Drosophila hydei*, Bertram *et al.*, 1991; in the ant, *Formica polyctena*, Welens *et al.*, 1992). Thus it is proposed (Fogg *et al.*, 1991; Maddrell *et al.*, 1992) that cation transport across the apical cell membrane could be by a similar mechanism to that proposed by Wieczorek *et al.* (1989). They suggest that primary active electrogenic proton transport by a V-type ATPase energises a secondary electroneutral K⁺/H⁺ or Na⁺/H⁺ exchange. The present results would be consistent with such a model explaining tubule function in *Spodoptera*.

In the present study, fluid secretion rates measured *in vitro* were markedly affected by the developmental stage. As described previously fluid secretion varied throughout larval development; the rate of secretion being relatively low at the beginning and end of the stadium compared with the mid-stadium. Secretion stopped in the prepupal and pupal stages and then restarted in the newly moulted adult. Thus, in the larvae, the maximal secretion rates tended to coincide with those periods when feeding activity was greatest (personal observation). This observation is similar to that reported in *Calpodes ethlius* by Ryerse, (1978) and in the 5th instar of *Locusta migratoria* Donkin, (1981). Similarly, Nicolson, (1976a) reported that in *Pieris brassicae* fluid transport increases during the feeding period of the last larval stage, decreases in the wandering stage and stops in the prepupa instar. Berridge, (1966) suggested that in *Dydercus*, the animal entered a period of fasting which coincided with an antidiuretic phase which may account for the lack of tubule fluid secretion in this period. Other workers have suggested that feeding activity in insects may stimulate the release of hormones (see Wigglesworth 1934; Maddrell, 1964 and Mordue, 1972). For

example, in the blood-feeding insects such as *Rhodnius* and *Glossina* it has been shown that a diuretic hormone is released in response to a blood meal (Maddrell, 1964; and Gee, 1975a, respectively). An association of feeding with the release of diuretic hormone has also been reported in *Locusta* (Mordue, (1966). Studies on adult locusts have also shown that blood volume depends on feeding activity (Mordue, 1969). Thus it is suggested that the release of diuretic hormone in response to feeding leads to increased fluid secretions by the Malpighian tubules and that water accumulates in the haemolymph in the absence of diuretic hormone. This explanation has been suggested to account for the variations in the relative water content observed in 5th instar *Locusta* (Donkin, 1981) and in 4th, 5th and adult *Schistocerca gregaria* (Lee, 1961).

Baehr *et al.*, (1979) investigated the changes in daily water content of 4th and 5th instar of *Locusta*, and showed that the relative water content varied from 72 to 77% with maximal values at the beginning and end of the stadium. In the present study, apart from the fifth stadium and the transition from the 6th instar to the prepupa, little variation in water content was observed in *Spodoptera* (84- 86% in 4th; 83-86.5% in 5th; but 79-85% in 6th/prepupae). However, the maximal value tended to occur at the beginning of the of the instar and, in 5th instar larvae, towards the end of the stadium. Donkin (1980) pointed out that the variations in relative water content in locusts was very similar to the patterns of change in haemolymph volume reported by Lee (1961) and Beenackers (1973) and that it was reasonable to assume that variations in water content may reflect changes in haemolymph volume. On the assumption that this argument is equally valid in the case of lepidopterans, it would suggest that in *Spodoptera* blood volumes were greatest at the start of the instar when, as mentioned above, tubule secretion is relative low. However, the pattern of change in relative water content and *in vitro* tubule secretion rates appear unrelated in *Spodoptera* which is in contrast to the findings of Donkin (1980) in *Locusta*.

CHAPTER 6

CONCLUSION

In this study the fine structure of the different regions of the Malpighian tubules of *Spodoptera littoralis* were studied at different stages in the life cycle. The results of this investigation suggested that the cells of these organs were specialised for transepithelial transport functions. In common with Malpighian tubules from other insect species, such as *Bombyx mori* (Teigler and Arnott, 1972), *Rhodnius prolixus* (Bradley, 1983; Maddrell *et al.*, 1985; Skaer *et al* 1990) and *Calpodes ethlius* (Ryerse, 1979), the apical surface of the epithelial cells was characterized by the presence of a brush border and the basal plasma membrane was folded, resulting in an increased surface area. Mitochondria were present within the microvilli of the larval and adult instars in all regions studied and were associated with the basal membrane foldings in the medial regions but not the proximal regions. Other differences between the proximal and medial tubule regions were noted. The proximal region of *Spodoptera littoralis* possessed a well-developed microvillar border and the epithelium in this region was characterized by marked depressions, but no canaliculi. This feature is similar to that seen in the same region of *Papilio demoleus*, Kumar and Srivastava, (1981). In contrast the medial and distal regions possessed microvilli which were considerably longer and more densely packed compared to that seen in the proximal region. In addition, considerable folding of the apical plasma membrane was apparent resulting in the formation of canaliculi or extracellular spaces that face the tubule lumen. Similar canaliculi have been described in other transporting epithelia, for example the distal secretory region of the salivary glands of *Calliphora erythrocephala* (Oschman and Berridge, 1970). In the proximal absorptive region of *Calliphora* salivary glands, canaliculi were absent. Thus there were distinct similarities between the fine structure of the medial and proximal regions of *Spodoptera* Malpighian tubules and the equivalent divisions of salivary glands of *Calliphora*. On this basis it is tempting to

suggest that, as in salivary glands of *Calliphora*, the medial region of Malpighian tubules of *Spodoptera* may be specialised for secretion of ions and water whilst the proximal region may be involved in reabsorption of salt and/or water. Patton (1953) has also suggested that in lepidopteran larvae in general, the medial region is responsible for the secretion of solute and water from the haemolymph to the tubule lumen and that the proximal tubules are responsible for reabsorption.

The proposal that the medial regions of *Spodoptera* tubules are responsible for ion and fluid secretion is supported by the physiological studies carried out as part of this investigation. This region is more-or-less equivalent to the yellow region in Malpighian tubules of *Calpodes ethlius* which has also been shown to secrete ions and water (Ryerse, 1977, 1979). The results obtained in the current physiological studies, together with evidence from other published work, permit a hypothetical model to be constructed to explain the mechanism involved in ion and water transport across the medial tubule epithelium in *Spodoptera littoralis*. This model (see Fig. 6.1) is intended as a stimulus for further experimentation which should enable it to be modified and improved.

The secretion of fluid by the Malpighian tubules of *Spodoptera* was shown to increase with increased K^+ concentration in the bathing medium. Indeed, K was essential for maximal rates of secretion to occur suggesting that this cation is the prime mover in fluid secretion by *Spodoptera* medial tubules as it is in numerous other insect species studied. Other workers have also shown that tubule fluid secretion in insects is dependent on ion transport (see Chapter 5). The secretion of ions and water requires movement across both the basal and apical plasma membranes of the tubule cells.

In the current study 10^{-5} M NEM almost completely inhibited fluid secretion by *Spodoptera* Malpighian tubules (see Chapter 5). NEM is considered to be a fairly specific inhibitor of V-type ATPases, suggesting that such an enzyme is involved in the fluid transport mechanism in *Spodoptera*. Recently, a number of workers have suggested that the apical cation extrusion mechanism involves a V-type ATPase (Fogg

et al., 1991; Zeiske, 1992). The suggestion is that a V-type ATPase pumps protons from the cytoplasm to the lumen and that the proton gradient generated energises a K^+ (or Na^+)/ H^+ antiporter which exchanges luminal protons for intracellular K^+ (or Na^+). Thus, the net result is that K^+ and/or Na^+ enter across the basal cell surface and are transported across the apical membrane to the lumen by the V-type ATPase linked to the antiporter. A similar mechanism has been located on the apical membrane of the midgut goblet cells and in the brush-border membrane of Malpighian tubules of *Manduca sexta* (see Schweickl et al., 1989; Wieczorek et al., 1989, 1991 and Wieczorek, 1992; Klein et al., 1991 and Klein, 1992). Furthermore, evidence for the apical localisation of the V-type ATPase has been provided by cytochemical studies using fluorescent labelled antibodies to this enzyme (Bowman et al., 1992). It is tempting, therefore, to propose a similar arrangement in the medial tubule region of *Sodoptera littoralis* (see Fig. 6.1).

In the majority of insect Malpighian tubule cells studied, the basal plasma membrane is reported to be relatively permeable to K^+ and relatively impermeable to Na^+ and Cl^- . A number of workers have suggested that K^+ may enter the cells passively as proposed in the Malpighian tubule cells of *Drosophila hydei* (Bertram et al., 1991) and those of *Locusta migratoria* (Morgan and Mordue, 1983). However, it has been pointed out that the electrochemical gradient across the basal plasma membrane may be less favourable to K^+ entry than to its exit across this cell surface (Baldrick et al., 1988; Fogg et al., 1991). As already discussed, other pathways for K^+ entry must exist. These may involve a basal membrane Na^+/K^+ ATPase exchange pump and/or $Na^+/K^+/2Cl^-$ co-transport (see Bertram, 1991 and Zeiske, 1992). The hypothetical model advanced here (Fig. 6.1) proposes that, in common with a number of other insect species (see Anstee and Bell 1975; Anstee et al 197; Anstee and Bowler, 1984; Phillips, 1981,1983; Maddrell and O'Donnell,1992;Zeiske,1992;) a basal membrane Na^+/K^+ ATPase is responsible for the exchange transport of intracellular Na for extracellular K^+ , thus maintaining a Na^+ gradient across the basal

Fig.6.1

A hypothetical model to explain ion transport across cells of the medial region of Malpighian tubules of *Spodoptera littoralis* :

A schematic diagram of a hypothetical model proposed to explain ion and water movement across the cells of Malpighian tubules of *Spodoptera littoralis*. In this model the basal (serosal) membrane faces the bathing medium, whereas the apical (mucosal) membrane faces the luminal side of tubule. In this model it is proposed that a $(\text{Na}^+ + \text{K}^+)$ -ATPase and $\text{Na}^+ / \text{K}^+ / 2\text{Cl}^-$ cotransporter are located on the basal plasma membrane and that the apical cation pump represents a V-type ATPase coupled with a $\text{K}^+(\text{Na}^+)/\text{H}^+$ antiporter. It is suggested that K^+ enter across the basal membrane by the above named transport processes and are passed into the lumen at the apical surface in exchange for H^+ which have been pumped out of the cell by the V-type ATPase. On the basis of evidence from other insect species (referred to earlier), it is proposed here that, in *Spodoptera* also, the basal membrane is permeable to K^+ but relatively impermeable to Na^+ and Cl^- so that the latter enter across the basal cell surface by a co-transport mechanism with Cl^- following cation movements into the tubule lumen, across the apical membrane, passively. Water movements are a secondary consequence of solute transport.

A possible mechanism for the endocrine control of these processes was discussed previously (see Chap. 5). It was tentatively suggested that, in common with other species, two second messenger systems, cAMP and $\text{IP}_3/\text{Ca}^{2+}$, may mediate the action of 5-HT and/or the natural diuretic hormone; the former stimulating the apical cation extrusion mechanism and the latter controlling Cl^- conductance.

a: V-type ATPase; b: $\text{K}^+(\text{Na}^+)/\text{H}^+$ antiporter; c: Na^+/K^+ -ATPase; d: $\text{Na}^+:\text{K}^+ : 2\text{Cl}^-$ cotransporter; Rc: hormone receptor site.

Fig. 6.1

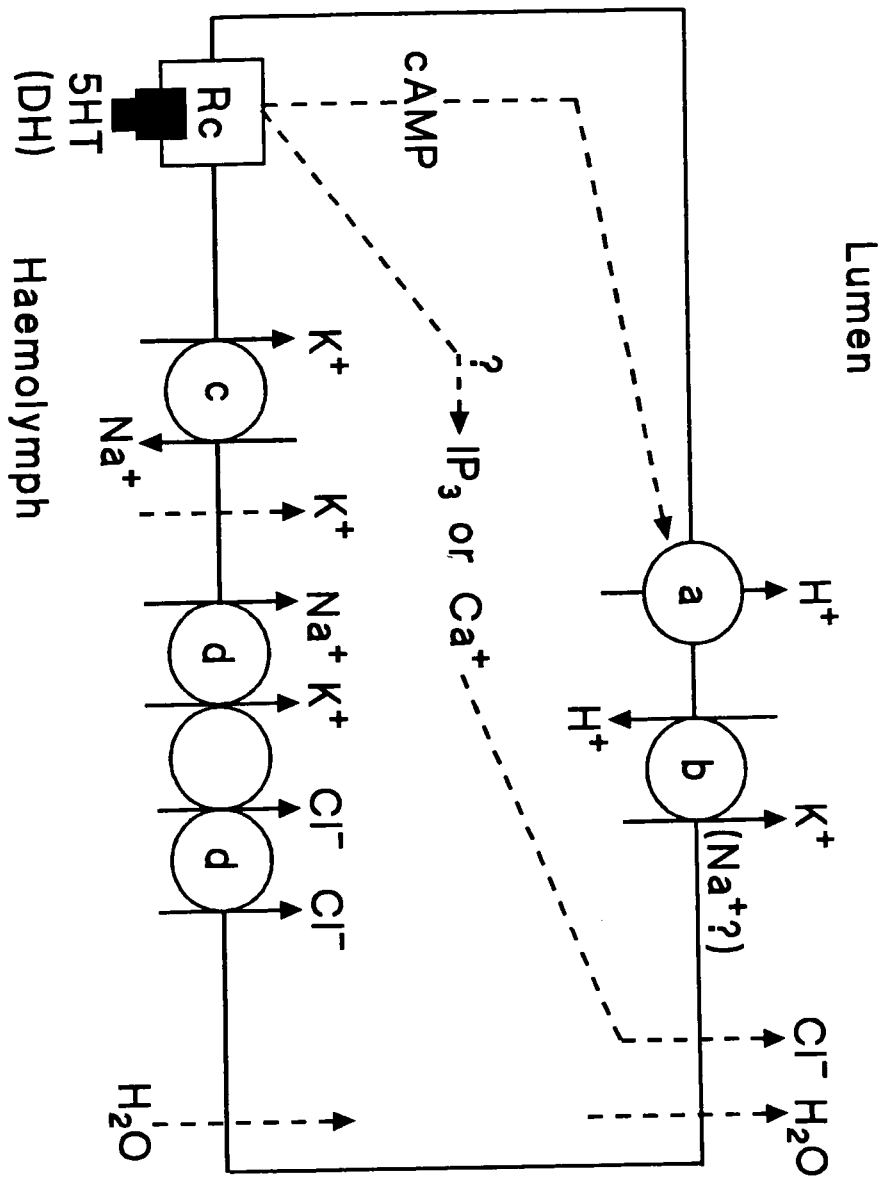

plasma membrane. Numerous researchers have questioned the presence of Na^+/K^+ ATPase in lepidopteran gut and Malpighian tubules (see Chapter 5). However, the presence of this enzyme in tubules of *Spodoptera* is indicated by the *in vitro* inhibition of fluid secretion by ouabain, a specific inhibitor of Na^+/K^+ ATPase activity (Skou, 1957). However, cytochemical studies whilst indicating the presence of this enzyme in the proximal tubules failed to confirm its presence in the distal tubules. This apparent anomaly was discussed in Chapter 5.

The rate of fluid secretion by medial tubules of *Spodoptera* was also inhibited by the loop-diuretic, furosemide, a specific inhibitor of Na^+ -coupled Cl^- transport (see Chapter 5). Similar effects on tubule secretion have been reported for furosemide with other insect species (O'Donnell and Maddrell, 1984; Baldrick *et al.*, 1988). Thus it was concluded that a Na^+/Cl^- or $\text{Na}^+/\text{K}^+/2\text{Cl}^-$ cotransport process was involved in fluid secretion by Malpighian tubules of *Spodoptera* with the Na^+ gradient generated by the Na^+/K^+ ATPase activity energizing the cotransport of Na^+ , K^+ and Cl^- across the basal cell membrane into the cell.

Evidence for an endocrine control of fluid secretion by the medial tubule region was provided by the observation that 5-HT and cAMP stimulated 'urine' production *in vitro*. Both of these agonists have been shown to stimulate Malpighian tubule secretion in other insect species (see Chapter 5; Maddrell, 1969; 1971; Nicholson and Millar 1983) and 5-HT is reported to act as a diuretic hormone in *Rhodnius prolixus* (Maddrell *et al.*, 1991). Berridge, (1970) studied the effects of 5-HT on salivary glands of *Calliphora* and suggested that its mode of action involved two second messenger systems, cAMP and $\text{IP}_3/\text{Ca}^{2+}$. This proposal is consistent with studies on other tissues which indicate that 5-HT binds at two distinct receptor sites, 5-HT₁ and 5-HT₂ (Berridge and Heslop, 1982). Activation via the 5HT₁ receptor is reported to elevate the intracellular second messenger cAMP whilst stimulation via the 5-HT₂ receptor site increases levels of IP_3 and/or Ca^{2+} . It is generally believed that in Malpighian tubules of insects, diuretic hormone or similar agonists stimulate fluid secretion by a

mechanism involving one or both of the above mentioned intracellular second messenger systems (Morgan and Mordue, 1984; Fogg et al., 1991). It is proposed that increased intracellular cAMP stimulates the apical electrogenic cation pump and that IP₃ or Ca²⁺ may regulate Cl⁻ movement in and out of the cell (Berridge, 1981, 1984; Fogg et al., 1991). Since both 5-HT and cAMP stimulated fluid secretion by medial tubules of *Spodoptera*, it is tempting to suggest that a similar mechanism is involved in their endocrine control with 5-HT acting to increase intracellular cAMP levels which stimulate the apical cation pump to secrete K⁺(and/or Na⁺) into the lumen. This proposal has been incorporated into the model shown in Fig. 6.1. However, further studies are necessary to confirm these suggestions and to investigate the extent to which an IP₃/Ca²⁺ second messenger system is also implicated. However, the fact that 1mM cAMP was less effective in stimulating fluid secretion than 5-HT may suggest that the latter is activating more than just the cAMP second messenger system in producing its effect.

The rate of fluid secretion *in vitro* was found to be related to developmental changes throughout the stadium. In larvae the rate of secretion varied throughout a given stadium, being lowest prior to and immediately after each moult. Secretion stopped completely in the prepupal and pupal instar and restarted in the newly moulted adult. To date, age-dependent effects on fluid secretion in insects are not well documented. Exceptions include studies on *Calpodes ethius* where the fluid secretion varied with age and was similarly switched-off in the early pupal stage (Ryerse, 1978) and *Locusta migratoria* (Donkin, 1980) where similar variations in larval secretion rates were reported throughout the stadia. Several workers have suggested explanations for such changes in the rates of fluid secretion. It is proposed that the increase in the rate of Malpighian tubule fluid secretion is linked to feeding activity. Thus, it is suggested that a period of active feeding may stimulate the release of a diuretic hormone (Wigglesworth, 1943; Maddrell, 1964; Mordue, 1972) and the period of fasting may be accompanied by an antidiuretic phase (see Berridge, 1966). This may well

explain the fluctuations in rates of secretion within a stadium ; food intake was low at the beginning and end of the stadium when secretion rates were similarly reduced. However, the total cessation of secretion at pupation is likely to be more a consequence of restructuring of the tubule cells associated with metamorphosis. It is likely, therefore, that these changes are related to changing titres of ecdysteroid and juvenile hormones. Ryerse (1980) has implicated ecdysone and juvenile hormone in controlling the developmental physiology of Malpighian tubules. He showed that 20-hydroxyecdysone switched off fluid secretion and initiated cellular remodelling at pupation and was also involved in triggering Malpighian tubule development and restoration of fluid secretion in the adult. The changes in cellular fine structure observed throughout larval, pupal and adult development in *Spodoptera* (see Chapter 3) are similar to those reported by Ryerse (1978, 1979) in *Calpodes ethlius*. Larval tubules showed a high rate of fluid secretion and exhibited well-developed basal membrane infoldings and mitochondria extending into the apical microvilli (see above). At pupation, the infolds are considerably reduced and mitochondria are withdrawn from the microvilli. The Malpighian tubules persist through metamorphosis and the infolds reform and mitochondria are reinserted in microvilli in the adult. Ryerse (1980) reported that ecdysone was responsible for these structural changes. Juvenile hormone was found to modify the influence of 20-hydroxyecdysone on Malpighian tubules of larvae of *Calpodes ethlius* at moulting. In this study, treatment with the juvenile hormone analogue methoprene prevented those changes in Malpighian tubule cell structure and function which normally accompany metamorphosis, an effect which suggests modification of normal changes which are likely to be controlled by ecdysteroid hormones in *Spodoptera littoralis*.

REFERENCES

- Akai, H. and Kobayashi, M. (1971). Induction of prolonged larval instar by the juvenile in *Bombyx mori* L. (Lepidoptera: Bombycidae). *Appl. Ent. Zool.* **6**, 138-139.
- Anstee, J.H. Baldrick, P. and Bowler, K. (1986). Studies on Ouabain-binding to (Na⁺/K⁺)-ATPase from Malpighian tubules of the Locust, *Locusta migratoria*. L. *Biochimica et Biophysica. Acta.* **860**, 15-24.
- Anstee, J.H. and Bell, D. M. (1975). Relationship of Na⁺/K⁺-Activated ATPase fluid production by Malpighian tubules of *Locusta migratoria*. *J. Insect. Physiol.* **21**, 1779-1784.
- Anstee, J.H., Bell, D.M. and Hyde, D. (1980). Some factors affecting Malpighian tubule fluid secretion and transepithelial potential in *Locusta migratoria*. L. *Experientia.* **36**, 198-199.
- Anstee, J.H., Bell, D. M. and Fathpour, H. (1978). Fluid and cation secretion by the Malpighian tubules of *Locusta*. *J. Insect Physiol.* **25**, 373-380.
- Anstee, J.H., Bell, D.M. and Fathpour, H. (1979). Fluid and cation secretion by the Malpighian tubules of *Locusta*. *J. Insect Physiol.* **25**, 373-380.
- Anstee, J.H. and Bowler, K. (1979). Ouabain-sensitivity of insect epithelial tissues. *Comp. Biochem. Physiol.* **62A**, 763-769.
- Anstee, J.H., and Bowler, K. (1984). Techniques for studying Na⁺, K⁺- ATPase. In *Measurement of Ion Transport and Metabolic Rate*. Ed. Bradley, E. and Miller, T.A., Springer-Verlag, New York, Berlin, Heidelberg, Tokyo. Springer series in *Experimental Entomology*, pp.187-220
- Aston, R.J. (1975). The role of adenosine 3':5'-cyclic monophosphate in relation to the diuretic hormone of *Rhodnius prolixus*. *J. Insect Physiol.* **21**, 1873-1877.
- Aston, R.J. (1979). Studies on the diuretic hormone of *Rhodnius prolixus*. Some observations on the purification and nature of the hormone and the dynamics of its release *in vitro*. *Insect Biochem.* **9**, 163-176.

- Atkinson, A., Atenby, A.D and Lowe, A.G. (1973). The determination of inorganic orthophosphate in biological systems. *Bioch. Biophys. Acta.* **320**, 195-204.
- Atzbacher, U.F., Hevert, E., Webervon-G. and Wessing, A. (1974). The influence of ouabain in the elimination of injected and orally applied dyes in *Drosophila hydei*. *J. Insect Physiol.* **20**, 1989-1997.
- Audsley, N., Coast, G. and Schooley, D. (1993). The effects of *Manduca sexta* diuretic hormone on the fluid transport by the Malpighian tubules and cryptonephric complex of *Manduca sexta*. *J. Exp. Biol.* **178**, 231-243.
- Babers, F. H. (1938) Analysis of the blood of the sixth-instar southern army worm, *Prpdenia eridania*. *J. Agric. Res.* **57**, 697-706.
- Baehr, J.C., Porcheron, M., and Dray, F. (1979). Haemolymph levels of juvenile hormone, ecdysteroids and protein during the last two larval instars of *Locusta migratoria*. *J. Insect Physiol.* **25**, 415-421.
- Baldrick, P. (1987). Studies on ion movement in Malpighian tubules of *Locusta migratoria* L. with particular reference to electrical events. Ph.D Thesis. University of Durham.
- Baldrick, P., Hyde, D. and Anstee, J.H. (1988). Microelectrode studies on Malpighian tubule cells of *Locusta migratoria*: Effects of external ions and inhibitors *J. Insect Physiol.* **34**, 963-975.
- Barrett, F.M. and Orchard, I. (1990). Serotonin-induced elevation of cyclic AMP level in the epidermis of the blood-sucking bug, *Rhodnius prolixus*. *J. Insect Physiol.* **36**, 625-633.
- Baumann, G. (1968). Zur wirkung des juvenil hormons: Electrophysiologische messunger an der zellmembran der speicheldrüse von *Galleria mellonella*. *J. Insect Physiol.*, **14**, 1459-1476.
- Baumann, G. (1969). Juvenile hormone: Effect on bimolecular lipid membranes. *Nature*, **223**, 316-317.
- Beenackers, A.M. (1973). The influence of corpora allata on flight muscle development in locusts. *J. Endocr.* **57**, 52-56.

- Bell, D.M. and Anstee, J.H. (1977). A study of the Malpighian tubules of *Locusta migratoria* by scanning transmission electron microscopy. *Micron*. **8**, 123-134.
- Benskin, J. and Vinson, S. B. (1973). Factors affecting juvenile hormone analogue activity in the tobacco budworm. *J. Econ. Ent.* **66**, 15-20.
- Berridge, M.J. (1965). The physiology of excretion in the cotton stainer, *Dysdercus fasciatus*, (Signoret).IV. Hormonal control of excretion. *J. Exp. Biol.* **44**, 553-566.
- Berridge, M.J. (1966). Metabolic pathways of isolated Malpighian tubules of the blowfly functioning in an artificial medium. *J. Insect Physiol.* **12**, 1523-1538.
- Berridge, M.J. (1967). Urine formation by the Malpighian tubules of *Calliphora*. I.Cations. *J. Exp. Biol.* **48**, 159-174.
- Berridge, M.J. (1968). Urine formation by the Malpighian tubules of *Calliphora*. II. Anions. *J. Exp. Biol.* **50**, 15-28.
- Berridge, M.J. (1970). The role of 5-Hydroxytryptamine and cyclic AMP in the control of fluid secretion by isolated salivary glands. *J. Exp. Biol.* **53**, 171-186.
- Berridge, M.J. (1980). The role of cyclic nucleotide and calcium in the regulation of chloride transport. *Ann. N. Y. Acad. Sci.* **341**, 157-171.
- Berridge, M.J. (1981). Electrophysiological evidence for the existence of separate receptors for 5-Hydroxytryptamine. *Molec. Cell. Endocrin.* **24**, 115-140.
- Berridge, M.J. (1984). Inositol trisphosphate and diacylglycerol as second messengers. *Biochem. J.* **220**, 345-360.
- Berridge, M.J. and Gupta, B.L. (1968). Fine structural localization of adenosine triphosphatase in the rectum of *Calliphora*. *J.Cell. Sci.* **3**, 17-32.
- Berridge, M.J. and Heslop, J.P. (1982). Receptor mechanism mediating the action of 5-Hydroxytryptamine. In *Neuropharmacology of Insects. Ciba Foundation Symposium 88*, Eds. Evered D. O'Conner, M. and Whelan, J., Ptman, London. pp. 260-274.

- Berridge, G. and Oberlander, H. (1966). The physiology of excretion in the cotton stainer *Dysdercus fasciatus* (Signoret). IV hormonal control of excretion. *J. Exp. Biol.* **44**, 553-566.
- Berridge, M.J. and Oschman, J.L. (1969). A structural basis for fluid secretion by Malpighian tubules. *Tissue and Cell.* **1**, 247-272.
- Berridge, M.J. and Oschman, J.L. (1972). *Transporting Epithelia*. Academic Press, New York.
- Berridge, M.J. and Patel, N.G. (1968). Insect salivary glands: Stimulation of fluid secretion by 5-hydroxytryptamine and adenosine-3',5'-monophosphate. *Science, N.Y.* **162**, 462-463.
- Berridge, M.J. and Prince, W.T. (1972). Transepithelial potential changes during stimulation of isolated salivary glands with 5-hydroxytryptamine and cyclic AMP. *J. Exp. Biol.* **56**, 139-153.
- Bertram, G., Schleithoff, L., Zimmerman, P. and Wessing, A. (1991). Bafilomycin A₁ is a potent inhibitor of urine formation by Malpighian tubules of *Drosophila hydei*: is a vacuolar-type ATPase involved in ion and fluid secretion. *J. Insect Physiol.* **37**, 201-209.
- Bindokas, V.P. and Adams, M.E. (1988). Haemolymph composition of the tobacco budworm, *Heliothis virescens* F. (Lepidoptera:Noctuidae). *Comp. Biochem. Physiol.* **90A**, 151-155.
- Bollenbacher, W.E., Smith, S.L., Goodman, W. and Gilbert, L.I. (1981). Ecdysteroid titer during the larval to pupal to adult development of *Manduca sexta*. *Gen. Comp. Endocrinol.* **44**, 302-306.
- Bowman, B.J., Dschida, W.J. and Bowman, E.J. (1992). Vacuolar ATPase of *Neurospora crassa*: electron microscopy, gene characterization and gene inactivation /mutation. *J. Exp. Biol.* **172**, 57-66.
- Bradford, M.M. (1976). A rapid and sensitive method for quantitation of microgram quantities of protein, utilising the principle of protein-dye binding. *Analyt. Biochem.* **72**, 248-254.
- Bradley, T.J. (1983). Functional design of microvilli in Malpighian tubules of the insect, *Rhodnius prolixus*. *J. Cell Sci.* **60**, 117-167.

- Bradley, T.J. (1985). The excretory system: structure and physiology. in *Comprehensive insect Physiology, Biochemistry and Pharmacology*. (Ed. by Kerkut, G.A. and Gilbert, L.I) . 4, pp.421-465.
- Bradley, T.J. and Nayar, J.K. (1987). An ultrastructural study of *Dirofilaria immitis* infection in the Malpighian tubules of *Anopheles quadrimaculatus*. *J. Parasit* . 73, 1035-1043.
- Bransby-Williams, W.R. (1972). Activity of two juvenile hormone analogues with *Hiliothis armigera* (Hubner). *Sitophilus zaemais* (Motshulsky) and *Ephestia cautella* (Walker). *East African Agric. Forest J.* 38, 170-174.
- Chapman, R.F. (1988). *The Insects Structure and Function*, third edition. pp. 574-578. Hodder and Stoughton, London, Sydney, Auckland, Toronto.
- Chase, A.M. (1970). Effects of antibiotics on epidermal metamorphosis and nucleic acid synthesis in *Tenebrio molitor*. *J. Insect Physiol.* 16, 865-884.
- Ciemior, K.E., Sehnal, F. and Schneiderman, H.A. (1979). Moulting, growth and survival of *Galleria mellonella* L. (Lepidoptera: Pyralidae) treated with juvenoids. *Z. Ang. Ent.* 88, 414-425.
- Cioffi, M. (1979). The morphology and fine structure of the larval midgut of moth, *Manduca sexta*, in relation to active ion transport. *Tissue and Cell.* 11, 467-479.
- Cioffi, M. (1984). Comparative ultrastructure of arthropod transporting epithelia. *Amer. Zool.* 24, 139-156.
- Coast, G.M, Cusinato, O., Kay, I. and Goldsworthy, G.J. (1991). An evaluation of the role of cyclic AMP as an intracellular second messenger in Malpighian tubules of the house cricket *Acheta domesticus* (L). *J. Insect Physiol.* 37, 563-573.
- Cohen, A.C. and Patana, R. (1982). Ontogenetic and stress related changes in haemolymph chemistry of beet armyworms. *Comp. Biochem. Physiol.* 71A, 193-198.
- Cotton, G. and Anstee, J.H. (1990). A structural and biochemical study on the effects of methoprene on flight muscle development in *Locusta migratoria* L. *J. Insect Physiol.* 36, 959-969.

- Curran, P.F. and McIntosh, J.R. (1962). A model system for biological water transport. *Nature. London.* **193**, 347-348.
- Curran, P.F. and Solomon, A.K. (1957). Ion and water fluxes in the ileum of rats. *J. Gen. Physiol.* **41**, 143-168.
- Dalton, T. and Windmill, D.M. (1980). Fluid secretion by isolated Malpighian tubules of the housefly, *Musca domestica*. *J. Insect. Physiol.* **26**, 281-286.
- Davis, W.I., Goodman, D., Martin, J.H., Mathes, J.L. and Rasmussen, H. (1974). Vasopressin-induced changes in toad urinary bladder epithelial surface. *J. Cell. Biol.* **61**, 544-547.
- Diamond, J.M. and Bossert, W.H. (1967). Standing-gradient osmotic flow. A mechanism for coupling of water and solute transport in epithelia. *J. Gen. Physiol.* **50**, 2061-2083.
- Diamond, J.M. and Bossert, W.H. (1968). Functional consequences of ultrastructural geometry in 'back-ward' fluid-transporting epithelia. *J. Cell Biol.* **37**, 694-702.
- Diamond, J.M. and Tormey, J.McD. (1966). Role of long extracellular channels in fluid transport across epithelia. *Nature. London.* **210**, 817-820.
- Donkin, J.E. (1981). Some effects of insect hormones on Na⁺, K⁺-ATPase and fluid secretion by the Malpighian tubules of *Locusta migratoria* L. Ph.D. Thesis, University of Durham.
- Donkin, J.E. and Anst e, J.H. (1980). The effect of temperature on the ouabain-sensitivity of Na⁺-K⁺-activated ATPase and fluid secretion by the Malpighian tubules of *Locusta*. *Experientia* **36**, 986-987.
- Dow, J.A. and O'Donnell, M.J. (1990). Reversible alkalization by *Manduca sexta* midgut. *J. Exp. Biol.* **150**, 247-256.
- Eichelberg, D. and Wessing, A. (1975). Morphology of Malpighian tubules of insects. *Fortschr. Zool.* **23**, 47-124.
- El-Ibrashy, M.T. and Mansour, M.H. (1970). Hormonal action of biologically active compounds in *Agrotis ypsilon* larvae. *Experientia.* **26**, 1095-1096.

- Ernst, S.A. (1972a). Transport adenosine triphosphatase cytochemistry. I. Biochemical characterization of ouabain-sensitive potassium-dependent phosphatase activity in the avian salt gland. *J. Histochem.* **18**, 251-263.
- Ernst, S.A. (1972b). Transport adenosine triphosphatase cytochemistry. II. Cytochemical localization of ouabain-sensitive potassium-dependent phosphatase activity in the avian salt gland. *J. Histochem.* **20**, 23-38.
- Ernst, S.A. (1975). Transport ATPase cytochemistry: ultrastructural localization of potassium-dependent and independent phosphatase activities in rat kidney cortex. *J. Cell Biology* **66**, 586-608.
- Fain, M.J. and Riddiford, L.M. (1975). Juvenile hormone titers in the haemolymph during late larval development of the tobacco hornworm *Manduca sexta* L. *Biol. Bull. (Woods Hole)* **149**, 506-521.
- Farmer, J., Maddrell, S.H.P. and Spring, J.H. (1981). Absorption of fluid by midgut of *Rhodnius*. *J. Exp. Biol.* **94**, 301-316.
- Farquharson, P.A. (1974). A study of Malpighian tubules of the pill millipede, *Glomeris marginata* (Villers). II. The effect of variations in osmotic pressure and sodium and potassium concentrations on fluid production. *J. Exp. Biol.* **60**, 29-39.
- Fisher, R.A. and Yates, F. (1963). *Statistical Tables for Biological, Agricultural, and Medical Research*, 6th edn. Oliver & Boyd, Edinburgh.
- Florkin, M. and Jeuniaux, C. (1974). Haemolymph: composition. In *The Physiology of Insect* (Ed. M. Rockstein). **5**, 256-297. Academic press, New York.
- Fogg, K.E. (1990). Studies on ion movements in Malpighian tubules of *Locusta migratoria* L. with particular reference to their endocrine control. Ph.D Thesis. University of Durham.
- Fogg, K.E., Anstee, J.H. and Hyde, D. (1990). Effects of corpora cardiaca extract on intracellular second messenger levels in Malpighian tubules of *Locusta migratoria* L. *J. Insect phsysiol.* **36**, 383-389.

- Fogg, K.E., Anstee, J.H. and Hyde, D. (1991). Studies on the subcellular distribution of (Na⁺+K⁺)-ATPase, K⁺-stimulated ATPase and HCO₃⁻-stimulated ATPase activities in Malpighian tubules of *Locusta migratoria* L. *Insect Biochem.* **21**, 749-758.
- Fogg, K.E., Hyde, D. and Anstee, J.H. (1989). Microelectrode studies on Malpighian tubule cells of *Locusta*: effects of cyclic AMP, IBMX and corpora cardiaca extract. *J. Insect Physiol.* **35**, 387-392.
- Fogg, K.E., Hyde, D. and Anstee, J.H. (1992). Assessment of a strontium capture technique for cytochemical localization of potassium-dependent phosphatase in Malpighian tubules of *Locusta*. *Physiological Entomology* **17**, 131-140.
- Forgac, M. (1989). Structure and function of vacuolar class of ATP-driven proton 'pumps'. *Physiol. Rev.* **69**, 765-796.
- Foure, J.C. (1943a). The phase of the lesser army worm, *Laphygma exigua* (Hubn) in S. Afr. **18**, 69-78.
- Foure, J.C. (1943b). The phase variation in the army worm, *Laphygma exempta* (Walker). *Sci. Bull. Dept. agric. For. S.Afr.*, No. 234.
- Fristrom, J.W. and Kelly, L. (1976). Effect of ecdysone and juvenile hormone on the Na⁺/K⁺-dependent ATPase in imaginal discs of *Drosophila melanogaster*. *J. Insect Physiol.* **22**, 1697-1707.
- Frizzell, R.A., Field, M. and Schultz, S.G. (1979). Sodium-coupled chloride transport by epithelial tissues. *Am. J. Physiol.* **236**, F1-F8.
- Fujita, M., Nakao, T., Tashima, Y. and Nakao, M. (1966). Potassium-ion stimulated p-nitrophenyl phosphatase activity occurring in a highly specific adenosine triphosphatase preparation from rabbit brain. *Biochimica et Biophysica Acta.* **117**, 42-53.
- Gee, J.D. (1975a). Diuresis in the tsetse fly *Glossina austeni*. *J. Exp. Biol.* **63**, 381-390.
- Gee, J.D. (1975b). The control of diuresis in the tsetse fly *Glossina austeni*: A preliminary investigation of the diuretic hormone. *J. Exp. Biol.* **63**, 391-401.
- Gee, J.D. (1976a). Active transport of sodium by the Malpighian tubules of the tsetse fly *Glossina morsitans*. *J. Exp. Biol.*, **64**, 357-368.

- Gee, J.D. (1976b). Fluid secretion by Malpighian tubules of the tsetse fly *Glossina morsitans*: The effects of ouabain, ethacrynic acid and amiloride, *J. Exp. Biol.* **65**, 323-332.
- Gelbic, I. and Sehnal, F. (1973). Effect of juvenile hormone mimics on the codling moth, *Cydia pomonella* (L) (Lepidoptera: Olethreutidae). *Bull. Ent. Res.* **63**, 7-16
- Gersch, M. (1967). Experimental examinations of the hormone control of the water balance and excretion of the larva of *Corethra* (Chanoborus). *Gen. Comp. Endocr.* **9**, 453,
- Gilbert, L.I. (1974). Endocrine action during insect growth. *Recent Prog. Horm. Res.*, **30**, 347-390.
- Girardie, A. and Joly, P. (1967). Mècanism physiologique de l'effect de groupe chez les agridiens. *Coll. Int. C. N. R. S. Paris.* **173**, 127-145.
- Gordon, R. and Burford, I.R. (1984). Effects of methoprene analogue on the larval and pupal stage of the yellow fever mosquito, *Aedes aegypti*. *J. Insect Physiol.* **30**, 279-286.
- Greenwald, L., Verderber, G., and Singley, C. (1984). Localization of Na⁺-K⁺ ATPase activity in the *Nautilus siphuncle*. *J. Exp. Zool.*, **229**, 481-484.
- Grimstone, A.V., Mullinger, A.M. and Ramsay, J.A. (1968). Further studies on the rectal complex of the mealworm *Tenebrio molitor*, L. (Coleoptera: Tenebrionide). *Phil. Trans. R. Soc. London.* **253B**, 343-382.
- Gupta, B.L., Hall, T.A. and Moreton, R.B. (1977). Electron probe X-ray microanalysis. In *Transport of Ions and Water in animals*. Ed. Gupta, B.L., Hall, T.A. and Moreton, R.B., Oschman, J.L. and Wall, B.J. Academic press, London, New York, San Francisco. pp. 83-143.
- Hammock, B.D. and Quistad, G.B. (1981). Metabolism and mode of action of juvenile hormone, juvenoids and other insect growth regulators. In *Progress in Pesticide Biochemistry* (Hutson, D.H. and Roberts, T.R., eds). **1**, pp. 1-83. John Wiley & Sons, New York.
- Hanrahan, J. and Phillips, J.E. (1983). Mechanism and control of salt absorption in locust rectum. *Am. J. Physiol.* **244**, R131-R142.

- Harvey, W.R., Coiffi, M., Dow, J.A. and Wolfersberger, M.G. (1983). Potassium ion transport ATPase in insect epithelia. *J. Exp. Biol.* **106**, 91-117.
- Harvey, W.R. and Zerahn, K. (1969). Kinetics and route of active K⁺- transport in the isolated midgut of *Hyalophora cecropia*. *J. Exp. Biol.* **54**, 269-274.
- Henrick, C.A. (1982). Juvenile hormone analogues: structure-activity relationships. In *Insecticide Mode of Action* (Coats, J.R. Ed.). pp. 315-402. Academic Press, London.
- Henson, H. (1937). The structure and post-embryonic development of *Vanessa urticae* (Lepidoptera). II. The larval Malpighian tubules. *Proc. Zool. Soc. Ser. (B)*, 161-175.
- Highnam, K.C., Hill, L. and Gingell, D.J. (1965). Neurosecretion and water balance in the male desert locust. *J. Zool. (London)*, **147**, 201-215.
- Hill, A.E. (1975). General mechanisms of salt-water coupling in the epithelia. In *Transport of Ions and Water in animals*. Ed. Gupta, B.L., Hall, T.A. and Moreton, R.B., Oschman, J.L. and Wall, B.J. Academic press, London, New York, San Francisco. pp. 183-214.
- Ilans, J. (1970). Mechanism of gene expression in *Tenebrio molitor*, juvenile hormone determination of translational control through transfer ribonucleic acid and enzyme. *J. Biol. Chem.* **25**, 1275-1281.
- Irvine, H.B. (1969). Sodium and potassium secretion by insect Malpighian tubules. *Am. J. Physiol.* **217**, 1521-1527.
- Iwao, S. (1968). Some effects of grouping in Lepidopterous insects. *Collq.Int. Centre Nat. Rech. Sci.* **173**, 185-210.
- Jones, G., Manczak, M. and Horn, M. (1993). Hormonal regulation and properties of a new group of basic haemolymph protein expressed during insect metamorphosis. *J. Biological Chemistry*, **268**, 1284-1291.
- Judy, K.J. and Gilbert, L.I. (1969). Morphology of the alimentary canal during the metamorphosis of *Hyalophora cecropia*, (Lepidoptera: Saturniidae). *Ann. Ent. Soc. Am.* **62**, 1438-1446.

- Jungreis, A. and Vaughan, G.L. (1977). Insensitivity of lepidopteran tissues to ouabain : absence of ouabain binding and Na^+/K^+ -ATPase in larval and adult midgut. *J. Insect Physiol.* **23**, 503-509.
- Karnaky, K.J., Kinter, Jr., Kinter, W.B. and Stirling, C.E. (1976). Teleost chloride cell. II. Autoradiographic localization of gill Na^+ , K^+ -ATPase in killifish, *Pundulus heteroclitus* adapted to low and high salinity environments. *J. Cell. Biol.* **70**, 157-177.
- Karnovsky, M.J. (1965). A formaldehyde-glutaraldehyde fixative of high osmolality for use in electron microscopy. *J. Cell. Biol.* **27**, 137A-138A.
- Kataoka, H., Troetschler, R.G., Li, J.P., Kramer, S.J, Carney, R.L. and Schooley, D.A. (1989). Isolation and identification of a diuretic hormone from the tobacco hornworm, *Manduca sexta*. *Proc. Natn. Acad. Sci. U.S.A.* **86**, 2976-2980.
- Kay, I., Coast, G., Cusinato, O., Wheeler, C.H., Totty, N.F. and Goldsworthy, G.J. (1991) Isolation and characterization of a diuretic peptide from *Acheta domesticus*. Evidence for a family of insect diuretic peptides. *Biol. chem. Hoppe-Seyler* **372**, 505-512.
- Kaye, G.I., Wheeler, H.O., Whitlock, R.T. and Lane, N. (1966). Fluid transport in the rabbit gall bladder. A combined physiological and electron microscope study. *J. Cell. Biol.* **30**, 237-268.
- Klein, U. (1992). The insect V-ATPase, a plasma membrane proton pump energizing secondary active transport: immunological evidence for the occurrence of a V-ATPase in insect ion transporting epithelia. *J. Exp. Biol.* **172**, 345-354.
- Klien, U., Loffelmann, G. and Wieczorek, H. (1991). The midgut as a model system for insect K^+ -transporting epithelia: immunocytochemical localization of a vacuolar-type H^+ pump. *J. Exp. Biol.* **161**, 61-75.
- Komnick, H. and Achenbach, U. (1979). Comparative biochemical, histochemical and autoradiographic studies of Na^+/K^+ -ATPase in the rectum of dragonfly larvae (Odonata: Aeshnidae). *Eur. J. Cell Biol.* **20**, 92-100.
- Kroeger, H. (1968). In, *Metamorphosis: A problem in development biology*. Ed. Etkin, W.E and Gilbert, L.I. pp.185-219. Appleton, New York.

- Kroeger, H. and Lezzi, M. (1966). Regulation of gene action in insect development. *A. Rev. Ent.* **11**, 1-22.
- Krueger, R.A., Broce, A.B. and Hopking, T.L. (1987). Dissolution of granules in the Malpighian tubules of *Musca autumnalis* during mineralization of the puparium. *J. Insect. Physiol.* **33**, 255-263.
- Kumar, P. and Srivastava, K.P. (1981). Studies on the Malpighian system of the larva of lemon butterfly, *Papilio demoleus* (L) Lepidoptera. *J. Morphol.* **28**, 1-8.
- Lange, C.E. (1987). Histopathology in the Malpighian tubules of *Dichroplus elongatus* (Orthoptera: Acrididae). Infected with *Perezia dichroplusae*, (Microspora: Pereziiidae). *J. Invertebrate Pathology* **50**, 146-150.
- Lee, R.M. (1961). The variation of blood volume with age in the desert locust *Schistocerca gregaria*. *J. Insect Physiol.* **6**, 36-51.
- Lehmberg, E., Ota, R.B., Furuya, K., Applebaum, S.W., Ferenz, H. and Schooley, D.A. (1991) Identification of a diuretic hormone of *Locusta migratoria*. *Bioch. Biophys. Res. Commun.* **179**, 829-838.
- Lehmberg, E., Schooley, D.A., Ferenz, H.J. and Applebaum, S.W. (1993). Characteristics of *Locusta migratoria* Diuretic hormone. *Archive of Insect Biochemistry and physiology* **22**, 133-140.
- Lezzi, M. and Gilbert, L.I. (1972). Hormonal control of gene activity in polytene chromosomes. *Gen. Comp. Endocr.* (Suppl.), **3**, 159-167.
- Locke, M. (1985). A structural analysis of post-embryonic development. In *Comprehensive Insect Physiology, Biochemistry and Pharmacology* (Kerkut, G.A. and Gilbert, L.I. Eds) **2**, pp. 87-149. Pergamon Press, Oxford.
- Loschiavo, S.R. (1976). Effect of the synthetic growth regulators methoprene and hydroxyprene on survival, development or reproduction of six species of stored-products insects. *J. Econ. Entomol.* **69**, 395-399.
- Maddrell, S.H.P. (1963). Excretion in the blood sucking bug *Rhodnius prolixus* Stal. I. The control of diuresis. *J. Exp. Biol.* **40**, 247-256.
- Maddrell, S.H.P. (1964). Excretion in the blood sucking bug *Rhodnius prolixus* Stal. III. The control of release of the diuretic hormone. *J. Exp. Biol.* **41**, 459-472.

- Maddrell, S.H.P. (1969). Secretion by the Malpighian tubules of *Rhodnius*: the movements of ions and water. *J. Exp. Biol.* **51**, 71-97.
- Maddrell, S.H.P. (1971). The mechanisms of insect excretory system. *Adv. Insect Physiol.* **8**, 199-331.
- Maddrell, S.H.P. (1977). The Malpighian tubules. In *Transport of Ions and Water in Animals*. Eds. Gupta, B.L., Moreton, R.B., Oschman, J.L and Wall, B.J., Academic Press, London, New York, San Francisco. pp.541-569.
- Maddrell, S.H.P. (1978). Physiological discontinuity in an epithelium with an apparently uniform structure, *J. Exp. Biol.* **75**, 133-145.
- Maddrell, S.H.P. (1980). Characteristics of epithelial transport in insect Malpighian tubules. In *Current Topics in Membrane and Transport*. Ed. Bronner, F. and Kleinzeller, A. Academic Press, New York. **14**, pp. 427-463.
- Maddrell, S.H.P. (1981). The functional design of the insect excretory system. *J. Exp. Biol.* **90**, 1-15.
- Maddrell, S.H.P, Herman, W.S., Frandale, R.W. and Riegel, J.A. (1992). Synergism of hormones controlling epithelial fluid transport on an insect. *J. Exp. Biol.* **174**, 65-80.
- Maddrell, S.H.P., Herman, W.S, Mooney, R.L. and Overton, J.A. (1991). 5-Hydroxytryptamine: a second diuretic hormone in *Rhodnius*. *J. Exp. Biol.* **156**, 557-566.
- Maddrell, S.H.P., Herman, W.S, Mooney, R.L. and Overton, J.A. (1993). Synergism of hormones controlling epithelial fluid transport on an insect. *J. Exp. Biol.* **174**, 65-80.
- Maddrell, S.H.P. and Klunswan, S. (1973). Fluid secretion by *in vitro* preparations of Malpighian tubules of the desert locust *Schistocerca gregaria*. *J. Insect Physiol.* **19**, 1369-1376.
- Maddrell, S.H.P. Lane, N.J., Harrison, J.B. and Gadiner, B.O.C. (1985). DNA replication in binucleate cells of Malpighian tubules of Hemipteran insects. *Chromosoma (Berl)* **91**, 201-209.

- Maddrell, S.H.P. and O'Donnell, M.J. (1992). Insect Malpighian tubules: V-ATPase action in ion and fluid transport. *J. Exp. Biol.* **172**, 417-429.
- Maddrell, S.H.P. and Overton, J.A. (1988). Stimulation of sodium transport and fluid secretion by ouabain in an insect Malpighian tubule. *J. Exp. Biol.* **137**, 265-276.
- Maddrell, S.H.P., Pilcher, D.E.M. and Gardiner, B.O.C. (1971). Pharmacology of Malpighian tubules of *Rhodnius* and *Carausius*: The structure-activity relationship of tryptamine analogues and the role of cAMP. *J. Exp. Biol.* **54**, 779-804.
- Manzelli, M.A. (1982). Management of stored-tobacco pest, the cigarette beetle (Coleoptera: Anobiidae) and tobacco moth (Lepidoptera: Pyralidae), with methoprene. *J. Econ. Entomol.* **75**, 721-723.
- Marshall, A.T., Cooper, P., Rippon, G.D and Patak, A.E. (1993) Ion and fluid secretion by different segments of the Malpighian tubules of the black field cricket *Teleogryllus oceanicus*. *J. Exp. Biol.* **177**, 1-22.
- Mathur, L.M.L. (1973). Histology alimentary canal of mature larva of *Prodenia litura* Fabr.(Lepidoptera) *J. Nat. Hist.* **7**, 653-664.
- Meyran, J.C. (1982). Segmental variations of intercellular junction in insect Malpighian tubules, a comparative research study of two species. *J. of Ultrastructure Research* **79**, 31-46.
- Moffett, D.F. and Koch, A.R. (1992). Driving forces and pathways for H⁺ and K⁺ transport in insect midgut goblet cells. *J. Exp. Biol.* **172**, 403-415.
- Mordue, W. (1966). Hormones and water balance in Locusts. In 'Insect Endocrines' Ed. Novak, V.J.
- Mordue, W. (1969). Hormonal control of Malpighian tubule and rectal function in the desert locust *Schistocerca gregaria*. *J. Insect Physiol.* **15**, 273-285.
- Mordue, W. (1972). Hydromineral regulation in animals. I. Hormones and excretion in locusts. *Gen. Comp. Endocrinol. Supl.* **3**, pp. 289-298.
- Morgan, P.J. and Mordue, W. (1981). Stimulated fluid secretion is sodium dependent in the Malpighian tubules of *Locusta migratoria*. *J. Insect Physiol.* **27**, 271-279.

- Morgan, P.J. and Mordue, W. (1983). Electrochemical gradients across *Locusta* Malpighian tubules. *J. Comp. Physiol.* **27**, 271-279.
- Morgan, P.J. and Mordue, W. (1984). 5-Hydroxytryptamine stimulates fluid secretion in locust Malpighian tubules independently of cAMP. *Comp. Biochem. Physiol.* **79C**, 305-310.
- Morgan, P.J. and Mordue, W. (1985). Cyclic AMP and locust diuretic hormone action. Hormone induced change in cAMP levels offer a novel method for detecting biological activity of uncharacterized peptide. *Insect Biochem.* **15**, 247-257.
- Muraleedharan, D. and Prabhu, K.K. (1981). Hormonal influence on feeding and digestion in a plant bug, *Dysdercus cingulatus*, and a caterpillar, *Hyblaea puera*. *Physiol. Ent.* **6**, 183-189.
- Nicolson, S.W. (1976a). Diuresis in the cabbage white butterfly, *Pieris brassicae*: fluid secretion by the Malpighian tubules. *J. Insect. Physiol.* **22**, 1347-1356.
- Nicolson, S.W. (1976b). The hormonal control of diuresis in the cabbage white butterfly *Pieris brassicae*. *J. Exp. Biol.* **65**, 565-575.
- Nicolson, S.W. (1980). Diuresis and its hormone control in butterflies. *J. Insect Physiol.* **26**, 841-846.
- Nicolson, S.W. (1992). Excretory function in *Tenebrio molitor*: Fast tubular secretion in a vapour-absorbing insect. *J. Insect Physiol.* **38**, 139-146.
- Nicolson, S.W. (1993). The ionic basis of fluid secretion in insect Malpighian tubules: advances in the last ten years. *J. Insect Physiol.* **39**, 451-458.
- Nicolson, S.W. and Harrahan, S.A. (1986). Diuresis in a desert beetle hormonal control of the Malpighian tubules of *Onymacris plana* (Coleoptera: Tenebrionidae). *J. Comp. Physiol.* **15B**, 407-413.
- Nicolson, S.W. and Isaacson, L.E. (1987). Transepithelial and intracellular potentials in isolated Malpighian tubules of tenebrionid beetle. *Am. J. Physiol.* **252**, F645-F653.
- Nicolson, S.W. and Millar, R.P. (1983). Effect of biogenic amines and hormones on butterfly Malpighian tubules: Dopamine stimulates fluid secretion. *J. Insect Physiol.* **29**, 611-615.

- Nijhout, H.F. (1975). Excretory role of the midgut in larvae of the tobacco hornworm, *Manduca sexta* (L). *J. Exp. Biol.* **62**, 221-230.
- Nijhout, H. F. and Williams, C. M. (1974). Control of moulting and metamorphosis in the tobacco hornworm, *Manduca sexta* (L): Cessation of the juvenile hormone secretion as a trigger for pupation. *J. Exp. Biol.* **61**, 493-501.
- Novak, F.J.S., Gräf, R., Waring, R.B., Wolfersberger, M.G., Wiczorek, H. and Harvey, W.R. (1992). Primary structure of V-ATPase subunit B from *Manduca sexta*. *Biochimica et Biophysica Acta.* **1132**, 67-71.
- O'Donnell, M. J and Maddrell, S.H.P. (1983). Paracellular and transcellular routes for water and soluble movements across insect epithelia. *J. Exp. Biol.* **106**, 231-253.
- O'Donnell, M. J and Maddrell, S.H.P. (1984). Secretion by the Malpighian tubules of *Rhodnius prolixus*: electrical events. *J. Exp. Biol.* **110**, 275-290.
- Oschman, J.L. and Berridge, M.J. (1970). Structural and functional aspect of salivary fluid secretion in *Calliphora*. *Tissue & cell.* **2**, 281-310.
- Palfrey, H.C. and Rao, M.C. (1983). $\text{Na}^+/\text{K}^+/\text{Cl}^-$ co-transport and its regulation. *J. Exp. Biol.* **106**, 43-54.
- Pannabecker, T.L., Andrews, F. and Beyenbach, K.W. (1992). A quantitative analysis of the osmolytes in the haemolymph of the larval gypsy moth, *Lymantria dispar*. *J. Insect Physiol.* **38**, 823-830.
- Patton, R.L. (1953). Excretion. In *Insect Physiology*. Eds. Roeder, K.D. New York, London. pp. 387-403.
- Peacock, A.J. (1975). Studies on the excretory and neuroendocrine systems of some orthopteran insects, with particular reference to *Jamaicana flava* (Caudell). Ph.D. Thesis, University of Durham.
- Peacock, A.J. (1976). Distribution of Na^+/K^+ activated ATPase in the alimentary tract of *Locusta migratoria*. *Insect Biochemistry*, **6**, 529-533.
- Peacock, A. J. (1981). Effects of sodium-transport inhibitions on diuresis and mid-gut (Na^+/K^+)-ATPase in the tsetse fly *Glossina morsitans*. *J. Insect. Physiol.* **38**, 553-558.

- Peacock, A.J. and Anstee, J.H. (1977). Malpighian tubules of *Jamaicana flava* (Caudell) 1. Structure of the primary cells. *Micron*. **8**, 19-27.
- Phillips, J.E. (1981). Comparative physiology of insect renal function. *Am. J. Physiol.* **241**, R241-R257.
- Phillips, J.E. (1982). Hormonal control of renal functions in insects. *Fed. Proc.* **41**, 2348-2354.
- Phillips, J.E. (1983). III. Osmoregulation and excretion. Cellular mechanisms and control of excretion in insects: recent advances. *Verh. Dtsch. Zool. Ges.* 55-68.
- Pilcher, D.E.M. (1970). The influence of the diuretic hormone on the process of urine secretion by the Malpighian tubules of *Carausius morosus*. *J. Exp. Biol.* **53**, 465-484.
- Pivovarov, N., Anstee, J.H. and Bowler, K. (1993). The use of Rb in a study of cell function in Malpighian tubules of locusts by X-ray microanalysis. *Cell Biology International*. **17**, 709-710.
- Poll, M. (1939). Contribution a l'etude de l'appareil urinaire des chenilles de Lepidopteres. *Ann. Soc. Zool. Belg.* **69**, 9-52.
- Prince, W.T. and Berridge, M.J. (1973). The role of calcium in the action of 5-hydroxytryptamine and cyclic AMP on salivary glands. *J. Exp. Biol.* **58**, 367-384.
- Racioppi, J.V. and Dahlman, D.L. (1980) Effects of L-canavanine on *Manduca sexta* (Sphingidae: Lepidoptera) larval haemolymph solute. *Comp. Biochem. Physiol.* **71A**, 445-447.
- Rafaëli, A. (1990). Diuretic hormones and Malpighian tubule function. In *Progress in Comparative Endocrinology* (ed. Epple, A., Scoes, C.G. and , M.H. Stetson, M.H.), New York: Wiley Liss. pp. 553-558.
- Rafaëli, A. and Mordue, W. (1982). The responses of the Malpighian tubules of locust to hormones and other stimulants. *Gen. Comp. Endocr.* **46**, 130-135.
- Rafaëli, A., Pines, M., Stern, P.S. and Applebaum, S.W. (1984). Locust diuretic hormone stimulated synthesis and excretion of cAMP: A novel Malpighian tubule bioassay. *Gen. Comp. Endocrin.* **54**, 35-42.

- Rafaeli-Bernstein, A. and Mordue, W. (1978). The transport of the cardiac glycoside ouabain by the Malpighian tubules of *Zonocerus variegatus*. *Physiol. Ent.* **3**, 59-63.
- Ramsay, J.A. (1952). The excretion of sodium and potassium by the Malpighian tubules of *Rhodnius*. *J. Exp. Biol.* **26**, 110-126.
- Ramsay, J.A. (1953). Active transport of potassium by the Malpighian tubules of insects. *J. Exp. Biol.* **30**, 358-369.
- Ramsay, J.A. (1954). Active transport of water by the Malpighian tubules of the stick insect *Dixippus morosus* (Orthoptera, Phasmidae). *J. Exp. Biol.* **31**, 104-113.
- Ramsay, J.A. (1955). The excretion of sodium, potassium and water by the Malpighian tubules of the stick insect, *Dixippus morosus*. *J. Exp. Biol.* **32**, 200-216.
- Ramsay, J.A. (1956). Excretion by the Malpighian tubules of the stick insect, *Dixippus morosus* (Orthoptera: Phasmidae): calcium, magnesium, chloride, phosphate and hydrogen ions. *J. Exp. Biol.* **33**, 697-708.
- Ramsay, J.A. (1976). The rectal complex in the larvae of Lepidoptera. *Philos. Trans. Royal. Soc. London.* **274**, 203-226.
- Ramsay, J.A and Bron, R.H.J. (1955). Simplified apparatus and procedure for freezing-point determination, upon small volumes of fluid. *J. Sci. Instrum.* **32**, 372-375.
- Recioppi, J.V. and Dahlman, D.L. (1980) Effect of L-canavanine on *Manduca sexta* (Sphingidae: Lepidoptera) larval haemolymph solute *Comp. Biochem. Physiol.* **67C**, 35-39.
- Retnakaran, A. (1973). Hormonal induction of supernumary insects in the spruce budworm, *Choristoneura fumiferana* (Lepidoptera: Tortricidae). *Can. Entomol.* **105**, 459-461.
- Reynolds, E. S. (1963). The use of lead citrate at high pH as an electron opaque stain. *J. Cell. Biol.* **17**, 208-212.
- Rhodin, J. (1958). Anatomy of Kidney tubules. *Int. Rev. Cytol.* **7**, 485-534.

- Riddiford, L.M. (1972). Juvenile hormone in relation to the larval-pupal transformation of the cecropia silkworm. *Biol. Bull. Mar. Biol. Lab. Woods Hole* **142**, 310-325.
- Riddiford, L.M. (1980). Insect endocrinology: action of hormones at the cellular level. *Ann. rev. Physiol.* **42**, 511-528.
- Riddiford, L. M.(1985). Hormone action at the cellular level. In *Comprehensive Insect Physiology , Biochemistry and Pharmacology* (G. A. Kerkut and L. I. Gilbert, eds.). **8**, pp.37-84. Pergamon Press,Oxford.
- Ryerse, J.S. (1977). Control of mitochondrial movement during development of insect Malpighian tubule. *Proc. microscopical.Soc.can.* **4**, 48-49.
- Ryerse, J.S. (1978). Developmental changes in Malpighian tubule fluid transport. *J.Insect. Physiol.* **24**, 315-319.
- Ryerse, J.S. (1979). Developmental changes in Malpighian tubule cell structure. *Tissue & Cell.* **3**, 533-551.
- Ryerse, J.S. (1980). The control of Malpighian tubule developmental physiology by 20-hydroxyecdysone and juvenile hormone. *J. Insect Physiol.* **26**, 449-457.
- Schatzmann, H.J. (1953) Herzglykoside als slemmstoffe fur den activen kalium and natrium transport duch die erythrocytenmembran. *Helv. Physiol. Pharmacol. Acta.* **11**, 346-354.
- Schmidt-Nielson, B. and Davis, L.E. (1968). Fluid transport and tubular intercellular spaces in reptilian kidneys. *Science* **159**, 1105-1108.
- Schooley, D.A. Judy, K.J., Bergot, B.J. Hall, M.S. and Jennings, R.C. (1976). Determination of the physiological levels of juvenile hormones in several insects and biosynthesis of the carbon skeletons of the juvenile hormones. In *the Juvenile Hormones* (Ed. by Gilbert, L.I.) pp. 101-117. Plenum Press, New York.
- Schwartz, L.M. and Reynolds, S.E. (1979). Fluid transport in *Calliphora* Malpighian tubules: a diuretic hormone from the thoracic ganglion and abdominal nerves. *J.Insect Physiol.* **25**, 847-854.

- Schweickl, H., Klein, U., Schindlbeck, M. and Wieczorek, H. (1989). A vacuolar-type ATPase, partially purified from potassium transporting plasma membranes of tobacco hornworm midgut. *J. Biol. Chem.* **264**, 1136-1142.
- Sehnal, F. and Granger, N. A. (1975). Control of corpora allata function in larvae of *Galleria mellonella*. *Biol. Bull., Woods Hol* **148**, 106-118.
- Sehnal, F., Metwally, M. M. and Gelbic, I. (1976). Reactions of immature stage of noctuid moths to juvenoids. *Z. ang. Ent.* **81**, 85-102.
- Shaaya, E. (1993). Interference of the insect growth regulator methoprene in the process of larval-pupal differentiation. *Archives of Insect Biochemistry and Physiology.* **22**, 233-243.
- Skaer, H.L.E.B., Harrison, J.B. and Maddrell, S.H.P. (1990). Physiological and structural maturation of a polarised epithelium: The Malpighian tubules of blood-sucking insect, *Rhodnius prolixus*. *J. of Cell Sci.* **96**, 537-547.
- Skaer, H.L.E.B., Maddrell, S.H.P. and Harrison, J.B. (1987). Properties of septate junctions in Malpighian tubules of *Rhodnius*. *J. Cell. Sci.* **88**, 251-265.
- Skou, J.C. (1957). Enzymatic basis for active transport of Na⁺ and K⁺ across cell membranes. *Physiol. Rev.* **45**, 596-617.
- Slàma, K. (1985). Pharmacology of insect juvenile hormone. In *Comprehensive Insect Physiology, Biochemistry and Pharmacology*. (G.A. Kerkut and L.I. Gilbert, eds.), **11**, pp. 357-394. Pergamon Press, Oxford.
- Slàma, K., Romanuk, M. and Sorm, F. (1974). Insect hormones and bioanalogues. Wien-New York: Springer-Verlag 477 pp, Viena.
- Slàma, K. and Williams, C.M. (1965). Juvenile hormone activity for the bug *Pyrrhocoris apterus*. *Proc. Natl. Acad. Sci., U.S.A.* **54**, 411-414.
- Smith, D.S. (1968). Insect cells their structure and function. Ph.D. Thesis university of Miami.
- Sohal, R.S. (1974). Final structure of the Malpighian tubules in the house fly, *Musca domestica*. *Tissue & Cell.* **6**, 719-28.

- Sohal, R.S., Peters, P. and Hall, T.E.A. (1976). Fine structure and X-ray microanalysis mineralized concentrations in Malpighian tubules of housefly *Musca domestica*. *Tissue & Cell*. **8**, 447-458.
- Sohal, R.S., Peters, P.O. and Hall, T.A. (1977). Origin structure composition and age-dependence of mineralised dense bodies (concretions) in the midgut epithelium of the adult housefly *Musca domestica*. *Tissue & cell* **9**, 87-102.
- Sokal, R.S. and Rohlf, F.J. (1969). Biometry: The principle and practice of statistics in *biological reseearch*. W.H. Freeman and Co., Sanfrancisco.
- Srivastava, K.P., Kumar, P. and Awisth, V.k. (1983). On the anatomy of the lemon-butterfly, *Papilio demoleus*. L.(Lepidoptera). *Zool. Anz. Jena*. **210**, 239 - 256.
- Staal, G.B. (1961). Studies on the physiology of phase induction in *Locusta migratoria*. R & F Thesis Wageningen, The Netherlands.
- Staal, G.B. (1975). Insect growth regulators with juvenile hormone activity. *Annu. Rev. Ent.* **20**, 417-460.
- Standlee, P.P and Yonke, T.R. (1968). Clarification of the description of the digestive system of *Heliothis zea*. *Ann. Ent. Soc. Amer.* **61**, 1478-1481.
- Sundaramurthy, V.T., Ahmed, N. and Mushtaq, N. (1978). Effect of Altosid on the blood protein of caterpillar of *Spodoptera litura* Fb (Lepidoptera: Noctuidae). *Curr. Sci.* **47**, 170-171.
- Sutcliffe, D.W. (1963). The chemical composition of haemolymph in insect and some other arthropods, in relation to their phylogeny. *Comp. Biochem. Physiol.* **9**, 121-135.
- Taylor, H.H. (1971a). Water and solute transport by the Malpighian tubules of the stick insect, *Carausius morosus*. The normal ultrastructure of the type I cell. *Z. Zellforsch.* **11**, 333-368.
- Taylor, .H.H. (1971b). The fine structure of type 2 cells in the Malpighian tubules of stick insect, *Carausius morosus*. *Z. Zellforsch.* **122**, 411-424.
- Teiger, D.J. and Arnott, H.J. (1972). Crystal development in the Malpighian tubules of *Bombyx mori* L. *Tissue & Cell* **4**, 173-185.

- Thomas, M.V. and May, T.E. (1984). Active potassium ion transport across the caterpillar midgut. II. Intracellular microelectrode studies. *J. Exp. Biol.* **108**, 293-304.
- Torres-Zamorano, V., Ganapathy, V., Sharawy, M. and Reinach, P. (1992). Evidence for an ATP-driven H⁺-pump in the plasma membrane of the bovine corneal epithelium. *Exp. Eye. Res.* **25**, 269-277.
- Trimmer, B.A. (1985). Serotonin and control of salivation in the blowfly *Calliphora*. *J. Exp. Biol.* **114**, 307-328.
- Troetschler, R.G. and Kramer, S.J. (1992). Mode of action studies on a *Manduca sexta* diuretic hormone. *Archs Insect Biochem. Physiol.* **20**, 35-47.
- Veenstra, J.A. (1988). Effect of 5-hydroxytryptamine on the Malpighian tubules of *Aedes aegypti*. *J. Insect Physiol.* **34**, 299-304.
- Wall, B.J. Oschman, J.L. and Schmit, B.A. (1975). Morphology and function of Malpighian tubules and associated structures in the cockroach *Periplaneta americana*. *J. Morph.*, **146**, 265-306.
- Welens, R., Leysens, A., Zhang, S.L., Lohrmann, E., Steels, P. and Van Kerkhove. E. (1992). Unmasking of the apical electrogenic H⁺ pump in isolated Malpighian tubules (*Formica polyctena*) by the use of barium. *Cell. Physiol. Biochem.* **2**, 101-116.
- Welsh, M.J. (1983). Inhibition of chloride secretion by furosemide in canine tracheal epithelium. *J. Membrane Biol.* **71**, 219-226.
- Wheelock, G.D., Petzel, D.H., Gillet, J.D. and Beyenbach, K.W. (1988). Evidence for hormonal control of diuresis after a blood meal on the mosquito *Aedes aegypti*. *Archiv. Insect Biochem. Physiol.* **7**, 75-89.
- Wieczorek, H. (1992). The insect V-ATPase, a plasma membrane proton pump energizing secondary active transport: molecular analysis of electrogenic potassium transport in the tobacco hornworm midgut. *J. Exp. Biol.* **172**, 335-343.
- Wieczorek, H., Putzeniechner, M., Zeiske, W. and Klein, U. (1991). A vacuolar-type proton pump energizes K⁺/H⁺-antiport in an animal plasma membrane. *J. Biol. Chem.* **266**, 14340-15342.

- Wieczorek, H., Weerth, S., Schindlbeck, M. and Klein, U. (1989). A vacuolar-type proton 'pump' in a vesicle fraction enriched with potassium transporting plasma membranes from tobacco hornworm midgut. *J.Biol. Chem.* **264**, 11143-11148.
- Wigglesworth, V. B.(1934). The physiology of ecdysis in *Rhodnius*. II. Factors controlling moulting and 'metamorphosis'. *Quart. J. Micr. Sci.* **77**, 191-22.
- Wigglesworth, V.B. (1972). *The principles of Insect Physiology*, seventh edition. Chapman & Hall, London.
- Wigglesworth, V.B. and Salpeter, M.M. (1961). Histology of the Malpighian tubules in *Rhodnius prolixus* Stal. (Hemiptera). *J. Insect Physiol.* **8**, 299-307.
- Williams, C.M. (1956) The juvenile hormone of insects. *Nature*, London. **178**, 212-213.
- Williams, C.M. and Kafatos, F.C.(1971). Theoretical aspects of the action of juvenile hormone. *Mitt. Schweiz. Ent. Gen. (Bull. Soc. Ent. Suisse)*. **44**, 151-162.
- Zeiske, W. (1992). Insect ion homeostasis. *J. Exp. Biol.* **172**, 323-334.
- Zheng, X.Y., Spaeth, D.D., Harvey, W.R. and Wolfersberger, M.G. (1992). Short communication 5'-p-fluorosulfonylbenzoyladenine binds to the 28 kDa subunit of larval *Manduca sexta* midgut vacuolar-type ATPase. *J.Exp. Biol.* **164**, 301-305.

