

Durham E-Theses

*Oil and state in the political economy of Iran,
1942-1979*

Mohammad Ali Mousavi

How to cite:

Mousavi, Mohammad Ali (1996) Oil and state in the political economy of Iran, 1942-1979. Doctoral thesis, Durham University.

Use policy

The full-text may be used and/or reproduced, and given to third parties in any format or medium, without prior permission or charge, for personal research or study, educational, or not-for-profit purposes provided that:

- a full bibliographic reference is made to the original source
- a <https://etheses.durham.ac.uk/id/eprint/5391/> is made to the metadata record in Durham E-Theses
- the full-text is not changed in any way

The full-text must not be sold in any format or medium without the formal permission of the copyright holders.

Please consult the [full Durham E-Theses policy](#) for further details.

UNIVERSITY OF DURHAM

The copyright of this thesis rests
with the author. No quotation
from it should be published
without the written consent of the
author and information derived
from it should be acknowledged.

OIL AND STATE IN THE POLITICAL ECONOMY OF IRAN, 1942-1979

**A THESIS SUBMITTED TO
THE FACULTY OF SOCIAL SCIENCES
IN CANDIDACY FOR THE DEGREE OF DOCTOR OF PHILOSOPHY**

CMEIS

By

MOHAMMAD ALI MOUSAVI

MAY, 1996



10 OCT 1997

ABSTRACT

In Iran, the regime of Mohammad Reza Shah deeply influenced the country's economic, political, and social life. Everything either began or ended with the state. The state was the most important institution in the country and enjoyed a significant monopoly in political and economic decision-making, trade, etc. It enjoyed autonomy from social pressures and pursued its own policies, whilst controlling political groups. Therefore, to analyse the function and behaviour of the state and the economic development of the country, I have used a political economy approach. To this end, a model has been constructed to describe the political structure of the Iranian state and to map the country's political and economic development. It has been argued that:

1. The political structure of the regime was authoritarian-bureaucratic, based on the three pillars of the state bureaucracy, the security machinery and the armed forces, and the network of court patronage. A parallel to this structure can be seen in the Safavid dynasty whose pillars of power were the same.
2. The decision-making process and exercise of power was manipulated by, and depended upon, the Shah and the ruling elite. This manipulation depended substantially on the degree of state autonomy from social and economic groups.
3. The state acted as the engine of economic growth and the main source of capital accumulation. Thus, the political system became the main economic decision-making body who dictated economic policies far more than the market. In spite of this direction, the state never questioned the essence of private capital accumulation.
4. Oil revenues, both by increasing the magnitude of resources at the disposal of the state and by easing structural constraints, substantially increased the capacity of the state to intervene in economy and society to pursue its own policies, and
5. Oil revenues provided a new kind of economy, built on rent and heavily reliant on the export of a single raw material, the production of which required little contact with the rest of the economy. It brought spectacular growth, yet at the same time engendered dependency on volatile markets. In the long run oil also created new international interdependencies as the state relied on foreign markets for capital, labour, and goods. Furthermore, Iran had no independent technological capacity and had to import semi-finished goods to meet its industrial needs. Therefore, a process of 'dependent development' was shaped during the 1960s and 1970s.

Copyright: 1996 by Mohammad Ali Mousavi

“The copyright of this thesis rests with the author.

Any quotation and information derived from it
should be properly acknowledged”.

To my wife, Heshmat

CONTENTS

	Pages
<i>Acknowledgement</i>	ix
<i>List of Tables and Illustrations</i>	x
<i>Abbreviations</i>	xiii
<i>Introduction</i>	1
CHAPTER 1. THEORETICAL FOUNDATION	6
1.1. <i>The Theoretical Basis for Model Construction about the Modern State:</i>	
<i>Internal Aspects</i>	7
1.1.1. Liberalism and Marxism: juxtaposition of the theory of the state	7
1.1.2. Weberian-Hintzean perspective: distancing from reductionist approach	9
1.2. <i>The Theoretical Basis for Model Construction about the Modern State:</i>	
<i>External Aspects</i>	12
1.3. <i>The State and Theory of Imperialism</i>	12
1.3.1. Classical theory of imperialism	13
1.3.2. New theories of imperialism	15
1.4. <i>Dependency Paradigm</i>	16
1.4.1. Postimperialism	18
1.4.2. The concept of dependent development	20
1.5. <i>The State and the World-System Perspective</i>	22
1.5.1. The concept of the semiperipheral state	24
1.6. <i>The State's Internal and External Behaviour</i>	27
1.6.1. The concept of state autonomy	27
1.6.1.1. Oil revenues and state autonomy	33
1.6.2. The concept of interdependence	33
1.7. <i>A Model for the Semiperipheral Capitalist State</i>	36
1.7.1. Method and techniques	43
CHAPTER 2. THE MODERN STATE FORMATION IN IRAN, 1500-1941	47
A: <i>The Safavid Dynasty (1500-1722):</i>	
2.1. <i>The Safavid Modern Centralised State</i>	47
2.1.1. The Safavid administration and military establishment	50

2.1.1.1. The administration	50
2.1.1.2. Provincial administration	55
2.1.1.3. Military function of the Safavid state	56
2.1.2. The economy and trade under the Safavids	58
2.1.2.1. Internal and foreign trade	60
2.1.3. The fall of the Safavid dynasty and the period of transition	62
B: <i>The Qajar Dynasty (1796-1925)</i>	
2.2. <i>The Qajar Weak State</i>	64
2.2.1. The Qajar administration and military establishment	65
2.2.1.1. The administration	65
2.2.1.2. Provincial administration	68
2.2.1.3. The Qajar army	69
2.2.2. The economy and state revenues	70
2.2.2.1. Foreign investment	72
2.2.2.2. Foreign trade	73
2.2.3. The Constitutional Revolution and the rise of Reza Khan	76
C: <i>Reza Shah and the Pahlavi Dynasty (1925-41)</i>	
2.3. <i>The State under the Rule of Reza Shah</i>	77
2.3.1. From the 1921 coup to the Pahlavi dynasty	77
2.3.2. The autocratic regime of Reza Shah	79
2.3.2.1. The army	80
2.3.2.2. The administration	81
2.3.2.3. Court patronage	82
2.3.3. Bureaucratic reforms	83
2.3.4. Economic policies	86
2.3.4.1. State industrialisation policy	88
CHAPTER 3. THE IRANIAN AUTHORITARIAN-BUREAUCRATIC REGIME	92
3.1. <i>The Bureaucratic Establishment of the Pahlavi Regime</i>	96
3.1.1. The political orientation of the bureaucracy and its structure	97
3.1.2. The executive power	100
3.1.3. The legislature	103

3.1.4. Political parties	106
3.2. <i>The administrative role of the bureaucracy and its failures</i>	108
3.2.1. Failure of the administration	112
3.3. <i>The Authoritarian Regime</i>	114
3.3.1. The military forces	115
3.4. <i>The Security Forces and Political Repression</i>	123
3.4.1. SAVAK	124
3.5. <i>The Monarchy-Centred Nationalist Mythology</i>	126
CHAPTER 4. STATE AUTONOMY AND SHAH-ELITE RELATIONS	129
4.1. <i>Dual Personality of the Shah: Grandiose Versus Passive Personality</i>	130
4.1.1. Grandiose years and the Shah's policy priorities	133
4.2. <i>The Shah by the Grace of the US</i>	135
4.2.1. US-Iran relations restructured	137
4.3. <i>The Shah and his Regional Concerns</i>	138
4.4. <i>The Shah, the Dominant Political Actor</i>	140
4.4.1. The ruling elite	141
4.4.2. The Shah-elite relations	145
4.5. <i>Control Through Economic Power</i>	146
4.5.1. The state's economic power and the non-ruling economic elite	148
4.5.2. The Pahlavi Foundation: a conduit for loyalty	149
4.6. <i>The Shah and the Autonomous State</i>	152
CHAPTER 5. THE STATE, OIL REVENUES, AND ECONOMIC DEVELOPMENT	156
5.1. <i>The Impact of Oil on the Economy, 1910-50</i>	157
5.2. <i>Oil and Government Fiscal Policy, 1950-77</i>	158
5.3. <i>The Impact of Oil and the Public-Private Sector Relations</i>	163
5.4. <i>The Impact of Oil Revenues on Development Programmes, 1950-77</i>	167
5.4.1. The first two Seven-Year Plans, 1949-1955; 1956-62	168
5.4.2. The Third and the Fourth Plans, 1963-67; 1968-72	169
5.5. <i>The Revised Fifth Plan, 1973-77</i>	174

CHAPTER 6. DEPENDENT DEVELOPMENT IN IRAN	186
6.1. <i>Centrality of the State in the Development Process</i>	189
6.2. <i>The State's Industrial Strategy</i>	192
6.2.1. The private sector: the weaker partner	196
6.2.2. Foreign finance, a directing element in the industrialisation process	199
6.2.3. State's industrialisation strategy and the agricultural sector	201
6.2.4. The transnational corporations	204
6.3. <i>Foreign Trade</i>	209
6.4. <i>The US-Iran Relationship</i>	214
<i>Conclusion</i>	219
<i>The State Structure</i>	221
<i>The State and the Process of Capital Formation</i>	223
<i>The State, Oil Revenues, and Economic Growth</i>	225
<i>Theoretical Findings and Methodological Considerations</i>	229
<i>Notes</i>	232
<i>Appendices</i>	250
<i>A. Wealth of the Shah</i>	251
<i>B. Tables (A1-A32)</i>	260
<i>Bibliography</i>	283

Acknowledgements

It is a pleasure to thank the many people who helped and supported me during the research and writing of this thesis. Chief among them I count Dr. Anoushiravan Ehteshami, for his advice, encouragement and perseverance with my writing style. Furthermore, I sought the benefit of discussions on various issues directly or indirectly related to this research, with a number of people, among them, Professor Tim Niblock and Dr. Emma Murphy (CMEIS) I should single out. Thanks are also due to the staff in CMEIS for their support throughout the research project, and the Middle East Documentation Centre at the University of Durham for help and provision of sources. The financial assistance of the Government of I.R. of Iran is also acknowledged.

A final debt, of a different nature, is owed to my parents for their unwavering support, to my wife who encouraged and helped me along the way, and my children Hamed, Narges and Sadeh who by their patience provided me with the necessary atmosphere during the research period.

List of Tables and Illustrations

<i>A: Tables</i>	Page
TABLE 2.1: The Safavid Shahs and Their Chief Ministers: During the Seventeenth Century	51
TABLE 2.2: Revenues of the Iranian State, 1800-1907	71
TABLE 2.3: Comparison of Foreign Investment and Trade; Iran, Turkey, Egypt, and India	73
TABLE 3.1: Composition and Social Basis of the Majles	104
TABLE 3.2: Composition of Central Government Consumption Expenditure, 1963-77	109
TABLE 3.3: Defence Expenditures	117
TABLE 5.1: Expenditure and Revenues Allocation in the Original and Revised Fifth Plan	175
TABLE 6.1: Loans Approved by IMDBI	197
TABLE 6.2: Foreign Investment and Loans Through CAPFI by Type of Activity	205
TABLE 6.3: Exports According to Production Type	211
TABLE 6.4: US Military Sales to Iran, 1955-78	215
TABLE A1: Oil Royalties Payment to the Iranian Government	260
TABLE A2: Historical Development of Iranian Oil Industry, 1913-1977	260
TABLE A3: Share of Oil Revenues in Government Revenues; the First to Fifth Plan	261
TABLE A4: The Share of Oil Revenue in Government's Foreign Exchange Receipts	261
TABLE A5: Share of Oil Revenues and Taxes in Government Budget	262
TABLE A6: GFCF and Consumption Expenditures, 1967-78	263
TABLE A7: Investment by the Private and Public Sectors in Iran; the First to Fifth Plans	263
TABLE A8: Public, Private and Total Investment in Industry and Mining	264
TABLE A9: Real Consumption and Expenditure, 1959-77	264
TABLE A10: Sectoral Allocation of Government Development Expenditures; The Second to Fifth Plans	265
TABLE A11: Sectoral Distribution of Credits During the First to the Fifth Plans	266
TABLE A12: Contribution to National Agricultural Production Surplus by Different Farm Units	266
TABLE A13: Trends in GDP, The selected years of the Fifth Plan	267
TABLE A14: Sectoral Composition of Iran's GDP	268
TABLE A15: The Share of Oil Revenues in Government Current Receipts and Payments,	

1959-78	269
TABLE A16: Wage and Price Inflation; the First to Fifth Plans and Selected Years	271
TABLE A17: Land Ownership after the Land Reform of 1963	272
TABLE A18: Major Commercial and Specialised Banks with Foreign Ownership, 1975	272
TABLE A19: Foreign Private Investment Through CAPFI, the Third to Fifth Plans	273
TABLE A20: Local and Foreign Investment in Industrial Machinery, the Third to Fifth Plans	273
TABLE A21: Iran's Foreign Trade, 1953-1978	274
TABLE A22: Iran's Foreign Trade as a Proportion of GNP, 1959-1975	275
TABLE A23: Industrial Dependence on Imports, 1979	276
TABLE A24: Leading Importers to Iran, 1959-1977	277
TABLE A25: Imports of Foods, 1970-1977	277
TABLE A26: Defence Budget as a Share of National Budget, 1941-1978	278
TABLE A27: Registered Foreign Firms by Type of Activity, 1973-77	279
TABLE A28: Defence Expenditures, 1963-78	280
TABLE A29: Average Annual Real Rate of Growth of Major Sectors; the third to fifth Plans	281
TABLE A30: Sources of Revenues in Development Plans; the First to Fifth Plans	281
TABLE A31: Sources of Revenues in Government Budget, 1973-78	282
TABLE A32: Manpower Supply and Demand by Major Occupation, the Fifth Plan	282
 <i>B: Graphs</i>	
GRAPH 5.1: Share of Oil and non-Oil Export in Government Budget and Foreign Exchange	159
GRAPH 5.2: Investment and Consumption Ratio of the Private Sector to the Public Sector	164
GRAPH 5.3: Share of Oil Income in Government Revenues: The First to Fifth Plans	170
GRAPH 5.4: Average Annual Real Rate of Growth of Major Sectors	174
GRAPH 5.5: Sectoral Allocation of Government Expenditure, the Second to Fifth Plans	177
GRAPH 5.6: Sectoral Composition of Iran's GDP, 1963-1977	179
GRAPH 6.1: Foreign Trade of Iran: Imports and non-Oil Exports	210
 <i>C: Charts</i>	
CHART 1.1: A Model for the Semiperipheral Capitalist State	38
CHART 1.2: The Impact of Oil Revenues on the State's Behaviour	41
CHART 2.1: The Position of the Officials Within the Safavid State	49
CHART 2.2: The New and Traditional Army During the Three Phases of the Safavids	57

CHART 3.1: The Shah and the Authoritarian-Bureaucratic Decision Making Process	94
CHART 3.2: The Role of the Shah and Prime Minister in the Public Sector	101
CHART 3.3: The Intelligence Co-ordination System of the Regime, 1970-78	122
CHART 4.1: The Ruling Elite and the Reporting Relationship with the Shah, 1965-76	144

Abbreviations

AEO	Iran's Atomic Energy Organisation
AIC	Agricultural and Industrial Company
AID	Agency for International Development
AIOC	Anglo-Iranian Oil Company
Asnad	Documents of the Spy Den (Documents of the American Embassy in Tehran)
ARMISH	Army Military Mission
ARMISH-	Army and Gendarmerie Military Mission
MAAG	
CAPFI	[Law] Concerning Attraction and Protection of Foreign Capital Investment
CBI	Central Bank of Iran
CENTO	Central Treaty Organization
DIBI	Development and Investment Bank of Iran
FF	Farah Foundation
GENMISH	Gendarmerie Military Mission
GDP	Gross Domestic Product
GFCF	Gross Fixed Capital Formation
GNP	Gross National Product
IA	Iran Almanac
ICOR	Incremental Capital-Output Ratio
IESC	International Executive Service Corp
IMDBI	Industrial and Mining Development Bank of Iran
IMF	International Monetary Fund
IOSS	Imperial Organisation for Social Service
IJMES	International Journal of Middle East Studies
ISC	Iran's Statistical Centre
ISI	Import Substitution Industrialisation
LDCs	Less Developed Countries
MAAG	Military Assistance Advisory Group
MEJ	Middle East Journal

NICs	Newly Industrialised Countries
NIGC	National Iranian Gas Company
NIOC	National Iranian Oil Company
NIPC	National Iranian Petrochemical Company
NISC	National Iranian Steel Company
PBO	Plan and Budget Organisation
PF	Pahlavi Foundation
SAVAK	The National Security and Information Agency
SCCMC	Sar Cheshmeh Copper Mining Company
SFIL	Student Followers of the Imam's Lines
SWB	BBC World Service Broadcasting
TAFT	Technical Assistance Advisory Group
TNC	Transnational Corporation

Introduction

The role of the modern state in Iran (from the 16th century) has influenced, and to a major extent, determined the creation of a modern economic system and its possible transformation over time, and the class structure of society. In the Post-World War II period, during which Mohammad Reza Shah Pahlavi (hereafter, the Shah) ruled Iran, the position of the state in economy and society was of crucial significance for the dynamic of the system. In a society where the state dominated all spheres of life, the political system shaped the organisational structure of its authoritarian and bureaucratic organs and determined their goals and functions in society. Therefore, the political, administrative, and economic elements of the system, under the Shah's rule, were so intertwined that it is impossible to analyse the latter two without understanding the former.

As a result, in this research, I have adopted an approach based on political economy in an attempt to provide a concrete understanding of the character and position of the state in Iran. While previously the main economic role of the modern state, in the pre-World War II era, was the mobilisation of resources for investment within a predominantly agrarian economy, in the new era of the Shah's rule, the state faced the task of distribution and allocation of the already centralised economic surplus in the form of oil revenues. This radically influenced the state structure and its behaviour, transformed the nature of state-economy and state-society relationship and inaugurated a period of rapid institutional change. Oil revenues helped to reinforce the autonomy of the state and strengthened the Pahlavi state, whilst increasing the ability of the state to bargain with advanced capitalist countries.

The thesis is divided in six chapters. Chapter one provides the theoretical foundation for the main topic of the study, and thus, is essential for a full understanding of the rest of the thesis. Rather than a general theory of the capitalist state, and of world-wide development, a model has been constructed which pursues the historically specific processes of state formation in a given social formation. In this model, the state is situated at the crossroads of transnational and domestic processes and changes. Thus, the state structure, its capacities and policies are influenced by the domestic and international circumstances in which it exists.

A central contribution of this model is to integrate the world-system and dependency perspectives on the one hand, and the Weberian-Hintzian approach on the other, to yield insights into the understanding of the structure and functions of the semiperipheral, dependent capitalist state in Iran. Furthermore, to extend our analytical framework into the state behaviour vis-à-vis internal and international capital, two key concepts, namely 'autonomy' and 'interdependence', are developed.

Therefore, one of the tasks of the analysis in this research is to use this model to describe the structural characteristics of the regime, and to map Iran's political process and economic development in terms of its class relations and qualitative and quantitative integration into the capitalist world.

Chapter two provides a historical-comparative study of the modern state in Iran, starting from the Safavid dynasty in the 16th century, in order to conceptualise the elements of continuity and change in the historical process of modern state formation in Iran. In a close examination of the rise of the modern state, elements of continuity and change are noted. For instance, a certain parallel between the rise and fall of the Safavid dynasty (the 16-17th century) and the twentieth century Pahlavi dynasty are noted; both dynasties based their power on three pillars, namely, the state bureaucracy, the armed forces, and the network of court patronage. Both dynasties represented peaks of national economic power, dominated to a great extent by the Shahs at the pinnacle. A second parallel is noticed within the Pahlavi dynasty itself, when the state during the rule of Reza Shah (1925-41) and Mohammad Reza Shah (1942-79) is compared.

In the Post-World War I period, the Iranian state and economy entered a new phase of development, with oil revenues assuming a growing significance in financing accumulation. Quantitative and qualitative examination of this development is the focus of chapters 3 to 6.

In chapter 3, the aim is to describe the political structure of the Shah's regime. This chapter analyses the authoritarian-bureaucratic establishment of the state, showing that the ultimate aim of the political structure was to protect the Shah and his dynasty, primarily from internal threats. Hence, the country's political system was based on the supreme loyalty to the Shah and the monarchy; overlapping responsibilities; and the virtual absence of any lateral communication within the administrative and military hierarchy. In addition, the authoritarian-bureaucratic establishment of the regime was

extensively used both as an instrument of power and control and as a tool for achieving developmental goals; an instrument for system maintenance and regime enhancement.

The decision-making process and exercise of power was manipulated by and depended exclusively upon the Shah and his relationship with the limited circle that was the ruling elite. Analysis of the state autonomy in Iran describes such manipulation. The main elements that enhanced the autonomy of the state - apart from the state's organisational character - were the massive oil revenues and the unequivocal US support. It is argued that in the 1960s and 1970s and in the absence of effective societal constraints, the political decision-making process was determined by a variety of factors. Most important among them was the set of beliefs and psychological attributes that shaped the Shah's policy priorities. It is further argued that if the Shah's self-esteem was reinforced by his psychological relationship with the US, his manipulation of political decision making was consolidated by the massive wealth which oil exports generated. This chapter also examines how the personal wealth of the ruling royal elite (mainly through the Pahlavi Foundation) was increased and, furthermore, how it was used as means of control and royal patronage.

Chapter 5 outlines the process of capital accumulation and policies of economic development which were pursued to renovate the economy's industrial base during the Shah's rule. In examining the Development Plans, it is argued that during most of this period, oil production and export acted as the leading sectors of the economy and the determinant of the increase in exports. Furthermore the availability of oil income over this period allowed rapid accumulation to take place without the need to mobilise domestic savings through taxation or other policies aimed at curbing the consumption of high income groups. However, the way in which oil revenues were allocated by the state compounded the existing obstacles and constraints to achieving an export-oriented non-oil economy. As a result, the unbalanced development of the Iranian economy was reinforced and led to a series of serious economic problems with deep social consequences. Thus, in an oil-based economy such as Iran, oil revenues provided a new kind of economy, built on rent and heavily reliant on the export of a single raw material, the production of which required little contact with the rest of the economy. It brought spectacular growth, yet at the same time engendered dependency on external volatile markets.

Chapter 6 mainly studies the relations with and influence of international capital over the political and economic development process during the Shah's regime. It is argued that international capital played a significant role in the process of accumulation of capital and the growth of the productive forces in Iran. In the changing international division of labour, Iran was a stable source of relatively cheap oil and also was active in the production and export of industrial goods during its drive for industrialisation.

The state which was tied to the international capitalist system, benefited from direct political and military support of the major capitalist nations. Being the sole recipient of oil income, the state played a central role in the 'alliance' with the local bourgeoisie and the TNCs. Nevertheless, in spite of these advances, Iran still was subordinated to the West, to an extent that the unevenness of capitalist development on a world scale and the ongoing dependent development process in Iran during the 1960s and 1970s, made Iran a weak constituent of the system. In this respect, firstly, its economic prosperity still rested on the export of a single primary product whose market it did not control. It was therefore vulnerable to shifts in demand and to manipulations of distribution by the oil company cartel and the world market. Secondly, whilst, the industrial policy of the regime, known as ISI, further increased the influence of the TNCs in the industrialisation process of the country, Iran had no independent technological capacity and had to import semi-finished goods to meet its industrial needs.

In addition, oil created new international interdependencies as the state relied on foreign markets for capital, labour, and goods. The number of choices, the range of options that oil revenues created, the things that oil money could buy, initially masked the growing dependency on foreign powers and markets. Having said this, it is nevertheless argued that Iran was, to a greater extent than in the past, an independent actor in the international capitalist system, although the stronger actors in this system - the advanced capitalist states - would seem to have encouraged her development only in so far as this would accord with their own interests.

In conclusion three points are raised:

- a) an overview of the structure and behaviour of the Shah's state with reference to the high degree of state autonomy from pressure groups, and its decreasing dependent relations within the capitalist world;
- b) the major theoretical contribution of this study which has been to effect a synthesis of perspectives derived from the above mentioned theories in understanding the state;

c) the benefit of the comparative method is to shed new light on why similar states behave differently (internally and externally) and why countries with similar situations end up at different degree of their development, class relations, etc. A second type of comparison which has been used is of an internal type (i.e. between the Safavid and the Pahlavi dynasty, between the rule of Reza Shah and Mohammad Reza Shah), where the historical-comparative methodology turns on a single case which yields much theoretical interest. It is by using this type of comparative method that we can notice the elements of continuity and changes within the process of modern state formation in Iran.

Chapter One: Theoretical Foundation

Some scholars have regarded the state as an instrument of class rule, others as an objective guarantor of production relations or economic accumulation, and still others as an arena for political class struggles. International relations as a modernisation approach regards states as separate phenomenon, autonomous from each other and only conditioned by agreed rules of same states.¹ In contrast, the radical approach took the state as a derivation of the world-system. For them, underdevelopment is a condition or symptom of capitalist domination.

As will be argued, to understand the rise of modern states in developing countries, we need to understand both internal and external aspects of state formation, in which states are shaped by the interaction of these two forces. These forces are, the structure of social classes, their relative power vis-à-vis the state, the external ordering of states, their position relative to each other, and their overall position in the world. Therefore, the state as the main body regulating internal affairs and external relations, is located at the intersection of the two and is shaped by both.

Thus, it is not enough to simply trace processes over time and within the national boundaries. Analysts should take into account the embeddedness of nations in changing international relations - such as wars, interstate alliance, balance of power, market flows, international division of labour - all within a system of global interdependence. As states are situated at the intersections of transnational and domestic processes and changes, their structure, capacities, and policies are influenced by the domestic and world circumstances in which they exist.

Internal and external forces mostly go hand in hand - not necessarily with equal weight - and sometimes are not distinguishable. Two points are worth mentioning in this regard. Firstly, state formation occurs in a historical context and is a lengthy process. Obviously the weight and the interrelationship between internal and external forces will vary during the process of state formation.²

Secondly and more importantly, it is argued that lack or deficiency of either of these forces - external and internal - will be filled partly by the state's intervention; the state will help to redefine and reshape itself. The timing and the nature of incorporation of the state into world system are important and it will influence the subsequent form of the state. While the internal and external processes influencing the state need to be examined, the analysis of the state structure and its organisations (i.e. the military and bureaucratic establishment), the important role state autonomy plays, the state position in the world system (i.e. periphery or semiperiphery), and the state status in relation to the core (i.e. dependent or interdependent), and its economic policies (i.e. dependent development) are of utmost importance. By focusing on theories explaining the internal and external relations of the state, an analytical base to construct a model of understanding the state will be established.

1.1. The Theoretical Basis for Model Construction About the Modern State: Internal Aspects

1.1.1. Liberalism and Marxism: juxtaposition of the theory of the state

Liberalism as Held argues is "the idea to define a private sphere independent of the state and thus to redefine the state itself, i.e. the freeing of civil society - personal, family and business life - from political interference and the simultaneous delimitation of the state's authority" (1984: 31).³ After extensive conflicts, during the 18th and 19th centuries, the Western world was more influenced by liberal democratic thinking - by allowing the people to express their judgement on the performance of those who governed them.

John S. Mill (1806-73) was an advocate of liberal democracy. For him, liberal democracy could develop further individuality in which public participation is a proper means of increased citizenship. Representative democracy is the best kind of government while the free exchange of goods on the market is the best way of maximising economic liberty. Thus, Mill argued that the neutral liberal state should ensure both the security of the individual and of property, and equal justice between individuals. Therefore, "if these things can be left to any responsibility below the

highest, there is nothing, except war and treaties, which requires a general government at all" (Mill 1972: 355).

The relationship between individuals and the state is the central problem facing liberal and liberal democratic theory. By this theory, as Mill (1972) argues, although the state must have a monopoly of coercive force, this force could deprive citizens of their freedom.

According to Marx and Engels, Mill's idea of security of person and property is contradicted by the reality of a class-divided society where the class structure determines the individual's life. An industrial capitalist state by defending the ownership of the means of production by capitalists can never be neutral. The state plays a central role in the integration and control of a class-divided society (for an overview of Marx's and Engels's account of class see Giddens et al 1982: 12-39). It is not the state, Marx argued, which underlies the social order, but it is the social order that underlies the state. True democracy can be established by the destruction of social classes and ultimately the abolition of the state itself. The state must wither away, leaving a system of collectively free, equal and self-governed society, Marx argued. By calling an end to the state, and reducing politics to economic and class power, Marxism tends to marginalize or exclude certain types of political issues. The ambiguity of Marx's view toward the state has led to different understandings and interpretations of the role of the state in society.

Contemporary Marxism can be categorised at least into three major camps, namely libertarians, the pluralists, and the fundamentalists (Held 1984b: 226). Libertarian Marxists (such as Herbert Marcuse) argue that Marx's position is a consistent opposition to the division of labour, state bureaucracy, and authoritarian leadership. For them, there can be no association with the state; for it is always the power apparatus of dominant economic interests. The road to socialism involves non-coercive means and requires a mass movement, independent from corrupted bourgeois state apparatus. The pluralist Marxists (such as Nicos Poulantzas) conceive the state institutions as significantly independent from the bourgeois class. These institutions - the party system, election, etc. - can be deployed against the interests of the dominant class. Transition to socialism is achieved by conquering the state and,

later, restructuring society. For the fundamentalist Marxist, the democracy of the liberal democratic state is no more than an illusion. The working class is exploited by capital, and frequent elections cannot alter it. The coercive structure of the state must be cracked by revolution. According to Marxist-Leninists a revolutionary party of the working class and a professional vanguard are necessary for the creation of socialism.

It can be argued that both liberal democratic thinking and Marxism are concerned with the protection of individual freedom and democracy. Equality and liberty can only be guaranteed if one considers the scepticism of liberalism about political power and the scepticism of Marxism about economic power. If the main failure of liberalism is to see markets as powerful mechanisms of co-ordination and, thus, to neglect the distorted nature of economic power in relation to democracy, Marxism's central failure is the reduction of political power to economic power and, thus, neglect the dangers of centralised political power. Accordingly, liberalism's account of the nature of markets and economic power must be doubted while Marxism's account of the nature of democracy must be questioned.

1.1.2. Weberian-Hintzian perspective: distancing from reductionist approach

The recent emphasis on the state is relying upon the works of the German scholars Max Weber and Otto Hintze on the state. Weber argued that states are compulsory associations claiming control over territories and the people within them. Administrative, legal, extractive, and coercive organisations are the core of any state. These organisations are variably structured in different countries. From the Weberian perspective:

“the state must be considered as more than the ‘government’.⁴ It is the continuous administrative, legal, bureaucratic and coercive systems that attempt not only to structure relationships between civil society and public authority in a polity but also to structure many crucial relationships within civil society as well” (Stepan 1978: xii).³

However, the state may be an abstract and general force, its power has to be materialised. This endows the power of the modern state with some further distinctive characteristics. State apparatuses acquire distinct political characteristics of their own. They can become the power bases for quite distinctive interests. Directly or indirectly,

the structures and activities of state profoundly condition the capacities classes have for achieving consciousness, organisation, and representation. The history of the state, Weber argues, cannot be reduced to class relations.

The state contains a differential set of institutions and personnel, embodying centrality, in the sense that political relations radiate outwards from a centre to cover a territorially demarcated area, over which it exercises a monopoly of authoritative, binding rule-making, backed up by a monopoly of the means of physical violence. Foremost among the state's institutions are the administrative apparatuses - a vast network of organisations run by appointed officials.

Weber extended the meaning of the concept of bureaucracy as was characterised by all forms of large-scale organisation. As economic life becomes more complex and differentiated, bureaucratic administration becomes more essential. But this Weberian view of the state does require us to see it as "much more than a mere arena in which social groups make demands and engage in political struggle or compromises" (Skocpol 1990: 8).

Hintze considers states as organisations which control territories. For him, firstly, the structure of social classes and, secondly, the external ordering of the states determine state organisations (1975: 183). This leads us away from basic features common to all polities, and toward consideration of the various ways in which state structures and actions are conditioned by historically changing internal and transnational contexts. International aspects impinge upon individual states through geopolitical relations of interest domination and competition, through world economic patterns of trade, investment flows and international finance. Using Hintze view, Skocpol argues that states necessarily stand:

"at the intersections between domestic socio-political orders and the transnational relations within which they must manoeuvre for survival and advantage in relation to other states" (1990: 8).

Thus, the modern state as Weber and Hintze conceptualised it, has been part of a system of competing and mutually involved states. Nonetheless, the position of the state in world politics and economy and its competition with other states should be

analysed within different theories, as will be argued, among them the world-system theory and the dependency paradigm.

Skocpol (1979) draws upon Weber and Marx and emphasises the two-dimensional view of Hintze, which determine the state organisation - namely, the structure of social classes, and the external ordering of the state. She expands the latter dimension in terms of military relations. Thus, the two basic sets of tasks are undertaken by a set of administrative and military organisations headed, and more or less well co-ordinated by, an executive authority for whom resources are extracted from society. These resource-supported administrative and coercive organisations are the basis of state power. This power can then be used with a degree of autonomy against either of the dominant class, or against foreign states (see also Tilly 1981 and Giddens 1981).

Mann (1986) assembles essentially the same dual theory of the state which identifies the two dimensions as: the domestic, economic/ideological aspect of the state and the military, international aspect of the state. The domestic aspect, he argues, would be likely to centre upon state-class relations due to the dominance of Marxified Weberian social theory. And as states would now be responding to two types of pressure and interest groups, a certain space would be created in which state bureaucracy could manoeuvre, play off classes against other factions, and states, and so take out an area and degree of power autonomy for itself. To put the two together would give us an initial account of state autonomy, to which we return later. Using his concepts of state power - 'despotic' and 'infrastructure' - conceptualisation of an institutionalised form of despotic state is possible, in which all significant social power must go through the authoritarian command structure of the state. Therefore, such a state's power is high in both dimensions: having high despotic power over civil society groups and being able to enforce it through infrastructure powers of the state. Later in the chapter, the features of the state as viewed from a Weberian-Hintzean perspective can help to explain autonomous state action: features such as the extra-national orientation of the state and the challenges it may face in maintaining domestic order.

From what has been said above, the emphasis of the Weberian-Hintzian approach is focused more on the bureaucratic-military structure of the state which is mainly shaped by domestic forces.

1.2. The Theoretical Basis for Model Construction about the Modern State: External Aspects

Major approaches which focus on the external aspects of state formation, structure and behaviour that are found in the literature - although it is a literature that rarely impinges upon the theory of the state as an explicit issue - are that of international relations, world system, and dependency. In the former tradition, each state is seen as having its own integrity and relating to other integral states, so that an important issue is the nature of each state's policy regarding war and defence, the balance of payments, and political and economic alliances. In this tradition, it seems, the role of the external dimension in state formation is very much neglected and is far from the contemporary reality of the state formation and functions.

The second tradition and, to a major extent, the dependency paradigm, both derive the individual state from the existence of a world system. Our interest in these perspectives are not in their historical deterministic approach which neglects the importance of the internal forces and to a major extent the centrality of the nation-state in the world polity, but rather on the way in which they emphasise the external forces shaping the state and its behaviour.

Because both theories partially focus on the concept of imperialism, a brief survey of classical and new theories of imperialism and later the notion of postimperialism is helpful.

1.3. The State and Theory of Imperialism

Within the Marxist tradition the term 'imperialism' was initially applied to the relations between 'advanced' and 'backward' countries within the capitalist system, and later to the totality of a particular phase (the monopoly phase) in the development of the system, characterised by a particular form of relationships among the 'advanced' countries, and between them and the 'backward' countries.

1.3.1. Classical theory of imperialism

The disparity between the development of productivity and the division of the world amongst the large capitalist firms, and the 'great powers', was for Lenin the key characteristic of the form imperialism took at the beginning of the twentieth century. It was an imperialism in which the most important aspect was the tension and rivalry between the leading capitalist states, given that there were no longer any 'open spaces' for capitalists to expand into. This rivalry, Lenin believed, was the product of a distinctly new form of internationalisation of capital.

Lenin (1969: 151-2) describes the main features of imperialism, the 'highest stage of capitalist development', as: 1) monopoly in the economic market; 2) creation of a financial oligarchy based on financial capital; 3) export of capital; 4) formation of international monopolist capital; and, 5) territorial division of the world. The reason for capital export was lack of profitable investment opportunities in capitalist countries, Lenin argues. In his words imperialism is:

"capitalism in that stage of development in which the dominance of monopolies and finance capital has established itself; in which the export of capital has acquired pronounced importance; in which the division of the world among the international trusts has begun; in which the division of all territories of the globe among the biggest capitalist powers has been completed..." (1969: 78).

The result of this would be a tendency towards a greater integration of the world economy, a considerable degree of capital movement, and an international division of labour which would restrict the growth of backward economies to the production of mineral and agricultural primary products. Nevertheless, the historical progressiveness of capitalism in the backward regions of the world - in the colonial and post-colonial periods - is analysed as being limited by the previously mentioned alliance between imperialism and traditional elite, the so-called 'feudal-imperialist alliance' (see the Sixth Congress of the Communist International, the Comintern, in 1928, in Degras 1960: 526-48). As the process of industrialisation in the backward countries was seen in contradiction not only with imperialism, but also with some internally dominant groups, the ability of the incipient national bourgeoisie to develop it in the post-colonial phase would depend upon their political capacity to assert themselves over

that alliance, and to impede the adoption of such policies as, for example, those of free trade which it sought to impose. This double contradiction in capitalist development in Latin America became the paramount base for the rise of dependency paradigm, to which we return below.

Lenin attempts to show that the economic partition of the world necessitated the political partition of the world. It seems, as Elson (1984) argues, Lenin confuses correlation with causation. In fact Lenin supplies no analysis of how the connection between the economic and political division of the world is actually made. Based on Lenin's argument, it is assumed that the actions of the leading 'great powers' necessarily reflect the interests of finance capital. The state is implicitly seen as a direct instrument of finance capital. Yet in spite of its reductionism, Lenin's theory of imperialism does not downgrade the importance of the state, nor does he dissolve the specificity of the nation state. Finance capital is assumed to exist in national blocs, and to require its own national state to further its interests abroad.

Rosa Luxemburg (1963) provides a systematic analysis of the effect which imperialism would have on the backward countries. However, her analysis is limited by the fact that, following the Marxist tradition of the period, she underestimates both the increase in real wages which takes place as capitalism develops in the advanced countries, and the internal inducement to invest provided by technological progress. Consequently she overplays the role of the periphery in the process of capital accumulation in the developed countries. The periphery has, indeed, played a role both qualitatively different and quantitatively less important than that which her analysis depicts (see Sweezy 1942: 124-9). Bukharin (1915, 1926) continually emphasises throughout the course of his work that imperialism is a phenomenon which connects the advanced and the backward economies, and criticises Luxemburg's views on the subject (see O'Brien 1975: 21).⁴

Much criticism of Lenin's theory of imperialism has centred on the emphasis placed on the export of capital (see O'Connor 1970; Warren 1980).⁵ Among the critics are Trotsky's contributions, and in particular that of 1930, in which he insists that the specific historical circumstances of individual countries would preclude their repeating the path to capitalist development traced out by the advanced nations.

1.3.2. New theories of imperialism

New theories of imperialism try to cope with the events that have occurred since the end of the World War II. Although the world today remains divided, the nature of the division has changed. There are hardly any colonies of significance left, the major competition for 'spheres of influence' has been for four decades between the West and the Soviet Union, and now between the economic poles within the capitalist world. The internationalisation of capital has become even more significant. Its dominant form today is the transnational corporations (TNCs).

Mandel modifies Lenin's theory of imperialism and illustrates it by modern developments, in which advanced capitalist societies are related to each other in a hierarchical relationship and Third World societies are subordinated to them. The underlying perspective is one of an essentially international economic system: capitalism extending and developing its international structure over time and determining to a significant extent the position and role of nation-states. He assumes that the activities of leading capitalist states will reflect the needs of the TNCs. He identifies the interests of the TNCs as being: "a successful struggle against crises and recessions", to be achieved through an international form of anti-cyclical economic policy (Mandel 1975: 328). This is a crucial step in his implicit reduction of state policy to an economic foundation. It is crucial because it represents the interests of the TNCs as simple and straightforward, and capable of satisfaction by appropriate state action. Galtung (1971: 301) defines new imperialism as:

"a system that splits up collectives and relates some parts to each other in relations of harmony of interest, and other parts in relations of disharmony of interest, or conflict of interest".

He moves further to distinguish different types of imperialism: economic, political, military, and so on. Hence, the peripheral state is influenced by imperialism to provide raw material and markets for the centre (economically), obedience and imitation (politically), discipline and production of traditional hardware (militarily) he argues (1971: 310).

The new theories of imperialism that have been shaped and advocated by the dependency school emphasise economic imperialism.

“The theory of neo-colonialism is the theory of economic imperialism: the economic domination of one region or country over another... It has been in form of control by the advanced capitalist countries over the liquid and real economic resources of economically backward areas” (O’Connor 1970:283).

It seems that theories of imperialism, although they had an influence on dependency and world-system theories, can not adequately conceptualise the existing relation between the industrial capitalist countries and developing countries. The existing world economy permits the industrialisation and economic development of peripheries. Although the dominant actor in this relation between the two, is the capitalist core, the latter should accommodate in its relations, the increasing role of the developing countries in world politics and economy. Therefore, the approach of postimperialism, as will be argued, to an extent, can provide a better framework to be used in our model.

1.4. Dependency Paradigm

Dependency analysis can be distinguished in three major approaches. The first is that begun by Frank (1967) and continued by other scholars such as Dos Santos (1979) and Marini (1972). Its essential characteristic is that it attempts to construct a ‘theory of underdevelopment’, based on the Latin American experience, in which the dependent character of these economies is the hub on which the whole analysis of underdevelopment turns. It suggests that underdevelopment is in fact the direct result of relationship of these economies with the developed capitalist countries (for critiques of this approach see Laclau 1971; Brenner 1977; Lall 1975, for empirical critics see Warren 1980; Chase-Dunn 1975). The second approach, found principally in Sunkel (1975) and Furtado (1966) is characterised by the attempt to reformulate the ECLA analyses of Latin American development (see also Prebisch 1963) from the perspective of a critique of the obstacles to national development. Finally, the approach which is the point of emphasis here is the one which deliberately attempts not to develop a mechanico-formal theory of dependency and concentrates its analysis on what has been called ‘concrete situations of dependency’, conceptualised by Cardoso and Faletto (1979).

One characteristic of the latter approach to dependency has been to incorporate more successfully into its analysis of Latin American development the transformations which are occurring and have occurred in the world capitalist system, and in particular the changes which became significant towards the end of the 1950s in the rhythm and the form of capital movement, and in the international division of labour. The emergence of the TNCs progressively transformed centre-periphery relationships, and relationships between the countries of the centre. As foreign capital has increasingly been directed towards manufacturing industry in the periphery, the struggle for industrialisation, which was previously seen as an anti-imperialist struggle, has become increasingly the goal of foreign capital. Thus dependency and industrialisation cease to be contradictory, and a path of 'dependent development' becomes possible.⁷ It is not a case of seeing one part of the world capitalist system as 'developing' and another as 'underdeveloping' or of seeing imperialism and dependency as two sides of the same coin - as claimed by the development of underdevelopment approach. But rather, in the words of Cardoso and Faletto:

"We conceive the relationship between external and internal forces as forming a complex whole whose structural links are not based on mere external forms of exploitation and coercion, but are rooted in coincidences of interests between local dominant classes and international ones..." (1979: 10-11).

The most significant feature of this approach is that it insists on how the general and specific determinants interact in particular and concrete situations. It is only by understanding the specificity of movement in these societies and a synthesis of these internal and external factors, that one can explain the particularity of social, political and economic processes in the dependent societies.

The preliminary definition of dependency offered by Cardoso and Faletto stresses the limits to development:

"From the economic point of view a system is dependent when the accumulation and expansion of capital cannot find its essential dynamic component inside the system" (ibid.: xx).

This formulation points to an international economic system within which the various nations occupy positions of qualitatively different levels of power and

influence. At the centre the advanced industrial nations control the key sectors of technology and finance, an advantage that shapes the special forms taken by industrialisation in the periphery.⁵

The principal contribution of dependency theory has been to provide an analysis of how imperialism affects the internal social structures of peripheral countries. In doing so, dependency theory has directed attention to variation among countries in the periphery and to the analysis of dependent development. Dependence is then defined most simply as a situation in which the rate and direction of accumulation are externally conditioned.

Nevertheless, dependence includes a wide range of disparate situations. The case of OPEC and the oil crises of the 1970s provided a powerful reminder that exporting primary products does not universally entail having a permanent weak or rigid position in international trade. Even more important, saying that a country is 'dependent' does not indicate that its relation to the international economic system is immutably fixed.

In all that was said above, this approach of the dependency paradigm leads away from the construction of models of stagnation and toward an analysis of dependent development, characterised by the association or alliance of the state, international and local capital. Hence, dependent development becomes the dominant aspect of dependence.

The reference to dependence, here in our model, is a broad and general one, in which the state rather than local bourgeoisie plays the main mediator in the process of dependent development. While using the analytical grounds of the theory as a 'concrete case of dependency' and its new approach of 'dependent development' as a special instance of dependence, the model is not bound to the assumptions of the dependency theory.

1.4.1. Postimperialism

Warren (1980), on empirical grounds, criticised both schools on the role of the TNCs. He gave credit to the classical Marxism with respect to the development of capitalism. However, it is the new approach of Becker and Sklar (1987), labelled

'postimperialism', that abandons the premise of the continuous imperialist nature of capitalist expansion and tries to accommodate the TNCs in the Marxist approach to development of capitalism in the Third World.

In this view, the TNCs offer the Third World access to capital resources, dependable markets, and technology. It suggests that beneath the usual differences regarding distribution of rewards there lies a mutuality of interest between politically autonomous states at different stages of economic development. Localisation or indiginization of labour and management of the TNCs is the condition of a viable relationship between the TNCs and the Third World state. The second condition of viability is the local participation in equity ownership, such as joint ventures. A class of managerial bourgeoisie consisting of local and foreign nationals emerges. Its members share a common situation of socio-economic privileges and common interests in political power and social control that are intrinsic to the capitalist mode of production. The upper stratum of the local bourgeoisie has evolved a cadre of class leaders dependent on the corporate form of organisation and class. This stratum is called by postimperialist theorists, corporate national bourgeoisie.

Economic stability that follows political stability becomes the common interest of both the TNCs and the state. On economic policy, the corporate national bourgeoisie favours an active local state and a more mercantilist policy of individual protection and substitution than TNCs prefer. Thus TNCs' economic relation is subject to the clashes between local nationalism and cosmopolitan internationalism of the managerial bourgeoisie. Postimperialism argues that the conflict will be mitigated by the disposition of the latter by the idea of doctrine of *domicile*, in which the TNC and its subsidiaries adopt and operate in *accordance* with the state policies. Parallel to the 'good citizenship' of TNC, capitalism itself has evolved an adaptive process to prevent the Third World defection from capitalism due to the harmful decisions against the Third World, by more accommodation to the most urgent demands of the developing world.

Postimperialism implies the beginning of a new post-nationalist age. The bourgeoisie has taken the lead, and the TNCs, the financial system, and other institutions should be analysed from the standpoint of transnational class development

(Sklar 1987). The instrument of corporate international bourgeoisie transcends the restrictive nation-state system. This analytical approach to the role of the TNCs provides us with an important explanatory tool to integrating the idea of 'dependent development' in the model. Because, dependency has been unable, to a major extent, to analyse the development taking place in the Third World partly because its static approach with regard to the role of the TNCs, has not been changed and redefined.

1.4.2. The concept of dependent development

Dependent development refers to cases:

“where capital accumulation and diversified industrialisation of a more than superficial sort are not only occurring in a peripheral country, but are dominating the transformation of its economy and social structure” (Evans 1979: 32).

Dependent development is not, it should be stressed, the total negation of dependency. It is rather dependence combined with development (ibid.). Therefore it is not a phase that all peripheral countries will be able to reach. Wallerstein (1974) claims that the more advanced exemplars of dependent development are semiperipheries which occupy their own distinct position within the world system. The significance of the notion of dependent development is that it presents a model of capitalist development, of which the central premise is the existence of a 'triple alliance' between international capital, the state, and local capital. Such an alliance is the balance between conflict and co-operation which is yet to be explored in the Iranian case of the 1960s and 1970s. Foreign capital is no longer an external force whose interests are represented internally by comprador bourgeoisie and agrarian exports. Instead, foreign capital shows an interest in the further development of local industry. As a result, there is no irreconcilable difference between local and international capital or between the latter and the state.

Viewing the internal structure of the dominant ruling class as a triple alliance also means rejecting the notion that dependent development represents the capitulation of local capital to imperialism. The dominance of the TNCs within the partnership is not taken for granted but seen as varying from industry to industry and over time. Nor is

the subordinate position of local capital taken for granted; rather it is assumed that the state and local industrial bourgeoisie have certain economic and political advantages that give their leverage in its bargain with the TNCs.

More importantly, the state - as has been the case in Iran and as in Brazil and South Korea - enforced a priority on local accumulation and pushed local industrialisation effectively. Therefore, the centrality of the state in the alliance and in development is special. States should enjoy autonomy domestically and have control over a sufficient segment of the surplus so that they can offer incentives as well as support their own activities. The state apparatus must be willing to oppose the TNCs where questions of local accumulation are at stake. This requires organisations, abilities, and resources more than just simple bargaining. Control over natural resources, the expansion of the state apparatus, (i.e. by creation of state enterprises) and technical expertise play a role in this respect.

This image of dependent capitalist state goes further than its role as an agent of accumulation. It is also an agent of social control. Although, Cardoso and Faletto (1979) and Evans (1979) emphasise the repressive nature of dependent capitalist state as a necessity to control the workforce - especially in those countries that are trying to push the process of dependent industrialisation further. In Iran as will be shown later, the use of force by the Shah's regime was more of a political nature.

However, if classical dependence was associated with weak states, dependent development is associated with the strengthening of strong states in the semiperiphery. Evans, therefore, argues that "The consolidation of state power may even be considered a prerequisite of dependent development" (1979: 11). Thus dependent development can be defined as growth within limits and advances for a minority of the population. By general reference to recent literature on dependency and post-imperialism, a conceptual model of dependent development which can describe the economic development of Iran in the 1960s and 1970s can now be presented. Its explanatory power is considerably enhanced, however, by considering another body of literature - world-system theory and its conceptualisation of the semiperiphery.

1.5. The State and the World-System Perspective

Just as modernisation theory saw the world economy as an aggregation of fragmented but similar units, albeit to some extent interdependent, so too the contemporary international relations theory saw the world as essentially divided into a set of units controlling particular territories. In contrast, the world-system perspective (like the theories of imperialism), seeks to get behind and beyond the surface appearance of international relations.

The way the world-system perspective differs from imperialism is that it takes a 'monist' rather than a 'dualist' view of the world system. There is a single world system into which all nations are integrated. It refers to a system because the relationships between its parts (the nation-states) are not taken to be random, arbitrary or haphazard. Rather, there is an interdependence of a regular and systematic kind between the parts. This interdependence is such that changes in one part of the system necessarily have implications for other parts of the system; the relationships between the parts keep the whole system functioning. Furthermore, it is a world perspective, because it views the world as a single whole, rather than as an aggregate of overlapping, but separate, sets of relations between states. The system is capitalist world-system because it is capitalism which provides the logic of the system, the basis for its essential interdependence.

World-system theory, associated above all with the work of historical sociologist Immanuel Wallerstein discussing the emergence of a capitalist world economy in the sixteenth-century Europe, and moving the analytical focus to the level of a global framework, within which a dependent or underdeveloped capitalism is the lot of most Third World nations. For Wallerstein:

“capitalism and a world economy (that is a single division of labour but multiple polities and cultures) are obverse sides of the same coin. One does not cause the other. We are merely identifying the same indivisible phenomenon by different characteristics” (1979: 6).

This capitalist world-system is more than the sum of its parts, and constitutes the level at which any effective analysis of any individual component states must begin, Wallerstein argues. He differentiates two kinds of world systems: world empires and

world economies; the former has a common political system, the latter do not. The world empire is an economic network across multiple cultures over which an encompassing state apparatus has formed. Empire states compete with each other for greater control. In such socio-economic system, as Chase-Dunn (1991) argues, the political organisation of force is the main determinant of social dynamics. Religion is used to legitimate the role of the palace. Codified law is created to centrally define correct behaviour and deviance across local communities which have formerly relied on unwritten moral tradition (The Safavid Iran is analysed here in this category).

At the global level, central to Wallerstein's approach is the idea of three positions in the capitalist world economy; a periphery, a core or strong state taking the greatest part of the international economic surplus, and a semiperiphery consisting of a stratum of states exploited by the core yet able to profit vis-à-vis the periphery. They form the basic and necessary structure of the world capitalist system, with all individual nation-states located in one or another of them. Mobility between the three positions is possible. This three layered structure is a normal and necessary condition of a world system.

One of the tasks of the analysis, here, will be to map Iran's development process in terms of quantitative and qualitative integration into the world-system. First, Iran had been a regional empire in the 17th and 18th centuries, without any subordinate relation with the European countries. Then it became a peripheral supplier of raw materials in the late 19th until the mid-1960s. Finally it became a semiperipheral state up until the 1979 revolution.⁸ Hence, such an analysis describes the state in Iran with regard to the country's international position and its integration into the capitalist world.

The world-system model has provoked a number of important criticisms since its original formulation in 1974.⁶ The world system theory looks over-deterministic, picturing a world determined only by capitalism and by those who control the capitalist core. The most telling of these criticism have to do with the methodological assumption of the world-system theory that defines capitalism as an economic system only in terms of its exchange side, that is, markets and trade between countries. There

is no equivalent importance attached to production relations and national internal class structure (see Laclau 1977). For Laclau:

“the fundamental economic relationship of capitalism is constituted by the free labourer’s sale of his labour-power, whose necessary precondition is the loss by the direct producer of ownership of the means of production” (1977: 23).

That is to say, it is in its production relations that we find the defining characteristic of capitalism. Hence, while wage labour was found in Europe from the 16th century on, other forms of labour were dominant in other areas of the world, making it impossible, according to Laclau, to call them capitalist.

A second related criticism is the characterisation of the entire world-economy today as capitalist, with no theoretical space for pre-capitalist or socialist mode of production within individual societies (see Worsley 1983). In addition, for Bernstein, the notion of ‘national economy’ and ‘world economy’ which are used extensively in the world-system theory, remain problematic because they cannot be taken as given entities (1982: 230-32). The globalist perspective paints an illusive picture of domination based on “a ‘passive receptacle’ notion of the Third World in which the internal class forces are non-actors, or even blank surfaces ready to be shaped and exploited by the core” (Petras and Brill 1985: 405), while the state is controlled by core power or dependent on core-based TNCs.

1.5.1. The concept of the semiperipheral state

As we have already hinted above, the structure of the world-system divided the world into positions of the core, semiperiphery, and periphery. The existence of a semiperipheral state enhances the stability of the world-system, Wallerstein argues. The world-system might work without semiperiphery economically but “it would be far less politically stable, for it would mean a polarised world-system” (Wallerstein 1979: 377). Wallerstein argues that the existence of semiperipheral states acts to depolarise the core-periphery hierarchy by providing intermediate actors whose very presence reduces the salience of potential conflict along the core-periphery dimension of inequality (*ibid.*: chapter 5).

The strategy of a state, Wallerstein claims, depend on its role in the world economy. Thus, Wallerstein differentiates the core-periphery distinction as:

“those zones in which are concentrated high-profit, high technology, high-wage, diversified production (the core countries) from those in which are concentrated low-profit, low technology, low-wage, less diversified production (the peripheral countries). But there has always been a series of countries which fall in between in a very concrete way, and play a different role. The productive activities of these semiperipheral countries are more evenly divided. In part they act as a peripheral zone for core countries and in part they act as a core country for some peripheral areas” (ibid.: 96-7).

Therefore, the semiperipheral state is the arena, where, because of a mix economic activities, state activity may do most to affect the future patterning of economic activity (ibid.: 274). Wallerstein employs two elements in his definition of the semiperiphery - the dichotomy between core and peripheral activities, and the notion that a state boundary encompasses an approximately equal balance of both core and peripheral activities. By this definition, there are no semiperipheral activities as such (Chase-Dunn 1991: 210). Rather there are semiperipheral states which contain a balance of both core and peripheral activities.

We may reconceptualise core-peripheral activities, using Chase-Dunn's (1991) analysis, on a continuum of relatively capital intensive/labour intensive forms of production, for a semiperipheral area to contain an intermediate level of production with respect to the core/periphery continuum. The semiperiphery idea, therefore, is an important one because it enables us to examine the ways in which intermediate actors have different strategies, and intermediate states, such as Iran, have different developmental possibilities - different in the sense of systematically differentiated from either typical core or typical peripheral regions.

For instance, when the core producers face a situation of 'over-supply', semiperipheral countries can, up to a point, pick and choose among core producers not only in terms of sale of their commodities (i.e. OPEC oil) but also in terms both of welcoming their investment in manufactures and of purchasing their producers goods. These shifts in advantages are reflected in:

“the policies of states, in the degree of their nationalism and militancy, and in the pattern of their international diplomatic alliances” (Wallerstein 1979: 99).

Thus, the definition of core-periphery described above focuses on relative levels of the capital intensity of commodity production on the one hand, and the power relationships among core-peripheral states on the other. One of the main structural features which reproduces this hierarchical relationship is the exercise of political-military power by the core states: to use political and military power to control the behaviour of other countries (see i.e. Petras 1981).

Peripheries in which the state is substantially controlled by core powers or dependent on core-based transnational corporations experience heightened levels of competition among contending groups of peripheral capitalists, and exacerbated class conflicts, though these may be largely invisible most of the time because of externally supported repression. These conditions explain the high levels of political instability and likelihood of authoritarian regimes, as well as the internal weakness of the peripheral states.

In all that was said above, semiperipheral countries are those in which there is a mix of core and peripheral activities, and there is a predominance of activities which are at intermediate levels with regard to the distribution of capital intensive/labour intensive production; where the state successfully pursues industrialisation and economic development to a major extent. The TNCs would have an interest in the process of industrialisation and the expansion of the domestic market. So they would act economically and politically to foster the growth of the national economy, albeit in a way which might exacerbate inequalities among classes.

As a result, the contradictions between the global rationality of the TNCs and the interests of the state and local capital are seen as potentially resolvable, provided that the overall conditions under which the alliance operates are not too unfavourable to continued capital accumulation in the semiperiphery.

As was mentioned earlier, the local bourgeoisie in the triple alliance observes the semiperipheral state as its negotiating instrument with the rest of the capitalist world-economy. In addition, autonomy and centrality of the semiperipheral state, and the rivalries between the two major camps of capitalism and Communism - up until the mid-1980s - would provide more room to the semiperiphery to manoeuvre, and force the TNCs to be on their best behaviour vis-à-vis the semiperipheral state.

There is also a competition between semiperipheral states, or a fear that they may lose out in a game of 'each on his own' against the core powers—they may come to favour a strategy of collective transnational syndicalism which inevitably pushes them 'leftward', more in terms of international policy. A good example might be the role of Iran and Saudi Arabia in oil-price hike in the framework of OPEC in 1973/4, while the two were competing for the share of international oil market in 1970-72.

1.6. The State's Internal and External Behaviour

Our reference to dependency and the world-system perspectives is, of course, not at all to imply that it is no longer appropriate to treat nation-states as central actors in the system. On the contrary, nation-state as was remarked earlier in the Weberian-Hintzian approach, continue to be viable and adaptive mechanisms for collective action. Some states, in fact, enjoy near total power to frame and execute policies, and many also reap the benefits of intense nationalism - of strong loyalties to the nation-state and those charged with its welfare. This, indeed, highlights the state autonomy, the importance of such autonomy for the state to pursue its own politico-economic objectives.

Therefore, emphasis on rapid change and mounting interdependence should not obscure the central role of national governments and states in world affairs. By the same token emphasis on nation-state should not downgrade the importance of the global position of the state and the growing interdependence of relations.

The concept of state autonomy will help us to analyse the state's behaviour towards social and economic groups and within the national borders. Furthermore, the concept of interdependent relations will describe the relation of a semiperipheral state (such as Iran) vis-à-vis the rest of the world.

1.6.1. The concept of state autonomy

State autonomy for Skocpol, means that:

"the state formulates and pursues goals which are not simply reflective of the demands or interests of social groups, classes, or society" (1985: 9).

State autonomy is not a fixed structural feature of any government system. It rises and falls and goes because crisis may precipitate the formulation of strategies and policies by elite or administrators who otherwise might not mobilise their own potential for autonomous action. Furthermore, the very structural potential for state autonomy changes over time in relation to societal groups.

The question whether the state is autonomous or reducible to society is one of the most important ways of differentiating theories of the state. Simple pluralist theory supposes the state to be largely autonomous. The state acts as an umpire between competing interest groups, and its neutrality with respect to different interest groups in society is guaranteed by its separateness and autonomy. Marxist theorists see the state as an instrument of the dominant class whose autonomy is an illusion to fool the working class to think that the state is neutral. Other theories of the state range between these two poles. For example, Poulantzas, a pluralist Marxist, argues that the capitalist state often acts with a 'relative autonomy' to preserve the capitalist system itself rather than simply serve the dominant class. The state arises out of society and is powerfully shaped and constrained by the social relations which surround it. States, then are not autonomous of society. They are only 'relatively autonomous'. However, for Poulantzas (1974) this relative autonomy is necessary if the state is to carry out important policies needed to evolve successfully to the next capitalist stage and thus to avoid revolution.

In contrast to Marxists, scholars in the Weberian tradition tend to take for granted that states are potentially autonomous and that the controllers of the means of coercion and administration may pursue goals at variance with dominant classes or any other social group. What more directly interests scholars in this tradition are variations in state *capacities*: 'stronger' or 'weaker' according to how closely states approximated the ideal type of centralised and fully rationalised Weberian bureaucracy, supposedly able to work its will efficiently and without effective social opposition.⁷ Because the officials attempt to implement policies that seem feasible with the means in hand, the state capacity is closely connected to the autonomous state's goal formation. Sovereign integrity and the stable administrative-military control of a given territory are prerequisites for any autonomous state to implement

policies. Beyond this, the availability of financial resources, and loyal, skilful civil servants are basic to state effectiveness in achieving the objectives (Skocpol 1985: 15). A state's means of raising and deploying financial resources tell us more than could any other single factor about its existing capacities to create or strengthen state organisations, to employ personnel, to gain political support, to subsidise economic enterprise, and to fund social programmes.

All in all, it is arguable that for Marxists like Poulantzas and for scholars who are influenced by Marx, such as Skocpol, Trimberger, and Hamilton, the state must have a moderate degree of autonomy from the dominant social class to carry out the economic policies needed to avert economic crises or, in the case of Hamilton, to reduce foreign dominance. For non-Marxists working within this general paradigm, the state must have at least a moderate degree of autonomy from all interest groups in order to carry out effective policies in that issue-area. However, they view state autonomy in fundamentally limited terms. All of them portray state autonomy as a short-lived phenomenon, emerging in periods of crisis and receding fairly quickly after the crisis has ended. But what happens when the autonomy is neither an ephemeral phenomenon, nor a limited one, but rather, when a state achieves a high degree of autonomy from society?

Gasiorowski (1993: 445) defines a highly autonomous state as:

“a state that can act with almost complete independence from social pressure in formulating and implementing its policies”

In the absence of societal constraint, the policies of a highly autonomous state are shaped by various other factors. The belief and psychological attributes of top state officials are likely to have much more impact on state policy making under a highly autonomous state than under a less-autonomous state. Organisational and bureaucratic processes operating within the state apparatus may play a much greater role. Abundance of resources such as state revenues, may enhance the state's policy making options in fundamental ways. Aspects of the international environment may also have a considerable impact, including the nature of the country's tie to the world

economy, its diplomatic and security relationships with other neighbouring and powerful countries,

Factors such as these do not, of course, necessarily force state policy to diverge from society's interests. However, state officials in a highly autonomous state feel much less compulsion to serve society's interests than officials in a less-autonomous state. As a result, when they are forced to choose between policy alternatives they are less likely to pursue policies that serve society's interests, especially its immediate interests.

Moreover, even if a state leader does carry out policies with the intention of serving society's interests, his conception of society's interests may differ substantially from that held by most members of society. In the absence of societal pressure, no mechanism exists that can force state policy to respond to the needs felt by society. Therefore, to the extent that state policy-making is shaped by factors such as the view of top state officials, organisational and bureaucratic processes, resource constraints, cultural matters, and aspects of the international environment rather than by societal pressure, it is likely to diverge from society's interests. If the divergence between state's policies and society's interests is considerable and persists over time, economic, political, or social crises may emerge. If so - as was the case in Iran of the 1970s - the government may face a legitimacy crisis which threatens its own existence. Nevertheless, too little autonomy from society may leave a state so mired down by social pressure that it cannot carry out the policies needed to avert crises and domestic unrest, while too much autonomy may enable it to ignore the interests of society altogether, creating similar crises and unrest (Gasirowski 1991: chapters 4-5).

In a state with little autonomy, powerful interest groups exert excessive pressure over such a state, forcing it to carry out policies that serve their interests, and preventing the state from serving the interests of society as a whole. One possible result is that such a state, due to its inability to implement policies that are needed to resolve economic, political and social crisis, faces in the long run, unrest and revolt.

The full potential of the concept of state autonomy can be realised in historical studies that are sensitive to structural changes within given polities. We can

differentiate different industrialised capitalist states through their degree of autonomy. In Germany, in contrast to Britain, it was the autonomous state that led the industrial revolution. Skocpol (1979), in her analyses of the French, Chinese and Russian revolutions, argues that weak states with little autonomy were constrained by the feudal classes to bring about the policies needed to avert economic crisis, and were consequently overthrown.

The extranational orientation of the state, the challenges it may face in maintaining domestic order, and the organisational resources that collectivities of state officials may be able to draw on and deploy, all of these features of the state - as viewed from a Weberian-Hintzian perspective - can help to explain autonomous state action. In an especially clear-cut way, combinations of these factors figure in Stepan and Trimberger's explanations autonomous state action. A key in Stepan's explanation of Brazilian and Peruvian corporatist regimes (1968 and 1964 respectively) is the focus on state autonomy: the formation of a strategically located cadre of officials enjoying great organisational strength through existing state organisations and also enjoying a unified sense of ideological purpose about the possibility and desirability of using state intervention to ensure political order and promote national economic development.

Trimberger (1978) by focusing on Japan's Meiji restoration, Turkey's Ataturk revolution, Egypt's Nasser revolution, and Peru's 1968 coup explains how autonomous bureaucrats, including military officials, seized and reorganised state power. Then they used the state to destroy an existing dominant class, a landed upper class or aristocracy, and to reorient national economic development. Thus, the state in these countries was sufficiently autonomous that it could reinforce reformist or revolutionary changes and undertake a 'revolution from above'. As she puts it:

"A bureaucratic state apparatus, or a segment of it, can be said to be relatively autonomous when those who hold high civil and/or military posts satisfy two conditions: 1) they are not recruited from the dominant landed, commercial, or industrial classes; and, 2) they do not form close personal and economic ties with those classes after elevation to high office" (1978: 4).

Thus, when the state is free of ties or alliances with dominant classes, 'revolution from above' may occur. Such a state desires to ensure political order and promotion of national economic development and to contain any possible upheavals from below.

Nevertheless, for Helco (1974) autonomous state actions are not all acts of coercion or domination; they are instead, the intellectual activities of civil administrators engaged in diagnosing societal problems and framing policy alternatives to deal with them. Therefore, the bureaucracy might be perceived as another source of state autonomy.

For Mann (1986: 135), autonomous state power is the product of the usefulness of enhanced territorial-centralisation to societal life in general. Because, this has varied considerably through the societies and so consequently has the power of states (oscillation between despotic and infrastructural powers).

However, in a peripheral country, state autonomy is crucial in its economic development policies. The integration of the peripheral state into the world economy leads to a highly uneven development of domestic forces of production. Structural heterogeneity ensues, with differentiation and polarisation of domestic classes, and of their alliances in relation to the state. Given the historical weakness of the domestic bourgeoisie in promoting industrialisation, the peripheral state must fulfil this function and intervene in the economy in order to secure the accumulation process. This function forces the peripheral state to accumulate political power and become relatively autonomous from the existing social classes and, therefore, to mediate between social classes (e.g., national and international bourgeoisie). The state develops its repressive, administrative, planning and ideological capacities in order to integrate and dominate civil society. To this end it applies strong ideological measures. In performing its functions, the state may face constraints and therefore take undesired actions. For instance, unable to reproduce capital, the state is inevitably forced to derive more revenues from the domestic economy (e.g., via austerity programs), from foreign borrowing, or from both. Political pressure and increased repression may parallel the economic pressure. The contradiction between labour and capital, Moghadam argues:

“is transformed into that between state and civil society, and the crisis of accumulation may become a crisis of legitimation” (1988: 230).

1.6.1.1. Oil revenues and state autonomy

The amounts and forms of revenues and credit available to a state grow out of structurally conditioned, yet historically shifting political balance and bargains among states and between a state and social classes. Thus, domestic institutional arrangements and international situations set limits difficult to change within which state elites must manoeuvre to extract taxes and obtain credit (*ibid.* P.17). However, in an oil exporting developing economy, state revenue is not limited by these factors.

As will be discussed, in an oil-based economy, the form, functions and limits of the state can be understood by relating the state to the following processes: 1) the general conditions of the internationalisation of capital, 2) the particular form of domestic accumulation, and 3) the unique conditions of civil society vis-à-vis the state, in a social formation. The increasing autonomy, provided by oil revenues, lead the oil-based state to an over-developed, repressive, and interventionist state which controls major economic functions, and has a potential for bargain with outsiders (Moghaddam 1988).

For example, windfall revenues from international oil sales can make states not only more autonomous from social groups, but also more vulnerable to crises because of the weaknesses of social roots and political pacts. In case of Iran, Katouzian (1981: 324) points out that:

“... oil revenues accrue to the state directly as large and independent sources of finance: the state does not even have to depend on the domestic means of production for their revenue....Once these revenues rise to a high level, making up at least 10 per cent of the national output, they begin to afford the state an unusual degree of economic and political autonomy from the production forces and the social classes of the country”.

Such constant oil revenues can enhance the state autonomy to a great extent.

1.6.2. The concept of interdependence

Interdependence is:

“a situation between disintegration and integration of political and economic processes...It is the prototypical phenomenon of an international system that derives its dynamics from the pursuit of the national interest as well as of interests that are narrower and larger than the national interest” (Hanrieder 1978: 155).

Interdependence relationship between developed and developing countries has increased but also that the relationship has become less subordinate. The increasing levels of interdependence limits certain options but opens others. This interdependence is, of course, asymmetric: for example, only six developed countries, which have only a tenth of world population, control two-thirds of world trade (Iglesias 1987). However, that increased economic interaction is a pre-condition for what Warren calls "a genuine equality among interdependent economies" (1980: 184).

Since the late 1960s, the major oil-producing countries and the NICs have challenged the static picture of a fixed industrial core and a fixed non-industrial periphery. It shows that the terms of interdependence have not remained absolutely disadvantageous to the Third World. One can argue that the oil producers, East Asian, and some Latin American countries, gained substantially from the changes in the global context of interdependence and also from the changes in the international capitalist system. Brewer (1980: 178) in his critique of the concept of dependency for implying that the process of development in the advanced countries is economically independent and self-sustaining, speaks of "relations of interdependence and dominance rather than of dependence". Leys (1977: 95) also speaks of a complex set of interdependency, and Ray (1973: 4-20) argues that, as it is impossible to achieve a state of non-dependence, it is preferable to speak of degrees of dependence in an interdependent world.

Increasing economic activities between developed and developing countries; geopolitical location of the country; and, other global issues such as environment, have increased the level of negotiation, co-operation and interaction between them. Thus, as a result of increasing interdependence, the bargaining power of developing countries has increased extensively.

During the early 1970s the increased power of oil-producing governments over the TNCs and the consumer countries dramatically altered the existing relations in favour of the former. Oil-based accumulation facilitated the integration of oil-producing states into the world economy, while OPEC's apparent ability to control prices and

output resulted in discussions about the rise of a major Third World cartel. The oil price hikes of the 1970s increased the interdependence relationship between the OPEC member countries and the developed world to a major extent.

During the 1970s, oil revenues led to a redistribution of the surplus between international oil capital and the oil-producing countries. It also led to a differentiation between petroleum-exporting countries and the rest of the Third World countries. Moreover, oil-based money capital, the so-called petrodollar, became a significant portion of the overall money capital available at the global level throughout the 1970s.

However, in majority of these cases, the developed countries dominated the relationship in their own favour (see Wachtel 1987; Knox 1991). In the Third World, the exception of the state's economic role, in combination with the extreme rarity with which the TNCs are actually expelled has left Third World states increasingly enmeshed in the transnational system of production organised in the first instance by the TNCs themselves. At the same time, the internationalisation of production has increased the need of the TNCs themselves for strong, predictable Third World partners. Evans (1990: 218) argues that both state officials and transnational managers know that their survival depends on their ability to achieve mutually acceptable accommodations.

Neither of these approaches denies that the developed countries dominated the existing interdependent relationship. For oil-exporting developing countries, the net revenue of export of oil was less than the net benefit it brought to developed countries through taxing the imported oil (Amirahmadi 1993), even leaving out the spill over effects and the gains from oil-related industry, in which the developed countries are most likely the major beneficiaries.

While in the 1970s the OPEC states appeared to be powerful and independent actors on the international scene, the 1980s reveal the limits of their autonomy. The 1980s have revealed the vulnerabilities and limits of both oil-producing states and oil-based accumulation. However, the interdependence relationship has been in favour of the developed countries. As Moghaddam argues, such an oil state is:

“a crisis-ridden state, and its ability to survive depends on both the availability of oil rents and its domestic political and ideological legitimation” (1988: 233).

It should be acknowledged that in this mutual relation of interdependence, the cases in which the recipient state - such as Iran of the 1970s - is able to turn the asymmetrical relations in its own favour are increasing. While increasing interdependence opens new opportunities and increases bargaining for developing countries, it limits other opportunities and limits the state's room for manoeuvre on other issues (i.e. the use of military force to solve economic problems, or the limits imposed on developing countries' production by the issue of global environment).

1.7. A Model for the Semiperipheral Capitalist State

An understanding of the state, its capacities and autonomy, its formation and reorganisation, its interactions and relations requires an efficient theoretical and methodological approach. All three theoretical approaches discussed above yield some interesting insights into the understanding of the structures and functions of the modern semiperipheral state. Rather than a general theory of world-wide development, we have a framework that requires the researcher to study the state in a given social context under the pressure of particular conjunctures of the world economy.

The state, as we saw earlier, is shaped by pressures and influences from domestic and external structures. The extent of these impositions and influences depends itself on the degree of the size, capacity (financially and intellectually), and effectiveness of the state structure. The outcome of such interactions of forces and influences on the state determines the behaviour of the state within the domestic polity, and vis-à-vis other countries. These two sets of behaviours can be traced fruitfully by analysing the notions of autonomy and interdependence respectively.

A central contribution of the present research is to indicate a solution to the problem of integrating the world-system and dependency perspectives on the one hand, and the Weberian-Hintzian approach on the other, into the theory of the formation, structure and function of the modern dependent capitalist state of Iran.

Thus, the recent theoretical perspectives such as postimperialism and dependent development have helped us to analyse the economic process involved in the country's transition to dependent capitalism. As important as the state has been in the development experience of the advanced industrial economies, it has proven even more central to the process of dependent development in the developing country. In 20th century Iran, the state's position as recipient and disbursing of vast oil revenues and the shah's role as originator of economic policies and as virtually the sole political arbiter, plus the characteristic weakness of the industrial capitalist class, combined to give the state a pre-eminent role in all economic, social, and political development. We shall see that this has been the case historically too, as the Iranian state from the Safavid dynasty's height in the 17th century onward has aspired to be a centralising monarchy with a great concentration of political, military, and economic power. Therefore, an analysis of state structures and organisations will help us to realise the state's capacity. The recent perspectives built on the Weberian-Hintzian theoretical approach (such as Skocpol and Evans) is useful in this respect.

Furthermore, the state in Iran, should be treated as an autonomous structure, a structure with a logic and interests of its own. Thus, such a state is a set of administrative, policing, and military organisations with a high degree of autonomy, headed and co-ordinated by the Shah and a limited circle of elites. Therefore, its organisational and financial capacity - which partly determines its degree of autonomy from social pressures - determines its degree of manoeuvre to freely act, initiate, and implement policies for society. Nevertheless, the structure and capacity of state autonomy is influenced, to a major extent, by the state's international position. The world-system theory provides us with a concept, namely semiperiphery, to define a level of relations between a developing economy and world capitalist economy. As a semiperipheral state with a high degree of autonomy, the Iranian state was, in the 1960s and 1970s, able to move its dependent client-patron relationship with the capitalist developed countries to an interdependent relation, in which it could bargain with the core countries, and furthermore, have a strong position vis-à-vis the TNCs in the 'triple alliance'.

CHART 1.1: A Model for the Semiperipheral Capitalist State

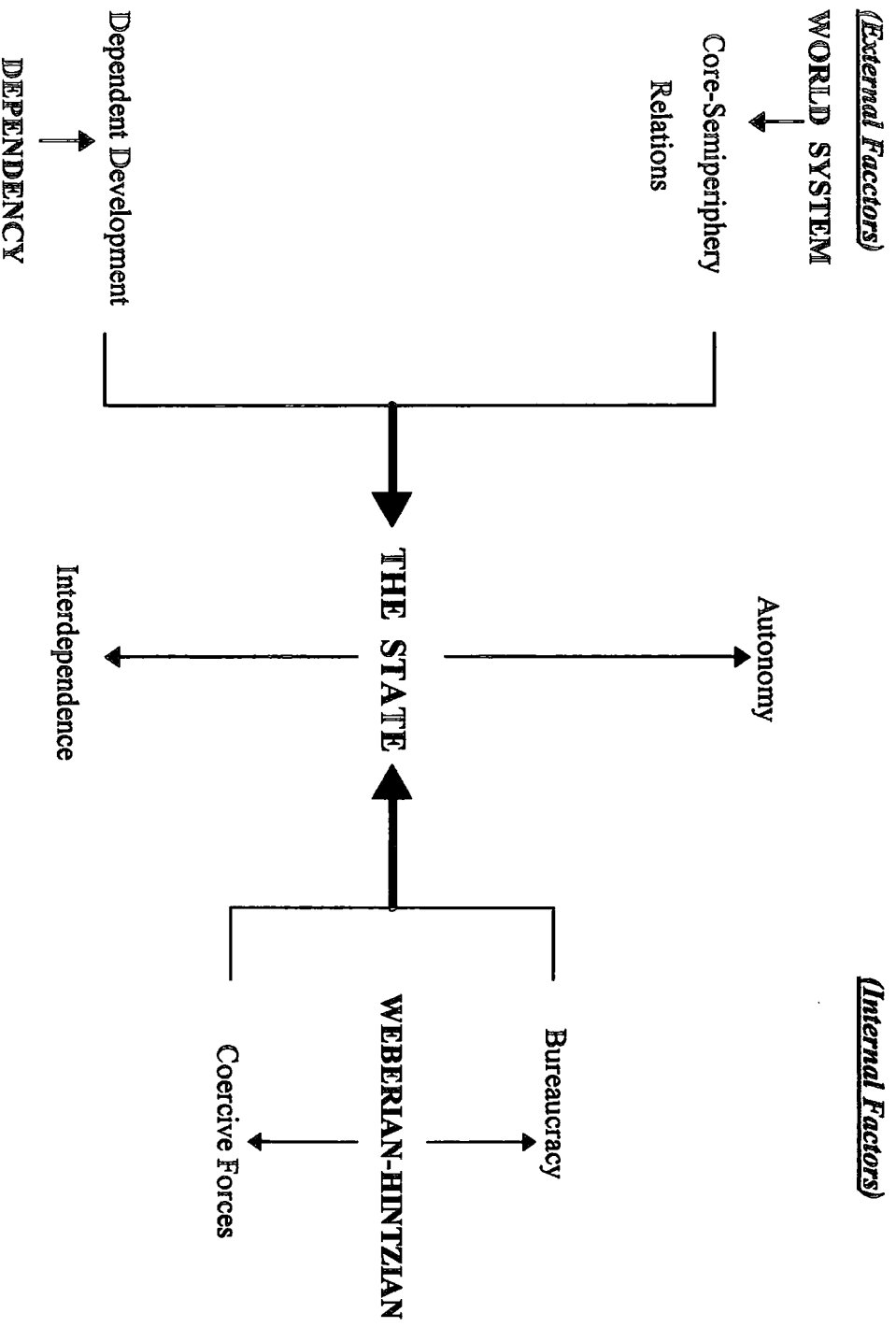

It seems that none of these perspectives taken alone can adequately account for the causes of continuity and changes in the process of modern state formation in Iran in general, and during the Shah's reign (1942-79) in particular. My essential point in all of this is to show that the three approaches complement one another.

As Chart 1.1 shows, in this model, as is the case for many developing countries, the state is situated at the intersection of transnational and domestic processes. By using concepts of autonomy, in which the state enjoys a degree of freedom from domestic economic and societal groups, and interdependence, in which it describes the relationship between the state and the rest of the capitalist world, this model is empowered to interpret the state interactions and behaviour with both external and internal structures.

Chart 1.1 shows how these perspectives complement one another in explaining the complex structure of the state, and as a result, the complex nature of the state's behaviour vis-à-vis both society at large and the rest of the capitalist world. In particular, such behaviour with local and international capital, known as the triple alliance, needs to be examined. It is the degree of autonomy of the state that outlines the behaviour of the state in relation to social and economic groups in society. Furthermore, realisation of the semiperipheral status for the state - through a difficult competitive process of political bargaining and economic development - enables the state to establish a new interdependent relationship in which its prior client-patron relationship with the core is circumscribed.

It will be noted that this is a complex, conjectural causal model (see Ragin 1987: 23-25). It consists of several factors - semiperiphery of the world system theory; dependent development of the dependency paradigm; and the structure of the bureaucracy and repressive apparatuses derived from the Weberian- Hintzian perspective. The theoretical work is informed and advanced by a solid case study of Iran that is not imprisoned inside one or another of the several perspectives, but rather which draws carefully on all of them, providing, in the process, a basis for the evaluation of their merits and deficiencies. It is through such case studies that a better integration of the theories can be effected and our knowledge of Third World states improved.

One of the tasks of the use of the model will be to map Iran's polity and development process in terms of quantitative and qualitative integration into the capitalist world. Firstly, during the Safavid dynasty (the 16th and 17th centuries), Iran was a regional empire, influencing politico-economics of the region while competing with other regional empires. Furthermore, while the Safavid Shahs enjoyed a hegemonic position in the state and economy, their contacts with the West could in no sense be considered dependent. Secondly, during the 19th century Qajar rule, the Iranian economy re-oriented toward England and Russia. The failure of the attempt by the Qajar Shahs to restructure the state institutions - while suffering military defeats at the hands of Russia and England - led to a cumulative process of disintegration of the traditional state, concomitant with the greater commercialisation of the economy. This situation can be characterised for the first time as one of dependence on the West. During the rule of Reza Shah (1925-41), the formation of a centralising authoritarian state with the modern bureaucratic institutions substantially enhanced the power and autonomy of the state to intervene in the polity and the economy of the country. Furthermore, its drive towards industrialisation was prompted by external factors: the end of British-Russian rivalries which formerly intensified the paralysis of the Qajar state; the changing international conditions; and, the pressure of circumstances arising from the world depression and the adjustment problems it created for the Iranian economy. During the late 19th century to mid 20th century period, Iran was integrated in the world capitalist economy and was a peripheral supplier of raw materials.

Finally, post-World War II period witnessed important changes in the international economy and the domestic political scene as well as the structure and autonomy of the state. This happened when the structure of the state witnessed a major expansion and modernisation. Oil revenues and the full US support enhanced the autonomy of the state. Its position in the world economy shifted from one of periphery to the semiperipheral state. Its dependent relation with the US was changing to more of interdependent relations. Reasons for these changes of the status were rooted in

CHART 1.2: The Impact of Oil Revenues on State's Behaviour

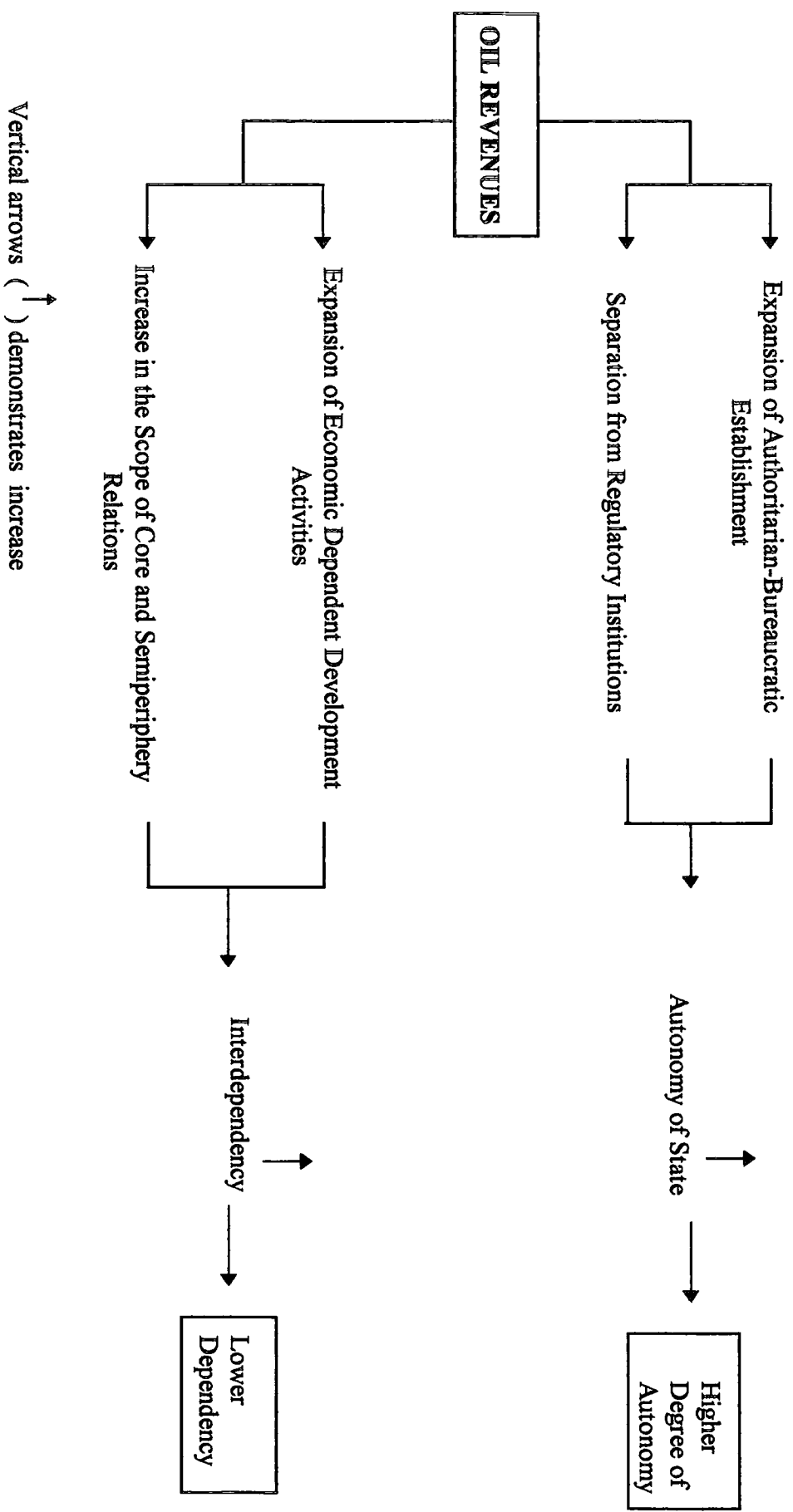

state's powerful machinery, its enhanced autonomy, the geopolitical location of the country, its increasing bargaining power, etc.

As a result, we need to investigate the process of modern state formation in Iran in order to highlight the elements of continuity and change in this process (chapter 2). We clearly need to probe the internal complexities of state structures, without going to the extreme of treating the state simply as a disconnected collection of competing agencies (chapter 3). Along with formal bureaucratic mechanism of both civil and military apparatus of the state, budgetary, legal, and ideological processes can be examined to discover the various ways and degrees to which the state achieves overall co-ordination of its activities (chapter 5). Furthermore, examinations of the reorganisation of state that accompany the end of major crisis - i.e. the 1953 coup and the 1963 uprising in Iran - might shed more light on fundamental issues in understanding state structure and behaviour. We need to investigate the elements that enhanced the state autonomy and therefore changed the process of decision-making in the country (chapter 4). How does the geopolitically strategic location of a country impact on the behaviour of the state internally and externally? And how do international balances of power and the accompanying new alliances and flows of coercive and economic resources affect the domestic doings of the state, i.e. the state position in relation to the triple alliance, both vis-à-vis private local capital and vis-à-vis the TNCs (chapter 6).

According to Chart 1.2, by integrating into the model, the independent variable of oil revenues, its influence on structures of the state, and its behaviour can be traced through the model as follows. As a result of the control of an internally independent, but externally dependent variable of oil revenues, the state is able to pursue the process of rapid industrialisation and economic development. The state becomes involved extensively in economic activities, either to compensate for the weakness of the national bourgeoisie, or to mediate between the local and international capital in the process of rapid industrialisation - which is one focal objective of the state. The state's economic involvement also includes a greater economic interaction with the rest of the capitalist world. Furthermore, as the sole recipient of oil revenues, it is able

to influence class alliances in society in its own favour. Its objectives are less constrained by financial resources.

Hence, the state becomes what Moghaddam (1988) calls interventionist, over-developed, highly autonomous, repressive, possessing power to bargain in the triple alliance. Nevertheless, this is a short-lived shift with long term impacts. As has been noted, autonomy is not a fixed issue and its fluctuation partly depends on the nature of the source of autonomy. Due to the dependent nature of oil exports, both its price and marketing policies - and consequently its revenues - are exposed to and controlled by the capitalist West.

Therefore, there exists a contradiction: oil revenues enhance state autonomy internally and increase bargaining power of the state externally. But it deepens the country's dependence on the capitalist world. This contradiction can be solved only when the state is able to internalise the factors which has led to enhancement of its autonomy and its capacity and the means which gives the state the power to bargain in the world system. This can be done - in the case of Iran of the 1970s, for example - by diversification of government financial resources, through a successful process of export-led industrialisation and efficient extractory institutions. Nevertheless, political liberalism by legitimisation of the rule of the regime - through expansion of its 'infrastructure' power, - using Mann's concept - and democratisation of its decision-making process will provide the state with the needed socio-political support in the process of economic diversification.

1.7.1. Method and techniques

The states in Brazil, South Korea, and Iran (during the 1960s and 1970s period) shared important characteristics. Their rulers had come to power through a coup. They established a strong authoritarian-bureaucratic establishment, and enjoyed a degree of autonomy from social groups. They were developmentalist states.

A systematic comparative study might well shed new light on why similar states take different behaviours (internally and externally). Such comparative studies show why countries with similar situations end up with different degrees of development, class relations, etc. The state structure, its autonomy, its place in the triple alliance, its

position in the world economy and its degree of interdependent relations with the core are the chief determinant factors in this comparison.

Comparison among societies serves to illuminate the various resolutions of the existing dilemmas - often in contrasting ways - in various national and temporal contexts.

The 'historical-comparative' method is applied to analyse the state as the main body of regulating the internal affairs and the external relations which is located at the intersection of the two, and is shaped by both. In this method of conduct, no limitation to any grand theory is appropriate. Thus, the 'historic-comparative' approach investigates the state in a broader, and interdisciplinary manner. Furthermore, the historical comparative functions as bright threads that, when woven into the fabric of historical narrative, allow the researcher to identify general patterns while at the same time preserving a sense of historical particularity. As Moore points out:

"...a comparative perspective can lead to asking very useful and sometimes new questions....Comparisons can serve as a rough negative check on accepted historical explanations...[It] *may lead to new historical generalisations*" (1966: xiii-xiv in Skocpol 1980, emphasis in original).

The role of the state in promoting basic economic transformation, and especially industrialisation, was especially salient in such nations as Brazil, South Korea and Iran. Moreover, such countries shared the difficulty of attempting to industrialise in a world dominated by international capital based outside their borders. Yet despite these basic similarities in the state's task and the world historical context, each of these countries presented a very different specific state structure and different relationships of state organisations to domestic and transnational elites. Heretofore, there has been a surprising lack of systematic comparisons of such cases across geo-cultural regions.

In the present research the logic of comparative-historical method will be used in two ways, both of which will help evaluate the manner in which key theoretical variables affected state formation and processes of change in each of several historical periods. First, the relevant comparisons of the Pahlavi Iran of the 1960s and 1970s

with other countries of similar characteristics namely South Korea and Brazil will be briefly considered. Second, the logic of the comparative-historical method will be turned upon a single historically and culturally significant country, Iran, which experienced the state in several historical epochs. A comparisons of the major two dynasties of modern Iran - the Safavid and the Pahlavi - will provide the basis for understanding the trend of continuity and change in the process of state formation of the country.

The plausible approach in our method in the study of the Iranian state ties the analytical approach to historical comparative method (see Somers and Skocpol 1980).⁸ This approach shows that despite differences in characteristics between states, some countries and states followed almost the same structural changes. On the other hand, by emphasising the similarities of the compared cases, it shows how, in spite of similarities, each case has had a different result in its structure. While this method has been used mostly in a cross-national comparison, here, in addition to the prevailing norm, a second type of comparison will be used. The historical comparative method focused on a single case, showing similarities and contrasting patterns. The latter comparison is particularly useful, when the model traces the elements of continuity and change in the process of state formation in a singular country.

Furthermore, a careful comparison of two main periods within the twentieth century - the states under Reza Shah and the Shah - will highlight the continuity in the structure of the state in spite of major changes in the world polity and economy. It further sheds light on the changes, particularly on the state's position in the world capitalist system; a move from peripheral to a semiperipheral state. The result is a qualitative time-series analysis comparing instances of state formation in a single country at different points in time. It is quite informative to investigate Pahlavi Iran (the period of 1942-79) in the context of a political economy approach. To this end, we use a conjunctural model, both on internal and external elements axes, and on economic and political axes.

In the course of this research, the attempt has focused on primary materials and official data - reports, diaries, official interviews and prints - especially in analysing the nature of politico-economic development of the country and the dominance of the

state decision-making process by the Shah and a limited circle of the ruling royal elite. However, a critical/analytical approach has also been applied in the course of such reading.

CHAPTER TWO: THE MODERN STATE FORMATION IN IRAN, 1500-1941

A: The Safavid Dynasty (1500-1722)

2.1. The Safavid Modern Centralised State

The Safavid dynasty signals the commencement of the modern state in Iran. Abbas I (known as Abbas, the Great) turned the kingdom, previously held together primarily by the ardent faith of a number of militant tribes, into a cohesive and stable monarchy. He consolidated the state by securing the borders, establishing a central administration, fortifying the economy and creating a standing army responsible not to the tribal heads but to the king as the head of the state. As one analyst states:

“Abbas I must be considered the chief architect of the modern Iranian state” (Yarshater, 1978: xvii).

The characteristics of a modern state, which became established during the Safavid period, and are the main features which distinguish it from the pre-Safavid states include sovereignty, territorial integrity, and legitimacy.

During the Safavid dynasty a concept of national border gradually emerged and Persia regained almost all its territory. Shah Abbas had a particularly well developed sense of what constituted hereditary territory. In his diplomatic correspondence with neighbouring monarchs, he was constantly emphasising the point that the particular piece of territory he was engaged in controlling at that particular time constituted part of his hereditary domains. As Savory points out:

“He was merely recovering territory which was rightfully his, the other side had no cause to feel any sense of grievance” (1974: 180).

It was with the same logic that he re-conquered Ghandahar from the Mongols in 1622 and Baghdad from the Ottomans in 1624. The only problem on the border issue were in the north-east and north-west. In both cases the border disputes arose not because of ambiguity, but rather resulted from the Safavid's failure to maintain the necessary military power in those regions.

On the issue of sovereignty, in the Safavid era as in the Western Europe of the absolutist state, absolute authority was in the hands of the king. However, the theory of the divine right of the king was reinforced in the case of the Safavid shahs by other powerful factors, namely their claims to be the representatives of the twelfth Imam of the Shi'ite and the supreme spiritual leader of the Sufi order (*Murshed-e Kamel*) respectively. This was, in essence, demanding unquestioning obedience from their subjects. Also, Kingly glory (*farr*) in form of the shadow of God in the Safavid period had its root in pre-Islamic history. The combination of the above three factors which mainly was established through a carefully planned policy as well as through propaganda, strengthened the sovereign's position beyond question.

How did this overwhelming power of the sovereign affect the people? Paradoxically, it was the common people who were least affected by it. Such authority was used against those who could pose a threat to the throne and absolute authority of the king, and moreover, those "who themselves held positions of power and influence who were at the mercy of the Shah's arbitrary power" (Savory 1974: 185). Thus, it was mainly the officials who stood between the shah and the mass of his people, who were considered to be the slaves of the shah; their lives, their property, and the lives of their children were at the disposal of the shah. Therefore, the existence of a class of state officials between the shah and people was by itself a guarantee of individual freedom and security within the lower echelon of society. This state of affairs, of course, depended on the shah's exercising his absolute power over those to whom he delegated his authority. Another important factor in mitigating the effect of the shah's absolute power on the mass of his subjects was the geographic, ethnic, political and social diversity of Safavid Iran. The communication problems posed by the mountainous and, in the north, densely forested, terrain meant that no matter how much power was apparently concentrated at the centre, a considerable degree of decentralisation occurred in fact.

The question of legitimacy preoccupied the Safavids more than any other ruling institution in Iran. The Safavid drew their legitimacy primarily from a centuries-old tradition of secular kingship and patrimonialism, but they also created a new, complex synthesis evoking several (primarily religious) bases of authority, particularly in the

CHART 2.1: The Position of the Officials Within the Safavid State

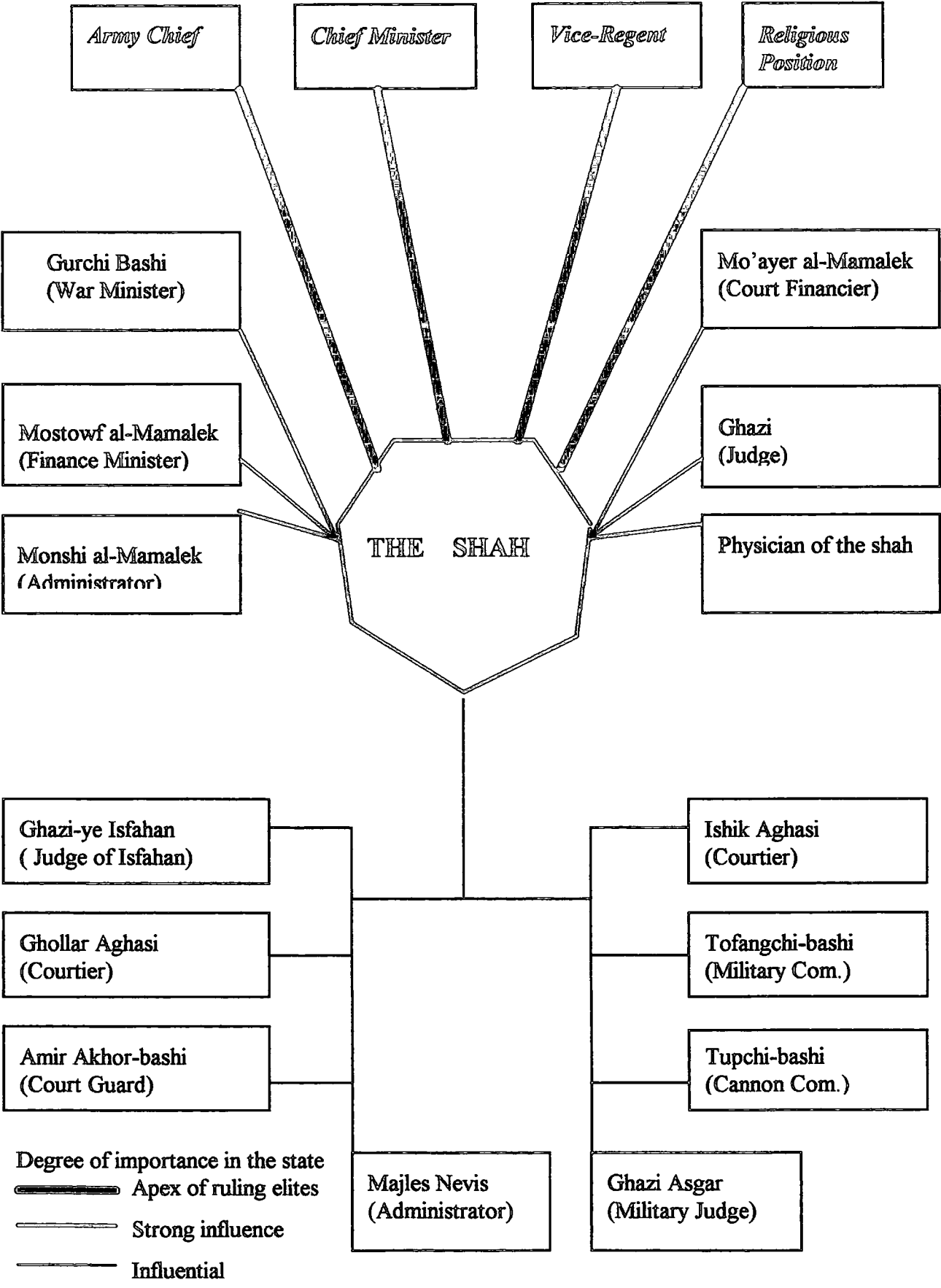

reign of the Ismail I. Therefore, the Safavid Shahs retained two other basic sources of legitimacy: firstly, as spiritual leader (*murshed*) of the Safavid order of Sufis; secondly, as the representative of Imam Mahdi, through a dubious genealogy which purported to establish their descent from the Imams of the Shi'ites (Savory 1986). Although, theoretically such a fabrication had no bearing on the legitimacy of their rule, they were able to convince a major part of the populous through a successful campaign of propaganda.

As a result, the Safavid shahs were obliged to 'shut the mouth' of those ulama who were inclined to assert that the shah had usurped their prerogative to being the legitimate representative of twelfth Imam. By making the office of *sadr* (the highest official religious authority) an organ of the political branch of the administration, the Safavid shahs were able to suppress any threat to their sovereignty on the religious plane.

2.1.1. The Safavid administration and military establishment

The Safavid state can be analysed in terms of three key institutions - the central bureaucracy, the provincial government, and the army. At the apex of Safavid administrative and social structure was the Shah.¹ He and his court constituted the apex of a substantial bureaucracy centred in the capital. Considering Chart 2.1, the highest officials of the court included *vazir-e a'zam* (chief minister), *amir al-omara* (commander in chief of the army), *sadr*, and vice-regent - although this post later was abolished. Then were senior military officers, religious judge, the state treasurer, and court dignitaries, e.g. the shah's personal physician. Below this highest stratum were numerous other posts and offices - court physicians, astrologers, palace eunuchs, artists and artisans.

Respect for the government order and regulations was mainly achieved during the Abbas I period, which was responsible for increasing security of public life.

2.1.1.1. The administration

The administrative organisation of the Safavid state was divided both horizontally along ethnic lines and vertically along the lines of state functions.² In horizontal

division, up to the time of Abbas I, the *qizilbash* (the tribal army who brought the Safavid dynasty to power) had dominated the military commands, provincial and some major central government posts.³ Persians were in control of the posts of viziers, the numerous classes of officials in the royal secretariat, the accountants, the clerks, the tax-collectors, and other officials of the financial administrations. In addition, the majority of ulama were Persian origin or lived among Persians. Vertically, the administration was divided into bureaucracy (*dolat-khaneh*), financial and judicial affairs, while at the same time these portfolios, were functionally divided into court (*dargah*) and chancery (*divan*).⁴ The daily functioning of the state was transacted by the state council (*divan-e a'la*) which incorporated the high ranking amirs.⁵

TABLE 2.1: *The Safavid Shahs and Their Chief Ministers During the 17th century*

The Shah	Period of Rule	Chief Minister
Abbas I	1587-1629	Khalifeh Sultan (1624-29)
Safi	1629-42	Khalifeh Sultan (1629-32) Mirza Taleb Nasiri (1632-34) Mirza Mohammad Taqi (1634-42)
Abbas II	1642-66	Mirza Mohammad Taqi (1642-45) Khalifeh Sultan (1645-54) Mohammad Beg (1654-61) Mirza Mohammad Mahdi (1661-66)
Sulaiman	1666-94	Mirza Mohammad Mahdi (1666-69) Sheikh Ali Khan Zangane (1669-89) Mirza Mohammad Taher (1691-94)
Hossain	1694-1722	Mirza Mohammad Taher (1694-99)

In part, the Safavid state was the inheritor of a bureaucratic system which resembled the traditional bureaucracy of the Persian state under the Teimurid and the Turkemans. The existence of the tightly-knit Sufi organisation of the Safavid, however, constituted an essential point of difference between the Safavid and their predecessors.

At top of the bureaucracy was chief minister (*vazir-e a'zam*). Looking at Table 2.1, it can be seen that the chief ministers generally had a lengthy stay in office and on frequent occasions continued to serve in the office after the shah who had appointed

them had died. This shows the continuity and consistency of the administrative policies which Abbas I had laid the foundations of. Other ministers, secretaries and high rankings of the royal secretariat were under the supervision of the chief minister. No letters of appointment to a post in the bureaucracy were valid without his seal. Except for the shah, he was the final authority of financial affairs. However, the technical business like preparing and auditing the budget, assessing taxes, and collecting the revenues, was in the hands of a large staff of accountants, clerks, tax-collectors and financial experts, under the direction of Minister of Finance (*mostowfi al-mamalek*) (*Tazkirat al-muluk*, trans., PP. 44-46, hereafter Minorsky, TM).

To investigate the evolution of the Safavid administration and the new army, we should look at three different periods: from Ismail I up to Abbas I (1501-88); the era of Abbas I (1588-1629); and, from the emergence of Safi to the fall of the dynasty (1629-1722). The first period (1501-88) was one of change and adjustment, during which the functions of the principal officers of the state were not clearly defined. As a result, the powers of one official frequently clashed with those of another. During this period, the tribal qizilbash dominated the army. They were ruling most of the provinces and were obliged to offer military services to the shah in time of need.

During this period, the shahs tried to balance the vertical division of the Safavid administration; the Turkeman 'men of sword' and the Persian 'men of pen'.⁶ Ismail I established the position of the shah's vice-regent (*vakil-e nafs-e nafis-e homayun*). For Savory (1986: 358-60) creation of this office represented an attempt on the part of Ismail to bridge the gap between a theocratic form of government (the Turk Sufi order) and a bureaucratic one (the Persian). The subsequent decline of the position of vice-regent (parallel to the decline of the office of *sadr*) was a shift from Ismail's earlier position:

"a decisive movement away from the concept of a theocratic state and towards the separation of religious and temporal powers" (*ibid.*).

It seems that this, was politically motivated, as an attempt to balance the power of Persians and the Turkemans within the state, because the Safavid shahs had no intention of creating a theocratic state. Ismail established the office of *sadr* to forge a link between the political institution and the religious institution on one hand, and to

impose a doctrinal uniformity throughout the Safavid state on the other. Hence, it was the political institution almost throughout the Safavid period which controlled the religious one.

The military command with the new post of commander-in-chief (*amir al-omara*) was under full control of the qizilbash. This new administration undermined the position of a Persian elite within the government vis-à-vis the Turkemans.

The authority of the chief minister was later increased and reinforced by a decrease in the power of *sadr*. In all, the authority of the shah increased and a corresponding curtailment of the influence of the qizilbash in political affairs was achieved by the end of Tahmasb.

During the second period (1588-1629), the administration of the Safavid state was reorganised on entirely new bases by Abbas I. In this period, Abbas the Great, established a new standing army. With the Georgian and the Caucasian prisoners of war, labelled as *gholams* (a counter balance to qizilbash revolt; see Morgan 1988), the army was balanced along three ethnic groups of qizilbash, Georgians, and the southerners. This balance ensured against any military coup attempt against the shah. In terms of the formation of the administration, phase two, or the reign of Abbas I (1588-1629), was the most important of the Safavid period. It was marked by the gradual transfer of tribal governmental power to the absolutist monarch. As the military strength of the qizilbash became a double-edged sword for the Safavid rulers, with the waning of unconditional qizilbash devotion to the shah, the question of how to check the power of the qizilbash became a problem of the first order for Abbas I.

The expenses of the new army, as opposed to the qizilbash which had been paid by the Turkeman chiefs who formed the military aristocracy of the early Safavid state and held all the important provincial governerships, was paid by the crown revenue. This revenue was drawn substantially from converting state land (*mamalek*) which mostly was *tyuls* of the qizilbash, to crown land (*khasseh*).⁷ Abbas I reinforced the policy of restricting the qizilbash by compulsory migration, supplanting them with Caucasians. This policy resulted in a change both in the forms of land ownership and in the socio-politics of the state. Thus Abbas I destroyed the aristocracy, as Chardin (1811) notes. A number of instances are recorded of people rising from obscure or lower class origins

to positions of influence, as well as many instances of sudden declines in fortune for those who incurred the shah's wrath. This was probably the main form of social mobility in the Safavid period. Chardin observes that the shah made appointments without regard to birth, asserting that there was no hereditary nobility in Iran and going so far as to claim that consideration was given only to one's office, merit and wealth.⁸ Such restrictive social mobility was due partly to the shah's fear of any possible power building by the nobles. One way of balancing such a threat was building a new elite class from the lower echelons of society who would always be grateful and loyal to the Shah. As will be argued, a close parallel to this kind of mobility is found in the Pahlavi dynasty (1925-79) who attempted to replace the traditional elite (landlords and nobles) with a new class of educated technocrats who had almost no connection to the nobility.

With the king's support, the political and administrative influence of the gholams increased substantially to the extent that, by the end of the 17th century, they had occupied one-fifth of all government posts. Thus, the old dichotomy between Turk and Persian had been further complicated by the emergence of the Caucasian (and Georgian) elements as a powerful 'third force' (Savory 1986: 364-5).

The greater centralisation of the administration under Abbas I is reflected in the improved status of the vizier, the head of the bureaucracy and leader of the Persian elements in the administration. Abbas I supported the chief minister by honouring him with the title of *e'temad ol-doleh* (trusted support of the state). The shah reinforced respect for law amongst the elite and in all levels of administration by empowering the law throughout the country, close inspection of its implementation by regional officials and by harsh punishment (Monshi, 1970: 525, trans.). Abbas I succeeded in the reorganisation and centralisation of the state in such a way that it continued to function for more than a century after his death.

Therefore, during the first phase of Safavid administrative development, the whole administrative system had a pronounced military character, and bureaucrats who had no military function had little influence. In phase two, Shah Abbas broke the power of qizilbash, and as a consequence of this and of the increased centralisation of the government, the power of the bureaucracy grew.

The third period (1629-1722) was one of gradual sclerosis and consequent decline both in the efficiency of the administration and the effectiveness of the army. In this period, despite the security and development achieved in the second period, no major effort was carried out to maintain the relative strength of the army. The military was weakened to the point where it was no longer able to check the intrusions of marauding tribesmen from Baluchestan and Afghanistan. At the same time, the bureaucracy while expanded in size, became more rigid and less effective in its organisation and operation.

A significant change throughout this entire period was the increasing rise to prominence of the crown domain. Rather than extending to the entire *khassah* administration, this development concerned a narrow inner circle. Within the crown domain it was the immediate entourage of the ruler, composed in large part of *gholams*, which usurped power and began to exercise a hold over the entire royal household and by extension, over the management of state affairs. During Sulaiman's rule, the council of the state was established in such a way that the chief minister, Sheikh Ali Khan, was excluded. Thus Shah Sulaiman's reign witnessed the emergence of a functional duality of power between an inner council engaged in decision-making, and a chancery that continued to oversee the implementation of fiscal policy (Matthee 1994: 94).

2.1.1.2. Provincial administration

The provincial government was, to a large extent, a replica of the central government. Excluding the posts of guard command (*ghurchi-bashi*), army chief commander (*amir al-omara*) and the Shah's vice-regent, the central administrative posts all existed, albeit on a smaller scale, in the provinces. Based on *Tazkirat*, the head of provincial government was called *vali* (viceroys).⁹ Chardin writes that each governor was assisted and observed by administrators who reported to, and depended on, the Shah. Falling from grace often entailed not just dismissal from one's post, but the confiscation of much of one's wealth. Under a strong monarch such as Abbas I, then, the central authority held the upper hand vis-à-vis its erstwhile provincial representatives. At other times, however both before and some time after his reign, the governors were able to rule more autonomously.

Although, to some extent, these governors were financially independent from the central government, they were obliged to pay parts of locally-generated revenues to the centre. The governors

“sent to the capital only limited sums of cash, but considerable stocks (*barkhane*) of local products for the King’s table and raw materials for the royal workshops” (Minorsky, TM: 25).

They were obliged to obey the legal code of the central government for taxation. In judicial affairs, criminal law was solely the responsibility of the governor. The provincial government also came to be shared out among the several components of the elite.

2.1.1.3. Military function of the Safavid state

In the Safavid regime, military success and internal restructuring invariably went together. As was noted, the qizilbash dominated the army in the first period (1501-88) while in the second period (1588-1629) the army was balanced along three ethnic groups to ensure against any military coup. In the third period (1629-1722), no major effort was carried out to maintain the new army. For instance, during Sulaiman I’s reign, while the number of paid soldiers was 80,000, but only 10,000 could be mobilised at any one time (Chardin 1811, V8: 216 trans.).

*Ghurchi-bashi*¹⁰ was the commander-in-chief of the army and had extensive influence over the shah on military issues. He was responsible for the well being of the army, employment of personnel, support and ammunitions, and superintendent of royal military workshops (*buyutat*). Thus the total number of the army personnel, consisting of the traditional and the new regiments, was 120,000 during the reign of Abbas I (Chardin 1811: V5: 314), and only 90,000 during that of Sulaiman (Kaempfer 1940: 73, 91). The traditional army during Sulaiman included the qizilbash (*ghurchiyan*) with 70,000 members and the royal guard numbering 12,000 - excluding the regional regiments (*molazeman*), which were under the command of the regional governors and consisted of about 58,289 soldiers (Minorsky, TM: 52-56; Dela Valle 1843).¹¹

The new standing army was consisted of the royal corps of slaves (*gholaman*),¹² artillery (*tupchiyan*),¹³ musketeers (*tofangchiyan*), infantry bodyguard (*jaza'eriyān*),¹⁴ and the falconet and the cannon regiments (*zanburakchiyan*).¹⁵

Abbas I established the new army, and attempted to utilise modern weaponry for it. This was one of the cornerstones of Abbas's successful centralisation policies aimed at containing tribal power. In his efforts he enjoyed foreign assistance, mainly from Europeans, such as that of the Sherly brothers. In the artillery and weaponry factory of Abbas I, as Sir Ross (1938: 29, 163, 222 quoted in Minorsky, TM: 51) points out, more than 200 labourers were working.

CHART 2.2: *The Number of the New and Traditional Army During the Three Phases of the Safavids*

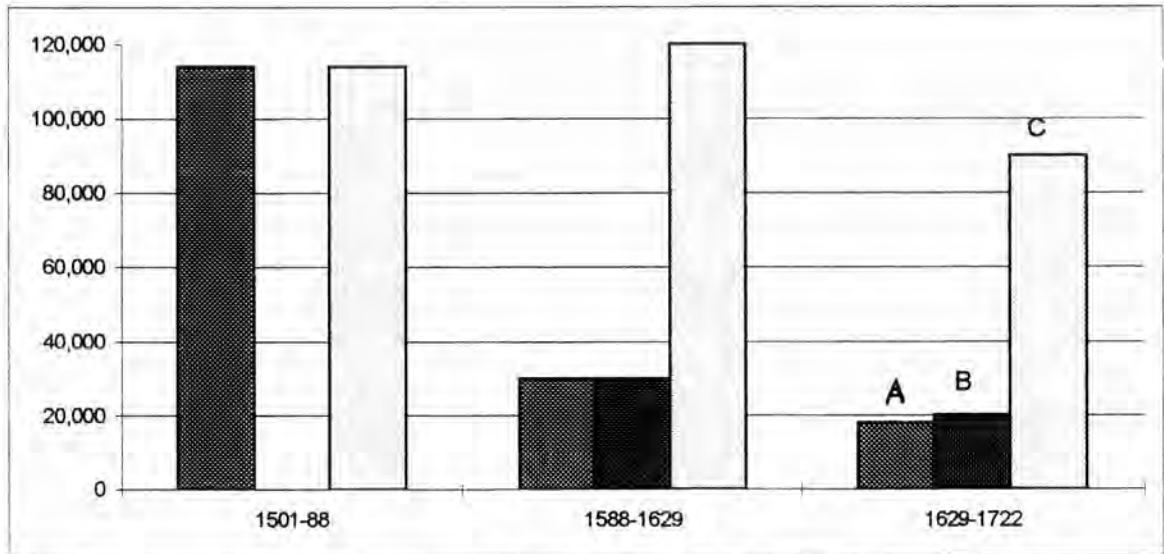

A: traditional army B: the new army C: the total number of regional and central armies

According to Chart 2.2, the numbers of the traditional army were decreasing relative to those of the new standing army. However, because of overall negligence towards the army, the total number of the new standing army was declining in the third period (1629-1722) relative to the previous period (1588-1629). Like the civilian bureaucracy, both officers and rank and file soldiers were paid with drafts from the land revenues.¹⁶

One crucial element which influenced the shahs to pursue reforms was the Ottoman factor. The Safavids tried to remain out of the circle of control of the Ottomans, who

claimed the control of the whole Muslim nation both politically and culturally. The Safavid shahs declared Shi'ism as the official religion of Iran - a different doctrine than that which existed in the Ottoman empire. They also recaptured Iranian territories from the Ottomans. At the time, the Europeans and the Ottomans were involved in occasional wars, and the eastern border of Europe had been attacked and partly occupied by the Ottomans. Aware of the differences between Iran and the Ottomans, the Europeans - among them were the King of Sweden, the King of Poland, and James VI of Scotland - tried to encourage Iran to take more military actions against the Ottomans.¹⁷ Thus, the Europeans both helped Iran to reorganise her army and administration, and were also, in general, successful in provoking the existing hostility between Iran and the Ottomans.

Thus, the Safavid shahs based their power on three pillars: the administration, the army, and the network of the court patronage. While the administration was an instrument for regime enhancement and control, the army played the crucial role of system maintenance and was the guarantor of the Safavid rule. Nonetheless, the policy-making and exercise of power was manipulated by, and depended exclusively upon the Shah and his relationship with limited key individuals in the court. The Safavid court maintained hegemony over other ruling classes, namely tribal chiefs, controllers of land revenues (and tyul holders), merchants, and official ulama.

2.1.2. The economy and trade under the Safavids

Studying the economy of the Safavids requires investigation of the rural and urban economies of Iran during that period. While the former was a combination of agricultural production, by settled peasants, and cattle breeding, above all in the hand of nomads, the latter was largely restricted to trade and light industries. The village was the basis of rural production, and authority over it was exercised by landowners, fief-holders or tenants. Villages and tribes were mostly isolated both from cities and from one another. The times of tax collection and of the division of sharecrops were the only times peasants would be in direct contact with a representative of the government or landlord. The tribal hierarchy, which was generally identical with the military hierarchy, would produce the market's meat. Although as time passed, their chiefs settled to a

great extent in cities, they were still able to control their tribes. Furthermore, from the 14th to 16th century, tribal chiefs generally “were the possessors of large fiefs or benefices” and thereby combined two social functions (see Fragner 1986: 493). However, in the same context, although landlords were generally the mediators between peasants and the administration, from the 15th century we repeatedly encounter:

“a tendency toward the development of a landowners class possessing far-reaching powers and authority” (ibid.).

The economic structure of the Safavid period was agriculture, in which land tenure was the key determinant. Land ownership was in forms of *melk* (private estate), *khasseh* (crown land), *mamalek* (state land), and *vaqf* (charitable or religious endowment land).

The Safavid shahs transformed large-size pre-Safavid *soyurghal*¹⁸ to smaller sizes (*tiyul*) - but these were large in number of holders. Nevertheless, by increase in crown estates, *tiyul* holders decreased in number. The central power was considerably strengthened by the prevention of the growth of large *tiyuls*, and its organs consciously directed their policy toward this end. Safavid *tiyuls* were subject to a time-limit and were not hereditary. Land was always connected with some services to be rendered to the state. The fundamental constituent of the *tiyul* was the grant of the tax yield from a particular area or of a part of that yield. Thus, it is beyond doubt that the principal reason for a form of *tiyul* which was different than the *suyurghal* was the intention to restrict, at least formally, the authority of the high amirs in the provinces.

During the Safavid period, tax was the main source of fiscal revenues for the state.¹⁹ Minorsky (1989: 209-228) estimated the total revenue of the state as 785,623 *tumans*.²⁰ The government expenditure for the same period was calculated as 491,796 *tumans*. Therefore, there was a major surplus in government balance of payments, which mainly, was saved in the state treasury.²¹

During the Safavid dynasty, the port custom and internal trade taxes²² became the main source of state revenues. Abbas I tried to nationally systematise the tax collection and to codify its practice.²³ Almost all taxes were in direct forms and were collected

throughout the country in accordance with the legal code prepared by the central government.

During the Safavid dynasty, an unprecedented economic prosperity - with its peak during the 17th century - was attained. The most important urban production included textiles, carpets, porcelain objects, high quality arms and armour, leather, and dyes. A second major sector of the urban economy centred on the productive activities organised by the shah in the royal household - chief among them were 30 royal workshops, each employing 150 workers (Chardin VII: 329-34).

2.1.2.1. Internal and foreign trade

Commerce was largely restricted to the urban sector of the economy and, at best, extended only to villages which were in the vicinity of towns. Although the city, above all, was the place of trade and exchange, the commercial development actually depended to a degree upon the quality and safety of the road. Trade was taking place mostly in cash money. In addition to the importance of the availability of cash capital, it was of vital necessity for the city to be attached to a supra-regional communication network (Fragner 1986: 524). Bearing this in mind, the existence of a well-organised, centralised state with the widest possible area of dominion was, therefore, highly advantageous to the intensification of Iranian internal trade.

Abbas I developed the communications network, secured roads, and invested in the infrastructure.²⁴ To safeguard and support internal trade, he ordered:

“if any merchant or traveller or resident were robbed, it was the duty of the governor to recover his money for him or replace it out of his own funds” (Monshi, V.I: 527-8, trans.).

By founding friendly relations with foreign countries, mainly in Europe, he boosted Iran's foreign trade. In spite of all these efforts, however, Iranian foreign trade was relatively minor, hindered by an undermonetarised economy and compounded by the difficulty of transportation.²⁵ Even the trade importance of Isfahan in the 17th century should be looked upon primarily as internal.²⁶ Abbas I tried to place Iran on a firm commercial footing, when Persia, as Humphrey (1991: 199) argues, was in danger of becoming a back water. Europeans became more interested in Iranian raw materials.

Increase in crown lands and a booming market for gems, minerals and other light manufactured products, raised government revenues through taxation and commission. However the state, except in silk and tobacco, essentially manifested no major interest for intervention in trade. The silk trade was a monopoly of the court and the tobacco trade was under its control.²⁷

While foreign trade was dominated by the Europeans and Armenians, the native merchants could only partially adapt to the mercantile requirements of the time and concentrated more on home markets.²⁸ In spite of this, the local merchants, every year “made a profit of 30% to 40% on their business capital” which itself was a substantial profit margin (Fragner 1986: 527). In spite of all efforts, in contrast to the situation in Europe, Iran lacked the dynamic element of capital investment necessary for greater production. This is partly because owners of capital were frightened of any investment, as the monopoly of investment was in the hands of the government, and furthermore, there always existed a risk of confiscation during the later Safavid period. The existing capacity was geared to production of luxury items used by the court, while foreign investment was for an immediate cash return. By the early 18th century with the increasing importance of European commercial shipping in inter-continental trade, Iran found itself pushed onto the fringe of the world economic scene.

In conclusion, throughout the Safavid period, Iran, in terms of the world system, may be characterised as a regional empire engaged in roughly egalitarian patterns of trade with the European core countries that centred on luxury items such as silk rather than on large-scale bulk commodities. The important set of countries in primary contact with Iran in the 17th century included its immediate neighbours, mostly regional-empires like Iran itself. In the 17th century, there was no major re-orientation of the economy for exports and no significant dependence on any imports, except for pepper and sugar, which were consumed by some urban classes but not yet the mass of population. In terms of the mix of raw materials and manufactures, balance of trade, and appointment of profits, Iran could certainly not be viewed as dependent on Europe. Both sides were fairly self-sufficient and structurally independent of each other. Thus when they interacted, they did so as relative equals. In the 17th century, moreover, the Safavid and the Ottoman empires were far too strong to be colonised and dominated by

the Western Europe. However it was too weak to compete with Europe in the new peripheries of Asia and Africa.

2.1.3. The fall of the Safavid dynasty and the period of transition

The Safavid's reign of 222-years was the longest for a millennium in Iran (and until now) and this durability constitutes further testimony to the political stability they enjoyed. The fall of the Safavids cannot really be conceived of as a single event, for the actual capture of Isfahan (the capital) by an invading army of Afghan tribesmen in 1722 was preceded by a process of decline and crisis extending over half of a century. The fall of the dynasty can be conceptualised in terms of simultaneous and interrelated economic, political, military, and ideological crises.

Economically, it involved fiscal crises and consequent problems of balance of payments in the late 17th century, inflation compounded with corruption, and growing tax exploitation of the population. A military decline came about with the alienation of the tribal armies through the replacement of qizilbash provincial governors by state-appointed intendants, which led to the dismantling of the traditional tribal cavalries. This coincided with the poor state of the new standing army which was largely neglected by the state. Faced with fiscal crisis, and at peace with the Ottomans, the later Safavid shahs allowed themselves to be convinced by the private harem council to save money by not spending it on the standing central army. At the political level, the rise of faction-ridden new groups to power at the court - the eunuchs, shah's harem, and the increasing involvement of the official religious dignitaries - precluded the making of coherent state policy. The bringing up of the royal princes in the highly artificial and sheltered atmosphere of the harem exacerbated the problem. On partly ideological grounds (i.e. the zealotry advocated by some official religious (Shi'ite) dignitaries), the Georgian military commanders and bureaucrats, Armenian merchants, Zoroastrian and Hindu communities, and Sunni tribal groups on the periphery of the empire in the Caucasus, Baluchestan, Khuzestan, and Afghan province were all alienated.²⁹

Lambton (1953: 107-9), Minorsky (1943: 23), and Savory (1986: 364) among some other historians and economists see the land conversion policy of the state as one major

element in the Safavid collapse.³⁰ Lackhart has tended to focus on the woeful personal inadequacies of the last several shahs, sometimes supplemented by a political factor or two. For Foran (1992: 298) the economic breakdown led to political collapse, as he argues that: "the economic crisis involved a tale of inflation, declining trade balances, state budget problems, tax farming of the customs and sale of offices, corruption, and growing tax exploitation of the population" which influenced the political institution by devastation.

In the same line Anderson (1974) argues, the weakening and withering of the established institutions of Abbas I, to a great extent, led to dismantling of the dynasty. However, the personality of the shah was, to a great extent, responsible for such a decay: a trend that had already undermined the state for half a century from within. Ceremonial extravaganzas, alcoholism, gluttony, and a whole range of indulgences monopolised the shahs' time and attentions. This was partly the result of Abbas I's policy of limiting the princes to the harem, which was implemented continuously throughout the Safavid period.

As a result, the Safavid dynasty lurched into an intertwined economic, political, and ideological crisis by the turn of the 18th century. It took the greater part of the 18th century to affect the transition from Safavids to Qajars - via Afghan invasion, Nadir's re-conquest and Asian campaigns, renewed civil wars to control the state power, Karim Khan's smaller Iran, another round of civil war, and finally, the rise of the new Qajar dynasty.

Afghans, Afshars, and Zands lacked the extensive royal domain of the Safavid, did far less building and commercial infrastructure, controlled the economy less determinedly and, for most part, commanded fewer resources. Furthermore, they had no centralised state identifiable with the totality of Iran and lacked military strength coinciding with centralised administration - the Afshar dynasty was militarily strong but administratively weak, while the Zand dynasty had an effective administration but lacked a powerful military establishment. The result was the reversal of the internal dynamic of economic development in the country, an enormous setback in the urban economy's development. Therefore, the Iranian state was weakened - or lost its meaning in the sense of its identification with the totality of Iran - as the central single

economic actor in the social formation, and as the political means of territorial integration of the country.

In multiple respects the 18th century provided a disastrous link between the promising political economy of the 17th, and the social formation of the 19th.

B: The Qajar Dynasty (1796-1925)

2.2. The Qajar Weak State

After a century of insecurity and internal war among different tribes, the Qajar dynasty was established in 1796 by a military force of tribal warriors led by Agha Mohammad Khan.³¹

The Qajar shahs tried to routinize their power by constructing a state-wide bureaucracy; stabilise their position by creating an effective standing army; and legitimise their dynasty by imitating the court manners of previous emperors (Abrahamian 1982: 38). However, failing to maintain a military build up, involved in major wars, with no administrative stability and little ideological legitimacy, the Qajar's power was primarily based on the old tribal military and on the use of a policy of 'divide and rule' whenever the regime was confronted by dangerous opposition. Furthermore, the Qajar dynasty ruled 19th century Iran with neither the instrument of coercion, nor the science of administration, but with the practice of prudent retreats and the art of manipulating all possible variations in the complex web of communal rivalries.

The bureaucracy was nothing but a collection of hereditary *mostowfi* and *mirza* (secretary) in the central and provincial capitals and the standing army by the end of the 19th century, was nothing but a handful of Cossacks. Furthermore, contrary to appointments in central government, regional appointments were mostly either hereditary or by request of provinces, tribes and nobles. Therefore, the method of appointment was a concession between the shah and regional magnates (Malcolm 1829, V. II: 412).

The Qajar family was large in size and its members were supported by being given offices at the court, or within the mini courts which existed in each province, and within them they were conducting their own policies rather than the central government

policies. Indeed foreign policy partially was consigned to the care of such provincial courts.³²

There was no group commitment to reform, which had made the reform dependant largely on the individual - whose dismissal would have returned everything to its initial step. The reformers lacked consistent purposes³³ and were not strong enough to win over the forces opposed to them, the royal court in particular. Although the Qajar shahs were receptive to new ideas and were willing to sponsor schemes of modernisation, due to this weakness, such schemes never materialised substantially.

There was no generally accepted system for succession, and thus contenders for the throne often looked for outside support. For instance, Britain and Russia intervened to support the succession of Mohammad Shah in 1834 and Naser al-Din Shah in 1848. This fact undoubtedly contributed to further weaknesses of the government. The increasing foreign influence and the Russia-Britain rivalries contributed to the failure of reform and development in the country. In general, the interests of Britain (and its colony India) and Russia were suited to preserve Iran as a weak buffer between them. By their constant interference and competitions they handicapped Iranian development, aligning themselves with conservative groups and contributing to the downfall of reformers.³⁴ Attempts by Iran to get the help of a third power in an effort to break out of this control failed.

2.2.1. The Qajar administration and military establishment

The Iranian political system during the Qajar period was characterised by a minimal government. All virtually economic and social functions were left to non-central government agencies. The army was in the hands of provincial rulers, the economy left to itself, and border problems and protection were left to the provincial governors. In such a situation, the Iranian government could not coerce, but was obliged to bargain with its subjects and its own local governors.

2.2.1.1. The administration

At the top of the bureaucracy, offices tended to become the private property of their holders and to be concentrated in the hands of a few families which were constantly

engaged in rivalries. Early governors were drawn from among the leading families and tribes, and included a large number of Qajar princes. Chief minister (*Sadr-e a'zam*) was head of the bureaucracy. However it is impossible to give an exact description of the duties which he had to perform. He was sometime placed at the head of every department, other times this power was divided among a few ministers.³⁵ As soon as the shah would become suspicious of the chief minister he would deprive him of office and in some cases of his life.

To analyse the Qajar bureaucracy, three stages are distinguishable; from the emergence of the dynasty to the reign of Mohammad Shah; the Naser al-Din Shah era; and from Mozaffar al-Din Shah to the Constitutional Revolution.

In the first period (1796-1848), Agha Mohammad Khan obtained and consolidated power through tribal networks, tribal conquests and tribal alliances. The Shah himself was minister of finance and treasurer.³⁶

Fathali Shah, a powerful king, discarded the tribal style in favour of the ancient traditions of imperial monarchy. Both as a result of an early relaxed political situation and in response to different administrative needs, the number of office holders began to proliferate (Hambly, 1991). Thus the administration and the royal household were developed mainly by imitation of the Safavid exemplar.³⁷

Nevertheless, the bureaucracy remained minimal as the state was involved in wars, and military strength failed to provide solutions to financial problems or, to create an extensive and viable administration. This failure meant that local communities preserved administrative autonomy. Furthermore, they expanded the positions within the bureaucracy, even without offices or functions, to recruit relatives. Nevertheless, the Qajars were successful in compartmentalizing the central palace into special sections for royal treasury, mint, etc.

Throughout this period no middle course appeared possible between concentration of authority in the hands of the chief minister, and its near fragmentation between competing factions of the bureaucracy who, in the absence of effective control, proceeded to carve out their own independent spheres of influence (Meredith 1971: 65).

While the bureaucracy of circa 1800 was quite rudimentary and small, during the second period (1848-96), the administration grew in size. The number of ministers rose from 6 to 9 and later to 13.³⁸ Such increase did not at all constitute the differentiation of the state apparatus and creation of specialised ministries, but occurred, at least partly, to stanch the various fiscal crises of the shah, through the auctioning of officerships, governorships, position in the mint, and in customs. As Curzon (1892 V. I: 450) argues:

“the bureau was set up at whatever spot the minister happens to be, whether in his house, an anteroom, or a court of the royal palace”.

There were some modernised areas of the state such as the postal service, the official newspaper, and telegraphs, which were mainly controlled by foreigners. In this period there was a growing tendency for change and reform, among a group of administrators, ulama and the intellectuals. Amirkabir the first Chief Minister of Naser al-Din Shah, sparked such a mood in urban society and paved the way for future reform both in chancery and the court.³⁹

However, due to pressure from the court, pressure groups, and foreign powers, no major structural change was achieved during the second period. Once more, the harem and the private quarters of the shah became very influential. The ruling elite, including the prince-governors, had to walk within these limits (*Nazem ol-Islam-e Kermani* quoted in *Shamim* 1372: 332).

In spite of all the efforts in this period, except in the time of Amirkabir, the administration remained inefficient, the army was in disarray, the financial affairs of the governments were so bad that every year about 150-200,000 unpaid *barats* and tax cheques were in people's hands and the country was vulnerable to foreign penetration.

The third period (1896-1905) was the gradual decay in the existing weak administration. Foreign influence within the administration increased dramatically.⁴⁰ The administration during *Mozaffar al-Din Shah* was shifting between two Chief Ministers, *Amin al-Sultan* and *Amin al-Doleh*, whose appointment was the product of the influence and pressure of Russia and Britain respectively, and their internal collaborators. Thus the pressure for reform which was gaining popularity among the merchants and intellectuals, prompted gradually increasing pressure for a radical change

of the system of rule. During this period, the royal writ and government orders had no more credit and value.

As Keddie, Ashraf, and Sheikholeslami argue, in traditional patrimonial bureaucracy of the Qajar, yearly auction of tax farms, arbitrary dismissals and punishment of high officials, and the relative lack of specialisation in government offices were common features of all the three periods.

2.2.1.2. Provincial administration

The failure to create a centralised bureaucracy meant that local communities preserved their administrative autonomy. In each provincial capital there was a copy (on a smaller scale) of the court at Tehran with all the burden which such a structure imposed on the local population. The provincial administration was headed by an appointed prince called *beiglar-beig*. Governors enjoyed considerable local autonomy and kept much of their jurisdiction's surplus. To control his activities, both the provincial royal minister and the finance minister (*mostowfi*) were appointed from the centre. During the Qajar era, local structure of power and wealth were often supported by the central government. This was an inescapable outcome of the balance policy of the Qajars. It was through this "pyramidal structure of power that government could reach its subject" (Sheikholeslami 1978: 289). The central-provincial relationship was an interdependent one. On one side, it was more effectively pronounced in the collection of taxes. On the other side, the local notables also enjoyed the legitimacy that recognition by the government brought them. This ensured their rights against other possible local rivals.

The performance of official functions by notables came about mainly because of their local roots rather than by assignment from the central government. This duality of authority structure created an axis of conflict between the centre and the region. The central government demanded more money as the cost of the government soared, and the region tried to retain as much of the taxes as possible.⁴¹ By the second half of the 19th century, governorships were systematically sold to the highest bidder - the one who promised to remit the most in taxes. This meant extra taxes to cover the extra cost of buying the post of governorship.

On the other hand, the provincial governor had his own representative in the capital, known as *vakil*. He was supposed to present the list of the expenditures and income for the previous year to the central government for ratification. The agents of important provincial governors in the court would, furthermore, try to resist any effort to strengthen the central government at the expense of the provinces - i.e. the case of agent of Zell al-Sultan in Tehran, Mirza Yussef.

Overall, most governors remained powerless outside the immediate vicinity of their provincial capitals, and some had no authority as they were too young or too incompetent - i.e. Kyumars Mirza, governor of Kerman.

2.2.1.3. The Qajar army

The Qajar army was not an autonomous institution fulfilling technically specific functions, and differentiated from other traditional institutional processes of the country. On the contrary, the army was closely tied, in its recruitment, financing, and administration, with the country's diffused social and economic structure.

The army, of course was not large enough to maintain a strong presence in the whole country, but it was enough to suppress several revolts. When it became necessary to extend his sovereign authority, the shah often had enough military power at his disposal to do so forcefully (Safari 1971: 35 based on a letter from Naser al-Din Shah to Mirza Hossain Sepahsalar in 1875-1876). The traditional army was composed of three different categories; irregular tribal warriors, the royal gholams, and militia. Royal gholams, mostly the Georgians, were, contrary to the situation during the Safavid period, under the command of the Qajar nobles. Theoretically, the traditional army was estimated to be around 80,000 (Mories 1882: 214) and the militia - which was raised and equipped by the provincial and city governors - was numbered around 150,000 (Abrahamian 1982).

The Qajar army went through many changes in the course of the 19th century, none of which solved its problems sufficiently to make it a particularly useful instrument of the state externally or internally. Abbas Mirza, the Crown Prince of Fathali Shah, after 1800 made efforts to modernise training and armaments, but the latter were of poor quality and the Russians (after some early setbacks) prevailed decisively in the wars of

1810-13 and 1826-28.⁴² Although this new army was supposed to eliminate tribalism, its recruitment and organisation policies were such that the problems of tribal rivalry continued to prevail.⁴³ For a brief time under Amirkabir around 1850, the army was systematically recruited, better trained, and regularly paid. Foundation of *Dar al-Fomun*, a technical-military college and initiating a new system to finance the army,⁴⁴ were among of his endeavours. Amirkabir's force quelled revolts in 1850 but degenerated again soon after his downfall and had to back down under English pressure over Afghanistan in 1853-56. In 1879, a Russian officer formed a Cossack brigade for the Shah's army, which became an effective tool of oppression and an aid for the execution of Russian policies. (Kazemzadeh 1968: 166-168)

Although lack of finance and modern weaponry were important in the failure of the rationalisation of the army, the incompatibility between the traditional social structure and the modern superstructure - that the reformists or the Shah hoped to impose upon the army - should probably be considered primarily accountable for its failure.

Hambly (1991) believes that the belief of Naser al-Din Shah that the territorial integrity of Iran would be preserved by Britain, and the increasing influence and vested interest by tribal chiefs in court, had further blocked any reform of the army. During the Naser al-Din Shah's rule, the actual size of the new army was 20,000 (while in theory it was 100,000 infantry and 30,000 cavalry, Foran 1993: 139). By the end of the second period and during the third period (1896-1905) 1,500 Cossacks were the only disciplined army of Iran (Yapp 1991: 197).

2.2.2. The economy and state revenues

The traditional tax system of the country inherited by Fathali Shah proved increasingly inadequate to provide for the growing needs of government. Thus arbitrarily imposed taxes became the chief means of revenue collection. It was at the level of provincial government, as noted previously, that fiscal arbitrariness and downright extortion received their fullest expression. The revenue sent to the capital was only a fraction of the collected revenue,⁴⁵ so, the central government was not the chief beneficiary. The royal treasury absorbed most of the revenue.⁴⁶ The sources of state income in the second period (1848-1896) were primarily the land tax, 78% of

total revenues in 1868, and the customs at about 11% (according to Thomson in Issawi 1971: 29-30). By 1911, the customs, due to increased trade, were up to over 40% of the total.⁴⁷ The land tax increased from one-tenth of land revenue to one-third by the end of the 19th century. This left little room for positive incentives towards greater regional productivity.⁴⁸ The custom tariff for foreigners was uniform and about 5%. The Russians and the British later decreased it to 1.5% (Shamim 1372: 353-54). The custom tariff for local businessmen was 3% in nominal term. However, adding the road and transit taxes, their tariff was actually much higher than foreigners, as foreigners did not have to pay extra taxes. The expansion of foreign trade made the customs even more profitable during the reign of Naser al-Din Shah. In ten years, by increasing foreign trade of the country, the shah's income from customs had tripled.

Katouzian (1981: 43) based on Gardone and Malcolm, estimates the annual revenue of the land tax (as the substantial share of the whole tax revenue) as 20 million tumans in the first decade of the 19th century, increased to 50 million tuman by the end of the century. According to his estimates for 1867, 1868 and 1885, less than 60% was spent on the army and the bureaucracy (the army taking 40%) and the rest of revenue was allocated mainly to the privy purse, pensions for the nobles and divines.

TABLE 2.2 *Revenues of the Iranian State, 1800-1907*

Year	Estimator	Revenues in Tumans	Revenues in Pound Sterling
1807	Gardane	2,000,000	2,000,000
1810	Malcolm	—	3,000,000
1820	Fraser	2,500,000	2,200,000
1839	Rabino	3,402,615	1,835,994
1853	Rabino	3,368,558	1,153,163
1868	Thomson	5,012,500	1,965,000
1876	Rabino	5,070,000	1,950,000
1888	Curzon	5,531,000	1,653,000
1907	Jamalzadeh	8,000,000	1,538,000

Source: Issawi 1971: 352; Foran 1993: 139

Fiscal crises occurred with some regularity in Qajar Iran, especially in two waves, from the 1820s to 1850, and from the 1880s onward. Table 2.2 gives an overview of

some estimates on the size of Iran's revenue from 1800 to 1907. Significantly, due to the depression of the Iranian currency, state revenues, expressed in pounds sterling reached their peak of 3 million in 1810, declined to 2.2 million in 1820, and never surpassed 2 million for the rest of the century, reaching in fact their second lowest level of just over 1.5 million pound sterling in 1907. As the Iranian state and economy became enmeshed in the world system over this period, the weight of this decline was presumably felt fiscally despite the gains in terms of tumans.

As a result, total public debt reached £7,650,000 in 1913. This consisted of £6,750,000 debt to Russia and Britain, plus floating debts of nearly £900,000 to other foreign creditors. It required annual servicing of £400-500,000, which ate up one-fourth of all government revenues (Brown; 1926: 240; Issawi 1971: 128, 339).⁴⁹ In 1922, the total debt to Britain was £5,590,000. In a search for revenues, numerous concessions were granted to foreigners i.e. tobacco, oil, custom. Neither the loans, nor the concessions helped the economy and the development of economic infrastructure. Rather they caused political turmoil, in which the economy and society both suffered very much.

2.2.2.1. Foreign investment

The total foreign investment in the 19th century was about £16,000,000 by the Russians while the total British investment for the same period was around £9,700,000.⁵⁰ In total, foreign investment in Iran did not exceed £30 million (\$150 million) (Issawi 1971: 595-600). Considering table 2.3, during the same period, the foreign investment in Egypt and Turkey were \$1 billion each, and in India was \$2 billion. Iran lagged behind in investment and infrastructural progress. Two factors were crucial in the success or failure of these countries. The first factor involves the state's pattern of rule, in which its attitude toward the change and reform would be essential. In Iran, the Qajar shahs were very reluctant to implement any change in the army and the administration. Their patrimonial system of administration would not allow for any internal factor concerns reform, and they were hesitant to make use foreign experience and advise.

TABLE 2.3 *Comparison of Foreign Investment and Trade; Iran, Turkey, Egypt, and India*

	Iran	Turkey	Egypt	India
Per Capita Foreign Trade (1913)	\$10	\$15	\$24	\$4
Foreign Investment: 19th century	\$150 million	\$1 billion	\$2 billion	
Growth of Foreign Trade: from 1800 to 1913	12 folds	12 folds	50 folds	50 folds
Railways (by 1900)	8 km.	3,500 km.	4,300 km.	56,000 km.

Source: Issawi 1971: 590-600, calculated by the author

The second factor concerns the attitude of foreign powers toward the country. Iran, at the centre of rivalries between Britain and Russia, was therefore paralysed with respect to receiving any foreign help. Furthermore, later Russian-British consent to keep Iran a weak and underdeveloped country, prevented Iran from utilising even its own limited resources.

2.2.2.2. Foreign trade

According to Issawi, the total trade of Iran increased 12-fold for the period of 1800-1913. It doubled between 1800 and 1860, but later quadrupled for the period of 1860-1913. The depreciation of local currency was partly responsible for this increase in trade. Malek (1991) estimates the depreciation of Iranian currency, relative to sterling to be about 410% in the 19th century. Furthermore, this growth was primarily indicative of the increased demand in the European market for Iran's raw and primary materials. This shift altered not only the volume but also the composition of Iran's exports and imports, with generally undesirable consequences for the national economy. The export of woollen products declined from 23 to a mere 1%, while at the same time, the share of raw cotton in the same total had increased from 1 to 7% (Issawi 1971: 130-31, 40). Displacement of Iranian trade in the 19th century was partly due to the changing international economic situation, and increasing penetration of European economy into Iran. In the past century, European manufactured goods superseded local Iranian commodities. The export of raw materials replaced the export of finished

goods. International market limits, curtailed the ability of Iran to export agricultural products.⁵¹

Among the reasons for the decline of industrial export were the penetration of foreign capital which favoured the European bourgeoisie, the decline of indigenous industry, the failure of the state and Persian money dealers to establish an autonomous local and national banking system, and, finally, the preference of Iranian merchants to invest in land rather than in industrial production. Consequently, this situation limited the emergence and growth of an independent bourgeoisie in Iran. In contrast, the partial custom policy favouring the European bourgeoisie led to the creation of a comprador bourgeoisie by the early 20th century in Iran - i.e. Some local merchants would prefer to travel using a foreign nationality to gain privileges (Ashraf 1970: 326-27).⁵²

While Russia had begun a rise to commercial and political hegemony in Iran, it had equalled if not surpassed Britain as Iran's leading trading partner by 1895; the gap continued to widen in favour of Russia through the next decade. In 1913, 55.5% of Iran's total imports were from Russia and 27.8% from Great Britain (and its colony India). For the same year, 71.5% of the country's total export was to Russia while 13.5% was exported to Great Britain (Foran 1993: tables 4.1, 4.2). This shows the extent Iran's trade depended on these two major powers. While in the beginning of the 19th century foreign trade was dominated by Iranian merchants, by the mid-19th century, a considerable part had passed into European control, which by World War I accounted for the bulk of Iran's foreign trade.

By the end of the 19th century, the reality of Qajar power fell far short of its projected ideal. In the view of Bharier:

"In 1900, Iran was a fairly primitive, almost isolated state, barely distinguishable as an economic entity....There were signs that the economy was developing but at the turn of the [20th] century it still remained one of the most backward countries in the world" (1971: 19-20).

We therefore notice Iran's transition from a regional empire to an increasingly integrated peripheral role in the capitalist world economy, both as a supplier of raw materials - silk, opium, cotton, fruits, and so on - and one traditional manufacture - carpet - and as a consumer of manufactured imports - textiles, hardware, and processed

agricultural products such as sugar and tea. The growing weakness of the Qajar state vis-à-vis Western states and their more powerful armies and economies was linked to processes of fiscal crisis and deligitimation internally. While contact with the world economy did create pressure for reforms and the elaboration of some new institutions, it did not result in any successful centralisation of the Qajar polity. The Qajar shahs were neither too strong (like the Safavids), nor too remote (like the 18th century dynasties) to be directly dominated. Furthermore, they faced two strong rivals, Great Britain and Russia, who completely disaggregated their dreams of strong central control internally. Dependence was imposed, as Foran argues:

“by military power, channelled into economic domination, and ended in substantial political and strategic control” (1993: 143-4).

This is not to say that all or even most of the internal economy was determined by the external relations, but rather that a critical threshold was crossed in this period such that increasingly large numbers of people were affected to a greater extent than ever before in their daily lives by external forces. This process extended to the Qajar state as well: its institutions were recast and weakened by their new relations to the West and civil society. As Abrahamian notes, the Qajars were:

“despots without the instruments of despotism, Shadows of God on Earth whose writ did not extend far beyond the capital; King of Kings who trembled before unarmed demonstrators; and absolutists ruling with the kind permission of the provincial magnates; the religious dignitaries, and the local officials” (1974: 13).

Notwithstanding, as Katouzian (1981) argues, the political economy of Iran was still controlled from the centre.

The state ultimately emerged in the period from 1800 to 1925 as a key actor in Iranian social formation. This is seen in the comparison between the weakness of the Qajar, caused by the external pressures and internal challenges, and eventual stability of Reza Khan's new state, which found its source of strength after 1921 in a new component in the Iranian state, an efficiently-administered army. In between these weak and strong states there existed from 1906 to 1921 a transitional state with its own new institutions - the Majles, and in civil society, the political parties, trade unions, and free press - which would eventually come into conflict with Reza Khan's vision of the state

2.2.3. The Constitutional Revolution and the rise of Reza Khan

The Constitutional Revolution (1906) (CR) originated in the call of the people for freedom, political participation and a move toward progress and prosperity in Iran. As a result of an urban multi-class populist revolution of artisans, merchants, ulama, workers, and lower classes, Iran became a constitutional monarchy. The institutions they created - Majles, constitution, trade unions - were new in the history of Iran (see Edward Browne, 1995, section II). In 1908, due to both external pressure and internal disunity, it was the tribal leader who succeeded to reap the rewards of the CR.

Although the CR succeeded in destroying the traditional centre of despotic power, it made no major attempt to transform the economic relations and political system, or to broaden its limited power base. In the words of Halliday:

“In the final analysis, no revolution occurred, and the state was not fundamentally altered by these events” (1979: 22).

The revolution failed due to the internal instability of its shifting alliances and due to the force brought to bear on it from outside. The articulation of the complexities of the Iranian social formation and the dependence imposed on Iran within the world system network. The coalition that carried the revolution was a shifting and a fragile one that could not hold itself together either politically or ideologically. It was rooted in the complex class structure which had experienced the Western impact in divergent ways. Ever increasing foreign intervention in the Iranian state and polity and later the impact of World War I, in which Iran was forcibly involved, caused a deterioration in the already fragile stability of the country.

While regional movements, with the idea of either secession or of implementing the constitution, were emerging, in the capital, the already inefficient central government was unable to respond to these challenges. Both the constitutional alliance and the monarchy it opposed had exhausted themselves. By 1920, so many forces had pulled Iran in different directions for so long that something had to give. All in all, by the late 1910s, the situation led to call among both the urban masses and the revolutionaries for establishment of a centralised and powerful government.

Furthermore, foreign factors paved the way for emergence of a centralised state in Iran. The Bolshevik revolution of 1917 put an end to the old British-Russian rivalries in

Iran and to their joint policy of dividing Iran (the Anglo-Russian Entente of 1907⁵³) and changed the historical situation of both the Qajar and the colonial competition. Britain later attempted to establish her own predominance in Iran through the Anglo-Iranian agreement of 1919 which would have given Britain virtual control over Iran's military and financial resources and would have made Iran her dependent ally.⁵⁴ After the Persia-Soviet Friendship Treaty of 1921,⁵⁵ however, Britain's dream "to bring Persia wholly within the orbit of the British Empire" withered (Lord Curzon cited in Elwell-Sutton 1955: 27). As a result, the temporary withdrawal of the Soviets and the uncertainty of the British - due to what Foran (1993) calls 'the new conjuncture in the world system' - , the weakness of the Qajar state, and the fragmentation of the social movement gave Reza Khan - a 42 years old officer who came from an obscure Turkish-speaking military family in Mazandaran, but who had risen through the ranks to head the Cossak Brigade in Qazvin - a chance to seize power through a British-sponsored coup of 1921.⁵⁶ The new order would be different from the old one, as will be seen, and the new stronger state would clamp down its hold on civil society and face a changing world system in which Britain was slowly declining.

C: Reza Shah and the Pahlavi Dynasty (1925-41)

2.3. The State Under the Rule of Reza Shah

The formation of the modern state with a unified and centralised administrative and military apparatus in the 1920s heralded a new phase in the political economy of Iran, and thus a new phase of state-economy relations. By this time, the political and economic preconditions for the formation of the nation-state were already in place: internal crises led to mass support for the formation of a strong centralised state; the inter-imperialist rivalry between the British and Russians ended; and, the government's new source of revenues through indirect taxation and oil, increased state income.

2.3.1. From the 1921 coup to the Pahlavi dynasty

The years 1921 to 1926 witnessed the transformation of Reza Khan to Reza Shah: his rise to power from Minister of War, to Commander in Chief, to the post of Prime

Minister, led finally in 1925, to his displacing Ahmad Shah Qajar, and establishing the Pahlavi dynasty.

During these years, reform was, indeed, urgently needed in the administration and the army. The traditional bureaucracy was unable to carry the new tasks of development and progress that the Majles had in mind. The traditional, weak and disorganised army was not even capable of restoring order in the capital, let alone defending the independence of Iran. After the February coup, there were a series of measures taken by the state to rationalise and expand its central administration.⁵⁷ At the core of these reforms was the creation of a centralised and unified national army which could end the widespread brigandage and political autonomy of the various regional governors and tribal chiefs, and defeat the popular movements in the north region. During his rise to power, Reza Khan had developed some political skills. He was too inarticulate to hold discussions and too poor a reader to master paperwork, but he was accustomed to command and quick to resort to violence to get his own way. By 1923, Reza Khan had become *de facto* ruler of the country, but still very cautious, he worked within the cabinet and parliamentary system established by the law. In this period he avoided a direct conflict with the leaders of *ulama* until he strengthened his position. In spite of his limited parliamentary skills, the division in the Majles prevented any unified opposition to his increasing autocracy.

During 1921-5, the crucial element in the establishment of a centralised state was the victory of central authority over provincial autonomy. In this respect, Reza Khan eradicated regional magnates and movements crushed Khiyabani's uprising in Azarbaijan, Jangali's movement in the north, Pasiyan's uprising in Khorasan, Simtqu's, rebellion in Kordestan, and Khaz'al revolt in Khuzestan. He used these military successes and increasing increments of state power to engineer his own rise to the monarchy after 1923, in a series of adroit political manoeuvres and manipulation of social forces.

With the creation of a professional and specialised officers corps, the hereditary officers and princes of the Qajar family were shorn of their ranks, and the old provincial levies and tribal contingents were replaced by an organised and effective military establishment (Banani 1961; Kazemi 1980). By 1925, the army was the most powerful

and centralised institution in the whole country, and Reza Khan, as the commander in chief of the newly created national army could exert his authority over almost all the regions of the country.

Reza Khan particularly stressed the three vital principles of constitutional intellectuals for attaining the establishment of the Iranian nation-state; constitutionalism, secularism, and nationalism. Nevertheless, Reza Khan supplanted constitutionalism by authoritarianism and coerced secularism and nationalism. By 1925, the Pahlavi dynasty was founded as the first of non-tribal origin and coming to power without reliance on tribal support.

2.3.2. The autocratic regime of Reza Shah

Reza Shah consolidated his power and strengthened his support on three pillars: the modern army, the administration, and court patronage. As we noted above, parallel to the centralisation of the military-administrative apparatus of the state, the parliament diminished its political significance and the polity shifted totally in favour of Reza Shah, who formally exerted absolute control over the state apparatus. From the 6th to the 13th Majles, it was the shah who “determined the outcome of each election, thus the complexion of each Majles through his administration involvement and his military-police forces and influence” (Abrahamian 1982: 138). The Majles became a “decorative garb covering the nakedness of military rule” (Matin-Daftari, *Khandaniha*, 5th April 1956). The administration remained in power, while having the confidence of the shah and not of the Majles. The political parties were destroyed,⁵⁸ independent new parties were closed, and any voice of dissent was silenced. The shah developed an absolute autocratic style of rule.

Once the control of Reza Shah over the state machinery was established, and the organs of the modern state had acquired the necessary strength, the state machinery was turned towards the levelling out the multi-ethnic structure of the society and the destruction of what had remained of the constitutional political organisations.

The central impact of the Constitutional Revolution on the new system was in its profound distance from the traditional despotism. It was no longer a stagnant, minimal, traditional patrimonial state, but rather a central developmentalist authoritarian state

with a growing modern administration and the modern army which was "before and above everything" (Reza Shah quoted in Wilber 1975: 49). Throughout the period of 1925-41, Reza Shah's regime relied heavily on its coercive apparatus and the support of its bureaucratic-military clientele to maintain its power. Equipped with the military, bureaucracy, and court patronage, Reza Shah was able to wield absolute control over the political system.

2.3.2.1. The army

Establishment of an absolute authoritarian rule became the main objective of the state for any reform or appointments.⁵⁹ The military was the backbone of this process. Anyone who questioned the state, authority or who was a possible threat to the shahs' rule was punished severely. This included not only the leaders of opposition but also the erstwhile close allies who were the architects of his reforms.

This system brought about a new socio-political structure that was different from both the Constitutional Revolution and the traditional Qajar despotism. In this system, both the new army and the modern administration became the means of national progress and the personal authority of Reza Shah.

The army was the vehicle through which he had advanced to the throne, and it continued to be the chief pillar of his reign. He dominated most ministries through his control of the army. Later, through his influence in the army, he controlled the Majles members, the press and the provincial magnates. Therefore the army was the guarantor of his rule and the preserver of his dynasty. He expanded the army of 40,000 in 1925 to 130,000 in 1941 together with some 20,000 in the reconstituted gendarmerie (Yapp 1991: 169).⁶⁰ The junior officers were mostly drawn from the lower middle classes and "perceived the army as a means of social advancement" (Ghods 1991: 223). By offering privileges to them, Reza Shah linked the military elite to his regime. The army relied partially on foreign advisors - i.e. the Swedish Colonel Nordquist who was air advisor to the government. Reza Shah safeguarded the continuous financial well-being of the army by direct transfer of revenues from the Ministry of Finance to the Ministry of War. One-third of the national budget was devoted directly to the army, while some other infrastructural projects were financed by other ministries but were mainly for the

benefit of the army. Further construction of roads and railways enabled rapid deployment of troops. There was, in addition, a special budget based on revenues from oil, tea and sugar. 30-35% of this revenues appears to have been devoted to military expenditure (Bharier 1971: 63-4). With regular pay, improved equipment, and rising morale, the army gave the shah its unqualified loyalty.

2.3.2.2. The administration

Rationalisation of the state administration was accompanied by functional and structural differentiation of the state apparatus and the creation of specialised ministerial branches which could play a more direct and active role in the economy. Reza shah transformed the Qajar minimalist government into one of some 90,000 full-time personnel employed in 10 ministries.⁶¹ The majority of civil servants were from the middle-income social groups and some from the lower classes.

The provincial division of *eyalat* and *velayat* were rearranged based on 11 *ostans* (provinces), 49 *shahrestan* (counties), and many *bakhsh* (municipalities) and *dehestan* (districts), each with its own administration.⁶² Thus, the hand of the state reached out from the capital directly into the provincial towns and counties.

During the latter half of the 1920s, with the help of foreign advisors the finances of the state were reorganised and effective measures were taken to regulate the civil service by establishing educational standards, introducing life tenure, and providing a table of ranks and a regular scale of promotion with fixed salaries. The same bureaucratic criteria were applied to the judicial and educational systems. Furthermore the formation of the modern bureaucratic state institutions substantially enhanced the power of the state to intervene in the economy.

The shah gathered around himself younger men of the civil service and the professions, many of them with Western education, to make up the emerging modern administrative elite of the country. It was the new men with high calibre who could initiate, plan and implement reform policies. Teymurtash, one of them, had all the skills that Reza Shah lacked, and as the Minister of Court, controlled Iran's foreign affairs and exercised an important influence over domestic affairs. Davar, successively the Minister of Interior, Justice and Finance, was the architect of judicial reforms.

However, both, along with some other high ranking administrators,⁶³ became the victims of Reza Shah's suspicion and, while the former was imprisoned and killed, the latter to avoid such a fate committed suicide. In spite of many changes in administration, corruption continued to be widespread. The shah, in order to satisfy the high ranking administrators (civil and military), would allow them to gain economic benefits from their position in office. The extent of corruption, therefore, within the administrative hierarchy, was believed to be considerable and it was generally assumed that this extended to the highest levels.

The formation of this new centralised and unified bureaucratic machinery in a predominantly pre-capitalist economy and amidst a diversity of socio-political structures and vertical dismemberment of the society, had important consequences for the distribution of power within the state itself. Bureaucratisation of the state apparatus was tantamount to the institutional separation of the state from the agrarian land-based economy and was the first pre-condition for autonomy of the state from the economically dominant classes. The degree of autonomy of the state, however, depended on the prevailing socio-economic and political relations within Iranian society. The absence of strong class structures and well-articulated class interests on a national scale, which was due to the backwardness of the Iranian economy, coincided with an emerging modern repressive administrative establishment. The combination resulted in a high degree of autonomy for the state.

2.3.2.3. Court patronage

The third pillar of the state was the court. Reza Shah who had no land or wealth upon rising to power, eventually accumulated enough wealth to become the biggest landlord and the richest man in Iran. By 1941 he had £3 million plus nearly 1.5 million hectares (2000 villages and related lands), mostly in the fertile lands of the northern provinces. As Millspaugh puts it: "The Shah was receiving gifts of villages" (1946: 25). These estates were collected through forced sale, confiscation of private and state land, *vaqf* and *khalesseh* lands, and dubious claim to royal domain (see British Minister to the Foreign Office, FO 371/Persia 1932/4-16077; also *ibid.* 1934/35-18992).⁶⁴ Reza Shah by abolishing the land tax in 1934 further improved the landlord's position. For

instance, while the Majles became increasingly dominated by big landlords, he allowed them to retain their lands and local influence in return for not opposing his policies. His circumstances meant that the impact of the changes he introduced could have little effect in the countryside. As he had the administration and the army behind him, no one dared to show any resistance to his land usurpation, while the new law was actually justifying his previously illegal claims. This wealth and property,

“financed the establishment of royal hotels, casinos, palaces, companies, charities, foundations, and led to a proliferation of court positions, salaries, pensions, and sinecures” (Abrahamian 1982: 137).

The court, thus grew into a wealthy landed military complex offering lucrative posts and favours to those willing to serve the Pahlavi dynasty.

2.3.3. Bureaucratic reforms

The inter-war conditions and the Soviet revolution, enabled Reza Shah to neutralise foreign influence and move toward administrative reform and economic development. However in both foreign policy and socio-economic reforms, his personal egocentricism and his narrow, personal vision of public interest set the direction. Trans-Iran Railway, which was economically an unprofitable waste project (Katouzian 1981), was a good example of this. Nonetheless, he built personal prestige and national pride through this project, while at the same time, another aspect of national pride was excoriated and attacked by Reza Shah to the extent that the Western code of dress was imposed to replace the local costumes.

If modernisation was his major goal, and centralisation his method, then nationalism and secularism were the ideology that aimed to legitimise both of the former. Nationalism looked upon by Reza Shah as a source of inspiration, a replacement for religion as the dominant ideology, to stand in as the culture of modernisation in the absence of culture of the national bourgeoisie.

Although Reza Shah never formulated a systematic blue print for modernisation, his long-term goal in reform was “to rebuild Iran in the image of the West - or, at any rate, in his own image of the West” (Abrahamian 1982: 37). Having undisputed political power, Reza Shah initiated a number of social reforms. He intended that, Iran should be

free of clerical and religious influence, nomadic uprising and ethnic differences. Hence, he pushed for the annihilation of regional powers, and the supplanting of domestic and religious traditions and values by Western values. Thus, Westernization of Persian manners became “a prominent part of the Pahlavi government’s reform program” (Ferrin to State Department, 1929 cited in Faghfoory 1993: 300).

European-type dress and hat became a gesture of modernisation, and “the way into the civilised world” (Reza Shah cited in Safa’i 1355: 101-4). As Premier Hedayat writes, the new dress was to make us “like them [Europeans] that they won’t make a fool of us” (n.d., 405-8).

Secularisation and modernisation were further imposed on other fronts; judicial and educational reforms, modern economic structures, and communication networks.

Reza Shah took on, and implemented, a concept of Iran as a distinct cultural and political entity moulded by history and language. The emphasis shifted to pre-Islamic Iran; the official Islamic calendar was changed, and teaching of the ancient history of Iran dominated the history course in the curriculum. Reform finally took place in the army, the administration, the education of judiciary system. In the judicial platform, between 1927 and 1939, various laws were promulgated as supplements to the new civil code of 1928.⁶⁵ It was mostly the secularisation of the shari’a by the abolition of the shari’a court and the adoption of a European model civil code in 1939 and a penal code in 1940, which was provisionally promulgated in 1926, using the French pattern for the civil code, and the penal code of Fascist Italy (see Banani 1961: 74).

Although these reforms provided the context for later capitalist development, the new law was, in practice, unable to define the ruler-ruled relations in the economic, social and political domains, due to the arbitrary rule of Reza Shah. Indeed, he used the new judicial system totally in his favour. For instance, he used the new justice ministry to legalise his acquisition of property, and to jail political opponents and the people who were reluctant to sell their property to him.⁶⁶ As Katouzian (1981) argues, Justice Minister Davar did not realise that even the law and court are not helpful in a lawless military-bureaucratic social system like that of Reza Shah.

Another important domain for reform was education. For Reza Shah, the function of education was to integrate the individual into society. Therefore, its main goal, other

than training bureaucratic and technical personnel, was to act as an instrument of socialisation for Reza Shah's nationalism.⁶⁷ A triple loyalty to God, the Shah, and *mihan*, (motherland) was stressed to bring about obedience, discipline and morality (Menashri 1992: 91-2). Loyalty to the state and ruler was promoted through the curriculum, mainly in teaching of pre-history of Iran, geography, and social sciences

It seems that the education expansion was consistent with the need of a industrialist, modernising state. That is why, while more than 85% of society were illiterate, the majority of educational spending was on capital intensive, urban oriented projects. Indeed, the average annual spending in education decreased from 6.8% of the budget during 1928-1933 to 4.9% for the period of 1934-1941 (Jamalzadeh, 1951: 32, see also *Mahnameh Rasmi-ye Vezarat-e Farhang*, V. 11-12, 1939: 88-104).⁶⁸ In Yapp's words:

"in many ways the education provided in Pahlavi Iran was superficial and it remained largely an urban phenomenon" (1981: 177).

The process of modernisation and reform in Iran, mobilised primarily with security and military pressure, was accompanied, to a considerable degree, by changes in social stratification: "a catastrophic dislocation of the lives of the common people" (as Karl Polani writes about the Industrial Revolution in Europe, quoted in Chehabi 1993: 228). It altered the class structure of Iran. New social classes and occupational groups emerged, and the powers of the old and traditional elites declined. A parallel can be found, as was argued earlier, during the reforms of Shah Abbas, when he tried to replace the qizilbash with new class of gholams and Persians in the army and provincial administration. The composition of the landholding upper class changed substantially. A new landlord class was firmly established - as an amalgamation of those old landlords with court favourites, army officers, and high bureaucrats who through their connection with Reza Shah and his court had acquired land.

The bazaar guilds were also, as Connally (1935: 462) states, oppressed and as a result of government policy and trade monopoly - and world trade conditions, - were practically ruined. However, a limited new middle class of bourgeoisie, who mostly were involved in economic activities through court patronage, did emerge. While the bazaar had remained ideologically close to the ulama, this modern bourgeoisie had identified itself with the internal nationalism of the centralised state.

2.3.4. Economic policies

The state economic policy during the 1921-41 period was not based on a coherent and systematic economic ideology. The general tendency, like the state's social policy, was towards the creation of a 'national economy' by providing the basic politico-legal and infrastructural requirements of a modern economy. Within this context, however, there were radical shifts in the form of state economic intervention.

The impact of the new state on economic development was far from the simple intent of creating a new economic order with its efforts directed in a unilineal manner towards the 'modernisation' of a 'traditional' economy. The rise of the authoritarian regime of Reza Shah removed from the political agenda any talk of fundamental economic reform, especially land reform. It enhanced the political power of the absentee landlords and strengthened the agrarian relations of production in the agricultural sector which became a major obstacle to rapid economic expansion over the next half century. For economic reform and agricultural tax imposition, Ghods (1991) argues Reza Shah was more concerned with the creation of a reliable flow of funds with which to finance development of the army and his own power base than with changing the basics of the Iranian economy.

In the absence of any modern long-term credit organisation and the lack of existence of large accumulations of money capital in the hands of the Iranian merchants, the concentration of funds through the state budget and private monopoly trade companies played an important part in financing fixed investment during the 1930s. The pace of capital formation particularly accelerated in the latter half of the decade. The major part of investment during this period was concentrated within the state sector. More than 40% of total government expenditure during the decade was invested: mainly in transportation and industry.

The state extended its control over the economic spheres, particularly over trade and industry by creation of system of monopolies. The state became the only active economic agent, and like the rest of the social system, economic modernisation centred around the Shah's own person. 'Etatism' naturally appealed to a man of Reza Shah's temperament.

Furthermore, the relatively high rate of capital accumulation during the 1930s was financed by domestic resources mainly through indirect taxation, such as tariffs and road taxes, profits of monopoly companies - foreign contribution was confined exclusively to technical assistance.

“It was to be a cardinal principle of government throughout the entire Pahlavi period that much of the impetus for development, together with control of key organisations and industries, should be in the hands of the state” (Hambly 1991: 229).

The state economic development ignored the agricultural sector, and the principal features became the development of modern industry based on an import substitution strategy and the construction of a nation-wide system of communications. The shah established monopolies, which were either controlled by the state, or awarded to favoured entrepreneurs. Most of these enterprises were poorly and corruptly administered. On many occasions, the shah used the government's development funds to enrich himself (Connally 1935: 460; Millspaugh 1946: 30).

As will be shown, the state's autonomy was enhanced by its control of the economy; i.e. monopoly of foreign trade, increasing oil revenues, and state-sponsored industrialisation. According to Table A1, the role of oil revenues, received from AIOC, changed substantially from the 1930s. In the mid-1920s the direct royalties represented about 10% of the government general budget, increased to about 30% between 1929 and 1932 and inclusive of petrol taxes, settled to about 25% during 1934-48 - extra revenues following the 1933 agreement which Reza Shah agreed to extend British control for an extra 28 years. It was also a significant source of foreign exchange, financing up to 30% of visible imports before 1943 (Issawi and Yeganeh 1962: 144-47).

Although the share of the Iranian government in the profits of the AIOC was very low (about one-tenth for the period 1919-30),⁶⁹ the issue of the distribution of the profits of the AIOC formed an important aspect of the relation of state power to capital accumulation during this period. Furthermore, the total profits of the company, compared to the entire investment outlays in the Iranian economy as a whole, constituted a formidable sum.⁷⁰ The emergence of oil as a key commodity in the world-

economy and of Iran as the fifth-largest producer in the 1920s and 1930s confirmed Iran's peripheral role in the world-system. Iran's exports consisted almost entirely of oil, agricultural product, and carpet while importing finished manufacturers and capital goods from its major trading partners - Germany, the Soviet Union, Great Britain and the US. During the world depression this pattern of trade worked against Iran as the value in rials of its raw material exports fell by 2 or 3 times while the cost of its import rose.

In the 1930s, foreign trade was under state scrutiny and monopoly, to a greater extent than the other sectors of economy. Export of most commodities came under state monopoly, while, for other goods, exporters were obliged to sell their foreign exchange earning to the government. Right to export, and monopoly rights were used extensively by the state to reward its royal favourite - i.e. monopolies like sugar and tea in 1925, opium in 1928 and tobacco in 1929. Russia and Britain lost their monopoly of Iran's foreign trade by the 1930s. The US trade with Iran grew fairly steadily from the 1920s. On the other hand, the sudden jump in Germany's share during the mid-1930s reflects the Iranian government's changing foreign policy at that time. Furthermore, the 1930s were transitional in the sense that Iran's economy moved closer to dependence on a single commodity to finance state projects and balance of trade (Table A1).

2.3.4.1. State industrialisation policy

Reza Shah's economic policy was characterised by an appetite for industrialisation far beyond the economic rationale. The drive for industrialisation was not the result of a pre-conceived plan by the government, but was prompted rather by the pressure of circumstances arising from the world depression, and the adjustment problems it created for the Iranian economy. However, the existence of the new state structure with its relative autonomy did play an important part in making the drive towards industrialisation possible.

The industrialisation policy however, was an indiscriminate imitation of the surface gloss of Western societies:

“the power-that-be in Tehran seems to regard machinery as a passport to equality with the greater nations of the world and as the only means of ridding

themselves and their country of an inferiority complex produced by a long history of internal corruption, and backwardness" (Connally 1935: 461).

At the beginning of the 20th century, the manufacturing industry of Iran was confined to small scale workshops, mainly for domestic markets. Although the foreign and domestic entrepreneurial attempts to establish manufacturing activity (such as sugar, matches, textile) failed in this period, in the late 1920s and 1930s, the same types of manufacturing industry were successfully established. The slow development of large-scale industry took place against the background of a lack of integration in the economy, and a generally low level of custom duties on imported manufactures (4 to 5%), not to mention a series of political changes. Particularly after the World War I, these industries were compensated to some extent by the proliferation of small-scale industry within the larger cities. These industries were mainly protected in the early 1920s by the high freight rate for the foreign goods.⁷¹ This was a tentative start of industrialisation, which in later decades was driven rapidly by state investment. Indeed, the founding of new factories accelerated as did the move towards larger factories from 1934 on.⁷²

There is little information available about the development of small-scale industries during the period 1925-41, but it is known that there were over 15,000 workshops and factories in operation in 1941 throughout the country (Bharier 1971: 171). It is possible that due to a drastic reduction in the inland freight rate, which reduced the protection of these workshops against imported goods, the number of workshops declined.⁷³

Many of the new factories introduced in the 1930s belonged to the state, or were somehow within the scope of its monopoly. By the end of the decade, the state was allocating about 20% of its budget to industry. Sugar, tobacco and cement were entirely state-controlled, while the first two were specifically state monopolies. Bharier (1971: 180) argues that, with the exception of 5 factories, it appears that all state-owned plants made relatively high losses. Industrial production rose from an insignificant proportion of GNP to about 5% between 1926 and 1947, with total employment in all industry reaching about 100,000 by the latter date.⁷⁴

However, if the state had failed to support these industries, almost all of them would have collapsed, while the policy of pushing away the traditional merchants made an

alternative route an almost impossible task. The state's limited source of revenue, had curtailed its endeavours in this respect. Furthermore, the lack of any attempt to alter agrarian relation in the country limited the scope of industrialisation. As Halliday argues: "this state provided the context for the late capitalist development of Iran but it was incapable itself of initiating the major changes required in this direction" (1979: 23-4).

Because of the state monopoly, the aim of the new class of entrepreneurs was to reap quick, high and safe profits, without much regard for augmenting sales by price-cutting or competition. They preferred non-competitive monopolies which they could exploit to the maximum level.

The period from 1925 to 1941 can be seen as a combination of economic expansion and political repression. Reza Shah clamped down on all forms of dissent in society through legalisation, and institutional and military measures. Those who were his main sources of support - army officers, bureaucrats, monopoly traders, industrialists, and a segment of the intelligentsia - were always under the threat of suspicion, confiscation, and death. Those who were opposed to him - the ulama progressive intellectual, tribes, part of working class - were ruthlessly repressed.

Others were closely watched (the guilds) co-opted or in-different (landlords). Therefore, Reza Shah's state lacked deep legitimation in civil society but was able to rule by this combination of extending material advantages to new groups, repressing long standing opponents and the losers in the developmental process, and keeping much of the population either apathetic, apolitical, or frightened.

Reliance on the army successfully underpinned this approach to power for most of his reign, and though social movement did occur, it was limited. Reza Shah's regime, despite its impressive institutions, by the 1930s had:

"no viable class base, no sound social props, and was thus without firm civilian foundations".

As Abrahamian (1982: 153-4) points out Reza Shah had become not a nation-builder but "a self-seeking founder of a new dynasty", not a genuine reformer but "an autocrat strengthening the conservative landed class", who had already created hatred among major section of society by his policies of either anti-religious or anti-democratic

sentiments. The Pahlavi state, therefore, was strong in as much as it had at its disposal powerful means of coercion. But it was weak in that it failed to cement its institutions of coercion into the social base to possess measures of legitimacy. In their absence, however, the tension in the world-system which had given him an opportunity to rise to power in 1921-25, proved his undoing in 1941.

With the application of foreign forces, the army did not resist, and the autocratic regime was undermined. Eventually Reza Shah, who had seemed so strong internally, was forced to abdicate. Thus as a result of external pressure, with his abdication, the social forces that he had so assiduously repressed were released. A semi-democratic polity emerged until the coup of 1953.

It might be said that Reza Shah in many ways resembled Ataturk of Turkey. Both aimed at transforming their traditional societies into modern nation-states. Both associated modernisation with Westernization: the past with administrative inefficiency, tribal anarchy, and social heterogeneity; the future with political conformity and ethnic homogeneity. Both attempted secularisation by attempting to wither the influence of religion in society and pushing the religious authorities to the periphery of society. Both alienated a section of society by attacking its cultural foundations. Both rose to power mainly with the assistance of the military, and held the conviction that social, cultural, and economic reforms could not be achieved without political absolutism. However, whereas Ataturk channelled the backing of the intelligentsia into the Republican party, Reza Shah, gradually lost his initial urban support, let alone the intelligentsia. Furthermore, while in Turkey, the religious authority did not challenge the status quo, in Iran, the ulama showed great concern and resentment against the secularism provoked by the state.

The removal of Reza Shah in 1941 led to the disintegration of his authoritarian regime and ushered in a period of limited political participation. There developed in Iran during the years after 1941 a tripartite struggle for influence between the Shah, the Majles and the occupying powers. However, major changes and reforms that achieved in the army, bureaucracy, polity and economy of the country during the Reza Shah's rule, set the ground on which Mohammed Reza Shah built his own rule.

Chapter Three: The Iranian Authoritarian-Bureaucratic Regime

The socio-political background and the character of the autocratic regime of the Shah during the period of 1953-77 was to some extent reminiscent of Reza Shah during the inter-war period. As Abrahamian (1982: chapter 9) has pointed out both leaders relied on their over-extended bureaucratic and military establishments - which, largely being their own creations and lacking strong ties with the prevailing social forces, functioned as subordinate tools in the hands of the two monarchs - and the system of court patronage which was at the centre of the clientalistic relations which characterised the channels of access of public institutions and policy for private interests.

In theory the Shah observed the 1906 Constitution - supplemented and amended later in 1907, 1925, 1949, 1957, and 1967 - which envisaged a constitutional monarchy with an independent legislature and independent judiciary. These amendments were made mainly to grant greater powers to the Shah not only to reign but to rule.¹ In practice the distinction between the executive authority of the Shah and the independence of the legislature and the judiciary became blurred and all were merely part of the monarch's executive arm. All important decisions were by imperial decree. The monarchy was the country's only institution, around which all power revolved without any formal checks and balances. Nevertheless informal checks and balances existed: namely the self-interest of the Shah in staying on the throne and the self-interest of those who depended upon the Shah as the source of all favours.

In the post-1953 coup period, the structure and policies of the Shah's regime began to change. The regime began a systematic attempt to exclude all the dominated classes from major political positions and to prevent them from participating in important economic decision making. It further adopted an economic strategy that promoted dependent capitalist development. These political and economic orientations, followed under the aegis of advanced capitalist countries, had a great impact on the country's class structure and class politics. The form and content of class conflict, that transpired in the 1960s and 1970s, emanated from the bureaucratic and repressive policies of the Shah's regime as well as from its alliance with international capital. Hence, these

policies reinforced the expansion of the bureaucracy and its repressive apparatus. Over time, an authoritarian-bureaucratic regime grew extensively in Iran (Moaddel 1993: 52).

Crucial differences existed between the general conditions that preceded the coup in Iran and those that preceded the inauguration of an authoritarian-bureaucratic regime in countries such as Brazil and South Korea. Cardoso (1978) observes that the Brazilian coup (1964) was the consequence of a change in the pattern of class alliance produced by foreign capital infiltration, whereby international capital became economically but not politically dominant. In contrast, pre-coup Iran, experienced little infiltration of international capital, save for the oil sector. In South Korea, Koo and Kim (1992: 123-4) argue that the continuing economic difficulties combined with political instability invited a military coup in 1961. It was rooted in internal politico-economic elements - the failure of the Chang's government to bring about a coherent programme to attack economic and social problems, while facing inordinate expectation for an immediate delivery of economic welfare and political democracy. Nevertheless, there were similarities between the 1953 coup in Iran and the 1973 coup in Chile. In broad outline they shared the combination of government problems, internal opposition and external intervention.²

In Iran power was distributed to a series of individuals or agencies with overlapping functions which were kept fragmented and weak. Loyalty was at a premium in a handful of trusted positions. The centres of this fragmented power were deceptive because the system had two sides - the bureaucratic side and the repressive side (Graham 1980: 131-2). The former consisted of what would be in a Western society the institutions of democracy: the Majles, the judiciary, the cabinet, the political parties, the provincial governors and the press. However, the function of these bureaucratic organisations were either controlled, monitored or duplicated by the authoritarian establishment of the regime which consisted of the military and police forces, SAVAK, Imperial Inspectorate, Special Bureau, military tribunals, and furthermore by powerful individuals without fixed positions, the economic power of the Pahlavi family, and the allocative and distributive power of the Shah and his regime - resulted from the oil boom. In some instances these two worlds converging in the royal court and in the person of the Shah. In other instances, personalities had connections with both worlds. Yet the one constant factor was the Shah's own direct

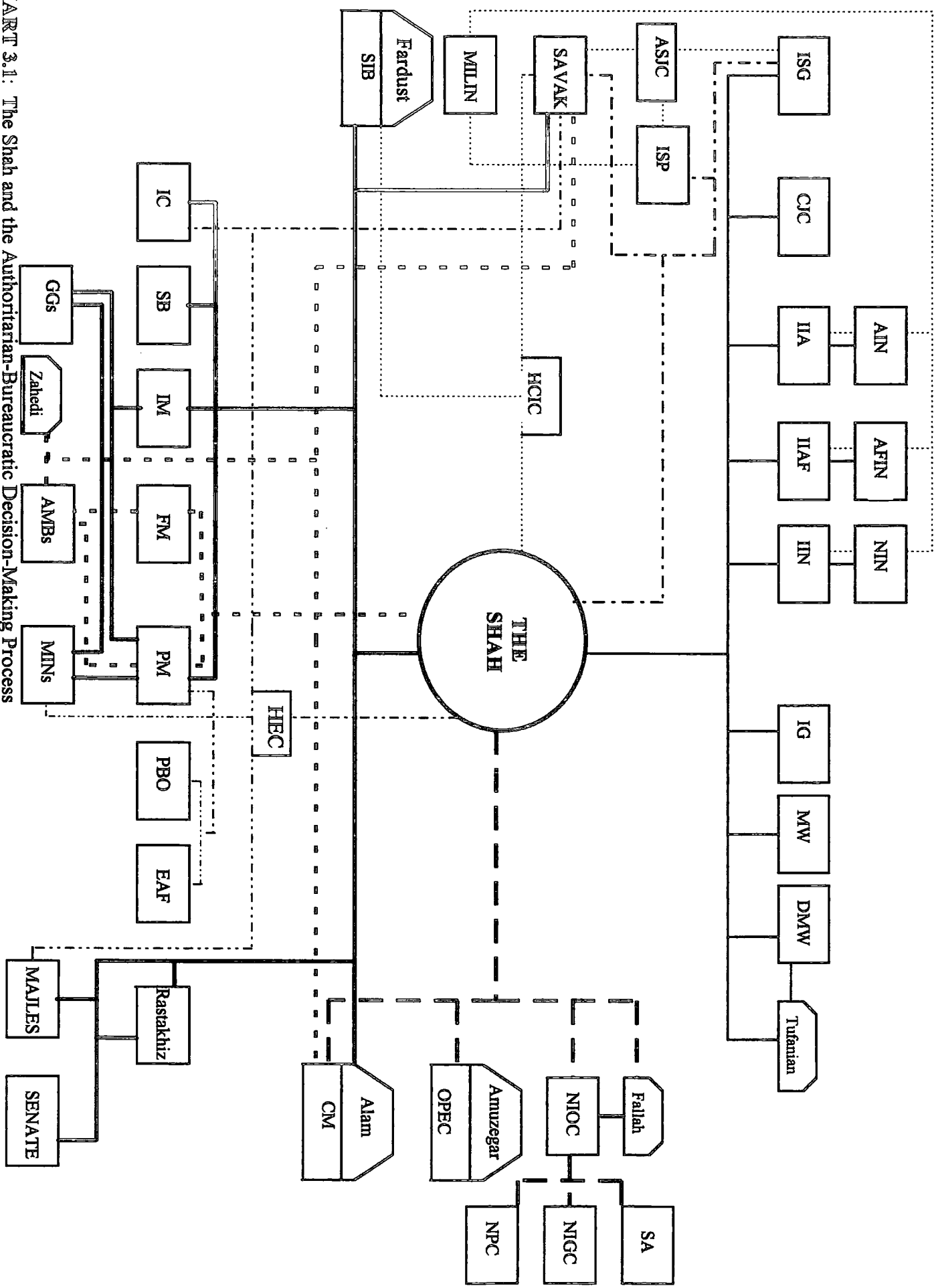









CHART 3.1: The Shah and the Authoritarian-Bureaucratic Decision-Making Process

Legend:

	Key individual
	Domestic Affairs
	Foreign Affairs
	Economic Affairs
	Intelligence
	Military
	Internal Security
	Oil

ASJC: Anti-Sabotage Joint Committee
GG's: Provincial Governors-General
IG: Commander Imperial Guards
IIA: Commander Iranian Army
IIAF: Commander, Iranian Air Force
IIN: Commander, Iranian Navy
IC: Imperial Commission
ISG: Commander, Gendarmerie
PBO: Plan and Budget Organisation
OPEC: Iran's Ministerial Representative
SA: Special Advisor on Oil Affair
SIB: Director, Special Intelligence Bureau

AFIN: Air Force Intelligence GA: Government Agency
AIN: Army intelligence PM: Prime Minister
AMB's: Iran's Ambassadors AEO: Atomic Energy Organisation
CJC: Chairman, Joint Chief of Staff GE: Government Enterprise
CM: Court Minister POC: Public-Owned Charity
DMW: Deputy Minister of War CG: Central Government
EAF: Minister of Economic affairs RA: Regional Authority
FM: Minister of Foreign affairs NIN: Naval Intelligence
HEC: High Economic Commission
ISP: Chief Imperial State Police
MILIN: director, Military Intelligence
MIN's: Other Ministers
MW: Minister of War
NIGC: Chairman, National Iranian Gas Company
IM: Minister of Interior
NPC: Chairman, National Petrochemical Company
NIOC: Chairman, National Iranian Oil Company
SB: Director, Special Bureau of the Imperial Court
HCIC: High Commission for Intelligence Cooperation
CIC: Commission for Intelligence Cooperation

relationships with a series of individuals either in their function as heads of agencies and ministries or as private citizens.

In many cases, individuals were ending up playing a more important role than the organisations they served or their appointed heads. Baldwin (1967: 29) has noted:

“Law [was] weaker than personalities. Much weaker, one [could] not expect that the ship of state, once set on course, [would] hold it” (in Farazmand 1989: 45).

It seems that the Shah conceived and used key individuals as an alternative channel to other established official ones. Writing in 1961, the Shah claimed that “I am a great believer in a plurality of administrative channels and in having alternative channels always available” (Mission 1961: 321). Soon after though, the emphasis on the authoritarian side of the regime increased considerably.

The court consisted of the royal family and a limited circle of key individuals. It was an additional instrument of autocratic rule in Iran and had its own organisation and immense wealth. Different branches of the court apparatus organised the Shah’s daily schedule, and thus controlled access to his person, and promoted the extensive economic interests of the Shah and his family. There was an extremely powerful executive arm of the court, the Special Bureau, whose task was to ensure that the Shah’s policies and orders were carried out. The most distinctive court institution was the Pahlavi Foundation. As will be discussed in chapter 4, the Foundation as a charity organisation was financed by the Shah’s wealth, was the largest industrial and commercial group in the country with extensive interests in all major economic fields and played a regulatory role in government business relations in the sense of giving incentives or withholding favours.

As Chart 3.1 shows, in order to operate the system, the Shah had effectively made himself the sole decision-making authority in every significant sphere of the country’s affairs. Three vital areas of defence, oil policies and foreign affairs were exclusive spheres for him. A few people such as Reza Fallah (deputy of NIOC), Jamshid Amuzegar (OPEC representative), the Court Minister Asadollah Alam and General Hasan Tufanian (the deputy Minister of War) were involved. In the area of intelligence and internal security, the dominant and leading players were: (a) at the organisational level, SIB and HCIC (both directed by Fardust and were answerable only to the Shah);

(b) at intelligence gathering level, SAVAK and the military intelligence unit; and, (c) at operational level, police and gendarmerie led by SAVAK.

The economic planning, however, was under the control of a broader community of elite within the bureaucracy. With the oil boom of 1973, the Shah increased his control of this sector as well and imposed severely his own will over the technocrats and manipulated the country's economic decision-making process. Thus, after the considerable increase in oil revenues from October 1973, the linkages between the economic and political policies of the regime were eroded, and had ceased to exist by 1977.

The civil service was watched over by the Imperial Inspectorate and Imperial Commission for mismanagement and corruption, and by SAVAK for political misbehaviour. Military intelligence offices were controlling the armed forces and paramilitary forces. SIB was to check and balance the overlapping intelligence and security organisations.

The inauguration of authoritarian-bureaucratic regime, resulted in a structural separation of the state from civil society, with no significant intermediary organisation that can connect the two.

3.1. The Bureaucratic Establishment of the Pahlavi Regime

The classical distinction between politics and administration could not be maintained in a system without stable law and independent institutions. Administration could not simply be the enactment of previously determined policies, for the administrative apparatus reflected the higher level of conflict and also provided none of its own mechanisms for resolving them (Macdaniel 1991: 97).

In a society like Pahlavi Iran, where the state dominated all spheres of life, the political system shaped the organisational structure and behaviour of its bureaucratic system and determined its goals and functions in society. The governmental and political processes affected the internal and external performance of the bureaucracy and its administrative behaviour. In Iran, the administrative and political systems under the Shah were so intertwined that it is impossible to analyse the former without understanding the latter.

The Shah's regime deeply influenced the country's economic, political and social life. Everything either began or ended with the government, and these connections always

had a decisive influence in matters. The government was the biggest business in the country and enjoyed significant monopoly rights in domestic and foreign trade (see chapter 5). Over one half of the country's economic activities was directly in the hands of the government, while it had indirect but firm control over the other half (IA 1968: 564). During the 1960s and in particular the 1970s, the government had expanded its activities to include an immense variety of undertakings that would tax the wisdom and ingenuity of even the most experienced administrators. Indicative of the increasing complexity of the government's economic operations, as will be shown, was the size of state's investment in economic development and its ever-expanding size of the national budget. Obviously, with so much influence in every aspect of economic and social life, no major changes could be introduced without proper government administration. Thus, the bureaucracy was expanded partly in response to the government's increasing economic activities and partly autonomously, at rates somewhat higher than the total non-oil GDP.³ Both state's investment in economic development plans, from the First Plan (1949-55) to the Fifth Plan (1973-77), and its national budget, between 1941 and 1978, had increased about 1000 times.

Variations and contradictions of policies were reflected in and even exacerbated by the administrative process, which had no fixed integrity to insulate it from political struggle (for contradiction in policies in the land reform see Hooglund 1982). With the plethora of overlapping agencies salient political conflicts penetrated throughout the administrative apparatus. The pronounced personalism of the Iranian bureaucracy surely served to heighten bureaucratic incoherence.

3.1.1. The political orientation of the bureaucracy and its structure

The bureaucracy in the 1960s and 1970s was the main instrument of not only policy formulation, development and administration, but also policy legitimisation and communication. It was the main instrument for carrying out the major structural socio-economic transformations in urban as well as rural Iran. It was, therefore, both as an instrument of power and control and as a tool for achieving developmental goals. This political and administrative role of the civilian bureaucracy was used as an instrument of power and control for system maintenance and regime enhancement and as a tool of developmental policy implementation (Farazmand 1989: 7-9).⁴

Therefore, because of the intensely political nature of the bureaucracy, no distinction could be made between the goals and function of the political system and those of bureaucracy. The latter was the organisational power behind the regime, and its goals were almost the same as the regime's for "the organisational framework of Iranian politics hinged upon the bureaucracy" (Afshami 1985: 57). The Iranian bureaucracy due to extreme centralisation and politicisation had special characteristics. It was, as Afshami correctly argues:

"structurally centralised, elitist in character, behaviourally formalistic, and functionally political".

Just as bureaucracies are conditioned by their political and socio-economic environments, their growth and expansion perpetuate the goals they are created to achieve. The overriding goals of the Iranian bureaucracy, therefore, were: (a) to enhance the Pahlavi regime and the personal interest of the Shah; (b) to enhance the process of capital accumulation in the interests of both local and international capital; (c) to legitimise the social system of capitalism with its social relations in Iran; (d) the formulation, development, and presentation to the Shah of policies and programmes that would enhance the above mentioned objectives; and, (e) to enhance its own power. From among these goals, the Iranian network of bureaucracy helped extensively the Shah to extend his control over all domains of society.

To operate the bureaucratic system under his control, the Shah carved himself into the cornerstone of the decision-making process. He regularly presided over the meetings of councils, commissions, and gave specific orders on various issues from important economic policies to unimportant issues such as preference of planting plane trees over pines.⁵ Since the ultimate head and manipulator of the state was the Shah himself, the bureaucratic state was dependent and accountable to no one but the Shah. This gave the bureaucracy an autonomy that was evident in Iranian society. However, at the same time, senior officials lived in fear of incurring the Shah's displeasure. For example, the measures to dampen the over-heated economy in late 1975 had been held up almost nine months because ministers were afraid of losing face and admitting to chaos. Furthermore, the fear from SAVAK was pervasive among civil servants. Many of SAVAK agents were among the rank and file of the various bureaucracies (Zonis 1975).

Hence, the sense of insecurity and the role of key individuals' in the political system made the search for informal power a significant character of the Iranian bureaucratic

system. While people obeyed the formal authorities, they actually complied with the orders of the men in control. Networks of informal ties based on clientalism generally predominated over and against the formal structure. Co-operation, trust, and initiative were discouraged by the all-encompassing fear of the arbitrary power of the ruler. It is in this context that the Shah ambassador to London (1976-9) points out that:

“Fear rather than rationality, fear rather than common sense, fear rather than patriotism, seems the growing force in the life of an Iranian public servant” (Radji 1983: 51).

The bureaucratic institution stupor and mediocrity that such a system encouraged were evident in the creation of the Rastakhiz in 1975. The party's effectiveness was doomed from the start because success would have made it an alternative power base to the Shah.

He trusted power in the hands of the military, but he always restrained himself from making a military general responsible for the top positions in the bureaucracy. For example when General Zahedi became the Prime Minister after the 1953 coup, a strong determined man who could have helped the Shah extensively to consolidate his rule, was politely ousted out of the country within two years. Furthermore, lip-service notwithstanding, the Shah was unwilling to risk decentralisation for fear that concessions might establish a chain reaction that would threaten the throne. Indeed the Shah, invariably created overlapping responsibilities and parallel agencies to reinforce the throne.

Government-business relations were based on a distribution-regulation pattern, and this created an environment of clientalism, discretionary policies and pressure to influence public policy. This was mainly due to the government policy of encouraging private initiative in development affairs (Bashiriyeh 1984: 46-7). On the surface the regime structured a corporate framework in order to channel diverse interests through state organisations. In practice the real business of politics went on behind the back of formal organisations. In other words, the representation of interests was based on clientalism. Clientalism consisted of relationships between the regime, which was capable of dispensing resources, and private interests with channels of access to public institutions attempting to influence public policy and extract resources. It was thus a more informal process based on individual relations between private interests and state institutions. Clientalist relationships were concentrated within the decentralised agencies

of the government of which the NIOC was the central financial institution, PBO was the important institution around which business interests circulated, and the Pahlavi Foundation was a conduit for pensions. However, for all practical purpose economic policymaking originated in the court which was also the centre of clientalistic relations.

Moreover, many bureaucratic agencies and organisations fulfilled no functions to attain prescribed political goals. They were simply created for special prominent individuals in order to satisfy their personal status needs, to co-opt them, or just keep them busy. As Tullock states:

“new organisations are sometimes proposed, not in terms of the function that they will perform, but in term of the persons that will be hired, as if their basic function was that of hiring employees” (Tullock 1965: 126).

The bureaucracy also served as the main vehicle for co-opting a large number of college graduates, some of them political opponents of the regime in the 1940s and 1950s (for example, more than 600 ex-members of the Tudeh party were co-opted to the political system reaching to high administrative and political positions) (see Abrahamian 1982; Bill 1975). Many of these individuals were easily co-opted into the system through the bureaucracy, the executive power in particular. The huge oil revenues of the 1970s made this technique an even more practical device for the system.

3.1.2. The executive power

At the top of this branch, was the Shah. From 1963 to 1978, the government grew from 12 miniseries with 150,000 civil servants to 19 ministries and 7 ministers of state with over 850,000 civil servants (IA 1978: 463).

The government was fashioned around the principle of sustaining the Shah's power, the hallmark of all authoritarian regimes. The Prime Minister and the cabinet were responsible for the implementation of state's policies and plans. Since, the experience of Mosaddegh, the Shah turned the premiership into the chief public administrator with rare opportunity to initiate policy of any significance. The post came to resemble more and more that of the old Grand Vizier of the Safavid and of the Qajar periods (Fardust 1991; Graham 1980). The comparative analysis, according to diagram a and b in Chart 3.2 shows the Prime Minister's power over the executive was undermined by the Shah. The two main bodies of politico-economic policy making, namely the cabinet and the High Economic Council were indeed headed by, and responsible to, the Shah. Premier

CHART 3.2. : The Role of the Shah and the Prime Minister in the Public Sector in the 1970s.

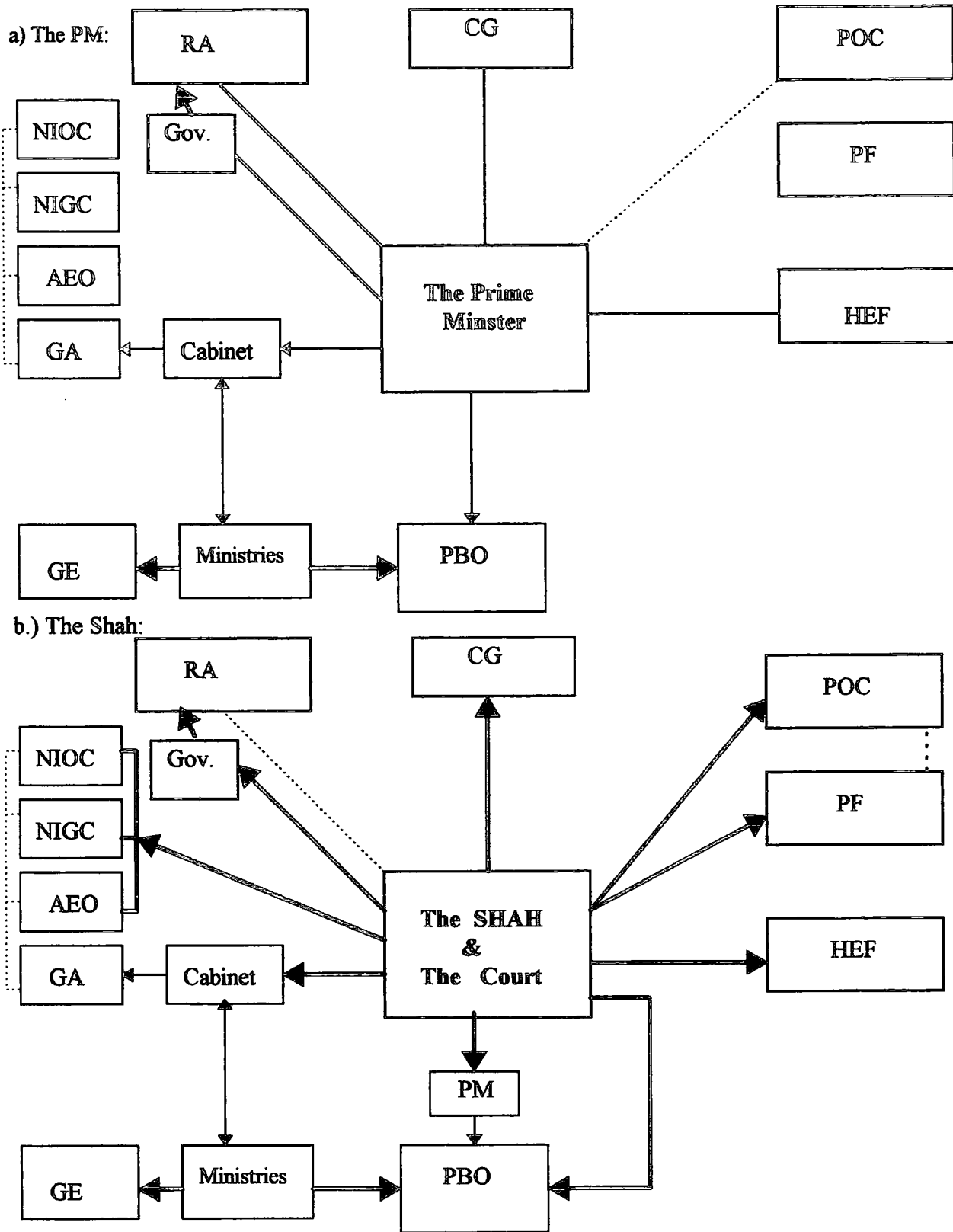

Strong influence →

Fair influence →

weak linkage

Fair Linkage ———

List of Legend in Chart 3.1, P. 94



Amir Abbas Hoveyda (1965-77) who accepted this subservient role was an astute interpretator of what the Shah wanted from the post of the prime minister. The cabinet would take no independent important decisions in main issues concerning the country. These decisions were reached in advance by the Shah or in private audience either with the prime minister or with individual ministers or heads of agencies. On these issues, at best the cabinet acted as a forum for working out the application of decisions. An Iranian of ministerial rank explained his experience in cabinet meetings as follows:

“at my first cabinet meeting I was very nervous; but then I almost laughed when I saw how frivolous the whole thing was. No one talked very much. I remember one day a minister got up and asked why do we bother to come here if no one discusses anything” (quoted in Graham 1980: 134).

Such attitudes stemmed from the Shah's control over their appointment and dismissal. Although the Constitution would have it otherwise, Parliament had actually no say in such executive appointments.

Ministers tended to use influence defensively, to protect their own position from the rivalries of other ministers or heads of government agencies. This created a considerable antagonism between ministers, often deliberately fostered by the Shah. An important by-product of this antagonism was that ministers continually sought to ensure their ministries were seen in a favourable light by the Shah, distorting facts and figures being one method amongst others (for ample examples in this respect see Alam 1991). The Shah was a master practitioner of the art of “government by distrust” (Fatemi 1982: 51) and the policy of “divide and rule” (Graham 1980: 131). Thus, his mode of governance became one of creating overlapping and competing bureaucracies, dependent on him. The Shah, knowing that facts were withheld or doctored (ibid: 135) reinforced his parallel government, which duplicated with little efficiency the institution it was monitoring. For instance, in 1975 the Shah created an Energy Ministry to be responsible for the country's energy policy. Nevertheless, this ministry had no control over the management and policy of NIOC, NIGC, and AEO, those of which reported direct to the Shah - never to the cabinet. Even the NIOC itself, was not consulted on oil price policy. Thus, the ministry theoretically responsible for energy matters had its ministry broken up into separate parts which could only be co-ordinated through the Shah.

Considering Chart 3.1, three vital areas of defence and intelligence, oil policy and foreign affairs were exclusive spheres for the monarch. In foreign policy, there were a

limited circle of individuals rather than organisations who carried out policy initiatives.⁶ At the top were Alam and the Iranian Ambassador to Washington, Ardeshir Zahedi. The Shah had daily meetings with the Foreign Minister who presented him with confidential reports arrived from the Iranian embassies. Moreover, he was furnished with intelligence reports on other countries by his intelligence organisations - SIB and SAVAK in particular - and by the CIA and British intelligence agents in Tehran (see Alam 1991).

For the Shah, burgeoning oil revenues was not only the source of realisation of his dreams and ambitions for Iran, but also a main instrument in keeping the elite in control and society at large in satisfaction, and hence preserving the monarchy. This was done by personally negotiating the oil contracts and price policy with foreign governments and companies (i.e. the major 1972 oil contract and the 1973 price policy), by giving specific directives to the NIOC and the Iran's representative in OPEC⁷ and by monitoring important affairs both in the policy-making and the operational level of the oil industry.

In many developing countries the one ministry that provides a separate power base is defence. In Iran, the Ministry of War had been kept in the hands of the military since defence was considered to be outside the sphere of civilian ministers. In the area of defence, as will be argued, the Shah effectively discouraged any horizontal links among the top generals, and involved himself in making decisions on all kind of military activity. By providing benefits and privileges, he isolated the officer corps from domestic politics and made them completely loyal and subservient to him. Purchase of military equipment was handled by General Tufanian, based on the Shah's prior decisions.

3.1.3. The legislature

The Constitution had given the legislature, consisted of the *Majles* (assembly) and the Senate, the authority to control the policies and acts of the cabinet on matters vital to the interest of the nation. It should approve any disposal of state property or funds, internally or foreign managed concessions and monopolies, and government borrowing. The Shah through the 1949 amendments of the Constitution gained the power to dissolve the *Majles* during a session. He also acquired authority to withhold

his signature from any bill passed by the parliament and also return them for reconsideration.

TABLE: 3.1: *Composition and Social Basis of the Majles, in percent*

	Constitutional Period	Reza Shah's Period	During the Shah until 1963	1963-67	1967-71
Civil servant	32	27	32.5	60.5	69.4
Landlord	29	40	40.5	13	0.5
Ulama	17	8	3	1	0.5
Bazaar merchant	11	11	9	6	1
Technical profession	9	12	13.5	15	22.5
Private sector employee	2	1.5	1.5	6	1
Lower classes	--	0.5	--	--	5.1

Source: for 1963-71, *Karname-ye Majles-e Shora-ye Melli (The Majles Report)*, Various issues; Shaji'i, 1963: 181, 265

Table 3.1 shows that the number of landowners in the Majles had increased from the Constitutional Revolution until 1963. The Majles, during the CR period, consisted of large landlords, government officials and ulama, consecutively. The first Majles (in the first CR) was led by merchants and ulama, and supported by the Qajar administration. The second Majles (1909-11), following the second CR, was dominated by landlords at the expense of merchants and the ulama. During the Pahlavi dynasty - until the land reform of 1963 - by the policy of forceful co-optation of landlords to the modernisation policy of Reza Shah, the landlords remained in power and were present in the Majles but more as urban-centred officials. However, their source of power, this time, was not their land or tribal connections but their connection to the court.

The 1963-78 period witnessed the enormous expansion of the economy and the bureaucracy. As a result, the Majles in this period - the 21st to 24th sessions - was represented more by government officials, professionals and businessmen. Through the effect of the land reform of 1963;

“the traditional landowners who occupied the key positions in the bureaucracy and legislature in the pre-land reform era lost their power basis qua landowners” (Ashraf and Banuazizi 1980: 54; see also Ashraf 1995).

They were in the Parliament with their new status as businessmen and industrialists. The Shah's policy of new elite recruitment from new social bases led to an increase in number of bureaucrats in the Majles, mostly from the middle class who had no connection to land ownership. In spite of the rapid industrialisation process, the representation of industrialist technocrats in the Majles remained minimal relative to the bureaucrats. In the 21st Majles (1963-67), for example government employees represented 60.5% of deputies, while the representation of landlords were limited to 13%. The trend was to continue with the rapid capitalist development of the country. In the next Majles (1967-71), educated professionals dominated the Parliament. 67.4% of the deputies had university education, while more than 69% of the deputies were bureaucrats. (see also the CIA report, 1976 in Asnad 1980: 73).

Although the Senate was provided for in the Constitution, its first session met in 1950. It numbered 60 members of which 30 were appointed by the Shah, 15 elected from Tehran and 15 from the rest of the country. Its role was to act as a conservative check upon the Majles, and consisted of former prime ministers, cabinet ministers, retired generals, business and professional men, all in all, a place for members of the loyal elite of the elder generation. In seven sessions, during the 1950-78 period, 80 % of Senators were landlords or of landlord origin.

From 1962 onwards, all Majles elections were controlled by the state by widespread use of the security forces and fraud. Only those, who were approved secretly by the regime were to be elected (Fardust 1991: 257). The Shah admits that "it was taken for granted that every one [candidates] cheated" (cited in Laing 1977: 221). However, by the establishment of the Rastakhiz party in 1975, secret introduction of such list of designated candidates became official, permitting no one other than the approved list to run for election.⁸

Thus, during the 1960s and 1970s, both Houses of Parliament played a role in enhancement and institutionalisation of the Pahlavi regime. However, in areas of concern to the Shah, they were nothing but a rubber stamp to his desires and a working committee at the government's disposal (Katouzian 1981: 123). They were functioning more as administrative rather than political organisations (Graham 1980: 137, 144).

3.1.4. Political parties

In the post-World War II period the most active and influential parties were the *Erade-ye Melli* (national will), the Communist *Tudeh* (masses)⁹, *Iran* Party which continued to be active with its liberal programme throughout the post-war years, *Hezb-e Zahmatkeshan* (the Toilers' Party) which was designed to speak for the industrialist workers, the *Pan-Iran* Party included ardent nationalists, and *Jebhe-ye Melli* (the National Front).

In 1950 the National Front attached itself to the prestige and personality of Dr. Mosaddegh. In time it came to include the *Iran* and the *Toilers* parties, religious leaders and independent deputies in the *Majles*. After the fall of Dr. Mosaddegh (1953) as the Prime Minister, his most vehement nationalist followers gathered in the *Nehzat-e Moghavemat-e Melli* (the National Resistance Movement, 1954). In the aftermath of the coup the political parties of the Mosaddegh era found themselves banned and a tight censorship imposed. Later in the 1950s two parties loyal to the Shah were set up - the ruling *Melliyun* (the nationalists) led by Premier Manuchehr Eghbal and the 'opposition' *Mardom* party (the peoples') headed by the then Interior Minister Alam. In 1960, some of the political parties including the National Front were reactivated once again.

However, the short period of quasi-party system was abandoned when by the end of 1963, the Shah began consolidating his power and let only those parties to flourish that had proved loyal to the Shah and his regime. By the 1960s only *Iran Novin* and *Mardom* parties, popularly known as the 'yes' and 'yes sir' parties, were allowed which dominated the houses of Parliament.¹⁰ No one really believed that this system represented something like a two-party system (Binder 1962: 221-2). These organisations were without substance and both wholly under the Shah's domination. On a couple of occasions when the leaders of the *Mardom* Party voiced criticism, they were dismissed: Ali-Naqi Kani in 1972, and his successor Naser Ameri were sacked (Halliday 1979: 46-7).

During the 1960s and 1970s, none of the parties were seriously involved as a means for political participation of the masses. Most party functions were done by the institutional interest groups, among which SAVAK was one of the most important (Razi 1970: 83).

By 1975, however, the Shah had decided to create a one-party system, to undertake a more active policy designed to mobilise support for the regime and to strengthen the state's political role, not merely in a passive but in an active way within Iranian society. In a new initiative he announced the establishment of a new single party, called *Rastakhiz-e Melli* (National Resurgence Party).

The party was used in three main ways: to channel and depoliticise public debate, to act as a parallel watchdog organisation of the administration, and a sort of popular police force.¹¹ To act as a unifying organ, the party had to 'educate' the nation the kingship ideology (see Hinnells 1975) - the mythology which for the Shah was the "spirit and ideology of Iranian [White] Revolution" (the Shah 1976: 183-4; Mission 1961: 336). Therefore, the party founded five newspapers (the daily *Rastakhiz*, the *Workers, Farmers, Youth*, and the *Theoretical Rastakhiz*) as one of the means to achieve this goal.

It had an additional and important purpose, namely to generate support for the regime and to provide a means of forcing people to compromise themselves by declaration of loyalty. Promotion, security, contacts - much could depend on whether someone was a party member or not.¹² The creation of *Rastakhiz* party dismissed the verbal claim of the Shah for a democratic political system in Iran.¹³ The Shah's word on the matter was blunt enough:

"We must straighten out Iranian's rank. To do so, we divide them into two categories: those who believe in Monarchy, the Constitution, and the Sixth Bahman Revolution [the White Revolution]; and those who don't...A person who does not enter the new political party [*Rastakhiz*] and does not believe in the three cardinal principals which I referred to will have two choices. He is either an individual who belongs to an illegal organisation, or is related to the outlawed Tudeh party, or in other words is a traitor. Such an individual belongs in an Iranian prison or if he desires he can leave the country tomorrow...because he is not an Iranian, he has no nation, and his activities are illegal and punishable according to the law" (*Keyhan International*, 8 March 1975).

Helped by SAVAK, the party took over the ministries that controlled thousands of livelihoods and tightened state supervision over organisations dealing with communications and mass media. Thus, it intensified state control over the salaried middle class, the urban working class, and the rural masses. The party became responsible for directing debate in society, including in the *Majles* and media - on non-contentious issues like rent and traffic. Key issues such as defence, oil policy, and

freedom of expression were never touched on in party debates or the Majles discussions.

The party, by the design of the Shah, was split into two wings - the Progressive Liberals led by Interior Minister Amuzegar, and the Constructive Liberals led by Hushang Ansari, the Finance Minister.¹⁴ The distinction between the party executive and the government was deliberately obscured, because one way or another, the majority of the Cabinet was represented in the party's Political Bureau.

In practice the party proved, as all single party systems under an authoritarian regime seem to do, to be just another extension of the executive. Instead of establishing stability, the party weakened the whole regime, cut the monarchy further from the country, and intensified resentment among diverse groups.

3.2. The administrative role of the bureaucracy and its failures

In line with increasing oil revenues, the role of the state expanded dramatically in the Fourth Plan period, and as of 1974 it was predicted to expand again. This meant that the burden of satisfying the rising level of expectations among the population would increasingly lie on the shoulders of the bureaucracy. In fact, the revised Fifth Plan turned out to be well beyond the absorptive capacity of the administrative apparatus of the state. Yet the state was to be caught in the unenviable position of being forced on the one hand to expand its role in the economy and on the other, of being made to fulfil the promises it had made, albeit at the urging of the Shah. The government did not refuse to carry out a programme it knew it could not implement. As will be shown, the surge in oil revenues radically expanded the role of the state in the economy. In every sector, oil money was to be spent on bigger projects and more wide-ranging social programmes. The demands of the Fifth Plan on the Iranian bureaucracy required an almost overnight expansion as well as a concurrent simplification of procedures.

According to Table 3.2, the administrative expenditure, accounted for a major share of the government national budget. The Table shows that the modernisation of the bureaucracy was a priority for the government in the 1960s. The development of the bureaucracy under the Shah was filled with ironies. Challenging new demands were placed upon it, and the administration grew rapidly in size and in technical expertise. In the years from 1965 through 1978, the number of Ministries expanded from 12 to 19.

TABLE 3.2: *Composition of Central Government Consumption Expenditure (in percent)*

	1963	1970	1976
<u>General Expenditure</u>	<u>62.7</u>	<u>68.9</u>	<u>68.1</u>
General administration	36.0	30.9	19.6
Military expenditure	26.7	38.0	48.5
<u>Specific Expenditure</u>	<u>37.3</u>	<u>31.1</u>	<u>31.8</u>
Education	21.1	14.6	12.2
Health	4.2	4.2	4.5
Social welfare	0.6	1.1	1.7
Agriculture	1.3	2.5	6.6
Transport and communication	5.3	3.3	1.1
Miscellaneous	4.6	5.3	9.1
Total	100.0	100.0	100.0
Total (billion rials)	(47.2)	(135.2)	(1170.0)

Source: PBO, *The Budget of 1977-78*; Karshenas table 7.15 P. 195

1 excludes extra budgetary accounts and local governments budget

The number of established civil servants¹⁵ increased from 97,000 in 1965 to 280,000 in 1973 and later to 850,000 in 1978, a 9 times increase over 13 years (Iran Almanac; Statistical Yearbook, various years). In 1975, the government announced that it will have opening for 102,000 new civil servant employees in the year 1975/6 (IA 1975: 430-1) which was more than the aggregate newly employed civil servants in the 1960s. However, the nature of their responsibility changed just as rapidly, for they were now charged with the rapid modernisation of virtually all aspects of the nation's life.

Public employment was perceived by the state as an appropriate channel to distribute oil income. The number of public employees increased from 660,000 in 1966 to 850,000 in 1972, an average of 25,000 new recruitment per year. But from 1973, the rate of public employment growth increased substantially, notifying the extensive impact of oil revenues in the expansion of the bureaucracy. Public employment had risen to 1.7 million in 1976 and around 2 million by 1978.¹⁶ Public employment constituted 7.6% of the country's work-force in 1956, rising to 19% in 1976 and over 20% in 1977 (Iran's Statistical Yearbook 1995: 70; 1978; IA, various years). To the number of public employees in 1977, should be added the extremely costly 100,000 foreign workers,¹⁷ many of whom were from the US and Europe and working in defence and defence

related fields. The direct share of public sector in work-force shows the vital importance of the public service in labour market.

Another major characteristic of the bureaucracy was the emerging dominance of the new, technocratically oriented younger generation of a major segment of the civil servants over the older, experienced traditional ones. In the 1960s and 1970s a formal degree was one of the principal criteria for filling jobs in the bureaucracy. Education and political power went together, and the higher the education, the more prestigious the government positions gained. The substantial increase in the number of universities and colleges and the number of students sent abroad for higher education resulted in large numbers of college graduates, and so the bureaucracy expanded very rapidly during this period, and graduates were easily absorbed by the bureaucracy, partly to respond to the more active role of the state and bureaucracy in the economy and social life. The Pahlavi regime by the 1970s created a large class of educated bureaucratic petit bourgeoisie composed of officers, civil servants, and professionals in Iran. For the first time, a partially Westernised class of bureaucratic technocrats emerged as a significant social and political force in Iran. In the period of 1971-77, the number of civil servants with higher education (BA and higher) almost tripled, rising from 22,000 in 1971 to about 60,000 in 1977 (IA, 1971, 1978). In 1975, 30% of them were educated abroad. This accounted for 2.9% of the total educated civil servants (IA 1976: 360).

Although, very often the formal economic and social goals of the bureaucracy were announced publicly, the actual manifestation of those goals were frequently delayed, forgotten or completely abandoned. Furthermore, there was always confusion about the organisational goals and objectives of the bureaucracy due to the continuous creation of new agencies, amalgamation or separation of the existing offices, and constant changes and revisions in their duties and functions. This confusion often caused delay, indecision, inaction, and conflict (for a case study on these points see Farazmand 1989).

Self-enhancement objective of the bureaucracy, however, were consistently pursued by the individual bureaucratic organisations. This was done through the annual budget preparation (by PBO), the review of agency performance, the formulation of proposals for organisational and administrative reform and improvement (to Administrative and Employment Organisation). Such proposals often contained requests for increase in agency personnel and greater organisational and administrative discretion in policy implementation as well as internal operational decision-making processes.

The country's administrative system was premised on overlapping responsibilities and therefore conflicting interests and intense rivalries among the actors; the virtual absence of any lateral communications within the administrative (and the military) hierarchy (Farazmand 1990: chapter 2; Mottale 1987; on the military see P. 122).

Secondly, the administration was highly centralised in management and decision-making, both geographically and bureaucratically. In 1972, against every six government employees working in the provinces, four were working in Tehran alone. However, the governors of towns in district places are virtually sent from Tehran, or a major provincial capital, by direct appointment. The manager of a small bank branch in a rural township, for example was virtually appointed by the bank chairman in Tehran; this goes for all other institutions, including education, finance, and so forth. For instance, the directors and managers of state firms and enterprises were mostly appointed by the Cabinet or other powers to be, generally without consultation with the permanent staff of those concerns. The independence of the state apparatus from the local elite would also encourage the arbitrariness and high-handedness of the central bureaucratic authority. Furthermore, Katouzian (1995: 19) argues that due to multi-ethnicity of Iranian society, the strict administrative centralism and the prevailing attitudes and policies of the Shah's regime towards the provinces had resulted in a considerable degree of conflict on ethnic and linguistic minorities. The hierarchy of power and decision-making was from top-to-bottom, resembling more of a military-form chain of command, a characteristic of an over-centralised state.

Thirdly, although almost all modern bureaucratic organisations show a degree of formalisms,¹⁸ the Iranian bureaucracy was marked by extreme formal structure and a high degree of formalism. The degree of formalism and bureaucratism was so pervasive that no political, economic, or social affair of the country could be run without the exercise of bureaucratic power. Self-perpetuating and self-serving bureaucratic organisations spent a great deal of time every year preparing achievement reports to demonstrate favourable achievements to the Shah (reported directly or in the annual Ramsar Conference every August). In fact these documents often distorted or even falsified facts in order to make the agency's work appear prestigious and significant (Bill and Leiden 1974).

Extreme degree of bureaucratisation had caused delay, indecision, and inaction. One high official recalled:

“When I reached the top, I realised that I had to follow through every decision myself if I wanted to be secure that it had been carried out” (Economist, August 28, 1976: 13).

Bureaucratisation was prevalent in every facade of the administration. This high degree of formalism was significantly functional to the political system, which considered rational administrative behaviour a challenge to the regime (Bill 1972; Binder 1962).

Finally, a most debilitating feature of the bureaucracy, as was pervasive in the monarchical system of the Shah, was its corruption, both actual and, perhaps even more so, perceived. The Shah's use of public money to enrich himself, as will be shown in the following chapter, was not new; it dated back at least to the latter part of the 1950s. The personalistic approach to government made it impossible for the Shah to distance himself from ubiquitous corruption. The institutionalisation of corruption meant that formal written laws and regulations had little to do with the actual activities and had little impact on how Iranians felt about legal and illegal behaviour. It was not uncommon to observe the making and implementing of important organisational decisions based on informal considerations and corruption and then stamping them with legal formalities. If one did not want to get a job done, one was able to hide behind bureaucratic rules and regulations.

3.2.1. Failure of the administration

The Iranian bureaucracy was not public service oriented; rather, it was a powerful political instrument in service of the monarchy and the Pahlavi regime under the Shah. Hence, the political role of bureaucracy seemed to outbalance its administrative role. As the political system maintenance and regime enhancement roles of bureaucracy outweighed its administrative public service role, it became a repressive tool of domination, maintaining control, and imposing constraints over population and permeates society.

The government decision-making process under the monarchy was cumbersome and highly centralised. The need to eliminate bureaucratic red tape and excessive centralisation, to streamline the decision-making process, to restructure the incentive system of public sector employees, and to fight ubiquitous corruption and lethargy was widely recognised especially after the advent of the oil boom. The then prevailing system in which even the most minor requests went to Tehran and large contracts were awarded

from Tehran had become anachronistic and presented a major roadblock to higher fixed capital formation. A start, seems, had been made in the direction of decentralisation, but the policy appeared to have remained more in law than practice (*Economist*, August 1976: 13).

A perceptive observer characterised the deficiencies of the system as follows:

“The de facto decisional apparatus continues to resemble the bureaucracy’s traditional, patrimonial system. It is a system marked by informal relations in which tensions and competition are everywhere evident. Officials are cautious not to offend superiors or to be identified with decisions and programs that might fail to realise expectations. In the absence of agreed achievement criteria, ambiguity prevails over whether one will be judged by performance standards, by paper credentials, or by family and friendship ties. The many elaborate, often redundant, procedures instituted to thwart administrative wrong-doing are ineffective in preventing serious conflicts of interest. Opportunities for personal gain are expected to offset low government salaries” (Weinbaum 1977: 442).

Despite the appearance of an extensive and the recently renovated bureaucratic machinery of the 1960s and 1970s, and having access to massive financial resources from the oil sector, the bureaucracy was severely handicapped in its goal oriented activities due to subordination to the court and the clientalistic nature of the form of representation of the state (Karshenas 1990: 195). The government resembling the characteristics of a rentier state was not under the same kind of pressure to develop an orderly and efficient bureaucracy (Mahdavi 1970: 466-7).

Another principal weakness of the bureaucracy was its structural instability to implement the excessive responsibility of both regime enhancement and development policies. Divided authority and insufficient co-ordination - particularly between the regional and central organisations or between municipalities and the ministries - severely impaired administrative efficiency. The administrative tasks were made doubly difficult because the existing governmental structures combined most of the disadvantages of overlapping and overcrowded ministries and organisations with excessive departmental independence, combined with many of the evils of excessive centralisation. That is to say, where greater local autonomy and fewer bureaucratic formalities seemed to be in order, the administration was handicapped by excessive bureaucratisation and centralised direction. And where inter-agency co-operation and policy co-ordination were absolutely essential, the needed central planning and supervision with no conflict of functions seemed to be lacking (Mcdaniel 1991: 98; Farazamnd 1990: 44-51).

In addition to these inefficiencies, overlapping jurisdictions existed and increased by the Shah personally among government offices. Some important constitutional relationships between the various branches of government were not satisfactorily clarified. The government's development activities, for example, were not always in harmony with its monetary, fiscal, trade, and defence policies. Altogether there was not enough collaboration among ministries and agencies (Foran 1993: 314; Graham 1980: 133-4).

Judged by contemporary standards of efficiency and streamlined organisations, the Iranian administration had many additional shortcomings of which over-classification, salary discrepancies, irregular promotion of civil servants combined with corruption and wastage are some examples. In a sense these problems were organically tied together. For example, the deficiencies in the administrative machinery, the high degree of centralisation, and corruption exacerbated the question of absorptive capacity.

3.3. The Authoritarian Regime

There are two types of political stability - one brought by increased participation, the other by repression (Pesaran 1982: 305). Of these, the state forged by the Shah between 1953 and 1978 clearly adhered to the method of repression as Reza Shah had done between 1925-41.¹⁹ In many respects the conditions of the rise of the Shah to power and the social and political character of his regime were similar to those of Reza Shah in the inter-war period. The Pahlavi state developed over a decade into an authoritarian regime relying on a repressive army and oil revenues as the twin sources of its hegemony in Iranian society.

The most important function which the repressive apparatus performed was that of guarantor of the regime's survival. However, it is essential to see how the apparatus was used, and in what manner its different branches were deployed. The Shah, as his father, used the army to crush resistance in towns and the countryside. Tangibly, direct intervention by the army is how both Shahs came to have effective power. After the major urban operation in crushing the mass uprising of June 1963 in Tehran and a number of other cities until the commencement of the revolutionary movement in 1977, the army remained garrisoned near towns, occupied universities and was sent into tribal areas on a number of small-scale campaigns. But having said this, it was not the army that played the most active repressive role in the country in the period of

1964-77: this was shared out among the other sections of the repressive apparatus, behind whom the army stood in reserve. Hence, the army played a major role in regional hegemony of the regime.

Evans (1978: 48-9) argues that in the case of dependent development, the need for repression is great and the coercive apparatus excludes the already activated urban popular sector. In Iran as in countries like Brazil and South Korea exploitation and repression were integral component of the state in its development process. In the latter two countries, repressive apparatus was extensively used to incorporate labour into the industrial structure, and keeping wages growing at a rate substantially lower than productivity and profit. This was because, in Brazil and South Korea, control of labour was one of the critical components of capital accumulation. Therefore, Evans notes:

“To complement the state bourgeoisie in the economic sphere a professional bureaucratic group is required to staff the coercive apparatus, and the military are the obvious candidate” (ibid.).

However, the prime objective repressive apparatus in Iran was to destroy all the political groups to preserve the monarchy on the one hand, and to provide stable condition for the inflow of international capital and technology on the other. In Iran the working class was bought in by the abundant oil revenues. Therefore, in Iran repression was aimed more at political objectives. Any opposition to the rule of the Shah and his alliance with the US was repressed. The political process gradually lost its relevance in affecting the course of decision making and “politics became depoliticised” (Moaddel 1993: 55). National integration was therefore maintained by brutal force. The army intervened when SAVAK failed to control anti-government movements. Before the establishment of SAVAK, the Shah used para-military groups to suppress any internal opposition to his oppressive rule. Among these were SUMKA (National Socialism of Iranian Workers) and the military wing of the Arya Party - led by military generals.²⁰

3.3.1 The military forces

For the Shah, a strong army was the foundation of the state. In reality, the existence of his regime and his father's was due to military intervention (in 1921 and 1953). Thus, his regime rested on the armed and security forces. However, while Reza Shah,

originally a military officer, put a distance between himself and the armed forces by becoming an autocratic monarch, the Shah increased this distance and made it much more difficult for any commander of the armed forces to challenge his position without challenging the very structure of the state.

The Pahlavi military machine, compared with pre-Pahlavi armies, was not only different in its size, institution, and organisation, but also with regard to its source of recruitment. The latter almost always was recruited from the tribes. Thus, the tribal structure was the determinant factor in the emergence of dynasties. During the Pahlavi era, however, the new modern army was established from the urban and rural inhabitants and young educated technocrats having no major connection with economic and political base of power.

The new army was a twentieth century creation with no strong pre-determined social character or historical role and with no more connection with the armies of Xerxes and Shah Abbas (Halliday 1979: 66). However, the regime tried to foster a sense of continuous military strength through the ages. Apart from this kind of propaganda, it was also an ideological construct, one designed to obscure the predominant discontinuity in Iran's military history. The members of the armed forces were constantly reminded in their training of the need to be loyal to the Shah and of the need to re-create the past greatness of Iran, a greatness inextricably linked in current mythology with the institution of monarchy. The Shah might have been reliant on the army as he was, but he also controlled it and was increasingly able to depoliticise it.

The army was "the eyes and ears, where necessary, his [the Shah's] iron fist, neutralising all those disloyal to the regime" (Graham 1980: 145). Furthermore, "the army" for the Shah was "the very cornerstone of this country's future" (Alam 1991: 523). Thus, modernisation of the army, as in the time of Reza Shah received priority and the major share of government revenues. The Shah emphasised to the American ambassador in 1970 that:

"...for us the acquisition of arms is a matter of life or death", therefore, "we shall find the means to finance our defence budget, even if it means our going hungry" (ibid.: 137).

The military forces consisted of The Imperial Armed, Air and Navy Forces and the Shah's personal guards being Guard Javidan (immortal), Guard Vazifeh (conscript)

and Capital's Division One. Furthermore, Law Enforcement Forces of the Police, the paramilitary Gendarmerie,²¹ and auxiliary organisations such as the Civil Defence Organisation, the National Resistance Forces,²² were parts of the enlarged military forces of the country.

It was the Shah himself who decided what arms to buy and how much. The defence decision making process was relatively simple:

“The Shah decides on all major purchases; his vice-Minister of War, Hasan Tufanian implements these decisions” (US Senate 1976: 7; see also General Ghara-Baghi BBC Document, programme. 18, tape no. 6).

The size of the armed forces increased from 200,000 men in 1963 to 413,000 regular personnel, 300,000 reserves, and 74,000 para-military forces in 1978. The ground, air force, and navy consisted of 285,000, 100,000 and 28,000 personnel respectively (the Military Balance 1978-79).

TABLE 3.3: *Defence Expenditures, million dollars.*

Year	1963	1965	1970	1972	1973	1974	1975	1976	1977	1978
Amount	200	250	860	950	1,350	5,500	7,600	8,200	7,900	9,900

Source: Table A28

Calculated based on \$1= 67 rials in 1974

According to Table 3.3, the annual defence budget increased from \$200 million in 1963 to \$1.3 billion in 1973, and later to \$10 billion in 1978, excluding \$1 billion allocation for paramilitary forces of gendarmerie and police (PBO 1978, part 3). Out of the 1976-7 budget of \$45 billion the Shah was spending \$9.3 billion on defence (*Financial Times*, 21 June & 11 August 1976).

The average annual increase of defence share in GDP was 5.3, 7.8 and 12.2 percent during the Third, Fourth and Fifth Plan periods respectively. One of the peculiarities of Iranian military expenditure was its very high import content. While arms imports were rising by 36.7% on average annual growth rate, it constituted about 30% of the country's total imports during the Fifth Plan - rising from 12.2% in the Fourth Plan period (Mofid 1987: table 5.3).

From 1955 to 1978, foreign military sales agreements between Iran and the US totalled \$20.7 billion, of which 92.5% accounted for the 1973-78 period. The Shah in 1976 placed an order for another \$12 billion worth of armament to be delivered by the

US by 1980, and an order for \$4 billion worth of Rapier intercept missiles in return for crude oil to be delivered by the UK (Table 6.4).

During the Fifth Plan (1973-78), defence expenditure accounted for 31% of public expenditures and more than 10% of the country's GNP. During the reign of the Shah, the military budget was growing faster than the rate of growth of the national budget. For instance, from 1954 to 1972, the military budget increased 34 times while the national budget increased 24 times (Table A26). In 1974/5, Iranian arms expenditures accounted for 46% of US arms sale abroad - more than four billion dollars - and kept more than a third of a million American employed in defence work (*The Scotsman*, 21 March 1975).

In addition to the registered defence budget, the secret budget was another source of military expenditures, part of the civilian accounts included sizeable military allocations such as the establishment of military posts and outposts, construction of military roads, housing, and training of military personnel. For example 70% of the public housing outlays during 1973-78 went for military construction (Moaddel 1993: 57-8; Abrahamian 1982: 435-6). Clawson (1993) correctly argues that in case of Iran, such priority given to military expenditure constituted a distortion of the country's overall socio-economic development.

Bribery and embezzlement were common in both foreign and domestic military contracts and had very much involved the royal family and the military elite. Furthermore, embezzlement included billions of rials of domestic military contracts - in construction of houses, military bases and airports, internal purchases, etc. - controlled by high ranking military personnel in addition to the royal family. It included 5% - and in cases 10 to 20 percent - of the price of the actual contract.²³ The Shah, being aware of the extent of involvement by the military ruling elite in financial malpractice, used this knowledge as a tool to dismiss and imprison some of the high ranking officials. For example, in 1976 rear-admiral Atta'i and his deputy rear-admiral Rafi'ee along with 12 other officers were sentenced in connection with \$120 million embezzlement concerning the development of the port of Bandar Abbas.

In the 1970s, oil revenues enabled the regime to purchase enormous quantities of weapons, while at the same time, it was encouraged by the US to become a regional power. Thus, the function of the army was partly to underwrite Iran's claim to regional

supremacy in the Middle East, Persian Gulf and Asia in the 1970s. As the Shah pointed out:

“We are not thinking of defending Jask and Chah-Bahar. We are thinking of Iran’s security perimeter and I am not speaking in terms of a few kilometres. Anyone versed in geographical, strategic matters and especially in possibilities of naval and air forces of today would guess how distant the frontier could be from Chah-Bahar” (*Keyhan International* 11 November 1972).

Thus, the Shah’s personal regional ambition made him the best nominee for the Americans, to police the Persian Gulf. By 1977, Iran had the largest navy in the Persian Gulf, the most up-to-date air force in the Middle East, and the fifth largest military force in the world (Abrahamian 1982: 435-6).

On the other hand, the army played a major domestic role. Combined with the security forces, it was a guarantor of the Pahlavi dynasty and would confront any potential internal fragmentation of the Shah’s regime. As US Senator Humphry put it in 1960:

“Do you know what the head of the Iranian army told one of our people? He said the army was in good shape, thanks to US aid - it was now capable of coping with the civilian population” (quoted in Halliday 1979: 75).

His concern for the army took two basic forms. Firstly, it was to transform the Iranian military into one of the greatest powers which, to this end, he solicited and for the most part obtained vast quantities of technical advice and advanced equipment. Secondly, he took great pains to ensure the army’s loyalty to his person and prevent any possibility of independent action on its part. His mechanism of control were multiple and effective. Highly trusted individuals, often family members, were put in the top posts (see Alam 1991: 60). The army as a whole was treated as an extremely privileged caste, cut off as far as possible from the rest of society and enjoying the special favour of the Shah. The Shah co-opted his officers by purchasing the best military equipment available and by giving them special prerogatives, among them, high pay, special privileges, access to new housing, and special discount stores.

The Shah’s capacity to control the army was not only a matter of keeping them materially happy and its top leadership insecure; above all, it was a function of the general economic and political ‘stability’ of the country. It seemed that:

“as long as the state has the money to meet the army’s demands and to ensure prosperity for the Iranian bourgeoisie, the Shah’s capacity to control the repressive apparatus will be considerable” (Halliday 1979: 71).

In short, military officers became a new privileged class, wholly dependent on the Shah for their livelihood. By providing these benefits, the Shah successfully isolated the officers corps from domestic politics and made them completely loyal and subservient to himself. The long-term result was that the upper class of the officer corps lost touch with the Iranian people.

The Shah created a multiplicity of offices and purposefully played them against each other. The result of this policy was that the military administration became unwieldy, with unclear lines of authority and a poorly defined structure. A problem emanated from the very structure of the armed forces: In theory, each service was headed by a general officer who was a member of the supreme commander's staff, similar to the American military system. However, in contrast to the latter, the commanding generals had little real authority over their commands. As the commander-in-chief of the armed forces, the Shah was reported to on a regular basis on all matters concerning the funding, organisation, and military preparedment of the services. What made this seemingly normal reporting requirement unusual was that the Shah made decisions on all kinds of military activities.²⁴ This made him the *de facto* commander of the individual services as well (Sullivan 1981: 74), and left little room for the development of initiative. In fact, initiative was the one factor likely to get a senior officer into serious trouble with the Shah.

Ever conscious of the possibility of a military coup against the monarchy, the Shah constantly manipulated his senior officers, just as he did other politically influential members of Iranian society. If a senior officer attained a position from which he might derive too much power or influence, he was subject to rapid retirement, demotion, or transfer.²⁵

The Shah's unique form of administration of the armed forces effectively discouraged any horizontal links among the top generals, thus, discouraging a sense of solidarity and mutual trust within the hierarchy, since a cohesive officer corps posed potential political danger. As a consequence, a possible co-operative structure within the army was undermined. Furthermore, the army began to resemble patrimonial armies that were, in Weber's words "incapable of any action without the ruler and completely dependent upon him" (Weber 1968 in Moaddel 1993: 61; Hodayun, BBC Document, programme. 18, tape no. 6). Whatever drawbacks this inefficient structure

may have had for administrative rationality of the armed forces, were offset for the Shah by its political advantages.

Quite separate from the loyal cadre of officers, were two distinct classes: the warrant and non-commissioned officers, and the conscripts. The former were drawn largely from the urban middle classes with a different attitude towards the Shah. The non-commissioned officers who had risen from the ranks were, in the main, ardent supporters of the Shah. The warrant officers were highly trained specialists who filled a variety of technical positions, but while they had received their education from the government, they had not been granted privileges commensurate with those enjoyed by the officer corps.

Even more loosely tied to the Shah's regime were the conscripts. Because they had not volunteered for duty, the conscripts were never fully trusted by the military cadre. During two years of military service, there was little to make them loyal to the Commander in Chief, the Shah. They were often kept in a position of near-servitude while other regular personnel were noticeably enjoying a wide range of privileges.

The Iranian armed forces in 1978-9 were in turmoil. Organised for the wrong war, divided by class and loyalty, lacking decisive leadership, and disunited among themselves, it was unable to control the situation (see General Jam *ibid.*; General Rezvani, *ibid.*; Zahedi in an interview, London *Keyhan*, 11 August 1994). Furthermore, the conscripts, who were present in the streets to confront demonstrators, disobeyed their commanders on frequent occasions. When the conscripts were ordered into the streets to face down the revolutionaries, they were met by people from the same strata of society who held the same values and beliefs as they did. Hence, these situations combined with the indecisive attitude pervasive among the top generals, resulted in a moral dilemma, in which the conscript was not enthusiastic to shoot the people in support of the Shah (see Ghara-Baghi BBC Document, program. 18, tape no. 6).

When the Shah fled the country on 16 January 1979, the military he left behind was a far cry from the one in which he had invested so heavily during his reign. The Shah may have hoped that the military would somehow be able to restore his throne, but the Iranian military forces were unable to preserve themselves, let alone the monarchy.

CHART 3.3: The Intelligence Coordination System of the Regime: 1970-78

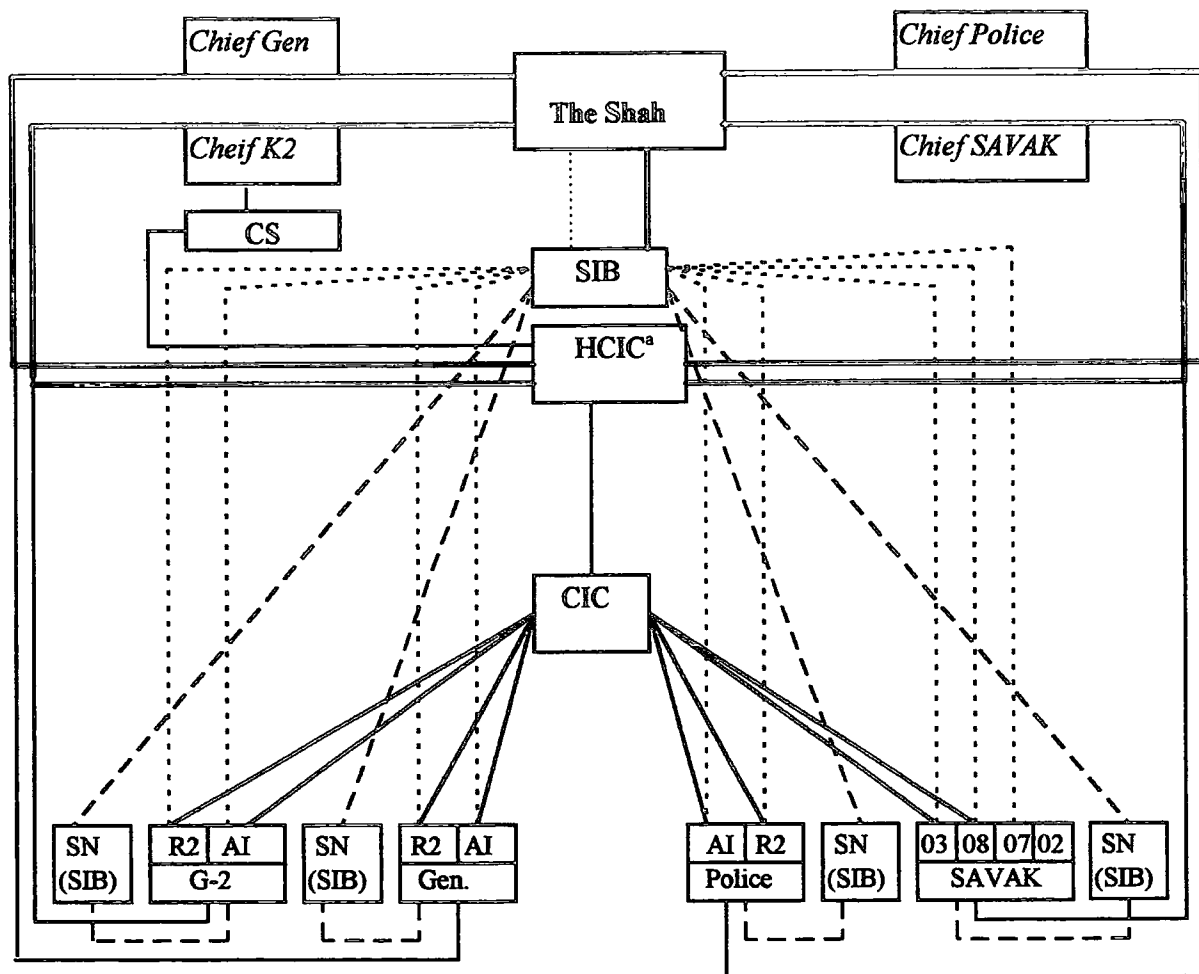

- Direct contact (with the Shah)
- Direct contact
- - - - Secret contact
- Contact through written report

SN: Secret Network

G-2: *Rokn-e Do* (Military intelligence) 02, 07, 08: Offices of SAVAK (External Intelligence)

Gen: Gendarmerie

03: Offices of SAVAK (Internal Security)

AI: Anti-Foreign Intelligence of G-2

R2: Internal intelligence of G-2

3.4. The Security Forces and Political Repression

Over twenty years the security services became the central pillar of the Shah's system of government. In matters of national security the judgement of such authorities had to be accepted without further debate. The armed forces may have been the ultimate guarantors of power; but the security forces ensured that the armed forces used the least to confront the opposition. Even in the security field the Shah wanted to have overlapping authority and alternative channels of control. Security services during the Shah's rule can be divided into two broad groups; the intelligence unit and the operational unit. The former consisted of SAVAK, the Special Intelligence Bureau (*Daftar-e Vizhe-ye Ettela'at*), the military intelligence or G-2 (*Rokn-e Do*), and Imperial Inspectorate (*Bazrasi-ye Shahanshahi*). The operational unit included the Gendarmerie, Police, and Imperial Guard (though each had its own limited intelligence unit). While each of these organisations acted independently of one another, there existed frequent overlapping and sometimes conflicting duties and functions.

As Chart 3.3 shows, while the military intelligence monitored the activities of officers within the armed forces, the Special Intelligence Bureau closely watched over SAVAK, and also guarding against any military coup or conspiracy. To increase efficiency in intelligence gathering, the 'High Council of Intelligence Co-ordination' (HCIC) was established in 1960 and headed by General Fardust. Its main objective was to co-ordinate planning and organising functions of the security forces. Members of the council were heads of SAVAK, gendarmerie, and police force, the chief of staff, and chief of G-2 (Fardust 1991). However, over time, the council was marginalised by SAVAK and later lost its importance by the establishment of the National Security Council headed by the Shah himself in the 1970s.

While the SIB and the HCIC were British model agencies,²⁶ the Military Intelligence and SAVAK (main part of the organisation) were modelled on the American system.

The Imperial Inspectorate was created in 1958 partly in response to US' accusation of corruption in the Iranian bureaucracy. It was primarily an investigative agency - probing into political, economic and social matters. Its prime concern was monitoring how ministers and individuals were carrying out the Shah's policies and investigating sensitive cases of misconduct or suspected disloyalty among high officials. It also appeared from time to time to monitor the activities of other members of the royal

family - especially their business involvement. Every organisation in Iran was under orders to co-operate with it and it was empowered to carry out regular, but unannounced, inspections in every sphere of central and provincial government (Mission 1961: 177). The heads of the Inspectorate were first General Pakravan, and later from 1971 General Fardust.

The SBI was the least-known of them, created in 1959, after the attempted coup by General Gharani. It was answerable neither to the Majles, the Rastakhiz Party, the cabinet, the police and SAVAK nor the armed forces - only to the Shah himself. Most important of all, as Chart 3.3 shows, it was responsible for secret monitoring and investigating the activities of the armed and security forces including SAVAK - through secret networks established by the Bureau, which only the Shah had been informed of.²⁷ Moreover, the Bureau was the most important channel of the news and analyses to the Shah. It prepared a daily report (only in one copy) to the Shah, containing the most important political intelligence, military, and administrative issues.

3.4.1 SAVAK

Sazman-e Ettela'at Va Amniyyat-e Keshvar (SAVAK) was established in 1957 with the help and influence of the CIA, the FBI, MI6 and Mossad - the Shah had already turned to the Israelis for the provision of his personal security (Laing 1977: 208; Halliday 1979: 75-90). It seems that the Shah preferred to have both overlapping authorities and different organisational systems within the security field. Responsibility of the Third office of SAVAK was similar to the FBI and MI5. The Second, Seventh and Eighth offices were responsible for espionage and anti-espionage activities, similar but smaller scale MI6 and CIA type organisations. The appointment of Fardust as the vice-Chief of SAVAK for 10 years, was the turning point in peaceful coexistence and merging of the two different American and British systems of intelligence in SAVAK. It operated under the protective cover of the military, organisationally affiliated to the Prime Minister's office, and answerable only and directly to the Shah. By the mid 1970s, the Anti-Sabotage Joint Committee, known as the *komiteh*, consisting of the police and the gendarmerie was established and led by SAVAK. In fact, it became the first stage of interrogation and torture, any political prisoner would have experienced. During the 1970s, both the intelligence gathering and operation against political opponents were entirely led by SAVAK.

SAVAK became a key instrument in the Shah's acquisition of absolute power. Since its establishment, it thrived on the Shah's deep-felt need to insulate himself and his regime from all potential enemies. It penetrated all aspects of Iranian life, infiltrating organisations through its network of agents and a large number of paid informers.²⁸ Iranians, particularly in urban areas, lived with the permanent fear that they were under surveillance (Macdaniel 1991: 66). SAVAK's functions were manifold: it gathered information on individuals and groups; infiltrated or directly controlled many organisations such as government-run trade unions (of which there were over one thousand in 1978); exercised influence over many aspects of government social and economic policy, which could easily be constructed as relevant to security; and pursued and punished enemies of the regime without limitations on its power.

SAVAK's all-embracing brief meant that it could overrule ministries and other government agencies. For instance, it interfered extensively with the ministry of information and culture on matters of censorship and artistic control.

Although the true number of political prisoners had never been verified, Amnesty International estimated 25,000-100,000 political prisoners in Iran in 1976. The repression was of course pervasive in political life. By the late 1970s, no area in the life of an Iranian was immune. The economy, culture, education, and all forms of communication were subjected to vigorous SAVAK scrutiny and control.

SAVAK's basic weapon was intimidation by a ruthless suppression of suspected opponents. The effect aimed at by SAVAK was to spread a deep sense of fear, suspicion, disbelief, and apathy throughout the country, and in so doing it formed an integral part of the state's overall relationship to Iranian society, including among the officials (for a case among many see Radji 1983: 37). Its activities either real or imagined, created a widespread fear and had Iranians being afraid of the mere threat of SAVAK's intervention. The extent which this policy effected the life of ordinary people is clear in this known proverb of the 1960s and 1970s that '*divar mush dareh, mush gush dareh*' (wall has its mouse and mouse has ears and is listening to what you say even in your private moments).

Some forms of intimidation were denial of exit visas and job promotion, refusal or withdrawal of grants, pressure on family or friends, threat of legal prosecution, exile, arrest and imprisonment. The ultimate form of intimidation was the threat of death.

Yet, even with its all power, SAVAK was subject to the same set of controls and instruments of surveillance of which it was a part. It was set off against the military security organisation and monitored by a still more secret, independent organisation, the SIB. No doubt this flowering of the coercive apparatus intimidated many of the Shah's potential opponents and destroyed a significant part of opposition, but it did so at enormous cost to the regime and the Shah's domestic and international reputation. Macdaniel (1991: 66-7) points out that his mastery of the instruments of autocratic rule proved their limitations in the actual governing of a modern society, which depends on more than the public fear of the ruler.

3.5. The Monarchy-Centred Nationalist Mythology

The idea of democracy was suppressed by the advent and consolidation of the Pahlavi monarchy, while secular ideology remained the dominant discourse both within the society and the state. The implementation of Reza Shah's modernisation programme resulted in an increasing dissociation of state ideology from religion. Although the ulama were instrumental in bringing Reza Shah to power, the official ideology of the new state began to glorify the pre-Islamic period (see Faghfoory 1993). During the rule of Reza Shah, nationalism began to be identified with the nation, and the concept of citizenship was substituted for religious allegiance (Moaddel 1993: 62).

The ideology of the state under Reza Shah and the dominant cultural trend within society by and large belonged to the same ideological universe, and the Shah's campaign against the ulama was reinforced by the anticlerical attitudes and secular orientations of a segment of the Iranian intellectuals. However, after World War I, the nationalistic feelings and secularism of this intellectual elite were organised more in the National Front under the leadership of Mosaddegh.

The pre-emption of the idea of nationalism from the monarchy and association of the regime with foreign interests during the oil nationalisation period were causing serious ideological problems for the Shah. What further cast doubt on the nationalism of the Shah was that his rule was established through the direct assistance of the US and Great Britain. Following the coup, the state was directed toward responding to the ideologies of the opposition, liberalism of the National Front and Communism of the Tudeh. It attempted to appreciate the idea of nationalism from the first and revolution from the

second. Then it took on an increasingly anti-Islamic character and at the same time drifted in an authoritarian direction.

The Shah began to portray his nationalism as a 'positive'²⁹ force- in response to Mosaddegh's ideology of negative nationalism - and to portray himself as the champion for revolutionary change. As the Shah proclaimed:

"Iran needs a deep and fundamental revolution that could, at the same time, put an end to all the social inequality and exploitation, and all aspects of reaction which impeded progress and kept our society backward" (the Shah 1967: 15).

From this period, the Shah associated his rule with the idea of modernisation, civilisation, and equality. These reforms provided a basis for the Shah's ideological campaign against his opposition. The Shah frequently referred to the ulama as 'black reactionists', the pro-Mosaddegh nationalists as 'destructivists', and the Communists as 'the red force of destruction' who combined to paralyse his action (The Shah 1967: 12). The Shah's ideologues were claiming that the ship of state was steering a proper course, navigated by an experienced captain capable of guiding it through the stormy waters of social change to the threshold of a 'Great Civilisation'. To provide his 'revolution' with a sense of continuity, the Shah was periodically adding other principles - to the initial principle of the land reforms of 1963 - to what he called 'the Shah-People's Revolution'.

In the 1970s, while the Shah was enjoying full control over the populous at large - through efficient monitoring and manipulation of the authoritarian-bureaucratic establishment - his desire for greater institutionalisation of the monarchy increased.³⁰ For him "the attainment of goals is not possible except by relying on the racial virtues and ancient qualities" (the Shah 1954 cited in Laing 1977: 141). Thus, among the most controversial of his actions were the widespread propagation of the ideology of kingship. The Shah in his interview with Fallaci stated:

"When there's no monarchy, there's anarchy, or an oligarchy or a dictatorship. Besides, a monarchy is the only possible means to govern Iran" (cited in Halliday 1979: 58).

To propagate the monarchy-centred national/kingship mythology further, emphasis was laid on the pre-Islamic history of Achaemenid. The twenty five hundredth anniversary of the Achaemenid dynasty at Persepolis was celebrated in 1971 to establish a historical continuity between the political past and the present. In 1976 the Islamic calendar was changed into a monarchical one, whose beginning was dated back to the accession of Cyrus the Great, from whom the direct descent of the Persian

crown was somewhat unhistorically claimed. Prime Minister Hoveyda, praised this decision of the Shah in the Parliament as:

“a reflection of the historic fact that during this long period, there has been only one Iran and one monarchic system and that these two are so closely interwoven that they represent one concept” (*Keyhan International*, 15 March 1975: 1).

Furthermore, these efforts were to create an illusion that the Pahlavi monarchy had clear and deep roots in the ancient kingship of the country.³¹

The state discourse became authoritarianism proper when in 1975 the Shah abruptly dissolved all the ‘official’ political parties and declared that the country had a one-party system, the Rastakhiz party. “One country, one Shah, and now one party” became the regime’s new slogan (Zabih 1979: 7). In principle, there was little difference in the state’s ideology under the two Shahs, even though the second Shah stretched the monarchy-centred nationalist discourse to its logical extreme (Moaddel 1993: 64).

Based on what has been said, the Shah based his power on three pillars: the state autonomy, the armed forces, and the network of court patronage. The authoritarian-bureaucratic establishment was used both as an instrument of power and control, and as a tool for achieving development goals; an instrument for system maintenance and regime enhancement. The repressive apparatus performed as the guarantor of the regime’s survival. The decision-making process and exercise of power, depended exclusively upon the Shah and his relationship with the ruling elite. Such exercise and manipulation of power depended on the autonomy of the state.

Chapter Four: State Autonomy and Shah-Elite Relations

The Pahlavi state had two social bases. At its narrowest, it could be reduced to the Shah, i.e. his vast decision making power, his extensive wealth and central position among the economic elite, and the general tendency to credit him for everything that the state made happen. As a set of authoritarian-bureaucratic institutions, the practical basis of the Pahlavi state could be broadened to include the court, heads of the army, security forces, the bureaucracy, and key individuals. While the court on the one hand, and the bureaucracy and the authoritarian apparatus on the other, were the main pillars of the Shah's regime, any influence in these institutions meant an influence in the political process of the country.

In the 1960s and 1970s and in the absence of effective societal constraint, the political decision making process was determined by a variety of factors. The most important of such factors - apart from the state's organisational character which was shown in chapter 3 - was the set of beliefs and psychological attributes that shaped the Shah's priorities. Certain critically important resource limitations and international constraints suddenly ceased to offset state policy-making in Iran, due to: the tremendous increase in Iran's oil revenues in the early 1970s; its growing military power; and, the British decision to withdraw its military forces from the Persian Gulf in the late 1960s and early 1970s. The Shah was able to enhance his quality of leadership, to tighten his control through money, and to expand the room provided to him by autonomy of the state. This situation enabled him to impose his personal ambitions as state priority policies and objectives. Thus, an analysis of the Iranian state in the post-World War II period cannot avoid focusing on the personality, vision and *modus operandi* of the Shah.¹

Therefore, the aim of this chapter is firstly, to examine the forces which shaped the Shah's set of beliefs and psychological attributes, namely his 'dual' personality and the US moral and politico-material support for his regime, secondly, the ways in which, the Shah could efficiently control the ruling elite, and thus the policy-making process.

4.1. Dual Personality of the Shah: Grandiose Versus Passive Personality

In political systems where there is a dominant figure, modes of psychoanalytic thinking can be productively used to analyse the political behaviour of a political leader and the relation of a leader to his followers, and thus to serve as part of the process of monitoring the 'pulse' of a political system (Zonis 1991). The point of emphasis here is that psychoanalytic theories can point to the behavioural components of the Shah's character which are significant and will help us to shed light on why he took or failed to take certain actions (see Kaplan 1990; Gronn 1993).

To understand the Shah's life, we should note, as Kets de Vries argues, the socio-cultural context of his life and examine it over time. The Shah's character highlights:

"the impact of the interplay of genetic predisposition, parental influences, and the effects of society [political circumstances] at each stage of [his] life" (Kets de Vries 1990: 426).

Indeed the pursuits of the Shah were heavily influenced by his personality and the experience of his early youth. The Shah had two contrasting characteristics. When he was in control and was not challenged, he would display his grandiose character, being a forceful, determined and active man. However, when he faced a challenge to his rule, he would turn into a passive, and indecisive man, lacking self-esteem and self-confidence (Sullivan 1981: 12-3; Zonis 1991: 17). These contradictions resulted from his personal struggles to compensate for his inadequate psychic supplies; his severe 'narcissistic imbalance' - which were the result of his childhood experiences in the form of indulgence, threats and rejections (for his childhood experience see Mission 1961; Ashraf 1980; Sorayya 1963; Fardust 1993).

Parental influence had a major role in shaping the dual personality of the Shah (see Mission 1961). Furthermore, such 'duality of personality' was evident in his years at Le Rosey school² (see Jacoby, diaries from his days in Le Rosey, *Newsweek*, No. 20, Feb. 1949; Fardust 1991: 42-44; Zonis 1991: chapter 2). The result of his childhood both in Tehran and in Le Rosey was that he had grown into a young adult with what psychoanalysts would characterise as severe narcissistic imbalance (Zonis 1991: 53-4). He was a young man lacking self-confidence. He himself believed that he may have grown up with some sort of a 'complex' (Alam³ 1991: 372). Fearlessness and a weak-willed

personality were what Reza Shah had always feared for in his son (Zonis 1991: 106). At the early stage of his rule, the Shah's identification with his father enhanced his sense of comfort and strength. He praised Reza Shah frequently for his strong personality (see in his *Mission* 1961: 12, 27, 36-7, 40-50). This praise served at least two purposes. It served to convey legitimacy for himself and his dynasty. Furthermore, by elevating the stature of his father, it served to provide a personal purpose - an idealised representation of his father which the Shah had created for himself during his formative years and into his adulthood.

Although the regime relied extensively on repressive armed and security forces, and oil revenues as the twin sources of its hegemony in Iranian society, the Shah relied on sources of moral support to maintain his capacity as the Shah and to substantiate his grandiose character - to be *Shahanshah* or the king of the kings. The principal means through which he received psychic strength was by: establishing close personal links with a few determined but absolutely loyal personal associates who particularly could help the Shah in his difficult moments.⁴ They included Alam, Peron, his twin sister Ashraf, Fardust, Shapur G., Hoveyda, Ayadi and Farah.⁵ For example, it seems in the 1963 uprising, it was Premier Alam who gave the necessary moral strength to the Shah to make the decision of military intervention and the dispersal of the protest (Alam 1991). The second major source of confidence which could generate the Shah's self-affirmation, was external support. In his childhood and early adulthood, the source of such support was God or 'divine protection' which had saved him from "dangers and perils" (the Shah 1961: 54-6, 222). "I receive messages... I have been chosen by God to perform a task. My visions were miracles that saved the country" (The Shah interviewed by Fallaci, in Fallaci 1973: 1). This conviction must have given him the first independent feeling of strength.⁶ It is not clear whether these claims were more than a political device from which he sought greater authority and legitimacy, were only public relations gimmicks, or a deeply held belief to help him overcome the passive quality more apparent in his youth.

However, going through the 1950s, the source of external moral support came to be the US. It is worth noting that US support for the Shah's regime was far from a politico-psychological support. Indeed, one of the major forces involved in the establishment and expansion of the Iranian authoritarian-bureaucratic state was the US. Throughout his

reign, the Shah utilised these two mechanisms to distance himself from his passive character, to enhance his own positive self, and to believe that the latter was his most dominant quality.

In his weakness, his propensity for withdrawal from threatening or challenging situations would increase (for his cases of withdrawal in 1953 see Ashraf 1980; for 1963 see Alam; for 1978-9 see Sullivan 1981).⁷ Such instances of withdrawal were frequent and consistent enough so that their occurrence constituted a pattern - a pattern that would provide him with comfort and calm. The Shah was quoted as saying:

“physically I am not afraid, but mentally you’re [I’m] always constantly afraid of something, either by yourself or something that might go wrong with yourself or with your friends or with your allies that you’re counting on” (The Shah interviewed by David Frost, 1979, quoted by Zonis 1991: 98).

In the context of the Shah’s prevailing passivity and weakness in the 1978-79 crisis, therefore, Arjomand (1988: 117) argues “with no doubt that the collapse of the man [the Shah] preceded the collapse of the monarchical regime”.

Confidence, for the Shah, in the international arena was slow in coming. To a great extent, ever since the 1953 coup, the Shah had been dependent on the US for military, economic, moral and political support. In order for the Shah to achieve confidence, it was necessary for him to shift away from his client patronage with the US to a growing independence. The importance of the confidence factor in the international arena for this analysis is that the Shah began to approach Iran’s internal problems with a self-confidence and presumed infallibility that was to lead the country toward what Vakil and Razavi (1984: 64-6) call: “wrong policy choice”. What had been painfully required in international politics, after many a humiliating experience, was now to be applied to the solution of domestic problems. The added confidence resulting from the 1973 surge in oil income sealed that infallibility in the Shah’s own mind, and made materialisation of his ambitions possible. This was, in spite of the fact that the increased complexity of the economy required ever greater delegation of authority at all levels (*ibid.*).

His relation with the ruling elite would alter to a major extent, from his time of control to the time of weakness. After surviving challenging situations, he further consolidated his

monopoly over the political process, and ensured that those beneath him in the system, co-operate fully with him.

In his positive and strong personality, he sought to 'modernise' Iran through 'rapid industrialisation', rush the country towards 'the Great Civilisation', to refashion the country in an image of power and international significance which would mirror his own grandiosity (for many instances which emphasise this aspect of the Shah see Karanjia 1977).

4.1.1. Grandiose years and the Shah's policy priorities

In the 1960s and 1970s, the Shah had finally thrown off the 'play boy' image which dogged his youth and emerged as a formidable statesman and politician. In the course of trying to realise his ambitions, he developed a personal arrogance which later become institutionalised (*The Times* 12 September 1971, 29 November 1978).

As Iran's resources increased with oil sales, realisation of his gratifying ambitions increased. "We shall not accept anything less than a first class position for Iran" (The Shah in an interview with daily *Keyhan*, cited in *Keyhan International* 17 September 1977: 6). Iran would regain the splendour of the Persian empire, the Iranian economy would attain Western European standards, and the Iranian army would become the strongest conventional, non-nuclear military power in the world, all in less than two decades (see the Shah in Alam 1991: 389; Fallaci 1974: 19; Karanjia 1977: 261, 243; Heikal 1981; *The Guardian* 23 July 1975). He made great efforts to develop Iran's economy in the 1960s and 1970s, using the state's growing revenues to promote rapid industrialisation. Cottam (1979: 362) notes that the Shah's ambition and grandiosity dominated his domestic and foreign policies (on the Shah's psychology see also Bayne 1968; Zonis 1991). In so doing, however, the Shah overemphasised Iran's financial resources, underestimated the country's absorptive capacity and ignored the social cost of such spending. As will be illustrated in chapter 5, his development programmes were grossly ill-suited to the country's social and economic conditions. He did not succeed in diversifying the single-commodity export economy. He did little to alleviate poverty and the disparity in income distribution that afflicted many classes and individuals in the country. He placed a high priority on building up Iran's armed forces and expanding its

role in regional and world affairs. However, he ruled in a highly authoritarian manner, repressing all forms of opposition and emasculating Iran's political institutions.

Two dramatic experiences had concerned the Shah. Firstly, was the humiliation of his father by the Allies, who forced him into abdication and exile in the wake of their occupation of Iran in 1941. Secondly was the humiliation that the internal opposition had heaped on him in the 1940s and especially in the 1950s. As a result of these experiences, two equally and related concerns became the obsessions of the Shah. These were firstly the pursuit of external security of his state and his dynasty through the expansion and equipping of the Iranian armed forces at the highest qualitative and quantitative level, and secondly, the construction and expansion of an administrative hierarchy, highly centralised, totally disintegrated and answerable only to him.

For the Shah, it was only himself who carried the merits: the magnificence, the genius gene in all subjects, and uniqueness in leadership. He remained convinced of the faultlessness of his conduct of government, thus wishing it to continue entirely unchanged under his successor (the Shah in Karanjia 1977: 263). It was the Shah's will which counted. He always claimed that he sought what was best for the country and the people. For him to achieve his objectives for Iran, required a strong leader "who is not dependent on people's vote [and] is free to act directly in their national interest" because the nation does not realise its interest due to its "ignorance" and lack of "maturity" (Alam 1991: 383; Radji 1983: 97). Such a high degree of self-esteem resulted in his claim that "the whole nation is mine without me having to stake some petty private claim. Everything is at the disposal of a ruler of strength" (the Shah to Alam - when he was presented with the title deed of the new palace on Kish island in his own name - in Alam 1991: 228; see also Radji 1983:180). For example, in 1975, the regime, having confidence in the continuing increase in oil revenues, signed a trade package calling for \$15 billion in purchases by Iran from the US, including 8 nuclear plants (*Keyhan International*, 4 September 1975). In the same year the Shah boasted that within two decades Iran would build 21 nuclear plants, in which, estimates for the capital costs of plant construction, infrastructure, nuclear fuel, and training programme could approach \$100 billion (*ibid.*, 1 September 1977). Such nuclear ambitions were a reflection of the grandiose fantasy that the Shah was pursuing.

In his heydays, magnification of himself was equal with humiliation of others.⁸ His continuous humiliating behaviour offended everyone. The Shah liked to give the impression that “anything we say is far too insignificant to merit his attention”, Alam argued and further pointed out that in serving him “ingratitude is all part of the job” (Alam 1991: 60, 218). For the Shah, the Pahlavi family was “a selfish bunch” of “good for nothing” who would be “totally lost” without him (Alam 1991: 473, 485). The ministers, thus, could not be more than a bunch of “donkeys” or people who had “as much intelligence as a herd of sheep” (Alam 1991: 393, 413).

4.2. The Shah by the Grace of the US

The Shah witnessed dissolution of the Iranian modern army - which was built by his father over two decades - in just a few days during World War II. For him, while the new army saved the Pahlavi dynasty vis-à-vis the internal unrest and regional movements, it was unable to protect the monarchy and to preserve territorial integrity of the country against major foreign assaults. Thus, reliance on an external power became a must in order for him to preserve his royal seat. He saw the US as the most powerful of protectors:

“As long as the Americans support me, we can do and say whatever we want”
(quoted by P. Salinger 1981:59 in Zonis 1991: 168).

Indeed, the US was the power ultimately responsible for the withdrawal of Soviet troops from Azarbaijan and Kordestan in 1946; for the 1953 coup which restored the Shah to his throne, for the massive military and economic assistance that allowed the Shah to stay in power after his restoration to the throne and for selecting the Shah’s regime to serve as a regional power as part of President Nixon’s foreign policy in the 1970s.⁹

Furthermore, underlying the political and economic ties between the Shah and the US was a special personal and psychological relationship that the Shah had developed with the US and its presidents. It was to a significant extent, a source of psychological well-being for the Shah’s political leadership (Zonis 1991: chapter 8; Sullivan 1981: 163). The Americans full confidence in the Shah and astounding new oil revenues, which made

purchasing military equipment from the US possible contributed to an extensive enhancement of the Shah's power within the state.

Nonetheless, the consolidation of American influence over the Shah and the Shah's utter dependence on the US did not occur until the overthrow of Mosaddegh. In the early 1950s, the central position, which the Shah had so assiduously cultivated after assuming the throne in 1941, rapidly collapsed, along with his morale. After his abrupt reinstatement of Mosaddegh, following the street demonstrations in 1952, the Shah's morale diminished in fear of a replication of the coup pattern in Egypt which led to the exile of King Farouq by the Free Officers. Therefore, the American-led coup of 1953, accomplished by the CIA, with participation of ARMISH, GENMISH and the instrumental role of MAAG, restored the Shah's power and rebuilt his personality as a "new man [who] for the first time, believes in himself" (Eisenhower 1963: 165; Rick 1982).¹⁰

Consequently, the regime committed itself to a formal alliance with the West, and tied not only Iran's foreign policy but also the country's socio-economic development to the interests of the capitalist world. This alliance constituted:

"the basis for the development of Iran's 'dependence relationship' with the United States at the cost of the country's traditional policy of nonalignment" (Saikal, 1980: 46).

The dependent relationship with the US was fostered as well by the oil consortium agreement of November 1954. American oil companies managed to win a 40% share in Iranian oil production from which they had previously been completely excluded on account of the British monopoly.¹¹

The commitment to Iran's stability as a bastion in support of US economic and political interests in the Eastern Mediterranean and the Middle East meant commitment to the monarchy through economic and military loans, credits, and grants during the 1950s and 1960s (see chap 6). The Shah later agonised over the possibility of abandonment by the US under the Kennedy administration, as he thought that the US was going to support a major change in Iran's political system. Although, the Shah was forced by the new Kennedy administration to announce the land reforms, US support for his regime continued.¹²

4.2.1. US-Iran relations restructured

The Nixon-Kissinger visit to Tehran in 1972 and its consequent result, i.e. a blank cheque to the Shah which guaranteed him access to some of the most sophisticated non-nuclear weaponry in the US military arsenal, restructured the US-Iran relationship for the 1970s.¹³ Americans granted the regime the status of the major regional power in the Persian Gulf.¹⁴ Now he felt that he was recognised as a world class strategist, and that the country was privileged to have entered a regional, strategic security-alliance with the US. As a result, by the early 1970s a strong military relationship with the US was moulded and later reasserted by the oil boom of 1973, and became the main conduit for realisation of the Shah's ambitions. However, there was a personality change by mid-1970s. Now and then, the Shah manifested a grandiosity and arrogance toward the West - as he was doing toward Iranians. He was fond of lecturing the West on its decadence and its failure to keep its own house in order (i.e. see the Shah quoted in Heikal 1981:96-7: Fallaci 1974).

During the 1960s and 1970s, the Shah was successful in persuading the establishment of a 'Shah-centric' foreign policy in US administration towards Iran. This policy reaffirmed the Shah's behaviour in which, effectively, all contacts with the US had to pass through his person or the institutions which were part of the system. The US policy was Shah-centric because over the years he had been such a faithful ally.

During the later 1970s, while the Shah's psychological dependence on the US crystallised, the election of Carter exacerbated his fear. He became uncertain about the new American interest in this part of the world, its commitment to previous agreements, and its attitude towards him as a ruler (Sullivan to the State Department, January/11/1978, in publications of SFI, hereafter Asnad, Vol. 12: 16). This was due to the receipt of contradictory and ambiguous signals from the Carter electoral campaign and later from Carter's administration.¹⁵ The resolve of the Shah was thus weakened by fostering doubt in the commitment of the US to his rule, which simultaneously encouraged the opposition to the Shah to believe that the US might support some alteration in the balance of power in domestic Iranian politics. To solve the contradictory signals and to strengthen his resolve, the Shah undertook a state visit to Washington in November 1977; President Carter had a stopover in Tehran in 1978. As a result of these

trips the Shah recovered his mood of confidence and satisfaction. Carter's support was beyond the Shah's expectation (Homayun, BBC Documentary, programme 20, tape no. 7). In Tehran, he declared:

"Iran because of the great leadership of the Shah, is an island of stability in one of the most troubled areas of the world...We have no other nation on earth...closer to us in planning our mutual military security... And there is no leader with whom I have a deeper sense of personal gratitude and personal friendship" (*Keyhan International*, 3 January 1978: 1).

However, in December 1978, General Azhari told Ambassador Sullivan:

"you must know this and you must tell it to your government. The country is lost because the king cannot make up his mind" (Sullivan 1981: 212).

The Shah had obviously been used to receiving advice from the US on internal politics. Brzezinski writes that "the Shah wanted the US to take responsibilities for the painful decisions needed to keep Iran intact" (Brzezinski, 1983: 371). It was not that he sought to evade the responsibility for making the difficult decisions. His capacity as a political leader had been substantially undermined, leaving him incapable of making firm and clear decisions. It was becoming "increasingly doubtful that the Shah could act on his own" (ibid. 372; Homayun, BBC Document, programme 20, tape no. 7).

4.3. The Shah and His Regional Concerns

For the Shah, it was not only the US and its presidents, with whom he was concerned. His relations with other states and over other crises and movements particularly in the Middle East and among Iran's neighbours, were of great concern to him. The region had been shaken by crises, upheavals, and changes of regimes which had on occasions worried the Shah and directly affected his regime.¹⁶ Therefore, the two main objectives of Iran's regional policy were namely: to minimise their negative effects; and, to establish a protective shell against any future crisis in the region. His regional policies would protect his monarchy and his international reputation, while serving the capitalist world, particularly the US.

The Shah was closely looking at the monarchical states, the popular movements, and the revolutionary states. He had assiduous deliberation with the US administration on these issues, receiving advice and instructions, and informing them of the steps he should

take or had taken. He was trying to build an alliance of Western-minded regimes in the region, his regime being its main pillar. The Shah supported King Hossein of Jordan and King Hassan of Morocco both financially and by providing military equipment. When King Hossein asked for some F-5 aircraft as a free gift, the Shah replied: "Give him what he asks" (Alam 1991: 374).

He was frightened by the example of Nasser's revolutionary Egypt and its concept of 'Arab nationalism' which was generating a revolutionary myth among the Arab and non-Arab countries of the region, including the small sheikhdoms of the Persian Gulf. Therefore, the Shah believed that his regime faced a greater menace in the south, from revolutionary Nasser, than in the north, from the Soviet Union (*The Guardian* 17 February 1967). He also feared Qadhafi who was a prominent advocate of revolutionary changes in the region. When Sadat replaced Nasser, the Shah initiated strong and friendly relations with Egypt. At the same time, his relations with Israel were sound and strong in politico-economic and military-security aspects. In 1973, he helped Israel by supplying it with oil during the hard period of the Arab-Israeli war and the consequent oil embargo.¹⁷ The Shah helped other North African states to confront the spread of revolution. Regardless of co-operation with the Algerian government in OPEC, the Shah was supporting Morocco - sometimes through Jordan - to suppress the Algerian backed Polisario.

The Persian Gulf for him was the place that he could realise his regional ambitions, and it was for the country "a matter of life or death" (the Shah, *The Guardian* 28 September 1971). He could not "tolerate radical regimes taking over the Arab Sheikdoms in the Persian Gulf" (in an interview by Borchgrave, *International Herald Tribune* 14 May 1973). Such concerns resulted in despatching 30,000 troops to assist the Sultan of Oman against the Dhofari rebels.

In 1973 the coup in Afghanistan particularly upset the Shah: the king was deposed and replaced by a President. The Shah helped the deposed King, exiled to Italy, to possibly retrieve his throne.¹⁸ When disappointed with the king's retreat, he helped the successor regime in Afghanistan to demonstrate that "it is we that call the tunes" (quoted in Alam 1991: 402). He was supporting the government in Pakistan. By sending tanks and aircraft to Pakistan, after their conflict with India in 1965, he could overcome an internal problem

of arm smuggling from Pakistani Baluchestan to rebels in Iranian Baluchestan (Laing 1977: 200-201). He was very cautious on developments in Pakistan and frequently used oil and economic aid to distance Prime Minister Bhutto from Arab leaders and bring Bhutto on his side.¹⁹

Hence, throughout his regional policy, the Shah followed his two major goals of building an alliance of Western-minded regimes, and strengthening moderate regimes by weakening the possible popular movements in other countries.

4.4. The Shah, the Dominant Political Actor

When the balance of forces within society is disrupted, it is the state that determines the new balance of forces (Ehteshami 1995: 16). Between the two World Wars the process of modernisation in Iran was accompanied by a considerable degree of change in social stratification. New social classes and occupational groups emerged and the power of the old and traditional elite declined. While the Constitutional Revolution failed to build a new political structure and set up a new base for the elite, Reza Shah undermined the old balance of forces: the religious elite was eliminated from the new system by a policy of undermining religion; the tribal structure as the main source of military elite recruitment was crushed; and, the traditional nobility was undermined. The policy of attacking the traditional sources of power was not only pursued but also intensified during the reign of the Shah, an alteration from its traditional source of wealth and social status to expertise and technical competence.

Within the context of the nation-state, tribal solidarity gave way to national solidarity. The military elite of the national armed forces replaced the old tribal army and became an active participant in national affairs. The bureaucratic elite, to a large extent, found a place for itself and became increasingly influential. The religious elite was pushed to the periphery of the new political structures. The economic elite, whilst prospering monetarily, did to a large extent lose its independence. By the 1960s, the Shah had achieved effective domination over the other groups within the state, the civilian politicians and the army, with whom on occasions, he had to share power. Such 'circulation' of elites was intentionally directed by the Shah, not through a competitive open process but by occasional use of force.²⁰

The Iranian political process in the 1960s and 1970s constituted a system in which the two principal actors might be considered as the Shah and his political elite - though it is impossible to analyse the latter without understanding the former. The decisions of the Shah, the dominant political actor, directly affected the political elite.²¹ It was the degree of control, financial autonomy, and the state organisations which would determine the influence of the Shah in the Iranian political process. As will be shown later, autonomy of the state further assisted the Shah to control the balance of power in his own favour.

4.4.1. The ruling elite

Excluding the Shah as the prime manipulator of the political process, the nobility, the bureaucratic and the military elites formed the main body of the ruling elite of the country. The religious and economic elites comprised Iran's non-ruling elite during this period as the ruling political elite are distinguishable from the non-ruling elite (for a general study of elite theory see; Pareto 1916; Mosca 1930; Michael 1949; Batomore 1964).

The ruling elite mostly secured and maintained its political influence and power as a result of characteristics other than that of qualitative superiority. The predominance of such groups were chiefly attributed to their connection to the Shah, their foreign support - namely the American and British embassies and later the TNCs - and partly to their professional skills. But whether their predominance depended upon manipulation or the use of force, the ultimate skill was organisational. Obviously, greater organisational skill in one group denoted a certain type of superiority over rival groups.

The system was rife with officially sanctioned corruption, bribe-taking, and greed, from the Shah down to the court minister and then down through the officer corps and the ruling elite, with each maintaining a mini-court of his or her own, surrounding themselves with clients. This absorption of the economic surplus and its disbursement throughout the upper echelons of Iranian society was one material base of the Shah's power which secured the allegiance of his associates to the state and to his person.

Family relations remained one of the most important factors in the Pahlavis' political decision-making process as it was traditionally considered a crucial element. The term 'thousand families' shows that a number of families had been contiguously represented in the political elite, i.e. only 40 families represented 410 seats in the Majles and 66 seats in

the Senate from 1906 to 1967.²² These elites were linked to one another in a complex web of kinship ties, social intercourse, economic co-operation, and political expediency. The power of the political elite was considerably buttressed and expanded by intensive inter-marriage. The branches of the family cluster had inter-married not only with each other, but also with an enormous number of other elite families to produce identifiable pairs of families.²³ The dominant pattern among them was their simultaneous membership in two or more elite categories, what Bill (1975: 23-7) calls 'linkage figures'. The Shah, of course, was the prototype of the linkage figure because of his ultimate control of direct involvement in each of the elite categories.

Among the ruling elite, the nobility consisted of two groups: the Pahlavi family with its 63 princes, princesses and cousins who applied immense influence in the political process; and, aristocratic families who mainly set up urban ventures - either before the land reform or those who survived the reform.²⁴ The latter were the traditional elites who had become modern by shifting their land and wealth to the urban industrial, agribusiness, and enterprise activities. Major figures among the royal family courtiers and confidants were Farah, Ashraf, Gholam-Reza Pahlavi, Alam, Ernest Peron, Dr. Ayadi, Ardeshir G. and Fardust.

Distributive and development policies rapidly increased the role and size of the state. In order to maintain control over this new state, the Shah turned increasingly to the bureaucratic elite, whose political functions now grew. The bureaucratic elite included a few hundred elder politicians, senior civil servants and high ranking administrators of the bureaucracy, and more importantly the emerging educated technocrats without whom the state apparatus would have been unable to function.

The bureaucratic elite in Iran was the most obvious reservoir of members of the national elite. In 1970, the civil bureaucracy was headed by an elite group whose number fluctuated between 450 and 500 persons. At the time, there were 22 ministers (including ministers without portfolio), 111 deputy ministers, and 331 director generals. A scattering of other individuals who were extremely powerful in the ministries bore titles such as 'high inspector' and 'technical advisor'.

The salaried bureaucratic elites were totally dependent on the state, but since they were the carriers of change, amongst them professionals who filled the posts in various

ministries, economic and social services organisations, companies, universities and institutes, they were able to influence the political process and push the system towards a more Western direction. It was high calibre people in this new bureaucratic elite that could initiate, plan, and implement policy reforms.

Iranian bureaucrats formed an important sector of society and were active participants in the political process. The all embracing nature of politics characterised the close relationship between the bureaucracy and the political system. They spent a considerable amount of time fostering good relationships with other political elites, influential people, party functionaries, and most important of all, the court elite. Thus, they were mostly functioning as career bureaucrats and as quasi-politicians. Furthermore, they increasingly played the role of businessmen. Such a tri-active role in the bureaucratic state brought the Iranian bureaucratic elite tremendous material and socio-political benefits.

Moreover, by virtue of their position they had a more lasting impact upon the society as a whole. Among them were the Majles and Senate members, ministers and deputy ministers, key figures such as Sharif-Emami, Hoveyda, Ansari, Zahedi, Fateh, and Amuzegar.

The military elite consisted of the high ranking heads of the security and military forces. There existed around 400 generals in the armed forces, either on active duty or retired, who were members of the military elite, among whom a dozen, such as Fardust, Khatami, Nasiri, Tufanian, were very influential.²⁵ The armed forces and thus the military elite was the most independent elite vis-à-vis the other ruling elite. They were recruited mainly from social groups other than from the landlords and urban merchants. Consequently, any threat from within the political structure to the throne lacked a military base and hence was limited. The presence of the American military officers and advisers - 40,000 by 1977 - would help the Shah to further extend his control over the military elite.

The military elite, with a privileged position rendered by the Shah, had continually expanded its scrutiny over the opposition groups. It also controlled the activities of members of the ruling elite even the Pahlavi family, in favour of and under the direct command of, the Shah. On two mornings a week, the Shah granted audiences to his 12 highest ranking generals, and frequent audiences to the heads of SAVAK, Special Bureau and Imperial Inspectorate.

CHART 4.1: The Ruling Elite and the Reporting Relationship with the Shah, 1965-76

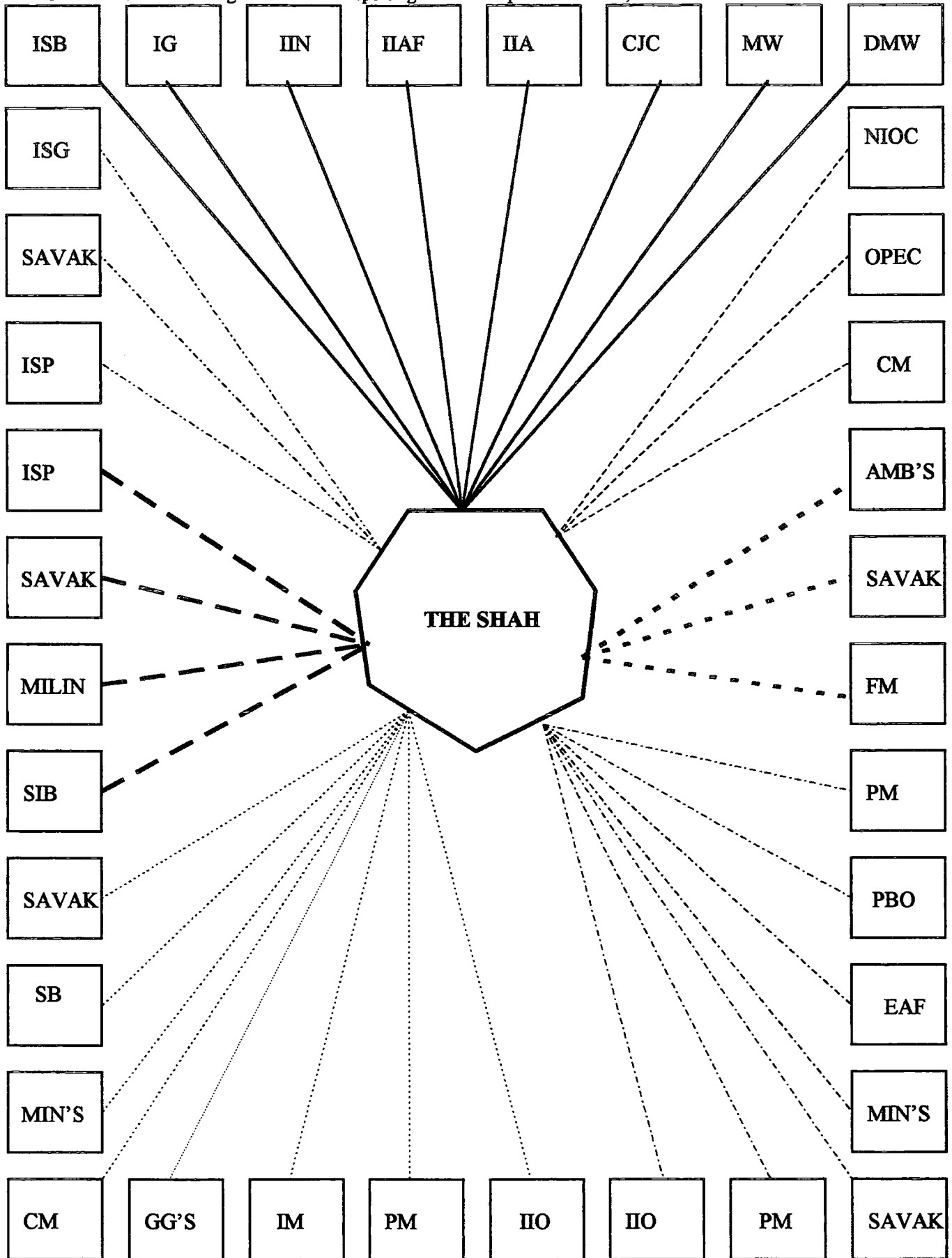

* Legend in Chart 3.1, P. 94

4.4.2. The Shah-elite relations

Most Third World post-colonial states, according to Hamza Alavi are “overdeveloped bureaucratic-military apparatus”, a system that governs the ruling ‘national elite’ and administers it (quoted by Ehteshami 1995: 16). Thus, in Iran, the Shah at the top of the authoritarian-bureaucratic establishment, administered the elite in a way that:

“to get things done, one needs power, and to hold on to power one must not ask any one’s permission or advice” (The Shah in an interview in 1973 quoted by Halliday 1979: 57).

During the 1940s, the Shah initially relied upon the support of a conservative coalition of traditional merchant bourgeoisie of the bazaar, the high clergy and the landlords. The Six-point reform programme of the Shah, labelled the ‘White Revolution’, the centrepiece of which was land reform. This marked the historic break of the regime with its powerful traditional allies, and indeed the elimination of an important fraction of this group, i.e. the absentee landlords. The 1954-63 period saw the gradual strengthening of royal authority, leading to the elimination of parliamentary opposition. Furthermore, the violent confrontation of June 1963 marked the end of political compromise with the traditional merchant bourgeoisie of the Bazaar and the clergy (Karshenas 1991: 90).

As Chart 4.1 shows, the Shah successfully imposed ultimate control over the ruling elite. Indeed, one of the most interesting aspects of Pahlavi Iran is that it was the Shah who held full executive power in a rapidly developing capitalist state, and that he had been able to increase his strength as this process unfolded. However, it is a simplification to concentrate only on the actions and position of the Shah in analysing Iranian politics: the Shah did not operate in a vacuum and obviously could not run the country single-handedly.

The Shah served to anchor the elite and very effectively neutralised its centrifugal tendencies, during the 1950s and early 1960s, by policies of co-optation and intimidation. The elite responded to this method of rule, according to Zonis “by coping with the system, not by attempting to alter it in fundamental ways” (1971: 329). The process of coping consisted basically of learning to operate within its norms while maximising the benefits that could be derived from it.

Within the political system, the Shah had used three different means simultaneously to control the political elite: economic power; politico-administrative power; and the security forces. This was explicated by his treatment of the royal appointment policies, including the frequent surprises and personal shake ups in the administration; overlapping bureaucratic responsibilities; astute undermining of exceptional individuals arising among the elite; the forcing of communications within the bureaucracy in vertical rather than horizontal lines; with his own personal appointment and direction of the key cabinet ministers; by frequent humiliation of the upper political elite including the generals of the armed forces in front of one another or by one another; and most important of all by personal administration, nourishment, and manipulation of the armed and security forces, which constituted the cornerstone of his power.

Furthermore, the Shah stimulated the rivalries and created stability for his rule within the state through a skilful balance of rivalries by dividing the power of the aggrandising elite figures and their offices- i.e. Alam versus Hoveyda; Farah and her office versus Alam and the ministry of court; SAVAK versus the SIB.²⁶ Because there had been as many dramatic examples of downward social mobility as upward mobility, even the highest ranking individuals could not afford to relax. Because of the existing sense of insecurity, members of the political elite, in particular, expended a great deal of time and energy in cultivating foreign connections and ties (see Radji 1983: 37, 194).

4.5. Control Through Economic Power

If the Shah's self-esteem was reinforced by his psychological relationship with the US, his manipulation of political decision making was consolidated by the massive wealth which oil exports generated. Therefore, the Shah by controlling the allocative process could influence directly the ruling elite or any other economically dependent social class.

Indeed, capital had been one of the major factors which cemented the Shah's system of government. Other than foreign support, three things in Alam's view could keep the Pahlavis in power: intelligence and quality of his counsel (loyal ruling elite), control over the army, and wealth. In the past, the monarchy was able to bind its power base with money either by controlling state revenue or by amassing a large private fortune, or both. More often than not these alternatives were indistinguishable since there was little

practical division between the private wealth of the shah and state funds - which was used to reward loyalty to the shah. Moreover, the shah did not have to make such a distinction since he regarded himself as embodying the state.

During the reign of Mohammad Reza Shah, the modernisation of the administration and windfall of oil revenues, coupled with the expansion of the economy, inevitably made the reward system more complex. Hence, out of necessity the distinction between state funds and the private wealth of the Shah, albeit on paper, became more clear. The budget became institutionalised so that a specific allocation was made for the 'Supreme Leadership of the State', which in 1976-7 amounted to \$43 million (PBO 1976-7: 19). More importantly, the expansion of the economy and the increased revenue from oil resulted in a shift in the direct burden of reward away from the royal money and on to state funds. The budget was even used to bankroll operations which the monarchy would have supported out of its own pocket in the past. For instance, the budget provided annual cash backing for such things as Tehran's privately owned exclusive Imperial Horse Society, the Imperial Country Club, the Imperial Aviation Club. In the 1976-7 budget, \$15 million was allocated for these three royal clubs (*ibid.*: 70-2).

The expansion of the economy also provided the Shah with greatly diversified resources to grant rewards. He utilised the granting of trading and manufacturing monopolies and restricted licences or agencies for international companies as a means of making people beholden to him. In a highly protected and expanding economy like that of Iran such concessions were highly profitable. The Shah permitted trusted individuals as intermediaries in large-contract negotiations with international companies in the defence and civilian fields. Shapur Reporter in the British-Iranian negotiations of British Chieftain tanks, and Abdol Hasan Mahvi in US-Iran military negotiations are only two examples, among many, in this regard.

Throughout the Pahlavi dynasty, a certain blurring and ambiguity of the distinction between state funds and royal funds was maintained. The NIOC is claimed to be one of the examples of such ambiguity in which it was a source of supplementary and secret funds for the regime to enrich the Shah personally and to sustain him in power (see Abrahamian 1982: 419-26; Graham 1980: 155-9). Graham (1980) documents that it was frequently transferred to a special account controlled by the Shah for either private use or

to pay the extra secret purchases for SAVAK and military forces. This kind of relationship existed between the NIOC and the royal family for quite a long time. For example in 1962 and in less than a month \$12 million was transferred from the NIOC to the Swiss account of the Pahlavi Foundation (ibid. 157-8). By the oil boom of 1973/4, the amount transferred, in one instance, reached \$2 billion, and in another occasion in 1976-7 to \$1 billion (ibid. P.156; Abrahamian 1982: 423).²⁷ It seems that during the premiership of Hoveyda, in practice, the court was returned to the Qajar style, everything was in the hands of the Shah, and what remained was controlled by key individuals such as Alam, Ashraf and a few members of the ruling elites.

The Shah by the 1970s had come to the belief that the nation consisted of nothing else but his loyal 'subjects'. Thus, for him "*l'etat, c'est moi*": everything in the country was either his or at his service (The Shah quoted in Radji 1983: 180; see also Alam 1991: 228).

4.5.1. The state's economic power and the non-ruling economic elite

The non-ruling economic elite consisted of the old-time and the new entrepreneurs, some of whom were prominent members of the noble, military, and bureaucratic elites, and who controlled all the major commercial enterprises and private firms, and were involved in major economic activities - some of them in collaboration with the TNCs.²⁸ In 1974, only 45 families controlled 85 percent of firms with a turnover of more than \$143,000 (Halliday 1979: 151; for a detailed list see Ehteshami 1995: 84-5).

The economic elite mainly constituted the leading bourgeoisie of Iran in the twentieth century. Hence, the bourgeoisie had three main origins: landowners, the bazaar, and the bureaucracy.²⁹ The oil revenue strengthened the state vis-à-vis the bourgeoisie. While the state's policy was a capitalist one, its numerous interventionist and clientalist policies weakened the industrial bourgeoisie.

The economic elite by itself could not influence power politically, largely because the state was neither an agent of a bourgeois class nor dependent on their wealth through taxation. On the contrary, as the sole recipient of oil revenues and the main economic player, the state became the major contributor of oil concessions and economic rewards. For instance, the government distributed the large amount of subsidies in the form of

cheap inputs and credit subsidies for those who could obtain access to government resources (Pesaran, 1995: 95-6). Thus, the economic agents were rather keen to use the protection and privileges offered by the state to maximise profits and be involved in safer economic activities. As a result the bourgeoisie as a whole was enjoying the economic boom, and was in many respects dependent on the state. Because it was unable to translate its wealth into political influence, it had no intention, or interest, in becoming independent of the state. Thus, it remained loyal to the mentor of the state - the monarchy. This situation assisted the state:

“to extend its influence even further and to consolidate its alliance with the comprador bourgeoisie as its senior partner” (Ehteshami 1995: 80).

The economic elite could influence the power structure only indirectly through its affiliation with the ruling elites.

Nevertheless, in 1975, the state began to increase its involvement in the daily life of this already dependent economic group. For instance, through the anti-profiteering campaign, in which more than 8000 businessmen and craftsmen - among them some prominent members of the economic elite - were arrested, the regime sought to tighten the screw against this emerging economically powerful bourgeoisie, which had been prospering due to the oil boom and strengthened by foreign economic ties.

4.5.2. The Pahlavi Foundation: a conduit for loyalty

While Reza Shah had been concerned with building up a personal fortune for the Pahlavi dynasty as a means of control and protection - for example, he seized 20% of Iran's cultivable land through confiscation, forceful sale, etc. and became the biggest landowner of his time - his son had less need to use force simply because money was available in more diversified forms. It was sufficient for Mohammad Reza Shah to exercise ultimate control over the state's economic apparatus. In spite of this, the Shah and his family did build a royal empire on wealth derived from the country's resources and state funds and favours. The royal family was involved in all ranges of major economic activities throughout the country either through single ownership or partnership (see Appendix 1).

The Shah, keeping over 1000 villages, sold 1106 of his villages, exceeding in value by 1959, of almost \$150 million. The value of his hotels and his belongings in 1959 was estimated to be worth around \$85 million (Ravasani 1990: 251) which was almost equal to the country's total exports. The Shah claimed in 1961 (and later in 1978) that he had donated his wealth to the Pahlavi Foundation and had received nothing from the Foundation. In a way, this means that the Shah, when he left Iran in 1978, should have had nothing of his own. But the Pahlavis' wealth amounted to billions of dollars inside and outside the country.

The Pahlavi Foundation (hereafter PF) was the most important disguise for the wealth of the royal family. The Foundation became a front for the Shah's financial holdings, which had made him and his family among the richest in the world. PF was used in three key ways to assist the Shah and his family. It was a tax haven for royal investments and a safe and institutionalised conduit for pensions to the family and the loyal elite;³⁰ a means of exerting economic control or influence by investing in specific sectors of the economy; and, a source of funds for royal ventures (Zonis 1971: 24).

"After the government itself" Zonis argues:

"it is the most powerful economic force in the country. It seems certain, however, that a great deal of its resources are spent maintaining and enhancing that economic power" (1971: 49).

The Foundation was established in 1958, but it was not until 1961, when the topic of royal wealth became politically sensitive, that the Shah chose to transfer the more substantial Pahlavi assets to the Foundation, valued at approximately \$135 million (Graham 1980: 157).³¹ Such a transfer of personal wealth to a supposed charitable relieved some pressure on the Shah from those who regarded Pahlavi assets as ill-gotten and as state fund. More importantly, PF could still be used for the very same purpose for which it was intended - to keep the Shah in power. However, what the Shah did was to institutionalise the extensive wealth of the Pahlavis under the charity organisations like the Farah Pahlavi Foundation, the Queen Pahlavi Foundation, the Ashraf Pahlavi Foundation, the Shahnaz Youth Clubs, and the most important of all, the PF. While the latter was receiving an annual subsidy of over \$40 million from the budget, the combined

annual subsidy for other heretofore foundations was over \$100 million (PBO, 1976-7: 70).

These charitable activities were used as means of royal patronage. With the oil boom, the business interests of the royal family prospered mostly in the private sector and more as a mediator in foreign trades and by being granted a monopoly. Thus, the well founded belief that royal patronage was the most effective guarantor of profitability and business security led those establishing industrial and commercial ventures to offer small stakes to members of the royal family or to the PF.

According to appendix 1, PF penetrated almost every corner of the nation's economy and was involved in a wide range of economic activities, and covered enterprises from almost all sectors of society, starting with banks (15 percent of all commercial banking and 30 to 50 percent of all private banking); investment companies and insurance firms. It was also represented on a large scale in the industrial sector such as vehicles (8 percent of the car market), building materials, pharmaceutical products, leather, office machines, mill industry (15 percent of total mill capacity), several agro-industrial enterprises, printing and publishing and shipping enterprises, tourism and leisure industry (i.e. full monopoly on casinos), hotels (70 percent of total bed capacity), housing and property abroad, and construction and office buildings. The Pahlavi family took part in every viable project which appeared to be profitable, even in many cases without providing capital itself.

The PF was mostly involved in economic activities inside Iran. But the wealth of the royal family was not limited to the boundaries of the country. In addition to the lists of banks, palaces, properties, jewellery, valuable art pieces, office buildings, factories, firms, etc. which were hardly possible to evaluate, the royal family transferred and invested a fortune abroad, in the US in particular. By the beginning of 1978, the banking system had accumulated a deficit of some \$3 billion, of which \$2.6 billion had been given in loans to the Iranians (mainly the royal family) and foreign capitalists who were fleeing the country even before the revolution was fully underway (Amirahmadi 1990: 20). During the 8 weeks preceding the imposition of crisis exchange controls earlier in November 1978, \$2.5 billion worth of funds was transferred abroad by 177 members of the ruling elite (The list was published by the striking employees at the CBI, 27 November 1978, *ibid.*)³²

However, as the royal family and their Foundations rarely quoted their wealth and ownership of companies, it is almost impossible to have a detailed list of wealth owned by them outside Iran. Western estimates place the fortune accumulated by the royal family at anywhere between \$10 and \$20 billion (*Washington Post*, 17 January 1979). However, the Iranian government filed a suit in an attempt to recover about \$36 billion which was claimed and documented to be diverted from Iran by the Shah and the royal family (personal account from Iran's representation at the International Tribunal at Hague).³³

The opponents of the regime and some analysts had contended that the system of industrial controls, licensing, tariffs, etc. was set up so that the Shah's family and close business associates would have an easy source of monopoly profits and political influence, and further that the Pahlavi family used their unrestrained political level to ensure: 1. That they became business partners of most major manufacturing enterprises, hotels, banks and insurance companies, and 2. That by resort to bribery, arm-twisting and enforced changes in the country's trade and banking regulations, they created an appropriate environment for their own purposes which often proved contrary to the objective of income. It is fair to say (and supported by facts) that almost all these methods of benefits and gains were utilised extensively by the Shah and the royal family and their associated circles; however, it is unlikely that most of the industrial regulations and the whole strategy itself was created with this purpose in mind. As will be shown later, the Shah's personal grandiose ambitions for industrialisation of the country was in no way less important than material gain by him and his ruling elite.

4.6. The Shah and the Autonomous State

It is useful briefly to outline the main factors that, after 1963, contributed to the increasing autonomy of the state from societal groups in Iran. Two main factors can be identified. The first was Iran's cliency relationship with the US, as will be discussed in chapter 6, beginning essentially in 1953 and lasting until the mid-1960s, during which, the US continued to provide large amounts of economic and security assistance to Iran, and after which the US-Iran cliency relationship began to decline (Gasirowski 1991). This economic and security assistance greatly strengthened the Iranian state. The US economic aid programme played a key role in modernising the Iranian economy, and initiating a long

period of very rapid economic growth which helped co-opt social forces. After the 1953 coup, the Shah used repressive apparatus together with the co-optive effects of Iran's rapid economic growth, against all sources of opposition.

A second factor that affected state autonomy in Iran in this period was the state's growing revenues in the form of oil income, which first exceeded its US aid revenue in 1958, and as will be discussed in chapter 5, became the primary engine of economic growth in Iran after the recession of the early 1960s (on the effect of oil revenue on state autonomy in Iran see Katouzian 1980: chapters 12-13; Skocpol 1982: 265-83; Moghadam 1988: 225-38).

As an external variable to the structure of society, and as the fountainhead of capital accumulation, the oil income,

“helped to reinforce the autonomy of the state as well as the supremacy of the Pahlavi court-related state and *comprador* bourgeois faction” (Ehteshami 1995: 78).³⁴

The land reforms of 1963, led to the state's autonomy from the landlords. Indeed, the state's autonomy from the established proprietary classes, namely the landlords and the merchant bourgeoisie, was a pre-condition for the state to restructure capital formation. The inception of such autonomy was the focal point of the industrial strategy of the state.

As was argued, repression and co-optation made possible by the US-Iran client relationship and Iran's growing oil revenues effectively destroyed all the country's established opposition organisation by the mid-1960s. Moreover, the Iranian political system during the 1960s and 1970s lacked intermediary political organisations connecting the state and civil society. This increased the state's autonomy in two main ways. First, it enabled the Shah to consolidate his personal control over the state apparatus, destroying the checks and balances on state policy-making embodied in the Constitution. This occurred mainly because the absence of an effective opposition enabled the Shah to gain control over the Iranian Parliament and neutralise it as a representative body. With the armed and security forces in control, the Shah was able to consolidate his control over the remainder of the state apparatus. By the mid-1960s the state apparatus had become highly centralised and highly personalised, with virtually all decision making authority concentrated in the hands of the Shah and a few loyal advisors; no institutional

mechanisms existed through which societal pressure could effectively influence state policy-making (see US Embassy 1976). Second, in the absence of social pressures, no mechanism existed that could force state policy to respond to the needs of society. Therefore, to the extent that state policy-making was shaped by factors such as the views of the Shah and the ruling elite, organisations and bureaucratic process rather than by social pressure, the state was able to carry out policies that otherwise it could not have.

Hence, the authoritarian establishment and the bureaucracy were two channels in which the Shah could impose his policies and objectives, by enjoying the autonomy of the state. The Shah's high degree of personal control over the state bureaucracy served essentially as an instrument for implementing his decisions rather than a mechanism for bringing expertise and public input into state policy making. As a result:

“the state's policies were often highly irrational and divergent from society's needs” (Gasiorowski 1994: 449; see also Razavi and Vakil 1984: chapter 4).

Foran notes that:

“The Shah was so closely identified with the state that he represented the hegemonic part of the ruling class. Autonomous from the rest of this class, he was both the most powerful actor in the polity and economy and the object of resentment by other sectors of the elite and a potential target of social movements from below. The Shah and state were thus autonomous within Iranian society, but dangerously so, from the point of view of their own long-term survival” (Foran 1993: 317).

Contrary to what classical political economy from Adam Smith to Karl Marx regarded the state as an ultimately determinate, not a determining socio-economic category - the state in Iran as a sole recipient of oil revenues and manipulator of coercive and bureaucratic power was a determining socio-economic factor (Katouzian 1981). Hence, the autonomous state, through the control of the means of allocation, became the principal line of demarcation between different social classes, and these classes became dependent economically upon the state.

Furthermore, the Iranian state's high degree of autonomy from society and its extensive revenues from US aid and programmes and from oil exports enabled it to dominate thoroughly the Iranian economy in the 1960s and 1970s. The state was autonomous, as the growth of bourgeoisie was dependent on and conditioned by the state.

The state's autonomy gave the Shah room to freely manoeuvre. Thus, policy-making in the Iranian autonomous state, with the absence of effective societal constraint, was shaped by various factors in this period, the most important among them, being the Shah's political and economic objectives and priorities. This, in turn, enabled the economy to pursue policies which increasingly distorted the economy and eventually produced a serious economic crisis in Iran. This is the issue to which we will return now.

Chapter Five: The State, Oil Revenues and Economic Development

The oil sector played a major role in the Iranian economy during the period 1940-78. During most of this period, oil production and exports acted as both a leading sector and as the determinant of the overall impact of an increase in exports. It contributed to the country's economic growth through linkages and spread effects and, most important of all, through contributions to GDP. Its share in GDP rose steadily from 13.9% in 1962 to 23.3% in 1972, peaking at about 50% in 1974 before falling back to 32.5% in 1977 (Table A14).

Oil exports were by far the largest and most dynamic individual item in the country's export sector, and its revenues dominated the government's fiscal resources. Nonetheless, many links that may have existed between the oil sector and the rest of the economy are not as apparent as the above information indicates.

The oil operation has both direct and indirect effects on the domestic economy. The indirect impact is through oil revenues; the direct impact is through forward/backward linkages which could be the prime force behind closer integration of the oil and non-oil sectors. Such an impact could be important because of the secondary and tertiary industries that could possibly develop around the oil sector.¹

With its advanced technology and low-labour orientation, the Iranian oil industry tended to be relatively deficient in backward and forward linkages (Fekrat 1979 in Looney 1985). The backward linkage tended to be negligible, or almost non-existent because obviously the failure of oil to generate backward linkage was a direct result of its highly capital-intensive and skill-intensive technology. Its input requirements were highly divergent from domestic factor supplies.² The forward linkage was negligible too. It failed to create the closer integration of the oil industry with the rest of the economy.

In the apparent absence of forward/backward linkages, it was the indirect or fiscal impact of the oil sector which transformed the economy. Government spending was totally determined by oil-export receipts; income generated in the non-oil sector was wholly induced by oil expansion; income increases induced by increases in oil exports continued to expand; and the level of imports and savings eventually increased to equal the initial increase

in public spending. The dominance of the fiscal impact in the 1960s and 1970s meant that the government had to play the leading role in initiating development. This role was either through active state participation or through financial channels. Development depended primarily on the magnitude of the fiscal linkage rather than on forward/backward linkages. Therefore, maximising the fiscal impact was a critical problem for the government. Its success rested on its ability to invest productively its fiscal proceeds, in which the investment priorities of the country were of the utmost significance. Therefore, mismanagement in economic decision-making could easily prevent the transformation of the economy and the attainment of its objectives such as growth, price stability, and employment.

5.1. The Impact of Oil on the Economy, 1910-50

In the first half of the twentieth century, the magnitude of direct influence of the oil industry was negligible, and the oil industry remained economically divorced from the rest of the Iranian economy.³

The only major connection between oil and the domestic economy was through the fiscal impact provided by payments of royalties, taxes and dividends to the government. Even in this respect, oil revenues accounted for only a small portion of the foreign exchange needed for imports - for both civilian and military purposes. Firstly, the Iranian government received only 10% of the export value on average from AIOC, secondly, the oil industry made a sluggish, though continuous, progress in both production and revenue (Table A1). As a result, the fiscal impact of oil revenues on the economy during this period was small, corresponding to its small magnitude, and it was further undermined by other factors. Among them were: (a) only a very small portion of oil revenues accrued to the Iranian government. Taxes paid by the AIOC to the British government were in some years more than three times the royalty payments to Iran; (b) the company's pricing policy was in favour of the British government i.e. the discount prices rendered to the British Navy during the World War I and onward; and, (c) a very low dividend policy was pursued by the AIOC. In 1948, the British government raised its tax revenues from the AIOC, thus lowering the company's dividend from which Iran drew its own income. Of the AIOC's net income of £79 million in that year, 35.5% was paid to the British government as taxes and 12.7% was

received by the Iranian government as royalties. The corresponding figures for the 1933-49 period were on average 19.5% and 11.9% (Katouzian 1981: 182-3 table 9.1, 9.2).

Analysis of the precise impact of oil revenues on the government budget operation for this period is almost impossible owing to the unavailability of reliable budget data and the absence of information on government reserve accounts. However, major features of fiscal impact of oil for this period can be distinguished since: (a) almost all receipts from oil before 1927 were channelled for current expenditures. In the 1930s, development expenditures became increasingly important, absorbing a share of oil revenues. In the 1940s, oil revenues were again included in the general budget, accounting for both current and development expenditures. It seems that the major share of oil revenues prior to 1942 was earmarked for non-routine expenditures, i.e. defence; and (b) during the 1910-50 period, the share of royalty payments in government revenues never exceeded 15% - showing that the lion's share of government finances came from sources other than oil, such as taxes, which counted for two-thirds of total revenues.

5.2. Oil and Government Fiscal Policy: 1950-77

The data suggests that, as in the period 1911-41, the direct influences or spread effects of the oil sector on the Iranian economy during the 1950-77 period were minimal. Looney (1985: 69) shows that manufacturing experienced only marginal forward/backward effects with the oil industry at best, indicating that the domestic economy was far from integrated with the oil sector.

Thus, indirect influences through fiscal channels were by far the most important medium through which developments in the oil sector were transmitted to the domestic economy. As the sole recipient of oil revenues, the government was, therefore, the dominant influence from the standpoint both of domestic resources mobilisation and resource allocation. With the state's extensive intervention in the economy, Iran experienced a period of rapid capitalist development.

In the 1960s and 1970s the state carried out extensive expenditure policies (investment and consumption) through the spending of oil income. This was carried out through subsidies, interest-free loans, privileged grants, gifts and entitlements, social security, free

education, high salaries and wages, etc. Throughout this period, the state was becoming larger in size and much more involved in social functions.

GRAPH 5.1: *Share of Oil and non-Oil Exports in Government Budget and Foreign Exchange, Selected Years*

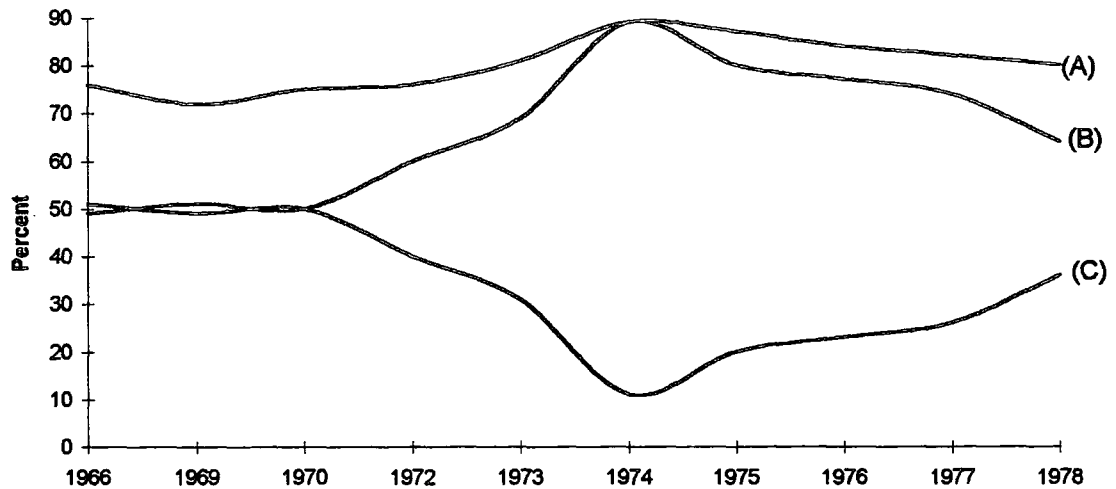

A: share of oil export in foreign exchange

B: share of oil income in government revenues

C: share of non-oil export in government revenues

Source: Tables A4, A15

As a percentage of government revenues and foreign exchange receipts oil income rose substantially over the 1963-78 period. Government revenues consisted of oil and non-oil income. According to Graph 5.1, oil revenues increasingly dominated the government budget, rising from 48% in the Third Plan to 78% in the Fifth Plan. By the same token, the share of the public sector in GFCF increased from 41% in the Second Plan to 66% in the Fifth Plan (Table A7). The share of tax income in government revenues dropped by half to 18% in the Fifth Plan compared to 35% in the previous Plan. As will be shown, the rise of oil revenues in the 1960s had been chiefly responsible for keeping government current revenues ahead of current expenditures, allowing public savings to rise despite an increase in current public expenditure by more than three times and investment expenditures by four times.

Graph 5.1 shows that the increasing dependence of the economy on oil revenues was even more striking in the foreign exchange sector. During the period 1960-78, the share of oil revenues in all foreign exchange receipts increased from 76% in 1963 to 81% in 1973 and later to 80% in 1978, after having fallen from its peak of 89% in 1974.

The significance of these developments lies in the fact that for the first time the government actually possessed the financial capability of which it had always dreamed. Oil revenues thus enabled the authorities to launch a series of ambitious development projects, thus freeing the state from the need to raise income domestically. Oil brought new forces to play which allowed for the restructuring of political life. It brought spectacular growth, yet at the same time, engendered dependency on volatile markets, which is one of the focuses of the next chapter.⁴ But the transformation that was brought about in the rest of the economy by the oil sector were more far-reaching than that. It produced a new kind of economy, built on rent and heavily reliant on the export of a single raw material, the production of which required little contact with the rest of the economy (Mahdavi 1970). Most critically, since the state was the sole recipient of oil revenues, the major impact of oil revenues on the economy was through the state's fiscal/financial channels. Consequently, the autonomy of the state vis-à-vis Iranian societal groups and the bourgeoisie increased further (Skocpol 1982).

The government budget was treated as an effective fiscal tool only to a limited extent (Amuzegar 1977: 192). Several important trends can be noted in government budget. On the revenue side, in spite of a deliberate campaign to reduce gradually the country's traditionally heavy dependence on oil, the actual trend was in the opposite direction.

The basic features of government revenues were as follows: (a) the relative share of oil income in total government revenues which, up until 1971, had stood at a fairly constant ratio of about 50%, reached 76.9% in the 1977 budget, after its peak of 86% in 1974 (Graph 5.1); (b) the share of public revenues (both oil and non-oil revenues) in GNP rose from about 20% in 1971 to 43% in 1975; (c) the relative share of tax revenues in total government budget, which during the 1960s stood at around 35%, reached 17% in the 1976 budget, after its lowest ever ratio of about 11% in 1974; (d) direct taxes, which accounted for about 23% of total non-oil revenues as late as 1971 increased to more than 35%, in 1976, displacing custom revenues as the largest source of tax income, but decreasing,

however, as a proportion of total government revenues compared with previous years (Table A6).

The heavy reliance by the government on an easy income of oil revenues for the conduct of its routine and development operations at the expense of traditional fiscal tools (taxation) was bound to produce a new element of risk. The risk was that the neglect of the necessary fiscal tools and taxation system threatened not only to deprive the government of additional revenues, but also to limit the number of policy tools available to direct economic activities. As long as the domestic economy was not used to raise further income through domestic taxation, the strengthening of the domestic economy was not reflected in the income of the state, and was therefore not a precondition for the existence and expansion of the state.⁵ High levels of external capital inflows coincided with the initial stages of state-building, creating a disjuncture between the development of regulatory, extractive, and distributive state institutions. Through its possession of massive oil revenues, the state weakened the extractive and regulatory institutions: being free from taxation and domestic revenues, the state created instead a large number of distributive institutions and sheltered itself from the political and social conflict that accompanies taxation, while at the same time distancing the public from taking any responsibility for financing the benefits it was receiving from the public sector. By receiving external rent, the Iranian state inevitably ended up performing the role of allocating the income that it received from the rest of the world.

Public expenditures fell into two broad categories: capital and current expenditures. Current expenditures had always been significantly higher than capital or development expenditures. Within the category of current expenditures, defence was by far the largest single item, accounting for about 27% of total budgeted outlays. While the defence expenditure increased eight times between 1972 and 1976, expenditures on housing (including civilian and military) and public office building went up by nearly ten times. The share of interest payments also rose considerably, reflecting the servicing of domestic public debt. Altogether, current expenditures up to 1975 tended to grow more rapidly than capital expenditures, reflecting (a) an increase in the government's welfare payments, (including food subsidies⁶); (b) the increasing requirements of defence and internal security; and, (c) the expansion of the civil service. Consequently, the share of investment in total expenditures

fell from 39% in 1971/2 to 32.5% in 1975/6, after its lowest ever 70s figure of 22.8% in 1973/4 (Table A6).

The pattern of public expenditures had the following typical properties: (a) armament and internal security absorbed significant amounts, and tended to increase at a relatively high rate. (b) public sector employment, which was the favoured method of channelling oil revenues into the economy, was regarded as a second form of domestic expenditure. (c) development plans were the means of investing oil revenues employed by the state, these covered capital-intensive industries, infrastructural projects and public utilities. (d) in social affairs, large increases were budgeted, especially for housing, education and health care. (e) starting in 1974 a new item foreign grants, investment and loans was added to the annual budget expenditures.

Luciani (1990: 74) argues that since the state is independent of the strength of the domestic economy, it does not need to formulate anything deserving the appellation of economic policy: "all it needs is an expenditure policy". A significant structural change in the pattern of public sector expenditure patterns occurred in the period 1973-78. During these years, oil revenues were a statistically significant variable explaining variations in public expenditures. Moreover, most variations in public expenditures were caused by fluctuations in oil revenues. Thus as government expenditures were highly dependent on oil revenues, the relationship between government expenditures and oil revenues underwent a visible structural change, beginning around 1975 for investment and around 1974 for consumption, suggesting that previous constraints on expenditures had suddenly been removed (Tables A9, A14).⁷

The main mediator between the oil sector and the rest of the economy turned out to be the state. It received revenues which were directed to the economy through public expenditure; since public expenditure embodied a large proportion of the national income, the allocation of these public funds among alternative applications had a great significance for future economic development. Thus, economic growth depended mostly on the state's expenditure policy and financial allocations in the development plans.

5.3. The Impact of Oil and the Public-Private Sector Relations

Three phases can be broadly distinguished with regard to the rate and structure of capital formation in Iran during the post-1953 period: (1) The 1955-9 period was one of rapid growth of real investment following the massive injection of external funds into the economy (namely oil revenues and foreign capital). Government investment in this period was confined largely to infrastructure and light industries, while private investment was focused on construction, transportation and light manufacturing. This was a period of compromise with the merchant bourgeoisie and landlords, during which the state followed a semi-liberal policy.

(2) The 1960-3 period was a period of political crisis for the regime. As was mentioned earlier in chapter 4, it led to the break in its alliance with the powerful traditional proprietary classes. The period witnessed a rapid decline in the pace of investment, in particular in the private sector, following the stabilisation policy of the government and the political uncertainties which characterised these years. The political and economic changes which took place in this relatively short time span created the basic elements for the new model of accumulation which took shape in the post-1963 period. The state's autonomy from the established proprietary classes, namely the landlords and the merchant bourgeoisie, was a pre-condition for this restructuring of capital. As a result:

“A new capitalist class closely connected to foreign capital and with slender social ties was virtually grafted into the economy and formed the focal point of the industrial strategy of the state” (Karshenas 1990: 112).

(3) The period of 1963-77 was the longest period of sustained accumulation in the recorded economic history of Iran, with a real annual rate of growth of 18.9% for GFCF. As will be shown, the share of GFCF in non-oil GDP rose steadily from 16.9% in 1962-3 to 30.9% in 1971-2, reaching 50.7% in the post-1973 oil boom years (*ibid.*: 111, table 5.1). Public sector investment in particular accelerated in this period as the government assumed the role of producer in basic and heavy industries such as steel, machine making, chemical and petrochemical. There was also a change in the structure of private investment as it moved into new consumer durable and intermediate products, - which created for the rapidly expanding domestic market - consumed by urban middle classes, rich peasantry, and sections of the urban working class.

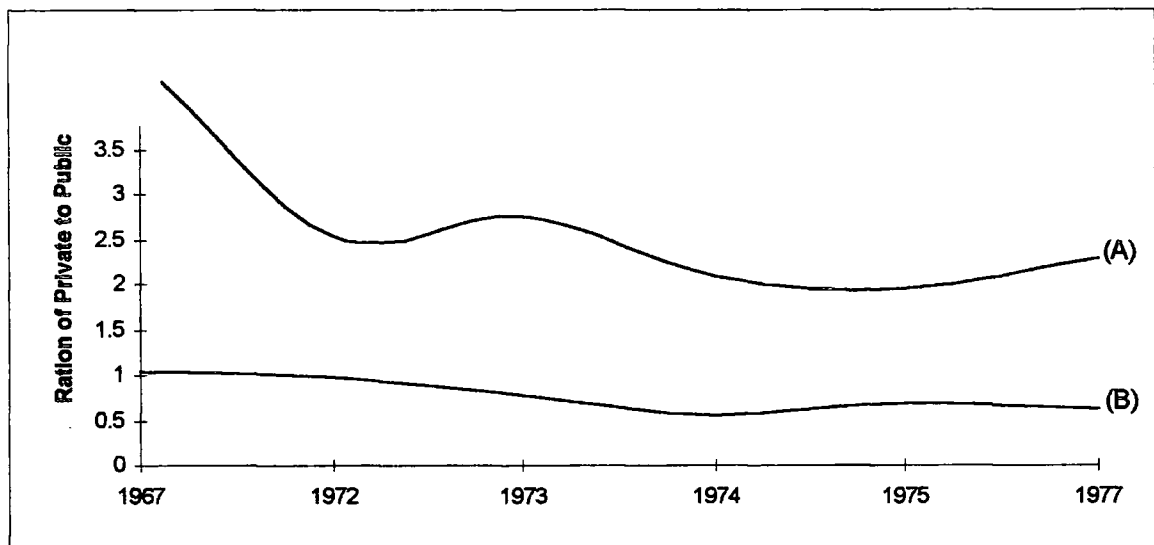
GRAPH 5.2: Investment and Consumption Ratio of the Private Sector to the Public Sector

A: consumption ratio B: investment ratio

Source: Table A6

According to Graph 5.2 the public sector's share of consumption and investment expenditure rose more or less steadily throughout the period. This rising trend was particularly pronounced in the case of the investment expenditures. The investment ratio between the private and public sectors decreased constantly. By Third Plan, government investment surpassed private investment, and the ratio fell below one. Under the influence of rising oil revenues, the government was able to steadily increase its share of fixed capital formation vis-à-vis the private sector's share. Thus, by the early 1970s, the government's real share in GFCF had reached a level of over 60%.

The ratio of public sector expenditure (consumption plus investment) to GNP increased from 25.1% in 1967/8 at the end of the Third Plan to 34.2% in 1972/3 at the end of the Fourth Plan. From mid-1974 this trend would increase once more to 42.9% by the end of the Fifth Plan (Table A6).

A distinct feature of the structural shift in the government's development expenditure in the post-1963 era was the increasing concentration of government investment in the industrial sector and its related activities, mainly heavy industry. As can be seen from Table A10, the share of government investment allocated to the industrial and energy sector grew from about 16% to 41% between the Second and Fifth Plan periods. Over the same period,

the share of physical infrastructure declined from 71% to 28.1%. The share of government investment allocated to traditional light industries fell from 77.3% during the Second Plan (1956-62) to 3.8% by the Fifth Plan period (1973-7), while the share allocated to heavy industry over the same period grew from 5.7% to 80%. Thus, real GFCF in the public sector grew at an average annual rate of 22% over the 1963-77 period; by 1967 it had surpassed the level of private investment.

The ratio of public investment to local investment in Iran in 1970-78, as published by IMF, was approximately three times higher than the corresponding ratios for 'statist' countries like South Korea and Mexico, and approximately six times higher than the corresponding ratios for Brazil and India.⁸

The possibilities of financing government investment through domestic resource mobilisation, either by taxation or other forms of government intervention, were not instrumental in determining the size of the government's development expenditure. Rather, it was the availability of external finance, namely oil revenues and foreign credits, which determined the magnitude of government investment. Since foreign credits were by and large a function of expected future oil revenues, the latter became the main determinant of planned investment.⁹

While oil revenues had a major impact on the government's expenditure patterns, the private sector did not seem to have been directly affected to a great extent. During the period 1963-77, private sector investment was influenced indirectly and strongly through public sector investment, both from the demand side and the supply side. On the demand side, the rapid growth of government investment contributed to the rapid expansion of the home market. Private investors were encouraged to increase their investment with the highly buoyant conditions of demand and the availability of resources for investment, namely labour, foreign exchange and capital. On the supply side also, it is expected to have contributed to the profitability of private investment through direct cost reduction and other indirect positive externalities. Government investment in infrastructure such as transport, communications, energy and irrigation and its development expenditure on social overheads such as education and health would have obvious positive effects in this respect. Such complementary and dynamic interactions between public and private investment are expected to be particularly strong in those economies with an ample supply of surplus labour

and substantial possibilities for increasing the productivity of labour through the introduction of advanced technology. The reason for this is that such an abundance of resources, minimises the 'crowding out' effect of public investment.¹⁰ In the same context, Ehteshami (1995: 77-8) argues the importance of public sector investment:

"As a capitalist state, it enabled private accumulation through expanding the market, and it facilitated capitalist reproduction through institutional control of labour and investment in infrastructure and those industries which, for one reason or another, were not attractive to the private sector".

The public sector's investment was designed to be limited in the Second Plan. Nevertheless, the state became an active investor owing to either (a) the inability of the private sector to fulfil the obligations assigned to it by the planners (Ehteshami 1995: 78); or (b) the pursuit of autonomy by the state in which the private sector became dependent on the state and reliant on its favours (Katouzian 1981). The politico-economic uncertainty and lack of clear planning objectives in the Second Plan (1956-62), and growing consolidation of authoritarian-bureaucratic structure of the regime from the Third Plan (1963-7) onward, further deteriorated the economic role of the private sector vis-à-vis the public sector. Thus, public expenditures led to a situation whereby the private sector's investment and expenditure was positively correlated to the government investment and expenditure.

By the Fourth Plan (1968-72), the public sector had surpassed private sector investment, rising from \$68 million in the First Plan (1949-55) to \$68.6 billion in the Fifth Plan (1973-78) - a thousand-fold increase (Table A3).

However, in spite of changes in the role of private and public sector investment, the former continued to dominate the consumption expenditures. This fact notwithstanding, Graph 5.2 shows that the consumption ratio between the private to public sectors declined steadily from 4.5 in 1967/8 to 1.96 in 1975/6, which indicates a growing share of public consumption relative to private consumption. The real ratio continued to decline too, showing the extent of increase in level of public consumption relative to private consumption (Table A9).

5.4. The Impact of Oil Revenues on Development Programmes, 1950-77

The crisis which ensued following the downfall of Reza Shah and the presence of foreign troops in Iran from 1941 to 1946 radically altered the balance of political forces in the country, and prolonged the period of political and economic uncertainty. This was characterised by frequent changes of government, decreasing production, food shortages, high unemployment, forced devaluation of the rial in order to benefit the allied forces with supply of cheap goods and foodstuffs, and rising prices.

This state of economic uncertainty continued well after the end of World War II, as various attempts by the government to solve the country's financial and economic crisis proved totally inadequate (For an analysis of the economic situation during this period see Mofid 1987: 34; Milspaugh 1946: 58-60; Katouzian 1981: 141-44; Pesaran 1995: 2-5).

During the political turmoil of the post-war years, there was a change in government approach to oil revenues, brought on by growing nationalism and resentment of foreign exploitation. In 1951, the government addressed itself to the use of oil revenues to create productive capacity in sectors other than oil. In the coming years, national economic planning was the vehicle utilised by the government for this objective. Particularly from 1956, after which oil revenues began to flow in on a large scale, the government found it both convenient and necessary to put oil revenues to use in the domestic economy through fiscal/financial allocation in planned development programmes (PBO 1968).

Oil revenues created forces which, through the state, moved the economy toward growth and prosperity. Firstly, oil wealth gave the state the ability to enhance public welfare; secondly, massive wealth helped the state to finance increased public spending and boost domestic economic activities. A large part of public expenditure went on investments in infrastructure, social service facilities, and productive capacity expansion; thirdly, the sheer increase in wealth, and the seemingly unstoppable dynamism of economic growth, clearly paved the way for the emergence of a new middle-income class in society, with civil servants, entrepreneurs, skilled technicians and the like, being regarded as the main force of stabilisation by the regime to counter the destabilising process of economic development; fourthly, public ownership of oil reserves gave national economic planners a rare and unconstrained opportunity to shape national economic priorities. Freed from the need for domestic savings, national authorities had extensive and flexible options to put together a set

of economically rational, socially unifying, and politically acceptable policies for the use of oil proceeds.

In fact throughout the Plans, and particularly after 1963, the Plans and their growth rate objectives were dictated by changes in the flow of oil revenues. A brief examination of the development Plans shows how, and to what degree and with what cost, the state succeeded in realising some of its main objectives.

In the course of economic change in the period after 1963, directions were determined not only by the economic plans but also by the Shah's reform programme - the White Revolution. In effect, the Third Plan (1963-7) was put aside to make way for the land reform programme. The Fourth Plan (1968-72), too, was modified over its course by the growing list of items within the Shah's programme. Furthermore, the role chosen for the PBO by the Shah, furthermore, varied from time to time.¹¹

As Maclachlan (1991: 623) correctly argues, Iranian policies on economic and social development can be understood only within the context of the Shah's political requirements for maximisation of economic growth, as a means of vindicating the gathering of effective political power into his own hands and the exclusion of all others from positions of real authority.

5.4.1. The first two Seven-Year Plans, 1949-1955; 1956-62

This period which covers the First and Second Plans witnessed political crisis and economic stagnation. The First Plan (1949-55) was to be financed by oil revenues and loans from the National Bank (*Bank-e Melli*) and the World Bank. In this plan priority was given to transportation and communication with 27.4% of funds being spent, followed by agriculture by 25% and industry by 14.3%.

The curtailment of oil production and exports and the incoming revenues caused by the British government's sanctions over the nationalisation act of the Iranian industry (1951-3) led to the complete abandonment of the Plan. During the Plan, the country's total oil revenues reached £76 million and the government was unable to obtain funds from alternative sources of credit. Thus only one-fifth of the originally planned investment expenditure was available for investment.

The Second Plan (1956-62) was similar in many ways to the First, including its source of funding. The total authorised expenditure of the Plan was \$1.12 billion. Transportation and communication, agriculture, industry, and social services accounted for 40.5%, 30%, 11.2%, and 18.5% of the Plan's allocation respectively. The Plan was funded by oil revenues (65.5%) and by loans provided mainly by international financial markets (27.1%) (Table A32).

Originally, 80% of oil revenues was to be set aside for development purposes each year. However, by increasing current expenditure, this was reduced to an average of 50% during the Plan. Such easy access to foreign exchange by the government did not prevent the country's move to the verge of bankruptcy and a deterioration in the terms of trade and balance of payments by 1962. A short period of growth in the economy between 1955 and 1960 ended with the onset of financial disorder and stabilisation policy from 1960 to 1963.

In reality, following the 1955 oil agreement, the rate of economic expansion proved to be greater than the weak infrastructure could stand. Consequently, inflation affected the economy with growing severity. At the same time, the flow of aid funds from the US began to fall off and the government found itself short of finance in view of the commitments to economic development and defence expenditures already made - as will be shown, a similar situation occurred in the second half of the 1970s. The country had proved unable to adjust the rate of economic growth to the creation of real domestic resources, a situation that was to recur several times.

During the 1950s, the gap between stated objectives and the availability of resources was too large to overcome. The first two plans were more financial allocation exercises than 'plans' in the technical sense of the term (Amuzegar and Fekrat 1971). Lack of physical targets or explicit objectives and strategy underlying the expenditures, uncertainties about the availability of financial resources, and a lack of co-ordination between various government agencies in this period caused delay and frustrations. Thus many projects and programmes diverged from their original allocations.

5.4.2. The Third and the Fourth Plans, 1963-67; 1968-72

The Third Plan (1963-67) was essentially an investment programme for the public sector, together with several forecasts of private sector activities. The main objective of the Plan was to increase national income by 6% annually.

GRAPH 5.3: Share of Oil Income in Government Revenues: The First to Fifth Plans

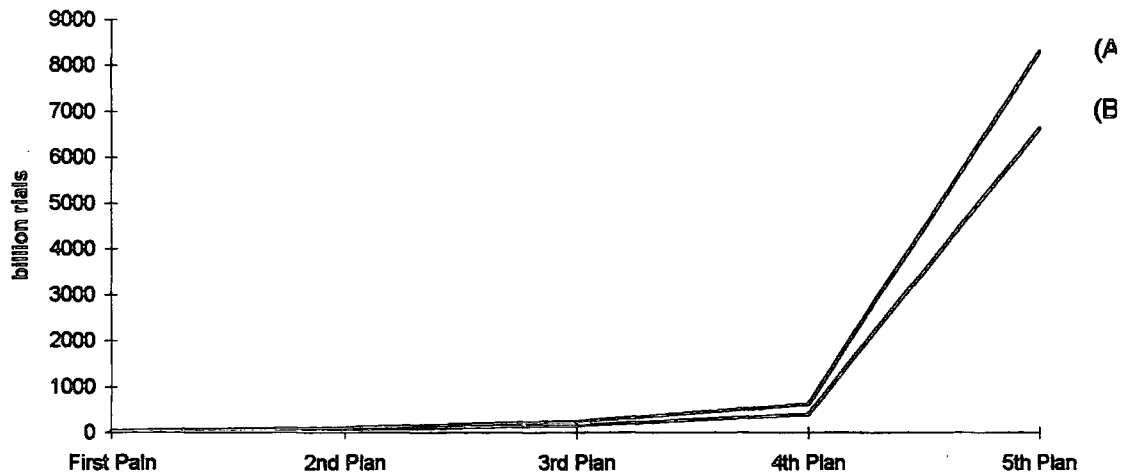

A: government revenues B: oil revenues

Source: Table A3

The Third Plan channelled a substantial portion of the indirect (fiscal) influences of the oil sector into development projects. Oil revenues of nearly 145 billion rials were by far the most important source of development funds during the Plan period (Graph 5.3). They accounted for 61.1% of development funds, followed by domestic financing (18.8%) and foreign loans (9%) (Amuzegar and Fekrat 1971, tables 3.3-3.5). Based on the sectoral allocation of the Third Plan, priority was given respectively to transport and communication with 26% of funds allocated, agriculture with 23%, and oil and energy with 16% (Table A10).

The dominance of the economy by the oil and industry sectors was evident in their annual growth rates of 13.6% and 12.7% respectively, leaving agriculture behind with a 4.5% growth rate per annum. Total investment for the Plan (based on the 1965 constant prices) amounted to about \$5.7 billion consisting of 43% by the public sector and 57% by the

private sector, together raising the GNP by 8.8%. The money supply was kept under control and the overall level of prices remained relatively stable during the Third Plan period.¹²

The actual sectoral allocation of the Third Plan deviated from the initial targets, however. The most important deviation was in the industrial sector, where it absorbed 8.2% of total public development outlays as against the 18.1% originally set by the Plan frame, mainly in favour of oil, energy and construction. The actual spending in the agricultural sector, influenced by the adaptation of the land reform and in contrast to the initial Plan's objectives, concentrated on the construction of large capital-intensive projects, such as six major new dams.

Contrary to the situation visualised in the Plan, the government continued to influence extensively the investment direction of the production process. It is worth noting that during the Third Plan: (a) in contrast to the original intentions of the Plan, the government started to establish a number of highly capital-intensive industrial project such as the Arak and Tabriz machine building plants; (b) while 70% of industry allocations went to new industries, 56% of the total public sector's industrial outlays was used by the TNCs, some of them in joint-venture agreements with the government agencies in such industries as petrochemicals and steel mills; (c) despite increased foreign exchange earnings of the oil sector, a balance of payments deficit soon appeared, growing from \$58 million in 1964 to \$212 million in 1967. Foreign loans, although substantial (\$580.7 million for the Third Plan period), were not adequate to cover the growing deficit.

The Fourth Plan (1968-72) began in an atmosphere of optimism in view of the success of the Third Plan and the promise of rising oil revenues (PBO 1968). Oil revenues rose more quickly than forecast, and funds available for the Plan were augmented. In terms of performance, the actual rate of growth during the period of the plan amounted to about 11.6% annually (2% above target). Emphasis on the agricultural sector, which was the partial case in the earlier Plans, was replaced by preoccupation with industry and the construction of infrastructure designed to support industrial expansion, with the justification that economic modernisation and acceleration of growth rate and rapid economic prosperity necessitate a total focus on the industry sector.

With the exception of agriculture and construction, all the sectoral value added targets were either attained or surpassed. Agriculture had the lowest growth at 3.9% per annum; oil

and services achieved the highest rate at 15.2% and 14.2% respectively, with the service growth almost twice the planned rate owing chiefly to the rapid expansion of government services. Industry grew at an average annual rate of almost 14% in real terms (almost as set by the target) (PBO 1973). The completion of major irrigation projects begun earlier and the inception of heavy industries¹³ generated confidence in the capability of the regime to steer the economy, both at home and abroad.

The government took the leading role as investor from the private sector. Although, the performance of the Fourth Plan compared with the previous ones was quite impressive, it was losing momentum perceptibly by the early 1970s (Bharier 1971:265; Looney 1988: 107). New and significant projects were no longer being brought forward, while inflation (including prices for foodstuffs) and wages were rising in urban areas.¹⁴ The priority in the Third and Fourth Plans, as can be read from the final investment programme, favoured services - especially social overhead capital - and suggested a shift away from directly productive activities.

For the 1964-73 period as a whole, Looney (1988: 107) argues that while the country's economic goals were not always attained, they had at least remained stable. During this period, economic development was pursued at the expense of other programmes, apart from defence which continued to absorb a major share of government budget. Emphasis was laid on government investment in infrastructure. At the same time, full utilisation of the country's oil-export capacity was pursued - by the 1970s oil production was approaching capacity - and consequently greater control over the oil industry had become a major government objective.

During this period GDP grew (in constant 1974 prices) at an average annual rate of around 10.5%. The average annual rise of the non-oil GDP by 11.5% during this period shows that the rapid growth was not simply the result of increased oil revenues (table A31). As was the case in the Third Plan, the method of formulating the Fourth Plan was essentially one of trial and error. Some other problems were also the same in both Plans: lack of statistics, inconsistency, shortage of concrete projects, lack of optimality considerations and so on. By the end of the Fourth Plan the country was experiencing difficulties in maintaining sufficient growth in its main productive sectors - agriculture and industry - to offset rapid growth in services and petroleum. Relative stagnation in the agriculture sector, rising income

levels that produced inflationary pressures, and increased urbanisation aggravated the problems. Food requirements had to be met increasingly by imports, thus reducing the availability of foreign exchange further.

Oil production was reaching its capacity level, foreign debt repayments and interest were a major drain on the country's foreign exchange holdings, and both development and military costs were growing rapidly. Incremental oil price adjustments between 1971 and 1973 temporarily relieved the balance of payments pressure. However, the long-term problems did not significantly improve, and by the end of the Fourth Plan, the government was anticipating a major balance of payments crisis at some point during the Fifth Plan (Maclachlan 1991: 627). More importantly, the Shah, having achieved some economic gains, was tending to turn his attention away from the problems of the economy more to oil affairs, foreign policy and defence:

“In 1973, when the most critical of decisions affecting the economy were made, the Shah appeared to be lacking in interest in this area [economy]” (Maclachlan 1991: 626).

Actually the Shah had his own views on the role of the national economy and disregarded the Plan altogether whenever it conflicted with his programmes.

It would be difficult to argue the case that Iran was anything other than an oil-based economy in 1972, though its efforts to develop non-oil resources were designed to keep the country from becoming wholly dominated by exports of one commodity and dependent on it for development.

In spite of its shortcomings, however, as Razavi and Vakil (1984: 35) argue, during the Fourth Plan period the Iranian economy reached a stage of development where it appeared that an increase in financial resources would open up new growth outlooks. Nevertheless, as will be shown below, even though these resources did finally materialise in the Fifth Plan period, the prospects for growth dimmed and were abruptly snuffed out.

5.5. The Revised Fifth Plan, 1973-7

At the beginning of the Fifth Plan, it seemed that Iran was well placed for the continuation of the successful industrialisation of the preceding Plan period. Existing rates of growth in the economy were already high. (EIU 1973). With a target set at 15.4% average per year, GDP was designed to be increased to \$36.4 billion by the end of the Plan. The Plan set the average annual growth rates for industry, agriculture, and oil sectors at 15.3%, 5.5%, and 11.8% respectively.

GRAPH 5.4: Average Real Rate of Growth of Major Sectors

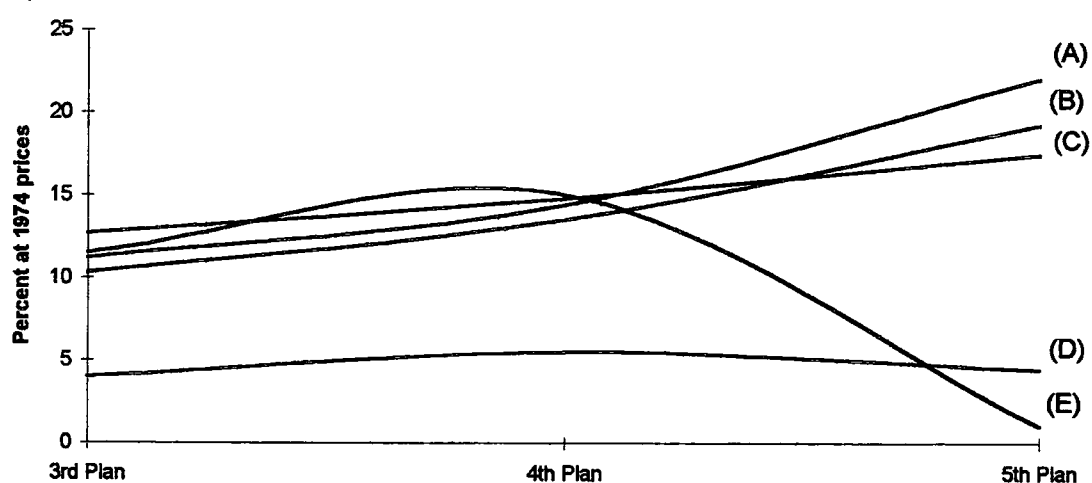

A: construction B: services C: industry D: agriculture E: oil

Source: Table A29

According to Graph 5.4, during the Fifth Plan, the average annual real rate of growth for these sector were 17.4%, 4.4% and 0.9% respectively. Nonetheless, oil (along with the service sector) stayed the dominant sector in the economy, contributing 38% to GDP, while industry and agriculture contributed 23.2% and 12.5% respectively. Structural changes, expected to come from the scheme of investment outlined above, were continuations of established trends. During the Fifth Plan, inflation was expected to remain at an average of about 4% annually.

TABLE 5.1: *Expenditure and Revenues Allocation to the Original and Revised Fifth Plan (1973-7)*

Expenditures:						
<i>Original Allocations</i>	billion rials		billion dollars		percent ¹	
Development exp.	1,560		20.6		46.7	
Payments of foreign loans	221.7		2.9		6.5	
Payment of domestic loans	63.9		0.8		1.8	
Current operating exp.	1,498		19.8		45	
TOTAL	3,344		44.1		100.0	
Expenditures:						
<i>Revised Allocations</i>						
1. Current Expenditure	3,393.3		50.2		40.9	
Public Affairs	452.8		6.7		5.4	
Defence	1,968.7		29.1		23.7	
Social Affairs	754		11.1		9.0	
Economic Affairs	217.8		3.2		2.6	
2. Fixed Investment	2,848.1		42.2		34.3	
3. Repayment of principals of foreign loans	405		6		4.9	
4. Investment abroad	905		13.4		10.9	
5. Others	745.1		11		9.0	
TOTAL	8,296.5		122.8		100.0	
Revenues						
	Original	Allocation		Revised	Allocation	
	billion rials	billion dollars	percent	billion rials	billion dollar	percent
Oil & Gas	1,577.4	20.8	47.0	6,628.5	98.2	79.9
Taxes ²	788.6	10.4	23.5	1,215	18	14.6
Foreign loans	433.4	5.7	12.0	150	2.2	1.8
Domestic loans and bonds	364.5	4.8	10.8	50	0.7	0.5
Others	180.1	2.4	5.4	253	3.7	3.0
Total	3,344	44.1 ³	100.0	8,296.5	122.8	100.0

Source: PBO, Iran's Fifth Development Plan 1973-78, Revised: A Summary, 1975

\$1=67.5 Rials

1) Author's calculation,

2) by adding the direct and indirect taxes.

3) Discrepancies due to rounding

4) Including 135 billion rials (\$2 billion) revenue from foreign investment and loans.

There was a concentration of development in the oil and industrial sectors by the state, in particular in the creation of a small number of large major capital-intensive, projects (i.e. Trans-Iranian Gas Pipeline, Sar-Cheshmeh Copper field) and in the expansion of existing ones. The aggregate effects of these major capital-intensive and energy-oriented projects in oil and industry were to localise the impact of state investment and to reduce the scope for schemes other than small-scale plants handled by the private sector.

In the original Fifth Plan, real sources were scarce. The transport, banking and civil service infrastructure were unable to support the ambitious expansion of the economy proposed under its \$20.6 billion investment programme.

However, perceiving the main constraint of the country's development to be the insufficient availability of foreign exchange, the Shah and his regime envisaged development only on the availability of foreign exchange (Mofid 1987: 40-41). Strengthened by successes in the Fourth Plan, the philosophy of the Shah and a section of senior economic decision-makers, was that the tide of opportunity for development of those areas of the economy other than oil had to be taken at the flood. There was a conviction that chances for sustained and controlled development might not appear again before oil exports had begun to fall as reserves became depleted (Maclachlan 1991: 628-9). As a result, the Plan should be targeted for a rapid industrialisation process at any costs.

Even though the original Fifth Plan was very ambitious, it was abandoned in favour of an even more ambitious version as oil prices rose in the last quarter of 1973. In the light of the oil price hike of 1973-74, a Revised Plan was declared in August 1974. By this time the assumption was that with the foreign exchange constraint removed in 1973-4, the other constraints, especially manpower and poor infrastructure, would not be serious (Amirahmadi 1990: 19; Pesaran 1982: 120-1). According to Table 5.1, the budget allocations in the Revised Plan were raised by 279% to \$122.8 billion - \$98 of which was from oil exports - and the forecast rate of growth in GNP was raised to 25.9% per annum.

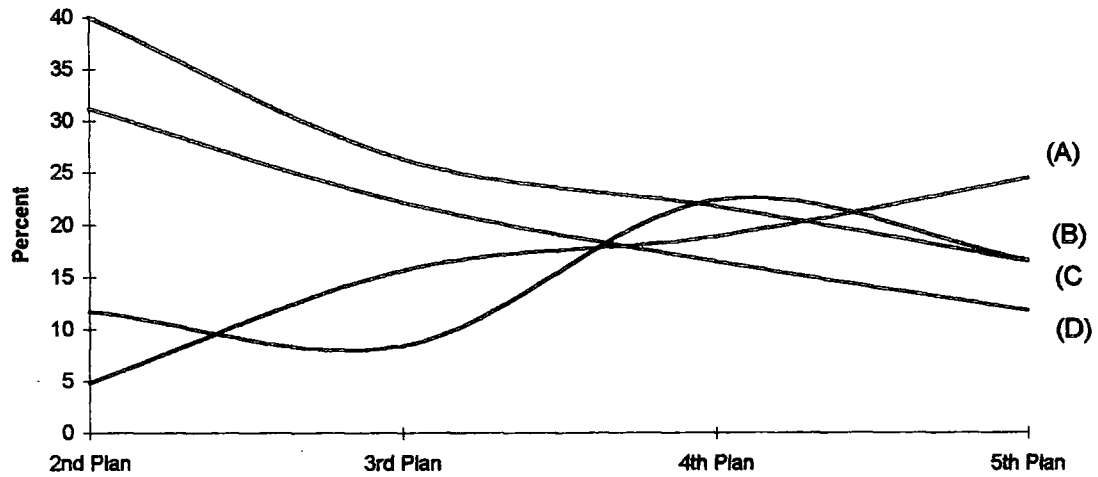
GRAPH 5.5: Sectoral Allocation of Government Expenditure, the Second to Fifth Plan

A: energy (oil and water)

B: industry

C: transportation

D: agriculture

Source: Table A10

According to Graph 5.5, government allocated more investment on oil and gas than other sector in the Fifth Plan (reaching 24.4%). Share of government investment on transport and agriculture continued to fall from 39.8% and 31.2% in the Second Plan to 16.4% and 11.7% in the Fifth Plan respectively. Public investment in industry and mine fluctuated during the Plans, decreasing from 11.7% in the Second Plan to 8.4% in the Third Plan, then increasing to 22.3% in the Fourth one and later declining to 16.5% in the Fifth Plan. Thus the Fifth Plan:

“continued promises that could not possibly be kept. In one motion, it radically expanded the role of the state in the economy. In every sector, oil money was to be spent on bigger projects and more wide-ranging social programs” (Razavi and Vakil 1984: 75).

While Iran was facing a major balance of payments crisis by the end of the Fourth Plan, the oil price increase in 1973-4 dramatically reversed the situation and converted Iran from a debtor to a creditor country. The accumulated balances on current account during the years 1973-8 reached around \$18 billion (Table A-15). Investment abroad took several forms ranging from loans made to various foreign governments (i.e. \$1.2 billion to Britain and \$1 billion to France) and international organisations such as the IMF and the World Bank (\$887

million in 1974-5), to direct investment in various private enterprises in Europe (Krupp for example) and the US. Furthermore, Iran gave financial aid to certain underdeveloped countries. On this basis, \$2.38 billion was disbursed in 1974-5 on foreign loans, grants, and investment. Other than purchasing prestige outside the country, these investments abroad represented the first attempt by the Iranian government to use oil surpluses as a means of leverage in foreign policy; in other words to buy influence.

On the revenue side, only oil income showed a substantial increase, during the Plan period, while the share of other sources of revenue such as taxes declined from 23.5% to 14.6% and loans from 10.5% to less than 3%. Revenues from exports of crude oil and natural gas for the period of the Fifth Plan amounted to \$84.27 billion against a revised Plan forecast of \$98.2 billion. The growth of oil sector was even less than during the 1963-78 period. It grew by 13.3% per annum over the 1963-72 period, but with the quadrupling of oil prices in 1973/4 and the subsequent weakening of the international markets, the oil sector lost its earlier momentum and in real terms showed only a slight increase over the 1973-8 period (Graph 5.5). Worse than this was the fact that the value of revenues was much reduced by the effects of inflation and of the high prices of imported goods. Relatively speaking, the share of the oil sector in GDP continued its upward trend throughout the Plan period. It rose steadily from 14.3% in 1963 to 35% in 1973, reaching a peak of near 50% in 1974. (Table A14).

On the expenditure side, increases were scheduled for all sectors. From 6,241 billion rials, 13.3% of funds was allocated for general affairs, 31.5% for defence affairs, 21% for social affairs, and 34.2% for economic affairs.

So long as the construction industry was booming, those made landless by the land reforms could be absorbed in the urban economy, but with the collapse of the construction boom in 1977 the numbers of unemployed quadrupled (Mansur 1979: 28 in Omid 1994: 35). It was mainly those ex-landlords who successfully compensated for their land in the land reform of the 1960s who were involved in this line of activity. Compared with the original Plan, housing allocation in the Revised Plan increased by 177%.¹⁵ The government building and installation programme absorbed 5.1% of the share of the Plan allocation (Mofid 1987: 108). Total fixed investment was set at \$42.2 billion, of which social affairs took the largest

share with \$19 billion, followed by industry and mines with \$12.54 billion. Agriculture was left with an allocation of only \$4.58 billion.

GRAPH 5.6: Sectoral Composition of Iran's GDP, 1963-1977

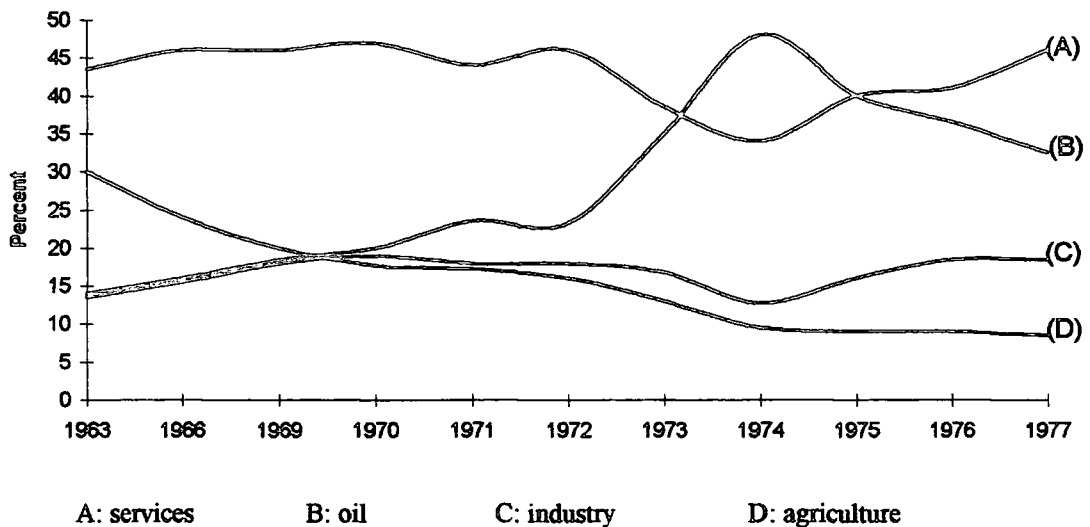

Source: Table A14

According to Graph 5.6, the share of industry in GNP increased from 13.5% in 1963 to 18.8% in 1970, and then remained relatively constant (around 18%) until 1977 except for 1974 which the sudden increase in oil revenue decreased the share of other sectors including industry in GNP. Throughout the 1960s and 1970s, while the share of industry and services remained relatively constant, the increasing share of the oil sector, compensated the falling share of the agriculture sector.

The continuous fall in the share of investment allocation and credit distribution for the agricultural sector, in contrast to industry and construction led to uninterrupted falls in agriculture's contribution to the GDP (for the share of credit allocation see Table A11). The Plan provided for a channelling of state funds into not more than 8,000 rural development poles at the expense of all settlements of less than 250 persons, which were to receive negligible investments, and other rural centres, which were to suffer much reduced financial allocations (Maclachlan 1991: 629) The effect of these policies was to reduce the confidence of private farmers and to accelerate movement off the land by the younger generation. The degree of urbanisation rose from 31% in 1956 to 49% in 1978. It is estimated that 50% of

increased population of urban areas during the decade from 1967 to 1976 was accounted for by rural migrants (Pesaran 1985).

The allocation of oil revenues was to lead to a flurry of promises by the Shah in the welfare area. Some of these promises such as better schooling, better social security, and improved health care, did materialise. But it was to create a high level of expectation among the population for an immediate improvement in their standard of living as well as a promise of achieving the 'Great Civilisation' within their own lifetimes. The fulfilment of a growing list of promises - which were supposed to be financed by oil revenues rather than by the internal industrial/agricultural production capacity - was extremely difficult to achieve. Furthermore the state bureaucracy was ill-prepared to execute these promises. Part of the failure of the Revised Fifth Plan was due not planning strategy, but to a total lack of economic discipline. Provisions of the Fifth Plan were abandoned almost completely. Expenditures were increasingly undertaken outside the framework of the Plan, since the Shah had apparently come to believe that he could transform Iran into a state than was the economical equal of countries in Western Europe, and that he was able to encourage a resurgence of ancient Iranian civilisation. Furthermore by allocating 24% of the Plan's revenue to defence expenditures, the Shah's aspiration for political hegemony in the Persian Gulf and an important role for Iran in the international arena were another feature of this grand Plan. Nevertheless, this was the time, when the country was beginning to suffer from major deficiencies. The country as a whole was already feeling the effect of social dislocation and inflation. Furthermore, the shortage of skilled labour became a major constraint. For instance, by the end of the Fifth Plan the number of deficiencies in the workforce topped over 700,000, among them 560,000 skilled and semiskilled labour, and 60,000 engineers and technicians (Table A34).¹⁶

Given the Shah's authorised simultaneous increases in welfare budgets, the spending on defence and augmented expenditures on government current account, the scene was set for a scale of demand for goods and services which the domestic economy could not supply. Moreover, it could not be met from abroad thanks to Iran's limited port and transport facilities.

While its original version, despite its faults and ambitious objectives, was a more rational approach to sustaining the pace of change and systematically strengthening the productive

sector, Maclachlan (1991: 627-33) argues that the Revised Fifth Plan appeared to be an economic failure, far from achieving its set objectives, despite the optimism that surrounded its inception. Indeed, in his view, on aggregate the government achieved little more after the oil boom than it had done under the original Fifth Plan, but at enormous inflated economic and social costs.

Expansion of supply rather than restriction in demand was the key phrase. Nowhere were the problems more serious than in the area of transport and manpower. Even with the prediction of such bottlenecks, the government preferred to follow the Shah's optimistic dictates, namely that innovative emergency resolutions of bottlenecks were required rather than trimming of targets.¹⁷

As was mentioned, during 1974, oil revenues increased to \$20 billion from just \$5 billion a year earlier. The government faced two alternatives: either to spend these revenues as they accrued, or pace its spending in line with the economy's ability to efficiently utilise the funds. Therefore, *absorptive capacity*¹⁸ should have been utilised by the government in implementing the country's development strategy. Then, the definition of absorptive capacity from a conceptual point of view is, as Amuzegar (1982: 121) describes:

“the maximum level of spending of foreign exchange by the government that yielded positive returns, given constraints on factors pre requisite and complementary to such spending”.

Examining the absorptive capacity of the economy over the period of the 1960s and 1970s shows the extent to which oil revenues relaxed or compounded the existing constraints in the economy. However, it is difficult to make this definition operational because the process of evaluating the present value of both monetary and nonmonetary returns from oil revenues over time in Iran, would be extremely complex if not impossible. Thus, an indirect macroeconomic approach to measure absorptive capacity would be looking at the country's incremental capital-output ratio (ICOR).¹⁹ It shows that the ICOR decreased significantly from 5.5 in 1960 to 1.3 in 1972 which means that the binding constraints in the economy were relaxing over the years. However, with the removal of financial constraint in 1973/4, while other major constraints were still binding, the ICOR rose to 9.22 in 1974 and later in 1976 to 11.2 (Mofid 1987: 136, table 3.24). This means that since these absorptive capacity constraints were expected to be binding, simply adding

to capital through physical investment reduced the productivity of that capital. The ICOR rose, showing the decline in additional aggregate output produced by the marginal change in capital stock. Beyond a certain point extra investment due to the high capital-output ratio did not lead to increased output, and thus:

“In ordinary developing countries, the aim is to increase the size of investment in order to increase the size of output increments; in Iran, they should have reduced the size of investment in order to increase their gains, i.e. reduce their losses” (Mofid 1987: 134).

To reduce the losses, a reduction in the size of investment was required (Karshenas 1990: 17-8; Graham 1980: 87).²⁰

As Vakil and Razavi (1984) argue, the Fifth Plan period was a time during which the process of economic planning, under the pressures of the political environment (the Shah in particular), was virtually returned to the mere formality of disbursing the financial resources.²¹

By 1977, the way in which oil revenues were allocated by the state compounded the existing obstacles to achieve an export-oriented non-oil economy. Furthermore, the unbalanced development of the Iranian economy was reinforced by the doubling the Fifth Plan expenditures in 1974.²² This situation led to a series of serious economic problems with deep social consequences, such as: a substantial increase in the rate of rural-urban migration; inflation; and an increasing imbalance between the agricultural sector and the industry sector. Furthermore, the rapid development strategy which the Shah had in mind in late 1960s and 1970s

“ceased to be relevant once capital became abundant, since then spending could run ahead of provision of other assets and create unbridgeable imbalances between demand for and supply of resources. It seems that adoption of grandiose new schemes by the government served to delay completion of projects already in hand and put up the costs of both. Many of the projects did not materialise and those that did competed for scarce resources and helped to push up wages and inflation” (Maclachlan 1991: 632).

By the end of the Fifth Plan period not one new additional petrochemical plant, steel mill or nuclear power station had been completed. The same was true of most industrial projects, that were begun or contracted for at the end of the Fourth Plan (*ibid.*).

The explosion of expenditure increased the volume of money supply in an unprecedented manner (by 61% for 1974; CBI 1974), which exacerbated the problems. The Fifth Plan (1973-77) witnessed an average annual rate of inflation of 15.7% compared with 2.6% for the period covering the Third and the Fourth Plans (1963-72) (Table A16). As a result of the increase in the aggregate demand, the manufacturers were forced to maximise their productive capacities, which in turn intensified inflationary pressures on the factors of production (Moghtader 1980: 69). At the same time, in order to alleviate internal inflationary pressures, the government relaxed import regulations and liberalised tariffs which resulted in an unprecedented influx of imports, which leading to the congestion of ports, roads, railroads, and transit frontiers. These not only revealed the infrastructural weaknesses of the economy but also caused a considerable amount of waste. Thus another main principle of the Revised Plan, which was to maintain rapid balanced and sustained economic growth with minimum price increase, had already been abandoned.

While oil revenues were the chief factor in raising the country's per capita income from \$250 in 1963 to \$1500 in 1977, in real terms the benefit of rising income was not equally shared among various groups in the country. Mehner (1978: 196) points out that during the Fourth Plan, industrial production per capita (\$367) was about three times the agricultural production per head (\$130), while its employment relative to agriculture sector was 1 to 2 (ISY 1995: 67) - another indication of the dualism in income distribution. The unfavourable trends in income and wealth distribution, among rural households, across different regions and between rural and urban areas, and in the country as a whole, that had prevailed in the early 1960s became even more pronounced in the 1970s. For instance, the consumption share of the top 20% of urban population rose from 52% in 1960 to 56% in 1975, while the share of the bottom 40% declined from 14% to 11% over the same period. This figure shows that there was a substantial rise in middle income groups in the urban areas - such as civil servants. The disparity was more severe when the urban and rural consumption expenditures were compared (Pesaran 1994: 9-10). The domestic market would therefore tend to be dominated by a highly differentiated and rapidly changing spectrum of luxury consumer goods - which reinforced this structure of the home market and the final demand facing industrial producers.

Other than the per capita 'distribution of income' among different sectors of the population, 'poverty' is another concept to quantify and discuss the income inequality. To this extent Azimi (1981) uses an index of biological subsistence - that is, the amount of material welfare necessary for survival - and identifies three levels of calorie intake, which in the specific conditions of Iran indicate three distinct poverty lines, namely, undernourished, severely undernourished, and dangerously undernourished. He shows that in 1972/3, 44% of the population were undernourished. Over one million (3% of the population) were categorised as dangerously undernourished (those with calcium intakes at 75% or less of the minimum requirement), while another six million people were severely undernourished (taking between 75 and 90 percent of the minimum calorie requirement) (Azimi 1981: Table 3, 8 in Katouzian 1981: Appendix to chapter 13).

Consequently, the Fifth Plan was much more than an investment programme. It brought great changes in the social and economic structure of the country and eventually led to a politico-economic explosion. As the experience of the development Plans implemented during the 1963-77 period shows, the size of development expenditure was frequently revised due to unexpected fluctuations in oil revenues. During this period when large unexpected increases in oil revenues alleviated the pressures of balance of payments and fiscal deficits, the government would respond by quickly increasing the size of its development expenditure and by starting various new investment projects.²³ During the subsequent periods, however, when oil revenues grew at or below average rates, new investment projects had to be postponed and resort to foreign borrowing had to be made in order to finance the many projects in the process of completion. This state of affairs implied that, irrespective of the existence of medium-term planning at the formal level, actual government investment was closely correlated to the proceeds from the oil sector, even at the short-term annual level. As Karshenas (1990: 172-5) has noted, variations in oil revenues explains more than 98% of variations in government investment.

Thus, all in all,

"in what remained throughout the Shah's reign an oil-based economy, growth was purchased mainly through expanding oil revenues, themselves largely a function of increased volumes of oil exports. Not only did this result in withdrawal of the nation's clearly finite oil reserves at an accelerated rate, but it meant continuing dependence on foreign markets together with reliance on foreign technology, high

levels of imports and the ceding of appreciable control over domestic economic policies to foreign interests" (Katouzian 1981: 324).

The state's strategy of economic development and the degree of autonomy it enjoyed from the bourgeoisie affected industrial development, distribution of wealth, and the stratification of social classes. Major beneficiaries of economic development in the 1960s and 1970s were international capital and the dependent bourgeoisie who, behind the protective shield of the state, were able to dominate the economy and reap substantial profit. The state's alliance with international capital antagonised the indigenous classes and helped determine the content of the revolutionary movement of 1977-79 (Karshenas 1990: 234-6). The resultant dependent development, in which the state was involved in a triple alliance, is what we return to now.

Chapter Six: Dependent Development in Iran

During the 1960s and 1970s, exploitation was disguised in a new and straight forward economic and commercial relationship. The new situation in the balance of power between international capital and developing countries was essentially determined by the fact that international capital lost its monopoly of the extraction of raw materials in the Third World. The most far reaching example had been in the oil sector. This does not mean, however, that its room for manoeuvre became increasingly smaller. International capital, as postimperialism (Becker and Sklar 1987) argues, found new possibilities to establish new forms of 'partnership relationship' on a new basis with some countries which have opted for capitalist development. This 'new basis' of relationship was an international division of labour between capitalist industrial countries and developing countries. It can be argued that this relationship did not totally remove exploitation but only modified it and was aimed at converting the former suppliers of agricultural produce and raw materials into raw material and industrial suppliers. This transformation established a new system which we term 'dependent capitalism'.

The framework for the analysis of such dependent development remained the reality of imperialism as a world wide system of capital accumulation. More than ever, the international economy was dominated by capitalist relations of production and exchange. The political and military resources of core states were used to maintain capital invested in the periphery. Dependency theory has contributed to the concept of dependent development by providing a useful framework for analysis of the effects of imperialism on the internal socio-political structure of peripheries, and thus on the emergence of dependent development as a special case of dependence.¹

A number of attempts have been made to apply some form of dependency theory to Iran (Keddie 1981: 143-4; Saikal 1980: 5-6; Pesaran 1982: 504). Abrahamian (1982: 427) believes that a 'minor industrial revolution' took place in the 1960s and 1970s. Ahmad Ashraf (1971) and Katouzian (1981) challenged the idea that economic growth alone meant anything like an integrated form of development. Keddie (1977) and Saikal (1980) attributed most of Iran's problems and accomplishments to its status as a rentier state, dependent on

oil revenues for its growth. Capital accumulation took place in late 19th and early 20th century in Iran even under conditions of 'classic dependence', that is, the export of primary products in exchange for manufactured goods. Nonetheless, the process of accumulation in the 1960s and 70s was, however, of a different order. It was different because it included a substantial degree of industrialisation, a more complex division of labour, and increased productivity. This implied such a process that I employ the concept of 'dependent development' - used by Peter Evans (1979) for Brazilian development.

However, my use of dependent development is a more wide-ranging one, aimed at discerning both the reality and limits of economic growth in Iran, concerned with the state and the industrialisation process, and its relation with international capital. Therefore, the Pahlavi state can be classified as a 'dependent capitalist' (Thiemann 1983). As a result, its power, was centred, partly, in the capitalist metropole. As Ehteshami (1995: 79) argues:

"In the evolving international division of labour, Iran would serve as a stable source of relatively cheap oil and a consumer of Western-supplied goods and services. As a semi-peripheral country (Wallerstein 1979), however, it would also be active in the production and export of some industrial products. Within this arrangement the Iranian bourgeoisie was able to participate in investment as a partner either of foreign capital or of the state, or of both. It can be said with a degree of certainty that the Pahlavi state's monopoly control of the country's hydrocarbon resources gave it the 'edge' over the domestic capitalist class factions, even though at the same time it deepened its exposure to external forces and international market processes. The edge at home at the same time strengthened the state's position vis-à-vis foreign capital and the supranational capitalist structures".

The dependent structure of the Shah's regime was characterised by: firstly, the 'triple alliance' - as Evans (1979) calls the association moulded between the state, the TNCs and their Western core states, and the local capitalists; secondly, the Shah's politico-military patronage to the USA; and thirdly, the oil rent. In such situation of dependent development, as argued earlier in chapter one, the centrality and strength of the state is essential.

Throughout the 1953-78 period, foreign capital played a major part in the development of local manufacturing by providing the needed finance, technology, and skilled labour. This was also the case in the Brazilian and South Korean industrialisation process for the 1960s and 1970s. In all three cases, it was unlikely that foreign capital would have sponsored industrialisation on its own without continual stimulation and pressure from the local elite. The difference was that in Iran, it was merely the state which pressured the TNCs, while in

the other two, the local bourgeoisie and economic elites were active in stimulating foreign capital to support industrialisation. In South Korea, the government forged a narrow developmental alliance with local conglomerate capital (*chaebol*) in order to pursue rapid economic growth, because the urgent need of the military junta was to establish its political legitimacy through economic prosperity. In the case of Iran and its weak bourgeoisie and highly autonomous state, such an alliance was in favour of the state. Here, local capital was dependent on the state, and the state never directly attempted or tried to strengthen the power base of the bourgeoisie.

In the triple alliance, while the state was one major partner, modification of TNCs' strategies and behaviour partly depended on the bargaining power of local capital. Bargaining in turn depended on the strength of private local capital and the state. In Iranian development, the state played a central role in fostering capital accumulation.

The dependence of the Shah's regime on the US changed from political dependence to a politico-military one, later to economico-military dependence. In the first stage of the first period of his rule (1941-45), the Shah was politically dependent on the US, as he was brought to power by the West, the US in particular. In the second stage of the first period (1945-53), political support continued involving co-operation at the military level. During the second period (1953-63), the regime depended on US economic and military assistance, in both forms of capital and technology. American military and security presence, along with administrative officers, were to build the army, SAVAK, the state's economic administrative machinery. During this period, Iran had embarked on capitalist development. In the third period (1963-79) the relations between Iran and the rest of the capitalist world moved toward interdependence relationship. However, the process of dependent development deepened, covering all areas of development. Prior to the rise in oil revenues in 1973, substantial American aid and credits - over one billion dollars for the period of 1950-64 from the US government - continued. Military help in the form of providing weaponry and financial credit, organisational and technical planning and support, continued apace.

By the boom of 1973 American involvement in the Iranian industrialisation, military build-up and weaponry was quite prominent.² With the expansion of oil revenues, the manoeuvring room of the Shah and his regime, vis-à-vis the Western world, increased. However, even though the relationship between Iran and the advanced capitalist countries

had certainly altered in many respects since the 1950s and 1960s, Iran continued to be a weaker partner in the international capitalist system and depended on outside support.

As Cardoso and Faletto (1979: xxi) argue countries of the semiperiphery remain dependent, because their capital goods sector are not strong enough to ensure:

“the continuous advance of the system, in financial as well as in technological and organisational terms”.

Although in the case of Iran, the financial constraints were removed by the sudden increase in oil prices in 1973, its organisational and technological dependence on the capitalist world remained unchanged. It is important to emphasise that the general notion of dependence used here, although it has some elements from the dependency theory, it is far different from the latter's assumptions and prescriptions, as have already been mentioned.

The oil price hike of 1973, in short term decreased Iran's dependence on international financial markets and furthermore, put the state in a powerful bargaining position. However, oil revenues depended more on the price and level of export, which both were issues of negotiation between the OPEC and the West. Therefore, while oil revenue was an independent factor in the domestic economy, it was dependent on the capitalist world. Furthermore, because oil revenues played a unique and crucially important part in the state budget and revenues and the growth of country's GNP (80-90% of government revenue and 35-50% of GNP for years between 1973-78), it provided the main link in Iran's economic dependence upon transnational capital. In more general terms, Iran's capitalist development had come about through the co-operation between the Iranian state and foreign interests, and also between the state and Iranian private capital. Iran's acquisition of skilled personnel, technology and training assistance from the advanced capitalist countries indicated the continued need for such co-operation if capitalist development was to continue.

6.1. Centrality of the State in the Development Process

Given the role of the state in the process of industrialisation and in the triple alliance mentioned above, the Iranian state played a central role in the process of dependent development. The increasing political decentralisation of international capital, a gradual process of learning within the state, and the increasing capacity of the state apparatus improved the bargaining position of the state vis-à-vis the West and its TNCs. Furthermore,

state enterprises, added to the capacity of the state and therefore its bargaining power. Over 200 major state owned firms were involved in major economic activities, in particular the large capital intensive industrial units. Government revenues from these enterprises in 1977-8 (1,116.7 billion rials) were three times the government revenues from taxes (397.6 billion rials) and second only to income from hydrocarbons (1,314.2 billion rials) (Ehteshami 1995: 81). Evans argues in more depth by suggesting that:

“Just as the existence of the TNCs changes the effects of imperialism, the creation of state enterprises change the institutional nature of the dependent capitalist state” (1979: 46).

The weakness of domestic bourgeoisie, the backward economy, the increasing desire of the Shah to industrialise the country rapidly, and to control the polity by dominating major economic sectors through the state apparatus, made state intervention inevitable and a necessity. The state assumed responsibility for the construction of roads, airports, heavy industry, and the provision of a financial infrastructure. In spite of such profound changes in the relationship between the state and the private sector, the essence of private capital accumulation remained unchanged.

Iran experienced rapid capitalist development characterised by the (1) separation of producers from the means of production (by the 1963 Land Reform), (2) freedom of the labour from pre-capitalist relations, (3) and the creation of a national market tied to the world market. Two periods marked the post-coup economic development of Iran (Moaddel 1993: 67). From 1953 to 1963, international capital began to infiltrate different sectors of the Iranian economy, thus the financial infrastructure for investment was laid, and many large scale projects were initiated and implemented by the state. During the 1963-1979 period, Iran experienced a remarkable economic growth which, as will be shown below, can be characterised as ‘dependent development’.

In this period, the state’s strategy for economic development affected the distribution of wealth, patterned class conflict, and determined the pattern of relation in the triple alliance. In the alliance, it was the overall autonomy, capacity, and resources of the state that counted in its relation’s with the TNCs and the West on one side and the local capitalists on the other. The process of dependent development changed the country’s class structure. In alliance with the state, international capital gained a dominant position over the agribusiness

and industry sectors - both technological and managerial - and banking. A dependent bourgeoisie also emerged that was closely tied to, and dominated by, international capital. This class was the product of the state initiated economic development, consisting of the royal family, the owners of private banks and modern commercial centres, industrialists, and those involved in agribusiness - in total the so called 'one thousand families'.

As was discussed in chapter three and four, the royal family, led by the Shah, dominated the polity and controlled the decision-making process. However, in Iran, the function of the state, as (1974) argues, did not confine itself to

"being the ideological and political reflection of a given socio-economic basis and securing the general conditions for the existence and development of this basis as the state apparatus of power; instead the state (was) to a certain extent itself the impulse or stimulus behind these relations and thus at the same time (consolidating) its own social bourgeois-capitalist basis" (cited in Muller 1983: 72).

The specific manifestation of the general tendency was reflected in Iran by the initiation and realisation of the so called 'White Revolution'. The material basis required by the Iranian state for the implementation of economic and social strategy grew from the production and sale of crude oil and natural gas. Crude oil was a source of accumulation which produced quite specific possibilities and characteristics in the country's economic structure and its growth potential. Profit from oil production played an extremely important role in the formation of state finance (see Table A3).

Because of growth in revenues, the role of the state budget as the centralising instrument of financial resources grew more important and the power and room for manoeuvre of the government increased in the economic reproduction process. By actively participating in social reproduction, the state could determine to a decisive extent the nature and rate of socio-economic development in Iran. This was expressed in the strengthening and extension of the state sector in the national economy, which were based in particular on disbursing the exploitation of the oil wealth and concentrating the growing oil revenues in the hands of the state. The state sector became the decisive mediator and agent in the development of capitalist relations of production, while itself, to a major extent was dependent on the conditions dictated by Western capitalism, in part through the oil market.

The enormous foreign exchange income from oil exports (over \$82 billion from March 1973 till March 1978) gave the state the financial possibilities to boost industrialisation and

to initiate economic restructuring on a large scale. This was reflected in the envisaged expenditure of the revised Fifth Plan for 1973-78 which totalled \$69.59 billion (including \$12.53 billion for industry and mining) (see Tables 5.1).

The state share in GFCF increased from 43% in the third plan to 66% during the Fifth Plan (Table A7). Mainly by means of its credit policy, the Iranian government reduced the cost of fixed capital, thus discriminating against small and medium size enterprises, which generally produced in a more labour-intensive way. The dominant role of the state sector was not therefore a result merely of its power to dispose of considerable financial resources but also its control of the key industries, such as the hydrocarbons by NIOC, NIGC, NIPC, metal industry by NISC, SCCMC, and heavy industry by machine building complexes in Arak and Tabriz amongst others, and other important sectors of power generation, etc. Furthermore, the state had firm control of the productive infrastructure and, not least, owned modern enterprises in the agrarian sector.

However, it is worth mentioning that the state stood the best chance of improving its position in industries involving extraction of raw materials, where technology was stable and fixed investment large; whereas in industries where intangible capital was more important and continual product innovation the rule, the TNCs had a stronger position.

6.2. The State's Industrial Strategy

The transfer of certain production facilities undoubtedly accelerates the pace of industrialisation in the developing countries and enables them to create new jobs. But this industrialisation is conceived as part of an internationally organised complex production process which defines or limits the possibilities and the extent of national shares in the process. The criterion applied is not the establishment of a complex industrial structure, especially in types of production where relatively advanced technological methods are used.

In Iran the main emphasis in the 1960s was on the strategy of ISI³ to provide urban consumers with various goods and - in the 1970s a deepening of this path - to undertake production of certain basic and intermediate goods such as chemicals, steel, and machine tools.

The basis for industrial development were laid during the 1953-63 period. These included certain measures taken by the state to encourage, facilitate and direct the country's industrial

development, among them the protection of foreign and domestic capital, guarantee for equitable compensation for losses,⁴ the provision of physical infrastructure, and the provision of financial infrastructure.

Iran's overall industrial growth rate was an impressive 15% annually between 1965 and 1975, registered 14.6% in 1976-77 and 9.4% in 1977-78. These rates may have been the highest in the Third World over this period, and were twice or more the average of the developing countries generally. Gross domestic fixed capital formation grew at a high 18.4% annual rate for 1963-77. These rates were somewhat deceptive however, in at least two respects: Industry's share of GNP at about 18% lagged well behind that of services (35%) and oil (35%) in 1977-78, and manufactured non-oil exports accounted for only 2-3% of all exports in 1975.

Data on output and share of specific industries suggests that the textile industry remained important, increasing production between 1965 and 1975, but falling behind motor vehicles in terms of the total value produced. Food processing also continued as an important sector. Assembly-type industries such as auto and electrical appliances became increasingly prominent.⁵

Other high-technology and capital-intensive sectors were in production of steel and aluminium (at great cost and with foreign help) whose output increased ten times but still lagged behind demand; petrochemicals and pharmaceuticals (marked by foreign technology and licensing); and machine tools in a plant at Arak. Important non-manufacturing sectors included construction, non-oil mining, transportation and banking, dominated by IMDBI - established in 1957 with 40% foreign ownership (see Moghtader 1980).

One of the outcomes of this policy of capital-intensive industrialisation was intense rise in the average investment-labour ratio. The ratio for the period 1963-72 is estimated at about \$4,000 and for the period 1973-78 over \$20,000 (Katouzian 1980: 267-68, tables 13.8 & 13.9). This means that while the average GNP per capita during the period of 1973-78 was less than \$2,000, the development strategy and the techniques of production chosen and encouraged by the state led to an average expenditure of \$20,000 per head in order to employ one more worker.

Despite the success indicated by the aggregate and sectoral data, Iranian industrialisation was plagued by a number of problems. At the core of its problems lurked structural

weaknesses deriving from the dependent nature of Iran's industrialisation process. The modern industrial sector as a whole was grossly dependent on foreign joint ventures, for capital, technology, management, and inputs. In this context, certain characteristic problems of the ISI strategy came to light. The problem of market size, limited consumption due to the low level of income in the country as a whole, lack of competitiveness of products on the world market because of high tariffs and monopoly licensing were among other problems. Furthermore the industrialisation process did not generate foreign exchange to finance its own intermediate and capital goods requirements, nor its needed consumer goods. Together with the high level of protection, this meant that the whole process of importing capital and intermediate goods and producing finished consumer goods for the domestic market could go on rather smoothly as long as the oil revenues kept rising. Lack of research and development activities and skilled labour, and the resulting overemphasis given to the degree of capital-intensity in industry, acted as an additional factor restricting the transfer of technology from the West - through the TNCs - to productive sectors of the Iranian economy.

Due to these reasons, plants ran at low capacity, resulting in failure to expand export potential. Other difficulties included the disastrous overtaxing of infrastructure during the oil boom (ports and roads) which led to great wastage of imports, endemic corruption, and capital flight after 1975 when the state mandated profit-sharing with workers in some industries and initiated an anti-profit-sharing campaign (For detail see Looney 1988:113, Katouzian 1980: 279; Halliday 1979:147, 166; Graham, 1980: 88-94). Pesaran (1982) locates the problems of ISI in the strategy and in the pattern of artificially high profits, lack of forward and backward linkages in the economy, discrimination against agriculture due to the overvalued rial, and the brake on employment caused by capital intensity.

The state by acquiring high-technology and capital-intensive industrial projects tried to achieve a rapid and short-cut process of industrialisation. The TNCs, in view of the limited supply of skilled labour and top professionals in Iran followed suit, undoubtedly accentuating the demand pressures on these already scarce human resources. For example, the Fifth Development Plan was short of 700,000 skilled personnel (see Table A 34). The military faced similar difficulties in recruiting. The air force had a shortage of 7,000 skilled personnel in 1976 and the navy which was a recently expanded force with little experience in

handling its new equipment, was in a worse condition. The trend, in view of shortage of skilled manpower, was towards the importation of foreign technicians, supervisors, and other intermediate levels of skilled personnel.

Based on the report by the Agency for International Development (AID):

“the scarcity of facilities for training and the consequent deficiencies of middle-management experience and engineering, technical and service skills being experienced by Iran is a symptom of rapid industrial development”, thus the industrialisation process “is necessarily heavily influenced by foreign talent imported to fill the gap” (AID 1972: 17).

Furthermore, AID's report points out that the International Executive Service (IESC) which was active in industrial development of most LDCs, “is oversubscribed in Iran with requests from clients”, making Iran, the second most active IESC country programme in the world (*ibid.*). US Senate (1976) anticipated that by 1980, 50 to 60 thousand American military personnel would have been necessary to run Iranian defence-related projects.

Two studies by Bildner (1973) and Daftary & Borghey (Yekom Consultants : 1975) on the role of the TNCs in Iran reinforces such findings. Based on these two surveys on the TNCs in Iran, managerial positions were monopolised by foreign employees as in technical management (91%), marketing (65%), financing (55%), quality control (100%), and in position of chief accountant (100%) (Yekom 1975: 51, Table III-11; Bildner in Alizadeh 1976: table 7).

The state played the dominant role in industrialisation in the 1960s, allocating oil revenues, building infrastructure, and co-ordinating the Iranian bourgeoisie and foreign capital in joint ventures through the grant of loans, licenses, and contracts. In industry, the state's share of ownership dropped from the 1941 level of 50% to 17% in 1963 after the transfer of shares in state factories as compensation for the ex-proportion of landed estates. But as oil revenues grew the state's role in industrial investments increased apace, from 40% in the mid-1960s to 60% in the 1970s. By virtue of its preponderant role in the highly-capitalised new sectors - steel, petrochemicals, and natural gas, machinery - the state proposed to invest \$46.2 billion during the Fifth Plan (1973-78), compared with the private sector's \$23.4 billion. Thus, local capital being weak, industrial development between 1953 and 1978 was generally attributed to the state's dominant role.

6.2.1. The private sector: the weaker partner

The private sector certainly played a supporting part in the industrialisation process. Local capitalists and middle class bureaucrats in the Pahlavi periods all enjoyed some contact with the royal family, for to succeed one had to be favoured by the court. The main activities in which local capital played a role were light industries, construction, and banking.

The active encouragement of private enterprise was an important element in the policy of the Iranian state. The opening up of the industrial sector to private capital in particular, which tried to increase the leaning of the private sector towards productive investments principally by making preparatory investments, granting credit, tax and duty relief and a series of other similar measures was an example. Attempts by the state, which were made as early as the Second Plan (1956-62), to promote private capital by loans did not lead to far-reaching qualitative change in the structure or production capacities of the Iranian bourgeoisie. In 1960-62 private investment stood at 48 billion rials in comparison with 70.6 billion rials state investment (Muller 1980: 77-8). During 1964-72 period, essentially new trends resulted from the industrialisation course of the government and the increased oil revenues and inflow of foreign capital. Active support from the state, which went hand in hand with the creation of a favourable climate for investment, led to a boom which came into full effect in the 1970s.

However, in spite of this gain, the regime never allowed the private sector to set up a political power base, as it was the case with any other socio-political groups. In this process the banks and financial institutions, mostly controlled by the state (i.e. IMDBI, ICB, DIBI banks), had a key function within the framework of state control of the economic policies and was crucial in determining the direction in which the private sector had to follow.

Apart from the quantitative aspects of the growth in volume of private investment - it increased from 56 billion rials in 1968/9 to 777 billion rials in 1977/8 (Muller 1980: 78) - there was a series of qualitative changes. Over a broad front, private capital penetrated all branches of industry apart from oil and gas, although much slower than the state. However, the degree of capital concentration in the private sector - and in particular in the sector of industrial enterprises - increased noticeably. During the period of Fourth plan, the PBO made available credit to the value of 34.8 billion rials for private sector investment. In the revised Fifth Plan, it reached 229.5 billion rials - more than 17% of the private resources

which had been earmarked for investment. The private sector also received 63.3 billion rials in the form of profit shares from state plants and municipal administrations (see also Table A11). Nevertheless, the relative proportion of public investment to private investment increased constantly from 0.75 in the Third Plan to 1.2 in the Fourth Plan, and finally to 2 in the Fifth Plan - meaning that during the Fifth Plan period, the government invested twice the private sector.

As already stated, within the private sector mainly by means of its credit policy, the government reduced the cost of fixed capital. Access to credit was generally difficult for small entrepreneurs because of their lack of securities, necessary know-how and contacts.

Table 6.1: Loans Approved by IMDBI, (classified by size), million rials (mr), percent in brackets

Size (mr)	The 1959-77 period				The 1977-78 Period			
	Number of Loans	%	Amount ¹ (mr)	%	Number of Loans	%	Amount ¹ (mr)	%
Up to 15	150	(16)	1,471	(0.9)	1	(0.9)	13.9	(0.4)
15-25	98	(10.4)	2,114	(1.3)	4	(3.5)	87	(0.2)
25-45	146	(15.6)	5,132	(3.1)	9	(7.9)	287	(0.7)
45-75	130	(13.9)	7,666	(4.7)	12	(10.5)	719	(1.9)
75-150	166	(17.7)	17,998	(11)	28	(24.6)	3,012	(8)
Over 150	248	(26.4)	129,226	(79)	60	(52.6)	33,684	(89.1)

Source: Moaddel 1993, table 3.7

1. Amounts are rounded.

According to Table 6.1, loans on favourable terms from government banks, which dealt only with a 'small number of large customers' were largely denied to small and medium-size industry. Furthermore, certain aspects of the tariff policy contributed to this differentiation.⁶ In other words, the financial framework structured Iran's industrial development, favouring large-scale industrial establishments and monopolies tied to the TNCs, at the expense of medium and small-scale producers.

The IMDBI's loan policies are indicative of this trend. In general, over 95% of total loans approved by IMDBI were loans over one million dollars, which clearly were out of the reach of small-scale industries (Table 6.1). By the end of summer of 1978 it had invested \$339 million in 155 industrial and agribusiness ventures, in most of which the TNCs were

involved. However, even financially powerful companies found themselves excluded from profitable, safe and promising sphere of investment because of the government's selective granting of licences. Small industries had no real opportunity to receive government orders and also suffered because its traditional markets were expanding less rapidly (lower income in agriculture) and because competition against cheap mass consumer commodities grew more and more acute. On the other hand these deteriorating conditions of existence were balanced by several favourable factors, like a general increase in demand and new markets - not least as suppliers for major industries - and to a certain extent the improvement of infrastructure conditions. Moreover, small and medium-size industry - regardless of the expanding development of large industry - still had at its disposal considerable production capacity and had put its own hallmark on the industrial landscape of Iran.

Another characteristic feature of state policy consisted of the promotion of ties between the upper classes and foreign capital. The triple alliance of the state, domestic and foreign capital often came together as partners in the founding of new enterprises. The close ties between the Iranian state capital and private foreign capital was doubtless one of the characteristic features of dependent capitalist development in Iran. In connection with this phenomenon, a tendency of differentiation between state-owned (large, modern Iranian-foreign enterprises) and local private companies became apparent. This tendency formed the basis for the continuing processes of differentiation and social regrouping within the Iranian bourgeoisie.

Contrary to the South Korean and Brazilian cases, for example, in Iran private capital was weak and leaning on the state for support and contribution. In the former cases, the presence of a group of large capitalists with sizeable capital and organisational resources and entrepreneurial skills limited the choices of the state elite. The privatisation of state enterprises in Iran (more in traditional industries), although strengthening the bourgeois class forces, did not, however, signify a surrender of the main positions of power by the state. The state continued to retain its command over the decisive sectors of the national economy, regardless of all its principles to encourage private initiative. This policy left local capital in a weaker position in its triple alliance with both the state and the TNCs. The private sector was leaning on the state for economic credit and favours, while politically it counted on receiving some support from the TNCs vis-à-vis the intrusive state.

6.2.2. Foreign finance, a directing element in the industrialisation process

The provision of financial infrastructure was crucial in determining the direction of industrial development in Iran. Thus, banks and financial institutions functioned as the main channel through which foreign capital infiltrated Iran's industry (see Table A18). One of the most important banks in this regard was the IMDBI. IMDBI became one of the most important mediums through which international finance capital gained access to the country's banking system and hence to industrial finance. While 60% of initial equity of IMDBI was chartered to Iranian nationals, the actual control of IMDBI's board of directors and executive committee, which was the ultimate authority for loan approval, was given to the foreign side, for the first five years.⁷ This dependence on international financial capital had naturally enabled the latter to exert considerable control over the bank's industrial policies. IMDBI was mediating between the interests of local entrepreneurs and foreign capital in the preparation for and realisation of major industrial projects. In this way, it gave a decisive boost to the process of binding together Iranian and foreign capital, at the same time promoting the concentration and centralisation of production and capital in the hands of a relatively restricted stratum of major Iranian capitalists who had close links with the TNCs (see Table 6.1). The dominant position of international financial capital was further expanded through its participation in a number of other specialist and commercial banks.

According to Table A18, 9 out of 14 (69%) of these banks were established between 1957 and 1959, supporting the claim by Moaddel (1993) that during the second stage of the Shah's regime (1953-63) the financial infrastructures was laid for the subsequent development of dependent capitalism. Data shows that foreign participants could have effective control over these banks, even with minority share holdings. The foreign shares were predominantly concentrated and controlled by financially powerful international banks, while the Iranian shares were dispersed and distributed among a considerable number of shareholders. The rate of concentration of shares varied between 90 to 100% for the former compared to 20% for the Iranian shares (Moaddel 1993: 81-2). Furthermore, the credit and aid policies of the US in the industrialisation process of Iran, assisted her in direct control over the policy initiation and its direction in areas US capital was being allocated. Injection of more than \$4 billion in the 1960s by the US government in the form of loans and credit was a major stimulus in the development process of the country.

Nonetheless by the late 1960s, while Iran was pushing for higher share of oil revenues (through renegotiation of agreements with the TNCs and their core states to sell more oil rather than bargaining over the oil price), the search for more foreign loans and investment continued. During the Fourth Plan, while American aid to Iran decreased substantially, Iran's external public debt increased to a cumulative total of \$5.9 billion (while it was \$500 million a decade earlier) of which just over 20% was in the form of supplier credits with an average maturity of ten years. Indeed just prior to the oil price hike of December 1973 it was foreseen that Iran could face serious debt servicing problems in the late 1970s unless certain rescheduling could be achieved. The situation, of course, changed with the surge in oil revenues. Some debt, the higher interest ones, were quickly paid off while others were left to run their course. The new situation was short lived however, as within three years Iran was back in the loan market. Therefore, in 1978 Iran was seeking, partly due to the revolutionary process though, over \$3 billion in medium-term credits.

Another partner in the triple alliance was foreign capital, whose role, during the Shah's rule, shaped the Iranian economy on a scale beyond the already significant one we have seen from 1850 to 1950. Nevertheless, after the oil price hike of 1973, TNCs were no longer a financier in the development of Iranian economy. The relative foreign investment in the economy to total investment, during the 1970s, decreased substantially in comparison to the 1950s and 1960s (Table A20). The TNCs became more involved in providing needed technology, manpower and managerial positions. Ansari, the Minister of the Economy and Finance, estimated total foreign investment in Iran, at the beginning of 1977, at \$5.2 billion, which was less than 4% of all capital invested in Iran (Foran 1993: 329). However, it was mainly concentrated in industry, and accounting for 9.4% of total investment in industry during the 1965-75 period (Gasirowski 1993: 453, table 1).

Foreign investment in Iran was mostly concentrated in some of the most important economic sectors: agribusiness, petrochemicals, electrical and non-electrical machinery, steel and aluminium industries. Furthermore, due to the high-tech orientation of these industries, the high technology inputs, skilled labour and management became important elements linking the TNCs with local industries. By contrast, the total foreign capital in South Korea for the 1960-79 period amounted around \$10 billion, accounting for 30% of its GFCF. Foreign capital constituted 26% of South Korea's country's GNP in 1976 (Koo and Kim

1992: 135; Castells 1992: 39). In comparison to the Iranian state, the South Korean government preferred attracting new capital through contracting for foreign loans which accounted for 92% of total foreign capital present in the country for the 1960-79 period. Private loans were channelled by the government to Korean companies, according to their compliance with the government strategic plans.

6.2.3. State's industrialisation strategy and the agricultural sector

Between 1968 and 1978, 14 huge agribusiness ventures of over 5,000 hectares each were established, mostly located near large dam projects. Investors included the government, private capitalists, international banks such as Chase Manhattan, Citicorp, and Bank of America, and the TNCs including Shell, Mitsui, John Deere, and Dow Chemical. Development and Resource Corporation (D&R), an American joint venture, played a crucial role in structuring Iran's agricultural development.⁸ By 1966, the establishment of farm corporations and agribusiness had become the state's official policy as the Shah began talking about his unique solution to Iran's agrarian malaise. This policy was directed toward establishing and expanding farm corporations and agribusiness. Because of this policy, a major share of the government budget for the agricultural sector was allocated to the agribusiness or related projects.

For instance, a major share of the agricultural sector allocations during the Second and Third Plans went for the construction of three dams and other large-scale projects. In the Fourth Plan (1968-73), the main emphasis was placed on the creation of large mechanised farming and husbandry, thus the government decided to dispossess the peasants working on some 250,000 acres of land.⁹ In this Plan period, 18% of the agricultural expenditure was allocated for the establishment of 34 new agribusiness. The revised Fifth Plan allocated 384,000 hectares of the best irrigated land for such establishments. Consequently, the number of peasant families possessing lands began to decline from the mid-1960s.

The share of agriculture in the GDP fell from 50% in the 1940s to 33% in 1959, 23% in 1969, and 9.2% in 1977-78. Iran's agricultural problems were aggravated by the poor performance of the new agribusiness and farm corporations. Huge agribusiness ventures with massive state and foreign investment in irrigation, tractors, and fertilisers did not contribute significantly to agricultural production. According to Table A12, 12.2% of the

national agricultural production surplus was contributed by modern large-scale farming. The share of farm corporations and agribusiness were only 2.4%. Considering that 87.8% of surpluses coming from the traditional farms was based on the traditional irrigation system, one may conclude that the state's construction of dams had had limited impact on agricultural production (Foran 1993: 323-5; Moaddel 1993: 75-6).

While the state development strategy failed to replace Iran's traditional agricultural cultivation with a more productive modern sector, the country lost its previous self-reliance on agricultural products. Foran (1993: 324) concludes that:

“the nature of the land reform and the inadequacies of the large-scale projects may have preserved the small size of most holdings for a time, but the maintenance and indeed extension of inequalities, creation and release of a huge army of landless agricultural workers, and spread of commercialised production and distribution all made the new system unmistakably capitalist in mode of production terms”.

The removal of power from the land-owning class was a major political consequence of the state's agrarian policies. The infiltration of international capital in this sector and the state's bias in favour of farm corporations and agribusiness further eroded the peasants' support for the state and antagonised the landowners. Landowners were compensated with shares in state-owned industries, worth around \$93 million, a move which turned some of them into industrial capitalists, while others diversified into real estate, trade and banking (Hooglund 1982: 78-83).

The land reform, furthermore, had a major impact on class structure of the country, in the rural areas in particular. The main political consequence of the land reform was the effective replacement of the all-powerful landlord in the villages by the obtrusive state. Some 45,000 large, mostly absentee landlords remained after the land reform, and as Table A17 indicates, 1,350 of them had substantial holdings of over 200 hectares. The total land held by such absentee owners was as much as 47 percent of all cultivable land, including the most fertile. 150,000 to 600,000 farmers owned 10-50 hectares of land each. This group emerged out of the former village headman, middleman, and production team leaders who received more land than ordinary sharecroppers. Along with the landlords, these middle class groups dominated the new rural political institutions, further consolidating their position as the most well-to-do individuals living in the countryside (Hooglund 1973: 233).

Worse off were the landless rural proletariat, around 1.4 million individuals (and more than seven million people including their families), constituting 40 to 50 percent of the population in villages, who lived by working part-time on other's land or migrating to nearby towns and distant cities, where they became part of the urban marginal classes (Table A17). Passive resistance and covert resentment on the part of the peasantry was apparently widespread in the 1960s and 1970s, signalling the ultimate failure of the political aim of the regime in creating a large class of loyal supporters in the countryside. The failure of the agricultural sector to cover the nutritional needs of the country led to an unprecedented dependence on agricultural and food imports.

By the mid 1970s Iran became the leading importer of food and agricultural products in the Middle East. Three to four percent annual growth rate in agriculture, against a population growth of about 3 percent, meant that agricultural production was virtually stagnant in per capita terms despite land reform, mechanisation, the spread of capitalist relations, and other changes.

However, as agriculture grew at 3-4% a year, consumption was rising by as much as 12% annually mainly due to increasing per capita income in urban areas and an increase in state consumption. This meant shortfalls in production of such necessities as wheat, barley, rice, meat, and dairy products. According to Table A25, food imports rose from under \$100 million in 1963 (with the agricultural balance of trade still positive as late as 1968), to \$111 million in 1970, \$270 million in 1972, \$1.9 billion in 1975, and \$1.8 billion in 1977 - equal to about 14% of Iran's food needs. In other words, from 1970 to 1977 the annual average increase in food imports was 48.7%, which clearly shows the depth of Iran's dependence on the import of this commodity (on agricultural growth see also Graham 1980: 43; Halliday 1979: 128; Pesaran 1982: 281; Katouzian 1981: 305).

Looked at another way, the value of food imports as percentage of GNP increased from 1% in 1970 to 4% in 1975 and fell to 2.5% in 1977 (Table A25). In other words, by the time oil revenues had increased, the state had massively increased imports of foodstuffs, both in absolute terms and as percentage of GNP. These massive imports were not only as a result of the agricultural failure to cover the nutritional needs of the country but also due to the political policy of buying off the society by making available (in abundance) broader variety of food commodities through imports.

6.2.4. The transnational corporations

Since the World War II, international capital has attached utmost importance to the process of industrialisation. It is essential to note that the aims and tasks of foreign capital in general and of the international monopolies in particular were transformed. International capital was no longer an external force whose interests were represented internally by comprador and raw material exporters. Instead, foreign capital, operating locally, shared with local capital, both private and state-controlled, an interest in the further development of local industry. This is not to deny that there was differentiation of local and foreign capital within the industrial structure. It was only to say that conflicts of interest became more subtle. Over the issue of industrialisation in general there was no split (Evans 1979: 9-10).

Unlike other developing countries, Iran's goal of attracting foreign capital, in the 1970s in particular, was not to obtain financial means to carry out planned investments, but rather to get access to modern technology and know-how. In fact it is, above all, in the case of Iran, their monopoly in the field of technology and management which gave foreign corporations a power to bargain with the Iranian government. Nonetheless, while the core states were closely concerned with the long-term development strategy of Iran, economically and socio-politically, the TNCs, as Halliday (1979) argues, were determined to ensure that they got their money back as quickly as possible, thus in this criterion, it was their short-term rather than the longer-term interests that governed their policy.

The 1,900 foreign corporations and banks which had established themselves in different Iranian industries - 1,000 of them during the 1973-77 period, Table A27 - largely gained control over the Iranian economy both through joint ventures and other forms not tied to property rights (Safari 1980 in Thiemann 1983: 90). In joint ventures, the foreign partner acted as supplier in various ways, i.e. in management, sale, financing, transport and information services, joint research and development projects, sub-supplies, etc.

The TNCs had major structural effects on the Iranian industry. Indeed, the production process relied heavily on the TNCs which supplied the needed skilled labour, managerial talent and international marketing expertise.

TABLE 6.2: Foreign Investment and Loans Through CAPFI by Type of Activity, million rials

ACTIVITY	Third		Fourth		Fifth		% of	
	Plan	%	Plan	%	Plan	%	Total	Total
Agribusiness	0	0	294	3	755	2.9	1,049	2.7
Automobile industry & transportation	95	3.2	583	5.8	1,835	7.2	2515	6.5
Building material	153	5.1	276	2.8	639	2.5	1,068	2.8
Electrical & electronic	227	7.6	1,040	10.4	1,795	7.1	3,062	8
Food	62	2	230	2.3	651	2.6	943	2.4
Hotels	0	0	293	3	295	1.2	588	1.5
Metallurgical	222	7.5	963	9.7	3,917	15.4	5,102	13.3
Mining	509	17.1	960	9.6	625	2.4	2,094	5.4
Petrochemicals	119	4	2,198	22	8,201	32.3	10,518	27.3
Pharmaceutical & Chemical	684	23.1	1,210	12.1	966	3.8	2,860	7.4
Rubber	754	25.4	1,224	12.3	2,617	10.3	4,595	12
Others	146	5	698	7	3,270	12.8	4,114	10.7
TOTALS	2,971	100	9,973	100.0	25,564	100.0	38,508	100.0

Source: calculated based on information from CBI, Annual report and Balance Sheet, 1970, 1972, 1975, 1978; Centre for the Attraction and Protection of Foreign Investments

According to Table 6.2, the preferred sectors for investment were the dynamic, structurally determinant branches such as the metallurgical, petrochemical, pharmaceutical and chemical industries, the steel and arms industries, the automobile industry, electrical engineering and electronics, rubber and tyre industry and even made inroads in such traditionally local industries as textiles and construction. Typical of the industry established with foreign participation was "its pronounced assembly characters" (Thiemann 1983: 92). Some of them like auto and electrical industries were merely assembling imported parts, adding very low amounts to the total value of finished products. This high degree of dependence of local industry on the TNCs, undoubtedly reduced the spread effects and linkages from these activities to the rest of the economy (Looney 1988: 114-5).

While countries like Iran were showing their desire for industrialisation in oil and gas industry, from the point of view of the strategic consideration of international capital, the orientation of industrialisation toward the establishment of raw material and energy-intensive

industries was in line with the efforts of foreign capital to extensively streamline and modernise their own economies in the capitalist industrial countries. Under the changing conditions in the oil-producing countries, the TNCs had no other choice to secure their energy and raw material supplies. The TNCs, therefore, were willing to help Iran expand into oil refining, petrochemicals, fertiliser, iron, steel and aluminium, because the West would get some of the finished products and would sell Iran the plants, equipment, technology, management, and some of the inputs, in addition to having some joint ownership. These included, above all, refineries (\$9.3 billion investment in oil industry in the Fifth Plan), gas pipeline, sectors of the petrochemical industry (to build 2 new complexes and invest a total of \$8 billion up to 1985), nitrogen fertiliser industry (to build two new complexes), steel and aluminium plants (increase Isfahan complex output from 700,000 to 5 million tons per year and build seven new complexes, and a new plant in Bandar Abbas) (Thiemann 1983: 94).

There were high hopes that the government would shortly gain revenues from these capital and energy-intensive industries. However, the value added in oil refining was very low and as a world surplus in refining capacity existed in petrochemicals, the market was facing serious competition. In addition, growing Iranian domestic market would undermine further the projected foreign currency earnings from massive investment in oil and petrochemical industries (Halliday 1978). Waterbury argues a further point that "none of these industrial schemes would be viable without oil, they are in no sense then creating a future without oil" (1991: 24).

The TNCs had concentrated in Iran's most important economic sectors: 14 out of 18 agribusiness ventures; 3 out of 5 large petrochemical plants; 4 out of 5 large chemical concerns; 14 out of 18 pharmaceuticals,¹⁰ all of plastics; all of autos; 37 of 42 producers of electrical and non-electrical machinery; and involvement in the steel and aluminium industries. Even food processing, construction, and textiles industries were increasingly supplied by the TNCs. The TNCs tended to be the largest companies in Iran, capital- and technology-intensive, and very profitable. Behind high protective tariffs reported and unreported rates of returns were possible between 50 to 200% - while local capitalists were enjoying 30-50% profit rates (Foran 1993: 329; Halliday 1979: 148).

Yekom's survey shows that the main source of finance for TNCs' activities in Iran was the local banking sector. Their basis for choosing local partners in the country was mainly the contribution a local firm could make in their activity. 60 % of the 23 major TNCs studied in this survey had used *only* local finance, while *none* had been financed through their parent companies. Furthermore, other than availability of local finance, other attractions for the TNCs were high local demand, large market, and high import duty. Nonetheless, while the country provided the TNCs with most of their needed finance and a market for their production, the TNCs contributed only less than 30% in terms of purchasing raw materials from the domestic Iranian market. This would lead to an increase in the country's imports and hence worsening its balance of payments situation (Yekom 1976: 113-16, tables B-2, B-3, B-5).

TNCs' share in Iran's annual GFCF was quantitatively small compared to the share by local capital - the state and private. However, qualitatively they had a decisive role in Iran's industrialisation process and the shaping of its dependent capitalist development. Their monopoly role in areas of technology - in both civil and military - management, know-how, and skilled labour were extraordinary. The Iranian state was also dependent on the corporations because equipment could only be installed and operated with their help. These international corporations had extended their influence to new areas so that their penetration of the Iranian economy increased considerably in some fields. It was also reinforced by the licensing system, which erected barriers against the entry of new industries, thus enabling the TNCs to reap substantial profits.

Typical of any industry established with foreign participation was its pronounced assembly character which increased considerably the dependence of the industrial sector, and thus the whole economy, on supplies from abroad. This trend is to be seen in the motor industry, the production of radio and television sets and numerous other electronic equipment, the pharmaceutical industry, the production of agricultural machinery, bicycles, port equipment, etc. The extent of dependence on imported raw materials and semi-finished goods was grave and exceeded 80% of overall production (Thiemann 1983: 93). The production of raw materials, semi-finished goods, complete components and spare parts imported from the capitalist countries was by 1978 between 85 to 100% in the pharmaceutical industry, 60 to 100% in the chemical industry, 80% in the textile industry,

80% in some branches of mechanical engineering and metal manufacture (car assembly, tractors, tyres, household appliances), more than 70% in some branches of the food industry (vegetable oil, margarine, meat), 57% in some branches of building material industry (bricks, glass, plaster, cement, metal sections, cables, paints, timber), and 41.5% in the paper industry (CBI 1979). Such findings are confirmed by Yekom's survey (1976).

In general, the industrial sector used imported machines to assemble imported parts with imported technology, sometimes in joint ventures. This was a feature of dependent development.

The Shah by the early 1970s tried not to abide fully by the demands of foreign capital and conditions of the TNCs. This was done partly through increased imports of consumer and finished goods. He thought that he could obtain the same results in development process without abiding by the rules laid down by the TNCs. The regime's policies aggravated the situation of dependent development, by interrupting the course of industrialisation led by the Western capitalism (as was the case in Brazil and South Korea) without introducing any alternative route, and wasting the country's assets on imports - from the TNCs themselves (Tables A21, A22). The result was that the country neither achieved the level of dependent industrialisation that was possible, nor did it free itself from the grip of the TNCs.

A rather relatively different case was the infiltration of international capital in South Korea. The nationalism of the Korean government rejected an excessive presence of foreign multinational corporations, fearful of their influences on society and on the political fate of the Korean nation. Thus, capital influx in to South Korea mainly took the form of loans. The effectiveness of the Korean state's development policies derived largely from the consistency of its policies (both political and economical, and through the years) in favour of large capital - local and international. This consistency in the mode of state intervention in the economy ensured 'business confidence' and promoted a favourable investment climate for both domestic and international capital. Hence, Iran, by the late 1970s, compared with countries at a similar level of development, such as Brazil, South Korea, and Taiwan, was less industrialised. Its financial and monopoly capital did not rely on its domestic industrial/agricultural capacity, but rather on depleting oil exports. However, for a brief period in the 1970s, Iran had seemed to be moving closer to this group in the semiperiphery.

6.3. Foreign Trade

The growth of the modern sector, due to its capital intensity and technological complexity, was tantamount to increasing Iran's dependence on imports of capital and intermediate goods, spare parts and machinery, and foreign specialist personnel. Moreover, the industrial development of the 1960s and 1970s was accompanied by the country's increasing dependence on the export of oil. Such dependence increased Iran's vulnerability to shortages and breakdowns of equipment (Pakravan 1981 in Moaddel 1993: 85) as well as to economic fluctuations in the world market. The industrial development of the 1960s and 1970s did not lead to a reduction in Iran's dependence on foreign trade. The country's trade dependence - measured by the ratio of total foreign trade to GNP - actually increased during the post-coup period. Iranian trade dependence was around 0.27 in the period between 1959 and 1966, increased to 0.38 in 1973 and then jumped up to 0.62 and 0.67 in 1974 and 1975 respectively, reflecting the effects of the increase in oil revenues on trade dependence (Table A8; see also Muller 1982: 84-5; Moaddel 1993: 85).

The penetration of the Iranian economy by international capital resulted in a change in the structure of its domestic production. It increased its concentration in external trade and in the production of oil, the most profitable commodity. This led to the development of an 'export enclave' economy characterised by uneven development - i.e. sectoral disarticulation. Inter-sectoral disarticulation was characterised by a lack of backward and forward linkages between different sectors of the economy, and intra-sectoral disarticulation because of a lack of such linkages within each of the main sectors of the economy - agriculture and industry. Small-scale production, dominated by the traditional sector, did not have significant backward and forward linkages with the large-scale state-promoted monopoly sector, the so called modern sector. The modern sector was vertically integrated with international capital and dominated by the latter. The state's strong support for the modern sector was undermining the traditional sector. Because domestic production was concentrated in exports, both upward and downward movements in export markets generated dislocation in investment, employment and industrial demand. Iran's economic difficulties in the 1970s, which triggered political conflict, was partly the result of its vulnerability to the destabilising effects of the world economy.

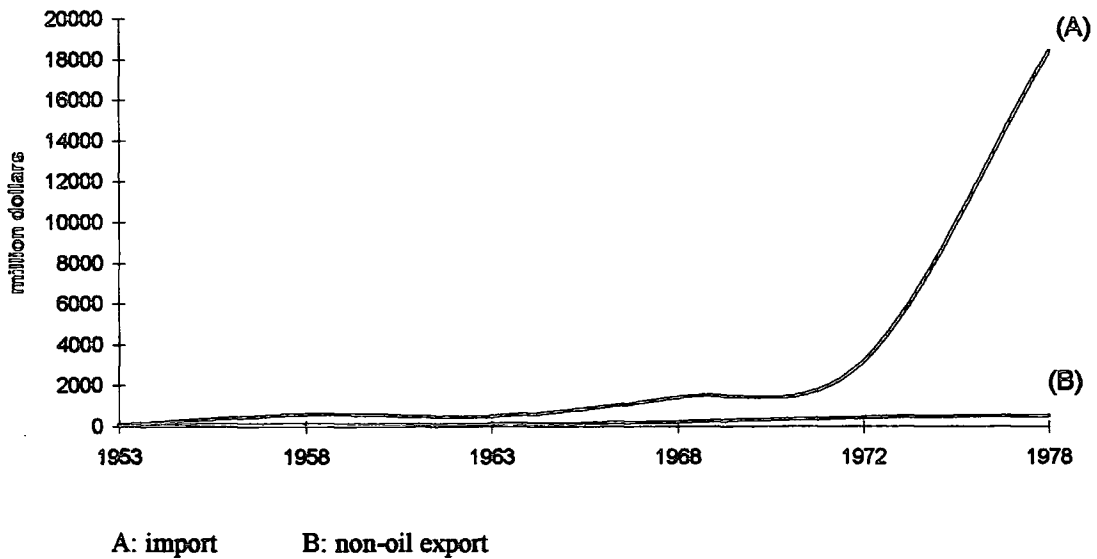
GRAPH 6.1: *Foreign Trade of Iran: Imports and non-Oil Exports*

Source: Table A21; UN, Statistical Yearbook, 1980: table 31

The key issues in terms of foreign trade are the balance of trade, the nature of imports and exports, and the terms of trade. Iran's imports exhibited an extremely high rate of growth over the 1963-73 period, and particularly after 1973. According to Graph 6.1, it increased from \$96 million in 1953 to \$518 million in 1963, \$3,160 million in 1972 and later to \$18,400 million in 1978; an almost 6 time increase for each of the periods between these years, or a staggering 190 times over 25 years. The composition of Iran's imports during the 1960s and 1970s has shown some interesting characteristics. Up to the oil price hikes of 1973, the composition of Iran's imports was changing such that the portion of consumer goods in the total was decreasing while imports of intermediate goods were increasing. Such a trend was in line with Iran's stage of industrialisation and development trend at this time. The oil price-led consumer boom of the early 1970s however completely changed the picture and assumed an increasing share of imports, from 15% in 1966 to 11.7% in 1971, to 17.6% in 1976 and then to 19% in 1977, accounting for a greater portion of total imports than at any time in the previous fourteen years. The public expectation for higher consumption - due to the oil-led development policy of the state in the early 1970s - was not halted by the decline in oil revenues in 1976 and after.

TABLE 6.3: *Exports According to Production Type, in millions of dollars, percent in bracket*

Export	Third Plan (1963-67)		Fourth Plan (1968-72)		Fifth Plan (1973-77)	
	Amount	%	Amount	%	Amount	%
Traditional	756	(94.4)	1,242.9	(80.4)	2,160.7	(75.3)
Industrial goods	45	(5.6)	303.2	(19.6)	710.8	(24.7)
TOTAL (non-oil)	801	(100.0)	1,546.1	(100.0)	2,871.5	(100.0)
		(21.3)		(17.2)		(3.3)
Oil export	2,967	(78.7)	7,458.6	(82.8)	84,270.0	(96.7)
TOTAL Export	3,768	(100.0)	9,004.7	(100.0)	87,141.5	(100.0)

Source: CBI, Annual Report and Balance Sheet, various issues

On exports, although revenues from oil exports soared, non-oil exports increased negligibly during the 1960s and 1970s. The relative non-competitive position of many local produced goods on the international market was and continued to be a serious long-term problem. As for the composition of exports, according to Table 6.3, the value of oil exports as a percentage of total exports increased from 78.7% in the Third Plan to 82.8% in the Fourth Plan and finally to 96.7% during the Fifth Plan period. The table also shows the dominant position of traditional and agricultural goods among non-oil export goods. The industrial exports goods increased from 5.6% of the total non-oil export goods in the Third Plan to 24.7% in the Fifth Plan. However, its share in the total export (oil and non-oil) decreased to less than one percent in the Fifth Plan. This means that the role of the new industrial export goods was reduced almost to nil.

Iran's foreign trade was oriented largely towards the advanced industrial nations, especially the US, West Germany, and Japan, as Table A24 on the sources of Iran's imports suggests. The US took the lead from Great Britain as the undisputed hegemonic core power in Iran after the 1953 coup. Multiple ties - economic, political, and strategic - were established between the two countries. American share in the 1954 oil deals, its direct investment in agribusiness, industry and banking in Iran were noted. In 1978, some 500 American firms had \$700 million invested in Iran and 12 large banks had another \$2.2 billion in assets in Iran. To its oil interests and investments should be added trade between the two countries, in which the US was among Iran's leading trade partners. A trade package calling for \$15 billion of purchases by Iran from the US including 8 nuclear plants was signed in

1975. Following this one, a bilateral agreement in mid-1976 projected \$40 billion in US-Iranian trade between 1976 and 1980.

There was moreover a massive arms trade in the 1970s - about \$20 billion with the US - which did not figure in trade data and which was thoroughly dominated by the US (Table A27). Total American economic and military aid to Iran from 1953 to 1960 came to over \$1 billion, a sum not surpassed by any other country in the Africa or the Middle East except Turkey (Baldwin 1967: 200-4). Aid between 1950 and 1970 totalled \$2.3 billion, over \$1.3 billion of which was military aid. In addition, the Shah's regime received \$1.3 billion worth of new weapon systems between 1950 and 1963 (Foran 1993: 344; Ramazani 1976: 327; Sick 1985: 8).

A transparent pattern of political influence followed this aid: the first \$68.4 million being announced within three weeks of the 1953 coup, \$127 million right after the 1954 oil deal, and other grants after Iran joined the Baghdad Pact in 1955 and CENTO in 1958. Among the European countries, according to Table A24, however, significantly below the US influence in Iran, Great Britain which once was the major player, had fallen behind West Germany as a leading trading partner, to a position of fourth overall. Britain's largest stake in Iran was a 40% share in the post-1954 consortium. In the 1970s Britain was a major arms seller, particularly of tanks, accounting for most of the \$971 million in exports to Iran in 1977-78 (Table A 24). It was also active in the car assembly industry, as well as banking. Compared with other OPEC nations, Iran in the mid-1970s was the largest single customer of UK exports. But all of this was a far cry from Britain's traditional position as a major power in Iran.

By the same token West Germany's economic recovery in the 1960s placed it in a strong economic position in Iran, as leading exporter from 1959 to 1970 and again in 1977. German investments in Iran fell in the 1970s (well behind Japan and the US), but were profitably placed in pharmaceuticals, steel, and agricultural machinery. The other European countries collectively accounted for about 20% of Iran's imports, led by France and Italy, with 3-5% each (*ibid.*).

Japan passed Britain by 1970 and almost equalled the US by 1977 as a supplier of imports to Iran (excluding arms sales), especially of electrical equipment. In 1975/6, Japan was the largest investor in Iran, with 40% of the total investments made in that year, in

almost all major industries involved by the TNCs (Table A19). However, Japanese investment, while significant, fitted within the broad pattern of Iran's dependence on the advanced industrial economies, thus not really posing a challenge to American hegemony in Iran.

The nature of imports further accentuated the dependent trend of Iran's development. Of \$18 billion in total imports in 1977-78, \$6.1 billion (33%) was imports of machinery and vehicles, \$5.3 billion (29%) of steel, chemical, paper, fibres, and so forth, \$4.3 billion (24%) was 'classified' (mainly military equipment), and \$2.2 billion (12%) was of food. The share of oil in total exports increased from 3% in 1953 to 87% in 1963, 86% in 1972, and to 98% in 1978 (Table A21). One way of measuring industrial dependence on imports is, Sodagar (1991) argues, the calculation of import ratio in unit industrial production. According to Table A23-1, in 1979, this ratio for capital goods was 76% - meaning that imported goods constituted the main part of a unit of capital good produced in Iran. For the same year the ratio of imports in unit production of intermediate and consumer goods were 49.5% and 43.5% respectively.

While little data on the terms of trade is available, what is certain is that reliance on oil exports was inherently unstable, as either the West would pass the costs of its own inflation back to Iran or prices for oil would decline, hampering Iran's ability to import. This profile of foreign trade of Iran was certainly that of a dependent country (Foran 1993: 342).

Several factors were responsible for the upsurge in Iran's imports. Among them were:

1. The growing dependence on imported food, which in turn implied that attempts to curtail domestic demand would have to take into account an already perceptible discontent with food shortage (see Table A25).
2. The fast growth of GFCF caused by the heavy internal investment programmes. This was particularly import consuming because there was a gradual increase in the 'installation of machinery'.
3. Arms and military equipment, of course, comprised a big part of the total imports. During 1974 the US alone sold \$3.3 billion worth of arms to Iran (more than half the value of Iran's total imports in 1974). Total US arms sale to all OPEC nations was \$4.4 billion during the same year (see Table A26).

4. The emergence of the newly rich middle class and the changing pattern of demand favoured import of consumption goods. The increased demand for passenger cars is one such example. During 1975 transport equipment accounted for about a quarter of British exports to Iran.

The net result of Iran's swelling imports was congestion of Iranian ports and transport system, costing Iran over one billion dollars for port demurrage in just one year, 1975. Furthermore, the goods had to be stored in open air until they could be finally cleared, which in many cases were damaged due to Iran's harsh climate conditions.

As was shown, the country's dependence was consolidated in two main ways. Firstly through foreign investment in major sectors of industry and mining, agriculture and commerce, secondly, through the production and export of a single commodity (oil) and increasing expansion of imports, including foodstuffs. This pattern of economic dependence was consolidated by political and military dependencies.

6.4. The US-Iran Relationship

From the beginning, US-Iranian relations were dominated by the Shah's concern with the issue of military security. Hence, as was shown in chapter 3, establishing a well-equipped and de-politicised Iranian military force was at top of his policy agenda throughout his rule.

Iran's dependence included areas other than economic field. He became entirely dependent on foreign powers, the US in particular, when his throne was openly challenged by political groups from 1941 to 1953. Later during the years from 1953 to 1963, American's increasing involvement in the setting up of the organisations of the armed and security forces added the military factor to the country's dependent character. The Shah's realisation that "there is no economic power without military power" (the Shah, *The Times*, 6 March 1976 in Laing 1977: 197) led to a situation in which the Shah, throughout his reign, developed military dependence on the US both on organisation and warfare, technically and operationally. While the basis of structure of dependence was laid down in this period, it was during the 1960s and 1970s that it deepened and became structural in the development process of the country.

While the MAAG's assisted the Iranian government in internal security, the TAFT's along with the 'white-collar mercenaries' (Rick 1981: 33) provided assistance in external

security. In both cases, military assistance accompanied American partial access to Iran's oil revenues; in the first case, the restructuring of the Anglo-Iranian Oil Company into the NIOC with sizeable American oil interests, and in the second, the escalation of oil prices in order to generate sufficient oil revenue to purchase the highly sophisticated and expensive weaponry and logistics system of American arms and technology industries. The share of Iran's military imports from the US in the 1970s shows that Iran played an important role in anti-recessionary policies of the US government for the oil, military and manufacturing industries. Furthermore, Hudson argues that "taken on balance, all US foreign assistance is ultimately military or paramilitary in nature, even its ostensibly economic aid: it is designed primarily to enable foreign countries to support a military superstructure capable of saving the US the cost of having to provide military service with its own armed forces" (M. Hudson, *The Political economy of foreign aid* in D. Goulet & M. Hudson *The Myth of Aid*, NY, 1971: 80 quoted by Ricks 1981: 28).

TABLE 6.4: *US Military Sale to Iran, 1955-78, in millions of dollars*

Year	Foreign Military agreement	Foreign Military sales Deliveries
1955-68	505.4	145.9
1969	235.8	94.9
1970	134.9	127.7
1971	363.9	75.6
1972	472.6	214.8
1973	2,171.4	248.4
1974	4,325.4	648.6
1975	2,447.1	1,006.1
1976	1,794.5	1,927.9
1977	5,713.8	2,433.1
1978	2,586.9	1,792.9
Total: 1955-1978	20,751.7	8,715.8

Source: Foreign Military Sales and Military Assistance Facts, December 1978, US Department of Defence, Security Assistance Agency figures have been rounded.

According to Table 6.4, total US military sales to Iran came to \$20.7 billion for 1950-77, \$20 billion of this after 1970, a sum which ate up almost 20% of Iran's total oil revenues and

on the American side accounted for over half of all US arms sales to foreign countries. By 1978, there were around 40,000 American military and civilian personnel in Iran, mostly enjoying diplomatic immunity with military technicians drawing \$9,000 a month salaries from the Iranian government - which amounted to about \$4 billion payments in the form of salaries. A 1977 US Senate report admitted openly that:

“the presence of US personnel and the presumed inability of Iranians to utilise all the recent arms purchases could give the US leverage over any Iranian intention that runs counter to US interests” (quoted in Foran 1993: 345).

US military mission to Iran from GENMISH (1943-76), ARMISH (1947-78), through the 1958 consolidation of ARMISH-MAAG (1958-62), and the arrival of TAFT (1973-78) assisted the US foreign policy makers by (1) holding the oil regions for the US, European and Japanese corporate interests, (2) preventing (and containing) the Soviet Union from access to the oil region, (3) gaining access to Iranian air space for intelligence gathering, to the land space for agribusiness, and to Iranian labour and markets for ‘modernisation’ and (4) assisting in the conversion of that country into a military ‘satellite’ as part of the US’ global interests (Rick 1981). Thus, US foreign policy and the military missions were in one way or another, an integral part of the post-World War II ‘global reach’ of the TNCs. Both worked towards strengthening the Pahlavi monarchy, establishing essential US programmes to provide security for the regime; and, to block any Soviet expansion into the capitalist controlled region and to secure US interests in the region.

AID’s emphasis (1972) which “the US investment in technical co-operation should match US interests” shows that presence of foreign personnel and technicians in both civil and military industry is one effective element in this regard which broadens the scope of dependence (ibid.: P.27).

This extensive American involvement meant that Iran’s socio-economic development and foreign policy objectives became closely tied to the interests of the capitalist world. In its relationship with Tehran, Washington acted as a ‘Patron power’ in upholding and securing the Shah’s regime and influencing the direction and substance of its policies in line with Western regional and international interests (Saikal 1980: 57-8). The presence of

more than 40,000 military personnel, mainly involved in military related projects, was an important tool in this respect. (Cockcroft, 1980: 144 in Stauth 1980).

To a great extent, ever since the overthrow of Mosaddegh in 1953, the Shah had been dependent on the US for moral, political and military support. Having re-instated the Shah on his throne through a CIA-supported military coup in 1953, the US had made its presence felt. Cottam (1979: 323) has indicated that "from 1953 to 1963 Iran could be described not only as an American client state but as an American dependency. The regime required full protection against external aggressors as for internal survival". However, the reform of 1963 and the successful growth period of 1963-73 provided the Shah and his regime a degree of loosening dependence - a period during which the US-Iran cliency relationship declined. In 1971, with the British pullout from the Persian Gulf, the Shah became the gendarme of the region, with the blessing of the Kissinger-Nixon strategy of global curtailment of the Soviet Union.

For instance, the dispatching of troops to Oman, in order to help Sultan Qabus in 1972, reflected a growing co-operation between the two states which served to enhance personal confidence of the Shah. By 1974 and as a consequence of the flow of billions of dollars of oil revenues to Iran, the dependent relationship between the two countries had altered significantly. While Iran increased its imports (both economic and military goods), its bargaining power increased. With the growing confidence of the Shah, the 'Nixon doctrine' with respect to Iran - which was to rely exclusively on the Shah for the protection of US interests in the oil-rich Persian Gulf region - had been thoroughly institutionalised in the US foreign policy.

As a result of all the above mentioned events, on the eve of the Tehran Oil Agreements in 1973, the Shah was almost a new man in the international arena. Graham (1980: 15) points out the way in which this occasion turned to a confidence-building phenomenon for the Shah:

"It was a performance to match the occasion. On 23 December 1973, while the Ministers representing the [Persian] Gulf members of OPEC were still in formal session, Mohammad Reza Shah Pahlavi, Shah of Iran, called a press conference. His announcement was a staggering new increase in the price of oil. The Shah displayed his usual polished manner but his tone had a new confidence - the confidence of a man who knew that his country's financial resources had quadrupled in just over two months".

However, it is important to note that in spite of a significant alteration in the degree of the dependence of the Shah and his regime on the US, and the increasing political and economical interdependence in their relationship, the basic dimensions of the Shah's dependency on the US did not change dramatically. The surge in oil revenues had provided a larger room for manoeuvre for the Shah. Thus, the basis for a degree of mutual dependence - between the semi-periphery state of Iran and the core country of the US - in which the US was the dominant player were laid. Iran was acting like a sub-Imperialist power (Bambira 1973: 153 in Kay 1993).

Conclusion

The integration of the Iranian economy into the world market was the prime mover in the process of socio-economic and political change which led to the dissolution of the pre-capitalist system¹. In particular, the state, forming an important mediating link in the process of integration, and having a central position in pre-capitalist agrarian relations, played a dominant role in the outcome of the process of economic transformation.

The Safavid Shahs had hegemonic positions in the state and economy, tapping surplus production by tribes, peasants and urban producers, and enjoying military, political and ideological dominance. The economy was predominantly agricultural but there was significant regional and minimal international trade in products such as textiles, porcelain and metalwork. Commercial contacts with the West (mainly with the Dutch and English East India Companies), could in no sense be considered dependent on the West; rather it was a regional empire, influencing the politics of the region and competing with other empires, i.e. the Ottomans.

During the period of the fall of the Safavid and the interval period before the rise of the Qajar dynasty, royal authority and control decentralised considerably. The Iranian state and economy were weakened just as a crucial moment in its history was approaching.

The failure of the attempts to restructure the state institutions, which resulted from the diffuse nature of political power in the early Qajar rule - followed by the military defeat of the Qajar army at the hand of the Russians, 1813, 1828 and British 1857, and subsequent foreign intervention in domestic politics - led to a cumulative process of disintegration of the traditional state, concomitant with the greater commercialisation of the economy.

Due to the weakness of the domestic bourgeoisie, the major phases of the development of the Iranian economy in the subsequent periods had their origin in changing external economic conditions and were largely initiated by the state. Its principal exports were raw cotton and silk, cereals and fruit, tobacco, opium, and carpets; its principal imports were cotton cloth, sugar, tea and metal goods - a peripheral supplier of mostly raw materials in the world economy. The political stalemate and

economic chaos that attended this struggle during and after World War I were among the most important factors in the military coup of 1921 which brought Reza Khan to the throne in 1925.

The formation of the modern state with a unified and centralised administrative and military apparatus in the 1920s heralded a new phase in the political economy of Iran. By this time the political and economic preconditions for the formation of the modern national state were already in place: support for a centralised-state formation; end of the British-Russian rivalries; and the growth of government revenues through taxes and oil royalties. Thus, the formation of the modern bureaucratic state institutions substantially enhanced the power of the state within society (i.e. to intervene in the economy). The impact of the new state on economic development was far from the simple intention to create a new economic order with its efforts directed in a unilinear manner towards the 'modernisation' of a 'traditional' economy².

The drive for industrialisation initiated by the state in the 1930s, Karshenas argues, was not the result of a pre-conceived plan by the government, but was prompted rather by the pressure of circumstance arising from the world depression and the problems of adjustment it created for the Iranian economy. Under a centralising authoritarian state, and fuelled by a gradually new oil-based economy, Iran embarked on what seemed to resemble a dependent capitalist course in the 1930s (1990: 233-4). The new state structure with a degree of autonomy played an important part in making the drive towards industrialisation possible.

Due to the extremely low bargaining power of the government vis-à-vis the AIOC, oil revenues made little contribution to the financing of accumulation over this period.

With the collapse of the authoritarian regime of Reza Shah, fundamental economic reforms such as the nationalisation of the oil industry and agrarian reform became central issues on the political agenda during the period of open politics in the immediate aftermath of the war (1942-53). The state and the economy entered a new phase of development with oil income becoming the predominant source of financing accumulation and expansion of state organisations.

We briefly examine the role of oil and state in the political economy of Iran during the period of 1942-1979, by recalling the empirical findings of chapter three to six.

The State Structure

The structural character of the regime was authoritarian-bureaucratic. Instead of modernising the political system, the Shah based his power on three pillars: the state bureaucracy, the armed forces, and the network of court patronage. There are parallels with the Safavid dynasty, in which the administration, the army and the court were the basis of power of the state. Both states enjoyed autonomy from social pressures. However, the Pahlavi state enhanced its autonomy by its control over oil revenues and receiving US support, whereas the Safavid shahs increased the state autonomy by establishing a new country-wide administration and successfully retaining the three sources of legitimacy.

In the absence of any major alliance with politically weighty classes and groups, the expansion of bureaucracy during the Shah's regime became another mechanism for the state's control of civil society and the maintenance of national integration. Its expansion was partly the result of the state's intervention in the economy. The bureaucracy became an instrument of power and control, a tool for achieving developmental goals; and an instrument for system maintenance and regime enhancement. On the other hand, the most important function which the repressive apparatus performed was that of guarantor of the regime's survival. The decision-making process and exercise of power, as was shown in chapter 3, was manipulated by, and depended exclusively upon, the Shah and his relationship with a limited circle that was the ruling elite.

Two phases can be distinguished with regard to political developments during the period of 1953-79. The 1953-63 period was one of reconstruction of the state's coercive and administrative apparatus. During this period, the country became closely integrated into the western political and military system, with the Shah relying heavily on American financial and technical assistance to reconstruct the army and reorganise the state bureaucracy. During this period there was a shift in the political alliance of the regime which led to the strengthening of the process of bureaucratisation and centralisation of power in post-1963 period. Two parallel developments were involved in this process: the continued expansion of government bureaucracy and its growing power of control over the society; and the increasing shift of power within the state from the legislative to the executive and within that to the court and the Shah.

After 1963, the court became the centre of power and dominated all the other state structures, including the government, the parliament and the party structure. Access to

political power became restricted to a small elite at the centre of which was the Shah and his family. During this period, the authoritarian-bureaucratic establishment of the regime was strengthened and the regime enjoyed the full support of the US, while the control over oil exports enhanced its autonomy from social pressures.

The socio-political background and the character of the authoritarian-bureaucratic regime of the Shah during the 1953-79 period was to some extent reminiscent of that of Reza Shah during the inter-war period. Both relied on their over-extended bureaucratic and military establishments and the system of court patronage which was at the centre of the clientelistic relations. Both shahs rose to power thanks to foreign support and intervention. Despite these similarities in political forms, however, essential differences existed in the nature of the state's economic involvement, the capacity of state organisations, and its position in the world economy, between the two periods. These differences pertained both to the capacity of the state to intervene in the economy and the autonomy of the state from social pressures to pursue its socio-economic policies. The substantial rise in oil revenues and easy access to foreign capital in the 1953-79 period provided a new economic condition for the state. This altered the role of the state in the process of accumulation. Thus the high degree of autonomy of the state from society, and the concentration of power in the hands of a small elite centred around the court and the monarch, together with the central role of the state in the distribution of a sizeable share of the investable funds in the economy, enhanced the power of the state's economic intervention.

The ultimate aim of the Iranian political and administrative structure was to protect the Shah and his dynasty primarily from internal threats, such as military coups and strong political rivals, (e.g. Mosaddegh in 1953). Hence, the country's political system was premised on (1) the supreme loyalty of all its primary and secondary members to the Shah and the monarchy; (2) overlapping responsibilities and thus conflicting interests and intense rivalries among these members; and (3) the virtual absence of any lateral communication within the administrative and military hierarchy.

Despite the appearance of an extensive and renovated bureaucratic machinery throughout the 1960s and 1970s, having access to massive financial resources from the oil sector, the bureaucracy was still severely handicapped in its goal oriented activities due to subordination to the court. With the plethora of overlapping agencies, salient political conflicts penetrated the administrative apparatus. The Shah had gradually

weakened its old economic allies and his regime's dependence on those allies. Distributive policies designed to ensure domestic peace had inadvertently created relatively large and complex state administrations, distributive states, unusual in that they emerged from the imperative to expand rather than to extract revenues. These bureaucracies were themselves one source of change. As the state's role grew, so too did its power. As the state's scope and autonomy grew, so with it grew the distance between the ruling elite and the population, as the popular perception of state services shifted from benevolence to entitlement. Therefore, the state was separated from society with no significant intermediate organisation connecting the two. Oil revenue enhanced the state autonomy and, owing to the lack of such intermediate organisations, it deepened the state-society gap. Indeed, the oil wealth "separated the state from society so much so that it would be difficult to find parallels anywhere in human history" (Katouzian 1981: 255).

The Iranian state was able to initiate massive petrochemical development and programmes of dam building and land resettlement, but there was no assurance that these were rooted in the needs, aspirations and skills of the Iranian people, which were hardly taken into consideration. Thus, although its industrial growth rate was immense, it lacked a foundation in social reality.

The State and the Process of Capital Formation

During the post World War II, period capital accumulation was mainly mediated through the state. Therefore, a brief analysis of the role of the state in the process of capital accumulation is enlightening. During this period, two phases can be broadly distinguished with regard to the rate and structure of capital formation in Iran during the post-1953 period. The first phase (1955-9) was one of rapid growth of real investment following the massive injection of external funds into the economy (namely oil revenues and foreign loans). Government investment in this period was confined largely to infrastructure and light industries, and private investment concentrated in construction, transportation and light manufacturing. This period was followed by two years of political crisis for the regime (1961-2) leading to the break in its alliance with the powerful traditional proprietary classes. Thus a rapid decline in the pace of investment occurred in particular in the private sector. The political and economic changes which took place in this relatively short span of time created the basic elements for the new

model of accumulation which took shape in the post-1963 period. The state's autonomy from the established proprietary classes, namely the landlords and the merchant bourgeoisie, was a pre-condition for this restructuring of capitalism.

The focal point of the industrial strategy of the state was formed by a new capitalist class closely connected to foreign capital. Secondly, the period 1963-77 was the longest period of sustained accumulation in the modern history of Iran, with a real annual rate of growth of 18.9% for GFCF. The share of GFCF in non-oil GDP rose from 16.9% in 1962-3 to 30.9% in 1971-2, and reached 50.7% in the post-1973 oil boom years. Public sector investment in particular accelerated in this period as the government assumed the role of producer in basic and heavy industries. There was also a change in the structure of private investment as it moved into new consumer durable and intermediate products, created for the rapidly expanding domestic market.

After the crisis of the early 1960s, there was a tightening in the hold of the state on society, and a growing concentration of political power in the hands of a small elite, at the centre of which was the Shah and his imperial court. The break with the traditional elite represented rather a shift towards a broadening of the state clientele, by incorporating the modern middle class employed in the bureaucracy and the modern sectors of the economy. The relationship of the regime with these classes, who were totally excluded from the political process, was based on the granting of material resources and economic privileges in exchange for passive political participation. The rapid growth of consumption of these classes laid the basis for the new model of industrial accumulation which took shape throughout 1960s and 1970s.

With respect to the role of international capital in the process of accumulation of capital, it seems beyond doubt that core capitalist states and TNCs had given some support to the growth of the productive forces in Iran. The Shah's regime in Iran, in spite of some disputes and disagreements with the core capitalist countries, was tied into the international capitalist system and benefited from direct political and military support of the major capitalist nations. Actually, it has been said that the Shah's regime was to some degree "a creation of US imperialism in the post-war epoch" and was "a result of the interventions of imperialism in 1953 and in the subsequent years of consolidation" (Halliday 1979: 172). However, the centrality of oil points to a further aspect of the changes since the post World War II period, namely the growing ability of the Iranian state to impose its terms on economic relations with advanced capitalist countries. The

history of some of these concessions in favour of the Iranian state (and some other OPEC member states) shows that the advanced capitalist countries had not made these concessions willingly.

In the case of Iran, the state, as the only recipient of oil revenues, determined how the revenues were channelled into the economy and which social groups were given privileged access to the increased consumption possibilities oil provided.

The Iranian state was able to impose quite strict regulations on TNCs investing in Iran, and through OPEC it was able to multiply its oil revenues in a few years. Nevertheless, in spite of these advances, Iran still was subordinated to the West, in a way in which the unevenness of capitalist development on a world scale and the ongoing dependent development process in Iran during the 1960s and 1970s, made Iran a weak constituent of the system. In this respect, its economic prosperity still rested on the export of a single primary product whose market it did not control. It was therefore vulnerable to shifts in demand and to manipulations of distribution by the oil company cartel and the world market. Furthermore, Iran had no independent technological capacity and had to import semi-finished goods to meet its industrial needs. Thirdly, Iran, as in its export, was vulnerable in its imports.

Having said this, it is, nevertheless, important to emphasise that Iran was to a greater extent than in the past an independent actor in the international capitalist system, although the stronger actor in this system - the advanced capitalist states - seemed to encourage its development only in so far as this would accord with their own interests.

In the long, run oil also created new international interdependencies as these states came to rely on foreign markets for capital, labour, and goods. The number of choices, the range of options that oil revenues created, the things that oil money could buy, - these factors initially masked the growing dependency on foreign powers and markets.

The State, Oil Revenues, and Economic Growth

The impact of oil revenues on the process of growth and structural change can not be analysed in abstraction from the institutional framework of the economy, and in particular from the nature of socio-historical factors which shape the role of the state in the economy (Karshenas 1990: 237). Oil gave the regime the resources to develop new allies among the national population.

The Shah's design was to link oil revenues strongly with economic growth. Oil revenues were spent on a variety of projects, most notably on material and human expansion of the civilian and military bureaucracies. The oil price hike of the 1970s substantially increased the capacity of the state to intervene in the economy, both by increasing the magnitude of resources at the disposal of the state and by easing the structural constraints which had previously limited the field of effective economic intervention by the state. The state thus assumed a much more significant role in setting the pace and structure of growth in the oil era. The number of government employees doubled between 1972 and 1974, and its expenditure for construction and military hardware reached legendary proportions. Oil was used to finance both economic growth and bureaucratic and military build up, which were in turn used to put the state in full control of society and domestic polity. Furthermore, the state sustained sizeable oil exports and near-dominant leadership within OPEC. Oil revenues enabled the Shah to restructure his regime's relationship with the international capitalist system and to enhance its status as a semiperipheral state. As such, it consolidated its relationship with, and reliance on, the US.

Without the presence of oil, the Shah would have had little success in implementing his policies; furthermore, Iran's relationship with the core capitalist states and with its Persian Gulf neighbours would have been fundamentally different.

The Shah had justified his style of political rule by achieving economic success. Concentration of political power in the Shah's hands during the 1960s and 1970s was on the grounds that such a system permitted a rapid and successful expansion of economic activity (Zabih 1979: 5).

Having considered the shortage of foreign exchange in much of the post-war period as the most critical single impediment to domestic economic development, the state saw oil revenues as the key, meeting all their needs and solving all their problems. As was demonstrated in chapter 5, the increasing oil revenue largely financed the high rate of capital accumulation. The government also adopted an expansionary monetary policy to stimulate private accumulation. The ease of access to external resources, i.e. oil income through exports and foreign borrowing, allowed the rapid acceleration of the rate of growth of investment and government expenditure without the need to curb the income and consumption of higher income groups. However, oil revenues provided a new kind of economy, built on rent and heavily reliant on the export of a single raw material, the

production of which required little contact with the rest of the economy. It brought spectacular growth, yet at the same time engendered dependency on volatile markets.

The more serious problems relating to the pattern of structural change over the 1953-77 oil period were the lopsided nature of industrial growth, which implied an excessive dependence on external resources, and the related problems of inadequate employment generation and a growing maldistribution of income. As the experience of Iran has shown, even the achievement of rapid economic growth may not by itself be sufficient to reduce economic duality over time (Amuzegar and Fekrat 1971; Karshenas 1990). Actually, the problems of growing economic duality and worsening distribution of income never received serious consideration in government policy formulation.

The main obstacles to developing the Iranian economy and to achieving a successful post-oil normalisation were to be found in the Iranian state itself: the hierarchy of the decision-making process, the high degree of autonomy of the state, compounded with its repressive nature, mismanagement and politicising its economic planning and mispending the oil revenue³. Furthermore, the chosen ISI strategy - the neglect of the agricultural sector - further exacerbated the problem⁴.

The Shah successfully linked oil revenues with economic prosperity and the regime's domestic and regional-international prestige. This policy enhanced the international status of the Iranian state, increased the domestic autonomy of the state, and made the process of rapid industrialisation possible. Yet if oil provided the opportunity for growth and proved to be a blessing for the state and the economy, it was also a curse, because it imposed limits on the economy which revenues alone could not remove. The inability of the state to diversify its source of revenues led to the increasing dependence of economic activity, and state autonomy, on oil revenues. The decline in oil revenues in 1976 heralded an economic crisis with socio-political consequences. Thus the "crisis of accumulation" started to become the "crisis of legitimation" (Moghadam 1988: 230).

Several tentative conclusions can be drawn from the analysis of the relationship between the oil sector and the state in the political economy of Iran during the 1942-79 period. Firstly, the strength of the state derived partly from the institutions inherited from Reza Shah's regime (i.e. a centralised bureaucracy, newly established military forces, and executive dominance) and partly from *statecraft* - that is, the ways in which state rulers use state instruments to enhance their own power over civil society. Furthermore, control over the oil sector and its revenues provided the state with massive financial

resources which allowed the state to pursue its objectives without any financial constraints.

Secondly, and more importantly, it is the character of a regime rather than a state structure that determines whether or not the state is developmental. Having said that, however, having a developmental state requires the existence of necessary structures. The most important element that determines the character of a regime, and consequently the ways in which state instruments are used, seems to be the manner and the social context in which state rulers came to power. The Shah came to power through foreign intervention and consolidated his rule through a foreign-supported military coup. Rather than gaining political legitimacy by broadening the political participation in the country's decision-making process, the Shah used either coercive forces to repress societal groups to an extreme extent, or economic rewards, concessions and offers of positions within the bureaucracy to satisfy the middle class and the technocrats.

Furthermore, the Shah sought to establish his regime's legitimacy on the basis of the ideology of kingship. However, with the surge of oil prices in the early 1970s, rewards rather than sound economic performance were successfully integrated in this process. As the sole recipient of oil revenues, the state's autonomy increased substantially. Thus, the state's priority to buy legitimacy gave way to further control of society and policy of forceful submission of the populace to support the Shah and his reforms, and the Pahlavi monarchy. Therefore, by 1975-6, repression had reached its peak.

Thirdly, the state's choice of a development strategy and major economic policies were not determined by domestic and world market factors alone, but rather, and to a major extent in the 1970s, by political considerations. For instance, the Shah's decision to double the expenditure of the Fifth Plan (1973-7) was due not to economic but to political rationality, enforced by his personal ambitions.

Fourthly, the dominant form of capital accumulation in Iran was shaped by the development alliance between the state and segments of capital. The state forged a narrow development alliance with the country's dependent bourgeoisie and international capital. In the 1970s, the state was the prime actor in this triple alliance. This alliance under the aegis of the state and the full co-operation of the TNCs

facilitated a remarkably rapid rate of economic growth, but produced enormous capital concentration and maldistribution of wealth.

Finally, the behaviour pattern of a developmentalist state such as Iran must be understood within the context of the state-class relations. There was a systematic attempt by the state to exclude all the dominated classes from major political positions and to prevent them from participating in important economic decision-making. The regime up to the 1970s pursued an unbalanced, highly concentrated pattern of capital accumulation. It pushed the political groups to the periphery of society and fostered the middle class - within the bureaucracy and economic elite - to rely heavily on the state's reward and concessions. This was possible because of the high degree of state autonomy and the absence of a strong politically motivated industrial bourgeoisie.

The weakness of organised labour and other popular sectors and social groups - a result mainly of the regime's bi-polar policy of suppression and co-option - permitted the dependent capitalist state of Iran to adopt its policies, including rapid industrialisation.

Theoretical Findings and Methodological Considerations

This research has argued that in the case of a semiperipheral country, where the state is centralised and enjoys autonomy from social pressures, a partial application of three theories - the capitalist interpretation of the nature of the state, namely the Weberian-Hintzian approach; the world-system theory, and the dependency paradigm - is necessary to help us understand the state, its structure, its capacity, and its position in the capitalist world economy.

The major theoretical contribution of this study has been to bring about a synthesis of perspectives derived from the above mentioned theories - dependent development, semiperiphery, and authoritarian-bureaucratic structure - and two concepts: autonomy, and interdependence.

A systematic comparative study has been made to shed new light on why similar states adopt different patterns of behaviour (internally and externally), and why countries with similar situations end up with different degrees of development, class relations, etc. In this study comparisons of several kinds have been made. The striking similarities between the coups in Iran in 1953 and in Chile in 1973 were

mentioned in chapter 3, suggesting the underlying combination of internal contradictions and external intervention at work in both cases. Furthermore, the crucial difference in the general conditions that preceded the Brazilian and South Korean military coups of the 1960s on the one hand, and the 1953 coup in Iran, mainly with respect to state alliance with local and foreign capital, were noted.

Iran's dependent development in the 1960s and 1970s was found to be significantly less than that of Brazil or the East Asian cases such as of South Korea. However, its room for manoeuvre vis-à-vis the core countries (in both economic and political terms) and its autonomy from local bourgeoisie were substantially more than these countries. This was mainly owing to the importance of its oil exports, and the country's strategic location for the core states, thus making possible the judgement that Iran *did* rise to a semiperipheral position in the world economy.

The second type of comparison used was of an internal type, and here a historical-comparative methodology turned on a single case yielded much theoretical interest. Again, both similarities and contrastive patterns in the process of state formation between the Safavid, the Qajar, and the Pahlavi dynasties were noted. For example, certain parallels between the rise and fall of the 16-17th century Safavids and the 20th century Pahlavis may be noted: both dynasties represented peaks of national economic power, dominated very much by the Shahs at the top, who established strong armies and bureaucracies as a successful means of control and regime enhancement. But the differences are equally instructive: the former was more of a regional empire, in no sense subordinated in its relations with the West, while the latter had been asymmetrically integrated in the capitalist world economy. The fall of the Safavids was traced to internal processes and conflicts between the state and the upper classes, while that of the Pahlavis involved an external dimension (dependence on Western capitalism, the US in particular) as well, which caused the withdrawal of some sections of the middle class and lower class support.

Economically, the lopsided nature of industrial growth, which implied an excessive dependence on the West, and related problems of inflation, inadequate employment generation and extensive maldistribution of income, derived in part by the economic crises of 1973-8, led to the generation of economic dissent and grievances. It was a limited circle of ruling elite which determined the trend and the direction of important policies. In addition, the repressive nature of the regime led to

the forceful passivity of major segments of society and thus to extensive disillusionment of the people and the increasing antagonism of the indigenous classes. It may be argued that oil revenues enhanced the state autonomy and provided the Shah's regime with the financial means to modernise the state and the economy on the socio-economic level and thus expand the ranks of the modern middle class and the industrial working class. Nevertheless, the regime failed to modernise on the political level. The failure to modernise on the political level inevitably strained the links between the regime and the social structure, blocked the channels of communication between the political system and the populace, and widened the gap between the ruling elite and the new social forces. As a result, a legitimacy crisis threatened not only the regime's own existence but also the very foundations of the prevailing social and economic order.

Notes

Chapter One: Theoretical Foundation

1 Generalising the rise of the modern state is a controversial issue due to the paradoxes and discontinuities of historical development. In addition, the feudalism-capitalism-socialism schema needs to be qualified. Feudalism existed extensively only in Europe, and the transitions have not sequentially ordered. Transition to Socialism has not always been via capitalism and through the existence of the working class. If we take individual states as our unit of analysis, as modernisation theorists did in the 1960s, then we can assume that the third world countries can modernise simply by following the same path to modernity as of the industrialised capitalist world - transition from feudalism to capitalism. However, such method of analyses and subsequent assumption of transition proved not to be appropriate. Vincent argues that: "It is wrong to assume that the European state should act as a model for developing countries" (1987: 7). Historical characteristics and the socio-political conditions of the rising modern state of the former are unique to itself, and no one can guarantee their similar repetition in another place or state. While there is no single root to modernity, the development of modern state is by no means a random issue.

2 Various combinations of four historical processes and forms of politics underlie the rise of the modern European state: the emergence of democracy, the spread of industrialisation, the evolution of nationalism, and the growth of Socialism (J. Anderson 1986: 4). Among them, one can argue, democracy and nationalism had a common origin in European Absolutism, while Socialism and industrialisation were in opposition to it. These four elements that grew out of the Absolutist period, provided the rise of the modern capitalist state.

3 Classical liberal state in contrast with the static rigidities of the *ancien regime* was established to guarantee the rights and liberties of the individual, while the invisible hand of the market guides the economy. Therefore, a minimal role was perceived for the state. In this state power was shared, representation was wide, and national sovereignty was defined. The struggle of working class and majority of the people modified the state's democratic feature and turned the state to a liberal democracy. Individuals entered into a social contract with the state - a contractual state - in exchange for the defence of their rights.

4 The two terms involve very different levels of conceptualisation. The complex character of the state cannot be reduced to the ways in which the institutional machinery of government functions. The state embraces a much wider range of functions than the technical and administrative questions of how the machinery of government operates.

5 The "consolidation of internal market in the periphery", which is to say the growth of import-Substituting Industrialisation (ISI), is followed in turn by the "internationalisation" of the domestic market (Cardoso and Faletto 1979: 114-38). As ISI moves from consumer nondurables to consumer durables, intermediary goods, and some capital goods, the penetration of the TNCs might become more intense - in financing and marketing the export-led production. O'Donnell (1973: 60-61) speaks of this situation as the transition from 'horizontal' to 'vertical' industrialisation.

6 For example see D. Hall, World-system theory, *The Annual Review of Sociology*, Vol. 8: 81-106, 1982; Skocpol, Wallerstein's world capitalist system: a theoretical and historical critique, *The American Journal of Sociology*, Vol. 82, no. 5, PP. 1075-1090, 1977.

7 Katzenstein (1978) concludes that the prototypical strong and weak states - subjects to the constraint from domestic societal groups - are those in Japan and the USA, respectively.

8 There are two other main approaches in comparative historical method (see Skocpol and Sommers 1980: 174-97). The 'juxtaposing case histories' is to persuade the reader that a given, explicitly delineated hypothesis or theory can repeatedly demonstrate its fruitfulness its ability convincingly to order the evidence - when applied to a series of relevant historical trajectories. The second approach, is in an opposite objective from that of already hinted above. It is to bring out the unique features of each particular case included to their discussions, and to show these unique features affect the working-out of putatively general social process. Hence it suggests, that particular nations, empires and states constitute relatively irreducible whole, each a complex and unique socio-historical configuration in its own right.

Chapter Two: The Modern State Formation in Iran, 1500-1941

1 The Safavid kings were as follows:

Ismail I (1501-24); Tahmasb I (1524-76); Ismail II (1576-77); Mohammad Khoda Bandeh (1578-87); Abbas I (Abbas the Great) (1587-1629); Safi I (1629-42); Abbas II (1642-66); Sulaiman I (1666-94); Hossain (1694-1722); Tahmasb II (1722-32); Abbas III (1732-36).

2 One of the main primary sources on the Safavid administration is *Tazkirat Al-moluk*, (hereafter Tazkirat, for its translation, heretofore Minorsky TM) written by an anonymous writer around 1725 (1137 hg), following the collapse of the Safavid dynasty, to be delivered to *Ashraf Afghan*, the successor of *Mahmud Afghan* the abolisher of the Safavid dynasty.

3 During the reign of Tahmasb, 114 posts of *amir* have been registered in books of *divan-e a'la*, of which Monshi (1616) chooses 72 of them as the most prominent and chiefs of all classes and tribes. 59 of these 72 are Turkemans (56 qizilbash) and the other 13 from all other non-Turkeman races including Persian. (Minorsky 1989:22).

4 This division is more based on Tazkirat al-moluk. Others like Savory count the administration equal to *dolat-khaneh* and divides it to court and chancery.

5 The first state council included four amirs namely the grand vizier or *sadr-e a'zam*, the minister of finance or *mostowfi al-mamalek*, the judiciary and religious minister or *sadr*, and the war minister or *amir al-omara*.

6 Based on Nasir al-din Tusi in *Akhlagh-e Naseri*, P.305, the pre-Safavid society is divided into 4 groups or classes; men of pen (*ulama*, scientists, those who executed great administrative and financial affairs), men of sword, men of affairs (such as merchants, craftsmen, artisans and tax-collectors) and husband men.

7 During Abbas I, the transferring policy was restricted to lands. Transferring a province to *khassseh*, was suggested for the first time by the grand vizier of Safi.

8 The policy of Abbas I to hire ordinary people in administrative positions, continued by other shahs. A poem describes this policy during the reign of Sulaiman.

Rafte rafte qashu ghalamdan shod,

Shaikh Ali Khan vazir-e Iran shod (Gradually the horse comb became a pen pox, Shaikh Ali Khan became Iran's grand minister (Bastani, 1969:146).

9 Other posts were assigned as *beiglar-beigi* (governor general), *hakem* (governor), *khan* (chief), and Sultan (which was used by the Safavid shahs to downgrade the Ottoman Sultans). Their responsibility and power were different in scale but somewhat alike in content Vali was the governor of border states and often the appointment was hereditary. He enjoyed more independence than the others with respect to the state. *Beiglar-beigi* was the governor of provinces and *hakem* was the ruler of major cities. *Beiglar-beigi* could have a number of *hakems* under his supervision. *Khan* generally refereed to the head of a tribe or a small city, while sultan retained the lowest position in the provincial governorship.

10 In most of the first phase, this title was called *amir al omara*.

11 Chardin believes their number to be 60,000 to 80,000 that were decreased by Abbas I to 30,000. In the time of Sulaiman, their number, as Kaempfer argues did not exceed 20,000.

12 Their number is 30 thousand for Dela Valle, 10 thousand for Chardin, and 15-18 thousands for Kaempfer (1940: 89, trans.).

13 Contrary to the general belief, this regiment was introduced into the Safavid armies before the reign of Abbas I, and not by Antony Sherly. Monshi(1616:427-8) points out that the *tupchian* regiment in the Balkh battle in 1603 was 10,000 soldiers with 300 artilleries. Abbas II dissimulated this regiment. Kaempfer says that during the Sulaiman reign these artilleries were only used as a show in front of the palaces.

14 They were 600 during the Abbas II era, as Tazkirat al-moluk points out, but were increased to 2,000, as Kaempfer (1940: 91, trans.) argues.

15 Both the traditional and the new army contained cavalry (*savareh nezam*) and infantry (*piadeh nezam*), in permanent and temporary regiments. All these regiments were organised in groups of 10, 100, or 1000 called *un-bashi* (10 people), *yuz-bashi* (100 people), and *min-bashi* (1,000 people) respectively.

16 For instance, an ordinary trooper would receive annually between 5 and 12 tumans (equal to £16.5 and £40) in the seventeenth century (Foran 1993: 24).

17 James VI wrote in 1601 to Abbas I about Antony Sherly and means of co-operation: "For when the kingdom of England, furnished with a most powerful fleet, and most famous for the circumnavigation of the whole glob, strikes the greatest terror into the hearts of the Ottoman people, there is no doubt that... we shall some day attain, both for yourselves and ours, an everlasting glory joined with the greatest advantage.... We hope the time will shortly come when, out of the mutual desire of all the princes, the hostile banners of the Turkish people torn to pieces and trodden underfoot, shall be exposed to mockery and derision" (translation of the letter in Arberry 1942: 31-2). Karl II the king of Sweden in a letter to the Shah of Iran wrote: "We should sign a military agreement against the Turks" (in Kaempfer 1940: 260). Yuhan III, the king of Poland angry for the reluctance of the Shah, and knowing the interest of the Safavid shahs in astrology, wrote in 1686 to Sulaiman: "now, the situation of the stars are in such a way, that calls us to jointly invade the Turks" (Kaempfer 1940: 261-2).

18 It represented a "hereditary grant of land with the title to the tax yields (or part of it), immunity from taxation, and prerogative rights which, in the case of large soyurghal, extended to administrative and judicial immunity" (Fragner, 86:510). Thus iqta was a right of tax collection to individual person for military services. In the 14th century, iqta "signified not only the ceding of beneficium but as well the actual land concerned" (Fragner 1986: 501).

19 The major forms of taxes based on Tazkirat al-moluk were, *olufeh*, *pishkar*, *dast-andaz*, *do-ashr*, *dah-yek*, *khedmataneh*, *sar-shomar*, *khaneh-shomar*, *bigar*, *shekar*, *eydi*, *no'ruz*, and etc.

20 Chardin gives almost the same figure.

21 Bastani (1969: 80) points that the crown revenue and government revenue had not been separated in this figure. The Shah's revenue and treasury was the main source of government budget. Abbas I at outset of his reign cashed most of crown golds and gems to overcome the cost of wars.

22 Transit goods were compelled to taxation by the cities they were going through. Extra ordinance such as *rah-dari* (road maintenance) was collected. As Hinz (quoted in Fragner 1986: 539) argues, in the 15th and 16th centuries, the price of an imported commodity in Istanbul was twice its originated price in eastern Iran mainly due to the local transit taxation.

23 The initial introduction of codification was during the *Qazan khan* (1295-1304).

24 He developed the road networks and paved part of them with stones. There is a myth that Abbas I had built 999 *karvan-sara* (resting place) on roads from his wealth. He ordered all regional governors, merchants and landlords to build roads and resting places.

25 One reason behind this decline is related to the Timurid interest in the eastern trade (mainly in Harat and Samarghand), neglecting the western trade of Iran (Tabriz, Baghdad and Sultanniyeh) which was the adjacent point of the East-West trades. Thus when at last the country was consolidated under the Safavid, and the internal preconditions for commercial recuperation of Iran were restored, it was already too late: world trade was now running along new tracks.

26 This, partially, was the reason which led him to receive British help to regain the control of Hormuz. Britain received a concession in trade for helping Abbas I to free Hormuz from Portuguese.

27 One reason that Abbas I banned the smoking of tobacco by 1618 in public offices (Bastani 1969: 128) was to increase its export.

28 Tavarnie (1681, trans.) believed lack of knowledge and ability and promiscuity among Iranian merchants were main reasons for foreign domination of Iranian trades. However, the privileges of Europeans in custom duties and their more receptive attitude towards Armenians on one hand, and lack of enough capital among local merchants on the other, count more for the non-local domination in Iranian trade.

29 Minorsky (1943: 23) emphasises on "the complete disappearance of the basic theocratic nucleus round which Shah Ismail had built up his state, without the substitution of some other dynamic ideology".

30 However, Savory (1986) concludes that the Safavid fell down because they failed to concile the irreconcilable: Turks and Persians, tribal organisation and urbanism, the peasant-nomadic tradition and the sedentary life, and Sufism and dogmatic shi'ism.

31 The Qajars, like many other Turkic tribes, migrated from Central Asia into the Middle East during the 14th century, but they did not appear on the political arena until the beginning of the 16th century. Allying with six other Turkic and Shi'i tribes known as the qizilbash (red heads), the Qajars helped install the Safavid family on the Iranian throne. The Safavids, although invited the leading Qajar chiefs into the royal court in Isfahan, they took the precaution of dispersing the Qajars, among them Aqqoyunlu, which Agha Mohammad Khan was from. The Aqqoyunlu Tukeman tribe claimed to be the descendant of Qajar Noyan, son of Sertaq a Mongul military commander (Shamim, 1372: 25).

32 Dealing with Ottomans, Russians, Afghans, and partly the British were assigned to the governor of Kirmanshah, Azarbaijan, Khorasan and Fars respectively.

33 For instance, Hossain Khan-e Sepahsalar Chief Minister of Naser al-Din Shah and for seven years his Minister of War, who launched a "far reaching programme including reform of army, administration, taxation, law and economy" failed to achieve anything apart from only the foundation of Cossack brigade. He did however, acquire "an unrivalled reputation for corruption" (Yapp 1987: 171).

34 There was a view within Britain that her interest would be best served by a strong Iran which would form a better buffer against the advance southwards towards India of Russia and which would also offer a better field for British economic enterprise. But in practice, the weak buffer theory that Russians were unanimous about it prevailed. It seems clear that "the net effect of the action of the two powers in Iran was to impede change and this is nowhere more clear than in the matter of the railway development" (Yapp 1987: 172).

35 In the dismissal *farman* (order) of Agha Khan-e Nuri,¹ the Shah dismissed the post of *sadr-a'zam* to directly control the bureaucracy and the ministers: "The post of *sadr-e a'zam* and its administration will be totally dismissed from the government of Iran and will be replaced by the council of ministers" (The Shah's order, dated the 20th of Moharram 1275hg, quoted in Adamiyat, 1356).

36 He recruited only three high-ranking administrators from the previous Zand court: the state accountant (*mostowfi*), the military accountant (*lashgar nevis*) and the royal minister (*vazir*). In personality he did not like the palace life. He refused to have the jewelled crown, and ordered his secretaries to communicate in plain and simple language instead of traditional esoteric terminology (Abrahamian, 1982:38).

37 The administration consisted of the war minister (*vazir-e lashgar*), the finance minister (*mostowfi al-mamlek*), the head of administrative secretariat (*monshi al-mamalek*), the watch dog over the accounts of each department (*saheb-e divan*), and the chief minister (*sadr-e a'zam*).

38 Ministries of *Owqaf* (Pension and Endowments), Post, Telegraph, Science, and Mines *Favayed-e A'mmeh* (Public Work, a non-existence Ministry, previously with the Ministry of Interior *Adliyah va Tejarat* (Justice and Trade), *Darbar* (Court), Press, *Jang* (War), *Dakheleh* (Interior), *Maliyah* (Finance), *Omur-e Kharejeh* (Foreign Affairs), *Gomrok* (Custom), *khazaneh* (Treasury, which was in most times a part of the Court Ministry), and *Baqaya* (In charge of government documents regarding the actual expenditure and income, and to collect the difference) (Sheikholeslami 1978: 225).

39 After his dismissal, he raises the point that "I had the intention of establishing the constitution, but they didn't give me any opportunity" (Mirza Yaghub Khan, 1290hg).

40 Even the coronation of Mozaffar al-Din took place by the loan provided by Britain through *Bank-e Shahanshahi*.

41 *Zell al-Sultan* points out that Iranian governors collect two kind of taxes; *asl* or the tax which they send to the central government, and *far'* or *tafavot-e amal*, which covers the cost of present and contribution to the court and payment to *mostowfis*. Indeed, a major part of it, is collected by the governor himself (Sheikholeslami 1978: 236).

42 The new army under the command of Abbas Mirza, was comprised of horse-artillery with 20 field-pieces, 12,000 regular cavalry, and 12,000 regular infantry. They were divided in different regiments, each comprised of one separate tribe.

43 Malcolm (1829, Vol. II: 358) points out that 'the different regiments were willing to be commanded by European officers but not by Persians of a different tribe'.

44 It was called *bunicheh* or the six-month maintenance allowance. This allowance for 1886 amounted to about £519,214.00 (Sheikholeslami 1978: 214).

45 In 1306hg Baluchestan sent 2 million qiran tax revenues to the capital, while the total tax collection was 8 million qiran.

46 During the reign of Agha Mohammad Shah, no distinction seems to have been made between privy and public purses. Fathali Shah recognised a formal distinction between them. The royal treasury was administered under the supervision of the Shah. Khazan al-Doleh, an slave girl who married the Shah, and Kheyr ol-Nesa Khanum, daughter of the Shah were in charge of the treasury with the help of tens of financial expertise (Tarikh-e Azodi 1327: 12-13 quoted in Meredith 1971: 76).

47 The custom revenue of Tabriz increased from 12,000 tumans in the beginning of the 19th century to 300,000 tumans in 1877 (Sani' al-Doled, VI: 348).

48 Direct taxes consisted of land tax, flock tax, poll tax, the tax on the profit of master craftsmen. The mint, the mines, the post and telegraph, passport issuance, timbre publication were other sources of fiscal revenues.

49 The first loan of the government was £500,000 from Imperial Bank in 1892 to compensate the British Tobacco concession. The aggregate loan from Russia in 1902 was £3,250,000 mainly to pay off the British loan. In 1911, 1913 tow further loans of £1,100,000 and £200,000 were received from the Russians. During the 1902-1913, the government received a total loan of £1,850,000 from the Anglo-Indian (the British) institutions.,

50 27% of Russian investment was allocated as loans to the government, 29% in form of mortgages, 23% investment in transportation and communication, 7% as capital share in the *Bank-e Esteghrazi*, 6% in fishing, and 12.5 percent in shipping and trade companies. The British investment included: 17.5 percent in form of loan; 28% was invested in Anglo-Persian Oil Company; 10% in the Imperial Bank; and, 31% as capital share in the Persian Railway Syndicate - which only a part of this invested in Iran. Furthermore, Belgians invested £500,000, mainly in railway and industry, while the Germans invested the same amount mainly in the carpet-making firms.

51 For example, the price of one bushel of wheat from \$1.5 in 1871 dropped to 23 cents in 1894. During the same period, exports of Iranian wheat was 8-fold while the total value of the wheat exported remained virtually constant (Mc Daniel, 1971 quoted in Turner 1980).

52 There were various privileges for foreign merchants or those Iranian merchant who would travel by foreign passport. Among them were: 1. capitulation law almost fully protected the European businessmen against arbitrary action on the part of Iranian officials; 2. commercial treaties, in which, favoured European firms to pay a fixed custom duty of 5 % *ad valorem*. Russia first took these advantages in 1813 and 1828 treaties. Britain later in 1841, and the others in following years took the

same advantages. Issawi (1983:232) argues that Europeans 'levied higher duties on their own exports than on their imports.' Thus the government was unable to impose tariff protection to shelter local industries.

53 By the Constantinople Agreement of 19 March 1915, Great Britain had extended her sphere of influence into the central 'neutral' zone in return for accepting full freedom of action for Russia in the northern zone: formal bifurcation seemed only a matter of time (Hambly 1991: 215).

54 Although the British, for their part, proceeded as if the ratification were a foregone conclusion, the agreement was never ratified and was abandoned by the end of 1920.

55 In 1920, the Soviet Union requested a new treaty between the two countries which was signed in 1921, days after Reza Khan's coup. The Treaty of Friendship in which it looked highly favourable to Iran, abrogated former Tsarist treaties, concessions (except for fisheries) and loan repayment claims. In April of the same year Russian troops left Iran and support was withdrawn from Kuchak Khan.

56 The bloodless coup of 21 February 1921 was carried out militarily by Reza Khan and politically by Zi'a. In fact there had been no government to topple. Weeks before the coup, Premier Vosuq was replaced by Sepahdar-e Rashti, and the latter, expecting the coup, resigned from office. Although the British authorities denied their involvement, the coup was initiated and backed by them (see Hambly 1991: 219; Keddie 1981: 87; Halliday 1979: chap. 2). In retrospect it seems that the coup was intended "as the alternative route to the achievement of the spirit of the 1919 Agreement - that is, a political stabilisation in Iran which would not pose a threat to the main local regional interests of the British Empire" (Halliday 1979: 44).

57 In 1922, the Fourth Majles enacted the first law regulating civil service in Iran; age, nationality, education, and other qualifications for civil servants were defined.

58 The Reformers Party was banned, the Socialist Party was dissolved, the Communist Party was crushed, the Revival Party that was faithful to Reza Shah was replaced by *Iran-e Now* Party (New Iranian Party) and later by *Taraghi* Party (Progressive Party; a model of Mussolini's fascist party and Ataturk's Republican Party). The *Traghi* Party was also dissolved on the suspicion of republicanism (Abrahamian 1982: 139).

59 To control the army he held the post of the Minister of War when he was the Prime Minister. Later as the Shah, Reza Khan controlled the armed forces by appointing non-military officials such as Forughhi as the Minister of War.

60 The army consisted of the cossack brigades and the gendarmerie. He created a united force by amalgamating the latter into the former, and disbanding the British-controlled South Persia Rifle. The army was supplemented by a small air force,¹ a mechanised brigade of 100 tanks, and a few gunboats in the Persian Gulf.

61 They were ministries of War, Interior, Foreign Affairs, Justice, Finance, Education, Post and Telecommunication, Agriculture, Imperial Court, and Industry, Trade and Transport. In 1934, Ministry of Health and Communications was added.

62 It led by *ostandar* (governor-general), *farmandar* (governor), *bakhshdar* (mayor), and rural council respectively. The majority of dehestans did not have an administration.

63 Such as Sardar As'ad, Tadayyon, Dashti, Rahnama.

64 During the World War II, his son Mohammad Reza, under pressure, in an order dated 19 September 1941 (30/6/1320), suggested the return of these lands and factories to the government and peasants. But this didn't happen until 1950, when a new established Bank of Omran hold responsibility to sell these lands in favour of the Shah's treasury. This sale excluded the large mechanised lands and took place during 1950-1958.

65 Among the supplements were various laws regulating trust funds, damages, methods of testimony in court, trial costs of aliens, jurisdiction of shari'a courts, and inheritance. The final version of the civil

code was passed on 16th September 1939 in 789 articles. By 1940 more articles were added to the civil code, in which the right of the state vis-à-vis individual person or society was increased.

66 Thereby he solved the problem of article 37 of the supplement of the constitution law, when his son decided to marry non-Iranian Fuziyeh.

67 Szyliowicz (1973: 252) argues that Reza Shah's educational ambitions were the product of a ruler who was at bottom distrustful of intellectual curiosity and critical inquiry. To train uncritical bureaucrats, docile engineers and military experts was the fundamental goal of the measures taken to improve and expand the system (in Matthee 1993: 334-5).

68 The number of schools rose from 1943 units in 1924 to 4505 units in 1936 with an enrolment rose from 96,000 to 300,517 students in respective years. *Ettela'at* daily newspaper (10/7/1926) based on official reports reported of only 722 units of school in 1924 with 50,000 students. It seems that data presented by Jamalzade include all rural, urban and nomad's schools and is closer to statistics presented by other writers (see Menashri 1992; Faghfoory 1993).

69 Under the Armitrage-Smith agreement of 1920, APOC paid £1 million to the Iranian government to settle outstanding claims. The original agreement was that APOC would pay a 16% of its 'net profit' as royal payment to Iran. In 1933 a new 60 years concession agreement was signed. The royalty paid by AIOC should be assessed on a tonnage basis (4 shilling per ton) plus various of the payments and guarantees. Some argue that this new deal by the government of Reza Shah with its prerogative of a new lengthy agreement was against the interest of the country.

70 Though the new concession signed in 1933 did lead to some increase in the oil revenues of the government per unit of production, it did not bring about any significant changes in the extremely unequal shares.

71 In 1900-1925, inland freight charge accounted for almost half of the market price of goods in Tehran (Bharier 1971: 172 fn. 10).

72 Sugar, cement, cotton textile, matches were the main industries.

73 Bharier (1971: 171) estimates the number of small workshop only in Tehran as 5000 by 1928. If this figure is close to reality, then the former figure shows a major decline in small workshop from 1920s to 1940s.

74 Based on a tighter definition of industrial workforce, by 1946, from 49,000 industrial work force, 50% were in the state owned factories (Review of the 2nd seven year plan, P.56, in Bharier 1971: 180).

Chapter Three: The Iranian Authoritarian-Bureaucratic Regime

1 Based on the 1907 Supplement, approval of laws concerning the revenues and expenditure of the country were especially reserved to the Majles. By the 1949 amendment, the Shah was empowered to disband either of the two house of Parliament separately or together, to have the final saying on any disagreement between the two house of Parliament and to preside personally over cabinet meetings. The amendment of 1957 empowered the Shah to return bills or laws on financial affairs to the Majles for re-examination. The 1967 amendment designated the Queen as the regent if upon the transfer of the Throne the Crown Prince should not have reached 20 years of age, unless another person shall not have been designated by the Shah.

2 More specifically, we can note the nationalisation of a key raw material (oil, copper), economic blockade by the world power, internal popularity but failure of the government to control the army and other elements of the state, and a coup plan designed by the CIA. (on Chilean coup see, Birns, L., *The End of Chilean Democracy*, NY: Seabury Press, 1974)

3 This was due to: (a) the government attitude of acting as a welfare state with rapid expansion of educational facilities, health and other social services; (b) growth of public administration, partly as a result of liberal employment; and, (c) salary rise.

4 System maintenance refers to the preservation of ongoing patterns of relationships of the system of monarchy and of the Pahlavi regime under the Shah. The term regime enhancement refers to the enhancement and promotion of the Pahlavi regime of the Shah ideologically, socio-economically, politically, and culturally (Farazmand 1989: 12)

5 Councils such as the High Economic Council, the High Administrative Council, the Ramsar Conference. On the latter example (pine tree), as a result, the administrators in Khorasan who found themselves only responsible to appease him, contemplated grubbing up their ancient pines (Alam 1991: 405).

6 The Prime Minister and the Foreign Minister were excluded from the circle. On one occasion the Shah pointed out that "I have forbidden Hoveyda's brother, our representative at the UN, to report directly to the Prime Minister" (Alam 1991: 357-8).

7 Under the Shah, Iran did not have an oil minister thus the finance minister usually represented Iran at OPEC ministerial meetings. However, when Jamshid Amuzegar, who had been Iran's Finance Minister and therefore de facto representative at OPEC for several years, was transferred to head the Interior Ministry, and even later when he became the Secretary General of the Rastakhiz party, he remained Iran's OPEC representative.

8 Based on the Rastakhiz party's by-law, all applications to stand for seats in various constituencies (for both the Majles and the Senate), had to be reviewed and decided on by the party. For example, in 1975 election, from around 7,000 applicants 710 were named to contest for the 268 Majles seats, and 83 candidates were announced for the 30 elective Senate seats.

9 The Tudeh party was organised in 1942 by a group of educated men most of whom had been imprisoned under Reza Shah as suspected Communists. Although at the beginning, the Tudeh party was proposing socialist programme and included some non-communist members in its leadership, later it fully turned to a Soviet-model Communism.

10 Until 1956, up to the nineteenth session of the Majles, some 136 members were elected for terms of two years. By the twenty-third Majles, inaugurated in 1971, the number of deputies had increased by 268, for a term of four years. In this session, 225 deputies were from the Iran Novin Party (the main stream of the later Rastakhiz Party), while the Mardom Party was represented by only 36 MPs. In the sixth Senate, inaugurated in 1971, the Iran Novin Party was represented by 28 of the elective seats and the Mardom Party by two seats.

11 For example, on the latter case, it was used to police the anti-profiteering and price campaign in 1975. In the name of the party, loyal groups were used to pack rallies staged to counter religious or political gathering during the 1977-78 period.

12 Although never being denied officially, there was a widespread rumour that to have a passport or an exit visa requires the membership of the party - which concerned even the religious families who wanted to go for pilgrimage to Saudi Arabia and Iraq. The official figures estimated the total membership at the end of 1976 to be over 5 million (IA 1977: 119).

13 The imposition of one-party system was in contrast with his early saying that "If I were a dictator rather than a constitutional monarch, than I might be tempted to sponsor a single dominant party such as Hitler organised or such as you find today in Communist countries" (Mission 1961: 137).

14 The main differences of the two wings, other than personal rivalries and competition for the post of prime minister, was that the Progressive Liberals tended to lean towards greater social welfare, encourage bureaucratic decentralisation and rapid growth but not at any price. The Constructive Liberals emphasised on high growth no matter what the consequences.

15 All government employees were divided into categories of established, non-established, daily hire, temporary, etc. Established contract was like a permanent contract which would guarantee a secure employment for civil servant.

16 The actual number might be higher. Approximation and ambiguity in official figures was one of the shortcomings of the administration (IA 1968: 566). If one adds civil servants who in 1978 were working in security organisations (an estimation of around 100,000), government charities, and government employees working in its enterprises and factories and also in government social services, i.e. municipalities, etc. (500,000 based on the available data for the 1960s), military personnel (800,000 overall consisting of 423,000 regular members of the armed forces, 75,000 of para-military, and 300,000 conscripts), and 850,000 established civil servants, the total number of public employees reaches about 2.5 million. However, if we consider the public employees working in organisations such as NIOC, PBO, CBI, and NIGC - that were not under the regulations of Employment and Administration Organisation - those who were working in the government ministries but under a non-established or daily contract, and those who were working in government charities, the total number will be even higher. There was no official data available for most of these agencies. (see also Statistical Yearbook, 1975, 1978, 1995; IA 1978, 1968; military balance 1978, 1979; Abrahamian 1982; Graham 1980).

17 The number of foreign workers, who possessed work permit in the country, passed 45,000 in 1976, and reached 60,000 by March 1977 who almost exclusively were hired and paid by the government or its related agencies. (*Rastakhiz*, in IA 1977: 379). It seems that considering the sensitivity of the regime towards the military affairs in general and the foreign military presence in particular, this figure does not include the 40,000 foreign military personnel working in Iran by 1978. The number of foreign workers being paid by the government might have reached around 100,000. Thus, the government should have paid about \$2 billion in 1975 only to those 20,000 foreign employees working in defence and defence-related fields (\$90,000 per person per year, Graham 1980: 91).

18 Almost all modern bureaucratic organisations show a degree of formalism. Riggs defines formalism as: "If you find an organisational chart which purports to describe the structure of a government department, with elaborate statements of the duties of each unit and post in the department, you will hold this chart formalistic if you see, the real people, and units in the department doing different things from those mentioned in the chart" (1964: 15 in Farazmand 1989: 55)

19 A third option - co-option - was pursued to a slight degree by the Shah as well, particularly at the elite level. However, this option was practised through successful employment of the repressive apparatus and oil revenues.

20 Military officers such as General Hasan Arfa, (the founder of the party, and three times Chief of Staff) General Akhavi (Minister of Agriculture, Chief of Rokn-e Do), General Aryana, General * Eram (in *Rokn-e Do*) were members of the military wing of the Arya Party. This party, with information provided by the British and the CIA, played an important role in disclosing the military section of the Tudeh party within the army.

21 Established in 1911 by the help of Swedish officers. From 1942 to 1976, it was advised by a team of specialist from the US. With its 2000 stations, it was the main instrument for rural control, while later functioned more as a counter-insurgency force.

22 The Civil Defence Organisation was established in 1957 under the ministry of interior, and supported by the armed forces, to safeguard the lives and properties of people and national resources against damages resulting from enemy bombing, nuclear attacks, and natural disasters. The National Resistance Forces was established in 1953 under the ministry of war and under the command of the armed forces, to defend respective homes and villages by organising resistance groups.

23 For example, Shahram (Ashraf's son) and General Khatami (the Commander of air forces and the Shah's son-in-law) received major bribes in return for influencing the Iranian military side to purchase from American designated companies including Northrop (*Financial Times*, 2 December 1977). In another case Bell paid bribes to key Iranian officials to win a \$500 million helicopter contract in Iran (*Financial Times* 23 February 1975). The Shah on one occasion received \$140 million over a \$1.5 billion contract with Germany. The contract later was cancelled. Shapur Reporter, a close friend of the Shah, received \$1 million to fix Chieftain contracts for the UK companies (*The Financial Times* 9 November 1977). Lockheed Scandal was a case of bribes involved in sale of C-130 transport planes to Iran in 1976, and in another instance bribes received for the purchase of F-14 jet fighters. (Alam 1991: 470-71, Graham 1980; see also Ghara-Baghi 1986: 94 for cases of embezzlement in local contracts).

24 Even issues such as transfer of officers above the rank of second lieutenant from one branch of the military to another, the promotion of commissioned officers, meeting of a general by another general, and even a visit to holy shrines in Iraq by junior officers required his authorisation (General Jam, BBC Document, programme. 18, tape 6; Halliday 1979: 68).

25 In three separate instances, the chief of staff was removed without warning. In 1966 General Hejazi, who had held in the position for a number of years was retired without notice. In 1969 his replacement, General Ariyan, was similarly retired. Two years later General Freydan Djam was suddenly removed and appointed ambassador to Spain, an action that was tantamount to political exile. (Zonis, 1971: 22-3; Bill 1972:42-4).

26 The Bureau and later the Council was proposed by the British MI6 when its head Hossain Fardust went to take special security courses in UK (Fardust 1991: 290-2).

27 A special network established within the Bureau headed by Brigade Safapur to infiltrate and gather information within the military and para-military forces. The Shah had asked Fardust to build an additional network within the Bureau to watch over SAVAK. Because Fardust was appointed vice-chief of SAVAK for over 10 years from 1961-71, to reorganise SAVAK, it was not difficult for the Bureau to create such network (Fardust 1991: 408-14).

28 SAVAK's employees - including informers - were estimated somewhere between 3,000 to 3 million. It seems that SAVAK by enjoying co-operation of the military/bureaucratic establishment, both physically and informational, did not need a very crowded organisation. Nonetheless, it employed a large number of part-time salaried informers.

29 That is "a policy of maximum political and economic independence consistent with the interests of one's country" (The Shah 1967: 125-7).

30 According to the Shah's assessment, when Reza Shah left Iran, the army deserted, the government collapsed, and the whole country effectively disintegrated because he had failed to institutionalise the monarchy and provide legitimacy for the Pahlavi dynasty in Iran (Fatemi 1982: 57).

31 By submitting to the kingship ideology, he was the "God's special representative on earth" (Hennells 1975: 97, 106), therefore, one had no right to oppose the Shah and his leadership in establishing 'order' and 'peace'.

Chapter Four: State Autonomy and the Shah-Elite Relations

1 There is no psycho-history of the Shah, but his character and his views can be gleaned through his own writings, and the interviews he gave to journalists and writers, and the memoirs and autobiographies of his close allies and relatives. see for example the Shah 1961, 1976, 1980; for a revealing insight to his character see the interview with Oriana Fallaci (1977) (see also Karanjia 1977, Alam 1991, Ashraf 1980).

2 Mohammad Reza studied for 5 years in Switzerland, 4 years of which was in this school in Rolle.

3 'The Shah and I' (diaries of Alam), edited by Alikhani in 1991 ranks as a historical source of the first magnitude. It is because Alam was much more than an official, he was a friend who escaped the Shah's net of suspicions. The diaries mostly fit with the events, or other diaries and books. However, the book suffers from some weaknesses: the original manuscript has been selected from by the Alam family and the editor of the book. The method of selections and reasons behind it are unknown. Furthermore, the ambiguity on the sincerity and truthfulness of Alam himself can be seriously questioned i.e. his continuous extreme praise on the Shah. The diarist never put any blame on his personal misgivings towards the Shah. While evidence suggests enormous personal gain by Alam and his own circle of relatives, courtiers and friends, there is not even a single reference to these in the book.

The second important diaries, 'Rise and Fall of the Pahlavi Monarchy' belongs to General Fardust. He was the confidante to the Shah on security issues, the only person who was with the Shah for 52 years - from his eighth year as his classmate in Tehran, later in Le Rosey and Officers College, serving him throughout his reign, and being the closest friend and advisor to the Shah in periods of his rule. His diaries suffers from the following weaknesses: it had been written and partly taped in prison, following the collapse of the Pahlavi regime (parts of the interviews were broadcasted on television); it was edited

by a government official and published after Fardust's death (as in the case of Alam). Furthermore, the role Fardust played in the weeks before and months after the revolution remains still a mystery. However, the diaries is one of the most detailed source for behind the scene information on the Pahlavi regime, in particular on personality of the Shah, the influential ruling elite and the security forces. The information given, as in the case of Alam's diaries, mostly matches with other documents and diaries. The difference between the two diaries (one very positive about the Shah and the latter partly critical of him) seems to lie mainly in their approach and the timing of these two writings. The former had been written during the grandiose years of the Shah and his regime, while the latter was written after the fall of the Shah. I have referred to these two books frequently.

4 Psychologists conceptualise such a special relationship as 'twinship'. It is found when an individual merges with another, in order to generate the self-affirmation and self-strengthening which comes from the association with powerful other. From the strength and speciality of the Shah's relation with his close friends, Alam, Ashraf and Peron were the only individuals who could fit in this category of twinship relation with the Shah (see Zonis chapter 2).

5 Peron, the son of a gardener at Le Rosey school and a close friend of the Shah, was apparently serving as a link between the court and the British intelligence services, during the Mosaddegh crisis in particular. Ashraf was heavily involved in promoting the Pahlavi dynasty's image of philanthropy and remained the titular head of the Imperial Organisation of Special Services, which had so many ex-government heavyweights that it became known as the 'elephants' graveyard'. Alam, the Court Minister, the individual whom the Shah trusted more than any one else, who was deeply involved in the political decision-making process, in both foreign and domestic policies, by achieving the trust of the Shah. Furthermore were: Fardust his friend from his childhood and the head of the Special Bureau; Shapur G., a British agent and a close friend who had a powerful influence over the Shah and thus on the system; Hoveyda the Prime Minister for over 12 years; Dr. Ayadi, his personal physician; and, Farah, his third wife and mother of the Crown Prince.

6 It seems that this was the first time he disagreed with his father who didn't believe such visions (on his father's rejection see Laing 1977; Fallaci 1973).

7 For example, in the 1963 uprising, his power was undermined severely. It is by no means clear that the Shah himself would have had the mental strength to issue the order to fire on the crowds in the 1963 uprising. He needed the external strength in the time of self-inflicted isolation and withdrawal caused by prevalence of his passive character. In 1963 uprising, Alam was the source of such strength to make the decisions for him. It was "I myself, as Prime Minister, [who convinced the Shah and] ordered the dispersal of a protest against social reforms on 5 June 1963" (Alam 1991: 113).

8 The Shah loved to be praised and magnified. The ruling elite would call themselves in public 'the house-born slave of His Majesty' and portray him as "a paragon of virtue whom God has bestowed on Iran," or as the one who is "really too great for this people" (Alam to the Shah in Alam 1991: 176, 372; Alam to Laing in Laing 1977: 231). Foreign dignitaries had used his occasional love for flattery to gain his attention. Portraying him as "De Gaulle of Iran" by the British Ambassador, "the greater man around" by Kissinger, and, "the Cyrus the Great of the time" by the Israelis were all examples of how to appease him (in Alam 1991).

9 'Nixon doctrine' was a response to the strategic weakness of the US in the waning years of South Vietnam. The US designated foreign states as regional powers and supported their effort to act as proxies for the US.

10 By 1951-53, the British concern was more on the effect of the victory of Mosaddegh on other external crisis. For her, Nasser would be emboldened to take action against the Suez Canal if Mosaddegh succeeded against the AIOC. Nevertheless President Truman worried more over the international oil industry and the stature of US oil firms. Later, with Republicans in power, the concern of D. Eisenhower in 1952 was that Mosaddegh was dragging Iran into chaos and the possibility of a communist take-over.

11 The British controlled 40% with the remainder divided between the Americans, French and the Dutch.

a) The American companies held 40%: Gulf, Mobile, Exxon, Standard of California, and Texaco 35% in total (each 7%); 5 major American companies held 5%.

- b) Dutch Bataafse Petroleum Maatschapping N.V. 14%.
 c) The Compagnie Francaise des Petrole 6% (Iran Yearbook 1977: 17).

12 For instance, the Shah's harsh tactics and suppression of the 1963 uprising "were accepted in the US as an unpleasant but necessary effort to break the hold of reactionary elements standing in the way of social progress" (Sick 1985: 11).

13 The Nixon-Shah relationship initiated twenty years earlier in 1953 when vice-president Nixon, arrived in Tehran and found the Shah prepared to co-operate with the US in opposing Soviet ambitions in the Persian Gulf. By the early 1970s, Washington regarded the ensuing 'vacuum' (by the British forces from the Persian Gulf) as requiring either an American presence or the presence of a powerful ally. As a result of American casualties and failure in Vietnam, the US government was unwilling to commit itself directly to maintain the stability of the region to ensure the flow of oil to the West. The Shah's ambition, his unquestioning reliance on and alliance with the US, and his military build up prepared Iran as the best possible nominee for the position of policeman in the region.

14 The Shah had waited for years to see this moment. Previously, he had dealt with successive US presidents but had never been given such status. President Eisenhower had dismissed his strategic analyses of the immediate threat of USSR to Iran; President Kennedy had pressed him for social reforms; and, President Johnson had only yielded to his request for modern fighter aircraft after the Arab-Israeli war of 1967.

15 President Carter stood for a foreign policy with two pillars. He sought the internationalisation of the American concern with human rights, and sought severe limitations on the international arms race, especially the sale of weapons to the Third World. On the one hand, the Shah was portrayed, in the 1970s, as the world's most vicious ruler. Martin Ennals the secretary general of Amnesty International announced that "no country in the world has a worse record in human rights than Iran" (*The Observer*, May 26 1974: 1). On the other hand, Iran was "the largest single purchaser of US military equipment" (US Congress 1976: iix). It seemed there was little doubt that Carter was referring to countries such as Iran. The US was sending contradictory signals to the Shah in 1978-9. Bakhtiyar, the last Premier of the Shah, points out: "Carter was a liberal.. Pentagon had another view, George Ball got mixed up in it all. Vance hated the king. Brzezinski had his idea of a bastion against the USSR, and wanted to play the army card" (Bakhtiyar, interviewed by Halliday, in MERIP no. 104, 1982: 13).

16 The most annoying regional events for the Shah were; in 1952 Nasser emerged in Egypt by toppling the Shah's former brother-in-law, King Farouq, from the throne; King Faisal of Iraq was murdered in 1958; Colonel Qadhafi seized power in Libya in 1969 in a bloodless coup; Sultan Qabus of Oman deposed his father in 1970, also in a bloodless coup. Thus, the Shah's regime was coping in the west by a revolutionary Ba'ath regime in Iraq, in the east by the uncertainties of the fluid situation in Pakistan and Afghanistan, and in the south by the Persian Gulf where the withdrawal of British power in 1971 had left a disturbing power vacuum.

17 One example was his order to sell in 1974 to Israel 130,000 tons of oil at the old rate of \$4 a barrel rather than \$17 (Alam 1991: 378).

18 The Shah agreed to pay \$11,000 monthly allowance and to buy him a house in Rome (Alam 1991: 359).

19 When Bhutto was arrested, the Shah threatened to cut off economic aid worth between 200 to 300 million dollars a year to Pakistan if the death sentence on Mr. Bhutto was carried out (*The Financial Times* 22 May 1978).

20 Pareto's concept of 'circulation of elites' draws attention to this problem. He means by circulation: 1. The replacement of individuals within the elite and 2. The replacement of one elite by another. The issue is whether this process of individual replacement is exclusive, or whether it is open, giving an opportunity to individuals from less privileged strata to join the ranks of the powerful and influential group.

21 The political elite was an increasingly cohesive group of individuals in the upper class who exercised and possessed power "to a greater degree than other members of Iranian society" (Zonis 1971: 5-6; Bill

1975: 17). Dye et al defines elites as "the few who have power; the masses are the many who do not. Power is deciding who gets what, when, and how; it is participation in decisions that allocate values for a society. Elites are the few who participate in decisions that shape our lives; the masses are the many whose lives are shaped by institutions, events, and leaders over which they have little direct control" (The Irony of Democracy: An introduction to American Politics, Monterey, CA: Brooks/Cole, 1987: 3).

22 These families include Aalam, Adl, Afkhami, Akbar, Alam, Amini, Ardalan, Ashtiyani, Bakhtiyari, Bayat, Bushehri, Daftari, Diba, Dolatshahi, Ebrahimi, Emami, Emami-Khoy, Eqbal, Esfandiyari, Farmanfarmai'an, Hakimi, Hedayat, Jahanbani, Khajeh-Nuri, Khalatbari, Mahdavi, Mansur, Pahlavi, Panahi, Pirnia, Qaragozlu, Qashqai, Qavam, Sadri, Saffari, Sami'ee, Vakili, Vosuq, Zand, Zanganeh Zolfaghari. (Bill 1975: 34).

23 For example, Nafisi/Khajeh-Nuri, Adl/Panahi, Afkhami/Zolfaqari.

24 People such as the Amini, Alam, Bushehri, Davallu, Farmanfarma'ian, Teymurtash, and Jahanbani.

25 Estimated Distribution of Officers in the Iranian Armed Forces.

Rank	General ^b	Colonel	LC [*]	Major	Captain	1st L. [*]	2nd L.	Total ^a
Army	180	1,900	4,800	6,900	11,400	5,700	5,600	36,500
Air Force	70	900	2,300	3,200	6,700	1,700	2,400	17300
Rank	Admiral	Captain	Com. [*]	LCom.	L. [*]	LJ [*]	Ensign	Total
Navy	140	200	500	700	1,100	1,600	500	3,600

a. All figures are rounded. b. Some sources indicate significantly more general and admiral officers.

* L: Lieutenant LC: Lieutenant Colonel; LJ: Lieutenant Junior; L. Com.: Lieutenant Commander; Com.: Commander

Source: US Department of Defence, Selected Manpower Statistics, 1979: 82 in W. Hickman 1982: 17

26 The basic rivalries existed between the Shah's twin sister, Ashraf, and his eldest sister, Shams and an antagonistic relationship between the Shah's three Queens with both sisters. On unremitting rivalry between members of the royal family, Sorayya (1963:65) wrote: "... a family at court who are always in a state of rivalry". Other lines of tension, for example, existed between the following institutions: ministry of interior-Tehran municipality, ministry of land reform-ministry of agriculture, SAVAK-Military Intelligence, Tehran chamber of commerce-Iranian chamber of mines and industries, Tehran University-National University, the Shah's ambassadors-minister of foreign affairs.

27 Hoveyda shows the extent of availability of such fund for the Shah when he stated: "Only 30 percent of development expenditure is in the hand of the government. The other 70 percent is in the hands of NIOC, NIGC, and the armed forces", all of which were directly controlled by the Shah (in Radji 1983: 96-7).

28 The former made their first fortune during the commercial boom of World War II and their second windfall during the oil boom of the 1970s, among them people such as Namazi, Sabet, Lajevardi, Elqanian, Vahabzadeh, and Rashidiyan. The new entrepreneurs built their business empires during the late 1960s mainly through their personal contacts with other ruling elites and multinationals - for example Khayyami, Reza'i, Yazdani. The close ties between local capital and foreign capital was embodied, for example in the person of Habib Sabet who apart from being vice-Chairman of IMDBI, had seats on the boards of directors of the Irano-British Bank, etc. He founded more than 40 enterprises and was a member or director of the boards of companies such as Television of Iran, Iran Volkswagen, Firoces Corporation, General Tyre and Rubber Co., and others.

29 Firstly were landowners who survived the land reform and received compensation either in the form of a share in government industries or cash. It was through the land reform that the industrial bourgeoisie expanded by being provided with capital. The ex-landlords became new industrialists and modern entrepreneurs. Secondly, the bourgeoisie was partly rooted in the bazaar. The bazaar controlled half of the country's handicrafts production, 70 percent of its retail trade and 75 percent of its wholesale trade. It took advantage of the import duty exemptions provided by the state in the 1960s and later in the 1970s from government policy of massive import. However, the bazaar had been in decline since the 1950s as its social, economic and political position had been undermined both because of the rise in the power of the interventionist state and also because of state opposition to the religious group which was

affiliated strongly to the bazaar. The third root of bourgeoisie was in the bureaucracy, in particular the civil (and military) services (see chapter 3). Hence, the bureaucratic elite was becoming an important partner of the bourgeoisie and thus, the non-royal function of the economic elite.

30 Based on article 7, note 7 amended to article 2 of tax law of 1969.

31 Fardust (1991: 254) points out that the Foundation was suggested by Alam to the Shah, as a scapegoat. The Foundation, as a non-profit-making organisation, replaced what was known as the Pahlavi Estate Office - created in 1951 to handle the proceeds of the sale of crown land to tenant farmers. The Shah from the outset of the Foundation appointed himself chief custodian, being entitled to 2.5% of the net revenues, which this he waived. (*Asasname-ye Bonyad-e Pahlavi*, Pahlavi Foundation Statutes, Chapter 1, Article 5; see also Alam 1991).

32 A charge was made against Ashraf, that she had appropriated \$3 billion either in the form of loans or profits through the PF and in other activities. In another instance, relatives of Farah led by Qotbi (her uncle) manipulated 80% of all contracts rendered by PBO, accounted for billions of rials. They would sell the contracts to others - the companies who actually had to execute the projects - by receiving 25% of nominal value of contracts (Fardust 1991: 215).

33 Although, members of the royal family had investments, deposit accounts, and a number of palaces and land in Europe, their bulk of investment and cash transfer had been to the US. When the Swiss government rejected to freeze the Shah's bank accounts in Swiss banks (to a request made in March 1979) Iran focused its attention on the US for such action. In December 1980, following the death of the Shah, the government of IR. Iran asked for \$10 billion in the form of cash guarantee - to be deposited in Algeria - against the estimated transfer of Iran's assets by the person of the Shah, as a part of a proposed plan to resolve Iran-American hostage crises. But in 1981, the government of IR. of Iran filed a suit against 62 alleged associates of the royal family, in the State Supreme Court of Manhattan, in an attempt to recover about \$36 billion which was claimed and documented to be diverted from Iran by family appointees and associates of the Shah.

34 The term comprador refers to that section of bourgeoisie that co-operated with international capital in the national economy to maximise its interests (Najmabadi 1987 in *ibid.*).

Chapter Five: The State, Oil Revenue and the Economic Development

1 The demand-induced influences refer to those forces that are directly associated with the growth of demand in the oil sector resulting from the expansion of operations in that sector, while the supply-induced influences embodies those influences that stem from an abundance of low-cost materials produced in the oil sector.

2 For example, during the 1960s, the AIOC used internal market for only 11% of its needed commodities including foodstuff (Table A1).

3 Until 1933 most of the domestic oil consumption was imported from Russia. Even after the 1933 agreement, which gave the AIOC monopoly over the Iranian market, due to AIOC's price policy, consumption of wood and charcoal increased substantially. Furthermore, the AIOC was not at all anxious to develop ancillary industries on which it would have to depend for supply. On backward linkages, less than 1% of national work force of 7 million in 1949 was employed by the AIOC and all the company's needs, even foodstuff, were imported from abroad.

4 The modernisation writers believed with optimism that oil would bring needed capital which would finally spark sustained growth, and ultimately participatory political stability. Dependency writers who were less optimistic pointed to the underlying similarities between oil and other commodities. Oil was a single export, a depletable raw material, and a commodity as dependent on unpredictable markets as any other. Oil would bring dependency and decline. Both predictions contained some truth.

5 Luciani (1990) believes that this is a unique situation, almost without parallel in history, where economic prosperity and progress are largely independent of a domestic economic production. On the contrary, whenever the income of the state is based on tapping the domestic economy, the state can grow and perform an allocative function only to the extent that the domestic economy provides the income which is needed to do so.

6 Subsidy payments alone on such consumer items as sugar, meat, eggs, rice and wheat, and on materials such as cement and chemical fertilisers were equal to 40% of their cost to the government (Amuzegar 1977: 197).

7 Using econometric techniques of data analysis, Looney (1985: 65) shows that a biased result is obtained for the pre-1975 years when oil revenues is correlated with government expenditures. This bias disappears when sub-periods 1959-73 and 1974-77 are created and examined separately.

8 The corresponding figure for South Korea in 1970-78 was 12.6%, for Brazil was 7.9%, for Mexico in 1972-78 was 16.2% and for India in 1975-78 it was 7.4% (The IMF, International Financial Statistics, Supplement on Output Statistics, Washington: IMF, 1984: 58-61). As these figures were according to The IMF, the comparison was made with the registered data by IMF on Iran in which public investment accounted for 46.6% of total investment (IMF, The International Monetary Fund, Supplement on Government Finance, Washington: IMF, 1986: 64-65). The discrepancy on data is presumably because different methods of measurement were used.

9 Being the main source of foreign exchange earnings in Iran, oil was bound to play a determining role in the debt servicing capacity of the country in the long run, both for the foreign creditors and the government.

10 With the classical assumption of full employment and given technology, public investment rather than being complementary becomes a substitute to private investment. The conventional arguments of 'crowding out' effect of public investment strongly rely on such assumptions. Furthermore, the financing of government investment by external funds also ruled out the possibility of financial crowding out by private investment.

11 In economic terms, in the later years the Shah's programme combined government planning of ever greater scope and scale: state ownership and management of strategic industries; private Iranian industrial investment, frequently through state stimulation; and the encouragement of foreign investment, especially in more technologically advanced sectors. While for Mehner (1976: 167) "the history of planning in Iran is an exiting chapter in Iranian national development", for Katouzian (1981: 231) "the plan was never adhered to, either in letter or in spirit".

12 While the first 2 years of the Plan were years of recession, the subsequent economic recovery, together with increase in development outputs (partly resulted from fuller utilisation of previously idle capacity), resulted in substantial increase in domestic supply of goods and services during the latter part of the Plan years.

13 Including the Isfahan steel mill, a petrochemical unit, an automobile assembly plant, and an aluminium smelter.

14 Price stability, as a major objective, was not fully realised over the Plan period. The GNP implicit price deflator rose on an average annual rate of 4.3% during this time compared with 0.6% for the Third Plan. During the Fourth Plan, the general price level was positively correlated with the overall shortage of supply, especially in the agriculture and construction sectors and movements in world price (Looney 1988: 107).

15 One of the side effect of the spiralling cost of land was higher rent and consequential demand for higher wages by the urban work-force, since housing had become the major element for living cost and as up to 60% of pay. From 1970 to 1974, the price of industrial lands increased by almost 9 times in Tabriz and by 100 times in Rasht. As much as 47% of the cost of housing was absorbed in land costs (Graham 1980: 89).

16 The initial manpower demand in the Fifth Plan estimated around 750,000. This number increased in the Revised Fifth Plan to 2,112,000, regardless of warning for inability of the country to supply such number of manpower, the skilled, technical and managerial work-force in particular. The manpower supply by the end of the Revised Plan covered over one million unskilled and semi-skilled labour, but it was inefficient to provide enough skilled labour. For instance the Revised Plan could supply less than

30% of required skilled and semi-skilled labour and about 50% engineer and medical staff demanded under the Revised Plan (IA 1977: 384; 1974: 445, 380; 1975: 381-5).

17 Indeed the Planning Division of PBO suggested the major constraints to appear in those areas, with the emphasis placed on port capacity and skilled manpower (Vakil 1984: 84).

18 Absorptive capacity is basically meant to characterise the limit to the rate of growth of investment set by all the domestic factors of production which either cannot be imported or face rapidly rising import supply prices. It refers to the organisational and human skill capacities for undertaking new investment projects.

19 Mofid (1987: 132) argues that ICOR should provide a good measurement of its absorptive capacity, given the other constraints. It means that for every extra units (rials) of output produced, how much rial of additional capital is needed. An increasing ICOR could therefore imply a lack of absorptive capacity.

20 The combination of falling real oil revenues and worsening price inflation, though particularly the former, persuaded the government to introduce measures to reduce the growth rate, fell to 3.1% in real terms in 1977-8 after many years of sustained high level of expansion, while the country's balance of payments sustained its position only by resort to expensive short-term borrowing abroad.

21 The planning procedure and institution in Iran suffered from major shortcoming, including the lack of a mechanism to generate regional balance in development activities. However, the critical factor for the failure of economic planning in Iran was the gradual loosening of various steps of the project evaluation process. This loosening took place in some instance to speed up the process, but more often to provide an environment suitable to personal decision making. The net result of economic planning as Razavi and Vakil (1984, chapter 3) describe was that it turned into a futile formality with no positive impact on the management of the economy.

22 Against all advice, the Shah decided to double the Plan's total expenditure allocations, previous to the oil price increase.

23 For example, the original version of the Third Plan proposed a total development expenditure of 190 billion rials over the Plan period. The balance of payments crisis of the early 1960s led the Cabinet to reduce the size of the Plan to 140 billion rials by a decree passed on September 1962. With the acceleration in the growth of oil revenues and easing off of the balance of payments problems, the size of the plan was once more increased to 230 billion rials halfway through its implementation. The actual size of development expenditure in the Third Plan was 204.6 billion. In the case of the Fourth Plan, the original size of planned development expenditure was 457 billion rials, which given the balance of payments problem of the late 1960s was too ambitious. The original Plan relied heavily on foreign borrowing (by 150 billion rials), which was believed to be made available by the American government in supporting the Iranian government in its new role of 'policing the Persian Gulf' after the evacuation of the British troops from the region. During the two last years of the Plan, with the Tehran Oil Agreement, oil revenues of the government grew by an unprecedented rate of 80% which led to an upward revision in the size of the Plan to 554.5 billion rials. The actual development expenditure over the Fourth Plan was 506.8 billion rials. The original version of the Fifth Plan which was conceived amidst the euphoria of rapid oil revenue increases of the early 1970s, envisaged a development expenditures of 1560 billion rials which was three times the size of the Fourth Plan. However, with the immense oil revenues increase of 1973-4, the size of the Plan was almost doubled to 2848 billion rials. The actual development expenditure during the Fifth Plan was 2555.1 billion rials.

Chapter Six: Dependent Development in Iran

1 Dependency can not be viewed as a purely external phenomenon. Cardoso and Faletto (1979: x) emphasises on "not just the structural conditioning of social life, but also the historical transformation of structure by conflict, social movement and class struggles." The expansion of capitalism in different countries in the periphery thus had varying consequences, even though all countries were subject to the same global system. In their view, a system is dependent when "the accumulation and expansion of capital can not find its essential dynamics component inside the system" (ibid. P. xx). The dominant centre of the world capitalism posses, by definition, the technological and financial sectors essential to production and capital accumulation. Even the semi-industrial LDCs, however, remain dependent, as their capital goods sector are not strong enough to ensure the "continuous advance of the system, in

financial as well as in technological and organisational terms" (ibid. P. xxi). In oil exporting economies, due to the dependent nature of oil revenues in the international oil-consumption market (dominated by advanced capitalist countries), the country's glutted financial sector remains dependent on the world policies.

2 From the early 1960s it was US pressure and support that had made possible both the 'White Revolution' and the development by the Shah of the military arsenal needed to dominate the Persian Gulf region.

3 Import substitution strategy was designed to move economies traditionally dependent on the export of primary commodities and raw materials to an industrial one. New infant industries would have to be protected from foreign competition by high tariff walls. Thus ISI, although seen as a temporary phenomenon, was implied and frequently meant monopolistic production and marketing at costs higher than similar products. It also meant lower-quality goods than those that could be imported. These industries were in general capital-intensive and under the best of circumstances not providers of large numbers of jobs.

4 In 1955 the Law Concerning the Attraction and Protection of Foreign Capital Investment in Iran was enacted, in which Article 3 provided the government guarantees equitable compensation for losses. In addition, investment guarantee agreements were signed with the US (1957) and Germany (1961). Favourable laws concerning taxes and subsidies were also passed. Five year exemption to new industries outside the area of Tehran, 50% tax cut to those who actually were inside the area, subsidies in the form of import duty rebates, subsidisation of water, electricity, and energy costs, etc., were offered to the industries selected for growth.

5 Dominated by the TNCs such as Siemens, AT&T, Phillips and General Motors, annual production of motor vehicles rose from 7,000 units in 1965 to 109,000 in 1975, television sets rose from 12,000 to 31,000, the phones from none to 186,000, and gas oven from 87,000 to 220,000.

6 For example, the highest interest rate was by the non-organised money market which was particularly widespread in rural areas. Another example is that the duty on imported investment goods was waived completely on condition that these imports were to the benefit of approved production investment. These definition covered almost only all major projects (Moaddel 1993; Muller 1983).

7 Among the foreign share holders were the Chase Manhattan Bank, the original initiator of IMDBI, as well as other monopolies from the US, Belgium, West Germany, France, Italy, Canada, Netherlands, Britain and Japan. By March 1975, during 15 years of operation, general loans given by IMDBI amounted 46,000 billion rials, in which half was in foreign currency (Muller 1983: 75).

8 By 1959, D&R had won the approval of a multi-billion dollar plan for the unified development of natural resources of Khuzestan including 14 dams, 6,600 megawatts of power production, irrigation canals, and large-scale farming.

9 The Iran-California Corporation, the Iran-Shellcott Co., International Agricultural Corporation of Iran, Naraghi Agro-Industries of Iran and America, Deskar, and Dezfoul Farm Corporation were among these.

10 Among the 18 large pharmaceutical enterprises there existed only 4 purely Iranian firms. The others owned or formed joint ventures by USA and German firms. Foreign investment shares were as follows:- 26% B.F. Goodrich, the USA in Abadan Petrochemical Co.; 50% Amoco, the USA in Kharg Chemical Co.; 40% Du Pont de Nemours, the USA in Polyacryl Iran Corp.; 50% Japanese consortium 'Iran Chemical Development Corp.' in Iran-Japan Petrochemical Co.; 40% British Industrial Plastics in Perspolis Resin Co.; IFC & Cabot Corp., the USA in Iran Carbon Co.; Zimmer, Germany in Parsylon (Iran Almanac and Book of Facts, 1978: 277). Since the end of the 1950s, numerous enterprises were set up in Iran, especially in the branches of industry mentioned above, enterprises which produce goods assembled from imported parts.

Conclusion

1 The Iranian experience in this respect may be contrasted with the case of Ottoman Turkey, where the relatively more successful attempts at reforming the central state institutions in the 19th century led to a totally different agrarian history in modern Turkey.

2 The rise of the authoritarian regime of Reza Shah removed from the political agenda any talk of fundamental economic reforms, especially land reform. It enhanced the political power of the absentee landlords and strengthened the pre-capitalist relations of production in the agricultural sector which became a major obstacle to rapid economic expansion over the next half century.

3 The cause of this misspending lies partly in its political character; over-expansion of authoritarian-bureaucratic establishment namely in arms purchases, bureaucracy and services; and, in its policy of politicising socio-economic planning.

4 For example, Iranian industries soon came to depend on the West for more than 65% of their inputs, including technology, intermediate goods and raw materials. The boom also changed the sectoral composition of GNP in favour of construction and service, despite huge industrial investments. In the industrial sector, the boom produced unprecedented concentration. In 1976, for example, the large scale industries (units with ten workers or more) produced 90% of industrial value added while employing about 18% of the industrial work force.

APPENDICES

Appendix 1: Registered Assets of the Pahlavi Foundation and the Royal Family (1978)

A: Banks/Investment Companies

1. Bank Omran (100%). Capital Rs5bn (\$70). Total assets Rs75bn. Investment Rs1.4bn. Dividend Rs30 m. commercial bank.
2. Omran Finance. In Greece. A major share-holder.
3. Omran Investment. The majority share-holder.
4. Bank Daryush. Capital Rs2bn (\$29m). Major share-holder.
5. Bank Iranshahr. Capital Rs3bn (\$42m). Total assets Rs38bn. Commercial bank.
6. Bank Etebarat (2%). Held 400 of original 20,000 shares. Capital Rs1.5bn (\$21m). Shahram (Ashraf's Son) was the major share-holder. Commercial bank.
7. Development and Industrial bank of Iran (1.3%). Capital Rs3bn (\$42m). Share valued by PF at \$700,000. Development bank.
8. Irano-British Bank (1%). Held 200 of original 20,000 shares. Widely believed to have purchased much larger stake subsequently. Capital Rs1bn (\$14m). Commercial bank.
9. Industrial Guarantee Fund. Capital \$11m. Industrial finance for small companies.
10. Omran Trinwall (39% held by Bank Omran). Capital Rs12m (\$170,000). Investment in Iran and overseas.
11. Iranshahr Finance (21% held through stake in Bank Iranshahr). Capital Rs70m (\$980,000). Commodities and securities trading.
12. First National Wisconsin Milwaukee, USA (5%). Held by Bank Omran.
13. Hipan-Iran (11%). Capital \$150,000. Spanish-Iranian service and investment group.
14. Shahryar Industrial Bank. IOSS the major share-holder. Development bank.
15. Arya Leasing. Major share holder. Loans.
16. International Development & Construction (30%). Capital Rs70m (\$1m). Ashraf Foundation. Investment in Iran and overseas.
17. Kurosh Investment & Housing Society. PF and FF were among the share-holders. Investment in housing development
18. Etebarat Investment & Loan.

B. Insurance

1. Bimeh Melli (80%). This stake is now believed greater. Capital Rs150m (\$2m). Total premiums approximately Rs800m. (Octopus, 1978, claims 100% ownership).
2. Middle East Insurance. (100%). Ashraf Foundation.

C. Property

In this list, the lands owned by the royal family are not listed. Furthermore, the value of the royal palaces and the goods and arts inside those palaces are not estimated in this list. (i.e., the value of the entrance door at the palace belonging to Farah was worth \$6 million (Ravasani 1991: 260).

Hotels (all 100%)

1. Tehran area: Darband; Hilton; Evin; Vanak
2. Caspian area: Babolsar New Hotel, and Motel; Chalus Old and New Hotels; Hyatt; Ramsar Old and New Hotels.
3. Other: Khorramshahr Hotel; Shiraz Hotel; Mashhad Hotel; Bu-ali Hotel in Hamadan; Abali Hotel; Shahi Hotel; Amol Hotel; Takhtsar New Motel and Hotel; Gachsar Old and New Hotel.
4. Less than 100% share in these hotels: Aria Sheraton, Kurosh Inter-Continental, Bandar Abbas, Daryush, Kuy-e Saran, Takht Jamshid, Noshahr and Perspolis Motel.

Tourist Complexes

1. Namak-Abrud complex near Chalus (100%).
2. Villas at Ramsar (1) and Babolsar (1) (100%).
3. Casinos: Ramsar Casino and Club; Hyatt; Kish Island (100%). Two more casinos along the Caspian coast was owned by the Shah's sister and by his brother (Radji 1983: 208).
4. Kish Island Development Board (20% held through Bank Omran): 3 hotels, casino and 1,300 villas when complete. (Octopus, 1978, claims 100% ownership).
5. Mehrabad Airport, Tehran: restaurant (25%).

Residential/Commercial

1. Sherkat-e Shahr-e Aram (0.4%). Satellite town development project.
2. Bungalow project near Niavaran, Tehran (219 units) (100%).
3. Vanak Tower Block (three block multi-story residential and shopping project), Tehran (100%).
4. Farahzad Development Project (30% held by Bank Omran). Construction of 25,000 upper-income units.
5. Levittshahr. Investment in \$500m new town via Bank Omran.
6. Arbita Construction (100%). Apartment project.
7. Shemiran Now. Township and urban development project.
8. Franko-Iranian. Township and urban development project.
9. Ati-Saz (Majority share holder). Multi-story residential project near Evin, Tehran.
10. Eskan (100% of the Iranian share). Joint venture with Reynolds Construction (the US). Two block multi-story residential and shopping project in Vanak, Tehran.
11. North Shahyad Development (100%). Capital Rs1b (\$14.5m). Ashraf Pahlavi.
Other smaller projects:
12. Pahlavi Foundation; Golzar, Now-Kar, Letmal Kan. A major share-holder in all of them. Kordin (100%, Apartment project), teklar Development (100% of the Iranian share, a joint venture with two Greek and Danish construction companies).
13. Mahmud Reza, the Shah's brother: Kolbeh, MGM, Greater Tehran Housing, Malek-Shahr (near Isfahan), Farah Abad. A major share-holder in all of them.
14. Keyvan, the Shah's nephew {son of Fatemeh}:Nashiran, Lutrek.
15. Shahram, the Shah's nephew: Iran Monir (100% with a French joint venture), Saman Iran, Kides Metal International (100% with a foreign firm), Iran-Nihon (100% with a Japanese venture), Elahiyeh.
16. Ashraf: Mahestan (100%), Saran Co. (100% with a foreign joint venture), SJA (100%). Bushehri - Ashraf's husband - with a foreign joint venture), Amk Chalus (?%). Bushehri
17. Pahlbod family, the Shah's son-in-law: Industrial city of Saveh Development, Anahita, Iran Mobile Homes, Faramin, Industrial city of Kurosh Development, Kurosh Bana, Mehr-Shahr, Ira (100%), Ira-sar (100%), Ira-Espi (100%, Joint venture with a French firm), Fiya-Tak (Joint venture with an Italian firm)

18. Gholam Reza, the Shah's brother: Tamishan (40%), Industrial Homes International (100% with Manijeh Pahlavi).

International

1. Pahlavi Foundation Building, 5th Avenue/52nd St., New York (100%). Book value 1975 \$14.5m.
2. Canal Street Project, New Orleans. Bank Omran in neighbourhood development scheme, believed on 50/50 basis with local interests

D. Industrial Holdings

Building Materials

1. Tehran Cement (25%). Capital Rs1.1bn (\$16m); Abyek Cement (believed substantial); West Cement. Cement.
2. Fars and Khuzestan Cement, believed substantial). Capital Rs7bn (\$100m). Cement. Graham 1980 under-estimates the capital to \$49m.
3. Iranit (30%). Cement imports, asbestos, cast-iron fittings.
4. Plast Iran, Building Material
5. Panasuz Stake held though Fars and Khuzestan Cement (95%). Production of asbestos material.
6. Other smaller factories: Par-Sweed (IOSS, building material); South Brick (Mahmud Reza, the Shah's brother); Tehran Plaster (100%, Shahram, the Shah's nephew and the Pahlavi Foundation).

Mines

1. Montex (35%). Capital Rs12m (\$170,000). Liquidate June 1977. Steel structures.
2. Sangvareh Mining (40%). Provision of building material from quarries.
3. Absang, (100%), the Farah Foundation.
4. Mahmud Reza Pahlavi owned these mines (100%): Mashad Turquoise; Dona; Norgan; Iran & Romania Mining; Dona-Steg (with Pahlavi Foundation).
5. Damavand mineral water. Bushehri with a french company.

Automotive Industry

1. GM Iran (10%). Capital Rs1.5bn (\$21m). Assembly of saloon cars and trucks. (Octopus, 1978 claims a majority share).
2. B.F. Goodrich Iran (9.5%). Stake believed to have expanded to around 45% as a result of divestiture of 58% share of US parent company. Capital Rs917m (\$13m). Tyre manufacture.
3. Bridgeston Iran (35%). Capital Rs1.85bn (\$26.5m). Mahmud Reza Pahlavi, joint venture with a Japanese company.
4. Iran John Dears. Capital Rs700m (\$10m) Abdol Reza Pahlavi, Tractor assembly line.
5. Hepco (10% held by Bank Omran). the Foundation is believed to hold an undisclosed 45% stake. Capital Rs 700m (\$10m) Joint venture with IDRO for road construction equipment.
6. Jeep, Capital Rs900m (\$13m), car assembly production.
7. Pishtazan (100%). Joint venture with Japanese Honda. Motorcycle and bicycle making.
8. Chassis (100%). Capital Rs600m (\$8.5m). Joint venture with German firm Tisen. Car chassis making and body work.

Metal Industry

1. Parshian Metal Forms. Capital Rs108m (\$1.55m). Pahlbod a major share holder, Metal sheets production
2. Navard Alumine Factories. Abdol-Reza Pahlavi
3. Saveh Navard. Manijeh (wife of Gholamreza Pahlavi)
4. Ahvaz Navard. IOSS and PF
5. Dac Tiran, PF, metal pipes
6. Alum Shars, Shams Pahlavi. Alumine products

Other Industries

1. Irfo. PF. Moulding
2. Zogaletsh. PF. Welding material
3. Tarabgin. PF. Production of heat and sound proofs
4. Iran Pencil (100%) Pahlavi Shrine

5. Ladal. PF. Chemical material
6. Pars Mill Industry IOSS
7. Pars Harir. IOSS, production of soft tissues
8. Abgineh, FF in joint venture with Belgieme Gelavril.
9. Shell Chemist Shahram Pahlavi with Netherland Shell, Anti-pest material

Textile Industry

1. Shah-Baf. Capital Rs4.8b (\$67m), Mahmud Reza Pahlavi
2. Iran Poplin. Capital Rs200m (\$300,000), Mahmud Reza Pahlavi
3. Azar (Isfahan) Shahram, Weaving
4. Karaj, Gholamreza Pahlavi, Weaving

Miscellaneous

1. National Cash Register Iran (\$38%). Office accounting machinery.
2. Sedco (5%). Capital Rs? Drilling operations.
3. Iran Skin and Leather Company (100%). Tanneries.
4. Khorasan Skin and Leather Company (100%). Tanneries.
5. Daru Pakhsh Pharmaceuticals (100%). Jointly owned by Foundation and the Imperial Organisation of Social Service (IOSS). Capital Rs1.2b (\$17.2m) Largest Pharmaceutical producer in Iran.
6. Union Carbide (Puerto Rico) (20%). Capital Rs? Batteries.

E. Printing/Publishing

1. Bungah-e Tarjomeh va Nashr-e Ketab (Book Distribution and Translation Company (100%). Capital Rs? Translation of foreign classics, Persian reprints.
2. The 25th Shahrivar Printing House (100%). Stake held through involvement in the IOSS. Capital Rs1b (\$14.3m) Printing of all school textbooks used in Iran.
3. Danesh-e No Printing and Publishing Company. Capital Rs100m (\$1.4m). Books for the young.

F. Agribusiness

1. Ahwaz Sugar Beet Factory (16%). Sugar mill and refinery.

2. Kermanshah Sugar Factory (0.4%). Capital Rs607m (\$8.5m). Sugar-beet processing.
3. Hamadan Sugar Factory (1%). Sugar mill and refinery.
4. Kuar Shiraz Sugar Factory (1.7%). Sugar mill and refinery.
5. Fariman Sugar Factory. Sugar mill and refinery.
6. Ghahestan Birjand Sugar Factory, Sugar mill and refinery.
7. Ziaran Meat Production (20%). Capital Rs400m (\$5.6m). Meat production and processing operational 1978.
8. Iran Shellcott (10%). Capital Rs500m (\$7m). Agribusiness in Khuzestan. In process of being restructured.
9. International Agribusiness Company of Iran (%2). Capital Rs441m (\$6.2m). Agribusiness in Khuzestan.
10. Agricultural and Industrial Company of Khuzestan (10%). Capital Rs700m (\$9.8m). Agribusiness in Khuzestan.
11. AIC of Jiroft (20%). PF
12. PF: AIC Iran-America; AIC Karun ; Takestan Rasin (100%); Omran Dasht, Alcohol and animal food, Iran Shell-Cat (10%)
13. Mahmud Reza Pahlavi: AIC Shahyaran; AIC Fadak; Kian-Shahr Agriculture; Iran Agriculture and Husbandry; Gol-Tapeh Agricultural Industry
15. Gholam Reza Pahlavi: AIC Tamishan (100%), AIC Aji; AIC Pars-Shahr; Silk Production; Sabz-Dasht Agri-construction;
16. Abdol-Reza Pahlavi: Dasht-e Naz (100%); Pishro Seed;
17. Shahram Pahlavi: Iran Country Development; Silk Production (100% with a Japanese company); Pasteurized Milk and Husbandry Complex;
18. AIC Galleh (100%) Ashraf Pahlavi
19. Pak Pasteurized Dairy Product, Bushehri
20. Ali Agricultural Organization (100%) Ali son of Alireza Pahlavi
21. Ahmad Reza & Roza Pahlavi: Tehran Yureh . Meat and grain import; Shahparan (100%);
22. Shahnaz Pahlavi & Jahanbani: Key-Dasht; Jahanmura;
23. Scottish Agriculture & Husbandry. Shams Pahlavi & PF
24. Varda, Nilufar daughter of Hamid Reza Pahlavi, Vinegar and food production
25. Newla Irigation & Agriculture, Keyvan Pahlavi-Nia

26. Shokufe Arya Vegetable Oil, Fateme Pahlavi & PF

Trade/Business

1. Omran Hygenes, PF, Import of food-stuff & cosmetics
2. Ward-Station, Mahmud Reza Pahlavi, Import of road construction equipment.
3. Bushehri: SolzIran, , Import and Export; Takinsaz, Import of electric appliances and glass; Poliran, Import and Export;
4. Mehr-Afarin Shahryar Pahlbod, Import and Export
5. John Deer Distribution, Abdol-Reza Pahlavi, Distribution of Agricultural machinaries
6. Shahavaran, Ahmad Reza Pahlavi, Import and Export
7. B & F, Bahman son of Gholamreza Pahlavi, Import and Export

Services/Leisure

1. April Music, Bushehri, Distribution of cassetes
2. NCR (38.9%) PF with American National, Distribution of electronic equipments

Other Fields

1. National Iranian Navigation Company (100%). Sold to NIOC in 1970.
2. Iran-Sed Digging, Pf with Sed Co., Oil & gaz excavation
3. Iran Maritime Services (100%0
4. Iran Footbal, PF, Perspolis Club
5. Basku Martime Services & Supplies, Mahmud Reza Pahlavi
6. CRC, Fateme Pahlavi, Bouling Building in Tehran
7. Japan Air services, Shahram Pahlavi
8. Shafigh family: Air-Taxi; Air Speceial Services; Yachting Association
9. Frankline Publication (100%) IOSS
10. CRY (100%) PF
11. Bushehri: Film Making Services; Iran Film Industry; Airsa Co. (100%) with Foreign company, Establishment Business;
12. Nan-Shahr (100%) Shams F., bakery production
13. Pahlbod: Damavand Navigation ; Mehr Sport Club
14. Canush Ahmad Reza Pahlavi, Bakery production

15. Darya-Kenar Sport Club (100%), Gholam Reza & PF
16. Mazon (100%) Simin-Dokht Atabay (Reza Shah's nephew)
17. Iran-Shekar, Kamran Atabay

1-all based on 1977 (1356) value prices)

Sources:

1. *Keyhan International, Financial Times, The Guardian*, Various issues in 1963-4, 1978, 1979, and 1985
2. Graham 1980: Appendix A, PP. 255-8
3. *Octopus-e Sad Pa* (Octopus With Hundred Tentacles)
4. Ravasani, *Dolat va Hokumat dar Iran* (The Government and the State in Iran), Tehran: Sham'e, 1991
5. Gerard de Villiers, 1977
6. Interview with the Iran's representation in International Court at Heague

Appendix 2: Tables A1-A32

TABLE A1: Oil Royalties Payment to the Iranian Government

(million dollars)

Years	Government Income ¹
1911-20	2.4
1921-30	8.5
1931-40	26.9
1941-51	82
Total	120

Source: Amuzegar and Fekrat, 1971: 18-9 table 2.1

¹ author's calculation.

The figures are rounded.

TABLE A2: Historical Development of Iranian Oil Industry, 1913-1977

Selected Periods	Average daily production (1000 b/d)	Average daily exports of oil (1000 b/d)	Average daily domestic consumption (1000 b/d)	Total oil revenue (mn, \$)
1951-54	33	9	24	---
1955-73	2226	1,032	105	16,270
1974-78	5635	5,062	421	91,129
Selected Years				
1950	664	602	19	45
1972	5,023	4,675	219	2,291
1974	6,022	5,532	296	17,691
1977	5,663	4,986	511	21,019

Source: Yeganeh, M., 1991: 79

TABLE A3: Share of Oil Revenues in Government Revenues; the First to Fifth Plan
(billion rials, percent in brackets)

Plans	Government Revenue	Oil revenue	Share of Oil (%)
First Plan (1949-55)	21	7.8	(37.1)
Second Plan (1956-62)	94.5	61	(64.5)
Third Plan (1963-7)	232	153.2	(66.0)
Fourth Plan (1968-72)	610	385	(63.0)
Fifth Plan (1973-7)	8,296.5	6,628.5	(80.0)

Source: PBO, Development Plans, various issues

TABLE A4: The Share of Oil Revenue in Government's Foreign Exchange Receipts
(percent)

Years	1960	1963	1966	1969	1970	1972	1973	1974	1975	1976	1977	1978
Share ¹	68	76	76	72	75	76	81	89	87	84	82	80

Source: From Table 15

¹ Authors calculation.

TABLE A5: Share of Oil Revenues and Taxes in Government Budget, selected Years and Plans
(in percent)

Year	Oil & Gas	Taxes	Others	Total
1962	42.7	33.5	23.6	100
1967	49.8	38.0	12.2	100
1972	58.9	32.9	8.1	100
1973	66.9	28.2	4.8	100
1974	86.4	11.3	2.3	100
1975	78.8	17.1	4.1	100
1976	77.4	18.6	3.9	100
1977	73.6	21.7	4.7	100
1978	63.4	29.0	7.6	100
First Plan	48.1	35.2	16.7	100
Second Plan	55.2	36.5	8.3	100
Third Plan	77.7	18.4	3.9	100

Source: Central Bank of Iran, Annual Report and Balance Sheet 1977, 1978, 1979; figures for the Plans from Moaddel 1993: 88, table 3.10

TABLE A6: GFCF and Consumption Expenditures: 1967-78

(billion rials; percent in brackets)

	1967/8	1972/3	1973/4	1974/5	1975/6	1977/8
GFCF	151	287	363	564	1100	1075
Public Sector	74	146	202	364	647	663
Private Sector	77	141	160	200	453	412
Ratio of Private to Public Sector	(1.04)	(0.97)	(0.79)	(0.55)	(0.7)	(0.62)
Consumption Expenditure	540	898	1,227	1820	2277	2638
Public Sector	98	253	325	581	769	799
Private Sector	442	645	902	1239	1508	1839
Ratio of Private to Public Sector	(4.5)	(2.55)	(2.77)	(2.1)	(1.96)	(2.3)
GNP (market price)	686	1,165	1851	3,176	3,676	3,686
Ratio of Public Expenditure to GNP	(25)	(34.2)	(28.5)	(30)	(38.5)	(40)

Source: Annual Budget and Balance Sheet, 1973, 1974, 1977; Amuzegar 1977: 28, 176

TABLE A7: Investment by the Private and Public Sectors in Iran; the First to Fifth Plan

(percent)

	Public Sector (a)	Private Sector (b)	Ratio of (a) to (b)
Third Plan (1963-7)	43	57	0.75
Fourth Plan (1968-72)	54.7	45.3	1.2
Fifth Plan (1973-8)	66.1	33.9	2

PBO, Outline of the Third Plan 1962-67; Ehteshami 78, table 14

TABLE A8: Public, Private and Total Investment in Industry and Mining: the Tird to Fifth Plan
(in billion rials, percent in parentheses)

	Third Plan (1963-7)		Fourth Plan (1968-72)		Fifth Plan (1973-7)	
Public investment	20	(30.3%)	125	(41.7%)	246.4	(44.3%)
Private investment	46	(69.7%)	175	(58.3%)	310.0	(55.7%)
TOTAL	66	(100.0%)	300	(100.0%)	556.7	(100.0%)
Ratio of Private to Public Investment.	2.3		1.4		1.26	

Source: PBO, The Fifth Development Plan, 1973-1977, persian text, 1977

TABLE A9: Real Consumption and Expenditure; 1959-77
(billion rials, 1974 constant prices)

Year	Consumption Expenditure					Investment Expenditure				
	Total	Private	Share %*	Gov. ¹	Share %*	Total	Private	Share %	Gov. ¹	Share %
1959	522.5	467.8	89.5	54.7	10.5	91.1	53.8	59	37.3	41
1961	520.3	463.6	89.1	56.7	10.9	100.6	65.5	65	35.1	35
1963	541	478.7	88.5	62.3	11.5	109.1	64.4	59	44.7	41
1965	584	483.8	82.8	100.2	17.2	166.3	87.6	52.7	78.7	44.3
1967	707.7	575.9	81.4	131.8	18.6	212.3	106.8	50	105.5	50
1969	813.9	628.4	77.2	185.5	22.8	254.8	105.4	41.4	149.4	58.6
1971	1084	800.9	73.9	283.3	26.1	334.9	145	43.3	189.9	56.7
1972	1210	855.6	70.6	355.3	29.4	410.6	202	49.2	208.6	50.8
1973	1362	927.7	71.4	389.7	28.6	463.3	211.3	45.6	252	54.4
1974	1819	1180	64.8	636	35.2	529	206.5	39	323	61
1975	2056	1327	64.5	728.4	35.5	874.6	447.5	51.2	427.1	49.8
1976	2409	1555	64.5	854.3	35.5	1181	522.7	44.2	658.5	55.8
1977	2521	1684	66.8	836.9	33.2	1083	471	43.8	612.1	56.2

Source: CBI, Iran's National Account 1959-77, Tehran, 1981'

1 government

TABLE A10: Sectoral Allocation of Government Development Expenditures; the Second to Fifth Plans (percentage)

Sectors	Second Plan (1956-62)	Third Plan (1963-7)	Fourth Plan (1968-72)	Fifth Plan (1973-7)
Social sectors ¹	12.5	11.7	4.6	3.8
Total (bn rials)	(75.2)	(204.6)	(506.8)	(2555.1)
Productive Sectors	87.5	73.4	79.2	69
Industry	11.7	8.4	22.3	16.5
Energy ²	4.8	15.6	18.8	24.4
Agriculture ⁵	31.2	23.1	16.4	11.7
Transport	39.8	26.3	21.7	16.4
Total	100.0	100.0	100.0	100.0
Industry				
Traditional industries ³	77.3	11.7	4.6	3.8
New industries ⁴	5.7	57.9	73.9	80
Credit to private sector	7.9	25.7	6.7	15.5
Other	9.1	4.7	14.8	0.7
Total	100.0	100.0	100.0	100.0
Total (bn rials)	(8.8)	(17.1)	(113.1)	(421.1)

Sources: CBI, Annual Reports and Balance Sheet, 1967, 1972, 1977; Karshenas 1990: 170, table 7.2

1 Includes housing, education, health, urban and rural development and tourism.

2 Includes water.

3 Includes textiles, food products and cement.

4 Including basic metals, chemicals and petrochemicals, paper, machinery and military industries.

5 Includes irrigation and water.

TABLE A11: Sectoral Distribution of Credits during the First to the Fifth Plans
(percentage)

Sectors	First Plan (1949-55)	Second Plan (1956-62)	Third Plan (1963-7)	Fourth Plan (1968-72)	Fifth Plan (1973-7)
Agriculture	27.8	21.7	21.6	17.4	9.4
Industry and Mine	20.0	7.7	31.6	22.3	16.5
Other Sectors	52.2	70.6	46.8	60.3	74.1

Source: Ministry of Agriculture, The Position and Problems of Agricultural Sector after the Islamic Revolution, 1983: 25

TABLE A12: Contribution to National Agricultural Production Surplus by Different Farm Units

Units	million rials	percent
Traditional ¹	97,395	87.8
Smal	(47,182)	(42.6)
Medium	(50,213)	(45.2)
Modern and Large	13,462	12.2
Partially and Fully Integrated	(10,837)	(9.8)
Corporations and Agribusiness	(2,625)	(2.4)
TOTAL	100,857	100.0

Source: Moaddel, 1993: 76, table 3.3

1. This includes traditional rainfed, partial, and full irrigation.

TABLE A13: Trends in GDP, The selected yerars of the Fifth Plan
(constant prices of 1974)

	1973		1978		Average annual rate of change
	billion rials	%	billion rials	%	%
Agriculture	286.5	10.0	339	9.4	4.6
Industry & Mine	387.7	13.5	684.3	19.1	15.5
Oil	1,450.6	50.5	1,284.9	35.8	-0.7
Services	749.6	26.0	1,281.3	35.7	15.3
GDP	2,874.4	100.0	3,589.1	100.0	6.9

Source: Annual Reports and Balance Sheet, CBI, 1977

TABLE A14: Sectoral Composition of Iran's GDP (at current prices)

(billion rials, percent in brackets)

Year	Agriculture	Oil	Industry and Mines	Services	Imputed rents	GDP
1960	105.6 (35.08)	36 (11.96)	33.3 (11.06)	129.2 (42.92)	-3.1 (-1.3)	301 (100.00)
1963	104.4 (30.25)	49.5 (14.34)	46.4 (13.45)	150.1 (43.49)	-5.3 (-1.54)	345.1 (100.00)
1966	113.2 (24.37)	74.5 (16.04)	71.7 (15.43)	213.9 (46.04)	-8.7 (-1.87)	464.6 (100.00)
1969	127.9 (19.9)	118.9 (18.5)	117.5 (18.29)	296.2 (46.09)	-17.9 (-2.79)	642.6 (100.00)
1970	126.3 (17.7)	140.5 (19.69)	134.1 (18.79)	335.2 (46.98)	-22.6 (-3.17)	713.5 (100.00)
1971	156.4 (17.33)	212.3 (23.52)	160.5 (17.78)	400.7 (44.39)	-27.2 (-3.01)	902.7 (100.00)
1972	182.8 (16.17)	263.4 (23.31)	202.8 (17.94)	521.7 (46.16)	-40.5 (-3.58)	1130.2 (100.00)
1973	219.7 (13.09)	586.7 (34.95)	282.4 (16.82)	645.7 (38.46)	-55.7 (-3.32)	1678.8 (100.00)
1974	289.8 (9.58)	1433.7 (47.37)	385.5 (12.74)	1026 (33.9)	-108.7 (-3.59)	3026.3 (100.00)
1975	306.2 (8.92)	1369.1 (39.89)	557.4 (16.24)	1352.4 (39.4)	-152.9 (-4.45)	3432.2 (100.00)
1976	387.5 (8.48)	1671.4 (36.57)	848.3 (18.56)	1881.3 (41.16)	-217.9 (-4.77)	4570.6 (100.00)
1977	459.3 (8.51)	1755 (32.52)	1005.9 (18.64)	2466.4 (45.71)	-290.5 (-5.38)	5396.1 (100.00)

Source: Pesaran 1994: 22, table 8

TABLE A15: The Share of Oil revenue in Government Current Receipts and Payments; 1959-78
(billion rials)

	1959	1960	1961	1962	1963	1964	1965
1. Current Receipts	501.6	528.1	538.7	569.8	618.8	701.4	817.3
Oil and Gas	335.4	358.0	391.3	437.2	470.8	555.4	607.5
Non-oil Exports	166.2	169.2	147.4	132.6	148	146	209.8
2. Current Payments	611.1	597.9	565.9	527.7	548.1	759.2	932.5
3. Net Current Account(1-2)	-109.5	-69.8	-27.2	42.1	70.7	-57.8	-115.2
4. Net Capital Account	68.8	16.6	89.4	2.2	-40.1	-45.2	19.4
5. Overall Balance (3-4)	-30	-55.4	61.4	30.3	30.6	95.4	-52.2
6. Total Revenue (bn rials)				52.9	58.7	68.7	90.9
Oil and Gas				(23.7)	(27.7)	(36.4)	(50.0)
Non-oil				(29.2)	(31.0)	(32.3)	(40.9)
7. Total Expenditure				54.9	65.8	78.9	106.1
Current				(41.5)	(47.2)	(52.2)	(63.7)
Capital				(13.4)	(18.6)	(26.7)	(37.1)
8. Budget balance(6-7)				-2	-7.1	-10.2	-9.9

	1966	1967	1968	1969	1970	1971
1. Current Receipts	940.8	1175	1325	1518	1690	2734
Oil and Gas	715.8	875.4	958.5	1099	1268	2114
Non-oil Exports	225	318.1	366.6	419.7	421.7	620
2. Current Payments	1089	1387	1804	2072	2365	3015
3. Net Current Account(1-2)	-148.4	-212.3	-479.6	-553.5	-675	-281
4. Net Capital Account	119.7	214.2	384.1	398.8	413.4	668
5. Overall Balance (3-4)	-24.4	-3.1	-99.7	-70.9	239.3	479
6. Total Revenue (bn rials)	96.2	110.1	129.4	150.4	173.4	258.3
Oil and Gas	(47.4)	(54.0)	(61.8)	(76.4)	(85.5)	(155.3)
Non-oil	(48.8)	(56.1)	(67.6)	(74.0)	(87.9)	(103.9)
7. Total Expenditure	108.3	135.5	168.7	196.9	232.1	284.4
Current	(70.5)	(82.1)	(98.8)	(114.4)	(135.2)	(168.4)
Capital	(37.8)	(53.4)	(69.9)	(82.8)	(96.9)	(116.0)
8. Budget balance(6-7)	-12.1	-25.4	-39.3	-46.5	-58.7	-32.9

TABLE A15: The Share of Oil revenue in Government Current Receipts and Payments; 1959-78
(Continued...)

	1972	1973	1974	1975	1976	1977	1978
1. Current Receipts	3337	6232	20922	21971	24618	25590	22738
Oil and Gas	2536	5073	18672	19053	20670	20904	18115
Non-oil Exports	801	1159	2250	2918	3497	4685	4622
2. Current Payments	3502	5879	12393	19025	21087	24496	21239
3. Net Current Account(1-2)	-165	353	8259	2946	3530	1094	1499
4. Net Capital Account	592	925	-3254	-3939	-1155	1505	-1683
5. Overall Balance (3-4)	493	1151	5076	-991	2288	2014	-579
6. Total Revenue (bn rials)	302.1	464.8	1,394.4	1,582.1	1,836.4	2,034.2	1,598.6
Oil and Gas	(178.2)	(311.3)	(1,205.2)	(1,246.8)	(1,421.5)	(1,497.8)	(1,013.2)
Non-oil	(123.9)	(153.5)	(189.2)	(335.3)	(414.9)	(536.4)	(585.4)
7. Total Expenditure	359.1	478.0	1,076	1,456.1	1,638.9	2,146.1	1,823.9
Current	(227.3)	(316.8)	(727.8)	(929.3)	(1,047.3)	(1,219.3)	(1,251.7)
Capital	(131.8)	(161.2)	(384.7)	(526.8)	(591.6)	(926.8)	(572.2)
8. Budget balance(6-7)	-58.6	-13.2	+317.9	+126.0	+197.5	-111.9	-225.3

Source: Pesaran 1994: 18-23, Tables 4 and 9

TABLE A16: Wage and Price Inflation; the First to Fifth Plan and Selected Years
(percent)

PLANS ¹ & YEARS	Consumer Prices	Wholesale Prices	Wage Prices ²
First Plan (1949-55) ³	3.9	4.2	
Second Plan (1956-62)	5	1.6	
Third Plan (1963-7)	1.5	0.24	3.7
Fourth Plan (1968-72)	3.7	3.7	12
Fifth Plan (1973-7)	15.7	13	34
1974	15.53	17.06	31.73
1975	9.93	5.37	50.85
1976	16.52	13.29	35.41
1977	25.1	14.62	33.76
1978	10.01	9.67	14.77

Source: Pesaran 1995: Table 3, P. 17

1 The figures for the Plans calculated by the author.

2 Based on the wages of unskilled construction workers.

3. annual average rate of change for the Plans; rate of change for the selected years

TABLE A17: Land Ownership after the Land Reform of 1963

(in hectares)

Size of holding	200 hectares	50-200 hectares	10-50 hectares	5-10 hectares	2-5 hectares	Less than 2 hectares	0 hectares
Number of owners	1,350	44,000	150,000-600,000	700,000	700,000	1,000,000	700,000-1,400,000

Source: Foran 1993: 318-25; Abrahamian 1982: 429-30

TABLE A18: Major Commercial and Specialized Banks with Foreign Ownership, 1975

(ranked according to the date of establishment)

Commercial / Specialized Banks	Date of Establish.	Iranian	Foreign	Foreign Partner
Russo-Iran Bank	1924	—	100	State Bank of UUR
Bank of Tehran	1957	65	35	Paribas International, Paris
Bank Etebarat Iran	1958	60	40	Credit Lyonnais, Paris
Foreign Trade Bank of Iran	1958	60	40	Bank of America
Irano-British Bank	1958	60	40	The Scotland & Catering
Mercantile Bank of Iran & Holland	1959	65	35	Algemene Bank, Holland
The Bank of Iran & the Middle East	1959	60	40	The British Bank of M.E.
The International Bank of Iran & Japan	1959	65	35	Bank of Tokyo
IMDBI	1959	85	15	many banks ¹
Iranian Bank	1959	65	35	Citibank, New York
Development & Investment Bank of Iran	1973	78	22	
Bank Dariush	1974	65	35	Continental Bank of Chicago
International Bank of Iran	1975	65	35	Chase Manhattan
Irano-Arab Bank	1975	65	35	

Source: US Department of Commerce, Iran: A Survey of Business Opportunities, 1977: 149 table 2

1. see Muller 1980: 77-8

TABLE A19: Foreign Private Investment Through CAPFI, the Third to Fifth Plan

(in million rials)

Country	Secon Plan	Third Plan	Fourth Plan	Fifth Plan	Total
USA	455	1,609	4,962	4,997	12023
Britain	278	230	988	662	2,124
W. Germany	44	196	1,449	2,998	4,687
France	127	173	512	1,493	2,305
Japan	0	20	415	11,485	11,920
Italy	n.a	71	138	1,118	1,327
Others	147	672	1,509	2,652	4,980
TOTAL	1051	2,971	9,973	25,405	39400

Source: Central Bank, Annual Reports and Balance Sheet, fot 1967, 1972, 1978

TABLE A20: Local and Foreign Investment in Industrial Machinery, the Third to Fifth Plan

(except for oil, gas, water and construction)

(in billion rials, percent in parentheses)

Investment	Third Plan (1963-7)	Fourth Plan (1968-72)	Fifth Plan (1973-7)
Local	55.50	137.20	904.30
Foreign	2.97	9.80	25.30
Ratio of foreign to local investment	(5)	(6.7)	(2.7)

Source: CBI, Annual Report and Balance Sheet, various issues from 1966 to 1978

TABLE A21: Iran's Foreign Trade; 1953-1978
 (in millions of dollars ¹)

Year	Imports	Exports	Exports	Balance	Balance
		(without oil)	(with oil)	(without oil)	(with oil)
1953	66.1	96.7	99.8	+30.6	+33.7
1958	605.9	103.8	402.6	-502.1	-203.3
1963	518.6	127.0	1,015.2	-391.6	+496.6
1968	1,408.9	214.8	2,003.7	-1,194.1	+594.8
1972	3,161.0	440.0	3,040.0	-2,721.0	-121.0
1978	18,400.0	520.0	24,020.0	-17,880.0	+5,620.0

Source: Bharier, *Economic Development in Iran*, 104-6 table 44; Katouzian, *The Political Economy of Modern Iran*, 325 table 16.2

¹ exchange rate used: \$1= 87.1 rials for 1953, 76.5 rials for 1958, and 75.75 rials for 1963, 1968.

TABLE A22: Iran's Foreign Trade as a Proportion of, GNP, 1959-1975
(in millions of dollars, at current prices)

	GNP	Foreign Trade	Trade
	[1]	[2]	Dependence
Year			[2] : [1]
1959	3,703	982	0.27
1960	4,104	1,159	0.28
1961	4,332	1,135	0.26
1962	4,611	1,099	0.24
1963	4,884	1,113	0.23
1964	5,468	1,451	0.27
1965	6,015	1,687	0.28
1966	6,465	1,837	0.28
1967	7,420	2,230	0.30
1968	8,389	2,565	0.31
1969	9,389	2,887	0.31
1970	10,463	3,229	0.30
1971	13,055	4,554	0.35
1972	16,420	5,470	0.33
1973	24,436	9,317	0.38
1974	41,653	25,850	0.62
1975	46,917	31,362	0.67

Source: Moaddel, 1993: 85 table 3.8; Central Bank of Iran; Annual Report and Balance Sheet, various issues

TABLE A23: Industrial Dependence on Imports, 1979(in million rials ¹, percent in parentheses)

Industries	Value of imports	Value of total input	Ratio of imports in unit production
Consumer goods	125.2	287.7	(43.5)
Intermediate goods	39.0	79.1	(49.5)
Capital goods	39.3	29.4	(76.3)
Others	0.42	0.57	(73.6)
TOTAL	193.9	405.8	(47.8)

Source: Sodagar 1991: 23, table 8.54

¹ figures are rounded

TABLE A24: Leading Importers from Iran; 1959-1977

(in million rials, percent in brackets)

Country	1959	1963	1965	1970	1972	1974	1977
W. Germany	124.3 (22.8)	109.2 (21.0)	180.5 (21.1)	347.9 (20.8)	327.6 (18.0)	1,185.0 (17.0)	2,747.0 (19.5)
USA	94.6 (17.4)	83.2 (16.0)	170.4 (19.0)	217.4 (13.0)	309.4 (17.0)	1,321.5 (20.0)	2,205.0 (15.6)
Japan	54.7 (17.4)	36.4 (16.0)	71.5 (19.0)	201.2 (13.0)	254.8 (17.0)	999.4 (20.0)	2,215.0 (15.6)
UK	78.2 (14.4)	78.0 (16.0)	114.7 (12.8)	162.7 (9.7)	218.4 (12.0)	529.5 (8.0)	916.5 (6.5)
France	21.2 (3.9)	31.2 (6.0)	45.1 (5.0)	77.5 (4.6)	91 (5.0)	242.1 (3.7)	634.5 (4.5)
Italy	19.5 (3.6)	20.8 (4.0)	41.4 (4.6)	67.9 (4.0)	72.8 (4.0)	199.4 (3.0)	775.5 (5.5)
Others	151.7 (27.8)	161.2 (30.6)	274.8 (34.1)	572.0 (30.0)	546 (32.3)	2,136.8 (49.2)	6,933.0
Total	544.2	520.0	898.4	1,676.6	1,820.0	6,613.7	14,100.0

Source: Iran Custom Administration 1964, 1973, 1978; Foran 1993:343

TABLE A25: Imports of Foods; 1970-1977

(in million dollars)

Year	Food & Live Animals	Beverages & Tobacco	Vegetables & Animal Oils	TOTAL	Food Imports as % of GNP
1970	68	1	42	111	1.04
1971	171	3	45	219	1.68
1972	206	4	59	269	1.64
1973	327	5	61	393	1.61
1974	852	13	240	1,105	2.65
1975	1,555	26	291	1,872	3.99
1976	1,232	77	137	1,446	2.37
1977	1,486	130	164	1,780	2.50

Source: Moaddel, 1990: 86 table 3.9

TABLE A26: Defence Budget as a Share of National Budget, 1941-1978
(million rials, percent in bracket)

Year	National	Defence Budget	Share of Defence
1942	3,760	593	(15.7)
1944	3,993	1,000	(25.0)
1946	4,312	1,096	(25.4)
1948	8,021	1,479	(18.4)
1950	10,687	2,478	(23.1)
1952	9,550	—	—
1954	12,456	2,544	(20.4)
1956	23,445	5,298	(22.5)
1958	39,660	8,378	(21.1)
1960	52,594	16,174	(30.7)
1962	54,667	14,448	(26.5)
1963	55,743	14,064	(25.2)
1965	74,725	17,163	(22.9)
1967	134,000	33,300	(24.8)
1969	174,100	46,800	(26.8)
1970	204,200	58,200	(28.5)
1971	231,000	65,000	(28.1)
1972	302,000	92,100	(30.4)
1973	578,100	91,000	(16.0)
1974	785,200	135,000	(17.0)
1975	1,903,000	373,000	(20.0)
1976	2,310,200	476,000	(21.0)
1977	3,153,600	567,000	(18.0)
1978	3,530,000	561,000	(16.0)

Source: United Nations, Statistical Yearbook, various issues for 1953- 1980

US \$1 = 67 rials in 1974.

The increase in the share of defence expenditures in the national budget is mainly because from 1973 upto 1978, the major military cost was the purchase of military equipment which was not included in the national budget.

TABLE A27: Registered Foreign Firms by Type of Activity, 1973-77

Activity	1973	1974	1975	1976	1977	TOTAL
agriculture	-	-	1	-	2	3
Mining	3	10	4	-	2	19
Industry	3	13	19	10	19	64
Power	-	-	-	-	-	-
Trade & hotels	19	44	77	60	51	251
Construction	10	23	64	55	54	206
Transportation & Communication	6	5	8	10	5	34
Insurance & credit	37	61	133	71	69	371
Social & public services	6	6	3	4	4	23
TOTAL	84	162	309	210	207	972

Source: CAPFI Report, 1978

TABLE A28: Defence Expenditure

(billion dollars).

Year	1959	1963	1965	1970	1971	1972	1973	1974	1975	1976	1977	1978
Amount	200	200	250	860	1,000	950	1,350	5,500	7,600	8,200	7,900	9,900

Source: The United Nation, Statistical Yearbok, Various issues for 1953-73; Graham table 8 P. 176 for 1974-8

Calculated based on \$1= 67 rials in 1974

TABLE A29: Average Annual Real Rate of Growth of Major Sectors; the third to fifth Plan
(percent at constant 1974 prices)

Sectors	Third Plan (1963-67)	Fourth Plan (1968-72)	Fifth Plan (1973-78)
Agriculture	4	5.5	4.4
Industry and Mine	12.7	14.8	17.4
Construction	11.2	14.4	21.5
Oil	11.5	15	0.9
Services	10.3	13.5	19.2
GDP at factor costs	9.9	13.1	8.5
Non-oil GDP	8.5	11.2	15.3

Source: Iran's National Accounts 1959-77, CBI 1981: Table 16, Persian text

TABLE A30: Sources of Revenues in Development Plans; the First to Fifth Plan
(percent)

Source of Revenues	First Plan (1949-55)	Second Plan (1956-62)	Third Plan (1963-7)
Oil	37.1	65	66.1
Loans	53.3	27.1	21.9
Domestic	(21.4)		(12.9)
External	(31.9)		(9)
Others	9.6	7.9	12
Total Revenues (billion rials)	21bn rials (100.0)	94.5bn rials (100.0)	232bn rials (100.0)

Sources: Amuzegar and Fekrat 1971:40-6, tables 3.3,3.4, 3.5

TABLE A31: Sources of Revenues in Government Budget; 1973-78
(billion rials, percent in brackets)

Source	1973	1974	1975	1976	1977	1978
Oil	178.2 (30)	311.3 (38)	1,205.3 (63)	1,246.8 (54)	1,409 (47)	1,436 (42)
Taxes	236.5 (40)	153.4 (31)	290.6 (15)	485.2 (21)	414.5 (14)	698.7 (20)
Others	166.1 (30)	263 (31)	407 (22)	578.2 (25)	1185.1 (39)	1,272.8 (38)
TOTAL	580.8 (100)	827.7 (100)	1,902.9 (100)	2,310.2 (100)	3008.6 (100)	3,407.5 (100)

Sources: The United Nation, Statistical Yearbook, 1978: table 201

TABLE A32: Manpower Supply and Demand During the Initial and Revised Fifth Plan by Major Occupation
(1000)

Personnel	Fifth Plan	Revised Plan	Supply	Deficit
Engineer	16	36.4	20.3	16.1
Medical staff	23	44.1	21.5	22.6
Education staff	57	287.4	230	57.4
Technicians	42	116.6	75	41.6
Skilled and semi-skilled	560	810	250	560 ¹
Unskilled	10	538	528	10
Miscellaneous	13	279.5	266	13.5 ²
Total	750	2,112,000	****	721.2

Source: Iran Almanac, 1977: 384; 1974: 445, 380; 1975: 381-5

1. 290,000 manufacturing technician, 270,000 construction technician.
2. of which 1500 should be senior administrator and personnel.

Bibliography

A: Newspapers and News Periodicals:

Economic Intelligence Unit, Country Profile, Iran (1967-79)

Ettela'at International (1995-6)

Ettella'at Siyasi-Eghtesadi (1989-96)

Farhang-e Towse'eh (1990-96)

Financial Times (1963-1979)

International Herald Tribune (1970-78)

Iran Times(Washington, DC)(1995-6)

Iran-e Farda (19956)

Kayhan (London) (1994-5)

Kayhan Hava'i (1992-5)

Kayhan International, (1978, 1979, 1985,)

MERIP Reports (1977-80)

Middle East Economic Digest (MEED)

Middle East Economic Survey (MEES)

The Guardian (1970-78)

The Times (1976-78)

B: Books, Journals and Conference Papers

Abrahamian, A., *Iran Between Two Revolutions*, Princeton: Princeton University Press, 1982

Abrahamian, E., European feudalism and Middle Eastern Despotism, *Science and Society*, Vol. 39, no.2, PP.129-156, summer 1975

Abrahamian, E., The crowd in the Persian revolution, *Iranian Studies*, Vol. II, No. 4, PP. 128-50, 1969

Adamiyat, F. and Nategh, H., *Afkar-e Ejtema'i va Siyasi va Eghtesadi dar Asar-e Montashernashode-ye Doran-e Qajar* (Social, Political, and Economical Thoughts in the Unpublished Material of Qajar Era), Tehran: Agah, 1356 (1977)

- Adamiyat, F., *Andishe-ye Taraqqi va Hokumat-e Ghamun, Asr-e Sepahsalar*, (The Thinking of Progress and the Government of Law, During Sepahsalar) Tehran: Kharazmi, 1351 (1972)
- Afkhami, G.R., *The Iranian Revolution.: Thanatos on a National Scale.*, Washington DC: The Middle East Institute, 1985
- Afshari, P., *Sadr-e Azam-haye Selsele-ye Qajari-ye* (Chief Ministers of the Qajar Dynasty), Tehran: IPIS, 1993
- Alam, A., *The Shah and I, Confidential Diary of Iran's Royal Court, 1969-1977*, London: I.B.Tauris, 1991
- Alavi, S. and Navab-Pour, R., *Dastan-e Enghelab; Ketab-e Marja'* (The Story of the Revolution; A Reference Book), London: Soundwords Ltd, 1992
- Alford, R., and Friedland, R., *Powers of Theory: Capitalism, the State, and Democracy*, Cambridge: University of Cambridge Press, 1985
- Algar, H., *Religion and State in Iran, The Role of Ulama in the Qajar Period, 1785-1906*, Berkeley: University of California Press, 1969
- Algar, H., Some observation on religion in Safavid Persia, *Iranian Studies*, Vol. 7, 287-93, 1974
- Alizadeh, P., 'Foreign Direct Investment, Transfer of Technology in the Non-Oil Sector of the Iranian Economy', (University of London, MA Dissertation, 1976)
- Amanat, M. & Keddie, N., *Iran under the later Qajars; 1848-1922*, in P. Avery, G. Hambly, and C. Melville, (eds.), *CHI*, Vol. 7, Cambridge: Cambridge University Press, 1991
- Amin al-Dowleh, M. Ali Khan, *Katerat-e Siyasi-ye Mirza Ali Khan-e Amin al-Dowle*, (The Political Diaries of Mirza Ali Khan-e Amin al-Dowle), edited by H. Farmanfarmaian, Tehran, 1341 (1962)
- Amin al-Sultan, Mirza Ali Asghar, (Chief Minister), *Dastur al-amal-e hokkam-e velayat*, (The Guidelines for the regional governors), Tehran: University Library of Tehran, 1305 hg, in Adamiyat, 1356 (1977), PP.454-471
- Amirahmadi, H., *Revolution and Economic Transition; the Iranian Experience*, NY: State University of New York Press, 1990
- Amirahmadi, H., The political economy of Iran's oil policy, in K. Gillespie and CM. Henry, *New World Order*, Florida: University Press Florida, 1995
- Amirsadeghi, H., (ed.) *Twentieth Century Iran*, London: Heinman, 1977

- Amuzegar, J., *An Economic Profile*, Washington DC.: The Middle East Institute, 1977
- Amuzegar, J., and Fekrat, A., *Iran: Economic Development Under Dualistic Conditions*, Chicago: University of Chicago Press, 1971
- Amuzegar, J., Oil wealth: a very mixed blessing, *Foreign Affairs*, 62: 814-835, 1982
- Anderson, J., The modernity of modern states, in J. Anderson (ed.), *The Rise of the Modern State*, Brighton (Sussex): The Harvester Press, 1986
- Anderson, P., *Lineages of the Absolutist State*, London: New Left Books, 1974
- Anderson, P., The Absolutist state of Western Europe, in D. Held et. al. (eds.), *States and Societies*, Oxford: Basil Blackwell, 1990
- Arasteh, R. The struggle for equality in Iran, *MEJ*, Vol. 18, 1964
- Arberry, A.J., *British Contribution to Persian Studies*, London: Longmans Green, 1942
- Arfa, H. *Under Five Shah*, London: John Murray, 1964
- Arjomand, S., *The Turban for the Crown: The Islamic Revolution in Iran*, New York: Oxford University Press, 1988
- Ashraf, A. & Banuazizi, A., The state, classes, and modes of mobilisation in the Iranian revolution, *State, Culture, and Society*, Vol. 1, no. 3, PP. 3-40, 1985
- Ashraf, A., From the white revolution to the Islamic revolution, in S. Rahnama and S. Behdad (eds.) *Iran After the Revolution, Crisis of an Islamic State*, London: IB. Tauris, 1995
- Ashraf, A., Historical obstacles to the development of a bourgeoisie in Iran, in M.A. Cook (ed.) *Studies in the Economic History of the Middle East*, 1970
- Ashraf, A., *Mavan'e-e Tarikhi-ye Roshd-e Sarmaye Dari dar Iran: Dore-ye Qajariyeh* (Historical Obstacles to the Development of a Bourgeoisie in Iran), Tehran: Payam, 1359 (1980)
- Ashraf, A., *Traditional Bourgeoisie and the Development Processes of 19th Century Iran*, Princeton: Princeton University Press, 1974
- Avery, P., Hambly, G., and Melville, C., *The Cambridge History of Iran, From Nader Shah to the Islamic Republic*, Vol. 7, Cambridge: Cambridge University Press, 1991
- Avery, P., *Modern Iran*, London: Ernest Benn Limited, 1965
- Banani, A., *The Modernization of Iran*, Stanford: Stanford University Press, 1961
- Bashiriyyeh, H., *The State and Revolution in Iran 1962-1982*, London: Croom Helm, 1984

- Bastani Parizi, M.E., *Siayasad va Eghtesad: Asr-e Safavi* (Politics and Economy: The Safavid Era), Tehran: Safi-alishah Press, 1348 (1969)
- Bayat, M., *Iran's First Revolution: Shi'ism in the Constitutional Revolution of 1905-1909*, Oxford: Oxford University Press, 1991
- Bayne, E.A., *Persian Kingship in Transition*, NY: American Universities Field Staff, 1968
- BBC Documentary, *Dastan-e Enghelab*, (The Story of the Revolution), London: BBC, 1992
- Beblawi, H. and Luciani, L. (eds.), *The Rentier State*, Kent: Croom Helm, 1987
- Beetham, D., Michels and his critics, *European Journal of Sociology*, V 22, 1981, PP.81-99
- Bernstein, H., Industrialisation, development and dependence, in H. Alavi and T. Shanin (eds.) *Introduction to the Sociology of Developing Societies*, London: Macmillan, 1982
- Bharier, J., *Economic Development in Iran 1900-1970*, London: Oxford University Press, 1971
- Bill, J.A., Class analysis and the dialectics of modernisation in the Middle East, *IJMES*, V.3, PP. 417-34, 1972
- Bill, J.A., *The Eagle and the Lion, The Tragedy of American-Iranian Relations*, New Haven: Yale University Press, 1988
- Bill, J.A., The patterns of elite politics in Iran, in G. Lenczowski (ed.) *Political Elite in the Middle East*, Washington D.C.: American Enterprise Institute for Public Policy Research, PP. 17-40, 1975
- Bill, J.A., The plasticity of informal politics: the case of Iran, *MEJ*, Vol. 27, PP.131-151, 1973
- Bill, J.A., *The Politics of Iran: Groups, Classes, and Modernization*, Merrill, 1972
- Binder, L., *Iran, Political Development in a Changing Society*, Los Angeles, CA: University of California Press, 1962
- Bottomore, T.B., *Elites and Society*, London: Watts, 1964
- Browne, E., *A Year Amongst the Persians, 1887-1888*, London, 1926
- Browne, E., *The Persian Revolution, of 1905-1909*, Washington, DC: Mage Publishers, new edition, 1995
- Brzezinski, *Power and Principle*, NY: Farrar, Straus & Giroux, 1983

- Bukharin, N., *Imperialism and the Accumulation of Capital*, London: Allen Lane, (new edition), 1972
- Bukharin, N., *Imperialism and World Economy*, NY: Monthly Review Press, 4th edition, 1973
- Cardoso, F.H. & Faletto, E. *Dependency and Development in Latin America*, (trans.), Berkeley: University of Californian Press, 1979
- Carr, E., *The climax of nationalism*, in E.H. Carr, *Nationalism and After*, London: Macmillan, 1945, (reprinted 1968)
- Castells, *Four Asian tigers with a dragon head, a comparative analysis of the state, economy, and society in the Asian Pacific Rim*, in RP Appelbaum and J. Henderson, *States and Development in the Asian Pacific Rim*, Newbury Park, CA: SAGE, 1992
- CBI, *Survey of the state of Iranian industry*, in Persian, Dec. 1979,
- CBI, *The Annual Report and Balance Sheet*, Various years, Tehran: CBI
- Chardin, J., *Voyages du Chevalier de Chardin en Perse Entres Lieux l'Orient*, Langles, 10 Vol., 1811, tran to Persian by M. Abbasi, *Siyahatname-ye Chardin*, 10 Vol., 1345 hs (1966)
- Chaudhry, K.A., *The price of oil: business and state in labour remittance and oil economies*, *International Organization*, 43:111-145, 1989
- Clawson, P., *Capital accumulation in Iran*, in P. Nore & T. Turner (eds.) *Oil and Class Struggle*, London: Zed, 1980
- Clawson, P., *The impact of the military on Iran's economy*, paper presented for the conference on *Between State and Market: Iran's Economy Since 1979*, Paris, 1993
- Cleaveland, W.L., *A History of the Modern Middle East*, Colorado: Westview Press, 1994
- Cochrane, A., *Industrialisation and the nineteenth century states*, in J. Anderson (ed.), *The Rise of the Modern State*, Brighton: Harvester Press, 1986
- Connolly, V., *The industrialisation of Persia*, *Journal of the Royal Asian Society*, July 1935
- Cottam, R., *Nationalism in Iran*, Pittsburgh: University of Pittsburgh Press, 1970
- Crystal, J., *Oil and Politics in the Gulf: Rulers and Merchants in Kuwait and Qatar*, Cambridge: Cambridge University Press, 1990
- Curzon, G., *Persia and the Persian Question*, 2 Vol., London, 1892

- Dabir al-Molk Farahani, M.M. Hosain, *Resale-ye siyasi* (Political Writing), 1287hg, in *Adamiyat*, 1356, PP. 417-448
- Daftary, F. & Borghey, M., (Yekom Consultants), *Multinational Enterprises and Employment in Iran*, (working paper), Geneva: International Labour Office, 1976
- De Villiers, G., *The Imperial Shah*, Boston: BUP, 1977
- Deyo, F.C., *State and labour: models of political exclusion in East Asian development*, in F.C. Deyo (ed.) *The Political Economy of the New Industrialism*, Ithaca, NY: Cornell University Press, 1987
- Dunleavy, P., and O'Leary, B., *Theories of the State, The Politics of Liberal Democracy*, London: Macmillan Education, 1987
- Echo of Iran, *Iran Alamanc, Book of Facts*, various issues, Tehran: Echoprint, 1960-79
- Ehteshami, A., *After Khomeini: The Iranian Second Republic*, London: Routledge, 1995
- Ehteshami, A., *Succession within and without the context of the Islamic Republic of Iran*, paper presented at the BRISMES Annual Conference, University of Exeter, 1987
- Ehteshami, A., *Unfettered trade: strategy not tactic*, *The Journal of Interdisciplinary Economics*, Vol. 2, PP. 91-105, 1987
- Else, M.J., *Iran: A Business Opportunity for the 1980s*, London: Metra Consulting Group, 1978
- Eskandar Beig Monshi, *Tarikh-e Alam-ara-ye Abbasi*, (The World-Glorifying History of the reign of Shah Abbas) 1616 (Vol I and II) and 1629 (Vol.III), ed. I. Afshar, 2 vol., Tehran, 1350 (1971)
- Evans, P., *Dependent Development; The Alliance of Multinational, State and Local Capital in Brazil*, Princeton, NJ: Princetone University Press, 1979
- Evans, P., Rueschemeyer, D. and Skocpol, T., *On the road toward a more adequate understanding of the state*, in P. Evans, et. al. (eds.), *Bringing the State Back In*, Cambridge, NY: Cambridge University Press 1990, PP. 347-66
- Evans, P., Rveschemeyer, D. and Skocpol, T.(eds.) *Bringing the State Back In*, Cambridge: Cambridge University Press, 1990
- Faghfoory, M.H., *The impact of modernization on the Ulama in Iran, 1925-1941*, *Iranain Studies*, V. 26, n. 3-4, 1993

- Fallaci, O., Mystically divine shah, interview, *Chicago Tribune*, 30 December 1973, sec. 2
- Fallaci, O., The Shah of Iran, interview, *New Republic*, Vol. 169, no. 22, 1 December 1974, PP. 16-21
- Farazmand, A., *The State, Bureaucracy, and Revolution in Modern Iran; Agrarian Reform and Regime Politics*, NY: Praeger, 1989
- Fardust, M.H., *Khaterat-e Fardust, Zohur Va Soghut-e Saltanat-e Pahlavi* (Fardust Diaries), 2 Vol., Tehran: Institute for Political Research and Studies, 1991
- Farmanfarma, Mirza A. Husain, *Majmu'e-ye Asnad (1303-1328hg), Siyagh-e Ma'ishat dar Ahd-e Qajar: Hokmrani va Molkdari* (The Collection of Documents), 2 Vol. ed. by Ettehadiyeh, M. and sa'dvandiyan, S., Tehran, 1362 (1983)
- Fatemi, K., Leadership by distrust: The Shah's *modus operandi*, *MEJ*, Vol. 36, no. 1 PP.48-61, 1982
- Fekrat, M.A., Growth of OPEC-type economies: preliminary theoretical inquiry, *Economia Internazionale*, February 1979
- Foran, J., *Fragile Resistance, Social Transformation in Iran from 1500 to the Revolution*, Oxford: Westview, 1993
- Foran, J., The long fall of the Safavid dynasty: moving beyond the standard views, *IJMES*, Vol.24, PP.281-304, 1992
- Fragner, B., Social and internal economic affairs, 1986, in P. Jackson (ed.) *The Cambridge History of Iran*, Vol. 6, Cambridge: Cambridge University Press, 1986
- Frank, L.P., Two responses to the oil boom: Iranian and Nigerian Politics after 1973, *Comparative Politics*, April, 1984
- Fraser, *Narratives of a Journey into Khorasan in the Years 1821-22*, London: Longmans, 1825
- Freund, J., *Sociologie de Max Weber*, Paris: PUF, translated by A. Nikgozar, Tehran: Nikan, 162 (1983)
- Gasiorowski, M.J., Policy making in a highly autonomous state, *The Journal of International Affairs*, Vol.8, PP. 440-82, 1993
- Gasiorowski, M.J., The 1953 coup d'etat in Iran, *IJMES*, Vol. 19, 1987
- Gasiorowski, M.J., *US Foreign Policy and the Shah: Building a Client State in Iran*, Ithaca: Cornell University Press, 1991

- Gelb, AH., Capital-importing Oil Exportes: Adjustment Issues and Policy Choices, The World Bank, staff working Paper No. 475, Washington: WB, 1981
- Ghods, R. Government and society in Iran, 1926-34, *MEJ*, Vol. 27, no.2, PP.219-230, 1991
- Giddens, A., A Contemporary Critique of Historical Materialism, London: Macmillian, 1981
- Giddens, A., et. al. (eds.), Classes, Powers, and Conflict, part I, London: Macmillan, 1982
- Gilbar, G.G., Trends in the development of prices in late Qajar Iran, 1870-1906, *Iranian Studies*, Vol.16, no.3-4, 1983
- Graham, R., Iran; The Illusion of Power, New York: St. Martins Press, 1980
- Greaves, R., Iranian relations with Great Britain and British India 1798-1921, in P. Avery et. al. (eds.) CHI, Vol.7, PP.374-425, 1991
- Gronn, P., Psychobiography on the coach: character, biography, and the comparative study of leaders, *The Journal of Applied Behavioural Science*, Vol 29, no. 3 PP. 343-58, 1993
- Hablutzel, R., Development Prospects of the Capital-Surplus Oil-exporting Countries, New York: World Bank, (paper no.483), 1981
- Hablutzel, R., Issues in economic diversification for the oil-rich countries, *Finance and Development*, 18, 2: 10-13, 1981
- Hall, D., State in History, Oxford: Basil Blackwell, 1986
- Hall, S., The state in question in G. Mclennan, D. Held and S. Hall (eds.) The Idea of the Modern State, Milton Keynes: Open University Press, 1984
- Halliday, F., Iran: Dictatorship and Development, Middlesex: Penguin Books Ltd, 1979
- Hambly, G.R.G., Iran during the reigns of Fath Ali Shah and Mohammad Shah, in Avery et. al. (eds.), CHI, Vol 7, 1991, PP.144-173
- Hambly, G.R.G., The Pahlavi autocracy: Riza shah, 1921-1941, in P. Avery, et. al. (eds.), CHI, Vol. 7, Cambridge: Cambridge University Press, 1991
- Hamilton, G., Chinese consumption of foreign commodities: a comparative perspective, *American Sociological Review*, Vol. 42, no. 6, 1977, PP. 877-91
- Hamilton, N., The Limits of State Autonomy, Princeton: Princeton University Press, 1982

- Hashemi Rafsanjani, A.K., *Amirkabir Ghahraman-e Mobareze ba Este'mar* (Amirkabir, the Champion of Struggle Against Colonialism), Tehran: Daftar-e Nashr, 1352 (1973)
- Hedayat, Mirza Gholi Khan, *Khaterat va Khatarat* (Memoires and Dangers), Tehran: Zavar, n.d.
- Heikal, M.H., *Return of the Ayatollah: The Iranian Revolution from Mosaddegh to Khomeini*, London: Andre Deutch, 1981
- Helco, H., *Modern Social Politics in Britain and Sweden*, New Haven, Conn.: Yale University Press, 1974
- Held, D., *Beyond liberalism and Marxism*, 1984 b in D. Held et. al. (eds.) *The Idea of the Modern State*, Milton Keynes: Open University Press, 1984
- Hickman, W.F., *Ravaged and Reborn: The Iranian Army*, 1982, Washington DC: The Brooking Institution, 1982
- Hinnells, JR., *Persian Mythology*, Scarborough (UK): Hamlyn, 1975
- Hinz, W., *The value of the tuman in the middle ages*, in M. Minovi and I. Afshar (eds.) *Yad name-ye Irani-ye Minorsky*, Tehran University of Tehran Press, 1969
- Hooglund, E., *Land and Revolution in Iran, 1960-1980*, Austin: University of Texas Press, 1982
- Hooglund, *The Khwushnishin population of Iran*, *Iranian Studies*, Vol. 6, PP. 229-45, 1973
- Hooper, B., *The Persian regencies: key to politics in the Middle East*, *Foreign Affairs*, Vol. 13, no.2, 1935, PP.295-308
- Humphreys, E., *The Royal Road: A Popular History of Iran*, Essex: Buckhurst Hill, 1991
- Iglesias, E., *Managing the world economy or reshaping world society?*, Paper delivered at the Fifth General Conference of European association of Development Institute, Amsterdam, 1987
- International Commission of Jurists, *Human Right in Iran*, Geneva: ICJ, 1976,
- IPIS, *Nehzat-e Mashrute-ye Iran; Bar Paye-ye Asnad-e Vezarat-e Khareje* (The Constitutional Movement of Iran; Based on the Documents of Foreign Ministry), edited by E. Safa'i, Tehran: IPIS, 1991
- ISC, *Iran's Statistical Yearbook*, (Persian) Tehran: ISC, Various issues, 1955-1979
- ISC, *Iran's Statistical Yearbook; 1993/4*, (Persian), Tehran: ISC, 1995

- Issawi, C. & Yeganeh, M., *The Economics of Middle Eastern Oil*, London: Faber and Faber, 1962
- Issawi, C., Iranian trades, 1800-1914, *Iranian Studies*, V. 16, nos. 3-4, 1983
- Issawi, C., *The Economic History of Iran, 1800-1914*, Chicago: University of Chicago Press, 1971
- Issawi, C., *The Iranian economy 1925-1975: Fifty years of economic development in G. Lenczowski (ed.) Iran Under the Pahlavis*, PP. 129-66, 1978
- Issawi, C., *European Economic Penetration; 1872-1921*, in P. Avery et. al. (eds.) *CHI*, Vol 7, PP 590-608, 1991
- Jamalzadeh, M.A., *Ganj-e Shaygan, Ya Owza-e Eghtesadi-ye Iran* (Abundant Treasure, or the Economic Situation of Iran), Berlin: Kaveh, 1335hg (1916)
- Jazani, B., *Capitalism and Revolution in Iran*, London, 1980
- Kaempfer, E. et. al., (1684-85) edited by W. Hinz, Leipzig, 1940, tran. to Persian by Jahandari, K., *Dar Darbar-e Shahanshah-e Iran*, Tehran: Anjoman-e Asar-e Melli, 1350 hs(1971)
- Kaplan, R.E., Introduction: Why character and leadership? *Journal of Applied Behavioural Science*, Vol. 26, no. 4, PP. 417-22, 1990
- Karanjia, R.K., *The Mind of A Monarch*, London: George Allen & Unwin, 1977
- Karshenas, M., *Oil, State and Industrialization in Iran*, Cambridge: Cambridge University Press, 1990
- Katouzian, H., Nationalist trend in Iran: 1921-26, *IJMES*, Vol. 11, 1979
- Katouzian, H., Problems of political development in Iran, *British Journal of Middle Eastern Studies*, Vol. 22, no. 1-2, 1995
- Katouzian, M.A., Oil versus agriculture, a case of dual resource depletion in Iran, *The Journal of Peasant Studies*, PP.347-69, 1978
- Katouzian, M.A., *The Political Economy of Modern Iran, Despotism and Pseudo-Modernism, 1926-1970*, London: Macmillian, 1981
- Kay, C., *Latin American Theories of Development and Underdevelopment*, London: Routledge, 1993
- Kazemi, F., *The military and politics in E.Kedourie and SG. Haim (eds.) Towards A Modern Iran*, London: Frank Cass, 1980
- Kazemzadeh, F., *Russia and Britain in Persia, 1864-1914: A Study in Imperialism*, New Haven: Yale University Press, 1968

- Keddie, N., Class structure and political power in Iran since 1796, *Iranian Studies*, Vol.11, P. 305, 1978,
- Keddie, N., *Roots of Revolution: an Interpretative History of Modern Iran*, New Haven: Yale University Press, 1981
- Keddie, N., The midas touch: black gold, economics and politics in Iran today, *Iranian Studies*, Vol. X, no. 4, PP. 243-66, 1977
- Kermani, Nazem al-Islam, *Tarikh-e Bidari-ye Iranian* (The History of Iranians' Awakening), 3 Vol., Tehran:1332 (1953)
- Kets de Vries, M.F.R., Leaders on the couch, *Journal of Applied Behavioural Science*, Vol 26, no. 4, PP. 423-31, 1990
- Khadim, M., *The Political Economy of Revolutionary Iran*, Cairo: The American University in Cairo, 1984
- Killick, T., *A Reaction Too Far; Economic Theory and the Role of the State in Developing Countries*, London: Overseas Development Institute, 1989
- Knapp, W., 1921-1941: The period of Riza Shah, in H. Amirsadeghi, *Twentieth Century Iran*, London: Heinemann, 1977
- Kohut, H., *The Analysis of the Self: A Systematic Approach to the Psychoanalytic Treatment of Narcissistic Personality Disorder*, NY: International University Press, 1971
- Koo, H., & Kim, EM., The developmental state and capital accumulation in South Korea, in RP. Appelbaum and J. Henderson, *States and Development in the Asian Pacific Rim*, Newbury Park, CA: SAGE, 1992
- Ladjevardi, H., The origins of US support for an autocratic Iran, *IJMES*, Vol. 15, PP. 225-39, 1983
- Laing, M., *The Shah*, London: Sidgwick & Jackson, 1977
- Lall, S. Is 'dependence' a useful concept in analysing underdevelopment? *World Development*, Vol. 3, no. 11 and 12, 1975
- Lambton, A.K.S., *Continuity and Change in Medieval Persia: Aspects of Administrative, Economic and Social History; 11th-14th Century*, NY: Bibliotheca Persica, 1988
- Lambton, A.K.S., *Landlord and Peasant in Persia, A Study of Land of Tenure and Land Revenue Administration*, London: Oxford University Press, 1953
- Lenczowski, G., *Iran Under the Pahlavis*, Stanford: Hoover Institute Press, 1978

- Lenin, V.I., *Imperialism, the Highest Stage of Capitalism: A Popular Outline*, Peking: Foreign Language Press (new edition), 1969
- Lewis, V., Is oil money spurring real development?, *The Banker*, 126: 883-886, 1976
- Luciani, E., The oil rent, the fiscal crisis of the state and democratization, in G. Salame (ed.) *Democracy Without Democrats? The Renewal of Politics in the Muslim World*. London: I.B. Tauris, 1994
- Luciani, G., Allocation vs production states; a theoretical framework, in G. Luciani and H. Beblawi (eds.), *The Rentier State*, Kent: Croom Helm, 1987
- Luciani, G., *The Arab States*, Kent: Routledge, 1990
- Luxemburg, R., *The Accumulation of Capital*, London: Routledge, (new edition), 1963
- Macdaniel, T., *Autocracy, Modernisation and Revolution in Russia and Iran*, Princeton (NJ): Princeton University Press, 1991
- Maclachlan, K.S., The Iranian economy, 1960-1976, in H. Amirsadeghi (ed.) *Twentieth Century Iran*, London: Heinmann, 1977
- Maclachlan, K.S., Economic development 1921-1979, in P. Avery et. al. (eds.) *Cambridge History of Iran*, Vol. 7 PP.608-38, 1991
- Mahdavi, H., The patterns and problems of economic development in rentier states: the case of Iran, in M.A. Cook(ed.), *Studies in the Economic History of the Middle Eastern*, London: Oxford University Press, 1970
- Majles-e Shuraye Melli (the Parliament), *Karname-ye Majles-e Shoray-e Melli* (The Majles Report), Various Issues, Tehran
- Makki, H., *Tarikhe Bist Saleh-ye Iran* (The History of Two Decades of Iran), 4 Vol., Tehran: Javidan, n.d.
- Malcolm, J. *Sketches of Persia*, London, 1845
- Malcolm, J. *The History of Persia*, 2 V., London, 1829
- Malek, M.H., Capitalism in 19th century Iran, *Middle Eastern Studies*, Vol. 27, no.1, Jan. 1991
- Mandel, E., *Late Capitalism*, London: New Left Books, 1975
- Mann, M., The autonomous power of the state: its origins, mechanism and results, in J.A. Hall, *States in History*, Oxford: Basil Blackwell, 1986
- Marx, K., *Selected Works*, in one Volume, 7th edition, NY: International Publishers, 1980

- Masud-Ansari, A.A., *Pas Az Soghut* (After the Fall), Tehran: Institute for Political Research and Studies, 1993
- Matin-Daftari, A., *Khandaniha* (Readable), Tehran, 5th April 1956
- Matthee, R., Administrative stability and change in late seventeenth-century Iran: the case of shaikh Ali Khan-e Zangane (1669-89), *IJMES*, Vol.26, PP. 77-98, 1994
- Mc. Daniel, R., Economic change and economic resiliency, *Iranian Studies*, V.4, n. 1, 1971, PP.36-49
- Mehner, H., Development and planning in Iran after WW2, in Lenczowski (ed.) *Iran Under the Pahlavis*, Stanford University: Hoover Institution Press, 1978
- Menshari, D., *Education and the Making of Modern Iran*, London: Ithaca, 1992
- Meo. L., *US Strategy in the Gulf: Intervention Against Liberation*, Massachusetts: Association of Arab-American University Graduates, 1981
- Meredith, C., Early Qajar administration: an analysis of its development and functions, *Iranian studies*, Spring-Summer, 1971
- Mills, C.W., *The Power Elite*, NY: Oxford University Press, 1972
- Millspaugh, A., *Americans in Persia*, Washington DC.: The Brooking Institution, 1946
- Ministry of Agriculture, *Mogheyyat va Masaleh-ye Bakhsh-e Keshavarzi Pas As Enghelab-e Eslami* (The Position and Problems of Agricultural Sector After the Islamic Revolution), Tehran, 1983
- Ministry of Information, Iran, Tehran: Ministry of Information, 1971
- Minorsky, V., *Persia: religion and history*, in V. Minorsky, *Iranica: 20 Articles*, Tehran: University of Tehran Press, 1964
- Minorsky, V., *Tazkirat al-moluk: A manual of the Safavid Administration*, Persian text in facsimile (British Museum ms.Or. 9496), translation and commentary, Gibb Memorial Series, n.s. XVI, London, 1943
- Mir Ahmadi, M., *Din va Dolat dar Iran* (Religion and State in Iran), Tehran: Amirkabir, 1369 (1990)
- Mir Ahmadi, M., *Tarikh-e Siyasi va Ejtemai-ye Iran dar Asr-e Safavi* (Socio-political History of Iran During the Safavid Era), Tehran: Amirkabir, 1371 (1992)
- Mirza Rafi'a, *Dastur al-moluk* (The Kings' Order), ed. by Danesh Pajuh, *Majalle-ye Danesh-kade-ye Adabiyat*, Tehran: University of Tehran, nos. 63-70, 1347-48 hs
- Moaddel, M., *Class, Politics, and Ideology in the Iranian Revolution*, NY: Columbia University Press, 1993

- Moghaddam, V., Oil, the state, and limits to autonomy: the Iranian case, *Arab Studies Quarterly*, Vol. 10, no. 2, 1988
- Moghtader, H., The impact of increased oil revenue on Iran's economic development (1973-76) in E.Kedouri and SG. Haim (eds.) *Towards A Modern Iran*, London: Frank Cass, 1980
- Mommsen, W.J., Max Weber and Roberto Michels: an asymmetrical partnership, *European Journal of Sociology*, 22, 1981, PP. 100-116
- Moor Jr., B., *Social Origins of Dictatorship and Democracy: Lord and Peasant in the Making of the Modern World*, Boston: Beacon Press, 1966
- Morgan, D., *Medieval Persia; 1040-1797*, Essex: Longman (Group UK), 1988
- Mories, J., *A Journey Through Persia*, London, 1882
- Mosca, G., *The Ruling Class*, (1896) trans. and ed. H.D. Khan and A. Livingston, NY: McGraw Hill, 1930
- Mottale, M., *Iran: The Political Sociology of the Islamic Republic*, Occasional Paper, Tel Aviv: The Dayan Center for Middle Eastern Studies, 1987
- Moulde, F.U., *Japan, China, and the Modern World Economy: Toward a Reinterpretation of East Asian Development ca. 1600 to ca. 1918*, Cambridge, NY: Cambridge University Press, 1977
- Mousavi, MA., 'The Role of the State in an Oil-Exporting Developing Economy' (University of Manchester, MA Dissertation, 1993)
- Mousavi, MA., *Oil and the state in the political economy of Iran: a comparative study of state's dependence in the periods of 1973-79, 1980-88, and 1989-93*, paper presented to the 14th Annual Conference of CIRA, Coventry, 1996
- Mousavi, MA., *The Shah-elite relations, 1953-79*, paper presented to the BRISMES Annual Conference, Durham, 1995
- Nasr, S.H., Religion in Safavid Persia, *Iranian Studies*, Vol. 7, PP. 271-86, 1974
- Nejati, G., *Jonbesh-e Melli Shodan-e Sanat-e Naft-e Iran va Kudetay-e 28 Mordad-e 1332* (The Nationalization of Oil Industry and the Coup of 1953), Tehran: Enteshar, 1365 (1986)
- Niblock, T., and Murphy, E., (eds.) *Economic and Political Liberalization in the Middle East*, London: British Academic Press, 1992
- Nomani, F., *Takamol-e Feodalism dar Iran* (Evolution of Feudalism in Iran), Tehran: Kharazmi, 1358 (1979)

- Octopus-e Sad Pa* (Octopus With Hundred Tentacles), 1978, n.p., n.a.
- Omid, H., *Islam and Post-Revolutionary State in Iran*, London: Macmillan 1994
- Pahlavi, Ashraf, *Faces in A Mirror: Memoirs from Exile*, NJ: Prentice-Hall, 1980
- Pahlavi, Farah, *My Thousand and One Days: An Autobiography*, trans. F. Harcourt, London: W.H. Allen, 1978
- Pahlavi, Mohammad Reza, *Answer to History*, trans. by M. Joseph, NY: Stein & Day, 1980
- Pahlavi, Mohammad Reza, *Mission for My Country*, NY: McGraw-Hill, 1961
- Pahlavi, Mohammad Reza, *The White Revolution*, 2nd edition, Tehran, 1967
- Pahlavi, Soraya, *The Autobiography of H.I.H. Princess Soraya*, trans. from the German by C. Fitzgibbon, London: Arthur Barker, 1963
- Palma, C., *Dependency: a formal theory of underdevelopment or a methodology for the analysis of concrete situation of underdevelopment? World Development*, Vol. 6, no. 7 and 8, 1978
- Pareto, V., *The Mind and Society*, (1916) trans. and ed. A. Livingston and A. Bongiorno, 4 vols., London: Cape, 1935
- Parker, N., Introduction (1983) in D. Held et. al., *States and Societies*, Oxford: Basil Blackwell, 1990
- Parsons, S.A., *The Pride and the Fall: Iran 1974-1979*, London: Jonathan Cape, 1984
- Parvin, M., *Military expenditure: a forgotten question, Iranian Studies*, Vol. 1, PP. 154-60, 1968
- PBO, *Fourth National Plan 1968-72*, Tehran: PBO, 1973
- PBO, *Iran's Fifth Development Plan 1973-78, Revised: A Summary*, Tehran: PBO, 1975
- PBO, *Outline of the Third Plan 1962-67*, Tehran: PBO, 1966
- PBO, *Summary of the Fifth National Development Plan 1973-77*, Tehran: PBO, 1973
- PBO, *The Budget, 2535 (1976-7); 2536 (1977-8)*, Tehran: PBO
- PBO, *The Fifth National Development 1973-77, Revised Edition*, Tehran: PBO, 1973
- Pesaran, M.H. and Karshenas, M., *Economic reform and the reconstruction of the Iranian Economy, MEJ*, Vol. 49, n.1, PP. 89-111, 1995
- Pesaran, M.H., *The system of dependent capitalism in pre- and post-Revolutionary Iran, IJMES*, Vol. 14, no. 4, PP. 501-22, 1982
- Pesaran, MH., *Economic development and revolutionary upheavals in Iran*, in H. Afshar (ed.), *Iran: A Revolution in Turmoil*, London: Macmillan, PP. 15-50, 1985

- Petras, J. and Brill, H., The tyranny of globalism, *Journal of Contemporary Asia*, Vol. 15, no. 4, 1985
- Petras, J. et. al. (eds.), *Class, State, and Power in the Third World*, Monclair, NJ: Allanheld, Osmun, 1981
- Petras, J., Dependency and world system theory: a critique and new directions, *Latin American Perspectives*, Vol. 8, no.3-4, 1981
- Petrushevsky, 1968, I.P., The socio-economic condition of Iran under the Ilkhans, in J.A. Boyle (ed.), *The Cambridge History of Iran*, V.5, PP. 303-421
- Prebisch, R., *Toward a Dynamic Development Policy for Latin America*, NY: UN, 1963
- Rajab-nia, M., *Sazman-e Eclari-ye Hokumat-e Safaviyeh*, (trans. of Minorsky, 1943, *Tazkirat al-moluk: A Manual of the Safavid Administration*, translation and commentary), Tehran: Amirkabir, 1368 hs (1989)
- Rajaei, F., The social origins of political elites in Iran: a historical review, *The Iranian Journal of International Affairs*, V.6, n.1-2, 1994, PP. 1-27
- Ramazani, R., Iran and the USA experiment in enduring friendship, *MEJ*, Vol. 30, PP.322-34, 1976
- Ravasani, S., *Dolat va Hokumat dar Iran (The Government and the State in Iran)*, Tehran: Bitā, 1991
- Rezun, M., Reza Shah's Court Minister Teymurtash, *IJMES*, Vol. 12, PP. 119-137, 1980
- Rick, T., Power politics and political culture: US-Iran relations, in S.K. Farsoun and M. Mashayekhi (eds.), *Iran, Political Culture in the Islamic Republic*, London: Routledge, 1992
- Ricks, T., Towards a social and economic history of 18th century Iran, *Iranian Studies*, Vol. 6, 1973
- Ricks, T., US military mission to Iran, 1943-1978: the political economy of military assistance, in L. Meo (ed.), *US Strategy in the Gulf, Intervention Against Liberation*, USA: AAUG, 1981
- Roemer, H.R., Comments on R. Savory, the Safavid state and polity, *Iranian Studies*, Vol. 7, no.1-2, PP.213-16, 1974
- Roemer, H.R., The Safavid period, 1986, in P. Jackson (ed.) *The Cambridge History of Iran*, Vol.6, PP.189-351, Cambridge: Cambridge University Press, 1986

- Roosevelt, K., *Countercoup: The Struggle for the Control of Iran*, NY: McGraw-Hill, 1979
- Rosenthal, EI., The role of the state in Islam: theory and the Mediaeval practice, paper presented to the Colloquium on Tradition and Change in the Middle East, Harvard, 1968
- Safa'i, E., *Reza Shah dar Ayine-ye Khaterat* (Reza Shah from the Mirror of Memories), Tehran, 1976,
- Safa'i, E.,(ed.) *Barghaye Tarikh* (Pages of History), Tehran: Sharq, 1350 (1971)
- Saikal, A., Iranian foreign policy, 1921-1979, in CHI, Vol. 7, 1991
- Saikal, A., *Rise and Fall of the Shah*, Princetone: Princeton University Press, 1980
- Samimi, M., *Behind the Peacock Throne*, (trans.), Tehran: Ettela'at, 1372 (1993)
- Sani' al-Doleh, M.H.K., *Mer'at al-Boldan-e Naseri* (Naseri's Cross-Country Observations), 1877-1882, 4 Vol., Tehran: Government Press, n.d.
- Savory, R.M., *History of Shah Abbas*, (trans of , Eskandar Beig Monshi, *Tarikh-e Alam ara-ye Abbasi*, 1616 & 1626), 2 Vol., Boulder (USA): Westview Press, 1978
- Savory, R.M., Notes on the Safavid state, *Iranian Studies*, Vol. 1, no.3, PP.96-103, 1968
- Savory, R.M., The Safavid administrative system, 1986, in P. Jackson (ed.) *The Cambridge History of Iran*, Vol. 6, Cambridge: Cambridge University Press, 1986
- Savory, R.M., The Safavid state and polity, *Iranian Studies*, Vol. 7, no. 1-2, PP.179-212, 1974
- SFIL, *Asnad-e Lane-ye Jasusi* (The Documents of Spy Den), Tehran: SFIL, 1980
- Sha'bani, R., *Mabani-e Tarikh-e Ejtemai-ye Iran* (Principles of Social History of Iran), Tehran: Ghums Press, 1371 (1992)
- Shaji'i, Z., *Nemayandegan-e Majles-e Shura-ye Melli Dar Bisto Yek Doreh-ye Ghamungozari* (The Majles Deputies in 21 Sessions), Tehran: University of Tehran, 1342 (1963)
- Sharh-e oyub va alaj-e navaghes-e mamlekati-ye Iran* (Explanation of problems and solutions of the Iranian government's shortcomings), National Library of Iran, 1275hg, n.p., n.a.
- Sheikholeslami, A.R., The patrimonial structure of Iranian bureaucracy in the late nineteenth century, *Iranian Studies*, Vol.11, PP. 199-258, 1978
- Sheikholeslami, A.R., The sale of offices in Qajar Iran, 1858-1896, *Iranian Studies*, Vol. 4, Spring-Summer 1971

- Sheikholeslami, AR., Administration in Iran: the Pahlavi period, 1925-79, *Encyclopedia Iranica*, Vol. 1, PP. 466-70, 1982
- Siaghi, MD., *Tazkirat Al-Muluk* (The Guidance of Kings), Circa. 1725 (1137 hg), edited, Tehran: Amirkabir, 1368 (1989)
- Sick, G., *All Fall Down, America's Tragic Encounter with Iran*, NY: Random House, 1985
- Skocpol, T., Bringing the state back in: strategies of analysis in current research, in P. Evans, et. al. (eds.), *Bringing the State Back In*, Cambridge, NY: Cambridge University Press 1990, PP. 3-43
- Skocpol, T., France, Russia, China: a structural analysis of social revolutions, *Comparative Studies in Society and History: An International Quarterly*, 1976, Vol. 18, no. 2 PP. 175-210
- Skocpol, T., Rentier state and Shi'i Islam in the Iranian revolution, *Theory and Society*, Vol. 11, no. 3, 1982
- Sodagar, R., *Roshd-e Ravabet-e Sarmaye Dari dar Iran; Marhale-ye Gostaresh* (The Development of Capitalist Relation in Iran), Tehran: Andisheh, 1369 (1990)
- Springborg, P., The contractual state: reflections on Oriental despotism, *History of Political Thought*, Vol. viii, no. 3, winter 1987, PP. 395-433
- Stauffer, A., Income Measurement in Arab states, in G. Luciani and H. Beblawi (eds.), *The Rentier State*, Kent: Croom Helm, 1987
- Stauth, G., *Iran: Precapitalism, Capitalism and Revolution*, Germany: V. Breitenbach, 1980
- Stepan, A., *The State and Society: Peru in Comparative Perspective*, Princeton, NJ: Princeton University Press, 1978
- Stevens, R., European visitors to the Safavid court, *Iranian Studies*, Vol. 7, no.1-2, PP.421-57, 1974
- Sullivan, W.H., *Mission to Iran*, NY: W.W. Norton & Co., 1981
- Supple, B., State and the industrialisation 1700-1914, in C.M. Cipolla (ed.), *The Industrial Revolution 1700-1914, The Fontana History of Europe*, Hassocks Harvester Press, 1976
- SWB, Reports 11-22 February, London: BBC World Service, 1979
- Tavanayanfard, H., *Tote 'ehaye Amperyalism dar Iran*, (The Conspiracies of Imperialism in Iran), 2 V., Tehran: Ketab, 1985

- Tavernies, J.B., *Les Six Voyages, Qu'il a fait en Tuqui, en Perse et aux Indes*, Paris, 1681, tran. to Persian by A. Nuri, ed. H. Shirani, *Safarname-ye Tavernies*, Tehran, 1336 hs (1957)
- Tilly, C., *As Sociology Meets History*, NY: Academic Press, 1981
- Tilly, C., *The Formation of National States in Western Europe*, Princeton: Princeton University Press, 1975
- Tolu'i, M., *Pedar va Pesar* (The Father and the Son), Tehran: Elm Press, 1994
- Trimberger, E.K., *Revolution From Above: Military Bureacrats, and Development in Japan, Turkey, Egypt and Peru*, New Brunswick: Transaction Books, 1978
- Tullock, G., *The Politics of Bureaucracy*, Washington DC: Public Affairs Press, 1965
- Tully, A., *CIA: The Inside Story*, NY: Willam Morrow, 1962
- Turner, B.S., *Capitalism and feudalism in Iran (1502-1979)*, in Stauth, G. (ed.), *Iran: Precapitalism, Capitalism and Revolution*, Germany: V. Breitenbach, 1980
- US Embassy, *Decision-Making in Iran, July 22, 1976*, reprinted in FSIL, Vol. 7, Tehran: FSIL, n.d.
- US House of Representative, *Iran: Evaluation of US Intelligence Performance Prior to November 1978*, staff report, Subcommittee on Evaluation, Permanent Select Committee on Intelligence, January 1979
- US Senate, *US Military Sale to Iran*, staff report to the Subcommittee on Foreign Assistance of the Senate Committee on Foreign Relations, 94th Congress. sess. 2, Washington: Government Printing Office, 1976
- Velayati, A.A., *Tarikh-e Ravabet-e Khareji-ye Iran; Mashruteh* (The History of Foreign Relations of Iran: The Constitutional Revolution), Tehran: IPIS, 1992
- Vincent, A., *Theories of the State*, New York: Basil Blackwell, 1987
- Warren, B., *Imperialism: Pioneer of Capitalism*, London: New Left Book, 1980
- Weber, M., *From Max Weber: Essays in sociology*, H.Gerth and C.Wright Mills (trans. and edited.) NY: Oxford University press, 1946
- Weber, M., *Economy and Society*, trans. G.Roth & edited by G. Roth & C. Wittich, 3 Vol., NY: Bedminster Press, 1968
- Weber, W., *The Protestant Ethic and the Sprit of Capitalism*, trans. by Chavy, London: Allen and Unwin, 1964
- Weinbaum, MG., *agricultural policy and development politics in Iran*, *MEJ*, Vol. 10, 1977

- Weiser, B., Behind Israel-Iran sales, US, *Washington Post*, 16 August 1987
- Wilber, D., Riza Shah Pahlavi The Resurrection and Reconstruction of Iran, NY: Exposition Press, 1975
- Wislon, R., Economic Development in the Middle East, London: Routledge, 1995
- Wittfogel, K.A., Oriental Despotism: A Comparative Study of Total Power, New Haven: Yale University Press, 1957
- Worsley, P., One world or three? a critique of the world-system theory of Immanuel Wallerstein, in D. Held et. al. (eds.), *States and Societies*, Oxford: Basil Blackwell, 1990
- Yaghub Khan, Mirza, *Tarhe arize-i ast ke be khak-e pa-ye mobarak bayad arze shavad* (a letter to Naser al-Din Shah), 1290hg, in F. Adamiyat and H. Nategh, *Afkar-e Ejtema'i va Siyasi va Eghtesadi dar Asar-e Montashernashode-ye Doran-e Qajar* (Social, Political, and Economical Thoughts in the Unpublished Material of Qajar Era), Tehran: Agah, 1356 (1977)
- Yapp, M.E., *The Near East Since the First World War*, Essex: Longman, 1991
- Yarshater, E., Forward to R. Savory, *History of Shah Abbas*, Vol. 1, Boulder (USA): Westview Press, 1978
- Yeganeh, M., The 1954 oil agreement, in B. Mostofi et. al. (eds.) *The Development of the Iranian Oil Industry 1954-1973*, London: SOAS, 1991
- Yusef Bin-Hasan, M. (Mostowfi al-Mamalek), *Dastur al-amal-e velayat* (Provincial Regulations), 1293hg, Tehran: University Library of Tehran, in Adamiyat, PP.449- 453, 1356 (1977)
- Zibakalam, S., *Moghaddamehi Bar Enghelab-e Eslami* (An Introduction to the Islamic Revolution), Tehran: Rozaneh, 1372 (1993)
- Zirinsky, M.P., Imperial power and dictatorship: Britain and the rise of Reza Shah, 1921-1926, *IJMES*, Vol. 24, 1992, PP. 639-663
- Zonis, M., *Majestic Failure, The Fall of the Shah*, Chicago: The University of Chicago Press, 1991
- Zonis, M., *The Political Elite of Iran*, Princeton: Princeton University Press, 1971
- Zonis, M., The political elite of Iran: A second stratum? in F. Takau (ed.) *Political Elites and Political Development in the Middle East*, NY: John Wiley, 1975

