

Durham E-Theses

Tool selection and rationalisation

W.G. Keating

How to cite:

Keating, W.G. (1996) Tool selection and rationalisation. Masters thesis, Durham University.

Use policy

The full-text may be used and/or reproduced, and given to third parties in any format or medium, without prior permission or charge, for personal research or study, educational, or not-for-profit purposes provided that:

- a full bibliographic reference is made to the original source
- a <https://etheses.durham.ac.uk/id/eprint/5305/> is made to the metadata record in Durham E-Theses
- the full-text is not changed in any way

The full-text must not be sold in any format or medium without the formal permission of the copyright holders.

Please consult the [full Durham E-Theses policy](#) for further details.

Tool Selection and Rationalisation

by

W. G. Keating BEng., MSc(CIT)

The copyright of this thesis rests with the author. No quotation from it should be published without the written consent of the author and information derived from it should be acknowledged.

A thesis submitted for the degree of

Masters of Science

by research

School of Engineering

University of Durham

April 1996



10 OCT 1997

Abstract

The work presented in this thesis is concerned with the selection of tooling and operating conditions for turning, and the subsequent rationalisation of these tooling and operating conditions.

There are five main levels of tool selection namely; operation, component, machine, multi-batch, and shop floor and tool store. Each level is analysed using different manufacturing paradigms and taking into consideration various objectives of tool selection.

Detail work is presented apropos of tool selection at the operation and component levels with proposals on how the other levels will form part of the overall selection systems. The concept of Tool Resource Structure is presented and proposals on how it should be an integral part of any Manufacturing Planning and Control system.

Various methods and a computer based system were developed for tool selection and rationalisation. These include; a geometry and heuristic module for selection at the operation level, a technology module that further optimises the tooling and cutting conditions, and a component module that performs rationalisation at the component level.

A number of examples are presented to describe the functionality of the tool selection and rationalisation system. The results of the computer based testing of the software were encouraging.

Acknowledgements

I would like to express my thanks to my supervisor Dr. P. G. Maropoulos for his help and patience throughout this process. I did it!

Special thanks to Professor J. E. L. Simmons for his encouragement and belief in my ability. I am not finished yet!

Thanks to Hugh Knox for his constant support and his practical approach to problems. We both have learned more than what is in this thesis?

Dedication

Wa'ed and Oisín Hamzah

Statement of Copyright

The copyright of this thesis rests with the author. No quotation from it should be published without his prior written consent and information derived from it should be acknowledged.

Declaration

No material from this theses has previously been submitted for a degree at this or any other university.

Table of Contents

CHAPTER 1	1
INTRODUCTION	1
CHAPTER 2	8
LITERATURE REVIEW	8
CHAPTER 3	17
TOOL SELECTION LEVELS	17
3. INTRODUCTION	17
<i>3.1 Definition Of Tool Selection</i>	<i>17</i>
3.1.1 Operation Level.....	17
3.1.2 Component Level	17
3.1.3 Multi-batch Level	18
3.1.4 Multi-machine Level.....	19
3.1.5 Shop Floor and Tool Stores Level	19
<i>3.2 Tool Selection Under Different Manufacturing Paradigms</i>	<i>19</i>
3.2.1 Process Based	20
3.2.2 FMS Cell.....	24
3.2.3 Cellular Based	26
3.2.4 Transfer Lines	28
<i>3.3 Conclusion</i>	<i>31</i>
CHAPTER 4	32
OPERATIONS PLANNING AND TOOL RESOURCE STRUCTURE	32
4. INTRODUCTION	32
<i>4.1 Manufacturing Resource Planning (MRP11)</i>	<i>34</i>
4.1.1 Front End.....	35

4.1.2 Engine.....	35
4.1.3 Back End	37
4.2 <i>Operations Planning and TRS Within the MRP11 Structure</i>	37
4.2.1 Computer Aided Design Link	39
4.2.2 Computer Aided Process and Operation Planning Link	40
4.2.3 Operations File	40
4.2.4 Tool Inventory	41
4.2.5 Tool Resource Structure Module.....	41
4.2.6 Timed-phased Operation Plans	42
4.2.7 Routing File.....	43
4.2.8 Bills of Material.....	43
4.2.9 Timed-phased Requirements Planning.....	44
4.2.10 Material, Tooling and Capacity Plans.....	44
4.3 <i>Conclusions</i>	44
CHAPTER 5	45
TOOL SELECTION SYSTEM	45
5. INTRODUCTION.....	45
5.1 <i>Tool Selection System - General Description</i>	45
5.2 <i>Geometry and Heuristic Module (TVRO_G)</i>	47
5.3 <i>Technology Module (TVRO_T)</i>	49
5.4 <i>Component module (TVRO_C)</i>	49
5.5 <i>Multi-batch module (TVRO_MB)</i>	51
5.6 <i>Multi-machine module (TVRO_MM)</i>	51
5.7 <i>Shop floor and tool stores module (TVRO_ST)</i>	52
CHAPTER 6	53
GEOMETRY AND HEURISTIC MODULES	53
6. INTRODUCTION.....	53
6.1 <i>Programme Initialisation</i>	53
6.1.1 Job Identification.....	54

6.1.2 Definition of the Operation	54
6.1.3 Preferred locking system.....	55
6.1.4 Finish, medium or rough cut and total depth of cut	55
6.1.5 Type of material to be machined and insert grade.....	56
6.1.6 Selection of machining profile.....	58
6.1.7 Line function	60
6.1.8 Arc function	61
6.1.9 Element test	61
6.1.10 Element test for lines	63
6.1.11 Lines in right to left machining (external).....	64
6.1.12 Lines in left to right machining (external).....	70
6.1.13 Lines in right to left machining (internal).....	73
6.1.14 Lines in left to right machining (internal).....	76
6.1.15 Element test for arcs.....	77
6.1.16 Arcs in right to left machining (external).....	78
6.1.17 Arcs in left to right machining (external).....	86
6.1.18 Determine maximum approach and trailing angles.....	86
6.2 Heuristic Tool and Cutting Data Selection Module	86
CHAPTER 7	90
TECHNOLOGY MODULE.....	90
7. INTRODUCTION.....	90
7.1 Depth Of Cut And Feed Rate Calculations.....	90
7.1.1 Finishing operations.....	90
7.1.2 Roughing operations.....	91
7.1.3 Cutting forces.....	92
7.1.4 Force constraints	92
CHAPTER 8	99
TOOL RATIONALIZATION.....	99

8. INTRODUCTION.....	99
8.1 Rationalization System.....	101
8.2 Rationalization at the Operation Level - TVRO_T.....	101
8.2.1 Detail Description of TVRO_T.....	104
8.3 Rationalization at the Component Level - TVRO_C.....	107
8.3.1 Detail Description of functionality	108
CHAPTER 9	116
EXAMPLES, RESULTS AND DISCUSSION	116
9. INTRODUCTION.....	116
9.1 Graphics and Heuristic Modules In Operation.....	116
9.1.1 Medium Roughing of a Profile - Operation Level.....	117
9.1.2 Multiple Operations Planning - Component Level	123
9.2 Technology and Rationalisation Modules In Operation.....	127
CHAPTER 10	138
CONCLUSIONS AND RECOMMENDATIONS	138
REFERENCES	142
APPENDIX	146

Chapter 1

Introduction

The task of tool selection and the definition of associated cutting conditions are essential parts of “operations planning” [1]. Over the last century operations planning has attracted a sizeable interest both from industry and academia. In considering anything remotely concerned with tooling one cogitates the works of Frederick Winslow Taylor, viewed by many as “the father of metal cutting”. In his 1906 presentation to the 27th Annual Meeting of the American Society of Mechanical Engineers, entitled, “The Art of Cutting Metals” [2], he remarked that:

“There are three questions which must be answered each day in every machine shop by every machinist who is running a metal-cutting machine, such as a lathe, planer, drill press, milling machine, etc., namely: What tool shall I use? What cutting speed shall I use? What feed shall I use?”

A lot has changed in the tooling domain since the presentation of this “monumental piece” of work, but the same questions need answering. Even though the responsibility of selecting the above mentioned parameters has in general, been removed from the machinist and made the responsibility of the process and operation planning personnel, the same questions must be answered. Because these personnel are removed from the shop floor the answering of these questions becomes more of a problem, and in essence the problem requires more attention as they may not be fully aware of the full operational characteristics of the machine tools. Even though in general, process and operation planning personnel have ‘come up through the shop floor’, the length of time they are away from the machines may lessen their direct knowledge related to the characteristics of the machine tools.

It is also worth quoting Frank B. Gilberth “a disciple of Taylor, the founder of Motion and Time Study”:

“Much toward standardising the trades had already been done. In this as in almost countless other lines of activity the investigator turns to the work of Frederick W. Taylor. It is a never-ceasing marvel concerning this man that age cannot wither nor custom stale his work. After many weary day’s study the investigator (Gilbreth) awakens from a dream of greatness to find that he has only worked out a new proof for a problem that Taylor has already solved.”

Subsequently the work described herein will not subscribe to the field of metal cutting other than to develop a system, using current information technology, that will aid in the selection and rationalisation of tooling and cutting conditions. The process of selection of both tooling and cutting conditions in industry is currently very much a manual activity that allows for process planners, with varied experiences, proposing different solutions for the same problem.

Chapter 2 outlines the current thinking in the field of tool and cutting data selection. It was not for another half a century after Taylor’s presentation before computers were considered for the selection of operating conditions. All the work to date is concerned with the selection of tooling and cutting parameters for either a single operation or a number of operations with respect to one component - which is acceptable when manufacturing under the philosophy of large batch sizes and high inventories. In contrast, today’s industries are working towards the implementation of Just in Time (JIT) philosophy, and aiming at carrying the minimum amount of stock necessary. Subsequently, batch sizes are generally on the decrease, and the ratio of machining time to set-up time per batch is reducing. This ratio is of even greater concern when batch sizes of one are becoming a common occurrence. Because of this, it is essential that a machine is 'geared-up' for a specified time span, with a wide variety of components of varying batch sizes and material using the minimum number of tools that is considered economical. This would mean machining a number of different batches at sub-optimum conditions because the set-up time for the optimum tooling may prove uneconomical for a particular multi-batch situation.

This new approach to tool selection brings with it problems such as; component material/insert compatibility, operating under sub-optimum conditions, and the economics of operating under such conditions. The machining of dissimilar materials generally calls for different tooling and cutting parameters. Manufacturing engineers will face the problem of determining whether it would be practical and economical to use a limited number of tools to machine a wide range of materials. Thus, a decision support system is required to suggest to the engineers whether the use of sub-optimum tooling is both practical and subsequently economical. The importance of such a system can be demonstrated in the following example. Suppose there are ten batches of 'one-off' which consist of one set-up each totalling 12 mins. This would account for 2hrs per shift - assuming all ten batches can be completed. At £6.74 per hour labour rate, this would cost £13.48 per shift. Running at 333% overhead recovery rate this would account for a loss in overhead recovery of £45 per shift; £225 / week / machine; £1000 / month / machine; £12000 / year / machine. Consider this is occurring on ten machines. This would account for a loss in overhead recovery of £120,000/yr. - roughly the cost of a medium sized CNC lathe.

In general, such a tool selection system will consider a number of different "operation plans". Each batch of components will have a set of defined tooling and operating parameters that will be optimum for that particular set-up. What the system will do is recommend the most practical and economical solution for a defined set of batches over a defined time span. The overall objective should be to reduce the number of set-ups and consequently see an increase in the ratio of machining time to set-up time.

Chapter 3 presents in detail the various tool selection levels and shows how each is influenced by any of the others. Tool selection is categorised into five main levels;

- Operation level
- Component level
- Machine tool level
- Multi-machine level, and
- Shop floor and tool stores level.

The operation level is concerned with the optimal selection of tooling and cutting conditions for a single cutting operation. The second level of tool selection is concerned with a component containing a number of different operations to be completed on one machine tool. In this situation sub-optimum tooling and cutting conditions may be required. Sub-optimum selection may be dictated by the number of tool positions available on the machine and this is the case when complex parts are machined using CNC machine tools. These sub-optimal conditions would be off-set by the increase in the ratio of machining time/set-up time. The third level is concerned with the production of a number of different components of various batch sizes and of different material all requiring to be machined on one machine tool. The complexity of this level is further increased by the variety of different materials that may need to be machined. Besides the use of sub-optimum cutting conditions there is also the possible sub-optimum use of inserts, that is, not using the optimum grade of insert for a specific material. The multi-machine level is concerned with rationalising tooling and assists in producing the Tooling Resource Structure for the components planned within a defined time span. The final level is concerned with the tool management aspect of tool selection. It defines the overall tool requirements and helps in the effective and efficient allocation and distribution of tools to machining resources.

Chapter 4 discusses the relationship between process / operation planning and the new concept of tool resource structure. Process planning is the 'bones' of defining the manufacturing process while operation planning is about putting 'meat' on those 'bones'. Operations planning is concerned in detailing each individual operation of the process plan for a component and involves the detail selection of tooling and the optimum operating conditions. Again this process requires a considerable amount of time and knowledge and is usually performed by someone with several years experience working in the particular process environment. A number of systems are available to aid the operations planner in the appropriate selection of tooling and cutting conditions, for example, Numerical Control machining software. These systems are still rather primitive in many ways and require a considerable amount of human intervention. Generally they have only taken the repetitive tasks away from the planner who requires the same level of

experience to perform his function. What is now required, is an operation planning system, which is part of a Computer Aided Process Planning (CAPP) system, and is capable of interpreting the process plan of a component and automatically determining the appropriate tooling and operating conditions. With this capability and a dynamic link with the Manufacturing Requirement Planning (MRP11) system, the advantages of creating an operations database are enormous. One of the main advantages is that it will aid manufacturing personnel to effectively plan their tooling requirement based on product requirements.

Tool requirement planning using a Tool Resource Structure (TRS) module would be responsible for the effective optimisation of operation plans as well as the planning and scheduling of tooling for a defined product demand. The TRS module would rely heavily on the Computer Aided Design (CAD) and CAPP modules to define the Bill of Materials (BOM), and the process and operation plans. It will also be dependent on the information received from the timed-phased requirement records of the MRP11 system and detailed records of tooling inventory. With the effective integration of CAD, CAPP, TRS and MRP11 the design and manufacturing link will be complete. In addition to the generation of the timed-phased requirement records for raw material, manufactured components and purchase items, TRS will produce a timed-phased operations plan that will contain the most effective set of tooling requirements.

Chapter 5 presents a general description of the tool selection system. It consists of six modules;

- Geometry module (TVRO_G) - used at the operation level;
- Cutting technology module (TVRO_T) - used at the operation level;
- Component module (TVRO_C) - used at the component level;
- Multi-batch module (TVRO_MB) - used at the multi-batch level;
- Multi-machine module (TVRO_MM) - used at the multi-machine level;
- Shop floor and tool stores module (TVRO_ST) - used at the shop floor and tool stores level.

Only the first three modules have been coded as part of this work.

Chapter 6 discusses the geometry and heuristic modules. The system is implemented using AutoCAD/AutoLisp. AutoCAD is a Computer Aided Design/Drafting application package capable of running effectively on 386DX machines upwards. AutoLisp is the built-in programming language of AutoCAD and is an implementation of the Lisp paradigm.

In using AutoCAD as the development tool there is no requirement to rewrite the graphics interface. AutoCAD allows access to its database via the AutoLisp programming language and this will advantageously help in the manipulation of any drawing. Additionally, by using AutoLisp as the programming language one minimises the problems of interfacing, as would not be the case in interfacing independently developed pieces of software. AutoCAD also allows for interfacing with dBase and Lotus, and has a C-language programming environment for developing AutoCAD applications.

The module is capable of selecting tool holders, on a geometric basis, for;

- right -> left external turning (linear elements);
- left -> right external turning (linear elements);
- right -> left external turning (arc elements);
- left -> right external turning (arc elements);
- right -> left internal turning / boring (linear elements); and
- left -> right internal turning / boring (linear elements).

The chapter also has the heuristics technology module of the graphics system. The module is programmed in AutoCAD/AutoLISP and recommends, the speed, feed, and depth of cut for a given operation. It's main purpose is to select at a heuristic level the appropriate cutting conditions.

Chapter 7 discusses the theoretical technology module for cutting data calculations. The module is programmed in Visual Basic. It interprets the information from the graphics

and heuristic based technology modules and performs a number of tests concerning the constraints of a machining operation.

Chapter 8 discusses the tool variety reduction. It presents the remaining levels of tool selection and describes in detail tool rationalisation at the component level.

Chapter 9 describes a number of examples which show the functionality of the various modules. Chapter 10 concludes on the work performed and gives recommendations for further research.

Chapter 2

Literature Review

Much academic work has been performed in the development of systems to aid manufacturing personnel in the optimum selection of cutting conditions. The earliest record of the use of computers in the optimum selection of machining conditions, which has been possible to locate, are those of Weill (3) in 1962: "The use of electronic computers for the determination of optimum cutting conditions", and of Ham (4) in 1962-63; "Economics of machining: analysing optimum machining conditions by computers." Other early work - without the use of computers - include that of Brewer (5), Brierley and Seikmann (6), Brewer (7), Wu and Ermer (8), Ermer and Wu (9), Crookall (10), and Bartalucci, Bedini and Lisini (11).

Bomoswani (12) considered the use of computers in the optimisation of machining parameters and stated:

"There is a growing tendency on the part of research workers to use electronic computers to optimise machining conditions."

That was in 1968, but twenty years later and relatively little has been adopted in industry. Bomoswani considered a simple cylindrical turning operation and used three criteria for the optimisation of cutting conditions, namely; maximum production, minimum total cost /piece, and maximum profit rate. Ten feeds and speeds are chosen and the total depth of cut is assumed to be taken in a single pass and two passes. For each combination of speeds and feeds the following are computed; power required, temperature due to cutting, and maximum profit rate. If power, temperature, vibration and chatter are not violated then the total cost, maximum production and maximum profit is calculated for each combination of feeds and speeds. From this the optimum cutting conditions are selected. The concern with such a system is that it is dependent on the sensitivity of data.

Bartalucci et al (13) have researched the problem of optimum machining conditions “from a general point of view, trying to determine the optimum machine tool and the optimum set of values for cutting speed, feed and number of cuts, which minimise the machining cost on this machine.” Their argument is that machine tools are often badly utilised and “the full power is very seldom absorbed during the cutting time”. In addition, the time of effective utilisation is often a small percentage of the machining cycle, “this produces an unnecessary increase of the invested capital, which augments the cost of the products and aggravates the factory financial situation.” Rather than investigate the maximum production rate obtainable, this work assumes a production rate and obtains the optimum machine tool and subsequently obtains the optimum cutting conditions using the minimum cost criterion. The argument for using the minimum cost criterion is; “the solution is evident because it brings us to identify a machine having a power corresponding to the maximum production cutting speed.”

Iwata et al (14) consider the probabilistic approach to the determination of operating conditions. The concept of dynamic programming and stochastic programming is used for simultaneously determining the optimum values of the cutting speed, feed, depth of cut and the number of passes.

Etin et al (15) were concerned with the selection of cutting tools for optimum machining by considering the workpiece and tool characteristics. Use is made of a descriptor language that defines the characteristics of the workpiece and tool, and for each elementary operational surface a cutting tool is selected.

Petropoulos (16) discusses the use of geometric programming - a non-linear programming technique - in the problem of unit cost optimisation and the subsequent determination of the optimal values of cutting speed and feed rate in turning, with cutting power and surface roughness as the forced constraints. This approach deals with the problem of minimising non-linear objective functions, subject to inequality constraints of a certain type and maximising product functions, the dual functions, subject to certain linear constraints. The original minimisation problem, called primal programme, is

transformed to a maximisation problem, termed dual programme, and this greatly simplifies the numerical solution of the optimisation problem.

Regarding the objective function as the unit cost equation and the inequality (lack of equality in magnitude) constraints as cutting power and surface roughness, the unit cost is minimised - using primal programming - and a range of coefficients obtain values. These values are used in the dual programme where the minimisation problem is turned into a maximisation problem subjected to linear constraints. Finally, the optimal value of the unit cost is calculated and subsequently the optimum cutting conditions operating under this cost. The only constraints considered were the maximum cutting power available and the surface roughness required. No consideration was made of the maximum cutting force permitted by the rigidity of the machine tool and accuracy required; the rigidity of tooling; the maximum feed rate and rotational speed available from the machine tool.

Optimisation of operating conditions in multi-pass operations is considered by Iwata et al (17) and Kals et al (18). Either the minimum production or maximum production rate criterion is selected for optimisation. Limits associated with the lathe and tool, and the constraints imposed by the requirements associated with product accuracy and surface finish are taken into consideration.

Kals and Hijink (19) discuss the development of a computer program for the calculation of optimum values of the machining variables in "multi-cut" turning operations. An optimisation criterion can be selected for minimum production costs and maximum production rate. The program has been used for determining the influence of the lathe specifications and accuracy demands on machining costs. The optimisation conditions can be considered as time consuming since the appropriate tools must be entered. The system is not capable of selecting the tools - therefore it has no real geometrical capabilities.

Wysk, Davis and Agee (20) presented a mathematical model for use in the selection of optimum machining parameters. The model developed considers probabilistic tool life

and the possibility of a catastrophic tool failure. It is argued that the task of selecting operating conditions can be formulated in accordance with any of the main production criteria where it is believed that they are an “oversimplification of the problem”. For instance, tool life is usually assumed to be deterministic, and occurrences such as catastrophic tool failure are generally excluded from the formulation. The paper presents “a formulation of the machining parameter selection problem in a context which is consistent with both recognised variability of tool life and the probability of tool failure. The relevant tool life equations are presented with all the refinements and additional variables that have been incorporated over the years since F. W. Taylor presented his first published work on tool life stating his well known equation.

It is argued that it is possible to believe that great advances have been achieved in the accuracy and utilisation of such deterministic equations. Unfortunately, it is concluded that this is not the case due to two major reasons:

- “The probabilistic nature of tool life”; and
- “The lack of experimental machining data upon which a rigorous regression analysis can be performed to define the form of the tool life model.”

The time required to recover from a catastrophic tool failure has been added to the minimum production time optimisation model, and is considered a function of speed, feed and depth of cut. As with most research the same optimisation criteria are used while in this case there is the added feature of the probabilistic nature of tool failure. No geometrical capabilities are presented and the selection of the required tooling is not considered.

An optimisation technique that considers machining conditions, machining constraints, and tool replacement strategy is proposed by Zdeblick et al (21) where a probabilistic approach is used in determining the optimal machining conditions and tool replacement intervals. Optimisation of the machining process has generally concerned itself with the direct machining costs. This paper argues that process feasibility and reliability have

become important from an overall manufacturing system viewpoint. The work takes into consideration the part and process oriented constraints, premature tool failures, overall process variability and the time-varying behaviour of machining.

Hinduja et al (22) present a procedure that calculates the optimum cutting conditions using minimum cost and maximum production criteria as the objective functions. The procedure additionally allows for multi-pass operations. For a given operation set-up, the search for the optimum is limited to feed versus depth of cut. Constraints used include power availability, workholding, surface finish and component accuracy.

Wang and Wysk (23) start by discussing the techniques available for machining data selection that are summarised as follows:

- Data retrieval methods
- Optimisation mathematical methods
- Empirical methods

The data retrieval method is basically a database of machining data for a selection of different combinations of materials, tools and operations. This data may be stored in handbook form or in a computerised database. In a computerised form, the operator indicates what component material, tool and operation is required and the system outputs the recommended cutting conditions. The stated disadvantages of such a system are:

- It requires a large amount of memory space for storing data; and
- The data it supplies is often too conservative and not optimal.

The optimisation methods employ three different objective functions, namely;

- minimise production cost
- minimise production time, and
- maximise total profit.

The major problems that are associated with this approach include:

- The number of model coefficients and variables. It usually takes a considerable database and then CPU time to generate a solution.
- It is only applicable to a number of machining operations, namely, turning, boring, drilling and reaming.
- Also, it has been stated that, for certain operations using high-speed steel tooling, the minimum and maximum cost may vary less than ten percent over all practical feeds and speeds.

The conclusion reached is that much time and effort should not be spent on optimisation of cutting data. The system is known as the ESMDS, that is, Expert System for Machining Data Selection. The following are the main components of ESMDS.

- Empirical equations are employed for operations which have been well investigated and concluded.
- A database has been constructed to cater for those operations which lack sufficient equation forms.
- An extensive knowledge base was compiled. It is claimed that this covers all of the common operations, materials and machine tools.
- A forward-reasoning scheme was adopted.
- The system, it is claimed, can provide efficient machining data in response to different user specified tool lives.

The system does not recommend the tool as it is assumed that the planners will perform this task. If this is the scenario, then such a system is not capable of performing the selection of the optimum tooling and therefore it is left to the experience of the planners who may not be consistent in their choices. It is claimed that an extensive knowledge base was compiled covering the most common operations, materials and machine tools. However, the data stored in this system is only valid for tool life ranges of 10-60 mins and the use of empirical equations do not generate optimal cutting conditions. There is no indication of the system being applied and tested in industry. Finally, ESMDS- according to the paper - does not take into consideration parameters such as weight of the component, dimensions, rigidity of the machine, component and tool.

In 1991, Maropoulos and Hinduja (24) published a paper concerned with the automatic selection of tooling and cutting conditions for rough turning. The basic outline of the system is:

- It selects the optimum tools for rough turning operations performed on a CNC centre.
- It assumes that the type of operation required and the area to be rough machined are defined.
- The system determines automatically the tools which can generate the required geometry.
- When no single tool can machine the entire area, pairs of tools are formed and the system generates the exact area each tool will machine.
- The selection procedure is based on calculating the optimum cutting data for the first and last pass of a multi-pass roughing operation taking into account the main process constraints namely power and work-holding.
- An additional function establishes the optimum number of tools for machining complex areas which include recesses. This function is known as “geometrical decoupling” and assists in avoiding a sub-optimum solution which is forced by geometric considerations.
- It is claimed that the system has been successfully tested for a large number of turned components of any geometric and production complexity.
- It is also claimed that the tools which result in the minimum machining cost have been supplied in a fast, accurate and efficient way.

Maropoulos and Hinduja (25) presented a paper in 1990 that considers the selection of tooling and operating conditions for finish turning performed on a CNC turning centre. Units of tools are selected for each respective finish operation. A unit will consist of one or more tools capable of machining the required geometry. The “effective unit cost (euc) parameter” is calculated for each tool. This represents the effective machining cost for a tool and subsequently tools are sorted in order of increasing euc. The euc considers the surface finish, diametrical tolerance and the specified production criterion. Both of the two previous references are part of the TECHTURN system (26).

Maropoulos and Hinduja (27) also did some work on tool regulation and tool wear balancing. This is concerned with the selection of a prescribed number of tools for a component on a turning centre and the optimisation of tool wear and tool changing on a machining cost basis.

Barkocky and Zdeblick (28) describe a knowledge-based system for planning machining operations, called CUTTECH. The system contains metal cutting technology and data that is used in recommending tooling and operating conditions. The system's functions are concerned with the tool selection, cut sequences, and operating conditions for a particular feature. The system acts as a *knowledge source* and a *knowledge collection point*. The CUTTECH system supplies the input in terms of plans and recommendations for the machining process, and in turn the machining process generates new variables and constraints as "plans are modified to meet actual production requirements". Subsequently, the new production techniques and data become new input to future production processes by their incorporation into the CUTTECH system. Therefore, this system differs in nature from the typical artificial intelligence system in that it "adds intelligence to a core of machinability data rather than adding practically to abstract geometrical concepts for machining". It is referred to as the "*bottom up*" approach in that it provides "*shop floor intelligence*". In summary the CUTTECH system is based on the following philosophy:

- Intelligent framework for practical knowledge and machining data.
- Group technology coding of common part features.
- Parameter selection based on current machining practices.
- Automate operation planning decisions.
- Emphasis on implementation.
- Practical in nature.

The process planning system developed by Giusti et al (29) includes an expert module called COATS, for turning operations. Milacic and Putnik (30) discuss tooling system design and consider the mutually inter-linked relation of various machining entities.

Arezoo and Ridgway (31) present an intelligent knowledge based system developed in Prolog and using a hybrid knowledge representation system (logical and rule based). A non-algorithmic solution is discussed by Domazet and Milacic (32) known as the production rule matrix method. The method formulates production rules in a table form instead of applying the logical IF and THEN statements. Additionally, the system includes inductive learning techniques and automatic rule generation.

Keating et al. (33) describe current research leading to a prototype Intelligent Tool Selection (ITS) system. The purpose of the system is to support process planning personnel and to promote consistency in the choice of cutting tools and conditions. The prototype embodies software modules and procedures. Keating et al. (34) describe a pilot implementation period in collaborating companies which enabled testing of the various component with promising results. Maropoulos et al (35) describe an advanced tooling system where by the methodology incorporates both algorithmic and knowledge based techniques.

Chapter 3

Tool Selection Levels

3. Introduction

This chapter will outline the various tool selection levels and also discuss each selection level under different manufacturing paradigms.

3.1 Definition Of Tool Selection

Tool selection is categorised into five main levels as defined by Maropoulos (36);

- Operation level;
- Component level;
- Machine tool level;
- Multi-machine level, and;
- Shop floor and tool stores level.

Figure 1 defines the flow of tool selection.

3.1.1 Operation Level

This level is concerned with the optimal selection of tooling and cutting conditions for a single operation. This level allows for optimum tooling and associated cutting conditions.

3.1.2 Component Level

At this level tool selection is concerned with a component containing a number of different operations to be completed on one machine tool. In this situation sub-optimum tooling and cutting conditions may be used - dictated by the

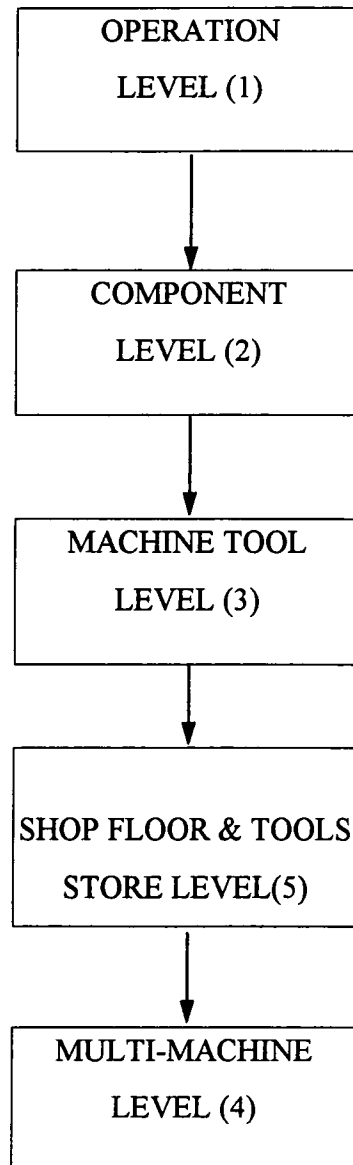

Figure 1: Sequence of tool selection levels

number of tool positions available on the machine. These sub-optimal conditions could be off-set by the increase in the ratio of machining time to set-up time.

3.1.3 Multi-batch / machine Level

This level is concerned with the production of a number of different components of various batch sizes and of different material all requiring to be machined on one machine tool. The complexity of this level is further increased by the variety of different materials

that may need to be machined. Besides the use of sub-optimum cutting conditions there may also be the possible use of sub-optimum use of inserts, that is, not using the optimum grade of an insert for a specific material.

3.1.4 Multi-machine Level

The multi-machine level is concerned with rationalising tooling and assists in producing the Tooling Resource Structure (TRS) for the components planned within a defined time span.

3.1.5 Shop Floor and Tool Stores Level

This level is concerned with the tool management aspect of tool selection. It defines the overall tool requirements and helps in the effective and efficient allocation and distribution of tools to machining resources.

3.2 Tool Selection Under Different Manufacturing Paradigms

Manufacturing firms are classified in the general context as either a "jobbing shop" or a "flow shop" [37]. The "job shop approach" allows for articles to be routed to work centres depending on the required processes. The "flow shop approach" allows for one or a relatively small number of products to follow a defined process route that has been specifically designed for the relevant products. By these definitions the complexity of tool selection ranges from complex for the "jobbing shop" to relatively simple for the "flow shop".

Within this whole band of manufacturing environments four basic layouts are possible:

- Process based
- FMS cell
- Group technology, and
- Transfer lines.

The various tool selection objectives and criteria that need consideration in these layouts are:

- Tool management and planning
- Technological / process requirements
- Tool rationalisation opportunities at resource unit level
- Time allowed to select tools
- Tool allocation horizon
- Importance of tool / work flow synchronisation
- Machining performance rating
- Set-up reduction rating
- Benefits from geometrical rationalisation, and
- Benefits from carbide rationalisation.

Each layout will be considered under the above stated objectives and criteria.

3.2.1 Process Based

Process based layouts are concerned with a group of similar machines, e.g., lathes, grouped together to perform a single process. This type of layout is not dedicated to any particular product range and therefore parts from different products are scheduled through various process based layouts. Parts usually travel longer routes because they are transported from one process based layout to another, e.g. turning to milling to grinding to plating. Greater flexibility is generally achievable in terms of the range of products that can be manufactured while the majority of these products would not be related to each other in any shape or form. A process based layout is typical of a jobbing shop environment where a number of different products are manufactured. Production personnel are only capable of operating machine tools in the "resource unit" they operate and are therefore generally inflexible. The variety of tooling in a process/functional layout is large but the tooling category per type of machine is limited, e.g. turning tools and associated inserts. Additionally, the management and planning of tooling is more complex when compared with other types of layout.

Tool management and planning

In the process based layout, the management and planning of tooling is a highly complex activity. Because of the nature of a process based layout a large number of different components are machined. This alone calls for a wide range / variety of tooling and carbides. Due to this high variety, the effective and efficient planning of tooling is crucial. It is important that tooling requirements are given great consideration because the incorrect resourcing of tooling will lead to an increase in down time.

Technological / process requirements

The process based layout contains a number of similar machines and because of this the process requirements can vary highly over a period of time. If such a layout contained a number of small, medium and large sized lathes, the requirements for these could vary considerably depending on the demand of various products. In the Switchgear industry the demand for high voltage gear and medium voltage gear can fluctuate considerably. During a period of high demand for HV gear the larger CNC lathes are more heavily loaded while during a period of high demand for MV gear the smaller CNC lathes are more heavily utilised. Because of this highly variable process requirements the selection and management of tooling is a highly complex activity. Tooling requirements must be matched to process requirements and this can be sensibly managed by connecting Tool Resource Planning (TRP) with Material Resource Planning (MRP).

Tool rationalisation opportunities at resource unit level

Plenty of opportunities exist for tool rationalisation in a process based layout. In a layout that contains a group of lathes the most prominent tooling are turning holders. Holders are selected on the basis of the geometrical requirements of the components. If the optimum holder was selected for each operation the number could be very large. For large batch manufacturing this could be feasible but as batch sizes are continuously on the decline the opportunity for a core number of tools could prove economical on a long

term basis. This would entail using sub-optimum tooling for a number of different components and this could be counter balanced by the benefits to be gained from reductions in set-up times. For example, the same tooling could be used for longitudinal turning and facing.

Time allowed to select tools

Due to the nature of a process based layout the time allowed to select tools is generally very short. As the type of components scheduled through such a resource unit can vary considerably over a period of time and because the component may not be repeated again, the time allotted for selecting tooling is relatively short. It is generally not feasible to spend a great length of time in selecting optimal tooling for components processed in this layout, as would be case for a transfer line where optimum tooling and operating conditions are of paramount importance.

Tool allocation horizon

The tool allocation horizon for a process based layout is short. As a component can be machined on a one off basis, or because the demand for that component may fluctuate, tooling is assigned to the resource unit for a short period of time. Once the component is manufactured the tooling is withdrawn from the resource unit. The tool management aspect is further complicated by this short tool allocation horizon.

Importance of tool / work flow synchronisation

Tool/work flow synchronisation in a process based layout is not as important when compared with other layouts. Some of the reasons for this can be attributed to: low levels of automation, personnel tend to focus on their own functional efficiency in this type of arrangement; the importance of bottlenecks is not very important - must get the work done and onto the next process based layout, and; if the tools are not available supervision will start manufacture of another component.

Machining performance rating

Machining performance rating is relatively low in a process based layout. In this type of layout machine tools manufacture various products and this subsequently calls for numerous set-ups over a period of time. A machine that produces only one type of component per week operates at a higher performance level than a machine that produces a large number of components per week. The greater the number of set-ups the lower the machining performance rating.

Set-up reduction rating

Numerous benefits can be gained from set-up reductions in a process based layout. Due to the nature of this type of layout it is inherent that set-up time plays an important role in achieving high performance levels. Greater opportunities exist for reductions in set-up time if one setting can be used for a variety of different batches.

Benefits from geometrical rationalisation

If the geometrical features of components can be limited for a particular process, the benefits to be gained are very high. This is a design function and better communication between design and manufacture can be greatly beneficial. Additionally, if components of the same or similar geometrical characteristics are grouped together benefits can be gained by using one set of tooling.

Benefits from carbide rationalisation

The use of different carbides is very much influenced by the type of material being processed, and the greater the material range the greater is the number of carbides. The benefits for carbide rationalisation in the process based layout is very high. By using the same carbide for a range of materials, benefits can be gained from a reduction in set-up times. When using one type of carbide the economic gains due to set up reduction will off-set the disadvantages of operating under sub-optimum cutting conditions.

3.2.2 FMS Cell

The underlying philosophy of an FMS layout is that it is capable of using the built in processes to manufacture a wide selection of different part types. In the case of a single FMS machine tool a pre-defined set of components are processed using a pre-defined set of tooling. In addition, while one component is being machined the operator will be setting-up another component ready to be moved into position when the previous one is complete. This allows for considerable reductions in machine set-up times. Where a number of processes are formed into a cell use would be made of robots, conveyors, and automated guided vehicles (AGV's). This type of arrangement allows for the minimum human intervention from the time the component enters the cell to the time it exits it. The FMS cell approach allows for the efficiency and utilisation levels associated with mass production while "retaining the flexibility of manually operated job shops; that is very general part flow patterns and machines that are capable of processing a wide variety of different part types." More complex scheduling problems are encountered if demand fluctuates and FMS are not suitable in terms of machine utilisation if the parts that flow through an FMS machine can vary greatly.

Tool management and planning

Tool management and planning in an FMS environment is a complex activity because the definition of an FMS environment implies the manufacturing of a wide range of different components/products. Because of the complex scheduling problems associated with such a layout, similar problems would be encountered with the scheduling of associated tooling.

Technological / process requirements

Technological / process requirements for FMS cells are variable because a number of the processes will vary in degree of usage dependent on the range of components being manufactured.

Tool rationalisation opportunities at resource unit level

The opportunities for tool rationalisation are plenty mainly because the nature of an FMS cell allows for it. The FMS cell is designed for the manufacturing of a medium range of parts and because of this a core set of tools could be established.

Time allowed to select tools

In a FMS cell environment the time allocated for selecting tooling and appropriate cutting conditions is marginally greater as in comparison to a process environment. There is lower variety of parts than process based and hence there is more time for tool selection

Tool allocation horizon

The tool allocation horizon in an FMS cell layout is generally short.

Importance of tool / work flow synchronisation

The importance of tool/work flow synchronisation is "very high" in an FMS cell environment. These types of layouts have a high degree of automation and due to this the change over from one set of tooling to another must coincide with the change over of products being processed.

Machining performance rating

Machining performance rating in an FMS layout is "mostly low". This is mainly due to; a number of different products are processed and this calls for increases in set-up time; the FMS cell can only operate as effectively and efficiently as the main bottleneck in the system - it is no good operating all resources at 100% efficiency if one of the resources is not capable of processing all what a previous resource has produced.

Set-up time reduction rating

The opportunities for set-up time reductions is "high". A range of similar components may be processed using a defined set of tooling and this tooling could therefore be set-up at a shorter time.

Benefits from geometrical rationalisation

The benefits to be gained from geometrical rationalisation are high and can occur if all products of similar geometry are processed during a defined period.

Benefits from carbide rationalisation

Benefits from carbide rationalisation are high if a variety of different materials are processed. The use of the same carbide on different materials is possible once the sub-optimum operating conditions are acceptable. It is important that the overall benefits are understood in terms of what they actually mean from an economical view point.

3.2.3 Cellular Based

The cellular based layout is product oriented and is the "name given to applied group technology". The concept of the cellular based layout is that it groups the people, processes, and machines required to manufacture a part family, usually a complete component or a sub-assembly of a product or even a complete product. Because of their nature cells are not as flexible as a process / functional based environment and subsequently would require to be re-designed for a different product. The distance travelled by a component / article can be considerably less than in a functional based layout. The cellular approach is similar to the "flow shop" environment because the products associated with the cell follow a defined process route that has been specifically designed for the relevant component / product. Production personnel are generally more flexible and can therefore operate a number of different machine tools. Due to this, the

work flow through a cell can be assisted more easily because the bottlenecks can be addressed much more quickly and effectively. The range of tooling is generally constant as the majority is well defined in advanced. In return, the logistics of tooling is less complex than in the functional layout.

Tool management and planning

The management and planning of tooling is less complex in comparison to the process and FMS based layouts. Cells are designed for a range of specific products and once the tooling is selected it generally stays static. Therefore, the supply of tooling to the cell is very much dependent on tool wear and the volume demand of the product.

Technological / process requirements

Because of the nature of a cell layout the technological/process requirements are "mostly repeatable". The cell is designed with a specific product(s) in mind and consequently the processes are designed around the product(s).

Tool rationalisation opportunities at resource unit level

As most cells are designed for a specific product range, the tooling is generally dedicated for each process, therefore tool rationalisation opportunities range from average to low.

The allowed to select tools

The time allowed to select tooling and associated cutting conditions is generally longer in comparison with the process and FMS based layouts. As a cell is designed the tool requirements can also be predicted.

Tool allocation horizon

Tooling is generally allocated for long periods of time because cells are dedicated to one or a small number of products. Therefore, once the tooling requirements are established it will not be changed until the introduction of a new product(s).

Importance of tool / work flow synchronisation

Tooling/work flow synchronisation is very important in a cell layout. The importance of having the correct tooling available at the right time is essential for the effective and efficient flow of the work piece/component.

Machining performance rating

The machining performance rating is high for a cell layout. In a cell the correct line balance is usually achieved and the resources are set-up to produce a limited number of components/products. When a resource is dedicated to a particular component/product which is produced at high volumes, performance should be greater when compared to the process and FMS layouts.

Set-up time reduction rating

The benefits of set-up reductions are low in the cell based layout. The main reason for this is that the most optimum tooling is used in a cell based environment.

Benefits from geometrical rationalisation

Benefits gained are low because optimum tooling is required.

Benefits from carbide rationalisation

Benefits gained are low because optimum carbides are required.

3.2.4 Transfer Lines

Transfer lines are employed when manufacturing one product or a group of very similar products on a mass production basis. The equipment and resources are designed around the processes required to completely manufacture the product, for example as in the automobile industry. The lines include the correct number of each resource that will

allow for the smooth flow of the product. Ideally no bottlenecks should occur on transfer lines because the major objective behind such layouts is to have it balanced throughout. If a bottleneck begins to appear the line is stopped immediately until the problem is resolved. With such layouts the minimum amount of work in progress is achievable. Transfer lines are very inflexible and would require to be redesigned when considering the introduction of a new product range or a variation of an existing product. Production personnel are specifically trained to operate efficiently and effectively throughout the transfer line. Every action/movement of the operator is planned well in advance and a defined training programme is pursued before they are allowed to operate on the line. Tooling requirements are very specific and in many instances are designed and developed for a particular function. Transfer lines allow for the use of optimum tooling and associated operating conditions. Additionally, because tooling is dedicated for very long periods of time logistics is considerably less complex.

Tool management and planning

The logistics associated with tooling on transfer lines is "relatively simple". The design of a transfer line considers; the processes, number of each process, and; the optimum tooling. Once the tooling is decided the only management aspects remaining are those associated with maintenance and replenishment.

Technological / process requirements

The technological requirements on a transfer line are "highly repeatable" because they are specifically designed around the product. In comparison with the cellular layout, the transfer line is optimally designed in terms of the type of processes and the capacity of each process.

Tool rationalisation opportunities at resource unit level

Tool rationalisation opportunities at resource unit level are "negligible" because optimum tooling and operating conditions are used throughout.

Time allowed to select tools

Plenty of time is available to select tooling for transfer lines. Selection of tooling is part of the process involved in designing a transfer line and subsequently the time is available for considering the most optimum set of tooling.

Tool allocation horizon

Tooling is assigned to transfer lines for "very long" periods of time. Introduction of new tooling is only deemed feasible if it contributes to the overall effectiveness and efficiency of the transfer line.

Importance of tool / work flow synchronisation

The importance of tool/work flow synchronisation is "very high" because the overall output of a transfer line is very much effected if these two variables are not properly managed. These factors must be considered in great detail at the design stage of the transfer line because one of the major objectives is to avoid bottlenecks.

Machining performance rating

Machining performance rating is very high because once they are set-up they produce the same product continuously.

Set-up time reduction rating

The opportunity for set-up reductions is low if not negligible on transfer lines. Tooling is set-up once for a specific process, so set-up reduction opportunities are basically zero.

Benefits from geometrical rationalisation

Benefits from geometrical rationalisation are negligible.

Benefits from carbide rationalisation

Benefits from carbide rationalisation are negligible.

3.3 Conclusion

Having presented the typical layouts applied in industry and the various tool selection objectives and criteria that need consideration, the major benefits could be gained by applying tool variety reduction and optimisation techniques to the process and FMS cell based layouts. The group technology and transfer lines layouts do not lend themselves to tool variety reduction and optimisation on the grounds that during the design process of these layouts the tooling aspect is taken into consideration - tooling is designed into these layouts.

The reasons for applying such techniques (tool variety reduction and optimisation) only to the process based and FMS cell layouts are supported by the discussions in the section entitled, tool selection under different manufacturing paradigms. By applying tool variety reduction and optimisation techniques to the process based and FMS cell layouts substantial benefits can be gained apropos of; tool management and planning, tool rationalisation opportunities, tool allocation horizon, machining performance, set-up reduction, geometrical and carbide rationalisation. The same benefits could not be obtainable for the group technology and transfer lines layouts for the reasons already discussed.

Chapter 4

Operations Planning And Tool Resource Structure

4. Introduction

This chapter discusses how the Computer Aided Design (CAD), Computer Aided Process Planning (CAPP) and Tool Resource Structure (TRS) modules could be integrated into a Manufacturing Resource Planning (MRP11) system. MRP11 is a widely used manufacturing planning and control system applied in the effective management of raw material, the manufacturing processes and the purchasing function. It is accountable for converting the organisations top level plan into a detailed plan of action in order to meet the required objectives.

CAD one of the more advanced technologies available to a manufacturing organisation. It has aided considerably in automating and managing the complex task of engineering design. Most CAD software packages are now capable of transferring information to other CAD systems and computer systems, for example, Numerical Control programming systems. The activity of creating the Bills of Material (BOM) is now very much an automated process. Because no links exist as such with MRP11 systems, the task of transferring the BOMs is still a manual process and generally takes much time. The creation of a dynamic link between these two systems would completely eliminate this non-value added activity.

Process-planning is the main link between design and manufacturing. This process is about defining a plan of action to convert a piece of metal into an already defined end product. The end product is designed by design engineers and it is the responsibility of process planners to define the manufacturing operations necessary to achieve the desired product specifications. The process planners are usually persons with a considerable amount of manufacturing process experience that has been obtained during a major part

of their working career on the shop floor. This scenario brings with it some searching questions apropos of how can this time consuming, and subjective process be automated. Various CAPP systems are being developed in order to address these concerns but a considerable amount of work is still required in relation to their industrial functionality. Such a system would greatly enhance the process planning process with the possibility of a dynamic link with the firm's MRP11 system. This link would aid in automatically creating the routing file on the MRP11 system that is currently input manually.

Operation planning is concerned in detailing each individual operation of the process plan for a component and involves the detail selection of tooling and the optimum operating conditions. Again this process requires a considerable amount of time and knowledge and is usually performed by someone with several years working experience in the particular process environment. A number of systems are available to aid the operations planner in the appropriate selection of tooling and cutting conditions, for example, Numerical Control machining software. These systems are still rather primitive in many ways and still require a considerable amount of human intervention. Generally they have only taken the repetitive tasks away from the planner who requires the same level of experience to perform his function. What is now required, is an operation planning system, which will be part of a CAPP system, capable of interpreting the process plan of a component and automatically determining the appropriate tooling and operating conditions. With this capability, and a dynamic link with the MRP11 system, the advantages of creating an operations database are enormous. One of the main advantages is that it will aid manufacturing personnel to effectively plan their tooling requirement based on product requirements.

The Tool Resource Structure (TRS) module of the system would be responsible for the effective optimisation of operation plans and the scheduling of tooling for a defined product demand. The TRS module will rely heavily on the CAD and CAPP modules to define the BOMs, and the process and operation plans. It will also be dependent on the information received from the timed-phased material requirement records of the MRP11 system and detailed records of tooling inventory.

With the effective integration of CAD, CAPP, TRS and MRP11 the design and manufacturing link will be complete. In addition to the generation of the timed-phased requirement records for raw material, manufactured components and purchase items, TRS will produce a timed-phased operations plan that will contain the most effective set of tooling requirements.

4.1 Manufacturing Resource Planning (MRP11)

Manufacturing Resource Planning, commonly referred to as MRP11, is a manufacturing planning and control system. Its predecessor was MRP, that is, Material Requirement Planning, which is responsible for the "disaggregation" of the Master Production Schedule (MPS). As it was realised that MRP could be used for more than the planning of material, but also, for the planning of shop floor operations, it was subsequently renamed MRP11. Currently MRP is an integral and very important part of MRP11. The MRP11 planning and control system deals with planning the acquisition of raw material right through to planning the delivery of the final product. For the system to function effectively it must have the correct information otherwise the overall manufacturing process will not be properly synchronised. The issue of correct information is one of great concern to those that are "managed by the database". Incorrect input data will result in incorrect detailed plans.

Each item on the MRP11 system has a timed-phased record and highlights the following four issues:

- the likely usage of an item within the period
- what orders are due in at the outset of a period
- the current and likely stock levels for a particular component / material at the end of the period and the
- planned replenishment orders for a particular component / material at the outset of a period.

A period can represent any length of time and is particular to each company that employs MRP11 system. This period could range from one day up to three or even six months.

At the end of each period MRP 'run' is performed and the result from this is the creation of "timed-phased requirements". Time-phased requirements for a particular product / component / material highlights its demand. Figure 2 demonstrates the generic structure of an MRP11 planning and control system. The system is defined as three major parts and the following sections will explain in more detail these various functions of the MRP11 system.

4.1.1 Front End

Resource planning and demand planning serve as inputs to the production planning stage which then serves as one of the three inputs to the Master Production Scheduling stage, the other two being, demand management and rough-cut capacity planning. This part of the MRP11 control system is commonly referred to as the "front end". The production planning stage sets the mission that manufacturing must achieve in order to accomplish the firm's objectives. The resource planning function aids the production planning stage and in the short term constrains the firm to what it can produce. In the long term it would be used to highlight the resource shortage for a particular demand and subsequently "financial appropriations are indicated". The demand management module is concerned with understanding every source of demand that is or will be made against the manufacturing capacity.

Once the production plan is established this will aid in compiling the Master Production Schedule (MPS) for the firm. The MPS is the anticipated schedule for manufacturing of products and serves as input to the Material Requirements Planning module. The MPS module requires the information as stored in the demand management module and in addition requires a 'rough indication' of the capacity available from the rough-cut capacity function.

4.1.2 Engine

The next part of the MRP11 system is referred to as the "engine". This includes the most important part of any MRP11 system, the Material Requirement Planning module. The

Manufacturing Resource Planning

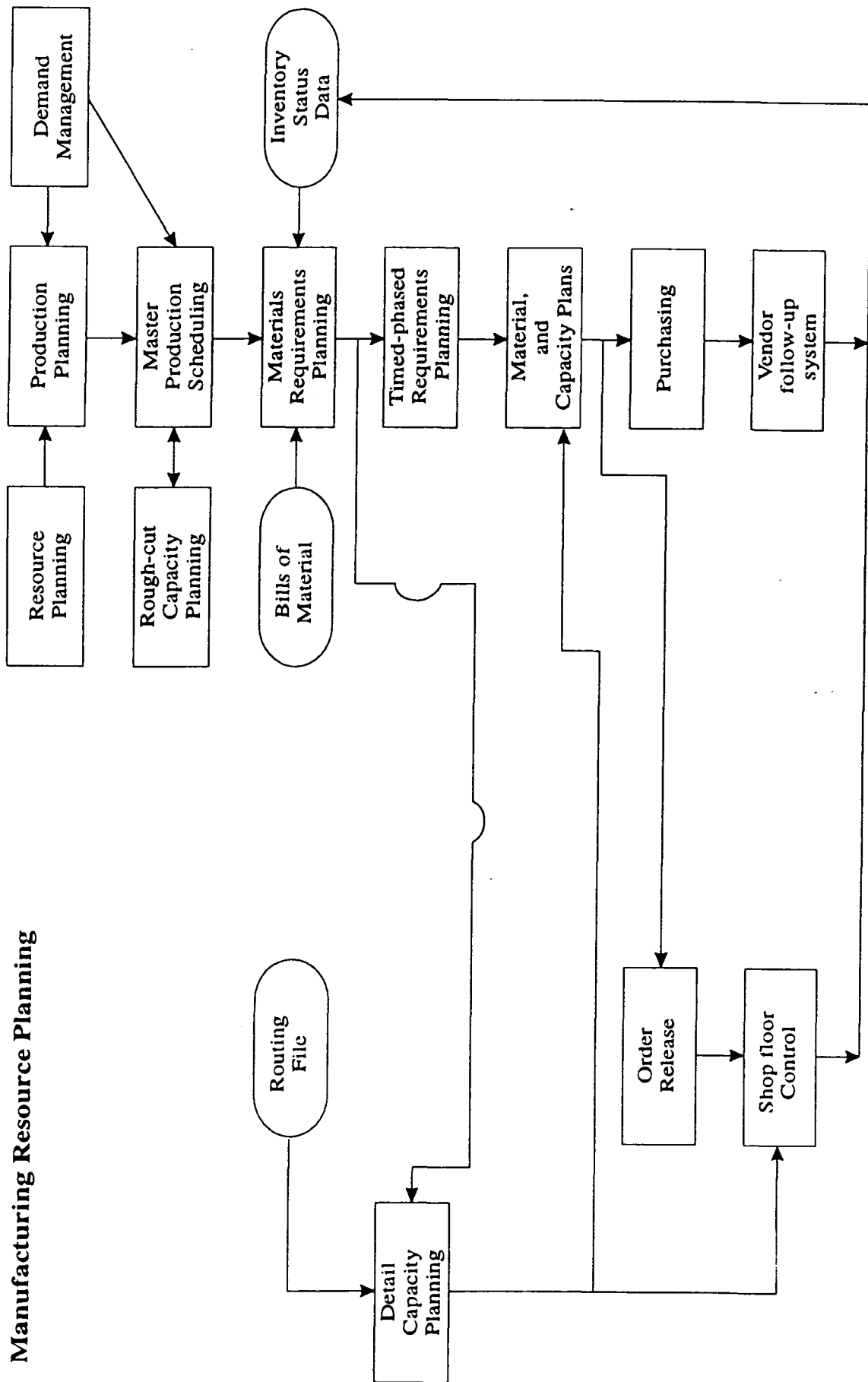

Figure 2: Generic Structure of an MRP11 Planning and Control System

primary purpose of the MRP module is to take a period-by-period set of master production schedule requirements and produce a timed-phased requirements plan for all the concerned components and raw material. It uses the bills of material to indicate what details are required for each component and uses the inventory status data in order to determine exactly what are the requirements for each component, raw material and 'bought out' components/services. The timed-phased requirement records are produced and subsequently used in determining the material and capacity plans which subsequently serve as input to the purchasing and order release modules. The routing file and the MRP module are the two main inputs to the detail capacity planning function which subsequently finalises the material and capacity plans. The engine is the 'workhorse' of any manufacturing planning and control system as it transforms the top level plan, from MPS, into detailed plans for manufacturing.

4.1.3 Back End

The final part of the system is referred to as the "back end". The material and capacity plans serve the order release and purchasing modules. The purchasing module is only concerned with those components / raw materials that have a bought-out content. The vendor follow-up system is used to establish the progress of orders. The plans received by the order release module are only applicable to manufacturing. The order release module releases orders onto the shop-floor as and when planned. The shop-floor control system and vendor follow-up systems feedback to the inventory status file and aid the next MRP run in determining the next set of timed-phased requirements.

4.2 Operations Planning and TRS Within the MRP11 Structure

Figure 3 shows the added features that are required for the introduction of Operations Planning (OP) and TRS modules into the MRP11 set-up. It contains six new features with amendments to four existing parts of the current MRP11 system. The new features include:

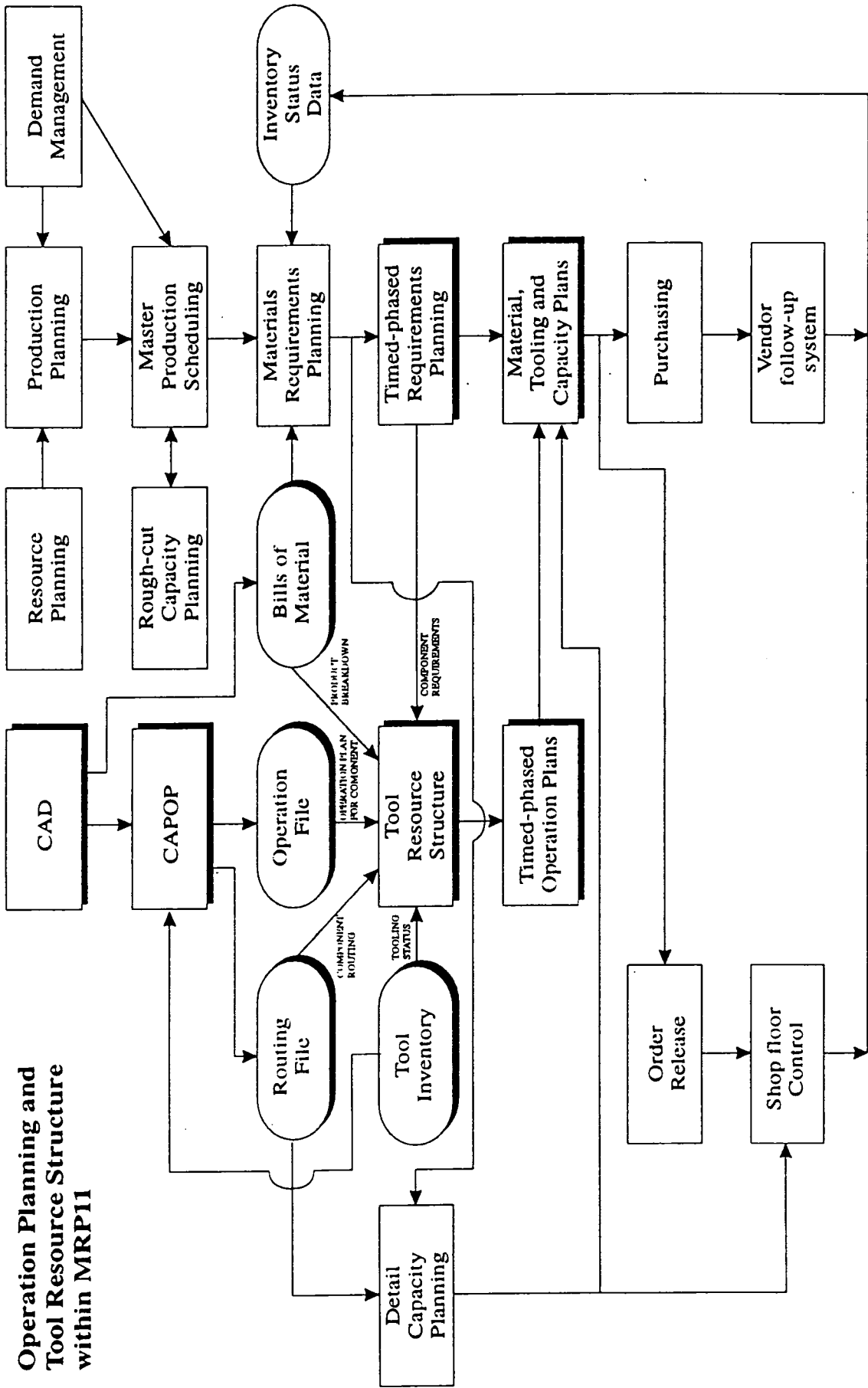

Figure 3: Operations Planning and Tool Resource Structure within the MRP11 Structure

- *CAD*: Computer Aided Design link with MRP11.
- *CAPP*: Computer Aided Process Planning link with MRP11.
- *Operation File*: A database file that contains the operation files of each component.
- *Tool Inventory*: A database file that contains the tooling inventory and various other attributes associated with tooling.
- *Tool Resource Structure*: A module that determines the TRS of components and products.
- *Timed-phased Operation Plans*: The production of operation plans for a defined period of time.

The current features that require amendments or have direct influence on the TRS module are:

- *Routing File*: The TRS module will require access to this large database file.
- *Bills of Material*: Access to this database file is required when determining the TRS for an entire product or a complete sub-assembly.
- *Time-phased Requirements Planning*: TRS will need the information generated at this stage to determine what components are to be manufactured in order to establish the tooling requirements.
- *Material, tooling and capacity plans*: This needs to be extended to include tooling plans.

4.2.1 Computer Aided Design Link

The computer aided design link serves to generate the bills of material for the MRP11 system. All CAD systems are capable of performing the task of generating the BOMs but none exist to cater for the dynamic interface that is required for the proposed system. Generally the scenario is that the BOM is created on the CAD system and then manually input into the MRP11 system. In order to reduce the amount of work involved a dynamic link is required. This would have the added benefit in the case of an engineering change - the change on the CAD systems would be reflected automatically on the

MRP11 system. The CAD link also serves as an input to the CAPP system. The link proposed would be dynamic in the sense that once the CAD has completed its task then the CAPP module can concern itself with process and operations planning. See Figure 3.

4.2.2 Computer Aided Process and Operation Planning Link

A number of Computer Aided Process Planning systems exist but none are directly linked into in the MRP11 structure and few commercial systems exist that have the dual capability of process and operation planning. The CAD system serves as the main source of information for the CAPP module. The information includes geometrical features, dimensions, material, tolerances, surface finish, etc.

The CAPP system should be segmented into two main systems; the process plans generator and the operation plans generator. The operations plan generator will consist of a number of sub-systems each capable of defining the optimum set of tooling and operating conditions for an operation. An example of this sub-system would be the technology module for the selection of tooling and cutting conditions for turning and milling.

The output from the CAPP module will comprise a routing file and an operation file for each component. These will be stored in the routing file and operation file databases respectively. Currently the routings file is created manually and no operations file exist on the MRP11 system. The dynamic creation of these two files by the CAPP module will reduce the amount of manual intervention.

4.2.3 Operations File

The operations file contains a clear and detailed definition of how an operation is to be performed. This will include information apropos of; the part number, operation type, component material, tooling, cutting conditions, and cost of the operation. The file is created as an outcome of the CAPP process where each operation for a defined component is considered in detail. The information stored on the operations file will not

be altered unless a rerun of the CAPP is performed when there is new tooling or process available that were not so originally. The operations file serves as one of the main sources of input for the TRS module.

4.2.4 Tool Inventory

For the TRS module to work effectively it requires a clear indication of the available tooling. No database as such exists at present within the MRP11 structure to cater for the tooling aspect. It is therefore necessary that such a database should exist since it will also be required by the CAPP module in determining the tooling at the operation planning stage. The database will include information on tooling for turning, milling, drilling and all other processes that are particular to the firm in question. Typical information would include; tool type, insert type, grade of insert, chipbreaker values and quantity in stock. Such databases exist in tool management systems.

4.2.5 Tool Resource Structure Module

The Tool Resource Structure (TRS) will ultimately have the final decision on the structure of the operation plans for a number of different components of different materials processed on a number of different machines all within a specified time frame - so the term 'timed-phased operation plans'.

The TRS module is the equivalent of the MRP module in that it determines the overall plan for operations, tooling requirements, tooling sequencing and planning and tooling purchasing requirements. The TRS module requires five main sources of inputs; tooling inventory, routing file, operations file, bills of material, and timed-phased requirements records from the MRP module. The output is a number of timed-phased operation plans.

The operation of TRS would be as follows::

- Check the time-phased requirements records from MRP in order to establish the components that need to be manufactured.
- For each component required to be manufactured, the routing file is accessed in order to determine its particular process plan.
- Using the process plan, TRS works through each individual operation and accesses the information for that component and operation in the operation file. This will suggest the tooling and operating conditions that was previously determined by the CAPP module.
- Having completed working through the MRP time-phased requirement records in the manner outlined, the TRS module will now hold for each manufactured component a set of operation plans.
- TRS will now consider all the operation plans in total and determine where the operation plans can be optimised. It will optimise at component level, material level, and machine level. A typical outcome may include machining a number of different components of different material with fewer tools when compared to the original by selected tools at the CAPP stage.
- The output from the TRS module is a time-phased set of operation plans for the time-phased requirement records produced by the MRP module.

The TRS module additionally accesses the BOM file when determining the potential cost of manufacturing a product. This potential cost is likely to be the worst scenario as any optimising on the operation plans due to the timed-phased requirements records would be no worse than if all optimum operating plans were used.

4.2.6 Timed-phased Operation Plans

The 'timed-phased operation plans' are a set of plans arrived at during a TRS 'run'. They are the operation plans that are required to manufacture those components identified in the timed-phased requirements records via the MRP 'run'. The plans supply information for the material, tooling and capacity plans module. Due to the change in demand from one time-period to another there is potential that no two sets of time-phased operation

plans would be the same. The exception may arise in the firm that operates a production line set-up where the same operation plans would be required from period to period.

4.2.7 Routing File

The routing file contains all the routings associated with a company's product range. Presently the function of process planning requires a considerable amount of time and experience on behalf of the production engineer. By introducing the CAPP module less experienced production engineers will be capable of performing the task of process planning. The dynamic link established will aid substantially in creating routings on the MRP11 system. The routing file is an important source of information for the TRS module, in addition with the operation file, as it informs the TRS module on how the component is proposed to be manufactured. Current MRP11 systems use the routing file for the detail capacity planning stage. In conjunction with the operation file, the TRS module can determine the Tooling Resource Structure for a component or sub-assembly or product.

4.2.8 Bills of Material

The TRS module will require access to this database in order to perform the following tasks:

- tooling requirements for a product,
- tooling cost per product,
- tooling budget based on forecast,
- identification of tool standardisation opportunities, and
- suggest nesting of components based on similar tooling / operations.

The BOM as it states is the total product breakdown by individual components. At present this is manually entered into the MRP11 system but with a dynamic link to CAD this process could be automated.

4.2.9 Timed-phased Requirements Planning

A link needs to be established with the times-phased requirement records and the TRS module. This will assist the TRS in establishing the optimum set of operation plans for a specified demand of components.

4.2.10 Material, Tooling and Capacity Plans

In present MRP11 systems this module is concerned with material plans and capacity planning. In addition it will also be concerned with the tooling plans for a specified period of time. It will receive information from the time-phased operation plans as to what tooling requires ordering.

4.3 Conclusions

Presently the task of process and operations planning are aspects of the manufacturing environment that are not dynamically linked to a firms MRP11 system. They are at present attended to by production engineers who have to manually enter the plans onto the system once the activities are complete. With the introduction of the TRS module into the overall MRP11 structure advantages will be gained apropos of optimisation on tooling, nesting of components, more effective planning and scheduling, and cost control. The TRS module in addition to the CAD and CAPP modules can be viewed as the closing of the link between design and manufacturing.

Chapter 5

Tool Selection System

5. Introduction

This chapter will discuss the overall selection system.

5.1 Tool Selection System - General Description

The tool selection system will consist of six modules all designed using AutoCAD/AutoLisp and EXCEL/Visual Basic. AutoCAD is a Computer Aided Design/Drafting application package capable of running effectively on 386DX machines upwards. AutoLisp is the built-in programming language of AutoCAD and is an implementation of the Lisp paradigm. Visual Basic is the built-in programming language of the EXCEL spreadsheet. The six modules will be:

- Geometry and heuristic module (TVRO_G) - used at the operation level;
- Cutting technology module (TVRO_T) - used at the operation level;
- Component module (TVRO_C) - used at the component level;
- Multi-batch module (TVRO_MB) - used at the multi-batch level;
- Multi-machine module (TVRO_MM) - used at the multi-machine level;
- Shop floor and tool stores module (TVRO_ST) - used at the shop floor and tool stores level.

Only the first three modules are complete under this work.

AutoCAD is used by the user for defining the geometry of the component. The TVRO_G module is initialised and this considers each operation in turn. It recommends an optimised list of tool holders for each operation, having first considered the maximum approach and trailing angles of the profile and checked with the tool holder data base to

establish the available tool holders. These lists are used in comparing the appropriate inserts to the component material and the tool holders. The module calculates the appropriate set of cutting conditions, based on the set of heuristic rules generated from manufacturing catalogues, for each operation and will finally produce a prioritised list of operation plans for each operation/feature.

The TVRO_T module is written in Visual Basic and it interprets the data created by the TVRO_G module. This module uses the metal cutting theory, as described in chapter 7, to further optimise the cutting conditions. It considers the tool holder, insert and machine characteristics in determining the most appropriate set of cutting conditions.

At this stage, a number of operation plans have been established for each feature that must to be produced on the component in question. The component module (TVRO_C) interprets each of these operation plans and subsequently recommends a high level operation plan for the component. This may involve using the operation plan for each feature as recommended by the previous modules, or readjusting these plans according to; the number of tool positions available on the machine and the ratio of machining time/set-up time. The TVRO_C module creates the TRS for each component.

The multi-batch module (TVRO_MB) will consider the high level operation plan of each component scheduled for machining. The module will recommend the most appropriate sequence these components should be machined within the production time frame. It will also assist in establishing the tool requirements for the machine operating within a specified production time frame. The multi-machine module (TVRO_MM) will be used in the rationalisation and identification of “core” tooling for a defined “resource unit”. The shop floor and tool stores module (TVRO_ST) will take into consideration all the tool requirements for a machining resource and assist in the effective and efficient allocation and distribution of tooling to these resources.

In using AutoCAD as the development tool there is no requirement to reinvent the graphics interface. AutoCAD allows access to its database via the AutoLisp

programming language and this can help in the manipulation of any drawing. Additionally, by using AutoLisp as the programming language one minimises the problems of interfacing, which usually arises when interfacing independently developed pieces of software. AutoCAD also allows for interfacing with dBase, Lotus and EXCEL applications, and has a C-language programming environment for developing AutoCAD applications.

5.2 Geometry and Heuristic Module (TVRO_G)

The TVRO_G module deals with the geometry and heuristic aspect of the tool selection system. It is capable of selecting tool holders, on a geometric basis, for;

- right -> left external turning (linear elements);
- left -> right external turning (linear elements);
- right -> left external turning (arc elements);
- left -> right external turning (arc elements);
- right -> left internal turning / boring (linear elements);
- left -> right internal turning / boring (linear elements).

The software is written in AutoLisp, which allows for the customisation of AutoCAD to particular individual requirements. The system embodies approximately three thousand five hundred lines of code and encompasses twenty three various functions. Appendix 1 gives a brief description of each function, and a summary regarding their interconnections can be viewed in Figure 4.

The selection of tool holders is primarily based on the element approach angle (EAA) and element trailing angle (ETA), and after calculating these angles for a specified profile the maximum approach and trailing angles of the profile are established.

The module is then used for the selection of tool holders, inserts and cutting conditions. It receives information apropos of the maximum approach and trailing angles of the

NOTE:

- NEXT
- ITERATE
- ◆ DECISION POINT

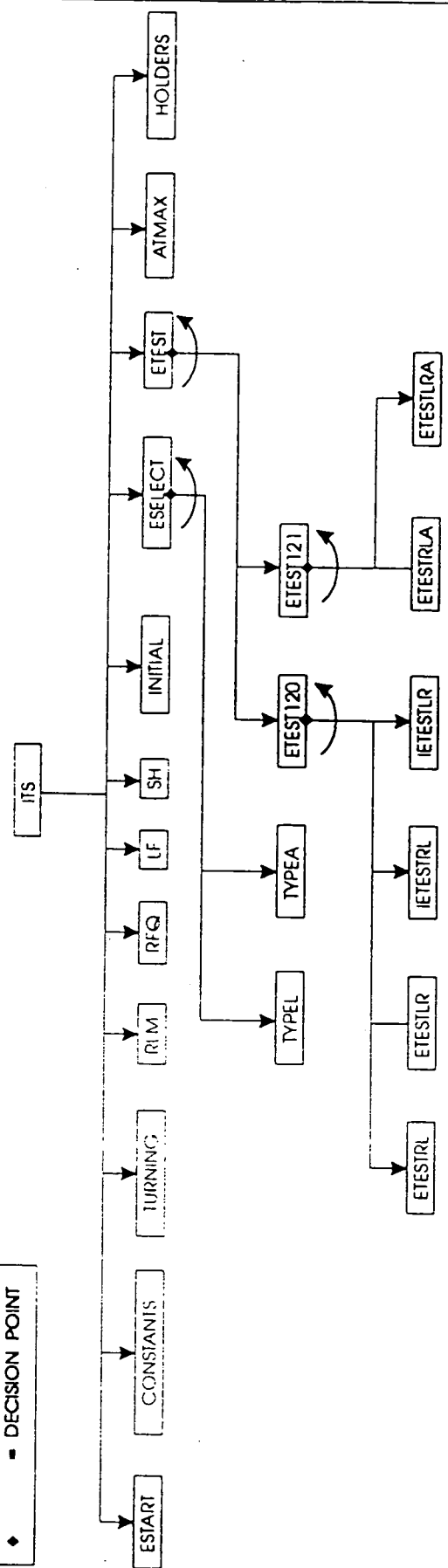

Figure 4: Summary of Geometry Module - Logic of Functions

machining profile. It will search for the appropriate holders, and search the insert data base for appropriate inserts for the chosen tool holders, taking into consideration the material characteristics of the component. A holder is considered suitable when its approach and trailing angles exceed those of the cutting profile. Inserts are selected for the holders on the basis of their shape, size and clamping method. Finally, the carbide grade must be suitable to machine the specified workpiece material. The following steps are followed:

- search the database for suitable tool holders.
- test and write suitable tool holders to file;
- search the database for suitable inserts;
- test tool holder code with the insert code;
- select the appropriate chip breaking diagram;
- calculate the appropriate cutting conditions.

Finally, the module will calculate and save to a file a prioritised list of tools (holders and inserts) and the associated cutting conditions.

5.3 Technology Module (TVRO_T)

The TVRO_T module will utilise some of the current developments in cutting technology for its various computations in determining the appropriate insert and cutting conditions for a particular operation. Use is made of the chip breaking diagram of each insert in calculating the optimum cutting conditions. The technology module recommends an optimum operation plan for each operation required to produce the component features. The operation plan for each of these operations will be used by the component module to establish the higher level operation plan of the component.

5.4 Component module (TVRO_C)

The component module (TVRO_C) takes into consideration the operation plans for each feature and determine the optimum higher level operation plan of the component. In

establishing this higher level plan it is necessary for the module to have access to a prioritised list of tooling and cutting conditions for each operation.

For a component with two very different operations, the TVRO_C module would recommend the operation plans as determined by the TVRO_T module. If the two operations were similar it may still maintain the plans recommended by TVRO_T. However, in some cases there are benefits in combining two operations, that is, finding one tool which will perform both. The ratio of machining to set-up time is a criterion in this decision making process.

In considering a component with, for example, five operations, and the knowledge that the machine can only hold four tools for any one setting, the TVRO_C module would recommend four new operation plans based on the five supplied by the TVRO_T module. The factors considered in arriving at the higher level operation plan are:

- Ratio of machining time/set-up time. If this ratio is low it may be feasible to reduce the number of set-ups by using a tool for more than one cut. In this process one may substitute the optimum cutting conditions with sub-optimum ones for the long term benefit of increased machine utilisation.
- The number of tool positions available on the machine for any one set-up. As already stated, if the number of different operation plans exceed the number of tool holder positions then tool number reduction and sub-optimum conditions would be considered. This may involve the straight forward use of the optimum conditions of one operation for another one when the operations are very similar. On a more complex basis such a substitution may require the application of sub-optimal cutting data.

This module produces the higher level operation plan for the component. Subsequently it establishes the Tool Resource for the component, and it aids in predicting the cost of manufacturing the product.

5.5 Multi-batch module (TVRO_MB)

The multi-batch module (TVRO_MM) will be concerned with the selection of tooling and operating conditions for a number of different batches scheduled for a machine within a specified production time span. This problem will involve dealing with a variety of different components with different materials that may include a wide range of higher level operation plans for each batch. Two of the major constraining factors at this level are;

- the number of tool holder positions available on the machine, and;
- the variation of material which may require that a number of components should be machined using less than optimum inserts, therefore the problem of material/insert compatibility arises.

The TVRO_MB module will take into consideration the higher level operation plan of each component. The module will determine from these plans the most suitable set of tooling based on the geometrical constraints of all components and the number of tool holder positions available. In determining the tool requirements for the machine, priority will be given to tools of low machining usage in order to reduce the negative impact such substitutions may have on machining performance. The substitution of carbides will be determined by scanning the prioritised operation plans arrived at during the first two selection levels, those being, the operation and component levels.

The module should also recommend the most suitable sequence in which these batches are to be machined, as the major objective of this module is to reduce the number of tool set-ups over a specified production time span. At this stage the Tool Resource Structure for the machine is defined and this will assist in establishing the tooling requirements of the machine for a given period of time.

5.6 Multi-machine module (TVRO_MM)

The multi-machine module (TVRO_MM) will be concerned with the rationalisation of tools and the identification of "core" tooling requirements for a defined "resource unit" (a

group of manufacturing resources considered as a whole, for example, a cell). This module finally aids in the process of Tool Variety Reduction and Optimisation at the shop floor level.

5.7 Shop floor and tool stores module (TVRO_ST)

The shop floor and tool stores' module (TVRO_ST) is the final stage is the selection process and addresses the tool management aspect. It will be concerned with the effective and efficient allocation and distribution of tool to the resource units.

Chapter 6

Geometry and Heuristic Modules

6. Introduction

This chapter will discuss in detailed the geometry module. The geometry module is an integral part of the overall system and forms the first process in the selection of tooling. The geometry module is used in determining the geometrical constraints of the component .

6.1 Programme Initialisation

The programme starts with the execute command and this controls the initialisation of all the other associated functions. The command is typed in at the keyboard and the function is executed like any other AutoCAD command.

Then the 'start point' function is executed which initialises a number of variables which will be used for storing the geometry of the profile. The list below shows the geometrical information required to define a cutting profile.

- user input start point of profile
- user input end point of profile
- selected entity list
- approach angles list of selected entities
- trailing angle list of selected entities
- initial value for approach angle of profile
- initial value for trailing angle of profile
- approach angle at the start point of an arc
- approach angle at the end point of an arc
- trailing angle at the start point of an arc

- trailing angle at the start end of an arc
- Maximum approach angle of selected entities
- Maximum trailing angle of selected entities
- Counter of elements
- Length of entity list

Apart from the cutting profile, the module needs information concerning the cutting tools. The following geometrical information is used to represent the geometric capabilities of cutting tools.

- maximum approach angle of available external tools
- maximum trailing angle of available external tools
- maximum approach angle of available internal tools
- maximum trailing angle of available internal tools
- clearance angle

6.1.1 Job Identification

Each component or 'job' is given a unique identification code. This is the first request the graphics module makes to the user to input information concerning the job being processed. The program will not allow the user to process without giving a job number and this number should not exceed five characters. This number is then concatenated with the word 'JOB' to form a name, for example, 'JOB12345'. This is subsequently concatenated with '.TXT' and '.RUN' respectively to form two files named 'JOB12345.TXT' and 'JOB2345.RUN'. Finally these are concatenated with 'C:/USER/' to form 'C:/USER/JOB12345.TXT' and 'C:/USER/JOB12345.RUN'. These two strings will then be used to open and close the two files in the USER directory on the 'C:' drive.

6.1.2 Definition of the Operation

A turning operation can be either external or internal and in each case an entirely different type of cutting tool is required. The TURNING function requests the user to

define whether the process is an external or internal turning operation (the user either inputs 'E' or 'I'). Any other reply will be rejected and an error message will appear indicating to the user that he has to type either of the two aforementioned characters.

It is also necessary to know the direction of machining and this function requests the user to type in the required direction. The user should type either 'R' (for right to left machining) or 'L' (for left to right machining). Any reply other than these two characters will result in an error message and the execution of the program will not continue until the correct character is inputted. The machining direction assists in narrowing down the tool holders available by selecting tool holders with the appropriate hand side.

6.1.3 Preferred locking system

Having selected the type and hand of tools, the next information required relates to the preferred locking system for the insert.. The user must type in 'S', 'M', 'P' or 'C', where; 'S' is for screw; 'M' for pin and top clamp; 'P' for pin / wedge; and 'C' for top clamp. Again an exact reply is required. The locking options are defined according to ISO. This is again used to reduce the options available to perform the required operation.

The insert's locking system is one of a number of rules used in industry in the selection of tooling - early on in the process they determine the type of locking system. This can be very much influenced by the availability of tooling within the organisation and the type of machining being performed. For example, the 'S' method is better suited for light operations, whilst 'M' is providing extra security in even the most severe roughing operations.

6.1.4 Finish, medium or rough cut and total depth of cut

The type of machining operation is defined and the following information is required.

- finish / medium / rough

- minimum cutting edge of insert required
- maximum cutting edge of insert required
- minimum cutting edge length
- maximum cutting edge length
- total depth of cut

The type of cut and the total depth of cut (a) are related as shown below:

Finish Cut - $0.5\text{mm} \leq a < 3\text{mm}$

Medium Cut - $3\text{mm} \leq a < 5\text{mm}$

Roughing Cut - $5\text{mm} \leq a < 12\text{mm}$

The user must define the type of cut by inputting 'F', 'M' or 'R', anything other than these characters will result in an error message requesting the correct information. The total depth of cut requires a real number. The reason for requesting the type of cut is that the process planners have at this stage decided on the appropriate machine tool for the specific operation. This, in conjunction with the stock of the material to be removed, is sufficient information for the operations planner to decide at this stage the type of cut - finish, medium or roughing. Knowing the type of cut helps to determine the cutting edge length required and this is used to eliminate all unsuitable tool holders. This is a rule frequently used subconsciously by the process planners in the selection of tooling and cutting conditions.

6.1.5 Type of material to be machined and insert grade

There is a direct relationship between the material type and the insert grade required for a cutting operation. The following information is required.

- type of material (e.g. steel)
- sub-group of material (e.g. mild steel)
- finish / medium / rough
- insert grade
- insert nose radius

The user is required to input the type of material being machined - such as steel, stainless steel, and cast iron. The user must respond with either 'S' for steel, 'T' for stainless steel, or 'C' for cast iron. A response other than these characters is not allowed and an error message will appear indicating to enter the correct information. By knowing the type of material being machined and the type of cut from the previous function, the insert grade and insert nose radius can be determined. The determination of these two variables is based on rules arrived at by process planners using tool manufacturers information. For example;

	Material	=	'S'
	Type of operation	=	'F'
=>	grade	=	'TP10', and
	Nose radius	=	'04'

Next, the various materials under the general material classification are displayed and the user is requested to select the nearest to the material being machined. This selected material with the insert grade will then be used in retrieving the range of cutting conditions stored in the database. This range of cutting conditions will then be used as a starting point in determining the final set of cutting conditions.

There are several material sub-groups each relating to the three main classifications - steel, stainless steel and cast iron. This information was extracted from tool manufacturers catalogues as shown below.

STEEL:

- Very soft, tacky steels. Low-carbon steels and plain ferritic steels.
- Free cutting steels. Other than free-cutting stainless steels.
- Structural steels, ordinary carbon steels. Low to medium carbon content (<0.5%C).
- High carbon steels, ordinary low-alloy steels. Low-alloy steel castings. Normal medium-hard steels for tough hardening. High carbon steels (>0.5%C).

- Normal tool steels. Medium-high alloy steel castings. Harder steels for tough hardening.
- Difficult tool steels. High-alloy steel castings. Harder steels with high hardness. Difficult high-strength steels. Hardened steels. Easier super alloys.

STAINLESS STEEL:

- Easy-cutting stainless steels. Free-cutting stainless steels.
- Moderately difficult stainless steels.
- Stainless steel difficult to machine. Stainless steel castings.

CAST IRON:

- Cast irons with low hardness. Grey iron.
- Cast iron with medium hardness. Grey iron.
- Low-alloy cast iron with low hardness. Malleable iron castings, nodular iron.
- Medium-hard alloy cast iron. Moderately difficult malleable castings. Nodular iron.
- High-alloy cast iron difficult to machine. Difficult malleable iron castings, nodular iron.

6.1.6 Selection of machining profile

A machining profile is made up of a number of entities. An entity can be a line or an arc. The entity selection function has nine local variables which are defined by the user as a result of choosing a number of entities on the component's profile.

- selected entity
- list of names of selected entities
- temporary entity list
- selection set
- number of entities in the selection set

- entity name
- selection of entities
- all entities

The machining profile definition function has ten global variables namely.

- start point of entity
- end point of entity
- start point of profile
- end point of profile
- centre point of the arc
- start angle of arc
- end angle of arc
- radius of the arc
- start point of selected entity
- end point of selected entity

This function is responsible for the selection of the machining profile. The function begins by setting the *sslist* and *temp_entlist* variables to '()' (no list). A selection set, *ssl*, is created by using the function 'sset' - this returns all stored entities of the specified drawing layer. The function 'ssleng' determines the number of entities, *ssleng*, in the selection set, *ssl*. The user is requested to indicate the start and end points of the machining profile - *spoint* and *epoint*. These are subsequently saved as *start* and *end* respectively. The list *sslist* is formed of the names of all selected entities by using the built in AutoCAD functions.

Each entity of the list *sslist* is tested in order to determine if its an 'arc' or 'line' type entity. If it is an 'arc' type entity, the following information is retrieved from the AutoCAD database; centre point (*cpt*), start angle of arc (*angs*), end angle of arc (*ange*), and its radius (*dist*). The two polar points (*p10* and *p11*) are then calculated and these represent either the start or end points of the arc. If it is a 'line' type entity, then its two points are retrieved from the database and assigned to *p10* and *p11* variables.

AutoCAD then redraws - in a different style - what it considers to be one of two entities associated with the start point and requests the user's confirmation of the correct entity. If the entity redrawn by AutoCAD is incorrect the user responds by typing 'N' and the correct entity will be redrawn. Having determined the type of entity, either line or arc, the functions, TYPEL or TYPEA respectively, are initialised.

6.1.7 Line function

This function has seven local variables;

- x co-ordinate of start point
- y co-ordinate of start point
- x co-ordinate of end point
- y co-ordinate of end point
- old list defining the point of an entity
- a variable used in correcting the start and end points of an entity

It uses three global variables;

- a counter
- list of entities in the machining profile
- start point of entity

The purpose of this function is to check the start and end co-ordinates of the line and to determine which set of points equal the start point as indicated by the user (*spoint*). The variables $x1$, $y1$, $x2$, and $y2$ are assigned the following values; the 'x' co-ordinate of the start point, the 'y' co-ordinate of the start point, the 'x' co-ordinate of the end point, and the 'y' co-ordinate of the end point respectively. If the point '*spoint*' is equal to the end point of the entity then the variable '*old*' is assigned to the start point of the entity. A new list is formed - variable '*new*' - where the start point is now defined in terms of $x2$ and $y2$. A substitution is then made that informs AutoCAD to re-define the start and end points of the entity. The variable '*new*' - the new start point co-ordinates - is now stored in the AutoCAD database against the DXF code 10, and the variable '*old*' - the new end point co-ordinates - is stored in the AutoCAD database against the DXF code 11. The

attributes of the entity are now changed in order to follow the direction of machining. The new end point of the entity will now form the start point, '*spoint*', of the next entity.

If the point '*spoint*' is equal to the start point of the entity then the process described above is not performed and the end point of the entity will form the start point, '*spoint*', of the next entity.

6.1.8 Arc function

This function has four local variables;

- centre point of the arc
- start and end angle of arc
- radius of the arc

It uses three global variables;

- a counter
- list of entities in the machining profile
- start point of entity

The function retrieves from the AutoCAD database, using the DXF codes, the values for the centre point (*cpt*), start angle of arc (*angs*), end angle of arc (*ange*), and the radius (*dist*). From this information the polar points are calculated for the start (*pols*) and end (*pole*) points of the arc. If the point '*pols*' is equal to the '*spoint*' then the start point of the next element '*spoint*' is assigned to the polar point that corresponds to the end angle of the arc. Otherwise the start point of the next entity is assigned the polar point that corresponds with the start angle.

6.1.9 Element test

The function has six local variables;

- element / entity type (arc or line)

- centre point of arc
- start angle of arc
- end angle of arc
- radius of arc
- polar point of start point

It has eight global variables;

- counter
- list of entities in the machining profile
- start point of entity
- tool approach angle
- tool trailing angle
- list of tool approach angles
- list of tool trailing angles
- start point of profile

The main purpose of this function is to initialise the element test for lines and arcs. After the element test for lines function is executed the '*spoint*' is made equal to the end point of the entity and this serves as the start point for the next entity. In the case of arcs, a test is required to establish whether point '*spoint*' is equal to the polar point equivalent of the start or end angle of the arc. If the point '*spoint*' is equal to the polar point (*pols*) of the start angle, then the point '*spoint*' will be set to equal the polar point equivalent to the end angle of the arc. If the opposite is true then the point '*spoint*' will be set equal to the polar point equivalent to the start angle of the arc. The point '*spoint*' will serve as the start point of the next element.

The function prints to the screen the approach and trailing angles for each entity. Two lists are formed to store the approach and trailing angles respectively for all the entities that make-up the machining profile. Then the maximum approach and trailing angles of the selected entities are calculated.

6.1.10 Element test for lines

This function has six local variables;

- entity start point - x value
- entity start point - y value
- entity end point - x value
- entity end point - y value
- distance moved in the x-axis from the start point to the end point
- distance moved in the y-axis from the start point to the end point

It also uses five global variables;

- direction the entity moves in the x-axis apropos of the starting point
- direction the entity moves in the y-axis apropos of the starting point
- counter
- list of entities in the machining profile
- machining direction
- type of turning operation

The function begins by extracting the (x, y) values for the start and end points of an entity. The process is aided by the use of four built-in functions of AutoLisp, namely, 'cadr', 'caddr', 'assoc', and 'nth'. The function 'nth' extract the required entity from the entity list '*entlist*'. The function 'assoc' in conjunction with the appropriate entity's DXF group code, retrieves the list of geometrical information applicable to the points of the entity. Finally the functions 'cadr' and 'caddr' are used to extract from this list of geometrical data the (x, y) values for the start and end points. The distance moved, '*dcp_x*', in the x-axis from the start point to the end point of the entity is deduced from the two points '*entep_x*' (entity end point -x value) and '*entsp_x*' (entity start point - x value). The distance moved, '*dcp_y*', in the y-axis from the start point to the end point of the entity is deduced from the two points; '*entep_y*' (entity end point - y value) and '*entsp_y*' (entity start point - y value).

If the distance moved, '*dcp_x*', in the x-axis from the start point to the end point of the entity is greater than zero then the direction, '*dir_x*', of the entity is considered positive and is assigned the value of '1'. If the distance moved, '*dcp_x*', is less than zero then the direction, '*dir_x*', is considered negative and is assigned the value of '2'. If the distance moved, '*dcp_x*', is zero then the direction, '*dir_x*', is considered to be zero and is assigned the value of '0'. If the distance moved, '*dcp_y*', in the y-axis from the start point to the end point of the entity is greater than zero then the direction, '*dir_y*', of the entity is considered positive and is assigned the value of '1'. If the distance moved, '*dcp_y*', is less than zero then the direction, '*dir_y*', is considered negative and is assigned the value of '2'. If the distance moved, '*dcp_y*', is zero then the direction, '*dir_y*', is considered to be zero and is assigned the value of '0'.

This function prints to the screen the values of '*dir_x*' and '*dir_y*' for each entity considered in the machining profile. Finally the function determines the initialization of the next test function and this is dependent upon the machining direction '*md*' and the type of turning operation '*turn*'.

6.1.11 Lines in right to left machining (external)

This function has no local variables but uses ten global variables;

- direction the entity moves in the x-axis relative to the starting point
- direction the entity moves in the y-axis relative to the starting point
- distance moved in the x-axis from the start point to the end point
- distance moved in the y-axis from the start point to the end point
- element angle
- approach angle of the element
- trailing angle of the element
- maximum approach angle of available external tools
- maximum trailing angle of available tools
- clearance angle

This function is initialised under the following conditions; line type entities, a machining direction of right to left, and external turning. The main purpose of this function is firstly to determine if the entity in question can be machined using the proposed direction of machining. Secondly, it will establish the approach, ('*EAA*'), and trailing, ('*ETA*'), angles of the entity. It will then perform a test in order to confirm if the entity can be machined, taking into consideration the maximum approach, ('*AAMAX*'), and trailing, ('*TAMAX*'), angles of the available tooling, and the specified clearance angle '*CANGLE*' between the tool and the workpiece. If either the approach or trailing angles of the element exceed the maximum values of the available tooling then a message will appear on the screen indicating that the entity can not be machined. Otherwise the element can be machined and the suitable tool's approach ('*TAA*') and trailing ('*TTA*') angles will be calculated.

This function comprises eight conditions which are described below. Each condition represents a scenario based on the direction of the entity in relation to the x and y axis.

Case 1: (+, -)

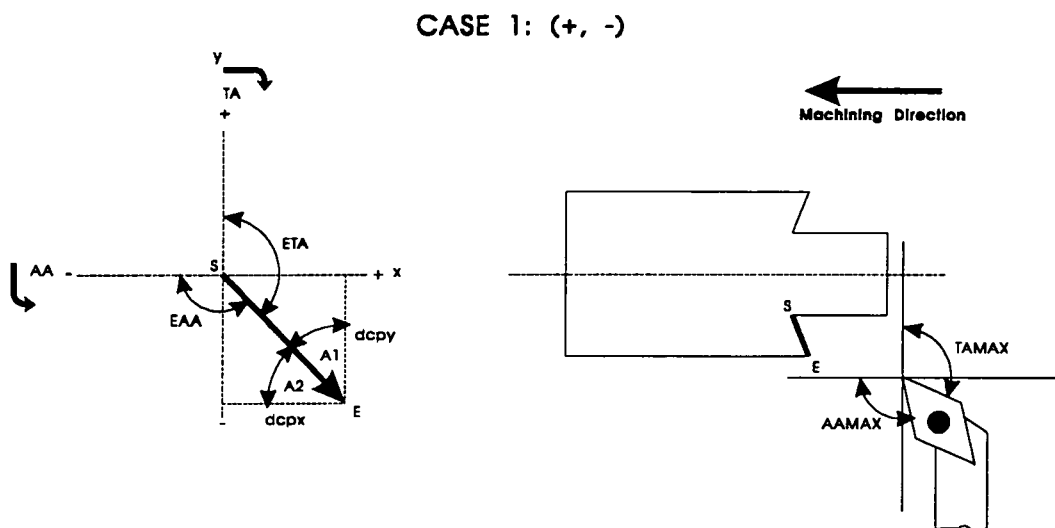

The first scenario represents a situation in which the entity has a positive direction in relation to the x-axis and a negative direction in relation to the y-axis. The values '1', (movement in the positive direction), and '2', (movement in the negative direction), are assigned to '*dirx*' and '*diry*' respectively. The element angle, ('*A1*'), element approach

angle (' EAA '), and trailing angle (' ETA ') are calculated. The main test in this scenario is to establish whether the element's approach angle, ' EAA ', is not greater than the maximum approach angle of the tools minus the specified clearance angle ' $(AAMAX - CANGLE)$ '. If the test is successful then the tooling approach, ' TAA ', and trailing ' TTA ', angles are calculated. If the test fails then a message will appear on the screen.

Case 2: (-, +)

The second scenario represents a situation in which the entity has a negative direction in relation to the x-axis and a positive direction in relation to the y-axis. The values '2', and '1', are assigned to ' $dirx$ ' and ' $diry$ ' respectively. The element angle, (' $A1$ '), element approach angle (' EAA '), and the trailing angle (' ETA ') are calculated. The main test in this scenario is to establish whether the element's trailing angle, (' ETA '), is not greater than the maximum trailing angle of the tools minus the clearance angle ' $(TAMAX - CANGLE)$ '. If the test is successful then the tooling approach, ' TAA ', and trailing, ' TTA ', angles are calculated. If the test fails then an appropriate message will appear on the screen.

CASE 2: (-, +)

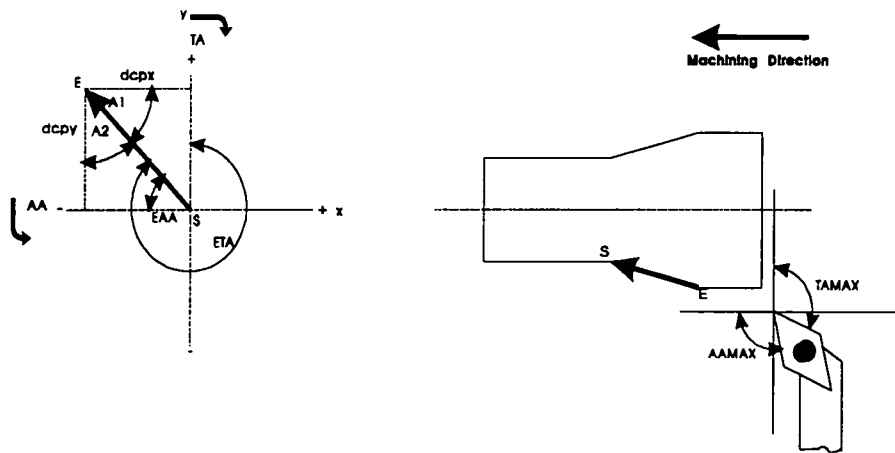

Case 3: (+, +)

Both directions in this case are positive. There is no further test in this scenario since the system predicts that it is not possible to produce such an entity when machining in this direction.

CASE 3: (+, +)

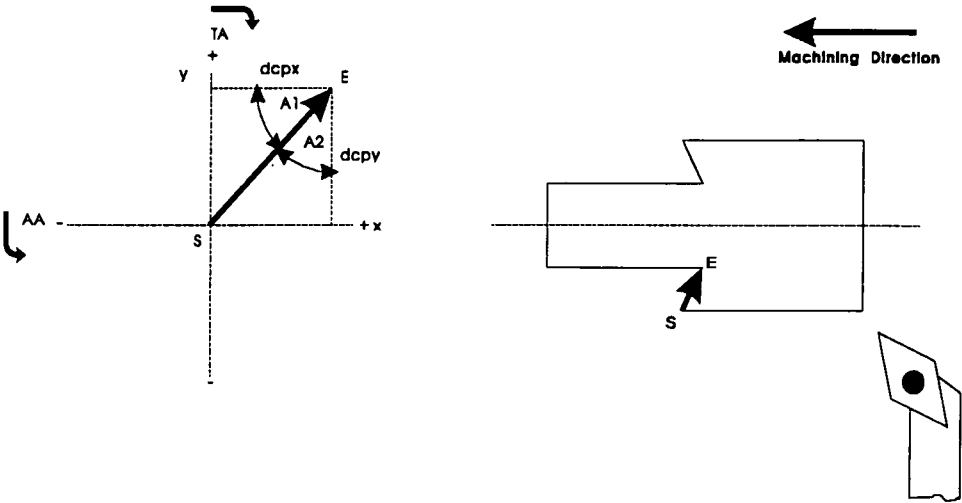

Case 4: (+, 0)

The fourth scenario represents a situation in which the entity has a positive direction in relation to the x-axis and there is no movement in relation to the y-axis. There is no test in this scenario since the system automatically identifies that it is not possible to produce the entity when machining in this direction.

CASE 4: (+, 0)

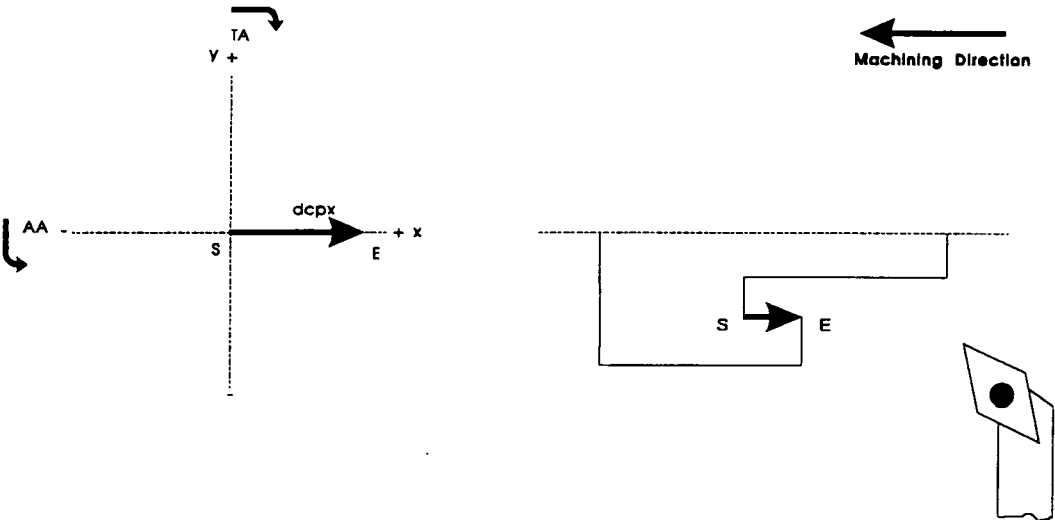

Case 5: (-, -)

In the fifth scenario both directions are negative. There is no test in this scenario as it is possible to produce the entity when machining in this direction.

CASE 5: (-, -)

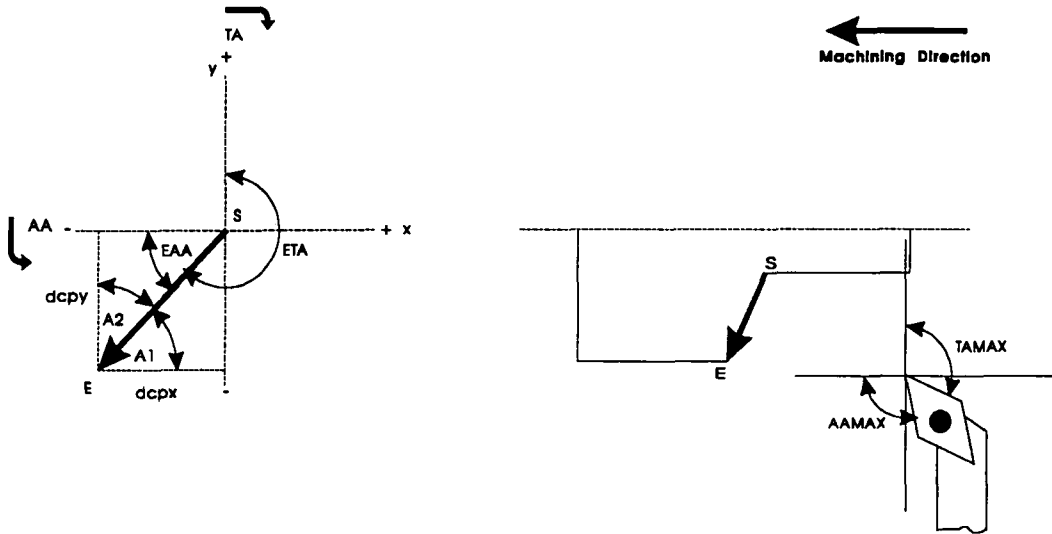

Case 6: (-, 0)

The sixth scenario represents a situation in which the entity has a negative direction in relation to the x-axis and there is no movement in relation to the y-axis. In this test there is no test as it is always possible to produce the specific entity when machining in this direction.

CASE 6: (-, 0)

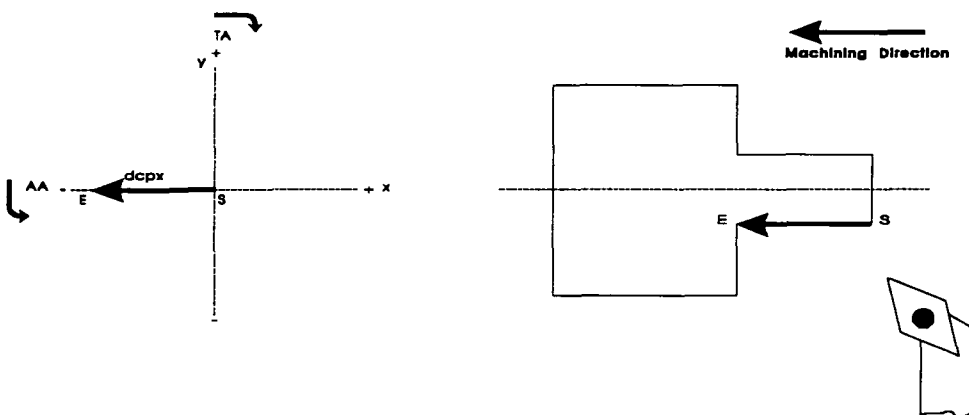

Case 7: (0, +)

This represents a situation in which the entity has no direction in relation to the x-axis and has a positive direction in relation to the y-axis. There is no test in this case as it is not possible to produce the entity when machining in this direction.

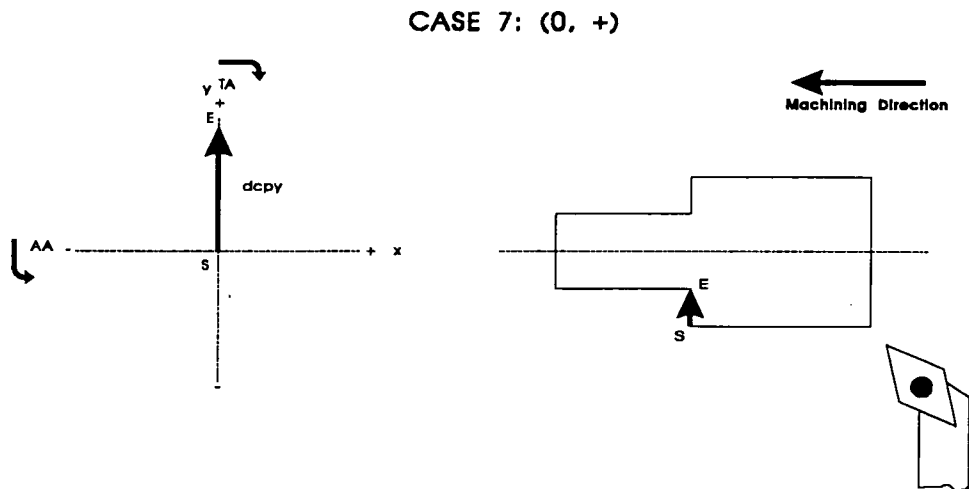

Case 8: (0, -)

The eighth scenario represents a situation in which the entity moves in no direction towards the end point on the x-axis and moves in a negative direction towards the end point on the y-axis. The tooling approach, 'TAA', and trailing, 'TTA', angles are calculated. There is no test for this scenario because this type of entity is easily machined

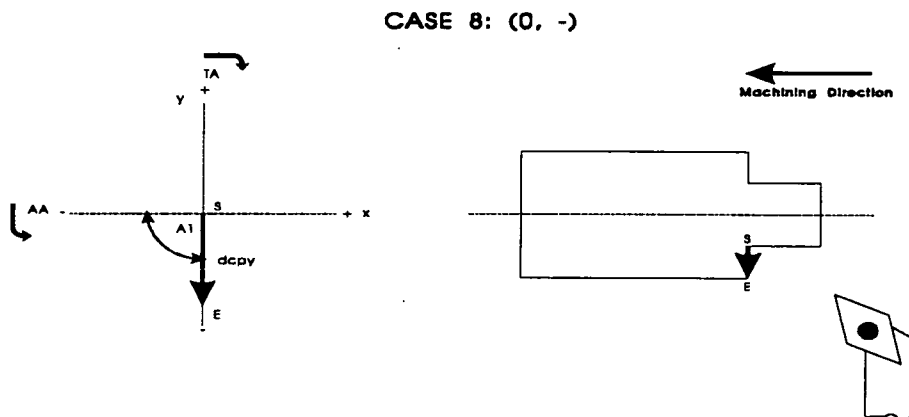

6.1.12 Lines in left to right machining (external)

This function uses variables which are the same as in the right to left situation described above. The following eight cases are considered herein and a similar approach is adopted in determining if the entity can be machined using the appropriate tools.

CASE 1: (+, -)

No test: This is always possible to machine.

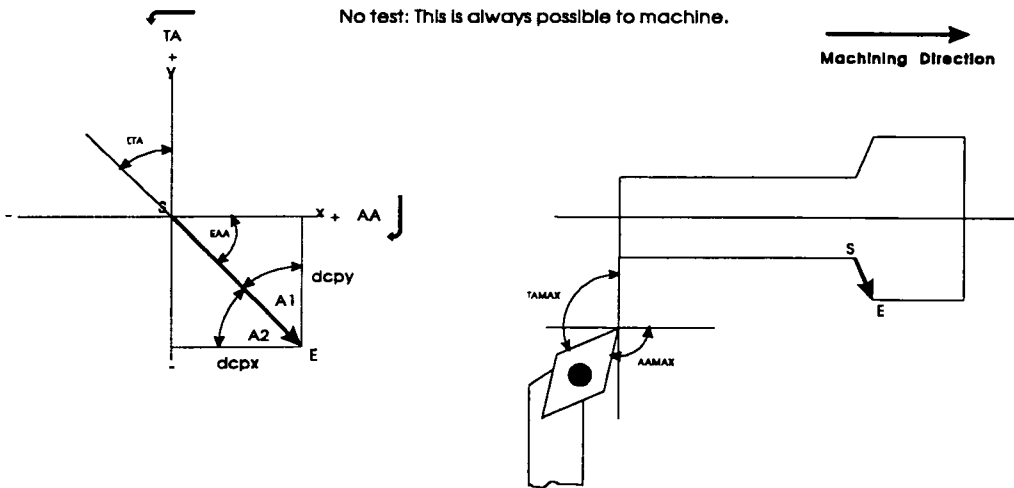

CASE 2: (-, +)

No Test: Impossible to machine.

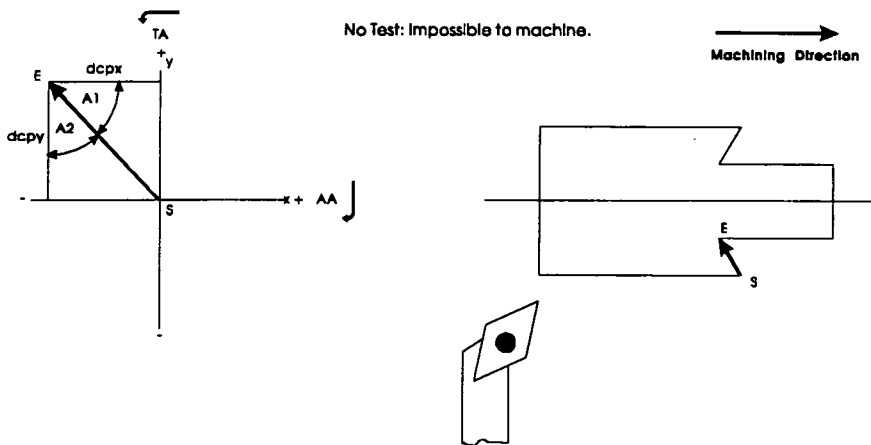

CASE 3: (+, +)

Test: Element trailing angle (ETA) must be less than or equal to the maximum trailing angle of tool (TAMAX) minus the clearance angle (CANGLE).

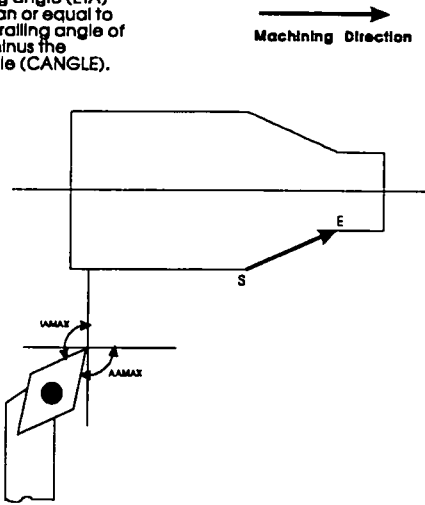
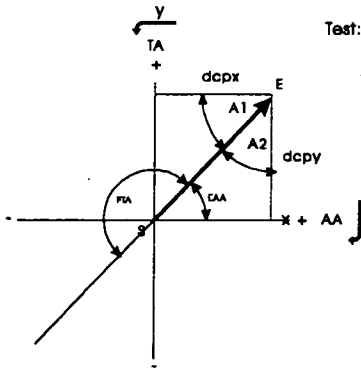

CASE 4: (+, 0)

No Test: Always possible to machine.

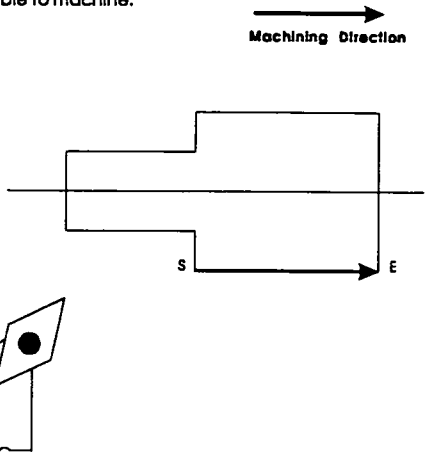
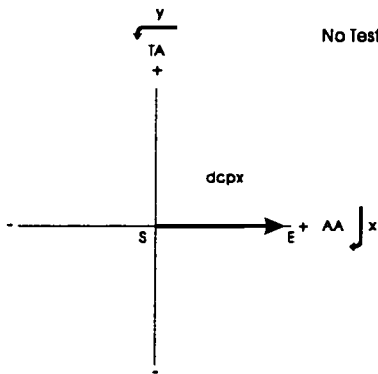

CASE 5: (-, -)

Test: The element approach angle (EAA) must be less than or equal to the maximum approach angle of the tool (AAMAX) minus the clearance angle (CANGLE).

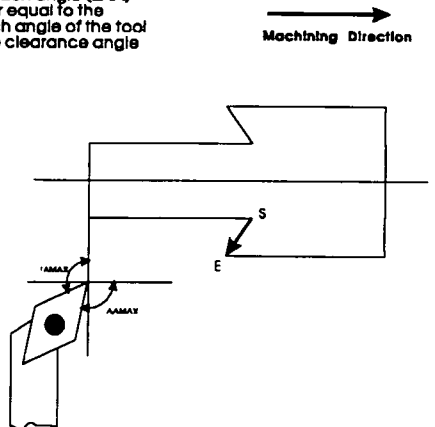
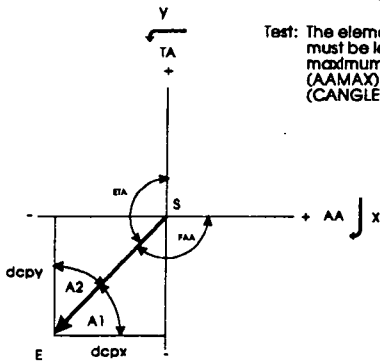

CASE 6: (-, 0)

No Test: Impossible to machine.

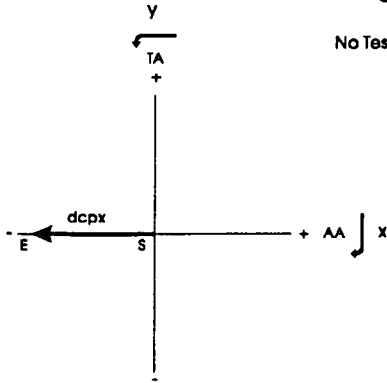

Machining Direction →

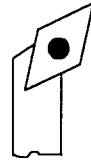
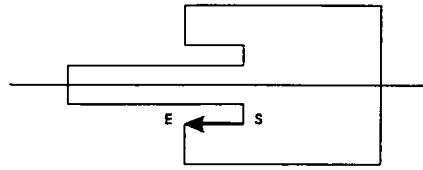

CASE 7: (0, +)

No Test: Impossible to machine.

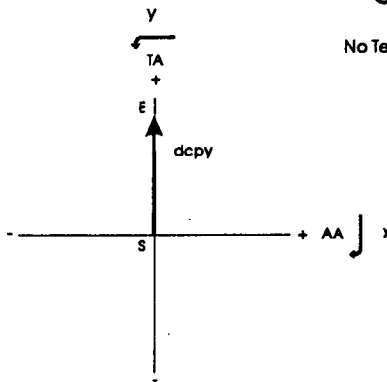

Machining Direction →

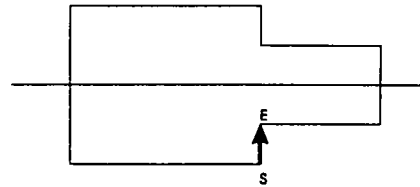

CASE 8: (0, -)

No Test: Always possible to machine.

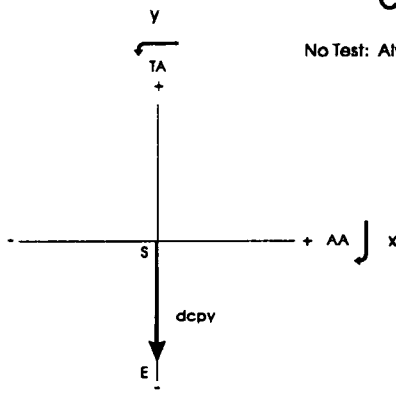

Machining Direction →

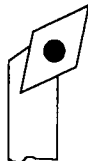
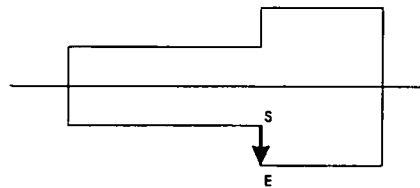

6.1.13 Lines in right to left machining (internal)

The variables in the two previously explained functions are used in this function in addition there are two extra global variables;

- maximum approach angle of available internal tools
- maximum trailing angle of available internal tools

The function comprises of eight conditions. Each condition represents a scenario of the direction the entity moves in relation to the 'x' and 'y' axes. Again, a similar procedure is adopted as outlined in the previous sections.

CASE 1: (-, 0)

No Test: The element is always machined.

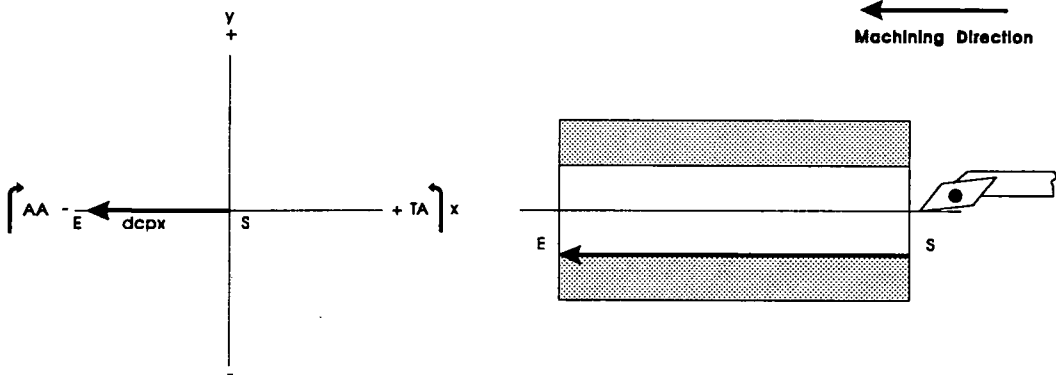

CASE 2: (+, +)

Test: The element approach angle (EAA) must be less than the maximum approach angle of the tool (AAMAX) minus the clearance angle (CANGLE).

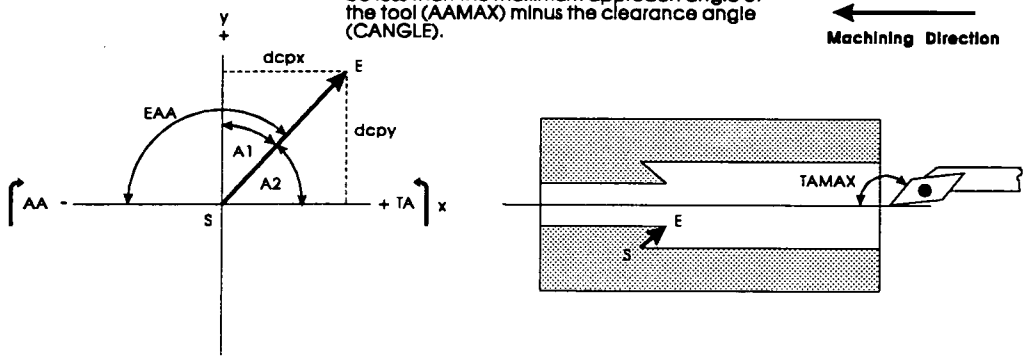

CASE 3: (0, +)

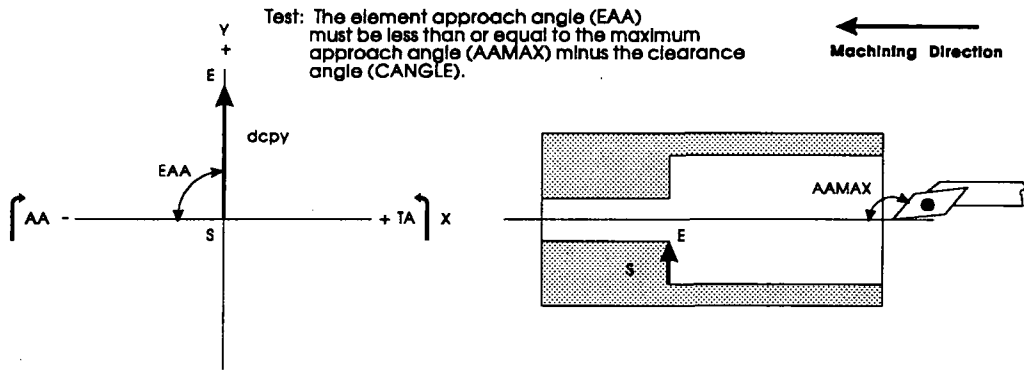

CASE 4: (-, +)

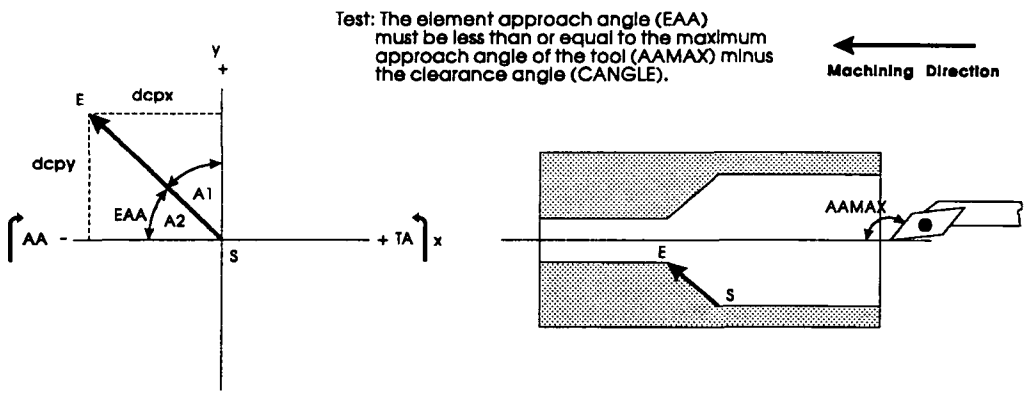

CASE 5: (-, -)

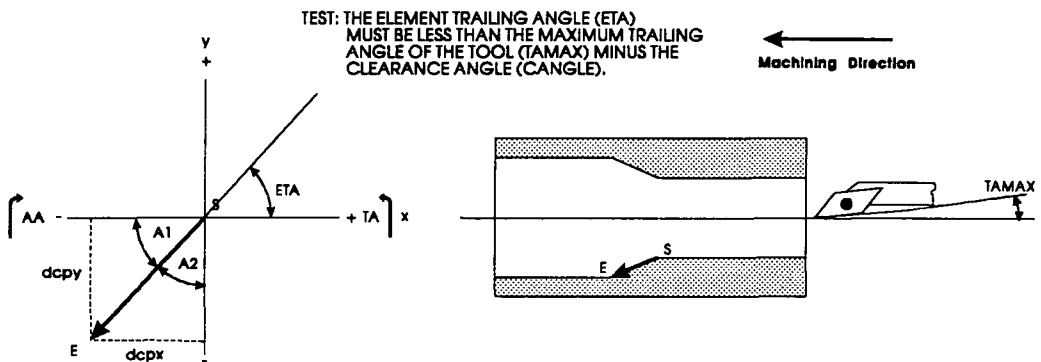

CASE 6: (0, -)

No Test: Element Impossible to machine.

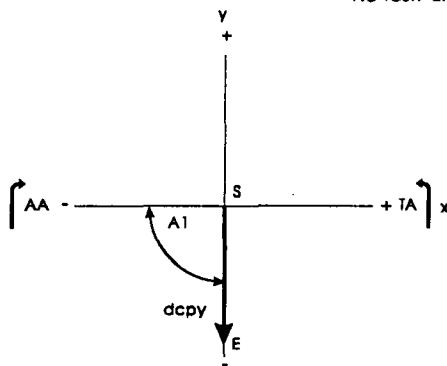

←
Machining Direction

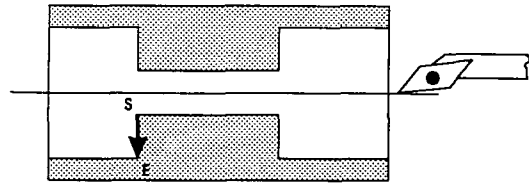

CASE 7: (+, -)

No Test: Element Impossible to machine.

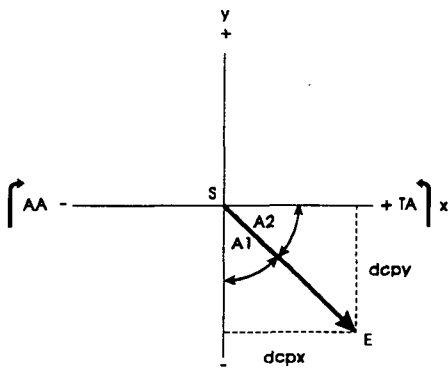

←
Machining Direction

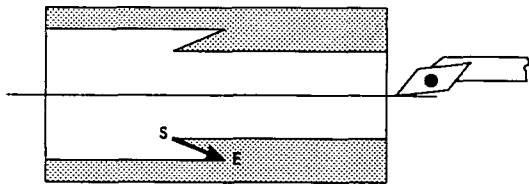

CASE 8: (+, 0)

No Test: Element Impossible to machine.

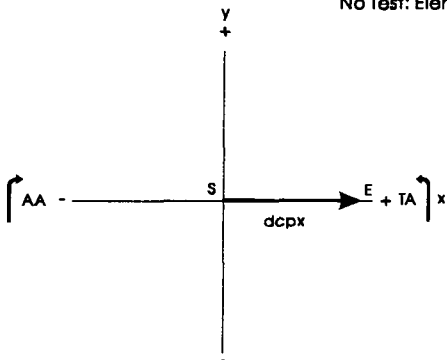

←
Machining Direction

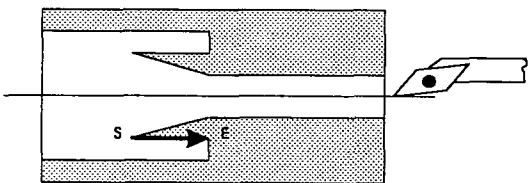

6.1.14 Lines in left to right machining (internal)

The variables in the three previously explained functions are used in this function. The method is very similar to the right to left internal machining and the only difference is the direction of machining.

6.1.15 Element test for arcs

This function has twelve local variables corresponding to:

- centre point of an arc
- start angle of an arc
- end angle of an arc
- radius of an arc
- polar point corresponding to the start angle of an arc
- polar point corresponding to the end angle of an arc
- x value of the start point of an arc entity
- y value of the start point of an arc entity
- x value of the centre point of an arc entity
- y value of the centre point of an arc entity
- x value of the polar point corresponding to the end angle of an arc
- y value of the polar point corresponding to the end angle of an arc

It uses fourteen global variables as shown below:

- list of entities in the machining profile
- start point of entity
- variable identifying which point is the start point of an entity
- the 'x' value of the distance from the centre point of the arc to the start point of the arc
- the 'y' value of the distance from the centre point of the arc to the start point of the arc

- the position of the starting point in the x-axis of the arc apropos of the centre point
- the position of the starting point in the y-axis of the arc apropos of the centre point
- machining direction
- approach angle of the arc at the start point
- approach angle of the arc at the end point
- tools approach angle
- trailing angle of the arc at the start point
- trailing angle of the arc at the end point
- tools trailing angle

The function begins by extracting the values from the entity list, for the centre point of the arc, start angle of the arc, end angle of the arc and radius of the arc. The process is aided by the use of three built-in functions of AutoLisp, namely, 'cdr', 'assoc', and 'nth'. The function 'nth' extracts the required entity from the previously compiled entity list. In conjunction with the appropriate DXF group code, the function 'assoc' retrieves the list of geometrical information pertinent to the points of the entity. The four DXF group codes used in this case include; Code 10 - centre point of arc; Code 50 - start angle of arc; Code 51 - end angle of arc; and Code 40 - radius of arc. Finally the function 'cdr' is used to extract the appropriate information from the list for the centre point of the arc, start angle of the arc, end angle of the arc and radius of the arc. The polar point related to the start point of the arc is calculated using the built-in function 'polar'. In addition, the 'x' and 'y' values of the start, end and centre points are calculated.

A test is performed to establish which point of the arc is equal to the start point of the entity. Depending on the outcome of this test the variable '*start_end*' will carry the value 'S' or the value 'E'. The value 'S' indicates that the start point of the arc is the start point of the entity relative to the machining direction '*md*' while the value 'E' indicates that the end point of the arc is the start point of the entity relative to the machining direction '*md*'. This correction is explained in Figure 5.



Figure 5: Establish which point of the arc is equal to the start point.

If the distance from the centre point of the arc to the start point of the arc in the x-axis, (*'spdcpx'*), is greater than zero, then the 'x' position of the starting point in the x-axis of the arc in relation to the centre point, (*'spdirx'*), is considered to be positive and is assigned the value '1'. If *'spdcpx'* is less than zero then *'spdirx'* is considered negative and is assigned the value '2'. If *'spdcpx'* is equal to zero then *'spdirx'* and is assigned the value '0'. A similar test is performed for the distance from the centre point of the arc to the start point of the arc in the y-axis, *'spdcpy'*.

The approach angle of the arc at the start and end points (*'AASP'* and *'AAEP'*) are calculated in order to establish which of the two is the largest. The largest is then assigned to the variable *'EAA'*, element approach angle. A similar process is followed for the trailing angles at the start and end points (*'TASP'* and *'TAEP'*) and the largest is assigned to the variable *'ETA'*, element trailing angle. The largest of both the approach and trailing angles are the minimum angles required for the tool to be able to create the arc profile. These will be compared with the approach and trailing angles of the tooling database.

6.1.16 Arcs in right to left machining (external)

This function uses the following global variables;

- end angle of arc
- start angle of arc
- list of entities in the machining profile

- the position of the starting point in the x-axis of the arc apropos of the centre point
- the position of the starting point in the y-axis of the arc apropos of the centre point
- maximum approach angle of tools available
- maximum trailing angle of tools available
- clearance angle
- element angle
- the 'x' value of the distance from the centre point of the arc to the start point of the arc
- the 'y' value of the distance from the centre point of the arc to the start point of the arc
- approach angle at the start point of the arc
- trailing angle at the start point of the arc
- approach angle at the end point of the arc
- trailing angle at the end point of the arc

This function is initialised under three conditions; arc type entities, a machining direction of right to left, and external turning. The main purpose of this function is firstly to determine if the entity in question can be machined using the proposed direction of machining. Secondly it will establish if the end angle, (*'endangle'*), and the start angle, (*'stangle'*) are within the acceptable limits for the particular entity. Thirdly, it will establish the approach and trailing angles at the start point and end point of the arc if the previous two steps are successful.

The function comprises of sixteen conditions. At the outset, the execution of this function will result in extracting the end angle and the start angle of the arc from the list *'entlist'*. It will also calculate the approach angle at the start and end points, *'AASP'* and *'AAEP'*, and the trailing angles at the start and end points, *'TASP'* and *'TAEP'*. The convention used in determining the direction is: where is the centre point in relation to start point of the arc.

Case 1: (+, -, S) and Case 2: (+, -, E)

The scenario represents a situation in which; the 'x' value of the distance from the start point of the arc, ('*spdcpx*'), to the centre point of the arc is positive, the 'y' value of the distance from the start point of the arc, ('*spdcpy*'), to the centre point of the arc is negative, and the actual start point of the entity, in accordance with the machining direction, is either the start point or end point of the arc.

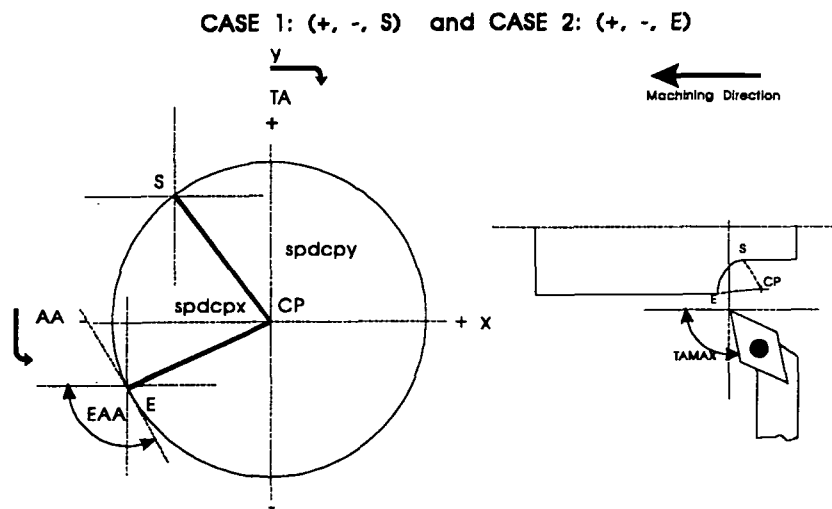

Test: The maximum element approach angle (EAA) of the arc is less than or equal to the maximum tool approach angle (AAMAX) minus the clearance angle (CANGLE).

Case 3: (+, +, S) and Case 4: (+, +, E)

This scenario represents a situation in which, the 'x' value of the distance from the start point of the arc, ('*spdcpx*'), to the centre point the arc is positive; the 'y' value of the distance from the start point of the arc, ('*spdcpy*'), to the centre point of the arc is positive; and the actual start point of the entity in accordance with the machining direction, is either the start point or end point of the arc.

CASE 3: (+, +, S) and CASE 4: (+, +, E)

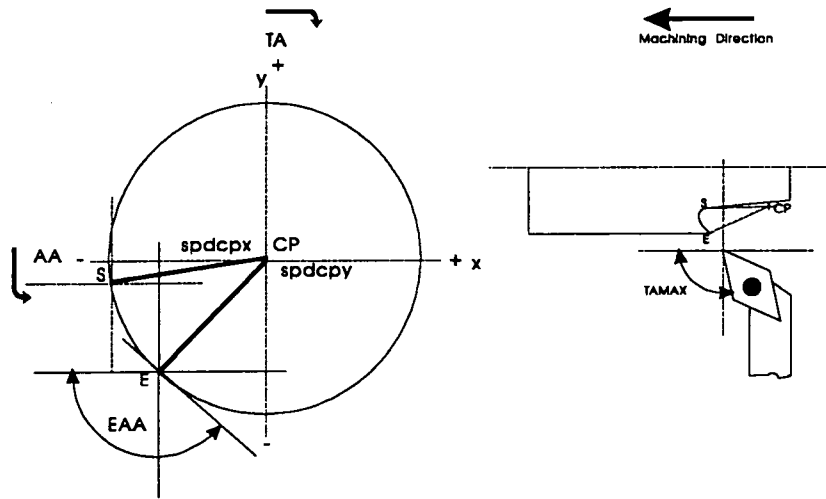

Test: The maximum element approach angle (EAA) of the arc is less than or equal to the maximum tool approach angle (AAMAX) minus the clearance angle (CANGLE).

Case 5: (+, 0, S) and Case 6: (+, 0, E)

CASE 5: (+, 0, S) and CASE 6: (+, 0, E)

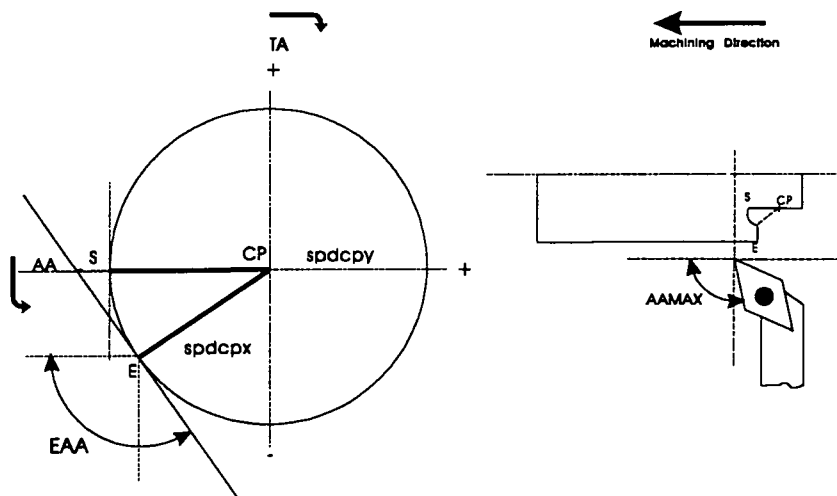

Test: The maximum element approach angle (EAA) of the arc is less than or equal to the maximum tool approach angle (AAMAX) minus the clearance angle (CANGLE).

This scenario represents a situation in which, the 'x' value of the distance from the start point of the arc, (*'spdcpx'*), to the centre point of the arc is positive; the 'y' value of the distance from the start point of the arc, (*'spdcpy'*), to the centre point of the arc to is zero; and the actual start point of the entity in accordance with the machining direction, is either the start point or end point of the arc.

Case 7: (-, +, S) and Case 8: (-, +, E)

This scenario represents a situation in which, the 'x' value of the distance from the start point of the arc, (*'spdcpx'*), to the centre point of the arc is negative; the 'y' value of the distance from the start point of the arc, (*'spdcpy'*), to the centre point of the arc is positive; and the actual start point of the entity in accordance with the machining direction, is either the start point or end point of the arc.

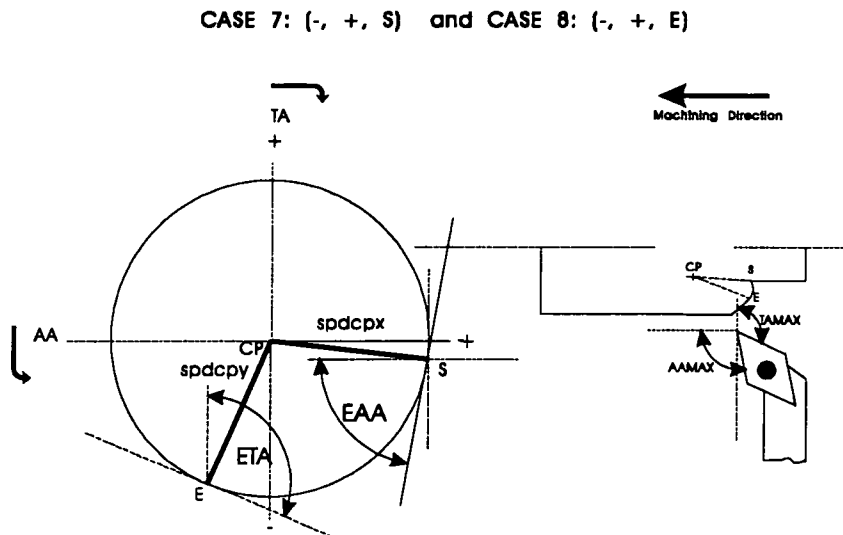

Test: The maximum element approach angle (EAA) is less than or equal to the maximum tool approach angle (AAMAX) minus the clearance angle. The maximum element trailing angle (ETA) is less than or equal to the maximum tool trailing angle (TAMAX) minus the clearance angle.

Case 9: (-, -, S) and Case 10: (-, -, E)

This scenario represents a situation in which, the 'x' value of the distance from the start point of the arc, ('*spdcpx*'), to the centre point of the arc is negative; the 'y' value of the distance from the start point of the arc, ('*spdcpy*'), to the centre point of the arc is negative; and the actual start point of the entity in accordance with the machining direction, is either the start point or end point of the arc.

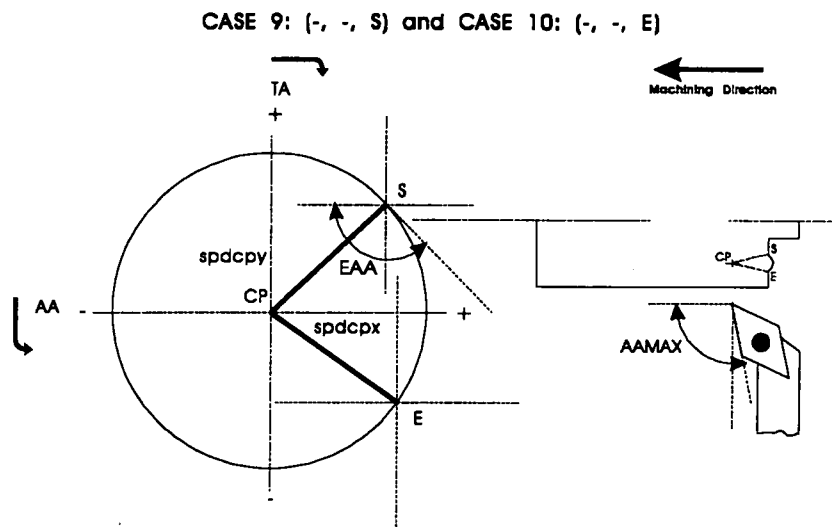

Test: The maximum element approach angle (EAA) is less than or equal to the maximum tool approach angle (AAMAX) minus the clearance angle (CANGLE).
The maximum element trailing angle (ETA) of the arc is less than or equal to the maximum tool trailing angle (TAMAX) minus the clearance angle.

Case 11: (-, 0, S) and Case 12: (-, 0, E)

This scenario represents a situation in which, the 'x' value of the distance from the start point of the arc, ('*spdcpx*'), to the centre point of the arc is negative; the 'y' value of the distance from the start point of the arc, ('*spdcpy*'), to the centre point of the arc is zero; and the actual start point of the entity in accordance with the machining direction, is either the start point or end point of the arc.

CASE 11: (-, 0, S) and CASE 12: (-, 0, E)

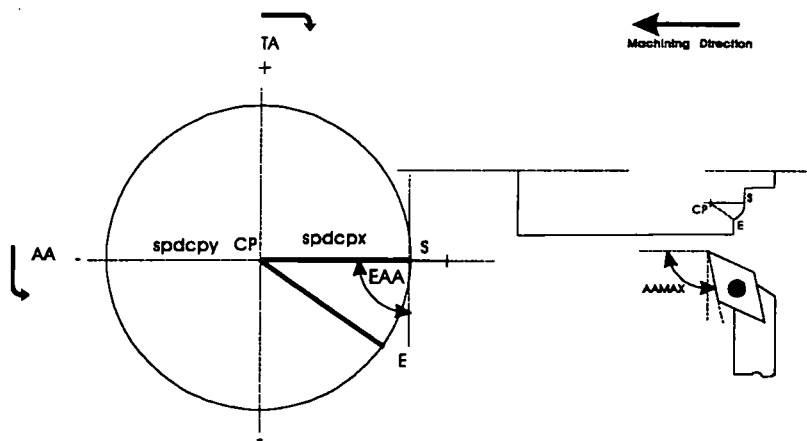

Test: The maximum element approach angle (EAA) of the arc is less than or equal to the maximum tool approach angle (AAMAX) minus the clearance angle. The maximum element trailing angle (ETA) is less than or equal to the maximum tool trailing angle (TAMAX) minus the clearance angle.

Case 13: (0, -, S) and Case 14: (0, -, E)

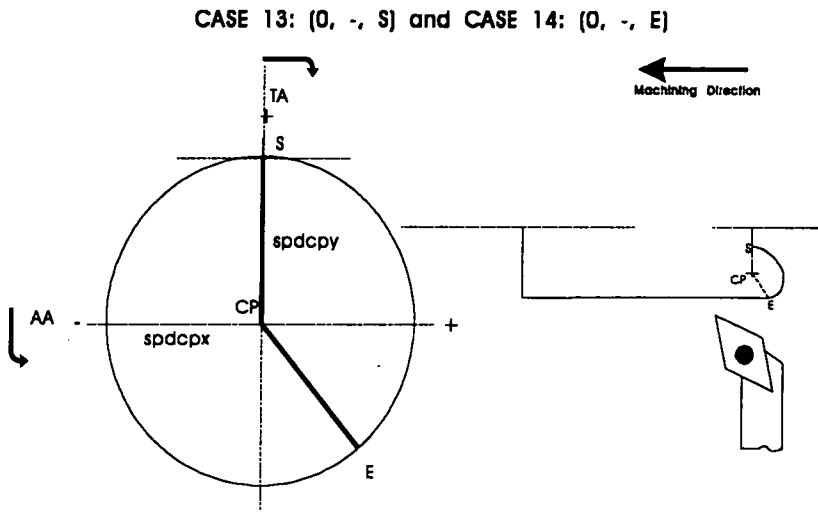

No Test: Not possible to machine this profile.

This scenario represents a situation in which, the 'x' value of the distance from the start point of the arc, (' $spdcpx$ '), to the centre point of the arc is zero; the 'y' value of the distance from the start point of the arc, (' $spdcpy$ '), to the centre point of the arc is negative; and the actual start point of the entity in accordance with the machining direction, is either the start point or end point of the arc.

Case 15: (0, +, S) and Case 16: (0, +, E)

This scenario represents a situation in which, the 'x' value of the distance from the start point of the arc, (' $spdcpx$ '), to the centre point of the arc is zero; the 'y' value of the distance from the start point of the arc, (' $spdcpy$ '), to the centre point of the arc is positive; and the actual start point of the entity in accordance with the machining direction, is either the start point or end point of the arc.

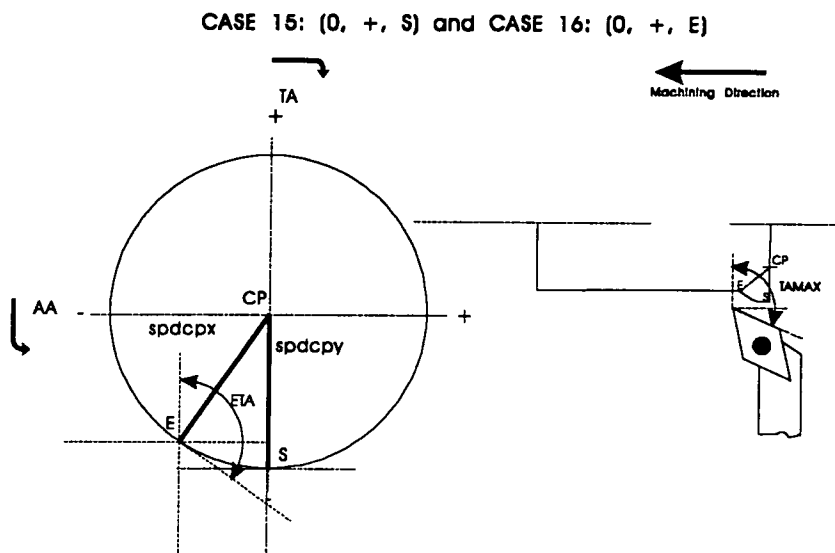

Test: The maximum element trailing angle (ETA) of the arc is less than or equal to the maximum tool trailing angle (TAMAX) minus the clearance angle (CANGLE).

6.1.17 Arcs in left to right machining (external)

This function uses the same global variables as previously explained function for right to left machining. The scenarios are very similar to those already explained.

6.1.18 Determine maximum approach and trailing angles

This function is used to calculate the maximum tool approach and trailing angles for the profile to be completely machined. The tool approach and trailing angles for each entity of the machining profile are considered in turn. The maximum of the approach and trailing angles are assigned to '*TAAMAX*' and to '*TTAMAX*' respectively. The two maximum values will then be used by the heuristic technology module in order to determine the appropriate tool holder, inserts and cutting conditions.

6.2 Heuristic Tool and Cutting Data Selection Module

This section will discuss the heuristic module. It is an integral part of the geometry module and is used in the selection of tool holders, inserts and cutting conditions, based on rules generated by production engineers using manufacturing catalogues.

Selection of holders

This function has two local variables;

- job file to save selected tool holders
- external holders file

It makes use of three global variables;

- machining direction
- shank sizes of tool holders
- tool holder locking system

This is the main function for the selection of tool holders. The function opens the job file created by the graphics module and the tool holders file. It then initialises the reading of the tool holders file.

Test and write

The purpose of this function is to select the most suitable tool holders. In this process the range of acceptable sizes of the inserts' cutting edge, the machining direction and the shank size are considered. This retrieved information is used to assess whether the selected entities can be machined. Typical information concerning a holder is; 'PCLNR2020-09A 95.0 95.0'. For this specific tool holder the following tests are performed:

- the insert locking system must be equal to 'P';
- the machining direction must be equal to 'R' (right to left);
- the shank size must be equal to '20 x 20';
- the length of the cutting edge must be greater than or equal to '09' (9mm);
- the maximum approach angle is less than or equal to '95.0 deg.';
- the maximum trailing angle is less than or equal to '95.0 deg.';

If the holder passes all these tests it is then accepted as a valid option and stored in the database for further consideration. If any of these tests should fail then this holder will not be considered in subsequent stages.

Match inserts

At this stage suitable inserts are retrieved and matched with the tool holders selected in the previous step. The insert information retrieved includes the grade, type of cut suitability and nose radius. The holder/insert matching process will first start by extracting the grade from the retrieved insert and then proceed to perform the following test on a typical insert, 'CNMG120408-M5-TP20';

- the second character of the tool holder code should be equal to the first character of the insert code, that is, the tool holder shape and insert shape respectively.
- the fourth character of the tool holder code should be equal to the second character of the insert code, that is, the clearance angle of the tool holder and the insert clearance respectively;
- the cutting edge length of the tool holder should be equal to the cutting edge length of the insert;
- the first character of the chip breaker type, for example 'M' for medium, should be equal to the type of cut specified, that is, finish, medium or rough;
- the nose radius of the insert should be equal to that associated with either finish, medium or rough cuts;
- the insert grade is compatible with the component's material

If the insert passes all these tests the next stage will be the selection of a chipbreaker.

Selection of chipbreaker

The chipbreaker determines the applicable ranges for the depth of cut and feedrate, which is known as the a-s diagram. Any combination of depth of cut and feedrate which is within the application range is guaranteed to produce discontinuous chip. For a selected holder/insert combination this process establishes the chipbreaker type of a retrieved insert. The function will then search the chipbreaker data file to retrieve the chipbreaker information. The information retrieved includes the minimum and maximum feeds, and the minimum and maximum depth of cuts. Having established the chipbreaker capabilities his leads to the calculation of the cutting data described below.

Cutting data calculations

This function inherits all the information concerning the selected holder, insert and chipbreaker. The function opens the cutting data file and retrieves appropriate cutting conditions and interpolates them for the operation in hand. The cutting data information is retrieved from the database in the following form: "3/TP20/0.15/275.0/0.35/220.0/0.60/165.0#". The first character represents the material type; the second group of characters, 'TP20', represents the insert grade; the third and fourth groups, '0.15' and '275.0', represent the first set of finishing feed and speed respectively; the fifth and sixth group, '0.35' and '220.0', represents the next set of feed and speed for medium roughing; and finally, the seventh and eighth group, '0.60' and '165.0', are the final values for feed and speed and corresponds to roughing operations.

The first character of this string, the material type, is tested in order to establish whether it is equal to the material specified by the user. The next test is used to establish if the insert grade is equal to the grade specified in the string. If both these tests are 'true' it will then use this string to interpolate the cutting conditions, otherwise a new line is read until the material and grade match that of the given material and insert.

Chapter 7

Technology Module

7. Introduction

The previous chapter explained the operation definition, tool selection, insert selection, and the heuristic technology module. This information will now be used, in determining the most appropriate set of tooling and cutting conditions using the following methods.

7.1 Depth Of Cut And Feed Rate Calculations

7.1.1 Finishing operations

Depth of cut

For finish machining the depth of cut (a) is equal to the total depth of cut (a_{stock}).

$$a = a_{stock} \quad (7.1)$$

The depth of cut must be within the chipbreaker range (Figure 6), that is:

$$a_{c \min} \leq a \leq a_{c \max}$$

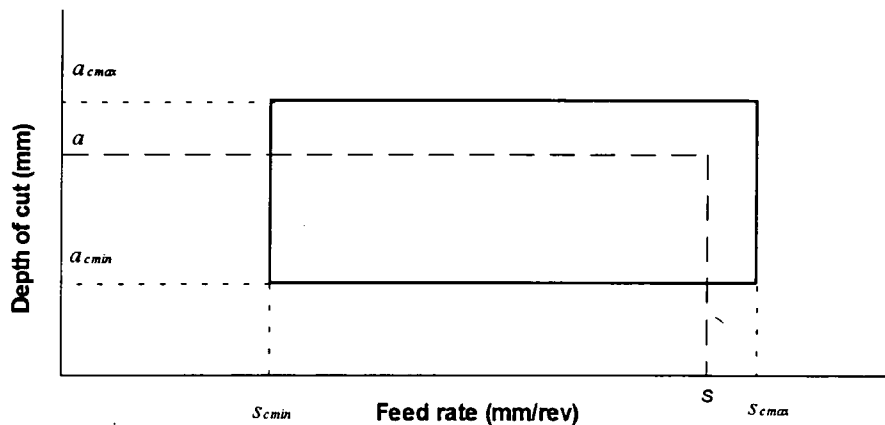

Figure 6. Chipbreaker application range diagram.

Feed rate

By using the surface roughness requirement (R_a) and the nose radius of the insert (r_e), the maximum allowable feed rate (s_{max}) is calculated using the following equation:

$$s_{r\ max} = (0.0312 \cdot r_e \cdot R_a)^{0.5} \quad (7.2)$$

The maximum allowable feed rate is then checked against the chipbreaker range where the maximum feed rate is determined by:

$$s = s_{max} = \min (s_{r\ max}, s_{c\ max})$$

Roughing operations

Depth of cut

The maximum effective cutting edge length of an insert is calculated as follows:

$$a_{t\ max} = \frac{2}{3} \cdot l_e \cdot \sin K \quad (7.3)$$

where; l_e = length of cutting edge;
K = tool's approach angle.

If the maximum effective cutting length ($a_{t\ max}$) is less than the maximum depth of cut due to chip-breaker diagram ($a_{c\ max}$) then the initial depth of cut (a) is set equal to the maximum effective cutting length ($a_{t\ max}$). Else, if the reverse is true, the initial depth of cut (a) is set equal to the maximum depth of cut due to chip-breaker diagram ($a_{c\ max}$).

The number of passes (n_{passes}) required to machine the total stock (a_{stock}) is calculated as follows:

$$n_{passes} = \text{int} \left(\frac{a_{stock}}{a} + 0.99 \right) \quad (7.4)$$

Feed rate

The maximum feed rate ($s_{r\ max}$) due to the nose radius (r_e) is given by:

$$s_{r\ max} = 0.8 r_e \quad (7.5)$$

If the maximum feed rate ($s_{r\ max}$), due to the nose radius (r_e), is less than the maximum feed rate ($s_{c\ max}$) due to the chip-breaker diagram, the initial feed rate (s) is equal to the maximum feed rate ($s_{r\ max}$). Else, if the reverse is true, the initial feed rate (s) is set equal to the maximum feed rate ($s_{c\ max}$).

7.1.3 Cutting forces

The cutting forces for a semi-orthogonal cutting operation are classified as follows:

- f_v = cutting force in the velocity direction;
- f_s = cutting force in the feed direction;
- f_a = cutting force in the depth of cut direction.

The following equations are used in calculating these cutting forces:

$$f_v = k_{sm} \cdot a \cdot s \quad (7.6a)$$

$$f_s = \text{ratiofs} \cdot f_v \quad (7.6b)$$

$$f_a = \text{ratiofa} \cdot f_v \quad (7.6c)$$

where; k_{sm} = specific cutting force (Nm);

ratiofs = ratio factor for f_s ;

ratiofa = ratio factor for f_a .

7.1.4 Force constraints

Velocity cutting force constraint

There are three main constraining forces which should be calculated during the machining operation, namely:

- f_{v1} = maximum force due to circumferential slip;
- f_{v2} = maximum force due to component throw-out;
- f_{v3} = maximum force due to machine tool power.

The following formula is used in calculating these constraining forces (refer to Figure 7):

$$f_{v1} = \frac{\mu \cdot f_g \cdot clmdia}{cpdia} \quad (7.7a)$$

where; μ = the coefficient of friction ($\mu = 0.3$);
 f_g = the clamping force (N);
 $clmdia$ = the clamping diameter inside the chuck (mm)
 $cpdia$ = the machining diameter (mm).

$$f_{v2} = \frac{0.5 \cdot (clmlen + \mu clmdia) \cdot f_g}{\sqrt{3} \cdot cpdist} \quad (7.7b)$$

where; $clmlen$ = the length of the workpiece inside the chuck (mm);
 $cpdist$ = maximum distance of the tool from the face of the chuck (mm).

$$f_{v3} = \frac{60000 \cdot P_{max}}{v_{max, power}} \quad (7.7c)$$

where; P_{max} = the maximum machine power (kW);
 $v_{max, power}$ = cutting velocity at maximum velocity (m/min).

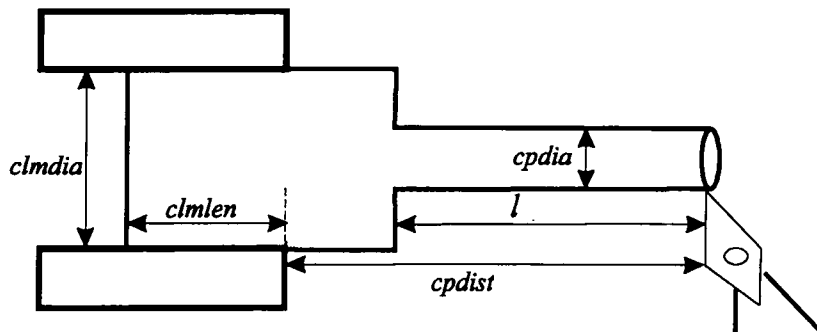

Figure 7. Major geometrical dimensions in calculating the constraining forces.

The cutting velocity corresponding to maximum power is calculated as follows:

$$v_{max, power} = \frac{\pi \cdot cpdia \cdot n_{max}}{1000} \quad (7.8)$$

where; n_{max} = is the maximum spindle speed (rpm) for maximum power.

Figure 8 shows the power-speed diagram of a machine tool. Clearly maximum power is available over a range of rotational speed (1200 to 3750 rpm). The maximum speed value is used in equation (7.8) in order to give a low constraining force using equation (7.7c)

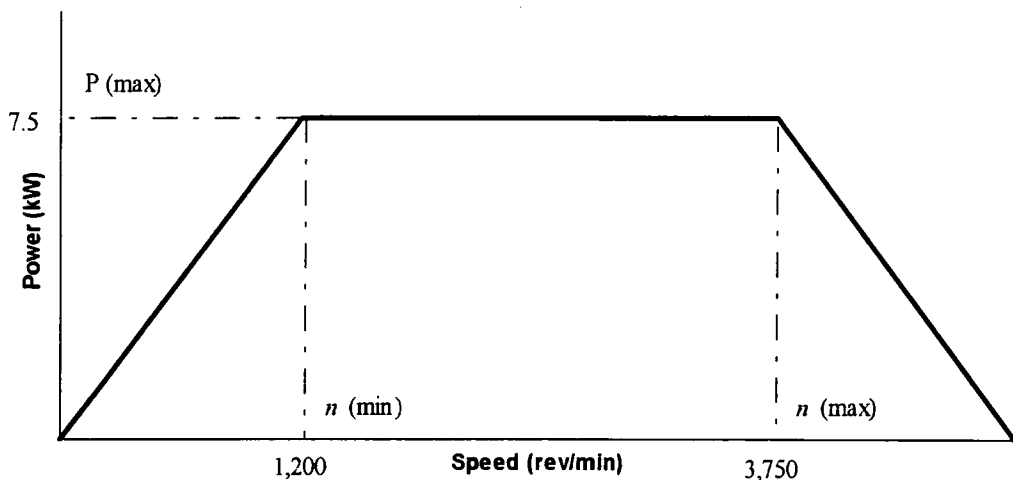

Figure 8. Power-speed diagram of a typical machine

The velocity cutting force (f_v) must be less than or equal to the minimum constraining force, that is;

$$f_v \leq \min (f_{v1}, f_{v2}, f_{v3}) \quad (7.9)$$

If this condition is not satisfied then a reduced velocity force is sought by reducing the feed rate for the same depth of cut. The feed rate is reduced to the minimum chipbreaking value ($s_{c min}$). If the condition still fails at this stage then the depth of cut will be reduced by increasing the number of passes by one and resetting the feed rate to its initial value.

$$n_{passes,new} = n_{passes} + 1 \quad (7.10)$$

and

$$a_{new} = \frac{a_{stock}}{n_{passes,new}} \quad (7.11)$$

where: $n_{passes,new}$ = new value for the number of passes;
 a_{new} = new depth of cut (mm).

This process will be repeated until the condition in equation (7.9) is satisfied.

Axial force constraint

The maximum axial force before the workpiece starts sliding in the chuck in the axial direction is given as:

$$f_{axial} = \mu \cdot f_g \quad (7.12)$$

where; f_{axial} = the maximum axial force (N).
 f_g = clamping force (N).

In longitudinal cutting the feed cutting force (f_s) satisfy the following condition;

$$f_s \leq f_{axial} \quad (7.13)$$

If this condition fails then a process, similar to the case described for the velocity cutting force constraint is applied to reduce the feed and depth of cut.

Radial force constraint

For single point support, the maximum radial force allowed can be calculated as follows:

$$f_{radial} = \frac{3 \cdot elc \cdot defcom}{cpdist^3} \quad (N) \quad (7.14)$$

where; f_{radial} = maximum radial force (N);

$$defcom = \frac{1}{2} \cdot (\text{diametral tolerance}) \quad (7.15)$$

$$elc = \frac{E \cdot \pi \cdot (D_{ext}^4 - D_{int}^4)}{64} \quad (7.16)$$

E = Young's modulus of elasticity (N/m²)

For longitudinal cuts, the depth of cut cutting force (f_a) must be less than the radial force, that is;

$$f_a \leq f_{radial} \quad (7.17)$$

If this condition fails, then a process similar to the one, as described for the velocity cutting force constraint, is applied to reduce the feed and depth of cut.

In the case of facing operations, the direction of the f_a and f_s force components is reversed and the following conditions should be satisfied:

$$f_a \leq f_{axial} \quad (7.18)$$

$$f_s \leq f_{radial} \quad (7.19)$$

At the end of this process all force related constraints have been satisfied and the values of depth of cut (a) and feed rate (s) are accepted as feasible cutting conditions.

Radial force constraint

Having calculated suitable depth of cut (a) and feed rate (s) this allows for the calculation of the cutting velocity. Cutting velocity influences tool life and the following optimisation criteria can be used.

- Optimum tool life for minimum cost:

$$T = \left(\frac{1}{\alpha} - 1 \right) \cdot \left(\frac{xt_3 + y}{x} \right) \quad (7.20)$$

- Optimum tool life for maximum production rate:

$$T = \left(\frac{l}{\alpha} - l \right) \cdot t_3 \quad (7.21)$$

- User defined tool life:

$$T = T_{user-defined} \quad (7.22)$$

where; l/α = velocity exponent in tool life equation

x = machine tool cost rate (£/min)

y = cost per cutting edge (£)

t_3 = tool changing time (min)

T = tool life (min).

The extended form of Taylor's equation is used for the calculation of cutting velocity for the optimal tool life.

$$V = \left(\frac{C}{T \cdot s^{1/\beta} \cdot a^{1/\gamma}} \right)^\alpha \quad (7.23)$$

Research within the Manufacturing and Design Research Group has resulted in an extended database of tool life constants (C_l , l/β , l/α) for finishing, medium roughing and roughing cuts, for different tool/workpiece combinations.

$$V = \left(\frac{C_l}{T \cdot s^{1/\beta}} \right)^\alpha \quad (7.24)$$

In this expression, C_l incorporates the influence of the depth of cut. This equation is used for the calculation of the optimal cutting velocity. The calculated velocity (V) should result in a spindle speed (n) which is within the useful range of the machine tool, that is, $n_{min} \leq n \leq n_{max}$.

$$n = \left(\frac{1000 \cdot V}{\pi \cdot d} \right) \quad (7.25)$$

where; d = cutting diameter (mm)

If the rotational speed is outside the machine tool range, it is set to the closest machine range value a suboptimal cutting velocity is calculated using equation (7.25).

At the end of the process described above, the three cutting parameters have been calculated.

Chapter 8

Tool Rationalization

8. Introduction

The previously explained work is concerned with the optimum selection of tool holders, inserts, and cutting conditions for a single operation. This Chapter will start by examining tool rationalization at the component, machine, multi-machine and tool store's level. It will then proceed to discuss in detail the rationalization at the component level.

Tool rationalization is important for the following reasons:

- Utilize similar tooling;
- Reduce the ratio of set-up time to manufacturing time;
- Reduce the cost of tooling;
- Improve tool management;
- Aid in standardization of tooling;
- Create a holistic view of the tooling problem.

Utilize similar tooling

Due to the nature of selection at the operation level it is likely that very similar tooling can be selected for the complete machining of a component. For example, two different tools can be selected for a facing and a longitudinal operation. On close examination it may be concluded that one tool could effectively achieve the same end result for the facing and longitudinal operations with little or no changes to the cutting conditions

Reduce the ratio of set-up time to machining time

The ratio of set-up time to machining time is very important. It is not satisfactory for the set-up time to be greater than the machining time because a large percentage of time is

attributed to non-value added activities and only a small percentage allotted to adding value. This is most significant when manufacturing organisations are seeking to create a Just in Time (JIT) environment, in the pursuit of minimising the amount of work in progress (WIP) and cash tied-up in stock. As the need arises to produce what is required then the ratio of set-up time to machining time is crucial to the economical production of small batch sizes. The possibility of using different tooling in preference to the optimum tooling then becomes real. Using one set of tools for a wide range of jobs may be more economic than using several sets of tools. The ratio of set-up time to machining time is an important criterion in this process.

Reduce the cost of tooling

Cost of tooling is an overhead and like all overheads must be minimized. Rationalization of the tooling will directly aid in reducing the overhead of a production facility. It will indirectly contribute to the reduction of the overhead by; less volume of tool stores, less management time, and reduced dealings with manufacturers of tooling, to name but a few.

Improve tool management

The overall management of tooling will be simplified by reducing the number of tools to a minimum. Less tooling means less cash tied up, less storage requirement, less variation in planning, fewer personnel, and simpler procedures for tool management.

Aid in standardization of tooling

A wide selection of tooling exists for the machining of various materials and the creation of the required component geometry. The type of materials an organisation requires during its manufacturing process will determine a main part of its tooling strategy. Just because five per cent of an organisation's machining is cast iron related, this should not warrant the automatic stocking of a wide selection of appropriate tooling. The breakdown by material class should be considered in establishing a realistic library of tooling for an organisation. The bias towards machining one type of material can obviously influence the standardization policy. In relation to geometry generation, it is

important to maintain commonality of shapes and sizes per machining cell in order to create a core tooling resource with the minimum number of tools.

Create a holistic view of the tooling problem

Rationalization is about taking a holistic view of the problem and arriving at an effective solution for the bigger system. It is about the optimum solution for the bigger problem not about arriving at the optimum solution for each individual part of the problem.

8.1 Rationalization System

The complete system will have five main modules concerned with rationalization at the component level, multi-batch level, multi-machine level and, shop floor and tool store's level. Only the rationalization at the operation and component level are complete at this stage. The remaining levels will form part of a future research programme. EXCEL and the built-in programming language, Visual Basic, are used as the programming tools because they are more effective than AutoLISP in the manipulation of data. The basic operation of the overall system is presented in Figure 9. The graphics and heuristic modules (TVRO_G) are discussed in Chapter 6.

8.2 Rationalization at the Operation Level - TVRO_T

The theory presented in chapter 7 is used in this part of the rationalization system. TVRO_T receives input from the TVRO_G module via operation data files. The TVRO_T module is broken into five main functions:

- ITS1 - retrieves and converts the AutoLisp files;
- ITS2 - collates the converted files;
- ITS3 - manipulates the chipbreaker data;
- ITS4(A) - technology equations;
- ITS4 - technology logic.



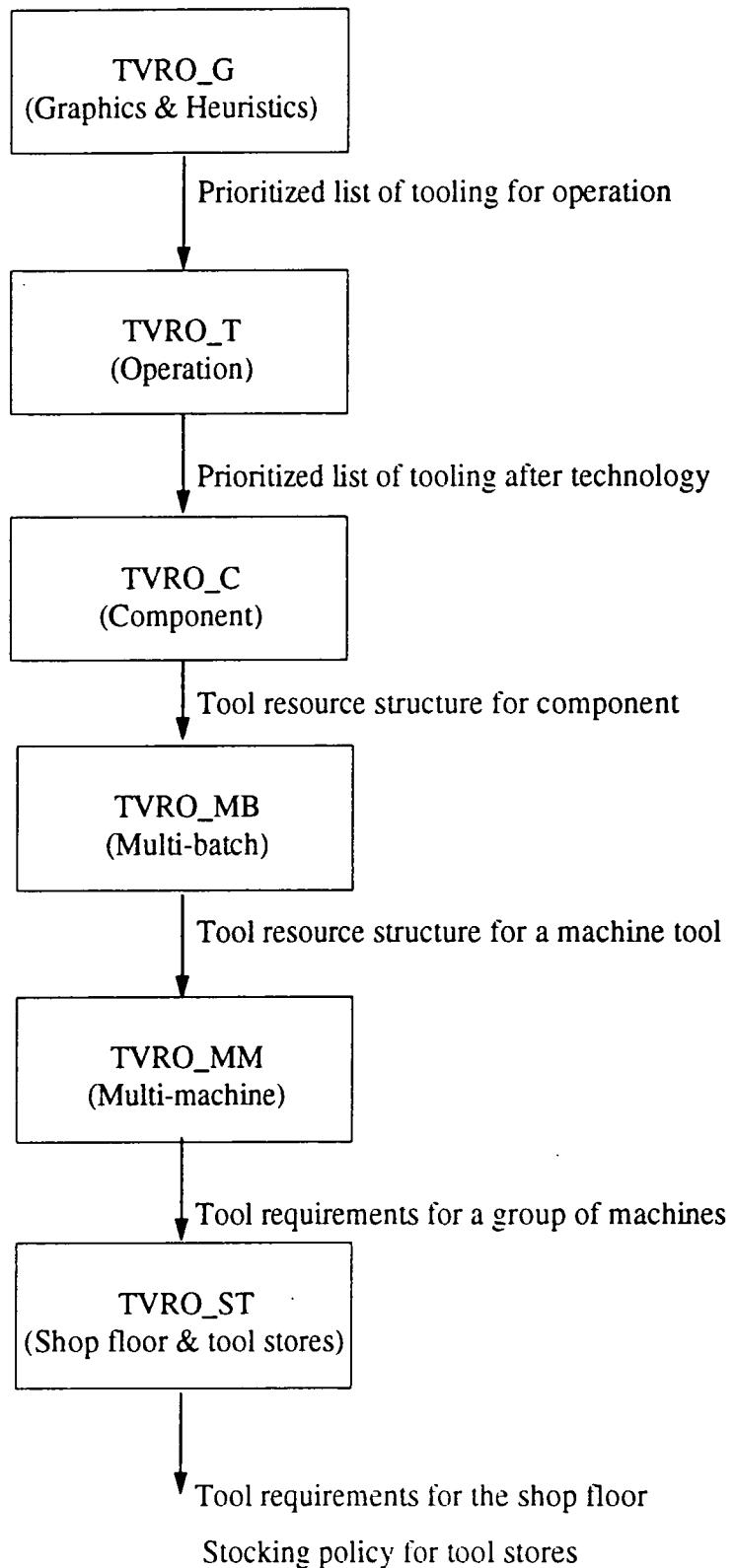

Figure 9: Overall functional operation of tool selection and rationalization.

The main purpose of the TVRO_T module is to further optimize the cutting conditions in relation to the machine tool being used. The system takes into consideration the generated forces attributed to a given depth of cut and feed rate, and compares these with the constraining forces. If the generated forces exceed the constraining forces then a reduction in the feed rate is initiated with no change in the depth of cut. The feed rate will be continuously reduced to the minimum allowed by the chipbreaker diagram. If the minimum is reached then the depth of cut is reduced and the process starts all over again. This process will continue until a suitable set of cutting conditions produce the generated forces that will not exceed the constraining forces as described in Chapter 6.

A summary of the TVRO_T module is as follows:

- ITS1 opens the text data files, produced by TVRO_G, for each operation and the associated general data for each operation. All the files are automatically converted into EXCEL format for easy manipulation.
- ITS2 collates, into one file, all the files associated with the component. For example, if the component required three operations then the number of job files would be three and these would be collated into a workbook. ITS2 also selects the optimum tool and cutting conditions for each operation using run time, approach angle and trailing angle as the selection criteria.
- ITS3 determines the maximum and minimum feed, and the maximum and minimum depth of cut for the insert using the chipbreaker information supplied.
- ITS4(A) contains the technology functions required for the technology evaluation.
- ITS4 defines the logic in which the technology equations are used. The tests considered at this stage include; the velocity force, the axial force, the radial force and the power requirement.

8.2.1 Detail Description of TVRO_T

ITS1

ITS1 is initialised by selecting the specially designed icon from the menu screen. ITS1 then informs the user that it will retrieve the operation files and convert them into the Microsoft Excel format. The user then has to acknowledge the message before proceeding any further. At this stage the user can also quit the process if so desired. The user is requested, via a message box, for the name of the job file. The default name will always be 'job?' where the user will replace the question mark with the job number, for example, job1. This will allow ITS1 to search the directory for all operation files having the prefix 'job1'. Obviously, this minimizes the amount of input required by the user. Having established all the files associated with the particular job, ITS1 will proceed in opening each file individually and formatting them. The basic formatting includes; breaking up the tool string as produced by the previous modules, the number of decimal places for the numerical columns and the auto fitting of each column. It then proceeds to reorganise the tool holder price, insert price and the number of cutting edges. At the end of this process the number of files opened will be determined by the number of operations required on the component. Figure 10(a) presents the ITS1 logic.

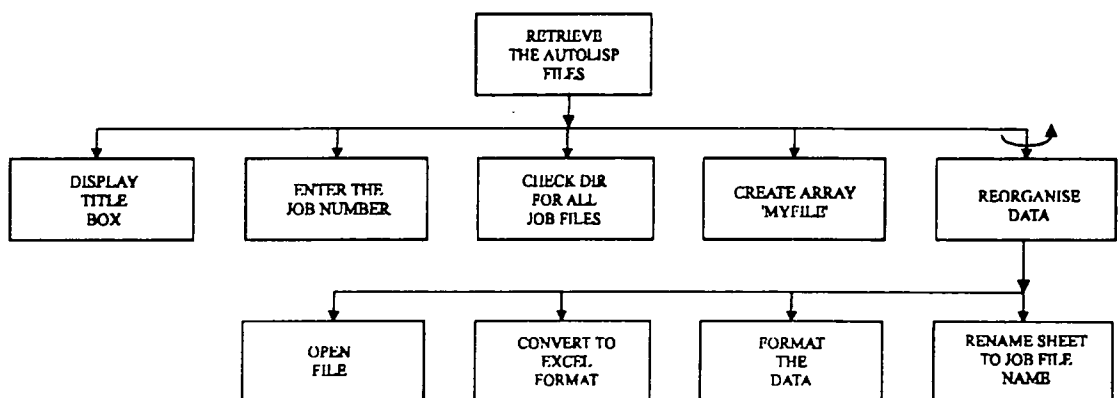

Figure 10(a): Data Handling - ITS1

The information contained for each operation in the job files include; tool holder, cutting length, approach angle, trailing angle, insert, chipbreaker type, insert grade, feed, velocity, depth of cut, material removal rate, volume to be removed, and run time - all determined by the TVRO_G module.

In addition to the operation files there is an additional file opened that contains the following information; total depth of cut, surface finish, type of cut, specific cutting force, clamping force, clamping diameter, maximum number of revolutions of machine, maximum power of machine, diametrical tolerance, optimization criteria, Young's Modulus, tool life coefficients, machine rate, tool change time, and machine efficiency. Clearly, when several operations are under consideration there is a considerable amount of information to be processed.

ITS2

ITS2 is initialized by selecting the specially designed icon. This informs the user that: "This function will collate all operation files into one Excel file. It then selects the optimum tool for each operation as recommended by the rules in TVRO_G." Having acknowledged this message by selecting the "OK" button, the user is requested to give

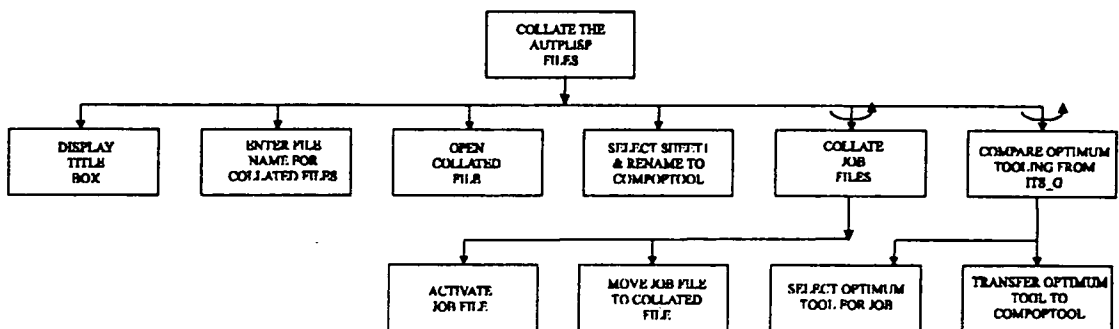

Figure 10(b): Data Handling - ITS2

the name of the file required to transfer all the operation files. The default file name is "JOBALL". The user is required to input the number of the job, for example, JOBALL1. A file is then created in the name of JOBALL1.XLS and the operation files and the data file are transferred. ITS2 adds an extra worksheet to the workbook called CompOpTool. This collates the optimum tool and the corresponding cutting conditions for each operation. Figure 10(b) shows the logic for ITS2.

ITS3

In a similar fashion, ITS3 is initialized by the specially designed icon. A message appears to the user indicating that “This function separates out the nose radius from the insert codes and retrieves the maximum and minimum feed and the maximum and minimum depth of cut as determined by the chipbreaker diagram”. Having acknowledged the message the user is requested to provide the identification of the JOBALL file that is required to be opened. If ITS3 is being initialised directly after ITS2 then the default file will be as specified when running ITS2, for example, JOBALL1.XLS. Having determined the chipbreaker type for each selection, ITS3 will then proceed to determine the maximum and minimum feed and the maximum and minimum depth of cut due to chipbreaking. The values for each of these variables are hard coded into ITS3. ITS3 will then proceed to update each operation worksheet within the workbook and the columns S-W are completed. The columns are denoted as follows; S = nose radius; T = maximum feed; U = minimum feed; V = minimum depth of cut; W = maximum depth of cut. All these columns are then formatted and the workbook is saved and closed. Figure 10(c) shows the logic for ITS3.

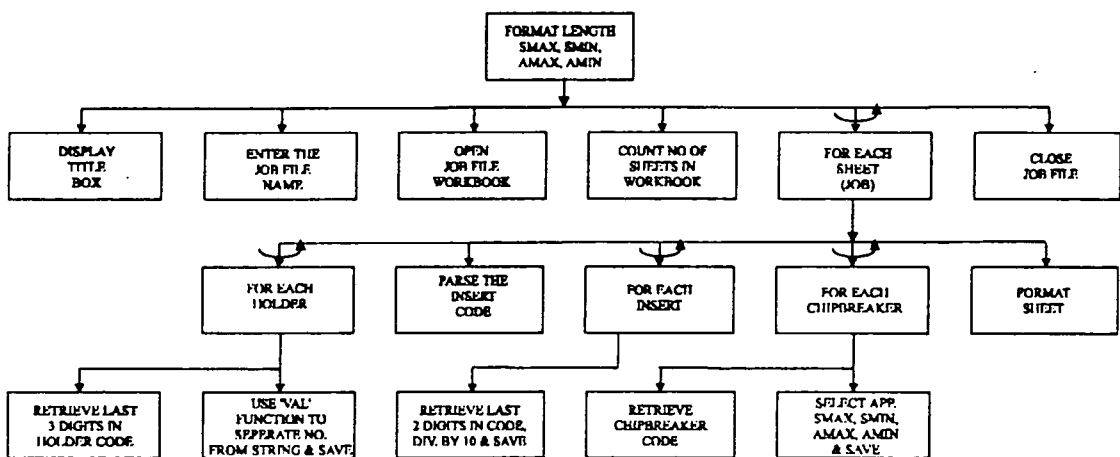

Figure 10(c): Data Handling - ITS3

ITS4 and ITS4(A)

ITS4 defines all the required equations, as outlined in chapter 7, to run the function ITS4(A). ITS4(A) is the technology function and like all other functions is initialized by

selecting its own icon. A message will appear to the user: "This is concerned with the use of the technology equations. Tests include: (1) check the velocity forces, (2) check the axial force, (3) check the radial force; and (4) check the power requirement.". Having acknowledge this message by selecting the "OK" button the user is requested to enter the JOBALL file name. Again, if this function was initialised after ITS3 then the last JOBALL in use will be displayed in the message box, otherwise the specific file name must be entered. It then retrieves data for the first operation from the data file and assigns them to the appropriate variables. It would then select the first operations sheet and work through each recommended set of tooling using the technology equations explained in Chapter 7. It will compare the operating forces against the constraining forces. If the operating forces exceed the constraining forces the feed and depth of cut will be incrementally reduced in that order until they reach their minimum values. If the situation occurs that both minimum values are reached and the constraints are not satisfied then this solution for the operation is not valid. Having worked through the operations sheet the solutions are saved. The solutions are then sorted using the following criteria; run time, approach angle and trailing angle. The optimum tool for each operation is selected and saved in the CompOpTool sheet. Figure 10(d) shows the logic for ITS4.

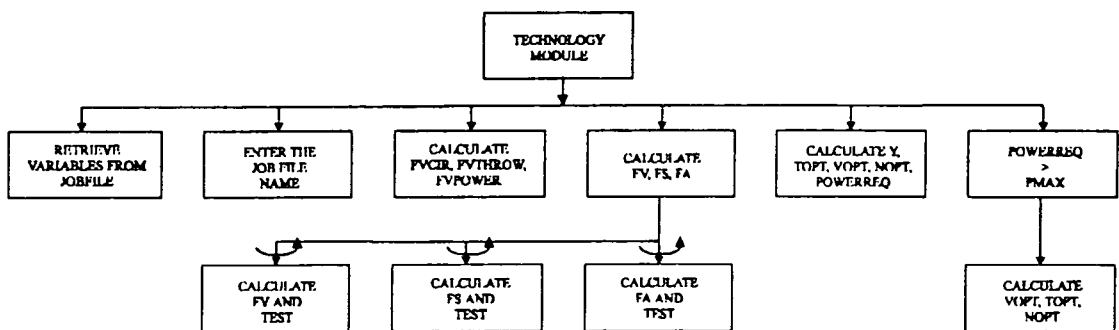

Figure 10(d): Technology - ITS4(A)

8.3 Rationalization at the Component Level - TVRO_C

This module considers the operation plans for the whole component. Its main purpose is to rationalize the tooling requirements for the component and in doing so consider the batch size. The module contains the following functions:

- ITS5 - time and cost functions;
- ITS5(A) - time and cost logic;
- ITS6 - exact match logic
- ITS7 - check the operation files for an exact match;
- ITS8 - similarity test.

8.3.1 Detail Description of functionality

ITS5

This contains the time and cost formulae.

- Calculate the total set-up time;

$$setup = tosut + (cosut \cdot batch) \quad (8.1)$$

where; $setup$ = total setup time (mins.);
 $tosut$ = tool setup time (mins.);
 $cosut$ = component setup time (mins.);
 $batch$ = batch size.

- Calculate the total run time;

$$runtime = oprun \cdot batch \quad (8.2)$$

where; $runtime$ = total run time (mins.);
 $oprun$ = operation run time (mins.).

- Calculate the ratio of set-up time to run time;

$$ratio = setup / runtime \quad (8.3)$$

where; $ratio$ = ratio of setup time to run time.

- Calculate the effective utilisation;

$$effutil = (runtime / (setup + runtime)) \cdot 100 \quad (8.4)$$

where; $effutil$ = effective utilisization (%);

- Calculate the total time; and

$$tottime = setup + runtime \quad (8.5)$$

where; tottime = total time (mins);

- Calculate the total cost.

$$tot\ cost = \left(\left(\left(\frac{tosu}{noce} \right) \cdot \left(\frac{runtime}{T_{opt}} \right) \right) + \left(\frac{setup + runtime}{60} \right) \right) \cdot (labrate + mcrate) + \left(y \cdot \left(\frac{runtime}{T_{opt}} \right) \right) \quad (8.6)$$

- Cost per cutting edge.

$$y = \left(\frac{coi}{0.75 \cdot noce} \right) + \left(\frac{1.3 \cdot coh}{400} \right) \quad (8.7)$$

where; noce = number of cutting edges;

T_{opt} = optimum tool life (mins);

labrate = labour rate (£/min.);

mcrate = machine rate (£/min.);

y = cost per cutting edge (£);

coi = cost of insert (£);

coh = cost of holder (£)

ITS5(A)

The ITS5(A) function is initialised by selecting the appropriate icon. This will then display a message box informing the user: "This function is concerned with checking the number of tool posts on the machine against the number of tools required to machine the component. It will use the formulae explained in ITS5 to calculate the appropriate time and cost." After acknowledging this message the user is requested to input the JOBALL file name.

The system will then check the number of tools in the CompOpTool file and check this against the number of tool posts available on the machine. A message box is then

displayed which highlights to the user if the number of tools exceeds or does not exceed the number of tool posts.

Finally, ITS5(A) creates a worksheet called SUMMARY which summarises the Tool Resource Structure (TRS) for the component. It contains the job, holder, insert, chipbreaker, insert grade, approach and trailing angles, total set-up time, total run time, set-up/run time ratio, effective utilisation, total time and total cost. The formulation of the TRS is vital for converting the machining requirements into tooling requirements. The tooling requirements can then be used for tool rationalization and tool management. Figure 11(a) shows the logic for ITS5.

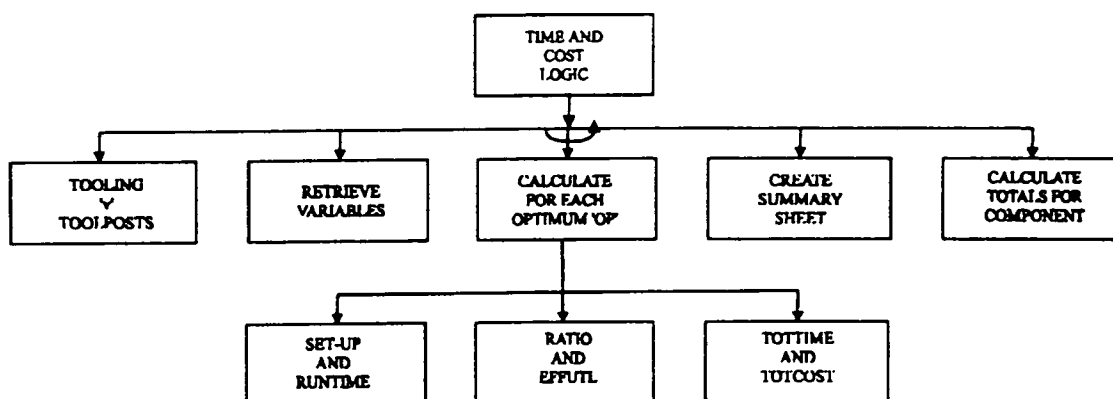

Figure 11(a): Time and Cost - ITS5

ITS6

This function is initialised in a similar manner by the user. The user must use two criteria is deciding to pursue the rationalization any further; first, if the number of tools exceeds the number of tool posts and second, if there are any exact (identical) tools in the TRS displayed in the SUMMARY sheet. For example a machine tool may only have the capacity for four tools. If the complete machining of a component requires five different optimum tools then due to the constraint of the machine these five tools need to be reduced to four. The function checks the SUMMARY sheet of optimised tooling for the component and establishes the exact tooling. It will then make the appropriate adjustments and recalculate the total time and cost. Figure 11(b) shows the logic for ITS6.

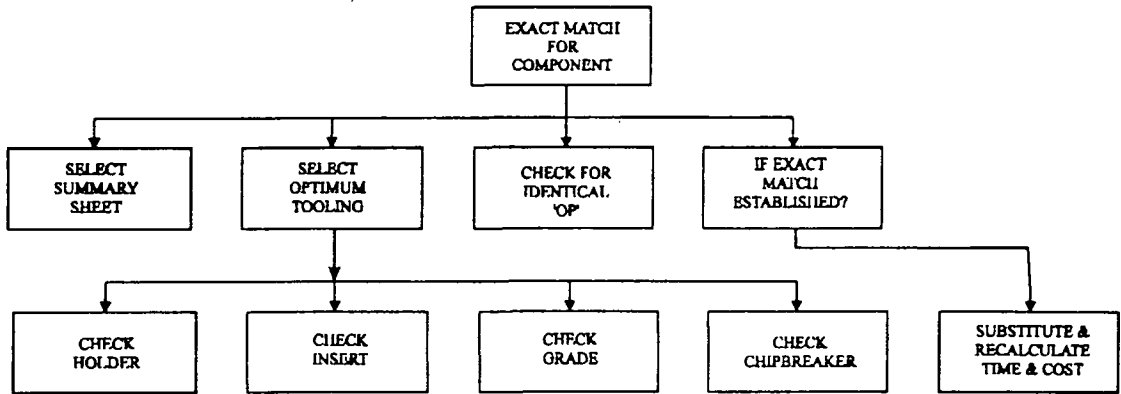

Figure 11(b): Exact match for component - ITS6

ITS7

This function implements the exact matching of tools described in ITS6. If a further reduction in tooling is required at the component level then, each operation file for the component is searched for an exact match. If an exact match is found that will perform all operations on the component this is considered as the optimum tool and the total time and cost are calculated. ITS7 selects a job file and then selects the optimum tool and cutting conditions. It then selects the other job files and then start the process of searching for an exact match by considering; tool holder, insert, insert grade, and chipbreaker. This process is repeated until an exact match is established. Figure 11(c) shows the logic for ITS7.

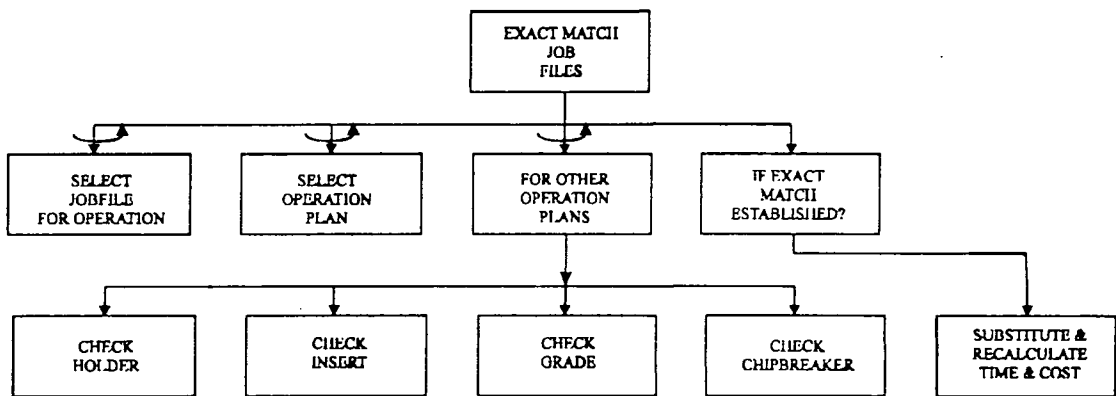

Figure 11(c): Exact match for component (Check job file) - ITS7

ITS8

If further reductions are required and there are no identical tools available, a similarity test is performed using the tool, insert, grade and chipbreaker as the similarity criteria. Figure 11(d) shows the logic for ITS8.

The first test is for the tool holder and the test is referred to as the 'Down Scaling Test'. The test is concerned with the substitution of an appropriate tool holder by taking into consideration the approach and trailing angles of the profile. A tool holder can be used for an alternative operation if its approach and trailing angles are larger than those of the original tool holder. However, there may be a case where the profile does not constrain the selection of a tool holder and therefore an alternative holder can be used even if its angles are smaller than those of the original tool. Because there will also be a change in insert, it is essential to first check if the original feed and depth of cut are within the chipbreaker capability of the new tool. If they are not, then it is necessary to recalculate the cutting conditions because the insert cannot operate outside the chipbreaker boundaries.

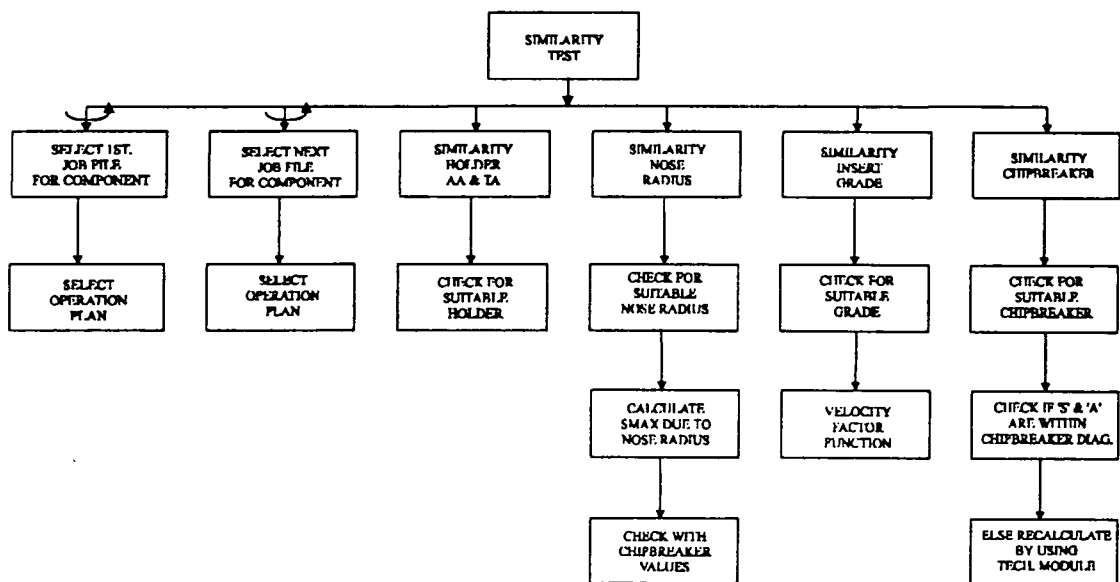

Figure 11(d): Similarity Test - ITS8

The second test is in relation to the nose radius of the insert. A large nose radius can always substitute a smaller nose radius in terms of its feedrate capability and the surface

roughness generated on the workpiece. Hence, the rule is that an insert with a larger nose radius replaces the insert with a smaller nose radius. When a substitution is proposed, one should also check whether the chipbreaker of the new insert can use the original value of feed rate. If yes, the substitution is acceptable, otherwise the feed rate for the operation is set equal to the maximum allowed by the new insert's chipbreaker.

The third test is in relation to the grade of the insert. This test is termed the 'velocity factor' test since the insert carbide grade test is directly influencing the cutting velocity. Table 1 shows the compatibility of modern grades for various material groups and also include the recommended cutting velocities for various feedrates. The table is used to identify whether a substitution of carbide grades is possible. For example, for material group 3, one cannot substitute a TP10 for a TP05. When a substitution is possible, as in the case of a TP15 being substituted by a TP20 for material group 3, the following procedure is adopted. If the calculated operating feed is 0.25 mm/rev for the TP15, then an interpolation is performed between velocities 275 and 220 to establish the ideal velocity using a TP20 insert. The ideal cutting velocity corresponding to feed of 0.25 mm/rev for the TP15 grade is found by interpolating between velocities 290 and 225. Using both of these interpolated values a factor is calculated. This factor is then multiplied by the originally calculated velocity for a new set of conditions. In summary;

- Material group = 3
- Original insert grade = TP15
- Proposed substitution = TP20
- Calculated feed rate using TP15 = 0.25mm/rev
- Calculated velocity using TP15 = 200m/min
- Velocity for TP15 @ 0.15mm/rev = 290m/min
- Velocity for TP15 @ 0.35mm/rev = 225m/min
- Velocity for TP15 @ 0.25mm/rev = 275.5m/min
- **Velocity for TP20 @ 0.15mm/rev = 275m/min**
- Velocity for TP20 @ 0.35mm/rev = 220m/min
- **Velocity for TP20 @ 0.25mm/rev = 247.5m/min**

- Factor = 247.5 / 275.5
- New velocity for TP20 substitution = 200 * (247.5 / 275.5) = 179.67m/min

STEEL Material Group No.	Recommended cutting velocity, m/min																	
	TP05			TP10			TP15			TP20			TP30			TP40		
	0.15	0.35	0.60	0.15	0.35	0.60	0.15	0.35	0.60	0.15	0.35	0.60	0.15	0.35	0.60	0.15	0.35	0.60
1	-	-	-	450	335	265	400	315	240	380	300	225	340	265	160	-	-	-
2	-	-	-	380	300	225	340	265	200	325	255	190	290	225	140	-	-	-
3	-	-	-	325	255	200	290	225	180	275	220	165	245	190	120	190	150	90
4	-	-	-	270	210	165	240	190	145	230	180	135	200	160	85	155	120	75
5	240	205	-	230	180	-	200	160	-	195	150	120	175	140	85	130	105	65
6	215	185	-	205	180	-	180	160	-	175	140	-	155	120	75	120	95	70
7	-	-	-	90	-	-	80	70	-	80	60	-	55	45	-	-	-	-
<i>Stainless Steel</i>																		
8	-	-	-	260	210	-	230	180	140	225	180	135	195	155	95	150	120	70
9	-	-	-	205	-	-	185	160	-	175	150	-	155	120	75	120	95	60
10	-	-	-	-	-	-	100	85	-	95	-	-	90	70	55	60	50	40
<i>Cast Iron</i>																		
11	265	210	160	255	200	150	230	180	140	220	170	130	190	150	90	-	-	-
12	210	170	125	205	160	130	185	145	110	175	140	105	155	125	-	-	-	-
13	190	150	-	180	160	-	160	130	-	150	120	95	-	-	-	-	-	-
14	160	125	-	-	-	-	135	105	-	130	100	80	115	90	60	-	-	-
15	130	115	-	-	-	-	110	100	-	-	-	-	95	75	50	75	60	40

Table 1: Compatibility of grades and recommended cutting velocities (m/min)

The fourth test is related to the chipbreaker. The procedure is as follows: Retrieve the calculated feed and depth of cut used with the original tool; for the proposed new tool check the calculated conditions against its maximum and minimum values of the chipbreaker diagram; if the calculated conditions are within the maximum and minimum values then proceed with the substitution; if they are outside the maximum and minimum values then recalculate the conditions using the technology module.

Only ITS1 to ITS7 are fully programmed under this work. The similarity test, ITS8, has not been implemented. The operation of the rationalization modules implemented will be explained with the use of a number of examples in the following chapter. Future work will involve the programming of the similarity test, ITS8, and, rationalization at the Multi-batch Level (TVRO_MB), Multi-machine Level (TVRO_MM) and the Shop Floor and Tool Stores Level (TVRO_ST).

Chapter 9

Examples, Results and Discussion

9. Introduction

This chapter presents a number of examples in using the system currently developed. The examples will demonstrate the use of the Geometry and Heuristics Module (TVRO_G) in selecting tool holders, inserts and cutting conditions at the operation level. It will then demonstrate the use of the Tecnology Module (TVRO_T) to further optimize the cutting conditions at the operation level by using the *tecnology* presented in Chapter 7. Finally it will illustrate the workings of the Component Module (TVRO_C) in optimizing the tooling and cutting conditions.

9.1 Graphics and Heuristic Modules In Operation

This section will demonstrate the workings of the two modules by using seven examples that will be explained below. But first, in order to run both modules it is necessary to follow the following initialization procedure:

- Initialise Windows;
- Initialise AutoCAD;
- Select File, New to create a new drawing;
- Give the drawing a file name, for example, STEEL1
- Load the ACAD.LSP file. This file includes definitions of commonly used functions and they will be defined automatically once loaded.
- The ACAD.LSP file has a function that will load all the sub-modules of the graphics and technology modules known as SELECTION.

Having loaded the modules, AutoCAD is now ready to select tool holders, inserts and cutting conditions for any defined job. Seven examples will be given to explain the workings of the modules. The text in *italics* is the response given by the user.

9.1.1 Medium Roughing of a Profile - Operation Level

The following will detail three examples, of the same geometrical configuration, involving steel, stainless steel and cast iron. The first example will describe the common elements associated with the execution of the modules while the remaining two will detail the specific elements associated with different material and material sub-classes.

Example 1 - Medium Roughing of Mild Steel

- Draw the machine profile:

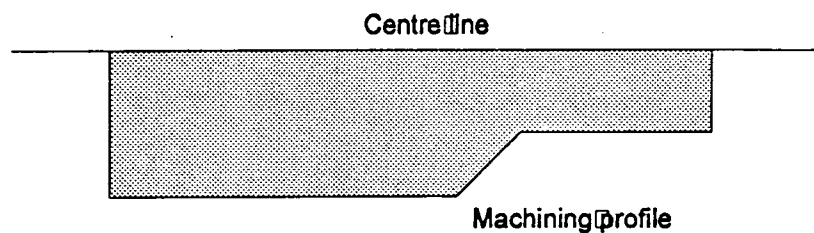

- At the "Command:" prompt type in ITSG and <CR>. This will initialise the graphics and technology modules.
- "Enter job identification number ?:" *JOB1* <CR>
- "External or internal turning (E/I) ?:" *E* <CR>
- "Right or left machining (R/L) ?:" *R* <CR>
- "Locking system - (1) Screw (2) Pin + Top Clamp (3) Pin/Wedge (4) Top Clamp (S/M/P/C) ?:" *P* <CR>

The screen will change to text mode and the following will be displayed:

- *****
TYPE OF CUT

Finish (=> 0.5 < 3.0)
Medium (=> 3.0 < 5.0)
Rough (=> 5.0 <= 12.0)
"Type of Cut (F/M/R) ?:" *M* <CR>

The screen will revert back to graphics mode and the following will be displayed:

- "Total depth of cut (mm)? " 15 <CR>
- "Type of Material - Steel; SStainless Steel; Cast Iron (S/T/C) ?:" S <CR>

The screen changes to text mode and the following subgroups of mild steel material class are displayed as shown below.

- *****
STEEL MATERIAL GROUP

 1. Very soft, tacky steels. Low-carbon steels and plain ferritic steels.
 2. Free cutting steels. Other than free-cutting stainless steels.
 3. Structural steels, ordinary carbon steels. Low to medium carbon content (<0.5%C).
 4. High carbon steels, ordinary low-alloy steels. Low-alloy steel castings. Normal medium-hard steels for tough hardening. High carbon steels (> 0.5%C).
 5. Normal tool steels. Medium-high alloy steel castings. Harder steels for tough hardening.
 6. Difficult tool steels. High-alloy steel castings. Harder steels with high hardness.
 7. Difficult high-strength steels. Hardened steels. Easier super alloys."Type of Steel ?:" 3 <CR>

The screen reverts back to graphics mode.

- "Start point of profile: " *Select as indicated below by asterisk.*
- "End point of profile: " *Select as indicated below by asterisk.*

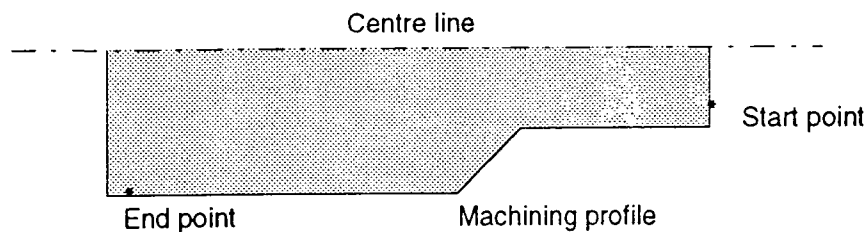

- "Correct entity (Y/N) ? <Y>:" Y <CR>

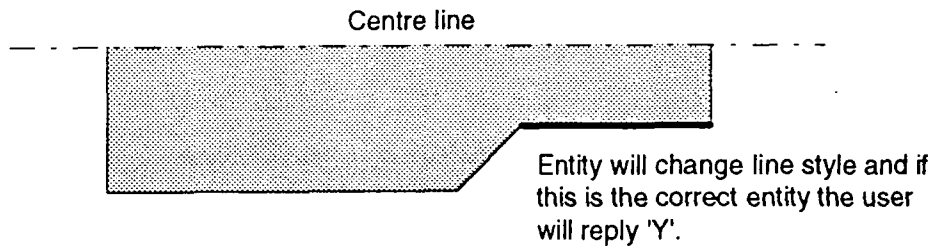

If this is the correct direction the complete machining profile will change style as shown.

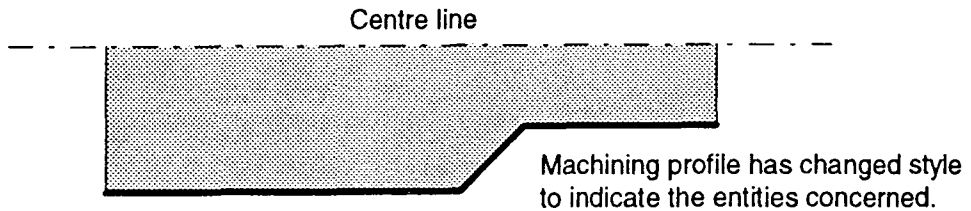

After analysing the profile the appropriate tool holders, inserts and cutting conditions are determined and the following file is compiled. The format of the file is as follows.

[Holder code] [Approach Angle] [Trailing Angle]
 [Insert code] [Insert grade] [Material type] [Insert grade] [feed1] [vel1] [feed2] [vel2]
 [feed3] [vel3] [smin] [smax] [amin] [amax] [feed] [vel] [doc] [Material removal rate]

PCLNR2020-09A 95.0 95.0

CNMG090308-MF2-TP20 3/TP20/0.15/275.0/0.35/220.0/0.60/165.0# 0.10 0.40 0.50 3.50 0.40 209.00 3.50 292.60

PCLNR2020-12A 95.0 95.0

CNMG120408-MF2-TP20 3/TP20/0.15/275.0/0.35/220.0/0.60/165.0# 0.10 0.40 0.50 3.50 0.40 209.00 3.50 292.60

CNMG120408-MF3-TP20 3/TP20/0.15/275.0/0.35/220.0/0.60/165.0# 0.15 0.40 1.00 4.00 0.40 209.00 4.00 334.40

CNMG120408-M3-TP20 3/TP20/0.15/275.0/0.35/220.0/0.60/165.0# 0.20 0.45 1.00 4.50 0.45 198.00 4.50 400.95

CNMG120408-M4-TP20 3/TP20/0.15/275.0/0.35/220.0/0.60/165.0# 0.20 0.45 1.00 5.00 0.45 198.00 5.00 445.50

CNMG120408-M5-TP20 3/TP20/0.15/275.0/0.35/220.0/0.60/165.0# 0.20 0.50 1.00 5.00 0.50 187.00 5.00 467.50

CNMG120408-MR5-TP20 3/TP20/0.15/275.0/0.35/220.0/0.60/165.0# 0.20 0.55 1.00 5.00 0.55 176.00 5.00 484.00

CNMG120408-MR7-TP20 3/TP20/0.15/275.0/0.35/220.0/0.60/165.0# 0.25 0.60 1.50 5.00 0.55 176.00 5.00 484.00

PCRR12020-12A 75.0 95.0

CNMG120408-MF2-TP20 3/TP20/0.15/275.0/0.35/220.0/0.60/165.0# 0.10 0.40 0.50 3.50 0.40 209.00 3.50 292.60

CNMG120408-MF3-TP20 3/TP20/0.15/275.0/0.35/220.0/0.60/165.0# 0.15 0.40 1.00 4.00 0.40 209.00 4.00 334.40

CNMG120408-M3-TP20 3/TP20/0.15/275.0/0.35/220.0/0.60/165.0# 0.20 0.45 1.00 4.50 0.45 198.00 4.50 400.95

CNMG120408-M4-TP20 3/TP20/0.15/275.0/0.35/220.0/0.60/165.0# 0.20 0.45 1.00 5.00 0.45 198.00 5.00 445.50

CNMG120408-M5-TP20 3/TP20/0.15/275.0/0.35/220.0/0.60/165.0# 0.20 0.50 1.00 5.00 0.50 187.00 5.00 467.50

CNMG120408-MR5-TP20 3/TP20/0.15/275.0/0.35/220.0/0.60/165.0# 0.20 0.55 1.00 5.00 0.55 176.00 5.00 484.00

CNMG120408-MR7-TP20 3/TP20/0.15/275.0/0.35/220.0/0.60/165.0# 0.25 0.60 1.50 5.00 0.55 176.00 5.00 484.00

PSRNR2020-12A 75.0 105.0

SNMG120408-MF2-TP20 3/TP20/0.15/275.0/0.35/220.0/0.60/165.0# 0.10 0.40 0.50 3.50 0.40 209.00 3.50 292.60
SNMG120408-M3-TP20 3/TP20/0.15/275.0/0.35/220.0/0.60/165.0# 0.20 0.45 1.00 4.50 0.45 198.00 4.50 400.95
SNMG120408-M4-TP20 3/TP20/0.15/275.0/0.35/220.0/0.60/165.0# 0.20 0.45 1.00 5.00 0.45 198.00 5.00 445.50
SNMG120408-M5-TP20 3/TP20/0.15/275.0/0.35/220.0/0.60/165.0# 0.20 0.50 1.00 5.00 0.50 187.00 5.00 467.50
SNMG120408-MR7-TP20 3/TP20/0.15/275.0/0.35/220.0/0.60/165.0# 0.25 0.60 1.50 5.00 0.50 187.00 5.00 467.50

PDJNR2020-15A 93.0 122.0

DNMG150608-MF2-TP20 3/TP20/0.15/275.0/0.35/220.0/0.60/165.0# 0.10 0.40 0.50 3.50 0.40 209.00 3.50 292.60
DNMG150608-MF3-TP20 3/TP20/0.15/275.0/0.35/220.0/0.60/165.0# 0.15 0.40 1.00 4.00 0.40 209.00 4.00 334.40
DNMG150608-M3-TP20 3/TP20/0.15/275.0/0.35/220.0/0.60/165.0# 0.20 0.45 1.00 4.50 0.45 198.00 4.50 400.95
DNMG150608-M5-TP20 3/TP20/0.15/275.0/0.35/220.0/0.60/165.0# 0.20 0.50 1.00 5.00 0.50 187.00 5.00 467.50

This example produces five operation plans with the highest material removal rate being 484.00 mm³/min. The selection process has established four suitable tool holders that are capable of producing the defined profile. Only one grade is selected as this is the optimum grade for the machining of mild steel. At this stage the cutting data calculations are based on the embodied heuristics and further refinement of these will be achieved during the technology process.

Example 2 - Medium Roughing of Stainless Steel

This example considers stainless steel for the same geometry workpiece as shown before.

- "Type of Material - Steel; SStainless Steel; Cast Iron (S/T/C) ?:" T <CR>

- *****
STAINLESS STEEL MATERIAL GROUP

- 8. Easy-cutting stainless steels. Free-cutting stainless steels.
- 9. Moderately difficult stainless steels.
- 10. Stainless steel difficult to machine. Stainless steel castings.

"Type of Stainless Steel ?:" 8 <CR>

Free-cutting stainless steel has been selected.

After analysing the profile the appropriate tool holders, inserts and cutting conditions are determined and the following file is compiled.

PCLNR2020-09A 95.0 95.0

PCLNR2020-12A 95.0 95.0

CNMG120408-MF2-TP30 8/TP30/0.15/195.0/0.35/155.0/0.80/95.0# 0.10 0.40 0.50 3.50 0.40 148.33 3.50 207.67
CNMG120408-MF3-TP30 8/TP30/0.15/195.0/0.35/155.0/0.80/95.0# 0.15 0.40 1.00 4.00 0.40 148.33 4.00 237.33
CNMG120408-M3-TP30 8/TP30/0.15/195.0/0.35/155.0/0.80/95.0# 0.20 0.45 1.00 4.50 0.45 141.67 4.50 286.88
CNMG120408-M3-TP301 8/TP30/0.15/195.0/0.35/155.0/0.80/95.0# 0.20 0.45 1.00 4.50 0.45 141.67 4.50 286.88
CNMG120408-M4-TP30 8/TP30/0.15/195.0/0.35/155.0/0.80/95.0# 0.20 0.45 1.00 5.00 0.45 141.67 5.00 318.75
CNMG120408-M5-TP30 8/TP30/0.15/195.0/0.35/155.0/0.80/95.0# 0.20 0.50 1.00 5.00 0.50 135.00 5.00 337.50
CNMG120408-MR5-TP30 8/TP30/0.15/195.0/0.35/155.0/0.80/95.0# 0.20 0.55 1.00 5.00 0.55 128.33 5.00 352.92
CNMG120408-MR5-TP301 8/TP30/0.15/195.0/0.35/155.0/0.80/95.0# 0.20 0.55 1.00 5.00 0.55 128.33 5.00 352.92
CNMG120408-MR7-TP30 8/TP30/0.15/195.0/0.35/155.0/0.80/95.0# 0.25 0.60 1.50 5.00 0.60 121.67 5.00 365.00

PCNR2020-12A 75.0 95.0

CNMG120408-MF2-TP30 8/TP30/0.15/195.0/0.35/155.0/0.80/95.0# 0.10 0.40 0.50 3.50 0.40 148.33 3.50 207.67
CNMG120408-MF3-TP30 8/TP30/0.15/195.0/0.35/155.0/0.80/95.0# 0.15 0.40 1.00 4.00 0.40 148.33 4.00 237.33
CNMG120408-M3-TP30 8/TP30/0.15/195.0/0.35/155.0/0.80/95.0# 0.20 0.45 1.00 4.50 0.45 141.67 4.50 286.88
CNMG120408-M3-TP301 8/TP30/0.15/195.0/0.35/155.0/0.80/95.0# 0.20 0.45 1.00 4.50 0.45 141.67 4.50 286.88
CNMG120408-M4-TP30 8/TP30/0.15/195.0/0.35/155.0/0.80/95.0# 0.20 0.45 1.00 5.00 0.45 141.67 5.00 318.75
CNMG120408-M5-TP30 8/TP30/0.15/195.0/0.35/155.0/0.80/95.0# 0.20 0.50 1.00 5.00 0.50 135.00 5.00 337.50
CNMG120408-MR5-TP30 8/TP30/0.15/195.0/0.35/155.0/0.80/95.0# 0.20 0.55 1.00 5.00 0.55 128.33 5.00 352.92
CNMG120408-MR5-TP301 8/TP30/0.15/195.0/0.35/155.0/0.80/95.0# 0.20 0.55 1.00 5.00 0.55 128.33 5.00 352.92
CNMG120408-MR7-TP30 8/TP30/0.15/195.0/0.35/155.0/0.80/95.0# 0.25 0.60 1.50 5.00 0.60 121.67 5.00 365.00

PSNR2020-12A 75.0 105.0

SNMG120408-MF2-TP30 8/TP30/0.15/195.0/0.35/155.0/0.80/95.0# 0.10 0.40 0.50 3.50 0.40 148.33 3.50 207.67
SNMG120408-MF3-TP30 8/TP30/0.15/195.0/0.35/155.0/0.80/95.0# 0.15 0.40 1.00 4.00 0.40 148.33 4.00 237.33
SNMG120408-M3-TP30 8/TP30/0.15/195.0/0.35/155.0/0.80/95.0# 0.20 0.45 1.00 4.50 0.45 141.67 4.50 286.88
SNMG120408-M3-TP301 8/TP30/0.15/195.0/0.35/155.0/0.80/95.0# 0.20 0.45 1.00 4.50 0.45 141.67 4.50 286.88
SNMG120408-M5-TP30 8/TP30/0.15/195.0/0.35/155.0/0.80/95.0# 0.20 0.50 1.00 5.00 0.50 135.00 5.00 337.50
SNMG120408-MR5-TP30 8/TP30/0.15/195.0/0.35/155.0/0.80/95.0# 0.20 0.55 1.00 5.00 0.55 128.33 5.00 352.92
SNMG120408-MR7-TP30 8/TP30/0.15/195.0/0.35/155.0/0.80/95.0# 0.25 0.60 1.50 5.00 0.60 121.67 5.00 365.00

PDJNR2020-15A 93.0 122.0

DNMG150608-MF2-TP30 8/TP30/0.15/195.0/0.35/155.0/0.80/95.0# 0.10 0.40 0.50 3.50 0.40 148.33 3.50 207.67
DNMG150608-MF3-TP30 8/TP30/0.15/195.0/0.35/155.0/0.80/95.0# 0.15 0.40 1.00 4.00 0.40 148.33 4.00 237.33
DNMG150608-M3-TP30 8/TP30/0.15/195.0/0.35/155.0/0.80/95.0# 0.20 0.45 1.00 4.50 0.45 141.67 4.50 286.88
DNMG150608-M3-TP301 8/TP30/0.15/195.0/0.35/155.0/0.80/95.0# 0.20 0.45 1.00 4.50 0.45 141.67 4.50 286.88
DNMG150608-M5-TP30 8/TP30/0.15/195.0/0.35/155.0/0.80/95.0# 0.20 0.50 1.00 5.00 0.50 135.00 5.00 337.50
DNMG150608-MR7-TP30 8/TP30/0.15/195.0/0.35/155.0/0.80/95.0# 0.25 0.60 1.50 5.00 0.60 121.67 5.00 365.00

This example produces four operation plans with the highest material removal rate being 365.00 mm³/min. Since the profile is the same as in Example 1, the same holders have been selected.

Example 3 - Medium Roughing of Cast Iron

This example considers cast iron.

- "Type of Material - Steel; STainless Steel; Cast Iron (S/T/C) ?:" C <CR>

 - *****
CAST IRON MATERIAL GROUP

 11. Cast irons with low hardness. Grey iron.
 12. Cast iron with medium hardness. Grey iron.
 13. Low-alloy cast iron with low hardness. Malleable iron castings, nodular iron.
 14. Medium-hard alloy cast iron. Moderately difficult malleable castings. Nodular iron.
 15. High-alloy cast iron difficult to machine. Difficult malleable iron castings, nodular iron.
- "Type of Cast Iron ?:" 11 <CR>

After analysing the profile the appropriate tool holders, inserts and cutting conditions are determined, for cutting grey cast iron, and the following file is compiled.

PCLNR2020-09A 95.0 95.0

PCLNR2020-12A 95.0 95.0

CNMG120408-M4-TP05 11/TP05/0.15/265.0/0.35/210.0/0.60/160.0# 0.20 0.45 1.00 5.00 0.45 190.00 5.00 427.50

PCNR2020-12A 75.0 95.0

CNMG120408-M4-TP05 11/TP05/0.15/265.0/0.35/210.0/0.60/160.0# 0.20 0.45 1.00 5.00 0.45 190.00 5.00 427.50

PSNR2020-12A 75.0 105.0

SNMG120408-M4-TP05 11/TP05/0.15/265.0/0.35/210.0/0.60/160.0# 0.20 0.45 1.00 5.00 0.45 190.00 5.00 427.50

PDJNR2020-15A 93.0 122.0

DNMG150608-M5-TP05 11/TP05/0.15/265.0/0.35/210.0/0.60/160.0# 0.20 0.50 1.00 5.00 0.50 180.00 5.00 450.00

Clearly, very few inserts are suitable for cutting grey cast iron. This example produces four operation plan with the highest material removal rate being 450.00 mm³/min.

9.1.2 Multiple Operations Planning - Component Level

This example will demonstrate the procedure for considering more than one cutting operation with respect to one component. It is assumed that the process planner has determined the process plan for the component and that it requires three operations as indicated below.

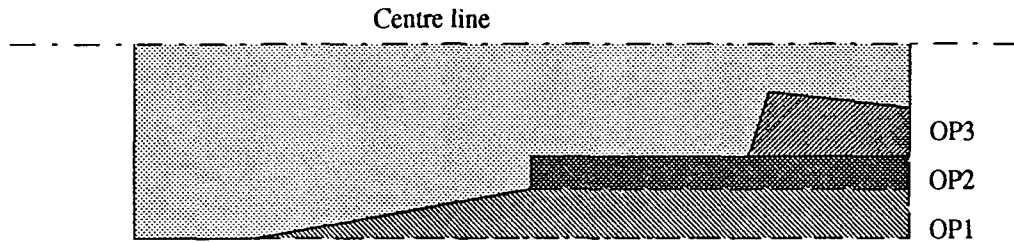

The original workpiece material shape and size is drawn on 'layer 1' of AutoCAD. The original shape is shown below.

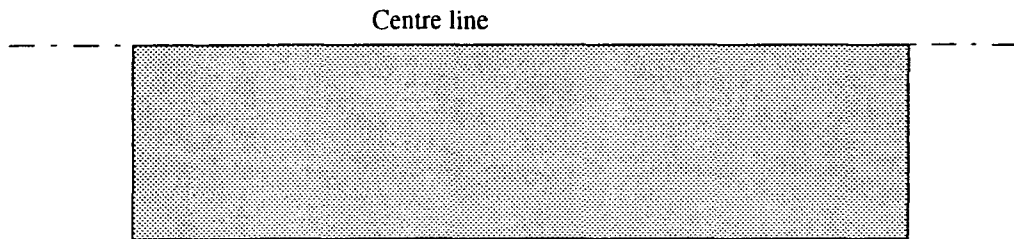

The current drawing layer is changed from '1' to '0' and the first machining profile is drawn as indicated below. The 'operation plan' for the first operation is determined.

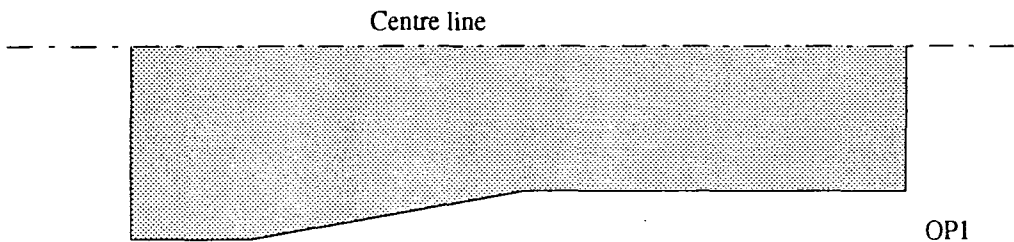

Next the profile for the second operation is drawn and the relevant operation plan is determined.

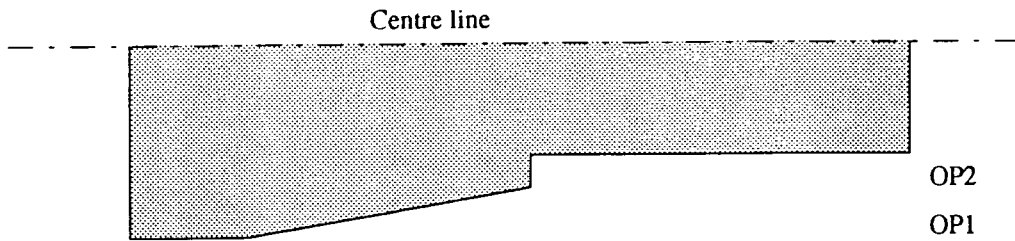

Finally the third machining profile is drawn and the specified operation plan is determined. The profile creates a recess to demonstrate the operation of the geometry module.

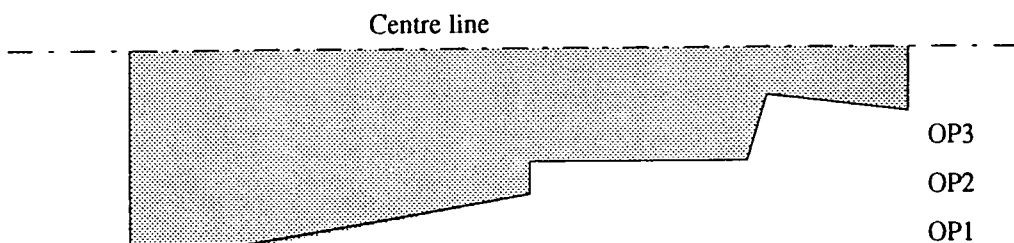

Each of the operations has produced a recommended list of tooling and cutting conditions. These lists are shown below. The next step in the development of the system is to determine the optimum 'operation plan' for the component. This will be considered in the component module.

OPERATION 1

PCLNR2020-09A 95.0 95.0

CNMG090308-MF2-TP20 3/TP20/0.15/275.0/0.35/220.0/0.60/165.0# 0.10 0.40 0.50 3.50 0.40 209.00 3.50 292.60

PCLNR2020-12A 95.0 95.0

CNMG120408-MF2-TP20 3/TP20/0.15/275.0/0.35/220.0/0.60/165.0# 0.10 0.40 0.50 3.50 0.40 209.00 3.50 292.60

CNMG120408-MF3-TP20 3/TP20/0.15/275.0/0.35/220.0/0.60/165.0# 0.15 0.40 1.00 4.00 0.40 209.00 4.00 334.40

CNMG120408-M3-TP20 3/TP20/0.15/275.0/0.35/220.0/0.60/165.0# 0.20 0.45 1.00 4.50 0.45 198.00 4.50 400.95

CNMG120408-M4-TP20 3/TP20/0.15/275.0/0.35/220.0/0.60/165.0# 0.20 0.45 1.00 5.00 0.45 198.00 5.00 445.50

CNMG120408-M5-TP20 3/TP20/0.15/275.0/0.35/220.0/0.60/165.0# 0.20 0.50 1.00 5.00 0.50 187.00 5.00 467.50

CNMG120408-MR5-TP20 3/TP20/0.15/275.0/0.35/220.0/0.60/165.0# 0.20 0.55 1.00 5.00 0.55 176.00 5.00 484.00

CNMG120408-MR7-TP20 3/TP20/0.15/275.0/0.35/220.0/0.60/165.0# 0.25 0.60 1.50 5.00 0.55 176.00 5.00 484.00

PCRR2020-12A 75.0 95.0

CNMG120408-MF2-TP20 3/TP20/0.15/275.0/0.35/220.0/0.60/165.0# 0.10 0.40 0.50 3.50 0.40 209.00 3.50 292.60

CNMG120408-MF3-TP20 3/TP20/0.15/275.0/0.35/220.0/0.60/165.0# 0.15 0.40 1.00 4.00 0.40 209.00 4.00 334.40

CNMG120408-M3-TP20 3/TP20/0.15/275.0/0.35/220.0/0.60/165.0# 0.20 0.45 1.00 4.50 0.45 198.00 4.50 400.95

CNMG120408-M4-TP20 3/TP20/0.15/275.0/0.35/220.0/0.60/165.0# 0.20 0.45 1.00 5.00 0.45 198.00 5.00 445.50

CNMG120408-M5-TP20 3/TP20/0.15/275.0/0.35/220.0/0.60/165.0# 0.20 0.50 1.00 5.00 0.50 187.00 5.00 467.50
CNMG120408-MR5-TP20 3/TP20/0.15/275.0/0.35/220.0/0.60/165.0# 0.20 0.55 1.00 5.00 0.55 176.00 5.00 484.00
CNMG120408-MR7-TP20 3/TP20/0.15/275.0/0.35/220.0/0.60/165.0# 0.25 0.60 1.50 5.00 0.55 176.00 5.00 484.00

PSRNR2020-12A 75.0 105.0

SNMG120408-MF2-TP20 3/TP20/0.15/275.0/0.35/220.0/0.60/165.0# 0.10 0.40 0.50 3.50 0.40 209.00 3.50 292.60
SNMG120408-M3-TP20 3/TP20/0.15/275.0/0.35/220.0/0.60/165.0# 0.20 0.45 1.00 4.50 0.45 198.00 4.50 400.95
SNMG120408-M4-TP20 3/TP20/0.15/275.0/0.35/220.0/0.60/165.0# 0.20 0.45 1.00 5.00 0.45 198.00 5.00 445.50
SNMG120408-M5-TP20 3/TP20/0.15/275.0/0.35/220.0/0.60/165.0# 0.20 0.50 1.00 5.00 0.50 187.00 5.00 467.50
SNMG120408-MR7-TP20 3/TP20/0.15/275.0/0.35/220.0/0.60/165.0# 0.25 0.60 1.50 5.00 0.50 187.00 5.00 467.50

PDJNR2020-15A 93.0 122.0

DNMG150608-MF2-TP20 3/TP20/0.15/275.0/0.35/220.0/0.60/165.0# 0.10 0.40 0.50 3.50 0.40 209.00 3.50 292.60
DNMG150608-MF3-TP20 3/TP20/0.15/275.0/0.35/220.0/0.60/165.0# 0.15 0.40 1.00 4.00 0.40 209.00 4.00 334.40
DNMG150608-M3-TP20 3/TP20/0.15/275.0/0.35/220.0/0.60/165.0# 0.20 0.45 1.00 4.50 0.45 198.00 4.50 400.95
DNMG150608-M5-TP20 3/TP20/0.15/275.0/0.35/220.0/0.60/165.0# 0.20 0.50 1.00 5.00 0.50 187.00 5.00 467.50

PDNNR2020-15A 63.0 152.0

DNMG150608-MF2-TP20 3/TP20/0.15/275.0/0.35/220.0/0.60/165.0# 0.10 0.40 0.50 3.50 0.40 209.00 3.50 292.60
DNMG150608-MF3-TP20 3/TP20/0.15/275.0/0.35/220.0/0.60/165.0# 0.15 0.40 1.00 4.00 0.40 209.00 4.00 334.40
DNMG150608-M3-TP20 3/TP20/0.15/275.0/0.35/220.0/0.60/165.0# 0.20 0.45 1.00 4.50 0.45 198.00 4.50 400.95
DNMG150608-M5-TP20 3/TP20/0.15/275.0/0.35/220.0/0.60/165.0# 0.20 0.50 1.00 5.00 0.50 187.00 5.00 467.50

This profile can be machined using any of six different tool holder / insert combinations.
Depending on the selection the metal removal rate varies from 292.60 to 484.0 mm³/min.

OPERATION 2

PCLNR2020-09A 95.0 95.0

CNMG090308-MF2-TP20 3/TP20/0.15/275.0/0.35/220.0/0.60/165.0# 0.10 0.40 0.50 3.50 0.40 209.00 3.50 292.60

PCLNR2020-12A 95.0 95.0

CNMG120408-MF2-TP20 3/TP20/0.15/275.0/0.35/220.0/0.60/165.0# 0.10 0.40 0.50 3.50 0.40 209.00 3.50 292.60
CNMG120408-MF3-TP20 3/TP20/0.15/275.0/0.35/220.0/0.60/165.0# 0.15 0.40 1.00 4.00 0.40 209.00 4.00 334.40
CNMG120408-M3-TP20 3/TP20/0.15/275.0/0.35/220.0/0.60/165.0# 0.20 0.45 1.00 4.50 0.45 198.00 4.50 400.95
CNMG120408-M4-TP20 3/TP20/0.15/275.0/0.35/220.0/0.60/165.0# 0.20 0.45 1.00 5.00 0.45 198.00 5.00 445.50
CNMG120408-M5-TP20 3/TP20/0.15/275.0/0.35/220.0/0.60/165.0# 0.20 0.50 1.00 5.00 0.50 187.00 5.00 467.50
CNMG120408-MR5-TP20 3/TP20/0.15/275.0/0.35/220.0/0.60/165.0# 0.20 0.55 1.00 5.00 0.55 176.00 5.00 484.00
CNMG120408-MR7-TP20 3/TP20/0.15/275.0/0.35/220.0/0.60/165.0# 0.25 0.60 1.50 5.00 0.55 176.00 5.00 484.00

PDJNR2020-15A 93.0 122.0

DNMG150608-MF2-TP20 3/TP20/0.15/275.0/0.35/220.0/0.60/165.0# 0.10 0.40 0.50 3.50 0.40 209.00 3.50 292.60
DNMG150608-MF3-TP20 3/TP20/0.15/275.0/0.35/220.0/0.60/165.0# 0.15 0.40 1.00 4.00 0.40 209.00 4.00 334.40
DNMG150608-M3-TP20 3/TP20/0.15/275.0/0.35/220.0/0.60/165.0# 0.20 0.45 1.00 4.50 0.45 198.00 4.50 400.95
DNMG150608-M5-TP20 3/TP20/0.15/275.0/0.35/220.0/0.60/165.0# 0.20 0.50 1.00 5.00 0.50 187.00 5.00 467.50

This profile can be machined using any of three different tool holder / insert combinations. Fewer tool holders are suitable than profile 1 since the maximum approach angle of the profile is 90°.

OPERATION 3

PSRNR2020-12A 75.0 105.0

SNMG120408-MF2-TP20 3/TP20/0.15/275.0/0.35/220.0/0.60/165.0# 0.10 0.40 0.50 3.50 0.40 209.00 3.50 292.60

SNMG120408-M3-TP20 3/TP20/0.15/275.0/0.35/220.0/0.60/165.0# 0.20 0.45 1.00 4.50 0.45 198.00 4.50 400.95

SNMG120408-M4-TP20 3/TP20/0.15/275.0/0.35/220.0/0.60/165.0# 0.20 0.45 1.00 5.00 0.45 198.00 5.00 445.50

SNMG120408-M5-TP20 3/TP20/0.15/275.0/0.35/220.0/0.60/165.0# 0.20 0.50 1.00 5.00 0.50 187.00 5.00 467.50

SNMG120408-MR7-TP20 3/TP20/0.15/275.0/0.35/220.0/0.60/165.0# 0.25 0.60 1.50 5.00 0.50 187.00 5.00 467.50

PDJNR2020-15A 93.0 122.0

DNMG150608-MF2-TP20 3/TP20/0.15/275.0/0.35/220.0/0.60/165.0# 0.10 0.40 0.50 3.50 0.40 209.00 3.50 292.60

DNMG150608-MF3-TP20 3/TP20/0.15/275.0/0.35/220.0/0.60/165.0# 0.15 0.40 1.00 4.00 0.40 209.00 4.00 334.40

DNMG150608-M3-TP20 3/TP20/0.15/275.0/0.35/220.0/0.60/165.0# 0.20 0.45 1.00 4.50 0.45 198.00 4.50 400.95

DNMG150608-M5-TP20 3/TP20/0.15/275.0/0.35/220.0/0.60/165.0# 0.20 0.50 1.00 5.00 0.50 187.00 5.00 467.50

This profile can be machined using any of two different tool holder / insert combinations. Again, a smaller selection of holders can machine this profile due mainly to the maximum trailing angle constraint of the profile.

The tool holders selected are based on the geometrical constraints of the cutting profile. Each tool holder is selected on the basis that the tool's approach (TAA) and trailing (TTA) angles are less than the element's approach (EAA) and trailing (ETA) angles minus the appropriate clearance angle (CANGLE). The above examples have demonstrated the geometrical and tool selection capability of the system. The results will serve as input to the technology and rationalisation modules. These modules will further refine the cutting conditions in using the various method discussed in chapter 8.

The importance of computer based tool selection is demonstrated by this component which requires three operations. By selecting the first tool for each operation the machining performance is much reduced when compared to the tools that are capable of removal rates of up to 484.0 mm³/min. The system highlights to the process planner the various options available and aids him in making a more objective decision at this stage.

9.2 Technology and Rationalisation Modules In Operation

The following will use a similar example as that previously described to demonstrate the technology and rationalization modules.

- Initialize Microsoft Excel.
- Load the various programs.
- Select the ITS1 icon.

The following message is displayed.

- “Retrieve the AutoLisp text files and convert them into Microsoft Excel format.”
- Select OK.

The following message is displayed.

- “Please enter job number (JOB?)” *JOB1 <OK>*

ITS1 will open all files associated with JOB1 and format them appropriately.

- Select ITS2 icon.

The following message is displayed.

- “This will collate all AutoLisp text files into one Excel file. It then selects the optimum tool for each operation as recommended by the heuristic module.”
- Select OK.

The following message is displayed.

- “Please enter the file name required to transfer all operation files (JOBALL)”
JOBALL1 <OK>
- Select ITS3 icon.

The following message is displayed.

- “This separates out the MaxFeed, MinFeed, DocMax and DocMin.”
- Select OK.

The following message is displayed.

- “Please enter the JOBALL file that is required to be open. (JOBALL1.XLS)” <OK>
- Select ITS4 icon.

The following message is displayed.

- “This is concerned with the use of the technology equations. Tests to be used are: [1] check the velocity forces, [2] check the axial force, [3] the diametrical test; and [4] check the power requirement.”
- Select OK.

The following message is displayed.

“Please enter the JOBALL file that is required for the technology calculations. (JOBALL1.XLS)” <OK>

There are 147 potential operation plans for JOB1OP1, 64 for JOB1OP2, and 48 for JOB1OP3. These can be seen in the following data sheets. Tables 2, 3 and 4 presents the data sheets for JOB1OP1.RUN, JOB1OP2.RUN and JOB1OP3.RUN respectively. The top operation plan for each machining operation forms the Tool Resource Structure (TRS) for the component.

Table 2: JOB IOP1.RUN

JOB IOP1.RUN

	A	B	C	D	E	F	G	H	I	J	K	L	M	N	O	P	Q	R	S	T	U	V	W	X	Y	Z	AA	AB	AC	AD	AE	AF
99	PDJNR2020	15A	93.00	122.00	DNMG150612	M3	TP20	0.45	188.00	4.50	241.06	57.85	5.12	4	15.00	1.20	0.45	0.20	1.00	4.50	0.22	3.00	428.10	16.83	283.21	0.85	42.00	17.02	2.47	28.84	59.02	38.63
100	PDNNR2020	15A	63.00	152.00	DNMG150604	M3	TP30	0.45	174.44	4.50	241.06	57.85	5.12	4	15.00	0.40	0.45	0.20	1.00	4.50	0.22	3.00	428.10	16.83	283.21	0.85	42.00	17.02	2.47	28.84	59.02	38.63
101	PDNNR2020	15A	63.00	152.00	DNMG150604	M3	TP30	0.45	174.44	4.50	241.06	57.85	5.12	4	15.00	0.40	0.45	0.20	1.00	4.50	0.22	3.00	428.10	16.83	283.21	0.85	42.00	17.02	2.47	28.84	59.02	38.63
102	PDNNR2020	15A	63.00	152.00	DNMG150608	M3	TP30	0.45	174.44	4.50	241.06	57.85	5.12	4	15.00	0.80	0.45	0.20	1.00	4.50	0.22	3.00	428.10	16.83	283.21	0.85	42.00	17.02	2.47	28.84	59.02	38.63
103	PDNNR2020	15A	63.00	152.00	DNMG150608	M3	TP30	0.45	174.44	4.50	241.06	57.85	5.12	4	15.00	0.80	0.45	0.20	1.00	4.50	0.22	3.00	428.10	16.83	283.21	0.85	42.00	17.02	2.47	28.84	59.02	38.63
104	PDNNR2020	15A	63.00	152.00	DNMG150612	M3	TP30	0.45	174.44	4.50	241.06	57.85	5.12	4	15.00	1.20	0.45	0.20	1.00	4.50	0.22	3.00	428.10	16.83	283.21	0.85	42.00	17.02	2.47	28.84	59.02	38.63
105	PDNNR2020	15A	63.00	152.00	DNMG150612	M3	TP30	0.45	174.44	4.50	241.06	57.85	5.12	4	15.00	1.20	0.45	0.20	1.00	4.50	0.22	3.00	428.10	16.83	283.21	0.85	42.00	17.02	2.47	28.84	59.02	38.63
106	PDNNR2020	15A	93.00	122.00	DNMG150604	M3	TP30	0.45	174.44	4.50	241.06	57.85	5.12	4	15.00	0.40	0.45	0.20	1.00	4.50	0.22	3.00	428.10	16.83	283.21	0.85	42.00	17.02	2.47	28.84	59.02	38.63
107	PDNNR2020	15A	93.00	122.00	DNMG150604	M3	TP30	0.45	174.44	4.50	241.06	57.85	5.12	4	15.00	0.40	0.45	0.20	1.00	4.50	0.22	3.00	428.10	16.83	283.21	0.85	42.00	17.02	2.47	28.84	59.02	38.63
108	PDNNR2020	15A	93.00	122.00	DNMG150608	M3	TP30	0.45	174.44	4.50	241.06	57.85	5.12	4	15.00	0.80	0.45	0.20	1.00	4.50	0.22	3.00	428.10	16.83	283.21	0.85	42.00	17.02	2.47	28.84	59.02	38.63
109	PDNNR2020	15A	93.00	122.00	DNMG150608	M3	TP30	0.45	174.44	4.50	241.06	57.85	5.12	4	15.00	0.80	0.45	0.20	1.00	4.50	0.22	3.00	428.10	16.83	283.21	0.85	42.00	17.02	2.47	28.84	59.02	38.63
110	PDNNR2020	15A	93.00	122.00	DNMG150612	M3	TP30	0.45	174.44	4.50	241.06	57.85	5.12	4	15.00	1.20	0.45	0.20	1.00	4.50	0.22	3.00	428.10	16.83	283.21	0.85	42.00	17.02	2.47	28.84	59.02	38.63
111	PDJNR2020	15A	93.00	122.00	DNMG150612	M3	TP30	0.45	174.44	4.50	241.06	57.85	5.12	4	15.00	1.20	0.45	0.20	1.00	4.50	0.22	3.00	428.10	16.83	283.21	0.85	42.00	17.02	2.47	28.84	59.02	38.63
112	PCRN2020	12A	75.00	95.00	CNMG120408	MR7	TP20	0.60	151.11	5.00	241.06	36.33	3.54	4	12.00	0.80	0.60	0.25	1.50	5.00	0.26	2.50	411.99	16.87	267.79	0.90	42.00	18.00	2.33	30.00	60.00	38.74
113	PCRN2020	12A	75.00	95.00	CNMG120412	MR7	TP20	0.60	151.11	5.00	241.06	36.33	3.54	4	12.00	1.20	0.80	0.25	1.50	5.00	0.26	2.50	411.99	16.87	267.79	0.90	42.00	18.00	2.33	30.00	60.00	38.74
114	PCRN2020	12A	75.00	95.00	CNMG120412	MR7	TP30	0.60	151.11	5.00	241.06	36.33	3.54	4	12.00	0.80	0.60	0.25	1.50	5.00	0.26	2.50	411.99	16.87	267.79	0.90	42.00	18.00	2.33	30.00	60.00	38.74
115	PCLNR2020	12A	95.00	95.00	CNMG120408	MR7	TP30	0.60	151.11	5.00	241.06	36.33	3.54	4	12.00	0.80	0.60	0.25	1.50	5.00	0.26	2.50	411.99	16.87	267.79	0.90	42.00	18.00	2.33	30.00	60.00	38.74
116	PCLNR2020	12A	95.00	95.00	CNMG120412	MR7	TP20	0.60	151.11	5.00	241.06	36.33	3.54	4	12.00	1.20	0.80	0.25	1.50	5.00	0.26	2.50	411.99	16.87	267.79	0.90	42.00	18.00	2.33	30.00	60.00	38.74
117	PCLNR2020	12A	95.00	95.00	CNMG120412	MR7	TP30	0.60	151.11	5.00	241.06	36.33	3.54	4	12.00	1.20	0.80	0.25	1.50	5.00	0.26	2.50	411.99	16.87	267.79	0.90	42.00	18.00	2.33	30.00	60.00	38.74
118	PCRN2020	12A	75.00	95.00	CNMG120408	MR7	TP20	0.55	158.89	5.00	241.06	36.33	3.54	4	12.00	0.80	0.60	0.25	1.50	5.00	0.26	2.50	411.99	16.87	267.79	0.90	42.00	18.00	2.33	30.00	60.00	38.74
119	PCRN2020	12A	75.00	95.00	CNMG120408	MR7	TP20	0.55	158.89	5.00	241.06	36.33	3.54	4	12.00	0.80	0.60	0.25	1.50	5.00	0.26	2.50	411.99	16.87	267.79	0.90	42.00	18.00	2.33	30.00	60.00	38.74
120	PSRN2020	12A	75.00	105.00	SNMG120408	MF3	TP30	0.40	182.22	4.00	241.06	36.33	3.54	8	12.00	0.80	0.40	0.15	1.00	4.00	0.17	3.75	370.22	33.02	236.01	1.02	42.00	20.43	2.06	32.72	62.43	39.03
121	PSRN2020	12A	75.00	105.00	SNMG120412	MF3	TP30	0.40	182.22	4.00	241.06	36.33	3.54	8	12.00	1.20	0.40	0.15	1.00	4.00	0.17	3.75	370.22	33.02	236.01	1.02	42.00	20.43	2.06	32.72	62.43	39.03
122	PSRN2020	15A	63.00	152.00	DNMG150608	MR7	TP30	0.60	151.11	5.00	241.06	57.85	5.12	4	15.00	0.80	0.60	0.25	1.50	5.00	0.26	2.50	410.88	16.83	266.95	0.90	42.00	18.06	2.33	30.07	60.06	39.40
123	PSRN2020	15A	63.00	152.00	DNMG150612	MR7	TP20	0.60	151.11	5.00	241.06	57.85	5.12	4	15.00	1.20	0.60	0.25	1.50	5.00	0.26	2.50	410.88	16.83	266.95	0.90	42.00	18.06	2.33	30.07	60.06	39.40
124	PSRN2020	15A	63.00	152.00	DNMG150612	MR7	TP30	0.60	151.11	5.00	241.06	57.85	5.12	4	15.00	1.20	0.60	0.25	1.50	5.00	0.26	2.50	410.88	16.83	266.95	0.90	42.00	18.06	2.33	30.07	60.06	39.40
125	PSRN2020	15A	93.00	122.00	DNMG150608	MR7	TP30	0.60	151.11	5.00	241.06	57.85	5.12	4	15.00	0.80	0.60	0.25	1.50	5.00	0.26	2.50	410.88	16.83	266.95	0.90	42.00	18.06	2.33	30.07	60.06	39.40
126	PSRN2020	15A	93.00	122.00	DNMG150612	MR7	TP30	0.60	151.11	5.00	241.06	57.85	5.12	4	15.00	1.20	0.60	0.25	1.50	5.00	0.26	2.50	410.88	16.83	266.95	0.90	42.00	18.06	2.33	30.07	60.06	39.40
127	PSRN2020	15A	93.00	122.00	DNMG150612	MR7	TP30	0.60	151.11	5.00	241.06	57.85	5.12	4	15.00	1.20	0.60	0.25	1.50	5.00	0.26	2.50	410.88	16.83	266.95	0.90	42.00	18.06	2.33	30.07	60.06	39.40
128	PSRN2020	12A	75.00	105.00	SNMG120412	MR5	TP20	0.55	176.00	5.00	241.06	36.33	3.54	8	12.00	0.80	0.55	0.20	1.00	5.00	0.22	3.00	343.77	33.02	226.89	1.06	42.00	21.25	1.98	33.60	63.25	39.56
129	PSRN2020	12A	75.00	105.00	SNMG120408	MR5	TP30	0.55	158.89	5.00	241.06	36.33	3.54	8	12.00	0.80	0.55	0.20	1.00	5.00	0.22	3.00	343.77	33.02	226.89	1.06	42.00	21.25	1.98	33.60	63.25	39.56
130	PSRN2020	12A	75.00	105.00	SNMG120412	MR5	TP30	0.55	158.89	5.00	241.06	36.33	3.54	8	12.00	1.20	0.55	0.20	1.00	5.00	0.22	3.00	343.77	33.02	226.89	1.06	42.00	21.25	1.98	33.60	63.25	39.56
131	PSRN2020	12A	75.00	105.00	SNMG120412	MF2	TP20	0.40	209.00	3.60	241.06	36.33	3.54	8	12.00	0.80	0.40	0.10	0.50	3.60	0.22	3.00	343.77	33.02	226.89	1.06	42.00	21.25	1.98	33.60	63.25	39.56
132	PSRN2020	12A	75.00	105.00	SNMG120412	MF2	TP20	0.40	209.00	3.60	241.06	36.33	3.54	8	12.00	1.20	0.40	0.10	0.50	3.60	0.22	3.00	343.77	33.02	226.89	1.06	42.00	21.25	1.98	33.60	63.25	39.56
133																																

Table 3: JOB1OP2.RUN

JOB1OP2.RUN

	A	B	C	D	E	F	G	H	I	J	K	L	M	N	O	P	Q	R	S	T	U	V	W	X	Y	Z	AA	AB	AC	AD	AE	AF
50	PDJNR2020	15A	93.00	122.00	DNMG150608	M3	TP20	0.45	198.00	4.50	132.40	57.85	5.12	4	15.00	0.80	0.45	0.20	1.00	4.50	0.22	3.00	429.10	16.83	283.21	0.47	42.00	9.35	4.49	18.21	51.35	32.89
51	PDJNR2020	15A	93.00	122.00	DNMG150612	M3	TP20	0.45	198.00	4.50	132.40	57.85	5.12	4	15.00	1.20	0.45	0.20	1.00	4.50	0.22	3.00	429.10	16.83	283.21	0.47	42.00	9.35	4.49	18.21	51.35	32.89
52	PDJNR2020	15A	93.00	122.00	DNMG150604	M3	TP30	0.45	174.44	4.50	132.40	57.85	5.12	4	15.00	0.40	0.45	0.20	1.00	4.50	0.22	3.00	429.10	16.83	283.21	0.47	42.00	9.35	4.49	18.21	51.35	32.89
53	PDJNR2020	15A	93.00	122.00	DNMG150604	M3	TP301	0.45	174.44	4.50	132.40	57.85	5.12	4	15.00	0.40	0.45	0.20	1.00	4.50	0.22	3.00	429.10	16.83	283.21	0.47	42.00	9.35	4.49	18.21	51.35	32.89
54	PDJNR2020	15A	93.00	122.00	DNMG150608	M3	TP30	0.45	174.44	4.50	132.40	57.85	5.12	4	15.00	0.80	0.45	0.20	1.00	4.50	0.22	3.00	429.10	16.83	283.21	0.47	42.00	9.35	4.49	18.21	51.35	32.89
55	PDJNR2020	15A	93.00	122.00	DNMG150608	M3	TP301	0.45	174.44	4.50	132.40	57.85	5.12	4	15.00	0.80	0.45	0.20	1.00	4.50	0.22	3.00	429.10	16.83	283.21	0.47	42.00	9.35	4.49	18.21	51.35	32.89
56	PDJNR2020	15A	93.00	122.00	DNMG150812	M3	TP30	0.45	174.44	4.50	132.40	57.85	5.12	4	15.00	1.20	0.45	0.20	1.00	4.50	0.22	3.00	429.10	16.83	283.21	0.47	42.00	9.35	4.49	18.21	51.35	32.89
57	PDJNR2020	15A	93.00	122.00	DNMG150612	M3	TP301	0.45	174.44	4.50	132.40	57.85	5.12	4	15.00	1.20	0.45	0.20	1.00	4.50	0.22	3.00	429.10	16.83	283.21	0.47	42.00	9.35	4.49	18.21	51.35	32.89
58	PCLNR2020	12A	95.00	95.00	CNMG120408	MRT	TP30	0.60	151.11	5.00	132.40	38.33	3.54	4	12.00	0.80	0.60	0.25	1.50	5.00	0.26	2.50	411.99	16.87	267.79	0.49	42.00	9.89	4.25	19.06	51.89	32.95
59	PCLNR2020	12A	95.00	95.00	CNMG120412	MRT	TP20	0.60	151.11	5.00	132.40	38.33	3.54	4	12.00	1.20	0.60	0.25	1.50	5.00	0.26	2.50	411.99	16.87	267.79	0.49	42.00	9.89	4.25	19.06	51.89	32.95
60	PCLNR2020	12A	95.00	95.00	CNMG120412	MRT	TP30	0.60	151.11	5.00	132.40	38.33	3.54	4	12.00	1.20	0.60	0.25	1.50	5.00	0.26	2.50	411.99	16.87	267.79	0.49	42.00	9.89	4.25	19.06	51.89	32.95
61	PCLNR2020	12A	95.00	95.00	CNMG120408	MRT	TP20	0.55	158.89	5.00	132.40	38.33	3.54	4	12.00	0.80	0.60	0.25	1.50	5.00	0.26	2.50	411.99	16.87	267.79	0.49	42.00	9.89	4.25	19.06	51.89	32.95
62	PDJNR2020	15A	93.00	122.00	DNMG150608	MRT	TP30	0.60	151.11	5.00	132.40	57.85	5.12	4	15.00	0.80	0.60	0.25	1.50	5.00	0.26	2.50	410.89	16.83	266.95	0.50	42.00	9.92	4.23	19.11	51.92	33.32
63	PDJNR2020	15A	93.00	122.00	DNMG150612	MRT	TP20	0.60	151.11	5.00	132.40	57.85	5.12	4	15.00	1.20	0.60	0.25	1.50	5.00	0.26	2.50	410.89	16.83	266.95	0.50	42.00	9.92	4.23	19.11	51.92	33.32
64	PDJNR2020	15A	93.00	122.00	DNMG150612	MRT	TP30	0.60	151.11	5.00	132.40	57.85	5.12	4	15.00	1.20	0.60	0.25	1.50	5.00	0.26	2.50	410.89	16.83	266.95	0.50	42.00	9.92	4.23	19.11	51.92	33.32

Table 4: JOB IOP3.RUN

JOB IOP3.RUN

A	B	C	D	E	F	G	H	I	J	K	L	M	N	O	P	Q	R	S	T	U	V	W	X	Y	Z	AA	AB	AC	AD	AE	AF	
HOLDER	CEL	AA	TA	INSERT	CB	GRD	S	V	D	VOL	COH	COIE	CEL	RAD	SX	SN	DN	DX	S	D	D	V	T	MRR	CT	TSUT	AB	RAT	UTL	TOTT	TOTC	
1	PDJNR2020	15A	93.00	122.00	DNMG150608	MF3	TP20	0.40	209.00	4.00	53.34	57.85	5.12	4	15.00	0.80	0.40	0.15	1.00	4.00	0.17	3.75	462.11	16.83	294.60	0.18	42.00	3.62	11.60	7.94	45.82	28.61
2	PDJNR2020	15A	93.00	122.00	DNMG150608	MF3	TP30	0.40	182.22	4.00	53.34	57.85	5.12	4	15.00	0.80	0.40	0.15	1.00	4.00	0.17	3.75	462.11	16.83	294.60	0.18	42.00	3.62	11.60	7.94	45.82	28.61
3	PDJNR2020	15A	93.00	122.00	DNMG150612	MF3	TP30	0.40	182.22	4.00	53.34	57.85	5.12	4	15.00	1.20	0.40	0.15	1.00	4.00	0.17	3.75	462.11	16.83	294.60	0.18	42.00	3.62	11.60	7.94	45.82	28.61
4	PDJNR2020	15A	93.00	122.00	DNMG150604	MF3	TP30	0.40	182.22	4.00	53.34	57.85	5.12	4	15.00	0.40	0.40	0.15	1.00	4.00	0.17	3.75	462.11	16.83	294.60	0.18	42.00	3.62	11.60	7.94	45.82	28.61
5	PDJNR2020	15A	93.00	122.00	DNMG150608	MF2	TP20	0.40	209.00	3.50	53.34	57.85	5.12	4	15.00	0.80	0.40	0.10	0.50	3.50	0.22	3.00	429.10	16.83	283.21	0.19	42.00	3.77	11.15	8.23	45.77	28.72
6	PDJNR2020	15A	93.00	122.00	DNMG150608	MF2	TP20	0.40	209.00	3.50	53.34	57.85	5.12	4	15.00	1.20	0.40	0.10	0.50	3.50	0.22	3.00	429.10	16.83	283.21	0.19	42.00	3.77	11.15	8.23	45.77	28.72
7	PDJNR2020	15A	93.00	122.00	DNMG150612	MF2	TP20	0.40	182.22	3.50	53.34	57.85	5.12	4	15.00	0.80	0.40	0.10	0.50	3.50	0.22	3.00	429.10	16.83	283.21	0.19	42.00	3.77	11.15	8.23	45.77	28.72
8	PDJNR2020	15A	93.00	122.00	DNMG150608	MF2	TP30	0.40	182.22	3.50	53.34	57.85	5.12	4	15.00	0.40	0.40	0.10	0.50	3.50	0.22	3.00	429.10	16.83	283.21	0.19	42.00	3.77	11.15	8.23	45.77	28.72
9	PDJNR2020	15A	93.00	122.00	DNMG150604	MF2	TP20	0.40	209.00	3.50	53.34	57.85	5.12	4	15.00	0.40	0.40	0.10	0.50	3.50	0.22	3.00	429.10	16.83	283.21	0.19	42.00	3.77	11.15	8.23	45.77	28.72
10	PDJNR2020	15A	93.00	122.00	DNMG150604	MF2	TP30	0.40	182.22	3.50	53.34	57.85	5.12	4	15.00	0.80	0.50	0.20	1.00	5.00	0.22	3.00	429.10	16.83	283.21	0.19	42.00	3.77	11.15	8.23	45.77	28.72
11	PDJNR2020	15A	93.00	122.00	DNMG150608	M5	TP20	0.50	187.00	5.00	53.34	57.85	5.12	4	15.00	0.80	0.50	0.20	1.00	5.00	0.22	3.00	429.10	16.83	283.21	0.19	42.00	3.77	11.15	8.23	45.77	28.72
12	PDJNR2020	15A	93.00	122.00	DNMG150604	M5	TP30	0.50	166.87	5.00	53.34	57.85	5.12	4	15.00	0.40	0.50	0.20	1.00	5.00	0.22	3.00	429.10	16.83	283.21	0.19	42.00	3.77	11.15	8.23	45.77	28.72
13	PDJNR2020	15A	93.00	122.00	DNMG150608	M5	TP30	0.50	166.87	5.00	53.34	57.85	5.12	4	15.00	0.80	0.50	0.20	1.00	5.00	0.22	3.00	429.10	16.83	283.21	0.19	42.00	3.77	11.15	8.23	45.77	28.72
14	PDJNR2020	15A	93.00	122.00	DNMG150612	M5	TP30	0.50	166.87	5.00	53.34	57.85	5.12	4	15.00	1.20	0.50	0.20	1.00	5.00	0.22	3.00	429.10	16.83	283.21	0.19	42.00	3.77	11.15	8.23	45.77	28.72
15	PDJNR2020	15A	93.00	122.00	DNMG150604	M3	TP20	0.45	198.00	4.50	53.34	57.85	5.12	4	15.00	0.40	0.45	0.20	1.00	4.50	0.22	3.00	429.10	16.83	283.21	0.19	42.00	3.77	11.15	8.23	45.77	28.72
16	PDJNR2020	15A	93.00	122.00	DNMG150608	M3	TP20	0.45	198.00	4.50	53.34	57.85	5.12	4	15.00	0.80	0.45	0.20	1.00	4.50	0.22	3.00	429.10	16.83	283.21	0.19	42.00	3.77	11.15	8.23	45.77	28.72
17	PDJNR2020	15A	93.00	122.00	DNMG150612	M3	TP20	0.45	198.00	4.50	53.34	57.85	5.12	4	15.00	1.20	0.45	0.20	1.00	4.50	0.22	3.00	429.10	16.83	283.21	0.19	42.00	3.77	11.15	8.23	45.77	28.72
18	PDJNR2020	15A	93.00	122.00	DNMG150604	M3	TP30	0.45	174.44	4.50	53.34	57.85	5.12	4	15.00	0.40	0.45	0.20	1.00	4.50	0.22	3.00	429.10	16.83	283.21	0.19	42.00	3.77	11.15	8.23	45.77	28.72
19	PDJNR2020	15A	93.00	122.00	DNMG150608	M3	TP30	0.45	174.44	4.50	53.34	57.85	5.12	4	15.00	0.80	0.45	0.20	1.00	4.50	0.22	3.00	429.10	16.83	283.21	0.19	42.00	3.77	11.15	8.23	45.77	28.72
20	PDJNR2020	15A	93.00	122.00	DNMG150608	M3	TP30	0.45	174.44	4.50	53.34	57.85	5.12	4	15.00	1.20	0.45	0.20	1.00	4.50	0.22	3.00	429.10	16.83	283.21	0.19	42.00	3.77	11.15	8.23	45.77	28.72
21	PDJNR2020	15A	93.00	122.00	DNMG150612	M3	TP30	0.45	174.44	4.50	53.34	57.85	5.12	4	15.00	0.40	0.45	0.20	1.00	4.50	0.22	3.00	429.10	16.83	283.21	0.19	42.00	3.77	11.15	8.23	45.77	28.72
22	PDJNR2020	15A	93.00	122.00	DNMG150612	M3	TP30	0.45	174.44	4.50	53.34	57.85	5.12	4	15.00	0.80	0.45	0.20	1.00	4.50	0.22	3.00	429.10	16.83	283.21	0.19	42.00	3.77	11.15	8.23	45.77	28.72
23	PDJNR2020	15A	93.00	122.00	DNMG150612	M3	TP30	0.45	174.44	4.50	53.34	57.85	5.12	4	15.00	1.20	0.45	0.20	1.00	4.50	0.22	3.00	429.10	16.83	283.21	0.19	42.00	3.77	11.15	8.23	45.77	28.72
24	PSRNR2020	12A	75.00	105.00	SNMG120408	MR3	TP30	0.40	182.22	4.00	53.34	38.33	3.54	8	12.00	0.80	0.40	0.15	1.00	4.00	0.17	3.75	370.22	33.02	226.89	0.24	42.00	4.52	9.29	7.72	46.52	28.81
25	PSRNR2020	12A	75.00	105.00	SNMG120412	MR3	TP30	0.40	182.22	4.00	53.34	38.33	3.54	8	12.00	1.20	0.40	0.15	1.00	4.00	0.17	3.75	370.22	33.02	226.89	0.24	42.00	4.52	9.29	7.72	46.52	28.81
26	PSRNR2020	15A	93.00	122.00	DNMG150608	MR7	TP20	0.60	151.11	5.00	53.34	57.85	5.12	4	15.00	0.80	0.60	0.25	1.50	5.00	0.26	2.50	410.69	16.83	266.95	0.20	42.00	4.00	10.51	8.69	46.00	28.89
27	PSRNR2020	15A	93.00	122.00	DNMG150612	MR7	TP20	0.60	151.11	5.00	53.34	57.85	5.12	4	15.00	1.20	0.60	0.25	1.50	5.00	0.26	2.50	410.69	16.83	266.95	0.20	42.00	4.00	10.51	8.69	46.00	28.89
28	PSRNR2020	15A	93.00	122.00	DNMG150612	MR7	TP30	0.60	151.11	5.00	53.34	57.85	5.12	4	15.00	0.40	0.60	0.25	1.50	5.00	0.26	2.50	410.69	16.83	266.95	0.20	42.00	4.00	10.51	8.69	46.00	28.89
29	PSRNR2020	12A	75.00	105.00	SNMG120412	MR5	TP20	0.55	176.00	5.00	53.34	38.33	3.54	8	12.00	1.20	0.55	0.20	1.00	5.00	0.22	3.00	343.77	33.02	226.89	0.24	42.00	4.70	8.93	10.07	46.70	28.92
30	PSRNR2020	12A	75.00	105.00	SNMG120408	MR5	TP30	0.55	158.89	5.00	53.34	38.33	3.54	8	12.00	0.80	0.55	0.20	1.00	5.00	0.22	3.00	343.77	33.02	226.89	0.24	42.00	4.70	8.93	10.07	46.70	28.92
31	PSRNR2020	12A	75.00	105.00	SNMG120412	MR5	TP30	0.55	158.89	5.00	53.34	38.33	3.54	8	12.00	1.20	0.55	0.20	1.00	5.00	0.22	3.00	343.77	33.02	226.89	0.24	42.00	4.70	8.93	10.07	46.70	28.92
32	PSRNR2020	12A	75.00	105.00	SNMG120408	MR5	TP30	0.40	209.00	3.50	53.34	38.33	3.54	8	12.00	0.80	0.40	0.10	0.50	3.50	0.22	3.00	343.77	33.02	226.89	0.24	42.00	4.70	8.93	10.07	46.70	28.92
33	PSRNR2020	12A	75.00	105.00	SNMG120412	MR5	TP30	0.40	209.00	3.50	53.34	38.33	3.54	8	12.00	1.20	0.40	0.10	0.50	3.50	0.22	3.00	343.77	33.02	226.89	0.24	42.00	4.70	8.93	10.07	46.70	28.92
34	PSRNR2020	12A	75.00	105.00	SNMG120408	MR2	TP30	0.40	182.22	3.50	53.34	38.33	3.54	8	12.00	0.80	0.40	0.10	0.50	3.50	0.22	3.00	343.77	33.02	226.89	0.24	42.00	4.70	8.93	10.07	46.70	28.92
35	PSRNR2020	12A	75.00	105.00	SNMG120412	MR2	TP30	0.40	182.22	3.50	53.34	38.33	3.54	8	12.00	1.20	0.40	0.10	0.50	3.50	0.22	3.00	343.77	33.02	226.89	0.24	42.00	4.70	8.93	10.07	46.70	28.92
36	PSRNR2020	12A	75.00	105.00	SNMG120408	M5	TP20	0.50	187.00	5.00	53.34	38.33	3.54	8	12.00	0.80	0.50	0.20	1.00	5.00	0.22	3.00	343.77	33.02	226.89	0.24	42.00	4.70	8.93	10.07	46.70	28.92
37	PSRNR2020	12A	75.00	105.00	SNMG120408	M5	TP30	0.50	166.87	5.00	53.34	38.33	3.54	8	12.00	1.20	0.50	0.20	1.00	5.00	0.22	3.00	343.77	33.02	226.89	0.24	42.00	4.70	8.93	10.07	46.70	28.92
38	PSRNR2020	12A	75.00	105.00	SNMG120412	M5	TP30	0.50	166.87	5.00	53.34	38.33	3.54	8	12.00	0.40	0.50	0														

- Select ITS5

The following message is displayed.

- “ITS5 is concerned with optimization of tooling for the component.”
- Select OK.

The following message is displayed.

- “Please enter the JOBALL file (JOBALL1.XLS)” <OK>

This then proceeds to produce the SUMMARY file for the component and this is the first option and the ideal TRS for the component.

OPTION 1

JOB	HOLDER	CEL	AANG	TANG	INSERT	CBR	GRADE	TOSUT	RUNTIME	RATIO	EFFUTL	TOTTIME	TOTCOST
JOB1OP2.RUN	PCLNR2020	12A	95.00	95.00	CNMG120408	MF3	TP20	42.00	8.96	4.69	17.58	50.96	32.29
JOB1OP1.RUN	PCRNR2020	12A	75.00	95.00	CNMG120408	MF3	TP20	42.00	16.31	2.57	27.98	58.31	37.54
JOB1OP3.RUN	PDJNR2020	15A	93.00	122.00	DNMG150608	MF3	TP20	42.00	3.62	11.60	7.94	45.62	28.61
								126.00	28.90	4.36	18.65	154.90	98.44

Table 5: Option 1 - Optimum solution for each operation.

A further rationalization is performed on the above option for exact operation plans (identical tools). The result is the same as no exact operation plans exist from the TRS of the component, that is, no operation plan is exactly the same as another in terms of; tool holder, insert type, approach and trailing angles, insert grade and chipbreaker.

OPTION 2

JOB	HOLDER	CEL	AANG	TANG	INSERT	CBR	GRADE	TOSUT	RUNTIME	RATIO	EFFUTL	TOTTIME	TOTCOST
JOB1OP2.RUN	PCLNR2020	12A	95.00	95.00	CNMG120408	MF3	TP20	42.00	8.96	4.69	17.58	50.96	32.29
JOB1OP1.RUN	PCRNR2020	12A	75.00	95.00	CNMG120408	MF3	TP20	42.00	16.31	2.57	27.98	58.31	37.54
JOB1OP3.RUN	PDJNR2020	15A	93.00	122.00	DNMG150608	MF3	TP20	42.00	3.62	11.60	7.94	45.62	28.61
								126.00	28.90	4.36	18.65	154.90	98.44

Table 6: Option 2 - Solution after exact (identical) test on option 1.

Then an exact match is sought for by searching all the operation files. The result is a selection of various operation plans that are capable in performing each operation. A total of 25 operation plans were identified as shown below under option 3. Option 3 is in order of preference with operation plan number 3 costing the cheapest.

OPTION 3

3	PDJNR2020	15A	93.00	122.00	DNMG150612	MF3	TP30	42.00	28.98	1.45	40.82	70.98	47.56
1	PDJNR2020	15A	93.00	122.00	DNMG150608	MF3	TP20	42.00	28.98	1.45	40.82	70.98	47.56
2	PDJNR2020	15A	93.00	122.00	DNMG150608	MF3	TP30	42.00	28.98	1.45	40.82	70.98	47.56
4	PDJNR2020	15A	93.00	122.00	DNMG150604	MF3	TP30	42.00	28.98	1.45	40.82	70.98	47.56
6	PDJNR2020	15A	93.00	122.00	DNMG150612	MF2	TP20	42.00	30.14	1.39	41.78	72.14	48.43
5	PDJNR2020	15A	93.00	122.00	DNMG150608	MF2	TP20	42.00	30.14	1.39	41.78	72.14	48.43
7	PDJNR2020	15A	93.00	122.00	DNMG150608	MF2	TP30	42.00	30.14	1.39	41.78	72.14	48.43
8	PDJNR2020	15A	93.00	122.00	DNMG150604	MF2	TP20	42.00	30.14	1.39	41.78	72.14	48.43
9	PDJNR2020	15A	93.00	122.00	DNMG150604	MF2	TP30	42.00	30.14	1.39	41.78	72.14	48.43
13	PDJNR2020	15A	93.00	122.00	DNMG150612	M5	TP30	42.00	30.14	1.39	41.78	72.14	48.43
10	PDJNR2020	15A	93.00	122.00	DNMG150608	M5	TP20	42.00	30.14	1.39	41.78	72.14	48.43
12	PDJNR2020	15A	93.00	122.00	DNMG150608	M5	TP30	42.00	30.14	1.39	41.78	72.14	48.43
11	PDJNR2020	15A	93.00	122.00	DNMG150604	M5	TP30	42.00	30.14	1.39	41.78	72.14	48.43
16	PDJNR2020	15A	93.00	122.00	DNMG150612	M3	TP20	42.00	30.14	1.39	41.78	72.14	48.43
21	PDJNR2020	15A	93.00	122.00	DNMG150612	M3	TP30	42.00	30.14	1.39	41.78	72.14	48.43
22	PDJNR2020	15A	93.00	122.00	DNMG150612	M3	TP301	42.00	30.14	1.39	41.78	72.14	48.43
15	PDJNR2020	15A	93.00	122.00	DNMG150608	M3	TP20	42.00	30.14	1.39	41.78	72.14	48.43
19	PDJNR2020	15A	93.00	122.00	DNMG150608	M3	TP30	42.00	30.14	1.39	41.78	72.14	48.43
20	PDJNR2020	15A	93.00	122.00	DNMG150608	M3	TP301	42.00	30.14	1.39	41.78	72.14	48.43
14	PDJNR2020	15A	93.00	122.00	DNMG150604	M3	TP20	42.00	30.14	1.39	41.78	72.14	48.43
17	PDJNR2020	15A	93.00	122.00	DNMG150604	M3	TP30	42.00	30.14	1.39	41.78	72.14	48.43
18	PDJNR2020	15A	93.00	122.00	DNMG150604	M3	TP301	42.00	30.14	1.39	41.78	72.14	48.43
34	PDJNR2020	15A	93.00	122.00	DNMG150612	MR7	TP20	42.00	31.98	1.31	43.22	73.98	49.80
25	PDJNR2020	15A	93.00	122.00	DNMG150612	MR7	TP30	42.00	31.98	1.31	43.22	73.98	49.80
23	PDJNR2020	15A	93.00	122.00	DNMG150608	MR7	TP30	42.00	31.98	1.31	43.22	73.98	49.80

Table 7: Option 3 - Exact (identical) test on operation files.

Option 1 and 2 are the same as already stated. Option 3 presents a number of single solutions to machine the complete component. If option 1/2 were selected, that is, three different operation plans, then the total cost is £98.44 as compared to £47.56 if option 3

was selected. Table 8 presents the difference in using option 3 as compared to option 1/2.

	Total set-up time (mins.)	Run time (mins.)	Ratio of set-up/run time	Effective utilisation %	Total time (mins.)	Total cost (£)
Option 1/2	126.00	28.90	4.36	18.65	154.90	98.44
Option 3	42.00	28.90	1.45	40.82	70.98	47.56
Δ	84.00 ↓	0.00	2.91 ↑	22.17 ↑	84.00 ↓	51.38 ↓

Table 8: Comparison between the various options.

The total time (TOTTIME) is reduced by 84 mins. This is attributed to the reduction in the total set-up time (TOSUT). The set-up time to machining time is reduced by 2.91 due to one set-up. This, therefore, increases the effective utilisation by 22.17%. The total cost (TOCOST) is reduced by £51.38 and this is attributed mainly to the reduction from three sets of tooling to one set.

The system has demonstrated the capability of optimizing on a set of tooling for a component. This information can then be used when considering the selection of tooling for a machine tool at Multi-Batch Level (TVRO_MB). A similar process is possible and this would aim in optimizing tooling at the multi-batch level, and aid in defining the TRS for the machine for a defined production time frame.

Without an effective and efficient computer based system process planners select tools without any objective criteria and in particular without comparing several alternatives which could result in widely different machining performance.

Chapter 10

Conclusions and Recommendations

Tool selection consists of five levels;

- Operation level;
- Component level;
- Machine level;
- Multi-batch level and;
- Shop floor and tool store level.

The operation level is concerned with the optimum selection of tooling and cutting conditions for each operation. The component level selects tooling and cutting conditions by considering the operation plans for each operation. It will optimize the individual operation plans. The machine level addresses the need to optimize tooling and cutting conditions for various batch sizes and of different material all requiring to be manufactured on one machine. The multi-machine level will consider a diverse number of components within a resource unit. While the shop floor and tool store level will deal with the tool management aspect of tool selection.

All the selection levels were discussed under different manufacturing paradigms namely; process based, FMS cell, group technology and transfer lines. In addition, the various objectives and tooling criteria that are required to be considered include:

- Tool management and planning;
- Technological /process requirement;
- Tool rationalization opportunities at resource unit level;
- Time allowed to select tools;
- Tool allocation horizon;

- Importance of tool / work flow synchronisation;
- Machining performance rating;
- Set-up time reduction rating;
- Benefits from geometrical rationalisation, and;
- Benefits from carbide rationalisation.

Operation Planning and the concept of Tool Resource Structure (TRS) was presented. Operation Planning deals with the detail selection of tooling and cutting conditions for an operation. The TRS concept is presented as an extension of the MRP11 system. It discusses the requirement for additions to the MRP11 system which include:

- Computer Aided Design link with MRP11;
- Computer Aided Process Planning link with MRP11;
- A database for operation plans;
- A tooling database;
- A module to determine the TRS for components and products, and;
- A module to plan the production of operation plans for a defined time period.

Various amendments are required to the existing parts of an MRP11 system for this integration, namely;

- The routing file;
- Bills of material;
- Time-phased requirement planning, and;
- Material, tooling and capacity plans.

The tool selection system, currently developed, was presented. This included; tool selection at the operation and component levels. The graphics and heuristic module manages the geometrical aspect of tool selection. It selects tools based on the geometrical constraints of the component taking into consideration both the approach and trailing angles of the tooling available. The heuristics system uses a number of

empirical rules established from industrial practice and tool manufacturers literature. The system presents the ideal operating conditions for the insert but do not take into consideration the machining constraints. The geometry module is capable of selecting tooling for;

- right to left machining for external turning (linear elements);
- left to right machining for external turning (linear elements);
- right to left machining for external turning (arc elements);
- left to right machining for external turning (arc elements);
- right to left machining for internal turning / boring (linear elements);
- left to right machining for internal turning / boring (linear elements).

The software is written in AutoLisp which allows for the customization of AutoCAD for a particular application. The end result from these two modules is a set of operation plans for each machining operation.

The next level developed in this work was the tool selection at component level. This was written using the Visual Basic - Excel programming language. It uses the current technology equations in determining a suitable set of cuttings conditions by considering a number of machining constraints. A set of operation plans are considered for the component which are further optimized in order to establish a set of tooling and operating conditions for the component.

A number of examples were presented to explain the working of the system. This involved the selection of operation plans at the operation level and subsequently the selection process at the component level.

The software is at a stage that will now perform tool selection and rationalisation from the operation up to the machine level for one type of material. It now requires further development to expand this to consider a number of different materials.

References

1. Zdeblick, W. J., "Computer -Aided Process and Operation Planning." your factory of the future - today, Cincinnati, Ohio: Metcut Research Associates, 1983, pp. 5-1 to 5-19.
2. Kops, L. & Ramalingham, S. (Ed.); On the art of cutting metals - 75 years later, A Tribute to F. W. Taylor. ASME, PED - Vol. 7. Presented at the Winter Annual Meeting of the ASME, Phoenix, Arizona, November 14-19, 1962.
3. Weill, R. et al; "The use of electronic computers for the determination of optimum machining conditions", Proceedings of the 3rd. International Mach. Tool Des. Res. Conference, University of Birmingham, September 1962.
4. Ham, I.,: "Economics of machining: analysing optimum machining conditions by computers", Sp 6460 Creative Manufacturing Seminars; pp. 196-364, ASTME, 1964.
5. Brewer, R. C.: "On the Economics of the Basic Turning Operation", Trans. Am. Soc. Mech. Engrs 80, 1479 (19
6. Brierley, R. G. & Siekmann, H. I.: "Machining Principles and Cost Control. McGraw-Hill, 1964.
7. Brewer, R. C.: "The Parameter Selection Problem in Tool Selection", Communication to C.I.R.P. Annual Assembly, Liège, 1965.
8. Wu, S. M. & Ermer, D. S.: "Maximum Profit as the Criterion in the Determination of the Optimum Cutting Conditions", Trans. Am. Soc. Mech. Engrs. B88, 435, 1966.
9. Ermer, D. S. & Wu, S. M.: "The Effect of Experimental Error on the Determination of the Optimum Metal Cutting Conditions", Trans. Am. Soc. Mech. Engrs., B89, 315, 1967.
10. Crookall, J. R.: " On the Optimisation of the Turning Operation. Communication of the C.I.R.P. Group "O", 1967.
11. Bartalucci, B., Bedini, R. & Lisini, G. G.: " On the Optimum Selection of Machine Tools in Turning Operation", Annals of the C.I.R.P. Vol. XVII, pp. 445-452, 1969.

-
12. Bomoswani, R.: "Optimisation of Machining Parameters Using A digital Computer", *The Indian Journal*, pp. 9-18, October 1968.
 13. Bartalucci, B., Bedini, R. and Lisini, G. G.: "On the Optimum Selection of Machine Tools in Turning Operations", *Annals of CIRP*, Vol. XVII, pp. 445-452, 1969.
 14. Iwata, K., Murotsu, Y., Iwatsubo, Y. and Lisini, G. G., "A probabilistic approach to the determination of optimum cutting conditions", *Journal of Engineering for Industry*, pp. 1099-1107, Nov. 1972.
 15. Etin, A. O. et al; "Tool selection for automatic machines", *Russian Engineering Journal*, Vol. LIII, No. 12, pp. 43-47, 1973.
 16. Petropoulos, P. G.: "Optimal selection of machining rate variables by geometric programming", *Int. J. Prod. Res.*, Vol. 11, No. 4, pp. 305-314, 1973.
 17. Iwata, K., Murotsu, Y. and Oba, F., "Optimisation of cutting conditions for multi-pass operations considering probabilistic nature in machining processes", *Transactions of the ASME, Journal of Engineering for Industry*, pp. 210-217, Feb. 1977.
 18. Kals, H. J. J., Hijink, J. A. W and Van der Wolf, A. C. H., "A comprehensive machining cost model of turning conditions in multi-cut operations", *Annals of the CIRP*, Vol. 27/1, pp. 465-469, 1978.
 19. Kals, H. J. J. and Hijink, J. A. W.: "A Computer Aid in the Optimisation of Turning Conditions in Multi-Cut Operations", *Annals of CIRP*, Vol. 27/1, 1978.
 20. Wysk, R. A, Davis, R. P. and Agee, M. H.: "Optimizing Machining Parameters in a Realistic Manufacturing Environment", 6th. North American Metalwork Res. Conf. Proc., pp. 304-309, 1978.
 21. Zdeblick, W. J., De Vor, R. E. and Kahles, J. F., "A comprehensive machining cost model and optimisation technique", *Annals of the CIRP*, Vol. 30/1, pp. 405-408, 1981.

-
22. Hinduja, S., Petty, D. J., Tester, M. and Barrow, G., "Calculation of optimum cutting conditions for turning operations", Proc. Instn. Mech. Engrs., Vol. 199, No. B2, pp. 81-92, 1985.
 23. Wang, Hsu-Pin (Ben) and Wysk, R. A.: "An Expert System for Machining Data Selection", Comput. and Indus. Engng., Vol.10, No.2, pp. 99-107, 1986.
 24. Maropoulos, P. G. and Hinduja, S.: " Automatic Tool Selection for Rough Turning Operations", Int. J. Prod. Res., 1991, 29(6), 1185 - 1204.
 25. Maropoulos, P. G. and Hinduja, S.; "Automatic tool selection for finish turning.", Proc. Instn. Mech. Engrs., Part B, 1990, 204, 43-51.
 26. Hinduja, S. and Barrow, G., "TECHTURN: a technologically oriented system for turned components", 1st. CAPE Conference, Edinburgh, pp. 255-260, April 1986.
 27. Maropoulos, P. G. and Hinduja, S.; A tool-regulation and balancing system for turning centres." Int. J. Adv. Manufact. Technol., 1989, 4, 207 - 226.
 28. Barkocy, B. E. and Zdeblick, W. J.: "A knowledge-based system for machining operation planning", The Carbide and Tool Journal, pp. 25-30, July - August 1985.
 29. Giusti, F., Santochi, M. and Dini, G., "COATS: an expert module for optimal tool selection", Annals of the CIRP, Vol. 35/1, pp. 337-340, 1986.
 30. Milacic, V. R. and Putnik, G. D., "Logical structure of tooling system design - fundamentals of tooling selection expert system", Information Control Problems in Manufacturing Technology, Selected papers from the 6th. IFAC/IFIP/IFORS/IMACS Symposium, MADRID, Spain, 1989, Puente, E. A. and Nemes, L. (ed.), Pergamom Press.
 31. Arezoo, B. and Ridgway, K., "An expert system for tool selection for turning operations", Proceedings of CAPES Conference, Edinburgh, November 1989.
 32. Domazet, D. and Milacic, V. R., "The automatic tool selection with the production rules matrix method", Annals of the CIRP, Vol. 39/1, pp. 497-500, 1990.

-
33. Keating, W. G., Lewis, P. R., Simmons, J. E. L. & Maropoulos, P. G.: "Intelligent Tool Selection System", *Journal of Materials Processing Technology*, 55, pp. 91-94, 1995.
 34. Keating, W. G., Simmons, J. E. L. & Maropoulos, P. G.: "Pilot Implementation of an Intelligent Tool Selection System". Proc. 8th. CAPES Conf., Edinburgh, August 1992.
 35. Maropoulos, P. G., Dai, J., Gill, P. A. T., Keating, W. G. and Lewis, P. R.: "An Advanced Tooling System for Turning"
 36. Maropoulos, P. G., "Cutting Tool Selection: An Intelligent Methodology and its Interfaces with Technical and Planning Functions." *Proceedings of the Institution of Mechanical Engineers, Journal of Engineering Manufacturing*, 1992 Vol. 206 No B1, pp. 49- 60.
 37. Vollman, T. E., Berry, W. L. and Whybark, D. C., *Manufacturing Planning and Control Systems*. 2nd. ed. Homewood, Ill.: Richard D. Irwin, 1979.

APPENDIX 1

Brief Description of TVRO_G Functions

- *TVRO_G* is the main function of the module and has direct control in initialising the majority of functions
- *ESTART* initialises the graphics system variables.
- *CONSTANTS* define the graphics system constants.
- *JOBID* job identification number.
- *TURNING* requests the type of turning operation being performed.
- *RLM* requests the direction of machining.
- *LOCKSYS* requests the preferred locking system.
- *FMRCUT* requests the type of cut required - finish, medium or rough, and the depth of cut
- *TOMTM* requests for the type of material to be machined.
- *ESELECT* requests the user to select the start and end points of the profile, and determines if the elements of the profile are lines or arcs.
- *TYPEL* is used to check the start and end points of line elements.
- *TYPEA* is used to check the start and end points of arc element.
- *ETEST* is used to call the appropriate ETEST functions, that is ETEST120 and ETEST121.
- *ETEST120* tests a defined linear element of the profile to determine its direction.
- *ETESTRL* is initiated for right -> left machining (external) and is used to determine if the defined linear element of the profile is capable of being machined using the tools available.
- *ETESTLR* is initiated for left -> right machining (external) and is used to determine if the defined linear element of the profile is capable of being machined using the tools available.
- *IETESTRL* is initiated for right -> left machining (internal) and is used to determine if the defined linear element of the profile is capable of being machined using the tools available.

- *IETESTLR* is initiated for left -> right machining (internal) and is used to determine if the defined linear element of the profile is capable of being machined using the tools available.
- *ETESTI21* performs a test on a defined arc element of the profile to determine its direction.
- *ETESTRLA* is initiated for right -> left machining (external) and is used to determine if the defined arc element of the profile is capable of being machined using the tools available.
- *ETESTLRA* is initiated for left -> right machining (external) and is used to determine if the defined arc element of the profile is capable of being machined using the tools available.
- *ATMAX* is used to determine the maximum approach and trailing angles.
- *EHOLDERS* searches the database for suitable tool holders.
- *TESTHOLDER* test and write suitable tool holders to file.
- *HOLDERINSERT* searches the database for suitable inserts.
- *MATCHINSERTS* test tool holder code with the insert code.
- *CHIPBREK* selects the appropriate chip breaking diagram.
- *CUTDATA* calculates the appropriate cutting conditions..

APPENDIX 2

Data Files For The Graphics And Heuristics Modules

HOLDERS

This data file stores tool holders and the information stored is as follows;

- the type of locking system;
- the insert shape;
- the tool style;
- insert clearance;
- hand of tool;
- shank height;
- shank width;
- tool length;
- cutting edge length;
- approach angle; and,
- trailing angle.

A typical record is; "PCLNR2020-09A 95.0 95.0".

INSERTS

This data file stores inserts and the information stored is as follows;

- insert shape;
- clearance angle;
- tolerance;
- insert type;
- cutting edge length;
- insert thickness;
- nose radius;

- chip breaker type; and,
- insert grade.

A typical record is; "CNMG190608-M4-TP20".

Chip breaking diagrams

This data file stores information for the chip breaking diagram and the information stored is as follows.

- chip breaker type;
- minimum feed rate;
- minimum depth of cut;
- maximum feed rate; and,
- maximum depth of cut.

A typical record is, "FF1/0.05/0.25/0.50/2.50#".

Cutting data

This data file stores information on cutting data. The information stored in this file is as follows;

- material type code;
- insert grade;
- recommended feed rate; and,
- recommended cutting velocity.

A typical record is, "3/TP20/0.15/275.0/0.35/220.0/0.60/165.0#".

