

## Durham E-Theses

---

### *Synthesis, characterisation and properties of some well-defined comb graft copolymers*

Abdul Cassim Mohamed Rizmi

#### How to cite:

---

Rizmi, Abdul Cassim Mohamed (1997) Synthesis, characterisation and properties of some well-defined comb graft copolymers. Doctoral thesis, Durham University.

#### Use policy

---

The full-text may be used and/or reproduced, and given to third parties in any format or medium, without prior permission or charge, for personal research or study, educational, or not-for-profit purposes provided that:

- a full bibliographic reference is made to the original source
- a <https://etheses.durham.ac.uk/id/eprint/5057/> is made to the metadata record in Durham E-Theses
- the full-text is not changed in any way

The full-text must not be sold in any format or medium without the formal permission of the copyright holders.

Please consult the [full Durham E-Theses policy](#) for further details.

**SYNTHESIS, CHARACTERISATION AND PROPERTIES OF  
SOME WELL-DEFINED COMB GRAFT COPOLYMERS**

**Abul Cassim Mohamed Rizmi**

A Thesis Submitted to the University of Durham for the Degree of Doctor  
of Philosophy

The copyright of this thesis rests  
with the author. No quotation  
from it should be published  
without the written consent of the  
author and information derived  
from it should be acknowledged.

Interdisciplinary Research Centre in Polymer Science and Technology

University of Durham

August 1997



20 NOV 1997

## ABSTRACT

### Synthesis, Characterisation and Properties of Some Well-Defined Comb Graft Copolymers

This thesis describes studies directed to the ring opening metathesis polymerisation of macromonomers and mesogenic monomers to produce graft copolymers and side chain liquid crystalline polymers respectively. The necessary background information relevant to the work described in this thesis is presented in chapter-1 and consists of four sections; namely, descriptions of metathesis polymerisation, anionic polymerisation, synthesis of graft copolymers and synthesis of side chain liquid crystalline polymers. The synthesis of the end capping reagent *exo*-5-norbornene-2-carbonyl chloride is described in chapter-2. The synthesis and characterisation of *exo*-5-norbornene-2-poly(styrylcarboxylate) macromonomers by living anionic polymerisation is discussed in chapter-3. Chapter-4 reports the synthesis, characterisation and properties of graft copolymers prepared by ring opening metathesis polymerisation of *exo*-5-norbornene-2-poly(styrylcarboxylate) macromonomers. Chapter-5 describes the synthesis of the mesogenic monomer; (*S*)-(-)-2-methylbutyl-4-(4-(10-(3-cyclopentenylmethoxy) decyloxy) phenylcarbonyloxy) benzoate, suitable for ring opening metathesis polymerisation to produce side chain liquid crystalline polymer. The attempted synthesis of side chain liquid crystalline polymer by ring opening metathesis polymerisation of the mesogenic monomer; (*S*)-(-)-2-methylbutyl-4-(4-(10-(3-cyclopentenylmethoxy) decyloxy) phenylcarbonyloxy) benzoate is reported in chapter-6. Finally chapter-7 summarises the conclusions and makes some suggestions for future work.

## **ACKNOWLEDGEMENT**

First and foremost, I would like to thank my supervisors, Professor W. J. Feast and Dr. E. Khosravi for their continuous guidance, support and encouragement throughout my stay in Durham. My thanks are also due to Tom Kiff for his help with anionic polymerisation, Dr. Alan Kenwright for help with interpretation of the nmr spectra, Julia Say for recording them, Gordon Forrest for GPC, DSC and TGA analysis and Ray Hart and Gordon Haswell for providing glassware and all the technical staff in the IRC and the chemistry department. Also I would like to thank my colleagues, past and present in the IRC for their support. The Defence Research Agency is acknowledged for providing some financial support for the work relating to side chain liquid crystal polymer synthesis. Finally, I would like to thank my parents for their loving care and continuous financial support without which none of these would have been possible and to my wife Shanaz for her patient, support and encouragement.

## **MEMORANDUM**

The work reported in this thesis was carried out at the Interdisciplinary Research Centre in Polymer Science and Technology at Durham University between January 1994 and December 1996. This work has not been submitted for any other degree and is the original work of the author except where acknowledged by an appropriate reference.

## **STATEMENT OF COPYRIGHT**

The copyright of this thesis rests with the author. No quotation from it should be published without his prior written consent and information derived from it should be acknowledged.

# CONTENTS

<i>Abstract</i>	<i>ii</i>
<i>Acknowledgement</i>	<i>iii</i>
<i>Memorandum</i>	<i>iii</i>
<i>Statement of Copyright</i>	<i>iii</i>
<i>Contents</i>	<i>iv</i>

## CHAPTER-1 GENERAL INTRODUCTION

1.1 Aims and Objectives	2
1.2 Olefin Metathesis	2
1.2.1 Definition and Historical Background	2
1.2.2 Metathesis Initiators	3
1.2.2a Classical Initiators	4
1.2.2b Well-Defined Initiators	5
1.2.3 Living Polymerisation	8
1.2.4 The Mechanism of Olefin Metathesis and Ring Opening Metathesis Polymerisation	9
1.2.5 Termination	12
1.2.6 Chain Transfer	12
1.2.7 Thermodynamic Aspects of Ring Opening Metathesis Polymerisation	13
1.2.8 Microstructure of Polymer Chains	14
1.3 Anionic Polymerisation	16
1.3.1a Anionic Polymerisation Carried Out in Protic Media	16
1.3.1b Anionic Polymerisation in Aprotic Media	17
1.3.2 Anionic Polymerisation Initiators	18
1.3.2a Aromatic Complexes of Alkali Metals	18
1.3.2b Alkali Metals	19
1.3.2c Organoalkali Metal Compounds	19
1.3.3 Solvents and Gegen-ion	22
1.3.4 Monomers	23

1.3.5 Applications of Living Anionic Polymerisation	24
1.4 Graft Copolymers	25
1.4.1 Grafting From Method	26
1.4.2 Grafting Onto Method	27
1.4.3 Macromonomer Method	28
1.4.4 Applications of Graft Copolymers	31
1.5 Liquid Crystalline Polymers	32
1.5.1 Lyotropic and Thermotropic Liquid Crystalline Polymers	34
1.5.2 Lyotropic Liquid Crystalline Polymers	35
1.5.3 Thermotropic Main Chain Liquid Crystalline Polymers	36
1.5.4 Thermotropic Side Chain Liquid Crystalline Polymers	36

## CHAPTER-2 SYNTHESIS OF *EXO*-5-NORBORNENE-2-CARBONYL CHLORIDE

2.1 Introduction	41
2.2 Synthesis of 5-Norbornene-2-Carboxylic Acid	41
2.3 Iodolactonisation of <i>Endo</i> Acid	44
2.4 Conversion of <i>Exo</i> Acid into Acid Chloride	47
2.5 Experimental	48
2.5.1 Synthesis of <i>Exo</i> -5-Norbornene-2-Carboxylic Acid	48
2.5.2 Separation of <i>Exo</i> and <i>Endo</i> Acids	49
2.5.3 Synthesis of <i>Exo</i> -5-Norbornene-2-Carbonyl Chloride	50

## CHAPTER-3 SYNTHESIS OF MACROMONOMERS BY LIVING ANIONIC POLYMERISATION

3.1 Introduction	52
3.2 Synthesis of <i>Exo</i> -5-Norbornene-2-(Polystyrylcarboxylate) Macromonomers	52
3.3 Characterisation of Macromonomers	56
3.4 Experimental	60
3.4.1 Purification of Solvents and Reagents	60
3.4.2 Preparation of the Anionic Polymerisation Apparatus	61
3.4.3 Anionic Polymerisation of Styrene and Macromonomer Synthesis	63

CHAPTER-4 RING OPENING METATHESIS POLYMERISATION OF  
MACROMONOMERS AND CHARACTERISATION OF  
POLYMERS

4.1 Introduction	65
4.2 Graft Copolymer Synthesis	65
4.2.1 NMR Tube Scale Polymerisation	72
4.2.2 Preparative Scale Polymerisation	75
4.3 Characterisation of Graft Copolymers	76
4.4 Experimental	90
4.4.1 A Typical NMR Scale Polymerisation	90
4.4.2 A Typical Preparative Scale Polymerisation	90
4.4.3 Controlled Fractionation of Graft Copolymers	91

CHAPTER-5 SYNTHESIS OF A POTENTIALLY RING OPEN  
POLYMERISABLE MESOGENIC MONOMER

5.1 Introduction	94
5.2 Monomer Synthesis	94
5.2.1 Synthesis of 4-Hydroxymethyl Cyclopentene	95
5.2.2 Synthesis of 10-Bromodecyl 3-Cyclopentenylmethyl Ether	98
5.2.3 Synthesis of 4-(10-(3-Cyclopentenylmethoxy)Decyloxy)Benzoic Acid	99
5.2.4 Synthesis of (S)-(-) 2-Methylbutyl 4-Hydroxybenzoate	100
5.2.5 Synthesis of (S)-(-) 2-Methylbutyl 4-(4-(10-(3-Cyclopentenyl methoxy)Decyloxy)Phenylcarbonyloxy)Benzoate	102
5.3 Optical Micrographs of Mesogenic Monomer	102
5.4 Experimental	105
5.4.1 Synthesis of Dimethyl 3-Cyclopentene 1,1-Dicarboxylate	105
5.4.2 Synthesis of 3-Cyclopentene 1,1-Dicarboxylic Acid	106
5.4.3 Synthesis of 3-Cyclopentenecarboxylic Acid	106
5.4.4 Synthesis of 4-Hydroxymethyl Cyclopentene	107
5.4.5 Synthesis of 10-Bromodecyl 3-Cyclopentenylmethyl Ether	108

5.4.6 Synthesis of Methyl 4-(10-(3-Cyclopentenylmethoxy)Decyloxy) Benzoate	109
5.4.7 Synthesis of 4-(10-(3-Cyclopentenylmethoxy)Decyloxy)Benzoic Acid	109
5.4.8 Synthesis of (S)-(-) 2-Methylbutyl 4-Hydroxybenzoate	110
5.4.9 Synthesis of (S)-(-) 2-Methylbutyl 4-(4-(10-(3-Cyclopentenyl methoxy)Decyloxy)Phenylcarbonyloxy)Benzoate	111
CHAPTER-6 THE ATTEMPTED SYNTHESIS OF SIDE-CHAIN LIQUID CRYSTALLINE POLYMERS	
6.1 Introduction	114
6.2 Polymerisation of Mesogenic Monomer	114
6.3 Results of Attempted Polymerisation	118
6.4 Experimental	124
6.4.1 Purification of Dichloromethane	124
6.4.2 A Typical Polymerisation	125
CHAPTER-7 CONCLUSIONS AND PROPOSALS FOR FUTURE WORK	
7.1 Conclusions	127
7.1.1 Ring Opening Metathesis Polymerisation of Macromonomers to Produce Graft Copolymers	127
7.1.2 Attempted Synthesis of Side Chain Liquid Crystalline Polymers by Ring Opening Metathesis Polymerisation	128
7.2 Proposals For Future Work	128
APPENDIX-1 General Procedures, Equipment and Instrumentation	130
APPENDIX-2 Analytical Data for Chapter-2	133
APPENDIX-3 Analytical Data for Chapter-3	140
APPENDIX-4 Analytical Data for Chapter-4	165

APPENDIX-5 Analytical Data for Chapter-5	192
APPENDIX-6 Analytical Data for Chapter-6	221
APPENDIX-7 Lectures and Conferences Attended	230
REFERENCES	235

**CHAPTER-1**  
**GENERAL INTRODUCTION**

## **1.1 AIMS AND OBJECTIVES**

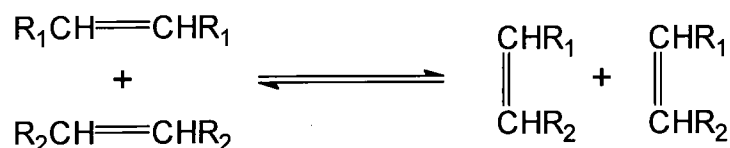
The aim of the work described in this thesis is to synthesise and to characterise well defined comb graft copolymers. Two different types of comb graft copolymer are discussed. One involves synthesis of polystyrene macromonomers carrying a norbornene unit at the chain end by living anionic polymerisation and subsequent living ring opening metathesis polymerisation (ROMP) of these macromonomers using well defined Schrock initiators. This approach gives graft copolymers with polynorbornene backbone chains carrying polystyrene grafts. The other type involves a study of the ring opening metathesis polymerisation of a cyclopentene unit attached to a mesogenic molecule in an attempt to produce side chain liquid crystalline polymers where the backbone is a low T<sub>g</sub> hydrocarbon polymer.

The main aim of the work reported is to extend the range of methodology in polymer synthesis with prime emphasis on precision and control. It is widely accepted that greater control over polymer structure, *i.e.* molecular weight, polydispersity and microstructure, will lead to better control of properties and functions. At present this type of control in polymer synthesis can only be achieved by employing living polymerisation techniques. Therefore living anionic and ring opening metathesis polymerisation procedures were used to synthesise these comb graft copolymers. The main purpose of this chapter is to present the necessary background information for the work described in this thesis. Thus this chapter is divided into four parts; namely, descriptions of metathesis polymerisation, anionic polymerisation, synthesis of graft copolymers and synthesis of side chain liquid crystalline polymers. In general only information relevant to the work described in this thesis is discussed in detail, information on related topics can be found in the literature cited.

## **1.2 OLEFIN METATHESIS**

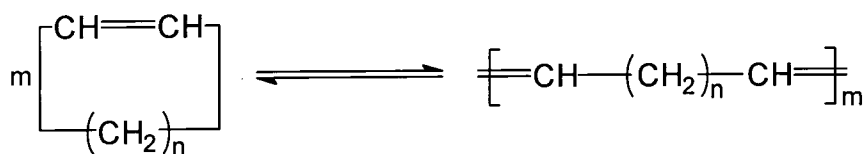
### **1.2.1 Definition and Historical Background**

Olefin metathesis is a catalytically induced bond reorganisation process and involves exchange of carbon-carbon double bonds. For an acyclic olefin, this leads to exchange of alkylidene units. This was first reported by Banks and Baily in 1964 and termed 'olefin disproportionation'.<sup>1</sup>



**Figure 1.1** General reaction scheme for the metathesis of an acyclic olefin

For a cyclic olefin, the metathesis reaction leads to ring scission and the formation of an unsaturated linear polymer.



**Figure 1.2** General reaction scheme for the metathesis of a cyclic olefin

The first example of an olefin metathesis involving a cyclic olefin (in fact only recognised as such some years later) was reported by Anderson and Merklings in a Dupont patent in 1955.<sup>2</sup> They successfully polymerised norbornene using a mixture of titanium tetrachloride and ethylmagnesium bromide. Calderon *et al.* demonstrated that disproportionation of acyclic olefins and ring opening polymerisations are one and the same chemical reaction. Accordingly, these types of reactions were named 'Olefin Metathesis'.<sup>3-6</sup>

### 1.2.2 Metathesis Initiators

In general the catalysts for olefin metathesis and ring-opening metathesis polymerisation are based on the transition metals of groups IV to IX of the periodic table. However, Mo, W, Re and Ru compounds have been shown to be the most generally effective catalysts. Metathesis catalysts can be divided into two major categories; namely, the ill-defined dual component systems, known as 'classical initiators', and 'well-defined' initiators. The well-defined initiators include transition metal carbenes, and metallocyclobutanes, both were predicted by Chauvin when he proposed his original mechanism for metathesis. Various aspects of metathesis have

been reviewed,<sup>7-23</sup> most comprehensively in a recent book 'Olefin Metathesis and Metathesis Polymerisation' by Ivin and Mol.<sup>24</sup> Therefore apart from a brief description of classical initiators, the remainder of this section is devoted to well defined initiators since they are of specific interest to the work discussed in this thesis.

### 1.2.2a Classical Initiators

Catalysts for a classical initiating system can either be homogeneous or heterogeneous and always contain a transition metal compound. Many of the commonly used catalyst systems are based on the chlorides, oxides or oxychlorides of Mo, W or Re. Although these compounds are sometimes effective by themselves, more commonly they require activation by a co-catalyst usually an organometallic compound or a Lewis acid. In some cases a third component called a promoter, is used as well. These promoters often contain oxygen; examples include O<sub>2</sub>, EtOH and PhOH.

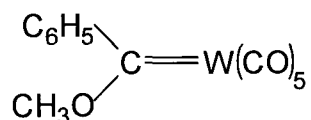
Some typical homogeneous catalyst systems are WCl<sub>6</sub>/EtAlCl<sub>2</sub>/EtOH, WOCl<sub>4</sub>/Me<sub>4</sub>Sn, ReCl<sub>5</sub>/Et<sub>3</sub>Al/O<sub>2</sub>. Examples of heterogeneous supported catalyst systems include MoO<sub>3</sub>/CoO/Al<sub>2</sub>O<sub>3</sub>, WO<sub>3</sub>/SiO<sub>2</sub>, Re<sub>2</sub>O<sub>7</sub>/Al<sub>2</sub>O<sub>3</sub>.

However these classical initiators suffer from many disadvantages:-

- the precise nature of the active site at the metal centre is not known, thus the system is ill-defined,
- the metal carbene must be generated before initiation and subsequent propagation can commence and this process usually proceeds in a very low yield,
- the activity of a given initiating system is dependent upon its chemical, thermal and mechanical history, and upon the order and the rate of mixing of the catalyst, co-catalyst and monomer,
- they have limited tolerance towards functional groups in the monomer or solvent,
- there is a lack of control of molecular weight and molecular weight distribution due to intra- or intermolecular reactions with the double bonds, and
- they display an element of irreproducibility.

### 1.2.2b Well-Defined Initiators

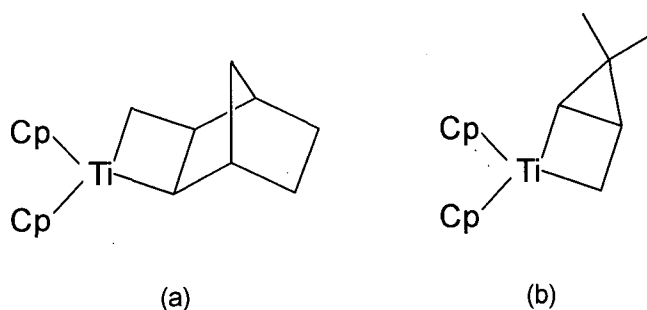
In 1964 Fischer reported the first stable metal carbene species that was shown to be capable of inducing olefin metathesis.<sup>25</sup>



**Figure 1.3** Fischer carbene

These heteroatom stabilised carbenes were shown to be reactive for the ring opening olefin metathesis polymerisation of highly strained olefins. Then in 1974 Schrock reported a second class of transition metal complexes.<sup>26</sup> The first of these so called 'Schrock alkylidenes' to be reported was  $[\text{Ta}(\text{CHCMe}_3)(\text{CH}_2\text{CMe}_3)_3]$  which was active for alkene metathesis, but not for ROMP. To date alkylidene complexes have also been prepared for Ti, Zr, Nb, Mo, W and Re largely in an effort to understand and control the olefin metathesis reaction they often catalyse.<sup>22</sup>

The first example of the living polymerisation of a cycloolefin was the polymerisation of norbornene by titanacyclobutane complexes (figure 1.4) reported by Grubbs.<sup>27</sup>



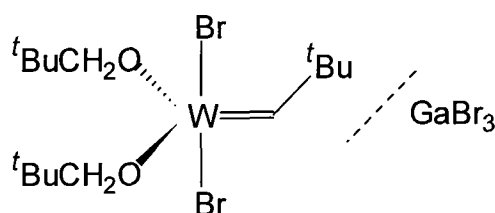
**Figure 1.4** Grubbs' well-defined titanacyclobutane initiators

In this case the polymerisation proceeds without termination or chain transfer to give polynorbornene with a narrow molecular weight distribution. The reaction is terminated by adding a ketone (typically benzophenone) or an aldehyde.

However, there are some drawbacks associated with this initiator system. Titanacyclobutanes require a temperature of 50°C in order to ring-open even

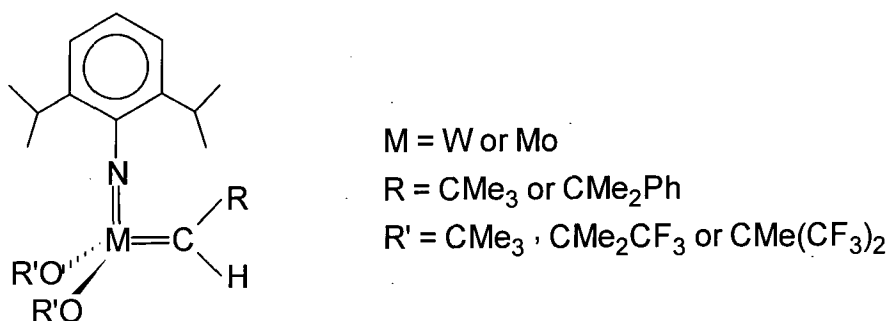
norbornenes and they are very reactive towards functionalities owing to the highly electrophilic nature of the metal centre, this also makes them difficult to prepare and handle.

Kress and Osborn prepared the first well characterised tungsten alkylidene complexes of the type  $W(CH-t-Bu)(OCH_2-t-Bu)_2X_2$ , ( $X=halide$ ).<sup>28-30</sup> Although these were inactive themselves, they formed highly active complexes on addition of a Lewis acid co-catalyst such as  $GaBr_3$ .



**Figure 1.5** Osborn's well-defined tungsten initiator/co-catalyst

Schrock and co-workers introduced well-defined tungsten and molybdenum initiators with bulky alkoxide and aryylimido ligands of the type  $M(CHR)(NAr)(OR')_2$ .<sup>31-36</sup>



**Figure 1.6** Well-defined Schrock initiators

The four co-ordination of these complexes allows a relatively small substrate to attack the metal to give a five co-ordinate intermediate metallocyclobutane complex, while bulky alkoxide and imido ligands prevents decomposition reactions that destroy the alkylidene ligand or intermolecular reactions that might result in ligand scrambling to give inactive complexes.

The living nature of polymerisations initiated by these complexes has been partly attributed to their relative inactivity towards unactivated double bonds (*i.e.* the

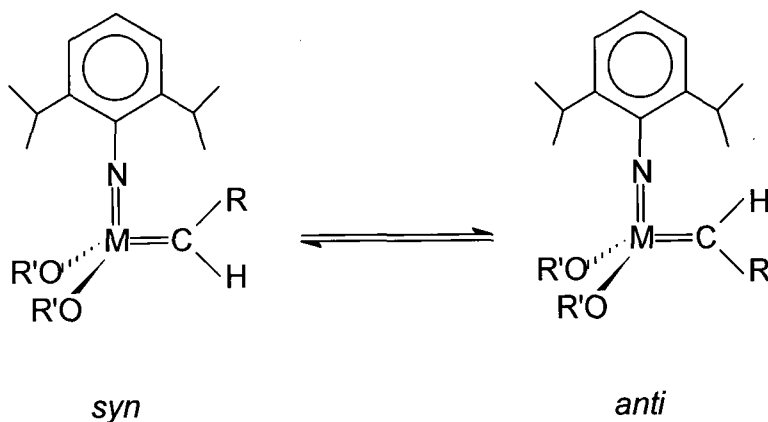
internal olefins present in the polymer chain). However, the most important feature of these compounds is that the identity of the active site on the initiator is known and can be studied by nmr during the course of initiation and propagation. Since the polymerisations are living, termination is achieved by adding a suitable capping reagent (an aldehyde, typically benzaldehyde or pivaldehyde) which cleaves the metal from the polymer chain in a controllable manner by a Wittig-like reaction. The polymers produced have very narrow molecular weight distributions which is typical of a well behaved living polymerisation.

Also the activity of the initiator can be altered by substituting the methyl groups on the alkoxide ligands with the more electronegative trifluoromethyl groups leading to a more active initiating system. The increased reactivity is believed to be due to the trifluoromethyl groups withdrawing electron density from the metal centre making it more electrophilic and a better acceptor for the incoming  $\pi$ -donor olefin. This effect is illustrated for the tungsten initiator by the observation that when R' is OCMe(CF<sub>3</sub>)<sub>2</sub> the initiator will readily metathesise acyclic olefins, but when R' is O-t-Bu it does not react readily with acyclic olefins.<sup>31,33-35</sup> Also by changing the alkoxide ligands, the stereochemistry of the resulting polymer can be altered. It has been found that the polymerisation of 2,3-bis(trifluoromethyl)norbornadiene using bis-t-butoxide Mo initiator gives high *trans* polymers whereas the hexafluoro-t-butoxide initiator gives high *cis* polymers.<sup>37,38</sup>

The molybdenum initiator is much less reactive than the tungsten analogue<sup>35</sup> and tolerates certain functional groups. On the other hand, the tungsten initiator does not tolerate any functional groups well due to its high reactivity and although polymerisation may be initiated, well defined polymers of functionalised monomers are not formed. The ability of well-defined Mo catalysts to tolerate functionalities have allowed the synthesis of redox-active polymers,<sup>39</sup> side-chain liquid crystal polymers,<sup>40-44</sup> metal clusters,<sup>45</sup> star block copolymers,<sup>46</sup> semiconductor clusters,<sup>47</sup> electroluminescent polymers<sup>48</sup> and conducting polymers.<sup>49</sup>

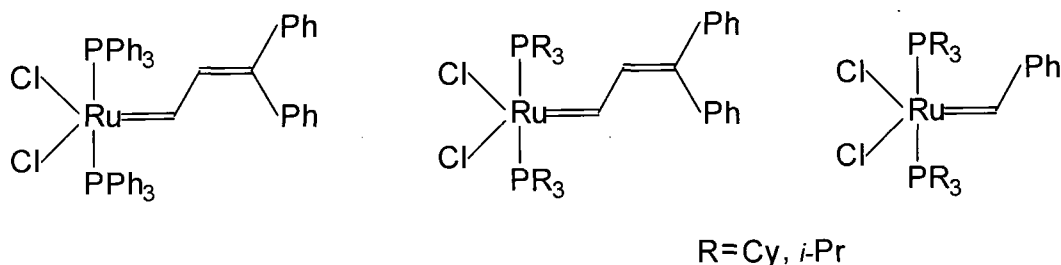
These initiators are not conformationally or structurally rigidly fixed. The presence of *syn* and *anti* rotamers<sup>50-53</sup> where in the *syn* rotamer, the alkylidene substituent points towards the imido nitrogen atom and in the *anti* rotamer, the alkylidene substituent points away from the imido nitrogen atom is well established. It has been suggested

that there is a relationship between the polymer *cis/trans* content and the ease of alkylidene rotamer isomerisation. In mixtures of initiators with different alkoxy ligands, intermolecular ligand exchange occurs faster than propagation allowing control over the *cis/trans* ratio in the product polymer.<sup>38,54</sup>



**Figure 1.7** *Syn* and *Anti* rotamers of Schrock initiators

Recently Grubbs and co-workers reported the synthesis of the first well-defined Ru based olefin metathesis initiators which are able to initiate living ring-opening metathesis polymerisation of strained cyclic olefins, even in the presence of protic solvents such as ethanol and water.<sup>55-58</sup>



**Figure 1.8** Grubbs' well-defined ruthenium initiators

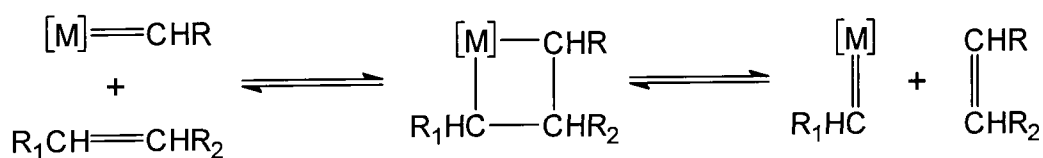
### 1.2.3 Living Polymerisation

A living polymerisation is a chain polymerisation which proceeds in the absence of the kinetic steps of termination or chain transfer. Thus once total conversion of the monomer has been attained, the growing polymer chain still remains active. Some of the important features of living polymerisations are<sup>59,60</sup>:-

- the polymerisation proceeds until all of the monomer has been consumed and further addition of monomer results in continued polymerisation,
- the number average molecular weight ( $M_n$ ) is a linear function of conversion and thus the molecular weight can be controlled by the stoichiometry of the reaction,
- the number of polymer molecules (and active centers) is a constant and is independent of conversion,
- the polymers produced have narrow molecular weight distributions,
- block copolymers can be prepared by sequential monomer addition,
- chain-end functionalised polymers can be prepared by use of appropriate initiators and terminating reagents.

#### 1.2.4 The Mechanism of Olefin Metathesis and Ring Opening Metathesis Polymerisation

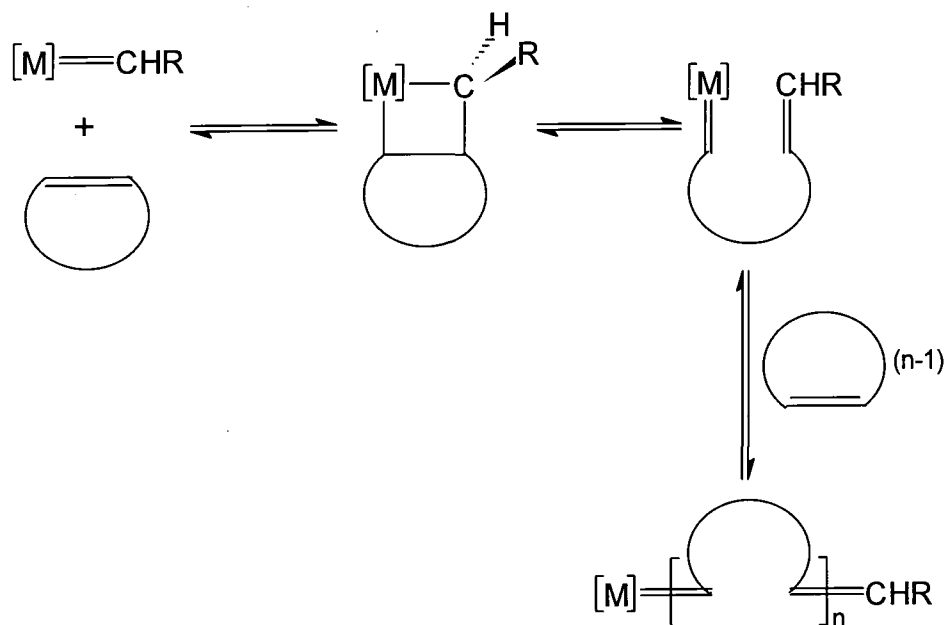
According to the 'pair-wise' mechanism proposed by Bradshaw, it was thought that two double bonds came together in the vicinity of the transition metal site and that the orbitals of the transition metal overlapped with those of the double bonds in such a way as to allow exchange to occur via a weakly held cyclobutane type complex.<sup>61</sup> This pair-wise mechanism has now been abandoned in favour of one proposed by Hérrison and Chauvin in which a metal-carbene complex is the propagating species.<sup>62</sup>



**Figure 1.9** Hérrison and Chauvin's mechanism of olefin metathesis

The process involves reversible [2+2] cycloaddition of the olefinic carbon-carbon double bond to a metal carbene species to form a metallocyclobutane which then ring opens either non-productively (degeneratively) to regenerate the original reaction mixture or productively to form a new olefin and a new metal carbene.

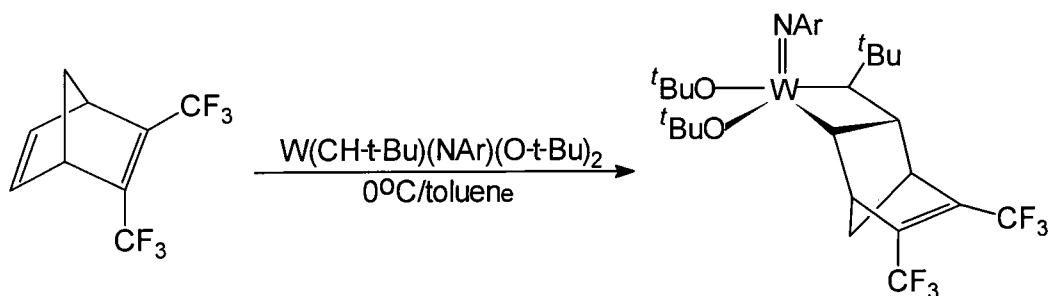
In ring opening metathesis polymerisation, since the carbon-carbon double bond is enclosed within a ring, repetition of this cycle of productive metathesis results in an unsaturated polymer chain.



**Figure 1.10** Mechanistic pathway of ring opening metathesis polymerisation

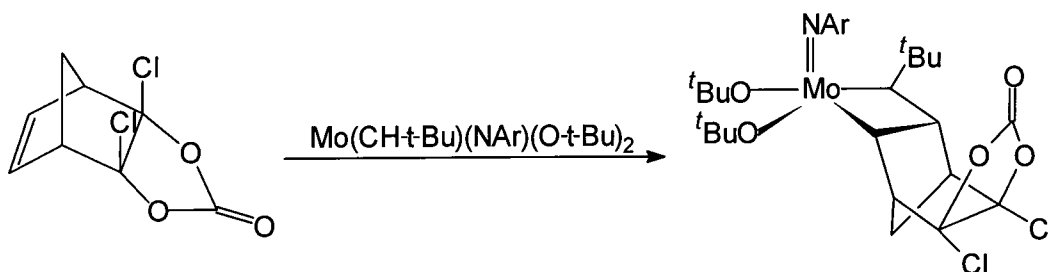
All the above steps are reversible, so the outcome of the metathesis of acyclic alkenes and ring opening polymerisation depends on reaction conditions, such as temperature, concentration, reaction duration, the nature of the olefin and the nature of the propagating polymer chain end.

The Hérrison and Chauvin mechanism has now become well established. The metathesis polymerisation of strained cyclic olefins initiated by stable metallocyclobutanes derived from Tebbe reagent was one of the earliest examples that supported this mechanism.<sup>27,63,64</sup> The simultaneous occurrence and interconversion of a tungsten metal carbene and tungsten metallacyclobutane during the ring opening polymerisation of norbornene by the  $W(CH-t-C_4H_9)(OCH_2-t-C_4H_9)_2Br_2/GaBr_3$  catalyst which has been observed by nmr is another example that supports this mechanism.<sup>65</sup> More recently Schrock and co-workers have identified a metallocyclobutane from the reaction of a tungsten carbene initiator and a fluorinated norbornadiene derivative by nmr spectroscopy.<sup>37</sup>



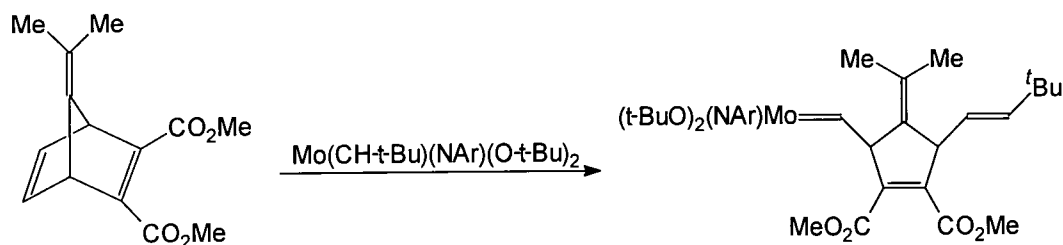
**Figure 1.11** The metallocyclobutane identified by Schrock and co-workers

They also reported the first observable circumstance where metallacycle formation is reversible for a norbornene derivative. The monomer 5,6-dichloro-5,6-dicarbonatonorbornene reacts with  $\text{Mo}(\text{CH-t-Bu})(\text{NAr})(\text{O-t-Bu})_2$  to give the metallacycle shown below which was identified by X-ray crystallography.<sup>19</sup> When the metallacycle was heated, the monomer was regenerated along with the starting neopentylidene complex.



**Figure 1.12** The first observable system where metallocyclobutane formation is reversible

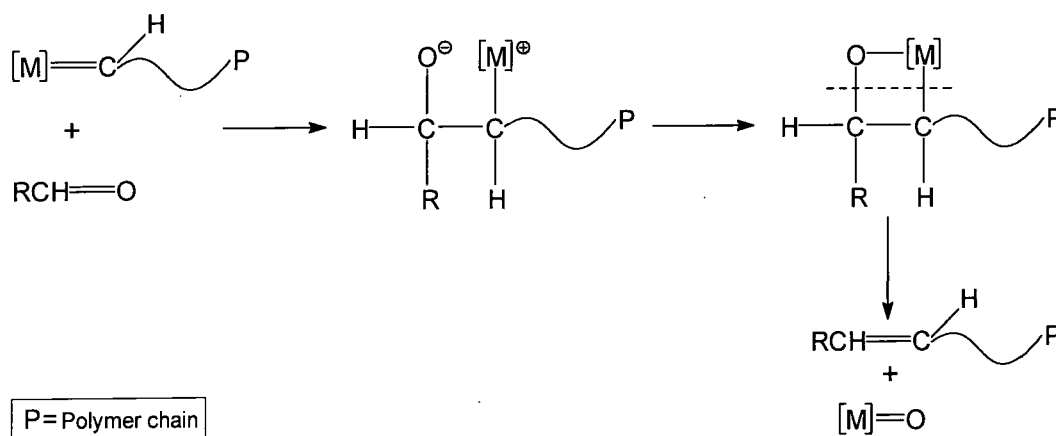
Schrock and co-workers also isolated a metal carbene species, namely the first insertion product of a potential polymerisation reaction, by reacting a well-defined molybdenum metal-carbene with the norbornadiene derivative shown below. The structure of the 1:1 adduct was established by X-ray crystallography.<sup>37</sup>



**Figure 1.13** The first insertion product isolated by Schrock and co-workers

### 1.2.5 Termination

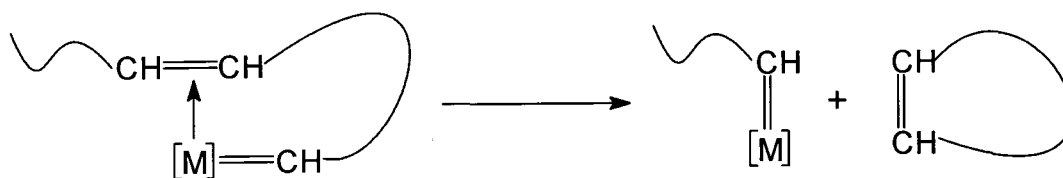
This is an irreversible reaction that destroys the propagating metal-carbene leading to termination of polymerisation. In ring opening metathesis polymerisation where metal-carbenes are the propagating species, termination is achieved by adding an aldehyde or a ketone which then undergoes a Wittig-like reaction to yield metal-oxide and the end capped polymer. This also enables functional groups to be introduced at the chain end by capping with substituted aldehydes or ketones.<sup>66</sup>



**Figure 1.14** Termination mechanism in ring opening metathesis polymerisation

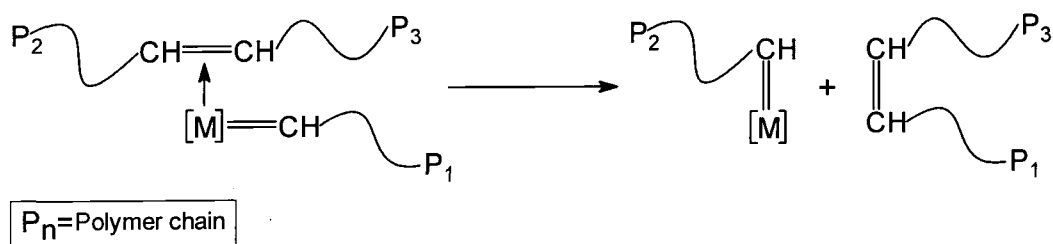
### 1.2.6 Chain Transfer

The propagating metal-carbene can react intramolecularly with one of the double bonds in the same polymer chain to produce a cyclic oligomer and transfers the active species as shown below. This intramolecular chain transfer reaction is also described as a 'backbiting' reaction.



**Figure 1.15** Intramolecular chain transfer in ring opening metathesis polymerisation

The chain carbene can also react intermolecularly with a double bond in a different polymer chain to produce a linear polymer chain and transfer the active species as shown below.



**Figure 1.16** Intermolecular chain transfer in ring opening metathesis polymerisation

These chain transfer reactions are not terminating reactions, since they do not destroy the propagating species. However, these reactions lead to broad molecular weight distributions and lack of molecular weight control. On the other hand cross metathesis between acyclic olefins and an active chain end results in the formation of a linear polymer and transfer of the active species. This reaction can be used to control the molecular weight of the polymer produced from a cyclic monomer. Here the acyclic olefin is termed a 'chain transfer agent'. Styrene and substituted styrenes have been investigated as chain transfer agents for living ring opening metathesis polymerisation systems.<sup>23,67</sup> These chain transfer agents can also be used to introduce functionalities to the polymer chain end.

### 1.2.7 Thermodynamic Aspects of Ring Opening Metathesis Polymerisation

For an addition polymerisation or any other reaction to occur the change in the Gibbs free energy ( $\Delta G$ ) must be  $\leq 0$ . This change is expressed as a function of the enthalpy change ( $\Delta H$ ), the entropy change ( $\Delta S$ ) and the temperature in K.

$$\Delta G = \Delta H - T\Delta S$$

For polymerisations the entropy ( $\Delta S$ ) is always negative since the monomers are combined with each other into macromolecules resulting in a reduction of their freedom. This makes the entropy term ( $-T\Delta S$ ) positive, and for a favourable reaction, the change in enthalpy has to be larger than or at least equal to the  $T\Delta S$  component. The temperature where  $\Delta G = 0$  is called *ceiling* temperature, and above this temperature, the polymerisation reaction does not take place.

In general the most favourable conditions for ring opening metathesis polymerisation of cycloalkenes are high monomer concentration, low temperature and high pressure. The enthalpy change ( $\Delta H$ ), is dependent on the ring strain. Therefore for highly strained 3,4,8 and higher membered monocyclic rings and for bicyclic rings, the enthalpy change is high (*i.e.* negative) and polymerisations go to completion at normal temperatures and monomer concentrations.

For monomers with low ring strain, that is 5, 6 and 7 membered rings, the reaction entropy is a major determining factor, since the reaction enthalpy is low. The  $\Delta G$  of polymerisation may also be sensitive to chemical factors such as the nature of substituents and their position on the ring.<sup>24</sup> Lower temperatures and higher monomer concentrations should favour polymerisation since this makes the entropy term  $-T\Delta S$  smaller.

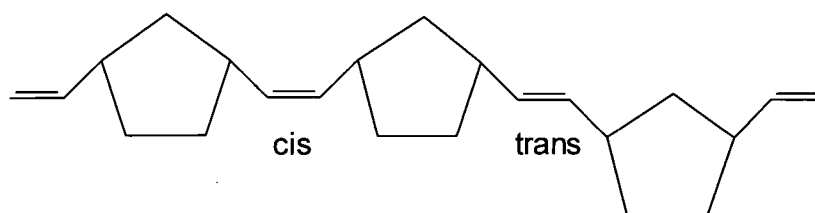
### 1.2.8 Microstructure of Polymer Chains

The way that the monomer unit is incorporated into the polymer chain determines the microstructure, that is the frequency and distribution of the isomeric repeat units, of the resulting polymer.<sup>7,12,24</sup> The microstructure of a polymer can be controlled in favourable cases by changing the catalyst system and the reaction conditions, so that it may be possible to synthesise a polymer with the required microstructure and associated physical properties for a specific application.

The 3-main factors which define the microstructure of polymers obtained by ring opening metathesis polymerisation are,

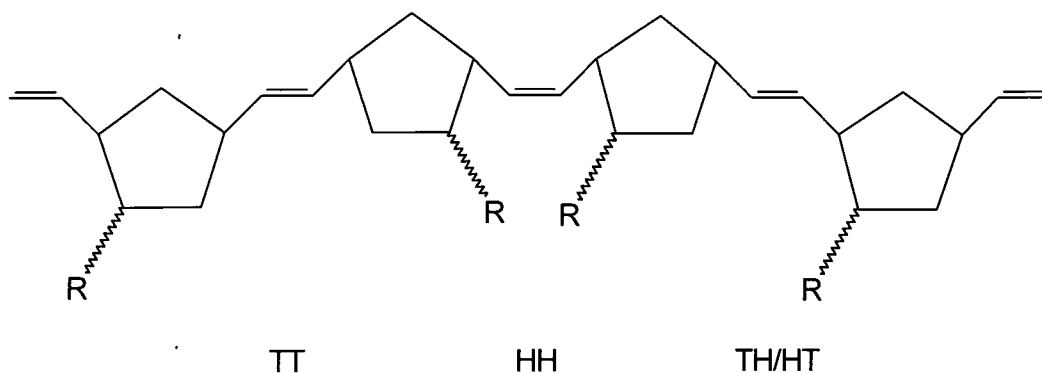
- *cis/trans* double bonds,
- head/head and head/tail placements, and
- tacticity

For a bicyclic monomer such as norbornene, the double bonds formed during the ring opening metathesis polymerisation can either be *cis* or *trans*.



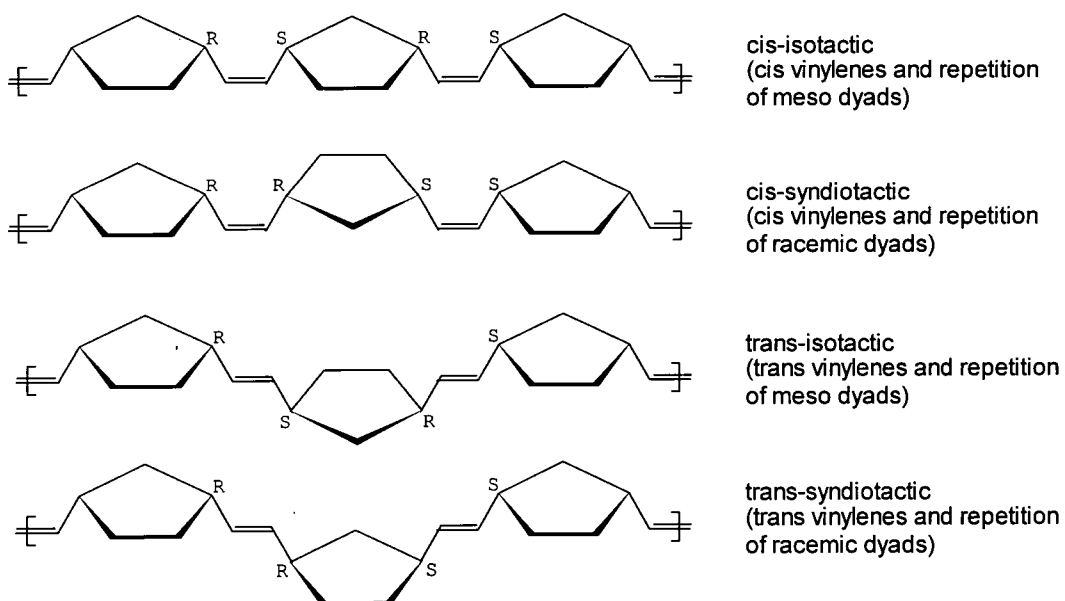
**Figure 1.17** *Cis/Trans* double bond effects in polymers of bicyclic monomers

Also unsymmetrically substituted monomer can result in polymers with head-head, head-tail or tail-tail structures.



**Figure 1.18** Head/Tail effects of an unsymmetrically substituted monomer

Tacticity effects may also arise from *meso* and *racemic* dyads as shown below.



**Figure 1.19** Tacticity effects of bicyclic monomers

The carbon atom  $\alpha$  to the double bonds are chiral and they may have the same or opposite chiralities, for chiral centres at equivalent positions in the repeat unit this results in *meso* and *racemic* dyads respectively. Sequences of *racemic* dyads results in syndiotactic polymer, while sequences of *meso* dyads results in isotactic polymer. A statistical distribution of dyads gives an atactic polymer.

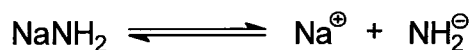
### 1.3 ANIONIC POLYMERISATION

Anionic polymerisations proceed via metal organic reactive sites; carbanions or oxanions, with their metallic counterions for electrical neutrality. In general the monomers best fitted for anionic polymerisation are those bearing an electron withdrawing substituent, to polarise the double bond and/or stabilise the propagating chain end. The solvents used in anionic polymerisation reactions have a significant influence on the propagation step. If the solvent is able to release a proton, it may react with the active site and terminate its growth. Thus on the basis of the type of solvent used, anionic polymerisation is divided into those carried out in proton donating solvents and those carried out in the absence of any proton donating compounds, the latter being living anionic polymerisations.

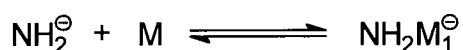
#### 1.3.1a Anionic Polymerisation Carried Out in Protic Media

Anionic polymerisation carried out in protic media are characterised by a competition between chain growth and chain transfer to solvent. If the new anion formed upon transfer to solvent is unable to reinitiate (by reaction with monomer), no polymerisation can take place. However, there are cases in which the anions originating from the solvent upon transfer can react with the monomer. The polymerisation of styrene in liquid ammonia initiated by sodium or potassium amide (figure 1.20) is an example of this type of reaction.<sup>68,69</sup>

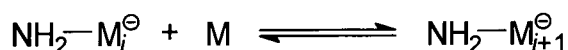
Dissociation of sodium amide into its ions:



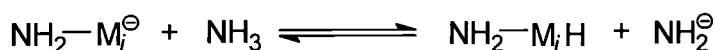
Initiation, assuming that the  $\text{NH}_2^-$  ions are the only initiating species:



Chain propagation:



Transfer to solvent:

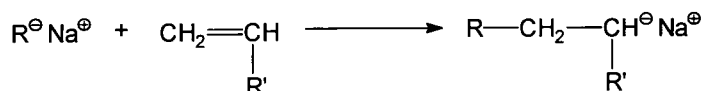


**Figure 1.20** Anionic polymerisation of styrene in liquid ammonia (where M represents styrene)

### 1.3.1b Anionic Polymerisation in Aprotic Media

The chief feature of anionic polymerisation in aprotic solvents is that they involve only two reactions; initiation and propagation (figure 1.21). Spontaneous transfer or termination will not take place, if proper systems and adequate reaction conditions are chosen. Thus the polymerisation is living.

Initiation



Propagation



**Figure 1.21** General reaction scheme for a living anionic polymerisation

The active sites retain their reactivity for times that are long as compared to the duration of the polymerisation process. As a consequence, anionic polymerisation will easily proceed to complete conversion of monomer, and the polymer chain still remains active. Thus, further addition of monomer will result in an increase in molecular weight. If initiation is fast enough with respect to propagation, the number of polymer chain present in the reaction medium is equal to the number of initiator molecules introduced. Consequently, the number average degree of polymerisation is given by the mole ratio of monomer consumed to initiator:

$$DP_n = \frac{\Delta[M]}{[I]}$$

This leads to 'Poisson-type' very narrow molecular weight distribution.

### 1.3.2 Anionic Polymerisation Initiators

Anionic polymerisation reactions can be initiated by three different classes of initiators;<sup>60</sup>

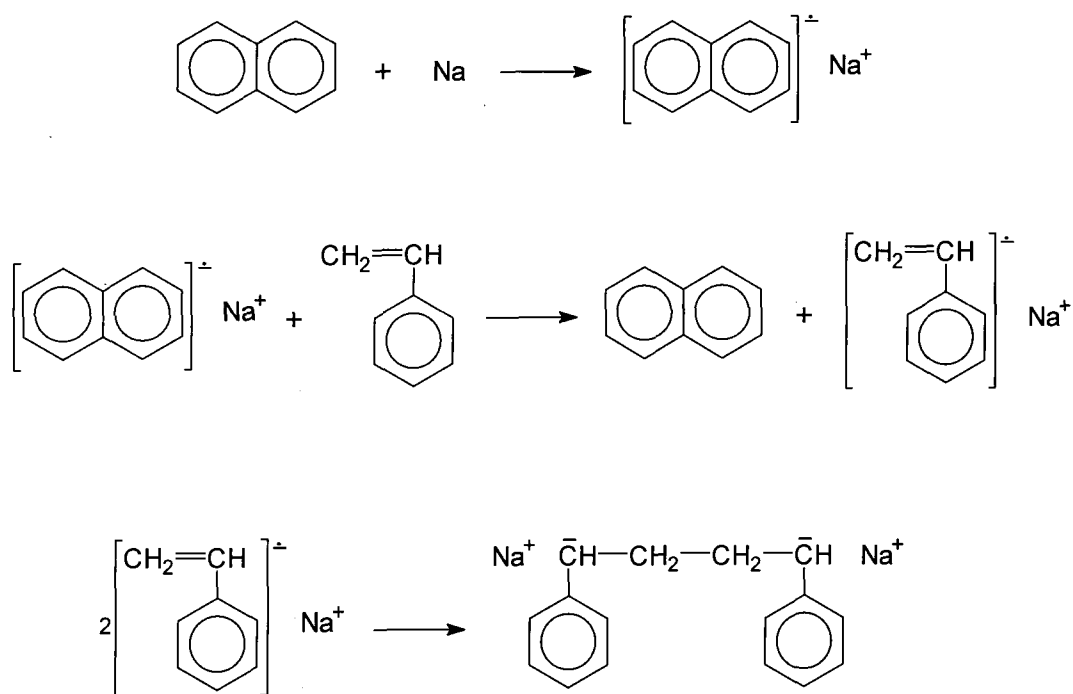
- aromatic complexes of alkali metals,
- Alkali metals, and
- organometallic compounds, mainly organolithium

These three types of initiator operate by one of the following mechanisms;

- direct addition of an anion to the monomer, or
- by initial electron transfer to form a radical anion

#### 1.3.2a Aromatic Complexes of Alkali Metals

These are initiators formed by the reaction of polycyclic hydrocarbons with alkali (and alkaline earth) metals. A typical example occurs in the polymerisation of styrene initiated by sodium naphthalene.<sup>70</sup>



**Figure 1.22** Polymerisation of styrene by sodium naphthalene

The reaction involves transfer of an electron from the alkali metal to naphthalene to form a naphthalene anion radical. Addition of styrene to the system leads to electron transfer from the naphthalene anion radical to the monomer to form a styryl radical anion. Dimerisation of the styryl radical anion leads to form a dicarbanion capable of propagating from both ends.

### 1.3.2b Alkali Metals

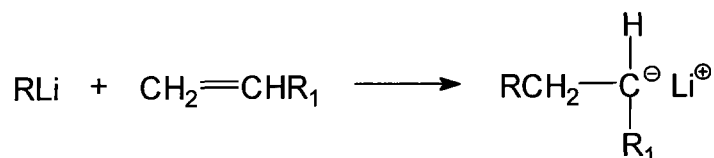
Initiation involves direct electron transfer from an alkali metal to the monomer, followed by dimerisation of the monomer radical anion to form the propagating dianion.<sup>60,71,72</sup> The initiation is heterogeneous and is also dependent on the surface area of the metal.

### 1.3.2c Organoalkali Metal Compounds

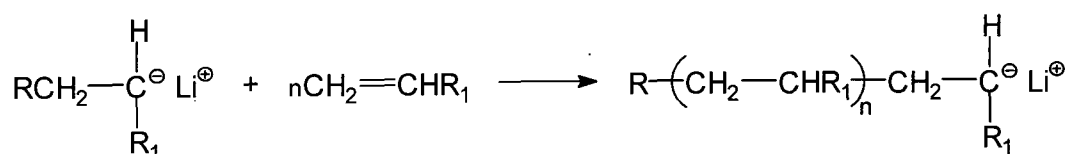
Of the organoalkali metal compounds which can initiate polymerisation of vinyl and other monomers, the most versatile are the organolithium type, since these are soluble in both polar and non-polar solvents.<sup>60</sup> Also they can be used under conditions which avoid undesirable side reactions, which are prevalent with the more basic metals. The initiation involves direct nucleophilic attack (figure 1.23) rather than electron transfer

to the monomer. This leads to a monofunctional chain growth reaction, which results in a better control of molecular weight distribution than the dianionic propagation involved in initiation by electron transfer.

#### Initiation



#### Propagation



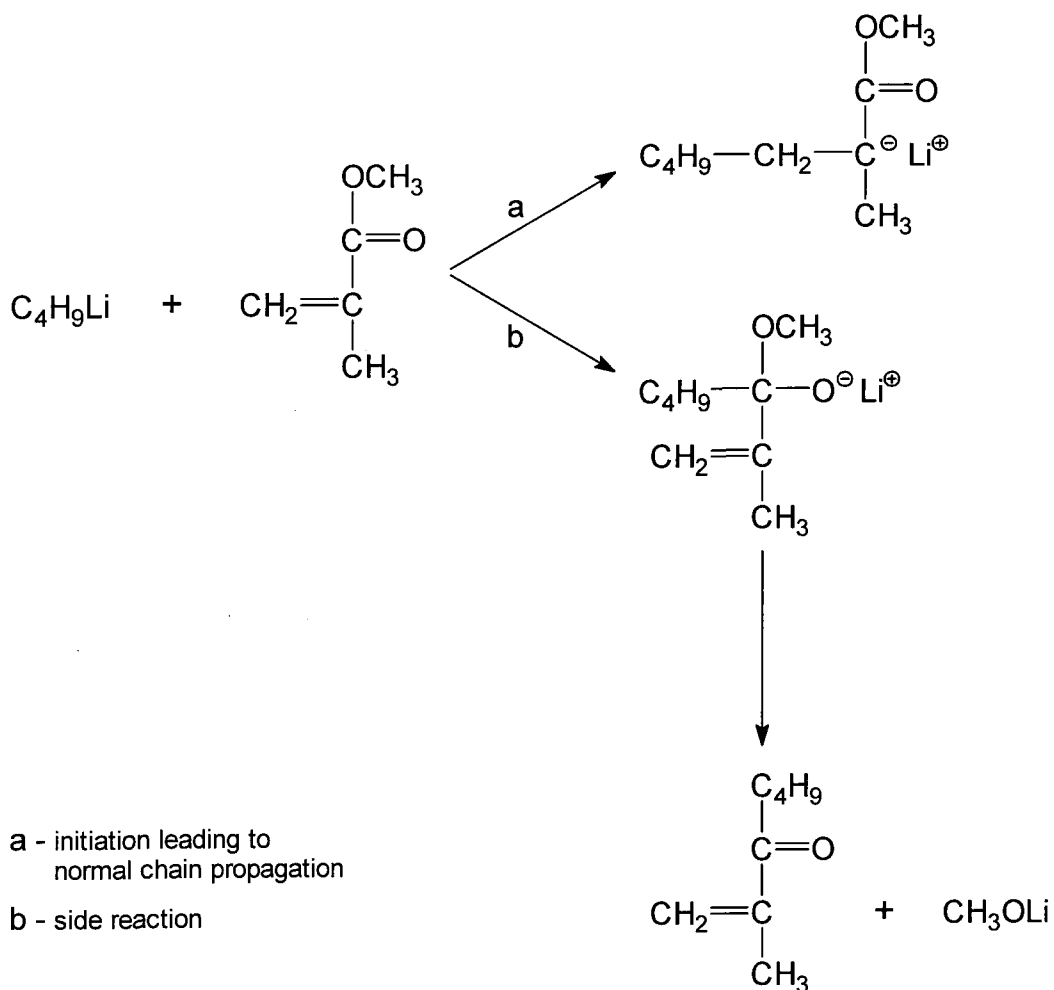
**Figure 1.23** General reaction scheme of an anionic polymerisation initiated by organolithium initiators

Styrene and dienes are the most thoroughly investigated monomers in homogeneous anionic polymerisation. This is partly because of their importance in technology and the fact that they can be prepared relatively free of side reactions using lithium alkyl initiators in hydrocarbon solvents such as hexane, cyclohexane and benzene, where the active centers remain stable for several weeks at room temperature in carefully purified systems.

The straight chain alkyls, ethyllithium and *n*-butyllithium do not initiate the polymerisation of styrene and the dienes rapidly. In contrast, branched chain alkyls, notably *sec*-butyllithium and *tert*-butyllithium produce very narrow molecular weight polymers particularly in benzene as solvent.<sup>72</sup>

Most of the vinyl monomers having polar substituents participate in various side reactions with the organolithium initiators. For instance, in the polymerisation of methyl methacrylate, beside initiating the polymerisation through the vinyl group, the organolithium compound also reacts substantially with the carbonyl function present in the monomer.<sup>72-74</sup> The product of the reaction at the carbonyl function can eliminate

lithium methoxide and form butyl isopropenyl ketone which could also react with the growing chain.



**Figure 1.24** Anionic polymerisation of methyl methacrylate using butyllithium as initiator

Oxiranes (ethylene oxide and propylene oxide) are another group of monomers of interest to the work described in this thesis. Although bases such as sodium and potassium alkoxides can initiate polymerisation of ethylene oxide by ring opening, lithium alkoxides are poor initiators, presumably because of their lower basicity. On the other hand, lithium carbanions reacts readily with ethylene oxide to form the alkoxide by ring opening, but any subsequent chain growth reaction is very slow.<sup>60</sup> Propylene oxide is relatively inert to alkali metal initiators including organolithiums as well.<sup>60</sup>

In anionic polymerisation, the growing carbanions (or carbanion pairs) are extremely reactive towards traces of oxygen, water or carbon dioxide and great care must be taken in purification and drying of the solvent and the monomer, and in handling the initiator solutions.<sup>71,72</sup> Polymerisations must be carried out under a blanket of high purity nitrogen or under vacuum. Even residual moisture on the walls of the polymerisation vessel causes initiator destruction. This can be circumvented by washing the vessel with a living polymerisation solution or initiator solution before polymerisation.

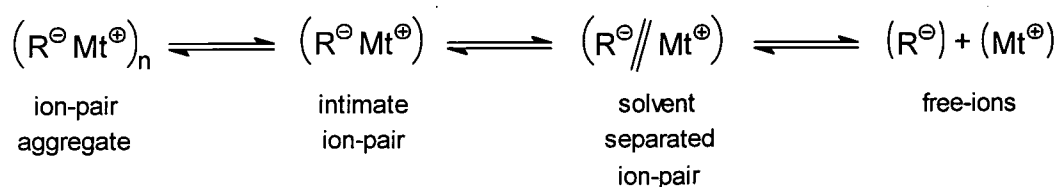
### 1.3.3 Solvents and Gegen-ion

Both the solvent and the gegen-ion have a pronounced influence on the rates of anionic polymerisation. In general, solvents to be used in living anionic polymerisation must meet the following requirements<sup>68</sup>:-

- they must be aprotic to prevent transfer and termination,
- they must be free of any electrophilic function which may react with the carbanionic sites, and
- they must allow polymerisation to proceed in homogeneous phase, *i.e.* they should dissolve the polymer.

Thus the range of solvents suitable for anionic polymerisation is severely restricted. Among non-polar solvents, *n*-hexane, cyclohexane and benzene are most commonly used as they are inert with respect to the active species. Lithium organic sites generally associate in non-polar solvents, but owing to the high rates of aggregation/dissociation, this does not affect the molecular weight and polydispersity of the polymer produced.<sup>60</sup> Toluene has been used in a number of cases, but it could give rise to transfer reactions.<sup>72</sup> The best polar solvents are tetrahydrofuran (THF) and dimethoxyethane (DME).<sup>75</sup> Polymerisation rate generally increases with increasing polarity of the solvent.

The propagating species in anionic polymerisation are ion-pairs and depending on the solvent, temperature and counter-ion, they can be present in several forms:



**Figure 1.25** Various forms of ion-pairs

The increasing polarity of the solvent alters the distance between the ions from an ion-pair aggregate through an intimate pair, solvent separated pair to a state of complete dissociation. Chain propagation significantly depends on the separation of the two ions and this separation will also control the mode of entry of an adding monomer. Thus free-ions propagate faster than a tight ion pair. Also the gegen-ion itself can influence both the rate and stereochemical course of the reaction.

### 1.3.4 Monomers

In general monomers susceptible to anionic polymerisation can be divided into two main classes; vinyl or diene monomers and cyclic monomers. Vinyl or diene monomers include those olefins having substituents that stabilise the negative charge when the monomer is incorporated in the active centre. They comprise the majority of monomers used and include non-polar monomers such as styrene, butadiene and isoprene and polar monomers such as vinyl pyridine, acrylates and vinyl ketones. In these cases charge delocalisation provides the necessary stabilising force. However, vinyl monomers having polar substituents are less useful because the high carbanionic reactivity tends to produce side reactions with the polar substituents.

Among the cyclic monomers, oxiranes, cyclic sulfides, cyclosiloxanes, lactones and lactams have been polymerised anionically. The active chain ends in these systems are heteroatoms (*i.e.* oxygen, sulfur *etc.*) and exhibit different reactivities. Thus the growing chain in the polymerisation of a cyclic oxide is an alkoxide, which is a considerably weaker base than a carbanion. Therefore the propagation reaction is considerably slower than those of the vinyl monomers and generally require the more basic counterions ( $K^+$ ,  $Cs^+$ ) for reasonable rates.<sup>60</sup>

### 1.3.5 Applications of Living Anionic Polymerisation

The lack of spontaneous transfer and termination reactions in living anionic polymerisation can be utilised to introduce various functional groups to the chain end, to synthesise block copolymers, macromonomers, graft copolymers, network polymers and for chain extension processes. The interest is further enhanced by the fact that the molecular weight can be chosen at will and the narrow molecular weight distribution of polymers produced.

In general termination of living anionic polymerisation is achieved by induced deactivation of active site by protonation. For this purpose water, alcohols, acids *etc.* can be used. In most cases the deactivation reaction (or 'killing') is very fast and goes to completion.

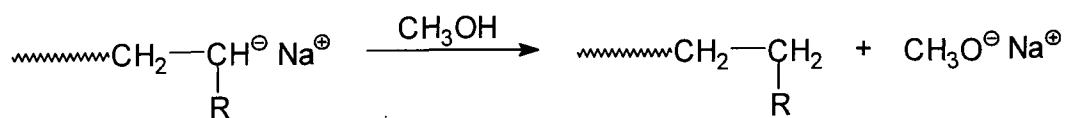


Figure 1.26 Induced deactivation of active site by protonation

Similarly various functional groups can be introduced to the living chain end. For example hydroxyl groups can be introduced to the chain end by reaction of the living polymer with oxirane (ethylene oxide) under conditions designed to avoid polymerisation of the latter monomer (namely; low temperature and  $\text{Li}^+$  or  $\text{Na}^+$  are better counterions than  $\text{K}^+$  for this purpose). Only one oxirane unit is added, the reaction goes to completion and protonation of the alkoxide gives the required alcohol function at the chain end.<sup>76</sup>

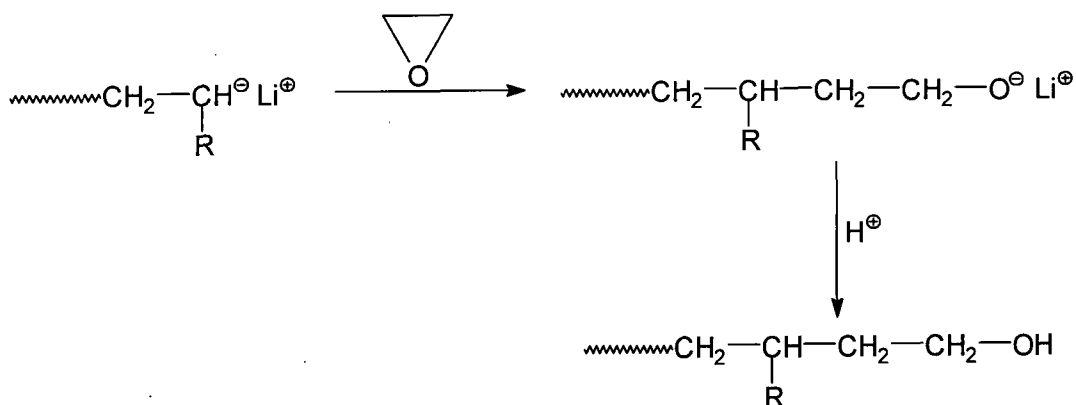
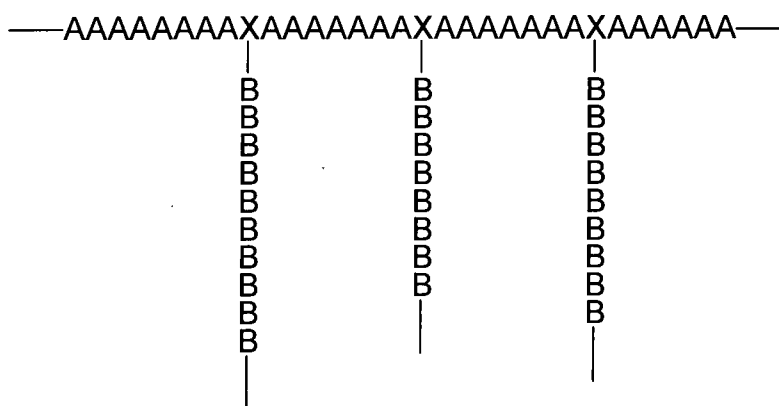


Figure 1.27 Introduction of hydroxy group to the living chain end.

Functional groups can also be introduced at the polymer chain end by using a functionalised initiator. These will be discussed further in relation to macromonomer synthesis *via* living anionic polymerisation later in this chapter.

#### 1.4 GRAFT COPOLYMERS

A graft copolymer is a polymer consisting sequences of one monomer attached to the backbone of the polymer of the second monomer. The simplest case of a graft copolymer can be represented by the following structure;



**Figure 1.28** Schematic representation of a graft copolymer

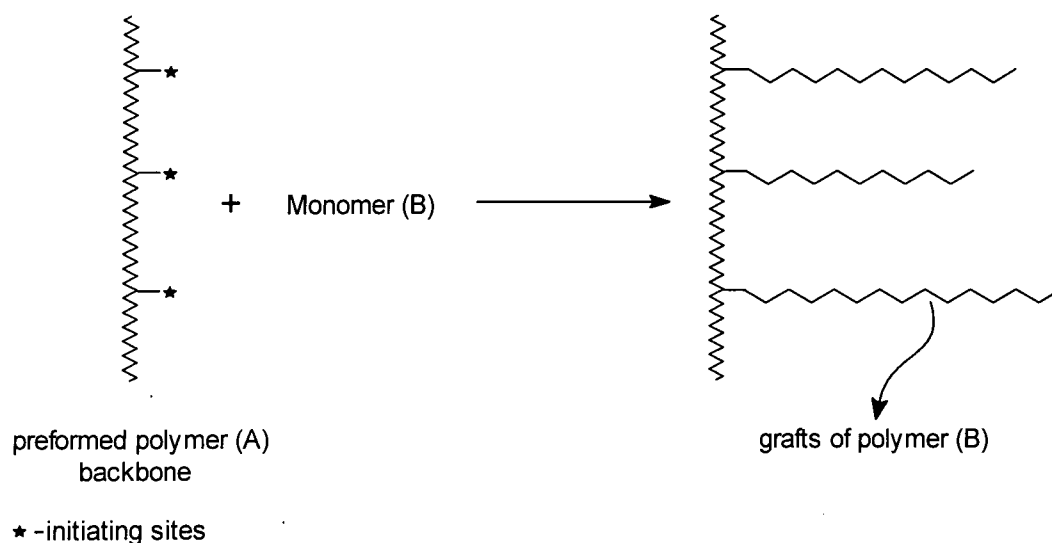
where a sequence of 'A' monomer units is referred to as the *main chain* or *backbone*, the sequence of 'B' units is the *side chain* or *graft*, and 'X' is the unit in the backbone to which the graft is attached. There are 3-main techniques for preparing graft copolymers;

- 'grafting onto' method,
- 'grafting from' method, and
- *via* macromonomers

The first two methods involve preparing the backbone first and then introducing the side chains. The macromonomer method involves preparing the side chain first and terminate with a polymerisable unit, then creating the backbone *via* polymerisation of the polymerisable group at the chain end.

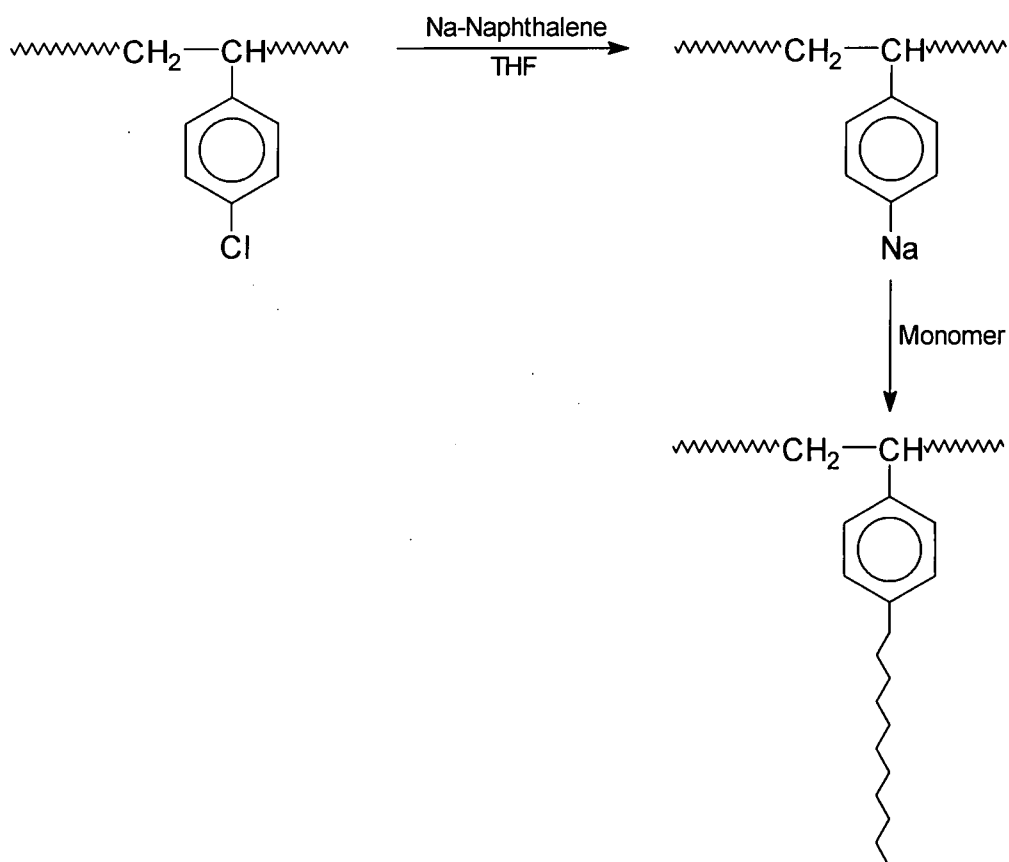
### 1.4.1 Grafting From Method

This involves propagation of monomers from an initiating group on the polymer backbone (figure 1.29).



**Figure 1.29** Schematic representation of 'grafting from' method

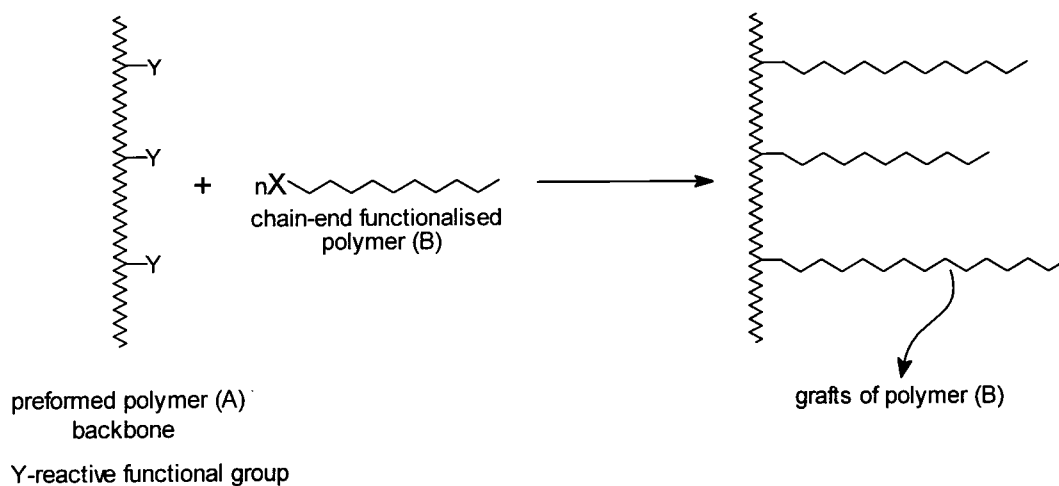
The monomer can be polymerised by any of the traditional modes of polymerisation. Backbones for free-radical graft copolymerisation require the presence of an atom or group that can be abstracted or displaced by another radical, by radiation of sufficient intensity or by mechanical degradation. Although free-radical graft copolymerisation methods are the simplest, oldest and most widely used, the least specific grafting sites and the most poorly defined branches result.<sup>77</sup> Backbones for ionic or condensation polymerisation require a reactive site or functional group capable of participating in specific chemical reactions. The products are relatively well-defined and the properties of the branches can be controlled.<sup>77</sup> Thus graft copolymer synthesis by anionic method involves the production of anionic centers on the polymer backbone by direct metallation or metal halogen interconversion on halogen containing polymers. For example, by incorporating small amounts of *p*-chlorostyrene into a polystyrene backbone, the chloro-group can be removed in the presence of sodium-naphthalene in THF (figure 1.30). The active polymer chain is then reacted with the desired monomer to produce side chains of the grafted polymer.<sup>78</sup>



**Figure 1.30** An example of graft copolymer synthesis by the 'grafting from' method

### 1.4.2 Grafting Onto Method

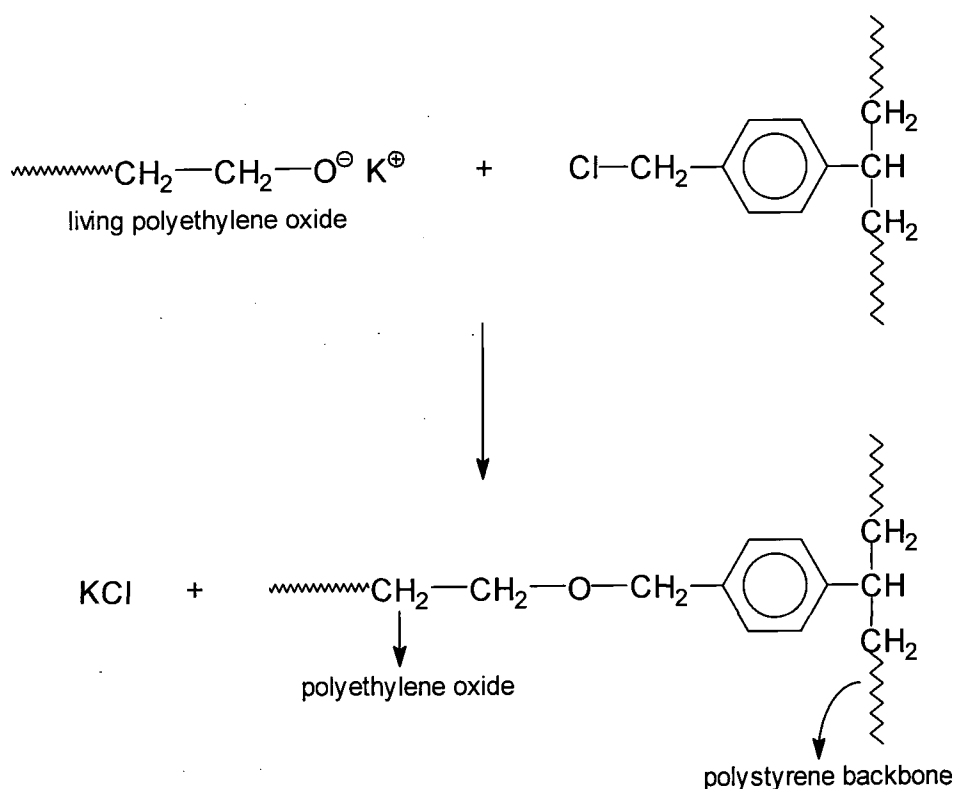
In 'grafting onto' method, a reactive functional group on the polymer backbone is coupled with a preformed polymer chain containing a suitable reactive functional group on its end.



**Figure 1.31** Schematic representation of 'grafting onto' method

Ionic polymerisation methods are most suitable for preparation of the graft unit, since polymers with controlled structures and reactive chain-end functionality can be prepared.<sup>77</sup> Backbone functionalities that can be used for anionic grafting onto reactions include electrophilic functionalities such as esters, anhydrides, benzylic-halides, nitriles, and pyridine groups. Although quantitative coupling is difficult, this method is fairly controllable.

For example, poly(styrene-g-ethylene oxide) graft copolymer has been made by the reaction of living polyethylene oxide with a partially chloromethylated polystyrene backbone (figure 1.32).<sup>68</sup>



**Figure 1.32** An example of graft copolymer synthesis by the 'grafting onto' method

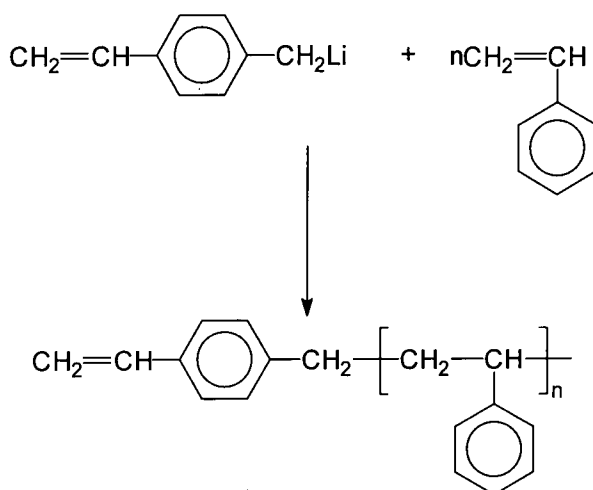
### 1.4.3 Macromonomer Method

A macromolecular monomer, abbreviated as macromonomer, is a short polymer chain fitted with a polymerisable group at the chain end.<sup>79</sup> In the 1970's Milkovich and colleagues developed the macromonomer method of preparing graft copolymers. They synthesised various macromonomers by end capping living anionic polymers with electrophiles possessing a polymerisable group and patented these polymers (macromonomers) under the trade mark 'Macromer<sup>®</sup>'.

Preparation of graft copolymers by the macromonomer method has several advantages compared with conventional methods, molecular weight and number of graft units can be controlled and combination between backbone and graft copolymer chains can be selected for desired purposes. Anionic polymerisation, cationic polymerisation, group transfer polymerisation and radical polymerisation have been used to synthesise macromonomers. Living ionic polymerisation methods provide control over molecular weight, molecular weight distribution and functionalisation of chain ends in the synthesis of macromonomers; thus living ionic polymerisation has been widely employed to synthesise well defined macromonomers.<sup>77,79,80</sup>

Anionic methods of synthesising macromonomers can be divided into two types, namely anionic initiation and end-capping of polymeric anions. Functional initiators are used in the first method, where the functional group remains unreacted after polymerisation. In the second method, a functional terminating group is used to end-cap the living anionic chain.

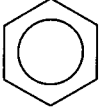


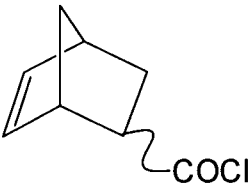

For example, *p*-vinylbenzyl lithium has been used as an initiator in the anionic polymerisation of styrene to produce *p*-styryl terminated macromonomers (figure 1.33).<sup>81</sup> However, one of the major drawbacks of this method is that chain end unsaturated functional groups could become involved in the polymerisation, leading to complex topologies and/or networks.<sup>80</sup>



**Figure 1.33** Anionic polymerisation of styrene using a functionalised initiator.

On the other hand, with the end-capping method, conventional anionic polymerisation can be directly employed and macromonomers with high functionality can be

produced.<sup>77,79,80</sup> Styrene is the monomer of choice because of its anionic polymerisability and availability. Milkovich reacted the anionic living end of polystyrene with ethylene oxide and then end-capped the resulting product with functional electrophiles to avoid side reactions of unreacted groups with carbanions. Asami and colleagues reported that direct end-capping reaction of living carbanions could be performed by selecting appropriate solvents and counter-ions.<sup>82</sup>

Monomer	Functional Terminating Agent
$\text{CH}_2=\text{CH}$ 	 / $\text{CH}_2=\text{CH}-\text{Si}(\text{CH}_3)_2-\text{CH}_2\text{Cl}$
	 / $\text{CH}_2=\text{CH}-\text{Si}(\text{CH}_3)_2-\text{Cl}$
	$\text{CH}_2=\text{C}(\text{R})-\text{C}_6\text{H}_4-\text{CH}_2\text{Cl}$
	
	$\text{CH}_2=\text{CHCH}_2\text{Br}$
	$\text{CH}_2=\text{CH}-\text{C}_6\text{H}_4-\text{CH}_2\text{Cl}$
	$\text{CH}_2=\text{C}(\text{CH}_3)-\text{COCl}$
	$\text{CH}_2=\text{CH}-\text{C}_6\text{H}_4-\text{CH}_2\text{Cl}$

**Table 1.1** Examples of monomers and functionalised capping reagents used in anionic polymerisation to synthesise macromonomers.<sup>80</sup>

In general, majority of macromonomers are subjected to free-radical polymerisation to obtain graft copolymers. This is because of its versatility and its tolerance towards most functional groups. However, the free-radical process is generally of little use whenever well-defined structures are required. Recently, well-defined graft copolymers have been prepared by ring opening metathesis polymerisation of macromonomers.<sup>83</sup> This involves the synthesis of macromonomers by living anionic polymerisation with a ring open polymerisable group at the chain-end and then living ring opening metathesis polymerisation of macromonomers using well-defined metathesis catalysts to get well-defined graft copolymers. Since both macromonomer and graft copolymer synthesis involves living polymerisation, this gives control over molecular weight and molecular weight distribution of side-chains and the backbone chain of graft copolymer. This is the main subject of this thesis and this method of graft copolymer synthesis will be discussed in detail in chapter-4.

#### **1.4.4 Applications of Graft Copolymers**

Graft copolymers can be used as surface modifying agents, compatibilisers for polymer blends, thermoplastics, medical materials and in various other applications.<sup>77,79,80,84</sup> However, the chief interest in graft copolymers originates from their properties as surface modifying agents. When a polymeric material is coated with a graft copolymer, the backbone of which is of the same chemical nature, the grafts (that are incompatible) will accumulate on the surface, thereby modifying it. Such graft copolymers can be used as antistatic agents, surface humidifiers, dye binding intermediates, adhesives and lubricants.

One of the early applications of graft copolymers prepared by the macromonomer method was for use as dispersing agents in non-aqueous emulsion coatings produced by ICI. The graft copolymer consisted of the grafted segment from the macromonomer soluble in the media and the main chain insoluble in the media. The steric repulsion of the grafted polymer chain prevented coagulation of the resulting polymer particles giving rise to stable polymer dispersion with a high solid content.<sup>79</sup>

The properties of polymer blends depends on the compatibility between the respective polymers used. Thus in immiscible cases, block and graft copolymers are used as a compatibiliser to overcome the incompatibility. For example, mixtures of polystyrene

and polybutadiene are incompatible and will form separate phases when mixed. However, incorporation of poly(butadiene-*g*-styrene) graft copolymer to the polystyrene-polybutadiene mixture stabilises the two phases. Here, the polybutadiene portion of the graft may be thought of as being 'solubilised' in the rubber particle with the whole particle being 'anchored' to the polystyrene matrix by the polystyrene portion of the graft. This process forms the basis for the preparation of high impact polystyrene (HIPS).<sup>85</sup>

Similarly, cellulose acetate is incompatible with polystyrene; even a few percent of one polymer mixed with the other gives white opaque films upon casting from solvents. However, addition of even a small amounts of the graft copolymer poly(styrene-*g*-cellulose acetate) results in formation of a clear transparent film.<sup>77</sup>

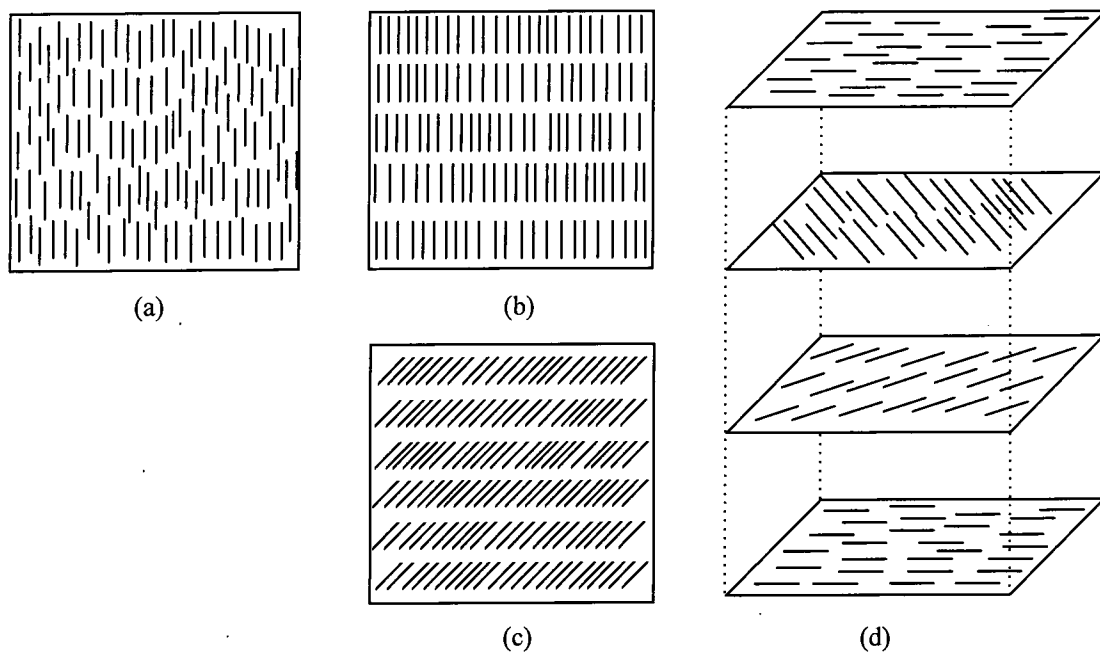
## 1.5 LIQUID CRYSTALLINE POLYMERS

The liquid crystalline state was first discovered by an Austrian botanist, Friedrich Reintzer, in 1888. He noted that cholesteryl esters had some unusual melting properties. Although these crystals had sharp melting points, the melt was opaque and upon heating to higher temperatures the opacity disappeared suddenly to give a normal clear liquid. This intermediate state was later termed 'mesophase'. Since mesophases have properties associated with both crystals and liquids, they are called 'liquid crystals'. Although liquid crystalline compounds have been known for more than 100 years, liquid crystalline polymers have gained prominence only in last 30 years. Various aspects of liquid crystalline polymers have been widely reviewed<sup>86-93</sup>. The following is a brief description about mainly the synthetic aspects of liquid crystalline polymers since one of the objectives of the work described in this thesis was to synthesise well defined side chain liquid crystalline polymers.

The liquid crystalline states or mesophases can be divided into 3 main categories;

- nematic,
- smectic, and
- cholesteric

The nematic mesophase describes an approximately parallel array of polymer chains or chain segments in a liquid crystalline domain but with no special order with regard to end groups or chain units. This type of molecular organisation is illustrated in figure 1.34a.



**Figure 1.34** Schematic representation of mesophases: (a) nematic; (b) smectic A; (c) smectic C and (d) cholesteric.

The smectic mesophase possesses a nematic type of order plus some additional order because of the alignment of end groups or chain units giving rise to a layered structure where the layers stack one on top of the other. There are several variations of smectic mesophase. The two most common variants are known as smectic A and smectic C and are shown in figure 1.34b and 1.34c. In smectic A the director (the preferred orientation of the mesogens) lies along the layer normal. In smectic C the director of each layer is inclined to an angle  $\omega$  to the layer normal, this angle being identical for all layers.

The cholesteric mesophase has nematic type order with a superimposed spiral arrangement of nematic layers (figure 1.34d). The class is called 'cholesteric' because this particular type of liquid crystalline order was first observed in esters of cholesterol. This type of ordering is also called 'chiral nematic' and can be found in

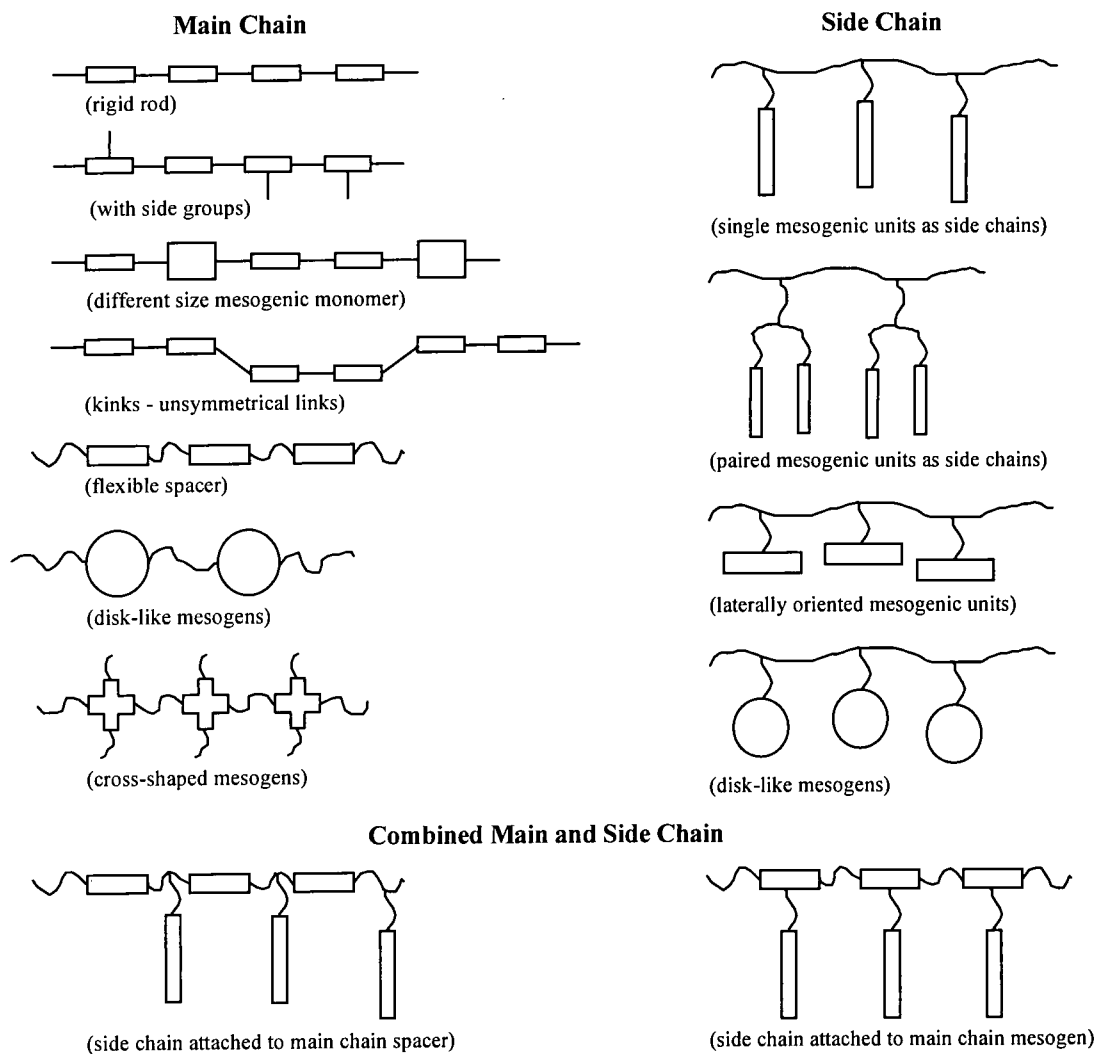
mesogenic systems containing a chiral center. Similarly, chiral smectic C ( $S^*_C$ ) can also be prepared with a mesogenic system containing a chiral centre to give a spiral arrangement.

Various methods are available to identify liquid crystal mesophases and generally they are used in a complementary fashion to get reliable information. These include;<sup>94</sup>

- **Polarising Microscope-** The liquid crystalline phases are identified by observing the characteristic textures developed in thin layers of the polymer when viewed through a microscope using a linearly polarised light source.
- **Differential Scanning Calorimetry (DSC)-** This is used to detect thermotropic mesophase transition temperatures.
- **X-Ray Diffraction-** Debye-Scherrer powder technique provides reliable information on the number of phases present.
- **Miscibility Studies-** The type of phase formed in a polymer liquid crystal is identified by examining the manner in which it mixes with a small molecule mesogen of known mesophase type.

### 1.5.1 Lyotropic and Thermotropic Liquid Crystalline Polymers

Liquid crystals can be divided into two major classes; lyotropic and thermotropic, depending upon whether the mesophase is observed by variation of solvent content or by variation of temperature. The thermotropic liquid crystalline polymers can be further subdivided into main chain and side chain liquid crystalline polymers. Various possible arrangements of mesogens in a polymer chain are illustrated in figure 1.35.



**Figure 1.35** Schematic representation of various possible arrangements of mesogens in polymer chain structures.

### 1.5.2 Lyotropic Liquid Crystalline Polymers

Lyotropic liquid crystalline polymers are formed by dissolving mesogenic polymer molecules in a suitable solvent. The addition of solvent reduces the crystalline melting points to manageable levels. The development of liquid crystalline solutions depends on the molar mass of the molecules, the solvent and the temperature, but most importantly on the structure of the polymer, which should be quite rigid. One of the most important groups of lyotropic synthetic polymers is the aromatic polyamides<sup>92</sup>. The rigidity of these polymers makes them inherently less soluble in common solvents. Thus the aromatic polyamides require the more aggressive, strong, protonating acids ( $H_2SO_4$ ,  $CF_3SO_3H$ ,  $CH_3SO_3H$ ) or protic solvents such as

dimethylacetamide or N-methyl pyrrolidone in conjunction with LiCl or CaCl<sub>2</sub> in 2-5% to effect solution.

A number of polyamides have become commercially successful because of the very high tensile strength of the fibres that can be spun from the nematic solution. One of the most significant of these aramid fibres is poly(*p*-phenylene terephthalamide) or Kevlar.

### 1.5.3 Thermotropic Main Chain Liquid Crystalline Polymers

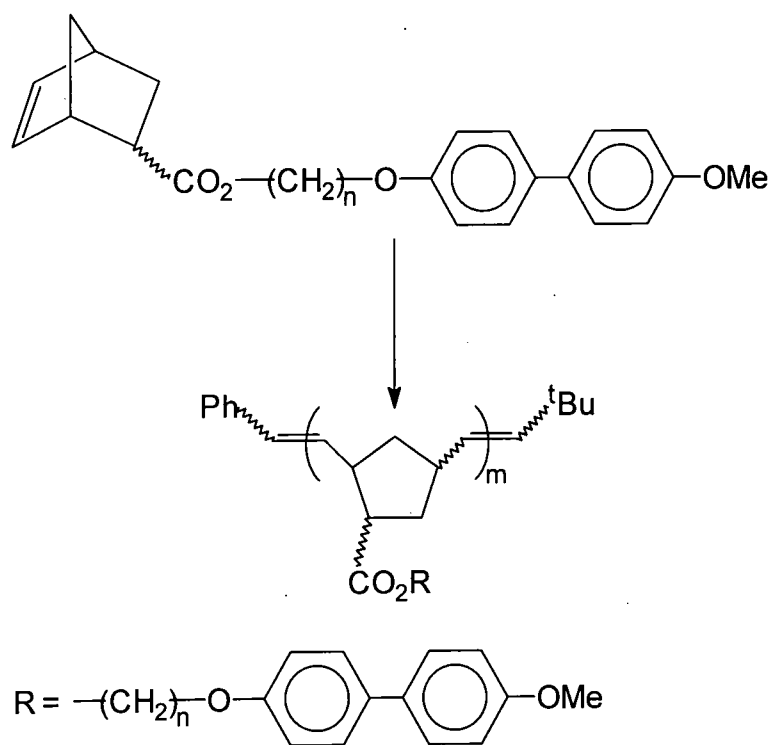
Thermotropic liquid crystalline polymers are materials which shows liquid crystallinity in a particular temperature range without the addition of any solvents. Many of these polymers are polyesters and are prepared by condensation polymerisation or ester interchange reaction in the melt. Among the commonly used monomer units are hydroxybenzoic acid, terephthalic acid, 2,6-naphthalene dicarboxylic acid, 2-hydroxy-6-naphthoic acid and 4,4'-biphenol. The polymers prepared from monomers of this kind tend to be very insoluble and have high melting points and mesophase ranges; for example, poly(*p*-hydroxybenzoic acid) melts at ~883K. This makes them difficult to process. Therefore various methods have been used to modify the polymer chain in order to reduce the melting points and these include;

- incorporation of flexible spacer units,
- copolymerisation of several mesogenic monomers of different sizes to give a random and more irregular structure,
- introduction of lateral substituents to disrupt the chain symmetry, and
- synthesis of chains with kinks, such as unsymmetrically linked aromatic units.

### 1.5.4 Thermotropic Side Chain Liquid Crystalline Polymers

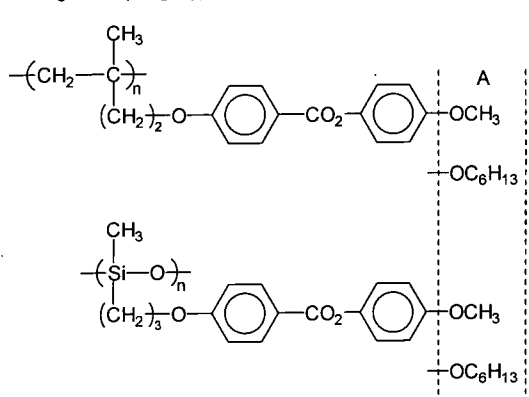
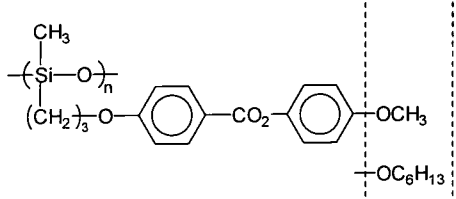
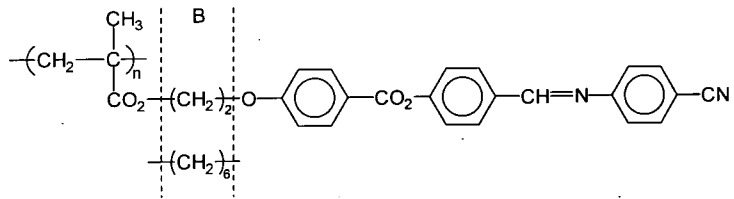
The side chain liquid crystalline polymers consists of two components; the mesogenic moieties and the polymer main chain to which they are attached. Mesogens may also be incorporated into both main chains and side chains. Cross-linking of side chain

liquid crystalline polymers leads to mesogenic thermosets or elastomers. Also mesogenic monomers that do not form mesophases leads to mesomorphic liquid crystalline polymers upon polymerisation.<sup>90</sup> These polymers are generally produced by free-radical addition polymerisation, condensation polymerisation or by modifying a preformed polymeric backbone. Thus side chain liquid crystal polymers with poly(acrylate)s, poly(methacrylate)s, poly(siloxane)s and poly(phosphazene)s<sup>95-97</sup> backbones have been prepared. However, the above methods of polymerisations lack control over molecular weight and molecular weight distribution. These shortcomings have been overcome by employing living cationic polymerisation,<sup>98-103</sup> group transfer polymerisation<sup>104</sup> and more recently living ring opening metathesis polymerisation.<sup>40-44,105</sup> Schrock *et al.* and Grubbs *et al.* have synthesised side chain liquid crystal polymers with fairly rigid poly(norbornene) backbones and more flexible poly(butadiene) backbones respectively by living ring opening metathesis polymerisation; an example of a norbornene monomer is shown below, poly(butadiene) backbones would be produced from polymerisation of cyclobutene or cycloocta-1,5-diene derivatives.



**Figure 1.36** Synthesis of a side chain liquid crystalline polymer by ring opening metathesis polymerisation.

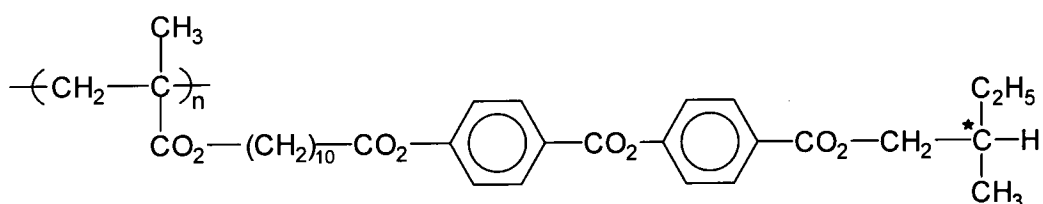
The extent to which a mesophase can develop in side chain liquid crystalline polymers is influenced by the flexibility of the backbone chain and whether the mesogen is attached directly to the chain or is pushed further away by the insertion of a flexible spacing unit. The direct attachment of a mesogenic group to the backbone (without a spacer group) does not always leads to liquid crystalline polymers. This is accounted for by steric hindrance imposed by the main chain on the packing of mesogenic groups. As a result, most polymers of this type are amorphous.<sup>90</sup> However, Ringsdorf and co-workers found that insertion of a flexible spacer between the rigid mesogen and the polymer backbone is necessary to preserve the liquid crystalline phase behaviour of the mesogen.<sup>106,107</sup> The flexible spacer partially decouples the motions of the polymer backbone and the mesogens, and enables the mesogens to become organised into liquid crystalline domains.

Polymer	Phase Transitions <sup>†</sup> (K)
<p>Segment A (end group)</p> 	<p>g 369 n 394 i</p> <p>g 410 s 451 i</p>
	<p>g 288 n 334 i</p> <p>g 288 s 385 i</p>
<p>Segment B (spacer group)</p> 	<p>g 361 n 580 i</p> <p>g 324 s 607 i</p>

<sup>†</sup> g = glassy; n = nematic; s = smectic; i = isotropic

**Table 1.2** The effect of structure (spacer and end group) on the type of mesophase and transition temperature.<sup>90</sup>

The effect of structure on the type of liquid crystal organisation and transition temperatures is shown in table 1.2. Segment A at the end of the mesogen favours nematic organisation if short ( $\text{CH}_3$ ,  $\text{OCH}_3$ ,  $\text{CN}$  etc) or smectic if long. Likewise, the spacer group (segment B) influences the nature of the liquid crystalline phase, shorter (2-6) units favouring nematic ordering and longer units favouring more stable smectic phase.<sup>91</sup> Shibaev *et al.* first synthesised the chiral smectic C ( $\text{S}^*\text{c}$ ) phase side chain liquid crystalline polymers with the chiral centre in its side chain (figure 1.37).<sup>108,109</sup> This was also the first example of a ferroelectric side chain liquid crystal polymer.



**Figure 1.37** First ferroelectric chiral smectic C side chain liquid crystalline polymer

Applications of ferroelectric side chain liquid crystalline polymers are expected in the area of display devices, pressure and temperature sensors *i.e.* as piezoelectric and pyroelectric devices and in non-linear optics.<sup>86,87,93</sup> In 1993, Idemitsu Kosan demonstrated the first ferroelectric side chain liquid crystalline polymer display.<sup>93</sup> This consisted of a layer of ferroelectric side chain liquid crystalline polymer ( $2\mu\text{m}$ ) constrained between two plastic substrates (each  $100\mu\text{m}$  thick). This type of display is expected to provide robustness and flexibility that is found in no other display type and advantages in the ease of processing.

An objective of the work reported here was to produce a similar side chain ferroelectric liquid crystal polymer based on a flexible hydrocarbon backbone. The reason for this target being associated with the long term stability and operating temperature of the material in device applications.

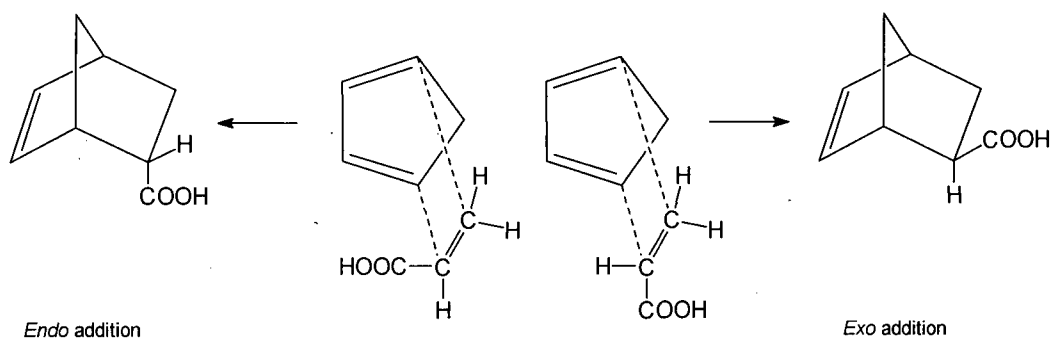
**CHAPTER-2**  
**SYNTHESIS OF *EXO*-5-NORBORNENE-2-CARBONYL**  
**CHLORIDE**

## 2.1 INTRODUCTION

This chapter describes the synthesis of 5-norbornene-2-carboxylic acid as a mixture of *exo* and *endo* adducts, the separation of the *endo* adduct from the *exo/endo* mixture via iodolactonisation and the conversion of the *exo*-acid into its acid chloride. The acid chloride obtained was used as an end capping reagent for living anionic polystyrene to produce well-defined polystyrene macromonomers. The macromonomer synthesis is described in the next chapter and the ring opening metathesis polymerisation of the macromonomers is the subject of chapter-4.

## 2.2 Synthesis of 5-Norbornene-2-Carboxylic Acid

There are two possible ways in which Diels-Alder addition of cyclic dienes with unsymmetrical dienophiles can occur. These are designated *endo* and *exo* addition and are illustrated in figure 2.1 for the addition of acrylic acid to cyclopentadiene which is the reaction of interest in this work. In this reaction as in many cases, mixtures of *exo* and *endo* addition products are formed.<sup>110-112</sup> The *endo* adducts are the products of kinetic control and are favoured by relatively short reaction times and low temperatures whereas the *exo* adducts are the products of thermodynamic control and are favoured by high temperature and long reaction times.<sup>111</sup>

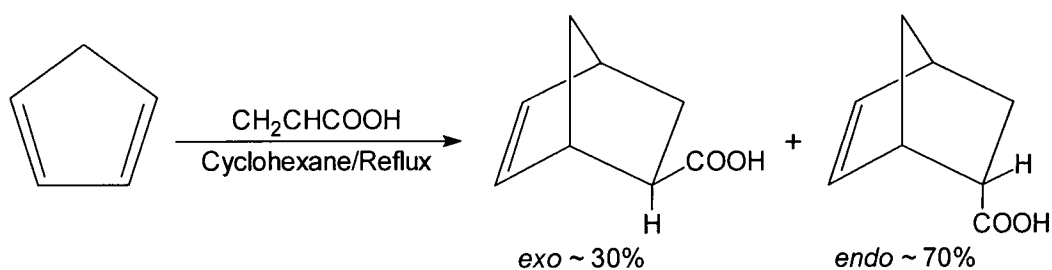


**Figure 2.1** Schematic representation of *exo* and *endo* addition in the Diels-Alder reaction of cyclopentadiene with acrylic acid

Many reactions of this kind are reversible and the Diels-Alder adducts dissociate into their components upon heating. This reversibility is required if the *exo* product is desired, thus the use of high temperature and extended reaction times in carrying out

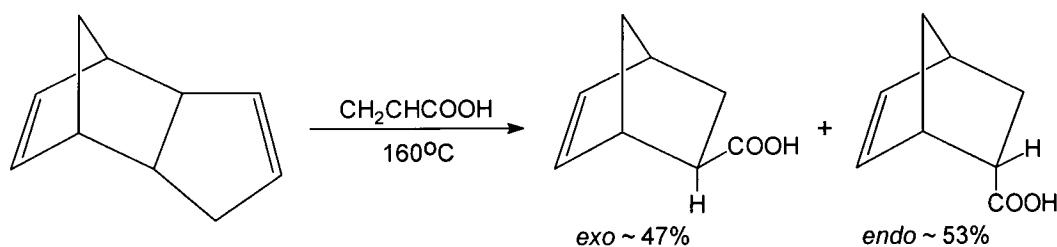
additions may permit repeated dissociation and recombination with the resultant formation of the thermodynamically more stable adduct at the expense of the kinetically favoured stereoisomer.<sup>111</sup>

Three different procedures were found in the literature for the synthesis of 5-norbornene-2-carboxylic acid. The standard procedure is the addition of acrylic acid to cyclopentadiene.<sup>110-112</sup> This procedure gives primarily *endo* adduct contaminated by *exo* isomer. The highest percentage of *exo* isomer that has been reported to have been obtained by this method is about 30%. Ivin *et al.* achieved this by adding freshly distilled cyclopentadiene to acrylic acid in cyclohexane at reflux temperature.<sup>113</sup> The yield of this reaction is almost 100%.



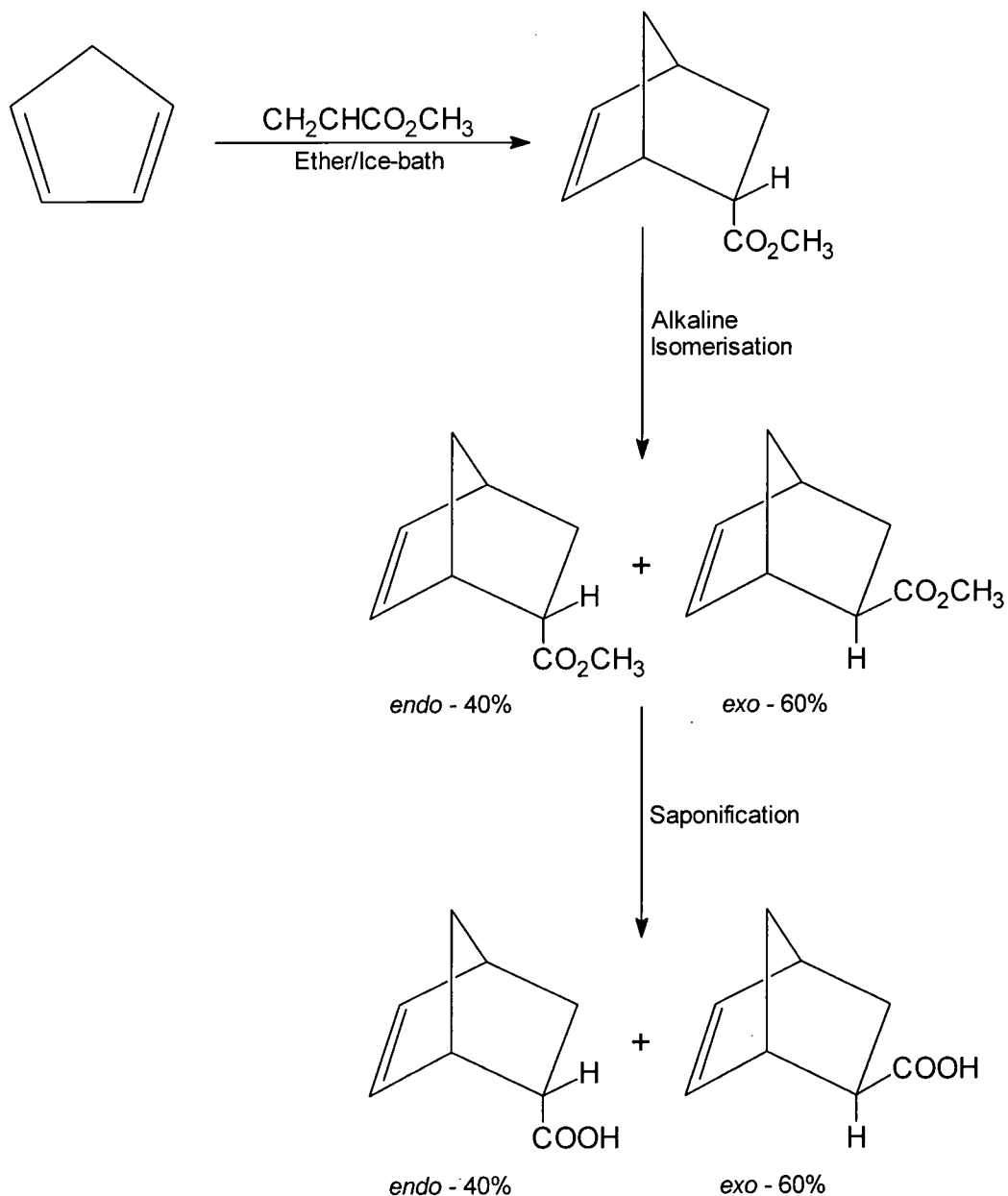
**Figure 2.2** Synthesis of 5-norbornene-2-carboxylic acid from cyclopentadiene and acrylic acid

The next method involves the use of dicyclopentadiene instead of cyclopentadiene.<sup>114</sup> In this case a mixture of dicyclopentadiene and acrylic acid is heated to 160°C in a pressure reaction vessel without any solvent. This procedure gives about 45-60% *exo* acid but the overall yield from this method is only about 50-60%.



**Figure 2.3** Synthesis of 5-norbornene-2-carboxylic acid from dicyclopentadiene and acrylic acid

The third procedure, reported by Roberts and Trumbull, increased the *exo* content by alkaline isomerisation of the *endo*-methyl 5-norbornene-2-carboxylate ester followed by saponification.<sup>115-116</sup> This procedure gives a mixture of 60% *exo* and 40% *endo* acids. The overall yield of this method is 62%.



**Figure 2.4** Synthesis of 5-norbornene-2-carboxylic acid by alkaline isomerisation and saponification of *endo*-methyl 5-norbornene-2-carboxylate ester

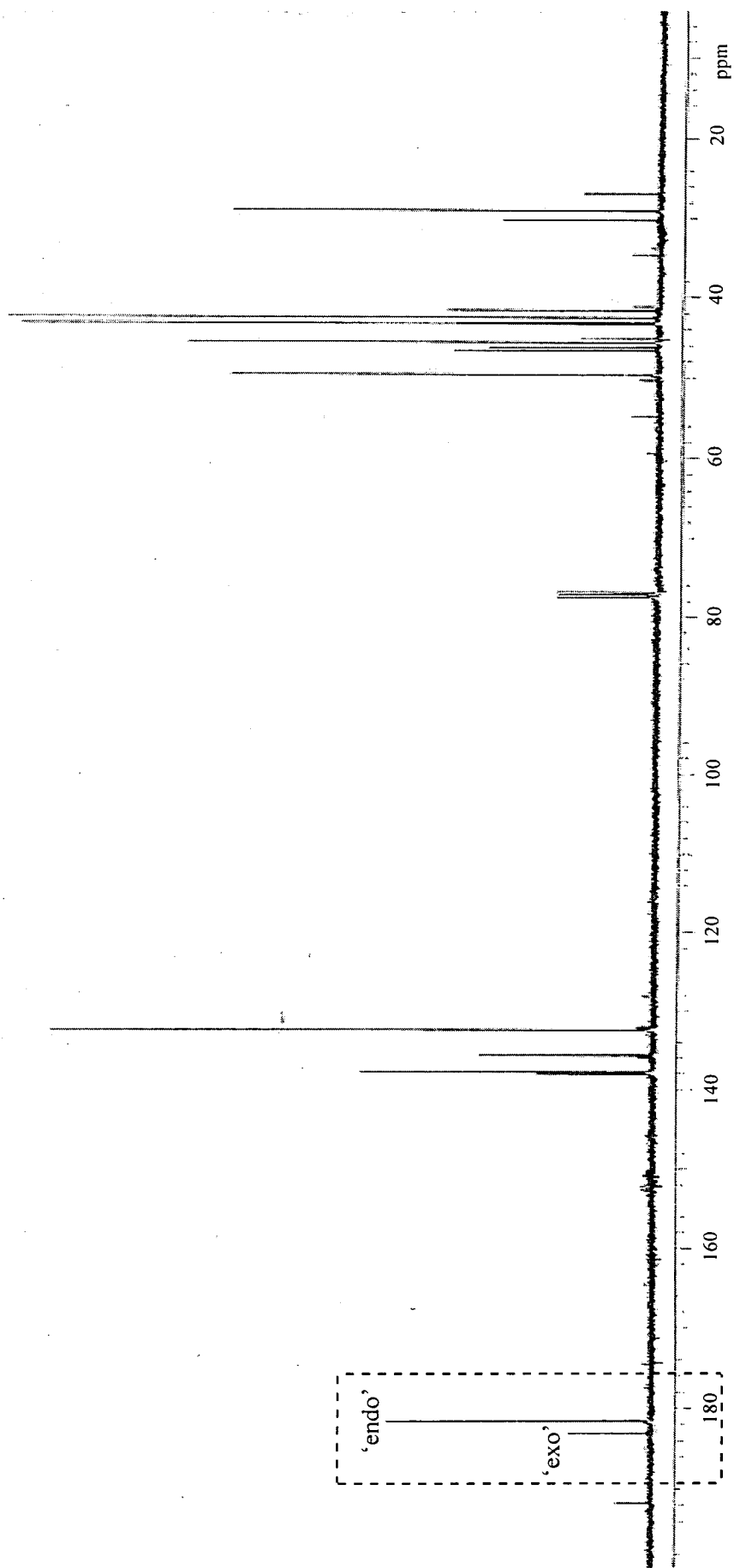
For the purpose of the work described in this thesis 5-norbornene-2-carboxylic acid was synthesised by two of the above procedures; the method of Ivin *et al.* and the

method using a mixture of dicyclopentadiene and acrylic acid. The method involving alkaline isomerisation of the *endo*-methyl 5-norbornene-2-carboxylate ester was not attempted.

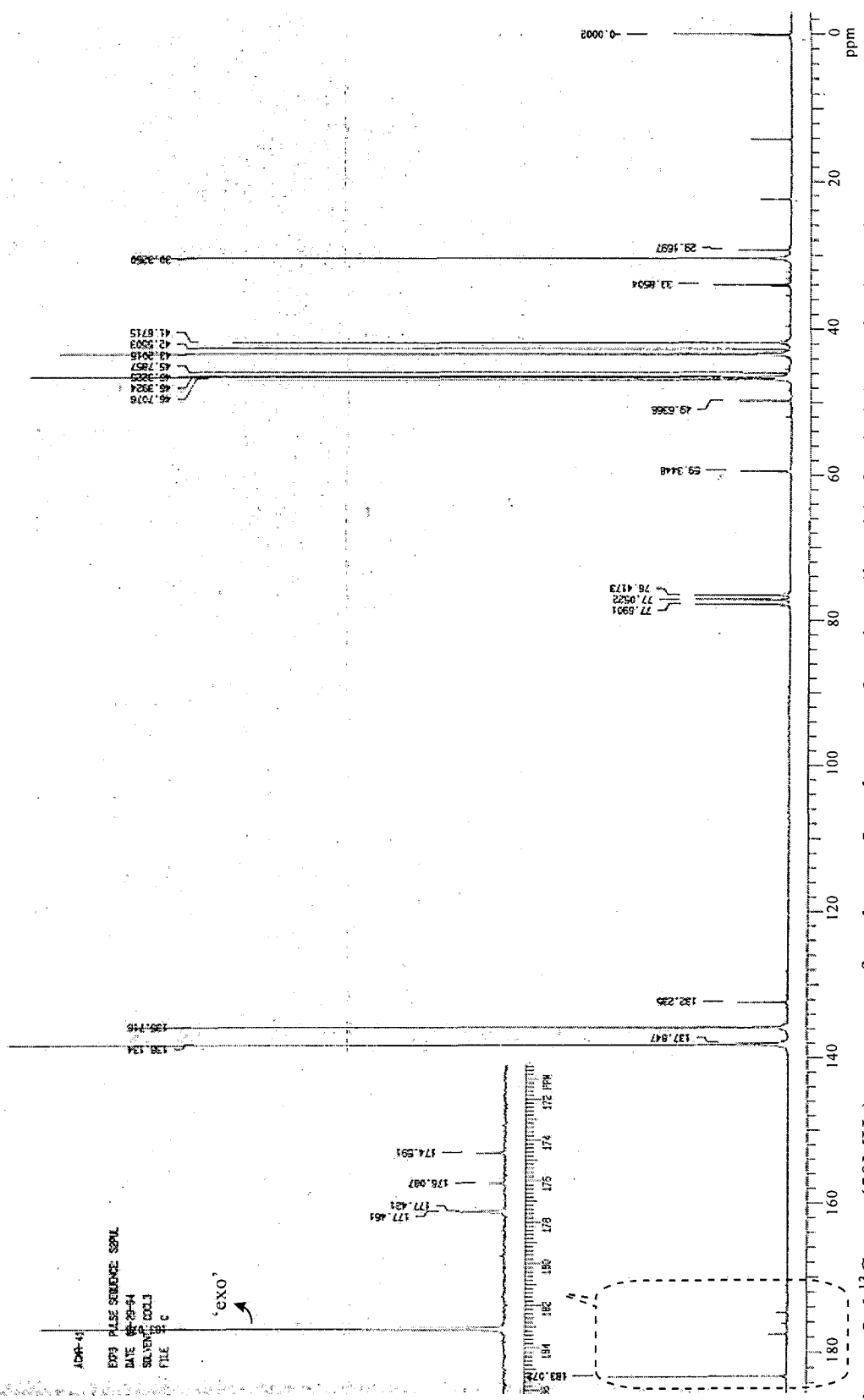
The advantage of synthesising 5-norbornene-2-carboxylic acid by the addition of cyclopentadiene and acrylic acid is that the reaction is fast and goes to almost 100% completion. Also the product can be used in the following step without any further purification. The major drawbacks of this method is that it requires freshly distilled cyclopentadiene, obtained by thermal cracking of dicyclopentadiene and the *exo* content is low. The *exo* content can be improved by using dicyclopentadiene instead of cyclopentadiene and carrying out the reaction in a pressure reaction vessel. The drawback of this method is that since 50% excess of acrylic acid is used, the crude product mixture has to be distilled to remove the excess acrylic acid. Also some polymers/oligomers were found as side products in the reaction mixture. These were not identified. The *exo* contents formed in both of these methods were determined by  $^{13}\text{C}$  nmr spectroscopy.<sup>113</sup>

### 2.3 Iodolactonisation of *Endo* Acid

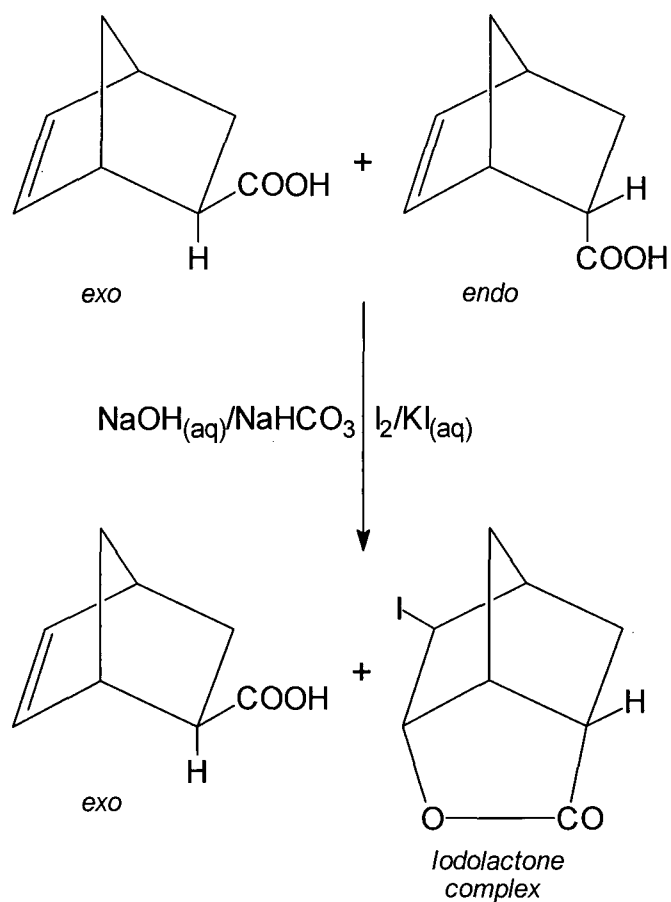
Pure *exo* acid was obtained after removal of the *endo* isomer *via* iodolactonisation of *exo/endo* acid mixture.<sup>115,117,118</sup> This was achieved by adding 10% aqueous NaOH followed by  $\text{NaHCO}_3$  and aqueous  $\text{I}_2/\text{KI}$  solution to the acid mixture to precipitate the *endo* acid as the iodolactone (figure 2.7). The *endo* acid precipitates as a dark brown/black oil. After removing bulk of the iodolactone precipitate from the separating funnel, final traces of the precipitate were removed by extracting with small portion of chloroform. The aqueous layer was then treated with 10% aqueous  $\text{Na}_2\text{S}_2\text{O}_3$  to remove excess iodine, acidified and extracted with chloroform to give the *exo* acid. The crude *exo* acid was used in the following step without any further purification. In the  $^{13}\text{C}$  nmr spectrum (figure 2.6) no carbonyl carbon signal was observed for the *endo* acid which occurs at 181.5ppm indicating that all the *endo* acid has been removed by this procedure; figure 2.5 shows the spectrum of the *endo/exo* mixture where both *endo* (181.5ppm) and *exo* (183.0ppm) carbonyl carbon signals are clearly seen.



**Figure 2.5**  $^{13}\text{C}$  nmr (50MHz) spectrum of *exo/endo*-5-norbornene-2-carboxylic acid (crude sample)



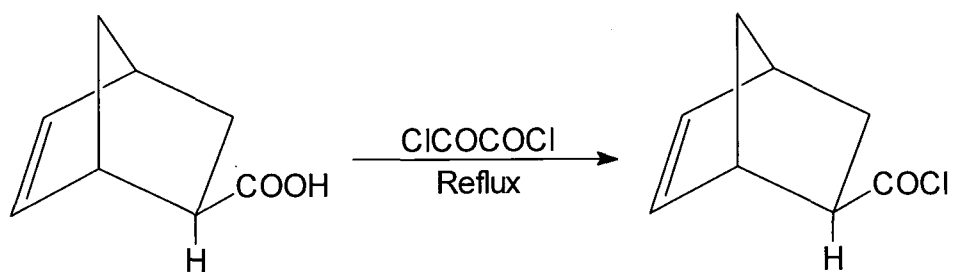
**Figure 2.6**  $^{13}\text{C}$  nmr (50MHz) spectrum of crude *exo*-5-norbornene-2-carboxylic acid after iodolactonisation of the *exo/endo* mixture



**Figure 2.7** Separation of *endo* isomer from the *exo/endo* mixture by iodolactonisation of *endo* acid

#### 2.4 Conversion of *Exo* Acid into Acid Chloride

The *exo* acid was converted into acid chloride by refluxing with oxalyl chloride.<sup>119</sup> After removing the excess oxalyl chloride, the crude acid chloride was distilled to give pure *exo*-5-norbornene-2-carbonyl chloride as a foul smelling liquid.



**Figure 2.8** Reaction scheme for the synthesis of *exo*-5-norbornene-2-carbonyl chloride

## 2.5 EXPERIMENTAL

All chemicals were bought from Aldrich Chemical Co. Ltd. and used as received without any further purification. Cyclopentadiene was obtained by pyrolysis of dicyclopentadiene at 180°C.

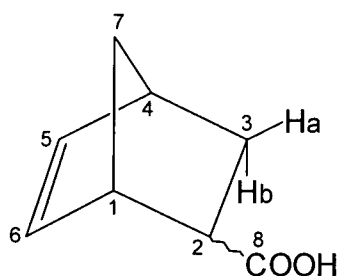
### 2.5.1 Synthesis of *Exo*-5-Norbornene-2-Carboxylic Acid

**Method-1:** Acrylic acid (103ml, 1.5mol), few crystals of hydroquinone and cyclohexane (450ml) were placed in a 1 litre 2-neck round bottom flask fitted with a condenser, with a drying tube attached to it and a pressure equalising dropping funnel. The mixture was refluxed using a stirrer/heater mantle, and freshly prepared cyclopentadiene was added slowly to the refluxing mixture under vigorous stirring so as to maintain the reflux from the heat produced by the reaction while the mantle heating was turned off. At the end of cyclopentadiene addition, the solution was left stirring vigorously for 10-20minutes and filtered to remove any polyacrylic acid formed. Finally solvent was removed using a rotary evaporator to give *exo/endo*-5-norbornene-2-carboxylic acid (211.4g, 98.2%). The product contained approximately 24% *exo*-acid as determined by  $^{13}\text{C}$  nmr spectroscopy. This was used in the following step without any further purification.

**Method-2:** Dicyclopentadiene (198g, 1.5mol) and acrylic acid (324g, 4.5mol) with some hydroquinone was placed in a 2 litre pressure reaction vessel equipped with an overhead stirrer and a thermocouple to measure the internal temperature. The sealed reaction vessel was heated to 160°C for 2 hours (or until a sudden increase in temperature to above 200°C due to exothermic reaction was observed). Finally the mixture was allowed to cool down to room temperature overnight. The product was obtained as a yellowish viscous liquid. This was distilled under vacuum to remove excess acrylic acid and to obtain pure 5-norbornene-2-carboxylic acid as a colourless viscous liquid. The  $^{13}\text{C}$  nmr showed it consisted of a 47% *exo* and 53% *endo* isomer mixture. The  $^1\text{H}$  and  $^{13}\text{C}$  nmr spectroscopic characterisation of this mixture is recorded below following the literature assignments.<sup>113</sup>

• **<sup>1</sup>H nmr**:-(*CDCl*<sub>3</sub>)  $\delta$  (*ppm*) 1.25-1.55 (m, H<sub>7</sub> and H<sub>3b</sub>), 1.9 (m, H<sub>3a</sub> and H<sub>2/endo</sub>), 2.24 (m, H<sub>2/exo</sub>), 2.9-3.0 (m, H<sub>1</sub>), 3.1 and 3.25 (2s, H<sub>4</sub>), 5.9-6.2 (m, H<sub>5</sub> and H<sub>6</sub>) and 12.1 (bs, H<sub>8</sub>).

• **<sup>13</sup>C nmr**:-(*CDCl*<sub>3</sub>)  $\delta$  (*ppm*) 28.96 (C<sub>3/endo</sub>), 30.18 (C<sub>3/exo</sub>), 41.54 (C<sub>4/exo</sub>), 42.43 (C<sub>2/endo</sub>), 43.07 (C<sub>2/exo</sub>), 43.22 (C<sub>4/endo</sub>), 45.56 (C<sub>1/endo</sub>), 46.25 (C<sub>7/exo</sub>), 46.57 (C<sub>1/exo</sub>), 49.59 (C<sub>7/endo</sub>), 132.31 (C<sub>6/endo</sub>), 135.58 (C<sub>6/exo</sub>), 137.73 (C<sub>5/endo</sub>), 137.97 (C<sub>5/exo</sub>), 181.49 (C<sub>8/endo</sub>), and 182.99 (C<sub>8/exo</sub>).



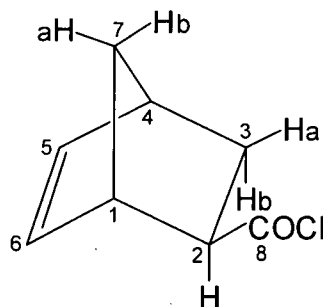
### 2.5.2 Separation of *Exo* and *Endo* Acids

The crude *exo/endo* acid mixture (72g, 47% *exo* as determined by <sup>13</sup>C nmr) was placed in a separating funnel (2l) and neutralised with 10% aqueous NaOH solution and sodium bicarbonate (36g) was added. The mixture was shaken thoroughly and aqueous I<sub>2</sub>/KI solution (1-1.5 litres, prepared by dissolving 101g of I<sub>2</sub> in 2000ml of water containing 200g of KI) was added in portions with shaking until the resulting mixture remained the colour of the I<sub>2</sub>/KI solution, *i.e.* black/pink. The solution was shaken occasionally over a period of an hour. The iodolactone of the *endo* acid precipitates as a dark brown/black oil. After removing bulk of the iodolactone from the separating funnel, final traces were removed by extracting with chloroform (3x50ml). The remaining aqueous layer was then treated with 10% aqueous Na<sub>2</sub>S<sub>2</sub>O<sub>3</sub> to remove excess iodine (the solution becomes colourless), acidified with H<sub>2</sub>SO<sub>4</sub> (1.8M) and extracted with chloroform (4x200ml). The chloroform extract was dried over anhydrous MgSO<sub>4</sub> and filtered. The solvent was removed using a rotary evaporator to give *exo*-5-norbornene-2-carboxylic acid (30g, 41.6%). The <sup>13</sup>C nmr spectrum of the crude *exo* acid showed no signal (around 181.5ppm) corresponding to the *endo* acid (figure 2.6). The crude *exo* acid was converted to acid chloride without any further purification.

### 2.5.3 Synthesis of *Exo-5-Norbornene-2-Carbonyl Chloride*

The crude *exo-5-norbornene-2-carboxylic acid* (46.95g, 0.34mol) and oxalyl chloride (80ml, 0.91mol, 2.7 equivalents) were placed in a 250ml round bottom flask fitted with a reflux condenser and a drying tube. The evolution of gas starts immediately, indicating that the reaction is taking place. After the evolution of gas has subsided (approximately 1 hour) the mixture was refluxed (70°C) for about 2 hours in an oil bath. The excess oxalyl chloride was then evaporated using a rotary evaporator and distilled (35°C/3mmHg) to give pure *exo-5-norbornene-2-carbonyl chloride* (27g, 50.7%). The following  $^1\text{H}$  and  $^{13}\text{C}$  nmr spectroscopic assignments were made with the aid of COSY and HETCOR spectra (appendix 2-figure A2.5 and A2.6).

- $^1\text{H}$  nmr:-( $\text{CDCl}_3$ )  $\delta$  (ppm) 1.40-1.55 (bm, 3H,  $\text{H}_7$  and  $\text{H}_{3\text{b}}$ ), 2.01 (m,  $\text{H}_{3\text{a}}$ ), 2.73 (m,  $\text{H}_2$ ), 2.98 (s,  $\text{H}_4$ ), 3.28 (s,  $\text{H}_1$ ), 6.12 (q,  $\text{H}_6$ ) and 6.21 (q,  $\text{H}_5$ )
- $^{13}\text{C}$  nmr:-( $\text{CDCl}_3$ )  $\delta$  (ppm) 31.19 ( $\text{C}_3$ ), 41.84 ( $\text{C}_4$ ), 46.26 ( $\text{C}_7$ ), 46.87 ( $\text{C}_1$ ), 56.29 ( $\text{C}_2$ ), 134.84 ( $\text{C}_6$ ), 139.00 ( $\text{C}_5$ ) and 176.56 ( $\text{C}_8$ ).



**CHAPTER-3**  
**SYNTHESIS OF MACROMONOMERS BY LIVING ANIONIC**  
**POLYMERISATION**

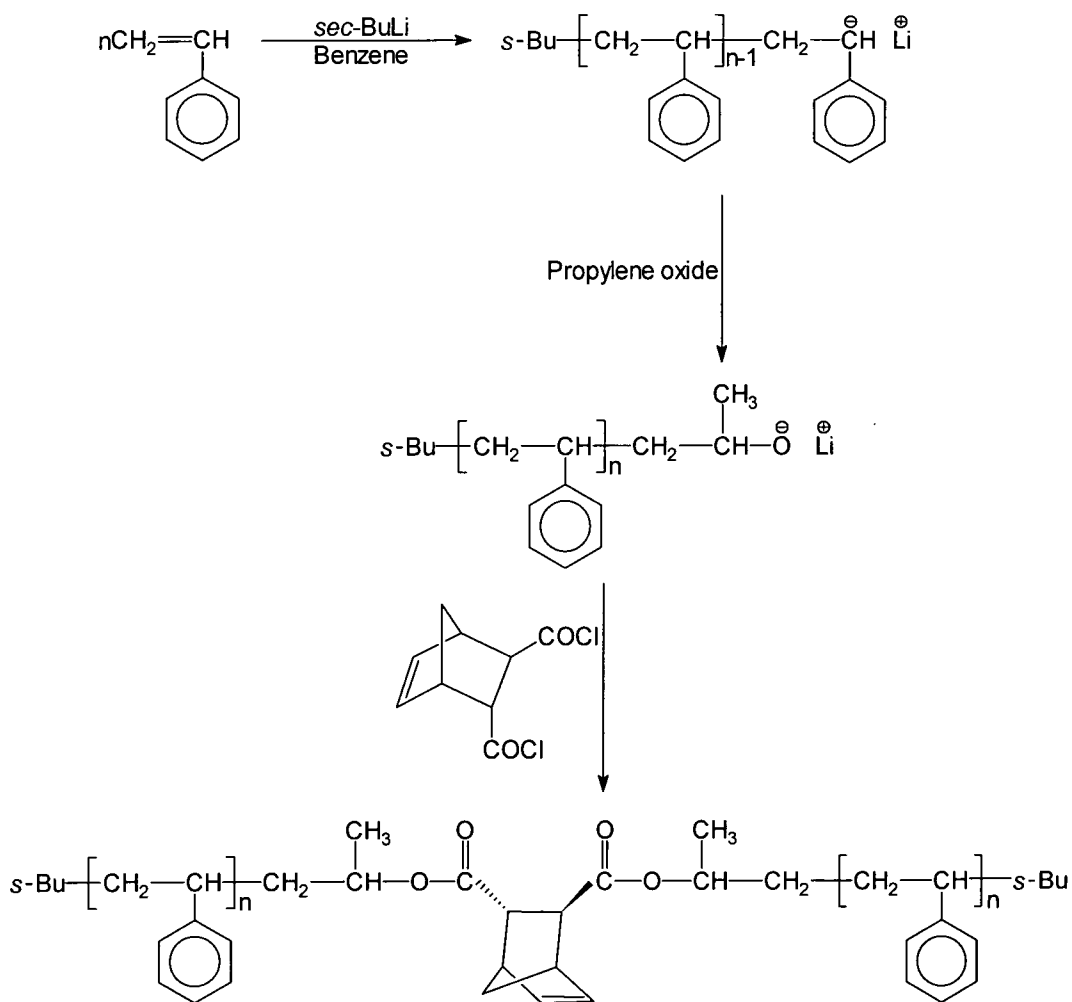
### 3.1 INTRODUCTION

This chapter describes the synthesis of *exo*-5-norbornene-2-(polystyrylcarboxylate) macromonomers by living anionic polymerisation and their characterisation. The synthesis involves anionic polymerisation of styrene followed by capping with propylene oxide and *exo*-5-norbornene-2-carbonyl chloride to give well-defined macromonomers suitable for ring opening metathesis polymerisation. These macromonomers are used to synthesise well-defined comb-graft copolymers by ring opening metathesis polymerisation which is described in chapter-4.

### 3.2 Synthesis of *Exo*-5-Norbornene-2-(Polystyrylcarboxylate) Macromonomers

Macromonomers can be prepared in many ways<sup>79,80</sup> as discussed earlier in chapter-1. However, methods based on living polymerisations are the best way to produce well-defined macromonomers, since this allows control of the molecular weight, molecular weight distribution and the introduction of functional groups at chain ends.<sup>59,75,79,80</sup> For these reasons *exo*-5-norbornene-2-(polystyrylcarboxylate) macromonomers were prepared by living anionic polymerisation.

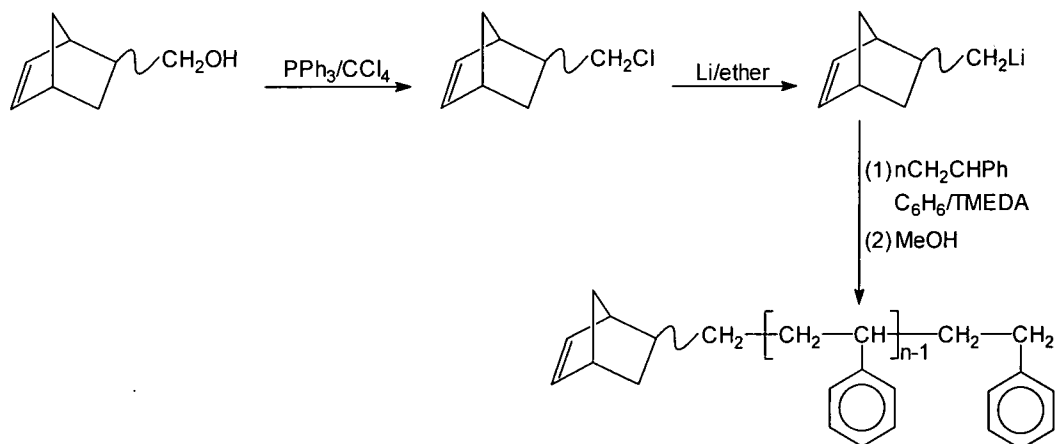
Previous work in this particular area includes the synthesis of an *exo/endo* mixture of 5-norbornene-2-(polystyrylcarboxylate) macromonomers by Norton and McCarthy<sup>120</sup> and of 5-norbornene-2,3-*trans*-bis(polystyrylcarboxylate) macromonomers by Feast and co-workers,<sup>83</sup> both sets of monomers were used to synthesise comb graft copolymers by ring opening metathesis polymerisation. In both cases the macromonomers were synthesised by living anionic polymerisation. In the former, living polystyrenes were capped with an *exo/endo* mixture of 5-norbornene-2-carbonyl chloride to produce the macromonomers as a mixture of *exo* and *endo* isomers in which each norbornene unit carries a single polystyrene chain. In the latter, living polystyrenes were capped with 5-norbornene-2,3-*trans*-dicarbonyl chloride to produce the macromonomers in which each norbornene unit carries two polystyrene chains (figure 3.1).



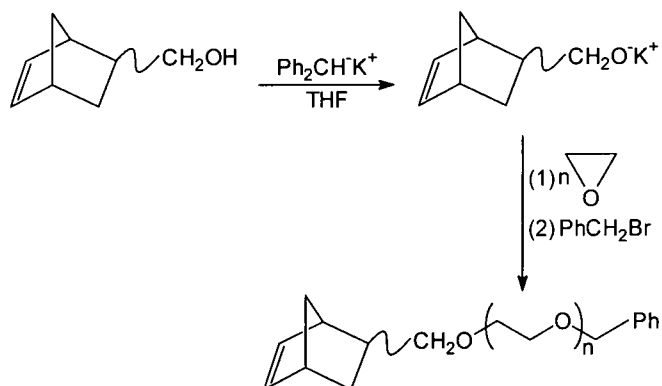
**Figure 3.1** Reaction scheme for the macromonomers synthesised by Feast and co-workers

Recently Fontanille *et al.* reported the synthesis of the *exo/endo* mixture of 5-norbornene-2-(polystyrylcarboxylate)s and a new *exo/endo* mixture of 5-norbornene-2-(polyethyleneoxidecarboxylate) family of macromonomers.<sup>121-123</sup> Apart from synthesising these macromonomers by end capping living polystyrene and ethylene oxide with the mixture of *exo/endo*-5-norbornene-2-carbonyl chloride, they also used novel norbornene based initiators to anionically polymerise styrene and ethylene oxide, thereby introducing the norbornene unit at the beginning of the chain (figure 3.2 and 3.3).<sup>122,123</sup> In this case the purpose of using a functionalised initiator approach was to avoid an ester link between the norbornene unit and the rest of the macromonomer chain. This is necessary because the presence of an ester link could inhibit complete hydrogenation of the final graft copolymer products prepared by ring

opening metathesis polymerisation of these macromonomers. Also the sensitivity of the ester function to hydrolysis could prevent the use of these graft copolymers in certain applications.

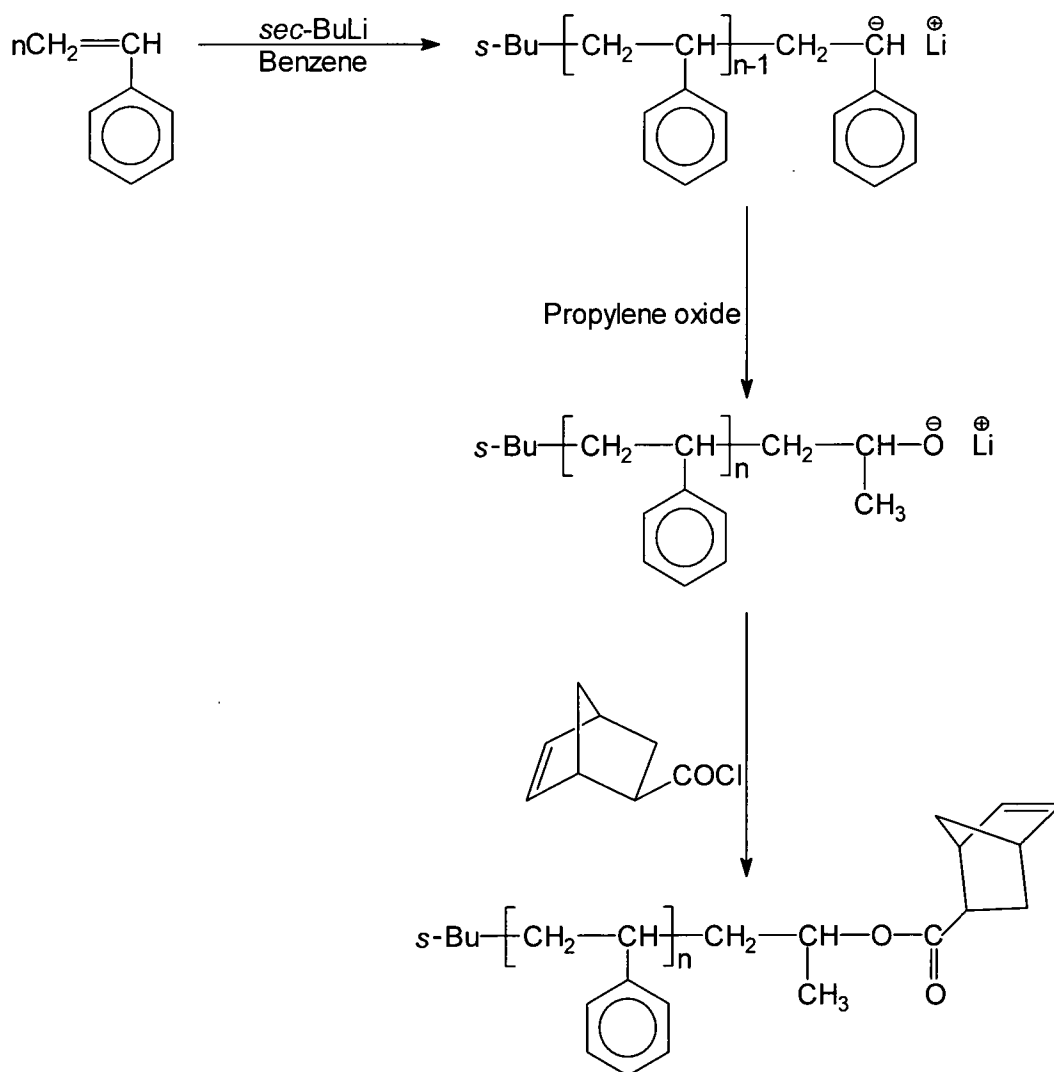


**Figure 3.2** Synthesis of *exo/endo*-5-norbornene-2-(polystyrene) macromonomer mixture using a functionalised initiator



**Figure 3.3** Synthesis of *exo/endo*-5-norbornene-2-(polyethylene oxide) macromonomer mixture using a functionalised initiator

The present work described here is a continuation of the work carried out by Feast and co-workers and involves synthesising *exo*-5-norbornene-2-(polystyrylcarboxylate) macromonomers by capping living polystyrene with *exo*-5-norbornene-2-carbonyl chloride. The synthesis was carried out in close analogy to the method described by Feast and co-workers<sup>83</sup> and the reaction scheme is outlined in figure 3.4.



**Figure 3.4** Reaction scheme for *exo*-5-norbornene-2-(polystyrylcarboxylate) macromonomer synthesis

Styrene was anionically polymerised at room temperature in benzene using *sec*-butyllithium as initiator. A sample of the living polymer was then withdrawn, terminated by adding nitrogen degassed methanol and the resulting polystyrene was analysed by GPC. The methanol was nitrogen degassed in order to remove  $\text{CO}_2$  which could cause coupling of polystyryllithium leading to higher molecular weight products and an inaccurate analysis.<sup>71</sup> The concentration of active ends in the polystyryllithium solution was calculated from the number average molecular weight ( $M_n$ ) of the quenched polystyrene sample. The living polystyrene was then capped with propylene oxide (slight excess). The above capping reaction is complete within 5 minutes and can be monitored by the replacement of the red colour associated with the

propagating polystyryl chain ends by an orange/yellow colour. Since the rate of reaction of lithium alkoxide with propylene oxide is much slower than that of polystyryllithium, the above procedure is expected to give polystyrylisopropyl alkoxide in which the product results almost exclusively from the addition of only one propylene oxide unit.<sup>83</sup> Also propylene oxide was chosen instead of ethylene oxide as described in some literature<sup>84,120</sup> because of its ease of purification and handling. This reaction was carried out in order to cap the strongly basic polystyryl anion. The resulting lithium 2-polystyrylisopropyl alkoxide is less reactive than polystyryllithium and this eliminates the possibility of side reactions resulting from polystyryl anion attack on the carbonyl function present in the final product *exo*-5-norbornene-2-(polystyrylcarboxylate) macromonomer.<sup>83,84,120</sup> Finally neat *exo*-5-norbornene-2-carbonyl chloride (slight excess) was added to the above solution under vigorous stirring. Again the reaction can be monitored by a colour change, in this case from an orange/yellow to a whitish colour. The mixture was stirred overnight. The product was then precipitated by adding to 10-fold excess of methanol, recovered by filtration and purified again by dissolving in THF or toluene and reprecipitating in methanol. The product was dried in a vacuum oven at 50°C for 3-days. In this way a series of macromonomers with different polystyrene block lengths were prepared.

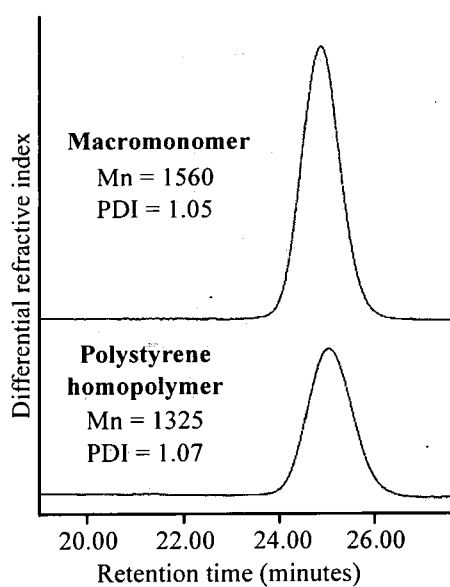
### 3.3 Characterisation of Macromonomers

All the macromonomers were characterised by gel permeation chromatography (GPC), <sup>1</sup>H nmr spectroscopy and infrared spectroscopy (IR). Table 3.1 gives the GPC analysis results for polystyrene homopolymers and final product macromonomers. The 'graft length' in table 3.1 means the approximate number of styrene units in the macromonomer. The GPC results indicates that these macromonomers have a very narrow molecular weight distribution (PDI).

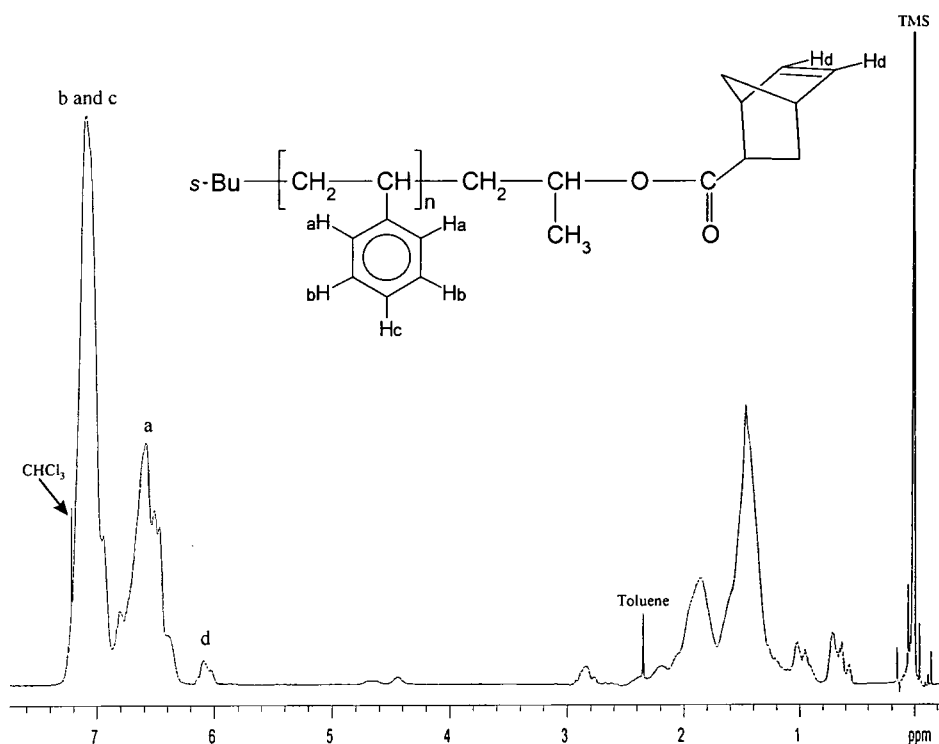
Sample	Polystyrene Homopolymer		Macromonomer		
	Mn	PDI	Mn	PDI	Graft Length <sup>†</sup>
1	1300	1.10	1460	1.08	12
2	1390	1.09	1600	1.08	13
6	1325	1.07	1560	1.05	13
11	-	-	1550	1.10	13
12	-	-	1650	1.12	14
3	2110	1.10	2250	1.05	20
4	2370	1.06	2590	1.05	22
13	-	-	2200	1.08	19
5	3400	1.04	3540	1.04	32
8	3270	1.10	3445	1.06	31
9	3385	1.07	3580	1.06	32
10	-	-	4740	1.08	44
14	4790	1.06	4930	1.08	46
7	-	-	10,170	1.13	96
15	-	-	13,230	1.08	127

<sup>†</sup> no. of styrene units

**Table 3.1** GPC analysis results of the macromonomers prepared



**Figure 3.5** A typical GPC trace of a macromonomer and polystyrene homopolymer

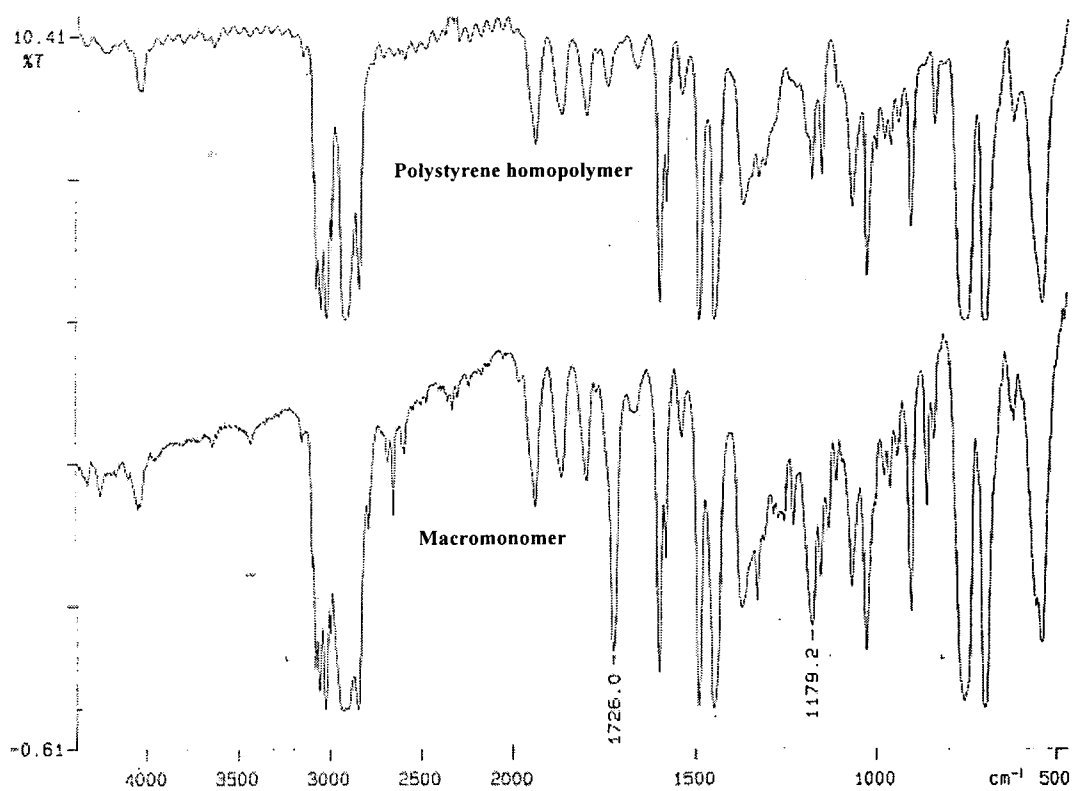


**Figure 3.6** A typical  $^1\text{H}$  nmr spectrum of a macromonomer ( $M_n = 2590$ )

The end capping reaction of living polystyrene was confirmed by nmr spectroscopy. The  $^1\text{H}$  nmr spectra of macromonomers are similar to those described in the literature<sup>83,120</sup> and show olefinic resonances around 6.0-6.2ppm due to norbornene which are resolved from the aromatic protons due to polystyrene (6.35-7.35ppm). From the  $^1\text{H}$  nmr of macromonomers it is possible to calculate the styrene:norbornene molar ratio by integration of the aromatic (6.35-7.35ppm) and olefinic (6.0-6.2ppm) proton resonances.<sup>83,120</sup> For low molecular weight macromonomers (upto about 3500), these values agree within experimental error with that calculated from GPC analysis as shown in the table 3.2. With higher molecular weight macromonomers ( $M_n > 4000$ ), the olefinic resonances in the  $^1\text{H}$  spectrum becomes less clearly observable (see Appendix A3-for  $^1\text{H}$  nmr spectra of all macromonomers) and thus similar calculations do not provide any useful information. Figure 3.7 shows infrared spectrum of a polystyrene homopolymer and a typical macromonomer. The IR spectra are generally very similar but those of the macromonomers exhibit ester  $\text{C}=\text{O}$  stretching at  $1726\text{ cm}^{-1}$  and ester  $\text{C}-\text{O}$  stretching at  $1179\text{ cm}^{-1}$  and agree with those of analogous materials described in the literature.<sup>83,120</sup>

Mn of Macromonomer (GPC)	Styrene:Norbornene Molar Ratio	
	GPC	NMR
1460	12.5:1	15.6:1
1600	13.9:1	14.8:1
1560	13.5:1	14.8:1
2250	20.1:1	21.4:1
2590	23.4:1	24.0:1
3540	32.5:1	31.3:1
3445	31.6:1	35.6:1
3580	33.0:1	27.9:1

**Table 3.2** Styrene:Norbornene molar ratio calculated from NMR and GPC methods for some low molecular weight macromonomers



**Figure 3.7** Typical IR spectra of a macromonomer and polystyrene homopolymer

### 3.4 EXPERIMENTAL

All chemicals were bought from Aldrich Chemical Co. Ltd. *Sec.*-butyllithium (1.3M) was used as received. Benzene, styrene and propylene oxide were purified as described below. *Exo*-5-norbornene-2-carbonyl chloride was synthesised as described earlier in chapter-2. The anionic polymerisation reaction was performed in a specially designed apparatus ("Christmas Tree," see figure 3.8) using a conventional high vacuum line. The capping reaction of living polystyrene was carried out in an inert atmosphere (dry nitrogen) filled glove box.

#### 3.4.1 Purification of Solvents and Reagents

##### a) Styrene

Styrene (325ml) was washed with 10% aqueous NaOH (3x125ml) and deionised water (3x125ml) in a separating funnel and dried over CaCl<sub>2</sub> overnight. After filtration it was distilled under nitrogen (66°C/45 mmHg). Distilled styrene (125ml) was placed in single-neck round bottom flasks (250ml) with a large oval shape P.T.F.E. coated stirrer bar and CaH<sub>2</sub> powder was added. This was connected to the vacuum line and degassed periodically by freeze-thawing over several days until the pressure of the frozen material was of the order of 10<sup>-4</sup> mmHg.

##### b) Benzene

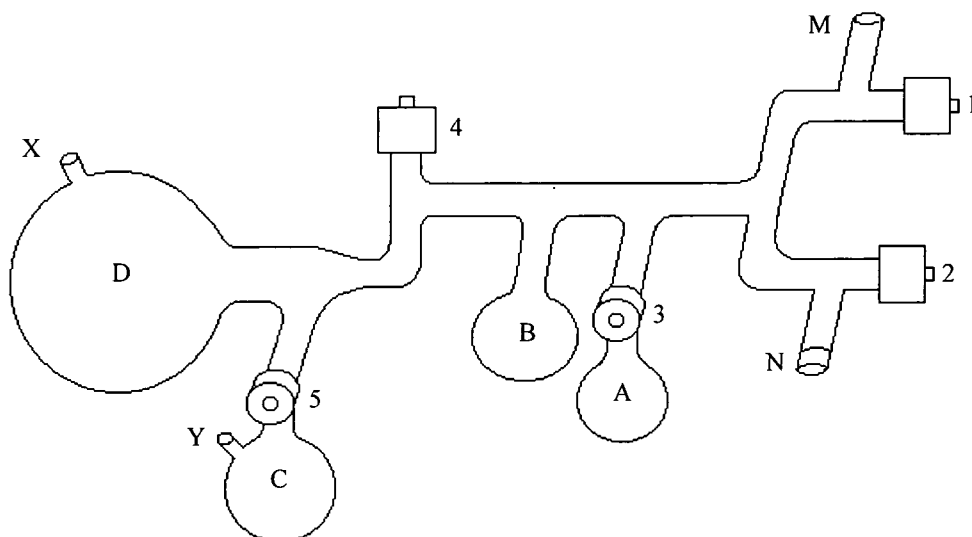
In a separating funnel benzene (400ml) was first washed with concentrated H<sub>2</sub>SO<sub>4</sub> (3x50ml) followed by deionised water (2x50-100ml), saturated NaHCO<sub>3</sub> solution (50ml) and again with deionised water (100ml). This was then azeotropically distilled in order to remove bulk of the water. Finally this was distilled under atmospheric pressure, placed in a single-neck round bottom flask (500ml) containing a large oval shaped P.T.F.E. coated stirrer bar and connected to the vacuum line with CaH<sub>2</sub> as the drying agent and degassed periodically by freeze-thawing over several days until the pressure of the frozen material was of the order of 10<sup>-4</sup> mmHg.

##### c) Propylene Oxide

Propylene oxide was degassed and stirred over CaH<sub>2</sub> overnight and distilled under vacuum into an ampule and handled in the glove box.

### 3.4.2 Preparation of the Anionic Polymerisation Apparatus

Anionic polymerisation reactions were carried out in a specially designed apparatus ("Christmas Tree") shown below. Anionic polymerisation reactions are moisture and air sensitive and require rigorous purification to remove all impurities. Therefore before each polymerisation the apparatus was cleaned as described below.



**Figure 3.8** Schematic view of the anionic polymerisation apparatus

- **Flask-A:** Holds the living polystyrene 'wash' solution to clean the entire apparatus.
- **Flask-B:** Benzene is distilled out from living polystyrene solution in flask 'A' into this.
- **Flask-C:** (also called 'side-arm C') Used to withdraw living polymer samples for analysis. A small amount of living polymer solution is placed in this flask and terminated by injecting methanol through the opening marked 'Y'.
- **Flask-D:** Main reaction flask where polymerisation is carried out. Initiator is injected into the flask through the opening marked 'X'.
- **M:** Greaseless 'O' ring ball joint. Connects to vacuum line for degassing the apparatus and vacuum transfer of benzene.
- **N:** High vacuum sliding joint. The ampule containing styrene is connected through this and vacuum transferred into 'D'.
- **1-5:** Youngs taps (interchangeable P.T.F.E. 'O' ring taps). The purpose of the Youngs tap (4) is to isolate the contents of flask 'D' from the rest of the apparatus

during polymerisation or when the rest of the apparatus needs to be degassed, for example before vacuum transferring styrene into flask 'D' as described above via 'N'.

- **X and Y:** Small opening (closed with Suba seal/8 mm o.d.) used to inject initiator solution, capping reagent etc.

A living polystyrene wash solution was prepared using styrene (0.5g in 10ml of benzene) and *sec*-butyllithium as initiator in the same way as described below (section 3.4.3), except the living polystyrene was not terminated/capped. This is then stored in the side arm flask 'A' for regular cleaning purposes before polymerisation.

After each polymerisation reaction, the apparatus was washed with toluene (x2), methanol (x2) and acetone. The apparatus was then connected to the water pump through the opening 'X' (while 'Y' is closed with a Suba-seal) and by slowly opening and closing Youngs taps '1' and '2' traces of acetone were removed from the apparatus. Then the opening 'X' was also closed with a Suba-seal and the whole apparatus was degassed overnight under high vacuum. The entire apparatus was then gently warmed using a hot air gun while it is still connected to the vacuum pump in order to remove traces of moisture. After allowing it to cool down, the apparatus was disconnected from the vacuum line while it is under vacuum and washed with living polystyrene wash solution in the following manner.

The living polystyrene wash solution in flask 'A' was released into rest of the apparatus and the entire apparatus was washed. The wash solution was then placed back in flask 'A'. A small amount of benzene was then distilled out of wash solution into flask 'B' by gently warming flask 'A' and cooling flask 'B'. Flask 'A' was then closed and the entire apparatus was washed with benzene. The benzene solution was then placed back in flask 'A' and the process was repeated (x6) until all traces of living polystyrene has been removed (when the colour of benzene solution remains unchanged/colourless after washing the entire apparatus). Final traces of benzene solution were placed back in flask 'A' by cooling flask 'A' in liquid air and gently warming the rest of the apparatus with a hot air gun. The apparatus was then connected to the vacuum line and degassed for 15 minutes. While the apparatus is

under vacuum, flask 'C' was closed since this is used only to withdraw polymer samples.

### 3.4.3 Anionic Polymerisation of Styrene and Macromonomer Synthesis

A typical synthesis is described below. Styrene (12.72g, 122.13mmol) was first distilled from  $\text{CaH}_2$  under vacuum into a pre-weighed ampule. According to the amount of styrene to be used, benzene (86g) was distilled under vacuum from  $\text{CaH}_2$  directly into the reaction flask ('D'). Styrene was then vacuum transferred from the ampule into the reaction flask ('D'). Soon after the mixture has thawed, *sec*-butyllithium (2.57ml, 3.34mmol) was injected into the reaction flask through the Suba-seal ('X') using a gas-tight syringe. Upon the addition of the initiator, the colour of the reaction mixture changes instantaneously to orange/red. The mixture was shaken thoroughly and placed in an ice-bath for about an hour.

A small amount of living polystyrene (2ml) was then placed in the side arm ('C') and capped with methanol and precipitated from methanol to obtain a sample of polystyrene homopolymer.

The remaining living polystyrene was transferred into a 250ml round bottom flask and propylene oxide (0.77g, 13.25mmol, in excess) was added with vigorous stirring. After stirring for about an hour, *exo*-5-norbornene-2-carbonyl chloride (0.88g, 5.62 mmol, 1.5 equivalents) was added and the mixture was stirred overnight. The product was precipitated by adding to methanol (10-fold excess) and reprecipitated from toluene into methanol. The resulting product was finally dried in a vacuum oven at 50°C for 3-days to give macromonomer as a pure white powder (12.08g,  $M_n=3540$ , PDI=1.04).

**CHAPTER-4**  
**RING OPENING METATHESIS POLYMERISATION OF**  
**MACROMONOMERS AND CHARACTERISATION OF**  
**POLYMERS**

## 4.1 INTRODUCTION

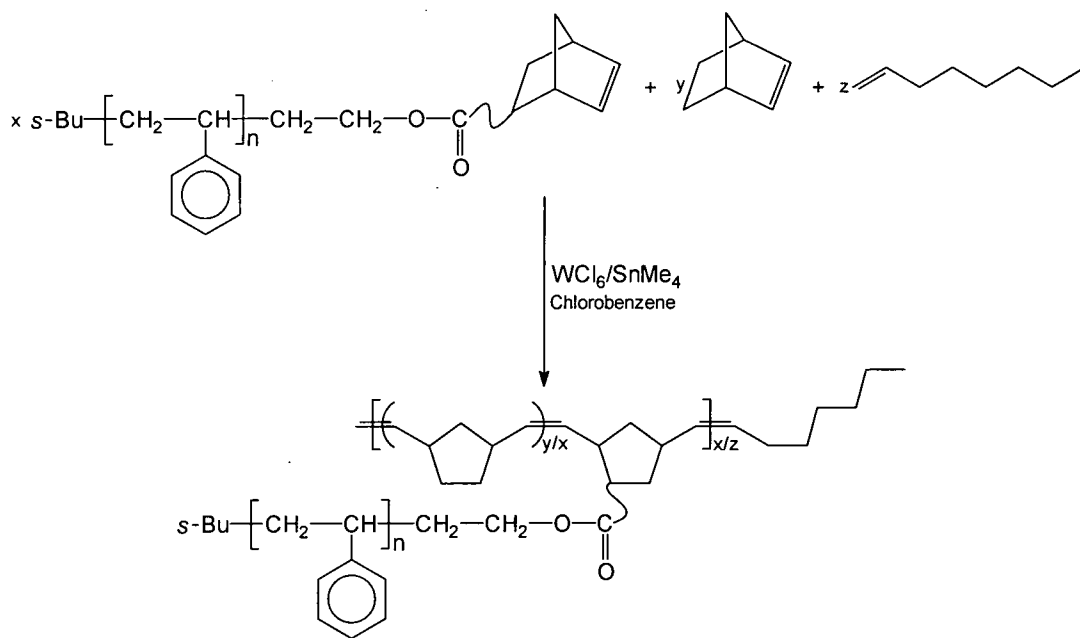
In this chapter, the synthesis of graft copolymers by ring opening metathesis polymerisation of macromonomers is described along with their characterisation. The *exo*-5-norbornene-2-(polystyrylcarboxylate) macromonomers prepared by living anionic polymerisation were ring opened polymerised using well-defined Schrock molybdenum initiators. The well-defined graft copolymers thus produced consisted of a polynorbornene backbone chain carrying a single polystyrene graft in each cyclopentane ring.

## 4.2 Graft Copolymer Synthesis

As discussed earlier in chapter-1, graft copolymers can be prepared by 'grafting onto', 'grafting from' and macromonomer method. However, the macromonomer method of synthesising graft copolymers provides greater control over the main chain and side chain molecular weights and the graft density.<sup>77,80,84</sup> Generally, macromonomer method of graft copolymer synthesis involves homopolymerisation or copolymerisation of macromonomers by free radical polymerisation. Although the free radical method tolerates various functional groups, it is not suitable for the synthesis of well-defined graft copolymers. This can only be achieved by employing living polymerisation techniques at both stages; *i.e.* to synthesise macromonomers and to polymerise the macromonomers to produce graft copolymers. In this way, control over side chain and the backbone chain can be achieved. Therefore the work described here involves living ring opening metathesis polymerisation of well-defined macromonomers synthesised by living anionic polymerisation to produce graft copolymers.

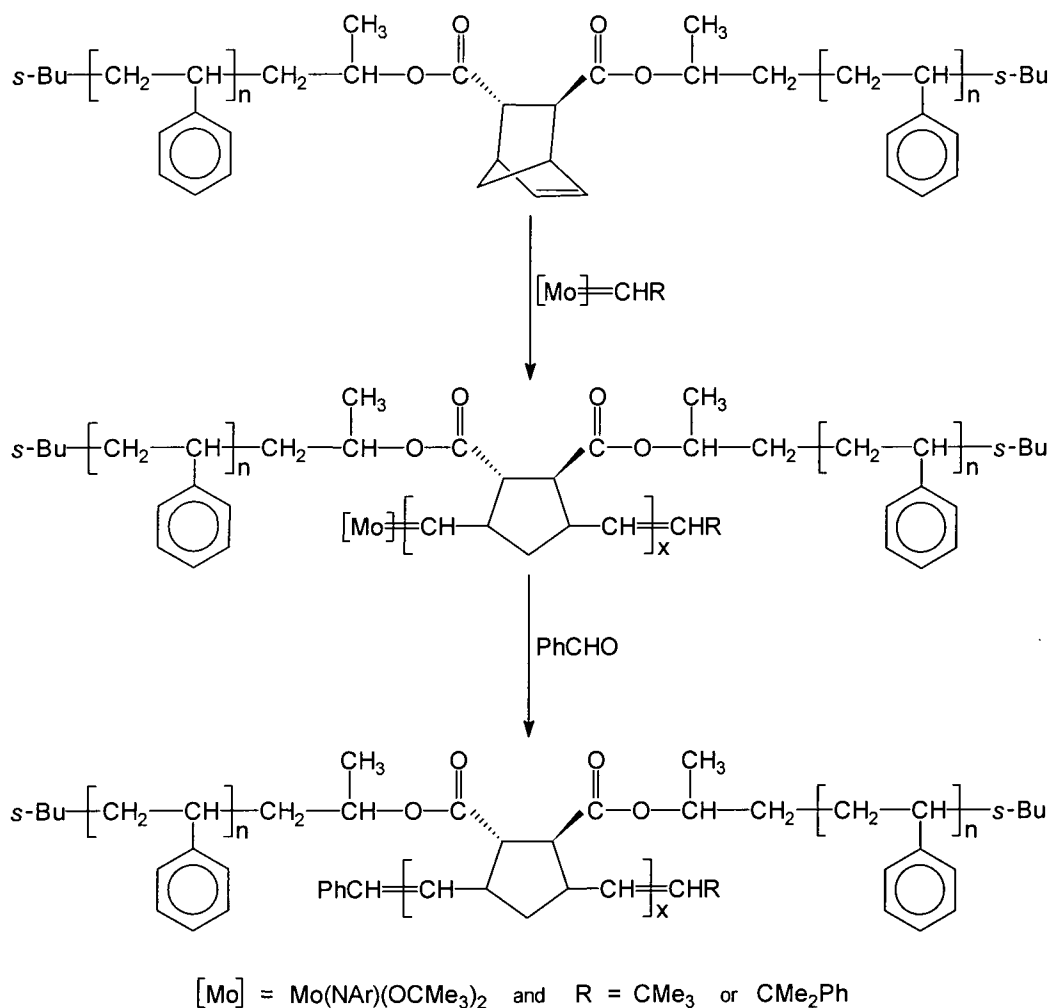
The earliest work on the coupled anionic and ring opening metathesis polymerisation to produce graft copolymers was reported by Norton and McCarthy.<sup>120</sup> They ring opened copolymerised a mixture of *exo/endo*-5-norbornene-2-(polystyrylcarboxylate) macromonomers synthesised by living anionic polymerisation, norbornene and oct-1-ene to produce graft copolymers (figure 4.1). However, they employed a classical ring opening metathesis initiator  $WCl_6/SnMe_4$ , for the polymerisation process. The graft copolymers prepared were relatively ill-defined and the yield of the polymerisation process was very low. The acyclic olefin, oct-1-ene, was present as a chain transfer

agent to limit the molecular weight of the products so as to have processable materials; simple polynorbornenes are relatively easily cross-linked and high molecular weight materials tend to become insoluble through cross-linking during storage and/or manipulation.



**Figure 4.1** Reaction scheme of poly(norbornene-*g*-styrene) graft copolymer synthesised by Norton and McCarthy

However, it was Feast and co-workers who used for the first time well-defined metathesis initiators to synthesise graft copolymers *via* macromonomer method.<sup>83,124</sup> They ring opened polymerised 5-norbornene-2,3-trans-bis(polystyrylcarboxylate) macromonomers having molecular weights in the range of 1200-5000 (*i.e.* 6-25 styrene units in each polystyrene graft) using well-defined molybdenum Schrock initiators. They used  $\text{Mo}(\text{CHR})(\text{NAr})(\text{OR}')_2$ , where R is  $\text{CMe}_3$  or  $\text{CMe}_2\text{Ph}$ , Ar is 2,6-diisopropylphenyl and R' is  $\text{CMe}_3$  as the initiator. The reaction scheme is shown in figure 4.2. They synthesised a range of graft copolymers by varying the macromonomer to initiator molar ratio. The graft copolymers produced had relatively narrow molecular weight distribution according to GPC analysis.



**Figure 4.2** Reaction scheme of the graft copolymer synthesised by Feast and co-workers

However, when they increased the macromonomer to initiator molar ratio beyond a certain limit, they observed that the polymerisation stops before complete consumption of macromonomers.<sup>83,124</sup> In this case the GPC trace shows two peaks; one due to product graft copolymer and the other due to unreacted macromonomer. Similarly, as they increased the polystyrene graft length, the threshold value of macromonomer to initiator molar ratio at which polymerisation stops before complete consumption of macromonomers gradually drops. The results are summarised in table 4.1. For example, polymerisation of the macromonomer with 6 styrene units in each polystyrene graft goes to completion up to a macromonomer to initiator molar ratio of about 26 and stops at 30 equivalents before complete consumption of macromonomers. On the other hand with 10 and 14 styrene units in each polystyrene

graft, the polymerisation goes to completion only up to about 16 and 9 equivalents respectively giving rise to graft copolymers with shorter polynorbornene backbones. With 25 styrene units in each polystyrene graft, the polymerisation does not go to completion even at 5 equivalents. This indicates that as the polystyrene graft length increases, the polynorbornene backbone chain length decreases. Since these limits are independent of the duration of reaction and the chain ends remain living (see below), they attributed this phenomenon to steric hindrance at the growing chain end.

Mn of Macromonomer	Graft Length <sup>†</sup>	[M]/[I] Ratio <sup>‡</sup>	No. of Peaks in GPC
1200	6	10	1
		26	1
		30	2
1600	8	10	1
		13	1
		15	1
		20	1
		25	2
2100	10	7	1
		16	1
		20	2
2800	14	9	1
		10	2
		12	2
5000	25	5	2
		11	2

<sup>†</sup> No. of styrene units

<sup>‡</sup> Macromonomer to initiator molar ratio

**Table 4.1** GPC analysis results for graft copolymers prepared from di-substituted macromonomers by Feast and co-workers

They demonstrated the living nature of these polymerisations by adding a comonomer to the polymerisation mixture which had been shown to have gone to completion according to GPC analysis (*i.e.* only one peak is observed in the GPC trace indicating

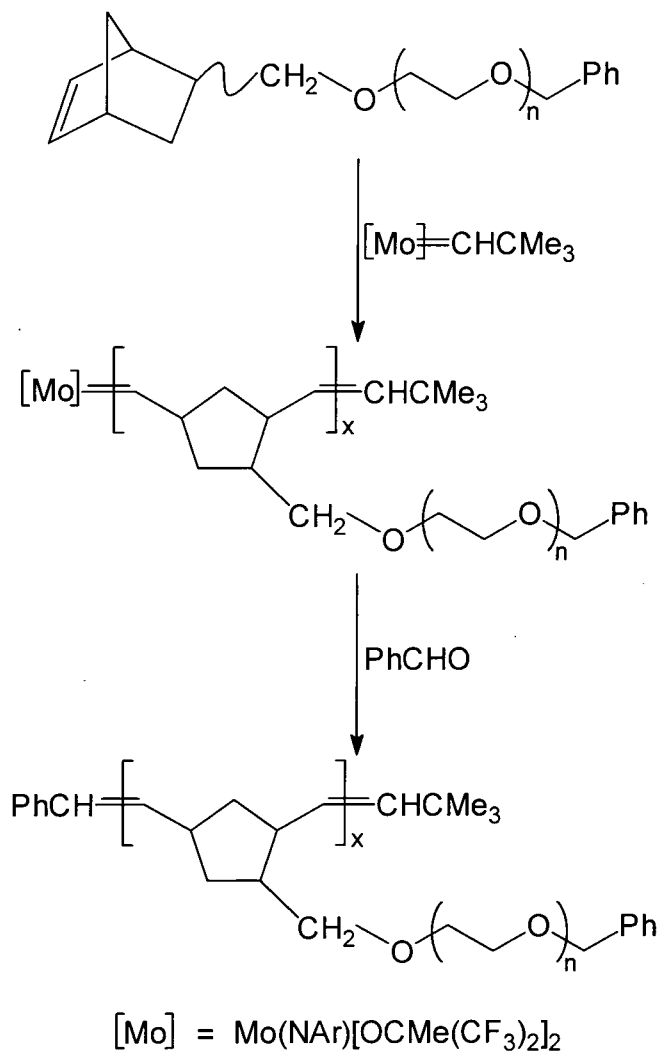
that all the macromonomer has reacted) and following the course of the polymerisation reaction by  $^1\text{H}$  nmr. When they added the comonomer, bis(trifluoromethyl)norbornadiene to the polymerisation mixture after all the macromonomer has been consumed, a new propagating alkylidene signal characteristic of poly[bis(trifluoromethyl)norbornadiene] appeared, confirming the living nature of these polymerisations. This also indicates that tapered and block copolymers can be prepared.

Similarly, when they added bis(trifluoromethyl)norbornadiene to the polymerisation mixture that was shown to exhibit two peaks in the GPC, due to product graft copolymer and unreacted macromonomer, the macromonomer peak disappears. This indicates that incorporation of a small, less sterically hindered monomer in the chain eliminates the steric hindrance effects and then the unreacted macromonomer in the mixture participates in further polymerisation. This further confirms that the polymerisation of macromonomers beyond a certain macromonomer to initiator molar ratio stops before complete consumption of macromonomers as a consequence of steric hindrance and not as a result of the deactivation of the initiator.

Similar work has also been reported by Fontanille *et al.*<sup>121-123</sup> They used  $\text{Mo}(\text{NAr})[\text{OCMe}(\text{CF}_3)_2]_2(\text{CH-t-Bu})$  initiator to ring open polymerise *exo/endo*-5-norbornene-2-(polystyrylcarboxylate) macromonomers having molecular weights 2700, 4800 and 11,000, up to a macromonomer to initiator molar ratio of 100. The graft copolymers produced had relatively narrow polydispersity. In the case of the macromonomers having molecular weights 4800 and 11,000, they observed 2-5% unreacted material in the GPC traces of the graft copolymers with the same retention time as macromonomers. They attributed this to unfunctionalised polystyrene homopolymers.

Fontanille *et al.* also ring opened polymerised *exo/endo*-5-norbornene-2-(polyethylene oxide) macromonomers having molecular weights 1500, 2800 and 4700 (figure 4.3). Initially they used  $\text{Mo}(\text{NAr})(\text{OCMe}_3)_2(\text{CH-t-Bu})$  as initiator. However the yields were very low and they attributed this to very low reactivity of the initiator. In contrast,  $\text{Mo}(\text{NAr})[\text{OCMe}(\text{CF}_3)_2]_2(\text{CH-t-Bu})$  initiator polymerised the macromonomers having molecular weights of 1500 and 2800 in toluene to complete conversions at 20 and 25 macromonomer to initiator molar ratios respectively. Although the graft copolymers

produced showed narrow polydispersity, they reported that the molecular weights obtained using a laser light scattering detector connected to the outlet of the GPC were well above the target molecular weights based upon macromonomer to initiator molar ratios.

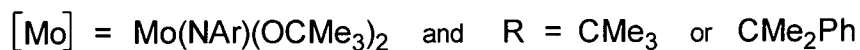
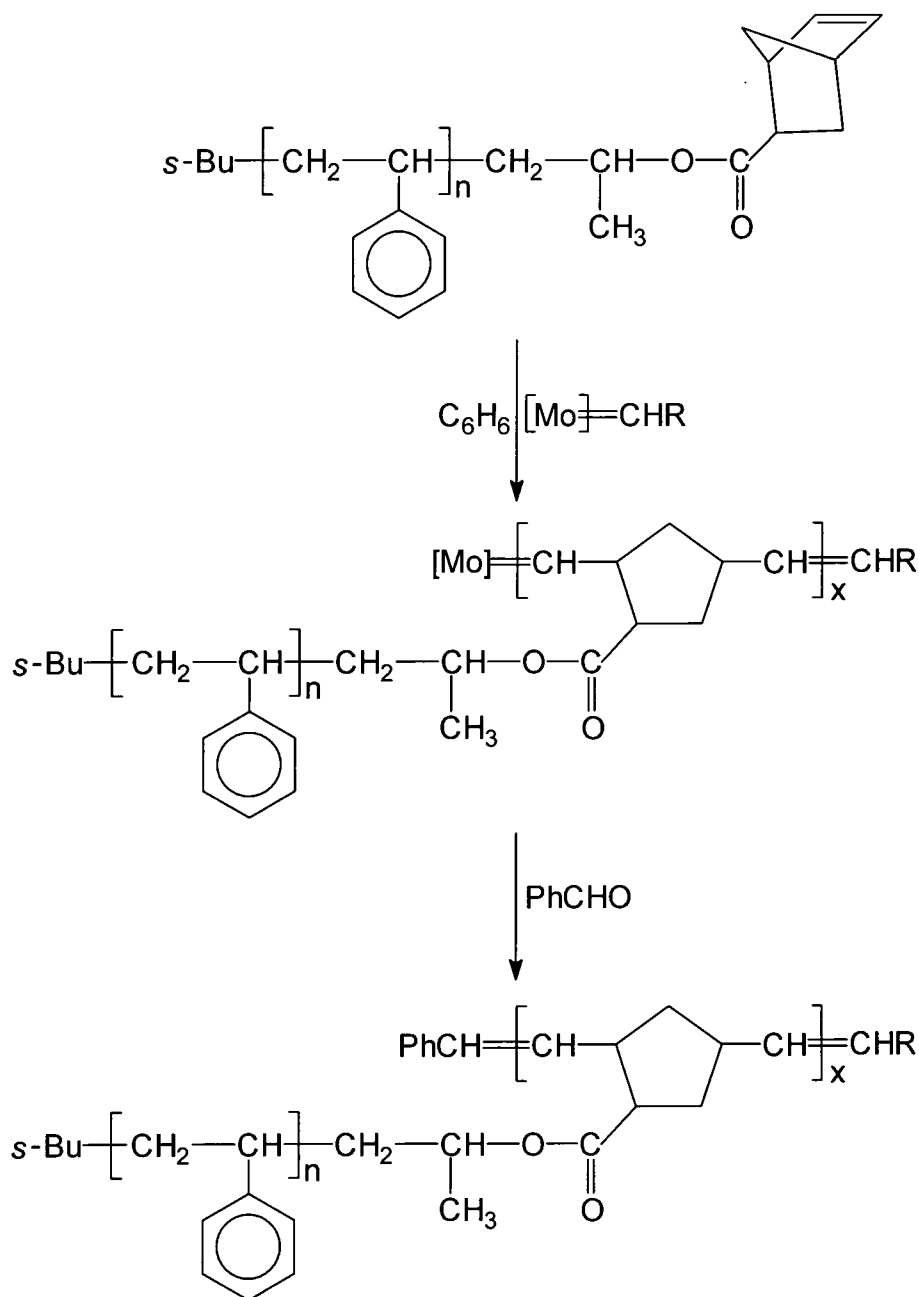


**Figure 4.3** Reaction scheme of poly(norbornene-*g*-ethylene oxide) graft copolymer synthesised by Fontanille *et al.*

They suggested that since both electron-rich oxygen atoms and carbon-carbon double bonds of the macromonomer compete for co-ordination to the transition metal carbene, a large amount of the initiator may become entrapped within polyethylene oxide chains and so would not be available for the co-ordination to the macromonomer olefinic unsaturation. This leads to rather low efficiency of the initiator when it is used to polymerise polyethylene oxide macromonomers. When

they polymerised the macromonomer,  $M_n=4800$ , in toluene, the polymerisation did not proceed beyond 30% conversion. With very high molecular weight macromonomers, *i.e.*  $M_n=11,000$ , no polymerisation was observed at all. However, when the solvent was changed to 1,2-diethoxyethane (which is similar to polyethylene oxide chains), the polymerisation of macromonomer,  $M_n=4800$ , proceeded to almost complete conversion (90%). They suggested that this is because the use of a solvent that is a stronger base than the repeating units of polyethylene oxide prevents the coordination to the metal by the oxygen atoms of the polyethylene oxide chains and allows the polymerisation to proceed to completion.

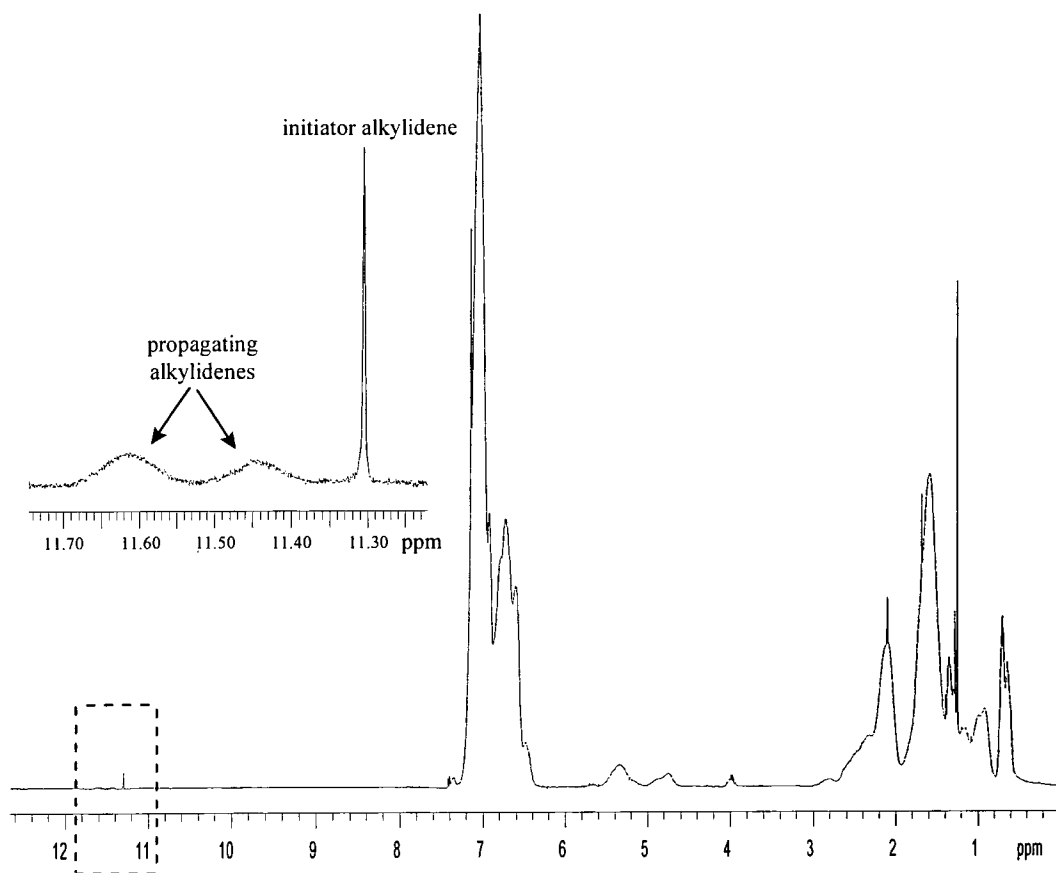
The work described here is a continuation of the work carried out by Feast and co-workers and involves synthesising graft copolymers having a polynorbornene backbone chain carrying one polystyrene graft in each cyclopentane ring. Since there is only one graft unit attached to norbornene, it is expected to lower the steric hindrance to formation of graft copolymers with longer grafts and backbone chains. Also the work involves systematically increasing the macromonomer to initiator molar ratio for a range of macromonomers having molecular weights between 1400 and 13,200 (*i.e.* from 12 to 127 styrene units in the polystyrene graft), in order to study the steric hindrance effect at the growing chain end. For this purpose  $\text{Mo}(\text{NAr})(\text{OCMe}_3)_2(\text{CHR})$  initiator, where R is  $\text{CMe}_3$  or  $\text{CMe}_2\text{Ph}$ , was used to ring open polymerise pure *exo*-5-norbornene-2-(polystyrylcarboxylate) macromonomers. The reaction scheme is given in figure 4.4. Initially the ring opening metathesis reactions were investigated on an nmr tube scale and later scaled up to obtain sufficient polymeric material for characterisation.



**Figure 4.4** Reaction scheme for the synthesis of graft copolymers

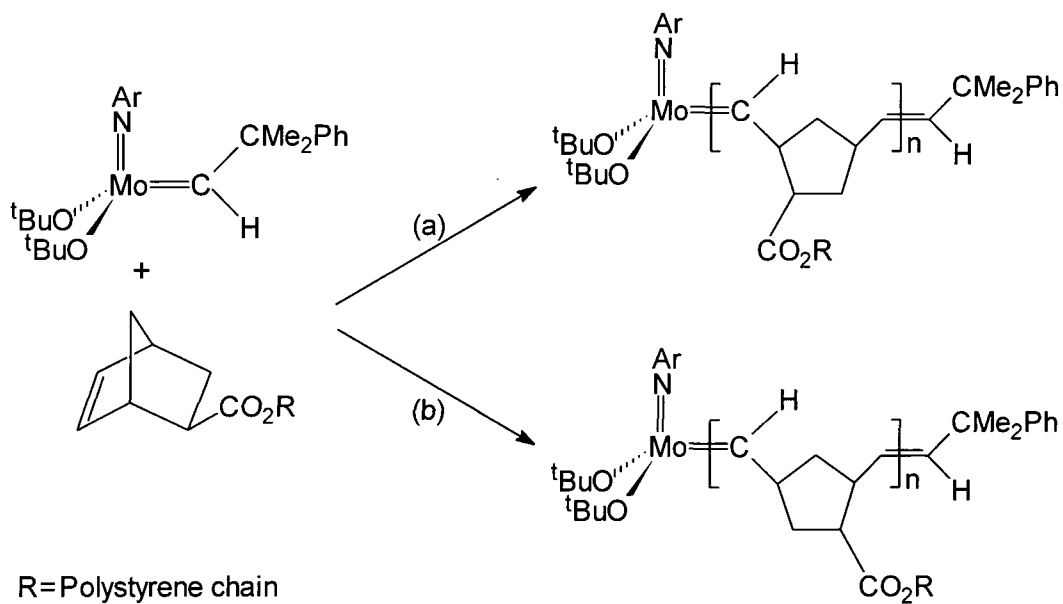
#### 4.2.1 NMR Tube Scale Polymerisation

In a typical nmr scale polymerisation, macromonomer (10-equivalents) was dissolved in benzene- $d_6$  (600 $\mu\text{l}$ ) and added to a stirred solution of initiator (~10mg) in the same solvent (400 $\mu\text{l}$ ). The polymerisation mixture was then transferred into a screw cap nmr tube and  $^1\text{H}$  nmr spectra were recorded at various times after mixing and analysed in order to understand the process.

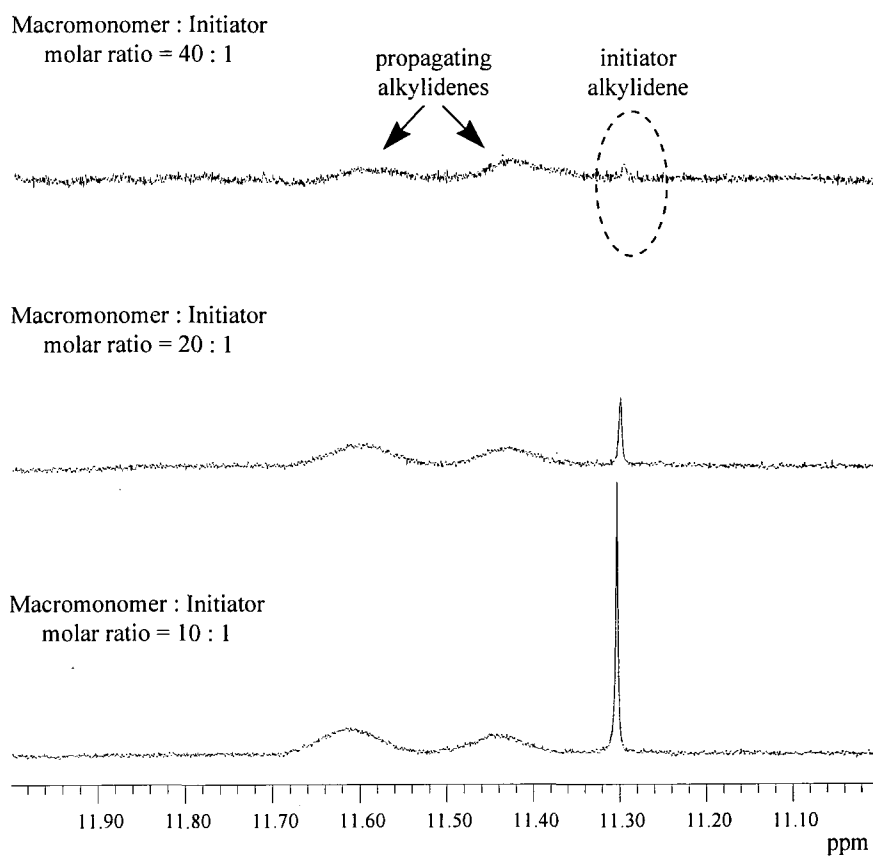


**Figure 4.5** A typical  $^1\text{H}$  nmr spectrum of an nmr scale polymerisation after adding 10 equivalents of macromonomer ( $M_n=1460$ )

The  $^1\text{H}$  nmr spectrum shows two broad unresolved signals at 11.44 and 11.62 ppm characteristic of the propagating alkylidenes (figure 4.5). These signals could be due to head or tail insertion of macromonomer to the active site [(a) and (b) in figure 4.6] leading to head-tail, tail-tail or head-head placements of repeat units in the polymer chain. The broad unresolved nature of these nmr signals could be due to complexity of the slightly differing environments of the nuclei. Also another signal was observed at 11.31 ppm characteristic of initiator alkylidene. On further addition of macromonomer to the polymerisation mixture, the intensity of this peak gradually diminishes (figure 4.7). This indicates that the rate of propagation for this system is faster than the rate of initiation. This also agrees with the literature findings that, for norbornenes and mono-substituted norbornenes the rate of propagation is faster than the rate of initiation.<sup>23</sup>



**Figure 4.6** Head (a) and tail (b) insertion of macromonomers at the active site in living ring opening metathesis polymerisation



**Figure 4.7** Alkydene regions of the  $^1\text{H}$  nmr spectrum of an nmr scale polymerisation at different macromonomer ( $M_n=1460$ ) to initiator molar ratio

Finally the living polymerisation mixture was capped with benzaldehyde and the resulting graft copolymer was analysed by GPC. The GPC results (table 4.2) revealed a relatively narrow polydispersity for these graft copolymers even though the rate of propagation was faster than the rate of initiation.

Sample	Macromonomer				Graft Copolymer	
	Mn	PDI	Graft Length <sup>†</sup>	[M]/[I] Ratio <sup>‡</sup>	Mn	PDI
1-9	1460	1.08	12	10	14,950	1.10
1-4				40	24,870	1.39
3-6	2250	1.05	20	10	19,330	1.09
3-3				30	38,045	1.17
5-4	3540	1.04	32	10	26,060	1.09

<sup>†</sup> no. of styrene units

<sup>‡</sup> macromonomer to initiator molar ratio

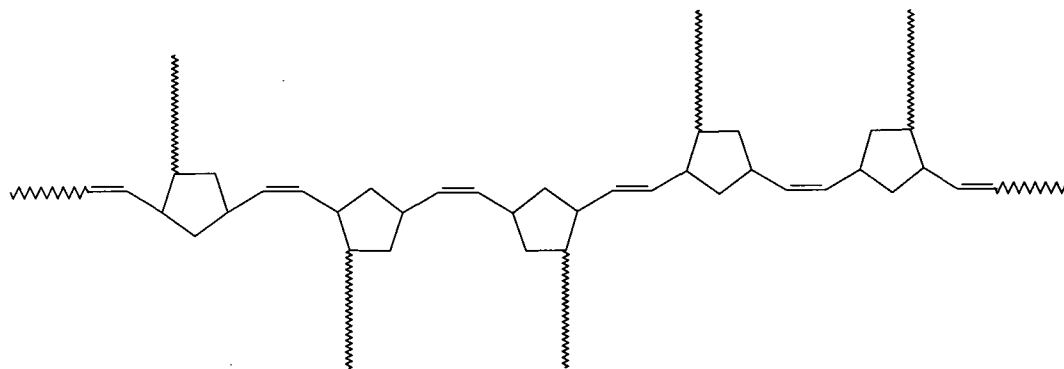
**Table 4.2** GPC analysis results for nmr scale polymerisation reactions

#### 4.2.2 Preparative Scale Polymerisation

In a typical preparative scale polymerisation, macromonomer (1-3g) was dissolved in benzene (5-10ml) and added in 3-5 equal portions at 15-20 minutes intervals to a stirred solution of initiator (10-30mg) in the same solvent (1-2ml) at room temperature. After stirring for about 4 hours the reactions were terminated by adding an excess of benzaldehyde. The polymerisation mixture was stirred for further 30 minutes and precipitated by pouring the mixture into an excess of methanol. The polymer precipitates as a white powder. The polymer was recovered by filtration, washed several times with excess of methanol and dried in a vacuum oven at 50°C. These polymeric samples were further purified by reprecipitating from THF into methanol and finally drying under vacuum at 50°C for 3-days. In this way polymerisations were carried out with macromonomers of Mn 1500, 2250, 3500, 10,200 and 13,200. In some cases, in order to get larger quantities of polymeric material, the polymerisations were carried out on a 20-30g scale.

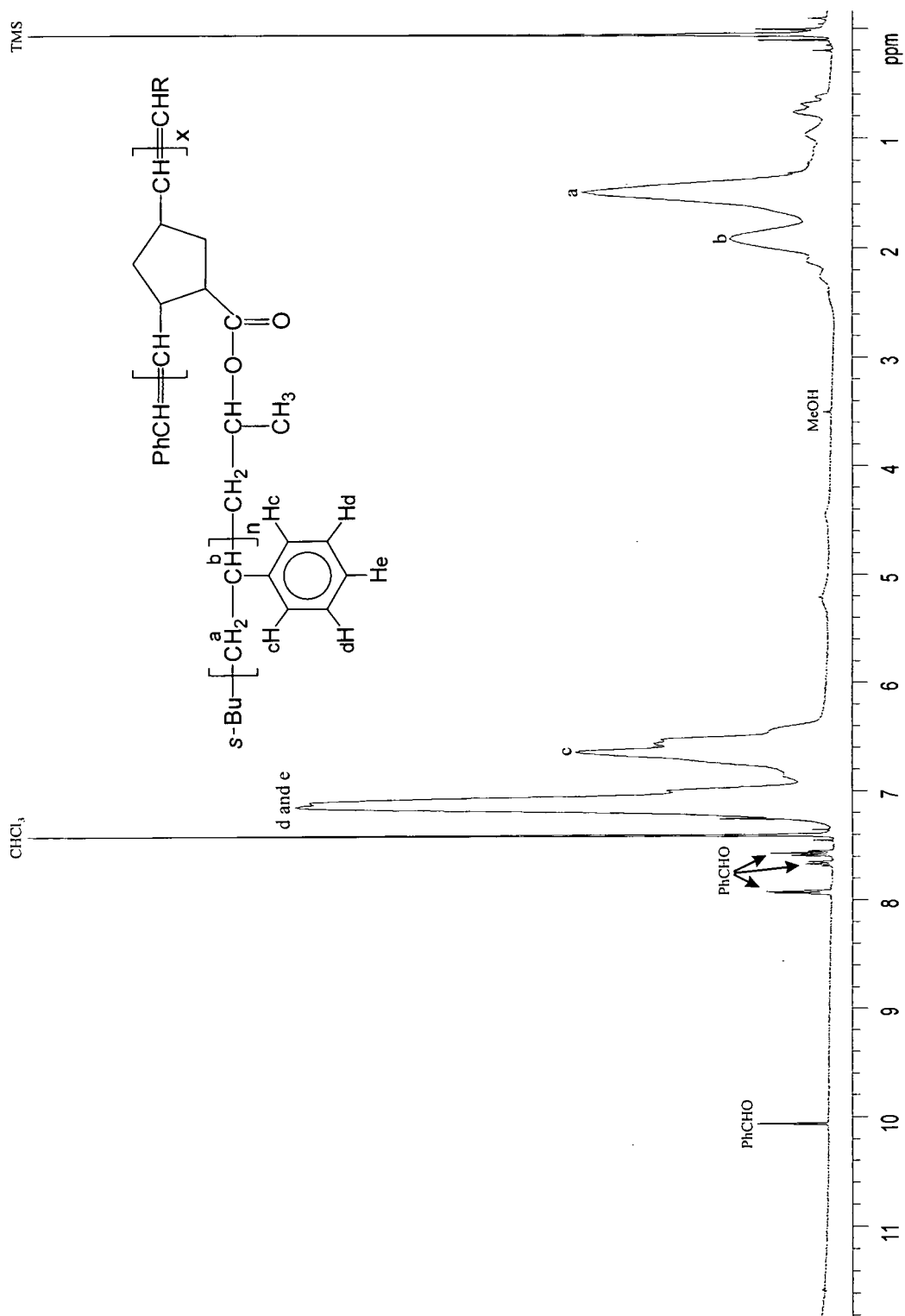
### 4.3 Characterisation of Graft Copolymers

All graft copolymers were characterised by gel permeation chromatography (GPC), differential scanning calorimetry (DSC) and thermogravimetric analysis (TGA).

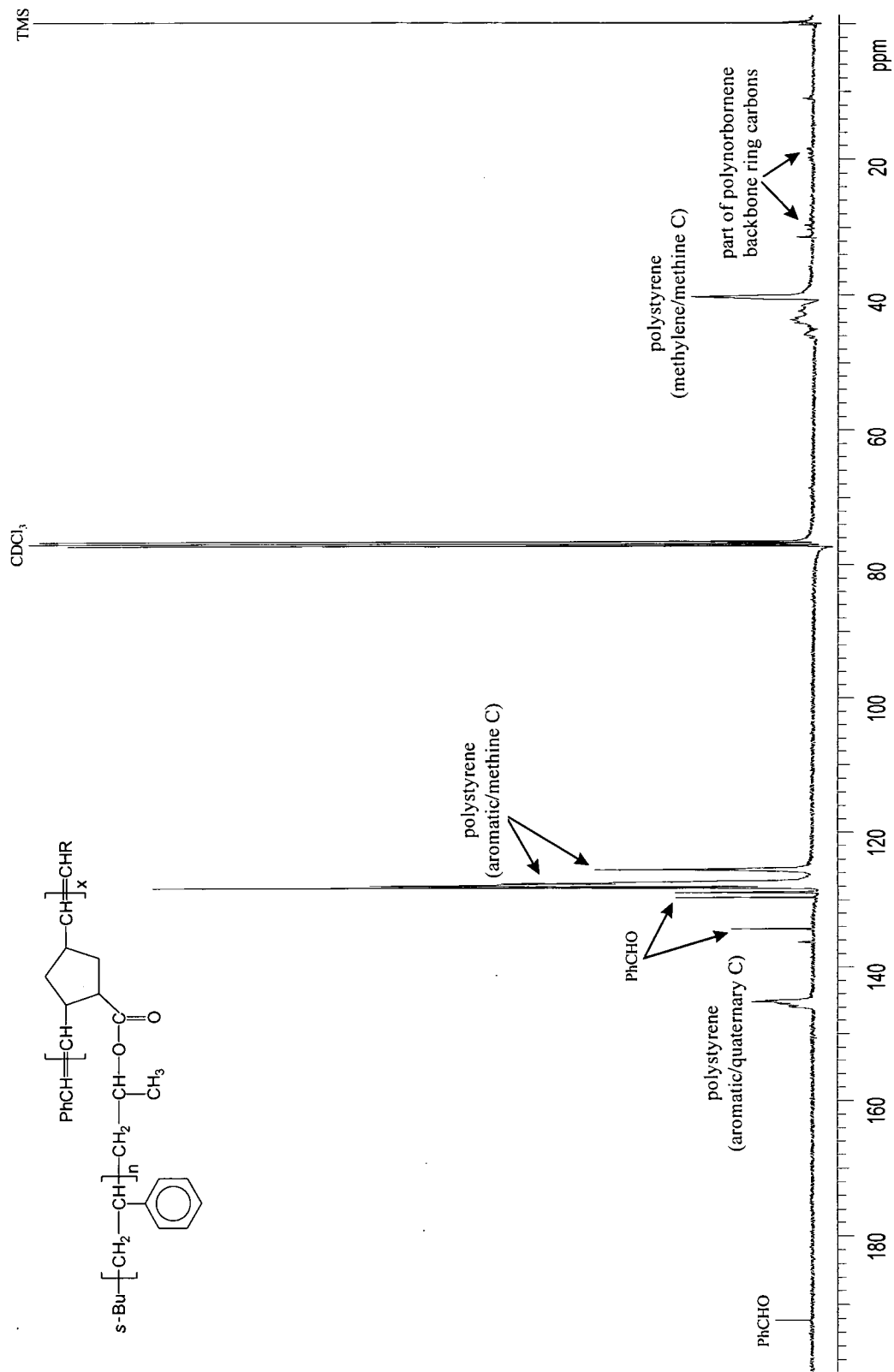


**Figure 4.8** Diagrammatic representation of the polymer microstructure

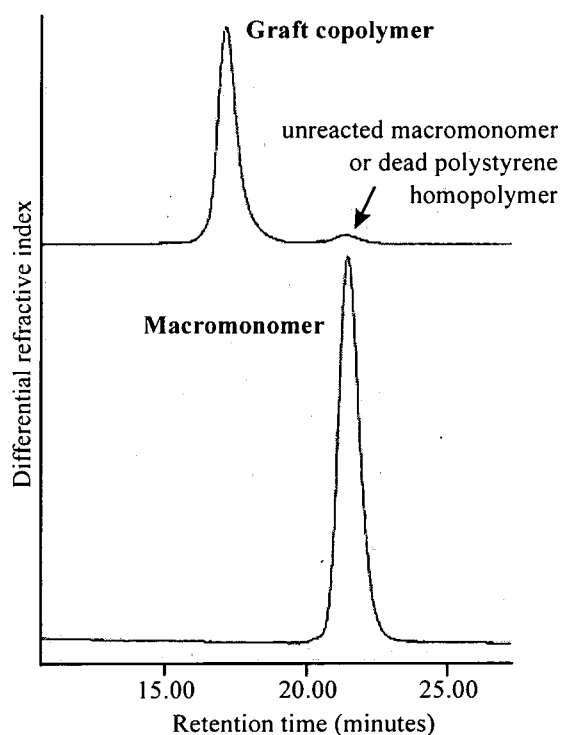
The polymer microstructure is represented diagrammatically in figure 4.8. Since *exo*-5-norbornene-2-carbonyl chloride was used to synthesise the macromonomer, the polystyrene chain in the macromonomer and in the graft copolymer have the same 'exo' configuration. However, the possibility of head-tail additions, *cis* and *trans* vinylene units and *meso* or *racemic* dyads means considerable microstructural variety is possible. Also the presence of polystyrene grafts further complicates the  $^1\text{H}$  and  $^{13}\text{C}$  nmr spectra. Therefore due to the complexity of these spectra, it was not possible to interpret them in terms of microstructural detail, as is often possible for polymers produced by ring opening metathesis polymerisation. A typical set of  $^1\text{H}$  and  $^{13}\text{C}$  nmr spectra of graft copolymers is shown in figure 4.9 and 4.10. The signals observed in both  $^1\text{H}$  and  $^{13}\text{C}$  nmr spectra of these graft copolymers are primarily due to polystyrene chains. In the  $^{13}\text{C}$  nmr spectrum polynorbornene ring carbons are expected to appear around 30-50ppm and some of these signals seems to overlap with that from polystyrene methylene and methine carbons and the rest can not be observed clearly and are difficult to assign with certainty. The vinylic carbons of the backbone chain are expected around 130-140ppm, but can not be seen clearly in the spectrum.



**Figure 4.9** A typical  $^1\text{H}$  nmr spectrum of a graft copolymer (sample 5-7 in table 4.4)



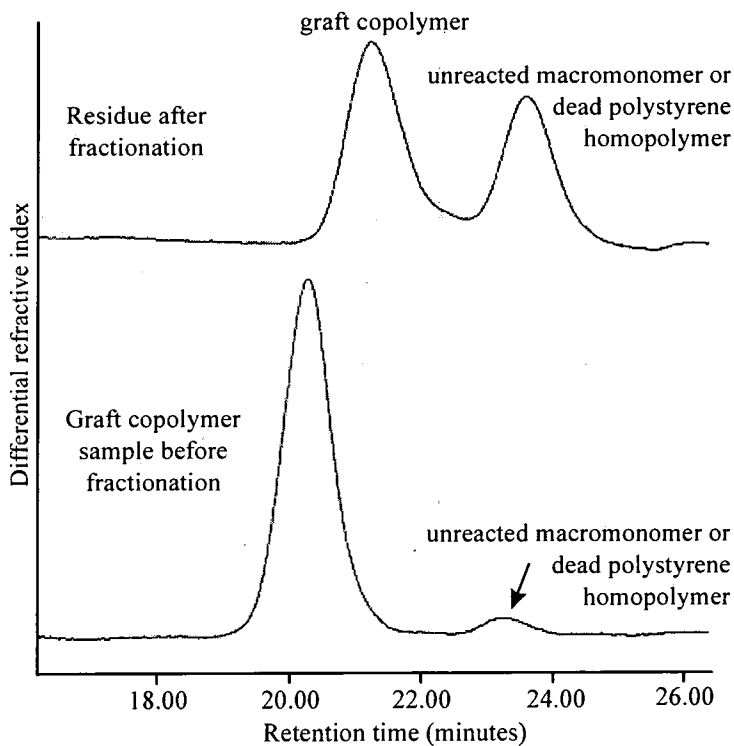
**Figure 4.10** A typical  $^{13}\text{C}$  nmr spectrum of a graft copolymer (sample 5-7 in table 4.4)



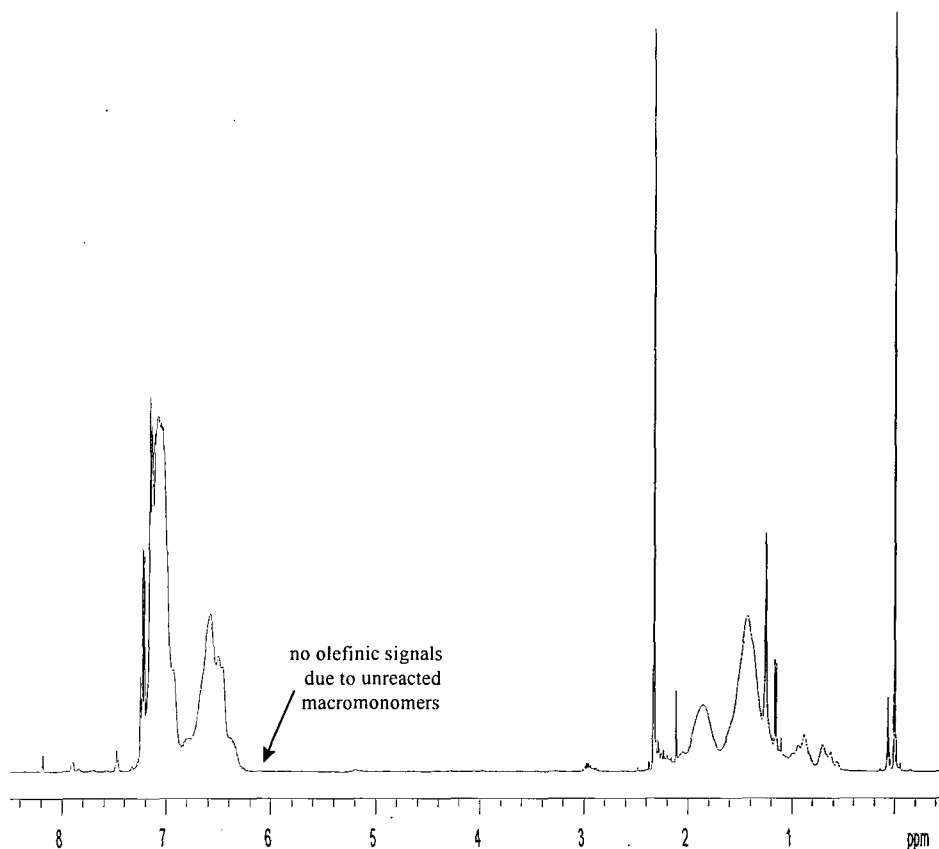
**Figure 4.11** A typical GPC trace of a graft copolymer and the corresponding macromonomer (sample 9-1 in table 4.4)

Typical GPC records for a graft copolymer and a macromonomer are shown in figure 4.11. Analysis of the GPC results for all these graft copolymers indicates a narrow polydispersity. However, all GPC traces showed a small peak at the same retention volume as that of the starting macromonomers. Since the proportion of this unreacted material is very small, it was difficult to identify by analysis of the olefinic signals in the  $^1\text{H}$  nmr spectrum of the graft copolymer product, if this minor component was due to unreacted macromonomer the olefinic signals should be resolved from the aromatic hydrogens and polymer chain vinylenes. Therefore, in order to find out whether this small peak is due to unreacted macromonomer or dead polystyrene homopolymer, a graft copolymer sample was subjected to fractionation in order to separate the product graft copolymer from the unreacted material. Attempts to separate all the graft copolymer from the unreacted material in the sample by fractionation failed but a residue which was considerably enriched with this minor product was obtained. After removing the bulk of the graft copolymer from the sample by fractionation, the residue was analysed by  $^1\text{H}$  nmr and GPC. The GPC trace of the sample before

fractionation and the residue (after fractionation) is shown in figure 4.12. Since the bulk of the graft copolymer has been removed, the relative intensity of the small peak in the initial graft copolymer sample has increased in the residual sample indicating a much greater proportion of this unreacted material. Because of this high proportion of unreacted material in this residue, its  $^1\text{H}$  nmr should confirm whether it is unreacted macromonomer or dead polystyrene homopolymer. No olefinic signals in the 6.0-6.2 ppm region (see figure 3.6) due to norbornene in the unreacted macromonomer was observed in the  $^1\text{H}$  nmr spectrum (figure 4.13). Thus it can be concluded that this small peak with the same retention time as that of macromonomer is in fact due to dead polystyrene homopolymer. This also agrees with the assumption reported by Fontanille *et al.* who also observed a similar small peak with the same retention volume as that of macromonomer in their graft copolymer samples of *exo/endo*-5-norbornene-2-(polystyrylcarboxylate) macromonomers and suggested that this could be dead polystyrene homopolymers without any reported experimental investigation.<sup>121</sup>



**Figure 4.12** GPC traces of the graft copolymer sample (sample 5-5 in table 4.4) subjected to fractionation



**Figure 4.13**  $^1\text{H}$  nmr spectrum of the residual graft copolymer after fractionation

The GPC results for all the graft copolymers prepared are tabulated in Tables 4.3 to 4.5. Here the graft length means the number of styrene units in the polystyrene graft. In some cases, two peaks were observed in the GPC trace; one due to product graft copolymer and another due to unreacted macromonomer (not dead polystyrene homopolymer). This is reported under the ‘number of peaks’ column. All these results indicate a narrow polydispersity for the graft copolymers prepared. However, these GPC data yielded no useful quantitative information since the numerical values for molecular weight are calculated with reference to calibration with linear polystyrene standards, and the hydrodynamic volume to molecular weight relationship for these comb-graft copolymers is, as yet, unknown.

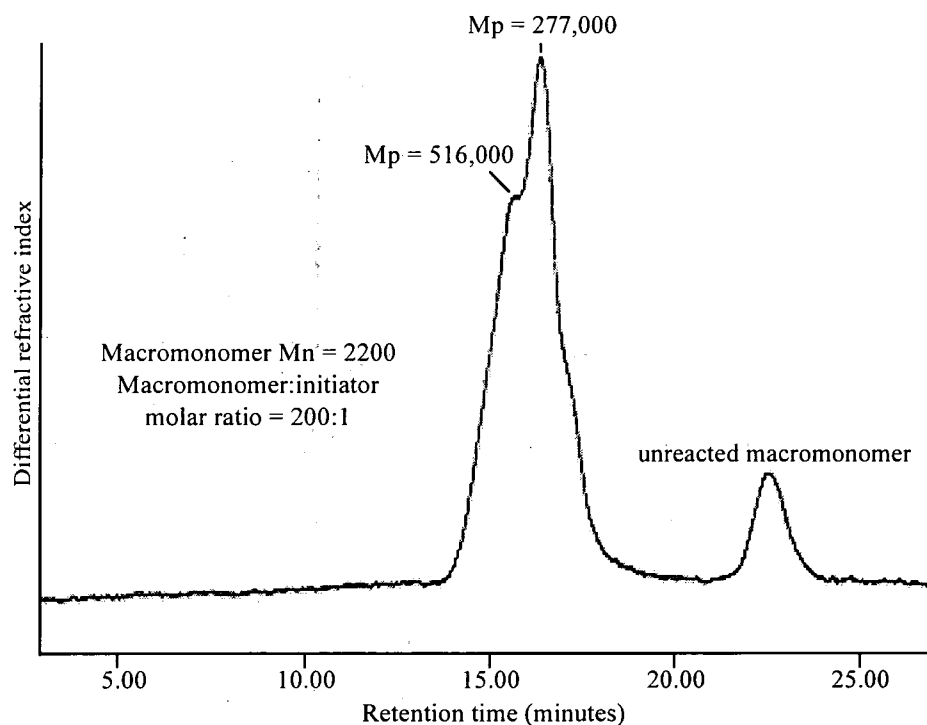
Sample	Macromonomer				Graft Copolymer		
	Mn	PDI	Graft Length <sup>†</sup>	[M]/[I] Ratio <sup>‡</sup>	Mn	PDI	No. of Peaks
1-11	1460	1.08	12	8	13,645	1.07	1
1-10				10	15,130	1.20	1
1-7				40	38,035	1.10	1
6-1	1560	1.05	13	50	60,440	1.13	1
6-2				60	72,985	1.16	1
6-3				120	101,590	1.28	1
11-1	1550	1.10	13	200	277,230	1.51	1
3-4	2250	1.05	20	30	36,310	1.07	1
3-5				40	44,780	1.06	1
3-7				40	48,175	1.13	1
3-8				50	60,590	1.10	1
13-1	2200	1.08	19	200	see figure 4.14		2

<sup>†</sup> no. of styrene units

<sup>‡</sup> macromonomer to initiator molar ratio

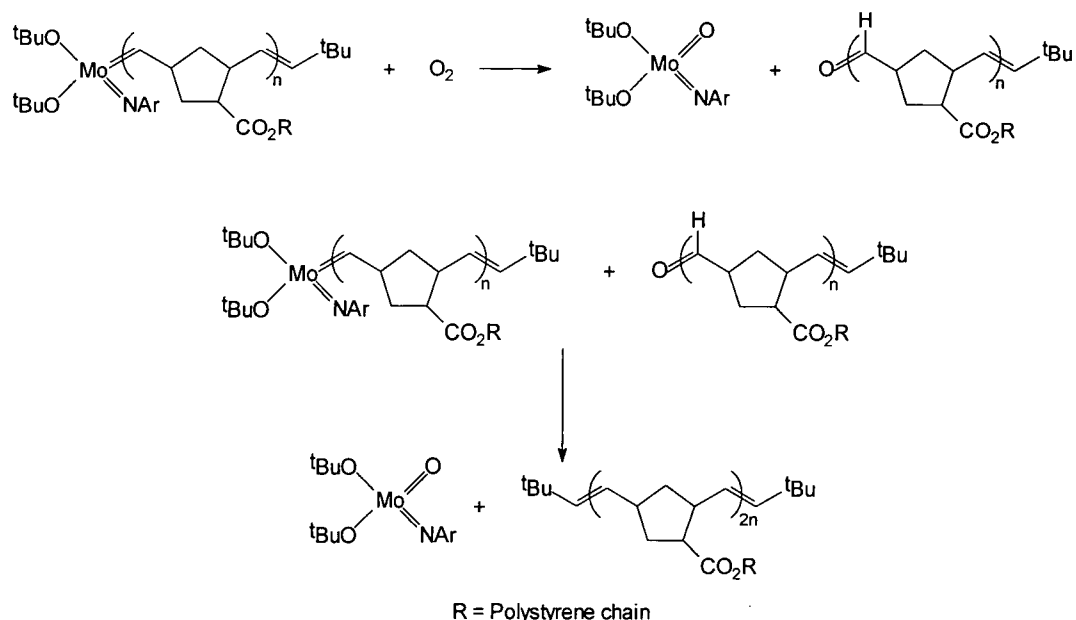
**Table 4.3** GPC analysis results of graft copolymers prepared from macromonomers with Mn around 1500 and 2250

Table 4.3 gives GPC analysis results of graft copolymers prepared from macromonomers having molecular weights around 1500 and 2250. Polymerisation of macromonomers with a molecular weight of 1550 goes to completion even at 200 equivalents (*i.e.* macromonomer to initiator molar ratio of 200). The broadening of molecular weight distribution at 120 and 200 equivalents (samples 6-3 and 11-1) could be due to mixing efficiency at such a high macromonomer to initiator molar ratios. On the other hand, faster rate of propagation than initiation for these systems could also have contributed to this broadening effect. Similarly, macromonomers with a molecular weight of 2250 were polymerised up to 50 equivalents. However, attempts to polymerise the macromonomer Mn=2200 at a ratio of 200 equivalents of macromonomer to one initiator resulted in a very broad partially resolved bimodal molecular weight distribution with a high molecular weight shoulder and an unreacted macromonomer peak (figure 4.14).



**Figure 4.14** GPC trace of the graft copolymer prepared with 200 equivalents of the macromonomer  $M_n=2200$

As discussed earlier for di-substituted norbornene macromonomers, the presence of an unreacted macromonomer peak suggests that the polymerisation reaction stops due to steric hindrance at the growing chain end before complete consumption of macromonomers. On the other hand, the molecular weight of the high molecular weight shoulder peak is approximately twice that of the main lower molecular weight graft copolymer peak. Therefore the high molecular weight shoulder could be due to bimolecular dimerisation of the living polymer induced by the impurity, dioxygen, introduced unintentionally at the termination stage. This effect was first reported by Feast *et al.* and the mechanism for this reaction is given in figure 4.15 below.<sup>125</sup> Another possible explanation for the appearance of this high molecular weight shoulder could be due to mixing efficiency, since the rate of propagation for these systems is much faster than the rate of initiation. This is less likely since it should just lead to broadening rather than the observed resolved shoulder at twice the molecular weight of the main peak. In practice, both effects may be operating.



**Figure 4.15** The mechanism for the bimolecular dimerisation of living polymers

Sample	Macromonomer				Graft Copolymer		
	Mn	PDI	Graft Length <sup>†</sup>	[M]/[I] Ratio <sup>‡</sup>	Mn	PDI	No. of Peaks
5-3	3540	1.04	32	10	23,865	1.06	1
5-5				10	23,110	1.09	1
5-1				20	37,035	1.07	1
5-2				30	47,515	1.08	1
5-7				50	76,390	1.16	1
9-1	3580	1.06	32	50	74,335	1.16	1
8-1	3445	1.06	31	100	130,780	1.13	1
14-1	4930	1.08	46	100	271,550	1.31	1

<sup>†</sup> no. of styrene units

<sup>‡</sup> macromonomer to initiator molar ratio

**Table 4.4** GPC analysis results of graft copolymers prepared from macromonomers with Mn around 3500 and 5000

Table 4.4 gives the GPC analysis results of graft copolymers prepared from macromonomers having molecular weights around 3500 and 5000. In this case polymerisation of the macromonomers with molecular weights of 3445 and 4930 goes to completion even at a macromonomer to initiator molar ratio of 100. Again

broadening of molecular weight distribution at 100 equivalents of macromonomers in sample 14-1 could be due to mixing efficiency and faster rate of propagation than initiation. However, no attempt was made to polymerise beyond macromonomer to initiator molar ratio of 100 for these two macromonomers. Some of these polymerisations were repeated and the GPC analysis results are also included in table 4.4 (sample 5-3 and 5-5, 5-7 and 9-1). In total these results are self consistent and indicate a reasonably well controlled living polymerisation; thus, for the same macromonomer, the macromonomer to initiator molar ratio determines the molecular weight and up to quite high molecular weights the polydispersity remains low.

Sample	Macromonomer				Graft Copolymer		
	Mn	PDI	Graft Length <sup>†</sup>	[M]/[I] Ratio <sup>‡</sup>	Mn	PDI	No. of Peaks
7-3	10,170	1.13	96	15	99,975	1.09	1
7-1				20	107,740	1.12	1
7-2				30	178,610	2.01	2
15-3	13,230	1.08	127	5	63,200	1.13	1
15-2				10	82,695	1.11	1
15-1				15	117,610	1.11	2

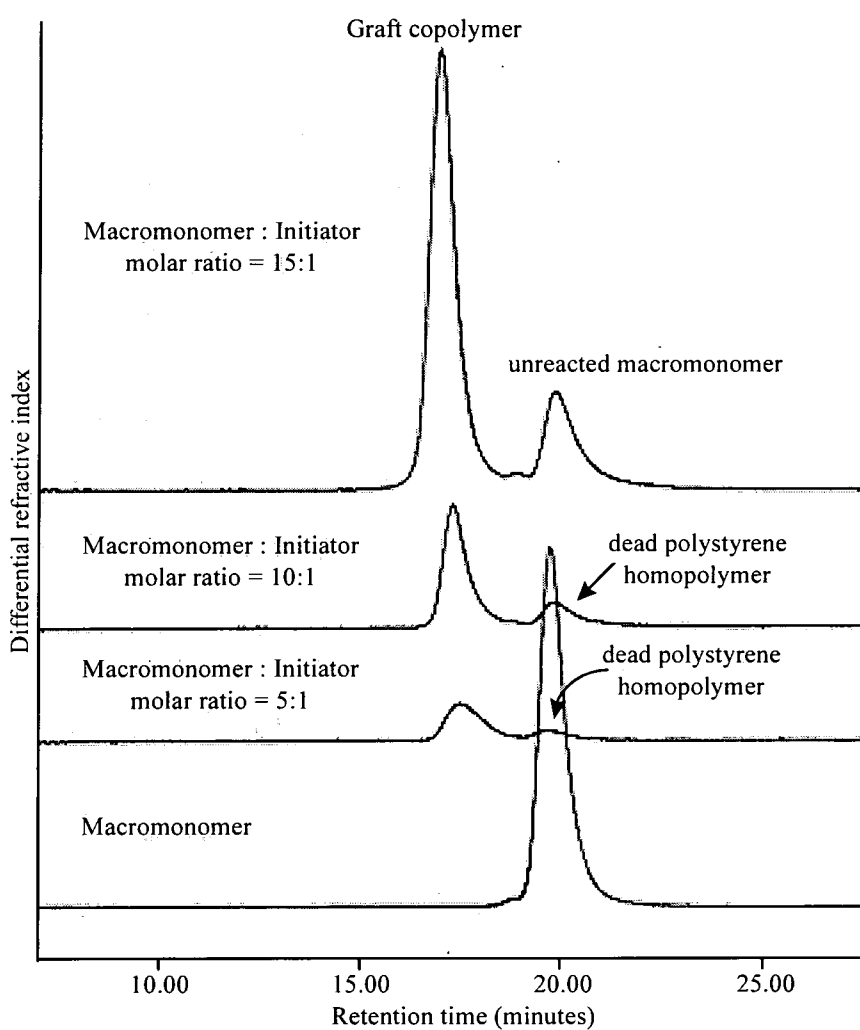
<sup>†</sup> no. of styrene units

<sup>‡</sup> macromonomer to initiator molar ratio

**Table 4.5** GPC analysis results of graft copolymers prepared from macromonomers with Mn of 10,170 and 13,230

Table 4.5 gives GPC analysis results for graft copolymers prepared from macromonomers having molecular weights of 10,170 and 13,230. In the case of the macromonomer with a molecular weight of 10,170, the polymerisation goes to completion only up to 20 equivalents. At 30 equivalents of macromonomer, the GPC trace shows two peaks, one due to product graft copolymer and another prominent peak with the same retention time as that of macromonomers (*i.e.* unreacted macromonomer) indicating that the polymerisation stops before complete consumption of macromonomers. Similarly, macromonomers with a molecular weight of 13,230 goes to completion only up to about 10 equivalents. At 15 equivalents, the

GPC trace shows a significant unreacted macromonomer peak indicating that the polymerisation again stops before complete consumption of macromonomers. All the GPC traces of graft copolymers prepared from macromonomer  $M_n=13,230$  are shown in figure 4.16. The GPC traces of graft copolymer prepared from macromonomer  $M_n=10,170$  are given in Appendix-4. As discussed earlier in this chapter, the appearance of an unreacted macromonomer peak is probably due to steric hindrance at the growing chain end causing the polymerisation to stop before all the macromonomer is consumed as the length of polystyrene grafts are increased.



**Figure 4.16** GPC traces of graft copolymers prepared from the macromonomer  $M_n=13,230$

As mentioned earlier, polymerisation of macromonomers with a molecular weight of 1550 (*i.e.* 13 styrene units) goes to completion at 200 equivalents. Similarly, macromonomer with a molecular weight of 3445 goes to completion even at 100 equivalents. This produces relatively long polynorbornene backbone chains while the polystyrene grafts are relatively short. On the other hand, when the macromonomer molecular weight is 10,170 or 13,230, polymerisation goes to completion only up to 20 and 10 equivalents respectively. Beyond this stage polymerisation stops before complete consumption of macromonomers. This leads to very short polynorbornene backbone chains while the polystyrene grafts are relatively long. Therefore as discussed earlier in this chapter for di-substituted norbornene macromonomers, as the polystyrene graft length increases, the polynorbornene backbone chain lengths obtained for these graft copolymers gradually decreases.

However, in contrast to two polystyrene grafts on the same norbornene unit, with one polystyrene graft on the norbornene unit, graft copolymers with relatively long backbone and side chains can be prepared. For example, with the disubstituted norbornene macromonomer having 14 styrene units in each graft, the polymerisation goes to completion only up to a macromonomer to initiator molar ratio of 9 and at a ratio of 10, the polymerisation stops before complete consumption of macromonomers. On the other hand, with the mono-substituted macromonomer having 13 styrene units in the graft, the polymerisation goes to completion even at a macromonomer to initiator molar ratio of 200. Again this is probably due to lowering of steric hindrance when there is only one polystyrene graft instead of two attached to the same norbornene unit. As observed by <sup>1</sup>H nmr, when there is only one polystyrene chain attached to norbornene unit, the macromonomer can add head or tail to the propagating chain end. This, in turn, reduces the steric hindrance at the growing chain end and give rise to high molecular weight graft copolymers.

Sample	Macromonomer		Graft Copolymer			
	GPC	[M]/[I]	GPC		DSC	TGA
	Mn	Ratio <sup>†</sup>	Mn	PDI	Tg/°C	Td/°C <sup>‡</sup>
1-10	1460	10	15,130	1.20	79.67	389
1-7		40	38,035	1.10	82.04	380
6-1	1560	50	60,440	1.13	79.59	379
6-2		60	72,985	1.16	80.05	380
11-1	1550	200	277,230	1.51	84.17	388
3-4	2250	30	36,310	1.07	89.26	392
3-5		40	44,780	1.06	89.63	395
3-8		50	60,590	1.10	87.87	399
5-5	3540	10	23,110	1.09	94.54	-
5-1		20	37,035	1.07	95.10	408
5-2		30	47,515	1.08	95.25	407
9-1	3580	50	74,335	1.16	93.55	405
8-1	3445	100	130,780	1.13	93.77	402
14-1	4930	100	271,550	1.31	91.97	407
7-3	10,170	15	99,975	1.09	101.13	414
7-1		20	107,740	1.12	101.91	417
7-2		30	178,610	2.01	101.06	410
15-3	13,230	5	63,200	1.13	100.17	409
15-2		10	82,695	1.11	100.00	420
15-1		15	117,610	1.11	99.57	412

<sup>†</sup> macromonomer to initiator molar ratio

<sup>‡</sup> for 2% weight loss

**Table 4.6** DSC and TGA results of the graft copolymers prepared

The DSC and TGA results for graft copolymers are listed in table 4.6. All the DSC traces are recorded in Appendix-4. In all cases, only one Tg was observed for these graft copolymers. This indicates that the polynorbornene and polystyrene segments do not undergo phase segregation. The Tg of these graft copolymers shows there is an overall increase in Tg on going from graft copolymers containing short polystyrene chains to longer polystyrene chains with very short polynorbornene backbone chains.

Thus graft copolymers having polystyrene grafts with 14 styrene units have T<sub>g</sub> around 80°C while those having 100 or more styrene units have a T<sub>g</sub> of about 100°C. The T<sub>g</sub> of polynorbornene is 35°C and that of polystyrene is 100°C. Thus it seems likely that the T<sub>g</sub> process observed is primarily associated with polystyrene grafts in these systems. A similar trend was also observed in relation to thermal decomposition temperatures, using 2% weight loss as an arbitrary criterion for degradation. As the polystyrene chain length of the graft copolymer increases, the thermal decomposition temperature also increases.

In conclusion, the work described here indicates that when there is only one polystyrene graft attached to the norbornene unit, steric hindrance at the growing chain end can be significantly reduced by head/tail addition. This in turn allows the preparation of very high molecular weight graft copolymers having longer polynorbornene backbone chains and relatively long polystyrene grafts than the di-substituted macromonomers investigated previously. Polymerisation of macromonomers M<sub>n</sub>=10,170 and 13,230 at different macromonomer to initiator molar ratio indicates that beyond a certain macromonomer to initiator molar ratio, these polymerisation reactions also stops before complete consumption of macromonomers. As described by Feast and co-workers for the di-substituted macromonomer,<sup>83,124</sup> this is likely to be due to steric hindrance at the growing chain end. However, the threshold value for macromonomer to initiator molar ratio at which the polymerisation stops before complete consumption of macromonomers for these systems is significantly higher than that for di-substituted macromonomers with similar amount of styrene units in the polystyrene graft. Similarly, the results also indicates that there is a relationship between the polystyrene graft length and the polynorbornene backbone chain length. Thus, macromonomers having shorter polystyrene grafts allow production of graft copolymers having long polynorbornene backbones and *vice versa*. The broadening of the molecular weight distribution of graft copolymers prepared at very high macromonomer to initiator molar ratios could be due to a combination of mixing efficiency effects and the faster rate of propagation than initiation.

## 4.4 EXPERIMENTAL

All the chemicals were bought from Aldrich Chemical Co. Ltd. The ROMP initiators,  $\text{Mo}(\text{N-2,6-}i\text{-Pr}_2\text{C}_6\text{H}_3)(\text{CHR})(\text{OR}')_2$ , where R is  $\text{CMe}_2\text{Ph}$  or  $\text{CMe}_3$  and R' is  $\text{CMe}_3$ , were prepared by Dr. Ezat Khosravi. Benzene- $d_6$  used in nmr scale polymerisations was dried over phosphorus pentoxide and vacuum transferred. Benzene used in preparative scale polymerisations was purified and dried as for anionic polymerisation (section 3.3.1b). Benzaldehyde was distilled directly into an ampule containing molecular sieves (type 4A). All manipulations involving polymerisation reactions (solvent, initiator and macromonomer) were carried out in an inert atmosphere (dry nitrogen) filled glove box.

### 4.4.1 A Typical NMR Scale Polymerisation

$\text{Mo}(\text{N-2,6-}i\text{-Pr}_2\text{C}_6\text{H}_3)(\text{CHCMe}_2\text{Ph})(\text{OCMe}_3)_2$  initiator (12.7mg, 0.023mmol) and *exo*-5-norbornene-2-(polystyrylcarboxylate) macromonomer ( $M_n = 1460$ , 335.8mg, 10-equivalents) were dissolved in benzene- $d_6$  (400 $\mu\text{l}$  and 600 $\mu\text{l}$  respectively) in separate sample vials. The macromonomer solution was then transferred into the initiator solution and stirred for 25 minutes. The mixture was transferred into a screw cap nmr tube and analysed by  $^1\text{H}$  nmr spectroscopy. After analysing by  $^1\text{H}$  nmr, the polymerisation mixture was placed back in the sample vial, more macromonomer (335.8mg in 600 $\mu\text{l}$  of  $\text{C}_6\text{D}_6$ , 10-equivalents) was added, stirred and transferred again into the nmr tube and analysed by  $^1\text{H}$  nmr spectroscopy as before. The above process was repeated 3-times (or until no more unreacted initiator can be observed in the  $^1\text{H}$  nmr spectrum) with further additions of macromonomer (335.8mg in 600 $\mu\text{l}$  of  $\text{C}_6\text{D}_6$ , 10-equivalents) into the initial polymerisation mixture and each time analysing by  $^1\text{H}$  nmr. Finally the polymerisation mixture was capped with benzaldehyde and after stirring for 30 minutes, precipitated by pouring into methanol (10-fold excess) to obtain the graft copolymers.

### 4.4.2 A Typical Preparative Scale Polymerisation

$\text{Mo}(\text{N-2,6-}i\text{-Pr}_2\text{C}_6\text{H}_3)(\text{CHCMe}_3)(\text{OCMe}_3)_2$  initiator (41.8mg, 0.086mmol) was dissolved in benzene (3ml) in a sample vial and placed in a single neck round bottom flask (250ml). The vial was washed with benzene (30ml) and added to the initiator

solution. *Exo*-5-norbornene-2-(polystyrylcarboxylate) macromonomer ( $M_n=3500$ , 30g, 100 equivalents) was dissolved in benzene (80ml) and added to the initiator solution in 5 equal portions at 15-20 minutes interval under vigorous stirring. After adding all the macromonomers, the mixture was stirred for further 3 hours. This was then capped with benzaldehyde (10-fold excess). After stirring for 30 minutes, the mixture was precipitated by pouring into methanol (10-fold excess). The precipitate was recovered by filtration, washed with excess methanol and dried in a vacuum oven at 50°C. Finally, the polymer was reprecipitated from THF into methanol and dried in a vacuum oven at 50°C for 3 days to give graft copolymer as a white powder.

#### **4.4.3 Controlled Fractionation of Graft Copolymers**

This was done in order to find out if the small peaks with the same retention volumes as that the starting macromonomers observed in all GPC analysis traces of graft copolymers was due to unreacted macromonomer or dead polystyrene homopolymer. The graft copolymer sample (2g) was dissolved in toluene (200ml *i.e.* 1% solution) in a beaker and transferred into a two-neck separating funnel (2l) with an overhead stirrer. The separating funnel was then immersed in a thermostated water bath. The solution was stirred vigorously using the overhead stirrer. While stirring, methanol was added until the solution turned cloudy. Then the temperature was raised to about 30°C (water bath) and left stirring until the solution became clear. Finally stirring was stopped and the stirrer paddle (P.T.F.E.) was raised above the solution level to prevent any polymer sticking onto it on cooling. The solution was allowed to cool-down slowly by reducing the water bath temperature by 1-2°C in every 2 hours or so. Also a 'cooling-coil' was used to cool the solution to about 18°C overnight. On slow cooling, a small layer of polymer rich solution separated at the bottom of the separating funnel. This polymer rich solution was drained into a sample vial and added to a large excess of methanol to precipitate the polymer. To the remaining solution in the funnel, more methanol was added while stirring until the solution went cloudy. This was then warmed up to 30°C. While warming more methanol was added (dropwise) until the solution went cloudy again, as on warming solution becomes clear. When the temperature has reached ~30°C and the solution has become clear, stirring was stopped and the solution was allowed to cool down overnight as before, a second

polymer rich layer was collected and precipitated. The above procedure was repeated until no more clear polymer rich layer could be observed at the bottom of the separating funnel. In this case up to 7 samples (over 10 days) were collected and analysed by GPC. The GPC traces indicated those samples to be 'pure' high molecular weight graft copolymer. In this way bulk of the graft copolymer was removed from the initial polymer sample.

The remaining polymer solution (residue) in the separating funnel was then transferred into a round bottom flask and the polymer recovered by evaporating the solvents (toluene and methanol) using rotary evaporator. The residue was dried in a vacuum oven at 50°C and analysed by GPC and <sup>1</sup>H nmr spectroscopy.

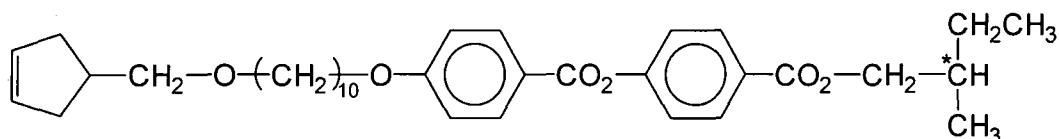
**CHAPTER-5**  
**SYNTHESIS OF A POTENTIALLY RING OPEN**  
**POLYMERISABLE MESOGENIC MONOMER**

## 5.1 INTRODUCTION

This chapter describes the synthesis and characterisation of a mesogenic monomer suitable for ring opening metathesis polymerisation to produce a side chain liquid crystalline polymer. In this case, cyclopentene is used as the ring open polymerisable functional group, so that a side chain liquid crystalline polymer with a flexible backbone chain could be produced. The attempted polymerisation of this mesogenic monomer will be the subject of next chapter.

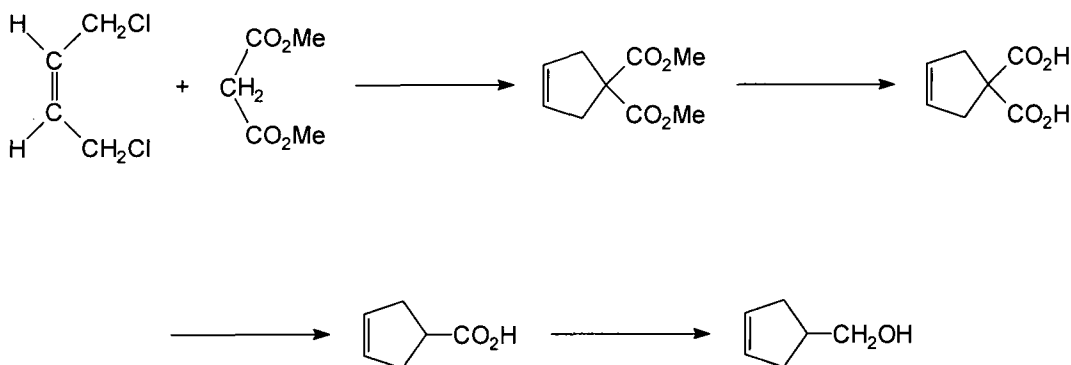
## 5.2 Monomer Synthesis

The structure of the ring open polymerisable mesogenic monomer to be synthesised is shown in figure 5.1.

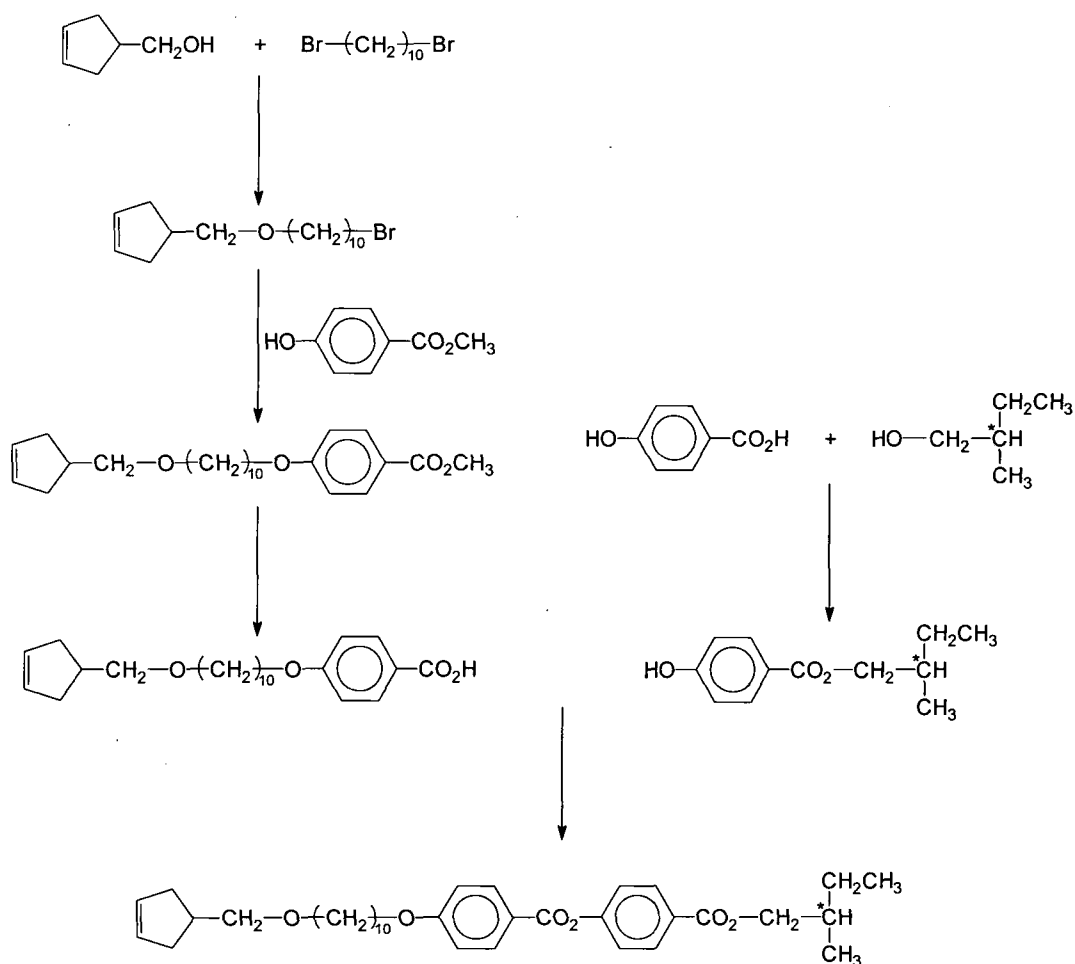


**Figure 5.1** The mesogenic monomer, (*S*)-(-) 2-methylbutyl 4-(4-(10-(3-cyclopentenylmethoxy)decyloxy)phenylcarbonyloxy)benzoate to be synthesised

It consists of a mesogenic unit with a chiral centre at one end linked to a cyclopentene ring via a flexible spacer. Therefore the synthesis involves preparing a suitable functionalised cyclopentene unit, in this case 4-hydroxymethyl cyclopentene and then linking the mesogenic unit via the spacer to the cyclopentene unit. The reaction schemes for the synthesis of 4-hydroxymethyl cyclopentene and the final mesogenic monomer are given in figure 5.2 and 5.3.



**Figure 5.2** Route to the synthesis of 4-hydroxymethyl cyclopentene

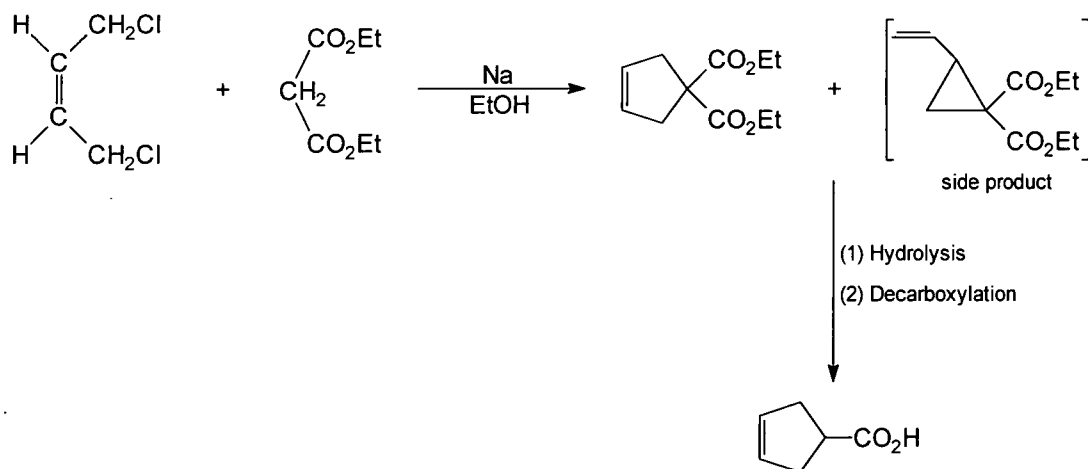


**Figure 5.3** Route for the synthesis of the mesogenic monomer

### 5.2.1 Synthesis of 4-Hydroxymethyl Cyclopentene

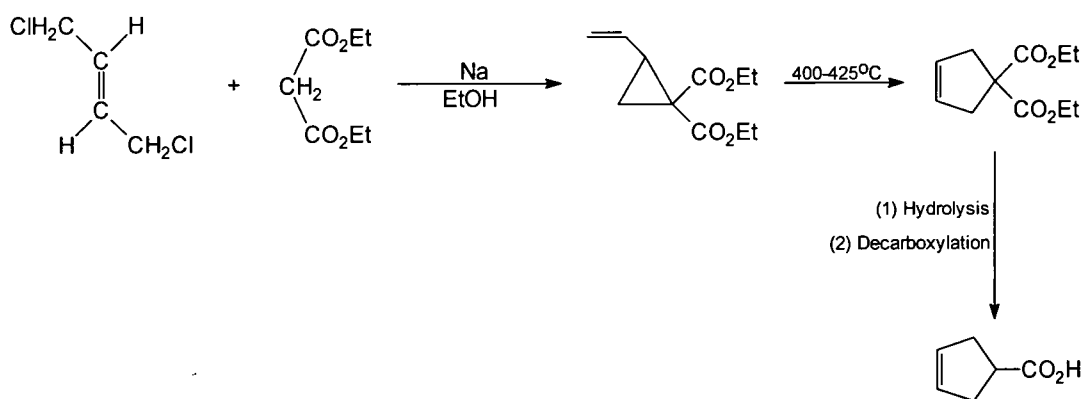
As shown in figure 5.2, the synthesis of 4-hydroxymethyl cyclopentene involves first synthesising the diester, dimethyl 3-cyclopentene-1,1-dicarboxylate and then converting it to 3-cyclopentenecarboxylic acid by hydrolysis and decarboxylation, and finally reducing to the required alcohol. In the literature several different methods are reported for the synthesis of 3-cyclopentenecarboxylic acid. These are summarised below. The major difference among these different procedures is the overall yield of the final product.

The method reported by Murdock and Angier involves cycloalkylation of diethyl malonate with *cis*-1,4-dichloro-2-butene to give diethyl 3-cyclopentene-1,1-dicarboxylate along with the isomeric diester (diethyl 2-vinylcyclopropane-1,1-dicarboxylate), followed by hydrolysis and decarboxylation to give 3-cyclopentene carboxylic acid.<sup>126</sup> The overall yield of this procedure is 19-33%.



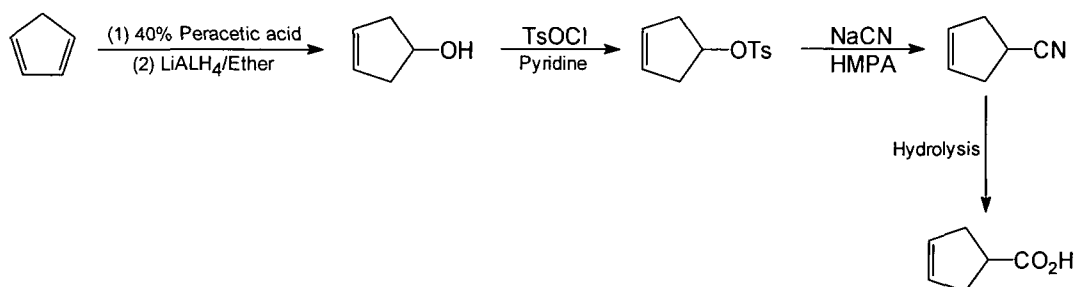
**Figure 5.4** Murdock's scheme for the synthesis of 3-cyclopentenecarboxylic acid

Meinwald and Gassman used *cis*-1,4-dibromo-2-butene instead of *cis*-1,4-dichloro-2-butene, but the yields were again very low.<sup>127</sup> Schmid and Wolkoff produced diethyl 3-cyclopentene-1,1-dicarboxylate by thermal rearrangement of diethyl 2-vinylcyclopropane-1,1-dicarboxylate at 400-425°C.<sup>128,129</sup> They prepared diethyl 2-vinylcyclopropane-1,1-dicarboxylate from diethyl malonate and *trans*-1,4-dichloro-2-butene. However, the overall yield from diethyl 2-vinylcyclopropane-1,1-dicarboxylate to 3-cyclopentenecarboxylic acid was low (32%).



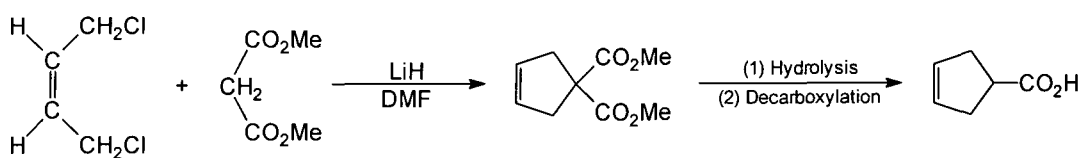
**Figure 5.5** Schmid and Wolkoff's route to synthesise 3-cyclopentenecarboxylic acid

Cremer and Blankenship prepared 3-cyclopentenecarboxylic acid from cyclopentadiene in 5-steps in 19% overall yield.<sup>130,131</sup>



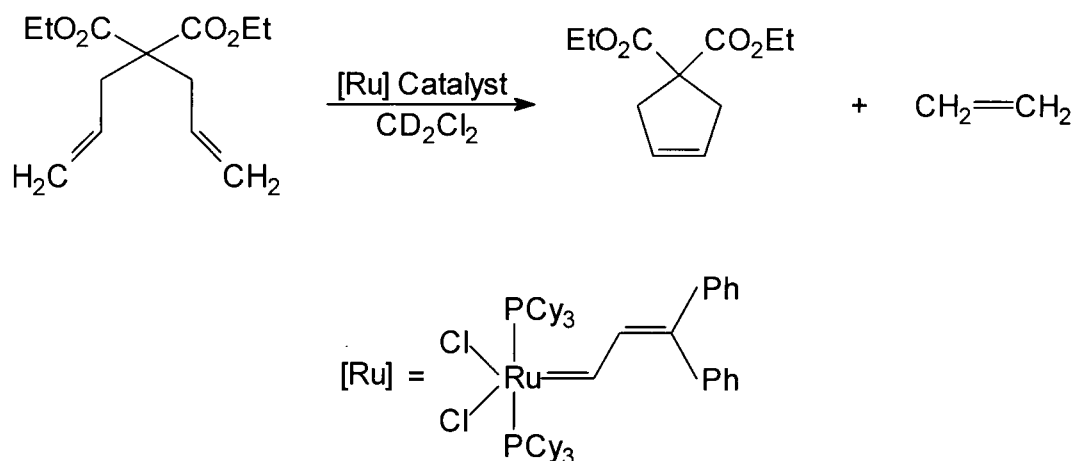
**Figure 5.6** Cremer's route to 3-cyclopentenecarboxylic acid

Green *et al.* found that the formation of vinylcyclopropane in the condensation between *cis*-1,4-dichloro-2-butene and malonic ester to be highly sensitive to changes in the base, the solvent and to a lesser extent functional groups (CO<sub>2</sub>Me, CO<sub>2</sub>Et, CO<sub>2</sub>-*t*-C<sub>4</sub>H<sub>9</sub>, CN) of the malonic ester. They modified the Murdock's procedure by using dimethyl malonate instead of diethyl malonate and synthesised 3-cyclopentenecarboxylic acid in 70% overall yield with lithium hydride as base and *N,N*-dimethylformamide as solvent.<sup>132</sup>



**Figure 5.7** Green's route to 3-cyclopentenecarboxylic acid

Recently, Grubbs *et al.* synthesised the diester, diethyl 3-cyclopentene-1,1-dicarboxylate by ring closing metathesis of diethyl diallyl malonate using a ruthenium catalyst.<sup>133</sup> The reaction is very fast and goes to almost completion.



**Figure 5.8** Grubbs' ring closing metathesis reaction to produce diethyl 3-cyclopentene-1,1-dicarboxylate

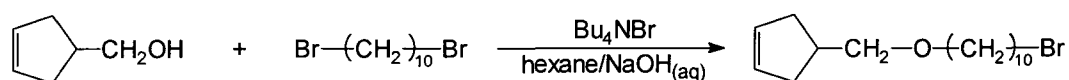
For the purpose of the work described in this thesis Green's procedure was adopted to synthesise 3-cyclopentenecarboxylic acid. Thus *cis*-1,4-dichloro-2-butene was condensed with dimethyl malonate to give dimethyl 3-cyclopentene-1,1-dicarboxylate. Since this procedure also produces a small amount of 2-vinylcyclopropane-1,1-dicarboxylate (5% according to the literature, but varying significantly) as a side product, the crude product was recrystallised from *n*-hexane to obtain pure dimethyl 3-cyclopentene-1,1-dicarboxylate. For analytical purposes, a small sample was further purified by sublimation.

The dimethyl 3-cyclopentene-1,1-dicarboxylate was then hydrolysed to give 3-cyclopentene-1,1-dicarboxylic acid. This was converted to 3-cyclopentenecarboxylic acid without further purification by heating to 180°C. The crude product was then distilled under reduced pressure to obtain pure 3-cyclopentenecarboxylic acid. Finally 3-cyclopentenecarboxylic acid was reduced to 4-hydroxymethylcyclopentene using lithium aluminium hydride as reducing agent.<sup>134</sup> Again the resulting crude product was vacuum distilled to give pure 4-hydroxymethylcyclopentene.

### 5.2.2 Synthesis of 10-Bromodecyl 3-Cyclopentenylmethyl Ether

The synthesis of 10-bromodecyl 3-cyclopentenylmethyl ether was carried out with minor variations to that reported in the literature for analogous reactions. It involves phase transfer catalysed substitution of dibromodecane by 4-

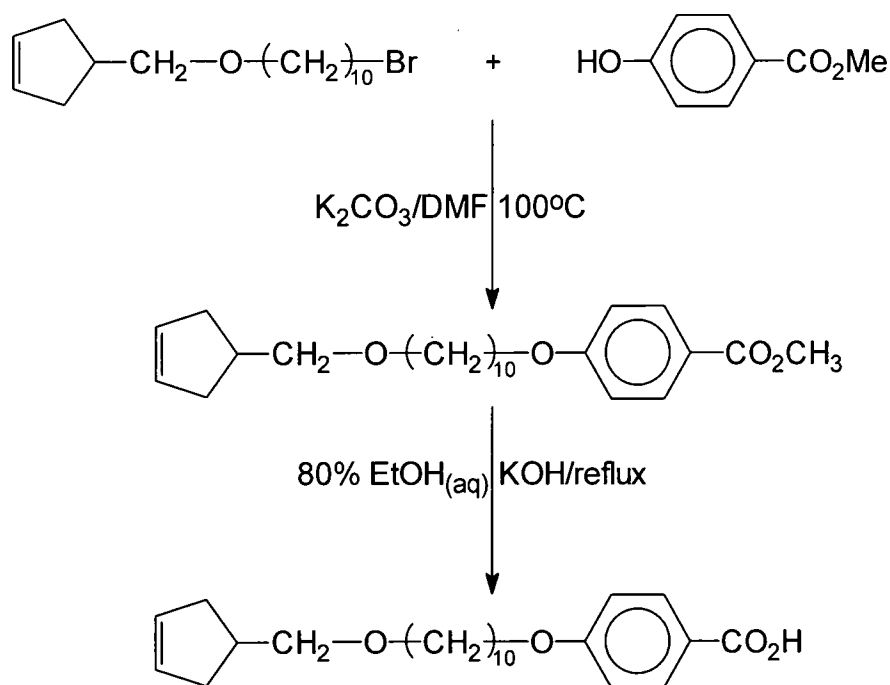
hydroxymethylcyclopentene.<sup>44,135</sup> In this case tetrabutylammonium bromide was used as phase transfer catalyst. One of the advantages of using the phase transfer catalyst for this type of reaction is that it does not require heating or dry solvents and it only involves simply stirring the reaction mixture overnight. However, for this particular reaction, the yields of this reaction was relatively low (40%). Since dibromodecane was used in excess (50%) in this reaction, it was necessary to remove this in order to prevent it reacting in the following step with methyl 4-hydroxybenzoate. Therefore the crude product mixture was passed through a silica gel column using hexane as eluent. Once all the excess dibromodecane had been removed, the product was eluted with 5% ether in hexane and then distilled to give 10-bromodecyl 3-cyclopentenylmethyl ether.



**Figure 5.9** Reaction scheme for the synthesis of 10-bromodecyl 3-cyclopentenylmethyl ether

### 5.2.3 Synthesis of 4-(10-(3-Cyclopentenylmethoxy)Decyloxy)Benzoic Acid

The 10-bromodecyl 3-cyclopentenylmethyl ether was then condensed with methyl 4-hydroxy benzoate to give methyl 4-(10-(3-cyclopentenylmethoxy)decyloxy)benzoate under standard Williamson conditions using potassium carbonate as the base and N,N-dimethylformamide as solvent.<sup>136</sup> The methyl 4-(10-(3-cyclopentenylmethoxy)decyloxy)benzoate was then directly hydrolysed without further purification to the corresponding acid, 4-(10-(3-cyclopentenylmethoxy)decyloxy)benzoic acid,<sup>136</sup> which was purified by recrystallisation from ethanol.



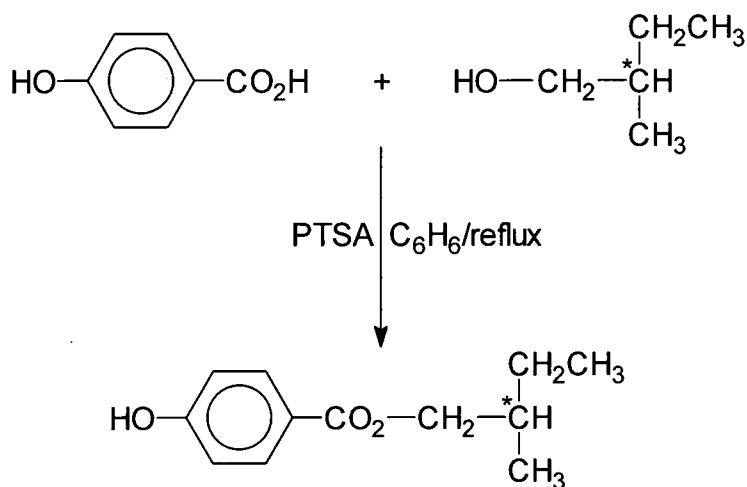
**Figure 5.10** Reaction scheme for the synthesis of 4-(10-(3-cyclopentenylmethoxy)decyloxy)benzoic acid

#### 5.2.4 Synthesis of (S)-(-) 2-Methylbutyl 4-Hydroxybenzoate

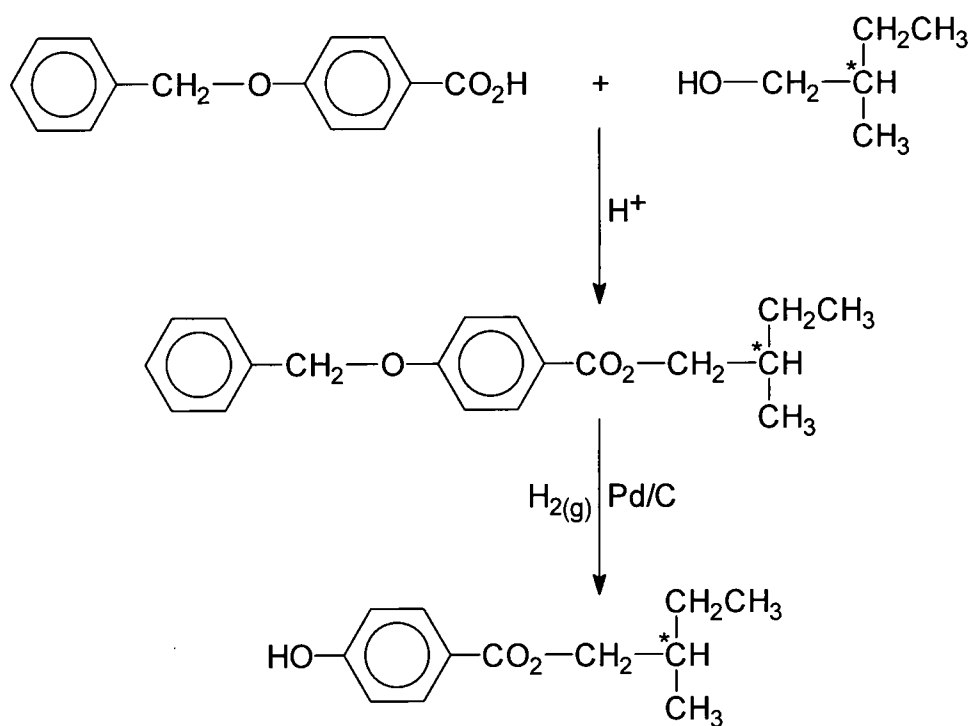
Two different types of procedure can be found in the literature for the synthesis of (S)-(-) 2-methylbutyl 4-hydroxybenzoate. One involves direct esterification of 4-hydroxybenzoic acid and (S)-(-) 2-methyl 1-butanol (figure 5.11)<sup>137,138</sup> and the other method involves protecting the hydroxy (OH) functional group in 4-hydroxy benzoic acid and deprotecting after esterification to yield (S)-(-) 2-methylbutyl 4-hydroxybenzoate (figure 5.12).<sup>139</sup>

According to the literature, (S)-(-) 2-methylbutyl 4-hydroxybenzoate has been synthesised in high yield by direct esterification of 4-hydroxybenzoic acid with (S)-(-) 2-methyl 1-butanol using 1,3-dicyclohexylcarbodiimide (DCC) and 4-dimethylaminopyridine (DMAP) in THF as solvent.<sup>137</sup> However, when the reaction was carried out according to the method described in the literature, it was found that it was difficult to purify the product. Therefore the reaction was carried out using *p*-toluene sulfonic acid as catalyst in benzene by azeotropic distillation.<sup>138</sup> The extent of the reaction can be followed by the amount of water collected and no side products are formed. Although the product looked pinkish in colour, no attempt was made to

remove the colour and this material was used in the following step without any further purification.



**Figure 5.11** The direct esterification method to synthesise (S)-(-) 2-methylbutyl 4-hydroxybenzoate

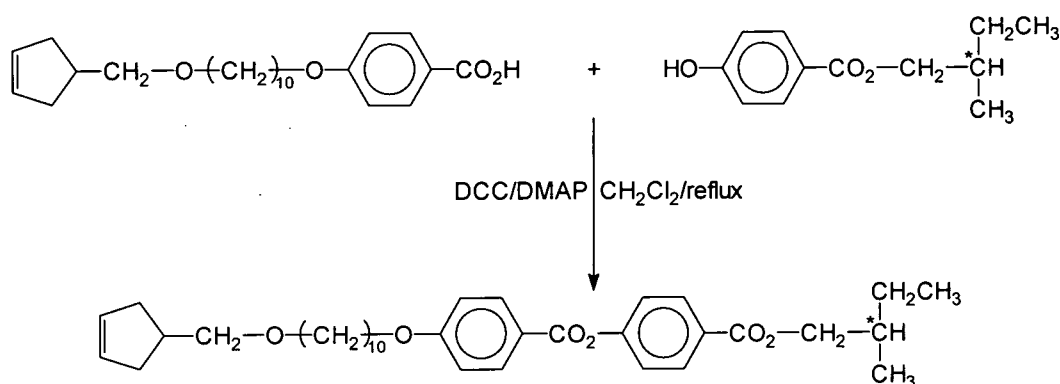


**Figure 5.12** Functional group protection method to synthesise (S)-(-) 2-methylbutyl 4-hydroxybenzoate



### 5.2.5 Synthesis of (*S*)-(-) 2-Methylbutyl 4-(4-(10-(3-Cyclopentenylmethoxy)Decyloxy)Phenylcarbonyloxy)Benzoate

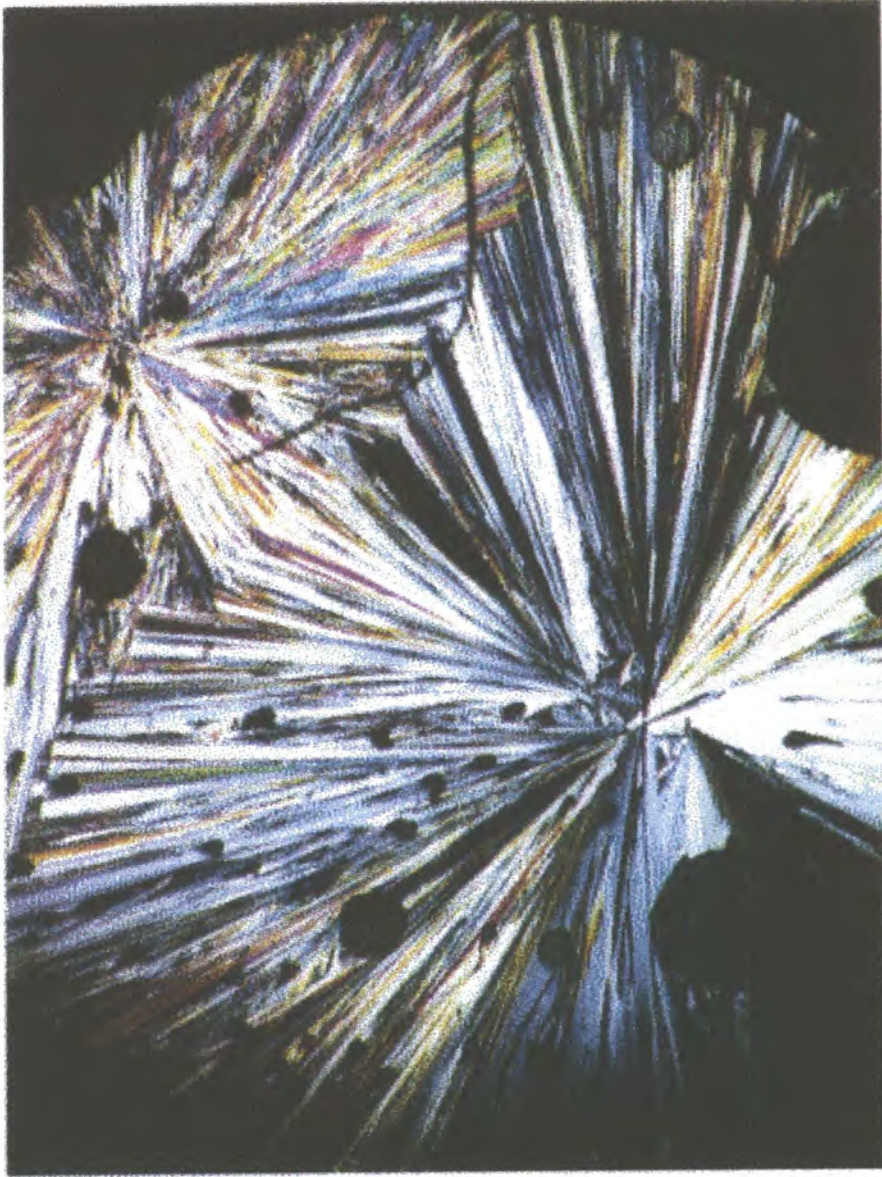
The final esterification between 4-(10-(3-cyclopentenylmethoxy)decyloxy)benzoic acid and (*S*)-(-) 2-methylbutyl 4-hydroxybenzoate was carried out using 1,3-dicyclohexylcarbodiimide (DCC) and 4-dimethylamino pyridine (DMAP) in dichloromethane.<sup>137,140</sup> The crude product was purified by silica gel column chromatography using 10% ethyl acetate in hexane as eluent to give pure (*S*)-(-) 2-methylbutyl 4-(4-(10-(3-cyclopentenylmethoxy)decyloxy) phenylcarbonyloxy) benzoate as white crystals in 5.8% overall yield.



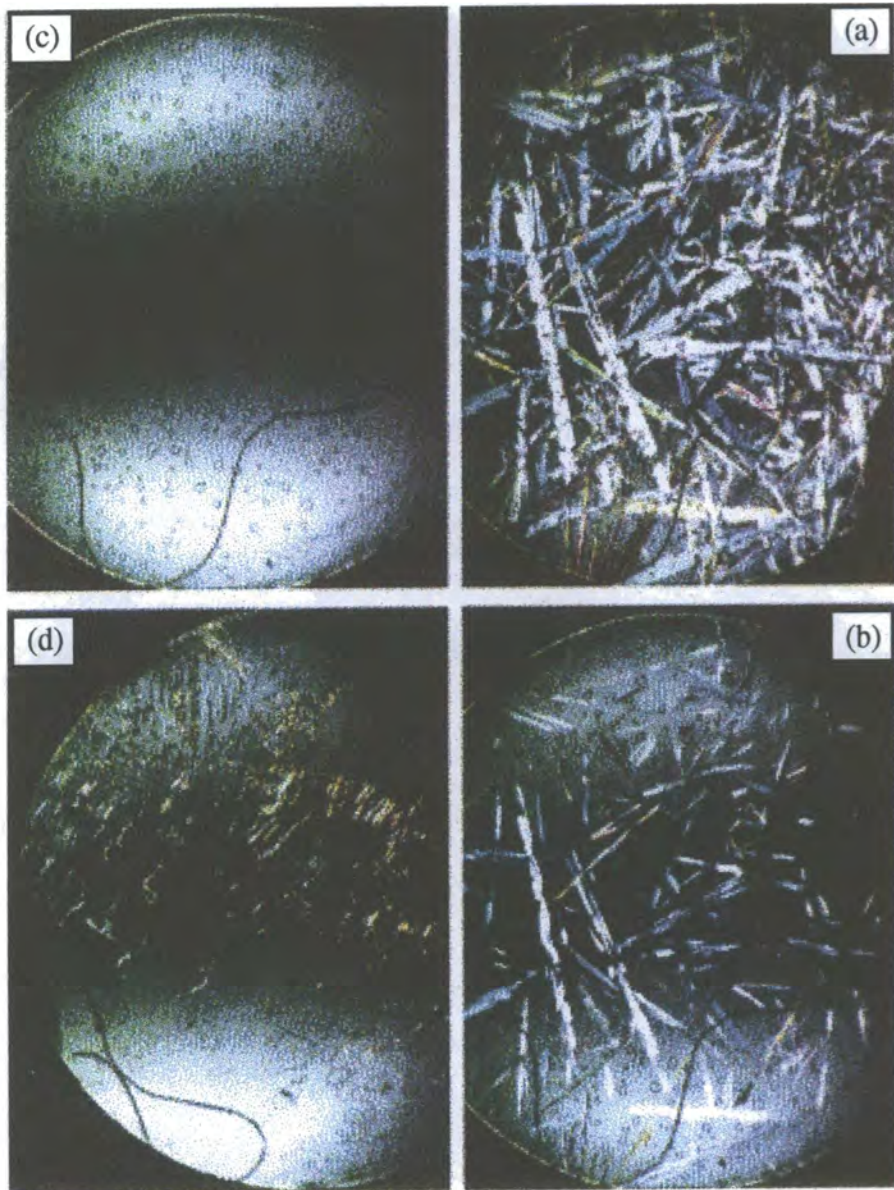
**Figure 5.13** Reaction scheme for the synthesis of (*S*)-(-) 2-methylbutyl 4-(4-(10-(3-cyclopentenylmethoxy)decyloxy) phenylcarbonyloxy) benzoate

### 5.3 Optical Micrographs of Mesogenic Monomer

In order to identify the presence of any liquid crystalline phases, a thin layer sample of the mesogenic monomer was viewed through a microscope using a linearly polarised light. The optical micrographs taken at room temperature and at various stages of heating are shown in figure 5.14 and 5.15. These micrographs indicates that upon heating the monomer the solid crystal changes directly to an isotropic liquid without any intermediate stage. This suggests that the mesogenic monomer is not a liquid crystalline material. However, it is possible that after polymerisation the side chain mesogens might display liquid crystallinity even though the monomer does not.<sup>90</sup>



**Figure 5.14** Polarising optical micrographs of the mesogenic monomer taken at room temperature (magnification x20)



**Figure 5.15** Polarising optical micrographs of the mesogenic monomer taken at (a) 29°C (b) 30°C (c) 32°C and (d) during cooling (magnification x20)

## 5.4 EXPERIMENTAL

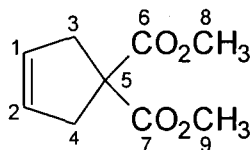
All the chemicals were bought from Aldrich Chemical Co. Ltd. N,N-dimethylformamide (water <0.005%), lithium hydride, lithium aluminium hydride (95%), 1,10-dibromodecane (97%), tetrabutylammonium bromide (99%), methyl 4-hydroxybenzoate (99%), (S)-(-) 2-methyl 1-butanol (99%), *p*-toluene sulfonic acid monohydrate (98.5%), 1,3-dicyclohexylcarbodiimide (99%) and 4-dimethylaminopyridine (99%) were used as received. Dimethyl malonate and *cis*-1,4-dichloro-2-butene were distilled prior to use. Diethyl ether was dried over sodium-benzophenone until it turned purple.

### 5.4.1 Synthesis of Dimethyl 3-Cyclopentene 1,1-Dicarboxylate

N,N-dimethylformamide (1litre) and dimethyl malonate (89.01g, 0.67mol) were placed in a three necked round-bottom flask (2litre), fitted with a reflux condenser, nitrogen inlet and a Suba-seal. The apparatus was purged with dry nitrogen and the mixture was cooled in an ice bath. Lithium hydride (13.5g, 1.7mol, 2.5 equivalents) was then added to the stirred reaction mixture. After the evolution of hydrogen ceased (approximately 2 hours), *cis*-1,4-dichloro-2-butene (91.67g, 0.73mol, 8% excess) was added and the mixture was allowed to warm to room temperature. The reaction mixture was stirred for 88 hours at room temperature. The resulting mixture was then divided into two portions and 500ml of water was added to each portion. After fizzing had subsided, each portion was extracted with 20% ether in hexane (4x200ml). The combined organic layer was washed with water (500ml) and brine (500ml). This was dried over anhydrous magnesium sulfate, filtered and the solvent was removed under vacuum to give dimethyl-3-cyclopentene-1,1-dicarboxylate as a white solid/powder (74.86g, 60.3%). An analytical sample was obtained by sublimation.

- **Mpt.** 55.6-60°C, after sublimation 62-63°C.
- **Elemental analysis**-Calculated/Found(%): C-58.69/58.69; H-6.57/6.63
- **Mass spectrum**-(EI): 184amu ( $M^+$ ), 152 ( $M^+ - CH_3OH$ ), 124 ( $M^+ - HCOOCH_3$ ) and 65 ( $C_5H_5^+$ ).
- **IR**-( $cm^{-1}$ ): 3020 (vinylic C-H stretching), 2963 (saturated aliphatic C-H stretching), 1725 (ester C=O stretching), 1438 (C-H deformation), 1255 (ester C-O stretching) and 703 (out-of-plane C-H deformations of the *cis*-CH=CH double bond).

- $^1\text{H}$  nmr-( $\text{CDCl}_3$ )  $\delta$  (ppm): 3.03 (s, 4H,  $\text{H}_3$  and  $\text{H}_4$ ), 3.74 (s, 6H,  $\text{H}_8$  and  $\text{H}_9$ ) and 5.64 (s,  $\text{H}_1$  and  $\text{H}_2$ ).
- $^{13}\text{C}$  nmr-( $\text{CDCl}_3$ )  $\delta$  (ppm): 40.95 ( $\text{C}_8$  and  $\text{C}_9$ ), 52.85 ( $\text{C}_3$  and  $\text{C}_4$ ), 58.76 ( $\text{C}_5$ ), 127.80 ( $\text{C}_1$  and  $\text{C}_2$ ) and 172.66 ( $\text{C}_6$  and  $\text{C}_7$ ).



#### 5.4.2 Synthesis of 3-Cyclopentene 1,1-Dicarboxylic Acid

Dimethyl-3-cyclopentene-1,1-dicarboxylate (61.5g, 0.33mol) and 80% aqueous ethanol (650ml) were placed in a round-bottom flask (1litre) fitted with a reflux condenser. Potassium hydroxide (26.2g, 0.47mol, 1.4 equivalents) was then added to the stirred reaction mixture. The mixture was stirred for 18 hours at 70-80°C and then concentrated by removing ethanol under reduced pressure. Water (400ml) was added and the mixture was washed with 20% ether in hexane (200ml). The resulting mixture was cooled in an ice bath. This was then acidified with concentrated sulfuric acid and extracted with ethyl acetate (3x200ml). The organic layer was dried over anhydrous magnesium sulfate, filtered and the solvent was removed under reduced pressure to give 3-cyclopentene 1,1-dicarboxylic acid as a whitish brown solid (52.2g, 0.33mol, 100%). The material obtained was used as the starting material for the following step without further purification since the diester was confirmed to be converted completely by IR.

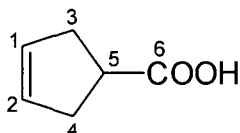
- **IR**-( $\text{cm}^{-1}$ ): ~3000 (broad/O-H stretching of carboxylic acid), 1713 (C=O stretching of carboxylic acid), 1406 (O-H deformation), 1292 (C-O stretching of carboxylic acid), 932 (O-H deformation) and 688 (out-of-plane C-H deformations of the *cis*-CH=CH double bond).

#### 5.4.3 Synthesis of 3-Cyclopentenecarboxylic Acid

3-Cyclopentene-1,1-dicarboxylic acid (63.46g, 0.41mol) was placed in a round-bottom flask (250ml) fitted with a reflux condenser which was attached to a gas bubbler. This was then heated in an oil bath to 180°C until the evolution of gas ceased

(1½ hours). The residual oil was distilled under reduced pressure (68°C/<1mmHg) to give 3-cyclopentenecarboxylic acid as a colourless oil (27.1g, 59.5%).

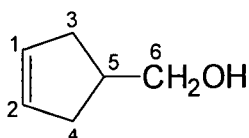
- **Elemental analysis**-Calculated/Found(%): C-64.27/63.92; H-7.19/7.31
- **<sup>1</sup>H nmr**-(CDCl<sub>3</sub>) δ (ppm): 2.69 (d, 4H, H<sub>3</sub> and H<sub>4</sub>), 3.16 (m, H<sub>5</sub>), 5.67 (s, H<sub>1</sub> and H<sub>2</sub>) and 11.90 (bs, H<sub>6</sub>).
- **<sup>13</sup>C nmr**-(CDCl<sub>3</sub>) δ (ppm): 36.23 (C<sub>3</sub> and C<sub>4</sub>), 41.44 (C<sub>5</sub>), 128.93 (C<sub>1</sub> and C<sub>2</sub>) and 183.08 (C<sub>6</sub>).



#### 5.4.4 Synthesis of 4-Hydroxymethyl Cyclopentene

Ether (90ml) was placed in a three necked round-bottom flask (250ml) fitted with a reflux condenser, pressure equalising dropping funnel and a nitrogen inlet and then lithium aluminium hydride (1.94g, 0.05mol, 1.5 equivalents) was added. 3-Cyclopentenecarboxylic acid (5.1g, 0.045mol) in dry ether (20ml) was then slowly added to the mixture while stirring so as to maintain a gentle reflux. After the addition was completed, the reaction mixture was heated to reflux for two hours. The reaction mixture was then cooled in an ice-bath and excess LiAlH<sub>4</sub> was quenched by dropwise addition of water (1ml) followed by 40% aqueous NaOH (5ml) under vigorous stirring over a period of 1-2 hours. The mixture was filtered and the filtrate was dried over anhydrous MgSO<sub>4</sub>. The solvent was then removed under reduced pressure and the crude product was distilled under vacuum (70°C/11-12mmHg) to give 4-hydroxymethyl cyclopentene (3.24g, 72.5%).

- **Elemental analysis**-Calculated/Found(%): C-73.43/72.10; H-10.27/10.33
- **Mass spectrum**-(EI): 98 amu (M<sup>+</sup>), 80 (M<sup>+</sup>-H<sub>2</sub>O) and 67 (M<sup>+</sup>-CH<sub>2</sub>OH).
- **<sup>1</sup>H nmr**-(CDCl<sub>3</sub>) δ (ppm): 2.05-2.20 and 2.35-2.55 (bm, 6H, H<sub>3</sub>, H<sub>4</sub>, H<sub>5</sub> and H<sub>6</sub>/hydroxy), 3.5 (d, 2H/ether, H<sub>6</sub>) and 5.65 (s, H<sub>1</sub> and H<sub>2</sub>).
- **<sup>13</sup>C nmr**-(CDCl<sub>3</sub>) δ (ppm): 35.51 (C<sub>3</sub> and C<sub>4</sub>), 39.15 (C<sub>5</sub>), 67.03 (C<sub>6</sub>) and 129.48 (C<sub>1</sub> and C<sub>2</sub>).

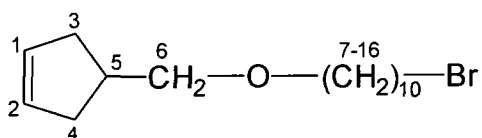


### 5.4.5 Synthesis of 10-Bromodecyl 3-Cyclopentenylmethyl Ether

4-Hydroxymethyl cyclopentene (10.3g, 0.105mol), 1,10-dibromodecane (63.5g, 211.6mmol, 2equivalents) and tetrabutylammonium bromide (17g, 52.7mmol, 0.5 equivalents) were dissolved in cyclohexane (80ml) in a round bottom flask (250ml). Then 50% w/w aqueous sodium hydroxide (50.75g) solution was added and the resultant two-phase mixture was stirred vigorously at room temperature for 23 hours. The reaction mixture was then poured into water (180ml) and the organic layer was separated. The remaining aqueous layer was extracted with ether (3x100ml). The combined organic solution was washed with dilute hydrochloric acid (120ml) and water (100ml), dried over anhydrous magnesium sulfate and the solvent was removed to give a pale yellow crude oil. The excess dibromodecane in the crude product was removed by silica gel column chromatography using hexane as eluent. Once all the excess dibromodecane has been removed, the product was eluted using 5% ether in hexane as solvent. The resulting crude product was fractionally distilled under reduced pressure to yield 10-bromodecyl 3-cyclopentenylmethyl ether as a colourless liquid (12.24g, 38.6mmol, 36.7%). The  $^1\text{H}$  and  $^{13}\text{C}$  nmr characterisation of this compound was made with the aid of COSY and HETCOR spectra (appendix-5).

•  $^1\text{H}$  nmr-( $\text{CDCl}_3$ )  $\delta$  (ppm): 1.20-1.43 (bm, 12H,  $\text{H}_{9-14}$ ), 1.56 and 1.85 (bm's, 4H,  $\text{H}_8$  and  $\text{H}_{15}$ /cannot identify which one is which), 2.06-2.10 and 2.44-2.49 (bm, 2x2H,  $\text{H}_3$  and  $\text{H}_4$ ), 2.55 (bm,  $\text{H}_5$ ), 3.31 (d, 2H,  $\text{H}_6$ ), 3.40 (t, 4H,  $\text{H}_7$  and  $\text{H}_{16}$ ) and 5.65 (s,  $\text{H}_1$  and  $\text{H}_2$ ).

•  $^{13}\text{C}$  nmr-( $\text{CDCl}_3$ )  $\delta$  (ppm): 26.13, 28.14, 28.72, 29.34, 29.40, 29.45, 29.64, 32.80 ( $\text{C}_{8-15}$ ), 34.04 ( $\text{C}_{16}$ ), 35.98 ( $\text{C}_3$  and  $\text{C}_4$ ), 36.66 ( $\text{C}_5$ ), 71.01 ( $\text{C}_7$ ), 75.22 ( $\text{C}_6$ ) and 129.49 ( $\text{C}_1$  and  $\text{C}_2$ ).



#### 5.4.6 Synthesis of Methyl 4-(10-(3-Cyclopentenylmethoxy)Decyloxy)Benzoate

Methyl 4-hydroxybenzoate (6g, 39.4mmol) and potassium carbonate (7.84g, 56.7mmol, 1.5 equivalents) were dissolved in N,N-dimethylformamide (60ml) in a two neck round bottom flask (250ml) fitted with a reflux condenser connected to a nitrogen inlet and a pressure equalising dropping funnel. The mixture was then heated to 100°C. 10-bromodecyl 3-cyclopentenylmethyl ether (12g, 37.8mmol) was then added dropwise with stirring over a period of 10 minutes. Five hours later more potassium carbonate (5.2g) was added. After stirring for further 17 hours, the reaction mixture was cooled and poured into water (300ml). This was extracted with ether (4x50ml), dried over anhydrous magnesium sulfate and solvent removed to yield methyl 4-(10-(3-cyclopentenylmethoxy)decyloxy)benzoate as brownish white crystals (15.42g, 39.68mmol). The crude product was hydrolysed without further purification.

#### 5.4.7 Synthesis of 4-(10-(3-Cyclopentenylmethoxy)Decyloxy)Benzoic Acid

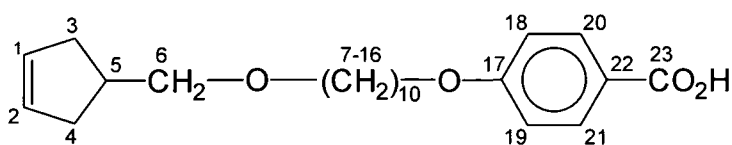
Methyl 4-(10-(3-cyclopentenylmethoxy)decyloxy)benzoate (15.42g, 39.68mmol, crude), potassium hydroxide (6.7g, 119.4mmol, 3 equivalents) and 80% aqueous ethanol (200ml) were placed in a round bottom flask (500ml) fitted with a reflux condenser. This was refluxed with stirring for one hour. The reaction mixture was then cooled and ethanol was removed in the rotary evaporator and diluted with water (400ml). The mixture was acidified with concentrated hydrochloric acid and extracted with ether (4x100ml). After drying over anhydrous magnesium sulfate, the solvent was removed to yield the crude product as a white solid/powder. This was recrystallised from aqueous ethanol to yield 4-(10-(3-cyclopentenylmethoxy)decyloxy)benzoic acid as white crystals (11.16g, 29.8mmol, 78.8%). An analytical sample was obtained by further recrystallisation from ethanol. The <sup>1</sup>H and <sup>13</sup>C nmr characterisation of this compound was made with the aid of COSY, HETCOR and DEPT spectra (appendix-5).

- **Mpt:** 73-74°C.
- **Elemental analysis**-Calculated/Found(%): C-73.76/73.52; H-9.15/9.18
- **Mass spectrum**-(CI): 374 amu (M<sup>+</sup>), 357, 277

• **IR**-( $\text{cm}^{-1}$ ):  $\sim 3475$  (O-H stretching of carboxylic acid), 2920 and 2852 (saturated aliphatic C-H stretchings), 1678 (C=O stretching of carboxylic acid), 1605 and 1514 (benzene ring), 940 (O-H deformation) and 846 (*p*-disubstituted benzene ring).

•  **$^1\text{H}$  nmr**-( $\text{CDCl}_3$ )  $\delta$  (ppm): 1.30 (bs, 10H,  $\text{H}_9\text{-H}_{13}$ ), 1.45 (bm, 2H,  $\text{H}_{14}$ ), 1.57 (bm, 2H,  $\text{H}_8$ ), 1.80 (bm, 2H,  $\text{H}_{15}$ ), 2.06-2.10 and 2.40-2.50 (bm, 2x2H,  $\text{H}_3$  and  $\text{H}_4$ ), 2.55 (bm,  $\text{H}_5$ ), 3.31 (d, 2H,  $\text{H}_6$ ), 3.41 (t, 2H,  $\text{H}_7$ ), 4.01 (t, 2H,  $\text{H}_{16}$ ), 5.64 (s,  $\text{H}_1$  and  $\text{H}_2$ ), 6.93 (d,  $\text{H}_{18}$  and  $\text{H}_{19}$ ) and 8.06 (d,  $\text{H}_{20}$  and  $\text{H}_{21}$ ).

•  **$^{13}\text{C}$  nmr**-( $\text{CDCl}_3$ )  $\delta$  (ppm): 25.96, 26.16, 29.08, 29.33, 29.45, 29.48, 29.51 and 29.65 ( $\text{C}_{8-15}$ ), 36.01 ( $\text{C}_3$  and  $\text{C}_4$ ), 36.66 ( $\text{C}_5$ ), 68.26 ( $\text{C}_{16}$ ), 71.06 ( $\text{C}_7$ ), 75.25 ( $\text{C}_6$ ), 114.16 ( $\text{C}_{18}$  and  $\text{C}_{19}$ ), 121.39 ( $\text{C}_{22}$ ), 129.52 ( $\text{C}_1$  and  $\text{C}_2$ ), 132.30 ( $\text{C}_{20}$  and  $\text{C}_{21}$ ), 163.63 ( $\text{C}_{17}$ ) and 171.65 ( $\text{C}_{23}$ ).

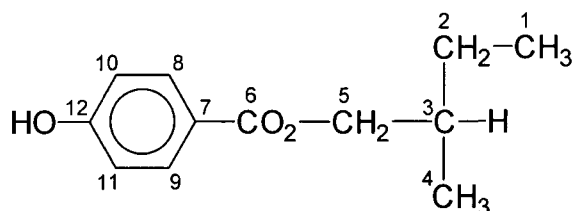


#### 5.4.8 Synthesis of (S)-(-) 2-Methylbutyl 4-Hydroxybenzoate

4-Hydroxybenzoic acid (7.83g, 56.6mmol), (S)-(-) 2-methyl 1-butanol (10.37g, 117.6mmol, 2 equivalents), *p*-toluene sulfonic acid monohydrate (0.5g, 2.63mmol, 5%) and benzene (60ml) were placed in a round bottom flask (100ml) fitted with a Dean-Stark apparatus. This was then refluxed until the calculated amount of water was collected. The reaction mixture was then diluted with ether (40ml) and washed with 5% aqueous sodium bicarbonate (22ml) and water (25ml). After removing the solvent, the excess (S)-(-) 2-methyl 1-butanol was removed on the vacuum line. to give (S)-(-) 2-methylbutyl 4-hydroxybenzoate as a pale pink viscous liquid (9.84g, 47.25mmol, 83.5%). This was used in the following step without any further purification. The  $^1\text{H}$  and  $^{13}\text{C}$  nmr characterisation of this compound was made with the aid of COSY and HETCOR spectra (appendix-5).

• **IR**-( $\text{cm}^{-1}$ ): 3445 (broad/phenolic O-H stretching), 2963 and 2877 (saturated aliphatic C-H stretching), 1682 (ester C=O stretching), 1608 and 1514 (benzene ring) and 851 (*p*-disubstituted benzene ring).

- $^1\text{H}$  nmr-( $\text{CDCl}_3$ )  $\delta$  (ppm): 0.94 (t, 3H,  $\text{H}_1$ ), 1.01 (d, 3H,  $\text{H}_4$ ), 1.27 and 1.52 (m, 2H,  $\text{H}_2$ ), 1.84 (m,  $\text{H}_3$ ), 4.09-4.22 (m, 2H,  $\text{H}_5$ ) 6.93 (d,  $\text{H}_{10}$  and  $\text{H}_{11}$ ), 7.95 (d,  $\text{H}_8$  and  $\text{H}_9$ ) and 7.6 (bs,  $\text{H}_{12}$ ).
- $^{13}\text{C}$  nmr-( $\text{CDCl}_3$ )  $\delta$  (ppm): 11.30 ( $\text{C}_1$ ), 16.52 ( $\text{C}_4$ ), 26.14 ( $\text{C}_2$ ), 34.30 ( $\text{C}_3$ ), 69.72 ( $\text{C}_5$ ), 115.38 ( $\text{C}_{10}$  and  $\text{C}_{11}$ ), 122.17 ( $\text{C}_7$ ), 131.92 ( $\text{C}_8$  and  $\text{C}_9$ ) 160.71 ( $\text{C}_{12}$ ) and 167.51 ( $\text{C}_6$ ).



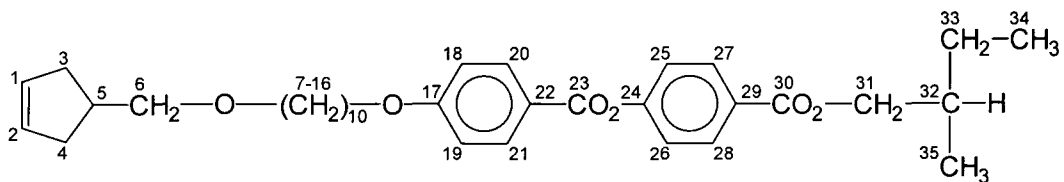
#### 5.4.9 Synthesis of (S)-(-) 2-Methylbutyl 4-(4-(10-(3-Cyclopentenylmethoxy)Decyloxy)Phenylcarbonyloxy)Benzoate

4-(10-(3-cyclopentenylmethoxy)decyloxy)benzoic acid (5g, 13.35mmol), (S)-(-) 2-methylbutyl 4-hydroxybenzoate (3.06g, 14.7mmol, 1.1equivalents), DCC (3.58g, 17.35mmol, 1.3 equivalents) and DMAP (0.24g, 2mmol, 15%) were dissolved in dichloromethane (100ml) in a two-neck round bottom flask fitted with a reflux condenser attached to a nitrogen inlet. This was heated under reflux with stirring for 68 hours. The reaction mixture was then cooled in the freezer for half an hour and the precipitate was filtered from the solution. The solution was then washed with dilute hydrochloric acid (1x50ml), saturated sodium bicarbonate (1x50ml) and water (1x100ml). This was dried over anhydrous magnesium sulfate and solvent removed to yield the crude product as a pink colour viscous liquid. This was purified by silica gel column chromatography using 10% ethyl acetate in hexane as eluent to yield (S)-(-) 2-methylbutyl 4-(4-(10-(3-cyclopentenylmethoxy)decyloxy) phenylcarbonyloxy) benzoate as a white solid (5.80g, 10.27mmol, 77%). The  $^1\text{H}$  and  $^{13}\text{C}$  nmr characterisation of this compound was made with the aid of COSY, HETCOR and DEPT spectra (appendix-5).

- **Mpt:** 33-34°C.
- **Elemental analysis**-Calculated/Found(%): C-74.44/74.33; H-8.57/8.69
- **IR**-( $\text{cm}^{-1}$ ): 2927 and 2850 (saturated aliphatic C-H stretchings), 1715 (ester C=O stretching), 1605 and 1512 (benzene rings) and 846 (*p*-disubstituted benzene ring).

• **<sup>1</sup>H nmr**-(CDCl<sub>3</sub>) δ (ppm): 0.96 (t, 3H, H<sub>34</sub>), 1.01 (d, 3H, H<sub>35</sub>), 1.31 (bs, 11H, *i.e.* 10H due to H<sub>9-13</sub> and 1H due to overlapping of H<sub>33</sub>), 1.42-1.62 (bm, 5H, *i.e.* 4H due to H<sub>8</sub> and H<sub>14</sub> and 1H due to overlapping of H<sub>33</sub>), 1.82 (bm, 3H, H<sub>15</sub> and H<sub>32</sub>), 2.06-2.11 and 2.40-2.50 (bm, 2x2H, H<sub>3</sub> and H<sub>4</sub>), 2.55 (bm, H<sub>5</sub>), 3.31 (d, 2H, H<sub>6</sub>), 3.41 (t, 2H, H<sub>7</sub>), 4.04 (t, 2H H<sub>16</sub>), 4.10-4.24 (bm, 2H, H<sub>31</sub>), 5.65 (s, H<sub>1</sub> and H<sub>2</sub>), 6.96 (d, H<sub>18</sub> and H<sub>19</sub>), 7.27 (d, H<sub>25</sub> and H<sub>26</sub>), 8.12 (t, H<sub>20-21</sub> and H<sub>27-28</sub>).

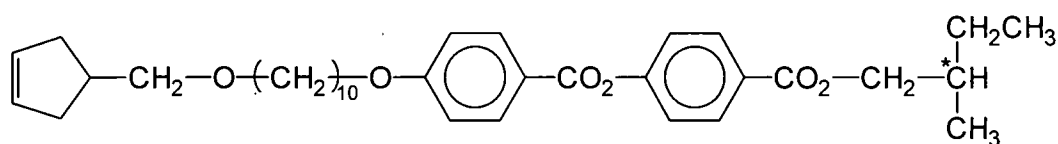
• **<sup>13</sup>C nmr**-(CDCl<sub>3</sub>) δ (ppm): 11.31 (C<sub>34</sub>), 16.54 (C<sub>35</sub>), 25.97, 26.15, 26.18, 29.07, 29.34, 29.46, 29.48, 29.51, 29.68 (C<sub>8-15</sub> and C<sub>33</sub>), 34.31 (C<sub>32</sub>), 36.01 (C<sub>3</sub> and C<sub>4</sub>), 36.69 (C<sub>5</sub>), 68.34 (C<sub>16</sub>), 69.63 (C<sub>31</sub>), 71.04 (C<sub>7</sub>), 75.25 (C<sub>6</sub>), 114.36 (C<sub>18</sub> and C<sub>19</sub>), 121.03 (C<sub>22</sub>), 121.81 (C<sub>25</sub> and C<sub>26</sub>), 127.93 (C<sub>29</sub>), 129.52 (C<sub>1</sub> and C<sub>2</sub>), 131.10 (C<sub>27</sub> and C<sub>28</sub>), 132.37 (C<sub>20</sub> and C<sub>21</sub>), 154.71 (C<sub>24</sub>), 163.73 (C<sub>17</sub>), 164.40 (C<sub>23</sub>) and 165.97 (C<sub>30</sub>).



**CHAPTER-6**  
**THE ATTEMPTED SYNTHESIS OF SIDE-CHAIN LIQUID**  
**CRYSTALLINE POLYMERS**

## 6.1 INTRODUCTION

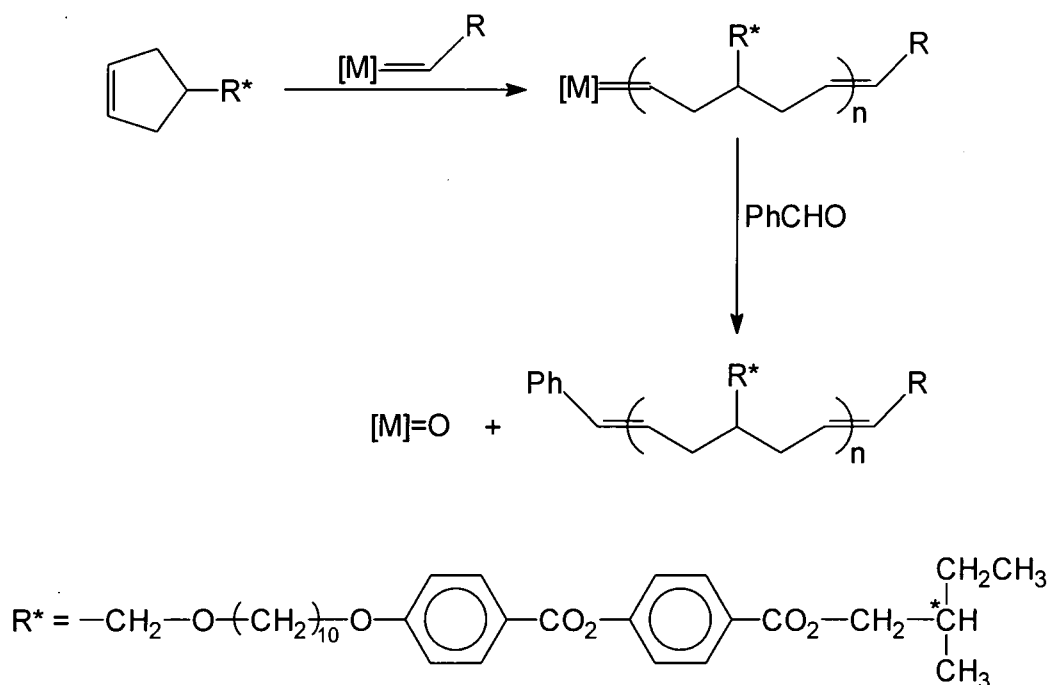
This chapter describes the attempted synthesis of side chain liquid crystalline polymers *via* living ring opening metathesis polymerisation. The functionalised cyclopentene monomer, (*S*)-(-) 2-methylbutyl 4-(4-(10-(3-cyclopentenylmethoxy) decyloxy)phenylcarbonyloxy)benzoate (mesogenic monomer) shown in figure 6.1 was subjected to polymerisation attempts using Schrock molybdenum and Grubbs ruthenium well defined metathesis initiators to produce a side chain liquid crystalline polymer with a flexible backbone chain.



**Figure 6.1** The structure of the mesogenic monomer

## 6.2 Polymerisation of Mesogenic Monomer

Recent advances in the synthesis of well defined metathesis initiators, some of which also tolerate various functional groups has enabled the synthesis of polymers with a variety of functional groups to be carried out by ring opening metathesis polymerisation. As discussed earlier in chapter-1, side chain liquid crystalline polymers are generally produced by free radical polymerisation, condensation polymerisation or by modifying a preformed polymeric backbone. However, these methods of polymerisations lack control over molecular weight and molecular weight distribution. Therefore the objective of the work described here was to synthesise well defined side chain liquid crystalline polymers by living ring opening metathesis polymerisation. Schrock *et al.*<sup>40-44</sup> and Grubbs *et al.*<sup>141</sup> have reported the synthesis of well defined side chain liquid crystalline polymers with polynorbornene and polybutadiene backbones by living ring opening metathesis polymerisation. The work reported here involves polymerisation of a cyclopentene based mesogenic monomer (figure 6.1). An outline of the polymerisation process is shown in figure 6.2.



**Figure 6.2** The outline of the proposed polymerisation of mesogenic monomer

As discussed in section 1.2.7,  $\Delta G$  of polymerisation of monomers with low ring strain, such as 5, 6 and 7 membered rings, is sensitive to chemical factors such as the nature of the substituents and their position in the ring.<sup>24</sup> Since the work reported here involves ring opening metathesis polymerisation of a substituted cyclopentene which also has a very low ring strain, it was necessary to analyse some of the previous work involving polymerisation of cyclopentene and substituted cyclopentenes by well defined metathesis catalysts in order to gain some insight into the types of catalysts and reaction conditions required to polymerise the mesogenic monomer.

Previous work involving the polymerisation of cyclopentene and substituted cyclopentene using well defined initiators has been carried out by Suguwara,<sup>142</sup> Dounis,<sup>143</sup> Schrock and co-workers.<sup>144,145</sup> Suguwara polymerised cyclopentene using  $Mo(N-2,6-i-Pr_2-C_6H_3)(OCMe_3)_2(CHCMe_3)$ ; (t-butoxy-Mo or Mo-t-Bu),  $Mo(N-2,6-i-Pr_2-C_6H_3)(OCMe_2CF_3)_2(CHCMe_3)$ ; (trifluorinated t-butoxy-Mo or Mo-F<sub>3</sub>) and  $W(N-2,6-i-Pr_2-C_6H_3)(OCMe_3)_2(CHCMe_3)$ ; (t-butoxy-W or W-t-Bu) initiators.<sup>142</sup> The trifluorinated t-butoxy-Mo initiator polymerised cyclopentene much faster than t-butoxy-Mo initiator. On the other hand t-butoxy-W initiator produced bimodal distribution in all cases. The effect of solvent on polymerisation was also investigated. The polymerisation seemed to proceed faster in toluene than in chloroform, and in the

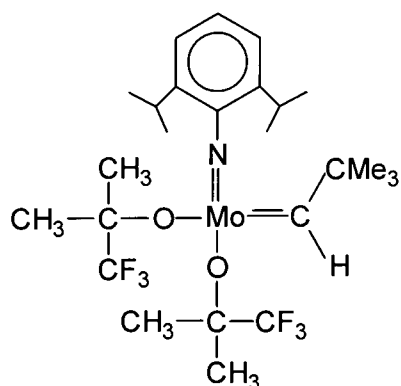
case of THF, the polymerisation was very slow and produced bimodal polymer distribution. Overall chloroform was found to be the best solvent. Since the polymers produced using trifluoro t-butoxy-Mo and t-butoxy-Mo initiators had polydispersities around two under all conditions, Suguwara concluded that these polymerisations proceed in a classical chain growth manner rather than through a living well defined process. Although the t-butoxy-W initiator produced bimodal distribution, it had a narrow molecular weight distribution polymer as the major component and thus it was concluded that this initiator led to a well defined living polymerisation process, with a side reaction leading to the minor product.

Contrary to these observations, Schrock and co-workers polymerised cyclopentene in toluene at  $-40^{\circ}\text{C}$  using t-butoxy-W initiator to give narrow distribution mono-modal polymer.<sup>144,145</sup> They also observed the replacement of the nmr signal of the initiator alkylidene by that of the propagating alkylidene. Therefore, they concluded that this reaction proceeds in a living manner. Similar results were also obtained by Dounis when he polymerised cyclopentene using t-butoxy-W initiator.<sup>143</sup> Again the polymer produced were mono-modal and showed narrow molecular weight distribution indicating a living polymerisation process. These discrepancies may indicate some problem with the quality of W-initiator available to Suguwara.

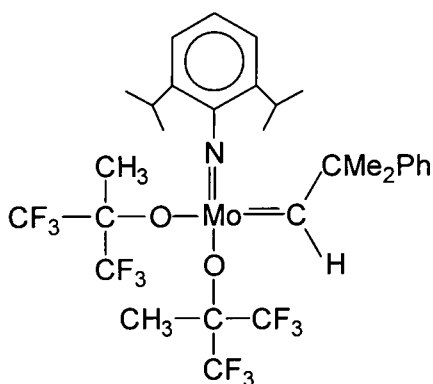
Suguwara also polymerised 4-methylcyclopentene.<sup>142</sup> In this case neither the t-butoxy-Mo nor t-butoxy-W were able to polymerise 4-methylcyclopentene even though they polymerised cyclopentene. The trifluorinated t-butoxy-Mo initiator polymerised 4-methylcyclopentene, but the reaction was very slow (20% yield at  $-55^{\circ}\text{C}$  after 4 hours). However,  $\text{Mo}(\text{N}-2,6\text{-}i\text{-Pr}_2\text{-C}_6\text{H}_3)[\text{OCMe}(\text{CF}_3)_2]_2(\text{CHCMe}_2\text{Ph})$ ; (hexafluorinated t-butoxy-Mo or Mo-F<sub>6</sub>) initiator polymerised 4-methylcyclopentene significantly faster (51% yield at  $-55^{\circ}\text{C}$  in 15 minutes). These results suggests that the polymerisation of 4-methylcyclopentene is thermodynamically much less favourable than that of cyclopentene. Also, all the polymers produced showed polydispersities around 2, and thus he concluded that these polymerisations proceeds *via* a classical chain growth manner rather than a well defined living process, as was observed for the polymerisation of cyclopentene using molybdenum centered initiators.

On the basis of above results for the polymerisation of cyclopentene and 4-methylcyclopentene, it was decided to use trifluoro and hexafluoro t-butoxy-Mo

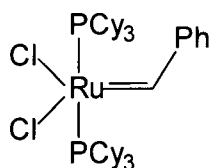
initiator to polymerise the cyclopentene based mesogenic monomer in chloroform as solvent. However, in one instance, Grubbs ruthenium based well defined initiator,  $\text{RuCl}_2[(\text{C}_6\text{H}_{11})_3\text{P}]_2(\text{CHPh})$  was also used in an attempt to polymerise this cyclopentene based mesogenic monomer. Different types of well defined initiators used in an attempt to polymerise this monomer are shown in figure 6.3. As discussed earlier in chapter-1, low reaction temperature and high monomer concentration work in favour of polymerisation of less strained monomers, such as 5,6 and 7 membered cycloalkenes. Therefore all polymerisations were carried out at low temperature ( $-55^\circ\text{C}$ ) and high initial monomer concentration.



$\text{Mo}(\text{N}-2,6-i\text{-Pr}_2\text{-C}_6\text{H}_3)(\text{OCMe}_2\text{CF}_3)_2(\text{CHCMe}_3)$   
(trifluorinated t-butoxy-Mo or Mo-F<sub>3</sub>)



$\text{Mo}(\text{N}-2,6-i\text{-Pr}_2\text{-C}_6\text{H}_3)[\text{OCMe}(\text{CF}_3)_2]_2(\text{CHCMe}_2\text{Ph})$   
(hexafluorinated t-butoxy-Mo or Mo-F<sub>6</sub>)



$\text{RuCl}_2[(\text{C}_6\text{H}_{11})_3\text{P}]_2(\text{CHPh})$   
(Ru)

**Figure 6.3** Types of well defined metathesis initiators used for the polymerisation

In a typical polymerisation, the monomer, initiator and the terminating reagent (benzaldehyde or ethyl vinyl ether) were dissolved in chloroform (approximately 0.5ml each) in separate sample vials and transferred into separate ampoules. These were then cooled to the required temperature in the cooling bath. Then the monomer solution was cannular transferred under a positive nitrogen pressure into initiator solution. After stirring the mixture for the prescribed period, the terminating reagent was added to quench the 'living polymer'. The mixture was stirred for about an hour and then allowed to warm to room temperature. The solution was then added drop-wise to excess methanol (10-fold excess) to precipitate and recover any polymer that may have formed. In some cases, in order to maximise the initial monomer concentration, the solvent in the initiator solution was removed under vacuum before adding the monomer solution. In the case of copolymerisation involving cyclopentene and the mesogenic monomer, both were dissolved together in chloroform and added to the initiator solution.

### 6.3 Results of Attempted Polymerisation

The results of all the polymerisation reactions are given in table 6.1 below.

No.	Monomer	Initiator	[M]/[I] Ratio <sup>†</sup>	Solvent	Temp. (°C)	Duration	Comments
1	mesogen*	Mo-F <sub>3</sub>	41	CHCl <sub>3</sub>	-55	22 hrs.	no polymer
2	mesogen*	Mo-F <sub>6</sub>	40	CHCl <sub>3</sub>	-55	24 hrs.	no polymer
3	4-methyl- cyclopentene	Mo-F <sub>6</sub>	475	CHCl <sub>3</sub>	-55	35 mins.	Polymer
4	mesogen*	Mo-F <sub>6</sub>	41	CH <sub>2</sub> Cl <sub>2</sub>	-90	1 hr.	no polymer
5	mesogen*	Mo-F <sub>6</sub>	42	CHCl <sub>3</sub>	-55	1 hr.	no polymer
6	cyclopentene /mesogen*	Mo-F <sub>6</sub>	233/60	CHCl <sub>3</sub>	-55	5 hrs.	no copolymer <sup>‡</sup>
7	mesogen*	Ru		CH <sub>2</sub> Cl <sub>2</sub>	-50	1 hr.	no polymer

<sup>†</sup> monomer to initiator molar ratio

<sup>‡</sup> only cyclopentene polymerises, see text

\* mesogenic monomer

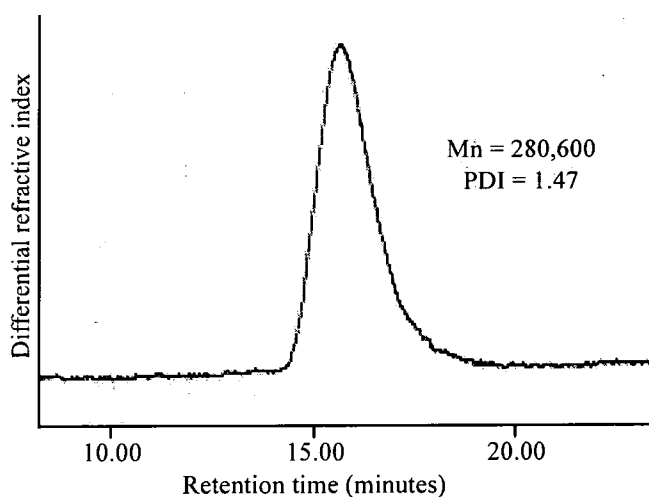
**Table 6.1** Results of the attempted polymerisation of the mesogenic monomer

### • Reactions No. 1 and 2

Initially, trifluoro t-butoxy-Mo initiator was used in an attempt to polymerise the mesogenic monomer in chloroform at  $-55^{\circ}\text{C}$  (reaction-1). However, even after 22 hours, no polymer was formed. Therefore the reaction was repeated under the same conditions using hexafluoro t-butoxy-Mo initiator (reaction-2). Again no polymer was formed even after 24 hours. The  $^1\text{H}$  nmr spectra (appendix-6) of both polymerisation mixtures after passing through a column of neutral alumina to remove the residual initiator showed the presence of olefinic protons of cyclopentene indicating that no polymerisation has taken place.

### • Reaction No. 3

In order to rule out that non-polymerisability of the mesogenic monomer is due to impurities in the solvent or the ineffectiveness of the experimental procedures, a sample of 4-methylcyclopentene was subjected to polymerisation following the work of Suguwara.<sup>142</sup> As expected, the polymerisation worked and the polymer produced showed a narrow molecular weight distribution ( $M_n=280,600$ ;  $PDI=1.47$ ). The GPC trace of this polymer is shown in figure 6.4. Thus, this reaction confirmed the effectiveness of the experimental procedures and the purity of solvents used in the polymerisation.



**Figure 6.4** The GPC trace of poly(4-methylcyclopentene)

#### • Reaction No. 4

The polymerisation of less strained monomers are favoured by lower temperatures. Therefore the polymerisation of the mesogenic monomer was attempted at  $-90^{\circ}\text{C}$  instead of  $-55^{\circ}\text{C}$ . In this case the solvent was changed from chloroform to dichloromethane since chloroform freezes at  $-64^{\circ}\text{C}$ . However, due to very high concentration of the polymerisation mixture, it tends to freeze at this temperature and thus the reaction was unsuccessful and no polymer was formed.

#### • Reaction No. 5

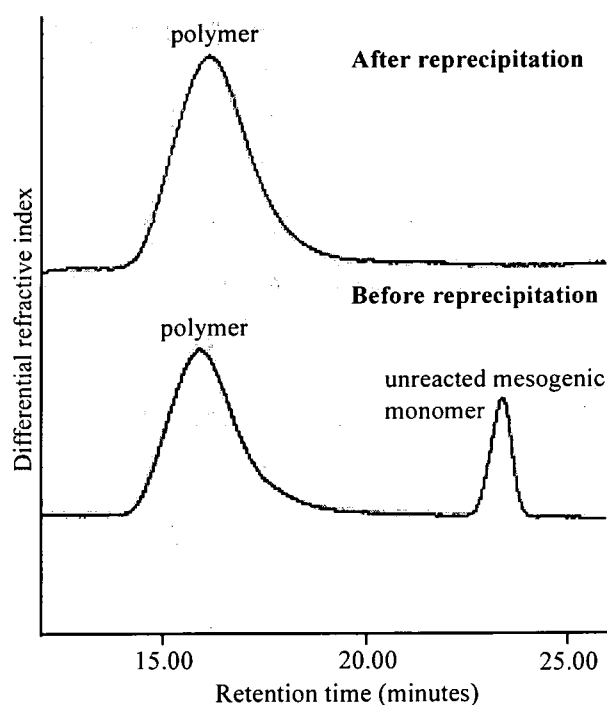
Since the polymerisation of less strained monomers are also favoured by very high monomer concentration, the mesogenic monomer was again subjected to polymerisation using hexafluoro t-butoxy-Mo initiator at  $-55^{\circ}\text{C}$  in chloroform. In this case in order to increase the initial monomer concentration, the solvent used to dissolve the initiator was completely removed under vacuum before adding the monomer solution to the initiator solution. In this way a very high initial monomer concentration was achieved. However, no polymer was formed after allowing the polymerisation reaction to proceed for an hour.

#### • Reaction No. 6

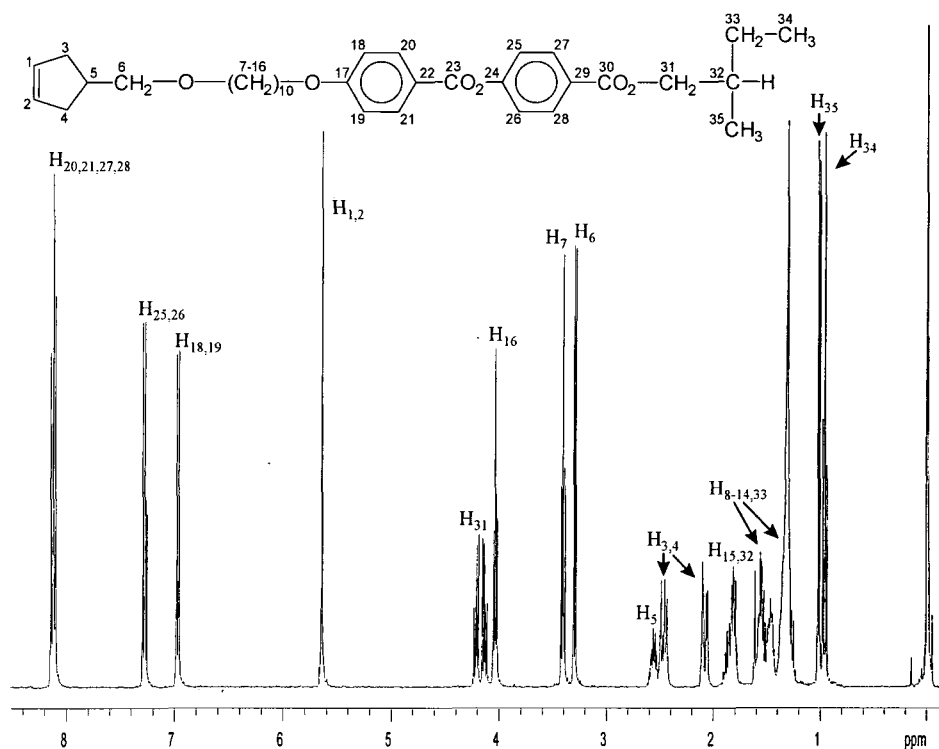
All attempts to homopolymerise the mesogenic monomer using trifluoro and hexafluoro molybdenum initiator failed. Therefore copolymerisation of the mesogenic monomer with cyclopentene was attempted using hexafluoro t-butoxy-Mo initiator to see whether the propagating alkylidene resulting with the reaction of cyclopentene initiates the polymerisation of the mesogenic monomer.

The GPC trace of the polymer recovered after precipitation showed two peaks (figure 6.5); one corresponding to the high molecular weight polymer and another with the same retention time as mesogenic monomer. After a single reprecipitation (from THF into methanol), the GPC trace showed only one peak, that of the high molecular weight polymer. The  $^{13}\text{C}$  and  $^1\text{H}$  spectra of the reprecipitated polymer sample confirmed that it was poly(pentenylene). However,  $^1\text{H}$  and  $^{13}\text{C}$  nmr spectra of the reprecipitated polymer showed some signals (very low in intensity) corresponding to the mesogenic monomer. Therefore in order to check whether this is due to traces of

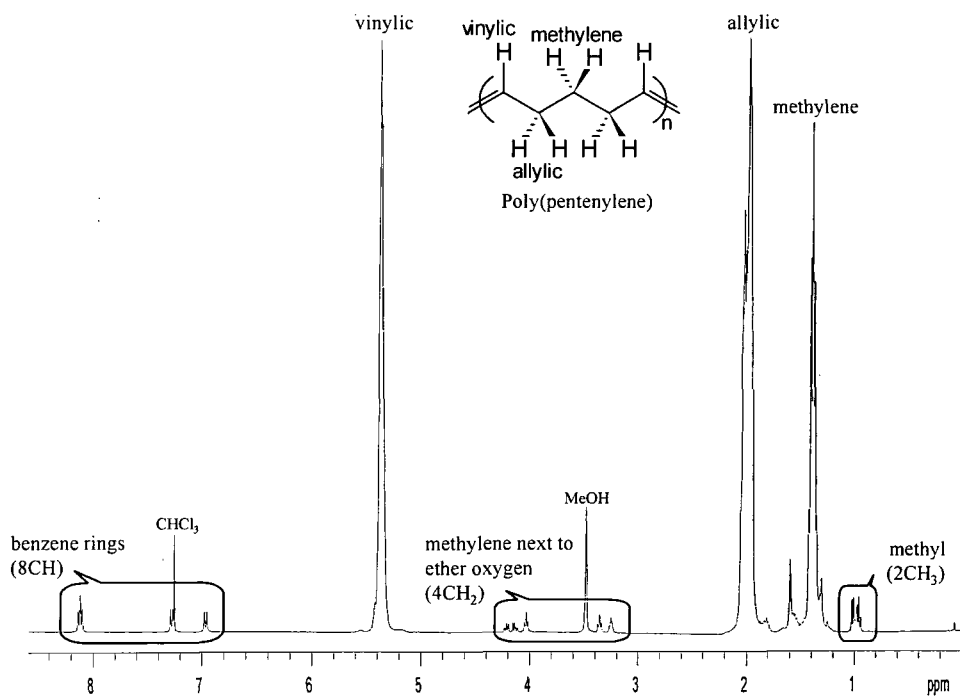
the unreacted mesogenic monomer, the polymer sample was again reprecipitated. Even after the second reprecipitation, the signals corresponding to the mesogenic monomer remained unchanged. All the  $^{13}\text{C}$  and  $^1\text{H}$  nmr spectra are given in appendix-6. The  $^1\text{H}$  nmr spectrum (figure 6.7) of the polymer sample after 2 reprecipitation cycles clearly shows signals due to benzene rings of the mesogenic monomer (6.96, 7.27 and 8.12ppm), methylene protons next to ether oxygens (3.31, 3.41, 4.04 and 4.10-4.24ppm) and methyl groups (0.96 and 1.01ppm). However, signals corresponding to the vinylic (5.65ppm), methylene (2.06-2.11 and 2.40-2.50ppm) and methine (2.55ppm) protons of the cyclopentene ring are missing (compare the  $^1\text{H}$  nmr spectra in figure 6.6 and 6.7). This suggests that a very small proportion of the mesogenic monomer might have been incorporated into the poly(pentenylene) polymer chain. One possible explanation is that initially the hexafluoro-Mo initiator initiates the polymerisation of cyclopentene. The resulting new propagating alkylidene then reacts with the mesogenic monomer and after inserting a single monomer unit into the growing poly(pentenylene) chain, the polymerisation stops due to the inactivity of the new propagating alkylidene unit leaving bulk of the mesogenic monomer unreacted. This leads to an unreacted mesogenic monomer peak in the GPC trace which upon reprecipitation disappears.



**Figure 6.5** The GPC traces of copolymerisation reaction between cyclopentene and the mesogenic monomer



**Figure 6.6** The  $^1\text{H}$  nmr spectrum of the mesogenic monomer



**Figure 6.7** The  $^1\text{H}$  nmr spectrum of the polymer prepared by copolymerising cyclopentene and the mesogenic monomer after 2 reprecipitation cycles.

• **Reaction No. 7**

As a final attempt to homopolymerise this monomer, the well defined Grubbs ruthenium initiator was used. The colour of the polymerisation mixture remained purple throughout the polymerisation indicating that the initiator is living. Only after adding the terminating reagent ethyl vinyl ether, the colour gradually changes to orange colour. However, again no polymer was formed.

Therefore all attempts to polymerise the mesogenic monomer using trifluoro- and hexafluoro t-butoxy-Mo initiator and ruthenium initiator failed. All these results suggests that the polymerisation of the mesogenic monomer is thermodynamically not favourable. Also the type of substituent and its position in the ring may have contributed to this effect.

## 6.4 EXPERIMENTAL

Cyclopentene, chloroform (99.9+% HPLC grade), calcium hydride, benzaldehyde, neutral alumina were purchased from Aldrich Chemical Co. Ltd. Dichloromethane and phosphorous pentoxide were bought from BDH Chemicals. The ring opening metathesis initiator  $\text{Mo}(\text{N-2,6-}i\text{-Pr}_2\text{C}_6\text{H}_3)(\text{OCMe}_2\text{CF}_3)_2(\text{CHCMe}_3)$  was prepared by Dr. Ezat Khosravi in the IRC laboratories and  $\text{Mo}(\text{N-2,6-}i\text{-Pr}_2\text{C}_6\text{H}_3)[\text{OCMe}(\text{CF}_3)_2]_2(\text{CHCMe}_2\text{Ph})$  was bought from Strem Chemicals Inc. The  $\text{RuCl}_2[(\text{C}_6\text{H}_{11})_3\text{P}]_2(\text{CHPh})$  metathesis initiator was prepared by Dr. David Snowden at IRC laboratories. He also provided the terminating reagent ethyl vinyl ether. 4-Methylcyclopentene was previously prepared and purified by Dr. K. G. Suguwara. Chloroform was dried and degassed over phosphorous pentoxide and vacuum transferred into ampules. Cyclopentene was distilled under atmospheric pressure (bpt. 44°C), dried and degassed over calcium hydride and vacuum transferred into ampules. Dichloromethane was purified as described below. Neutral alumina was dried at 200°C in the vacuum oven overnight. The solvents for polymerisation were passed through a short column (approximately 10cm) of oven dried neutral alumina before use. Benzaldehyde was purified as described earlier in chapter-4. The solutions of initiator, monomer and terminating reagent were prepared in an inert atmosphere (dry nitrogen) filled glove box. The polymerisation reactions were carried out under nitrogen using a conventional vacuum line and in a special cooling bath or in acetone/dryice, acetone/liquid air bath. The ampules used in these polymerisation reactions were specially designed so as to have a long neck (approximately 15cm) and only the base of the ampule containing the polymerisation mixture was immersed in the coolant. This was necessary in order to prevent any air leaks due to shrinkage of P.T.F.E. Youngs taps at very low temperatures.

### 6.4.1 Purification of Dichloromethane

In a separating funnel dichloromethane (200ml) was first washed with concentrated sulfuric acid (3 x 30ml) followed by de-ionised water (1 x 50ml), saturated sodium bicarbonate (1 x 30ml) and again with de-ionised water (1 x 50ml). This was initially dried over calcium chloride overnight, filtered and further dried and degassed over calcium hydride and vacuum transferred into ampules.

### 6.4.2 A Typical Polymerisation

A typical example of the procedures adopted for the polymerisation of the mesogenic monomer and 4-methylcyclopentene is described below.

The initiator  $\text{Mo}(\text{N-2,6-}i\text{-Pr}_2\text{C}_6\text{H}_3)(\text{CHCMe}_2\text{Ph})[\text{OCMe}(\text{CF}_3)_2]_2$  (17.8mg, 0.023mmol) was dissolved in chloroform (0.5ml) in a sample vial and transferred into an ampule. The mesogenic monomer (793.4mg, 1.405mmol, 60 equivalents) and cyclopentene (370mg, 5.432mmol, 233 equivalents) were dissolved together in chloroform (1ml) in a sample vial and transferred into another ampule. Similarly, benzaldehyde (approximately 200mg) was dissolved in chloroform and placed in a separate ampule. The solvent used to dissolve the initiator was then removed from the ampule under vacuum. All 3 ampules were then placed in the cooling bath and cooled to  $-55^\circ\text{C}$ . At the same time the ampules were connected separately to the vacuum line while they are still closed with Youngs taps and evacuated. The Youngs taps were then opened under a positive nitrogen pressure and replaced with Suba seal caps. Then the monomer solution was cannular transferred into the initiator ampule under nitrogen pressure. The reaction mixture was stirred for 5 hours and terminated with benzaldehyde by cannular transferring the benzaldehyde solution under nitrogen pressure into the ampule containing the polymerisation mixture. After stirring for about  $1\frac{1}{2}$  hours, the polymerisation mixture was allowed to warm to room temperature. Finally, the polymerisation mixture was added drop wise into methanol (10-fold excess). The precipitated polymer was filtered and dried in the vacuum oven at room temperature overnight.

In the case of polymerisation reactions 1 and 2 (table 6.1) where no polymer was formed, the polymerisation mixture in methanol was passed through a short column (4cm) of oven dried neutral alumina to remove bulk of the residual initiator and the eluted solution was concentrated and analysed by  $^1\text{H}$  nmr (appendix-6) for any signs of polymerisation.

**CHAPTER-7**  
**CONCLUSIONS AND PROPOSALS FOR FUTURE WORK**

## 7.1 CONCLUSIONS

### 7.1.1 Ring Opening Metathesis Polymerisation of Macromonomers to Produce Graft Copolymers

The work described in this thesis indicates that well defined poly(norbornene-*g*-styrene) graft copolymers can be prepared by living ring opening metathesis polymerisation of well defined *exo*-5-norbornene-2-(polystyrylcarboxylate) macromonomers, synthesised by living anionic polymerisation. Since both macromonomer synthesis and polymerisation of macromonomers to produce graft copolymers involve living polymerisation techniques, the above procedure allows control over molecular weight and molecular weight distribution of both the graft chains and the backbone chains and the graft density. The initiation and propagation steps of ring opening metathesis polymerisation of macromonomers can be followed by <sup>1</sup>H nmr spectroscopy which confirms that the polymerisation is living. The nmr scale polymerisations indicate that for this system the rate of propagation is faster than the rate of initiation. Since there is only one polystyrene graft attached to the norbornene unit, steric hindrance at the growing chain end can be significantly reduced by head/tail addition. This in turn allows preparation of very high molecular weight graft copolymers having longer polynorbornene backbone chains and relatively long polystyrene grafts than the di-substituted macromonomers investigated previously. Polymerisation of macromonomers at different macromonomer to initiator molar ratio indicates that beyond a threshold value of macromonomer to initiator molar ratio, these polymerisations stop before complete consumption of macromonomers, due to steric hindrance at the growing chain end. However, the threshold value of macromonomer to initiator molar ratio at which the polymerisation stops before complete consumption of macromonomers for these systems is significantly higher than that for di-substituted macromonomers with similar amount of styrene units in the polystyrene graft. Similarly, the results also indicates that there is a relationship between the polystyrene graft length and the polynorbornene backbone chain length. Thus, macromonomers having shorter polystyrene grafts allow production of graft copolymers having long polynorbornene backbones and *vice versa*. The broadening of molecular weight distribution of graft copolymers prepared at very high macromonomer to initiator molar ratios could be due to a combination of

mixing efficiency effects and the faster rate of propagation than initiation. DSC analysis of these graft copolymers indicate that polynorbornene and polystyrene segments do not undergo phase segregation. Also the T<sub>g</sub> process observed seems to be primarily associated with polystyrene grafts in these systems.

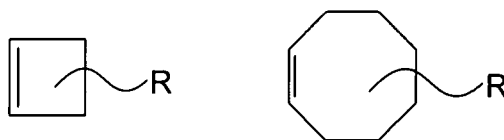
### **7.1.2 Attempted Synthesis of Side Chain Liquid Crystalline Polymers by Ring Opening Metathesis Polymerisation**

The potentially mesogenic monomer, (*S*)-(-)-2-methylbutyl-4-(4-(10-(3-cyclopentenylmethoxy) decyloxy) phenylcarbonyloxy) benzoate was successfully prepared. Although the monomer did not exhibit any mesophases, it was expected to exhibit liquid crystallinity upon polymerisation. However, all attempts to polymerise this monomer using Schrock molybdenum and Grubbs ruthenium well defined initiators failed. The lower ring strain associated with cyclopentene ring, the type of substituent attached to the ring and the position of the substituent on the ring could all have contributed to the non-polymerisability of this monomer.

## **7.2 PROPOSALS FOR FUTURE WORK**

The work described in this thesis involved synthesising well defined graft copolymers with polynorbornene backbone chain and polystyrene grafts. This work illustrated that coupled living anionic and living ring opening metathesis polymerisation allows to synthesise well defined graft copolymers with control over molecular weight and molecular weight distribution of graft and backbone chains, and graft density. Thus this synthetic route has the potential to prepare a variety of well defined graft copolymers with different combinations of backbone and graft chains. This can be achieved by changing the type of monomer and the capping reagent/functionalised initiator used in anionic polymerisation to produce a ring open polymerisable macromonomer. Thus it would be worth exploring the potential of this synthetic route to prepare well defined graft copolymers with polyethylene backbone chains and polystyrene or polyethylene oxide grafts. This requires synthesising polystyrene or polyethylene oxide macromonomers with a mono-cyclic alkene such as cyclobutene or cyclooctene as the ring open polymerisable functional group. These macromonomers can either be prepared by end capping living polystyrene or

polyethylene oxide or by employing a functionalised anionic initiator (figure 7.1). The subsequent living ring opening metathesis polymerisation of these macromonomers should yield the graft copolymer with a poly(alkenamer) backbone chain. Hydrogenation of this graft copolymer should yield the desired well defined poly(ethylene-g-styrene) or poly(ethylene-g-ethylene oxide) graft copolymers. Since macromonomers with a range of ring open polymerisable mono-cyclic rings (cyclobutene, cyclooctene *etc.*) can be prepared, this procedure also allows control of the graft density along the graft copolymer backbone chain. The graft copolymers described in this thesis were synthesised employing Shrocks molybdenum initiators, namely  $\text{Mo}(\text{N}-2,6\text{-i-Pr}_2\text{-C}_6\text{H}_3)(\text{OCMe}_3)_2(\text{CHR})$  where R is either  $\text{CMe}_3$  or  $\text{CMe}_2\text{Ph}$ . However, it would be worth attempting to ring open polymerise these macromonomers using Grubbs ruthenium initiator  $\text{RuCl}[(\text{C}_6\text{H}_{11})_3\text{P}]_2(\text{CHPh})$ , due to its greater tolerance towards functional groups, lower cost and tolerance towards moisture.



R =  $\text{CH}_2\text{Cl}$  and  $\text{CO}_2\text{Cl}$  (as an end capping reagent) or  
 $\text{CH}_2\text{Li/K}$  (as a functionalised initiator)

**Figure 7.1** Functionalised cyclobutenes and cyclooctenes that could be used to synthesise ring open polymerisable macromonomers

In the case of the attempted side chain liquid crystalline polymer synthesis, the primary objective to use a cyclopentene ring as the ring open polymerisable unit was to produce a side chain liquid crystalline polymer with a low T<sub>g</sub> hydrocarbon backbone chain. Although cyclopentene based mesogenic monomer can not be ring open polymerised, the desired objective could be achieved by substituting cyclopentene with cyclobutene or cyclooctene to give a flexible, low T<sub>g</sub> hydrocarbon polymer backbone.

**APPENDIX-1**  
**GENERAL PROCEDURES, EQUIPMENT AND**  
**INSTRUMENTATION**

## GENERAL EXPERIMENTAL PROCEDURES

The glove boxes used throughout this work were either the modified Miller Howe dry box or MBraun MB 150B-G dry box. Both were fitted with freezers (-20 to -40°C). The inert gas was oxygen-free nitrogen and the working conditions were 2-6 ppm oxygen and 5-7 ppm water in the former and <1ppm oxygen and water in the latter. Apparatus was transferred in and out of the box *via* vacuum/nitrogen ports.

The vacuum/nitrogen lines were fitted with Youngs valves and greaseless joints to allow handling of materials either under nitrogen or under vacuum. Dry oxygen-free nitrogen was supplied through a gas bubbler (silicone oil) and either a molecular sieve or P<sub>2</sub>O<sub>5</sub> column. Vacuum was provided by an Edwards silicone oil diffusion pump (63mm) connected to an Edwards 5 two stage backing pump for anionic polymerisation work and for all other work Edwards 5 two stage pump was used.

The thermostated cooling bath used for the polymerisation of mesogenic monomer was a HAAKE F3-Q model and the cooling fluid was silicone oil (sil. 100, 60°C to -75°C).

## INSTRUMENTATION AND PROCEDURES FOR MEASUREMENTS

- **NMR-** <sup>1</sup>H, <sup>13</sup>C, COSY, HETCOR and DEPT spectra were recorded either on a Varian VXR 400 nmr spectrometer at 399.953 MHz (<sup>1</sup>H) and 100.577 MHz (<sup>13</sup>C) or Varian Gemini nmr spectrometer at 199.532 MHz (<sup>1</sup>H) and 50.289 MHz (<sup>13</sup>C). Deuterated chloroform or deuterated benzene was used as solvent. All the nmr spectra given in this thesis were recorded at 399.953 MHz (<sup>1</sup>H) and 100.577 MHz (<sup>13</sup>C) unless it is stated in the text.

- **INFRARED SPECTRA** were recorded on a Perkin Elmer 1600 series FTIR. The spectra were recorded as solvent (chloroform) cast films (macromonomers) or KBr discs.

- **ELEMENTAL ANALYSIS** were carried out on a Exeter Analytical, Inc. CE-440 elemental analyser.

- **MASS SPECTRA** were recorded either on a VG analytical model 7070E mass spectrometer or VG TRIO 1000 mass spectrometer coupled to HP5890 SERIES II gas chromatography.

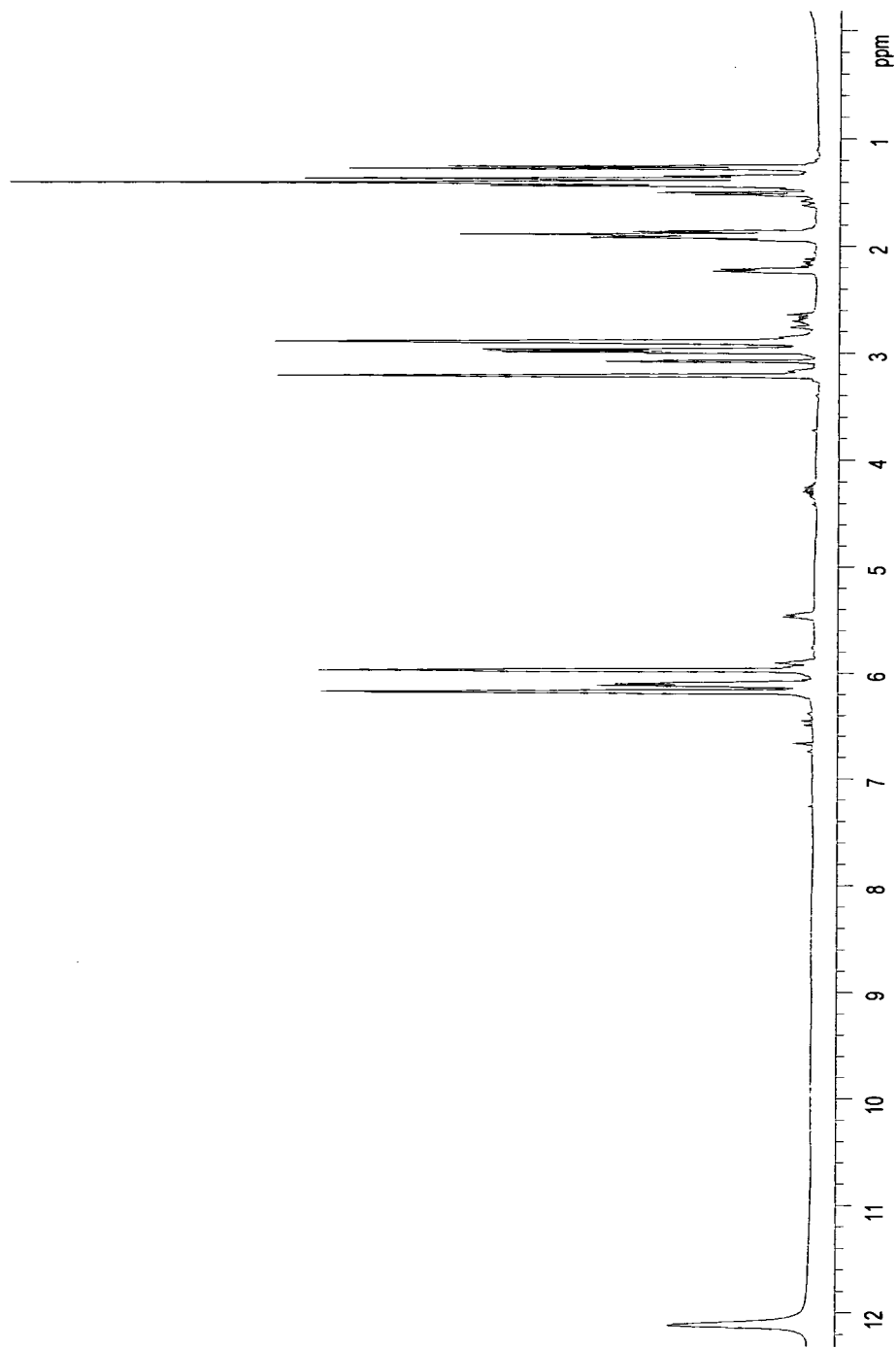
- **GEL PERMEATION CHROMATOGRAPHY (GPC)** analyses were performed on chloroform solutions using a Knauer HPLC pump (Model 64), Waters Model R401 differential refractometer detector and 3 PLgel columns with pore sizes of  $10^2$ ,  $10^3$  and  $10^5 \text{ \AA}$  (column packing PLgel  $5 \mu\text{m}$  mixed styrene-divinyl benzene beads). The sample solutions (concentration 0.2%) were filtered through a Whatman WTP type  $0.2 \mu\text{m}$  filter to remove any particulate before injection. The columns were calibrated using Polymer Laboratories polystyrene standards (162-770,000amu).

- **DIFFERENTIAL SCANNING CALORIMETRY** was carried out using a Perkin Elmer DSC 7 differential scanning calorimeter over the temperature range of  $25^\circ\text{C}$ - $200^\circ\text{C}$  (heating rate  $10^\circ\text{C min}^{-1}$ ).

- **THERMOGRAVIMETRIC ANALYSIS** was performed using a Stanton Redcroft TG 760 thermobalance. TGA traces were recorded by increasing the sample temperature from  $20^\circ\text{C}$  to  $650^\circ\text{C}$  by  $10^\circ\text{C}$  per minute under a nitrogen atmosphere and the 2% weight loss temperature was taken as the decomposition temperature.

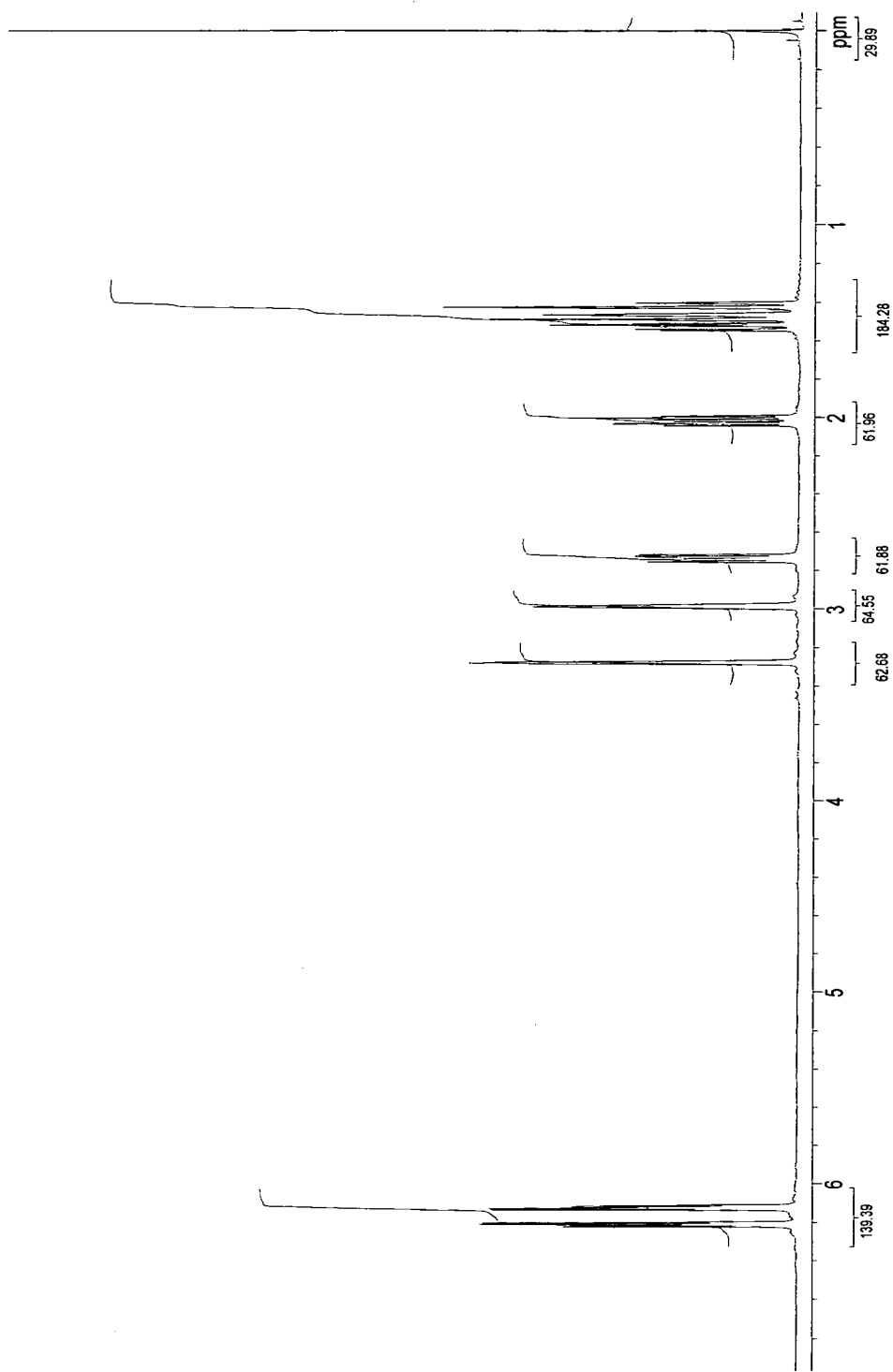
**APPENDIX-2**

**Analytical Data for Chapter-2**

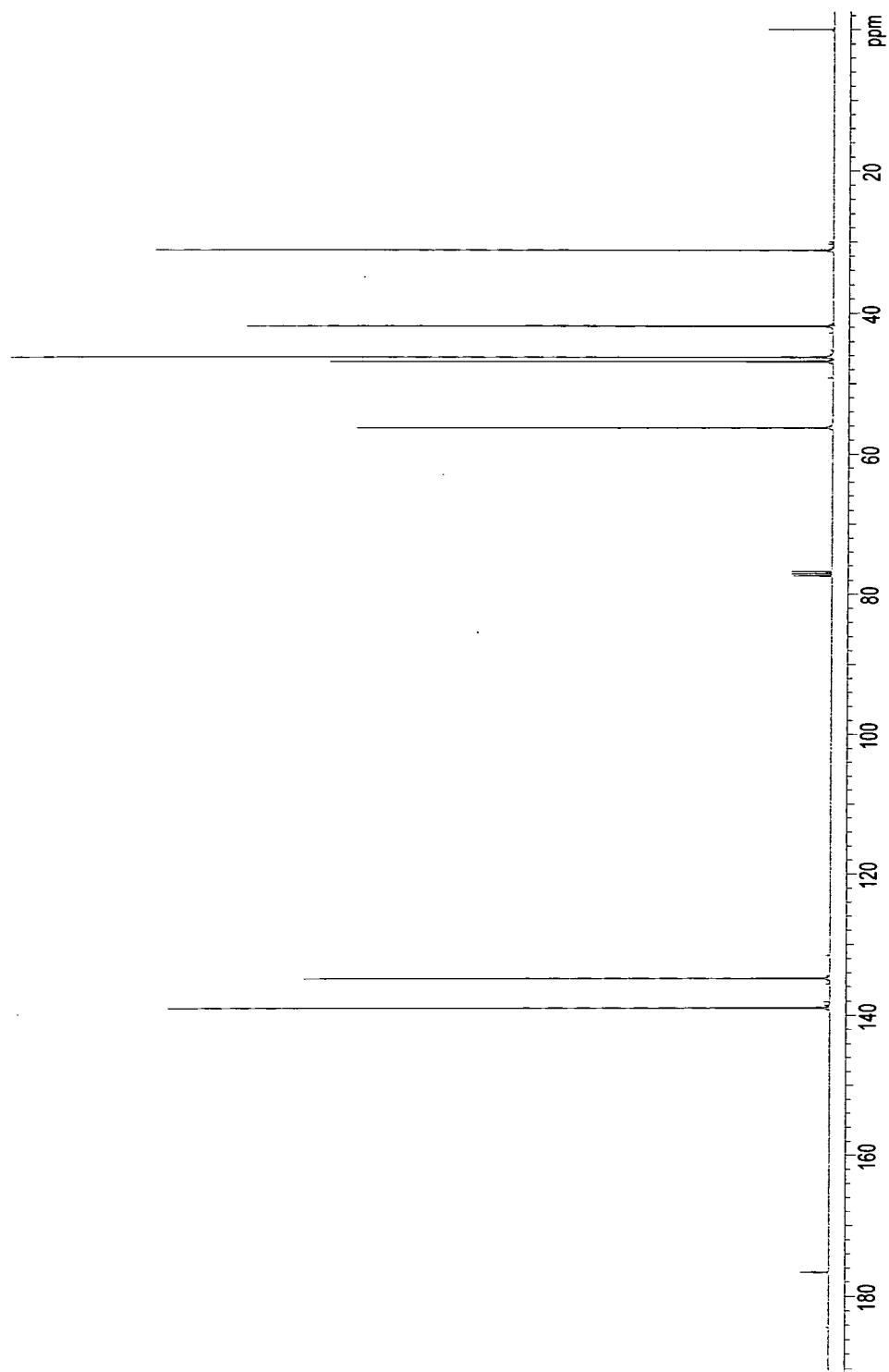


**Figure A2.1** <sup>1</sup>H nmr spectrum of crude *exo/endo*-5-norbornene-2-carboxylic acid





**Figure A2.3** <sup>1</sup>H nmr spectrum of *exo*-5-norbornene-2-carbonyl chloride



**Figure A2.4**  $^{13}\text{C}$  nmr spectrum of *exo*-5-norbornene-2-carbonyl chloride

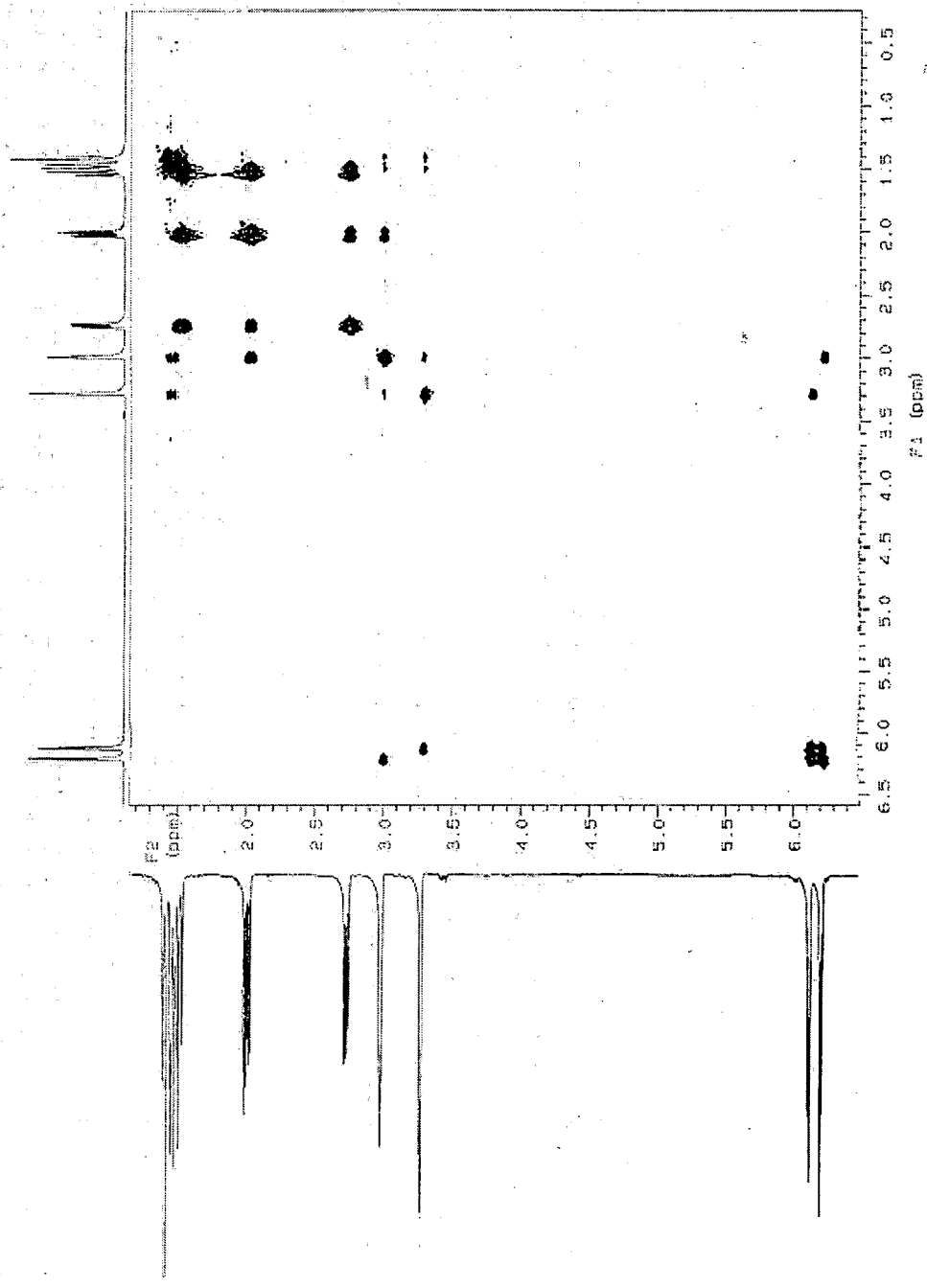


Figure A2.5 COSY nmr spectrum of *exo*-5-norbornene-2-carbonyl chloride

6-10  
Fig.  
1.

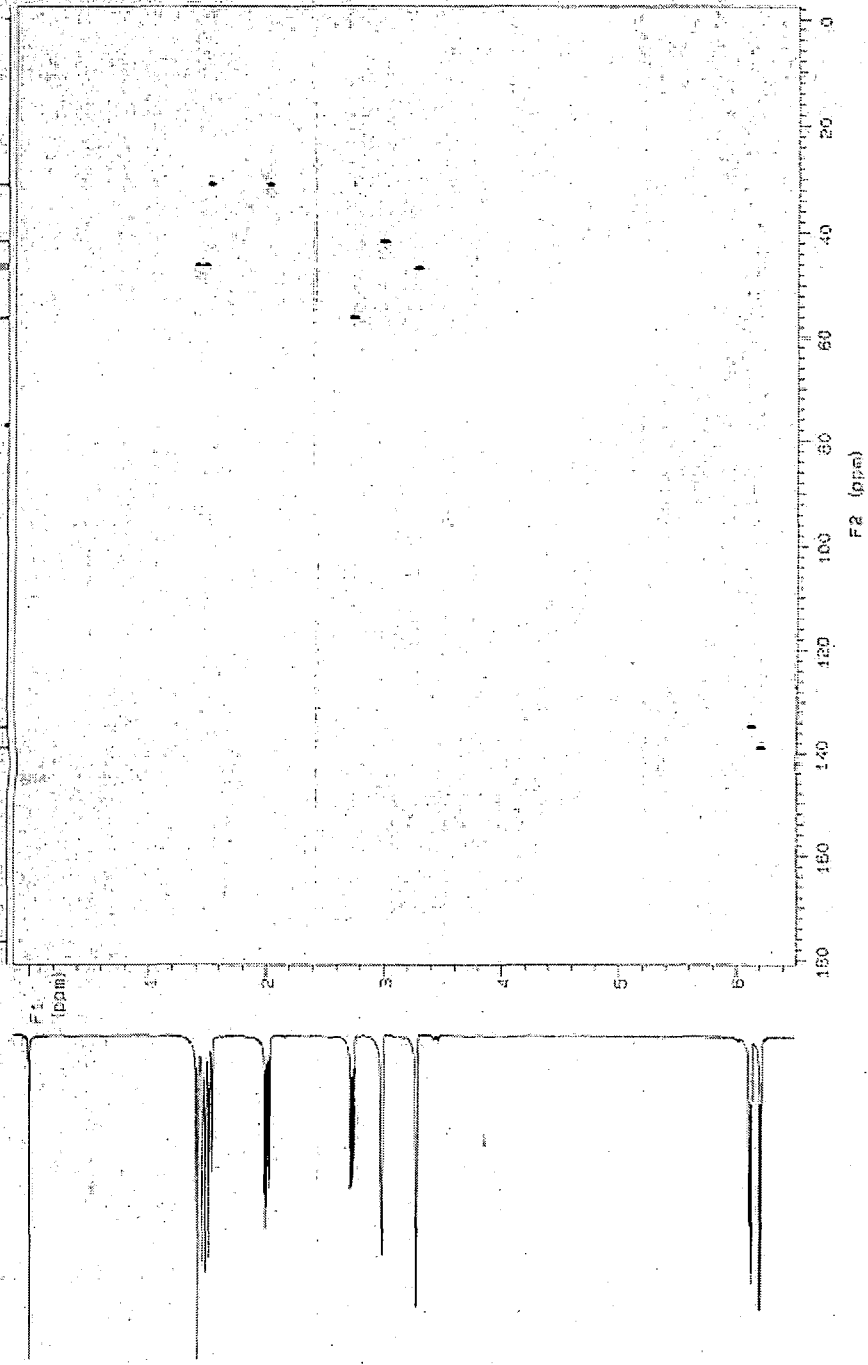


Figure A2.6 HETCOR nmr spectrum of *exo*-5-norbornene-2-carbonyl chloride

**APPENDIX-3**

**Analytical Data for Chapter-3**

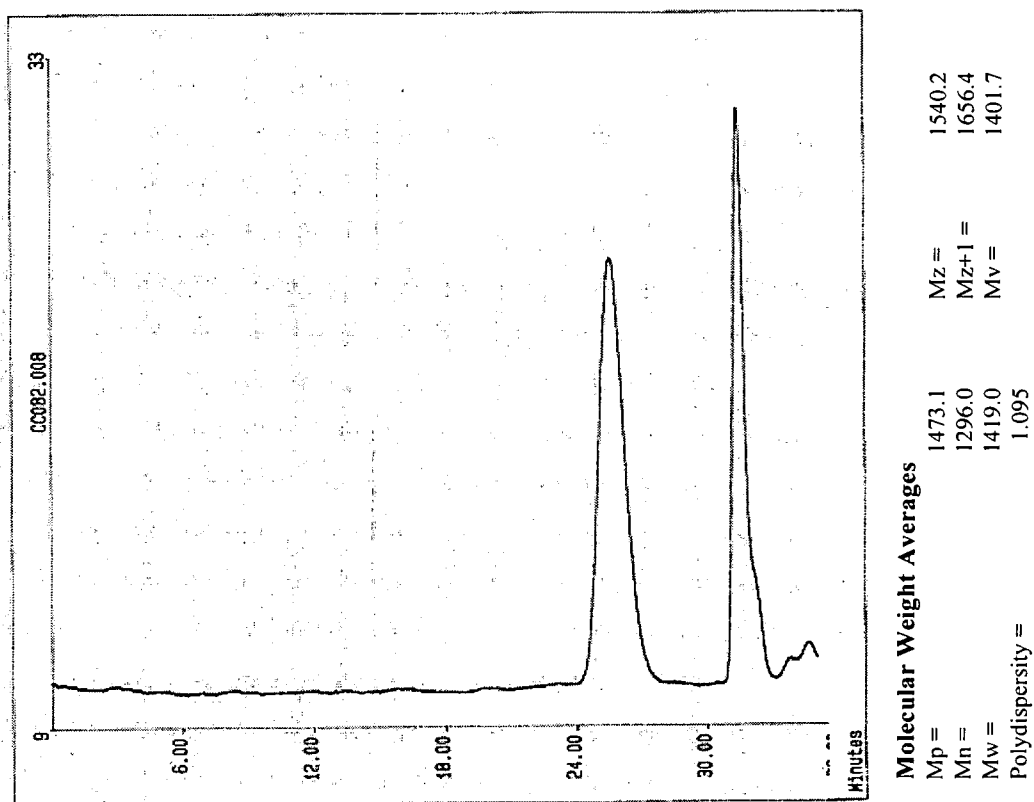


Figure A3.1 GPC trace of polystyrene homopolymer (sample-1)

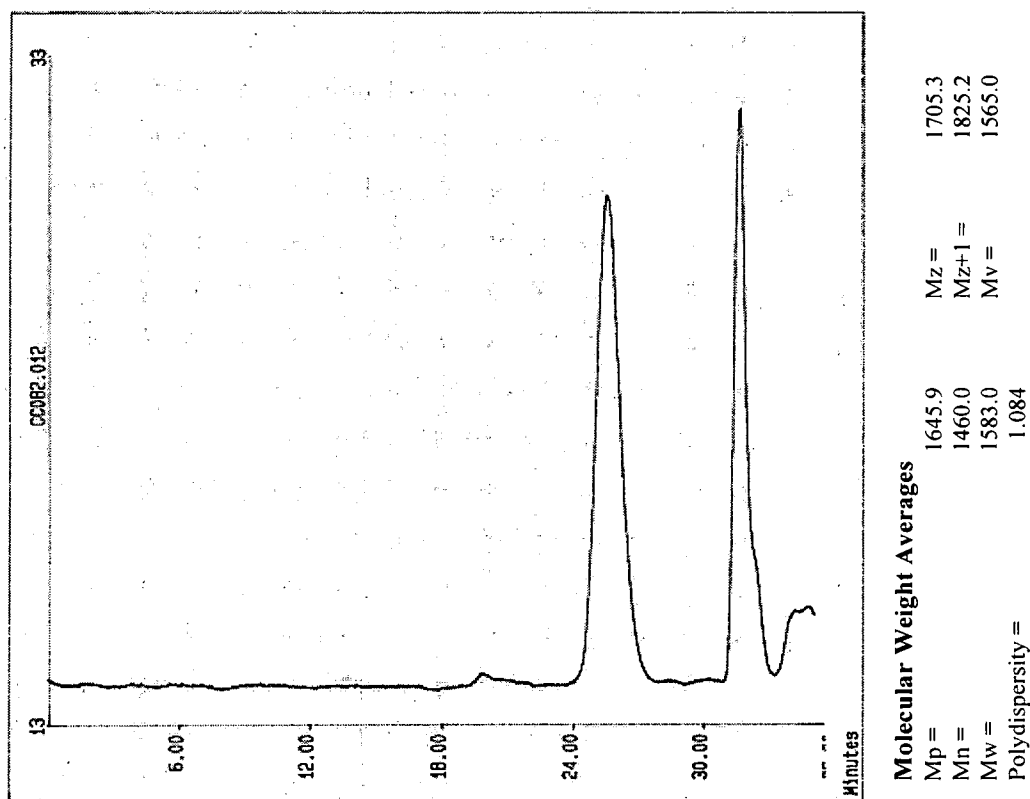


Figure A3.2 GPC trace of *exo*-5-norbornene-2(polystyrylcarboxylate) macromonomer (sample-1)

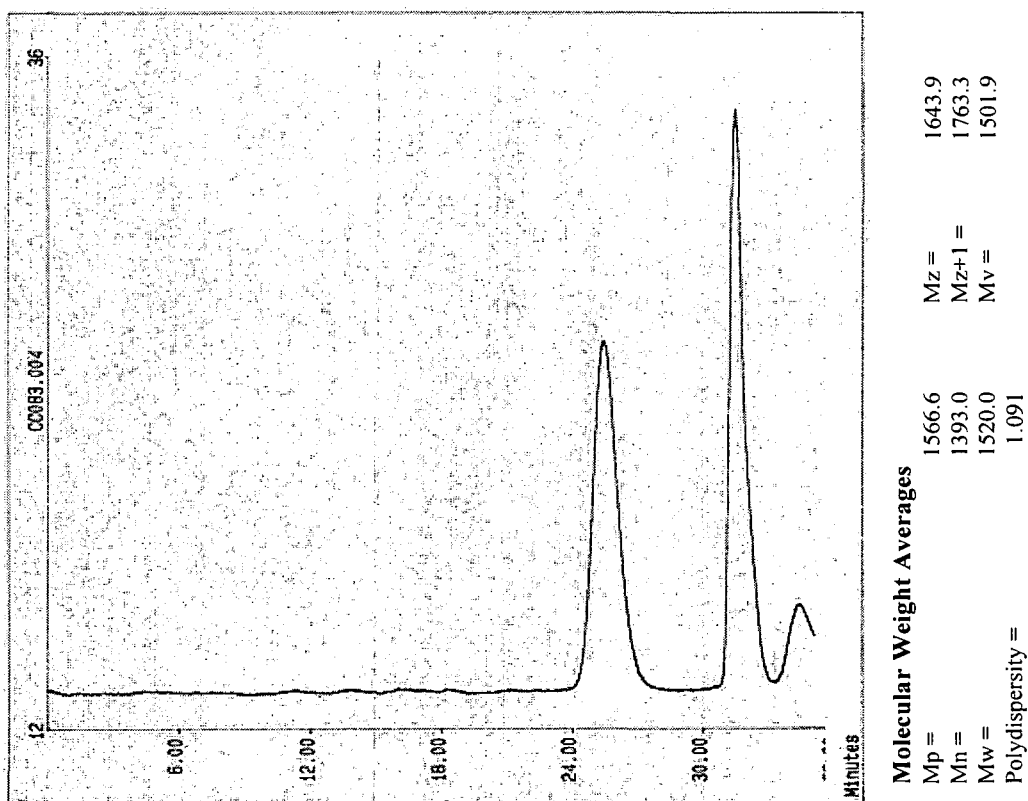


Figure A3.3 GPC trace of polystyrene homopolymer (sample-2)

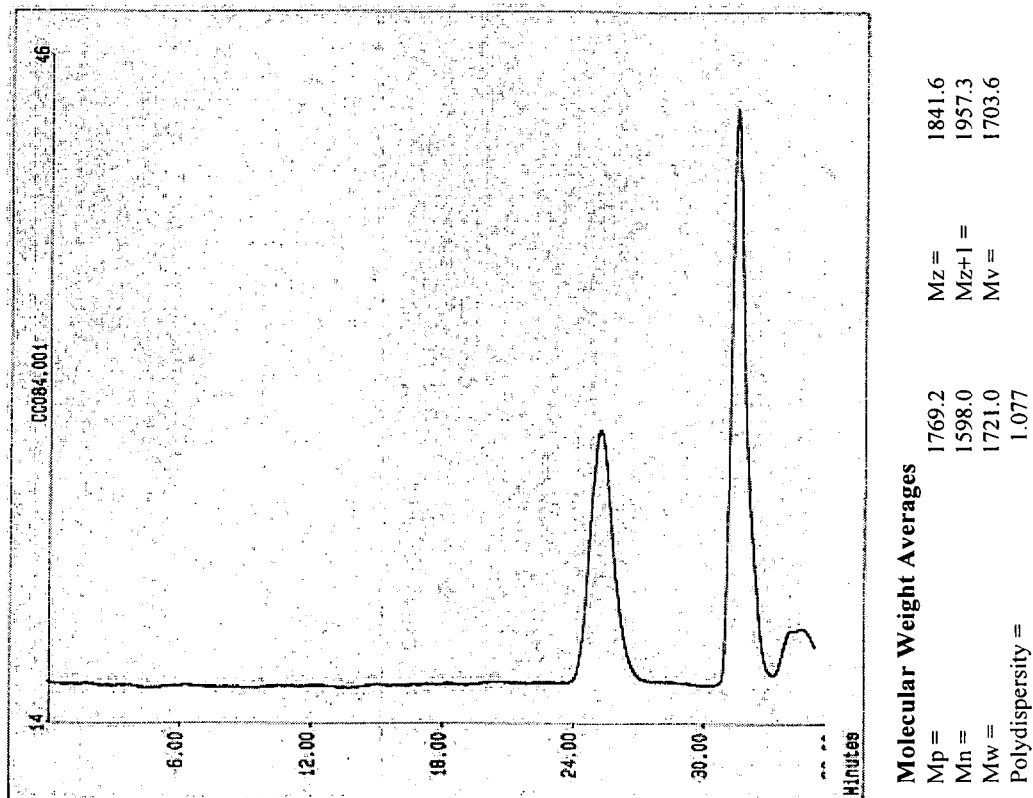


Figure A3.4 GPC trace of *exo*-5-norbornene-2(polystyrylcarboxylate) macromonomer (sample-2)

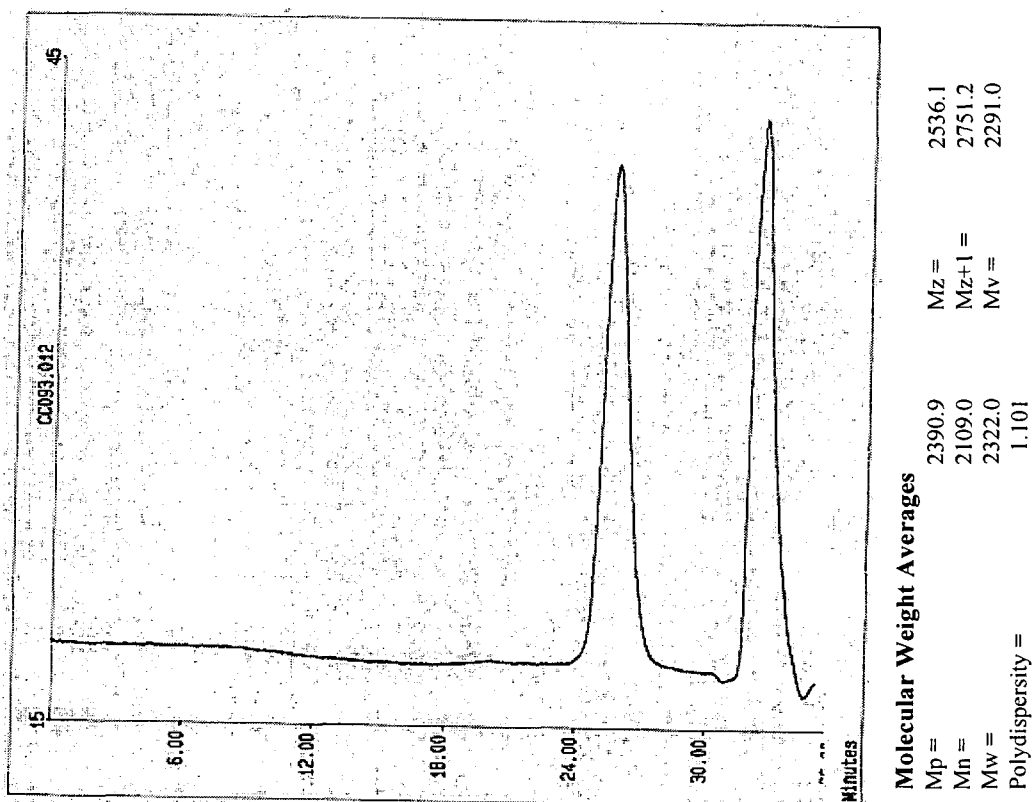


Figure A3.5 GPC trace of polystyrene homopolymer (sample-3)

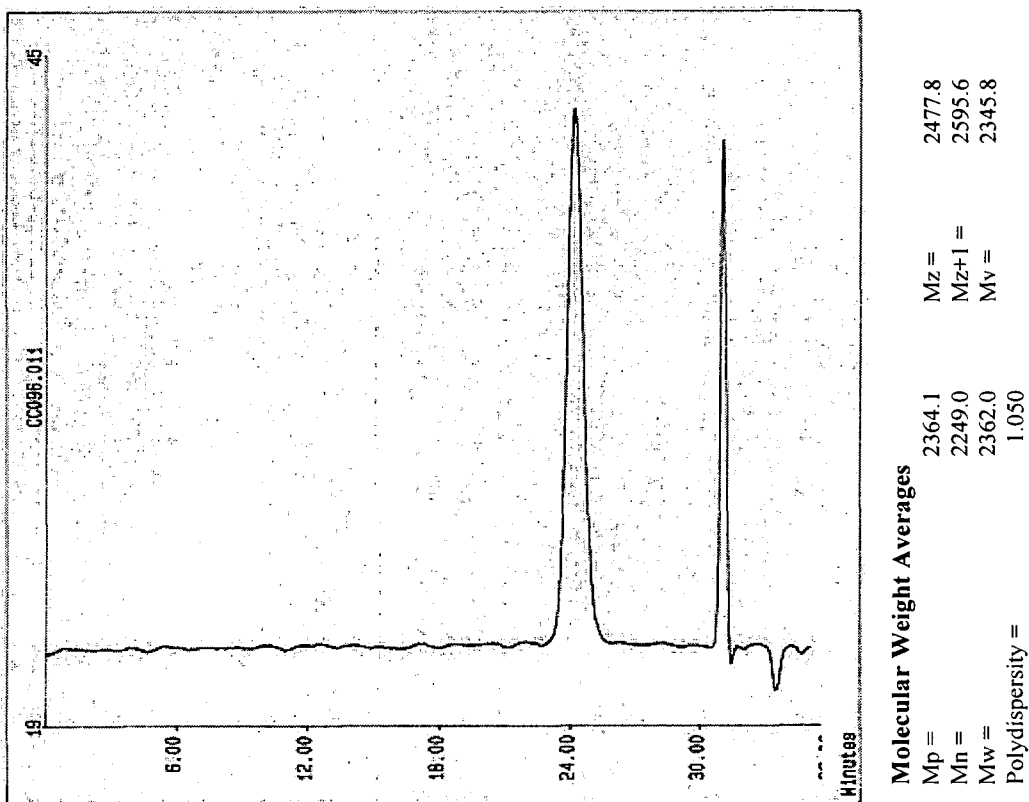


Figure A3.6 GPC trace of *exo*-5-norbornene-2(polystyrylcarboxylate) macromonomer (sample-3)

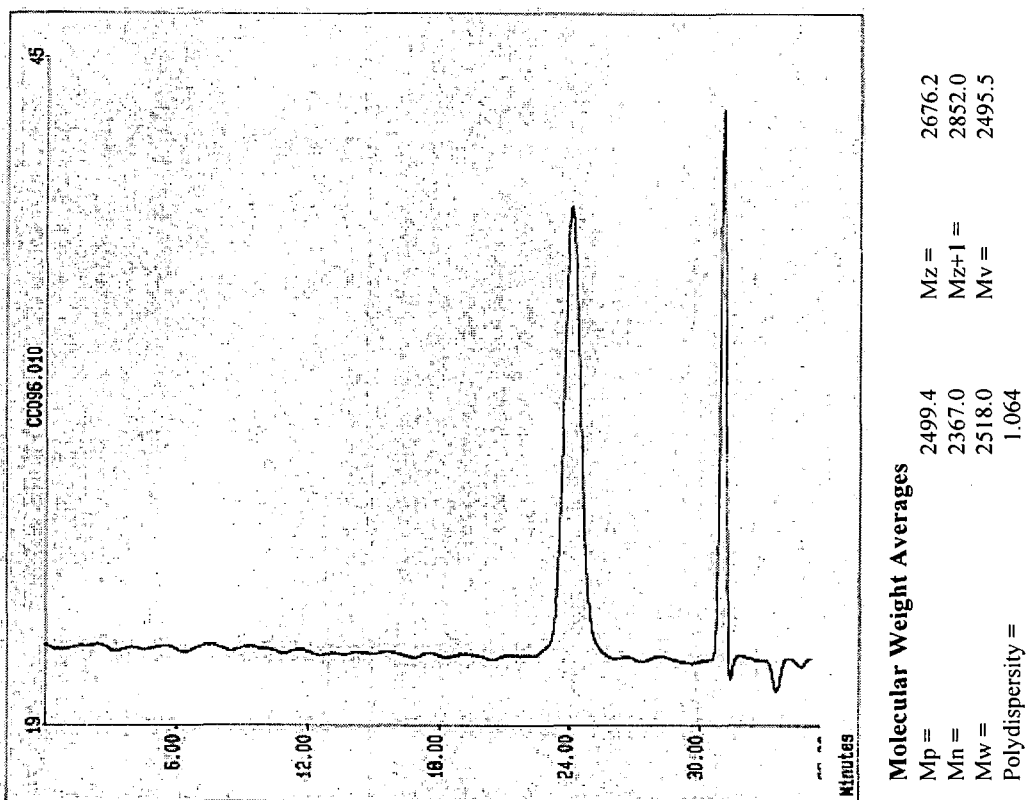


Figure A3.7 GPC trace of polystyrene homopolymer (sample-4)

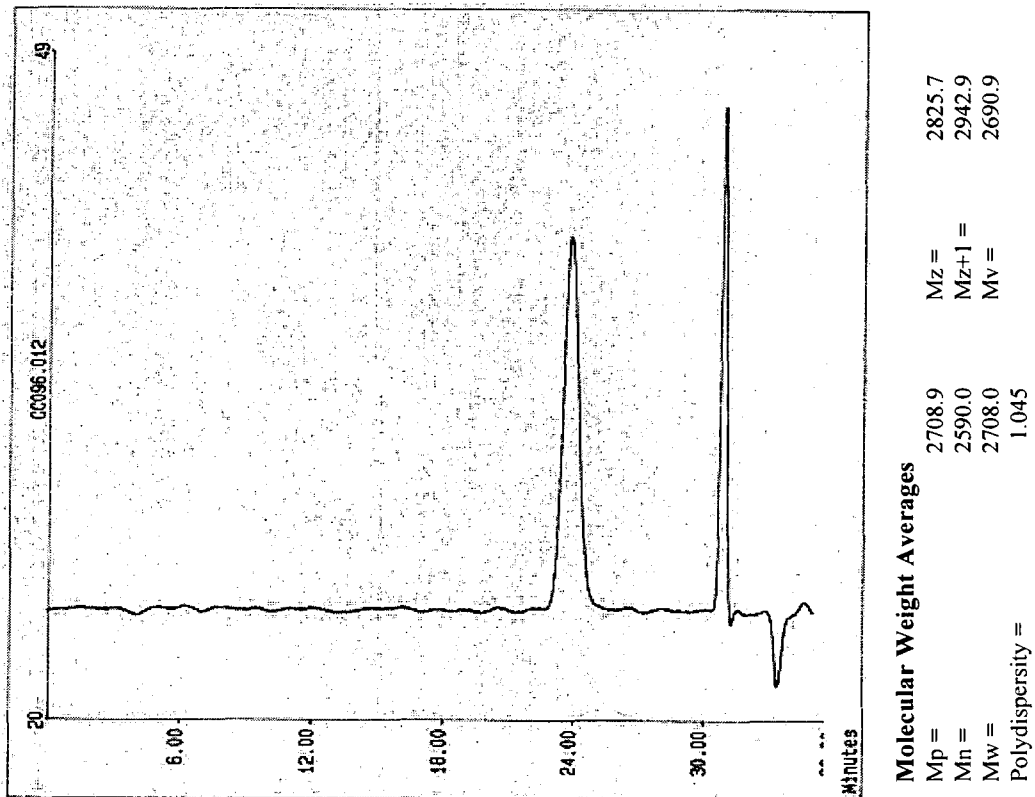


Figure A3.8 GPC trace of *exo*-5-norbornene-2(polystyrylcarboxylate) macromonomer (sample-4)

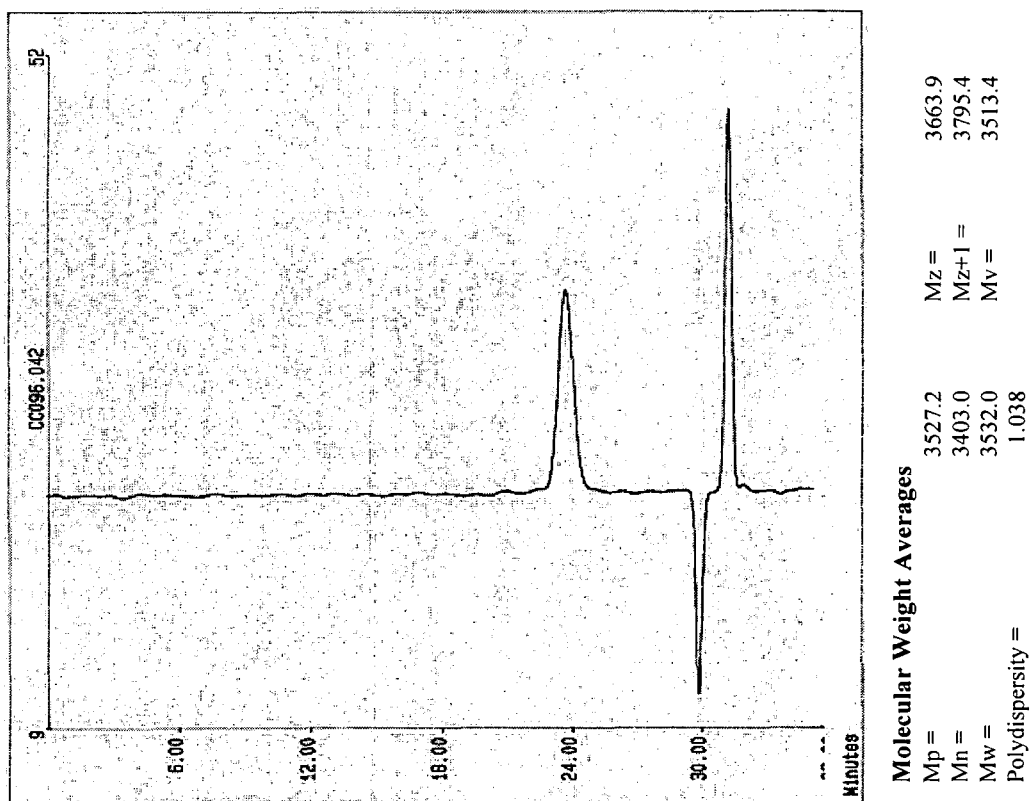


Figure A3.9 GPC trace of polystyrene homopolymer (sample-5)

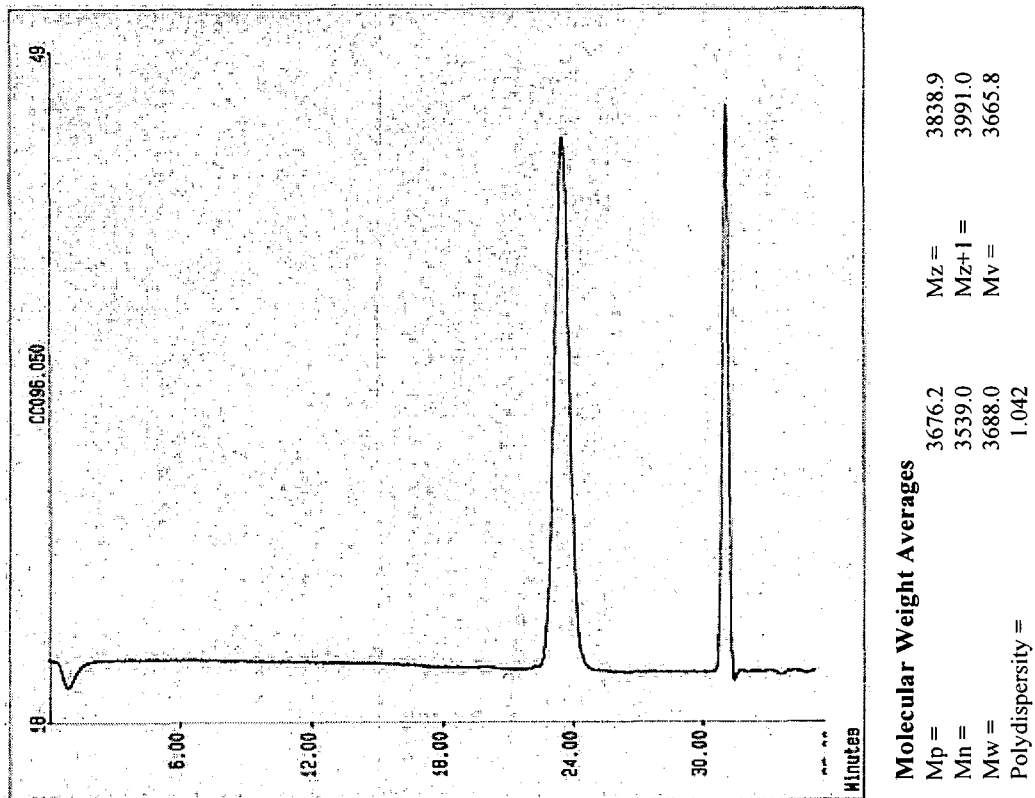


Figure A3.10 GPC trace of *exo*-5-norbornene-2(polystyrylcarboxylate) macromonomer (sample-5)

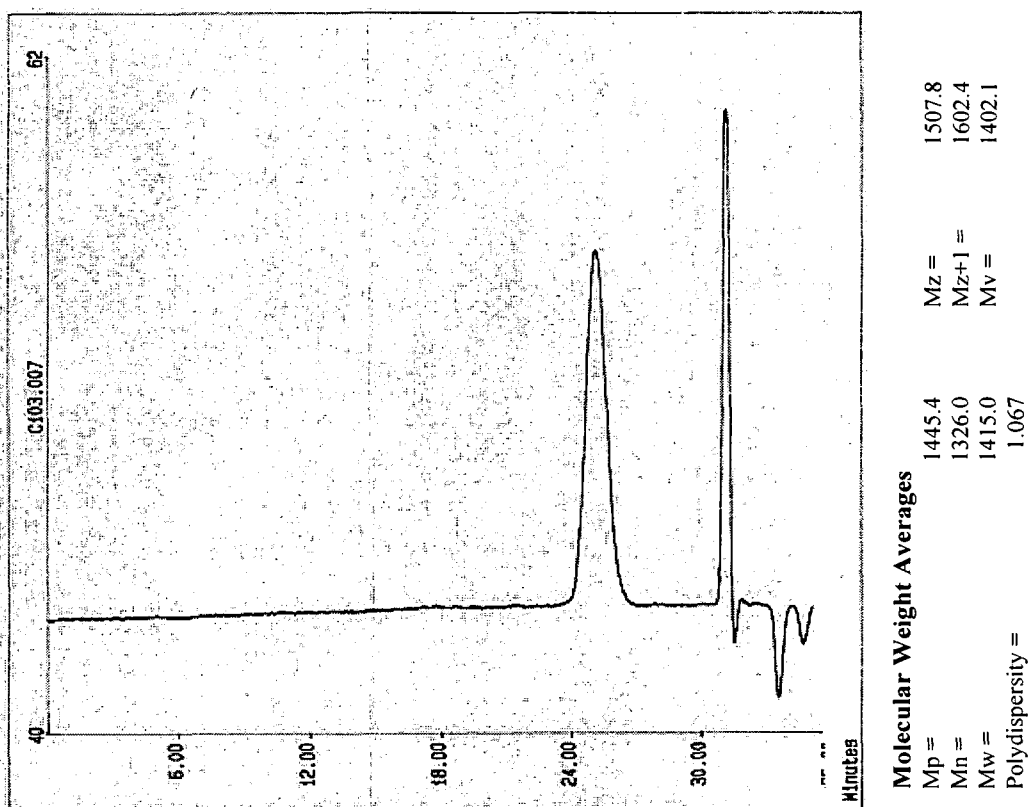


Figure A3.11 GPC trace of polystyrene homopolymer (sample-6)

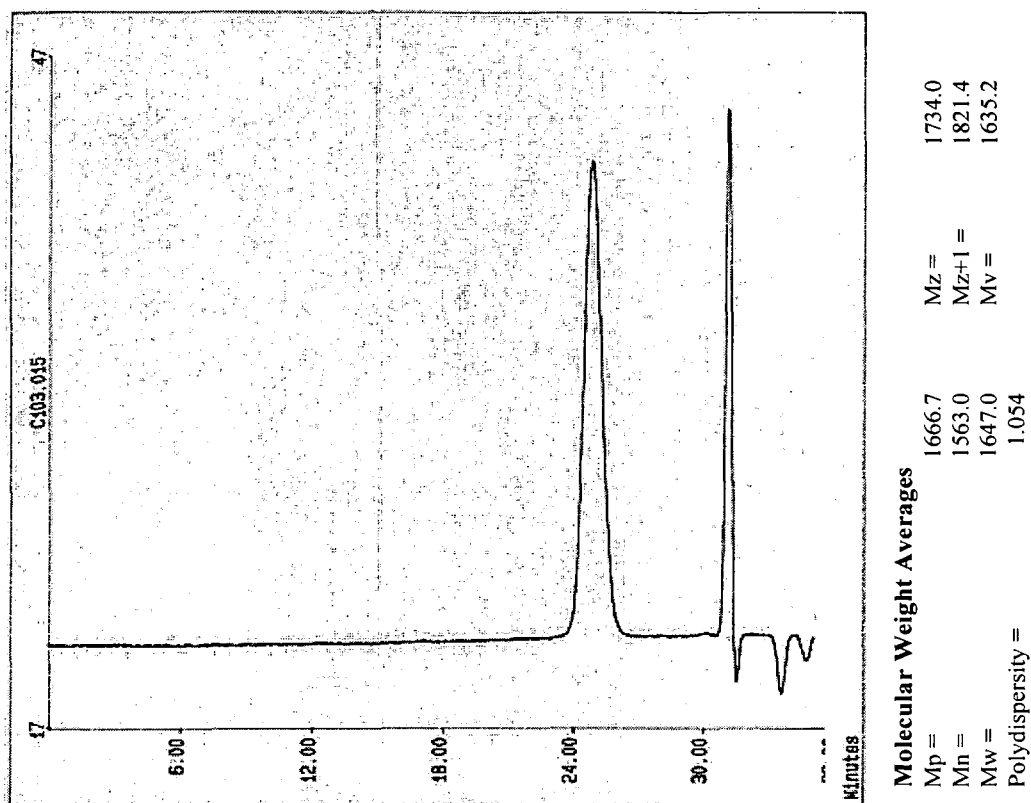


Figure A3.12 GPC trace of *exo*-5-norbornene-2(polystyrylcarboxylate) macromonomer (sample-6)

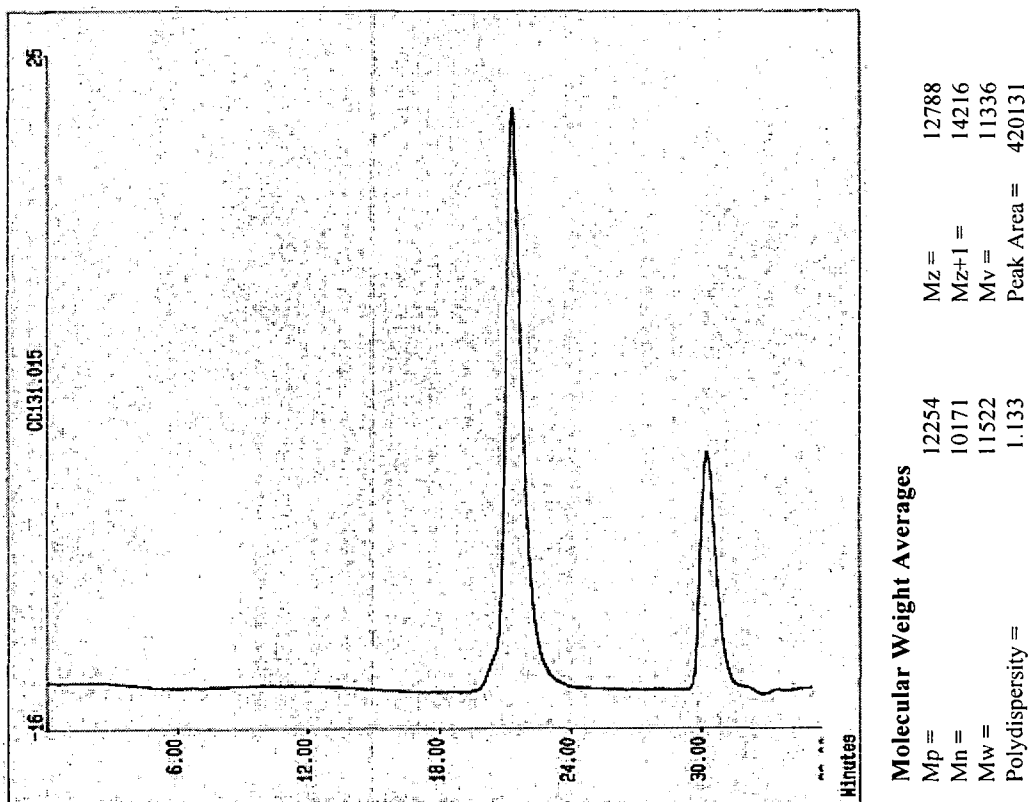


Figure A3.13 GPC trace of *exo*-5-norbornene-2(polystyrylcarboxylate) macromonomer (sample-7)

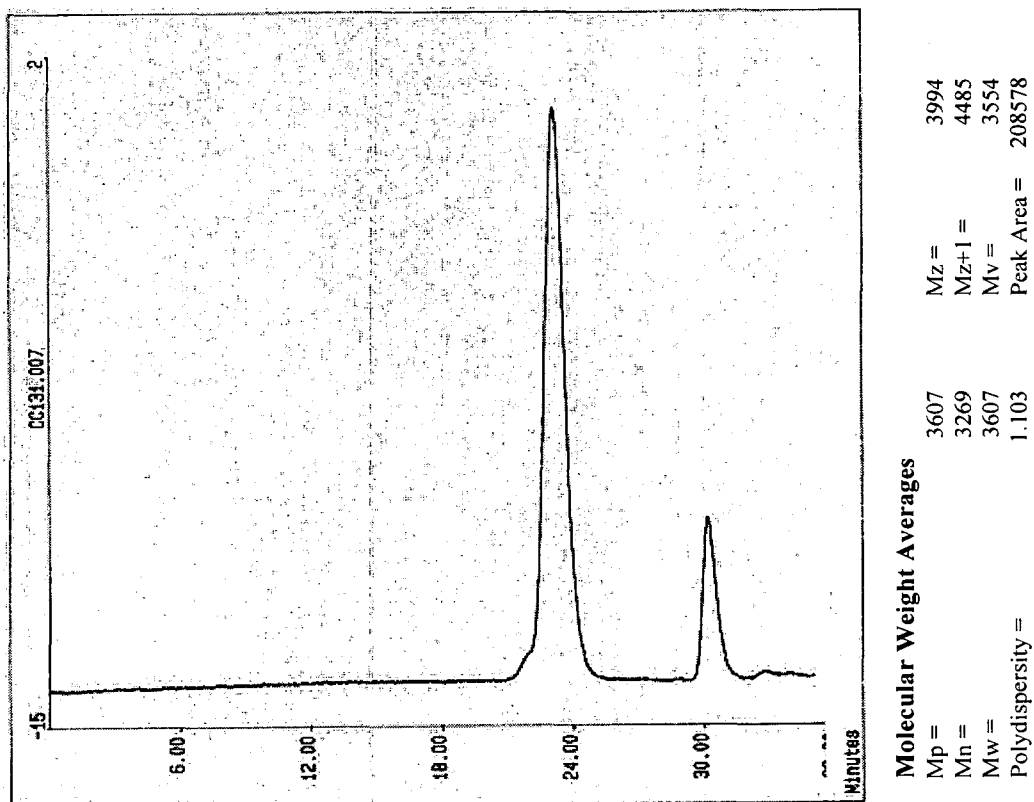


Figure A3.14 GPC trace of polystyrene homopolymer (sample-8)

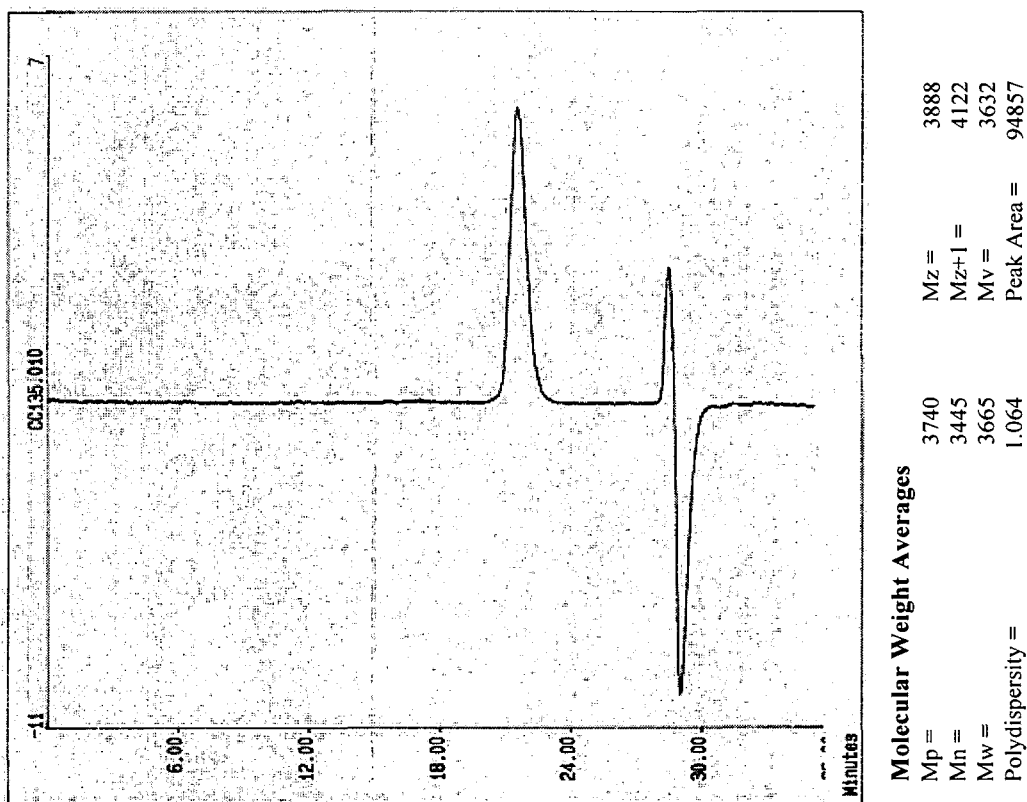


Figure A3.15 GPC trace of *exo*-5-norbornene-2(polystyrylcarboxylate) macromonomer (sample-8)

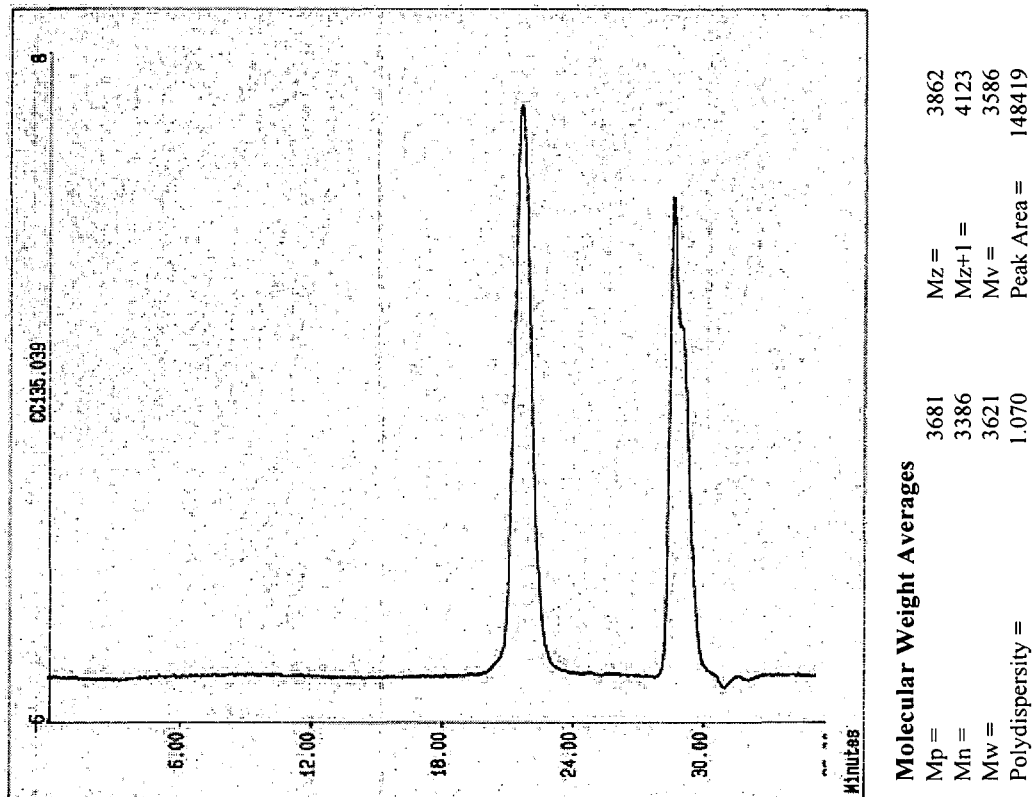
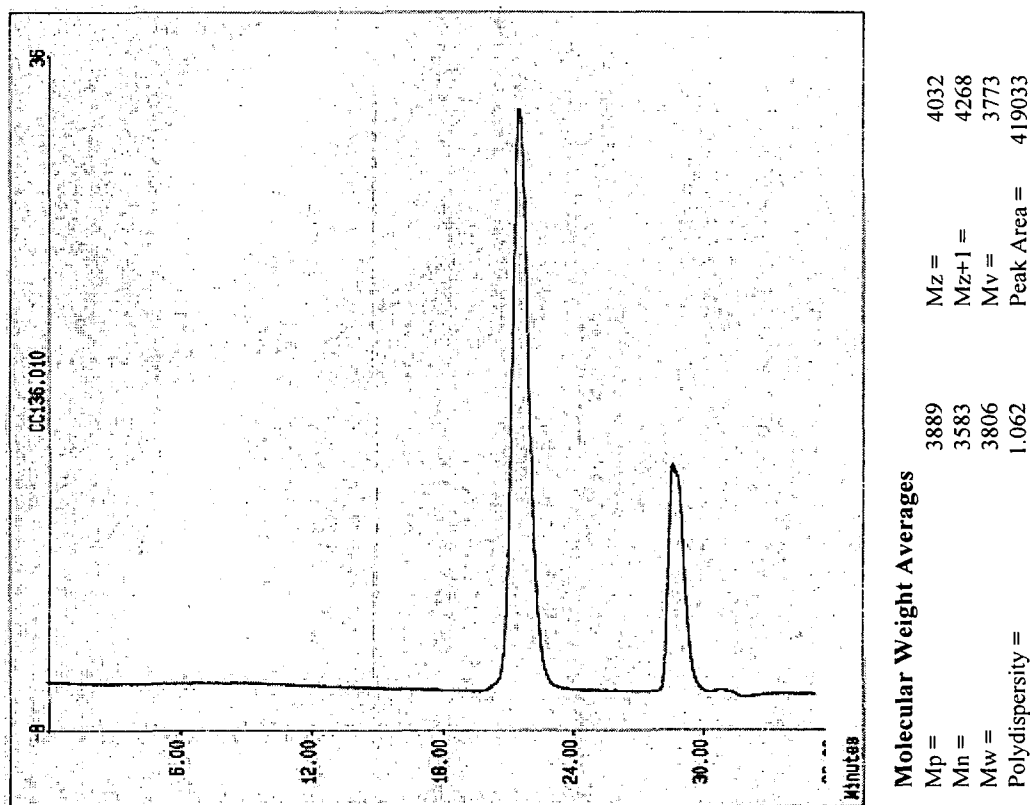
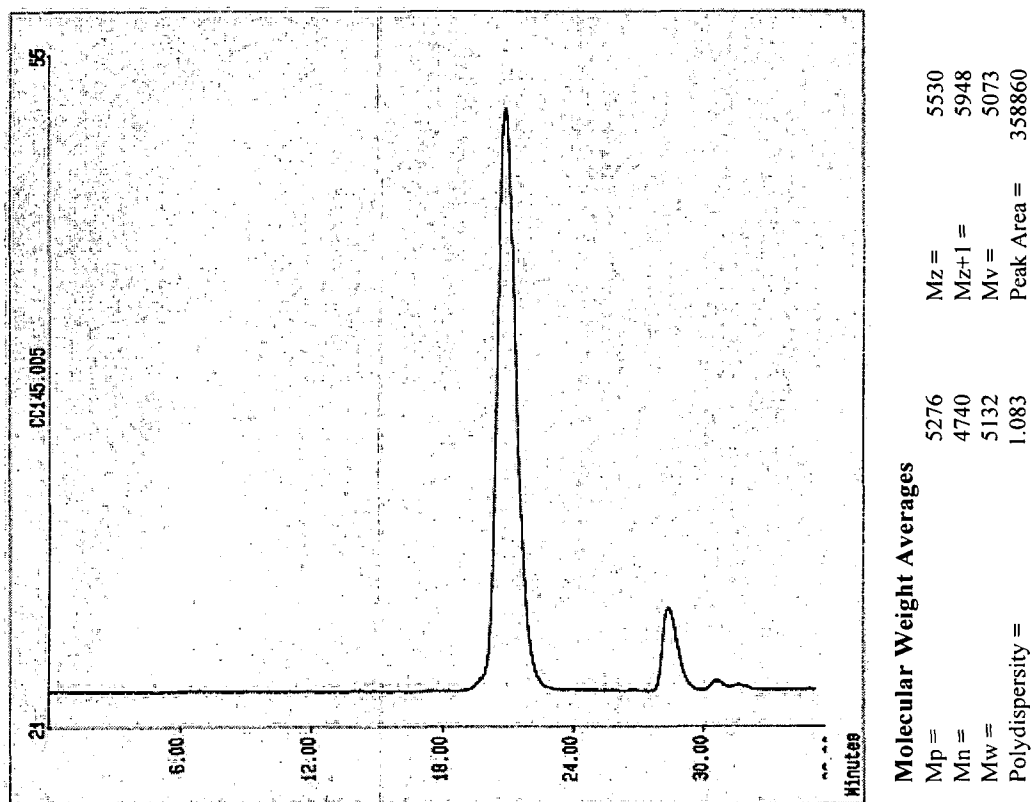


Figure A3.16 GPC trace of polystyrene homopolymer (sample-9)



**Figure A3.17** GPC trace of *exo*-5-norbornene-2(polystyrylcarboxylate) macromonomer (sample-9)



**Figure A3.18** GPC trace of *exo*-5-norbornene-2(polystyrylcarboxylate) macromonomer (sample-10)

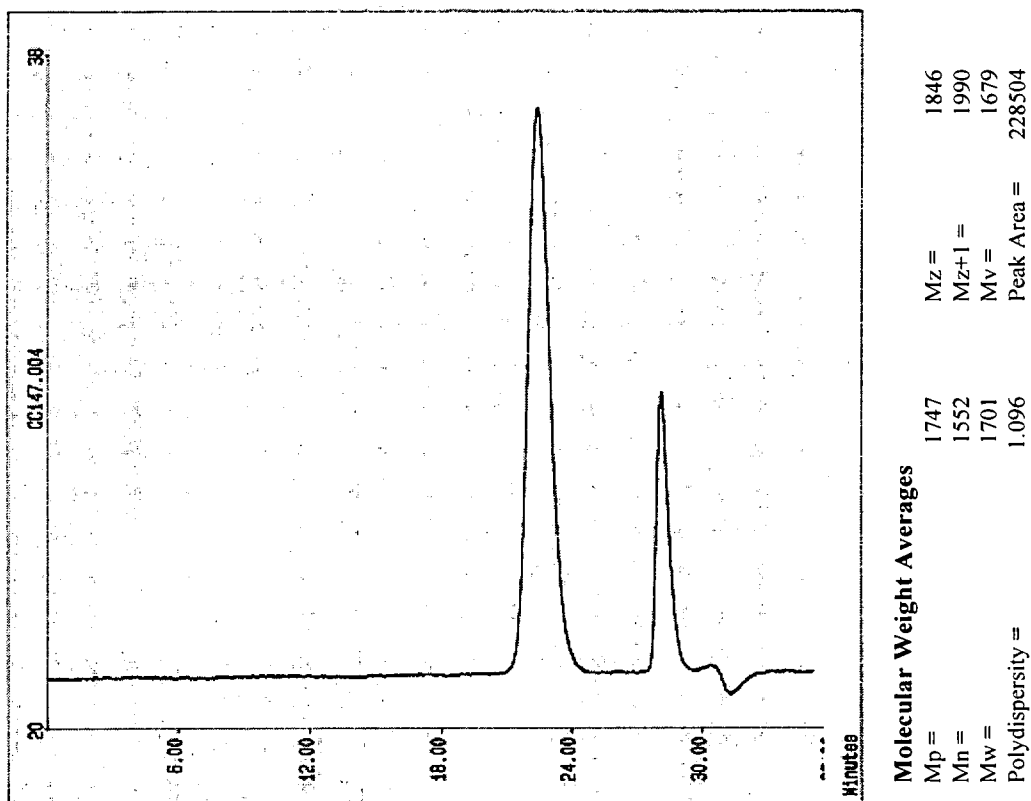


Figure A3.19 GPC trace of *exo*-5-norbornene-2(polystyrylcarboxylate) macromonomer (sample-11)

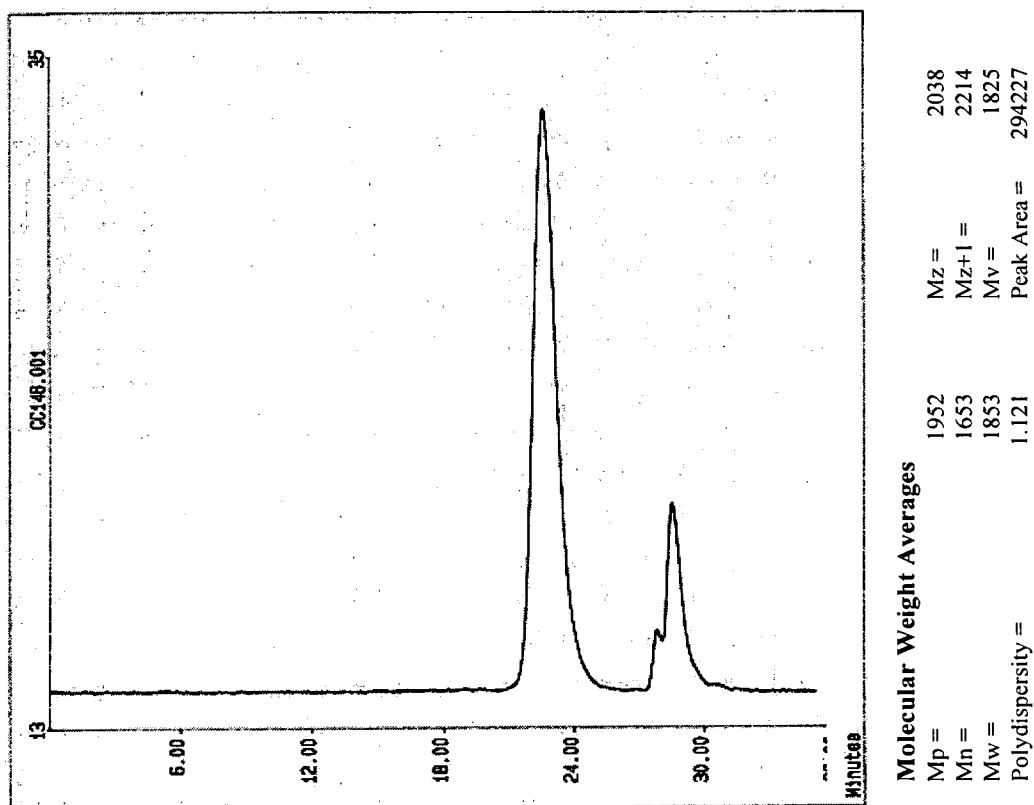


Figure A3.20 GPC trace of *exo*-5-norbornene-2(polystyrylcarboxylate) macromonomer (sample-12)

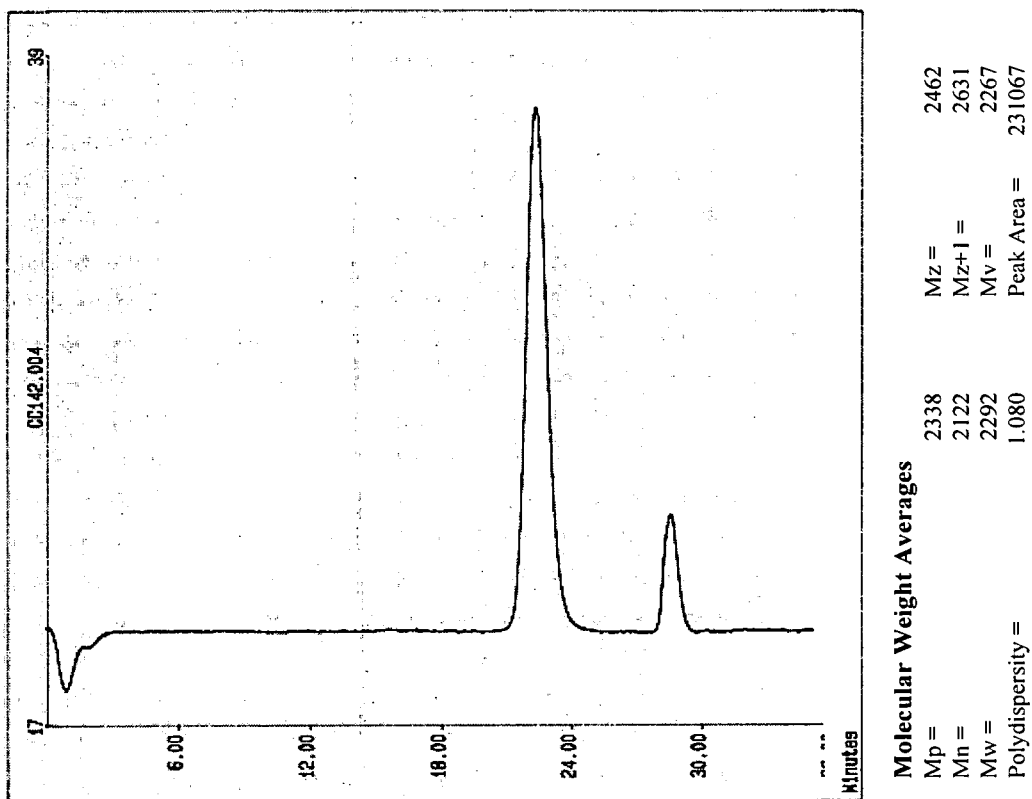


Figure A3.21 GPC trace of *exo*-5-norbornene-2(polystyrylcarboxylate) macromonomer (sample-13)

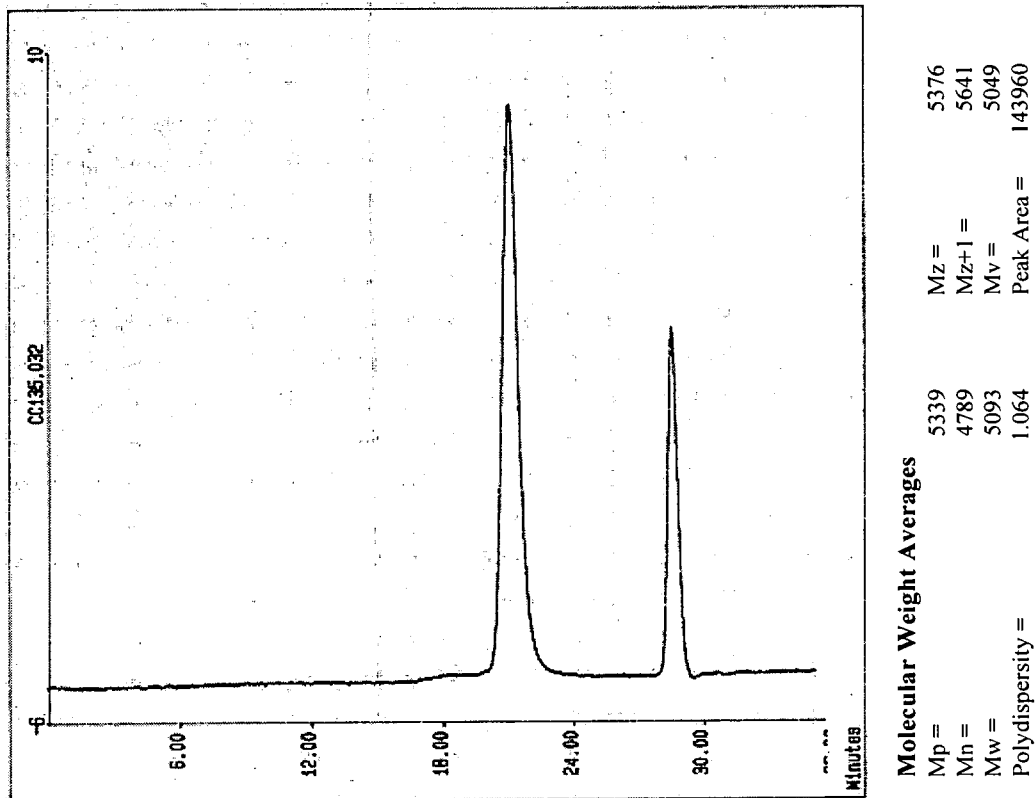


Figure A3.22 GPC trace of polystyrene homopolymer (sample-14)

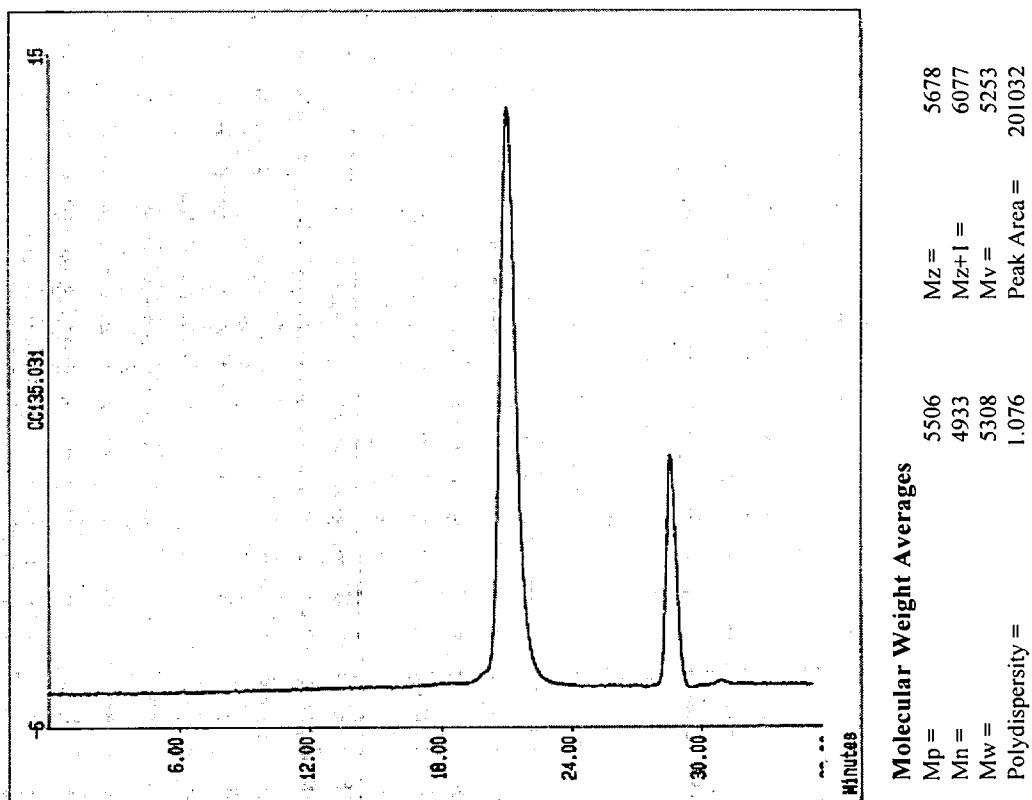


Figure A3.23 GPC trace of *exo*-5-norbornene-2(polystyrylcarboxylate) macromonomer (sample-14)

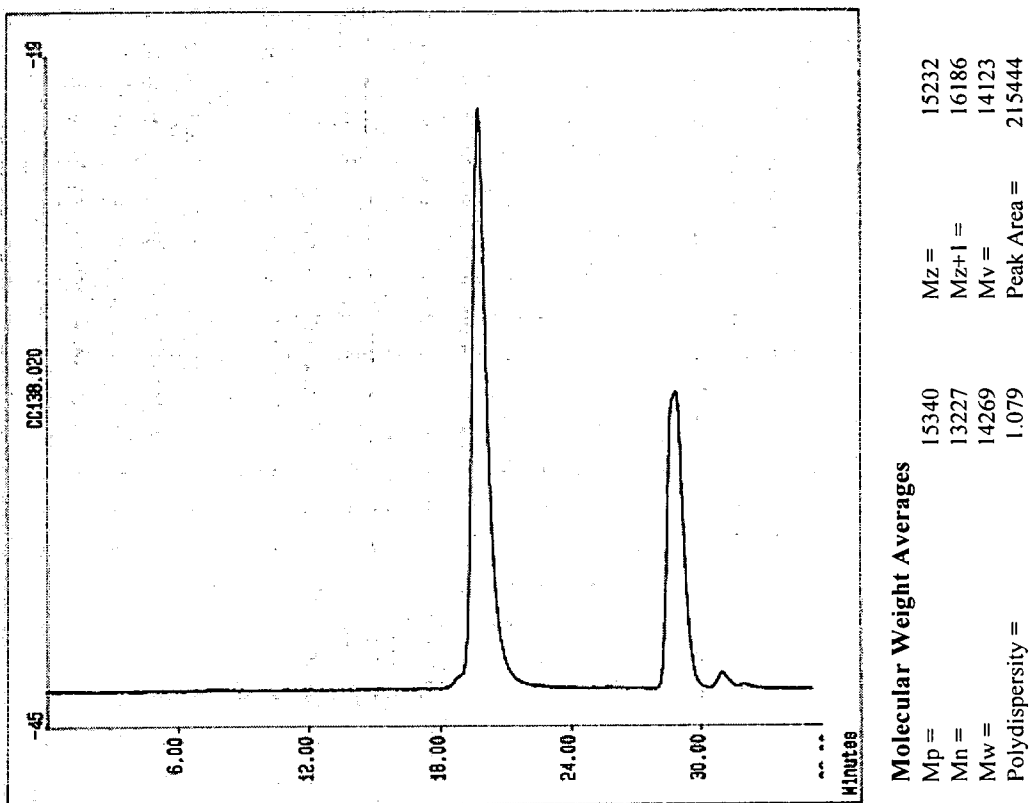
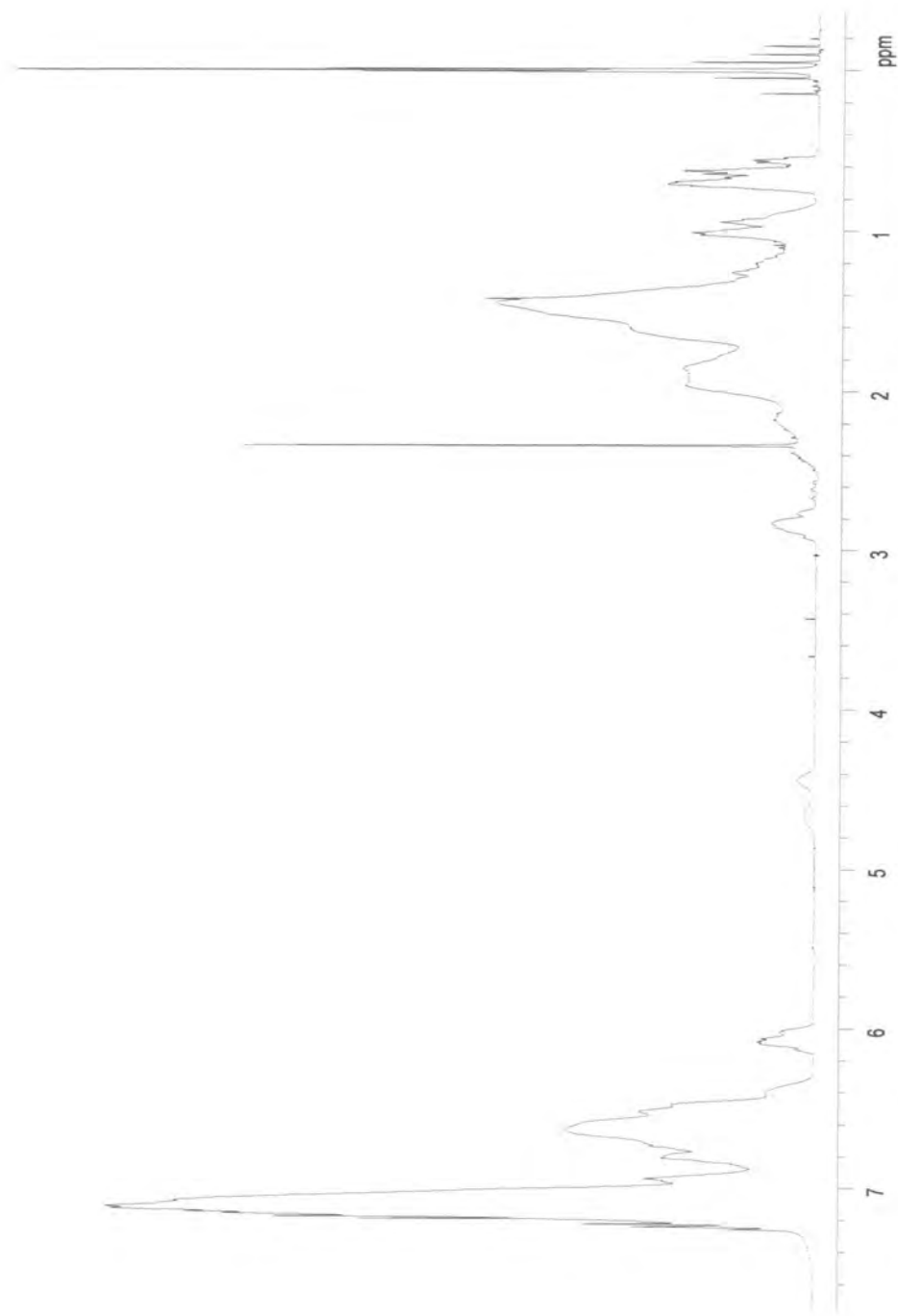
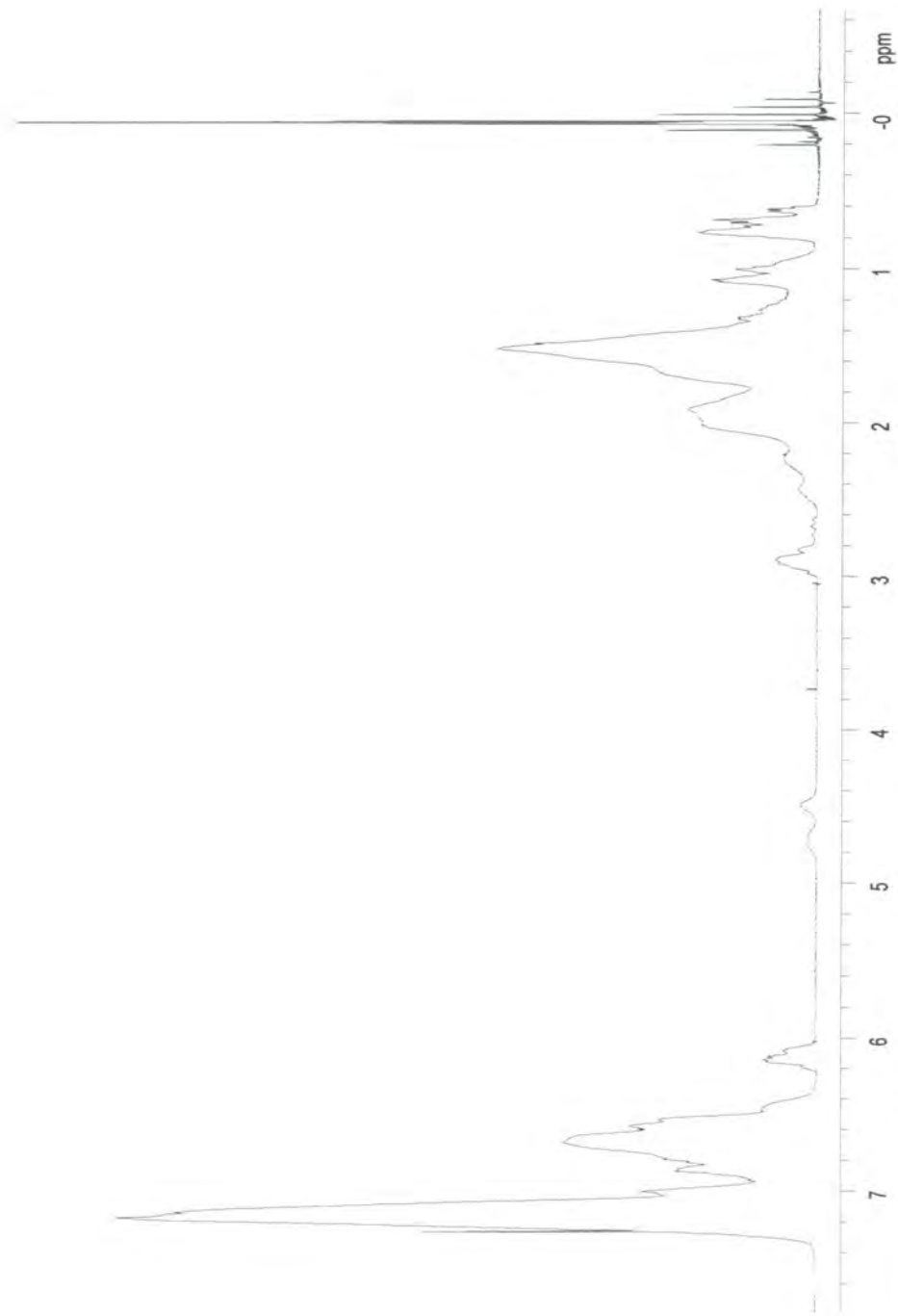


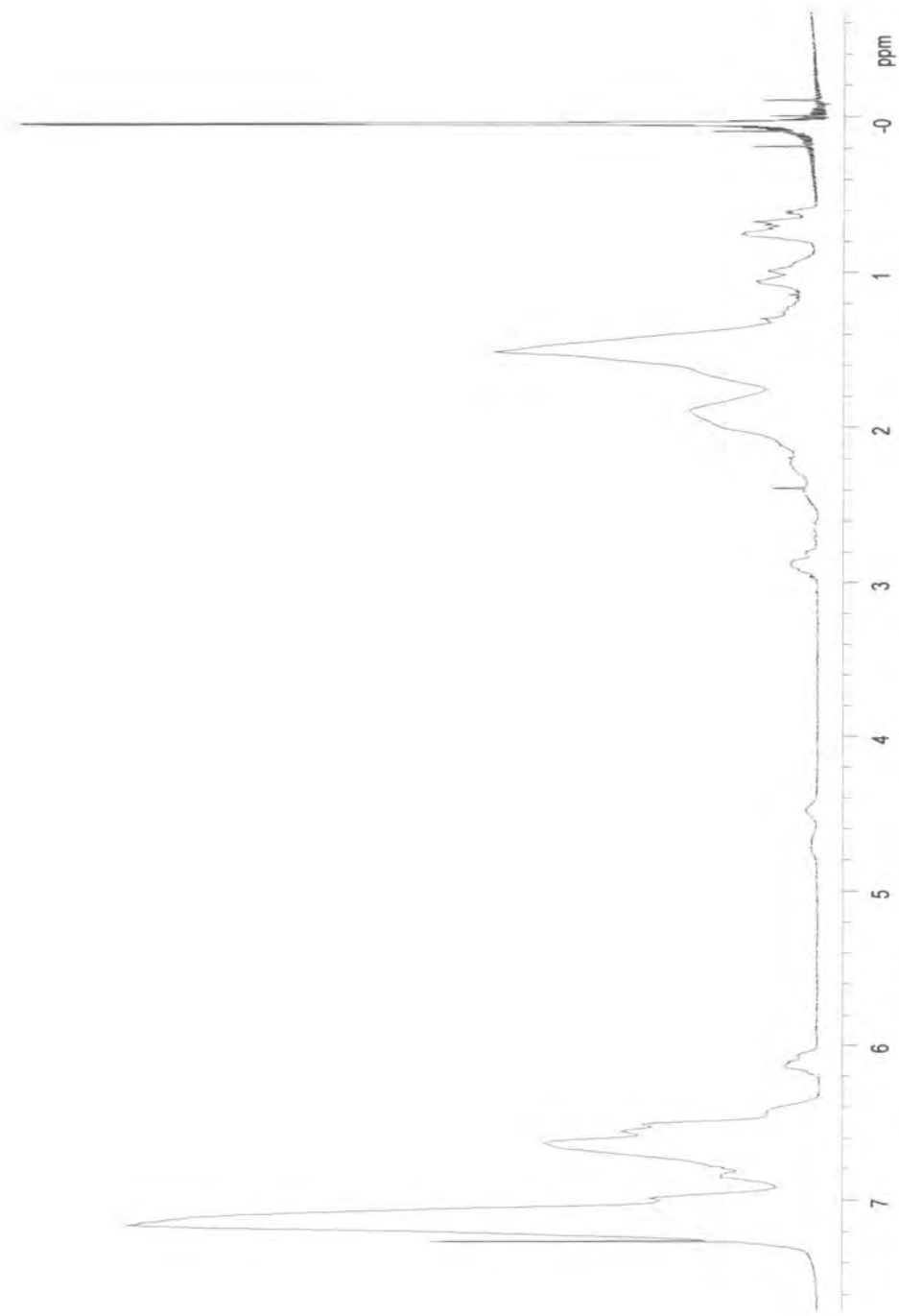
Figure A3.24 GPC trace of *exo*-5-norbornene-2(polystyrylcarboxylate) macromonomer (sample-15)



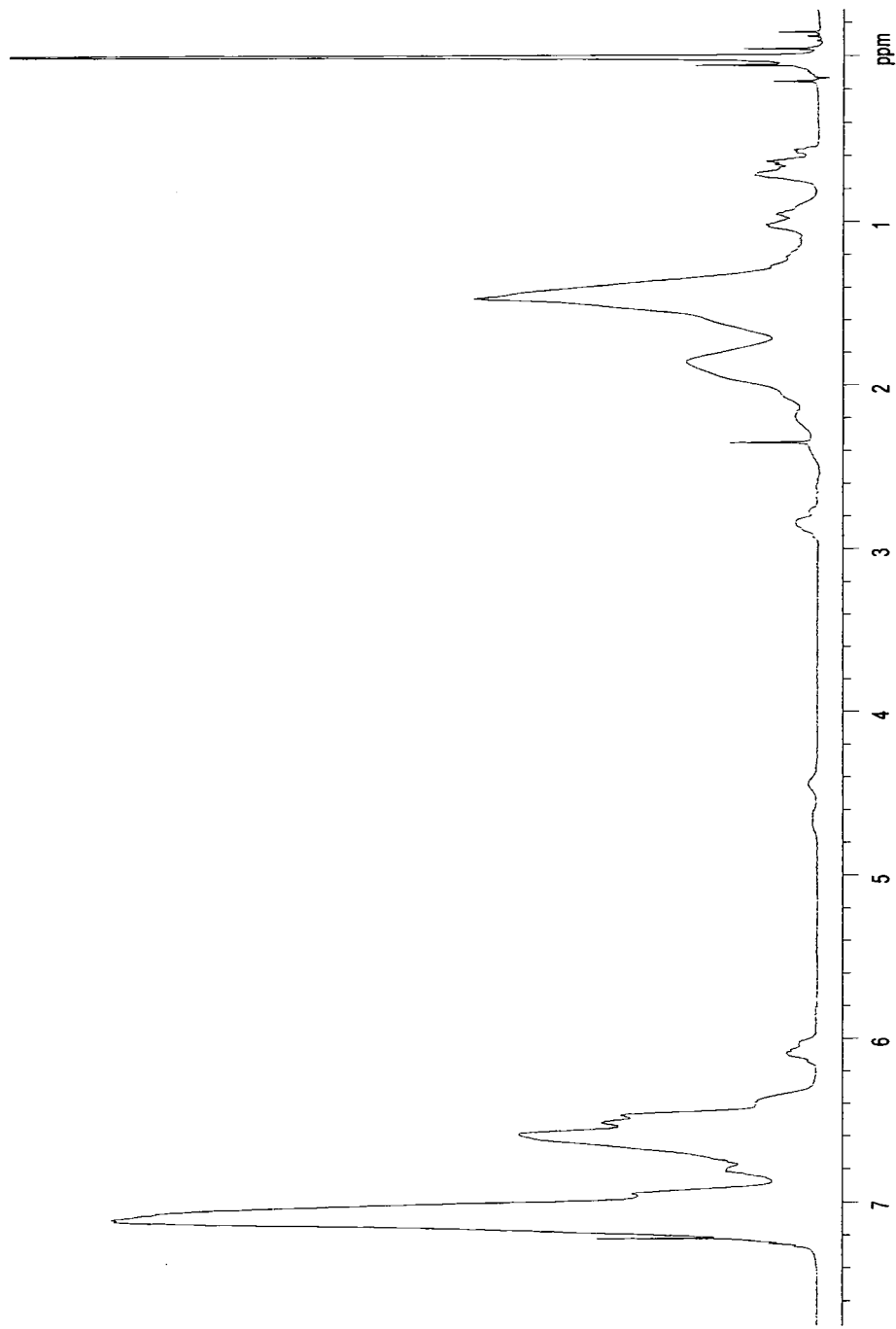
**Figure A3.25**  $^1\text{H}$  nmr spectrum of macromonomer (Sample-1/ $M_n=1460$ )



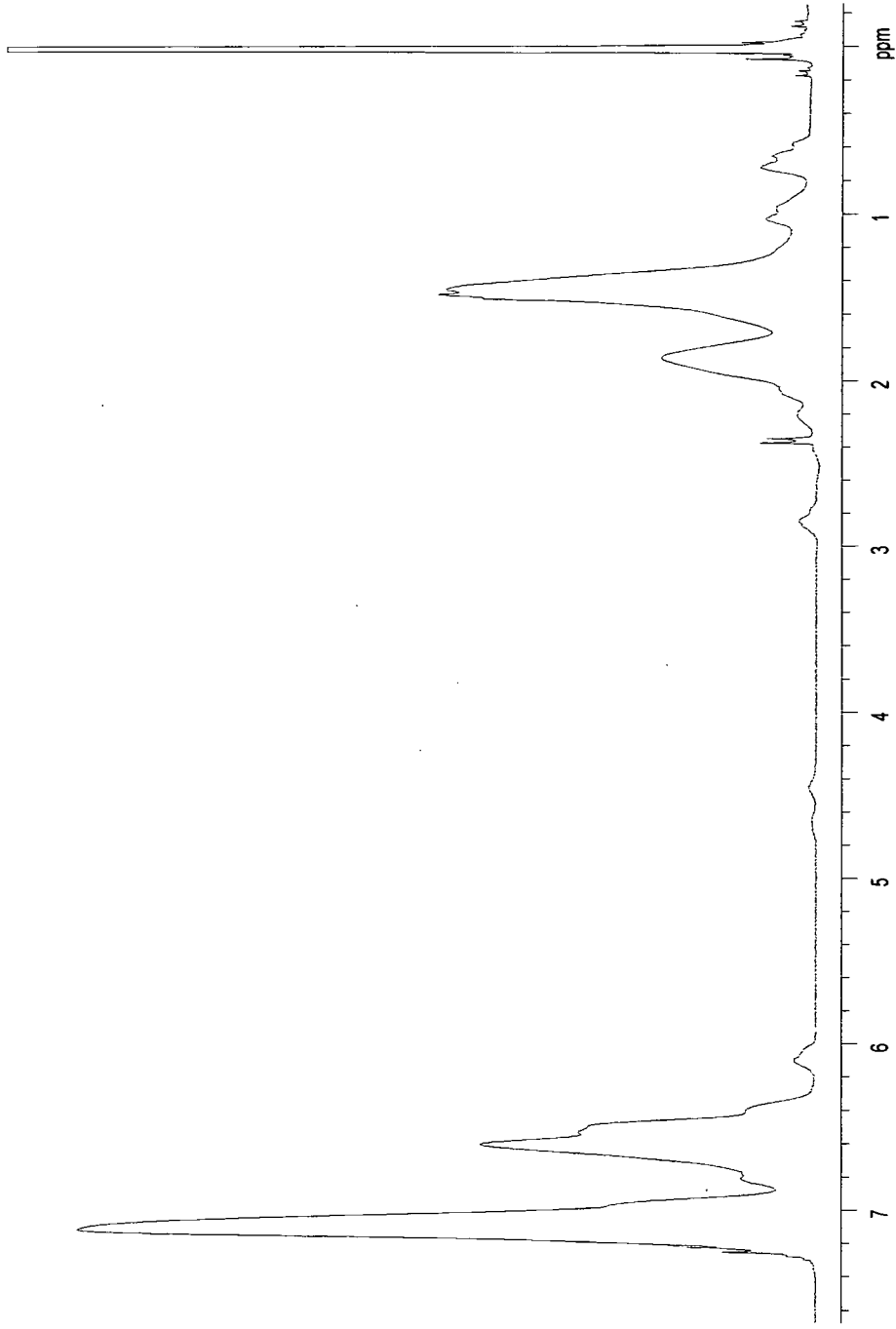
**Figure A3.26**  $^1\text{H}$  nmr spectrum of macromonomer (Sample-2/ $M_n=1600$ )



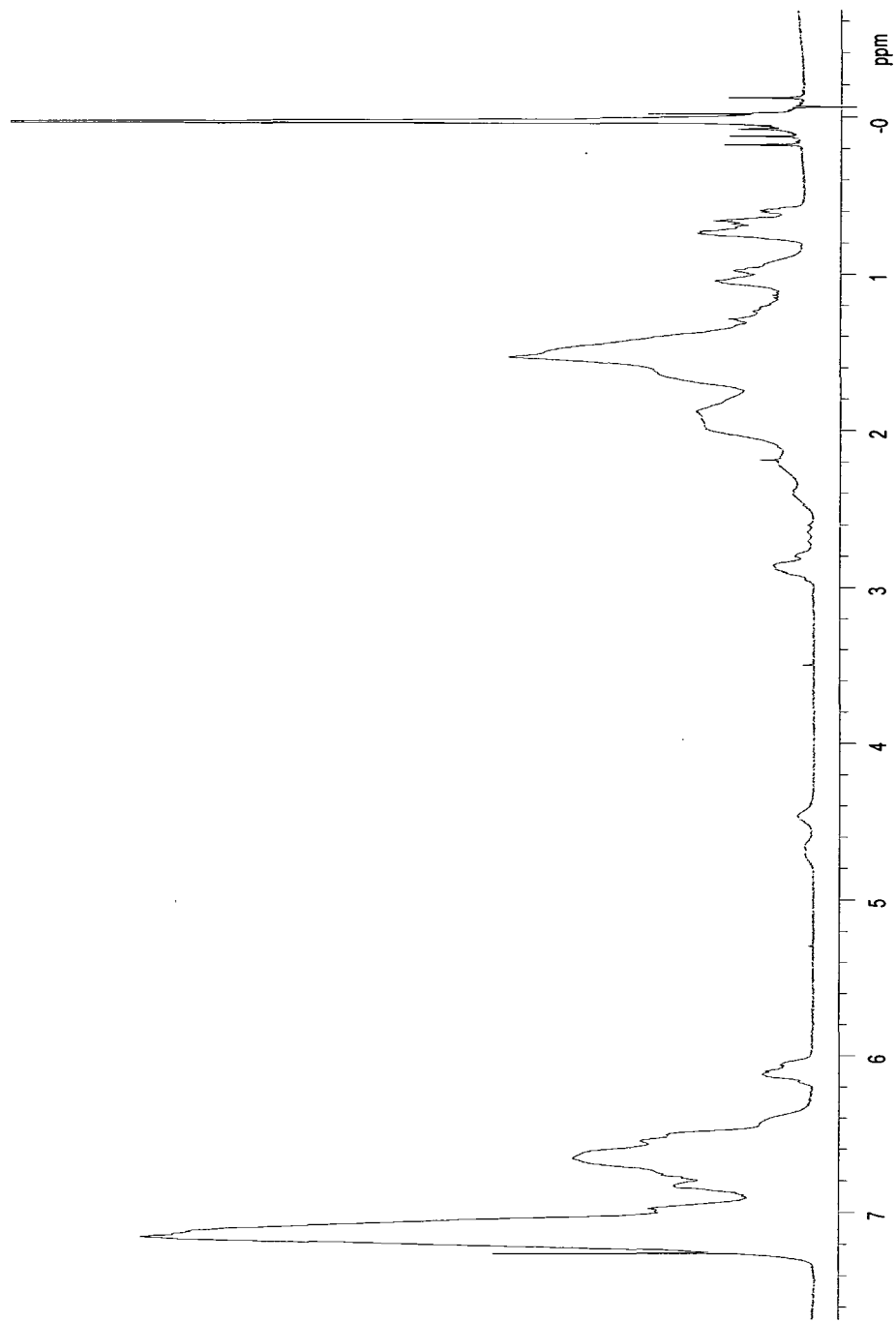
**Figure A3.27**  $^1\text{H}$  nmr spectrum of macromonomer (Sample-3/Mn=2250)



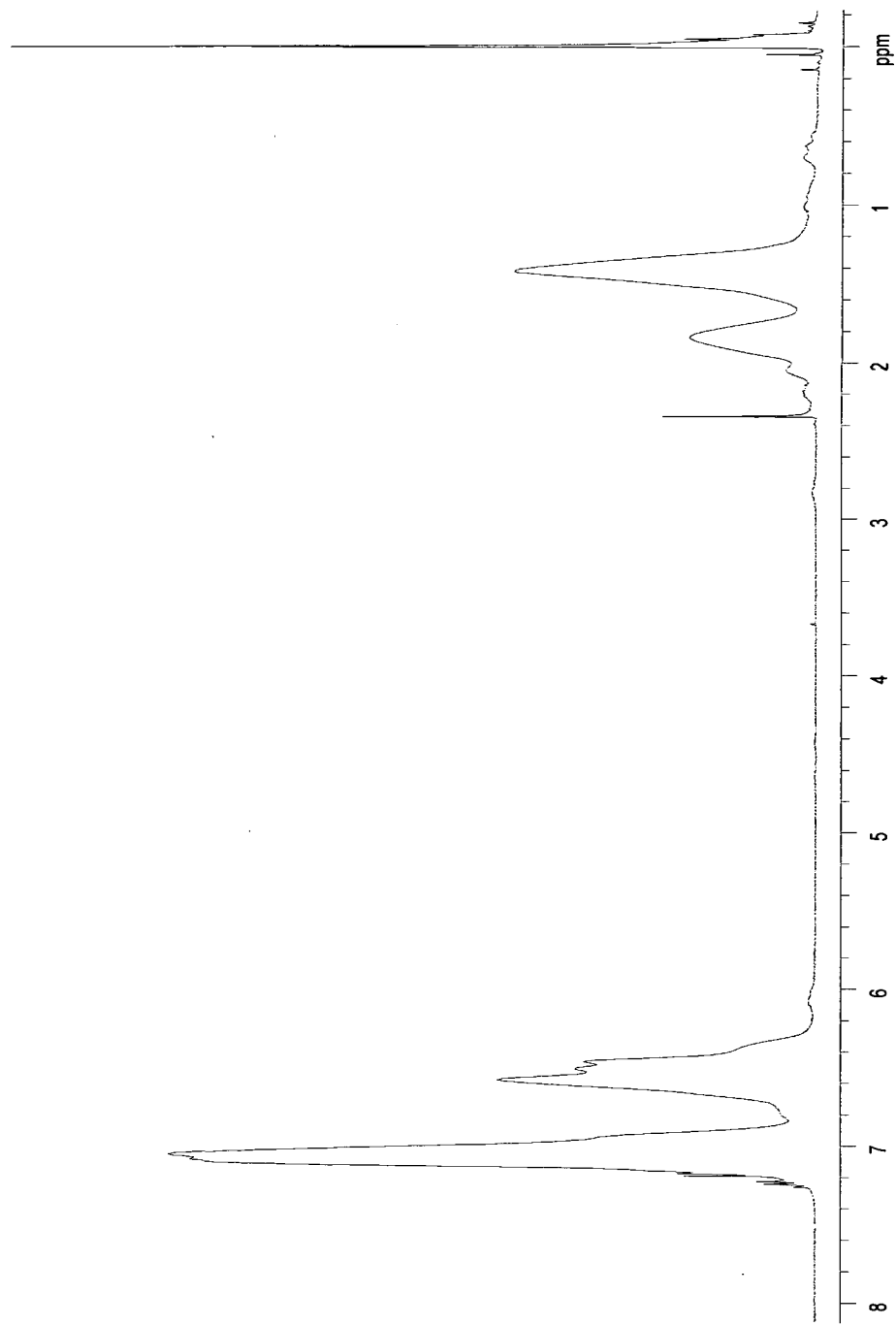
**Figure A3.28**  $^1\text{H}$  nmr spectrum of macromonomer (Sample-4/Mn=2590)



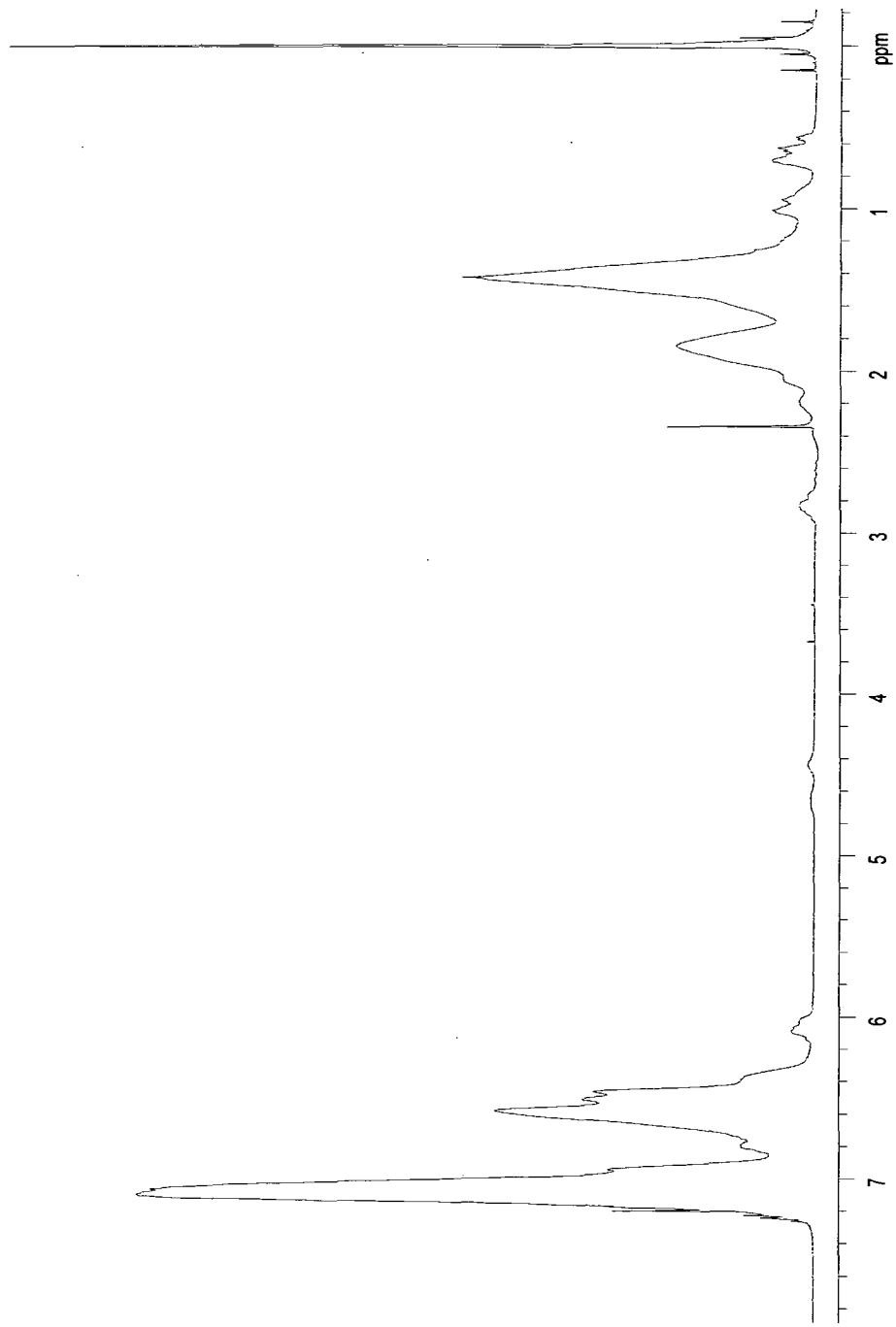
**Figure A3.29** <sup>1</sup>H nmr spectrum of macromonomer (Sample-5/Min=3540)



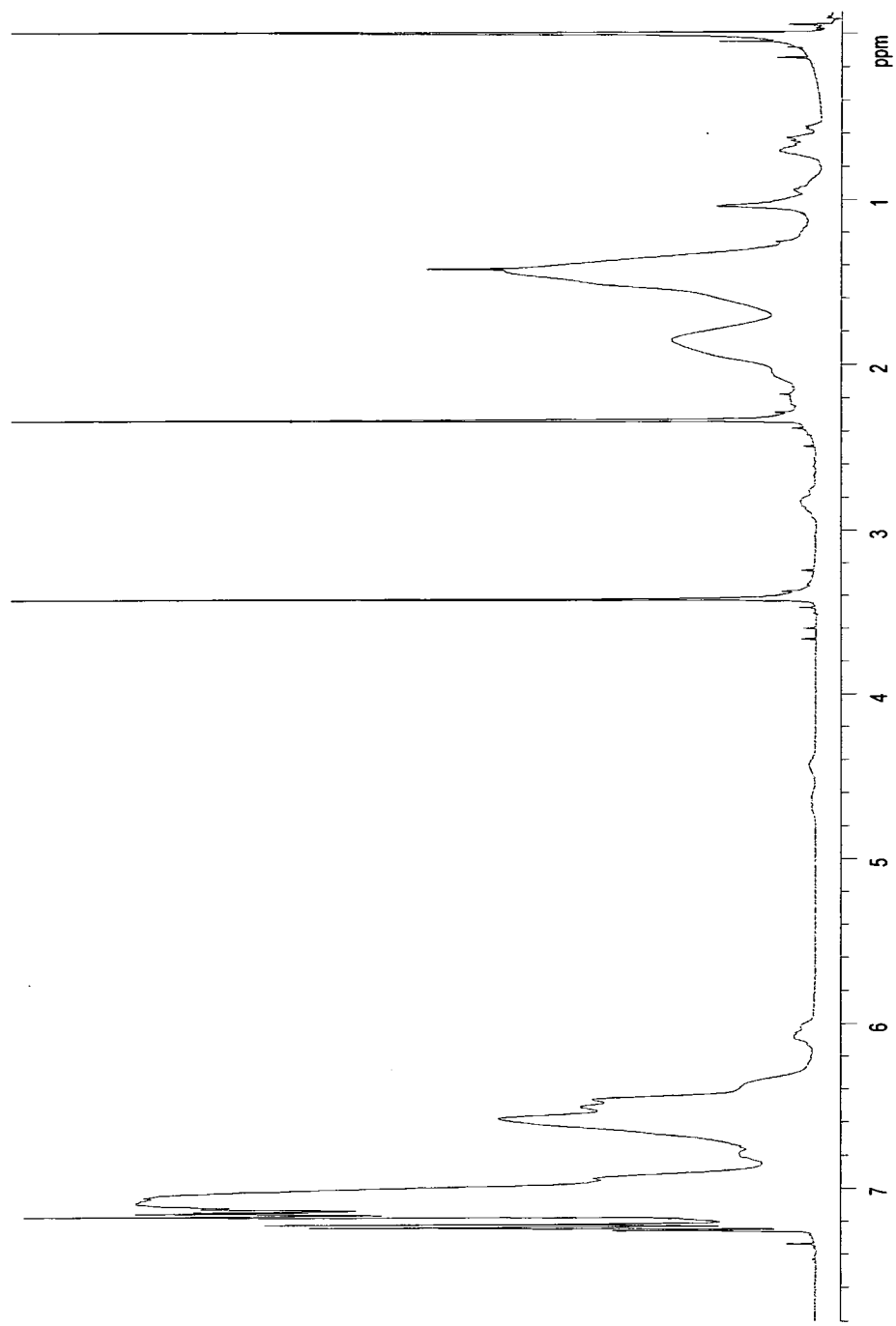
**Figure A3.30**  $^1\text{H}$  nmr spectrum of macromonomer (Sample-6/ $M_n=1560$ )



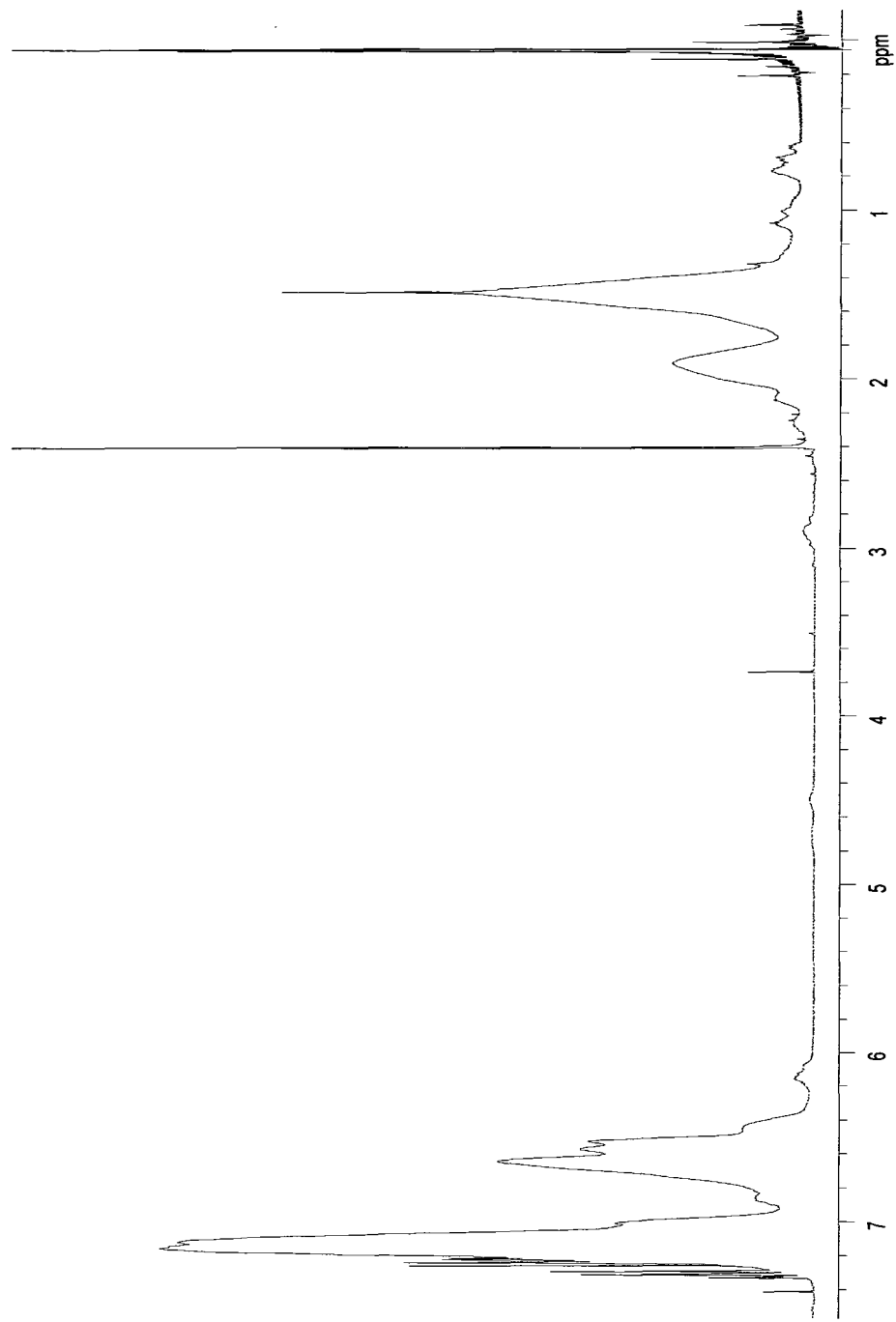
**Figure A3.31** <sup>1</sup>H nmr spectrum of macromonomer (Sample-7/Mn=10,170)



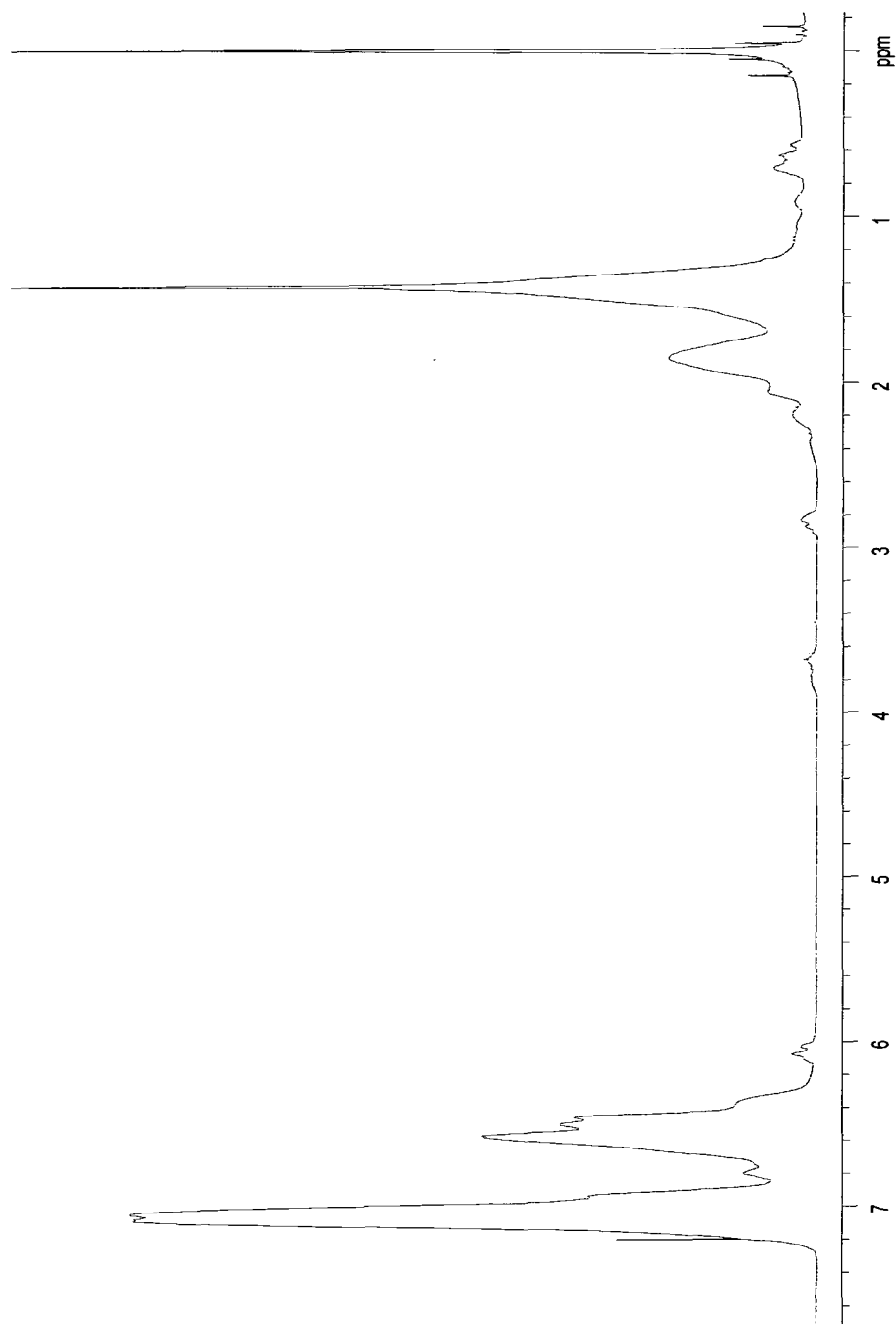
**Figure A3.32** <sup>1</sup>H nmr spectrum of macromonomer (Sample-8/Mn=3445)



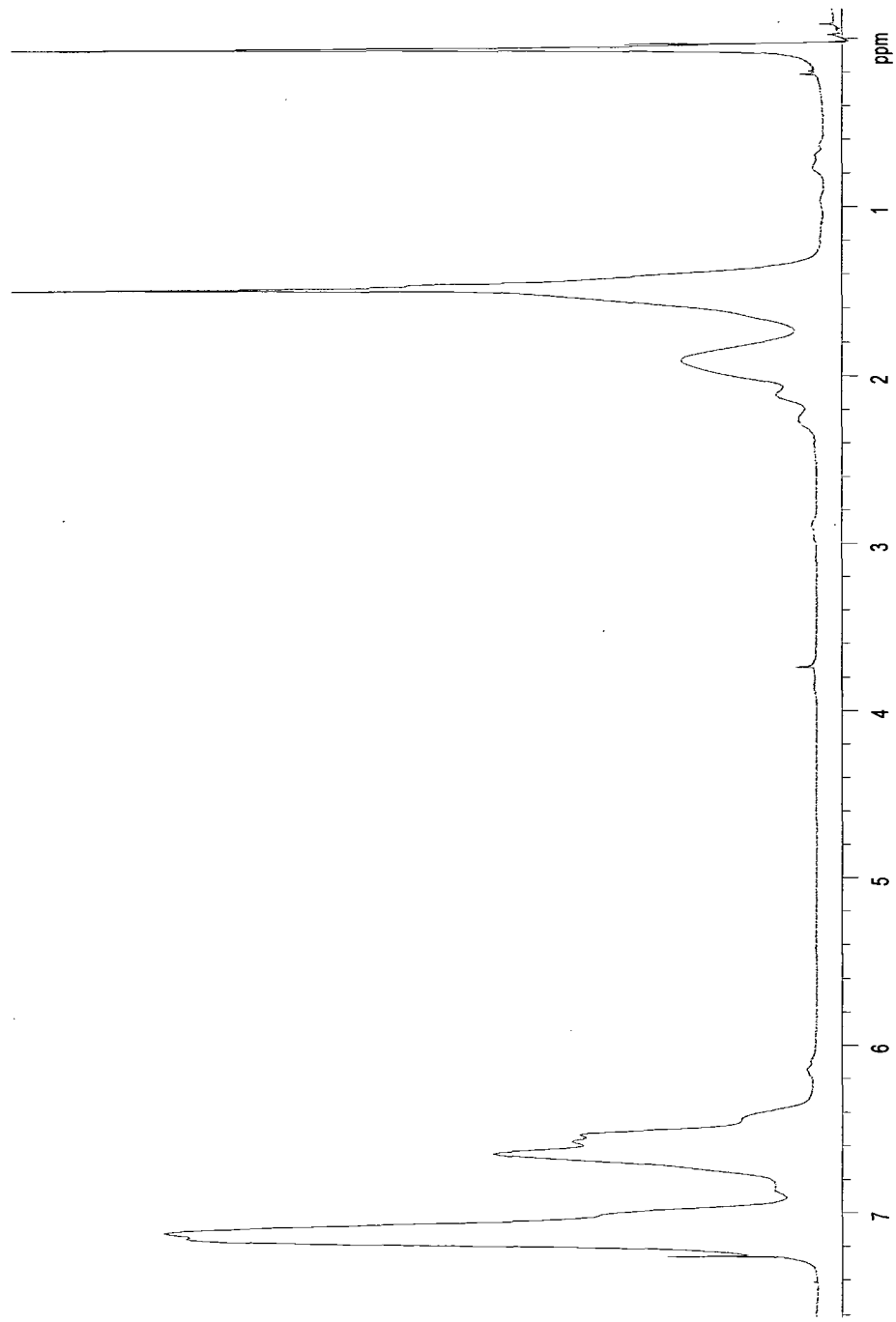
**Figure A3.33** <sup>1</sup>H nmr spectrum of macromonomer (Sample-9/Mn=3580)



**Figure A3.34**  $^1\text{H}$  nmr spectrum of macromonomer (Sample-10/ $M_n=4740$ )

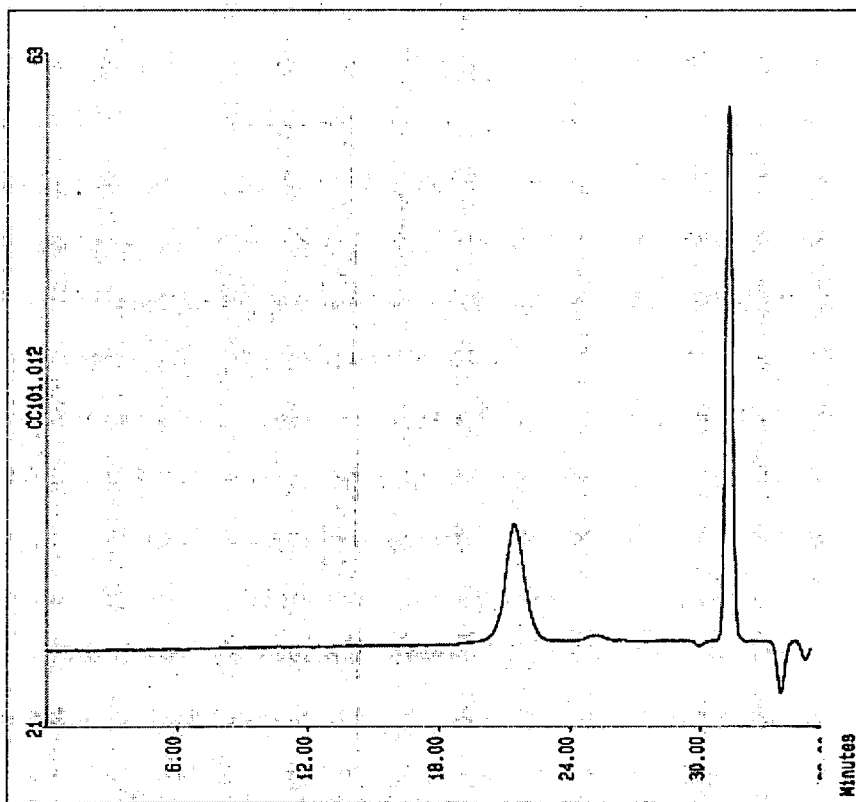


**Figure A3.35**  $^1\text{H}$  nmr spectrum of macromonomer (Sample-14/Mn=4930)



**Figure A3.36** <sup>1</sup>H nmr spectrum of macromonomer (Sample-15/Mn=13,230)

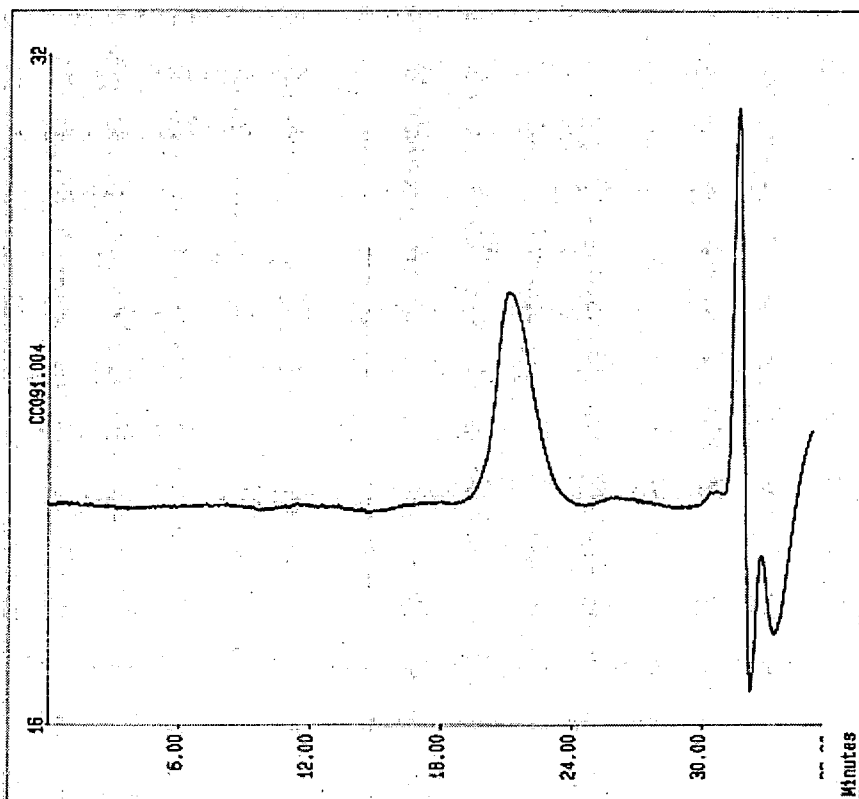
**APPENDIX-4**  
**Analytical Data for Chapter-4**



**Molecular Weight Averages**

Mp =	16065.8	Mz =	18288.6
Mn =	14949.0	Mz+1 =	20441.4
Mw =	16496.1	Mv =	16249.4
Polydispersity =	1.103		

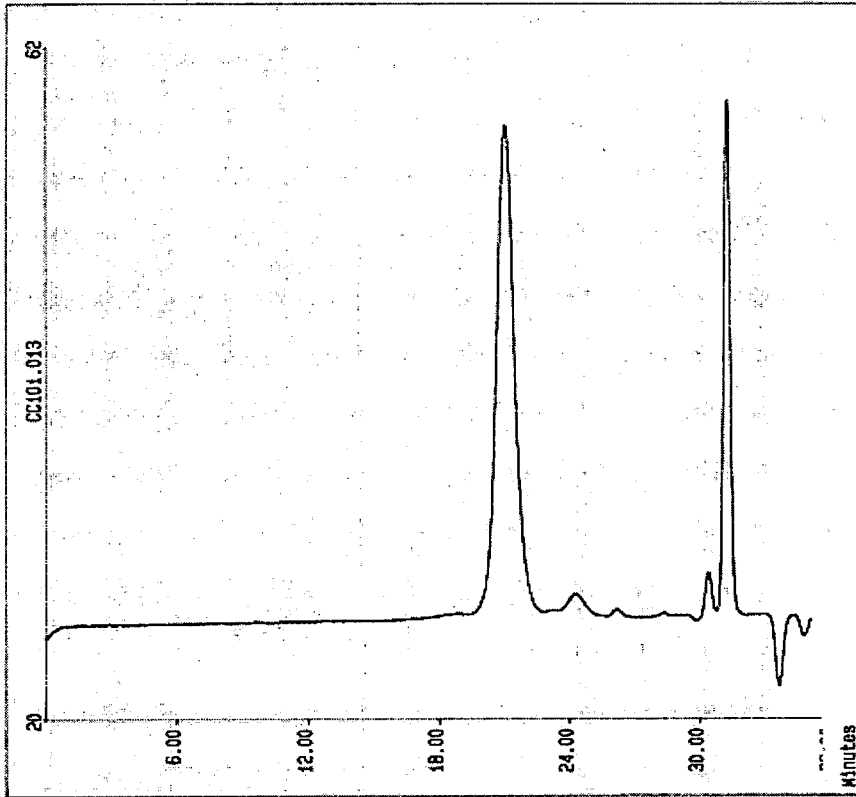
Figure A4.1 GPC trace of sample 1-9



**Molecular Weight Averages**

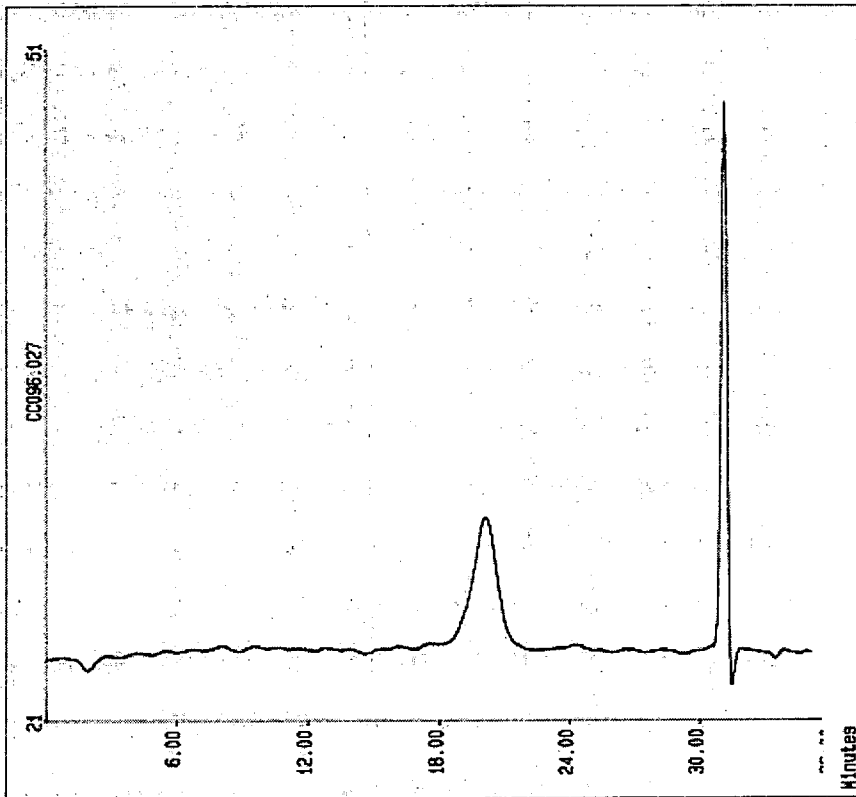
Mp =	38167.0	Mz =	45832.0
Mn =	24871.5	Mz+1 =	58871.3
Mw =	34447.4	Mv =	32918.4
Polydispersity =	1.385		

Figure A4.2 GPC trace of sample 1-4



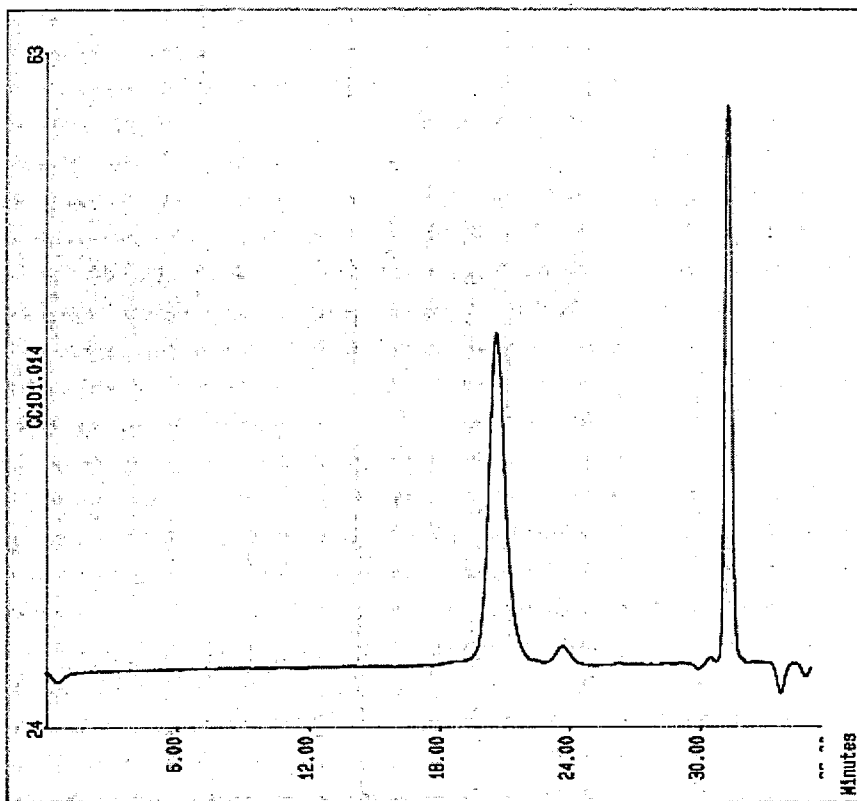
Molecular Weight Averages			
Mp =	21129.4	Mz =	22995.3
Mn =	19328.0	Mz+1 =	25037.8
Mw =	21113.9	Mv =	20842.8
Polydispersity =		1.092	

Figure A4.3 GPC trace of sample 3-6



Molecular Weight Averages			
Mp =	38043.3	Mz =	52347.6
Mn =	38042.4	Mz+1 =	61964.8
Mw =	44320.8	Mv =	43256.7
Polydispersity =		1.165	

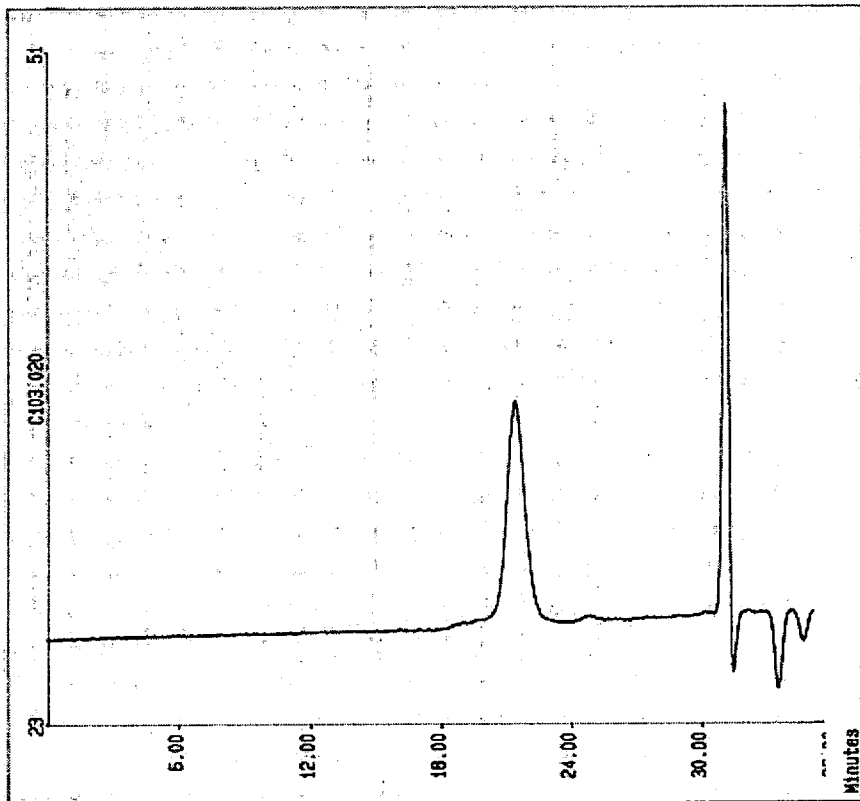
Figure A4.4 GPC trace of sample 3-3



**Molecular Weight Averages**

Mp =	28432.7	Mz =	30488.9
Mn =	26060.0	Mz+1 =	32786.5
Mw =	28262.4	Mv =	27934.8
Polydispersity =	1.085		

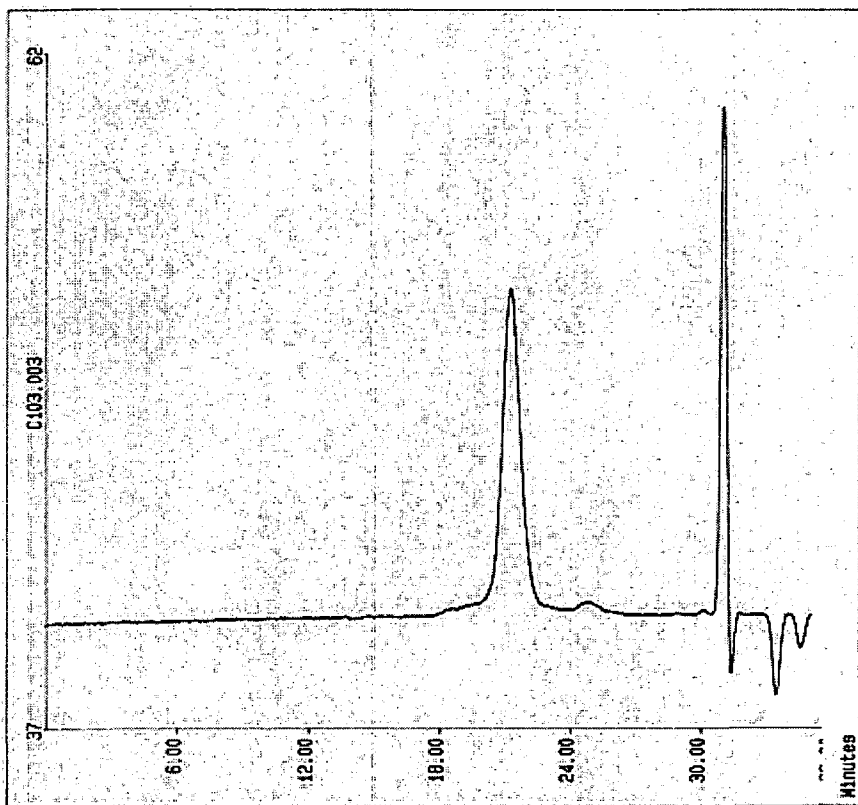
Figure A4.5 GPC trace of sample 5-4



**Molecular Weight Averages**

Mp =	14682.8	Mz =	15671.9
Mn =	13645.2	Mz+1 =	16724.3
Mw =	14642.2	Mv =	14491.1
Polydispersity =	1.073		

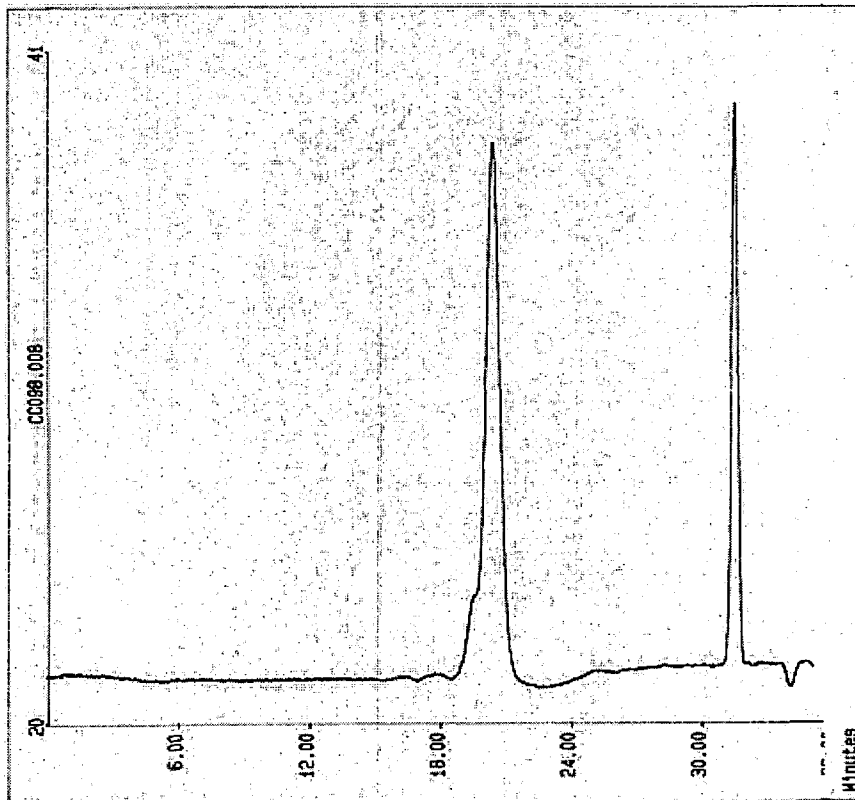
Figure A4.6 GPC trace of sample 1-11



**Molecular Weight Averages**

Mp =	16010.6	Mz =	29637.5
Mn =	15130.3	Mz+1 =	69976.0
Mw =	18221.7	Mv =	17439.6
Polydispersity =	1.204		

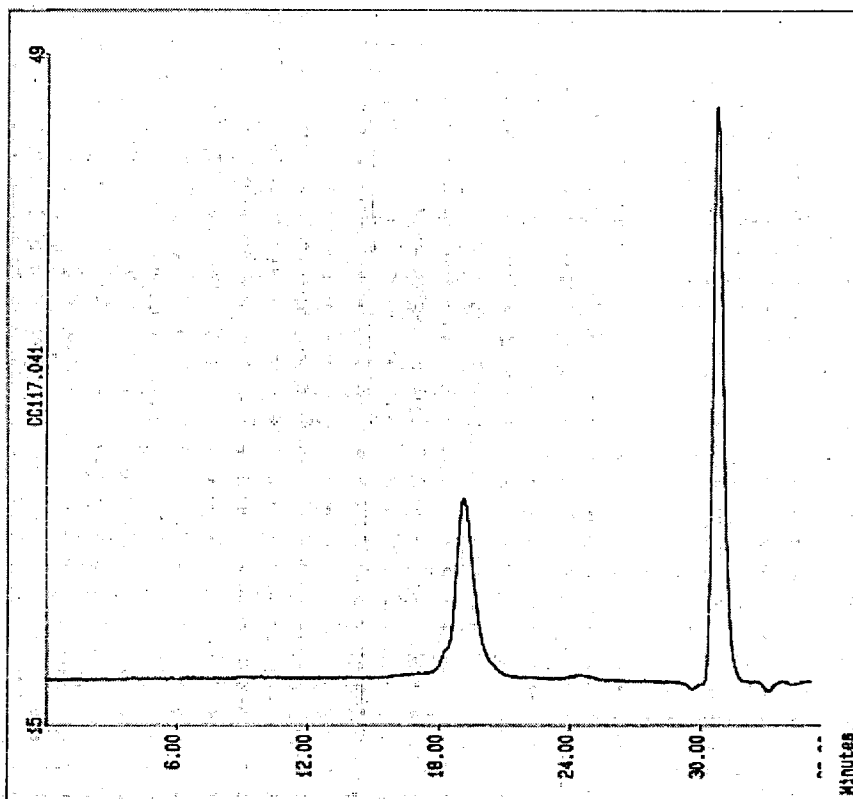
Figure A4.7 GPC trace of sample 1-10



**Molecular Weight Averages**

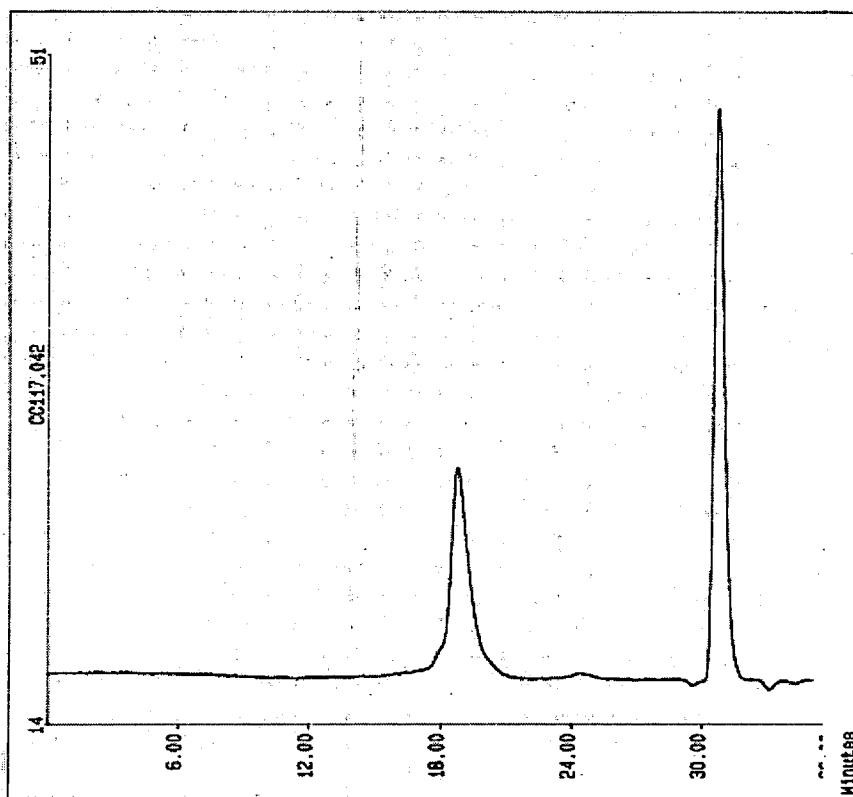
Mp =	37882.8	Mz =	46927.6
Mn =	38035.2	Mz+1 =	53866.7
Mw =	41785.7	Mv =	41128.3
Polydispersity =	1.099		

Figure A4.8 GPC trace of sample 1-7



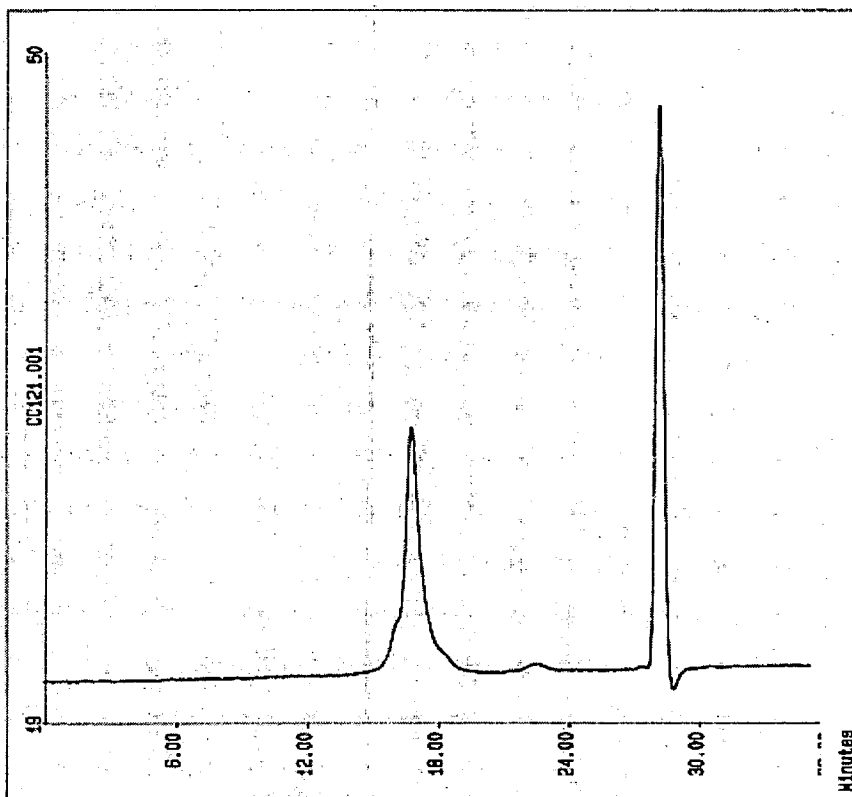
Molecular Weight Averages			
Mp =	68350	Mz =	76836
Mn =	60443	Mz+1 =	86736
Mw =	68176	Mv =	66968
Polydispersity =	1.128	Peak Area =	101194

Figure A4.9 GPC trace of sample 6-1



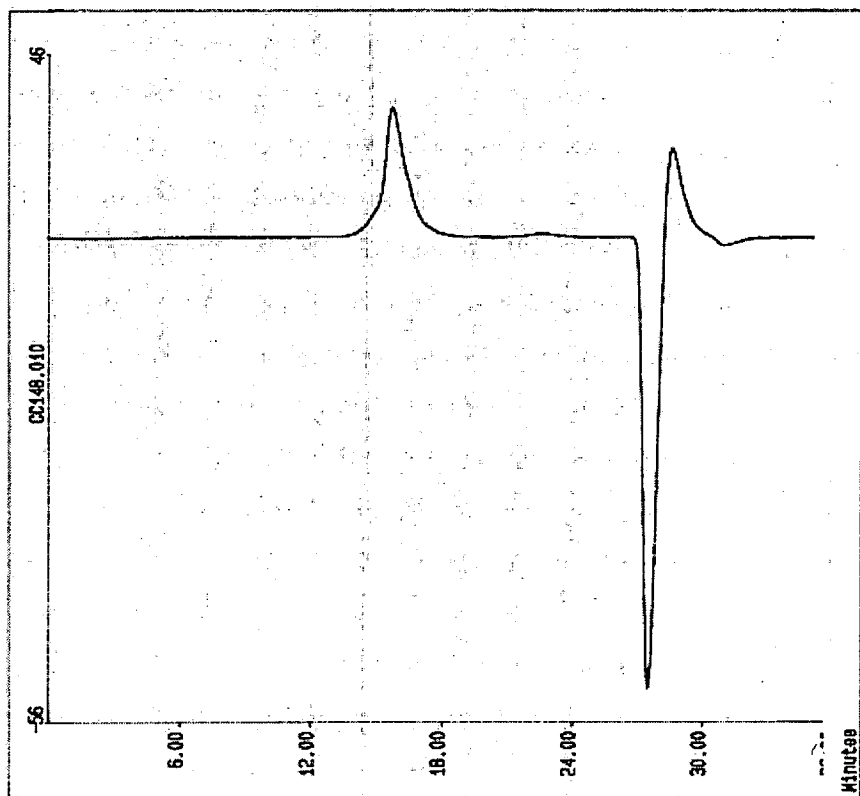
Molecular Weight Averages			
Mp =	91820	Mz =	96929
Mn =	72984	Mz+1 =	110792
Mw =	84615	Mv =	82868
Polydispersity =	1.159	Peak Area =	131099

Figure A4.10 GPC trace of sample 6-2



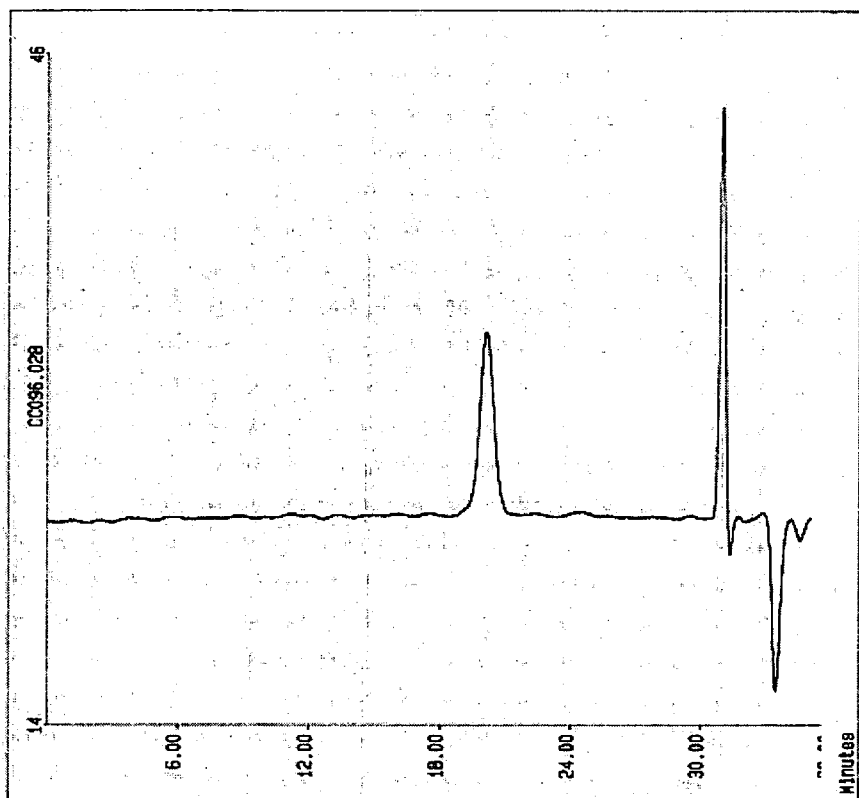
Molecular Weight Averages	
Mp =	133067
Mn =	101591
Mw =	130223
Polydispersity =	1.282
Mz =	161159
Mz+1 =	198154
Mv =	125985
Peak Area =	129139

Figure A4.11 GPC trace of sample 6-3



Molecular Weight Averages	
Mp =	413197
Mn =	277228
Mw =	419600
Polydispersity =	1.514
Mz =	659799
Mz+1 =	1079553
Mv =	393855
Peak Area =	301739

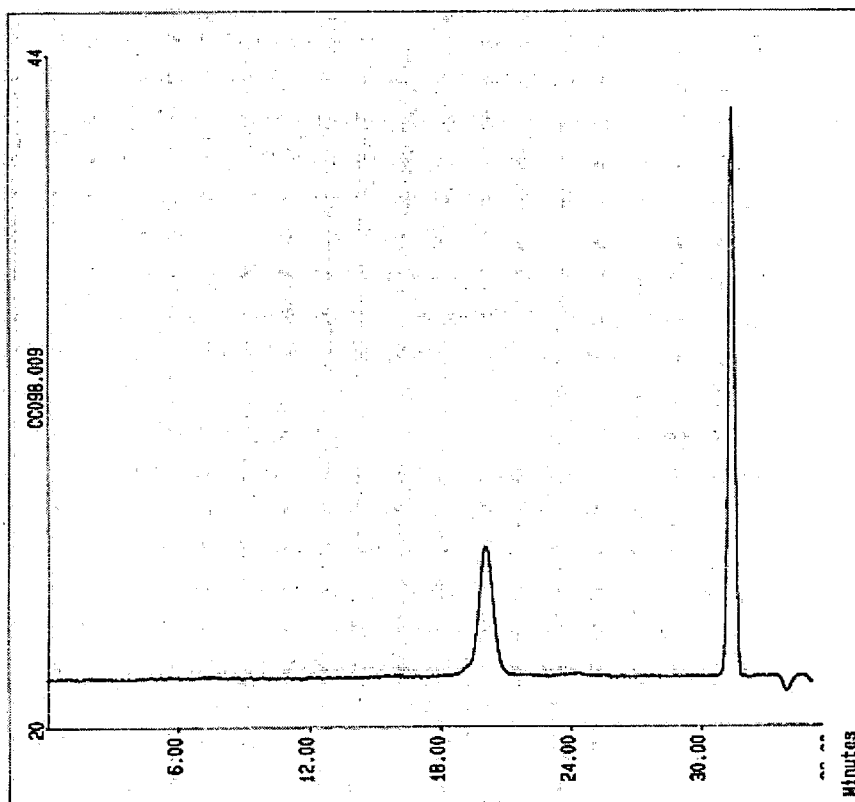
Figure A4.12 GPC trace of sample 11-1



**Molecular Weight Averages**

Mp =	37783.5	Mz =	41640.3
Mn =	36308.1	Mz+1 =	45201.0
Mw =	38749.3	Mv =	38353.8
Polydispersity =	1.067		

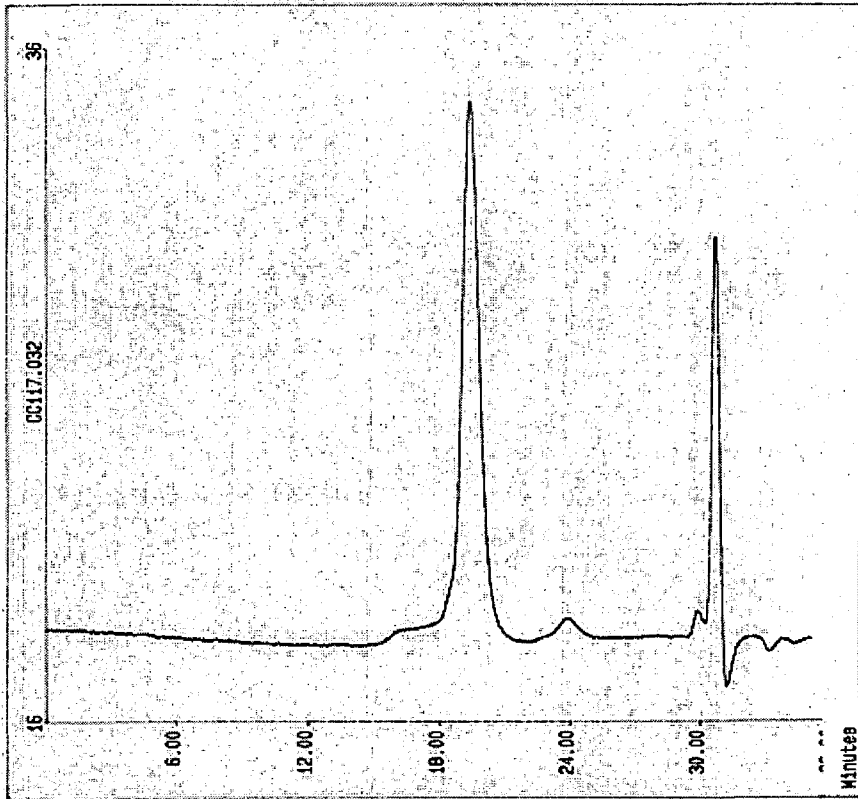
Figure A4.13 GPC trace of sample 3-4



**Molecular Weight Averages**

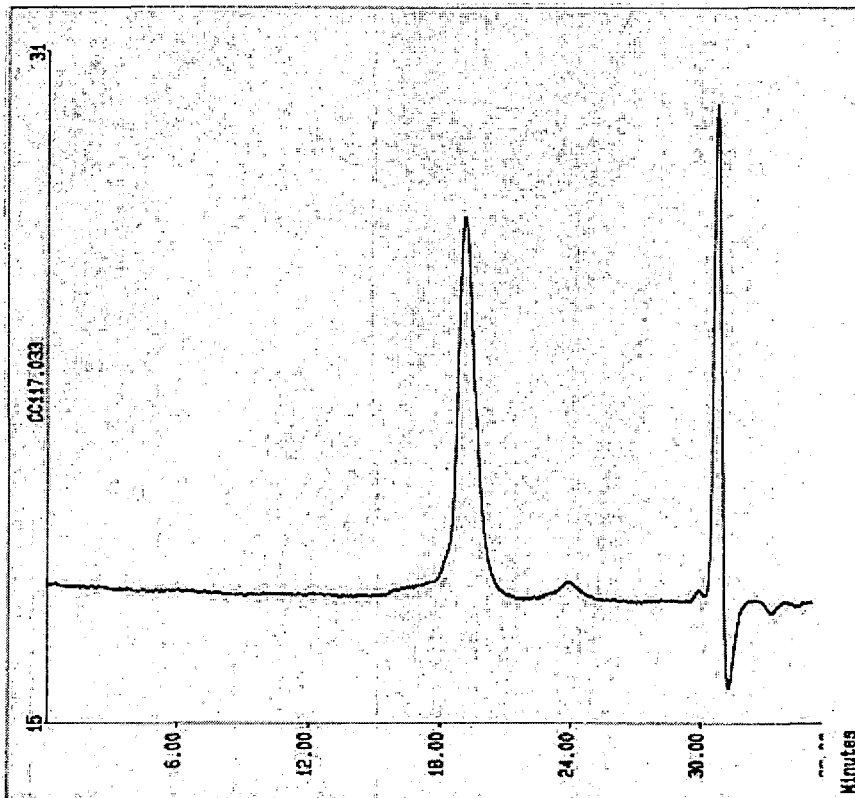
Mp =	45946.0	Mz =	50852.7
Mn =	44782.9	Mz+1 =	54760.8
Mw =	47581.4	Mv =	47129.6
Polydispersity =	1.062		

Figure A4.14 GPC trace of sample 3-5



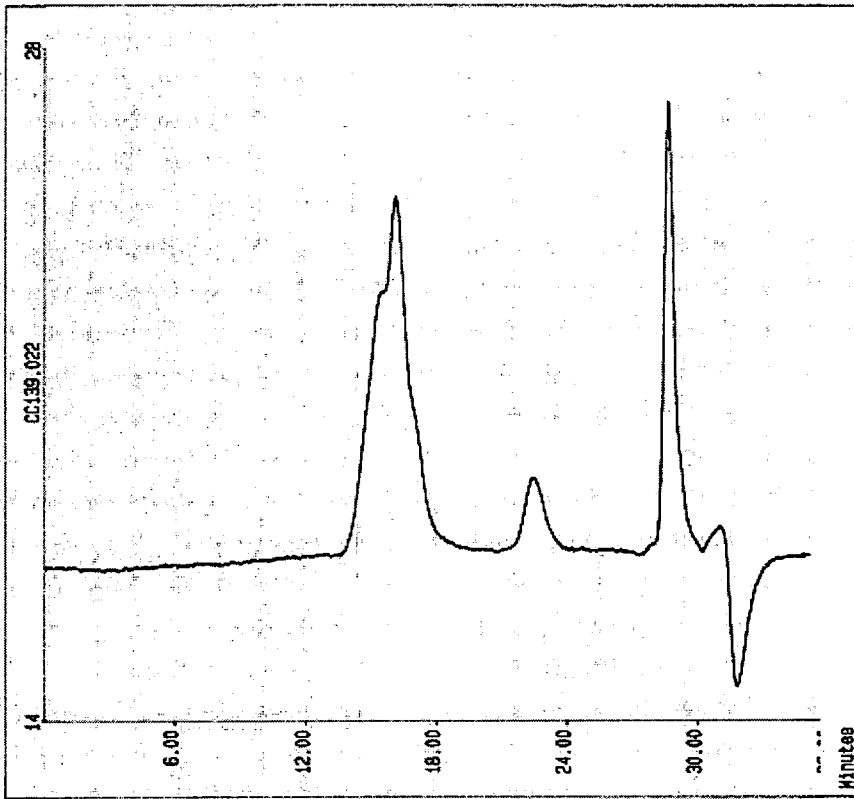
Molecular Weight Averages			
Mp =	53533	Mz =	60953
Mn =	48175	Mz+1 =	68990
Mw =	54216	Mv =	53282
Polydispersity =	1.125	Peak Area =	184152

Figure A4.15 GPC trace of sample 3-7



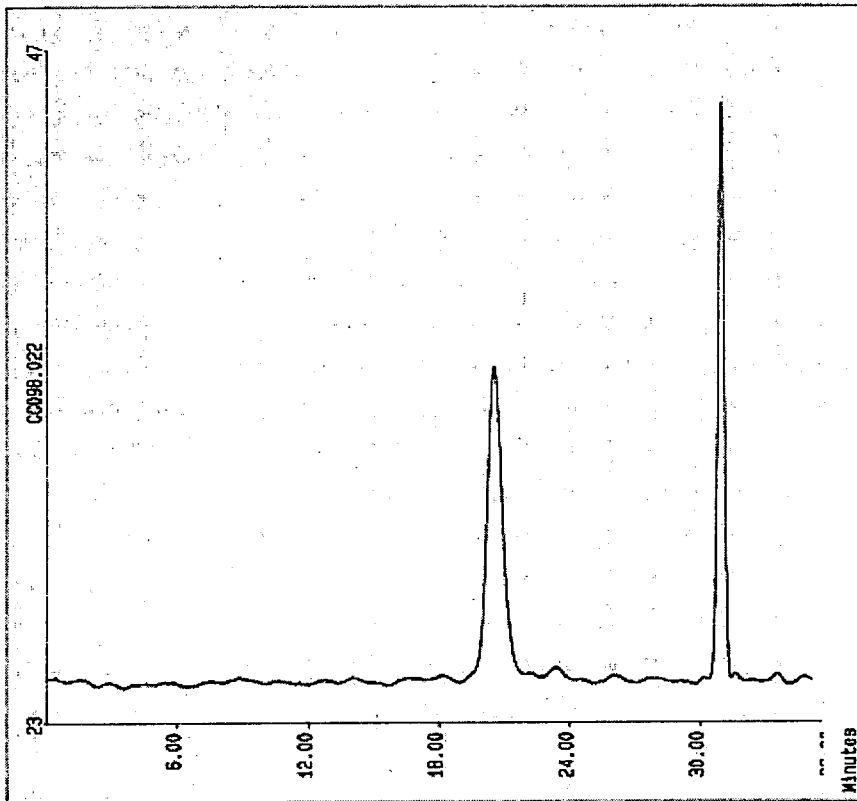
Molecular Weight Averages			
Mp =	69292	Mz =	72903
Mn =	60592	Mz+1 =	79768
Mw =	66554	Mv =	65641
Polydispersity =	1.098	Peak Area =	93777

Figure A4.16 GPC trace of sample 3-8



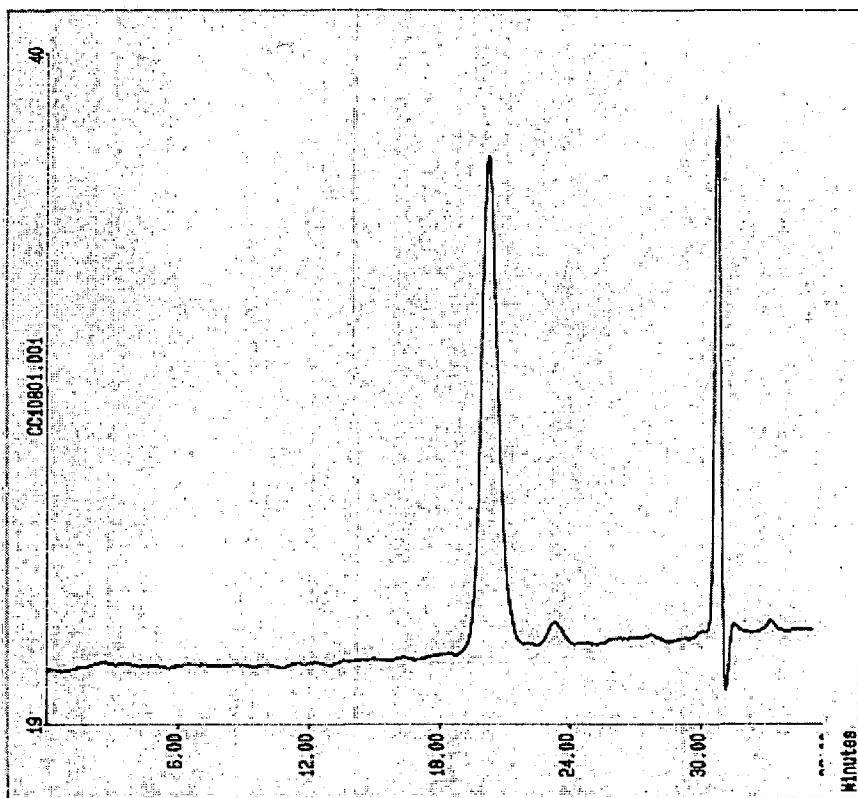
Molecular Weight Averages			
Mp =	285260	Mz =	736655
Mn =	247826	Mz+I =	1070887
Mw =	442875	Mv =	407394
Polydispersity =	1.787	Peak Area =	172282

Figure A4.17 GPC trace of sample 13-1



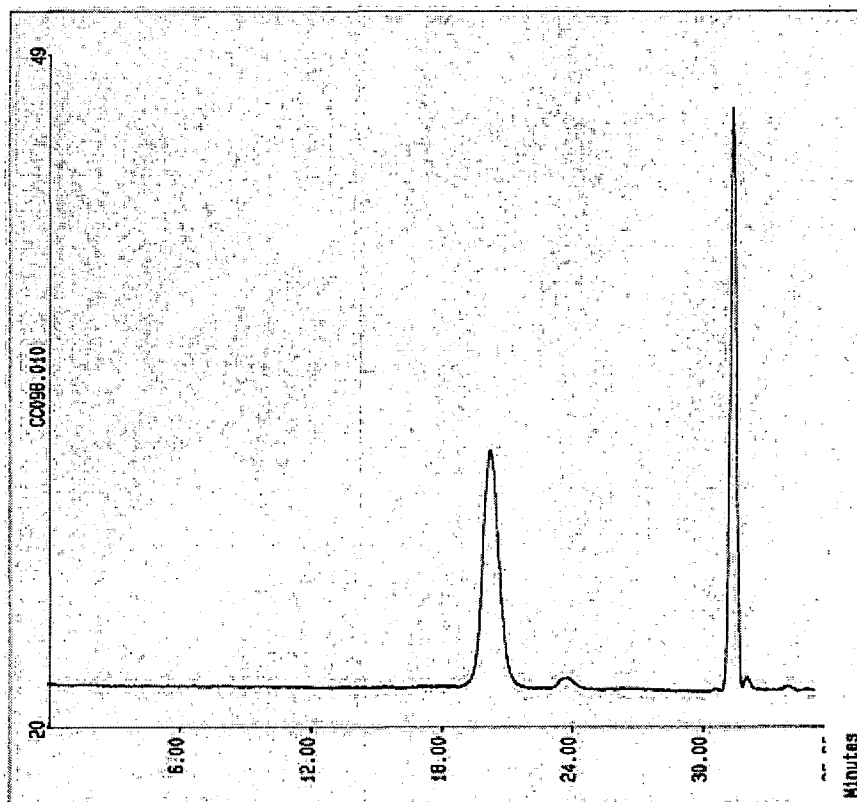
Molecular Weight Averages			
Mp =	25675.0	Mz =	26880.2
Mn =	23863.4	Mz+I =	28427.7
Mw =	25362.6	Mv =	25138.3
Polydispersity =	1.063		

Figure A4.18 GPC trace of sample 5-3



Molecular Weight Averages			
Mp =	25221	Mz =	-
Mn =	23111	Mz+1 =	-
Mw =	25188	Mv =	-
Polydispersity =			1.091

Figure A4.19 GPC trace of sample 5-5



Molecular Weight Averages			
Mp =	39770.3	Mz =	42648.5
Mn =	37034.4	Mz+1 =	45662.1
Mw =	39787.7	Mv =	39370.8
Polydispersity =			1.074

Figure A4.20 GPC trace of sample 5-1

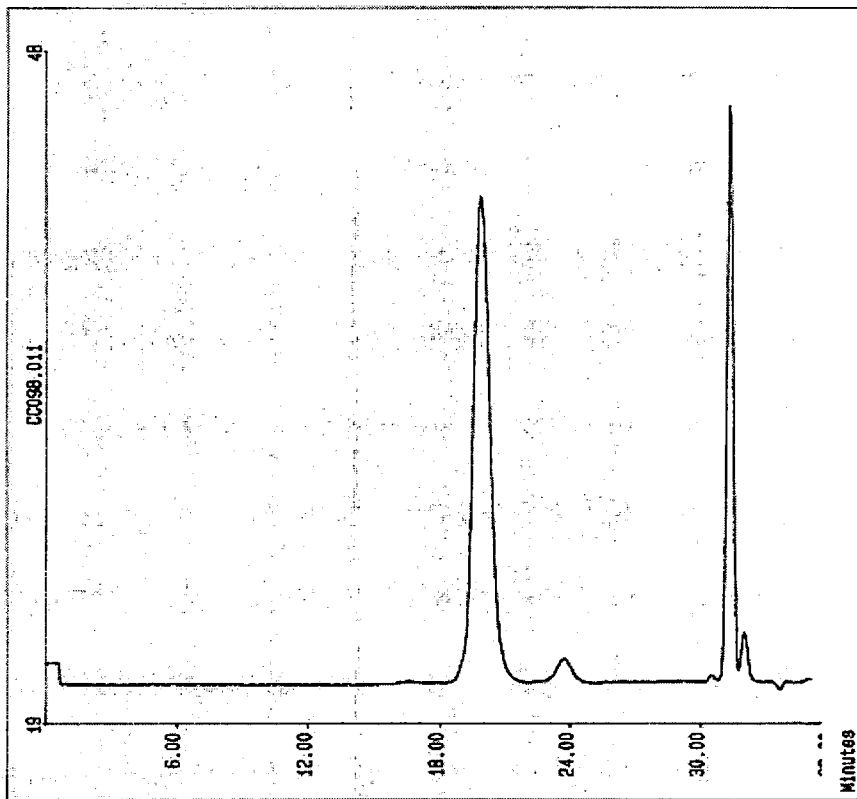


Figure A4.21 GPC trace of sample 5-2

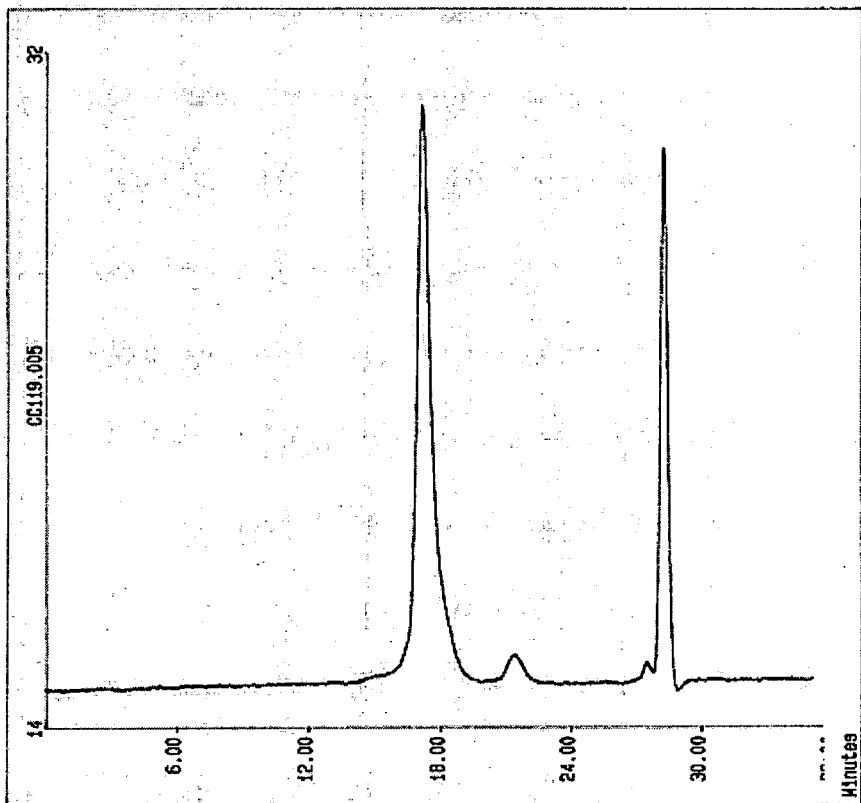
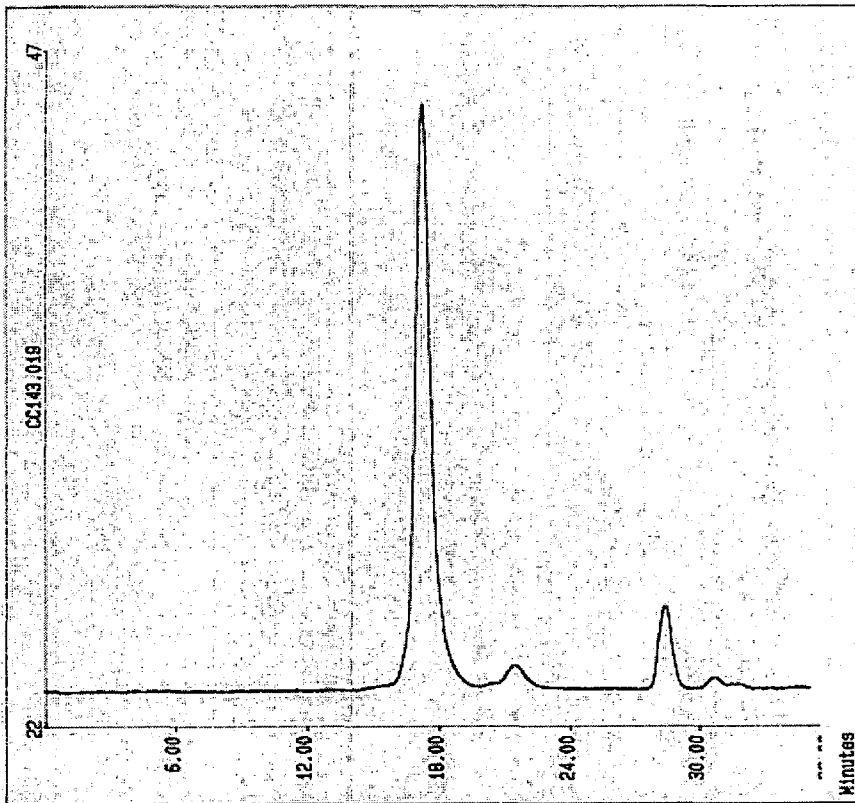
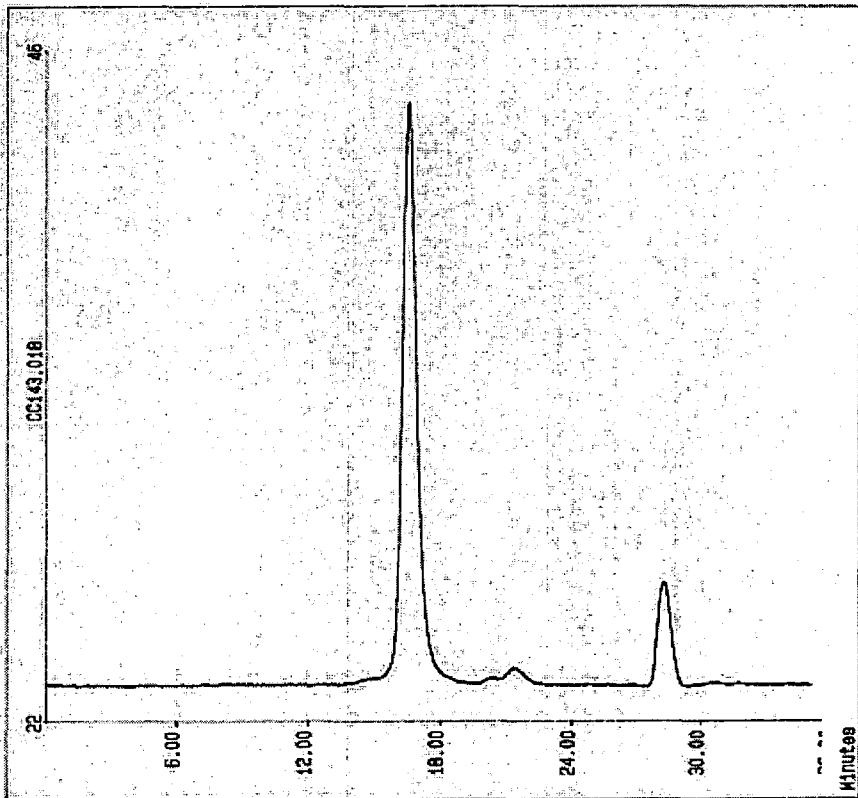


Figure A4.22 GPC trace of sample 5-7



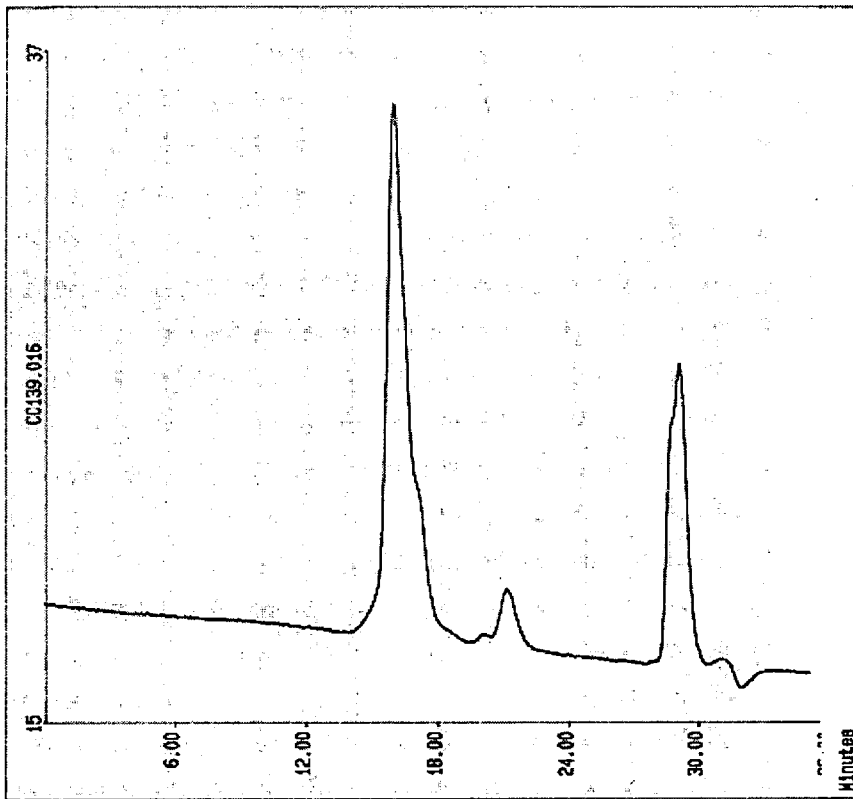
Molecular Weight Averages			
Mp =	90923	Mz =	97096
Mn =	74334	Mz+1 =	108591
Mw =	86103	Mv =	84470
Polydispersity =	1.158	Peak Area =	223078

Figure A4.23 GPC trace of sample 9-1



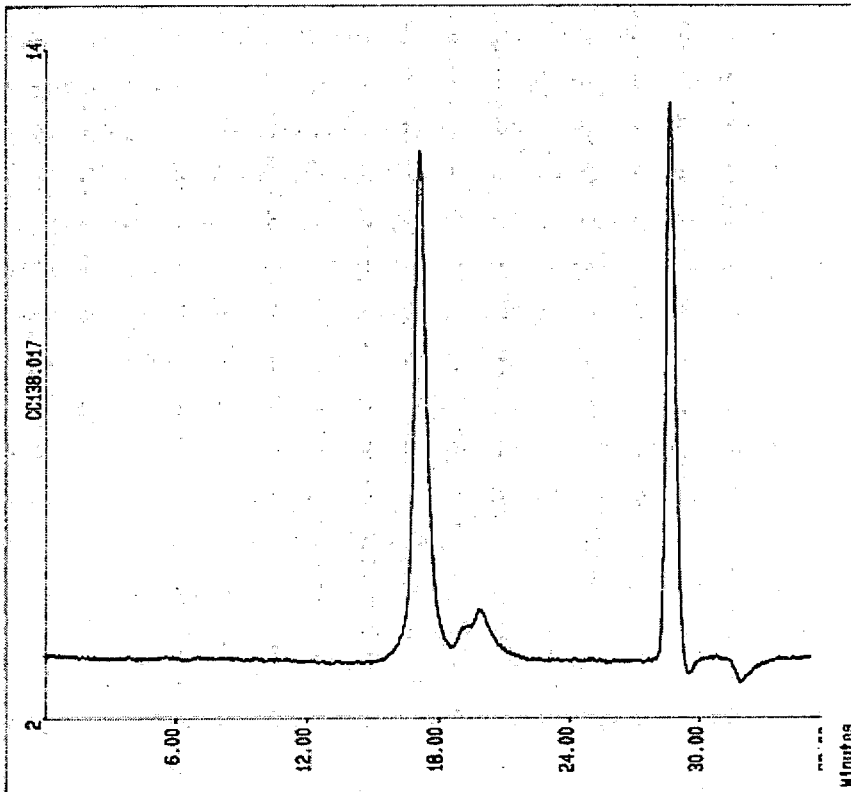
Molecular Weight Averages			
Mp =	152604	Mz =	162326
Mn =	130781	Mz+1 =	177707
Mw =	147276	Mv =	145014
Polydispersity =	1.126	Peak Area =	195318

Figure A4.24 GPC trace of sample 8-1



Molecular Weight Averages			
Mp =	416078	Mz =	446611
Mn =	271552	Mz+1 =	559050
Mw =	355366	Mv =	342776
Polydispersity =	1.309	Peak Area =	235007

Figure A4.25 GPC trace of sample 14-1



Molecular Weight Averages			
Mp =	110836	Mz =	118841
Mn =	99974	Mz+1 =	130452
Mw =	109028	Mv =	107647
Polydispersity =	1.091		

Figure A4.26 GPC trace of sample 7-3

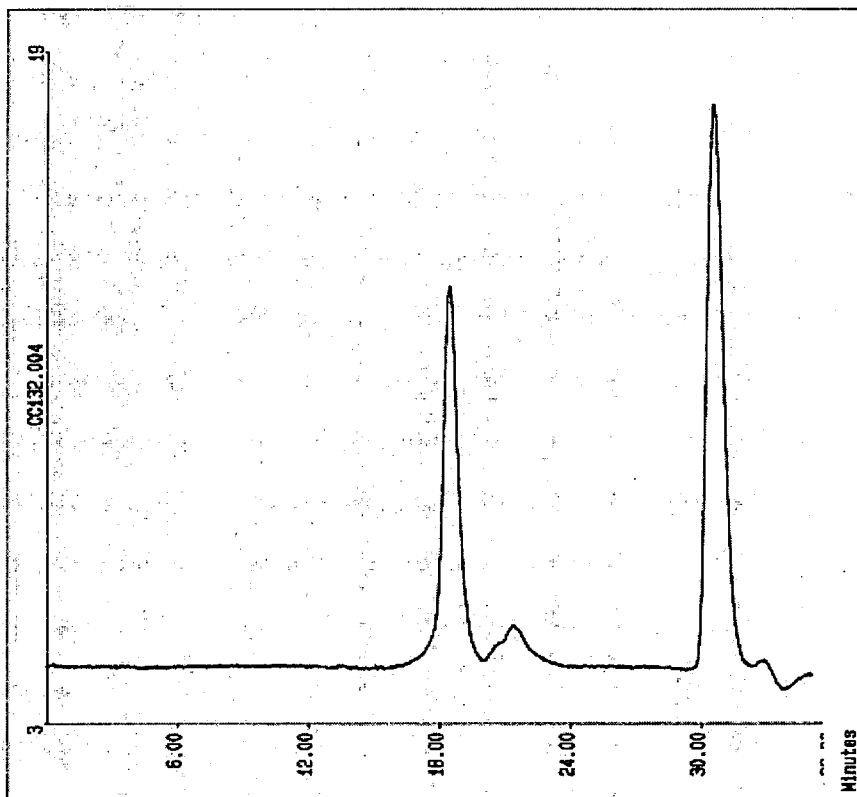


Figure A4.27 GPC trace of sample 7-1

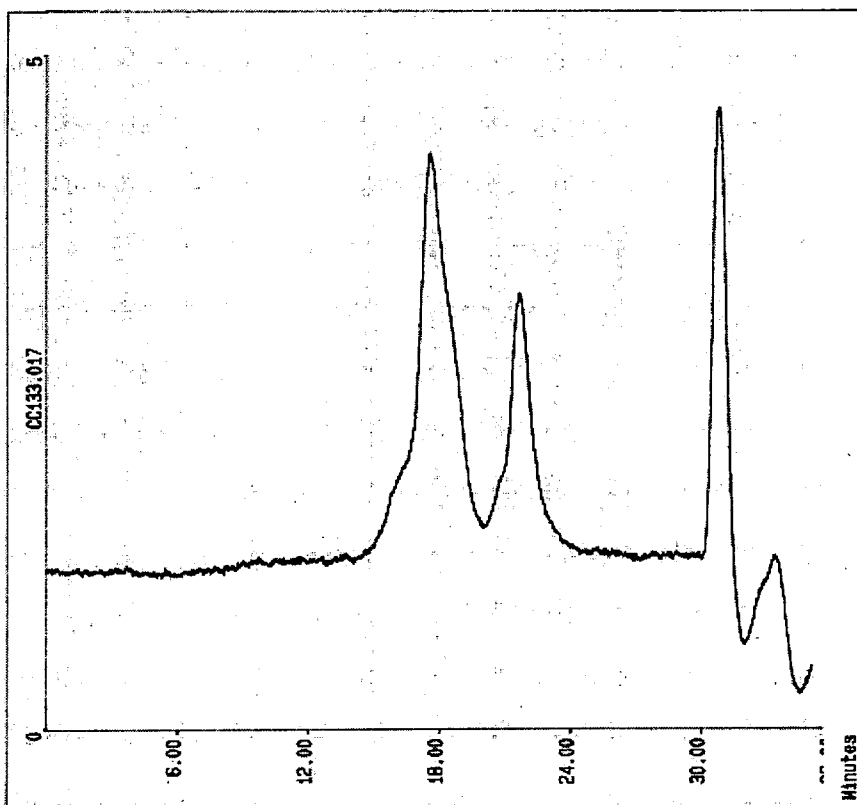
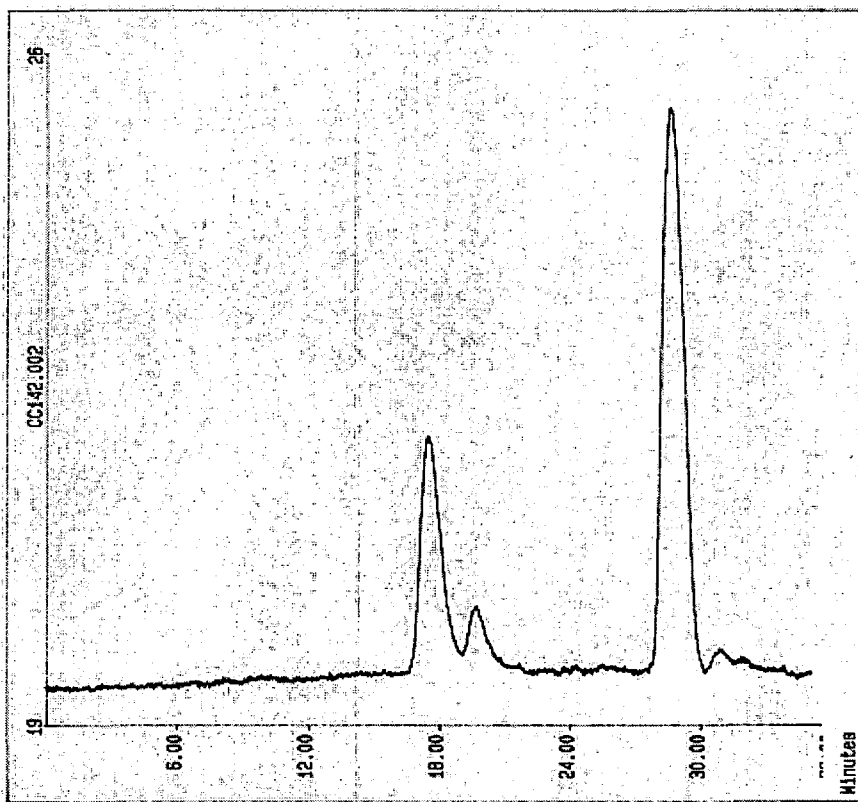
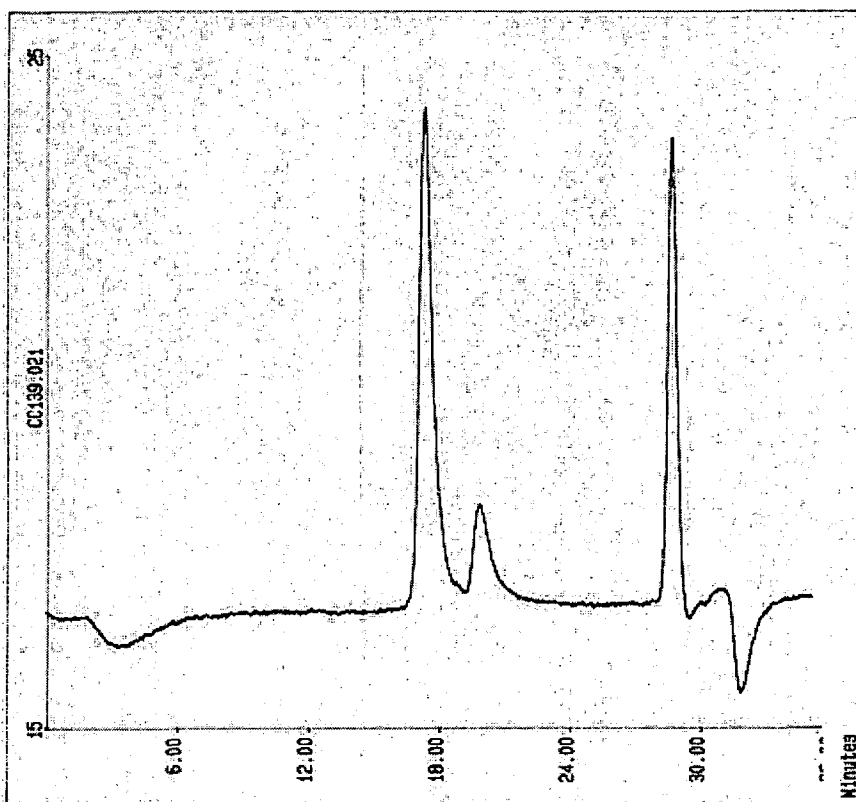


Figure A4.28 GPC trace of sample 7-2



Molecular Weight Averages			
Mp =	78171	Mz =	79324
Mn =	63196	Mz+1 =	86818
Mw =	71334	Mv =	70134
Polydispersity =	1.129	Peak Area =	27971

Figure A4.29 GPC trace of sample 15-3



Molecular Weight Averages			
Mp =	98292	Mz =	98816
Mn =	82692	Mz+1 =	105547
Mw =	91360	Mv =	90191
Polydispersity =	1.105	Peak Area =	68711

Figure A4.30 GPC trace of sample 15-2

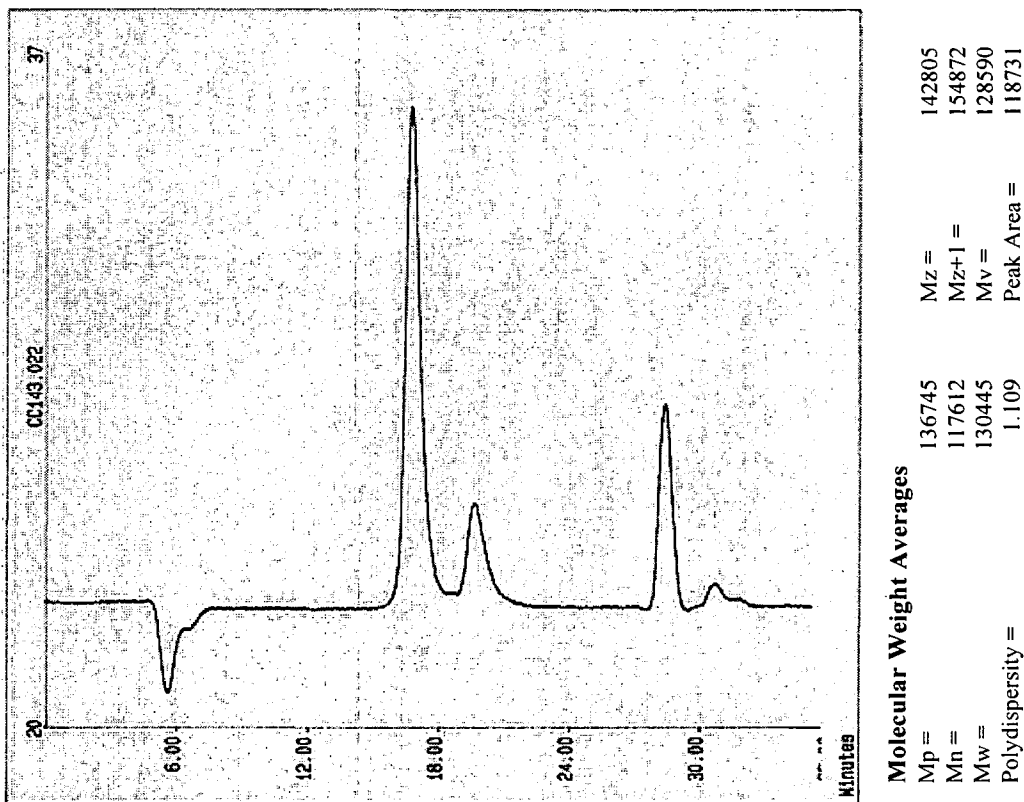


Figure A4.31 GPC trace of sample 15-1

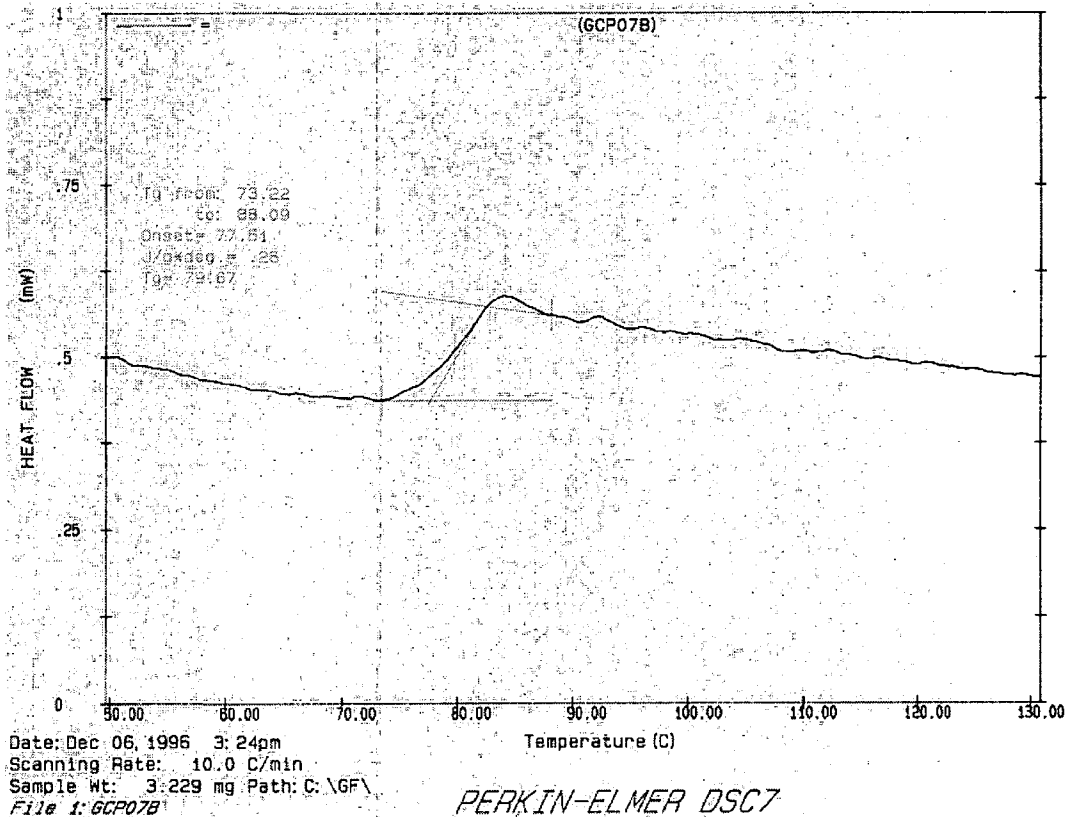


Figure A4.32 DSC trace of sample 1-10

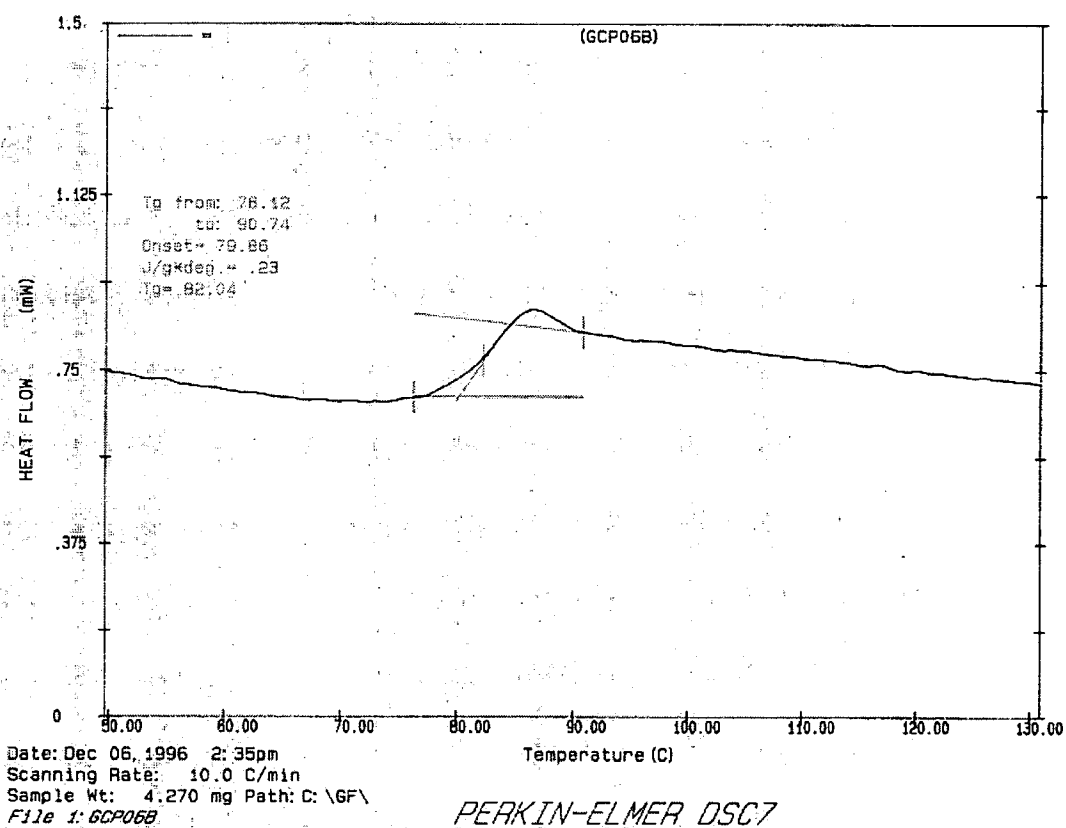


Figure A4.33 DSC trace of sample 1-7

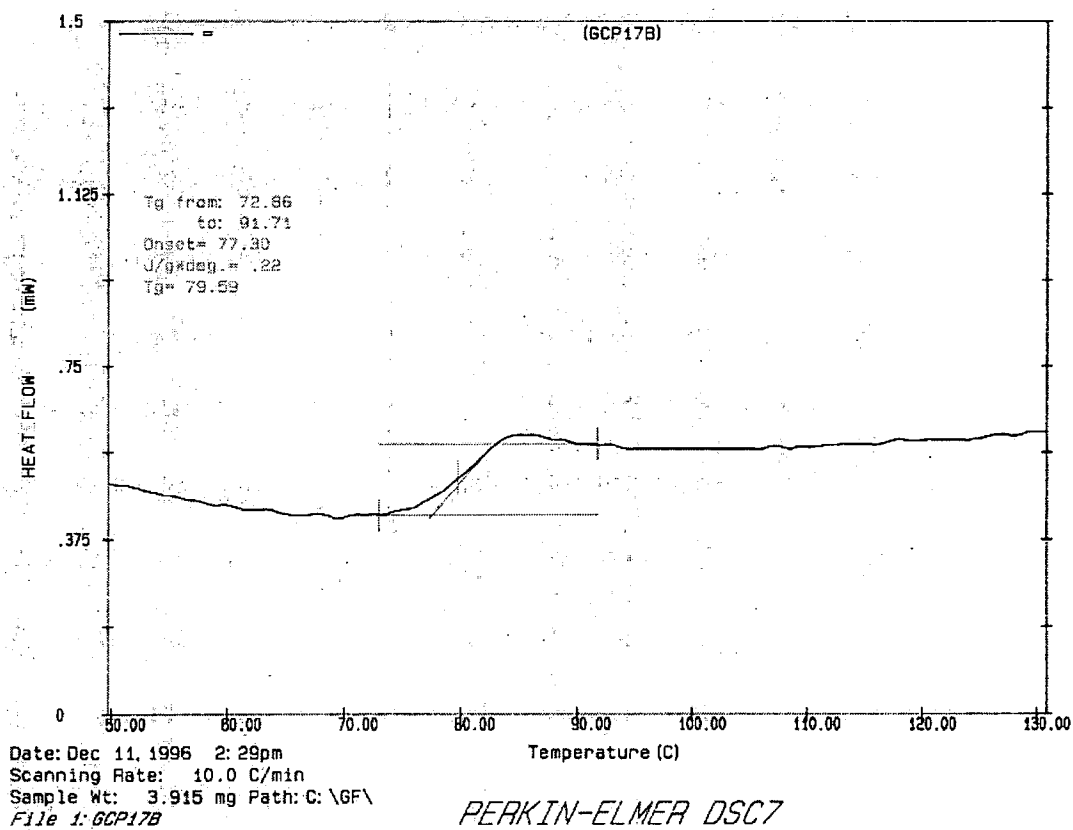


Figure A4.34 DSC trace of sample 6-1

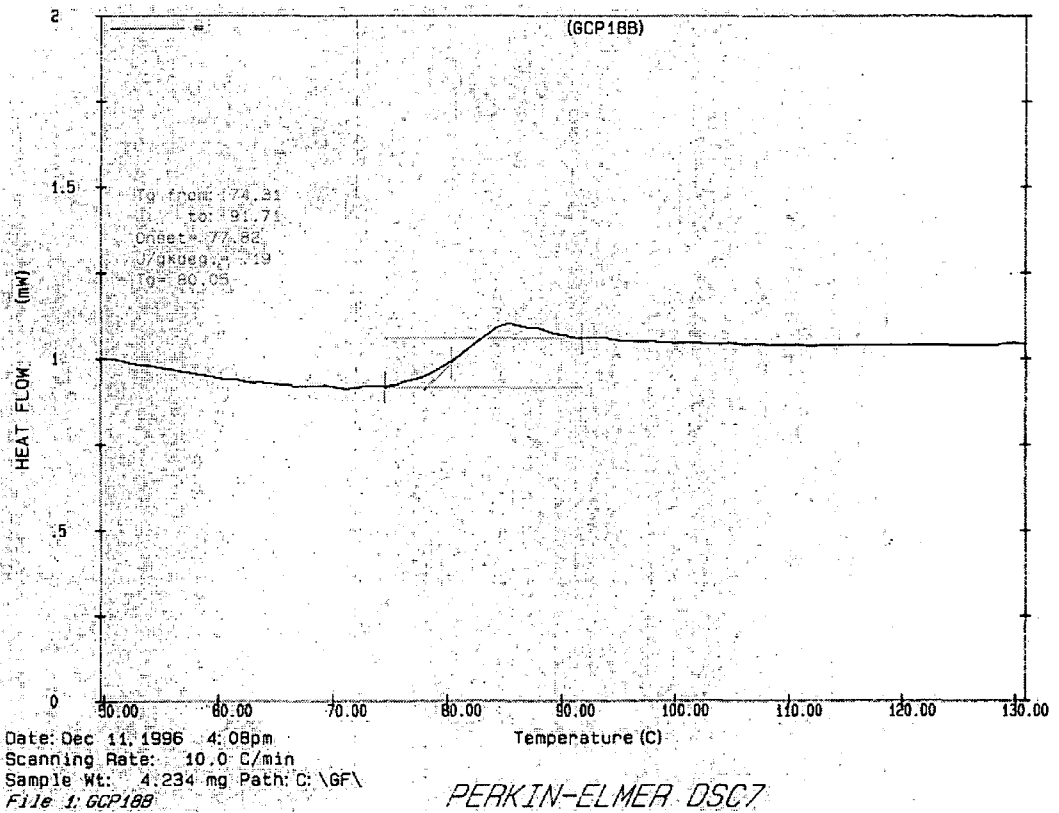


Figure A4.35 DSC trace of sample 6-2

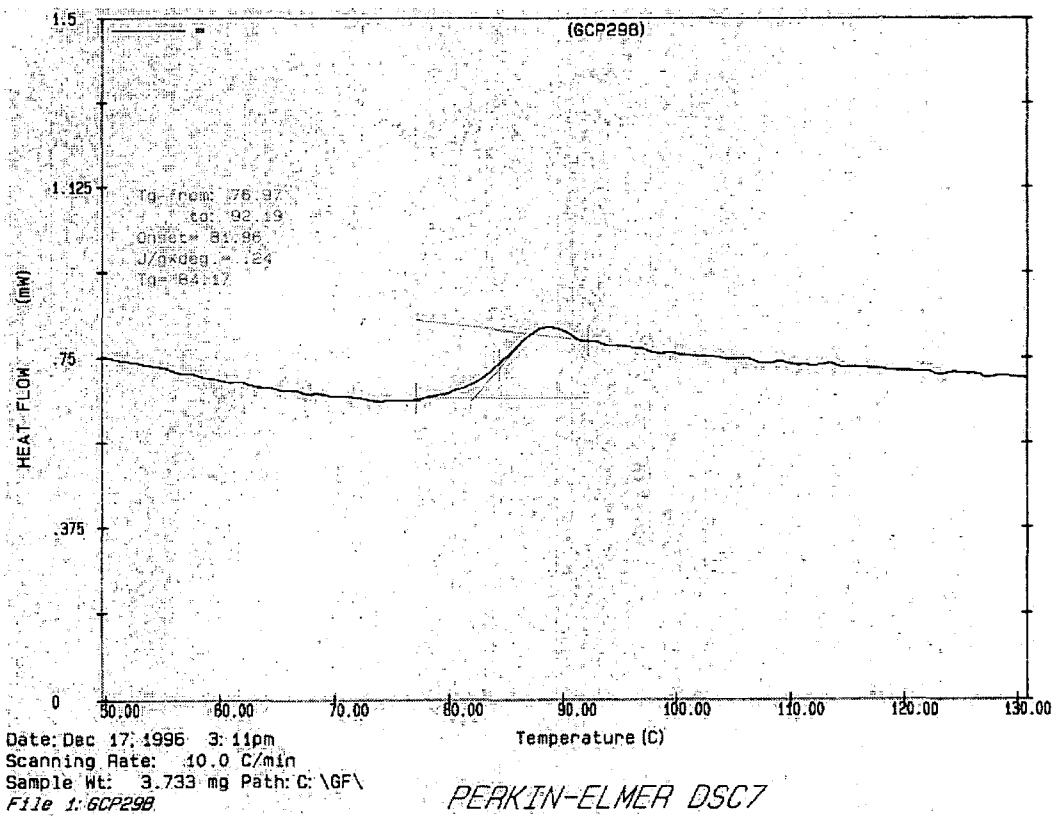


Figure A4.36 DSC trace of sample 11-1

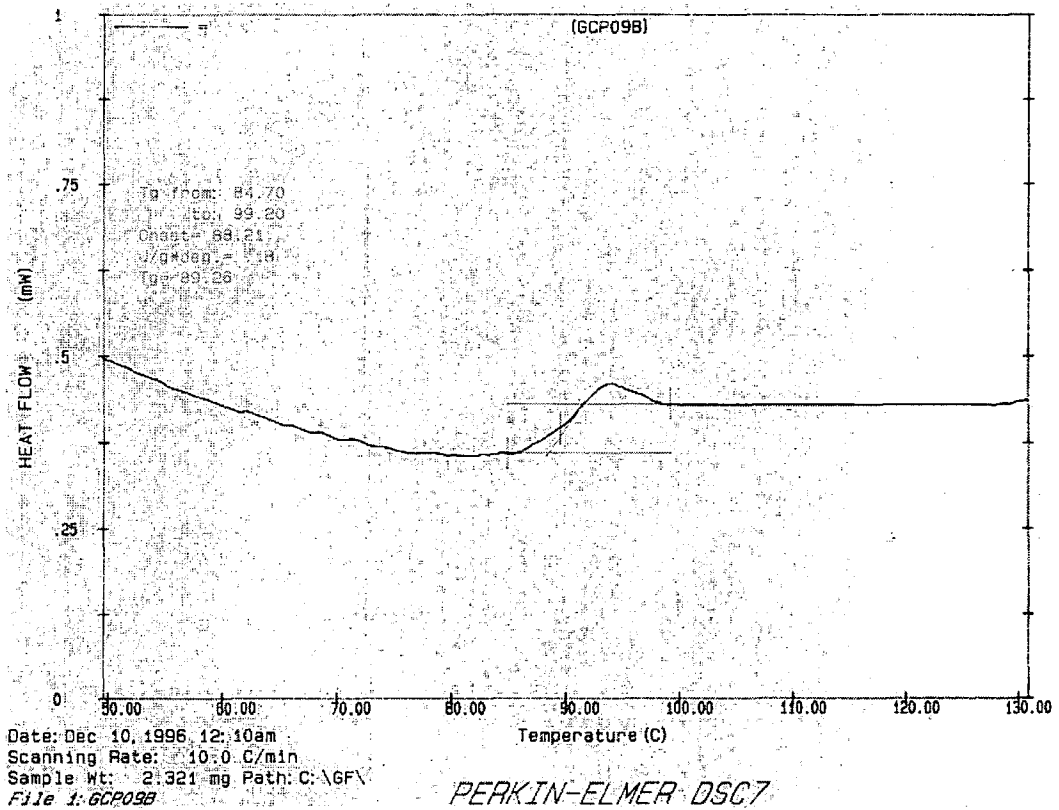


Figure A4.37 DSC trace of sample 3-4

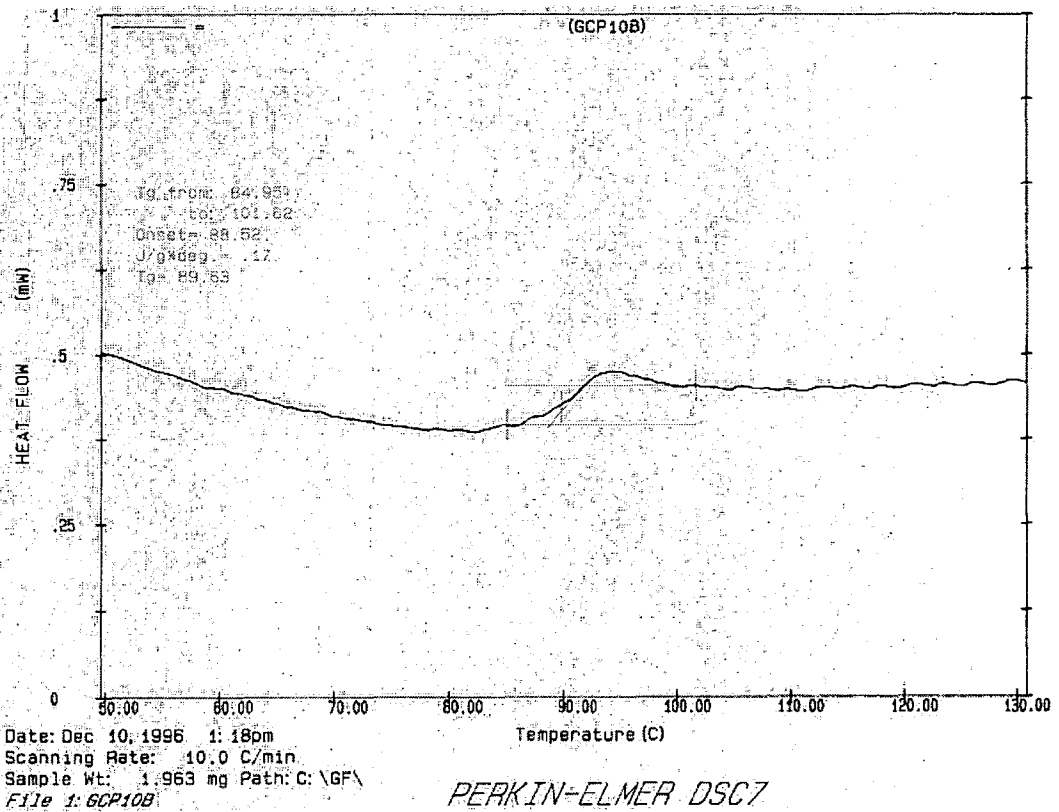


Figure A4.38 DSC trace of sample 3-5

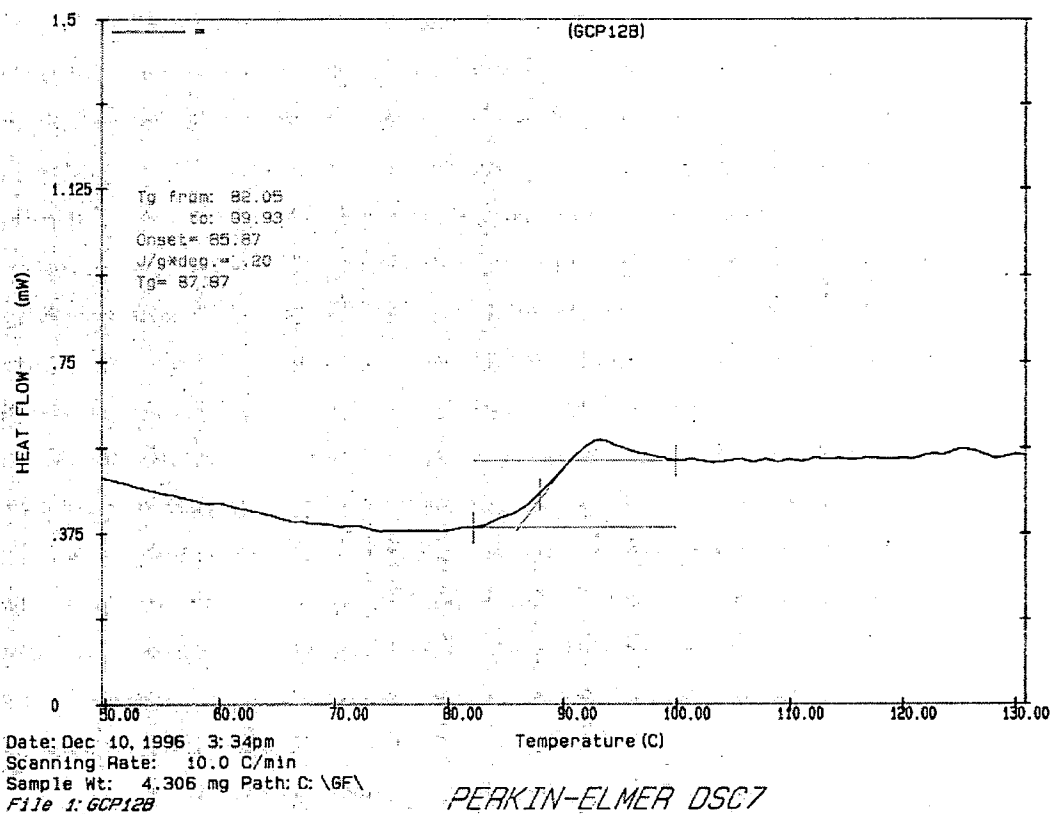


Figure A4.39 DSC trace of sample 3-8

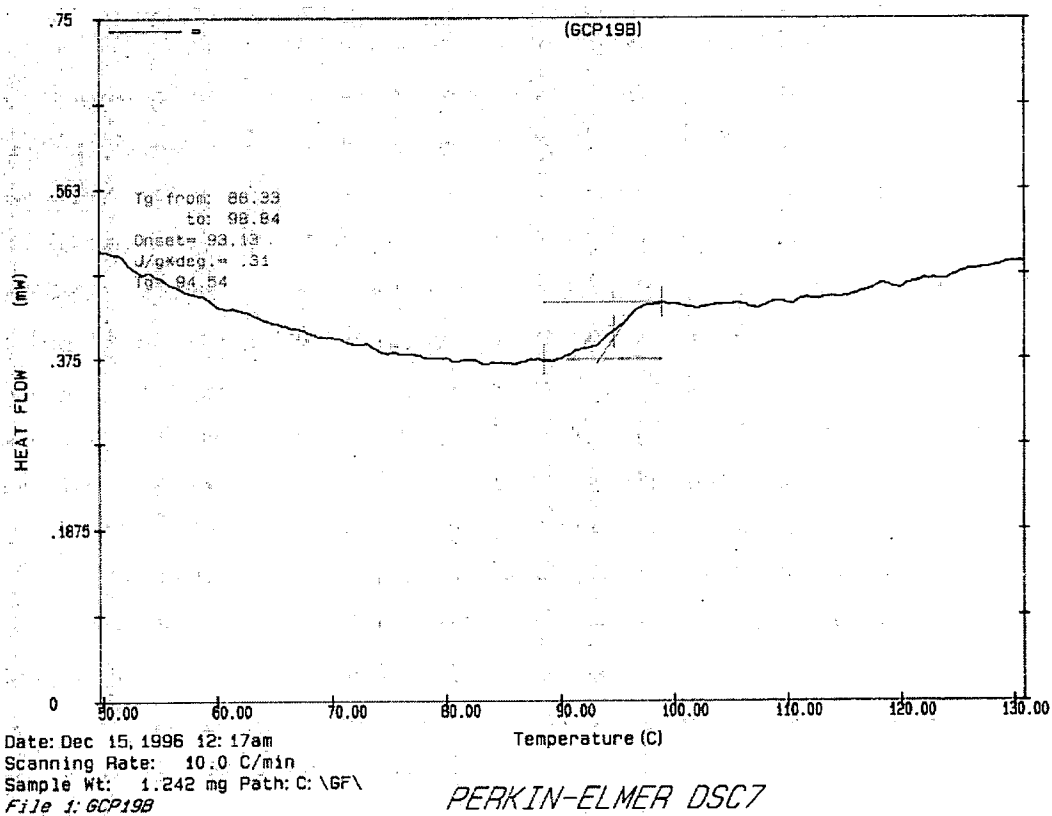


Figure A4.40 DSC trace of sample 5-5

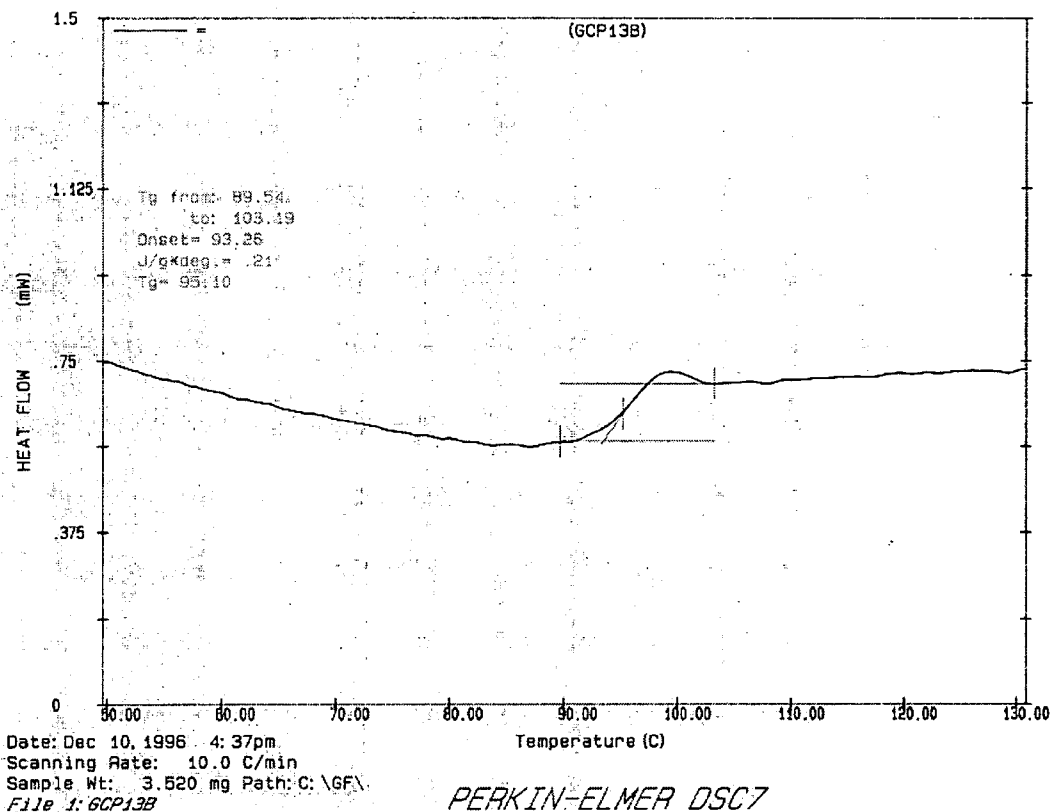


Figure A4.41 DSC trace of sample 5-1

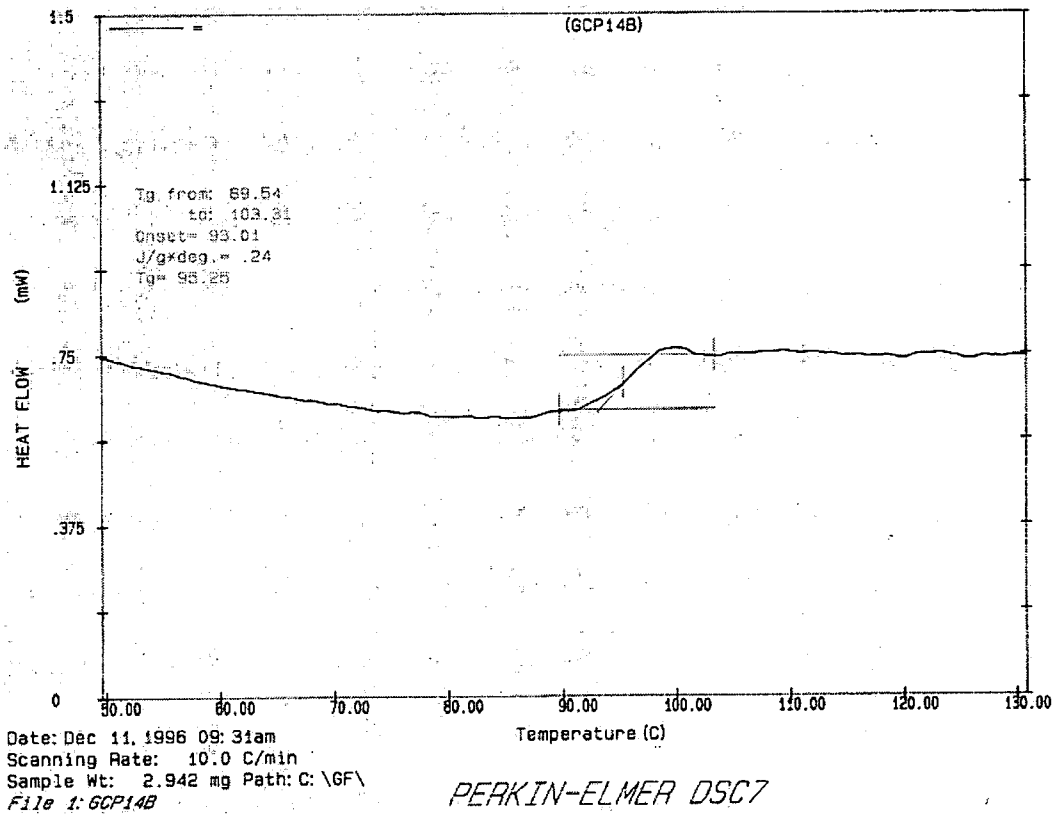


Figure A4.42 DSC trace of sample 5-2

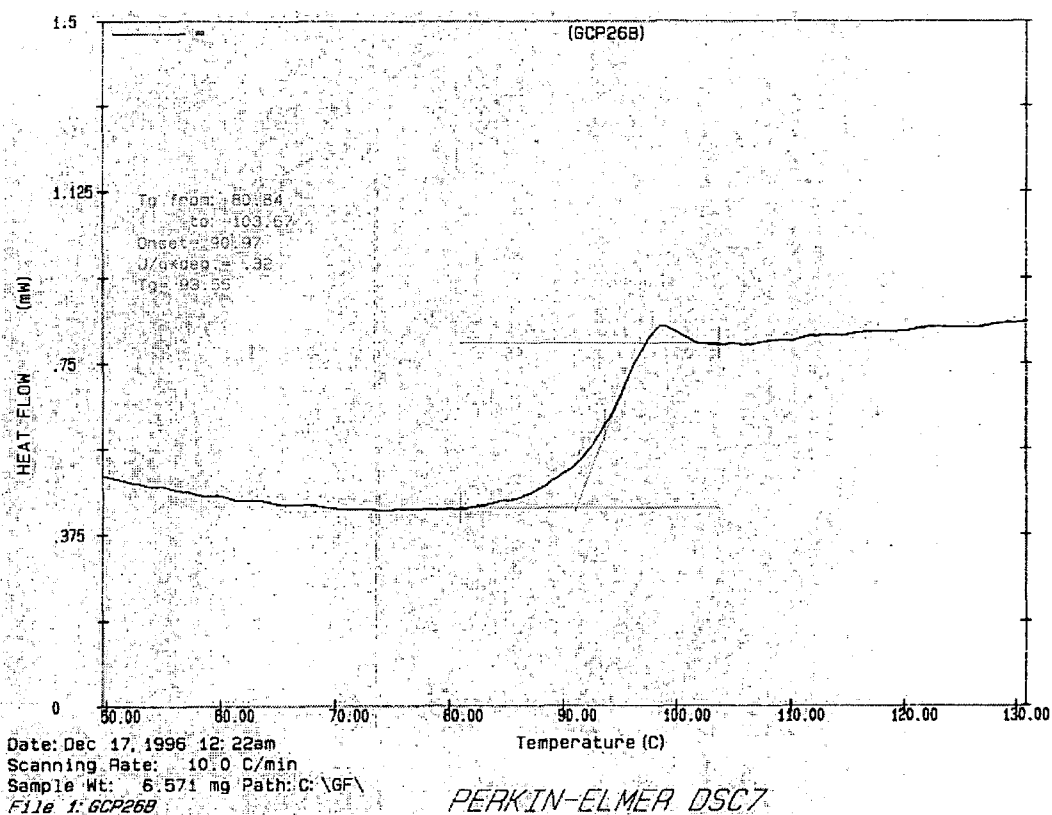


Figure A4.43 DSC trace of sample 9-1

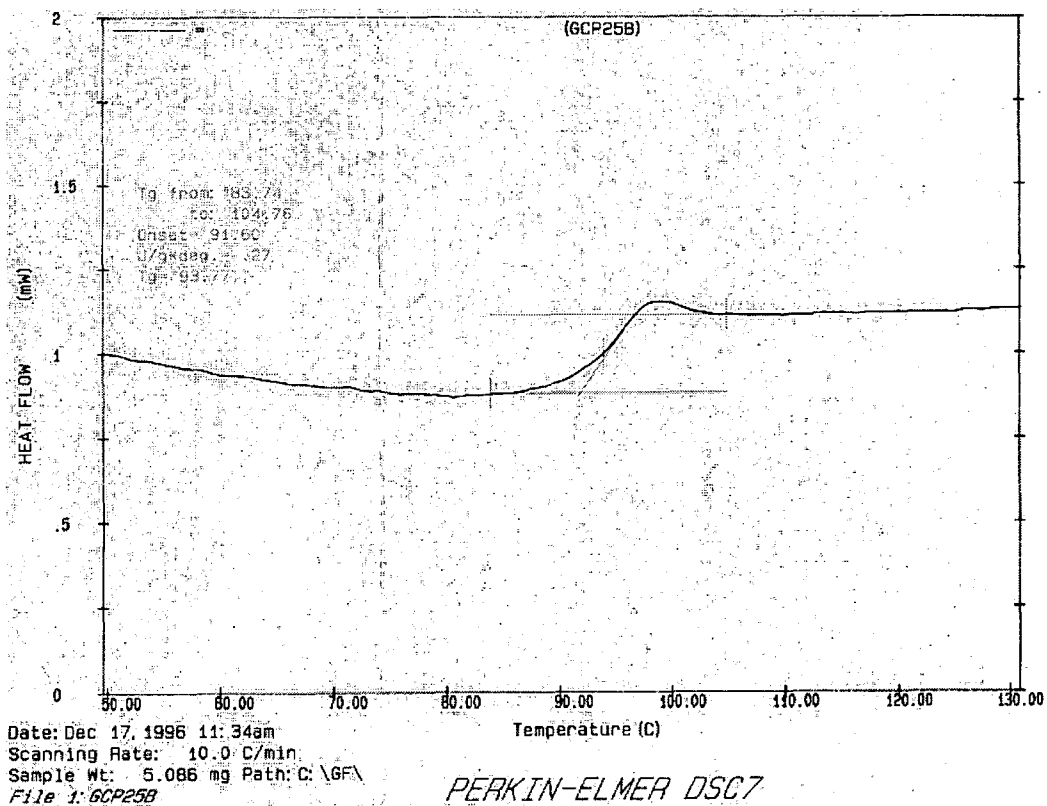


Figure A4.44 DSC trace of sample 8-1

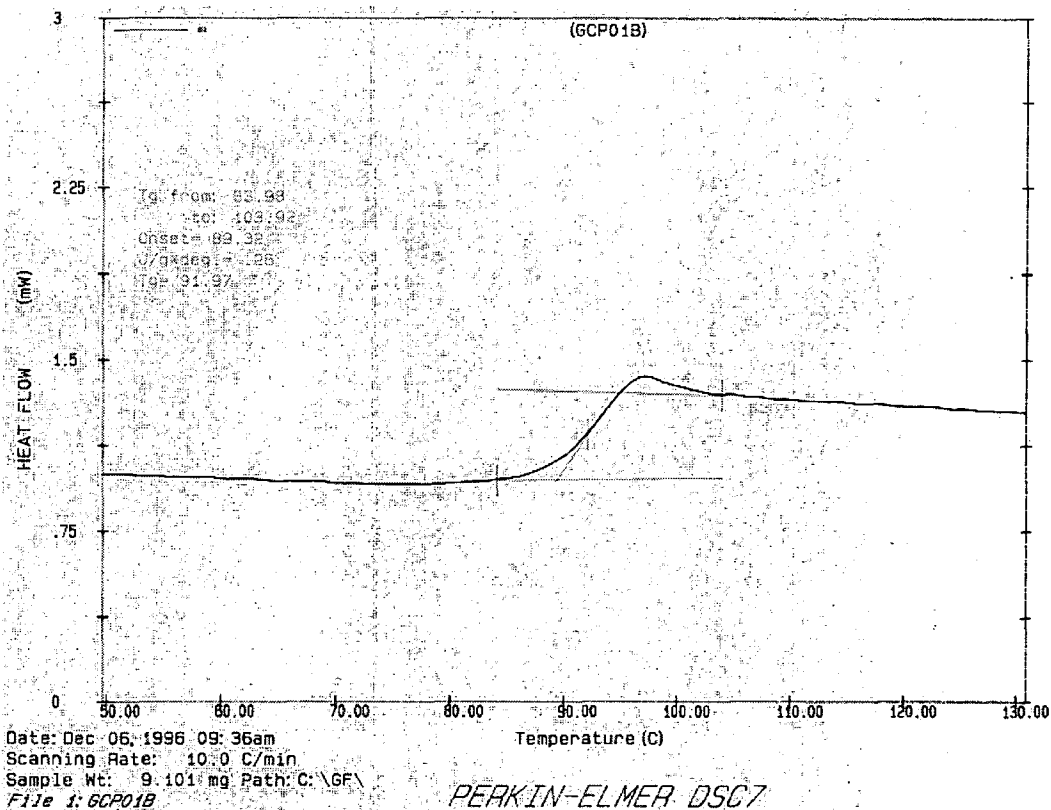


Figure A4.45 DSC trace of sample 14-1

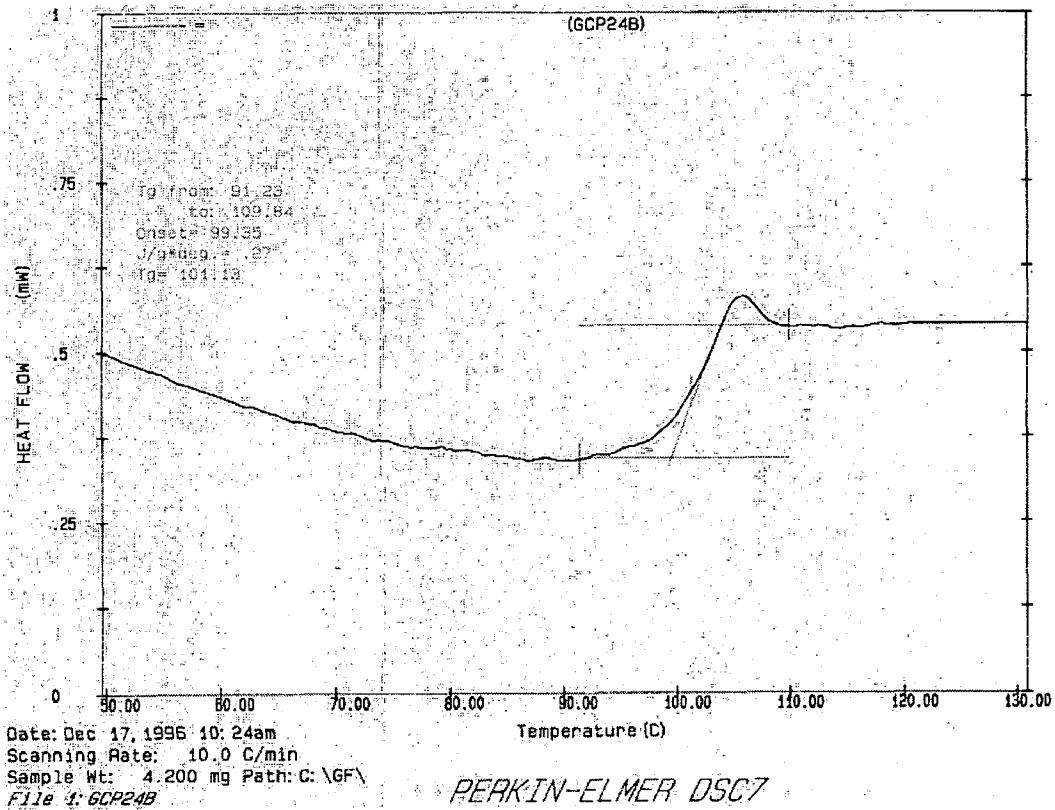


Figure A4.46 DSC trace of sample 7-3

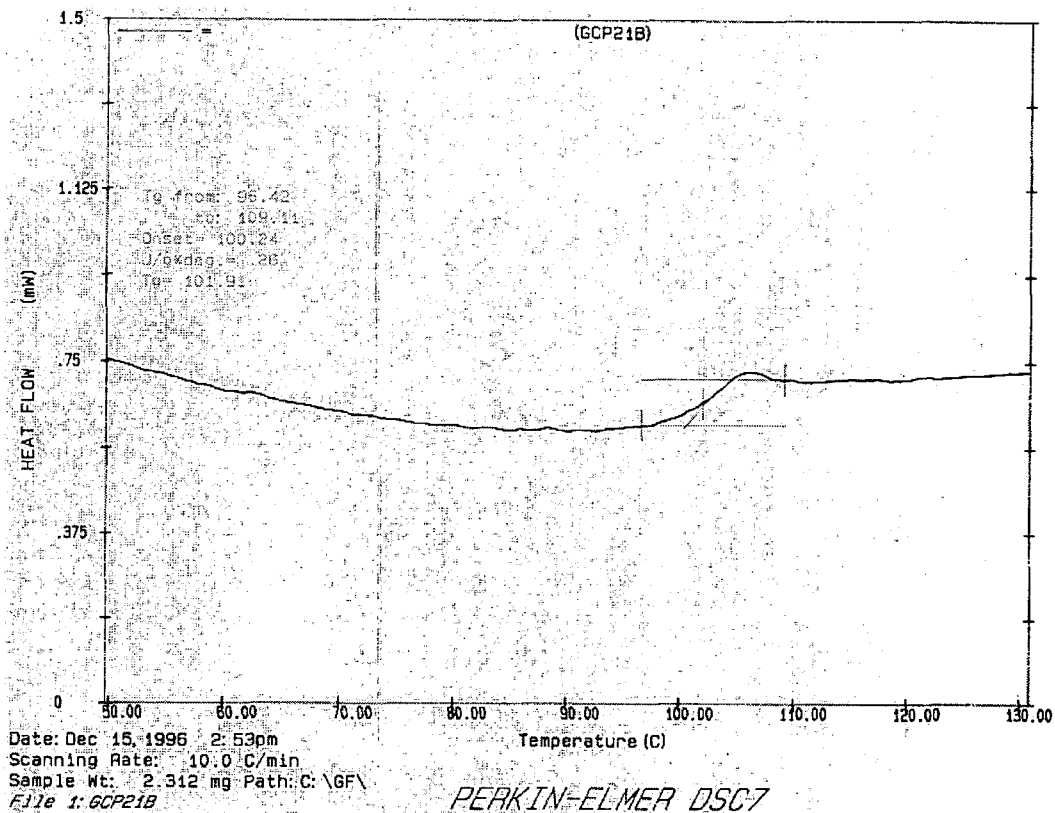


Figure A4.47 DSC trace of sample 7-1

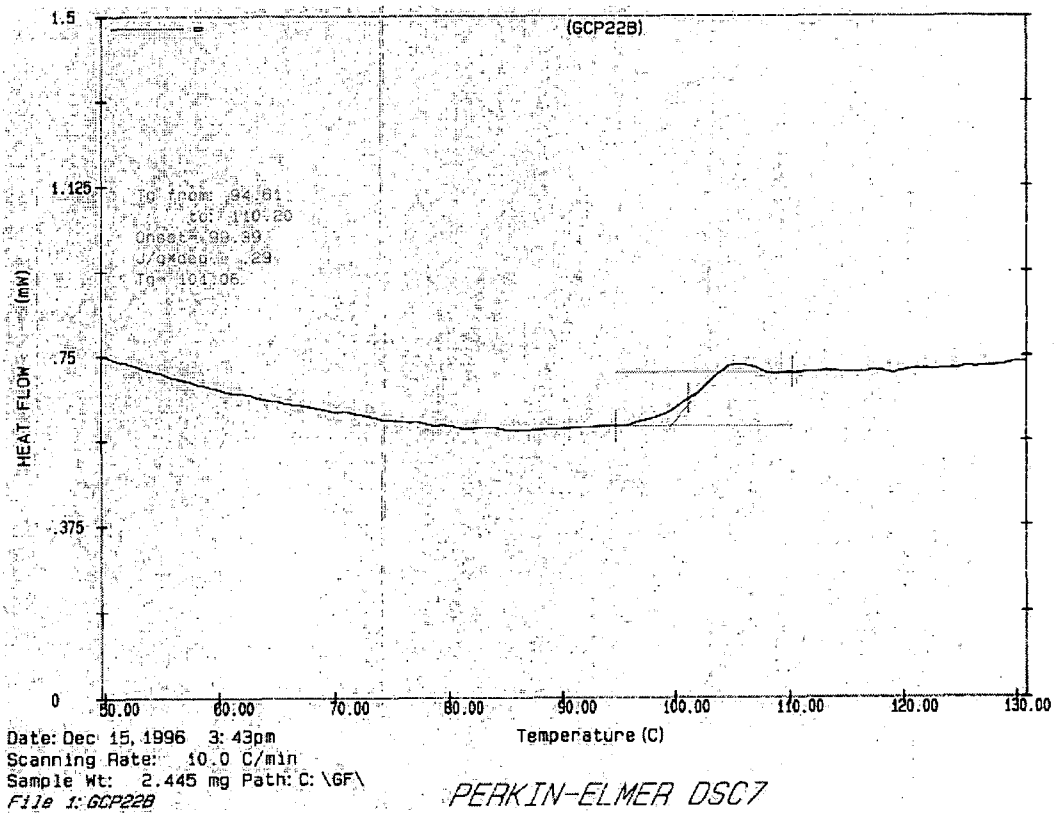


Figure A4.48 DSC trace of sample 7-2

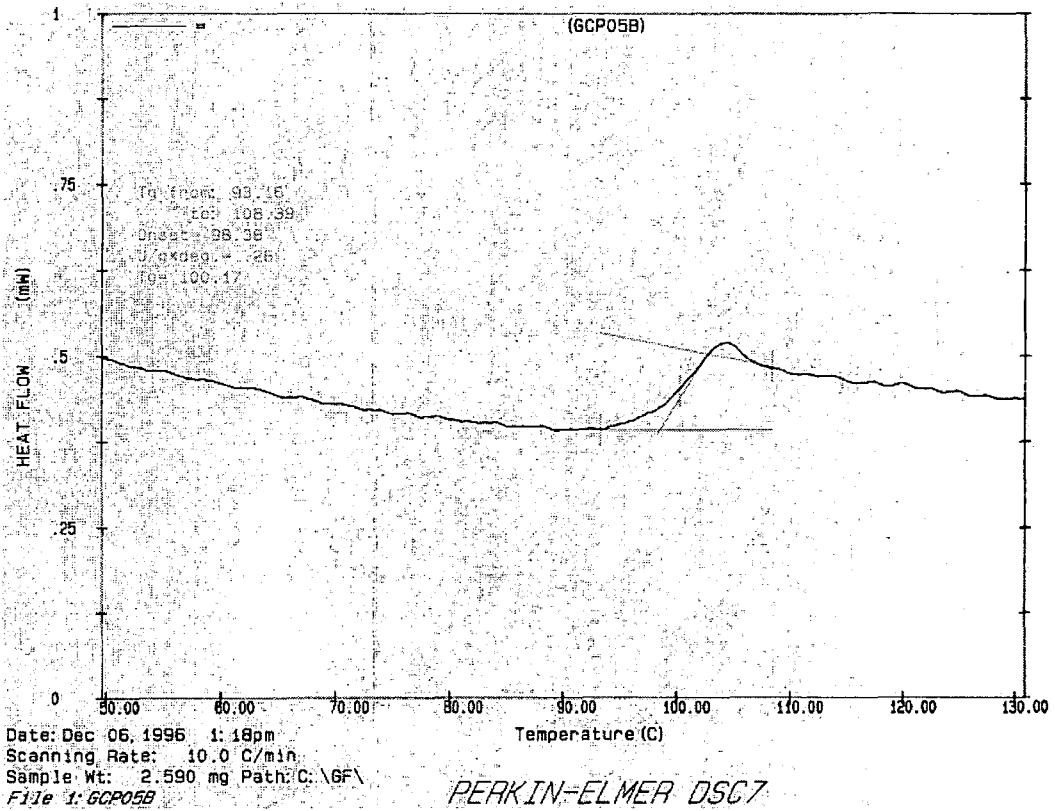


Figure A4.49 DSC trace of sample 15-3

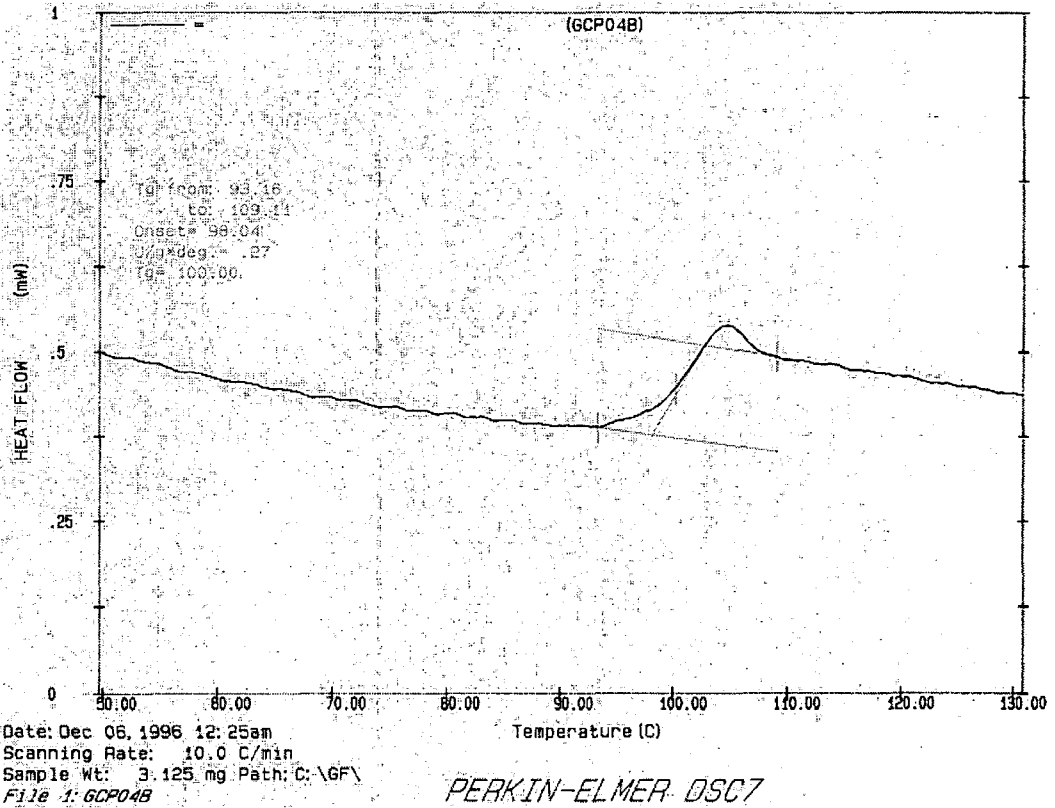


Figure A4.50 DSC trace of sample 15-2

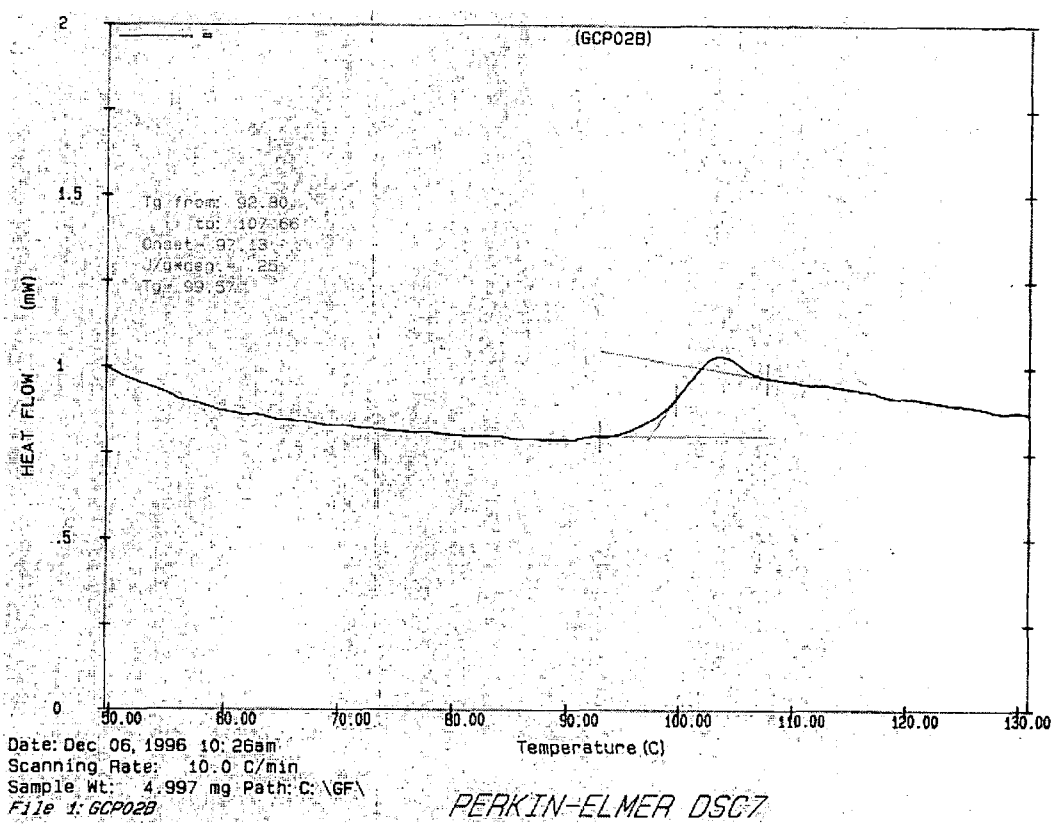
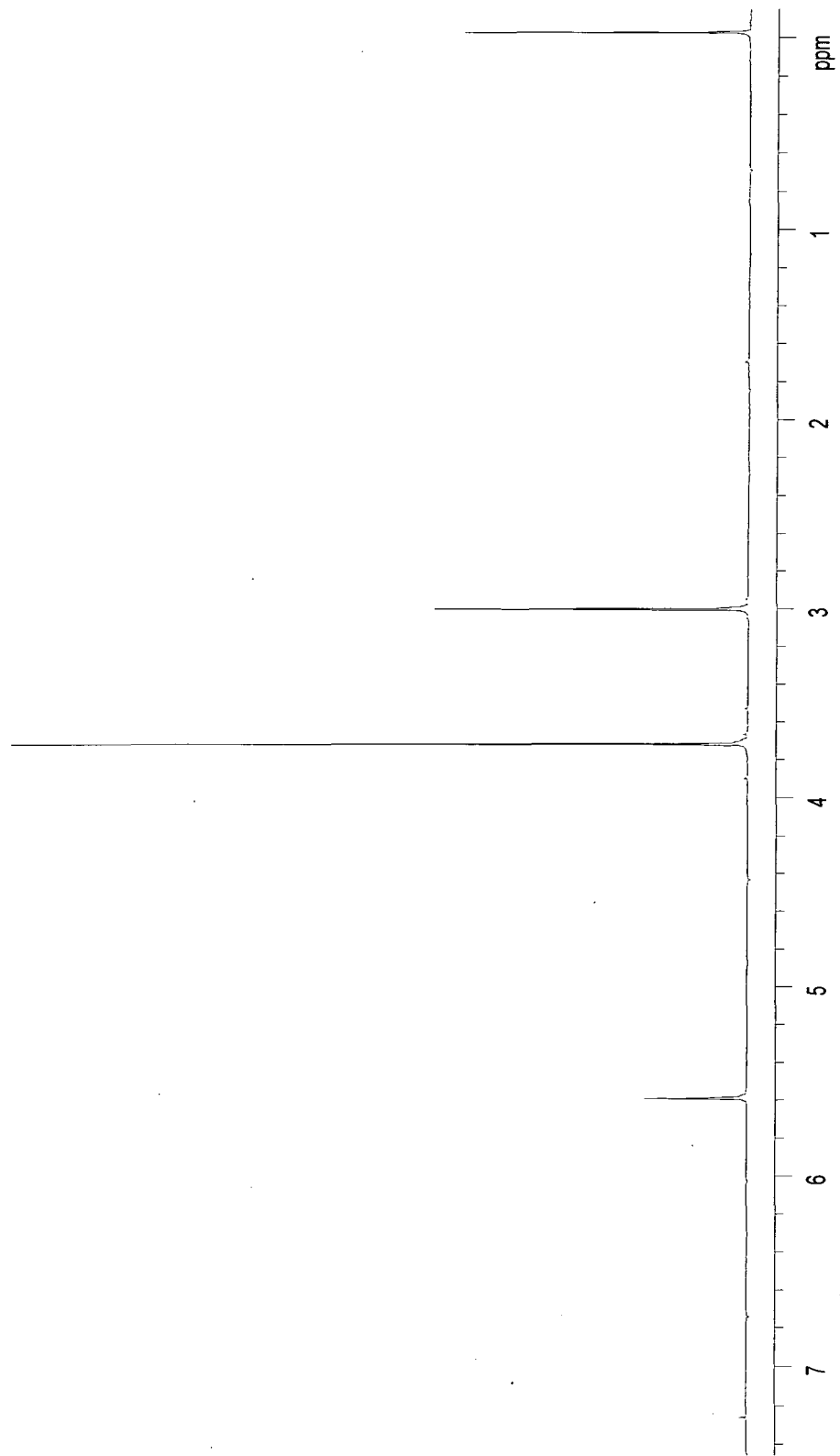
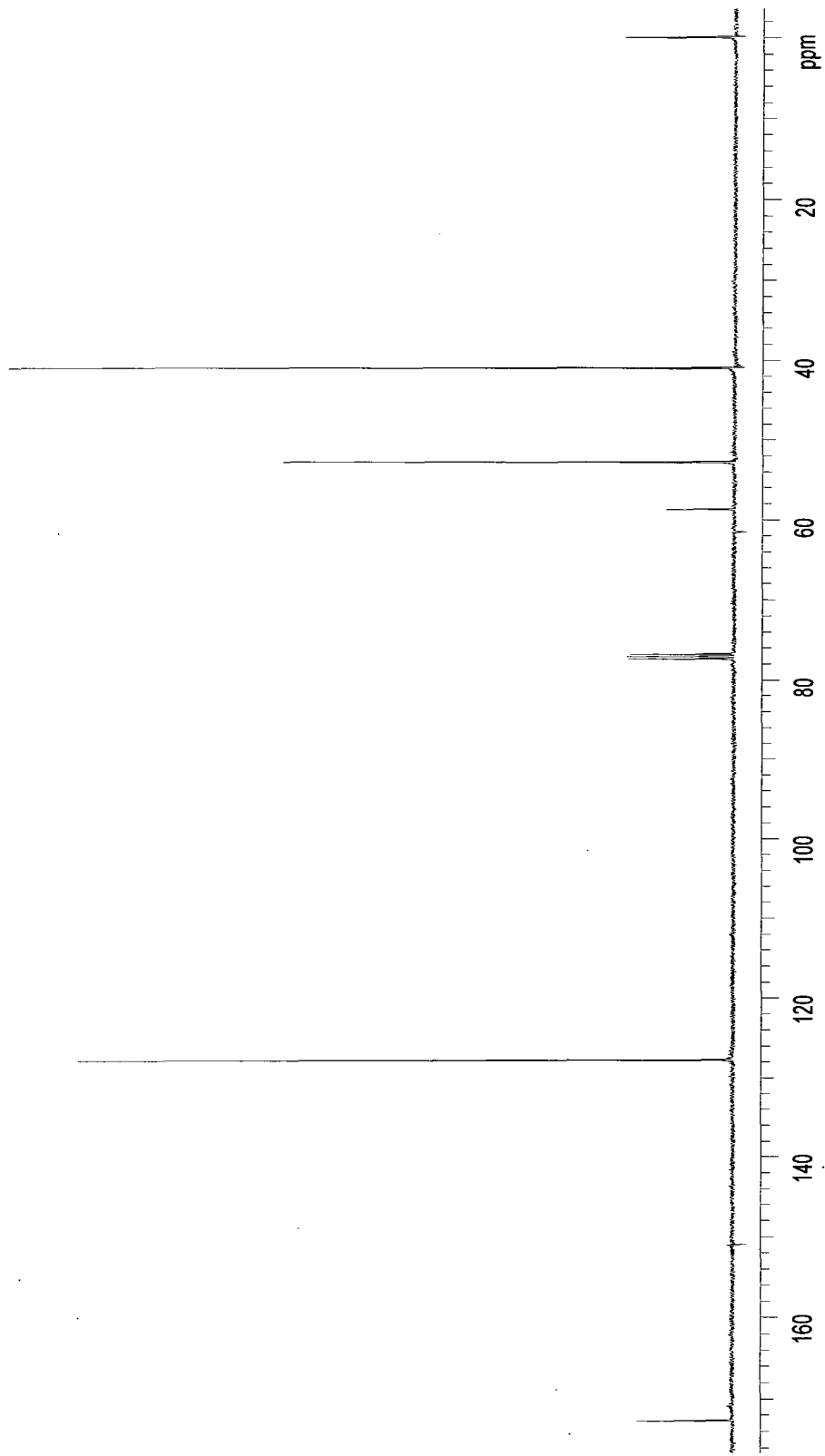


Figure A4.51 DSC trace of sample 15-1

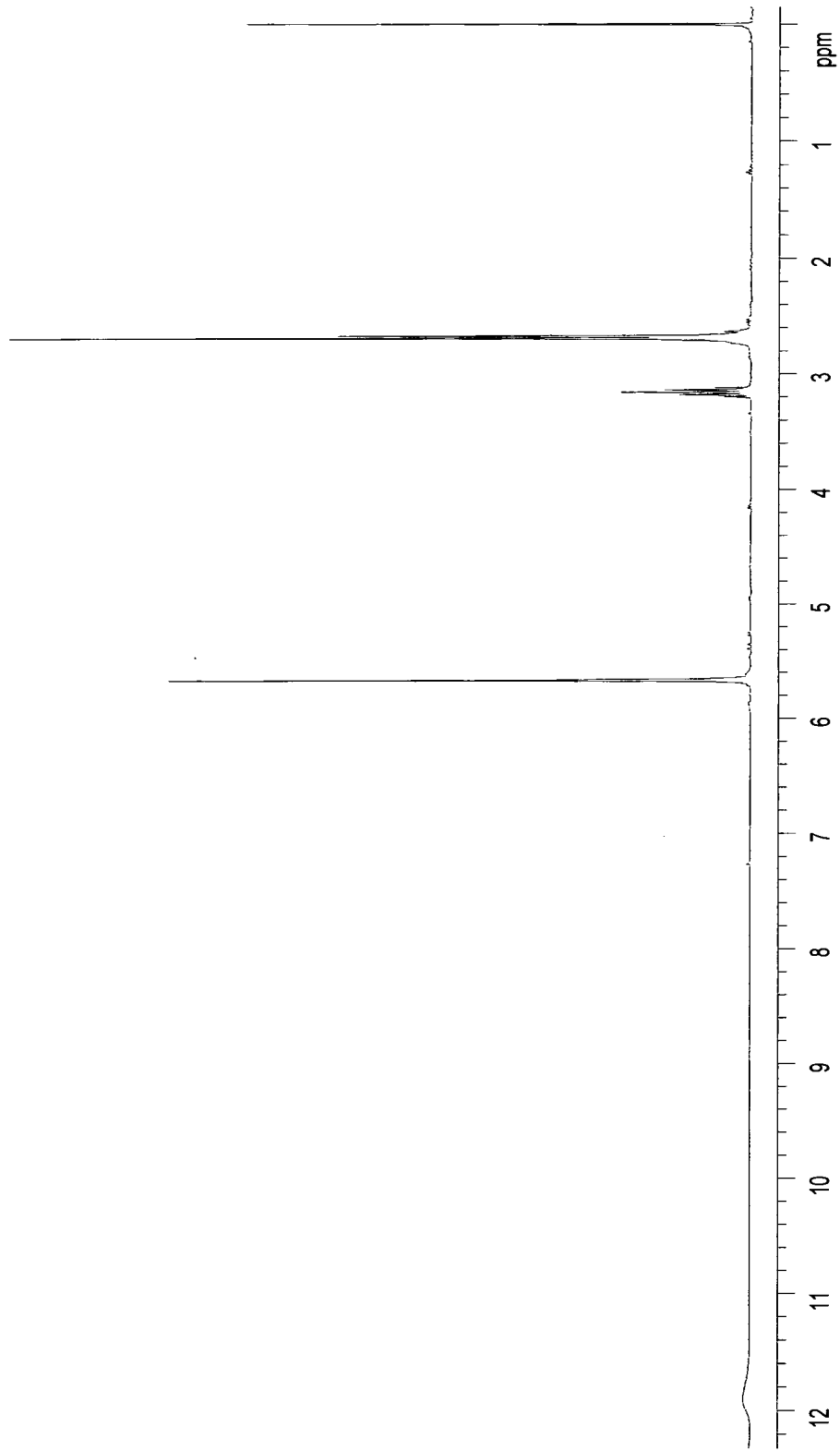
**APPENDIX-5**  
**Analytical Data for Chapter-5**



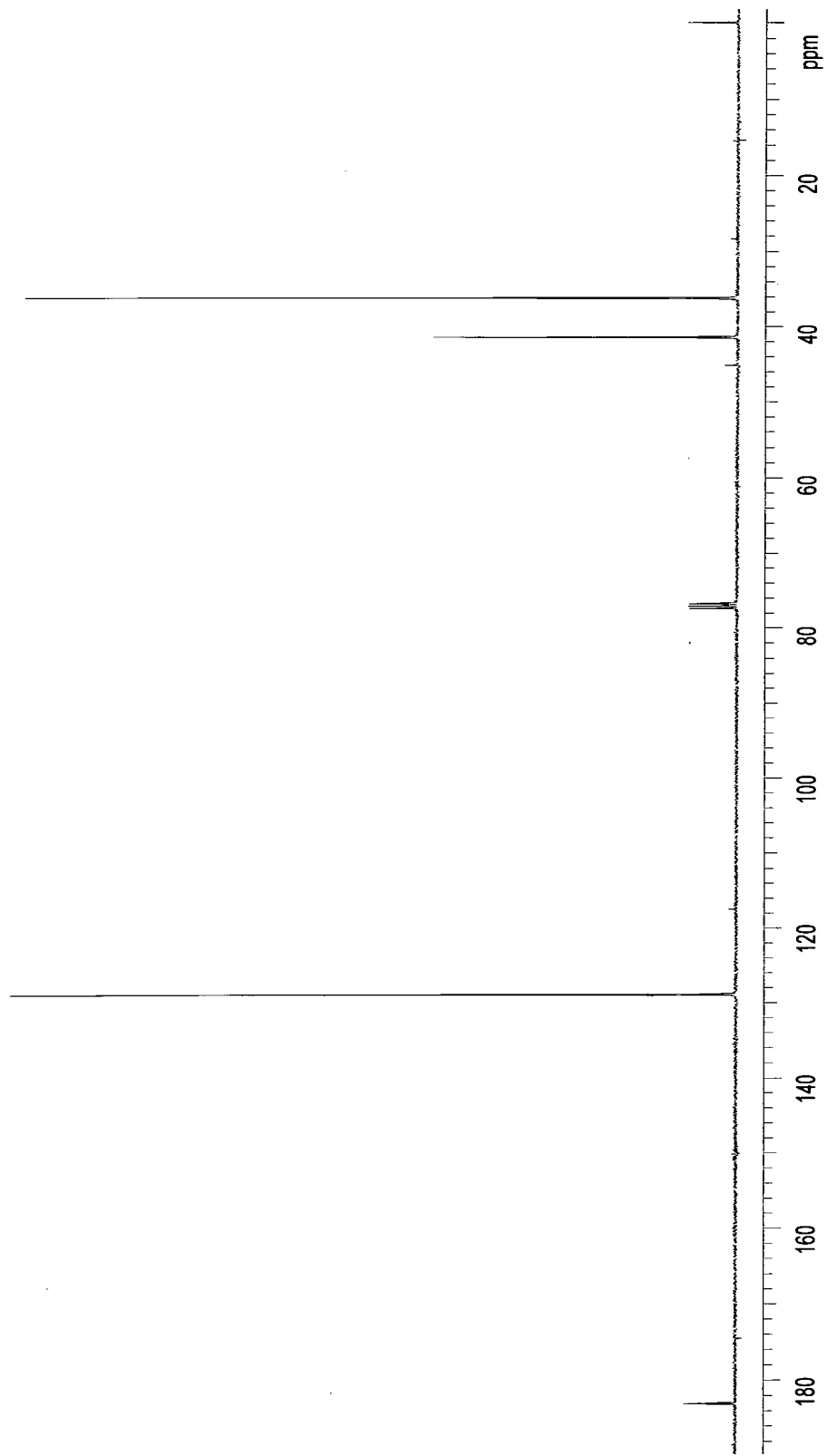
**Figure A5.1** <sup>1</sup>H nmr spectrum of dimethyl 3-cyclopentene 1,1-dicarboxylate



**Figure A5.2**  $^{13}\text{C}$  nmr spectrum of dimethyl 3-cyclopentene 1,1-dicarboxylate



**Figure A5.3**  $^1\text{H}$  nmr spectrum of 3-cyclopentenecarboxylic acid



**Figure A5.4**  $^{13}\text{C}$  nmr spectrum of 3-cyclopentenecarboxylic acid

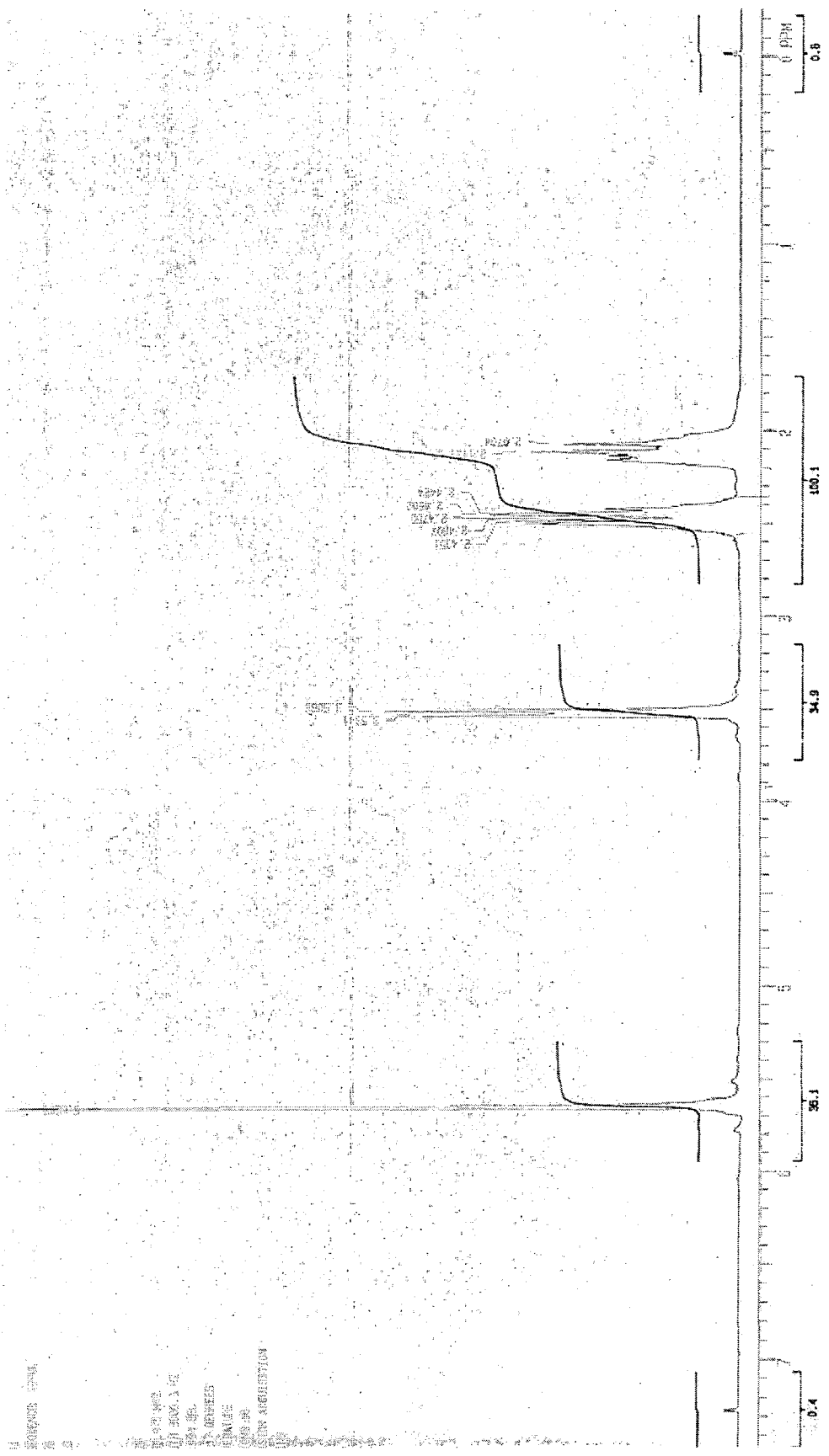
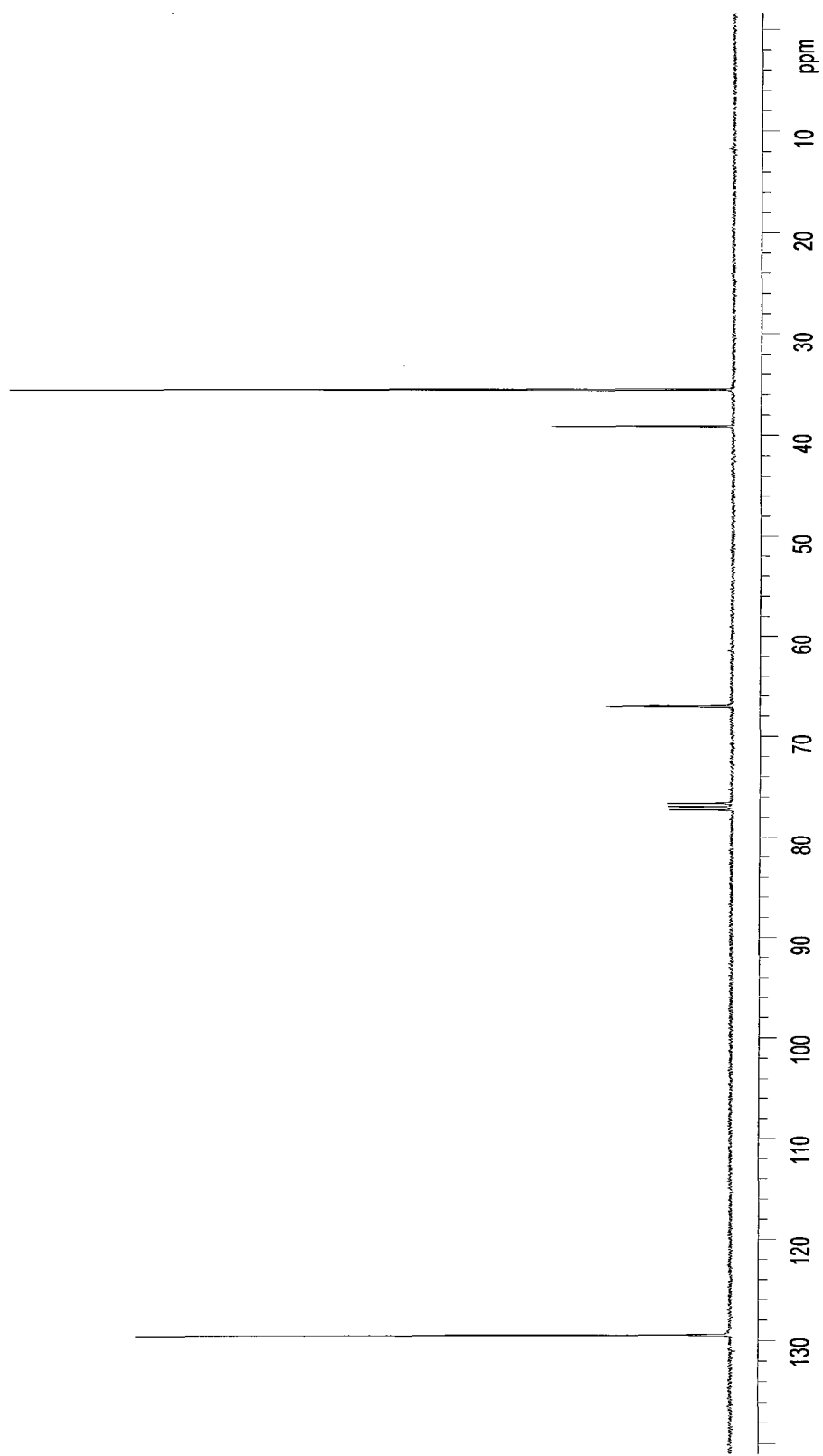
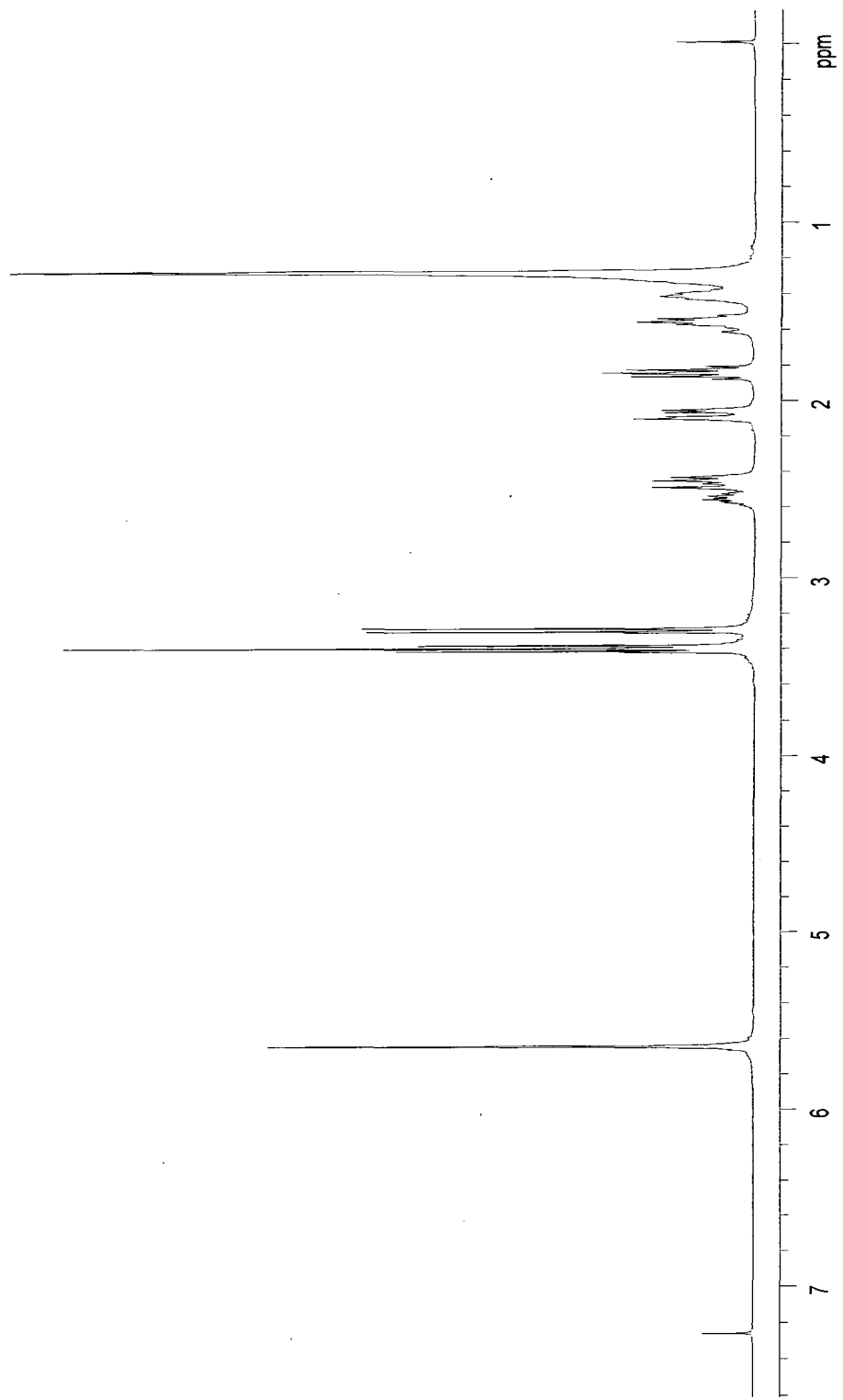


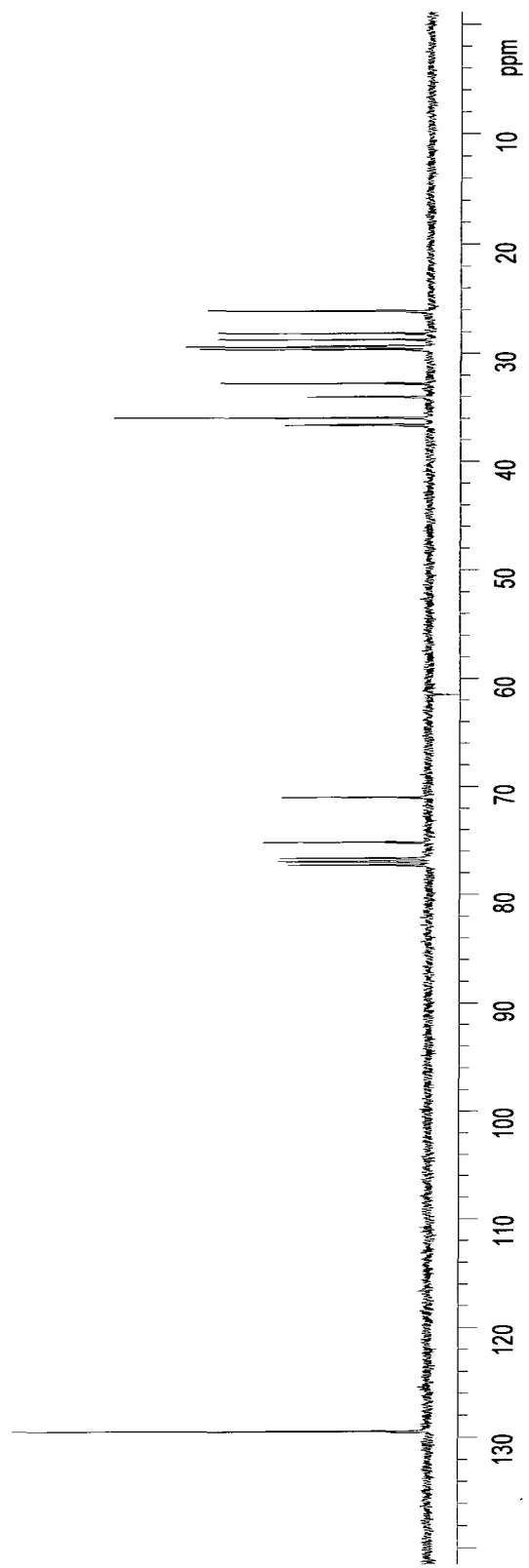
Figure A5.5 <sup>1</sup>H nmr (200MHz) spectrum of 4-hydroxymethyl cyclopentene



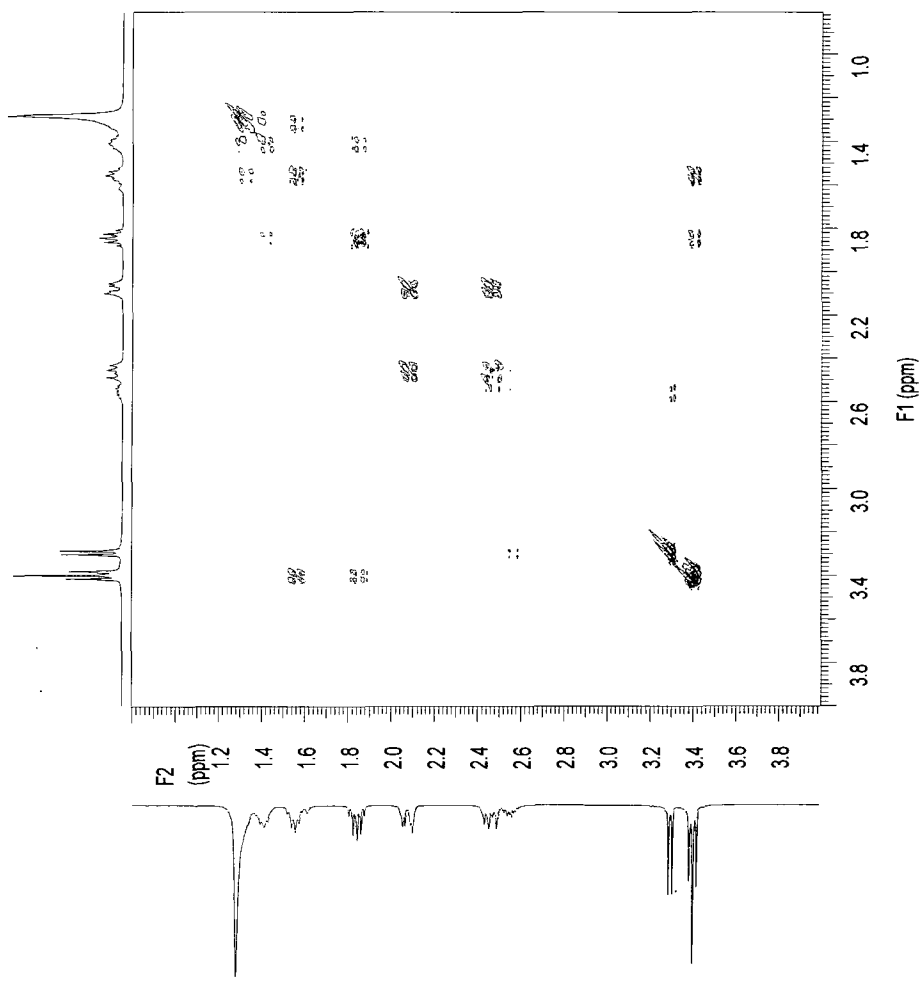
**Figure A5.6**  $^{13}\text{C}$  nmr spectrum of 4-hydroxymethyl cyclopentene



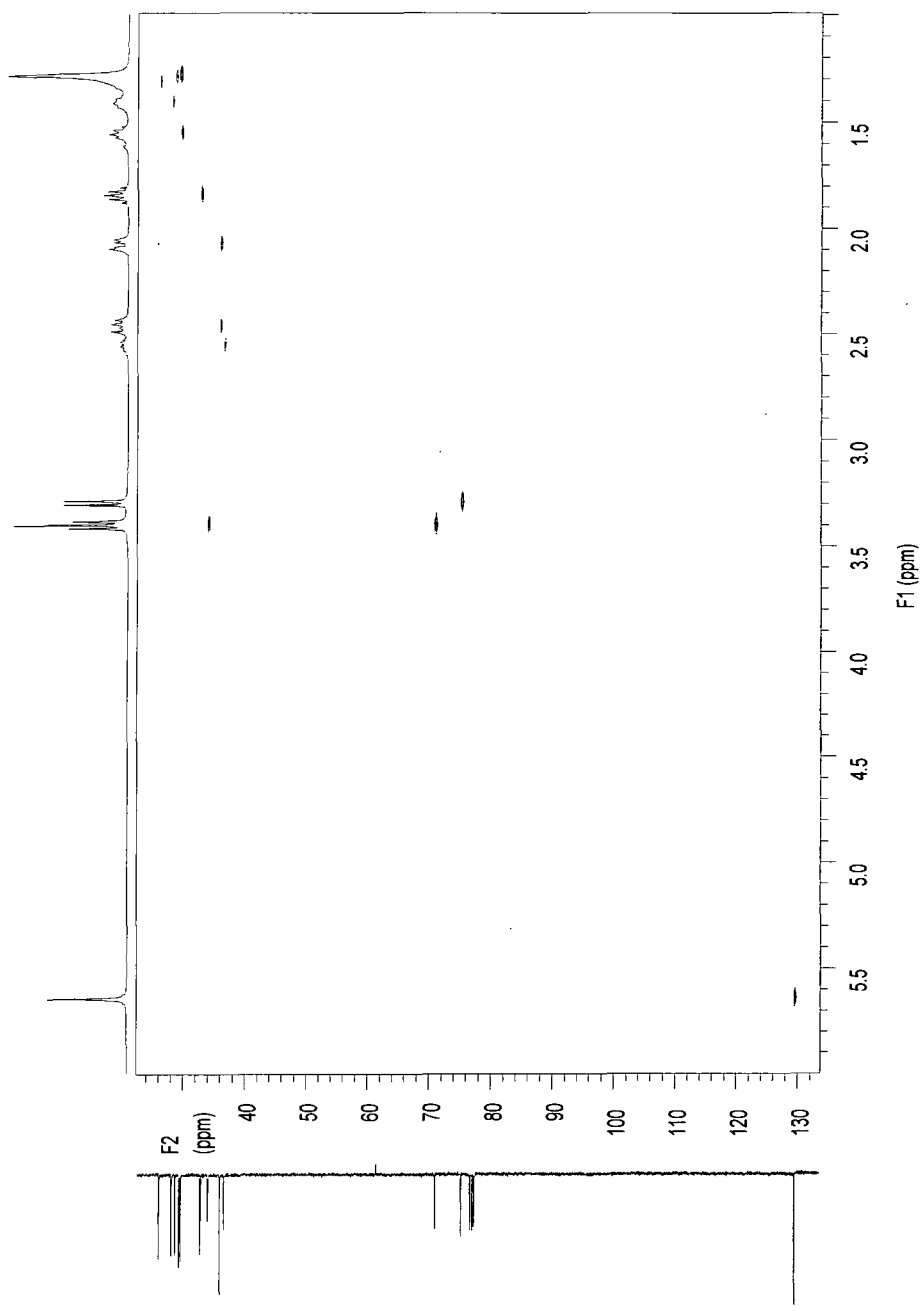
**Figure A5.7**  $^1\text{H}$  nmr spectrum of 10-bromodecyl 3-cyclopentenylmethyl ether



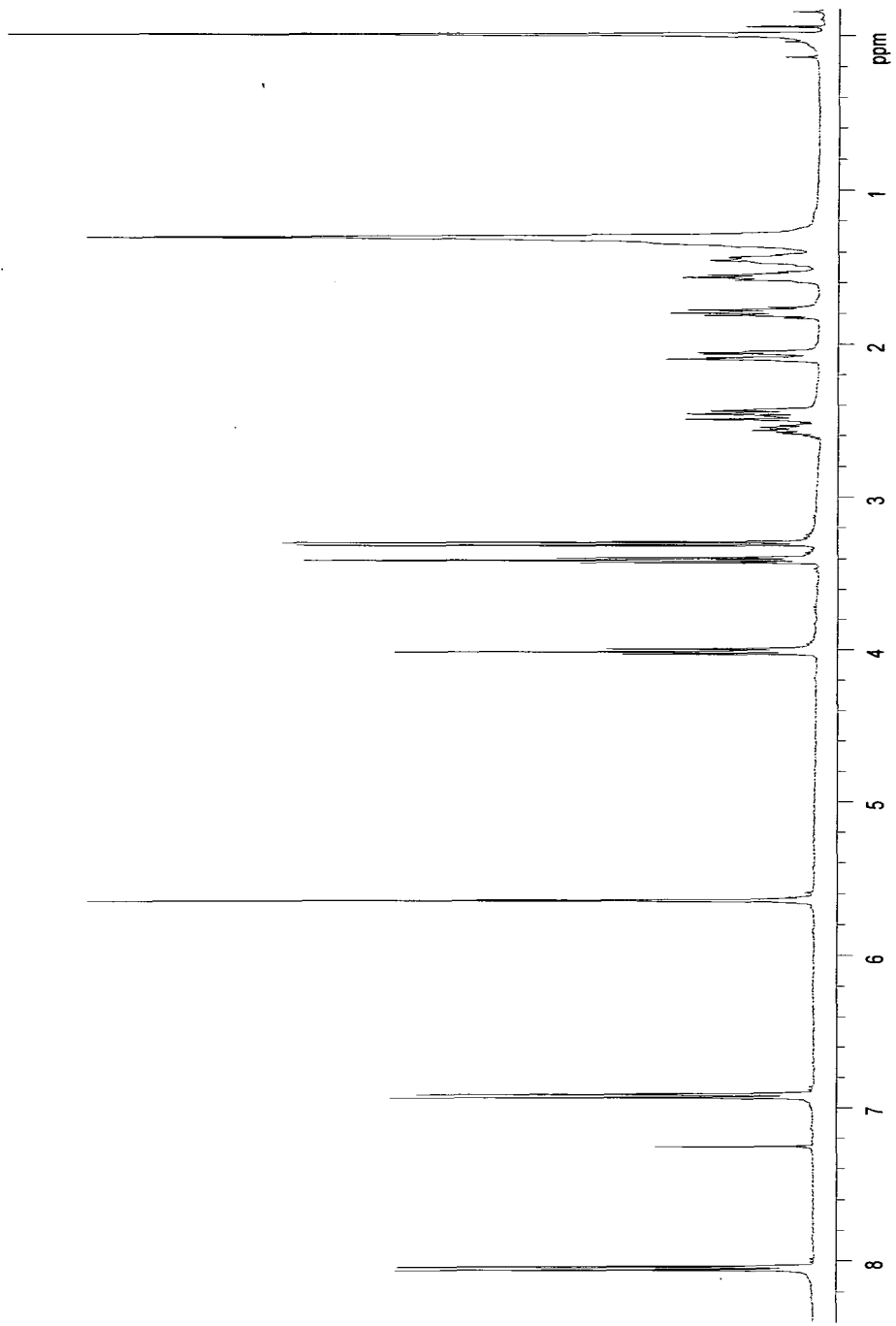
**Figure A5.8**  $^{13}\text{C}$  nmr spectrum of 10-bromodecyl 3-cyclopentenylmethyl ether



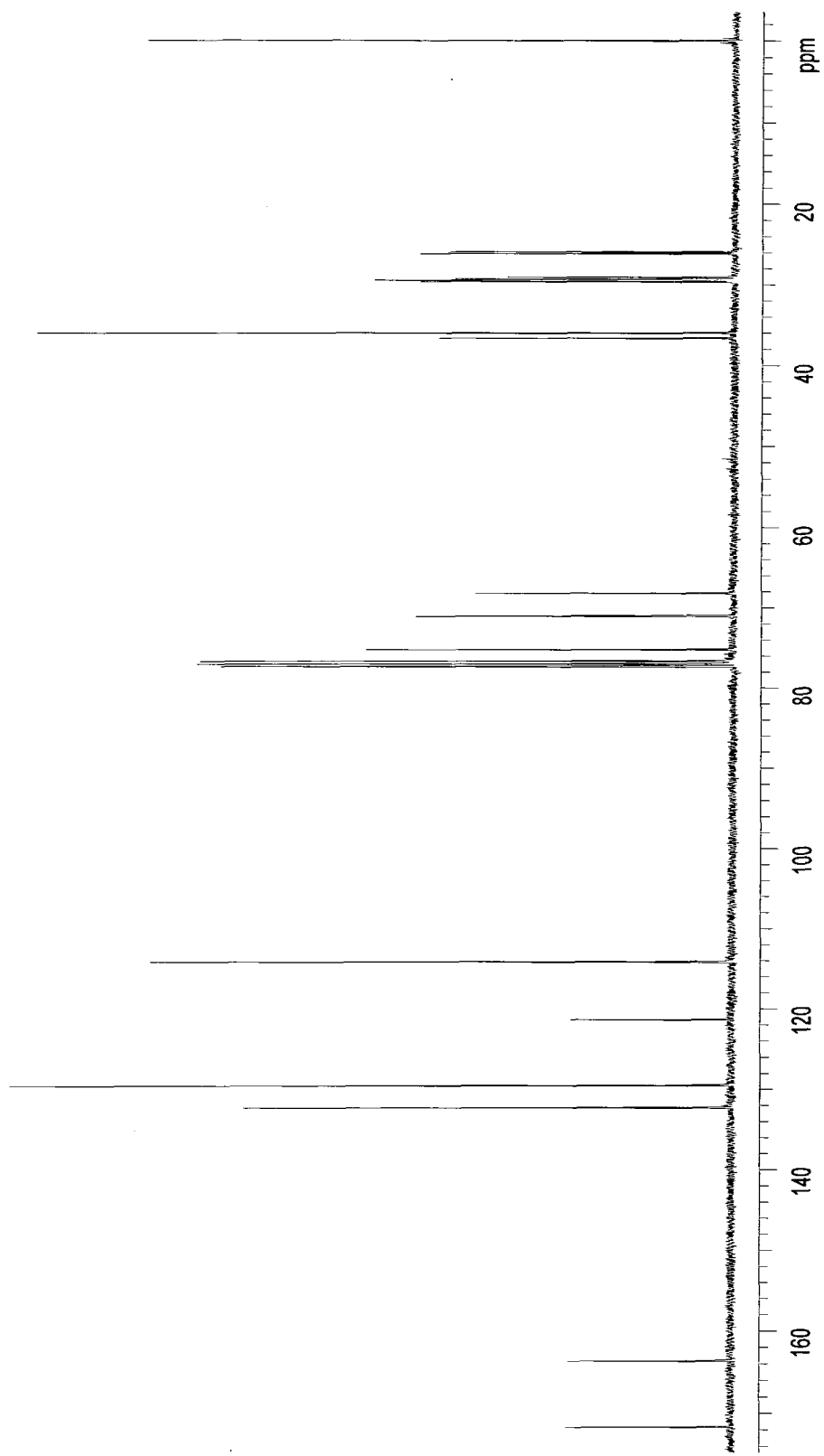
**Figure A5.9** COSY nmr spectrum of 10-bromodecyl 3-cyclopentenylmethyl ether



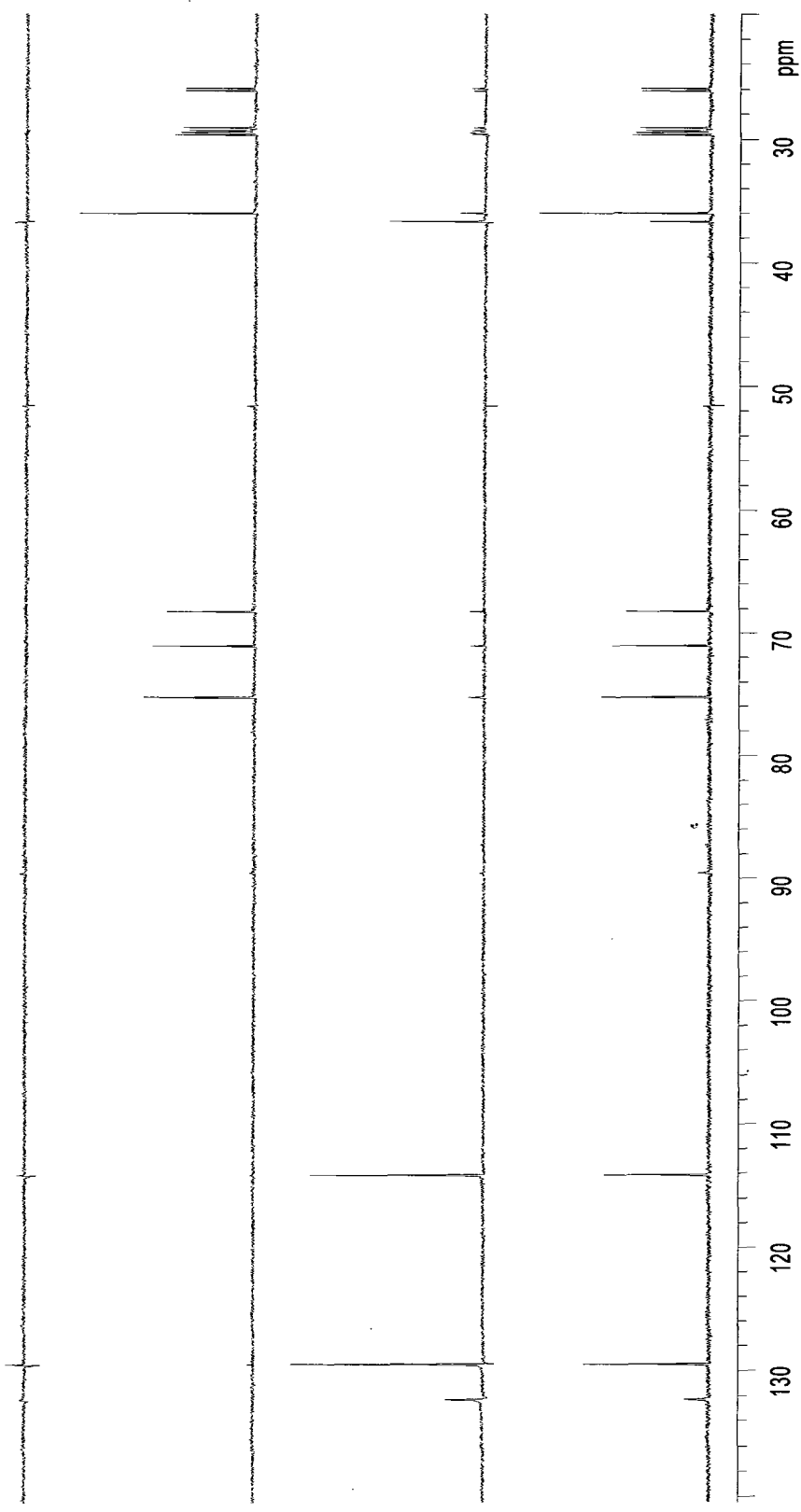
**Figure A5.10** HETCOR nmr spectrum of 10-bromodecyl 3-cyclopentenylmethyl ether



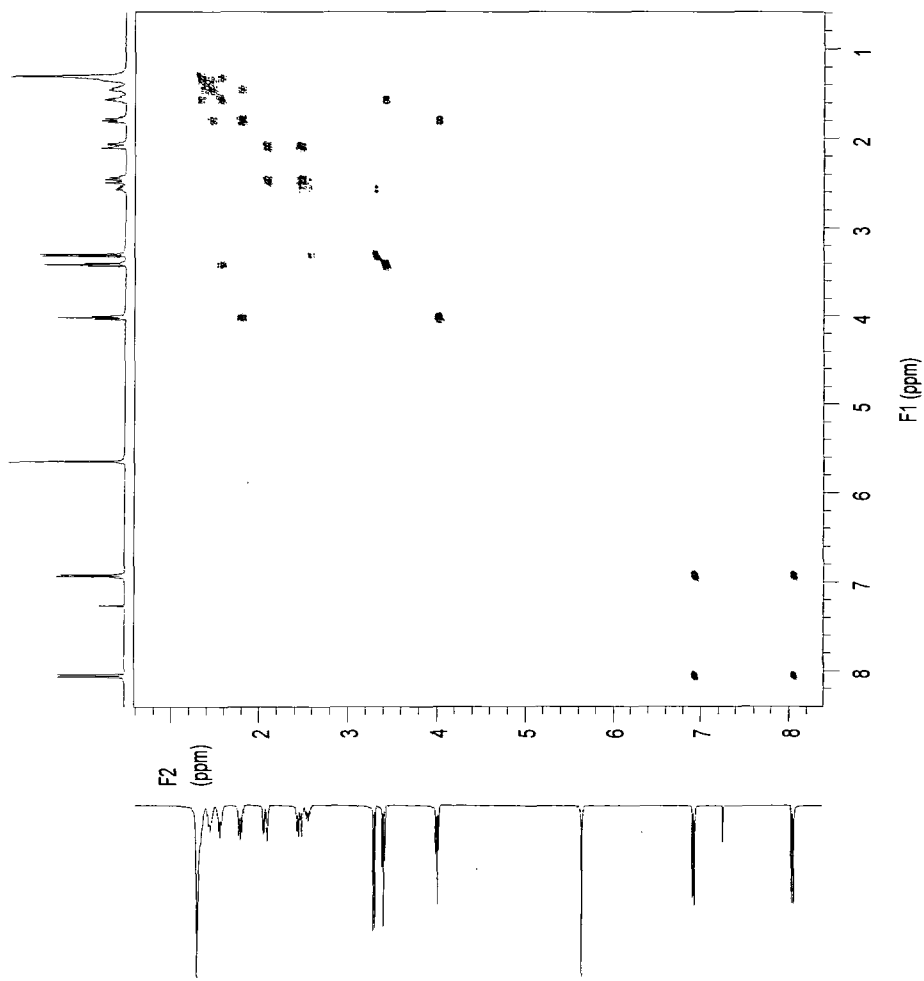
**Figure A5.11** <sup>1</sup>H nmr spectrum of 4-(10-(3-cyclopentenylmethoxy)decyloxy)benzoic acid



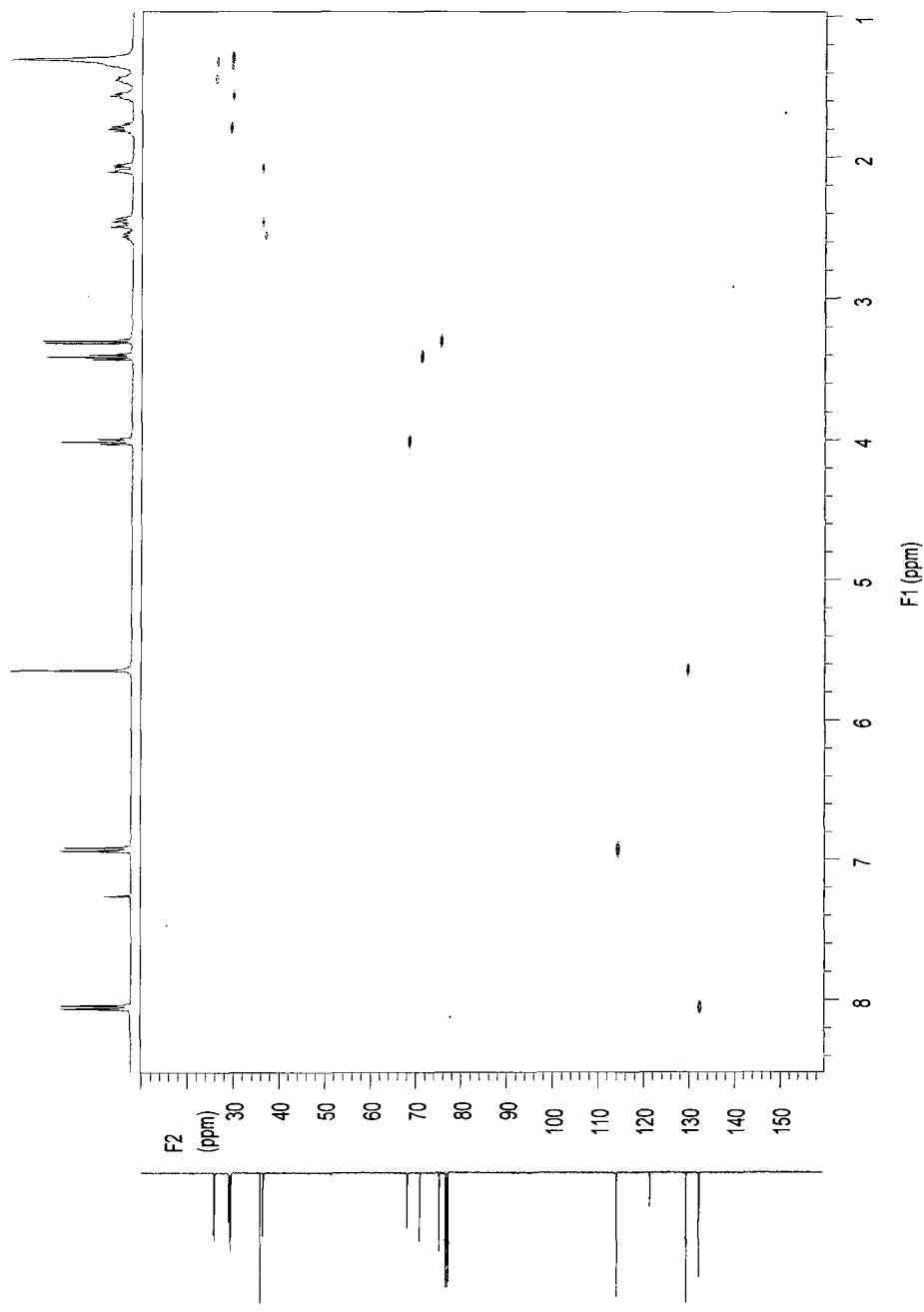
**Figure A5.12**  $^{13}\text{C}$  nmr spectrum of 4-(10-(3-cyclopentenyloxy)methoxy)decyloxy)benzoic acid



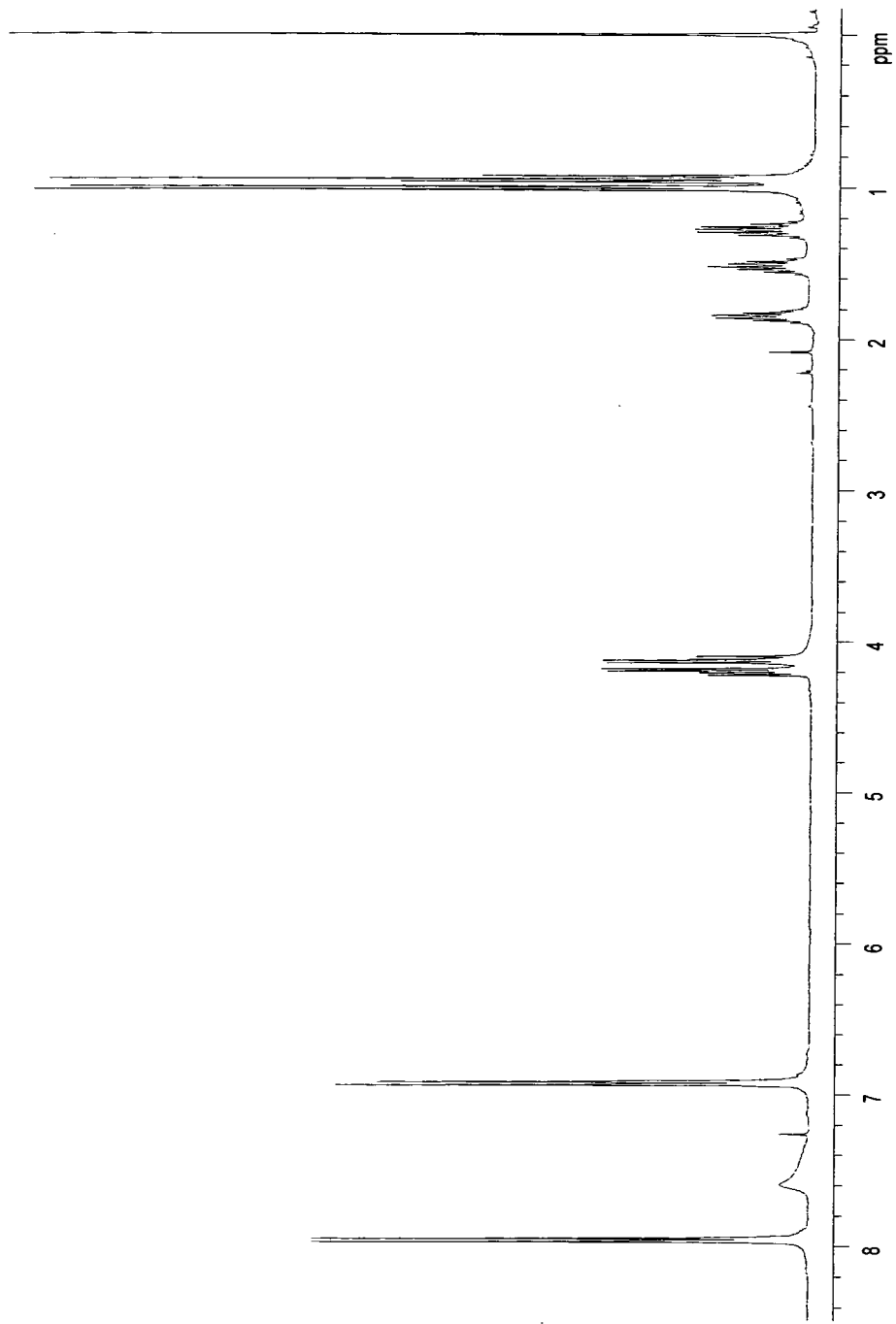
**Figure A5.13** DEPT nmr spectrum of 4-(10-(3-cyclopentenylmethoxy)decyloxy)benzoic acid



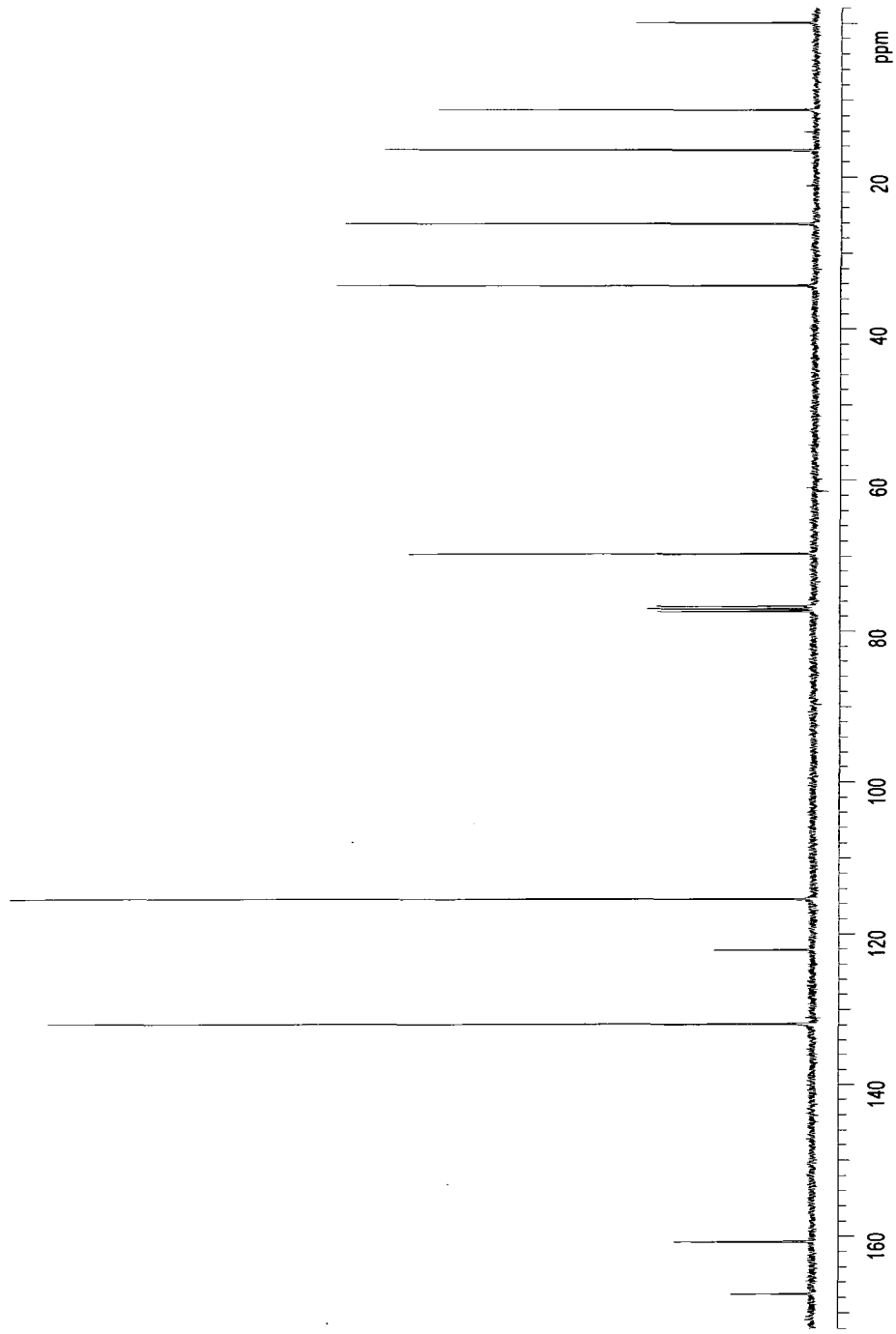
**Figure A5.14** COSY nmr spectrum of 4-(10-(3-cyclopentenyloxy)decyloxy)benzoic acid



**Figure A5.15** HETCOR nmr spectrum of 4-(10-(3-cyclopentenylmethoxy)decyloxy)benzoic acid

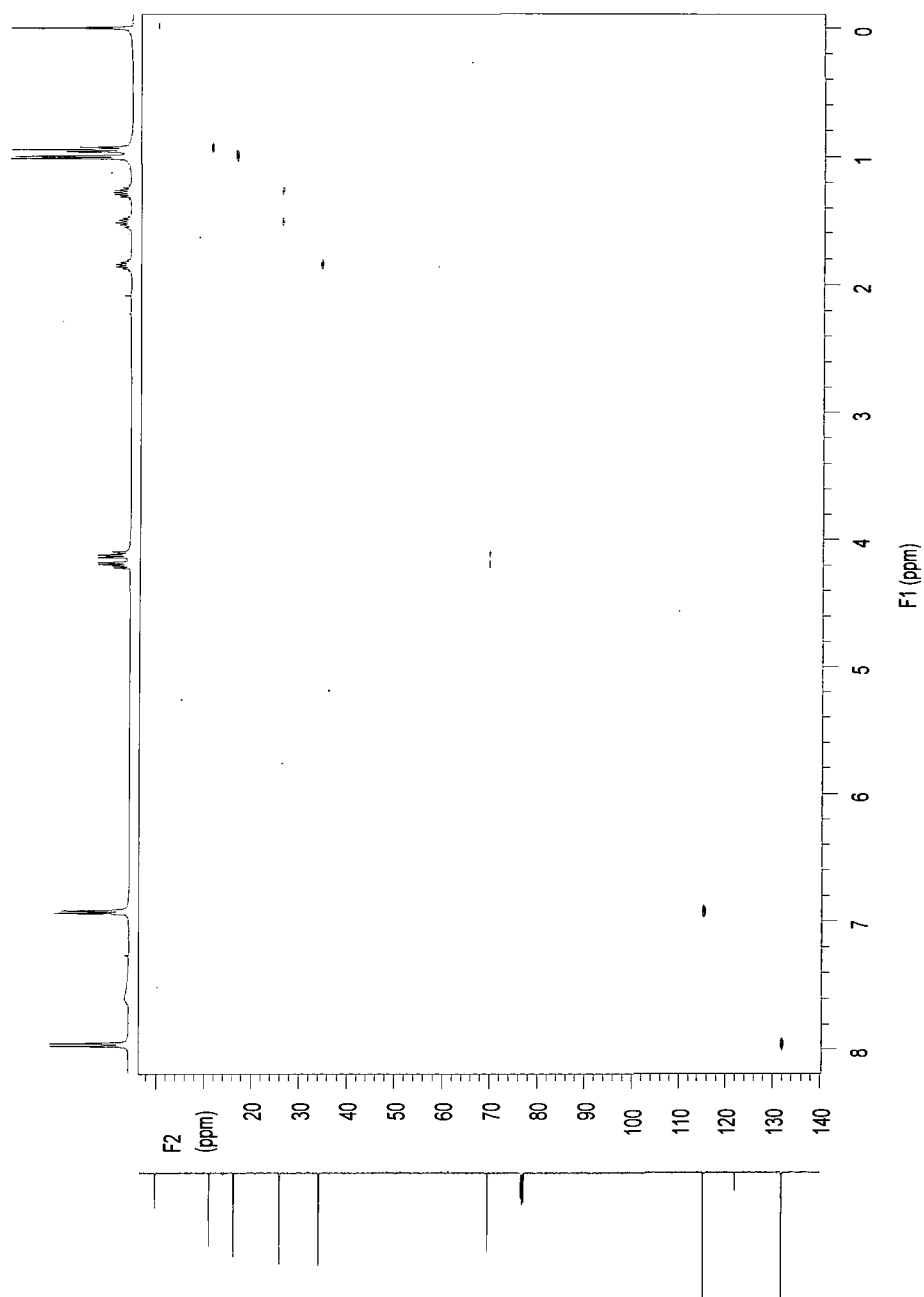


**Figure A5.16** <sup>1</sup>H nmr spectrum of (S)-(-)-2-methylbutyl 4-hydroxybenzoate

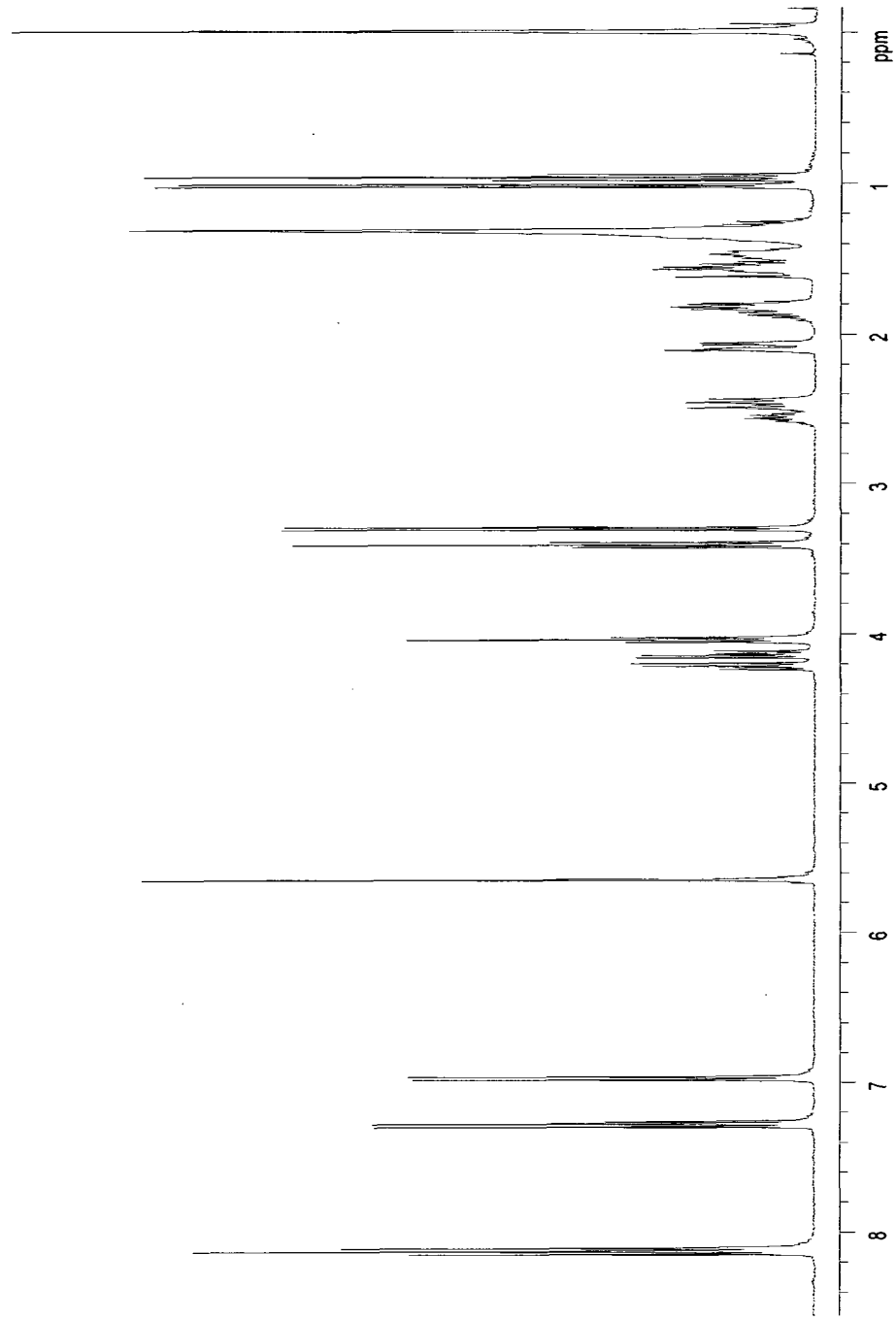


**Figure A5.17**  $^{13}\text{C}$  nmr spectrum of (S)-(-) 2-methylbutyl 4-hydroxybenzoate

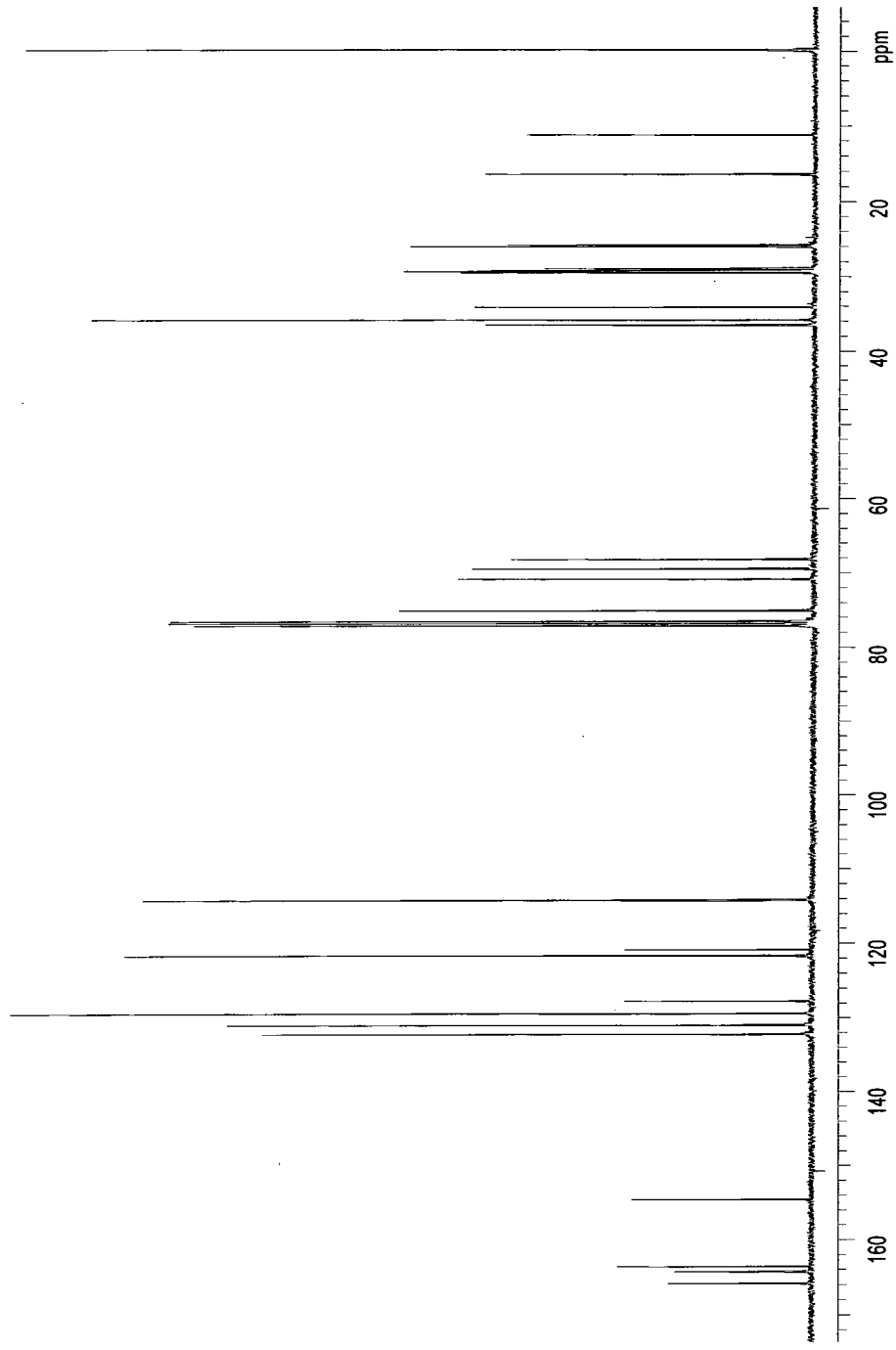




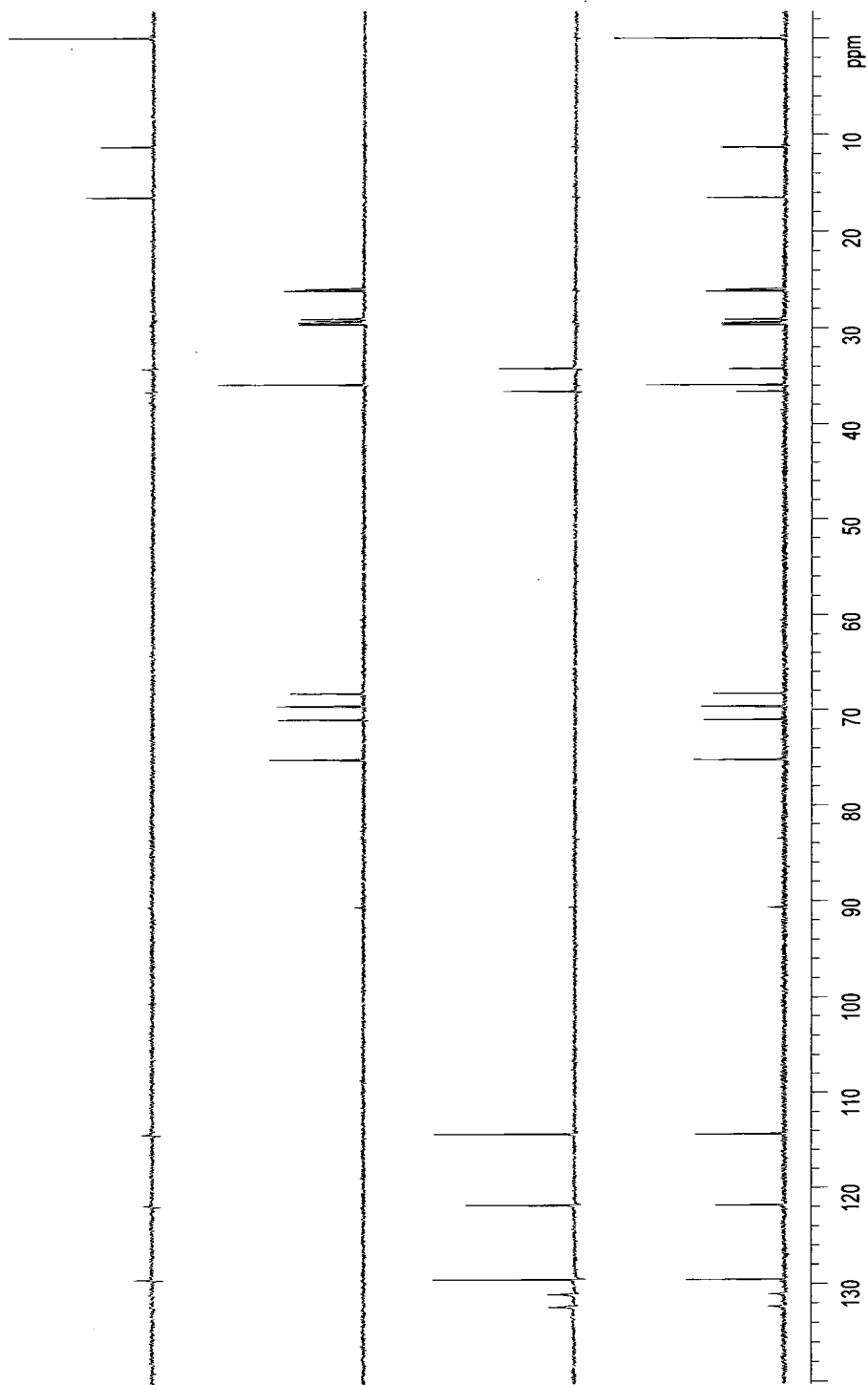
**Figure A5.19** HETCOR nmr spectrum of (S)-(-)-2-methylbutyl 4-hydroxybenzoate



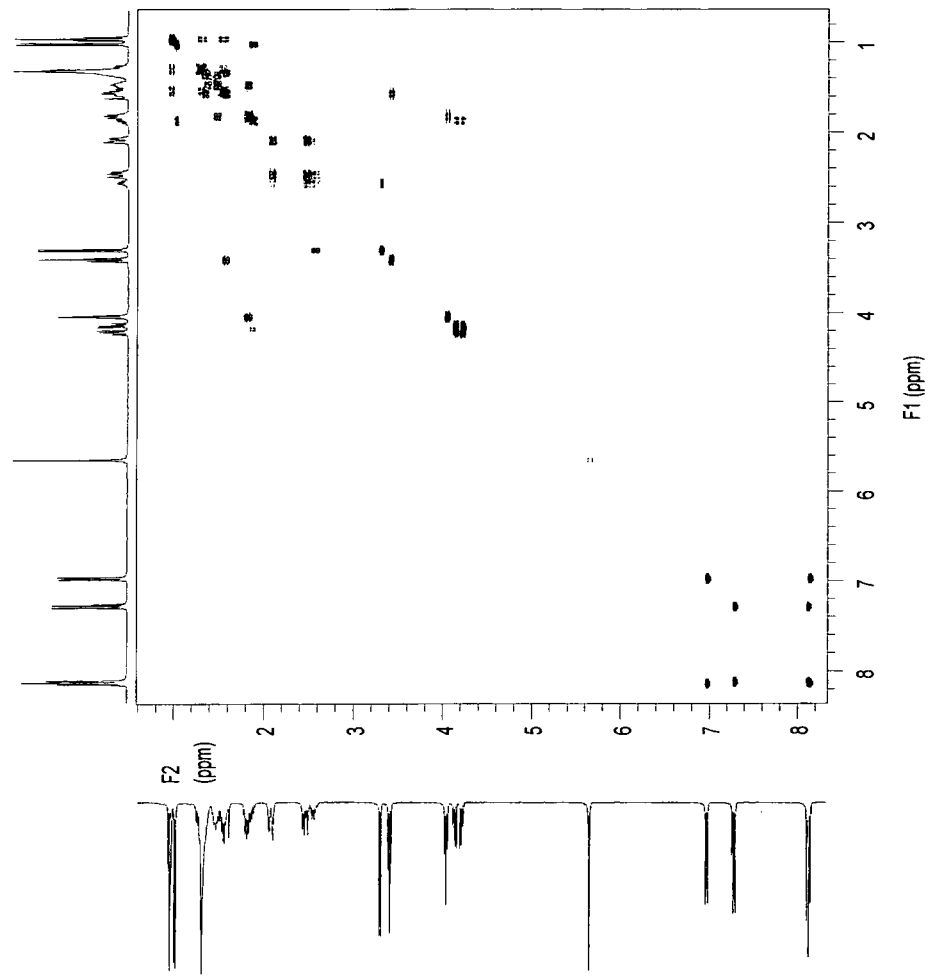
**Figure A5.20** <sup>1</sup>H nmr spectrum of (S)-(-) 2-methylbutyl 4-(4-(10-(3-cyclopentenylmethoxy)decyloxy)phenylcarbonyloxy benzoate



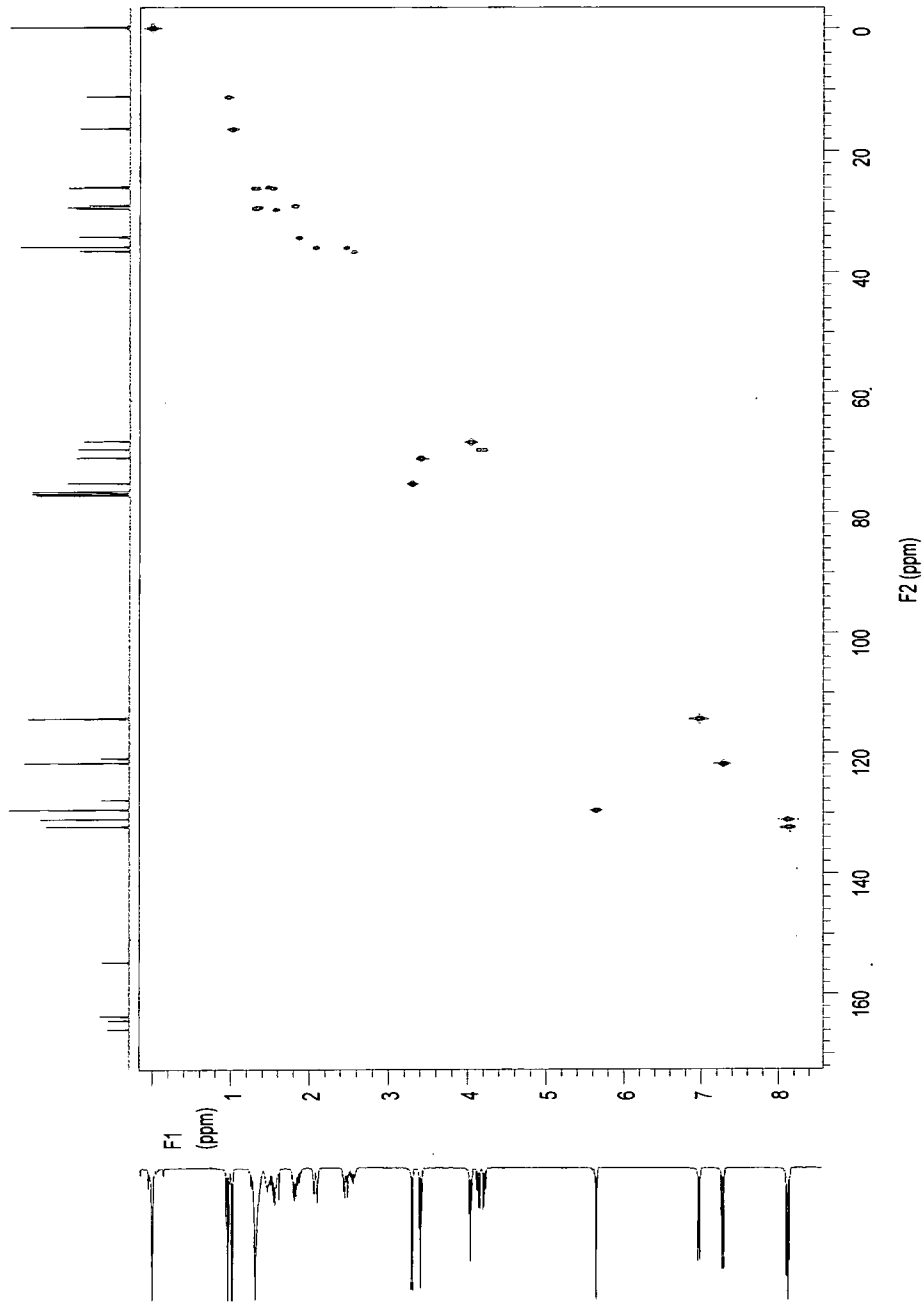
**Figure A5.21**  $^{13}\text{C}$  nmr spectrum of (S)-(-) 2-methylbutyl 4-(4-(10-(3-cyclopentenylmethoxy)decyloxy)phenyl)carbonyloxy benzoate



**Figure A5.22** DEPT nmr spectrum of (S)-(-)-2-methylbutyl 4-(4-(10-(3-cyclopentenylmethoxy)decyloxy)phenyl)carboxylate benzoate



**Figure A5.23** COSY nmr spectrum of (S)-(-)-2-methylbutyl 4-(4-(10-(3-cyclopentylmethoxy)decyloxy)phenylcarbonyloxy benzoate



**Figure A5.24** HETCOR nmr spectrum of (S)-(-) 2-methylbutyl 4-(4-(10-(3-cyclopentenylmethoxy)decyloxy)phenyl)carbonyloxy benzoate

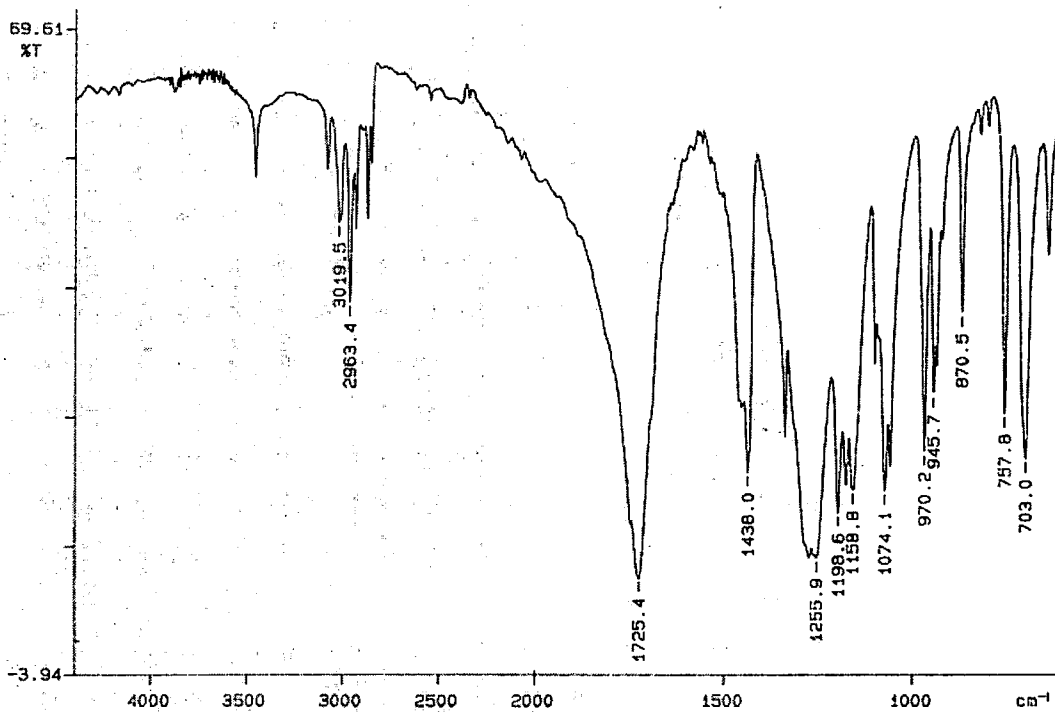


Figure A5.25 Infrared spectrum of dimethyl 3-cyclopentene 1,1-dicarboxylate

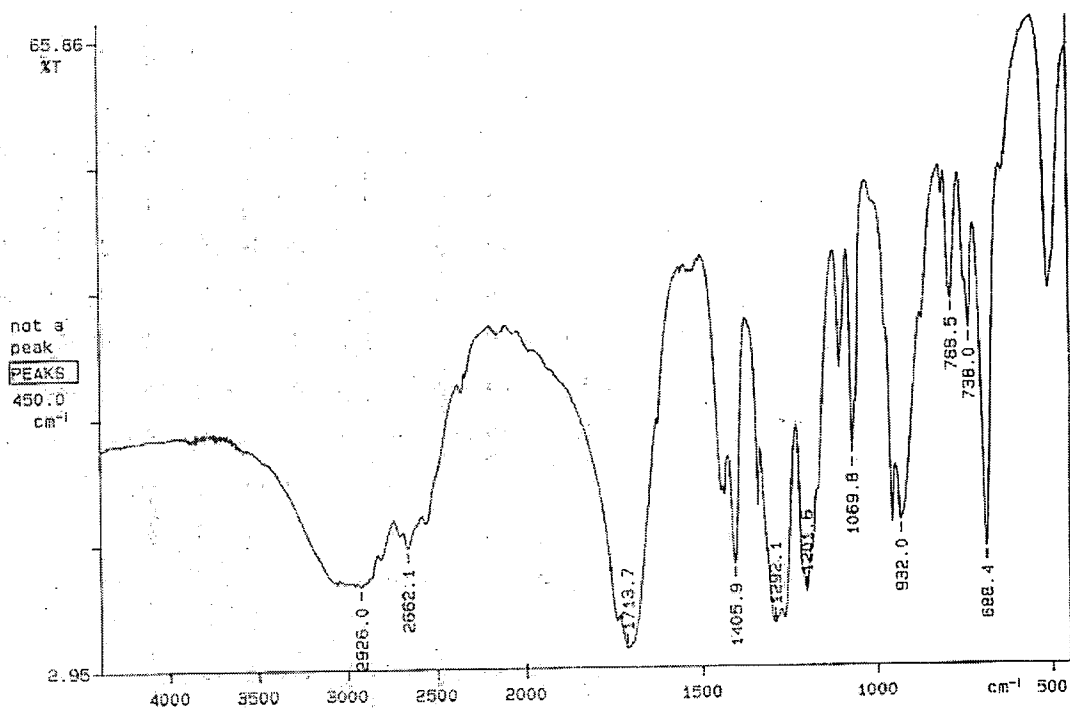


Figure A5.26 Infrared spectrum of 3-cyclopentene 1,1-dicarboxylic acid

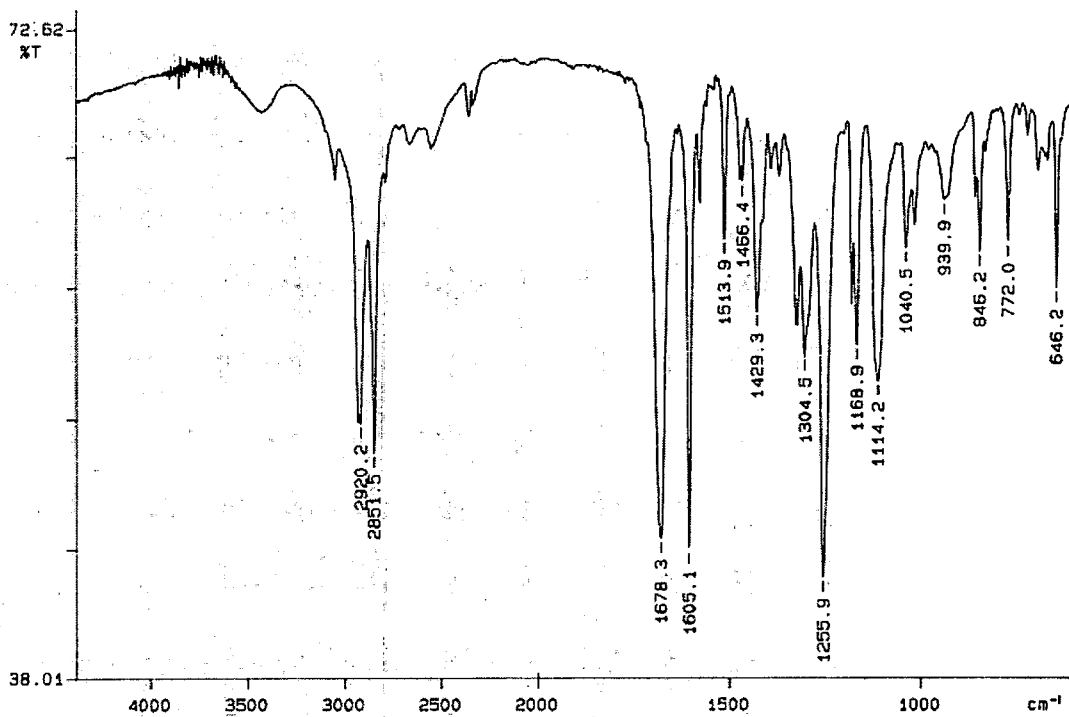


Figure A5.27 Infrared spectrum of 4-(10-(3-cyclopentenylmethoxy)decyloxy)benzoic acid

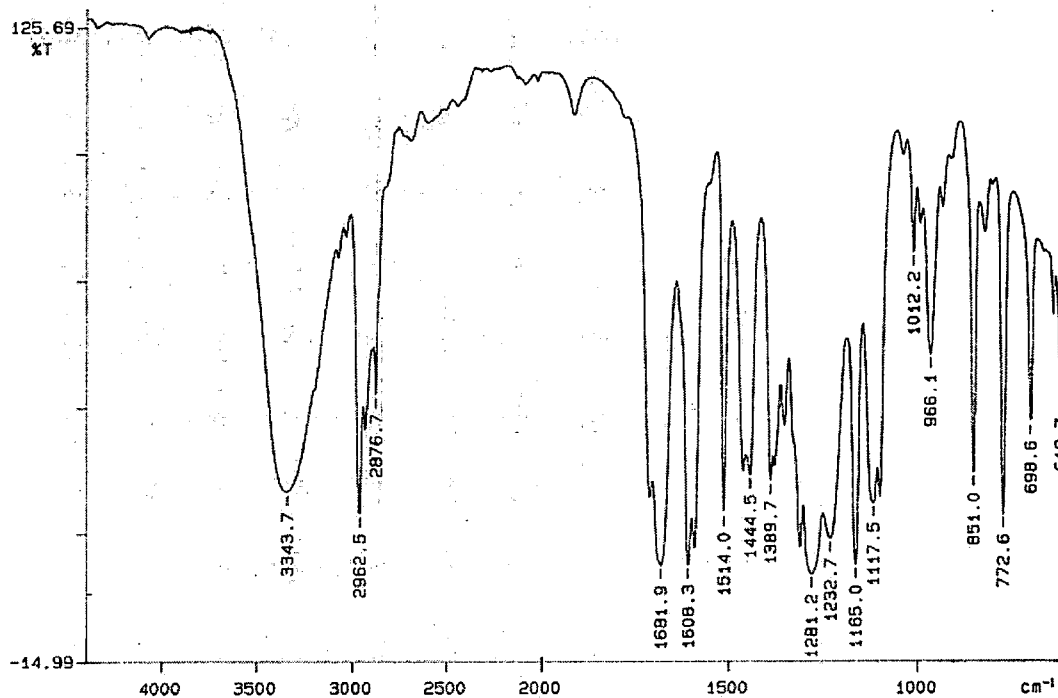
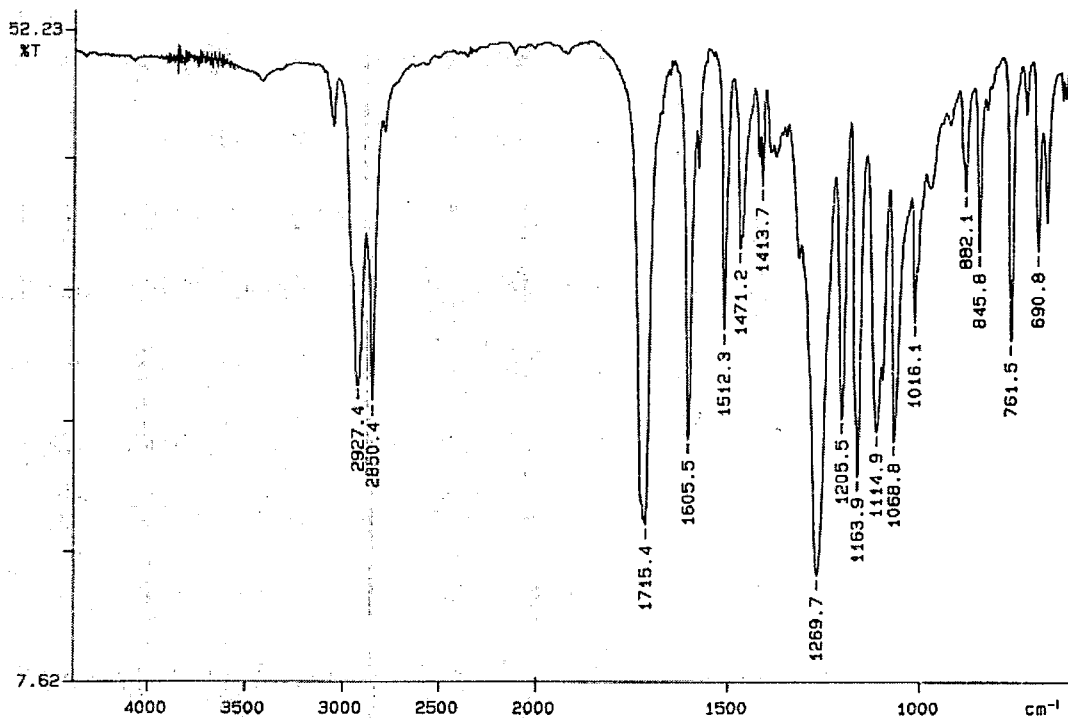
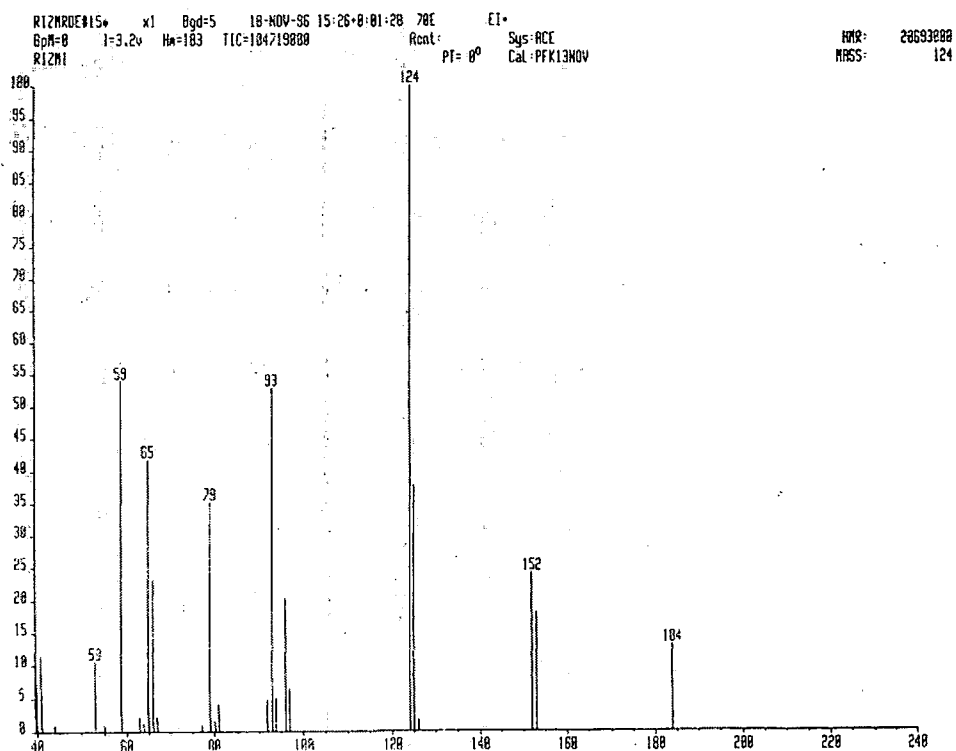


Figure A5.28 Infrared spectrum of (S)-(-) 2-methylbutyl 4-hydroxybenzoate



**Figure A5.29** Infrared spectrum of (*S*)-(-) 2-methylbutyl 4-(4-(10-(3-cyclopentenylmethoxy)decyloxy)phenylcarbonyloxy benzoate



**Figure A5.30** Mass spectrum of dimethyl 3-cyclopentene 1,1-dicarboxylate

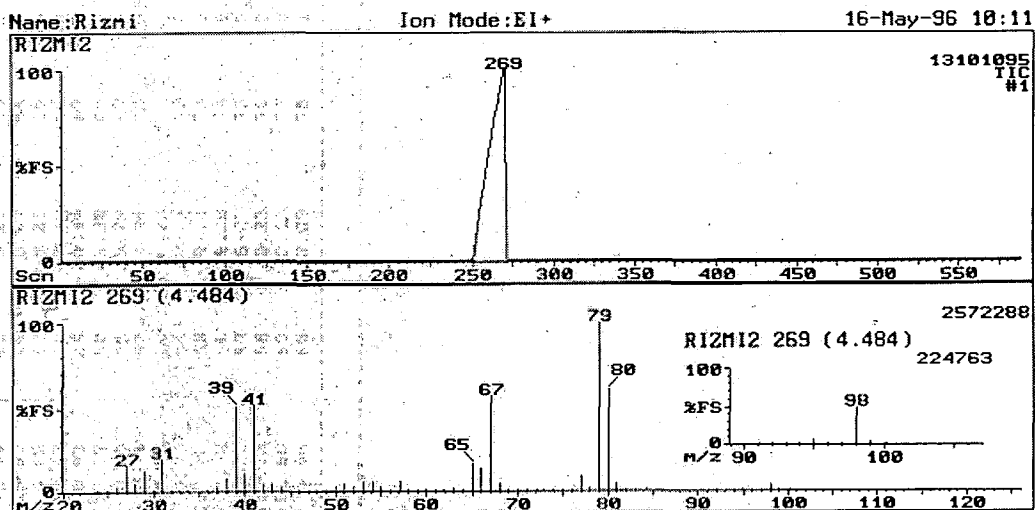


Figure A5.31 GC-Mass spectrum of 4-hydroxymethyl cyclopentene

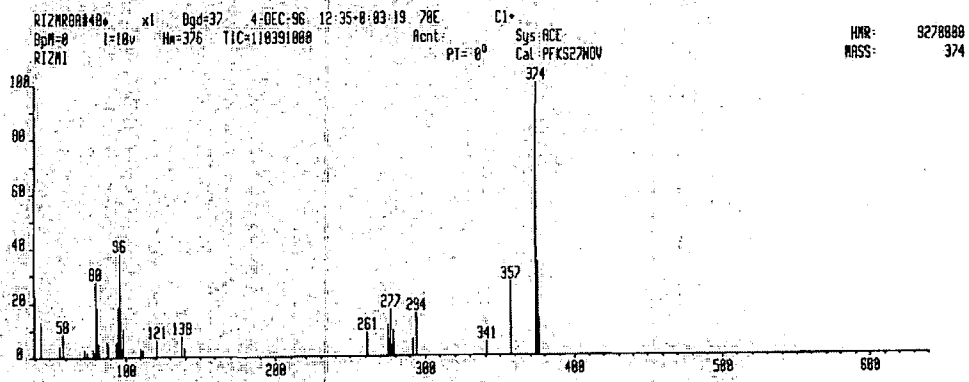
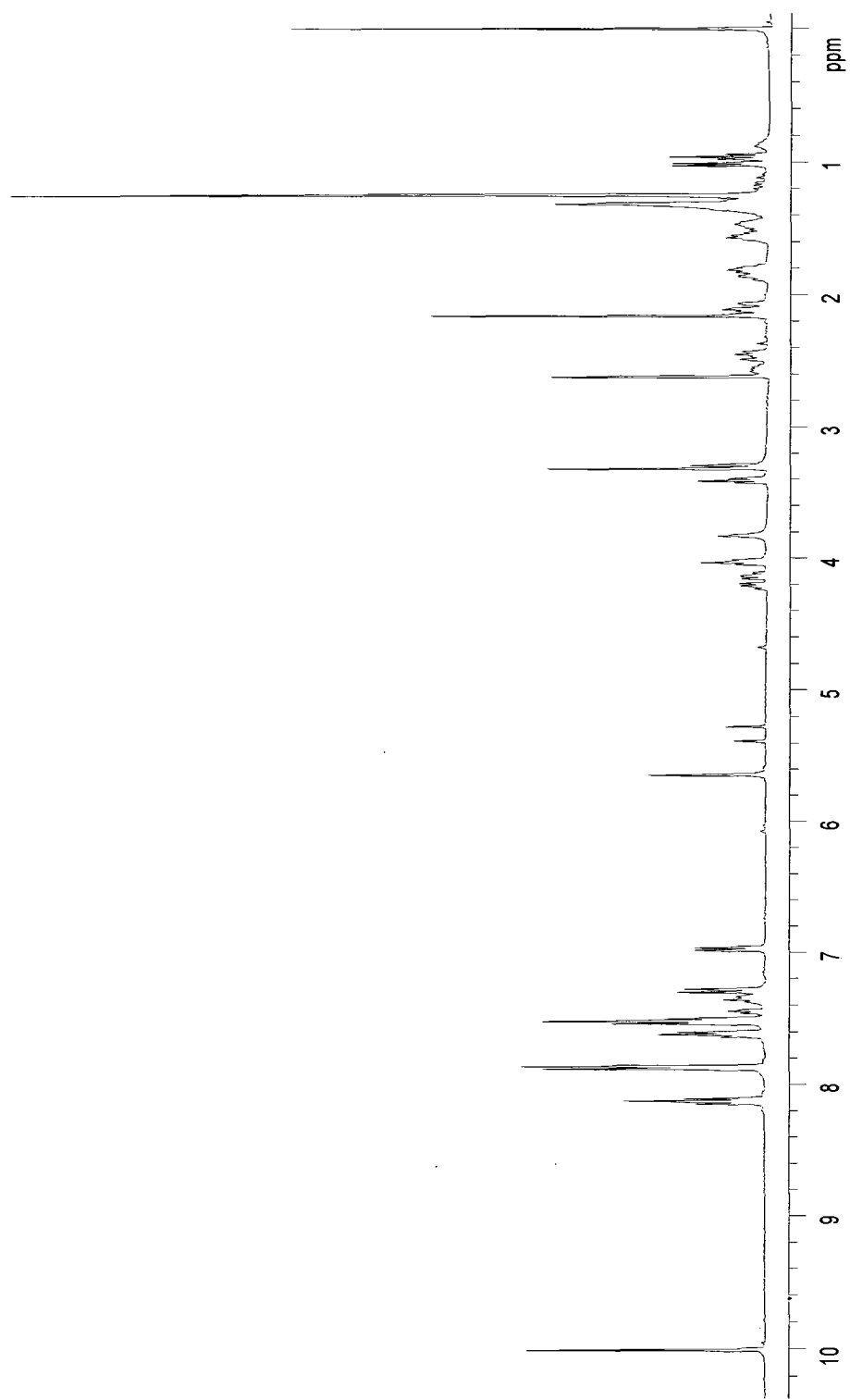
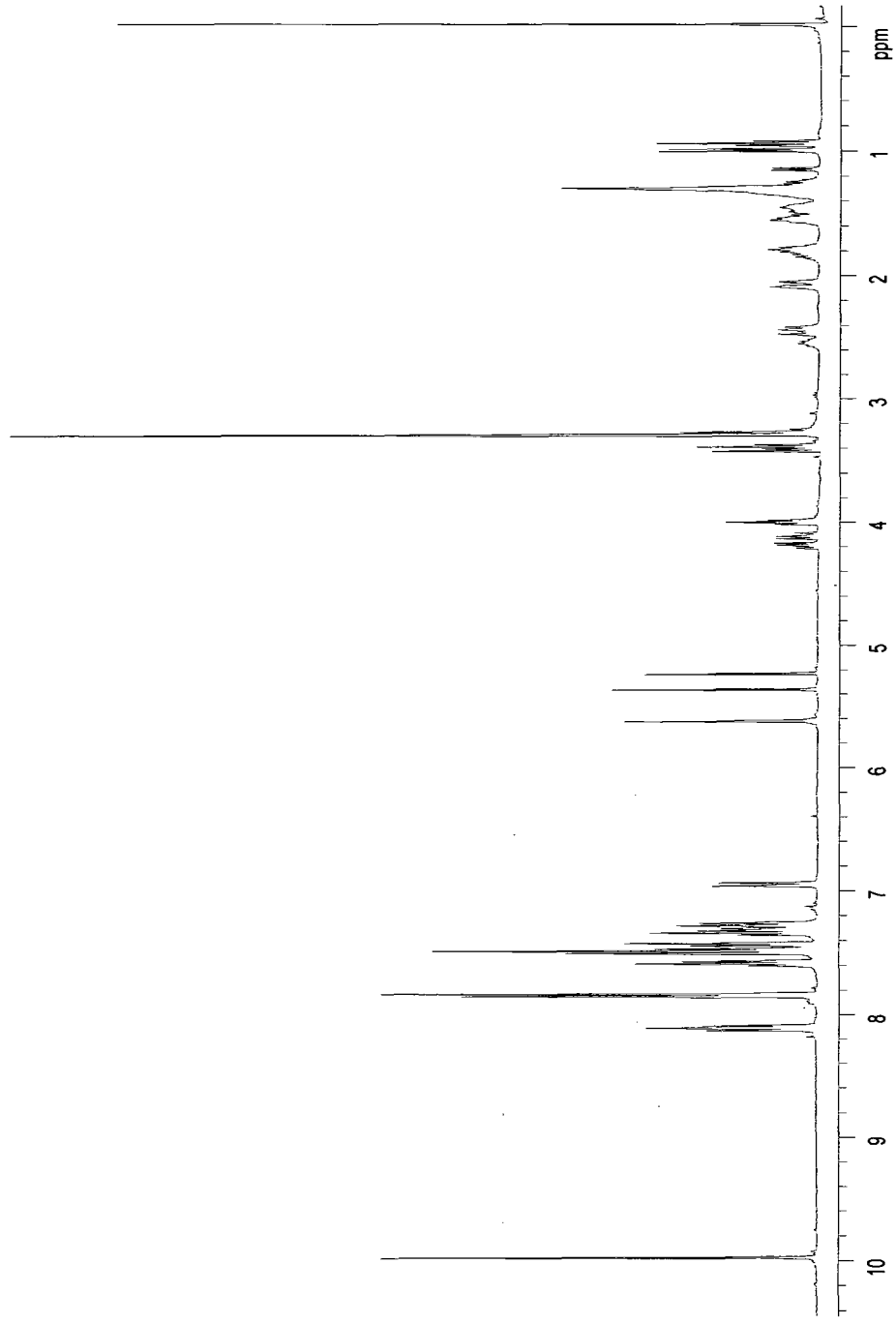


Figure A5.32 Mass spectrum of 4-(10-(3-cyclopentylmethoxy)decyloxy)benzoic acid

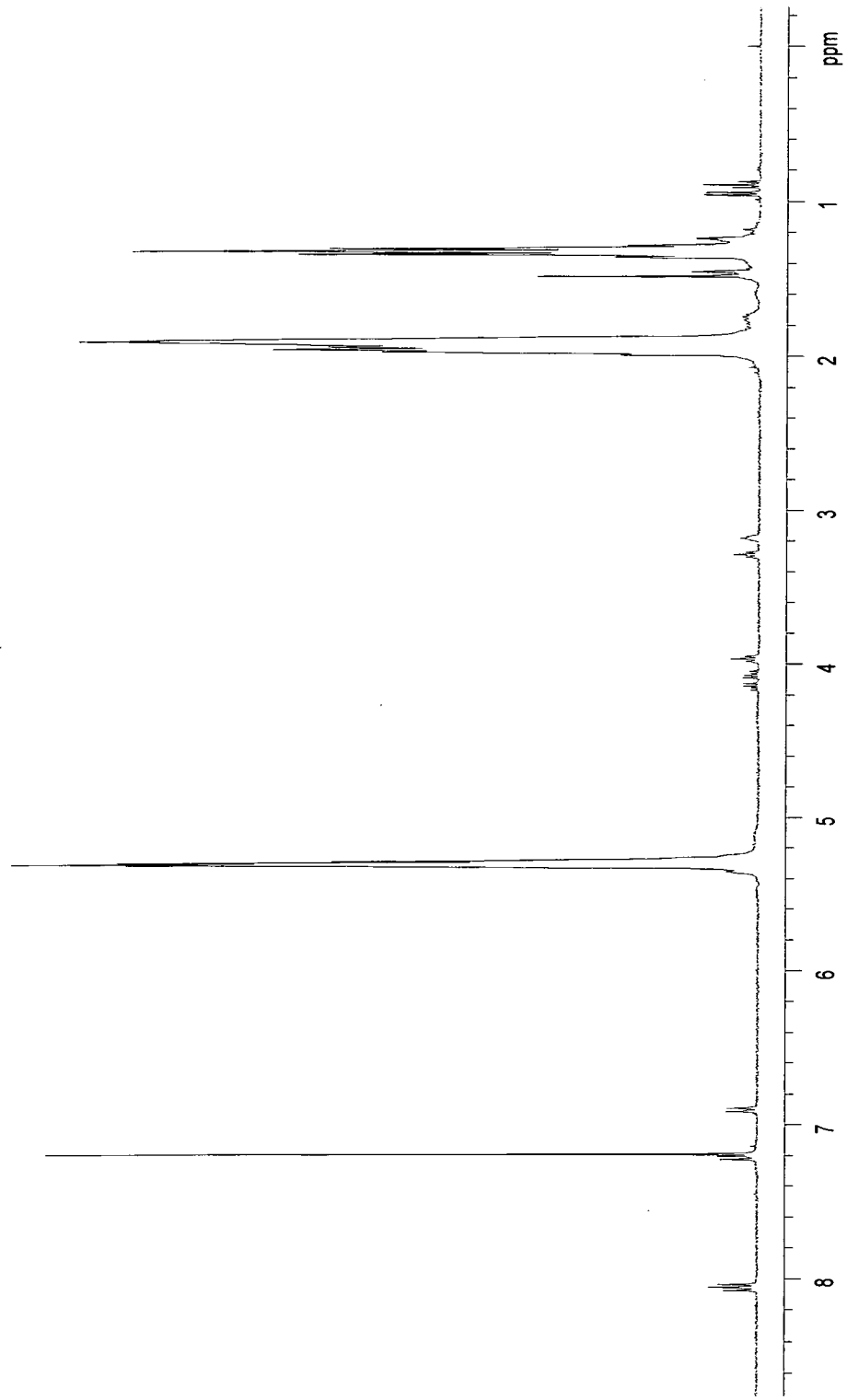
**APPENDIX-6**  
**Analytical Data for Chapter-6**



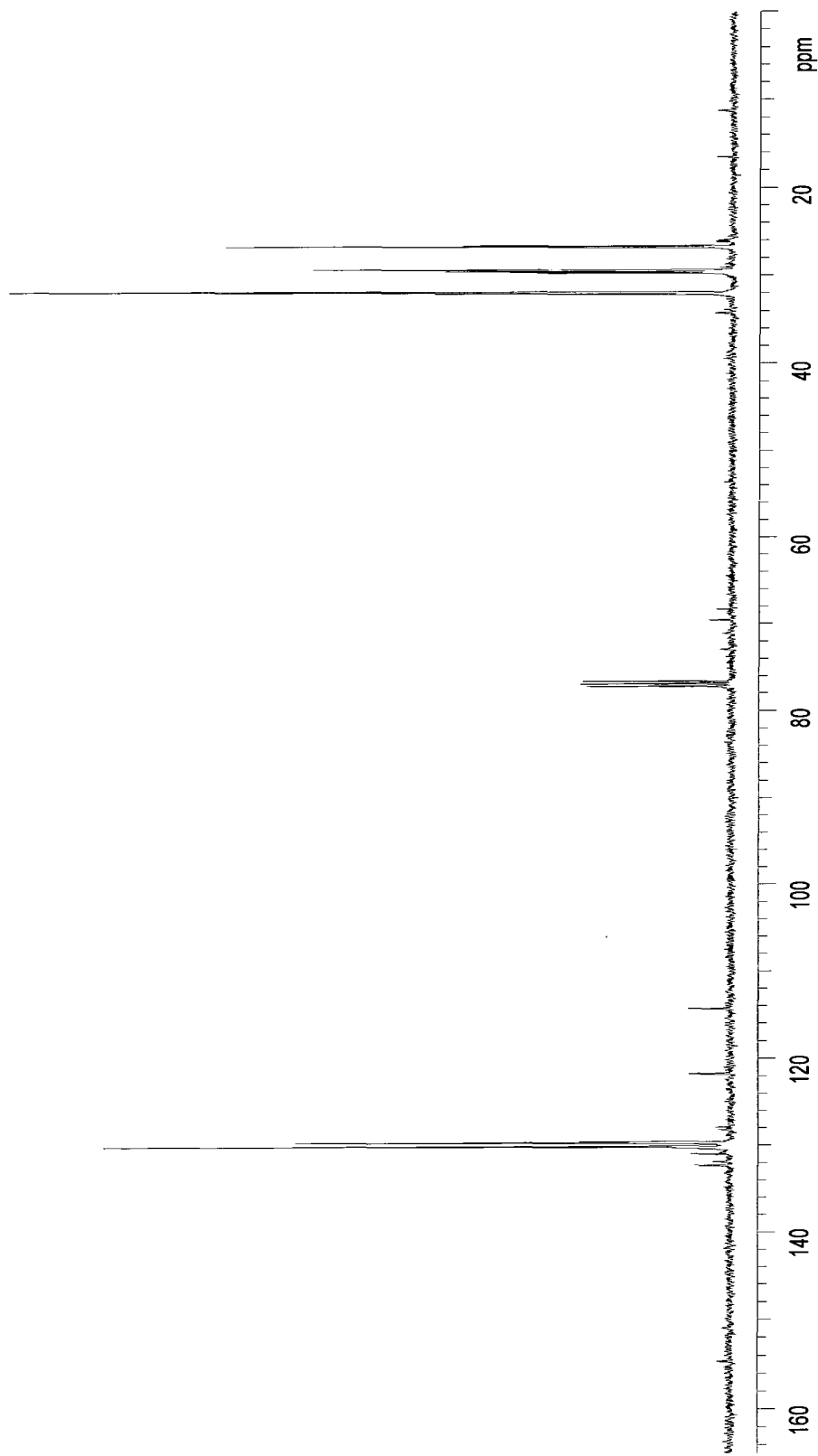
**Figure A6.1**  $^1\text{H}$  nmr spectrum of the polymerisation mixture after precipitating in methanol (reaction no. 1 in table 6.1)



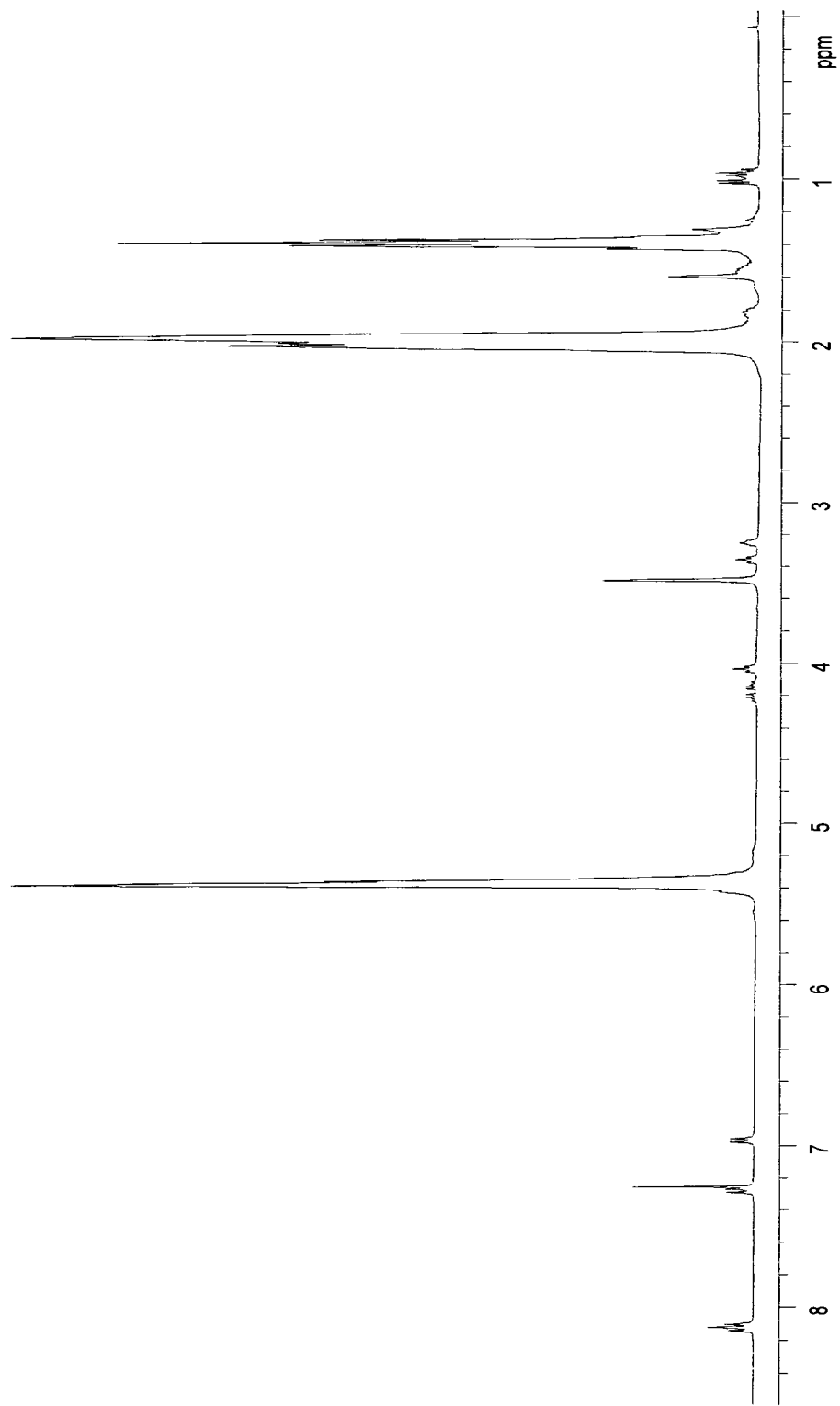
**Figure A6.2**  $^1\text{H}$  nmr spectrum of the polymerisation mixture after precipitating in methanol (reaction no. 2 in table 6.1)



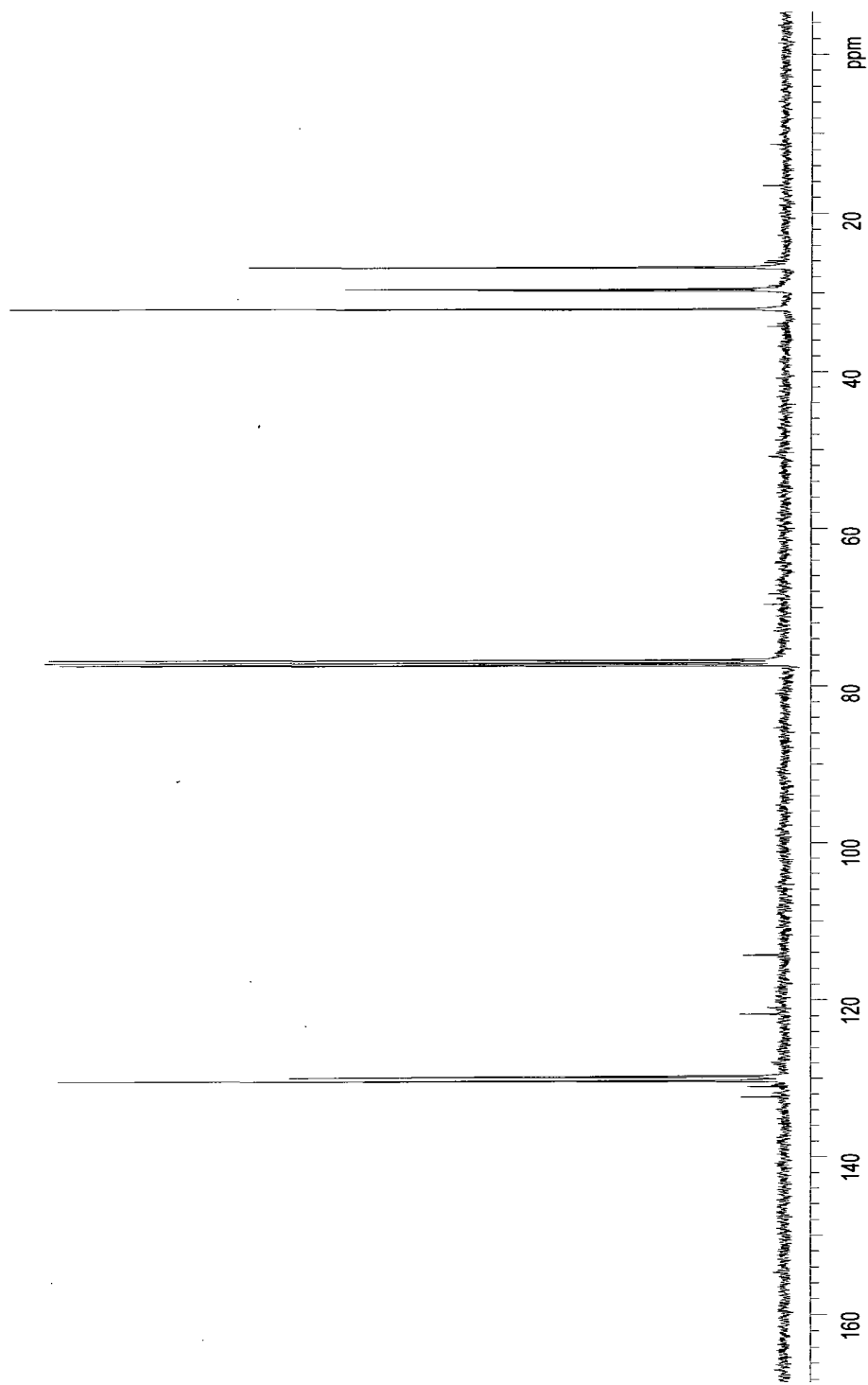
**Figure A6.3**  $^1\text{H}$  nmr spectrum of the polymer after first reprecipitation (reaction no. 6 in table 6.1)



**Figure A6.4**  $^{13}\text{C}$  nmr spectrum of the polymer after first reprecipitation (reaction no. 6 in table 6.1)



**Figure A6.5** <sup>1</sup>H nmr spectrum of the polymer after second reprecipitation (reaction no. 6 in table 6.1)



**Figure A6.6**  $^{13}\text{C}$  nmr spectrum of the polymer after second reprecipitation (reaction no. 6 in table 6.1)

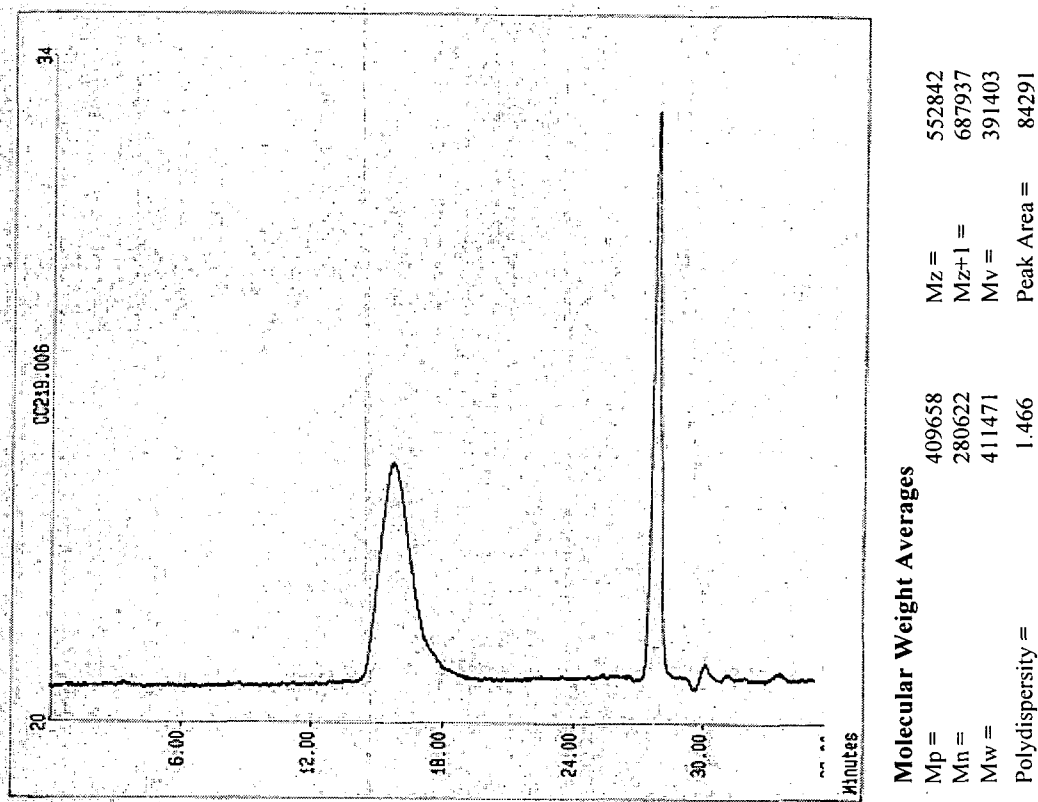


Figure A6.7 GPC trace of poly(4-methyl cyclopentene); reaction no.3 in table 6.1

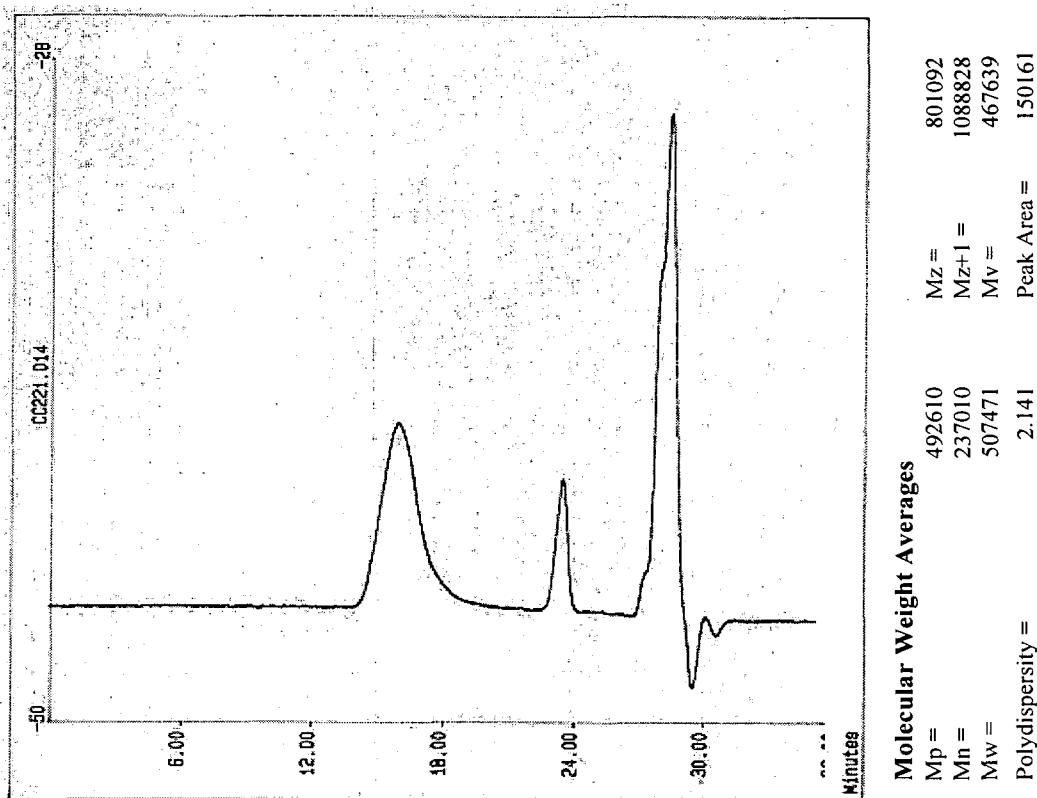
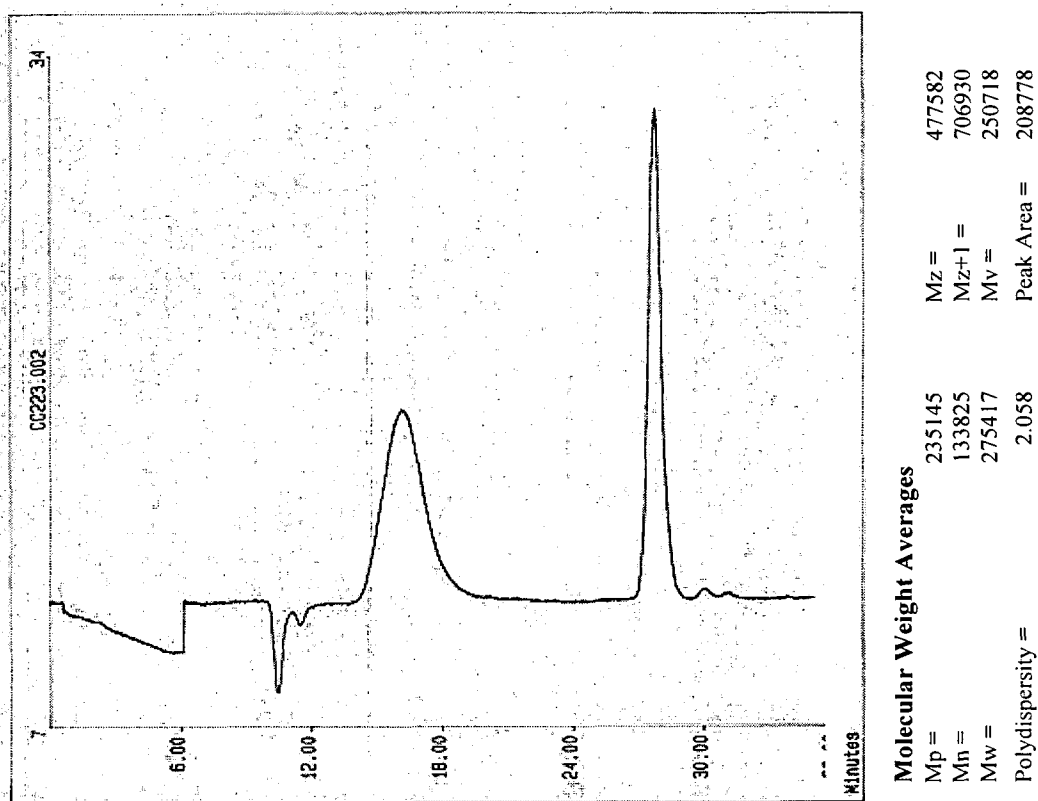


Figure A6.8 GPC trace of polymer (reaction no. 6 in table 6.1) before reprecipitation



**Figure A6.9** GPC trace of polymer (reaction no. 6 in table 6.1) after reprecipitation

## **APPENDIX-7**

### **Lectures and Conferences Attended by the Author**

**UNIVERSITY OF DURHAM**  
**Board of Studies in Chemistry**  
**Colloquia, Lectures and Seminars Attended**

**1994**

- January 26 Prof. J. Evans, *University of Southampton*  
Shining Light on Catalysts
- February 23 Prof. P. M. Maitlis, *University of Sheffield*  
Why Rhodium in Homogeneous Catalysis
- March 2 Dr. C. Hunter, *University of Sheffield*  
Non Covalent Interactions between Aromatic Molecules
- March 10 Prof. S. V. Ley, *University of Cambridge*  
New Methods for Organic Synthesis
- April 20 Prof. P. Parsons, *University of Reading*  
New Methods and Strategies in Natural Product Synthesis
- October 19 Prof. N. Bartlett, *University of California, USA*  
Some Aspects of Ag(II) and Ag(III) Chemistry
- November 2 Dr. P. G. Edwards, *University of Wales, Cardiff*  
The Manipulation of Electronic and Structural Diversity in Metal  
Complexes - New Ligands for New Properties
- November 23 Dr. J. Williams, *University of Loughborough*  
New Approaches to Asymmetric Catalysis

## 1995

- March 1 Dr. M. Rosseinsky, *University of Oxford*  
Fullerene Intercalation Chemistry
- April 26 Dr. M. Schröder, *University of Edinburgh*  
Redox Active Macrocyclic Complexes: Rings, Stacks and Liquid  
Crystals
- November 17 Prof. David Bergbreiter, *Texas A&M University, USA*  
Design of Smart Catalysts, Substrates and Surfaces from Simple  
Polymers
- November 22 Prof. I. Soutar, *University of Lancaster*  
A Water of Glass? Luminescence Studies of Water Soluble Polymers

## 1996

- January 17 Prof. J. W. Emsley, *University of Southampton*  
Liquid Crystals: More than Meets the Eye
- March 6 Dr. Richard Whitby, *University of Southampton*  
New Approaches to Chiral Catalysts: Induction of Planar and Metal  
Centred Asymmetry
- March 12 Prof. V. Balzani, *University of Bologna, Italy*  
Supramolecular Photochemistry
- March 13 Prof. Dave Gamer, *University of Manchester*  
Mushrooming in Chemistry
- October 22 Prof. B. J. Tighe, *University of Aston*  
Synthetic Polymers for Biomedical Application: Can We Meet  
Nature's Challenge?

November 12 Prof. R. J. Young, *UMIST*

New Materials: Fact or Fantasy

November 19 Prof. R. Grigg, *University of Leeds*

"The Assembly of Complex Molecules by Palladium-Catalysed  
Queuing Process"

**CONFERENCES, MEETINGS AND SEMINARS ATTENDED BY THE  
AUTHOR**

**1995**

- 19-21 April Macro Group UK Family Meeting, 'Aspects of Polymer Chemistry', Loughborough University of Technology
  
- 10-14 July 11<sup>th</sup> International Symposium on Olefin Metathesis and Related Chemistry, University of Durham<sup>†</sup>
  
- 3-16 September NATO / Advanced Study Institute Summer School on 'Ring-opening Metathesis Polymerisation of Olefins and Polymerisation of Alkynes' Akcay, Balikesir, Turkey<sup>†</sup>
  
- 26-27 September IRC Club Meeting, University of Durham<sup>†</sup>

**1996**

- 10-12 April Macro Group UK Family Meeting, 'Aspects of Contemporary Polymer Science', University of Manchester<sup>†</sup>
  
- 3 June The Melville Lectureship, University of Cambridge
  
- 5-6 June IRC Polymer Physics Course, University of Leeds
  
- 20-21 June IRC Polymer Engineering Course, University of Bradford
  
- 29 July-2 August International Conference on 'Recent Advances in Polymer Synthesis', University of York<sup>†</sup>

<sup>†</sup> presented a poster

## **REFERENCES**

1. Banks, R. L., Bailey, G. C., *Ind. Eng. Chem. Prod. Res. Dev.*, **3**, 170 (1964)
2. Anderson, A. W., Merckling, N. G., U.S. Patent 2721 189, *Chem. Abstr.*, **50**, 3008i (1955)
3. Calderon *et al.*, *Chem. Eng. News*, **45**, 51 (1967)
4. Calderon, N., Chen, H. Y., Scott, K. W., *Tetrahedron Lett.*, 3327 (1967)
5. Calderon, N., Ofstead, E. A., Judy, W. A., *J. Polym. Sci. Part A-1*, **5**, 2209 (1967)
6. Calderon, N., Ofstead, E. A., Ward, J. P., Judy, W. A., Scott, K. W., *J. Am. Chem. Soc.*, **90**, 4133 (1968)
7. Ivin, K. J., *Olefin Metathesis*, Academic Press (1983)
8. Ivin, K. J., Saegusa, T., *Ring-Opening Polymerisation*, Elsevier Applied Science Publishers (1984)
9. Drugatan, V., Balaban, A. T., Dimonie, M., *Olefin Metathesis and Ring-Opening Polymerisation of Cyclo-Olefins*, 2<sup>nd</sup> Ed., Wiley Interscience (1985)
10. Feast, W. J., Gibson, V. C., *The Chemistry of the Double Bond*, Vol. 5, John Wiley & Sons (1989)
11. Feast, W. J., *Comprehensive Polymer Science*, Vol. 4, Pergamon (1989)
12. Amass, A. J., *Comprehensive Polymer Science*, Vol. 4, Pergamon (1989)
13. Ivin, K. J., *Encyclopaedia of Polymer Science and Engineering*, 2<sup>nd</sup> Ed., Vol. 9, John Wiley & Sons (1987)
14. Grubbs, R. H., Novak, B. M., *Encyclopaedia of Polymer Science and Engineering*, 2<sup>nd</sup> Ed., Supplement Volume, John Wiley & Sons (1989)
15. Ofstead, E. A., Wagener, K. B., *New Methods of Polymer Synthesis*, Mijs, W. J., ed., Plenum Press (1992)
16. Grubbs, R. H., Tumas, W., *Science*, **243**, 907 (1989)
17. Novak, B. M., Risse, W., Grubbs, R. H., *Adv. Polym. Sci.*, **102**, 47 (1992)
18. Schrock, R. R., *Acc. Chem. Res.*, **19**, 342 (1986)
19. Schrock, R. R., *Acc. Chem. Res.*, **23**, 158 (1990)
20. Schrock, R. R., *Pure & Appl. Chem.*, **66**, 1447 (1994)
21. Schrock, R. R., *J. Organomet. Chem.*, **300**, 249 (1986)
22. Feldman, J., Schrock, R. R., *Progress in Inorganic Chemistry*, **39**, 1 (1991)

23. Feast W. J., Khosravi, E., *New Methods of Polymer Synthesis*, Vol. 2, Ebdon J. R., Eastmond, G. C., ed. Blackie Academic and Professional (1995)
24. Ivin, K. J., Mol, H., *Olefin Metathesis and Metathesis Polymerisation*, Academic Press (1997)
25. Fischer, E. O., Maasbol, A., *Angew. Chem. Int. Ed.*, **3**, 580 (1964)
26. Schrock, R. R., *J. Am. Chem. Soc.*, **96**, 6796 (1974)
27. Gilliom, L. R., Grubbs, R. H., *J. Am. Chem. Soc.*, **108**, 733 (1986)
28. Kress, J., Wesolek, M., Osborn, J. A., *J. Chem. Soc., Chem. Commun.*, 514 (1982)
29. Kress, J., Osborn, J. A., *J. Am. Chem. Soc.*, **109**, 3953 (1987)
30. Kress, J., Osborn, J. A., *J. Am. Chem. Soc.*, **105**, 6346 (1983)
31. Schavarien, C. J., Dewan, J. C., Schrock, R. R., *J. Am. Chem. Soc.*, **108**, 2771 (1986)
32. Murdzek, J. S., Schrock, R. R., *Organometallics*, **6**, 1373 (1987)
33. Schrock, R. R., Feldman, J., Cannizzo, L. F., Grubbs, R. H., *Macromolecules*, **20**, 1169 (1987)
34. Schrock, R. R., DePue, R. T., Feldman, J., Schavarien, C. J., Dewan, J. C., Liu, A. H., *J. Am. Chem. Soc.*, **110**, 1423 (1988)
35. Schrock, R. R., Murdzek, J. S., Bazan, G. C., Robbins, J., DiMare, M., O'Regan, M., *J. Am. Chem. Soc.*, **112**, 3875 (1990)
36. Schrock, R. R., DePue, R. T., Feldman, J., Yap, K. B., Yang, D. C., Davis, W. M., Park, L., DiMare, M., Schofield, M., Anhaus, J., Walborsky, E., Evitt, E., Krüger, C., Betz, P., *Organometallics*, **9**, 2262 (1990)
37. Bazan, G. C., Khosravi, E., Schrock, R. R., Feast, W. J., Gibson, V. C., O'Regan, M. B., Thomas, J. K., Davis, W. M., *J. Am. Chem. Soc.*, **112**, 8378 (1990)
38. Feast, W. J., Gibson, V. C., Marshall, E. L., *J. Chem. Soc., Chem. Commun.*, 1157 (1992)
39. Albagli, D., Bazan, G. C., Schrock, R. R., Wrighton, M. S., *J. Am. Chem. Soc.*, **115**, 7328 (1993)
40. Komiya, Z., Pugh, C., Schrock, R. R., *Macromolecules*, **25**, 3609 (1992)
41. Komiya, Z., Pugh, C., Schrock, R. R., *Macromolecules*, **25**, 6586 (1992)
42. Pugh, C., Schrock, R. R., *Macromolecules*, **25**, 6593 (1992)

43. Komiya, Z., Schrock, R. R., *Macromolecules*, **26**, 1387 (1993)
44. Komiya, Z., Schrock, R. R., *Macromolecules*, **26**, 1393 (1993)
45. Chan, Y. N. C., Schrock, R. R., *Chem. Mater.* **5**, 566 (1993)
46. Saunders, R. S., Cohen, R. E., Wong, S. J., Schrock, R. R., *Macromolecules*, **25**, 2055 (1992)
47. Yue, J., Sankaran, V., Cohen, R. E., Schrock, R. R., *J. Am. Chem. Soc.*, **115**, 4409 (1993)
48. Lee, J. K., Schrock, R. R., Baigent, D. R., Friend, R. H., *Macromolecules*, **28**, 1966 (1995)
49. Craig, G. S. W., Cohen, R. E., Schrock, R. R., Esser, A., Schrof, W., *Macromolecules*, **28**, 2512 (1995)
50. Schrock, R. R., Crowe, W. E., Bazan, G. C., DiMare, M., O'Regan, M. B., Schofield, M. H., *Organometallics*, **10**, 1832 (1991)
51. Oskam, J. H., Schrock, R. R., *J. Am. Chem. Soc.*, **114**, 7588 (1992)
52. Oskam, J. H., Schrock, R. R., *J. Am. Chem. Soc.*, **115**, 11831 (1993)
53. Schrock, R. R., Lee, J.K., O'Dell, R., Oskam, J. H., *Macromolecules*, **28**, 5933 (1995)
54. Bröeders, J., Feast, W. J., Gibson, V. C., Khosravi, E., *Chem. Commun.*, 343 (1996)
55. Nguyen, S. T., Johnson, L. K., Grubbs, R. H., *J. Am. Chem. Soc.*, **114**, 3974 (1992)
56. Wu, Z., Benedicto, A. D., Grubbs, R. H., *Macromolecules*, **26**, 4975 (1993)
57. Nguyen, S. T., Grubbs, R. H., *J. Am. Chem. Soc.*, **115**, 9858 (1993)
58. Lynn, D. M., Kanaoka, S., Grubbs, R. H., *J. Am. Chem. Soc.*, **118**, 784 (1996)
59. Quirk, R. P., Lee, B., *Polymer Int.*, **27**, 359 (1992)
60. Morton, M., *Anionic Polymerisation: Principles and Practice*, Academic Press (1983)
61. Bradshaw, C. P. C., Howmann, E. J., Turner, L., *J. Catal.*, **7**, 269 (1967)
62. Hérrison, J. L., Chauvin, Y., *Makromol. Chem.*, **141**, 161 (1971)
63. Tebbe, F. N., Parshall, G. W., Reddy, G. S. J., *J. Am. Chem. Soc.*, **100**, 3611 (1978)

64. Tebbe, F. N., Parshall, G. W., Ovenall, D. W., *J. Am. Chem. Soc.*, **101**, 5074 (1979)
65. Kress, J., Osborn, J. A., Greene, R. M. E., Ivin, K. J., Rooney, J. J., *J. Am. Chem. Soc.*, **109**, 899 (1987)
66. Mitchell, J. P., Gibson, V. C., Schrock, R. R., *Macromolecules*, **24**, 1220 (1991)
67. Crowe, W. E., Mitchell, J. P., Gibson, V. C., Schrock, R. R., *Macromolecules*, **23**, 3534 (1990)
68. Rempp, P., Merrill, E. W., *Polymer Synthesis*, 2<sup>nd</sup> Ed., Hüthig & Wepf (1991)
69. Higginson, W. C. E., Wooding, N. S., *J. Chem. Soc.*, 760 (1952)
70. Szwarc, M., Levy, M., Milkovich, R., *J. Am. Chem. Soc.*, **78**, 2656 (1956)
71. Morton, M., Fetters, L. J., *Rubber Chem. Technol.*, **48**, 359 (1975)
72. Bywater, S., *Encyclopaedia of Polymer Science and Engineering*, 2<sup>nd</sup> Ed., Vol. 2, John Wiley & Sons (1985)
73. Goode, W. E., Owens, F. H., Myers, W. L., *J. Polym. Sci.*, **47**, 75 (1960)
74. Owens, F. H., Myers, W. L., Zimmermann, F. E., *J. Org. Chem.*, **26**, 2288 (1961)
75. Rempp, P., Franta, E., Herz, J. E., *Adv. Polym. Sci.*, **86**, 145 (1988)
76. Richards, D. H., Szwarc, M., *Trans. Faraday Soc.*, **55**, 1644 (1959)
77. Dreyfuss, P., Quirk, R. P., *Encyclopaedia of Polymer Science and Engineering*, 2<sup>nd</sup> Ed., Vol. 7, John Wiley & Sons (1987)
78. Greber, G., Tölle, J., *Makromol. Chem.*, **53**, 208 (1962)
79. Kobayashi, S., Uyama, H., *Macromolecular Design: Concept and Practice*, Polymer Frontiers International Inc. (1994)
80. Yamashita, Y., *Chemistry and Industry of Macromonomers*, Hüthig & Wepf (1993)
81. Nagasaki, Y., Tsuruta, T., *Makromol. Chem.*, **187**, 1583 (1986)
82. Asami, R., Takaki, M., Hanahata, H., *Macromolecules*, **16**, 628 (1983)
83. Feast, W. J., Gibson, V. C., Johnson, A. F., Khosravi, E., Mohsin, M. A., *Polymer*, **35**, 3542 (1994)
84. Kawakami, Y., *Encyclopaedia of Polymer Science and Engineering*, 2<sup>nd</sup> Ed., Vol. 9, John Wiley & Sons (1987)

85. Bovey, F. A., Winslow, F. H., ed., *Macromolecules: An Introduction to Polymer Science*, Academic Press, Inc. (1979)
86. Donald, A. M., Windle, A. H., *Liquid Crystalline Polymers*, Cambridge University Press (1992)
87. McArdle, C. B., ed., *Side Chain Liquid Crystalline Polymers*, Blackie (1989)
88. Wunderlich, B., Grebowicz, J., *Adv. Polym. Sci.*, **60/61**, 1 (1984)
89. Dobb, M. G., McIntyre, J. E., *Adv. Polym. Sci.*, **60/61**, 61 (1984)
90. Shibaev, V. P., Platé, N. A., *Adv. Polym. Sci.*, **60/61**, 173 (1984)
91. Finkelmann, H., Rehage, G., *Adv. Polym. Sci.*, **60/61**, 99 (1984)
92. Kwolek, S. L., Morgan, P. W., Schaeffgen, J. R., *Encyclopaedia of Polymer Science and Engineering*, 2<sup>nd</sup> Ed., Vol. 9, John Wiley & Sons (1987)
93. Blackwood, K. M., *Science*, **273**, 909 (1996)
94. Cowie, J. M. G., *Polymers: Chemistry & Physics of Modern Materials*, 2<sup>nd</sup> Ed., Blackie Academic & Professional (1991)
95. Singler, R. E., Willingham, R. A., Lenz, R. W., Furukawa, W. A., Finkelmann, H., *Macromolecules*, **20**, 1727 (1987)
96. Allcock, H. R., Kim, C., *Macromolecules*, **22**, 2596 (1990)
97. Allcock, H. R., Kim, C., *Macromolecules*, **23**, 3881 (1990)
98. Percec, V., Lee, M., Jonsson, H., *J. Polym. Sci., Polym. Chem. Ed.*, **29**, 327 (1991)
99. Percec, V., Lee, M., *Macromolecules*, **24**, 2780 (1991)
100. Percec, V., Lee, M., *Macromolecules*, **24**, 1017 (1991)
101. Percec, V., Lee, M., Ackermann, C., *Polymer*, **33**, 703, (1992)
102. Sagane, T., Lenz, R. W., *Macromolecules*, **22**, 3763 (1989)
103. Sagane, T., Lenz, R. W., *Polymer*, **30**, 2269 (1989)
104. Percec, V., Tomazos, D., Pugh, C., *Macromolecules*, **22**, 3259 (1989)
105. Maughon, B. R., Weck, M., Mohr, B., Grubbs, R. H., *Macromolecules*, **30**, 257 (1997)
106. Finkelmann, H., Happ, M., Portugall, M., Ringsdorf, H., *Makromol. Chem.*, **179**, 2574 (1978)

107. Finkelmann, H., Ringsdorf, H., Siol, W., Wendorf, J. H., *Mesomorphic Order in Polymers and Polymerisation in Liquid Crystal Media*, Blumenstein, A., ed., ACS Symp. Ser. 74 (1978)
108. Shibaev, V. P., Kozlovsky, M. V., Beresnev, L. A., Blinov, L. M., Platé, N. A., *Polym. Bull.*, **12**, 299 (1984)
109. Shibaev, V. P., Platé, N. A., *Pure and Appl. Chem.*, **57**, 1589 (1985)
110. Jerry March, *Advanced organic chemistry: Reactions, Mechanisms and Structure*, John Wiley & Sons (1992).
111. Martin, J. G., Hill, R. K., *Chem. Rev.*, **61**, 537 (1961).
112. Carruthers, W., *Some Modern Methods of Organic Synthesis*, Cambridge University Press (1986).
113. Ivin, K. J., Lapienis, G., Rooney, J. J., *Polymer*, **21**, 436 (1980).
114. US. Patent No. 3, 641,108.
115. Ver Nooy, C. D., Rondestvedt, C. S., *J. Am. Chem. Soc.*, **77**, 3583 (1955).
116. Roberts, J. D., Trumbull, E. R., Bennett, W., Armstrong, R., *J. Am. Chem. Soc.*, **72**, 3116 (1950).
117. Berson, J. A., Ben-Efraim, D. A., *J. Am. Chem. Soc.*, **81**, 4083 (1959).
118. Tamelen van, E. E., Shamma, M., *J. Am. Chem. Soc.*, **76**, 2315 (1954).
119. Adams, R., Ulich, L. H., *J. Am. Chem. Soc.*, **42**, 599 (1920).
120. Norton, R. L., McCarthy, J., *Macromolecules*, **22**, 1022 (1989)
121. Breunig, S., Heroguez, V., Gnanou, Y., Fontanille, M., *Macromol. Symp.*, **95**, 151 (1995)
122. Heroguez, V., Gnanou, Y., Fontanille, M., *Macromol. Rapid Commun.*, **17**, 137 (1996)
123. Heroguez, V., Breunig, S., Gnanou, Y., Fontanille, M., *Macromolecules*, **29**, 4459 (1996)
124. Feast, W. J., Gibson, V. C., Johnson, A. F., Khosravi, E., Mohsin, M. A., *J. Mol. Catal. A: Chemical*, **115**,37 (1997)
125. Feast, W. J., Gibson, V. C., Khosravi, E., Marshall, E. L., Mitchell, J. P., *Polymer*, **33**, 872 (1992)
126. Murdock, K. C., Angier, R. B., *J. Org. Chem.*, **27**, 2395 (1962)
127. Meinwald, J., Gassman, P. G., Crandall, J. K., *J. Org. Chem.* **27**, 3366 (1962)

128. Schmid, G. H., Wolkoff, A. W., *J. Org. Chem.* **32**, 254 (1967)
129. Hosomi, A., Mikami, M., Sakurai, H., *Bull. Chem. Soc. Jpn.*, **56**, 2784 (1983)
130. Cremer, S. E., Blankenship, C., *J. Org. Chem.* **47**, 1626 (1982)
131. Johnson, C. R., Keiser, J. E., Sharp, J. C., *J. Org. Chem.* **34**, 860 (1969)
132. Deprés, J. P., Greene, A. E., *J. Org. Chem.* **49**, 928 (1984)
133. Dias, E. L., Nguyen, S. T., Grubbs, R. H., *J. Am. Chem. Soc.* **119**, 3887 (1997)
134. Hutchison, A., Grim, M., Chen, J., *J. Heterocyclic Chem.*, **26**, 451 (1989)
135. Crivello, J. V., Narayan, R., *Macromolecules*, **29**, 433 (1996)
136. Whitcombe, M. J., Davis, F. J., Gilbert, A., Mitchell, G. R., *Polym. Comm.*, **32**, 380 (1991)
137. Chen, J. H., Chang, R. C., Hsiue, G. H., Guu, F. W., Wu, S. L., *Liq. Crystals*, **18**, 291 (1995)
138. Polish Patent No. PL 140618 BI
139. Suggested by the sponsors (Defence Research Agency)
140. Trollsås, M., Sahlén, F., Gedde, U. W., Hult, A., Hermann, D., Rudquist, P., Komitov, L., Lagerwall, S. T., Stebler, B., Lindström, J., Rydlund, O., *Macromolecules*, **29**, 2590 (1996)
141. Maughon, B. R., Weck, M., Mohr, B., Grubbs, R. H., *Macromolecules*, **30**, 257 (1997)
142. Suguwara, K. G., *Ph.D. Thesis*, University of Durham (1994)
143. Dounis, P., *Ph.D. Thesis*, University of Durham (1994)
144. Schrock, R. R., Yap, K. B., Yang, D. C., Sitzmann, H., Sita, L. R., Bazan, G. C., *Macromolecules*, **22**, 3191 (1989)
145. Schrock, R. R., Krouse, S. A., Knoll, K., Feldman, J., Murdzek, J. S., Yang, D. C., *J. Mol. Catal.*, **46**, 243 (1988)

