

Durham E-Theses

Intimate Bodies, Violent Struggles: The poetics and politics of nuptiality in Syria

A. MARIA A. KASTRINOU

How to cite:

KASTRINOU, A. MARIA A. (2012) *Intimate Bodies, Violent Struggles: The poetics and politics of nuptiality in Syria*. Doctoral thesis, Durham University.

Use policy

The full-text may be used and/or reproduced, and given to third parties in any format or medium, without prior permission or charge, for personal research or study, educational, or not-for-profit purposes provided that:

- a full bibliographic reference is made to the original source
- a <https://etheses.durham.ac.uk/id/eprint/4923/> is made to the metadata record in Durham E-Theses
- the full-text is not changed in any way

The full-text must not be sold in any format or medium without the formal permission of the copyright holders.

Please consult the [full Durham E-Theses policy](#) for further details.

Intimate Bodies, Violent Struggles

The poetics and politics of nuptiality in Syria

A. Maria A. Kastrinou

Thesis submitted for the degree of Doctor of Philosophy in
Anthropology

Durham University
2012

Abstract

Intimate bodies, violent struggles: The poetics and politics of nuptiality in Syria

Caught between conflicting historical fantasies of an exotic Orient and images of the oppressive and threatening Other, Syria embodies both the colonial attraction of Arabesque *par excellence* simultaneously along with fears of civilization clashes. In anthropology the road to Damascus is a road less travelled, a road perilously understudied. Venturing on such a road, this ethnography is one of few contemporary anthropological accounts of Syria, and the first to situate itself among the Druze community as well as the transient spaces of/between the communal, the national and the global.

Undertaken in the years immediately preceding the so-called Arab Spring, and caught amidst the personal familial relations and ruptures of a close-knit sectarian community, the relationship between the *intimate and the violent* became central in framing the empirical and theoretical endeavour. The fine and fragile line between intimacy and violence was pervasive and raised questions such as: How are relations formed, performed, and challenged within the Syrian context? How are power relations of intimacy and violence embodied and to what extent are such relations constitutive of social reality within the contexts of the Syrian polity? Encountering issues of class, gender, sect, state, capitalist globalisation and Western governmentality, this thesis is based on fourteen months of ethnographic fieldwork within the Druze community and dance research inside Syria. Specifically, this ethnography takes the *nuptial body* as the epicentre of historical, social, political and economic power relations, as a practical embattled territory, and traces the choreographies of power through Syrian bodies in (a) dances and transformative rituals within the Druze community, (b) on the state-funded stages of folklore festivals, and (c) through the European Union's sponsoring and investing in Syrian professional dances. Choreographing power relations and clashes between/within empires, the thesis develops the concept of *nuptiality* as the relational idiomatic frame of violent intimacies that produce the body as an arena of contestations and struggles, a fragmented plane upon which power relations emerge.

But bodies move in elusive, subversive and powerful rhythms, simultaneously performing, defying and crystallising their own subjugations and transformations – it is these moving bodies, in intimate spaces that this ethnography is about. This theoretical approach, and its own intimate methodological forbearer, is used to challenge regnant theories of power and relationality in contemporary Syria, as well as essential purveyances of Arab bodies. Instead, the concept of *nuptiality* is used simultaneously to explain hegemonic quests for bodies, and the captivating force and fluidity of embodied everyday struggles.

Contents

Abstract	2
Contents	3
List of figures and tables	6
Note on Arabic transliteration	7
Glossary	8
Statement of copyright	9
Acknowledgements	10

Chapter One

Intimate bodies, violent struggles: The poetics and politics of nuptiality in Syria	15
Becoming an anthropologist: Photograph of a little girl in the desert	15
On navigation	17
Anthropology as epistemology	17
Scope and theoretical framework of thesis	20
Synopsis of thesis	22
Anthropology and Events	26

Chapter Two

Emplacing research: History, anthropology and methods	37
Introduction: Middle East and anthropology	37
Emplacing the Druze: History and contemporary regional realities	40
Syria: French Mandate, Independence, United Arab Republic and the Ba’th Party’s rise to power	46
Emplacing anthropology in Syria since 1970	49
Emplacing research practice	60
Intersubjective research praxis: Practice into theory	65

Chapter Three

Two houses in Jaramana	75
Introduction: On houses	75
Jaramana	80
Two houses in Jaramana	87

<i>Bayt</i> Abud-Haddad-----	89
<i>Bayt</i> Ouward -----	103
Conclusion: Two <i>bayts</i> in Jaramana-----	110

Chapter Four

Of bodies, souls and transformations: Birthing and dying in Jaramana-----	115
Enthusing bodies: Reflections-----	115
Encountering life and death in Jaramana -----	116
The Body and Druze theosophy-----	117
Dying in Jaramana -----	123
Birthing in Jaramana-----	140
Conclusion: Life-cycle transformations and the embodied struggles of Druze becomings-----	150

Chapter Five

Nuptiality or, a wedding in Jaramana -----	152
Introduction: The problematic framework of endogamy-----	152
Talking of marriage-----	156
Nuptial bodies, intimate boundaries-----	171
Procrustean bodies of the margins: Intimate and volatile struggles -----	178
Procrustean bodies of the martyrs -----	182

Chapter Six

Poetics of an empire: Folklore festivals, nuptials and the Syrian state-----	186
Introduction -----	186
Part 1: Theorising the state-----	186
Part 2: Choreographies of empire: Spaces for the realisation of intimacy -----	205
The finale: The intimate discord of empire -----	212
Conclusion: Requiem for a marriage or, nuptial intimacy in the state-of-empire -----	216

Chapter Seven

Arab youth politics in Syria: Becoming young in the Middle East -----	223
Introduction -----	223
Of uprisings, backgrounds and theoretical frameworks -----	224
Singing Jowlan: Performing identities, reforming histories and embodying politics -----	229

On inventiveness and (in) dependence: The political economy of networking in Damascus University and beyond -----	235
Love and other crimes: Desires and discourses of resistance-----	241
Of revolutions and conclusions or, Sham’s youth and the life of politics -----	248

Chapter Eight

On the nuptial limits of empires or, an Arab dance last spring -----	253
Methodological reflections on art and anthropology-----	253
An Arab dance -----	254
Alf Mabrouk: Writing a performance -----	257
Analysis: An Arab dance last spring -----	262
Intertextual movements instead of a conclusion-----	282

Chapter Nine

The intimate and violent struggles ahead -----	285
Funerals, weddings and demonstrations-----	285
Poetics and politics of nuptiality -----	288
The intimate and violent struggles ahead-----	292

Appendix I -----	296
-------------------------	------------

Bibliography -----	301
---------------------------	------------

List of figures and tables

Figures

Figure 1.1: Little girl in the desert, photo by author, July 2008.

Figure 3.1: Damascus (grey) and Jaramana (black), Fahmi and Jaeger (2009).

Figure 3.2: Spatial composition of ethnic residence in Jaramana, ‘Syrian majority’ correlates to the physical and social space of my fieldwork and it is an overwhelmingly Druze majority, Fahmi and Jaeger (2009).

Figure 3.3: (left) ‘Main districts of Druze settlement before the migration to Hawran’ (Firro 1992: 35).

Figure 3.4: (right) ‘Druze settlement in Syria, Lebanon and Palestine’ (Firro 1992: 30).

Figure 3.5: ‘The Druze villages in Mt. Lebanon, Wadi al-Taym, Iqlim al-Billan and al-Ghuta’ (Firro 1992: 41).

Figure 3.6: Historical expansion of Jaramana from a village to an urban suburb, 1941–2009, Fahmi and Jaeger (2009).

Figure 3.7: Map of Jaramana with significant social, religious and political markers.

Figure 3.8: *Bayt* Abud-Haddad lineage diagram.

Figure 3.9: The house at the beginning of the 20th Century. Drawing by Tariq Abud-Haddad, 2009.

Figure 3.10: *Bayt al-sheta*. Photograph by author, 2009.

Figure 3.11: The *qā’a*, internal ground elevation is called ‘*ataba* (threshold), see Weber 2009: 236. Drawing by Tariq Abud-Haddad, 2009.

Figure 3.12: The *ivan*. Photograph by author, 2009.

Figure 3.13: Drawing of the three phases in the development of *bayt* Abud-Haddad. Drawing by Tariq Abud-Haddad, 2009.

Figure 3.14: Ground plan of *bayt* Abud-Haddad. Drawing by Tariq Abud-Haddad, 2009.

Figure 3.15: Inside the courtyard house of *bayt* Abud-Haddad. Drawing by Tariq Abud-Haddad, 2009.

Figure 3.16: Lineage diagram of *bayt* Ouward.

Tables

Table 2.1: Entries for Syria (Strijp 1992).

Table 2.2: Comparison of number of anthropological monographs published across different states in the Middle East (Strijp 1992).

Note on Arabic transliteration

I transliterate Arabic words based on the standard modern Arabic conventions used by the International Journal of Middle Eastern Studies (IJMES), except in the case of proper nouns and words with a standard Romanisation, where I employ either the form most commonly used or the form nearest to the colloquial dialect of the Druze community in Jaramana.

Glossary

‘ors: wedding

‘uqqal: Druze religious initiates

‘alaqa, *‘alaqat*: relation

‘ayb: shame, shameful

bakhūr: burning incense

bayt: house, family, lineage, or line in a poem

da‘wa: religious call

ḥafleb: party

ḥammām: bath, akin to Turkish bath

jama‘iya: association, collective, club, charity

janāḥ: marriage

juhhal: uninitiated Druze

leish: why, also the name of a dance troupe

madafa: room for the reception of guests

manqaf: Druze ceremonial space used for funerals

qahwa murrah: bitter Arabic coffee, mainly served in ceremonial situations

shaykh, or *mashāykh*: religious elder

Ṣaniya: metallic tray used for serving food

taqamus: human-to-human reincarnation

tawḥīd: the religious doctrine followed by the Druze

tesbt al-ra‘abeh: a small bowl of fear

Statement of Copyright

The copyright of this thesis rests with the author. No quotation from it should be published without the prior written consent and information derived from it should be acknowledged.

Acknowledgements

Relying on the kindness of strangers is characteristic of projects that span four years and three countries. I have been extremely blessed because most of these strangers have become families and fellow travellers. This work is not only my own, although the mistakes herein are, but the result of such interactions, and I am very grateful to my past and present teachers, to friends and colleagues in Greece, Syria and the UK, and my families in Syria and in Greece.

The very first essay I wrote as an undergraduate student of anthropology was for a course taught by Dr Stephen M. Lyon; the essay was about Bedouin sword dances. Since then, and throughout all the years of my studies, Dr Lyon has been a dedicated supervisor, an inspiring anthropologist and a valuable colleague. I cannot thank him enough for his encouragement, support and discretion, as for teaching me not only anthropology but also how to become an anthropologist. I would also like to thank my two other supervisors, Dr Christopher Davidson and Dr Elisabeth Kirtsoglou for all their support and encouragement. I thank my examiners Dr Lori Allen and Professor Robert H. Layton for their comments, insights and extremely helpful suggestions, as well as for making the Viva such a rich and rewarding experience. Many thanks to the Anthropology Department, the Wolfson Institute in Durham and the Folklore Society for providing financial support to my anthropological adventures.

I am infinitely indebted to the warm hospitality and kind generosity of Professor Sulayman N. Khalaf and his extended family in Al-Raqqa. Professor Khalaf has been my anthropological father, and words are not enough to thank him for initiating me into Syrian ethnography, for providing crucial support and advice throughout all the phases of this thesis, and for teaching me the importance of ethnographic detail and anthropological rigour. His work and conduct are constant sources of inspiration.

Many people have supported me in embarking on fieldwork in Syria. Specifically, I am indebted to the help, hospitality and advice of His Excellency the Syrian Ambassador in London, Dr Sami Khiyami.

I am thankful to His Excellency, Vice Minister of Culture, Dr Ali al-Qayem, for his personal support in my anthropological endeavour. I am particularly indebted to the support and enthusiasm shown by everyone at the Directorate of Theatre and Music, without whom this project would not have been possible. Specifically, I would like to thank the Director, Dr Salim Ajaj Alhafiri, whose support has been invaluable. Furthermore, I would like to thank Mr. Salim Kheireddine, founder of the Druze Heritage Foundation in London, for his valuable insights and for providing me with all the Foundation's publications regarding the Druze.

I am grateful to the Greek Embassy in Syria, particularly to the Defence Attaché Col. Giorgos Makrigiannis and his wife Dora, who supported, cared and helped me in uncertain times and who provided a home away from home and a warm Greek family. Thanks go to Mr. Pantelis for making my stay in Qassa' all the more sweet. From Durham University, I would like to thank Professor Paul Starkey and his wife Janet, for providing valuable contacts within Damascus University and for all their interest and support in my work. My sincere gratefulness goes to Professor Abdul Nabi Isstaif, from Damascus University, and to his kind and generous Damascene

family, who took me in and provided invaluable care, inspiration and support throughout my stay.

Research on folklore and dance in Syria would not have been easy without the cooperation and support of the many troupes, directors and dancers that partook in my anthropological project. I would like to thank all the troupes for their time, support, and for allowing me to follow the intimate details of their work. Particular thanks go to Enana, Ornina, Leish, and Sima troupes as well as Al-‘Ojeili’s folklore troupe from Al-Raqqa. I am grateful to Samir and Mais Seifan for their support and guidance at the early stages of the project. Many thanks go to the incredibly talented dancer and my dancing ‘guardian angel,’ Sakher al-Monem, through whom I met most of the dancers and troupes in Syria. Special thanks also go to Wassim Sukar, from Enana, for his invaluable support and friendship. Finally, the course of this project would have been very different without the inspiration, friendship and support from Noura Murad and Leish Troupe. Their work, dances and passion have guided me into unknown and truly fascinating new territory.

To my friends and colleagues I owe special thanks for providing much needed intellectual stimulation, companionship, and for simply putting up with me during the intense period of writing up. I am grateful to Dr Mark Jamieson and Dr Iain Edgar for their support at the early stages. I am grateful to Dr Thomas Henfrey and Dr Claudia Merli, for providing intellectual stimulation and growth, reading and commenting on draft chapters, and most crucially for their continuous support and invaluable friendship over the years. Matt Wootton and Dr Mwenza Blell shared my dreams, hopes, and anxieties with incredible understanding and love, and their friendship has been a true blessing. With Fouad Gehad Marei we shared our adventures in the Middle East and vented our academic frustrations – I thank him for his friendship, intellectual stimulation and help with transliteration. Many thanks to Richard Simpson for his comments and our heated discussions over chapter 8. Special thanks to Dr Stavroula Pipyrou for almost miraculously appearing every time I was in crisis. Her sincere enthusiasm, humour and anthropological acuteness have been a true gift. Many thanks go to Dr Gavin Weston for initiating me into the theory of violence.

I am indebted to all the dear persons in my life for their love, understanding and all the good times, especially to my cousins Amilia Kanta and Marianthi Theodoropoulou, and to my friends Marija Markovic, Panagiotis Varelas, Dimitris Skordos and Fadi Shehadeh. I am grateful to Panagiotis Palavos and his family for particularly going out of their way to help me during two intense writing up months in Greece. Adonis Eksarxos is the person who taught me words and I am eternally grateful that he has been for so many years a constant source of inspiration. Living in Sacriston for the past three years has been a pleasure, and I must thank my neighbours, especially Anne, Erica and Sue for all their support. Neither Sacriston nor our house would have been such a playful and fun place without our little friends Ben, Brad, Jordan, Katie, Lucy, Shannon, and Will.

Moreover, my sincere gratitude goes to all those working in the numerous cafés in Athens, Damascus, Durham and Newcastle, that for the past four years have provided a shifting office space. Most of my writing occurred in the Settle Down Café in Newcastle, and I thank Graham and Josephine for not only turning a blind eye to my overdue stays, but for providing generous smiles, support and wisdom.

There are two people whose presence and traces in my life and my work are impossible to qualify, impossible to measure, impossible to adequately thank for. My mother, Eleftheria Kastrinou, is the source of my inspiration, and has supported me in every step and way, teaching me to love, to learn, and to struggle. Steven Emery, the hand that holds my heart, has approached every corner of my thesis, as of myself, with unwithered passion and unshakable belief. Without them I would not make it. My love and my words are always with them.

Finally, this work would not be possible without the love, care, inspiration and support from my Syrian families and friends, whose worlds animate this thesis and who have coloured my senses in deep, untranslatable ways. Ethical and safety concerns dictate their anonymity, yet I am eternally indebted to them. My Syrian brothers and sisters, particularly Anna, Kareem, Salih and Tariq allowed me into to their houses, companies and stories, while their comfort, warmth, sincerity and friendship have sustained me well beyond fieldwork, their friendship is a precious gift. Zahra has been a sister, a dear friend, and has offered invaluable inspiring intellectual and ethnographic advice throughout the years. I am forever indebted to her for permitting me to feature in her life and share her stories through my thesis.

In Jaramana I was blessed to have been adopted by two households and their extended families, and to have been embraced with so much generosity, kindness and love. It is not an exaggeration to note that in the families (*bayts*) of Abud-Haddad and Ouward I was reborn, not only as an anthropologist but also as a better person. Without them, none of this would have been possible. I dedicate this work to them, and particularly to my mother Eleftheria and to my two Druze mothers, Umm Samir and Umm Nidal – all women of incredible strengths, wits and capacity for love. It is because of them that the familiar became strange and the strange familiar.

To my mothers, with love



Leish rehearsal of Alf Mabrouk. Photograph by author, 2009.

In reality, understanding is usually a result of *enforced* displacement, of crises that wrench a person out of his or her habitual routines of thought and behavior, rather than a product of philosophical choice or idle curiosity. Understanding others requires more than an intellectual movement from one's own position to theirs; it involves physical upheaval, psychological turmoil, and moral confusion. This is why suffering is inescapable concomitant of understanding – the loss of the illusion that one's own particular worldview is universally tenable, the pain of seeing in the face and gestures of a stranger the invalidation of oneself. [...] It is here, in what I call the fugitive imagination, rather than in European salons and seminars, that we may recognize and be reconciled to the sometimes painful truth that the human world constitutes our common ground, our shared heritage, *not as a place of comfortably consistent unity but as a site of contingency, difference, and struggle.*

Jackson 2006: 257-258 (emphasis in the original)

Chapter One
*Intimate bodies, violent struggles: The poetics and politics of
nuptiality in Syria*

Becoming an anthropologist: Photograph of a little girl in the desert

On my very first trip to Syria, in July 2008, I took a photograph that I have been very fond of ever since. The photograph is of a little girl, perhaps seven or eight years old. The girl wears a long colourful dress (*galabiyah*), a white scarf around her waist, a turquoise hat. She has no shoes. Next to the girl, there is a similarly colourful three-wheeled bike, painted in blue and green. Under the wheel there is a sticker on each side in the colours of the Syrian flag and a sticker with the letters 'SYR' written in English in the middle. A plastic heliotrope decorates the upper part of the light, underneath it a CD and a red cloth hang. Some rugs hang from the carrier. An animal tent can be seen in the background. The girl poses playfully in front of the camera lens. She holds the handlebar with one hand, the other is lifted at the level of her head – a fist, it seems like she's waving something at us. She bites her lips and they smile. One foot on the ground, the other on the footrest, the little girl seems ready to take off on an exciting journey, the kind that only children know.

The photograph was taken in Hawi al-Hawa, a small village in the prefecture of Al-Raqqa, in Northeast Syria. I had been invited by a Syrian anthropologist, Professor Sulayman Khalaf, whose doctoral thesis was based on fieldwork conducted in this very village (Khalaf 1981). I must admit that every time I meet an academic whose work has inspired me, I get quite excited. Like meeting a Hollywood star, I was excited to meet the anthropologist as well as the many persons from the 'cast' of his ethnography. We were walking an initial and initiating tour in his twenty-seven year old fieldsite – a tour through anthropology itself. And when we reached the outskirts of the village, the little girl came to play. She was alone where the village stopped and agricultural farmland began. Her surroundings and her rugged clothes were ample evidence that she belonged to one of many nomadic families that travel throughout the Euphrates region to work as seasonal agricultural labours or by herding other people's animals. These are not Bedouins, I was told many times, they are the rural poor, forced by economic necessity to lead a nomadic life.

What was more startling, to me, was the apparent contradiction between the happiness of this beautiful child and her surrounding conditions. Her playfulness made her poverty almost irrelevant, and at the same time made poverty extremely present. She seemed oblivious to her dire conditions, oblivious even to the dangers of playing with strangers. But why do I like this photograph so much? Is it because of its romantic carefree naïveté? Does the old-fashioned three-wheeled vehicle with a little girl in the driver's seat ready to fly from the desert to the stars, somehow embody an Orientalist 'authentic' Syria, an imagination that transforms inequality into a tourist attraction, an attraction of some yet to be discovered authenticity, romantic notion of freedom and nature of the kind that Rousseau described?

It took me two years to decipher why, really, I like this photograph. The resemblance was not between an imagined Syria and a little girl in the desert, the resemblance rather was between the little girl and myself. I do look like her, or in any case did, when I first arrived in Syria. Excited, with ill-fitting tools, ready to take off, sure to have an adventure. I arrived in Syria filled with expectations and images and with little experience. My twenty-two years of age did not amount to much of an adulthood, whose knowledge anyway I had only experienced second-hand, having spent most of my time in school and university. And in the preparatory year prior to my fieldwork in Syria, how many books could I have read, and how could I have better prepared myself for what was coming? I was that little girl, excited at the sight of strangers, leaning against an imaginary old carriage, oblivious to where she is, and just happy to be. So happy indeed, that the excitement was all that mattered. And so, I arrived in Syria with very little idea of what it was that I was looking for, with a certainty of an impending adventure, and with equipment that was too big for me to carry (a heavy semi-professional camera, recording devices, video). With the benefit of hindsight, I am not sure that I would repeat the venture again. I would argue against it by deeming the affair too immature, too ill-prepared. Besides all of the obstacles in the process of this research, it is perhaps because of this little girl that I have, finally, made it. Her excitement, however immaterial and childish, is what has carried me through. She – and a certain amount of good luck. The immense luck to meet and share a year with some of the most beautiful and generous people I have ever met, and the immense luck to find myself in their stories and events of their lives. That is how a story far from finishing begins.



Figure 1.1: Little girl in the desert. Photograph by author, July 2008.

On navigation

This chapter introduces the main ideas, threads and concepts that are dealt in the thesis, along with significant events that not only colour my writing but also continue to run parallel with it. This chapter firstly provides the background, themes and aims of the thesis: anthropology as epistemology, scope and framework, synopsis of thesis and contributions. Secondly, it elaborates on the significance of events as analytical problems, and also as experiences that embody, shape and colour both fieldwork and writing process.

Anthropology as epistemology

At first, seemingly unrelated words and images would emerge from the bottom of my Arabic coffee cup. Anna would read them with as much surprise as I would hear her speak, both of us sitting under the mild afternoon sun in the open courtyard of my 'adopted' family's house in Jaramana. Then, she would weave them into stories, in

artistic and colourful tapestries, and I would ask her questions, urge her to go on. And she would, repeating ‘it is just for fun.’ Often, when Anna came to our house, lots of coffee would be brewed and offered, and Anna would spend many hours reading into our cups, ‘just for fun.’ Perhaps Anna would now read these on the bottom of my cup:

Becomings. The event. The Others. Power.

Like reading the coffee, these words are characteristic aspects of my research but bear no metaphysical meanings – just physical, embodied and fragmented realities. These are the realities of an epistemological discipline, which does not only search for ‘what is’ knowledge, but also how ‘knowledge’ is constituted, in brief by addressing questions such as: how do we know what we know? In anthropology there is a further distinction; not only we ask ‘what may we know about X’ but also ‘how do our ethnographic subjects know what they know’ and ‘how do we, researchers, know what we know?’ In such an epistemological endeavour, subjectivities like anthropologists’ and their ethnographic interlocutors’ are always already socially constructed as much as they intersubjectively co-construct each other. What becomes anthropological ‘knowledge’ in the end is a conglomeration of interactive epistemological questions regarding self-knowledge production alongside the ‘other’s’ knowledge production. This meeting of knowledge production tropes (Strathern 2005) can potentially be violent (Jackson 2006), instructive or destructive, but only through such an epistemological collision may the (more interesting) questions of the what-s and the why-s of certain knowledge productions be fruitfully addressed.

It is because of such epistemological concerns that my thesis begins as a coffee reading.

‘Becomings’ refers to the ethnographer, the anthropologist, and the writer. The person who perceives the world, like anyone else, through his/her own subjectivity, the person who undertakes the ‘cognitive journey’ (Amit 2000) during fieldwork towards the impossible ‘tenet of Sameness’ (Argyrou 2002: 1), an inhabitant of ‘fugitive imagination’ (Jackson 2006), but also a persona that not only, within certain

limits and data triangulation methods, constructs his/her fieldwork, but also who in turn is constructed through it. Perhaps this is what the fox in the Little Prince meant by taming and understanding: first and foremost to tame one's awareness.¹ For, the process of fieldwork or getting a doctorate is not only an academic rite of passage for perseverance, but actually, the start of an endless anthropological *becoming*. In becoming an anthropologist through this thesis, my reflections and reflexivity are not present only in a separate methodological chapter. They feature as methodological and theoretical aspects in every chapter. Writing about 'others' could not happen without exposing and dwelling on the ambiguities of our, real or fictive, mutual co-dependence.

'The Event' is no social drama (cf. Turner 1982). It refers to a specific, although not always singular, event that took place during my fieldwork. It was rupture, a violent clash, that did not involve directly the ethnographer, but which inevitably coloured and left a lasting mark on my looking glass. Coming to terms with this event, in all its fragmented continuities and stitched-up singularities, has been a major preoccupation of my key interlocutors and a personal matter to me. Not only was I unable to ignore it, but it was inevitable that it coloured my thesis. Thus, 'the event,' an indication of things that unexpectedly happen, also structures my thesis, in a way that I hope embraces ambiguities and raises questions.

'Hell is other people' wrote Sartre in his play *No Exit* (1989), but I would timidly add 'maybe, but also they are heaven too.' In this thesis 'Others' refers to the ethnographic field, to the examples, depictions, descriptions and discussions of Syrians that feature in the subsequent chapters. Social reality is largely constructed, but if I was to write about an imaginative work I would have stayed at home and written a novel. This characterisation, thus, refers to the epistemological terrain of 'what is known' and of 'how/why it is known' within the contexts of a Middle Eastern ethnography about Syria. In terms of my work this translates into the ethnographic descriptions and examples that make up the largest portion of my thesis, and also contribute significantly to the understudied Syrian landscape and to the much less studied contexts of the specific religious community that I happened to live with.

¹ ' "One only understands the things that one tames," said the fox' (Saint Exupéry 1991).

Finally, 'Power' refers to both relations of power, running through all relations, but also to theoretical frameworks, the anthropological analysis that takes into account the anthropologist, certain singularities, and the ethnographic context in order to provide a meta-commentary. Thus, the Foucauldian analytical paradigm of power/knowledge has informed my descriptions and interpretations of the Syrian social reality, whilst my own reflections and reflexivity aim to illuminate and make clear the debates surrounding writing culture (Clifford and Marcus 1986). At the same time, however, I must admit a certain theoretical promiscuity in regards to fitting my ethnographic data to pre-ordained analytical modes. In this respect, I have done my utmost to follow what Sillitoe (1996: 13–14) has termed 'ethnographic determinism,' which I understand as the anthropological rigor and fidelity first and foremost to the ethnography observed, participated in, and recorded.

Scope and theoretical framework of thesis

This thesis maps power relations in contemporary Syria and the ways in which these are embodied, negotiated and contested. Specifically, power relations are traced through the construction of nuptial bodies as relational spaces and sites of intimacy and violence, or violent intimacy, in contemporary Syria. Proposing the concept of *nuptiality* as an alternative political view to kinship and marriage theories within a relational framework of power, the thesis argues that bodies become intimate through relational practices such as marriages, that function as an idiom of relationality in general, but this is a form of intimacy that may readily turn into violence.

The thesis explores issues of relationality through struggles within families of a religious and classed community, as well as power relations along the lines of the Syrian state, its position within the global capitalist system and the perpetuation of Western governmentality. Along the theoretical continuum of intimacy and violence, I argue that nuptial bodies are not only the recurrent referent that diverse power relations strive to inscribe and possess but also that processes of nuptiality frame the contingent relational modes of social reality through the creation of intimate/violent places and bodies. Building on Herzfeld's notion of cultural intimacy (2005), I trace intimacy in movements, bodies and relations through which people, places,

institutions and other abstractions come closer, and become tactile, specific, familiar. Violence within the realm of intimacy (cf. Appadurai 1998) refers particularly to the poetics of violence as a result of closeness and intimacy, as the result of the touch (Deleuze and Guattari 2005 [1987]; Manning 2007).

Nuptial bodies, and the concept of *nuptiality*, refer to two interrelated definitions: ‘nuptial bodies’ refer to the nexus of pervasive relations that are created and sustained through the idiom of kinship. ‘Nuptiality’ refers to an idiomatic relationality that frames any relation and creates modes of knowing, a governmentality of conducting relations as an emergent historical, social, political and economic phenomenon out of which relations in contemporary Syria make sense. These two definitions are interrelated since agents both use/manipulate relations of kinship and/or create fictive kinship relations so as to pursue their own goals, but also the poetics of nuptiality hold structural social assumptions about ways of relating and knowing as a practical embodied ontology, as a socio-political contingent *habitus* (Bourdieu 2007 [1977]; Bourdieu and Wacquant 1992).

However, the concept of nuptiality differs significantly from previous uses of kinship within and outside of the anthropological and Middle Eastern contexts because I use it as a way of understanding processual developments as well as singular events within a specific historical, social, political and economic milieu. With the body as the tactile phenomenological horizon of possibilities and becoming (Merleau-Ponty 1962 [1945]; Deleuze and Guattari 2005 [1987]), I argue that nuptiality, contrary to prevalent ideas of kinship, tradition and endogamy, is a contemporary phenomenon of interrelations within the Syrian social fabric. In this way, nuptiality as a theoretical framework perhaps raises more questions than it, or a doctoral thesis, can answer: How do Syrians relate? How do they form, perform and deform existing and emerging relations? To what extent can relations be viewed as processual or as singular? Is there any possible analytical metaphor or problematic by which relations may be comparatively studied horizontally as much as vertically? How can we analyse relations between families, communities, classes, genders, rural, urban, society and state? Is Syria an isolated island or is it part of a capitalist globalisation? Rising questions and critically engaging with Syrian and Middle Eastern ethnography, much tormented not only through political struggles, wars, and internal violence but also

through analyses that (re) produce inequalities as endemic and static elements of ‘culture,’ is perhaps the only road ahead.

Nuptiality, as a social idiom of framing relations that, following Foucault, I take to be relations of power, emerges through the intersubjective movements of intimate subject-making and place-making: proximities of persons, places, and affairs. The politics of nuptiality emerge simultaneously with its poetics, across the spectrum of intimate–violent relations. The phrase ‘poetics and politics’ may be an overused cliché, but often clichés bear relevance, and in this case poetics and politics refers to existence and multipurpose experiences of a specific relational mode of power/knowledge. The thesis follows the struggles that create the body as a contested political, economic and social territory within a close-knit religious community in Syria, the Druze population in the suburb of Jaramana. Located in the peripheries of Damascus, and on the fringes of the Syrian state, this is where intimate and violent struggles for bodies are being fought the most. However, the struggles that animate bodies as intimate and violent sites in Jaramana also partake in different arenas within the Syrian polity, such as state policies and intellectual, artistic contestations on the Syrian nuptial body.

Synopsis of thesis

Tracing the contours of embodied struggles in Syria, the thesis starts by looking at the historical, political and social emplacement of the Druze in their long history, as well as within contemporary Syria. Chapter two provides historical, theoretical and methodological background that foregrounds the thesis.

In chapter three, the city of Jaramana, and its Druze inhabitants are introduced in detail. The chapter explores relations in space and time through contextualisation within the historical construction of a heterodox Islamic community, as well as the contemporary realities of the urban suburb. Two Druze families, their histories, genealogies, and their houses animate classed and gendered differences and similarities within the religious community, through which the chapter explores the construction of spatial intimacy within the social fabric of a Druze neighbourhood. The concepts of making place through history and continuous intimate interactions

are introduced in this chapter, thus locating fieldwork physically as much as intimately.

Focused on cosmological beliefs and contemporary practices, chapter four explores the centrality of the body and its constant transformations through not only local reincarnation beliefs but also contemporary political and social struggles that permeate the Druze community. Specifically the chapter explores the role of the body in Druze cosmology and ritual practice (death and birth). Through body rituals and body transformations, this chapter shows that becoming a Druze is always a social process, negotiated and resisted through, among others, bodily practices. Locating the body as a site of struggle through practices, beliefs and rituals, this chapter offers novel contributions regarding Druze practices in Jaramana, and, importantly, provides a dynamic, political view of relational processes and ritual intersubjectivity, whilst substantiating the body as a site of struggle.

Chapter five focuses on the poetics and politics of wedding rituals in Jaramana in order to explore the relation between bodies and marriages, and specifically how bodies become intimate through social praxis in wedding rituals. Alongside ethnographic descriptions of historical and present-day weddings, the chapter discusses the concepts of body-politic and cultural intimacy, exploring the nuptial body in terms of its political extensions as well as in terms of communal and societal relations. Discussing the poetics of the social construction of relational intimacies through nuptial rituals, the chapter argues against static notions of kinship and ritual, introducing the concept of nuptiality as a form of social relationality by which bodies become intimate and socially appropriated. Theoretically the chapter combines current debates on the anthropology of the body with the concept of cultural intimacy as the everyday reification of the state, and formulations of violence as a form of cultural intimacy in times of crises. Therefore, the chapter extends the definitions of cultural intimacy and violence in order to incorporate them not at the level of state–subject but at the level of the communal and the familial, noting that the poetics of both intimacy and violence presuppose one another.

After relating the anthropological theories of intimacy and violence that describe the relations between state and subject as also appropriate in depicting intra-communal

struggles and reifications, chapter six moves from the local context of Jaramana to the national realm of the regime's cultural policies, and from the communal staging of weddings to the national stages of folklore festivals. This chapter is a combination of political theories of the state, the political economy of the Syrian state, and ethnographic analyses of how the Syrian state through its cultural policies attempts to naturalise, neutralise and command potentially threatening identifications through a spatial poetics of nuptial intimacy that transform the state. The chapter deals with the construction and (re) use of nuptiality and intimacy by the Syrian state in order to choreograph, through its consensual cultural policies, a space in which 'it' (the state) becomes the guardian and the precondition of ethnic, religious, and 'cultural' differences. Contrary to dominant applications of nation-state theories, the chapter explores how the state uses a cosmopolitan rhetoric to spatially naturalise and neutralise potentially threatening differences, whilst reifying the 'state' as an arbitrator of diversity and presupposition of 'cultural' harmony, arguing that the export of European-based formulations of nation-state are not only ethnocentric but inappropriate within the Syrian context. The chapter concludes by hinting at how the habits of dancing, entertaining and wedding are not always a 'safe' policy on the behalf of the state because they may create or open up subversive places of enactment.

Chapter seven extends the research focus through a selection of three ethnographic case studies from different communities of Damascus, and from a specific age category, in order to show the different ways that young people relate, challenge and reinforce power. Specifically, youth responses to different forms of authority are examined: external power (Israeli occupation), the Syrian state, and the authority of parents and sectarian communities. By locating Syrian youth within contemporary struggles through ethnographic case studies, this chapter aims to sketch a nuanced, complex and colourful picture of the multifaceted ways that young people reinforce, resist and negotiate power relations in contemporary Syria. Through demonstrating the complex, multiple, and diverse ways the Syrian youths situate themselves within power relations, and form civil societies, this chapter aims to further the understanding of power relations in broader contexts than those of communities or the state.

Chapter eight brings together the relational frameworks of power from the community and the state and situates them within the globalised contexts of market forces and Western governmentality, exploring the role and significance of the nuptial body as an international arena of struggle. Specifically, combining art, everyday life and politics through a Syrian contemporary dance performance that is centred around the nuptial ritual, the chapter explores different powers and regimes of knowledge that constitute the Syrian body as their site of struggles. These ‘empires’ come in the form of the Syrian state and the European Union, and conflict along local sectarian lines. The nuptial body, however, both reinforces as well as eludes them. The chapter brings together the three realms of local, national, and global struggles on the nuptial body and demonstrates how intimate and violent struggles take place upon it.

In conclusion, chapter nine recaps the themes of the thesis and points to future research directions. The four main aims of this thesis contribute to regional knowledge, anthropological theory and political analyses of the contemporary Middle East, and include:

- 1) Original ethnographic contributions regarding the Druze community in Damascus – this is the first ethnographic study to be conducted among a Druze community in Syria;
- 2) Ethnographic and political contributions regarding the interaction and interrelations between state and communities in contemporary Syria, and how such interactions seriously undermine the dominant model of the nation-state as a theoretical model applicable to Syria;
- 3) Contributions to regional and interdisciplinary understanding of Syria and the Middle East through challenging views of Syria/region as an isolated closed system and accounting for wider historical, political and economic relations within the contexts of globalisation; and
- 4) Contributions to anthropological theory (a) through critical engagement with notions of power, state and relationality, (b) the deployment of the body as an analytical field of struggles, and (c) the development of the concept of *nuptiality* as the connecting link between relations of intimacy and violence.

Becomings. The event. The Others. Power.

These four themes run throughout my work. They are intimate bodies and they are violent struggles, and they structure each chapter, and some more than others, with distinctive flavours. I will elaborate more about them in the introduction and you will encounter them in the following chapters. But maybe they don’t run through my

work. Perhaps they dance with each other, affecting the movements that will follow, changing partners, interacting and clashing with one another. The resulting pages are their choreographies. I am not sure whether you will enjoy them (they are not here to provide entertainment) but I hope you are tempted to dance.

Anthropology and Events

‘But how did it all begin?’ asks Calasso a number of times in the first few pages of his seminal *The Marriage of Cadmus and Harmony* (1993), a work that explores as much as provokes the boundaries between mythology, philosophy and contemporary critique. From a bull and a girl, to Europa’s abduction by Zeus, to the myriad myths that came before and after, Calasso notes ‘stories never live alone: they are branches of a family that we have to trace back, and forward’ (Calasso 1993: 10). This is not only true of myth but of stories in general as they transverse space and time, convoluting through their oral propensities lives, events, and experiences (see Gilsenan 1996; Jackson 2006). But, to have a story is to have a narrative, a story line. And to have a story line presumably there must be something else – even though the story and the narrative continual change, reform and perform the story. What comes before the story? How did it all begin?

A dramatic event. The event of meeting somebody. An eventful night. Events are the subjectively recognisable cognitive places of arrival or departure; we use them as stigmata on the body of our stories to mark a start, turn, or an end. They are challenging not only because there is no objective way in subjective relations and experiences to demarcate what constitutes an event, and what the difference between the event and the story might be. This is particularly relevant to the anthropological discipline, as we often need to make sense out of disparate events, as we need to weave theoretical threads, as we need to write our own stories. It is this space between events and stories that I venture on in this section and through which I explore my own ‘how did it all begin.’

Regarding the arrival of unexpected events during fieldwork, Caton confesses/accuses that he ‘was not trained to see it [the event]’ (1999: 6, cf. 2005). Steven Caton is an American anthropologist specialising, among other things, in Yemen and in linguistic anthropology. Allow me to divert a little from my Syrian

event in order to re-tell Caton's story as a powerful example of how events during fieldwork not only colour perceptions but often enough they change the face of the fieldwork site itself in unforeseen ways.

Caton conducted fieldwork in Yemen Arab Republic between 1979–1981 (1990, 2005). His main site was within the tribal location of Khawlan al-Tiyal, in a *hijra* (sanctuary) settlement. His research was concerned with the role of poetry and the structures of poetic genres in Yemeni tribal poetry and society. During Caton's fieldwork a serious event took place which resulted in a large conflict that eventually involved not only the local tribes but also the state: a young man from the sanctuary was accused by a neighbouring tribe of forcefully abducting two girls that had gone missing. The conflict escalated from an intertribal conflict of honour to one that involved a range of regional players. The anthropologist was much influenced by this event, not only because he found himself amongst shootings, but he was also detained by the Yemeni police under charges of espionage. What is important here, besides the specifics of Caton's story, is how this incident affected both the anthropologist, his relations, perceptions of the field and research, as well as the fact that this event not only influenced but also changed his field dramatically during and after his fieldwork stay. It is also interesting to note that it took Caton almost twenty years to discuss and analyse the 'event.' That is, the event as 'an analytical problem' (Caton 1999: 6) for anthropology. Caton puts forth significant arguments in regards to problematising 'the' event, which I shall briefly outline here as they relate directly to the empirical and theoretical framework of my work.

Caton's first question is one of interpretive emphasis: is an event to be analysed as a singular point or as part of an ongoing process, or, put differently, should historians and other social scientists focus on the 'longue durée' (cf. Braudel 1958) or on single events? Caton further complicates his historical critique by classifying anthropologists who have dealt with 'ethnographic moments' as either processual (see Gluckman 1958), generalised social dramas (see Turner 1982), or as moments in history that may transform the socio-political system of which they are part (see Sahlins 1991). To overcome the dichotomy posed by singular events versus on-going processes, Caton turns to Foucault's definition of 'eventalization': 'making visible a singularity at places where there is a temptation to invoke a historical constant, an

immediate anthropological trait, or an obviousness which imposes itself uniformly on all' (1991b: 76–78), and he elaborates:

To 'eventalize' is not then a project of recuperating the event for historical analysis, or looking at particularly dramatic moments that can be seen to be disruptive or challenging of a normative order, so much as it problematises the assumption of the latter as the taken-for-granted – the everyday, the normal, the uniform, the continuous, whether this be the norm of a functionalist anthropology or a totalization of a structuralist one – and to do so by revealing the struggles that go on the course of everyday life by people who have different stakes or interests than those articulated by the normative order. If that is the case, then we have to rethink our notion of the event. It isn't a periodic or a cyclic phenomenon which appears in a moment of disruption, only then to be reabsorbed by the normative order; it is in a sense always already there, though under the surface or in the background, and then appears spectacularly for a while. (Caton, 1999:8)

Caton critiques the discursive bias in the production and framing of anthropological knowledge production that often prioritises the linear narrative construction and the normative aspects of events against other qualities such as ambiguity and fluidity. This argument is further directed against Foucault and underpins the remainder of Caton's contributions: (a) the necessity to account for one's own positionality; and (b) to account for the re-texting of the event as a story (cf. Seremetakis 1991).

Caton's arguments are not opposed to analyses of unbounded processes, or long-dureés where those are more useful frames of analysis; Caton's critique is useful for it uncovers some intimate anthropological tensions (obsessions perhaps?) between empirical experiences in the field and our theoretical conduct outside of it. While in the field we experience events as singular and bounded, upon return we are inclined to analyse these as parts of greater processes and affairs. Both these modes of analyses are equally important as well as constitutive of one another, nevertheless, Caton has a good point (a point further articulated in his ethnographic and reflexive descriptions and structuring of his book (2005) than from his own analysis): he gives different, almost random, pieces of his story through which he is able to explain not only the event, but his own position in it, as well as his own confusion towards it – the familiar experience of things not making sense. Let me now relate Caton's understandings to the events that structured my fieldwork as much as my theoretical understandings and contributions.

Event 1: Sensing Damascus, finding refuge in Jaramana

I returned to Syria at the end of August 2008 for a planned stay of twelve months. My initial visit to Syria had helped me to ‘see’ the country, derive information regarding Arabic classes at the University of Damascus, as well as to consolidate initial contacts, but I had not been able to make solid plans as to where my fieldsite was to be based. Ideally, I wanted to find a family home in which to stay and live the workings of ‘everyday life in Syria.’ Since I had more practical and pressing matters at hand, namely to learn basic Arabic in the University of Damascus, for the first three months I settled in a room of a Christian Orthodox orphanage and elders’ home, a presumably ‘secure’ place that some Greek friends had helped me to find. The orphanage was located centrally in the up market Christian neighbourhood of Al-Qassa’, a seven minute walk to the Christian gate of the old walled city, Bab Touma. My first three months in Syria were mostly spent between the University of Damascus, brief journeys around the country, and a lot of stress as to where I might find my fieldsite. I tried to find a room to let, but it seemed to me that all the places I could find were catering to the needs of foreign students.

During this time I became good friends with Karem, the younger brother of a Syrian friend, Zahra. I had met Zahra in England and she had generously provided the details of her family so that I could get in touch with them. Karem, Zahra’s brother, was studying architecture, and he kindly showed me into his home in the suburb of Jaramana, as well as introduced me to an extensive network of his friends. In October, I received an invitation from one of Karem’s friends, Samira, to visit her at her family’s home in Daḥiyat al-Asad. Daḥiyat al-Asad is an area located twenty minutes outside of Damascus, on a hilltop overlooking the city lights. Initially, it was a location of army camps; it developed residentially in order to accommodate army officers and their families. Samira’s family was from Lattakia, and belonged to the Alawi sect, the heterodox Islamic religious sect whose adherents include Syria’s president. She lived with her mother and father, her six sisters and two brothers. Her father was a retired army officer. Samira’s invitation was extended from a visit to an extended stay at her house for the duration of my fieldwork in Syria. I stayed at Samira’s house for a month in December 2008. This was my first intimate and prolonged stay in a Syrian household. I used to share a room with Samira and her sister, I learnt about the Alawi religion with her mother, and discussed nationalist

politics as the father watched the daily news. I was rather excited by the prospect of gaining an intimate understanding of a family that belonged to the ruling military elite of the country. However, this did not work out as planned. The family faced many serious internal conflicts, and just after Christmas I started featuring in them – without always understanding how or why. On New Year's Eve I found myself almost homeless in Damascus, and, cursing my luck, ready to give up my Ph.D.

The city of Jaramana, four kilometres from Damascus, many times in its history has acted like a refugee. Located within the fertile plains of al-Ghuta, Jaramana was one of few villages with a majority of Druze population. In 1967, a Palestinian refugee camp was established on its northern border while, since 2003, an influx of Iraqi refugees have settled in its vicinity.

The last five days of 2008 had left me tormented, weak and disheartened. The New Year found me with no place to stay, no fieldsite, and the possibility of no research at all. Karem told me to bring my stuff and move into his house. I was unsure of yet another move into a family, but I did not have many other options. I was very grateful to Karem and his family, although at that point I was not expecting much to turn out in terms of research outcomes. I knew that Karem's family belongs to another minority religious sect, the Druze, which had prohibitions regarding sharing information about their religion, and I was very much doubtful that I would be 'allowed' into that social milieu. Fortunately, my fears never materialised. In Jaramana, and in Karem's family, *bayt* Ouward, I found a refuge, a safe haven, and a base from which to begin my ethnographic journey (not realising that it had already begun). Karem's mother, Umm Nidal, took me in when I was most in need, and provided me with discrete, generous, and motherly care. Karem used to say as a joke that 'now that my mother is on your side you will be a winner!' This turned out to be true. Umm Nidal helped me find a house 'traditional and appropriate,' as she noted, for my research, and opened her own house up for me. Throughout my fieldwork, I would visit her daily, go out with her, travel to her village in Sweida, and sleep over often.

Towards the end of January I met Karem's friend Tariq, a neighbour and a fellow student at the University of Damascus. Tariq was tall, handsome and very stylish. He

spoke good English and was very polite. He said that his family home is an old Arabic house, down the road, and that they had a spare room since his brother married and moved out. They had not rented before to anyone, but they would like me to visit and see the house. Umm Nidal and Karem were very excited about this prospect, they said that this house would be the ‘best’ for my research because the family not only is very well known and respected in Jaramana, they are also very ‘traditional,’ ‘religious,’ and ‘authentic’ Druze of Jaramana. The visits and negotiations between the two families on my behalf lasted for almost a month, and Umm Nidal made sure that everything was all right for my pending movement. It is through the families of Karem, *bayt* Ouward, and Tariq, *bayt* Abud-Haddad that I came to live in Jaramana. I lived between these two very different but very kind families until the end of my fieldwork, and it is through them that I got to share a glimpse of their lives. This is how it all begun, or then again, no.

Event 2: Zahra's secret

It is a formal requirement of most Ph.D. programmes in Anthropology that the student must present a preparatory research proposal in order to be granted the permission to embark on fieldwork. An unwritten law of doing fieldwork, however, is to challenge if not completely disregard one's previous research themes and preconceptions in favour of the ‘realities on the ground’ that one is to encounter. Actually, this is the foundational basis for the theoretical and practical undertaking of field research in the first place, so that the empirical collides with the theoretical and in so doing they interpenetrate and alter each other. This type of condition is what Jackson (2006) describes as ‘fugitive imagination’ – the result of displacement, force, collision, and in my view, the most profound contribution of anthropology. This sudden change, however, draws into question, as it should, all of our previous preconceptions and proposals. It makes us adapt, change, and challenge our assumptions. This phenomenological condition of fieldwork is not entirely unexpected; it is an unwritten rite of passage. Although to be expected, ‘reality’ comes and the anthropology arrives on the ‘ground’ in many different shapes and forms, for which it is difficult to imagine any adequate training. Zahra's story is such an unexpected event.

Zahra, Karem's sister, was my first Syrian friend. I met her in the UK, where she first relayed to me her story, a story that I had no idea at the time would so strongly affect my research and indeed the geography of the fieldsite itself. When Zahra first told me, in London, her story of love and rupture with her family and religious community, I was deeply affected, in a personal sort of way. But I did not think that this would affect me or my doctoral thesis the way it did. Could this London related story be 'the' event, could her narrated story constitute the first ethnographic moment, even before my fieldwork had officially started? Was the event Zahra's story, the actualities of what was going on, or was the event her telling of it to me? Months later, I met Karem, Zahra's younger brother, and we became friends. Then I met Karem's friends and I was hosted for a month in one of his friends' house. Are these events in themselves, results of the initial event, or maybe an unrelated series of coincidences? Then, perhaps I would not make much out of the event had I and Zahra's mother not developed a very intimate personal relationship in which she shared with me her fears of an imagined 'event' without knowing that that 'event' had already taken place, and I responded to her with the implicit knowledge that her fears had already materialised. Jackson (2006) notes that understanding others entails a mini-death of one's own preconceptions. In anthropology, this symbolic death coincides with a symbolic rebirth. This rebirth is not an objective understanding of the other (debatable if ever possible) but an intimate relation, an intimate way of knowing and appreciating the parameters through which to know, even if that is manifested during silence. To me, Zahra's mother became my Syrian mother, the person who guided and helped me to be born within the contexts of the Druze Jaramana, a primary key informant, a guiding light, someone who connected me with broader social networks, and someone who shared so many intimate moments with me as I did with her. In the contexts of Jaramana, through the fictive kinship of the two families I lived with I became an honorary or, as they called me, a 'Catholic' Druze. And what is more, I also became, as my two families put it, their daughter. However, within the realms of the anthropological liminality in which one often comes to call 'home' or 'family' more than one location, and between two sides or stories, that of Zahra and of her mother, my rebirth in Jaramana was a result of these events, and my socialisation a result of not only the moral tensions of my own positioning, but also of the intimate pain and agony that Zahra and her mother shared with me.

For me it was the intimate acquaintance with the event of Umm Nidal's (Zahra's mother) pain, more than anything, that coloured every marriage we attended and every social gathering we went to. It was her pain, her depression, and deteriorating mental state that confused me, shocked me, and intrigued me to figure out why marriage, a social happening that was of recurrent mention and importance within both the community as well as in most dance performances, or rather the cultural specific mode of expression, a process I call nuptiality, is of significance. The *event* of marriage. The *event* of a conversation that took place in London and in Jaramana. And then the process, the continuous movement towards becoming intimate, that also leads to becoming violent. This is nuptiality: the conflicting versions of events and the deferred processes of becoming intimate, a context in which bodies are formed and performed through their movements towards intimacy. If we are to problematise the 'event,' as Caton urges, then we have to question the event exposing the inherent ambiguities between singularity and multiplicity, process and happening. Zahra's story of falling in love with the 'wrong' person is hardly atypical (see chapters 5, 7 and 8). Her mother's reaction to it, however, can be both related to broader socio-political normative orders (chapter 5) as well as to a very personal response (for a different approach see chapter 8). More importantly however, the event of the response cannot be collapsed to any one mode of analysis.

This is how I came to be re-born as an anthropologist-in-waiting through conflicts that are at once unexpected, intimate and violent. In problematising events, then, we should also view them as not absolute but relational and as inclusive of people and relations: an event can be meeting a person. Through this thesis, I was born in, or probably married into anthropology partly out of the intimate and violent conflict of this family, and it was the local contexts of my birth (or marriage) through which I understood and related Jaramana to Syrian and to global contexts. Thus, my position and understanding is both relative and situational. I address and expose these tensions throughout the thesis by being both reflexive of my own positionality but also by the theatrical enactment of my own writings as staged constructions and shifting choreographies.

Zahra's love and marriage story as much as her mother's and family's responses may be said to be singular events with specific responses. Regardless of their specificity, such stories are not wholly atypical (see chapter 5 and 7). Further to their socially recurrent motif, I was surprised and rather confused to 'discover' that issues of marriage contestations and negotiations also featured centrally with my research outside the domains of the Druze community in Jaramana. The more I interacted with dancers, directors and choreographers, the more I watched performances, rehearsals, and the more I attended dance festivals, the motif of marriage became all the more profound and recurrent. Most folklore festivals in Syria, organised and funded by the state, were staging marriage ceremonies. Most performances by the two most famous professional dance troupes, Enana and Ornina, treated marriage as the central act or the final conflict resolution. The two contemporary dance troupes that operate in Syria, Leish and Sima, also thematically were influenced by marriage as an idiom and a site of intimacy and confrontation. To me, the anthropologist with a research predisposition for studying the political extensions of social dancing between three different publics in Syria, I eventually had to understand that dance was one example, one possibility out of many others, by which the recurrent pre-occupation with marriage arose and was dealt with. In short, as I was to realise, the connecting link, the theme that ran through all of my different research arenas and one of the most frequent and significant 'obsessions' of my informants was not dance but issues of relating expressed through the idiomatic use of marriage. In this respect, there is a slight irony in my anthropological endeavour depicted clearly in the last day of my prolonged fieldwork in Syria: celebrating my stay, my two Druze families and other relatives and friends came together on the night of my departure with a wedding feast, dressed me as a bride with jewellery and gifts, and cried with me – using the metaphor of a daughter leaving the household to marry away. More than anything else, it was this instance that signified my nuptial entry, rather than departure, into the intimate realm of the community.

Event 3: Arab uprisings in 2011

Where does fieldwork end? To what extent do our fieldnotes shape our subsequent writings? And how much of 'current affairs' fit in an anthropological thesis? During the writing up period of this thesis in 2011, dramatic and unprecedented events took place in Syria and the wider region. These events not only challenge the theoretical

and historical presuppositions of despotic resilience in the Middle East, they actively change the social and political landscapes within Syria and the region, and therefore inevitably morphed my writings as well. Although not part of the ethnographic-based fieldwork and anthropological analyses, the Arab uprisings are not external to this thesis.

Anthropologists in the Middle East and beyond have often been accused of avoiding conflict zones (Cohen 1977), placing too much emphasis on the micro-level realities of everyday life and failing to account for wider or sudden political, economic and social changes – similar to Caton’s (1999) accusation that he was not trained to see events and change but rather processes. One of the most paradigmatic examples of ‘missing the revolution’ comes from the father of symbolic anthropology, Clifford Geertz. As he claims, he somehow managed to arrive in the field too early or too late, and thus ‘miss’ the conflicts and upheavals in both Java and Morocco (Geertz 1995). As I am writing this thesis from the relative safety of England, some of my Syrian friends have been arrested and tortured. Others joined the army. All of my families and friends live in uncertainty and pain. In these current contexts, the continuum of intimacy and violence enters a whole new scale.

Perhaps, there is something that can be done so that the revolution will not be missed, even if the circumstances do not allow the anthropologist to carry out fieldwork during the actual upheaval. This includes asking politically relevant questions and providing anthropologically reliable answers. Looking at the situation in Syria today, and at the wider region of the Middle East, three important questions arise: What are these events? What caused them? And, what will come out of them? As anthropologists, instead of answers, we ought to sketch the parameters that account for the interrelations between global processes, governmental policies, and everyday practices that shape and structure experience. The interconnections between global and local practices structure this thesis through tracing how bodies become intimate and violent sites of struggle between a Druze community, the Syrian polity and state, and globalised techniques of governmentality. The events comprising the global and local struggles through the Arab uprisings have emerged as the paradigmatic political struggles of which the more rudimentary everyday intimacy and violence are parts thereof. My fieldwork was conducted before the Arab

uprisings. However, although momentous and unexpected events happen, as Caton argues, maybe such events were always there but we could not see them. This thesis, then, explores the intimate and the violent that are so readily readable now in Syria, prior to the uprising (see chapters 5,6,7 and 8).

Yet, while events such as the Arab uprisings and the escalation of violence and unrest in Syria run parallel to this thesis, there is little that an anthropologist – or any external observer – can say or do with certainty. Instead of results or conclusion – premature in any case – perhaps the most honest summary of what is going on in Syria today is the one that my friend Anna gave:

It is very easy to be dead now, without knowing why or how or who did that. And nobody knows the truth. Some say it is the security, some say outside forces. Some say they are the people in Syria. Some say that they want the freedom. Some say they want a war. (Anna, Skype chat, 24/4/11)

This precisely is the point where events and stories are convoluted, indistinguishable, the space where neither is reducible to the other. It is a state of crisis where all become relative, and relational. In such a state, missing or not the revolution becomes irrelevant. This is not a space whose centre is the anthropologists, but nevertheless smells like Conrad's *Heart of Darkness*. If anything, it feels like Taussig's (1984) 'culture of terror – space of death.'

But how did it all begin? Did it start from a man's self-immolation in Tunisia? Did it start in Daraa during a protest or a festival? Perhaps it all began from a wedding in Jaramana.

Chapter Two

Emplacing research: History, anthropology and methods

Introduction: Middle East and Anthropology

Since the collapse of the Ottoman Empire, the Arab Middle East has been an arena of political challenges, a local and global locus of penetration, domination and resistance. Political rivalries, economic interests and shifting socio-cultural understandings are not only reflected through history books and current affairs, but also through the different theoretical approaches that are used in understanding the geographic and social landscape within the discipline of anthropology. The region of Middle East and North Africa (MENA) is a popular area of study specifically in disciplines such as political science, international relations and history. Although in recent years there has been a surge in anthropological writings concerning the region, especially in Syria anthropology is still catching up with other disciplines. In 1977, through an annual anthropological review, Cohen had noted the relative reluctance of anthropologists to engage with conflict areas. Almost ten years later, Abu-Lughod (1989) stressed the geographical bias of the majority of MENA monographs in avoiding urban, complex or war zones. 'Peripheral' areas, usually villages, with governments that pursued a pro-Western foreign policy such as Yemen, or Morocco, seemed to be preferred by anthropologists in contrast to large urban centres, such as Beirut, areas of conflict, such as Palestine, and states that had less amicable relations to Western states (and the universities that provided the anthropologists), such as Syria.

Abu-Lughod classifies the 'zones of theory in the anthropology of the Arab World' (1989: 267–306), in a way still current and useful today, according to the following main analytical strands: Orientalist and colonial critiques (Asad 1973; Said 1978), segmentary lineage theories (Evans-Prichard 1949; Gellner 1981), 'harem' theory and feminist/gender anthropology (Abu-Lughod 1986; Nelson 1974, 1991; Joseph 2003, 2006), and the anthropology of Islam (Asad 1986; Gellner 1981; el-Zein 1977; Geertz 1968; Gilson 1990; Tapper 1995). Although some of anthropology's most prominent theoreticians have conducted research in the Middle East (such as Bourdieu in Algiers, Gellner and Geertz in Morocco, Davis in Libya), Abu-Lughod argues that Middle Eastern ethnographies suffer from both theoretical and practical

limitations, such as lack of rigorous analytical studies that challenge prevalent modes of Orientalist construction of Muslim ‘subjects.’ Many things have changed in the past two decades: anthropological research in MENA has expanded in volume and in rigour, reflecting both the on-going changes in the region as well as the shifts and turns within the discipline. But some things have not changed that much: anthropological research in Syria remains limited, and the same is true in respect of ethnographic accounts of Druze communities throughout the Levant.

In the twenty years that have passed since Abu-Lughod’s review, there has been a more rigorous shift in theoretical understandings of the Middle East through approaches better suited to understanding the complexities of the region and its vast interrelations. Namely, some of the studies that have given new theoretical and ethnographic breadth include Gilsean’s (1996) study of narrative, violence and power in a Lebanese village (an anthropological bible); studies of public culture such as Armburst (1996) on public culture in Egypt and Abu-Lughod’s (2005) research on television; studies on the negotiations of power between states and subjects such as Carapico’s (1998) and Zubaida’s (1989, 2003) works on issues of power and civil society; works that combine history, critical theory and ethnography in understanding the area such as Mitchell (1991), and Mundy and Smith (2007). The cross fertilisation between feminist/gender studies, Islam, post-structuralism, and critical theory is bearing fruitful results for the understanding of the Middle East that include works like the *Politics of Piety* (Mahmood 2005); *Veil: Modesty, Privacy and resistance* (El-Guindi 1999, also see 2008) the two edited volumes by Zuhur (2000, 2003) on arts and politics (also see: Karayanni 2010; Shay 2002; van Nieuwkerk 1997); social relations and kinship (Mundy 1995; Joseph 1999), and critical works such as the politics of birth in Palestine (Kanaaneh 2002), and nationalism, resistance and motherhood (Jean-Klein 2000, 2001, 2003). These works not only aid in foregrounding research within contextual, dynamic and sensitive empirical domains, but, equally importantly, advance a nuanced, relational, and agentive view of the negotiations that shape subjects, states and everyday life both locally but also globally, as parts of the interrelated processes of economic capitalist markets, colonial and post-colonial hegemonies, and in terms of the emergence of ‘Western governmentality’ (Pels 1997). These works are important steps in the direction of challenging prevalent domains of knowledge production, that perpetuate what Spivak (1988: 285) calls

‘epistemic violence.’² This thesis adds to this emerging literature through both novel empirical insights into Druze and urban life in contemporary Syria, but also through political and anthropological analyses of the connections between community, state, intellectuals and global governmentality.

This chapter traces the anthropological, historical and political contours of knowledge production regarding the MENA region, with an emphasis on Syria and the Druze community. The chapter outlines the extent and nature of existing anthropological research, hinting at gaps, and benefiting from research in other disciplines. It provides the necessary historical, political and theoretical background for the appreciation of the complex past and present of the Syrian polity and its Druze communities. Moreover, it situates and justifies the theoretical and methodological contexts³ of research that the remainder of the thesis explores. The aim of this chapter is to engage with literature and history in a way that both situates and contextualises research, as well as to provide a critical but not extensive outline of what has already been done. In this direction, the chapter provides a detailed introduction on Druze and Syrian history. Emphasis is placed on this section since both the Druze community and the recent history and politics of the Syrian state need be contextualised in order for the intimate and volatile interrelationships between the two to be appreciated. Moreover, methodological theoretical perspectives are provided in framing the research undertaken. Finally, the chapter concludes with a methodological note regarding research. The aim of this chapter is not to provide an exhaustive literature background, but rather to point out connections, gaps, and processes that are necessary for the appreciation of Syria and the Druze as well as the preliminary harbours from which this thesis begins its ethnographic journey.

² For an example of gender and Orientalism as epistemic violence in the production of knowledge regarding Muslim and Middle Eastern ‘terrorists’ see Brunner (2007).

³ I understand that the word ‘context’ is highly problematic not only because of its literary connotations and bias (con-text) that presuppose not only a text to be read, meaning to be deciphered, and a linear narrative, but also because of the term’s origins and use in military history, and I thank Claudia Merli for pointing this out.

Emplacing the Druze: History and contemporary regional realities

Druze is the popular name of a heterodox Islamic sect that emerged during the Fatimid Dynasty in 11th Century Cairo. The speculations for the origins of the name ‘Druze’ are diverse and contested but in most probability, as Khuri (2004: 5) argues,⁴ the name follows the general Middle Eastern pattern of name-giving for minority religions by the dominant Sunni populations: the name of the sect has been bestowed on them and comes from an early apostle-turned-heretic of the religious doctrine, Muhammad bin Isma’il al-Darazi (Khuri 2004:18). ‘Druze’ is considered derogatory by most of the followers of the doctrine, who, although using it, prefer to be referred as *mumwaḥid* (pl. *mumwaḥiddun*), meaning followers of the *Tawḥīd* doctrine, *ahl al-tawḥīd* (‘people of *tawḥīd*’, Khuri 2004: 18), or *Bani Ma’rūf* (‘the sons of benevolence’, see Betts 1988: 16; Khuri 2004: 19).⁵ For reasons of simplicity, I shall refer to the social category of the adherents as ‘Druze,’ while reserving *mumwaḥid* for explicitly religious affairs.

This section outlines Druze religion, history and politics, providing the reader with the necessary knowledge foregrounding the chapters that follow (specifically chapters 3, 4, 5). However, there are a number of limitations in providing a history of the Druze religion that must be kept in mind. Firstly, interpreting Druze religion has been, and continues to be, a largely Orientalist and highly speculative intellectual exercise. Most translations and interpretations of the Druze Epistles, the sacred religious book, depend upon the treatises of the continental father of Orientalism Silvestre de Sacy,⁶ and tend to regard religion as a static relic of the past. Secondly, since the 11th century Druze historians and popular renditions of tradition have rebuilt a mythological history, they ‘have reconstructed the history of mankind in accordance with their beliefs... [Historical figures are no longer historical] they are

⁴ ‘Other fanciful, but unfounded, theories link them [the Druze] to the French Crusader chief, the Comte de Droix, or derive their name from the word *‘durs’*, meaning ‘cleaver’ or ‘industrious’, or from *‘turs’*, meaning ‘shield’, or trace them to Bani Dariza, a tribe that lived in the vicinity of Mecca at the dawn of Islam. None of these derivations is compatible with the cultural pattern of coining names for sects in Arab society. The pattern is to call a sect by the name of the person thought to be the founder – often to the displeasure of adherents who like to be known by their dogma or some aspect of it. Calling sects by names that they do not like reflects the negative attitude of the dominant Sunni community, which has always seen in the rise of sects, attempts to divide the unity of Islamic *umma*.’ (Khuri 2004: 5)

⁵ For the cosmology and theosophy of the *Tawḥīd*, see chapter 4.

⁶ On the legacy of Sacy as the father of Orientalism, see Said (1978: 123–130); for Sacy’s work on the Druze Epistles, see Naufal (2005: 9–28).

what the Druze Epistles teach. Thus, history has become ahistoric, and the ahistoric history' (Firro 1992: 15). Thirdly, historiography in the bosom of a diverse and conflicting Middle East becomes a potent tool of political legitimacy, and history becomes the battleground for contesting opposing forces (Hazran 2009: 484): this is precisely the case of historical writings pertaining to the Druze throughout the 20th century particularly in Lebanon.⁷ Fourthly, while Druze religious and social practices are mostly public, Druze religious scriptures and religious knowledge are secret, and access to them is allowed only to an initiated small part of the community (the *'uqqa*). Most Druze and most of my informants were not initiated (*jubba*). Therefore, I have not been able to access any religious scriptures or discuss religion with members of the *'uqqa*. This means that for the historical section below I had to rely on second hand accounts that were not always verifiable through fieldwork. Finally, ethnographic material is scarce in terms of both Syria and Druze societies, and at times haunted with ethnocentric and generalising bias.⁸ As a way of exposing, rather than solving, these limitations I have included in the following chapters extensive contextualised ethnographic descriptions.

Tawḥīd *history and theosophy*

During the Abbasid Empire (750–1258 AD) regional Islamic dynasties emerged throughout the Muslim world (Cleveland 2004: 19). The Fatimid Dynasty conquered Egypt in 969 AD, founded Cairo as the dynastic capital and built the great mosque of Al-Azhar (Firro 1992: 5). Islamic dynasties were enriched through diverse local practices and the flourishing of different Islamic schools of thought (Hourani 2005 [1991]: 188); consequently this produced a hive of intellectual activity akin to the much later European Enlightenment, of philosophical and scientific development through re-discoveries and Islamic re-interpretations of classical antiquity,

⁷ An example of the political rewriting of Druze and Lebanese history is Kamal Jumblatt's *I speak for Lebanon* (1982). For a compelling and detailed analysis of the Druze political historiography in contemporary Lebanon see Hazran's 'Between authenticity and alienation: The Druzes and Lebanon's history' (2009), also see revisionist Lebanese historian Salibi (2005). For the different social and political contexts that Druze communities exist in, see Betts (1988: xii–xiii).

⁸ There are two fascinating anthropological studies of Druze communities: Sweet conducted extended fieldwork research in a Lebanese Druze village in the 1960s (1967, 1974), and Khuri carried out a comparative short-term ethnographic project of Druze communities in Jordan, Lebanon and Syria (2004). Other related studies include the sociological study of Lebanese Druze kinship structures by Alamuddin and Starr (1980), and the ethnomusicological study of Hood (2007), Oppenheimer (1980), and Bennett (2006). For other works regarding the Druze see the following annotated bibliographies: Fandi and Abu-Shakra (2001), and Gulick (1968: 195, 196, 202, 219).

neoplatonic philosophy, Gnosticism, Hinduism, Persian thought and the emergence of Sufi mysticism. Religious interpretation of the Quran and political factions had led to the emergence of three strands of Islam: the Sunni, Shi'i and Isma'ili.⁹ The Fatimid Dynasty adopted Isma'ili Islam as the official dynastic religion.

Isma'ili Islam, like Sunni and Shi'i, takes the Quran to be God's Word revealed, while it shares with Shi'a Islam the messianic concept of Imamate on the return of the divinely guided Imam (*al-mahdi* or *al-qa'im*).¹⁰ The Isma'ili doctrine is based on the concept of an ineffable God and on the neoplatonic theory of divine emanations (Abu-Izzeddin 1984: 89–90; Betts 1988: 21; Firro 1992: 5–6). The theory of divine emanation means that everything that exists emanated or was created not *ex nihilo*, since nothing can be created out of nothing, but only out of God who is incomprehensible and who is Existence and the only Existent (Abu-Izzeddin 1984: 87–90). Furthermore, Isma'ili emanation sees creation and history as consisting of cycles and stages (*adwār* and *awḳār*, Firro 1992: 6), in which periodic divine manifestations, perceived as cycles of manifestation (*dawr al-kashf*) take place (Abu-Izzeddin 1984: 101), proceeding periodically to higher revelations. Through the lenses of neoplatonic emanation, Quranic interpretation 'took on two meanings, one exoteric (*ẓahir*) and the other esoteric (*baṭ'in*)' (Firro 1992: 6). This is connected to an 'Islamic adaptation of Platonic ideas' (Abu-Izzeddin 1984: 93) similar to Sufism, of the representational connection between formal revelation as a symbol (*ẓahir, tanẓīl*) and esoteric interpretation (*baṭ'in, t'awīl*), or put differently, the symbol and the symbolised (*al-mathal wa al-mamthūl*): '*ẓahir* and *baṭ'in* are *mathal* and *mamthul*' (Abu-Izzeddin 1984: 93; see also Firro 1992: 6). Thus, a first divine emanation was manifested through Sunni *al-shari'a* (*ẓahir* or exoteric Islam) and a second through Shi'i *al-ṭariqa* (*baṭ'in* or esoteric Islam).

The Fatimid ruler al-Hakim bi-Amr Allah (996–1021) emerged as the last manifestation of divinity, and made a public declaration (*siyil*) in 1017 that a new era had dawned, after *al-shar'ia* and *al-ṭariqa*, the final cycle of *al-haqīqa* (truth, self-

⁹ For a history of the development of the three Islamic traditions see Firro (1992: 4–5).

¹⁰ For a detailed history and description of Isma'ili doctrine see (Abu-Izzeddin 1984: 87–101).

realisation and unity).¹¹ Re-appropriating Sufi terminology and Isma'ili doctrine, the *tawḥīd* religion holds that God manifests himself to humans according to their capabilities and perceptiveness through periodic manifestations, of which *tawḥīd*, personified in al-Hakim, signalled the final manifestation.¹² The *tawḥīd* doctrine shares with Isma'ilism the concept of God as Existence¹³ and the neoplatonic idea of divine emanation. However, being the last divine manifestation, adds the final parameter (*tawḥīd*), a requirement that only through which unity is achieved, differentiating and defining itself thus as a completely different religion.¹⁴ With caliph-imam al-Hakim bi-Amr Allah, the third and last cycle of divine manifestation began and, after 25 years in 1046, ended. During the period of the Druze *da'wa* (divine call) new adherents would sign their names and profess their faith by binding oath taking. The finite period of proselytism ended in part due to the historical circumstance (in 1021 al-Hakim bi-Amr Allah disappeared and his successors persecuted adherents of *tawḥīd*), and in part because based on Druze cosmology only those who are prepared to receive the blessing of self-realisation, a finite number in any given time, would enter *al-haqiqa*.

During the rule of al-Hakim religious and social changes took place, such as the revocation of the *imāma* hereditary system (Firro 1992: 10), abolition of slavery and redistribution of state property (Abu-Izzedin 1984: 79), while under the new doctrine, *Muwaḥhid* men and women were granted equal rights in marriage, divorce and property, and polygamy was denounced.¹⁵ The *Muwaḥhidun* were granted equality and the vindication of divine justice ('*adl*) through the continuous transmigration of the *Muwaḥhid* soul only to a *Muwaḥhid* body (Firro 1992: 12). Ritual and symbolism were deemed unnecessary mediums for the realisation of God's unity since they were emblems of previous cycles of manifestation and since relationship

¹¹ Alternatively, these stages are also referred as *tanẓīl*, *t'awīl* and *tawḥīd* or *islam*, *iman* and *ihṣan*; see Makarem (2005: 2).

¹² 'Islam (*ḡabīr*) is the door to *iman* (*baṭīn*), and *iman* is the door to the ultimate goal (*tawḥīd*), the highest stage of religion' Epistle 9 cited in Firro (1992: 12).

¹³ 'God is Existence as such, and accordingly He is the only Existent; nothing outside Him exists. He is the Whole. No limitation can be attributed to Him. He is unlimited. [...] Existing things are expressions of God's Unity, they are not parts that constitute a whole; because if one of those existing things ceased to exist, the divine Unity, the One, does not diminish' (Makarem 1974: 41–42).

¹⁴ For a juxtaposition of similarities and difference between Islam and Druze religion, and the argument that *tawḥīd* comprises a whole different religion, see Betts (1988: 17–18).

¹⁵ See Alamuddin and Starr (1980) and Layish (1982) for contemporary law and practices of Druze communities in Lebanon and Israel.

to the Divine is envisioned as a personal Gnostic journey (Khuri 2004, 2006: 61–78). During this final revelatory period ‘there were to be no more rituals, nor equivocation. “A spiritual doctrine without any ritualistic impositions” was born’ (Taqiyyuddin in Makarem 1974: 23). Finally, seven duties (*al-shurūṭ al-sab‘a*) for social conduct were instituted to be applied in communities of *tawḥīd* adherents: ‘1) Recognition of al-Hakim and strict adherence to monotheism. 2) Negation of all non-Druze tenets. 3) Rejection of Satan and unbelief. 4) Acceptance of God’s acts. 5) Submission to God for good or ill. 6) Truthfulness. 7) Mutual help and solidarity between fellow Druze’ (Betts 1988: 19). Based on the Gnostic eclectic perception that divine knowledge cannot be acquired by everybody, the Druze Epistles were viewed as an intimate divine manifestation that should not be shared neither openly nor widely with people that may be incapable of grasping it or prone to corrupt it.¹⁶ This Gnostic eclecticism further differentiated the community of believers, this time internally, through distinguishing between those enlightened and initiated into accessing the secret and sacred knowledge, the *‘uqqal*, and those uninitiated, the *jubhal* (Betts 1988: 16). This distinction has created a differentiated power balancing mechanism in which the *‘uqqal* are the representatives of religious authority and within the *jubhal* rests political authority (Khuri 2004).

Aspects of Druze history and social structure

The mosaic mapping of Syrian religious and ethnic communities is a result of various social, political, and economic conditions that historically have affected Syria. The area of modern day Syria has been a crossroads since ancient times (located and partaking in ancient Mesopotamia, and the battle grounds of collisions and invasions from ancient Greeks, and between the Roman and Sassanid Empires), as well as the fertile ground of Christian and Islamic civilisations (the first Islamic Caliphate was found by the Umayyad Empire in Damascus, 661–750 AD). Syria was part of the Ottoman Empire from 1517 until the defeat of the Ottoman Empire after World War I in 1918. During that time, Ottoman or Greater Syria, known as *Bilad al-Sham*, included modern day Lebanon, Palestine, Jordan and parts of southern Turkey. The

¹⁶ Consider the following passage from Lebanese Druze leader and founder of the Progressive Socialist Party, Kamal Joumlatt (1982: 33): ‘Our dogma is based on initiation; only initiates know how to read and understand the holy books that we call the Books of Wisdom. It is an extension of the Greek and Egyptian hermetic schools - the esoteric traditions – which have passed into Muslim Sufism. At present only a Druze [sic] who has known the ‘message’ in a previous life can be initiated, if he is worthy.’

Ottoman Empire was organised in provinces (such as Damascus and Aleppo) and smaller districts (*sanjak*), and administered through confessional communities known as the *millet* system, whose religious rights and social autonomy were protected by the Ottoman Empire, as long as they paid their taxes (Abu-Husayn et al. 2006; Khoury 1991). Furthermore, Druze communities attained a special status within the Ottoman Empire, especially after the establishment of the Druze Emirate in Lebanon (Abu-Izzeddin 1984: 211; Betts 1988: 72; Fawaz 2006). However, this does not mean that all different Druze communities at different historical times had the same relationships with the central authorities in Istanbul and Damascus, neither with/within each other; relations with local populations, authorities and between geographically different Druze communities varied significantly.¹⁷ Differences in social structure and stratification such as the feudal system in Lebanon and the peasant societies in Syria have created, and to different degrees sustained, diverse political structures in these places (Khuri 2006: 61–78).

Yet, there are also aspects that bind Druze communities together. It is not only that Druze souls become reincarnated into Druze bodies (chapter 4), nor solely the strict practices of endogamy (chapter 5) that make the Druze communities of the Levant exhibit elements of both religious as well as ethnic groups; there are also shared, although always shifting, mythologies and imaginaries as well as embodied mundane practices that constitute them as ‘imagined’ communities (Anderson 1991). Narratives of persecution from the *maghreb* to the mountains of the Levant (after the disappearance of al-Hakim in 1021), as well as the different forms of persecution faced during the Ottoman Empire constitute a common repository that still frame different community members’ arguments regarding solidarity, and the upholding of secrecy as a form of group protection. Real or fictive, community is an important narrative strategy as well as an everyday practice:

Rather than religion, it is our social relations, our mores and our culture which link us to one another and distinguish us from the non-Druses [sic]. This shared sense of community and morality has more in common with nationalism and a rather vague sense of nationhood than with religious sectarianism (Joumblatt 1982: 36).

¹⁷ See Provence (2006) for a discussion of a popular peasant revolt in Sweida in 1889; in 1910 there was an armed conflict between Ottoman authorities and the Druze of the Hawran; see Abu-Husayn et al. (2006) for a discussion of the Ottoman perspective regarding the dissident Druze community in Sweida at the start of the 20th century.

Since the collapse of the Ottoman Empire, Druze communities have often been ‘accused of isolationism and separatism’ (Schenk 2005), often referred to as ‘Druze particularism’ (Firro 2001). But, there are significant differences between the different Druze populations that live in contemporary Syria, Lebanon, Israel and Jordan, in terms of their histories, social structures and political involvement in national and regional affairs. Specifically, Druze communities do not share a unified approach in their regional and national politics. Betts notes that in Syria the Druze are viewed with suspicion by the Sunni majority (and especially before the ascendancy of Ba’th into power as ‘a troublesome, separatist minority to be dealt with as little as was necessary’ (Betts 1988: xii). In Lebanon, the Druze comprise ‘a pivotal group that held the balance between ruling Christian majority and growing Muslim minority’ (Betts 1988: xii), while in Israel, the Druze are the smallest of the three Arab communities but ‘the only Arabs to be trusted’ by the Israeli state (Betts 1988: xiii; Firro 1999, 2001; also see chapter 7 for the different approach of the Druze from the Israeli occupied Golan Heights).

Syria: French Mandate, Independence, United Arab Republic and the Ba’th Party’s rise to power

Contemporary Syria emerged from the dissolution of the Ottoman Empire, the Arab Revolt and the subsequent colonisation of the Arab world by European powers. Immediately after the dissolution of the Ottoman Empire, a Greater Syria included parts of Lebanon, Palestine and Jordan. Palestine and Jordan came under the British Mandate, whereas Syria fell under French mandate. The French implemented ‘divide and rule’ over Syria, creating semi-autonomous areas based on sectarian lines that they reinforced (Velud 2000). Mandate Syria was divided in four states: Aleppo, Damascus, Latakia and the Druze mountain (also known as Hawran, or Jabal al-Arab). The Syrian national struggle for independence was very long, and began as a local revolt in the Druze area and soon became a full-blown national revolt (1925–1927), led by the Druze Pasha Sultan Al-Atrash (Hood 2007; Provence 2006). Syrian Independence was formally implemented on April 17th, 1946.

The years between Syrian Independence and union with Nasser’s Egypt (as United Arab Republic, 1958–1961) offer a peculiar matrix of establishment of democratic

institutions and freedoms along with the political instability of successive military coups and the 'struggle for Syria' (Seale 1986) between rival regional powers, such as Iraq and Egypt. This period is also one of economic growth, specifically for landowning elites (Khalaf 1981), especially since economic and social changes brought about through a market of free enterprise resulted in the concentration of wealth and power in the hands of few elites. In a country whose majority were disadvantaged peasants, this concentration of wealth facilitated social pressures and popular discontent (Batatu 1999; Khoury 1991; Khalaf 1981, 1991; Hinnebusch 1990, 1991). During this time, many progressive movements took root, especially in the countryside, such as socialist and communist parties (Batatu 1999) that challenged the power monopoly of notable and elite politics. During the same period, the Arab–Israeli conflict began in 1948, engaging and, to some extent, humiliating the newly formed Arab states, as well as introducing an influx of Palestinian refugees throughout the Arab Middle East. The rise of nationalism(s), the unstable political climate, and the growing economic inequalities (Khalaf 1981), favoured the foundation of the Arab Resurrection (Ba'th) Party in Damascus by young nationalist intellectuals (Galvani 1974: 5; Kaylani 1972). Ba'th (Arab Socialist Resurrection Party) was established by intellectuals Michel Aflaq and Salah al-Bitar in 1947, and it combined socialism with ideals of Arab nationalism and pan-Arab unity (as in the slogan *wahda, hurriya, ishtirakiya*: unity, freedom, socialism).

Ten years after the establishment of the Ba'th Party in Syria, Nasser consolidated his leadership in the Middle East, and he was transformed from a local, Egyptian 'actor of history' (Nasser 1955: 55–56) to that of the Arab Leader, through his successful political manoeuvring of the Suez crisis and subsequent Suez-Sinai War in 1956, in which 'overnight [he] became the hero of the Arab and anti-colonial world' (Ali 2004: 104; Cleveland 2004: 312; Lewis 1964: 132–133). Nasser was able to exploit the fragile environment in Syria (Kaylani 1972) and as 'every independent Muslim ruler of Egypt' (Lewis 1964: 122) he took the road to Damascus. The objective of the UAR was a total union of Arab Socialism, which fed on the hopes of Arab Nationalism. However, the UAR was an 'awkward entity' (Cleveland 2004: 314). The internal political and military problems of Syria were very hard to deal with from Cairo; Nasser had come to dominate the union, contributing to its failure. The short-lived union dissolved, lasting for just three years (1958–1961). In the years of the

UAR a Military Committee (MC) was formed in Egypt by ambitious Syrian officers. This committee was able to organise itself and gain power within the Syrian Army in the years following the dissolution of UAR, and on March 8th, 1963 carried out a successful coup in Damascus. As the military lacked the popular and political organization base, it invited the Ba'th Party in to government.

The ideological basis of Ba'th, as formulated by its founders Michel Aflak and Salah Bitar was a combination of Arab nationalism and socialism, while its 'anti-imperialist struggle had both nationalist and class aspects' (Galvani 1974: 5; Kaylani 1972). Populist rather than strictly ideological (Hinnebusch 1990, 1991), Ba'th's support base was among traditionally disadvantaged minorities (such as the Alawi) and army officers, such as Akram Hourani (Galvani 1974: 5). The army, minorities and the rural base were all interconnected and instrumental in Ba'th's rise to power (see Khoury 1991; Hinnebusch 1991).

From 1963 to 1966, the political leaders of Ba'th dominated the stage of Syria. In this period, internal antagonisms were consolidated between two factions of the party: the 'old cadres', such as Al-Bitar, whose ideological basis was Arab socialism and whose policy was based on gradual change; and the more radical Marxist faction, led by Hamud Al-Shuti and members of the military committee such as Salah Jadid and Yusuf Zu'ayyin (Khalaf 1981). On February 3, 1966, a counter-coup, this time from inside the government, was successfully led by the latter (Galvani 1974: 8). In the period 1966–1970, known as the Neo-Ba'th, the new leadership, although politically organised on a narrow basis, was able to implement radical socialist policies. It was also able to build up wider mobilization through *munaẓẓamat sha'biya* (popular organizations) (Khalaf 1981: 168; Galvani 1974: 10–12), such as the General Federation of Peasants (GFP) and the General Federation of Labour Unions (GFLU). During this period, three important developments took place: (1) the grassroots organization of the party expanded greatly in rural areas; (2) the old 'notable' upper classes further lost their economic and political powers, consolidating, thus, their historical reversal of power; poor peasants, minorities and middle classes were the benefactors of the regime's policies; and (3) the 1967 June war (Six Days War) catastrophe signalled not only a second pan-Arab humiliation, but internal party antagonisms over the strategies to be followed.

The radical policies of the Neo-Ba'ath as well as the Arab defeat of 1967 had a direct effect on the regime, as it was losing its legitimisation and support not only among the traditional elites or the business community, but also from its popular base. The political, economic and social problems were epitomized by Hafez Al-Assad's seizure of power on the 13th November 1970, in what was called *al-ḥaraka al-taṣḥīḥiyya* (the Corrective movement of November, see Khalaf 1981: 181). Seeking to re-establish the authority of his regime by gaining broader social support, Assad's policy, from the 1970s until his death in 2000, had sought to deal with the two-fold problems of (a) regional and international foreign relations since 1967, including the peace negotiations for the return of the occupied territories of the Golan Heights and the settling of Israel–Palestine conflict (Hinnebusch 1996; Perthes 2001; Seale 2000) and (b) economic policies such as *al-infītāḥ 'ala al-sha'ab* (opening to the people) and *al-infirāj* (relaxation and/or politico-economic liberalization) (Khalaf 1981: 181). As Patrick Seale has argued, Hafiz al-Assad was able to transform Syria from a playground over which other powers fought into a major regional player. At the same time, a nationalist foreign policy and the development of state capitalism helped strike a precarious balance between the regime, the private sector and the changing dynamics of the region and world (Haddad 2012; Rabo 2005).

Emplacing anthropology in Syria since 1970

Published in 1992 by Ruud Strijp, the *Cultural anthropology of the Middle East: a bibliography* undertakes the task of cataloguing in the order of monographs, articles and fieldwork based studies, anthropological research partaking to different countries of the Middle East conducted and published between the years 1965–1987, in English, French and German. Considering Abu-Lughod's claim that anthropologists have preferentially engaged with the Middle East, it is interesting to note the distribution of research in the area. For the sake of convenience, the first table summarises the entries for Syria, while the second table compares entries for monographs across selected countries of the Middle East:

Table 2.1: Entries for Syria (Strijp 1992)

Book Part	Cited Works	Page number	English	French	German	Total number of works
Monographs	4	82–83	1	0	3	4
Articles	16	333–334	15	1	0	16
Added Studies Articles	–2	405–406	1	0	1	2

Table 2.2: Comparison of number of anthropological monographs published across different states in the Middle East (Strijp 1992)

Countries	Number of Monographs	Page Number
Algeria	30	24–29
Egypt	35	30–37
Jordan	6	54–55
Lebanon	12	55–58
Morocco	41	60–69
Palestine	3	73

The above tables indicate Syria as among the least-studied countries for anthropological research with just four monograph entries (only one of which in English), while Morocco, Egypt and Algeria top the list not only with the number of entries but also with anthropologists such as Abu-Lughod, Bourdieu, Capranazo, Geertz, Gellner, Gilsenan, and Rabinow. Even though Syria was one of the most stable countries in the Middle East before 2011, one might suspect that Abu-Lughod’s claim regarding the preferential bias of anthropologists might have something to do with Syria’s relative political isolation. However, this is a question that needs closer examination and research, something outside the scope of this thesis.

Middle Eastern societies have been described as mosaic (Eickelman 1981), a claim befitting Syria, which is comprised of diverse and polymorphous religious and ethnic groups (Antoun 1991:1; Van Dam 1996). Today, Syria’s population is estimated to be 22,517,750, with a total median age of 21.9 years and a growth rate of 0.913%.¹⁸ Religious communities include Sunni Muslims (74%), Shia Muslims (13%, and

¹⁸ Population statistics taken from CIA – The World Factbook, <https://www.cia.gov/library/publications/the-world-factbook/geos/sy.html>, Nov. 2011.

estimated 10% is Alawi), Christians (10%), and Druze (3%), while ethnic groups include Arab (90%), Kurdish, Armenian, Assyrian, and Circassian (9.7%).¹⁹

On one hand, Syria's recent history and politics is well documented by historians and political scientists. This is especially true for the rise, consolidation and development of the Ba'th Party and the ruling dynasty of the Assads (Batatu 1999; Hinnebusch 1990; Van Dam 1996; Perthes 2001). This literature tells the story of a broad radicalisation of the agrarian movements since the end of the French Mandate, and how that led, through historical particularities and social, political and economic conditions, to a 'revolution from above' (Hinnebusch 2001) – an abrupt reversal of the political elite through the rise to power of the Ba'th Party and the consolidation of the regime through Assad (Khalaf 1981; Khoury 1991; Salamandra 2004). On the other hand, however, ethnographic knowledge of Syria is remarkably scarce, with only a handful of ethnographic accounts that are, accordingly, disparate in both time and space.²⁰ This leads to a gap in our understanding of everyday realities and lives in Syria, and represents a paucity of bottom-up analysis of how life and politics are constituted, negotiated and contested. In this section, an outline of the historical processes on-going since the 1970s is detailed through a selective yet critical review of the most relevant ethnographic studies, which underline not only the contestations embedded in the everyday lives of Syrians but also the contestations and debates within the rather intimate field of Syrian ethnography.²¹

History through ethnographies

The experience of years of single-party authoritarian rule exhibit a remarkable stability in Syria's internal and external policies. While Syria is often described along

¹⁹ Statistical information regarding religion and ethnicity is not collected by the Syrian state, and thus estimates vary. The statistics used have been derived from CIA – The World Factbook, <https://www.cia.gov/library/publications/the-world-factbook/geos/sy.html>, Nov. 2011; and "World Directory of Minorities: Syria Overview". Minority Rights Group International. <http://www.minorityrights.org/?lid=5266&tmpl=printpage>, Accessed Nov. 2011.

²⁰ Anthropological studies of Syria include: Antoun and Quataert (1991); Khalaf (1981); Rabo (1986, 2005); Salamandra (2004); Shannon (2006). Other ethnographically informed accounts of Syria include: Borneman (2007); Chatty (1974, 1986); Chatty and Rabo (1997); Khoury (1983); Lindisfarne (2000); Rugh (1997).

²¹ In terms of Syrian ethnography/anthropology the author has only been able to consider works published in English. There exists considerable scholarly works outside the English language, especially in French and in German scholarship, these, regrettably, were inaccessible to the author due to language barriers.

different sectarian and ethnic lines, rather than a confessional underlying system of power, the stability of the regime has been attributed to more complex and more 'pragmatic' networks of power and patronage (Antoun 1991; Khoury 1991; Haddad 2012; Hinnebusch 1991; Khalaf 1991; Seale 1991). Of course, this is not to say that there has been no opposition in the consolidation and maintenance of power or conflict that could be described along religious denominations: the brutal suppression of the Muslim Brotherhood opposition in Aleppo (1980) and Hama (1982) (Drysdale 1982: 3) along with the illegal status of many oppositional political parties are prime examples of the 'tolerance' the regime has shown to opposition movements. Nevertheless, the Ba'thist regime has been able to retain control (and to an extent, support) throughout all these years, as well as during times of popular opposition (such as when the Syrian military joined forces with Lebanese Maronites during the Lebanese Civil War, see Lawson 1984; Perthes 1997; Melhem 1997) and economic crises such as in 1986. Hinnebusch (1990, 1991) argues that the authoritarian regime has been able to do so due to the popular organisation base of the party, the support of the middle and lower classes, and its power within the military, and thus the acquisition of a *populist* as well as *popular* support base.

Populist and pragmatic political choices on both domestic and foreign fronts have been some of the building blocks of the regime. Therefore, the earlier 'socialist' policies of land redistribution and nationalisation, the limited economic liberalisations, and the more recent neo-liberal ventures of Bashar's 'social market' have aided the regime in attracting and interconnecting a wide and heterogeneous range of interests in its support base (Hinnebusch 2001). On the domestic front, through the regime's integration on several levels of life (Khalaf 1981, 1991), such as powerful networks of patronage (Antoun 1991) or business networks (Haddad 2012), and the creation of popular political organisations, federations and unions (Galvani 1974), the regime has succeeded in gaining a popular support base. Yet, 'the main source of government legitimacy is its regional and foreign policy, and there appear to be few Syrians who disagree with its stance' (Strindberg 2004: 55). The careful manipulation of geography and politics as a frontier country with Israel (Hinnebusch 1996; Perthes 2001; Seale 2000), and the propagation and propagandising of Syria's anti-Western voice within the fragile environment of the Middle East have further helped the consolidation of the status quo.

Khalaf's study of the interrelations between kinship and village structure in a time of radical political and economic transformation offers a unique blend of personal and historical accounts of the micro-macro changes that were brought about by the socialist agrarian transformations initiated by the Ba'th Party since 1963 (Khalaf 1991: 63).²² In its struggle for legitimation and consolidation of power, during a period of 'revolution from above' (Hinnebusch 2001), the Ba'th regime implemented 'socialist' policies such as land reform and redistribution (Hinnebusch 1991:37) which greatly affected the rural social and economic structures (Khalaf 1981, 1991). Through these policies, the Ba'th party was able to mobilize nationalist-populist ideologies of the time (such as Arab Nationalism and Socialism, see Rubin 1991) in its recruitment of 'rural intelligentsia' (Hinnebusch 1991: 32), and to provide the basis of popular/mass support from rural peasantry. The demolition of latifundist capitalism (Hinnebusch 1991: 37) resulted in the political and economic disempowerment of the historically elite group in Syria: the urban 'notables' (Khoury 1991, 1997), while allowing previously disenfranchised groups, such as rural peasantry and minorities, to ascend to power (Khoury 1991: 27).

Methodologically diverse, Khalaf's work simultaneously mixes the historical record with villagers' experience, the ethnographer's pen with the actors' voices, diffusing and mixing simultaneously the symbolically constituted boundaries between scientific objectivity and people's subjective 'truths.' This methodological polyphony is accomplished through multiple approaches, such as an historical outline of processes and changes in the region and in Syria from the 1920s, participant observation, and eight participants' narratives of life histories. Theoretically, the thesis is structured in two parts: the first concerning the historical socio-economic and political changes occurring in Syria from the beginning of the twentieth century, and the second concerning the life changes of particular actors, and hence the social changes through their perspectives. This theoretical approach is based on the dialectic relation between micro-macro levels of economic, social and political transformations (Khalaf 1981: 90).

²² Published only as a Ph.D. thesis microfilm, Khalaf's study has featured in and influenced some of the most important scholars of Syria, for example see Batatu 1999 and Hinnebusch 1990.

Meticulous in its carefully detailed historical as well as personal perspectives, Khalaf's ethnography of a rural village, Hawi Al-Hawa, in Al-Raqqa, Northern Syria, captures the dynamics of change and their dialectic relationship between socio-economic transformations.²³ The native anthropologist is able to combine a multiplicity of resources and observations (history, archival research, participant observation, interviews, letters, primary and secondary evidence) into a fractal picture of a changing village through a detailed study of the historical processes of change: from the 'old order' (Khalaf 1981: 45) of tribal solidarity, to the 1950s entrepreneurial capitalism, to socialist reforms, 'corrections' and transformations.

The second half of Khalaf's thesis juxtaposes the life histories of eight persons-personas, in a letter format usually directly addressing the author. The directness and the apparent lack of anthropological editing provide forceful accounts of real people with real lives: people who constantly make and re-make their living under factors of change. The metaphor of the theatre – so much used by the author himself – is most appropriate: the anthropologist/playwright/director has already set the stage (a few chapters before) on which the history of the village and the history of the greater region (Syria, Middle East) will meet the eight different glances, and histories (rather than history) will continue to unfold. Hence, the reader is able to locate the personas within their historical times, and is able to connect how the greater socio-economic and political changes in Syria's transformation from a rural tribal organised society to a socialist state with capitalist economic openings (after Hafiz Al-Assad's 'corrective movement') have affected eight people's everyday lives. Therefore, it does not come as a surprise when Hajj Khalaf sharply criticises the new socialist regime while longing for the 'old order,' since the socialist reforms, especially the land reforms initiated in 1963, redistributed much of the land he owned to his fellahin. Also, through the voices of the younger personas we learn of the increasing value of education and of their flexibly adoptive strategies for subsistence and success in social and political life. Through the historical understanding of social and economic shifts in a changing village society we are able to appreciate those actors' needs for shifting strategies, and, thus, to agree with Khalaf's conclusions on the differing perspectives between generations (Khalaf 1981: 568) and on the increasingly social

²³ For another ethnography of social transformation in the Euphrates region see Rabo 1986.

demand for the cultural collagist or *mukhadram* (Khalaf 1981: 513) in a shifting society of mobilisational politics (Khalaf 1981: 162–3).

Furthermore, Khalaf suggests that the marginality and apparent deviance of most of his personas acting as *mukhadrams* places them in a liminal state of role ambiguity and of acute social awareness, which is actually a very rational strategy contingent on the shifting times in which they live. This allows Khalaf to recast the debate of tradition versus modernity with a new light: by describing and explaining the social and economic transformations from Bedouin tribal leaders to the ‘Cotton Shaykhs’ to the infrastructural socialist changes of Ba’th in the 1960s, the peasants and their new forms of empowerment (and a different kind of domination) through Unions and greater access to both means of production (land) and education, the author is able to show how certain traditional values and systems of practices are maintained and yet, ‘how the dynamics of “tradition” operate within the broader context of modernizing change; they show how people in their labour to advance their interests within a modernizing context creatively utilize the framework of traditional cultural forms to negate the very traditionalism which is normally associated with such terms’ (Khalaf 1981: 563).

Through the modern appropriation of tradition and the metaphor of the *mukhadram*, Khalaf sketches the contingency of an impressive flexibility to shifting social and economic contexts of his characters, uncovering the rationality of the seeming ‘bundles of contradictions’ (Khalaf 1981: 523). Syrians combine and recombine the old and the new, the traditional and the modern, the Islamic and the socialist – and they do so creatively, navigating the changing realities of their lives.

While Khalaf engages with questions of social deviance through the emergent personhood of the *mukhadram*, more recent publications (such as Cooke 2007; Salamandra 2004; Wedeen 1999) deal with the themes of deviance, resistance and opposition to the Syrian regime, within elite groups (such as old notable Damascene families in Salamandra’s ethnography), or other groups of the so-called intelligentsia (writers, artists, filmmakers, cartoonists, persons comprising the empirical accounts provided by Cooke 2007 and Wedeen 1999). Because these works have considerable weight within the anthropology of Syria, and because they deal with issues of power

and politics immediately relevant to my work, I will outline them below.

Salamandra's (2004) ethnography deals with issues of urban and elite deviance. Salamandra's ethnography demonstrates that the ruralization of urban Damascus resulting from the proclaimed class struggle of the Ba'th party, and the complete political (and to a lesser extent economic) disempowerment of the traditional hierarchies and elite urban class, has caused (or maintained) a proliferation of elite identities (Salamandra 2004: 7). These urban and mostly old-Damascene elites negotiate and challenge the political legitimacy of the Ba'th Party through claims of authenticity and distinction – both in terms of cultural heritage and traditional history as well as by embracing and reappropriating 'westernized' conspicuous consumption (Salamandra 2004). The paradigm of manipulating history and tradition in strategies of contesting and legitimizing political power is not, of course, specific to Syrian political history (Wedeen 1999), as the political anthropology of nation and ethnic group formation demonstrates (see Anderson 1991; Alonso 1994; Scott 1985).²⁴

Specifically, Salamandra's ethnography describes the different strategies of Damascene elite identity construction, based on notions of authenticity and distinction. These notions are publicly performed and displayed by members of the Old Damascene upper and upper-middle class. 'Old' and 'Damascene' are categories informants themselves use to denote the historical or perceived change in the composition of the capital's population after the 'socialist revolution from above' (Hinnebusch 2001) in 1963. The consequences of the change of the status quo were mostly felt by the Damascene elite who were those mostly affected by land redistribution and political disempowerment. The change of power as well as the forces of urbanisation caused an influx of village migrants in the capital, a 'ruralisation' (Ginsburg et al. 2002; Khalaf 1981) of city life. Salamandra, studying

²⁴ Claims to history and a shared, naturalised heritage for consolidating, protesting and negotiating political power are strategies widely used in the formation of the Middle East as ethnographic studies of Jordan (Layne 1989), the Gulf States (Khalaf 2000), Druze particularism and newly invented traditions in Israel (Firro 2005), and Arab–Israeli nationalisms (Alonso 1994; Eickelman 1981; Muslih 1987) show.

elite class identities, argues that socialist policy has actually not only proliferated class-identities but produced new class divisions (Salamandra 2004: 49).²⁵

Locating her work within the growing body of ethnographies of 'identity-as-resistance-against-state-domination' (Salamandra 2004: 19), Salamandra argues that elite Damascene identity is created, re-created and maintained through a practical discourse of authenticity as traditional-cultural legitimation. Yet, this 'return to the old' (Salamandra 2004: 4) is a quintessentially modern phenomenon (Salamandra 2004: 15). Salamandra's ethnography is profoundly influenced by the contexts of her fieldwork: class-based, it reflects a particular view of culture and authenticity. However, this work lacks wider class-based analysis that would make it historically and theoretically contextualised within the Syrian society; gender-influenced as the ethnographer's own experiences obviously influenced her writing (very honest and brave of her to admit so), especially her perspectives on competition as a form of sociality (Salamandra 2004: 5, 65). This colouring of ethnography is, of course, unavoidable if not constitutive of the experiential model of anthropological fieldwork. Secondly, Salamandra's work is colourful and engaging, intersected with some vivid ethnographic descriptions, but her use of 'resistance' although frequent (for examples, see, Salamandra 2004: 83, 109, 126, 135, 146, 153), is neither clearly defined nor critical. The use of the concept in a variety of different situations stipulates questions of meaning: what counts as resistance, what as reaction, what is contestation, and how do we differentiate amongst these? Focusing her ethnographic evidence and subsequent analysis on a distinctive part of Damascene society (those with alleged descent from the old notable Damascene ruling classes) the author does not account for competing perceptions amongst other societal strata, and the historical and economic manipulation of her participants by the current regime. Political economist Hinnebusch (1991) and anthropologist Khalaf (1981) both show how the old 'notables' may have lost a lot of their property and political influence, especially during the early period of radical socialist policy implementation (1963–1967), nevertheless as more liberal policies were initiated by the Neo-Ba'thist regime these families were able to maintain political and economic affluency by their greater

²⁵ This argument is highly contested, for a political economy perspective see Hinnebusch 1991; for criticisms regarding the lack of clear methodology and reflection on 'class' see Lindisfarne's (2006) review of Salamandra's work.

access to education and thus easier access to professions of influence either within or outside the government. Hence, the question of what sort of resistance and against whom becomes more complex (see chapters 5, 6 and 8) as we consider that the resistance Salamandra suggests is professed to be directed against a 'state' which to certain extents does serve the class interests of her participants.

Wedeen's book *Ambiguities of domination: Politics, rhetoric and symbols in contemporary Syria* (1999) discusses how the Syrian 'regime can do without legitimacy' (1999:7) by means of a different, more economical (1999: 152) strategy of domination, that of compliance. 'Assad's cult' (1999: 2,6,32), maintains the regime is sustained by its 'disciplinary-symbolic power' (Wedeen: 145): a form of power that delineates the extent of appropriate citizenship and public conduct. Syrians, Wedeen argues, are united in their common disbelief of the claims that the regime makes, yet comply with it by the politics of 'acting as if' (Wedeen 1999: 67). This argument however presupposes that most Syrians are cynical strategists, an argument that I take to task throughout this thesis (specifically in chapters 6, 7,8; also see Abu-Lughod 1990; Mitchell 1990).

Wedeen's work is theoretically rich, and at times provoking, yet there are some problems. Firstly, Wedeen's claims about 'Syrians' are too general: her material derives almost exclusively from within the confines of an intellectual elite: writers, actors, filmmakers, cartoonists. It is questionable to what extent the views of this rather select group are upheld within the wider population. Secondly, the historical-political analysis of Syria is based almost exclusively on its comparison to the post-soviet experience in Eastern Europe. Although such a comparison between Syria and Eastern Europe can be fruitful, Wedeen's treatment of Syria within this prism of analysis and without adequate contextualisation of Syria's historical particularities, and the wider politics in the Middle East, makes her treatment of Syria dangerously ahistorical.

Finally, Miriam Cooke recounts her acquaintances with Syrian dissident intellectuals, and describes their stories. In the introduction to her book she describes her endeavour:

Syria has been linked with Iraq as a sponsor of international terrorism and a military dictatorship. It is both. At least, the state is. Yet there is another Syria: a country where dissident patriots seek a space to express their conscience and their creativity in circumstances unimaginable to most outsiders. In *Dissident Syria: Making oppositional arts official*, I traverse the abyss between these two Syrias, between the power of the state and the power of culture. It is this other Syria, largely unknown to Americans, that I want to bring to light in the pages that follow (Cooke 2007: 3).

Cooke's explorations on Syrian intellectuals are based on her six-month stay in Damascus and on her encounters with intellectuals there. Her book draws heavily from both Wedeen's and Salamandra's works, and shares with them their problems in generalising the arguments of a select political configuration and presenting them in a historical and political vacuum. Similar to Wedeen, Cooke presents dissident accounts without reference to their local contexts, while analysing the Syrian case comparatively to post-socialist East Europe, with the implicit assumption that perhaps neo-liberal capitalism is going to 'rescue' Syria, too. Furthermore, Cooke's simplistic dichotomy of the 'two Syrias' fails to account for the variety and complexity of the Syrian society.²⁶ Her uncritical embracing of intellectuals as revolutionaries who 'encourage change through literature and discourse' (Dandashli cited in Cooke 2007: 29), along with her unproblematised discussion on 'democracy and freedoms' (ibid.: 30–35) coupled with her stated 'mission' to aid these intellectuals in being heard in the wider world (ibid.: 164) propagates a very problematic approach (for a critique on enlightenment and the missionary endeavours in social science, see Sahlins 1999; for a nuanced gender analysis on 'saving others' see Abu-Lughod 2002).

Although insightful regarding the relationship between intellectuals and the state, this body of literature does little in critically analysing the relevance of social and historical contexts to the rise and membership of intellectual groups. As a result, the analyses that they bear tend to be ahistorical in terms of understanding power struggles within as well as outside Syria, and also little connected to the everyday realities of life in Syria – realities outside of these elite configurations (see chapter 8). However, in recent years, some fascinating ethnographies have emerged about Syria,

²⁶ For complex anthropological accounts of the contours, complexities and multiplicities of power relations in Syria, see Chatty and Rabo (1997); Khalaf (1981); Lindisfarne (2000); Rabo (2005); Rugh (1997); Sato (2001); Shannon (2006).

two of them located in Aleppo, one by anthropologist Rabo (2005) and the other by ethnomusicologist Shannon (2006), and an ethnography of Orthodox Christians in Northeast Syria (Sato 2001). Rabo's *A shop of One's Own* (2005) manages to surpass some of the main conceptual and ethnographic problems pertaining to power and deviance that works like Cooke's, Salamanda's, and Wedeen's do not. Rabo navigates the worlds of traders in the main trading centre (*souq*) of Aleppo, with both diligence and sensitivity to detail, specifically exploring how the traders create place out of space, and how they relate not only with one another, but also with the wider Aleppine society, the Syrian state, and the global markets that they are part of. The strikingly beautiful ethnography of Shannon explores issues of music and modernity in contemporary Aleppo, providing thick descriptions of the complex performances of music, religiosity and sociality. Last but not least, Sato (2001) explores issues of identity and memory, highlighting how a Christian minority relates in complex ways to the Syrian polity and state. These works provide both thick descriptions as well as rigorous analysis, texturing the ethnographic terrain of anthropology in Syria in deep and nuanced colours.

Emplacing research practice

Levi's 'grey zone,' is a 'zone of ambiguity' (Levi 2004: 90) in which there is no clear boundary between victim and victimiser, a space where 'compassion and brutality can coexist in the same individual and in the same moment' (Levi 2004: 90), a time of horrifying 'normalcy' (Agamben 2004), a time of the banality of evil (Ardent 2004), and a space that makes judgment impossible: 'victim and executioner are equally ignoble; the lesson of the camps is brotherhood in abjection' (Rousset, in Agamben 2004: 438). The *Sonderkommando*, the Special Squad in Auschwitz that was comprised largely of Jewish inmates, represented one such case of the 'grey zone.' The Squad lived separately from the rest of the prisoners, sometimes enjoying certain privileges, and its task was to take care of the crematoria: to keep the order of the inmates, to regulate the gas chambers, to inspect the corpses, and to supervise cremation. Once, during a work break, a game of football took place, one team represented the inmate *Sonderkommando* squad, the other their officers, the SS. The game proceeded 'as if, rather than at the gates of hell, the game were taking place at the village green' (Levi 2004: 89), and what is more, this apparent normalcy firmly emplaced 'the burden of

guilt' depriving the victims of the 'solace of innocence:' 'it is consummated, we have succeeded, you no longer are the other race; the antirace, the prime enemy of the millennial Reich ... you too, like us and like Cain, have killed the brother. Come, we can play together' (Levi 2004: 89).

Surviving the concentration camps of WWII, Levi is said to have become a writer in order to 'bear witness' (Agamben 2004: 437). Agamben threads Levi's narrative in order to expose, or rather dwell, on another subject:

What is at issue here, therefore, is a zone of irresponsibility and '*impotentia judicandi*' that is situated not *beyond* good and evil but rather, so to speak, *before* them. With a gesture that is symmetrically opposed to that of Nietzsche, Levi places ethics before the area in which we are accustomed to consider it. And, without our being able to say why, we sense that this 'before' is more important than any 'beyond' – that the 'underman' must matter to us more than the 'overman.' This infamous zone of irresponsibility is our First Circle, from which no confession of responsibility will remove us... (Agamben 2004: 439, emphasis in original)

Impotentia judicandi literally means the incapacity to bring about a final decision during a judicial trial,²⁷ and in reference to Levi, Agamben unpicks the two Latin words for witness: *terstis*, 'the person who, in a trial or lawsuit between two rival parties, is in the position of a third party;' and as *superstes*, the 'person who has lived through something, who has experienced an event from beginning to end and can therefore bear witness to it' (Agamben 2004: 438). Levi's position firmly marks him as a *superstes*, but as such also makes his testimony neither neutral nor objective, not the testimony of a third party to be accepted in the court. And neither is Levi interested in judgement or pardon. What the 'grey zone' does is to bring law and ethics face to face, to bring the witness–*terstis* and the witness–*superstes* to continually mirror their unresolved struggles. I think that *impotentia judicandi* not only describes Levi's grey zone, but that this tension is the constitutive tension of anthropology (Moore 1999). Through fieldwork and particularly through participant observation we become witness–*superstes*, we partake, participate and bear witness to events that we become part of, relationships that we form and form us intersubjectively. The academic act of writing, upon our 'return' asks of us to become witness–*terstis*, to resume an 'ethical'

²⁷ I am grateful to Dr Claudia Merli for providing me with the literal translation of this phrase and for sharing her knowledge and enthusiasm of Agamben with me.

distance and to offer testimonies as a third party. But the impossibility of witnessing does not go away by conflating law and ethics, as Agamben shows. And this is the strength of the discipline: its tensions, its unresolved dilemmas that face us, as anthropologists, at every stage of our endeavour, from the conception of a project, to fieldwork, to writing up. I continue to struggle with the impossibility of anthropology, and I have done so in every chapter, through different ways, some more reflective, others more reflexive. As I discuss in chapter 1, anthropology is an epistemological science, and as such it continually conflates the different meanings of witnessing. In this section, however, I outline some of the more formal aspects of my fieldwork in Syria, such as relations with persons, communities, and host governments. In the chapters that follow, more specific methodological reflections are explored.

I conducted long-term (14 months in total) fieldwork, based primarily on the method of participant observation in the Druze community of Jaramana. To an extent, fieldwork was also multi-sited (Marcus 1995): I travelled outside of Jaramana to meet interviewees, as well as to directly observe folklore festivals, dance performances and dancers. Fieldwork and participant observation entail ethical choices, responsibilities and dilemmas that the researcher has to take in order to ensure the well-being, safety and consent of her participants (see ASA guidelines); these dilemmas become all the more astute when one conducts fieldwork in an authoritarian state with a strong secret security apparatus. Before embarking on and during cross-national fieldwork, I did my utmost to have a candid and honest relation with the host government. I met, informed, and took advice from his Excellency the Syrian Ambassador in London, Sami Khiyami. Upon my first 'pilot' visit to Syria, I consulted with Syrian academics from within and from outside the University of Damascus, as well as with personnel from the Greek Embassy in Damascus, as to the most ethical, safe and morally responsible way of conducting my affairs, for my research as well as for the well being of the persons and communities that I would carry out my research with. Based on their advice I decided that the most responsible way to conduct research would be to have honest relationships with the host government, and after deliberations and following local advice I submitted an application to the University of Damascus which outlined my research and requested formal affiliation with the University as a visiting researcher, and an official research permit. This application

was submitted before I embarked on long-term fieldwork, in August 2008. The research permit was granted almost a year later, in June 2009, and the process involved some less and some more serious adventures, but in the end, this process helped both my research as well as my host community and participants. However, because I was ‘known’ and at times ‘under scrutiny’ from official state apparatuses, I had to be extra diligent in order to protect my research informants. Presuming or knowing that I was ‘watched’ meant that I could not follow certain research interests (such as the topic of direct resistance), for example when I was invited to certain oppositional meetings I had to politely decline because my presence there might have drawn attention and endangered participants. Also, field notes were written in Greek, names were coded and kept safe and locked away as a precautionary measure, while I monitored and censored my online interactions and telecommunications. Especially when one is in a foreign country, hyper-vigilance may be the safest road to travel. Vigilance, heightened protection, and the feeling of arbitrariness of security tactics, however, helped me to embody some of the aspects of living in Syria and to bring me closer to my research participants.

As anthropologists, we have a critical responsibility to inform and protect our research communities and participants (see ASA guidelines). This becomes a greater challenge when the community involved in the research is suspicious and protective of ‘outsiders’ as the Druze communities have historically been; also when members of the community are not sufficiently acquainted with academic structures and what anthropological research might entail. Fieldwork in Jaramana involved a long, slow process of acquaintance, gaining access, building trust, establishing rapport and negotiating informed consent; this was established by participant observation and the daily negotiations with the host families.²⁸ I was as clear and open as possible regarding what anthropology and what my research in Syria were about. When my written Arabic was good enough I wrote a short essay about anthropology and my research in Syria, which I read and showed to anybody interested. Yet, the single-most important informed consent negotiated and access granted occurred when my host parents would talk to other members of the community on *behalf* of me, explaining what anthropology, and my research was about. This marked not only that they knew and had ‘tested’ me sufficiently, but also that they *shared* the responsibility

²⁸ For a day in the life of Umm Samir, and of the anthropological process, see Appendix I.

of representing me to, as well as protecting me from others. This process was slow, gradual and occurred in different ways in the two families I stayed with. Although most of the time during participant observation I was not taking direct notes, nor asking direct questions, as time went by people themselves would instruct me to take notes, or bring my camera, sometimes they would ask to see my (Greek) notes, and often comment very favourably about my writing character. The fact that I would take photographs of events such as marriages and funerals slowly turned me into a local resident photographer and paparazzi: people would not only ask me to take photographs of them, but also asked to see and comment on wedding photographs and video material – thus stills and video were not only used to record but also to elicit information (see chapter 4). However, there are certain religious prohibitions against photography and video, especially when persons involved are initiated (*'uqqal*), and I was always following local advice in order to avoid undue intrusion.

All of the photographs and video material collected have been shared with participants and their future and present uses negotiated with them individually and every time. However, for the photographs and video from public events such as festivals I have not been able to negotiate consent with all the persons involved (see ASA guidelines), but as an official guest of either the Ministry of Culture or of the independent dance troupe performances I have observed (including Enana, Ornina, Leish and Sima), I have obtained consent from them. Although I did not conduct any interviews within the Druze community, I conducted thirty recorded and unrecorded semi-structured interviews with dancers, dance directors, and state officials such as the Vice Minister of Culture, the director of Theatre and Music. Consent was verbally obtained from all these interviewees. This material has helped me understand the social, political, and economic landscape regarding the arts and dance outside of Jaramana, but most of this material has not found its way directly into the thesis, but will be used in the future. Similarly, I formed intimate close relations and conducted short-term fieldwork (approximately two months comprising weekly stays over the duration of fieldwork) with a Muslim family in Al-Raqqa. This experience has been very helpful in providing me with a comparative basis but has not found its way directly into this thesis.

While most of the officials and dancers I interviewed and observed did not want to be anonymous, research in Jaramana was predicated on the principles of trust, privacy and anonymity. All names and personal information that can be identified have been anonymised and changed, while certain information has also been altered in order to avoid recognition of any individual. The process of anonymising the thesis, as well as including certain ‘sensitive’ subjects, events and relationships has been carried out together with research participants, especially from the two Druze families, *bayt* Abud-Haddad and *bayt* Ouward. Both families have been actively involved during fieldwork as well as in the process of writing up. During a return to fieldwork in October 2010, I was able to specifically outline and explain my thesis to the two families. Specifically Zahra, whose story features in this work, has read, commented and contributed to most of the chapters in the thesis. Similarly, my brothers Karem and Tariq have helped with double checking and obtaining data, as well as providing me with their architectural sketches for their houses (chapter 3). We have discussed together and decided that is not an infringement on their intellectual property rights to use their drawings without their real names but with pseudonyms in order to protect their privacy. Similarly, chapter 8 evolved through the personal involvement of Noura Murad, the director of the dance troupe and performance that are the focus, and she has read, commented and agreed to its inclusion in my thesis. This work, thus, in itself represents the social nature of both fieldwork and of writing up, the continued involvement of research participants, and the social project of anthropology.

Intersubjective research praxis: practice into theory

First, it [intersubjectivity] resonates with the manner in which many non-Western peoples tend to emphasize identity as ‘mutually arising’ — as relational and variable — rather than assign ontological primacy to the *individual* persons or objects that are implicit in any intersubjective nexus. (...) Second, the notion of intersubjectivity helps us elucidate a critical characteristic of preliterate thought, namely, the way it tends to construe *extrapsychic* processes that we construe as *intrapsychic*. The unconscious (...) is in a preliterate society more likely to be called the unknown. (...) Finally, the notion of intersubjectivity helps us unpack the relationship between two different but vitally connected senses of the word *subject* — the first referring to the empirical person, endowed with consciousness and will, the second, to abstract generalities such as society, class, gender, nation, structure, history, culture, and tradition that are subjects of our thinking but not themselves possessed of life (Jackson 1999: 7).

I do not want to venture into abstract theoretical understandings of intersubjectivity, just to hint at their relevance²⁹ by delineating some of the ways that intersubjective relations have affected both research methods *as well as* research theory. Thus, in this section I will illustrate through brief examples how my relationships were intersubjectively constituted, and relate this to the overarching theoretical framework that has been used in this thesis. Although somewhat unorthodox, the combination of research methods and theory is my way of underlining how interconnected these practices, for conducting fieldwork and of writing anthropology, really are.

Palestine and Christmas

Orientalism is described by Said (1978) as a set of discursive practices that classify and order the world according to relations of power, methods and techniques of unequal divisions into Occident and Orient, in which one resembles the dominating and the other the dominated.³⁰ Savigliano expands on notions of Orientalism and colonisation to refer to hegemonic processes of internal colonisation,³¹ specifically she develops the concept of ‘autoexoticism’ in reference to her study of the history and politics of, the local and inseparably global, Argentinean tango. Autoexoticism refers to those local ‘indigenous’ practices of ‘looking for identity through the Western mirror’ (Savigliano 1995: 179).³² Yet, ‘everyone has had one’s own Orient, pertaining to space and time, most often of both’ (Todorova 1997: 12), but sometimes this Orientalist frame shifts from ‘a discourse about imputed opposition ... [to one of] imputed ambiguity,’ (Todorova 1997: 17), as in discourses of balkanism and within the contours of a European Orientalism that turns exotic

²⁹ For further elucidation on issues of intersubjectivity and anthropology, see Boskovic (2002); Butler (1990); Jackson (1999); Rapport (1997).

³⁰ Some examples of the critical debates regarding Said’s Orientalism include: Carrier (1992); Fox (2002); Richardson (1990); and Thomas (1991).

³¹ Defining hegemony has been debated in anthropology (see Kurtz 1996; Smith 2004; Trouillot 2001). Gramsci defines hegemony as ‘intellectual and moral leadership’ (Gramsci in Kurtz 1996: 103), and Smith notes that ‘hegemony is about the mastering of history’ (2004: 217). I employ the concept of hegemony, following Gramsci, Kurtz and Smith, to underline the ways by which consent plays a role in both maintaining as well as potentially subverting the status quo. The Gramscian notion of consent that I employ as above differs from the ways Kant, among others, employ the term (see Harvey 2009).

³² ‘Exoticism and autoexoticism are interrelated outcomes of the colonial encounter, an encounter that is asymmetric in terms of power. And they contribute to the further establishment of imperialism. Perhaps exoticism is one of the most pervasive imperialism manoeuvres. The promises of incorporation into Civilization through Progress can produce a stumbling development filled with economic fits and starts... Exoticism creates the abstract, unfulfillable desire for completeness in the colonized while extracting his or her bodily passion. Exoticism is a colonial erotic game played between unequal partners’ (Savigliano 1995: 75–76).

others to stigmatised brothers (see Buchowski 2006). Many strands, local and global but most often contradictory, of Orientalism and autoexoticism exist in Greece, my home country: ‘Greece’s own place in the East/West divide has been equivocal, even though in the language of international diplomacy Greece has firmly identified as “European”’ (Karayanni 2010: 8). And I can identify with Karayanni when he describes his feelings when listening to Arabic radio stations:

...an indulgence in the foreign and exotic culture that was quite close geographically and yet far away, forcefully distanced by political ideologies. While I envisioned the moves, my ears drunk in the melodies and the *maqāms*, or musical roads, which were as familiar to my sensibility as the family features that you recognise in a close relative with whom you are not on speaking terms because of family feuds (Karayanni 2010: 7–8).

From the perspective of Greek geography, ‘our’ near East was a place as close to become palpable, familiar and threatening, as sufficiently far away to remain exotic, and to act as a negative foil. But this geographic and social distance has always been peculiar. I am not going to talk about Greek nationalism and Orientalism, others have done so in a much more lucid and textured way (Karayanni 2010: 121-157), I just want to point out that I grew up under a rigid, homogenising but always under threat nationalism, perpetrated in the school and by the media, which pursued a paradoxical discourse: we were, it said, the cradle of democracy, the birthplace of Europe, yet still we had to strive hard to become European, to discover, it seemed, a long-lost grandeur that we must have lost sometime, somewhere in the Ottoman Empire. But, at the same time I grew up in the doubly unconventional household of not only a single mother but of a revolutionary in the most genuinely Marxist way. European identity politics were not only a bourgeois issue, but something used to shift attention from social, political and economic inequalities (and this I learned in an embodied way, through the struggles of my mother, a proletarian, in and out of her workplace). I still remember the Christmas day when I got my first book presents: one was the illustrated poem by Odysseas Elytis, ‘I Podilatissa’ (she, the bicycle rider, my translation), the other was a collection of drawings and poems of the Intifada by Palestinian children. Up until now, I cannot dissociate one mental image from the other.

We all carry different and shifting forms of Orientalism and autoexoticism, and so does the endeavour of anthropology, and, so I carried to fieldwork my own luggage and bias, and, although I cannot yet say it with certainty, mine had to do with a sense of inexplicable belonging as well as with a sense of urgency and common struggles.

Tall, blonde, with blue eyes

Many months after I had been living in Jaramana, Karem and his best friend Salih shared with me a funny story regarding the first time we all met, which I paraphrase. The story goes like this: Karem's sister, Zahra, had informed her brother that he will receive a call from a Greek friend of hers who was going to do research in Syria, and who might need help and friends. During my first visit to Syria in June 2008, I called Karem and arranged to meet him outside the hotel in which I was staying. Karem came with his best friend Salih, and on their way to meet me they engaged in wishful thinking: 'Oh, she's European... Different from Syrian girls... Imagine, she's going to be tall, blonde, and with blue eyes, fair skin...' The conversation continued (and I wish I could print the expressive gestures my two friends made) until they saw me: Short, with dark skin and eyes, and short, curly hair. 'We thought that you might be Salih's sister [Salih is of similar hair, height and skin tone] but you certainly were not European!'

Anthropologists are often critiqued for their Orientalist research, but as the above story illustrates, it is not only research and researchers that may perpetuate hegemonic relations into their research. In fact, through the incessant processes of globalisation, inequality is not measured only in terms of capital but also in the terms and conditions available for the structuring of worlds. Anthropologists and research participants are as culprits and as saints. What is important is not to stop at this statement, but to share, in a way, our funny stories – and to create new ones.

Our common ancestors: the ancient, the political and the relational

The fact that I was not Druze, not Syrian, not Arab, not quite European but Greek had significant (and at times surprising) repercussions for conducting research in Jaramana and in Syria. Not only entry visa fees for Greek citizens were significantly less than most other European countries, but because I could not be directly placed

within the immediate known webs of knowledge and networks of familiarity and difference, because I was not perceived to be enmeshed in the familiar (stereotypical) fabric of the Middle East, nor as a threatening, imposing or completely ignorant outsider (a European, an American, an Orientalist), I was often an ambiguous, almost liminal person, and I was often given the benefit of doubt. As my access to and trust of the community increased over time and through involvement, I was projected upon and projected in a favourable light, and more often than not, this entailed the idiomatic use of common ancient ancestry. Being Greek was an important and favourable aspect of my social construction in Jaramana, because ancient Greek philosophy is considered one of the spiritual ancestors of *tawḥīd* and hence it was said that we are kinship relatives.³³

Furthermore, my gender, my sexual unavailability (the fact that I was engaged to an English partner whom my families and friends met, and the social prescriptions of endogamy), and the close caring relationships I developed with my two Druze mothers, situated me in an ambiguous but less problematic niche from other possible categories. Also, as I was ‘adopted’ by two *bayts* (see chapter 3) that occupied different yet very respectable positions within the social rubric of Jaramana, allowed me not only to move between their two social milieus but a more general ease of movement at large within the Druze community of Jaramana. Should my positionality have been different, other opportunities and problems would have arisen:

M: Umm Nidal [mother of Zahra], how would you say that people here view me?

UN: Oh, everybody likes you, Maria is like Feirouz [famous Lebanese singer]... You are very kind and polite (*m'rweh*), smart, strong...

M: And how would you say they'd view me if I was the same person, with the same studies, family situation, but instead of Greek I was from here?

UN: [Long, emotional pause] You know the answer to this. [Long pause] The society here... they would not see you with the same eyes.

M: And you, how would you see me, Umm Nidal?

UN: [Very long and emotional pause] I am part of my society.

³³ The idiomatic use of kinship took different forms, some people would trace a literal blood line between ancient Greeks and the Druze, others would stress the spiritual affinity as a metaphorical kinship. Additionally, consider the following passages from Joubblatt: ‘We trace our line back to Hermes Trimegistes... Socrates, Pythagoras and Plato are widely read in our little country... it is a kind of tiny humanist Greece, an *agora*... The Druses [sic] are truly rational: they have that ‘Greek commonsense’ (1982: 32, 37).

If I was not Greek, then I would be in the situation of Zahra... This conversation took place in July 2009, during a long and hard discussion that had to do with Zahra living in Europe.

Doing ethnography is a reaching towards the possibility of becomings, it is not only learning of each Other, not only learning from each other, but engaging in the unstable relational process of opening up possibilities of otherness, and sameness, possibilities of a 'tenuous and ephemeral' game: 'as I reach toward, I reach not toward the "you" I ascertain but toward the "you" you will become in relation to our exchange' (Manning 2007: 7). In doing long term fieldwork, anthropologist and informants engage in a relationship of assembling and re-assembling possibilities of becomings (Deleuze and Guattari 2005 [1987]); as such, in terms of methodology, fieldwork is the relational process of becomings, of shifting and altering the potentialities of how to change, and this process occurs to both anthropologist and informants. In different degrees, our gestures involve us in a common becoming. Only then, only after we have tried and allowed to be reached, to be touched, only after we permit other possibilities to shift our ontological being into an ontogenetic becoming, is the anthropologist, or anyone, able to sense a change of the shifting logic of senses. Yet touch, the reaching forward, becomes the movement of possibilities, and these possibilities include both coming together as well as coming apart; they entail a close movement, an intimacy, but also the possibility of violence, of hurting, of causing pain. Inflicting violence here, presupposes the touch. As in our personal anthropological triangle between Zahra, her mother and the Greek anthropologist.

Relationality constitutes the basis of not only my methodological becoming-anthropologist, but also the basic foundation of this work. The concept of relationality has fruitful elaborations in both philosophy (Deleuze and Guattari 2005 [1987]) and anthropology (Mitchell 1991; Strathern 1990, 2004 [1991]). I drew inspiration from these works to use relationality to denote that: (1) relations are constitutive of reality; (2) terms such as reality and everyday life (used in the pages that follow) are empirically constituted through relationships; (3) personhoods, rituals, and practices are emerging, shifting relational processes. Furthermore, these

shifting always-changing relations are structuring, meaning that contingent power relations are to be traced, historised and be analysed through them.

Interpretation, use and analysis of not only my relational involvement in Jaramana and Syria, but also of the relational frameworks of becoming Druze and becoming Syrian, emerge and are elaborated throughout this thesis. The complexities and contradictions of everyday life and practice in Syria are impossible to fit or be understood only through one abstract theoretical scheme. However, relationality has been chosen as the basic theoretical foundation of the thesis for a number of reasons. Firstly, relationality offers the most fruitful and ‘best fit’ between ethnography conducted and available anthropological theory. This is because not only beliefs and practices in Syria are relational, i.e. they shift and change depending on relations, but also personal relations and construction of personhoods are never finished or static affairs. In this respect, relationality allows to locate events, practices, and personhoods in all their complexity and dynamics as always changing becomings.

Secondly, a relational approach in ethnography permits the study of power relations and politics on a more nuanced and specific basis than that of other less relationally embedded methodologies (Wedeen 1999). Finally, a relational approach allows power relationships to emerge in different prisms and ways, and thus to partially overcome some of the criticisms in Marxist or Foucauldian approaches (and use these more creatively), especially in regards to issues of agency, social change, and the body as an analytical site (see below).

Embodiment and body-becomings

This thesis traces the relational frameworks of power through the ways these become embodied, negotiated and contested. The ‘body’ thus, becomes both a methodological ‘place’ (*topos*) from which ethnographic investigations begin, as well as a philosophical and political trope from which anthropological analyses emerge. In this respect, this section outlines some of the most prominent works on the body and embodiment; works that have not only been influential in general but that have particularly shaped the way the ‘body’ and embodiment have been employed in this thesis.

Marx and Engels proclaimed that ‘man’ not only shapes his world but is, in turn, shaped by it through a dialectic interaction: ‘We have to say that labour created man himself [...] the hand that became free and could henceforth attain ever greater dexterity and skill, and the greater flexibility thus acquired was inherited and increased from generation to generation. Thus the hand is not only the organ of labour, it is also the *product* of labour’ (Engels 2007 [1882]: 26, emphasis in original).

The body’s ‘career’ in anthropology (Cowan 1990: 21–27; Csordas 1999; Lock and Farquhar 2007), we may say, has ‘roots in the prehistory of anthropological thought’ (Herzfeld 1987: 96), having formed a large part of the ethnographic descriptions and taxonomic relations to exotic ‘others.’³⁴ However, the first time that the ‘body’ enters the social sciences in something other than a descriptive platform, as a way ‘in which from society to society men know how to use their bodies,’ (Mauss 2007 [1935]: 50) is in 1935 in a tiny article published by Marcel Mauss. Through the ‘...notion of social “habitus”...[in which] we should see the techniques and work of collective and individual reason’ (Mauss 2007 [1935]: 53), Mauss argues that the ‘man’s first and most natural technical object, and at the same time technical means, is his body’ (Mauss 2007 [1935]: 56). Mauss was the forerunner for the anthropological as well as philosophical developments in which, almost half a century later, the ‘body’ becomes a fruitful field of debate and knowledge production in symbolic and structural anthropology (Douglas 1966, 1970; Turner 1967), while the phenomenology of Merleau-Ponty sets the ‘body’ as the phenomenological horizon of perception, as both object and subject, taking Mauss’ ‘techniques of the body’ one step further: ‘Insofar as I have hands, feet; a body, I sustain around me intentions which are not dependent on my decisions and which affect my surroundings in a way that I do not choose’ (Merleau-Ponty 1962 [1945]: 440).

In the contexts of 20th Century existential Being-in-the-world (Heidegger 1985 [1927/1962]) and phenomenological body as the horizon of perception (Merleau-Ponty 1962 [1945]), questions of the historical and political construction not only of perception but of the body itself began to arise: how ‘natural,’ political, and ‘historical’ can a body become?

³⁴ In Linnaeus’ anthropological taxonomy, ‘subdivisions’ of human groups (American, European, Asiatic and African) are divided according to their bodies’ skin colour, physique and clothing, see Herzfeld (1987: 96–97).

‘The ‘body politic’, [becomes] a set of material elements and techniques that serve as weapons, relays, communication routes and supports for the power and knowledge relations that invest human bodies and subjugate them by turning them into objects of knowledge’ (Foucault 2006 [1977]: 355).

In viewing the body as a system of knowing, as the object and subject of power relations, a site where power struggles are constructed, take place and are reproduced, Foucault’s archaeological ‘diggings’ and subsequent genealogical ‘tracings’ address issues of and on the body in terms of power (employed as subtle, dispersed, horizontal *and* vertical), and knowledge systems (or knowledge-power: regimes of truth that control, constrain, limit, police, regulate, and determine what can be thought), through his archaeological historical studies (‘history’ is viewed as sudden ruptures and discontinuous epochs in which different ‘discourses’ operate; this does not refer to the technique or the process of discoursing, but what is possible to say and think within a system of articulating and practicing knowledge: what can be true in a given historical period). Foucault argues that there is a historical rupture around the 18th century in discourse (1991 [1977], 1998 [1978], 2005 [1970]), a dramatic shift in power-knowledge, which is characterised in the transformation of ‘right over death’ (simply put, the medieval right of the lord to take the life of his subjects) to ‘power over life:’ ‘Now it is over life, throughout its unfolding, that power establishes its domination; death is power’s limit, the moment that escapes it’ (1998 [1978]: 138). This archaeological rupture transforms power-knowledge regimes, firstly by transforming the *body as machine*: ‘Its disciplining, the optimization of its capabilities, the extortion of its forces, the parallel increase of its usefulness and its docility, its integration into systems of efficient and economic controls, all this was ensured by the procedures of power that characterised the *disciplines: an anatomo-politics of the human body*’ (Foucault 1998 [1978]: 139, emphasis in original).

In the contexts of post-enlightenment capitalism in Western Europe, the body itself becomes an economic instrument, through its economic use as a form of labour power: ‘The body becomes both a productive body and a subjected body’ (Foucault 2006 [1977]: 354). Interlocked with its development as machine and labour power, the body, says Foucault, is ‘invested’ in power relations: ‘But the body is also directly

involved in a political field; power relations have an immediate hold upon it; they invest it, mark it, train it, torture it, force it to carry out tasks, to perform ceremonies, to emit signs' (Foucault 2006 [1977]: 353).

Bourdieu's theory of practice rests upon the concept of habitus, 'history turned into nature' (Bourdieu 2007 [1977]: 78) which he defines as: 'systems of durable, transposable dispositions, structured structures predisposed to function as structuring structures [...] the habitus is the source of the series of moves which are objectively organised as strategies without being the product of a genuine strategic intention' (Bourdieu 2007 [1977]: 72–73). Bourdieu develops the dialectic of embodiment in order to underline the everyday, practical, and material dimensions of habitus:

But it is the dialectical relationship between the body and a space structured according to the mythico-ritual opposition that one finds the form par excellence of the structural apprenticeship which leans to the em-bodying of the structures of the world, that is, the appropriating by the world of a body thus enabled to appropriate the world (Bourdieu 2007 [1977]: 89).

This thesis is about bodies: their constructions, extensions, and their political ramifications. Herein, the 'body' is variably considered as a phenomenological horizon (Merleau-Ponty 1962), as a body without organs and the realm of relational possibilities and becomings (Deleuze and Guattari 2005 [1987]; Manning 2007), and as an analytical tool for researching power relations and the inscriptions and investments of political, social and economic struggles (Bourdieu 2007 [1977]; Foucault 1991 [1977]). In the chapters that follow, power relations are traced through and on bodies, bodies that may become singular, or multiple, bodies that become idols, idols that become subverted, and through nuptial bodies that dance on the limits of empires. These bodies, identified or unidentifiable, gendered and engendering, become the local and global sites and ways, paving the ways that nuptiality becomes the relational idiom of power in contemporary Syria.

Chapter Three

Two houses in Jaramana

Introduction: On houses

During summer nights in Damascus, the light of street lamps or the light of the moon cast shadows on the walls of buildings, making houses appear in the abstract: upside-down, reflected. The subtle play of light and dark, the uneven distribution of shades and shadows on uneven walls, on yellow, orange, and grey cracks, resemble veins, like the veins on the hand of a worker or a dancer. In the dim lights of the night, houses, as if through their visible pumping veins, come to life. For houses have veins. They are continuously in the making, inhabited and inhabiting, lived in and out, changing. They decay as much as they endure, and similar to looking at the hands of a pianist or a farmer, the wrinkles of a face or the pages of a history book, each shadow and each shade are seeds, traces and stories.

In this chapter I trace the stories of two family houses in Jaramana. Historically a Druze agricultural village in the vicinity of the Ghuta plains on the outskirts of the Syrian capital, Damascus, Jaramana is one of the most densely populated areas of Syria, inhabited by Druze, Christians and Muslims, as well as refugees from Palestine and Iraq and displaced persons from the Golan Heights. During my fieldwork in Syria (July 2008–September 2009, October 2010), I spent nine months (January–September 2009, October 2010) living in the city of Jaramana. Due to an array of events (see chapter 1), I spent one month (January 2009) living in the household of the Ouward family, while afterwards I resided with the family of Abud-Haddad. Throughout this time, I moved between these two households, participating in the lives of their members, learning the language, the customs, the habits, meeting their relatives and friends. The suburb of Jaramana and the Druze community are focal points of this thesis, but also the results of my own physical, emotional and intellectual movements between these two households and their social networks. Put another way, what I came to know of Jaramana, the Druze community, and of the two houses are the direct results of my interactions with these two families. But why the emphasis on houses in this chapter?

The word house (*bayt*) has at least three meanings in Arabic: it means house; it means the family or minimal lineage (Chatty 1974: 101); and it is also the word used for a line in a verse (Irwin 2006: 6). Thus, *bayt* may denote the unit of spatial living arrangements, as in the English usage. The definition of *bayt* as family or lineage extends through space and time to include important socio-political and economic units of spatio-temporal relationships, relations fictional and real, of consanguinity and affinity that may share the same living arrangements. The word *bayt* may also include members of an extended family that may not share the same living arrangements but a common ancestry: i.e. *bayt* Abud-Haddad includes all the family members that share the same house, male offspring and their children who have moved out of the family house, and also other family households who share a common ancestor – for Abud-Haddad this is three generations. *Bayt*, within the Druze community of Jaramana, also has connotations of maximal lineage, similar to what Chatty describes for the two Bedouin tribes she discusses, as *fakhad* (maximal lineage) and *'ashīra* (sub-tribe) (Chatty 1974: 100); many families in Jaramana stated that they have different organisation of social structure from Bedouins and other Arabs, that they do not have tribes as the 'Others do.' However, *bayt* is often used akin to *'ashīra* or *qabīla*, for example in historical narratives regarding conflicts and feuds within Jaramana, while also *qabīla* is used by Lebanese Druze (see Alamuddin and Starr 1980). Much has been written regarding Arab social organisation, segmentation and lineage, in anthropology;³⁵ however, for the purposes of this chapter I use the term *bayt* in its fluid local to Jaramana meaning, to denote the minimal lineage of households in Jaramana, but also maximal lineage (where this is the case it is stated explicitly for maintaining clarity). The term *bayt* is useful to work with because it is both pervasively in use within the Syrian contexts as well as fluid: everybody in Syria has a *bayt* but what that precisely means, who it includes and excludes, varies greatly depending on circumstance and time. How does the material structure of a house connect with the relational idiom of house as a lineage classification?

'Houses are the most personal units in the built environment,' writes Stefan Weber (2009: 227) in his extensive study of urban transformation in Damascus during the late Ottoman Empire (1808–1918), 'venues for negotiating social status, power and

³⁵ For representative works regarding segmentary lineage theory and its development in anthropology see: Patai (1955); Murphy and Kasdan (1959); Peters (1967); Gellner (1969); Keyser (1974); Meeker (1976); Geertz, Geertz, and Rosen (1979); Dresch (1986); Lindholm (1986); Abu-Lughod (1989).

influence' (Weber 2009: 397). Weber states that 'traditional Damascene houses are houses with various living rooms (*uda/ umad*) on two floors, grouped around one or two more spacious courtyards,' noting that 'the house looks "inwards"' (Weber 2009: 231–232) since the windows of the house face the internal courtyard of the house, and since 'as a rule of Damascene architecture, representation takes place mainly in the interior parts of the house' (Weber 2009: 233). Moreover, in his comprehensive study of Damascene houses, Weber dispels some of the gender stereotypes often held in reference to Arab societies and their houses. Arab houses in general have been described through gendered classifications as divided between male and female, or private and public spaces. The gendered divisions of Damascene houses have been classified through two dichotomies, the *haramlik* (family section) and the *selamlik* (guest section). Weber, however, notes that these classifications are the Turkish terms that specifically refer to palace architecture, and there are no historical records demonstrating that the Damascenes used these terms in reference to their houses (Weber 2009: 232); instead, the Damascene house was functionally divided into the outer part (*al-barrani*) and the inner part (*al-junwani*). These classifications, Weber argues, did not connote gender distribution 'just spatial disposition' (Weber 2009: 232): 'houses are private, but not inaccessible... The interior spaces and facades were elements of social representation directed at outsiders' (Weber 2009: 397).

Weber distinguishes between two main building phases of architectural development: the first occurred in the middle of the 18th century when courtyard houses were built with a varied array of architectural characteristics. The second phase took place during the late Tanzimat reforms of the Ottoman Empire during the late 19th Century. During this time of economic and political reorganisation, courtyard houses were characterised by 'strict symmetry... a sense of order and uniformity... regularity and measurability' (Weber 2009: 302–304). The rooms in traditional elite houses that had been used multifunctionally began to be functionally defined (Weber 2009: 239), reflecting global influences: 'European centres became the new horizons rather than the local Beirut or Cairo,' yet Istanbul remained 'the decisive point of reference' (Weber 2009: 396). The changes in the architecture of urban, middle and upper class houses in Damascus redefined the notion of 'traditional' Damascene house into a symmetrical building block structure looking into a central courtyard, embodying a

new emerging governmentality structuring not only the house, but broader political and social conduct. Also, different housing structures appeared, such as *konaks* (Weber 2009: 331) and apartment buildings (Weber 2009: 365), and in contrast to the inward-looking traditional courtyard houses, these structures were oriented so as to be 'looking out' to the street (Weber 2009: 331). At the start of the 20th century, houses were 'almost exclusively organised around families' (Weber 2009: 360, 364). Finally, Weber notes that the construction of courtyard houses dropped dramatically after the 1920s and 1930s as such types of house no longer fulfilled 'the criteria of class distinction' (Weber 2009: 395), which increasingly became more global and metropolitan.

In anthropology, there has been one house that shook the theoretical foundations of previous functionalist, structuralist, and symbolic analyses. 'The house is a world within a world,' wrote Pierre Bourdieu (2005 [1990]: 282) about the Kabyle village house of a Berber-speaking community in Algeria, 'but one that always remains subordinate, because, even when it displays all the properties and relationships that define the archetypal world, it remains an inverted reflexion, a world in reverse.' Bourdieu describes the Kabyle house through a series of oppositions (light/dark, dry/wet, male/female) and relations (associations based on activities, placement of objects, animals, reception of guests, etc.), as a universe built on differences and resemblance, within the different spaces of the house as well as the house as a unit in relation to the world outside of it. What is interesting and radical in Bourdieu's analysis is that the Kabyle house is not described in terms of stable or given spaces – spaces where certain functions take place – but relationally, through the on-going interactions of 'things,' humans, animals, the seasons, wetness and dryness, light and shade, and located within the relational webs of the world inside and outside of the house. In this sense, the house is not organised around certain 'cultural' or 'practical' principles, the house *is* a relationship. As Mitchell puts it, Bourdieu's Kabyle house is very different from functional explanations of house organisation (Mitchell 1991: 49) that classify houses as discrete objects framed and organised to accommodate certain functions. The oppositions that the Kabyle house entails are not fixed categories or 'an effect not of spatial coordinates but of polar forces... such polar forces occur themselves not as a structure of oppositions but as an unstable play of differences' (Mitchell 1991: 50).

Bourdieu's description also departs from analyses of symbolic or cultural 'codes' because here there is no referent and no external, stable signifier, but only interrelations within specific contexts that emerge continuously, resembling and differing from each other:

There is nothing symbolic in this world. Gall is not associated with wormwood because it symbolises bitterness. It occurs itself as a trace of bitterness. The grain does not represent fertility, and therefore the woman. It is itself fertile, and duplicates in itself the swelling of a pregnant woman's belly... Such resemblances and differences do not form a separate realm of meaning, a code apart from things themselves; hence this very notion of 'thing' does not occur... There are, rather, the necessary relations at work in a world where nothing occurs except as something that resembles, differs from, duplicates or re-enacts something else. (Mitchell 1991: 61)

Houses are embodiments – dimensional embodiments in space and time: 'a process caught up in this life-and-death, not an inert framework that pretends to stand apart... there is no mere house, but rather an active housing, engendered in the forming of a household and sustained as an aspect of its vigour, never as a neutral framework. Housing is not an object or container but a charged process, an inseparable part of life that grows, flourishes, decays and is reborn' (Mitchell 1991: 52–53). Apt and abstract at once: physical, dialectical and dynamic interactions, associations and transformations. They are tactile and material, tracing the spaces that they occupy and at the same time tracing a changing historical past, a precarious present, and an ambivalent future (future is always ambivalent precisely because of the effect of materiality and touch: physical, predestined to decay, to fall prey to its own material foundations upon time and space, and to be reborn). Houses thus embody the social processes of a relational, contextual and fluid world, within the contexts of an unstable game between resemblance, difference and deferral.

The connections between house as a kinship idiom of varying degrees of relational interactions, and house as the material structure, become apparent as both are embodiments of active, engendering and changing social processes and practices.

In this chapter, two Druze households, their histories, genealogies, and their houses animate classed and gendered differences and similarities within the religious community, through which the chapter explores the embodiment of spatial intimacy

within the social fabric of a Druze neighbourhood. The concepts of making place through history and continuous intimate interactions are introduced in this chapter, thus locating fieldwork physically as much as intimately. In terms of organisation, this chapter firstly locates Jaramana historically, geographically and socially, and then explores *bayt* Ouward and *bayt* Abud-Haddad in terms of their family composition and history, houses and the different milieus they occupy.

The chapter will show how a deterministic interpretation of the material character of a house as epiphenomenal of the social character, the ‘traditional’ and ‘modern’ outlooks of its inhabitants is a superficially apparent means by which to analyse and compare *bayts*. Indeed, it was on the basis of such distinctions that my move from *bayt* Ouward to *bayt* Abud-Haddad was sanctioned. Yet, as alluded to above, the chapter will also show the contradictions, limitations and ironies inherent in such an approach. For, it is the clarity provided by the half-light that reveals the subtle veins of the *bayts*, their pulsating changeability and heterogeneity and all the contradictions, resemblances and ironies that that entails.

Jaramana

Jaramana is four kilometres southeast of Damascus (Jaramana Council 2000), located along the highway between the capital and Damascus International Airport. With approximately 200,000 inhabitants (Hoshan 2009),³⁶ Jaramana has one of the highest population densities in the country: 15,000 inhabitants per km² (Fahmi and Jaeger 2009).³⁷



Figure 3.1: Damascus (grey) and Jaramana (black), Fahmi and Jaeger (2009)

³⁶ Population statistics and other demographic indicators are estimations and vary. The main reason for this variation is the recent influx of Iraqi refugees most of whom are not officially registered. Furthermore, Syrian citizens may be primary residents in other places (for example, the village of their origin) than the ones they reside. The Central Bureau of Statistics of the Syrian Arab Republic estimated 114,363 inhabitants in Jaramana in 2006 (Central Bureau of Statistics, SAR, 2009). Informal population estimates put the number as high as 400,000 residents.

³⁷ Indicative: the average population density in the country is 96 inhabitants per km²; Damascus has the highest population density with 13,152 inhabitants per km² (Central Bureau of Statistics, SAR, 2009).

Historically a Druze village, the social fabric of contemporary Jaramana includes a majority Druze population,³⁸ as well as Syrian Christians and Muslims, and Iraqi and Palestinian refugees. It is estimated that half of its residents are Iraqi refugees (Hoshan 2009, Harding 2009).³⁹ Because of this swift change in population, Jaramana has been portrayed as the ‘refugee city’ (Fahmi and Jaeger 2009; UNRWA 2010) or ‘Damascus’ own Little Iraq’ (Harding 2009:1).

The ‘unruly’ description of Jaramana's development (Harding 2009:1) over the past decade is not unfounded. However, the Jaramana I experienced is very different from the written portraits of Jaramana. While Iraqi presence in certain parts and neighbourhoods of Jaramana can be described as overwhelming, there are parts of Jaramana, for example its historical centre, that are inhabited almost exclusively by members of the Druze community. Both *bayt* Ouward and *bayt* Abud-Haddad live within the vicinity of the historical centre of Jaramana, and the physical as much as the social worlds that these two families exhibit, and many other Druze families, do not map neatly onto Jaramana’s other inhabitants. In most cases, the Druze community of Jaramana at the time of fieldwork, occupied different spatial *and* social milieus from Jaramana’s Christians, Muslims, Iraqis and Palestinians. Although interaction between Druze inhabitants and ‘others’ existed, it was rather limited while physical and social spaces were segregated. Thus, the Jaramana I explore is the Jaramana that I was able to navigate through the two Druze families and their social networks, and is enclosed within the limits of the Druze community. With them and together I met the Jaramana of their families, extended in time and space, of their relatives, neighbours, friends, and businesses. Having the anthropological predicament I observed and participated in their lives and it is through them, their relations and the relations I built with them that I was acquainted with a different city and a different social and physical landscape than that of media portrayals. The

³⁸ Generally, the Druze population is estimated to be a million world wide, of which 420,000 in Syria, 390,000 in Lebanon, 75,000 in Palestine, 15,000 in Jordan and 80,000 in the rest of the world including North and Latin America, Australia, West Africa and Europe (Makarem 2007). In Syria, the majority of Druze population resides in the municipality of Sweida in Jabal al-Arab.

³⁹ Syria, due to its proximity, entry requirements and favourable socio-political environment, is the largest recipient of refugees from Iraq. Syria’s Deputy Foreign Minister during that time, Dr. Faisal al-Miqdad, citing 2007 UNCHR estimates, notes that Iraqi refugees in Syria currently exceed 1.2 million out of a total population of 18 million (al-Miqdad 2008: 19).

Jaramana I know is different to that of my informants, but also different to Jaramana as a refugee city.

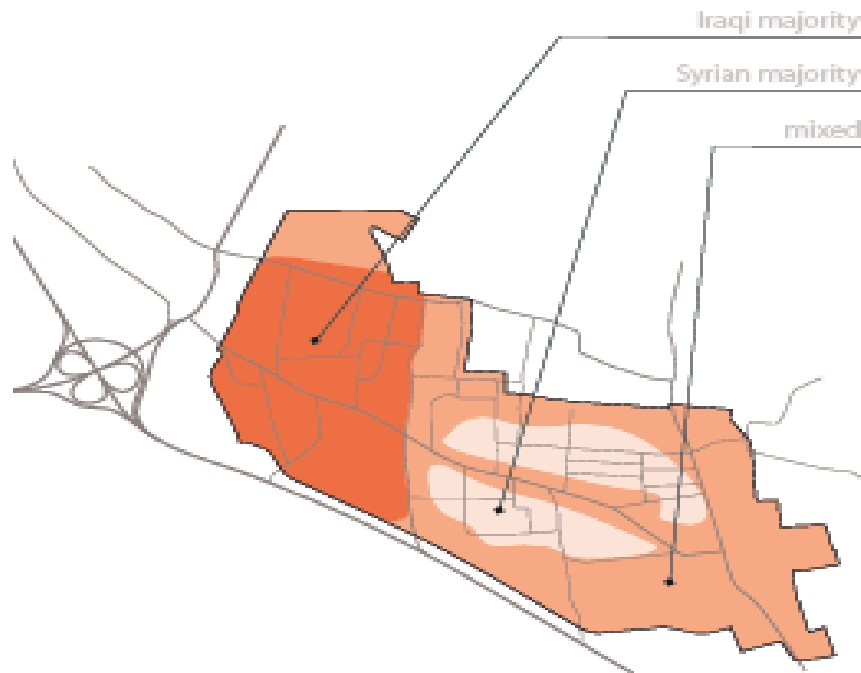

Figure 3.2: Spatial composition of ethnic residence in Jaramana, 'Syrian majority' correlates to the physical and social space of my fieldwork and it is an overwhelmingly Druze majority. Fahmi and Jaeger (2009)

Jaramana in History

There are two studies focusing on Jaramana, one published in Arabic by Jaramana Council in 2000, and an online publication concerned with Iraqi refugees and urban planning in Jaramana by Fahmi and Jaeger (2009). Jaramana Council states that Jaramana is as old and as continually inhabited as Damascus, but does not provide specific historical references as to when the village was established as Druze. Fahmi and Jaeger (2009: 21) on the other hand, do not provide a date but estimate the development of Jaramana as a Druze village in the late 19th century. Historical resources complicate matters further since mention of Jaramana occurs only in passing, as a Druze agricultural village in the vicinity of Damascus' agricultural provinces, the fertile plains of al-Ghuta (Batatu 1999: 14; Abu Chakra 2005: 175; Betts 1988). However, there is ample evidence that if not Jaramana, Druze villages surrounding Damascus existed since the start of the Druze Call (*da'wa*) in 11th century: 'together with Jabal al-Ala, the Acre plain and Damascus (with its environs), Wadi al-Taym is regarded as the Druze community's oldest centre' (Abu Chakra

2005: 172), and Betts (1988: 70) mentions that by the time of Crusades in Syria, Druze communities were present in the Ghuta region of Damascus. Firro, who is the most important historian of the Druze in the English language, cites the Ghuta within the first five oldest Druze settlements, but he mentions that the village of Jaramana was established after 1860 (Firro 1992: 34) (see Figure 3.6 and 3.7).⁴⁰

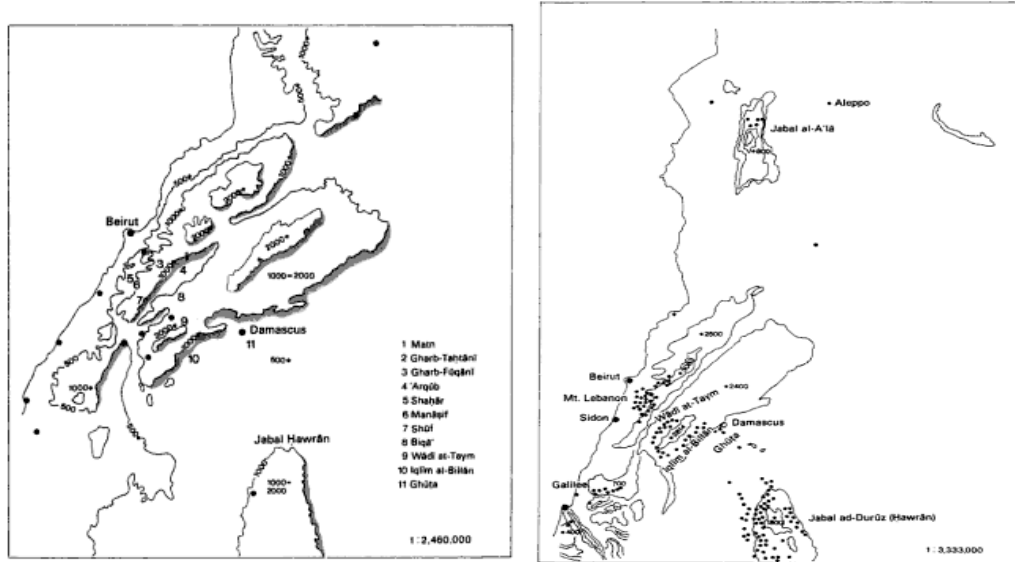

Figure 3.3: (left) 'Main districts of Druze settlement before the migration to Hawran' (Firro 1992: 35)

Figure 3.4: (right) 'Druze settlement in Syria, Lebanon and Palestine.' (Firro 1992: 30)

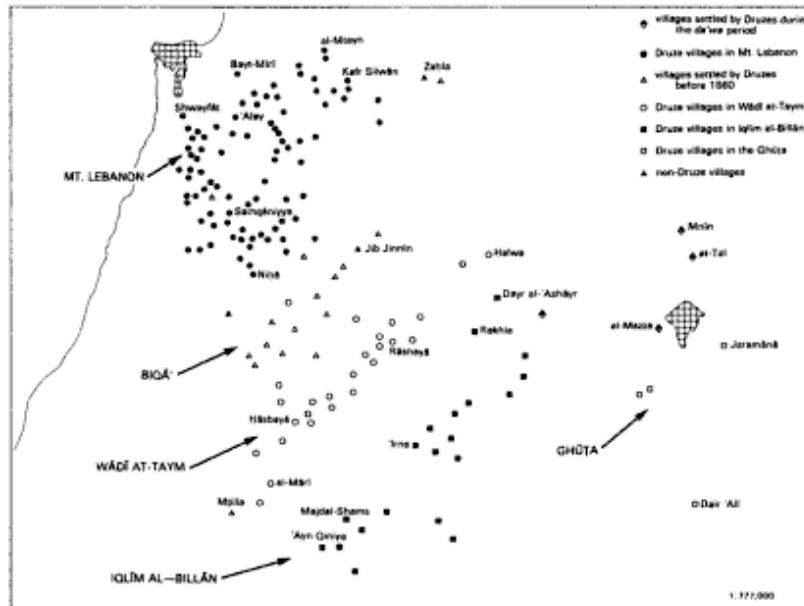

Figure 3.5: 'The Druze villages in Mt. Lebanon, Wadi al-Taym, Iqlim al-Billan and al-Ghuta.' (Firro 1992: 41)

⁴⁰ Both Abu Chakra (2005) and Firro (1992) derive their information from the Druze chronicler Ashrafani who lived in the first half of the 17th century and his manuscript includes the history of Druze settlements during the period of the *da'wa* – see Firro 1992: 33–34; Muhammad al-Ashrafani, *Umdat al-'arifin fi qisas al-nabiyyin wal-umam al-salifin* (manuscript).

Most of my informants in Jaramana supported the view of the Council (2000) regarding Jaramana’s ancient and Aramaic past, while they also argued that the Druze had settled the village since the start of the *da’wa*. However, based on family genealogies and oral histories collected during fieldwork, a lot of Jaramana’s inhabitants arrived in the village at the start of the 20th century, while some of the oldest families in Jaramana, those considered *‘abl al-Jaramana* (such as *bayt Abud-Haddad*, introduced in the following section) could trace their genealogies and residence in Jaramana up to 200 years ago. Although more research is necessary, for the purposes of this thesis it is safe to assume that while Druze settlements around Damascus date among the first of the religious community, Jaramana must have become a Druze village some 150–200 years ago. The Figures below summarise the population and spatial changes in Jaramana since 1940 (Fahmi and Jaeger 2009).

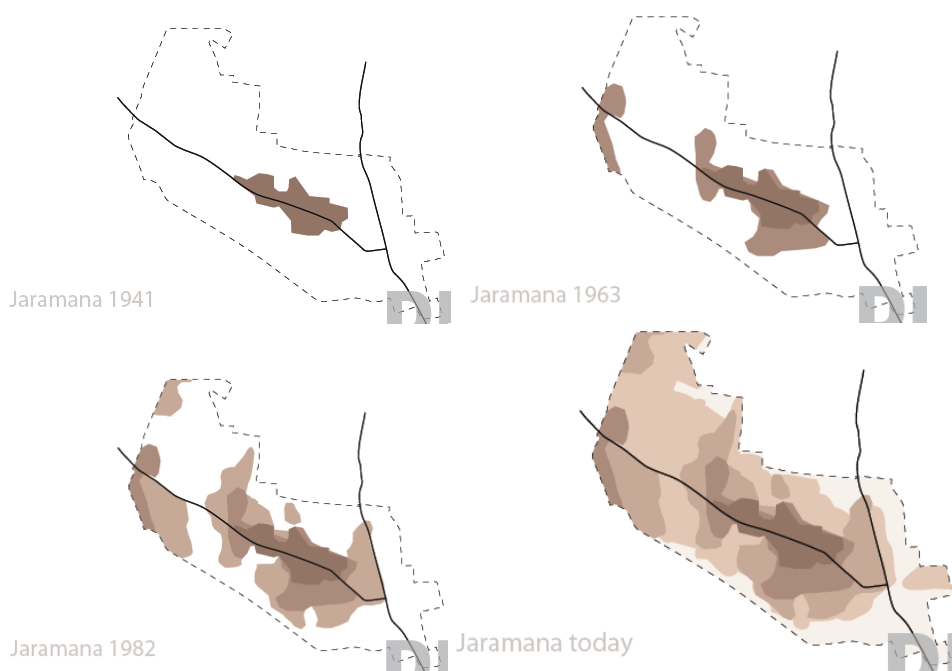

Figure 3.6: Historical expansion of Jaramana from a village to an urban suburb, 1941–2009 (Fahmi and Jaeger 2009).

Based on data from Fahmi and Jaeger (2009), in 1940 the population of Jaramana was 1,800 people, in 1960 it was 5,000, in 1982 it was 65,000, in 1999 it was 70,000, and in 2004 it was 114,000 (Fahmi and Jaeger 2009: 21–25). The authors note that the rural-to-urban population drift caused internal migration to larger urban centres

and Druze immigrants from villages came to Jaramana. In the 1980s the authors note that there was an increased influx of Christians and other Syrians into Jaramana due to its location, cheap real estate and processes of gentrification that were taking place in the Old City of Damascus.

Jaramana – A Druze geography

Geographically, Jaramana borders with Jaramana Refugee Camp to the north, a Palestinian refugee camp of more than 18,500 inhabitants established in 1967 (UNRWA 2010). The eastern side of Jaramana borders the village of Mleha and is comprised of large and small farms, most of which engage with small-scale agriculture and some with animal husbandry (chickens, a few sheep and milking cattle). In this vicinity there are also a few factories producing oil, soap, juice, paints, bricks and other goods. The development of industry in Jaramana, as overall in Syria, started in the 1970s and was marked by a shift from a largely agricultural village (producing fruits, vegetables, walnuts, wheat and wood) to that of an urban suburb. Economic activities in contemporary Jaramana include a wide variety of shops with consumer goods, farmlands converted to apartment buildings to fulfil the needs of the ever-increasing population, and entertainment venues such as open-air restaurants and play grounds (called *moubtada*).

Furthermore, social networks, developed through varying degrees of intimate communal and family relations, transform Jaramana from a space to a socially constructed place (Harvey 2009; Rabo 2005). These relations of intimacy figure on to the social as well as the physical landscape of Jaramana through material and immaterial markers, traces that underline a social geography through history and social relations. For example, different neighbourhoods in Jaramana may be associated with different families, periods of Druze migration, as well as the places from where migrants arrived (i.e. Sweida, Jabal al-Ala, Lebanon). Also, different nationalities and different religions usually reside in different geographic locations. Furthermore, the social geography of Jaramana contains elements of social stratification in terms of social status and class: the religious centre of Jaramana is associated with the oldest, politically and religiously important families, certain streets and new developments are associated with professional middle classes, and some areas, particularly where refugees reside, are associated with the urban poor. In the

remainder of this section the most important geo-political landscape markers in Jaramana are outlined.

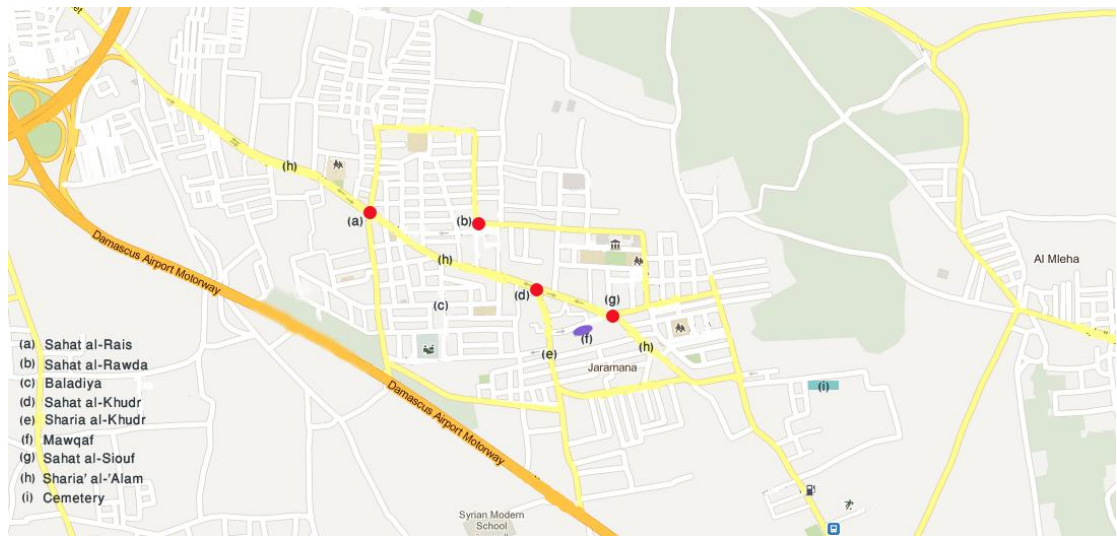

Figure 3.7: Map of Jaramana with significant social, religious and political markers

Running parallel to the airport highway, Sharia al-Alam diametrically cuts through the city. Meaning ‘street of the world’ this is the main high street of Jaramana – its name rather well suited since it is the central and the busiest street of Jaramana. A dual carriageway, it runs through the commercial centre of the city, and is the main connecting road between Jaramana and Damascus. Sharia al-Alam is filled with shops: from car services, to restaurants, telecommunications and electronics to food and clothes shops. Residents of Jaramana often compare sharia al-soyouf Alam to *souq al-Hamidiya* – the renowned covered market (*souq*) in Damascus city. Residential quarters occupy both sides of the main street and extend in both directions.

Sharia al-Alam starts at the northern boundary between Jaramana and Jaramana Refugee Camp. Sharia al-Alam has three squares, the first of which is *sahat al-rayes* (president’s square). The area between the Jaramana arch and *sahat al-rayes* is the area most densely populated by Iraqi refugees and one of the cheapest areas in Jaramana. Further down the high street, on the east is *sahat al-rawda*, a square in which many restaurants and cafes have been recently built. Almost at the same level but on the west of sharia al-Alam is the junction of *Baladiya*, the street that houses the administrative governmental offices of Jaramana, three private banks, and new planned housing apartments.

Further south along sharia al-Alamis *saḥat al-Khudr*. This square is very small, deplete of markers, and surrounded by two falafel, one ice cream and several clothes shops. This inconspicuous square marks the historical and religious centre of Jaramana and is also the area where a number of the oldest and most important families in Jaramana reside. The square on the western side of sharia al-Alam leads to sharia al-Khudr, where the Druze shrine (*mijlis*) of al-Khudr is located at the ground level floor of an apartment building. Al-Khudr is the Arabic name for Saint George, who the Druze consider a ‘holy man’ (cf. Khuri 2004). The *mijlis* is not always open, depending on the schedule of its care-taker, but it is always open on a Thursday, the ‘holy’ day of the Druze when the religious initiated (*‘uqqal*) go there to ‘read.’ The shrine is open to Druze and non-Druze, women and men. Many a passer-by stop at the front and kiss the iron green door, drink water from a tap on the outside, or light a candle. During my second fieldwork visit in 2010, a much larger religious temple was being built some ten metres from the original *mijlis*.

The last marker on sharia al-Alamis *saḥat al-soyuf* (square of the swords), built in the 1990s to commemorate those fallen in the battles of Syrian independence against the French colonial mandate (1921–1943). This is an imposing statue of four swords touching each other and forming a shield, under which a woman with a child along with a man wearing the traditional Druze trousers (*shirwāl*) and a soldier stand. In religious terms this area is also of importance as between it and sharia al-Khudr lie the female and male places of ritual mourning (*mawqaf*, see chapter 4). Finally, on the southern-most boundary of Jaramana is the Druze cemetery (called *turbeh* or *marbara*).

Two houses in Jaramana

Imprinted in my field notes and memories, day and night, my remembered Jaramana is bursting. It is always busy, jammed with the traffic of cars and people. Chaotic in its constant movement and urban development somehow it retains the feeling of enclosure – an almost mystical relation between its crowded commercial streets and the small neighbourhoods and seemingly hidden old Arabic houses that spring beside. These constant movements of people, news, and goods render Jaramana in a state of constant regeneration, a constant juxtaposition of images, not always complementary, and always in a constant state of flux. Most of all, however, Jaramana is the place of the two Druze families that I lived with, and through whom

my intimacy with Syrian life and culture began, and in which it is based. And so my memories are tainted with the smell of cardamon in Arabic coffee and the taste of sweet tea, with the warmth of Umm Samir's smile and the shelter of Umm Nidal's embrace, with communal activities such as cooking, cleaning and drinking mate, and with evenings of dancing *dabkeh* with the *shabāb* (guys, friends).

I owe much to my two mothers in Jaramana, Umm Samir of *bayt* Abud-Haddad and Umm Nidal of *bayt* Ouward, who welcomed me into their house and who eventually adopted me into their homes, families and stories and who made me an honorary 'Catholic' Druze. These women and their respective households share certain similarities and differences. Both are Druze, live in close proximity to one another, both introduced me to strangers as their daughter, and both of these women were the first people to understand, and translate, my broken Arabic at the start of fieldwork. However, *bayt* Abud-Haddad is perceived as more religious and more traditional than *bayt* Ouward, and indeed my movement into *bayt* Abud-Haddad was sanctioned on these terms: Umm Nidal arguing it would be better for my research to stay with this 'traditional' Druze family.

The two families occupy quite different social networks within and outside of Jaramana: members of *bayt* Ouward are involved in a number of associations, political and intellectual circles inside as much as outside of Jaramana and the Druze community, while *bayt* Abud-Haddad almost exclusively interact within the Druze community of Jaramana. Before the anthropologist arrived, the two families did not have social relations although they knew of one another. Interestingly, 'sharing an anthropologist' between them, meant that increasingly the two families met more often and invited each other into their houses for official meals, at the beginning, and less formal gatherings as they got to know each other better. I still remember the first time I visited *bayt* Abud-Haddad with Umm Nidal: we were received in the formal living room, both Umm Nidal and Umm Samir were very reserved, Umm Nidal was making what appeared to me as unreasonable requests regarding my living arrangements (i.e. bringing down one of the walls of the more than a hundred years old house in order to build a small kitchen for my own use!), while during the second visit when we were invited to sit in the family's living room Umm Nidal requested a chair – there were only cushions on the floor. The initial meetings were filled with

different kinds of embodiments regarding perceptions of status and class, between the two families. Although *bayt* Abud-Haddad is not in strictly Marxist terms working class, because they do not sell their labour in return for wages, their manual occupation and religious background are in stark contrast to the secular, leftist and intellectual background of *bayt* Ouward, which is certainly middle class in terms of both occupation and social networks. Moreover, visual differences between the two households were overwhelming: one household lived in a traditional courtyard house, the other in an apartment flat; in one there were beds, sofas, chairs and tables, in the other there were cushions and mattresses on the floor; one family was secular, the other religious; in one house there was alcohol and cigarettes, in the other house there was no alcohol and smoking in front of elders was forbidden.

But perhaps there is more than meets the eye. Besides, in the relational framework where becoming is a constant process, and where absolute definitions are unsettled, i.e. in a framework such as that of Jaramana, emblems of modernity and tradition may hide more than what they explain. Tradition and modernity are hugely contested terms within the discipline of anthropology,⁴¹ not only because these crude classifications more often than not perpetuated a hierarchically divided world, but also because when uncritically used they obscure and deform the complex and interrelated processes that everyday life entails. The persistence of this problematic dichotomy, however, underlines, among others, certain visualist biases. In the sections that follow, I am using these visualist biases through the examples of houses as consciously crude metaphors for tradition and modernity, ‘inwardness’ and ‘outwardness,’ in order to trace their merits, expose their limits, and reflect on the ironies emerging from the use of ‘traditional’ and ‘modern’ inside and outside of Jaramana.

***Bayt* Abud-Haddad**

The Family

Bayt Abud-Haddad is one of the oldest and most religiously significant families of Jaramana, a family that has, and continues to provide many religious *shaykhs* and

⁴¹ For example, see Geertz (1963); Latour (1993 [1991]); Rabinow (1989); Miller (1994); Sahlins (1999).

members of the *'uqqal* (initiated, see chapter 2). *Bayt* Abud-Haddad is widely considered *'abl al-Jaramana* (people or natives of Jaramana), which means that the family and the locals trace their genealogical origins (*aṣl*) from Jaramana. However, genealogies and origins are relational classifications, socially constructed and varying according to context and in relation to other frames of reference. For example, members of *bayt* Abud-Haddad date their family's arrival in Jaramana to about – 150–200 years ago, which based on the available historical record roughly correlates to the Druze settlement of Jaramana. The family traces its Druze origins to the first ancestor convert to the Druze doctrine from Tunisia in the 11th Century. Without chronological specificity, the ancestors were persecuted in Tunisia and migrated to Syria, to Jabal al-Ala near Aleppo. A great-grandfather of *bayt* Abud-Ouward moved to Jaramana approximately 150 to 200 years ago.

The family has an interesting 'weapons of the weak' story regarding the origins of their double-barrelled name. The household's members' registered name is Haddad, however the family is known in Jaramana as Abud-Haddad. This is because sometime either in the late Ottoman Empire or during the French Mandate, the state enforced conscription to all eligible males, except for males that were the only sons, and thus considered as 'heads' and providers within a family. At the time the family had three eligible sons and in order to avoid the army one registered the family name with the authorities (Haddad), the other son registered his mother's family name (Abud) and the third son was registered with a completely new name. Thus, none of the three sons were conscripted to the army.

Abu Samir, or Ali, the father of the family, is the son of Hussein Haddad and his second wife Nadira Latif. Hussein had one son and four daughters from his first wedding, and when his first wife died he remarried Nadira and had a son (Ali) and a daughter. However, Hussein died five years after his second marriage, and Nadira, who never married again, looked after her children and Hussein's four other daughters. Hussein's eldest son from his first marriage, Hassan, attempted to inherit most of his father's inheritance for himself, taking advantage of the Muslim Shari'a Law that was implemented in Damascus and its environs. Nadira, however, did not allow that to happen. She took advantage of the Druze Codes for inheritance (that provide equal rights to siblings for inheritance) and fought a legal battle with Hassan

through the religious courts in Sweida. Nadira won and protected the rights not only of her two children but also of the four daughters of her late husband's first wedding. Hassan broke ties with the family, and Nadira nurtured all remaining six children until they were married. Nadira's story is a very important story within the family and the village. Up to this day, Ali and his half-sisters are very close.

Umm Samir, Amal, is a distant matrilineal cousin of Abu Samir (mother's brother's daughter). Amal's mother died when she was 11 years old, leaving behind nine children. Amal's father remarried a year later, and Amal and her siblings passed some difficult years after that marriage. Amal was forced to quit secondary education and enrol in seamstress classes. By age fourteen, Amal was looking after the household, her younger siblings, and earning an income. At this time she fell in love with Ali and they got married. Just before his marriage, Ali used to work as a small-scale farmer, first tending a small parcel of family land and then selling this in the 1970s to buy a smaller piece of land on the eastern side of Jaramana, in order to advance his business (intensify production) and be able to afford to pay the *mahr* (bride-price, see chapter 5) for his marriage (for a more intimate account of the history and daily life of Ali and Amal, and *bayt* Abud-Haddad, see Kastrinou 2010). Umm Samir, apart from being one of the most welcoming and loving people I have ever met, is one of the wittiest women that I know, with an inexhaustible stream of jokes and caustic (but never sarcastic or cynical) humour. I have never seen her angry or losing her temper (even when there are more than ten grandchildren of varying ages and demands running between her legs, crying, eating, jumping off the windows). She is in her early 50s, mother of ten, grandmother of fifteen (at the time of writing), a woman of small rounded stature, just rounded enough to smooth out the edges, to accompany her warm and comforting personality. A testament to a life of physical hardship, Umm Samir's hands are rough and dry, her legs swollen with the visible evidence of a vascular illness – both conveying the story of a hard-working life.

Umm and Abu Samir have ten children, aged between 15 to 35.⁴² During the time of my prolonged fieldwork stay six of their children were married and resided at different houses with their spouses and children, and four were living at the house: Nadira (15), Mwataz (17), Jihad (19) and Tariq (23). Tariq is the first offspring from

⁴² All ages are current to 2009, when fieldwork was carried out.

the family to go to the University, he is also a talented painter and sculptor. Tariq's existential explorations and his anthropological curiosity provided me a significant gateway to his house, inasmuch as his 'community' and 'culture' (and I suspect that his curiosity regarding the foreign anthropologist was precisely what led me into his house, a house that never before had 'rented' a room, and in which no 'foreigners' had stayed). He is an invaluable interlocutor, a dear friend and a brother. The oldest daughter of the family had successfully passed the University exams but never enrolled into a degree; she got married during the same year. The other four sons of the family are self-employed in manual jobs. Of the siblings, two sons and four daughters have been married, most of them within the extended family (see kinship diagram below), and the daughters work at home.

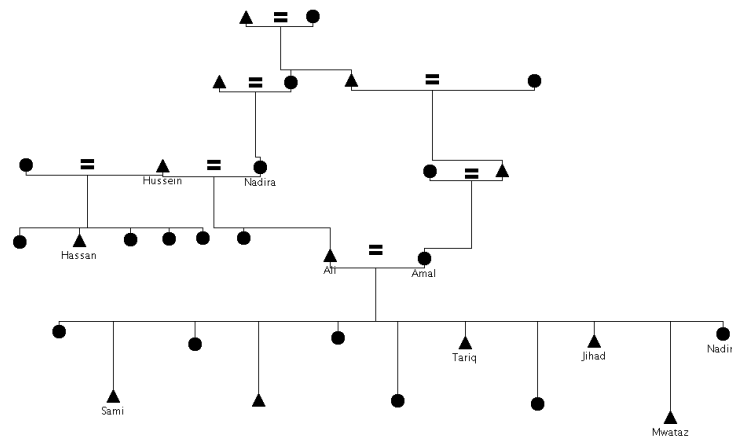

Figure 3.8: Bayt Abud-Haddad lineage diagram

In *bayt* Abud-Haddad, rarely a day would go by when some of the sons, daughters, in-laws and grandchildren would not visit the house.⁴³ On such occasions, the daughters or daughters-in-law and their children would spend the whole day in the house, taking care of the children, of house errands, and of the food that would be communally prepared for the evening meal when all of the family would come together. Less often, Abu Samir would take Umm Samir in his work van in the

⁴³ Residence in Jaramana follows the patterns of patrilocality as the extension of socio-economic relations more than as in actual geographic proximity; although families do prefer to live in close proximity to their extended families. Upon marriage the groom and his family are expected to provide the house for the new-wed couple. In the past, this could have meant accommodation of the new bride within the family quarters of the groom's father's house. The Arabic house, with its numerous separate rooms surrounding an internal garden, provided adequate facilities for the accommodation of more than one nuclear family. However, as Umm Samir noted: 'Arabic houses were not made for just one family. But, now, everybody wants to live in their own apartment...'

morning and drive her to the house of a daughter or a daughter-in-law, where she would stay the day. During summertime, Umm Samir would wake up at five o' clock, sweep and mop inside and outside spaces, water the plants, and by six or seven Abu Samir and other household members would wake up and after a short breakfast comprised of *maqdots*, olives, yogurt and *zater*, would go to the farmland that the family owns, at the edge of Jaramana, to tend the land, picking apricots and walnuts. On Fridays, however, Umm Samir made sure to stay at home because the milkman would bring twenty kilograms of fresh cow's milk from which Umm Samir made yogurt and cheese.

The house

Circa the turn of the 20th century a house (*bayt*) is⁴⁴ built in Jaramana, not atypical of houses in the greater vicinity of the village. The house forms a rectangular shape imprinted upon an open space, and is made out of typical Damascene construction material: mud-brick supported by wooden beams.⁴⁵ The rectangular construction comprises of four, almost square, spacious rooms adjacent to one another.

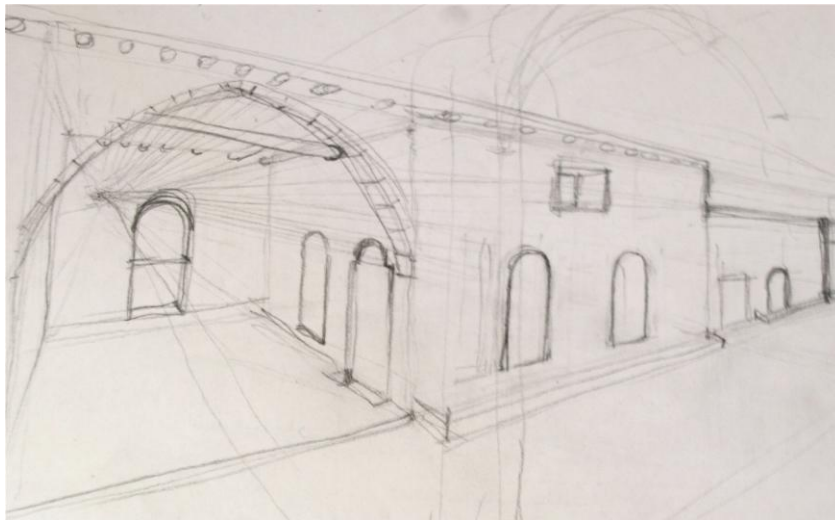

Figure 3.9: *The house at the beginning of the 20th Century. Drawing by Tariq Abud-Haddad, 2009.*

⁴⁴ The description is presented in ethnographic present tense.

⁴⁵ Houses were constructed on the basis of both (a) availability of construction material in the greater geographic area, and (b) resources of the household (Hourani 2005: 126–127). For example, regional construction material for Damascus included wattle and daub, mud-brick and wood, for Aleppo grey stone, for Sweida basaltic black stone, and for Raqqqa mud and hay.

The rooms of the house are (in order from the bottom of the photograph): *bayt al-sheta*, a kitchen/family room; *qā'a*, a reception/guest room; *ivan*, a north-facing, open reception room (it has only three walls); and, finally, another *qā'a*.

The house is readily accessible to the passer-by as its form and doors are visible; it is 'open' in the sense that it is not surrounded by a wall or a gate; such architecture is typical to what is generally referred to as a 'village house' in Syria, opposed to an Arabic or 'city house' (see Hourani 2005: 126, Tergeman 1994: xvi–xvii, 16, 31). Entry to the house is possible either through the open space of the *ivan*, which interconnects the two reception areas (*qā'a*) with doors; or through *bayt al-sheta* which has a separate door facilitating access from the outside, not interconnected through any other gateways to the rest of the rooms.



Figure 3.10: Bayt al-sheta. Photograph by author, 2009.

Bayt al-sheta is a literal description of the function of this space: meaning the house of winter, it becomes the most comfortable room during wintertime for household members to live in, warmth is provided by a wood-burning fire. Maybe as a euphemism, this room delineates a spatial difference in terms of social boundaries of intimacy: it is the family space, and as such it may appear as 'cold' or 'impermeable' for 'outsiders' as only household members or very close relatives and neighbours may enter it. Furthermore, the house of winter can both literally as well as figuratively be

conceptualised as a ‘house’ on its own, as in its name, a stand-alone entity. Subdivided with a wall into two unequal parts, this room combines being a family sitting room in the larger space, along with being the centre of food preparation by having a small kitchen and storage area in the smaller part. Members of the household use this room as their somewhat more intimate zone or private family space. During the night, the women of the household along with young children sleep here. Also, this is the room associated with food preparation and giving birth.⁴⁶

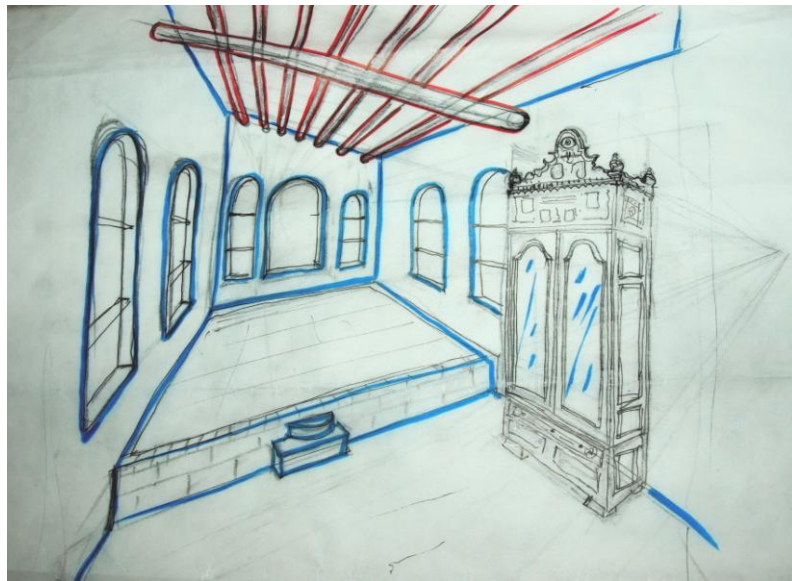

Figure 3.11: The qā'a, internal ground elevation is called 'ataba (threshold), see Weber 2009: 236. Drawing by Tariq Abud-Haddad.

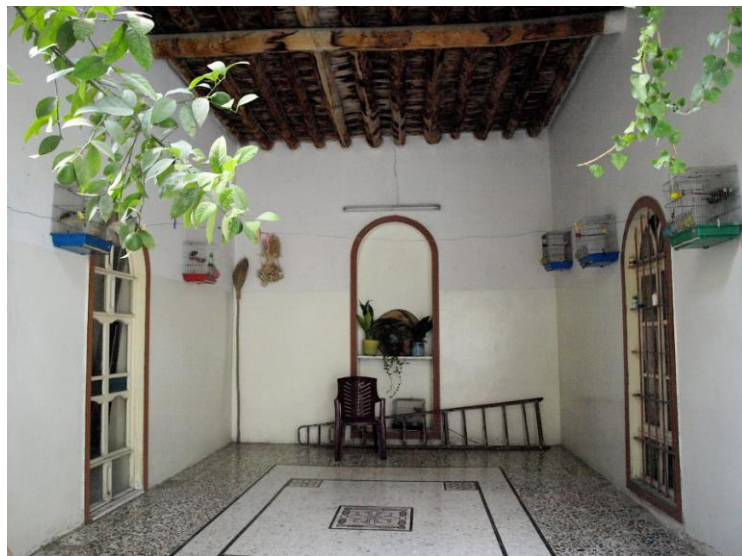

Figure 3.12: The iwan. Photograph by author, 2009.

⁴⁶ Umm Samir proudly recounted how she gave birth to all her ten children in *bayt al-sheta*.

Together, the three spaces of the *ivan* and the two *qā'as* (double plural: *qā'atein*; plural: *qā'atat*) form a cluster of rooms dedicated to the reception of guests and visitors. Since entry to these three rooms is different from *bayt al-sheta*, a spatial distinction is embodied in the housing arrangements through the structural manifestation of two separate quarters, one of them specifically designed for the exclusive use of household members (*bayt al-sheta*), while the other (*qā'as* and *ivan*) for the accommodation and entertainment of persons with varying degrees of connectedness to household members.

The *ivan* generally refers to an area, usually an entrance to the *qā'a* with a 'large circular arch which had spread westwards from Iran' (Hourani 2005: 126). In the case of this house, it refers to the large space between the two *qā'as*, which resemble a room without one of its walls. The *ivan* functions as a cool guest or family sitting room during the hot summer months by combining the provision of shade and breeze through air circulation during the hot summer months. Its floor is mosaic with beautiful inlaid Damascene geometric patterns.

The word *qā'a* literally means 'room or chamber' but is used to designate the main reception room of the house (which, in different areas of Syria and the Arab Middle East, can also be called *majlis*, see Hourani 2005: 126). The two *qā'as* are spacious rooms fitted with low cushions (made of hay or rugs), abutting two or more walls, thus forming an imaginary circle or semi-circle of sitting space on which guests and hosts are accommodated. The floors are dressed with carpets (either bought from the city market or from Jabal Al-Arab⁴⁷ which has a long tradition in woollen carpet manufacture). The walls have integral cavities that act as shelves for the display of objects (such as guns or coffee pots, and later photographs) or as storage spaces for pillows and mattresses. Walls and surfaces are decorated with textiles: hangings, rugs and carpets. Hourani (2005: 127) notes the important and pervasive role that textiles played in Arabic houses. Low, soft furnishing, textiles, the minimal use of furniture, make these rooms not only welcoming but also very *tactile*, an almost kinaesthetic experience of entering and being-in-the-house. Thus, visiting and being a guest is not only about entering into certain prescriptive relations of power and patronage, but an almost phenomenological state, a state of host-ness and guest-ness.

⁴⁷ Also known as Jabal al-Hawran and Jabal al-Druz, in the southwest of Syria.

The reception of guests, and the social relations that are formed, maintained and reciprocated, are practices of daily activity, practices that hold significant social, political and economic value. As such, social visits reproduce forms and ways of *relating*, belonging, and being. The architecture of Druze houses embodies this relational social practice in a way that, as Piot observes for Kabre houses: it is not the ‘real’ practices that derive from an ‘ideal’ model but rather the ‘ideal’ which derives from reality (Piot 1999: 127). Having guests (*doḡūf*) is not only symbolic of power (Khuri 2004: 141), solidarity and generosity (Khalaf 1981: 57), but an embodied relation, and it is estimated that eighty percent of a Druze house is dedicated to guestrooms. The space of the reception of guests varies widely across the socio-economic spectrum, in that the number, decoration and size of *qā’a* rooms corresponds positively with both wealth and respectability of its owner. On the higher end of the social hierarchy, the *shaykh* (religious leader) or the *mukhtar* (political and economic leader) of a village has a separate house for the accommodation of guests. This guesthouse is called *madafa*,⁴⁸ and through its visibility (Gilsenan 1996) it is a distinguishing trace of power (Khuri 2004: 141): ‘under its [*madafa*’s] arches coffee beans were roasted and pounded, clients earned and symbolic capital accumulated’ (Khalaf 1981: 128). Khuri (2004: 142) notes that ‘in Jabal al-Arab today, the first room to be built and furnished in a new house is the *madafa*, and the primary supplies are coffee and coffee pots.’

One can argue, and certainly my Syrian interlocutors did, that a *qā’a* or a *madafa* is not considered as such in the absence of coffee and the ritualised exchange of coffee making, serving and drinking. Coffee pots, coffee beans, a metal base with coal for a small fire and two small coffee cups are necessary accessories for the *qā’a*, as guests, sometimes even before they physically enter the house, are welcomed with bitter Arabic coffee (*qahwa murrah*). Below is an excerpt from the diary of a nationalist revolutionary, Rustum Haydar, regarding his reception in Jabal al-Arab, during his journey to join the forces of King Feisal from Damascus to Transjordan in 1918:

When a guest arrives in a village to stay in the guest-house [...] it is not customary among the Druze to start conversing with travellers before

⁴⁸ Weber (2009: 237) states that the word *madafa* is of a recent origin as the term does not appear in Ottoman sources; in the cities of Bilad al-Sham the term *manzūl* would be used instead. Other multifunctional and prominent rooms in the house would be the *qā’a* and the *murabba*’ (Weber 2009: 236).

they have rested awhile. The master of the house remains standing [all of the time] to show respect for the guest and to carry out the duties of hospitality (*al-qira*); he moves in and out, welcoming the guests every time he re-enters, saying, *Ablan wa sablan*. This welcome is repeated many times... The coffee is offered [using] one cup or two, or ... [at most] three, the same cup touching the lips of ten or twenty people without being washed... (Haydar in Salibi 2006: 131)

The repeated *ablan wa sablan* (welcome) to the guests is a common stereotype of the Druze throughout Syria, since even though the process of welcoming is ritualised and expanded in time in all social occasions and groups, only the Druze repeat it throughout the duration of a visit.

As Khuri notes, ‘nothing surpasses the ritual of serving coffee in complexity and symbolism’ (Khuri 2004: 142). In practice, the ritual serving and drinking of coffee is the processual performance of the social bonds of exchange between host and guest, negotiating through interchanging expressions of honour, respect and gratitude the roles of giving and receiving (i.e. receiving coffee and giving honour, or giving hospitality and taking prestige), whilst the actual consumption of coffee through a single shared cup is a metaphor for consuming hospitality and solidarity, a direct and powerful embodiment of the relation.

Finally, the first *qā‘a* is also the place where the male members of the household sleep.

Fifty years later, and the house of Abud-Haddad has changed. The structure of the main four rooms (*bayt al-sheta*, first *qā‘a*, *ivan*, and second *qā‘a*) remains the same but the exterior of the house has expanded to occupy an almost square courtyard in front of it. There are walls surrounding the house and its courtyard, while a distinct entry point, a gate, to the house quarters has been built.

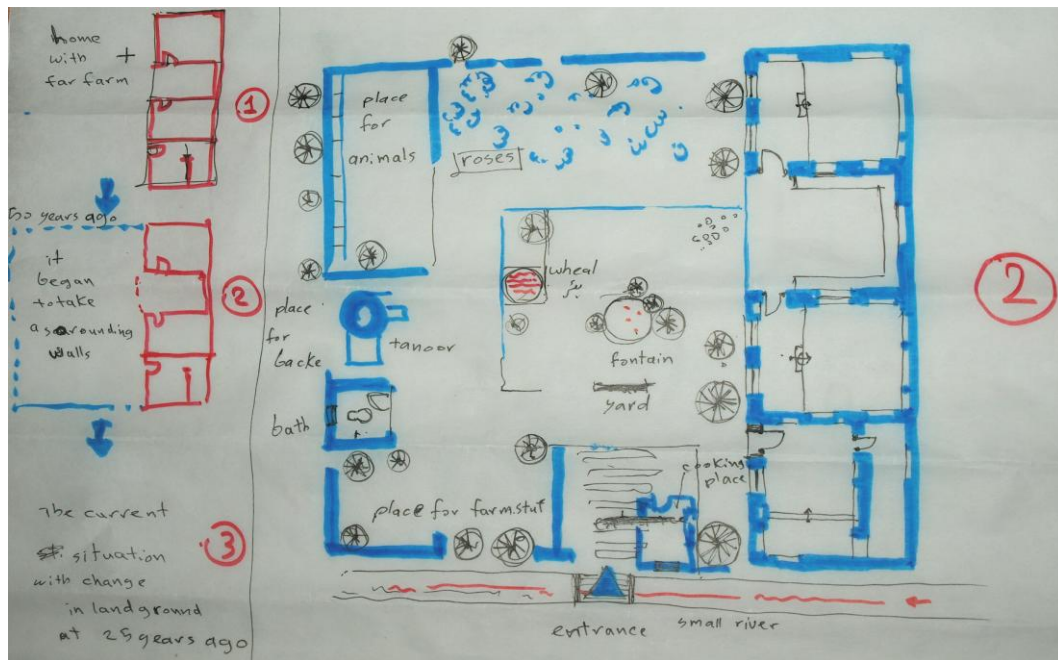

Figure 3.13: Drawing of the three phases in the development of bayt Abud-Haddad. Drawing by Tariq Abud-Haddad, 2009.

A small irrigation canal runs across the southern side of the house; there is a small, wooden, man-made bridge across the irrigation canal that is the gateway into the household quarters. Upon entering the house through this gate, a household member or a visitor, is greeted by a fountain of water occupying the centre of the courtyard. On his/her right side stands the old house. Behind the fountain, on the northern-most side of the house's walls, the visitor is greeted by a colourful flower garden with roses, geraniums, ferns, jasmine and a few orange and lemon trees. Then, s/he may notice the scattered evidence of household activities and subsistence, clockwise from *bayt al-sheta*: the external cooking space on the right of the entrance; the scattered farming tools and instruments on the left of the entrance; a recently built private restroom; the *tamūr*, an oven for making thin Arabic bread, composed of a domed metallic surface with a coal fire located under it;⁴⁹ between the *tamūr* and the fountain in the centre, there is a *ba'ar*, a millstone for wheat; and in the corner between the *tamūr* and the flower garden, there is a stable for the household's animals: a horse for transportation, a cow for milk, and a few sheep for household or local consumption

⁴⁹ Bread making was a gendered household activity performed by female members; every household had facilities for making bread, while it was considered *'ayb* (shameful) to purchase bread already made. For the significance of bread as a staple, see Hourani (2005: 127).

during special occasions, such as when prestigious visitors would arrive, and during religious or social celebrations.⁵⁰

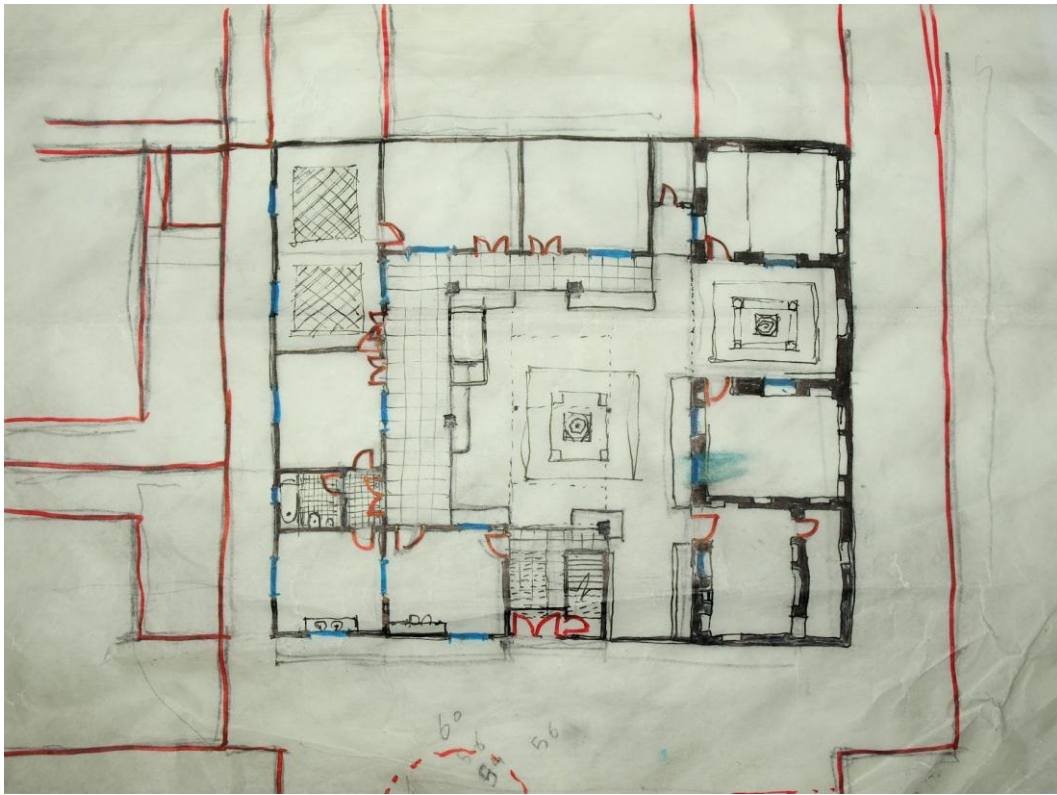

Figure 3.14: Ground plan of bayt Abud-Haddad. Drawing by Tariq Abud-Haddad, 2009.

Winter of 2003: the household members watch television in the living room, located on the left of the main entrance to the house quarters, furnished with cushions abutting the three walls (the fourth is saved for the television), a thick reddish carpet, and an old *sobiya*⁵¹ in the middle of the room. The position of the entrance is the same as in 1950 (described above), the irrigation canal does not exist anymore, and much has changed in *bayt* Abud-Haddad. The house has been changing radically since the 1980s.

The structure of the oldest part of the house (*bayt al-sheta*, *qā'a*, *ivan* and second *qā'a*) has remained the same, but *bayt al-sheta* is no longer in use (its floor removed, it functions as a shed for old and out-of-use things, construction material, etc.), and the second *qā'a* now functions as a walk-in closet and storage for long-life foodstuff (big

⁵⁰ A note on diet: diet, varied along socio-economic strata, comprised mainly of staple rice and bread, and of fruit and vegetable; the consumption of meat was relatively rare. Also, see Hourani (2005: 127).

⁵¹ Wood-burning stove used for warmth during winter. More recent stoves burn petrol, or heating oil (*mazout*), which is subsidised from the state.

jars of olives, olive oil, pickles and marmalade jars, jars of *maqdots*⁵²). Two large rooms stand where the flower garden used to be. The room on the left is used by the household offspring for sleeping and studying. The room on the right used to be the private room for their grandmother, it has remained empty since her death, a couple of years ago, but now it is being prepared to accommodate the first-born son of the household and his soon-to-be bride. They will live in this room temporarily until their own apartment house is built on the household's owned farmland at the edge of the city. The two rooms were built between 1975 and 1982, and their first residents were displaced Druze refugees from the Golan Heights.

The animal stable has been substituted with a very large 'salon,' the most formal reception room of the house, and is furnished with sofas, tables and chairs. However, this room is sparingly used, only on the rare occasion that a *shaykh*, a visiting group of *shaykhs*, or a very prestigious guest arrives. Shoes and less-used household equipment (like an electric vacuum cleaner) find their way into this room.

Next to the salon, in the space that the *tanūr* used to occupy, a family/living room has been built. The room has two entrances, one open to the courtyard at the centre of the house complex, the other opening to a small hallway. The hallway contains a sink, and connects the living room to the restroom (which stands in the same place as the 1950s version but has been rebuilt and includes a bath tub) and to the kitchen. The living room contains cavities in the wall that function as wardrobes, the floor is decorated with a thick blue carpet, and abutting three walls, cushions and pillows on the floor provide seating.

The floors of the hallway, restroom and kitchen are tiled. The kitchen is spacious, containing a fridge, a gas oven/stove, melamine cupboards on the walls for storage, and a large marble sink underneath a window that looks out to the neighbourhood street. The kitchen communicates with a second living room (on the right) via a large, sliding internal window: during eating times the large metallic *ṣaniya* (large metallic or copper tray that food is served on, see Khalaf 1981: 57) passes through the window from the kitchen to the living room and the family sits on the floor to eat around the tray.

⁵² *Maqdous*: baby aubergines stuffed with walnuts, garlic and pepper; they are preserved in oil and usually served during breakfast.

In the central courtyard, where the fountain used to exist, a mosaic with a central Damascene geographic pattern is covering the earth. Pergolas with vines cover the open internal area of the courtyard, providing shade and grapes in the summertime, leaves for vine leaves stuffed with rice and meat (*yialanji*) during the spring. Planters with trees and flowers form an imaginary square around the central courtyard. Tiled, slightly elevated verandas construct a liminal space between the newly built rooms of the house and the internal open space of the yard. On the right of the entrance is a concrete staircase that leads to the floor above. Concrete cones spur out in the open, foundations for a future first floor. It is now, more than ever before, that *bayt* Abud-Haddad resembles a *traditional* Damascene house.

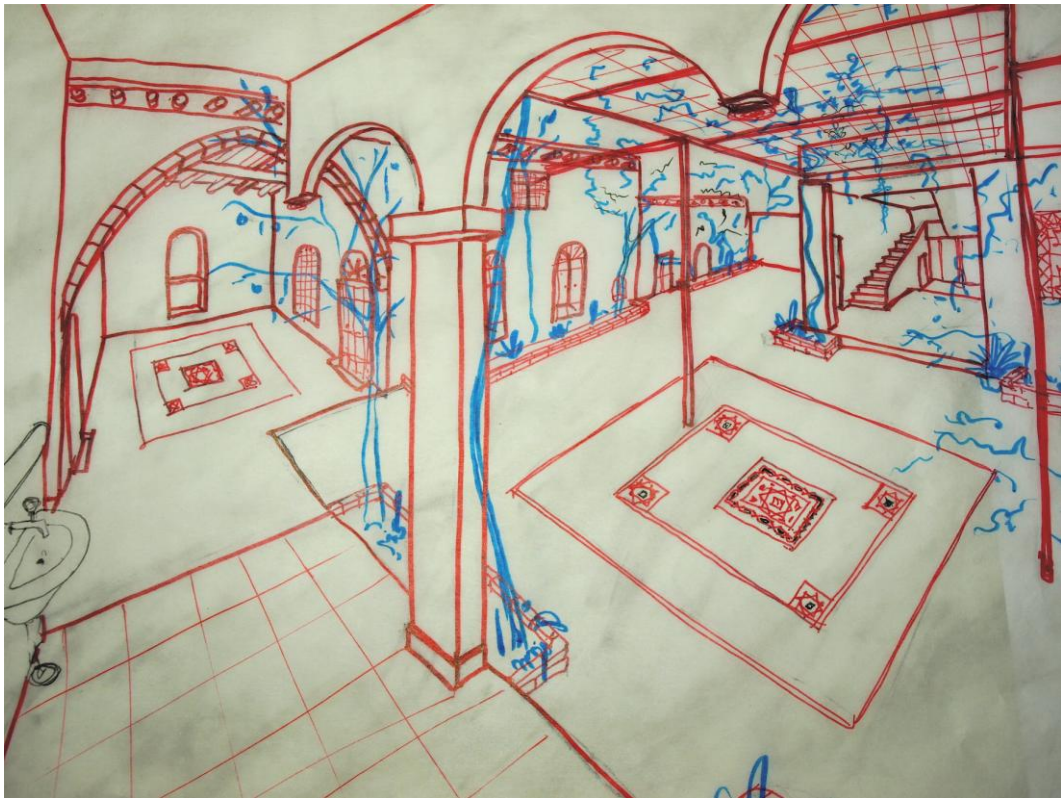

Figure 3.15: Inside the courtyard house of bayt Abud-Haddad. Drawing by Tariq Abud-Haddad, 2009.

Bayt Ouward

The Family

Bayt Ouward traces its origins from a certain tribe in Yemen. Based on the family's genealogical tree,⁵³ three ancestral brothers migrated around 1500 to Lebanon, and settled in three different villages. Ouward was one of the brothers, and the head of the extended lineage (*bayt*) and settled in Lebanon. The father of Abu Nidal, Karem, migrated to Jaramana in the 1920s, and after three generations the family traces their origins back to Lebanon. Karem married a woman from a village in the Chouf Mountains, Lebanon, and had five children, born and raised in Jaramana, four daughters and Farid. Farid Ouward, born in 1941, was the only male heir of *bayt* Ouward. Farid inherited the family house, which is located along the main street that runs through Jaramana, sharia al-Alam. His sisters live in close proximity to Farid's house.

Farid Ouward is married to his matrilineal cousin (mother's sister's daughter), Najwa, and they have four children: Zahra, Hiba, Nidal and Karem. Najwa's parents were born in the village of Gharifeh in Lebanon, but migrated to Sweida, capital of the Druze province in Jabal Al-Arab at the beginning of the 20th Century. Najwa's father, now in his 90s, lives in his grand European-styled mansion in Sweida, and proudly recalls the days he was a General in Sultan Pasha Al-Atrash's army during the Syrian Independence Revolution (1925–1927) and how later after the WWII, he cooperated with the British Forces to finally attain complete Independence from the French. Najwa grew up with her five sisters and three brothers in Sweida, and moved to Jaramana after her marriage with Farid Ouward.

Najwa was born in 1952, in the principal town of Jabal Al-Arab, Sweida. She received primary education in Sweida and when she finished school she successfully passed the national university examinations, into the Mathematics Department of Damascus University. Her father and family, however, vetoed against young Najwa's movement to Damascus, and instead she enrolled in a local institute in Sweida to acquire

⁵³ The genealogical information for the two families was derived as oral histories and cross-checked with different members of both families, usually with the fathers and/or elders from the patriline, since lineage is derived patrilineally. Both families mentioned genealogical family trees dating centuries, and although both families mentioned a book that contains such information, I have not seen it.

teaching qualifications. Najwa explained to me, as we were looking through her black and white photographs from the times of her teaching qualifications – photographs of young Najwa with long hair and rather short skirts, that becoming a teacher was a much more accepted occupational path for a young woman. However, her family valued education and, like other well-off families of the late 1960s, also saw the economic and social benefits of such a financial strategy in times of social change and especially in times of radical reforms (see Khalaf 1981 for an example of adaptive economic strategies regarding education; see Khuri 2004 regarding Druze attitudes towards education). Najwa’s two brothers were both studying at university: one for an engineering degree in Damascus and the other in Spain for medical studies. The decision of Najwa’s family to ‘keep’ her in Sweida may be a correlate of both social as well as financial considerations, since supporting another family member away from home could have drained the family budget. Under such light, what may appear as a ‘traditional’ ‘gender inequality’ could be understood as a pragmatic socio-economic move on behalf of Najwa’s family.

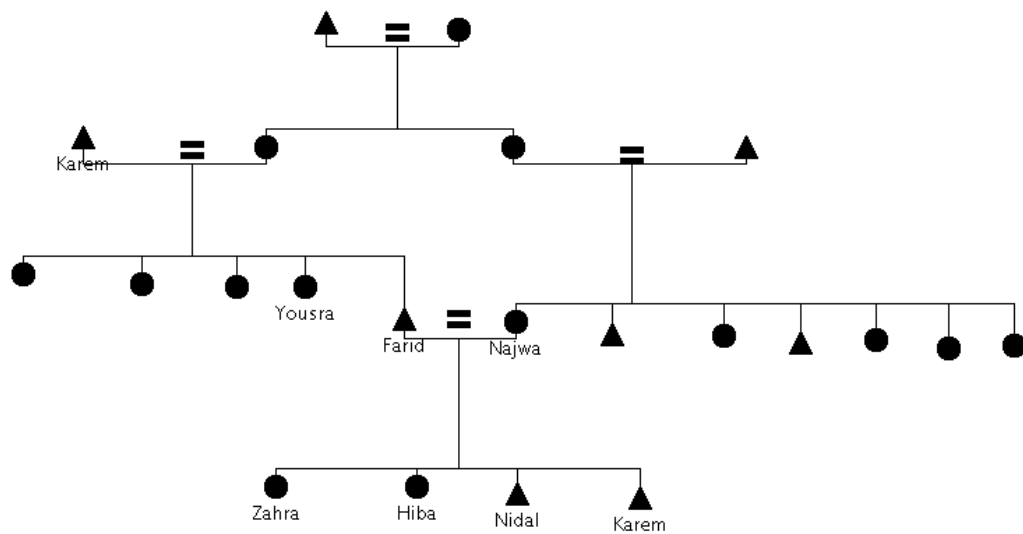

Figure 3.16: Lineage diagram of Bayt Oumard

Prior to her marriage in 1973, Najwa had met Farid in a few family gatherings, had heard about him, and admired his knowledge and political adventures. Farid had studied history in the University of Cairo, between the years 1960–1968, during the swirl of Nasserism and its painful aftermath after the Six Day War in 1967. His leftist inclinations led him to become involved in several intellectual and activist circles in

Cairo, and although he was never a sworn Nasserite, he supported (and still does) the broad ideological platform of Arab socialism (*al-ishtirākīya al-‘arabiya*).

However, Farid’s acquaintance with Arab socialism in Egypt, as well as his support of the Lebanese Social Progressive Party headed by the Druze Kamal Jumblatt, brought him at odds with the Syrian regime upon his return to Syria in 1969. At the time, Syria was ruled by the radical Marxist faction of the Ba’th Party, headed by Salah Jadid (1968–1970). Farid spent five months in the prison as a prisoner of conscience. Upon his release the secret services (*mokhbābarāt*) kept a close watch over him. Farid worked as a high-school history teacher for several years, in rural provinces of Syria; he believes that his postings to relatively secluded rural places were not coincidental. During the early 1980s, however, a time of political turmoil in Syria, Farid was made to ‘voluntarily’ retire from his teaching job, due to political suspicions against him. It was during this time that Farid, along with his sisters and their husbands, decided to start a family business and convert their house into the form it has today. Prior to the establishment of the family business, Najwa worked as a history schoolteacher in local schools in Jaramana.

In 1985, Farid suffered a life-threatening stroke, in the course of which he suffered an internal brain haemorrhage and was operated upon. The operation was successful, and after five months of hospitalisation, Farid was healthy again. However, because he underwent brain surgery, Farid received a medical certification of ‘brain damage.’ With this certificate, the state authorities and secret services cannot arrest him, or so Farid claims, on the basis of his political conviction: ‘I am free to say whatever I want, for, if I show them this paper they know that I’m just mad and hence they cannot arrest me!’ I cannot be sure of the certificate, as I never saw it, but Farid thoroughly enjoys occupying a risqué oppositional stance vis-à-vis the government in Syria, which he constantly describes as a dictatorship. He routinely makes jokes against the president and the lack of freedom in his country, whether he is with his family, friends or in his business with customers. Apart from making jokes against the regime, Farid also enjoys talking about philosophy, history and politics, as well as listening to, especially, music and artists such as Sabah Fakhri, Feirouz, and Asmahan. He is involved in a number of political and artistic organisations, and he is a well-known patron and host of (usually politically risqué) musical gatherings.

When Najwa got married to Farid, they moved into his house in Jaramana. Najwa, who is a very beautiful woman, was very much in love with Farid, who was much older than her: 'We used to discuss everything... From our daily routine, to philosophy and politics. Sometimes we'd converse until the early hours of the morning. He taught me a lot, but he also wanted and heard my opinion... Apart from the eleven years that separated us, we were truly equal.' As a married woman, Najwa entered the University of Damascus and graduated from the History Department. Before her graduation, Najwa had given birth to their first daughter, Zahra.

Najwa had a miscarriage prior to the birth of Zahra, and when her daughter arrived everyone in the family rejoiced upon the news of the healthy baby. 'The family – well, my auntie Yousra to be precise – were less happy for the birth of my sister, Hiba,' said Zahra in a humorous tone in July 2009. 'When Hiba was born I was almost four years old, and my mother returned from the hospital with Hiba and a doll for me. She said that my sister had brought this gift, and for many years I believed that Hiba had been in the belly of our mother with the doll!' We: Zahra, Najwa and I, were sitting in the living room with the air-conditioning on, sipping Arabic coffee, laughing at the caustic humour of Zahra. Her humour alongside the recollections from childhood that she and her mother were recreating, aimed to alleviate the tensions of Zahra's eminent departure. Zahra has been living in Europe for the past eight years, currently completing a doctorate. Her younger sister, Hiba, has joined Zahra in Europe, studying for two Master diplomas. Emigration is very common in Syria: to Gulf, Europe, Americas, legally and illegally, for work and studies. Yet, it is considered quite uncommon for females to pursue higher studies outside Syria. Although Umm Nidal helped her daughters to get into higher education and to travel outside of Syria, she is anxious about their marriage prospects: 'an over-qualified woman is difficult to find an equal husband in our society... and the more they [her daughters] grow older the more difficult it becomes.' Zahra has passed 30 years and her sister Hiba is approaching 30. And Umm Nidal's daughters are not visiting Syria very often: more than a year had passed since Zahra's previous visit. Now she has been in Syria for a week and she was due to leave in an hour.

‘Yousra was happier when Nidal arrived... But I couldn’t understand how my mother became Umm Nidal from Umm Zahra!’ Keeping with Arabic traditions, the Druze follow the prevalent Arabic cultural patterns in naming: the parents take the name of their first-born son, and in his absence, the first born-daughter. Nidal is in his late twenties, has studied business and technology, and is running an Internet café with a friend. Umm Nidal had been trying to find him a bride during my stay there, that is a bride other than the girl that Nidal was in love with – someone that by Umm Nidal’s understanding was ‘uneducated’ and not equal to him. Thus, although Nidal had remained in Syria, his marriage preferences also caused tensions within the family.

On the day of her departure, Zahra’s humour was concentrated on Yousra, Farid’s elder sister who lives in the same building. The two women had a verbal fight the day before, and Yousra decided to go for an excursion at the holy places in Sahba so that she would not be present at the time of Zahra’s departure. A bundle of pressures surround Zahra’s presence in the house: the pressures of when and whether she will return to Syria, the pressures of who is to blame for Zahra’s departure. In recreating pleasant common memories with her mother, Zahra is not only evoking the ties that bind a mother-daughter relation, but paints a picture of Yousra, as the eternal common, for her and for Najwa, enemy. Zahra is remaking the story of childhood from her current point of view, an attempt to reinforce the relationship with her mother.

The story continues, Zahra narrates how she used to play in the neighbourhood always beyond her curfew, Najwa recalls that Zahra used to be *galīzab* (undisciplined). Najwa would punish by grounding or spanking her, but Zahra would continue to disobey. Hiba was more fearful and would stay at home, standing by the window making precautionary expressions to Zahra regarding how late or how angry their mother was. Najwa nods her head in agreement, and prefers to look at me during the story. I wonder whether this is to make sure that I understand or because she’s avoiding looking at her daughter whose departure is daunting and painful. Maybe she also knows that the memories of childhood narrated are not so innocent... they contain the implications, the tensions and disagreements of the

family today (see chapters 1, and 5). Family relations were strained, although at that point, still brewing under the surface. Umm Nidal was concerned about her two daughters living in Europe: will they return, will they marry a Druze, is it her fault for letting them go? Abu Nidal was continuing talking about philosophical and political matters, but remained largely indifferent to domestic politics, leaving all the burden to be shouldered by Umm Nidal. Nidal did not approve of his sisters' life outside of Syria and outside of the Druze realm of endogamy. He understood their reasons, but he argued somewhat cynically 'these are our traditions, this is our society, we cannot change them.' Only Karem, the youngest offspring of the family, 22 years old at the time, supported his sisters. Karem was finishing his degree at Damascus University, and he also hoped to study abroad in Europe. Being the youngest also saved him the social pressure of marriage. During Zahra's brief visit, it was Karem who was helping her, secretly, attain some official papers that she needed for her impending marriage in Europe.

After Zahra's departure Najwa went back to her shop. We had a short discussion about weddings and wedding gifts, and she went back to her house in order to find something to show me. She took time to return.

The House

When speaking of houses what is to be considered traditional and what is to be considered modern? The house of *bayt* Abud-Haddad is located near Al-Khudr, in an enclave of houses. The one-storey traditional Damascene house has two windows looking at the street – the windows are located in the later additions of the structure (kitchen and family room). Apart from those windows the house abides by the 'traditional' requirements of having a central courtyard, of having no windows to the outside and thus being inward looking (cf. Weber 2009, and above). In contrast, *bayt* Ouward live at the second floor of a three storey apartment building with windows and balconies overlooking the busiest street in Jaramana, sharia al-Alam. The house has all modern conveniences, and, at least as much as windows are concerned, the house seems to 'look out' over the world – metaphorically as well as literally since it overlooks sharia al-Alam, street of the world. Furthermore, while in *bayt* Abud-Haddad most of the social activities happen on the floor, *bayt* Ouward uses chairs, sofas and tables.

In the 1980s the housing structure was re-built from a ground level courtyard house into a three-storey high apartment building. The ground floor of the apartment was converted into one spacious shop that looks out to busy sharia al-Alam, while on the back of the ground floor the apartment of Yousra, Farid's eldest divorced sister, is located. There are rooms and open spaces in the basement, functioning as storage for the business, and a big open space that functions occasionally as a reception or *ḥaflah* (party) room.

Abu and Umm Nidal, Farid and Najwa, live on the spacious first floor of the apartment building. The apartment is approximately 150 m², with nine rooms, marble floors and balconies to the front (overlooking sharia al-Alam) and rear of the house. Entrance to the house is by way of a big reception hallway (big enough to contain a large wooden dining table that fits 10–16 people). On the left side of the hallway there are sliding doors that lead to a very large living room decorated with baroque-style sofas and armchairs, along with Damascene in-laid mother-of-pearl wooden tables. From the top right corner of the hallway there is the kitchen, decorated with wooden (Mediterranean style) cupboards abutting the room, a large marble sink and marble surfaces, a large window looking out on the sharia al-Alam on top of the sink. In the kitchen there is a small round plastic table that is used seldom by the family for eating. Food consumption occurs in different spaces depending on the occasion: when formal guests arrive, dinning takes place at the dining table. If a few relatives or friends happen to pass by in time for breakfast or lunch, then they might eat at the kitchen table or, during the summer, at the back-facing balcony. The family will either eat downstairs at Yousra's apartment (this is the usual place for lunch) or on smaller knee-level foldable tables, in the family room next door.

The family room, *qā'a*, is a much smaller room in comparison to other rooms in the house. On parallel walls there are two large sofas, a television and an old oil-burning heater (*sobiya*). During the cold winter months, this is the room the family spends much of its time in, eating, discussing, entertaining close friends, watching television, and taking naps. As this room is one of the smaller in the house it is the warmest. The *qā'a* leads to the room where the two sons of Farid and Najwa, Nidal and Karem, sleep. The room is simple, painted in light green, with two single beds, a wall-

closet and some shelves. On the right of the sons' room, there is a similar room for the family's daughters, Zahra and Hiba. The room is decorated in a similar arrangement to their brothers', only the walls are painted light pink. A large family bathroom separates the offspring's rooms with that of their parents. Najwa's and Farid's bedroom has not changed much since their wedding, in a 1970s style, with two simple single beds put together, a dressing table with a mirror, and a large wooden closet. All of the furniture is a matching set.

A spacious hall containing an impressive library connects the four bedrooms and leads to a rather large room that is used currently as the study space of the youngest son, Karem, who studies at the University of Damascus. The large room contains desks, a computer, a stereo, bookshelves and a sofa with two armchairs. This room is used by the two sons, Nidal and Karem as a study and reception room. The room has an exit to the back balcony, which becomes a focal space during late spring and summer.

Conclusion: Two *bayts* in Jaramana

Today more than a refugee city, Jaramana increasingly bears the marks of gentrification: the continuous development in real estate, new entertainment spaces and cultural hubs are emerging, and the city is increasingly inhabited by artists, intellectuals and University students. However, at the same time that processes of gentrification appear on the landscape of Jaramana, the Druze community seems to be redefining its boundaries more actively and more publicly than ever before: building a grand temple, establishing entertainment halls specifically designated for religious celebrations, the increasingly visual display of Druze symbols on windows, cars and doors, and the intimate almost exclusive social relationships between the Druze inhabitants which make visual the spatial boundaries of Druze social networks. Making place out of space, as Harvey (2009) notes, characterises human societies, and in Jaramana more specifically this interaction is a result of both social changes that have increased migration of different ethnic and religious persons into the city which has resulted into the redefinition of communal groups and boundaries (Barth 1969), and vis-à-vis these newcomers has sustained processes of re-imagination of the community (Anderson 1991) as a distinguishable entity. Thus, while the Druze community, especially communities like Jaramana that existed in the

vicinity of a Muslim majority, had historically refrained from publicly displaying religious affiliation as a way of protection (see chapter 2), the community now is publicly displaying its religion in a way that makes it visually more Druze than ever before. Being a Druze, to use a phrase from Khuri (2004), in Jaramana entails intimacy in both social relations as well as in spatial distinction.

However, while processes of re-imagining and re-defining Druzeness are on-going in Jaramana, the Druze community is by no means homogeneous. Economic, social and political differences stratify the Druze community within Jaramana, along broader divisions that cut across Syria's religious imagined communities, most notable of which is class (Batatu 1999; Haddad 2012; Hinnebusch 1990). This chapter explored these intra-communal differences through the close examination of two Druze families and their houses in Jaramana. Differences between the two families and households include religious, occupational and political affiliations. *Bayt* Abud-Haddad comes from a very religious background, and even though the household I lived in had no *'uqqal* members, because of association, are very concerned with religious matters, as well as social and religious piety. Because of this, other households in Jaramana perceived them as 'very religious' and 'traditional.' On the other hand, *bayt* Ouward, and specifically Umm and Abu Nidal and their offspring are secular, often criticising organised religion. In terms of occupation, Abu Samir used to be a small-scale agricultural farmer, while in the past decade (in which major water supply problems reached the orchards of Damascus) he has diversified his income by building an apartment block at the edge of his farm that provides income from rentals, and more recently he rented the farmland and it became an open-air restaurant (he rented it precisely because it is not 'good' to have direct dealings with entertainment business coming from a religious background; cf. Khuri 2004). Most of Abu Samir's male offspring work in self-employed manual jobs, most of his daughters have been married and work within their houses, and one of his sons, Tariq, has gone to University. Both Abu Nidal and Umm Nidal have university degrees, while all their sons and daughters have gone to university and have professional jobs. Umm and Abu Nidal have a family business which they own (along with other members of Abu Nidal's family) and run. Politically, *bayt* Abud-Haddad are rather reserved regarding their views of the government per se, however, when such conversation does arise Umm and Abu Samir express views very similar

to the state rhetoric regarding Syrian nationalism and they seem favourable to the President and the status quo in general. In contrast, Abu Nidal and all of his nuclear family are very vocal regarding the ‘dictatorship’ in Syria, with both Abu Nidal and his eldest daughter actively participating in leftist oppositional and intellectual movements.

The two family homes were used as examples not only of material structures, but as metaphors of tradition and modernity. But, how can the crude distinction between tradition and modernity hold when the most traditional Arabic house is as recent as the modern apartment? Besides *bayt* Abud-Haddad’s history of their double-barrelled name underlines instances of non-conformity and subversion; while after I finished fieldwork in 2009, *bayt* Abud-Haddad moved into an apartment. And how ‘modern’ is a middle class intellectual family that frames its internal tensions and conflicts within the ‘traditional’ idiom of Druzeness and endogamy (see chapters 5 and 8)?

‘Tradition’ has many translations and more connotations within Jaramana. It is *turāth*, heritage, and it is *‘ādāt wa taqāīd*, customs and traditions (shared habits); modernity is *ḥadāthaa*. But to describe a ‘traditional’ way of life in the sense of upholding certain customs and traditions, or to describe a family as ‘traditional,’ usually the second translation is used (*‘ādāt wa taqāīd*). In Jaramana, *‘āyleb taqāīdiyieb* (traditional family) may refer to the way of life of a given family, their relation to religion (*dīn*), their upholding of certain values or characters that are considered Druze (see Khuri 2004), division of labour, clothing, and social networks. Although terms such as ‘traditional’ and ‘modern’ are both gendered and classed (for middle class associations of modernity see Watenpaugh 2006), they are always already fluid and relational, shifting in-between contexts and audiences. Yet, the epidemic use of the word ‘tradition’ in common parlance, in Jaramana as in most of the world, has to do with religion (for Druze middle classes religious involvement is associated with lack of education), education and profession (class and gender markers), with outfit (clothes, headscarfs, piety in dressing), with ‘decency’ in terms of moral and social conduct that upholds Druze values and avoids scandals (such as premarital relations or marriage to non-Druze, these are broadly defined issues of honour: see Stewart (1994) for critical and precise usages of the word). Because of its positive connotations that concept is also allocated to families that are not engaged in a serious conflict within the community.

For most of these connotations, *bayt* Abud-Haddad fulfils the definitional demands of ‘traditional,’ indeed it is recognised widely in Jaramana as such, and even my own movement into it, ‘helping my research,’ was because it was an opportunity to witness (on the impossibility of witnessing, see Agamben 2004) the ‘traditional’ (*taqlīdi*) way of Druze Jaramanian life. As much as the family of Abud-Haddad is considered ‘traditional,’ their actual house is similarly considered ‘traditional,’ while the family and house of Ouward is considered ‘modern.’

Yet, as evidenced through the development of the two family homes, as generalised characteristics, the distinction between tradition and modernity are not enough and rather than explaining they seem to obscure difference with absolute and hegemonic notions. However, because these classifications are used locally, they should be understood within the local contexts of relations, associations and social distinctions, such as class and status in the case of the two families, that diversify and stratify the Druze community internally. Similarly to perceptions of origin, where the family of *bayt* Abud-Haddad is considered *more local than bayt* Ouward, even though in other circumstances they trace their genealogy to Tunisia, traditional and modern are internal markers of social distinction (Bourdieu 1984). In these contexts, this chapter has underlined some important foundations for the remainder of the thesis: classifications such as tradition, modernity, but also kinship and lineage are themselves relational frames of reference in space and time, and thus should be understood within the relational contexts in which they emerge (cf. Abu-Lughod 1986; Khuri 2004; Chatty 1977, 1986; see chapters 1, 2, 5).

If houses are embodiments, and traces of the ongoing, unstable game of moral and lived resemblances and differences, as Bourdieu (1990) and Mitchell (1991) argue, then the houses themselves are the traces and processes of living. The only problem, then, is that while the ‘the house is a world within a world’ (Bourdieu 1990: 282), the world within and outside the house is expanded. There is the difficulty of finding moral universes, in or out of a house, in isolated and absolute being-in-themselves, not only because of processes of globalisation (Appadurai 2001) but because no ‘culture’ and no moral universe is a whole in and by itself (Wolf 1997), always an effect of myriad encounters (including colonial, Orientalist, see Asad 1973; Said 1978), that leave their traces and are embodied not only in the spaces of houses but

also on the tensions and within the contradictions of those inhabiting the houses. Houses are embodiments, but their traces, resemblances and differences are more nuanced and complex than the location of their doors and windows.

Chapter Four

Of bodies, souls and transformations: Birthing and dying in Jaramana

Enthusing bodies: Reflections

Kohl that paints eyes of newborn children and of brides, kohl that paints Bedouin eyes and belly dancers', for protection and for beauty. Earth, 'ard, on the eyes of the departed, so they leave this world sabaan, full. Bodies bathed in salt water and perfumes – smells that linger on the thresholds of life, death, and the transformations therein. New clothes and old passions. Bitter coffee and cardamon. Sugar and coconut for the new tooth, animal fat of designated ethnicity for the wedding, the neighbour's dinner in funerals. Tastes and smells, acts, events and sights and relations ritual, habitual and everyday. Bodies. Surrounded. Masked. Naked. Engulfed and engulfing. Bodies that perform. That change. That are acted upon. Or act upon other bodies. Bodies that, like smells, linger and dance on the thresholds. Dead bodies and eternal souls that come back, and they are born and re-born, easy to touch but hard to hold on. Bodies that struggle with other bodies, smaller and bigger; body parts dismembered and re-membered, in the struggles of sweat, blood, and lochia.

I was looking for dances, all sorts and any. Folklore and pop, group dances and solos, oriental and western and some place other. I came looking for dances with my notepads and credentials, a camera, video recorder, past theories and future chapters. A step here and a movement there, I came looking for dances, choreographies and improvisations that I would somehow clumsily enter, decipher, and maybe dance. I came looking for dances, and this was an excuse to come, and once there, I extended the arms and the legs of my excuse and tried to peep through the thighs. Embarrassed of the plasticity of my excuse as by my ogling eyes, I repeated to myself and to others that I came here looking for dances. Abu Nidal, then, introduced me to tarab music, old cassettes of Sabah Fakhri and local dissident ḥafleh-s, and told me this is the music and these are the dances. Abu Samir turned on the television Saudieh, where women of presumed Iraqi nationality danced their long untied hair, he said that these are not our dances. Little Sarah, Nadwa and Lina were all, many times, playfully made to dance for me. And I was made to dance, among friends and friends of friends and relatives, in weddings, in gatherings. I was looking for dances, still.

Turned heads. And shoulders. And I was looking for dances, but I could not find dances, maybe because they were not looking for me, maybe because there were no dances. I was looking for dances but how could I find body-less bounded dances? I tried tracing bodies. Ethnic and gendered, political, fragile and dangerous, placid and enduring, wrinkled and regenerating. Can I talk of the sensations without sensualising? I can't talk of dance or of struggle, without a body. But then there is not one body, and there is not an unchanging body. I struggle with bodies, I guess. No, I confess, openly and honestly, that I struggle with bodies. So, I take the easy or the hard way out, or in, it depends on the frame of reference, and I write. I write a story, with begging middle and end, of how events and narratives from Jaramana constantly construct bodies through what is known in anthropology as life-cycle rituals. Birth, marriage and death. Familiar tripartite structure. Or series of stories, because they all came to me when I was looking for dances and not bodies, and because they tamed me, and made me see dances. And besides, whatever you may say, ritual is like writing something with a light pencil and then having life or any body to walk over it, in muddy shoes, sweaty feet, toes filled with sea or desert sand and bloodied heels. And bodies dance on it and well beyond it.

Encountering life and death in Jaramana

Every birth is different. Every mortuary ritual varies. Yet, birthing and dying in the Druze community of Jaramana are ceremonials through which the ritual and the everyday interpenetrate one another, temporal and spatial occasions that negotiate religious, political and socio-economic orders, instances where the cosmological and the ordinary, life and death become intertwined. This chapter describes birth and death in Druze Jaramana through detailed, contextualised and reflexive ethnographic accounts that are analysed in terms of history, society, religion and politics. As this thesis looks into the construction and negotiation of the body as a field of political, socio-economic and gendered struggles through the interlocking public arenas of the state, and the community, we cannot proceed any further without looking into the social basis of corporeal beginnings and endings and how the body is constructed and negotiated within the base-level of community. In this chapter, birth and death rituals and practices are viewed as dynamic transformative, events through which corporeality and its social boundaries are at once constructed and contested. As such, this chapter deals with the construction of bodies as a field of struggles within the Druze community and specifically addresses two questions: how is the body constructed/contested/negotiated through Druze ritual practices? And to what extent do ritual life-cycle events constitute fields of struggles?

Although ritual practices and life-cycle events are dynamic and always embedded within the contexts of social practice, research on Druze rituals has not been adequately theorised, and does not include anthropological understandings of the interactions between ritual theories and practices (see Bourdieu 2007 [1977]; Bell 1992), people and histories (i.e. Wolf 1997; Asad 1973), people and power (see Foucault 1991[1977]) and the practical narrative as well as embodied becomings therein (see, for example, Deleuze and Guattari 2005 [1987]; Gilson 1996; Jackson 2006; Seremetakis 1991). Ethnographic descriptions and analyses of Druze ritual and life cycle practices are haunted by two interrelated problems. The first is the inadequacy of anthropological or ethnographic studies (Sweet 1974; Khuri 2004; Hood 2007), and the relative abundance of Orientalism, found in travel (Seabrook 1928), missionary and academic literature (Hitti 1928) of previous centuries. This problem of accessibility and resources creates a veil of obscurity concerning contemporary Druze social structures, as Betts (1988) has rightly pointed out. The

second problem arises, partly as a result of the confrontation with the lack of material and the apparent novelty of the endeavour, and partly as an impetus to fill-in the knowledge gaps. This is the problem of over-generalisations, dangerous simplifications, and the relative lack of historical and political contextualisation. The result is at times more effective (Khuri 2004) or stuck in lengthy detailed descriptions (Hood 2007) of the ritual ‘stages’ as these take place ‘among the Druze’. These descriptions are often a-temporal, and engrossed as authoritative writings on an a-political culture (Clifford and Marcus 1986); they deny plurality, intentionality and partaking in a wider world of connections to their, depicted as passive, actors, while their own academic credibility goes undisclosed and is taken for granted. Through my descriptions I wish to foreground the ways I learnt what I have learnt with my Druze relatives and friends, and also to analyse life-cycle rituals as embodied and transformative performances of political, social and gendered subjectivities and not as static relics of an 11th century heretical religion. In this regard, Seremetakis’ analysis of mortuary practices is closer to my idea of Druze rituals: ‘divinatory practices are self-reflexive metacommentaries on social and cosmological order... they can shatter the normative surfaces of everyday life... [they] are transformative ... rather than residues of destroyed totalities’ (Seremetakis 1991: 2).

This chapter firstly provides a background literature discussion on research regarding Druze religion and cosmological beliefs. This discussion aims to situate fieldwork within relevant literature and debates, but I am hesitant to draw overarching conclusions regarding Druze ritual theory and practice. I describe natal and mortuary ritual practices situating them ethnographically and analytically within the fieldwork experience as well as the wider Syrian polity. The chapter ends with remarks on ritual transformations, embodied contestations and the interactions between local and not-so-local politics.

The Body and Druze Theosophy

O you who are distracted, how can he who is devoid of his corporeal means obtain knowledge? O you who are heedless, how can he who abandoned his sensual faculty reach ignorance? And O you who are perplexed, how can the souls exist by themselves? And how can they settle in their origin, and yet have a life and procure their pleasures? (al-Muqtana Baha’uddin, Druze Epistle 75, cited in Makarem 1974: 54–55)

In Druze theosophical perspectives the body is portrayed as the garment or shirt (*qamis*) of the soul: a temporal body dresses an eternal soul, and as the corporeal body withers, the soul passes to another body, because as shown above, the soul cannot be manifested or expressed but only through its corporeal means. The familiar philosophical dichotomy of body/soul is cast in a non-dualistic light in the passage above as well as throughout the 111 Epistles that make the holy scriptures of the Druze Canon, *Rasabl Al Hikmah* (written between 1017–1042) (Abu-Izzeddin 1984: 108; Firro 1992: 13). The emphasis shifts from duality to the ‘strict and uncompromising’ (Abu-Izzeddin 1984: 111) unity of God, and unity of all that He has created – this concept is the basis of the *tawḥīd* doctrine,⁵⁴ the foundation of Druze religious beliefs in the absolute unity of God. This interlocking of spirituality (*laṭīf*) and corporeality (*kaṭbīf*) within an ongoing process of soul actualisation in corporeal embodiment, forms the basis of the Druze belief in reincarnation, or human-to-human transmigration of the soul (*taqamus*).⁵⁵ As the belief in reincarnation frames the construction and negotiation of the ‘body’ in ritual and everyday practices in the Druze community of Jaramana, in this section the relationship between the body and soul will be explored in the light of Druze theosophical beliefs and their historical background, providing thus, an imperative foil or abet for discussing contemporary Druze births and deaths.

Divine Struggles: Druze cosmogony and the five cosmic principles (al-ḥudūd al-khamsa)

Tawḥīd cosmology sees God as both transcendent (*munaẓẓab*) and immanent (*manjūd*): ‘the absolute Existent transcends the world while being immanent in it’ (Makarem 2005: 3). In Druze cosmogony the world is a manifestation of God’s Will and it came to be through five successive cosmic principles, otherwise known as dignitaries or luminary entities *al-ḥudūd al-khamsa* (Makarem 1974: 40–49; Abu-Izzeddin 1984; Firro 1992). These five cosmic principles are: the ‘*Aql* (translated as Universal Mind, Intelligence or Nous), *Nafs* (Universal Soul and Activity), *al-Kalima*

⁵⁴ *Tawḥīd* is translated as ‘unity in being,’ and it is derivative of Arabic verb root w-h-d, to be one (Betts 1988: 15). The descriptive noun for the follower of the *tawḥīd* is *Muwabbid* (sing., *muwabbidun* pl.), while the name Druze was somewhat derogatively bestowed to them by the Sunni majority (see Khuri 2004). *Tawḥīd* is also translated as Unitarianism or Monism.

⁵⁵ Druze reincarnation takes place from human to human only, and the Arabic word used by Druze is *taqamous*. Other groups, such as the Alawis, believe that reincarnation may take place between human and any other living form, this is called *tanashoukb* and it is very different from Druze cosmological beliefs. Some authors wrongly translate *tanashoukb* as the Druze belief in reincarnation.

(the Word, principle of being), *as-Sabiq* (Precedent or Right Wing, cosmic unity) and *at-Tali* (the Follower or Left Wing, physical unity and corporeality).

Makarem (2006) states that these cosmic principles are derived from an esoteric interpretation of the Quranic verse (36:82) '*Inama 'amruhu idha 'arada shay'an 'an yaqūla labu kun fa yakūn.*' (His '*amr*' ('nature', 'activity'), when he wills a *shay'* ('desired thing'), is to say to it, 'Be', and it is.):

The '*amr* or *irāda* corresponds to '*aql*'; the *shay'* corresponds to the *nafs*; the *qawl* (in the phrase *an yaqūla*) corresponds to the *kalima*; the imperative *kun* to the *sabiq*; and the implementation of *kun*, namely, *yakūn*, corresponds to the *tali*, in other words, that which follows. (Makarem 2006: 4; also see Abu-Izzeddin 1984: 116)

The first principle '*Aql*, was 'issued from His [God's] sparkling Light' (Hamza ibn Ali Epistle 13 in Makarem 1974: 44). As 'the cause of all causes' (Isma'il ibn Muhammad, Epistle 39 in Makarem 1974: 44), '*Aql* is at once the divine Will, Thought and Vision (see Makarem 1974: 43).⁵⁶ '*Aql* is eternal and perfect within itself, although less perfect than the absolute perfection of God who created it, and its divine purpose is to be in perfect union with the One. However, as '*Aql* was enjoying perfect union with God, it became aware of its own self, of its own perfection. This self-consciousness led to self-indulgence and arrogance eventually making it aware of its separateness from union with God. '*Aql*'s emergence as a self-conscious entity (subject) is described by Makarem (1974: 45–46) as a God-afflicted temptation, personified in the emergence of the Adversary, which constitutes the Druze original sin.

In its plight against the Adversary, '*Aql* developed a passion to return to God: this active yearning gave rise to *Nafs*.⁵⁷ This entity is the 'spiritual nature of the universe' (Makarem 1974: 46) and it 'defines the boundaries of being' (Hamza, Epistle 13, Ibid.). *Nafs* is both spirituality *and* action, since it emerged as an activity from the

⁵⁶ '*Aql* has been translated into English as Universal Mind, Intellect or Intelligence but as Makarem convincingly argues only the Greek *nous* is the closest translation, and translations do not encompass the full array of meanings in the Arabic word, such as the combination of divine Will, Thought and Vision, as well as the original signification of the infinite noun which is 'to bind' (Makarem 1974: 43; also see Abu-Izzeddin 1984: 113).

⁵⁷ *Nafs* is usually described as Universal soul; Makarem (2006: 4) translates the term as 'wish', 'desire', 'endeavour' and 'eagerness'; it is important to stress that Druze *Nafs* is distinct from what we would nominally describe as 'soul' since it combines passion *and* activity, spirituality and *agency* – see Makarem 1974: 46–47.

interaction between 'Aql and Adversary and represents the divine resolution (*mashī'a*, see Ibid.). As such the second cosmic principle establishes an active form of spirituality combining agency and desire.

However, *Nafs* also looked inwards, engaging in self-indulgence (Makarem 1974: 47), which resulted in the emergence of the Antagonist (*an-nid*) who aided the Adversary in promoting deflection from perfect unity with God. As a result of *Nafs*' struggles, the third luminary entity was issued from *Nafs*: *al-Kalima* (the Word of God). *Al-Kalima* helped in 'Aql's and *Nafs*' struggle so that there would be no single distraction to divert from realising union with the One. From this luminary entity the fourth principle was issued, the creation and perfection of cosmic reality (*ḥad al-jirmaniyīn*, Makarem 1974: 48), which translates into cosmic harmony and order. The fourth cosmic principle, *al-Sabiq* (Precedent or Right Wing) strived 'against the darkness of selfhood' (Makarem 1974: 48), and through its struggles the fifth cosmic principle emerged, *al-hikma al-laṭīfa* or *at-tali* (Intelligible Wisdom or the Follower, also known as the Left Wing), in order to overcome "the darkness of individuality" (Makarem 1974: 48). The last cosmic principle signified the 'externalisation of God's Will [...] the perfection of all corporeal beings (*ḥad al-jismaniyīn*)' (Makarem 1974: 48), and it came to denote corporeality.

In this rendition of cosmic genesis we may notice firstly, that God is absolute Existence (Makarem 2005: 3), out of whose Will (*irāda*) cosmic principles emerge successively, each 'issued' almost in amoebic fashion out of necessity from the previous principle's imperfection, which is namely its self-awareness and thus deflection from its purpose of being in complete union with God. Druze cosmogony is permeated with successions of constitutive tensions, tensions that are created and resolved (*mashī'a*) through constant struggles of unity and disunity: cosmological and constitutive struggles between individualism and union. *Tawḥīd's* cosmogony provides an intriguing account of the emergence of everything spiritual and physical as a gradual cosmic emergence through the struggles of five luminary entities that constitute a cosmological map in which struggles are the primary cause and result of the 'cause of all causes,' 'Aql, whilst divine afflictions and imperfection get translated into relational positionalities whose struggle create a dialectical causality in which the much-later philosophical preoccupation of object–subject dichotomy emerges and

gets solved (or struggles to this purpose). Thus, combining Unitarian transcendence with dialectical and dynamic causality, Druze cosmology is underpinned with ideas of union, separateness and struggle.

Human struggles: bodies and rituals

In Druze theosophy the existence of the world is borne out of an amoeba-like process in which principles are constituted *because* of their relations and subsequent struggles. It is *relationships* that create separate entities (subjects) and not the existence of separate objects that form (subjective) relationships as a consequence.⁵⁸ But *tamḥīd* was borne long before the Enlightenment and the philosophical problematic of object and subject or body and mind, and following a Foucauldian critical history of ideas, it is rather difficult to escape our own contemporary discursive formations and epistemological bias, constituted partly through the dichotomy of mind and body, and jump to analyse what this cosmology could have meant for the 11th century Druze theosophists. Nevertheless, considering our comprehensive limitations, we can only afford a contemporary analysis of *tamḥīd*.

Relations, portrayed as struggles of unity and separateness in Druze cosmogony, resemble ‘total social phenomena’ in the Maussian sense. As it is the relationship that constitutes objects and subjects accordingly, and thus disrupts unity, relations constitute the original sin in Druze genesis. Concurrently, however, inasmuch as relations are part of the cosmic problem of inhibiting complete union with God, they are also part of the divine solution (*mashī’a*) because it is only through relations that cosmic principles emerge and the cosmic world is completed. The consequences of such cosmology are twofold: there is not an inherently virtuous or evil quality in matter but these qualities emerge through interaction (see Makarem 1974: 50) and, cosmic union is only established or destroyed through relations. Here the concept of continued struggling with one’s self is elevated to a virtuous and divine struggle. Since evil is not considered an inherent substance of matter, but something that emerges in relation to relations, this view is radically anti-essentialist. It emphasises the dynamic aspect of relations, and their potentiality for either evil or good. For human beings, this means that ‘all souls are created equal with an equal tendency to

⁵⁸ The clearest example of this argument is the cosmogonic emergence of *Nafs* as a result of ‘*Aql*’s activity.

good and evil and are free to choose between right and wrong' (Abu-Izzeddin 1984: 117).

Secondly, the creation of the physical world is the last act of divine cosmogony, which signifies the closure of the cosmic cycle and the last step in resolving the original sin. As such, the last principle, *Al-tali*, presupposes, includes and deconstructs all previous dignitaries. The corporeal world thus, is the last and necessary aid and resolution. This is the context where the physical body is established and in which the human exists as both soul and body, as the quintessential combination of God's divine Will, Thought and Action (*'Aql*) and corporeal unity (*Al-tali*).

The human soul is to the human body as it is meaning to a word. Just as a meaning makes sense only when expressed through its word, so must the human soul be expressed in a human body. The human soul realises itself in the human body. The human body, therefore, serves as the sole medium for the human soul to achieve actualisation and to participate in the progress of man toward knowledge and self-realisation. The true knowledge of the oneness of God, through which man realises his purpose of feeling as much in union with the one as is humanly possible, can only be achieved through man's gradual yet continuous spiritual experience and through his constant preparedness for the Gnostic discovery of human union with the One. For the Druze, the span of a single life is not enough for an individual to realise this ultimate purpose. (Makarem 2006: 5)

This human body, therefore, underlines issues of complementarity and opposition, which are not however binary because they are borne out of the amoebic processes of creation.

On one hand, the Unitarian doctrine states that God is Existence, in which His creations are perfect and imperfect, enjoying unity and indulging in self-awareness, in a context in which His principles are entrenched in a constant struggle that is indeed an inherent struggle. This idea connects to the representation of the body and to reincarnation beliefs as the eternal spirit and action (*'Aql* and *Nafs*) can be expressed only in corporeal terms – the last perfection of creation. Thus body and soul are at once deconstructed and re-constructed as affiliates, as necessary for the actualisation of man, who is in constant struggle to achieve being-in-the-world, but a being in the world which does not entail, as it does for Heidegger, the loss of responsibility.

Through reincarnation, man's spirit is constantly invested on earth and this manifestation happens directly after death since whereas the soul is internal it can only find expression and realisation through corporeality. Under the tenet of reincarnation the body becomes much more than a medium (Makarem 1974, 2006), it becomes the phenomenological horizon through which being, experience, knowledge are realised, whilst at the same time it cannot disassociate itself by virtue of the metaphorical weight of the original sin.

Dying in Jaramana

The previous section has delineated the historical and theosophical background of Druze beliefs. Historical particularities and specific belief systems are not, on their own, sufficient explanatory modes or causal links to understand contemporary practices. Nonetheless, because the Druze are a particular religious community about which little research has been conducted, these references are necessary. In the sections that follow, contemporary ritual practices of birth and death are discussed and analysed. I begin with an exploration of rituals and practices surrounding death, and then birth. The ethnographic descriptions in this part of the chapter appear in actual chronological order; encounters that shaped my perceptions and understanding of death, reflecting the slow process through which access and familiarity fluctuated and thus forms a significant part of the ways I came to 'know' about death rites and rituals. Beginning with practices of death and then going to birth, although it may seem counter-intuitive, also emphasises the Druze beliefs of reincarnation, by which death is the start of a new life.

In Jaramana, as in Damascus, burials take place rather quickly, either eight hours after death or on the next day. Death announcements travel by way of Abu George as well as through word of mouth and telephones. Close relatives arrive at the house of the deceased, and the body is ritually washed by same gender carers or spouse, gender seclusion does not happen in the case of children. The body is dressed in fine clothes and covered with a white shroud (*kafan*). In the case of an unmarried man or woman,

they are dressed in bridal clothes and a candle is placed near the head.⁵⁹ Then, usually the morning after death, the body is taken to the women's *mawqaf*, located off Sharia al-Khudr and near the male *mawqaf*. The male *mawqaf* is open on the top, while the women's is enclosed. After a couple of hours, men congregate outside the women's *mawqaf*, the body is placed in the coffin which is then closed (Hood 2007: 150), and carried on the arms and shoulders of non-immediate relatives, in a procession with the religious *mashāykh* at the head, to the male *mawqaf*. There, the coffin is placed on an elevated platform, where relatives and individuals give eulogies enumerating the person's life history and good deeds (*shahadat* – testimonies). Next, the *mashāykh* recite *ash'ār dīniyya* (religious poetry) and call the final prayer. The coffin is then carried either by a procession or in a van to the north-western border of Jaramana where the Druze cemetery (*turbeh* or *marbara*) is located. Only men are permitted in the cemetery. The body is taken out of the coffin and some ground sand is placed on the eyes of the dead, so that s/he leaves *sabaan* (fulfilled, as in not hungry) and because 'we come from the earth and return to the earth,' explained Umm Samir adding that '*khalās* (finish, as in 'done'), now the soul has left it is just the body.' Finally, the body is placed in the earth and the grave is cemented on the top and bottom. Although Hood (2007: 152) mentions that the cemetery is visited by relatives for forty days after death, informants in Jaramana stated that they do not visit the cemetery: 'In our religion we believe that the body is not important – the soul is. In death only the body is lost. The soul will come back.'

Announcing Death

Jaramana's Druze inhabitants do not wake up in the morning to the sound of *adbān*, the Muslim call for prayer, as neither mosques⁶⁰ exist nor a commandment for the public expression of religiosity (Khuri 2004), since relation to God is perceived as a personal, not public, matter. Instead, they frequently wake up to the sound of Abu George's⁶¹ voice coming out of a megaphone on a car: 'With contentment and submission, we declare the death of...' (Khuri 2004: 226). Then Abu George gives the name and the family of the deceased person, and relays all the relevant

⁵⁹ Candles are symbolically lit during the wedding ritual phase of claiming the bride on the threshold of the bride's father's house, see chapter 5.

⁶⁰ Jaramana has two recently built mosques that are on the outskirts of the suburb, not audible in the central Druze-concentrated areas, to accommodate the influx of Muslim Iraqi refugees.

⁶¹ Abu George is a pseudonym of the Christian-sounding nickname of the original person.

information: the time of the funeral in the *mawqaf*, or, if the deceased person has died somewhere else, such as in Sweida, the place and time for the busses that will travel there and back. This loud and public way of announcing death and facilitating the communal exchange of condolences seems to exist only in Jaramana and Jabal al-Arab (Hood 2007: 148), yet the public declaration of death is noted in studies of Druze mortuary rituals (Hood 2007: 148). Abu George's role is a kind of social institution, a position mediating religious doctrine and social solidarity in which the advert of human loss escapes the confines of a particular family or village and transforms itself into a communal affair. Indeed, based on Druze cosmology and belief in reincarnation (*taqamus*), the death of someone not only affects those who knew her/him while alive, but also those who might have known her/him in a past life, and those to who s/he might be a relative or a friend in the future (Bennett 2006; Oppenheimer 1980). Thus, death is not the abrupt cessation of relationships, but their corporeal and on-going transformations.

Furthermore, Abu George's announcement is not less public than the social expectation (read obligation) to publicly attend funerals: '*kenl al-balad*' (all of the region), '*lāzim*' (must) were the most frequent replies to my questions regarding who attends funerals, followed by critical expressions such as *ḥarām*⁶² should one who is able to, decide not to attend. Khuri (2004: 227) explains attendance at funerals as a religious duty rewarded (*'ajr*) in the afterlife and as a marker of social status, while Hood adds that the obligation to attend is a fulfilment of the Druze commandment '*ḥifẓ al-ikhwān* (protecting or safeguarding the brethren)' in addition to the performance of the religious duty of mercy (*al-raḥma*) (Hood 2007: 147). Although these analyses are the logical deductions of religious and social theories, they are not convincing explanations of the contexts out of which practices emerge, are sustained or eliminated. In short, they do not take into account social dynamics, neither do they tell us anything about the social sustainability and political economy of the aforementioned socio-religious commandments.

A more convincing account, and one that is closer to my own fieldwork experience of the public and communal aspect of the Druze death announcement, comes from

⁶² Similarly to Islamic norm, '*ayb*' refers to things socially forbidden, whereas *haram* to things forbidden by God and thus carries serious implications.

Sweet's (1974) analysis of visiting patterns and social flows in a Lebanese Druze village. Sweet describes the striking pervasiveness of the 'continuous movement of formally or informally structured visiting over all time dimensions' (1974: 112), a movement that enmeshes villagers into webs of complex social, political and economic relations. Within these webs, internal and external boundaries are constructed or diffused through constant negotiations (Sweet 1974: 114–115), and out of which the viability of the 'village' as the most successful social and economic unit of production depends (Sweet 1974: 114). Although Sweet's analysis is not beyond the limitations of the time and contexts of her research, it does provide both thick descriptions as well as dynamic analysis of the social fabrics that make social networks 'the essence of life' (Sweet 1974: 113) in a Druze context.

Sweet categorises visits as *preliminary* and/or *in themselves* (1974: 116), the first type refers to visits that cement and foreshadow future visits and transactions (partaking to alliances, contracts, etc.), while the latter refers to annual ceremonies and life-cycle events that are 'conspicuously ceremonialised and are rituals in themselves' (Sweet 1974: 118). To the extent that all social interactions and relations are preliminary in the sense that they are not abstracted from an uninterested subject without history or future, and without ability of intersubjective interactions, then Sweet's high ceremonials⁶³ are always already preliminary too. To the extent that rituals are never 'in themselves' but external to their relations (Deleuze and Guattari 2005 [1988]), and neither social action nor rituals are bounded and separate entities from everyday praxis (Bell 1992; Bourdieu 2007), then this part of Sweet's analysis is also somewhat elliptic. Nevertheless, her analysis does point out the importance of social dynamics that characterise any such relations, the pervasive habitus of communal visits, and the socio-political and economic negotiations that take place within the realm of visits. These visits form the significant backbone or context through which social interactions, including the publicity of the funeral announcement, take place.

Specifically regarding 'high ceremonials' such as death, Sweet (1974: 118) notes that 'they may lift an event in the lives of people out of individual or small-scale impact and socialize it within the community framework at a range of involvement commensurate with the status of the family or individual affected.' The public

⁶³ For a critical review of the differences between 'ritual' and 'ceremonial' see Bell (1992: 70).

announcement of death, and the recognised obligation to attend the funerals of other Druze in Jaramana are not only 'prime occasions for the public reconfirmation of communal ties and religious values' (Hood 2007: 147). They are also performances: creative instances of intersubjective articulation and expression. As performance they are also bound to the contexts in which they emerge, that is to local politics and relations of power, and they have the potential of creating spaces for negotiation and resistance. In the ethnographic description in the following section, the political and temporal negotiation of the mortuary ritual as a vehicle of simultaneously both hegemony and resistance becomes clear.

The spectacle of death

[Fieldnote March 31st, 2009] Abu Hasan came by in the morning to announce the death of Naji Jaber, a famous middle-aged Druze actor widely known as Abu Antar (one of his TV roles) who died of cancer. Amidst the 'allah yarhamou' (May God have mercy on his soul) that were exchanged, Abu Hasan was excited to inform us that Jaramana had come to a halt: the streets were packed with people and TV vans, famous actors that were attending the funeral, and visitors from Lebanon, 'millioun, millioun al-nas!' (millions of people). We walked Abu Hasan to the door, exchanging 'al-awad bi-salamatikom' (may God compensate your sorrows through a healthy life) when we noticed a TV van parked outside our home. As Abu Hasan was leaving, two female neighbours, the age of Umm Samir, were coming back from the street, dressed in black and wearing the Druze white futah (head scarf). We greeted each other and with enthusiasm and humour they told us about all the famous artists that had arrived in Jaramana from Syria and Lebanon, and how most of them wore huge black glasses – in order to disguise themselves but to no avail!

Death is a communal affair (Khuri 2004; Hood 2007) and communicating news of death cannot but be shared between family members (Umm Samir and Abu Hasan) and between neighbours. As a communal affair, death is not an individual loss but affects the whole of Druze community; hence, condolences are not given only to the deceased's immediate family but are exchanged between all members of the community, regardless of personally knowing the deceased person. During a Druze funeral there is a social expectation that whoever can, will attend the funeral; nevertheless, the number of those who attend constitutes a marker regarding the social status of the deceased (Khuri 2004: 227). In the case of Naji Jabr, the plethora and celebrity status of the funeral attendants is a clear social marker. However, almost inevitably, the numbers and status of funeral attendees somewhat shifts the social and religious emphasis on the deceased and his/her community, allocating attention upon the high profile participants. This shift not only creates a spectacle of death and of attending celebrities, but relocates Jaramana from the minority, closed,

'dirty' and 'unruly' suburb to the centre of attention. In this way, the visitors who come to condole and honour the deceased's life, metaphorically honour the minority community of Druze and Jaramana. The advert of famous 'outsiders' in Druze Jaramana is an expression of the cultural and social significance of the group, notable in Abu Hasan's enthusiasm, which at the same time constitutes the Druze as a coherent separate entity as well as an integral part of the cultural milieu within Syria and the wider region. Not only the community's cohesion and importance is reconfirmed, but through the humorous social commentary of the neighbours the 'theatrical partitions' (Jackson 2006: 281) of the celebrities are deconstructed, showing how while a Druze middle-aged woman might well be at the margins of cultural and political developments, she nevertheless has the power to recognise and, as in this case, ridicule those who occupy central-stage.

Umm Samir suggested to Tariq, her son, to 'take me to see.' I dressed in black and Umm Samir gave me her futah – I hesitated to wear it, thinking it might be something of a religious blasphemy for a non-adherent. As if she'd read my thoughts, Umm Samir placed the futah on my head saying repeatedly "ādi , 'ādi ' (normal). She told Tariq to let me go inside the women's mawqaf, but he was uneasy and hesitant and afterwards told me he'd prefer me not to since women 'may understand...'

There is a difference between mother's and son's attitudes regarding permitting access to the religious ritual to a foreign anthropologist. The mother seems much more flexible in granting access, perhaps because she occupies a more secure social position that grants her the space and authority to interpret and manipulate the situation much more leniently than her unmarried son who, in a way, is himself still being socialised into the religious formalities while also still struggles to achieve an independent status within the community. This is significant because at first it seems ironic and contradictory that 'older and conservative' generations are actually more socially flexible. However, as we noted in the discussion of the different houses (chapter 3), those with greater social legitimacy have greater dexterity in interpreting normative behaviours.

Sharia al-Khudr was full of black-dressed people. Shopkeepers were standing at the doors of their shops, looking curiously at the masses. We took a right turn to the mawqaf street, it was packed with people and journalists. Outside of the female mawqaf a large group of women were waiting to go in. Peeping through I could see the white metallic door with the five-coloured star open, women in black and white amphitheatrically sitting facing a small platform (that, I could not see but I knew it was there from informants' descriptions). Men had started gathering around the male mawqaf, some ten metres up the same street. Tariq and I went up to Fadi's terrace that was overlooking the

male mawqaf and the street. On the terrace to the left al-Jazeera's crew was filming and reporting. The usually grey skyline of Jaramana was also transformed: on terraces and balconies people eagerly watched.

If our house and the communication of news between a relative and two neighbours can be described as a microcosm, then the image from the streets of Jaramana is its logical larger scale implementation. The street ambiance hardly resembles other funeral atmospheres, while the influx of people on the streets, the continuous flow of information and the not always discrete curiosity resemble a society of spectacle. 'Life is presented as an immense accumulation of spectacles. Everything that was directly lived has receded into representation' Guy Debord (2005 [1977]: 1–7) argues, because modern conditions of production resulting from the accumulation of capital and division of labour, serve to alienate and isolate workers from what they produce. Within the contexts of a political 'Western' philosophy that has evolved a visual bias, 'the language of the spectacle consists of signs of the dominant system of production – signs which are at the same time the ultimate end-products of that system.' (Debord 2005: 2) In Debord's sense, mass media only partly contribute to the society of spectacle: 'the spectacle is not a collection of images; it is a social relation between people that is mediated through images.' (Debord 2005: 1) In Jaramana, the occasion of Naji Jaber's funeral was not only a spectacle because of its publicity and entertaining ambiance. Mediated by his TV persona the deceased and his high-profile attendees (but also the media stereotypes of Jaramana, see chapter 3; and the Druze, see Khuri 2004) provide for the representation-mediated relationship that Debord places at the crux of his 'spectacle' society (Debord 2005: 3). Attracted by the outside visitors that are not just visitors but famous celebrities, inhabitants break away with the formalities of traditional hospitality and instead take to the streets in order to get near and see those representations unmediated.

Ironically, following Debord, neither the physical proximity nor the actual seeing of a celebrity ever ceases to be unmediated, informed and constructed by the mass media the representation is only reaffirmed, along with the pervasiveness of the structures of domination that brought it into being. However, this spectacle of death conforms with Jaramana's relations to the 'outside world' and the multi-fold interpretations of a funeral as spectacular reaffirm that both Druze and Jaramana are as much as they always have been parts, maybe marginal but nevertheless parts, of wider socio-

political and economic relations of production and reproduction.⁶⁴ Rituals like funerals instead of being static bounded entities are always already part of the wider webs of interconnections and historical interrelations. But can relations of domination as described by Debord be actually subverted and resisted from the margins?

After an hour, at 1pm, a closed coffin covered with a blue cloth was carried out of the women's mawqaf and in procession led by fifteen mashāykh into the male mawqaf, and there it was placed on a stone elevation. The mawqaf does not have a roof and is of an asymmetrical rectangular shape. On the side of the entrance there is the platform, while on all surrounding walls there are rows of seats. People came in, offered condolences, and before the mashāykh begin their prayers, speeches were made by family members and other dignitaries, testimonies (shahadat) of the deceased's life deeds. One of the testimonies, by someone from the Artists' Union, mentioned the President of the Republic, Al-rayes Bashar Al-Assad, and people started clapping: 'it is not correct to clap in the mawqaf, but people must clap when they hear that name' Tariq said somewhat uneasy and somewhat jokingly when I asked why the mashāykh aren't clapping. After the epitaph speeches, the fifteen mashāykh surrounded the coffin, making a half-circle around it reciting ash'ār dīniyya (religious poetry) – Tariq noted that they make this formation with their bodies because 'it is not nice to have your back turned (to the deceased and the audience) as the Muslims do.' At the end of the prayers envelopes with money (as explained by Tariq) were passed around to the mashāykh as charitable donations. The coffin, finally, was carried outside amidst loud shouting and war-like intonations and placed in a white van. Naji Jaber was buried the same day in the Bab M'Sala cemetery. [In the following weeks I would be asked, mainly by young women, to show the photographs taken in order to check out the attending celebrities. Unfortunately, my photographs must have been somewhat disappointing since no celebrities were identifiable.]

Debord stresses the tautology and pervasiveness of the Society of Spectacle. Yet some of the examples above, such as the open defiance of the Druze *mashāykh* in clapping for the president, the co-construction and affirmation of difference (and superiority) between 'us' and 'Muslims' in Tariq's explanation, as well as that so many celebrities had to come and honour a Druze in Jaramana, provide powerful narratives of subversion and manipulation of the spectacle in a counter-hegemonic way. While both the Druze religious minority and the suburb of Jaramana lie at the margins of state sovereignty and spectacle capitalism, this does not stop the marginalised in reinforcing and resisting the very 'centre' that both constructs and exploits them (see Seremetakis 1991). That is not to say, however, that the alternative counter-hegemonic embodiments challenge their structural domination – on the contrary it furthers crystallises it by adopting the structuring dichotomy of centres and

⁶⁴ See for example, Batatu (1999: 11–32) for the historical and economic interrelations between urban Damascus and the rural fertile countryside that surrounds it, al-Ghouta, of which Jaramana is part.

peripheries (Bourdieu 1994: 90–91). Yet, celebrity deaths can also be read through an existential prism:

The difference between our responses to the death of stars and to the death of mere mortals hinges on the depth of our attachment, not to them, but to the narratives in which they figure – narratives that hold out the illusory promise that mortals and immortals may merge. [...] [What is more profoundly mourned is] the death of a narrative that had connected our own subjectivity to the wider subjectivity of the world. [...] We need heroes, gods, and stars to be sure, but above all we need to feel that *we* participate in the divine and that *they* are within our reach, within the realm of our own choosing. (Jackson 2006: 283–285, emphasis in original)

Although I do not believe that there is an innate need in human beings to believe in heroes, gods or stars (that this subjective attachment is instead something itself constructed within our historical, socio-political and economic realms) Jackson points correctly to the ‘need’ in passing across different kinds of man-made borders such as mortality/immortality, or between our subjectivity and the subjectivity of the world (the Syrian state attempts to address this need through cultural policies, see chapter 6). In this way the spectacular celebrity funeral in Jaramana becomes an intersubjective game of hide and seek in which the roles are interchangeable (but never the same), all players hide from and seek each other while crossing over or permeating into different worlds and through curiosity and critique interact with one another.

Months after the public spectacle of Naji Jaber’s funeral this story was narrated by Abu Samir and Abu Talal: ‘On the same day, after Abu Antar’s (Jaber’s nick name from a famous role) funeral, the funeral of an old Druze woman took place. She was living on her own, she was poor, she had no children or relatives. But all the people who were there for Abu Antar’s funeral went to hers too. She must have had a very good soul and God rewarded her.’ This is another example of celebrity deaths providing the context or pretext for a narrative structure to arise in which the celebrity-quality, some star-like light spills over ordinary men and women.

Narratives of life and death

[Fieldnote April 6th 2009] *His wife, Latifah, woke up in the morning to make breakfast for their two children. She came in [the bedroom] to wake him up and found him dead! He knew he had a heart problem, may God have mercy on his soul, but he did not want to do the operation. He was*

coughing. Even though he was such an active person, always making jokes, and he was handsome, and tall. He was young, 45. Even his colour was so natural seeing him in the open hearse inside the women's mawqaf, made you think he'd wake up! His death is such a shock (moufāj'a) – no one expected it... And there were so many people at the mawqaf mourning the first day: 1000 women, 2000 men. Do you remember how the night before his death we were all together, his two sisters too, at the ḥafleh musiqiya?'

Umm Nidal had just returned home from the funeral. The signs of exhaustion and mourning were easily readable in her red eyes and tense body. Sharing bitter tea and condolences, *al-awda bi-salamtik*, we talked about death. The deceased man was an affinal relative, her brother, Faris, was married to the deceased's sister, Suha, and the two families, living in close proximity in Jaramana have a warm, on-going relation. As a tragic irony, the day before his departure, Umm Nidal, two of the deceased's sisters and I had been celebrating at an entertainment centre in Jaramana, in a *tarab* music party organised by Abu Nidal. Umm Nidal started the discussion by the narration of the chronologically closer events: the 'inside' details of when death arrived, the colour of the deceased's face. These details are both intimate and are shocking, while the story's narration was punctuated with the advert of contingency.

She said that he was the youngest of Suha's brothers, they are eight in total: five brothers and three sisters. His father had also died young, of heart disease, in his forties. They were orphaned at a young age. She repeated proudly how the mother of the deceased had accomplished to send all of her children to university, and she died only shortly after the last one's graduation. The family came from a peasant, poor background, and the brothers finished university while working in farms picking apples. Umm Nidal gave me short descriptions of all of the siblings: engineers, scientists, a dentist and teachers, the brothers living abroad in the United Arab Emirates and Saudi Arabia, one of the sisters living in Lebanon, and the two that I know living in Jaramana. They are all here now. Umm Nidal's face was now less stressed, her posture, lying on the couch, more relaxed.

A similar version of this life-story was weaved later in the night in the company of nine relatives. Enacted and embodied through additional information or nodding of heads in agreement, an epitaph was re-created and shared, a commemoration of adversity and persistence in equal measure, featured in the epigrammatic communal remembering and re-telling of his life story, struggles of the past, and the eminent struggles of the future for his wife and two children, which made death not only tragic but collective. Gilsean elegantly connects narratives, powers and persons through narrative structures of social life and through the enactment of stories in a changing society (1996: 57), by performing a literary analysis of everyday life and an anthropological analysis of oral stories. Applying this technique to Umm Nidal's story, we notice how she presents the deceased as part of a wider family, whose

struggles and successes he is an integral part, including all the culturally relevant information, such as his lineage, father and mother, and professional occupations of his siblings. Furthermore, the recollection of hardship, both economic (poverty, work in farms) and psychological (loss of father), in the narrative of someone's life adds a heroic dimension to the character of the deceased – a dimension that not only draws him vividly to the outsider anthropologist, but justifies his life and acutely hints at the tragedy of his death. In this regard, forgetting or leaving outside the mortuary certain negative characteristics such as his temperament or 'control over his wife,' is also an active process.⁶⁵

Umm Nidal's story and the subsequent re-telling by the group of gathered relatives was not just directed at painting a portrait of the deceased man. As the act of storytelling is always a form of intersubjective dialogue, Umm Nidal and her relatives collectively, dialectically and actively constructed a temporal space that allowed them to negotiate the life and deeds of the dead man, transforming at once his life and death into a collective epitaph: 'storytelling is both dialectically imperative and perennially redemptive' (Jackson 2006: 253). Or, put differently:

Stories take us out of ourselves. Stories belong to the in-between spaces of intersubjectivity [...] storytelling is a modality of working with others to transform what is given, or what simply befalls us, into forms of life, experience, and meaning that are collectively viable. (Jackson 2006: 252)

Towards the end of our conversation Umm Nidal's commentary became more detached as she moved the conversation from the particular death to general mortuary rituals of the Druze: how here mourning lasts for three or seven days, how the dead is dressed with his finest garments, how the dead is not covered like Muslims are, how men and women have different mawqaf and different houses that they congregate because it is more 'relaxed,' how people, neighbours or distant relatives, cook for the family of the deceased, and how we would go together to the deceased's house the day after.

Umm Nidal and I slip to the seemingly objective sharing of general information regarding Druze mortuary practices, a common relationship between anthropologist and informant (see Cowan 1990: 96–97). However, allow me to use Umm Nidal's narrative as an excuse to sketch some practices pertaining to the ritual of death in Jaramana, beyond the specific narration. This sketch shall be brief since both Khuri (2004) and Hood (2007) have provided extensive accounts of the funeral day – the sketch will also underline the differences between those accounts and practices

⁶⁵ I was given this information months later by a member of his extended family.

widely held in Jaramana, and in doing so the very concept of statically defined ritual. Ritual practice is always changing and especially since the rapid urbanisation of Jaramana (chapter 3), ritual practices have become more ‘condensed.’

Al-'usbū' or pain is like a soap

After bereavement, the deceased's family is seldom left alone: relatives, neighbours and eventually most of the region's household representatives visit them, spending long hours in the company of the family. Pain is perceived as a communal affair/obligation and taking part in sharing the pain is socially more important than from happy occasions (Ammar 1998 in Hood 2007: 147). This is because extreme pain, duress and stress that result from the occasion of a beloved's departure are perceived as dangerous for the mental state of the family; the expression describing this condition is *ta'abān nafsīyan* (exhaustion of self/spirit), *ta'ab* (n.) literally means ‘tiring out’ but is widely used in Syria to describe an array of negatively perceived mental states ranging from sadness, to depression and mental health diseases. The common denominator of these mental states is the indulgence in an individualised affliction, which is perceived as an antisocial behaviour and thus challenges communal solidarity. ‘All things are born small and grow up. Only pain is born large and then gets smaller. Like the soap,’ explained Umm Samir, pointing out that pain gets smaller only through communal bonds and sharing. The reconciliation between personal pain and communal solidarity comes from the communal embodiment and sharing of pain that combines individual and social loss into a designated spatio-temporal ceremonial ritual: *Al-'usbū'*.

Although there has been adequate attention regarding the funeral ritual amongst the Druze, almost nothing has been written about the pervasive and encompassing weekly ritual of the *Usbu'a* that starts on the funeral day and goes on for a week. While Hood (2007) does not even mention this custom, Khuri provides a problematic description.⁶⁶ *Al-'usbū'* (lit. week) is a social ritual that lasts for a week after the deceased's funeral in which throughout most of the day and evening the family of the deceased receives condolences and visits either in the *mawqaf* or, more

⁶⁶ ‘After a week, the family of the deceased holds a special ceremony in memory of the dead called *al-usbu'* (the seventh day), during which they share a ‘sacrificial meal’; this brings a formal end to the funeral ritual’ (Khuri 2004: 230).

often, in the house of the deceased. During the *Usbu'a* visitations, the deceased's family receives guests who come to offer condolences and spend time with the bereaved family. Gender segregation is strictly followed in this occasion, through the designation of separate rooms or more often houses, that accommodate female and male guests (usually a near-by relative or neighbour provides their house which tends to be used for the male visitors).

[April 7th 2009, 20:00] Girding the walls of a large living room space, thirty-two women dressed with black clothes and white headscarves stood up as Umm Nidal and I entered the fourth storey apartment located on a road perpendicular to Sharia al-'Am. In the elevator, she instructed me to say in formal Arabic 'ana ḥzint ktir ; al-'awad bi-salamatikom' (I am very sad; may God compensate [your sorrows] through well-being), yet the tragedy and unfamiliarity of the situation made me uneasy at the first instance: women that I knew and that I did not know stood up, from the left side of the room to the right. Was I to greet every one? Even the ones that are not relatives? How would I know who's a relative and who is not?

Following Umm Nidal's movements and taking cues from the standing women I soon realised that, in death as well as in any social gathering in the Druze community of Jaramana, whenever a new person arrives to the house all the people already there stand up and greet by shaking hands or, depending on social proximity and gender, three kisses on the cheeks. Death is not an altogether different situation, and the ritual etiquette that exists in everyday practices is further extenuated, as salutations become condolences (ta'āzi) that are shared with everyone present, and by extension within the whole of community and Druze religion. Death is not an 'individual thing' but a communal affair of the highest degree, a practice that strengthens communal solidarity further through the cosmological beliefs in human reincarnation.

Latifah, the deceased's wife, was first on the line. Red eyes without tears, a posture of sad and beautiful dignity, a woman in her forties whose quiet pain and restraint filled the room. Afterwards, Umm Nidal told me 'Look at his wife... She's so young... Ya ḥarām!' Next in the line was Umm Hussein, the deceased's sister. In her early fifties, Umm Hussein is a stunning woman, very tall, beautiful, and usually very jovial. I was staggered by the redness of her eyes and her stark transformation. I could hardly keep my tears. Yet I was most taken aback by Layla, the deceased's unmarried sister. Without sleep and with little food for the past days, Layla was tired and in distress. She'd rock her body forwards and backwards. I spent the better amount of three hours next to her. She kept asking whether I remembered how we had danced together the night before her brother died, and whether I had any brothers and sisters.

People sat silently, maybe quietly wiping up some stray tears, or talking in low voices and small sentences to the person next to them. The physical geography of what was a spacious living room was completely transformed: black-dressed women sitting on couches and on chairs covered the walls. The women sat and a loud stillness sat with them: few words and sobs crosscutting the room, vocal and mostly wordless presences. Contrary to the Arabic customs of hospitality, there were no offerings to guests. Neither drink nor food existed in the sitting room – if someone wanted a drink or a snack they discretely went to the kitchen or asked a child to bring them some water. It was like sitting and waiting for tiredness to wear the body out, for pain and for realisation to come.

[April 9th 2009] 'These were not songs... well, not exactly. They are stories (qiṣ aṣ)... famous and old, religious, mythological,' replied Umm Nidal on our way back from the mortuary house near

midnight. When we arrived the living room was filled with black-dressed women. Somewhere in the middle of the room, a woman in her seventies with henna dyed red hair would sing a stanza and then the rest of the women would repeat in unison. I couldn't understand much of what was said, but it lasted around fifteen minutes and most of those present participated in the singing. Some women were crying, while Layla was rocking her body, as if she was part of an ecstatic dhikhr performance. Umm Nidal summarised the story for me:

'A well-known, much respected family engages their only son; but he dies the day before his wedding – he dies we don't know why... from natural causes... Someone tells the departed's bride-to-be to take a big platter and to fill it up with food from a house where sadness has not entered. She searches and searches and visits all the houses in the village, and none is happy. Finally she goes to the house of her groom-to-be, sees the family distressed but no one tells her why. So, she goes and cooks the food herself.'

'The point of these stories is to lessen the pain (takhaḥīf al-ḥazīn) through stories that show that everything that happens is God's wish,' added Umm Nidal, noting that if I want I can take photographs for my research. I thanked her and said that I just would not feel comfortable to do that.

The house was full with people, forty-five that I could count. The large living space was filled with mostly middle-aged and older women, the small apartment kitchen was filled with people of a younger age: the deceased's teenage children, their peers, and their cousins. I was invited into the kitchen where conversations and curiosities run high. I guess that my hosts think that it will be better and more 'relaxed' for me to be in the company of people closer to my age. I am afraid that sometimes my age, my 'adoption' and people's care for me inhibit me from establishing a 'research role' or an 'academic profile,' but I guess that always all research is intersubjective and a derivative of the things that you want and you can explore within a specific context. In short, everything that takes place is important and also varied according to the situation, age, gender, prestige. Besides, I would never do anything that could insult my hosts, and I have to lay my trust on to them in finding out what is appropriate or not. For example: Visits to the house of the dead happen throughout the day, in mornings as well as in evenings. I have asked Umm Nidal if she can take me with her when she goes in the mornings but she'd been uneasy about it, stating, 'Old people go in the morning. Young girls like Mona and you come in the evening.'

Descending out of the kitchen and into the living room many of the women had left, the circle now was more familiar, more intimate. Layla was resting with her legs on a couch, other relatives were sitting cross-legged. Tiredness and with it some calmness had started settling in, and conversations were brief and unrelated to death. 'And what can we do? Life goes on,' said Umm Nidal.

It was around ten-thirty when the men (brothers, brothers-in-law and cousins of the deceased) arrived. The men were receiving condolences in a neighbours' house near by. They brought platters of food, the women quickly set the table while the last visitors excused themselves amidst invitations to join. Roasted rolls of minced meat with tomatoes, roasted chicken with vegetable, and different kinds of salads were laid on the table along with Arabic bread and plastic plates and cutlery. We sat down to eat, the food was delicious, but Latifah and Layla hardly ate some salad. What was left was stored in the fridge and some of it went into plastic bags for other relatives to take home. We left at midnight.

The ceremonial visits defining *al-'usbū'* emphasise life over death, community over the individual: as the weekly visits shift the emphasis from the dead to the dead's

living relatives, they provide through this rite of passage the liminal *communitas* (Turner 1995), which here is not a structural inversion of everyday powers but the extenuation of certain ordinary practices located within the specific social habitus (Sweet 1974; Bourdieu 2005 [1990]), and by way of shifting the emphasis to the community aid in the incorporation process of the bereaved family. This process of *communitas* and incorporation is done through the embodiment of both pain and community expressed in the almost constant physical presence of the surrounding other Druze bodies. Loss and community solidarity are simultaneously embodied by the mere presence of other people as well as through practices of sharing food and telling stories (*ḥaki qiṣaṣ*). The physical tiredness that results from the constant intersubjective interaction with others is perceived as an equivalent to exhausting emotional pain and thus preventing tiredness (*ta'ab*) in affecting the mind and sociality of those immediately affected. Furthermore, the social and religious emphasis on the deceased *per se* slowly transforms during the *usbu'a* to a social emphasis on the living, realigning the cosmological perspective of the parodic body and eternal soul with the existential presence of living social bodies. As such, the closure of the *usbu'a* ceremony does not signify the closure of the death ritual since neither events nor rituals are bounded entities, but their constant interpenetration.

Modernising al-'usbū' : local politics in Jaramana

I heard that in the funeral of Faris, bayt Jamil, neighbours of my son's bride's family... well, they made the funeral seven days in the mawqaf but, ya ḥarām, people weren't going [did not visit]! 'This is ḥarām,' another woman exclaimed, while a second one added that 'this not correct... when someone dies the whole country (balad) should attend!' 'Now in Sweida it is only three days...' another woman added, some of the women nodded their heads and the polite discussion moved on.

Since the early 2000s a public debate has been going on in Jaramana. The debate is about Druze mortuary ritual practices and whether these should 'adapt' to modern times – an expression of which is the above discussion among middle-aged Druze women during an invitation for lunch from Umm Samir's neighbour in honour of her son who was getting married the same day, an interesting link to the continuity between wedding and funeral rituals.

As it is customary with debates, this one too has (at least) two main sides to it. One side of the debate, described by my informants in English as the 'traditionalists,' is headed by the current *Shaykh al-balad* (the highest religious authority of the Druze in

the suburb of Jaramana), and argues for the preservation of ritual practices intact. The other side of the debate, described as the ‘modernists,’ argues for changing or altering some of the practices in order to accommodate the changing modern circumstances. The ‘modernist’ side is headed by a Shaykh who is both popular especially among the younger generations, as well as outspoken regarding Druze community and faith.

There are three main points of disagreement regarding the mortuary ritual between the ‘traditionalist’ and ‘modernist’ camps in Jaramana. These, namely, include: the duration; spatial arrangements; and closure of the mortuary ritual known as *al-’usbū’*. Specifically, the ‘modernists’ argue for a reduction in the duration of *usbū’a* from seven to three days of mourning, condolences and visits, while the ‘traditionalists’ argue for the preservation of the full seven-day duration. The ‘modernists,’ allegedly ‘more scientific’ argue that in an industrial society people have to work for wages and live by different rhythms, and so a week off work is not only highly disruptive but a ‘waste of time’ and ‘not modern.’ ‘This shaykh says that we should not change all our traditions but some in order to be more comfortable in our modern circumstances’ (also see chapter 3).

The second point of disagreement addresses concerns over the place that condolences and visits should be held during the *usbū’a* ritual: in the *mawqaf* or in the deceased person’s house. The ‘traditionalists’ argue that it should be optional for the immediate family to decide where condolences should be given, as long as certain customs, such as the segregation of women and men, are adhered to. The Shaykh of Jaramana has been reportedly to state that it is more ‘respectable’ for the deceased to hold the *usbū’a* in the house that he lived in – in fact, because the Shaykh is a neighbour of Latifah, when her husband died she had to follow his advice on how and where to practice the *usbū’a*. However, the ‘modernists’ see the deceased’s house as a symbolic maker of wealth, power, status, and arguing that in death everyone is equal, they state that everyone should share the same space – this is the *mawqaf*. To this argument they also note the ‘modern’ arrangement of apartment houses that do not lend themselves easily to the segregation of men and women (regarding houses, see chapter 3).

The final disagreement is in regards to the time of ritual closure of the weekly mourning. The closure to the ritual traditionally comes during the morning/afternoon of the seventh day of mourning in which visitors give their condolences to the family of the departed. The modernists argue that this ritual visit should take place during the evening of the seventh day and not during the day, because of people's working commitments. Accommodating 'tradition,' a practical notion of community and 'modernity' are concerns emblematic of life in Jaramana, as in most other places. Yet, many of my informants, ranging from teenagers to elders, take a dialectic view of this public debate, blurring and challenging crude dichotomies of 'traditional' and 'modern' (see chapters 3, 5, 7, 8): they openly and pragmatically pick-and-choose between the positions of the different camps, criticising politely both, and in the end abide by whatever they see fit. And whereas there are people who are more or less exclusively on one side of the camp, most, like our neighbours hint at problems through pointing out some, rather embarrassing, examples of what happens when community, religion, and practice are not exactly coordinated. By pointing out situations that are not exactly 'right,' they avoid direct criticism to any one camp, but through reaffirming some apparent 'fundamentals' such as communal reaction to death, they are able to manoeuvre themselves between the different arguments, while simultaneously showing that 'fundamentals' as such, are always already and only contextual.

Umm Samir's polite contributions to the discussion in our neighbour's house are paradigmatic of the discrete but accurate diplomacy exercised as she only nodded or added '*ya ḥarām*' to statements that obviously were against a perceived Druze solidarity, such as the comment that people had not attended a deceased's funeral. When a neighbour mentioned that in Sweida the ritual has been altered, Umm Samir's expression was polite but blank. In our private conversations Umm Samir has expressed at length her sincere admiration for the 'ancient' and 'beautiful' customs that the community has and she is quite adamant that there is no good reason for change. Furthermore, Umm Samir's husband is related to the Shaykh of Jaramana, being part of the Shaykh's *bayt* (house), a *bayt* with a long local genealogy and religious power, she is politically allied and related to the so called 'traditionalists.' This does not mean necessarily that because people are related to a specific camp or family they will be completely and unquestionably allied to all sides

of the debate. For example, Tariq, Umm Samir's son, chooses to agree with some of the points of both camps:

I think seven days is better because it is good for remembering the dead.
I prefer *al-mawqaf* because it means equality for all people. I want the *usbu'a* in the morning because you should make the effort.

At the same time, contemporary conflicts and debates are enmeshed within the historical local political conflicts of the area. Many years ago, maybe hundred or a hundred and fifty – no one is able to say with precision, a big fight broke out in Jaramana between two powerful *bayts* over which one will provide the *mukhtar* of the area. Rivalries broke out, killings took place, and the Druze peasants of the village became divided between these opposing fractions, which resulted in the village being divided in two and having two different *mukhtars*. As years passed by, the conflict grew somewhat weaker, but only in the past twenty years have mixed marriages been publicly accepted (as an old lady put it '*ma biya'to ba'adon*' – they would not give/marry to each other). However, although this conflict is not anymore a source of friction within the Druze community in Jaramana, it still provides a backbone to social alliances, jokes and internal stereotyping. Interestingly, although the Druze influx of immigrants from other places in and out of Syria has somewhat changed the balance of power in Jaramana, the two families figure prominently in the social, economic, political and religious affairs of the suburb, while many families claiming original roots from Jaramana ally themselves to one or the other household. Perhaps, then, it is not so surprising to note that the 'traditionalist' and 'modernist' camps conform to this division of power.

Birthing in Jaramana

Having combined ethnographic description, fieldnotes and anthropological analyses, the above section has outlined the complex parameters regarding dying in contemporary Jaramana. Alongside the discussion of Druze theosophical beliefs, 'death' in Jaramana combines contemporary ritual and political practices through which not only ideas about the body and the soul, but also about the status and politics of the community are structured, negotiated, reinforced and challenged. The following section turns to 'birthing' in order to view how this too forms a contemporary arena of social and political struggles.

Announcing pregnancy

Usually my conversations with Umm Samir took place in the midst of house errands and food preparation. Sometimes in the summer, the daily routine was more prone to change as we would often visit the houses of her two eldest sons, which stand side by side on the edge of the family's plot of land. In the early morning of June 3rd 2009, Umm Samir told me in casual conversation over our morning tea that after Abu Samir returns from *barra*⁶⁷ we would go to the farm (*bourieb*), slipping at the end of her sentence in a casual tone that Sarah and Lina, her daughters-in-law, were pregnant (*ḥaml*: pregnancy, *ḥāmel*: pregnant). With my excitement in stark contrast to Umm Samir's understatement, I asked how many months into their pregnancy the two women were, and was surprised to find out that they were into their fourth month. I didn't show it, but at the time I felt a particular anthropological angst, which I guess is the feeling of a fieldworker suddenly becoming aware of her own limitation in terms of 'access' into a given community: simply put, taking into account that we lived at the same house and that sons and daughters-in-law visit at least once a week, why was I left out of sharing the happy news?

When we went to the *bourieb* (farm), I happily congratulated the two women, who received my wishes with a certain shyness and understatement. I was perplexed by their reactions but did not dare ask for a further explanation in fear that they might not want to discuss this with *me*.

Umm Samir spoke frequently about how her husband and her mother-in-law (*hamata*) became very happy (*m'basat*) every time that she would announce a new pregnancy (*bijib walad*: to 'bring'/give birth to a child), but it wasn't until a year later⁶⁸ that Umm Samir and I talked extensively on perceptions and practices pertaining to pregnancy. One of the first things that Umm Samir mentioned was that the pregnant woman firstly announces the pregnancy to her mother and then her mother-in-law (*hamata*), showing the degree of proximity in social relations and hinting at the shared responsibility and support that will develop between pregnant woman, offspring and grandmothers; this links different generations but also underscores the status change in the case of the pregnant woman. However, the announcement itself can happen

⁶⁷ See Sweet 1974.

⁶⁸ During a follow-up research trip in October 2010, funded by Folklore Society.

anytime between the first and third months of pregnancy, and Umm Samir noted how the pregnant woman prefers to delay: *'balki biysīr shī'* (in case something happens). Uncertain in both medical and cosmological senses, delaying and understating the social significance of pregnancy for three months or more is perceived as creating a private space for the couple simultaneously connected to cultural idioms and prohibitions concerning the protection from evil spirit (*jinn*) and the 'evil eye' (*'ayn al-ajraq*). Delayed, understated and private, the announcement of pregnancy is in sharp contrast to the immediate and public announcement of death in Jaramana. And although birthing in Druze cosmological terms is an expression of the eternal soul, a manifestation of *taqammus* (reincarnation) and a reaffirmation of the religio-ethnic community, on the level of practice it shares with the wider Arab held social ambivalence towards sexuality as polluting (Khuri 2001) and an impetus for the social control of women as a 'serious source of female moral inferiority... [because] pregnancy is itself incontrovertible evidence of sexual activity... [and] since fertility calls attention to their sexuality, women downplay it; they even try to keep pregnancies secret for as long as possible' (Abu-Lughod 1986: 132).

Prenatal practices

The early stages of the pregnancy are of heightened significance for both pregnant woman and foetus. Women in Jaramana discuss these changes as both emotional and physical. Specifically, it is perceived that, approximately between the first and fifth month, the pregnant woman's personality changes (*taghayor nafsi*), simultaneously with changes in her body and appetite: she needs a lot of sleep, she wants to eat more fruits and drink milk, but she doesn't eat a lot. These psychosomatic changes provide for a liminal geography of changing and forming relations both between mother and child, as well as the social status of woman as a mother in Druze community. During this time, the pregnant women 'as pragmatic actors manoeuvring among various networks of power' (Kisch 2009: 729) utilize a combination of medical knowledge systems in order to get advice (*istisara*): monthly visits to the medical doctor, in combination with guidance and customs derived from older women, friends and neighbours. Up to approximately ten years ago, in Jaramana, existed a traditional midwife, *qabīla nisayah* or *qabīla Arabiyeh*.⁶⁹ This woman would provide folk (*sha'abi*)

⁶⁹ *'Qabīla'* means tribe, *'nisayah'* is women's, and *'Arabiyeh'* means Arab's.

healing advice to pregnant woman and eventually would be the one to assist in childbirth. In the years prior to the spreading of social health and medicine, in the area of Jaramana would operate two such midwives, who due to their profession are frequently described as ‘those who have given birth to all of Jaramana’ (interview with the daughter of the late midwife).

The fifth month of the pregnancy is perceived as an important threshold for the transition of the pregnant woman into a mother: during this time the woman begins to ‘feel’ the movement (*ḥaraka*) of the child inside her, whilst physiological discomforts of the previous stage will most probably end, and she will become more comfortable (*tartāḥ*) and happy (*saīda*) for the upcoming birth. The change to motherhood is accompanied with changes in responsibility as well as social capital: ‘*al-bint toufakir bas bil-naḥsa*’ (the girl thinks only of herself) said Umm Samir, noting the change in personhood and social responsibility as well as status capital that comes with giving birth.

During the sixth and seventh months of pregnancy social relations between pregnant woman, the unborn child, and the future father are forged through material connections and gifts: this is the time when father and mother-to-be begin making preparations for the arrival of the new family member, such as buying new clothes for the child (*shou bidi-jiblou al-walad*), new furniture for the baby and/or for the house (these are viewed as gifts of the husband to the mother of his child), as well as appropriate arrangements and provisions for the reception of guests that will flood the house after birth (special tea and sweets for treating guests). Material belongings as well as gift exchanges provide for a Maussian socially and materially constructed relationality in which bonds between the couple, the child, and the wider social circle are formed and reinforced.

During the last stages of the pregnancy the workload of the woman in the household is significantly reduced through the cooperation between other female relatives residing either in the household or from the circle of extended family and friends.

Birth (Wilāda)

Umm Samir frequently mentions with contained pride how she gave birth to all her children by herself in *bayt sheta* (kitchen and female sleeping area of Arabic house, see chapter 3); her last birth took place in 1994. Although birthing at one's home has empowering connotations of female strength (*an-nisoua al-arabi qaoui*, Arab women are strong, informant's comment), women's opinions in Jaramana are complex and divided on the question of where and under what system of knowledge the birth should take place: some consider the hospital safer and cleaner (*andaj*) since blood and bodily fluids are handled and disposed of outside of the home, while others express fears of being 'cut' (referring to the Caesarean Section) and mention the lack of privacy.⁷⁰ Nevertheless, all of the women informants in Jaramana that have given birth in the past ten years have done so in the hospital.

The pregnant woman goes to the hospital accompanied by a small number of close relatives, usually her husband, her mother and her mother-in-law (*hamata*).⁷¹ Mother and relatives are said to welcome (*yousaqbalouna*) and bless (*monbāarakouna*) the child in its arrival to the world. Husband and relatives present the mother and newborn child with gifts (such as gold, clothes for the child, etc.) and exchange wishes such as '*alf mabrouk*' (congratulations), '*wouzḥou kbair aleina*' (his face is blessing for us) and to the mother specifically '*allah ykhaliki ili*' (may God give you strength). If there are no further complications in mother's and child's health, then they all leave the hospital and return to the house on the second day of the birth. The days before and after the birth, the pregnant woman should try to walk – this is supposed to help in childbirth as well as in lactation.

⁷⁰ The regulation, control, management but also the construction and objectification of 'population' through biopolitics as part of forms of power/knowledge is a well known Foucauldian position. For strategies of politicised reproduction and nationalised maternity in the contexts of Palestinian-Israeli citizens see the excellent comprehensive study of Kanaaneh 2002; for the multi-fold narratives and strategies of Palestinian women in Israeli maternity hospitals, see Kisch 2009: 745; for a detailed analysis on the medicalisation of childbirth with specific emphasis on Caesarian Sections and other medical and contested practices within the context of the Thai internal colonisation of the Muslim minority, see Merli 2008: 61–93.

⁷¹ When a birth takes place at home, the pregnant woman is assisted only by other women; this is true for both the Druze community in Jaramana as well as for Syrian Muslim communities. Husband or other male relatives present are not allowed in the ward during childbirth.

An Arabic proverb states that after birth the new mother's tomb remains open for forty days (*al-qabr maftūḥ*).⁷² During this dangerous period, *mala'ika* (angels) are said to surround the new mother and especially the newborn baby. The divine blessings of angels intermix with the doors of heaven and death, a metaphor that underlines the porous line between life and death and underscores the physiological and social transformations from womanhood to motherhood and from unborn to born, during the uncertain time in which postpartum rituals and practices take place. During these forty days, the new mother is called by the feminine descriptive noun *nafasa*. This is derived from the Arabic root verb n-f-s incorporates diverse meanings such as 'to breathe' and 'to be precious.' During this time, the *nafasa* is confined to her husband's house, taken care of by relatives, and is encouraged to relax, 'breathe', while she receives (or so is expected to) golden gifts from her husband and many social visits to her house. Also, *Nafs* in Druze cosmogony is envisioned as the passionate activity of God's Will and Thought (Makarem 1974). The noun *nafs* means 'self' and in Islamic theology it refers to the self of a person, individual uniqueness, as well as to selfish and/or dangerous desires.⁷³ These forty days signal the re-making of *nafasa's* self, and the making of her offspring through prescriptions and taboos on what enters and surrounds their bodies. For the same porosity that defines the uncertainty between life and death, also defines the relationship between self and body, and body and society.

The forty-day period after birth, is called *al-tabaqāt al-arbaʿīn* (*tabaqāt pl., tabaqa sg.*), and is a period of tremendous uncertainty, ambiguity, and importance for the new mother as well as for the offspring. Specific ritual practices, dietary adjustments, and care for the body of mother and child takes place in these forty days, which is a ritual customarily observed, with similarities and differences, within different communities in Syria and across Muslim communities. Birth is a rite of passage for mother and offspring as it transforms the woman to mother and since it brings the child to life.

⁷² This proverb, as well as many of the associated customs and beliefs regarding the *arbaʿīn*, are not particular to the Druze community but practiced throughout the Middle East (see Abu-Lughod 1986; Kisch 2009: 734; Granqvist 1947). However, descriptions and explanations in this section are based on fieldwork with the Druze community in Jaramana.

⁷³ For a thought-provoking discussion on the dialectics of binary oppositions in Islamic ideology and practice see Anderson 1985: 205–209.

In Druze beliefs, births are perceived as always already rebirths of Druze souls into new ‘clothes’ (Bennett 2006; Khuri 2004). Thus, transition and transformations are not only physical or ritual practices but intrinsically connected to the Druze cosmos: the constant re-making in reincarnation of both *‘Aql*, *Nafs* and *at-Tali*. Furthermore, cosmological beliefs can only be substantiated through social practice and through society. The forty-day ritual confinement then, is a rite of passage (van Gennep 1960) that includes separation, liminality and incorporation and forms and re-forms a relationship between mother, offspring and society. In this sense, the forty-day period could be conceptualised as the ritual, that is a bounded event (postpartum) that underscores an unbounded processes (reproduction of society and reaffirmation of cosmological order).

Although ritual practices are interpenetrated by cosmological and religious beliefs, nevertheless postpartum practices in Jaramana offer a fascinating perception of the materiality of social relations as well as of cosmological beliefs, since the relation between mother, offspring and society is established and reinforced through material ‘stuff’ and practices: they are established on, by, and through the body. The ‘body’ as born, as capable of birth, life, death, the ‘body’ that lactates, that is bathed or not bathed, the body that is both agentive and passive, the transformative and transforming body, a body that is a field of possibilities, and the phenomenological horizon of perceiving as well as being-in-the-world. *Al-tabakat al-arbain* are the stages that ritually thread the porosity of interrelations between ‘stuff’ that are at once material, cosmological and social substances: water, lochia, milk, blood.

During these forty days, the *nafasa* and her newborn must stay at home in order to become well (*biyḍal bil-bayt, minshān yiḍal koweies*). This spatial confinement is explained in terms of lack of body strength (*ḍayf al-jism*), pollution taboos and relationality between offspring and *nafasa*. Pregnancy fluids that flow from the vagina are considered both socially polluting (*talawuth*) as well as threatening for the mother, as she is perceived to be prone and ‘afraid of getting sick’ (*tamraḍ*). Finally, an almost physical bond that persists after birth connecting mother and baby and its sudden breakage, such as if a mother leaves the confines of the house, is envisioned as directly affecting the offspring (*athar bil-wlād*), as well as in permitting air and producing gas in lactation.

The *nafasa* must eat food considered beneficial (*moufīdeh*) such as: warm drinks, milk (*ḥalīb*), sesame paste (*ḥalāweh*), all kinds of meat (*laham*, from the second day of childbirth, chicken liver, *sawdet djej*), garlic (*tbūm*), potatoes (*baṭ aṭ a*), and drink plenty of a tea especially served for childbirth. This tea, *bakebrat ma jaws*, is made with cinnamon, cloves, ginger and something called *kboulounjan*; these ingredients are boiled together and served with sugar and walnuts in a ball to the new mother as well as to the guests.⁷⁴ She must stay in to welcome the guests (*youqābil al-dyūf*). Both tea and food aid in the elimination of fluids, and the strengthening of the *nafasa*'s body and subsequently enriching the lactation milk. These substances help in the process of lactation ‘*bi-tjib al-ḥalīb, traḍā’a*’ (to bring the milk), and ‘*ta’ati samāga*’ ([for the milk] to be full, strong); lactation is not only a physical necessity between *nafasa* and offspring, but an affection into the future of her offspring since milk from lactation will protect the child from imminent danger (*kbaṭ ar*) as well as from all future sicknesses (*min kul al-amrāḍ*).

Furthermore, during these days, the *nafasa* abstains from activities in which potentially dangerous substances may enter her body, such as sexual intercourse and bathing; at the same time, the baby's body undergoes a series of different bathing regimes. Full-bodied bath of the mother is perceived to affect lactation because it makes the milk lighter (*bi-khafīf al-ḥalīb*) and to endanger the health of the newborn. Thus, with the exception of dry-baths, bathing after birth is strictly prohibited, and depending on personal choice, the *nafasa* will have a bath between a week to twenty-five days after birth. Although bathing will continue to affect lactation up to approximately six months, and thus women try to take baths as infrequently as they can, on the fortieth day the ritual re-incorporation of the *nafasa* is denoted primarily through a big celebratory bath (*ḥammām*) that would, in the past, take place at the local public bath (*ḥammām al-balad*). During this bath, the new mother is ceremonially washed by her mother-in-law (*hamata*) and other close female relatives, and her body would be massaged with olive oil. This marks her own ritual re-birth and return to fertility, the passage from *nafasa* to mother as well as wife, and this passage is symbolically made possible through the incorporation of the *nafasa* through her

⁷⁴ This tea is highly diuretic and aids in fluid elimination; it is also used during painful menstruation.

hamata. The day continues with the new mother paying short visits to relatives' houses, a brief visit to the *mijlis* or other site of religious/spiritual activity, and, during my fieldwork, a walk to the high street shops of Jaramana. Although younger generations do not emphasise or designate the incorporation ritual of the fortieth day, many informants noted that in the evening the relatives of the new mother would simulate a party 'like that on the day of her wedding' (*mitle ka'an iyām 'orsa*).

The proverb of the *nafasa's* tomb remaining open for forty days acts as a metonymic contiguity for the postpartum vagina that remains open and excretes lochia in that time frame, and which associates the *nafasa* in an uncertain position between life and death. In this instance, the vagina is simultaneously the blessed threshold through which the fetus passed into social life, as well as a vulnerable, polluted (*talamuth*) and life-threatening wound that through excessive bleeding or potential infection may cost the life (and milk) of the new mother. As such, the vagina is socially constructed as a porous spatial-temporal dimension that through it, life passes but also life is taken. This permeable relationship of the vagina with life and death through the porosity of tomb and womb acts as the synecdochic metaphor for *nafasa's* whole body.

Through both spatial confinement, and regulation of substances that enter and leave the body (such as food, drink, lactation and bathing water) a relation is established between liquids that permeate the body: the body's relations with its surrounding becomes fluid and potentially dangerous, while the materiality of both *nafasa's* and offspring's bodies emerge as fields of a diverse range of potentialities.

Offspring postnatal care and practices

The newborn is bathed and dressed with new clothes at least once per day for the first few months (*bi-ḥammamou kul iyanm, w bi-ghayiarlou malabison*). Contrary to the mother who must avoid bathing for at least forty days, the newborn is bathed every night for the first week in warm salted (*māleḥ*) water, as a health protection. During the second to the fifth week since birth, the body of the baby is massaged with olive oil (*zeit al-zeitūn*) before the night sleep, this is in order to provide the baby's skin with elasticity and beauty. During the same timeframe, white *kohl*, a Middle Eastern

eye cosmetic, is applied to the eyes of the baby; this is thought to benefit vision and protect against eye-related diseases.⁷⁵ After the second week the offspring is bathed in perfumed water with a mixture of herbal flowers (*juhrah*), this is said to consolidate a 'pure' skin and to make body odours such as odours of sweat and mouth to smell like flowers.

‡ ohūr: *male circumcision and the prelude to marriage*

After the first week of birth the male offspring undergoes circumcision (*‡ ohūr*). The actual operation happens in a hospital, but years ago it would be made by a special person and there would have been a family celebration: '*mithle hafleh al-'ors*' similar to a wedding party. In this celebration, relatives and friends gather in the male offspring's house and are treated to non-alcoholic drinks (*sharāb*), sweets (*helon*). The baby is dressed into two or more new changes of clothes, and the celebration is considered a small predecessor for his future wedding (*uqbal 'orson*). Interestingly, this act is celebrated precisely because it resembles nuptiality (chapter 2, chapter 5) rather than sexuality, whereas in general pregnancy is related more to sexuality and downplayed. Furthermore, the prism of nuptiality permits the more ethnographically consistent interpretation of constantly changing engendering relationships (that affect all relationships not just different genders) rather than gender relations (see chapter 5). Depending on the family and scale of celebrations, there are ululations (*zaghlouta*), dancing (*raqs*), and *tarnmediab* (similar to women's ululations but for men). Contrary to the Syrian Muslim practices of circumcision, this event is not considered a religious ceremony, and there is no religious authority or shaykh present (also see Khuri 2004); similarly to other places where circumcision is practiced, *tobour* is considered a health-related necessity that protects from disease (*ahsan lil-sāḥa*) and is viewed as 'cleaner' (*andaf*). Gifts to mother and baby are exchanged within the nuclear family, especially from the father and his family expressing love and respect (*moubtam fibon*), usually in the form of gold presents (*qataat dahab*). Flows of relationships through gift-giving are also circulated between the family and the wider social neighbourhood in Jaramana, initiating the offspring into the relational exchanges of belonging and becoming Druze.

⁷⁵ Also, see Karayanni 2004/2010: 29–32, for other uses of *kohl* in the cycle of 'becomings' (31) and an impressive post-modernist analysis of such practices within a post-colonial framework.

Conclusion: Life-cycle transformations and the embodied struggles of Druze becomings

On the occasions that Umm Samir and I would take an evening stroll in the busy streets of al-Khudr and al-Alam, she would greet and introduce me to people who were relatives (*qarāyeb*) or family (*‘āyleh*). Then, I might have asked what relatives these are, and Umm Samir would have provided for me a longer or shorter genealogy (usually longer such as distant cousins or consanguine relatives). Sometimes she would just laugh and reply *‘kulna qarāyeb hounīk’* (we are all relatives here, ‘we are all born in each others’ houses’ Oppenheimer (1980)). Umm Samir’s answer, not unusual, is not only based on actual or perceived kinship relations, but kinship as a mode of relating encompassing complex narratives informed by Druze cosmological beliefs and religious conducts, as well as with ritual practices that connect, form and embody historical, socio-political and local relations within the contours of life-cycle transformation in the contemporary Druze community of Jaramana. The religious kinship that connects all the Druze and separates them from other Syrian and Levantine communities based on the beliefs of reincarnation, is transformed on the ground as a form of religious-based ethnicity, and family metaphors such as ‘we are born in each other’s houses’ (Khuri 2004) practically reinforce religious cosmology while embed subjectivities into communal kinship structures whose practices of continuous embodied transformations bind religion to ethnicity, in which the notion of ethnic ‘blood’ becomes the Druze re-incarnated eternal soul.

As the human soul is cosmologically involved in the continuous and eternal struggles of perfection and union with the divine, so does the human body become the embattled territory of ritual transformations that mark its beginnings and endings. These ritual marks are parodic, of course, but mark the body through embedding it in the religious and social geographies of being a Druze (Khuri 2004) and also of becoming in Jaramana. These beginnings and endings, birthing and dying, are both dynamic, never-ending processes as well as local and contingent upon the specific contextualities of life in Jaramana. Unbounded and never final, birthing and dying in Jaramana are transformations – the necessary embodiments of the soul in religious metaphysics and the dialectic and intersubjective ‘binding’ of the body within the

socio-political contexts of a minority community in the periphery of Damascus, and a minority ethno-religion within the wider contexts of Syria and the Levant. From the centre of cosmological Druze beliefs to the peripheries of the contemporary Druze polity, these ritual transformations socially construct and politically mark the body as the site par excellence of fragmented and continuous embodiments, of political, religious, social and historical transformative struggles.

Chapter Five

Nuptiality or, a wedding in Jaramana

Introduction: The problematic framework of endogamy

The Middle Eastern family has been characterised as patrilineal, patrilocal, patriarchal, extended, occasionally polygynous, and emphatically endogamous. The first five of these six traits are found also in one or more of the cultures contiguous to the Middle East. The sixth, endogamy, and especially in its most conspicuous Middle Eastern form which is marriage between a man and his father's brother's daughter (*bint 'amm* in Arabic), is practically non-existent outside the Middle Eastern culture area. (Patai 1955: 371)

The above quote is quite indicative of a large part of anthropological theory regarding the Middle East. Endogamy, mentioned above, is particularly problematic because of its history and academic baggage in association with segmentation theories, and because unlike other strands of segmentation, it has received little attention. Segmentation theories often analyse endogamy as the structural result of tribal social organisation in which it takes the form of parallel cousin marriage.⁷⁶ These modes of analyses are concerned with social segmentation (fission and fusion), lineage and kinship as political organisation principles, and tribal conflict and alliance. Theories of segmentation, especially since the 1980s, have been criticised as outmoded, atemporal, ahistorical, essentialising and hegemonic views of 'Arab culture.'⁷⁷ But what has replaced segmentary lineage theories? Directly and indirectly, many of the assumptions and biases of the segmentary lineage theory, such as endogamy – the practice of intermarriage which in its structuralist renditions maintains that this is a strategy for keeping resources and women within the family unit, remain problematic, as is explored in this chapter.

Debates on marriage and endogamy in recent years have taken many courses, for example: regarding the role of prescription and preference (see Donnan 1988; Needham 1963), a shift from kinship structure and genealogy to looking at the actual residence unit (Mundy 1995; Lyon 2004: 73), the use of kinship as an idiom or metaphor for patron-clients relationships (Lyon 2004: 2), the symbolic and discursive

⁷⁶ For example, see: Cole (1985); Dresch (1986, 1988); Eickelman (1981); Evans-Pritchard (1949); Gellner (1981); Holy (1989); Keesing (1975); Keyser (1974); Meeker (1976); Murphy and Kasdan (1959); Pitt-Rivers (1977); Salzman (1978).

⁷⁷ For criticisms of segmentation and/or lineage theory see: Abu-Lughod (1989); Caton (1987); Dresch (1986); Fernea (1975); Joseph (1994); Khuri (1990); Lindholm (1986).

analysis of marriage rituals, practices and perceptions (Abu-Lughod 1986; Argyrou 1996; Cowan 1990). Understanding endogamy as a result of fluid and dynamic interactions, and in an attempt to break away or surpass some of the impasses borne out of segmentation, scholars have focused on social change through individual historical narratives (Khalaf 1981), social closeness (Eickelman 1977), the fluid and flexible socially constructed boundaries of insider and outsider (Rugh 1997), and more recently by applying theories of relationality (Joseph 1999). Rugh, an anthropologist with a long and notable career in the Middle East, writes of marriage and family relations in a Syrian village family that within the family, inside and outside distinctions operate but these are not impenetrable boundaries (Rugh 1997: 131, 217). Instead marriage symbolises a sign of intimacy with outsiders, but these relations differ on account of a number of variables, and are structured according to the idiom of relationality rather than individuality. Rugh explains household relations as being built on unbalanced specialised relationships through which persons are socialised relationally rather than individually, i.e. based on the roles and relationships with different members of the household (Rugh 1997: 223).

An ambitious attempt at critiquing the perceived wisdom regarding the Arab family employing more recent philosophical and psychological theories has been made by anthropologist Suad Joseph. Using anthropology, psychology and feminist critique, Joseph attempts to unpick and challenge understandings of Arab family through processes of 'selving' (i.e. the process by which personhoods emerge; Joseph 1999: 3) as neither individualist nor corporatist (Joseph 1999: 11). Noting that a simple definition of relationality as 'selves ... shaped in relationship to others' is too obvious, Joseph redefines the concept as the 'historically and culturally specific constructs of relationality in the contexts of intimate relationships of families in the Arab world. It is about intimate relationality as a foundational framework, underwriting notions of self that do not conform to the individualistic, separative, bounded, autonomous constructs subscribed to in much of Western psychodynamic theory' (Joseph 1999: 2). Joseph further elaborates on the definition of relationality describing it as 'a process by which persons are socialised into social systems that value linkage, bonding and sociability. Relationality is a process by which socially oriented selves are produced under different regimes of political economy.' Up to now, Joseph's definition of relationality is close to the definition of relationality that has been employed in this

thesis (chapter 2), especially if we were to substitute the more problematic and psychological 'self' with the more cross-cultural dexterous view of 'personhoods' (Carrithers et al.: 1985). Unfortunately, however, Joseph's elaboration of relationality and 'intimate selving' does not hold up to the author's own definition in terms of historical and political contexts. Her analysis of what she calls 'patriarchal connectivity' (Joseph 1999: 11), for example, abounds with assertions and axioms about the 'Arab family' that differ only in rhetoric to the segmentary predecessors of the discipline. Having criticised the shortfalls of corporatist theories, Joseph herself asserts such a position by claiming that 'family is valued over and above the person' (Joseph 1999: 12). Her definition of patriarchal connectivity is even more problematic: 'I use patriarchy here to mean the privileging of males and seniors and the mobilization of kinship structures, morality, and idioms to legitimate and institutionalize gendered and aged domination' (Joseph 1999: 12). Joseph then goes on to assert that 'family and/or community are valued more highly than the person' (Joseph 1999: 13) whilst not providing any nuanced or anthropological/ethnographically based definition of either family or community. Through that statement, Joseph seems to unquestionably abide by very specific hegemonic notions of what a person *is* – an essentialist and generalising notion that is the diametric opposite of relationality. Thus, Joseph seems to be combining the most problematic aspects of both segmentation and feminist theory (of the 1980s). For another example, consider her conception of patriarchy: 'patriarchy entails cultural constructs and structural relations that privilege the initiative of males and elders in directing the lives of others' (Joseph 1999: 12). Gender here is not a relational performative idiom of power relations (Butler 1990) but an essential trait of males and elders. 'The gendered and aged domination legitimated by kin structures, morality, and idioms that has been entailed in patriarchy subsidized and has subsidized psychodynamic processes that helped craft hierarchical oriented selves. Intertwined, connectivity and patriarchy have helped produce selves trained in the psychodynamics of domination, knowing how to control and be controlled' (Joseph 1999: 13). If this is not a hegemonic re-interpretation of an Orientalist assumption regarding a-political, ahistorical, and essential 'cultural' or 'psychic' traits of the Arab family, then what is it?

In studies of Druze religion and society, endogamy strays away from its parallel cousin in segmentation to acquire a more communal definition: endogamy is defined

strictly through social and religious prohibitions of marriage between a Druze and a non-Druze (Alamuddin and Starr 1980; Khuri 2004; Layish 1982). This form of endogamy, itself problematic in the literature because it is considered as an unchanging 'given' in the history of the Druze community, is not strictly speaking, correct. In Jaramana, Damascus and Sweida, I heard many a stories of interfaith affairs and marriages ('what is prohibited is desired' an Arabic proverb states), while the Druze Lebanese political elites have a long history of marriage outside of the religious community.

Theories of kinship, segmentation and endogamy all have their merits in the development of our discipline and our understandings pertaining to the Arab Middle East. However, their largest setback has been their structuralist tendencies that contribute to (a) emphasising and generalising 'common' cultural patterns or structures at the expense of specificities and differences; (b) ignoring the turbulent historical and political developments and their effects in the region; and (c) avoiding critical engagement with the problematic and structuring relationship between informant and researcher. The biggest challenge in both anthropological theories of kinship as well as the anthropology of the Middle East remains the accommodation of structure and 'culture' within an active framework of history and politics. Attempts have been made to upset such rigid and hegemonic dichotomies by placing the history and politics of certain 'traditional' ideas such as family and gender as the results, not causes, of the colonialist and post-colonial realities in perceiving and enframing the Middle East as a site of European and capitalist domination (Asad 1973; Mitchell 1991; Said 1978), and more recently as how these processes of interactive co-construction have contributed to shaping the internal responses from local intellectuals and philosophers (Kassab 2010). This thesis and this chapter contribute to such approaches with reference to the Druze community in Syria. In this chapter, I begin from the assertion that perhaps anthropologists have been asking the wrong sort of questions regarding endogamy and marriage. In order to build a relational framework of the poetics and politics of weddings in Jaramana, and in order to avoid some of the common pitfalls, this chapter approaches practices of marriage, as previous chapters have approached questions of households and life-cycle transformations, through a series of struggles. Three questions structure the chapter and approach: what can be said about wedding poetics in terms of local

imagined ideals as well as local practices? How are bodies constructed as sites of struggle and politics through weddings? And how do bodies become intimate through social practice in weddings? In order to address these questions contextually, the chapter starts with a narrative of the ideal Druze wedding interspersed with instances of wedding practices, and then offers ethnographic discussion on the poetics of nuptial bodies through wedding ceremonies, and the contested politics of nuptiality in Jaramana and beyond. This chapter is the beginning of a political answer to these questions by locating marriage at the crux of the body-politic, and through contextualising the body, as a contested and contesting field of struggles. This is a contextual response to essentialist, evolutionist and culturalist claims regarding Arab bodies (cf. Feldman 2004: 209). I provide contingent, historical, social, political and economic viewpoints of how the nuptial body emerges as a site of strife.

Talking of marriage

‘Fifty years ago, weddings were conducted mainly by way of the family (*ṭ arīqa ā’iliyeh*),’ Abu Samir said in an affirmative tone. It was the start of summer, late afternoon, and the electricity was cut, as part of daily electric blackouts that had become very much a routine. It was still very hot outside, so Abu Samir, Umm Samir and I sat in the cool shade of the family room, wondering when the electricity would return and along with it the television and the electric fans. The house was unusually quiet as children and grandchildren had dispersed, leaving the three of us in the house. Summer is the wedding season in Syria, and Jaramana was actively partaking in an array of marriages, parties, and celebrations. I had been invited to attend many such occasions by both *bayt* Abud-Haddad and *bayt* Ouward. As it was a unique opportunity to have Umm and Abu Samir together and without interruptions, I decided to grasp the occasion and ask ‘how was your wedding?’ Marriage (*jamāʿ*) is best described as an unbounded event that constantly colours a community’s lived practices and is a constant theme of discussion and participation: people talk a lot about each other’s wedding celebrations (*ʿors*) whilst children are socialised very early on the prospects of their own marriages: young girls when dressed nicely are ‘like brides’ (*mitel al-ʿarūs*) while young boys are given nick names such as ‘Abu Ali’ (father of Ali). Abu Samir took the initiative and described to me how weddings in Jaramana *were supposed* to happen back in the old traditional ways. His and Umm Samir’s responses did not answer my question. Based on local notions of shyness and respect

that frame interpersonal relations in Jaramana, it is not considered appropriate for a married couple to make a big deal out of their own wedding. Their responses were also situated for their specific audience, the anthropologist and adopted daughter who was conducting 'research.' In answering generally about the ritual practices of weddings, Abu and Umm Samir were answering to me, thinking and framing their narrative around things that they thought would be useful to me. Furthermore, their narratives fluctuated between past and present, their wedding and weddings of other people in the family and in the area. Their responses also entailed a certain local knowledge: what it means if this or that house conducted a wedding in this or the other way. They entailed an extended local knowledge connecting the ritual in Jaramana to rituals in Damascus or Sweida. Although they did not answer my specific question, as it rarely happens when conducting ethnography (for a somewhat similar instance see Cowan 1990: 91–97), they did provide something equally valuable: a picture of a shared, but not necessarily uncontested, 'ideal' practice of how traditional Druze weddings should be, or used to be, or are.

In the conversation with Umm and Abu Samir I did not use a recorder, I just noted, with their help, the structure of the ritual, and later on that day I wrote about the conversation in my fieldnotes. In the course of my remaining fieldwork, I asked Abu and Umm Samir clarifying questions, I carried either the actual notepad or the wedding ritual or a mental note of it in weddings, I asked other informants questions, and I added their comments onto to Umm and Abu Samir's reply, along with my observations. Upon return and throughout the writing up process, I sent versions and reconstructions of the Druze wedding ritual back and forth through e-mail to Druze friends and informants, and they added details, corrected mistakes, sometimes disagreeing with the reconstructions, or often noting that if Umm and Abu Samir said so, it must be correct. In the following part of this chapter I am reconstructing a multiple and textual version of the Druze ritual. As all reconstructions are as valid as varied, and if we accept that an 'original' never really existed, then the notes that follow are reconstructions and versions. The descriptions below are elaborate and detailed because I have opted for inclusiveness rather than, or perhaps at times at the expense of effectiveness. This I have done in order to include as much as possible the different authors and their personal stories within the structure of the wedding, because in this way, this textual version becomes more readily unsettled: revealing

discontinuities, fragments, and contestations both in the practice of writing, as in the practice of living in Jaramana. Finally, although not unproblematic, the more laborious detail-inclusive approach has been taken since never before have the wedding rituals of Jaramana been documented, and there have only been skeletons of this Druze ritual in other works (Hood 2007; Khuri 2004). The second part of the chapter explores the poetics and politics of nuptiality and intimacy.

Initiating pre-marital negotiations

A prospective bride may have been a patrilineal or matrilineal cousin, a neighbour or 'someone seen in the street,' noted Umm and Abu Samir. The groom-to-be would firstly express his interest to his mother, who would try to find out more about the girl and her family through unofficial channels, or through arranging an unofficial visit to the prospective girl's household, in which she would indirectly gather information about the girl, her family, and her marital status. The mother of the groom would play a pivotal role throughout the negotiations and ritual. Should the prospective mothers-in-law as well as bride and groom agree upon the possibility of a future marriage, a more official pattern of visits would begin that would result in the engagement of the couple (*al-khṭoubeh*). This visit, unofficial as it is, saves face to both families if the girl is otherwise engaged. Umm and Abu Samir had to decline many interested prospective grooms and their mothers when their daughter Ilaf, a local beauty, became engaged. Similarly, Zahra and Hiba were pressured by their mother to attend dinner parties with many a prospective Druze husband. The two girls often agreed, but only to please their mother, and such initial contact did not lead to anything more.

Al-Khṭoubeh: The engagement process

The engagement is usually a long process that results in the exchange of rings (*khatib*) between a prospective bride and groom. During this process, which can last from a few weeks to years, the families and extended families of prospective bride (*'arīs*) and groom (*aris*) become involved through a complex pattern of visits, arrangements and negotiations.⁷⁸

⁷⁸ For an excellent ethnographic account of processes and transactions during engagement and marriage in a different corner of the Middle East, see Mundy 1995.

The first phase of the *khṭoubeh* consists of a visit of close female relatives of the groom to the house (*bayt*) of the future bride. The aim of the visit is for the two households to better acquaint themselves. The frequency of such visits depends on several factors, such as social and geographic distance between the two families. 'It is a tradition that during this visit the mother of the future bride will ask her daughter to make coffee in order to treat the guests,' noted Umm Samir, in order to show off the housekeeping and hospitable talents of the girl. Many such female visits may take place between the two families (and less official if the families know each other), while it is not uncommon, especially today, that the future groom accompanies his female relatives. During a different visit by the male relatives of the prospective groom, the official request to marriage takes place. The bride's father kindly replies to the marriage request that he will need a bit of time in order to ask relatives, brothers and cousins of the bride, as well as the bride herself, for their consent to marriage.

The waiting time varies up to approximately a week. Both Umm and Abu Samir, and many other Druze interlocutors, took great care to note that Druze women, contrary to their Muslim counterparts, are equal to Druze men and the consent of the bride must be explicit. This claim should not be taken at face value, there is ample evidence that consent from either bride or groom may be a result of other kinds of pressures. Nevertheless, this claim of gender equality relates more to politics, imagined communities and boundary making (Barth 1969) than anything else. The father of the bride-to-be then replies to the father of the groom: 'tawakalna 'ala allah, idha allah 'ataka nahnou 'ateināk.' With this sentence the engagement becomes official (*ṣārat makhtoubeh*), and the two families begin the preparations for the religious and social sanctioning and celebration of the marriage.

Engagement Celebration

The groom's family is responsible for letting relatives and neighbours know when the engagement will take place. Druze engagements often combine the religious sanctioning of the future marriage with the social celebration. On the day of the celebration, male guests of both families arrive at the groom's house (or, if there is a bigger space/house of some other relatives) and they are greeted (*istiqbāl*) by the immediate and high-ranking elders or shaykhs of the family. Females usually congregate at the house of the bride. Religious shaykhs meet in a separate room (where only initiates are allowed) and bless the golden rings that the couple will exchange. Then, the oldest or highest ranking shaykh, stands in front of the gathered and seated male guests, and they stand up. The shaykh reads an extract from the Quran, the *fātiḥa* (known as *kirā'at al-fātiḥa wa katabat al-kitāb*), and the guests repeat it after him. This religious blessing of the engagement acts as a socio-religious binding contract, and guests and families exchange congratulations and wishes. When the religious endorsement is over, the guests are treated to sweets and bitter Arabic coffee (*qahwa murrah*) by the groom's family. Abu Samir mentioned that in previous years the elders of the two families would kiss each other's large moustaches (*bosa shawārib* – Druze men used to have very specific long moustaches), to denote closeness and honourable commitment to each other, a potent physical symbol that would be 'more important than a [legal] contract' (*aham min 'aqd!*).⁷⁹

The celebration then moves to the bridal house, where the bride's celebration will take place (*sabrat al-'arūs*) in a parade formation with musical instruments, singing, clapping and dancing sometimes accompanied by a show of arms such as swords and pistols. Whilst the Druze of Sweida usually sing and dance a specific musical genre called *jawifīyah* (see Hood 2007: 46–49), the Druze inhabitants of Jaramana distinguish themselves by a specific genre of song/dance called 'arada. As an example of a more elaborated and 'most traditional' engagement and wedding celebration, I was given the video cassette from the engagement and wedding of Sarah Abud-Haddad with her cousin (FSS) and only male heir of *bayt* Haddad, Sami. From this video, an example of *arada* sang is 'mbarak ya *ẓein al-'arsān*' (congratulations to you, the best of men). The female relatives of the groom awaited for the parade to arrive

⁷⁹ I have not found evidence of this practice outside of Jaramana or among younger generations in Jaramana.

in front of the bride's house and welcome them with loud welcome rhyming calls and songs that are generically called *'ānīḥa* (this is the sound that the women make in front of each stanza), while other female guests sing women's songs specific to the occasion (*agḥāni nisowān*). The bride and groom greet each other and enter the space (a sitting room or a courtyard) in which the evening party will take place, and they sit in specially embellished chairs, usually slightly elevated from the rest of the space. Just before they take their places the gathered crowd sings to them *'arada* (*bi-zīfouhon ma 'arada*).

The engaged couple remain standing while the mother of the groom appears with a large tray (*ṣaniya*) which holds the two golden rings that the couple will exchange as well as other golden gifts for the bride (earrings, necklaces, bracelets, etc.). The mother of the groom dances with the tray in her hands and then she passes the tray to other members of the groom's family and friends. Finally, the tray reaches the bride and groom and they present one another the two engagement rings while the crowd claps, and the women ululate (*zāglouta*). Then, the groom's family passes, greets and dresses the bride with gold; similarly the bride's family place gold on the groom (*bi-labisouon dabab*). All the guests will then stand in a queue and will personally greet and congratulate the bride and groom.

When all the greetings have been exchanged, the groom and the male guests will leave the house of the bride and will continue the celebration elsewhere, with more music, songs, dances and food. The bride and female guests will stay to celebrate at the bride's house, where the bride will be the first to dance in front of and for her guests.

However, most of the described ritual phases and practices are highly variable amongst the Druze of Jaramana. The above details come from the narratives of elders regarding 'ritual order' as well as from my own fieldwork and watching of 'traditional wedding' video material that inhabitants have generously offered. The variability of 'ritual order' depends on how close the two families are, how competitive, how religious (if a shaykh or the offspring of a shaykh is getting married there is generally much less singing and dancing), as well as if this is the first wedding of the couple. Also, the ritual is very different for the Druze of Sweida or for mixed

marriages between Jaramana and Sweida. The most astute difference in the ritual celebration is that in Sweida the party (*sabra*) at the end of the night is gender mixed (*mouhlata*) whilst in Jaramana it is segregated. Such differences in ritual order often take the claims to either a firmer identity of Druzeness and autonomy, as in the case of Sweida, or a more metropolitan, Damascene⁸⁰ and refined heritage, in the case of Jaramana. Traditions within an imagined religious community as the Druze, are also influenced locally, rather than just religiously.

Marriage transactions

Much has been written about wedding transactions and exchanges such as bride-price and dowry in the Middle East (Goody 1990). The most instructive and relevant analysis of people, goods and transactions comes from Mundy (1995). Mundy argues that property exchanges and transactions, such as those occurring during weddings, have either been linked to structuralist segmentation analyses of social organisation, or have been ignored altogether: ‘the problem of differentiation in time, space and class has not been at the core of studies of Arab kinship’ (Mundy 1995: 124). Using different case studies from her ethnography in rural Yemen, Mundy paints a more complex picture in which class, status and historical circumstance internally differentiate the village households, their marriages and their transactions: ‘marriage is far from a merely secondary alliance, a shuffling exchange of women between men who make society; marriage is itself structuring, or so at least it is among those with property’ (Mundy 1995: 125). In her study, Mundy distinguishes among three kinds of payment that take place during a marriage: cost of wedding celebrations; a payment from the groom or his family to the bride’s guardian called *shart*, and the endowment of the bride, called *mabr* (Mundy 1995: 131–132). Mundy shows that these payments are highly relative to the families and individuals involved.

Mundy clearly explains, without diminishing complexity, the wedding transactions that take place in a Yemeni rural village, and her analysis is valuable here as an example of the variations of possible transactions and exchanges. In Jaramana, there are different types of transactions during marriages but the topic of payments per se is a taboo subject and seldom openly discussed; in fact many informants from a

⁸⁰ Damascene engagement celebrations are gender segregated.

variety of ages and social groups mentioned that these are not important for the Druze – this was often mentioned in opposition to Sunni Muslims of Damascus – because there is equality not only between genders but also as a community of believers. However, practically, during the process of engagement and marriage, at least three types of payment may be identified. The first is called *maber* or *mokadam* and is a transaction from the groom and his household to the household of the bride, discussed before the *khutbeh* celebration and paid in full before the wedding. Part of this payment, which may not be in cash, may go to compensate the bride's family, another part may go towards wedding preparation, while a third part of it is agreed to be given to the bride in the case of a divorce. The second type of transaction is the *jibāʿ* (from *jabaʿa*: to make ready), and is the bridal trousseaux comprised of household furniture, furnishings, as well as clothes and jewellery, that the bride will take to her new house, and which belong to her. The third type of major transaction consists of the gifts that the new affinity unit of bride and groom receive from their relatives, extended families, and wedding guests. These gifts are usually given to the new couple in the last days of their wedding ritual and may include cash, gold jewellery, as well as expendable goods such as foodstuff (Umm Samir noted that 'in Samir's wedding we filled a room with gifts of rice and sugar!').

There are two crucially important factors that affect the aforementioned marriage transactions in Jaramana. The first factor, as commented upon by Mundy, has to do with internal differentiation within the Druze families of Jaramana, in terms of class, wealth and status. Poorer families may not be able to make the same transactions and festivities as wealthier families, and middle class families may choose to abide by a different mode of distinction than 'traditional' families. The other factor that specifically affects the Druze of Jaramana has to do with the religious and political authority of religious shaykhs to intervene, interpret and shape public conduct. In the context of esoteric interpretation of religion and the relative absence of public jurisprudence (such as in Shari'a), the shaykh of Jaramana has the authority to prescribe whether and how much a family should spend for marriage transactions. The shaykh also has the final say not only in granting divorce but in deciding property and inheritance rights after divorce. Thus, differences not only exist between Druze communities in different regions, but also emerge in historical succession to different shaykhs. Thus, marriage transactions are generally understated

in Druze Jaramana as a difference of equality between them and their Muslim neighbours, and at the same time reflect not only local but also religious politics and alliances.

The wedding week

The arrangement of the wedding is primarily the responsibility of the family of the groom. However, it is a largely social activity in which relatives, friends and neighbours participate. Formally, the wedding ritual lasts for seven days, although in many respects, it is an unbounded event. The following is a description of each of the days.

Day 1: Jama'iyā 'āylat al-'arīs

The family and close relatives and friends of the groom meet in the groom's house to form an 'organising committee' (*jama'iyā*) in order to arrange the wedding celebration. This committee is responsible for inviting guests, and all religious and social arrangements, venues, food, clothes and other necessities. Weddings are typically large communal affairs that include at least two hundred invitees. This occasion also initiates the week-long celebrations by way of a dinner at the groom's household.

Day 2: 'Bijjīnou al-'ajīn wa bisharou assabīyah'

'They make the dough and the girls celebrate!' Umm Samir noted regarding the second day, a day of celebration and preparation by the female members of the groom's household. Preparation includes making bread and food, only the older women actually do the baking while the younger ones, especially children, dance, sing and ululate (*zāglouta*).⁸¹ At the end of the gathering, each household leaves with a bucket of dough from which they make bread in their own homes at night (in the traditional round oven, *tanūr*). In the house of the bride, the bride and her close relatives and friends make the preparations for the clothes, furniture and soft furnishings that she will take to her new home.

⁸¹ This is the local term used in Jaramana, the standard Arabic term for ululation is *zaghareed*.

Day 3: *Jibāz* parade

The bride's trousseau is transferred from her natal home to her nuptial house through a public parade consisting of her close and/or high standing relatives. Members of the groom's family are also present, but neither the bride nor the groom attend the parade. Singing and dancing takes place in the streets, mainly by the groom's family, and the nuptial house/apartment is arranged.

Food preparation and celebrations continue in the groom's house where the bread that was baked the previous day is brought back to groom's house, and female relatives and friends start preparing the *kubbeh*, a delicious and time consuming food that is served before and during the wedding.⁸²

Day 4: *Ḥammām al-balad*

Jaramana has one public bath (*ḥammām al-balad*), and on the fourth day of the wedding week the bride used to go to the *ḥammām* along with her female relatives and close friends, as well as occasionally with the females from the groom's family in order to be washed and prepared. The bride would be cleansed, her hair combed, incensed with aromatic herbs (*bakhūr*) as protection against evil spirits, and henna applied on her hands. The women would celebrate, eat, sing and dance until the early evening. Nowadays, this ritual cleansing more often takes place at the bride's house within the intimate circle of female relatives and friends.

The ritual of the ceremonial bath is a part of most Syrian weddings; in Damascene Muslim weddings the groom and his male relatives would go to the *ḥammām* in the morning, while the bride and her relatives would go in the evening (see chapter 8). Visiting the *ḥammām* is considered a very jovial experience (see Tergeman 1994: 12, 59–60). As the public bathhouses have become less fashionable (and more touristy) in past decades, in Jaramana the bride has the 'day of the bath' in the vicinity of her own house. The public bathhouse is only still used for the groom, who has his bath on the morning of the day of his wedding.

⁸² 'A wonderful dish made of lean meat and fine burghul... which is shaped and stuffed, fried or baked and served in many different ways. This mild but delicious dish is counted among the special meals' Fadel and Schami (2005: 46-47).

Day 5: *Sabrat al-'arūs wa al-'arīs*

Two separate pre-wedding celebrations are occasioned, one for the bride and one for the groom. These celebrations are gender segregated⁸³ so that in the bridal celebration female relatives and friends of both houses attend, and the same holds for the groom's celebration. The two social occasions may take place in the respective houses of the couple, or at a specially designed spaces for wedding receptions (*salat al-'ors*). Many guests are invited to each celebration, where dinner ('ashā) and accompanying sweets are paid for by the bride's family as a farewell gift to their daughter. In the bride's party, the bride sits on a special throne-like seat, while chairs are set around and back from the space leaving an empty space in the middle for dancing. The bride welcomes guests by slowly dancing around the seated guests, as does the groom's mother. Usually before dinner is served, the groom comes, along with some male relatives of the bride (father and brother), to make a brief appearance at the party before leaving again. Throughout the duration of the bridal party, the bride will change many evening dresses (from three to seven, according to status), these are the dresses of her trousseaux that have been specially made for the occasion of her marriage and that have not been worn before. Every time the bride changes her dress, she has to dance around her guests. The guests also dance, usually following the lead of the groom's mother, who participates enthusiastically. At the end of the evening the bride will wear the final dress: her white bridal dress. Usually this is an emotional time for the bride, her family and friends and many tears are shed. After this, the groom's mother and relatives will eventually leave, leaving the bride and her closest relatives and friends to celebrate more intimately, and they will return to the groom's party. They invite everyone to the wedding by saying '*al-khamīs bil balad*' (lit. on Thursday in the area, even though the wedding does not necessarily happen on a Thursday). At the groom's party there is also a lot of singing (*'arada, zajeḥ*) and dancing (*dabkeh*) and it is traditional to serve *kubbeh al-'arīs*: *kubbeh* of the groom, made with the home-made Arabic bread (*khobz 'arabī*).

⁸³ This practice is similar to the Damascene Sunni tradition of gender segregation; the Druze of Sweida hold a mixed gender celebration.

Day 6: *Yawm al-'ors*

(1) *Ḥammām al-'arīs*, Groom's bath: While the bride is being prepared and dressed in her house, the groom and his close male relatives and friends parade through Jaramana holding his nuptial clothes on large trays that are danced around by men. The groom either goes to the public bathhouse or to a house of a close relative or friend in order to be washed and dressed for his wedding. The men's parade sings and dances with *'arada*, occasionally firing gunshots, while women of the household where the ritual *ḥammām* will take place recite *'āwība*. During the bathing and dressing of the groom, the groom becomes the butt of jokes, and is subject to playful beating by his close male friends, a process in the ritual resembling the structural ritual reversal of roles. The male parade is then served a big lunch.

(2) Wedding contracts: For a wedding to be official vis-à-vis both the state and the Druze religious authorities, there are two religious contracts (sing. *aqd*) that must be fulfilled. The first is the official, governmental registration of the marriage in the Muslim religious court in Al-Kaser al-Adli, central Damascus; this contract is known locally as *'katb kitāb*' (the writing of the book), or as *kitāb al-maḥkameh* (official writing), and may take place anytime from the *khṭ oubleh* until after the marriage. The second contract, is the Druze religious contract known as *aqad al-aqd* (contracting The contract), conducted by two or more Druze shaykhs on the day of the marriage. Both contracts need two witnesses from each side as well as oral permission from bride and groom.

The religious contract takes place after the groom's bath, usually in the groom's house or, if the house of the bride is far away, at an adjacent space to the bride's house.⁸⁴ The bride and groom's male relatives greet the guests that arrive and welcome them with bitter Arabic coffee (*qahwa murrab*). When everybody has arrived and the groom is welcomed with *'arada*, the religious shaykhs conduct a private ceremony behind closed doors in which they recite religious texts and bless the wedding rings. Then a shaykh will come out and address the groom and gathered guests, informing the crowd *'al-kitab maktoub*' (the writing/contract has been written), and he along with the audience will recite the *fatīha* invocation from the Quran. Some

⁸⁴ The details described have been collected through narratives and from video material, as I have not and could not attend the male ceremony.

guests may want to make impromptu short poetic speeches and claps, congratulations and songs and dances soon erupt. Usually the songs sung come from traditional Druze genres of men's songs of nationalistic and bravery themes (Hood 2007: 40–62). The house of the groom offers sweets to its guests and as the excitement increases, they prepare to parade to the bride's natal home.

(3) *Jaybet al-'arūs*: Bringing the bride: A group of the groom's female relatives goes to the bride's house where the bride and her female relatives wait for them. '*Jīnā wa jīnā wa jīnā, jibna al-'arūs wa jīnā*' (we came, we came, to bring the bride we came) sings the female parade of the groom when they approach and when they will later leave the house of the bride. The parade is headed by the groom's mother, followed by women with musical instruments (most often a *darbakeh*), whilst everybody is singing, ululating, clapping and performing '*āwīha*'.⁸⁵ The groom's parade forms a chorus outside the bride's house and waits to be greeted with competing '*āwīhas* from the bride's female guests. The groom's parade arrives in order to take (*ya'k'hadha*) and bring the bride (*yjibou al-'arūs*) to the groom's house. There is a stark contrast between the two groups of women, a contrast that is established upon arrival and maintained well after the parade's departure with the bride. Leading the songs and dances, the groom's mother greets the bride's group and enters the house with her group. Inside she leads the songs and dances, inviting and luring the guests into participating, in what appears to be a structural reversal of hospitality norms, since she and her group take over, in an almost conquering atmosphere, the natal house of the bride. The loud songs and extroverted dances of the groom's group are received and responded to with similarly 'loud' silences and tears from the bride and her family, in a way that powerful movements and dances mix with stillness, pain and seriousness that performatively are as powerful. These different communal performances symbolise the liminality of the ritual: the pain of separation, for the side of the bride and her house, and the initiation of a new house member for the

⁸⁵ Most of the songs sung are traditional marital chants, praising the bride, her beauty, chastity, fair colour, her mother and family. Metaphors abundant, most of them comparing her to flowers or the moon, others saying how the groom's side has come to take the bride on a horse. These songs/chants are known as '*āwīha*' – the name and actual sound is used at the beginning of such chants and between double stanzas which are repeated by the audience/ group (*jama'iyā*). These chants are polyphonic, usually with a main leader chanting the first line and the group repeating it and saying '*āwīha*'. The leader of the chants changes every so often, with the mother of the groom playing a major role (especially at this instance), along with other special relatives and musically talented guests. The chants, as mentioned above, are based on prescribed structures and rhythms, use well known metaphors and symbols, yet a lot if not most of them are on-the-spot improvisations.

family of the groom. When the men have conducted the religious contract they arrive at the bridal home. First, the cousins, brothers and father of the bride enter the women's space and kiss the bride farewell in an emotional outburst with tears and sobs. The bride, accompanied by her tearful parents and jovial mother-in-law, will walk out of the house, joining the male parade amidst the sounds of women's *'āwītha* and men's *'arada*.

'Bringing the bride' is a significant embodied and performative process of the ritual, relating previous to future processes of the marriage celebration to each other (for something similar in Cyprus see Argyrou 1996). In this way, its name and practice designates a *moment of action*, which presupposes other actions, and leads to future ones. It is not a state in itself, it resembles the moment of passage.⁸⁶ As a dynamic process, this is also an example of gender performativity (Butler 1990). In this process of the ritual, gender roles, masculinities and femininities are constructed as an idiom of power relations in that they are not inherent individual characteristics but communally performed hierarchies of power: the groom's female group is communally performing a masculine show of power, whereas the bride's family and guests (including the male members of her family) communally enact a feminine performance. Thus, gender identity is not only 'performatively constituted by the very 'expressions' that are said to be its results' (Butler 1990: 25), but is also an expression of gendered relations of power. Gender is not an inherent quality in the bodies of males and females, but rather a social construction emerging performatively and relationally out of specific contexts and power dynamics.

(4) As the bride and groom leave the bride's house, the guests sprinkle them with white rice. Relatives and friends of the bride stay behind, but a female friend or a sister may accompany the bride. The couple is led out of the bride's house and into the groom's by a male and female relative of the groom each holding a white candle. Just before the couple enter their new house, bride and groom stamp the light of the candles out with their feet. The candles are thought to bring good luck. Also, just before entering the groom's house, the groom's mother passes to the bride a piece of dough, which the bride throws at the house's entrance. If the dough gets stuck on

⁸⁶ Its duration can and does vary immensely, from 20 minutes to hours.

the wall then it is a good sign for prosperity and fertility. If the dough does not stick, the bride tries until successful.

(5) *Sabrat al-'ors*: Wedding celebration. The wedding celebration takes place in the groom's house, although it can also take place in a large restaurant or reception. The geography of the space is similar to the *kehṭ oubeb* or bridal celebrations, with two thrones beautifully and colourfully embellished for the newly-weds. The guests queue to congratulate the couple and to give them gifts of either money or gold. It is usual that father and mother of the groom are the first to kiss the couple and wish them well. The bride and groom, then, change their rings from the right to their left hand. Women ululate and sing, while male relatives start singing and dancing, usually performing 'arada with sword dances. After a few dances, dinner ('ashā) is served to the wedding guests, usually comprised of *mansaf*, a burgul dish with nuts and lamb, or *uzj*, rice with peas and meat; both dishes are served with extra fat (*samneh 'arabi*) which is a symbol of prosperity and is thought to increase stamina. Depending on religious status, class and outlook of the families, there may or may not be alcohol. Live music or a DJ may be present and guests and couples dance together until late in the night when bride and groom retreat to their private room.

Day 7: *Sabbieh*

The house of the bride's family invites bride and groom and bride's family for breakfast/lunch and they exchange gifts. The mothers of bride and groom discretely find out if everything went according to plan during the 'night of entrance' (*leylet al-dukbla*). But in most resources from informants (also see Westheimer and Sedan 2007: 85) there seems not to be a specific ritual to denote consummation of marriage or any form of public acknowledgement. The subject of sexuality whether during the first night of wedlock, before or after it, is a taboo and is not discussed openly. Both Zahra and Hiba, for example, discussed with me that Druze families are much more puritanical regarding matters of sexuality than their Muslim or Christian counterparts in Syria, and usually spouses go into wedding with little prior knowledge or advice. In my role of honorary adopted daughter I was in no position to ask the adopted parents of either of my families directly on the subject, although I brought it to Najwa's attention in comparison to Sunni rituals, in which she mentioned that nothing similar happens in Druze weddings. The sensitivity of the subject is by itself

an important marker of the significance of the nuptial rather than sexual relationalities enmeshed in wedding practices.

Nuptial bodies, intimate boundaries

Kholud's wedding was a bit of a surprise as she had gone past the prime wedding age at least a decade and a half ago, because, I was told, she did not want to leave her grief-stricken mother who had lost two of her sons. But now she had agreed to marry someone from Sweida, someone of whom her family knew little about, but there was a little relief mixed with conserved expectations. Kholud's bridal party (*sabrat al-'arūs*) took place at the *madafa*⁸⁷ of her matrilineal cousin, but perhaps because of miscommunication, the party was not well-attended. Because of the low turn out, Kholud's entrance was delayed, and her family was trying to call friends, relatives and neighbours to come: 'Turn up the music so people know we're having a wedding here!' I heard the cousin say. Kholud came, wearing jeans and a nice shirt rather than the elaborate *jihāz* dresses that brides usually wear. We had a great time and, because of the low turn out, my Syrian brother Tariq whispered that 'we have to dance to fill the space.'

Kholud's wedding celebration was much better attended than her bridal party. But her bridal party night underlines the importance of who and how many attend a wedding. How many people and who attends one's marriage ceremony is a matter of great interest as well as of great importance in Jaramana. Numbers and persons are reflective of family alliances, politics, and status: in Kholud's case she had come from one of the more important local and religious families of Jaramana, she is the daughter of Abu Samir's half-sister, but without the communication networks of a living father and brothers she had to solely rely on the networks of her cousins, while, at the same time, her marriage was not as spectacular as a young woman's, perhaps because she was older, perhaps because she was more independent than most since she has her own business. Kholud's uneasy and somewhat anxious bridal celebration underlines something that is an *a priori* to traditional weddings in Jaramana, as described above: that they are social affairs and large participation is

⁸⁷ Reception space, formal living room, see chapter 3.

needed. Specifically, the cousin's call to turn the music louder so that everybody knows and hopefully comes in to the party shows that rather than being a result of familiarity, marriage invitations are a means of maintaining but also of forging new relations of intimacy between participants. There is an expectation within the local Druze community, that even among strangers there is an obligation to participate in fellow Druze rituals (this is also true for funerals; see chapter 4, and Hood 2007: 147).

To make a wedding in Jaramana, thus, is to make everybody involved: preparations and celebrations presuppose the participation of a large number of people that will partake in the occasion. Relatives, but also neighbours and friends, are intrinsically involved not only during the celebrations of *kbutbeh* and *'ors* but also during the food preparations, the *jibāz* parade, and the more intimate instances such as washing and dressing of the bride and groom. Attendees become intimate and familiar with each other through these practices, and the society is re-assembled and re-formed at large through these ceremonies.

Furthermore, not only are relations formed through the social participation in the wedding, but certain performative groups are also formed during these practices. For example, throughout the engagement and wedding process, relatives and guests become almost divided into two separate groups: one comprising of the groom, his family, relatives, neighbours and friends, the other of the bride, her family and guests. These groups are characterised by a structural antagonism that reaches a dramatic climax during the stark ritual antithesis of *jaybet al-'arūs* (bringing of the bride). There is a resemblance between the groom and his group, the bride and her group: the two groups come not only to *represent* either bride or groom, the two groups *become* the bride and the groom, while bride and groom themselves become traces of masculinities and femininities, traces of family alliances, traces of Druze endogamy, resemblances and embodiments of gendered, classed, and communal power relations. As the two social groups come to resemble the bride and groom, they collectively trace and ritually embody the gendered and relational power hierarchies that bind the two competing groups. The irony is, of course, that the bride and groom themselves become a trace of the collective, an excuse or opportunity for the performance and embodiment of social relations, as they soon come to appear as

static idols amongst the moving groups that act intimately to resemble them, but of which the bride and groom are mere duplicates, never quite fully able to duplicate by and in themselves the collective nuptial bodies that emerge from the two social formations:

There are, rather, the necessary relations at work in a world where nothing occurs except as something that resembles, differs from, duplicates or re-enacts something else. This vibration of echoes and repetitions always carries the paradox of such repetition – what occurs is always the same as yet different from what it duplicates. In the face of this paradox, moreover, nothing is decided, no simple hierarchy of truth is accepted. Where everything occurs as the trace of what precedes and follows it, nothing is determined as the original. (Mitchell 1991: 61)

The bride and groom become idols, meaningful in their traces, repetitions and interrelations through their resemblance into collective nuptial bodies, as they mostly sit still and elevated, heavy in garments, make-up and the gaze of their social benefactors.

Bride and groom as idols and resemblances, as the idols of performative, embodied social power relations, make the nuptial body elusive, almost ghostly to find, to construct, to analyse. However, representations have the ability to blur the boundaries of their own actualities, unlike symbols that entail hierarchies of representation between signifier and signified. In fact, it does not make much sense to talk about the construction of the bride or groom's nuptial body, not only because it is very hard to locate in the midst of all those bodies around them, but because in anthropological terms it would be a biased mistake to singularise the nuptial body, since bodies exist in relation to other bodies, combining, dividing, forming, reforming, deforming, and always entailing traces and resemblance to their previous and future performances. Taking into account the local contexts, such as being Druze, in Jaramana, and carrying the political myth and realities of a minority in the vicinity of Damascus, the Druze nuptial body converges upon the socio-political body-politic (chapter2).

The bodies of the bride and groom should be understood in relation to their guests; their stillness underlines that the two nuptial bodies are reassembled onto the moving, gendered categories of their guests. In the end, the antagonism or ritual tension between the two groups of bride and groom does not get resolved through

the union of bride and groom, it only gets delayed and deferred as if in an on-going unstable Derridian theatrical play; it is not therefore appropriate to talk about the bride or the groom's nuptial bodies per se. In Druze weddings, it only makes sense to speak about bodies that, through the nuptial ritual, become *extended* and *enlarged* in order to stretch and include, but not reduce or eliminate their difference. Consider the myth of Procrustis as a metaphor for the social and political extension of bodies:

Procrustis: The surname of Damastis, or Polypimon. A thief, whose field of action was located between Megara and Athens. He would catch the passer-by and make them lay down on one of the two beds that he had. Those who were tall he would put on the short bed and those who were short on the long bed. Of course, tall people's feet would exceed the short bed's length and Procrustis would cut them off, while the short ones were put upon the longer bed and Procrustis would pull them in order to elongate them. This was how he would kill those he would catch. He was killed by Theseas in the same way (Krinelos 1995: 589).

The whole social fabric of the Druze body-politic is cast in a ritual praxis that attempts a theatrical initiation and the incorporation of two bodies into a social union of intimacy not only between the bodies of the bride and groom, but a cultural intimacy between all those attending. In this way, we can understand not only why the guests participate but also why they embody different structural antagonisms in a way that emphasises the relational intimacies between unstable and performative social categories (for example masculine and feminine, family alliances, etc.) more than it does the actual union of two 'individuals,' which, as such, do not exist as absolutes but as relationships.

As the nuptial bodies of bride and groom become enlarged, constructed and extended upon the bodies of their families and their respective guests, and as the nuptial ritual comes to be resembled and re-assembled on bodies other than the bodies of bride and groom, the bodies of the guests, categorised and embodying the relational power struggles, come themselves to represent a binding nuptial intimacy between them. Here is the space of the micro-anatomy of the body-politic (see chapter 2), the space transformed by cultural intimacy into something even more minute and powerful to re-form not only an imagined but an embodied community: a body boundary so binding that it becomes nuptial intimacy. This boundary, a kind of social skin (cf. Turner 2007 [1980]), is elastic: always in relation to other bodies, and the ritual enactment through the wedding celebration marks just one specific

instance, hinting and tracing on-going processes of the past, the present and the future. The body-boundaries of the idols of the bride and groom become extended in space to include the social formation of communal gendered nuptial bodies that, in practice, signifies the relationship of the whole social body-politic getting married.

In the Druze marriages of Jaramana wedding guests not only participate but also embody the nuptial union through resembling, in space, the enlarged nuptial bodies of bride and groom. However, the spatial geography of nuptial intimacy dialectically depends and is constructed also through *time*. On a time-space continuum the nuptial body emerges not only processually through the ritual of marriage, but it demands specific regimes of knowing, of history, mythical and real. Essentially, the question of time and the nuptial body is a question on *Otherness* and difference (cf. Deleuze 1994; Heidegger 1985 [1962]). Layers of otherness are constructed through the constitutive tensions of the spatial use of religious and regional boundaries such as the differences and similarities entailed in the performance of the Jaramana wedding ritual vis-à-vis Damascene as well as Sweida weddings. But the temporal construction of communal nuptial bodies is a construction that challenges as well as reifies not only *other* bodies, but other bodies of *other* times: this 'other' for the Druze is the historically, mythically and religiously performative state of emergency regarding a constantly threatening being-in-a-world-of-others (see chapters 2 and 3). Being-in-a-world-of-others is a perpetual state of social emergency regarding the minority ethno-religious status of the Druze, and is expressed at its apex during the most elaborate celebration of being Druze (Khuri 2004), the practice of strict endogamy, which is none other than the ritual of marriage. The challenge here, for the practice of endogamy and for the perpetuation of practical beliefs as aspects of Druzeness, is the precarious balancing act between an intimate ritual knowledge of a fluid, flexible and at times volatile nuptial body (cf. Grosz 1994) that is only realised through social participation, and the simultaneous branding and guarding of this intimate insight from all those uncertain outsiders. In the ritual of the wedding, many different layers of religious and social intimacies may be traced, layers that point to differentiations within the Druze of Jaramana (i.e. the religious ritual blessing that Shaykh and only initiated *'uqqal* are allowed to watch), the Druze of Sweida (i.e. competitions and antinomies during mixed weddings), as well as the Druze and religious others

(however, Christian or Muslim friends and neighbours may be invited to attend; this depends on personal relations between the families).

The positionality and gradual re-assemblance of the anthropologist from an outsider to an honorary adopted daughter, is helpful in illustrating this gradual process of othering, differentiating and making intimate. I was only gradually permitted into attending more and more aspects of the wedding ritual process, and many times, especially if a family was 'religious' or not very close to my families, I was kindly asked not to take any photographs or videos. However, there are cases in which people are not permitted an invite to any of the co-centric circles of ritual Druzeness because they are 'other.' Such was the case with Tariq Abud-Haddad's two American friends whom he had invited to the wedding party of his cousin, Kholud. As soon as his two eldest brothers found out about the invitation, they had a big fight, forcing Tariq to retract and cancel his invitation because, as the brothers stated, 'we don't want strangers in our weddings.' Somewhat ironically, I was not only invited,⁸⁸ but I also happened to discuss the matter with the two brothers. They explained how 'our' weddings, rituals and religion are the result of historical temporal narratives of survival struggles against persecution, so much so that their intimate knowledge forms an integral aspect of being Druze, how such guests would change the atmosphere of the ritual even through their presence because they could not connect (with the social nuptial bodies), and how they did not want either 'Americans' nor any other tourists to see their rituals as a tourist attraction or a museum souvenir. They said I was different not only because I come from Greece, and we resemble (*tusbeh*)⁸⁹ each other, but because I am part of the family. The 'Americans,' thus, were

⁸⁸ In addition to attending the ritual celebrations, I also helped in preparing and cleaning the courtyard before and after the celebrations, and I performed hosting duties as part of the bride's extended family, Bayt Abud-Haddad, such as serving welcoming sweets, Arabic coffee and drinks to the guests, including the groom's relatives from Sweida, whom I doubt ever found out that I was not the biological daughter of Abu and Umm Samir. At least this time it was not as embarrassing (or funny) as another time when Abu and Umm Samir introduced me as their daughter to a religious shaykh, who then suggested his nephew as a possible husband for me, and Abu and Umm Samir had to explain why that would not be possible based on the principles of Druze endogamy.

⁸⁹ This is a powerful local idiom of embodied intimacy in which it is believed that Druze people physically resemble and look alike each other; here is an indicative quote from Kamal Joumblatt, Druze founder and leader of the Socialist Progressive Party in Lebanon: 'One can always tell a Druze [sic], by his bearing and manners. The Druses are alert and lively but they behave with great dignity and courtesy in society. They are polite and use special words to express their emotions or to articulate their thoughts. They speak Arabic better than most, and much better than the Christians who do not pronounce the hard consonants. ... Even their faces are different. If there is one Druze in a crowd of 20, it will always be easy to pick him out. Passing time has not changed our race, for custom forbids the Druses to marry outside their community: there were few exceptions to this rule.' (Joumblatt 1982:

not allowed to attend not just because a marriage in Jaramana is an intimate, local affair but also because the marriage process itself is a structuring, performative intersubjective process of layering ways of knowing, relating through the structuring of intimate others, others that include the community in Jaramana, but also Druze from Sweida and neighbours of other local religions. Complete strangers or tourists would be a structural anomaly, an anomaly that by political and historical choice the two brothers chose not to involve in a process of getting to know through participation in intimate *othering* processes.

The wedding ritual not only constructs social gendered nuptial bodies through the embodied practices of the participants but also constructs, in time and in space, a geography of relational nuptial intimacy structured upon the ontological and political parameters of layered intimate others. Herzfeld (2005) quotes the notion of ‘cultural intimacy’ to denote shared idiosyncrasies, ways of knowing, often awkward or embarrassing, that separate the cultural ‘insider’ from the outsider, noting that this kind of intimate knowledge is the ‘stuff’ that constructs and sustains nation-states on the level of everyday practices. In a similar manner, in Jaramana’s weddings the nuptial bodies are formed, reassembled, and constituted through relational performances, in which the micro-economics of movements envelope relationally the participants through nuptial intimacy, which serves to reify the imagined Druze community into an embodied solidarity, along with reifications of structuring power relations such as gender. Inscribing intimacy and Druzeness onto bodies that become nuptial ‘does not mean that a body can be “read” in isolation from others.’ Cowan 1990: 90)

The nuptial body is unattainable, that is always becoming but which never becometh, and in this way, insofar as ‘nuptial’ is a collective potentiality (the on-going horizon of becoming) bodies are then always nuptial. Perhaps ironically, they [the bodies of bride and groom] are the least ‘nuptial’ during the wedding ceremony itself, where they sit still while nuptial relations are performed and reinforced around them. Therefore, the nuptial body is not an essentialised body or thing but an embodied

36) The ‘exceptions’ that Joumblatt mentions at the end of his speech include his own family tradition of marrying out with women of very high social status. Informants explain that in the case of families with the status of ‘Emir,’ such as Joumblatt’s, it is appropriate to marry a wife of equal social standing, even if that means that she could be non-Druze.

trace of nuptial ritual and communal intimacy, whose enactment, contrary to the Western practice of ‘pre-nuptials’ that denote a legal contract in advance of a wedding, here the enactment of nuptial bodies/ritual/intimacy becomes a kind of *social* contract. As both the legal contract, and the social contract pre-suppose some future rupture, disharmony, discord, challenge from within or challenge from without, such contractual enactments reinforce the body as a site of struggle (see chapters 2, and 4).

But what happens to the ontology of Druze endogamy and to the social practice of nuptial intimacy when these collide with the numerous forbidden interfaith and same-gender love affairs in Damascus? And how much distance stands between forbidden nuptials and full-blown sectarian violence?

Procrustean bodies of the margins: intimate and volatile struggles

Zahra is a Druze woman who fought and still struggles with her family and community because of her decision to marry outside both the Druze sect and Syria itself (see chapters 1 and 3). Her story is real, and lies on the thin lines of intimacy and violence, lines that at times make the body itself marginal. This is how Zahra describes her family:

I grew up in a middle-class intellectual family. My parents are intellectual in different ways, but somehow in a complementary way. Although both of them are teachers of history and they come from the same [extended] family, they are very different in dealing with children, money, politics and society. Both of them don't care for religion very much. They are simply secular or not religious. My father is hooked on politics. He used to criticise our dictator and autocratic political regime, but also our religion ‘the Druze’ and the religious people. He considers this as being backward. Compared with Islam and Christianity, the Druze religion was and still is not a subject of criticism, reform or discussion. For example, one cannot read the holy books [epistles] of the Druze until one becomes a ‘wise’ [initiated, *‘uqqal*] Druze or a Shaykh. However, my father was not happy to see his daughters going out, dressing in short skirts or be involved with liberal intellectual groups. When he had the power and I was dependent – mostly economically – he refused my request to study music. The reason was clear: he disliked seeing his daughter getting in contact with and being a part of one of the rare open and mixed communities in Damascus. Otherwise, he encouraged my interaction with his own intellectual group. In short, I was allowed to be intellectual under his control... My mother is a smart, elegant, dynamic and modern woman. She supported me to dress in short skirts, to learn music and to

keep going out far away from my father's control. More importantly, she helped me to come to Europe. She learned to benefit out of the corrupted system in order to get her rights and the rights of her children, something that my father altogether prefers to avoid. She fought to get comfortable household machines as a modern woman. She was very much interested in social issues and gender affairs. She is very much aware of disadvantages of women in Syrian society, in particular in our Druze society. My mother was a feminist until I became a feminist. Then she became a typical Druze mother, who wants to maintain the family pride and protect herself from social blame.

Zahra's family is one of the more liberal, intellectual and oppositional families that I have met both inside and outside of Jaramana. With the excuse of an old serious health problem of the brain, in order to surpass censorship, Zahra's father is perhaps the most vocal and expressive pro-democracy activist I met in Syria, someone who always 'talks politics' and a stern believer in a secular and democratic civil society (*mujtama' madani*) and polity. Thus, Zahra grew up in the rather left-wing environment of her family and state, not unlike other pupils of her age, she played the flute and the violin and had heard more of Marx and Arab Socialism than she had about Druze religious beliefs and practices. She studied in the University of Damascus, and with moral support from her mother, Najwa, she continued doctoral studies in Europe.

Eight years since she left Syria, the prospects of Zahra's return were diminishing. She had found a prestigious job and most importantly a love with whom she wanted to spend the rest of her life. But Zahra was reluctant to break this news to her family, uncertain and scared of their reactions. Not only would Zahra bring 'shame' to herself and to her family, but as the Druze faith and practice is based on strict endogamy (Alamuddin and Starr 1980; Khuri 2004), she would be breaking one of the most fundamental laws in the community's doctrine and solidarity. This, having grave repercussions for social reproduction and solidarity, could cause real problems, such as communal stigma, excommunication and ostracism, not only for Zahra but for her family as a whole. Zahra eventually told her parents that she intends to marry the man she loves. Her parents did not accept it, her father stated that 'you are free to do whatever you want, but should you marry this man you will no longer be part of this family.' Two years on and Zahra has been married – she has been married at the cost of losing her family and her place in the Druze community and neighbourhood. Her relations with father and elder brother, Nidal, have been

completely severed, her mother's mental and physical health has drastically deteriorated, while she still tries to convince her daughter, through emotional blackmail or threats, to divorce her husband and come back. Because of the health condition of her mother, and the marriage prospects of her three siblings that might be affected, Zahra's marriage still remains the dark secret of her family.

Unintentional heroes: the nuptial body as the practical limit of civil society (and of other intellectual theories)

Even though Zahra's parents understand and propagate the rhetoric of civil liberties and individual freedoms, they cannot accept the same doctrine for their own daughter. In a context where social capital and networks equate to political and economic capital, such deviance from the socially constructed rules of communal solidarity can have very real effects. They are themselves intellectuals, but the limits of their theories appear where action begins. Theory, then, becomes a form of social capital (Bourdieu 1986; Portes 1998) and is important and relevant insofar as it does not pit the intellectual against a whole system of social, political and economic transactions. It is safe as long as it does not translate into action and so long as confrontation remains on a theoretical level. Intellectual theories on resistance, democracy, civil society in petty bourgeois intellectual families such as Zahra's, become markers of social status and prestige, a currency of social distinction in the educated lexicon of an emerging middle class as long as they don't touch the body – and more specifically the socially reproductive nuptial body. Thus here we note a conglomeration of practices of Druze endogamy *within* the political and economic frameworks of the middle class.

Yet, the inertia characterising the discrepancy between the ideals and the actions of Zahra's parents should be analysed not within the particularities of a single family, but as a generalized political aspect of a class-based intellectual activity. Her parents' intellectualism finds historic resonance within the broader 'oppositional' movements and elite classes that works like Wedeen's (1999), Salamandra's (2004) and Watenpaugh's (2006) explore (see chapter 2). This is a very specific intellectual movement: certain disenfranchised elites within Syrian society use the rhetoric of 'resistance to the regime,' and manipulate the fashionable vocabulary of 'democratisation' and 'modernisation' (inherently neo-colonial terms) in their political

struggles *within* Syrian politics (see chapters 6 and 7 for detailed analysis of these terms). As such, the intellectual discourse on civic freedoms becomes an elite, eclectic, discourse – a narrative to be understood and implemented within the confines of a specific, limited group. In lieu of this, this discourse reflects local elite power struggles and not radical social change at large. Zahra’s parents cannot accept that their daughter will marry ‘outside’ of the community, even though they too believe in civil society and individual freedoms. They can not accept it, not because they are pretentious, but because they are aware that the intellectual discourse they abide to is separate from everyday life and practice. It is a political tool and a status distinction (Bourdieu 1984), but it cannot be the manifesto for social life because, as a discourse which is group particular (elite) and a political tool, it does not take into account everyday life – in a sense it is unconcerned with and irrelevant to the lived experiences of the majority of working class Syrians.

And so, Zahra’s parents find themselves positioned within an ironic liminal state: instigators and propagators of social change, but only up to a certain, comfortable, safety zone. This is how Zahra’s mother, maybe feeling responsible for her daughter’s liberal upbringing, described herself through a popular joke:

There was a man fishing on the shore and he falls in the sea. He cannot swim and cries out for help. Passersby gather at the shore and they all stand watching the drowning man, too afraid to jump in and save him. Somehow, another man is accidentally pushed into the water. He can swim so rescues the angler, while the hoard of onlookers applaud his brave heroic act as he comes out of the sea. And he replies: “You may call me a hero, but I’m searching for the dog who pushed me into the water!” (Zahra’s mother, August 16 2009). This is the point at which our unintentional hero can take the plaudits no more, slips quietly back into the mass of onlookers, and finds solace as another faceless and inconspicuous member of the crowd.

The nuptial body can never be singular but exists in plural form through its representation and embodiment upon the social body-politic, where the idols of bride and groom are re-cast in a unidirectional fashion so that the communal whole may represent the idols but the idols themselves cannot represent the nuptial bodies,

since their actualisation is but for their extension and enlargement in the social whole. This process connects to the ancient Greek myth of Procrustis in two interesting ways: firstly Procrustis could be compared to the Druze ‘imagined community’ which constructs itself through prescribed norms and practices, prescribed upon individual nuptial bodies which are made to ‘fit’ within the ethno-religious expectations of a community of practice. In this case, what happens to those bodies that do not fit into the religious and social expectations of a procrustean body-boundary? And, secondly, to lay in anybody’s bed, especially without the social sanctioning of doing so, is an intimate but uncertain, potentially dangerous game – but here is precisely where the myth is reversed in the Druze community and through the practice of wedding, since Procrustis can be seen as the benign and protecting *measure* (gk. *metron*) that runs through individual bodies, connecting them, either by extension or by shortening, to the rest. In this case, Theseas is transformed from hero to villain, to the individual that threatens to kill society by the same tools. However, the antithesis of Procrustis/ Theseas is also an antinomy between two structural extremities – and structural extremities are always already connected like the different sides of the same coin, in a way in which the intimate body boundaries between individual social nuptial bodies are interconnected through the constitutive tension, a small thread, separating and at once uniting intimacy and violence.

On the tense marginal thread between intimacy and violence, walk those who choose to defy the social norms of Druze endogamy, those like Zahra.

Procrustean bodies of the martyrs

Syria has been walking on a tense rope of intimate violence since March 2011. An intimate rope that has become violent and whose main danger is of becoming circular...

Appadurai, slightly turning Herzfeld’s (2005) notion of ‘cultural intimacy,’ in his paper ‘Dead certainty: Ethnic violence in the era of globalisation’ (1998) explores the ‘dead certainty’ of deadly uncertainty: how once intimate bodies, such as those of friends and neighbours, can suddenly be turned into vehicles of deceit and danger, and from once intimate bodies, during periods of crises and ethnic, collective or civil violence, they can become bodies to be fought, penetrated, mutilated, and lacerated.

‘Ethnocidal violence evidently mobilises some sort of ambient rage about the body as a theatre of deception, of betrayal, and of false solidarity’ notes Appadurai (1998: 238), exposing ‘a horrible range of intimacies’ (Appadurai 1998: 239) in which ‘the body remains a site of intimacy, and in the many different forms that bodily violence takes in different contexts, there is a common thread of intimacy gone berserk’ (Appadurai 1998: 240).

A brief illustration with Zahra: Zahra’s body never became nuptial – never really agreed to reproduce the body-politic that would render it unthreatening in as much as intimate. But what of Zahra’s mother? For her, her daughter’s body remains intimate,⁹⁰ and for whose intimacy she stubbornly continues to fight for through emphatically denying not only the legitimacy of her daughter’s marriage but also the finality and irreversibility of the event of her marriage. Zahra’s mother continues to try to persuade her daughter to return to Syria in two ways. Either as a trap, a conspiracy, that her daughter has fallen into (‘it’s your husband that trapped you, he had it all planned out’), or as a hypocritical, deceitful daughter (‘you are not my daughter,’ ‘I did not raise you like this,’ ‘you are a traitor’). Oscillating between an outsider’s conspiracy and an insider’s betrayal, Zahra’s mother refuses to see herself reflected on the body of her daughter, denying not only her responsibilities and avoiding not only the question of her intellectual, secular rhetoric and conservative practice, but her narrative of conspiracy and betrayal is permeated by the inherent ambiguities of intimacy and power: unpredictability and fluidity. This resonates with rhetoric theories in which rhetorical persuasion operates by instigating movements [in the mother’s case these are oscillations which represent alternative rhetorical strategies and movements in different directions] along a continuum between the extremes of familiarity and the most uncertain and unknown (the space of the so-called ‘inchoate’ which *is* the unknown, but doesn’t exist statically at one end of a spectrum but can emerge at any moment by virtue of a changed situation or circumstance – which requires delineation and response, see Carrithers (2008), Fernandez (1986)). This instable ambiguity that characterises intimate relations also plays a significant role in theories of violence, in which intimacy is easily translocated into deceit and betrayal.

⁹⁰ In both phenomenological as well as patriarchal terms of ownership and belonging.

The experience of violent ostracisation from one's family due to a breach of nuptial relationality (endogamy), is not unique to Zahra or to the Druze community (see Anna's story in chapter 7). The current advisor to President Bashar al-Assad, Bouthaina Shaaban, has written about her story of ostracism from her family because she chose to marry a Muslim man of different ethnicity (Shaaban 1988: 6–11). Neither is the response of Zahra's mother unique: the same narrative frames used by Zahra's mother have been used by Syrian President, Bashar al-Assad, in his three speeches addressing the population after the recent turmoil. 'Turmoil' can barely describe what has been going on in Syria since March 2011, when unprecedented protests erupted questioning the almost 50 years old authoritarian regime, and the 40 year old Assad family dictatorship. State corruption, repression and brutality collide with economic and demographic problems, peaceful protests are bathed in blood, at the same time that rumours or realities of foreign infiltrators or religious sectarianism provide a volatile mix for the multi-religious and ethnic make up of Syria. Certain signs now, not only the protracted violence, and the death toll, but also the publication and iconisation of mutilated bodies not only by the opposition, or even the sensationalist Western media, but by the Syrian government itself, point not only to a visual pornography of violence but to very dangerous future directions.

It is a truism to say that violence breeds violence, and in Zahra's, as in Syria's, case it is fair to say that intimacy breeds violence, that violence is the result of intimacy for to be afflicted, a movement must firstly be made, a movement towards, a touch (chapter 2; Manning 2007). Intimate violence, similar to nuptial intimacy which entails its rituals and processes, paints its own aesthetics. These aesthetics invest bodies, forming and performing on and through them the particular poetics of violence, a body-politic of mutilations, penetrations, lacerations. The theme of intimacy and violence will be further explored in the next chapter. For now, let us just use one last metaphor. If Zahra's body became procrustean because of its metaphorical 'killing' on the bed of Druzeness, then the mutilated bodies of Syrian martyrs in the thousands that have either extended to breaking point or violently lacerated are also procrustean since they did not fit to already unfitting beds. Still, unfortunately, this is not the gravest of threats that surrounds Syrians at this stage. The danger of Procrustis, or any villain or monster, is not being exposed as the monster and being killed in the same way, as Theseas did. The problem, rather, is one

of intimacy. Theseas not only needs Procrustis to become a hero, but he becomes Procrustis in applying the same procrustean methods to kill him.

Chapter Six

Poetics of an Empire: folklore festivals, nuptials and the Syrian State

Pleasure and power do not cancel or turn back against one another; they seek out, overlap, and reinforce one another. They are linked together by complex mechanisms and devices of excitation and incitement. (Foucault 1998 [1978]: 48)

Introduction

The nuptial form of relationality, through which the body becomes a site of and for struggles through its transformations and political extensions (as explored in chapters 4 and 5), is not unique to the Druze community of Jaramana. In this chapter, the political extensions and contestations of the body within the realms of the Syrian state are explored. This chapter is a combination of political theories of the state, the political economy of state representation, and ethnographic analyses of how the Syrian state through its cultural policies attempts to naturalise, neutralise and command potentially threatening sectarian identifications through a spatial poetics of nuptial intimacy that transform the state into a local empire. It is an exploration of the mechanisms by which the Syrian state *attempts* to obtain popular consent through its internal cultural policies, and in doing so, the ways that it builds and reifies itself as an almost transcendental empire, legitimate to rule over its polymorphous contemporary polity. The chapter is divided into two parts. Through two cases studies from folklore festivals, part one demonstrates that the cultural policies of the Syrian state are neither ‘nationalistic’ nor homogenising, two tactics through which the nation-state is often conceptualised, but rather strategise multiculturalism and the secular rhetoric of cosmopolitanism. Therefore, part one argues that the Syrian state should be better considered as a *state-of-empire* rather than a nation-state. Part two explores the details of the Syrian state’s choreographies of empire, demonstrating how the state employs nuptiality and intimacy in order to inscribe itself and become reified through the daily practices of its citizens.

Part 1: Theorising the state

Marx and Engels noted that every state is a dictatorship, representing and implementing the interests of its ruling classes; Weber noted that states possess the legitimate monopoly of power. But, can we ask what the state ‘is’? Giambattista Vico

in his lifetime was awarded only once an academic prize for an essay, now lost, regarding the etymology of the term ‘state:’

...in Italian, *stato* is used as the past perfect participle of the verb for ‘be’ (*essere*, significantly, a cognate of the English word *essentialism*, but directly derived from *stare*, stand, be in a certain state or condition). Such an etymology represents the state as the ultimate eternal verity, that which ‘has [always] been,’ and as such an outstanding example of what we would today call *naturalization*. In that case, the transformation of a verb particle into a noun – *lo stato*, the state – bears witness to a process of reification. (Herzfeld 2005: 73)

The ‘state’ has been a particularly ‘elusive’ object of study (Abrams 2006 [1988]: 113) because conceptualisations of the term oscillate between the slippery, and often dichotomous, analytical tropes that cast ‘it’ as either an objective, distinguishable entity set apart from society, or as a subjective, non-existing, and almost illusionary effect of political systems and/or of historical and political relations of power. Shifting the emphasis from what the state ‘is’ to what can be known in a given historical time (‘epoch’), Foucault traces the historical emergence of the ideas regarding the ‘art of government’ (in 16th century Europe) to that of the ‘state’ (from the 18th century onwards), and how these concepts relate to new regimes of knowledge and techniques of power, specifically the objects and issues of population, security apparatuses and the economy – all of which for Foucault operate not by ‘constraining individuals but by producing them... as a political subject’ (Mitchell 2006 [1999]: 178; Foucault 2007). Foucault denies the apparent agency, unity, and functionality attributed to the state as a ‘mythicized abstraction’ (Foucault 2006 [1991]: 142), instead proposing the concept of governmentality as the methods, tactics, and possibilities of conduct under different arrangements of power/knowledge: ‘it is the tactics of government which make possible the continual definition and redefinition of what is within the competence of the state and what is not’ (Foucault 2006: 143).

Abrams (2006: 122) suggests a need to ‘abandon the state as a material object of study [...] while continuing to take the *idea* of the state extremely seriously.’ Combining unlikely bedfellows such as Marxist thought (specifically Engels and Poulantzas) and Durkheim, Abrams views the state as a social fact but not a thing (Abrams 2006: 122), and he defines it as an ‘ideological project,’ as ‘the distinctive collective misrepresentation of capitalist societies’ (Abrams 2006: 122). Mitchell,

building upon and expanding on Foucault, suggests that contrary to an 'idea,' the state is rather an 'effect' of contingent relations, methods and techniques of disciplinary power: 'the apparent boundary of the state does not mark the limit of the processes of regulation. It is itself a product of those processes' (Mitchell 2006: 175–176). For Mitchell, this 'structural effect' is 'produced by the organized partitioning of space, the regular distribution of bodies, exact timing, the coordination of movement, the combining of elements, and endless repetition, all of which are particular practices' (Mitchell 2006: 180). Thus, it is through social practice that the state becomes assembled into existence, and hence, as Herzfeld (2005: 2) puts it, even through 'little acts of essentialising' in everyday life the state becomes reified, it becomes a 'permanent fixture,' or in Harvey's (2009: 264) words, the state 'achieves a presence in relational spacetime by way of its material effects.'

Harvey agrees with Abrams and Mitchell that states are reproduced and reified through everyday practices, but contra Mitchell (and Foucault) he argues that the driver of regulation, discipline and management practices that reify the state in both space and time is the process of capital circulation within capitalism: 'if the state did not already exist in some form or other the circulation of capital in space and time would have to create some kind of territorial organisation very much like one' (Harvey 2009: 266). He also criticises Abrams on his dismissal of the state's materiality: 'borders are, to be sure, social construction, but when turned into elaborate physical fortifications, they render moot the dismissal of the materiality of the state as an inadmissible reification' (Harvey 2009: 267). Instead, Harvey proposes the following definition for the state:

A dialectically constituted construct, a 'relative permanence' caught between absolute, relative, and relational definitions, between material social practices, representations, and ways of living. It is the outcome of distinctive processes of place making caught up in an interactive politics of territorialization (Harvey 2009: 279).

Abrams', Mitchell's and Harvey's frameworks for understanding the state and the problematic that accompanies the term, are all important foundations in starting to explore issues of state–subject relations in Syria. In other words, their nuanced theses comprise the foundational presuppositions that frame my own expeditions into the fiercely debated *territory* of the state. They are also important in a second, more instrumental way to the arguments made in this chapter. Firstly, emphasis is placed

on the ideological, historical, and embodied practices, as much as economic processes that constitute and reify the state. Secondly, these theories are dialectic and relational conceptualisations, thus viewing the 'state' not as *a priori*, not as the aggregate result of modernisation, and not as a universal given. As such, I have found them a more fruitful theoretical premise upon which to understand the uneasy and often contradictory relationship between the Syrian state⁹¹ and the Syrian people. This relationship has only and exclusively been previously defined rather simplistically as repressive and authoritarian, a unilateral imposition of domination and coercion on behalf of the state onto subjugated subjects with little or no agency (see chapter 2). Denying Syrians (and Arabs and other Others) agency vis-à-vis the political realities of their everyday lives consolidates them as non-actors not only in their country's political formations but almost as void spaces onto which the power struggles of global capitalism attempt to inscribe and become either their modern and democratic beneficiaries or their witch hunters. Instead, the focus on reification helps to provide a different avenue in exploring 'the possibilities and the limits of creative dissent' (Herzfeld 2005: 1), of the ways that power relations are never one-sided, but always unstable, and to different degrees negotiated, reinforced and resisted.

Finally, the aforementioned theoretical premises are helpful in evading some of the usual traps, binarisms and ethnocentric bias often represented in debates partaking to the 'nation-state.' Although none of these theorists explicitly state it, they all underscore that the almost 'transcendental association' of the state with the nation (Mitchell 2006: 176) is a quite specific and subsequent ideological project of the state and therefore by no means universal (Abrams 2006; Harvey 2009). This is rather pertinent for a new paradigm shift in the way that Middle Eastern states and people have been theorised; a relationship theorised as a top-down imposition. This imposition has been explored almost exclusively in terms of modernisation theories and specifically through debates on the present and future, successes and failures of nation-states within the Middle East. The more nuanced of such understandings may view nations as imagined communities (Anderson 1991) and nationalism as the 'entry

⁹¹ As mentioned above, states are different from the sum of their institutional forms such as governments and regimes. However, in the Syrian case, there are certain correlations between state and regime since for the past forty years these have worked interchangeably. Thus, in this chapter there is a degree of interchangeability between 'regime' and 'state,' although I understand how problematic that might be.

to, participation in, identification with, a literate high culture which is co-extensive with an entire political unit and its total populations' (Gellner 1983: 95). The consensus is that because the Middle East lacks 'a homogeneous national population' which is the 'basic requirement of the externally imposed nation-state' somehow the 'nation-state has failed to take root in the Middle East' (Tibi 1996: 174–179), creating thus 'states without foundations' (Kelidar 1993). A homogenous population is not a prerequisite of the nation-state but a result of such processes (Anderson 1991; Mitchell 2006), and a result that is constantly contentious and never quite complete (Herzfeld 2005). More recently, Al-Barghouti (2008) offers a nuanced historical analysis of the mistranslation and thus mis-realisation of the territorially based notions of nation and state to the 'indigenous' notions of *ummah* and *dawla*. That certain power structures and frontiers had and are being continually imposed by other more powerful capitalist powers, is an undeniable fact (see Ali 2003), but it should not presuppose that people and polity either accepted or failed to accept, since that robs most of the postcolonial world, along with all those internally colonized (to borrow a term from Gramsci's *Modern Prince*), of any agency (Sahlins 1999), and it is simply empirically unfounded. Neither is the problem a definitional one, something akin to a perpetual misunderstanding between Arabs and their internal and external 'rulers.' Rather, the issue this chapter challenges is that the theories of nations, nationalisms and nation-states contain a tautological effect in that they often presuppose and require both a 'state' and a 'nation.' Not only is this conception historically ethnocentric, but empirically it distorts the situation on the ground. Placing emphasis on the state and viewing nationalism or the concept of the nation as only one of many tactics and techniques through which reification of the state is substantiated is, I believe, more fruitful and more responsible. In the pages that follow it will become clear that the Syrian state uses alternative methods to 'nation' and 'nationalism' in order to inscribe itself in the relational details and the intimate lives of its citizens.

Cultural policies – cultural politics: Why folklore festivals?

Folklore has been studied primarily as a 'picturesque' element. [...] Folklore should instead be studied as a 'conception of the world and life' implicit to a large extent in determinate (in time and space) strata of society and in opposition [...] to 'official' conceptions of the world. [...] This conception of the world is not elaborated and systematic [...] it is,

rather, many-sided – not only because it includes different and juxtaposed elements, but also because it is stratified. (Gramsci 1999: 360)

What is possible to learn of/about the Syrian state and its relationship to its heterogenous polity through its cultural policies, and specifically through state-organised folklore festivals? Anthropologists have long suspected that dance entails much more than body movements in the vicinity of music,⁹² since dance occupies the intersection between concepts and practices of pleasure, power and the technology of the body (cf. Bourdieu 2007 [1977]; Foucault 1991 [1977], 1998 [1978]), through the ways by which it embodies (Bourdieu 1977: 87–95) and negotiates the boundaries of cultural performances.⁹³ Recent anthropological theories converge on the point that dance constitutes a site of ‘both gender struggle and class struggle’ (Washabaugh 1998: 9), while much of this literature emphasises the study of gendered contestations.⁹⁴ In regards to the Middle East, recent works reflect nuanced attempts to disentangle the historical, social, cultural and political frameworks of arts and popular culture(s) in a region located along long and complex historical and cultural crossroads, as within economic and political struggles, and attempt to understand the formations and transformations, the visions and divisions pertaining to cultural production, performance and practice, whether it is musical, danced, theatrical or within the myriad contours of everyday life’s manifestations.⁹⁵ Such works focus on issues of modernity, tradition, Western hegemony and its negotiations and resistance, and issues of power relations specifically pertaining to gendered struggles. Less emphasis, however, has been paid to the political ramifications of cultural policies and politics *internally*, vis-à-vis state and subjects.

⁹² See Blacking and Kealiinohomoku (1979); Cowan (1990); Gell (1985, 1998); Hanna (1988); Schieffelin (1976); Shand (1998); Steingress (1998).

⁹³ See Bauman (1977); Bateson (1972); Butler (1990); Cowan (1990); Goffman (1990 [1959]); Kirtsoglou (2004); Reed (1998); Savigliano (1995).

⁹⁴ See Abu-Lughod (1986); Cowan (1990); Hanna (1988); Butler (1990); McNay (1992); Kirtsoglou (2004)- but see Manuel (1988) for a different view.

⁹⁵ Examples of this emerging trend include Sheifa Zuhur’s edited volumes on performing arts (2000, 2003), and monographs such as Shannon’s ethnomusicology study of Syrian music and modernity (2006), Armbrust’s work on popular culture in Egypt (1996), van Nieuwkerk’s work on female singers and dancers in Cairo (1995), and Potuoğlu-Cook’s analysis of the processes of neoliberal gentrification in Istanbul (2008), Salamandra focuses on Syrian melodrama and the ways it acts as an opportunity for covert political commentary (2004) as well as a medium of cultural production and dialogue. In an analytically vigorous light, Abu-Lughod (2002, 2005) analyses Egyptian melodrama as ‘popularizing a distinctive configuration of narrative, emotion and subjectivity’ in its introduction of a distinct ‘Western sensibility’ in the Egyptian household, employing Foucault’s notion of a ‘technology for the production of new kinds of selves’ (Ginsburg et al. 2002: 116).

One of the few arenas of public life where state representatives and citizens come directly into contact in a demarcated space is during popular festivals sponsored by the Syrian state. These festivals often take the form of national and international folkloric exposes, most notable of which are: the Bosra International Festival, the Silk Road Festival, and the National Folklore Festival in Idleb. In the contexts of authoritarian, one-party rule and in the absence of open and free elections, these festivals provide opportunities as well as excuses for the interaction of the Syrian state with its subjects as means of renewing and consolidating legitimacy, consent and animated enforcement of state loyalties. Of course, public spectacles as well as folklore are fields of exploitation and expressions of power that most states use and abuse in the reinforcement of their policies.

In forging the nation Assad and the Ba'th put to use history, archaeology and the cultural and scientific achievements of the Arabs. A commonly held view was that Syria had been asleep for ten centuries, denatured by alien control, but must now be stirred to life, a prerequisite for which was an understanding of the past (Seale 1989: 459).

Cultural policies and cultural politics are important arenas of 'forging the nation' as Seale notes, not only for the Syrian state, but for any state. The appropriation, invention or re-invention of history through claims of common heritage, ownership, or culture not only presuppose a static understanding of the past but are also deeply political and politicised narratives, which, through careful manipulation, represent claims to both legitimacy as well as authority. In most governments, history is carefully assembled from many stories, and fitted within the narrow paradigms of one grand narrative appropriate for the nation-state (Anderson 1991; Hobsbawm 2006 [1983]). As for folklore dance, it offers an interface to the state, being one of the many possible stages upon which to reach out, perform and portray its own historical and political visions and divisions: 'as an embodiment of cultural heritage, the dancer becomes inscribed in nationalist histories and is reconfigured to conform to these histories' (Reed 1998: 511; also see Shay 2002 for the relationship specifically between State and folklore dance companies). As a public performance and a public spectacle (Foucault 1991), the officially sanctioned narratives of history and culture are manifested, appropriated and performed in ways that go beyond verbal propaganda: dances as embodied practices do not only tell the sanctioned story which substantiates government's power, they embody state narrative, its contradictions and limitations, they *become* the state: 'spectacles make power palpable,

publicly visible and practical' (Wedeen 1999: 21). Furthermore, dances interact with audiences, through the visible display of power, and by inscribing 'tangibly' (Wedeen 1999: 22) on the bodies of the dancers and audience the sanctioned repertoire of their own practices.

Overview of folklore festivals in Syria

Through public festivals of popular culture and folklore, the state does not only sponsor and organise the event, but also sponsors, manages and structures what is, could be and what is not 'popular culture,' while also creating a space for the enactment, embodiment and visible celebration of what is at once popular and official discourse. State interest and investment in cultural affairs began during the age of Syria's union with Nasser's Egypt (UAR 1959–1963). Cairo had long been the cultural capital of the Arab world and already had a well-developed ensemble of theatrical, musical and dance troupes (Shay 2002: 126–162). Nasser's Egypt, the UAR and the subsequent Ba'thist Syrian Arab Republic were also influenced by Soviet policy – especially cultural state policy in the valorisation of national, working class values and practices (Wedeen 1999). Both folklore research as well as folklore performance became highly subsidised by the state, and increasingly came to represent the state rhetoric and policy.

Today, festivals organised and sponsored by the Syrian state address both local as well as international audiences. Since Hafez al-Assad's rise to power in 1970, the Bosra International Festival has been annually or bi-annually organised in the ancient Roman amphitheatre in Bosra, Daraa, the largest and best preserved amphitheatre of Roman times. Since 1978, the Bosra festival has been established as a bi-annual⁹⁶ week-long celebration featuring folklore dance troupes from all over the Arab countries and the world, alongside local Syrian folklore troupes and popular music concerts. Its aims, as described by the official Syrian Arab News Agency (SANA) include:

The festival aims at [sic] spreading international cultural heritage and exchanging creative and artistic experiences among the Arab and foreign

⁹⁶ In recent years the Bosra Festival has become annual, yet, as an anonymous employee in the Directorate of Theater and Music that oversees the organisation of the Festival notes, the state budget allocated has not significantly changed since the 1970s.

countries to develop, maintain and introduce those countries to the cultural legacy of Syria's heritage and specifically that of Daraa. (Milhem 2009⁹⁷).

Other festivals include the ten-day Mahabba Festival in Lattakia (est. 1989, also known as Love Festival, renamed al-Basel after Basel al-Assad's death, see Sabbagh 2009), Syrian Song and Music Festivals in Aleppo, Euphrates Pearl Festival (est. 1977, Al-Kazhali 2009), Damascus International Fair (Zain 2010), Damascus International Festival of Theater (est. 1994, Sabbagh 2008), Arab Pioneer Creators Festival (Ghossoun 2008), and Al-Qalaa and Al-Wadi Festival in Homs (Said 2009).

Public spectacles and celebrations formed a significant part of Hafiz Assad's nation-building agenda; Bashar al-Assad continued and reinforced his father's policy: since 2000 many more festivals and public spectacles had been established in Syria, addressing local, regional and international audiences. These include the establishment of the National Idleb Festival, a weeklong competition between regional Syrian folklore troupes and music concerts (Ismael 2009),⁹⁸ Film and Theatre festivals in Damascus, the Platform for Contemporary Dance in Damascus, the Silk Road festival and smaller local festivals such as the Sweida Mountain Festival (Milhem 2009), Amrit Culture and Art Festival in Tartus (est. 2003, Milhem 2009), and Phoenix Bird Festival in Tartus (est. 2009, Allafi and Eyon 2009).

During the forty-one years that the Syrian regime has been in power, folklore festivals and national dance ensembles have been affected by many changes. These changes include (1) the political isolation of Syria in recent years as well as the shifting political alliances that have affected the country, and the participation of international troupes in its festivals; (2) financial constraints and unequal resource distribution for different festivals,⁹⁹ and (3) the emergence of private dance troupes

⁹⁷ See Said 2009, for details on the organization of the festival and the international groups involved, such as groups from India, Italy, Greece, France, Spain, Belgium, Russia and Netherlands. I attended the Bosra Festival in 2009 as a guest of the Directorate of Music and Theatre.

⁹⁸ I attended Idleb Festival in 2009 as a formal guest of the Directorate of Music and Theatre.

⁹⁹ Although the number of festivals has increased, the budgets of some of the festivals have not. In conversations and interviews with the staff of the Directorate of Theatre and Music I was told that even though Bosra festival is the oldest-running and one of the most successful festivals, its budget had not increased since 1971. Whereas such public engagements were once lavish and extravagant performances of state-hood, presently it falls upon the public employees to 'make-do' with a limiting budget, inviting troupes based on affordability rather than fame or desirability. For example, Bosra Festival used to be of the most celebrated festivals beyond the borders of Syria with participants such as Feirouz, and a great variety of international, especially Easter European participation.

(i.e. Enana and Ornina dance troupes), which are more popular than the national state troupe (Omayyia).¹⁰⁰

Finally, folklore festivals in Syria reflect and embody certain structural, economic, and social inequalities. While cities like Damascus and Aleppo have become the frequent hosts of International and contemporary festivals, such as Theatre, Music, Dance and Cinema, often destined for intellectual and middle class local audiences as well as high-profile Arab and international participants and guests, the cities of the rural countryside such as Idleb, Bosra, Lattakia, Tartus, Der Er-zor and Sweida, host folklore and popular arts festivals, with clearly more local participation and audience. In Syria the class differences and power structure of high-culture (*thaqāfā*) and popular culture (*al-fonoūn al-sha'abiyeh*) becomes geographically inscribed in the local inequalities between urban centres and rural countryside, and thus the distribution of different kinds of festivals reflects rather than a unified 'forging the nation' entrenched geographic/regional, class, social and rural–urban divides.¹⁰¹ But why would the state impose itself in such a way as to denigrate its own nationalist rhetoric? I am suggesting in this chapter that, on the contrary, this more divisive approach (which I refer to through recourse to the concept of empire), is actually a powerful/the principal means by which the Syrian state seeks legitimacy from its heterogeneous polity.

Case study 1: A festival for external consumption

Out of all public spectacles, it is the Silk Road Festival that combines a grand historical narrative along with aspects of Syrian popular culture:

¹⁰⁰ This does not mean that folklore dance ceased to be. Local usually smaller in size dance troupes have emerged as volunteer clubs and associations, comprised mainly of youngsters, and especially in rural parts of Syria there groups attract a lot of attention and devotion from youths (usually un-paid) as spaces of participation and expression.

¹⁰¹ Specific examples firstly include festivals that are destined solely for external consumption, such as the Silk Road Festival, see below. Or, the 'high-culture' festivals that take place in Damascus and Aleppo that are made up of artists, intellectuals, and target a middle class audience. Theatre and Cinema festivals are the oldest ones, but more recently the Contemporary Dance platform was established and the Aleppo women's festival. Lastly, examples of festivals destined for local consumption include the folklore festivals in Idleb, Sweida and Lattakia. The Bosra festival belongs to this category because although 'international' the same folklore dance troupes still participate and the festival no longer has the international calibre in the eyes of the Syrians, while also it virtually shares the same local folklore dance troupes that participate in all other local folklore festivals.

The idea of the festival was founded about that trade caravans in the ancient world were moving cities full of forms of human activities starting from China through Asia for three years. [...] All this made Syria the unique country in the World that is not only crossed by Silk Road Caravans but it is the crossroads of these caravans that meet on its land arriving from the four corners of the world. As well as being the homeland for the most important forms of world dialogue through history which granted its people the continuity of creation, the tradition of hospitality, the warm cordiality and living in harmony, safety and peace. [sic] (Speech of H.E Dr. Eng Saadalla Agha Al Kalaa Minister of Tourism at the Opening Ceremony of Silk Road Festival 2006)

The Silk Road festival, sponsored by the Ministry of Tourism and established in 2002, is primarily destined for external consumption: it is arranged as a multi-functional tourist guide of Syria, taking place for the duration of five days in different historically significant locations, such as Damascus, Aleppo, Palmyra, Raqqa, Rassafah, Lattakia, and Hama,¹⁰² combining the historical and the folklore, offering foreign journalists and delegations of diplomats the opportunity to ‘experience’ Syrian culture and history:

In intimate meeting, where the authentic past hugs the shining present, and East comes together with the West; [...] creating a bridge for dialogue between the world’s nations in East and West on Syrian lands which were the cradle for civilizations and religions, and an intersection point of the roads and paths of International Trade, where caravans from the four corners of the world gathers. [sic] (Silk Road 2010 – New Destination towards Beautiful Past, Ministry of Tourism, Syria)

Through archaeological tours, folklore dance performances from Syrian regional dance troupes, to local food tasting sessions, the festival aims to bring to life Syria as the significant geo-political crossroads between continents, cultures, regions and religions (see Al-Jazaeri and Sabbagh 2010; for the view from a participant’s perspective, see Pomichalova 2008 and Mohr 2007). Reproducing its unique and heterogeneous historical and cultural heritage, the Syrian Ministry of Tourism projects an image of Syria as the harmonious and cosmopolitan state: at each region and each village that the festival makes a stop, the foreign diplomats and journalists are treated to a different ‘taste’ of local popular life and traditions: beginning at Damascus citadel, the audience experiences the city as it is imagined to have been

¹⁰² Every year locations and dates of the festival vary; the above were the locations of the 2008 Silk Road Festival, which took place between 10-15 of October, and which I attended. In this section I combine my fieldwork with archival research and information I could find out about the Festival in other resources.

during the silk route age: khans, horses, camels, local people mingling with sellers of all kinds (performed by Ornina dance troupe), the meeting of different civilizations as represented by folklore dance troupes from China, Russia, and Turkey.¹⁰³ In the Euphrates area, along the important archaeological sites, the audience witnesses Bedouin dances and aspects of everyday 'traditional' life: Al-Ujeili's folklore dance troupe from Raqqa treats the audience with fascinating *dabkeh* dances theatrically directed to include aspects of everyday work and celebration, along with Bedouin women dancing with swords,¹⁰⁴ while the audience is further acquainted with 'unity in diversity' through the ancient civilisation of Aleppo and through the Mediterranean life in the *sāhel* (literally, coast) of Lattakia (Allafi and Sabbagh 2010).

Through the tour of Syria's ancient monuments, the Silk Road Festival *mixes* ancient history with popular culture and folklore. Ancient history, although not directly mentioned within folklore dance performances, is nevertheless implied through at least their geographic proximity, with folklore performances that take place in ancient venues or historically significant venues such as the citadel of Damascus and the amphitheatre in Palmyra.¹⁰⁵ And, although ancient history alludes to specific time-periods, popular folklore performances are almost a-historical in that they depict 'traditional' as both inside and beyond history, as static and exotic, something that could have 'started' a long time ago, but which also indefinitely continues today. This mixing of history and culture, provides the Silk Road Festival with a *grand narrative* that runs through it, connecting together every performance with every stop of the Festival. This grand narrative is constructed, among other things, in terms of a time-scale: linear and large, this time scale begins with the Ugarit alphabet, the Roman Palmyra, the Islamic civilisation and leads up today¹⁰⁶ – and in this Festival all these developments are presented as both a linear evolutionary history and inextricably connected and continued through the existence of modern Syria.

¹⁰³ Observations are based on fieldwork material from Silk Road Festival in 2008.

¹⁰⁴ Observations are based on fieldwork material as well as interview with the Raqqa folklore group founder and director, Ismail Al-Ujeili (April 2009) and interviews, focus groups and direct observation with dancers (June 2009).

¹⁰⁵ As part of the 2010 celebrations of Silk Road Festival, Enana performed 'Zenobia the Queen of the East' in Palmyra: 'Director of Tourism Promotion Department at the Ministry of Tourism Ahmad al-Youssef said the Ministry is keen on making Palmyra a main stop in the festival annually with the aim to familiarize foreign tourists with its great civilization. "The journey to Palmyra is a journey back to the deep-rooted past," said a group of the journalists participating in the festival' (Haifa 2010).

¹⁰⁶ This grand narrative is constructed through speeches in the Festival, Syrian media coverage, and was portrayed in a personal interview with His Excellency Vice Minister of Culture, Dr. Ali Al-Qayem (September 2009).

Thirdly, this linear grand narrative that spans across millennia and civilisations is told with authority by *the authority*: not only does it include the authorised and sanctified version of history, connected in a convenient linear way, but it is intended to be listened to and exported out of the country through the media (as both examples of Syria's rich heritage, as well as for the governments ability to produce and entertain such an expensive and elaborate event):

The annual event, which is organized by the Syrian Ministry of Tourism, is considered as one of most [sic] important tourism and media manifestations as it revives heritage and embodies dialogue among different cultures through the interaction among the participants, in addition to conveying a positive image about Syria and its magnificent tourist destinations. (Al-Jazaeri and Sabbagh 2010)

However, the issue of government's authority or authoritarianism in presenting and representing history is generally viewed as an appropriate government policy by most Syrian citizens, who see such events as empowering in underscoring Syria's rich historical and cultural heritage, which appears undermined by the international audiences and media.¹⁰⁷ Told by the authority, this amalgam of ancient history and folklore traditions *legitimises* the Ministry and State authorities in terms of history and culture, to speak for/instead of the different populations, religious and ethnic groups that inhabit Syria today, even though sometimes the historical and cultural claims appear rather extravagant (see Wedeen 1999). This legitimating is not only a self-fulfilling prophecy but in doing so, the state becomes the protector, the patriarchal father-like symbol of Syria in past and in present.

The Silk Road Festival has a very special relationship with its audience: mainly directed towards non-Syrian journalists and diplomats, the festival and by extension the Syrian government promotes a specific political agenda. Firstly, to the audience the performance of history and culture is represented as a form of *social consensus* between local populations and the Ba'thist state. This representation has serious implications for the Syrian as well as international community since the political system is often portrayed as authoritarian, totalitarian and repressive (see, for example, George 2003). Yet, in a festival that literally travels through Syria, showcasing historical depth as well as national variation, a more colourful picture of

¹⁰⁷ Based on audience accounts and general public's responses to such events during my fieldwork, I attended the Silk Road Festival in 2008.

cultures and regional styles emerges while ethnic groups are also somewhat represented (Assyrian, Bedouin, etc.). This helps the Syrian government to substantiate its claims against accusations of repression, as well as to 'market' itself as a successful paradigm of *cosmopolitanism* within the Middle East (see Hanley 2008) – as the place that is in direct opposition to sectarian and conflict zones of neighbouring Iraq and Lebanon.

Finally, the Silk Road Festival, in both its title and performances, functions as a powerful metaphor of the cultural, geo-political and economic crossroads at which Syria is located. Using the metaphor of the 'crossroads' of civilization and religions is not something new in Syria's foreign policy. Yet, the Festival through its tourist historical attractions and its folklore dance performances embodies this metaphor constructing a visual politics for the future of Syria as an important player in the struggle for the Middle East. This is not a recent political strategy, as Seale notes regarding Hafez al-Assad's policies in the 1980's:

Syria's promotion of its rich archaeological past was part of Assad's exercise in nation-building. The often heard theme that history had placed Syria at the centre of the world was an indirect way of saying that it lay today at the centre of regional power and decision-making. (Seale 1989: 460)

Having explored how the Syrian state presents itself to external, international audiences as the heir of an unchanging and harmonious cosmopolitanism, let us consider how the state conducts its internal politics in local folklore festivals.

Case study 2: A local-global festival

The state... is a bid to elicit support for or tolerance of the unsupportable and intolerable by presenting them as something other than themselves, namely, legitimate, disinterested domination. The study of the state, seen thus, would begin with the cardinal activity involved in the serious presentation of the state: the legitimating of the illegitimate. (Abrams 2006: 122)

The city of Idleb, green and tranquil, lies in the North of Syria, capital city of a municipality by the same name, bordering Turkey on the north and the municipalities of Haleb and Lattakia. The municipality is known for its ancient history, its natural beauty, and also for its popular arts, heritage and traditions – especially its distinguished male wedding dances of sword and shield.

A folklore festival celebrating local Idleb and Syrian traditions was established here in 2007, by the Minister of Culture at the time, Dr. Riad Nassan Agha, who himself comes from Idleb. In 2009 I attended the third 'Green Idleb's Festival for Popular Arts' (*mabrajān Idleb al-kbaḍrā' lil-fonoūn al-sha'abiyeh*) as a formal guest of the Directorate of Theatre and Music. Spreading over nine days, the festival was organised by the Ministry of Culture's Directorate of Theatre and Music in co-ordination with the municipality (*moḥāfaza*) of Idleb and the local Cultural Centre (*al-markaz al-thaqāfī*). The main venue of the festival was the city's amphitheatre. Every night the festival would host two or three different folklore dance troupes and a musical concert (*ḥafleh musiqieh*) by Syrian artists and well-known orchestras. For nine days the city of Idleb resembled a micrographic image of a Syrian cultural cosmopolis, where all the different dance troupes represented all the different regions and traditions of Syria. More than 16 dance troupes participated in the festival, interestingly as we shall later discuss, representative of most of Syria's municipalities and regions: Tartous, Lattakia, Ifrin (Kurdish village near Aleppo), Idleb (three dance troupes), Sweida, Hashaka (two groups), Raqqa, Hama, Daraa as well as the state dance ensemble Ommaya. In 2009, Idleb festival was part of wider cultural celebrations of Jerusalem (Al-Quds) as the cultural capital of the Arab world, and two Palestinian refugee troupes opened the festival. Although the festival is comprised of Syrian dance troupes, on the third day of the festival exceptionally a Turkish dance troupe performed as an honorary guest. Further to the main performances, the Cultural Centre hosted a book fair, painting and musical instruments exhibitions, as well as academic lectures regarding popular arts and heritage. Official organisers, dignitaries, participating groups, and journalists were accommodated by the Directorate, and entertained with excursions, lunches and dinners. The festival was very well organised and covered widely by local and national media. On the first day, official speeches were made by the Mayor of Idleb and Dr. Ajaj Salim, head of the Directorate, who noted that 'dance is the first and foremost shared human language.' Most impressive of all the speeches was the one delivered by the Minister of Culture, Dr. Nassan Agha. In this section, I translate and analyse parts of his opening speech, because his Excellency's rhetoric underlines important points in the state's dialectics of addressing internal affairs and its subjects and citizens.

The audience greeted him warmly and enthusiastically, clapping and standing up for him. And his Excellency, talking without notes and looking the audience straight into the eye, delivered a powerful and passionate speech. Dr. Nassan Agha's speech began with the ancient civilizations that had developed from this land in the historical past, moving to connecting the Syrians to the Arabs, to 'our friends' the Turks, and finally to the celebration of Al-Quds, through the predicament of a common cultural heritage. As for Idleb, his Excellency gave one of the most beautiful descriptions: 'in this beautiful land [of Idleb] the art was sown/fertilized and inspiration grew' (*bi hazibi al-'ard at-ṭ ayeba namat al-fanoūn wa kabura al-ibtidā*). But the minister was quick to point out that art and creativity are not only for those who live in Idleb, nor for the Syrians, not even for the Arabs alone; they are to be shared and celebrated by the whole of humanity: 'and this is why it is important that this festival takes place here – because this is the land of Culture.'

Dr. Nassan Agha, interestingly, moved beyond the rhetoric of culture and folklore to provide legitimacy for dance itself: 'they ask why a dance festival. We say yes, because we respect the popular arts which are the building blocks of our identity (*hawiyā*). And from this very local festival with the very local audience, the Minister of Culture went further, challenging a monolithic view of identity by adding that popular arts 'take colours from the West, and from the East, and make multi-colour identities' reflecting a 'universal soul' (*roūḥ al-ummah*) reconciling the superficial divisions of religions, nations and locations.

Coming from the representative of an authoritarian regime, Dr. Nassan Agha's speech strikes as dialectic and nuanced, it is a speech that generally goes well beyond the rigidity and generalisations that one might expect from a dictatorial and repressive regime, such as the one his Excellency represents. The speech incorporates elements of compliment and hospitality extended to those countries that are represented as official guests (Qatar, Palestine, Turkey). The emphasis on culture, especially popular arts (*fanoūn al-sha'abieh* as opposed to *fanoūn*, art), as something colourful (*molawan*) but also shared and universally binding is in itself a rather modernist humanistic position, in contrast to much of the literature presenting state representations of folklore under the unified one-colour umbrella of an eternal

state (Shay 2002). In the precarious game of rhetorics, the Minister does a good job of balancing and connecting the local, the national and the international. His words travel in many directions and simultaneously address different audiences: the people of Idleb, distinguished guests, neighbouring countries and the ‘world.’

The Minister of Culture addresses the world from Idleb in a speech as general and humanistic so as to address a complex and ‘colourful’ humanity, a speech that celebrates cultural heritage as the base of a diverse and yet shared and common world. The Minister in his speech does not mention the diverse social make up of Syria, the ‘colourful’ religious, ethnic and regional identities that live within Syrian borders. Syria is a motherland, the cradle of civilisation, in the Minister’s speech, she’s a country as old as civilisation, old and immortal. As such, its importance lies in the eternal past and not at the ‘colourful’ present. At first instance, the Minister’s speech may appear irrelevant or counter to the contexts of its delivery: a local folklore festival in the Syrian rural countryside. And this is because the minister does not directly address the audience of the festival, neither is his speech relevant to the different Syrian troupes that have no mention. In contrast, his speech addresses the historical heritage, in the case of Syria, and a vague humanistic shared culture worldwide. He fails to mention the cultural and social variations within his country, which are being so clearly represented on stage as well as being the main reason for the existence of the festival itself.

The Minister talks about culture as the common ground or shared soul of all humanity, hinting at an opportunity for global peace and dialogue based as much on appreciation of difference as of similarity. Interestingly, the global outreach of the Minister’s speech finds correlation in the festival that he has established, and as such the global humanity that he addresses in his speech could be a metaphor of a shared Syrian locality: inasmuch as humanity is made from a colourful array of peoples and cultures, so is colourful the internal heterogeneous make-up of Syria. Syria resembles a miniature globe, a place where people from different religious, ethnic and regional backgrounds are united in difference, where the festival’s stage becomes the sanctioned place for the expression of difference, a place managed, controlled and watched by the state.

However, should the Minister have mentioned the internal heterogeneity of Syria, its diverse religious and ethnic minorities (see chapter 2), he would have risked running counter the secular Ba’thist rhetoric, and, even more precariously, he could have provided a public recognition to groups and to the problems that officially do not even exist, such as the Kurdish ethnic minority, but also the potentially threatening acceptance of sectarian identities. In a polity where religion is both instrumental and dividing, the Syrian state recognises only three religions: Muslim, Christian, Jew (officially excluding heterodox religious groups that often consider themselves as an altogether different religion, such as the Druze) and only one ethnicity: Arab (excluding Kurds and Assyrians). The socialist claims of the Ba’th Party have long withered from its practice and rhetoric, it is a secular Arab nationalism that the Party publicly perpetuates. In terms of rhetoric and state policy, it emphatically refuses to recognise the existence of minorities. Not only would such recognition legally transform Syrian into a country with minorities but it could dangerously empower not only separatist strands, but also popular demands for a more democratic representational government. Thus, if the state was to accept religious and ethnic minorities it would inevitably accept that itself was a minority government. For, the Syrian ruling family would be publicly Alawite, representing a specific sect. Of course to say that Syria’s problems and ruling composition are solely sectarian issues would be naïve at best: not only has most of the Alawi population only benefited slightly from the regime, but also the regime’s beneficiaries extend beyond sects to the ruling classes and the emerging urban businessmen – issues that have more to do with economic interests and class rather than sociologies of religion or tribal solidarities (see Haddad 2012). Thus, an acknowledgment of religious and ethnic diversity could on one hand translate as an acknowledgment of sectarian and competing differences, and on the other hand it could also unmask the sectarian and ‘cult’ mythical dimension of state power and thus strengthen *political* differences.

The ‘world in a city’ as much as ‘Syrian worlds’ is what the Idleb festival, the Minister’s speech and the diverse choreographies are best described as, insofar that the cosmos here is bounded upon the Syrian state sovereignty. A local, state-bound cosmopolitanism, then, rather than ‘nationalism’ seems more adequate to describe the festival in Idleb and by extension the internal cultural policies of the Syrian state. The state does not attempt to homogenise its ethnic and religious heterogeneous

make-up; on the contrary it promotes heterogeneity and ‘difference,’ utilizing a modern reappropriation of cosmopolitanism (see Kant 1795; Harvey 2009; Gills 2005) that sounds incredibly similar to the European Union’s motto ‘unity in diversity.’

Towards a definition of state-of-empire

Empire (Ln. *imperium*) is derived from the Latin verb *imperare*, ‘to command.’ Interestingly, the Arabic word for empire comes from Greek (*afroqatoria*). At the most basic definitional level empire denotes a model of governance whereby different countries, states and nations are ruled over by one power. Historically, the term is associated with the Ancient Roman Empire, the empires of the Middle Ages, the Ottoman Empire, and also with the practices of colonialism, i.e. British Empire. Contemporary usage of the term is associated with the works of Hardt and Negri (2001), to denote the new de- and re-territorialising tendencies of global capitalism, by which the sovereign rights of nation-states become surpassed by a new form of supranational world order (2001: 9–10; see Harvey 2009: 272 for criticisms). For the purposes of analysing the Syrian state’s internal cultural policies, I use ‘empire’ as a conceptual tool in order to describe the tactics and methods of the state as ‘the legitimate governance of and over *difference*.’ These tactics and methods are some of the ways that the Syrian state attempts to represent itself and to gain legitimate consent from its population; it is not by any means the only tactic that the Syrian state uses. Empire is used as a foil to the nation-state in order to highlight the differences of these two political strategic projects in regards to ruling over a polity. Thus, while nation-states govern by imposing homogeneity (Anderson 1991; Scott 1998), the state-of-empire constitutes, manages and is sustained by internal heterogeneity. Otherwise, why a state that is renowned for being oppressive, authoritarian and inflexible spend so much time and effort on the maintenance, nurturing and reification of ‘difference’? Nation-state and state-of-empire are distinguished through the tactical utilization of difference, the strategic manipulation of ‘essentialisms’ (Herzfeld 2005; cf. Spivak 1988), while both manipulate and construct the imagined and invented histories and traditions. However, where the nation-state strategises an eternal homogenous and singular mythology that reifies the state as the eternal precondition of the nation, the empire utilises and fabricates

an internal heterogeneity in order to become its necessary *a priori*. Therefore, whereas the nation-state aims to obliterate difference, a state of empire aims to command difference, a difference that it itself creates as its reason *d'être* and which controls in the name of empire. State becomes the legitimate ruler over a single nation, while the empire functions as the consensual ruler of multiplicities and legitimises itself through a reified co-construction of both 'state/emperor' and 'diversity.' In short, through the empire, the state not only manages difference but renders difference possible only under its patronage.

Part 2: Choreographies of Empire: spaces for the realisation of intimacy

The strategic use of 'difference' in potentially embarrassing as well as actually threatening political identifications through the rhetoric of a locally based cosmopolitanism recasts the Syrian state as a state of empire, rather than a nation-state. This state of empire is choreographed in folklore festivals through the ritual of marriage. As a tactical union of wedhood and dance, folklore festivals provide the spaces not only for the expression of sanctioned differences within the Syrian polity, but also become the spaces where both difference and intimacy are realised, since enacted, danced, and embodied, these 'differences' become personal, tangible and palpable, while at the same time the Syrian Empire becomes ever more elusive. In this part of the chapter, the tactical use of the nuptial ceremony is ethnographically described and analysed in order to portray how nuptial bodies become politically intimate, but also intimidated and intimidating. Through two ethnographic examples, one of a marriage performance and the other of audience reaction, we will see how the Syrian Empire reifies itself through bodies and embodied struggles, and how the politicisation of the nuptial body as well as the negotiations of power are choreographed in folklore festivals.

Poetics of Empire: what's in a marriage?

There were many a wedding that week in Idleb. On stage, marriages in succession took place, coloured through the hues of regional troupes: Assyrian, Druze, Kurdish, Sunni and Shi'i, rural and urban. The folklore troupes danced their customs, costumes, and traditions by performing their ritual marriages on stage. For most groups, the combination of folklore and dance necessarily meant marriage: marriage

as the most celebrated rite of passage, a celebration enacted through dance, and dance that is sanctioned through the social ritual of marriage. As marriage legitimises a union between two peoples, in the contexts of festivals it provides legitimacy to the socially and religiously ambiguous act of dancing (van Nieuwkerk 1997). Nuptial ceremonies lend themselves easily to folkloric reappropriations and theatrical adaptations as they are always already staged, even when not on stage, directed through reappropriations of ritual practices, enacted through costumes, celebrated through the idiomatic extremes of separation and union. In Arabic, happiness (*faraḥ*) also means wedding (*ʿors*), and the wish ‘to your happiness’ (*faraḥak*) is given to unmarried youths as a wish for marriage. Dancing is considered an expression of happiness (van Nieuwkerk 1997). However, marriage is also ‘happiness baked with sadness’ since the union of the bride and groom presupposes the separation of the bride from her natal home, a separation forcefully ritually enacted in most of Syrian weddings and on stage as ‘taking the bride’ (*jib al-ʿarūs*). Of course, Syrian marriages are elaborate and unbounded affairs (see chapters 5 and 8). There exist many differences, rituals and practices regarding marriages across as well as between Syria’s heterogeneous regions and communities. As a bundle of so many rites and traditions, marriage’s attraction for folkloric exposes is clear: everyone does it, celebrates it, but also all do it in a different manner. It is a celebration of difference but of a difference that is widely known and understood: of differences common to most. In the year 2009, it was the young dance troupe Toutoul from the municipality of Raqqa, in North-Eastern Syria, that captivated the audience and won the folklore competition. Below is an ethnographic description of their performance.

The Dance and the Marriage

The stage is set with a red chariot in the middle and a metallic *ṣaniya* (tray). The music begins and on the stage a woman appears dressed in Bedouin clothes on a solo dance with the tray in her hands. Soon, more women join the dancer: they are all dressed in Bedouin garment of colourful layers of *galabiyah* with long sleeves and silk headscarves (particular of Aleppo and Mosul). Among them, there is a singer with a microphone who starts singing live traditional Bedouin wedding songs, and another woman holding in her hand an elaborate incense burner (*mabkhara*, vessel for burning incense, *bakhūr*, used, among other, in marriage ceremonies to purify the

bride and drive away bad spirits). The group of eight women surrounds a beautiful girl that is dressed differently: she is wearing a long back velvet *'abāyah* embroidered in gold. Two men in Bedouin clothes make a grand entrance from the left and right of the stage, and perform a dance with spears. The women surround the woman dressed in the black *'abāyah*, and change the headscarf (*mandil*) on her head with a *niqab* made of golden coins that covers the face except for the eyes, but leaves the long hair and the neck uncovered.¹⁰⁸ Because of these symbolic transformations the audience infers that the woman in the black is a bride on the road for her marriage. The bride enters the chariot, and four men carry it on their shoulders while the women follow behind in a parade fashion singing songs and chanting *'āwība*.

These are the first three minutes of an hour-long performance. The contexts are set less so by dancing and more by the exquisite use of readable and polysemic symbolism: the metallic tray as a symbol of the impending consumption of food and commensality that will take place during the later stages of the wedding, the *bakhūr* to guard against evil spirits, the singing of wedding chants, the differentiated clothes, and the symbolic dressing of the bride through the change of her ordinary headscarf to the golden *niqab* – a transformation from a girl to something blindingly mystical, expensive and elusive, tantalising and fearful. There is also the introduction of men, who at this stage interact little with the women. It is important to note that all this information obtained from the stage through symbols are readily accessible to the Syrian audience that watches the performance: costumes and ritual practices may vary significantly across Syria but the symbolism of nuptial transformation and transition are widely understood.

The first appearance of male dancers on stage was almost aesthetic, even though it was full of vitality. As the parade of the chariot continues, the women that follow the parade begin to dance with swords, and soon they are joined by men who dance with spears. Their dance is powerful and joyful at the same time, as the journalist next to

¹⁰⁸ Note that both artistic appropriations on stage as well as regional costumes vary greatly depending on region but also depending on individual affiliations and religiosity. The traditional dress of Bedouin women in the Raqqā region of north-east Syria, similarly to the Bedouin clothes in the Syrian Desert and across the Iraqi border, may at times be considered un-Islamic depending on Islamic doctrine since hair and neck are not completely covered. On the other hand, Bedouins are known for their military might and autonomy, their clothes reflect this, and also Bedouin women are known for their free spirit that almost entitles them to a preferential treatment in terms of religious orthopraxy.

me informs that ‘only Bedouin women are allowed to dance with swords!’ The performance itself makes good use of this ‘strategic essentialism’ through the interplay of flexible masculinities and femininities that become idioms of power relationships rather than statically ascribed roles. Of course, Bedouin women are known as possessing the tradition of carrying arms and even going to war – a ‘possession’ directly derived from a moral cosmology of ‘autonomy’ ascribed and self-ascribed to the group as a whole rather than solely as a gender-related stereotype. The direction of the dance performance plays eloquently with this stereotype: from early on five women follow the parade dancing with swords – this is also significant because these women might be part of the woman’s or man’s family escorting the bride to her new home. The direction of the performance regarding gender addresses many issues of importance: that the Bedouin women are different from other Syrian women – a metaphor that by extension makes Bedouins in general different from the rest of Syrian communities, but also within the contexts of the performance, gender becomes an idiom of power relationships crosscutting sex performatively enacted on stage. An idiom of relationality and not of given ‘naturals.’

The parade stops but the dancing continues: now women with swords occupy the stage and men with spears in a dance, intercepted from time to time with female wedding *’āwība*. They all dance solo and soon musicians on stage accompany them: a *darbokah* and a *mizmar*. The women leave their swords and start dancing with their veils – a foreshadow perhaps that not only does resistance have many faces but also power – occasionally making duets with the men. But a scarf is left on the front of the stage as the women reside on the back, and two men are left to fight over it. A woman comes, as if to tease them, or to put them in order. And she makes them dance in the *dabkeh* circle.

A traditional coffee grinder is brought on stage: a big, elaborately decorated wooden pestle and mortar, whose musical sound from the grinding of coffee makes a loud public invitation (Khalaf 1981; Gilseman 1996). As men ground the coffee, women bake bread on stage. These gender-specific practices are brought unobtrusively on stage, in a way of discreet interplay and intermixing. The director here has almost accomplished the unthinkable: not only does ‘folklore’ and ‘staged’ are supposed to be things rigid, dead and static, but in front of our bare eyes they become both real

and playful. Soon enough the female dancers are making bread while the male are dancing around them. Then, they bring a very big brass pan – another symbol of the impending commensality. In another subversive scene the bride with the golden *nigab* comes out of the chariot and dances with two swords in her hands in front of the bread-loaded tray. A beautiful, enticing and graceful dance, the bride takes almost the posture of an epic warrior or a monster, as beautiful and out of reach at the same time.

And the dances continue. More group dances upon group dances – beautiful combinations of *dabkeh* including intermixed, women and men alone, in all different formations. More than half an hour of *dabkeh* accompanied by live music and the audience enchanted by both the direction, the choreographic act as well as by the astonishing energy and enjoyment of the young dancers.

The performance finishes with more *dabkeh*, a *dabkeh* in which a couple from a different group joined and in which the choreographer and director of the group partook. From the excitement, a male dancer misjudged his moves and jumped, ever so gracefully, off the stage. Everyone enjoyed the performance, especially the journalists I was sitting with, who said that they finally saw something exciting. And the dance troupe, after their performance was completed, went around the audience with the tray full of bread and treated us (*dyāfa*).

As the dance performance finished amidst the clapping of the audience, I must admit I was somewhat perplexed. I had seen the bride, I had seen the symbols, heard the songs, even celebrated and eaten the nuptial bread. But which one or where was the groom? Who got married in the end? Where was the union between the bride and groom?

Dancing nuptial intimacy in the state-of-empire

Toutoul's performance contains many aspects that are shared across Syria, such as the commensality of coffee and bread and of course dancing in the contexts of weddings. It also contains these folkloric elements that make the performance distinguished as 'Bedouin,' strategic essentialisms including the specific costumes and the female sword dance performances. Many note that 'when folk dance is presented

on stage it is no longer *folk* dance' (Ruyter 1995). In Toutoul's performance, however, relations between performers as well as between performers and audience are intersubjective, playful and fluid, in a way that makes the performance less 'folkloric' and more of a performative dance celebration. This celebration incorporates body transformations (the dressing of the bride), playful engendering (women with swords or teasing the men), and the making and sharing of social bonds through dancing as well as through consumption (bread and coffee are the traces of commensality and reciprocity). These processes not only happen in front of the audience but *with* the audience (i.e. food sharing). In this way the performance accomplishes to unite ethnological and stereotypical colours of a Syrian Bedouin heritage with the forms and formations of the festival, celebrating a union of difference. A real wedding, then, but between who?

The bride is a central aspect of the performance through her impressive transformation, her separateness in the chariot, her sword dancing. The groom, however, is at best indistinct: as male performers come and go, dancing and fighting, the groom is not distinguished by any specific ritual or rite of passage, and there is no one in particular that can be distinguished either through attire or attitude as the groom. Moreover, the performance itself finishes through a series of dabkeh, occupying thirty minutes, and no evident union of bride and groom. The bride stands as the lone metaphor for a union, and, through her transformations and objectifications, she becomes nuptiality, recasting the groom as irrelevant, as even artistically 'excessive' on stage. In this way, she undergoes the social transformation of a body from a state of anonymity and potentially threatening sexuality, into the realm of socially appropriate nuptiality. Thus, her representation on stage is doubled as both object and subject of marriage and nuptiality, as the 'condensed' form of a wedding idol.

Chapter five, dealing with nuptial intimacy through the wedding rituals of Jaramana, explored the idol-like roles of bride and groom whose nuptial bodies are actually the least nuptial in the performance of the wedding ceremony, since from singular, volatile, sexual bodies they are socially transformed through the embodied multiplicity of the surrounding social bodies, in a way that the nuptial body can not make sense but only as the conversion and extension of the socio-political body

politic. Toutoul's performance as a whole, as is the indistinctness of the groom, are more or less 'faithful' enactments of a wedding celebration in which emphasis is placed on the social multiplicity of reproduction through the enlargement of the bodies of bride and groom into the greater nuptial social categories, the social sanctioning of nuptial intimacy that sets the parameters of relating within a social context.

In the ritual of wedding, as on stage in Idleb festival, the nuptial body extends and incorporates the socio-political body politic. At the same time, we may speak of not only an extended nuptial body, but also of the political extensions of nuptiality. During the festival and throughout Toutoul's performance, runs the theme of a union between dissimilars, a union of differences. Through the tactical almost irrelevance of the groom, this theme is emphasised and embodied in the performance by the idiomatic use of the nuptial rite: the union of difference becomes a union between different families, but also on stage it becomes a union between different generations (i.e. young performers and the middle-aged bread maker), a union between tradition and modernity, and a marriage between performers and audience. The audience in Idleb can in no way be described as 'passive,' but is being in the ritual through not only their gazes or there-ness, but also through creating bigger or smaller *spaces of enactment*: clapping, chanting, singing and dancing, as well the consumption of the nuptial offers of bread and coffee. In this way, they are too transformed in resembling wedding guests. It is through the bodies of wedding guests and participants, as explored in chapter five, that the wedding ritual and nuptial bodies are realised, since it is the social bodies of the participants that create the procrustean contexts of nuptial intimacy. This nuptial intimacy is the embodied practice of relating and associating within the social, religious and political contexts of the community.

However, in the parameters of state-sponsored folklore festivals the social ramifications of nuptial intimacy become political micro-economics: not only does the audience becomes the invited guests of a wedding, but audience and performers unite together as guests in a process that constructs the state as an invisible but always present host. Hosts and guests share a relationship of gifts, obligations and reciprocation (chapter 3). In this context then, performers and audience came to

simultaneously occupy multiple roles such as the state's guests, but also the nuptial union through the gendered embodiments of groom and bride. The union between stage and amphitheatre comes to represent a nuptial union between two different groups from different regions. In this intimate process of embodying nuptiality, performers and audience turn into idols or objects, like the bride and groom, that pave a nuptial intimate relation not only between themselves but also with the host-state. Indeed, there is a cunning similarity between the lone bride in 'Toutoul's performance and the audience: through an objectifying gaze of the state they both become the reversed idols for something larger than their bodies. The 'irrelevant' groom here becomes the elusive but ever-present Emperor-state, to whom both performers and audience consent to marry, thus consenting to create and reinforce it.

This marriage, however, is a marriage between persons already married: persons and bodies that have already undergone and partaken in their own communal, classed, ethnic and religious social nuptials. Here, the choreography of the festival attempts to imitate the nuptial choreographies of the different socio-political locales, in order to create a spatial geography of power relations. In a sense, the secular cosmopolitan state of the Syrian empire attempts to claim the nuptial intimacy out of religious or social connotations through constructing a template of relating. This circular and reifying narrative of intimacy makes the empire not the groom, but something more pervasive as well as perverse. It transforms the state-of-empire into an embodying nuptial space, a space that becomes the only precondition of all and any marriages. The state of empire becomes thus the patron and the guardian of unions as well as the presumed foundation of a harmonious co-existence between dissimillars. Within the matrix of Syrian religious and ethnic heterogeneity, an intimate cosmopolitanism is realised by means more oppressive and subtle as it further baptises itself as the absolute precondition for even the possibility of marriage.

The finale: The intimate discord of Empire

Let us now explore further the geography of power through the intimate nuptial choreographies between the state and the festival audience.

Some fires burn more than others

[August 10th, 2009] *Bosra is on fire. Red lights shine through the night in the ancient Roman amphitheatre. The smoke pours onto the stage, where the famous pop singer, Ali Deek, and his orchestra have set the audience and the stage on metaphorical fire. Everyone is dancing: old men in traditional attire, women with children in their hands, with or without hijab on their hair, young men and women in groups, people in the front rows, at the back, on the stairs, officials, guests and dignitaries along with ordinary, village people. The impressive Roman theatre of Bosra, one of the world's best preserved, located in the municipality of Daraa, is filled beyond its fifteen hundred capacity. On the fourth day of the 21st International Bosra Festival (mahrajān Bosra al-dawly), the excitement is hard to contain, it spills and collects in the empty space between the stage and the rows where the audience sits – groups of people ride on the tide of this excitement and land on that in-between space where the stage ends and the seats begin. The police are called, and the festival's organisers give orders, to keep the line, to make human chains, to obscure the way to the stage. And as soon as the policemen make a human chain, they begin dancing as well. The atmosphere is extraordinary... Astonished, I have never seen anything like it. It is as if I am in some old-fashioned movie in which the happy ending is celebrated by a spontaneous outburst of dance. All people, officials and policemen included, have joined in an enchanting organic dance of dabkeh. United by this fiery dance, the amphitheatre is spatially reconstructed into a space of intimacy and transgression in which the seeming chaos makes perfect cultural sense.*

[March 25th, 2011] *Daraa is on fire. The municipality in which Syria's first and longest running cultural festival is located, the Bosra International Festival, established in 1971, a year after Hafiz al-Assad came to power, has become the centre of violent clashes between the Syrian state and the Syrian people. Ironically, at the heart of the Syrian state's cultural policies, Daraa seems to be the one farthest away from the state's grip... On March 18th, unprecedented protests began as fifteen youths were arrested for writing revolutionary slogans on a wall, inspired by the tide of what is called the 'Arab Spring.' On the first day of protest, six people were killed. As the month rolled to an end, more than sixty had lost their lives in clashes with the police in the municipality of Daraa. The governor's residence was set on fire; a similar destiny awaited the Ba'th Party offices. Newsagents rushed to say that the veil of fear and the wall of silence had, at long last, fallen in Syria. But as the people of Daraa buried their dead, most of the country watched, uncomfortably maybe, but just watched. April brought more protests, and an estimated five hundred deaths. May saw, among other towns and neighbourhoods, Daraa besieged. Towards the start of summer the number of martyrs has surpassed a thousand. Protests have spread and so has blood. Now, who guards the stage, and more importantly, who will join the dance?*

The marriage of Cadmus and Harmony and the burial of the martyrs

The gods didn't realise, nor did men, that that wedding feast in Thebes was the closest they would ever get to each other. The next morning, the Olympians left the palace. Cadmus and Harmony woke up in the bed Aphrodite had made for them. Now they were just a king and queen. (Calasso 1993: 387–388)

Cadmus, Phoenician prince son of King Agenor from Sidon, had left his land behind in search of his sister Europa, abducted by Zeus in the guise of a white bull. His search brought him to Greece at a time when the Olympian gods had fled Olympus as the Titan Typhon had succeeded in overthrowing and capturing Zeus. Cadmus' road brought him near to the cave where Typhon was slowly dismembering Zeus, pulling out his sinews and taking over his thunderbolts. Typhon appeared in front of

Cadmus, full of his newly acquired powers and imitating Zeus – an act at once powerful and ridiculous (ridiculous precisely because of his imitation that foreclosed difference more than resemblance), challenged Cadmus to a competition. Cadmus competed with the monster, but only to trick him; in the meantime Zeus escaped and gathered his strengths. Typhon was to be incarcerated in the depths of Etna, and Cadmus, as a gift from Zeus, was promised a wife, Harmony, and the kingdom of a great city that he would found. That is how Cadmus, a mortal, travelled to Samothrace to take Harmony, the daughter of Aphrodite and Ares brought up by Zeus' lover Electra, as his immortal wife, and then to travel until he came to the place in which he founded his city, Thebes.

Yet, genealogies and even histories are but a contextual footnote here. A single event is of interest, an event that, magnificent as it was and perhaps because of this uniqueness, united and separated mortals and immortals at a singular point, at a junction that was never to be crossed again. In the marriage of Cadmus and Harmony it was the last time that the Olympian gods came close to mortals in their human shape. A moment in space and in time of union not only between Cadmus, a mortal, and Harmony, a goddess, but a public acknowledgment of some private intimacy that united the couple but also that ran between mortals and immortals, an intimacy that could be nothing but momentary: a closeness rendered possible insofar as it was beyond time itself, insofar it was singular, a moment that allowed time to begin and to be separated into the myth, the present, the future.¹⁰⁹

Harmony, then, was the precondition of the splendid celebrations, Zeus' gift embodied, his promise of 'cosmic harmony' enacted, in a marriage celebrated by gods and mortals alike. But Harmony was never a process, and could not be imprisoned in time. She was a shy girl in Samothrace, a woman given Hephaestus' ill-fated necklace in Thebes. In her later years she would continue her life as a snake, while all her progeny, children and grandchildren, were to be lacerated like no other (Calasso 1993: 389). And this is not paradoxical, only a bit ironic. Because Harmony was not a precondition for unions between dissimilars but the precondition for the celebration of difference through the brief actualisation of intimacy, a closeness

¹⁰⁹ Of course, this was only possible because of the gift Cadmus gave to the Greeks: 'with the alphabet, the Greeks would teach themselves to experience the gods in the silence of the mind.' (Calasso 1993: 390)

between mortals and immortals in an elusively similar form. In this way, Harmony *was* the marriage; before she was the wishful promise of union, and after, her tormented progeny were just a testament of what had once been; they were the necessary discord that is the result of harmony. Thus, Sallust is tilted ninety degrees: ‘these things never happened, but are always,’ becomes in Harmony a definite temporality that is always present not because it exists but because it *happened*. The irony of the story is, then, that because it did happen, once, it cannot happen again. The proof is not only myth, but in Harmony’s outcomes, her daughters: Agave, Autonoë, Ino and Semele.

The myth of Cadmus and Harmony haunts all states – it is right there near the presumptuous roots of their own mythical creation and eternal existence, imprinted as an immortality that surrounds (often suffocating) a mortal polity, and in its most dangerous form, becoming the immortal *a priori* for even the merest existence of its mortal subjects, built on the incongruity of a promised but never materialised marriage. The marriage of Cadmus and Harmony enters the study of the reification of the Syrian state-of-empire through folklore festivals, ironically but not paradoxically, as a potent metaphor (the most splendid marriage of time), not only as an expression of the immortal state offering the promise of harmony between itself and its mortal subjects, but also because most of the folklore festivals, if not all, are staged marriages. Dances and theatre acts that represent traditional or village marriages, marriages as metaphors of the staged union between tradition and modernity, authenticity and globalisation, marriage between the state and the subjects, and finally marriage as a practice under the patronage of the benevolent state. Connecting folklore to marriage and authority, the Syrian state attempts to create a public simulacrum of not only reified self-gratification but also a spatial intimacy between its subjects. It promises an embalmed Harmony, tempting but dead, to an uninterested Cadmus, but the state is never quite Zeus, and the actualisations of its promise becomes as powerful and as ridiculous as was Typhon the moment of his glory, that moment before his fall. When the extravagant marriage of Cadmus and Harmony becomes a state affair, then the subtle titillating beauties and ironies of the myth become state policy. The policy may go on, entrenched as it may become in spatial practices of co-construction, reification and constitution in which the state as much as its subjects are responsible for sustaining, a process which

Herzfeld (2005) so eloquently calls ‘cultural intimacy’ and in which the spaces of construction are mutually embodied and performed, comedies or tragedies depending on the time. But this theatre policy breaks down with the burial of its very own actors and martyrs. The blood that fed the thirsty grain fields of Daraa doesn’t just change the face of the land on which it was spilt, it transforms the intimacy between state and subjects, an intimacy performed and practiced, in both colour and density.

Conclusion: Requiem for a marriage or, nuptial intimacy in the state-of-empire

In October, I was drinking mate with Abu Samir, when he recalled an incident that occurred a few months back. A car had accidentally hit and fatally injured someone from Jaramana. The driver was not from the area, he was from Qamishli in North-Eastern Syria, and he was not Druze. Nevertheless, the family of the driver requested the Druze shaykhs of Jaramana to initiate a process of conflict resolution or truce called *sulḥa*.¹¹⁰ Usually this process, as an alternative to revenge, involves the payment of bloodmoney¹¹¹ from the family of the guilty to that of the victim. This form of collective responsibility also points to a collective form of relating. Abu Samir was adamant in his attempt to convince me that the Druze don’t take the blood money but as a token symbolic gesture. What mattered more to Abu Samir was that the two families arranged to have a common dinner (*‘ashbā*) in Jaramana. Food was brought and prepared from both families and many a person from both Jaramana and Qamishli came to attend (an empty field was rented in order to cater for the high numbers of people who attended). Abu Samir’s elaborate and detailed descriptions of the foods and of the interactions not only show the importance of commensality and collective relationality with regards to both issues of justice but also issues of cross-religious interaction. Abu Samir noted with pride that by the end of the *sulḥa*, conflict resolution had turned into a marriage (*sārat mitle ‘ors*). The emphasis had been placed on life, not death, on to changing relationships and intimacies within the

¹¹⁰ For an anthropological analysis of the Druze processes of conflict resolution and peaceful settlement see Khuri 2004: 133-136; for an ethnographic example regarding conflict processes in Eastern Syria see Khalaf 1990.

¹¹¹ See Gilson 1996: 170-173 for an ethnographic example and commentary on the practice of ‘bloodmoney’.

contexts of death. Most of the time, governments and states are much less flexible in both their conflicts as well as their proposed resolutions.

This chapter has shown how the Syrian state not only attempts to obtain popular consent and legitimacy through its internal cultural policies, but also how through strategising ‘difference’ and ‘culture’ it recasts itself as a benevolent empire over diversity – a state-of-empire as intimate and as necessary as any socially sanctioned nuptial. The chapter has dealt with the construction and use of nuptiality and intimacy by the Syrian state in order to choreograph, through its consensual cultural policies, a space in which ‘it’ (the state) becomes the guardian and the precondition of ethnic, religious, and ‘cultural’ differences. Contrary to dominant applications of nation-state theories, the chapter argued that the Syrian state is more fruitfully conceptualised as a state-of-empire rather than a nation-state.

The chapter firstly explored the ways by which the Silk Road Festival is used by the Syrian state to showcase the country’s historical significance and its cultural complexity to a foreign audience. In this festival, the distant historical past is combined with difficult-to-place-historically folklore performances in an amalgam of traces that promotes a distinct historical continuity between Syria’s historical past, along with rich Oriental folklore overtones. This picture painted by the Ministry of Tourism interestingly does little in terms of fulfilling its rhetoric of Syrian resistance against the exogenous hegemonic forces (President Dr. Bashar Assad announced in 2005 that ‘the price of resistance is less than the price of chaos,’ and he re-iterated this view in a recent interview¹¹²), at least insofar as the contexts of interpretation of the festival performances, do not challenge the Orientalist dichotomies which prescribe the political geography of ‘Orient’ and ‘Occident’, and by which ‘exotic others’ are both constructed and exploited (Kastrinou Theodoropoulou 2009). However, what the Festival, and by extension the Syrian government, accomplish is to demonstrate that they can successfully and colourfully put on a national, historical and folkloric entertainment show: an entertainment that combines snippets of knowledge with exotic overtones. In this way, the Silk Road Festival not only doesn’t challenge but also engages with Orientalist stereotypes in a process of auto-exoticisation (see Savigliano 1995). In doing so, the Syrian state indirectly becomes

¹¹² Al-Manar’s Interview with Syrian President Bashar Assad, Interview conducted by Amr Nassif 24/03/2010, <http://www.almanar.com.lb/newssite/NewsDetails.aspx?id=130804&language=en>, accessed Sept 25, 2010.

the *manager* of cultural heritage and production, and from its managerial position is able to re-negotiate its own exoticisation and Otherness vis-à-vis its foreign audience. This, in turn, becomes a tool for political propaganda as it shows how on one hand the Syrian state is a successful manager of local cultural production, and on the other it shows its willingness to negotiate its Otherness with its audience, portraying its ability to showcase a 'better' or more 'authentic' Orientalist representation.

Secondly, the Minister's speech in Idleb Festival explored how the state uses a cosmopolitan rhetoric to spatially naturalise and neutralise potentially threatening differences, whilst reifying the 'state' as an arbitrator of diversity and presupposition of 'cultural' harmony, demonstrating that formulations of nation-state are not only ethnocentric but inappropriate within the Syrian context. The poetics and politics of Idleb festival provided the backbone to a discussion of how the Syrian state relates and deals with the heterogeneous religious and ethnic identities not through homogenising processes, but through a valorisation of 'difference' and an emancipation of 'culture' through state cosmopolitanism that not only turns the state into an empire but also renders the potentially violent sectarian differences politically unthreatening.

Promoting an internal cosmopolitan policy of 'unity in diversity' the Syrian state not only allows heterogeneity but actively encourages it through public spectacles such as folklore festivals. In these festivals, the similarity that is shared across the different participating groups is the stage on which they perform. The stage is also a precondition of the state-of-empire: it is only *this* space and stage on which difference must be presented. The cosmopolitanism of the Syrian Empire is based on strategic use of diversity, heterogeneity and difference. However, this 'difference' is not any difference but state-defined, sanctioned and regulated. A folklore festival, such as in Idleb, maps Syria through a geographic imaginary. This map is both eternal as well as in perpetual danger: mapping the imaginary of 'difference,' the folklore festival presents differences that may be ethnic, religious, gendered and classed as a matter of *regional* variation that is inherent to the immortal continuation of the Syrian Empire. The festival, its presenters, and performers never mention directly their religious or ethnic affiliation. These affiliations are the results of the audience's intimate reading

into the region. However, on stage such differences are defined and categorised as *regional* differences.

Thirdly, the chapter ethnographically described one of the folklore performances from Idleb festival. This performance, as most of the performances in Syrian folklore festivals, is based on the ritual of wedding. Through the staged ritual wedding, the political dimensions of the nuptial ritual in regards to the Syrian state and audience were questioned, and issues of how the nuptial ritual serves the authoritarian regime to choreograph and sustain a relation of intimacy and dependency among its subjects were explored. The section hinted at the possibilities of internal contradictions and discord of the empire's narratives and practices through audience interaction and the creation of spaces of enactment (for further elaboration see chapters 8 and 9). The marriage of Cadmus and Harmony came down as a special myth, as the last time that mortals and immortals appeared together in celebration, unthreatening and non-invading to each other. The Bedouin wedding performed by Toutoul in Idleb Festival bears much similarity to the wedding of Cadmus and Harmony. The myth, as the performance, stands as a prototype for the sanctioning not of an individual union but of a public and shared acknowledgement between Olympus and earth – it is a point of union and a point of departure, a plane or field where two different orders or scales, the god and the human, share the same space. And it is this spatial commensality that makes the myth and the marriage unique, a commensality of proximities, intimacies and future ruptures.

Unlike so much of the anthropological literature on marriage and kinship, a literature of contracts, exchanges, legitimating of offspring and management of resources (see chapter 4),¹¹³ in this mythical marriage it is *space* that is important, shared and it is through space that the possibilities of an actual and mutual relationality between Olympians and humans takes place. Of course, these potentialities were but temporary, never to be realised. Still this is irrelevant since it is the establishment of this spatial field of possibilities that actually 'sets history in motion' and not its outcomes. It is also through the spatial proximity that both gods and humans, like Empires and subjects, are realised and reified: form is rendered intelligible and

¹¹³ In the marriage of Cadmus and Harmony, apart maybe of some divine kinship, the concept as a whole is ubiquitously absent.

constituted vis-à-vis each other. In the marriage of Cadmus and Harmony questions of power and hierarchy, union and relationality, become aspects of geography and geometry in which space and form are the choreographic parts of power relations. And choreography, in as much as power, needs space to be enacted. Mutual space is instrumental for the palpability of power, and this simple reality in the myth is also applicable to policies of the state: for the state to exist it needs to be reified by its subjects, and here again it is space that plays an important role: it is through geography – spatial, bodily and rhetorical – that the choreographies of power may be enacted: the President’s portraits dominating the Syrian streets, the different regional groups dancing on the same stage (see Harvey 2009; Mitchell 2006; Scott 1998; Shay 2002). So it is the shared space that’s in a marriage which sets the stage of relationality, and which is the precondition of the union. It is in this space that the Syrian state plays its most intimate, and perhaps dangerous, game, utilising both aspects of the dance performance, that of marriage and that of choreography. State sponsored festivals are the most obvious and intriguing examples of such shared spaces due to their organisation, participation and clear delineation in both space and time.

Spatial proximity and joyful intimacy, did not of course erase the difference of kind, or of scale, between mortals and immortals, like the gods’ earthy adventures and love affairs did not make them more human but rather reinforced their divine status, a hierarchy that plays on the hands of the state in its attempt to emulate the Olympians as a perpetual immortality and as a necessary dependence of those staged to the patronage of the state. Thus space is important in both classical myth as well as state mythology.

In the face of Harmony a celebration of difference was consummated – a celebration of a nuptial union between Gods and mortals – she was marriage in that an elusive resemblance of *forms* actually fostered the difference between gods and humans to such an extent that the harmonious celebration would never cease to be repeated and imitated but at the same time could never be exactly reproduced. Harmony, in that instance, constituted the eternal phantom to marriage and to the state: a repressive expectation to follow nuptial unions. Thus, clumsy unions ensue under the haunting possibility of harmony.

Haunting as much as hunted by the Samothracean goddess, the Syrian regime forges itself as a divine sovereign through the embodied practices of empire – enacted through the celebration of difference during its folklore festivals. The difference between the mythical wedding of the Phoenician prince and the Syrian state folklore festivals is that the first was a celebration of difference and the latter an imitation of a celebration of difference. Of course in the first case this celebration was between mortals and immortals while in the case of the Syrian state, as many other states, immortality always weaves into the self-reified narrative of the state.

From mythical to state-staged marriages, and from the burial of martyrs to the repositioning of intimacies, we may note that just as Harmony reinforces rather than dissolves distinctions, state folklore festivals do likewise: bringing the state and its subjects just close enough for the latter to realise its distance from the former. Folklore dance easily lends itself on the stage of carefully choreographed politics (Shay 2002), exposing, reinforcing and occasionally challenging the spectacular ambiguities of domination (Wedeen 1999), through a reification of the state (Abrams 2006; Herzfeld 2005; Mitchell 2006) spatially enacted and simultaneously constructed (Harvey 2009). This provides the spatial precondition for the forging of a binding intimacy dressed in cultural and national terms. The Syrian choreographic politics of state-sponsored folklore festivals help forge an idea of the state as the precondition for ‘cultural’ harmony within a bounded polity and territory. This cultural intimacy may bring the heterogeneous communities of Syria together through different regional dance troupes in folklore festivals, assuming and recasting the ‘state’ as the precondition of heterogeneous co-existence. In crises however, these cultural policies turn into threats: ‘it is us or it is (sectarian) chaos.’

The so-called Arab Spring came in January 2011. Irrespective of what its short or long-term results may be, it reminded us what may happen when people realise the spaces opened up through their own voices and bodies. In Syria now, it is hard to imagine the soldiers joining in the dance, as the policemen in the folklore festival in Daraa had done some years ago. And it is not difficult to see how the burial of the martyrs turns more readily into protest rather than *sulha*. However, somewhere between myth and reality, policies and dances, stands a reminder that the distance

from the marriage of Cadmus and Harmony to the burial of the martyrs can never be bridged by the substitution of one pair of bloodied hands with another, whether these hands are local or foreign.¹¹⁴ Should the marriage of Cadmus and Harmony be relegated to myth and aborted from state folk stages, there will be no regrets. And the dance goes on.

¹¹⁴ In reference to speculations regarding foreign intervention, *see* Van Der Pilj 2011.

Chapter Seven

Arab youth politics in Syria: Becoming young in the Middle East

Introduction

Democracy, civil society and likewise their 'promotion' have for a long time shaped foreign policies inside as much as outside the countries of the Middle East. Since January 2011, however, these notions and policies have been challenged by a new emerging concept, that of the 'Arab Youth.' While 'Arab Youth' is coined to denote the grassroots nature of the uprisings, as a political category it may be reinforcing the paternalistic presumptions of authoritarian regimes and global hegemonic power structures, who use it to undermine the capacity of the wider population for democratic change. Without empirically grounded and theoretically challenging works, 'Arab Youth' may perpetuate the same inequalities and top-down misunderstanding that 'democracy promotion' connotes within the Middle East. By locating Syrian youth within contemporary struggles through ethnographic case studies, this chapter aims to sketch a nuanced, complex and colourful picture of the multifaceted ways that young people reinforce, resist and negotiate power relations in contemporary Syria. Although this chapter is structured around three case studies taken from young Syrians, I employ the term 'youth' in order to refer to a much needed paradigm shift in theoretical perspective of analyzing the struggles that crosscut the Middle East. In previous chapters of the thesis I have explored power relations within households, life-cycle events of a religious community, and how the state becomes the reified guardian of cultural harmony through its cultural policies. In this chapter, I select three ethnographic paradigms from different communities of Damascus, and from a specific age category, because of my own positionality in it, in order to show the different ways that people relate, challenge and reinforce power. Specifically, I look at youth responses to different forms of authority such as external power (Israeli occupation), the Syrian state, and the authority of parents and sectarian communities.

Of uprisings, backgrounds and theoretical frameworks

Shortly after the Tunisian and Egyptian uprisings and the ousting of their respective presidents, the expatriate Syrian activist Ammar Abdulhamid wrote in *The Guardian* an article titled ‘Syria is not ready for an uprising.’ Among his arguments was the following:

Syria is still suffering from the isolation it has experienced since the 1980s. As a result, the exposure of its people to the world outside their borders is relatively weak, at least in comparison with the situation in Tunisia and Egypt. Consequently, there are really no independent civil society institutions to speak of: no free unions, no independent student bodies, no active political opposition parties – in short, no structures that could enable people to organize themselves and rally others. (Abdulhamid, 2011)

Much has changed in the social and political landscape of Syria during the subsequent months of 2011, after local demonstrations in the agricultural prefecture of Daraa, hit by drought, economic deprivation and corruption, were bathed in blood in a futile and provocative show of force by the Syrian regime (Kastrinou 2011). Sites of fire sprung up throughout Syria in the months following, enhanced by the justified demands for change, by the Syrian state’s numerous enemies, and most of all, perhaps, by the state’s own disproportionate and bloody reaction. In a rapidly shifting terrain, the promises of ‘Arab Spring’ – a misnomer at best – turned grim, with fatalities numbering more than 2000 by the end of summer 2011. Of course, neither Abdulhamid, nor others, could have foreseen what was about to happen. Although Syria shared with Tunisia and Egypt economic, demographic and political similarities such as the rising cost of living, inflation, high unemployment rate, a young population and an authoritarian forty-year old regime, a ‘youth uprising’ seemed socially, politically and economically unlikely to take place in Syria. Below, I will briefly sketch the arguments of that narrative, as a prelude to problematising terms and theoretical frameworks such as ‘civil society’ and ‘youth.’ Then, the main section of the chapter will explore three ethnographic cases drawn from fieldwork conducted in Syria (2008–2009, 2010) among Syrian youths aged 20–35 years of age. These case studies not only bring a ‘taste’ of the challenges Syrian youths face, but also provide an empirically grounded framework from which to investigate the realities and potentialities of Arab youth politics. Further, these examples aid in

framing the comparative ground on which a fruitful comparison can be made between Syrian and other Arab youths.

Background

At the start of 2011 the economic situation in Syria was bad, with the political and economic system favouring some groups over others, while recent policies of state-controlled liberalisation were resulting in the increasing accumulation of capital in the hands of the country's political and business elites. But central Damascus' American-style coffee shops, expensive restaurants and the few shopping malls that host the high-end designer clothes were only just emerging, while the government still subsidised basic foodstuff, *mazot* (heating oil), healthcare and education. The contradictions of a socialist (in name) system and of liberal economic reforms were there, but so was the pretext of a social government, and the cliental systems that create dependence. German-based Syrian economist Dr. Salam Said noted in an interview (February 20, 2011):

The economic situation is bad [in Syria], but still is not that bad as in Egypt. The middle class in Syria is disappearing, but is still relatively significant. The effects of liberalization are taking place slowly. Decisions related to subsidies and liberalization policies are designed to serve the interest of economic and political elites, but also to keep a minimum of popularity for the government.

Politically, too, Syria shared with Egypt and Tunisia an autocratic repressive regime. Similar to Egypt, the army functions as a powerful military and political institution,¹¹⁵ directly involved in the government – the Ba'th Party came to power in 1963 through a military coup – and provided the president, who became president under an internal party power struggle with the support of the Army in what is known as the Corrective Movement of 1970. Like the former regimes of Tunisia and Egypt, Syria has little respect for human rights or freedom of speech. State brutality against opposition climaxed in the early 1980s when the army was deployed to suppress the

¹¹⁵ However, the institutionalisation and historical development of the military in Syria is very different from Egypt. The military in Syria is strongly sectarian, and, specifically its high-ranked officials mainly belong to the Alawi sect, the same sect that the president belongs to. A similar division of power exists within the intelligence services, the *mukhabarrat*. The military as a sectarian institution dates back to the era of the French Mandate over Syria in which the colonial policy of divide-and-rule encouraged disenfranchised religious minorities to climb the ranks of the military and through it, to gain power (Khoury, 1991: 26–27). The military continued to be an alternative route to power by otherwise politically weak minorities after Syrian Independence and continues today.

Muslim Brotherhood, killing thousands and bombing large parts of Aleppo and most of Hama. More recently, after Hafiz al-Assad's death in 2000, and the succession to the country's presidency of his son Dr. Bashar al-Assad, there were signs of political democratisation that culminated in what is known as Damascus Spring. These signs included the release of some political prisoners, some limited freedom of expression and political debate by main opposition figures. Yet, Damascus Spring was as short-lived as its fading signs and soon turned into Winter: less than a year had passed when major opposition personalities were imprisoned and political movements banned (George 2003). Like many authoritarian regimes, there was strong control over print and televised media, restrictions regarding the Internet,¹¹⁶ and an overwhelming popular discourse contesting the pervasiveness of the *mukhabarrat*, secret police, with close ties with the Syrian army.

However, unlike Egypt and Tunisia (and many other Middle Eastern regimes) Syria had successfully integrated internal and foreign policies in a way that Syrian foreign policy internally legitimises the regime.¹¹⁷ Adopting a resistance discourse, Syrian foreign policy employed a narrative that is firmly pro-Palestinian, anti-Israel and anti-imperialist Western domination – and its puppet regimes – in the Middle East. A long-time ally of Iran, supporter of Hamas and Hezbollah, the Syrian regime had always branded itself under the banners of Pan-Arabism and resistance to Zionist and external forms of domination (Hinnebusch 2001). As the banner of the ultimate resisting Arab regime, and as a state whose land is still occupied by Israeli forces in the Golan Heights, Syrian foreign policy not only legitimises the continual implementation of the Emergency Law, but, perhaps more importantly, represents the popular voice of the Syrian people who do see resistance to Israel and the USA as necessary for the maintenance of an ever so elusive Arab dignity. This means that although the regime did face internal opposition, it also enjoyed wide-ranging popular support in regards to its foreign policies. In short, Syrian popular opinion and state policy are roughly on the same line: 'unity, freedom, socialism' was a slogan I heard frequently, although not always seriously, among the working-class older generation.

¹¹⁶ Internet related restrictions have recently been relaxed as a direct result of the Tunisian and Egyptian uprisings; see York 2011; The Economist 2011.

¹¹⁷ See recent interview of President Bashar al-Assad with The Wall Street Journal, 31 January 2011 (<http://online.wsj.com/article/SB10001424052748703833204576114712441122894.html#articleTabs%3Darticle>)

Furthermore, Syria's socio-political composition was very different from that of Tunisia and Egypt. Often described as the 'cradle of civilisations and religions' (in state rhetoric), Syria is a very heterogeneous state comprising of diverse religious (Sunni, Shi'a, Christian, Alawi, Druze, Isma'ili) and ethnic groups (Arab, Kurdish, Armenian, Circassian), divided across a complex array of regional and class-based borders (Antoun 1991). Having experienced first-hand the devastation of foreign occupation and sectarian violence from the Iraqi refugees (Syria is the largest host country for Iraqi refugees), most Syrians, it seemed, supported the 40 year old secular political system. And although the Ba'thist regime had been described as sectarian in favouring the Alawi sect's reign of power (van Dam 1996), the government's policies, perhaps due to the necessity of counterbalancing sectarian-based opposition and public opinion, had been notably pro-Sunni (with the exception of the army and security forces, see Landis 2007 for excellent research on Syrian state rhetoric in school textbooks). Actually, the Syrian regime had been so successful in intermixing sectarian politics and regionalism with cultural heritage and a distinct kind of Syrian nationalism, that it has been able to perpetuate a persuasive cosmopolitan rhetoric reinforcing a political attitude as a hegemonic but harmonious 'empire' under which Syrians are both nationals and different (cf. the EU's 'unity in diversity') – this for example, is most clearly represented through the lavish cultural festivals and other cultural projects that the state undertakes (see Kastrinou Theodoropoulou 2011; Seale 1989: 459–460; Wedeen 1999: 18–24; Cooke 2007: 19–35).

Finally, a Syrian popular uprising seemed unlikely not only because of economic and political legitimisation of the regime, but also because opposition parties and movements were thought unable to mobilise wide-ranging popular support. The Syrian polity was frequently criticised for its lack of civil society and opposition movements,¹¹⁸ an impairment that was politically connected to a repressive 'police' state. However, as in the cases of Tunisia and much more Egypt, to base the success of a popular uprising on the weakness or strengths of internal struggles of the military/security apparatuses seems unfair if not wholly disempowering for the millions of protesters. What is usually described as the Syrian Opposition is a rather

¹¹⁸ Some recent examples of media coverage claiming the absence of 'civil society' in Syria include: Al-Jazeera's "A kingdom of silence"; Abdulhamid in Guardian's "Syria's not ready for an uprising".

diverse and fragmented body of actors (Pace and Landis 2009). Certain factions within the opposition include banned political parties (i.e. one of the two communist parties, Nasserist, nationalists), while others are class-based movements (for an example of the resistance movement within the urban Sunni elite, see Salamanda 2004), and largely discredited (especially after its association with the Bush administration's attempts to topple the Syrian regime), thus opposition movements (whatever they might be) had little impact on the vast Syrian majority of lower middle and working class people.

Syria might have been economically managing, socially heterogeneous, politically somewhat legitimate and in terms of its opposition forces fragmented, but it was not shielded from popular uprisings. If 'civil society' was exterior and lacking in Syria, as Abdulhamid put it, how could an uprising take place in the first place? And, to what extent may young people play a role in making or breaking a regime or an uprising?

Theoretical frameworks

Abdulhamid's use of civil society to mean formal and 'modern' institutions that either exist or do not within a given society is similar to the definition of civil society by Gellner (1994), in which civil society is the result of a capitalist market economy, and of Western modernity. But greater scrutiny from case studies within the Middle East (Zubaida 2001) and from a wider variety of cultures and historical time-periods (Layton 2006), draws into question the view of civil society as a recent phenomenon. For example, in relation to Syria, Watenpaugh demonstrates how the emerging bourgeois classes at the turn of the 20th century in Syria strived to reappropriate a classed western-dominated modernity through the creation of civil society organisations such as scouts (2006: 279, 294), noting that 'being modern' not only required the creation of social spaces, but also the invention of new social classifications such as 'youth' (Watenpaugh 2006: 294; cf. Hobsbawm 1995: 270–292). Similarly, Mitchell shows that during late 19th century colonial Egypt, 'Cairo's youth' posed a challenge to both colonial authorities and the local emerging middle-classes,¹¹⁹ because they were viewed as obstacles to the discipline of the population.

¹¹⁹ 'Youth' was a troublesome category along with other social issues such as the status of women and dealing with the 'crowd' (Mitchell 1988: 118).

Nancy Lindisfarne, an anthropologist with years of fieldwork research in Syria and the wider region, argues that the only way to critique as well as synthesise a theoretical framework that is relevant to realities on the ground is by ‘starting from below’ (Lindisfarne 2002). Starting from below, in this chapter I explore ethnographic situations in which Syrian youth negotiate different forms of power and authority. These empirically grounded encounters of power and resistance offer a nuanced and colourful picture, simultaneously along challenging dominant perceptions regarding the exteriority of democracy and civil society, and the recent vague inventions of ‘youth’ as a de-contextual political force. I employ the term ‘youth’ not to generalise or essentialise a profoundly large category of people of a similar age, but in order to underline the complexities and challenges of a large segment of the Syrian population, of which, because of my research and because of my age, I came to know intimately well. In my title, then, ‘becoming young’ points to the problematic re-invention of youth as a convenient political strategy during the historic shifts that shape the Arab world. More importantly, however, it is a call not to the ‘Arab Youth’ (if this can ever be a category) but for the need for a change in the ways that knowledge production regarding the Middle East operates. A call to arms for academic engagement to become young: colourful, nuanced and radical.

Singing Jowlan: performing identities, reforming histories and embodying politics

*Bayna Rita wa ‘oyūnī bunduqiya // wa alazi ya’rifu Rita // yanḥanī wa yuṣālī // li ilāhin
fil‘oyūnī al‘assaliya*

‘Between Rita and my eyes – a rifle/ and he who knows Rita/ kneels and prays/ to the god in the eyes of honey’ (poem by Mahmoud Darwish, music by Marcel Khalife)

Sami has just been awarded a BA degree in English Literature from Damascus University. He is 25 years old. Handsome, confident and extroverted. He is from the Israeli occupied Golan Heights (pronounced Jowlan in the Syrian dialect). His nationality is Syrian. His religion is Druze. It is the beginning of April 2009 and Sami is hosting a goodbye party in his student flat in Mezzeh. He is returning tomorrow to the Golan Heights. For good. Or until peace is signed by Syria and Israel.

The Golan Heights have been occupied by Israeli forces since the Six Days War in 1967, and the majority of the Syrian Druze population residing in the fertile

mountain has declined Israeli offers of citizenship. As Syrian nationals under occupation, residents of the Golan do not have identity cards or passports but ‘travel documents’: ‘we live under occupation and travel like dogs,’ noted Mamduh, a Syrian Druze sociology student from Golan. Syrian nationals of either side of the border cannot move freely between the two territories, if and when such movement occurs it is usually permanent.¹²⁰ There is one exception to this rule: a student from Golan may study for a university degree in Syria, and can return to Golan for two months every summer for the duration of the study period. When the student completes her/his degree, as in Sami’s case, it is time to return, for good, back to the occupied Golan Heights.

Sami’s student flat is full of his friends, a couple of his relatives (those who permanently reside in Syria), as well as the conspicuous universal signs of a good student party: plenty of alcohol, a couple of water pipes, friendly banter, flirting, singing and dancing. The singing starts with old and famous Arabic songs, *tarab* music, and people take turns in leading a song. Then someone starts singing Sabah Fakhri’s *Ya māl al-Shām* and couples take to the dance floor. Soon dances interchange between couple-dancing (a variant of Oriental dance) and group *dabkehs*.

To dance is to perform and embody intersubjective relations, forging relations between the performers, between the audience and the performers, whilst using the body not as a simple medium of expression but as the physical tactile horizon of experience, an interface whose boundaries are always under construction, a space that embodies multiple identities (see Cowan 1990). Through dancing, a different geography of space arises, a geography that physically expresses relations of belonging and in which dance becomes a ‘moral obligation to reciprocate a sign of closeness [...] the duty to dance is represented as an exchange’ (Van Aken 2006: 214). In manifesting interconnections and social exchanges, dancing in Sami’s party constituted, maintained and reinforced relationships of intimacy between Sami and his Syrian friends, friends that were Muslim, Christian and Druze, creating and negotiating a space where religious identities and internationally contested borders are transgressed.

¹²⁰ Marriages between Druze in either side of the border is one way to facilitate an on-going interaction, with the expense of one of the spouses moving away from her/his natal place.

Someone, here or there, in the middle of dancing would exclaim ‘Ya Jowlan!’ or ‘Ya Sami!’ As the night and dances moved on, references to the Golan Heights and to Sami became more frequent and more acute. The musical repertoire had now changed to include Druze traditional songs, alongside other Arab and Syrian ones. Suddenly, I realised that most if not all the songs sung and danced were relevant to Sami, relevant to the Golan Heights, and relevant to present day politics: not only were there specific songs from the Druze of Golan, but the participants, by way of shouting or by inserting or changing lyrics to popular songs, made all songs and dances of the night relevant to a historic as well as a present day context. Identities were ‘mixed’, rearranged and reshuffled, combined as in an artistic re-appropriation of a traditional carpet. But the colours and designs, the complex identities and borders, were not simply collapsed into each other, or simplified. They were reconnected or choreographed in a way that they kept their multiplicities and their contradictions. History was not simply embodied through dance: it was remade into a politicised present.

By performing war songs and dances with reference to an historic Druze past, party participants were validating Golan as simultaneously Druze and Syrian. Druze-ness can be understood in both sectarian terms and the community’s ‘particularism’ (Betts 1988; Firro 1992) to be a politically suspicious engagement, but also it can be understood within the contexts of Arab Syrian diversity and can be used for nation forging. By singing and dancing about both Druze and Syrian/Arab contexts, Sami and party participants, the particularism of the local community was strongly attached to a Syrian/Arab polymorphous ideal, constituted and united against a common external enemy (Israel), and thus through dancing history to establish performatively a relation among the community but also between the community and the rest of the Syrian Arab Republic, and so, in a way reinforcing the primary means of state rhetoric.

And then came Rita:

‘Between Rita and my eyes – a rifle/ and he who knows Rita/ kneels and prays/ to the god in the eyes of honey’

*And I kissed Rita
When she was young*

And I remember how she clung on to me
And how my arm was covered by the loveliest of braids
And I remember Rita
The way a sparrow remembers its puddle
Ah, Rita
Between us a million sparrows and images
And many dates
Fired at by a rifle
Rita's name was a feast in my mouth
Rita's body was a wedding in my blood
And I was lost in Rita for two years
And for two years she slept on my arm
And we made promises
Over the most beautiful of cups
And we burned in the wine of our lips
And we were born twice
Ah, Rita! I could not turn my eyes from yours
Except for two naps and honey-coloured clouds, before this rifle
Once upon a time
Oh, the silence of dusk
In the morning my moon migrated to a far- away place
Towards those honey-coloured eyes
And the city swept away all the singers
And Rita
Between Rita and my eyes — A rifle

A combination of love and war, on a theme that runs across the spectrum, artificial anyway, of the personal made political and vice versa, this is a very popular and powerful song *Rita wa al-bunduqiya* written by Palestinian national poet Mahmoud Darwish and sung by Lebanese composer and singer Marcel Khalife. The speaker grows up with 'Rita', falls in love with her, they are involved in a passionate relationship for two years, until the 'rifle' comes between them, destroying a city, sweeping away all its singers. The last stanza is particularly interesting (and hard to translate) as it starts with the phrase '*kān ya makān*' (Once upon a time or literally there was a place), a phrase used to begin stories with, especially fairy or epic tales, but not to end them. In this stanza, a narrative outside the relationship between speaker and 'Rita' emerges (it runs throughout the poem but it is here that it becomes clear) describing how this 'rifle' sweeps away both Rita and the singers – both of which are emblems of happiness (*farah*), and intellectual or inspirational activity. My Syrian friends explained to me that 'Rita' might have been an Israeli woman with whom the poet might have had a romantic relationship until the 1967 war separated them. Other elaborations or interpretations include that Rita might have been killed by an Israeli rifle, or that Rita was Israeli and subsequently became a rifle, another

interpretation is that the speaker himself took a rifle and killed Rita (presumably because they found themselves in opposing battlefields). The mastery of Darwish's poem, so elegantly and ingeniously written, is that it permits and accommodates all these interpretations; subsequently one of the poem's successes is precisely allowing multi-layered meanings to emerge. In doing so, and particularly by not assigning any agency to the rifle (or to anything else in the poem), the poet succeeds in vividly portraying a situation, a context, in which individuals are forced or swept along, and where the city seems to have the agency to do so. Yet, the fatalistic inclination of the poem is to some degree overcome in the last stanza: it is only in the last lines of the poem that the speaker starts telling the story of the city, the singer and the rifle. Presumably, this is because the story has not yet finished.

Thus 'Rita' is polysemic, almost emblematic. During Sami's party, 'Rita' gave way to something else:

*Bayna kbāli wa 'oyoūnī bunduqīya: 'Between my uncle and my eyes – a rifle.'*¹²¹

The first stanza was altered and sung solo by Sami's cousin, Sakher, married and residing in Damascus. We were all sitting in a circle, and were stunned by the different turn that the familiar song took. The two cousins will probably never see each other again, separated by the Israeli occupation, the only chance to see each other would be at the border between Syrian Quneitra and occupied Majdal Shams. Physical distance, a no-man's land between, and rifles pointing either side. The family idiom was exaggerated by inserting 'uncle' instead of romantic love, and by Sakher's performance directed to his cousin. And while the separation of lovers is painful, the separation of families is deemed not only unnatural, but tormenting both on personal and social levels (see Rugh 1997).

Since Darwish's poem already ventures to bridge the space between the personal and the political, the insertion of the family idiom adds another dimension. By doing so, Sakher not only exposes the unnaturalness of families separated by borders;

¹²¹ The song was sung in Sami's goodbye party by one of his male cousins, Sakher, who has been married 'into' Syria. People usually marry 'into' families not countries; this notion is more often applied to a new bride going into the family of her groom. But in Sakher's case, Syria was appropriately personified as his new family, since he had left Jowlan to be married with a Syrian Druze and to settle permanently there. Now, his cousin Sami was going back, and the next time he'd probably see him would be in the borders, divided by lines of ceasefire and rifles.

thematically, he transforms the popular song from a love song into the more traditional repertoire of war songs (see Hood 2007), which usually evoke and revenge family separations and affairs. Thus, the alteration of the song does not only add the familiar dimension, but thematically relates it to all the previous traditional war songs that had been sung.

As the song contains references to the 1967 War, the historic references for the Druze inhabitants of the Golan Heights are more than relevant. But, in a way this is not a song about history, in the sense that it is not about what happened sometime in the past – this is a song about what is happening now, it's a song about living the history. Performatively adjusted to the current contexts, the song is both creative and contemporary as it relates Sami's situation, a metaphor for the occupation, within the present day 'interests' of Syrian youth, a metaphor for the specific song's popularity. Inserting the historical and family specific context into the song, though, also does something else: where traditional Druze and Syrian songs talked and related to war, fight and occupation, this song, not particularly Druze or Syrian or revolutionary, is related. Therefore, it is not that specific songs can be made relevant, but that *any* and *all* songs can be turned into a narrative of contemporary power relations, between states and between individuals. In this way, neither the inhabitants of the Golan Heights nor their Syrian relatives and friends are disempowered by the status quo: by making history contemporary they create relations across borders, generations, genres of music and dance, and through these performances they challenge and resist both essentialised views of history and tradition as well as the imposition of a predestined politics. They are making traditional themes, like those of war songs, relevant to their everyday experience, they are challenging history by performing it, and they construct relations that are transgressions across borders, bridging the personal, the communal and the particular (Druze) with the national and the international. This process of re-invention of both tradition and modernity, local and global, is similar to what Van Aken calls 'the daily re-invention of *dabkeh*' (2006: 218):

... *dabkeh* is continually reinvented and the variations that occur create symbolic markers between different generations of men, but also between different criteria of belonging and fashions followed by young men. (Van Aken 2006: 219)

We sung and danced at Sami's party, and we sung and danced at the Quneitra border near Majdal Shams on the 17th of April, the Syrian National Day. And our dancing meant that nothing is final as long as relationships are forged, created and maintained across different borders. This is done not really with 'as if' politics (Wedeen 1999), it is done through embodied performative relations. History and songs and politics and dances and identities are performed as a means of both making and maintaining relationships and preparing for battle, a theme pervasive in traditional Druze songs of war. Thus, instead of seeing history or identities as stories or banners static and of the past, young Syrians from either side of the border transgress internationally contested frontiers by performing and thus making and re-making their past, present, future as well as the frontiers themselves.

The Syrian Arab youth are located within very complex webs of identities and politics, and they not only have agency in writing and telling their stories, but they have the potential of changing history and politics through their embodied dances and intertextual songs.

On inventiveness and (in) dependence: The political economy of networking in Damascus University and beyond

Arab youth and especially university students played an important role in the recent revolutions of Egypt and Tunisia (although it is reductionism at best and often patronising to describe the wide-ranging popular mobilisation as a 'youth revolution'). In the previous example we saw an instance of how young Syrian students negotiate, crystallise and challenge complex identities, histories and politics through embodied practices. In this section we will look at the complex milieu of university life in Damascus and through the example of a specific type of networking we will analyse the ways in which a form of civil society and its political economy may pose challenges to different forms of domination.

Student life in the University of Damascus is as heterogeneous and varied as life outside of it. Regional, religious, class, gendered and political affiliations play out in and between lectures, exams and gatherings. Formally, there is an elected student representative body, Student Commission, that negotiates student demands and there are several youth parties represented such as Ba'th, and other parties represented in

parliament, along with more religious-based affiliations (that are not official parties). Upon entering the University students are invited to join organisations and parties, and I often heard that students joined the Ba'th youth party in order to 'have less trouble' or an 'easier time' during their studies, or 'better networking with professors.'

In the heterogeneous setting of Syria, where the political interacts with the social and the economic on a constant basis, it is very hard, almost impossible to separate these spheres of constant interaction in the everyday lives of Syrians. The Syrian state (and for 'state' I have in mind Foucault's understanding of the modern 'welfare' state) lies in some respects, on the fringes of the everyday life of Syrians – the life of the Syrian family or business man – in that contrary to developed capitalist welfare states, it has few resources to provide certain services and facilities (such as adequate pensions, unemployment benefits, social insurance; almost 1/3 of Syrian economy comes from the informal sector). In this context, relationships are both personal and very important. Thus, it is not surprising to note that capital, social and economic, is generated through personal relations – *'alaqat*. From the mundane to the sublime, relations in Syria directly affect all spheres of interaction, performing the role of a Syrian insurance system. It is through relationships that people reinforce family, communal and religious solidarity, it is through relations that people make their businesses or find work – thus, personal relationships not only inform but form social life in providing simultaneously and interdependently social as well as economic capital. One ingenious Syrian example of forming and maintaining relations is the practice of *jama'iya*. This example challenges perceptions of Syrians as having a 'dependence culture' upon the public sector, as well as claims for a *lack* of civil society in Syria.

Literally, *jama'iya* (pl. *jama'iyat*) means a social gathering or grouping; formally it denotes an institutional organisation, association or charity.¹²² More commonly

¹²² The only anthropological reference to organisations of *jama'iya* is in Khalaf's 1981 Ph.D. *Family, village, and the political party* (pg. 168-171). Khalaf discusses how the Ba'th party since 1966, in an attempt to consolidate its popular base in remote villages established official collectives such as *Al-Jama'iya Al-Fallahiya* - Peasant Collective, whose aim was to gain support and reinforce official policies through popular involvement and mobilisation (Khalaf 1981: 173). Such officially registered associations, can be directly influenced by Party politics as mentioned by Khalaf, or could be similar to 'charitable organisations.' In order for a *jama'iya* to be officially registered it needs the agreement of the Ministry of Culture or Work. For example, in Jaramana there are three such officially registered

however, *jama'iyat* are informal groups, neither registered nor affiliated in any way with the state. In the informal context, a *jama'iya* is a social gathering of a standard number of people (it can range from 3 or 4 to more than 100), which meets in a scheduled manner (i.e., once a week, a month, etc.), requires membership in the *jama'iya* group, and usually entails an agreed fee which is payable at every gathering, in a rotational manner, to a different member of the group each time. These socio-economic groups are pervasive¹²³ in urban Syria,¹²⁴ and are usually comprised of networks of friends, family members, members of a specific occupation, or neighbours, sometimes cross cutting religious or ethnic divides, constituting what Dr. Said (2011) called 'an alternative to savings account or insurance.'

Functioning as a rotating credit association, a school or university student could create a *jama'iya* with 3 other friends, they could meet every week on a designated day, let's say on a Thursday, and every Thursday each would give 50SYP (£0.68) to the *jama'iya*, and the sum of the money (200SP or £2.73) would go to one of the members of the *jama'iya* and s/he could use it as pocket money. The next week, the same amount of money would go to another member, so that by the end of the month all members of the *jama'iya* would have rotated. These organisations usually range in numbers, frequency of meeting, as well as in fees: ranging contributions can be from 50SYP to 50000SYP (£690), or even more.¹²⁵ Another example is *jama'iya al-'āyleh*, *jama'iya* of the family. For example, in the working-class family I lived with, the married daughters and sons held weekly gatherings with their children and spouses, on a rotational manner, in their houses (14 members and their children). In this *jama'iya* no fees were paid directly, but the host family of the week would reciprocate with food. This would provide maintenance of family and extended family bonds through a scheduled pattern, sociality as well as sharing of food costs and relaxation for the women who were invited. However, the *jama'iya al-'āyleh* of a neighbouring middle-class family included 20 female relatives, they would meet once per month,

charitable associations: (1) *Jama'iya al-bi'a* (Environmental association); (2) *Jama'iya al-Khayriyeh* (a charity for Jaramana's poor); (3) *Jama'iya al-Moutaqibin* (association of those retired). Such official organisations usually have a founding and organising committee, members have to pay a fee, and fees are concentrated in a common treasury and spent on some common goal: i.e. on improving cleaning facilities, providing a stipend or award to a local student to continue to higher studies, or arranging an excursion.

¹²³ The majority of people from Damascus that I talked to were involved in at least one *jama'iya*.

¹²⁴ Informants in rural places in Syria did not practice this kind of socio-economic formation.

¹²⁵ Once I was told that a complex of apartment buildings had been built through the *jama'iya* of seven Alawi military officers (sectarian as well as occupational members).

the hostess would change every month and it would be her that would receive the fees, each had to pay 1000 SYP (£14), which meant that for any given month, a woman could have as spending money the quite extravagant in Syrian contexts amount of 20,000 SYP (£273 – this is equivalent to the monthly salary of an experienced and well-paid civil servant!). The usual meeting place of *jama'iyat* is the host's house, in the case of students that could be university and coffee places.

It is a stereotype that Damascenes are incessant businessmen, and this stereotype finds an ingenious way of manifesting itself not only by the existence of informal organisations but also through the pragmatic explanations of *jama'iyat* that Syrians themselves give. The concept of deriving benefit (*istafāda*) plays an interesting role in this instance: contrary to (but not necessarily contradicting) the capitalist idea of benefit as economic profit, especially as the accumulation or concentration of capital, the concept of *istafāda* signifies a type of on-going relationship, more closely related to Mauss' idea of gift-giving and reciprocity: it does not produce any profit but it is a kind of saving. Therefore, two complementary reasons are given by Syrian informants regarding the function and existence of *jama'iyat*.

Firstly, there are social benefits (*fa'ida ijtīmā'iya*) to *jama'iya*, including: the maintenance of social relationships that are harder to uphold otherwise in the busy rhythms of urban life; an organised but informal space of sharing news and expression; it is often said that *jama'iyat* have become the modern day ḥammāms in which gossip and searching for appropriate marriage partnerships can take place; and finally, they provide a nice excuse to evade or postpone other commitments. Some *jama'iyat* have a social aim such as those created by neighbours for maintenance of communal spaces. This creation of communal, shared spaces between household and state is a classic example of civil society (Layton 2006).

Financial benefits (*fa'ida mādiya*) include: 'helping each other economically;' 'a way to help each other without involving the government or the bank' (most people in Syria do not have direct dealings with banks and avoid direct dealings with government officials as well); and 'better than the bank (borrowing from the bank) because it doesn't have interest.' Said (2011) noted, that 'private banks with giro-account appeared just a few years ago in Syria. State banks were not capable of offering this

kind of accounts with check systems (like in France) or money automat (like in Germany or the UK). Also as a saving account, one should note that people and the private economic sector didn't (do not even now) trust the state... They don't want to show off their money... The private sector has suffered from the "nationalisation" process in the past.'

Khalaf (1981) places the concept of *jama'iyat* in the anthropological literature as state-organised and manipulated in order to draw a popular base of support and mobilisation in centres and peripheries of state power. In such forms, *jama'iyat* translate as collectives or cooperatives (see also Hinnebusch, 1990; Batatu, 1999). The formal establishment of these organisations begins in the period of the struggle and consolidation of the Ba'th party (1966-1970), the ruling regime in Syria. Historically, by tracing informants' narrative accounts, the establishment of informal *jama'iyat* roughly corresponds to the period after this consolidation of state power, during the early 1980s – a period in which Syrian society and economy experienced unprecedented change both in relations of power and government, as well as in economic developments signified by rapid urbanisation, changes in the fabric of social life (fragmentation, physical and social mobility, immigrants, refugees) and other changes (redistribution of wealth, agrarian laws, implementation of policies) which reflect the political and economic hierarchies and priorities of the time. In the face of such changes, the state in terms of services, facilities, welfare and economy, was very limited in what it could offer, while people experiencing those changes found ways to not only adapt but 'benefit' from the situation. In creating *jama'iyat* Syrian urbanites were able to respond to some of the demands of this new field by creating ad-hoc self-organised networks and groupings that to some extent fulfilled certain social and economic necessities.

But, is the newly invented *jama'iyat* something completely new to Syria? And how is it that, based on my research, the above-mentioned informal *jama'iyat* seem to be a specific urban engagement?

Hourani, leading historian of the Middle East, writes about the medieval Arab city:

The quarter belonged to its inhabitants, and in a sense was an extension of the houses. Its privacy was protected, in case of need, by its young

men, sometimes organised into groups [...]which had a continued existence and possessed a certain moral ideal. [...] There was a tendency for the inhabitants of a quarter to be linked by common origin, religious, ethnic or regional, or by kinship or intermarriage; such links created a solidarity which might be strong. (Hourani 2005: 123)

Shiham Tergerman (1994) beautifully depicts relationships between family and neighbourhood in her autobiographic book *Daughter of Damascus*, while Salamandra, an anthropologist, more recently comments on the political ‘old Damascus revivalism’ (2004: 106) especially as depicted through soap-operas about everyday life in the quarters of Old Damascus (ibid.: 105–124; Salamandra 2005). The Arabic term for a quarter or a neighbourhood is *ḥāra* and during my fieldwork the most famous reviving Old-Damascus soap-opera was called *Bab al-ḥāra* (Gate of the neighbourhood) and was taking place during the French occupation of Syria, while the specific quarter of the old city was the last neighbourhood resisting the French.

The residential unit, in fact the spatial physical proximity of residence, has historically provided an additional network of reliance, support, as well as conflict in Syrian urban places. Neighbouring relations have always acted as forces of multiplication of other ‘ties that bind’, i.e. as a means of sociality and solidarity in addition to other ties such as kinship, ethnic, religious, etc. The neighbourhood then, as extension of households and ties, has been multiplying ‘relationships’ through physical proximity. Interestingly, such relationships between neighbours have decreased but are still manifest in the older, usually poorer quarters of the city. For example, during my residence in *bayt* Abud-Haddad, whose house is more than 100 years old, and their neighbourhood is one of the oldest in Jaramana (see chapter 3), in August we received several times gifts of fruit and vegetables from neighbours who have cultivated land. These ‘gifts’ are called *ḵhair al-seneh* (blessing of the year), are the first fruits of the land, and are exchanged and reciprocated ritually.¹²⁶ Furthermore, the more recent *jama’iya al-badīqa* or *jama’iya niswān al-ḥāra* are organisations explicitly based on the neighbourhood and residential unit.

Thus, it would be somewhat unfair to say that the formation of *jama’iya* is a wholly new phenomenon, a direct result of the modern urban historical contexts of Syria.

¹²⁶ This type of ‘gift’ is connected to greater religious, social and metaphysical assumptions, which are not the subject of this chapter.

Maybe it wouldn't be too audacious if we were to hypothesise that genealogically the newly invented *jama'iya* lies with the token of neighbouring relations as these developed through time and history, under the specific social and economic fabric and pressures of urban life, in which proximity is physically 'forced upon,' as are also other kinds of relationships, but which such a physical condition is less likely to be found outside the urban space. Nevertheless, the *jama'iya* is not simply another word to describe what could be called the '*ḥāra sha'abiyeh taqlīdiyeh*' (Khalaf personal communication 2010) – the traditional popular neighbourhood, if such thing ever existed or ever ceased to exist.

From genealogical proximities, to the historical, political and socio-economic development, the practice of *jama'iya* underlines a Syrian inventiveness and efficiency in creating spaces and organisations that occupy the in-between space of state and household (couldn't this space be translated as civil society? See Layton 2006). In this respect, the *jama'iya* plays a role parallel to the State, and at the same time beyond the reach of the state by combining simultaneously the political with the social and the economic with the personal. As such, we could even argue that through such organisations based on the on-going promise of personal ties and trust, Syrians potentially but not necessarily undermine the authority of the State and the extent to which it can affect their everyday lives.

However, following the same line of argument, the *jama'iya* can be undermining an even more pervasive form of authority, sometimes theorised as the most powerful form of relating not only in Syria but in the Middle East as a whole, and instead of multiplying relationships, could be seen as transgressing them to such an extent as to break or divide them... I am referring to relations of authority and dependence as manifested through the ties that bind much more pervasively and unquestionably than any state power, those of family and sectarian relationships, which will be further explored in the next section.

Love and other crimes: desires and discourses of resistance

We are sitting at a coffee shop, my friend Anna and I, talking about – well, things that girls our age talk about...such as men, boyfriends and sex. In discussing sexual encounters outside of wedlock and outside Anna's religious and regional affiliations,

she notes:

With my logic and my head I can see that I do nothing wrong in having relationships outside marriage, with so-called ‘inappropriate’ or ‘forbidden’ suitors... I know, I understand that all these are dead, backwards Oriental traditions that make no sense. But still, I can’t help feeling somehow ashamed that I do these things... I guess the problem is that I have Orientalism in my head.

Echoing Anna’s auto-exotic¹²⁷ self-criticism, in *What is really wrong with the Middle East*, Brian Whitaker states:

‘Arab society,’ Halim Barakat, the Syrian-born sociologist wrote, ‘is the family generalized or enlarged, and the family is society in miniature.’ The same can be said of politics, with the Arab family as a microcosm of the Arab state as a family writ large... The regimes – even the most unpopular ones – are products of the societies they govern and to grasp the nature of the problem we have to start by looking at society’s building blocks. (Whitaker 2009: 48–49)

However, there is something *really* wrong with this line of argument, telling us deceptively little about the ‘Arab family’ and state it attempts to analyse. By alleging an equation between the Arab family and the Arab state, not only does the author simplify, over-generalize and essentialize both, but he also indirectly denies the complexities and histories of power relations by implying that patriarchy (cf. Abu-Lughod 1996; Hatem 1987) is something essential to the Arab family structure. This also implies, idealistically, that the structures of domination in the Middle East are a ‘natural’ and inevitable *product* of that essential Arab culture. It presupposes that a *structure* of vertical power (patriarchy) is a *cultural* endemic characteristic of Arab society (at least a simplified generalization of the immense variance of a so-called culture that occupies great spatial and temporal space), rather than historically, politically, socially and economically situated and intersubjectively performed, produced, reproduced and challenged (see Lindisfarne 2002; Mitchell 1990). This is a logically flawed argument since neither ‘culture’ or power constitute entities nor are they ahistorical, static and apolitical. There is no defensible definition of culture that assumes the *a priori* existence of unchanging power relations (Lyon 2005, 2006). Even when the concept of ‘culture’ is used rhetorically to stimulate political barricades and to form political strategies, always already it remains a discursive and practical open-

¹²⁷ Quoted from Sivigliano (1995) to describe the complex processes of auto-exoticisation in the contexts of hegemonic post-coloniality. In Anna’s case this could be referred to as self-Orientalising (also see chapter 2).

ended question (for valid criticisms against the concept of culture in anthropology see Abu-Lughod 2006). Culture, then, is certainly not inherently oppressive, since things, concepts and practices are constituted continually and through relations external to them, always variant in space and in time. Neither is culture a-temporal, and, nor are Arab regimes solely ‘products of the societies they govern,’ there exist connections of course, but there are also global connections and recent events only justify this. Ignoring these philosophical understandings as well as the turbulent post-colonial waters that bleed into and make the ‘Middle East’ bleed today is not only academically irresponsible but politically suspicious – to say the least.¹²⁸

But let us return to Anna.

Anna comes from a professional family of Alawi background, her parents are doctors, politically they ascribe to the left and are considered open-minded. A year ago Anna had told me that she grew up without learning about religion or sectarian differences, that her parents emphasized the importance of *love* rather than sectarian or other affiliations when it comes to marriage preference. But a year later, her parents’ opinions had changed, it seems overnight and Anna felt their pressure as a great constraint. Now Anna has finished her degree (attaining some of the highest marks in her department) and has started working. She was in a relationship with a Christian man, and she felt that she could never tell her parents. The solution for Anna is to obtain a scholarship for further study abroad, in Europe, and to build her life there: a double life that is, distance permitting her a life abroad without telling and upsetting her parents about her choices. ‘Being honest here,’ Anna said, ‘wouldn’t help anybody.’

Anna’s story is similar to many stories of young educated women who travel abroad in search of better professional and social opportunities. Manal, 29, a successful lecturer in the University of Damascus, chose to stay in Syria. She lives an hour outside of Damascus, her family is Muslim, and for the past nine years she has been involved in a love relationship with a musician, the only-son of a Christian family, Khalid. As there are only religious courts endorsing marriage, Manal and Khalid cannot have a civil marriage and, should they want to get married, one of them

¹²⁸ For a different version of history and society in the Middle East see Ali 2003.

would have to change their religion. Neither Manal nor Khalid is especially religious (Manal wears the *hijab* and fasts during Ramadan but does so for ‘social reasons’), the problem is that neither of their families would approve of such a union. Manal fears the reactions of her family should they find out, reactions that as she notes would entail either her banishment from the family, or more grave retributions against her lover and herself. Running away, she says, would not solve anything, but create more problems, fears and uncertainties. Excluding many of the complexities of Manal’s and Khalid’s relationship, Manal embraces the impasse that she lives in, noting that she cannot stop loving Khalid, nor can she abandon her family and career. She chooses to stay put, and to remain unmarried (becoming *‘ānissa*, a spinster).

Tawfiq also leads a double life of sorts, ‘being Druze’ (Khuri 2004) and homosexual. However, Tawfiq refuses to compromise any of these two aspects of his life, in a way refusing to abide by simplistic categories that conflict identities with practices: ‘I want my special tradition, my special language, my special rituals. I want to be special – I want to be Druze and be different.’ Tawfiq is active within ‘gay’ networks of Damascus through social media and through meetings with other men in central Damascus. He accepts ‘being gay,’ as he calls it, as a part of himself, at the same time he is also in love with one of his female cousins: ‘I would tell her [about my sexuality] if we had a relationship or if we got married. And I think that she’d accept it... because that’s what love is about.’ He envisions his being Druze, Arab and gay as not mutually exclusive. Tawfiq notes, ‘I think that my mother knows there is something special in me.’ Would he ever tell his family openly, should he fall in love with another man? ‘No, I cannot even conceive of hurting one hair from my mother’s head... I would never allow that to happen.’ At the same time, Tawfiq likes to spend his salary buying new fashionable clothes, much to the distaste of his father, spend his time in ‘gay’ chat rooms and in rendezvous, adopting a certain ‘pride’ that has much in common with the extrovert indications of a globalised ‘being gay’ discourse (cf. Kirtsoglou 2004: 102–124).

How can we understand Anna’s, Manal’s and Tawfiq’s ‘love crimes’? Are these indeed ‘crimes,’ can desires constitute discourses and practices of resistance? And, if they do, what is this resistance, to what or who is it directed, what are its implications, and is it strategically effective?

Foucault suggests studying power relations ‘through the antagonism of strategies’ (Foucault, 1982: 780) by ‘using resistance as a chemical catalyst so as to bring to light power relations’ (ibid.). Casting a critical eye over the usually ‘thick’, sophisticated but often inconsequential and/or romanticising studies of resistance,¹²⁹ Abu-Lughod suggests treating resistance strategies encountered in the field as a ‘diagnostic of power’ (Abu-Lughod 1990: 41), searching for the implications of resistance, and enabling us ‘to trace how power relations are historically transformed’ (ibid.: 42):

With the shift in perspective I am advocating, asking not about the status of resistance itself but about what the forms of resistance indicate about the forms of power that they are up against, we are onto new ground. In addition to questions such as whether official ideology is really ever hegemonic or whether cultural or verbal resistance counts as much as other kinds, we can begin to ask what can be learned about power if we take for granted that resistances, of whatever form, *signal sites of struggle*. (Abu-Lughod 1990: 47, my emphasis)

Anna’s and Manal’s stories of love can be viewed as resistance practices and discourses: a tactical use of desire against their parents’ wishes and authority, and as resistance against social conventions such as the practice of sectarian intermarriage.¹³⁰ Simultaneously, resistance against parental authority not only implies but also reconfirms and reinforces the power relations between generations. These power relations between generations, and therefore resistance strategies also, are both economically and socially interdependent since both Anna and Manal¹³¹ rely (and through that relate) on the economic and social capital of their parents (Abu-Lughod, 1990: 49; cf. Khalaf, 1981; Rugh, 1997).¹³² Furthermore, the girls’ transgression and defiance against the social expectation of sectarian marriage (by immigration out of this milieu and by remaining unmarried) point to the direction of the power of sectarian politics. Of course, ‘sectarian politics’ is a very problematic term because it is often used to denote a residual of essentialist ‘traditional-cultural-original’ power structures within a ‘modern’ timeframe. However, if we were to take a

¹²⁹ For example, see Comaroff and Comaroff, 2002; Gilson, 1996; Ortner, 1995; Mitchell, 1990; Scott, 1985.

¹³⁰ Same religious sect marriage preference is not the only criterion in marriage negotiations; class and region also play important roles.

¹³¹ Even though both girls could be economically independent they choose to live in the household of their parents.

¹³² Relations between parent and children, generally and in Syria particularly, are very complex affairs, which engage different realms of social, emotional, and economic ‘ties that bind,’ and the realms of these complex relationships are never in themselves deterministic but ongoing and varying.

contextualized, historical, dynamic, political and socio-economic analysis of 'sectarian' politics, we would ask the following question: what roles have 'sectarian' politics played and are playing in the formation of the 20th and 21st century Syrian state and polity?

The Ba'thist regime in Syria has effectively negotiated a secular state in which sectarian or class-based differences are substituted with (an almost evolutionary) regional cultural variation. The state rhetoric of this type of secularism (in which Syrian nationalism corresponds to the Syrian state-of-empire political discourse of local cosmopolitanism) is most visually powerfully propagated through state-sponsored cultural and folklore festivals in which the otherwise viewed as 'sectarian', religious and ethnic difference is celebrated as a *cultural-regional* difference, with the state emerging as its grand patron. Another example of the negotiations between state and subjects on secularism and sectarianism comes from Anna's open-minded, leftist Alawi parents. The apparent contradiction between sectarian affiliation and leftist political inclination is emblematic in the way that the Ba'thist secular rhetoric has successfully and strategically been re-appropriated by Syrian middle classes. By proclaiming one type of difference, that of cultural-regional variation, the state rhetoric actually facilitates the opening of Pandora's box in that the existence of difference is inscribed but what *kind* of difference is negotiable depending on different socio-political and economic contexts. Therefore, although the state openly celebrates secularism through cultural-regional variation, at the same time it provides little in the way of economic and social incentives that could potentially challenge socio-economic networks that are based on sectarian (among other such as class) relationships. Could it, in fact, be the case that the state rhetoric of secularism and cultural variation has actually rigidified sectarian boundaries, breathing new life into these relations by way of its failure to establish social 'welfare' institutions and services? But can't this resurgence also be explained through a critical investigation paradigmatic of a greater 'modernity,' of how the hegemonic attempt to 'fix' identities actually contributes to their proliferation?¹³³

¹³³ Wedeen (1999) views discrepancies between official rhetoric, citizens' public endorsement and private resistance to it as practices of 'as if' politics. Notwithstanding the assumptions of public vs. private dichotomies, Wedeen's analysis falls in the category of analysing resistance as 'impression management, which makes of them [those who resist] cynical manipulators' (Abu-Lughod 1990: 47).

Taking resistance as a diagnostic of power, it is easy to see the alternative implications and interpretations for the three different ‘love crimes’. For example, Anna’s solution to her resistance against parental authority and social conformity is to leave Syria, its economic and social challenges, altogether behind. In this instance, her form of resistance becomes almost congruent to the technologies of the self in a restructuring capitalism in which the construction of personhood as ‘individual’ becomes possible through the consumption of a hegemonic discourse that allures to an entity that geographically gratifies itself as ‘West’, calls itself ‘liberal’ and ‘open-minded’ by dividing the world hierarchically and ever-so unequally, dominant and neo-colonial through its economic and ‘cultural’ monopoly on ‘opportunities’ – which Anna’s resistance strategy inevitably perpetuates. This hegemonic discourse does not simply delineate geography, for example Europe as the ‘most attractive optional exile,’ but structures the concept of freedom within the parameters of possession and property – an ownership of freedom that appears politically and manifests itself as geographically bound, while simultaneously it is something to be exported and something that can be found in some place else; in the politics of ownership, this neo-colonial discourse of freedom does not perceive it as something to struggle, not a process, and not something that for example, the Syrians can themselves *make*.

Manal’s self-inflicted martyrdom, on the other hand, is not a passive adherence to parental and social authorities through the embodiment of the traditional concept of spinster (*‘ānissa*), but the situational re-appropriation of this concept in order to maintain her financial independence, her familial networks and her lover, albeit in a precarious balance. Nevertheless, as a diagnostic, this resistance strategy does point out the resilience of the dominant power structures within Syria, resisting but also accommodating them. Both the cases of Anna and Manal, illustrate the complex ways that desires become discourses of resistance, showing the struggles that Syrian youth often face, and the challenges and opportunities they consciously leave untaken in undermining their socio-political milieu.

An accommodation of a different kind takes place in Tawfiq’s narratives and practices. Adopting the seemingly fixed categories of being Druze and gay in a way that is both situational and not mutually exclusive, Tawfiq challenges the gendered

stereotypes of both local Druze and the 'gay' hegemonic discourses. His is an instance of gender performativity (Butler 1990), an instance not only of:

... alternative sexualities, but primarily about alternative *textualities* – that is, about conflicting readings of existing cultural texts, and about the reflexive capacity of the social actor 'to use a particular cultural text to produce a specific orientation towards a given ideology' (Moore 1986: 97) in an inconsistent manner. ... Through contradictory and intertextual performances the subjects [...] institute a rift between their own readings and the readings of others, as well as within their own readings... they resignify performative stereotypes effecting the production of multiple (and conflicting) texts that interact within a seemingly single performance. (Kirtsoglou 2004: 37)

By performing multiple textualities, Tawfiq challenges the rigidity of those power relations that construct the categories of 'Druze' and 'gay' as separate entities. At the same time, however, these categories are re-produced as separate and strengthened in Tawfiq's practice of closure. However, at the same time that gender emerges as situational and performative, homosexuality or being 'gay' in Tawfiq's parlance and practice points to his resistance against normative forms of authority (such as sectarian/communal identities and obligations) but also, much like in Anna's strategy, to the hegemony of a global discourse which categorises, constructs and 'consumes' sexualities permeating its own exploitative structuring structures.

Of revolutions and conclusions or, Sham's youth and the life of politics

If the step were not being taken, if the stumbling-forward ache were not alive, the bombs would not fall, the throats would not be cut. Fear the time when the bombs stop falling while the bombers live – for every bomb is proof that the spirit has not died. And fear the time when the strikes stop while the great owners live – for every little beaten strike is proof that the step is being taken. And this you can know – fear the time when Mansel will not suffer and die for a concept, for this one quality is the foundation of Mansel, and this one quality is man, distinctive in the universe. (Steinbeck 2000: 156–157)

So, is the Syrian regime safe from its youth's rage?

Throughout this chapter I have looked at examples of, mainly Damascene, Syrian youth's aspirations, the challenges they face, the inventiveness and multiple forms of resistance they employ. These include the embodiment of politics through performing and thus re-forming identities and histories in Singing Jowlan, the

economically inventive and socially ingenious social structure of the *jama'iya*, and the challenges embedded in love and in resistance that youths face. Since both the anthropology of Syria and that of Arab youth are scarcely a theme of academic endeavour, I have sketched a nuanced complex picture of what such an enterprise could entail, hopeful that it will inspire further debate and will contribute to future understandings. But this is not the time to play prophets of the future wearing our academic credentials like badges of honour. A year ago, no one, certainly no academic, would have foreseen or imagine history unfolding, tyrants trembling, or international hypocrisy parodied, under the will of Arab peoples – the unlikely revolutionaries turned into exemplary beasts of democracy, using the most etymological meaning of the word, despite all the years of imperialist propaganda and local suffocation they suffered. I am an anthropologist not a prophet, and I am sure that whatever happens, Syrians including Syrian youth, will always surprise and impress me.

As a last note, I also wish to relate my findings comparatively to what is going on now in the Middle East, to the revolutionary tide that has swept Tunisia, Egypt, and now Libya, Yemen, and Bahrain, tomorrow maybe Jordan. In 'A veiled tango' Syrian economist Samir Aita depicted, back in 2008, a vivid political conversation between a company of Damascene youth, noting:

Syria's young – under-employed and politically frustrated – are hoping for some more immediate, modest change. What they want is to work and live, here or elsewhere, be free to talk about politics, economy and society – and to dance. [...] They're quite a sight, these apparently carefree young Syrians dancing. They must have spent hours practising. Girls in jeans and shirts, with a headscarf covering their hair, dance a tango with boys. (They've only started wearing the hijab in the past two years.) Now and then the mood is lighter, with a salsa or a rumba. [...] Young Syrians don't dream of great political changes, let alone of revolution. Just of being able to talk politics. They just want the DJ to play that tango again so they can dance. Even with their heads covered. (Aita 2008)

Today, the Syrian regime is often at the bitter end of criticism regarding political freedoms, such as freedom of expression and human rights abuses. Putting aside for a moment the real effects of regime domination (manifested in tortures, imprisonments and brutal killings), the rhetorical parlance regarding 'human rights' and 'freedom of expression' has been colonised and invested with hegemonic meaning throughout the course of the 20th century in numerous neo-colonial

projects. As Falk (2011) notes, 'these ideas, to a large extent [were] nurtured in the hothouse of Western consciousness and then innocently exported as a sign of good will, like "nationalism" a century earlier.' But nothing is innocent in international politics and these ideas were co-opted not only to disguise subtler forms of post-colonial domination but also to justify the necessity of capitalist patronage in contexts which freedoms, rights and democracy become commodities to be exported and imported based on global market demands. In the case of Syria, the paradox of selling and buying rights, freedoms and democracy reached its climax during the years of the Bush administration, where the USA actively sought a regime change in Syria by overtly or covertly funding oppositional movements, usually based outside of Syria. US plans did not work out. Actually, they had the opposite effect: discrediting certain opposition forces as well as, to some extent, the legitimate demands for change or reform.

At the start of 2011, commentators rushed to say that Syria is unlikely to experience the uprising it did. One of the most frequent causations is that the regime is so oppressive that 'civil society' cannot exist in Syria. Of course in neo-liberal parlance this concept myopically translates into NGOs, charitable organizations, human rights groups, and not necessarily political parties, even less, this concept is ethnocentrically blind when it comes to indigenous forms of organisation that occupy the space between state and household. As a concept genealogically related to Enlightenment ideas of rationality and citizenship, state and subject, and the social institutions that help in negotiating this relationship but without questioning it, the concept of civil society rests on the presumption of the *de facto* relations that constitute state and subject as well as reinforces the status quo through apolitical, fragmented participation of a mediatory nature. Furthermore, the concept of civil society, in both describing and theorizing the practice of good citizenship, is used as both a political *theory* and a political *method* of 'measuring' 'democratic participation'. This is highly problematic because theory and method, being tautological, only serve to reinforce their common assumptions, revealing a circular infallible logic.

Even if we were to consent to some sort of usefulness in the term civil society as defining the broad in-between space between state and household, then it would be very biased, if not indeed Orientalist, to legitimise certain expressions of civil society,

such as institutionalised, bureaucratic NGOs, in favour of indigenous forms of social and communal organisations, such as the *jama'iya*. For social networks are not a phenomenon of a liberal 'West', wherever that might be, but an emergent result of human interaction, something so necessary that it actually creates sociality. It is simply unfounded the belief that civil society is an epiphenomenon of modernity existing only within the realm of liberal capitalism and its greater or lesser patrons and clients (Layton 2006). Power elites, religious authorities, communal committees, cooperatives, unions, and neighbourhood and kinship ties: all these are spaces where individuals come together not only as individuals but as aggregates of social action occupying, connecting, reinforcing or challenging the space between state and individual subjects (see Eickelman and Piscatori 2004). Furthermore, such narratives regarding the 'lack' of civil society in Syria not only underestimate its people, but deny them the mere ability to have and exercise any kind of agency (cf. Sahlins 1999). The ethnographic examples here point in the opposite direction.

The ethnographic examples in this chapter clearly demonstrate that Syrian youths have the agency and the power to challenge, change or reinforce the context of their lives, the contexts of their freedoms and dominations. Is the Syrian state safe from their rage? This is not my answer to give. But what I can say is that neither the state nor the neo-colonial global capitalism can ever be safe in front of the youth and in front of its rage. Need and capacity for change exist, in Syria as everywhere else. And change takes place everyday. In the final analysis, only the Syrians can shape when and how their desires will be manifested. Nevertheless, a cautionary mark is necessary: although the Arab 'youth' should definitely be further explored and debated, this should happen in relation to broader social, political and economic contexts. Furthermore, in terms of revolutions, although in recent contexts the youth may embody narratives of systemic failure, it would be uncritical to presuppose that such narratives are only emblematic of youth.

Finally, irrespective of whatever resistance strategy the youth choose, even irrespective of its results, revolutionary action and thought, much like a person always constituted by its relations, are fundamentally forged by the sweat of labour, but always on the street. As shown, resistance may not always have liberating

implications. Nevertheless, no type of resistance and no type of rebellion or revolution is ever futile, irrespectively of what the 'next day' brings.

Chapter Eight

On the nuptial limits of Empires or, an Arab dance last spring

I view art as a system of action, intended to change the world rather than encode symbolic propositions about it. (Gell 1998: 6)

Methodological reflections on art and anthropology

The work of an artist is parental: she creates, grooms and on stage, lets her work free to fly away, to change, sometimes in both meaning and in form. The work of an anthropologist is promiscuous: flirting with, and clashing between an unattainable cultural difference and cultural sameness, she is always already trying to translate something that does not belong to her but which in the end may provide the seeds for her own artistic creation. For, the act of writing, like any art, is always performative and creative inasmuch as it is always somewhat farcical. It is creative because it translates and interprets across different stages, and it is slightly farcical because translation and interpretation are the sisters of another phantom practice, that of resemblance. Across her subjective bias, the anthropologist tries simultaneously to touch the art and its reception. Standing with one foot on the stage and the other in the amphitheatre, she transforms the inherent imbalance of the awkward position into a coherent phantom, which defers its meaning through writing.

This farce, resemblance, or attempt to relate and to make sense is not unique to anthropologists, it runs through artists and audience. Only the result is somewhat different in form: the anthropologist has run in and out of the performance, in and out of the audience, in an out of herself, in her attempt to describe that cognitive journey with words. The result is unique, but it also bears great responsibility for all involved.

In this chapter, I have excused myself to enter into different realms, and I have tried to make them look alike: I have excused myself into Syrian homes and politics, as I have inserted myself into dance theatre rehearsals and performances, and I have been very promiscuous, for my own political and social reasons as well as my own subjective situationality (Emery 2010: 49, 74–88), in mixing all of these together, and

embroiling them into my own understanding. In this chapter, I take an artistic creation, a dance, and I take everyday things from my time in Syria and I connect them, taking liberties with both. And so, art becomes my ethnographic site and everyday life on the streets and neighbourhoods of Damascus becomes art.

There are always slight discrepancies in the making, resemblance and interpretation / translation of art into written word, into politics. This discrepancy is constitutive of art as well as of writing. Neither art nor writing can ever turn into the other. Thankfully, there are always things that elude resemblances, and it is this deferral that makes creating and living promiscuous but not prostitution: it is the awareness of all the things that elude us that can make the art of dance and writing liberating.

An Arab dance

In October 2009, the Syrian movement theatre troupe Leish performed *Alf Mabrouk* (Congratulations! 2009) inside the basement of Damascus Citadel in Syria. *Alf Mabrouk* is a site-specific performance, in which the audience actively participates through following the performers into different rooms and spaces. The troupe toured in Syrian cities and in Amsterdam, Holland, for the duration of a year. Leish is the first, among very few, movement theatre troupes operating in Syria. Described as a ‘rare’ (Al-Khodor 2010) breathtaking and a ‘must-see’ performance (Atassi 2009), a ‘rebellious cry in an oppressive society’ (Houli 2010), the performance has received far-reaching appraisals from both within as well as outside of Syria.¹³⁴

The performance explores the complex milieu of multiple, and often contradictory, Syrian and Arab identities in religious ceremonies and contemporary practices through a performative ritual marriage that intersubjectively involves performers and audience alike in a contemporary ritual play of engendered subjectivities, intimate desires and violent deprecations. The performance explores the fragmented and contested ritual nuptial body as an opportunity for engaging with contemporary debates and conflicts, but also as the site *par excellence* of such struggles. The theme of the performance is not marriage itself, however, but rather what goes on before

¹³⁴ See for example, Lebanese newspaper Al-Akhbar, Kan’an 2010; comments from French and German Ambassadors in Damascus in SANA 2009. All press releases regarding Leish’s performances have been kindly provided in English translations from the troupe’s archive.

marriage: the ‘taboo’ of premarital relations. The performance offers a lens through which to trace Imperial movements, gendered contours and ritual body struggles contextualised within, and juxtaposed against, the broader socio-cultural, historical and political landscape of contemporary Syria. *Alf Mabrouk* uses ritual and gendered relations as opportunities or excuses to go beyond them, exposing angles that affect interpersonal relations, especially the conflict between personal desire and social obligation, an axis inscribed onto the nuptial body and extensions of the continuum of intimacy and violence – themselves metaphors for different kinds of power struggles in which the Arab Syrian body delves in the 21st century.

Why not?

Leish in Arabic means ‘why,’ and through experiments with theatre, contemporary dance, academic research and ritual practice, Leish troupe ponders: ‘why not?’ (*leish la*). Established in 1999 by Noura Murad, its current artistic director, the troupe is an interdisciplinary group of artists and intellectuals working within the realm of contemporary movement theatre (Kostrz 2008), who aim to address and challenge theatrical and everyday conventions.

Noura Murad, the founder, artistic director and performer in Leish, comes from a well-known Damascene Muslim family. Her parents were intellectuals: her mother a film-maker, her father a film-critic and a journalist. Noura was born in Russia in 1972, where she spent the first 8 years of her life, while her parents were studying there. She completed her school studies in Damascus and finished the Damascus High Institute of Dramatic Arts. As an actress she has worked in numerous Syrian theatrical plays as well as television and radio productions. Between 1998–1999, she studied in France, in Theatre du Mouvement Company (Kostrz 2008). There, she was influenced by the theatrical method of ‘autoportrait’. She returned to Syria at the end of 1999 and taught at the High Institute of Dramatic Arts until 2003.

Licensed through the Artists’ Union, Leish is one of the very few independent troupes in Syria, independent in the sense of not being a recipient of public funding or working within the ‘conventional producing rules in the Directorate of Theatre and Music’ (Ismael, 2010). Its work has been supported financially by: the Goethe Institute in Damascus; Dar Al Fikr; The Arab Fund for Arts and Culture (AFAC),

The Young Arab Theatre Fund (YATF), The French Cultural Centre in Damascus (CCF) and French Institute of the Middle East (IFPO). *Alf Mabrouk* was funded by French–German Elysse, Hivos, and Radio Arabesque.

The troupe operates within the remit of a broader intellectual coalition named the ‘Identities Project’ (2006–2016). The aim of the Identities Project is to [de]construct a vocabulary of Arab movements based on the religious attitudes and practices of the three religions of the Middle East (Islam, Christianity, Judaism) and specifically ‘...the influence of rituals in the formation of identity. Our approach is interdisciplinary: dancers, actors and musicians collectively study the various rituals in a series of workshops prior to the performance’ (interview with Murad, Wagner 2009).

Leish’s performances challenge and confront ritual practice vis-à-vis modern subjectivities, contesting ‘ritual order’ and by extension social assumptions and expectations, such as gender roles and ideas of community. Social conventions are brought to life through a series of tensions; tensions often depicted through subjectivities and their plight to confront, or adapt to, socially constructed norms and practices.¹³⁵ The troupe has authored a number of performances as well as making national and international appearances, winning the Best Scenography Award in Cairo International Festival for Experimental Theatre (2000). Or put differently, Leish troupe forces the audience ‘to find and see themselves in the details of our work... They know the funeral, they know the wedding and maybe they expect something and I always, always want to not [be] doing what they expect from me, and to shock them in a way’ (Interview with Murad, 11/9/09).

Focusing on the ritual of marriage, the body, and contemporary dance, *Congratulations!* is the second performance within the Identities Project, the first, *Once they die, they’ll realize* (2008) dealt with the theme of fear through the ritual of funeral,

¹³⁵ ‘...Through research and experimentation, our work aims to construct a Movement Theatre vocabulary particular to the current Arabic context by identifying the symbols we use to construct the sentences, paragraphs, and eventually the stories of our lives. Movement Theatre is a modern artistic form that uses the body and voice (not words), as the primary tools in storytelling. We collaborate with artists across disciplines, bringing dancers, singers, musicians, and actors together in our performances. Through a variety of creative methods, Leish’s work aims to dissolve the traditional boundary between observer and observed’ (brochure of Leish troupe, 2009).

while a third performance regarding the rituals of childbirth is currently being prepared.

Alf Mabrouk: Writing a performance

To what extent a movement theatre performance may be scripted, de-scripted, described and interpreted is a matter of great many debates (Cowan 1990; Gell 1998; Layton 1981). But I think that the same debates hold true with regards to all of our field notes (Clifford and Marcus 1986; States 1996). Below, I ethnographically describe and anthropologically interpret a performance that I have watched in different stages of its development (ranging from initial rehearsals to the final performance in 2011), and in different settings (inside Syria 2009–2010, in Holland during the group's participation in the Jullidance Festival 2010, and through a video recording of the first performance in Damascus Citadel during October 2009). The performance is structurally described based on the six scenes of which it is comprised. These descriptions however, are always already intersected through my gaze and subjective interpretations. Views and interpretations are further influenced by the performance's gender segregation of the audience: the audience is divided into male and female members, and thus my understandings are based on what I saw as part of the female audience.

Director: Noura Murad

Performers: Ramzik Gabrillian, Francois Peyer, Fayhaa' Abu Hamed, Noura Murad

Scenography: Bardu Bejan, Scenario: Radwan Taleb, Music: Shadi Ali

Scene 1

A female and a male usher, dressed in black jeans and white shirts, divide the audience into two segregated gendered groups, and lead their respective gendered groups into a small room. Sounds of breathing, of heartbeats permeate the room. This segregation will remain until the very last scene of the performance. One, two shadows appear on the stage that become four, and for a second they seem like knives. The shadows belong to four performers that enter the room in parallel same-gendered pairs: each pair is tied together with a white ribbon, all performers wear a long white veil covering their faces – the ribbons and veils are symbols of marriage.

At first they seem like they are walking in a marionette type fashion, then like dancing, then they remind me of horses galloping, their riders bearing spears or emblems of war. The movements are tense and coordinated, in a way that makes the gendered distinction appear superficial, or a mirror image, a reflection. Tension and coordination. Is this a dance? Is it a pantomime? Is it dabkeh? Is it something being born or something trying to stay alive? We, the audience, are perplexed. We feel the tension, and we are coordinated by the ushers and by our perceptions. Are we too close to the performers? The performers take four Damascene wooden in-laid plates filled with sugared almonds (*moulaabas*) and align themselves in the middle of the room, where the audience is offered the traditional wedding sweets and moves to the next room.

Scene 2

We are guided into a long, narrow and dark room – the last members of the audience almost forced in by the performers. The gender segregation of performers and audience is further reinforced by a long, white, but transparent curtain that divides the room into two halves. The performers are also divided and segregated by the curtain. The two female performers face the female audience. We can somewhat make out through faint silhouettes that the other side of the curtain is similarly arranged. The two couples engage in an exploratory game of both the person that is tied to them as well as the person that stands behind the curtain. The two female performers, almost diagonally arranged, start dancing with *almost* the same moves. Their steps are not as coordinated as in the previous scene as one of them seems to be lagging behind. Coordination becomes a symbol of difference, until the moves are extenuated so as to lead to a rupture, a virtual fight between the two performers. This rupture, embodied in the tensions of the binding and dividing rope, becomes a small war when one of each of the two opposite gendered performers try to see each other, they try to touch, they attempt to lift the veil, but the rope of their gendered couple ties them and holds them back. The curtain becomes a battlefield, or a sea. As they draw closer to each other, the performers, who are tied to them, try to hold them back,¹³⁶ attempting to spatially separate a union that has not even begun. The

¹³⁶ In order to maintain simplicity and clarity hereafter, but with no intention of essentialise the multiple roles that each performer embodies, the male and female performers who are restricting their same-gender pairs are mentioned as the ‘restrictors,’ while the male and female performers who are exploring each other behind the curtain are going to be described as the ‘explorers.’

exploration of the 'other' side, filled with curiosity and desire, becomes a battle, a battle of ribbons which exerts tensions and limits movement.

Scene 3

Four white transparent curtains make a box in the middle of the room. The audience is guided inside the box which has rectangular window-like apertures. Male and female audience concentrate on opposite sides of the box and look out of the apertures. We, the females, see the male performer, the one who was restricting his same-gender counterpart in the previous scene in our field of vision. The male audience gazes out to the female restrictor. These two performers now begin a solo auto-erotic dance. But it is no dance – they seem overtaken, in no way able to control their bodies and desires. His solo begins slowly, uncertainly. Shy almost, but tense. We suspect what he's doing... but can it be true, on stage (which is not really on stage as we feel like we are peeping from our windows into a 'private' space...)? As their moves become tenser, the audience continues, albeit reluctantly, to peep out. The performers finish and retreat.

Scene 4

The audience moves out of the box and into the space of the previous performance. And we come to occupy their space... As if the roles have been reversed, as if their 'private' has become our 'public'. Again, it feels strange to go into the same space that just moments ago... It feels... shameful, unclean... And somehow, voyeuristic. Yet, being outside the curtain box feels, strangely, liberating. We have to peep in through the windows again, but this time maybe it feels more 'normal', maybe because we're looking in rather than out, maybe because we got used to it. The performers that had initiated the exploration of one another in scene two (male and female), enter the box tied together with a long white ribbon. Inside the box, there is an area on the floor bounded by another white rope. The two performers start a duet dance within the boundaries of this space, occasionally allying the floor boundaries. They begin, slowly and shyly at the start, an oriental dance: characteristic 'oriental' movements of the shoulders and breasts, shimmies and weaves of the torso and the hips. The female's dance is coy and feminine, sometimes childish, sometimes not so, and the male performer follows her lead, dancing with the same innocent desire. Their dance somehow combines innocence with seduction, inhibition with passion.

They touch each other, whirl around, and kiss. Their bodies seem less tense now, but somehow I sense that the audience is tense. We suspect something is wrong. As the couple dance, the two other performers enter the box. They all start a ‘rope game’ (*la‘ab al-kbeyt*), a game played by children in the neighbourhoods of Damascus, a game of infinite convolutions. The lovers are ensnared within the rope webs, being in and out of them, and moving along to their almost mechanical waves. We move to the next room.

Scene 5

This room is very big. There is a familiar curtain cutting it in half. The female audience moves to the right side of the curtain, the male to the left. Next to the curtain on either side there is a big metallic tray (*ṣaniya*) on the floor. The tray is filled with white rice. In front of the tray there is a smaller metallic bowl. The setting looks like a *ḥammām* – a bath. The tray, the rice, the bath – all these things constitute the iconography of marriage.

There, the male and female restrictors await their counterparts (the ones engaged in the sexual/childish game of the previous scene) while thumping a stone against the ground – thumping that is accompanied by the contorting bodies of their pairs. The scene is choreographed with the female ‘restrictor’ sitting on her knees at the back of the room while the female ‘explorer’ stays at the front (the same arrangement is visible on the other side, where the two male performers are similarly arranged). Sudden, strong and powerful thumping is echoed across the room, and produces a frightening call. Female and male ‘lovers’ shake with every hit, as if they feel it as a whip on their bodies. They seem in pain, struggling for air, their faces both confused and guilty. As their bodies move and tremble to the sounds of pounding, almost unwillingly they are moving closer and closer to face the source of the sound. With her final pounding, the female restrictor stands up from the floor and moves closer to the female ‘explorer,’ who stands slouched next to her facing the audience. The ‘restrictor’ pokes slowly and violently at the ‘explorer,’ inspecting and punishing, with an amazingly expressive face of ruthlessness, powerfulness, and yet somehow an empathy, as if she’s telling her pair ‘I told you not to. Now we have to be punished.’ She shakes and trembles, submitting to the rite of punishment: her head falls and the ‘restrictor,’ almost detached picks it up. The couple face each other and fall, through

a mutually accepted and submitted duet, in each other's arms, attempts to reconnect or to regain their balance. The 'restrictor' leads her pair into the large metallic plate, and, using the smaller bowl, pours white rice instead of water on her head, which is bent over the 'explorer's' body. Then, the 'explorer' washes herself, in the same slow and painful manner before taking the 'restrictor's' hand and using it to clean/scrub her face as she steps out of the bath. The 'explorer' wipes the hand with a white handkerchief and they both get out of the bath almost in tears. They dance, intensely, coordinated, with their hands inflicting hits on the wall, the floor, and the other's hand. They are in pain; their hands cover their mouths. Male and female 'explorers' face the curtain but not each other. The female 'restrictor' brings a veil, and carefully she dresses her same-gender pair with it, and she wears her own. Then she brings the ropes and ties one to her pair and to herself. Male and female 'restrictors' slide open the curtains. Male and female 'explorers' start moving in the same steps as in scene 1, and they tie another ribbon to the extended fists of their same-gender partners. Moving along the swirling step, they form a quadrant with the two 'lovers' in the front, and their 'restrictors' directly behind them. In coordination they move on to the next room.

Scene 6

The four performers make a large circle that is bounded by the ropes on their wrists, the audience is led inside the circle, for the first and last time in a non-segregated fashion. The music begins with a slow tune played by an *ud*. The performers start to move first their shoulders, then to extend their arms, and their legs, then to turn around with extenuated torso movements. Emphasis shifts to the head, legs and feet, and with a bang of the foot against the floor, a dabkeh that had been deconstructed starts to re-form. The music runs faster and faster and so do the movements of the performers, who move around the circle, engulfing the audience. The dabkeh is coordinated, implementing every part of the body, and at times stifling. Does it represent a vicious circle? The audience now is centre-stage. As the music and the dance run faster and faster, movements become less and less tense. Can the dance be liberating, then? As the performers dance and jump around the audience, almost inconsequentially they drop their ropes, letting the audience inside the circle, and they, just leave... Job done.

Analysis: An Arab dance last spring

In the contexts of Syria's heterogeneous ethnic and religious matrix, contexts that translate nuptiality into the ritual and everyday practices of procrustean social bodies (chapter 5), as well as into the legitimising rhetoric of the state of empire (chapter 6), *Alf Mabrouk* invites the problematic of nuptiality, intimacy and violence onto the public, political stage. The performance becomes particularly pertinent to the recent popular uprisings and revolutions in the Arab World, in Tunisia, Egypt, Bahrain, Yemen and Syria. These uprisings have been named as the 'Arab Spring' or the 'Arab Awakening,' terms or misnomers that envisage Arab society and polity as having been in a 'limbo' all those years before, and mystically finally woken up. The ethnography of *Alf Mabrouk*, interpenetrated by the art of everyday life in a Damascene neighbourhood, demonstrate that 'springs' do not come all that suddenly. Furthermore, as the anthropological analysis of a dance performance will go on, current events, uninvited, merge it seems into a dance that had started long ago. The blood that runs on the streets and fields of Syria, inasmuch as the dance performance itself, push and pose this question: at a moment when people are dying on the ground, how can a dance performance, and by extension arts and the 'body,' be understood in terms less abstract and maybe more culturally and pragmatically sensitive to the situation on the ground? In this respect, *Alf Mabrouk* is a good example of the forces that compete over the control of both bodies and minds.

What follows provides an ethnographically grounded political analysis of the performance, an analysis that traces the political contours of power and powers as they run in the dance and as they relate to local Syrian politics. I argue that nuptial bodies become the embattled territory over which struggles between different powers occur. These conflicting power regimes include the local ethno-religious communities, the Syrian state-of-empire, but also the European Union and particular European states that battle over structuring and funding their own imperial and imperialistic goals through artistic appropriations of the nuptial body. In order to disentangle the multiple struggles of/for bodies, the analysis of *Alf Mabrouk* is structured into five processual analytical 'dance steps,' which aid and substantiate the argument of how nuptial bodies both construct power struggles as well as become their limits.

The first step deconstructs what is perhaps the most evidently problematic theme of the performance, gender, a theme widely covered in Middle Eastern studies. In deconstructing gendered relations as aspects of the social geography, the second step asks what kind of subjectivities we may discover in the performance. Step three, following the discussion of subjectivities, asks how these may or may not become the subjects of power, and thus explores the multiple power struggles on the nuptial bodies, such as the struggles between the EU's cultural imperialism and the Syrian state's nuptial-based cosmopolitanism. However, as these two different hegemonies are structured on and around nuptial bodies, step four explores the ways that the nuptial bodies simultaneously elude both clear classifications as well as absolute forms of domination, whilst in turn directly question the limits of the power of Empires. Step five provides an alternative practice of intimacy in relation to contested nuptial bodies. The chapter concludes with illustrations from creative relational local understandings and nuptial extensions that instead of being procrustean become liberating.

Step 1: Gender as social geography

'Gender' structures the performance thematically even before it starts, as the ushers segregate the audience into male and female groups, dividing up couples and mixed companies that have come together to the performance. This creates an initial uneasiness, as people are forced to not only become part of the performance, but to join a group of same-gendered strangers.

NM: This separation between men and women ... it forces the audience to meet each other after the performance and talk about it... Last year, for example, (*laughs*) the men audience tried to, like, be in...

MK: Sneak into [the performance]?

NM: Yeah, yeah – because they were very angry, like “why can't we see what's happening in the other side?” And for me it was great! Because in life they never, never asked this question: *why* are we separated? It's just because it is like this, it's just because it's the religion... it's the ritual. (10/9/2009)

If ritual 'order' and ritual practice (Bell 1992; Bloch 1986) appear as the unchanging and unchallengeable pieces of a social or religious 'order,' transplanting their social structures of gender segregation onto a conventionally non-segregated stage (the theatre) lays open the structural foundations of both ritual and theatre. At the same time, this juxtaposition of familiar processes but out of context induces a strange

familiarity, an existential angst of the uncanny, not-being-at-home (Heidegger 1985: 233): 'it is like saying to the audience: You are spelt in these rituals; you are part of them' (Jamous 2009). This experience aims to confuse and question the grammar of the moral order, and it is not always welcome:

The males saw their specified performance and the females saw their own. Only the angels roaming in the place and Noura Murad herself could see the whole performance...In every moment of the performance, we were not able – neither morally nor artistically – to interpret that as a director's viewpoint of a certain sex, because of one reason: we could not watch the other side of the performance!!! (Mohammad 2009)

In addressing the moral and artistic use of gender segregation imposed upon the audience, Mohammad condemns the spatial separation of the performance on the grounds of a visual bias that seeks to find the 'whole picture.' This idea, namely that a visual, panopticon-like view, holds some sort of objective truth is in its turn an effect of the visualist bias as well as the commoditisation of vision into a spectacle to be consumed (Dedord 2005 [1977]). Not only is *Alf Mabrouk* a site-specific performance that forces the audience to walk along rooms, corridors and curtains, it also creates an experience through the modern adaptation of musical wedding elements, the smells of *gar* and *misk*, and the bitter-sweet taste of *moulabas*, all of which tantalise and contribute to a sensual experience of the performance.

Even visually, it was not a 'half' performance, as silhouettes of the other side *could* be seen, and *could* be sensed, through fragmented apertures and transparent curtains, out of which, the constructed gender segregation of the audience at the start of the performance was, step by step, deconstructed throughout the play. Let me explain.

The opposite couples engage in an exploratory game, an exploration of both the person that is tied to them as well as the person that stands opposite to them, on the other side of the stage. The two opposing couples dance through opposite but complementary movements, while the performers who stand in opposition to each other attempt to draw closer to discover the performer who lies behind the veil, on the opposite side of the stage. As man and woman from the opposite groups draw closer to each other, the two restrictors try to hold them back, an attempt to distance the male and female explorers, an attempt to spatially separate a union that has not

yet been achieved. The exploration of the 'other' side, initially out of a naïve curiosity, becomes a battle, a battle of ribbons which exerts tensions and limits movement. Interestingly, although the relationship between the two 'gendered' groups is characterised by a desire of mutual exploration, the relation between the same-gender performers is characterised by an intimate restriction. The symbol of this restriction is the ribbon which ties the two performers together and which performatively describes the conflict in-between them.

The first two scenes of the performance establish the context of the conflict: contexts and conflicts that are embodied in ropes and tensions throughout the performance. These include the construction and negotiation of social, individual and gendered subjectivities. 'Self' is constructed on the basis of gendered groups whose relationship with each other is one of mystification and exploration. Although there is an obvious gender-divide, the performance moves beyond gender in the way that the movements of both genders develop fairly similarly, like mirror images across the rooms and the transparent curtains, pointing out that such a gender divide exists insofar as there is a distance to separate and something to obscure vision. In this way 'fixed' gender roles are questioned, while the two opposing performers become intrinsically connected through their common desire to explore each other.

NM: The feminine–masculine issue is that everybody wants to be with the other but... I don't want to say that women are, like, have a worse condition than men – No. Everybody is in the same condition. Everybody has the same pressure: the other side is unknown...
(10/9/2009)

Gender, thus, becomes an aspect of social geography rather than an inherent identity. The use of space in the performance underlines that masculinities and femininities are historically, socially, and intersubjectively constructed and performative since difference is located on the perceived 'unknown' otherness – rather than something natural or essential – as an idiom of power relationships rather than as something fixed and eternal. This builds and extends on the performative aspects of gendered social geography as established through nuptial intimacy in wedding rituals (see chapter 5). Between each of the two same gender performers, gender relations as an idiom of power relationships in general are clearly expressed:

Congratulations! spotlights woman's suppression against a woman, and

man's against man within the frame of rebelling against customs, conventions and social types. There also is a focus on the paradox of single personality of a man or a woman. This rebellion, as Murad clarifies, is not genuine, but is a sort of submission to the society's want of stereotyping man-woman's relationship. This rebellion contains a lot of fear and expectation of society's reaction towards the rebellion that eventually gives up to purification, customs and conventions (SANA 2010).

Throughout the performance, between the same gendered couples there develops an almost homoerotic dependency, sometimes expressed through binding ropes that restrict, such as in scene 2, and at other times it is expressed by the pain of return to one's intimate, familiar and protective but nevertheless tormenting cell (as in scene 5).

Of course, much has been written regarding gender and gendered relations in the Arab Middle East (Abu-Lughod 2002; Mahmood 2001; Lindinsfarne 2002). But what the performance is successful in doing is using the Syrian nuptial ritual practices such as those of 'bringing the bride,' or the day of *ḥammām* (see chapter 5), in a general form but from the intimate 'within' of the Syrian polity and through transforming these familiar practices. Gender, thus, forms the fluid contexts in which contingent power relations take place, and performers' bodies are tactically de-gendered simultaneously with the gendering of the physical space: in a way, 'gender' moves out of the bodies of the dancers and into the ropes and the curtains. This sexualisation of place is a result rather than a cause of social geography which itself is symptomatic of the practices of relating, the relationality within contexts of social hierarchies. And this is how the bodies of the performers may be said semantically to *not* be about gender.

Step 2: Multiple tensions and tense multiplicities

But if the performance is not about gender, then what is it about?

NM: The first thing that you will see is the shadows of the performers on the ground [...] we're looking for an image to have two bodies in one. (10/9/2009).

These multiplying shadows establish the contexts of shifting modes of relating, the multiple relations that interpenetrate the performers as individuals and as a group.

We see one, two, then four shadows in scene one, then duets dancing in the second scene, while in scene three we peep out to a solo dance. In scene four we see them all quadrupled and entangled in a web of ropes. In this way, multiple relations are constructed performatively and intersubjectively between performers and the ‘tight places’¹³⁷ in which they move, underlining not only the fluidity of identities and identifications, but exploring through their tense and multiple dances the possibilities of becoming (Manning 2007; Deleuze and Guattari 2005 [1987]). The body, as the site *par excellence* of *becoming*, is constructed through the multiple tense positions and relational possibilities that it occupies throughout the performance:

NM: The Arabic body is tense in general. When your mind follows only orders and does not question anything, this is reflected on your body... Religious-social traditions have a lot of power, and you don’t question anything... The body is a corner, a hidden part of us – but the body expresses your feelings. The body cannot lie. [...] Tense because you don’t know what’s happening – as a machine according to your tradition. Not relaxed or free. In all my performances the body is tense. (13/7/2010)

In the above quote Noura’s singularised ‘Arabic’ body is a practical essentialisation (Herzfeld 2005: 26–33). If, however, words such as ‘religion’ and ‘tradition’ are taken to mean contingent socio-political understanding and practices, the potentialities of bodies used on a specific time-place scale, then the tension of bodies may be understood more appropriately as being the result of – and at the same time the site of – struggles. Hence, tension is both the result as well as the effect of the body as a site of struggles. The intensity of, inasmuch as the multiplicity in form, inform the struggling subjectivities of the performance.

Step 3: The nuptial body as site for and subject of struggles

In the previous section we explored the multiple and tense ways that the ‘subject’ and/or ‘subjectivities’ were formed and performed. The post-structuralist emphasis on subjectivities, however, is often criticised as so relativistic that power relations lose their significance and force. In order to address such criticisms we need look at the subject of power, or as Foucault put it, the subject and power (1982). This means considering power-resistance as two sides of the same coin, in which resistance

¹³⁷ NM: Not only because it gives us different spaces to work with, but [we chose] ‘tight’ places, like all your choices in everyday life: limited and small. (13/7/2010)

forms and informs a diagnostic of power (Abu-Lughod 1990; chapter 7). In the performance this diagnostic translates into tensions: tensions of the binding and unbinding ropes. But this leads to a relevant question: whose subject? Or, what struggles are Syrian bodies parts of?

In order to provide an answer we must locate, construct and deconstruct the ‘Arab body’ as a subject of power, contextualised within the performance as well as in the broader socio-political and economic milieu of contemporary Syria. As a site of tensions and struggles, we must trace the different directions that the ropes take. In order to do this, we shall take three side-steps, so as to follow three of the different powers that exert pressures.

Side-step 3.1: Funding the dance, investing in the body

Leish is not unique in that it receives funding almost exclusively from European resources and cultural exchange programs: ‘there are no Syrian local independent sponsors, only local partners who organise events (festivals, venues, etc.). Actually, foreign culture centres, like the French, are considered ‘local’ partners, because they are based in Damascus’ (Noura Murad, 13/7/10). The limited economic support from Syrian government or the absence of local Syrian sponsors is a recurrent difficulty for Syrian dancers and choreographers because this economic situation often forces them to either work within the already well-established dance theatre companies, such as Enana and Ornina, or to seek out external funding.

For much of the past decade, the main problem between Syrian dancers and external sponsors was one of foreign policy: the international political isolation of Syria made the investment climate in the arts unfavourable. However, this political and economic climate was changing by the time I started my fieldwork. 2008 was the year that Syria’s developing friendship with Turkey (see Lawson 2010) was cemented through the latter’s intermediary role in unofficial breakthrough negotiations between Syria and Israel, while in the same year Syria’s political isolation from Europe was broken when President Sarkozy visited Syria and President Al-Assad visited France. In April 2009, for the first time Damascus was part of the ‘Platform for Contemporary Dance in the Middle East,’ a European-funded programme that in association with local partners in Jordan, Lebanon and Palestine aims to bring a

week-long contemporary dance performance and workshops from the European dance scene to the Middle East. The Damascus part of the performance was organised through the meticulous efforts of Mais Seifan (personal interview, 16/6/09), a Syrian Germany-trained dancer and choreographer.

External funding, as any funding, does not come free of conditions. It might induce the aura of an outdated fashion to say, in Marxist terms, that economic power dialectically relates to social and political power, but as long as power ‘invests’ the body (Foucault 2006 [1977]: 353) it would be at best naïve to believe that public festivals and arts occur and are funded in terms of ‘art for art’s sake’¹³⁸ outside of the social, political, economic and historical parameters of their existence. In practice, however, the interaction of European states, and the European Union as a political and economic superstructure, with their past Levantine colonies through arts exemplifies the contours of a powerful, both economic as well as politico-social, investment of cultural imperialism and neo-colonialism:

NM: ‘Gender’ is the only way to get money, to fund performances. In political terms, EU decides the subject and Arab choreographers and dancers talk about it! There are other conditions as well, it asks, for example, three different artists to be exchanged, that’s how we have Francois in the performance (and it wasn’t easy for him to ‘embody’ an Arab body). We also get technical support, the sound designer. Unfortunately external funding is the only opportunity to work without the government. (13/7/10)

Cultural exchange, of course, sounds like a good thing; one might even argue that policies such as these are the way forward for the reconciliation of difference between the social stereotypes of ‘East’ and ‘West.’ However, strategic essentialisms, like ‘identities’ (Butler 1990), are the *results* and not the causes of the differing value hierarchies (Herzfeld 2004), hierarchies that are the effects of unequal power relations that render hierarchies intelligible within global capitalism (Appadurai 2001; Said 1978; Mitchell 1990; Wallerstein 2004; see chapter 6). It is not illegitimate to ask why does the EU fund the ‘arts’ in Syria/Middle East, and specifically, why does it invite funding applications on specific topics such as ‘gender.’ As an answer, I quote *verbatim* from my conversation with Noura Murad directly after the end of her performance in Women’s Festival, Aleppo:

¹³⁸ Although this was argued by Diana Jodo-Hokan, German-born organiser of Women’s Festival in Aleppo, during a personal interview, 16/10/10.

NM: The festival is supposed to be about Arab Women and the organisers invited mostly European artists and only two Arabs. There are many reasons for this, one is that the European artists usually have external funding so the organisers don't have to pay for them. They put them in four-star hotels and they put us in two star ones. Their standards are completely different. There are artists in Syria and in the Arab world that asked them to invite them and they did not, they choose to use this to advance their own personal connections and networks. Yes, I know that the Arabs cannot easily see the Western art because they can't move freely outside the Arab world, but why don't you give local artists the chance to show and develop their art? They come here to lecture us, to teach us about gender. There are too many politics and economics in cultural exchange programs. Many times they bring to meetings an Ambassador to tell us what to do – I always have fights. (16/10/10)

Noura's reply echoes Said (1978: 7–8):

The scientist, the scholar, the missionary, the trader, or the soldier was in, or thought about, the Orient because he *could be there*, or could think about it, with very little resistance on the Orient's part. Under the general heading of knowledge of the Orient, and within the umbrella of Western hegemony over the Orient during the period from the end of the eighteenth century, there emerged a complex Orient suitable for study in the academy, for display in the museum, for reconstruction in the colonial office, for theoretical illustration in anthropological, biological, linguistic, racial, and historical theses about mankind and the universe, for instances of economic and sociological theories of development, revolution, cultural personality, national or religious character.

To Said's list of Orientalist practices, we should now add those bureaucratic organisations such as so-called civil society institutions (in the neo-liberal sense and not in the Gramscian definition), NGO's and developmental agencies, human rights groups and some activists – in short the new formations of imperialistic and hegemonic perpetuation, this time under the guises of universal and humanitarian 'gifts'.¹³⁹ Moreover, the constraints that are entailed in obtaining sponsorship from foreign funding are not unique to Leish. In her play *Yasmine's Home*, the director of Ashtar Theatre in Ramallah, Palestine, Iman Aoun, emphasises the problems and unequal relations of foreign funding for arts (Atallah 2011). Although cultural exchange programmes rhetorically stress 'dialogue' and co-operation, often the inequalities inherent in political and economic relations are far from equal.

¹³⁹ See Stirrat and Henkel (1997); for NGOs as state formations see Ali (1996, 2000) and Trouillot (2001: 132); for anthropological debates regarding universal human rights see Cowan et al. (2001).

In the works of Hardt and Negri (2001), Empire is formulated as the *new* phase of the international and historical tendencies of global capitalism in which traditional bounded territorial sovereignty, as in the ‘state,’ becomes obsolete.¹⁴⁰ This work provides some valuable and timely descriptions of the continuously shifting ‘sands’ of global capitalism. However, scepticism remains as to whether these ‘new’ imperial structures may not be as new as to comprise a wholly different phenomenon from that of imperialism. ‘Gender,’ for one, is one of the oldest and most frequently used avenues for the dissemination and structuring of bodies into disciplinary structures of governmentality. In *Colonising Egypt*, Mitchell (1991: 111–112) shows ‘gender’ or the ‘status of women’ to be one of the main concerns of the British colonial administrators. The ‘status of women’ not only creates a visible site for the realisation of a modern liberal subject, an individual, but is also a fertile ground for the exporting of a certain ‘morality,’ ‘equality,’ and ‘civilisation.’ Gender thus, already defined unequally, becomes the site of disciplinary technique (Mitchell 1991). This is how categories such as ‘women’ and ‘gender’ become absolute, fixed within the defining structures of a global capitalism. It is here that both women and gender become properly objectified as the imports of cultural imperialism and get invested into mechanical bodies of disciplinary reproduction. As disciplinary techniques shift and change according to historical, political, social and economic circumstances, the overt Orientalism of the colonial era has turned into cultural hegemony and imperialism. The colonial administrations may be gone, but neo-colonial structures such as Cultural Centres and policies of ‘dialogues’ remain in Syria, as elsewhere. These centres and policies not only set the parameters, the themes that local artists must include in their work (turning artistic creation into ‘homework’) but through their funds attempt to invest into even the most subversive of arts. If the performance of Leish may be said to be challenging the very stereotypes that it was financed to portray, then its transgressive nuptial bodies still, nevertheless, bear the trade mark of their funders – the bodies and their transgressions become commodified, carrying the financial and political mark of that which made the performance, at least economically, possible.

¹⁴⁰ For a good critique on why states are not becoming obsolete, see Harvey 2009. For an analysis of the ways the contemporary European Union resembles an Empire, see Zielonka 2007.

Side-step 3.2: Our Oriental selves: notes on auto-orientalism

Interestingly, although the relationship between the two ‘gendered’ groups is characterised by a desire of mutual exploration, the relation between the same-gender performers is characterised by an intimate restriction. The symbol of this restriction is the ribbon which ties the two performers together and which performatively describes the conflict in-between them. This tie, represents the relationship between individual and society: how an individual, following her or his personal desires, comes into conflict with socially prescribed rules and expectations – this is underlined by the theme of pre-marital heterosexual relations, and how such relations are considered inappropriate and shameful (*‘ayb*). The ribbon, thus, is indicative of the relationship, intimate but filled with pressures and tensions, between the individual and her/his society, between individual, personal desires and social obligations and rules.

NM: Each one of us, as Arabic people, we have two personalities: one of them wants to be free, wants to change; but the other... the other is very, very, very traditional. [...] The conflict is in each one of us. Man or woman. We have this like double personality that makes us suffer for real. [...] During the performance we’re trying to separate this double personality and trying to talk about this conflict, trying to talk about how sometimes I make my own rules, but I’m always not comfortable with these, because I have all the basic religious-social rules in me. (10/9/2009)

Since at the start of the performance we have one shadow of the body and only later this shadow separates into two, interconnected, bodies, the analysis can be taken one step further: the relationship between personal and public, or individual and society, is a tension that constructs and is inseparable from the ‘self.’ This means that both individual desires and social norms exist first and foremost within the ‘self.’ The tension of the rope, then, the conflict between the connected performers, is an *internal* struggle.

However, there is a slight problem in depicting a social phenomenon as an internal subjective struggle. The problem is that ‘self’ is constructed on the axis of individualism, the person becomes an atom enmeshed in particular contractual relationships with other individuals and the state, in which s/he acts individually, rationally, and bares individual responsibility. This conception of personhood, of

dyadic relationships, and of personal accountabilities is Kantian in origin (cf. Sahlins 1999), while in history and politics it is connected with a hegemonic practice of neo-colonial expansion through a European-bound modernity, and an essentialist rationality and a denial of relationality that allows performativity of multiple identities, divided and multiple personhoods (Mitchell 1991; Strathern 1990), and personhoods constructed through relationships. The performance underlines the tensions of a hegemonic, globalised, isolated body through the shadow play at the start, and the socialisation/consummation of dance at the very end.

At the same time, the theatrical space on which the performance takes place sets a number of different tensions regarding the social geography of gendered power relations onto Arab bodies, nuptially procrustean as they become the kin and the enlarged metaphors of bride and groom:

There is a psychological link between the theme of the performance which is the oriental wedding, and the denotations of the place which is a long, narrow basement in the ancient citadel of Damascus. The basement/prison summarizes the sought meaning: that the collective unconsciousness of Eastern societies (especially Arab ones) is still dwelling in the prison of these inherited rituals that turned into law characterized by force and obligations. This low [sic] of reality is being reproduced all along generations, never letting temptation to sneak out of its cage, for the holy body is the source of forbidden desires, so it was inevitable to impose a rigid censorship on such a sensual experience. (Jillo 2009)

Hinting at the highly sexualized although gendered segregated spaces, the above quote from the article ‘Cultural taboos in the basement of Eastern Unconsciousness,’ published by the widely-circulated state run *Tishreen* newspaper, figuratively describes a view commonly held by many of the journalists that wrote an appraisal for the performance, such as the condemnation of ‘backwardness and reactionary ideologies’ (Atassi 2009) and ‘the faultiness of culture’ (Ismael 2010). Setting aside the Jungian reference, these largely intellectual narratives constitute the ‘Arab body’ not only as a fixed identity/entity in space and time but also en-frame it within the (political) dichotomies of Orientalism (Said 1978): the Oriental vs. the Occidental, the Eastern/Arab vs. the Western/European, an oppressive heritage and ‘culture’¹⁴¹ vs. a ‘democratic’ modernity. These dichotomies, political as they are since they advance a

¹⁴¹ See chapter 6, for an analysis of ‘culture’ as used by the Syrian state as a politically unthreatening category.

specific political, economic and social view of the world, are the shared experiential nexus of many post-colonial settings.

Gender as a topic, and art as a method, feature dramatically in the internal debates and politics concerning Syrian ‘modernity:’ its re-appropriations, legitimacy, as well as who can and cannot be ascribed the term. For example, ‘gender’ narrowly defined as the ‘status of women’ has historically from the 19th century been portrayed as an objective measure of modernist progress (see Mitchell 1991); while art, for example music in Syria, concentrates the paradoxes of modernity, tradition and authenticity (see Shannon 2006). In Arab philosophy and liberal thought, Kassab (2010) describes the second half of the 20th century as expressed through the inward turn of thought, the seclusion, pessimism and extreme auto-leeching from the philosophical movements within the Arab world. Furthermore, historians such as Elisabeth Thompson (2000) and Keith Watenpaugh (2006) contextualise gender relations in Syria at the turn of the 20th century, along other social stratifications and power relations such as class, within the period of the ‘colonial contract’ (Watenpaugh 2006: 280) of the French Mandate, offering valuable insights on the interconnectedness and fragmentations of the experiences of colonialism, modernity and the development of bourgeoisie middle classes. During the colonial mandate and postcolonial independence the new socio-economic formations that had arisen in Syria sought to establish themselves economically as much as symbolically within the political milieu of Syria but also, through a metropolitan desire (Watenpaugh 2006; see chapter 7), sought to attain a global presence. Watenpaugh argues that the emerging Syrian bourgeoisie were not only the result of an economic modernity but in turn sought to be modern in being middle-class. This included a change of narrative and a change in praxis. Changing practices included the proclaimed gender equality as a social characteristic of a certain class in Syria, whose symbolism had both a local political resonance as well as partook in a globalised mode of ‘distinction’ (Bourdieu 1984) in terms of class embodiments and simultaneously the embodiment of neo or post colonial hegemony (Salamandra 2004).

Thus, when *Alf Mabrouk* establishes gendered relations as an aspect of social geography, it does not only comment upon unchanging traditions and ritual practices (which are never of course unchanged), but acts as an example upon which to locate

a *moral economy of the Arab body* as the historically constructed site on which a hegemonic neo-colonial modernity battles with locally gendered and classed antinomies. This is a battle over the inscription of a gendered Arab body-politic, and at the same time the subordination of Arab middle classes into the paradoxical, itself gendered, frame of the relationship:

The West's impulse to assert the universality of modernity exists simultaneously with the denial that the non-Westerner – no matter how successfully he or she incorporated into their lives the constituent elements of being modern – could ever be *really* modern. In this case, the multilingual and sartorially correct 'young Arab' is condemned, in perpetuity, to a hyphenated existence somewhere between a 'real' modernity and its exquisite shadow in the East. (Watenpaugh 2006: 307)

Thus, in gendering social geography, Syrian art critics and journalists, themselves parts of a classed intelligentsia (see Salamandra 2004), become the modern intellectual children of Orientalism (Said 1978), which by singularizing and condemning 'tradition' become themselves carriers of neo-colonialism. The classed internal appropriations of neo-colonialism as auto-exotisation (Savigliano 1995) and auto-Orientalisation point out the real difficulties in 'provincialising Europe' (Chakrabarty 2000) since 'Europe' is not really external but constitutive of local classed relations. Noura, whose early works had been particularly criticized for 'importing French culture,' replies:

NM: I have a very very religious aunt. I don't think that she really likes my work, but she's the only one of my relatives that will call me before or after a performance to ask how I am doing. She's honest. People who hide their desires, or do different things from what they say they do. That is how my work is most relevant to my personal background, the educated, intellectual urban elite. Other people don't have these pretensions. (13/7/10)

Side-step 3.3: A state-of-empire

The Syrian state also builds its own form of 'Empire' through the same 'tools' that *Alf Mabrouk* is built, namely ritual marriage and dance. In state-sponsored folklore festivals, the bodies of the dancers are not only inscribed with an authored tradition (and thus made singular and rigid, whilst tradition becomes static and politically unthreatening), but they establish a triangle between dancers-audience-state of intimate co-dependence (something like the relationship between same-gendered couples) because the state emerges not only as the 'facilitator' or 'guardian' of

tradition and of marriages (on and off stage, marriages of audience and state, or between audience and sanctified tradition), but also as the *precondition of any* marriage. This is a circular logic that reifies the state (chapter 6).

In *Alf Mabrouk*, direct references to the state are silent. This, however, is a loud silence. In a country where most public performances and spectacles make vocal praise to the president and the state (Wedeen 1999), *Alf Mabrouk's* insistent indifference is a clear political statement: 'We know that you exist but there is no place for you here. You are outside our bodies. You are outside.'

Of course, individual desires and constraints cannot be outside of the social and political contexts in which they exist – so, along with other powers, the state is present and battles over and with the bodies of its subjects. In the battle over the structures of the construction of subjectivities, *Alf Mabrouk* deconstructs and questions these struggles of domination in which both the hegemony of the state as well as the hegemony of neo-colonial discourse take place.

Step 4: Limits of empires

The nuptial ritual attests to the sanctioning of social reproduction through nuptial bodies. This reproduction is illustrated in the nuptial ceremony through the idolised bodies of the bride and groom that are extended and enlarged so as to incorporate the social body-politic onto the bodies of the wedding guests (see chapter 5). The guests in turn, re-make the social contexts of nuptiality, shifting the meanings from a union between two people to an intimate realisation of communal, classed, and ethno-religious sociality (see chapters 4 and 5). This practice of making intimacy social, intersubjective and embodied, the practice of making socially-extended nuptial bodies, has powerful political extensions when it reaches the public stages of folklore festivals organised by the Syrian state (chapter 6). The use of folkloric staged nuptials during the organised manifestations of the 'state,' recast the authoritarian regime as the popular and populist guardian of difference and as the precondition of peaceful heterogeneous co-existence in Syria. This in effect turns the state into an Empire through the use of a statist cosmopolitanism in reinforcing legitimacy. In these contexts the nuptial ritual transforms into enforced consent: the intimate ceremonies provide both the stuff of 'cultural intimacy' (Herzfeld 2005) as well as a geographic

intimacy: a closeness, proximity and touchability – a form of familiar materiality and practice which in turn reinforces the ‘state-effect’ (Mitchell 2006) and reifies the state as eternal, as the bearer of harmony, and as a very real necessity for co-existence.

Through *Alf Mabrouk*, two more powers come to the forefront in struggling for the possession of Arab/Syrian bodies and for the possession of nuptial intimacies that run through them and permeate the structures of everyday life. Firstly, we noted how the European Union as a political and economic body, but also European states individually through their cultural centres, acutely resemble an empire in the sense that their cultural policies and political funds perpetuate a neo-colonial hegemony through cultural imperialism. The EU’s cultural imperialism is exemplified in regards to the cultural exchange programs in the Middle East and resonate particularly powerfully in the logistics and performance of *Alf Mabrouk* since the performance was funded in order to promote a specific civilizing mission that renders ‘gender’ crystallised and which engenders local perceptions and practices as inevitably ‘lagging.’ Even as the performance challenges fixed perceptions of masculinities and femininities by allocating them as aspects of a relational social geography, the performance paradoxically cannot shake off its own ‘product placement’ tag as an advertising product of imperial socio-economics.

Secondly, we explored the ways that Leish’s performance has been received by local audiences as a commentary on the ‘backwardness’ and ‘imprisonment’ of the ‘Eastern consciousness.’ These responses were analysed as forms of hegemony, as the internalisation of a neo-colonial Orientalist narrative, and as forms of auto-exoticisation that are interpenetrated by a globalised ‘hierarchy of value’ (Herzfeld 2004). However, the processes of auto-exoticisation are complex and these internalised neo-colonial critiques are not only examples of the re-colonisation of the post-colony, but also relate to internal Syrian power struggles and modes of distinction and differentiation. Concomitantly, these critiques resonate globally as well as locally within the Syrian polity, they are the rhetorics of an intellectual middle class and relatively disenfranchised elite. They form the reappropriation of the intelligentsia’s class-struggle against both the state’s authoritarianism as well as the powers of communal sectarianism. This class-based commentary relegates the ‘body’ into the ‘backward’ waters of a hegemonic defined static tradition, whilst attempting

to the capture the ‘minds.’ However, as we have seen also in the case of Zahra’s parents (see chapters 1, 3, 5), this modernist liberal rhetoric against social and state conventions falls short when subversive nuptials threaten to touch and penetrate the bodies of their own sons and daughters.

The choreography of *Alf Mabrouk* exposes and plays with all these different forces that struggle over the possession of the nuptial body, the forces of society, the state of Empire, the imperialism of the EU, and the internal class dynamics. In the dance, the nuptial bodies of the performers become the crossroads of battles, sites of and for struggles (see chapters 4, 5, 6). If battles are structured against and on nuptial bodies, could we perhaps speculate who wins? In order to reply to this question let’s consider the last scene of the performance.

The performance ends dramatically with the dancers ironically celebrating through a dance of dabkeh a marriage that isn’t theirs – a marriage that stands as a metaphor for a failed attempt at social change, a failed fulfillment in the realisation of personal potentialities.

This finale can be understood in different ways. Firstly, the dabkeh can be seen as resembling the social, ethnic, political and religious constraints to personal freedom. It is a vicious circle and there is no solution as the audience remains closed-in and tight to its conventions, claustrophobic and disempowered by its own rules and traditions. As Noura puts it, ‘[there is a] big prison in ourselves and we don’t want to get out. We don’t want to change. We are part of society, part of the prison’ (10/9/2009). This is the point at which our unintentional hero (chapter 5) can take the plaudits no more, slips quietly back into the mass of onlookers, and finds solace as another faceless and inconspicuous member of the crowd. And thus, the play ends, hinting that change is an individual struggle and that as long as there is not change on a personal level, there cannot be change on any other level such as the social and political.

However, if there is agency, if the body is both struggling as well as a site for struggles (as demonstrated in chapter 4, 5, 6), then it can both subjugate and liberate itself. If a body can be socially and politically inscribed, if it can desire, if it can be

purged, wiped clean and start again, then it can also inevitably dance back, liberating itself from its own constraints, finding its tempo and choosing its own inscription. Tradition, too, can break free of its monopolising authors, and be seen as dynamic and liberating as the music of the *ud* increases with the movements of the dancers, exposing a peculiar new-found powerfulness which, as they leave the stage dancing leave the audience wondering where they are going to.

The battle over the possession of nuptial bodies has no final winner, since nuptiality is itself the constant movement, the dance and the becoming that can never really be captured within a single, however powerful, frame of domination. However, as nuptial bodies are enmeshed in the constant battles of becomings, then how come they seem to constantly re-emerge as sites for the realization of intimacy inasmuch as violence?

Let us return to the scene of the *ḥammām*. After the pounding of the stones and bodies, the same-gender couples enter, together, into a metallic bowl and rinse themselves with white rice. During wedding dinners, a rice dish with lamb meat, called *mansaf*, is traditionally offered in large metallic trays (*ṣamiya*) such as the ones that the two performers enter. Here, the nuptial bodies take the place of the sacrificial lamb as the purged sacrificial offering to a social communion. This image relates to a story described by the late antiquity philosopher Pausanias, regarding the love story between one of Artemis' priestesses, Comito, and a handsome man by the name of Melanippos. They fell in love but their parents denied them nuptial union. The couple was sacrificed in the name of Artemis because they had used the goddess's temple as their nuptial chamber:

The external facade of the temple imposes the 'law of men.' The nuptial interior subverts it. But if the interior becomes the exterior, the world is threatened by the adolescent *diable au corps* that then invades it. So the world strikes back and strikes to kill. Sacrifice and hierogamy¹⁴² are two forces that presuppose each other, are superimposed over each other and interlocked. They oppose each other, but they also support each other. Each is the aura of the other. The girl who is going to be sacrificed seems to be waiting for her spouse. While the background to erotic pleasure is dark and bloody. Everything that happens is a pendular motion between these two forces. Facing each other, each, in its gaze, reflects the other. Hierogamy tends toward the destruction of the law,

¹⁴² Hierogamy (gk.) literally means sacred (*hieros*) nuptial (*gamia*).

whereas sacrifice reconstructs its bloody base. All it takes to upset this equilibrium is a ‘successful love.’ But history makes sure the equilibrium survives (Calasso 1993: 291–292).

Here the affinity of intimacy and violence re-emerges within the contours of the dialectic between nuptiality and sacrifice. Moreover, if in the above passage we were to substitute hierogamy and sacrifice with intimacy and violence, we could describe the scene of the *ḥammām*. What about history though?

The metallic bowl that rinses the performers with rice while they stand in the *mansaf* goes by the name *tesbt al-ra’abeh*: a small bowl of fear.

In the performance, this fear is the ‘unknown,’ which through explorations and restrictions, never managed to become known. An attempt was made and the journey started. In the *ḥammām* scene, the significant act is that of return: the dancers return willingly to their restrictors, in an instance that the known familiarity turns into a homo-erotic refuge: exposing the intimacy of gender relations through mutual pain and also protection, itself a metaphor extending to include a range of endogamies, a range of nuptial relationalities.

Empires collide on and simultaneously ricochet wide of the nuptial body – this is what *Alf Mabrouk* actually brings to the forefront by juxtaposing the local perceptions and practices of marriage on the stage. The global modernist conceptions as well as the State’s presumptuous attempt to legitimise itself ultimately never reach a complete closure, they cannot penetrate the nuptial body that is continually re-made as a communal/sectarian/religious sanctuary and may form part of local resistance discourse against ‘empires.’ Here it would not be too exaggerated to underline the structural similarities between gender and religious, ethnic, and other boundaries and classifications.

But to say that the body is the stronghold of sectarianism would at best be essentialist, at worst racist. This is where the ‘small bowl of fear’ returns: a fear of an unknown that in times of crises turns into Appadurai’s ‘dead certainty,’ a deadly re-appropriation of difference and intimacy used within the always specific historical, political and social contexts of crises. *Tesbt al-ra’abeh*, the small metallic bowl of fear is

not only the fear of the unknown, it is a ‘fear of the known’, a fear borne out of an awareness of the fine line between intimacy and violence; and what is more is itself the historical contingency, the ‘moment’ or the ‘event’ (Badiou 2005; Caton 1999; see chapter 1), that turns nuptiality into sacrifice, intimacy into violence.

Step 5: Creative interpretations, relational intimacies and back to Druze cosmology

Hierogamy is the premise of sacrifice, but on the part of the gods. It is that first mixing of the two worlds, divine and human, to which sacrifice attempts to respond, but with a response that is merely human, the response of creatures living in the realm of the irreversible, creatures who cannot assimilate (or expel) without killing. To the erotic invasion of our bodies, we reply with the knife that slashes the throat, the hand that hurls the stone. [...] Hierogamy and sacrifice have in common taking possession of a body, by either invading it or eating it. But, as Prometheus would have it, to assimilate a body men had to kill it and eat its dead flesh. In the meantime the smoke would envelop the gods. And, in reply, the gods would envelop the bodies like a cloud and suck out their juices drenched in eros. (Calasso 1993: 292–293)

We have already reappropriated Calasso’s passage to the context of *Alf Mabrouk* with an initial substitution between hierogamy/sacrifice and intimacy/violence. There is one last substitution we need to make. The ancient gods need to give their place to relational modes and to sociality, thus leaving an adequate space for both agency as well as historical contingency and becoming. This space in the performance is delineated by the hand that picks up the metallic bowl and purifies both the sacrifice and the nuptial, as these converge into a violent intimacy. But can the hand choose a different course?

[Fieldnote, June 2009] Summer evening, spent with my Syrian family [bayt Abud-Haddad] in the interior garden of our house. Visitors have come, and one of them, Umm Khalid, is an older woman, in her 60’s. She’s a beautiful, sturdy woman, wears the traditional Druze fouta, she’s vibrant, funny, extrovert and direct. She asks me where I come from, ‘min al-yunān’ (from Greece) I reply. Taking me by complete surprise she replies: ‘Oh, al-yunān is beautiful! My son has married one from there, and we have visited your country!’

Suspecting that I might not have understood correctly, I asked Tariq that evening what Umm Khalid said. He gave me this answer: ‘In our community there are some people who accept this [marrying out]. Maybe they are a bit sad, but what can be done, they love the person and must accept that some are born here but are not Druze. It is natural for the soul to return where it belongs.’

The use of local beliefs in reincarnation in order to explain the otherwise unacceptable marriage between Druze and non-Druze, is an ingenious paradigm that

shows that 'beliefs' and 'traditions' are not fixed, but malleable, open to creative interpretation and re-appropriation. Of course, this understanding also holds its own problems, but, contrary to an inherent relationship of violent intimacy it recasts social and cultural intimacy as the result of sociality. In this way it is a subversive paradigm of social conditionality. It is not the specific rules (the prohibition for marrying outside) that make a 'community' or a 'society' but the very fact that for this 'community' and 'society' to exist there must be social relations. Social relations, therefore, are the building blocks, and it is these relations that Umm Khalid maintains through her interpretation. This story presents a picture of 'tradition' as not fixed but always open to people's creative interpretation and re-appropriation within a relational and not absolute frame. And it shows that it is possible to resolve the apparent tensions of intimacy and violence, nuptial and sacrifice, without recourse to neocolonial enlightened discourses, without breaking vital social bonds, through using local knowledge. This story is, thus, an example of how intimacy may not turn into violence. The apparent irony is that such a dialectical and creative re-interpretation of cosmology in order to maintain the intimate family relationship comes not from an 'educated' middle-class person, but from a working-class 'traditional'¹⁴³ old lady.

Intertextual movements instead of a conclusion

'There is no body that exists before it moves,' writes Manning (2007: xvii) and Barucha adds that identity becomes when movement stops,¹⁴⁴ citing examples of torture in which the body is immobilised over long periods of time, as a way of capturing the person, of distilling and fixing on it an unambiguous identity, upon a previously moving body-target. I think of Appadurai's description, 'making persons out of bodies' (1998: 241; also see Feldman 2004) in situations of ethnic or civil conflicts, the intimacy between proximates turning macabre in an attempt to erase the 'taxonomic hybridity' of symbolic structures (Douglas in Appadurai 1998: 231) and of intimate every day relations whose daily fluidity abruptly changes during times of crises. It reminds me of Zahra, her mother's narrative of her daughter as either the victim of deceit or the deceitful.

¹⁴³ To see how tradition is used as local stratification, see chapter 3.

¹⁴⁴ In his opening speech for the conference 'Dance/Body at the crossroads of culture,' Nicosia, Cyprus, 2011. My attendance to the conference was funded by Wolfson Institute.

And then, I see them both, Zahra and her mother, in Leish's performance, dancing together, tied with ropes, ropes of everlasting bonds, entanglements of love, intimate and restrictive, full of tensions, pretensions, and fear and pain. The mother is the restrictor, the solo dancer, and the one who thumps the stone. Zahra is the restricted, the explorative, the childish and the vulgar. Both are punished: I see them in the *ḥammām*, and in that scene I cannot tell who is who anymore – 'two antonyms of a single woman' (Snajj 2009). I cannot imagine the dabkeh scene, though, and I feel guilty. I must say that I talked of this performance many times to them both, and I must confess that I persuaded Zahra's mother to go and watch it. A month later she would find out Zahra's secret. I knew Zahra's secret, I knew her mother's nightmares, and I knew that mothers' nightmares often turn true, and hers would turn true in a month or so. I cannot say with certainty what I wanted to achieve... Did I want to just have my 'informant's' reception of the performance, a curious anthropological triangulation? Were my ultimate motifs benign? Did I want to foreshadow something to her? Did I have the right to do so? Did I have the right to not do anything? Like an idiot I asked if she liked the performance. "It was nice," she said.

The final scene changes in my mind. Zahra and her mother are still in the *ḥammām* but around them there are people – lots of people. I am not sure if they are dancing, but they move, run, shout. Zahra's story is interpenetrated by flashing lights, by Al-Jazeera TV screens of breaking news and live correspondents. A bloodbath, they say, and I know not whose blood it is or why: is it Zahra's, her mother's, martyrs of either side? Bathing in blood, mother and daughter, amongst other blood stained bodies.

'I don't have any answers to give,' said Noura Murad, and the same holds true for the anthropologist. Nevertheless, in the analysis of the performance the marginal stories of love and art form the basis of an excursion into the limits of powers and resistance, as both metaphors of power (Mitchell 1990) and as practical tensions played on and through intimate and violent bodies. The sequence of our analysis moves in (dance) steps: from subjects to subjects of power, subjects of Empires, and at the same time to the limits of Empires. These subjects dance on the limits of power, they are bodies that play with, resist and reinforce their classifications, and as

in the performance where bodies in motion defy a straightforward identity, they continue to move and to dance. They continue to move, to dance, on the limits of the monarchs that attempt to possess them, as between the approximate limits of intimacy and violence.

Chapter Nine

The intimate and violent struggles ahead

Funerals, weddings and demonstrations

'Khalid's wedding is cancelled. There are no weddings nowadays,' said Zahra's mother during a phone conversation in June 2011. The spring and summer months are the preferred marriage time in Syria, almost creating a 'wedding season,' throughout which the evening quietness is usually intersected by music coming from wedding parties. But since March 2011, marriages have turned into funerals. When young unmarried people die or are killed, then it is a tradition to be dressed in bridal clothes and for the funeral procession to sing wedding instead of mourning songs (Hood 2007). When people are killed unjustly, they become martyrs (Bennaker 2008). And turning a martyr's wedding into a funeral is a political choice:

When a Palestinian comrade and a *shabīd* (martyr) sacrifices for his country he writes a letter to his mother beforehand on whether he wants his funeral to be *mouzahara* (demonstration) or '*ors* (wedding). A friend of Rashid died in such a way some years ago and he wrote to his mother that he wants a demonstration. Up to this day when Rashid visits his friend's mother she says to him 'we did not even make him a wedding,' *ya ḥarām...* (Talal, 24/10/10)

This conversation took place in Talal's one-room flat in the Old City, ten of us cramped inside a small room with Mohammad's violin, plenty of '*araq*, beers and mouldy cheese, a speciality from Homs, revolutionary songs and the music of Umm Kalthoum. Our young company, ages ranging from 23 to 27, was comprised mostly of Damascus University students, some of them involved with the communist/socialist movement of Kassioum.¹⁴⁵ They were of Christian, Alawi and Druze origins. Mohammad's Christian family, communists from Homs, had given him a Muslim name – a practice common in communist or leftist families that attests to an attempt to break religious barriers. Our night was filled with the sweet air of *nargileh* (water pipe), music, dance, and heated political conversations regarding the 'global north and south,' Palestine, and political student movements. Little could we have suspected of what the future held. Five months after my last fieldwork visit and that conversation, unrest in the Syrian countryside erupted leading to a widespread

¹⁴⁵ Kassioum is a movement, not a party, attempting to bring together people from all different communist and leftist parties in Syria. It publishes a newspaper and has online publications and blogs.

uprising, that, by UN estimates, has cost more than 4,000 civilian, protester and army lives by the end of December 2011. Some from our company, and many of their friends have been arrested since, fortunately with no casualties until now. Were there ‘signs’ foreshadowing the uprising, and if yes, why couldn’t we see them? What is going on in Syria today? What, if anything, can we make of tomorrow? Can understandings of power relations, such as the concept of nuptiality, help us in deciphering what is going on – on the ground? Can poetics be turned into politics, or put differently, what is so powerful about nuptial bodies that can turn a funeral into a wedding and a wedding into a protest? And can a wedding drum or *dabkeh* ever beat the gun?

Traces and the continuum of intimacy and violence in war and peace

There is a strand of theoretically rigorous and ethnographically rich work that argues that the question of violence and social suffering should be addressed in all the multiple, contradictory and non-linear ways that ‘violence’ itself emerges as an aspect of human interaction (Das et al. 2000; Kleinman et al. 1997; Scheper-Hughes and Bourgois 2004). This strand of theory, proposes a nuanced way of seeing violent episodes as not only absolute or unique events that abruptly erupt and then disappear, but rather as the traces of power relations and violence on a continuum of everyday practice. In this way, structural power and violence (Farmer 2004: 287–288) – the economic, social, and political marginalisation that manifests through this infrastructure – interconnects with symbolic (Bourdieu 2004: 339–340) and everyday violence (Scheper-Hughes 2004: 176–179) through which dispositions and dominant hierarchies are naturalised and embodied, such as gendered and sectarian relations, as well as the ‘unspeakable crime of intermarriage’ (Wacquant 2004: 320; see chapters 5, 6, 8). In this respect, it appears that the state is more fruitfully envisaged outside the Weberian framework as holding the monopoly to violence, and perhaps instead as the expression and reification of power relations operative subtly within the rubric of everyday life, at the conjunction of local and global forms of governmentality (chapters six and eight). The ‘stage of siege’ (Benjamin 1969 in Taussig 2004) that the Syrian state and polity continually re-invent in the form of emergency laws, resistance, political rhetoric, and the ongoing stream of outside threats, partly reflects the limitations of the regime’s exercise of power since a violent show of force underlines the limits of power: a power that is actually more pervasive when its

explicit exercise is rendered redundant (Arendt 1970: 41–56; Foucault 1991 [1977]). The military regime's response to the current crisis in Syria with a disproportionate show of violence, brutal killings and arbitrary arrests underlines both the precariousness of its position, but also the continuation of routinised terror, albeit in a more dramatic manner, that perpetuated and evolved multilaterally in its forty years of rule. More disconcerting, however, is not only the Syrian regime's ability to inflict pain, to kill, to arrest and to disappear, even when such practices go obviously well beyond the legal rendering of *crimen exceptum*; as Scheper-Hughes (2004: 179) notes regarding the military dictatorship of Brazil, 'the military is not an educational, charitable, or social welfare institution; violence is intrinsic to its nature and logic.' What is disconcerting, and what the concept of nuptiality offers to the study of Syria, is an understanding of the grey zone (Levi 2009) between not only state and subjects, but the contingent, historical, and contemporary mode of relationality by which intimacy breeds violence and vice versa. Therefore, it is not only the military machine of a state gone berserk that causes violence, but the complexities of the contemporary techniques (in the Foucauldian sense) which structure the body as a site of ethnic, religious, gendered and class struggles (chapters 2,3,4,5,7). As a site of and for struggle in periods of crises, embodied ambiguities regarding political, ethnic or religious affiliations become forcefully inscribed on to bodies, making intimate and/or making them *other*: 'through violence, bodies of individual persons become metamorphosed into *specimens* of the ethnic category for which they are supposed to stand' (Malkki 2004: 132, emphasis in the original). Malkki shows how, during the Rwandan civil war and genocide, body maps delineating perceived ethnic difference were used in order to rule out uncertainties or ambiguities between Hutu and Tutsi. Appadurai (1998) explains the poetics of such macabre taxonomies as an attempt to exorcise intimacy.

In a similar, albeit less dramatic, fashion Zahra's mother argues that her daughter occupies an uncertain intimacy as either a victim of deceit or as a deceitful 'outsider' (chapter 5). The President of Syria, Dr. Bashar al-Assad has also blamed the prolonged and violent uprising on uncertain intimacies: Syria has fallen victim to external conspiracies, while internal dissidents are branded as deceitful outsiders. Can the violence and communal ostracisation directed against Zahra by her own mother not principally be related to the broad scale terrorism of a state that is often

portrayed as the patriarch? Could the response of Zahra's mother, or the many underreported honour killings, not be the silent signs through which nuptiality breeds intimacy and violence in both peace and war? And shouldn't nuptiality, rather than being viewed as a cultural 'trait' be instead viewed as a historical, political, economic and social technique of governmentality? Throughout this thesis I argue that nuptiality considered as a mode of relating within contingent historical and political contexts, is not only an insightful way to understand local perspectives and practices of relations, but provides a grounded backdrop for understanding how bodies become both intimate and violent. On the continuum of violence, the theoretical contributions of this work are instilled within the original framework of relating intimacy to violence. At the same time we must not forget that Syria is located in the Middle East, an area of immense political and economic contestations and an arena of and for international conflicts and penetrating interests. Relations, affects and politics within Syria are thus part of global contestations and struggles, not of isolated 'culture areas.'

Poetics and politics of nuptiality

Following bodies that move, dance and stand still, bodies that make place out of space, inhabit and are inhabited by houses, bodies that are born, that give birth, that die, bodies that dance and become extended in wedding ceremonies, bodies whose political extensions dance on the state's stage and dance on the shifting stages of a post-modern dance troupe (chapters 3–8), this thesis moves among, within and between the intimate and violent locales that constitute Syrian social reality. Bodies, embodiment and relationality are not only the anthropological tropes of this thesis but also its methodological tropes (chapter 2). Throughout the preceding pages, the poetics and politics of relationality and embodiment in contemporary Syria have followed the movements of the Druze community in Jaramana, the poetics and politics of legitimacy of the Syrian state, and the struggles of local and global empires to inscribe themselves precisely upon their limits: on moving bodies.

The thesis explored issues of relationality through struggles within families of a religious and classed community, as well as power relations along the lines of the Syrian state, its position within the global capitalist system and the perpetuation of Western governmentality. Power relations map onto bodies, restricting or facilitating

movement, inscribing marks and playing the drums of different step routines. Yet, as much as power relations converge onto bodies, they also ricochet off them. There is always something that eludes inscription, a trace perhaps of subversion or resistance, a trace that hints at the power relations as embodied, negotiated and contested. Yet, a 'body' is never singular, nor as such, exists. Bodies are socially made, and in Syria they *become* nuptial through complex arrays of social and political practices, methods and techniques. *Nuptiality* here refers to the relational frameworks of power as these operate within the complex politics of Syria today. Instead of culture and kinship analysis, nuptiality is a Syrian governmentality: contingent methods and techniques of relating that attempt to produce a certain kind of person, a specifically assembled and organised body. Undoing and unpicking the relational frameworks of power operative in Syria, the thesis argues that bodies become intimate through relational practices such as marriages, that function as an idiom of relationality in general, but this is a form of intimacy that may readily turn into violence. Nuptial bodies become 'nuptial' through social practices, hence, nuptial bodies are the results of struggles, and thus historically formed out of social, political and economic formations and contestations.

Thus, nuptial, intimate and violent threads run through all and every chapter of this thesis. Chapter one introduced the scope and aims of the thesis by tracing the intimate and violent events that coloured the lives and perceptions of both ethnographer and research participants. Similarly, chapter two traced the historical, political, social, theoretical and methodological threads that foreground the thesis within the histories and politics of Druze and Syrian landscapes, the anthropological theory and practice within the contours of relational intersubjective frameworks, power relations and the body. Chapter three moved in the physical and social landscape of Jaramana, exploring the intimate details of two houses through their histories, genealogies and the social spaces they occupy within the Druze community. Intimate traces of social relations shape Jaramana's landscape, yet this intimacy is borne out of social struggles, unstable games of relating and of inscribing the body. Chapters four and five followed those relational struggles in their intimate and violent details of inscribing bodies through life-cycle events such as death, birth and marriage. The body emerges as a territory of struggle, a changing domain of relating, constantly inscribed with power relations.

Chapter five specifically explored how bodies become intimate and violent through wedding ritual praxis. Discussing the poetics of the social construction of relational intimacies through nuptial rituals, the chapter introduced the concept of nuptiality as a form of social relationality by which bodies become extended, intimate and socially appropriated, extending the definitions of cultural intimacy and violence in order to incorporate them not at the level of state–subject but at the level of the communal and the familial, noting that the poetics of both intimacy and violence presuppose one another. However, nuptial relationality, through which the body becomes a site of and for struggles through its transformations and political extensions, is not unique to the Druze community of Jaramana. The political extensions and contestations of the nuptial body play a significant role within the realm of the Syrian state’s practices of legitimacy and reification: the Syrian state through its cultural policies *attempts* to naturalise, neutralise and command potentially threatening sectarian identifications through a spatial poetics of nuptial intimacy that transforms the state into a local empire. Chapter six showed that by strategising multiculturalism and the secular rhetoric of cosmopolitanism in folklore festivals, the Syrian state emerges as a *state-of-empire*, while through the state’s choreographies of empire, nuptiality and intimacy become the main means of inscription onto the bodies of the polymorphous Syrian society.

Nuptial relationality within the Druze community and of the Syrian state, raises the broader issues of power relations and resistance. In chapter seven, these issues were explored through ethnographic examples from different communities of Damascus, and from a specific age category, revealing the multifaceted ways that young people relate, challenge and reinforce power structures. This chapter also located people not only as passive actors in their respective communities or authoritarian state, but also as active agents and performers of relationality.

All the threads, tied and loose, from previous chapters were brought together with local intellectual movements and global struggles in a dance performance that moves along the intimate and violent realms of Syrian nuptiality in chapter eight. Syrian nuptial bodies become constituted through local as much as global struggles. Specifically, combing art, everyday life and politics through a Syrian contemporary

dance performance that is centred around the nuptial ritual, the chapter explored different powers and regimes of knowledge that constitute the Syrian body as their site of struggles. These ‘empires’ come in the form of the Syrian state and the European Union, and conflict along local sectarian lines. The nuptial body, however, both reinforces as well as eludes them. Three realms of local, national, and global struggles converge, clash and ricochet on/off the nuptial body, in ways both intimate and violent.

Time and nuptiality

This thesis comes at a time of particular turbulence within Syria, the wider region and the world in general. A time of economic crises, a time of uprisings, a time of blood, and hopefully a time of hoped-for change. This is also precisely a time in which crucial details of what is going on inside Syria are missing, a time when violence escalates on the ground, a time of pornographic and desensitising news media reportages. This, then, is precisely the time for anthropologists to provide thick descriptions, sensitive ethnographies, and to engage with renewed rigour with questions that interrelate and expose the paradoxes of power in the construction of personhood, the construction of communities, citizens and global subjects. For Syria, this is a period in which mystification becomes cultural and political policy. But what this work shows is that such top-down reconstructions of Syria are neither reflective nor helpful in understanding the multiplicities of becoming or the complex mechanisms of power that operate on the ground.

Through detailed ethnographic descriptions and anthropological investigation, this work offers novel ethnographic data in the study of both the Syrian polity and the Druze community in particular. Moreover, the thesis performs a complex and nuanced anthropological and political analysis of the ways that persons, communities, and the Syrian state relate to one another within a global framework of hegemonic processes. The work offers a unique way of tracing the subtle but nevertheless violent ways that the Syrian state attempts to intersect nuptial bodies, and to construct itself as a reified empire. This empirically grounded analysis of the Syrian state as a state of empire, not only questions the theoretical validity of nation-state as a paradigm for the Middle East, but contradicts most other work that cast the Syrian state as exercising power purely through coercion. As the recent bloodshed in Syria

shows, it is not only the coercion but also the break down and failure of the state's intimate consent mechanisms that have ruptured and bred violence. Or as Arendt puts it:

Violence can always destroy power; out of the barrel of a gun grows the most effective command, resulting in the most instant and perfect obedience. What never can grow out of it is power (Arendt 1970: 53).

The intimate and violent struggles ahead

[July 31st, 2009] I was impressed by the First Mountain Festival that took place in the city of Sweida, the capital city of the mainly Druze prefecture of the same name in Jabal al-Arab. Unlike other festivals, it was organised more as an entrepreneurial exhibition/ bazaar in which one could buy anything from tourist souvenirs and clothes to cars. It will last for a month. With our friends from Jaramana and Karem's cousins from Sweida we attended a folklore performance by the local group Kanaatha (whom I had met in Idleb). The troupe always has very engaging and energetic acts, this combined with live music and the intimacy of the location made both performers and audience enjoy themselves and pulled audiences off their seats into dancing and singing. During the intermittent breaks, the audience, largely made of youth, would divide into two groups, one on the right and the other on the left side of the amphitheatre, and shout in response to each other political slogans. For example, the right side would with one voice chant: 'Souriya, allah, Bashār wa bas' (Syria, God, Bashar and nothing else) and the left side would reply 'bil roūh, bil dam, nafītk ya Bashār' (with our soul and our blood, we sacrifice for you Bashar). Karem explained that this was a little bit 'silly' and that the groups were using the traditional genre of jaffa, a kind of singing in response (see Hood 2007), appropriated with the state-sanctioned public slogans.

Two years later, in 2011, and I hear the same slogans re-appropriated within the contexts of the uprising, in places other than folklore festivals, in places of amateur-shot youtube uploads of popular demonstrations throughout Syria. There, 'Souriya, allah, Bashār wa bas' now becomes 'Souriya, allah, *ḥurriyeh wa bas*' (Syria, God, freedom and nothing else), and 'bil roūh, bil dam, nafītk ya Bashār' becomes 'bil rouḥ, bil dam, nafdik ya balad' (with our souls, our blood we sacrifice for you our country). Could folklore festivals, instead of unilaterally inscribing audience's bodies with the prescribed embodiments of the state-of-empire, actually open up spaces of enactment and performance in which the audience is not only able to realise the manufactured rhetoric of the state, but to realise their distance and difference from the state? And could the social poetics of public performance, such as clapping after the president's name in funerals (chapter 4) or shouting pro-regime slogans actually have helped constitute new creative and subversive spaces of enactment and becoming out of repetitive and mundane public habits? Repetition, habit, creativity

and subversion are some of the terrains of becoming that anthropologists need to study further, within and outside of the Middle East.

Ethnography must develop closer, more intimate bonds within Syria and the Middle East, by asking difficult political questions, providing thick descriptions, and through rigorous engagement of theory and practice. Specifically in reference to the new theoretical framework of nuptiality, more research is needed to outline the histories, politics and economics of nuptiality, research that will clearly relate how this relational concept is a historical and contingent construction. In order for nuptiality to be grounded as a method of contemporary governmentality, more research is needed on how relations emerge and are embodied in Syria and how they change and shift according to different communities, regions, classes and political affiliations. Thus, nuptiality needs be studied in other communities, terrains, and locales. This should be accompanied with ethnographies of the state, its multiple techniques, methods, and modes through which 'it' casts and reifies itself and the ways 'it' is recast and subverted in the lives of its 'subjects.' Especially during such times of transformation, nuanced and less cursory accounts of state and/in everyday realities are needed. In this respect, following the call of philosopher Kassab (2010), future research should also strive to engage in comparative studies within and beyond Syria and the Middle East.

Violence is always the result of a touch, it is always entailed in the politics of intimacy. The touch is a process of approaching, of making intimate, of rendering possibilities within the vicinity of touching. The vicinity of touch is an ambiguous space, it is the vicinity of afflicting a kiss or a hit. The torturer to inflict pain must first touch the victim, two lovers touch to kiss: touch is the moving forwards whether to inflict pain or pleasure. There is the grey zone: violence as a result of closeness, intimacy as a result of pain. In this territory, bodies become knife-edges: they dance, they cut, they re-assemble. The road to Damascus is still long, the dance laborious, the encounter intimate, and at times violent, and the possibilities always infinite. The dance goes on.

A prayer

I am not a religious person. I never have been. Perhaps because prose suits me better than poetry. Hands and bodies better than ideological immortal transcendental truths.

Khayr ileina– blessing on us, a phrase used for the newborn, a phrase spoken by Umm Samir to me. *Khayr ilei* – blessing on me, my reply, my infinite reply to Umm Samir, Umm Nadil and their – our families.

I miss you. I terribly miss you. I long to return to you. And I know not of how or when. The media outlets blast out breaking news of Syria, and I try very, very hard to mute them. Before they break me. I am powerless, timid. I feel guilty – for the past two months I have been consciously muting the news, turning the channels, lowering the voices. I miss you and I want to be with you. I miss you and I am scared. I exorcise my fears and my longing through your cooking recipes, through Arabic coffee, Argentinean mate, and *bakhūr* (incense) for the evil spirits and the blue eyes. And when we talk on the phone, we cannot talk. We cannot tell.

Last week my closest four Syrian friends and I had a video-chat through skype, ‘ the last time, who knows for how long, that the five of us see each other together,’ they told me. Tariq, Karem, Anna and Salih. It was Karem’s last night in Damascus. The next day he flew to the United Arab Emirates. He was no longer a student, and his army service was due to begin. Tariq enrolled in a master’s degree at the University, and so he is ‘safe’ from the army. Anna and Salih are also in the University. How I miss you, guys. In better conditions, we shall meet up soon again.

Once upon a time, there was a little girl. She wore a colourful *galabiyah*, she had no shoes, and she smiled to strangers. One day she took off. I have not seen her since, but when I do, I’ll tell her that I have not forgotten. I’ll ask her, in turn, to tell my beloved families that I love them. That all my prayers are to them. And, that I believe.



Leish rehearsal of Alf Mabrouk. Photograph by author, 2009.

Appendix I

Theatre of the not-so-obscure: Cooking as unfolding

--

Umm Samir is an artist. She sculpts the hummus in the shape of the sun. Makes colourful rays with spices: paper, *summāq*, paprika. Once, she made a drawing of a chicken skeleton and decorated the bare bones with the feathers of the sacrificed meal. She wants the details to be beautiful, she tells me: the plate, the pillow, the pray.

Umm Samir is an artist. Umm Samir is a tailor. Umm Samir is a cook.¹⁴⁶

--

Tabah roḥo

Sweet winter afternoon in the ancient city. The sun is shining but it is still too cold to stay outside. We are sitting on the floor of the living room; between us courgettes, a few large tomatoes, a kettle of nearly but not quite boiled water, a small glass of mate. She's peeling tomatoes, talking about Ahlam, her youngest daughter: 'she didn't go to nursery but straight to primary school.. our children don't like to leave home.. she knew all the letters of the alphabet before she started... her older brothers and sisters taught her. She's good at school, she's *shāṭ ra* (clever).'' Umm Samir stresses her last phrase as she looks up, finished with the tomatoes she passes the glass of mate to me.

Courgette, *kusab* in Arabic, next. Finely chopped.

A broad clear smile paints her face as she recalls how all her ten children came to her aid for their homework. But she could only help until grade seven.

The almost mechanical movement of chopping stops, then starts again. "But they give up when they reach the baccalaureate."

Umm Samir cooked *tabah roḥo*.¹⁴⁷ A soul for the plate of the poor or the poor for the sake of the soul?

--

Broad beans and broad beans with coriander and garlic (foul wa foul ma' tsisjabarah wa thūm)

April 21, 2009: the broad beans come fresh in a big plastic case, five kilos, maybe more. Peeling the bean from its large coat is a delicate, time-consuming process. It entails dealing with each bean separately, carefully snatching the top part open,

¹⁴⁶ A version of this writing has been published as: "The theatre of the not-so obscure: cooking as unfolding." *ELISS*, 3(2): 18-23.

¹⁴⁷ Literally, 'food of the soul', a euphemism as the food is also known as the 'the food of the poor'.

inserting a finger along the green side line, ripping the bean open length-wise, then using the big thumb to separate the fruit from its garment.

“I used to be *shāṭra* (clever) in school, a good student. [Says Umm Samir as she’s showing me how to peel a bean.] Back then, we used to live in the farm, and there was no secondary school in Jaramana¹⁴⁸. There was no public transportation and it took a long time to travel. Well, my father did not permit me to study in the secondary school because it was difficult and dangerous for a young girl to be travelling alone in such big distances. [She notes, as she grabs another bean, with only a hint of a sigh; then, a tone more affirmative] The director of the school really wanted me to continue... [A break from the broad beans, a slight pause.] Well, to make a long story short, [the phrase Umm Samir uses is *al mohim*, translated literally as “that which is important”. This phrase is a short breath, an intersection to the story by some cooling down breeze. A conscious anti-climax that shares peculiar similarities to a Derridian exergue.] During the same time my mother died, I became an orphan, and we were nine siblings, so we had to stay together and many of my brothers and sisters were still very young... I was maybe eleven years old. After a year my father got married again. So, I learnt the craft of sawing and I had a job. A skirt was worth five Syrian liras. Well, *al mohim*, after my father got remarried, difficult days came: his wife was very difficult (*sa’ab*), and I had to work hard in the house and in the farm. It wasn’t only me; it was hard for all my brothers and sisters [*bajintou*, literally ‘sad’ as a verb in passive voice]. I got married to Abu Samir when I was 14, and everything got better after, *alham du lila*.”

The broad beans are boiled and then slightly fried with coriander and chopped garlic cloves. But not everyone likes coriander and Abu Samir always prepares a smaller casserole without the embellishments. She sketched her life with her husband simply:

‘Our life was hard but my mind did not get *ta’ebet* (tired). When I was pregnant for the first time, Abu Samir (her husband) *mbasaṭ kūr* (he got really happy/excited) – he gave me so many kisses!’ She added as if with a slip of the tongue, turning slightly embarrassed. ‘Every time I got pregnant Abu Samir got so excited and if anyone told us that we should stop having children, Abu Samir wanted to kill them!’

--

Courgettes filled with rise, minced lamb and spices

Early afternoon in the internal courtyard of the old Arabic house. Sitting under a shade, in a constant game of hide and seek with the sun. Ten kilos of courgettes foreclose the work of this difficult meal. It is the early summer, and the sun causes the anatomically looking kitchen instrument to reflect its beams. It has a blade shaped between a knife and a shoe fitter, and it is used to swap the inside out of the courgette: piercing the top of the courgette and removing a cone-shaped flesh from the inside. Green skin and yellow flesh are separated into different bowls, to be differently prepared and only to emulate a past connection (in proximity) at a later stage.

¹⁴⁸ Jaramana is a suburb of Damascus, four miles away from the capital.

Three of Umm Samir's grandchildren instruct each other into play. Their mother is doing errands around the house. Umm Samir sits down on the mosaic with one leg crossed and the other extended, her dress slightly raised, revealing the contours of myriad little red veins. I try to imitate her experienced, delicate moves. As we invade the courgettes, she spills out instances of the troubled years of her life... Her mother's early departure, her father's second marriage, her forced quitting off school. She talks to me bit-by-bit or, courgette-by-courgette, in her usual inconsequential manner and she always finishes a story or a phrase with an *alham du lila*.

When the emptying of the courgettes will finish, the minced lamb will be slightly fried, then mixed with rice and spices making the filling for the courgettes, and all will be brought to boil with tomato sauce in a large cassarole.

--

Maqdous or the making of the social fabric

Part I: Ingredients

The summer dances on the steps of its fruits, activities of the house and the farm, delineated and marked in space and time, as in site-specific contemporary dance performances or some ancient, unbound ritual: June is the month of *mish-mosh* (apricots), July of *tout al- Shām* (Damascene berries); August of *jaws* (walnuts).

One early morning Umm Samir, her son Ali, and I go to gather walnuts from the family's land: Ali climbs on the top of the old tree to shake the branches and we pick up the fallen fruits from the ground. Umm Samir notes that when the walnut trees used to be more this was a communal job for the young men and women of Jaramana, a celebration *'id al-jaws*. The walnuts will be cleaned and let to dry under the sun. They will mature for a year before they are used.

Evidence of the impending process had slipped through our gate since last week. At first, in the form of a plastic blue bag with runner beans from our neighbours in *bayt*¹⁴⁹ Abu Khalid. Then, a more definitive sign, from our relatives *bayt* Abu Salih in the shape of baby aubergines (*betinjan*). "*Khayr al-seneb*", blessing of the year, Umm Samir explained, are gifts of the first summer harvest. "These are the most *ṭ ayeḥ* (delicious)," she added.

Bayt Abu Salih's baby aubergines were the first of this year, and they signified one thing: the period of making maqdous had arrived.

A Levantine delicacy, maqdous is made from baby aubergines stuffed with crushed walnuts, mixed with red peppers and garlic and preserved in olive oil. Made between late August and September, by the women of most Syrian households, to last for family breakfasts for the next year, this is a long industrious process – as time-consuming as anything enchanting or tasty. The taste of maqdous is particular, varying between households: tangy yet warming, slightly pickled but rich, the different ingredients strong and complimenting.

¹⁴⁹ *Bayt* means both house and family or lineage.

Part II: Procedure

“*Bukera, insballab*”: the baby-aubergines and the walnuts sat in the kitchen for a couple of days, foreshadowing the uncertain definity of Umm Samir’s ‘god willing, tomorrow’. My own excitement grew proportionally: not only did I love eating maqdous, not only I enjoyed sitting with Umm Samir and filling my thoughts and note-pages with the footnotes of her life, but, I must confess, I had grand designs for the making of maqdous. A process that takes up days, the ambitious anthropologist wanted to film the *whole* process of maqdous-making, from start to finish, in secret my plans amounted to surpassing El-Guindi’s *Ghurbal* (1995). I made sure Umm Samir understood that I want to film the process, and every day I’d ask Umm Samir when we will start and her reply would be the same.

On the third day I woke up at eight o’clock and found Umm Samir crushing walnuts in the courtyard, and Fatima, her eldest daughter who was visiting, swiping the floor. On the kitchen counter boiled baby-aubergines carefully placed on a large circular tray. “Oh. When did you start? Why didn’t you wake me up?” I enquired, probably resembling one of Umm Samir’s grandchildren. “I just started, sweetie. Don’t worry, you haven’t missed anything. I just boiled the aubergines at six. Bring your camera.” She replied, slightly amused by my reaction, in a kind, reaffirming voice.

The camera starts by looking at Fatima who swipes the floor as her two children play almost between the broom and her legs. It pauses at Umm Samir, who welcomes the camera while crushing walnuts. Then, the camera moves through the house to the kitchen to meet the aubergines. As it retreats back to the courtyard, Fatima’s young daughter, two-year old Lulu, spills a glass of water on the floor and her mother, myself and the camera help rectifying the accident. The camera eventually finds its way out of the house at the place where Umm Samir is sitting. The lens zooms at the movement of the hands that crush walnuts, then the picture opens up to include the whole picture of Umm Samir, and the walnuts. I drag a plastic chair and place the camera on it. The screen sees a tray of walnuts at the centre and Umm Samir and I at its ends.

I ask her to tell me the recipe and I jot down some notes: “It is very simple. Boil slightly the aubergines with water enough to cover them, make sure the aubergines are under the water by placing on top an old cloth and a plate, otherwise they will go black. Let them cool down. Crash walnuts and garlic, add red peppers if you have, and salt. When the aubergines are cold, slice each one open sideways, and fill it with the mixture. When you have finished, place them neatly in a big glass jar, adding salt upon each layer. Close the jar and let it stand for one or two days. Then, take the lid off and carefully place the jar upside down so that the red juices leave but the aubergines stay. In this manner let it stand for a couple of days, until there is no more juice. Then, fill up to the top with olive oil. They will last for a year.”

The end of the recipe coincides with the arrival of Umm Samir’s other daughter, Ilaf, and her three daughters. Fatima and Ilaf prepare mate and sit with us, one of them jokingly noting, “We’re going to be famous, we are filmed today!” while the young cousins start running around the courtyard; the two youngest ones sit with us. We start chatting, entertaining the babies, crushing and occasionally nibbling on walnuts. Soon, the children discover the camera; their mothers attempt to discourage them

from getting into the picture or playing with it, shouting “*laa, mama*” (no, mum¹⁵⁰) and “*ayb*” (shame). Yet, the children are too excited to listen. The camera becomes the centre of their activities and entertainment. A bit later I will move the camera to a windowsill, a last attempt to recover my project. Two more of Umm Samir’s grandchildren come to the house. Seven children and four adults, we are outnumbered. The children invade the recording camera: actors, singers and directors. Somewhere in the background we are crushing nuts, sharing mate and discussing news and anthropology. We mix the spices and start filling the aubergines. The children are performing one by one, or all in garrison and the camera submits to their delight. I submit to their invasion as well, and later on, I ask of them to play the anthropologist: I pass the camera to the oldest one, 10-year-old Sarah, and show her the basic functions. Now, she’s so professional and serious, zooming in and out of our working hands. The role of the recording anthropologist gains in popularity and the rest of the grandchildren want to take turns in the direction. Huda teaches and supervises. Umm Samir, Fatima, Ilaf and I laugh at their insights, sharing looks appreciating that this is, maybe always has been, beyond our control. *Maqdous*, mate and camera, mothers, daughters and granddaughters, everything seems so interrelated, inextricably interconnected in the recording tape as it did in that courtyard. And somehow I realise now, that my grand plot had worked: making *maqdous* is the making of everything else entailed other than *maqdous*.

--

A good meal: slow movements, unexpected invasions, subtle ingredients; intoxicating but never overpowering.

Epilogue and Preface

A series of stories, pauses and repetitions.

Fragments of life, moments of preparation, tastes of food.

The anthropological encounter, a process itself – a process like cooking.

I often get the feeling that anthropology, like life, lingers in the finer, always artistic, details of the usual and the everyday.

Acquiring the tastes, learning the tasks of peeling and chopping, akin to ethnography and life stories, is always a process and in process.

P.S.

I will always try and never quite achieve to describe the fragmented sigh of breath treasured in Umm Samir’s *al mobim*.

Alham du lila.

¹⁵⁰ Relatives call young children with the name describing their relation to them and by which the child should call them back.

Bibliography

- Abdulhamid, A. 'Syria is not ready for an uprising.' *The Guardian* (Feb. 7) (<http://www.guardian.co.uk/commentisfree/2011/feb/07/syria-uprising-egypt-tunisia-days-of-rage>)
- Abrams, P. 2006 [1988]. 'Notes on the difficulty of studying the state.' Sharma A. and Gupta A. (eds.), *The anthropology of the state: A reader*. London: Blackwell, pp. 112-130.
- Abu Chakra, E. 2006. 'The Druze and Arabism.' Salibi, K. (ed), *The Druze: Realities and perceptions*. London: Druze Heritage Foundation, 171-182.
- Abu-Husayn, A. R. and Akarli, E. D. 2006. 'The subordination of the Hawran Druze in 1910: The Ottoman Perspective.' Salibi, K. (ed), *The Druze: Realities and perceptions*. London: Druze Heritage Foundation, pp. 115-128.
- Abu-Izzeddin, N. 1984. *The Druzes: A new study of their history, faith and society*. Leiden: E. J. Brill.
- Abu-Ludhod, L. 2006. 'Writing against culture.' H.L. Moore & T. Sanders (eds), *Anthropology in theory: Issues in epistemology*. London: Blackwell Publishers, pp. 466-479.
- Abu-Lughod, L. 1986. *Veiled Sentiments: Honor and Poetry in a Bedouin Society*. Egypt: The American University of Cairo Press.
- Abu-Lughod, L. 1989. 'Zones of Theory in the Anthropology of the Arab World.' *Annual Review of Anthropology*, 18: 267-306.
- Abu-Lughod, L. 1990. 'The romance of resistance: Tracing transformations of power through Bedouin women.' *American Ethnologist*, 17(1): 41-55.
- Abu-Lughod, L. 2002. 'Do Muslim Women Really Need Saving? Anthropological Reflections on Cultural Relativism and Its Others.' *American Anthropologist*, 104 (3): 783-790.
- Abu-Lughod, L. 2005. *Dramas of nationhood: the politics of television in Egypt*. Chicago: University of Chicago Press.
- Agamben, G. 2004. 'The witness.' N. Scheper-Hughes and P. Bourgois (eds), *Violence in war and peace: An anthology*. Oxford: Blackwell Publishing, pp. 437-442.
- Agha Al Kala, E. D. 2006. 'Speech of H.E Dr. Eng Saadalla Agha Al Kalaa Minister of Tourism at the Opening Ceremony of Silk Road Festival 2006,' Ministry of Tourism, Syria. On-line: <http://www.syriatourism.org/index.php?module=subjects&func=viewpage&pageid=2721>, accessed September 2010.
- Aita, Samir. 2008. "Un Tango Voile: Soucis et reflexions de jeunes de la Syrie actuelle". *Le Monde Diplomatique*. (May).
- Alamuddin, N. S. and Starr, P. D. 1980. *Crucial bonds: Marriage among the Lebanese Druze*. New York: Caravan Books.
- Al-Barghouti, T. 2008. *The Umma and the Damla: the nation state and the Arab Middle East*. London: Pluto Press.
- Ali, K. A. 1996. 'The politics of family planning in Egypt.' *Anthropology Today*, 12.
- Ali, K. A. 2000. 'Making "responsible" men: Planning the family in Egypt.' C. Bledsoe, S. Lerner, and J. Guyer (eds), *Fertility and the male life-cycle in the era of fertility decline*. Oxford: Oxford University Press.
- Ali, T. 2003. *The clash of fundamentalisms: Crusades, jihads and modernity*. London: Verso.
- Al-Jazaeri, R and Sabbagh, H. September 25, 2010. 'Silk Road Festival 2010 Kicks off Today.' *Syrian Arab News Agency (SANA)*. <http://www.sana.sy/print.html?sid=309485&newlang=eng>, accessed September 2010.
- Al-Jazeera*. 2011. 'Syria: 'A kingdom of silence'' <http://english.aljazeera.net/indepth/features/2011/02/201129103121562395.html>, accessed February 2011.
- Al-Kazhali, I. August 6, 2009. 'Euphrates Pearl Festival for Shopping and Arts Opens in Deir Ezzor.' *Syrian Arab News Agency (SANA)*

- Al-Khodor, A. A. 2010. 'Congratulations! A rare movement theatre performance!' *Thavra* Newspaper (29/10/10), Syria. Trans. A. Mahdi.
- Allafi, F. and Eyon, M. August 26, 2009. 'First Phoenix Festival to launch on Thursday.' *Syrian Arab News Agency (SANA)*.
- Al-Manar's Interview with Syrian President Bashar Assad, Interview conducted by Amr Nassif 24/03/2010, <http://www.almanar.com.lb/newssite/NewsDetails.aspx?id=130804&language=en>, accessed Sept 25, 2010.
- al-Miqdad, F. 2008. 'Iraqi refugees in Syria.' *Forced migration review*, Iraq Special Issue, pp. 19-20.
- Alonso, A. M. 1994. 'The Politics of Space, Time and Substance: State Formation, Nationalism and Ethnicity.' *Annual Review of Anthropology*, 23: 379-405.
- Amit, V. 2000. 'Introduction: Constructing the field.' V. Amit (ed), *Constructing the field: Ethnographic fieldwork in the contemporary world*. London: Routledge.
- Anderson, B. 1991. *Imagined communities*. London: Verso.
- Anderson, J. W. 1985. 'Sentimental ambivalence and the exegesis of "self" in Afghanistan.' *Anthropological Quarterly*, 58 (4): 203-211.
- Antoun, R. T., and D. Quataert. (eds). 1991. *Syria: Society, culture, and polity*. Albany: State University of New York Press.
- Antoun, RT. 1991. 'Ethnicity, clientship, and class: Their changing meaning.' Antoun, R.T. and D. Quataert (eds), *Syria: Society, culture and polity*. Albany: State University of New York Press, pp. 1-12.
- Appadurai, A. (ed). 2001. *Globalization*. Duke University Press.
- Appadurai, A. 1998. 'Dead certainty: Ethnic violence in the Era of Globalization.' *Public Culture*, 10 (2): 225-247.
- Arendt, H. 1970. *On violence*. London: A Harvest Book, Harcourt, Inc.
- Argyrou, V, 1996. *Tradition and modernity in the Mediterranean: The wedding as symbolic struggle*. Cambridge: Cambridge University Press.
- Argyrou, V. 2002. *Anthropology and the Will to Meaning: A Postcolonial Critique*. London: Pluto Press.
- Armbrust, W. 1996. *Mass Culture and Modernism in Egypt*. Cambridge: Cambridge University Press.
- Asad, T. (ed). 1973. *Anthropology and the Colonial Encounter*. New York: Ithaca Press.
- Asad, T. 1986. *The Idea of an Anthropology of Islam*. Washington D.C.: Center for Contemporary Arab Studies, Georgetown University Press.
- Association of Social Anthropologists of the UK and the Commonwealth (ASA). 2011. 'Ethical Guidelines for Good Research Practice.' (<http://www.theasa.org/ethics/guidelines.shtml>), accessed November 2011.
- Atallah, T. 2011. 'Yasmine's Home: Putting Foreign Funding in Palestine on Trial.' *Al-Akhbar* English. <http://english.al-akhbar.com/content/yasmine's-home-putting-foreign-funding-palestine-trial>, accessed 20/9/11.
- Atassi, Y. 2009. 'Congratulations: Wandered Identities weltering in a bitter reality.' *Baladna* Newspaper (8/10/09), Syria. Trans. A. Mahdi.
- Badiou, A. 2005. *Being and Event*. Translation by Oliver Feltham. New York: Continuum.
- Barth, F. 1969. *Ethnic groups and boundaries. The social organization of culture difference*. Oslo: Universitetsforlaget.
- Batatu, H. 1999. *Syria's peasantry, the descendants of its lesser rural notables, and their politics*. Princeton: Princeton University Press.
- Bateson, G. 1972. 'A Theory of Play and Fantasy,' in *Steps to an Ecology of Mind*. New York: Ballantine Books, pp. 177-193.
- Bauman, R. 1977. *Verbal Art as Performance*. Rowley, Mass.: Newbury House.
- Bell, C. 1992. *Ritual theory, ritual practice*. New York. Oxford University Press.
- Bennacer, D, 2008. 'Bearing Witness to the (In)visible: Activism and the performance of witness in Islamic orthopraxy.' *Performance Research*, 13 (3): 64-76.

- Bennett, A. 2006. 'Reincarnation, sect unity, and identity among the Druze.' *Ethnology*, 45 (2): 87-104.
- Betts, B. R. 1988. *The Druze*. London: Yale University Press.
- Blacking J. and Kealiinohomoku J (eds). 1979. *The Performing Art: Music and Dance*. The Hague: Mouton.
- Bloch, M E. F. 1986. *From blessing to violence: History and ideology in the circumcision ritual of the Merina of Madagascar*. Cambridge: Cambridge University Press.
- Borneman, J. 2007. *Syrian episodes : sons, fathers, and an anthropologist in Aleppo*. Princeton: Princeton University Press.
- Boskovic, A. 2002. 'The "Intersubjective turn" and the question of subject in contemporary anthropology: A review article.' *Campos* (2): 55-65.
- Bourdieu, P. 1984. *Distinction: A social critique of the judgement of taste*. Cambridge: Harvard University Press. Translated by R. Nice.
- Bourdieu, P. 1986. 'The forms of capital.' J. Richardson (ed), *Handbook of Theory and Research for the Sociology of Education*. New York: Greenwood, pp. 241-258.
- Bourdieu, P. 1994. 'Did you say "Popular"?' *Language and Symbolic Power*. Cornwall: Polity Press, pp. 90-102.
- Bourdieu, P. 2004. 'Gender and symbolic violence.' Farmer, P. 2004. 'On suffering and structural violence: A view from below.' N. Scheper-Hughes and P. Bourgois (eds), *Violence in war and peace: An anthology*. Oxford: Blackwell Publishing, pp. 339-342.
- Bourdieu, P. 2005 [1990]. *The logic of practice*. Cambridge: Polity Press.
- Bourdieu, P. 2007 [1977]. *Outline of a theory of practice*. Cambridge: Cambridge University Press.
- Bourdieu, P. and L. J. D. Wacquant. 1992. *An Invitation to Reflexive Sociology*. The University of Chicago Press.
- Braudel, F. 1958. 'Histoire et sciences sociales: La longue durée.' *Annales. Histoire, Sciences Sociales* 13 (4): 725-753.
- Brunner, C. 2007. 'Occidentalism meets the female suicide bomber: A critical reflection on recent terrorism debates; a review essay.' *Sings: Journal of Women in Culture and Society*, 32 (4): 957-971.
- Buchowski, M. 2006. 'The Specter of Orientalism in Europe: From Exotic Other to Stigmatized Brother.' *Anthropological Quarterly*, 79(3): 463-482.
- Butler, J. 1990. *Gender trouble : feminism and the subversion of identity*. London: Routledge.
- Calasso, R. 1993. *The Marriage of Cadmus and Harmony*. London: Jonathan Cape. Translation by Tim Parks.
- Carapico, S. 1998. *Civil society in the Yemen : the political economy of activism in modern Arabia*. Cambridge: Cambridge University Press.
- Carrier, J. G. 1992. 'Occidentalism: The world upside-down.' *American Ethnologist*, 19 (2): 195-212.
- Carrithers, M. and Collins, S. and Lukes, S. (eds). 1985. *The category of the person: anthropology, philosophy, history*. Cambridge: Cambridge University Press.
- Carrithers, M. B. 2008. 'From Inchoate Pronouns to Proper Nouns: A Theory Fragment with 9/11, Gertrude Stein, and an East German Ethnography', *History and Anthropology*, 19(2): 161-186.
- Caton, S. C. 1987. 'Power, Persuasion, and Language: A Critique of the Segmentary Model in the Middle East.' *International Journal of Middle East Studies*, 19 (1): 77-101.
- Caton, S. C. 1990. *"Peaks of Yemen I summon": poetry as cultural practice in a North Yemeni tribe*. Berkeley: University of California Press.
- Caton, S. C. 1999. '"Anger be now thy song" The anthropology of an event.' Unpublished, provided by *The Occasional Papers of the School of Social Sciences*, Institute for Advanced Study, Princeton. Available at <http://www.sss.ias.edu/files/papers/paperfive.pdf>, accessed May 2011.
- Caton, S. C. 2005. *Yemen chronicle: An anthropology of war and mediation*. New York: Hill and Wang.

- Central Bureau of Statistics, Syrian Arab Republic. 2009. 'SEX RATIO & POPULATION DENSITY BY MOHAFAZAT ACCORDING TO 1970 - 1981 -1994 - 2004 CENSUSES.' <http://www.cbssyr.org/yearbook/2009/chapter2-EN.htm>. (Accessed June 2010)
- Central Bureau of Statistics, Syrian Arab Republic. 2009. 'Taouja' alsakan wa almousakin fi mouhafajat dimasq hasab tadad 2006.' <http://www.cbssyr.org/General%20census/census%202004/pop-man.pdf>. (Accessed June 2010)
- Chakrabarty, D. 2000. *Provincializing Europe: Postcolonial Thought and Historical Difference*. Princeton: Princeton University Press.
- Chatty, D. 1974. *From Camel to Truck: A study of the pastoral economy of the Al-Fadl and the Al-Hassana*. Los Angeles: University of California, University Microfilms International. (Ph.D. Thesis)
- Chatty, D. 1977. 'Leaders, Land, and Limousines: Emir versus Shaykh.' *Ethnology*, 16(4): 385-397.
- Chatty, D. 1986. *From Camel to Truck: The Bedouin in the Modern World*. New York: Vantage Press.
- Chatty, D. and A. Rabo. 1997. *Organizing women : formal and informal women's groups in the Middle East, Cross-cultural perspectives on women*. Oxford: Berg.
- CIA - The World Factbook, <https://www.cia.gov/library/publications/the-world-factbook/geos/sy.html>, Nov. 2011.
- Cleveland, W. L. 2004. *A History of the Middle East*. Oxford: Westview Press.
- Clifford, J. and Marcus G. E.(eds). 1986. *Writing culture: the poetics and politics of ethnography*. London: University of California Press.
- Cohen, E. 1977. 'Recent Anthropological Studies of Middle Eastern Communities and Ethnic Groups.' *Annual Review of Anthropology*, 6: 315-347.
- Cole, Donald P. 1985. 'The Household, Marriage and Family Life among the Al Murrah Nomads of Saudi Arabia.' S. E. Ibrahim and N. S. Hopkins (eds), *Arab Society: Social Science Perspectives*. Cairo: The American University in Cairo Press, pp. 19-211.
- Comaroff, J. and Comaroff, J. 2002. 'Of Revelation and Revolution.' Vincent, J. (ed). *The Anthropology of Politics: A Reader in Ethnography, Theory, and Critique*. Oxford: Blackwell Publishers.
- Cooke, M. 2007. *Dissident Syria: Making Oppositional Arts Official*. London: Duke University Press.
- Cowan, J. K. 1990. *Dance and the body politic in northern Greece*. Oxford: Princeton University Press.
- Cowan, J. K. and Dembour, M. B. and Wilson, R. A. 2001. *Culture and Rights: Anthropological perspectives*. Cambridge: Cambridge University Press.
- Csordas, T. J. 1999. 'The body's career in anthropology.' H. L. Moore (ed), *Anthropological Theory Today*. Cambridge: Polity Press: 172-205.
- Das, V. and Kleinman, A. and Ramphela, M. and Reynolds, P. (eds). 2000. *Violence and subjectivity*. London: University of California Press.
- Debord, G. 2005 [1977]. *The society of the spectacle*. London: Rebel Press. Translation by K. Knabb.
- Deleuze, G and Guattari, F. 2005 [1987]. *A thousand plateaus: capitalism and schizophrenia*. London: University of Minnesota Press. Translated by B. Massumi.
- Deleuze, G. 1994. *Difference and Repetition*. London: The Athlone Press. Translated by P. Patton.
- Donnan, H. 1988. *Marriage among Muslims: Preference and choice in Northern Pakistan*. Leiden: E. J. Brill.
- Douglas, M. 1966. *Purity and Danger: An analysis of concepts of pollution and taboo*. London: Routledge and Kegan Paul.
- Douglas, M. 1970. *Natural Symbols: Explorations in cosmology*. New York: Pantheon Books.
- Dresch, P. 1986. 'The significance of course events take in segmentary systems.' *American Ethnologist*, 13 (2): 309-324.

- Dresch, Paul. 1988. 'Segmentation: Its Roots in Arabia and Its Flowering Elsewhere.' *Cultural Anthropology*, 3 (1): 50-67.
- Drysdale, Alasdair. 1982. 'The Asad Regime and Its Troubles.' *MERIP Reports*. No. 110, Syria's Troubles. (Nov.- Dec.), pp. 3-11, 36.
- Eickelman, D. 1977. 'Ideological Change and Regional Cults: Maraboutism and Ties of 'Closeness' in Western Morocco.' R. P. Werbner (ed), *Regional Cults* (A.S.A. Monographs in Social Anthropology, 16). New York and London: Academic Press, pp. 3-28.
- Eickelman, D. F. 1981. *The Middle East: An anthropological approach*. London: Prentice- Hall.
- Eickelman, D. F. and Piscatori, J. 2004. *Muslim Politics*. Oxford: Princeton University Press.
- El-Guindi, F. 1999. *The Veil: Modesty, privacy and resistance*. Oxford: Berg.
- El-Guindi, F. 2008. *By noon prayer: The rhythm of Islam*. Oxford: Berg.
- El-Zein, A. H. 1977. 'Beyond Ideology and Theology: The Search for Anthropology of Islam.' *Annual Review of Anthropology*, 6: 227 - 254.
- Emery, S. B. 2010. *In better fettle: Improvement, work and rhetoric in the transition to environmental farming in the North York Moors*. Ph.D. Thesis, Durham: Durham University.
- Engels, F. 2007 [1882]. 'On the part played by labor in the transition from Ape to Man.' M. Lock and J. Farquhar (eds), *Beyond the body Proper: Reading the anthropology of material life*. London: Duke University Press: 25-29.
- Evans-Pritchard, E. E. 1949. *The Sanusi of Cyrenaica*. Oxford: Clarendon Press.
- Fadel, M. and Schami, R. 2005. *Damascus: Taste of a city*. London: Haus Publishing.
- Fahmi, F. and Jaeger, P. 2009. *Jaramana: Refugee city*. Zurich: ETH, Studio Basel, Contemporary City Institute. URL: <http://www.studio-basel.com/Projects/Beirut-Damascus/Student-Work/Damascus-Jaramana.html>. (accessed May 2010).
- Falk, R. 2011. 'The toxic residue of colonialism.' *Al-Jazeera* (Feb 14). (<http://english.aljazeera.net/indepth/opinion/2011/02/20111213201140768988.html>) (accessed February 2011).
- Fandi, T. and Abu-Shakra, Z. 2001. *The Druze heritage: an annotated bibliography*. London: Royal Institute for Inter-Faith Studies.
- Farmer, P. 2004. 'On suffering and structural violence: A view from below.' N. Scheper-Hughes and P. Bourgois (eds), *Violence in war and peace: An anthology*. Oxford: Blackwell Publishing, pp. 281-289.
- Fawaz, L. 2006. 'The Druze-British connection in 1840-1860.' Salibi, K. (ed.), *The Druze: Realities and perceptions*. London: Druze Heritage Foundation, pp. 105-113.
- Feldman, A. 2004. 'On cultural anesthesia: From *Desert Storm* to *Rodney King*.' N. Scheper-Hughes and P. Bourgois (eds), *Violence in war and peace: An anthology*. Oxford: Blackwell Publishing, pp. 207-216.
- Fernandez, J. W. 1986. *Persuasions and Performances: The Play of Tropes in Culture*. Bloomington: Indiana University Press.
- Fernea, Robert. 1975. 'Anthropology of the Middle East and North Africa: A Critical Assessment,' *Annual Review of Anthropology*, 4: 183-206.
- Firro, K. M. 1992. *A History of the Druzes*. Leiden: E. J. Brill.
- Firro, K. M. 1999. *The Druzes in the Jewish State: A brief history*. Leiden: Brill.
- Firro, K. M. 2001. 'Reshaping Druze particularism in Israel.' *Journal of Palestine Studies*, 30 (3): 40-53.
- Firro, K. M. 2005. 'Druze *maqamat* (shrines) in Israel: From ancient to newly-invented tradition.' *British Journal of Middle Eastern Studies*, 32 (2): 217-239.
- Foucault, M. 1982. 'The Subject and Power.' *Critical Inquiry*, 8(4): 777- 795.
- Foucault, M. 1991 [1977]. *Discipline and Punish: The birth of the prison*. Translated by A. Sheridan. London: Penguin Books.
- Foucault, M. 1991b. 'Questions of method.' G. Burchell et al. (eds), *The Foucault effect: Studies in governmentality*. Chicago: Chicago University Press, pp. 73-86.
- Foucault, M. 1998 [1978]. *The Will to Knowledge: The History of Sexuality: 1*. Translated by A. Sheridan. London: Penguin Books.

- Foucault, M. 2005 [1970]. *The order of things: An archaeology of the human sciences*. New York: Routledge.
- Foucault, M. 2006 [1977]. 'The body of the condemned.' H. L. Moore and T. Sanders (eds), *Anthropology in theory: Issues in Epistemology*. Oxford: Blackwell Publishing.
- Foucault, M. 2006 [1991]. 'Governmentality.' Sharma A and Gupta A. (eds.), *The anthropology of the state: A reader*. London: Blackwell. 131-143.
- Foucault, M. 2007. *Security, territory, population : lectures at the Collège de France, 1977-78*. Senellart, M. (ed). Basingstoke : Palgrave Macmillan. Translated by G. Burchell.
- Fox, R. G. 2002. 'East of Said.' Vincent, J. (ed), *The anthropology of Politics: a reader in ethnography, theory and critique*. Oxford: Blackwell Publishers.
- Galvani, J. 1974. 'Syria and the Baath Party.' *MERIP Reports*, 25: 3-16.
- Geertz, C. (ed). 1963. *Old societies and new states: The quest for modernity in Asia and Africa*. New York: Free Press.
- Geertz, C. 1968. *Islam observed: religious development in Morocco and Indonesia*. New Haven: Yale University Press.
- Geertz, C. 1995. *After the fact: Two countries, four decades, one anthropologist*. MA: Harvard University Press.
- Geertz, C. and Geertz, H. and Rosen, L. 1979. *Meaning and order in Moroccan Society*. Cambridge: Cambridge University Press.
- Gell, A. 1985. 'Style and meaning in Umeda dance.' Spencer, P. (ed), *Society and the Dance: The Social Anthropology of Process and Performance*. Cambridge: Cambridge University Press.
- Gell, A. 1998. *Art and Agency: An Anthropological Theory*. Oxford: Clarendon Press.
- Gellner, E. 1969. *Saints of the Atlas*. Chicago: Chicago University Press.
- Gellner, E. 1981. *Muslim Society*. Cambridge: Cambridge University Press.
- Gellner, E. 1983. *Nations and Nationalism*. Ithaca: Cornell University Press.
- Gellner, E. 1994. *Conditions of Liberty: civil society and its rivals*. Harmondsworth: Penguin.
- George, A. 2003. *Syria : neither bread nor freedom*. London: Zed.
- Ghossoun, 2008. 'Under Patronage of President al-Assad, Arab Pioneer Creators Festival Opened' *Syrian Arab News Agency (SANA)*.
- Gills, B. K. 2005. "'Empire" versus "Cosmopolis": The clash of globalizations.' *Globalizations*, 2(1): 5-13.
- Gilsenan, M. 1990. *Recognizing Islam: Religion and society in the modern Middle East*. London: I.B. Tauris.
- Gilsenan, M. 1996. *Lords of the Lebanese Marches: Violence and Narrative in an Arab Society*. London: I.B. Tauris Publishers.
- Ginsburg F. D. and Abu-Lughod L. and Larkin B.(eds). 2002. *Media Worlds: Anthropology on New Terrain*. London: University of California Press.
- Gluckman, M. 1958. 'Analysis of a social situation in modern Zutland.' *The Rhodes-Livingstone Papers*, 28. Manchester: Manchester University Press.
- Goffman, E. 1990 [1959]. *The presentation of self in everyday life*. London: Penguin Books.
- Goody, J. 1990. 'Marriage and property in the Arab world.' *The Oriental, the ancient and the primitive: Systems of marriage and the family in the pre-industrial societies of Eurasia*. Cambridge: Cambridge University Press, pp. 361-382.
- Gramsci, A. 1999. *A Gramsci reader: Selected writings 1916-1935*. Forgacs, D. (ed.). London: Lawrence and Wishart.
- Granqvist, H. 1947. *Birth and childhood among the Arabs*. Helsingfors: Soderstroms.
- Grosz, E. 1994. *Volatile bodies: Toward a corporeal feminism*. Bloomington: Indiana University Press.
- Gulick, J. 1968. 'The Arab Levant and Annotated Bibliography.' L. E. Sweet (ed), *The Central Middle East: A Handbook of anthropology, vol. I*. Connecticut: Human Relations Area Files, Incorporated, pp. 111-232.
- Haddad, B. 2012. *Business Networks in Syria: The Political Economy of Authoritarian Resilience*. Stanford: Stanford University Press.
- Haifa. 2010. 'Silk Road Festival Tourists Evoke Magnificence of Palmyra.' *Syrian Arab News*

- Agency (SANA). <http://www.sana.sy/print.html?sid=310758&newlang=eng> (accessed October 2010).
- Hanley, W. 2008. 'Grieving cosmopolitanism in Middle East studies.' *History Compass*, 6(5): 1346-1367.
- Hanna, J. L. 1988. *Dance, Sex and Gender: Signs of Identity, Dominance, Defiance, and Desire*. London: The University of Chicago Press.
- Harding, H. 2009. 'Tallying the cost.' *Syria Today*. 51 (July): <http://www.syria-today.com/index.php/july-2009/362-business-features/2017-tallying-the-cost>. (accessed May 2010).
- Hardt, M and Negri, A. 2001. *Empire*. Harvard University Press.
- Harvey, D. 2009. *Cosmopolitanism and the geographies of freedom*. West Sussex: Columbia University Press.
- Hatem, M. 1987. 'Class and patriarchy as competing paradigms of Middle Eastern Women.' *Society for Comperative Study of Society and History*: 811-818.
- Hazran, Y. 2009. 'Between authenticity and alienation: the Druzes and Lebanon's history.' *Bulletin of SOAS*. 72 (3): 459-487.
- Heidegger, M. 1985 [1927/1962]. *Being and Time*. Oxford: Basil Blackwell. Translated by J. Macquarriet and E. Robinson.
- Herzfeld, M. 1987. *Anthropology through the looking-glass: critical ethnography in the margins of Europe*. Cambridge: Cambridge University Press.
- Herzfeld, M. 2004. *The body impolitic: artisans and artifice in the global hierarchy of value*. London: The University of Chicago Press.
- Herzfeld, M. 2005 [1997]. *Cultural Intimacy: Social poetics in the nation-state* (second edition). London: Routledge.
- Hinnebusch, R.A. 1990. *Authoritarian power and state formation in Ba'thist Syria: Army, Party, and Peasant*. Oxford: Westview Press.
- Hinnebusch, R. A. 1991. 'Class and State in Ba'athist Syria.' Antoun, R. T. and Quataert, D. (eds), *Syria: Society, Culture, and Polity*. Albany: State University of New York: 29- 48.
- Hinnebusch, R. A. 1996. 'Does Syria Want Peace? Syrian Policy in the Syrian-Israeli Peace Negotiations.' *Journal of Palestine Studies*, 26 (1): 42-57.
- Hinnebusch, R. A. 2001. *Syria: Revolution from Above*. London: Routledge.
- Hitti, P. K. 1928. *The Origins of the Druze People and Religion: With extracts from their sacred writings*. New York: Columbia University Press.
- Hobsbawm, E. J. 1995 (1975). *The Age of capital 1848-1875*. London: Abacus.
- Hobsbawm, E. J. 2006 [1983]. 'Introduction: Inventing traditions.' E. J. Hobsbawm and T. Ranger (eds), *The Invention of Tradition*. Cambridge: Cambridge University Press.
- Holy, L. 1989. *Kinship, Honour and Solidarity: Cousin Marriage in the Middle East*. Manchester: Manchester University Press.
- Hood, K. 2007. *Music in Druze Life: Ritual, values and performance practice*. London: Druze Heritage Foundation.
- Hoshan, H. 2009. 'Iraqi refugees in Syria worry as governments dispute.' *Alarabiya*. Translation: Farid, S. Sunday, 13 September. <http://www.alarabiya.net/articles/2009/09/13/84841.html> (Accessed May 2010).
- Houli, A. 2010. 'Congratulations! A rebellious cry in an oppressive society!' *eSyria, eHoms* (31/7/2010), <http://www.esyria.sy/ehoms/index.php?p=storie&category=activities&filename=201007312010011> (accessed 10/4/2011). Trans. A. Mahdi.
- Hourani, A. 2005 [1991]. *A History of the Arab Peoples*. London: Faber and Faber.
- Interview of President Bashar al-Assad with The Wall Street Journal, 31 January 2011 (<http://online.wsj.com/article/SB10001424052748703833204576114712441122894.html#articleTabs%3Darticle>) (Accessed February 2011).
- Irwin, R. 2006 [1999]. *The Penguin anthology of classical Arabic literature*. London: Penguin Books.
- Ismael, M. 2009. "Third "Green Idleb" Festival for Folk Arts Starts". *Syrian Arab News Agency*

- (SANA). <http://www.sana.sy/print.html?sid=234423&newlang=eng>
- Ismael, S. M. 2010. 'Movement marriage starts with body divorce: 'Congratulations!' from Damascus citadel's basement to riwak.' *Tishreen Newspaper* (20/7/2010), Syria. Trans. A. Mahdi.
- Jackson, M. 1999. *Minima Ethnographica: Intersubjectivity and the Anthropological Project*. Chicago: University of Chicago Press.
- Jackson, M. 2006. *The politics of storytelling: Violence, transgression and intersubjectivity*. Copenhagen: Museum Tusulanum Press.
- Jamous, M. 2009. 'Wedding... Transferred from pleasure to imprisoning.' *Al-Nour Newspaper* (14/10/09). Trans. A. Mahdi.
- Jaramana Council (*mijlis balad jaramana*). 2000. *Jaramana... jara al-fayba': bayna al-turāth wa al-hadāthaa*. Jaramana, Syria.
- Jean-Klein, I. 2000. 'Mothercraft, Statecraft, and Subjectivity in the Palestinian intifada.' *American Ethnologist*, 27 (1): 100-127.
- Jean-Klein, I. 2001. 'Nationalism and Resistance: The Two Faces of Everyday Activism in Palestine during the Intifada.' *Cultural Anthropology*, 16 (1): 83-126.
- Jean-Klein, I. 2003. 'Into Committees, out of the House?: Familiar Forms in the Organization of Palestinian Committee Activism during the First Intifada.' *American Ethnologist*, 30 (4): 556-577.
- Jillo, M. 2009. 'Congratulations! Cultural taboos in the basement of Eastern consciousness.' *Tishreen Newspaper* (31/10/09), Syria. Trans. A. Mahdi.
- Joseph, S. (ed.) 1999. *Intimate selving in Arab Families: Gender, self, and identity*. Syracuse: Syracuse University Press.
- Joseph, S. (ed.) 2003-2007. *Encyclopedia of women & Islamic cultures*. Vol. 1-6. Leiden: Brill.
- Joseph, S. 1994. 'Brother/Sister Relationships: Connectivity, Love, and Power in the Reproduction of Patriarchy in Lebanon.' *American Ethnologist*, 21 (1): 50-73.
- Joseph, S. 1999. 'Introduction: Theories and dynamics of gender, self, and identity in Arab families,' Joseph, S. (ed.), *Intimate selving in Arab Families: Gender, self, and identity*. Syracuse: Syracuse University Press, pp. 1-17.
- Joumblatt, K. 1982. *I speak for Lebanon*. London: Zed Press. Translated by Michael Pallis.
- Kan'an, W. 2010. 'Noura Murad, Damascene bridal as you've never seen it before!' *Al-Akhhbar Newspaper* (23/7/10), Lebanon. Trans. A. Mahdi.
- Kanaaneh, R. A. 2002. *Birthing the nation: strategies of Palestinian women in Israel*. London: University of California Press.
- Kant, I. 1795. *Perpetual Peace: A Philosophical Sketch*.
<http://www.mtholyoke.edu/acad/intrel/kant/kant1.htm>. Accessed October 2011.
- Karayanni, S. S. 2010 [2004]. *Dancing fear and desire: Race, sexuality and Imperial politics in Middle Eastern dance*. Ontario: Wilfrid Laurier University Press.
- Kassab, E. S. 2010. *Contemporary Arab Thought: Cultural critique in comparative perspective*. New York: Columbia University Press.
- Kastrinou Theodoropoulou, A. M. A. 2011. 'The marriage of Cadmus and Harmony and the burial of the martyrs: Syrian dances in the Arab spring.' *Jadaliyya*.
<http://www.jadaliyya.com/pages/index/1759/the-marriage-of-cadmus-and-harmony-and-the-burial->. Accessed June 2011.
- Kastrinou-Theodoropoulou, A. M. A. 2009. 'Setting the Syrian stage: A case study of dance and power.' *Durham Anthropology Journal*, 16(1) 2009: 3-12.
- Kaylani, N. M. 1972. 'The Rise of the Syrian Ba'ath, 1940-1958: Political Success, Party Failure.' *International Journal of Middle East Studies*, 3 (1): 3-23.
- Keesing, Roger. 1975. 'Patrilineal Descent and the Permutations of Descent Systems.' Roger Keesing, *Kin Groups and Social Structure*. New York: Holt, Rinehart and Winston, pp. 25-61.
- Kelidar, A. 1993. 'States without foundations: The political evolution of state and society in the Arab East.' *Journal of Contemporary History*, 28(2): 315-339.

- Keyser, J. M. B. 1974. 'The Middle Eastern case: Is there a marriage rule?' *Ethnology*, 13 (3): 293-309.
- Khalaf, S. N. 1981. *Family, Village and the Political Party: Articulation of social change in contemporary rural Syria*. Los Angeles: University of California, University Microfilms International. (Ph.D. Thesis)
- Khalaf, S. N. 1990. 'The settlement of violence in Bedouin society,' *Ethnology*, 29 (3): 225-242.
- Khalaf, S. N. 1991. 'Land Reform and Class Structure in Rural Syria.' Antoun, R. T. and Quataert, D. (eds.) *Syria: Society, Culture, and Polity*. Albany: State University of New York, pp. 63- 78.
- Khalaf, S. N. 2000. 'Poetics and Politics of Newly Invented Traditions in the Gulf: Camel Racing in the United Arab Emirates.' *Ethnology*, 39 (3): 243- 261.
- Khoury, P. S. 1983. *Urban notables and Arab nationalism : the politics of Damascus, 1860-1920*, Cambridge Middle East library. Cambridge: Cambridge University Press.
- Khoury, P. S. 1991. 'Continuity and Change in Syrian Political Life: The Nineteenth and Twentieth Centuries.' *The American Historical Review*, 96 (5): 1374-1395.
- Khoury, P. S. 1991. 'Syrian political culture: A historical perspective.' R. T. Antoun and D. Quataert (eds.), *Syria: Society, culture and polity*. Albany: State University of New York Press, pp: 13-27.
- Khuri, F. I. 1990. *Tents and pyramids: Games and Ideology in Arab Culture*. London: Saqi.
- Khuri, F. I. 2001. *The body in Islamic culture*. London: Saqi Books.
- Khuri, F. I. 2004. *Being a Druze*. London: Druze Heritage Foundation.
- Khuri, F. I. 2006. 'Aspects of Druze Social Structure: "There are no free-floating Druze!'" Salibi, K. (ed), *The Druze: Realities and perceptions*. London: Druze Heritage Foundation, pp. 61-78.
- Kirtsoglou, E. 2004. *For the Love of Women: Gender, Identity and Same-Sex Relations in a Greek Provincial Town*. London: Routledge.
- Kisch, S. 2009. 'Reproductive encounters: Negev Bedouin women's lay encounters at childbirth in an Israeli hospital.' *Anthropological Quarterly*, 82 (3): 719-754.
- Kleinman, A. and Das, V. and Lock, M. 1997. *Social suffering*. London: University of California Press.
- Kostrz, M. 2008. 'New movement in theatre.' *Syria Today*, March 2008.
- Krinelos, D.I. 1995. 'Procrustis.' *Encyclopedic dictionary of Greek mythology with the genealogies of gods and heroes*. Vol. B: 589. Athens: Ekdoseis Gnosi kai Biblio. (translated from Greek by author).
- Kurtz, D. V. 1996. 'Hegemony and anthropology: Gramsci, exegeses, reinterpretations.' *Critique of Anthropology*, 16 (2): 103-135.
- Landis, J. 2007. 'Syria: Secularism, Arabism, and Sunni Orthodoxy,' E. Doumato and G. Starrett, (eds), *Teaching Islam: Textbooks and Religion in the Middle East*, London & Boulder: Lynne Rienner Publishers, pp. 177-196. (<http://faculty-staff.ou.edu/L/Joshua.M.Landis1/Islamic%20Education%20in%20Syria.htm>)
- Latour, B. 1993 [1991]. *We have never been modern*. Cambridge, MA: Harvard University Press.
- Lawson F. H. 1984. 'Syria's intervention in the Lebanese civil war, 1976: a domestic conflict explanation.' *International Organization*, 38: 451-480.
- Lawson, F. H. 2009. 'The beginning of a beautiful friendship: Syrian-Turkish relations since 1998.' Lawson F. H. (ed), *Demystifying Syria*. London: Saqi in association with London Middle East Institute SOAS, pp. 180-205.
- Layish, A. 1982. *Marriage, divorce and succession in the Druze family: A study based on decisions of Druze arbitrators and religious courts in Israel and the Golan Heights*. Leiden: E. J. Brill.
- Layne, L. L. 1989. 'The Dialogics of Tribal Self-Representation in Jordan.' *American Ethnologist*, 16 (1): 24-39.
- Layton, R. 1981. *The Anthropology of Art*. London: Granada.
- Layton, R. 2006. *Order and anarchy: Civil society, social disorder and war*. Cambridge: Cambridge

- University Press.
- Levi, P. 2004. The gray zone. N. Scheper-Hughes and P. Bourgois (eds), *Violence in war and peace: An anthology*. Oxford: Blackwell Publishing, pp. 83-90.
- Lewis, B. 1964. *The Middle East and the West*. London: Weidenfeld and Nicolson.
- Lindholm, C. 1986. 'Kinship structure and political authority: The Middle East and Central Asia.' *Comparative Studies in Society and History*, 28 (2): 334-355.
- Lindisfarne, N. 2000. *Dancing in Damascus: stories*. Albany: State University of New York Press.
- Lindisfarne, N. 2002. 'Starting from below: fieldwork, gender and imperialism now.' *Critique of Anthropology*, 22 (4): 403-423.
- Lindisfarne, N. 2006. Review Salamandra 2004. *Journal of the Royal Anthropological Institute*, 12: 722-723.
- Lock, M. and Farquhar, J. (eds). 2007. *Beyond the body Proper: Reading the anthropology of material life*. London: Duke University Press.
- Lyon, S. M. 2004. *An Anthropological Analysis of Local Politics and Patronage in a Pakistani Village*. Lampater: The Edwin Mellen Press.
- Lyon, S. M. 2005. 'Culture and Information: An Anthropological Examination of Communication in Cultural Domains in Pakistan.' *Cybernetics and Systems: An International Journal*, 36(8):919-932.
- Lyon, S. M., and M. D. Fischer. 2006. 'Anthropology and Displacement: Culture, Communication and Computers Applied to a Real World Problem.' *Anthropology in Action*, 13(3):40-53.
- Mahmood, S. 2005. *Politics of piety: The Islamic revival and the feminist subject*. Oxford: Princeton University Press.
- Makarem, J. M. 2007. 'Druze Population.' *American Druze Heritage*, <http://americandruze.com/Druze%20Population.html>, accessed August 2011.
- Makarem, S. 2006. 'The Druze faith.' Salibi, K. (ed.), *The Druze: Realities and perceptions*. London: Druze Heritage Foundation, pp. 1-7.
- Makarem, S. N. 1979 (1974). *The Druze Faith*. New York: Caravan Books.
- Malkki, L. H. 2004. 'From Purity and exile: Violence, memory, and national cosmology among Hutu refugees in Tanzania.' N. Scheper-Hughes and P. Bourgois (eds), *Violence in war and peace: An anthology*. Oxford: Blackwell Publishing, pp. 129-135.
- Manning, E. 2007. *Politics of touch: Sense, movement, sovereignty*. London: University of Minnesota Press.
- Manuel, Peter. 1988. *Popular Musics of the Non-Western World: An Introductory Survey*. Oxford: Oxford University Press.
- Marcus, G. E. 1995. 'Ethnography in/of the world system: The emergence of multi-sited ethnography.' *Annual Review of Anthropology*, 24: 95-117.
- Mauss, M. 2007 [1935]. 'Techniques of the body.' M. Lock and J. Farquhar (eds), *Beyond the body Proper: Reading the anthropology of material life*. London: Duke University Press, pp. 50-68.
- McNay, L. 1992. *Foucault and Feminism*. Cambridge: Polity Press.
- Meeker, M. E. 1976. 'Meaning and society in the near East: Examples from the Black Sea Turks and the Levantine Arabs (II).' *International Journal of Middle East Studies*, 7 (3): 383-422.
- Melhem, H. 1997. 'Syria between Two Transitions.' *Middle East Report*. No. 203, Lebanon and Syria: The Geopolitics of Change. (Spring): 2-7.
- Merleau-Ponty, M. 1962 [1945]. *Phenomenology of Perception*. Translated by Colin Smith, London: Routledge & Kegan Paul.
- Merli, C. 2008. *Bodily practices and medical identities in Southern Thailand*. Uppsala: Uppsala Universitet ((Uppsala Studies in Cultural Anthropology).
- Milhem R. August 16, 2009. 'Amrit Culture and Art Festival Kicks off in Tartous.' *Syrian Arab News Agency* (SANA).
- Milhem, R. August 5, 2009. 'Bosra International Festival, a Window for Spreading Global Cultural Heritage.' *Syrian Arab News Agency* (SANA).

- Milhem, R. July 22, 2009. 'First Mountain Festival ... Various Events and More.' *Syrian Arab News Agency* (SANA).
- Miller, D. 1994. *Modernity: An ethnographic approach*. Oxford: Berg.
- Minority Rights Group International. 'World Directory of Minorities: Syria Overview'. <http://www.minorityrights.org/?lid=5266&tmpl=printpage>, Accessed Nov. 2011.
- Mitchell, T. 1990. 'Everyday Metaphors of Power.' *Theory and Society*, 19(4): 545-577.
- Mitchell, T. 1991. *Colonising Egypt*. London: University of California Press.
- Mitchell, T. 2006 [1999]. 'Society, economy, and the state effect.' Sharma A and Gupta A. (eds), *The anthropology of the state: A reader*. London: Blackwell, pp. 169-186.
- Mohammad, Y. 2009. '“Congratulations!?”: Half a performance by Leish troupe within half an article!' *Shamlife Magazine* (17/10/09), Syria. Trans. A. Mahdi.
- Mohr, D. 2007. 'The Axis of Evil is after all not so bad.' *Algemeen Dagblad* (2 November). On-line: <http://www.syriatourism.org/modules.php?op=modload&name=News&file=article&sid=1589&mode=thread&order=0&thold=0> (Accessed September 24 2010).
- Moore, H. L. 1999. 'Anthropological theory at the turn of the century.' H. L. Moore (ed), *Anthropological Theory Today*. Cambridge: Polity Press, pp. 1-23.
- Mundy, M. 1995. *Domestic government : kinship, community and polity in north Yemen*. London : Tauris.
- Mundy, M. and Smith, R. S. 2007. *Governing property, making the modern state : law, administration and production in Ottoman Syria*. London : I.B. Tauris.
- Murphy, R. F. and Kasdan, L. 1959. 'The structure of parallel cousin marriage.' *American Anthropologist*, 61 (1): 17-29.
- Muslih, M. 1987. 'Arab Politics and the Rise of Palestinian Nationalism.' *Journal of Palestine Studies*, 16 (4): 77-94.
- Nasser, Gamal Abdel. 1955. *The Philosophy of the Revolution*. Cairo.
- Naufal, T. P. 2005. 'Silvestre de Sacy on the Druze.' Salibi, K. (ed), *The Druze: Realities and perceptions*. London: Druze Heritage Foundation, pp. 9-28.
- Needham, R. 1963. 'Some disputed points in the study of prescriptive alliance.' *Southwestern Journal of Anthropology*, 19: 186-207.
- Nelson, C. 1974. 'Public and Private Politics: women in the Middle Eastern World.' *American Ethnologist*, 1 (3): 551-563.
- Nelson, C. 1991. 'Old Wine, New Bottles: Reflections and Projections Concerning Research on Women in Middle Eastern Studies.' E. Sullivan and J. Ismael (eds), *The Contemporary Study of the Arab World*. Alberta: University of Alberta Press.
- Oppenheimer, J. W. S. 1980. '"We are born in each other's houses:" Communal and patrilineal ideologies in Druze village religion and structure.' *American Ethnologist*, 7 (4): 621-636.
- Pace J. and Landis J. 2009. 'The Syrian opposition: The struggle for unity and relevance, 2003-2008.' F. H. Lawson (ed), *Demystifying Syria*. London: Saqi in association with London Middle East Institute SOAS. 120-143.
- Patai, R. 1955. 'Cousin-right in Middle Eastern Societies.' *Southwestern Journal of Anthropology*, 11 (4): 371-390.
- Pels, P. 1997. 'The anthropology of colonialism: Culture, history, and the emergence of Western governmentality.' *Annual Review of Anthropology*, 26 (1): 163-183.
- Perthes, Volker. 1997. 'Syria's Involvement in Lebanon.' *Middle East Report*. No. 203, Lebanon and Syria: The Geopolitics of Change. (Spring), pp. 18.
- Perthes, Volker. 2001. 'Syrian Regional Policy under Bashar al-Asad: Realignment or Economic Rationalization?' *Middle East Report*, No. 220. (Autumn), pp. 36-41.
- Peters, E. 1967. 'Some structural aspects of the feud among the camel-herding Bedouin of Cyrenaica.' *Africa*, 27: 261-282.
- Piot, C. 1999. *Remotely Global: Village modernity in West Africa*. London: The University of Chicago Press.

- Pitt-Rivers, Julian. 1977. *The Fate of Shechem or, The Politics of Sex: Essays in the Anthropology of the Mediterranean*. Cambridge: Cambridge University Press.
- Pomichalova, A. 2008. 'Silk Road Festival in Syria.' <http://www.sbbc.org.uk/node/2956> (Accessed September 24 2010).
- Portes, A. 1998. 'Social Capital: its origins and applications in modern sociology.' *Annual Review of Sociology*, 24: 1-24.
- Potuglu-Cook, Ö. 2006. 'Beyond the glitter: Belly dance and neoliberal gentrification in Istanbul.' *Cultural Anthropology*. 21(4): 633-660.
- Provence, M. 2006. 'Druze Shaykhs, Arab Nationalists and Grain Merchants.' Salibi, K. (ed), *The Druze: Realities and perceptions*. London: Druze Heritage Foundation, pp. 139- 153.
- Rabinow, P. 1989. *French modern: Norms and forms of the social environment*. Cambridge, MA: MIT Press.
- Rabo, A. 2005. *A shop of one's own: Independence and reputation among traders in Aleppo*. London: I.B. Tauris.
- Rabo, Annika. 1986. *Change on the Euphrates: villagers, townsmen, and employees in northeast Syria*. Stockholm: Studies in Social Anthropology.
- Rapport, N. 1997. *Transcendent Individual: Towards a Literary and Liberal Anthropology*. London: Routledge.
- Reed, S. A. 1998. 'The politics and poetics of dance.' *Annual Review of Anthropology*. 27: 503-532.
- Richardson, M. 1990. 'Enough Said: Reflections on Orientalism.' *Anthropology Today*, 6 (4): 16-19.
- Rugh, A. B. 1997. *Within the circle: Parents and children in an Arab village*. New York: Columbia University Press.
- Ruyter, N. L. C. 1995. 'Some Musings on folk dance.' *Dance Chronicle*, 18(2): 269-279.
- Sabbagh, H. August 2, 2009. 'The Twentieth Session of al-Mahabba Festival Kicks Off in Lattakia.' *Syrian Arab News Agency (SANA)*.
- Sabbagh, H. December 13, 2008. 'Participants in Damascus International Festival of Theater Describe It as Opportunity for Dialogue and Exchanging Ideas.' *Syrian Arab News Agency (SANA)*.
- Sahlins, M. 1991. 'The return of the event.' A. Biersack (ed), *Clio in Oceania*. Washington D.C.: Smithsonian.
- Sahlins, M. 1999. 'What is Anthropological Enlightenment? Some Lessons of the Twentieth Century.' *Annual Review of Anthropology*, 28: i-xxiii.
- Said, E. W. 1978. *Orientalism*. London: Routledge & Kegan Paul.
- Said, H. July 16, 2009. 'Al-Qalaa and Al-Wadi Festival Kicks off with Arab-Cuban Music.' *Syrian Arab News Agency (SANA)*.
- Said, H. July 29, 2009. '21st Bosra International Festival Celebrates Jerusalem.' *Syrian Arab News Agency (SANA)*.
- Saint Exupéry, A. 1991. *The little prince*. Translated by K. Woods. Mammoth.
- Salamandra, C. A. 2004. *A New Old Damascus: Authenticity and distinction in urban Syria*. Bloomington: Indiana University Press.
- Salibi, K. 2006. 'Jebel Druze as seen by Rustum Haydar.' Salibi, K. (ed), *The Druze: Realities and perceptions*. London: Druze Heritage Foundation, pp. 129-38.
- Salzman, P. C. 1978. 'Does Complementary Opposition Exit?' *American Anthropologist*, 80 (1): 53-70.
- Sartre, J. P. 1989. *No exit, and three other plays*. New York: Vintage International.
- Sato, N. 2001. *Memory and social identity among Syrian Orthodox Christians*. PhD thesis. Durham: Durham University.
- Savigliano, M. E. 1995. *Tango and the political economy of passion*. Oxford: Westview Press.
- Schenk, B. 2006. 'Druze identity in the Middle East: Tendencies and developments in modern Druze communities since the 1960s.' Salibi, K. (ed), *The Druze: Realities and perceptions*. London: Druze Heritage Foundation, pp. 79-93.
- Scheper-Hughes, N. 2004. 'Bodies, death, and silence.' N. Scheper-Hughes and P. Bourgois

- (eds), *Violence in war and peace: An anthology*. Oxford: Blackwell Publishing, pp. 175-185.
- Scheper-Hughes, N. and Bourgois, P. 2004. *Violence in war and peace: An anthology*. Oxford: Blackwell Publishing.
- Schieffelin, E. L. 1976. *The Sorrow of the Lonely and the Burning of the Dancers*. New York: St. Martin's Press.
- Scott, J. C. 1985. *Weapons of the Weak: Everyday Forms of Peasant Resistance*. London: Yale University Press.
- Scott, J. C. 1998. *Seeing like a state: How certain schemes to improve the human condition have failed*. London: Yale University Press.
- Seabrook, W. B. 1928. *Adventures in Arabia: Among the Bedouins Druses Whirling Dervishes and Yazidee Devil-worshippers*. London: George G. Harrap & Co. Ltd.
- Seale, P. 1986. *The Struggle for Syria*. London: Yale University Press.
- Seale, P. 1989. *Assad of Syria: The struggle for the Middle East*. Berkeley: University of California Press.
- Seale, P. 2000. 'The Syria-Israel Negotiations: Who is Telling the Truth?' *Journal of Palestine Studies*, 29 (2): 65-77.
- Seremetakis, N. C. 1991. *The last word: Women, death, and divination in Inner Mani*. London: University of Chicago Press.
- Shaaban, B. 1988. *Both right and left hand: Arab women talk about their lives*. London: The Women's Press.
- Shand, Angela. 1998. 'The Tsifte-teli Sermon: Identity, Theology, and Gender in Rebetika.' Washabaugh, W. (ed), *The Passion of Music and Dance: Body, Gender and Sexuality*. Oxford: Berg, pp. 127- 132.
- Shannon, Jonathan Holt. 2006. *Among the jasmine trees: music and modernity in contemporary Syria*. Middletown, Conn.: Wesleyan University Press.
- Shay, A. 2002. *Choreographic Politics: State folk dance companies, representation and power*. Middletown: Wesleyan University Press.
- 'Silk Road 2010 – New Destination towards Beautiful Past,' *Ministry of Tourism, Syria*. On-line: <http://syriatourism.org/modules.php?op=modload&name=News&file=article&sid=2825>, accessed on October 7, 2010.
- Sillitoe, P. 1996. *A place against time: Land and environment in the Papua New Guinea Highlands*. Amsterdam: Harwood Academic Publishers.
- Smith, G. 2004. 'Hegemony.' D. Nugent and J. Vincent (eds), *A Companion to the Anthropology of Politics*. Oxford: Blackwell Publishing, pp. 216-230.
- Snaij, B. M. 2009. 'Congratulations: Movement restorations for endless weddings.' *Shurufat al-Sham* (2/11/09), Syria. Trans. A. Mahdi.
- Spivak, G. C. 1988. 'Can the subaltern speak?.' C. Nelson, and L. Grossberg (eds), *Marxism and the interpretation of culture*. Chicago: University of Illinois Press, pp. 271-313.
- States, B. O. 1996. 'Performance as a metaphor.' *Theatre Journal*, 48 (1): 1-26.
- Steinbeck, J. 2000. *The Grapes of Wrath*. London: Penguin Modern Classics.
- Steingress, Gerhard. 1998. 'Social Theory and the Comparative History of Flamenco, Tango, and Rebetika.' Washabaugh, W. (ed), *The Passion of Music and Dance: Body, Gender and Sexuality*. Oxford: Berg, pp. 151-171.
- Stewart, F. H. 1994. *Honor*. Chicago: Chicago University Press.
- Stirrat, R. L and Henkel, H. 1997. 'The Development Gift: The problem of reciprocity in the NGO world.' *The ANNALS of the American Academy of Political and Social Science*, 554 (1): 66-80.
- Strathern, M. 1990. *The gender of the gift: Problems with women and problems with society in Melanesia*. London: University of California Press.
- Strathern, M. 2004 [1991]. *Partial Connections* (Updated edition). Oxford: AltaMira Press.
- Strathern, M. 2005. *Kinship, Law and the Unexpected: relatives are always a surprise*. Cambridge: Cambridge University Press.
- Strijp, R. 1992. *Cultural anthropology of the Middle East: a bibliography* (vol. 1). Leiden: E. J. Brill.
- Strindberg, A. 2004. 'Syria under Pressure.' *Journal of Palestine Studies*, 33 (4): 53-69.

- Sweet, L. E. 1967. 'The Women of 'Ain Ad Dayr.' *Anthropological Quarterly*, 40 (3), Appearance and Reality: Status and Roles of Women in Mediterranean Societies (Special Issue): 167-183.
- Sweet, L. E. 1974. 'Visiting patterns and social Dynamics in a Lebanese Druze village.' *Anthropological Quarterly*, 47 (1): 112-119.
- Syrian Arab News Agency (SANA). 2009. 'Leish Troupe presents show of 'Congratulations!' performance in Damascus Citadel.' Trans. A. Mahdi.
- Syrian Arab News Agency (SANA). 2010. 'Damascus - SANA.' Personal archive of Leish Troupe. Trans. A. Mahdi.
- Tapper, R. 1995. "Islamic anthropology" and the "Anthropology of Islam".? *Anthropological Quarterly*, vol. 68: 185-193.
- Taussig, M. 1984. 'Culture of Terror - Space of Death: Roger Casement's Putumayo Report and the explanation of torture.' *Comparative Studies in Society and History*, 26 (1): 167-497.
- Taussig, M. 2004. 'Terror as usual: Walter Benjamin's theory of history as state of siege.' N. Scheper-Hughes and P. Bourgois (eds), *Violence in war and peace: An anthology*. Oxford: Blackwell Publishing, pp. 269-271.
- Tergeman, S. 1994. *Daughter of Damascus*. Austin: University of Texas at Austin. Translation from Arabic by A. B. Rugh.
- The Economist*. 2011. 'Media freedom in Syria: A show of strength or a sign of weakness?' (Feb 9), http://www.economist.com/blogs/newsbook/2011/02/media_freedom_syria.
- Thomas, N. 1991. 'Anthropology and Orientalism.' *Anthropology Today*, 7 (2): 4-7.
- Thompson, E. 2000. *Colonial citizens: Republican rights, paternal privilege, and gender in French Syria and Lebanon*. New York: Columbia University Press.
- Tibi, B. 1996. 'Old tribes and imposed nation-states in the Middle East.' Hutchinson J. and Smith A. D. (eds), *Ethnicity*. Oxford: Oxford University Press, pp. 174-179.
- Todorova, M. 1997. *Imagining the Balkans*. Oxford: Oxford University Press.
- Trouillot, M. R. 2001. 'The anthropology of the state in the age of globalization: Close encounters of the deceptive kind.' *Current Anthropology*, 42(1): 125-138.
- Turner, T. S. 2007 [1980]. 'The social skin.' Lock, M. and Farquhar, J. (eds), *Beyond the body Proper: Reading the anthropology of material life*. London: Duke University Press, pp. 83-103.
- Turner, V. 1967. *The forest of symbols*. Ithaca: Cornell University Press.
- Turner, V. 1982. 'Social dramas and stories about them.' *From ritual to theatre: Essays by Victor Turner*. New York: Performing Arts Journal Publication, pp. 61-88.
- Turner, V. 1995. *The ritual process: structure and anti-structure*. New York: Aldine de Gruyter.
- UNRWA. 2010. 'Jaramana Refugee Camp.' <http://www.unrwa.org/etemplate.php?id=149> (accessed June 2010).
- Van Aken, M. 2006. 'Dancing belonging: Contesting dabkeh in the Jordan Valley, Jordan.' *Journal of Ethnic and Migration Studies*, 32(2): 203-222.
- Van Dam, N. 1996. *The struggle for power in Syria: Politics and society under Asad and the Ba'th Party*. London: I.B. Tauris Publishers.
- Van Der Pijl, K. 2011. 'Arab revolts and nation-state crisis.' *New Left Review*, 70 (July-August): 27-49.
- Van Gennep, A. 1960. *The rites of passage*. London: Routledge & Kegan Paul. Translated by M. B. Vizedom and G. L. Caffé.
- van Nieuwkerk, K. 1997 [1995]. *A trade like any other: Female singers and dancers in Egypt*. Austin: University of Texas Press.
- Wacquant, L. 2004. 'The new "peculiar institution": On the prison as surrogate ghetto.' N. Scheper-Hughes and P. Bourgois (eds), *Violence in war and peace: An anthology*. Oxford: Blackwell Publishing, pp.318-323.
- Wagner, C. 2009. 'Syrian theatre explores male-female relationships.' *The Power of Culture*, <http://www.powerofculture.nl/en/current/2009/february/leish>. (Accessed July 2011).

- Wallerstein, I. M. 2004: *World-Systems Analysis: An Introduction*. Durham, North Carolina: Duke University Press.
- Washabaugh, W. (ed) 1998. *The Passion of Music and Dance: Body, Gender and Sexuality*. Oxford: Berg.
- Watenpaugh, K. D. 2006. *Being Modern in the Middle East: Revolution, Nationalism, Colonialism, and the Arab Middle Class*. Oxford: Princeton University Press.
- Weber, S. 2009. *Damascus: Ottoman modernity and urban transformation 1808-1918* (Vol. 1). Denmark: Proceedings of the Danish Institute in Damascus.
- Wedeen, L. 1999. *Ambiguities of domination: politics, rhetoric, and symbols in contemporary Syria*. Chicago: University of Chicago Press.
- Westheimer, R. K. and Sedan, G. 2007. *The olive and the tree: The secret strength of the Druze*. New York: Lantern Books.
- Whitaker, B. 2009. *What is really wrong with the Middle East*. London: Saqi.
- Wolf, ER. 1997. *Europe and the People without History*. London: University of California Press.
- York, J. C. 2011. 'Unblocking Syria's social media.' *Al-Jazeera*, (Feb 12), (<http://english.aljazeera.net/indepth/opinion/2011/02/20111212122746819907.html#>)
- Zain, H. July 11, 2010. 'ENANA Group inaugurates Artistic Festival accompanying 57th session of Damascus International Fair.' Syrian Arab News Agency (SANA). <http://www.sana.sy/print.html?sid=297797&newlang=eng>
- Zielonka, J. 2007. *Europe as Empire: The Nature of the Enlarged European Union*. Oxford: Oxford University Press.
- Zubaida, S. 1989. *Islam, the people and the state: essays on political ideas and movements in the Middle East*. London: Routledge.
- Zubaida, S. 2001. 'Civil society, community, and democracy in the Middle East.' S. Kaviraj and S. Khilnani (eds), *Civil society: history and possibilities*. Cambridge: Cambridge University Press, pp. 232-249.
- Zubaida, S. 2003. *Law and power in the Islamic world*. London : I. B. Tauris.
- Zuhur, S. (ed) 2000. *Images of enchantment: Visual and performing arts of the Middle East*. Cairo: The American University in Cairo Press.
- Zuhur, S. (ed) 2003. *Colors of enchantment: Theater, dance, music, and the visual arts of the Middle East*. Cairo: The American University in Cairo Press.