

## Durham E-Theses

---

*Middle to upper Devonian (givetian and frasnian)  
shallow-water carbonates of Western Europe: fades  
analysis and cyclicity*

Joanna Garland

### How to cite:

---

Garland, Joanna (1997) Middle to upper Devonian (givetian and frasnian) shallow-water carbonates of Western Europe: fades analysis and cyclicity. Doctoral thesis, Durham University.

### Use policy

---

The full-text may be used and/or reproduced, and given to third parties in any format or medium, without prior permission or charge, for personal research or study, educational, or not-for-profit purposes provided that:

- a full bibliographic reference is made to the original source
- a <https://etheses.durham.ac.uk/id/eprint/4897/> is made to the metadata record in Durham E-Theses
- the full-text is not changed in any way

The full-text must not be sold in any format or medium without the formal permission of the copyright holders.

Please consult the [full Durham E-Theses policy](#) for further details.

**Middle to Upper Devonian  
(Givetian and Frasnian)  
Shallow-Water Carbonates of Western Europe:  
Facies Analysis and Cyclicity**

**Joanna Garland**



The copyright of this thesis rests with the author. No quotation from it should be published without the written consent of the author and information derived from it should be acknowledged.

**A thesis submitted in partial fulfilment of the degree of Doctor of Philosophy  
at the Department of Geological Sciences, University of Durham.**



1997

- 3 APR 1998

The copyright of this thesis rests with the author. No quotation from it should be published without prior written consent and information derived from it should be acknowledged.

No part of this thesis has been previously submitted for a degree in this or any other University. The work described in this thesis is entirely that of the author, except where reference is made to previous published or unpublished work.

## Abstract

The Middle and Upper Devonian (Givetian-Frasnian) shallow-water carbonate facies of western Europe were deposited as a large-scale transgressive succession over continental facies of the Old Red Continent. The transgression was in a northerly direction, reaching the southern Ardennes by the lower Eifelian and the Aachen area of Germany by the middle Givetian. Carbonate sedimentation continued through to the middle Frasnian, when a major pulse in relative sea-level rise drowned the platform.

The carbonate platform had a complex internal structure, with three major palaeosettings. During the Eifelian, a storm-influenced homoclinal ramp existed over much of the Ardennes. Sedimentation was mostly open-marine in nature, with a protected back-ramp and tidal-flats. The Givetian saw a transition from a ramp to shelf setting, with stromatoporoid reefs at the shelf edge providing protection for a broad shelf lagoon. The shelf had an ESE-WNW trend and extended from Boulogne (northern France) in the west to Aachen (western Germany) in the east. East of the river Rhine in the Rheinisches Schiefergebirge area of Germany, and in Southwest England, isolated carbonate complexes developed. These were positioned either on the shelf-edge, within the shelf or upon topographic highs within the basin. Synsedimentary tectonism and volcanism strongly influenced their development.

As a result of their areal extent, lagoonal environments were studied extensively in shelf and isolated complexes. Palaeontology and sedimentology were used to identify 14 major microfacies within the lagoonal successions, which could be broadly categorised into four major groups. The semi-restricted subtidal microfacies group has a rich faunal assemblage which, although diverse, did not represent fully open-marine deposition. Sedimentation was entirely subtidal in nature. The restricted subtidal microfacies group is either characterised by monospecific fossil assemblages (chiefly molluscs or amphiporoids), or by macrofossil-poor facies. These facies represent poorly-circulated, subtidal environments which may have been subjected to fluctuating salinities. The intertidal microfacies group is characterised by fenestral limestones, which are commonly poorly-fossiliferous. Finally the supratidal microfacies group is typified by dolomudstones, microbial laminites and calcretes.

A metre-scale cyclicity is prevalent in these lagoonal facies and two major types of cycle have been identified. Subtidal cycles show a decrease in circulation, decrease in diversity of organisms and increase in fluctuation of salinity upwards through the cycle. Peritidal cycles shallow upwards from a subtidal base through to an intertidal or supratidal cap. Subtidal cycles seem particularly common within the isolated carbonate complexes, yet both peritidal and subtidal cycles are identified in the shelf lagoon. The distribution of facies and cycles was controlled by a complex interaction of eustasy and differential subsidence. The setting (i.e., whether it was the shelf lagoon, or isolated carbonate complex) also influenced this distribution.

Fischer plots were used successfully to correlate successions across the carbonate platform, and to identify areas of condensed or expanded sedimentation. Cycles were calculated to have a duration of approximately 42,000 years for the Upper Givetian. The magnitude of relative sea-level change was in the order of 1-3m. The development of the metre-scale cyclicity is best explained by orbital forcing, yet this signature has been overprinted by autocyclic and tectonic noise. Third-order eustatic sea-level fluctuations were delineated by major marine transgressions, and a eustatic sea-level curve was established for the study area.

## Acknowledgements

First and foremost, I would like to thank Maurice Tucker and Colin Scrutton for initiating this project, for continually correcting my dodgy grammar (I think I know when to use hyphens and semi-colons now!), and for their supervision throughout my time at Durham. NERC, who funded this PhD., should be thanked for sending me on 'holiday' every summer.

My fieldwork in Germany, Belgium and Devon was greatly improved by the helpfulness of many people. For the initial introduction to Devonian geology, I would sincerely like to thank Alain Preat and his colleagues at Brussels University. The help that Trevor Burchette and Marie-Louise Frey gave with outcrop information in the Aachen area was also very much appreciated. The RWK quarry works in Dornap, and E&JW Glendenning Ltd company at Linhay Hill, Devon were kind enough to allow me access to their quarries. A big thank you should go to Angela and Caroline who were great field assistants and kept me vaguely sane in the field! Will we ever forget the German techno clubs and smelly Parisian men????! A huge thankyou should also go to the Jerram family (Roger, Jill, Laura, Nell) for constantly putting up with me arriving on their doorstep in Brussels every other weekend!

This thesis has been greatly improved by healthy discussions in the department, down the pub and at conferences. In particular I would like to thank Phil Heckel, Thomas Becker, and Carl Brett for their useful comments on the European Devonian and for an insight into the Devonian of New York. I would also like to thank Howard Armstrong for helping me with my stromatoporoids, Simon Grant for his French translation, discussion on cyclicity, and his chocolate, and Gail Radcliffe for helping with the conodont biostrat.. I would also like to acknowledge the help of Gilbert Larwood who sadly passed away during my time at Durham.

The geology department at Durham has been a great place to work over the last three years, mainly due to the friendliness of the staff. A huge thankyou should go to Julie and Ron for making over 400 thin sections for me - I bet you'll be glad to see the back of me! The vast amount of time that George Ruth and Dave Stevenson spent fixing and adding bits to my computer is also much appreciated. Thanks must also go to Dave Asbery, Dave Schofield, Gerry, Alan, Karen, Carol, Claire, and also to Ken Thomson and Dick Swarbrick for helping me get a job!

The postgrad and postdoc geology community, namely Gail, Jonny, Ziad, Simon, Moly, Adam, Wayne, Alun, Caroline, Matt, Ian, Martyn, Mark, Gary, Toby, Andy, Paul, Otter, Janine, Lee, and Sarah are thanked for their friendship and their everlasting willingness for a spontaneous beer sesh! I'm sure it must be beer o'clock! I small thankyou must also go to Mr. Mohammed Khalil for always giving me something to talk about at coffee time!

My friends from home, Liverpool and Durham: Trina, Trisha, Beki, Track, Adrian, Jo Moore, Si Knight, Hamster, Matster, Rene, Lisa, Jason, and Dave should all be thanked for their friendship and constant belief that I wouldn't be a student for the whole of my life! I would also like to thank my sister, Emma, for introducing me to Star Trek!!!!

Without the help of my parents, Margaret and Doug, I would not be here today writing these acknowledgements. I would like to thank them from the bottom of my heart for giving me the opportunities in life and always believing I would get a 'proper' job in the end!

Finally, all my love and thanks go to Dougal Jerram for helping through my PhD, for loaning me his computer, and for his wonderful companionship. Next step is to get you your E-type!!

Cheers everyone!

*For my family and Dougal*

# CONTENTS

|  |           |
|--|-----------|
| <b>1. INTRODUCTION</b> .....   | <b>1</b>  |
| 1.1 AIMS OF STUDY .....  | 1         |
| 1.2 TECHNIQUES USED .....  | 2         |
| 1.3 TERMINOLOGY .....  | 4         |
| 1.4 OUTLINE OF THESIS .....  | 6         |
| <b>2. BIOSTRATIGRAPHY AND REGIONAL GEOLOGY</b> .....                             | <b>8</b>  |
| 2.1 BIOSTRATIGRAPHY AND RADIOMETRIC DATING .....                                 | 8         |
| 2.2 REGIONAL GEOLOGY .....   | 13        |
| 2.2.1 <i>Pre-Devonian</i> .....  | 13        |
| 2.2.2 <i>Lower Devonian</i> .....  | 14        |
| 2.2.3 <i>Middle Devonian</i> .....   | 17        |
| 2.2.3.1 <i>Eifelian</i> .....  | 18        |
| 2.2.3.2 <i>Givetian</i> .....  | 20        |
| 2.2.4 <i>Upper Devonian</i> .....  | 24        |
| 2.2.4.1 <i>Frasnian</i> .....  | 25        |
| 2.2.4.2 <i>Famennian</i> .....   | 27        |
| 2.2.5 <i>Post Devonian</i> .....   | 29        |
| 2.2.6 <i>Synthesis</i> .....   | 30        |
| <b>3. PALAEOECOLOGY OF MIDDLE TO UPPER DEVONIAN CARBONATE ENVIRONMENTS</b> ..... | <b>33</b> |
| 3.1 STROMATOPOROIDS .....  | 33        |
| 3.1.1 <i>Domal stromatoporoids</i> .....   | 35        |
| 3.1.2 <i>Bulbous stromatoporoids</i> .....                                       | 36        |
| 3.1.3 <i>Tabular stromatoporoids</i> .....                                       | 37        |
| 3.1.4 <i>Columnar stromatoporoids</i> .....                                      | 38        |
| 3.1.5 <i>Branching stromatoporoids</i> .....                                     | 38        |
| 3.1.5.1 <i>Amphipora</i> .....   | 38        |
| 3.1.5.2 <i>Stachyodes</i> .....  | 40        |
| 3.2 CALCAREOUS ALGAE AND CYANOBACTERIA .....                                     | 41        |
| 3.2.1 <i>Chlorophytes (calcareous green algae)</i> .....                         | 43        |
| 3.2.1.1 <i>Dasycladaceae</i> .....   | 43        |
| 3.2.1.2 <i>Codiaceae</i> .....   | 44        |
| 3.2.2 <i>Calcified cyanobacteria ('blue-green algae')</i> .....                  | 46        |
| 3.2.2.1 <i>Girvanella Group</i> .....  | 46        |
| 3.2.2.2 <i>Hedstroemia Group</i> .....   | 47        |
| 3.2.2.3 <i>Renalcis Group</i> .....  | 47        |
| 3.2.2.4 <i>Wetheredella Group</i> .....  | 49        |
| 3.3 FORAMINIFERA .....   | 49        |
| 3.4 OSTRACODES .....   | 51        |
| 3.4.1 <i>Lepertitiid ostracodes</i> .....  | 51        |
| 3.5 'CALCISPHERES' .....   | 53        |
| 3.6 CORALS .....   | 53        |
| 3.7 BRACHIOPODS .....  | 55        |
| 3.8 MOLLUSCS .....   | 56        |
| 3.9 OTHERS .....   | 58        |
| 3.10 PALAEOECOLOGICAL RECONSTRUCTION .....                                       | 58        |
| <b>4. MICROFACIES ANALYSIS</b> .....   | <b>62</b> |
| 4.1 RAMP MICROFACIES .....   | 66        |
| 4.1.1 <i>R1 microfacies - bioturbated wackestones</i> .....                      | 67        |
| 4.1.2 <i>R2 microfacies - bioclastic packstones</i> .....                        | 68        |
| 4.1.3 <i>R3 microfacies - stromatoporoid floatstones</i> .....                   | 69        |
| 4.1.4 <i>R4 microfacies - oolitic/peloidal/bioclastic grainstones</i> .....      | 70        |

|  |            |
|--|------------|
| 4.1.4.1 R4a microfacies - oolitic grainstones .....                      | 71         |
| 4.1.4.2 R4b microfacies - peloidal grainstones .....                     | 72         |
| 4.1.4.3 R4c microfacies - bioclastic grainstones.....                    | 73         |
| 4.1.5 R5 microfacies - gastropod/bivalve wackestones.....                | 76         |
| 4.1.6 R6 microfacies - leperditicoid ostracode packstones.....           | 76         |
| 4.1.7 R7 microfacies - laminated dolomudstones .....                     | 77         |
| 4.1.8 Environmental reconstruction.....                                  | 79         |
| 4.2 LAGOONAL SHELF MICROFACIES .....                                     | 81         |
| 4.2.1 Semi-restricted subtidal microfacies group .....                   | 83         |
| 4.2.1.1 S1 microfacies - Intraformational breccias .....                 | 83         |
| 4.2.1.2 S2 microfacies - stromatoporoid floatstones .....                | 85         |
| 4.2.1.3 S3 microfacies - bioclastic wackestones to grainstones.....      | 88         |
| 4.2.2 Restricted subtidal microfacies group.....                         | 92         |
| 4.2.2.1 S4 microfacies - <i>Amphipora</i> floatstones.....               | 92         |
| 4.2.2.2 S5 microfacies - bioclastic wackestones.....                     | 95         |
| 4.2.2.3 S6 microfacies - macrofossil-poor micrites.....                  | 97         |
| 4.2.2.4 S7 microfacies - peloidal/oolitic grainstones .....              | 104        |
| 4.2.3 Intertidal microfacies group.....                                  | 109        |
| 4.2.3.1 S8 microfacies - laminoid-fenestral limestones .....             | 109        |
| 4.2.3.2 S9 microfacies - bioclastic grainstones with vadose cements..... | 114        |
| 4.2.3.3 S10 microfacies - fenestral laminites .....                      | 117        |
| 4.2.4 High intertidal-supratidal microfacies group .....                 | 120        |
| 4.2.4.1 S11 microfacies - intraformational breccias .....                | 120        |
| 4.2.4.2 S12 microfacies - laminites and stromatolites .....              | 121        |
| 4.2.4.3 S13 microfacies - dolomicrites.....                              | 126        |
| 4.2.4.4 S14 microfacies - calcretes .....                                | 129        |
| 4.2.5 Microfacies associations and summary.....                          | 135        |
| <b>5. DEVELOPMENT OF THE MIDDLE TO UPPER DEVONIAN CARBONATE</b>          |            |
| <b>COMPLEXES .....</b>   | <b>137</b> |
| 5.1 BROAD SHELF LAGOON.....  | 137        |
| 5.1.1 Eifelian-Givetian boundary.....                                    | 144        |
| 5.1.2 Lower Givetian .....   | 146        |
| 5.1.3 Upper Givetian.....  | 154        |
| 5.1.4 Givetian-Frasnian boundary.....                                    | 165        |
| 5.1.5 Lower Frasnian.....  | 166        |
| 5.1.6 Cyclicality .....  | 170        |
| 5.1.7 Summary.....   | 172        |
| 5.2 ISOLATED CARBONATE COMPLEXES .....                                   | 174        |
| 5.2.1 Shelf-edge reefal complexes.....                                   | 177        |
| 5.2.1.1 Attendorf Reef Complex .....                                     | 178        |
| 5.2.1.2 Brilon Reef Complex .....  | 182        |
| 5.2.1.3 Torbay Reef Complex .....  | 189        |
| 5.2.2 Inner shelf reefal complexes.....                                  | 199        |
| 5.2.2.1 Balve Reef Complex .....   | 200        |
| 5.2.2.2 Dornap Reef Complex .....  | 204        |
| 5.2.3 Trough reefal complexes.....                                       | 209        |
| 5.2.3.1 Langenaubach Reef Complex .....                                  | 209        |
| 5.2.4 Summary.....   | 212        |
| <b>6. MIDDLE AND UPPER DEVONIAN RELATIVE SEA-LEVEL FLUCTUATIONS.....</b> | <b>214</b> |
| 6.1 CONTROLS ON CARBONATE DEPOSITION.....                                | 214        |
| 6.2 CARBONATE RESPONSE TO RELATIVE SEA-LEVEL FLUCTUATIONS .....          | 216        |
| 6.3 PARASEQUENCES .....  | 217        |
| 6.4 PARASEQUENCE STACKING PATTERNS AND FISCHER PLOTS .....               | 220        |
| 6.5 METRE-SCALE CYCLICITY IN THE DEVONIAN.....                           | 222        |
| 6.5.1 Type A cycles.....   | 223        |
| 6.5.2 Type B cycles.....   | 227        |
| 6.5.3 Type C cycles.....   | 232        |
| 6.5.4 Upper Eifelian successions .....                                   | 233        |

|  |            |
|--|------------|
| 6.5.5 Ardennes-Aachen-Eifel area.....  | 236        |
| 6.5.5.1 Givetian strata.....   | 236        |
| 6.5.5.2 Frasnian.....  | 246        |
| 6.5.6 Isolated platforms.....  | 247        |
| 6.5.6.1 Shelf-edge.....  | 248        |
| 6.5.6.2 Inner shelf.....   | 253        |
| 6.5.6.3 Trough.....  | 256        |
| 6.5.7 Magnitude and duration of small-scale relative sea-level fluctuations..... | 256        |
| 6.6 MECHANISMS CAUSING METRE-SCALE CYCLICITY.....                                | 261        |
| 6.6.1 Sedimentary mechanism.....   | 261        |
| 6.6.2 Tectonic mechanism.....  | 263        |
| 6.6.3 Eustatic mechanism.....  | 264        |
| 6.7 DISCUSSION.....  | 268        |
| 6.8 3RD ORDER EUSTATIC FLUCTUATIONS OF THE GIVETIAN AND FRASNIAN.....            | 273        |
| 6.9 SUMMARY.....   | 274        |
| <b>7. SYNTHESIS AND CONCLUSIONS.....</b>   | <b>277</b> |
| 7.1 COMPARISONS BETWEEN THE SHELF LAGOON AND ISOLATED PLATFORMS.....             | 277        |
| 7.2 SUMMARY OF CONCLUSIONS.....  | 279        |
| <b>REFERENCES.....</b>   | <b>283</b> |
| <b>A1. THIN-SECTION DESCRIPTIONS.....</b>  | <b>305</b> |
| A1.1 THIN-SECTION CHECK-LIST.....  | 305        |
| A1.2 THIN-SECTION TABLES.....  | 309        |
| A1.2.1 Alt Breinig Quarry.....   | 310        |
| A1.2.2 Beauraing Quarry.....   | 311        |
| A1.2.3 Bellignies-Bettrechies Quarry.....  | 313        |
| A1.2.4 Bleiwäsche Quarry.....  | 315        |
| A1.2.5 Bleiwäsche Road Cutting.....  | 317        |
| A1.2.6 Broadridge Wood Quarry.....   | 318        |
| A1.2.7 Cul d'Houille Quarry.....   | 321        |
| A1.2.8 Dourbes Quarry.....   | 324        |
| A1.2.9 Froid Lieu Quarry.....  | 325        |
| A1.2.10 Glageon Quarry.....  | 327        |
| A1.2.11 Goodrington Road Cutting.....  | 331        |
| A1.2.12 Hanielsfeld Quarry.....  | 332        |
| A1.2.13 Heggen Quarry.....   | 333        |
| A1.2.14 Keldenich Quarry.....  | 336        |
| A1.2.15 Linhay Hill Quarry.....  | 338        |
| A1.2.16 Medenbach Quarry.....  | 341        |
| A1.2.17 Nismes Quarry.....   | 343        |
| A1.2.18 Oberrödinghausen Quarry.....   | 344        |
| A1.2.19 Olloy-sur-Viroin Quarry.....   | 347        |
| A1.2.20 Resteigne Quarry.....  | 349        |
| A1.2.21 Rydon Quarry.....  | 351        |
| A1.2.22 Sourd d'Ave Section.....   | 353        |
| A1.2.23 Teerstraßenbau Quarry.....   | 355        |
| A1.2.24 Vaucelles Quarry.....  | 357        |
| A1.2.25 Voßbeck Quarry.....  | 358        |
| A1.2.26 Walheim Section 1.....   | 360        |
| A1.2.27 Walheim Section 2.....   | 361        |
| A1.2.28 Walheim Southern Limb.....   | 362        |
| <b>A2. DETAILED SEDIMENTARY LOGS.....</b>  | <b>365</b> |
| A2.1 ALT BREINIG QUARRY.....   | 366        |
| A2.2 BEAURAING QUARRY.....   | 368        |
| A2.3 BELLIGNIES BETTRECHIES QUARRY.....  | 372        |
| A2.4 BLEIWÄSCHE QUARRY.....  | 377        |

|                                       |            |
|---------------------------------------|------------|
| A2.5 BLEIWÄSCHE ROAD CUTTING .....    | 381        |
| A2.6 BROADRIDGE WOOD QUARRY.....      | 382        |
| A2.7 CUL D'HOUILLE QUARRY .....       | 385        |
| A2.8 DOORBES QUARRY .....             | 390        |
| A2.9 FRIOD LIEU QUARRY .....          | 393        |
| A2.10 GLAGEON QUARRY.....             | 396        |
| A2.11 GOODRINGTON ROAD CUTTING.....   | 407        |
| A2.12 HANIELSFELD QUARRY.....         | 408        |
| A2.13 HEGGEN QUARRY.....              | 409        |
| A2.14 KELDENICH QUARRY.....           | 418        |
| A2.15 LINHAY HILL QUARRY.....         | 420        |
| A2.16 MEDENBACH QUARRY .....          | 424        |
| A2.17 NISMES QUARRY .....             | 427        |
| A2.18 OBERRÖDINGHAUSEN QUARRY .....   | 429        |
| A2.19 OLLOY-SUR-VIROIN QUARRY.....    | 435        |
| A2.20 RESTEIGNE QUARRY.....           | 439        |
| A2.21 RYDON QUARRY .....              | 446        |
| A2.22 SCHMIDHOF QUARRY.....           | 448        |
| A2.23 SOURD D'AVE.....                | 450        |
| A2.24 TEERSTRASSENBAU QUARRY .....    | 453        |
| A2.25 VAUCELLES QUARRY.....           | 459        |
| A2.26 VENWEGEN QUARRY .....           | 461        |
| A2.27 VOBBECK QUARRY .....            | 462        |
| A2.28 WALHEIM SECTION 1.....          | 466        |
| A2.29 WALHEIM SECTION 2.....          | 468        |
| A2.30 WALHEIM SOUTHERN LIMB .....     | 472        |
| <b>A3. CYCLE THICKNESS DATA .....</b> | <b>475</b> |

## TABLE OF FIGURES

|   |    |
|---|----|
| FIGURE 1-1 SCHEMATIC DIAGRAMS SHOWING THE GEOMETRIES OF CARBONATE PLATFORMS IN THE STUDY AREA .....   | 5  |
| FIGURE 2-1 STRATIGRAPHIC COLUMN TO ILLUSTRATE THE STANDARD DEVONIAN SUCCESSION OF SERIES AND STAGES, AND THEIR RELATIONSHIP TO CONODONT, GRAPTOLITE, AMMONOID AND DACRYOCONARID (TENTACULITE) ZONES ..... | 9  |
| FIGURE 2-2 TIME-SCALE FOR THE DEVONIAN USING CONODONT BIOSTRATIGRAPHY AND RADIOMETRIC DATING .....  | 11 |
| FIGURE 2-3 COMPOSITE LITHOSTRATIGRAPHIC CHART COVERING SW ENGLAND, SOUTHERN BELGIUM AND WESTERN GERMANY..   | 12 |
| FIGURE 2-4 MIDDLE SILURIAN PALAEORECONSTRUCTION OF TORSVIK <i>ET AL.</i> (1996).....  | 14 |
| FIGURE 2-5 LIKELY PALAEOGEOGRAPHY FOR EARLY DEVONIAN EURAMERICA (LOCHKOVIAN TO EMSIAN) .....  | 15 |
| FIGURE 2-6 PALAEORECONSTRUCTION FOR THE GIVETIAN (MIDDLE DEVONIAN) .....  | 18 |
| FIGURE 2-7 PALAEOGEOGRAPHY DURING THE MIDDLE DEVONIAN IN WESTERN AND CENTRAL EUROPE.....  | 20 |
| FIGURE 2-8 SCHEMATIC PALAEOGEOGRAPHY OF WESTERN EUROPE DURING THE GIVETIAN/ FRASNIAN STAGES .....   | 22 |
| FIGURE 2-9 GENERALISED RECONSTRUCTION OF THE SEA-FLOOR ACROSS PART OF THE DEVONIAN SHELF DURING THE MID GIVETIAN .....  | 23 |
| FIGURE 2-10 PALAEOGEOGRAPHIC RECONSTRUCTION FOR THE FAMENNIAN.....  | 25 |
| FIGURE 2-11 A COMPOSITE DIAGRAM TO SHOW THE RELATIONSHIP BETWEEN DEEP AND SHALLOW WATER DEPOSITS IN THE UPPER DEVONIAN OF SOUTHERN BRITAIN .....  | 28 |
| FIGURE 2-12 LOWER CARBONIFEROUS (DINANTIAN) OUTCROPS AND UPLAND AREAS TO SHOW GENERALISED PALAEOGEOGRAPHIC FEATURES FOR NORTHERN BRITAIN.....   | 29 |
| FIGURE 2-13 HERCYNIAN ZONES AND LOCALITIES OF WESTERN EUROPE .....  | 30 |
| FIGURE 2-14 SYNTHESIS OF UPPER SILURIAN TO LOWER CARBONIFEROUS EVENTS IN WESTERN EUROPE.....  | 31 |
| FIGURE 3-1 TYPICAL ENVIRONMENTAL DISTRIBUTION OF STROMATOPOROID GROWTH FORMS .....  | 35 |
| FIGURE 3-2 FIELD PHOTOGRAPH OF BULBOUS STROMATOPOROID, IN LIFE POSITION, SURROUNDED BY <i>AMPHIPORA</i> BRANCHES. ....  | 36 |

|  |     |
|--|-----|
| FIGURE 3-3 A) FIELD PHOTOGRAPH OF <i>AMPHIPORA</i> DISPLAYING DENDROID NATURE OF THE STROMATOPOROID. B) PHOTOMICROGRAPH SHOWING WELL-DEVELOPED AXIAL CANAL (ARROWS) SO COMMON IN <i>AMPHIPORA</i> .....  | 39  |
| FIGURE 3-4 SIMPLIFIED ENVIRONMENTAL RECONSTRUCTION IN THE NEWTON ABBOT - TORQUAY AREA (ENGLAND), SHOWING THE ABUNDANCE OF <i>AMPHIPORA</i> IN LAGOONAL ENVIRONMENTS .....  | 40  |
| FIGURE 3-5 PHOTOMICROGRAPH OF THE DENDROID STROMATOPOROID, STACHYODES .....  | 41  |
| FIGURE 3-6 GENERALISED DEPTH DISTRIBUTION (ABUNDANCE AND DIVERSITY) OF MAJOR GROUPS OF LIVING MARINE CALCAREOUS ALGAE AND CYANOBACTERIA .....  | 42  |
| FIGURE 3-7 ENVIRONMENTAL DISTRIBUTION OF SKELETAL CALCAREOUS ALGAE IN UPPER DEVONIAN REEF AND BANK COMPLEXES OF WESTERN AUSTRALIA AND ALBERTA .....  | 42  |
| FIGURE 3-8 A) PHOTOMICROGRAPH SHOWING THE CHARACTERISTIC INTERIOR RECTANGULAR 'CELLS' OF <i>DEVONOSCALE</i> . B) PHOTOMICROGRAPH OF <i>ISSINELLA</i> DISPLAYING CYLINDRICAL NATURE. C) PHOTOMICROGRAPH OF THE CLUB-SHAPED CODIACEAE <i>LABYRINTHOCONOUS</i> .....  | 45  |
| FIGURE 3-9 A) PHOTOMICROGRAPH OF A CYANOBACTERIALLY-COATED ONCOID. B) PHOTOMICROGRAPH OF <i>GIRVANELLA</i> (G) COATING/ENCrustING AN <i>AMPHIPORA</i> BRANCH (A). C) PHOTOMICROGRAPH OF <i>RENALCIS/IZHELLA</i> AGGREGATES DISPLAYING INFLATED HOLLOW CHAMBERS. D) PHOTOMICROGRAPH OF <i>WETHEREDELLA</i> DISPLAYING HEMISPHERICAL SHAPE AND THIN MICRITIC WALLS ..... | 48  |
| FIGURE 3-10 A) GEOMETRIES OBTAINED BY SECTIONING AN IRREGULARLY-SHAPED CALCAREOUS BODY (PARATHURAMMINID) IN DIFFERENT PLANES WHICH CORRESPOND TO SEVERAL 'GENERA' OF FORAM. B) PHOTOMICROGRAPHS SHOWING THE VARIETY OF MORPHOLOGIES THAT PARATHURAMMINIDS DISPLAY IN THE STUDY AREA .....  | 50  |
| FIGURE 3-11 PHOTOMICROGRAPH OF A LEPERDITIID OSTRACODE .....   | 52  |
| FIGURE 3-12 OSTRACODE ASSEMBLAGES IN THE MIDDLE AND UPPER DEVONIAN OF THE PALAEOETETHYS .....  | 52  |
| FIGURE 3-13 A) PHOTOMICROGRAPH OF 'NORMAL' CALCISPHERES. B) PHOTOMICROGRAPH OF A CALCISPHERE WITH WELL-PRESERVED SPINES .....  | 53  |
| FIGURE 3-14 PHOTOMICROGRAPH OF <i>THAMNOPORA</i> .....   | 55  |
| FIGURE 3-15 PHOTOMICROGRAPH SHOWING SOME OF THE INTERNAL FEATURES OF A STRINGOCEPHALID .....   | 56  |
| FIGURE 3-16 MODERN DISTRIBUTION OF MAJOR FOSSILISABLE NONVERTEBRATE GROUPS RELATIVE TO SALINITY .....  | 57  |
| FIGURE 3-17 PHOTOMICROGRAPHS OF A CRINOID OSSICLE DISPLAYING SYNTAXIAL CALCITE OVERGROWTHS .....   | 60  |
| FIGURE 3-18 PALAEOECOLOGICAL RECONSTRUCTION OF MIDDLE AND UPPER DEVONIAN BACK-REEF AND LAGOONAL ENVIRONMENTS OF WESTERN EUROPE .....   | 61  |
| FIGURE 4-1 MAP OF WESTERN EUROPE SHOWING LOCATION OF LOGGED SECTIONS .....   | 64  |
| FIGURE 4-2 STANDARD MICROFACIES TYPES OF WILSON (1975) AND FLÜGEL (1972, 1982) .....   | 65  |
| FIGURE 4-3 A) INTERBEDDED GREEN-GREY MARLY SHALES (MICROFACIES R1) AND BIOCLASTIC LIMESTONES (MICROFACIES R2). B) PHOTOMICROGRAPH OF VERY FINE-GRAINED OOLITIC GRAINSTONE. R4A MICROFACIES. C) PHOTOMICROGRAPH OF R4A MICROFACIES. D) PHOTOMICROGRAPH OF BIOCLASTIC GRAINSTONE, MICROFACIES R4C .....  | 75  |
| FIGURE 4-4 A) MICROFACIES R6, LEPERDITICOPID WACKESTONES. B) PHOTOMICROGRAPH IN CROSSED-POLARISED LIGHT TO SHOW THE RADIAL-FIBROUS CALCITE CEMENTS INSIDE THE OSTRACODE TEST. C) MICROFACIES R7, DOLOMUDSTONES .....   | 78  |
| FIGURE 4-5 PALAEOENVIRONMENTAL RECONSTRUCTION OF THE EARLY MIDDLE DEVONIAN RAMP SETTING IN NORTHERN FRANCE, SOUTHERN BELGIUM AND WESTERN GERMANY .....   | 80  |
| FIGURE 4-6 STRATIGRAPHIC COLUMN INDICATING AGES OF THE CARBONATE COMPLEXES IN THE STUDY AREA .....   | 82  |
| FIGURE 4-7 PIE CHART TO SHOW RELATIVE PROPORTIONS OF SEMI-RESTRICTED SUBTIDAL FACIES, RESTRICTED SUBTIDAL FACIES, INTERTIDAL FACIES AND SUPRATIDAL FACIES .....  | 83  |
| FIGURE 4-8 FIELD SKETCH OF S1 FACIES. BRECCIA IS ON AVERAGE 30CM THICK, WITH A VARIETY OF CLASTS INCLUDING STROMATOPORIDS, MUDSTONES AND LAMINITES .....   | 84  |
| FIGURE 4-9 PIE CHART SHOWING DISTRIBUTION OF MICROFACIES TYPES .....   | 85  |
| FIGURE 4-10 A) FIELD PHOTOGRAPH OF S2 MICROFACIES. B) PHOTOMICROGRAPH OF CORALS WHICH HAVE BEEN ENCRUSTED BY STROMATOPORIDS. C) BIOHERM DEVELOPMENT, MICROFACIES S2. D) PHOTOMICROGRAPH OF BIOCLASTIC GRAINSTONE/RUDSTONE (MICROFACIES S3A) .....  | 91  |
| FIGURE 4-11 A) PHOTOMICROGRAPH OF BIOCLASTIC PACKSTONE (MICROFACIES S5). B) HISTOGRAM SHOWING THE BED THICKNESS RANGE AND FREQUENCY FOR MICROFACIES S6. C) FIELD PHOTOGRAPH OF MICROFACIES S6. D) PHOTOMICROGRAPH OF S6A FACIES. E) PHOTOGRAPH OF VERTICAL OR TUBULAR FENESTRAE (MICROFACIES S6C). F) PHOTOMICROGRAPH OF A VERTICAL CAVITY .....                       | 99  |
| FIGURE 4-12 A) ONCOID WACKESTONE (MICROFACIES S6D). B) INTERNAL COMPOSITION OF ONCOID IN S6D MICROFACIES. C) STORM LAYERS IN AN OTHERWISE MUD-DOMINATED FACIES (S6E MICROFACIES). D) PHOTOMICROGRAPH OF PELOIDAL GRAINSTONE (MICROFACIES S7A). E) PHOTOMICROGRAPH OF S7B OOLITIC GRAINSTONE FACIES .....   | 108 |
| FIGURE 4-13 FOUR MAJOR FABRICS DISPLAYED IN FENESTRAL LIMESTONES .....   | 110 |
| FIGURE 4-14 A) PHOTOMICROGRAPH OF S8A MICROFACIES. B) FIELD PHOTOGRAPH OF FENESTRAL PELOIDAL GRAINSTONES (MICROFACIES S8B). C) PHOTOMICROGRAPH OF MICROFACIES S8B. D) FIELD PHOTOGRAPH OF S9 FACIES. E) .....  |     |

|  |     |
|--|-----|
| PHOTOMICROGRAPH DISPLAYING GRAVITATIONAL VADOSE CEMENTS (ARROW) ON THE UNDERSIDE OF A STRINGOCEPHALUS VALVE. F) PHOTOMICROGRAPH OF FENESTRAL LAMINITE (MICROFACIES S10) .....  | 116 |
| FIGURE 4-15 CHARACTERISTICS OF MODERN MICROBIAL LAYERS .....   | 122 |
| FIGURE 4-16 CLASSIFICATION OF STROMATOLITES, AFTER LOGAN <i>ET AL.</i> (1964).....   | 123 |
| FIGURE 4-17 A) FIELD PHOTOGRAPH OF MUD CHIPS (MICROFACIES S11). B) FIELD PHOTOGRAPH OF MICROBIAL LAMINITES (MICROFACIES S12A). C) PHOTOMICROGRAPH OF CRYPTMICROBIAL LAMINITES. D) FIELD PHOTOGRAPH OF LLH-S STROMATOLITE (MICROFACIES S12B). E) PHOTOMICROGRAPH OF S13 FACIES.....   | 128 |
| FIGURE 4-18 A) CHARACTERISTIC CALCRETE PROFILE AT CUL D'HOUILLE SECTION. B) FIELD PHOTOGRAPH SHOWING THESE THREE HORIZONS. ....  | 130 |
| FIGURE 4-19A) PHOTOGRAPH OF CRACKS/VEINS CONTAINING CLASTS OF THE HOST ROCK, SUPPORTED BY A MILKY-WHITE SOFT MATRIX. B) PHOTOMICROGRAPH OF CRACKS/VEINS, SO COMMON IN THE S14 MICROFACIES. C) PHOTOMICROGRAPH SHOWING TEXTURES ASSOCIATED WITH CALCRETE DEVELOPMENT. D) SKETCH OF POTENTIAL ROOT STRUCTURES. E) PHOTOMICROGRAPH OF CALCRETE HORIZON DEVELOPED AT BROADRIDGE WOOD QUARRY..... | 132 |
| FIGURE 4-20 STAGES IN CALCRETE DEVELOPMENT IN EXPOSED CARBONATE SEDIMENTS.....   | 134 |
| FIGURE 4-21 SCHEMATIC CARTOON SHOWING DEPOSITIONAL ENVIRONMENTS OF THE FOURTEEN MICROFACIES IDENTIFIED IN THE STUDY AREA.....  | 136 |
| FIGURE 5-1 GENERALISED GEOLOGICAL MAP SHOWING THE OUTCROPS OF DEVONIAN ROCKS IN THE ARDENNES-AACHEN-EIFEL AREA.....  | 139 |
| FIGURE 5-2 MAPS SHOWING LOCALITIES OF LOGGED SECTIONS (X ) IN THE BROAD DEVONIAN SHELF LAGOON.....   | 142 |
| FIGURE 5-3 STRATIGRAPHIC CHART SHOWING CONODONT ZONES, LITHOSTRATIGRAPHIC NAMES AND AGES OF THE SUCCESSIONS STUDIED IN THE LOWER GIVETIAN RAMP AND GIVETIAN-FRASNIAN BROAD SHELF LAGOON.....   | 143 |
| FIGURE 5-4 GENERALISED LOG OF THE UPPER GIVETIAN GLAGEON SUCCESSION .....  | 145 |
| FIGURE 5-5 CORRELATION OF LOWER GIVETIAN SUCCESSIONS IN THE ARDENNES. SEE TEXT FOR DISCUSSION. ....  | 148 |
| FIGURE 5-6 SCHEMATIC CROSS SECTION THROUGH THE LOWER GIVETIAN OF THE FRENCH AND BELGIAN ARDENNES SHOWING THE LOGGED SUCCESSIONS AND LATERAL VARIATION IN PLATFORM GEOMETRY.....  | 151 |
| FIGURE 5-7 CORRELATION OF UPPER GIVETIAN SUCCESSIONS IN THE ARDENNES. SEE TEXT FOR DISCUSSION. ....  | 156 |
| FIGURE 5-8 CORRELATION OF UPPER GIVETIAN SUCCESSIONS IN THE AACHEN AREA. SEE TEXT FOR DISCUSSION. ....   | 162 |
| FIGURE 5-9 GIVETIAN-FRASNIAN BOUNDARY AT SOURD D'AVE, SOUTHERN ARDENNES .....  | 166 |
| FIGURE 5-10 CORRELATION OF LOWER FRASNIAN SUCCESSIONS IN THE AACHEN AREA. SEE TEXT FOR DISCUSSION. ....  | 169 |
| FIGURE 5-11 SUMMARY DIAGRAM SHOWING LONG-TERM RELATIVE SEA-LEVEL CURVE, PLATFORM GEOMETRY AND KEY FACIES.....  | 173 |
| FIGURE 5-12 A) LOCATION MAP SHOWING DISTRIBUTION OF DEVONIAN ISOLATED CARBONATE COMPLEXES IN WESTERN GERMANY B) LOCATION MAP SHOWING DISTRIBUTION OF DEVONIAN CARBONATE COMPLEXES IN SOUTHWEST ENGLAND. C) KEY FOR FIGURE.....   | 175 |
| FIGURE 5-13 THREE TYPES OF ISOLATED DEVONIAN CARBONATE COMPLEX.....  | 176 |
| FIGURE 5-14 PALAEORECONSTRUCTION SHOWING THE ORIGINAL SHAPE OF THE ATTENDORN REEF COMPLEX AND DISTRIBUTION OF ITS FACIES. ....   | 179 |
| FIGURE 5-15 FACIES DISTRIBUTIONS AT THE HEGGEN QUARRY, ATTENDORN REEF COMPLEX .....  | 181 |
| FIGURE 5-16 A) DISTRIBUTION OF THE BRILON ATOLL-REEFS. B) IDEALISED BIOZONATION OF THE BRILON REEF COMPLEX .....   | 184 |
| FIGURE 5-17 FIVE CYCLE-TYPES IDENTIFIED AT THE BLEIWÄSCHE QUARRY, BRILON REEF COMPLEX.....   | 188 |
| FIGURE 5-18 SCHEMATIC FACIES RELATIONSHIPS FOR THE DEVONIAN OF SOUTHWEST ENGLAND.....  | 190 |
| FIGURE 5-19 LOCATION MAPS SHOWING NON-PALINSPASTIC DISTRIBUTION OF FACIES AND LOCATION OF LOGGED SECTIONS FOR A) LOWER TO MIDDLE GIVETIAN AND B) UPPER GIVETIAN. ....  | 191 |
| FIGURE 5-20 GENERALISED LOG FOR THE BROADRIDGE WOOD QUARRY, SHOWING PRIMARY FACIES GROUPS.....   | 192 |
| FIGURE 5-21 GENERALISED LOG FOR THE LINHAY HILL QUARRY, SHOWING PRIMARY FACIES GROUPS.....   | 195 |
| FIGURE 5-22 FIELD PHOTOGRAPH OF BULBOUS AND DENDROID STROMATOPOROID HORIZON (MICROFACIES S2) AT LINHAY HILL QUARRY.....  | 196 |
| FIGURE 5-23 CROSS-SECTION THROUGH THE BALVE REEF DURING MIDDLE/UPPER DEVONIAN BOUNDARY TIMES.....  | 201 |
| FIGURE 5-24 GENERALISED LOG OF OBERRÖDINGHAUSEN SUCCESSION, BALVE REEF COMPLEX .....   | 202 |
| FIGURE 5-25 A) MAP SHOWING LOCATION OF STUDIED QUARRIES. B) CROSS-SECTION THROUGH HANIELSFELD AND HAHNENFURTH QUARRIES .....   | 205 |
| FIGURE 5-26 PHOTOGRAPH OF COLUMNAR STROMATOPOROIDS WITHIN THE SCHWELM FACIES (MICROFACIES R3). ....  | 206 |
| FIGURE 5-27 GENERALISED LOG FOR VOßBECK QUARRY, DORNAP REEF COMPLEX, SHOWING PRIMARY FACIES GROUPS.....  | 207 |

|  |     |
|--|-----|
| FIGURE 5-28 GENERALISED FACIES MAP SHOWING THE DISTRIBUTION OF DEVONIAN REEF FACIES IN THE LANGENAUACH-BREITSCHEID REEF COMPLEX .....  | 211 |
| FIGURE 5-29 SUMMARY DIAGRAM COMPARING AGE, SIZE, THICKNESS, SEDIMENTATION STYLE, CYCLICITY AND INFLUENCE OF TECTONICS/VOLCANICS IN THE ISOLATED CARBONATE COMPLEXES OF WESTERN GERMANY AND SOUTHWEST ENGLAND. .... | 213 |
| FIGURE 6-1 DISTRIBUTION OF RECENT CORAL REEFS.....   | 215 |
| FIGURE 6-2 THREE STYLES OF PARASEQUENCE STACKING PATTERNS, WITH THEIR GENERALISED FACIES ASSOCIATIONS. ....  | 219 |
| FIGURE 6-3 A) CHARACTERISTICS OF A FISCHER PLOT. B) SYNTHETIC FISCHER PLOT SHOWING HOW STACKING PATTERNS CAN BE RELATED TO LONG-TERM SEA-LEVEL HISTORY. ....   | 221 |
| FIGURE 6-4 SCHEMATIC REPRESENTATIONS OF TYPE A CYCLES.....   | 226 |
| FIGURE 6-5 SCHEMATIC REPRESENTATIONS OF TYPE B CYCLES.....   | 229 |
| FIGURE 6-6 PHOTOGRAPHS OF B3 CYCLE-TYPES.....  | 231 |
| FIGURE 6-7 SCHEMATIC REPRESENTATIONS OF TYPE C CYCLES.....   | 234 |
| FIGURE 6-8 A) FISCHER PLOT FOR THE UPPER EIFELIAN SUCCESSION AT GLAGEON QUARRY. B) FISCHER PLOTS FOR FIVE OTHER UPPER EIFELIAN SUCCESSIONS IN THE BELGIAN AND FRENCH ARDENNES.....                                 | 235 |
| FIGURE 6-9 CORRELATION OF FISCHER PLOTS FOR THE UPPER EIFELIAN AND LOWER GIVETIAN SUCCESSIONS IN THE BELGIAN AND FRENCH ARDENNES.....  | 237 |
| FIGURE 6-10 HIGHLY SIMPLIFIED AND IDEALISED CARTOON OF RELATIVE ELEVATIONS OF FAULT BLOCKS IN THE LOWER TROIS FONTAINES FORMATION IN THE ARDENNES. ....  | 238 |
| FIGURE 6-11 CORRELATION OF FISCHER PLOTS FOR THE LOWER AND MIDDLE FROMELENNES FORMATION IN THE ARDENNES.....   | 242 |
| FIGURE 6-12 CORRELATION OF FISCHER PLOTS FOR THE UPPERMOST GIVETIAN SUCCESSIONS IN THE ARDENNES AND AACHEN AREA.....   | 245 |
| FIGURE 6-13 CORRELATION OF FRASNIAN FISCHER PLOTS IN THE AACHEN AREA.....  | 247 |
| FIGURE 6-14 A) FISCHER PLOT FOR THE HEGGEN QUARRY, ATTENDORN REEF COMPLEX. B) FISCHER PLOT FOR BLEIWÄSCHE QUARRY, BRILON REEF COMPLEX. C) FISCHER PLOTS FOR SUCCESSIONS IN THE TORBAY REEF COMPLEX.....            | 252 |
| FIGURE 6-15 FISCHER PLOTS FOR A) OBERRÖDINGHAUSEN QUARRY, BALVE REEF COMPLEX, B) VOBBECK QUARRY, DORNAP REEF COMPLEX, AND C) MEDENBACH QUARRY, LANGENAUACH REEF COMPLEX.....                                       | 257 |
| FIGURE 6-16 ESTIMATED DURATION OF THE GIVETIAN CONODONT ZONES (FROM HOUSE, 1995A) WITH CORRELATION TO THE ARDENNES LITHOSTRATIGRAPHY (FROM PREAT AND WEIS, 1994). ....   | 260 |
| FIGURE 6-17 MODEL FOR FORMATION OF SHALLOWING-UPWARDS CYCLES BY TIDAL FLAT PROGRADATION.....   | 262 |
| FIGURE 6-18 TIDAL FLAT ISLAND MODEL FOR PRODUCTION OF SHALLOWING-UPWARDS CYCLES.....   | 263 |
| FIGURE 6-19 ILLUSTRATION OF THE VARIATIONS IN THE EARTH-MOON-SUN SYSTEM, WHICH EFFECT THE AMOUNT OF SOLAR ISOLATION REACHING THE EARTH.....  | 264 |
| FIGURE 6-20 GENERAL MODEL FOR METRE-SCALE CYCLICITY PRODUCED BY GLACIO-EUSTASY.....  | 266 |
| FIGURE 6-21 SEA-LEVEL CURVE FOR THE LAST 125,000 YEARS.....  | 267 |
| FIGURE 6-22 EUSTATIC SEA-LEVEL CURVE FOR THE GIVETIAN AND FRASNIAN.....  | 275 |
| FIGURE 6-23 EUSTATIC SEA-LEVEL CURVE PRODUCED BY JOHNSON <i>ET AL.</i> (1985), WITH COMPARISON TO MAJOR TRANSGRESSIONS IDENTIFIED IN THE STUDY AREA.....   | 276 |

## TABLE OF FIGURES

|  |     |
|--|-----|
| TABLE 3-1 TABLE CATEGORISING BASIC GROWTH FORMS OF STROMATOPOROIDS .....   | 34  |
| TABLE 3-2 CORAL FAUNAL CHARACTERISTICS OF THE MAJOR LIMESTONES FACIES.....   | 54  |
| TABLE 4-1 PREVIOUS WORK PUBLISHED ON THE GIVETIAN AND FRASNIAN LAGOONAL CARBONATES IN THE STUDY AREA WITH RESPECT TO FACIES DESCRIPTIONS. .... | 62  |
| TABLE 4-2 SUGGESTED PUBLISHED WORK DOCUMENTING MIDDLE DEVONIAN RAMP FACIES.....  | 66  |
| TABLE 4-3 TABLE TO SHOW LIST OF LOGGED LAGOONAL SUCCESSIONS IN THE STUDY AREA.....   | 81  |
| TABLE 4-4 CHARACTERISTICS OF S6 SUBMICROFACIES.....  | 97  |
| TABLE 4-5 ORIGINS OF MICROBIAL MATS AND THEIR MECHANISMS OF DEPOSITION.....  | 121 |
| TABLE 5-1 LIST OF STUDIED SUCCESSIONS, AND THEIR LOCATIONS.....  | 141 |
| TABLE 5-2 ELEVEN DIFFERENT CYCLE-TYPES IDENTIFIED IN THE GIVETIAN AND FRASNIAN OF THE ARDENNES-AACHEN-EIFEL STUDY AREA.....                    | 170 |
| TABLE 5-3 TABLE OF PUBLISHED WORK ON WÜLFRAETH AND BERGISCH GLADBACH CARBONATE COMPLEXES .....   | 174 |

|   |     |
|---|-----|
| TABLE 5-4 APPROXIMATE FORMER SIZE (AREA) AND THICKNESS OF STUDIED ISOLATED CARBONATE COMPLEXES .....  | 177 |
| TABLE 5-5 LIST OF SUCCESSIONS STUDIED IN THE ATTENDORN, BRILON AND TORBAY REEF COMPLEXES.....   | 178 |
| TABLE 5-6 TABLE ILLUSTRATING THE PROPORTION OF MICROFACIES IN THE BLEIWÄSCHE QUARRY SUCCESSION.....   | 185 |
| TABLE 5-7 LIST OF SUCCESSIONS STUDIED IN THE BALVE AND DORNAP REEF COMPLEXES. ....  | 199 |
| TABLE 5-8 LOCATION OF THE STUDIED SUCCESSION IN THE LANGENAUACH REEF COMPLEX.....   | 209 |
| TABLE 6-1 SCHEMATIC REPRESENTATIONS OF 5 MAJOR CYCLE-TYPES, INCLUDING SCHEMATIC PALAEOBATHYMETRIC CHARTS AND CHARACTERISTICS OF CYCLES..... | 218 |
| TABLE 6-2 MICROFACIES PERMUTATIONS IN TYPE A.....   | 224 |
| TABLE 6-3 MICROFACIES PERMUTATIONS IN TYPE B CYCLES.....  | 227 |
| TABLE 6-4 MICROFACIES PERMUTATIONS IN TYPE C.....   | 232 |
| TABLE 6-5 ESTIMATED DEPOSITIONAL WATER DEPTHS FOR THE 21 MAJOR MICROFACIES.....   | 258 |
| TABLE 6-6 PROS AND CONS OF THE THREE MAJOR MECHANISMS GIVING RISE TO METRE-SCALE CYCLICITY.....   | 268 |
| TABLE 6-7 CALCULATION OF MIDDLE DEVONIAN ORBITAL FREQUENCIES .....  | 271 |
| TABLE 7-1 SUMMARY OF THE MAIN CHARACTERISTICS OF THE SHELF LAGOON AND LAGOONS WITHIN THE ISOLATED COMPLEXES.....                            | 278 |

# ***CHAPTER ONE***

|                             |          |
|-----------------------------|----------|
| <b>1. INTRODUCTION.....</b> | <b>1</b> |
| 1.1 AIMS OF STUDY.....      | 1        |
| 1.2 TECHNIQUES USED.....    | 2        |
| 1.3 TERMINOLOGY.....        | 4        |
| 1.4 OUTLINE OF THESIS.....  | 6        |

## 1. Introduction

### 1.1 Aims of study

The Givetian and Frasnian shallow-water carbonates of western Europe were deposited in three distinctive palaeosettings. Initially, the carbonate platform had a ramp geometry on which deposition ranged from open-marine outer ramp facies to restricted intertidal facies. The middle Givetian saw the transition from a ramp to shelf geometry. In northern France stromatoporoid reefs developed along the shelf-edge enabling a broad shelf lagoon to develop in the Belgian Ardennes-Aachen-Eifel area. Farther east in Germany and in Southwest England isolated carbonate complexes with central lagoons (atolls) developed.

Previous work on the Givetian and Frasnian carbonates has concentrated mainly on their palaeontological and broader sedimentological aspects (e.g., Lecompte, 1970; Krebs, 1974; Burchette, 1981). However, more recently there has been an increasing interest in the lagoonal facies in terms of detailed facies analysis (e.g., Preat and Mamet, 1989) and preliminary studies into the metre-scale cyclicity which are so pervasive in these sediments. These studies, however, have mostly been developed on only a very local scale or even on a single exposure. Comparisons between the lagoonal facies seen in the different palaeosettings are lacking in the literature, and there has been only tentative investigation into the mechanisms which may be producing the cyclicity.

Therefore the aims of this study are to:

- i) present detailed sedimentological studies of the lagoonal facies exposed on the shelf *and* isolated platforms and to produce a composite microfacies scheme applicable to both palaeosettings,
- ii) present detailed sedimentological studies of the ramp setting to produce a ramp microfacies scheme,
- iii) use microfacies analysis to characterise the types of metre-scale cyclicity and to determine the development of the carbonate complexes with respect to relative sea-level fluctuations,
- iv) make comparisons between the shelf lagoon and isolated complexes in terms of facies and cycle distributions,
- v) determine the mechanisms causing the cyclicity,

vi) produce a sea-level curve for the Middle and Upper Devonian.

## **1.2 Techniques used**

### ***Choice of localities***

The fieldwork for this study was undertaken in four separate field seasons: September 1994, February 1995, May to August 1995 and July to September 1996. Initial help in September 1994 was provided by Alain Preat at the University of Brussels, where he introduced the Devonian stratigraphy of the Belgian Ardennes and suggested some potential outcrops to study. A one-week field season in February 1995 was then spent in Southwest England where Colin Scrutton provided information on suitable outcrops. The two major field seasons were completed in the summers of 1995 (Germany) and 1996 (Belgium/France). All information about suitable outcrops to study was derived from the literature and geological maps, and use of correct lithostratigraphy was accepted therein.

Most exposure in the study area occurs in either abandoned or working quarries; there is very little natural outcrop of the Devonian carbonates. Therefore, the ability to study suitable outcrop was determined by whether access could be gained to the working quarries, or by the state of the present-day exposure of abandoned quarries (since many either had completely overgrown or were now land-fill sites). The choice of locality was also determined by the degree to which the facies had been dolomitised and by the degree of structural discontinuity since it was important to construct as continuous a sedimentary log as possible for the study.

### ***Sedimentary logging techniques***

Field sedimentary logs were constructed at a detailed 1:10 scale. Thorough descriptions of the rocks were made including bed thickness, bed-thickness variation, colour, sedimentary structures, composition, faunas (including size, shape, amount of abrasion, orientation and identification), and textural classification (using both Dunham (1962) and Folk (1962) schemes). Photographs were also taken. The exposure of successions was variable; therefore, different sampling regimes were needed. If the succession was very overgrown or lichen-covered a dense sampling regime was needed, whereas where there was superb exposure, fewer samples were collected for thin-section analysis. Samples were collected both for facies analysis and fossil identification.

Appendix 2 presents the detailed sedimentary logs for the study area, which encompass both field observations and thin-section interpretations.

### *Thin-section descriptions*

549 thin sections and acetate peels were studied for this thesis. Full petrographic descriptions were made following the methodology presented in Appendix 1. The samples were classified on a textural level using Folk (1962) and Dunham (1962) schemes, and were further classified using the microfacies scheme presented in Chapter four. For full details on thin-section descriptions and the approaches used, the reader should refer to Appendix One.

### *Microfacies approach*

Many microfacies schemes for European Devonian lagoonal carbonates have been presented in the literature in the past few decades (e.g., Krebs, 1974; Preat and Mamet, 1989). Initially this study used the scheme discussed by Preat and Mamet (1989) in which 13 microfacies were identified, ranging from open-marine, through to lagoonal and supratidal deposits. However, this microfacies scheme was incomplete since there were facies present in the field and thin section which did not 'fit' into the scheme. This microfacies model covered only the Belgian shelf lagoon; therefore, it was imperative that a composite microfacies scheme was produced covering all lagoonal facies present in both the shelf lagoon and isolated platforms. The microfacies scheme and consequent depositional model was derived from field observations and thin-section information and is discussed in Chapter 4.

### *Cycle analysis*

Once all the field observations and thin-section data had been collated, the microfacies could be used to characterise the metre-scale cyclicity which is so pervasive in the lagoonal sediments. Cyclicity was determined by assessing the vertical stacking of microfacies in the successions. The base of a cycle was identified from the initial backstepping of a less restricted facies-type over a more restricted facies-type. Cycles could therefore be either transgressive-regressive or wholly regressive. Fischer plots were then constructed to identify any trends in cycle thickness which could be a result of longer-term relative sea-level fluctuations. These cycle stacking patterns are a potential tool for correlation.

### 1.3 Terminology

Several key words are used throughout the thesis which have, in the past, had rather ambiguous meanings. This Section clarifies the nomenclature used in the following Chapters.

**Carbonate platform** This thesis will follow the definition presented by Tucker and Wright (1992) where a carbonate platform constitutes '*a thick sequence of mostly shallow-water carbonates*'. This general term encompasses carbonate ramps, rimmed shelves, isolated platforms and epeiric platforms (the last not present within the Devonian of western Europe).

**Carbonate ramp** A carbonate ramp is considered to be a gently dipping slope on which shallow-water facies gradually pass offshore into deeper, mud-dominated facies. There is no abrupt break in slope and barrier-reefs are absent. Homoclinal (gentle dip) and distally-steepened ramps are differentiated (Tucker and Wright, 1992; Fig. 1-1a).

**Shelf** A rimmed shelf is a shallow-water platform with a distinct break in slope to deeper-water environments (Tucker and Wright, 1992). The break in slope, or shelf-margin, is usually rimmed by either barrier-reefs, or oolite shoals, or both. This marginal rim provides protection from turbulent waters so that a landward lagoon can develop (Fig. 1-1b).

**Isolated platform** Burchette (1981) defined an isolated reef complex as 'an organic buildup which developed upon submarine elevations within shelf areas or basins and was isolated from direct input of terrigenous sediments'. Two types can be distinguished: reef mounds without lagoons (table reefs) or **atolls** with central lagoons. Both of these isolated platforms are surrounded by deep sediments, yet with an atoll differentiation can be made between fore-reef, reef-core and back-reef facies (Fig. 1-1c).

**Reef complex** This term is considered to embrace the fore-reef, reef-core, and back-reef facies. Inter-reef or basinal facies are **not** included (Fig. 1-1c).

**Reef** This term is restricted to rigid, wave-resistant structures which had topographic relief above the adjacent sea-floor and were constructed of a framework of organisms which show some zonation consequent upon their near-surface position (Braithwaite, 1973).

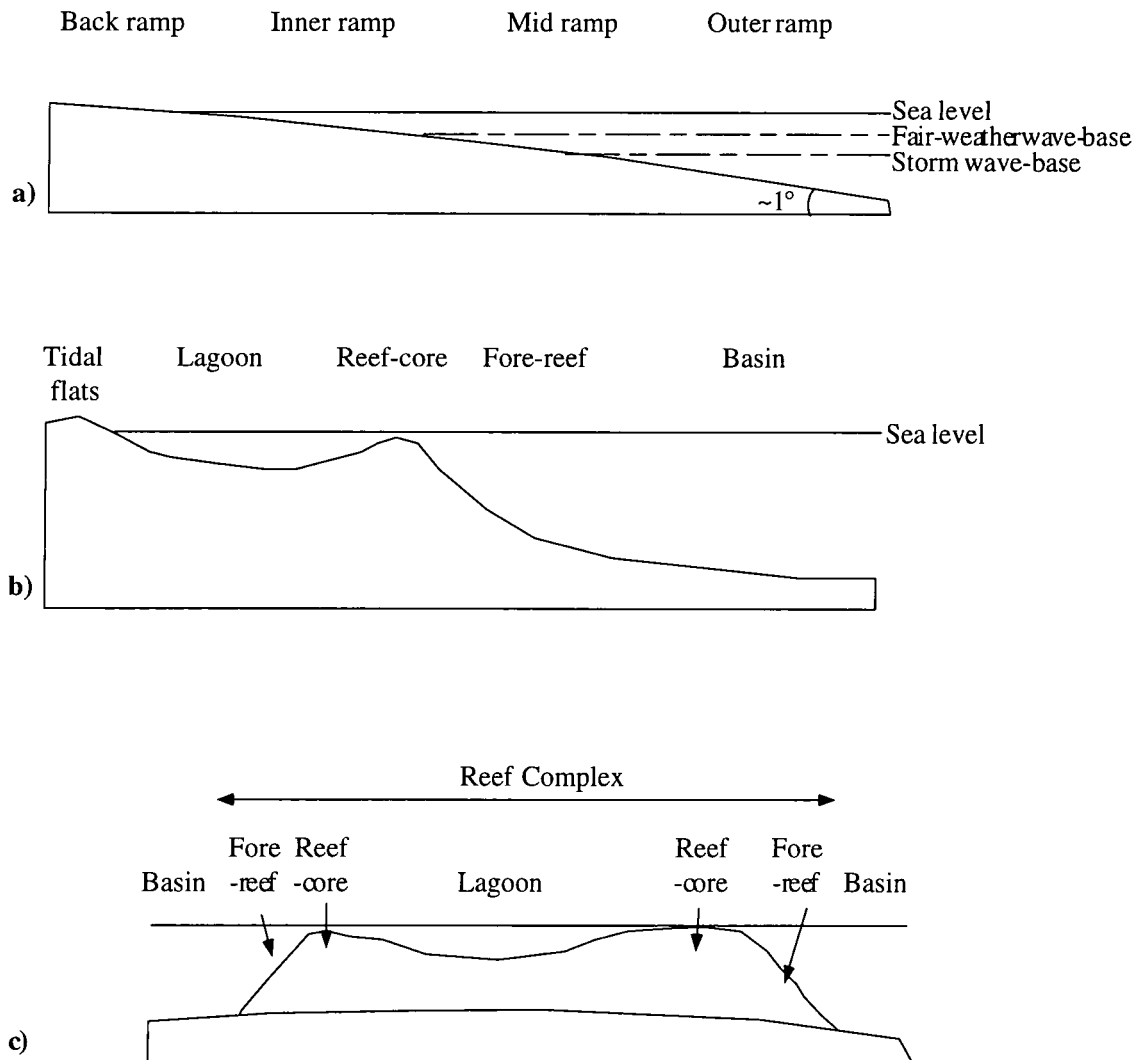

**Figure 1-1** Schematic diagrams showing the geometries of carbonate platforms in the study area. a) carbonate ramp b) rimmed shelf c) isolated platform.

**Lagoon** The term lagoon refers to the area behind a barrier reef or sand-shoal, which has protection from the turbulent zone (Fig. 1-1b). A lagoon can be 'open' where the barrier-system is poorly developed and the lagoon is subjected to wave and tidal motions. Or the lagoon can be 'closed', where there is poor circulation, low-energy deposits, hyper- or hyposalinity and a highly restricted faunal diversity. The lagoon at its shoreline can have an extensive tidal-flat area where intertidal and supratidal facies are deposited. The term **back-reef** is used synonymously with lagoon. Playford (1969) suggested use of the term '*platform interior*' to reflect a restricted lagoonal environment. However, that nomenclature will not be used in this thesis.

**Bioherm** This term describes small, lensoid, biogenic buildups which are laterally impersistent (Cummings, 1932).

**Bank** Playford (1969) defined a bank accumulation as '*a deposit composed of skeletal or non-skeletal carbonate material that accumulated topographically higher than the adjacent sea floor, and in which reef growth was essentially absent.*'

**Study area** The study area encompasses areas in Belgium, France, England and Germany. An East-West outcrop belt in the Belgian and French Ardennes (from Valenciennes in the West to Wellin in the East), the Aachen and Eifel areas of Germany expose the Middle and Upper Devonian shelf lagoon. The Torquay area of Southwest England, and Brilon, Balve, Dornap, Attendorn and Langenaubach areas of western Germany expose Middle and Upper Devonian isolated carbonate complexes.

**Cycle** A cycle can be defined as '*a sequence of sediments which change their character progressively from one extreme type to another followed by a return to the original type*' (Whitten and Brooks, 1972). Carbonate cycles commonly show shallowing-upward trends where deep-water facies are overlain by shallower facies. Cyclicity can occur on many scales from tens of centimetres to hundreds of metres.

**Parasequence** This term was first used by Van Wagoner *et al.* (1987) to describe '*a relatively conformable succession of genetically-related beds or bedsets bounded by marine flooding surfaces and their correlative surfaces.....Parasequences are progradational and therefore the beds within parasequences shoal upward*'. Therefore, a parasequence is essentially another term for a shallowing-upward cycle.

#### 1.4 Outline of thesis

**Chapter one:** Brief introduction to the thesis, including aims and objectives of the study, methodology and explanation of the terminology.

**Chapter two:** Introduction to the study area. The biostratigraphy, dating and lithostratigraphic terms for the Devonian are discussed, with a brief overview of the regional scale geology, palaeoclimatology, and plate tectonics.

**Chapter three:** Introduction to the principal faunas and floras in the back-reef and lagoonal environments of the Middle and Upper Devonian of western Europe. Two major groups of fossils are discussed in detail: stromatoporoids and calcareous algae. The

foraminifera, ostracodes, calcispheres, corals, brachiopods and molluscs are only briefly described. The likely habitats of each of the fossils are discussed in detail so as to construct a broad palaeoecological model for the Devonian environments.

**Chapter four:** Description and interpretation of the carbonate microfacies identified in the study area. Two microfacies schemes are presented, encompassing both the ramp and shelf facies. Macroscopic and microscopic aspects of the carbonates are described and likely depositional environments are proposed.

**Chapter five:** Large-scale evolution of the carbonate complexes. The carbonate complexes (broad shelf lagoon and individual isolated complexes) are discussed with respect to their development, demise, shape, size, tectonic and volcanic influences, facies and cyclicity. The lagoonal environments are the main facies of interest, but reference is made to the carbonate complexes as a whole where appropriate.

**Chapter six:** Discussion of the relative sea-level fluctuations in the Middle and Upper Devonian. Chapter six includes an overview of the controls on carbonate deposition, and then discusses in full the major types of metre-scale cyclicity in the study area and how they are distributed. Fischer plots are constructed to aid correlation between successions. The magnitude and duration of cycle are estimated and the mechanisms which may be producing the cyclicity are presented in detail. Finally, a eustatic sea-level curve for the Middle to Upper Devonian is constructed.

**Chapter seven:** Brief discussion and summary of conclusions.

**Appendix one:** Tabulation of thin-section descriptions.

**Appendix two:** Detailed sedimentary logs encompassing both field and microscopic information. Logs are drawn at a 1:55 scale.

**Appendix three:** Tabulation of cycle-thickness data.

**Enclosure One:** Photomicrograph atlas

# CHAPTER TWO

|  |          |
|--|----------|
| <b>2. BIOSTRATIGRAPHY AND REGIONAL GEOLOGY</b> ..... | <b>8</b> |
| 2.1 BIOSTRATIGRAPHY AND RADIO-METRIC DATING.....     | 8        |
| 2.2 REGIONAL GEOLOGY.....                            | 13       |
| 2.2.1 <i>Pre-Devonian</i> .....                      | 13       |
| 2.2.2 <i>Lower Devonian</i> .....                    | 14       |
| 2.2.3 <i>Middle Devonian</i> .....                   | 17       |
| 2.2.3.1 Eifelian.....                                | 18       |
| 2.2.3.2 Givetian.....                                | 20       |
| 2.2.4 <i>Upper Devonian</i> .....                    | 24       |
| 2.2.4.1 Frasnian.....                                | 25       |
| 2.2.4.2 Famennian.....                               | 27       |
| 2.2.5 <i>Post Devonian</i> .....                     | 29       |
| 2.2.6 <i>Synthesis</i> .....                         | 30       |

## 2. Biostratigraphy and regional geology

### 2.1 Biostratigraphy and radiometric dating

In the Devonian both biostratigraphy and radiometric dating has been used to construct a chronostratigraphic chart. Graptolites, goniatites, tentaculitids, brachiopods and conodonts have all been used biostratigraphically for correlation (Johnson *et al.*, 1985; Oliver and Chlupác, 1991). Conodonts, however, are probably the most useful of the five: they are not as sensitive to changes in facies and they cover the whole of the Devonian period (unlike the goniatites which are absent in the oldest Devonian rocks, and the graptolites which do not occur post-Lower Devonian (Johnson *et al.*, 1985)). Conodonts are also abundant and, being from pelagic organisms, have potential for high-resolution biozonation worldwide.

The Devonian is divided into three series (the Lower, Middle and Upper Devonian), and seven stages (from oldest to youngest: Lochkovian, Pragian, Emsian, Eifelian, Givetian, Frasnian and Famennian). As with many of the periods in geological history, the Devonian has undergone several revisions with respect to stage terminology and dating. These changes are inevitable as knowledge increases and dating techniques improve. The Subcommittee on Devonian Stratigraphy was set-up in 1973 when it proposed to define the Devonian series and stages in order to establish, for the first time, a standard for worldwide correlation. The most recent stratigraphic column is presented in Figure 2-1 (Oliver and Chlupác, 1991). This combines the results of conodont workers (Lower Devonian by Klapper and Johnson (1980), Eifelian by Weddige (1977), Givetian and Upper Devonian by Ziegler (1979)); ammonoid workers (chiefly House (1988), but with the recent revision of Chlupác and Turek (1983)); graptolite zonal modifications of Jaeger (1988); and the tentaculite zonation of Alberti (1979). Radiometric dating of the Devonian still remains rather poor, therefore a combination of biostratigraphy, radiometric dating and common sense is needed when assigning absolute ages to stages. When radiometric dating first became popular, the Devonian was estimated as having a duration of 50Ma (395Ma to 345Ma, Friend and House, 1964). These dates were further substantiated by statistical techniques performed by Gale *et al.* (1979) giving the start of

| Series                        | Stages         | Conodont zones      | Ammonoid zones  |   | Dacryoconarid zones                      | Important evolutionary events   |   |
|-------------------------------|----------------|---------------------|---|---|--|---|---|
|                               |                |                     | Graptolite zones  |   |  |   |   |
| UPPER DEVONIAN                | FAMMENIAN      | Si.praesulcata      | WOCLUM.   | Ac.carinatum<br>C.euryomphala<br>W.sphaeroides<br>K.subarmata |  | ◀ Extinction of clymenids<br><br><br><br><br><br>◀ First clymenids<br>Last dacryoconarids<br>◀ Extinction event |   |
|                               |                | Pa.expansa          |   | CLYMENIA  |  |   | Pi.piriformis<br>Or.ornata<br>Pg.acuticostata<br>P.serpentina |
|                               |                | Pa.postera          | PLAT.   |   |  |   | Pl.annulata<br>Pro.delphinus<br>Ps.sandbergeri                |
|                               |                | Pa.trachytera       |   | CHEILOLOC   |  |   | Sp.pompeckji  |
|                               |                | Pa.marginifera      | Ch.curvispina   |   |  |   |   |
|                               |                | Pa.rhomboida        |   |   |  |   |   |
|                               |                | Pa.crepida          |   |   |  |   |   |
|                               |                | Pa.triangularis     |   |   |  |   |   |
|                               |                | Pa.gigas            |   | Cr.holzapfeli   | H.ultimus                                |   |   |
|                               | FRASNIAN       | An.triangularis     |   | Manticoceras cordatum   | H.tenuicinctus                           |   |   |
| u. m. Pol. l. m. asymmetricus |                |                     | Ko.lamellosus<br>Pet.feisti<br>Pon.pernai<br>Ph.arenicum<br>Ph.lunulicosta<br>Ph.amplexum |   |  |   |   |
| MIDDLE DEVONIAN               | GIVETIAN       | Pa. disparilis      | PHARCICER   |   | N.bianulifera                            |   |   |
|                               |                | Sch.herm.-Pol.crist |   |   |  |   |   |
|                               |                | Pol.varcus          |   | Maen.terebratum   |  |   |   |
|                               |                | Pol.ensensis        |   | Maen.molarium   |  |   |   |
|                               | EIFELIAN       | T.k.kockelianus     |   | Cabr.crispiforme  | N.otomari                                | ◀ First Stringocephalus   |   |
| T.k.australis                 |                |                     | Pinacites jugleri   | N.chlupaciana<br>N.pumilio<br>Su.sulcata sulc.                |  |   |   |
| Pol.cost.costatus             |                |                     |   |   |  |   |   |
| Pol.cost.partitus             |                |                     |   |   |  |   |   |
| LOWER DEVONIAN                | EMSIAN         | Pol.cost.patulus    | Anarcestes  |   | N.holynensis                             |   |   |
|                               |                | Pol.serotinus       |   |   | N.richteri                               |   |   |
|                               |                | Pol.inversus        | Teich.discordans  |   |  |   |   |
|                               |                | Pol.gronbergi       | Anetoceras  |   | N.cancellata<br>N.elegans<br>N.barrandei |   |   |
|                               |                | Pol.dehiscens       |   |   | N.praecursor<br>N.zlichovensis           | ◀ First goniatites<br>◀ Last graptolites  |   |
|                               | PRAGIAN        | Pol.pirenae         | M.yukonensis  |   | N.acuaria                                | Guer.strangulata  |   |
|                               |                | Eogn.s.kindlei      | M.thomasi   |   |  |   |   |
|                               |                | Eogn.sulcatus       | M.fanicus<br>M.kayseri  |   |  | N.sororcula   |   |
|                               | LOCHKOVIAN     | Ped.pesavis         |   | M.hercynicus  |  | Par.intermedia  | ◀ Start of global distribution of dacryoconarids              |
|                               |                | Anc.delta           |   | M.praehercynicus  |  | Hom.bohemica<br>Hom.senex   |   |
| O.eurekaensis                 |                |                     |   |   | dacryoconarids unknown                   |   |   |
|                               | I.w.woschmidti |                     | M.uniformis   |   |  |   |   |

Figure 2-1 Stratigraphic column to illustrate the standard Devonian succession of series and stages, and their relationship to conodont, graptolite, ammonoid and dacryoconarid (tentaculite) zones (from Oliver and Chlupác, 1991).

the Devonian at 394Ma and the end at 345Ma (Dineley, 1984). Fission-track data and analysis of acid volcanics by Odin (1982), however, gave quite a different duration for the Devonian (411Ma to 360Ma). More recently Fordham (1992) has used the approach of graphic-correlation analysis, calibrating conodont zonation using high-precision U-Pb zircon dates supplied by Tucker *et al.* (1990). This gives the duration of the Devonian as 408.5Ma to 354Ma (Fig. 2-2). Ebert and Tucker (1997), however, used bentonites in the Appalachian Basin to date the Silurian/Devonian boundary at 417Ma. House (1995a) reflected on radiometric data which had been produced in the last decade and suggested that an average should be made of the available reliable data so that at least an estimate for the duration of the Devonian could be approached. An average of 47.1Ma was ascertained; however, this still does not solve the conflict of when the Devonian started and ended, let alone the duration of series and stages within the Devonian. This is clearly an area where more research needs to be done, or different approaches need to be used.

The Givetian and Frasnian are the main focus of interest in this thesis. As the study area covers a large area (from Southwest England, through northern France, southern Belgium and extending eastwards into western Germany), lithostratigraphical terms vary. Figure 2-3 presents a composite biostratigraphic and lithostratigraphic chart for the study area. As the Devonian is a well-researched period, once again lithostratigraphic terms have varied through the decades. The lithostratigraphic terms which this thesis will follow uses the most up-to-date information available. The terms for Southwest England are derived from a succession at Newton Abbot (near Torquay) which is documented by Selwood *et al.* (1984) for the British Geological Survey Memoir. A number of sources were used for the Belgian successions. Bultynck *et al.* (1991) provide excellent detailed descriptive work and lithostratigraphic charts for the Middle Devonian of both the northern and southern parts of the Dinant Basin. For the Upper Devonian (Frasnian), Blicek *et al.* (1988) was consulted. The German lithostratigraphic nomenclature appears to be a little more complicated. Many terms are used by different authors for the same rock units, and so a combination of Johnson *et al.* (1985) for the Eifelian, Givetian and Frasnian, and Krebs (1974) for the divisions of the Massenkalk was used.

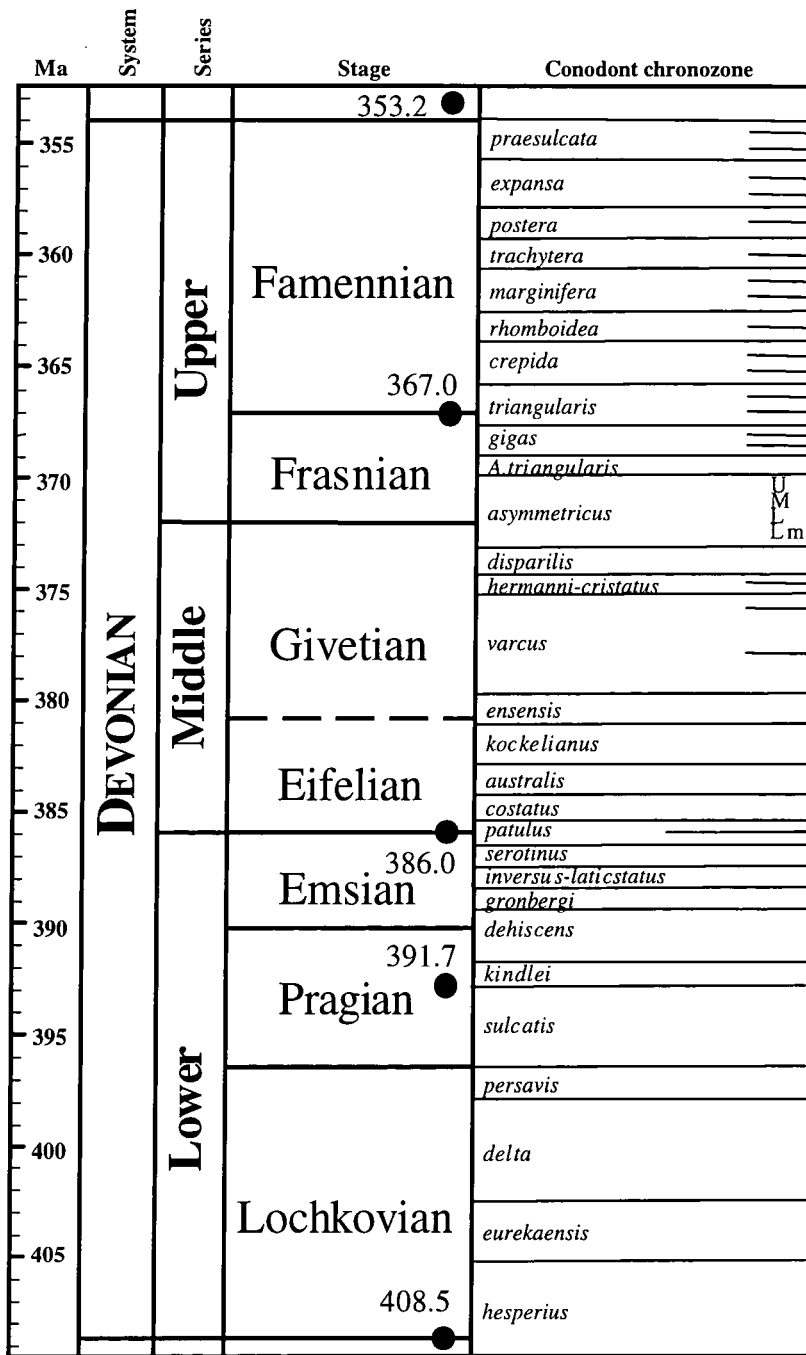

Figure 2-2 Time-scale for the Devonian using conodont biostratigraphy and radiometric dating (from Fordham, 1992). Lochkovian to Pragian chronostratigraphy of Ziegler (1971), Emsian to Famennian chronostratigraphy of Johnson *et al.* (1985). Tie points are supplied from Harland *et al.* (1990).

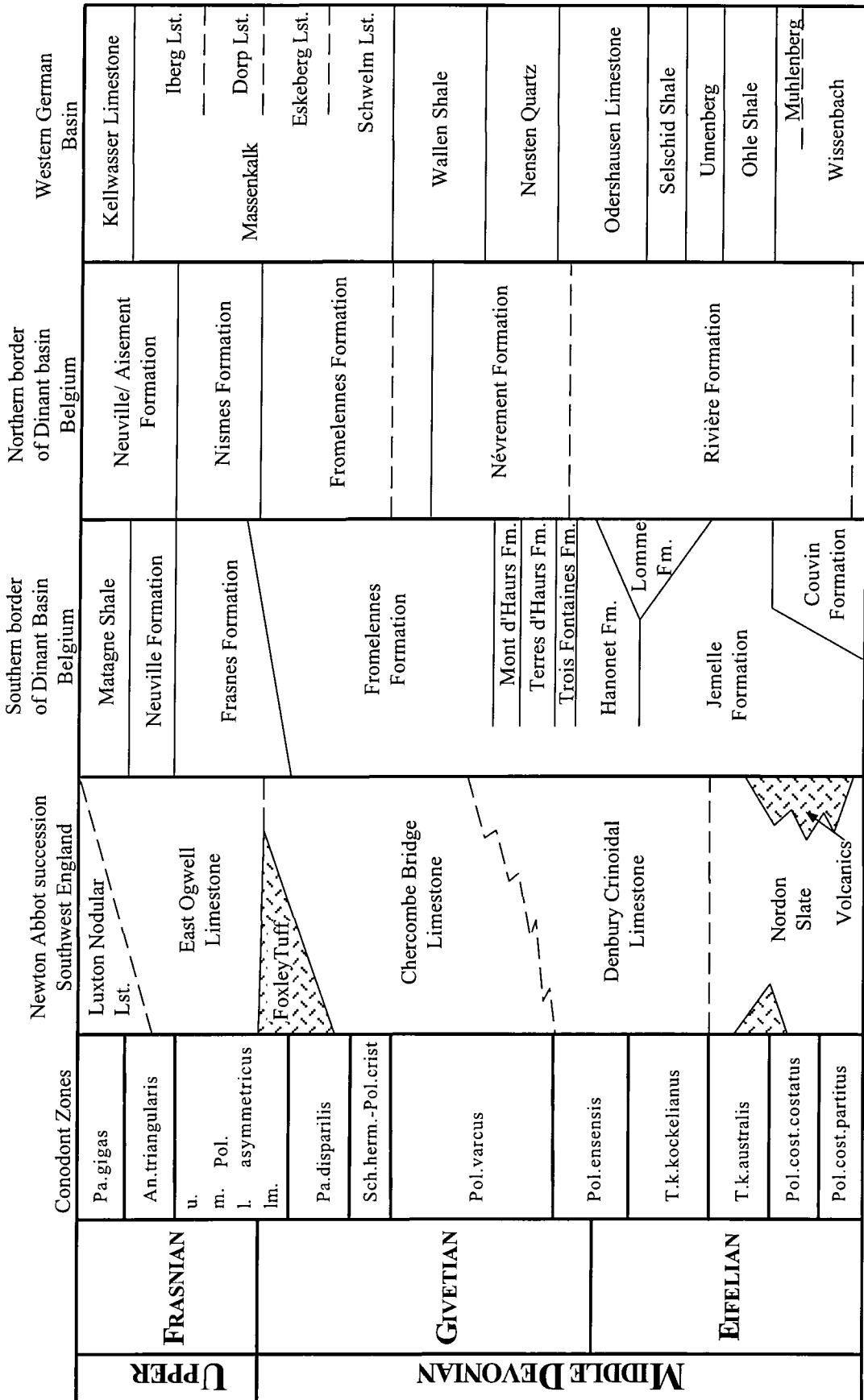

Figure 2-3 Composite lithostratigraphic chart covering SW England, southern Belgium and western Germany. Data compiled from various sources: Newton Abbot succession from Selwood *et al.* (1984), Dinant Basin successions from Bultynck *et al.* (1991) (Eifelian & Givetian) and Blicek *et al.* (1988) (Frasnian), western German succession from Johnson *et al.* (1985) and Krebs (1974). Dashed lines denote inferred biostratigraphic positioning of lithostratigraphic unit.

## 2.2 Regional geology

This Section aims to give some background into the geological development of western Europe, concentrating on Southwest England, southern Belgium, and the Rhenisches Schiefergebirge area of Germany. Styles of sedimentation, palaeoclimates, palaeoreconstructions and the overall structural development of the area will be discussed from the Pre-Devonian through to the Lower Carboniferous.

### 2.2.1 Pre-Devonian

During Silurian times the study area was located on the western edge of the Baltica/Avalonia plate (collectively known as Baltica) (Fig. 2-4) (Scotese and McKerrow, 1990; Torsvik *et al.*, 1993; Torsvik *et al.*, 1996). The latitude of Avalonia/Baltica at this time is still open to much debate. Kent and Van der Voo (1990) suggested 20°S at the Silurian/Devonian boundary. Torsvik *et al.* (1990), however, suggested that during the Silurian Baltica and Avalonia were in fact separate continents, with Avalonia at 30°S and Baltica on the equator. However, in a more recent publication, Torsvik *et al.* (1996) suggested latitudes of approximately 15°S for the Baltica/Avalonia continent and that by this period in time the continents had sutured. The world maps of Scotese and McKerrow (1990) suggest that Avalonia/Baltica was positioned at around 25°S. This small selection of palaeolatitudes for the end Silurian reflects the extent to which palaeomagnetic data are used to reconstruct the continents, and how a consensus is needed.

To the north of the Avalonia/Baltica continent the Iapetus Ocean still remained open, providing separation from the Laurentian palaeocontinent (which included Scotland, Northwest Ireland, Greenland and Alaska). Much of the tectonic history of the Silurian was concerned with the closure of the Iapetus ocean. This closure was probably instigated in Norway (Scandian orogeny) as early as 425Ma (Torsvik *et al.*, 1996); however, it was not until the Middle to Late Devonian when final suturing occurred (Torsvik *et al.*, 1988). This closure gave rise to the formation of the Caledonides of Scotland and northern Britain. The landmass which formed by the collision of Laurentia and Baltica/Avalonia was known as the 'Old Red Sandstone' continent or 'Euramerica'.

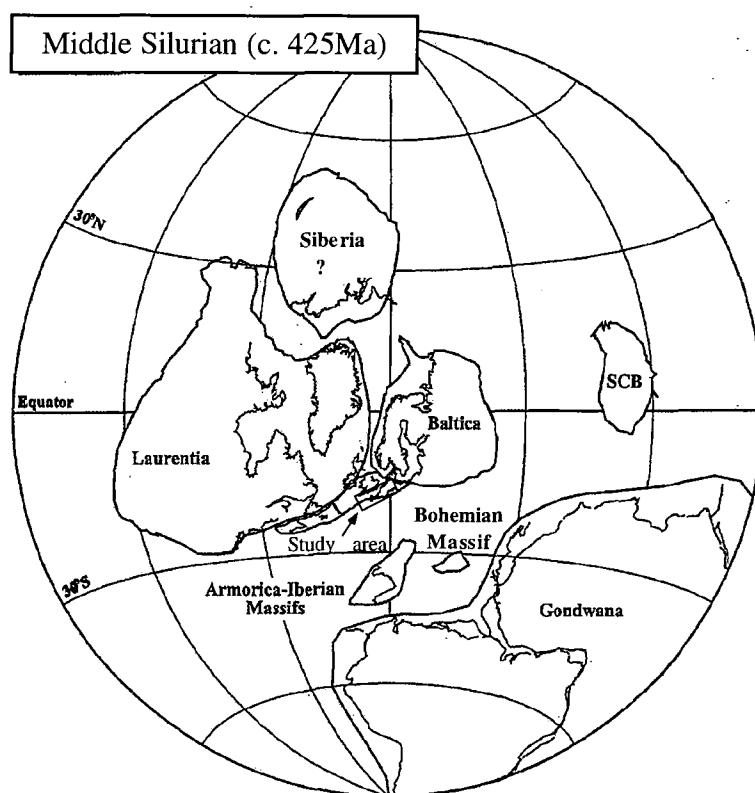

Figure 2-4 Middle Silurian palaeoreconstruction of Torsvik *et al.* (1996). SCB = South China Block.

Silurian lithofacies of Baltica/Avalonia suggest the entire continent was positioned within the 'carbonate belt' (Witzke, 1990). This accounts for the thick mixed carbonate-clastic successions seen in Scandinavia, and the presence of evaporites in the Timan and Baltic areas (Witzke, 1990). In the study area Silurian rocks are generally covered by younger deposits. House and Selwood (1964) noted the presence of Silurian limestones near Portloe Cove in Devon. However, most of Devon and Cornwall lay on the fringe of the Caledonides (a land area named Pretannia; Bassett *et al.*, 1992) and experienced mild deformation, uplift and erosion during the Silurian (Burchette, 1981; Bassett *et al.*, 1992).

### 2.2.2 Lower Devonian

The Lower Devonian encompasses the Lochkovian, Pragian and Emsian (Fig. 2-1). Its duration is approximately 22.5My (Fordham, 1992). However, more recent radiometric dating by James Ebert (pers. comm. 1997) suggests an extended duration of 26My. The Lower Devonian is probably best known for its expansive deposits of Caledonian molasse known as the Old Red Sandstone.

Strike-slip and compression were the main tectonic regimes during the Lower Devonian as Baltica/Avalonia continued to be obliquely subducted below the Laurentian margin (McKerrow, 1988). Laurentia was fixed on the equator, and during the Lochkovian southern Britain was thought to have been at latitudes of 30°S, and by Emsian times at 25°S (Scotese and McKerrow, 1990; Torsvik *et al.*, 1996). This reflects the northwesterly propagation and rotation of the Baltica/Avalonia plate underneath Laurentia. Latitudinal velocities at this time were thought to be in the order of 8-10cm/year (Torsvik *et al.*, 1996).

The Lower Devonian Old Red Sandstone of southern Britain, northern Belgium and northern Germany accumulated as a thick clastic wedge between the developing continent in the north (Caledonides) and the expanding Rheic Ocean in the south (Allen, 1979). The study area was positioned in what is termed the northern external zone of the Hercynian 'geosyncline' (Burchette, 1981) which experienced mild uplift and erosion during the Silurian followed by strong subsidence and creation of accommodation space in the Devonian.

The extent of the Old Red Sandstone Continent varied throughout the Devonian, but during the Lower Devonian it was thought to include much of Britain, Scandinavia and America (Fig. 2-5; Witzke, 1990). In fact, South America appears to be the only area without an extensive Devonian continental record (Dineley, 1984).

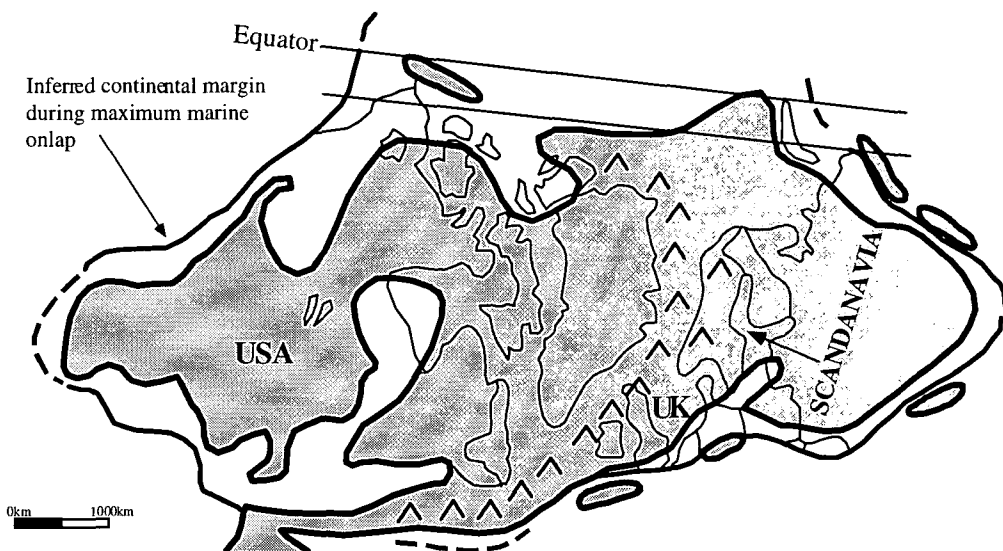

**Figure 2-5** Likely palaeogeography for Early Devonian Euramerica (Lochkovian to Emsian). The shaded area indicates the extent of the land mass,  $\blacktriangle$  indicates mountains (adapted from Witzke, 1990).

The Lower Devonian Old Red Sandstone of the British Isles represents for the most part alluvial and lacustrine associations (Dineley, 1984). It outcrops in many parts of Britain, especially in the Welsh borderlands (Wright and Marriot, 1996b), South Wales (Allen, 1979; Owen, 1995), Midland Valley of Scotland (Anderton *et al.*, 1985; Haughton, 1989; Smith, 1995), and also the Dingle and Sherkin Basins of southern Ireland (Anderton *et al.*, 1985). In all areas the majority of sedimentation is of a fluvial/ alluvial nature. The Midland Valley of Scotland displays thick successions (up to 9km) of Old Red Sandstone which were deposited in fault-bounded sub-basins (Armstrong and Paterson, 1970; Haughton, 1989). This deposition has been attributed to alluvial fan development, where conglomerates, sandstones, muds and volcanics show broad coarsening-up cycles that have a tectonic signature (Haughton, 1989). The source of these sediments was likely to have been the active basin-margin fault escarpments. Smith (1995) also suggested that the Old Red Sandstone sediments and volcanics of the Midland Valley were deposited under sinistral strike-slip regimes in the Lower Devonian.

The Lower Old Red Sandstones of Central and South Wales comprises a 2km thick succession of muds, sandstones and conglomerates which are mainly fluvial in nature (Allen, 1979). These sediments were once again sourced from the Caledonian uplands in the north (Allen, 1979). Calcretes are a common feature within many of the Welsh successions (Wright and Marriot, 1996a) and it is suggested that the Old Red Sandstone calcretes formed under a semi-arid climate with a strong seasonal moisture regime (Woodrow *et al.*, 1973; Wright and Marriot, 1996a). In the Welsh borderlands Lochkovian successions show rare incursions of brackish water faunas (Barclay *et al.*, 1994). Wright and Marriot (1996b), however, disputed these marine incursions since there were no characteristic sedimentary structures (i.e., estuarine tidal facies) suggesting a marginal marine facies. Further south in Devon and Cornwall the Lochkovian nonmarine Dartmouth Slate can be seen in Southeast Devon, suggesting the palaeoshoreline was south of this region (Bluck *et al.*, 1992). Clastic rocks of Pragian and Emsian age in Southeast Devon are neritic in nature (House and Selwood, 1964; Richter, 1965; Burchette, 1981), suggesting a marine transgression over this area and movement of the palaeoshoreline in a northwards direction (Bluck *et al.*, 1992).

The Lower Devonian sandstones of the Rhenisches Schiefergebirge area were mainly marine in nature (Wunderlich, 1970; Goldring and Langenstrassen, 1979; Kasig and

Wilder, 1983). These facies formed a belt which bordered the majority of the Old Red Continent (Fig. 2-5). Open shelf and near-shore clastics were deposited on a relatively gently dipping ramp which had no significant break in slope (Goldring and Langenstrassen, 1979). Compared to the distinctive Old Red Sandstone continental facies, the shoreline facies do not have many distinguishing features, and often it was difficult to tell if it was even Devonian in age. The rate of sediment input was very high (approximately 30cm/1000years), and this coupled with high subsidence rates led to extremely thick successions being deposited (5km in the Lenne and Siegen Troughs) (Goldring and Langenstrassen, 1979). Brachiopod and bivalves were the dominant faunas in these environments, and there are also very well preserved ichnofabrics.

In the southern Rhenisches Schiefergebirge area basinal sediments were being deposited during the Lower Devonian (Pragian to Emsian) (Krebs, 1979). The Hunsrück Shale basinal sediments were very localised and represent the oldest Devonian basinal sediments in the Rhenisches Schiefergebirge area (Krebs, 1979).

The Lower Devonian of the Dinant Basin in Belgium is a purely terrigenous regime of both continental and marine deposition (Tsien *et al.*, 1977; Milhau *et al.*, 1989). Clastic material was sourced mainly from the northern Caledonides; however, small land masses within the basin (Franco-Alemannian, Rocroi, and Stavelot islands) were also very localised sources of sediment (Tsien *et al.*, 1977). Sedimentation was once again rapid and a broad transgression of marine facies over fluvial facies from the south to north can be identified (Burchette, 1981). Indeed, this transgression had reached the northern flanks of the Dinant Basin by Lochkovian times (Lecompte, 1970), and the northern Eifel areas by the Emsian.

### 2.2.3 Middle Devonian

The Middle Devonian covers both the Eifelian and Givetian stages (Fig. 2-1). Styles of sedimentation differ in both of these stages, therefore they will be considered separately. Palaeoreconstructions of Scotese and McKerrow (1990) show that during the Middle Devonian Euramerica (Laurentia/Avalonia/Baltica) continued to move northwards, which in turn was accompanied by the appearance of warm-water carbonate deposition (Fig. 2-6). A palaeolatitude of 15°S for southern Britain is suggested by Scotese and McKerrow (1990). Heckel and Witzke (1979) positioned the Middle Devonian Europe in the palaeotropics, due to the presence of oolitic facies.

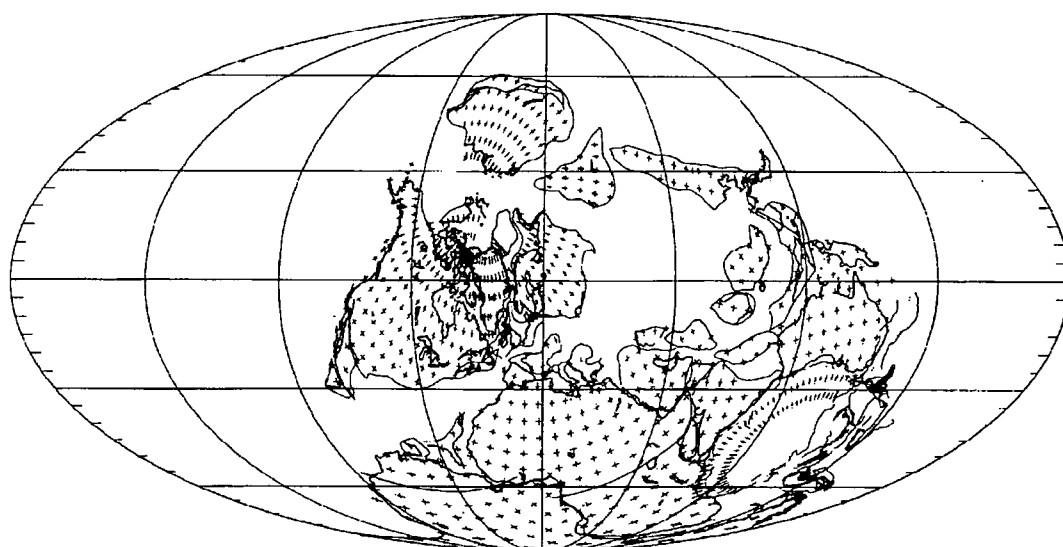

**Figure 2-6 Palaeoreconstruction for the Givetian (Middle Devonian) from Scotese and McKerrow (1990).**

### **2.2.3.1 Eifelian**

The Eifelian is the oldest stage of the Middle Devonian. Fordham (1992) suggested the Eifelian had a duration of approximately 5My (from 386Ma to 381Ma). In the study area the Eifelian is represented by a major transgression and development of a broad carbonate ramp which supported a mixed carbonate and siliciclastic depositional regime (Preat and Boulvain, 1988). This carbonate ramp was transgressive from south to north. Carbonate deposition started in the Belgian Ardennes by lowermost Eifelian times and is represented by the Formation de Couvin, the Jemelle Formation and the Hanonet Formation (Preat, 1989; Bultynck *et al.*, 1991). Southwest England saw the Denbury Crinoidal limestone initiated in the late Eifelian (Burchette, 1981; Selwood *et al.*, 1984). Carbonate deposition in the Rhenisches Schiefergebirge, however, did not start until earliest Givetian times (Krebs, 1974; Burchette, 1981). Deposition in the Eifelian was still clastic in nature and similar to that of the Lower Devonian.

Sedimentation during the Eifelian in Southwest England had many variations, reflecting the complex palaeogeography of the area. In Cornwall most deposition was marine deep water clastics, yet in northern Devon continental and marginal marine Old Red Sandstone facies dominated (Goldring *et al.*, 1968). The Eifelian of the study area (Southeast Devon) is represented by a transition from clastic to carbonate shallow-marine deposits. In the Newton Abbot area the Nordon Slates represent the earliest Eifelian deposition (Scrutton,

1977a; Selwood *et al.*, 1984). These are dominated by greenish weathering, black, or blue-grey slates which are variably fossiliferous with benthonic communities (Selwood *et al.*, 1984). Spilites and tuffs are locally interbedded. There is a thin transitional sequence of shales and limestones which then grade into the fossiliferous Upper Eifelian Denbury Crinoidal Limestones (Scrutton, 1977a, b; Scrutton and Goodger, 1987). The Denbury Crinoidal Limestone contains crinoids, corals, brachiopods and rare bryozoan fragments (Scrutton, 1977a; Scrutton and Goodger, 1987), suggesting open marine conditions. This accumulation of crinoid debris probably formed the foundation for the thick carbonate platform succession which extends into the Givetian and Frasnian stratigraphy (Scrutton and Goodger, 1987).

The Eifelian of the Dinant basin in Belgium is mostly carbonate in nature, and is represented by small organic buildups and interbedded shales and sandstone deposited on a homoclinal ramp (Burchette, 1981; Preat, 1989; Casier *et al.*, 1992). The progradation of these carbonate facies over clastic facies of Lower Devonian is in a northwards direction, so that in the Dinant basin carbonate facies occur earlier than in the more northerly Namur basin. The earliest Eifelian is represented by the Couvin and Jemelle Formations (Bultynck *et al.*, 1991). The Formation de Couvin is dominated by crinoidal limestones and this grades into the Jemelle Formation which is mainly lower-energy shales (Bultynck *et al.*, 1991). The Hanonet Formation represents the uppermost parts of the Eifelian. Tsien (1972) and Preat (1989) recognised that the Hanonet Formation had a broadly regressive nature in the Dinant Basin, shallowing from outer ramp (>60m) fine-grained argillaceous mudstones, to bioclastic grainstones and rudstones of the inner ramp (between 25m and 0m depositional depth). The Hanonet Formation displays varying thicknesses in a number of outcrops in the Dinant basin and this has been attributed to a pre-existing palaeotopography prior to the Middle Devonian (Kasimi and Preat, 1996).

During the Middle Devonian of Germany three main structural features existed which controlled sedimentation (Krebs, 1971; Krebs, 1974; Fig. 2-7). The **external shelf**, encompassing the Eifel area to the west of the River Rhine was a site of typical northwards transgressing, shallow-water, clastic and carbonate sedimentation similar to that of the Dinant and Namur basins. Indeed the Eifelian stage was named after the type-locality in the Eifel area. The Eifel area carbonates are fully marine in nature with a rich brachiopod assemblage (Kasig and Wilder, 1983). They represent shelf carbonates which developed on

the outer shelf margin of the Old Red Continent (Krebs, 1974). Near the shoreline these Eifelian carbonates grade into coarse clastic sediments. The eastern part of the outer shelf (east of the River Rhine, Bergish Land and Sauerland), however, was a very mobile area with high subsidence and sedimentation rates (Krebs, 1974). Deposition was almost entirely clastic in nature, similar to that of the Lower Devonian (Krebs, 1971; Krebs, 1974). The **central trough** was dominated by shaley, pelagic, deep-water sediments. Stable submarine rises were common in the trough, with thin cephalopod limestones occurring on top (Krebs, 1971; Krebs, 1974). The **inner shelf** sediments of the Rhenish Trough were shallow-water in nature, transgressing onto the 'Mittel-Deutsche Schwelle'. It was not until the Givetian that carbonate sedimentation dominated in western Germany.

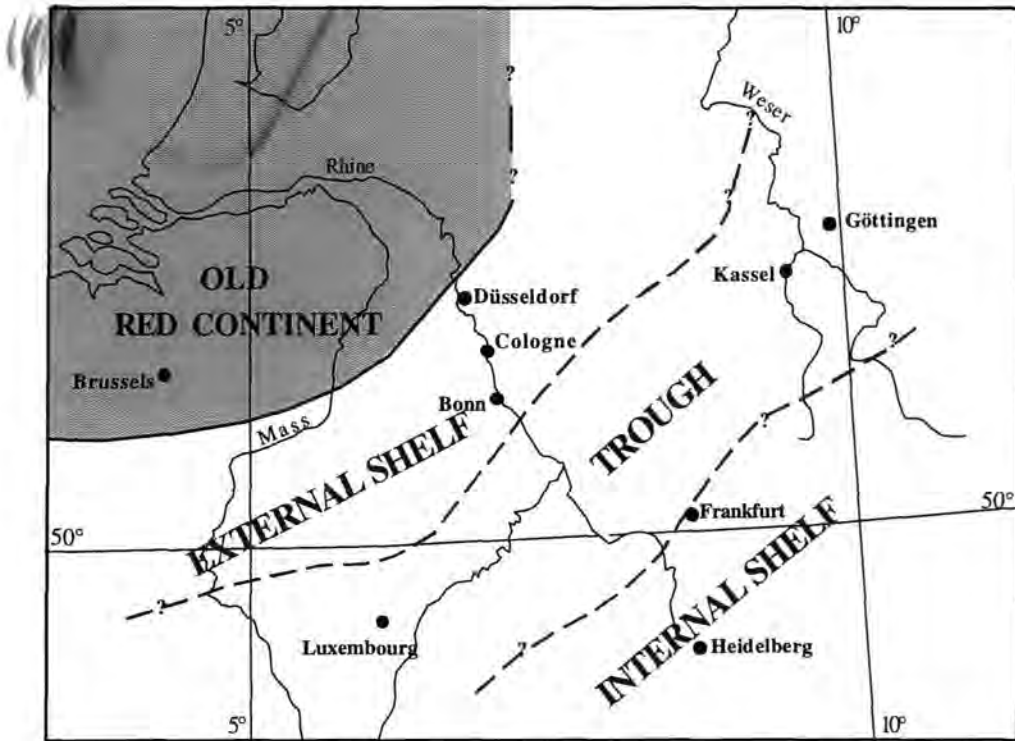

Figure 2-7 Palaeogeography during the Middle Devonian in western and central Europe (from Krebs, 1974).

### 2.2.3.2 Givetian

The Givetian is the youngest stage in the Middle Devonian. Fordham (1992) suggested the Givetian had a duration of approximately 9My (381Ma to 372Ma) by using radiometric dating. More recently, House (1995a) critically reviewed the proposed duration of the Givetian, since estimates ranged from 5Ma (Odin and Odin, 1990) to 11Ma (McKerrow *et*

*al.*, 1985). House (1995a) examined Givetian microrhythms of the Montagne Noire, France, where it was presumed that they had a climatic precessional signature. The 353 microrhythms thus gave a 7.1Ma duration to the Givetian, very similar to the figure of 7.0Ma which was attained from averaging all published data for the duration of the Givetian (House, 1995a). The Givetian, along with the Frasnian, are the main time-periods of interest for this thesis, and thus will be discussed in more detail in Chapter 5.

The Givetian of western Europe saw the development of a true carbonate platform. The shelf edge can be traced from Southwest England, through northern France, south of the Dinant basin, and then northeastwards through the central Rhenish Schiefergebirge (Fig. 2-8), and this was often the site of reef-development (Burchette, 1981; Preat and Mamet, 1989). The start of reef growth was once again older in the south than the north, reflecting the progress of the Devonian transgression over the shelf (Burchette, 1981).

The Givetian of Southwest England once again had a complicated palaeogeography (Scrutton, 1977a; Bluck *et al.*, 1992; Fig. 2-9). Deep-water sedimentation continued through from the Eifelian in Cornwall, with the presence in the Givetian of deep-water distal limestone turbidites (Tucker, 1969; Gauss and House, 1972). These turbidites were sourced from a southwesterly provenance (Tucker, 1969), coincident with the shelf edge rise which runs south of the area. In North Devon sedimentation was still clastic in nature, having accumulated in shallow-water prodelta and delta-platform environments (Webby, 1965; Webby, 1966; Goldring *et al.*, 1968). This contrasted dramatically with the carbonate successions in South Devon. The Eifelian crinoidal limestones provided a base on which Givetian reef limestones could develop in the Torquay area of Southeast Devon (Scrutton, 1977b). These reefs were thought to have developed on the elevated shelf-edge rise (Scrutton, 1977b). The Torbay reef complex had a central lagoon (Scrutton, 1977a; Garland *et al.*, 1996) and it is assumed that the geometry of the complex was one of an isolated atoll (Scrutton, 1977a, b). However, severe Variscan thrusting and deformation hampers detailed palaeogeographical reconstructions. Thick accumulations of volcanic tuffs were deposited over Southeast Devon in the latest Givetian, possibly providing local short term topographic highs capable of sustaining carbonate deposition (Scrutton, 1977a).

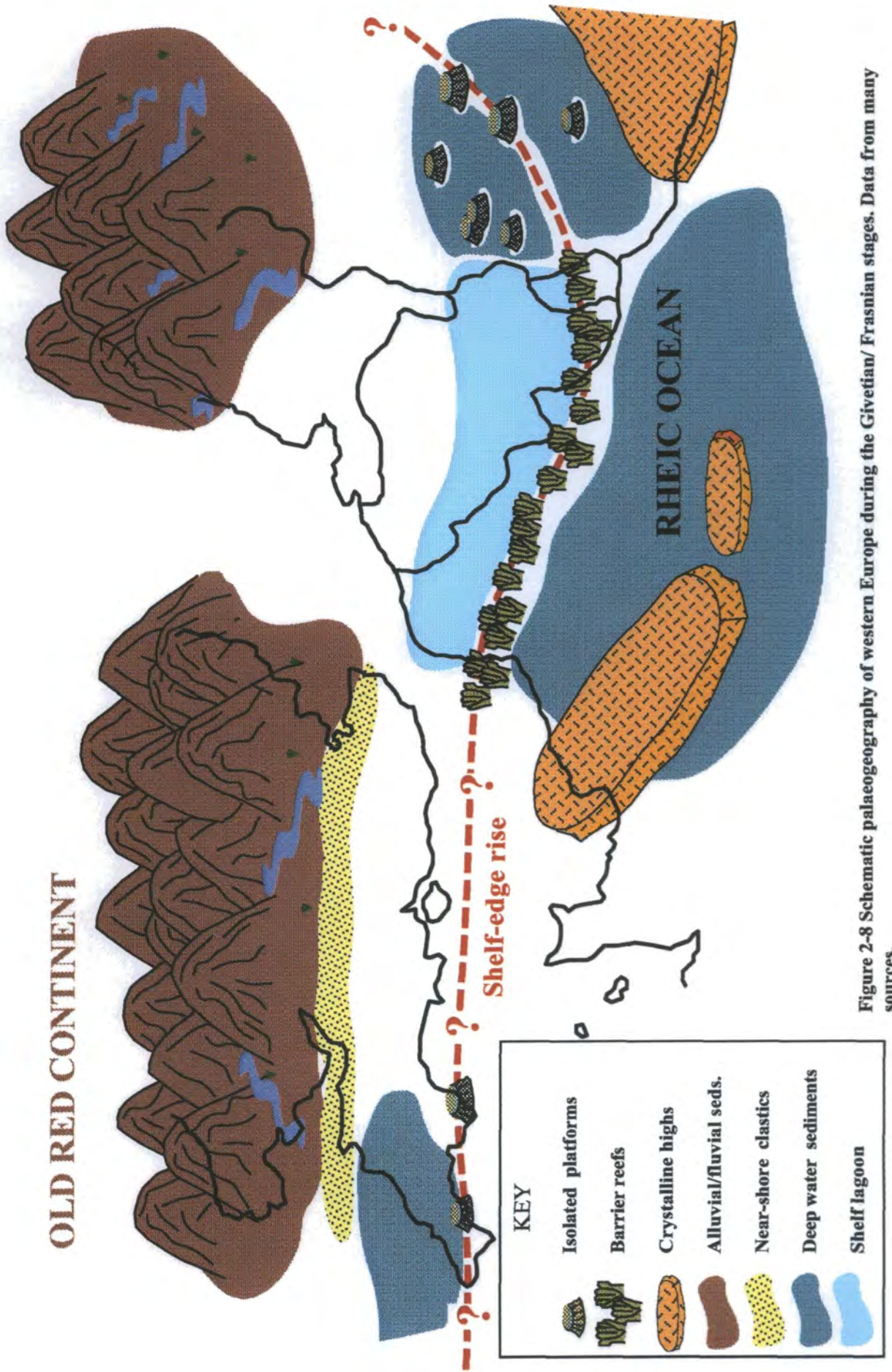
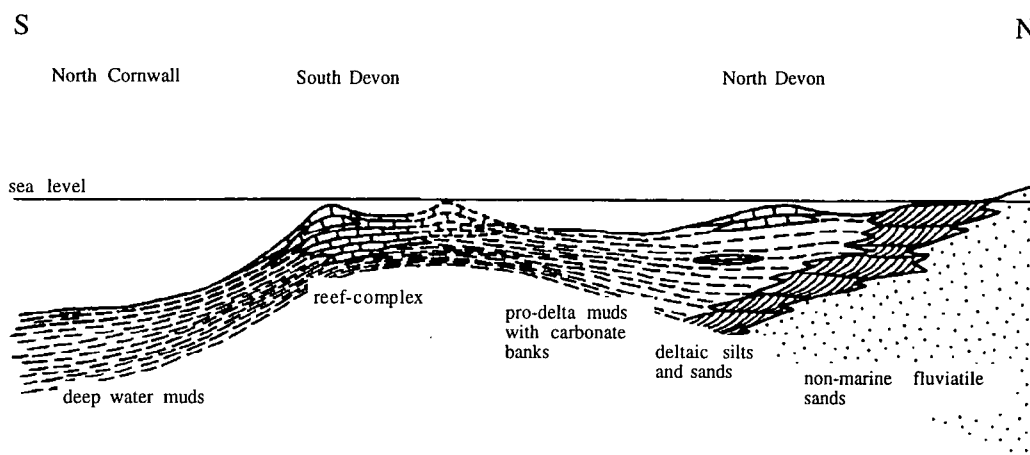

Figure 2-8 Schematic palaeogeography of western Europe during the Givetian/ Frasnian stages. Data from many sources.



**Figure 2-9** Generalised reconstruction of the sea-floor across part of the Devonian shelf during the mid Givetian (from Scrutton, 1977a).

The Belgian Ardennes and Eifel areas of Germany saw the development of a large shelf lagoon during the Eifelian/Givetian boundary times when stromatoporoid-coral reefs developed along the shelf edge and provided restriction. Taking into account the 33% shortening of these sediments during the Variscan orogeny, the lagoonal zone reached 50-60km in width from reef to shore (Burchette, 1981). This style of sedimentation continued until the end of the Givetian, when transgression caused back-stepping of the margin in the direction of the Old Red Continent (Burchette, 1981). The broad shelf lagoon was dissected into numerous tilted fault blocks, each a few kilometres wide, which is typical of passive tectonism in a backarc setting (Preat and Weis, 1994).

Further east in the Aachen area of Germany west of the River Rhine, sedimentation during the Lower Givetian was clastic in nature consisting of red and greenish-grey sandstones (Kasig and Neumann-Mahlkau, 1969; Kasig, 1980; Kasig and Wilder, 1983). This succession is overlain by the Upper Givetian limestones (Upper Stringocephalus Beds) which at the base reflected open marine sedimentation. However, further up the succession the sediments were lagoonal in nature (Kasig, 1976; Kasig and Wilder, 1983) and represented an eastwards extension of the shelf lagoon present in southern Belgium.

The Givetian succession east of the River Rhine differs greatly from that in the Eifel and Aachen areas. The lower and middle Givetian is characterised by the 'Schwelm' facies: dark grey, fine-grained, well-bedded fossil-rich limestones deposited in an open-marine bank

setting (Krebs, 1971; Krebs, 1974; Burchette, 1981). These 'Schwelm' limestones always form the lower part of the Massenkalk sequence (Fig. 2-3), and developed upon the marine clastics of the Eifelian. The Upper Givetian carbonate complexes east of the River Rhine differ dramatically from those of the broad shelf lagoon in Belgium. They were predominantly isolated carbonate complexes (atolls) with a central lagoon, which Krebs (1974) suggested developed in three palaeogeographically distinct sites (refer also to Figure 2-8):

1. Type A - Isolated carbonate complexes developed on submarine rises, or upfaulted blocks within the Rhenish Trough (i.e., Langenaubach).
2. Type B1 - Isolated carbonate complexes developed at the shelf edge rise (i.e., Attendorn, Brilon)
3. Type B2 - Isolated reefs on banks within the external shelf, which are separated laterally by shale basins (i.e., Balve, Dornap)

All of these isolated carbonate complexes, apart from Langenaubach, were initiated in the Upper Givetian, with continued sedimentation through most of the Lower Frasnian (Krebs, 1974).

#### **2.2.4 Upper Devonian**

The Upper Devonian encompasses both the Frasnian and Famennian stages. Different styles of sedimentation are represented in both stages, therefore the Frasnian and Famennian will be considered separately. Global-scale palaeoreconstructions of Scotese and McKerrow (1990) suggest that Euramerica was still steadily moving in a northwards direction, with palaeolatitudes for southern Britain at approximately 12°S for the latest Devonian (Famennian). Although Euramerica experienced relatively little palaeolatitudinal change through the Upper Devonian, major plate reorganisation was occurring further south in Gondwana (Kent and Van der Voo, 1990). For the first time in the Devonian, Gondwana was positioned over the South pole, hence instigating ice-house conditions and a major period of glaciation (Fig. 2-10; Kent and Van der Voo, 1990; Scotese and Barrett, 1990).

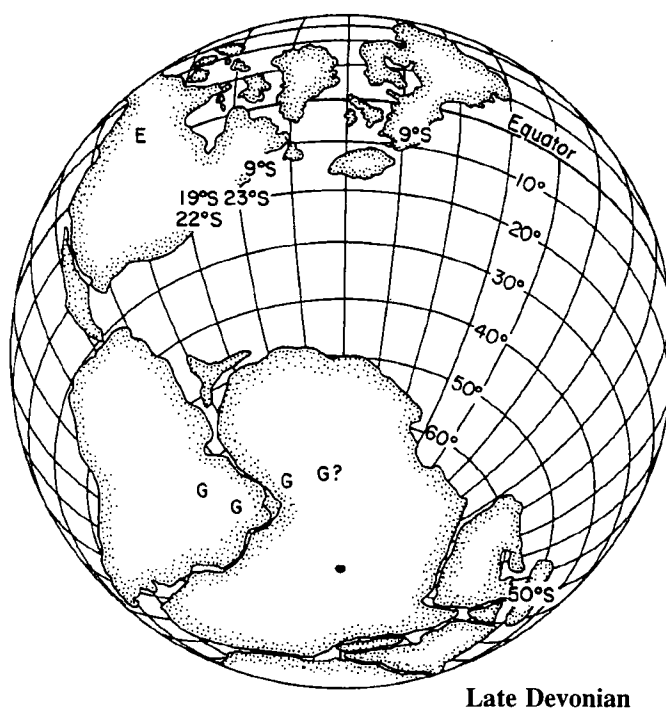

**Figure 2-10** Palaeogeographic reconstruction for the Famennian. G = glacial relicts, E = Evaporites (from Kent and Van der Voo, 1990).

#### 2.2.4.1 Frasnian

The Frasnian stage is the oldest stage in the Upper Devonian. Its duration is thought to be approximately 5My (from 372Ma to 367Ma; Fordham, 1992). The Frasnian stage is characterised by a complex succession of deepening events (Johnson *et al.*, 1985). By early Frasnian times the Dinant Basin in Belgium was dominated by deeper water carbonates (Burchette, 1981). This drowning of reefs did not occur in the Rhenisches Schiefergebirge area until the middle Frasnian (Krebs, 1974) and in Southwest England the sea-level rise affected the reefs in early to middle Frasnian times (Burchette, 1981; Butler, 1981). At, or near the end of the Frasnian stage there was a major extinction (Kellwasser Event) which killed many of the shallow-water corals and stromatoporoids (McLaren, 1982; House, 1985; Johnson *et al.*, 1985; Scrutton, 1988; Scrutton, 1997). The main driving force for this extinction was thought to be the changing environment (Scrutton, 1988). The late Devonian was a time of cooling climates and coupled with the rapidly increasing sea level led to stressed conditions in the shallow seas (Scrutton, 1997). Deep water faunas were only mildly effected by this environmental change, and indeed many of these basinal faunas diversified during this period (Scrutton, 1997).

In Southwest England the Frasnian sea-level rise was represented in most palaeogeographical settings. In Cornwall, the Frasnian is represented by grey slates and rare pillow lavas (Goldring *et al.*, 1968). In South Devon subsidence of the Torbay reef complex apparently started in late early to mid Frasnian times, ending carbonate deposition (Scrutton, 1977a, b). The youngest limestones in the area had a characteristic pinkish colour and were very similar to the deep-water mudmounds of the late Frasnian of Belgium (Scrutton, 1977a, b; Burchette, 1981). These bioherms were dated as mid to late Frasnian (Scrutton, 1977a). The Frasnian sediments of North Devon represented clastic facies of continental, delta platform and prodelta slope environments (Goldring, 1962). As these were of a similar environment to the Middle Devonian, it was suggested that this clastic sedimentation was able to keep pace with the increase in rate of subsidence/sea-level rise (Goldring *et al.*, 1968).

Following the end Givetian transgression in the Dinant and Namur Basins of Belgium, isolated red-coloured reef-mounds of Frasnian age developed basinwards of the barrier reef (Burchette, 1981; Blicek *et al.*, 1988). Three phases of mudmound development have been recognised in the southern part of the Dinant Basin (Preat and Boulvain, 1988). As is so common with Devonian carbonate buildups, these Frasnian mudmounds were thought to have a diachronous nature, being younger in the north than the south (Coen and Cornet, 1977). This is likely to be related to the northerly transgression of the area, which is associated with increasing clay sedimentation (Preat and Boulvain, 1988). A characteristic of these mudmounds is the 'stromatactis' structures so often developed (Blicek *et al.*, 1988). The mudmounds are considered deep-water buildups that developed below wave base (Lecompte, 1954; Dreeson *et al.*, 1985). Preat and Boulvain (1988) suggested initial mudmound development was at approximately 100m depth, well below the photic-zone. Barrier reefs were still present in the lower Frasnian along the shelf edge rise further north near Phillipeville, enabling lagoonal sedimentation to continue (Tsien, 1972; Tsien *et al.*, 1977). The end of carbonate deposition coincides with deposition of the Matagne Formation shales (Fig. 2-3). These are a series of dark coloured, black to greenish shales (Bouckaert *et al.*, 1972) which represent either an increase in subsidence rate (Tsien, 1980) or the presence of oxygen-depleted waters (Casier, 1987).

Apart from a small transgression at the base of the Frasnian allowing turbiditic limestone deposition (Grenzschiefer), the Aachen and Eifel area of Germany had continued lagoonal

sedimentation in the Lower Frasnian (Kasig and Wilder, 1983). The major upper Frasnian transgression is recorded in the Aachen area at the *An. triangularis* to *Pa. gigas* conodont zones (Fig. 2-3; Kasig *et al.*, 1978; Wilder, 1989). Nodular limestones and marly shales overly the stromatoporoid limestones, following the death of the reefs (Hollerbach and Kasig, 1980; Kasig, 1980; Kasig and Wilder, 1983; Walter *et al.*, 1985). This process of deepening reached a peak with the deposition of thick successions of black shales (up to 900m; Krebs, 1971; Krebs, 1974) similar to the Matagne Shales in Belgium.

Isolated carbonate complexes of the Rhenisches Schiefergebirge continued growth through to the end of the middle Frasnian (Krebs, 1974). The terminal stage of reef growth showed a change from rapid and continuous subsidence to little or no subsidence (Krebs, 1974). Following the death of the reefs, either nondeposition or sedimentation of condensed cephalopod limestones prevailed on the submarine rises (Krebs, 1971; Krebs, 1974). Consequently in the neighbouring basins thick deposits (up to 700m; Krebs, 1971) of deep-water silty shales, locally rich in ostracodes were deposited (Tucker, 1969; Krebs, 1971; Tucker, 1973). These were termed 'Schwellen' and 'Becken' facies respectively by Schmidt (1925). This style of sedimentation continued through the late Frasnian to Famennian (Tucker, 1973).

#### **2.2.4.2 Famennian**

The Famennian is the youngest stage of the Devonian, and is thought to be approximately 13My in duration (Fordham, 1992; Fig. 2-2).

In Southwest England, a broad cross-section from deep water to continental environments existed from South Devon through north Devon and into Wales (Fig. 2-11; Goldring *et al.*, 1968). In Southeast Devon thick sequences of deep-water ostracode slates with intercalated tuffs were deposited in small basins, and reduced successions with ammonoids and cephalopods deposited upon submarine rises (similar to the German 'Becken' and 'Schwellen', see section 2.2.4.1; Dineley, 1961; Goldring *et al.*, 1968). In North Devon a continuing transgression was recorded throughout the Famennian (Goldring, 1962; Webby, 1966). Lagoon and marsh sediments (Upcott Beds) were succeeded by tidal-flat, beach, and offshore prodelta deposits (Baggy Beds) and finally neritic fossiliferous sandstones and shales (Pilton Beds) were deposited. By the end of the Famennian the transgression had extended across South Wales (Webby, 1966).

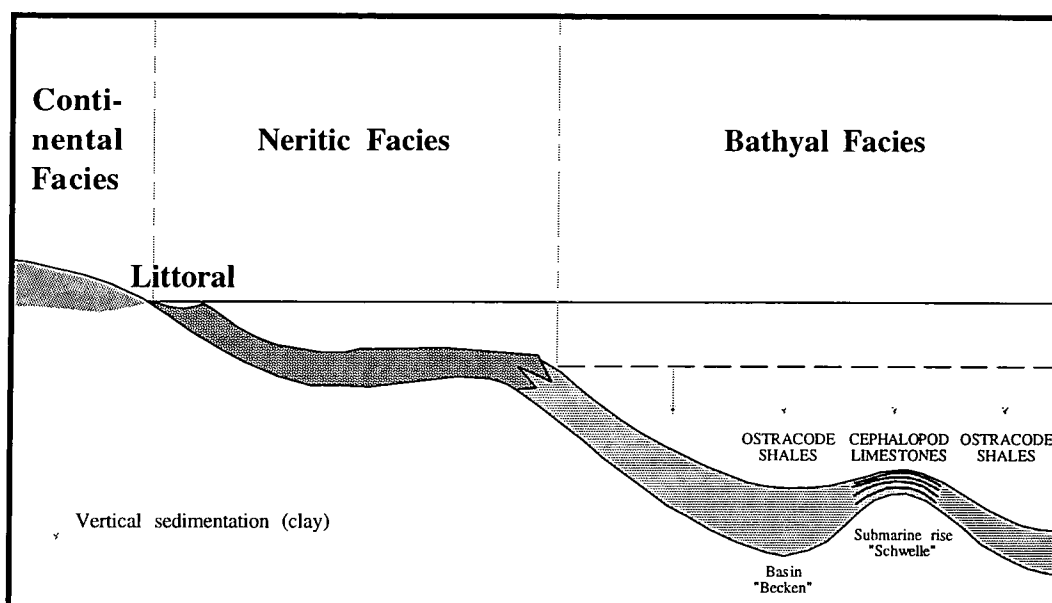

**Figure 2-11** A composite diagram to show the relationship between deep and shallow water deposits in the Upper Devonian of southern Britain (based on Rabiën, modified from Goldring, 1962).

Contrary to the southern British Famennian successions, the Belgian and western German (Eifel and Aachen area, west of the River Rhine) deposits from a regressive succession (Walter *et al.*, 1985; Blicek *et al.*, 1988). Deep-marine sediments of upper Frasnian age shallow into coastal, shallow, and then back-shore deposits (Blicek *et al.*, 1988), with their distribution being a response to the prograding coastline. Further north on the eastern edge of the Brabant Massif the Frasnian limestones had already undergone intense karstification (Walter *et al.*, 1985). Differentiation between depositional environments was very clear, and a broad deep-water, through shallow open-marine, lagoonal tidal flat, to continental alluvial cross-section could be drawn from south to north (Wilder and Kasig, 1983). In the uppermost Famennian, calcareous facies reappeared which continued through to the Carboniferous (Wilder and Kasig, 1983).

East of the River Rhine in the German Rhenisches Schiefergebirge area, deep-water sedimentation of a 'Becken' and 'Schwellen' nature, similar to the upper Frasnian, persisted (Krebs, 1971). Before middle Lower Carboniferous times, however, it is apparent that some of the reef complexes and cephalopod limestones emerged above sea level and were subjected to erosion (Krebs, 1971).

### 2.2.5 Post Devonian

During the Carboniferous the closure of the Rheic Ocean between northern Europe and Gondwana and several other oceans (Pleionic Ocean and Phoibic Ocean) resulted in the amalgamation of the western half of Pangea (Riding, 1974; Scotese and McKerrow, 1990; Torsvik *et al.*, 1990). The Hercynian/Variscan Orogeny had its climax in the Westphalian, deforming much of the southern margin of Baltica/Avalonia. Much of the deformation was of a transpressive nature, since Gondwana rotated in a clockwise manner during collision (Scotese and McKerrow, 1990). Northern Europe was drifting northwards during the Carboniferous from approximately 5°S in the Viséan, to 5°N by the Westphalian (Scotese and McKerrow, 1990).

The Lower Carboniferous of western Europe saw a continued transgression of marine facies onto the Old Red Sandstone Continent (Anderton *et al.*, 1985). A mosaic of rapidly subsiding basins and positive land masses had a strong influence on sedimentation in Britain (Cope *et al.*, 1992; Fig. 2-12). In Belgium and western Germany sedimentation was concentrated into the northwards propagating Hercynian basin, where carbonate environments were established over the sandy shelf and littoral deposits of upper Devonian age (Wilder and Kasig, 1983; Anderton *et al.*, 1985; Walter *et al.*, 1985). Further east of the Rhine, early Carboniferous successions record the presence of deep-water sediments, with periodic influxes of limestone turbidites from the Brabant carbonate platform (Meischner, 1971).

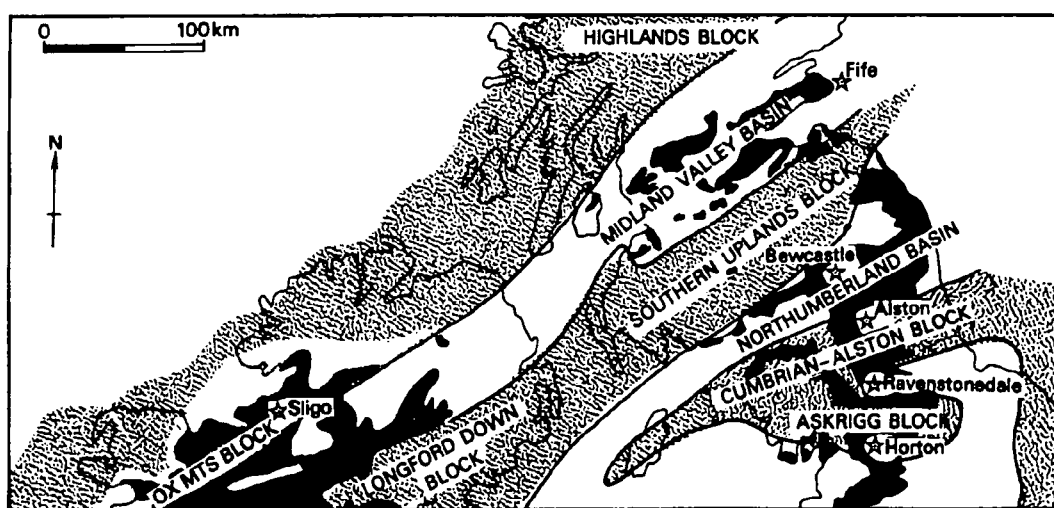

Figure 2-12 Lower Carboniferous (Dinantian) outcrops (shaded black) and upland areas (stippled ornament) to show generalised palaeogeographic features for northern Britain (from, Anderton *et al.*, 1985).

The Hercynian Orogeny affected the study area extensively. A transect of the Hercynian fold belt from Britain to northern Spain shows two major fold zones, separated by a metamorphosed zone (Fig. 2-13; Riding, 1974). The Rhenisches Schiefergebirge area, Ardennes and Southwest England lie directly within the northern foldbelt. In this foldbelt deformation may have been initiated as early as the Viséan, yet the major phase of deformation occurred post mid-Westphalian times (Riding, 1974). The Hercynian deformation produced NE-SW trending folds and thrusts (Anderton *et al.*, 1985) which has hampered many attempts at palaeogeographic reconstructions for the Devonian, especially of Southwest England (Scrutton, 1977a, b).

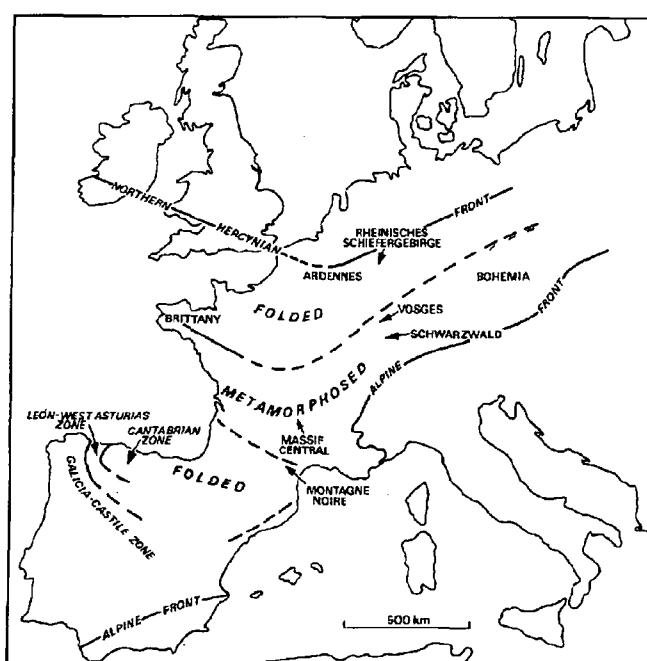

Figure 2-13 Hercynian zones and localities of western Europe (from Riding, 1974).

### 2.2.6 Synthesis

As the previous Sections have discussed, the Devonian of the study area (Southwest England, Ardennes of Belgium, and western Germany) shows a complex interaction of plate motions, varying climates, complicated local palaeogeographies, differing styles of sedimentation and fluctuating sea levels. Figure 2-14 presents a synthesis of the data discussed in earlier sections, so as to provide 'snapshots' for the Early Devonian, Middle Devonian, Upper Devonian and Lower Carboniferous.

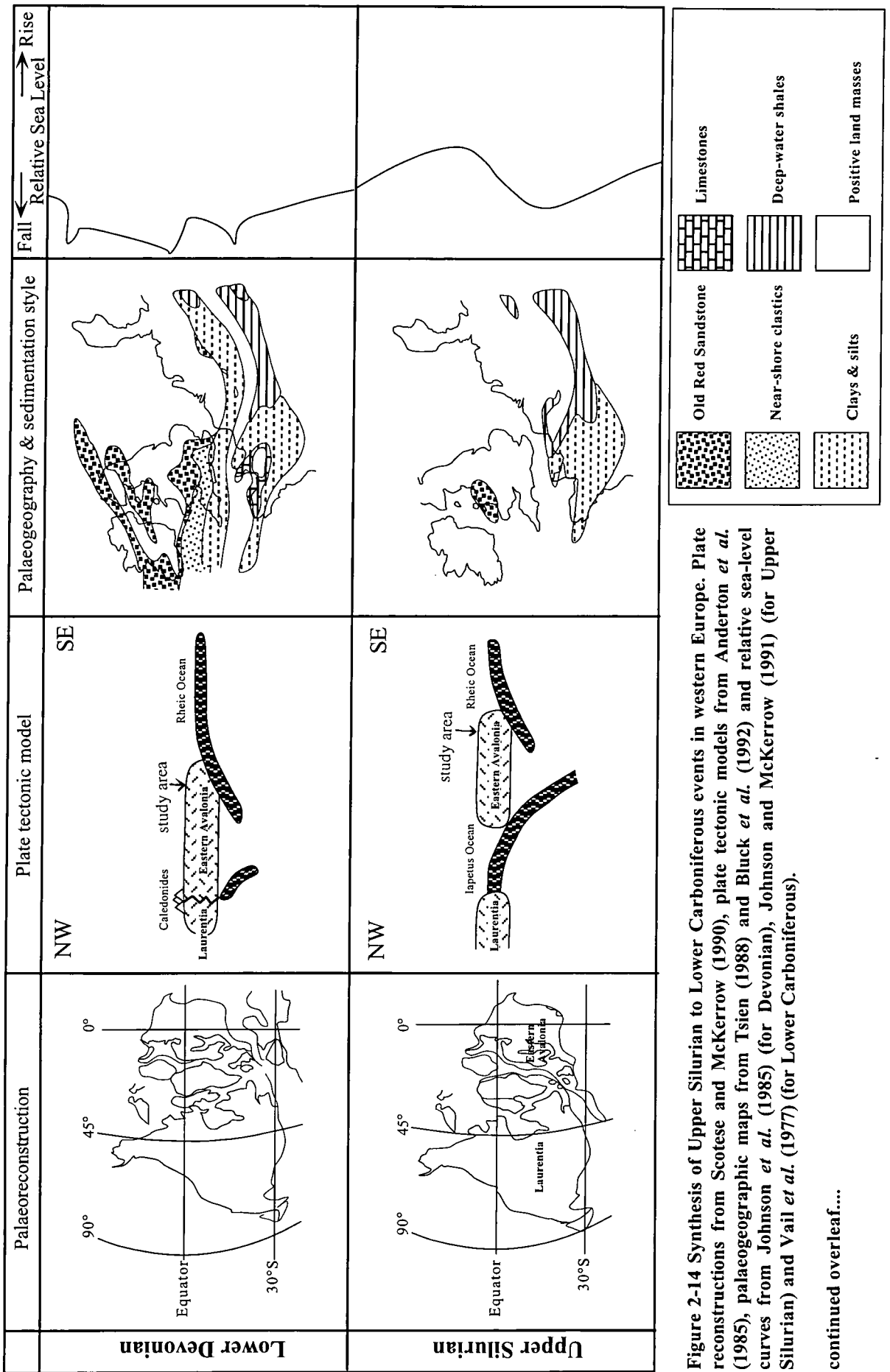

Figure 2-14 Synthesis of Upper Silurian to Lower Carboniferous events in western Europe. Plate reconstructions from Scotese and McKerrow (1990), plate tectonic models from Anderton *et al.* (1985), palaeogeographic maps from Tsien (1988) and Bluck *et al.* (1992) and relative sea-level curves from Johnson *et al.* (1985) (for Devonian), Johnson and McKerrow (1991) (for Upper Silurian) and Vail *et al.* (1977) (for Lower Carboniferous).

continued overleaf....

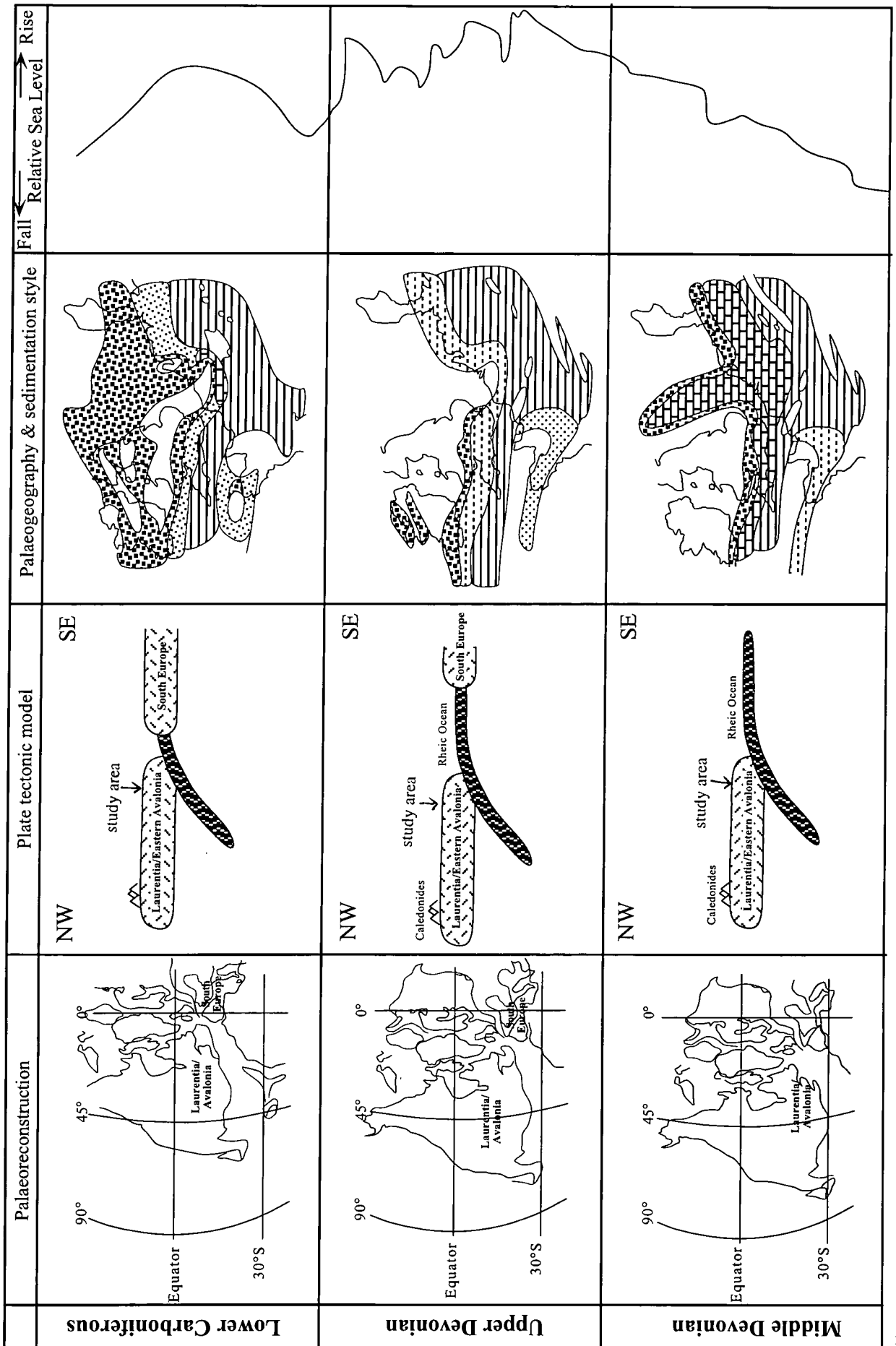

Figure 2-14 continued.

# CHAPTER THREE

## 3. PALAEOECOLOGY OF MIDDLE TO UPPER DEVONIAN CARBONATE ENVIRONMENTS 33

|   |    |
|---|----|
| 3.1 STROMATOPOROIDS.....  | 33 |
| 3.1.1 <i>Domal stromatoporoids</i> .....                        | 35 |
| 3.1.2 <i>Bulbous stromatoporoids</i> .....                      | 36 |
| 3.1.3 <i>Tabular stromatoporoids</i> .....                      | 37 |
| 3.1.4 <i>Columnar stromatoporoids</i> .....                     | 38 |
| 3.1.5 <i>Branching stromatoporoids</i> .....                    | 38 |
| 3.1.5.1 <i>Amphipora</i> .....                                  | 38 |
| 3.1.5.2 <i>Stachyodes</i> .....                                 | 40 |
| 3.2 CALCAREOUS ALGAE AND CYANOBACTERIA.....                     | 41 |
| 3.2.1 <i>Chlorophytes (calcareous green algae)</i> .....        | 43 |
| 3.2.1.1 <i>Dasycladaceae</i> .....                              | 43 |
| 3.2.1.2 <i>Codiaceae</i> .....                                  | 44 |
| 3.2.2 <i>Calcified cyanobacteria ('blue-green algae')</i> ..... | 46 |
| 3.2.2.1 <i>Girvanella</i> Group.....                            | 46 |
| 3.2.2.2 <i>Hedstroemia</i> Group.....                           | 47 |
| 3.2.2.3 <i>Renalcis</i> Group.....                              | 47 |
| 3.2.2.4 <i>Wetheredella</i> Group.....                          | 49 |
| 3.3 FORAMINIFERA.....   | 49 |
| 3.4 OSTRACODES.....   | 51 |
| 3.4.1 <i>Leperditiid ostracodes</i> .....                       | 51 |
| 3.5 'CALCISPHERES'.....   | 53 |
| 3.6 CORALS.....   | 53 |
| 3.7 BRACHIOPODS.....  | 55 |
| 3.8 MOLLUSCS.....   | 56 |
| 3.9 OTHERS.....   | 58 |
| 3.10 PALAEOECOLOGICAL RECONSTRUCTION.....                       | 58 |

### 3. Palaeoecology of Middle to Upper Devonian carbonate environments



This Chapter introduces the principal fauna and flora found in the back-reef and lagoonal environments of the Middle and Upper Devonian of western Europe. Stromatoporoids and calcareous algae are discussed in detail since they are very common and well represented in the study area. Foraminifera, ostracodes, calcispheres, corals, brachiopods and molluscs of the Middle to Upper Devonian are only briefly described. The likely habitats of each of the fossils are discussed in detail to build up a broad palaeoecological reconstruction of the Devonian environments.

#### 3.1 Stromatoporoids

Stromatoporoids are an extremely important fossil group in the Middle - Upper Devonian carbonate environments of western Europe. They are common within open-marine, fore-reef, reef-core and back-reef facies, and their varied morphologies have fundamental implications for palaeoecological studies. Stromatoporoids have been considered by different authorities to be hydrozoans, sponges, encrusting Foraminifera, bryozoans, algae, or an extinct phylum with no modern counterparts (Clarkson, 1989). They are now widely accepted as belonging to the phylum Porifera (sponges) because of their similarities to living sclerosponges (Stearn, 1972, 1975; Scrutton, 1985). Stromatoporoids were sessile, benthic animals which lived in relatively shallow water with likely maximum depths of 15-20m (Playford, 1980). The skeleton is calcareous and finely reticulate in structure, composed of distinct horizontal laminae and vertical pillars (Scrutton, 1985) which supported soft tissue in the upper few millimetres of the skeleton during life (Kershaw, 1988). The internal structure of the stromatoporoid is highly variable; in some specimens the laminae are dominant, whilst in others the pillars dominate, and their classification is based in these differences (Kershaw, 1988).

The growth forms of stromatoporoids are markedly variable. They range in size from millimetres in diameter (such as *Amphipora*, a branching stromatoporoid) to three metres or more. In field studies it is useful to describe the growth-form of stromatoporoids. This not only helps classification purposes, but also helps to determine probable palaeoenvironments. However, to identify stromatoporoids to genus or species level it is necessary to examine thin sections. Using the classification schemes of Stearn (1982) and Young and Scrutton (1991) stromatoporoids can be divided into five major categories on

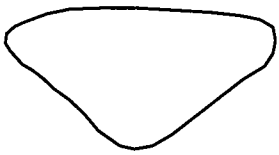
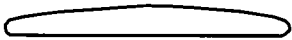
the basis of their growth forms: domal, bulbous, tabular, columnar, and branching (Table 3-1).

|           |  |   |
|-----------|--|---|
| DOMAL     | Forms with an upwardly convex surface and a broad base. The widest part is below the midpoint of the height, with a width:height ratio of less than 3:1.   |     |
| BULBOUS   | Forms with convex upper surfaces that taper downward to a small base. The widest part is above the midpoint of the height, the sides are not subparallel, and the width:height ratio is less than 3:1. |     |
| TABULAR   | Forms which are broad with a width:height ratio of 3:1 or greater. The upper surface is essentially horizontal or gently undulating. The term laminar stromatoporoid is also used.                     |     |
| COLUMNAR  | Forms which are tall, with sides subparallel and height greater than width.  |   |
| BRANCHING | Stick-like, digitate and dendroid forms.   |  |

**Table 3-1 Table categorising basic growth forms of stromatoporoids. Data compiled from Stearn (1982) and Young and Scrutton (1991).**

An important observation is made by Kershaw (1988) with regards to field studies of stromatoporoids. Since most stromatoporoids occur in solid limestone, the geologist or palaeontologist will see only a section through the stromatoporoid. This presents problems when trying to interpret a three-dimensional geometry from a two-dimensional section. For example a domal form, when sectioned on its edge, may appear laminar in shape. Laminar forms will still appear laminar, and it's likely that complex branching forms will show highly irregular shapes. Therefore, caution must be taken when using this morphological approach to describing stromatoporoids.

The variety of sizes and morphologies of stromatoporoids reflects species-type and the environment in which they lived (Fig. 3-1). Factors such as water turbulence and the

amount of light flux able to reach the stromatoporoid (i.e., water depth and quality) were important influences on their distribution (Stearn, 1982). Kershaw (1988) suggested that domal and tabulate types dominated higher-energy conditions in reefs whereas delicate branching and unstable bulbous stromatoporoids were more common in muddy, low-energy environments such as lagoons.

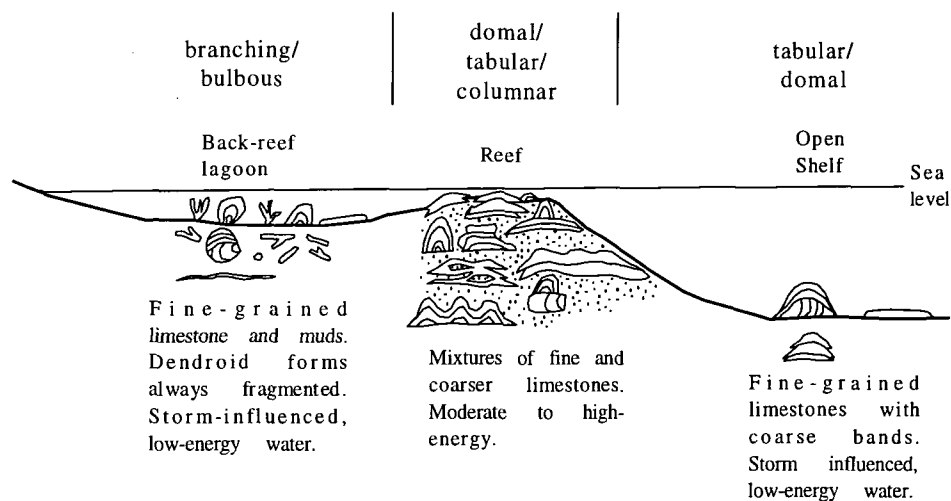

**Figure 3-1 Typical environmental distribution of stromatoporoid growth forms (adapted from Kershaw, 1988)**

The following sections describe the main stromatoporoid types seen in the Middle and Upper Devonian back-reef and lagoonal environments of western Europe.

### 3.1.1 Domal stromatoporoids

Domal stromatoporoids are not common constituents of Middle and Upper Devonian back-reef environments. When present, they can reach up to 60cm in diameter and are often very broken up, reflecting reworking and transportation, and are rarely found in life position. They are associated with a rich faunal assemblage of colonial corals, solitary corals, *Stachyodes*-types stromatoporoids, broken up laminar stromatoporoids and crinoids. No formal identification of the domal stromatoporoids has been made, as it is outside the scope of this study.

**Environmental significance:** Domal or massive stromatoporoids are common constituents of reefal facies in Devonian carbonate build-ups (Krebs, 1974; Scrutton, 1977a). In the reef subfacies of German isolated carbonate complexes, domal stromatoporoids are

associated with *Alveolites*, *Favosites* and *Heliolites* tabulate corals, and *Hexagonaria* and *Phillipastrea* rugose corals which are mostly in life position (Krebs, 1974). The shape of domal stromatoporoids (flat base and streamlined convex top) ensures it to be stable in higher energy environments. The presence of abraded and overturned domal stromatoporoids in high-energy back-reef facies suggests the stromatoporoids probably dwelled in the reef, and were later incorporated into back-reef facies by storms or currents.

### 3.1.2 Bulbous stromatoporoids

Bulbous stromatoporoids are very common within the back-reef environments of the Devonian of western Europe. They have not been identified in a formal manner in this thesis as this is outside the scope of the study. However, studies in similar Devonian Reef Complexes of Western Australia by Cockbain (1984) suggested *Actinostroma* was the most common genus of bulbous stromatoporoid in the platform interior. In the field the bulbous stromatoporoids have a distinctive ball or globular shape (Fig. 3-2) and in thin section they have a varying morphological nature; some have a regular network of laminae and pillars, and others have a more irregular vesicle system. This reflects the diversity in species rather than adaptations to different environments. In the study area the size of the bulbous stromatoporoids range from about 5cm diameter to 60cm diameter.



Figure 3-2 Field photograph of bulbous stromatoporoid, in life position, surrounded by *Amphipora* branches. Photograph taken in the Canning Basin, western Australia, courtesy of Colin Scrutton.

The bulbous stromatoporoids are associated with dendroid stromatoporoids (*Amphipora*), and microfossils such as ostracodes and algae. They are rarely found in life position, having been overturned as a result of their unstable morphologies requiring suitable sediment support around the base.

Environmental significance: Bulbous stromatoporoids are thought to have inhabited calm water environments since their bulbous shape would have been unstable in higher energy environments (Kershaw, 1988). They are very common in many Devonian lagoonal successions (i.e., Canadian reef complexes, Playford, 1969; Western Australian reef complexes, Playford, 1969; Western European reef complexes, Krebs, 1974; SW English complexes, Scrutton, 1977a, b; Moroccan complexes, Cattaneo *et al.*, 1993), and are always interpreted as lagoonal or platform interior.

### 3.1.3 Tabular stromatoporoids

Tabular, or laminar stromatoporoids are classed as having a width:height ratio of greater than 3:1. These stromatoporoid forms are not common within the back-reef and lagoonal facies of western Europe, and therefore have only been described by their morphology (no formal identifications have been made). The tabular stromatoporoids are sometimes found in higher energy back-reef environments (such as in the Attendorf Reef Complex, Germany) where storms have dislodged and transported them. The stromatoporoids reach up to 200mm in length and 25mm in height. However, they are more commonly broken up reaching only 100-120mm on average.

Environmental significance: The tabular stromatoporoids are most often found in reef-margin and fore-reef facies (i.e., Western Australian complexes, Playford, 1969, 1980; Central European complexes, Heckel, 1974; Krebs, 1974), as their streamlined geometries are better adapted to higher energy environments. This can be further supported by the evidence of Mayall (1979) where tabular stromatoporoids were interpreted as living in a uniformly high-energy environment, and Kershaw and Riding (1980) interpreted a succession where tabular stromatoporoids reflected upper fore-reef environments. However, there has been some controversy over the environmental significance of tabular stromatoporoids as they have also been sighted in back-reef environments in SW England (Scrutton, 1977a; Stearn, 1982). In this situation the morphology of the tabular

stromatoporoid may have reflected the need to spread its weight on the soft sediment, so that it did not sink.

### 3.1.4 Columnar stromatoporoids

No occurrence of columnar stromatoporoids have been found or reported in the study area.

### 3.1.5 Branching stromatoporoids

Two genera of branching or dendroid stromatoporoid have been identified in the back-reef and lagoonal facies of the study area: *Amphipora* and *Stachyodes*. *Amphipora* has delicate branches and tends to be more common in the micritic, lower energy, lagoonal environments. *Stachyodes* is a more robust dendroid stromatoporoid and occurs in higher energy back-reef facies.

#### 3.1.5.1 *Amphipora*

*Amphipora* is a very easy stromatoporoid to distinguish. In the field it displays a spaghetti-like morphology and gives a bafflestone or floatstone texture to the limestone. *Amphipora* branches are on average 3mm in diameter and reach up to 30mm in length (Fig. 3-3a). In thin section they usually have a distinctive axial canal, and a marginal row of reticulate tissue and vesicles (Fig. 3-3b). The *Amphipora* branches tend to be fragile and are commonly found broken and in a disturbed rather than life position.

**Environmental significance:** *Amphipora* is extremely common in the calm-water, lagoonal facies of the Middle and Upper Devonian world-wide. It has been recorded in successions in Devon (Scrutton, 1977a, b; Garland *et al.*, 1996), Belgium and northern France (Preat and Mamet, 1989), Rhenisches Schiefergebirge area of Germany (Krebs, 1974; Kasig, 1980; Burchette, 1981), Canning Basin in Western Australia (Read, 1973) and Devonian reef-complexes of Western Canada (Wong and Oldershaw, 1980). As a result of its exclusive appearance in back-reef facies it is thought that *Amphipora* was adapted to environments of either low oxygen or salinity. They were bottom-living animals and probably lived in 'thickets' covering a wide area (Fig. 3-4) (Scrutton, 1977a, b; Kasig, 1980). Although *Amphipora* was not thought to have constructed small patch-reefs, it did

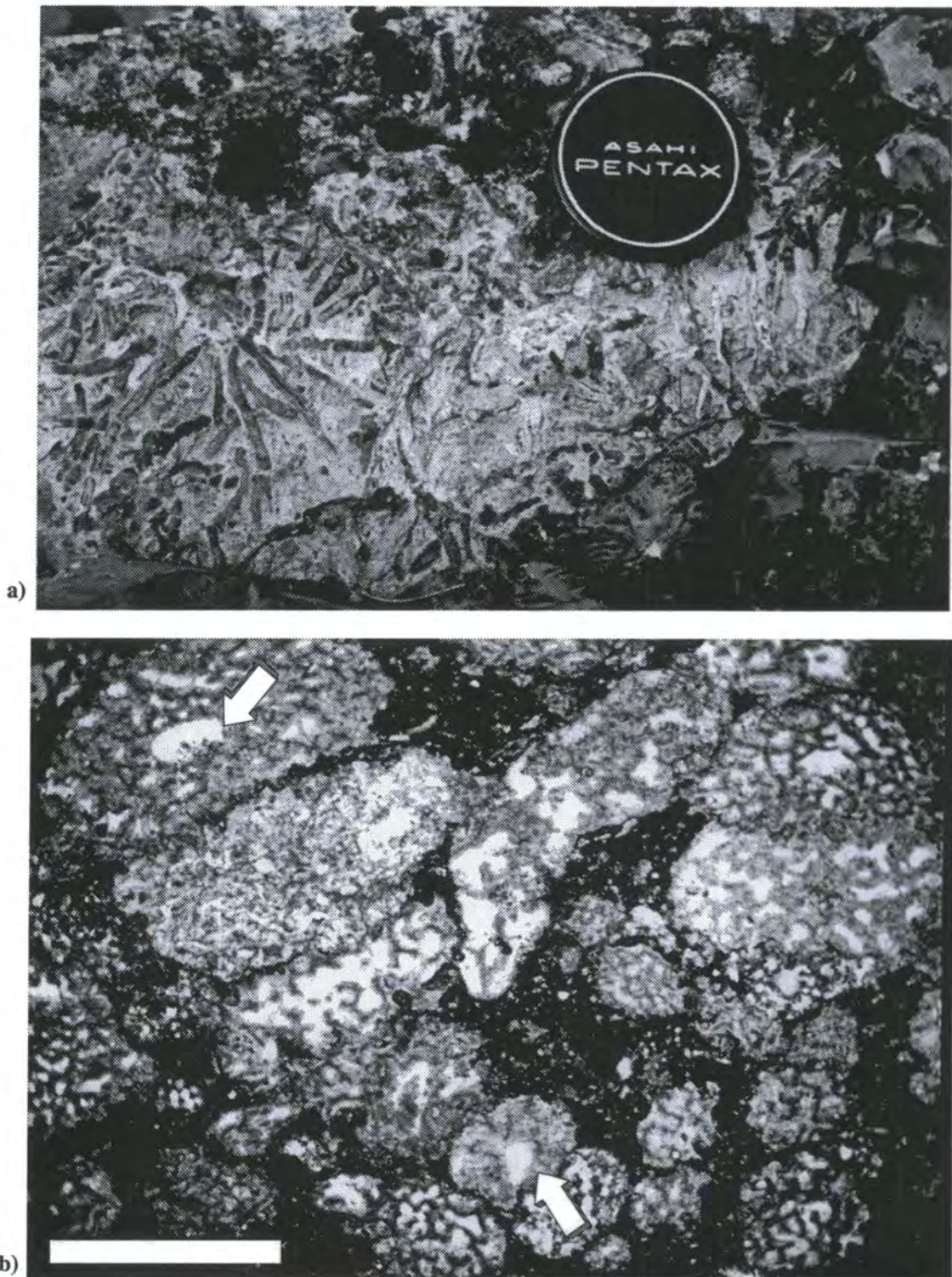

Figure 3-3 a) Field photograph of *Amphipora* displaying dendroid nature of the stromatoporoid. Photograph taken at Broadridge Wood quarry, Torbay Reef Complex. Lens cap 40mm diameter for scale. Photograph courtesy of Colin Scrutton. b) Photomicrograph showing well-developed axial canal (arrows) so common in *Amphipora*. Sample number BW24, Broadridge Wood quarry, Torbay Reef Complex. Scale bar = 3mm.

have baffling properties which trapped sediment between its branches. Read (1973) suggested the optimum water depth for *Amphipora* limestones was 1 m or less for similar facies in the Upper Devonian Pillara Formation in Western Australia.

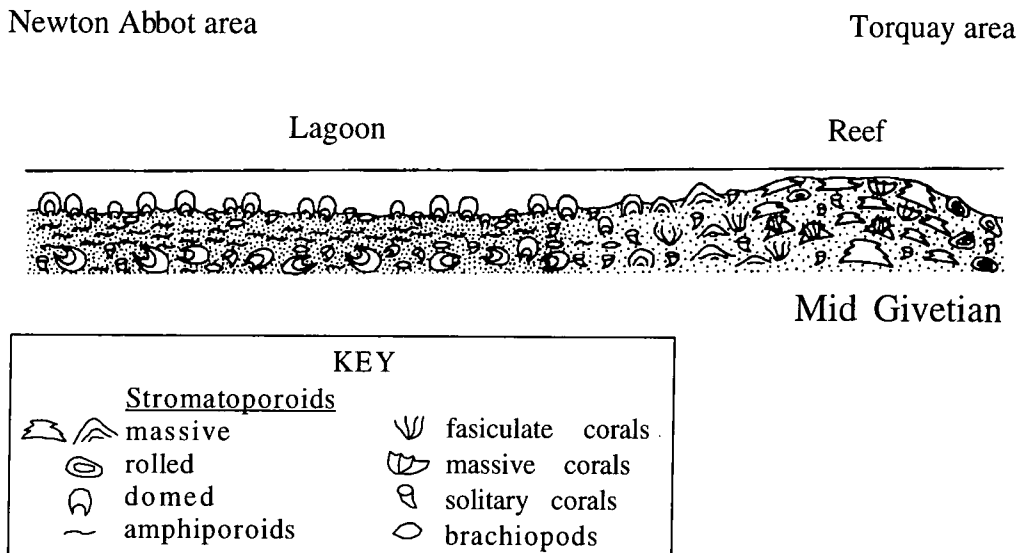
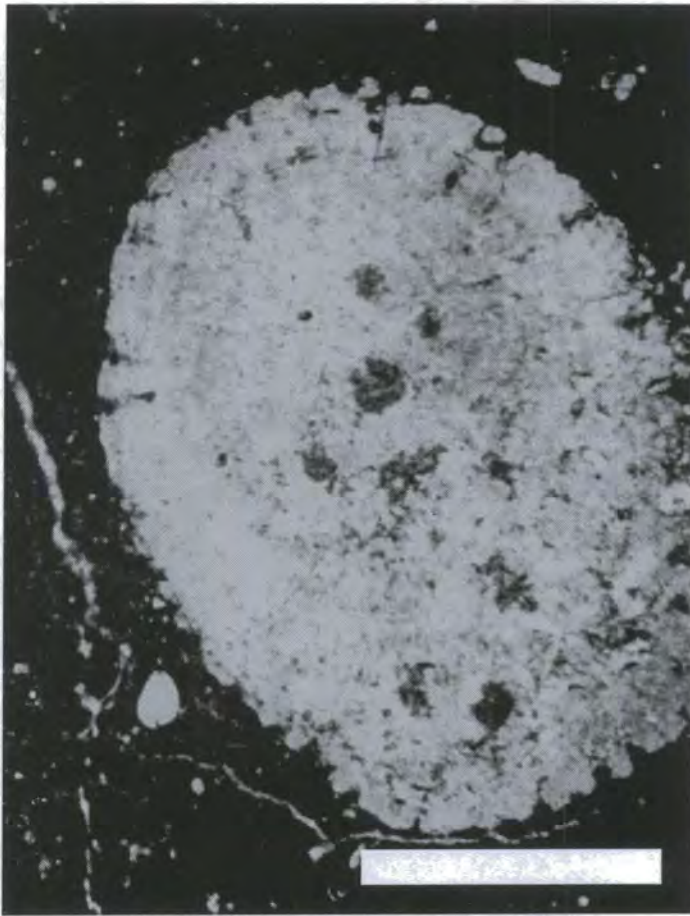

Figure 3-4 Simplified environmental reconstruction in the Newton Abbot - Torquay area (England), showing the abundance of *Amphipora* in lagoonal environments (redrawn from Scrutton, 1977a).

### 3.1.5.2 *Stachyodes*

*Stachyodes*-type dendroid stromatoporoids are common in the immediate back-reef facies of Middle and Upper Devonian carbonate complexes. In the field they have a milky coloration reflecting the spar-filled vesicles within the skeleton. The branches are larger than those of *Amphipora*, commonly being 6-10mm in diameter, and may or may not display an axial canal (Fig. 3-5). They are often preserved as broken grains ranging from 10-40mm in diameter and are usually found in association with broken tabular and domal stromatoporoids and tabulate corals.

Environmental significance: Krebs (1974), Burchette (1981) and Stearn (1982) suggested that *Stachyodes* probably dwelled in niches within the reef, in the fore-reef and near the leeward side of the reef due to the greater strength in their thick branches and their association with broken laminar stromatoporoids which ideally live in well-oxygenated, high-energy waters. They were later incorporated into back-reef facies by currents and storms. Their broken nature therefore reflects constant reworking in a relatively high energy depositional environment.



**Figure 3-5** Photomicrograph of the dendroid stromatoporoid, *Stachyodes*. Note the micrite-filled internal vesicles. Sample number SA17, Sourd d'Ave section, southern Belgium. Scale bar = 2mm.

### 3.2 Calcareous algae and cyanobacteria

Calcareous algae and cyanobacteria are an important components of the carbonate sediments in the Middle and Upper Devonian and are widely distributed in most of the major facies belts. Their distribution and growth forms closely reflect the environment in which they lived (Wray, 1977), and therefore make important environmental indicators. As algae are photosynthetic, light intensity and quality are fundamental factors controlling their distribution. Different genera and species are able to live at specific water depths depending on the pigments and metabolic processes they possess (Fig. 3-6) (Wray, 1977). Water energy also effects the distribution of marine algae and cyanobacteria, with some taxa requiring high energy environments, and others only being able to survive in conditions of gentle water movement (Wray, 1977). Thus, algae and cyanobacteria occur in specific ecological niches and have been used for palaeoenvironmental reconstructions (Fig. 3-7).

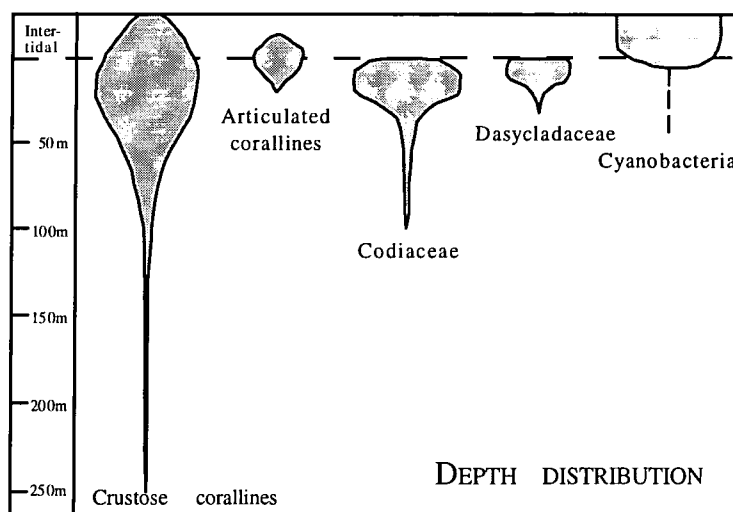

Figure 3-6 Generalised depth distribution (abundance and diversity) of major groups of living marine calcareous algae and cyanobacteria (adapted from Wray, 1977).

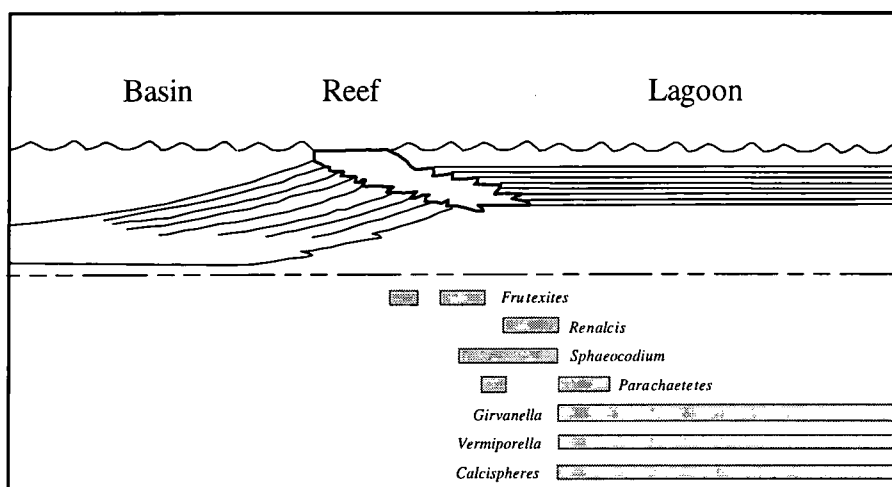

Figure 3-7 Environmental distribution of skeletal calcareous algae in Upper Devonian reef and bank complexes of western Australia and Alberta (adapted from Wray, 1977).

Of the two main divisions of eukaryotic algae (red algae and green algae), the green are most common in the study area. Red algae (Rhodophycophyta) have not been discovered during the present study; however, Preat and Racki (1989) have noted the presence of Solenoporaceae in some Belgian back-reef successions.

Green algae and cyanobacteria are rarely bigger than 1-2mm, so that thin-section analysis is imperative for the determination of their presence and for identification purposes. The algae and cyanobacteria have been identified to varying levels (from family to genus), depending on the state of preservation.

### 3.2.1 Chlorophytes (calcareous green algae)

The Chlorophytes are extremely common in the Middle and Upper Devonian of western Europe. They can be divided into 3 major groups: Dasycladaceae, Codiaceae and Charophyceae. Of these groups the Dasycladaceae and Codiaceae are well represented in the study area. The green algae had a wide range of morphologies and inhabited mainly terrestrial and freshwater environments. However, the Dasycladaceae and Codiaceae were thought to be exclusively marine plants (Wray, 1977).

#### 3.2.1.1 Dasycladaceae

The Dasycladaceae are essentially cylindrical, spherical or club-shaped algae that are attached to the sea floor (such as *Halimeda* today) (Brasier, 1988). In the Devonian they were major contributors to the production of carbonate mud, as they easily broke up into millimetric-sized particles. Dasycladaceae at present day live between 0m and 20m depth (Fig. 3-6).

In this study, three major genera have been identified: *Devonoscale*, *Kamaena*, and *Issinella*. *Devonoscale* and *Issinella* are by far the most abundant dasyclads identified. Other Dasycladaceae have also been distinguished, but no formal identification has been made.

*Devonoscale* and *Kamaena* are simple cylindrical algae ranging from 0.1mm to 1.5mm in length. These two algae are morphologically very similar, and because of relatively poor preservation in the studied samples they are therefore very difficult to distinguish from each other. As a result of the partial development of septa across the cylinder of *Devonoscale* and *Kamaena*, rectangular 'cells' are preserved (Fig. 3-8a). The cylinders are generally straight tubes, rather than tapering. The short preserved length of this algae is a reflection of its delicate nature. *Devonoscale* and *Kamaena* are associated with microfossils such as ostracodes, Parathuramminid forams, calcispheres and other algae.

Environmental significance: *Devonoscale* and *Kamaena* are found in low-energy, micrite-dominated facies suggesting they inhabited a shallow, calm water, restricted lagoonal environment.

*Issinella* is similar to *Devonoscale*, being a simple cylindrical algae up to 0.8mm in length. *Issinella*, however, has no internal septa, and displays a tapering rather than straight geometry (Fig. 3-8b). These algae have been sighted in many Devonian successions

including the Holy Cross Mountains of Poland (Racki and Sobon-Podgórska, 1993), and southern parts of Belgium (Preat and Racki, 1989).

Environmental significance: *Issinella* is found in fine grained micrites, suggesting a calm-water, restricted environment.

### 3.2.1.2 Codiaceae

In the study area the Codiaceae are poorly represented. Two major types have been identified: Labyrinthoconids, and *Palaeoporella*. It is still not clear whether the Labyrinthoconids belong to the Codiaceae (Racki and Sobon-Podgórska, 1993), or have affinities with the calcisponges. However, for the purpose of this study they are being considered as Codiaceans.

The Labyrinthoconids are not a dominant contributor to the flora in the Middle and Upper Devonian of western Europe. They are relatively rare, although they have several distinguishing characteristics. One is the complex anastomosing nature of the internal elements (Fig. 3-8c). The shape of the Labyrinthoconids is commonly fan or club shaped, ranging in size from 0.3mm-1mm diameter.

The *Palaeoporella* are known to be the oldest Codiacean green algae, ranging from the latest Cambrian into the Devonian (Johnson, 1966). This genus consists of an unsegmented, cylindrical thallus which bifurcates (Wray, 1977). In the study area, *Palaeoporella* is not a common constituent. It is often not very well preserved being broken into 2mm 'sticks' which makes identification difficult.

Environmental significance: Wray (1977) suggests that the present-day distribution of living calcareous Codiaceans provides a good basis for interpreting the environmental regimes of the ancient Codiaceae. Therefore, they are most common and diverse in shallow, lagoonal waters. This line of reasoning can also be supported by the association of the Devonian Codiaceans with low-energy micritic facies rich in Dasycladaceae which were also thought to have preferred shallow lagoonal environments.



a)

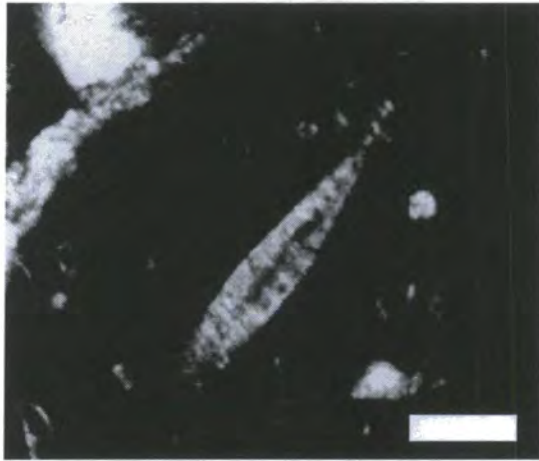

b)

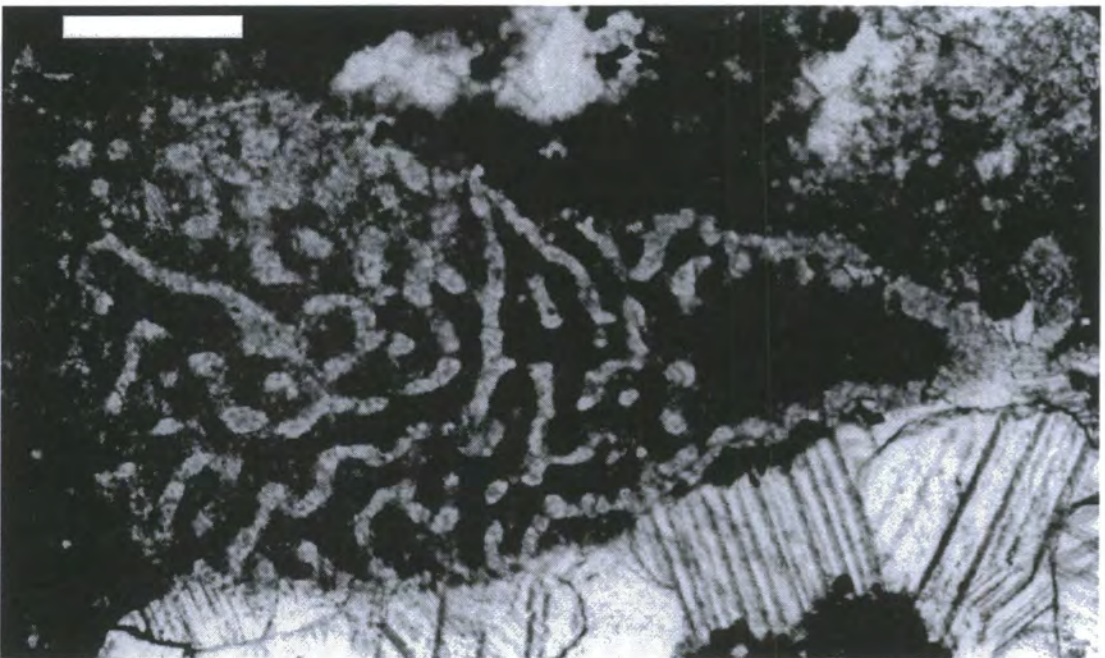

c)

Figure 3-8 a) Photomicrograph showing the characteristic interior rectangular 'cells' of *Devonoscale*. Sample number R5, Resteigne quarry, southern Belgium. b) Photomicrograph of *Issinella* displaying cylindrical nature. Sample number KL8, Keldenich quarry, Sötenich, Germany. c) Photomicrograph of the club-shaped codiaceae *Labyrinthoconous*. Sample number KL6, Keldenich Quarry, Sötenich, Germany. Scale bars = 0.2mm.

### 3.2.2 Calcified cyanobacteria ('blue-green algae')

Cyanobacteria, formerly blue-green algae, are more closely related to bacteria than eukaryotic algae (Riding, 1991). As with the green algae they have varying morphological forms either amalgamating to form stromatolitic and reefal deposits or occurring as skeletal fossils. The calcified cyanobacterial sheaths are commonly irregular bushy masses or tubes arranged in radial fans or tangled masses (Riding, 1991). The dark calcitic sheaths that are precipitated around the cyanobacteria are thought to be for protection from intensive light, since the cyanobacteria are sometimes exposed to subaerial conditions (Wray, 1977).

Four major groups of calcified cyanobacteria have been identified in the present study: Girvanella group, Hedstroemia group, Renalcis group, and Wetheredella group. Each group has identifiable characteristics, therefore making it easier to distinguish between them. The Girvanella group is by far the most common calcified cyanobacteria seen in the study area, with sightings of Hedstroemia group, Renalcis group and Wetheredella group algae being rare. In some instances the cyanobacteria are difficult to identify, for example in oncoids where the cyanobacteria have provided the microbial laminae (Fig. 3-9a). In such cases small tubules and filaments are apparent though any formal identification is beyond the scope of this study. The main groups identified are described below.

#### 3.2.2.1 Girvanella Group

The Girvanella group is generally represented by the genus *Girvanella*. *Girvanella* is characterised by flexuous, tubular filaments of uniform diameter composed of relatively thick calcareous walls (Fig. 3-9b). The filaments often occur as masses twisted together, and can be found encrusting fossils animals such as the dendroid stromatoporoids *Amphipora* and *Stachyodes*, encrusting lumps of micrite (to form oncoids) or loose within a micritic matrix. Encrustations are commonly 1mm thick, and individual masses are up to 6mm x 3mm diameter.

Environmental significance: *Girvanella* is associated with relatively low energy lagoonal facies. Since it encrusts *Amphipora* it is suggested that *Girvanella* was subtidal, preferring low energy waters and a soft micritic substrate. Machielse (1972) also identified *Girvanella* in the Devonian successions of western Canada and suggested a quiet, slightly restricted subtidal environment.

### 3.2.2.2 Hedstroemia Group

*Bevocastria* spp. is considered part of the Hedstroemia group; however, in morphology it's fairly similar to *Girvanella*. *Bevocastria* tend to have branching tubular filaments of varying diameter. Once again they have secreted thick calcareous walls. *Bevocastria* also encrust the dendroid stromatoporoid *Amphipora*, with encrustations reaching only 0.5mm thick. *Bevocastria* are not common in the successions studied.

Environmental significance: *Bevocastria* is often associated with micritic facies rich in calcispheres and other algae, suggesting a similar subtidal, calm lagoonal habitat to that of *Girvanella*. *Bevocastria* is abundant in the lagoonal Middle Devonian Stringocephalus Beds of the Holy Cross Mountains, Poland (Racki and Sobon-Podgórska, 1993).

### 3.2.2.3 Renalcis Group

The Renalcis group is characterised by aggregates of hollow micritic chambers which have an inflated appearance. The growth forms can vary from simple colonies made up of a few chambers to complex botryoidal aggregates of many chambers (Wray, 1977). In the study area it is often difficult to distinguish between different genera in the Renalcis group.

Renalcis group fossils are usually found as unattached clotted lumps in a micritic matrix, or as encrusters on both globular and dendroid stromatoporoids (Fig. 3-9c). Encrustations are rarely thicker than 0.5mm, and individual lumps are recorded up to 1mm diameter. In the study area they are not major contributors to the carbonate sediment.

Environmental significance: The environment in which *Renalcis* thrived is somewhat difficult to determine. Its bushy non-massive form suggests it may have enjoyed calm water, muddy conditions. However, *Renalcis* has been identified in the high-energy organic-reef facies of the Redwater Reef, Canada (Machielse, 1972) and the Belgian reefs (Tsien, 1979), in debris beds of the Ancient Wall Complex in western Alberta (Playford, 1969), and in lagoonal facies of the Holy Cross Mountains, Poland (Racki and Sobon-Podgórska, 1993). Since in the study area *Renalcis* is seen to encrust stromatoporoids which lived in the more oxygenated shallow waters of the lagoon, it is suggested that *Renalcis* lived in the same environment.

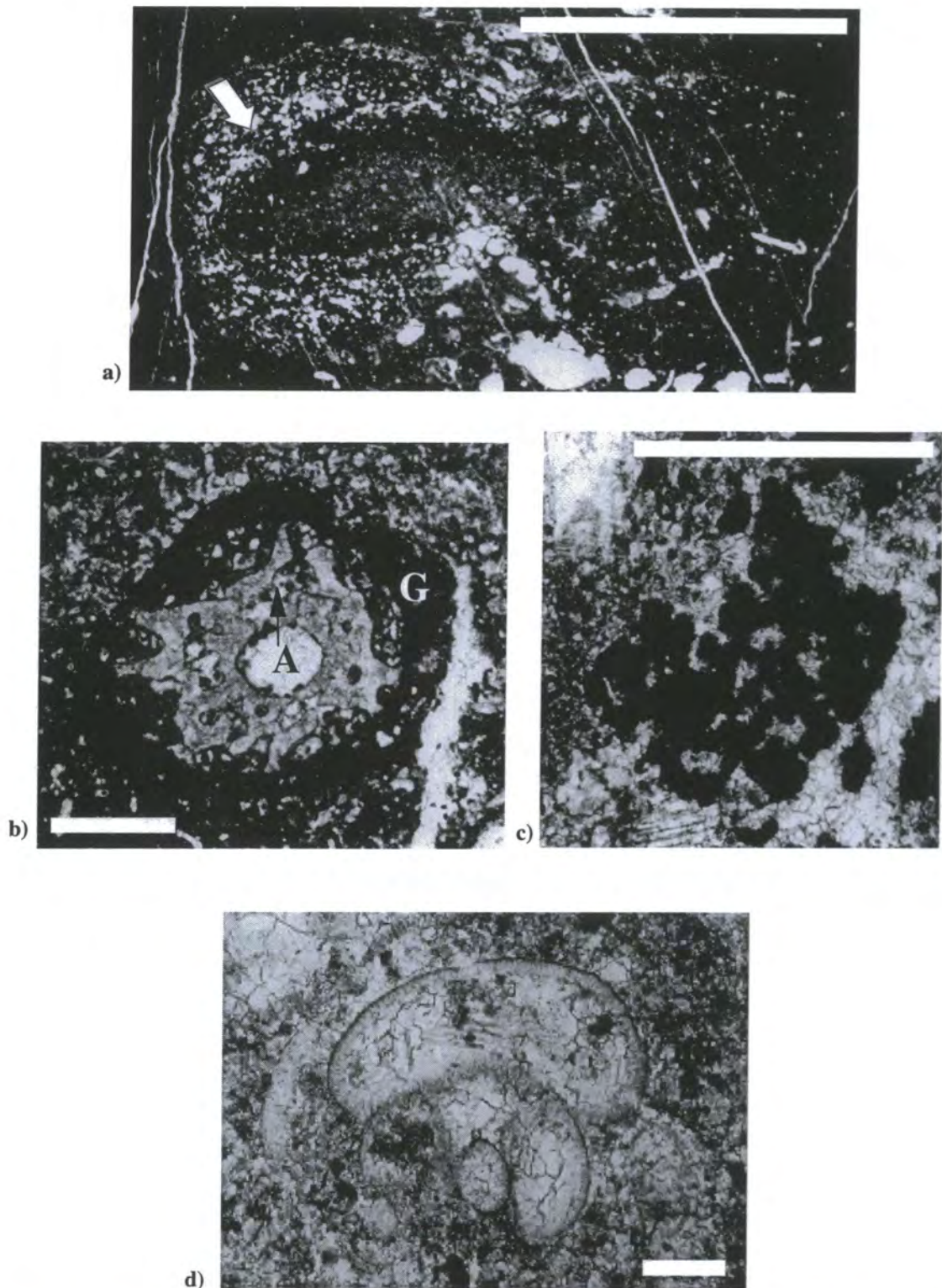

Figure 3-9 a) Photomicrograph of a cyanobacterially-coated oncooid. The cyanobacteria (arrowed) is difficult to identify, yet is likely to belong to the *Girvanella* group. The nucleus of the oncooid is a micrite lump (M). Sample D6, Dourbes quarry, southern Belgium. Scale bar = 5mm. b) Photomicrograph of *Girvanella* (G) coating/encrusting an *Amphipora* branch (A). Sample number BL25, Bleiwäsche quarry, Brilon Reef Complex, Germany. Scale bar = 1mm. c) Photomicrograph of *Renalcis/Izhella* aggregates displaying inflated hollow chambers. Sample number MB4, Medenbach quarry, Langenaubach Reef Complex, Germany. Scale bar = 1mm. d) Photomicrograph of *Wetheredella* displaying hemispherical shape and thin micritic walls. Sample number MB18, Medenbach quarry, Langenaubach Reef Complex, Germany. Scale bar = 0.2mm.

#### 3.2.2.4 *Wetheredella* Group

The *Wetheredella* are short encrusting tubes, hemispherical or round in cross section, with a dense micritic wall. Each tube is on average 1mm diameter, and in the study area the *Wetheredella* rarely reach larger than 10mm diameter aggregates (Fig. 3-9d). Their occurrence in lagoonal facies are rare, with only three being sighted. They appear not as encrusters but as individual aggregates, associated with a rich assemblage of stromatoporoids, ostracodes and forams.

Environmental significance: *Wetheredella* has been documented in many carbonate complexes especially the Belgian reefal complexes (Tsien, 1978; Mamet and Preat, 1986). It's primary role is thought to be an encrusting one, forming thick crusts on stromatoporoids, corals and bryozoans (Chuvashov and Riding, 1984). This explains its dominance within reefal facies of Belgian bioherms (Tsien, 1978; Mamet and Preat, 1986). The poor abundance of *Wetheredella* in the lagoonal successions, and the fact that it is found as individual aggregates rather than in its encrusting form suggests that lagoonal facies are not the prime ecological habitat of *Wetheredella*. It prefers higher energy reefal environments.

### 3.3 Foraminifera

The Subfamily Parathuramminacea are the only foraminifera identified in the study area. These are a group of enigmatic fusulinid forams which have a thin dense micritic (microgranular) wall and are generally unilocular. The division of the parathuramminids into genera and species proves very difficult because of the variable 'cuts' that a thin section may produce (Fig. 3-10a). This has been very problematic in the last few decades as many 'new' species that were described may have been sections through the same foram species (Racki & Sobon-Podgórska, 1993). Hence this study has not striven to distinguish the parathuramminids to species level, or even generic level, and has grouped them all as 'parathuramminids'.

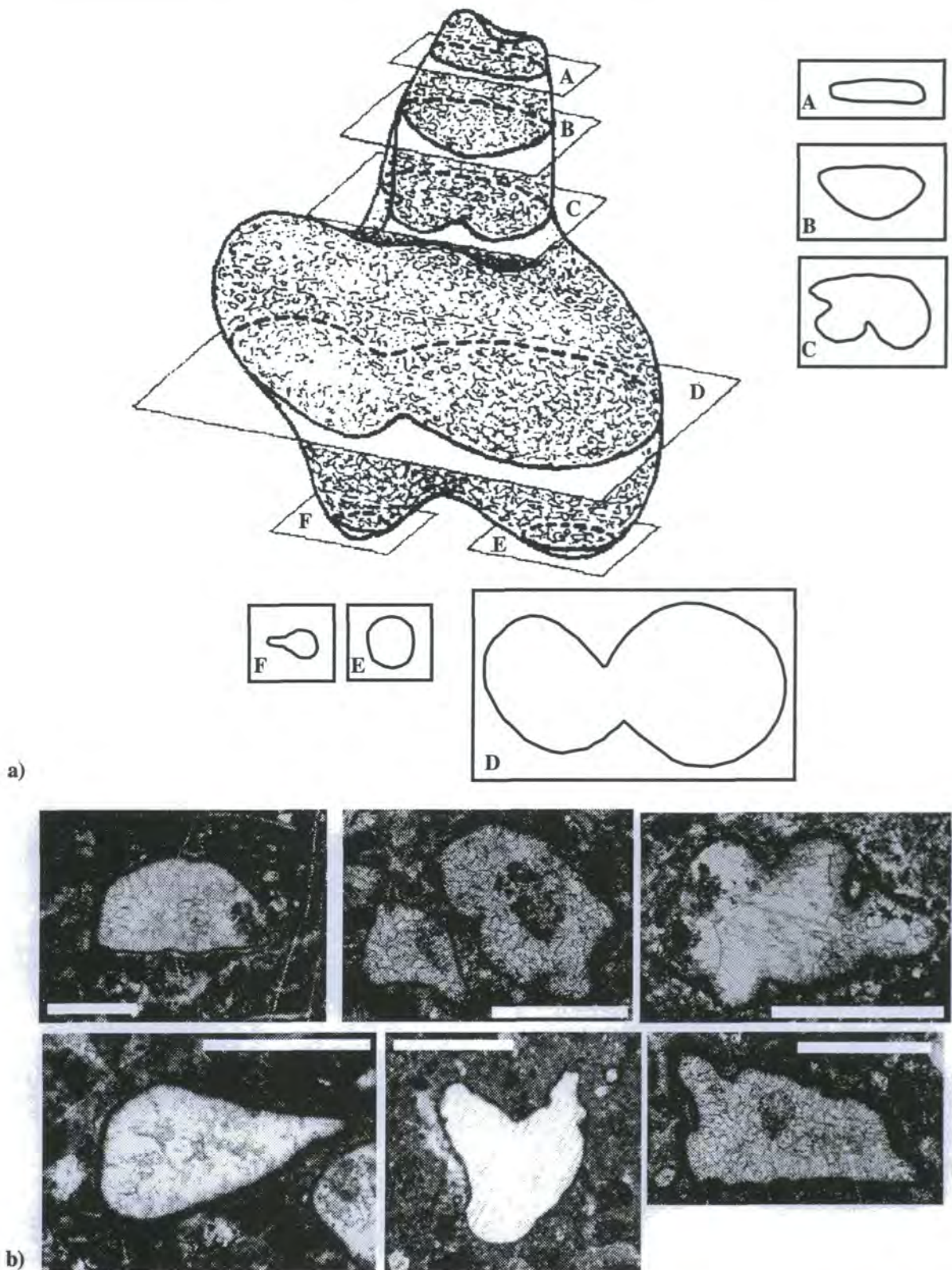

Figure 3-10 a) Geometries obtained by sectioning an irregularly-shaped calcareous body (parathuramminid) in different planes which correspond to several 'genera' of foram. A = *Parastegnammina*, B = *Corbiella*, C = *Bisphaera elegans*, D = *Bisphaera malevkensis*, E = *Archaeosphaera*, F = *Archaelagena* (adapted from Racki and Sobon-Podgórska, 1993). b) Photomicrographs showing the variety of morphologies that parathuramminids display in the study area. Scale bars = 0.5mm.

The parathuramminids range from 0.3mm to 3mm in diameter (average 1mm). They take up a variety of shapes from spherical, rounded and oval through to unusual and complex forms (Fig. 3-10b). This may reflect the cut-effect of thin sections, or may indeed suggest different species. They are mainly associated with micritic facies rich in calcispheres, ostracodes and algae, yet they are also present in facies with a rich faunal assemblage of stromatoporoids and corals.

**Environmental significance:** The parathuramminids probably liked a muddy rather than sandy substrate as reflected in the dominantly micritic matrix present in the samples. The association with algae suggests that the waters were probably shallow lagoonal in nature. Parathuramminids are very rare in the open-marine facies of the Middle and Upper Devonian. The presence of a dense microgranular wall has enabled the parathuramminids to be well preserved in the rock record.

### **3.4 Ostracodes**

Ostracodes are predominantly benthic or pelagic Crustacea that live in a wide range of habitats including freshwater lakes, brackish lagoons and estuaries, forest humus, hypersaline lagoons and open-marine seas. It has often been observed that the size, shape and ornament of benthic ostracodes broadly reflects the stability, grain size and pore size of the substrate on, or in which they live (Brasier, 1988). Certain species and genera of ostracodes also prefer to live under specific salinity ranges, and hence provide fundamental evidence in palaeoenvironmental and palaeoecological reconstructions (Brasier, 1988).

Ostracodes are abundant in most facies belts in the Middle and Upper Devonian of western Europe. They have been identified from open-marine environments through to restricted lagoons. The level to which the ostracodes have been identified in this study is variable: most have been collectively grouped as 'small ostracodes' as further discrimination is outside the scope of this study. However, one order of ostracodes, the Leperditicopida, have been distinguished from the others. This is mainly because of their size (they reach up to 10mm in length), and because they have important palaeoenvironmental implications.

#### **3.4.1 Leperditiid ostracodes**

The Leperditicopida are identified by their relatively large size (up to 10mm long) and smooth, thick, calcareous valves (Fig. 3-11). They are mostly found with their valves

separated and occur in 'nests' on bedding surfaces. They occur within micritic limestones, rich in calcispheres and rare birdseye fenestrae.

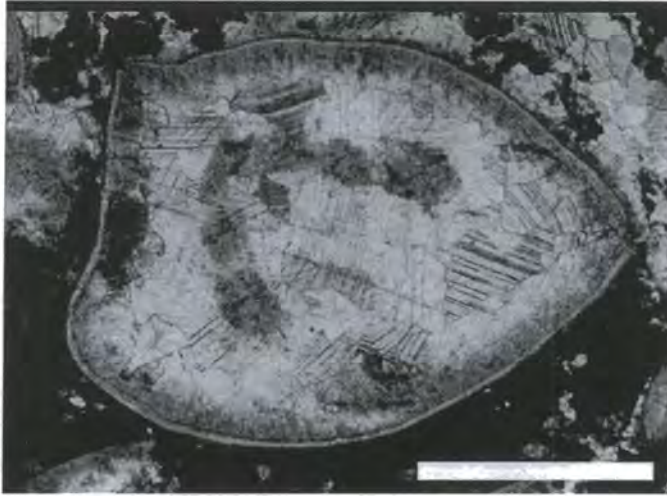

**Figure 3-11** Photomicrograph of a Leperditiid ostracode. Note the smooth, well-preserved calcitic shells and its large size. Sample number BB6, Bellignies-Bettrechies quarry, northern France. Scale bar = 2mm.

Environmental significance: Leperditiid ostracodes are present in many mid-Palaeozoic successions, often occurring as monotypic faunas in great quantities but with no other or very few other associated fossils (Braun and Mathison, 1986). For this reason, they are considered to be restricted forms that could tolerate living conditions that deviated from the norm (Braun and Mathison, 1986). Studies by Casier *et al.* (1995) in northern France indicated that Leperditiid ostracodes were indicative of highly restricted lagoonal conditions (Fig. 3-12). Berdan (1968) suggested the Leperditiids were adapted to temporary exposure, with Benson (1961) envisaging hypersalinity. However, there is no relationship between hypersalinity and Leperditiid ostracode appearances within the area of study.

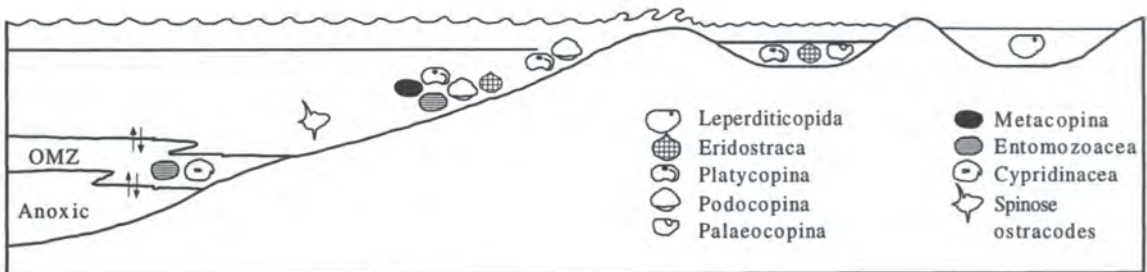

**Figure 3-12** Ostracode assemblages in the Middle and Upper Devonian of the Palaeotethys (from Casier *et al.*, 1995). OMZ = Oxygen minimum zone.

### 3.5 'Calcspheres'

Calcspheres are spherical 'balls' of calcite less than 0.1mm in diameter, often having a thin micrite rim, rarely being spinose or having an ornamented rim (Fig. 3-13a, b). The actual affinities of calcspheres are somewhat poorly understood. Rupp (1967) and Brasier (1988) suggested they belong to the green algae, maybe being a reproductive plant spore (related to the Dasycladaceae). Affinities with the forams have also been implied (Tucker, 1991), and recent work has suggested there are two types of 'calcspheres': 1) Those which are present in Mesozoic open-marine pelagic sediments with known affinities to the dinoflagellates ('calcspheres'), 2) Those present in mainly Palaeozoic successions that are of an unknown affinity ('calcareous spheres') (Hart, *pers. comm.*). This line of thought, however, is not widely accepted and throughout this study I shall refer to these calcareous balls as 'calcspheres'.

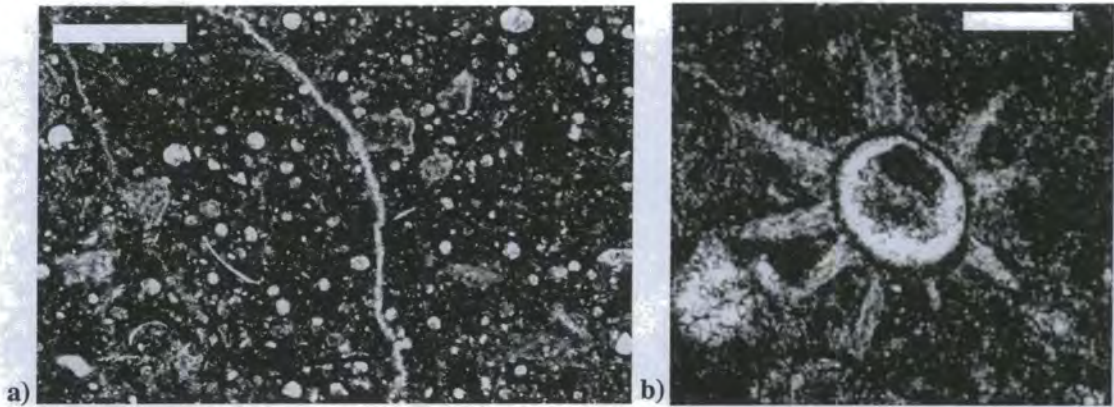

**Figure 3-13** a) Photomicrograph of 'normal' calcspheres. Note the small size (scale bar = 0.5mm), spherical shape and dark micritic rims. Sample number R6, Resteigne quarry, southern Belgium. b) Photomicrograph of a calcsphere with well-preserved spines. Sample number BL7, Bleiwäsche quarry, Brilon Reef Complex, Germany. Scale bar = 0.1mm.

**Environmental significance:** Calcspheres are extremely abundant in calm-water facies of Middle and Upper Devonian lagoons, and Riding (1979) suggested they were adapted to shallow-water restricted shelf environments. Interestingly, they are rarely sighted in open-marine facies, and are uncommon in higher energy back-reef environments.

### 3.6 Corals

Corals are not as common as stromatoporoids and on the whole are poorly represented in the back-reef and lagoonal environments of the Middle and Upper Devonian. Detailed work, however, by Scrutton (1977b) and Scrutton and Goodger (1987) in the Torbay Reef

Complex, England, has identified several assemblages of both tabulate and rugose corals which were found in lagoonal and platform interior facies (Table 3-2). These include the tabulate corals *Remesia*, *Scoliopora*, *Alveolites*, *Caliapora* and *Thamnopora*, and rugose corals *Temnophyllum*, *Stringophyllum*, *Grypophyllum* and *Dendrostella* which were found at the lagoonal succession at Broadridge Wood quarry in the Lemon Valley, Devon (Scrutton and Goodger, 1987).

| Dark, well-bedded limestones without <i>Amphipora</i>  | Dark, well-bedded limestones with <i>Amphipora</i>   |
|--|--|
| c <i>Acanantophyllum</i><br>c <i>Amplexocarina</i><br>r <i>Calceola</i><br>m <i>Ceratophyllum</i><br>r <i>Cyathophyllum</i> (C.)<br>r <i>C.</i> ( <i>Peripaedium</i> )<br>c <i>Cystiphyllodes</i><br>m <i>Dendrostella</i><br>m <i>Dohmophyllum</i><br>c <i>Grypophyllum</i><br>m <i>Heliophyllum</i><br>c <i>Mesophyllum</i><br>c <i>Stringophyllum</i><br>c <i>Thamnophyllum</i><br><br>m <i>Alveolites</i><br>c <i>Caliapora</i><br>m <i>Coenites</i><br>m <i>Heliolites</i><br>c <i>Thamnopora</i><br>m <i>Trachyopora</i> | r <i>Dendrostella</i><br>r <i>Grypophyllum</i><br>r <i>Stringophyllum</i><br>m <i>Temnophyllum</i><br><br><br><br><br>r <i>Alveolites</i><br>m <i>Caliapora</i><br>c <i>Thamnopora</i> |

**Table 3-2 Coral faunal characteristics of the major limestones facies. The abbreviations c (common), m (moderately common), and r (rare) give a general indication of relative importance (adapted from Scrutton, 1977b and Scrutton and Goodger, 1987). NB only corals present in lagoonal facies are shown.**

Thamnoporoids are probably the most common tabulate corals identified in the Middle and Upper Devonian lagoons. These are feather-like ramose, cerioid, favositids with colonies reaching up to 60mm long, and individual corallites being 1-4mm in diameter (Fig. 3-14). Thamnoporoids have been identified in many reef-complexes including the Torbay Reef Complex (Garland *et al.*, 1996), Pillara Limestone of the Canning Basin, Western Australia (Read, 1973), Kaybob Reef, Alberta (Wong and Oldershaw, 1980), Holy Cross Mountains, Poland (Racki, 1992), Belgian successions (Preat and Mamet, 1989), and many of the western German isolated complexes (Krebs, 1974).

Environmental significance: Although the Thamnoporoids are rarely preserved in life position, they are associated with *Amphipora*. This suggests calm, shallow, lagoonal conditions with poor circulation which were probably subject to considerable variations in temperature and salinity (Klovan, 1964).

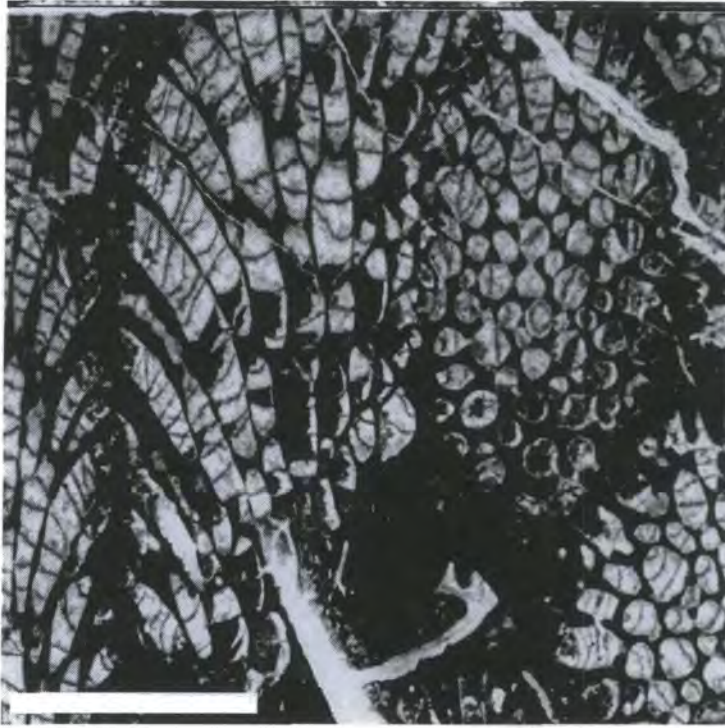
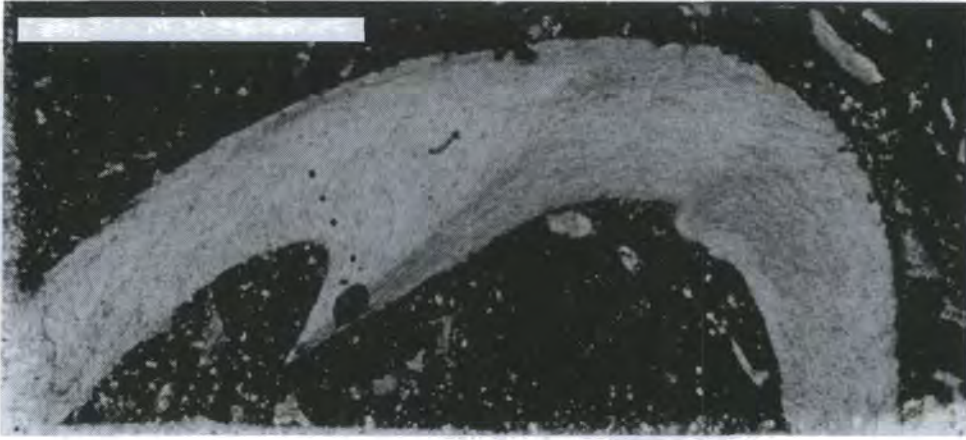

Figure 3-14 Photomicrograph of *Thamnopora*, courtesy of Colin Scrutton. Scale bar = 1cm.

### 3.7 Brachiopods

Brachiopods are not common constituents of the carbonate rocks in the study area. They tend to dominate the earliest Middle Devonian where more open-marine conditions existed. When present, they appear as small (2mm to 20mm long), broken but well preserved calcitic shells with a variety of ornaments and shapes. Brachiopod spines are also preserved, especially in finer-grained lower-energy facies. No formal identification of the brachiopods has been made; however, the Stringocephalid brachiopod has been distinguished from the others, mainly due to its large shape and relative abundance within back-reef facies.

Stringocephalids are large terebratulid brachiopods up to 6cm in length. They have very thick (up to 5mm), unornamented biconvex calcitic valves with a short non-strophic hinge and a pedicle foramen. They are often found in 'nests', either articulated, or disarticulated and slightly broken. When disarticulated it is possible to see the characteristic internal plates (Fig. 3-15). They are often associated with gastropods, bivalves and *Stachyodes* stromatoporoids. Stringocephalids appear restricted to the Givetian (late Middle Devonian), and are therefore useful chronostratigraphically (Blodgett and Dutro jnr., 1992).



**Figure 3-15** Photomicrograph showing some of the internal features of a Stringocephalid. Note the internal plates (P) and thick, calcareous, non-ornamented smooth shell. Sample number R8, Resteigne quarry, southern Belgium. Scale bar = 2mm.

Environmental significance: Since the stringocephalids possessed a pedicle foramen it is likely that they anchored themselves to either a soft substrate, or rocks and dead shells (Clarkson, 1989). This accounts for the tendency for them to be found *in-situ* in nests or clusters. They are associated with a rich faunal assemblage, suggesting near-normal marine, well-oxygenated environmental conditions. They are common in high energy facies therefore it is interpreted that stringocephalids preferred shallow, turbulent water conditions in the immediate back-reef environment. Racki (1992) envisaged *Stringocephalus* inhabiting marginal shoal environments in the early-middle Givetian of Poland.

### 3.8 Molluscs

The molluscs include both bivalves and gastropods, and throughout this study no formal identification has been made of these beyond class level. Both bivalves and gastropods are common.

The gastropods range in size from 3mm up to 35mm long. They are typically neomorphically altered to calcite, since they originally had an aragonitic shell; however, there are also examples of bi-mineralic shells. In the field the gastropods are found as monospecific assemblages or are in 'nests' together with rare bivalves, solitary corals and *Amphipora* branches.

Environmental significance: Gastropods are tolerant of continental, fresh-water, brackish, normal-marine and hypersaline conditions (Heckel, 1972; Fig. 3-16), suggesting they are not very good environmental indicators unless careful identification is made. However, as Heckel (1972) pointed out, where gastropods are very abundant in monospecific assemblages with few or no other fossils, this can indicate either hyper- or hypo- saline environments.

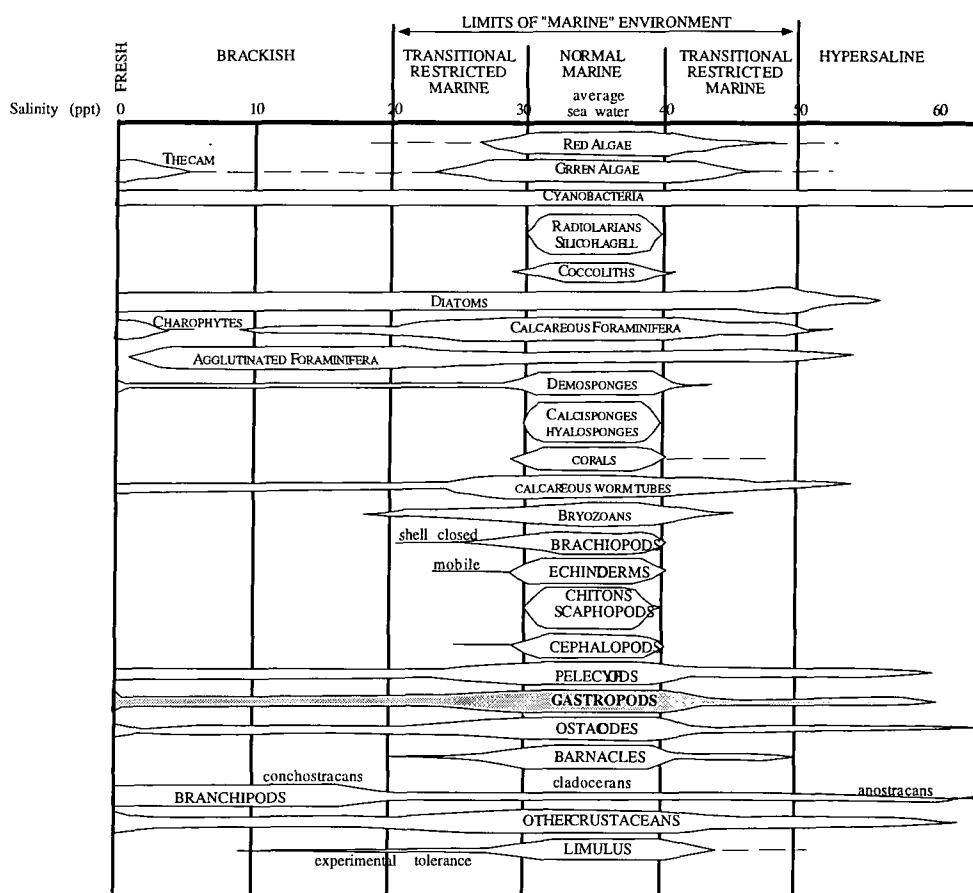

Figure 3-16 Modern distribution of major fossilisable nonvertebrate groups relative to salinity. Thickness of bar roughly reflects diversity of taxa (from Heckel, 1972).

The bivalves are not as common as gastropods in the study area. When identified they reach up to 15mm in length and are always found with the valves disarticulated and often broken. Once again the bivalves were originally aragonitic in nature and are now neomorphically altered to calcite. They tend to be reworked into bed-parallel accumulations, and are rarely found with other macro-fossils.

Environmental significance: The bivalves are not found in life position, therefore determining their ecological niche is somewhat difficult. They are not often found with

other macrofossils, so it is suggested that they inhabited restricted conditions within the lagoon.

### 3.9 Others

Crinoid ossicles are common constituents in immediate back-reef, reefal and open-marine facies of the Middle and Upper Devonian. Commonly they are extensively reworked and broken up and are therefore rather small, on average 2 to 5mm diameter. They are never found in life position. In thin section they often have pitted and abraded edges and commonly display syntaxial calcite overgrowths (Fig. 3-17). The crinoid stems are associated with both low and high energy facies.

**Environmental significance:** Crinoids are tolerant of normal or near-normal marine conditions and therefore provide useful environmental indicators. They appear to thrive in both calm and turbulent waters. They were rare in restricted lagoonal environments.

Tentaculites, bryozoans and trilobites are all very rare in the limestones studied. They dominate normal marine environmental conditions and are generally associated with calm, low-energy waters.

### 3.10 Palaeoecological reconstruction

The previous Sections have introduced the principal faunas and floras present in the study area. Using the inferred ecological habitats of these fossils it is therefore possible to reconstruct the palaeoenvironmental setting for the Middle and Upper Devonian. Figure 3-18 displays how the main fossil groups are distributed.

In the highly restricted lagoons leperditiid ostracodes, gastropods and calcispheres were present. The restricted lagoons hosted a large abundance of floras: Dasycladaceae, Codiaceae, Girvanellids, Hedstroemids, and Renalcids. There is also a rich microfossil assemblage of parathuramminid forams, calcispheres, and ostracodes. Rare macrofossils include *Amphipora*, bulbous stromatoporoids, thamnoporoids, and molluscs.

The high-energy back-reef and reef environment was a home to many robust macrofossils including laminar stromatoporoids, domal and larger bulbous stromatoporoids, branching stromatoporoids (i.e., *Stachyodes*), corals, *Stringocephalus* brachiopods, molluscs and crinoids. Wetheredellids and Renalcids group algae are also common.

These faunal associations can further be used in conjunction with sedimentological features to devise a microfacies scheme for the Devonian back-reef and lagoonal environments of western Europe. These concepts will be discussed in Chapter 4.

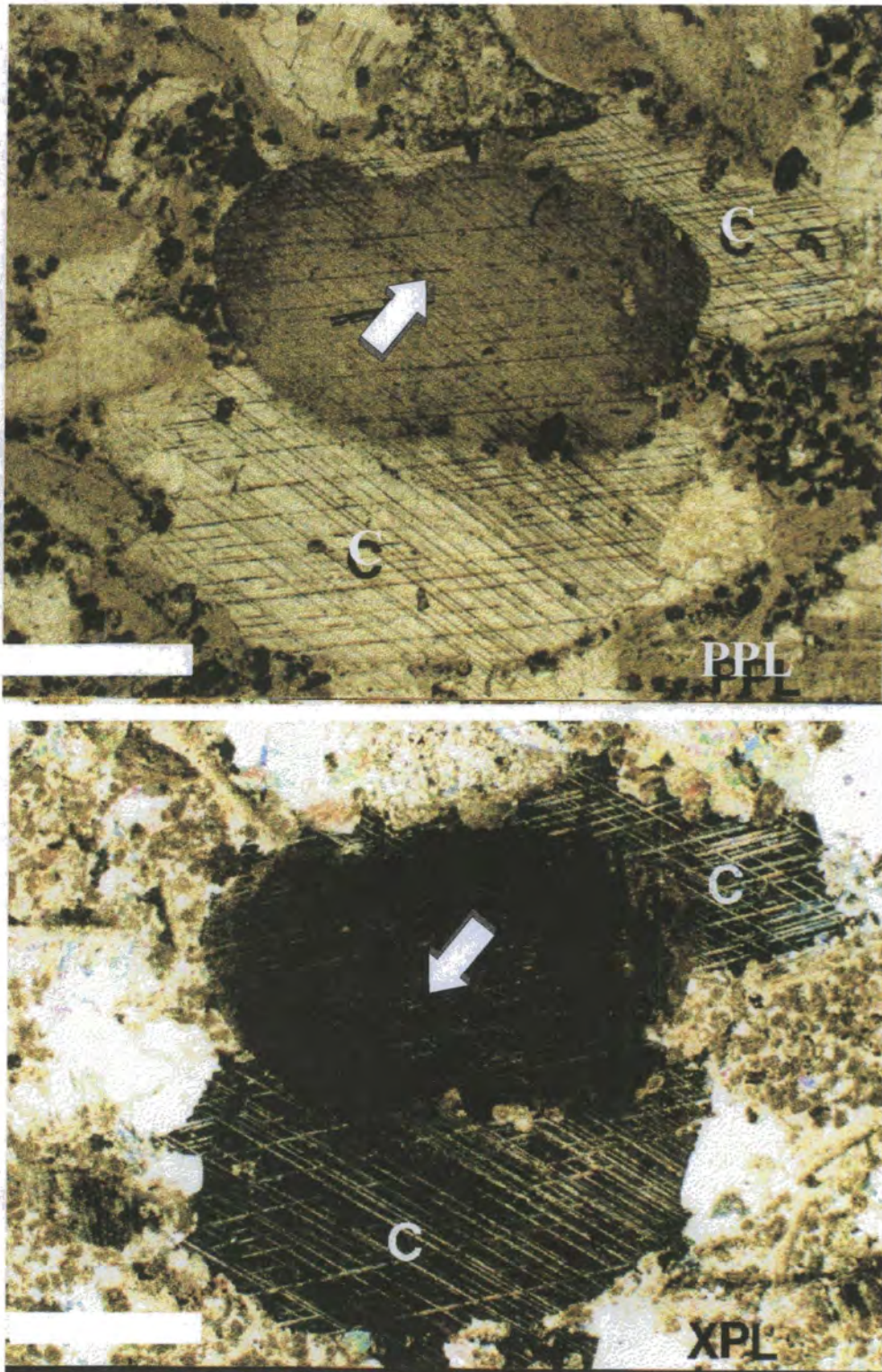

**Figure 3-17** Photomicrographs of a crinoid ossicle (arrow) displaying syntaxial calcite overgrowths (C). Note the optical continuity of the calcite in crossed polarised light. Sample number FL15, Froid Lieu quarry, southern Belgium. Scale bars = 1mm.

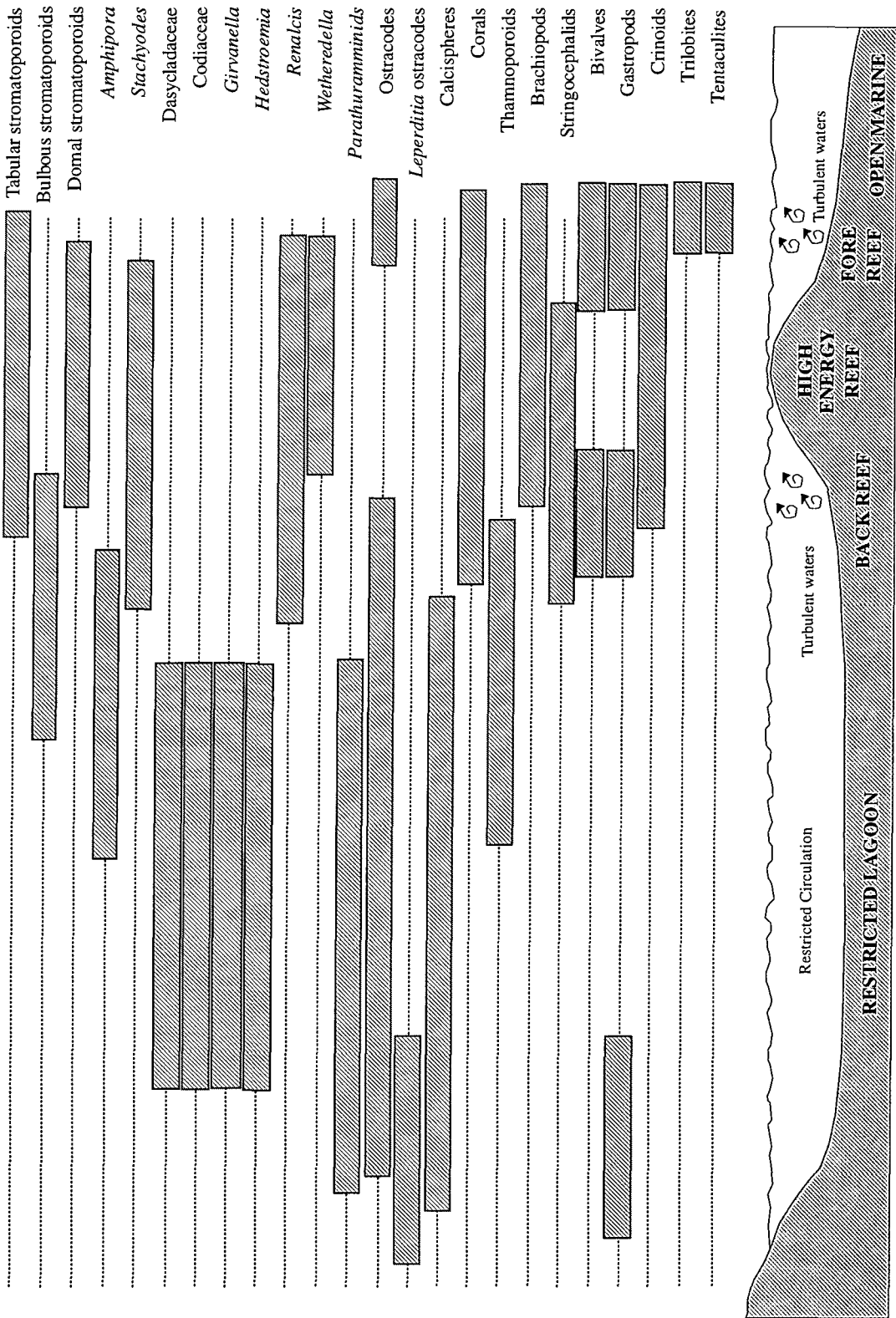

Figure 3-18 Palaeoecological reconstruction of Middle and Upper Devonian back-reef and lagoonal environments of western Europe. See Section 3-10 for details.

# CHAPTER FOUR

|  |           |
|--|-----------|
| <b>4. MICROFACIES ANALYSIS</b> .....                                     | <b>62</b> |
| 4.1 RAMP MICROFACIES .....   | 66        |
| 4.1.1 R1 microfacies - bioturbated wackestones.....                      | 67        |
| 4.1.2 R2 microfacies - bioclastic packstones.....                        | 68        |
| 4.1.3 R3 microfacies - stromatoporoid floatstones.....                   | 69        |
| 4.1.4 R4 microfacies - oolitic/peloidal/bioclastic grainstones.....      | 70        |
| 4.1.4.1 R4a microfacies - oolitic grainstones.....                       | 71        |
| 4.1.4.2 R4b microfacies - peloidal-grainstones.....                      | 72        |
| 4.1.4.3 R4c microfacies - bioclastic grainstones.....                    | 73        |
| 4.1.5 R5 microfacies - gastropod/bivalve wackestones.....                | 76        |
| 4.1.6 R6 microfacies - leperditicoid ostracode packstones.....           | 76        |
| 4.1.7 R7 microfacies - laminated dolomudstones.....                      | 77        |
| 4.1.8 Environmental reconstruction.....                                  | 79        |
| 4.2 LAGOONAL SHELF MICROFACIES.....                                      | 81        |
| 4.2.1 Semi-restricted subtidal microfacies group.....                    | 83        |
| 4.2.1.1 S1 microfacies - Intraformational breccias.....                  | 83        |
| 4.2.1.2 S2 microfacies - stromatoporoid floatstones.....                 | 85        |
| 4.2.1.3 S3 microfacies - bioclastic wackestones to grainstones.....      | 88        |
| 4.2.2 Restricted subtidal microfacies group.....                         | 92        |
| 4.2.2.1 S4 microfacies - <i>Amphipora</i> floatstones.....               | 92        |
| 4.2.2.2 S5 microfacies - bioclastic wackestones.....                     | 95        |
| 4.2.2.3 S6 microfacies - macrofossil-poor micrites.....                  | 97        |
| 4.2.2.4 S7 microfacies - peloidal/oolitic grainstones.....               | 104       |
| 4.2.3 Intertidal microfacies group.....                                  | 109       |
| 4.2.3.1 S8 microfacies - laminoid-fenestral limestones.....              | 109       |
| 4.2.3.2 S9 microfacies - bioclastic grainstones with vadose cements..... | 114       |
| 4.2.3.3 S10 microfacies - fenestral laminites.....                       | 117       |
| 4.2.4 High intertidal-supratidal microfacies group.....                  | 120       |
| 4.2.4.1 S11 microfacies - intraformational breccias.....                 | 120       |
| 4.2.4.2 S12 microfacies - laminites and stromatolites.....               | 121       |
| 4.2.4.3 S13 microfacies - dolomicrites.....                              | 126       |
| 4.2.4.4 S14 microfacies - calcretes.....                                 | 129       |
| 4.2.5 Microfacies associations and summary.....                          | 135       |

#### 4. Microfacies analysis

The Givetian and Frasnian lagoonal carbonates of western Europe have been studied with respect to facies characteristics by many authors (see Table 4-1). Although, individually, the microfacies schemes offered by these authors are very detailed and well-argued, it is important in this thesis that a complete microfacies scheme is used covering both the lagoonal facies present in the broad shelf lagoon and those present in the isolated platforms (atolls). Therefore, Chapter 4 aims to synthesise the observations made in the field areas and presents a composite microfacies scheme for both palaeogeographic situations.

This Chapter also presents a microfacies scheme for the ramp setting which developed prior to the shelf lagoon. These facies often provided the stable base on which the shelf complexes developed (see Chapters 2 and 5 for a more detailed discussion). It was important to make a distinction between ramp and shelf microfacies schemes since these platform geometries, together with many other factors, dictated which depositional environments were present. As the ramp facies were not the primary objective of study for this thesis, they are not described in as great detail as the shelf facies.

| Area of study              | References   |
|----------------------------|--|
| Belgian Ardennes           | Preat and Kasimi, 1995<br>Preat and Carliez, 1994<br>Boulvain <i>et al.</i> , 1994<br>Casier and Preat, 1991<br>Preat and Mamet, 1989<br>Preat, 1989<br>Preat and Boulvain, 1988<br>Boulvain and Preat, 1987<br>Preat <i>et al.</i> , 1987<br>Preat and Boulvain, 1982 |
| Rhenisches Schiefergebirge | Hering, 1994<br>Hong, 1992<br>Machel, 1990a<br>Städter and Koch, 1987<br>Wilder, 1985<br>Kasig and Wilder, 1983<br>Kasig, 1980<br>Krebs, 1974<br>Krebs, 1971<br>Krebs, 1968<br>Krebs, 1966   |

**Table 4-1** Previous work published on the Givetian and Frasnian lagoonal carbonates in the study area with respect to facies descriptions.

| Area of study                | References   |
|------------------------------|--|
| Torbay Reef Complex, England | Garland <i>et al.</i> , 1996<br>Scrutton and Goodger, 1987<br>Selwood <i>et al.</i> , 1984<br>Mayall, 1979<br>Scrutton, 1977a<br>Scrutton, 1977b<br>Braithwaite, 1967<br>Braithwaite, 1966 |

Table 4-1 continued.

The logging, sampling and thin-section techniques used in this study are discussed in detail in Chapter 1. Appendix 1 presents the thin-section information obtained during this study and the reader is asked to refer to Appendix 2 for logged sections which encompass both field observations and thin-section information. Comparisons are made with the Standard Microfacies Types of Wilson (1975) and Flügel (1982) (Fig. 4-2). In total, 30 Givetian and Frasnian successions were logged in Southwest England, northern France, southern Belgium and western Germany (Fig. 4-1) and 549 thin sections or acetate peels were examined to provide the basic observational information needed to produce the microfacies schemes presented in this Chapter.

Finally, an atlas of microfacies photomicrographs are presented in Enclosure One.

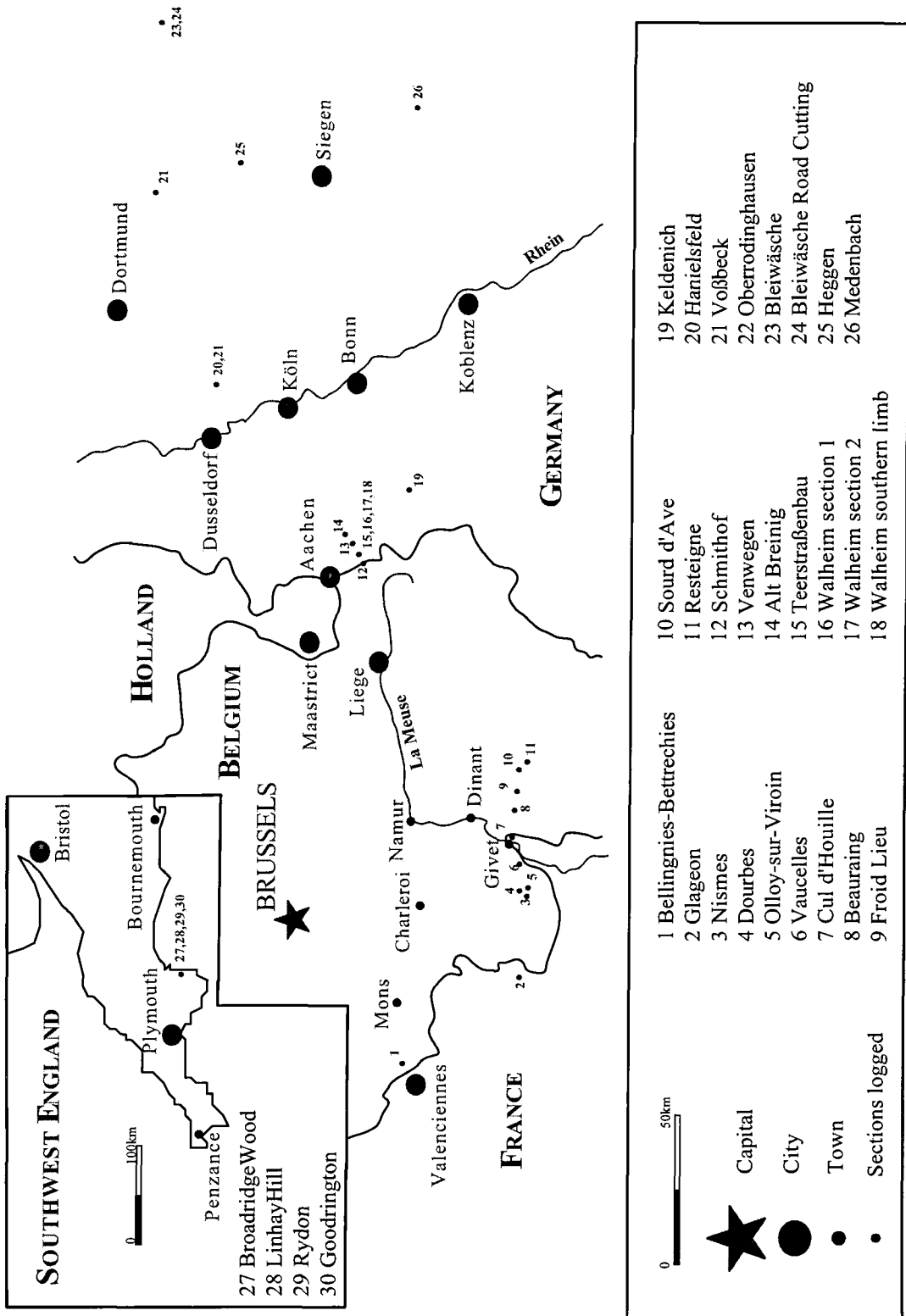

Figure 4-1 Map of western Europe showing location of logged sections. Sections 1, 2, & 20 are early-middle Givetian ramp facies, sections 3 to 19 are located within the broad shelf lagoon, sections 21-30 are in isolated platforms.

|           | Basin  | Open shelf sea | Deep shelf margin   | Foreslope | Organic buildup | Winnowed edge sands | Shelf lagoon open circulation | Restricted circulation shelf and tidal flats | Evaporites on sabkhas salinas |
|-----------|--|----------------|---|-----------|-----------------|---------------------|-------------------------------|--|-------------------------------|
| SMF types | 1, 2, 3  | 2, 8, 9, 10    | 2, 3, 4   | 4, 5, 6   | 7, 11, 12       | 11, 12, 13, 14, 15  | 8, 9, 10, 16, 17, 18          | 16, 17, 18, 19, 24, 21, 23, 22               | 20, 23                        |
| SMF type  | Lithology  |                | Environment   |           |                 |                     |                               |  |                               |
| 1         | Spiculite. Dark clayey mudstone or wackestone, organic-rich, or siliceous spiculitic calcisiltite.   |                | Basinal, deep water, with slow sedimentation.   |           |                 |                     |                               |  |                               |
| 2         | Microbioclastic calcisiltite. Fine-grained grainstone or packstone. Small scale ripple cross-lamination.   |                | Open sea shelf near the lower slope.  |           |                 |                     |                               |  |                               |
| 3         | Mudstone and wackestone. Pelagic microfossils and megafaunas.  |                | As 1 and 2.   |           |                 |                     |                               |  |                               |
| 4         | Microbreccia or bioclastic-lithoclastic packstone. Graded, rounded grains. Quartz, chert and carbonate detritus.   |                | Fore-slope talus, resedimented limestones.  |           |                 |                     |                               |  |                               |
| 5         | Grainstone-packstone or floatstone with bioclasts of reef.   |                | Reef flank facies.  |           |                 |                     |                               |  |                               |
| 6         | Reef rudstones, no matrix material.  |                | Debris from the reef - commonly in high-energy zone.  |           |                 |                     |                               |  |                               |
| 7         | Boundstones, framestones, bindstones, bafflestones.  |                | Reef  |           |                 |                     |                               |  |                               |
| 8         | Wackestone with whole organisms. Well-preserved infauna and epifauna.  |                | Shelf lagoon with circulation, low-energy water below normal wave-base.                     |           |                 |                     |                               |  |                               |
| 9         | Bioclastic wackestone. Fragments of diverse organisms, bioturbated.  |                | Shallow waters with open circulation close to wave base.                                    |           |                 |                     |                               |  |                               |
| 10        | Packstone - wackestones with coated and abraded bioclasts.   |                | High-energy environment particles moving down slopes to lower-energy settings.              |           |                 |                     |                               |  |                               |
| 11        | Grainstones with coated bioclasts, in sparry cement.   |                | Areas with constant wave action at or above wave base.                                      |           |                 |                     |                               |  |                               |
| 12        | Coquina, bioclastic packstone, grainstone or rudstone. Certain organisms dominate.   |                | Slopes and shelf edges.   |           |                 |                     |                               |  |                               |
| 13        | Oncoid (biosparite) grainstone.  |                | Moderate to high-energy areas, very shallow waters.   |           |                 |                     |                               |  |                               |
| 14        | Lags. Coated and rounded particles, mixed with ooids and peloids. May be blackened and iron-stained. Thin beds.  |                | Slow accumulation of coarse material in zone of winnowing.                                  |           |                 |                     |                               |  |                               |
| 15        | Oolites of well-sorted ooids. Cross bedded.  |                | High-energy environment on oolite shoals, beaches and tidal bars.                           |           |                 |                     |                               |  |                               |
| 16        | Grainstone with peloids. Faecal pellets, in places mixed with ostracode tests or forams.   |                | Shallow water with only moderate water circulation.   |           |                 |                     |                               |  |                               |
| 17        | Grapestone, pelsparite or grainstone with aggregate grains, isolated and agglutinated peloids, some coated grains.   |                | Shelf with restricted circulation and tidal flats.  |           |                 |                     |                               |  |                               |
| 18        | Foraminiferal or dasycladacean grainstones.  |                | Tidal bars and channels of lagoons.   |           |                 |                     |                               |  |                               |
| 19        | Fenestral, laminated mudstone - wackestone, grading rarely into pelsparite with fenestral fabrics. Ostracodes and peloids, sporadic forams, gastropods and algae.  |                | Restricted bays and ponds.  |           |                 |                     |                               |  |                               |
| 20        | Microbial stromatolite mudstone.   |                | Commonest in the intertidal zone.   |           |                 |                     |                               |  |                               |
| 21        | Spongistrome mudstone. Convolute microbial fabric in fine-grained micrite lime mud sediment.   |                | Tidal ponds.  |           |                 |                     |                               |  |                               |
| 22        | Micrite with large oncoids, wackestone or floatstone.  |                | Low-energy environments, shallow water, back-reef; often at the edges of ponds or channels. |           |                 |                     |                               |  |                               |
| 23        | Unlaminated, homogenous, unfossiliferous pure micrite; evaporite minerals may occur.   |                | Hypersaline tidal ponds.  |           |                 |                     |                               |  |                               |
| 24        | Rudstone or floatstone with coarse lithoclasts and bioclasts. Clasts usually consist of unfossiliferous micrite; may be imbricated or cross bedded, sparse matrix. |                | Lag deposit in tidal channels.  |           |                 |                     |                               |  |                               |

Figure 4-2 Standard Microfacies Types of Wilson (1975) and Flügel (1972, 1982). Table reproduced from Tucker and Wright (1992).

#### 4.1 Ramp microfacies

Shallow water carbonates were deposited in the study area from early Middle Devonian (Eifelian) times (see Section 2.2.3). The transition from clastic to carbonate deposition reflected the northward transgression of marine facies over the Old Red Continent (Krebs, 1974). Carbonate deposition was initiated in a homoclinal ramp or bank setting, where a slight slope existed with no true barrier or topographic differentiation (Krebs, 1974; Preat and Kasimi, 1995). Subsidence during this period of deposition was uniform and slow (Krebs, 1971). In the Rhenisches Schiefergebirge area of Germany, these bank facies are known as the 'Schwelm' facies; in the Belgian Ardennes they are represented by the Hanonet and lower Trois Fontaines Formations and in Southeast Devon, England they are represented by the Denbury Crinoidal Limestone (see Figure 2-3). Due to the transgressive nature of these deposits, the ages of the successions differ. In the southern-most parts of the study area (SW England and southern Belgium) the ramp facies are late Eifelian and early Givetian in age; yet further north in the Rhenisches Schiefergebirge the Schwelm facies are middle to late Givetian in age. The ramp facies generally consist of homogenous successions of dark, fossiliferous, well bedded, bioclastic carbonates. Stromatoporoids, corals, crinoids, brachiopods and molluscs are all locally abundant. Ramp facies were not extensively studied for this thesis. Successions at Glageon, Bellignies-Bettrechies, Resteigne, Olloy-sur-Viroin, Froid Lieu, Walheim Southern Limb, Hanielsfeld and Teerstraßenbau quarries (see Figure 4-1 for locations and Appendix 2 for logs) were logged and sampled to determine a very generalised microfacies scheme. For more detailed work on these carbonates the reader should refer to the publications suggested in Table 4-2.

| Area of study                | References   |
|------------------------------|--|
| Rhenisches Schiefergebirge   | Krebs, 1974<br>Krebs, 1971<br>Krebs, 1968  |
| Belgian Ardennes             | Preat and Kasimi, 1995<br>Boulvain <i>et al.</i> , 1994<br>Casier and Preat, 1991<br>Preat, 1989 |
| Torbay Reef Complex, England | Selwood <i>et al.</i> , 1984<br>Scrutton, 1977a<br>Scrutton, 1977b                               |

**Table 4-2 Suggested published work documenting Middle Devonian ramp facies.**

Logging of the 8 successions, consequent sample collection and thin-section analysis has identified 7 major ramp microfacies (R1 to R7). R1 represents the deepest subtidal microfacies and R7 represents the shallowest microfacies. Section 4.1.8 synthesises these 7 depositional environments and proposes a composite environmental reconstruction.

#### **4.1.1 R1 microfacies - bioturbated wackestones**

Fossiliferous mudstones and wackestones with whole organisms characterise microfacies R1. This microfacies is the most common ramp facies identified in the study area and is present in most successions logged. This facies is usually very well bedded, with planar beds ranging between 3cm and 171cm in thickness, averaging 10 to 30cm. A rich open-marine faunal assemblage is present, including abundant crinoids, gastropods, bivalves, brachiopods, trilobites and solitary corals. Many of these shells are concentrated in small nests, or are scattered throughout the bed. The larger faunas (gastropods, bivalves) are often unbroken. However, shelly, bioclastic material is associated with the matrix phase. The matrix is a dark grey colour, micritic, usually thoroughly bioturbated and often marly, friable and argillaceous (Fig. 4-3a). Rarely the facies are dolomitised (Glageon and Teerstraßenbau quarries), or slightly nodular (Walheim Southern Limb section). Large scale sedimentary structures such as cross bedding are not present.

In thin section, parathuramminid forams, small ostracodes, brachiopod spines, bryozoans, tentaculitids, trilobites and rare dasycladacean algae can also be identified. Peloids are not a common constituent. Crinoids are the most common bioclast, being 2mm in diameter on average. Syntaxial cements are not developed. Brachiopods are usually very thin shelled and have both crenulated and smooth shells. Ostracodes are a very common bioclastic component also. They are often very well preserved, being less than 0.5mm in length with valves still articulated. Gastropods and bivalves were originally aragonitic in nature and therefore are now recrystallised to calcite spar. Gastropods are locally abundant and are commonly very small (less than 10mm in length). Bivalves are sometimes bi-mineralic in nature and are often disarticulated. Tentaculites, bryozoans and trilobites are rare. The matrix associated with microfacies R1 is micritic, not peloidal and often dolomitised or recrystallised to calcite microspar. Bioturbation is very common. Sometimes it occurs in discrete patches and is picked out by dolomitisation, or the matrix is thoroughly bioturbated resulting in a homogenised micrite. Often the matrix is clay-rich and

argillaceous. Marine fibrous cements are sometimes precipitated inside the chambers of gastropods. Rarely bioclasts are aligned, or bivalve shells are in a hydraulically stable position suggesting storm reworking.

*Depositional environment:* The presence of a fully open-marine assemblage of faunas is suggestive of an open-marine depositional environment. The micritic matrix and well preserved bioturbation structures indicate deposition well below normal wave base. Storms occasionally impinged into this environment, therefore an environment at or just below storm wave base is likely (see Figure 4-3a and Section 4.1.2). Similar microfacies have been identified by Casier *et al.* (1992) and Preat and Kasimi (1995) in the Belgian Ardennes and an open-marine environment below or at storm wave base has been suggested.

#### **4.1.2 R2 microfacies - bioclastic packstones**

Bioclastic packstones are represented in the Glageon, Bellignies-Bettrechies, Teerstraßenbau, Olloy-sur-Viroin, Resteigne and Walheim Southern Limb successions and is a very common microfacies. Bed thickness ranges from 4cm to 147cm, yet is more commonly 20cm to 50cm in thickness. The bedding is usually planar and laterally persistent, with sharp bases. A rich faunal assemblage of crinoids, brachiopods (including stringocephalids), corals (mainly solitary, or the colonial thamnoporoids) and bivalves is present. Gastropods and branching stromatoporoids are rare constituents. Many of the bioclasts are broken and disarticulated. Unidentifiable shell hash is a common constituent in the matrix phase. The matrix is mainly micritic in nature, although a mix of spar and matrix is not uncommon. Sedimentary structures are common in this facies. Graded bedding is especially common, where accumulations of bioclasts at the base of a bed grade into a relatively bioclast-free facies. Bioclasts are often in a hydraulically stable position and/or concentrated in discontinuous lenses. Cross bedding or lamination is sometimes identified.

Thin-section analysis also identifies ostracodes, brachiopod spines, forams and bryozoan and trilobite bioclasts. Peloids are also common grains. All bioclasts are very fragmented, on average 1mm to 5mm in diameter/ length. Crinoids and brachiopods are the most prevalent bioclasts; crinoids are commonly broken into 1mm bioclasts, whereas several species of brachiopod are broken into 1-4mm long bioclasts. Brachiopods are often aligned

parallel to each other and in a hydraulically stable position. Micrite envelopes are rare. Bivalves are also broken into 1-3mm long bioclasts and sometimes have a micrite envelope. The matrix is mostly micritic in nature, yet in many samples recrystallisation to calcite microspar or dolomitisation is extremely common. Preserved bioturbation structures are uncommon. The matrix is rarely peloidal.

*Depositional environment:* The varied fauna preserved in microfacies R2 suggests an open-marine depositional environment. The presence of graded bedding, lenses of bioclast lags and bioclasts which are preserved in a hydraulically stable position indicate deposition above storm wave base (Tucker and Wright, 1992). The graded beds could well have been deposited by storms, yet they lack the characteristic erosional bases (although they do have sharp bases) and sole structures were not identified. Deposition is likely to have been distal in nature since no hummocky cross stratification or swaley cross stratification is seen. Marly shales with a full open-marine assemblage have been identified at Walheim Southern Limb section in Germany (Fig. 4-3a; Section A2.30). These marls are interbedded with bioclastic packstones of R2 microfacies affinities and represent a unit approximately 4m thick known as the 'Grenzschiefer'. These alternating marly shales and bioclastic limestones are thought to be turbiditic in origin (Meischner, 1964; Kasig, 1980; Kasig and Wilder, 1983). In the Belgian successions the facies are likely to have been storm-derived. Microfacies R2 is equivalent to Microfacies 2 of Preat and Kasimi (1995), where deposition within the zone of storm-wave action is envisaged.

#### **4.1.3 R3 microfacies - stromatoporoid floatstones**

Stromatoporoid, or stromatoporoid-coral floatstones are represented in the Bellignies-Betrechies, Glageon and Hanielsfeld quarries. This facies is very easy to identify in the field, due to the presence of recognisable, large macrofaunas. The strata are generally well bedded, range from 12cm to 110cm in thickness, commonly being about 50cm in thickness. The limestones generally display a floatstone texture, variably composed of laminar stromatoporoids, domal stromatoporoids, branching stromatoporoids, corals (both solitary and colonial), gastropods, crinoids, brachiopods (including stringocephalids) and bivalves. The faunas rarely construct recognisable 'bioherms'. Stromatoporoids are variable in size; laminar stromatoporoids can reach up to 450mm long, with domal stromatoporoids being 240mm in diameter. Laminar stromatoporoids appear to dominate. Corals are mainly

branching colonial types and some are thamnoporoids; however, colonies reaching 410mm in diameter are not uncommon. Faunas with reef-building abilities (i.e., the stromatoporoids and corals) are rarely preserved in life position. Solitary corals, brachiopods, molluscs and crinoids are all associated with the matrix phase (because of their relatively small size); however, they are probably more abundant volumetrically than the stromatoporoids and colonial corals. Some crinoids reach up to 7mm in diameter at the Hanielsfeld quarry; however, they are more commonly 2-3mm in diameter. The matrix is micritic in nature, bioturbated and often quite clay-rich and argillaceous. In thin section small broken-up shelly material is also present in the micritic matrix. Often the matrix is neomorphically altered to microspar, or dolomitised to fine-grained dolomite. No large-scale sedimentary structures have been identified in this facies.

*Depositional environment:* Microfacies R3 contains faunas which are open-marine in nature. The bioconstructors (stromatoporoids and corals) are not found in life position. However, they are not very broken-up suggesting little transportation and moderate-energy environments. The dislodging and accumulation of these stromatoporoids and corals may have been storm related. The matrix is, or was originally, micritic. These stromatoporoid floatstones were probably deposited in low- to moderate-energy marine environments (mid ramp). No large-scale cross bedding has been identified, which may have suggested higher-energy conditions and the matrix is micritic, suggesting little attrition and washing away of the lime mud. This facies has been widely described in the Devonian literature. Krebs (1974) recognised these stromatoporoid-coral-brachiopod facies in the Schwelm facies of the Rhenisches Schiefergebirge area. Boulvain *et al.* (1994), Preat and Kasimi (1995) and Kasimi and Preat (1996) all recognised this facies in the Eifelian to lower Givetian of the Belgian Ardennes and suggested shallow-marine depositional systems.

#### **4.1.4 R4 microfacies - oolitic/peloidal/bioclastic grainstones**

Microfacies R4 consists of grainstone facies. This microfacies can be refined into 3 subfacies. Microfacies R4a consists of oolitic grainstones, R4b of peloidal grainstones and R4c of bioclastic grainstones. On the whole, microfacies R4 is not common within the logged successions and is only identified at Glageon, Bellignies-Bettrechies and Froid Lieu quarries.

#### 4.1.4.1 R4a microfacies - oolitic grainstones

Oolites dominate this R4a grainstone microfacies. This microfacies is very distinctive in the field and has been identified at both the Glageon and Bellignies-Bettrechies quarries. The rock has a very sugary texture in hand specimen and commonly lacks discernible macrofaunas. Ooids are distinct in hand specimen and sometimes reach up to 0.5mm in diameter. Peloids, broken-up bioclastic material and intraclasts are also common. Most grains are spherical or oval in shape and where a long axis is distinct no alignment is apparent. Bedding is mostly planar and ranges from 9cm to over 150cm.

Thin-section analysis shows that ooids are 0.1mm to 0.5mm in diameter. The overall texture of the rock is often very well sorted. Ooids range in shape from perfectly spherical to elongate (Fig. 4-3b). Rarely, several generations of ooid can be identified. Most ooids are superficial, having only one laminae. The laminae are mainly isopachous (~0.05mm thick); however, some ooids display lamina with asymmetric thicknesses. Both radial and concentric textures are well developed in the laminae. In crossed polarised light, ooids display a distinctive 'cruciform' extinction pattern. Some 'normal' ooids are seen, having two or three identifiable laminae. Compound ooids are also locally abundant (Fig. 4-3c). The nucleus of the ooids is commonly a peloid, small broken-up bioclasts and rarely *Girvanella* or another ooid. The shape of the ooid is often determined by the morphology of the nucleus (Fig. 4-3b). Ooids are also associated with other grains, mainly peloids, lithoclasts and broken-up bioclasts. Peloids are especially common and bioclasts often possess a micrite envelope.

The matrix to this facies is always sparitic, with several generations of cement. Grains with long axes are rarely aligned and no lamination or graded bedding has been identified.

*Depositional environment:* Oolitic grainstones are common in moderate to high-energy environments with constant wave action. Modern-day ooids form in several different situations, including shoals on the Bahama platform, tidal deltas in the Arabian Gulf, lakes in the Great Salt Lake Utah and foreshore zones along the Yucatan shoreline in Northeast Mexico (Halley, 1977; Tucker, 1991). Water depths are usually less than 5m, yet can be as deep as 15m (Tucker, 1991).

The oolitic grainstones studied in the Glageon and Bellignies-Bettrechies quarries do not display any cross-bedding. The nucleus of many of the ooids is bioclastic and composed

mainly of molluscan material. This may suggest that the source for these nuclei may have been slightly restricted in nature, since there is no typically 'open-marine' faunas providing a nucleus. A large percentage of the ooids are superficial in nature, which Illing (1954) argued represents relatively low-energy environments. Bathurst (1967) also recognised thin carbonate films on sand-grade grains in low-energy environments of the Bahama Banks. Although these films would not be preserved, they may illustrate incipient ooid formation (Flügel, 1982). The presence of compound or composite ooids can be indicators of a break in deposition (Flügel, 1982). The strong radial-fibrous structure preserved in the ooids is also apparently characteristic of quiet-water ooids, where there may be salinities deviating from normal marine values (Flügel, 1982). This evidence points towards microfacies R4a being a low-energy deposit. However, the matrix of these oolites is sparitic, suggesting a higher-energy environment. This presents a paradox where apparently calm-water peloids are in a moderate- to high-energy deposit.

I suggest these relatively thin ooid accumulations represent small, laterally impersistent sand banks within the moderate-energy, ?slightly restricted, subtidal zone. Interestingly, Preat and Kasimi (1995) examined the oolitic grainstones from the same successions and suggested an intertidal environment, due to the presence of keystone vugs. The samples examined in this study have not yielded any evidence for intertidal conditions.

#### **4.1.4.2 R4b microfacies - peloidal grainstones**

Peloidal grainstones, with a variable bioclastic component, characterise microfacies R4b. At outcrop scale these rocks are fairly well bedded, ranging from 14cm to 40cm in thickness. A sugary or grainy texture, as with the oolitic grainstones, is identifiable. No large-scale sedimentary structures (cross bedding, graded bedding) can be identified. Macrofossils are uncommon. This faces can be identified at the Bellignies-Betrechies and Glageon quarries.

In thin section peloids are the most common grain. They are subspherical or oval in shape and on average 0.1mm to 0.3mm in diameter. They are commonly fairly well sorted. Most peloids have a microcrystalline fabric, with rare cyanobacterial inclusions. Some peloids are micritised grains, discernible by the elongate shape and incomplete micritisation; some still have a bioclastic centre. The peloids do not exhibit regular stripes or internal patterns.

Where peloids do have a long axis, alignment is apparent in some situations. Also associated with the peloids are broken-up bioclasts, algae and cyanobacteria. These include crinoids, *Girvanella*, *Wetheredella*, parathuramminids, ostracodes, brachiopods, branching stromatoporoids, gastropods and bivalves. These grains are variably micritised; the bivalves and gastropods appear to be preferentially affected by microbial micritisation. Small micritic lithoclasts and ooids are rare components of this microfacies.

The matrix to the peloidal grainstones is usually sparitic; however, variable amounts of micrite can also be present. Often no early marine cements are present and cements are generally of a very fine-grained calcitic nature.

*Depositional environment:* Peloids are common constituents of many carbonate rocks. The origins of peloids are numerous, including faecal, algal and recrystallised ooids/bioclasts (Flügel, 1982). The lack of internal fabric to many of these peloids, their subspherical shape and sheer abundance would suggest a faecal origin. These could be produced by gastropods, ostracodes, worms, brachiopods or bivalves, all of which are associated with the sediment. Algal or cyanobacterial peloids are also probably present, though in a much smaller abundance. These peloids are more irregularly shaped and have more diverse sizes. Some of the peloids which display an elongate oval shape are cortoids. These are strongly micritised bioclasts.

Peloids are common constituents of many Recent subtidal and shallow intertidal environments (Flügel, 1982). The presence of broken-up, micritised grains suggests an environment where there is persistent winnowing. SMF 16 of Wilson (1975) adequately describes this microfacies and suggests environments with shallow water, yet only moderate circulation (Tucker and Wright, 1992). Therefore it is likely that microfacies R4b was deposited in a moderate-energy, marine (because of the varied associated faunal assemblage) environment.

#### **4.1.4.3 R4c microfacies - bioclastic grainstones**

Bioclastic grainstones are rare in the study area. They have only been identified in Glageon, Froid Lieu, Walheim Southern Limb and Bellignies-Betrechies quarries and are very localised accumulations. They range from 36cm in thickness to 90cm in thickness.

The bioclasts are often extremely broken-up and are rarely identifiable in hand specimen, although crinoids, brachiopods and corals are sometimes discernible.

Thin-section analysis identifies a varied faunal assemblage. This includes brachiopods, brachiopod spines, bivalves, crinoids, stromatoporoid debris, corals and gastropods. Peloids are also a common grain. Most of the faunas are invariably broken into bioclastic material 2-4mm in length. Crinoids are common constituents, being on average 1mm to 4mm in diameter and displaying syntaxial cements (see Fig. 3-17). Brachiopods are also abundant, as are brachiopod spines which can reach up to 3mm in length (Fig. 4-3d). Much of the molluscan material is recrystallised because of its original aragonitic mineralogy and possesses a micrite envelope. The bioclasts are sometimes aligned parallel to each other, but this is not always the case. Peloids are generally subspherical in shape and are faecal in origin. The matrix to this facies is sparitic with several generations of cement being identified. Apart from rare isopachous cements around peloids in Walheim Southern Limb quarry, no early marine cements have been identified. However, syntaxial cements are common around crinoids and drusy and equant cements are also present.

*Depositional environment:* The varied faunal assemblage present in this facies suggests an open-marine depositional environment. Most of the bioclasts are broken-up and were probably intensively winnowed. The sparitic matrix suggests moderate- to high-energy environments where any remaining lime mud/micrite would have been washed out. The high percentage of brachiopod spines may also suggest a high-energy environment, since brachiopods often possess spines to stabilise themselves in a mud or grainy substrate (Clarkson, 1986). The spines have not been extensively reworked or broken, suggesting little transportation or attrition. Wilson (1975) suggests deposition of SMF 11 microfacies in a winnowed platform where there was constant wave action at or above wave base. Boulvain *et al.* (1994) and Preat and Kasimi (1995) have studied similar facies in northern France and have suggested a similar shallow open-marine environment above wave base.

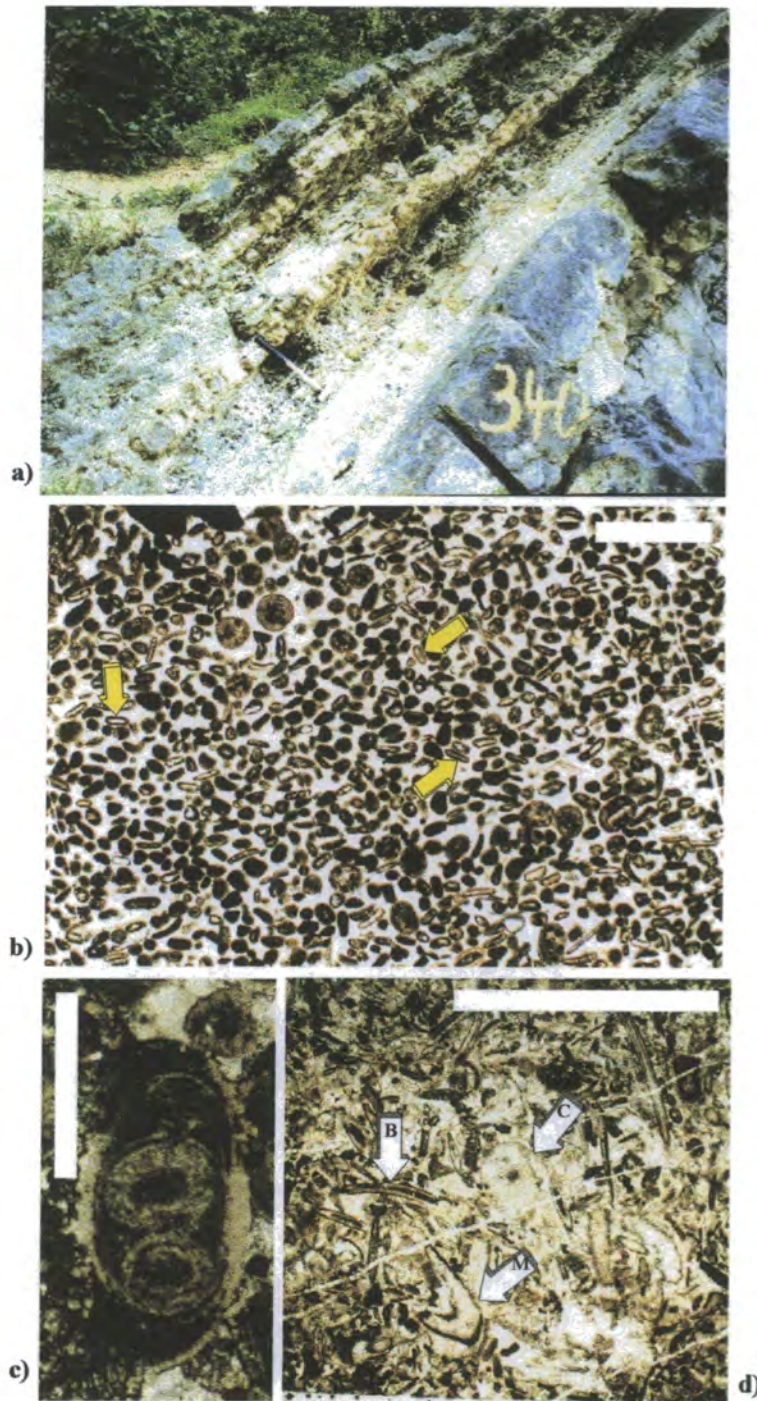

**Figure 4-3** a) Interbedded green-grey marly shales (microfacies R1) and bioclastic limestones (microfacies R2). Photograph taken at the Walheim Southern Limb section, Aachen, Germany. Hammer is 42cm long for scale. b) Photomicrograph of very fine-grained oolitic grainstone. R4a microfacies. Most ooids are superficial with only one lamina (arrows). Sample number GL17, Glageon quarry, northern France. Scale bar = 1mm. c) Photomicrograph of R4a microfacies. Compound ooid with several micritic and oolitic laminae. Note oval shape of final ooid. Sample BB12, Bellignies-Bettrechies quarry, northern France. Scale bar = 0.5mm. d) Photomicrograph of bioclastic grainstone, microfacies R4c. Note presence of crinoids (C), recrystallised mollusc material with micritic rims (M) and abundance of brachiopod spines (B). Sample number GL15, Glageon quarry, northern France. Scale bar = 5mm. Also refer to Enclosure One

#### 4.1.5 R5 microfacies - gastropod/bivalve wackestones

Mudstones and wackestones containing sparse mollusc faunas characterise microfacies R5. This facies is not very common having only been identified in the Bellignies-Bettrechies quarry. In the field this facies is well bedded, with thickness ranging from 9cm to 67cm. Both gastropods and bivalves are common in small nests or lenses. Gastropods are on average 10mm in length and bivalves 10-20mm long. Most bivalves are articulated and gastropods are not broken up. Rare solitary corals are the only other macrofaunas associated with this facies. The matrix consists of bioturbated micrite.

*Depositional environment:* The presence of only molluscs suggests that environmental conditions may be slightly restricted (Heckel, 1972). This depositional environment is low-energy, below wave-base, based on the micritic matrix and well-preserved faunas. Similar facies have been described by Preat and Kasimi (1995), where an open lagoonal environment was suggested. This facies also typifies the standard microfacies type (SMF) 8 of Wilson (1975), where well-circulated shelf lagoons are envisaged.

#### 4.1.6 R6 microfacies - leperditicopid ostracode packstones

Wackestones and packstones containing leperditicopid ostracodes characterise microfacies R6. In this present study microfacies R6 has only been found at the Bellignies-Bettrechies succession. However, studies by Casier *et al.* (1995) and Preat and Kasimi (1995) have identified this facies at two other successions in France. At outcrop scale bedding ranges in thickness from 14cm to 37cm and is generally planar. The ostracodes are very conspicuous, being thin-shelled and up to 10mm long. Sometimes they can be seen as bed-parallel lenses and accumulations; however, more often the ostracodes occur articulated in dense monospecific nests. The ostracodes often provide useful geopetal information with their shells being part micrite- and part spar-filled. Rare gastropods are associated also with this facies-type.

In thin section, the leperditicopid ostracodes are very well preserved, with both valves still joined and fibrous cements precipitated inside (Fig. 4-4a, Fig. 4-4b). Mechanical compaction has sometimes broken the valves *in situ*. Again, leperditicopid ostracodes dominate the bioclasts; however, smaller ostracodes are locally common, as are dasycladacean algae and cyanobacteria. Other grains include peloids and rare ooids. The

matrix is both sparitic and micritic. The micrite is peloidal and bioturbated. No sedimentary structures are present, apart from the alignment of bioclasts parallel to bedding.

*Depositional environment:* Leperditicopid ostracodes are indicative of highly restricted environmental conditions (see Section 3.4.1; Benson, 1961; Berdan, 1968; Braun and Mathison, 1986; Casier *et al.*, 1995). This suggests that periodically small restricted bays were established for these faunas. Casier *et al.* (1995) envisaged a bay completely cut-off from the open-marine realm. The sediments provide no evidence of exposure (i.e., mud polygons, birdseye fenestrae, palaeosols), and the presence of a micritic matrix and the superb preservation of the ostracodes suggest low-energy waters. However, the localised alignment of ostracodes suggests occasional reworking by waves/storms/currents. There is no evidence of hypersalinity.

#### **4.1.7 R7 microfacies - laminated dolomudstones**

Very fine-grained dolomudstones characterise microfacies R7. This microfacies has only been identified at the Bellignies-Bettrechies and Glageon successions (Sections A2.3 and A2.10) and is relatively rare. At the outcrop scale the dolomudstones are thinly bedded, ranging from 5cm to 20cm in thickness. They are always unfossiliferous, and often laminated with some laminae being contorted (Fig. 4-4c). Bioturbation sometimes disturbs lamination.

In thin section it is apparent that lamination is due to the percentage of opaque or clay minerals in the matrix and not to grain-size variations. The dolomite is mostly fabric-retentive. Crystals are very fine-grained, commonly less than 0.05mm in diameter and have both xenotopic and idiotopic mosaics. Anhedral and euhedral crystals are both common. Coarser-grained dolomite is present in discrete diamond- or lozenge-shaped patches, 0.5mm in diameter.

*Depositional environment:* This facies was probably originally micritic in nature since it has been dolomitised to a fine-grained mosaic and primary sedimentary structures have been preserved. The coarser-grained dolomite could either be related to i) the volume decrease associated with the dolomitisation process producing cavities in which dolomite cements was precipitated, or ii) dissolution and replacement (pseudomorphing) of an evaporite (gypsum/anhydrite) crystal. The facies appears unfossiliferous, which suggests

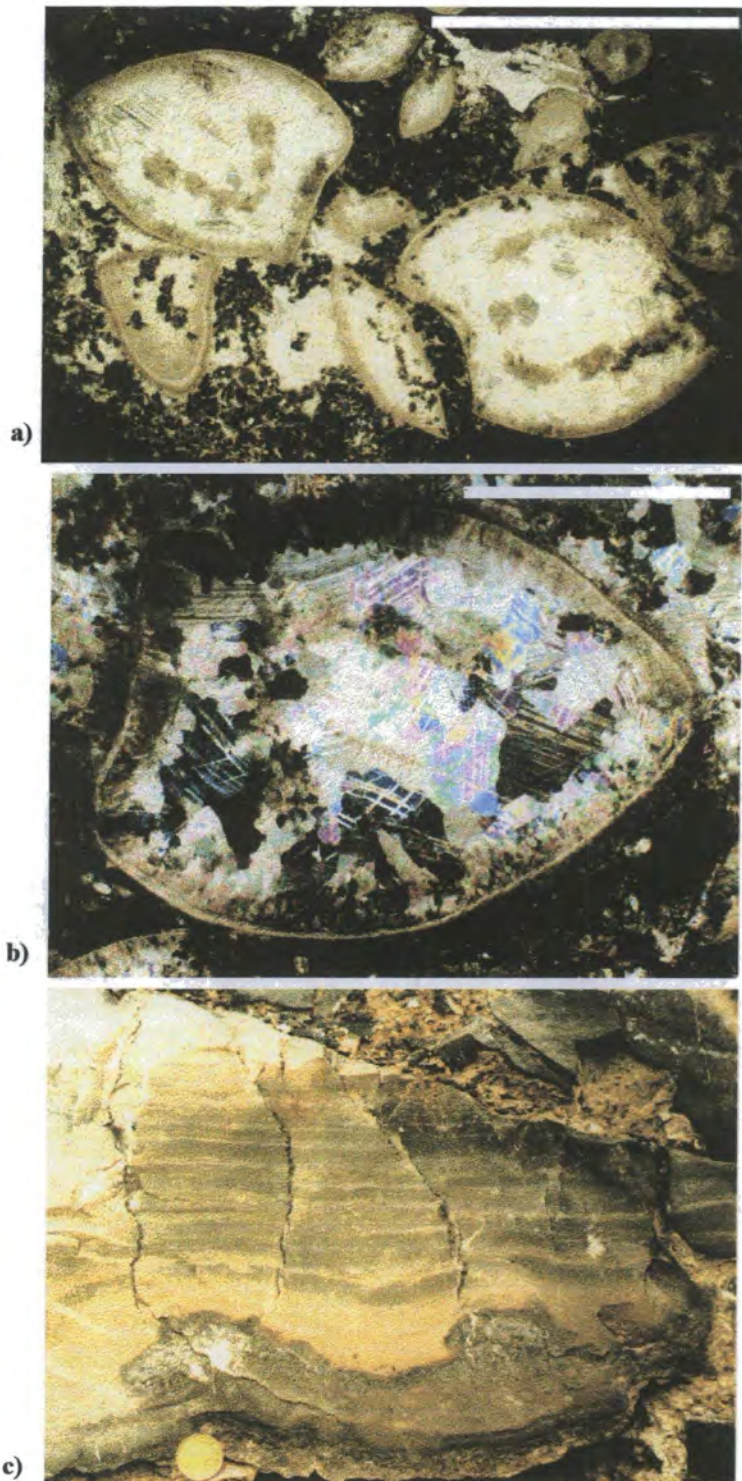

**Figure 4-4** a) Microfacies R6, leperditicopid wackestones. The leperditicopid ostracodes are thin-shelled yet remarkably well preserved. Sample number BB6, Bellignies-Bettrechies quarry, northern France. Scale bar = 5mm. b) Photomicrograph in crossed-polarised light to show the radial-fibrous calcite cements inside the ostracode test. The fibrous calcite crystals are on average 0.4mm long and are columnar in form. Burial baroque dolomite is also present as a cavity fill. Scale bar = 2mm. c) Microfacies R7, dolomudstones. Note slightly contorted laminae, which are possibly stromatolitic in nature. Bellignies-Bettrechies quarry, northern France. Coin 2cm diameter for scale. Also refer to Enclosure One.

that environmental conditions were not suitable to support faunas. However, since these rocks have been dolomitised it is possible that microfossils may have been present and later dolomitised with little fabric-retention. The lack of body-fossils could suggest restricted circulation, anoxia, or exposed conditions. Similar facies have been identified by Casier *et al.* (1995) in the Devonian in northern France and Morrow and Labonte (1988) in the Devonian of Northwest Territories in Canada, where intertidal or supratidal environments were envisaged. This facies is also extremely similar to Lower Palaeozoic dolostones of the North China Platform, where a tidal flat environment was suggested (Feng and Jin, 1994). The lamination may represent original microbial mats, yet the microscopic detail has now been destroyed by the dolomitisation process. The contorted laminae may indeed represent small stromatolitic structures. The presence of possible evaporite pseudomorphs would also support this elevated depositional environment.

#### **4.1.8 Environmental reconstruction**

The microfacies described in Sections 4.1.1 to 4.1.7 were all deposited in a ramp setting where there were small restricted embayments, as recorded by microfacies R5 and R6. Figure 4-5 presents an environmental reconstruction for this ramp setting. The ramp was thought to be a homoclinal ramp where there was a relatively uniform slope from coast to basin (Preat and Kasimi, 1995). This ramp was influenced by storms and may have been of a beach barrier-lagoon system which would account for the restricted R5 and R6 facies. Oolitic, peloidal and bioclastic grainstones were deposited as impersistent sand banks around fair-weather wave-base where there was constant attrition. In slightly deeper waters, between normal and storm wave-base, microfacies R2 and R3 were deposited. Microfacies R2 represents skeletal debris derived from shallower waters and deposited in deeper waters through storm processes. Bioturbated mudstones and wackestones of microfacies R1 were deposited near or just below storm wave base.

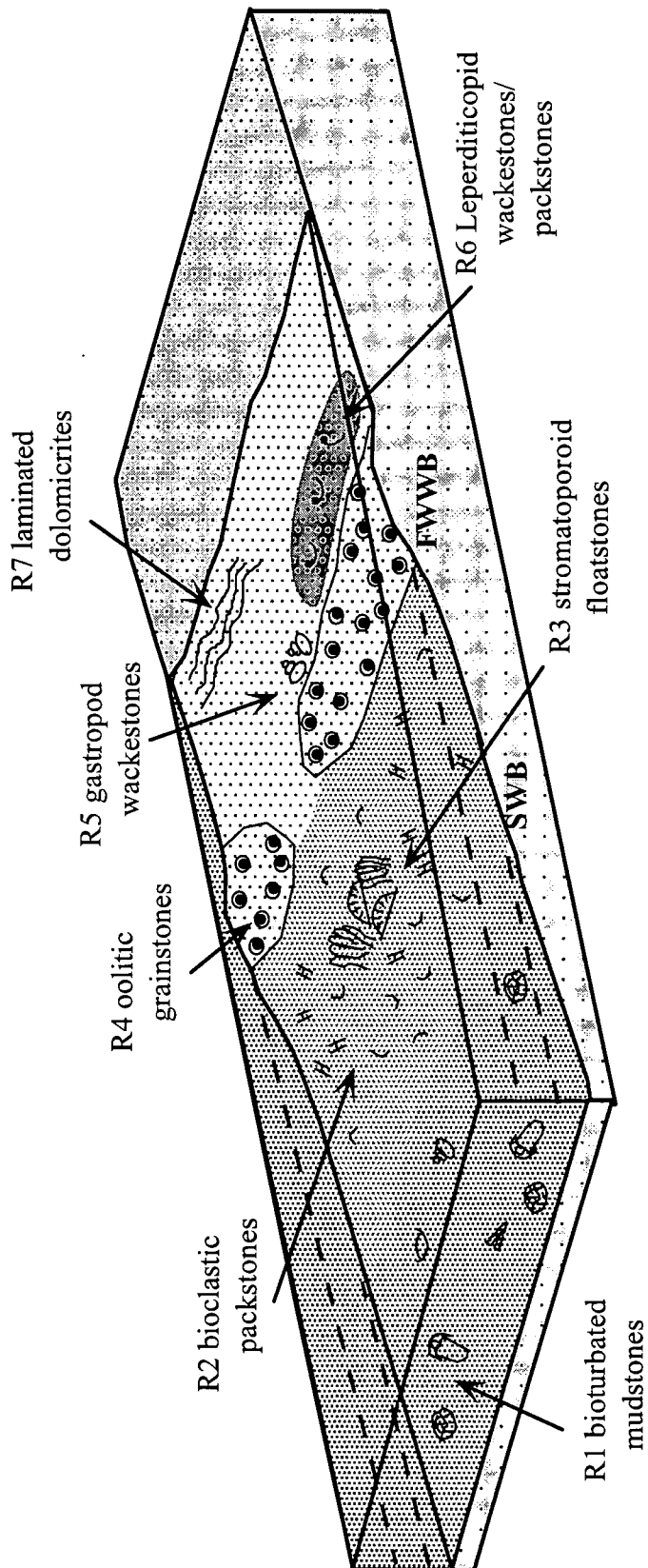

Figure 4-5 Palaeoenvironmental reconstruction of the early Middle Devonian ramp setting in northern France, southern Belgium and western Germany. The reconstruction shows the likely depositional environments of the 7 major microfacies identified in this study. SWB = storm wave-base, FWWB = fair-weather wave-base.

## 4.2 Lagoonal shelf microfacies

This thesis concentrates mainly on the middle to upper Givetian and Frasnian lagoonal successions of western Europe. The sediments are almost entirely carbonate in nature and are deposited in two broad depositional settings: a vast shelf lagoon covering much of northern France, southern Belgium and Eifel areas of Germany and isolated carbonate complexes within the shelf, on the shelf-edge rise and within the trough (Fig. 2-8). These lagoonal facies have been examined in 27 successions, as explained in Table 4-3. Since lagoonal facies were examined in different palaeogeographical settings, their ages differ (Fig. 4-6). Generally, lagoonal sedimentation is oldest in the southern part of the study area (southern Ardennes, SW England) and then transgressed in a northwards direction so that the youngest initiation of lagoonal sedimentation was in the latest Givetian (Balve). The carbonate complex at Langenaubach is the youngest in the study area. However, its development was strongly related to volcanic activity. Its position in the trough meant that it needed a stable, raised subsurface to develop upon. Therefore the carbonates were not established until volcanic activity (spilitic lavas and tuffs) had ceased (Burchette, 1981).

| Carbonate Complex                                | List of logged successions   |
|--|--|
| Broad shelf lagoon (Belgium, Germany and France) | Nismes quarry<br>Dourbes quarry<br>Olloy-sur-Viroin quarry<br>Vaucelles quarry<br>Cul d'Houille quarry<br>Beauraing quarry<br>Froid Lieu quarry<br>Sourd d'Ave road section<br>Resteigne quarry<br>Schmithof quarry<br>Venwegen quarry<br>Alt Breinig quarry<br>Teerstraßenbau quarry<br>Walheim section 1<br>Walheim section 2<br>Walheim Southern Limb<br>Keldenich quarry |
| Torbay Reef Complex (UK)                         | Broadridge Wood quarry<br>Linhay Hill quarry<br>Rydon quarry<br>Goodrington road cutting   |
| Brilon Reef Complex                              | Bleiwäsche quarry<br>Bleiwäsche road cutting   |

**Table 4-3** Table to show list of logged lagoonal successions in the study area.

|                           |                         |
|---------------------------|-------------------------|
| Balve Reef Complex        | Oberrödinghausen quarry |
| Attendorn Reef Complex    | Heggen quarry           |
| Dornap Reef Complex       | Voßbeck quarry          |
| Langenaubach Reef Complex | Medenbach quarry        |

Table 4-3 continued.

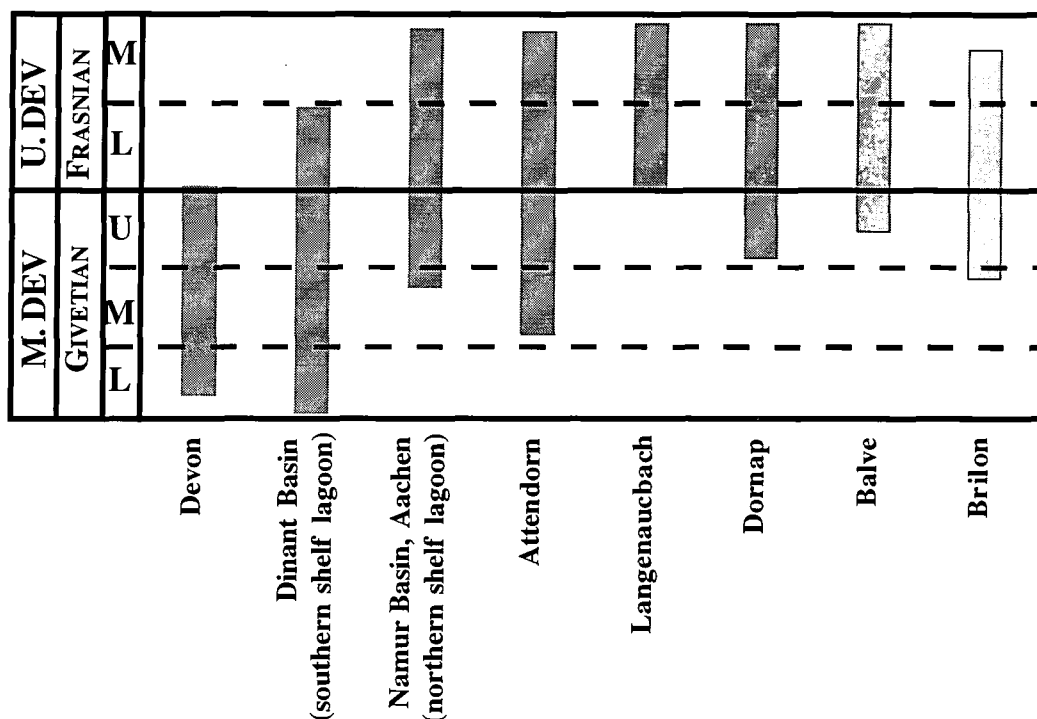
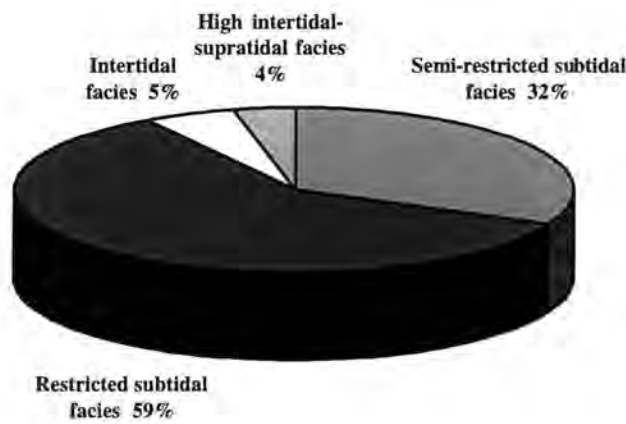

Figure 4-6 Stratigraphic column indicating ages of the carbonate complexes in the study area.

Detailed logging of these 27 successions (Appendix 2), consequent sample collection and thin-section analysis (Appendix 1) has identified 25 sediment-types which represent 14 major shelf lagoonal microfacies (S1 to S14). S1 represents the 'least restricted' subtidal microfacies and S14 represents the 'most restricted' supratidal microfacies. These 14 microfacies can be assigned to four microfacies groups: semi-restricted subtidal facies, restricted subtidal facies, restricted intertidal facies and restricted high intertidal-supratidal facies. The following Sections (Section 4.2.1 to 4.2.4) describe the microfacies in detail and Section 4.2.5 synthesises these observations and interpretations and presents an environmental reconstruction for the Givetian and Frasnian carbonate lagoons.

### 4.2.1 Semi-restricted subtidal microfacies group

The term 'semi-restricted' suggests environmental conditions which were near normal-marine, yet were not entirely open-marine, being restricted behind a barrier (usually stromatoporoid reefs). These facies are often richly-fossiliferous with domal, bulbous and branching stromatoporoids, colonial and solitary corals, brachiopods, crinoids and molluscs all being represented (see Chapter 3). This group of microfacies represents both high- and low-energy depositional environments, often in close proximity to the barrier reef complex. The semi-restricted subtidal microfacies are common within the shelf successions and represent 32% of the total thickness for all successions (Fig. 4-7). The semi-restricted subtidal microfacies group encompasses microfacies S1, S2 and S3.

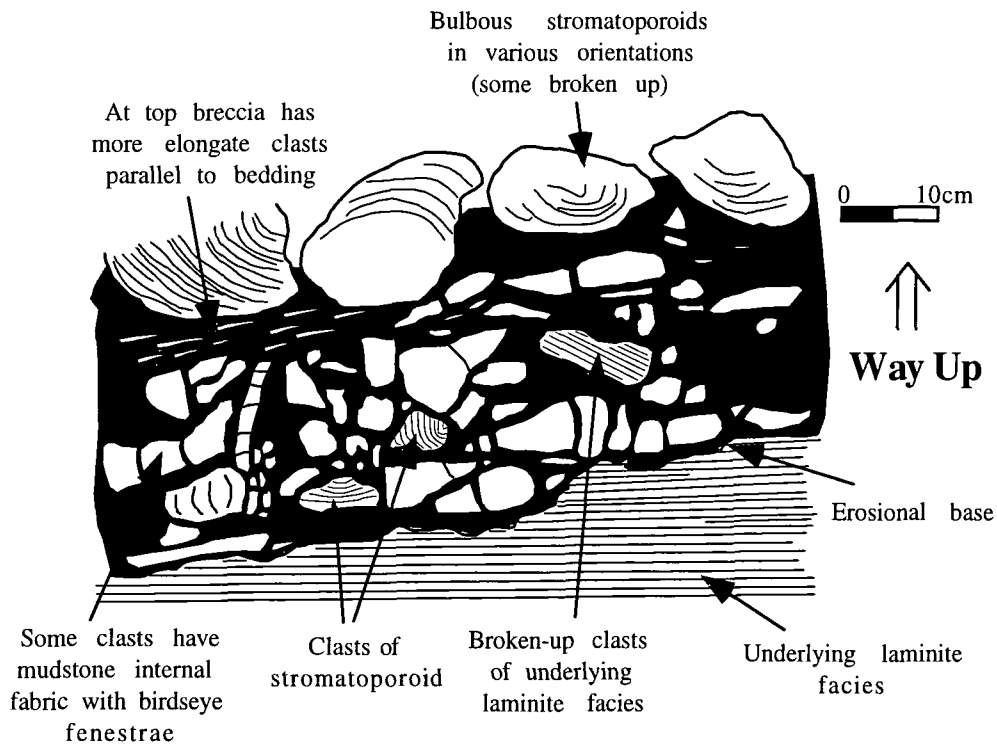

**Figure 4-7** Pie chart to show relative proportions of semi-restricted subtidal facies, restricted subtidal facies, intertidal facies and supratidal facies. Percentages are calculated with respect to total logged thickness.

#### 4.2.1.1 S1 microfacies - Intraformational breccias

The S1 microfacies is characterised by breccia deposition. Within the successions logged its presence is very rare, with only one sighting in Walheim Section One, at Aachen (see Section A2.28). At outcrop scale an abrupt erosional surface at the base of this facies is present (Fig. 4-8), which has an amplitude of up to 7cm. The breccia is mainly clast-supported and poorly-sorted. Clasts are angular to subangular in shape and range in size from less than 1cm diameter to 10cm diameter. The composition of clasts varies; in many

instances clasts are similar to the underlying laminite facies. However, broken-up bulbous stromatoporoid clasts, birdseye-fenestral limestone clasts and fossil-poor micrite clasts are also extremely common. Many of the clasts, especially at the base of the breccia, show an alignment parallel to bedding. Yet in the centre of the breccia clasts show no preferred orientation. No imbrication can be seen and there are no indicators suggesting a preferred transport direction. The top of the breccia provided a surface colonised by bulbous stromatoporoids. The breccia is between 30cm and 40cm thick.



**Figure 4-8** Field sketch of S1 facies. Breccia is on average 30cm thick, with a variety of clasts including stromatoporoids, mudstones and laminites. The erosional surface has an amplitude of up to 7cm. Most clasts are angular to subangular in shape. Sketch drawn @ 6.0m on Walheim Section 1, Aachen, Germany.

*Depositional environment:* Since most clasts are angular or subangular, a short transport distance is envisaged. Some of the laminite clasts have been ripped-up from the underlying beds, therefore this facies is likely to be an intraformational breccia. The base of the unit is erosional in nature, yet there is only a maximum of 7cm amplitude which suggests there was no major channel system. The deposition of the breccia was short-lived, as bulbous stromatoporoids soon colonised the surface. There is no evidence of subaerial exposure.

A similar facies-type has also been recognised by Krebs (1974) in the carbonate complexes of the Rhenisches Schiefergebirge. Krebs (1974) suggested two possible origins of these 'rudite' facies:

1. As a result of local erosion of tidal flats during episodic storms in the shelf lagoon.
2. Through erosion of underlying carbonate muds when a new transgression of the sea resulted from minor subsidence.

Since the breccia separates two very different deposits (intertidal-supratidal laminites and semi-restricted, subtidal stromatoporoid floatstones), it is probable that it represents a transgressive lag where sedimentation was outpaced by the increasing subsidence rate/rise in sea-level. The transgression culminated in the colonisation of the breccia surface by stromatoporoids.

#### 4.2.1.2 S2 microfacies - stromatoporoid floatstones

Microfacies S2 is characterised by stromatoporoid floatstones. Stromatoporoids are dominated by bulbous-types and branching types. Rarely domal stromatoporoids and laminar stromatoporoids can be seen. Microfacies S2 is very common, encompassing 25% of the total logged thickness (Fig. 4-9) and can be identified in most shelf successions.

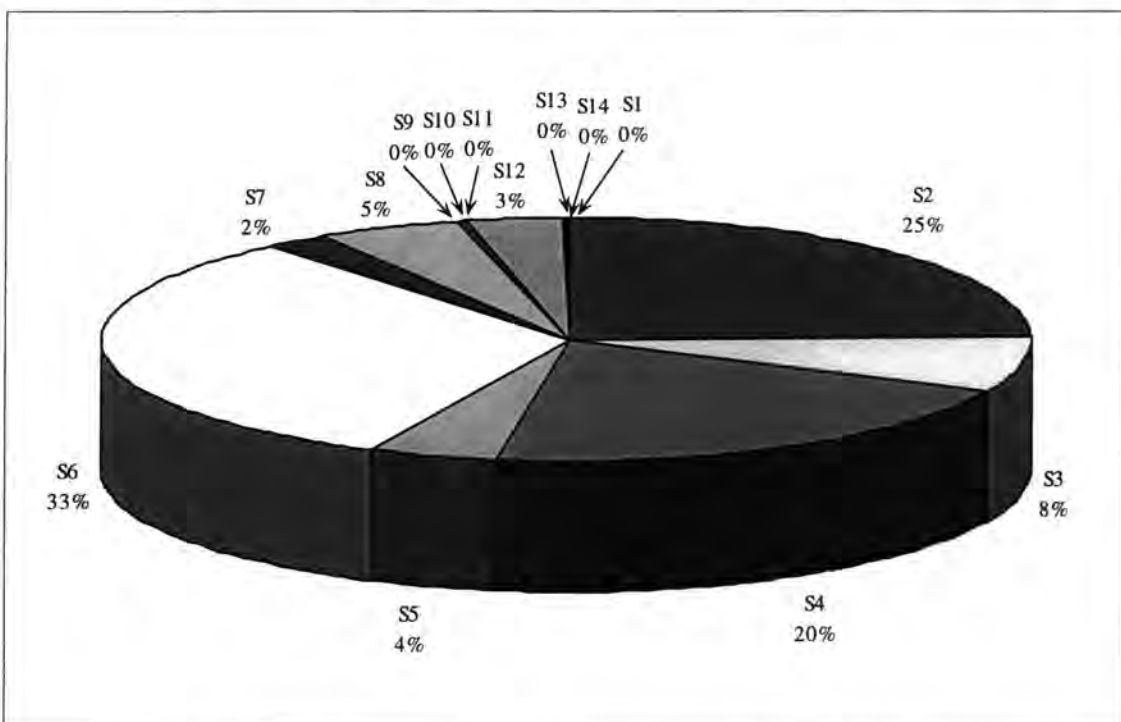

Figure 4-9 Pie chart showing distribution of microfacies types, with regards to total logged thickness.

Microfacies S2 is often very easy to distinguish in the field, due to its rich faunal assemblage. Bedding is often massive in nature, irregular and ranges between 5cm to 197cm, commonly being between 40cm and 100cm. Bulbous stromatoporoids, which are characterised by having a convex upper surface which tapers downwards to a small base (see Section 3.1.2), are especially common in this microfacies (Fig. 4-10a). The bulbous stromatoporoids vary greatly in size from 5cm in diameter to 60cm diameter. They are commonly distributed in size-specific groups with some beds having bulbous stromatoporoids about 5cm to 15cm in diameter and others having larger stromatoporoids. However, it is not uncommon to also get a variety of sizes in one unit. Sometimes it is possible to see a distinct increase in size of the stromatoporoids through a unit, as displayed in Oberrödinghausen quarry, Balve Reef Complex (see Section A2.18 for log). Often the bulbous stromatoporoids are not preserved in life position, having been overturned by more turbulent waters. The shape of bulbous stromatoporoids leads to them being fundamentally unstable unless the base was supported by soft sediment. The bulbous stromatoporoids are usually fairly well preserved.

Also associated with the bulbous stromatoporoids are *Amphipora*, *Stachyodes* and other dendroid stromatoporoids, rare domal stromatoporoids and laminar stromatoporoids, solitary corals and colonial corals. Thamnoporoids are especially common in this microfacies and are sometimes encrusted by stromatoporoids. They are commonly branch fragments 40mm in length. *Amphipora*, along with other dendroid stromatoporoids including *Stachyodes*, is locally abundant and forms a bafflestone texture with the bulbous stromatoporoids. As with the thamnoporoids, *Amphipora* is sometimes encrusted by other stromatoporoids, or by cyanobacteria (*Girvanella*). Occasionally, *Amphipora* branches are aligned parallel to bedding, possibly due to reworking by waves or due to compaction. Solitary corals are often associated with this microfacies, but have not been formally identified. They are usually well preserved and are rarely encrusted by stromatoporoids (Fig. 4-10b). Sometimes it is possible to see the solitary corals in nests, or small accumulations and lenses. Colonial corals are not very common in comparison to the stromatoporoids. In this study the colonial corals have not been formally identified; however, Scrutton and Goodger (1987) and Scrutton (1977b) have recognised several species in the platform interior of the Torbay Reef Complex, which are summarised in Table 3-2. The colonial corals are usually fairly well preserved. Where colonial corals are

present, they are often associated with an increase in laminar and domal stromatoporoids, which on the whole are quite rare. Rare *Wetheredella* cyanobacteria are identified in this S2 facies.

The matrix of the S2 facies is usually micritic in nature. Peloids are a common constituent and it is also often bioturbated. Sometimes the matrix is replaced by fine-grained dolomite, which often has a red colouration in hand specimen, reflecting the high iron content. This is especially common in the Torbay Reef Complex in Southwest England and preferential dolomitisation of the fine-grained matrix is also present in Cul d'Houille quarry, southern Ardennes. In Beauraing quarry in the Southern Ardennes, the matrix is especially bituminous having an extremely dark brown/black, friable nature. Bioclasts including ostracodes, calcispheres and parathuramminid forams are common in the matrix phase of many S2 facies. Sometimes the matrix is very bioclastic (for example in Vaucelles quarry, Linhay Hill quarry, Keldenich quarry and Heggen quarry, see Appendix 2), with stringocephalid brachiopods, bivalves, gastropods and crinoids, all variably broken up. Often where the matrix is richly bioclastic there is also an association with domal and laminar stromatoporoids.

The S2 microfacies displays a variety of textures from floatstone through to framestone. However, a floatstone texture, where the rock is matrix supported, is most common. In this situation the organisms are often aligned parallel to each other (especially the dendroid stromatoporoids) suggesting a certain amount of reworking and turbulence in the waters. These facies are laterally persistent and cover a wide area. Bindstone or framestone textures can be seen at Walheim section 1, Keldenich quarry and Walheim Southern Limb where the organisms have clearly built a rigid framework (Fig. 4-10c). These carbonate buildups have a somewhat biohermal nature (*sensu* Cummings and Shrock, 1928) where the buildup is not laterally persistent. Commonly these bioherms also have laminar and domal stromatoporoids associated with them.

*Depositional environment:* Microfacies S2 is very common within many Devonian lagoonal successions and its likely depositional environment has been widely discussed (see Table 4-1; Playford, 1969; Read, 1973; Racki, 1992; Cattaneo *et al.*, 1993). The presence of a rich faunal assemblage suggests environments which were near normal-marine in terms of salinity and oxygen. As discussed in Section 3.1.2, bulbous stromatoporoids are

thought to have inhabited calm water environments since their bulbous shapes would have been unstable in higher-energy conditions. Wilson (1975) also suggested their subspherical shape probably represented an adaptation to prevent fine sediment accumulation on the colony. The laterally persistent floatstone facies which are composed of variably-orientated bulbous and dendroid stromatoporoids were probably deposited as sheeted deposits covering a wide spatial area. These facies had been slightly reworked, with the stromatoporoids overturned or aligned to each other. Read (1973) envisaged depths of 3m or less for equivalent facies in the Canning Basin of western Australia and are as close as 100m to the reef (Wilson, 1975 from Read, 1973). The rare examples of relatively undisturbed biohermal buildups represent *in situ* growth of stromatoporoids and incorporation of bioclastic material. These bioherms reach up to 60cm in thickness and the presence of laminar and domal stromatoporoids suggests higher-energy conditions. All of the S2 facies are interpreted as being deposited in close proximity to the barrier-reef, in back-reef, well oxygenated, slightly turbulent waters.

#### **4.2.1.3 S3 microfacies - bioclastic wackestones to grainstones**

Wackestones, packstones, grainstones and rudstones with diverse organisms characterise microfacies S3. This microfacies is relatively common, representing 8% of the total logged thickness (Fig. 4-9). Microfacies S3 is divided into two subfacies. Microfacies S3a is dominated by grainstones and rudstones, where bioclasts are primarily derived from the reef. However, microfacies S3b is characterised by a semi-restricted faunal assemblage, dominated by the terebratulid brachiopod *Stringocephalus*.

##### **4.2.1.3.1 S3a microfacies - bioclastic grainstones**

Microfacies S3a is common mostly in isolated platform successions (i.e., Oberrödinghausen quarry, Heggen quarry, Bleiwäsche quarry and Rydon quarry). It is characterised by bioclastic grainstones and rudstones. Bedding ranges from 7cm to 231cm in thickness; however, it is mostly between 20cm and 70cm in thickness. Debris from the reef is a common constituent in this facies. *Stachyodes* branches are particularly common, are generally broken up into 5-10mm bioclasts and are often aligned parallel to bedding. Crinoids are very common also, as are bulbous stromatoporoids, domal stromatoporoids, laminar stromatoporoids, solitary corals, thamnoporoids, other colonial corals and rare *Amphipora* branches. All of the grains are invariably broken-up and angular in nature. The

bulbous and domal stromatoporoids can reach up to 31cm in diameter, but are never found in life position. Laminar stromatoporoids are commonly 10cm in length and aligned parallel to bedding. Thin-section analysis shows the predominance of *Stachyodes*, crinoids and thamnoporoids (Fig. 4-10d). The bioclasts are often very abraded and have a micrite envelope. The thamnoporoids are sometimes encrusted by stromatoporoids. Crinoids range in size from less than 0.5mm to 9mm in diameter. Once again they often possess microbial borings around their margins, have an irregular (?abraded) outer surface and syntaxial cements are especially well developed. Other bioclasts include gastropods, ostracodes, brachiopods, brachiopod spines and parathuramminid forams. Rarely cyanobacteria is seen encrusting bioclasts. Peloids are locally abundant.

The matrix is sparitic in nature. Often several generations of cement can be identified; syntaxial cements are common around crinoids, rare isopachous cements occur around bioclasts and finally very fine-grained calcite fills the remaining interparticle porosity. Sometimes the calcite cements are replaced by dolomite and authigenic quartz has also been identified. The texture of this facies is either grainstone or rudstone in nature. A characteristic feature of microfacies S3a is graded bedding. Accumulations of bioclasts are present at the base of the bed and this grades into relatively fossil-poor horizons. Brachiopods are sometimes seen in hydraulically stable position and graded bedding can also be seen on a thin-section scale. Geopetals in pores of some stromatoporoids are also present.

*Depositional environment:* Bioclastic grainstones and rudstones of microfacies S3a were deposited in moderate- to high-energy, turbulent environments, on the lee-side of the reef. Most of the material which composes this facies was derived from the reef. Those units which show graded bedding were probably deposited by storms. The microbial encrustations which are present on some bioclasts indicate strong current action in the shallow, near-reef regions of the back-reef lagoon (Krebs, 1974). The areal distribution of these facies are always near to the reef rim and microfacies S3a has only been identified in isolated platforms of western Germany and SW England. The localised deposition of this facies may be related to the destruction and effectiveness of the barrier reef. If the reef was 'closed', the back-reef environment may have been dominated by calmer water sedimentation (i.e., stromatoporoid floatstones of S2 affinities). However, if the reef was locally open, higher-energy waters could have impinged upon the back-reef environment.

Another explanation could relate to the dominant wind directions of the area. Tucker and Wright (1992) noted that the facies distribution on an isolated platform is strongly influenced by prevailing wind and storm directions and thus may account for the apparently localised distribution of these S3a microfacies.

#### 4.2.1.3.2 S3b microfacies - *Stringocephalus* wackestones/packstones

Microfacies S3b is most common in the shelf lagoon and is especially well demonstrated in Teerstraßenbau quarry, Resteigne quarry, Vaucelles quarry and Olloy-sur-Viroin quarry (see Appendix 2 for logs). This facies is also locally abundant in the Torbay Reef Complex in Southwest England. Bedding is commonly 10cm to 40cm in thickness and mostly well bedded. The terebratulid brachiopod, *Stringocephalus*, is characteristic of this microfacies. They are usually densely abundant, commonly 20mm to 60mm in length and variably preserved, sometimes being disarticulated and broken-up. They possess very thick shells (up to 6mm in thickness) which sometimes have a micrite envelope. Often they are preserved in a hydraulically stable position. The stringocephalids are associated also with a rich assemblage of dendroid stromatoporoids (especially *Stachyodes* and rare amphiporoids), rare bulbous stromatoporoids, small gastropods (4mm long on average) which occur in nests, bivalves, crinoids, thamnoporoids and rare solitary corals. Sometimes the matrix is rich in leperditicopid ostracodes. The texture of the rock ranges from wackestone through to packstone. Often these bioclastic accumulations are not laterally persistent and lens in and out along a surface. Rarely the bioclasts are aligned at an angle to bedding, suggesting probable cross-bedding. Often the bioclasts (especially the stringocephalids) are in clusters or nests, close to life position. They are also often concentrated at the base of the unit which then grades into a poorly-fossiliferous horizon. The matrix is mostly micritic in nature.

Thin-section analysis also identifies the presence of small ostracodes (<0.5mm in length), parathuramminid forams, dasycladacean algae, cyanobacteria and calcispheres. Also shell hash is common, mostly composed of 0.5mm long angular clasts of probable brachiopod. Peloids are also an important constituent volumetrically. The matrix is commonly intensely peloidal and often bioturbated. Pyrite, present within the matrix, is also important in the Linhay Hill quarry.

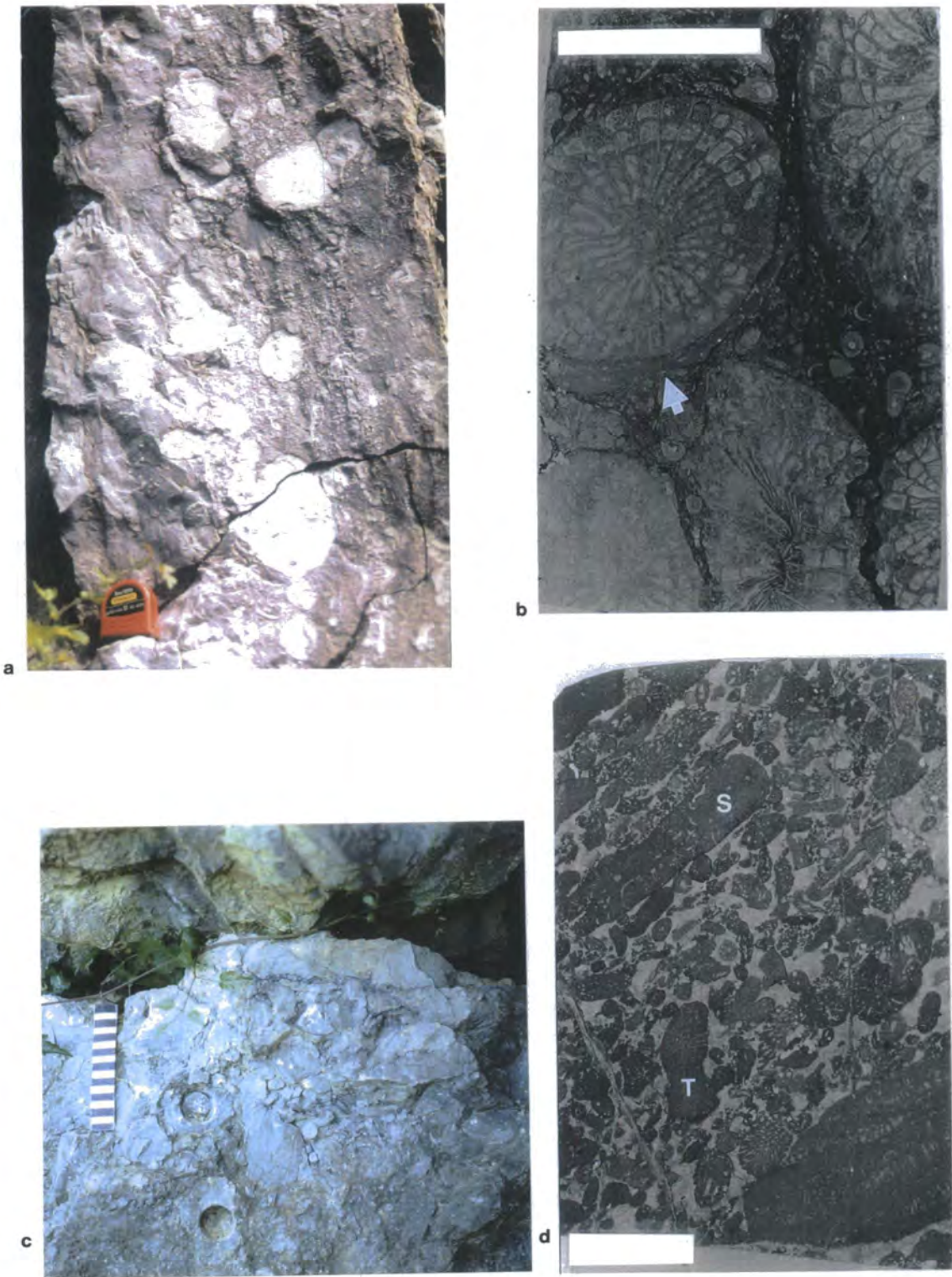

Figure 4-10 a) Field photograph of S2 microfacies. Bulbous stromatoporoids (B) dominate this facies, with an interstitial matrix of *Amphipora* branches, thamnoporoids and rare solitary corals. Photograph taken at Walheim Section 1, Aachen, western Germany. Tape measure is 5cm diameter for scale. b) Photomicrograph of corals which have been encrusted by stromatoporoids (arrow). Microfacies S2. Sample number R1, Resteigne quarry, southern Ardennes. Scale bar = 1cm. c) Bioherm development, microfacies S2. Stromatoporoids are bulbous, domal, dendroid and laminar in geometry. Photograph taken at Walheim Southern Limb section, Aachen, western Germany. Scale is in 1cm increments. d) Photomicrograph of bioclastic grainstone/rudstone (microfacies S3a). Note the abundance of thamnoporoids (T) and dendroid stromatoporoids (S). Sample number RQ17, Rydon quarry, Torbay Reef Complex, England. Scale bar = 1cm. Also refer to Enclosure One

*Depositional environment:* Microfacies S3b is characterised by a rich fauna of a semi-restricted nature. Stringocephalids are mostly found in back-reef successions world-wide. The association with a variety of stromatoporoids, gastropods, bivalves and crinoids suggests well-oxygenated waters. The stringocephalids had a pedicle foramen and therefore their mode of life was to attach themselves to a soft substrate or to dead shells. Their thick shells may suggest they were tolerant of high-energy, turbulent waters. The sedimentary structures present in this facies (i.e., graded bedding) suggest the bioclasts were probably reworked and deposited by storms, maybe to a lower-energy environment where a peloidal, bioturbated, micritic matrix could then accumulate. Hong (1992) has documented this facies in the Brilon Reef Complex and also suggested highly agitated waters (storms and strong currents) brought the stringocephalids from the reef edge into the lower-energy lagoonal environment.

The localised appearance of this microfacies in dominantly shelf lagoon successions is probably related to the age of the buildups. The stringocephalid brachiopods were thought to be exclusively Givetian in age (Blodgett and Dutro, 1992); therefore, they would only be present in successions of this time period.

#### **4.2.2 Restricted subtidal microfacies group**

The restricted subtidal microfacies group is by far the most common in the study area, totalling 59% of the total logged thickness (Fig. 4-7). The term 'restricted' is used with regards to circulation, oxygen or salinity. This set of microfacies is characterised by macrofossil-poor micrites, or by monospecific fossil assemblages. It includes *Amphipora* floatstones (microfacies S4), bioclastic wackestones (S5), macrofossil-poor micrites (S6) and peloidal grainstones (S7).

##### **4.2.2.1 S4 microfacies - *Amphipora* floatstones**

S4 microfacies are characterised by *Amphipora* wackestones, floatstones and bafflestones. This microfacies is very common within both the isolated platforms and shelf lagoon and comprises 20% of the total logged thickness (Fig. 4-9). *Amphipora* is an extremely important stromatoporoid in Devonian platform interiors and occurs worldwide. *Amphipora* is thought to be indicative of environments where there was restricted circulation (see Section 3.1.5.1). Microfacies S4 can be divided into three submicrofacies. S4a is most common and is characterised by *Amphipora* wackestones, floatstones and

bafflestones, where the *Amphipora* branches are well preserved. Microfacies S4b consists of *Amphipora* grainstones where the *Amphipora* branches are variably preserved. S4c is locally abundant and is composed of thamnoporoid floatstones.

#### 4.2.2.1.1 S4a microfacies - *Amphipora* wackestones/floatstones/bafflestones

Microfacies S4a is extremely common in the study area and is composed of *Amphipora* wackestones, floatstones and bafflestones. It is present in nearly all the logged successions. Bedding is mostly planar and ranges from 4cm to 206cm in thickness, commonly being 10cm to 50cm thick. *Amphipora* branches are the most common constituent. They are on average 3-4mm in diameter, range in length (up to 40mm) and display a spaghetti-like morphology (Fig. 3-3a). The *Amphipora* branches display various textures; they are often aligned parallel to bedding, are scattered throughout a bed, completely dominate the unit (bafflestone) (Fig. 3-3b) or are nested in discrete pockets. Rarely the *Amphipora* branches are aligned at an angle, suggesting cross bedding. They are commonly fairly well preserved and sometimes coated by *Girvanella* (Fig. 3-9b), which produces an identifiable dark rim to the *Amphipora* branches in the field. Rarely they appear to wrap around bulbous stromatoporoids, or grow in close association with them. This facies can grade into unfossiliferous mudstones of S6 affinities and can also overlie bulbous stromatoporoid floatstone facies (S2).

Also associated with *Amphipora* are thamnoporoids, which are locally very abundant. The thamnoporoids are up to 8cm in length, usually well preserved and commonly have the same textural attitude (i.e., aligned, in discrete pockets, or scattered) to the *Amphipora* branches. *Stachyodes*, which sometimes also possess a dark cyanobacterial rim, are uncommon constituents. Small solitary corals, small bulbous stromatoporoids, bivalves, gastropods, stringocephalid brachiopods and ostracodes (including leperditicoid ostracodes) are all locally present, but never common.

Thin-section analysis of S4a facies also identifies the presence of calcispheres, parathuramminid forams, crinoids, cyanobacteria (*Girvanella* and *Renalcis*), dasycladacean algae and ostracodes. Peloids are often locally very abundant. The matrix in this facies is extremely variable. Mostly it is a medium to dark grey colour, micritic and thoroughly bioturbated. Often discrete pockets of microspar are identified picking out bioturbation. The matrix is sometimes argillaceous. Dolomitisation is common, especially

in the successions of the Torbay Reef Complex, Southwest England. Here the matrix is a pink/red colour. The matrix is altered to fine-grained dolomite, where well-developed euhedral crystals are on average 0.2mm in diameter, are zoned and have an iron stain. Usually the matrix is preferentially dolomitised; however, often the vesicles in the *Amphipora* branches are sometimes rich in dolomite rhombs also.

*Depositional environment:* *Amphipora* is extremely common in many Middle and Upper Devonian carbonate complexes of the world and is distributed only in lagoonal or back-reef environments (platform interiors of Playford, 1969). *Amphipora* was thought to be best adapted to warm temperatures, intense light and probably endured fluctuating salinities (Heckel and Witzke, 1979). Krebs (1974) and Scrutton (1977a) suggested the impoverished faunal assemblage associated with this microfacies indicated an environment which had a more restricted circulation. Krebs (1974) also speculated that this environment was more saline. Kasig (1980) and Racki (1992) postulated that the *Amphipora* branches had baffling properties and trapped fine-grained lime mud to form dense 'meadows' or 'entangled networks'. This process occurred mainly in sheltered, quiet environments (Krebs, 1968; Jamieson, 1971). The presence of the dense accumulations of *Amphipora* branches and their sometimes uniform orientation suggest that these accumulations were deposited close to the living site of the amphiporoids. Waters were probably calm, since there is a dominance of micritic rather than sparitic matrix. Both Playford (1980) and Dineley (1984) suggested optimum depths of less than 10m for this facies. However, Read (1973) and Racki (1992) offered a more refined depth of less than 1m for similar facies in the Canning Basin in Western Australia and Holy Cross Mountains of Poland, respectively.

#### 4.2.2.1.2 S4b microfacies- *Amphipora* grainstones

*Amphipora* grainstones of S4b affinities are not very common, only being present in some back-reef successions of the isolated platforms. In the field they have a very light grey colour and generally show similar components to microfacies S4a. In thin section *Amphipora* branches are the major constituent; however, they have variable preservation. Cyanobacterial coatings are common and the margins of the *Amphipora* branches are often abraded and pitted. Other bioclasts include parathuramminid forams, calcispheres, dasycladacean algae and ostracodes. Peloids are extremely abundant. Alignment of

bioclasts parallel to bedding is often apparent. The matrix of this facies is invariably sparitic in nature. Many types of spar have been identified. Isopachous cement surrounding peloids is sometimes identified; however, the cements are mostly medium-grained calcites. Fine-grained pyrite is often associated with the matrix. Authigenic quartz is common. Rare spar-filled cavities (up to 1.5mm in length) are identified.

*Depositional environment:* *Amphipora* grainstones were deposited in similar back-reef environments to microfacies S4a; however, they represent higher-energy episodes. This microfacies has been identified mainly in the isolated complexes of the Rhenisches Schiefergebirge, where Krebs (1974) suggested deposition in shallow and moderately agitated waters near, yet still below, the intertidal zone.

#### 4.2.2.1.3 S4c microfacies - thamnoporoid floatstones

Wackestone and floatstone facies which are composed mainly of thamnoporoids are rare in the study area, occurring only at Keldenich quarry (see Section A2.14 for log). The thamnoporoids are up to 4cm in length and they completely dominate the units. Bioclasts of stringocephalids, ostracodes, gastropods and bivalves are associated. Small solitary corals are also frequently seen, as are *Amphipora* branches and other dendroid stromatoporoids. In thin section a rich algal component is also present, with *Labyrinthoconous*, *Devonoscale* and other dasycladaceans being identified. Calcispheres are also common, as are ostracodes. The matrix is micritic, peloidal and bioturbated.

*Depositional environment:* Microfacies S4c is likely to have been deposited in a similar environment to the *Amphipora*-dominated microfacies S4a. A micritic matrix suggests low turbulence. The presence of a richer faunal assemblage may indicate slightly more open circulation.

#### 4.2.2.2 S5 microfacies - bioclastic wackestones

Bioclastic wackestones with impoverished or restricted faunas characterise microfacies S5. This facies is relatively uncommon comprising only 4% of the total logged thickness (Fig. 4-9).

In the field this facies is well bedded. The beds are commonly planar, ranging between 10cm and 40cm thick. The facies is dominated by either gastropods or bivalves. Gastropods are particularly common, often very small (5mm long), yet locally reaching up

to 32mm long. Gastropods are often present in 'nests', in impersistent accumulations parallel to bedding or are scattered throughout a unit. The gastropods are invariably poorly-preserved since their original aragonite shell has been replaced by a more stable calcite spar. However, the gastropods commonly have a micrite envelope developed before dissolution and thus identification and preservation is made possible. When the gastropods accumulate at the base of a unit, this commonly grades into a relatively unfossiliferous horizon, or horizons with tubular fenestrae (S6c facies - see Section 4.2.2.3.3). Also associated with the gastropods are bivalves, rare solitary or colonial corals and leperditicopid ostracodes. The matrix is micritic in nature. Accumulations dominated by bivalves are not as common as those dominated by gastropods (Fig. 4-11a). Where present, the bivalves are up to 50mm in length and are often preserved in a hydraulically stable position (concave-up). Also associated with the bivalves are rare gastropods and dendroid stromatoporoids. These faunas often accumulate at the base of a unit and generally grade into an unfossiliferous upper portion.

In thin section, small ostracodes (less than 1mm long), well preserved thamnoporoids, calcispheres, parathuramminid forams, dasycladacean algae, codiacean algae, faecal peloids and rare cyanobacteria and *Amphipora* branches are identified. However, the facies is often dominated by only molluscan material (Fig. 4-11a). Bioclasts are mostly aligned parallel to each other and often the chambers in gastropods are part-filled with micrite and spar, providing good geopetal textures. The matrix is micritic in nature, often peloidal and usually bioturbated. Rarely an admixture of spar and micrite is seen and sometimes the micrite has been neomorphically altered to microspar. Sometimes the matrix is argillaceous and rich in clay seams.

*Depositional environment:* The impoverished faunal assemblage of dominantly gastropods and bivalves suggests deposition in restricted conditions. Gastropods and bivalves are tolerant of hyper-, hypo- or normal salinities, yet when they are abundant in these monospecific fossil assemblages this usually indicates extreme salinities (see Fig. 3-16; Heckel, 1972). The dominantly micritic matrix suggests deposition in calmer waters; however, the bioclasts have been undoubtedly reworked; they are often broken up, aligned parallel to bedding, or preserved in a hydraulically stable position. Transport was probably not far though. Preat *et al.* (1987) and Preat and Mamet (1989) have also identified this facies in the broad shelf lagoon of the study area and suggested a similar depositional

environment of low-energy, restricted, intermittently agitated lagoons. In the absence of any indications of evaporitic conditions, the lagoons were probably occasionally hyposaline.

#### 4.2.2.3 S6 microfacies - microfossil-poor micrites

Microfacies S6 is by far the most common facies in the study area, comprising 33% of the total logged thickness (Fig. 4-9). It is present in all of the successions studied and is very characteristic of Devonian lagoonal successions world-wide. The facies is commonly extremely well bedded, with planar continuous units (Fig. 4-11b). Bedding thickness ranges from 2cm to 185cm, yet is mostly 5cm to 40cm in thickness (Fig. 4-11c). In the field the facies is characterised by homogenous, poorly fossiliferous, light to dark grey beds, with only rare sedimentary structures (i.e., vertical fenestrae, oncoids) or identifiable organisms. The facies are sometimes argillaceous or bituminous. The facies is invariably bioturbated resulting in the homogenous texture. Often microfacies S6 grades from a bioclastic base (microfacies S5), or from an *Amphipora*-rich unit (microfacies S4). Thin-section analysis of these seemingly-dull facies identifies a plethora of microfossils, floras and micro-sedimentary structures. Thus this S6 facies can be divided into a further 6 submicrofacies, as listed in Table 4-4 and discussed in Sections 4.2.2.3.1 to 4.2.2.3.6.

| Microfacies | Characteristics                             |
|-------------|---|
| S6a         | Microfossil-rich wackestones and packstones |
| S6b         | Poorly fossiliferous mudstones              |
| S6c         | Micrites with tubular/vertical fenestrae    |
| S6d         | Oncolites                                   |
| S6e         | Mudstone/grainstone storm deposits          |
| S6f         | Micrites rich in leperditicopid ostracodes  |

**Table 4-4 Characteristics of S6 submicrofacies. See Sections 4.2.2.3.1 to 4.2.2.3.6 for details.**

##### 4.2.2.3.1 S6a microfacies - microfossil wackestones/packstones

Microfossil-rich wackestones and packstones are the most common S6 facies. This facies can be seen within most of the documented successions and in both the broad shelf lagoon and in the isolated platforms. Macrofossils are, on the whole, poorly represented in this facies; however, rare gastropods, bivalves and dendroid stromatoporoids are scattered within some units. Commonly the facies is a mid-grey to dark-grey colour.

Thin-section analysis identifies a plethora of microfaunas and floras which are not identifiable at hand specimen scale. These include calcispheres, parathuramminid forams, small ostracodes, dasycladacean algae (especially *Devonoscale*) and codiacean algae. Rare *Girvanella*, *Renalcis*, *Wetheredella* and shell hash are also seen. The calcispheres are especially common, scattered throughout beds (Fig. 4-11d). Ostracodes are mainly disarticulated, 0.7mm in length with no specific orientation. The parathuramminid forams are in many shapes and sizes and may represent several species, or different cuts of just one species (see Fig. 3-10). Often the dasycladacean algae, commonly 0.5mm long, are seen to dominate a thin section. Peloids are locally very abundant, as are lumps of micrite (on average 1-2mm in diameter). The matrix is always micritic, often peloidal and thoroughly bioturbated. Often discrete bioturbation structures can be deciphered where microspar is present in 4-9mm diameter, spherical patches. Fine-grained neomorphic dolomite is also sometimes identified in discrete patches. Preservation of primary sedimentary structures is very rare in this facies.

*Depositional environment:* Microfossil-rich wackestones and packstones are common within many Middle and Upper Devonian restricted successions. Kazmierczak *et al.* (1985), Racki (1992) and Preat and Racki (1993) recognised this facies in the Holy Cross Mountains of Poland and suggested these peculiar communities record specific high stress environments due to abnormal salinity, eutrophy and high calcium content. Biomicrites and micrites present in the isolated platforms of eastern Rhenishes Schiefergebirge were thought by Krebs (1968) and Krebs (1974) to be deposited in the central, restricted part of the lagoon where water agitation was much reduced and increasingly euxinic or more saline conditions inhibited benthonic life. The poorly-fossiliferous micrites in the reef-interior of the Torbay Reef Complex in Southwest England were also likely to have been deposited in calm lagoonal waters with poor circulation (Scrutton, 1977a; Garland *et al.*, 1996). Devonian lagoonal banks in Michigan, USA, were studied by Tyler (1969) where micrites dominated mainly by algae or bacteria were supposed to be deposited in a sheltered lagoon in maybe only 1m water depth. Once again the circulation of the lagoonal waters were said to be inhibited. Microfacies S6a has been extensively documented in the broad shelf lagoon of the southern Ardennes (e.g., Preat and Boulvain, 1982; Preat *et al.*, 1987; Preat and Mamet, 1989; Casier *et al.*, 1991), where restricted, calm, shallow lagoonal sedimentation was envisaged.

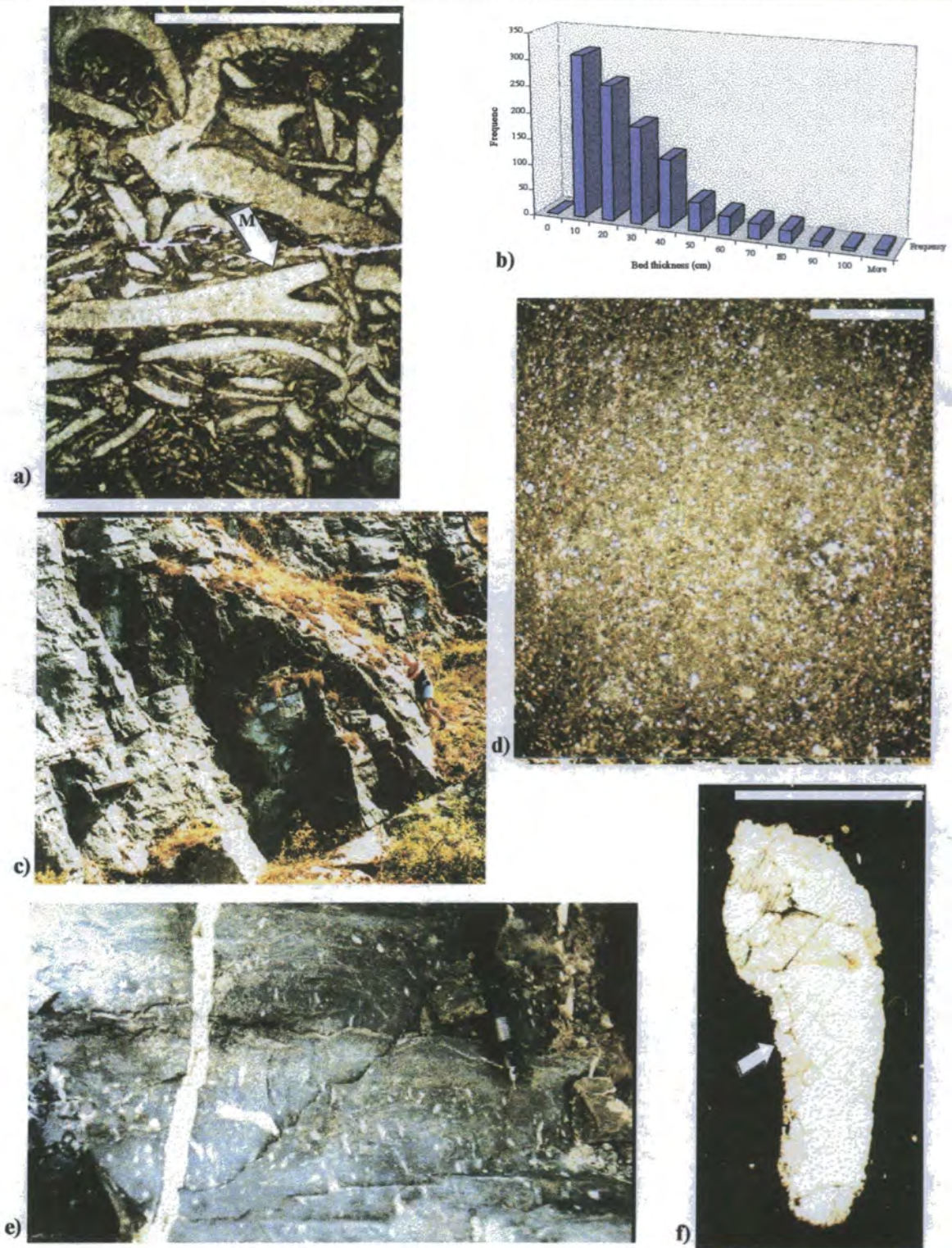

Microfacies S6a shows great similarities to all of the above examples. Therefore, deposition in a lagoon, where there was restricted circulation, possibly with elevated or decreased salinities and calm shallow waters is proposed. It is difficult to assess oxygen levels. However, the abundance of algae and microfossils do not suggest poorly-oxygenated waters.

#### 4.2.2.3.2 S6b microfacies - macrofossil-poor mudstones

This facies is common within many successions. In the field it has a homogenous mid-grey colour, with very few bioclasts. In thin section calcispheres, parathuramminid forams, dasycladacean algae (especially *Devonoscale*), small ostracodes and rare codiacean algae are the main constituents, yet are relatively rare. Calcispheres are the most abundant grain and are sometimes preserved with spines intact (see Fig. 3-13b). Bioclasts rarely show any preferred orientation or alignment. The matrix is a homogenous micrite which has been thoroughly bioturbated. Some discrete burrows are notable for the local development of dolomite rhombs. Peloids are locally common and in some case define burrows. In Linhay Hill quarry at the Torbay Reef Complex in Southwest England the facies locally has a somewhat shaley or laminated appearance.

*Depositional environment:* The deposition of microfacies S6b is similar to that of S6a: a calm water, shallow, restricted lagoon. This microfacies is equivalent to Microfacies 9a of Preat and Mamet (1989).

#### 4.2.2.3.3 S6c microfacies - micrites with tubular/vertical fenestrae

This microfacies is identified mostly in the broad shelf lagoon and can be very clearly seen at Resteigne quarry, Keldenich quarry, Vaucelles quarry, Olloy-sur-Viroin quarry and Dourbes quarry. Bleiwäsche quarry in the Brilon Reef complex, also displays this facies well. In the field it is characterised by spar-filled vertical, tapering 'tubes' on average 5mm-6mm long and 1mm wide (Fig. 4-11e), yet they can reach up to 20mm in length. They are scattered throughout a unit and are usually present in poorly-fossiliferous units, where peloids, calcispheres, ostracodes, dasycladacean algae and codiacean algae are the main components. Peloids are especially common and are often densely compacted or welded around the margins of the fenestrae (Fig. 4-11f). Rare concentrations of pyrite can be seen along these margins also. The vertical fenestral cavities are spar-filled. Early diagenetic

cements such as vadose calcite or marine radial-fibrous cement are not seen and coarse-grained calcite or baroque dolomite dominate. There are no internal structures (e.g., alveolar septal filaments) to the cavities. The matrix to this facies is always micritic, sometimes altered to patchy microspar and often peloidal.

*Depositional environment:* The term 'tubular' fenestrae has been used to describe near-vertical burrows (Tebbutt *et al.*, 1965; Read, 1975; Cressman and Noger, 1976; Grover and Read, 1978; Preat and Mamet, 1989) and also root tubes (Tebbutt *et al.*, 1965; Riding and Wright, 1981), therefore this term does not have any specific palaeoenvironmental implications. Other microscopic features need to be used to determine a depositional environment. Most of the evidence presented in this Section points to a burrow-origin for these vertical fenestrae. The welded peloids which surround the tubular fenestrae probably formed when the burrowing organism 'pushed' its way through the sediment. The welding or compaction of the peloids aided preservation since without a spar-fill, which may have happened some time after deposition, this feature would not have had any preservation potential. Shinn (1983a) recognised that many subvertical cavities are compacted and thus not preserved in modern day carbonates unless early cementation has taken place. All of the features present also suggest subtidal deposition; there are no laminoid fenestrae which are so common in many intertidal deposits and there is no evidence of microbial laminites, mud cracks or subaerial exposure. There is also no evidence to support a 'root' origin (i.e., alveolar structures, rhizcretions, needle fibre calcite etc.) for these cavities. Therefore, microfacies S6c was probably deposited in shallow, restricted, subtidal lagoonal environments where burrowing organisms were abundant.

#### 4.2.2.3.4 S6d microfacies - oncoidal wackestones

Microfacies S6d has only been identified in the broad shelf lagoon successions and is especially common in Dourbes quarry, Cul d'Houille quarry, Beauraing quarry and Walheim Southern Limb section. In the field this facies is very distinctive, as it is characterised by oncoidal wackestones. The oncoids range in size from 1mm to 70mm in length and commonly have an oval shape (Fig. 4-12a, b). They are a chocolate-brown to grey colour with a clear marginal coating. They commonly dominate the rock, with only rare dendroid stomatopoids, ostracodes (including *Leperditia*), parathuramminid algae and calcispheres. Thin-section analysis identifies a cyanobacterial origin to the coating,



predominantly *Girvanella*. The *Girvanella* is mostly well-preserved, with clear filaments (see Fig. 3-9a). The coatings range in thickness; commonly they are about 1mm, but can reach up to 6mm thick. The laminae are commonly smooth rather than crinkled. The nucleus of these oncoids are mostly lumps of micrite. However, rare dendroid stromatoporoids are also coated. The matrix to these facies is micritic (the same material as the nucleus to the oncoids), bioturbated and slightly peloidal in nature. The oncoids do not show any preferred orientation, being scattered within units.

*Depositional environment:* The oncoids present in this study are stromatolites which have an SS-C type texture in the Logan *et al.* (1964) classification (see also Section 4.2.4.2). They are thus spheroidal structures which have concentric cyanobacterial laminae and a distinct and identifiable nucleus (lumps of micrite, in this case). Ginsburg (1960) suggested oncoids are generally indicative of permanently submerged shoal water areas, or areas in the low intertidal zone. For SS-C type oncolites, Logan *et al.* (1964) offered a more refined depositional environment of turbulent, subtidal waters. Wilson (1975) SMF type 22 very adequately describes microfacies S6d and suggests that micrite with large oncoids are typically deposited in shallow water back-reef environments, with restricted circulation, often located on the edges of ponds or channels. The apparent need to have agitated turbulent waters to develop SS-C oncolites somewhat contradicts the micritic matrix in which they are found. Therefore, it is probable that the oncoids were formed in higher-energy environments and were then transported into lower-energy, restricted environments where fine-grained micrite was abundant. The presence of the *Leperditia* ostracodes also supports a restricted depositional environment.

#### 4.2.2.3.5 S6e microfacies - mudstone/grainstone storm events

Microfacies S6e is not very common within the logged successions, only being identified at Nismes quarry, Cul d'Houille quarry and Walheim Southern Limb Section. In the field the facies is characteristically thinly-bedded (average about 10cm) and has a laminated appearance. Thin-section analysis suggests this lamination is a result grain-size and textural differences (Fig. 4-12c). The background sediment is mostly micritic in nature, and poorly fossiliferous. Ostracodes are rare constituents. The thickness of these mudstone laminae ranges from 0.3mm to 11mm in height. Concentrations of peloids and ostracode tests set in a sparitic matrix characterise the second laminae. Peloids are commonly 0.1mm

diameter, subspherical shape and very well sorted. They are probably faecal in origin. Often a thin isopachous cement has precipitated around these peloids and a later very fine-grained calcite filled the remaining interparticle porosity. Ostracodes are particularly common in these laminae, on average 0.5mm in length, always disarticulated, aligned parallel to bedding and often in a hydraulically stable position. These laminae are commonly thinner than the mudstone laminae, being 3mm to 5mm in height. Often an abrupt and erosional base can be seen.

*Depositional environment:* The background poorly fossiliferous mudstone facies is very similar to S6b facies, where there is an impoverished fauna, yet the matrix is thoroughly bioturbated. Shallow lagoons with calm waters and restricted circulation was the postulated depositional environment for this facies. The presence of pelsparite laminae with erosional bases and winnowed ostracode tests is suggestive of small storm events within this lagoonal environment.

#### **4.2.2.3.6 S6f microfacies - micrites with leperditicopid ostracodes**

Microfacies S6f is characterised by the presence of *Leperditia* ostracodes. These purse-shaped, large ostracodes are very conspicuous in the field, being on average 4mm in length and often very densely packed (see Fig. 4-4a). This facies is especially common at Keldenich quarry and Olloy-sur-Viroin quarry, in the southern Ardennes. Often the ostracodes are nested on one surface, where they are very well preserved with both valves intact. Thin-section analysis also identifies the presence of calcispheres, small ostracodes, parathuramminid forams, codiacean algae, dasycladacean algae and peloids. However, leperditicopid ostracodes dominate. Wackestone, packstone and grainstone textures are identified and rarely bioclasts are aligned parallel to each other. The matrix is mostly micritic in nature and often bioturbated.

*Depositional environment:* The proposed environmental interpretation of leperditicopid ostracodes has already been discussed extensively in Sections 3.4.1 and 4.1.6. Extremely restricted conditions, probably with respect to salinity and circulation, were likely. The presence of a mostly micritic matrix and the good preservation of the ostracodes suggests the waters were probably not very turbulent. Deposition was, however, still subtidal in

nature, as there is no other evidence to support intertidal or supratidal environments (i.e., mud cracks, birdseye fenestrae, evaporites etc.). The ability of the ostracodes to tolerate extreme salinities (probably low salinities) may well explain their apparent dominance in certain horizons. This facies has also been identified by Krebs (1974), Preat *et al.* (1987), and Preat and Mamet (1989) in the broad shelf lagoon of the study area. Leperditicopid ostracodes are also documented in tidal-flat environments in the Devonian of Arctic Canada (Smith and Stearn, 1982).

#### **4.2.2.4 S7 microfacies - peloidal/oolitic grainstones**

Microfacies S7 is characterised by grainstones dominated by either peloids or ooids. This microfacies is not common, representing only 2% of the total logged thickness (Fig. 4-9). Bedding ranges from 3cm to 97cm in thickness, yet is commonly 10cm-40cm. This facies can be seen in many successions in both the broad shelf lagoon and isolated platforms. Commonly the facies is well bedded and sedimentary structures on the whole are rare. Microfacies S7 can be divided into two subfacies. Microfacies S7a is dominated by peloids with only a rare oolitic component, whereas microfacies S7b is dominated by ooids.

##### **4.2.2.4.1 S7a microfacies - peloidal grainstones**

Peloidal grainstones are the most common subdivision of the S7 microfacies and are represented in both the broad shelf lagoon and isolated platform successions. In the field this facies commonly has a 'sugary' or 'sparkly' texture, representing the cement component. This facies is poorly fossiliferous with only rare dendroid stromatoporoids and ostracodes being identified in the field. No sedimentary structures are observed. Peloids are the most abundant constituent in microfacies S7a (Fig. 4-12d). They are mostly subspherical or oval in shape, 0.05mm to 0.2mm in diameter with a homogeneous microcrystalline fabric. Some peloids are up to 0.6mm in diameter and these types generally have more irregular shapes and anastomosing internal fabrics. Elongate peloids, up to 1mm long, are also present and these represent micritised bioclasts (cortoids). Lithoclasts are a common component. They range from 0.2mm to 45mm in length, are subangular to subrounded in shape and rarely show any alignment. They are composed of micrite or pelsparite and occur in discrete patches, which are sometimes in line with bedding. Other grains include rare aggregate grains, oncoids, dasycladacean algae, *Renalcis* and other cyanobacteria, calcispheres (often with a thick micrite rim),

parathuramminid forams, ostracodes, codiacean algae, *Amphipora* branches, brachiopods, crinoids, corals and bivalves (with intensive micrite envelopes).

The matrix is mostly sparitic in nature, with several cement types being identified. In most situations only one generation of fine- to medium-grained calcite can be identified. However, isopachous or fibrous cements surrounding peloids can often be seen. Local development of baroque dolomite is also identified. Authigenic quartz is common in many examples. Locally micrite is common. The distribution of micrite and spar is usually related to the abundance of peloids. Where peloids are abundant and have a relatively low packing order a sparitic matrix dominates. However, where there are relatively few peloids, or where they have been so overcompacted so as to be unidentifiable, a micritic matrix is apparent. This distribution therefore is related to compaction and also to bioturbation. Spar can often be seen to dominate in specific patches which are related to bioturbation.

This facies is grain supported with a grainstone texture. It is mostly well sorted; however, where there is an abundance of lithoclasts the facies is not so well sorted. Sometimes a crude lamination can be seen, either with peloids and dasycladacean algae, or with peloids and lithoclasts. This is a size sorting feature and the laminae are rarely laterally continuous.

*Depositional environment:* This microfacies is very similar to microfacies R4b, yet there is a lesser bioclastic component in microfacies S7a. The origin of these peloids varies.

1. The small (0.05mm to 2mm) peloids are probably faecal in nature; they have no internal fabric, are generally subspherical in shape, well sorted and very abundant. This peloid-type is the most common in the study area.
2. Elongate peloids (up to 1mm long) may represent micritised bioclasts and are thus cortoids.
3. Local abundance of irregularly-shaped peloids which have an anastomosing internal fabric can also be seen. These peloids are relatively poorly sorted, having variable sizes (0.05mm to 0.6mm) and probably represent detritus of cyanobacteria or algae (Flügel, 1982).
4. Peloids of intraclastic origin formed from reworking of carbonate mud by currents can be termed 'pseudopellets' (Fahraeus *et al.*, 1974).

These pseudopellets have been discussed as originating in back-reef environments in the

Rhaetian (Fabricius, 1966) and in restricted shallow waters in the Devonian (Carss and Carozzi, 1965). This peloid-type is not particularly abundant in the study area.

Peloids are particularly common in Recent shallow subtidal to intertidal environments (Flügel, 1982). The dominance of peloids and only a small percentage of bioclastic material suggest deposition in shallow, yet restricted environments. Wilson (1975), Scoffin (1987) and Tucker and Wright (1992) suggested peloids usually typify environments with moderate or restricted circulation. The waters here were probably quite turbulent, resulting in a grainstone texture to the facies.

#### 4.2.2.4.2 S7b microfacies - oolitic grainstones

Oolitic grainstones are not very common, only being identified in two successions: Cul d'Houille and Nismes quarries. In the field this facies is usually grey in colour and ooids or peloids are easily identifiable. Small lithoclasts can also be seen and the rock often has a 'sugary' texture. Macrofossils are rare; however, *Stachyodes* was identified in the Nismes succession.

Ooids dominate the grain component of this facies. These ooids have three forms.

1. The majority of ooids are superficial in nature where there is only one lamina coating a dominantly peloidal nucleus. These laminae display a finely preserved radial calcite microfabric (Fig. 4-12e). These ooids are commonly 0.2mm to 0.6mm in diameter and are well sorted.
2. Compound ooids are locally present where several ooids are coated by radial calcite laminae. These ooids are up to 4mm in diameter.
3. Locally, ooids have several laminae yet have an irregular shape (Fig. 4-12f). The peloids which provide the nucleus for these ooids are spherical in shape and the first ooid coating is also spherical and concentric around this peloid. However, later ooid coatings have a more oval or asymmetric shape and interstitial micrite, or even cyanobacterial material, is common. These ooids reach up to 1mm in length. The matrix associated with this facies is often micritic (wackestone texture) and a very low packing order is observed.

Peloids are also associated with microfacies S7b, yet are volumetrically subordinate. Lithoclasts are particularly common in many samples, usually 1-2mm long, well rounded and composed of pelsparite, dense micrite or cyanobacteria. Cyanobacteria are locally abundant, apparently binding some ooids. Bioclasts play a very minor role, with only rare ostracodes being identified. The matrix in this facies is mostly sparitic, although small amounts of residual micrite is often still preserved. Isopachous cements are often precipitated around ooids and peloids and a later fine-grained calcite cement fills the remaining interparticle porosity. Where grains have a long axis, alignment parallel to bedding is seen. Size sorting is also sometimes apparent.

*Depositional environment:* The morphology, size, number of laminae and microstructures of ooids can be used to elucidate their depositional environment (Flügel, 1982). As discussed in Section 4.1.4.1, the presence of superficial ooids with a strong radial calcite microfabric suggests relatively low-energy environments where salinities may deviate from the norm (Illing, 1954; Flügel, 1982). The greatly reduced number of bioclastic nuclei, dominance by peloids and association of cyanobacteria would also support this hypothesis of abnormal salinities. The presence of polyooids suggests breaks in deposition (Flügel, 1982). Carozzi (1957) and Carozzi (1960) devised a model where nucleus size and lamina thickness can be related to local water energy. The superficial ooids present in some samples probably represents Situation 5 of his model where the local water energy is greater than the energy needed to move the smallest grain. Therefore the smallest grains become superficial ooids, yet larger particles remain unchanged. So relatively low-energy environments are envisaged. The presence of residual micrite also supports a lower-energy environment. The asymmetric peloids which are locally present (Fig. 4-12f) are often associated with marginal marine or hypersaline environments (Flügel, 1982).

All of the evidence provided by these ooids and associated grains suggests deposition in protected lagoons which were likely to have had elevated or lowered salinities. The water turbulence is somewhat difficult to determine. The matrix in many examples is mostly sparitic with only small amounts of residual micrite remaining. Isopachous marine cements surround many ooids and peloids suggesting moderate-energy environments with turbulent waters (*cf.* Tucker, 1993). Where the ooids have a more asymmetric morphology and an increased percentage of micrite in the matrix, a lower-energy environment is likely.

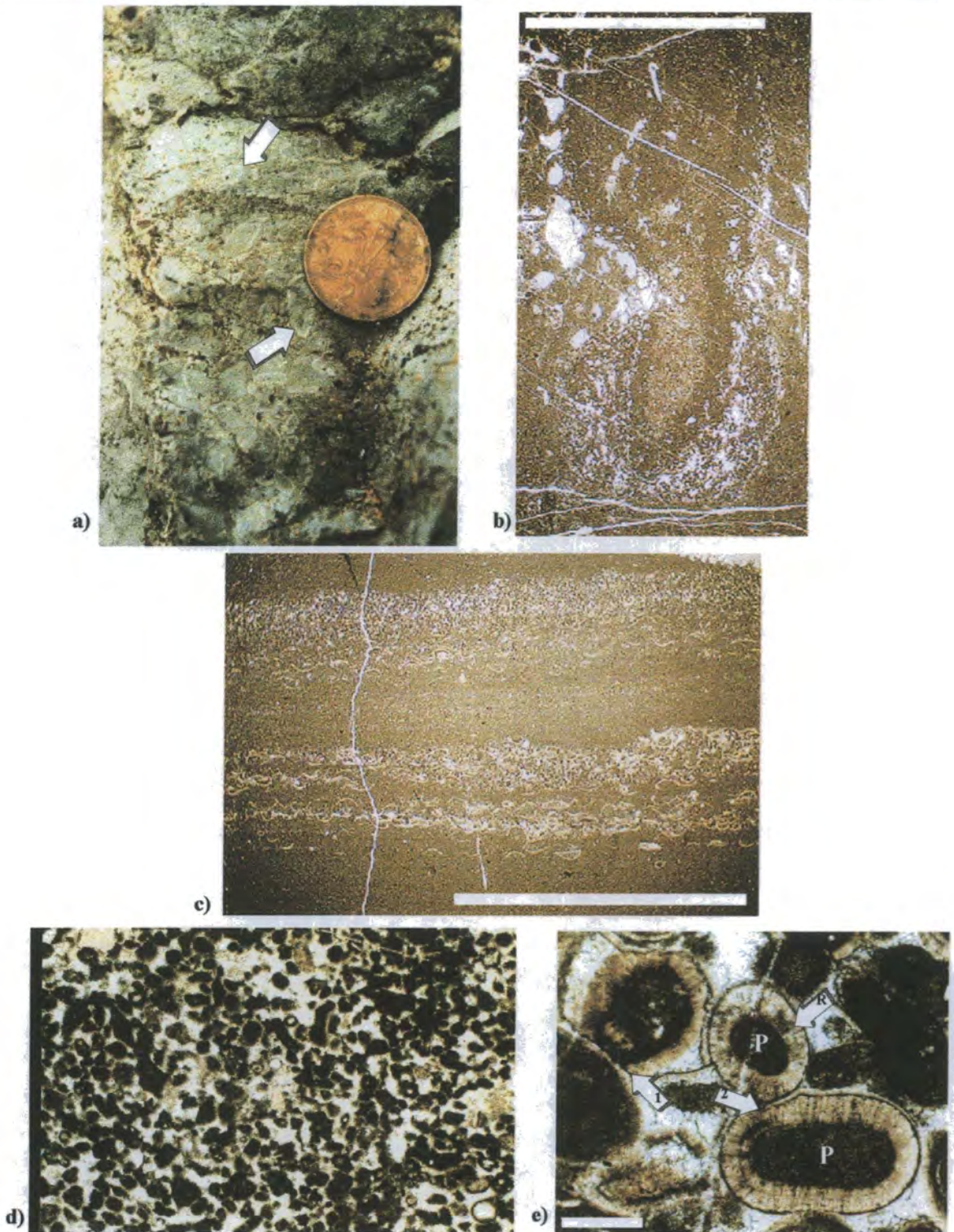

**Figure 4-12** a) Oncoid wackestone (microfacies S6d). Note most of the oncoids are oval in shape and are picked out by a thin, light-coloured cyanobacterial coating (arrow). Photograph taken at 42.1m Cul d'Houille quarry, southern Ardennes. Coin 26mm diameter for scale. b) Internal composition of oncooid in S6d microfacies. Muddy cortex is coated by filamentous *Girvanella*. Sample number D6, Dourbes quarry, southern Ardennes. Scale bar = 5mm. c) Storm layers in an otherwise mud-dominated facies (S6e microfacies). Ostracodes are commonly aligned parallel to bedding. Sample number N1, Nismes quarry, southern Ardennes. Scale bar = 5mm. d) Photomicrograph of peloidal grainstone (microfacies S7a). Peloids are small, subspherical and very abundant. Sample number BG13, Beauraing quarry, southern Ardennes. Scale bar = 2mm. e) Photomicrograph of S7b oolitic grainstone facies. Note the ooids are superficial in nature, with a well-developed radial calcite microfabric (R) and peloidal nucleus (P). Note also the high packing order where many peloids show a 'fitted fabric' with distorted ooids (1) and pitted ooids (2). Sample number CDH13, Cul d'Houille quarry, southern Ardennes. Scale bar = 0.2mm.

Also refer to Enclosure One

### 4.2.3 Intertidal microfacies group

The intertidal zone lies between normal high tide and normal low tide, is exposed either once or twice daily and commonly accumulates as a belt landward of the subtidal zone and seaward of the supratidal flats (Shinn, 1983a). Modern tidal flats are complex environments with many subenvironments including tidal channels, levees, ponds, intertidal flats, areas of superficial crusts and microbial mats (Tucker and Wright, 1992). The climate, tidal regime, topography, local wind conditions, amount of biological activity and wave action greatly influence the extent of the intertidal zone and the types of intertidal deposits (Tucker and Wright, 1992).

In the study area intertidal deposits account for approximately 5% of the total logged succession (Fig. 4-7), where three major microfacies groups can be identified. Fenestral limestones are common in the intertidal zone and characterise microfacies S8a and S8b. Facies which have undergone early diagenesis in a vadose environment characterise microfacies S9. Microfacies S10 consists of fenestral laminites. Extensive studies of Modern intertidal deposits by many workers has aided the recognition of these depositional environments in ancient successions.

#### 4.2.3.1 S8 microfacies - laminoid-fenestral limestones

Fenestrae, a term coined by Tebbutt *et al.* (1965), are voids in a rock which are syngedimentary in origin and are larger than intergranular pores (usually 1-5mm). These pores may or may not have an internal sediment fill and are commonly spar-filled in ancient rocks. The distinguishing characteristic of fenestrae is that the spaces have no apparent support in the framework of primary grains composing the sediment (Tebbutt *et al.* 1965). Fenestrae have four main morphological forms: laminoid, irregular, tubular and spherical (Fig. 4-13). When describing fenestrae it is very important to describe their morphological form since this usually reflects their origin (Grover and Read, 1978; Shinn, 1983a; Shinn, 1983b; Bain and Kindler 1994; Demicco and Hardie, 1994). Laminoid fenestrae are probably the most distinctive fenestral type, often being parallel or subparallel to bedding. They are also associated with microbial mats and are thought to have formed through desiccation processes in the intertidal to supratidal zone (Demicco and Hardie, 1994; see Sections 4.2.3.1.1, 4.2.3.1.2 and 4.2.3.3 for further discussion). Irregular fenestrae (also known as birdseyes (Ham, 1952) and forming the rock-type loferite (Fischer, 1964)) are

equidimensional or irregular in shape and rarely show any preferred orientation. Their origins and hence depositional environments, are numerous and are further discussed in Sections 4.2.3.1.1 and 4.2.3.1.2. Tubular fenestrae or pseudo-fenestrae (as discussed in Section 4.2.2.3.3) are most likely to represent burrows or rootlets and thus could be developed in subtidal, intertidal or supratidal environments. Spherical or bubble-shaped voids (sometimes known as keystone vugs) are thought to form by post-depositional decay of organic matter and escape of biogenic gases (Demiccio and Hardie, 1994), commonly occurring in high-energy subtidal swash zones or in intertidal environments.

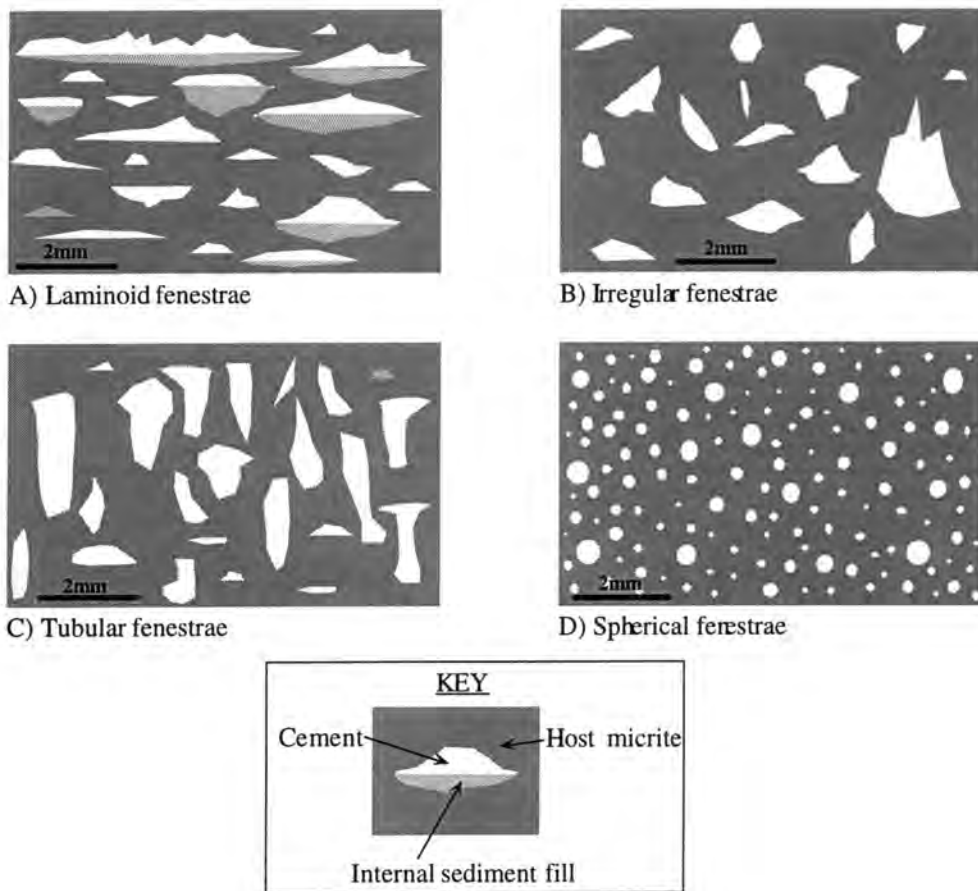

**Figure 4-13** Four major fabrics displayed in fenestral limestones. A) Laminoid fenestrae commonly have a sediment fill at the base and are aligned parallel or sub-parallel to bedding. Desiccation is the most likely origin. B) Irregular fenestrae are equidimensional or irregular in shape and have complex origins. C) Tubular fenestrae are elongate and result from burrowing or roots. D) Spherical fenestrae form by degassing in high-energy swash environments. See text for further discussion.

Microfacies S8 is the most common intertidal facies described in the study area, representing 5% of the total logged thickness (Fig. 4-9). It is especially common in the broad shelf lagoonal successions, but has also been extensively recorded at the Brilon and

Torbay Reef Complexes. Microfacies S8 can be further subdivided; S8a represents mud-supported laminoid-fenestral limestones, whereas microfacies S8b are peloidal grainstones with laminoid-fenestral cavities.

#### 4.2.3.1.1 S8a microfacies - fenestral mudstones

Fenestral mudstones with a variable bioclastic or peloidal component characterise microfacies S8a. These facies are seen mostly in successions within the broad shelf lagoon, but have also been identified in the Torbay Reef Complex, Dornap Reef Complex and Brilon Reef Complex. This facies is often well bedded, ranging between 10cm to 50cm on average. The rock is commonly a very light grey colour, very hard and is riddled with laminoid and irregular fenestrae. Tubular fenestrae are also sometimes associated with this facies but are volumetrically subordinate. The laminoid fenestrae are 1-3mm in width, mostly bed parallel and often form a complex, interconnecting network. They are spar-filled and are found in facies with a mudstone or wackestone texture. Bioclasts are not a common component, yet where present include rare gastropods, bivalves, ostracodes and *Amphipora* branches. This S8a facies often grades up from an *Amphipora*-rich horizon (microfacies S4) or from poorly-fossiliferous horizons (microfacies S6).

Thin-section analysis identifies a rich microfossil and floral assemblage including calcispheres, parathuramminid forams, small ostracodes, *Devonoscale* algae, *Labyrinthoconous* algae and *Girvanella*. The facies is commonly extremely peloidal. Fenestrae are well developed, forming as bed-parallel laminoid-types (also apparently 'concentrically' arranged around bioclasts (Fig. 4-14a)), irregular voids, or as tubular voids. The laminoid fenestrae commonly have irregular floors and tops, yet smooth floors are preserved on some fenestrae by the presence of internal sediments. This provides excellent geopetal information. The internal sediment fill is mechanically deposited and composed of very fine-grained silt or light-coloured micrite. The silts are often greyish in colour and contrast greatly with the matrix of the rock. Fine-grained pyrite is also sometimes associated with this sediment phase as are rare, very small peloids. Sometimes the fenestrae are completely filled by sediment. Several types of cement can be seen including isopachous fibrous calcite around the edges of fenestrae, and equant and drusy spar. Rarely the fenestrae are infilled with baroque dolomite. The matrix is commonly composed

of homogeneous micrite, which is variably peloidal. Fine-grained dolomite is locally abundant, especially in the Torbay Reef Complex.

*Depositional environment:* Both laminoid and irregular fenestrae are the dominant void-shape in microfacies S8a. Laminoid fenestrae are perhaps the most distinctive fenestral morphology and are commonly interpreted as forming through desiccation process (Shinn 1968; Demicco and Hardie, 1994). When compared to modern environments this process is most likely to have occurred in the intertidal or lower supratidal zone where there was periodic wetting and drying (Ginsburg *et al.*, 1977; Hardie and Ginsburg, 1977; Shinn, 1983b). Laminoid fenestrae in the study area commonly have a mechanically deposited internal sediment-fill of silt or very fine-grained micrite. Using the criteria of Flügel (1982) these sediments are vadose in origin since they are mechanically deposited, vary from the external matrix of the rock, fill primary vugs and are overlain by cements. The presence of vadose silt further supports elevation into the freshwater vadose meteoric realm and periodic subaerial exposure. The association of pyrite with some silts may suggest that they also could have formed by gas (H<sub>2</sub>S) evolution from decaying organic matter (Cloud, 1960). Laminoid fenestrae are often associated with microbial mats occurring between mat laminae which may contain moulds of the cyanobacterial filaments (Davies, 1970; Logan *et al.*, 1974; Hardie and Ginsburg, 1977; Flügel, 1982). There is, however, no evidence of microbial mats in microfacies S8a. Demicco and Hardie (1994) also noted that laminoid fenestrae can be produced through compaction of spherical gas bubbles. The presence of vadose silts in the study area, however, supports an intertidal to supratidal depositional environment.

Irregular fenestrae form by a number of different processes, which are often very difficult to distinguish between. They can form through desiccation, as demonstrated experimentally by Shinn (1968). They can also form by decaying organic matter producing gas bubbles, leaching of evaporites or by inclusion of air during subaerial exposure and reflooding in intertidal zones as noted by Flügel (1982; pgs 220-221). Bain and Kindler (1994) also noted the presence of irregular fenestrae in Bahamian aolianites which had a rainstorm origin. Although the inability to be able to determine the origin of irregular fenestrae hinders assignment to a distinctive depositional environment, their association with laminoid fenestrae and internal vadose sediment-fills suggests intertidal to supratidal environments.

Tubular fenestrae are present in some examples of microfacies S8a (Fig. 4.14a). These are thought have originated from burrows or roots as discussed in Section 4.2.2.3.3. Ginsburg and Hardie (1975) noted that there were numerous vertical burrows in the Recent Bahaman tidal flat deposits which were exposed 70% of the time. Since the intertidal environment is a relatively-stressed environment (variable salinities, water energy, desiccation), organisms were thought to have only occupied one or two burrows during their lifetime (Walker and Laporte, 1970). This may account for the relative lack of vertical fenestrae, compared to laminoid fenestrae.

Since the fenestrae have excellent preservation, it is proposed that early cementation played an important role. Early cementation needs an active diagenetic environment and thus intertidal or supratidal fenestrae are often preserved well (Shinn, 1983a). Similar Devonian facies have been documented by Preat and Boulvain (1982), Preat *et al.* (1987) and Preat and Mamet (1989) in the southern Ardennes; Kasig (1980) and Wilder (1985) in the Aachen area of Germany; Krebs (1974) and Hong (1992) in the Brilon Reef Complex, Germany; Playford (1969), Read (1973) and Playford (1980) in the Canning Basin in western Australia; Playford (1969) in the Reef Complexes of Alberta, Canada; Smith and Stearn (1982) in the southern Ellesmere Island, Arctic Canada and Roche and Carozzi (1970) in southern peninsula of Michigan, USA.

#### 4.2.3.1.2 S8b microfacies -fenestral peloidal grainstones

Microfacies S8b is not as abundant as microfacies S8a, being described only in the Cul d'Houille, Teerstraßenbau and Bleiwäsche quarries. Strata are commonly well-bedded and range from 9cm to 96cm, commonly being around 25cm thick. In the field the facies have a distinctive 'sparkly' texture, reflecting the high spar content (Fig. 4-14b). It has a very light-grey colour and is commonly hard. This spar is not only present as a matrix phase, but also occurs within the fenestrae. Fenestrae are mostly laminoid in nature, forming complex, bed-parallel, interconnecting networks (Fig. 4-14b, c). These fenestrae are commonly 2-5mm long and sometimes have an internal sediment-fill at the base. This sediment-fill is composed of very fine-grained peloids. The spar in the fenestrae is calcite and sometimes poikilotopic, encompassing several fenestrae. The margins of fenestrae are often composed of welded or amalgamated peloids, which appear to preserve the shape of the fenestrae. Irregular fenestrae are also present, having an unusual, or equidimensional

shape, with no apparent orientation. Some tubular fenestrae are present, but are subordinate in number.

The host-rock is peloidal grainstone. The peloids are on average 0.05mm in diameter and are very well sorted. However, they are often concentrated around the margins of fenestrae. Thin, isopachous cements often form around the peloids. The facies is poorly-fossiliferous with only rare calcispheres, *Devonoscale* and ostracodes being identified. Fine-grained calcite is the main interparticle cement.

*Depositional environment:* The morphology of the fenestrae present in microfacies S8b is very similar to that of microfacies S8a and thus reference should be made to the discussion in Section 4.2.3.1.1 concerning their origin. The major differences between microfacies S8b and S8a is the composition of the host rock and cementation or diagenetic processes. S8b microfacies are composed of peloidal grainstones, which were presumably deposited in more agitated waters than the muds of S8a affinities. The presence of isopachous cements around many peloids suggests early diagenesis within the phreatic zone. Tucker and Wright (1992) noted that the most common cement in modern intertidal zones is acicular aragonite with isopachous geometries. These modern analogies, along with the presence of laminoid fenestrae, suggests deposition of microfacies S8b within the lower intertidal zone. The presence of poikilotopic calcite spar cannot elude to any depositional environment since it is a burial cement.

Shinn (1983b) cautioned, however, that not all grainstones with fenestrae are indicative of intertidal conditions. Bahamian subtidal grainstones of Holocene age contain fenestrae-like voids. Most of these voids have either an irregular or laminoid morphology. Other features of the facies include a fully open-marine faunal assemblage, however, which supported a subtidal depositional environment. This is a feature which is not present in microfacies S8b.

Microfacies S8b has also been identified by Preat and Mamet (1989) in the Belgian Ardennes.

#### **4.2.3.2 S9 microfacies - bioclastic grainstones with vadose cements**

Microfacies S9 is not common within the logged successions, occurring at only one horizon in Resteigne quarry, southern Ardennes. This microfacies is characterised by the presence of vadose cements. At outcrop scale the bed is 67cm thick and has an undulatory

and irregular upper surface. The facies is richly fossiliferous. *Stringocephalus* brachiopods are especially common in the top 30cm of the bed (Fig. 4-14d) and are associated with solitary corals, small colonial corals (thamnoporoids), crinoids, gastropods and shell hash. Commonly geopetal textures can be identified within the chambers of gastropods. The unit is patchily-cemented, especially in the top 30cm (Fig. 4-14d). Mostly the matrix is a dark-grey, peloidal micrite.

Thin-section analysis confirms the abundance of stringocephalid brachiopods. The shells are thick (3mm), well preserved, with rare micrite envelopes. Gastropods also display very well-developed micrite envelopes, are neomorphically altered to calcite spar, are well preserved and generally 10mm in length. The matrix is composed of an admixture of peloidal micrite and several generations of cement. The peloidal micrite is generally winnowed away in most parts, but is present in discrete patches. Early diagenetic cements are represented by the discrete development of vadose cements fringing the base of bioclasts (Fig. 4-14e). These calcite cements are 0.25mm to 0.5mm in length and only occur on the underside of bioclasts. Isopachous cements are common around many bioclasts and finally a late stage (burial) baroque dolomite is developed. No other sedimentary structures have been identified in this microfacies.



**Figure 4-14** a) Photomicrograph of S8a microfacies. Fenestrae are well-developed and are laminoid (L), irregular (I) and also tubular (T) in nature. The fenestrae commonly have an internal sediment fill at their base (arrow) and some fenestrae are completely filled with internal sediment (S). Sample number BW32, Broadridge Wood quarry, Torbay Reef Complex, England. Scale bar = 2mm. b) Field photograph of fenestral peloidal grainstones (microfacies S8b). The fenestrae are mostly laminoid in nature and present a complex interconnecting network. Photograph taken at 34.1m at Walheim Southern Limb Section, near Aachen, western Germany. Finger 16mm wide for scale. c) Photomicrograph of microfacies S8b. Note the dominance of laminoid fenestrae (L), which sometimes have an internal peloidal fill at the base (P). Sample number WSL21, Walheim Southern Limb Section, near Aachen, western Germany. Scale bar = 2mm. d) Field photograph of S9 facies. Note the dominance of *Stringocephalus* brachiopods, with their distinctive internal plate (P). The rock is patchily cemented, especially at the base of the bioclasts (arrow). Photograph taken at 5.1m at Resteigne quarry, southern Ardennes. Scale bar = 5cm. e) Photomicrograph displaying gravitational vadose cements (arrow) on the underside of a *Stringocephalus* valve. Sample number R9, Resteigne quarry, southern Ardennes. Scale bar = 2mm. f) Photomicrograph of fenestral laminite (microfacies S10). The facies are dominated by very small peloids and are poorly fossiliferous. 'Clotted' cyanobacteria are locally common (C). Laminoid fenestrae are apparent often having an internal sediment-fill of vadose silt at their base (arrows). Sample number BL5, Bleiwäsche quarry, Brilon Reef Complex, western Germany. Scale bar = 5mm.

Also refer to Enclosure One

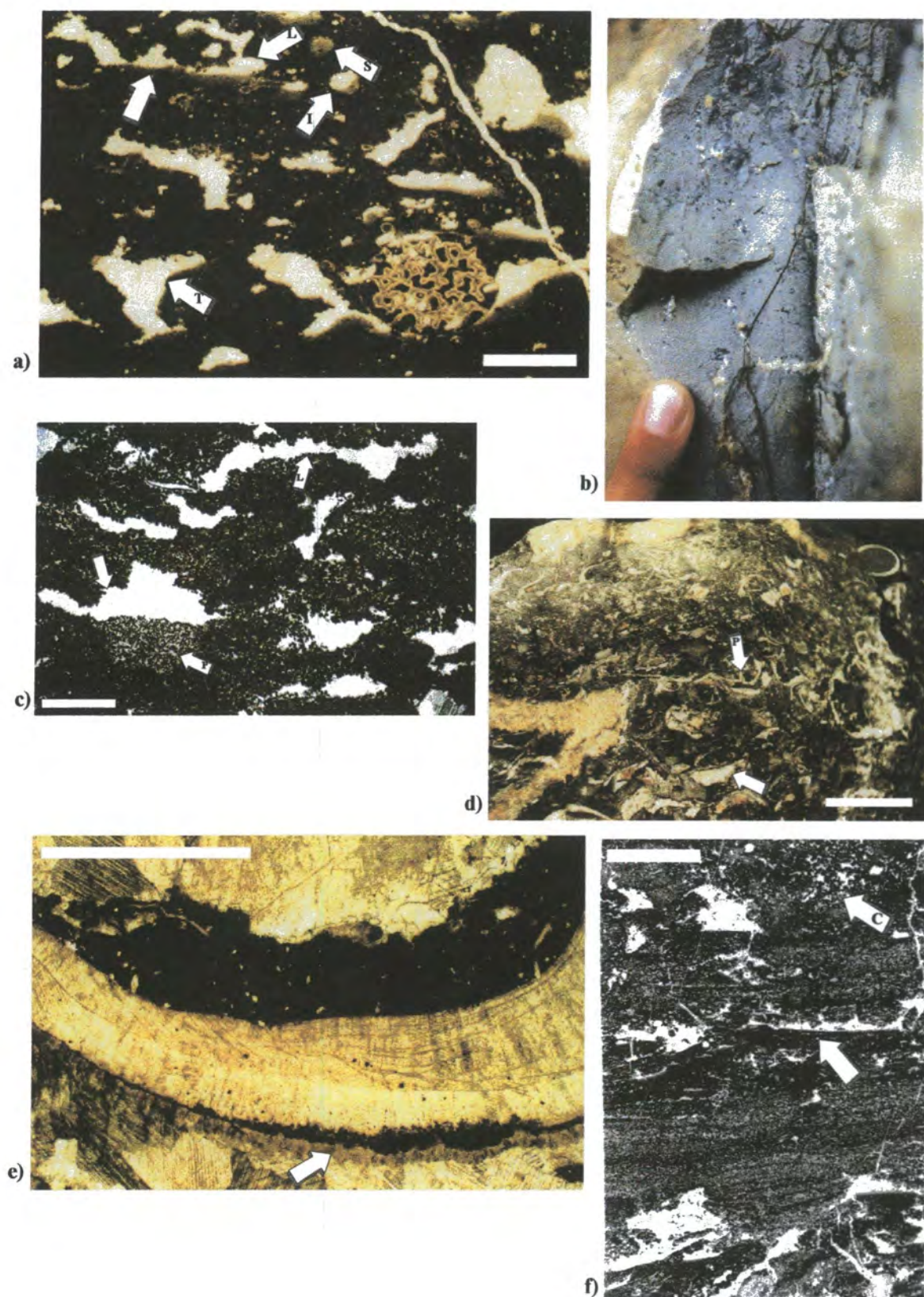

Figure 4-14 For figure caption see previous page.

*Depositional environment:* The bioclasts and other constituents of this microfacies resemble that of microfacies S3b, which was deposited in shallow, slightly restricted waters (see Section 4.2.1.3.2). The presence of well-developed microstalactitic cements in microfacies S9 suggests that meteoric diagenesis has affected this rock and the facies has been subjected to vadose conditions. Tucker and Bathurst (1990) also comment that in the vadose zone dissolution of aragonite takes place and replacement of aragonitic grains is common. Therefore the dissolution of the gastropods present in this facies may well have also occurred in the vadose zone. These gastropods, however, possess well developed micrite envelopes so dissolution would have had to take place after the microbial micritisation process. Preat and Mamet (1989) also recognised a similar facies in the southern Ardennes and suggested an environment with sediment reworked by storm waves and subsequently subjected to expose and vadose diagenesis.

#### 4.2.3.3 S10 microfacies - fenestral laminites

Microfacies S10 is relatively rare, being seen in the Walheim Southern Limb Section, Beauraing, Dourbes, Broadridge Wood and Bleiwäsche quarries (see Appendix 1 and Appendix 2). The facies are mostly well bedded and characterised by fenestral, microbial or cryptmicrobial laminites (*sensu* Kennard and James, 1986). Bedding ranges from 5cm to 45cm. Millimetric laminae are clearly visible at outcrop-scale, commonly alternating between chocolate-brown and light-grey colours. Fenestrae are distinctive by their sparry appearance and laminoid (bed-parallel) nature. This facies sometimes grades into microbial laminites with no apparent fenestrae (microfacies S12), associated intraformational mudchips (microfacies S11), or fenestral limestones (microfacies S8).

Peloids are the most common grain in microfacies S10 (Fig. 4-14f). They mostly occur in bed-parallel laminae along with poorly-preserved cyanobacteria or within lime mudstone laminae. The peloidal laminae may be up to 4mm in thickness, whereas cyanobacterial or mudstone laminae are thinner at 1mm-1.5mm. Laminae are often wavy or undulatory in nature, but are usually fairly continuous. 'Clotted' cyanobacteria are sometimes present (Fig. 4-14f). Bioclasts are subordinate in number and include a very impoverished assemblage of ostracodes, calcispheres, *Amphipora* branches and parathuramminids. The matrix to this facies is composed of both micrite and sparite. Where peloids dominate, a spar cement is present. This cement is commonly fine-grained calcite, with no specific

mosaic. However, a rare isopachous cement is sometimes seen around some peloids. Authigenic quartz is locally abundant.

Fenestrae are mostly laminoid in morphology, reaching up to 8mm in width (Fig. 4-14f) and commonly 0.1mm-1mm in height. An internal sediment-fill of very fine-grained vadose silt is common. The margins of the fenestrae often consist of welded peloids. These peloids probably aided in preservation of the fenestrae. Medium- to coarse-grained calcite spar is present within the fenestrae, sometimes having a drusy mosaic. Tubular and irregular fenestrae are also present, but are not common.

*Depositional environment:* Lamination in tidal-flat sediments generally results from spring or storm tide deposition (Ball *et al.*, 1963). Shinn (1983a) suggested that horizontal laminae, whether they be late Palaeozoic or Recent, are restricted to the upper intertidal or supratidal environments, since burrowing organisms would otherwise destroy the structures. However, Demicco and Hardie (1994) and many others have pointed out that these cryptmicrobial or microbial laminites can develop in many settings and can originate in several different ways. Thus, it should not be assumed that they are always peritidal in origin (see discussion in Section 4.2.4.2).

Microfacies S10 commonly displays laminites which are wavy or crinkled in morphology and have a fenestral component. The laminae always have a peloidal grainstone unit where very fine-grained peloids dominate and alternate with either a muddy or cryptmicrobial unit. The presence of clumps of cyanobacteria attests to microbially-influenced sedimentation. This is a repetitive process whereby (1) cyanobacteria colonise a surface and (2) storms deposit peloids into the high intertidal zone which the cyanobacteria then trap, thus producing lamination.

Since the cyanobacteria are poorly preserved, it is difficult to establish what role they had in producing the lamination. In modern tidal flats three types of microbe can be identified, each having a different sediment-binding role (Demicco and Hardie, 1994). For example motile filamentous cyanobacteria agglutinate grains to their sticky sheaths and commonly form continuous layers. Immotile filamentous cyanobacteria on the other hand are often arranged into small tufts or bundles which baffle or trap grains. Finally mats dominated by non-filamentous coccoid cyanobacteria generally form internally unlaminated sediments

with a clotted fabric. Since, in the study area lamination is mostly continuous, motile filamentous cyanobacteria may have been the dominant microbe.

Smooth, continuous cyanobacterial mats are typical of levee-crest high intertidal environments of Andros Island in the Bahamas where exposure occurs up to 90% of the time (Demicco and Hardie, 1994). Smooth mats are also the most abundant type in the Trucial coast, and are most commonly found in shallow pool and channel sites in the tidal flats (Tucker and Wright, 1992). Microbial laminated fenestral carbonates are also deposited in the intertidal zone of Shark Bay, Western Australia (Tucker and Wright, 1992). The use of Modern examples to interpret ancient analogues is extremely useful in situations such as these. However, caution should be used since ancient microbes could have had very different sediment-binding roles than those described today. The association of laminoid fenestrae with the microbial mats in the study area suggests that lamination has been disrupted, possibly through desiccation processes. Tucker and Wright (1992) and Demicco and Hardie (1994) suggested the presence of fenestral laminites indicates peritidal environments. It is important to note that some of the open-space structures in microfacies S10 are in fact 'shelter' fenestrae and thus were penecontemporaneous 'gaps' within the structure of the microbial mats which easily accommodated early cementation.

Similar facies in the Permian of West Texas, USA (Shinn 1983a), in Late Triassic facies of Salzburg Austria (Flügel, 1982) and in the Late Triassic of Sicily (from Flügel 1982) have also been described, where upper intertidal to supratidal depositional environments were envisaged. Fenestral laminites have also been documented in the Devonian of the Ardennes (Boulvain and Preat, 1986; Preat and Carliez, 1994); of the Brilon Reef Complex (Krebs, 1968; Krebs, 1974; Hong, 1994); of the Canning Basin, Western Australia (Read, 1973); of New York State, USA; of the Polish Góry Swietokrzskie Mountains (Preat and Racki, 1993); of the western Canadian basin (Machielse, 1972); of Michigan, USA (Roche and Carozzi, 1970) and of the Northwest Territories in Canada (Morrow and Labonte, 1988).

#### 4.2.4 High intertidal-supratidal microfacies group

Supratidal sediments are deposited above normal high tide and are exposed to subaerial conditions most of the time. They are subject to flooding by spring and storm tides and this is when the majority of sedimentation occurs (Shinn, 1983a). The main influence on supratidal deposition is the prevailing climate (Tucker and Wright, 1992).

In the study area supratidal deposits represent 4% of the total logged thickness (Fig. 4-7). The supratidal microfacies group can be divided into four major groups. Intraformational breccias and mud cracks characterise microfacies S11. Cryptmicrobial laminites and stromatolites typify microfacies S12. Microfacies S13 is composed of dolomicrites which have pseudomorphs of evaporites. Finally, calcrete development (microfacies S14) typifies prolonged exposure in the supratidal zone.

##### 4.2.4.1 S11 microfacies - intraformational breccias

Microfacies S11 is poorly represented in the study area, only being well-developed at Resteigne quarry, Bleiwäsche quarry and Walheim Section 1. The facies is commonly poorly bedded, locally grading from cryptmicrobial laminites (microfacies S12) or into poorly-fossiliferous horizons (microfacies S6) or into laminites again. The units are often thin, averaging 4cm-14cm in thickness. The facies is characterised by mud polygons, or mud chips/breccias associated with the destruction of mud polygons. Well-preserved mud polygons have only been identified at Resteigne quarry in the southern Ardennes, where they reach 18cm in diameter. Mud chips, however, have been more widely observed and are mostly associated with the upper surface of laminite facies (Fig. 4-17a). Intraclasts of laminites (mudchips) are angular and can be up to 50mm in length, or as small as 3mm. They are distributed either parallel to- or inclined to bedding and tepee structures are locally seen. These horizons are usually laterally continuous, as far as the outcrop will allow. The matrix is mostly micritic.

*Depositional environment: "Probably no single sedimentary structure is better known or more indicative of a depositional environment than polygonally-arranged mudcracks caused by shrinkage of carbonate mud" (Shinn, 1983a).*

Mud cracks, or mud polygons arise from the drying and desiccation of carbonate muds or microbial laminites during exposure in the supratidal zone. These 'muds' are therefore often thin storm-derived deposits, or microbial mats. Mud polygons, because of their desiccated

nature, are highly susceptible to erosion and redeposition by storms. This is when thin intraclast lags composed of mudchips are deposited. These mud chips, or intraclasts are angular in nature suggesting only a very short transport distance. Indeed when Hurricane Donna hit Florida Bay in 1960, flat-pebble breccias were ripped-up from mud polygons and almost instantaneously redeposited on a small supratidal flat (Shinn, 1983a).

Microfacies S11 is only locally developed in the study area where it is probably deposited through storms in the supratidal zone.

#### 4.2.4.2 S12 microfacies - laminites and stromatolites

Sediments with a microbial or cryptmicrobial<sup>1</sup> lamination are very common within the rock-record. Their origins, however, are not so easy to determine since there are many mechanisms which can produce microbially-laminated sediments and these processes can occur in several different environments (Demicco and Hardie, 1994). Microbial structures can be divided into two main groups: laminites and stromatolites. Laminites are generally planar, wavy or crinkled and without significant relief, whereas stromatolites are "*discrete, in-place structures with recognisable boundaries that are characterised by 'gravity-defying' internal lamination reflecting addition of material to a discrete surface*" (Demicco and Hardie, 1994).

Microbial laminites generally originate in four main ways (Table 4-5). However, in ancient examples it is often quite difficult to differentiate between these different origins.

| Origin of laminite                          | Mechanism   |
|---|---|
| Non-microbially influenced sedimentation    | Mechanical deposition preferentially into depressions or irregularities   |
| Microbially influenced sedimentation        | Cyanobacteria agglutinates or baffles sediments. Continuous, wavy or crinkled laminae                                 |
| Precipitated fabrics                        | May be biogenic or abiogenic. Crystalline layers precipitated due to supersaturation of carbonate in the pore waters. |
| Little or no sedimentation or precipitation | Long periods of microbial mat development with very little storm detritus or carbonate precipitation.                 |

**Table 4-5 Origins of microbial mats and their mechanisms of deposition. See Demicco and Hardie (1994) for discussion.**

<sup>1</sup> A term coined by Kennard and James (1986) where sedimentary rocks are *believed* to have formed through the sediment-binding role of cyanobacteria, yet there is now little preservation of the cyanobacteria themselves.

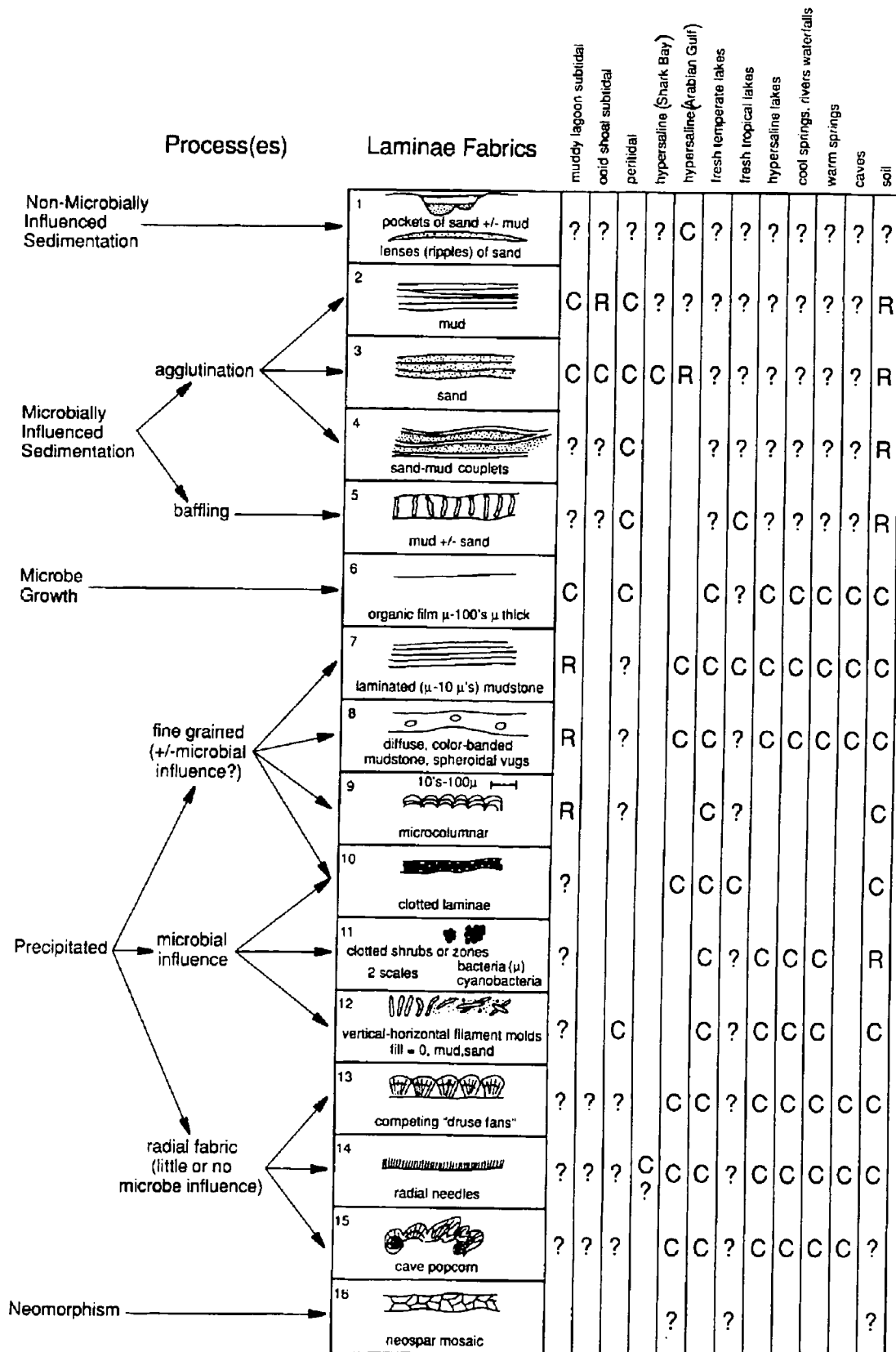

Figure 4-15 Characteristics of modern microbial layers. C = common, R = rare. Figure taken from Demicco and Hardie (1994).

The differing characteristics that microbial mats portray (i.e., composition, continuity of laminae, origin) can allude to the environment in which they were deposited, since not all microbial mats are deposited in peritidal environments (Fig. 4-15).







| Stromatolite-type                             | Stromatolite-mode                                       | Example  |
|---|---|--|
| <b>LLH</b><br>Lateral Linked<br>Hemispheroids | <b>-C</b><br>Close lateral linkage<br>of hemispheroids  |    |
|   | <b>-S</b><br>Spaced lateral linkage<br>of hemispheroids |    |
| <b>SH</b><br>Stacked<br>Hemispheroids         | <b>-C</b><br>Constant basal radius                      |    |
|   | <b>-V</b><br>Variable basal radius                      |   |
| <b>SS</b><br>Spheroidal<br>Structures         | <b>-I</b><br>Inverted stacked<br>hemispheroids          |  |
|   | <b>-C</b><br>Concentrically stacked<br>hemispheroids    |   |
|   | <b>-R</b><br>Randomly stacked<br>hemispheroids          |   |

Figure 4-16 Classification of stromatolites, after Logan *et al.* (1964).

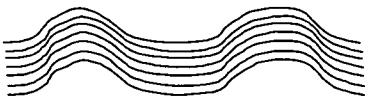
Three major morphologies can be seen in stromatolites (Logan *et al.*, 1964; Fig. 4-16). LLH stromatolites are characterised by small domes which are laterally linked to each other, either closely (-C), or spaced (-S). SH stromatolites are discrete, vertically stacked, hemispheroids (domes) which are not linked laterally to other hemispheroids. These can have either a constant basal radius (-C) or variable basal radius (-R). Finally SS stromatolites are discrete spheroidal structures which coat particles (oncoids). These have already been discussed in Section 4.2.2.3.4. Combinations of these annotations can be used

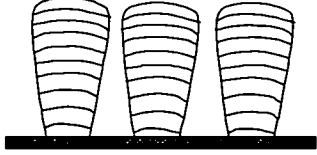
to describe complex morphologies. The environmental significance of stromatolite development is not unique, since it involves a complex interaction of factors such as relief, sedimentation rate, periodicity of sediment input, influence of burrowing, climate and type of microbe. This will be further discussed in Section 4.2.4.2.2. Further reference should be also made to Section 4.2.2.3.4 and Figure 4-15.

In the study area laminites are the most common high intertidal-supratidal deposit identified, accounting for 3% of the total logged thickness (Fig. 4-9). They are mostly developed in the broad shelf lagoon, yet are also seen in the Brilon Reef Complex. Microfacies S12 can be further divided, on the basis of origin of the laminites. Microfacies S12a is composed of continuous, planar couplets where evidence of a microbial component is lacking (cryptmicrobial) whereas microfacies S12b has more relief to the laminae and a convincing microbial aspect.

#### **4.2.4.2.1 S12a microfacies - cryptmicrobial laminites**

Planar laminites, characterising microfacies S12a are common within many broad shelf lagoon successions. Bedding is commonly thin, on average 5-30cm thick, yet can locally reach up to 165cm thick. In the field this facies is very distinctive, due to its light grey to buff colouration and banding on a millimetre scale (Fig. 4-17b). Lamination is often laterally continuous, although discrete bioturbation can locally destroy this feature. The facies sometimes grades into a fenestral laminite (microfacies S10) and rarely mud polygons cap this facies. Intraformational breccias, composed of angular mud chips of laminites sometimes interfinger with this facies. Rarely, erosion surfaces cut into the top of this facies (see Figure 4-8). Macrofossils are absent.

Thin-section analysis identifies two main types of laminae; mudstone and grainstone (Fig. 4-17c). The mudstone laminae are slightly 'clotted' in nature with a very small peloidal component. 'Stringers' of cyanobacteria are locally seen. Bioclasts are uncommon. However, pyrite is apparent as is rare detrital quartz. These laminae are on average 0.2mm to 0.75mm in thickness and are often thinner than the grainstone laminae (although they can reach up to 6mm in thickness). Lamination is mostly laterally continuous and bed-parallel. The grainstone laminae are more peloidal in nature. Peloids are characteristically very small (0.05mm) and are sometimes graded. These laminae are thicker than mudstone laminae, commonly being 0.5mm to 2mm. Lamination sometimes occurs in lenses, yet is

mostly laterally continuous. Pyrite is a common component. Sponge spicules are sometimes identifiable.

*Depositional environment:* Laminites of S12a affinities are deposited by a two-fold process. Initially, microbial mats colonise a surface, then either storms or tides impinge onto these mats where the cyanobacteria either agglutinate or baffle the sediment. This process is then repeated. The storm sediment is mostly composed of peloids and graded microlaminae can sometimes be seen. Thus mudstone/cyanobacterial laminae represent 'background' sedimentation, whereas peloidal grainstones are event beds. The environment in which these cryptmicrobial mats developed is not one where there were many burrowing organisms, since the continuous, bed-parallel lamination is well preserved. This rules out most subtidal and lower intertidal environments. Similar facies have been identified in modern supratidal environments of the Great Bahama Bank (Demicco and Hardie, 1994, pg. 92 figure 70D).

This facies has been extensively documented in the Devonian of the study area (i.e., Boulvain and Preat, 1986; Preat and Mamet, 199:).

#### **4.2.4.2.2 S12b microfacies - microbial laminites/ LLH stromatolites**

Microfacies S12b is composed microbial laminites or LLH stromatolites where laminae are wavy and have a clear cross-cutting nature. In the study area this facies is only seen in the broad shelf lagoon and is especially well developed at Alt Breinig quarry near Aachen in Germany. This facies is mostly thinly bedded, on average 10-30cm in thickness. It is very distinctive in field, having a wavy lamination which possesses a vertical relief (Fig. 4-17d). The facies is commonly light-grey in colour and is unfossiliferous.

Thin-section analysis once again identifies two major laminae; peloidal grainstone and mudstone. The pelsparite laminae are extremely peloidal where peloids range between 0.1mm to 0.5mm in diameter. They are mostly well sorted and sometimes show grading. The peloids often possess an internal fabric which appears cyanobacterial in nature. Intraclasts are also locally abundant. They are commonly elongate, subangular or angular and can be up to 2mm in length. Laminae have variable thickness (from 0.5mm to 4mm) and commonly have a wavy and cross-cutting nature although they do tend to be laterally continuous on the whole. The sparitic cement is composed of fine-grained calcite.

Mudstone laminae are apparently unfossiliferous and have a 'clotted' appearance with some identifiable peloids. Cyanobacteria are again not well preserved. The laminae have variable thickness (0.5mm to 5mm, 1mm on average) and are commonly not laterally continuous.

*Depositional environment:* The laminites or LLH stromatolites probably originate by the interaction of several mechanisms. There is an obvious microbial component since the facies exhibits domal or hemispheroidal structures which are 'gravity-defying' (*sensu* Demicco and Hardie, 1994; Fig. 4-19d) as sediment is present on near-vertical sides on the dome (Fig. 4-19d). Thus cyanobacteria must have assisted deposition by agglutinating the sediment. The flanks of these hemispheroids, however, also have 'wedge-like' laminae which apparently onlap onto the main hemispheroid. These wedges of sedimentation have all the morphological characteristics of bedload deposition where microbial process may not have played such an important role.

Logan *et al.* (1964) and Shinn (1983a) suggested that LLH-S stromatolites characterise the upper intertidal or supratidal environment, where there may be high tides and wetting by storm-waves. Demicco and Hardie (1994) also concluded that stromatolites with lenticular or wavy-bedded units typify peritidal development. Hardie and Ginsburg (1977) noted the presence of well-laminated stromatolites, 6cm in height and 12cm in diameter on the tidal creeks of Andros island.

The presence of LLH stromatolites in the study area is not well documented. Wavy and thrombolitic laminites have been documented by Boulvain and Preat (1987) in Givetian of the southern Ardennes where their association with fenestral laminites and channel-fill deposits suggested a complex and highly interactive intertidal-supratidal palaeosetting.

#### **4.2.4.3 S13 microfacies - dolomicrites**

S13 microfacies is characterised by unfossiliferous dolomicrite. The dolomicrites are relatively uncommon, being identified only in the broad shelf lagoon at Sourd d'Ave section, Keldenich quarry and Walheim Section 2. The beds are usually fairly planar and well bedded; however, at Sourd d'Ave a slightly undulating upper surface is recognised. At outcrop scale the rock is unfossiliferous, rather hard, with no sedimentary structures present. A mottled texture is rarely seen at Keldenich quarry.

In thin section the rocks are very fine-grained dolomites. The dolomite crystals are often well-developed rhombs and are admixed with very fine-grained micrite. Fossils are rare, yet include a very restricted assemblage of ostracodes and parathuramminid forams. In discrete patches, coarser-grained microspar or dolomite occurs (Fig. 4-17e). These patches have a specific form, with straight edges and a diamond or lozenge shape. They are on average 1mm in diameter. No other sedimentary structures are preserved.

*Depositional environment:* These dolomicrites are similar to the R7 facies identified within the ramp successions, except that they are not laminated. Once again this facies was likely to be originally micritic in nature, but later was replaced by very fine-grained dolomite. Some of the micrite still remains in many samples. The lack of a rich fossil assemblage suggests restricted circulation. No sedimentary structures are preserved, so it is possible they have been destroyed by bioturbation. The presence of discrete patches of dolomite having straight-edges and specific forms would suggest the dolomite is pseudomorphing another mineral. Either gypsum or anhydrite are probable suggestions for this mineral. Evaporite minerals are associated with many peritidal carbonates and more readily occur in arid or semi-arid environments (Tucker and Wright, 1992). This facies has also been described by Preat and Mamet (1989) and Preat and Carliez (1994) where dolomitic pseudomorphs after gypsum are common. As with the facies described here, the dolomite crystals within the pseudomorphs are coarser than those of the matrix (Preat and Mamet, 1989). Demicco and Hardie (1994) commented that intrasediment growth of evaporite crystals (halite, gypsum or anhydrite) provides unequivocal evidence of post-depositional crystallisation in an evaporitic environment. Wilson (1975) suggested that unlaminated, homogeneous, unfossiliferous micrites with evaporitic crystals (SMF 23) were mostly deposited in hypersaline tidal ponds. These facies therefore are interpreted as being deposited in a shallow, calm, highly restricted environment that was then subjected to evaporitic, subaerial conditions.

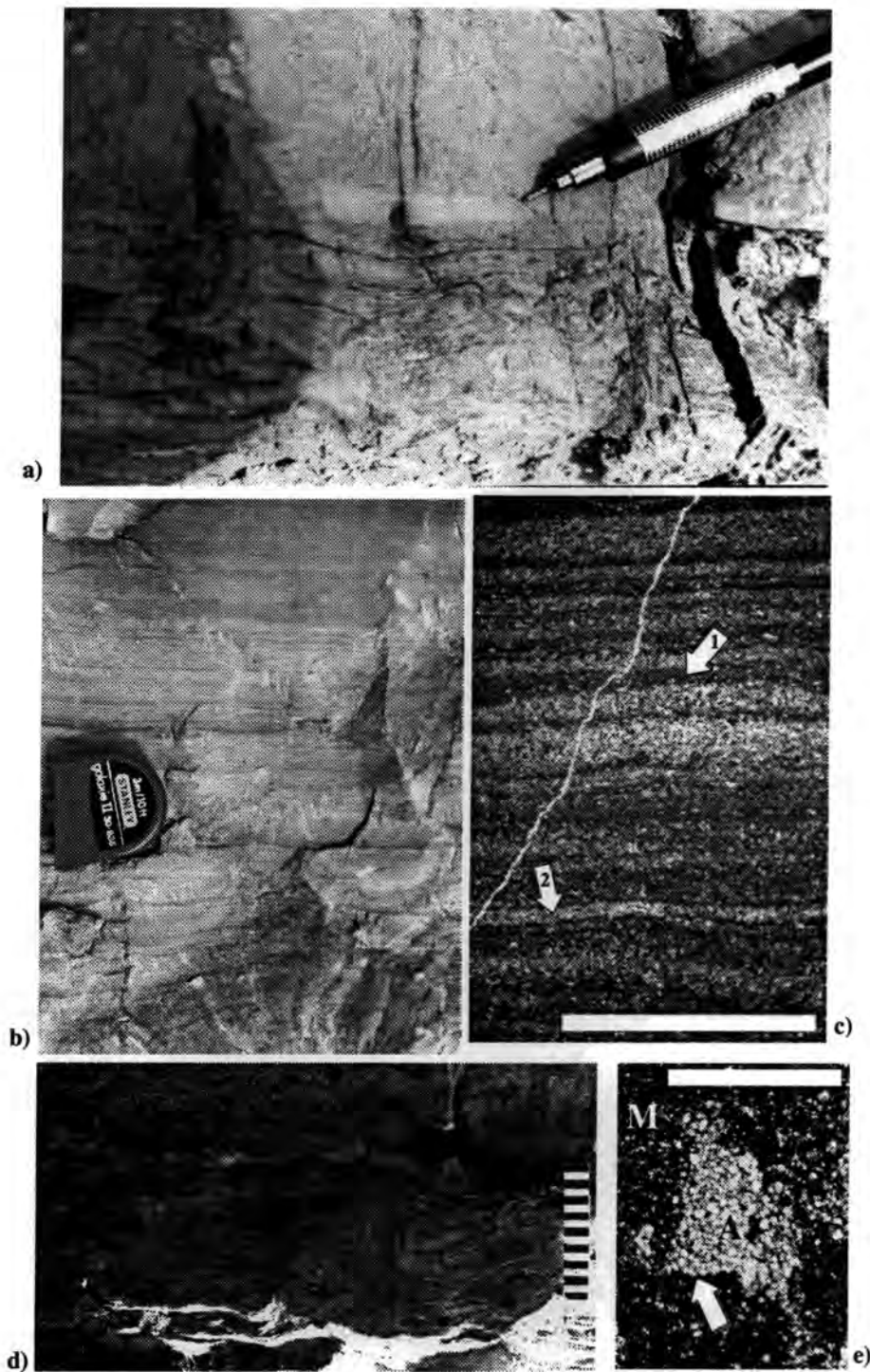

**Figure 4-17** a) Field photograph of mud chips (microfacies S11). The mud chips are derived from mud polygons which were desiccated and redeposited during storms in the supratidal zone. Photograph taken at Resteigne quarry, southern Ardennes. Width of pencil barrel = 10mm for scale. b) Field photograph of microbial laminites (microfacies S12a). Note the lateral continuity of the laminae. Photograph taken at Resteigne quarry, southern Ardennes. Tape measure 5cm in diameter for scale. c) Photomicrograph of cryptomicrobial laminites. The laminae are composed of (1) mudstones which display a 'clotted' texture and (2) peloidal grainstones. Sample number R15, Resteigne quarry, southern Ardennes. Scale bar = 5mm. d) Field photograph of LLH-S stromatolite (microfacies S12b). The hemispheroids have relief of approximately 6cm and are laterally linked. Photograph taken at Alt Breinig quarry, near Aachen, western Germany. Scale is in 1cm increments. e) Photomicrograph of S13 facies. Note the fine-grained slightly peloidal matrix (M), patchy microspar development and pseudomorphing after ?anhydrite (A). Note also the straight-edges to the pseudomorphed crystal (arrow). Sample number KL13, Keldenich quarry, Sötenich, western Germany. Scale bar = 1mm.

Also refer to Enclosure One

#### 4.2.4.4 S14 microfacies - calcretes

S14 microfacies are characterised by the development of calcrete profiles. These calcretes occur at three horizons; at the base of the Broadridge Wood quarry section and at 37.4m and 40.0m at the Cul d'Houille section (see Sections A2.6 and A2.7 for logs). The upper surface of these calcrete units are generally very well defined and abrupt. Often the surface is undulating. This S14 microfacies is laterally continuous and very distinctive in the field. It is best developed at 40.0m in the Cul d'Houille section, where it reaches up to 30cm in thickness. In this calcrete 3 main horizons can be identified: an argillaceous horizon at the top of the unit (Horizon 1), a horizon with anastomosing veins and cracks containing clasts of the host rock (Horizon 2) and at the base the little altered bedrock (Horizon 3) (Fig. 4-18).

Horizon 1, which is dominated by buff coloured, argillaceous clays, can be up to 12cm in thickness, but is laterally discontinuous. Clasts of the host limestone are common components. These clasts are generally subangular to subrounded in shape and range from less than 1mm in diameter to greater than 100mm in diameter. Where the clasts have a long axis, they are generally aligned parallel to bedding. The argillaceous matrix generally wraps around the clasts.

The contact between horizons 1 and 2 is transitional. Horizon two is characterised by anastomosing veins or cracks which are filled with clasts of the host limestone and supported by a cream coloured, very soft matrix (Fig 4-19a). In thin section this matrix consists of an admixture of clays and calcite and dolomite crystals/grains (Fig. 4-19b). The calcite crystals have probably been washed in. They range from 0.2mm to 3mm in diameter and are subangular to subrounded in shape. They show no graded bedding, yet have a close packing. Dolomite crystals are not as common, yet where present show a well-developed euhedral rhombic shape and are inclusion-rich. Rarely the dolomite crystals are dissolved or plucked-out, leaving a rhomb-shaped void. The clays associated with the matrix are a beige colour and fibrous or elongate in nature. Iron-staining or impregnation is a common feature of this rock and it preferentially surrounds cavities or clasts (Fig. 4-19c). The iron is opaque or a dark-red colour in thin section and is apparent in three forms; as equant well-developed hexagonal crystals, as filamentous, bushy or hairy masses, or as very fine-grained masses.

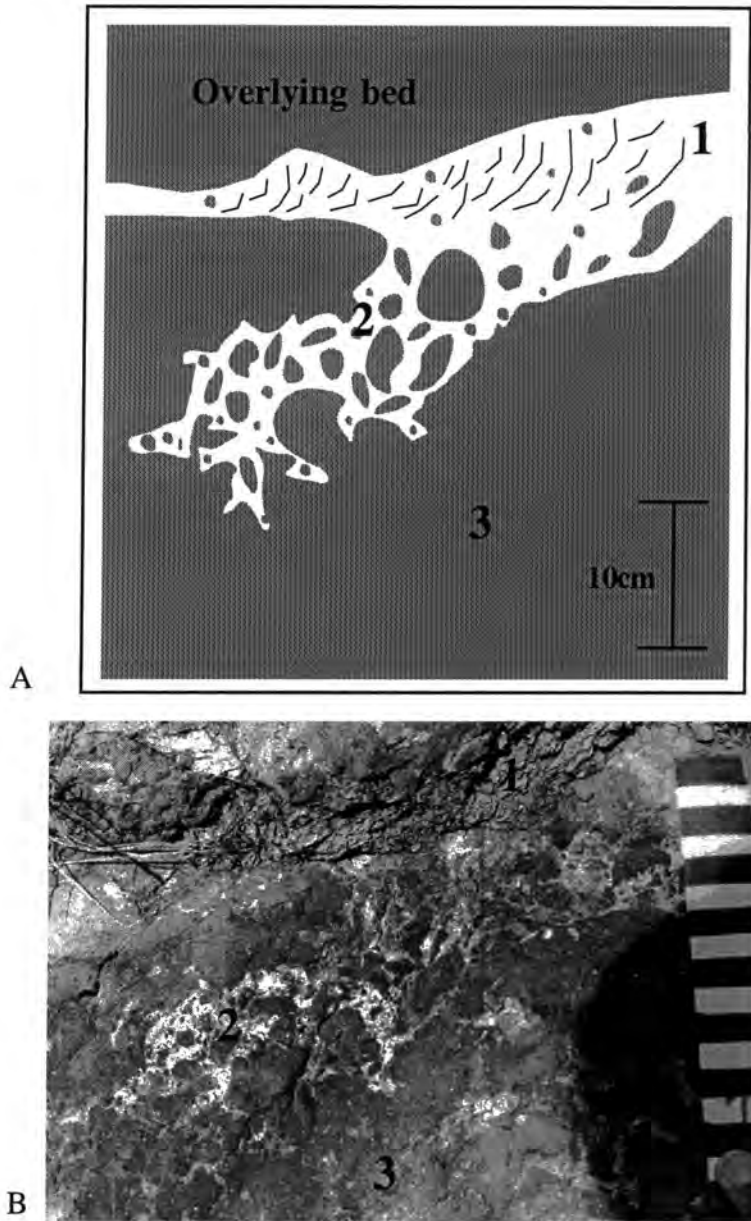

**Figure 4-18** a) Characteristic calcrete profile at Cul d'Houille section. 1 - argillaceous, buff-coloured clay-rich horizon. Up to 12cm in thickness. Contains small clasts of host rock. 2 - horizons with anastomosing veins/cracks. Cracks contain small clasts of host rock in soft white-coloured matrix. 3 - bedrock. b) Field photograph showing these three horizons. Photograph taken at 40.0m, Cul d'Houille quarry, southern Ardennes. Scale divisions = 1cm.

The clasts in horizon two vary in size from less than 1mm to up to 50mm in diameter. They are generally subrounded in shape. The clasts are composed of monospecific, slightly fossiliferous micrite, the same as the host rock. In thin section rare fenestrae are present, as are vadose microstalactitic cements. Calcite-filled circum-granular cracks are present around some grains. Another feature of interest is the presence of calcite-filled voids which are surrounded by dense peloids (Fig. 4-19d). These 'coated' features are on average

1.25mm in diameter and once again are surrounded by an iron coating. No alveolar structures have been identified.

The host rock is composed of fossiliferous micrite. The micrite is slightly peloidal and completely bioturbated. Bioclasts include well-preserved leperditicopid ostracodes, calcispheres and rare dendroid stomatoporoids.

Circum-granular cracks are a very prominent feature in the S14 microfacies of Broadridge Wood quarry (Fig. 4-19e). They generally surround grains such as dendroid stomatoporoids and clasts. A characteristic of this rock is the mottled and floating textures it exhibits. Clasts of the host rock (a slightly bioclastic micrite) are surrounded and supported by a microspar matrix. This matrix is generally fine-grained; however, it does become medium-grained in discrete pockets. The clasts range in size from 0.2mm to 10mm in diameter and are generally angular or subangular in shape. At the Broadridge Wood section an argillaceous upper unit (horizon 1 of Cul d'Houille) is not present.

*Depositional environment:* Most of the features present in these rocks are suggestive of subaerial exposure and development of calcrete horizons. It is difficult to determine if there was a biogenic component. The macrofeatures and overall structure of the unit at Cul d'Houille is similar in appearance to some modern day calcretes of Barbados (James, 1972). The latter calcretes are coated with a superficial crust (not present at Cul d'Houille); however, loose chalky limestones underlie these crusts and developed to a depth of several metres until recognisable marine limestone. These latter features are very reminiscent of the section at Cul d'Houille.



Figure 4-19a) Photograph of cracks/veins containing clasts of the host rock, supported by a milky-white soft matrix. Photograph taken at 40.0m, Cul d'Houille quarry, southern Ardennes. b) Photomicrograph of cracks/veins, so common in the S14 microfacies. The fill of the cracks is composed of detrital calcite (C) and rare dolomite. The matrix (M) is dominated by clays (sepiolite or palygorskite?) and well-developed hematite crystals (H). Sample number CDH28, Cul d'Houille quarry, southern Ardennes. Scale bar = 2mm. c) Photomicrograph showing textures associated with calcrete development. Iron-staining is particularly well developed and preferentially surrounds cavities or clasts. Sample number CDH28, Cul d'Houille quarry, southern Ardennes. Scale bar = 1cm d) Sketch of potential root structures. Note the dense array of peloids surrounding the calcite filled sphere, the possible coating of cyanobacteria and the iron-staining surrounding the feature. Sketch drawn from sample CDH28, Cul d'Houille quarry, southern Ardennes. Scale bar = 0.5mm. e) Photomicrograph of calcrete horizon developed at Broadridge Wood Quarry. Note the development of circum-granular cracks (arrows) and floating texture to clasts (C). The mottled matrix is also very common in these alpha calcretes. Sample number BW1, Broadridge Wood quarry, Torbay Reef Complex, England. Scale bar = 1cm. Also refer to Enclosure One

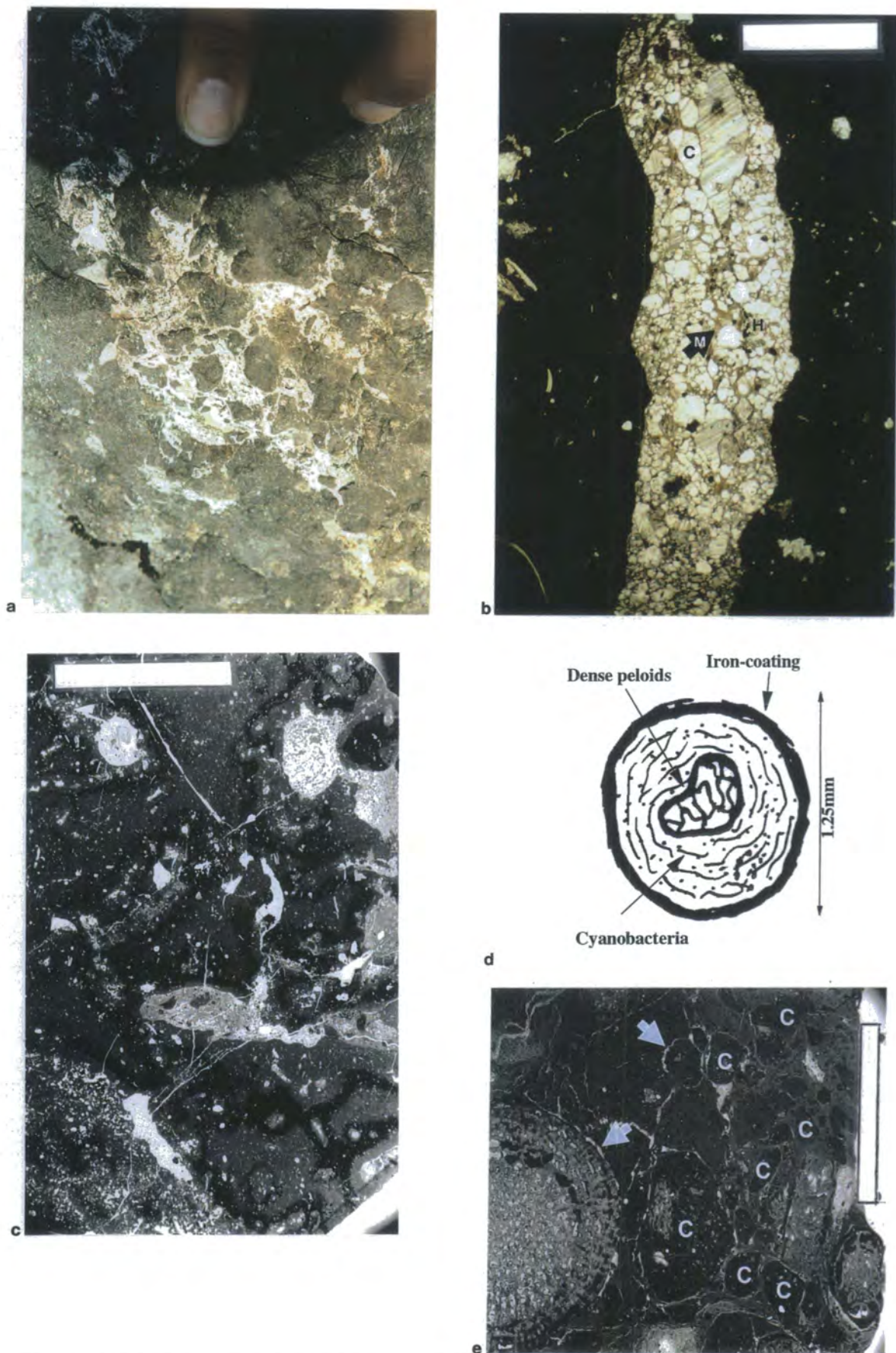

Figure 4-19 (caption on previous page)

The origin of the cracks is probably related to wetting and drying and temperature changes. These cracks, which are of variable shape and size are common in many calcretes (Wright and Tucker, 1991). The fill of the cracks and veins is an admixture of clay and broken calcite crystals. The calcite crystals could have formed near or at the surface of this unit and were later reworked into the veins and cracks. It is difficult to identify the clays without xray diffraction (not undertaken in this study); however, they are similar to sepiolites and palygorskites described by Hay and Wiggins (1980) and Watts (1980). Sepiolite is a common clay mineral in modern calcretes and precipitates mainly as thin layers, veinlets and cavity-fills (Hay and Wiggins, 1980). It is also associated with very mature calcretes and dolomites (Watts, 1980). It is an authigenic mineral. Palygorskite is also common in many modern and ancient calcretes (Watts, 1980). The concentration of red-staining (hematite) around the cracks/veins indicates oxidation and thus exposure to air or oxidising pore-waters. This characteristic is also recorded in Quaternary soils of Spain (Atkinson, 1986) and tropical soils of Rwanda (Stoops, 1989). The filamentous nature of the iron may also indicate a microbial influence, since it shows great similarities to encrusted iron microbes of the Belgian deep-water mud-mounds (see pg. 28 of Monty, 1995) and Devonian hematite-stained limestones in the Czech Republic (Mamet *et al.*, 1997).

Microstalactitic cements within voids indicate precipitation within the vadose zone. Circum-granular cracks are also a characteristic feature of calcretes (Wright and Tucker, 1991). All of the features present in the horizon at Cul d'Houille are indicative of an alpha-type calcrete, as described by Wright (1990). This calcrete-type is suggestive of a non-biogenic origin. The distribution of alpha calcretes is apparently climatically controlled and occur in more arid climates with little biological activity (Wright and Tucker, 1991). The only evidence of possible vegetation is the presence of coated, calcite-filled voids (Fig. 4-19d). These are possibly root tubules, although no alveolar fabrics are present. These features are very similar to the Carboniferous rendzinas documented by Wright (1983; page 163, figure 4F).

The calcrete horizon present at Broadridge Wood Quarry is indicative of an alpha-type calcrete also. Circum-granular cracks, floating grains and mottled textures are all suggestive of subaerial calcrete horizons that developed with a non-biogenic influence (Wright, 1990).

The amount of time which it takes to form a calcrete horizon is dependant on numerous factors such as climate, temperature, host rock (whether it is indurated or loose) and sea-level fluctuations. The maturity of a calcrete, however, is time-related. Tucker and Wright (1992) recognised 5 stages of calcrete which developed in exposed carbonate sediment (Fig. 4-20). Stage 1 represents immature calcretes and stage 5 a mature calcrete. The calcretes at Cul d'Houille and Broadridge Wood are likely to be at stage 2 or 3.

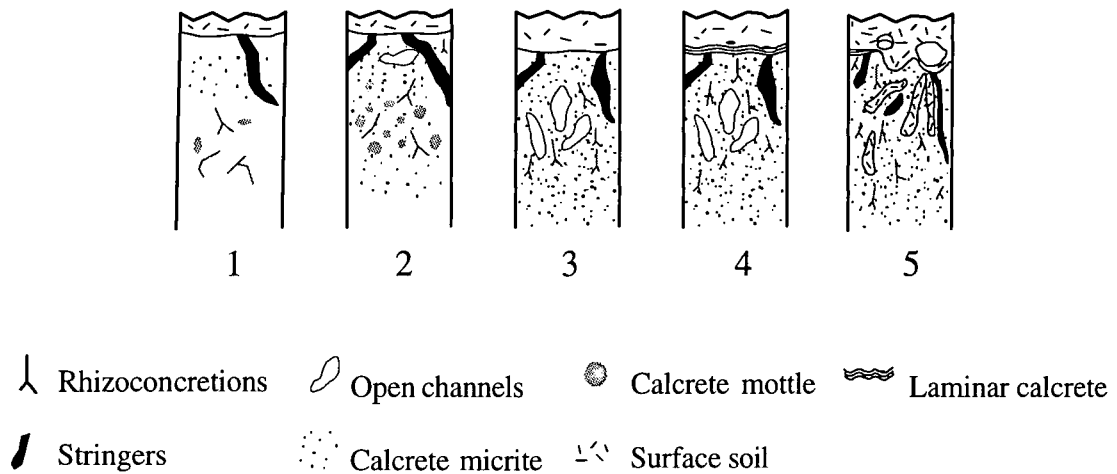

**Figure 4-20 Stages in calcrete development in exposed carbonate sediments. Stage 1 is the most incipient calcrete and stage 5 is the most mature, multi-brecciated calcrete. Diagram taken from Tucker and Wright (1992).**

#### 4.2.5 Microfacies associations and summary

The microfacies described in Sections 4.2.4.1 to 4.2.4.4 were all deposited in highly interactive platform interior or lagoonal environments which occurred in two main palaeosettings: a broad shelf lagoon or isolated carbonate platform. Characteristics of modern-day carbonate systems have aided interpretation of these facies. However, since their deposition depends upon the complex interaction of factors including water energy, prevailing climate (including average temperature, temperature fluctuations, wind), salinity, topography, tidal ranges and response of organisms to these variations, factors all of which for the Devonian are largely unknown, the proposed environmental interpretations are by no means unique and a best-judgement has been made with the available data.

Figure 4-21 synthesises the data presented in Section 4.2 as a schematic cartoon. As a recap, fourteen major microfacies are identified which can be grouped into four main groups. Microfacies S1, S2 and S3 are included in the 'semi-restricted subtidal facies group', where sedimentation was always subtidal in nature and facies had a rich faunal assemblage which although diverse, did not represent fully open-marine deposition. Microfacies S4, S5, S6 and S7 were either poorly fossiliferous, or had a restricted faunal assemblage (i.e., *Amphipora*, gastropods) and were deposited in shallow, often low-energy, restricted waters. The remaining microfacies (S8-S14) can be grouped into the intertidal facies group (S8, S9, 10, S11) and supratidal facies group (S12, S13, S14) although differentiating between intertidal and supratidal deposition often proves very difficult. Calcrete development (S14) represents prolonged exposure in supratidal-subaerial environments and is the most restricted microfacies recorded in the area.

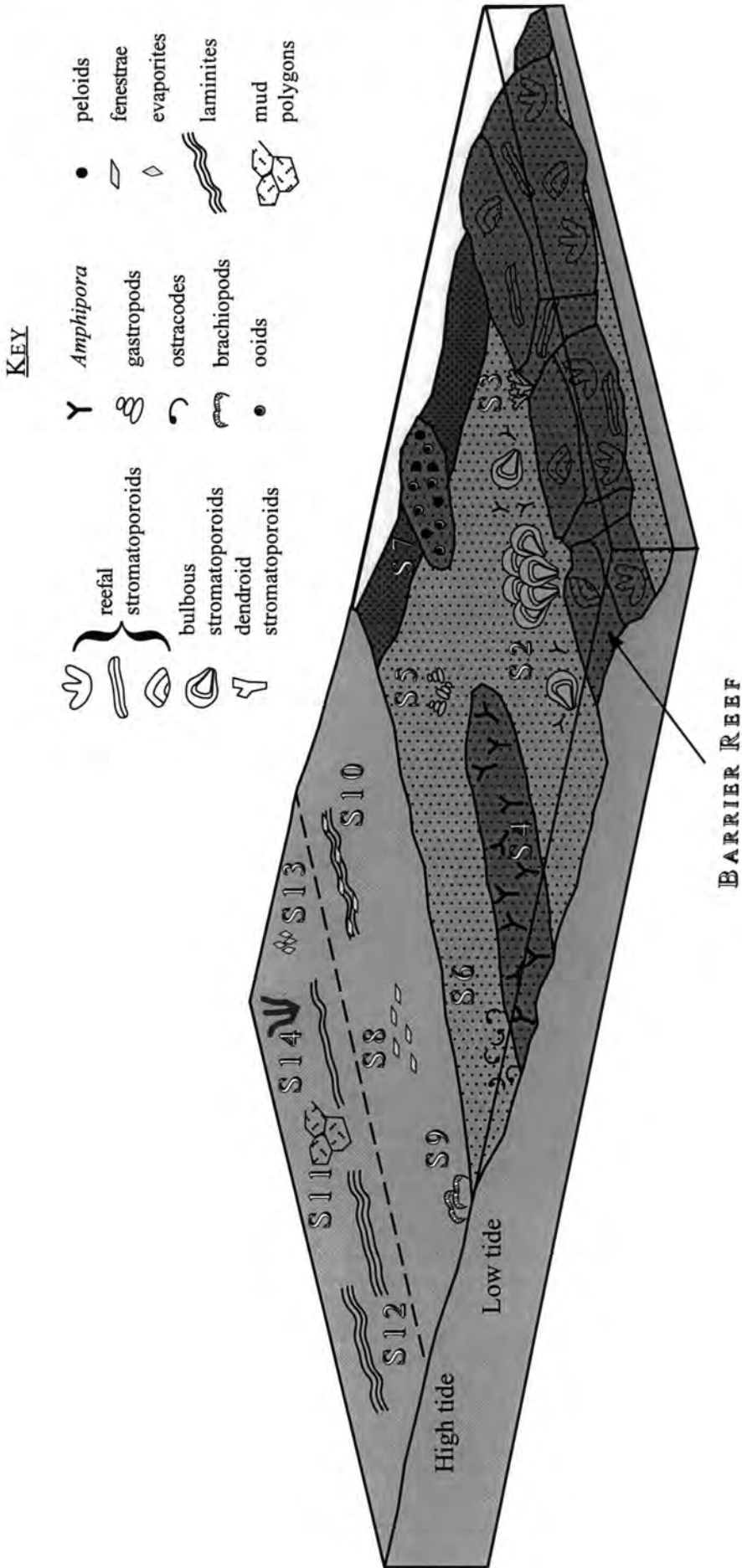

Figure 4-21 Schematic cartoon showing depositional environments of the fourteen microfacies identified in the study area. For discussion see Section 4.2.5.

# CHAPTER FIVE

|   |            |
|---|------------|
| <b>5. DEVELOPMENT OF THE MIDDLE TO UPPER DEVONIAN CARBONATE COMPLEXES</b> | <b>137</b> |
| 5.1 BROAD SHELF LAGOON.....   | 137        |
| 5.1.1 Eifelian-Givetian boundary.....                                     | 144        |
| 5.1.2 Lower Givetian.....   | 146        |
| 5.1.3 Upper Givetian.....   | 154        |
| 5.1.4 Givetian-Frasnian boundary.....                                     | 165        |
| 5.1.5 Lower Frasnian.....   | 166        |
| 5.1.6 Cyclicity.....  | 170        |
| 5.1.7 Summary.....  | 172        |
| 5.2 ISOLATED CARBONATE COMPLEXES.....                                     | 174        |
| 5.2.1 Shelf-edge reefal complexes.....                                    | 177        |
| 5.2.1.1 Attendorn Reef Complex.....                                       | 178        |
| 5.2.1.2 Brilon Reef Complex.....  | 182        |
| 5.2.1.3 Torbay Reef Complex.....  | 189        |
| 5.2.2 Inner shelf reefal complexes.....                                   | 199        |
| 5.2.2.1 Balve Reef Complex.....   | 200        |
| 5.2.2.2 Dornap Reef Complex.....  | 204        |
| 5.2.3 Trough reefal complexes.....  | 209        |
| 5.2.3.1 Langenaubach Reef Complex.....                                    | 209        |
| 5.2.4 Summary.....  | 212        |

## **5. Development of the Middle to Upper Devonian carbonate complexes**

This Chapter documents the evolution and development of the carbonate complexes studied for this thesis. A differentiation is made between the geometries of the carbonate complexes. Initially the broad shelf lagoon covering the Belgian Ardennes through to Aachen and Eifel areas of Germany will be discussed. Section 5.2 will document the development of isolated carbonate complexes in Germany and Southwest England. Although Chapter 5 concentrates mainly on back-reef environments, the development of the complexes as a whole will be discussed. Throughout this Chapter reference will be made to the Appendices (1 and 2) since this is where thin-section information and detailed logs are presented.

### **5.1 Broad Shelf Lagoon**

Middle and Upper Devonian sedimentation in the Ardennes, Aachen and Eifel areas occurred on a shelf setting which bordered the Old Red Continent (Brabant Massif) to the north (See Figure 2-8). The shelf was fringed to the south by a barrier-reef system, which trended in a broadly WNW-ESE direction from the Boulogne area in northern France through to southeast Belgium. The development of this barrier-reef enabled back-reef sedimentation to occur in a broad shelf lagoon, a focal area of this study.

Underlying the carbonate shelf, Lower Devonian clastics (fluvial and marginal marine) unconformably lie upon Lower Palaeozoic strata (Burchette, 1981). The deposition of carbonate facies and the development of a carbonate platform was diachronous in a northerly direction. The transgression over fluvial clastics had reached Dinant by Lochkovian times; by the Emsian it had reached the Eifel area, and in the Namur and Aachen areas carbonate sedimentation was initiated in the early Givetian (Burchette, 1981).

Initially, the carbonate platform in the Ardennes-Eifel-Aachen area had a ramp geometry where there were gentle dips and no sudden breaks in slope. At the beginning of the Givetian, however, differentiation of pelagic, reef and back-reef facies occurred, suggesting evolution of the platform into a shelf, where stromatoporoid-reefs developed on the southerly shelf margin (Tsien, 1971). The largest area of this complex was occupied by shelf-lagoons (see below). The shelf was bounded to the south by a pelagic shale basin, itself a westerly extension of the Rhenohercynian Trough.

The orientation of the lagoon in the Givetian and Frasnian shelf setting was likely to have mimicked the Old Red Continent margin, thus running in an east-west direction. The shelf-lagoon was thought to have reached 50-60km in width from reef to shore (Burchette, 1981) and covered an area of maybe 15,000km<sup>2</sup> (accounting for the 30-50% shortening produced by the Variscan Orogeny; Wunderlich, 1964; Sanderson, 1984). Styles of sedimentation and thickness of formations were influenced by several factors:

1. The proximity of the carbonate platform to the Old Red Continent. Sediments fringing the Old Red Continent are much thinner than those near the reef (1-2m in the periodically exposed massif (Kimpe *et al.*, 1978) compared to 1700m in the southern limb of the Dinant Basin). Back-reef sedimentation also has a more restricted nature closer to the shore, with evidence of exposure horizons, whereas near the reef, facies show a more diverse assemblage and sedimentation is mostly subtidal in nature.
2. Areal position within the lagoon. The Givetian platform was dissected by fault-blocks trending normal to the palaeoshoreline (Kasimi and Preat, 1996). Differential subsidence of these fault blocks resulted in thickness variations across the shelf.
3. Presence of crystalline basements, providing positive land masses. It is difficult to assess the influence which crystalline basements such as the Stavelot-Venn and Rocroi Massifs had on shelf sedimentation. For example the massifs may have dissected the shelf, or provided clastic input to essentially carbonate-dominated areas, but because of the poor outcrop in the area these influences are as yet unknown. Present-day outcrop patterns would clearly suggest the Stavelot-Venn inlier separated the Eifel area and the Ardennes-Aachen area (Fig. 5-1), yet its influence during the Devonian is hard to determine.

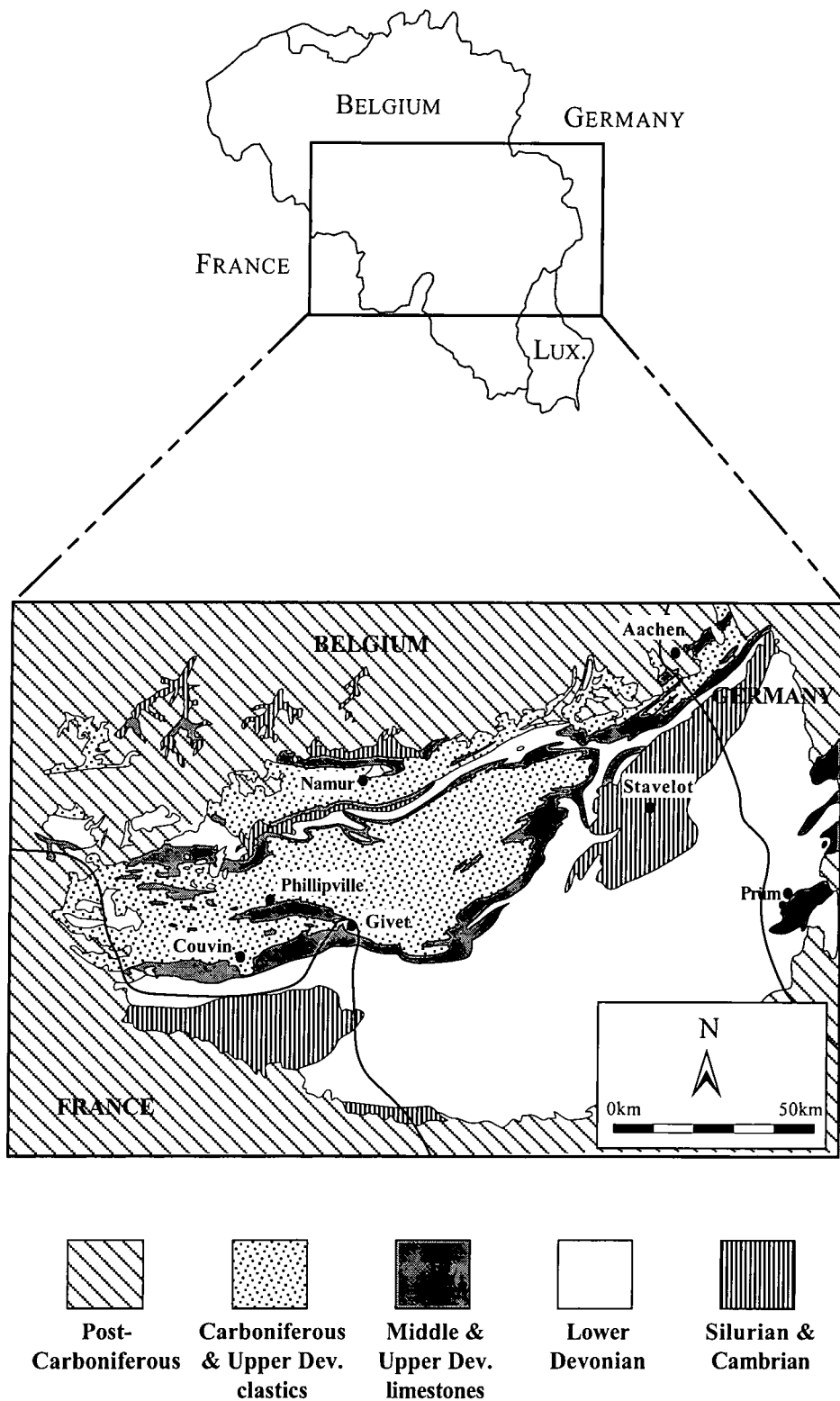

Figure 5-1 Generalised geological map showing the outcrops of Devonian rocks in the Ardennes-Aachen-Eifel area.

Middle and Upper Devonian limestones occur in a broad band trending E-W across southern Belgium and northern France and in a NE-SW direction in the Aachen and Eifel areas of western Germany (Fig. 5-1). The majority of outcrops lie in the Dinant and Namur anticlines, the Aachen area north of the Stavelot-Venn Massif and in small anticlines in the Eifel area. Back-reef sedimentation can be seen as far west as the Ferques inlier (Wallace, 1969; Wallace, 1976; Brice *et al.*, 1979; Brice *et al.*, 1984; Brice, 1988; Brice *et al.*, 1989); however, this area has not been examined in this study due to problems of accessibility. The most easterly outcrops within the shelf lagoon are seen in the Aachen and Eifel areas of Germany with the eastern margin delineated by the River Rhine (reflecting an ancient fault-system?).

Nineteen successions throughout the outcrop tract in southern Belgium, northern France and Aachen area of Germany have been studied (Fig. 5-2; Table 5-1). The strata range from early Givetian through to the middle Frasnian where both ramp and shelf successions have been studied (Fig. 5-3). The following Sections aim to document the large-scale evolution of the shelf lagoon through the Givetian and Frasnian with respect to facies-types, early diagenesis and cyclicity. For detailed logs the reader should refer to Appendix 2, and for thin-section information, Appendix 1 tabulates the findings.

| Age and facies-types                  | Location                      | Topographic map number and co-ordinates   | Thickness of log          |
|---------------------------------------|-------------------------------|---|---------------------------|
| <b>Givetian ramp facies</b>           | Glageon quarry                | 1:25,000, Sheet 57(5-6), co-ordinates not available. Working quarry S of Glageon, near Trélon   | 140.5m<br>(Section A2.10) |
|                                       | Bellignies-Bettrechies quarry | 1:25,000, Sheet 51(1-2), Roisin-Erquennes<br>05.5360 55.7555  | 63.1m<br>(Section A2.3)   |
| <b>Givetian ramp and shelf facies</b> | Teerstraßenbau quarry         | 1:50,000, Map L5302, Aachen<br>r:25.1260 h:56.1825  | 83.5m<br>(Section A2.24)  |
| <b>Givetian shelf facies</b>          | Alt Breinig quarry            | 1:50,000, Map L5302, Aachen<br>r:25.1571 h:56.2100  | 35.4m<br>(Section A2.1)   |
|                                       | Beauraing quarry              | 1:25,000, Sheet 58(3-4), Agimont-Beauraing<br>06.3945 55.5245   | 42.8m<br>(Section A2.2)   |
|                                       | Cul d'Houille quarry          | 1:25,000, Sheet 58(3-4), Agimont-Beauraing<br>06.3265 55.5270   | 62.1m<br>(Section A2.7)   |
|                                       | Dourbes quarry                | 1:25,000, Sheet 58(5-6), Olloy-sur-Viroin - Treignes. 06.1445 55.4970   | 41.8m<br>(Section A2.8)   |
|                                       | Froid Lieu quarry             | 1:25,000, Sheet 59(5-6), Ponderôme-Wellin, co-ordinates not available. East of Froid Lieu village, set back N of N40 road.              | 28.8m<br>(Section A2.9)   |
|                                       | Keldenich quarry              | 1:25,000, Map 5405, Mechernich<br>r:25.4200 h:55.9933   | 38.5m<br>(Section A2.14)  |
|                                       | Nismes quarry                 | 1:25,000, Sheet 58(5-6), Olloy-sur-Viroin - Treignes. 06.1150 55.4845   | 24.9m<br>(Section A2.17)  |
|                                       | Olloy-sur-Viroin quarry       | 1:25,000, Sheet 58(5-6), Olloy-sur-Viroin - Treignes. 06.1350 55.4850   | 43.6m<br>(Section A2.19)  |
|                                       | Resteigne quarry              | 1:25,000, Sheet 57(5-6), co-ordinates not available. Quarry N of Resteigne near the River Lesse on the road to Belvaux                  | 88.0m<br>(Section A2.20)  |
|                                       | Sourd d'Ave section           | 1:25,000, Sheet 59(5-6), Ponderôme-Wellin, co-ordinates not available. Roadside outcrop on junction between N835 and N94 at Sourd d'Ave | 37.5m<br>(Section A2.23)  |
|                                       | Vaucelles quarry              | 1:25,000, Sheet 58(1-2), co-ordinates not available. Overgrown quarry NW of Vaucelles, on road to Doische                               | 19.6m<br>(Section A2.25)  |
|                                       | Venwegen quarry               | 1:50,000, Map L5302, Aachen<br>r:25.1500 h:56.1981  | 11.5m<br>(Section A2.26)  |
|                                       | Walheim southern limb         | 1:50,000, Map L5302, Aachen<br>r:25.1315 h:56.1831  | 40.0m<br>(Section A2.30)  |
| <b>Frasnian shelf facies</b>          | Schmithof quarry              | 1:50,000, Map L5302, Aachen<br>r:25.1150 h:56.1750  | 22.4m<br>(Section A2.22)  |
|                                       | Walheim section 1             | 1:50,000, Map L5302, Aachen<br>r:25.1311 h:56.1875  | 15.6m<br>(Section A2.28)  |
|                                       | Walheim section 2             | 1:50,000, Map L5302, Aachen<br>r:25.1320 h:56.1885  | 39.5m<br>(Section A2.29)  |

Table 5-1 List of studied successions, and their locations.

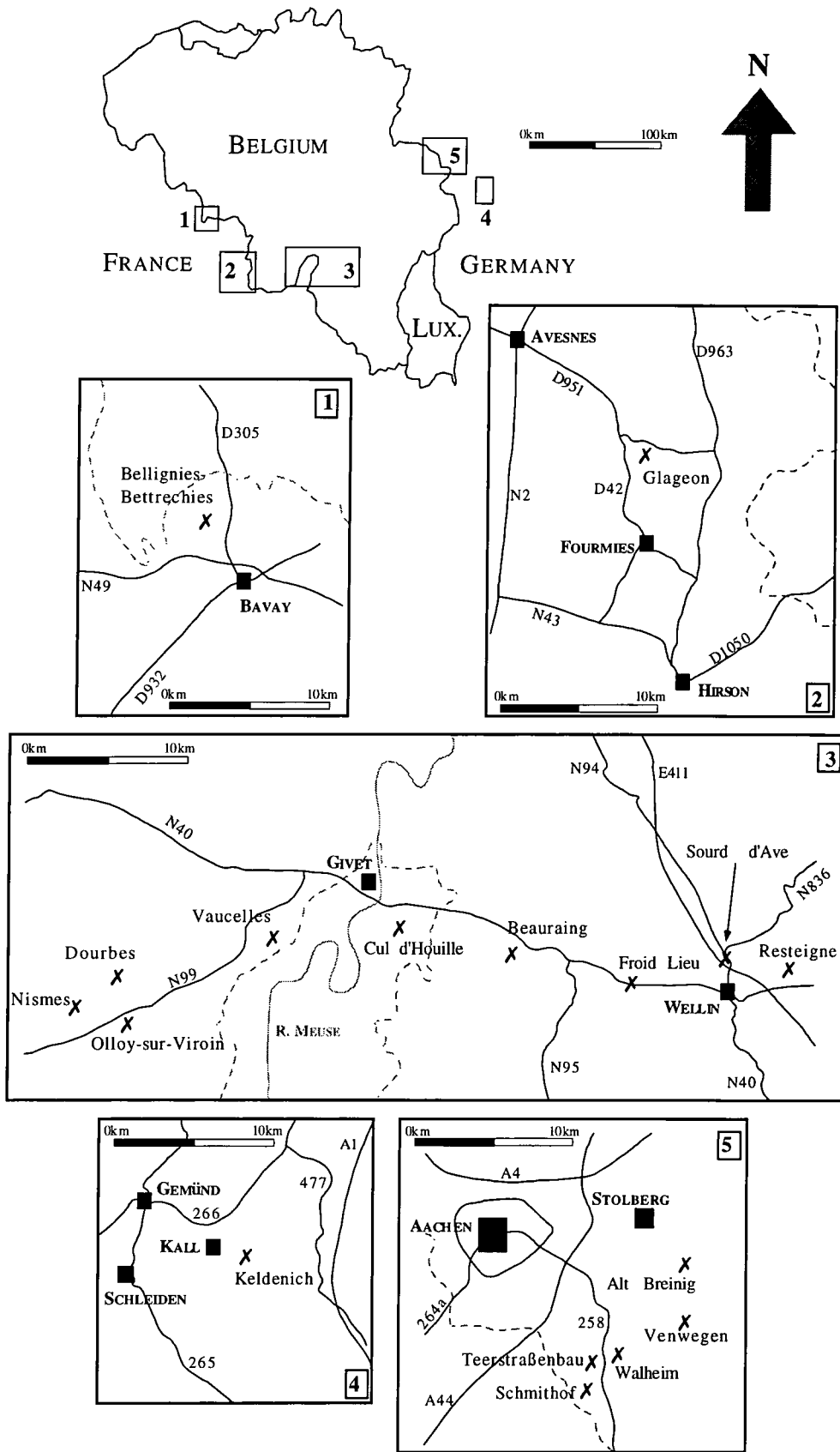

Figure 5-2 Maps showing localities of logged sections (X) in the broad Devonian shelf lagoon.

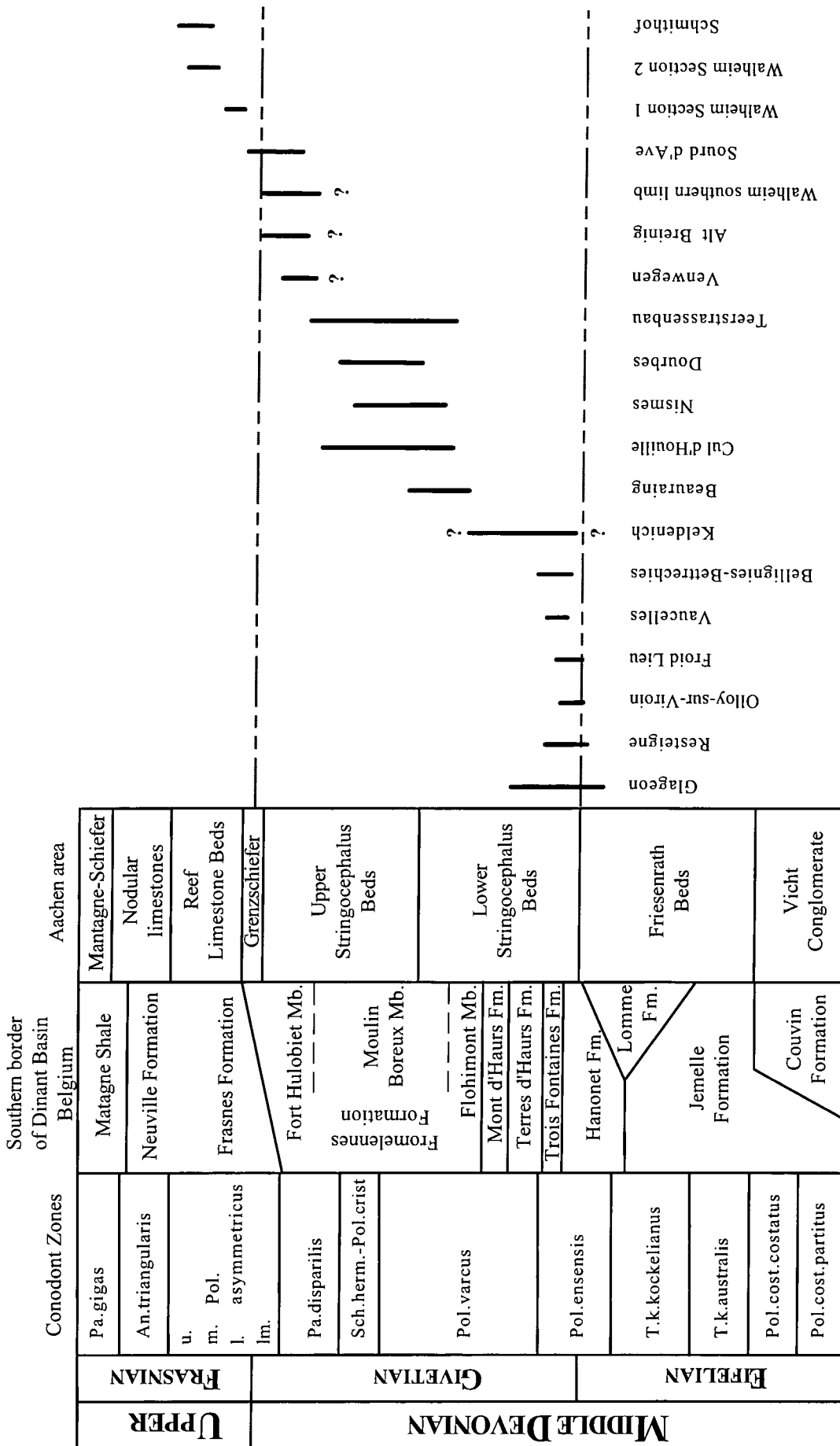

Figure 5-3 Stratigraphic chart showing conodont zones, lithostratigraphic names and ages of the successions studied in the lower Givetian ramp and Givetian-Frasnian broad shelf lagoon. Data from various sources.

### 5.1.1 Eifelian-Givetian boundary

#### *Ardennes*

The base of the Givetian in the Ardennes sees the transition from ramp to shelf facies. Ramp facies of late Eifelian and early Givetian age have been studied in the Ardennes in several successions, including Glageon quarry, the base of the Resteigne quarry and base of Olloy-sur-Viroin and Froid Lieu quarries (Table 5-1). The facies descriptions have already been discussed in Chapter 4, where seven major microfacies were identified ranging from outer ramp to intertidal-supratidal. Since these ramp successions are not the focus of the study, the reader should refer to the publication list supplied in Table 4-2 for more detailed information.

The upper Eifelian to lower Givetian ramp was of a homoclinal-type where there was no distal steepening and gentle, uniform slopes of only a few degrees inclination prevailed (Preat and Kasimi, 1995). This environment was often subjected to periodic storms, as represented by thin graded beds and redeposition of shallow-water faunas into deeper environments (microfacies R2). The ramp was also dissected by a number of fault blocks, with differential subsidence rates during the Eifelian (Kasimi and Preat, 1996). This had a profound effect on sedimentation styles and resulted in varying thickness of sediments across the platform (Bultynck, 1970).

The basal 72m of the succession at Glageon quarry are in the upper Eifelian-lowermost Givetian Hanonet Formation and represent the longest logged succession in ramp facies. The succession is open-marine in nature, with deposition varying from outer ramp argillaceous mudstones and wackestones to high-energy inner ramp oolitic and peloidal grainstones. Bioclasts are diverse and abundant, with crinoids, brachiopods, brachiopod spines, bivalves, gastropods, bryozoans, tentaculitids, trilobites, corals and stromatoporoids (see log in Section A2.10 and thin-section tables in Section A1.2.10). The matrix is mostly micritic, apart from the volumetrically subordinate high-energy grainstones which are sparitic. Bioturbation is common, especially in middle and outer ramp environments (R1, R2 and R3). Bedding is regular and well bedded. In the lowermost parts of the Resteigne, Olloy-sur-Viroin and Froid Lieu quarries where the youngest Eifelian-Givetian ramp facies are exposed (just before the transition into lagoonal shelf facies) open-marine, outer to mid ramp facies are also seen (microfacies R1 and R2).

Other successions in the Hanonet and lower Trois Fontaines Formations show evidence of intertidal to supratidal sedimentation (Preat and Kasimi, 1995). Presumably these localities were situated nearer to the palaeoshoreline in shallower waters. Sedimentation, however, is entirely subtidal in the successions studied for this thesis.

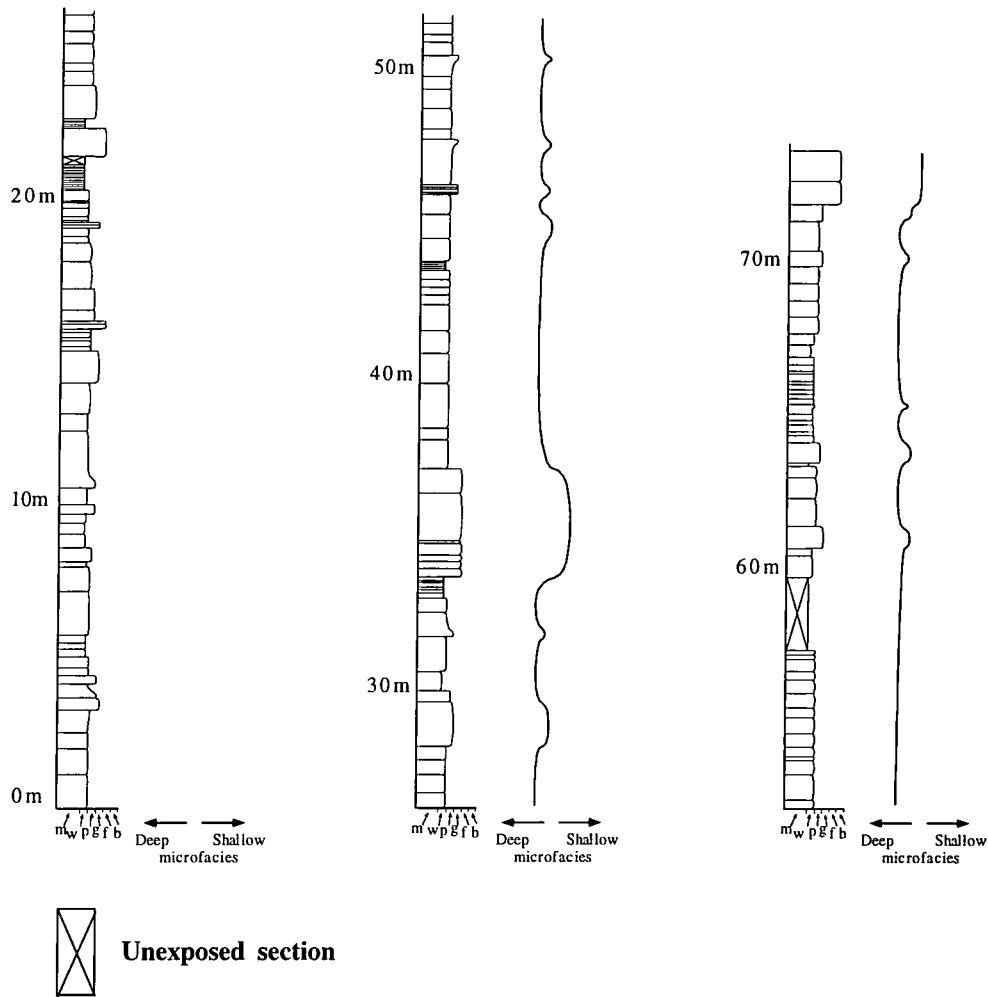

**Figure 5-4** Generalised log of the upper Givetian Glageon succession.

The local evolution of these upper Eifelian to lower Givetian facies at Glageon shows a cyclic deep-shallow-deep trend from base to top (Fig. 5-4). The majority of the succession is dominated by interbedded outer ramp and mid ramp facies which are richly fossiliferous (microfacies R1 and R2). Between 33.5m and 37m, however, a change in water energy is recorded by the development of local oolitic banks. Although cross bedding is not seen, individual beds reach up to 1.5m and are dominated by ooids with subordinate peloids. Sedimentation is entirely subtidal in nature. The base of the Trois Fontaines Formation (just above the Eifelian-Givetian boundary) in many successions throughout the Ardennes is characterised by the development of a thick (up to 5m) stromatoporoid biostrome. This

can be seen at Glageon, Resteigne and Olloy-sur-Viroin and represents the transition into a shallow shelf depositional environment with lagoonal conditions. This is further discussed in Section 5.1.2. Boulvain *et al.* (1994) studied a similar succession in Glageon quarry and recognised a broad shallowing-upward through the Hanonet into the lower Trois Fontaines Formation. However, their proposed facies model does not include the R4a oolitic bank microfacies, which may indicate its impersistent nature. Work on ostracode assemblages by Casier *et al.* (1995) also identified similar shallowing-upward trends.

### ***Aachen***

The uppermost Eifelian and lowermost Givetian strata in the Aachen area are dominated by clastics which show a broadly regressive character (Richter, 1970; Hollerbach and Kasig, 1980). Carbonate sedimentation was not initiated until the middle Givetian (Kasig and Wilder, 1983); therefore, the Givetian-Eifelian boundary was not studied for this thesis.

### ***Eifel***

The Eifelian stage in the Eifel area is characterised by the widespread development of biostromes interbedded with bioclastic limestones. These carbonates are richly fossiliferous, especially in corals (Lütte and Oekentorp, 1988; Birenheide and Gabrielli, 1993), stromatoporoids and brachiopods (Ochs and Wolfart, 1961). The facies are open-marine in nature and were deposited on a bank or in a ramp setting, which had a variable clastic input (Krebs, 1974). These facies have not been studied for this thesis.

### **5.1.2 Lower Givetian**

For the purpose of this study the lower Givetian is considered to encompass the upper *Pol. ensensis* and lower *Pol. varcus* conodont zones. This therefore includes the Trois Fontaines, Terres d'Hairs and Mount d'Hairs Formations in the southern border of the Dinant Basin, the Névrement Formation in the northern part of the Dinant Basin and the Lower Stringocephalus beds of the Aachen and Eifel areas (Fig. 5-3).

### ***Ardennes***

The lower Givetian in the Ardennes sees the transition of the carbonate platform from a ramp to shelf geometry. During a period of relative low subsidence at the end of the Eifelian, sediments were able to accrete up to or near sea level so that bioconstructing

organisms stabilised the platform, forming an organic rim. This semi-continuous rimmed-shelf trended in a broad east-west direction through northern France, where small outcrops of the barrier are exposed (see Figure 6, page 76, Preat and Mamet, 1989).

Landward of the barrier-reef, in the Ardennes area, the base of the Givetian is characterised by the development of a laterally persistent stromatoporoid biostrome. This biostrome reaches up to 5m in thickness and is composed primarily of stromatoporoids (laminar, bulbous, domal and dendroid types, including *Stachyodes*), and corals including *Thamnopora*, *Scoliopora*, *Sociophyllum* and *Trachypora* (Preat *et al.*, 1984). Crinoids and other bioclasts only play an important role towards the top of the complex where thick accumulations of *Stringocephalus* brachiopods occur, giving the rock a rudstone texture (see Figure 4-14d). This unit is of particular environmental significance since the presence of keystone vugs and gravitational cements suggests deposition in the high subtidal to intertidal environment (see thorough discussion in Section 4.2.3.2 and Figure 4-14e). These very distinctive bioclastic accumulations are not laterally persistent over a wide area.

The Trois Fontaines Formation, the oldest formation in the lower Givetian, is most completely exposed in the Resteigne quarry, the most easterly studied exposure in the Ardennes area. Above the widespread biostrome at the base of the Trois Fontaines Formation, facies are of a lagoonal nature showing variable faunal diversities, sedimentary textures and water energies (see detailed log in Appendix 2). The formation can be broadly split into two units which show distinct characteristics (Fig. 5-5).

The lower unit (6m to 42m) is dominated by subtidal deposition. Microfacies S6 dominates this section where calcispheres, ostracodes (including *Leperditia*) and dasycladacean algae are particularly abundant. These facies are locally intensely bioturbated, as seen by the horizons of vertical spar-filled fenestrae (see Figure 4-11e) and the lack of well-preserved sedimentary structures. Accumulations of euryhaline faunas such as gastropods and bivalves (microfacies S5) are commonly interbedded in this basal succession. Periods of increased water circulation are represented by the development of small stromatoporoid biostromes (i.e., @9m) and by the influx of reef-derived bioclasts (microfacies S3). The bioclastic components are mostly composed of *Stringocephalus* brachiopods and corals, which are commonly encrusted by cyanobacteria. These units were probably deposited through storm activity.

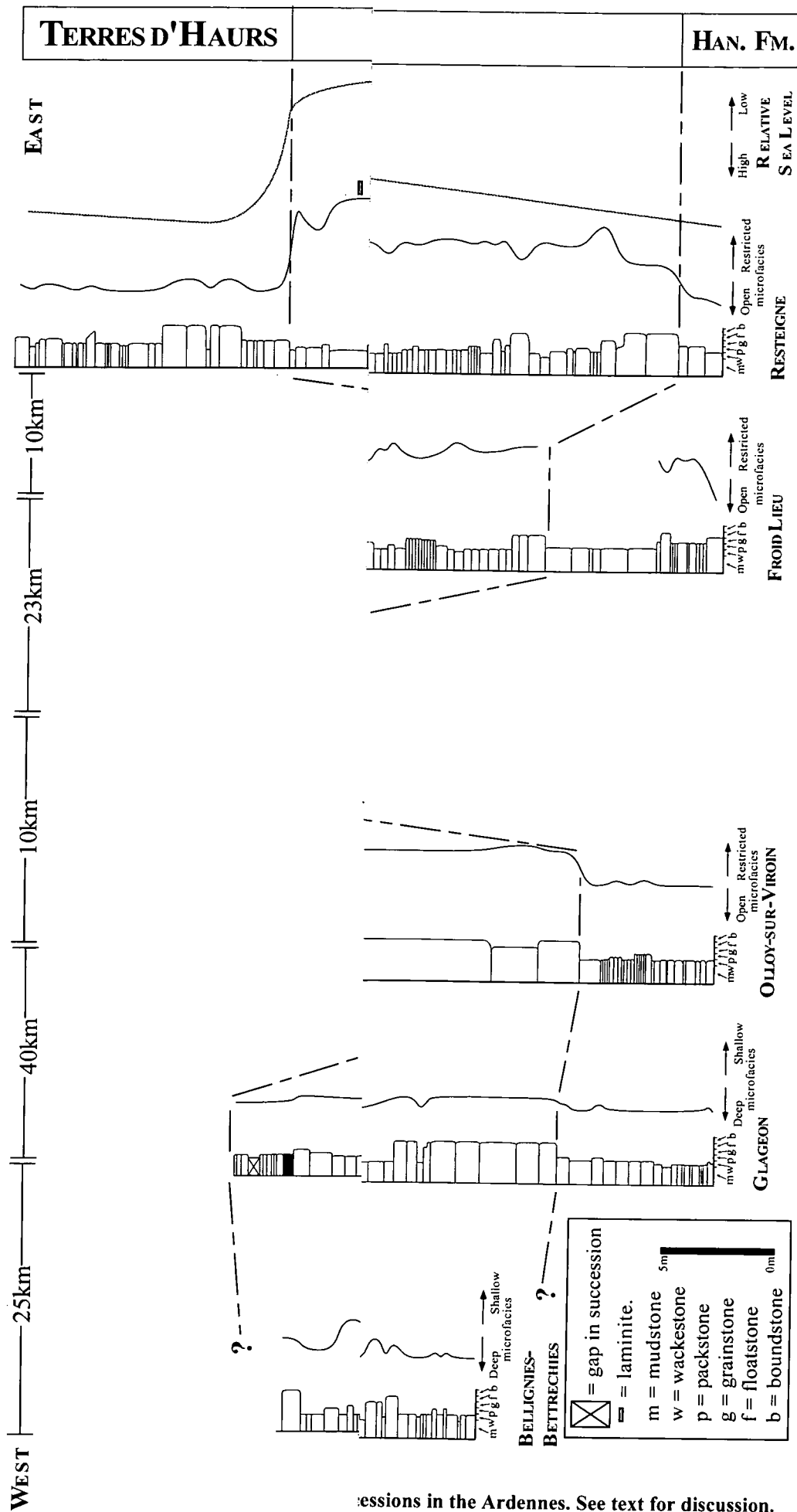

Successions in the Ardennes. See text for discussion.

The lower unit of the Trois Fontaines Formation records deposition which is subtidal in nature. The lagoonal environment had poor circulation and variable salinity, with only periodic influence by storms and near normal-marine waters. Those organisms adapted to these restricted conditions (i.e., dasycladacean algae, ostracodes, parathuramminid forams) flourish in this environment, as shown by their relatively low diversity but often extremely high abundance. *Amphipora*, unusually, is not abundant in the succession at Resteigne.

The upper unit of the Trois Fontaines Formation (42m to 73.5m) is characterised by the development of microbial laminite and mud polygon horizons, indicating periods of exposure in the high intertidal to supratidal environment. The laminites range from 10cm to up to 4m in thickness and locally show intraclast horizons where mudchips have been reworked from mud polygons through periodic storms (see example in Figure 4-17a). The laminites are commonly very planar, with little or no convolute structure to them. Bioturbation is apparent in localised areas, but is on the whole uncommon. In thin section peloidal grainstone lamina were mechanically deposited through storms whereas mud lamina reflected the cryptmicrobial component.

Interbedded with these microbial laminites are mostly poorly fossiliferous mudstones and wackestones (microfacies S6) representing deepening of the environment into the shallow subtidal lagoonal zone. Again storm action is reflected by accumulations of *Stringocephalus* and gastropods. Horizons of irregular and laminoid fenestrae are also present in this upper unit.

Above the uppermost laminite horizon (@73.5m), the succession shows a very dramatic deepening and back-stepping into open-marine, highly fossiliferous rocks of the Terres d'Hairs Formation. A 3m thick biostrome can be seen near the base of the Terres d'Hairs Formation which is dominated by favositids (*Pachyfavosites*), *Trachypora* and *Thamnopora* (fossil identifications of Preat *et al.*, 1984).

Several other outcrops in the Trois Fontaines Formation of the Ardennes tie-in very well with the succession seen at Resteigne, although the exposure is never as complete (Fig. 5-5). The uppermost Hanonet and lower unit of the Trois Fontaines Formations can be seen at Olloy-sur-Viroin and at Froid Lieu quarries, where incomplete successions show a richly-fossiliferous base (high diversity accumulations of the Hanonet Formation) which are then capped by a biostrome. Faunas in the biostrome at Froid-Lieu are less diverse than

those seen at Resteigne and Olloy-sur-Viroin suggesting water circulation may have been restricted more quickly at this locality.

The succession at Froid Lieu is dominated mainly by low-energy, poorly-fossiliferous subtidal mudstones and wackestones (S6 microfacies). Periodic emergence into the intertidal zone is represented by the development of fenestral horizons, yet emergence into the high-intertidal or supratidal zone is never recorded. The succession at Olloy-sur-Viroin also shows subtidal and low intertidal-dominated sedimentation, although work by Preat *et al.* (1987) discovered laminites higher in the succession which were obscured by tipping during my field season in 1994-5. These laminite horizons occur approximately 10m above the succession logged for this study, and therefore the boundary with the upper unit of the Trois Fontaines Formation can be situated therein. Of interest in the Olloy-sur-Viroin section are the nests of *Leperditia* ostracodes which can be seen at the higher levels in the quarry (~41m, see Section A2.19 for log and A1.2.19 for thin-section descriptions). The ostracodes are densely packed, commonly articulated (very little attrition) and appear to be close to life position. These ostracodes are indicative of high-stress environments where circulation in the lagoon was very poor and salinities fluctuated.

The lower and upper units of the Trois Fontaines Formation can also be seen in the Vaucelles quarry. A monotonous succession of well-bedded mudstones and wackestones up to 9m thick represents the lower unit of the Trois Fontaines Formation (see Figure 4-11c). Above 9m, four separate laminite horizons can be identified, variably interbedded with well-bedded mudstones, or *Stringocephalus* accumulations (S3 microfacies). As with the Olloy-sur-Viroin section, *Leperditia* ostracodes are particularly abundant at Vaucelles, especially in the upper parts of the succession.

The most westerly successions at Bellignies-Bettrechies and Glageon in the French Ardennes, are also lower Givetian in age, yet their development differs greatly from that seen in Belgium. A thick succession at Glageon can be seen through the Hanonet Formation (see discussion in previous Section) and the boundary between the Eifelian and Givetian is also determined by the development of a biostrome, as with the Belgian successions. However, it is there that the similarities end. The succession at Glageon, after the biostrome, returns to sedimentation which is essentially open-marine in nature. Diverse faunal assemblages including crinoids, bivalves, brachiopods, gastropods, corals (colonial

and solitary) and stromatoporoids are identified, and graded storm deposits are common (see Section A2.10). Therefore, it is suggested the carbonate platform in the west still had a ramp geometry where it was maybe too deep for the development of an organic barrier (Fig. 5-6). A boundary between the upper and lower units of the Trois Fontaines Formation may be drawn at 103.5m where the development of microbial laminites and the presence of pseudomorphs of anhydrite suggest very shallow sedimentation (high intertidal to supratidal zone). However, this correlation is very tentative (Fig. 5-5). The base of the Terres d'Haus Formation can be drawn at the top of the logged succession (information provided by Boulvain *et al.*, 1994).

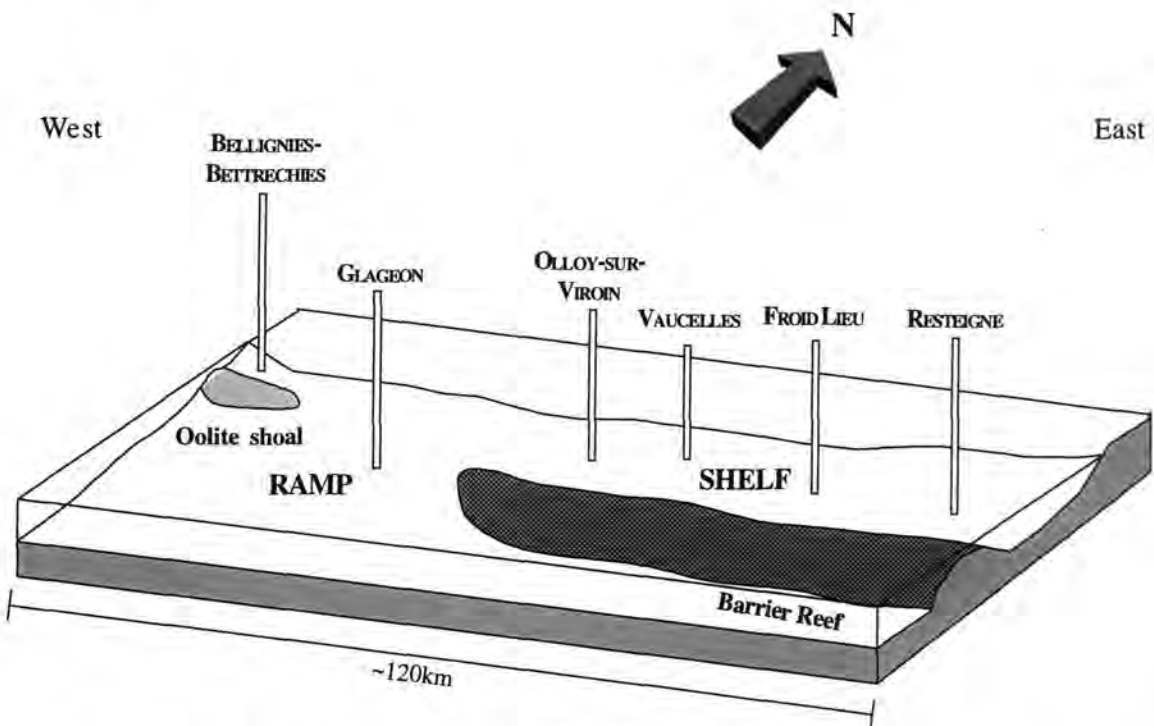

**Figure 5-6** Schematic cross section through the lower Givetian of the French and Belgian Ardennes showing the logged successions and lateral variation in platform geometry.

The most westerly succession at Bellignies-Betrechies is of lower Givetian age, in the Névremont Formation of the northern Dinant Basin (Preat and Mamet, 1989). The Névremont Formation broadly correlates with the Trois Fontaines, Terres d'Haus and Mont d'Haus Formations. The succession at Bellignies-Betrechies is probably one of the most exciting since there are a wide variety of facies-types represented; they are well exposed and relatively easy to identify. Sedimentation throughout the succession was characterised by fluctuations between open-marine and restricted conditions (see Section A2.3 for detailed log).

Open-marine sediments are richly fossiliferous with crinoids, corals, tentaculitids, gastropods, bivalves and stromatoporoids (laminar, domal, bulbous, dendroid). Bioturbation is variable and can sometimes be picked out by vertical fenestrae. Small biostromes regularly developed, sometimes disturbed by storm activity, but often with organisms preserved in life-position (microfacies R3). Oolitic banks developed at one horizon (@ 36m), reaching 1m in thickness (microfacies R4a).

Restricted sedimentation is reflected by the dense accumulations of *Leperditia* ostracodes (microfacies R6). These ostracodes either accumulated as bed-parallel lenses (storm-derived) or more often occur articulated in dense monospecific nests (see Figure 4-4a, 4-4b). This microfacies is only seen at the Bellignies-Betrechies quarry and represents shallow, highly restricted conditions. Indeed, Casier *et al.* (1995) envisaged a bay completely cut-off from the open marine realm (see Figure 3-12). Microbial laminites are also extremely abundant in this succession (microfacies R7). Although the facies is now intensely dolomitised, the dolomitisation was fabric-retentive so that laminae are still identifiable at hand-specimen scale. Pseudomorphs of evaporites are also present. This represents sedimentation in the intertidal or supratidal zone (see discussion in Section 4.1.7).

The succession at Bellignies-Betrechies, as with Glageon, is thought to have been deposited on a carbonate ramp. This ramp was influenced by storms and experienced periodic restriction, possibly behind oolite banks. Correlation of the Bellignies-Betrechies succession with other successions proved rather difficult since there are no distinctive marker bands. The succession may lie within the Trois Fontaines section since a distinction between subtidal-dominated facies (0-21m) and supratidal-influenced facies (21-63m) can be made, reflecting the 'lower' and 'upper' units seen at Resteigne quarry (Fig. 5-5).

Correlation of the logged lower Givetian successions picks out thickness variations across the carbonate platform (Fig. 5-5). Glageon and Resteigne, the two most complete sections, show very similar thicknesses for the lower Givetian. However, the succession at Vaucelles is particularly thin, since information from Preat and Boulvain (1982) can correlate the base of the Trois Fontaines Formation just 2m below the start of the logged succession. Thickness variations across a platform could result from different sedimentation rates, differential effects of erosion (i.e., unconformities cutting out a

substantial amount of the stratigraphy), differential compaction or by differential subsidence. Since the succession at Vaucelles was essentially deposited in the same environment as Resteigne, they are likely to have had similar sedimentation rates. Equally, as the facies are so similar, compaction would probably have had the same effect on both successions. There is no evidence of an unconformity in the Vaucelles quarry. Therefore, the most likely explanation would be differential subsidence of fault blocks. It has already been discussed that through the Eifelian movement on fault blocks gave rise to dramatic thickness variations across the carbonate platform, and it would appear that these fault blocks were equally as active throughout the lower Givetian.

The Mont d'Hairs Formation has not been examined for this study, due to poor exposure.

### ***Aachen***

The lower Givetian Lower *Stringocephalus* Beds of the Aachen area consist of red and green-grey clastics, which show an increasing carbonate component up through the succession (Kasig and Wilder, 1983). It is not until the upper Givetian that reef and back-reef sediments were deposited; therefore, the lower Givetian has not been studied in this area.

### ***Eifel***

Interbedded restricted subtidal and intertidal facies characterise the middle Givetian Spickberg Beds of the Sötenich syncline. Due to intense dolomitisation and poor outcrops it is difficult to ascertain the position of the barrier-reef in the Eifel area (Krebs, 1974).

The short succession at Keldenich quarry in the Sötenich syncline exhibits variable facies-types, which are semi-restricted subtidal, restricted subtidal, intertidal or supratidal in nature. Unique to this succession is the unusual dominance by corals rather than stromatoporoids. *Thamnoporoids* are particularly common, often forming as bafflestone horizons (microfacies S4c). *Stromatoporoids* are present at two horizons (@7m and 16m; see Section A2.14) where small, laterally impersistent (over 10m) bioherms developed. These bioherms are associated with *Stringocephalus* brachiopods and tabulate corals. Interbedded with coral bafflestones are wackestones and packstones dominated by *Leperditia* ostracodes (microfacies S6f). These ostracodes are very conspicuous in the field due to their large size (6mm long). They are mostly disarticulated, suggesting

reworking and are very densely packed. Microfossils including calcispheres, parathuramminid forams, small ostracodes and also algae (dasycladaceans mostly) are associated with this microfacies. Bioturbation is prevalent, being picked out either by calcite-filled tubular fenestrae or by the horizons having a distinctive mottled texture where sedimentary structures are not preserved. Accumulations of bivalve and gastropod bioclasts (S5 microfacies) are also seen.

Intertidal sedimentation is recorded by the development of several fenestral horizons. These horizons occur throughout the short succession, where the fenestrae are laminoid or irregular in shape and have an internal sediment fill at their base. Some fenestrae are totally filled by this mechanically-deposited sediment. Two horizons can be identified where sediments were deposited in the supratidal zone. These horizons are represented by unfossiliferous dolomicrites which have lozenge-shaped pseudomorphs of evaporite minerals (see Figure 4-17e). These horizons are only seen at 13m and 14.5m.

It is difficult to determine the local evolution of the lagoon at Keldenich since outcrop is rather scrappy and a continuous, long succession is difficult to construct. The local depositional environment throughout the succession periodically fluctuates from semi-restricted subtidal through to intertidal. Therefore, Keldenich is interpreted as being located dominantly tidal flat environment during the Middle Devonian. At one stage in its history (between 13m and 15m) supratidal sedimentation is recorded, suggesting the long-term relative sea-level history was at its lowest at this point. Recorded upon this long-term sea-level history were smaller sea-level fluctuations (on the scale of only 1-3m) which produce the distinctive cyclic sedimentation pattern. This cyclic component will be discussed in Section 5.1.6 and Chapter six.

### 5.1.3 Upper Givetian

The upper Givetian is considered in this study to include the Fromelennes Formation of the southern Dinant Basin and the Upper Stringocephalus Beds of the Aachen area (Fig. 5-3). The upper Givetian of the Eifel area was not studied for this thesis.

#### *Ardennes*

Five successions in the Fromelennes Formation of the Belgian and French Ardennes have been studied with regards to facies, local evolution of the succession and cyclicity (see

Figure 5-3). Stratigraphic positioning of these successions **within** the upper Givetian has proved difficult, since only one succession (Sourd d'Ave) includes the Givetian/Frasnian boundary. The Fromelennes Formation can be divided into three members: Flohimont Member, Moulin Boreux Member and Fort Hulobiet Member (Bultynck *et al.*, 1991). The base of the succession at Beauraing is within the Flohimont Member; Cul d'Houille, Dourbes, and Nismes successions are within the Moulin Boreux Member; and the lower part of the Sourd d'Ave section is positioned in the Fort Hulobiet Member (Bultynck *et al.*, 1987). The Flohimont Member represents a transgression into open marine facies and therefore has not been extensively studied.

The longest succession studied in the Moulin Boreux Member is at Cul d'Houille north of Fromelennes. This section is an overgrown railway cutting, exposing 62m of stratigraphy. Three distinct packages of sedimentation can be determined in the Cul d'Houille succession (Fig. 5-7).

The lower unit is characterised by interbedded facies where the semi-restricted subtidal, restricted subtidal, intertidal and supratidal microfacies groups are all represented (0m to 22.5m, see Section A2.7 for detailed log). These facies have a very pervasive cyclic component, which will be discussed in Section 5.1.6 and Chapter 6. Semi-restricted subtidal sedimentation is represented by stromatoporoid-coral floatstones and bafflestones. Compared to the lower Givetian successions, stromatoporoid floatstone horizons are smaller (commonly between 50cm and 80cm in thickness), more common and have an increased coralline component. Bulbous stromatoporoids are again the most dominant form, ranging from 4cm to 15cm in diameter. Dendroid stromatoporoids including *Amphipora* and *Stachyodes* are important constituents. Of the corals, *Thamnopora* is a particularly common tabulate coral and solitary corals are locally abundant. These bioconstructors are locally seen in life position, having a bafflestone or framestone texture. More commonly, they are in a disturbed position, suggesting storms dislodged them. The matrix to this S2 microfacies is composed of peloidal micrite, and locally this has been altered to dolomite.

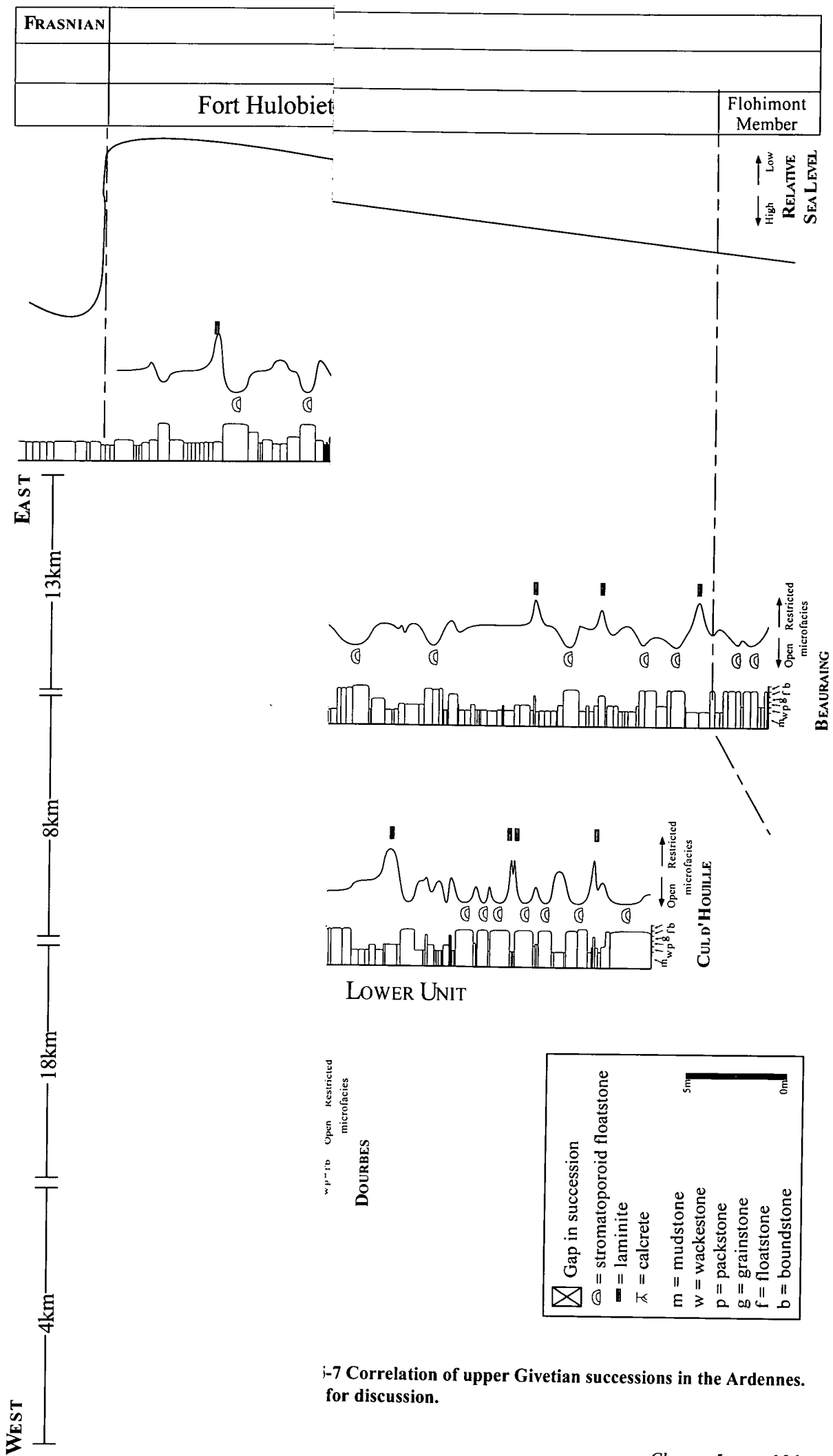

i-7 Correlation of upper Givetian successions in the Ardennes. for discussion.

Restricted subtidal sedimentation is represented by *Amphipora* floatstones (S4), fossil-poor mudstones and wackestones (S6) and peloidal grainstones (S7). *Amphipora* floatstones and bafflestones are abundant between 15-18m, yet are not present elsewhere in the lower unit. Poorly fossiliferous mudstones and wackestones occur throughout the lower unit. Horizons rich in ostracodes are commonly seen (microfacies S6e) representing the impingement of storms into the low-energy restricted lagoon. Oncoids (S6d) are locally abundant in specific horizons. Bioturbation is prevalent, destroying most primary sedimentary structures. The facies is locally very peloidal, and rare ooids are also present. Higher energy intercalations in the subtidal lagoon of Cul d'Houille are recorded by the development of peloidal grainstones. Intraclasts up to 3mm long are also common, as are oncoids reaching 8mm in length. Often these intraclast/oncoid horizons are parallel to bedding. Calcite spar dominates the matrix yet early diagenetic cements are not precipitated. Dolomite is a common constituent.

Intertidal sedimentation is represented by thin fenestral horizons. These are not common. Intertidal to supratidal laminites are, however, extremely well developed. Five horizons can be identified in the lower unit. The laminites are of microfacies S12a-type, where lamination is mostly planar and the cryptomicrobial component does not have a substantial topography to it. The laminites are particularly thin, commonly being only 6 or 8cm in thickness near the base of the succession. They do reach up to 70cm thick towards the end of the lower unit, however. Bioturbation in this high intertidal to supratidal environment was uncommon. Laminites locally directly overlie biostromes (@ 5.5m and 6.6m; see log in Section A2.7), suggesting sedimentation could not keep pace with the relative drop in sea level since restricted subtidal and intertidal deposits were not recorded.

The middle unit represents a distinct shallowing where there is no evidence of semi-restricted subtidal facies (22.5m to 42m). The least restricted facies are *Amphipora* floatstones and bafflestones (S4) where several horizons can be seen. The volumetrically most important facies is S6, where successions up to 2m thick have been deposited. These rather monotonous facies are characteristically well bedded with a very subordinate macrofossil component. Oncoids are locally abundant, where cyanobacteria have coated lumps of micrite and rare bivalves can also be identified. Thin-section analysis identifies calcispheres, peloids and forams as the major grains, attesting to the highly restricted, relatively shallow subtidal nature of this facies. Laminite horizons are again very well

developed in the middle unit. Mudstone and peloidal grainstone laminae are the major components and as with the laminites in the lower unit, laminae are laterally persistent and generally planar and flat. Bioturbation is rare.

The most distinctive facies in the middle unit is the development of two calcrete horizons at 37.5m and 40.0m (microfacies S14). These horizons have an anastomosing crack network, which emanates from the upper surface and is filled by a milky-white, calcite-rich residue (see Figures 4-18 and 4-19). This facies has already been extensively discussed in Section 4.2.4.4. The development of calcrete horizons represents prolonged exposure in the supratidal zone, where relative sea level was at its lowest. As with the lower unit, a metre-scale cyclicity is an obvious feature in the middle unit, and is fully considered in Section 5.1.6.

The upper unit continues from 42m to the end of the section at Cul d'Houille and is very similar to the lower unit where interbedded stromatoporoid floatstones and laminites occupy a large percentage of the succession. The base of the upper unit has a very interesting oncolite horizon, where oncoids reach up to 3cm in diameter (microfacies S6d; see Figure 4-12a). The core of the oncoid is always composed of lumps of micrite, and a light-grey marginal coating of the filamentous cyanobacteria, *Girvanella*, can be seen. These laminae are very smooth and continuous around the nucleus. Oncolites are frequently seen throughout the upper unit. Stromatoporoid floatstones contrast to those in the lower unit since they have fewer coralline components. Bulbous and dendroid stromatoporoids are the major constituents where bulbous stromatoporoids reach up to 13cm in diameter. Corals are locally encrusted by stromatoporoids.

Deposition in the higher-energy, restricted, subtidal environments is characterised either by oolitic or peloidal grainstone horizons. Oolitic grainstones are only seen at 44.2m, yet peloidal grainstones with a substantial intraclast and cyanobacterial component occur throughout the upper unit. High intertidal to supratidal environments are again dominated by microbial laminite development (microfacies S12a).

The presence of semi-restricted subtidal stromatoporoid floatstones and lack of calcrete horizons suggest that long-term relative sea level was higher during the upper unit. Smaller-scale relative sea-level fluctuations overprint this sea-level history.

Other successions in the Moulin Boreux Member also show this tripartite style of sedimentation. The succession at Dourbes, although not as complete as the Cul d'Houille section, also shows the initial interbedded biostrome/laminite sedimentation style (0m to 11m), followed by shallower, more restricted sedimentation of the middle unit (11m to 30m) which is capped by a return to interbedded S2, S6 and S12 microfacies (30m to 42m; see Appendix A2.8 for detailed log and Figure 5-7). Calcrete horizons are not developed at Dourbes quarry, and the most restricted facies is represented by microbial laminites. The microbial laminites occur throughout the succession at Dourbes where they are of both type S12a and S12b. Type S12a has mostly flat lamination, fluctuating between high-energy storm deposited peloidal grainstones and lower-energy microbial mudstone. Type S12b, however, has a more stromatolitic nature where lamination is wavy and fenestrae are locally abundant. Facies types, apart from the calcrete, are essentially the same as those seen in Cul d'Houille. Oncoids, again, are well developed at specific horizons, locally reaching up to 7cm in length. Peloidal and oolitic grainstones can be seen at several intervals, yet are concentrated mainly in the upper unit. Horizons rich in bulbous stromatoporoids (S2 facies) occur in the lower and upper units. Corals are not an important constituent.

The short succession at Nismes quarry, the most westerly logged succession in the upper Givetian also exposes Moulin Boreux Member strata (Fig. 5-7; Section A2.17). Facies are remarkably similar once again to those seen at Cul d'Houille and Dourbes with stromatoporoid biostromes, *Amphipora* horizons, poorly-fossiliferous mudstones, peloidal grainstones and laminites all being well-represented. As with Dourbes, corals do not play a significant role in biostrome development, with bulbous and dendroid stromatoporoids being volumetrically the most important. Storm events within the muddy, calm-water lagoon are recorded by horizons of peloidal grainstone or ostracodes within a predominantly mudstone facies (microfacies S6e). Laminites tend to have continuous planar laminae, being of type S12a. The microbial component is often well preserved in this facies. Calcretes are not seen at this succession. The succession can be divided into the familiar three units and correlates well to Dourbes and Cul d'Houille sections (Fig. 5-7).

The succession at Beauraing displays facies characteristic of semi-restricted subtidal, restricted subtidal, intertidal and supratidal environments which are so characteristic of the upper Givetian lagoon in the Ardennes (Section A2.2 for detailed logs). The log at

Beauraing does not show the familiar tripartite sedimentation pattern, suggesting it is slightly older, placing it in the lower unit of the Moulin Boreux Member. The very base of the succession is within the Flohimont Member of the Fromelennes Formation (Preat and Mamet, 1989). Microfacies S6 is particularly common at Beauraing where it has a mainly mudstone texture which has been thoroughly bioturbated. Laminite horizons are abundant in the succession, especially near the base and top. These laminites are of type S10 and S12b where there is a very influential microbial component to the facies and fenestral cavities are abundant. Of particular interest in the Beauraing quarry is the presence of a volcanic ash horizon at 22.1m. This horizon has a distinctive orange coloration, and in thin section silt- and quartz-grade particles and clays are abundant. No attempt has been made to extract suitable minerals for dating purposes, as this is outside the scope of this study.

Sourd d'Ave, the most easterly succession studied in the Ardennes, exposes the Fort Hulobiet Member of the Fromelennes Formation and also the boundary between the Givetian and Frasnian (Fig. 5-7). The Fort Hulobiet Member also displays restricted facies. Poorly fossiliferous horizons are very common, and these are interbedded with higher energy peloidal and sometimes oolitic grainstone facies (S7). Laminite horizons are uncommon, yet dolomicrites with pseudomorphs of evaporite minerals are apparent, suggesting the palaeoclimate may be becoming more arid. This boundary between the Givetian and Frasnian is very distinctive in the field, characterised by a transition from restricted lagoonal facies to open marine interbedded marly shales and nodular limestones. This boundary is further discussed in Section 5.1.4.

Correlation of the upper Givetian succession in the Ardennes identifies abrupt thickness variations across the carbonate platform (Fig. 5-7). For example the middle unit at Nismes appears considerably condensed compared to the other sections. The same arguments which were used to explain thickness variations in the lower Givetian (i.e., different sedimentation rates, erosion etc.) can be used here, with the most likely explanation being differential subsidence on the active fault blocks. Therefore, the area around Nismes would have been a structural high.

Since there are no definitive marker bands within the upper Givetian in the Ardennes it is difficult to correlate between successions with accuracy. The three units which have been

identified in the logged successions are therefore particularly useful packages not only for correlation purposes, but also to identify condensed and thickened successions.

### *Aachen*

Since the 1960's much work has been done in the Aachen area since it exposes many outcrops in the Givetian and Frasnian 'Upper *Stringocephalus* Beds' (Fig. 5-3). Kasig (1966) did most of the pioneering work in identifying facies-types and recognising the cyclic nature of the rocks. He did not, however, consider what may be causing the cyclicity until 1980, suggesting it could be either eustatic or tectonic related. The mechanisms causing the cyclicity will be further discussed in Chapter six. For this study four upper Givetian outcrops have been examined, covering most of that time period (Fig. 5-8). Outcrops are mostly in abandoned quarries, which are now invariably overgrown; therefore, complete sections were often difficult to accomplish.

Initially, sediments of upper Givetian age were deposited on a carbonate ramp, where open marine bioclastic wackestones and packstones dominated. These ramp facies are well exposed at Teerstraßenbau quarry (see Section A2.24 for detailed log). The base of the succession is dominated by interbedded mudstones, wackestones and packstones of microfacies R1 and R2 affinities (0m-26m). Crinoids are particularly abundant in these facies, along with brachiopods, solitary corals, bivalves and gastropods. The units are variably bioturbated and deposition was in the outer to mid ramp environment. Dolomitisation is more important in the higher parts of the succession (13m-39m). The dolomite is fabric-destructive and of a burial origin, thus hindering facies analysis. Rare undolomitised horizons do expose units rich in *Stringocephalus* brachiopods, dendroid stromatoporoids (only rare *Amphipora*), gastropods and bivalves which often occur as very thick (up to 80cm) accumulations. Locally these accumulations show graded bedding, suggesting storm or current reworking. These dolomitised units record the transition from a ramp to shelf setting.

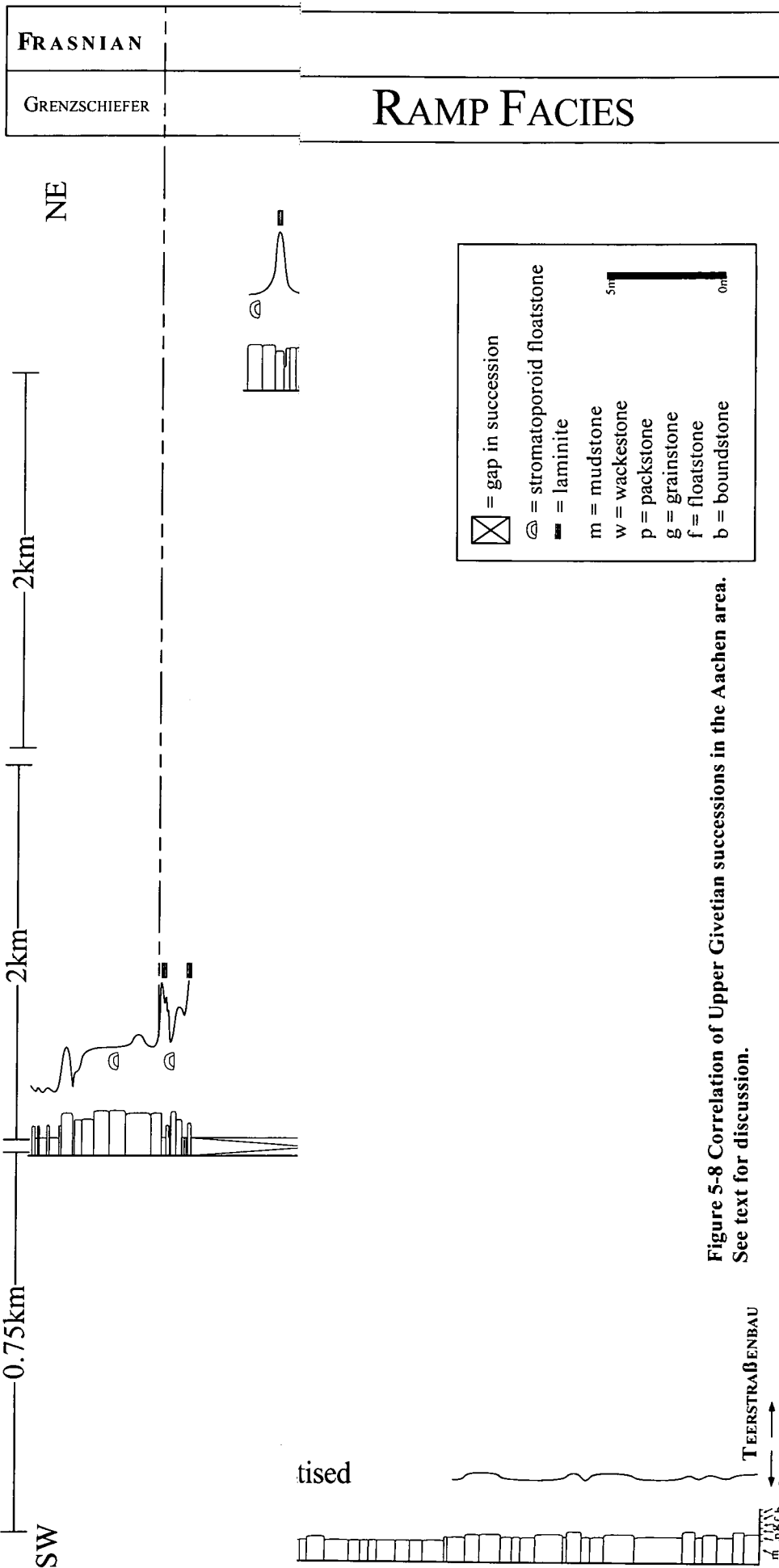

Figure 5-8 Correlation of Upper Givetian successions in the Aachen area. See text for discussion.

From 40m to the top of the log (83m) the succession is characterised by lagoonal deposition. Although the succession is incomplete, the local evolution of the lagoon at Teerstraßenbau quarry shows a broad shallowing from *Stringocephalus*-rich storm-deposited accumulations (microfacies S3) interbedded with bioclastic horizons (S5 facies) through to interbedded fenestral limestones and laminite horizons (microfacies S8 and S12). Small biostromes (S2 facies) and poorly fossiliferous horizons (S6) can be seen throughout this upper part of the succession. This evolution from highly-fossiliferous to poorly-fossiliferous facies, the associated decrease in salinity and circulation and decrease in water depth not only records a shallowing in the long-term relative sea-level history, but also a seaward retreat of the barrier-reef so that facies become more and more restricted. The nature of this barrier-reef is difficult to assess, as it has either been faulted out and eroded, or covered by Mesozoic rocks. In the Aachen and Eifel areas the lagoonal deposits are the only portions of the reef complex which are still preserved (Burchette, 1981). The presence landwards of restricted lagoonal facies would suggest that the reefs can be regarded as true barrier-reefs, where comparisons could be made with the westerly extension of the shelf present in northern France (see Lecompte, 1970 for details).

Three other successions at Venwegen, Alt Breinig and Walheim Southern Limb expose late upper Givetian facies which are lagoonal in nature. Dolomitisation again plays an important role, locally being fabric destructive thus preventing facies analysis. This process has effected the complete succession at Venwegen and the basal 8m of the section at Walheim Southern Limb. The succession at Walheim Southern Limb, however, does expose the Givetian-Frasnian boundary, thus making a useful correlation section. As with the Ardennes sections, the base of the Frasnian is characterised by a sudden transgression and landward retreat of the barrier-reef. Therefore, open-marine facies are seen to directly overlie restricted lagoonal facies. It is only during this deepening phase that the barrier-reef is exposed. These will be further discussed in Section 5.1.4.

The late upper Givetian strata in the Ardennes region show variable facies, from semi-restricted subtidal through to supratidal. The facies are extremely similar to those seen in the Ardennes, with stromatoporoid biostromes recording the deepest, most circulated waters and laminites representing deposition in the intertidal to supratidal zone. Throughout the late upper Givetian the subtidal lagoon at Aachen was dominated by low-energy waters. The matrix to most subtidal facies is micritic, where peloids are abundant

and bioturbation destroys sedimentary structures. *Amphipora* was a locally important constituent where the branches formed thickets which covered a vast area over the lagoon. These branches had baffling properties and are often seen in near-life position. Bioclasts were not abundant; however, forams, ostracodes and calcispheres did contribute substantially to the microfossil community. Cyanobacteria were important, especially in the creation of oncoids (microfacies S6d) and in the baffling of sediment in the intertidal to supratidal zone where stromatolites were present. One horizon at Alt Breinig displays the binding role of cyanobacteria particularly well, where low amplitude LLH-C stromatolites developed (@34m, see Section A2.1 for log and Figure 4-17d for field photograph). Impersistent high-energy intervals in the subtidal lagoon are recorded by peloidal grainstones or by thin ostracode accumulations. Intraclasts, oncoids and algae (especially dasyclads, and more unusually, codiaceans (?*Palaeoporella*)) also contribute to these horizons. Fenestral horizons are locally seen in the Aachen area, especially at Walheim Southern Limb. Here the fenestrae are laminoid, irregular and tubular, yet differ from those seen in the Ardennes as they are associated with a peloidal grainstone facies (microfacies S8c, see Figures 4-14b and 4-14c). This would suggest that the intertidal zone was an unusually high-energy environment in the Aachen area.

Although the sedimentation style in the Ardennes tract could be divided into three phases, it is apparent that this is not possible in the Aachen area (Fig. 5-8). A distinction can be made between ramp and shelf facies, and the early upper Givetian is characterised by a broad regression. The middle and late upper Givetian, however, show no distinctive changes in sedimentation style, suggesting the long-term relative sea-level history remained at a rather constant low. Although this constant relative sea-level low resulted in sedimentation which shows little long-term evolution, small-scale sea-level fluctuations were overprinting this sea-level history, producing a very pervasive metre-scale cyclicity. This feature will be further discussed in Section 5.1.6 and Chapter 6. The Givetian-Frasnian boundary saw a dramatic rise in relative sea-level which will be discussed in the following Section.

### *Eifel*

The upper Givetian of the Eifel area, as with the rest of the shelf, is characterised by interbedded biostromes and restricted lagoonal facies (Burchette, 1981). These facies,

however, are poorly exposed and intensely dolomitised and therefore have not been studied for this thesis.

#### 5.1.4 Givetian-Frasnian boundary

The Givetian-Frasnian boundary is important in the study area, since it records a very sudden transgression and landward retreat of the shelf-margin barrier-reef. Biostratigraphically the base of the lower *Pol. asymmetricus* conodont zone marks the boundary between the Givetian and Frasnian stages (Oliver and Chlupáč, 1991). In the southern Dinant Basin this is represented by the Frasnés Formation and in the Aachen area by the Grenzschiefer.

The Givetian-Frasnian boundary has been studied in two successions, at Sourd d'Ave and Walheim Southern Limb. The succession at Sourd d'Ave has been extensively studied in the past few decades, and was proposed by Bultynck *et al.* (1987) for the boundary stratotype. Here the Givetian-Frasnian boundary is recorded by the very sudden transition into interbedded marly shales and nodular limestones (Fig. 5-9). Examination of the ostracode assemblages suggests deepening is progressive from a marginal basin environment at the beginning of the Frasnian to a deep basinal environment (Bultynck *et al.*, 1987). These facies show a rich faunal assemblage including bryozoans, brachiopods, bivalves, gastropods, tentaculitids, nautiloids and fish fragments (Bultynck *et al.*, 1987). This deep-water intercalation continued until the early middle Frasnian (middle and upper Frasnés Formation) when barrier-reef and lagoonal deposition was re-established (Burchette, 1981).

A similar transition into deep-water open-marine facies can be seen at Walheim Southern Limb in the Aachen area of Germany. Here the open-marine package is 5m thick and a distinct transgression is recorded therein. This is characterised by the development of a biostrome (locally up to 4m in height; possibly the barrier-reef?; see Figure 4-10c) followed by interbedded marls and nodular limestones (Grenzschiefer; Fig. 4-3a). Meischner (1964) suggested the interbedded marls and limestones represented turbidites. However, the present study did not recognise erosional bases, sole marks or other sedimentary structures suggestive of such deposits. The facies do unequivocally record a brief shift into an open-marine environment, which after 4-5m of sediment return to restricted lagoonal facies.



**Figure 5-9** Givetian-Frasnian boundary at Sourd d'Ave, southern Ardennes. The Upper Devonian facies are well-bedded, restricted limestones which very quickly pass into nodular limestones and marly shales of the Frasnian. Note bedding is overturned. Outcrop approximately 8m high.

### 5.1.5 Lower Frasnian

For the purpose of this study the lower Frasnian is considered to encompass the Reef Limestones of the Aachen area. The lower Frasnian has not been studied in the Ardennes or Eifel areas, due to poor outcrop and intense dolomitisation. Two reefal-horizons, with their corresponding lagoonal facies, have been recognised in the early to middle Frasnian of the Ardennes areas (Burchette, 1981; Tsien, 1988). However, dolomitisation has overprinted these units making facies analysis practically impossible (Lecompte, 1970). Tsien (1988) suggested syndepositional faulting along the shelf margin was still important during the lower Frasnian since the basin was more mobile than the relatively stable shelf. Similar dolomitised facies are also present in the Eifel area, yet only the broadest stratigraphical details are still identifiable (Burchette, 1981). Richter (1970), however, studied the Upper Devonian Walleisheim Dolomite and suggested that the early diagenetic dolomite represented intertidal to supratidal deposition.

## Aachen

The lower Frasnian Reef Limestones of the Aachen area consist of 125m of cyclic lagoonal carbonate facies (Kasig, 1966; Hollerbach and Kasig, 1980; Kasig, 1980; Wilder, 1985). These facies have been studied in three abandoned quarry sections at Schmithof and southeast of Walheim (Walheim Sections 1 and 2).

The best outcrops are seen at the Schmithof quarry and Walheim Section 1 where facies are well exposed and easily identifiable (see Sections A2.22 and A2.28 for detailed logs). Schmithof quarry also exposes the boundary with the overlying 'nodular limestones' which represents the final drowning of the carbonate platform (Fig. 5-3). Lower Frasnian lagoonal facies range from semi-restricted subtidal through to supratidal. Biostromes (microfacies S2), in contrast to the upper Givetian are particularly well developed in the lower Frasnian. They occur more abundantly, are thicker (commonly 2-3m) and faunas are locally preserved in near-life position, suggesting there were only weak storms in the lagoon. Bulbous stromatoporoids are the major constituents, sometimes reaching 30cm in diameter, yet more commonly being 8-10cm in diameter. *Thamnopora* is locally seen to grow on top of the bulbous stromatoporoids, and *Amphipora* also has a close relationship with the bulbous stromatoporoids, inhabiting the interstitial spaces and baffling sediment. Bulbous stromatoporoids (mostly *Actinostroma* and *Clathrodictyon*, Kasig (1976)), also colonised transgressive lags (microfacies S1), suggesting this facies (S2) represented the deepest, yet most oxygenated and best-circulated lagoonal environments. A common feature associated with the lower Frasnian biostromes is an erosional base. These can have an amplitude up to 7cm and are not seen elsewhere in the shelf lagoon. Walheim Section 1 records the only occurrence of this brecciated transgressive deposit in the study area (see Section 4.2.1.1 and Figure 4-8 for details). This would suggest that transgressive pulses in the lower Frasnian were more sudden than those in the Givetian.

Restricted subtidal environments are characterised by *Amphipora* thickets. These facies occur extensively in the lower Frasnian where the *Amphipora* branches are invariably in life position. Poorly fossiliferous horizons are interbedded with these *Amphipora* thickets, commonly grading up into microbial laminite horizons (see detailed logs in Appendix 2). Dolomicrite horizons with pseudomorphs of anhydrite represent the most restricted,

supratidal environments, where the prevailing climate would have been arid. Interestingly, fenestral horizons are not as common in the lower Frasnian as in the Givetian.

Correlation of successions in the Aachen area is difficult, since outcrops are short and discontinuous. However, two marker horizons at the base (Grenzschiefer) and top (Nodular Limestones) of the Reef Limestone Beds do help. The succession at Schmithof is younger than those at Walheim, since approximately 10m above the end of the log the transition to deeper-water middle Frasnian 'nodular limestones' is exposed. Walheim Section 2 is approximately the same age as Schmithof as sediment styles are similar, and nodular and marly shales outcrop approximately 15m NW of the end of the section (representing the 'Nodular Limestone' beds) (Fig. 5-10). The oldest succession is Walheim section 1, as the 'Grenzschiefer' is positioned approximately 30m below the start of the log (Kasig, 1966). As the lower Frasnian 'Reef Limestone Beds' average 125m thick in total (Kasig, 1980), a gap of approximately 25m between Walheim Sections 1 and 2 can be gestimated.

It is clear from the varying facies-types that the lagoon around the Aachen area experienced small-scale fluctuations in relative sea level. This resulted in a distinctive metre-scale cyclicity (see discussion in Section 5.1.6 and Chapter 6). Another magnitude of cyclicity can also be identified. Using the facies packages which record a maximum (microfacies S2) or minimum (microfacies S12) in water depth, a longer-term local relative sea-level history may also deduced (Fig. 5-10). This identifies periods of relative highs and lows in sea level, which are correlatable between sections. Unfortunately, the inability to construct a complete section through the whole of the lower Frasnian hinders our full understanding of the sea-level history.

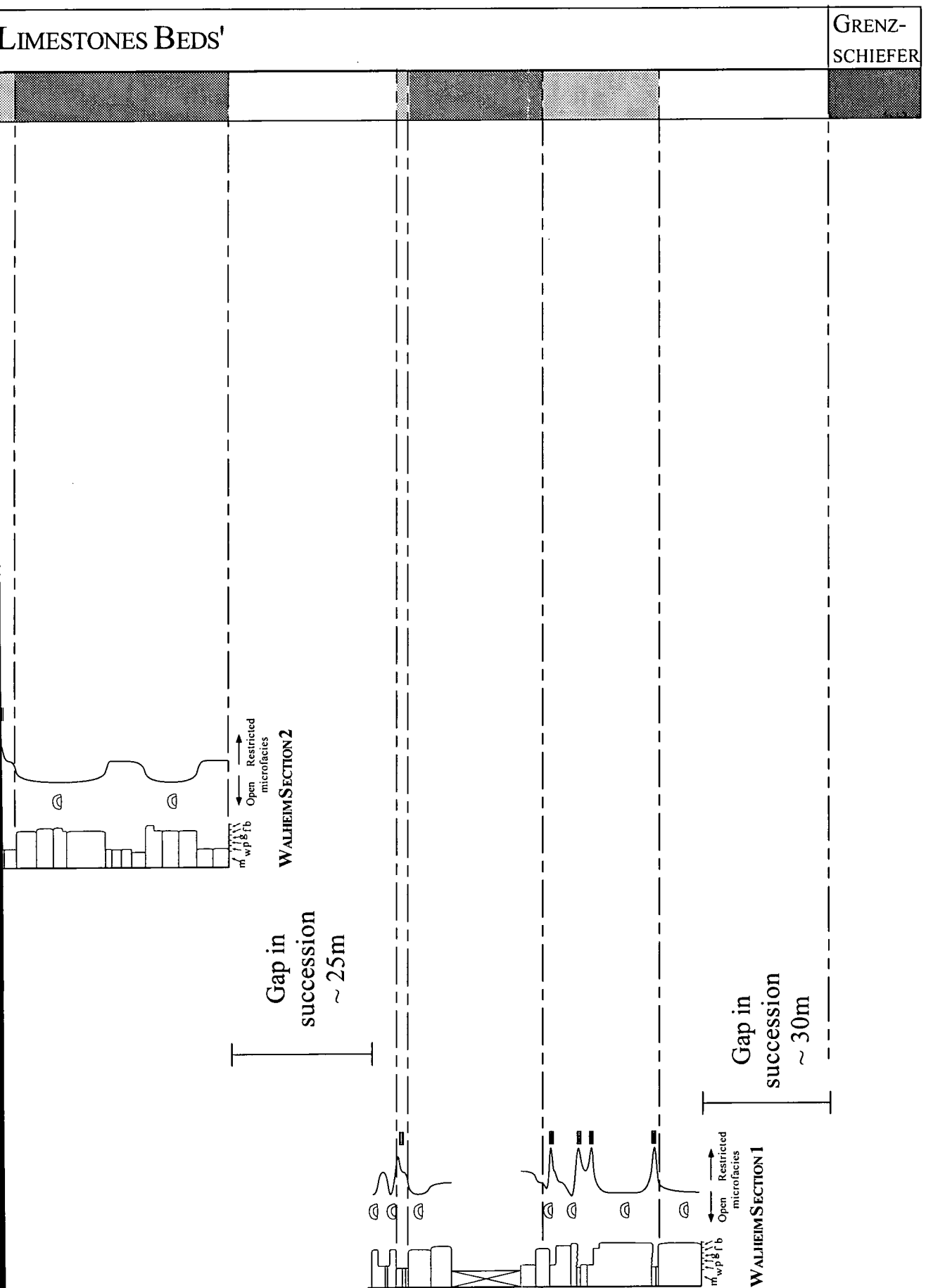
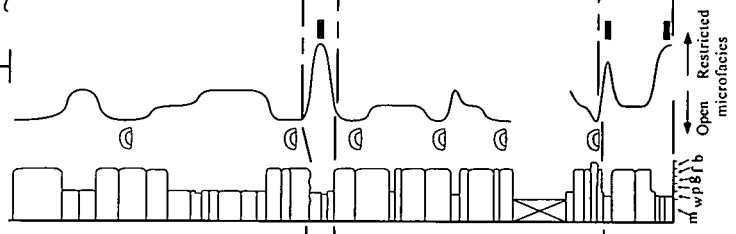

Figure 5-10 Correlation of Lower Frasnian successions in the Aachen area. See text for discussion.

**NODULAR LIMESTONES**

Gap in succession ~ 10m

2km



SCIMITHOFF

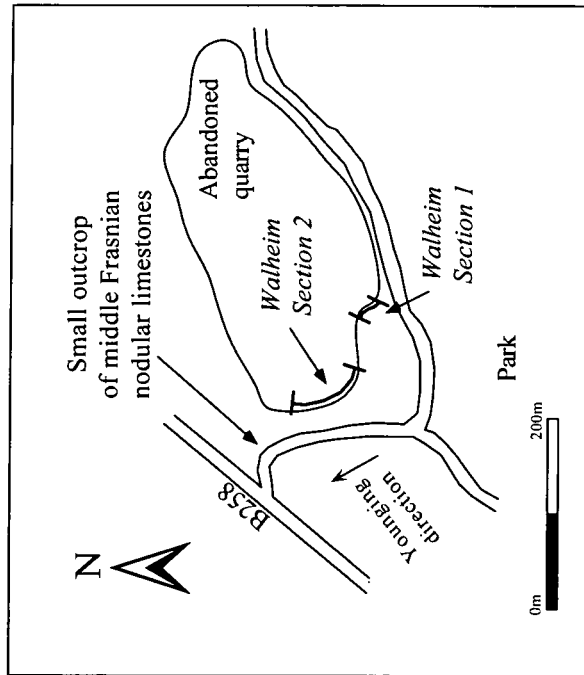

- ⊖ = stromatoporoid floatstone
- ⊖ = laminites
- m = mudstone
- w = wackestone
- p = packstone
- g = grainstone
- f = floatstone
- b = boundstone

- ⊖ = Gap in succession
- ▨ = Relative low sea level
- ▨ = Relative high sea level
- ▨ = Basinal open-marine sedimentation

5m 0m

### 5.1.6 Cyclicity

A metre-scale cyclicity is very pervasive throughout the Givetian and Frasnian of the Ardennes-Aachen-Eifel area. These cycles are very well-developed in the lagoonal facies, yet can also be seen in the Givetian ramp facies. Cyclicity was determined by assessing the vertical stacking of facies in the successions. The base of a cycle is identified by the initial backstepping of a less restricted facies-type over a restricted facies-type. Cycles can therefore be either transgressive-regressive or wholly regressive. This depends on the rate of the ensuing transgression and the ability or inability of sedimentation to pace subsidence.

Three major groups of cycle-type have been established (Table 5-2). Type A and Type B cycles are associated with shelf successions. Type A cycles show evidence for a decrease in circulation, decrease in diversity of organisms and decrease/increase in salinity upward through the cycle. It is difficult to determine if there is a shallowing-upward component to these cycles. Type A cycles are entirely subtidal in nature. Type B cycles shallow-upwards. These cycles also show a decrease in diversity of organisms and increase in fluctuation of salinity, up through the cycle. Type C cycles are associated with ramp facies and generally show shallowing-upward trends. This is often also accompanied by an increase in spar component and increase in abrasion of bioclasts.

| Cycle-type | Characteristics   | Occurrence  |
|------------|---|---|
| A1         | Cycles have semi-restricted subtidal bases and restricted subtidal tops. They show a decrease in circulation-, decrease in diversity of organisms and increase in salinity upwards through the cycle. Cycles are both symmetrical and asymmetrical.<br>Cycle thickness ranges from less than 0.5m to 6.5m, yet averages 1.9m. | Common throughout the Givetian and Frasnian successions. Particularly abundant in the 'lower unit' of the Trois Fontaines Formation (lower Givetian) and in the upper Givetian Fromelennes Formation. |
| A2         | Cyclicity within the restricted subtidal facies. These cycles show a decrease in diversity upwards through the cycle, synonymous with a ?decrease in salinity. Cycles are mostly asymmetric (regressive).<br>Cycle thickness ranges from 0.2m to over 7m, with an average thickness of 1.9m.                                  | Common throughout the Givetian and Frasnian, but especially in the upper Givetian Fromelennes Formation and the middle Givetian of the Eifel area (Keldenich).  |
| A3         | Cyclicity within the semi-restricted subtidal facies. These cycles show an increase in energy and decrease in diversity of organisms upwards through the cycle. Cycles are regressive. The cycle is 5.4m thick.   | Only seen in one horizon in the lower Givetian of Olloy-sur-Viroin.   |

**Table 5-2 Eleven different cycle-types identified in the Givetian and Frasnian of the Ardennes-Aachen-Eifel study area.**

|    |   |   |
|----|---|---|
| B1 | Cycles which shallow from a semi-restricted subtidal base to an intertidal cap. Shallowing is accompanied by a decrease in diversity of organisms and increase in fluctuating salinity. Cycles are both transgressive-regressive, and regressive.<br>Cycle thickness ranges from 0.3m to 5.7m, averaging 2.5m.                                | Not very common cycle-type. Distributed through all time periods.   |
| B2 | Cycles which show shallowing from restricted subtidal facies to intertidal facies. Shallowing is accompanied by a decrease in diversity of organisms and increase in fluctuating salinity. Cycles are mainly regressive, without any transgressive component.<br>Cycle thickness ranges from 0.1m to 6.2m, with an average thickness of 2.1m. | Common cycle-type. Seen mostly in the lower Givetian at Resteigne, Froid-Lieu Keldenich and at Teerstraßenbau |
| B3 | 'Complete cycles' which fully shallow from a semi-restricted subtidal base through to a supratidal cap. Shallowing is accompanied by a decrease in diversity of organisms and increase in fluctuating salinity. Cycles are regressive (asymmetrical).<br>Cycle thickness ranges from 0.2m to over 9m, with an average thickness of 2.1m.      | Common throughout the Givetian and Frasnian shelf successions.  |
| B4 | Cycles which shallow from subtidal restricted facies to supratidal facies. Shallowing is accompanied by a decrease in diversity of organisms and increase in fluctuating salinity. Cycles are mostly asymmetric.<br>Cycle thickness ranges from 0.2m to 4.7m, with an average of 1.2m.  | The most common B-type cycle, occurring at all stratigraphic levels in the Ardennes, Aachen and Eifel areas.  |
| B5 | Cyclicity within the intertidal to supratidal zone. Cycles are asymmetric (regressive).<br>Cycle thickness is 0.2m.   | Only seen in one horizon at upper Givetian Walheim Southern Limb Section.                                     |
| C1 | Cycles which shallow from outer to inner ramp facies. Cycles are regressive, being asymmetrical.<br>Cycle thickness ranges from 0.2m to over 10m, with an average thickness of 2.8m.  | Identified in all ramp successions. Most common C-type cycle.   |
| C2 | Cycles which shallow from outer to inner ramp. Cycles show an increase in spar matrix, and increase in abrasion. Cycles are asymmetric.<br>Cycle thickness ranges from 0.4m to 5.4m, averaging 2.5m.  | Identified both in the lower Givetian successions at Glageon and Bellignies-Betrechies.                       |
| C3 | Cycles which shallow from open marine ramp to restricted ramp facies. Cycles show a decrease in diversity of organisms, and increase in lime-mud. Cycles are asymmetric.<br>Cycle thickness ranges from 0.2m to 7.4m, averaging 2.5m.   | This cycle-type is most prominent in the lower Givetian ramp succession at Bellignies-Betrechies.             |

Table 5-2 continued.

Patterns of cycles can often be seen in successions, which are related to various external forces. For example the presence of a type of cycle may relate to a specific position in the longer term sea-level history; it can be predicted that type B5 cycles would occur where the longer-term sea-level was at a low. This in turn would relate to the time period of that

cycle. The type of cycle may also relate to the relative position of the succession with regards to the shoreline; a succession nearer the shoreline would be likely to record shallower facies, have more exposure surfaces and therefore be of a specific cycle-type. These concepts, the stacking patterns which the cycles portray and other magnitudes of cyclicity are all considered fully in Chapter 6.

### **5.1.7 Summary**

The Givetian and Frasnian carbonates of the Ardennes-Aachen-Eifel area show both open marine and restricted facies. The distribution of the facies-types depends on the areal position of the succession and also its vertical position with respect to time. Figure 5-11 presents a composite diagram showing the major facies characteristics through time, variations along the carbonate platform and the long-term sea-level curve, summarising all of the data presented in Sections 5.1.1 to 5.1.6.

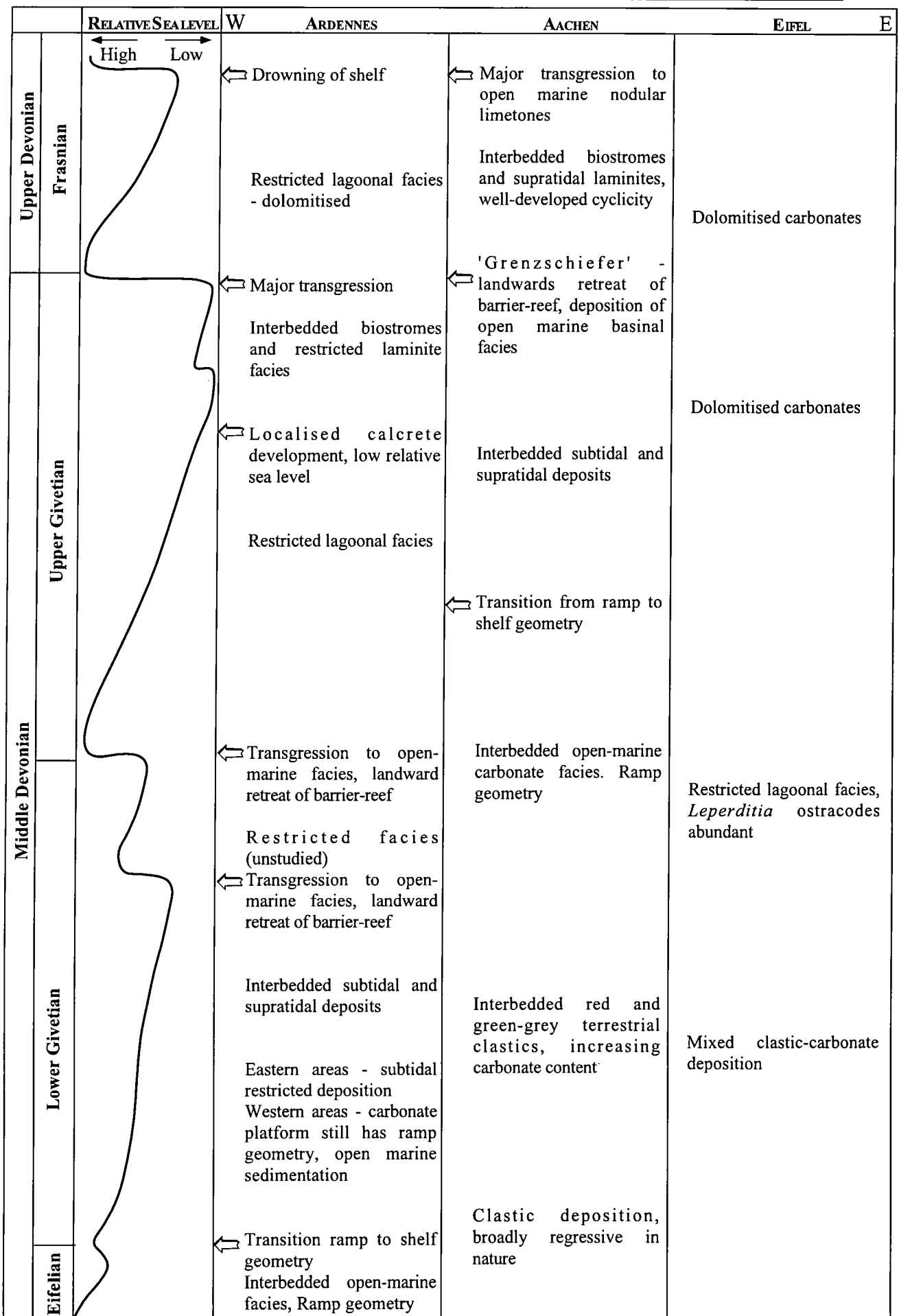

Figure 5-11 Summary diagram showing long-term relative sea level curve, platform geometry and key facies.

## 5.2 Isolated Carbonate Complexes

Isolated carbonate complexes, as defined by Burchette (1981) are “*organic buildups which developed upon submarine elevations within shelf areas or basins and were isolated from direct input of terrigenous sediments*”. Within the Devonian strata of Germany and Southwest England two types of isolated carbonate complex can be identified; i) those with a central lagoon (e.g., Attendorn, Balve) and ii) those with a table-reef geometry without a central lagoon (e.g., Warstein). This thesis concentrates on the former, where lateral facies variations across the carbonate complex are well differentiated.

Six isolated carbonate complexes have been studied; Attendorn, Brilon, Torbay, Balve, Dornap and Langenaubach (Fig. 5-12). These complexes were chosen for study because of accessibility of suitable outcrop and reasonably weak post-sedimentary deformation and lack of destructive diagenesis (such as dolomitisation). For those complexes not studied, the reader is asked to refer to the list of published work presented in Table 5-3.

| Unstudied isolated carbonate complexes with central lagoon | List of published work                                  |
|--|---|
| Wülfrath   | Karrenberg, 1954<br>Burchette, 1981                     |
| Bergisch Gladbach  | Dietz <i>et al.</i> , 1935<br>Jux, 1969<br>Hering, 1994 |

**Table 5-3 Table of published work on Wülfrath and Bergisch Gladbach Carbonate Complexes.**

In the Rhenisches Schiefergebirge local tectonic movements, which were controlled by deep-seated granites, had a strong influence on styles of sedimentation (Burchette, 1981). The development of rising crystalline domes, flanked by subsiding basins led to the localised initiation of reefs which grew mainly on the subsiding flanks of the positive structures (Krebs and Wachendorf, 1973; Krebs, 1976). Shales and turbidites were deposited in the mobile deep basins.

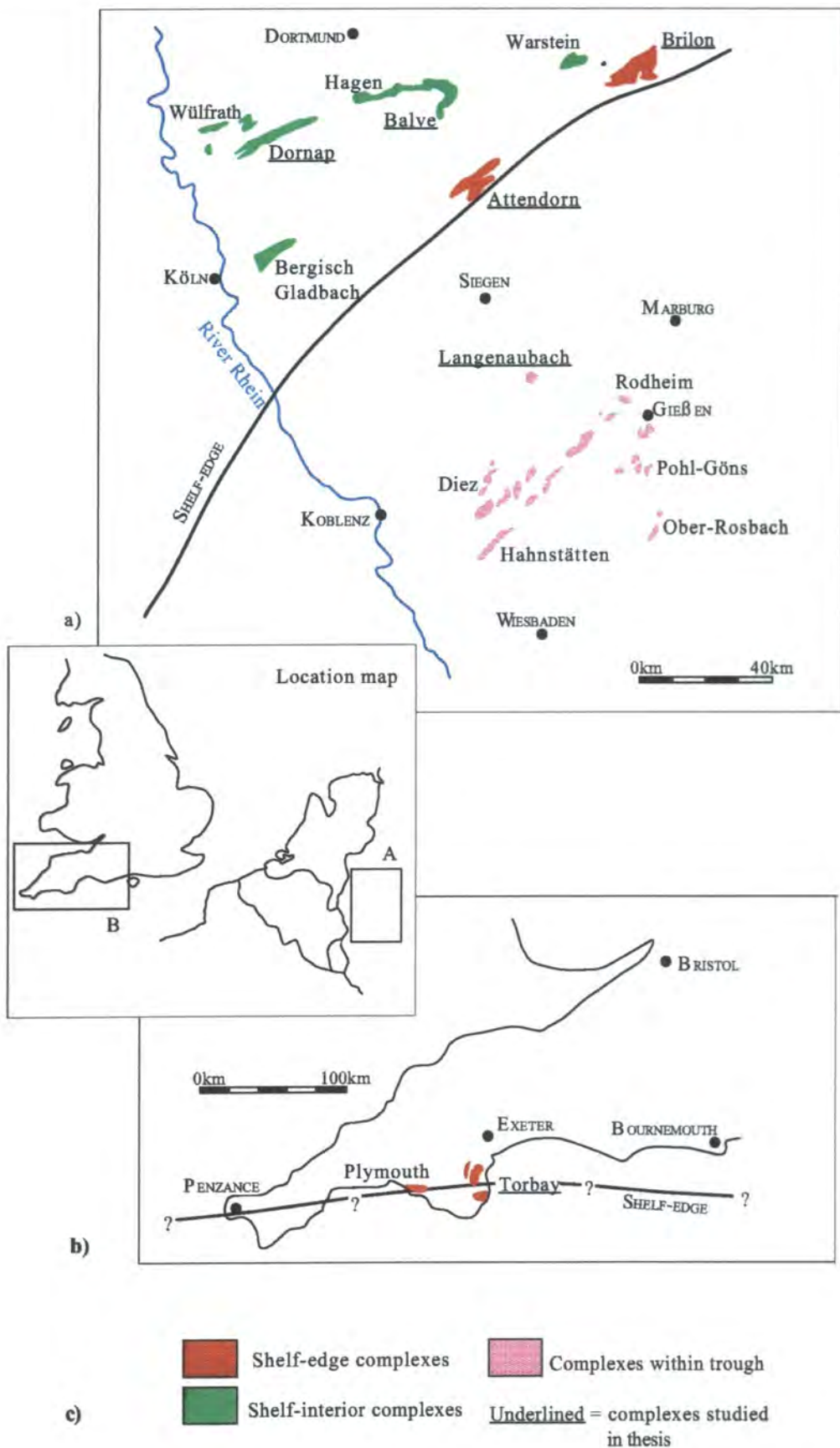
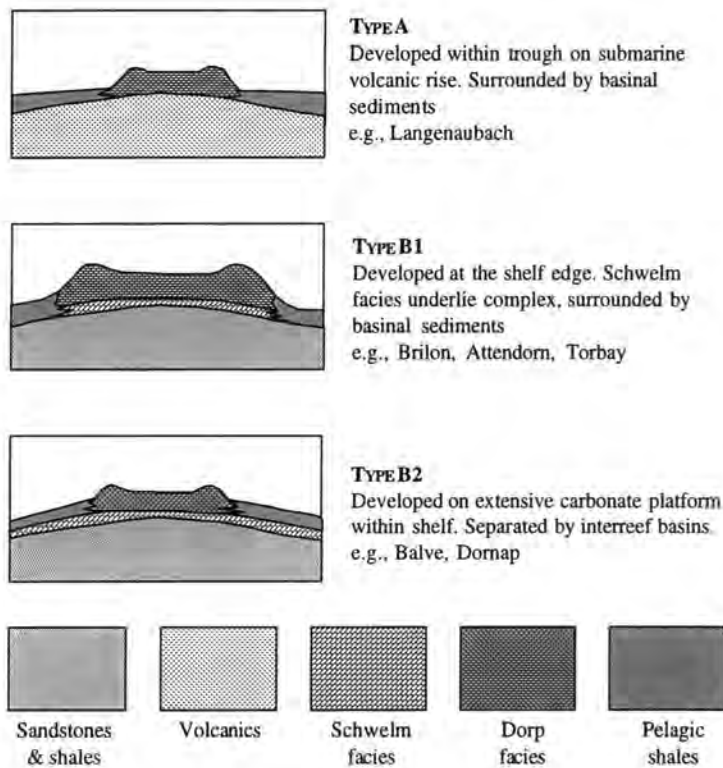

Figure 5-12 a) Location map showing distribution of Devonian isolated carbonate complexes in western Germany (modified from Krebs, 1974). b) Location map showing distribution of Devonian carbonate complexes in Southwest England. c) Key for Figure.

Work by Krebs (1971, 1974) recognised three different palaeosituations where isolated carbonate complexes developed in the Middle and Upper Devonian in western Europe (Fig. 5-13). Those which developed along the shelf edge (type B1 of Krebs, 1974) include Attendorn, Brilon and Torbay Reef Complexes. Type B1 complexes are distinguished by their large size (Table 5-4), their position on the shelf edge rise and their enclosure by time-equivalent off-reef pelagic sediments. These buildups also have both a bank (ramp) and reef (shelf) phase. Type B2 complexes are situated *within* the broad shelf rather than on the shelf edge. These include the complexes of Balve and Dornap which were studied for this thesis. Characteristic inter-reef basins occurred between these complexes, where deep pelagic shales and turbidites were deposited. The complexes themselves tend to be smaller than those of B1 type. Finally, type A complexes were developed within the Rhenish trough and are associated with submarine volcanics. Langenaubach, which was studied for this thesis, developed in the trough where ophitic lavas and tuffs built up to sea level. Carbonate sedimentation did not prevail until volcanism had ceased at the end of the Middle Devonian. The carbonate complexes of type A are surrounded on all sides by basinal sediments.



**Figure 5-13 Three types of isolated Devonian carbonate complex. Adapted from Krebs (1974). See Section 2.2.3.2 also.**

| Carbonate complex | Types (Krebs, 1974) | Approximate thickness   | Approximate size                        |
|-------------------|---------------------|-------------------------|---|
| Langenaubach      | A                   | >200m (Krebs, 1966)     | 20km <sup>2</sup> (see Section 5.2.3.1) |
| Attendorn         | B1                  | 950m (Gwosdz, 1971)     | 70km <sup>2</sup> (Krebs, 1974)         |
| Brilon            | B1                  | >1000m (Krebs, 1974)    | 144km <sup>2</sup> (Hong, 1992)         |
| Torbay            | B1                  | ~500m (Scrutton, 1977a) | 1000km <sup>2</sup> (Scrutton, 1977a)   |
| Balve             | B2                  | 1,300m (Krebs, 1974)    | ?                                       |
| Dornap            | B2                  | ~400m (Gotthardt, 1970) | ?                                       |

**Table 5-4** Approximate former size (area) and thickness of studied isolated carbonate complexes. Table modified from Krebs (1974).

The ages of the carbonate complexes vary (see Figure 4-6). Their initiation is broadly transgressive in nature towards the north, with the oldest complexes developing on the shelf edge (Brilon, Torbay) and the younger complexes developing within the shelf (i.e., Balve, Dornap). Langenaubach is an exception to this rule, however, since its development was primarily controlled by volcanism.

The distribution of facies in the isolated carbonate complexes is controlled by several factors. Many of the complexes are fault-bounded (e.g., Brilon, Attendorn, Balve), with differential subsidence playing an important role in sedimentation rates, overall thickness of the complexes and distribution of facies. The influence of volcanics is particularly important in some complexes (especially those in the trough) and strongly controlled their development. Prevailing wind direction and climate in general was a strong control on facies distribution, especially on the development of the reef and deposition of storm-derived facies. Finally, their position on the shelf (i.e., on the shelf edge, within the shelf, or in the trough) had subtle controls on facies distributions. For example the shelf edge was more mobile than the inner shelf and trough and was therefore more susceptible to base-level fluctuations. This is represented by deposition of essentially cyclic sediments, reflecting water-depth variations.

### 5.2.1 Shelf-edge reefal complexes

Three complexes which developed on the shelf edge (type B1 complexes of Krebs, 1974) have been studied: Attendorn, Brilon and Torbay. Shelf-edge complexes are generally larger and thicker than those developed within the shelf and trough (Table 5-4). Many complexes are fault-bounded and are influenced by syndimentary volcanism, usually in the form of tuffitic bands. It is difficult to assess if the shelf-edge itself was in fact fault-bounded (Burchette, 1981). The complexes also display more variable back-reef facies,

including semi-restricted subtidal, restricted subtidal, intertidal and supratidal (see following Sections for details). Table 5-5 documents the location of the studied sections, Appendix 1 provides thin-section information and Appendix 2 presents the detailed logs for these successions.

| Reef Complex     | Name of succession       | Location (Topographic map number and co-ordinates)              | Thickness of log           |
|------------------|--------------------------|---|----------------------------|
| <b>Attendorn</b> | Heggen quarry            | 1:50,000, Map 12, Hochsauerlandkreis<br>r:34.2691 h:56.6871     | 164.22m<br>(Section A2.13) |
|                  | Grevenbrück quarry       | 1:50,000, Map 12, Hochsauerlandkreis<br>r:34.3057 h:56.6858     | no log                     |
| <b>Brilon</b>    | Bleiwäsche quarry        | 1:25,000, Map 4518, Madfeld<br>r:34.7900 h:57.0350              | 43.62m<br>(Section A2.4)   |
|                  | Bleiwäsche road cutting  | 1:25,000, Map 4518, Madfeld<br>r:34.7977 h:57.0357              | 9.43m<br>(Section A2.5)    |
|                  | Stemmel quarry           | 1:25,000, Map 4518, Madfeld<br>r:34.7980 h:56.9900              | no log                     |
| <b>Torbay</b>    | Broadridge Wood quarry   | 1:50,000, Sheet 202, Torbay and South<br>Dartmoor, SX 8390 7712 | 31.21m<br>(Section A2.6)   |
|                  | Linhay Hill quarry       | 1:50,000, Sheet 202, Torbay and South<br>Dartmoor, SX 7680 7107 | 51.12m<br>(Section A2.15)  |
|                  | Rydon quarry             | 1:50,000, Sheet 202, Torbay and South<br>Dartmoor, SX 874 741   | 21.65m<br>(Section A2.21)  |
|                  | Goodrington road cutting | 1:50,000, Sheet 202, Torbay and South<br>Dartmoor, SX 895 582   | 12.5m<br>(Section A2.11)   |

**Table 5-5 List of successions studied in the Attendorn, Brilon and Torbay Reef Complexes.**

### 5.2.1.1 Attendorn Reef Complex

The Attendorn Reef Complex extends northeast of Attendorn towards Finnentrop and Grevenbrück in the Sauerland area of western Germany (Fig. 5-12; Fig. 5-14). It has been most extensively studied by Krebs (1968, 1971, 1974) and Gwosdz (1971, 1972), yet since 1974 very little data have been published on this complex.

The Attendorn Reef Complex was initiated in the middle Givetian and carbonate sedimentation continued through to the *Pa. gigas* conodont zone of the Frasnian (Gwosdz, 1971; Krebs, 1971; Krebs 1974). Carbonate sedimentation was initially of bank (Schwelm) facies where up to 300m accumulated on the northwestern flank of the Attendorn syncline (Gwosdz, 1971). Carbonates of the Dorp facies were subsequently deposited and showed a distinct lateral variation in facies so that an atoll-shaped isolated carbonate complex was defined (Fig. 5-14; Krebs, 1971). The Dorp facies could be divided into pelagic, fore-reef, reef-core and back-reef, with the back-reef facies covering the largest area in the complex.

The Attendorn Reef Complex covered an area of 70km<sup>2</sup>, allowing for the 33% shortening by Variscan tectonics (Krebs, 1974). These Dorp reef successions reached thicknesses up to 650m attaining the greatest thickness in the northwestern part of the complex. Krebs (1971, 1974) suggested these increased thicknesses represented the ability of reef sedimentation to keep pace with the continuous strong subsidence on the highly mobile shelf-edge hinge. The Attendorn reef complex is fault-bounded (?synsedimentary) on its southeastern margin (Krebs, 1971).

A change in the rate of subsidence of the reefal areas and a widespread transgression led to the drowning of Attendorn reef where black shales were deposited over the deepest parts of the central lagoon and thin cephalopod limestones covered the reef rim. (Krebs, 1974). This occurred as early as the *Ancyrognathus triangularis* conodont zone in some parts of the reef (Gwosdz, 1971). Deposition of thick successions of black shales continued in the inter-reef basins (up to 450m; Kamp, 1968) which, compared to very thin deposits of cephalopod limestones on the reef-highs, suggests the inter-reef basins now had greater subsidence and the reef-highs were relatively stable (Krebs, 1974).

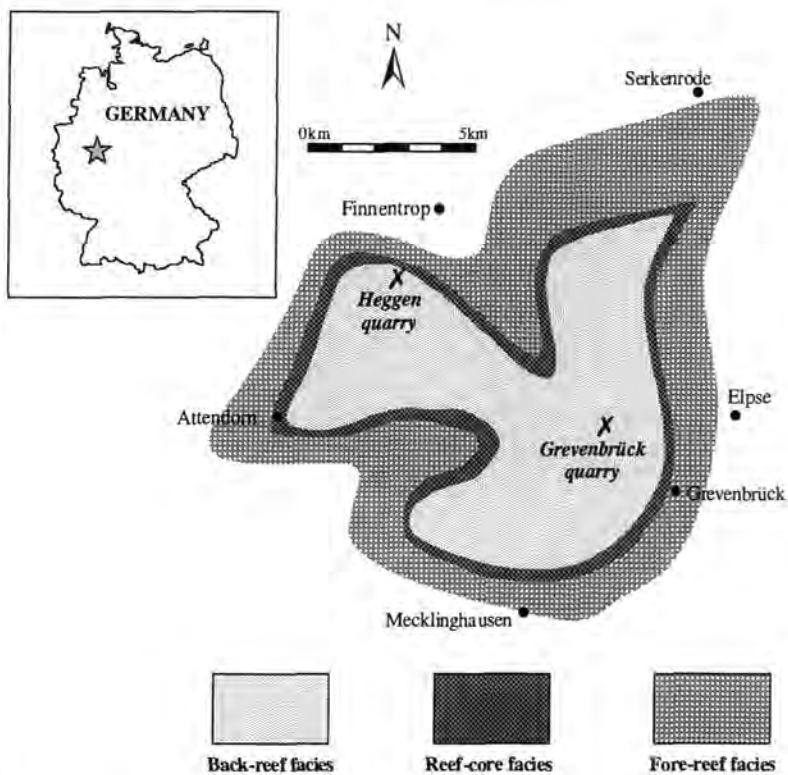

Figure 5-14 Palaeoreconstruction showing the original shape of the Attendorn Reef Complex and distribution of its facies. X marks locations of the two studied sections. Figure modified from Krebs (1971).

An economically important pyrite-sphalerite-barite ore deposit is situated 4km south of the Attendorn Reef Complex in the pelagic deposits of the Meggen Basin. This deposit is time-equivalent to the Attendorn Reef Complex (Krebs, 1972). To date there has been little evidence of time-equivalent volcanics around the Attendorn area.

Back-reef facies have been studied at two successions in the Attendorn Reef Complex, where very different successions are exposed (Table 5-5; Fig. 5-14).

A 165m thick succession is exposed at an overgrown abandoned quarry, southeast of Heggen (See Section A2.13 for detailed log). Strata dip subvertically and the succession youngs towards the NNW. Sedimentary structures such as graded bedding were used to determine the way-up of the succession.

Thinly-bedded, bioclastic grainstones with a rich faunal assemblage (microfacies S3a) are particularly well-developed in this succession. These facies are dominated by dendroid stromatoporoids (especially *Stachyodes*), broken-up laminar stromatoporoids (commonly 10cm long), crinoids and corals. Locally, reef-derived coral colonies, up to 42cm diameter, can be seen. Interbedded with bioclastic grainstone facies, yet volumetrically subordinate, are facies dominated by *Amphipora* and thamnoporoids (microfacies S4b). Again these are in a sparitic matrix, reflecting the persistent high energy of this depositional environment. The presence of *Amphipora* branches is thought to indicate slightly more restricted conditions (either in terms of salinity or circulation?). Local, small biohermal-like buildups can be seen in the Heggen quarry where bulbous and laminar stromatoporoids, with a lesser dendroid stromatoporoid component, dominate (microfacies S2). The fauna is well preserved with little reworking and attrition by strong waves or currents.

Diagenetic processes have occurred extensively at the Heggen quarry succession, with dolomitisation being the most pervasive process. Course-grained dolomite rhombs overprint both the matrix and bioclasts and often this process is so pervasive that facies assignation is impossible. The dolomitisation appears to preferentially affect bedding surfaces, or tectonic cracks/veins suggesting this was not an early diagenetic process.

The succession at Heggen quarry shows a very crude evolution through time (Fig. 5-15). The base (0m to 37.5m) is a very mixed, interbedded bioclastic grainstone, *Amphipora* grainstone and stromatoporoid floatstone succession. The central part of the succession

(55m to 90m) has a lesser *Amphipora* (microfacies S4) component, and the upper part returns to interbedded S2, S3 and S4 facies.

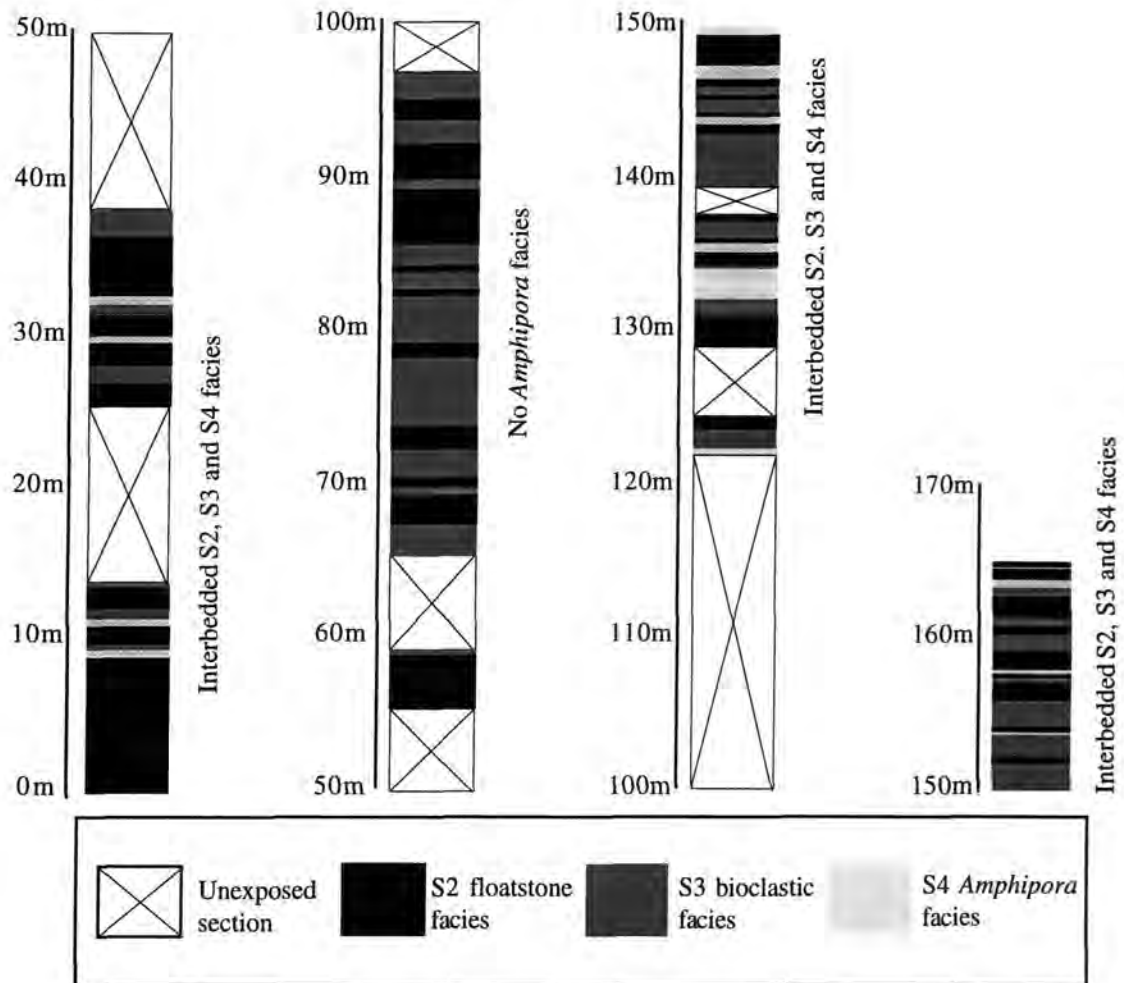

**Figure 5-15** Facies distributions at the Heggen quarry, Attendorn Reef Complex. Lower and upper parts of the succession are characterised by interbedded stromatoporoid floatstones (microfacies S2), bioclastic grainstones/ rudstones (S3a) and *Amphipora* grainstones (S4), whereas the middle part of the succession is *Amphipora*-free.

The presence or absence of *Amphipora*-dominated facies may be related to the influence of currents within the lagoon. Where there is an admixture of both reef-derived and lagoon-derived grains in the immediate back-reef facies (lower and upper parts of succession) both storms and strong currents would have played an important role; storms would have derived material from the reef, whereas currents could have generated accumulations of the *Amphipora* branches from the lagoon interior. In the central part of the succession, however, where there is an absence of *Amphipora*, currents may have played only a minor role in sediment accumulation. It is also interesting to note that this central part of the succession also records thick successions of stromatoporoid floatstones (microfacies S2),

with only minor storm (S3) accumulations. Therefore, during this stage of sedimentation there was an apparent storm- and current-quietness.

Another succession in back-reef facies can be seen at Grevenbrück quarry on the B236 road 1km northwest of Grevenbrück. The succession is very different from the high energy deposits seen at Heggen. Strata here are pervasively dolomitised and facies are very difficult to identify. However, where the strata are not so altered, facies are of a micritic and poorly-fossiliferous nature; they can be assigned to the S6 microfacies group. Krebs (1971) also noted the presence of *Amphipora* floatstones which had a dark micritic matrix (microfacies S4). The presence of poorly-fossiliferous horizons and monospecific fossil assemblages suggests deposition within a restricted environment. Therefore, this central part of the Attendorn Reef Complex represents a low-energy lagoon.

Examination of these successions suggests that at least two major subenvironments within the back-reef area of the Attendorn Reef Complex can be identified. High-energy grainstone and rudstone deposits can be seen at Heggen quarry and these are interpreted as being deposited in the immediate back-reef environment on the lee-side of the reef. Fine-grained, poorly-fossiliferous horizons have been seen in the Grevenbrück quarry and this succession is thought to have been located in the central, restricted part of the back-reef lagoon (see Figure 5-14). In this study only sedimentation of a subtidal nature has been identified. However, Krebs (1968) has noted the occurrence of fenestral, laminated peloidal grainstones in another succession in the complex. Therefore, the lagoon, infrequently, became elevated when an intertidal zone developed above shallow reef-debris flats (Krebs, 1968).

#### **5.2.1.2 Brilon Reef Complex**

The Brilon Reef Complex is located between Bleiwäsche, Brilon and Madfeld in the Nordrhein-Westfalen area of Germany (Fig. 5-12). Due to the extensive quarried outcrop and cores, the Brilon Reef Complex is probably one of the best understood Devonian reefal complexes in Germany. The complex is of type B1 (Krebs, 1974), being situated on the palaeoshelf edge. Both Schwelm and Dorp facies are identified, yet underlying these carbonates is a thick pile of basic lavas which until 1990 (Machel, 1990a) had not previously been documented. Clearly volcanism played an important role in the initiation of

sedimentation and this continued throughout carbonate deposition in the form of tuffitic bands (Hong, 1992).

Carbonate sedimentation started in the form of ramp facies in the upper Givetian (Machel, 1990a). These carbonate facies are approximately 70m thick and show no well-defined reefal zones thus having typical Schwelm characteristics (Machel, 1990a). Dorp facies were deposited from the latest Givetian (lower *Pol. varcus* conodont zone) through to the *An. triangularis*/*Pa. gigas* boundary in the middle Frasnian (Machel, 1990a; Hong, 1992; see Figure 2-1 for stratigraphic table). The thickness of these facies is around 630m (Machel, 1990a), yet locally can reach up to 1,000m (Paekelmann, 1936). After deposition of the Dorp facies, approximately 35m of Iberg facies can be identified (Machel, 1990a). These facies show no clearly defined reef zones, very much like the Schwelm. Carbonate deposition was terminated at the *An. triangularis*/*Pa. gigas* boundary where non-deposition and a hiatus prevailed (Stritzke, 1986). Typical 'schwollen' and 'becken' deposition of nodular limestones and shales continued through the rest of the Upper Devonian (Stritzke, 1989).

The shape of the Brilon Reef Complex is well-constrained due to the extensive outcrop (Fig. 5-16). Its asymmetric, ellipsoidal shape trends in a WNW-ESE direction and palaeoreconstructions suggest it would have covered an area of approximately 144km<sup>2</sup> (Hong, 1992), one of the biggest isolated complexes in Germany. From early Givetian through to late Frasnian, movement on the NW-SE trending Altenburen fault (located on the Northeast margin of the complex) influenced sedimentation and may explain the differential thickness of the Dorp facies across the complex (Krebs, 1974; Burchette, 1981).

As with many of the isolated complexes, Dorp facies across the Brilon Reef Complex were laterally impersistent with three major zones being identified: fore-reef, reef-core and back-reef. Fore-reef facies are dominated by debris-flow deposits, and further basinwards, turbidites (Stritzke, 1989). These rhythmically produced debris flows interfingered with *in-situ* limestones, claystones and red iron ores (Stritzke, 1989). Reef facies are characterised by laminar stromatoporoids, tabulate corals, rare rugosan corals and dendroid stromatoporoids such as *Stachyodes* (Städter and Koch, 1987). Corals are volumetrically

subordinate (Hong, 1992). Back-reef facies cover the largest area in the Brilon Reef Complex (Fig. 5-16).

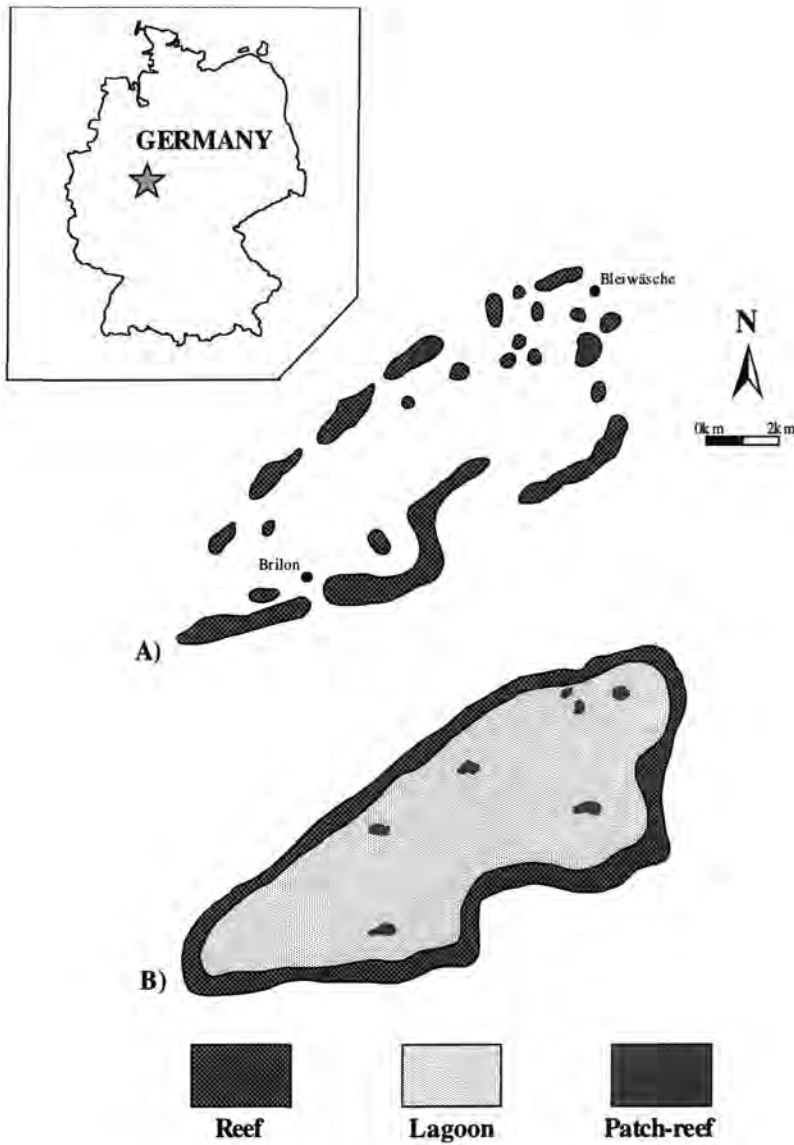

**Figure 5-16 a) Distribution of the Brilon atoll-reefs. b) Idealised biozonation of the Brilon Reef Complex. Diagrams adapted from Hong (1992).**

Two back-reef successions have been studied near Bleiwäsche in the northeastern part of the complex (Table 5-5). The best succession can be seen at the Eley quarry, West of Bleiwäsche, where a 44m log was constructed. Sedimentation is extremely variable, from subtidal through to supratidal (Table 5-6; see log in Section A2.4).

| Semi-restricted microfacies group |    | Restricted microfacies group |    |    | Intertidal microfacies group |     | Intertidal/supratidal microfacies group |      |
|-----------------------------------|----|------------------------------|----|----|------------------------------|-----|---|------|
| S2                                | S3 | S4                           | S6 | S7 | S8                           | S10 | S11                                     | S12  |
| 30%                               | 1% | 30%                          | 5% | 8% | 22%                          | 2%  | 1.5%                                    | 0.5% |
| Total: 31%                        |    | Total: 43%                   |    |    | Total: 24%                   |     | Total: 2%                               |      |

**Table 5-6** Table illustrating the proportion of microfacies in the Bleiwäsche quarry succession. Percentages are calculated with respect to total thickness of facies.

One of the most common microfacies are *Amphipora* floatstones and bafflestones (microfacies S4). The *Amphipora* branches are commonly scattered throughout the bed, or occur as dense thickets. There is very little reworking and the amphiporoids are well preserved. The matrix to this facies can be spar or micrite. This reflects the highly variable water energy at this locality. Rarely, *Amphipora* branches are encrusted by *Girvanella* (See Figure 3-9b). Dasycladacean algae are a locally abundant component to this microfacies. In the Bleiwäsche quarry section, *Amphipora* facies commonly grade into, or are overlain by, poorly-fossiliferous mud-wackestones (microfacies S6) or by fenestral mudstones and wackestones (S8 microfacies).

Stromatoporoid floatstones, dominated by bulbous morphologies, occur frequently throughout the succession. Locally, bedding is quite massive (locally in excess of 1.5m). The stromatoporoids are commonly 8-12cm in diameter and are locally in life-position. Also associated are amphiporoids and *Stachyodes*. The matrix is mostly micritic, very peloidal and has a rich microfossil assemblage including calcispheres, ostracodes and forams. Commonly, stromatoporoid floatstones grade into *Amphipora*-dominated bafflestones (See Section A2.4). An unusual feature in the Bleiwäsche quarry section is the relatively low proportion of the S6 poorly fossiliferous microfacies (Table 5-6). Where present, these horizons are rich in dasycladacean algae, calcispheres, forams and ostracodes.

Intertidal and supratidal deposits are very common in the Bleiwäsche successions, with fenestral horizons being particularly abundant. Fenestrae commonly form as an interconnecting network, associated either with microfossil-rich micrites (S8 microfacies) or microbial laminites (S10 microfacies). Commonly the fenestrae have an internal

sediment-fill of vadose silt at their base. Microstalactitic cements are locally present. Laminites are well developed, especially in the middle of the succession (see log in Section A2.4). These commonly show horizons of mudchips (mudchips are on average 8-9mm in length, very angular with no specific orientation), which represent storms impinging on to the high-intertidal to supratidal environment. The development of microbial laminites and consequent mud polygons are the most restricted facies seen at Bleiwäsche quarry.

The varied facies and energy levels seen at the Bleiwäsche quarry and Bleiwäsche road cutting suggest these successions were located within the tidal flat environment during the lower Frasnian. Other successions in the Brilon Reef Complex have alluded to the periodic development of patch reefs within the back-reef environment (Machel, 1990a; Hong, 1992; Fig. 5-16). These stromatoporoid framestones were 3-6m in height and each covered an area of 200-700m<sup>2</sup> (Hong, 1992). They appeared to develop mostly in the late Givetian to earliest Frasnian, during the initial stages of reef-development (Machel, 1990a). Sedimentation in the lagoon was not strongly influenced by storms. There is very little reef-derived debris in the back-reef environment and there is very little reworking of faunas. Storm and current deposition was important in the high-intertidal to supratidal zone so that microbial mats could be deposited and mud polygons reworked. The storms, however, did not impinge to greater water depths. The succession at Bleiwäsche quarry displays only a very subordinate bioclastic component, with rare gastropods.

Diagenesis of facies in the Brilon Reef Complex shows several stages of development (Machel, 1990b). Early diagenesis occurs most prolifically in fore-reef and reef-core facies where meteoric effects have been detected (Machel, 1990b). The back-reef environment appears to have been only marginally affected where rare microstalactitic cements are identified. Later stage diagenesis, associated with uplift in the Carboniferous, has also been identified, where deep fissures cut into the reef facies and are subsequently sediment-filled (Machel, 1990b).

Boreholes in the Brilon Reef Complex can allude to the overall local evolution of the lagoonal environment (Machel, 1990a). Sedimentation was initially of low-energy, subtidal facies and then the succession was dominated by intertidal to supratidal intercalations (Machel, 1990a). This change in sedimentation was related to either a change in

subsidence rate (high subsidence to low subsidence rate; Machel, 1990a) or longer-term sea-level histories.

The most prominent feature of the back-reef sediments in the Brilon Reef Complex is the cyclicity. The cyclicity occurs on a number of scales, from decimetre, to metre to hundreds of metre (overall evolution, which has already been discussed). Several types of decimetre and metre-scale cycle have been identified (Fig. 5-17), and follow the scheme presented in Table 5-2 for the shelf lagoon.

Type A. Cycles which show a decrease in circulation-, decrease in diversity of organisms and increase in salinity upward. These cycle-types are two-fold.

A1) Cycles which have a semi-restricted, subtidal, S2 bulbous stromatoporoid base and are capped by restricted *Amphipora* floatstones/ bafflestones (S4) or macrofossil-poor wackestones (S6) or grainstones (S7). These cycles are both asymmetric (regressive) and symmetric (transgressive-regressive) and range from 1.09m to 3.09m in thickness.

A2) Cycles which display only facies in the 'restricted microfacies' group. Cycles have an *Amphipora*-rich base (S4) and are capped by fossil-poor micrites (S6) or peloidal grainstones (S7). Cycles range from 1.9m to 2.7m in thickness and are asymmetric (see Section A2.4). These cycles show a decrease in fossil diversity upward, synonymous with an increase in fluctuating salinity. They also probably show shallowing, especially where capped by peloidal grainstone (S7) facies.

Type B. Cycles which show shallowing-upwards. This is also accompanied by a decrease in diversity of organisms and increase in salinity fluctuation. Three different types can be identified (B1, B2, and B3 of Table 5-2).

B1) Cycles which shallow from semi-restricted subtidal facies through to intertidal facies. These cycles have S2 bulbous stromatoporoid floatstones at their base, then have a restricted subtidal horizon (either *Amphipora* bafflestones or poorly-fossiliferous facies) and are then capped by fenestral mudstones and wackestones (S8) or fenestral laminites (S10). These cycles range from 0.76m to 4.08m in thickness and are either completely regressive or transgressive-regressive.

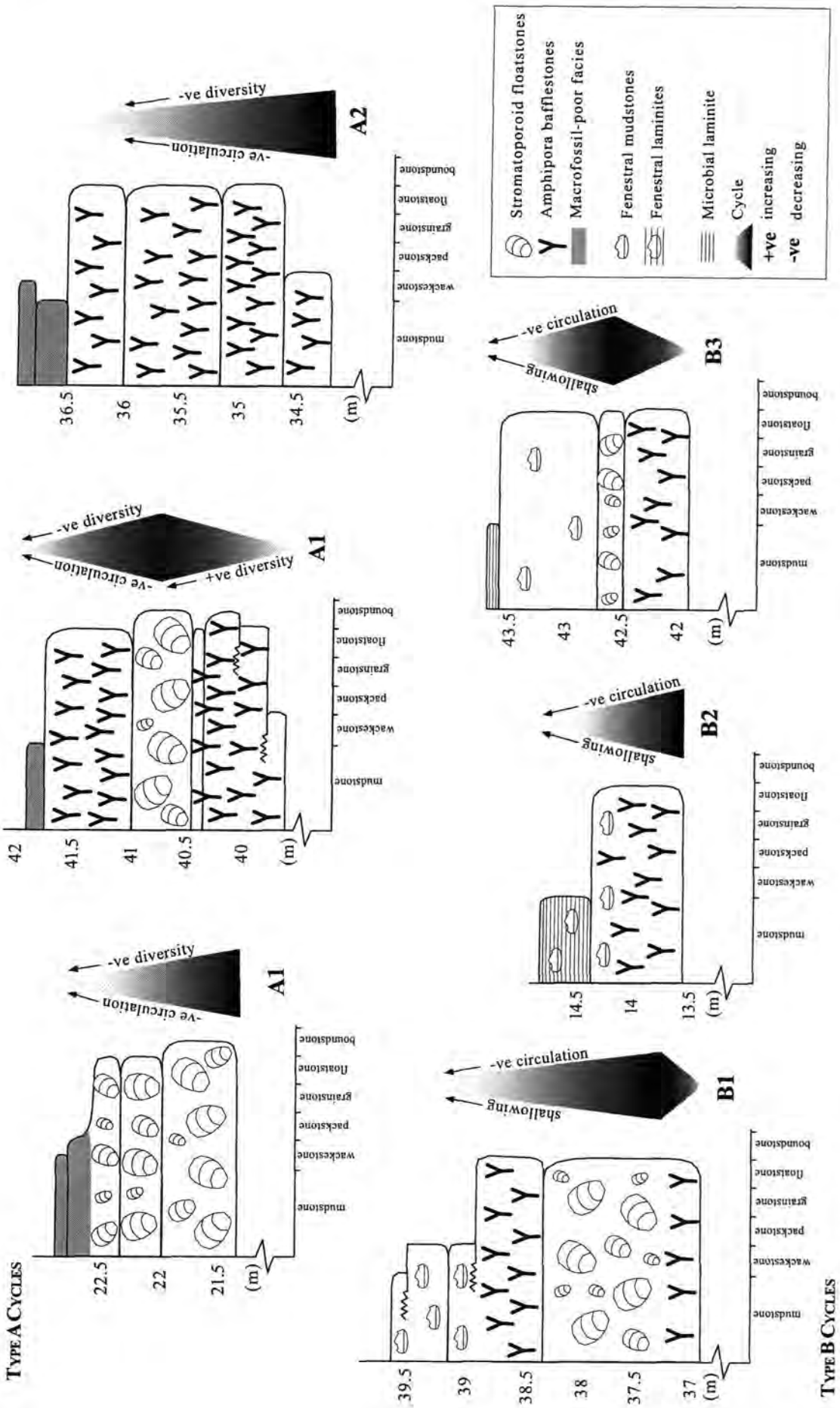

Figure 5-17 Five cycle-types seen at Bleiwäsche quarry, Brilon Reef Complex. See text for discussion.

B2) Cycles which have a 'restricted subtidal' base and an intertidal cap. These cycles commonly have an *Amphipora*-rich or poorly-fossiliferous base (S4, S6 or S7 facies) which are then capped by fenestral limestones (S8, S10 microfacies). These cycles range from 0.42m to 1.29m in thickness and are regressive (asymmetrical).

B3) Cycles which fully shallow to high intertidal-supratidal deposits. These cycles have a restricted subtidal base (S6 microfacies) and are capped by microbial laminites (S12). These cycles are particularly thin, ranging from 0.25m to 0.6m in thickness. They show a regressive trend (asymmetrical).

Cyclicity is not only apparent in the back-reef facies of the Brilon Reef Complex. Städter and Koch (1987) noted that reefal deposits were also periodically subjected to elevation into the intertidal-supratidal zone. This was recorded as early diagenetic (microstalactic) cements, thick syntaxial overgrowths and shifting  $\delta^{13}\text{C}$  values from 2.5‰ to 1.5‰. To date, no correlation between reef and back-reef facies using cyclicity as a correlative tool has been attempted.

The causal mechanisms of this cyclicity are further discussed in Chapter 6.

### 5.2.1.3 Torbay Reef Complex

The Torbay Reef Complex is situated between Torquay, Ashburton and Brixham in Devon, Southwest England. Exposure of the reef complex is poor, with the best exposures seen along the coast and in abandoned and working quarries inland. Severe Variscan folding and thrusting and relatively poor inland exposure have hampered palaeogeographical reconstructions. However, the major facies variations have been documented and a broad palaeogeographical setting of an isolated carbonate complex has been established by Scrutton (1977a, b) and Scrutton and Goodger (1987). The carbonate complex is thought to have developed on a topographic high along the shelf-edge margin, with an easterly extension of the South Devon Basin separating it to the North from near-shore clastics and continental facies on the Old Red Continental margin (Selwood and Thomas, 1986; Fig. 5-18).

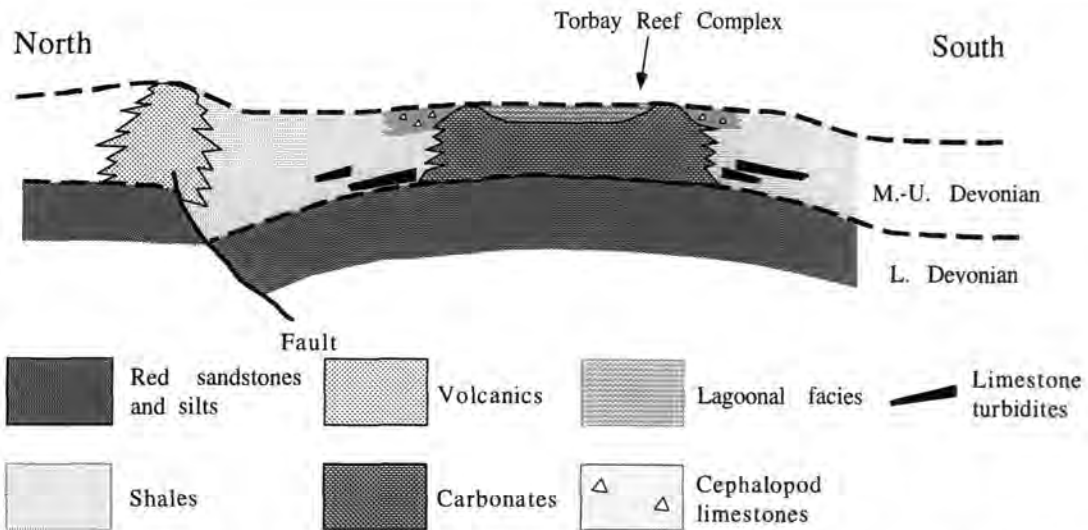

**Figure 5-18** Schematic facies relationships for the Devonian of Southwest England (modified from Selwood and Thomas, 1986).

Most Middle Devonian work in Torbay Reef Complex has concentrated primarily on the reef facies, where detailed palaeontological and sedimentological aspects have been discussed (Braithwaite, 1966, 1967; Scrutton, 1977a, b; Scrutton, 1978; Mayall, 1979; Selwood *et al.*, 1984). Until 1996 the back-reef carbonates had not received detailed attention, although their setting within the general interior platform sequences had been described in a key section by Scrutton and Goodger (1987). Garland *et al.* (1996) discussed the sedimentological, palaeontological and cyclic aspects that these back-reef facies display and this is further considered in this Section.

The Torbay Reef Complex developed upon thin crinoidal banks (Denbury Crinoidal Limestone) of late Eifelian age (Selwood *et al.*, 1984; Scrutton and Goodger, 1987). These crinoidal facies are comparable to the Schwelm facies of the Rhenisches Schiefergebirge, although there are subtle faunal differences with stromatoporoids being very limited in the Denbury Crinoidal Limestone.

Reef development within the Torbay Reef Complex shows a shifting pattern throughout the Givetian (Fig. 5-19). In the lower to middle Givetian, reef limestones, composed mainly of massive and laminar stromatoporoids with a diminutive coral component, are located in the Torquay area, being especially well developed at Long Quarry Point (Scrutton, 1978). Back-reef deposits are located behind this reef-core and can be best seen in the Lemon Valley (Broadridge Wood quarry), Ashburton area (Linhay Hill quarry) and north of Newton Abbott (Rydon quarry) (Fig. 5-19). The western margin to the Torbay

Reef Complex is not seen in the study area. It is either covered by younger sediments, or has been thrust out. Deep-water shales and turbidites are seen, attesting to the isolated nature of the complex (Scrutton, 1977b). Towards the end of the Givetian, reef-core facies had shifted to Brixham (exposed at Berry Head; Mayall, 1979). The reefs had similar faunal components to the Torquay reef, with tabular and massive stromatoporoids being the major components (Mayall, 1979). The development of reef-core facies at Brixham enabled back-reef sedimentation to occur on the lee-side. This can be seen at Goodrington, although the facies are now extensively dolomitised and tectonically dislocated (Fig. 5-19).

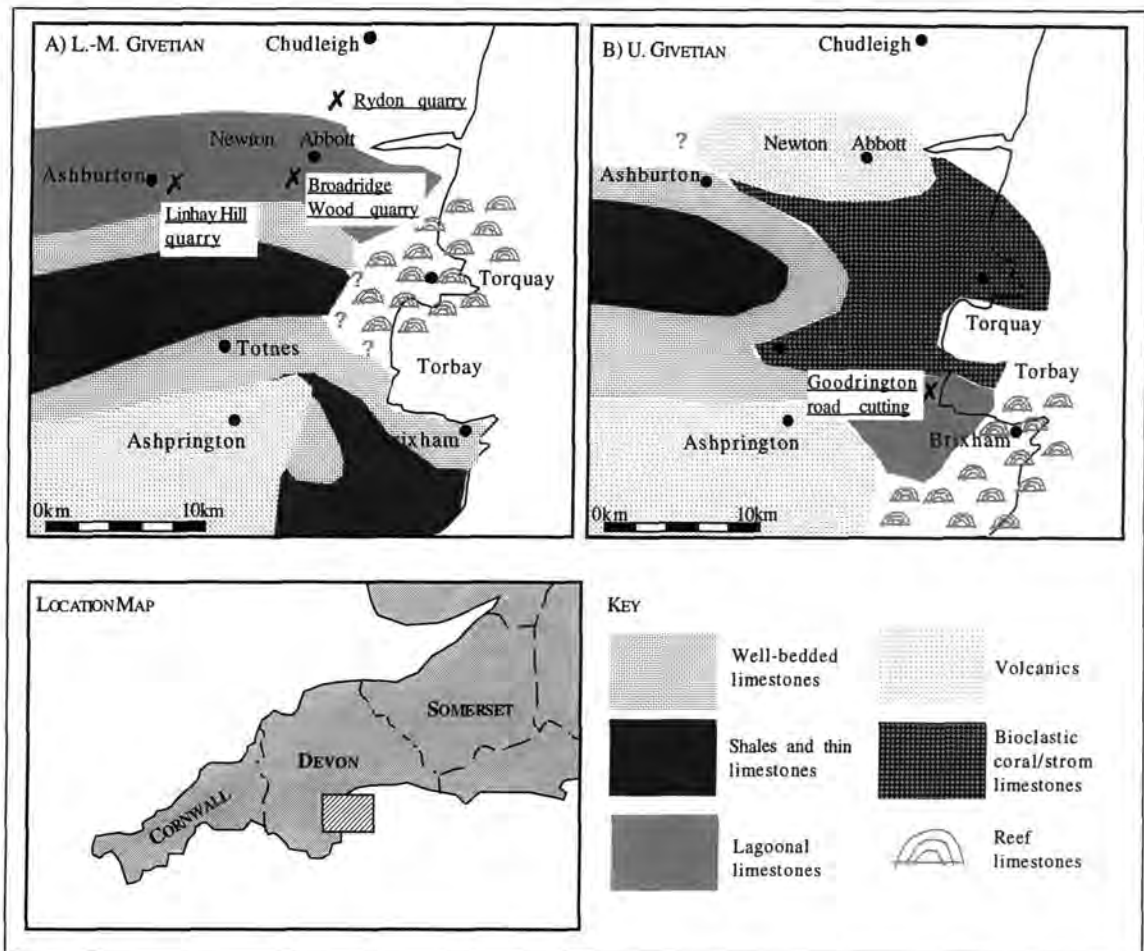

**Figure 5-19** Location maps showing non-palinspastic distribution of facies and location of logged sections for A) Lower to middle Givetian and B) Upper Givetian. Modified from Scrutton (1977b).

The total thickness of the limestones in the Torbay Reef Complex is around 500m, when volcanic strata are discounted (Scrutton, 1977a). As Scrutton (1977a) discussed, the size of the complex is somewhat more difficult to determine, due to the poor outcrops and severe tectonic complications. The N-S shortening of the Devonian during the Variscan Orogeny could have been as much as 50%, thus giving the Torbay Reef Complex an area

of 1000km<sup>2</sup> (Scrutton, 1977a). These estimates should be used with caution, however, since many assumptions have been made during the calculations.

Carbonate sedimentation around the Torquay area ceased in the latest Givetian or early Frasnian, although elsewhere in the area carbonates were still being deposited until middle Frasnian times (Scrutton, 1977a). A general transgression then prevailed, where shales and thin turbidites were deposited in basins and nodular limestones developed on topographic highs.

Four successions in back-reef facies of the Torbay Reef Complex have been studied with respect to detailed facies analysis (Table 5-5; Fig. 5-19).

The succession at Broadridge Wood quarry was discussed by Scrutton and Goodger (1987) where its situation within the platform interior was ascertained. It exposes the uppermost part (approximately 150m above the base; Scrutton and Goodger, 1987) of the Chercombe Bridge Limestone. Conodont faunas put the succession within the *Pol. varcus* zone of the lower Givetian (Selwood *et al.*, 1984).

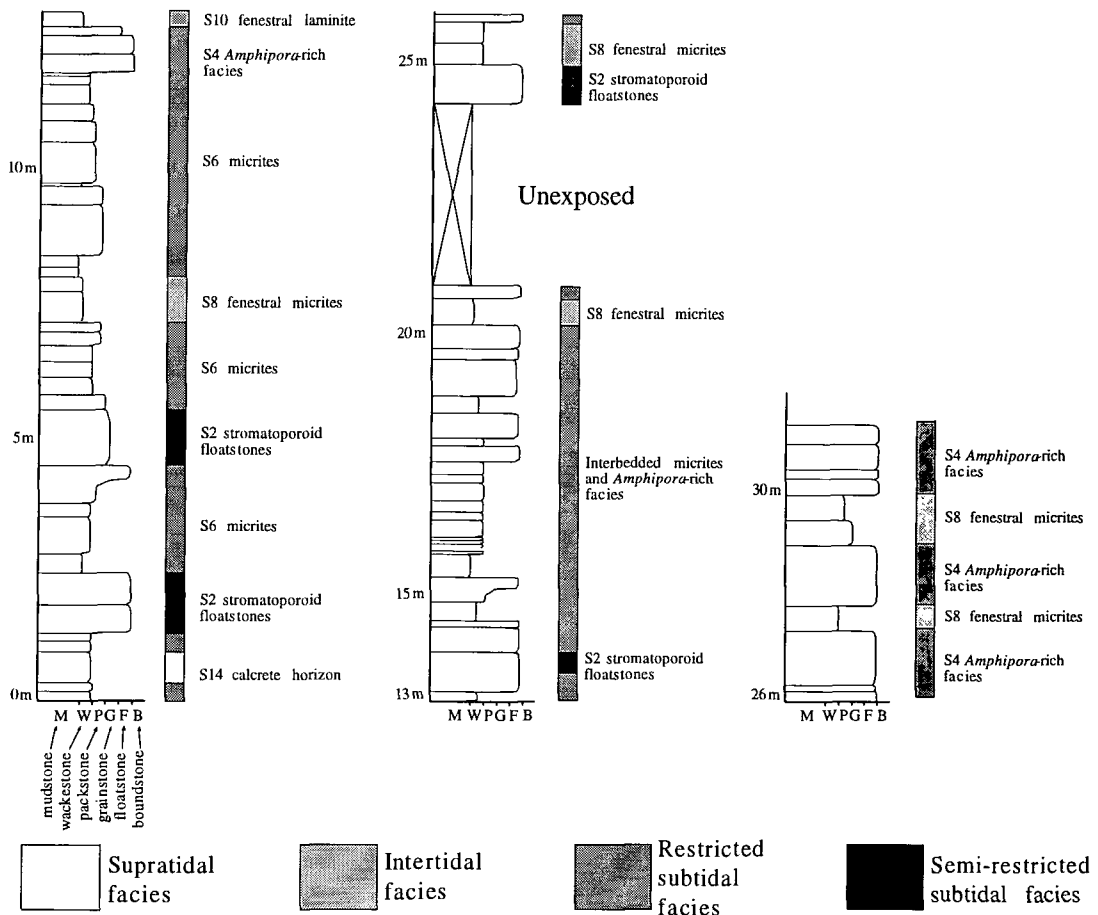

Figure 5-20 Generalised log for the Broadridge Wood quarry, showing primary facies groups.

The succession at Broadridge Wood quarry shows a series of facies-types which can be seen in the summary log in Figure 5-20, or can be seen in the detailed log in Section A2.6. The succession starts with a particularly interesting horizon where a calcrete has developed. This is a unique horizon since it is the only example of S14 microfacies in the back-reef facies of the Torbay Reef Complex and indeed of any isolated carbonate complex in the study area. The host rock is composed of a slightly bioclastic micrite, yet the most prominent feature in this rock is the anastomosing cracks and veins which penetrate through it. These circum-granular cracks often surround bioclasts and are both spar and sediment filled (with peloids) (see Figure 4-19e). The rock exhibits a 'floating' texture where angular clasts have no apparent support and is a mottled colour. This horizon represents an alpha-type calcrete of Wright (1990) where there is no apparent biogenic influence. The amount of time which it took for this calcrete to develop is difficult to assess; however, this horizon unequivocally represents subaerial exposure for a prolonged period of time.

Above the calcrete horizon the succession is dominated by subtidal deposition for the next 7m. Interbedded horizons of stromatoporoid floatstones (S2 microfacies), *Amphipora* floatstones and bafflestones (S4) and poorly-fossiliferous micrites (S6) are characteristic. The stromatoporoids in S2 microfacies are small, bulbous in shape and are variably orientated suggesting the waters were sometimes turbulent. *Amphipora* branches are well preserved in the S4 microfacies (see Figure 3-3a), commonly being aligned parallel to bedding. Scattered corals, including *Remesia*, *Scoliopora* and *Thamnopora* have also been documented (Scrutton and Goodger, 1987). An interesting feature associated with the facies at Broadridge Wood quarry (and Linhay Hill quarry) is that they commonly have a pink-coloured matrix. This coloration is related to the dolomitisation of the original micrite matrix, where the dolomite rhombs have a red iron-stained rim to them. This diagenetic process appears to be mainly restricted to the highly-fossiliferous horizons; however, it does occur in some rare fossil-poor horizons also.

From 7m to the end of the succession at Broadridge Wood quarry, there is an increasing component of intertidal deposition (fenestral micrites and fenestral laminites). These fenestral facies are interbedded with S6 micrites and S4 *Amphipora*-rich facies. The horizons contain both laminoid and tubular fenestrae which often have an internal sediment-fill of vadose silt (see Figure 4-14a).

The facies succession at Broadridge Wood quarry suggests it was situated in the restricted part of the lagoon, which was dominated by low-energy waters. The presence of several horizons of fenestral limestones and the presence of the calcrete horizon at the base suggest that there was frequent elevation into the intertidal zone of the tidal flat environment and on one occasion there was prolonged subaerial exposure. A long term evolution in the local depositional environment can be seen at Broadridge Wood, from dominantly subtidal at the base (just above the calcrete) to increasingly more intertidal-influenced. Scrutton and Goodger (1987) also noted that on the upper ledges of the quarry (@ ~24.5m on log) a more diverse coral fauna is seen associated with the bulbous stromatoporoids, suggesting a period of increased marine influence.

Several faces in the Linhay Hill quarry, NE of Ashburton, are available to study the Givetian back-reef facies; however, thrusting is common within these successions and hampers the construction of a long, continuous log. The succession at this locality is thought to be Givetian in age, yet to date, conodont information has not been made available.

The succession at Linhay Hill quarry is very similar to that at Broadridge Wood, in that it is dominated by interbedded horizons of *Amphipora* bafflestones (S4 microfacies), bulbous-shaped stromatoporoid floatstones (S2) and fossil-poor micrites (S6 microfacies). At Linhay Hill quarry, however, there is no evidence of intertidal deposition (Fig. 5-21). In the basal 7.5m bioclastic horizons are also particularly conspicuous, with *Stringocephalus* dominating. These thick-shelled terebratulid brachiopods can commonly be 35mm wide, are mostly disarticulated and are associated with solitary corals (*Temnophyllum* sp., Scrutton, 1977a), *Thamnopora*, gastropods and rare *Amphipora* branches.

Above 7.5m the logged succession is mostly dominated by interbedded *Amphipora* bafflestones-floatstones and poorly-fossiliferous micrites. *Amphipora* is usually apparent as dense thickets which, along with the S2 facies, most often has an extremely red matrix (Fig. 5-22).

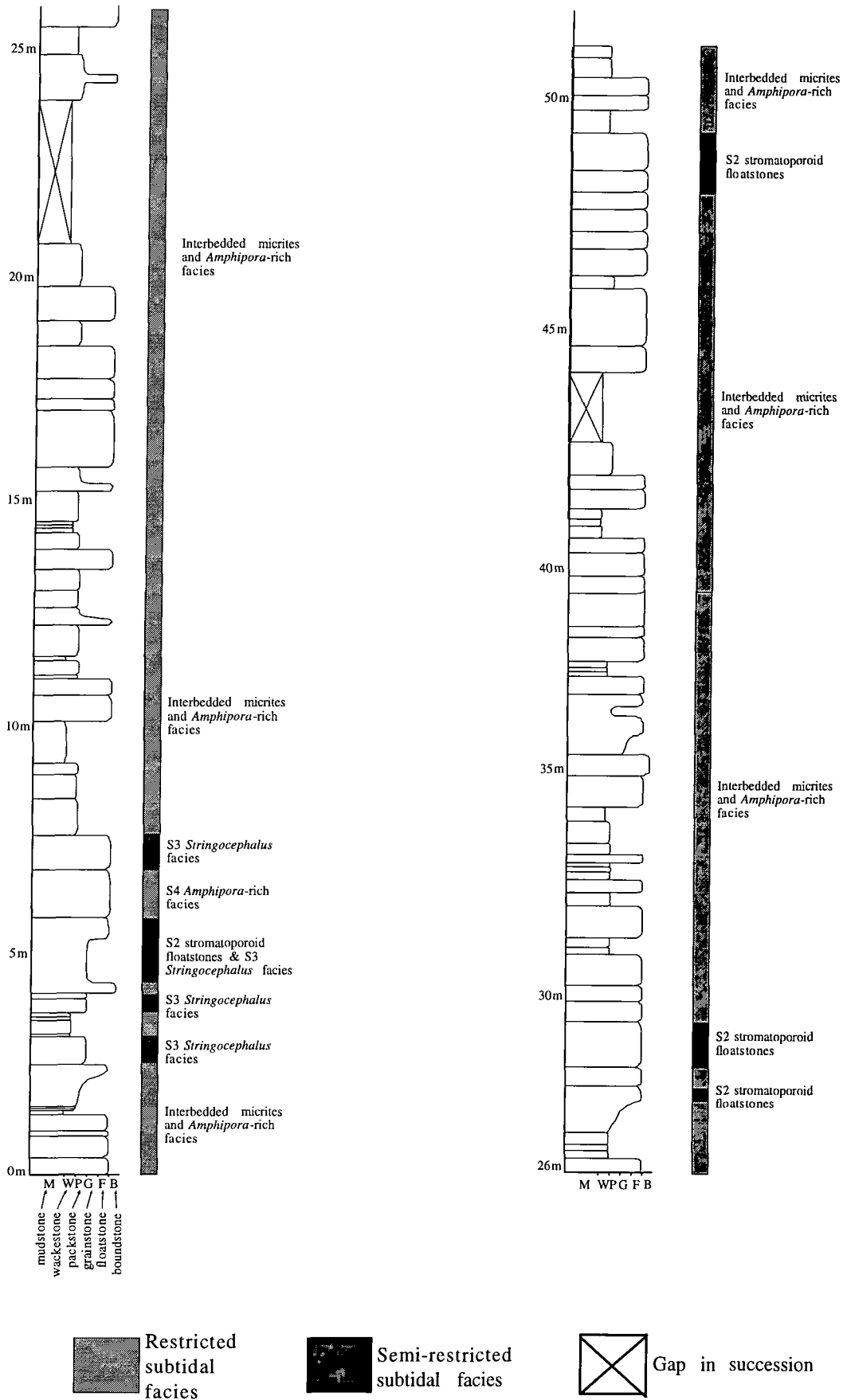

Figure 5-21 Generalised log for the Linhay Hill quarry, showing primary facies groups.



**Figure 5-22** Field photograph of bulbous and dendroid stromatoporoid horizon (microfacies S2) at Linhay Hill quarry. The matrix has been altered to iron-rich dolomite, resulting in a reddened colouration. Photograph courtesy of Colin Scrutton.

Macrofossil-poor micrites (S6) are mostly bioturbated and rich in microfossils; however, locally the facies appears laminated. This possibly indicates periods of time where the water salinity was too severe for benthos to inhabit; thus there were no burrowing organisms to disturb the lamination. Interestingly in the Linhay Hill succession there is no evidence of algae. This is highly unusual, since many of the Middle Devonian lagoonal environments were rich in dasycladaceans and to a lesser extent codiaceans. Although the dasyclads and codiaceans were thought to be able to survive restricted environments (Wray, 1977), the conditions at this locality may have just been too harsh (salinities greatly fluctuating, increasingly poor circulation) to support the algae. However, calcispheres and forams were able to adapt to these environments. Horizons of well-preserved gastropods are also seen interbedded with the fossil-poor micrites.

The succession at Rydon quarry displays quite different facies from those seen at Broadridge Wood and Linhay Hill. A section on the eastern wall of this abandoned quarry exposes 21m of high-energy, fossiliferous back-reef facies. The rocks dip towards the south, but later examination of geopetal evidence in thin sections suggests the strata are in

fact overturned. Thrust faults and folding can also be seen in the quarry faces. This succession is equivalent to the 'Rydon south quarry' of Scrutton (1977a).

The succession at Rydon quarry shows varying facies types, which are both subtidal and intertidal in origin (Appendix 2.21). Bioclastic grainstones and rudstones of microfacies S3a are particularly common (See Figure 4-10d for photomicrograph). These facies have a varied fauna, dominated by dendroid stromatoporoids (mostly *Stachyodes*, but also *Amphipora*), *Thamnopora*, crinoids and solitary corals. The facies rarely shows graded bedding and therefore deposition within the zone of constant wave agitation, rather than storm deposition is inferred. Peloidal grainstones of microfacies S7a affinities are common, mainly in the upper parts of the succession. In both the S3a and S7a microfacies the matrix is sparitic. Several generations of cement can often be identified, with common syntaxial cements around crinoids, isopachous cements surrounding grains and a later diagenetic ferroan calcite or baroque dolomite infilling or replacing the remaining porosity. Locally, bioclastic wackestones and *Amphipora* floatstones are interbedded with the grainstone facies, representing migration or evolution into lower-energy depositional settings. A little farther north in the roadcutting along the Newton Abbott Bypass Scrutton (1977a) recorded the presence of a small patch-reef within this back-reef environment. Fenestral horizons are locally developed representing elevation into the intertidal environment. Scrutton (1977a) also noted the presence of these intertidal facies.

The succession at Rydon quarry is interpreted as having been situated near a shallow tidal-flat environment, where small-scale relative sea-level fluctuations or tidal-flat progradation resulted in deposition of interbedded facies-types. The succession does not show any characteristic longer term evolution.

A short succession was studied at Goodrington road cutting (Table 5-5; Section A2.1). However, detailed facies analysis was difficult as many horizons had been dolomitised. The road cutting exposes upper Givetian facies of the Goodrington Limestone, which is part of the Brixham Limestone Group (Scrutton, 1979). Therefore, it represents the facies of the younger of the two carbonate complexes developed in the area. The dolomitisation at this locality is fabric destructive, making identification of microfacies near impossible. Where dolomitisation was not so pervasive horizons of *Amphipora* floatstones and bafflestones interbedded with poorly-fossiliferous micrites were seen. Scrutton (1978) also identified

bands rich in small stromatoporoids and corals (including *Temnophyllum* sp. and *Heliolites* sp.). The presence of interbedded horizons of *Amphipora* and fossil-poor facies suggests back-reef environments in the Goodrington area during the late Givetian.

### Synopsis

The successions studied in the Torbay Reef Complex are located within the lagoon. The nature of this lagoonal environment varied from locality to locality. The succession at Linhay Hill was probably located in the central, more restricted part of the lagoon, since it shows no evidence of emergence into the intertidal or supratidal zone and in many cases shows extremely restricted (unbioturbated, laminated mudstones) facies. The successions at Broadridge Wood were likely to have been located nearer to tidal flats, since there is evidence of intertidal deposition, with prolonged exposure in the supratidal zone at the base of Broadridge Wood. Rydon quarry was maybe situated closer to the lee-side of the reef, however, since facies are characteristic of high-energy depositional environments and are highly-fossiliferous. This environment was also subject to periodic elevation in the intertidal zone. The succession at Goodrington is younger than the other successions and represents deposition in the back-reef environment of the Brixham Reef.

Back-reef facies in the Torbay Reef Complex show a pervasive metre-scale cyclicity. Two major types of cycle are seen.

Type A. Cycles which show increasing salinity and decreasing circulation upward. These cycles have either an *Amphipora*-rich (S4), bioclastic (S3) or stromatoporoid-rich (S2) base and are capped by a fossil-poor micrite horizon (S6). Sedimentation is entirely subtidal in nature and cycles range from less than 1m to 6m in thickness. Cycles are asymmetric. It is difficult to determine if these show any shallowing or deepening trends.

Type B. Cycles which shallow-upwards. These are seen at both Broadridge Wood quarry and Rydon quarry, where the cycle has a subtidal base (commonly either S2 stromatoporoid floatstones or *Amphipora* floatstones (S4)) and is then capped by intertidal fenestral facies. Cycle thickness ranges from 1.3m to 5.2m. There is also evidence for an increase in salinity and decrease in circulation upwards through the cycle.

Further discussion and possible causes of this cyclicity are discussed in Chapter 6.

Correlation between sections in the Torquay Reef Complex is hampered by poor inland exposure, Variscan thrusting and folding, insubstantial stratigraphic control and lack of useful marker horizons to hang sections on. The development of a calcrete horizon is potentially a useful marker, since it records a period of lowstand of sea level. However, no correlative horizons of similar age have been documented in other shallow-marine facies. A karstic horizon has been identified within the Daddyhole Limestone (Scrutton, pers. comm. 1997); however, this is Eifelian in age and thus not correlative with the calcrete at Broadridge Wood. Fischer plots may be a useful tool in correlation and are further discussed in Chapter 6.

### 5.2.2 Inner shelf reefal complexes

Isolated reefal complexes which developed *within* the Rhenish shelf (type B2 of Krebs, 1974) differ from other isolated complexes in several ways. A broad carbonate platform existed between the River Rhine and Warstein and this provided the base to these type B2 isolated complexes (Fig. 5-12; Krebs, 1974). Inter-reef basins commonly formed between complexes where pelagic shales and turbidites were deposited. Many of the isolated complexes were fault-bounded (i.e., Balve; Krebs, 1971). Isolated complexes within the shelf were very variable in size and thickness (from 300m-1300m; Krebs, 1971, 1974). Both atoll and table reef complexes developed in the Rhenish shelf. In this study, Balve and Dornap Reef Complexes were studied in terms of facies and cyclic analysis of lagoonal environments. Table 5-7 gives the locations of the studied successions whereas Appendices 1 and 2 present thin-section information and detailed logs, respectively.

| Reef Complex | Name of succession      | Location (Topographic map number and co-ordinates)          | Thickness of log          |
|--------------|-------------------------|---|---------------------------|
| Balve        | Oberrödinghausen quarry | 1:50,000, Map 12, Hochsauerlandkreis<br>r:34.2045 h:56.9555 | 98.21m<br>(Section A2.18) |
| Dornap       | Voßbeck quarry          | 1:50,000, Map 32, Kreis Mettmann<br>r:25.7475 h:56.8075     | 51.46m<br>(Section A2.27) |
|              | Hahnenfurth quarry      | 1:50,000, Map 32, Kreis Mettmann<br>r:25.7348 h:56.8018     | no log                    |
|              | Hanielsfeld quarry      | 1:50,000, Map 32, Kreis Mettmann<br>r:25.7285 h:56.8017     | 9.2m<br>(Section A2.12)   |
|              | Dornap Core             | Drill core in hole H2 on SE margin of Hahnenfurth quarry.   | no log                    |

Table 5-7 List of successions studied in the Balve and Dornap Reef Complexes.

### 5.2.2.1 Balve Reef Complex

The Balve Reef Complex is situated near Iserlohn in the Sauerland area of Germany. Carbonate facies are preserved in the northeasterly dipping Remscheid-Altena anticline, which explains the present day boomerang-shaped outcrop pattern (see Figure 5-12). The Balve Reef Complex is in fact part of a bigger reef complex also encompassing the Hagen area (Krebs, 1971, 1974). Small inter-reef basins formed between the major complexes (i.e., Iserlohn Basin). However, this present study only examined the Balve Complex.

Carbonate sedimentation characteristically started with Schwelm deposits which were richly fossiliferous in nature. Assemblages including brachiopods (stringocephalids and spiriferids), corals (*Hexagonaria*, *Favosites*, *Heliolites*) and stromatoporoids (*Stromatopora*) have been identified (Jux, 1960; Krebs, 1974). These facies are underlain by a 500m thick series of grey-green clastics (Jux, 1960). Deposition of Dorp facies, where the carbonates could be differentiated into off-reef, fore-reef, reef-core and back-reef, was initiated in the late Middle Devonian (Fig. 5-23; Krebs, 1971). Off-reef facies are characterised by thick (700-800m) accumulations of pelagic shales and reef-derived limestones (Eder, 1970; Krebs, 1971). In the western rim of the Balve Reef Complex, reef-core facies consist of massive stromatoporoids (up to 50cm in diameter), solitary corals, crinoids and brachiopod communities. Many of these organisms show encrustation by stromatoporoids or algae (Krebs, 1971).

The thickness of Dorp facies reaches over 1000m in some areas of the complex (Krebs, 1974). As with the Attendorn Complex, the greatest thickness is at the northwestern margin. The Balve Complex is believed to have developed on a faulted margin (see Figure 5-23), where uplift was greatest in the south and subsidence greatest in the north. This would account for the thickness-variations across the complex. The areal extent of the complex is difficult to ascertain. Synsedimentary faulting and volcanicity played a very important role in the development of the Balve Reef Complex. To the south of the complex in the Garbeck area, 250m of basic lavas and volcanic tuffs rest directly upon limestone facies. These are thought to be time-equivalent to the Schwelm facies (Krebs, 1971) and were probably related to fault movement on the southeastern margin of the Balve Complex (Fig. 5-23).

Dorp-style sedimentation continued through to the middle Frasnian, where the ensuing transgression resulted in deposition of nodular limestones and shales (Krebs, 1971; Krebs, 1974).

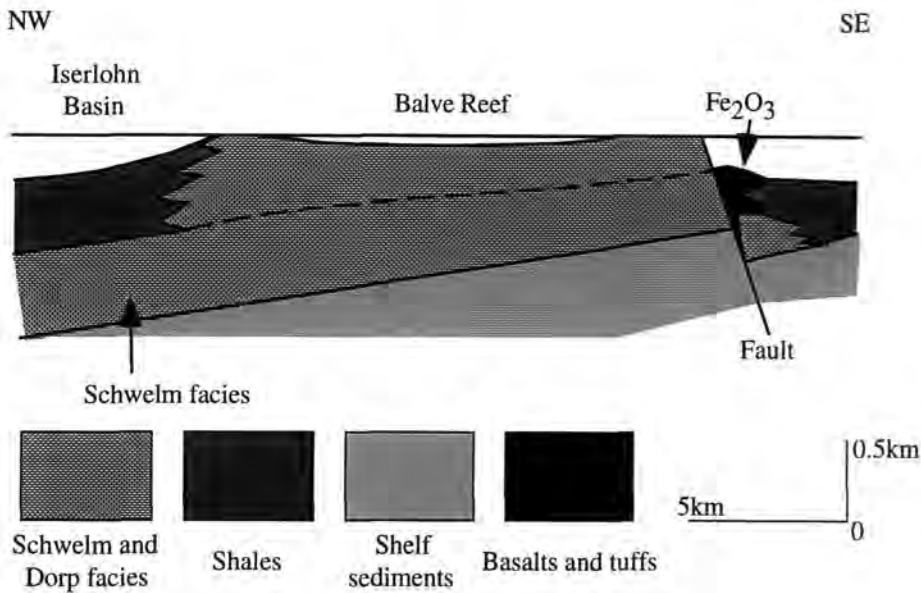

**Figure 5-23** Cross-section through the Balve Reef during Middle/Upper Devonian boundary times. Note vertical exaggeration. Adapted from Krebs (1971).

Back-reef facies have been studied at just one locality at the Emil quarry, Oberrödinghausen, where a 98m succession was studied (Table 5-7, Section A2.18). Sedimentation is almost entirely subtidal in nature, and two distinct sediment packages have been identified (Fig. 5-24).

The lower package is characterised by interbedded semi-restricted subtidal and restricted subtidal facies (0-28m). Semi-restricted subtidal facies are volumetrically subordinate, being characterised by small biostromal buildups or stromatoporoid floatstones (microfacies S2). Locally bulbous stromatoporoids are seen in life position. They are commonly small, averaging 6-8cm in diameter. Associated with this facies are dendroid stromatoporoids (*Amphipora*) and colonial corals. *Thamnopora* is particularly common.

Interbedded with these stromatoporoid floatstones or biostromes are restricted subtidal facies. Both S4 and S6 microfacies are recognised. Horizons rich in *Amphipora* are particularly abundant (microfacies S4). The *Amphipora* branches commonly occur in discrete nests (reflecting life position?), are scattered throughout the unit, or occur as bed-parallel accumulations. Often the branches are encrusted by cyanobacteria (*Girvanella*).

*Stachyodes* and *Thamnopora* are also associated with these facies, commonly being well-preserved. Small solitary corals are locally present also. The matrix to this facies commonly consists of peloidal micrite, locally being thoroughly bioturbated. Poorly fossiliferous facies are not common until 16m, where several horizons occur through to 28m. Bedding is usually thin and regular, with macrofossils being uncommon. Peloids are the major constituent of this facies, with calcispheres and parathuramminid forams playing only a minor role.

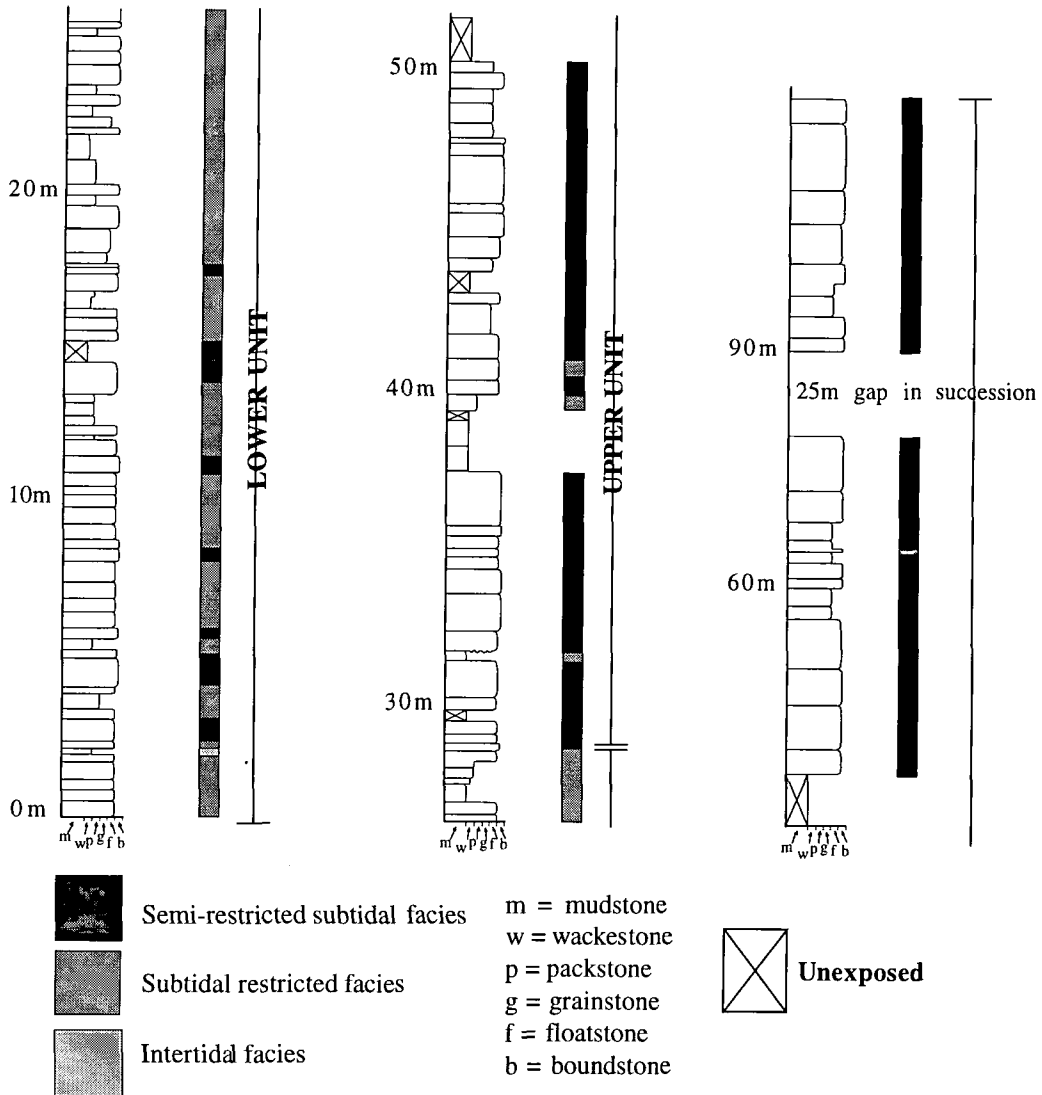

Figure 5-24 Generalised log of Oberrödinghausen succession, Balve Reef Complex.

This lower package reflects a period in the lagoon where circulation was generally poor and only organisms which were adapted to these harsh conditions were able to exist (i.e., *Amphipora*). Deposition was in shallow, low-energy, subtidal waters where there was very little turbulence.

The second package of sediments (28m to 98m) represents a transition into higher-energy, better-circulated lagoonal conditions where semi-restricted subtidal deposition prevailed (Fig. 5-24). Microfacies S2 dominates this part of the succession, where massive beds (commonly over 1m thick) rich in bulbous and rare domal stromatoporoids occur. These stromatoporoids can reach up to 30cm in diameter, and locally increase in size through a unit (e.g., at 33m, see detailed log in Section A2.18). They are commonly not preserved in life position, where turbulent waters have dislodged and overturned them. The transport distance is probably not far. Thamnoporoids are locally abundant, and interstitial gaps house dendroid stromatoporoids and small corals. Laminar stromatoporoids are not seen. The matrix to this facies is commonly a mix of spar and micrite, reflecting higher-energy conditions. Higher in the succession crinoids become abundant. Storm-influenced horizons rich in *Stachyodes* and crinoids frequently impinged on to this back-reef environment (microfacies S3). The bioclasts are commonly abraded and the facies has a sparitic matrix. *Amphipora*-rich horizons are not abundant in this second sedimentary package.

This second sediment package represents an increase in circulation and energy of the depositional environment. Organisms are more diverse and reef-derived material is commonly interfingered in the back-reef succession. The shift in sedimentation style may represent a shift in the position of the reef-margin (closer to the succession at Oberrödinghausen) or may reflect a more 'open' intercalation in the history of the reef where the barrier was not providing restriction.

Although sedimentation was almost entirely subtidal at Oberrödinghausen, Krebs (1971) has recognised the development of microbial laminites in other areas. A succession further East near Asbeck also yields intertidal and supratidal deposits (Schudack, 1993; Schudack, 1996), suggesting this area was positioned closer to the Devonian palaeotidal flat area. These facies show a well-developed metre-scale cyclicity, which have been attributed to both to periodic fault movement (Schudack, 1993) and to orbital forcing (Schudack, 1996).

Cyclicity in the Oberrödinghausen succession is of type B, where cycles show a decrease in circulation and decrease in diversity of organisms upwards through the cycle. The cycles range from under 1m to 6m in thickness, averaging 2.9m. This concept of cyclicity will be further discussed in Chapter 6.

### 5.2.2.2 Dornap Reef Complex

The Dornap Reef Complex is probably one of the smaller complexes within the Rhenish Shelf, situated East of Düsseldorf in the Nordrhein-Westfalen area of Germany. Extensive quarrying in the past 30 years had exposed numerous outcrops of Givetian and Frasnian Schwelm and Dorp facies (Fig. 5-25). Many of these quarries are now inaccessible, yet with permission access can be gained in working quarries. The original size of the Dornap Reef is difficult to determine. However, outcrop patterns suggest it is larger than the nearby Wülfrath Reef Complex which is estimated at 17km<sup>2</sup> (Krebs, 1974). The thickness of the Dorp facies reaches up to 400m (Gotthardt, 1970). Facies relationships suggest the original shape of the Dornap Reef Complex was isolated and of type B2 (Krebs, 1974).

The complex is underlain by Schwelm facies. The Schwelm facies can be studied at the Hanielsfeld quarry and can also be seen in cores taken in the Hahnenfurth quarry. In the Dornap area these facies are richly fossiliferous, especially in crinoids, corals (both solitary and colonial), laminar, branching and columnar stromatoporoids and brachiopods (Fig. 5-26). Often the facies are argillaceous and strata are commonly poorly bedded. Interbedded horizons of stromatoporoid floatstones (R3 microfacies) and argillaceous mudstones (R1 microfacies) are common.

Development of a reef complex probably started in the late Givetian to early Frasnian. Fore-reef, reef-core and back-reef facies can be differentiated (Krebs, 1974). Fore-reef facies are commonly composed of rudstones and grainstones, with a high content of *Stachyodes*, crinoids and brachiopods. Several generations of cement are seen and often bioclasts are encrusted by cyanobacteria (Krebs, 1974). Reef facies are dominated by tabular stromatoporoids and stromatoporoid-trapped skeletal debris (Krebs, 1974).

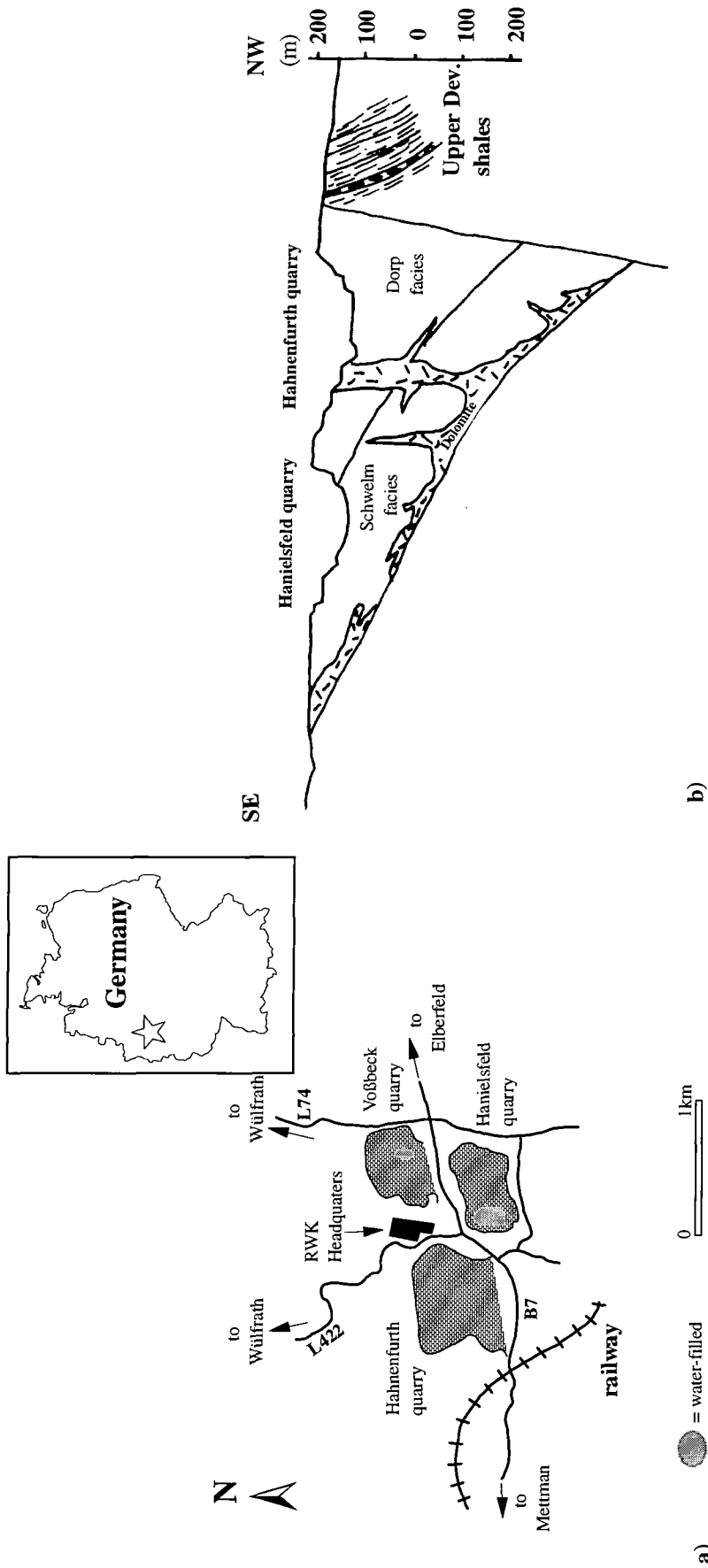

Figure 5-25 a) Map showing location of studied quarries. b) Cross-section through Hanielsfeld and Hahnenfurth quarries. Adapted from Gotthardt (1970).



**Figure 5-26** Photograph of columnar stromatoporoids within the Schwelm facies (microfacies R3). Picture taken from the Dornap core at Hahnenfurth quarry. Scale bar in 1cm increments.

Back-reef facies are volumetrically the most important in the complex and can be studied in the Voßbeck and Hahnenfurth quarries (Table 5-7). Voßbeck quarry is now abandoned and rather overgrown; however, fairly continuous logs are attainable (Fig. 5-27). Hahnenfurth quarry, although still working and not at all overgrown, is problematic since tectonism has strongly effected the strata, so much so that a log is not possible. Observations with regards to the facies-types are still possible though. The succession at Voßbeck quarry is dominated by horizons of *Amphipora* floatstones and bafflestones (microfacies S4). The *Amphipora* branches are commonly densely arranged as thickets, suggesting very little post-mortem transportation. They are also seen in small nests. Also associated with the *Amphipora* branches are parathuramminid forams, calcispheres dasyclads and ostracodes. The matrix is commonly intensely peloidal. *Girvanella* commonly coats amphiporoids and this can be especially well developed in the Hahnenfurth quarry where a dark rim is seen around the stromatoporoids.

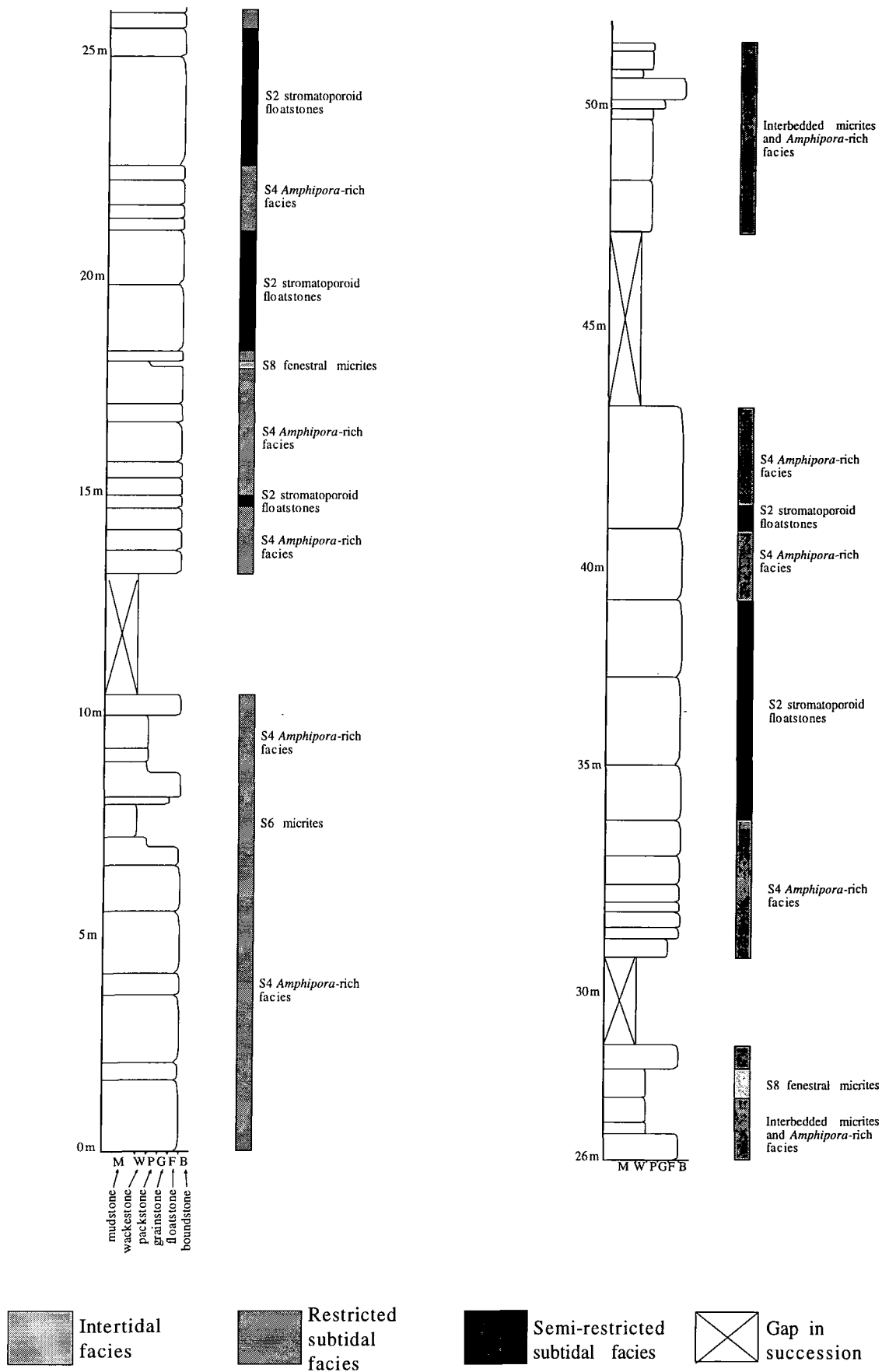

Figure 5-27 Generalised log for Voßbeck quarry, Dornap Reef Complex, showing primary facies groups. See Section A2.27 for detailed log.

Small biostromes dominated by bulbous stromatoporoids are common between 18m and 40m in the succession (Fig. 5-27). Bedding is often massive and a rich assemblage of dendroid stromatoporoids (mostly amphiporoids, but also *Stachyodes* and others) are associated. Interbedded with the *Amphipora* facies are poorly-fossiliferous (microfacies S6) and fenestral (microfacies S8) horizons. The fenestral horizons are particularly interesting since they represent elevation into the intertidal zone in an otherwise subtidal-dominated succession. The fenestrae in these horizons are laminoid, commonly 2mm long and have an internal sediment fill of very fine grained silty micrite. Fenestrae are commonly associated with poorly-fossiliferous mudstones.

Bioclastic horizons are not common within the back-reef facies of the Dornap Reef Complex. Local accumulations of gastropods and bivalves are seen at the Hahnenfurth quarry (microfacies S5) representing restricted subtidal environments. Krebs (1974) also recorded local accumulations of echinoderm (crinoid) debris within back-reef environments. These accumulations show graded bedding and are interpreted as being deposited during heavy storms through reef-channels from the fore-reef or reef into the back-reef environment. The accumulations are not laterally continuous and have a large tongue-shaped geometry. These facies would be equivalent to S3a microfacies in this study.

Often the facies at both Voßbeck and Hahnenfurth quarries are very dolomitised. The micrite is preferentially dolomitised yet the mosaic is fabric destructive. The dolomitisation is a common feature in the Dornap Reef Complex and often determines where quarrying is undertaken (see Figure 5-25; Gotthardt, 1970). Within the Dornap succession there is no evidence of volcanism and there is no syndimentary faulting.

The back-reef successions of the Dornap reef complex are dominated by low-energy, restricted facies. A broad evolution at Voßbeck quarry can be seen where sedimentation is initially restricted in nature, then between 13m to 40m there is an increased influence of both semi-restricted and intertidal conditions and then the deposition returns to a subtidal, restricted nature (Fig. 5-27).

As with many of the Devonian back-reef successions, the succession at Dornap displays cyclicity. The cyclicity takes two forms, which are very similar to those seen in the Torbay Reef Complex:

Type A. Cycles which show evidence of increasing salinity and decreasing circulation upward. Two different types can be seen: (i) Cycles which have a semi-restricted subtidal base (microfacies S2) and an *Amphipora*-rich (S4) top, or (ii) cycles which have stromatoporoid-rich (S2 or S4) base and are capped by a restricted subtidal fossil-poor micrite (S6). These cycles range from 90cm to over 8m in thickness and sedimentation is entirely subtidal in nature.

Type B. Cycles which shallow-upwards. These are not so common as Cycle-type A and are mostly seen in the middle of the succession. The cycle has a subtidal semi-restricted base (S2 stromatoporoid floatstones), is followed by an *Amphipora*-rich horizon (S4) and is then capped by intertidal fenestral facies (S8). Cycle thickness is on average 4m-5m. There is also an increase in salinity and decrease in circulation upwards through the cycle.

The generation of these cycles is further discussed in Chapter 6.

### 5.2.3 Trough reefal complexes

Isolated carbonate complexes which developed within the trough are the smallest of the three types. Elbingerode was probably the biggest, reaching approximately 44km<sup>2</sup> (after equilibrating for 33% shortening of the Variscan tectonism; Krebs, 1974). These type A complexes are associated with extensive volcanics of basaltic nature. The volcanics commonly formed the base upon which reefs developed. Therefore, volcanicity before and during reef-growth had an important control on sedimentation. Carbonate complexes were surrounded by basinal sediments. The Langenaubach Reef Complex is the only type A complex examined for this study. Table 5-8 locates the studied section and Sections A1.2.16 and A2.16 present thin-section data and detailed logs.

| Reef Complex | Name of succession | Location (Topographic map number and co-ordinates)  | Thickness of log      |
|--------------|--------------------|---|-----------------------|
| Langenaubach | Medenbach quarry   | 1:50,000, Map 1, Neuauflage Quarry 0.7km NW of Erdbach, on road L3042 (no co-ordinates available) | 34.4m (Section A2.16) |

Table 5-8 Location of the studied succession in the Langenaubach Reef Complex.

#### 5.2.3.1 Langenaubach Reef Complex

The Langenaubach Reef Complex is situated in the southwest part of the Dill Syncline, in the Lahn-Dill region of Germany (Fig. 5-12). Krebs (1966) first documented the facies

variations seen in the Frasnian Iberg Limestone, where fore-reef, reef-core and back-reef facies could be differentiated. Subsequent severe Variscan tectonic dislocation hampered palaeogeographic reconstruction; however, the association of facies attested to the isolated nature of the complex (Fig. 5-28). The Langenaubach Reef Complex falls into the type A category of Krebs (1974) in that it was constructed upon a volcanic submarine rise within the Rhenish trough. The complex was surrounded on all sides by basinal sediments (Krebs, 1974). Carbonate sedimentation was initiated at the *Pol. asymmetricus* conodont zone and continued through to the upper *Pa. gigas* zone (Krebs, 1966; see Figure 2-1 for stratigraphic column). Tuffs are intercalated with the carbonate sediments and volcanic outpourings were common in the surrounding basinal sediments (Krebs 1966). Regional subsidence led to the death of the reefs and typical 'becken' and 'schwollen' sedimentation prevailed. The size of the complex has not been estimated, since Tertiary sediments cover much of the western part of the complex. Using the outcrop pattern of Krebs (1966) and assuming 33% shortening by Variscan tectonics, a guesstimate of 20km<sup>2</sup> can be made. The thickness is in excess of 200m (Krebs, 1966).

Back-reef facies were examined in one section at the large working quarry 2km southeast of Medenbach (Table 5-8). Here strata are dipping 047/30NW where the quarry exposes both reef-core and back-reef facies. The logged succession is dominated by *Amphipora* floatstones and bafflestones (microfacies S4) with rare interbeds of poorly fossiliferous mud-wackestones (see Sections A1.2.16 and A2.16). Commonly the *Amphipora* branches are nested, suggesting little or no post-mortem transportation. Microfossils and floras are locally abundant including *Renalcis* (see Figure 3-9d), ostracodes, forams and calcispheres. Solitary corals, *Stachyodes*, crinoids and overturned small bulbous stromatoporoids are locally present, though not abundant. Sedimentation is entirely subtidal and highly restricted in nature. Late diagenetic dolomitisation is pervasive.

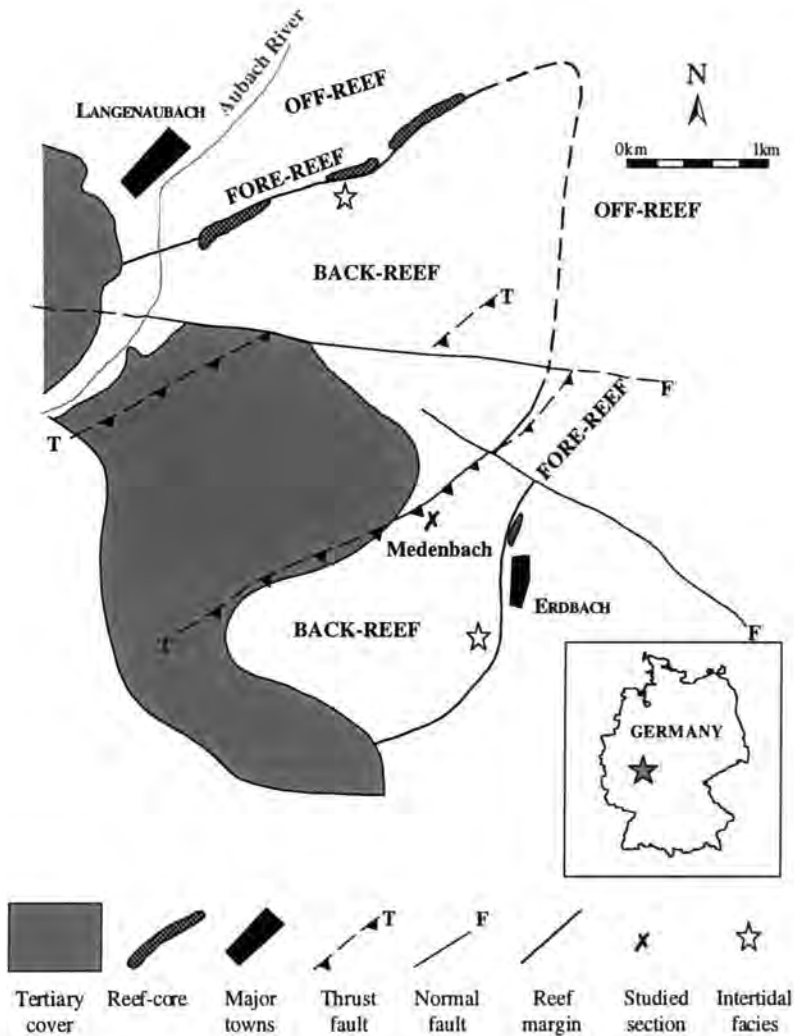

**Figure 5-28** Generalised facies map showing the distribution of Devonian reef facies in the Langenaubach-Breitscheid Reef Complex. Map modified from Krebs (1966).

Although sedimentation at Medenbach is low-energy, subtidal and highly restricted in nature, Krebs (1966) noted the presence of several fenestral, stromatolitic and laminated horizons in a nearby exposure at Erdbach. This clearly suggests the development of tidal flats, yet it is not apparent how laterally or vertically persistent these flats were. Thus, Medenbach was probably situated in the more central, restricted, ?deeper part of the lagoon whereas Erdbach was in a shallower tidal-flat location (Fig. 5-28). Local bioclastic horizons consisting mainly of crinoid debris are also present in the immediate back-reef environment, representing impersistent ?storm-derived accumulations (Krebs, 1966).

The succession at Medenbach does not obviously show any cyclic component; however, the development of interbedded intertidal and supratidal deposits nearby would implicate small-scale sea-level fluctuations influenced sedimentation in the back-reef environment.

#### 5.2.4 Summary

Figure 5-29 summarises the key features identified in the isolated carbonate complexes. Comparisons can be made between the complexes which developed in differing palaeosettings.

Shelf-edge reef complexes are always developed upon ramp facies, they generally show the thickest facies and are some of the largest isolated complexes in the study area. Lagoonal facies are highly variable, with semi-restricted through to supratidal facies recorded. Metre-scale cyclicity is well developed and there is evidence for synsedimentary faulting and volcanism.

Inner-shelf reef complexes also develop upon ramp and bank carbonate facies, yet their sizes and thicknesses are variable. Lagoonal facies are generally subtidal in nature; however, this may reflect the position of the logged succession being in the deeper parts of the central lagoon rather than on the tidal flats. Therefore the apparent lack of tidal-flat facies may just reflect poor outcrop exposure. Cyclicity is developed, yet is mostly subtidal in nature. Synsedimentary faulting is interpreted in the Balve Reef Complex, yet not in the Dornap Reef Complex.

The isolated reef complexes developed in the trough are the smallest seen in the study area and are also the thinnest. The complexes develop on basalts and their initiation, growth and demise are controlled by these volcanic outpourings. Lagoonal deposition is dominantly subtidal, yet this may reflect lack of outcrop in the palaeotidal-flat environment. Cycles are much thicker than in the other complexes and are entirely subtidal in nature.



|                                     |   | TROUGH COMPLEXES   |
|-------------------------------------|---|--|
| Location                            | ATT   | LANGENAUACH  |
| Age                                 | Middle-middle   | Lower Frasnian - middle Frasnian   |
| Underlying facies                   | Schwelm facies  | Basalts  |
| Shape                               |    |   |
| Size                                | 70  | ~20km <sup>2</sup>   |
| Thickness                           | 9   | >200m  |
| Lagoonal facies-types               |  <p>11% restricted facies<br/>29% semi-restricted facies</p> <p>Immediate environment high-energy facies, derived from and intercalations well facies. Central Centre of lagoon of <i>Amphipora</i>-rich poor horizon supratidal depo</p> |  <p>98% restricted facies<br/>2% semi-restricted facies</p> <p>Central, restricted lagoon dominated by <i>Amphipora</i> bafflestones and floatstones, Local evidence for microbial laminites and fenestrae.</p> |
| Cyclicality                         | A1, A3<br>Range in from 0.66m to 8.3m, averaging 3.02m  | A1, A2<br>Range in thickness from 3.6m to 14.37m, averaging 7.19m  |
| Syn-sedimentary tectonics/vocanics? | Fault on the edge of the complex, Devonian thickness varies the reef complex  | Numerous tuff interbeds and penecontemporaneous lavas.   |

Figure 5-29 Summary diagram of trough complexes in Northern Germany and Southwest England.

# CHAPTER SIX

|  |            |
|--|------------|
| <b>6. MIDDLE AND UPPER DEVONIAN RELATIVE SEA-LEVEL FLUCTUATIONS</b> .....                | <b>214</b> |
| 6.1 CONTROLS ON CARBONATE DEPOSITION.....  | 214        |
| 6.2 CARBONATE RESPONSE TO RELATIVE SEA-LEVEL FLUCTUATIONS.....                           | 216        |
| 6.3 PARASEQUENCES.....   | 217        |
| 6.4 PARASEQUENCE STACKING PATTERNS AND FISCHER PLOTS.....                                | 220        |
| 6.5 METRE-SCALE CYCLICITY IN THE DEVONIAN.....   | 222        |
| 6.5.1 <i>Type A cycles</i> .....   | 223        |
| 6.5.2 <i>Type B cycles</i> .....   | 227        |
| 6.5.3 <i>Type C cycles</i> .....   | 232        |
| 6.5.4 <i>Upper Eifelian successions</i> .....  | 233        |
| 6.5.5 <i>Ardennes-Aachen-Eifel area</i> .....  | 236        |
| 6.5.5.1 <i>Givetian strata</i> .....   | 236        |
| 6.5.5.2 <i>Frasnian</i> .....  | 246        |
| 6.5.6 <i>Isolated platforms</i> .....  | 247        |
| 6.5.6.1 <i>Shelf-edge</i> .....  | 248        |
| 6.5.6.2 <i>Inner shelf</i> .....   | 253        |
| 6.5.6.3 <i>Trough</i> .....  | 256        |
| 6.5.7 <i>Magnitude and duration of small-scale relative sea-level fluctuations</i> ..... | 256        |
| 6.6 MECHANISMS CAUSING METRE-SCALE CYCLICITY.....  | 261        |
| 6.6.1 <i>Sedimentary mechanism</i> .....   | 261        |
| 6.6.2 <i>Tectonic mechanism</i> .....  | 263        |
| 6.6.3 <i>Eustatic mechanism</i> .....  | 264        |
| 6.7 DISCUSSION.....  | 268        |
| 6.8 3RD ORDER EUSTATIC FLUCTUATIONS OF THE GIVETIAN AND FRASNIAN.....                    | 273        |
| 6.9 SUMMARY.....   | 274        |

## 6. Middle and Upper Devonian relative sea-level fluctuations

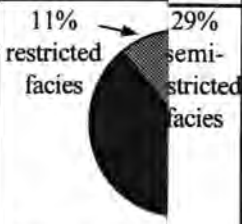
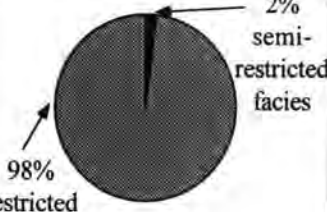
### 6.1 Controls on carbonate deposition

The production, distribution and deposition of shallow-water carbonates depend on the complex interaction of several external and internal controls. These principles governing carbonate sedimentation have been extensively discussed by Schlager (1992), Sarg (1988), Handford and Loucks (1994) and Crevello *et al.* (1989), and will therefore only be briefly reviewed in this Chapter.

The location and large-scale architecture of a carbonate platform depends fundamentally upon three factors: climate, geotectonics and sea level (Sarg, 1988; Tucker and Wright, 1992). Modern day coral reefs are spatially limited to 20° north and south of the equator, since their growth is controlled by minimum winter temperatures (Fig. 6-1; Schlager, 1992). Indeed corals and green algae, the major contributors to modern shallow-water carbonates, can only exist in tropical waters 35° either side of the equator (Schlager, 1992; Tucker and Wright, 1992). However, it is not true to say that all carbonate accumulations are limited to these latitudes since temperate carbonates (consisting chiefly of benthic forams and molluscs) are now known to be widely distributed at higher latitudes in both the past and present (James and Clark, 1997). The tectonic setting controls the style of carbonate deposition, where rimmed shelf, ramp, epeiric platform and isolated platform can be differentiated. Tectonics also has a strong influence on the degree of clastic input into a basin, which intrinsically hinders carbonate deposition. Relative sea level is strongly affected by the global proportion of glacial ice and ocean water, amongst other factors, and is therefore also related to climate and tectonics. The thickest and most widespread carbonate accumulations are deposited in times of highstand (Tucker and Wright, 1992).

Tectonics, climate and sea level have a strong influence on the location and geometry of a carbonate platform, yet the physiochemistry of the oceanic environment will determine the rates and styles of carbonate growth and production. Carbonate rocks are essentially produced *in situ*, differing fundamentally from siliciclastic sediments which are derived from an external source. Therefore, the ability of a carbonate platform to develop depends largely on the organisms contributing to the sediment. Many carbonate secreting organisms are photosynthetic or have a symbiotic relationship with photosynthetic organisms and are therefore highly sensitive to light intensity, water depth, temperature, nutrient supply,

salinity, turbulence and clastic influx. Many of these organisms enjoy nutrient-poor, clear, warm waters (Hallock and Schlager, 1986).

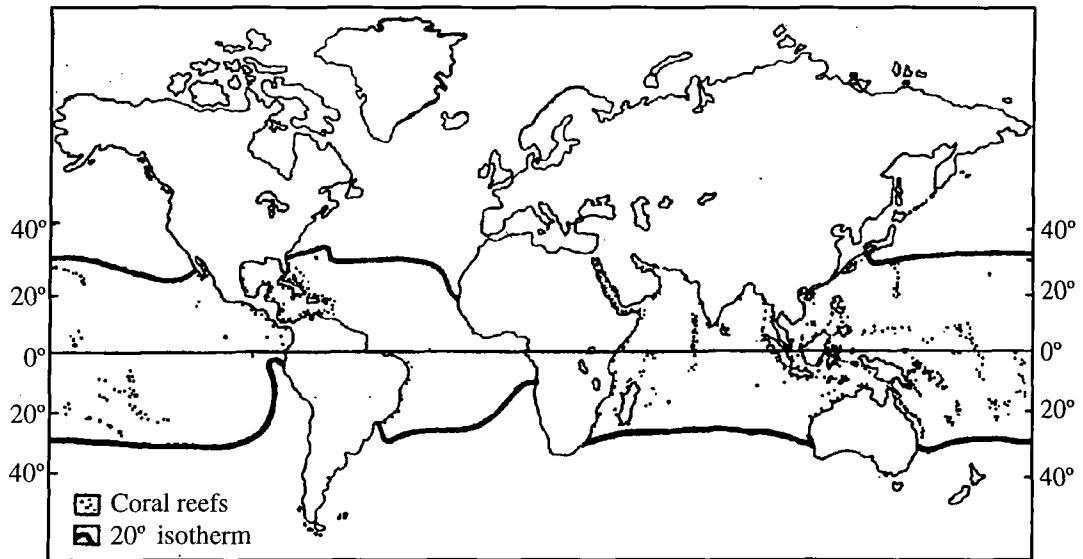

**Figure 6-1** Distribution of recent coral reefs (after Schlager, 1992).

Most organic productivity takes place in less than 10-15m of water, an environment known as the '*carbonate factory*' (Tucker and Wright, 1992). Below the photic zone<sup>1</sup> carbonate productivity drastically decreases, since photosynthetic organisms cannot survive. This water depth usually lies between 50m to 120m (Schlager, 1992). Many physiochemical factors also inhibit carbonate productivity. For example a large proportion of the carbonate-secreting organisms, such as corals, are stenohaline, surviving only in normal marine waters (30-40‰ salinity). Brackish or hypersaline lagoons are not inhabited by such a diverse array of organisms, yet those euryhaline faunas and floras (in particular green algae) which have found a niche in those environments are locally present in great abundance. Turbid waters, where there is either an input of siliciclastics (especially clays) or where lime mud is in suspension, hinders the production of carbonate, since it decreases the amount of light penetrating the water column and therefore discourages the growth of photosynthetic organisms (Tucker and Wright, 1992). An influx of nutrients, either by way of clastics or oceanic upwelling, can also dramatically reduce the productivity of a carbonate system. An increase in nutrients will promote the growth of green algae and bacteria which in turn reduces light intensity and increases bioerosion of the carbonate

<sup>1</sup> The base of the photic zone is defined by biologists as the level where oxygen production by photosynthesizers and oxygen consumption by respiration are in balance (Schlager, 1992).

system. This will eventually cause carbonate productivity to deteriorate. Water energy has an important impact on carbonate production since many organisms are adapted to specific energy regimes. For example, many of the reef-building organisms are well adapted to turbulent high-energy waters, accounting for the location of reefs along the margins of shelves.

Since the production of carbonate is so intrinsically related to internal forces of the oceanic realm, the 'growth potential' or sedimentation rate across a platform varies (Schlager, 1992). The growth potential along a rim of a platform, where accumulation rates of up to 2.3m/1000yr have been recorded in modern systems (Tucker and Wright, 1992), is significantly higher than that of a lagoon. Sedimentation rates in lagoonal environments only reach 0.1m to 0.5m/1000yr. This may lead to an 'empty bucket' scenario where carbonate production at the shelf margin paces a relative sea-level rise, raising the height of the rim and thus leaving the lagoon empty (Schlager, 1992). Ramp carbonates do not show the same marked growth differential, but do exhibit a decrease in productivity along the ramp profile as water depths increase towards the basin.

Net sedimentation rates in the Devonian would appear to have been lower compared to modern-day systems. This is not surprising, since it is difficult to calculate accurately the effects of compaction (especially if the overburden has later been eroded away), and the amount of time lost through exposure surfaces is also difficult to assess. Yang *et al.* (1995) analysed a Middle and Upper Devonian peritidal carbonate succession in California and calculated that subtidal shallow shelf sedimentation had an average rate of 0.28m/1000yr; intertidal deposits were deposited at 0.16-0.19m/1000yr and supratidal deposition was at a significantly slower rate of 0.06m/1000yr.

## **6.2 Carbonate response to relative sea-level fluctuations**

The thickness of a succession and style of sedimentation record the intimate relationship between carbonate production rates, tectonic change and eustatic sea-level change. The sum of tectonic rates (either uplift or subsidence) and rates of change in eustasy result in a *relative sea-level change*. The *accommodation space* provided by the change in relative sea level represents the accumulation potential of the carbonate sequence (Sarg, 1988). The response of carbonate production to the creation of accommodation space will determine whether the carbonate system keeps-up, catches-up, or gives-up (*sensu* Kendall

and Schlager, 1981; Sarg, 1988; Soreghan and Dickinson, 1994) and thus dictates the facies distribution, overall thickness of the carbonate sequence and the geometry of the carbonate platform.

Since modern-day accumulation rates for shallow-water carbonates average 1m/1000yr, sedimentation should be able to keep up with both passive margin subsidence (averaging 0.01-0.1m/1000yr) and long-term eustatic sea-level changes (brought about by plate-tectonic derived ocean-basin fluctuations, averaging 0.01m/1000yr; Tucker and Wright, 1992). However, fault-induced subsidence or sea-level rise related to glacial melting can produce rapid rates of relative sea-level change which carbonate production may not be able to pace. In these scenarios the carbonate platform will be temporarily flooded so that deeper-water sediments will directly overlies shallow-water facies. So long as the amplitude of base-level fall is not large enough to submerge the platform top below the photic zone, carbonate productivity should continue. Following a transgressive pulse there is a lag time whilst carbonate production resumes to its normal rate (Read *et al.*, 1986). It has been postulated that this lag-time occurs because the carbonate factory cannot go into full production until sea level has risen enough to allow sufficient circulation (Handford and Loucks, 1994). For the Holocene this lag time was in the order of 2000-5000 years (Schlager, 1991).

Rapid falls in relative sea level will lead to widespread exposure of the carbonate platform. During this lowstand period the areal extent of the platform which is still in the subtidal photic zone will be decreased, since much of the platform will be experiencing subaerial exposure. The only carbonate-producing areas in shelf settings will be the slopes immediately seaward of the shelf margin, where the amount of sediment produced is gradient-related (Handford and Loucks, 1994). Thus carbonate production rates are commonly at their lowest during rapid relative sea-level drops.

### 6.3 Parasequences

Parasequences are defined by Van Wagoner (1985) as 'a relatively conformable succession of genetically related beds or bedsets bounded by marine flooding surfaces and their correlative surfaces'. The term 'small-scale cycle' is used synonymously with parasequence. A marine flooding surface is a surface which separates younger strata from older, across which there is evidence of an abrupt increase in water depth (Van Wagoner *et al.*, 1988).

The use of the term *marine*, however, can sometimes be rather misleading, since these flooding surfaces can also occur in environments which are not fully marine (such as restricted platform interiors/lagoons). Parasequences commonly show a shallowing-upward or regressive trend; however, during the flooding event transgressive facies (commonly lags) can be deposited, giving rise to a transgressive-regressive parasequence (Arnott, 1995). Parasequence thickness can range from less than 1m to 10's of metres, depending upon the amount of accommodation space available, the magnitude of the relative sea-level increase, carbonate accumulation rate and the mechanism producing the sea-level fluctuation. This is further discussed in Sections 6.6 and 6.7. Soreghan and Dickinson (1994) identified five major cycle- (or parasequence-) types, which have been summarised in Table 6-1. Keep-up cycles tend to be aggradational, whereas catch-up and catch-down cycles are progradational. Give-up cycles are aggradational to retrogradational and only record deep water facies.

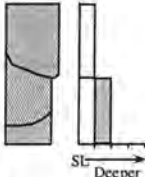
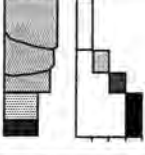
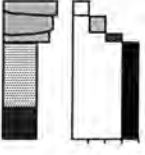
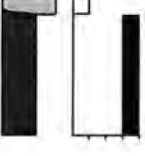
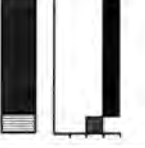
| CYCLE-TYPE                 | SCHEMATIC LOG   | CHARACTERISTICS  |
|----------------------------|---|--|
| Keep-up                    |  | Carbonate production = creation of accommodation space.<br>Cycles record maximum accommodation ⇒ 'thickness complete'.<br>Cycles are dominantly aggradational ⇒ 'facies incomplete'.<br>Cycles dominated by shallow-water facies.  |
| Catch-up                   |  | Carbonate production initially < creation of accommodation space, but progressively overtakes sea level at highstand.<br>Cycles record maximum accommodation ⇒ 'thickness complete'.<br>Cycles are progradational ⇒ 'facies complete'.<br>Deep-water to shallow-water facies present.  |
| Catch-down (foreshortened) |  | Carbonate production initially < creation of accommodation space. Sea-level fall occurs rapidly enough to force but not eliminate progradation. Condensed set of progradational facies.<br>Cycles do not record maximum accommodation ⇒ 'thickness incomplete'.<br>Cycles are dominantly progradational ⇒ 'facies complete'. |
| Catch-down (truncated)     |  | Carbonate production initially < creation of accommodation space. Sea-level fall occurs rapidly enough to stop progradation. Exposure surfaces or shallow-water facies directly upon subtidal facies.<br>Cycles do not record maximum accommodation ⇒ 'thickness incomplete'.<br>Cycles are thwarted ⇒ 'facies incomplete'.  |
| Give-up                    |  | Carbonate production < creation of accommodation space.<br>Limited aggradation, but all facies are subtidal<br>Cycles do not record maximum accommodation ⇒ 'thickness incomplete'.<br>Cycles are thwarted ⇒ 'facies incomplete'.  |

**Table 6-1** Schematic representations of 5 major cycle-types, including schematic palaeobathymetric charts and characteristics of cycles. Reproduced from Soreghan and Dickinson (1994).

A parasequence set is a succession of genetically-related parasequences which form a distinctive stacking pattern that is bounded, in many cases, by major flooding surfaces (Van Wagoner, 1985). Stacking patterns of parasequences in parasequence sets can be progradational, aggradational or retrogradational depending upon the rate of creation of accommodation space and the ability of the carbonate factory to pace this creation (Fig. 6-2). Assuming the mechanism creating parasequences is not autocyclic, progradational stacking patterns, where there is a thinning-upward trend of parasequence thickness and intertidal facies dominate over subtidal facies, will develop during a relative fall in sea level. This reflects the reduction of accommodation space produced by the long term sea-level fall. Retrogradational stacking patterns are commonly developed during transgression and are characterised by thickening-upward parasequences which are progressively dominated by subtidal deposition. Aggradational stacking patterns, where cycles are more-or-less of the same thickness, are commonly developed when long-term relative sea level is stationary. These can be developed either during highstands or lowstands of sea level; however, generally the cycles are thinner in the lowstand than in the highstand (Tucker, 1993).

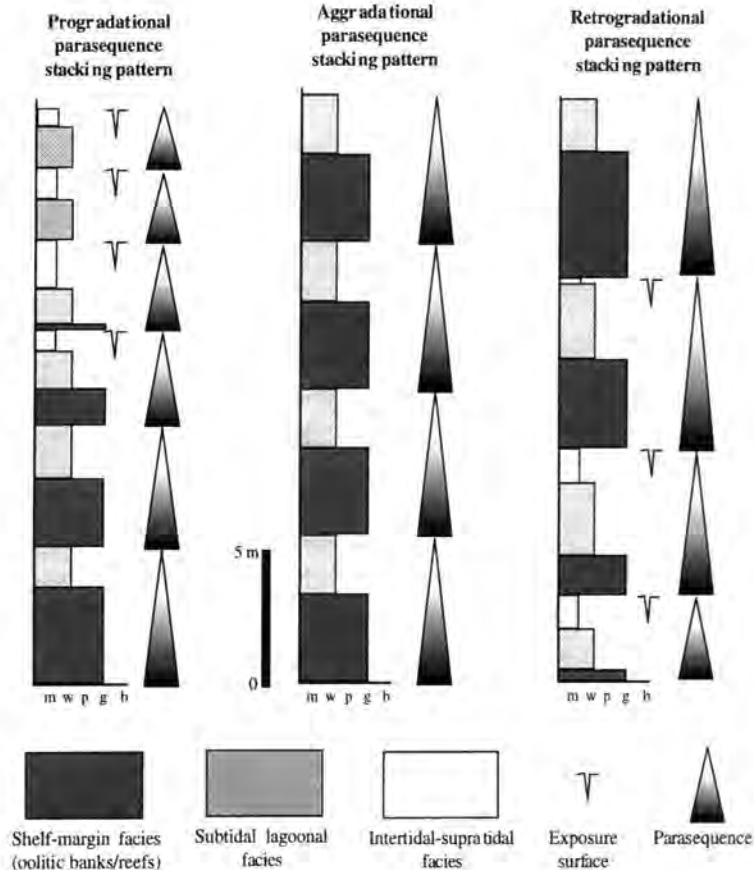

**Figure 6-2** Three styles of parasequence stacking patterns, with their generalised facies associations.

#### 6.4 Parasequence stacking patterns and Fischer plots

The vertical stacking pattern of parasequences (i.e., whether they show an aggradational, progradational or retrogradational trend) are most likely controlled by long-term changes in accommodation space and therefore provide a critical link between individual cycles, the large-scale depositional sequences, and their component systems tracts (Goldhammer *et al.*, 1990; Montañez and Osleger, 1994). Parasequence stacking patterns are comparable to 'parasequence sets' of the sequence stratigraphic terminology of Van Wagoner *et al.* (1988).

The study of parasequence stacking patterns has been proven in the past as a very powerful correlation tool (i.e., Cambrian cycles of the Appalachians, Osleger and Read, 1991; Ordovician carbonates of USA, Sadler *et al.*, 1993, Montañez and Osleger, 1994; Devonian cycles of Nevada USA, Elrick, 1995, to name but a few). The use of stacking patterns for correlation is particularly important where poor exposure hinders the lateral tracing of individual cycles, such as in the present study area.

Fischer plots are a popular tool in cycle stratigraphy as an aid to graphically illustrating deviations from average cycle thickness (Fischer, 1964; Sadler *et al.*, 1993). The graph plots 'cumulative departure from mean thickness' against 'cycle number', so that thicker-than-average cycles enter the plot with a positive slope and thinner-than-average cycles enter the plot with a negative slope (Fig. 6-3a). This provides an objective plot of cycle-thickness variation.

The interpretation of these thickness variations can, however, be subjective (Sadler *et al.*, 1993). If cycles are assumed to be eustatic in origin, Fischer plots are interpreted as mimicking long-term sea-level histories. Retrogradational stacking patterns (thicker-than-average cycle trends) develop in the transgressive systems tract and thus plot on the rising limb of the Fischer plot. Progradational stacking patterns are developed in the late highstand and thus plot on the falling limb of the plot (Fig 6-3b). The Fischer plot technique helps interpret cyclic successions in terms of sequence stratigraphy, especially where large-scale architectures such as onlap and downlap are difficult to interpret at outcrop scale.

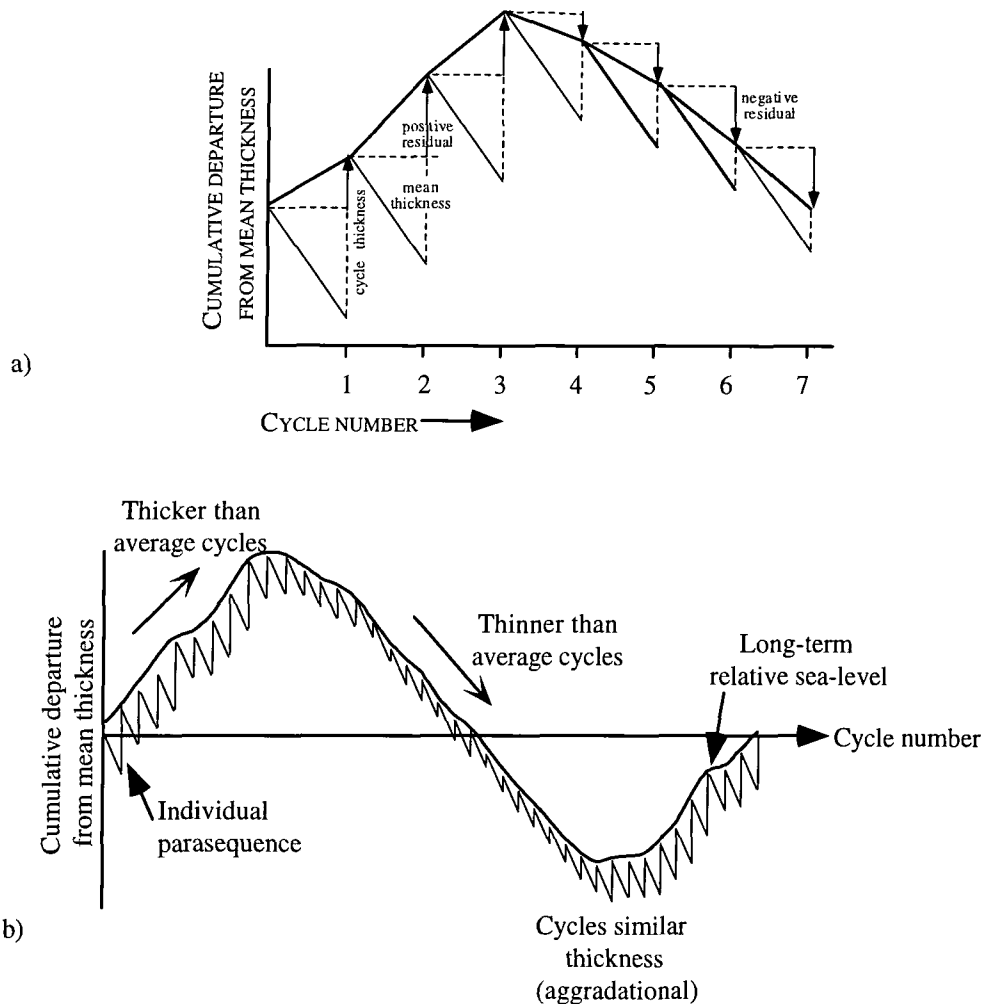

**Figure 6-3 a) Characteristics of a Fischer plot. Cycle number is plotted against cumulative departure from mean thickness, so as to gain an objective visualisation of cycle-stacking patterns (adapted from Sadler *et al.*, 1993). b) Synthetic Fischer plot showing how stacking patterns can be related to long-term sea-level history.**

Limitations to this technique, however, must also be recognised if interpretations are to be valid. Sadler *et al.* (1993) cautioned that Fischer plots of less than 50 cycles may not ensure a robust estimate of average cycle-thickness, and therefore produce an insubstantial plot, especially when it is intended to apply a statistical analysis. When dealing with intertidal and supratidal facies, 'missed beats' may occur where oscillations in relative sea level have not been recorded in the sedimentary strata through emergence, and therefore the complete cycle history has not been recorded. Fischer plots will also inevitably pick up 'noise' where autocyclic processes such as tidal flat progradation, or indeed periodic faulting, overprints a eustatic signature. Ideally, Fischer plots should only be used with cycles which show full regression to intertidal-supratidal facies, since it is only then that one can be sure that accommodation space has been completely filled, and that the Fischer

plot gives a long term trend in relative sea-level change. Using Fischer plots for subtidal cycles means that the plot may not necessarily reflect the full amount of accommodation space available. However, many studies in the past decade (e.g., Osleger and Read, 1991; Osleger, 1991; Jennette and Pryor, 1993; Elrick, 1995) have used Fischer plots with subtidal cycles successfully, and in many cases clear correlations to the up-dip peritidal cycles can be made. Therefore, this tool should not be dismissed because cycles are subtidal in nature; however, the implications of what the Fischer plot means in terms of accommodation space should be understood beforehand. Finally, Montañez and Osleger (1994) noted that the plots are not corrected for isostatic response to sediment and water loading.

With all of these cautions aside, Fischer plots are still extremely useful for comparing successions and for assessing variation in long-term sea level.

### **6.5 Metre-scale cyclicity in the Devonian**

Chapter 5 and Table 5-2 in particular briefly discussed the cycle-types present in the study area. Sections 6.5.1 to 6.8 will expand on these initial findings, discussing the different types of cycle, their vertical stacking patterns, Fischer plots, relation to a longer-term sea-level history and the mechanisms causing the cyclicity. Appendix 3 tabulates all cycle thickness information presented in the study.

In the Devonian successions, cyclicity was determined by assessing the vertical stacking of facies in the successions. The well-established definition of a cycle being 'bounded at the base by a flooding surface where there is evidence of an abrupt increase in water depth' is sometimes a little difficult to apply to the Devonian shelf facies, since variations in water depth are locally difficult to establish. Therefore, in this study, the base of a cycle was identified by the initial backstepping of a less restricted facies over a more restricted facies. It is interpreted, however, that less-restricted facies do represent an increase in water depth since there will be a more diverse faunal assemblage and an increased circulation in the lagoon when sea level is high and the lagoon is 'open'. As relative sea level falls, the lagoon may be influenced less by marine waters and restricted facies will be deposited. Using these principles cycles can therefore either be transgressive-regressive, or wholly regressive, depending upon the rate of relative sea-level rise and the ability of carbonate production to pace the increase in creation of accommodation space.

The development of a particular cycle depends on a number of interrelated factors. The most important is the amount of accommodation space available for sediment to fill, which in turn is fundamentally controlled by rate of relative sea-level change. Therefore, the longer-term relative sea-level history will also have a substantial influence on cycle type (see Figure 6-2). The positioning of a succession within the carbonate platform will also have some control on the consequent cycle type, since successions which are located on the palaeotidal flats will more likely record intertidal and supratidal facies, and commonly emergence. In deeper-water successions relative sea-level oscillations may have occurred too far above the sediment surface to cause a distinct change in facies and therefore cyclicity is not recorded.

To recap Table 5-2, three major groups of cycle-type have been established in the study area. Type A and Type B cycles are associated with shelf successions. Type A cycles show evidence for a decrease in circulation, decrease in diversity of organisms and increase in fluctuation of salinity upward through the cycle. It is difficult to determine if there is a shallowing-upward component to these cycles. Type A cycles are entirely subtidal in nature. Type B cycles distinctly shallow-upwards. These cycles also show a decrease in diversity of organisms and increase in fluctuation of salinity, up through the cycle. Type C cycles are associated with ramp facies and generally show shallowing-upward trends. This is often also accompanied by an increase in spar content and increase in abrasion of bioclasts.

### 6.5.1 Type A cycles

Type A cycles are entirely subtidal in nature and can be subdivided into three groups (Table 6-2).

#### *Type A1 cycles*

Type A1 cycles include both semi-restricted subtidal and restricted subtidal microfacies (Fig. 6-4). There are several permutations of this cycle (Table 6-2). For example, the cycle could have a stromatoporoid floatstone microfacies (S2) at its base, followed by an *Amphipora*-rich unit (microfacies S4), then capped by a fossil-poor horizon (microfacies S6). Alternatively the base could be a stromatoporoid floatstone (S2), directly capped by a microfossil-poor horizon (S6). These cycles show a decrease in circulation, decrease in diversity of organisms and increase in fluctuation of salinity upwards through the cycle. It

is unclear if there is an associated shallowing. The cycles are broadly regressive in nature and are similar to the aggradational (keep-up) cycles of Soreghan and Dickinson (1994) where the cycle is not able to prograde fully into intertidal-supratidal facies. Sedimentation was unable to pace the initial rise in relative sea level since facies were not deposited during the deepening event.

Cycles can also be transgressive-regressive, where facies record the rise in relative sea level. This results in a more symmetrical cycle style; for example, where the cycle has a fossil-poor base (S6), overlain by a stromatoporoid floatstone (S2), then an *Amphipora*-rich horizon (S4), finally capped by another fossil-poor horizon (S7) (Fig. 6-4). A1 cycles range in thickness from less than 0.5m to 8.4m, averaging 2.2m. They are by far the most common cycle-type throughout the Devonian shelf lagoon successions, and a total of 124 cycles were recorded.

| A1 cycle, facies permutations<br>(base → top of cycle) | A2 cycle, facies permutations<br>(base → top of cycle) | A3, cycle facies permutations<br>(base → top of cycle) |
|--|--|--|
| S2-S4  | S4-S2-S6   | S2-S3  |
| S2-S5  | S4-S3-S4   | S3-S2-S3   |
| S2-S6  | S4-S2-S6   |  |
| S2-S7  | S6-S2-S6   |  |
| S3-S4  | S6-S3-S6   |  |
| S3-S5  | S3-S2-S3-S4  |  |
| S3-S6  | S4-S2-S4-S6  |  |
| S2-S3-S4   | S4-S2-S4-S7  |  |
| S2-S4-S6   | S5-S4-S3-S6  |  |
| S2-S4-S7   | S6-S2-S6-S7  |  |
| S2-S5-S6   | S6-S4-S2-S4  |  |
| S2-S6-S7   | S6-S4-S2-S6  |  |
| S3-S2-S4   | S6-S4-S2-S7  |  |
| S3-S2-S6   | S4-S3-S2-S3-S7   |  |
| S3-S6-S3   | S6-S4-S2-S6-S7   |  |
| S4-S2-S4   | S6-S5-S4-S6  |  |
|  | S4-S5  |  |
|  | S4-S6  |  |
|  | S4-S7  |  |
|  | S5-S6  |  |
|  | S5-S7  |  |
|  | S6-S7  |  |
|  | S4-S5-S6   |  |
|  | S4-S6-S7   |  |
|  | S5-S4-S6   |  |
|  | S5-S6-S7   |  |
|  | S6-S4-S6   |  |
|  | S6-S4-S7   |  |
|  | S6-S5-S6   |  |
|  | S6-S4-S6-S7  |  |
|  | S6-S4-S5-S6  |  |
|  | S6-S5-S4-S6  |  |

**Table 6-2** Microfacies permutations in type A cycles. Cycles are either transgressive-regressive, or wholly regressive. Refer to Chapter 4 for microfacies descriptions.

### ***Type A2 cycles***

Type A2 cycles record facies variations within the restricted subtidal depositional environment. Table 6-2 records the different facies-permutations within the cycle group; however, the most common A2 cycle has an *Amphipora*-rich horizon (S4) at the base and is capped by a fossil-poor horizon (S6 microfacies) (Fig. 6-4). Type A2 cycles show a decrease in faunal diversity upwards through the cycle, synonymous with a probable decrease in salinity. The facies variations may reflect a progressive closure of the lagoon, where the circulation became more restricted and salinities more fluctuating. As with A1-type cycles, type A2 cycles are broadly similar to keep-up cycles of Soreghan and Dickinson (1994).

Some A2 cycles also show a transgressive-regressive trend (Table 6-2), as sediments were deposited in the relative rise in sea level. A2 cycle thickness ranges dramatically from 0.2m to over 14m, averaging 2.22m. A2 cycles are relatively common, with 81 cycles being identified in the studied successions.

### ***Type A3 cycles***

Type A3 cycles are relatively rare in the Devonian successions, mostly occurring in the isolated platforms. Type A3 records cyclicity within the semi-restricted subtidal depositional environment. Cycles are mostly asymmetrical, with a stromatoporoid floatstone (S2) at the base, and then capped by either *Stringocephalus*-rich facies or *Stachyodes* grainstones (S3 microfacies). Therefore, type A3 cycles record increasing energy upwards through the cycle. Type A3 cycles are rarely symmetrical. Cycle thickness ranges from 0.9m to 5.8m, averaging 3.1m.

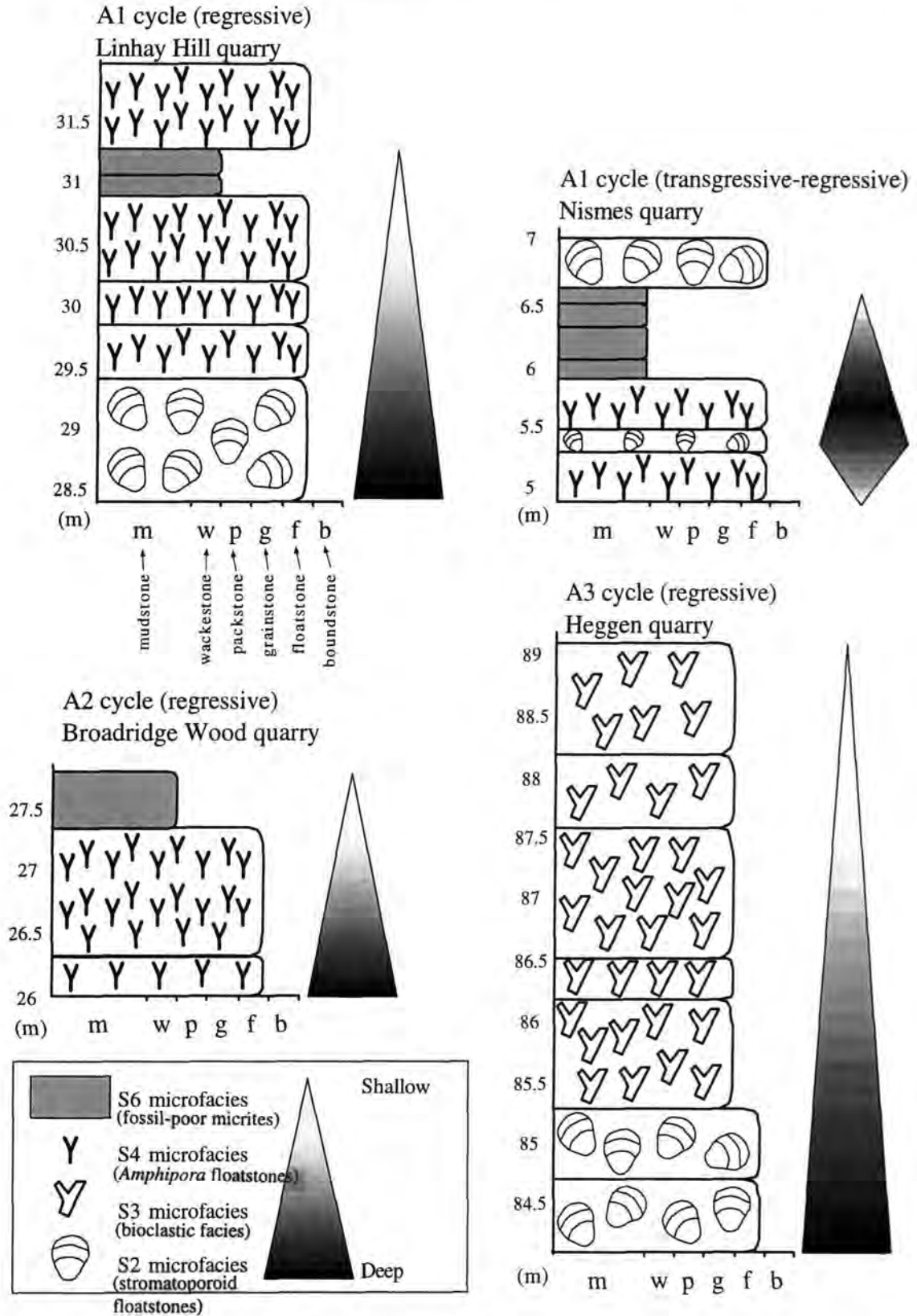

Figure 6-4 Schematic representations of type A cycles.

### 6.5.2 Type B cycles

Type B cycles shallow-upwards from base to top. They can be subdivided into five groups (Table 6-3).

| B1 cycle, facies permutations (base → top of cycle) | B2 cycle, facies permutations (base → top of cycle) | B3 cycle, facies permutations (base → top of cycle) | B4 cycle, facies permutations (base → top of cycle) | B5 cycle, facies permutations (base → top of cycle) |
|---|---|---|---|---|
| S2-S8   | S4-S8   | S2-S12  | S4-S12  | S8-S11-S12  |
| S3-S8   | S6-S8   | S3-S12  | S5-S13  |   |
| S2-S4-S8  | S6-S10  | S2-S6-S12   | S6-S11  |   |
| S2-S6-S8  | S7-S8   | S2-S8-S11   | S6-S12  |   |
| S2-S6-S10   | S7-S10  | S2-S8-S12   | S6-S14  |   |
| S3-S5-S8  | S4-S6-S8  | S2-S10-S11  | S4-S6-S12   |   |
| S4-S2-S8  | S4-S6-S10   | S3-S6-S12   | S6-S4-S12   |   |
| S6-S2-S8  | S4-S8-S10   | S4-S2-S12   | S6-S7-S12   |   |
| S1-S2-S3-S9   | S5-S6-S8  | S6-S2-S12   | S6-S7-S14   |   |
| S2-S3-S8-S10  | S5-S6-S10   | S6-S2-S13   | S6-S8-S12   |   |
| S2-S4-S6-S8   | S6-S4-S8  | S2-S4-S6-S12  | S8-S6-S12   |   |
| S4-S2-S4-S8   | S7-S6-S8  | S2-S4-S6-S13  | S12-S4-S12  |   |
| S4-S2-S6-S8   | S8-S4-S8  | S2-S6-S7-S12  | S4-S5-S8-S13  |   |
| S8-S4-S2-S8   | S8-S6-S8  | S2-S6-S8-S11  | S5-S4-S6-S12  |   |
|   | S4-S5-S6-S8   | S2-S6-S11-S12                                       | S6-S4-S6-S12  |   |
|   | S6-S4-S6-S8   | S4-S3-S6-S12  | S6-S8-S10-S12                                       |   |
|   | S6-S5-S6-S8   | S6-S2-S6-S12  | S8-S4-S6-S12  |   |
|   | S6-S4-S7-S10  | S6-S3-S6-S12  | S6-S4-S5-S6-S8-S11                                  |   |
|   |   | S1-S2-S4-S6-S12                                     | S6-S10-S12-S11-S12                                  |   |
|   |   | S6-S3-S4-S6-S8-S12                                  |   |   |

**Table 6-3** Microfacies permutations in type B cycles. Cycles are either transgressive-regressive, or wholly regressive. Refer to Chapter 4 for microfacies descriptions.

#### Type B1 cycles

Type B1 cycles show shallowing from semi-restricted subtidal facies to an intertidal cap. Shallowing is accompanied by a decrease in diversity of organisms and increase in fluctuating salinity. There are several styles of facies organisation in B1 cycles (Table 6-3). For example, the base of the cycle may have a stromatoporoid floatstone base (S2 microfacies), followed by an *Amphipora* floatstone (S4), then a fossil-poor unit (S6), capped finally by a horizon rich in fenestrae (S8 microfacies) (Fig. 6-5). This cycle-style is asymmetrical and wholly regressive. Alternatively, cycles can be transgressive-regressive, where the rise in relative sea level was slow enough to allow sedimentation to continue. These cycles are typified by restricted subtidal facies at the base (either S4 *Amphipora* floatstones or S6 fossil-poor mudstones-wackestones), which further transgress into semi-

restricted subtidal facies (S2) and then show progressive shallowing back into restricted subtidal then intertidal facies.

Since type B1 cycles show evidence for shallowing upwards, they can be compared to the catch-up cycles of Soreghan and Dickinson (1994). Rare cycles, for example those which have semi-restricted subtidal bases, with intertidal deposits lying directly upon them (i.e., no restricted subtidal facies) typify the catch-down (truncated) cycles of Soreghan and Dickinson (1994), where there has essentially been a forced regression (*sensu* Posamentier *et al.*, 1992).

Type B1 cycles are not very common, with only 22 examples being recorded. Cycle thickness ranges from 0.3m to 5.7m, averaging 2.7m.

### ***Type B2 cycles***

Type B2 cycles show shallowing from restricted subtidal facies through to intertidal facies. Shallowing is accompanied by a decrease in diversity of organisms and increase in fluctuating salinity. Cycles are mainly regressive, with the most common cycle-type having an *Amphipora*-rich base (S4), followed by a fossil-poor horizon (S6), and capped either by a fenestral mudstone (S8), fenestral laminite (S10), or both (Fig. 6-5). Type B2 cycles are not fully progradational since semi-restricted facies are not recorded. This may be because the sea-level rise was not large enough to invoke well-circulated waters in the lagoon, or that the transgressive pulse was too quick for sedimentation to keep up. B2 cycles are common in the logged successions, with 44 cycles being documented. Cycle thickness ranges from 0.1m to 6.2m, averaging 2.1m.

### ***Type B3 cycles***

Type B3 cycles show complete shallowing from a semi-restricted subtidal base, through to a high intertidal-supratidal cap (Fig. 6-6). The most common B cycle has a stromatoporoid floatstone base (S2), followed by an *Amphipora*-rich horizon (S4), then a fossil-poor unit (S6) and capped by a microbial laminite (S12) or dolomudstone (S13). Rarely, a transgressive lag (microfacies S1) or erosional surface is present at the base of the cycle (Fig. 6-5). Cycles are mostly regressive, yet transgressive-regressive cycles are not uncommon. These cycle-types occur where the rise in relative sea level is slow enough so that sedimentation is able to pace the creation of accommodation space. Table 6-3 documents the different facies permutations seen in type B2 cycles.

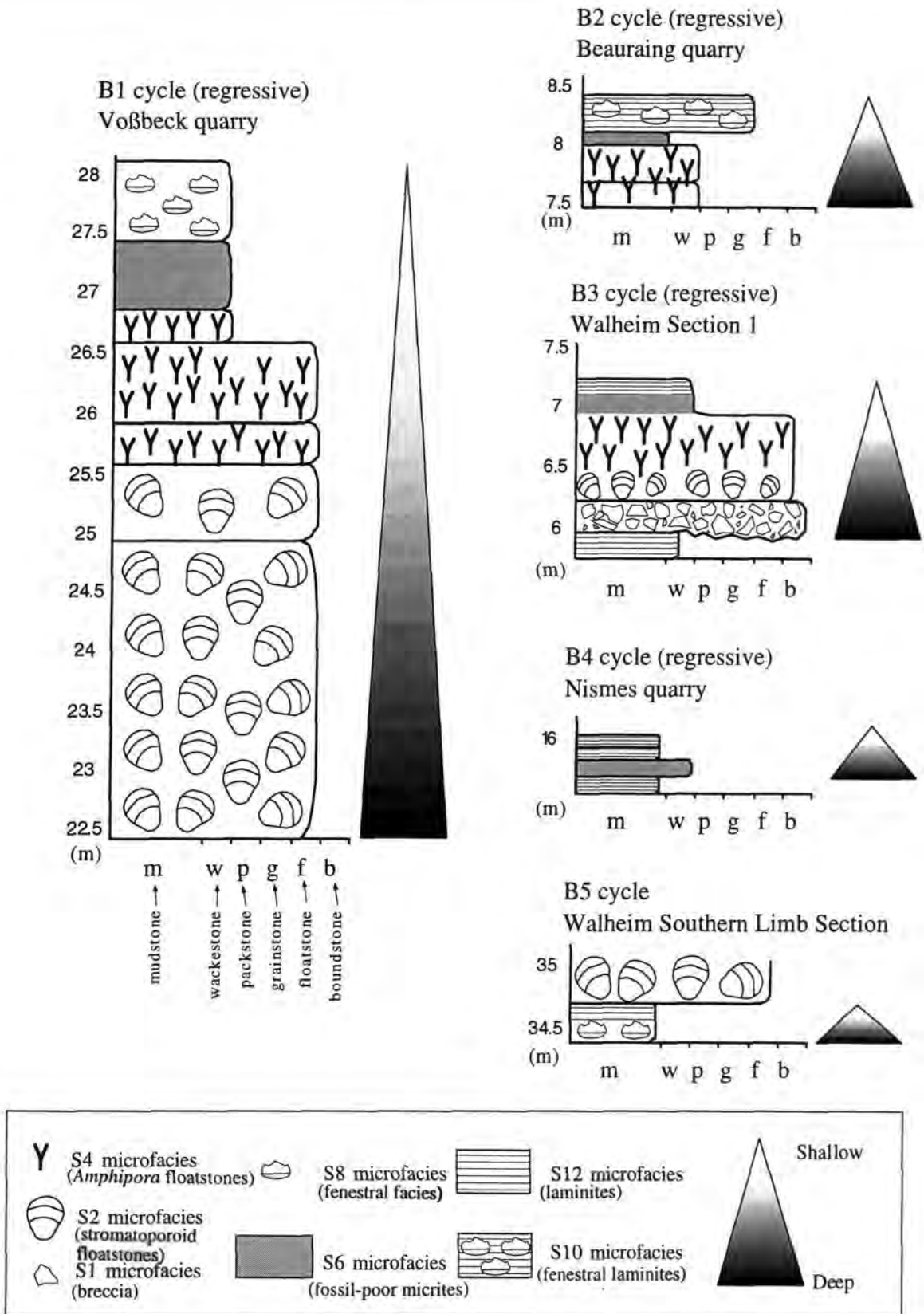

Figure 6-5 Schematic representations of type B cycles.

Type B3 cycles can be compared to the catch-up cycles of Soreghan and Dickinson (1994), in which sedimentation initially lags behind creation of accommodation space, but progressively overtakes sea level at highstand. The resultant cycle is both facies complete and thickness complete, being fully progradational units. It is also true to say that some cycles in the B2 category also show catch-down (both foreshortened and truncated; see Table 6-1), where high intertidal-supratidal facies directly overlie semi-restricted subtidal facies, omitting restricted subtidal and low intertidal facies. These cycles probably developed in response to a forced regression.

Type B3 cycles are relatively common, with 41 cycles being identified. These cycles are distributed mainly within the broad shelf lagoon. Cycle thickness ranges from 0.2m to over 9m, averaging 2.1m.

#### ***Type B4 cycles***

B4 cycles show evidence for shallowing from restricted subtidal facies through to high intertidal-supratidal facies (Fig. 6-5). This regression is also accompanied by a decrease in faunal diversity and an increase in fluctuating salinities, reflecting the progressive closure of the lagoon and fall in relative sea level. Cycles can be both regressive, and transgressive-regressive, depending upon the ability of carbonate production to pace the rise in sea level (Table 6-3). The most abundant B4 cycle has a fossil-poor unit (S6 microfacies) at the base and is capped by a microbial laminite (S12). Other supratidal facies, including dolomudstones (S13) and calcretes (S14), form the caps to type B4 cycles.

As with type B2 cycles, B4 cycles do not reflect a 'complete' regressive cycle, since semi-restricted facies were not deposited at the base. This suggests that either the rise in relative sea level was not of a high enough magnitude to increase the circulation of the lagoon, or that the rise in relative sea level was so quick that carbonate sedimentation could not pace it.

Type B4 cycles are substantially thinner than most of the other cycle-types. Cycle thickness ranges from 0.2m to 4.7m, averaging only 1.3m. B4 cycles are most common in the broad shelf lagoon, rather than in the isolated platforms.

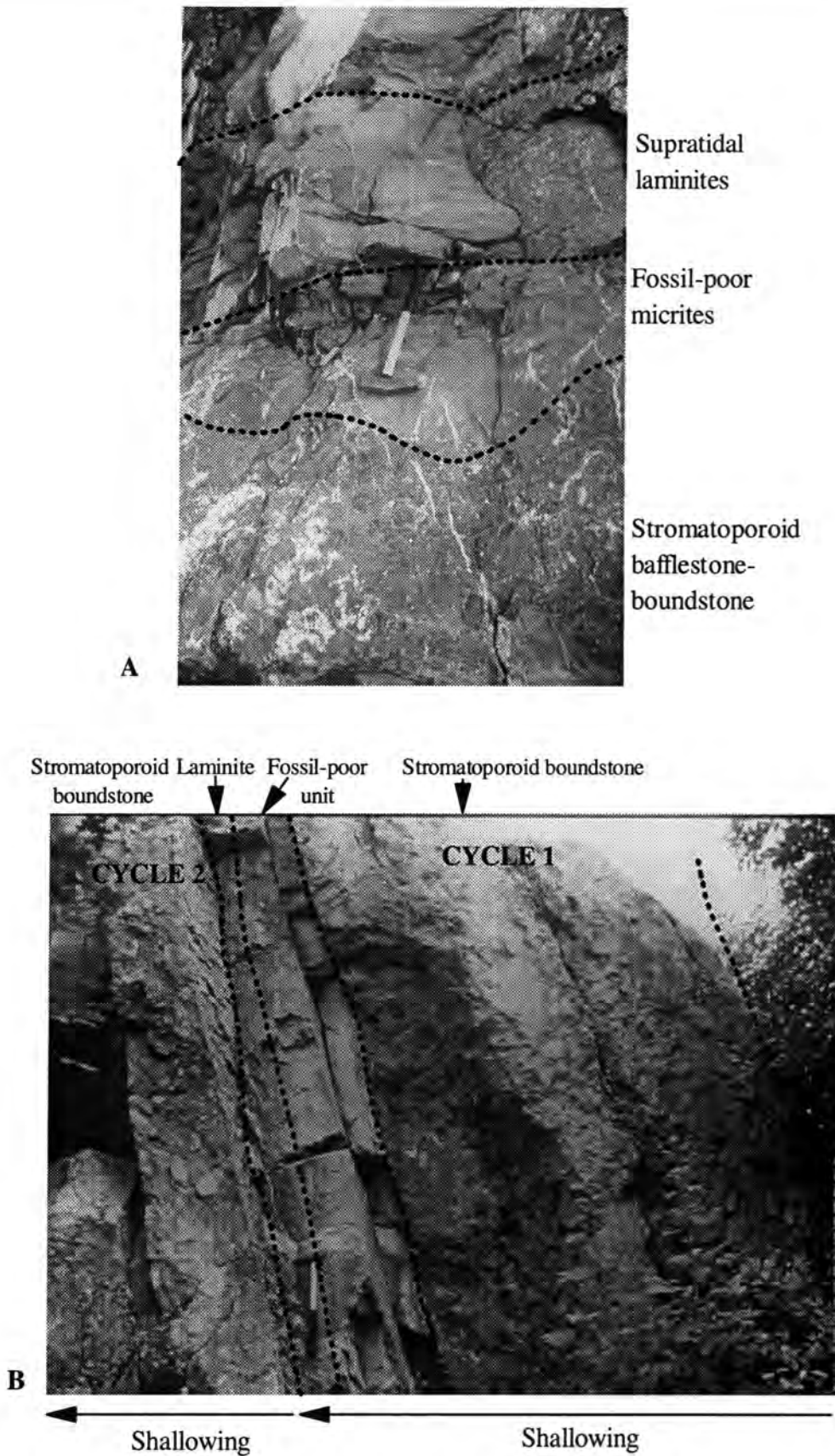

Figure 6-6 Photographs of B3 cycle-types. Cycles are 'complete', having a semi-restricted subtidal base, followed by a restricted subtidal horizon and capped by a microbial laminite. Photograph A is taken at Bleiwäsche quarry, Brilon Reef Complex; photograph B is taken at Walheim Section 1, Aachen, Germany. Hammer is 42cm long for scale.

### *Type B5 cycles*

Type B5 cycles are extremely rare, only being identified in one succession in the shelf lagoon. The base is characterised by a fenestral mudstone (S8 microfacies), followed by an intraclast horizon (S11) and is capped by a microbial laminite (S12). The cycle is 0.2m thick and regressive (Fig. 6-5).

### 6.5.3 Type C cycles

Type C cycles show evidence of facies variation within ramp successions. Type C cycles can be subdivided into 3 groups (Table 6-4).

| C1 cycle, facies permutations<br>(base → top of cycle) | C2 cycle, facies permutations<br>(base → top of cycle) | C3, cycle facies permutations<br>(base → top of cycle) |
|--|--|--|
| R1-R2  | R1-R4  | R1-R7  |
| R1-R3  | R5-R1-R4   | R1-R4-R7   |
| R1-R2-R3   |  | R3-R7  |
| R2-R1-R2   |  | R4-R6  |
| R2-R1-R3   |  | R5-R6  |
|  |  | R5-R7  |
|  |  | R6-R7  |
|  |  | R2-R1-R6   |
|  |  | R3-R4-R6   |
|  |  | R6-R5-R7   |
|  |  | R1-R2-R4-R7  |
|  |  | R5-R3-R2-R7  |

**Table 6-4** Microfacies permutations in type C cycles. Cycles are mostly regressive. Refer to Chapter 4 for microfacies descriptions.

### *Type C1 cycle*

Type C1 cycles show shallowing from outer ramp facies through to mid ramp facies. They are dominantly regressive, with a bioturbated mudstone (R1 microfacies) at the base, and either storm influenced bioclastic packstones (R2) or stromatoporoid floatstones (R3) at the top of the cycle (Fig. 6-7). Locally, C1 cycles can be transgressive-regressive (Table 6-4).

Type C1 cycles are the most common cycle-type in the ramp successions. They range from 0.2m to over 10m in thickness, averaging 2.8m. They show evidence for shallowing only up to fair-weather wave-base.

### *Type C2 cycle*

Type C2 cycles display evidence of shallowing from outer ramp facies through to inner ramp facies (Fig. 6-7). Facies permutations are variable (see Table 6-4), yet most commonly the cycles have an argillaceous mudstone (R1 microfacies) at the base and immediately shallow into oolitic facies (R4). There is an increase in spar cement and an

increase in abrasion. This cycle type is rare, recording full shallowing to fair-weather wave-base. Cycle thicknesses range from 0.4m to 5.4m, averaging 2.5m.

### ***Type C3 cycle***

C3 cycles shallow from open-marine ramp facies to restricted ramp facies. Cycles show a decrease in diversity of organisms and increase in lime-mud content. Facies stacking patterns are very variable (Table 6-4). Type C3 cycles only occur in one succession (Bellignies-Bettrechies quarry), where thickness ranges from 0.2m to 7.4m, averaging 2.5m. Cycles are mainly regressive.

### **6.5.4 Upper Eifelian successions**

Type C1 cycles are the most common in the upper Eifelian ramp succession at Glageon quarry. The succession is characterised mainly by outer to mid ramp facies, yet shallowing into the inner ramp environment, represented by oolite banks and C2-type cycles, can be identified at 35m (Fig. 6-8a; see Appendix 2 for logs). Average cycle thickness for the upper Eifelian is 3.5m, somewhat thicker than seen in the younger lagoonal sediments. Cycle thickness ranges from less than 1m to over 7m and each cycle has a regressive trend.

The plot for the upper Eifelian (Fig. 6-8a) shows a subdued cycle thinning followed by a more pronounced pattern of cycle thickening. Broadly, the shallowest facies (i.e., the oolitic facies) occur just before the development of the thicker cycles. The overall pattern would indicate a long-term regression followed by a transgression. This plot mimics the plots calculated by Kasimi and Preat (1996) for other upper Eifelian successions in France and Belgium (Fig 6-8b), suggesting regional or eustatic rather than local mechanisms were causing these depositional trends.

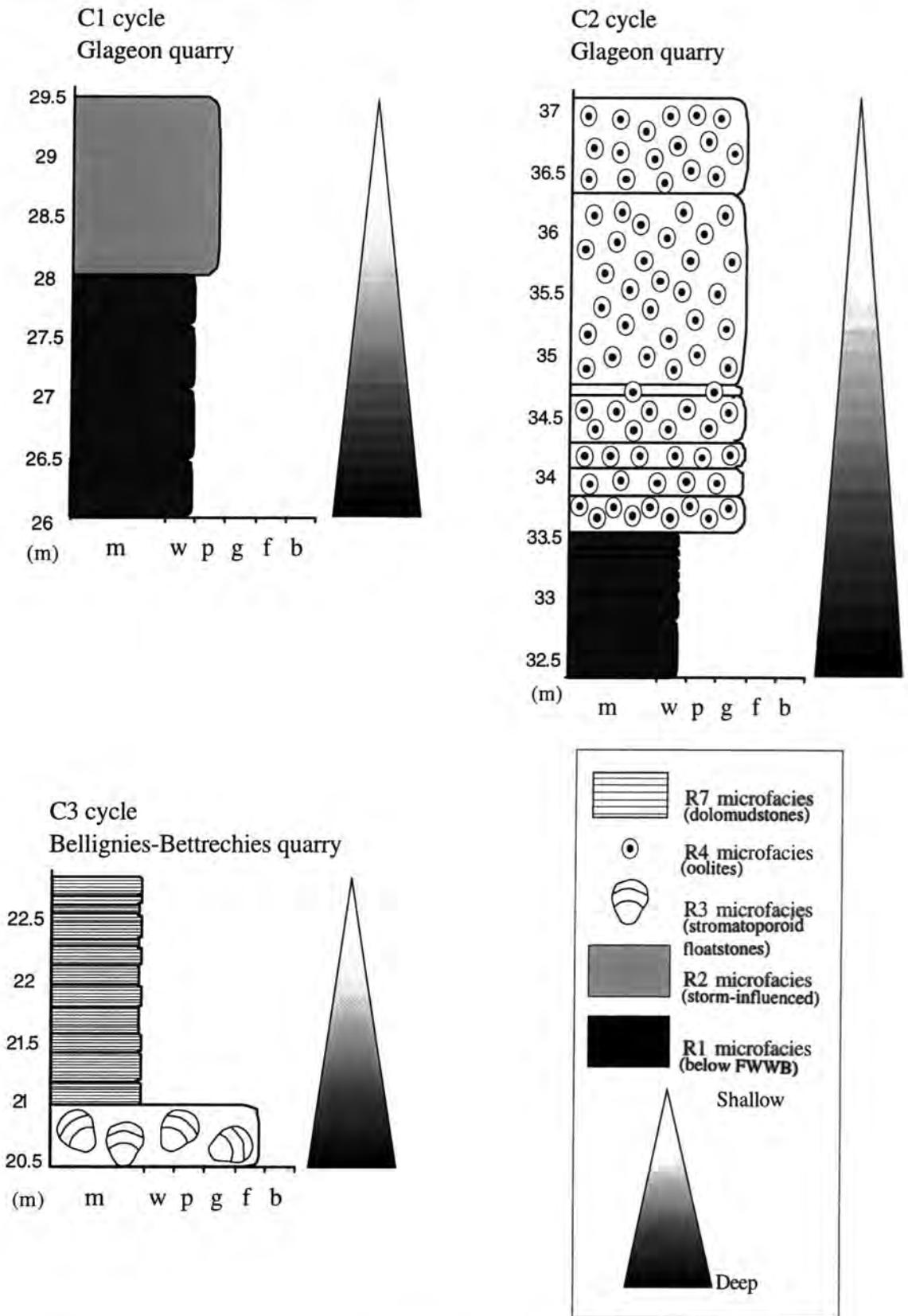
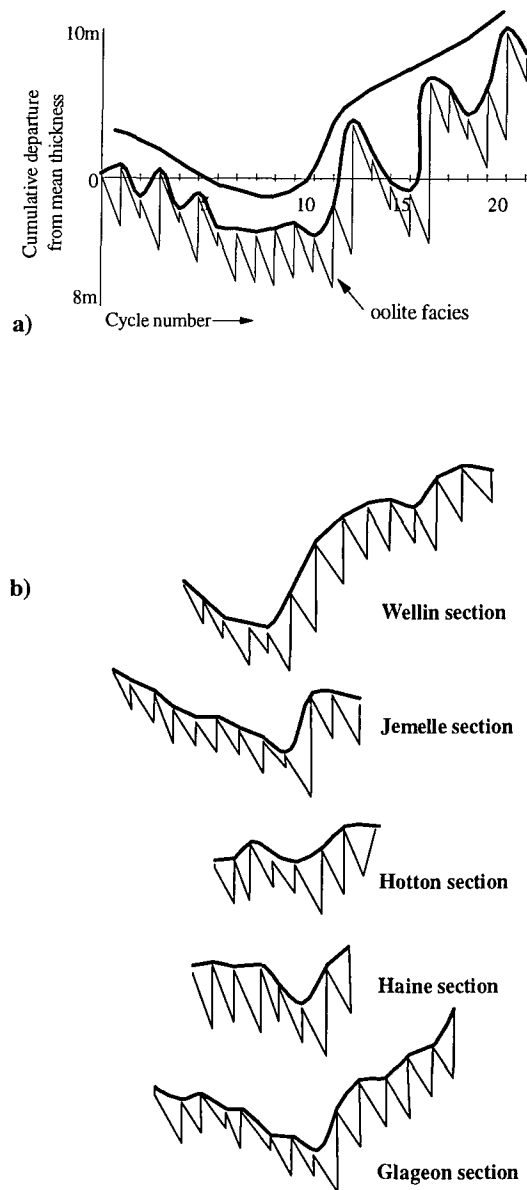

Figure 6-7 Schematic representations of type C cycles.



**Figure 6-8** a) Fischer plot for the upper Eifelian succession at Glageon quarry. b) Fischer plots for five other upper Eifelian successions in the Belgian and French Ardennes (adapted from Kasimi and Preat, 1996).

Cycles in the Eifelian rarely show full regression into intertidal environments. The cycles build up to either storm wave-base or fair-weather wave-base (similar to the Ordovician cycles of Cincinnati; Jenette and Pryor, 1993). An explanation for this may be that the pulses of relative sea-level fluctuation may have been of a short duration and thus sediments were unable to build up to sea-level before the next deepening event. Alternatively, sediments may be unable to aggrade to intertidal facies because turbulent high-energy waters above fair-weather wave-base were constantly reworking and

redepositing sediments to other environments, and therefore this depositional environment did not actually record sedimentation. Thus, wave-base is effectively controlling cyclicality.

## 6.5.5 Ardennes-Aachen-Eifel area

### 6.5.5.1 Givetian strata

#### *Lower Givetian*

Six successions in the Ardennes and one succession in the Eifel area were studied in lower Givetian strata. Sediments were informally divided into two units: the lower unit was denoted by the lack of laminite horizons, and the upper unit was characterised by the development of several laminite horizons (see Figure 5-5). The cycle-types seen in the lower Givetian were not only influenced by these long-term sedimentation styles (and consequently long-term trends in accommodation space), but also on the local areal positioning of the succession upon individual fault blocks within the shelf.

Figure 6-9 presents a correlation panel for Fischer plots of the lower Givetian successions. It can be seen from the panel that although individual cycles may not be traceable from succession to succession, **trends** in cycle thickness are regional and correlatable. There are many cycle-types represented in the lower Givetian. Cycles range from subtidal dominated (type A cycles) to fully regressive cycles with a subtidal base through to supratidal cap (B3). Many cycles are, however, either type A, or type B1/B2 where cycles are capped by fenestral horizons rather than supratidal facies. Fully regressive cycles (B3) are rare in the lower Givetian.

Trends in cycle-type are somewhat difficult to pick out since the cycle-type depends not only the ability of carbonate production to pace any change in relative sea level, but it also depends on the subsidence or consequent uplift of the respective fault blocks. For example the lowermost part of the lower Givetian sees a negative slope followed by a positive slope on the Fischer plot, a trend which can be seen in all successions. However, the cycle-types are different in each succession. At Rosteigne quarry the lowermost part of the Trois Fontaines Formation is dominated by low-energy subtidal deposition (and consequently type A cycles), yet at Froid Lieu and Olloy-sur-Viroin quarries type B1 and B2 cycles are present, as cycles shallow into the intertidal zone. This would suggest that the Rosteigne area was a more rapidly subsiding fault block during the lowermost Givetian, whereas the Froid Lieu and Olloy-sur-Viroin blocks were at a relative high (Fig. 6-10).

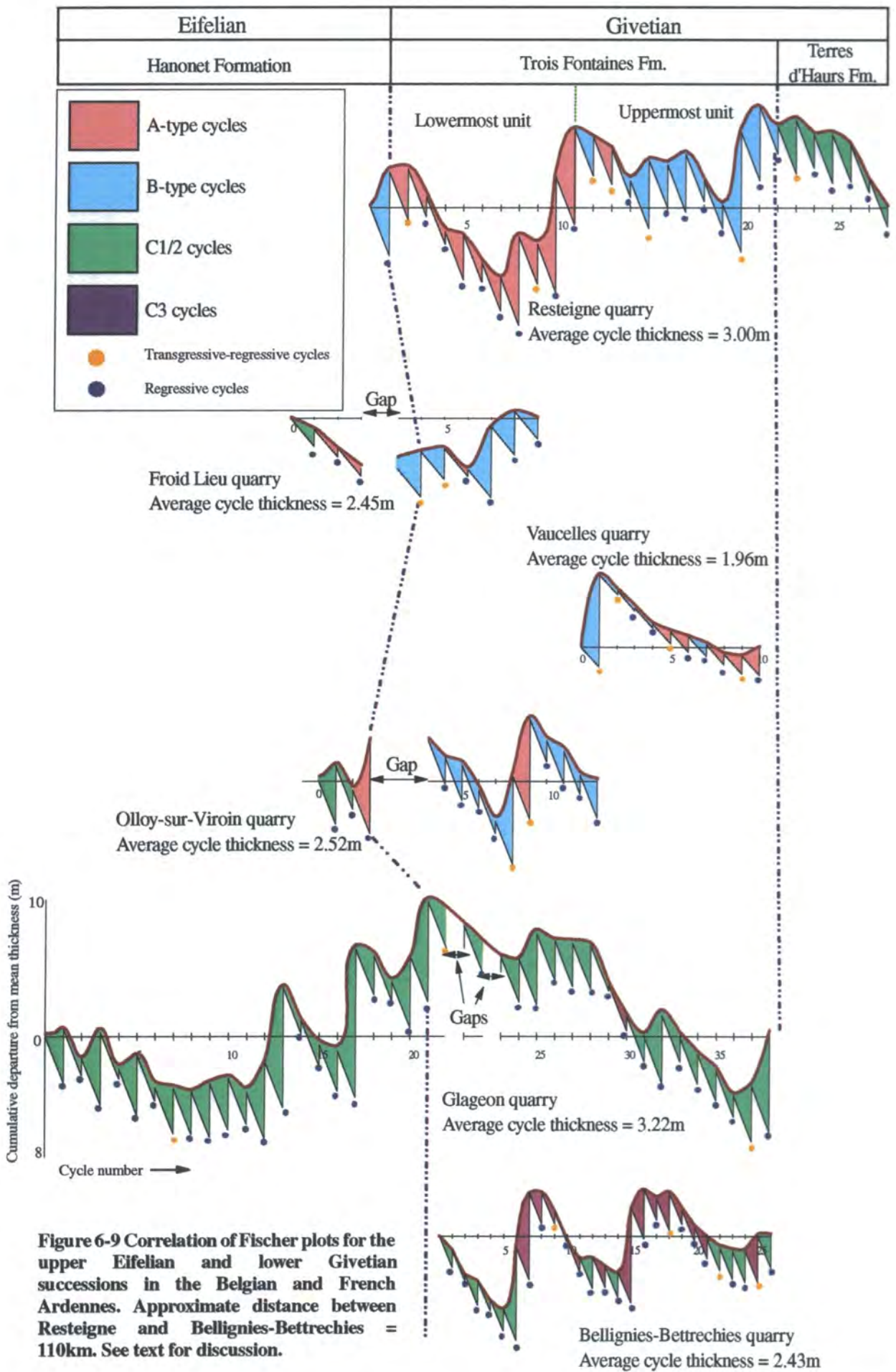

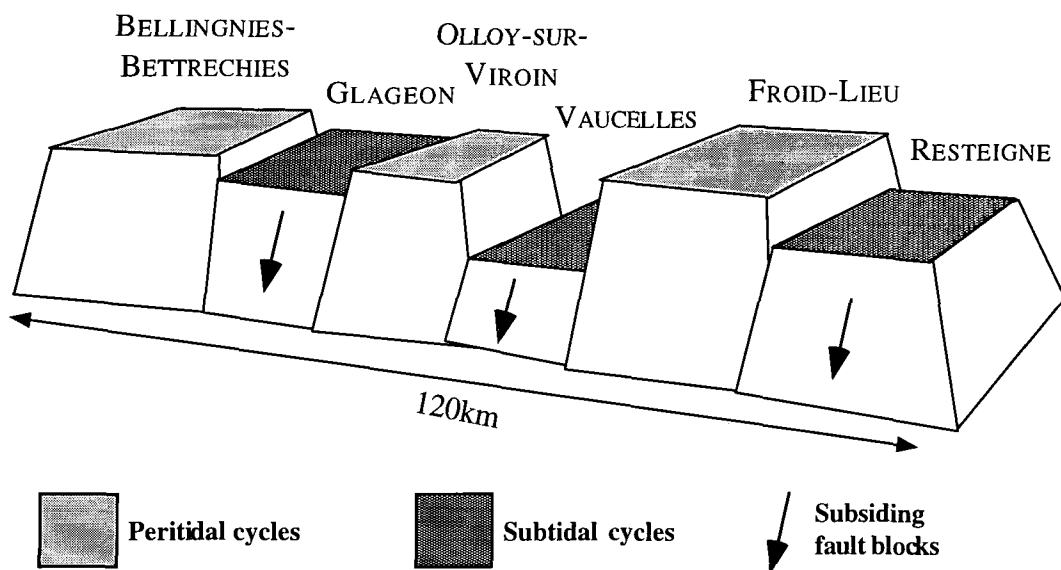

**Figure 6-10** Highly simplified and idealised cartoon of relative elevations of fault blocks in the lower Trois Fontaines Formation in the Ardennes. Vertical scale is exaggerated. See text for discussion.

Farther to the west, where the carbonate platform still had a ramp geometry, a similar trend can be seen in the Fischer plots, where there is an initial negative slope (indicating decreased accommodation space) followed by a positive slope (thicker cycles - increased accommodation space). Naturally facies and hence cyclicity differ from that seen in the shelf successions. Yet, it is suggested that Glageon quarry was situated on a subsiding fault block since sedimentation was entirely open-marine in nature (cycle-types C1 and C2); whereas the Bellingnies-Betrechies area was situated on a palaeohigh or nearer to the shoreline since restricted and even intertidal facies are recorded (and consequently C3 cycle-types).

The relative subsidence/uplift of these fault blocks is also recorded in the average cycle thickness. For example where rapid subsidence is envisaged, average cycle thickness for the lowermost Givetian is 3.3m and 2.7m (Resteigne quarry and Glageon quarry, respectively). Yet where the fault blocks are highest, average cycle thickness is slightly thinner at 3.0m, 2.7m and 2.3m (Froid Lieu, Olloy-sur-Viroin, Bellingnies-Betrechies quarries).

In the lower Trois Fontaines Formation, cycles are both transgressive-regressive and wholly regressive in nature (Fig. 6-9). Regressive cycles are most common, and are distributed mostly on the falling limbs (negative slopes) of the Fischer plots. The rare cycles which do show transgressive deposits at the base of the cycle (i.e., initial and

maximum flooding surfaces can be differentiated) tend to be distributed on the rising limbs of the Fischer plots, for example at Resteigne and Olloy-sur-Viroin successions. This would suggest that transgressive facies were only recorded during the small-scale deepening events when accommodation space was at its maximum (i.e., where there are thicker cycles), and thus infers that the rises in relative sea level were magnified during these times.

The uppermost part of the Trois Fontaines Formation (at Resteigne, Glageon and Bellignies-Bettrechies sections) shows two thinning-thickening cycle packages (parasequence sets) which are superimposed upon a longer-term negative slope (Fig. 6-9). It is during this package of sediments that evidence for periodic emergence into the supratidal zone is recorded by the presence of several laminite horizons.

At Resteigne quarry, cycle-types B2, B3 and B4 dominate the upper Trois Fontaines Formation. Cycle thickness is extremely variable, with some B3 cycles reaching 7.5m thick. This would suggest that the carbonate production rate was only slowly outpacing creation of accommodation space, so that thick, 'facies complete' (*sensu* Soreghan and Dickinson, 1994) cycles developed.

A similar Fischer plot trend can be seen both at Glageon and Bellignies-Bettrechies quarries. Sedimentation remained open-marine in the Glageon quarry section, and hence cycle-type is either C1 or C2. However, there was emergence into the intertidal zone at one stage in Glageon's sedimentation history (cycle number 30; see Figure 6-9), which is recorded as a type C3 cycle. Sediments in the Bellignies-Bettrechies quarry become increasingly restricted during the upper Trois Fontaines Formation, where cycles are capped by intertidal or highly restricted subtidal facies and are of type C3.

The succession at Vaucelles quarry records the long-term negative slope in its Fischer plot, yet the superimposed thinning-thickening trends are not apparent. As suggested in Chapter 5, the succession at Vaucelles is considered to be condensed, since cycle thickness is substantially thinner than in other successions (1.96m average) and the overall succession is thinner. Both subtidal dominated cycles (type A) and cycles with a supratidal cap (type B3 and B4) are recorded, with type A cycles more common towards the top of the succession (Fig. 6-9). The fault block upon which Vaucelles was located was likely to have been relatively elevated during the initial parts of the middle Trois Fontaines Formation, so

that accommodation space was reduced and relative sea level was low. However, during the latest Trois Fontaines times subsidence of the fault block may have played a more important role so that subtidal sedimentation was the norm.

For the upper part of the Trois Fontaines Formation, cycles are mostly regressive. Transgressive-regressive cycles are apparent, locally occurring in a regular pattern where two to four regressive cycles are followed by one transgressive-regressive cycle (see for example Resteigne and Vaucelles succession, Figure 6-9). This pattern is not seen basin-wide, however. Cycles which have a transgressive base commonly form when the rate of creation of accommodation space is slow, and therefore carbonate production is able to pace the deepening event. The distribution of these transgressive deposits may therefore be related to the long-term accommodation potential of the system and hence long-term relative sea-level fluctuations. It is interesting to point out that the classic relationship between sediment type and cycle thickness trend (i.e., negative slopes of the Fischer plots showing increasing proportions of intertidal-supratidal cycles, positive slopes showing increased proportions of subtidal cycles) is not applicable in the Lower Givetian. Progradational, regressive (thinning-upwards) stacking patterns can be dominated by both subtidal cycles and peritidal cycles, as can retrogradational, transgressive (thickening-upwards) stacking patterns (Fig. 6-9). This may suggest that the longer-term trend in the Fischer plot does not truly represent lower order eustatic sea-level fluctuations, and that there must have been local interference by tectonic movement or autocyclic processes.

Cycle thickness for the lower Givetian averages 2.7m, substantially thicker than seen in the upper Givetian Fromelennes Formation.

### ***Upper Givetian***

Upper Givetian successions outcrop at Sourd d'Ave, Beauraing, Cul d'Houille, Dourbes and Nismes in the Belgian Ardennes and also at Walheim Southern Limb, Teerstraßenbau, Venwegen and Alt Breinig in the Aachen region of Germany. The upper Givetian Fromelennes Formation could be divided into three member in the Ardennes area, of which Beauraing exposes the Flohimont Member and Moulin Boreux Member, Cul d'Houille, Dourbes, and Nismes exposes the Moulin Boreux Member, and Sourd d'Ave outcrops in the Fort Hulobiet Member (see Figure 5-7). The successions at Aachen broadly correlate with the Fort Hulobiet Member. A metre-scale cyclicity is pervasive throughout the upper

Givetian successions and is commonly very easy to identify in the field. Cyclicity is recorded as both type A and type B cycles, with their distribution not only related to long-term trends in accommodation space, but also influenced by local fault-block movement, as with the Givetian.

Figure 6-11 presents a Fischer plot correlation panel for the Flohimont and Moulin Boreux Members of the Fromelennes Formation in the Ardennes. Correlation of individual cycles is difficult; yet, broad correlation of trends in cycle-thickness can be made.

The lower part of the Moulin Boreux Member is characterised by a large-scale thinner-than-average cycle package followed by a thicker-than-average cycle package. This can be seen at Beauraing, Cul d'Houille, Dourbes and Nismes quarries (Fig. 6-11). Cycles are of both type A and type B. Type A cycles are the most common, typically having a stromatoporoid floatstone unit at the base and capped by a poorly fossiliferous horizon. Where type B cycles are present, shallowing is often incompletely recorded as supratidal laminite horizons locally directly overlying semi-restricted biostromal facies (i.e., at 5.5m and 6.6m at Cul d'Houille; see Appendix A2.7 for details). This would suggest that carbonate production was periodically unable to pace the drop in relative sea level, since restricted subtidal and intertidal facies were not recorded.<sup>\*1</sup> Cycles during this time period are mostly asymmetric, with only periodic transgressive facies deposited (Fig. 6-11). This implies that rises in relative sea level were, most of the time, at a swift enough pace for sedimentation to severely lag behind and hence not record the deepening events. The transgressive-regressive cycles do have a vague pattern in their distribution, where commonly two to five regressive cycles are deposited which is then punctuated by one (or sometimes two) transgressive-regressive cycles. This pattern may relate to a longer-term trend in relative sea level, which is discussed in Section 6.7.

The distribution of cycle-types does not appear to follow any specific pattern, although cycles which record supratidal or intertidal caps (type B) do tend to be distributed on the falling limb of the slopes (Fig. 6-11). If Fischer plots were interpreted to represent long-term sea-level histories, this pattern is what one might expect: there would have been a reduction in accommodation space and therefore sedimentation would have been more likely to build up to and above sea level. Type B cycles are, however, also recorded on the rising limbs of the Fischer plot, particularly at Cul d'Houille. Here, type B cycles are

---

\*1 forced regression

|                       |                      |
|-----------------------|----------------------|
| <b>Givetian</b>       |                      |
| Fromelennes Formation |                      |
| Flohimont Member      | Moulin Boreux Member |

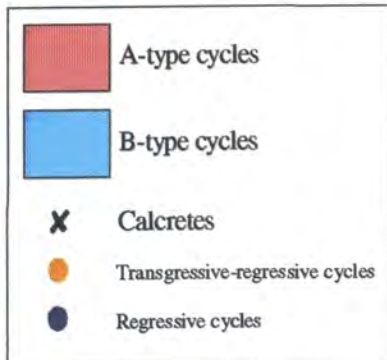
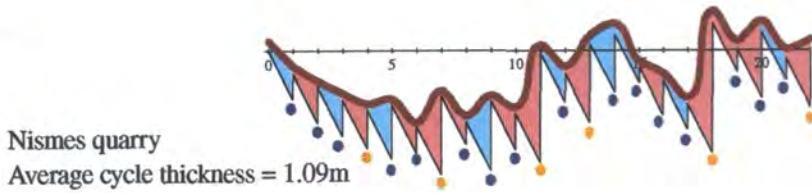
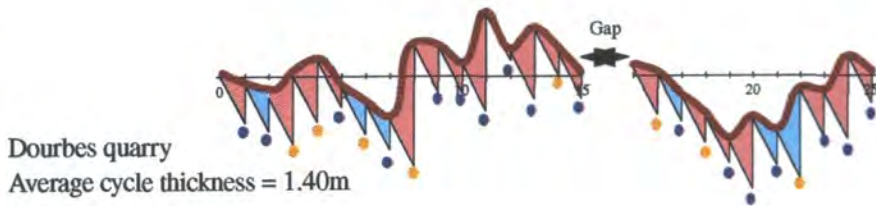
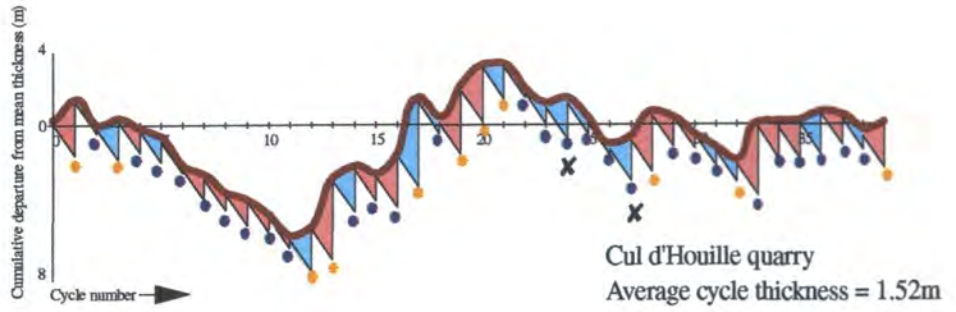
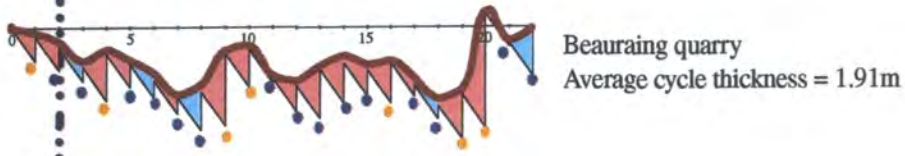

Figure 6-11 Correlation of Fischer plots for the lower and middle Fromelennes Formation in the Ardennes. See text for discussion.

especially thick as they record full shallowing from semi-restricted stromatoporoid boundstone bases through *Amphipora*-rich facies and poorly-fossiliferous facies to supratidal laminites. These B3 cycles show catch-up characteristics of Soreghan and Dickinson (1994) terminology and are both facies and thickness complete (see Table 6-1). B4 cycles are also present, where semi-restricted facies are not developed and shallowing is recorded from the restricted subtidal zone through intertidal to the supratidal zone.

The initial thinning-thickening trend in Fischer plots is then repeated in the upper part of the Moulin Boreux Member. This trend can be seen at Cul d'Houille, Dourbes, and Nismes. The falling limb at Cul d'Houille is characterised by B-type cycles, with two of the cycles being capped by calcretes (see Figure 6-11). The development of these calcrete horizons would suggest there was exposure of the local area for a sustained period of time. However, these calcretes were not formed over a regional area, as they cannot be seen elsewhere. Laminites, which are interpreted as forming in the high intertidal to supratidal zone, are well developed in the other successions at this time and may represent the lateral equivalents of the calcretes. It is interpreted that this period represents either a lowstand in relative sea level, or where the rate of drop in sea level is at its greatest.

The rising limb of the Fischer plot shows a complex array of cycle-types. At Cul d'Houille the package takes on a more aggradational rather than thickening trend, and is dominated mainly by subtidal cycles. At Dourbes, on the other hand, the rising limb has two B-type cycles at the base, and is then followed by subtidal (type A) cycles. Nismes displays a very abrupt thickening package which is the result of just one unusually thick cycle (i.e., number 18 is 2.92m thick, almost three times as thick as the average cycle thickness), and is then followed by an aggradational trend (i.e., cycles are more or less of average thickness). Cycles are mostly subtidal in nature, as with Cul d'Houille. These differing patterns may reflect the differing structural character of the areas, where Nismes was situated on a rapidly subsiding fault block, producing periodic thick cycles, yet the Cul d'Houille/Dourbes areas were on relatively stable fault blocks.

The upper part of the Moulin Boreux Member has a similar pattern in distribution of regressive and transgressive-regressive cycles to that seen in the lower part. The successions are mostly characterised by regressive cycles, yet this is punctuated after

approximately three to five cycles, by a transgressive-regressive cycle. The origins to these patterns will be discussed later.

The Fort Hulobiet Member in the Ardennes broadly correlates to successions in the Upper Stringocephalus Beds of the Aachen area. It is difficult to assess how much of the stratigraphy is omitted between the Moulin Boreux and Fort Hulobiet Members, since successions are incomplete. Yet it is likely to be approximately 50m. These uppermost Givetian successions in both the Ardennes and Aachen areas show a positive-negative-positive-negative trend on Fischer plots (Fig. 6-12).

Teerstraßenbau and Venwegen quarries show the initial rising limb, where cycles are thicker than average. Cycles are mostly of type B, having a subtidal base and either a fenestral or microbial laminite cap, indicating intertidal to supratidal depositional environments. The falling limb is short, and characterised by thinner-than-average B-type cycles. The following rising limb can be seen in all successions and is again typified by supratidal-capped type B cycles. This indicates that the long term sea level may have been at a lowstand during this time, or that the successions were positioned close to the palaeotidal-flat area. Most cycles are regressive.

The latest Givetian is characterised by a negative slope on the Fischer plot which can be seen at Sourd d'Ave and Walheim Southern Limb (Fig. 6-12). Both successions show type-B cycles which thin towards the Givetian/Frasnian boundary. The base of the Frasnian represents a dramatic deepening, where open-marine interbedded nodular limestones and marly shales were deposited. Cycles are of type C1.

Overall cycle thickness in the upper Givetian is much thinner than that seen in the lower Givetian, at 1.56m (compared to 2.7m). Type B cycles are more abundant also, suggesting that the long-term sea level was lower than in the lower Givetian.

| Givetian   | Frasnian                      |
|--|-------------------------------|
| Fort Hulobiet Member/ Upper Stringocephalus Beds | Grenzschiefer/<br>Frasnes Fm. |

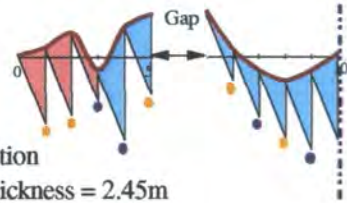
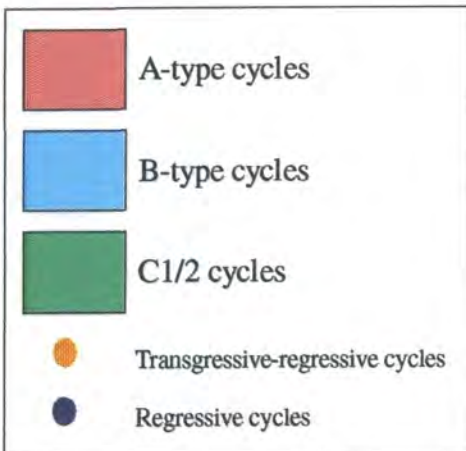
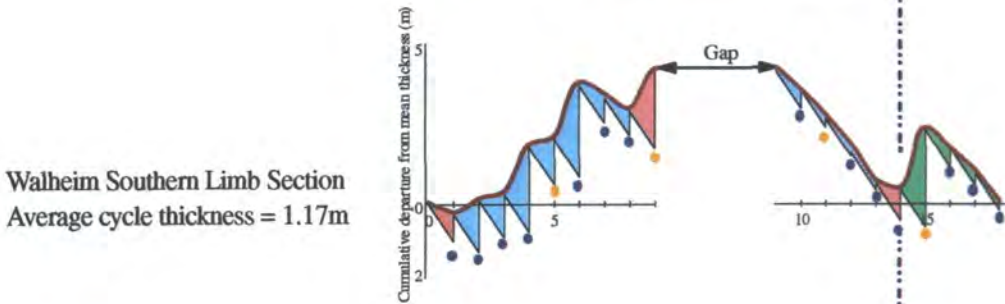
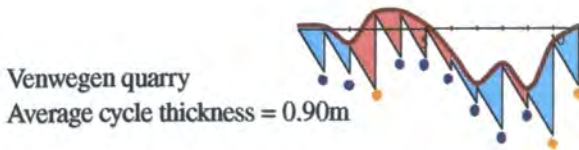
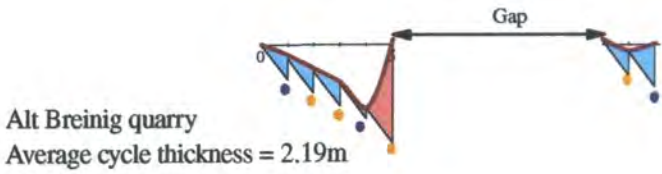

**Figure 6-12** Correlation of Fischer plots for the uppermost Givetian successions in the Ardennes and Aachen areas. Approximate distance between Alt Breinig and Sourd d'Ave = 100km. See text for discussion.

### 6.5.5.2 Frasnian

Frasnian and upper Givetian successions in the Aachen area have been extensively studied in the past two decades, in terms of palaeontology and cyclicity (e.g., Kasig, 1976; Kasig, 1978; Kasig, 1980). Kasig (1980) identified an 'ideal cycle' as having an *Amphipora*-rich base, followed by a horizon of bulbous stromatoporoids, and capped by laminated and textureless lime muds. It was suggested that all stromatoporoids were preserved in life position and the cycles represented a 'growth cycle'. Intensive studying of these successions, however, has uncovered little evidence to support these ideas. Horizons of bulbous stromatoporoids only locally have an *Amphipora* layer underlying them, and the bulbous stromatoporoids themselves are often overturned and abraded. Indeed, *Amphipora* commonly overlies the bulbous stromatoporoids, rather than being underneath them (see logs in Appendix 2). Therefore, an 'ideal' shallowing upwards cycle would have a bulbous stromatoporoid base, an *Amphipora*-rich horizon overlying this, followed by a fine-grained poorly fossiliferous micrite, finally capped by a microbial laminite (see Figures 6-5 and 6-6).

Frasnian strata were studied at three short successions in the Aachen area: Walheim Sections 1 and 2 and Schmithof. The complete cycle-thickness pattern through the Frasnian is impossible to determine, since successions are incomplete and do not cover the whole of the stratigraphy (see Figure 5-10). However, correlation between two successions is possible, using relative thickness below the nodular shales (see Section 5.1.5) and also Fischer plots (Fig. 6-13).

Lower parts of the Reef Limestone Beds are exposed at Walheim Section 1. Cycles are mainly type B, and Walheim Section 1 exposes the only record of a transgressive lag-deposit. The lag is composed of ripped-up clasts of laminite facies and fenestral facies (see Figure 4-8) and occurs at the base of a B3, 'complete' cycle. Overlying the lag is a horizon of bulbous stromatoporoids, which then fully shallowed into subtidal restricted facies, and was capped by a thin microbial laminite. The cycle is thin at only 1.3m, and cycle thickness on the whole for this lower package of Frasnian sediments averages only 1.7m. The presence of this transgressive lag would suggest that the increase in relative sea level was prolonged enough so that underlying sediments were reworked and subsequently redeposited on the ravinement surface (Arnott, 1995). Cycles in this package of sediments

are, on the whole, regressive, indicating that the rises in relative sea level were too quick for sedimentation to pace.

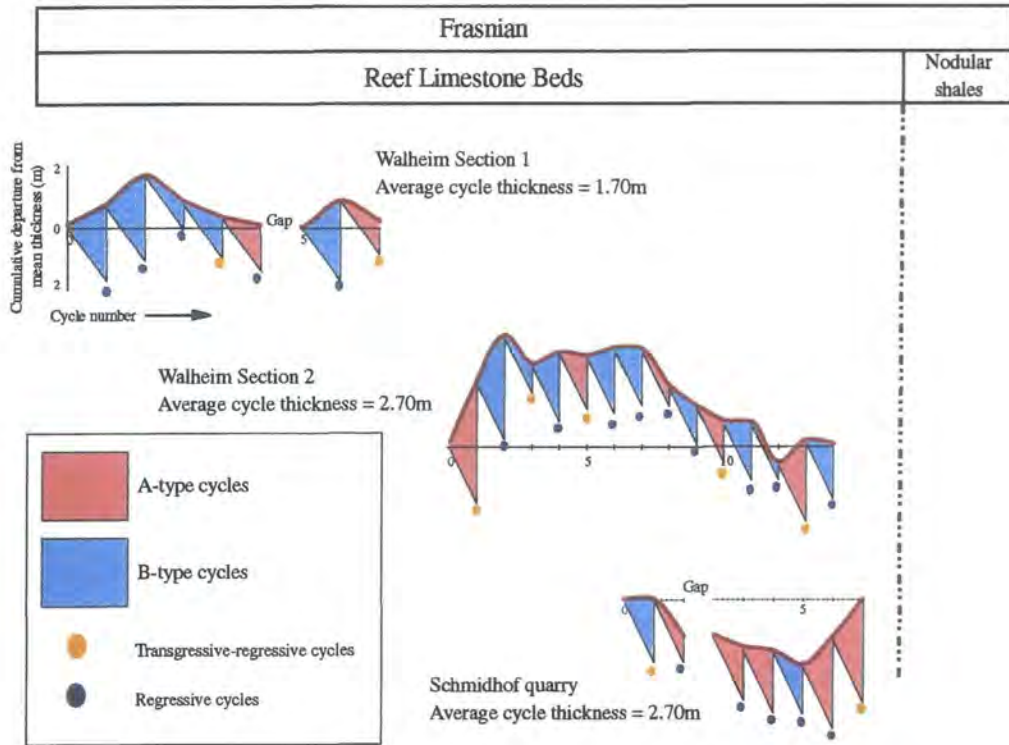

Figure 6-13 Correlation of Frasnian Fischer plots in the Aachen area. See text for discussion.

The upper parts of the Reef Limestone Beds show both subtidal-dominated and subtidal-intertidal cycles. The Fischer plots exhibit a thickening-thinning trend, and as with much of the Givetian and Frasnian, cycle-types show no predictable pattern on the Fischer plot curve. Subtidal cycles commonly have a stromatoporoid floatstone base, and are capped by poorly-fossiliferous facies, whereas, subtidal-intertidal cycles have either a microbial laminite or dolomicrite capping the cycle. Both transgressive-regressive and fully regressive cycles are seen, yet regressive cycles are most abundant.

Cycle thickness for the upper parts of the Reef Limestone Beds averages at 2.7m, 1m thicker than seen in the lower Reef Limestone Beds.

### 6.5.6 Isolated platforms

Metre-scale cyclicity within the isolated platforms has already been discussed in Chapter 5, and this Section aims to expand on those initial findings. All cycles are either of type A or B and are transgressive-regressive or wholly regressive. When studying cyclicity in the isolated platforms, initial impressions are that sedimentation is mainly subtidal in nature,

and hence type A cycles dominate. It is important to consider, however, that as the isolated platforms are restricted in size, tidal flats may not be extensive. Therefore, the probability of studying successions in the central subtidal parts of the lagoon are statistically more likely than in the tidal flat, and subtidal-dominated cycles are hence more likely. Unfortunately, poor outcrop in the study area does not often allow comparisons between central lagoonal successions and tidal flat successions to be made.

With these considerations aside, it is possible to assess cycle-thickness variations and also to comment upon possible controls on cycle development. For the purpose of clarity, and because of the lack of suitable biostratigraphic control, the isolated platforms will be discussed in terms of their palaeosetting (i.e., inner shelf, shelf edge, trough; *sensu* Krebs, 1974). Unfortunately it is extremely difficult to correlate the isolated complexes with successions in the Ardennes.

#### 6.5.6.1 Shelf-edge

Three isolated platforms which developed upon the shelf edge have been studied in terms of cyclostratigraphy: Attendorn, Brilon and Torbay (see Section 5.2.1 for details).

##### *Attendorn Reef Complex*

One succession, Heggen Quarry, was studied in the Attendorn Reef Complex. Heggen quarry was situated in the immediate back reef environment where facies were composed of interbedded richly fossiliferous bioclastic grainstones, small biostromes or stromatoporoid-coral floatstones and *Amphipora* floatstones. The succession can be divided into three units, relating to the presence or absence of *Amphipora*-rich facies (see Figure 5-15), and this is reflected also in the cycle-type.

Cycles in the Heggen succession are all type A, subtidal cycles (Fig 6-14a). A1 cycles and A3 cycles are well-represented and their distribution mirrors the pattern seen in facies distribution. A1 cycles, which commonly have a stromatoporoid floatstone base and an *Amphipora*-floatstone cap, are distributed in the lower and upper parts of the succession. Cycles in these lower and upper units show a high proportion of transgressive deposits, with transgressive-regressive cycles being in almost equal abundance as wholly regressive cycles. This would suggest that, periodically, the rise in relative sea level was slow enough for transgressive facies to be deposited. The distribution of transgressive-regressive and

regressive cycles does not appear to follow any clear pattern, indicating that long-term patterns in accommodation space was not influencing cycle-type during these times.

The middle part of the succession is typified by type A3 cycles (Fig. 6-14a). These cycles show a stromatoporoid floatstone facies at the base, capped by a bioclastic grainstone. Since cyclicity is entirely within the semi-restricted facies group, cycles show a regressive trend. Many of the bioclastic grainstones are interpreted as storm deposits, therefore this style of cyclicity may reflect internal depositional processes, rather than external allocyclic mechanisms. The lack of restricted subtidal facies may suggest that at this time long-term sea level was at a highstand, so that the lagoon was well-circulated and semi-restricted facies were prevalent.

The Fischer plot for the Heggen succession shows a strong positive-negative pattern (Fig 6-14a). Cycle-type is not associated with any particular stage on the long-term curve, since A1 cycles occur on both the rising and falling limbs. Average cycle thickness for the Heggen succession is 3.02m.

### ***Brilon Reef Complex***

Metre-scale cyclicity in the Brilon Reef Complex is extremely well developed and has already been extensively discussed in the previous Chapter (see Section 5.2.1.2 and Figure 5-17 for details). To recap, both A-type (A1 and A2) and B-type (B1, B2, B3) cycles have been identified, where cycles range from 0.25m to 4.45m in thickness and are either transgressive-regressive, or wholly regressive. Figure 6-6 shows a field photograph of a B-type cycle, where the base is dominated by bulbous stromatoporoids, which is then followed by a poorly-fossiliferous horizon and is finally capped by a supratidal laminite. B-type cycles are particularly common in the Bleiwäsche succession and are typically thinner than subtidal cycles.

The distribution of cycle-type does follow a broad trend where 'packages' of type B cycles dominate the falling limbs of the Fischer plot, and subtidal A-type cycles are common on the rising limbs or at the top of a slope (Fig. 6-14b). This relates to the accommodation potential, since the thicker subtidal-dominated cycles would occur where there was a transgression or highstand in relative sea level, and thinner intertidal-capped cycles would be common where there were lowstands in relative sea level. These patterns mimic the 'idealised' situation where peritidal cycles occur on falling limbs and subtidal cycles occur

on rising limbs, suggesting that eustasy had a strong role to play as a causal mechanism for the cyclicity. Städter and Koch (1987) also noted that reefal deposits of the Brilon Reef Complex were periodically subjected to elevation into the intertidal-supratidal zone, confirming the role of eustasy rather than an autocyclic mechanism. The majority of cycles in the Bleiwäsche succession are wholly regressive, although transgressive-regressive cycles do periodically occur on the rising limbs and near the base of falling limbs of the Fischer plot (Fig. 6-14b).

A decimetre-scale 'cyclicity' can also be seen in supratidal facies, where laminites are interbedded with intraclast (mudchip) horizons (i.e., at 25m; see log in Appendix 2.4). This facies variation reflects storm events where hurricanes or strong storms impinged onto the high-intertidal to supratidal environment, reworking desiccation cracked surfaces. Hong (1992) also noted a decimetre-scale cyclicity in intertidal fenestral facies of the Brilon Reef Complex. This order of cyclicity is not comparable in magnitude to the metre-scale cyclicity already described, being related to local climate conditions rather than larger-scale eustatic sea-level fluctuations or autocyclic processes.

### ***Torbay Reef Complex***

The Torbay Reef Complex offers the opportunity to compare central lagoon successions with successions which were located on the palaeotidal flats (see Section 5.2.1.3). Three successions were studied: Broadridge Wood quarry located on the low-energy, protected tidal flats, Linhay Hill quarry positioned in the subtidal central lagoon, and Rydon quarry situated in the immediate back-reef environment.

A metre-scale cyclicity is well developed in the Torbay Reef successions, and has already been briefly discussed in Chapter 5. Broadridge Wood quarry exhibits both subtidal cycles and peritidal cycles, with peritidal (type B) cycles being most common (Fig. 6-14c). Type B cycles are mostly capped by fenestral facies, yet cycle number 1 is capped by a calcrete horizon, suggesting prolonged exposure in the supratidal zone and a lowstand in relative sea level. Subtidal cycles commonly have an *Amphipora*-rich base and are capped by poorly-fossiliferous facies. These cycles are distributed at the top of a rising limb on the Fischer plot (Fig. 6-14c), forming an aggradational package as cycle thicknesses approximate that of the average (2.39m). Type B cycles are distributed on both the rising and falling limbs of the Fischer plots, suggesting that although accommodation potential

was variable, sediments were regularly able to build up to and above sea level. These cycles display catch-up characteristics (*sensu* Soreghan and Dickinson, 1994; see Table 6-1) although they are not always 'facies complete' since semi-restricted facies are not always recorded. This suggests that either the magnitude in sea-level rise was not great enough for semi-restricted conditions to be established, or that the rise in sea level was of such fast pace that sedimentation was unable to keep up with it. However, transgressive deposits are recorded in many of the cycles, therefore the former suggestion seems the most plausible. As one might expect, cycles which do record transgressive deposits are thicker than average and are thus restricted to the rising-limb of the Fischer plot.

Linhay Hill quarry, being located in the central part of the lagoon, is characterised by subtidal deposition, and hence type-A cycles (Fig. 6-14c). A1 and A2 cycles are represented. A1 cycles either have a stromatoporoid floatstone (S2) or *Stringocephalus* packstone (S3) base, and are variably capped by *Amphipora* wackestones/floatstones (S4), bioclastic wackestones (mostly gastropods; S5), or poorly-fossiliferous facies (S6). Facies boundaries are often gradational. A2 cycles mostly have an *Amphipora*-rich base and are capped by poorly fossiliferous facies. A broad evolution of the succession can be seen, where type A1 cycles dominate in the lower parts (up to cycle number 6), and then A2 cycles are more common. Cycles are mostly regressive. The cycle thickness trends at Linhay Hill quarry take on a very interesting pattern (Fig. 6-14c). Packages of cycles (commonly 5-6 cycles) show distinct thinning-upwards stacking patterns, which are followed by a thicker-than-average cycle forming the base to the next 'package' of thinning-upwards cycles. These asymmetric stacking patterns may be a result of the overprinting of different amplitudes of sea-level change, referred to as composite eustasy (i.e., a 20,000 year cyclicity superimposed upon a 100,00 year cyclicity). These concepts are discussed in Section 6.6. Average cycle thickness for Linhay Hill quarry is 2.04m.

Rydon quarry was the shortest succession studied, and is dominated by relatively high-energy deposits. Cycles are mostly subtidal in nature, yet some cycles are capped by fenestral limestones interpreted to have formed in the intertidal zone. The distribution of type A/B cycles does not have any particular pattern, although type B cycles do have 5 subtidal cycles in between them, possibly suggesting the operation of composite eustasy. The succession is not really long enough, however, to try to substantiate these suggestions.

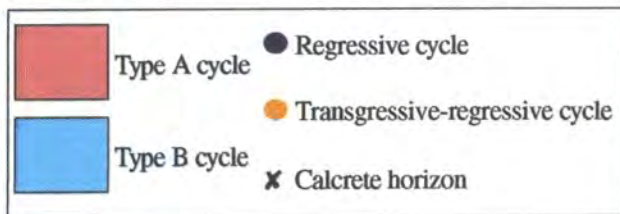
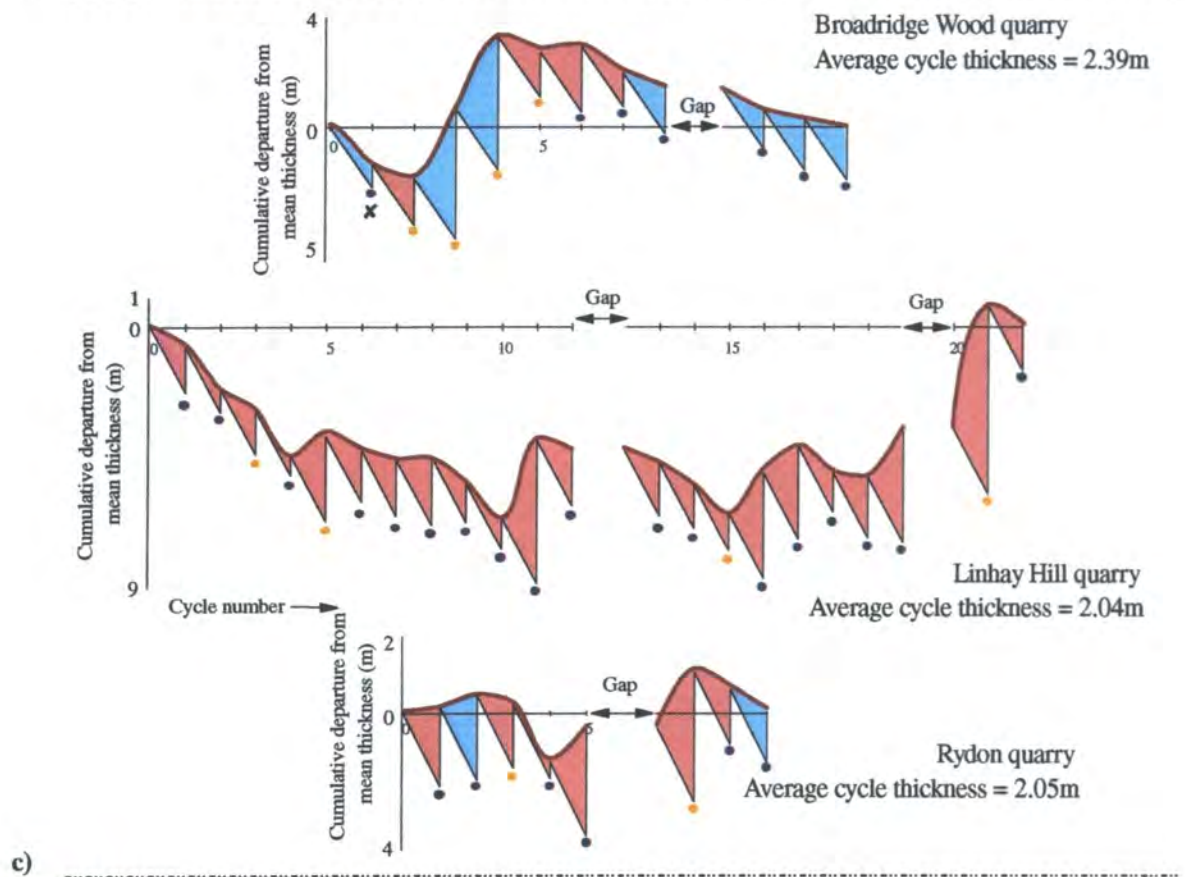
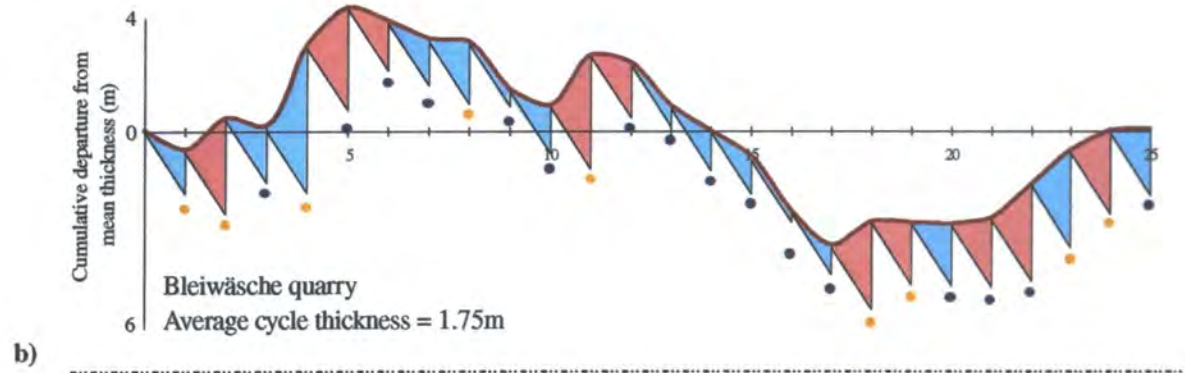
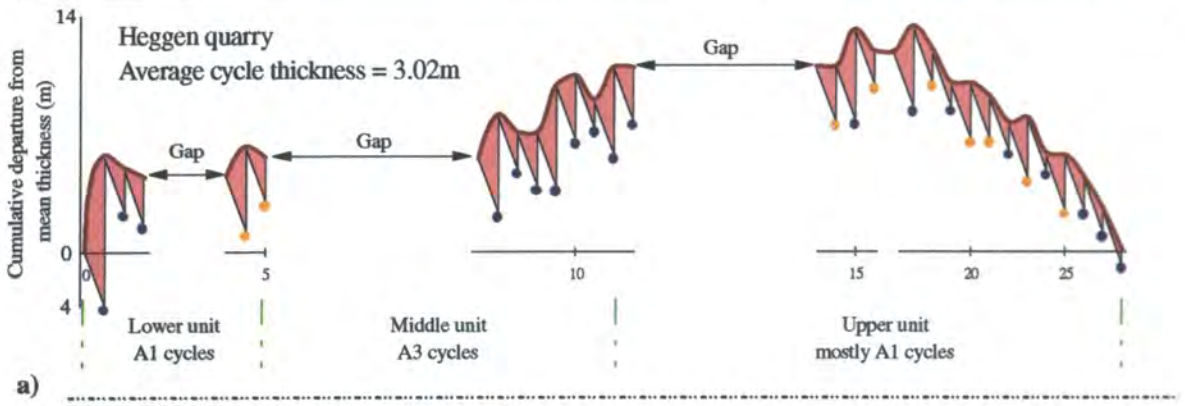

Figure 6-14 a) Fischer plot for the Heggen quarry, Attendorn Reef Complex. b) Fischer plot for Bleiwäsche quarry, Brilon Reef Complex. c) Fischer plots for successions in the Torbay Reef Complex. No correlation is intended. See text for discussion.

Correlating the successions in the Torbay Reef Complex proves very difficult, since the area has been severely dislocated by tectonics and there is poor stratigraphic control in the successions. The calcrete horizon could be a useful marker horizon, since it indicates a period of lowstand in sea level, or where the sea-level drop was at its greatest rate. However, the other two successions do not show such lowstands of sea level, suggesting maybe that Broadridge Wood quarry is either younger or older. Since there is an abrupt facies change into the Foxley tuffs only 25m above the top of the succession at Broadridge Wood (Scrutton and Goodger, 1987), it is anticipated that the Broadridge Wood quarry section is in fact younger than the others.

#### **6.5.6.2 Inner shelf**

Two isolated platforms which developed within the shelf have been studied in terms of cyclostratigraphy: Balve and Dornap (see Section 5.2.2 for details).

##### ***Balve Reef Complex***

Back-reef facies in the Balve Reef Complex have been studied at Oberrödinghausen quarry. Sedimentation was almost entirely subtidal in nature, apart from a fenestral horizon identified at 2m. Analysis of the sediments has divided the logged succession into two units: the lower unit is characterised by restricted subtidal sedimentation, whereas the upper unit represents better circulated, semi-restricted sedimentation. This division can also be seen on the Fischer plot (Fig. 6-15a).

The lower unit is characterised by mostly A1 cycles, where bulbous stromatoporoids are the major component of the basal unit, and these are commonly capped by *Amphipora* floatstones. These cycles show a decrease in diversity of organisms and decrease in circulation upwards. Cycles average 2.33m in thickness. Type A1 cycles typically plot on the falling limb of the Fischer plot since they are thinner than average. Aggradational stacking patterns are also superimposed upon this pattern (i.e., between cycles 4-7, where cycle thickness is more or less equal to the average) yet do not detract from the overall thinning-upwards trend of the unit. Although there is no direct evidence for a shallowing-upwards trend in the type A1 cycles there is evidence of increased restriction, which suggests that the lagoon was influenced less by marine waters possibly due to a lowering of relative sea-level. A1 cycles are similar to the keep-up cycles of Soreghan and Dickinson (1994) where facies are entirely subtidal.

The second sedimentation unit is characterised mainly by A3 cycles. Thick stromatoporoid biostromes characterise the base of the A3 cycles, which are then capped by bioclastic grainstones. The bioclastic grainstones are commonly rich in *Stachyodes* and crinoids and are thought to have been derived from reefs during storms or hurricanes. Sedimentation is entirely within the semi-restricted subtidal facies group. A3 cycles are generally thicker than A1 cycles, averaging 3.05m, and therefore plot on the rising limb of the Fischer plot (Fig. 6-15a).

Cycles within the Oberöddinghausen succession are mainly regressive, yet rare transgressive facies are recorded. It would be difficult to interpret the trend of the Fischer plot as mimicking the long-term pattern of relative sea level, since the plot actually **mirrors** what is recorded in the sediments. For example, as the Fischer plot curve is dropping (equating to a long-term fall in relative sea level), the lagoonal sediments within the cycles were becoming more influenced by marine waters, suggesting a rise in relative sea level rather than a fall. This may suggest that there are other factors influencing sediment-style rather than just eustasy.

The succession at Oberöddinghausen is situated within the subtidal lagoon, where intertidal and supratidal deposits were not recorded. Other successions which were positioned on the tidal flats of the Balve Reef Complex have recently been studied (Schudack, 1993; Schudack, 1996), and a pervasive metre-scale cyclicity has been recorded. Cycles are peritidal, possessing intertidal-supratidal caps. It was initially interpreted that cycles could be explained by abrupt movements on the Lenne fault to the NE of the margin ('jerky' subsidence) producing the accommodation space (Schudack, 1993). However, more recent work has calculated cycle duration to be approximately 21,500 years and this superimposes upon a 400,000 year cyclicity. Therefore it has been suggested that orbital-forcing played an extremely important role in cycle creation (Schudack, 1996). It is difficult to assess if the outcrops which preserve these tidal-flat deposits are in fact the same age as the succession at Oberöddinghausen quarry, yet it is not unrealistic to suggest that these two outcrops do represent lateral equivalents of one another. Therefore, if a eustatic signature is so strong in the tidal-flat cycles, it may also be assumed that this is the fundamental mechanism producing the subtidal cyclicity also.

### *Dornap Reef Complex*

Several outcrops have been studied in back-reef facies of the Dornap Reef Complex, yet only Voßbeck quarry was suitable for cyclostratigraphic studies. Sedimentation could be divided into three units (see Figure 5-27 and Section 5.2.2.2). The lower unit was characterised by restricted subtidal sedimentation; the middle unit had very variable depositional environments, including semi-restricted subtidal, restricted subtidal and intertidal facies; finally the upper unit saw sedimentation return to restricted subtidal depositional environments.

The three packages of sediments can also be seen in the Fischer plot, where each unit has a certain trend in cycle thickness (Fig. 6-15b). The lower and middle units plot on a rising limb where cycle thickness is greater than average. The lower unit is characterised by an A2 cycle which shows facies variation within the restricted subtidal zone. The cycle has a thick accumulation of *Amphipora*-rich units at the base, which is followed by a poorly-fossiliferous horizon and is capped by a peloidal grainstone. The cycle is extremely thick at 8.09m. The middle unit has both A and B-type cycles. B-type cycles are typically B1 in nature, where they are capped by a fenestral limestone. This is interpreted as indicating intertidal depositional environments. In the middle unit it is not uncommon to have transgressive facies at the base of a cycle. This would suggest that the rise in sea level was slow enough so that carbonate production was able to keep pace with it. The upper unit, where sedimentation is entirely subtidal in nature, is characterised by a thinner-than-average cycle pattern. Cycles are regressive and typically of A2 type, having an *Amphipora*-rich base and poorly fossiliferous cap.

The distribution of differing cycle-types may give some indication of the variation in magnitude of relative sea-level change. For example, the middle unit records greater relative sea-level fluctuations (i.e., from semi-restricted environments through to intertidal environments) than either the lower or upper units. This may be related to the **actual** variations in magnitude of sea-level rise/fall, or may be explained by subsidence being greater during the lower and upper units, opposing any fall in sea-level and hence not recording intertidal facies. There is, however, little evidence of synsedimentary faulting, or of the complex being thicker from one margin to another. This would suggest that the reef complex was not developed upon a fault block, and that differential subsidence did not

play an important role. True variations in magnitude of sea-level fluctuation could be derived from composite eustasy, where for example, a precessional cyclicity could be overprinting an eccentricity cyclicity. During such a period of time, the interaction of the two orders of cyclicity would produce variable magnitudes of sea-level change, as seen in Voßbeck quarry. The origin of these variations will be further discussed in Section 6.6.3.

Average cycle thickness for Voßbeck quarry is 4.38m.

### **6.5.6.3 Trough**

#### ***Langenaubach Reef Complex***

Langenaubach Reef Complex is one of the smallest complexes studied, with an area of 20km<sup>2</sup>. Only one short succession in the back-reef facies was studied at Medenbach quarry, due to accessibility problems. Medenbach quarry exposes lagoonal facies which have been variably dolomitised. Facies are entirely subtidal in nature and are dominated by *Amphipora* floatstones and bafflestones. Poorly-fossiliferous horizons are identified, but are rare. Cyclicity is very poorly developed (Fig. 6-15c). A2 type cycles are typical, having a thick *Amphipora*-rich base and capped by a thin poorly-fossiliferous horizon. This cycle-type represents a decrease in diversity of organisms and decrease in circulation up through the cycle. Cycle thickness is variable, from 3.6m to 14.4m. Average thickness is 7.18m, substantially thicker than any of the other reef complexes.

The succession at Medenbach quarry was situated in the deep central lagoon of the reef complex. Other successions do expose tidal-flat facies, which appear to be cyclic (Krebs, 1966). This would suggest that small-scale relative sea-level fluctuations did occur, yet they may have been too small to affect the deeper-water environments.

### **6.5.7 Magnitude and duration of small-scale relative sea-level fluctuations**

To determine the magnitude of relative sea-level change needed to produce a metre-scale cyclicity, one must turn to the environmental information provided by fauna, flora and sedimentology. Chapters 3 and 4 extensively discuss the environmental interpretations for faunas, floras and microfacies, and these interpretations will be used to infer magnitudes in sea-level fluctuation. Table 6-5 provides a summary of these data.

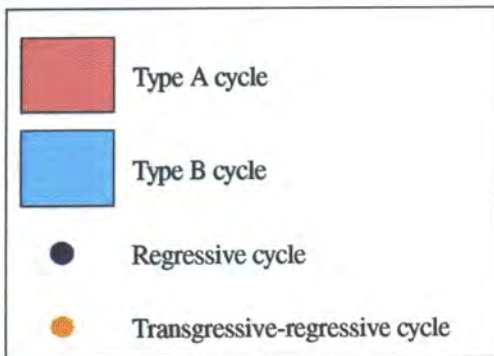
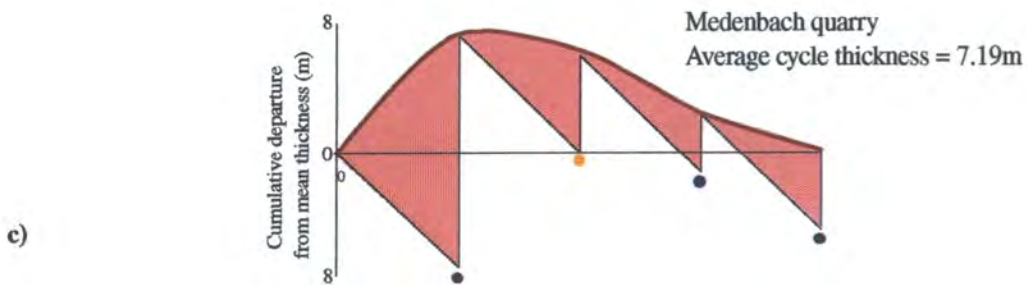
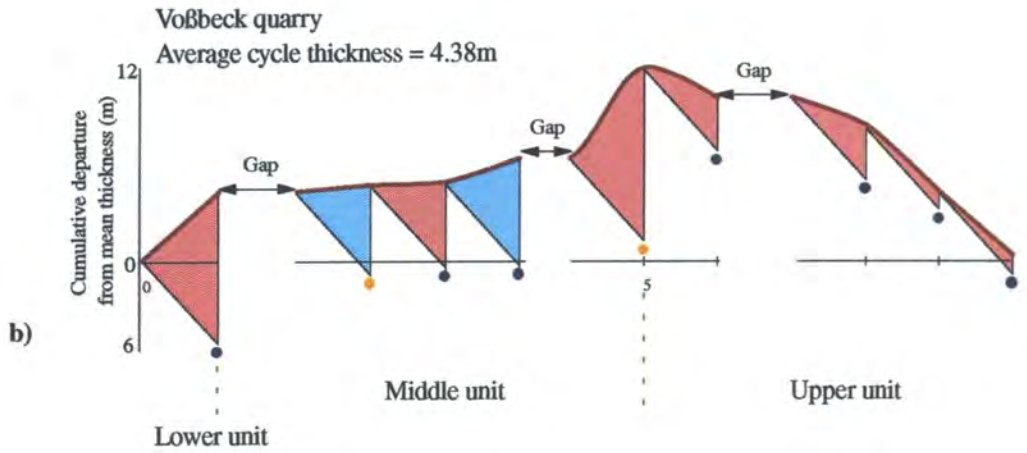
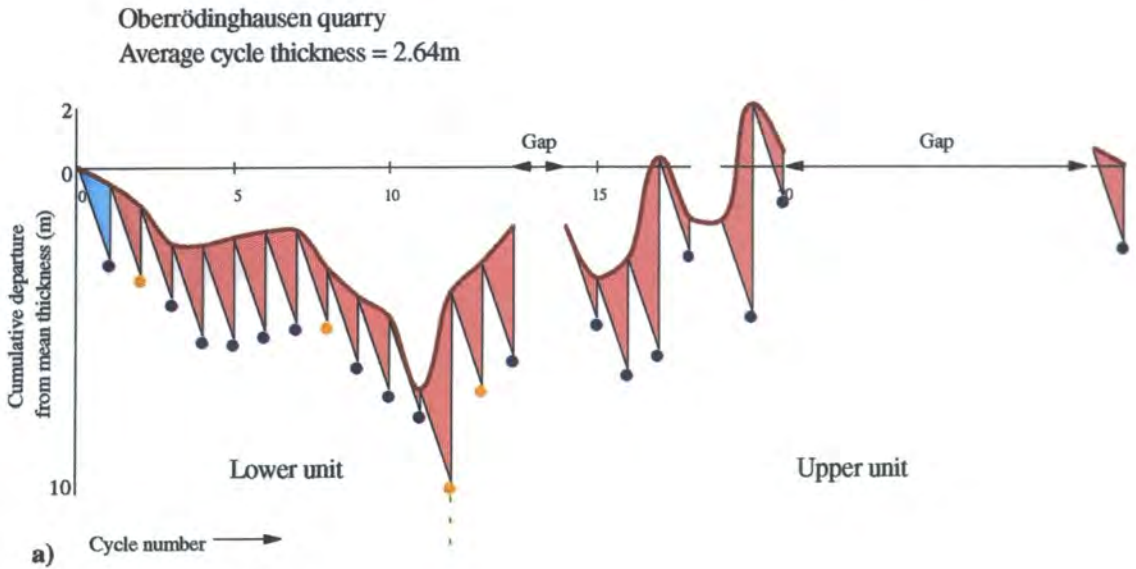

Figure 6-15 Fischer plots for a) Oberrödinghausen quarry, Balve Reef Complex, b) Voßbeck quarry, Dornap Reef Complex, and c) Medenbach quarry, Langenaubach Reef Complex.

| Microfacies | Environmental evidence  | Approximate water depth       |
|-------------|---|-------------------------------|
| S1          | Transgressive lag   | ?1-3m                         |
| S2          | Bulbous stromatoporoids, low-energy   | ≥3m                           |
| S3          | <i>Stachyodes</i> -rich, storm derived  | ?                             |
| S4          | <i>Amphipora</i> -rich, low-energy, restricted circulation                      | ~1m                           |
| S5          | Restricted faunas, bioturbation   | ?~1m                          |
| S6          | Rich in dasyclads, vertical fenestrae, oncoids, low-energy, restricted          | ~1m                           |
| S7          | Peloidal grainstones, relatively high energy, poorly fossiliferous              | <1m                           |
| S8          | Irregular, birdseye fenestrae   | intertidal                    |
| S9          | Meniscus and microstalactitic cements   | intertidal-supratidal         |
| S10         | Laminoid fenestrae, microbial laminites   | intertidal                    |
| S11         | Reworking of desiccation cracks   | high intertidal to supratidal |
| S12         | Cyanobacteria, mud cracks   | high intertidal to supratidal |
| S13         | Unfossiliferous dolomicrites, pseudomorphs of evaporite minerals                | supratidal                    |
| S14         | Calcrete development  | supratidal/subaerial          |
| R1          | Open marine faunas, good preservation, below storm wave-base                    | ~>10m-30m                     |
| R2          | Reworking, broken-up faunas, between storm wave-base and fair-weather wave-base | ~5m-20m                       |
| R3          | Reworking, broken-up faunas, between storm wave-base and fair-weather wave-base | ~5m-20m                       |
| R4          | Oolite banks, shallow waters  | <5m                           |
| R5          | Well-preserved faunas, restricted circulation, subtidal, bioturbation           | ?<5m                          |
| R6          | Highly restricted ostracode assemblages, low-energy, rare storm beds            | shallow restricted            |
| R7          | laminated dolomicrites  | intertidal to supratidal      |

**Table 6-5 Estimated depositional water depths for the 21 major microfacies.**

Using the approximate depositional depths of microfacies, it is clear that cyclicity within the shelf (S- microfacies) recorded relative sea-level fluctuations of a maximum of 3m, and most fluctuations were probably in the range of 1-3m. Accurate relative sea-level fluctuations for the ramp (R microfacies) are a little more difficult to determine, since the facies could have been deposited in a wider range of water depths (Preat and Weis, 1994; see Table 6-5). It is probable that fluctuations with a magnitude of 1-3m were occurring on the ramp also, but whether the depositional environments were able to record these

small fluctuations is a different matter. Therefore it is likely the sediments on the ramp are recording a higher magnitude sea-level fluctuation, probably 5-10 m rather than 1-2m.

The duration of cycles is very difficult to determine accurately since successions are incomplete, absolute dating is not on a sufficiently high resolution, and 'missed beats', where there has been non-deposition through exposure (i.e., where calcretes developed) are undoubtedly present. Probably the best exposed and most complete succession studied is at Cul d'Houille where almost the whole of the Moulin Boreux Member of the Upper Givetian Fromelennes Formation is exposed. The Moulin Boreux Member encompasses the top of the Middle *varcus* to Upper *disparilis* conodont zones (Preat and Weis, 1994; Fig. 6-16). Recent estimations of conodont zone duration have been provided by House (1995a), and calculations suggest the Moulin Boreux Member is approximately 1.9My in duration (Fig. 6-16). The Cul d'Houille succession starts 10m from the base of the Moulin Boreux Member, which equates to approximately 7 cycles (average cycle thickness = 1.52m). 38 cycles have been identified in the logged succession, and when accounting for the extra 7 cycles, this gives an estimate of cycle duration as 42Ky. This gives an average carbonate accumulation rate of 0.037m/1000yr, similar to figures for other ancient carbonate platforms (e.g., 0.04m/1000yr for the Upper Cretaceous Bahama platform; 0.05m/1000yr for the Upper Permian of Texas; 0.05m/1000yr for the Barremian-Aptian platform carbonates of France; from Tucker and Wright, 1992). The figure of 0.037m/1000yr, however, does allow for compaction or breaks in sedimentation through exposure.

Estimations for the cycle duration of the lower Givetian and Frasnian would be desirable; however, incomplete successions and poor biostratigraphical control severely hampers calculations.

Preat and Carliez (1994) have also estimated cycle duration using the Cul d'Houille succession, which has resulted in a rather different figure. They suggested that biostratigraphic divisions were not precise enough for the Devonian, and that resolution was not possible below 0.5My for each conodont zone (this was before the House (1995a) publication). Therefore they turned to Read *et al.* (1986), where a model for the generation of carbonate cycles was produced. Preat and Carliez suggested that the cycles

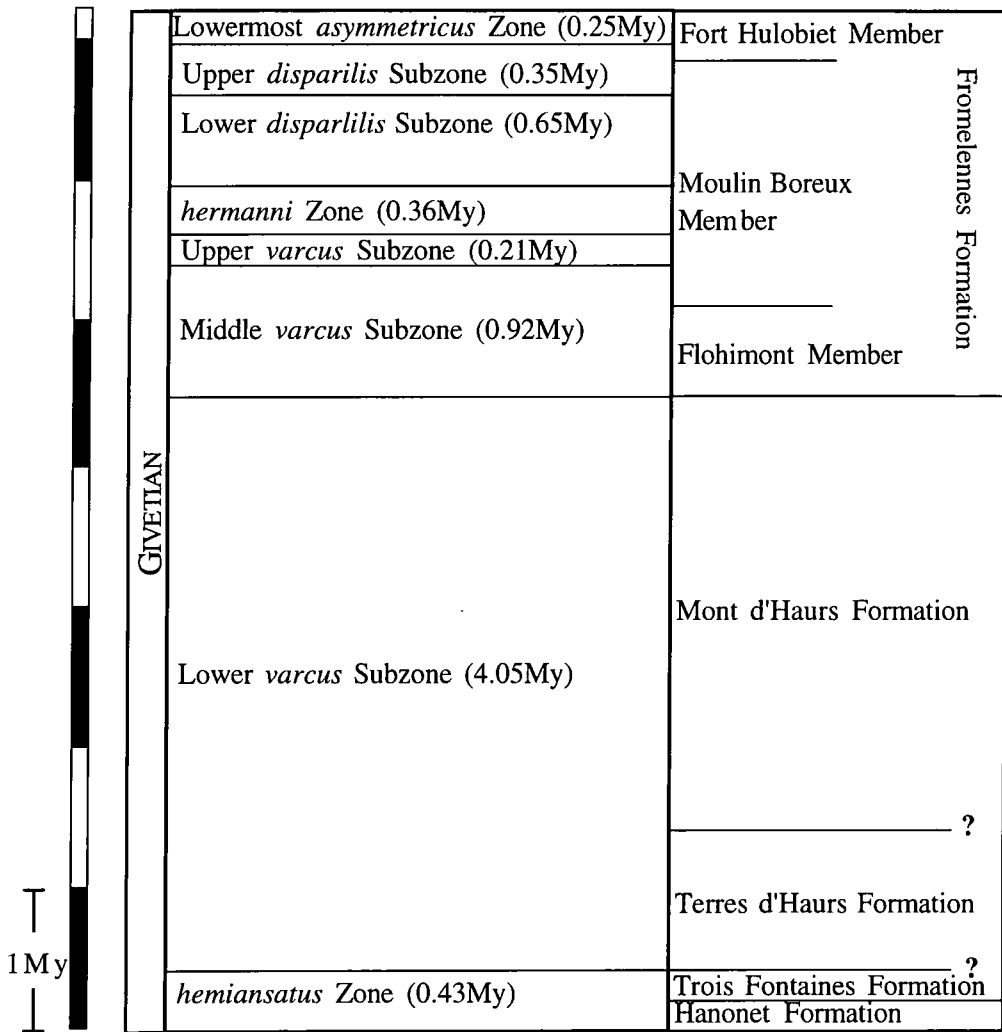

Figure 6-16 Estimated duration of the Givetian conodont zones (from House, 1995a) with correlation to the Ardennes lithostratigraphy (from Preat and Weis, 1994).

in the Fromelennes Formation were similar to the cycles that Read *et al.* (1986) modelled and proposed a cycle duration of 1,000 to 5,000 years for the Givetian cycles. From the calculated figures in this study, however, it is suggested that the 1,000-5,000 year duration is an underestimate. Interestingly, if 1.5m thick cycles had formed in 1,000 years this would give an accumulation rate a 1.5m/1000yr, at least two orders of magnitude greater than what is seen in other ancient carbonate platform sequences.

Recent detailed work on the Eifelian ramp biostratigraphy, facies and cyclicity by Kasimi and Preat (1996) suggested that cycles were between 17,000 and 53,000 years duration, with an average of 35,000 years.

## **6.6 Mechanisms causing metre-scale cyclicity**

Metre-scale cyclicity is a feature of many shallow-water carbonate successions throughout the sedimentary record. Three mechanisms have been invoked to explain the repetition of these shallowing-upward cycles: sedimentary, tectonic and eustatic, and these will be briefly discussed in this Section.

### **6.6.1 Sedimentary mechanism**

Two types of autocyclic sedimentary mechanism can be employed to explain metre-scale cyclicity.

The tidal-flat progradation model, as described by James (1984), allows shallowing-upwards cycles to be generated by the progradation of a tidal-flat wedge under conditions of long-term relative sea-level rise (Fig. 6-17). The large subtidal area is the major source of carbonate production (the carbonate 'factory'), and these sediments are deposited on the tidal flats through storms, waves and currents. As the tidal flat area becomes larger and progrades over the platform, the area of carbonate production decreases, and eventually ceases to be active. The continuing relative sea-level rise will submerge these tidal flats, and after a certain amount of lag-time, carbonate production will be rejuvenated and the process will repeat itself (Fig. 6-17). For this model to be plausible, sediments must build up to sea level; however, cycles do not necessarily have to be laterally persistent since the model allows for one area to be undergoing tidal flat progradation whilst another area is undergoing subsidence.

Pratt and James (1986) invoked the 'tidal flat island model' to explain laterally impersistent shallowing-upwards cycles. They suggested that many shallow epeiric seas (especially lower Palaeozoic) consisted of numerous low-relief supratidal islands and intertidal banks which were surrounded by water. In this scenario the platform is never completely exposed or submerged, as tidal flat islands migrate at differing paces and have different shapes and sizes. Yet these settings do keep pace with long-term relative sea-level rises/falls. The model suggests that islands accrete vertically until sedimentation has reached the supratidal zone. Progradation then takes place until neighbouring subtidal areas become too small for tides and eventually carbonate production ceases (Fig. 6-18). The focus of sedimentation then shifts again, keeping this autoregulatory process continuing. Inherent in this model is

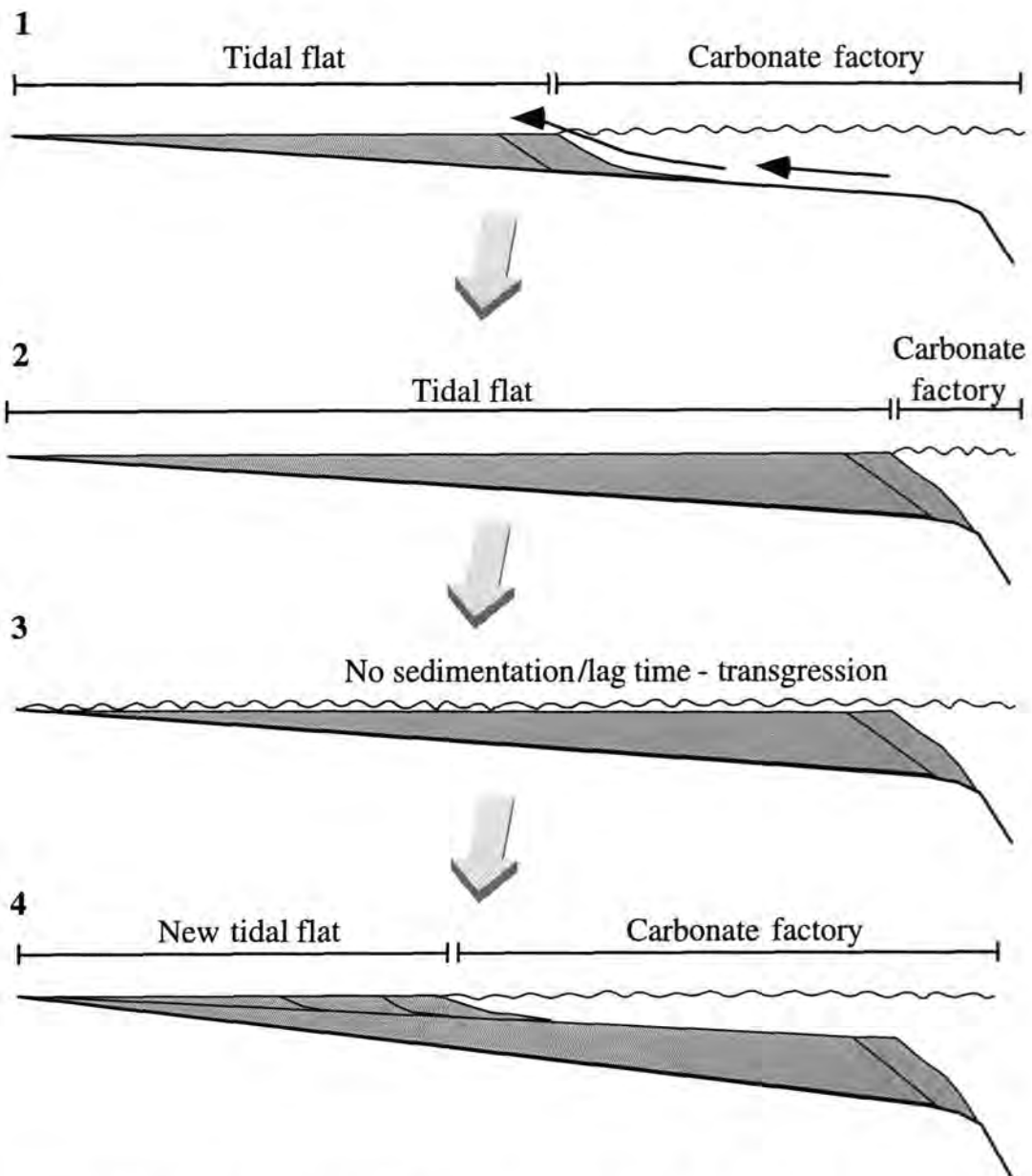
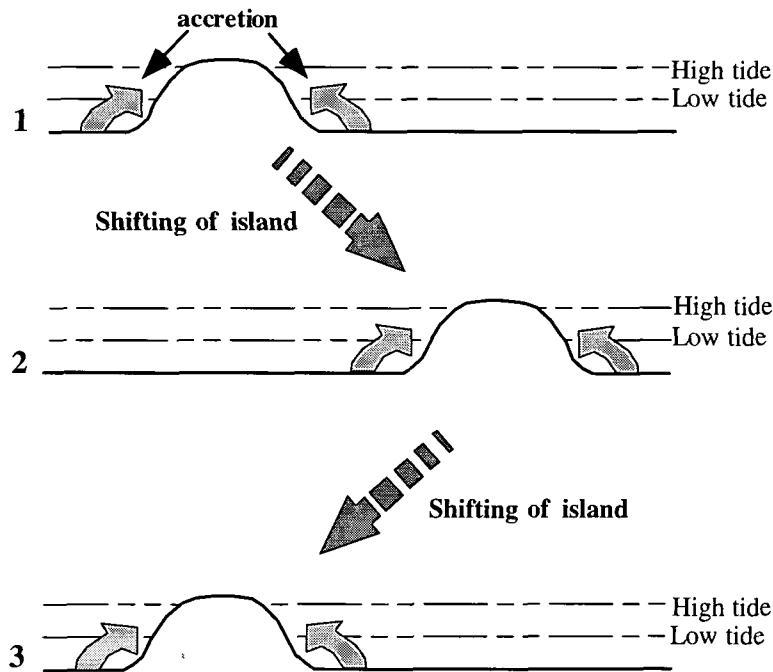

Figure 6-17 Model for formation of shallowing-upwards cycles by tidal flat progradation (after James, 1984). See text for discussion.

the inability to trace 'cycles' laterally, and that rise in relative sea level was constant, although it was acknowledged that any periods of sea-level fall would produce widespread synchronous exposure surfaces.



**Figure 6-18** Tidal flat island model for production of shallowing-upwards cycles (after Pratt and James, 1986). (1) Small areas of sedimentation (tidal islands) accrete to the supratidal zone, and shift laterally as a result of hydrographic forces (i.e., tidal channel migration). (2) The old tidal island is then submerged by the continuing transgression and is able to produce sediment again (3).

### 6.6.2 Tectonic mechanism

Although it has been well established that plate tectonics has a strong influence on long-term first order cycles, a tectonic mechanism for short term episodic creation of accommodation space is a little more difficult to envisage. Cisne (1986) suggested that synsedimentary strike-slip faulting at a platform margin would produce a small relative sea-level rise and hence record cyclicity. This theory was used to explain the Triassic Lofer cycles of the Alps. A problem with this mechanism would be the periodicity. Faulting would have to be periodic and predictable to explain the repetition of cycles, yet faults are similar to earthquakes in their apparent randomness with relation to time. Cloetingh *et al.* (1985) suggested that small-scale events including earthquakes and volcanic outpourings will cause in-plane stress variations in the lithospheric and continental plates. Depending upon whether stresses were decreased or increased this would lead to subsidence or uplift of the basin margin and thus transgression or erosion. The calculated magnitudes of sea-level variation as a result of in-plane stress could be in the order of 2m/1000 years. However, there is still the problem of periodicity of the earthquakes and volcanic outpourings.

### 6.6.3 Eustatic mechanism

Glacio-eustasy is probably one of the most popular explanations for the creation of metre-scale cycles in the geological record. It is essentially driven by orbital perturbations which occur on a 10Ky to 1.0My periodicity and are referred to as the Milankovitch rhythms after the astronomer who identified them. The interactions between the Earth, Moon and Sun have a fundamental effect on climate as they periodically alter the amount of solar insolation reaching the Earth, which not only affects presence/absence of ice sheets, but also changes climatic regimes, and erosional and weathering processes (House, 1995b). Three different durations of cycle have been recognised in the Milankovitch Band (Fig. 6-19).

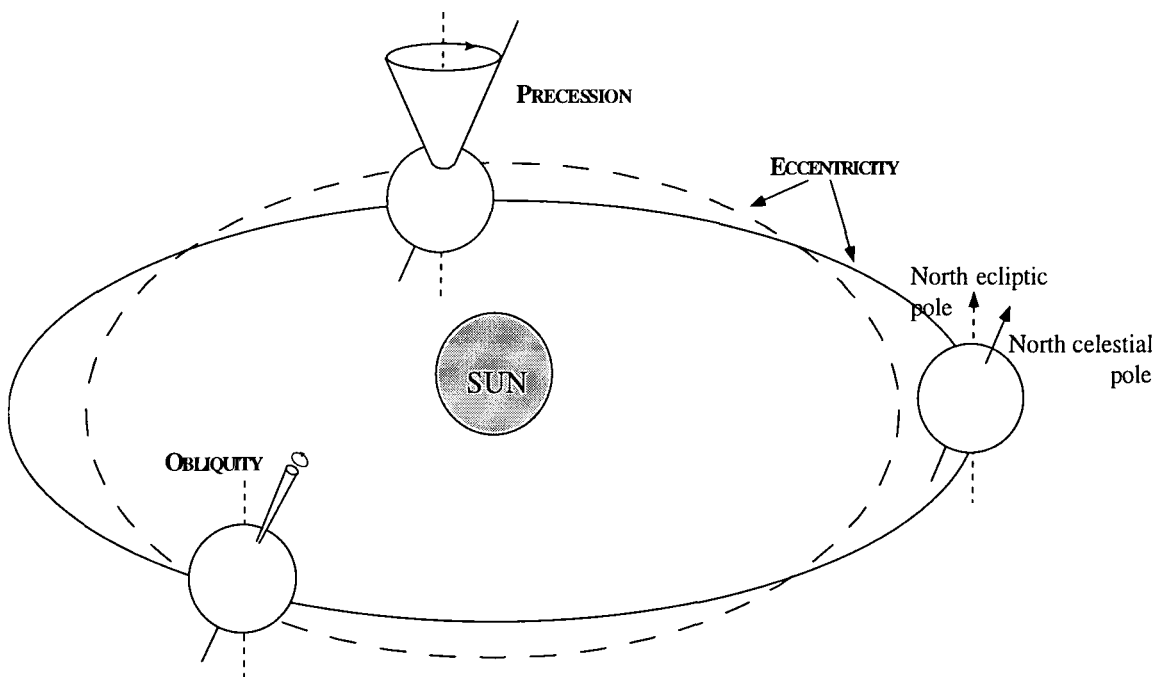

**Figure 6-19** Illustration of the variations in the Earth-Moon-Sun system, which effect the amount of solar isolation reaching the Earth. See text for details.

Precessional cycles record the wobble of the Earth's axis, which is a function of the Sun and Moon pulling on the Earth's equatorial bulge. At present-day the projected axis of the Earth lies close to the Pole star; yet the movement of the axis through time follows a roughly cone-shaped envelope, returning to its original position every 19-23Ky (Schwarzacher, 1993). As a result the equinoxes move around the elliptical orbit of the Earth and thus change the contrast between summer and winter temperatures (de Boer and Smith, 1994).

The obliquity cycle records the variation in the angle of tilt of the Earth's axis, with respect to the perpendicular to the ecliptic, the plane on which the Earth rotates around the Sun (de Boer and Smith, 1994). At present-day the plane lies at  $23.5^\circ$ , and this angle varies by  $3.5^\circ$  fluctuating from  $21.5^\circ$  to  $24.4^\circ$ , with a periodicity of about 41,000 years (House, 1995b). This changes the amount of solar insolation reaching the Earth from the sun and affects the climate firstly by changing the intensity of the seasons (especially at high latitudes) and also by altering the pole to equator climatic gradient, thus altering ocean circulation (House, 1995b).

The longest cycle of the Milankovitch band is known as the eccentricity, and this records the path of the Earth-Moon system around the Sun. The orbit varies between near-circular to elliptical, and when it is elliptical there are major variations on the amount of insolation which the Earth receives. The amount can vary by up to 30% at extremes of the ellipse (House, 1995b). The eccentricity of the orbit is highly variable; however, the 106Ky and 410Ky cycles are the strongest.

Astronomical forcing has a direct effect on eustasy because it alters the climate and more importantly glacial ice volumes. During times of maximum ice development, global sea-level is low since the water is taken up in ice. Alternatively, when glaciers are melting, sea level will rise. The magnitude of sea-level fall/rise will also depend upon the type of cyclicity. Precessional cycles have a shorter duration and therefore record sea-level fluctuations of only a few metres, whereas, eccentricity cycles may produce sea-level fluctuations in the order of 10's metres. These glacio-eustatic signatures are then picked up in the sedimentary rock record as cycles.

A feature of some sedimentary cycles which have been attributed to glacio-eustasy is the overprinting of short-term precessional cycles over longer-term eccentricity cycles (e.g., Triassic of northern Italy, Goldhammer *et al.*, 1987; Goldhammer *et al.*, 1990). Here, cycles are bundled into groups of five, where the basal cycle is thickest and following cycles progressively thin upwards until the base of the next bundle of cycles. The amount of subsidence will also affect how these climatic signatures are recorded in the rock record (Fig. 6-20; Goodwin and Anderson, 1985). At this point, it should also be noted that different cycles have different 'curves' (Hardie, 1986). From the sea-level curve which was derived for the last 125,000 years, it is clear that precessional cycles are symmetrical, yet

eccentricity cycles are strongly asymmetrical (Fig. 6-21). The asymmetrical sea-level curve is explained by a ice melting at a much faster rate than it does to form. Therefore, sea-level rise is quick, yet sea-level fall is at a more steady pace.

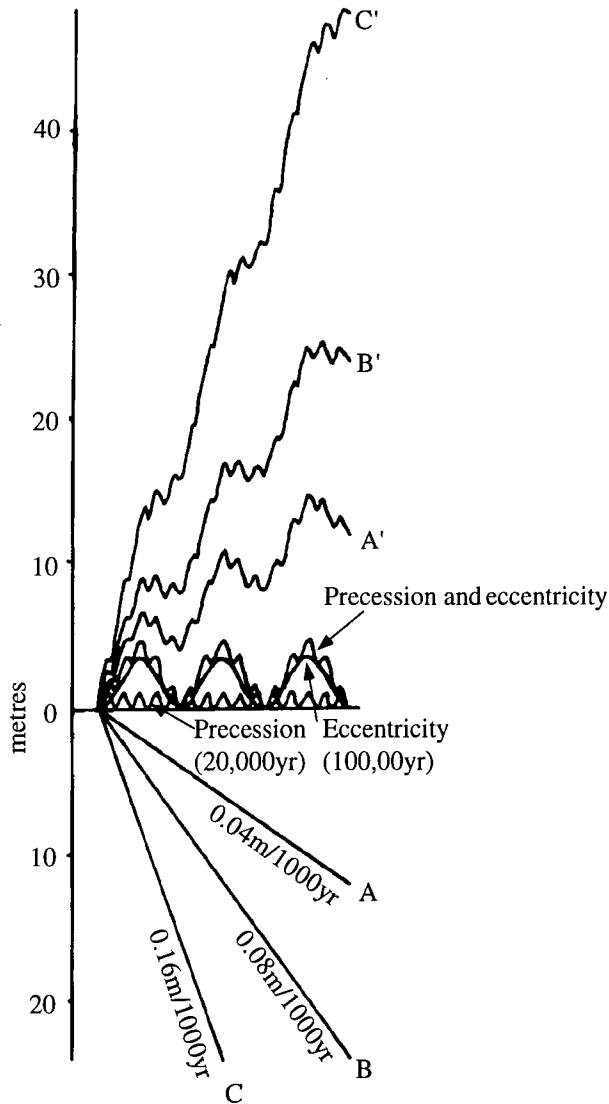

**Figure 6-20** General model for metre-scale cyclicity produced by glacio-eustasy. In this model precessional cyclicity is superimposed upon the eccentricity cyclicity, and modelled for various subsidence rates (A, B, C). Where there is a low subsidence rate the resultant sediment package may have abundant erosion surfaces (A'), and where there is a high subsidence rate thick sediment packages will be deposited. From Goodwin and Anderson (1985).

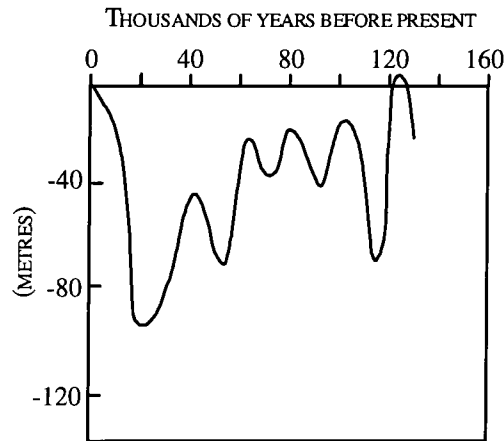

**Figure 6-21** Sea-level curve for the last 125,000 years. Note the superimposition of 20,000 year cyclicity on a 100,000 year cyclicity. Note also the asymmetry of the 100,000 year cycle (from Hardie, 1986).

Clearly when icehouse climates prevail (i.e., the lower Cambrian, much of the Carboniferous-Permian, and the Tertiary), orbital forcing will inevitably produce waxing and waning of ice-sheets. But how do these orbital perturbations influence the ocean volumes in greenhouse periods, when there are no polar ice caps (such as in the Givetian and Frasnian when mean temperature was 30°C; Brand, 1989)? The amount of solar insolation reaching the Earth is still variable, whether there is continental ice or not. Simple principles behind thermal expansion of water can account for sea-level fluctuations in the order of 1m per °C (Donovan and Jones, 1979). This is within the correct order of magnitude, considering small-scale sea-level fluctuations are only a few metres in the Middle and Upper Givetian. It is appropriate for greenhouse times that orbital forcing signatures are termed orbital-cycles rather than glacio-eustatic cycles, since this does not imply that continental ice was necessary for the model.

Wright (1992) recognised that cycles which developed during greenhouse periods were much thinner and of shorter duration than those seen in icehouse times and suggested that they formed in response to the smaller amplitude precessional and obliquity cycles, and that the eccentricity cycle was not recorded. Only third-order changes influenced the types of small-scale cycle developed (Wright, 1992). Compared to the icehouse cycles, greenhouse cycles typically have only thin subtidal bases with substantial intertidal-supratidal caps. This was because the changes in insolation triggered only small sea-level fluctuations, resulting in the creation of only minor accommodation space which could be quickly filled by shallow-water sedimentation.

The signatures which distinguish an orbital forcing mechanism from both tectonic and autocyclic mechanisms is that cycles will be traced laterally on a regional or even global scale, and cycles will show a periodicity.

## 6.7 Discussion

Differentiating between the three mechanisms when assessing a sedimentary section is not straightforward. Therefore, Table 6-6 presents evidence for and against each mechanism.

| Mechanism   | Evidence for ✓  | Evidence against ✗  |
|-------------|---|---|
| Sedimentary | <ul style="list-style-type: none"> <li>✓ Inability to trace single cycles laterally (may be just a function of poor outcrop, however)</li> <li>✓ Mechanism would produce idealised shallowing upwards cycle</li> </ul>  | <ul style="list-style-type: none"> <li>✗ Presence of entirely subtidal cycles</li> <li>✗ Cyclicity also seen in deep-water and reef-core facies</li> <li>✗ Some cycles have transgressive facies at their base</li> <li>✗ Development of calcrete horizons</li> </ul> |
| Tectonic    | <ul style="list-style-type: none"> <li>✓ Most isolated platforms are developed upon active fault blocks, and the shelf is dissected into fault blocks each with differential subsidence</li> <li>✓ Evidence of syndimentary volcanic activity</li> </ul>  | <ul style="list-style-type: none"> <li>✗ Mechanism cannot account for repetitiveness of cyclicity</li> <li>✗ Presence of transgressive deposits at the base of cycles</li> <li>✗ No evidence of coarse grained debris shed off fault blocks</li> </ul>                |
| Eustatic    | <ul style="list-style-type: none"> <li>✓ Cycles are regular</li> <li>✓ Duration of upper Givetian cycles calculated at ~42,000 years, well within Milankovitch band (obliquity cycles)</li> <li>✓ Greenhouse climate, therefore cycles likely to be of a shorter duration and magnitude (e.g., obliquity)</li> <li>✓ Can laterally correlate packages of cycles</li> <li>✓ Cyclicity not restricted to lagoonal facies, also seen in the reef-core and in deep-water facies</li> <li>✓ Mechanism can explain transgressive facies at bases of cycles, and also prolonged subaerial exposure through missed beats</li> <li>✓ Devonian metre-scale cyclicity is evident world-wide, mechanism needs to be global and not local</li> </ul> | <ul style="list-style-type: none"> <li>✗ Do not often see a well-developed pattern in superimposition of cycles</li> <li>✗ Cycle-types are not restricted to specific parts of the sea-level curve</li> </ul>   |

**Table 6-6 Pros and cons of the three major mechanisms giving rise to metre-scale cyclicity.**

Although the sedimentary mechanisms proposed by Pratt and James (1986) and Ginsburg (reviewed in James, 1984) provide good explanations for the development of some regressive type B cycles in the study area, the inability to account for many other features

makes the mechanism doubtful. For example, a large percentage of the cycles in the study area are entirely subtidal in nature. This is not easily explained by the autocyclic mechanisms, as it is imperative in their models that sediments build up to the intertidal zone as this is what eventually terminates carbonate production. Therefore, ideally, only cycles with peritidal caps should develop. The establishment of calcrete horizons also proves difficult to explain. Prolonged subaerial exposure is interpreted when calcretes are developed, and many of these calcretes show pendant or microstalactitic cements. However, as Elrick (1995) pointed out, if autocyclic processes were the driving force behind cycle development, vadose features would not be able to form since there would be no hydraulic head to push meteoric fluids down through the sediment. Hardie *et al.* (1991) have contested that vadose cementation is occurring in supratidal flats in the present-day Bahamas, an area which has been subjected to continuous sea-level rise. However, there has been no evidence for prolonged subaerial exposure in these supratidal environments.

Another strong argument against an autocyclic process is that many cycles show transgressive facies at the base. In both autocyclic models sedimentation is supposed to cut-out when the carbonate factory becomes areally restricted. It is not until the area has subsided (or until the island has shifted with the tidal island model) that circulation is restored, and sedimentation can continue. This mechanism will not allow for 'transgressive' facies to be deposited because the transgression can only occur if carbonate production ceases. The final piece of evidence precluding a tidal-flat progradation mechanism is that cyclicity is also seen in the reef-core facies (e.g., at Bleiwäsche Reef Complex; Städter and Koch, 1987) and also in deep-water facies (i.e., the Givetian rhythmic pelagic micrite/marl beds of the Montagne Noire, House, 1995a; Upper Devonian banded shales of the Rhenish Slate Mountains, Piecha, 1993). This contemporaneous cyclicity must be driven by an external force.

The tectonic mechanism rules itself out almost straight away, as it does not have the ability to create predictable, periodic movements on a continual basis. Normal fault movement is often clustered in time, and separated by uncertain time periods (Satterley, 1996). The magnitude of movement is also likely to vary (Satterley, 1996). However, there is lots of evidence to suggest that tectonic movement may have **modified** cyclic signatures. During the lower Givetian, for example, there is clear evidence that differential subsidence on fault blocks gave rise to condensed successions (i.e., Vaucelles), and it was also interpreted that

some fault blocks were relatively elevated compared to others (compare for example the lower Trois Fontaines Formation at Resteigne and Froid Lieu). Many of the isolated platforms were constructed on tilted fault blocks, which were clearly active during reef growth as there is evidence of gross thickness variations across the platform. Many isolated complexes also show evidence of volcanic outpourings, presumably related to fault movement. Although tectonism clearly influenced Middle and Upper Devonian platform development, it is doubtful that it was the major mechanism producing the pulses in creation of accommodation space.

The most attractive mechanism, which can explain the majority of the features discussed in this Chapter, is orbital-forcing. One of the most important features of the orbital-eustatic mechanism is that it can explain the wide array of cycle-types described in the area. Subtidal and peritidal cycles are common in the Devonian, and these can both develop as a result of ocean-level fluctuations. There is no necessity for cycles to aggrade to sea-level, since carbonate production will continue and sediments will continuously aggrade until there is another rapid flooding event. It has been suggested that the relative sea-level fluctuations needed to produce the cycles are in the order of 1-3m. Where sedimentary environments are shallow enough to record these fluctuations, a well-developed peritidal (type B) cycle is deposited. However, where sedimentary environments are deeper (such as in the deeper-water lagoons of the isolated complexes) these metre-scale sea-level fluctuations may be of a large enough magnitude to alter substantially the sedimentary environment. This may explain why many of the deeper central lagoons in the isolated carbonate complexes have much thicker subtidal cycles, as they may represent longer term, higher magnitude, sea-level fluctuations rather than metre-scale fluctuations.

The orbital forcing mechanism can account for transgressive deposits at the base of cycles. The rate of sea-level rise is important when considering the ability for sediments to be deposited. If the rate of sea-level rise is high, carbonate production is likely to severely lag behind the creation of accommodation space and thus sediments will not be deposited. However, when the rate of sea-level rise is slower, sedimentation may be able to track the transgression. The rate of absolute sea-level rise is unlikely to change for any specific orbital cycle; however, a composite eustasy, where there are two or more orbital forces interacting will modify the rates, by either exaggerating or nullifying them (see Figure 6-20). In an ideal situation this would produce a predictable distribution of transgressive-

regressive and regressive cycles, yet this is not seen in the studied successions. It is possible that this pattern is being overprinted by tectonic or autocyclic modifications, or that the actual lag-time, when carbonate production needs to re-establish itself after exposure, is variable. The answer is difficult to differentiate.

Section 6.5 portrayed how packages of cycles could be correlated over a large area, attesting to a regional rather than local control. Individual cycles have been estimated as representing approximately 42,000 years. Although this is a very rough calculation, and other estimates are unable to be substantiated due to lack of biostratigraphic control, it does lie within the Milankovitch band, and is most likely to represent the obliquity cycle (Table 6-7).

| Cycle        | Cycle duration in the Mid-Devonian |
|--------------|------------------------------------|
| Precession   | 16.8Ky, 19.9Ky                     |
| Obliquity    | 32.1Ky, 39.5Ky                     |
| Eccentricity | 123.0Ky, 413.9Ky                   |

**Table 6-7 Calculation of Middle Devonian orbital frequencies (from Berger *et al.*, 1989a, b).**

In some successions (i.e., the middle Givetian Linhay Hill quarry), there is a 'bundling' of cycles (between 4-6) which show thinning-upwards stacking patterns. This may suggest the effect of composite eustasy, where precession cycles were superimposed upon an eccentricity cycle. Composite eustasy is apparent in all successions as variations in cycle thickness pick out longer-term accommodation trends (as seen on Fischer plots). If eustasy was the only mechanism influencing cycle-development, one might expect an idealised distribution of cycle types, where thicker subtidal-cycles showing retrogradational thickness trends were dominant in the transgressive part of the succession and truncated peritidal cycles were more common in regressive parts of the succession. However, this pattern is not seen, suggesting that subsidence may have been variable through time and that autocyclic processes were overprinting the eustatic signature.

Although packages of cycles could be traced across the platform, it was impossible to trace individual cycles. Indeed, where cycle packages could be traced, some successions contained more cycles than others. This anomaly can be explained in two ways. Firstly, cycle origin could be completely autocyclic, wherein individual cycles are not likely to be traced. However, as mentioned above there are several lines of evidence against this

mechanism. Secondly, there could be 'missed beats', where sedimentation was either too deep to record the small-scale sea-level fluctuations (such as in the central lagoons of the isolated platforms) or where the area was exposed, for example during calcrete development. It is possible that the calcretes represent several 'missed beats', as they are interpreted to have taken a substantial amount of time to form.

Although orbital forcing is the most attractive explanation for cycle development, it clearly does not work on its own. Tectonic influences such as variable subsidence rates invariably modify cycle-type distribution, and it is highly likely that autocyclic processes did affect cycle development. However, it is suggested here that orbital forcing is the primary mechanism for cycle development and best explains the features seen in the Middle and Upper Devonian strata.

Other people have worked on the cyclicity of the study area, notably Preat and Carliez (1994), Weis and Preat (1994), Preat and Weis (1994), Kasimi and Preat (1996), and Carliez and Preat (1997) in the Ardennes, Hering (1994) in the Bergisch Gladbach isolated platform of Germany, Schudack (1993,1996) in the Balve Reef Complex and Hong (1992) in the Brilon Reef Complex. Much of the work in the Ardennes area by Preat and his co-workers has suggested that the metre-scale cycles (which they have termed both 5th and 6th-order in different publications and have interpreted to be only 1,000-5,000 years in duration) result from very low amplitude relative sea-level oscillations which were essentially controlled by subsidence. They also said that the bundling of the cycles into parasequence sets did not indicate orbital forcing within a Milankovitch band. Clearly there are problems with these interpretations, as many of them are based on the anomalously low cycle duration. A subsidence-controlled cyclicity cannot explain many of the features that have been described in Section 6.5, and therefore it is suggested here that it is an insufficient mechanism. Hering (1994) produced an extremely detailed piece of work on the sedimentology and cyclicity of the middle Givetian Bergisch Gladbach isolated platform in Germany. He recognised two orders of cyclicity which could be attributed to Milankovitch rhythms and therefore suggested an orbital forcing control. Schudack (1993) suggested that the metre-scale cyclicity which was developed on the tidal flats of the Balve Reef Complex could be attributed to abrupt subsiding movements on the Lenne fault, to the northeast of the complex. More recent work, including spectral analysis and a more thorough biostratigraphy, has calculated the metre-scale cycles to have had a duration of

21,500 years. It was also interpreted that these cycles were superimposed upon a 400,000 year cycle. Therefore, in 1996 Schudack suggested that Milankovitch forcing was the most likely mechanism causing the cyclicity. Hong (1992) also attributed cyclicity in the Brilon Reef Complex to eustatic sea-level fluctuations.

Small-scale cyclicity in the Devonian is apparent worldwide. It occurs not only in shallow-water carbonates (e.g., USA - Goodwin and Anderson, 1985; Dorobek, 1987; Elrick, 1995; Yang *et al.*, 1995; Canada - Harvard and Oldershaw, 1976; Wong and Oldershaw, 1980; Fejer and Narbonne, 1992; McLean and Mountjoy, 1994; China - Yuansheng *et al.*, 1996; Poland - Preat and Racki, 1993; Australia - Playford, 1969; Read, 1973), but also in marine clastic systems (USA - Brett and Baird, 1996; Batt, 1996), alluvial settings (Ireland - Kelly and Sadler, 1995), lacustrine settings (Scotland - Donovan, 1980; Astin, 1990) and deep-water settings (France - House, 1995a). Interestingly, only three of the publications cited above do not attribute the cyclicity to orbital perturbations (Wong and Oldershaw (1980) and Morrow and Labonte (1988) suggested autocyclic mechanisms, whereas Preat and Racki (1993) suggested local fault-block movement). Read (1973) did not attribute any mechanism to the observed cyclicity in the Canning Basin, Australia. One might infer from this that Devonian cyclicity has been recorded worldwide and that it is not just restricted to tidal-flat facies; thus an orbital forcing mechanism would appear to be the most likely explanation.

### **6.8 3rd order eustatic fluctuations of the Givetian and Frasnian**

Four major transgressions are recorded in the Middle Givetian-Middle Frasnian strata: at the base of the Terres d'Hours Formation, at the base of the Fromelennes Formation, at the base of the Frasnian and at the base of the nodular limestones/Mantagne Shale (Fig. 6-22). The transgressive facies are characterised by open-marine sediments, with rich faunal diversities (argillaceous shales, marly shales, limestone turbidites). They are correlatable worldwide and fit in well with sea-level curves published by Johnson *et al.* (1985) (Fig. 6-23). Regressions and times of relative lowstands of sea level are characterised by the cyclic lagoonal facies which have been the focus of this study.

Several orders of cyclicity have been identified in the successions studied for this thesis. The metre-scale cycles have been extensively discussed, and are interpreted to originate from orbital forcing processes (precessional/obliquity cycles) although autocyclicity and

tectonics are overprinting signatures. These are 5th-order cycles (i.e., durations of 10,000-100,000 years). Metre-scale cycles show trends in cycle thickness, which can either be thinner than average, average, or thicker than average, which appear on a Fischer plot as falling limbs, horizontal sections and rising limbs, respectively. These reflect longer-term trends in accommodation space, produced by a combination of eustasy and subsidence. These cycles roughly approximate to a 100,000 year to 500,000 year (eccentricity?) cyclicity, and are 4th order cycles. Large scale 3rd order transgressive-regressive 'sequences' are in the order of 3-4My duration. The whole of the Devonian shows a broad transgressive trend, from base to top, and these 3-4My cycles are also superimposed upon this trend (Johnson *et al.*, 1985; Fig. 6-23).

## 6.9 Summary

In summary, two major types of metre-scale cycle have been identified in the studied successions. Subtidal cycles (type A) show a decrease in circulation, decrease in diversity of organisms and increase in fluctuation of salinity upwards through the cycle. Peritidal cycles (Type B) shallow upwards from a subtidal base through to an intertidal or supratidal cap. The distribution of these cycle-types is related to the amount of accommodation space available, which in turn is controlled by subsidence and small-scale sea-level fluctuations. Subtidal cycles seem particularly common within the isolated carbonate complexes; however, this may just reflect the fact that the logged successions were located in the central subtidal lagoon, rather than on the tidal flats. Both peritidal and subtidal cycles are identified in the shelf lagoon, and their distribution is related not only to longer-term sea-level fluctuations, but also to differential subsidence. Cycles are mainly regressive in character; however, transgressive-regressive cycles are not uncommon. Their distribution does not produce a clear pattern, and deposition of the transgressive deposits could either be attributed to the rise in relative sea level being slow enough so that carbonate production was able to pace it, or that the lag time was variable for carbonate production to restart after the initial transgression.

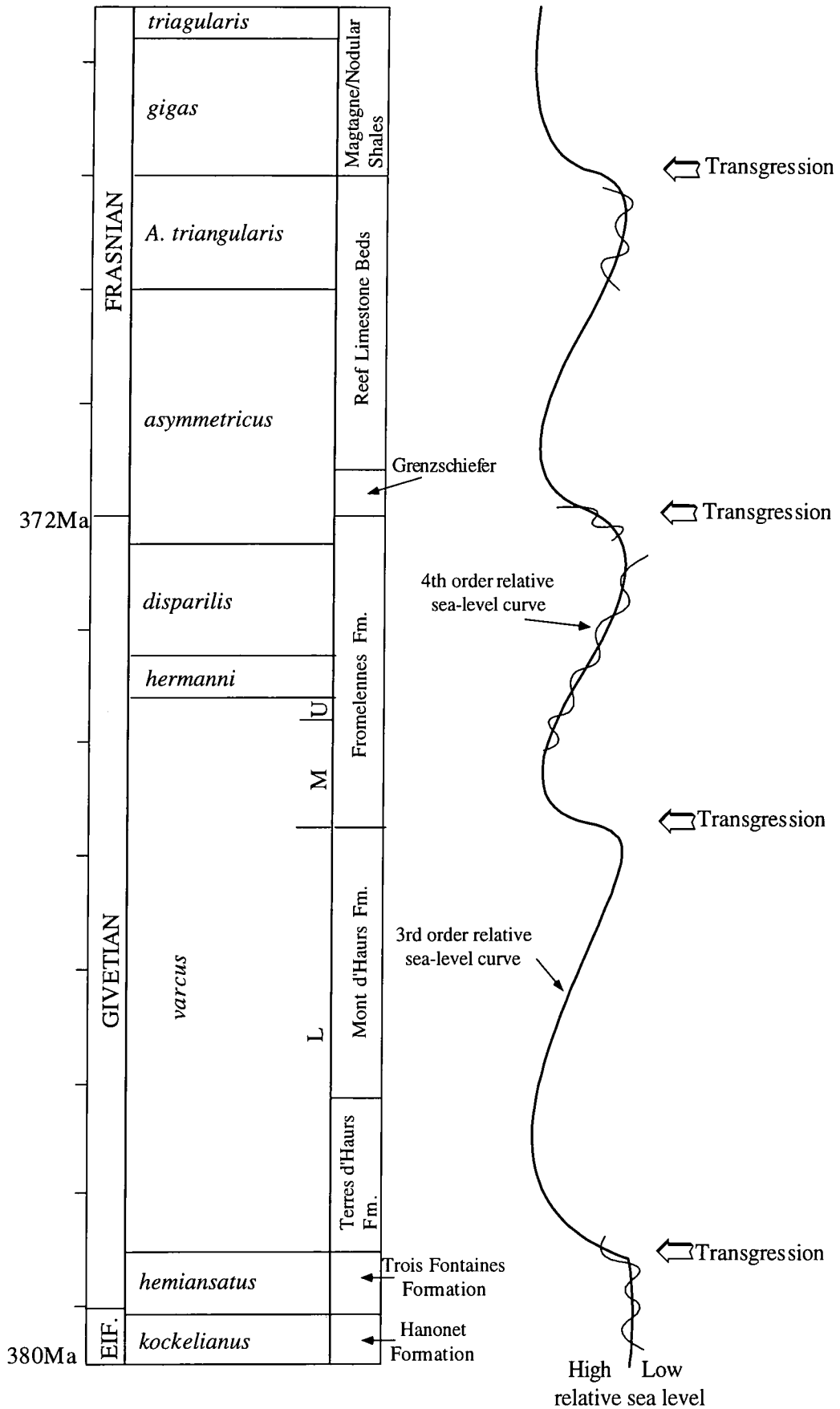
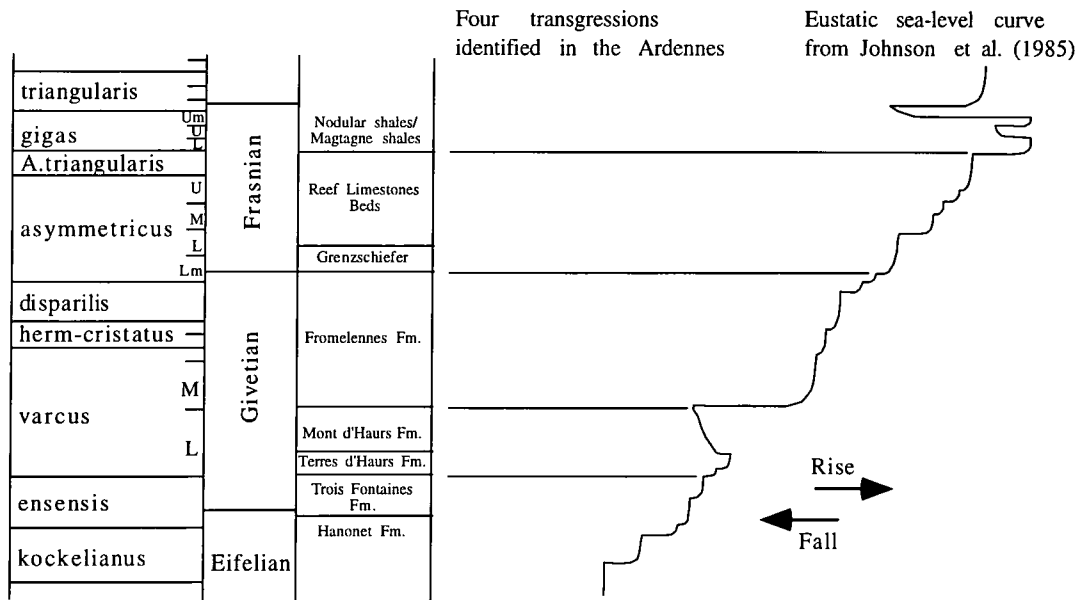

Figure 6-22 Eustatic sea-level curve for the Givetian and Frasnian. Absolute time-scale from Fordham (1992). Conodont zone duration from House (1995a) and Fordham (1992).



**Figure 6-23** Eustatic sea-level curve produced by Johnson *et al.* (1985), with comparison to major transgressions identified in the study area.

Long-term evolution of the cyclicity through the Givetian and Frasnian in the shelf lagoon can be determined; however, due to poor biostratigraphical control this is not possible for the isolated complexes. Correlation between packages of cycles which showed similar thickness trends could be made across the platform; yet, tracing individual cycles was not possible. It was concluded that the metre-scale cyclicity was most likely to have been controlled by short-term (20,000 year to 40,000 year) orbital perturbations. Cycle duration for the upper Givetian was calculated at 42,000 years, and the magnitude was probably in the order of 1-3m. Overprinting this orbital-forcing signature were the effects of autocyclic processes (tidal-flat progradation) and differential subsidence of fault blocks. Differential fault-block movement was of great importance as it had a strong influence on the cycle-type distribution, where subtidal cycles were common in rapidly subsiding fault blocks, and peritidal cycles were common in stable elevated blocks. Several scales of cycle were interacting with each other, where metre-scale cycles (5th order) were superimposed upon 4th order cycles (100,000-400,000 years), which were then superimposed upon 3rd order cycles (3-4My in duration). Third-order cycles are delineated by major marine transgressions which can be correlated worldwide.

# *CHAPTER SEVEN*

|   |            |
|---|------------|
| <b>7. SYNTHESIS AND CONCLUSIONS</b> .....                             | <b>277</b> |
| 7.1 COMPARISONS BETWEEN THE SHELF LAGOON AND ISOLATED PLATFORMS ..... | 277        |
| 7.2 SUMMARY OF CONCLUSIONS .....                                      | 279        |

## 7. Synthesis and conclusions

This thesis has presented the results of fieldwork and laboratory work to describe and interpret the Middle to Upper Devonian shallow-water cyclic carbonate successions of western Europe. This chapter synthesises the information and provides a summary of conclusions.

### 7.1 Comparisons between the shelf lagoon and isolated platforms

It is useful, at this point, to summarise the main differences between the Devonian shelf lagoon and isolated platforms, with regards to the size, facies distributions, cyclicity and influence of tectonics/volcanics (Table 7-1).

One of the major differences between the shelf and isolated complexes is the size. The shelf lagoon is clearly much larger than the isolated complexes, covering an area of approximately 15,000km<sup>2</sup>. The influence of volcanics is very limited in the shelf lagoon, suggesting there are few volcanic centres within the shelf, yet there are centres near Torbay and within the Rheinisches Schiefergebirge. All areas appear to have been hugely influenced by syndimentary tectonics, which resulted in thickness variations across the platforms.

The facies seen in the shelf lagoon and in the lagoons of the isolated complexes are not as different as one may have first thought. Reef-derived deposits (microfacies S3) are lacking in the shelf lagoon, yet many of the other facies occur in all settings. It is very noticeable that intertidal and supratidal deposits are far more abundant in the rimmed-shelf rather than in the isolated platforms. In many modern day rimmed-carbonate platforms, tidal flat areas are extensive. For example the Arabian Persian Gulf Trucial Coast has a protected lagoon behind oolite banks. The subtidal lagoon itself is probably only approximately 5km wide, whereas the extensive tidal flats are up to 10km in width (Shinn, 1983a). The internal composition of these tidal flats is not comparable to the Devonian shelf since they have a high anhydrite and gypsum content, reflecting the arid climate. However, the Trucial Coast can be used as an example of how lagoons can have extensive tidal flat areas. By way of contrast, in many modern-day atolls, irrespective of their size, lagoon beaches or protected tidal flat environments cover only a small area compared to the subtidal environments (Wiens, 1962). Although the Devonian isolated platforms are not true atolls, their size and shape are comparable to the modern-day atolls and this may be a useful analogy as to why

tidal flat environments are not extensive in these small isolated platforms. It is also important to realise, however, that when studying the isolated platforms only a very 'limited' area of the platform is being examined. Therefore it is statistically more likely to sample an area within the subtidal lagoon rather than the tidal flats. With these considerations in mind it is important to consider all information provided by the literature with regards to which other facies are present, especially in study areas with poor outcrop.

| Characteristic                  | Shelf lagoon  | Shelf-edge isolated platforms   | Inner shelf isolated platforms   | Isolated platforms within trough                               |
|---------------------------------|---|---|--|--|
| Size                            | ~15,000km <sup>2</sup>  | 70 km <sup>2</sup> -1,000km <sup>2</sup>  | ?  | ~20km <sup>2</sup>   |
| Age                             | Lower Givetian - middle Frasnian.   | Variable, mostly middle Givetian - middle Frasnian.   | Upper Givetian - middle Frasnian.  | Lower Frasnian - middle Frasnian.                              |
| Semi-restricted subtidal facies | Dominated by stromatoporoid floatstones. No reef-derived storm deposits.                                | High- and low-energy facies recorded. Reef-derived storm debris common.   | Mainly low-energy stromatoporoid floatstones.  | Poorly represented, low-energy stromatoporoid floatstones.     |
| Restricted subtidal facies      | Common, bioclastic wackestones, <i>Amphipora</i> -rich facies, fossil-poor facies, peloidal grainstones | Common, peloidal grainstones, <i>Amphipora</i> -rich facies and fossil-poor facies. Bioclastic facies not common. | Common - mostly <i>Amphipora</i> floatstones and wackestones.  | Common - mainly dominated by <i>Amphipora</i> -rich facies.    |
| Intertidal facies               | Common. Fenestral limestones. Bioclastic grainstones with microstalactitic cements                      | Common. Fenestral limestones.   | Reported in the Balve Complex as common. Rare at Dornap.   | Present, locally common, but not studied.                      |
| Supratidal facies               | Microbial laminites common. Rare calcretes.   | Locally present. Laminites well developed in Brilon.  | Reported in the Balve Complex as common. Not reported at Dornap.   | Present, but not studied. Not common.                          |
| Cyclicity                       | Subtidal and peritidal. Average thickness ~2m.  | Subtidal and peritidal. Average thickness ~2.4m.  | Mostly subtidal in studied successions. Reported peritidal cycles elsewhere in Balve Reef. Average cycle thickness = 3.5m. | Subtidal in the studied section. Average cycle thickness = 7m. |
| Tectonic influence              | Differential subsidence of fault blocks.  | Most complexes influenced by syndepositional tectonics.   | Thickness variations across Balve complex, not at Dornap.  | None reported.   |
| Volcanic influence              | Rare tuff bands.  | Apparent at Torbay and Brilon.  | Lavas at Balve, not present at Dornap  | Extensive volcanism  |

**Table 7-1 Summary of the main characteristics of the shelf lagoon and lagoons within the isolated complexes.**

Cyclicality is developed in all settings, yet it is best developed in tidal-flat environments (i.e., shelf lagoon and where the tidal-flat facies have been examined in the isolated platforms). In the deeper central parts of the lagoons a cyclicality is still recorded, but the cycles are thicker than in tidal flat environments. It has been interpreted that the magnitude of sea-level fluctuation (1-3m) may not have been deep enough to penetrate the central lagoons, and only when relative sea-level magnitudes are higher can a change in facies occur. The cycles within the subtidal lagoon therefore represent a longer-term cyclicality.

This study thus concludes that although the size, shape and settings associated with the Middle Devonian carbonate complexes differ, the same faunas and floras inhabit the lagoons, sedimentological processes within the lagoons are similar and external forces such as tectonics and orbital forcing clearly influence facies distributions. The only major difference is that tidal flats appeared to have been more extensive in the broad shelf lagoon compared to the interiors of the isolated platforms.

## 7.2 Summary of conclusions

- ☆ Middle and Upper Devonian carbonates were deposited during a large-scale, long-term transgression over continental Old Red Facies. The transgression was diachronous, reaching the southern parts of the Ardennes/Eifel areas by the lowermost Eifelian and the northern parts of the Rheinisches Schiefergebirge by the late Givetian.
- ☆ The Middle and Upper Devonian carbonate platform could broadly be divided into three major palaeosettings.
- ☆ The Ardennes area saw the development of a homoclinal ramp in the Eifelian. The ramp was storm influenced, and possessed rich open-marine faunal assemblages. Microfacies analysis identified seven major facies within the Eifelian-lower Givetian ramp setting, which ranged from open-marine below wave-base, through to intertidal. Intertidal facies were recorded as laminated, unfossiliferous dolomudstones. Restricted environments, where circulation was poor and salinities were fluctuating were dominated by *Leperditia* ostracodes. It is thought the ramp may have been of a beach barrier-lagoon system which would account for the restricted facies. Oolitic, peloidal and bioclastic grainstones were deposited as impersistent sand banks around fair-weather wave-base where there was constant attrition. In slightly deeper waters, between fair-weather and storm wave-base, bioclastic packstones (with skeletal debris derived from shallower waters) and

stromatoporoid floatstones were deposited. Bioturbated mudstones and wackestones were deposited near or just below storm wave base.

- ☆ The base of the Givetian saw the transition from a ramp to shelf geometry over much of the Ardennes area. Stromatoporoid reefs developed along the shelf edge and provided protection for an extensive shelf lagoon. The shelf area extended from Boulogne in the west and to Aachen in the east. Shelf sedimentation continued through to the middle Frasnian, until subsidence and a major transgression drowned the platform.
- ☆ Isolated carbonate platforms developed in the Rheinisches Schiefergebirge area of Germany and in southwest England. Six isolated platforms were studied. Attendorn Reef Complex, Brilon Reef Complex and Torbay Reef Complex were positioned on the shelf-edge, Balve Reef Complex and Dornap Reef Complex were located within the shelf and Langenaubach Reef Complex was positioned within the trough.
- ☆ Because of their areal extent, lagoonal environments were extensively studied in shelf and isolated complexes. Faunal and floral distributions were related to circulation, salinity and exposure. In the highly restricted lagoons leperditiid ostracodes, gastropods and calcispheres were present. The restricted lagoons hosted a large abundance of floras: Dasycladaceae, Codiaceae, Girvanellids, Hedstroemids, and Renalcids. There was also a rich microfossil assemblage of parathuramminid forams, calcispheres, and ostracodes. Rare macrofossils included *Amphipora*, bulbous stromatoporoids, thamnoporoids, and molluscs. The high-energy back-reef and reef environment was home to many robust macrofossils including laminar stromatoporoids, domal and larger bulbous stromatoporoids, branching stromatoporoids (i.e., *Stachyodes*), corals, *Stringocephalus* brachiopods, molluscs and crinoids.
- ☆ Using palaeontological and sedimentological information, a microfacies scheme could be devised for the Middle and Upper Devonian lagoons. Fourteen major microfacies were identified which could be divided into four groups. The **semi-restricted subtidal microfacies group** had a rich faunal assemblage which, although diverse, did not represent fully open-marine deposition. Sedimentation was entirely subtidal in nature. This broad facies band was thought to have been deposited near or at the immediate back-reef environment. The **restricted subtidal microfacies group** was either characterised by monospecific fossil assemblages (chiefly molluscs or amphiporoids), or

by macrofossil-poor facies. These facies represented poorly circulated, subtidal, stressed environments which may have been subjected to fluctuating salinities. The **intertidal microfacies group** was characterised by fenestral limestones, which were commonly poorly-fossiliferous. Finally the **supratidal microfacies group** was typified by dolomudstones, microbial laminites or calcrete development.

☆ The development of the shelf lagoon and lagoons located in the isolated complexes were subject to a complex interaction of parameters. In the shelf lagoon there is evidence of thickness variation across the shelf, which can be attributed to differential subsidence of the fault blocks which dissect the lagoon. The subsidence of these fault blocks also influenced the facies distributions. Rapidly subsiding fault blocks were generally characterised by subtidal deposition, whereas stable fault blocks allowed sedimentation to build up to sea level where intertidal and supratidal facies were deposited. This fault block movement continued throughout the Middle Devonian. The position of the succession in relation to the shoreline also influenced the style of deposition, since intertidal-supratidal facies were more likely to be deposited close to the shoreline than in the deeper central lagoon. Small-scale and large-scale relative sea-level fluctuations also strongly controlled facies distributions, and this resulted in a pervasive metre-scale cyclicity.

☆ The main factor governing the development of the isolated complexes was their position with respect to the shelf-edge. Those complexes which developed upon the shelf-edge were always developed upon ramp facies, showed the thickest accumulations and were some of the largest isolated complexes in the study area. Facies were extremely variable from semi-restricted subtidal through to supratidal and a metre-scale cyclicity was commonly well-developed. Syn-sedimentary faulting clearly influenced the development of many of the shelf-edge complexes, as there are major thickness variations across the platforms.

☆ Reef complexes which are located within the shelf also developed upon ramp and bank carbonate facies, yet their sizes and thicknesses were variable. Lagoonal facies were generally subtidal in nature; however, this may reflect the position of the studied successions being in the deeper parts of the central lagoon rather than on the tidal flats. Therefore the apparent lack of tidal-flat facies may be a consequence of poor exposure.

Cyclicality is developed, yet is mostly subtidal in nature. Synsedimentary faulting is identified in the Balve Reef Complex, but not in the Dornap Reef Complex.

- ☆ The isolated complexes within the trough are the smallest seen in the study area and are also the thinnest. The complexes developed on basalts and their initiation, growth and demise were controlled by volcanism. Lagoonal deposition in the studied section was dominantly subtidal, but this probably reflects the lack of outcrop in the palaeotidal-flat environment. Metre-scale cycles are much thicker than in the other complexes.
- ☆ Analysis of all lagoonal successions identified two major types of metre-scale cyclicality. Subtidal cycles show a decrease in circulation, decrease in diversity of organisms and increase in fluctuation of salinity upwards through the cycle. Peritidal cycles shallow upwards from a subtidal base through to an intertidal or supratidal cap. Cycles are mostly regressive, yet transgressive-regressive cycles are not uncommon. Subtidal cycles seem particularly common within the isolated carbonate complexes; however, this may just reflect the fact that the logged successions were located in the central subtidal lagoon, rather than on the tidal flats. Both peritidal and subtidal cycles are identified in the shelf lagoon, and their distribution is related not only to longer-term sea-level fluctuations, but also to differential subsidence of fault blocks.
- ☆ Fischer plots proved to be a useful correlative tool in the shelf successions. However, poor biostratigraphical control in the isolated complexes made correlation between the shelf and isolated complexes impossible.
- ☆ The metre-scale cyclicality was most likely to have been controlled by short-term (20,000 year to 40,000 year) orbital perturbations. Cycle duration for the upper Givetian was calculated at 42,000 years, and the magnitude of sea-level rise/fall was in the order of 1-3m. Overprinting this orbital signature were the effects of autocyclic processes (tidal flat progradation) and differential subsidence of fault blocks.
- ☆ It was concluded that several scales of cycle could be identified. Third-order eustatic sea-level fluctuations were delineated by major marine transgressions, and a eustatic sea-level curve was established. This curve fitted well with other eustatic curves for the Middle and Upper Devonian worldwide.

## *REFERENCES*

---

## References

- Alberti, G.K.B. 1979.** Zur Dacryoconariden (Tentaculiten) Chronologie des herzynischen Unter- and Mittel-Devons. *Senckenbergiana Lethaea*, **60**, 223-241
- Allen, J.R.L. 1979.** Old Red Sandstone facies in external basins, with particular reference to southern Britain. In: *The Devonian System* (M.R. House, C.T. Scrutton & M.G. Basset, eds.). *Special Papers in Palaeontology*, **23**, 65-80
- Anderton, R., Bridges, P.H., Leeder, M.R. & Sellwood, B.W. 1985.** *A Dynamic Stratigraphy of the British Isles*. George Allen Unwin, pp301
- Armstrong, M. & Paterson, I.B. 1970.** The Lower Old Red Sandstone of the Strathmore region. *Report of the Institute of Geological Sciences*, **70/12**
- Arnott, R.W.C. 1995.** The parasequence definition - are transgressive deposits inadequately addressed? *Journal of Sedimentary Research B*, **65**(1), 1-6
- Astin, T.R. 1990.** The Devonian lacustrine sediments of Orkney, Scotland; implications for climate, cyclicity, basin structure and maturation history. *Journal of the Geological Society London*, **147**, 141-151
- Atkinson, C.D. 1986.** Tectonic control on alluvial sedimentation as revealed by an ancient catena in the Capella Formation (Eocene) of northern Spain. In: *Paleosols: Their recognition and interpretation* (V.P. Wright, ed.). Blackwell Scientific Publications, 139-179
- Bain, R.J. & Kindler, P. 1994.** Irregular fenestrae in Bahamian eolianites: a rainstorm-induced origin. *Journal of Sedimentary Research A*, **64**(1), 140-146
- Ball, M.M., Shinn, E.A. & Stockman, K.W. 1963.** Geologic effects of Hurricane Donna (Abstract). *American Association of Petroleum Geologists Bulletin*, **47**, 349
- Barclay, W.J., Rathbone, P.A., White, D.E. & Richardson, J.B. 1994.** Brackish water faunas from the St. Maughans Formation - the Old Red Sandstone section at Ammons Hill, Hereford and Worcester, UK, re-examined. *Geological Journal*, **29**, 369-379
- Bassett, M.G., Bluck, B.J., Cave, R., Holland, C.H. & Lawson, J.D. 1992.** Silurian. In: *Atlas of Palaeogeography and Lithofacies* (J.C.W. Cope, J.K. Ingham & P.F. Rawson, eds.). *The Geological Society Memoir*, **13**, 37-56
- Bathurst, R.G.C. 1967.** Oolitic films on low-energy carbonate sand grains, Bimini Lagoon, Bahamas. *Marine Geology*, **5**(2), 89-109
- Batt, R.J. 1996.** Faunal and lithologic evidence for small-scale cyclicity in the Wanakah Shale (M. Devonian) of Western New York. *Palaios*, **11**(3), 230-243
- Benson, R.H. 1961.** Ecology of ostracode assemblages. *Treatise of Invertebrate Paleontology*, pt Q, Arthropoda **3**, 56-63

- Berdan, J. 1968.** Possible paleoecological significance of Leperditiid ostracodes. *Geological Society America, Program, Annual Meeting, Northeastern Section*, p17
- Berger, A., Loutre, M.F. & Dehant, V. 1989a.** Influence of the changing lunar orbit on the astronomical frequencies of Pre-Quaternary insolation patterns. *Paleoceanography*, **4**, 555-564
- Berger, A., Loutre, M.F. & Dehant, V. 1989b.** Pre-Quaternary Milankovitch frequencies. *Nature*, **323**, 133
- Birenheide, R. & Gabrielli, P. 1993.** Stratigraphie und Korallen des unteren Mittel-Devon im NE-Teil der Rohrer Mulde in der Eifel. *Senckenbergiana Lethaea*, **73**(1), 7-24
- Blieck, A., Brice, D., Fiest, R., Guillot, F., Majeste-Menjoulas, C. & Meilliez, F. 1988.** The Devonian of France and Belgium. In: *Devonian of the World* (N.J. McMillan, A.F. Embry & D.J. Glass, eds.). *Canadian Society of Petroleum Geologists Memoir*, **14**(1), 359-400
- Blodgett, R.B. & Dutro jr., J.T. 1992.** Stringocephalus (Brachiopoda) from Middle Devonian (Givetian) rocks of the Baird Group, western Brooks Range, Alaska. *Oklahoma Geological Survey Bulletin*, **145**, 91-111
- Bluck, B.J., Cope, J.C.W. & Scrutton, C.T. 1992.** Devonian. In: *Atlas of Palaeogeography and Lithofacies* (J.C.W. Cope, J.K. Ingham & P.F. Rawson, eds.). *The Geological Society Memoir*, **13**, 57-66
- Bouckaert, J., Mouravieff, A., Streel, M., Thorez, J. & Ziegler, W. 1972.** The Frasnian - Famennian Boundary in Belgium. *Geologica et Palaeontologica*, **6**, 87-92
- Boulvain, F., Coen-Aubert, M., Mansy, J.L., Proust, J-N. & Tourneur, F. 1994.** Le Givetien en Avenois (nord de la France): palaeoenvironments et implications palaeogeographiques. *Bulletin de la Société belge de Géologie*, **103**(1-2), 609-619
- Boulvain, F. & Preat, A. 1987.** Les calcaires laminaires du Givetien supérieur du bord sud du bassin de Dinant (Belgique, France). Témoins d'une évolution palaeoclimatique. *Bulletin de la Société Géologique de Belgique*, **109**, 609-619
- Braithwaite, C.J.R. 1966.** The petrology of Middle Devonian limestones in South Devon, England. *Journal of Sedimentary Petrology*, **36**(1), 176-192
- Braithwaite, C.J.R. 1967.** Carbonate environments in the Middle Devonian of South Devon, England. *Sedimentary Geology*, **1**, 283-320
- Braithwaite, C.J.R. 1973.** Reefs: Just a problem of semantics. *American Association of Petroleum Geologists Bulletin*, **57**(6), 1100-1116
- Brand, U. 1989.** Global climatic changes during the Devonian-Mississippian: stable isotope biogeochemistry of brachiopods. *Palaeogeography, Palaeoclimatology, Palaeoecology*, **75**, 311-329
- Brasier, M.D. 1988.** *Microfossils*. Unwin-Hyman, pp193

- Braun, W.K. & Mathison, J.E. 1986.** Mid Devonian events in Western Canada - the Dawson Bay-Wait Mountain-Slave Point interlude. *Bulletin of Canadian Petroleum Geology*, **34**(4), 426-451
- Brett, C.E. & Baird, G.C. 1996.** Middle Devonian sedimentary cycles and sequences in the northern Appalachian Basin. *Geological Society of America Special Paper*, **306**, 213-241
- Brice, D. 1988.** Le Devonien de Ferques (Boulonnais-France) Historique. Synthèse des données nouvelles en stratigraphie, sédimentologie, paléontologie et tectonique, conclusions. *Biostratigraphies du Paléozoïque*, **7**, 7-24
- Brice, D., Bultynck, P., Deunff, J., Loboziak, S. & Streel, M. 1979.** Données biostratigraphiques nouvelles sur le Givétien et le Frasnien de Ferques (Boulonnais, France). *Annales de la Société géologique de Nord*, **XCVIII**, 325-344
- Brice, D., Colbeaux, J-P. & Leplat J. 1984.** Compte rendu de la session extraordinaire des Sociétés Belges de géologie dans le Palaeozoïque de Ferques (Bas-Boulonnais). *Bulletin de la Société belge de Géologie*, **94**, 235-250
- Brice, D., Milhau, B., Mistiean, B. Roharh, J-C. & Vidier, J-P. 1989.** Le Givétien supérieur (Devonien à Ferques (Boulonnais-France): Observations nouvelles. *Annales de la Société géologique de Nord*, **CVIII**, 113-123
- Bultynck, P. 1970.** Révision stratigraphique et paléontologique de la coupe type du Couvanien. *Mémoires de l'Institut géologique de l'Université de Louvain*. **XXVI**, 1-152
- Bultynck, P., Casier, J-G., Coen, M., Coen-Aubert, M., Godefroid, J., Jacobs, L., Loboziak, S., Saartnaer, P. & Streel, M. 1987.** Pre-Congress excursion to the Devonian stratotypes in Belgium. *Bulletin de la Société belge de Géologie*, **95**, 249-288
- Bultynck, P., Coen-Aubert, M., DeJonghe, L., Godefroid, J., Hance, L., Lacroix, D., Preat, A., Stainer, P., Steemans, Ph., Streel, M. & Tourneur, F. 1991.** Les Formations du Devonien moyen de la Belgique. *Mémoires pour servir à l'Explication des Cartes Géologiques et Minières de la Belgique memoir*, **30**, pp105
- Burchette, T.P. 1981.** European Devonian Reefs: A review of current concepts and models. In: *European Fossil Reef Models* (D.F. Toomy, ed.). *Society of Economic Paleontologists and Mineralogists Special Publication*, **30**, 85-142
- Butler, D.E. 1981.** Marine faunas from concealed Devonian rocks of southern England and their reflection of the Frasnian transgression. *Geological Magazine*, **118**(6), 679-697
- Carozzi, A.V. 1957.** Contribution de l'étude des propriétés géométriques des oolites - l'exemple du Grand Lac Salé, Utah, USA. *Institut National Genevois Bulletin*, **58**, 1-52
- Carozzi, A.V. 1960.** Microscope arched flow structures and spiral structures in sedimentary rocks. *Institut National Genevois Bulletin*, **60**, 4-23

- Carss, B. & Carozzi, A.V. 1965.** Petrology of Upper Devonian pelletal limestones, Arrow Canyon Range, Clark County, Nevada. *Sedimentology*, **4**(3), 197-222
- Casier, J-G. 1987.** Etude biostratigraphique et paléocéologique des Ostracodes du récif de marbre rouge du Hautmont à Vodelee (partie supérieure du Frasnien, bassin de Dinant, Belgique). *Review Paléobiology*, **6**(2), 193-204
- Casier, J-G., Kasimi, R. & Preat, A. 1995.** Ostracodes from the Eifelian/ Givetian transition at Glageon (Avesnois, France). *Geobios*, **28** (4), 487-499
- Casier, J-G. & Preat, A. 1991.** Evolution sédimentaire et Ostracodes de la base du Givetien à Resteigne (bord sud du Bassin de Dinant, Belgique). *Bulletin de l'institut Royal des Sciences Naturelles de Belgique*, **61**, 157-177
- Casier, J-G., Preat, A. & Kasimi, R. 1992.** Ostracodes and sedimentology of the upper part of the Eifelian and the base of the Givetian at Couvin (southern border of the Dinant Basin, Belgium). *Bulletin de l'Institut Royal des Sciences Naturelles de Belgique, Science de la Terre*, 75-108
- Cattaneo, G., Tahiri, A., Zahraoui, M. & Vachard, D. 1993.** Givetian reefal sedimentation in the Northwestern Moroccan Meseta. *Comptes Rendus de l'Académie des Sciences, Series II*, **317**(1), 73-80
- Chlupáč, I. & Turek, V. 1983.** Devonian goniatites from the Barrandian area, Czechoslovakia. *Rozprawy Ústředního ústavu geologického*, **46**, 1-159
- Chuvashov, B. & Riding, R. 1984.** Principle floras of Palaeozoic marine calcareous algae. *Palaeontology*, **27**(3), 487-500
- Cisne, J.L. 1986.** Earthquakes recorded stratigraphically on carbonate platforms. *Nature*, **323**, 320-322
- Clarkson, E.N.K. 1989.** *Invertebrate Palaeontology and Evolution*. Unwin Hyman Ltd., pp382
- Cloetingh, S. 1988.** Intraplate stresses: A tectonic cause for third-order cycles in apparent sea level. In: *Sea level changes - An integrated approach* (C.K. Wilgus, B.S. Hastings, C.G.St.C. Kendall, H.W.Posamentier, C.A. Roass & J.C.Van Wagoner, eds.). *Society of Economic Paleontologists and Mineralogists Special Publication*, **42**, 19-29
- Cloud, P.E. jr. 1960.** Gas as a sedimentary and diagenetic agent. *American Journal of Science (Bradley Volume)*, **258**(A), 35-45
- Cockbain, A.E. 1984.** Stromatoporoids from the Devonian Reef Complexes, Canning Basin, Western Australia. *Geological Survey of Western Australia Bulletin*, **129**, 1-108
- Coen, M. & Cornet, 1977.** Distribution et extension stratigraphique des récifs à *Phillipsastrea* dans le Frasnien de l'Ardenne. *Annales de la Société géologique de Nord*, **96**, 325-333

- Cope, J.C.W., Guion, P.D., Sevastopulo, G.D. & Swan, A.R.H. 1992. Carboniferous. In: *Atlas of Palaeogeography and Lithofacies* (J.C.W. Cope, J.K. Ingham & P.F. Rawson, eds.). *The Geological Society Memoir*, **13**, 67-86
- Cressman, E.R. & Noger, M.C. 1976. Tidal-flat carbonate environments in the High Bridge Group (Middle Ordovician) of central Kentucky. *Kentucky Geological Survey, Series X*, **18**, 1-15
- Crevello, P.D., Wilson, J.L., Sarg, J.F. & Read, J.F. (eds.) 1989. *Controls on carbonate platform and basin development. Society of Economic Paleontologists and Mineralogists Special Publication*, **44**, pp405
- Cummings, E.R. 1932. Reefs or bioherms? *Geological Society of America Bulletin*, **43**, 331-352
- Cummings, E.R. & Shrock, R.R. 1928. Niagaran reefs in Indiana and adjacent states and their stratigraphic relations. *Geological Society of America Bulletin*, **39**(2), 579-620
- Davies, G.R. 1970. Algal-laminated sediments, Gladstone Embayment, Shark Bay, Western Australia. In: *Carbonate Sedimentation and Environments, Shark Bay, Western Australia* (B.W. Logan, G.R. Davies, J.F. Read & D.E. Cebulski, eds.). *American Association of Petroleum Geologists Memoir*, **13**, 169-205
- de Boer, P.L. & Smith, D.G. 1994. Orbital forcing and cyclic sequences. In: *Orbital Forcing and Cyclic Sequences* (P.L. de Boer & D.G. Smith, eds.). *International Association of Sedimentologists Special Publication*, **19**, 1-14
- Demicco, R.V. & Hardie, L.A. 1994. *Sedimentary structures and early diagenetic features of shallow marine carbonate deposits*. Society of Economic Paleontologists and Mineralogists Atlas Series, **1**, pp265
- Dietz, C., Fliegel, G. & Fuchs, A. 1935. Erläuterungen zum Blatt Lindlar Nr. 2846, geologische karte von Preussen, Berlin.
- Dineley, D.L. 1961. The Devonian system in South Devonshire. *Field Studies*, **1**(3), 121-140
- Dineley, D.L. 1984. *Aspects of a Stratigraphic System: The Devonian*. Macmillan, pp223
- Donovan, D.T. & Jones, E.J.W. 1979. Causes of worldwide changes of sea level. *Journal of the Geological Society*, **136**, 187-192
- Donovan, N. 1980. Lacustrine cycles, fish ecology and stratigraphic zonation in the Middle Devonian of Caithness. *Scottish Journal of Geology*, **16**, 35-50
- Dorobek, S.L. 1987. Cyclic platform dolomites and platform to basin transition of Jefferson Formation (Frasnian), SW Montana and East-Central Idaho. *American Association of Petroleum Geologists Bulletin*, **71**, 1004
- Dreeson, R., Bless, M.J.M., Conil, R., Flajs, G. & Laschet, C. 1985. Depositional environment, palaeoecology and diagenetic history of the 'Marbre rouges à crinoïdes de Baelen' (Late Upper Devonian, Verviers synclinorium, eastern Belgium). *Annales de la Société géologique de Nord*, **108**, 311-359

- Dunham, R.J. 1962.** Classification of carbonate rocks according to depositional texture. In: *Classification of Carbonate Rocks* (W.E. Ham, ed.). *American Association of Petroleum Geologists Memoir*, **1**, 108-121
- Ebert, J.R. & Tucker, R.D. 1997.** Dating the Silurian-Devonian Boundary: Lochkovian K-bentonites from Cherry Valley, New York, USA and Gaspé, Canada. *International meeting on Cyclicity and Bioevents in the Devonian System*, Abstracts. p26
- Eder, F.W. 1970.** Riff-nahe detrische Kalke bei Balve im Rheinischen Schiefergebirge (Mittel-Devon, Garbecker Kalke). Bochum University dissertation.
- Elrick, M. 1995.** Cyclostratigraphy of Middle Devonian carbonates of the eastern Great Basin. *Journal of Sedimentary Research B*, **65**(1), 61-79
- Embry, A.F. & Klovan, J.E. 1971.** A late Devonian reef tract on northeastern Banks Island, Northwest Territories. *Bulletin of Canadian Petroleum Geology*, **19**, 730-781
- Fabricius, F.H. 1966.** Beckensedimentation und Riffbildung an der Wende Trias/Jura in den Bayerisch-Tiroler Kalkpen. *International Sedimentary Petrog. Series* **9**, pp143
- Fahraeus, L.E., Slatt, R.M. & Nowlan, G.S. 1974.** Origin of carbonate pseudopellets. *Journal of Sedimentary Petrology*, **44**(1), 27-29
- Fejer, P.E. & Narbonne, G.M. 1992.** Controls on Upper Devonian metre-scale carbonate cyclicity, Icefall Brook, Southeast British Columbia, Canada. *Bulletin of Canadian Petroleum Geology*, **40**(4), 363-380
- Feng, Z.Z. & Jin, Z.K. 1994.** Types and origins of dolostones in the Lower Paleozoic of the North China Platform. *Sedimentary Geology*, **93**(3-4), 279-290.
- Fischer, A.G. 1964.** The Lofer cyclothem of the Alpine Triassic. In: *Symposium on cyclic sedimentation* (D.F. Merriam, ed.). *State Geological Survey of Kansas Bulletin*, **1**, 107-149
- Flügel, E. 1972.** Microfazielle Untersuchungen in der Alpinen Trias. Methoden und Probleme. *Mitteilungen der Gesellschaft der Geologie und Bergbaustudenten in Österreich*, **21**, 9-24
- Flügel, E. 1982.** *Microfacies Analysis of Limestones*. Springer Verlag, pp632
- Folk, R.L. 1962.** Spectral subdivision of limestone types. In: *Classification of Carbonate Rocks* (W.E. Ham, ed.). *American Association of Petroleum Geologists Bulletin*, **1**, 62-84
- Fordham, B.G. 1992.** Chronometric calibration of Mid-Ordovician to Tornaisian conodont zones: a compilation from recent graphic-correlation and isotope studies. *Geological Magazine*, **129**(6), 709-721
- Friend, P.F. & House, M.R. 1964.** The Devonian Period. In: *The Phanerozoic Time-Scale: A Symposium*, *Quarterly Journal of the Geological Society of London*, **120**, 233-236
- Gale, N.H., Beckinsale, R.D. & Wadge, A.J. 1979.** Rb-Sr whole rock dating of acid rocks. *Geochemical Journal*, 27-29

- Garland, J., Tucker, M.E. & Scrutton, C.T. 1996.** Microfacies analysis and metre-scale cyclicity in the Givetian back-reef sediments of south-east Devon. *Proceedings of the Ussher Society*, **9**, 31-36
- Gauss, G.A. & House, M.R. 1972.** The Devonian successions in the Padstow area, North Cornwall. *Journal of the Geological Society*, **128**, 151-172
- Ginsburg, R.N. 1960.** Ancient analogues of recent stromatolites. *XXI International Geological Congress*, **22**, 26-35
- Ginsburg, R.N. & Hardie, L.A. 1975.** Tidal and storm deposits, northwestern Andros Island, Bahamas. In: *Tidal deposits a casebook of Recent and Fossil Counterparts* (R.N. Ginsburg, ed.). Springer-Verlag, New York, 201-208
- Ginsburg, R.N., Hardie, L.A., Bricker, O.P., Garrett, P. & Wanless, H.R. 1977.** Exposure index: A quantitative approach to defining position within the tidal zone. In: *Sedimentation of the modern carbonate tidal flats of northwest Andros Island, Bahamas* (L.A. Hardie, ed.). Johns Hopkins University Press, 7-11
- Goldhammer, R.K., Dunn, P.A. & Hardie, L.A. 1987.** High frequency glacio-eustatic sea-level oscillations with Milankovitch characteristics recorded in Middle Triassic cycle platform carbonates, northern Italy. *American Journal of Science*, **287**, 853-892
- Goldhammer, R.K., Dunn, P.A. & Hardie, L.A. 1990.** Depositional cycles, composite sea-level changes, cycle stacking patterns, and the hierarchy of stratigraphic forcing: Examples from Alpine Triassic platform carbonates. *Geological Society of America Bulletin*, **102**, 535-562
- Goldhammer, R.K., Lehmann, P.J., & Dunn, P.A. 1992.** Third-order sequence stratigraphy and high frequency stacking patterns of Lower Ordovician platform carbonates, El Paso Group, Franklin Mountains west Texas. In: *Paleokarst, Karst Related Diagenesis and Reservoir Development: Examples from Ordovician-Devonian Age Strata of West Texas and the Mid Continent* (M.P. Candelaria & C.L. Reed, eds.). *Society of Economic Paleontologists and Mineralogists*, Permian Basin Section, **92-93**, 59-92
- Goldring, R. 1962.** The bathyal lull: Upper Devonian and Lower Carboniferous sedimentation on the Variscan geosyncline. In: *Some aspects of the Variscan Foldbelt* (K. Coe, ed.). Manchester University Press, 75-91
- Goldring, R., House, M.R., Selwood, E.B., Simpson, S. & Lambert, R.St.J. 1968.** Devonian of Southern Britain. In: *International Symposium on the Devonian System* (D.H. Oswald, ed.). Calgary, 1-14
- Goldring, R. & Langenstrassen, F. 1979.** Open shelf and near-shore clastic facies in the Devonian. In: *The Devonian System* (M.R. House, C.T. Scrutton & M.G. Basset, eds.). *Special Papers in Palaeontology*, **23**, 81-97
- Goodwin, P.W. & Anderson, E.J. 1985.** Punctuated aggradational cycles: A general hypothesis of episodic stratigraphic accumulation. *Journal of Geology*, **93**, 515-533.

- Gotthardt, R. 1970.** Riffkalksteine aus dem Mitteldevon des Rheinisches Schiefergebirges und dem Dogger Luxemburgs. *Geologische Mitteilungen*, **10**, 41-60
- Grover, G. jr. & Read, J.F. 1978.** Fenestral and associated vadose diagenetic fabrics of tidal flat carbonates, Middle Ordovician New Market Limestone, Southwestern Virginia. *Journal of Sedimentary Petrology*, **48**(2), 453-473
- Gwosdz, W. 1971.** Stratigraphie, Fazies, und Paläogeographie des oberdevons und unterkarbons im Bereich der Attendorn-Elspe Riffkomplexes (Sauerland, Rheinisches Schiefergebirge). Hochschule Darmstadt Dissertation
- Gwosdz, W. 1972.** Stratigraphie, Fazies und Paläogeographie des Oberdevons und Unterkarbons im Bereich des Attendorn-Elsper Riffkomplexes (Sauerland, Rheinisches Schiefergebirge). *Geologisches Jahrbuch A*, **2**, 1-71
- Halley, R.B. 1977.** Ooid fabric and fracture in the Great Salt Lake and the geologic record. *Journal of Sedimentary Petrology*, **47**, 1099-1120
- Hallock, P. & Schlager, W. 1986.** Nutrient excess and the demise of coral reefs and carbonate platforms. *Palaios*, **1**, 389-398
- Ham, W.E. 1952.** Algal origin of the 'Birdseyes' limestone in the McLish Formation. *Oklahoma Academy of Science Proceedings*, **33**, 200-203
- Handford, C.R. & Loucks, R.G. 1994.** Carbonate depositional sequences and system tracts - responses of carbonate platforms to relative sea-level changes. In: *Carbonate Sequence Stratigraphy: Recent Developments and Applications* (R.G. Loucks & J.F. Sarg, eds.). *American Association of Petroleum Geologists Memoir*, **57**, Chapter 1, 3-42
- Hardie, L.A. 1986.** Stratigraphic models for carbonate tidal-flat deposition. *Colorado School of Mines Quarterly Journal*, **81**, 59-74
- Hardie, L.A., Dunn, P.A. & Goldhammer, R.K. 1991.** Field and modelling studies of Cambrian carbonate cycles. Virginia Appalachians - Discussion. *Journal of Sedimentary Petrology*, **61**, 636-646
- Hardie, L.A. & Ginsburg, R.N. 1977.** Layering: The origin and environmental significance of lamination and thin bedding. In: *Sedimentation of the modern carbonate tidal flats of northwest Andros Island, Bahamas* (L.A. Hardie, ed.). Johns Hopkins University Press, 50-123
- Harland, W.B., Armstrong, R.L., Cox, A.V., Craig, L.E., Smith, A.G. & Smith, D.G. 1990.** *A Geologic Time Scale 1989*. Cambridge University Press, pp263
- Harvard, C. & Oldershaw, A. 1976.** Early diagenesis in back-reef sedimentary cycles, Snipe Lake Reef Complex, Alberta. *Bulletin of Canadian Petroleum Geology*, **24**(1), 27-69

- Haughton, P.D.W. 1989.** Structure of some Lower Old Red Sandstone conglomerates, Kincardineshire, Scotland - deposition from late-orogenic antecedent streams. *Journal of the Geological Society*, **146**, 509-525
- Hay, R.L. & Wiggins, B. 1980.** Pellets, ooids, sepiolite and silica in three calcretes of the southwestern United States. *Sedimentology*, **27**, 559-576
- Heckel, P.H. 1972.** Recognition of ancient shallow marine environments. In: *Recognition of ancient sedimentary environments* (J.K. Rigby & W.M.K. Hamblin, eds.) *Society of Economic Paleontologists and Mineralogists Special Publication*, **16**, 226-286
- Heckel, P.H. & Witzke, B.J. 1979.** Devonian World Palaeogeography. In: *The Devonian System* (M.R. House, C.T. Scrutton & M.G. Basset, eds.) *Special Papers in Palaeontology*, **23**, 99-123
- Heckel, P.H. 1974.** Carbonate buildups in the Geological record: A review. In: *Reefs in time and Space* (L.F. Laporte, ed.) *Society of Economic Paleontologists and Mineralogists Special Publication*, **18**, 89-154
- Hering, G. 1994.** Milankovitch-Zyklen in mitteldevonischen Schelf-Carbonaten den Rheinischen Schiefergebirges. *Göttinger Arbeiten zur Geologie und Paläontologie*, **65**, 1-63
- Hollerbach, A. & Kasig, W. 1980.** Organic matter in Palaeozoic sediments of the Aachen region east of the Brabant Massif. *Mededelingen Rijks Geologische Dienst*, **32**(14), 106-110
- Hong, T. 1992.** Mikrofazies, Paläobiologie und Palökologie im nordöstlichen Teil des Briloner Riff Komplexes (Mittel- und Oberdevon) im Ostsauerland, Deutschland. *Diss. RWTH Aachen, Verlag Shaker*, pp165
- House, M.R. 1985.** Correlation of mid-Palaeozoic ammonoid evolutionary events with global sedimentary perturbations. *Nature*, **313**, 17-22
- House, M.R. 1988.** International definition of Devonian System boundaries. *Proceedings of the Ussher Society*, **7**, 41-46
- House, M.R. 1995a.** Devonian precessional and other signatures for establishing a Givetian timescale. In: *Orbital Forcing timescales and cyclostratigraphy* (M.R. House & A.S. Gale, eds.) *Geological Society Special Publication*, **85**, 37-49
- House, M.R. 1995b.** Orbital forcing timescales: an Introduction. In: *Orbital Forcing Timescales and Cyclostratigraphy* (M.R. House & A.S. Gale, eds.) *Geological Society Special Publication*, **85**, 1-18
- House, M.R. & Selwood, E.B. 1964.** Palaeozoic palaeontology in Devon and Cornwall. In: *Present views on some aspects of the geology of Cornwall and Devon* (K.F.G. Hosking & G.T. Shrimpton, eds.) *Publication Royal Geological Society, Cornwall, Penzance*, 44-86

- Illing, L.V. 1954.** Bahaman calcareous sands. *American Association of Petroleum Geologists Bulletin*, **38**, 1-95
- Jaeger, H. 1988.** Devonian Graptoloidea. In: *Devonian of the World* (N.J. McMillan, A.F. Embry, & D.J. Glass, eds.). *Canadian Society of Petroleum Geologists memoir*, **14(3)**, 431-438
- James, N.P. 1972.** Holocene and Pleistocene calcareous crust (caliche) profile: Criteria for subaerial exposure. *Journal of Sedimentary Petrology*, **42**, 817-836
- James, N.P. 1984.** Shallowing-upwards sequences in carbonates. In: *Facies Models* (R.G. Walker, ed.). *Geoscience Canada Reprint Series*, **1**, 213-228
- James, N.P. & Clark, J. 1997.** Cool-water carbonates. *Society of Economic Paleontologists and Mineralogists Special Publication*, **56**, pp440
- Jamieson, E.R. 1971.** Paleocology of Devonian reefs of western Canada. *North American Paleontological Convention Proceedings Journal*, 1300-1340
- Jennette, D.C. & Pryor, W.A. 1993.** Cyclic alternation of proximal and distal storm facies - Kope and Fairview Formations (Upper Ordovician), Ohio and Kentucky. *Journal of Sedimentary Petrology*, **63(2)**, 183-203
- Johnson, J.G., Klapper, G. & Sandberg C.A. 1985.** Devonian eustatic fluctuations in Euramerica. *Geological Society of America Bulletin*, **96**, 567-587
- Johnson, J.H. 1966.** A review of the Cambrian algae. Colorado School of Mines, **61(1)**, pp162
- Johnson, M.E. & McKerrow, W.S. 1991.** Sea level and faunal changes during the latest Llandovery and earliest Ludlow (Silurian). *Historical Biology*, **5**, 153-169
- Jux, U. 1960.** Die Devonischen Riffe im Rheinischen Schiefergebirge. *Neues Jahrbuch für Geologie und Paläontologische Abhandlungen*, **10(2)**, 186-258
- Jux, U. 1969.** Die Schlade - ein geologisches Forschungsgebiet von überörtlicher Bedeutung: Landschaftsverband Rheinland Beitr. zur Landesentw., no. 9.1, 27-46
- Kamp, H. V. 1968.** Hauptversammlung der Deutsch. Geologie Gesellschaft in Hagen/Westfalen, Exkursion E, *Exkursionsführer*, 21-22
- Karrenberg, H. 1954.** Zur Stratigraphie und Tektonik des Velberter Sattels. *Geologisches Jahrbuch*, **69**, 11-26
- Kasig, W. 1966.** Biofazielle und feinstratigraphische Untersuchungen im Givetium und Frasnium am Nordrand des Stavelot-Venn-Massivs. *Unpublished Thesis, RWTH Aachen*, pp175
- Kasig, W. 1976.** Cyclic growth of reefs in the Middle and Upper Devonian of the north-western 'Rhenisches Schiefergebirge', Germany. *Reef Newsletter*, **3**, 9-10

- Kasig, W. 1978.** Cyclic reef growth in the Upper Devonian of the northwestern 'Rheinisches Schiefergebirge', Germany. *Reef Newsletter*, **5**, 12-13
- Kasig, W. 1980.** Cyclic sedimentation in a Middle-Upper Devonian shelf environment in the Aachen region, FRG. *Mededelingen Rijks Geologische Dienst*, **32(3)**, 26-29
- Kasig, W. & Neumann-Mahlkau, P. 1969.** Die Entwicklung des Eifeliums in Old-Red-Fazies zur Riff Fazies im Givetium und Unteren Frasnium am Nordrand des Hohen Venns (Belgian-Deutschland). *Geologische Mitteilungen*, **8(4)**, 327-388
- Kasig, W., Speath, G., Stolidis, I. & Walter, R. 1978.** Stratigraphie, Paläographie, und Tektonik des nördlichen linksrheinischen Schiefergebirges - *Excursionsführer 130, Hauptversammlung DGG*, Aachen 1978, Exk. **1**, pp26
- Kasig, W. & Wilder, H. 1983.** The sedimentary development of the western Rhenisches Schiefergebirge and the Ardennes (Germany/ Belgium). In: *Intracontinental Fold Belts* (H. Martin & F.W. Eder, eds.). 185-210
- Kasimi, R. & Preat, A. 1996.** Eifelian-Givetian siliciclastic carbonate ramp system, Belgium and France. Second Part: Cyclostratigraphy and palaeostructuration. *Bulletin des Centres de Recherché Exploration - production Elf Aquitaine*, **20**, 61-90
- Kazmierczak, J., Ittekkot, V. & Daegens, E.T. 1985.** Biocalcification through time: environmental challenge and cellular response. *Paläontologische Zeitschrift*, **59**, 15-33
- Kelly, S.B. and Sadler, S.P. 1995.** Equilibrium and response to climatic and tectonic forcing: a study of alluvial sequences in the Devonian Munster Basin. In: *Orbital Forcing Timescales and Cyclostratigraphy* (M.R. House & A.S. Gale, eds.). *Geological Society Special Publication*, **85**, 19-36
- Kendall, C.G.St.C. & Schlager, W. 1981.** Carbonates and relative changes in sea level. *Marine Geology*, **44**, 181-212
- Kennard, J.M. & James, N.P. 1986.** Thrombolites and stromatolites: two distinct types of microbial structures. *Palaios*, **1**, 492-503
- Kent, D.V. & Van der Voo, R. 1990.** Palaeozoic palaeogeography from palaeomagnetism of the Atlantic-bordering continents. In: *Palaeozoic Palaeogeography and Biogeography* (W.S. McKerrow & C.R. Scotese, eds.), *Geological Society Memoir*, **12**, 49-56
- Kershaw, S. 1988.** Stromatoporoids: a beginners guide. *Geology Today*, December, 202-206
- Kershaw, S. & Riding, R. 1980.** Stromatoporoid morphotypes of the Middle Devonian Torbay Reef Complex at Long Quarry Point, Devon. *Proceedings of the Ussher Society*, **5**, 13-23
- Kimpe, W.F.M., Bless, M.J.M. & Bouckaert, J. 1978.** Palaeozoic deposits of the Brabant Massif in Belgium and the Netherlands. *Mededelingen Rijks Geologische Dienst*, **30**, 37-103

- Klapper, G. & Johnson, J.G. 1980.** Endemism and dispersal of Devonian conodonts. *Journal of Paleontology*, **54**, 400-455
- Klovan, J.E. 1964.** Facies analysis of the Redwater Reef Complex, Alberta, Canada. *Bulletin of Canadian Petroleum Geology*, **12**, 1-100
- Krebs, W. 1966.** Der Bau des oberdevonischen Langenaubach-Breitschieder Riffes und seine weitere Entwicklung im Unterkarbon (Rheinisches Schiefergebirge). *Abhandlungen der Senckenbergischen naturforschenden Gesellschaft*, **511**, 1-105
- Krebs, W. 1968.** Facies types in the Devonian back-reef limestones in the Eastern Rhenish Schiefergebirge. In: *Recent developments in carbonate sedimentology in Central Europe* (G. Müller & G.M. Friedman, eds.), Springer-Verlag, 186-195
- Krebs, W. 1971.** Devonian reef limestone in the eastern Rhenish Schiefergebirge. In: *Sedimentology of parts of Central Europe, Guidebook VIII*. International Sedimentology Congress, 45-81
- Krebs, W. 1972.** Facies and development of the Meggen Reef (Devonian, West Germany). *Geologische Rundschau*, **61**, 647-671
- Krebs, W. 1974.** Devonian carbonate complexes of Central Europe. In: *Reefs in time and space* (L.F. Laporte, ed.). *Society of Economic Paleontologists and Mineralogist Special Publication*, **18**, 155-208
- Krebs, W. 1976.** The tectonic evolution of Variscan *meso-Europa*. In: *Europe from crust to core* (D.V. Ager & M. Brooks, eds.). Wiley, London, 119-139
- Krebs, W. 1979.** Devonian basinal facies. In: *The Devonian System* (M.R. House, C.T. Scrutton & M.G. Basset, eds.). *Special Papers in Palaeontology*, **23**, 125-139
- Krebs, W. & Wachendorf, H. 1973.** Proterozoic-Paleozoic geosynclinal and orogenic evolution of Central Europe. *Geological Society of America Bulletin*, **84**, 2611-2630
- Lecompte, M. 1954.** Certain data on the genesis and ecologic character of Frasnian reefs of the Ardennes. *L'Institut Royales des Sciences Naturelles de Belgique*, Volume Jubilaire I, 153-194
- Lecompte, M. 1970.** Die Riffe im Devon der Ardennes und ihre Bildungsbedingungen. *Geologica und Palaeontologica*, **4**, 25-71
- Logan, B.W., Hoffman, P. & Genelein, C.D. 1974.** Algal mats, cryptalgal fabrics and structures, Hamelin Pool, Western Australia. In: *Evolution and Diagenesis of Quaternary Carbonate Sequences, Shark Bay, Western Australia* (B.W. Logan, ed.). *American Association of Petroleum Geologists Memoir*, **22**, 140-193
- Logan, B.W., Rezak, R. & Ginsburg, R.N. 1964.** Classification and environmental significance of algal stromatolites. *Journal of Geology*, **72**, 68-83

- Lütte, B-P. & Oekentorp, K. 1988.** Die stratigraphische Verteilung der Solitären Rugosa im Givetium (Mittel-Devon) der Eifel (Rheinisches Schiefergebirge). *Newsletters in Stratigraphy*, **20**(1), 29-42
- Machel, H.G. 1990a.** Facies interpretation of the Brilon Reef using a model for Devonian reef carbonates. In: *Zur geologie des Briloner Riffs; Teil I* (B. Schwerdtferger, ed.). *Geologisches Jahrbuch Reihe D: Mineralogie, Petrographie, Geochemie, Lagerstättenkunde*, **95**, 43-83
- Machel, H.G. 1990b** Early submarine diagenesis, fissure formation and pre-tectonic late diagenesis in the Brilon Reef. In: *Zur geologie des Briloner Riffs; Teil I* (B. Schwerdtferger, ed.). *Geologisches Jahrbuch Reihe D: Mineralogie, Petrographie, Geochemie, Lagerstättenkunde*, **95**, 85-137
- Machielse, S. 1972.** Devonian algae and their contribution to the western Canadian sedimentary basin. *Bulletin of Canadian Petroleum Geology*, **20**(2), 187-237
- Mamet, B. & Preat, A. 1986.** Algues Givetiennes du Bord du Bassin de Dinant et des régions limitrophes. *Annales de la Société géologique de Belgique*, **109**, 431-454
- Mamet, B., Preat, A. & De Ridder, C. 1997.** Bacterial origin of the red pigmentation in the Devonian Slivenec Limestone, Czech Republic. *Facies*, **36**, 173-188
- Mayall, M.J. 1979.** Facies and sedimentology of part of the Middle Devonian limestones of Brixham, South Devon, England. *Proceedings of the Geological Association*, **90**, 171-179
- McKerrow, W.S. 1988.** The development of the Iapetus Ocean from the Arenig to the Wenlock. In: *The Caledonian - Appalachian Orogen* (A.L. Harris & D.J. Fettes, eds.). *Geological Society Special Publication*, **38**, 405-412
- McKerrow, W.S., Lambert, R., St.J. & Cocks, L.R.M. 1985.** The Ordovician, Silurian and Devonian periods. In: *The Chronology of the Geological Record* (N.J. Snelling, ed.). *Geological Society of London Memoir*, **10**, 73-80
- McLaren, D.J. 1982.** Frasnian - Famennian extinctions. *Geological Society of America Special Paper*, **190**, 477-484
- McLean, D.J. & Mountjoy, E.W. 1994.** Allocyclic control on Late Devonian buildup development, Southern Canadian Rocky Mountains. *Journal of Sedimentary Research B*, **64**(3), 326-340
- Meischner, D. 1971.** Clastic sedimentation in the Variscan geosyncline east of the River Rhine. In: *Sedimentology of parts of Central Europe* (G. Müller, ed.). Fieldtrip guidebook, 8th International Sedimentology Congress, Heidelberg, 9-44
- Meischner, K.D. 1964.** Allodapische Kalke, turbidite im riff-nahen Sedimentations-Becken. *Developments in sedimentology*, **3**, 156-191

- Milhau, B., Brice, D & Meilliez, F. 1989.** An incomplete section in the Mondrepuis Formation in the Hulle Valley in the NE rim of the Rocroi Massif (Ardennes). *Annales de la Société géologique de Nord*, **CV11**, 271-280
- Montañez, I.P. & Osleger, D.A. 1994.** Parasequence stacking patterns, third-order accommodation events, and sequence stratigraphy of the Middle-Upper Cambrian platform carbonates, Bonanza King Formation, Southern Great Basin. In: *Carbonate Sequence Stratigraphy: Recent Developments and Applications* (R.G. Loucks and J.F. Sarg, eds.). *American Association of Petroleum Geologists Memoir*, **57**, Chapter 12, 305-326
- Monty, C.L.V. 1995.** Rise and nature of carbonate mud-mounds. In: *Carbonate Mud-Mounds: Their Origin and Evolution* (C.L.V. Monty, D.W.J. Bosence, P.H. Bridges & B.R. Pratt, eds.). *Special Publication of the International Association of Sedimentologists*, **23**, 11-48
- Morrow, D.W. & Labonte, M. 1988.** The Lower Devonian Corridor Member, Northwest Territories, Canada: An example of deposition on a tidal flat island complex. In: *The Devonian of the World* (N.J. McMillan, A.F. Embry & D.J. Glass, eds.). *Canadian Society of Petroleum Geologists Memoir*, **14(2)**, 495-516
- Ochs, G. & Wolfart, R. 1961.** Geologider Blankenheimer Mulde. *Abhandlung der Senkenberischen Naturforschenden Gesellschaft*, **501**, 1-100
- Odin, G.S. 1982.** *Numerical Dating in Stratigraphy*. Wiley International Science Publication, pp1040
- Odin, G.S. & Odin, G.S. 1990.** Echelle numérique des temps géologique. *Géochronique*, **35**, 12-21
- Oliver, W.A. Jr. & Chlupác, I. 1991.** Defining the Devonian: 1979-89. *Lethaia*, **24**, 119-122
- Osleger, D.A. 1991.** Subtidal carbonate cycles: Implications for allocyclic versus autocyclic controls. *Geology*, **19**, 917-920
- Osleger, D. & Read, J.F. 1991.** Relation of eustasy to stacking patterns of metre-scale carbonate cycles, Late Cambrian, USA. *Journal of Sedimentary Petrology*, **61(7)**, 1225-1252
- Osleger, D.A. & Read, J.F. 1993.** Comparative analysis of methods used to define eustatic variations in outcrop: Late Cambrian interbasinal sequence development. *American Journal of Science*, **293**, 157-216
- Owen, G. 1995.** Senni beds of the Devonian Old Red Sandstone, Dyfed, Wales - anatomy of a semi-arid floodplain. *Sedimentary Geology*, **95(3-4)**, 221-23
- Paekelmann, W. 1936.** Bl. Brilon: Erl. z. geol. Karte von Preussen, Lfg. 341
- Piecha, M. 1993.** Stratigraphie, Fazies und Sedimentpetrographie der rhynisch und zyklisch abgelagerten, tief oberdevonischen Becken sedimente in Rechts-rheinischen Schiefergebirge (Adorf-Bänderschiefer). *Courier Forschungs Institut Senkenberg*, **163**, 1-151

- Playford, P.E. 1969.** Devonian carbonate complexes of Alberta and Western Australia: a comparative study. *Geological Survey of Western Australia, Report 1*, 1-43
- Playford, P.E. 1980.** Devonian "Great Barrier Reef" of Canning Basin, Western Australia. *American Association of Petroleum Geologists Bulletin*, **64**(6), 814-840
- Posamentier, H.W., Allen, G.P., James, D.P. & Teeson, M. 1992.** Forced regressions in a sequence stratigraphic framework: Concepts, examples, and exploration significance. *American Association of Petroleum Geologists Bulletin*, **76**, 1687-1709
- Pratt, B.R. & James, N.P. 1986.** The St. George Group (Lower Ordovician) of western Newfoundland: tidal flat island model for carbonate sedimentation in shallow epeiric seas. *Sedimentology*, **33**, 313-343
- Preat, A. 1989.** Sedimentology, facies and depositional environments of the Hanonet (Upper Eifelian) and Trois Fontaines (Lower Givetian) Formations in Couvin area (Dinant Basin, Belgium). *Bulletin de la Société belge de Géologie*, **98**(2), 149-154
- Preat, A. & Boulvain, F. 1982.** Etude sédimentologique des calcaires Givetiens à Vaucelles (Bord sud du synclinorium de Dinant). *Annales de la Société Géologique de Belgique*, **105**, 273-282
- Preat, A. & Boulvain, F. 1988.** Middle and Upper Devonian carbonate platform evolution in Dinant and Namur Basins (Belgium, France). In: *IAS 9th European Regional Meeting Excursion Guidebook, Leuven-Belgium, Sept 1988* (A. Herbosch, ed.). Excursion A1, 1-25
- Preat, A. & Carliez, D. 1994.** Microfacies et cyclité dans le Givetien Supérieur de Fromelennes (Synclinorium de Dinant, France). *Bulletin de la Société Géologique de Belgique*, **117**, 227-243
- Preat, A., Coen-Aubert, M., Mamet, B. & Tourneur, F. 1984.** Sédimentologie et Paléocologie de trois niveaux récifaux de Givetien inférieur de Resteigne (Bord sud du Bassin De Dinant, Belgique). *Bulletin de la Société belge de Géologie*, **93**, 227-240
- Preat, A., Gelener, G. & Boulvain, F. 1987.** Etude sédimentologique des calcaires du Givetien inférieur d'Olloy-sur-Viroin (bord sud du Bassin de Dinant). *Annales de la Société géologique de Nord*, **TCV1**, 251-265
- Preat, A. & Kasimi, R. 1995.** Eifelian - Givetian siliciclastic carbonate ramp systems, Belgium and France. First Part: Microfacies and sedimentary model. *Bulletin des Centres de Recherche Exploration - production Elf Aquitaine*, **19**(2), 329-375
- Preat, A. & Mamet, B. 1989.** Sedimentation of the Franco-Belgian Givetian carbonate platform. *Bulletin des Centres de Recherche Exploration - production Elf Aquitaine*, **13**(1), 47-86
- Preat, A. & Racki, G. 1993.** Small-scale cyclic sedimentation in the Early Givetian of the Góry Swietokrzyskie Mountains: Comparison with the Ardennes sequence. *Annales Societatis Geologorum Poloniae*, **63**, 13-31

- Preat, A. & Weis, D. 1994.** Sea level fluctuations in the Belgian carbonate Devonian: Sediments and sequential approach (Part 1). *Bulletin Société Géologique de France*, **165**(5), 469-483
- Racki, G. 1992.** Evolution of the bank to reef complex in the Devonian of the Holy Cross Mountains. *Acta Palaeontologica Polonica*, **37**(2-4), 87-182
- Racki, G. & Sobon-Podgórska, J. 1993.** Givetian and Frasnian calcareous microbios of the Holy Cross Mountains. *Acta Palaeontologica Polonica*, **37**(2-4), 255-289
- Read, J.F. 1973.** Carbonate cycles, Pillara Formation (Devonian), Canning Basin, Western Australia. *Bulletin of Canadian Petroleum Geology*, **21**(1), 38-57
- Read, J.F. 1975.** Tidal-flat facies in carbonate cycles, Pillara Formation (Devonian), Canning Basin, Western Australia. In: *Tidal Deposits: A casebook of Recent examples and fossil counterparts* (R.N. Ginsburg, ed.). Springer-Verlag, 251-256
- Read, J.F., Grotzinger, J.P., Bova, J.A. & Koeschner, W.F. 1986.** Models for generation of carbonate cycles. *Geology*, **14**, 107-110
- Richter, D.K. 1970.** Zur Petrographie und Genese der Dolomite in der Eifel. Ruhr-University Bochum dissertation.
- Richter, M.D. 1965.** Stratigraphy, igneous rocks, and the structural development of the Torquay area. *Transactions of the Devonshire Association*, **97**, 57-75
- Riding, R. 1974.** Model of the Hercynian Foldbelt. *Earth and Planetary Science letters*, **24**, 125-135
- Riding, R. 1979.** Devonian calcareous algae. In: *The Devonian System* (M.R. House, C.T. Scrutton, M.G. Bassett, eds.) *Special papers in Palaeontology*, **23**, 141-144
- Riding, R. 1991.** *Calcareous algae and stromatolites*. Springer-Verlag, pp571
- Riding, R. & Wright, V.P. 1981.** Paleosols and tidal flat/lagoon sequences on a Carboniferous carbonate shelf: sedimentary associations of triple disconformities. *Journal of Sedimentary Petrology*, **51**, 1323-1339
- Roche, J.E. & Carozzi, A.V. 1970.** Petrography of back-reef carbonates: traverse group (Givetian) of the northern part of the Southern Peninsula of Michigan. *Bulletin du Centre de Recherches de Pau*, **4**(1), 137-189
- Rupp, A.W. 1967.** Origin, structure, and environmental significance of Recent and fossil calcispheres (abstract). *Geological Society of America Special Papers*, **101**, p186
- Sadler, P.M., Osleger, D.A. & Montañez, P. 1993.** On the labelling, length, and objective basis of Fischer plots. *Journal of Sedimentary Petrology*, **63**(3), 360-368
- Sanderson, D.J. 1984.** Structural variation across the northern margin of the Variscides in NW Europe. In: *Variscan tectonics of the North Atlantic Region* (D.H.W. Hutton & D.J. Sanderson, eds.). *Special publication of the Geological Society*, **14**, 149-166

- Sarg, J.F. 1988.** Carbonate sequence stratigraphy. In: *Sea level changes - An integrated Approach* (C.K. Wilgus, B.S. Hastings, C.G.St.C. Kendall, H.W. Posamentier, C.A. Ross & J.C. Van Wagoner, eds.). *Society of Economic Paleontologists and Mineralogists Special Publication*, **42**, 156-181
- Satterley, A.K. 1996.** The interpretation of cyclic successions of the Middle and Upper Triassic of the Northern and Southern Alps. *Earth Science Reviews*, **40**, 181-207
- Schlager, W. 1991.** Depositional bias and environmental change - important factors in sequence stratigraphy. *Sedimentary Geology*, **70**, 109-130
- Schlager, W. 1992.** Sedimentology and sequence stratigraphy of reefs and carbonate platforms. *American Association of Petroleum Geologists, Continuing Education Course Notes Series*, **34**, pp71
- Schmidt, H. 1925.** Schwellen- und Beckenfazies im ostrheinischen Paläozoikum. *Zeitschrift der Deutschen Geologischen Gesellschaft*, **77**, 226-234
- Schudack, M.E. 1993.** Karbonatzyklen in Riff- und Lagunenbereich des devonischen Massenkalkkomplexes von Asbeck (Hönnental, Rheinisches Schiefergebirge). *Geologie und Paläontologie Westfalens*, **26**, 77-106
- Schudack, M.E. 1996.** Sedimentäre und biofazielle Zyklen und Massenkalk des Hönnentals (Sauerland) - Beispiele für devonische Milankovic-Zyklen. *Jahrestagung der Paläontologischen Gesellschaft*, **66**, 81
- Schwarzacher, W. 1993.** *Cyclostratigraphy and the Milankovitch Theory*. Developments in Sedimentology, **52**, Elsevier, pp225
- Scoffin, T.P. 1987.** *An Introduction to Carbonate Sediments and Rocks*. Chapman and Hall, pp274
- Scotese, C.R. & Barrett, S.F. 1990.** Gondwana's movement over the South Pole during the Palaeozoic: evidence from lithological indicators of climate. In: *Palaeozoic Palaeogeography and Biogeography* (W.S. McKerrow & C.R. Scotese, eds.), *Geological Society Memoir*, **12**, 75-85
- Scotese, C.R. & McKerrow, W.S. 1990.** Revised World maps and introduction. In: *Palaeozoic Palaeogeography and Biogeography* (W.S. McKerrow & C.R. Scotese, eds.), *Geological Society Memoir*, **12**, 1-12
- Scrutton, C.T. 1977a.** Facies variations in the Devonian limestones of eastern South Devon. *Geological Magazine*, **114**(3), 165-195
- Scrutton, C.T. 1977b.** Reef facies in the Devonian of eastern South Devon, England. *Memoirs Bureau de Recherches Geologiques et Minières*, **89**, 125-135
- Scrutton, C.T. 1978.** Eastern South Devon. In: *International symposium on the Devonian System (P.A.D.S. 78)* (C.T. Scrutton, ed.). *Palaeontological Association*, 27-49
- Scrutton, C.T. 1985.** Chapter 2: Sponges, chaetetids and stromatoporoids. In: *Atlas of invertebrate macrofossils* (J.W. Murray, ed.) Longman, 3-10

- Scrutton, C.T. 1988.** Patterns of extinction and survival in Palaeozoic corals. In: *Extinction and Survival in the Fossil Record* (G.P. Larwood, ed.). Clarendon, Oxford, 65-88
- Scrutton, C.T. 1997.** The Palaeozoic corals, I: origins and relationships. *Proceedings of the Yorkshire Geological Society*, **51**(3), 177-208
- Scrutton, C.T. & Goodger, K.B. 1987.** Sequence of coralline faunas and depositional environments in the Devonian carbonate succession of the Lemon Valley, near Newton Abbot, South Devon. *Proceedings of the Ussher Society*, **6**, 474-482
- Selwood, E.B., Edwards, R.A., Simpson, S., Chesher, J.A., Hamblin, R.J.O., Henson, M.R., Riddolls, B.W. & Waters, R.A. 1984.** *Geology of the country around Newton Abbot*. BGS Memoir for 1:50 000 geological sheet 339, pp212
- Selwood, E.B. & Thomas, J.M. 1986.** Variscan facies and structure in central SW England. *Journal Geological Society London*, **143**, 199-207
- Shinn, E.A. 1968.** Practical significance of birdseye structures in carbonate rocks. *Journal of Sedimentary Petrology*, **38**, 215-223
- Shinn, E.A. 1983a.** Tidal flat. In: *Carbonate Depositional Environments* (P.A. Scholle, D.G. Bebout & C.H. Moore, eds.). *American Association of Petroleum Geologists Memoir*, **33**, 171-210
- Shinn, E.A. 1983b.** Birdseyes, fenestrae, shrinkage pores and loferites: A reevaluation. *Journal of Sedimentary Petrology*, **53**(2), 619-628
- Smith, G.P. & Stearn, C.W. 1982.** The Devonian carbonate-clastic sequence of southwest Ellesmere Island, Arctic Canada. In: *Arctic geology and geophysics* (A.F. Embry & H.R. Balkwill, eds.). *Canadian Society of Petroleum Geologists Memoir*, **8**, 147-154
- Smith, R.A. 1995.** The Siluro-Devonian evolution of the southern Midland Valley of Scotland. *Geological Magazine*, **132**(5), 503-513
- Soreghan, G.S. & Dickson, W.R. 1994.** Generic types of stratigraphic cycles controlled by eustasy. *Geology*, **22**, 759-761
- Städter, T. & Koch, R. 1987.** Microfacies and diagenesis of Givetian carbonates (Brilon anticline, Rhenish Slate Mountains). *Facies*, **17**, 215-230
- Stearn, C.W. 1972.** The relationship of the stromatoporoids to the sclerosponges. *Lethaia*, **5**, 369-388
- Stearn, C.W. 1975.** The stromatoporoid animal. *Lethaia*, **8**, 89-100
- Stearn, C.W. 1982.** The shapes of Paleozoic and modern reef-builders: a critical review. *Palaeobiology*, **8**(3), 228-241

- Stoops, G. 1989.** Relict properties in soils of humid tropical regions with special reference to Central Africa. In: *Paleopedology: Nature and Application of Paleosols* (A. Bronger & J.A. Catt, eds.). Catena Supplement, **16**, 95-106
- Stritzke, R. 1986.** Conodont biofacies of Middle and Upper Devonian limestones, Brilon area, West Germany. *Palaeogeography, Palaeoclimatology, Palaeoecology*, **52**, 215-226
- Stritzke, R. 1989.** Stratigraphie, Faziesanalyse und Paläogeographie im Oberdevon des Briloner Vorriffgebets (Ostsauerland). *Fortschritte in der Geologie von Rheinland und Westfalen*, **35**, 75-106
- Tebbutt, G.E. Conley, C.D., & Boyd, D.W. 1965.** Lithogenesis of a distinctive carbonate rock fabric. *Contributions to Geology*, **4**, 1-13
- Torsvik, T.H., Smethurst, M.A., Bridan J.C. & Sturt, B.A. 1990.** A review of palaeomagnetic data from Europe and their palaeogeographical implications. In: *Palaeozoic Palaeogeography and Biogeography* (W.S. McKerrow & C.R. Scotese, eds.), *Geological Society Memoir*, **12**, 25-41
- Torsvik, T.H., Smethurst, M.A., Meert, J.G., Van der Voo, R., McKerrow, W.S., Brasier, M.D., Sturt, B.A. & Walderhaug, H.J. 1996.** Continental break-up and collision in the Neoproterozoic and Paleozoic - a tale of Baltica and Laurentia. *Earth-Science Reviews*, **40**(3-4), 229-258
- Torsvik, T.H., Sturt, B.A., Ramsay, D.M., Bering, D. & Fluge, P.R. 1988.** Palaeomagnetism, magnetic fabrics and the structural style of the Hornelen Old Red Sandstone, Western Norway. *Journal Geological Society, London*, **145**, 413-430
- Torsvik, T.H., Trench, A., Svensson, I. & Walderhaug, H.J. 1993.** Paleogeographic significance of Mid-Silurian palaeomagnetic results from southern Britain - major revision of the apparent polar wander path for eastern Avalonia. *Geophysical Journal International*, **113**(3), 651-668
- Tsien, H.H. 1971.** The Middle and Upper Devonian reef complexes of Belgium. *Petroleum Geology of Taiwan*, **8**, 119-173
- Tsien, H.H. 1972.** Middle Devonian and Frasnian stratigraphy of Belgium. *Ministere des Affaires economiques*, Document 7, 1-25
- Tsien, H.H. 1979.** Palaeoecology of algal-bearing facies in the Devonian (Couvanian to Frasnian) reef complexes of Belgium. *Palaeoecology, Palaeoclimatology, Palaeobiology*, **27**, 103-127
- Tsien, H.H. 1980.** Les régimes récifaux dévoniens en Ardenne. *Bulletin de la Société belge de Géologique*, **89**(2), 71-102
- Tsien, H.H. 1988.** Devonian palaeogeography and reef development of northwestern and central Europe. In: *Devonian of the World* (N.J. McMillan, A.F. Embry & D.J. Glass, eds.). *Canadian Society of Petroleum Geologists Memoir*, **14**(1), 341-358

- Tsien, H.H., Mouravieff, N.A. & Lacroix, D. 1977.** *Excursion organisée dans le Devonian de la Belgique*, pp31
- Tucker, M.E. 1969.** Crinoidal turbidites from the Devonian of Cornwall and their palaeogeographic significance. *Sedimentology*, **13**, 281-290
- Tucker, M.E. 1973.** Sedimentology and diagenesis of Devonian pelagic limestones (Cephalopodenkalk) and associated sediments of Rhenohercynian Geosyncline, West Germany. *Neues Jahrbuch für Geologie und Paläontologische Abhandlung*, **142**(3), 320-350
- Tucker, M.E. 1991.** *Sedimentary Petrology*. Blackwell Scientific Publications, pp260
- Tucker, M.E. 1993.** Carbonate diagenesis and sequence stratigraphy. *Sedimentology Review*, **1**, 51-72
- Tucker, M.E. & Bathurst, R.G.C 1990.** *Carbonate Diagenesis*. IAS Reprint Series, 1, pp312
- Tucker, M.E. & Wright, V.P. 1992.** *Carbonate Sedimentology*. 2nd Reprint, Blackwell, pp482
- Tucker, R.D., Krogh, T.E., Ross jnr., R.J. & Williams, S.H. 1990.** Time-scale calibration by high-precision U-Pb zircon dating of interstratified volcanic ashes in the Ordovician and Lower Silurian stratotypes of Britain. *Earth and Planetary Science Letters*, **100**, 51-58
- Tyler, J.H. 1969.** Genesis and environmental energy of a Devonian lagoonal bank near Alpena, Michigan. *Journal of Sedimentary Petrology*, **39**(2), 509-520
- Vail, P.R., Mitchum jnr., R.M. & Thompson III, S. 1977.** Seismic stratigraphy and global changes of sea level, 4. Global cycles of relative changes of sea level. *American Association of Petroleum Geologists Bulletin*, **26**, 83-97
- Van Wagoner, J.C. 1985.** Reservoir facies distribution as controlled by sea-level change: Abstract and Poster Session, *Society of Economic Paleontologists and Mineralogists Mid-Year Meeting*, Golden, Colorado, 91-92
- Van Wagoner, J.C., Mitchum, R.M., Posamentier, H.W. & Vail P.R. 1987.** Seismic stratigraphy interpretation using sequence stratigraphy, part 2: key definitions of sequence stratigraphy. In: *Atlas of Seismic Stratigraphy* (A.W. Bally, ed.). *American Association of Petroleum Geologists Studies*, **27**(1), 11-14
- Van Wagoner, J.C., Posamentier, H.W., Mitchum, R.M., Vail, P.R., Sarg, J.F., Loutit, T.S. & Hardenbol, J. 1988.** An overview of the fundamentals of sequence stratigraphy and key definitions. In: *Sea level changes - An integrated Approach* (C.K. Wilgus, B.S. Hastings, C.G.St.C. Kendall, H.W. Posamentier, C.A. Ross & J.C. Van Wagoner, eds.). *Society of Economic Paleontologists and Mineralogists Special Publication*, **42**, 39-45
- Walker, K.R. & Laporte, L.F. 1970.** Congruent fossil communities from Ordovician and Devonian carbonates of New York. *Journal of Paleontology*, **44**, 928-944

- Wallace, P. 1969.** The sedimentology and palaeoecology of the Devonian of the Ferques inlier, northern France. *Quarterly Journal of the Geological Society of London*, **125**, 83-124
- Wallace, P. 1976.** Palaeontological Association field meeting on palaeoecological techniques, Boulonnais, northern France. *Unpublished field guide*.
- Walter, R., Speath, G. & Kasig, W. 1985.** An outline of the geological structure of the Northeastern Hohes Venn area and of its northern foreland. *Neues Jahrbuch für Geologie und Paläontologische Abhandlung*, **1-3**, 207-216
- Watts, N.L. 1980.** Quaternary pedogenic calcretes from the Kalahari (southern Africa): mineralogy, genesis and diagenesis. *Sedimentology*, **27**, 661-686
- Webby, D.B. 1965.** The Middle Devonian marine transgression in North Devon and West Somerset. *Geological Magazine*, **102**(6), 478-488
- Webby, D.B. 1966.** Middle - Upper Devonian Palaeogeography of North Devon and West Somerset, England. *Palaeogeography, Palaeoclimatology, Palaeoecology*, **2**, 27-46
- Weddige, K. 1977.** Die conodonten der Eifel-Stufe im Typusgebiet und in benachbarten Faziesgebieten. *Senckenbergiana Lethaea*, **58**, 271-419
- Weis, D. & Preat, A. 1994.** Sea level fluctuations in the Belgian carbonate Devonian: Geochemical and isotopic (Sr, C and O) approaches (part II). *Bulletin Société Géologique de France*, **165**(5), 485-497
- Whitten, D.G.A. & Brooks, J.R.V. 1972.** *Dictionary of Geology*. Penguin Reference Books, pp495
- Wiens, H.J. 1962.** *Atoll Environment and Ecology*. Yale University Press, pp532
- Wilder, H. 1985.** Microfazielle und geochemische Untersuchungen zum oberdevonischen Stromatoren-Riffsterben am Nordrand des mitteleuropäischen Varistikums. PhD Thesis, RWTH Aachen, pp178
- Wilder, H. 1989.** Neue Ergebnisse zum oberdevonischen Riffsterben am Nordrand des mitteleuropäischen Variscums. *Fortschritte in der Geologie von Rheinland und Westfalen*, **35**, 57-74
- Wilson, J.L. 1975.** *Carbonate facies in geologic history*. Springer Verlag, pp471
- Witzke, B.J. 1990.** Palaeoclimatic constraints for Palaeozoic palaeolatitudes of Laurentia and Euramerica. In: *Palaeozoic Palaeogeography and Biogeography* (W.S. McKerrow & C.R. Scotese, eds.), *Geological Society Memoir* **12**, 57-73
- Wong, P.K. & Oldershaw, A.E. 1980.** Causes of cyclicity in reef interior sediments, Kaybob Reef, Alberta. *Bulletin of Canadian Petroleum Geology*, **28**(3), 411-424
- Woodrow, D.L., Fletcher, F.W. & Ahrnsbrak, W.F. 1973.** Palaeogeography and palaeoclimate at the deposition site of the Devonian Catskill and Old Red facies. *Geological Society of America Bulletin*, **84**, 3051-3064
- Wray, J.L. 1977.** *Calcareous algae*. *Developments in Palaeontology and Stratigraphy*, **4**, pp185

- Wright, V.P. 1983.** A rendzina from the Lower Carboniferous of South Wales. *Sedimentology*, **30**, 159-179
- Wright, V.P. 1990.** A micromorphological classification of fossil and recent calcic and petrocalcic microstructures. In: *Soil Micromorphology: A Basic and Applied Science* (L.A. Douglas, ed.). Developments in Soil Science, **19**, 401-407
- Wright, V.P. 1992.** Speculations on the controls on cyclic peritidal carbonates: ice house versus greenhouse eustatic controls. *Sedimentary Geology*, **76**, 1-5
- Wright, V.P. & Marriot, S.B. 1996a.** A quantitative approach to soil occurrence in alluvial deposits and its application to the Old Red Sandstone of Britain. *Journal of the Geological Society*, **153**(6), 907-913
- Wright, V.P. & Marriot, S.B. 1996b.** Brackish water faunas from the St. Maughans Formation - the Old Red Sandstone section at Ammons Hill, Hereford and Worcester, UK - Discussion. *Geological Journal*, **31**(1), 89-91
- Wright, V.P. & Tucker, M.E. 1991.** *Calcretes*. IAS reprint Series Volume 2, Blackwell Scientific Publications, pp352
- Wunderlich, F. 1970.** Genesis and environment of the 'Nellenköpfchenschichten' (Lower Emsian, Rheinian Devon) at locus typicus in comparison with modern coastal environment of the German bay. *Journal of Sedimentary Petrology*, **40**(1), 102-130
- Wunderlich, H.G. 1964.** Mass, Ablauf und Ursachen orogener Einengung am Beispiel des Rheinischen Schiefergebirges, Rhurkarbons und Harzes. *Geologische Rundschau*, **54**, 861-882
- Yang, W. Harmson, F. & Kominz, M.A. 1995.** Quantitative analysis of a cyclic peritidal carbonate sequence, the Middle and Upper Devonian Lost Burro Formation, Death Valley, California - a possible record of Milankovitch climatic cycles. *Journal of Sedimentary Research*, **B65**(3), 306-322
- Young, G.A. & Scrutton, C.T. 1991.** Growth form in Silurian heliolitid corals: the influence of genetics and environment. *Palaeobiology*, **17**(4), 369-387
- Yuansheng, D., Yiming, G., Yi, W., Benpei, L. & Qinglai, F. 1996.** Devonian Sequence Stratigraphy and Sea Level Change Cycles in South China. *Journal of China University of Geosciences*, **7**(1), 72-79
- Ziegler, W. 1971.** Conodont stratigraphy of the European Devonian. *Geological Society of America Memoir*, **127**, 227-284
- Ziegler, W. 1979.** Givetian and Upper Devonian conodont zonation. In: *Devonian conodont biostratigraphy* (G. Klapper & W. Ziegler, eds.). *Special Papers in Palaeontology*, **23**, 199-224

# APPENDIX ONE

|   |            |
|---|------------|
| <b>A1. THIN-SECTION DESCRIPTIONS.....</b> | <b>305</b> |
| A1.1 THIN-SECTION CHECK-LIST .....        | 305        |
| A1.2 THIN-SECTION TABLES .....            | 309        |
| A1.2.1 Alt Breinig Quarry.....            | 310        |
| A1.2.2 Beaurainq Quarry.....              | 311        |
| A1.2.3 Bellignies-Bettriches Quarry ..... | 313        |
| A1.2.4 Bleiwäsche Quarry .....            | 315        |
| A1.2.5 Bleiwäsche Road Cutting.....       | 317        |
| A1.2.6 Broadridge Wood Quarry.....        | 318        |
| A1.2.7 Cul d'Houille Quarry.....          | 321        |
| A1.2.8 Dourbes Quarry.....                | 324        |
| A1.2.9 Froid Lieu Quarry .....            | 325        |
| A1.2.10 Glageon Quarry.....               | 327        |
| A1.2.11 Goodrington Road Cutting.....     | 331        |
| A1.2.12 Hanielsfeld Quarry.....           | 332        |
| A1.2.13 Heggen Quarry.....                | 333        |
| A1.2.14 Keldenich Quarry .....            | 336        |
| A1.2.15 Linhay Hill Quarry.....           | 338        |
| A1.2.16 Medenbach Quarry.....             | 341        |
| A1.2.17 Nismes Quarry.....                | 343        |
| A1.2.18 Oberrödinghausen Quarry .....     | 344        |
| A1.2.19 Olloy-sur-Viroin Quarry.....      | 347        |
| A1.2.20 Resteigne Quarry.....             | 349        |
| A1.2.21 Rydon Quarry.....                 | 351        |
| A1.2.22 Sourd d'Ave Section.....          | 353        |
| A1.2.23 Teerstraßenbau Quarry .....       | 355        |
| A1.2.24 Vaucelles Quarry.....             | 357        |
| A1.2.25 Voßbeck Quarry.....               | 358        |
| A1.2.26 Walheim Section 1 .....           | 360        |
| A1.2.27 Walheim Section 2 .....           | 361        |
| A1.2.28 Walheim Southern Limb .....       | 362        |

## A1. Thin-Section Descriptions

The following Appendix outlines the format to which thin sections and peels were described, and includes a table-summary of the key features of each thin-section sample. It is important to note that throughout the study hand specimens, thin sections and peels were studied to determine microfacies features, and to allocate a microfacies number. Due to the high quality of thin sections it was possible to obtain detailed information about the texture and diagenesis of the rock. Peels showed the major components of the rocks and the major diagenetic features; however, the detail to which this was described was not as high as for the thin sections.

The thin sections studied were mostly of a 'standard' size, 3cm x 2cm. Where textures were on a larger scale, 5cm x 4cm thin sections were examined. Thin sections were not stained. Acetate peels were made from around 130 of the larger hand specimens collected. Their size varied and Table A1-1 summarises the techniques which were used to make the peels. Acetate peels were stained using a solution of Alizarin Red S and potassium ferricyanide.

1. Prepare 2 staining solutions
  - A: Alizarin Red S - concentration 0.2g/100ml of 1.5% HCl
  - B: potassium ferricyanide - concentration 2g/100ml of 1.5% HCl
2. Mix solutions A and B in the proportion 150ml A to 100ml B
3. Cut sample
4. Polish with 400 then 1000 grade carborundum, wash thoroughly
5. Using 5% HCl immerse polished surface for approximately 45 seconds
6. Immerse in stain for approximately 45 seconds, agitating slightly
7. Wash with distilled water
8. Dry rock completely
9. Cover surface with acetone, role acetate paper over acetone, taking care not to trap bubbles.
10. Leave for up to half a day to dry
11. Peel acetate sheet. trim and mount between two glass slides

**Table A 1-1 Table summarising technique used to make acetate peels.**

### A1.1 Thin-section check-list

The format to which thin sections and peels were described followed an amalgamation of points made by Flügel (1982) (checklist for microfacies studies, p394-402) and Tucker and Wright (1992) (diagenetic processes, p315-316). Full petrographic descriptions were

made of all thin sections and peels and a summary of the components can be seen in Section A1.2

## **1. GRAINS**

a. Systematic designation according to groups (peloids, ooids, skeletal grains etc..)

b. Detailed description of grains:-

### *i) Skeletal grains*

- whole skeletal grains or fragments
- systematic designation according to groups, genera and species (if possible)
- classification of algal groups
- function of organisms as sediments binders, sediment bafflers, framework builders, or essential rock-building constituents
- biogenic encrustations of bioclasts
- micrite rims around bioclasts
- intragranular pores filled with micrite or sparite
- are aragonitic hard parts preferentially dissolved?
- size, sorting and rounding of bioclasts

### *ii) Peloids*

- shape and rounding
- frequency
- size and sorting
- occurrence of peloids, i.e., scattered, lenses, nested
- colour and grain size of micrite in peloids and matrix
- occurrence together with bioturbation structures
- occurrence together with algae or aggregate grains
- shelly bioclasts micritised or recrystallised?
- do the peloids exhibit regular structures

### *iii) Aggregate grains*

- grapestones, algal lumps, or lumps
- which particles are agglutinated?
- are the particles in the aggregate grains truncated on the edges?
- do the aggregate grains occur in association with algae or microbial laminites?
- is the type of cement in the aggregate grain the same as that between the aggregate grains?
- size
- do the aggregate grains occur in sparry or micritic limestones?

### *iii) Oncoids*

- microbial oncoids?
- foraminiferal oncoids?
- shape of oncoids
- do the oncoids exhibit a more or less regular structure or are discontinuities in growth visible?
- do truncated or very differently orientated laminae occur?
- are the oncoid laminae planar or crinkled?
- size of oncoids
- are the oncoids deformed?
- do the nuclei of the oncoids correspond to the material available in the sedimentary environment?
- are the oncoids embedded in a fine-grained matrix or in sparite?
- do barrel-shaped oncoids have orientation patterns?
- what is the frequency in comparison with other particles?

### *iv) Ooids*

- superficial or normal ooids?
- frequency, size and sorting
- do tangential structures, radial structures, or micritic rings occur?
- are the lamellae regularly formed or are there indications of microbial borings and microbial coatings?

- how thick are the ooid laminae?
- how big are the nuclei of the ooids?
- is the ooid size uniform, although the nuclei have different sizes?
- what is the ratio of ooid laminae thickness to nucleus diameter?
- do the ooid nuclei correspond to the sedimentary material available?
- do compound ooids occur?
- are several generations of ooid recognisable?
- do broken ooids occur?
- are ooids which are already present used as nuclei for new ooids?
- are there deformed, snouted ooids?
- do leached (half-moon) ooids occur?
- do the ooids have a asymmetrical shape?
- are the ooids formed together with carbonate crusts?
- do ooids occur in a micritic or sparitic matrix?
- do ooids occur alone, or are they mixed with other particles?
- is the packing index high or low?

#### v) *Coated grains*

- which particles exhibit micrite envelopes?
- do all or only a part of the particles have micrite envelopes?
- can micritisation be proved?
- is the diversity of the organisms which occur together with the cortoids low or high?
- is there any indication of the cortoids having been transported?

#### vi) *Lithoclasts*

- can intraclasts and extraclasts be identified?
- are the particles in the clasts truncated?
- do the particles in the lithoclasts differ to other particles in the sample?
- do the lithoclasts exhibit compaction features?
- do the lithoclasts have a colour different to other particles?
- are the cements in the lithoclasts and in other particles similar?
- shape and size
- are the clasts flat?
- are the clasts rounded?
- do the clasts exhibit parallel orientation or cross-bedding?
- frequency

#### vii) *Terrigenous particles*

- which minerals or rock fragments occur?
- are the mineral grains rounded?
- frequency
- are the minerals concentrated into certain zones?
- are the terrigenous particles enclosed by other particles?

c. Size, sorting, and rounding of grains

d. Relative abundance of the grains

## **2. MATRIX**

- a) Homogenous or inhomogenous?
- b) Micrite/ Microspar/ Spar - relative proportions
- c) Are there clotted fabrics, bioturbation, lamination?

## **3. FABRIC**

- a) Grain-support, or matrix-support

- b) Folk/ Dunham classifications
- c) Microfacies assignation
- d) Is the fabric homogenised by bioturbation?
- e) What is the packing index or the kind of grain contacts?
- f) Do the grains exhibit a preferred orientation?
- g) Is a current-dependant intricate-structure recognisable?
- f) Do geopetal structures exist?
- h) Do the particles exhibit graded bedding?
- i) Is the sediment laminated?
  - is the lamination faintly or clearly marked?
  - are there laminites or rhythmites?
  - do laminated or laminoid fabrics occur?
  - thickness, continuity of laminae?
  - do the laminae exhibit erosional features?
  - which type do the laminoid fabrics correspond to?
- j) Are there fenestral cavities present?
  - shape, size, frequency
  - are there thrombotic structures?
  - do the voids correspond to birdseyes, stomatactis or dissolution?
  - is the internal sediment micrite, laminated micrite or silt?
  - does the internal sediment exhibit cross-lamination or slump structures?
  - what type of carbonate cement is in the top part of the small voids?
- k) Are there discontinuity planes with borings?

#### **4. DIAGENESIS**

- a) Is there microbial micritisation?
- b) Cements:
  - what types of cement (i.e., interparticle, intraparticle, shelter)?
  - how many generations of cement?
  - are there differences in colour of the various types of cement?
  - is there a micritic cement?
  - does the cement between the particles correspond to that inside the particles?
  - crystal size
  - do vadose cements occur?
  - is there vadose silt in the voids which are lined with cements
- c) Neomorphism
  - bioclasts or matrix?
  - aggrading or degrading?
  - replacement or recrystallisation?
- d) Dissolution
  - individual bioclasts or in matrix?
- e) Compaction
  - mechanical or chemical?
- f) Mineralisation

## A1.2 Thin-section tables

The following Sections tabulate the information collected from analysis of 420 thin sections and 129 peels. The tables aim to show the major features of the rock including microfacies assignment (as described in Chapter 4), texture (using Dunham (1962) classification), grains, matrix and fabrics. The tables do not cover the diagenetic features present in the rock. The tables are arranged in alphabetical order with respect to the name of the logged section. Reference should be made to Table A1-2 for explanatory notes on how to read the tables.

| Feature  | Explanation   |
|--|---|
| Thin Section/<br>Peel  | TS = <u>T</u> hin <u>S</u> ection    P = <u>P</u> eel   |
| Texture  | M = <u>M</u> udstone    W = <u>W</u> ackestone    P = <u>P</u> ackstone    G = <u>G</u> rainstone<br>F = <u>F</u> loatstone    Bf = <u>B</u> afflestone    Bi = <u>B</u> indstone    B = <u>B</u> oundstone<br>D = <u>D</u> olomite<br><br>(NB Any combination of these symbols may be used to indicate varying textures) |
| Grains   | The relative proportions of <i>grains</i> ( <u>not</u> whole-rock proportions) are represented as follows:<br><br>○ = <1%    ◦ = 1-20%    ● = 21-40%    ● = 41-60%    ● = >61%<br><br>(NB These percentages are determined by visual estimations - no point-counting was undertaken)                                      |
| Matrix   | M = <u>M</u> icrite    S = <u>S</u> par    Ms = <u>M</u> icrospar    D = <u>D</u> olomite<br><br>(NB Any combination of these symbols may be used to indicate several types of matrix)  |
| Biocurbation/<br>Micrite envelope/<br>fenestrae/<br>geopetals/<br>gravity cements/<br>lamination | ✓ indicates presence thereof  |
| Others   | If any other important information is needed it is added as a footnote, the number indicated in the 'others' box  |

Table A 1-2 Key explaining symbols used in thin-section tables.

### A1.2.1 Alt Breinig Quarry

○ = <1%     · = 1-20%     ● = 21-40%     ● = 41-60%     ✱ = >61%

| Sample number       | AB1   | AB2   |  |  |  |  |  |  |  |  |  |  |  |  |  |  |  |  |  |  |
|---------------------|-------|-------|--|--|--|--|--|--|--|--|--|--|--|--|--|--|--|--|--|--|
| Height              | 34.0m | 34.0m |  |  |  |  |  |  |  |  |  |  |  |  |  |  |  |  |  |  |
| Thin Section/ Peel  | TS    | TS    |  |  |  |  |  |  |  |  |  |  |  |  |  |  |  |  |  |  |
| Microfacies         | S12b  | S12b  |  |  |  |  |  |  |  |  |  |  |  |  |  |  |  |  |  |  |
| Texture             | G     | G     |  |  |  |  |  |  |  |  |  |  |  |  |  |  |  |  |  |  |
| Grains:             |       |       |  |  |  |  |  |  |  |  |  |  |  |  |  |  |  |  |  |  |
| Peloids             | ●     | ·     |  |  |  |  |  |  |  |  |  |  |  |  |  |  |  |  |  |  |
| Lithoclasts         | ●     | ●     |  |  |  |  |  |  |  |  |  |  |  |  |  |  |  |  |  |  |
| Oncoids             |       |       |  |  |  |  |  |  |  |  |  |  |  |  |  |  |  |  |  |  |
| Ooids               |       |       |  |  |  |  |  |  |  |  |  |  |  |  |  |  |  |  |  |  |
| Aggregate grains    |       |       |  |  |  |  |  |  |  |  |  |  |  |  |  |  |  |  |  |  |
| Quartz/ silt grains |       |       |  |  |  |  |  |  |  |  |  |  |  |  |  |  |  |  |  |  |
| Bioclasts:          |       |       |  |  |  |  |  |  |  |  |  |  |  |  |  |  |  |  |  |  |
| Bulbous stroms.     |       |       |  |  |  |  |  |  |  |  |  |  |  |  |  |  |  |  |  |  |
| Laminar stroms.     |       |       |  |  |  |  |  |  |  |  |  |  |  |  |  |  |  |  |  |  |
| Dendroid stroms.    |       |       |  |  |  |  |  |  |  |  |  |  |  |  |  |  |  |  |  |  |
| Stachyodes          |       |       |  |  |  |  |  |  |  |  |  |  |  |  |  |  |  |  |  |  |
| Amphipora           |       |       |  |  |  |  |  |  |  |  |  |  |  |  |  |  |  |  |  |  |
| Colonial corals     |       |       |  |  |  |  |  |  |  |  |  |  |  |  |  |  |  |  |  |  |
| Solitary corals     |       |       |  |  |  |  |  |  |  |  |  |  |  |  |  |  |  |  |  |  |
| Thamnoporoids       |       |       |  |  |  |  |  |  |  |  |  |  |  |  |  |  |  |  |  |  |
| Bivalves            |       |       |  |  |  |  |  |  |  |  |  |  |  |  |  |  |  |  |  |  |
| Gastropods          |       |       |  |  |  |  |  |  |  |  |  |  |  |  |  |  |  |  |  |  |
| Shell hash          |       |       |  |  |  |  |  |  |  |  |  |  |  |  |  |  |  |  |  |  |
| Brachiopods         |       |       |  |  |  |  |  |  |  |  |  |  |  |  |  |  |  |  |  |  |
| Brachiopod spines   |       |       |  |  |  |  |  |  |  |  |  |  |  |  |  |  |  |  |  |  |
| Crinoids            |       |       |  |  |  |  |  |  |  |  |  |  |  |  |  |  |  |  |  |  |
| Tentaculites        |       |       |  |  |  |  |  |  |  |  |  |  |  |  |  |  |  |  |  |  |
| Trilobites          |       |       |  |  |  |  |  |  |  |  |  |  |  |  |  |  |  |  |  |  |
| Bryozoans           |       |       |  |  |  |  |  |  |  |  |  |  |  |  |  |  |  |  |  |  |
| Ostrocodes          | ○     |       |  |  |  |  |  |  |  |  |  |  |  |  |  |  |  |  |  |  |
| Leperditia          | ·     |       |  |  |  |  |  |  |  |  |  |  |  |  |  |  |  |  |  |  |
| Calcspheres         |       |       |  |  |  |  |  |  |  |  |  |  |  |  |  |  |  |  |  |  |
| Forams              |       |       |  |  |  |  |  |  |  |  |  |  |  |  |  |  |  |  |  |  |
| Sponge spicules     |       |       |  |  |  |  |  |  |  |  |  |  |  |  |  |  |  |  |  |  |
| Umbellids           |       |       |  |  |  |  |  |  |  |  |  |  |  |  |  |  |  |  |  |  |
| Undetermined        |       |       |  |  |  |  |  |  |  |  |  |  |  |  |  |  |  |  |  |  |
| Codiaceans          |       |       |  |  |  |  |  |  |  |  |  |  |  |  |  |  |  |  |  |  |
| Dasycladaceans      |       |       |  |  |  |  |  |  |  |  |  |  |  |  |  |  |  |  |  |  |
| Girvanella Gp.      |       | ✱     |  |  |  |  |  |  |  |  |  |  |  |  |  |  |  |  |  |  |
| Renalcis Gp.        |       |       |  |  |  |  |  |  |  |  |  |  |  |  |  |  |  |  |  |  |
| Hedstroemia Gp.     |       |       |  |  |  |  |  |  |  |  |  |  |  |  |  |  |  |  |  |  |
| Wetheredella Gp.    |       |       |  |  |  |  |  |  |  |  |  |  |  |  |  |  |  |  |  |  |
| Matrix              | S     | S     |  |  |  |  |  |  |  |  |  |  |  |  |  |  |  |  |  |  |
| Bioturbation        |       |       |  |  |  |  |  |  |  |  |  |  |  |  |  |  |  |  |  |  |
| Micrite envelope    |       |       |  |  |  |  |  |  |  |  |  |  |  |  |  |  |  |  |  |  |
| Fenestrae: Tubular  |       |       |  |  |  |  |  |  |  |  |  |  |  |  |  |  |  |  |  |  |
| Laminoid/irregular  |       | ✓     |  |  |  |  |  |  |  |  |  |  |  |  |  |  |  |  |  |  |
| Geopetals           |       |       |  |  |  |  |  |  |  |  |  |  |  |  |  |  |  |  |  |  |
| Gravity cements     |       |       |  |  |  |  |  |  |  |  |  |  |  |  |  |  |  |  |  |  |
| Lamination          | ✓     | ✓     |  |  |  |  |  |  |  |  |  |  |  |  |  |  |  |  |  |  |
| Others              | *1    |       |  |  |  |  |  |  |  |  |  |  |  |  |  |  |  |  |  |  |

\*1 Grains aligned parallel to bedding

|         |  |
|---------|--|
| Texture | M=Mudstone, W=Wackestone, P=Packstone<br>G=Grainstone, F=Floatstone, Bf= Bafflestone<br>Bi=Bindstone, B=Boundstone, D=Dolomite |
| Matrix  | M=Micrite, Ms=Microspar, S=Spar, D=Dolomite  |

## A1.2.2 Beuraing Quarry

○ = <1%    · = 1–20%    ● = 21–40%    ● = 41–60%    \* = >61%

| Sample number       | BG1  | BG2  | BG3   | BG4  | BG5   | BG6   | BG7   | BG8   | BG9   | BG10  | BG11  | BG12  | BG13  |
|---------------------|------|------|-------|------|-------|-------|-------|-------|-------|-------|-------|-------|-------|
| Height              | 0.5m | 2.6m | 3.45m | 8.3m | 11.5m | 15.5m | 19.1m | 20.0m | 22.1m | 26.4m | 29.5m | 29.8m | 31.9m |
| Thin Section/ Peel  | TS   | TS   | TS    | TS   | TS    | TS    | TS    | TS    | TS    | TS    | TS    | TS    | TS    |
| Microfacies         | S4a  | S6b  | S12a  | S10  | S12b  | S7a   | S6a   | S2    | -     | S4a   | S12a  | S12b  | S7a   |
| Texture             | W    | M    | D     | G    | G     | G     | P     | FB    | M     | F     | M     | G     | G     |
| Grains:             |      |      |       |      |       |       |       |       |       |       |       |       |       |
| Peloids             |      |      |       | ●    | ●     | ●     | ●     |       | ●     |       | ●     | ●     | ●     |
| Lithoclasts         |      |      |       |      |       |       |       |       | ●     |       |       | ·     |       |
| Oncoids             |      |      |       |      |       |       |       |       |       |       |       |       |       |
| Ooids               |      |      |       | ○    |       |       |       |       |       |       |       |       |       |
| Aggregate grains    |      |      |       |      |       |       |       |       |       |       |       | ●     |       |
| Quartz/ silt grains |      |      |       |      |       |       |       |       | ●     |       |       |       |       |
| Bioclasts:          |      |      |       |      |       |       |       |       |       |       |       |       |       |
| Bulbous stroms.     |      |      |       |      |       |       |       | ●     |       |       |       |       |       |
| Laminar stroms.     |      |      |       |      |       |       |       |       |       |       |       |       |       |
| Dendroid stroms.    | ·    |      |       |      |       |       |       |       |       |       |       |       |       |
| Stachyodes          |      |      |       |      |       |       |       |       |       | ·     |       |       |       |
| Amphipora           | ●    |      |       | ○    |       |       |       |       | ○     | ●     |       |       |       |
| Colonial corals     |      |      |       |      |       |       |       |       |       |       |       |       |       |
| Solitary corals     |      |      |       |      |       |       |       |       |       |       |       |       |       |
| Thamnoporoids       | ●    |      |       |      |       |       |       |       |       |       |       |       |       |
| Bivalves            |      |      |       |      |       | ○     |       |       |       |       |       |       |       |
| Gastropods          |      |      |       |      |       |       |       |       |       |       |       |       |       |
| Shell hash          |      |      |       |      |       |       |       |       |       |       |       |       |       |
| Brachiopods         |      |      |       | ○    |       |       |       |       |       |       |       |       |       |
| Brachiopod spines   |      |      |       |      |       |       |       |       |       |       |       |       |       |
| Crinoids            |      |      |       |      |       |       |       |       |       |       |       |       |       |
| Tentaculites        |      |      |       |      |       |       |       |       |       |       |       |       |       |
| Trilobites          |      |      |       |      |       |       |       |       |       |       |       |       |       |
| Bryozoans           |      |      |       |      |       |       |       |       |       |       |       |       |       |
| Ostrocodes          |      | ●    |       |      |       | ○     | ○     |       | ○     | ·     | ○     |       |       |
| Leperditia          |      |      |       |      |       |       |       |       |       |       |       |       |       |
| Calcspheres         | ○    |      |       | ○    | ·     |       |       |       |       |       | ○     |       | ○     |
| Forams              |      |      |       | ○    |       |       |       |       |       | ·     |       |       | ·     |
| Sponge spicules     |      |      |       |      |       |       |       |       |       |       |       |       |       |
| Umbellids           |      |      |       |      |       |       |       |       |       |       |       |       |       |
| Undetermined        |      |      |       |      |       |       |       |       |       |       |       |       |       |
| Codiaceans          | ○    |      |       |      |       | ·     |       |       |       |       |       |       |       |
| Dasycladaceans      |      |      |       |      |       | ·     |       |       |       |       |       |       |       |
| Girvanella Gp.      |      |      |       |      |       |       |       | ·     |       |       |       |       |       |
| Renalcis Gp.        |      |      |       | ·    |       |       | ●     |       |       |       |       |       |       |
| Hedstroemia Gp.     |      |      |       |      |       |       |       |       |       |       |       |       |       |
| Wetheredella Gp.    |      |      |       |      |       |       | ○     |       |       |       |       |       |       |
| Matrix              | M,D  | M,D  |       | S,M  | S,M   | S,M   | M,D,S |       |       | M     | M,S   | S,M   | S     |
| Bioturbation        | ✓    | ✓    |       |      |       |       |       |       |       |       |       |       | ✓     |
| Micrite envelope    |      |      |       | ✓    |       | ✓     |       |       |       | ✓     |       |       |       |
| Fenestrae: Tubular  |      |      |       |      |       |       |       |       |       |       |       |       |       |
| Laminoid/irregular  |      |      |       | ✓    | ✓     |       |       |       |       |       |       |       |       |
| Geopetals           |      |      |       |      |       |       |       |       |       |       |       |       |       |
| Gravity cements     |      |      |       |      |       |       |       |       |       |       |       |       |       |
| Lamination          |      |      |       | ✓    | ✓     |       |       |       |       |       | ✓     | ✓     |       |
| Others              |      |      | *1    |      |       |       |       | *2    | *3    | *4    |       |       |       |

\*1 Altered to dolomite

\*2 Thin section through bulbous stromatopoid

\*3 Sample of volcanic tuff?

\*4 Some bioclasts aligned parallel to bedding

|         |  |
|---------|--|
| Texture | M=Mudstone, W=Wackestone, P=Packstone<br>G=Grainstone, F=Floatstone, Bf= Bafflestone<br>Bi=Bjndstone, B=Boundstone, D=Dolomite |
| Matrix  | M=Micrite, Ms=Microspar, S=Spar, D=Dolomite  |

## Beauraing Quarry

○ = <1%    • = 1-20%    ● = 21-40%    ● = 41-60%    \* = >61%

| Sample number       | BG14  | BG15  | BG16  |  |  |  |  |  |  |  |  |  |  |  |  |  |  |  |  |  |  |
|---------------------|-------|-------|-------|--|--|--|--|--|--|--|--|--|--|--|--|--|--|--|--|--|--|
| Height              | 35.2m | 36.1m | 42.8m |  |  |  |  |  |  |  |  |  |  |  |  |  |  |  |  |  |  |
| Thin Section/ Peel  | TS    | TS    | TS    |  |  |  |  |  |  |  |  |  |  |  |  |  |  |  |  |  |  |
| Microfacies         | S6b   | S6b   | S6a   |  |  |  |  |  |  |  |  |  |  |  |  |  |  |  |  |  |  |
| Texture             | M     | M     | MW    |  |  |  |  |  |  |  |  |  |  |  |  |  |  |  |  |  |  |
| Grains:             |       |       |       |  |  |  |  |  |  |  |  |  |  |  |  |  |  |  |  |  |  |
| Peloids             | •     |       |       |  |  |  |  |  |  |  |  |  |  |  |  |  |  |  |  |  |  |
| Lithoclasts         |       |       |       |  |  |  |  |  |  |  |  |  |  |  |  |  |  |  |  |  |  |
| Oncoids             |       |       |       |  |  |  |  |  |  |  |  |  |  |  |  |  |  |  |  |  |  |
| Ooids               |       |       |       |  |  |  |  |  |  |  |  |  |  |  |  |  |  |  |  |  |  |
| Aggregate grains    |       |       |       |  |  |  |  |  |  |  |  |  |  |  |  |  |  |  |  |  |  |
| Quartz/ silt grains |       |       |       |  |  |  |  |  |  |  |  |  |  |  |  |  |  |  |  |  |  |
| Bioclasts:          |       |       |       |  |  |  |  |  |  |  |  |  |  |  |  |  |  |  |  |  |  |
| Bulbous stroms.     |       |       |       |  |  |  |  |  |  |  |  |  |  |  |  |  |  |  |  |  |  |
| Laminar stroms.     |       |       |       |  |  |  |  |  |  |  |  |  |  |  |  |  |  |  |  |  |  |
| Dendroid stroms.    |       |       |       |  |  |  |  |  |  |  |  |  |  |  |  |  |  |  |  |  |  |
| Stachyodes          |       |       |       |  |  |  |  |  |  |  |  |  |  |  |  |  |  |  |  |  |  |
| Amphipora           |       |       |       |  |  |  |  |  |  |  |  |  |  |  |  |  |  |  |  |  |  |
| Colonial corals     |       |       |       |  |  |  |  |  |  |  |  |  |  |  |  |  |  |  |  |  |  |
| Solitary corals     |       |       |       |  |  |  |  |  |  |  |  |  |  |  |  |  |  |  |  |  |  |
| Thamnoporoids       |       |       |       |  |  |  |  |  |  |  |  |  |  |  |  |  |  |  |  |  |  |
| Bivalves            |       |       |       |  |  |  |  |  |  |  |  |  |  |  |  |  |  |  |  |  |  |
| Gastropods          |       |       |       |  |  |  |  |  |  |  |  |  |  |  |  |  |  |  |  |  |  |
| Shell hash          |       |       |       |  |  |  |  |  |  |  |  |  |  |  |  |  |  |  |  |  |  |
| Brachiopods         |       |       |       |  |  |  |  |  |  |  |  |  |  |  |  |  |  |  |  |  |  |
| Brachiopod spines   |       |       |       |  |  |  |  |  |  |  |  |  |  |  |  |  |  |  |  |  |  |
| Crinoids            |       |       |       |  |  |  |  |  |  |  |  |  |  |  |  |  |  |  |  |  |  |
| Tentaculites        |       |       |       |  |  |  |  |  |  |  |  |  |  |  |  |  |  |  |  |  |  |
| Trilobites          |       |       |       |  |  |  |  |  |  |  |  |  |  |  |  |  |  |  |  |  |  |
| Bryozoans           |       |       |       |  |  |  |  |  |  |  |  |  |  |  |  |  |  |  |  |  |  |
| Ostrocodes          | ●     | •     | ●     |  |  |  |  |  |  |  |  |  |  |  |  |  |  |  |  |  |  |
| Leperditia          |       |       |       |  |  |  |  |  |  |  |  |  |  |  |  |  |  |  |  |  |  |
| Calcispheres        | ●     | ●     | *     |  |  |  |  |  |  |  |  |  |  |  |  |  |  |  |  |  |  |
| Forams              |       | ●     | ○     |  |  |  |  |  |  |  |  |  |  |  |  |  |  |  |  |  |  |
| Sponge spicules     |       |       |       |  |  |  |  |  |  |  |  |  |  |  |  |  |  |  |  |  |  |
| Umbellids           |       |       |       |  |  |  |  |  |  |  |  |  |  |  |  |  |  |  |  |  |  |
| Undetermined        |       |       |       |  |  |  |  |  |  |  |  |  |  |  |  |  |  |  |  |  |  |
| Codiaceans          |       |       |       |  |  |  |  |  |  |  |  |  |  |  |  |  |  |  |  |  |  |
| Dasycladaceans      |       |       |       |  |  |  |  |  |  |  |  |  |  |  |  |  |  |  |  |  |  |
| Girvanella Gp.      |       |       |       |  |  |  |  |  |  |  |  |  |  |  |  |  |  |  |  |  |  |
| Renalcis Gp.        |       |       |       |  |  |  |  |  |  |  |  |  |  |  |  |  |  |  |  |  |  |
| Hedstroemia Gp.     |       |       |       |  |  |  |  |  |  |  |  |  |  |  |  |  |  |  |  |  |  |
| Wetheredella Gp.    |       |       |       |  |  |  |  |  |  |  |  |  |  |  |  |  |  |  |  |  |  |
| Matrix              | M     | M     | M     |  |  |  |  |  |  |  |  |  |  |  |  |  |  |  |  |  |  |
| Bioturbation        |       | ✓     | ✓     |  |  |  |  |  |  |  |  |  |  |  |  |  |  |  |  |  |  |
| Micrite envelope    |       |       |       |  |  |  |  |  |  |  |  |  |  |  |  |  |  |  |  |  |  |
| Fenestrae: Tubular  |       |       |       |  |  |  |  |  |  |  |  |  |  |  |  |  |  |  |  |  |  |
| Laminoid/irregular  |       |       |       |  |  |  |  |  |  |  |  |  |  |  |  |  |  |  |  |  |  |
| Geopetals           |       |       |       |  |  |  |  |  |  |  |  |  |  |  |  |  |  |  |  |  |  |
| Gravity cements     |       |       |       |  |  |  |  |  |  |  |  |  |  |  |  |  |  |  |  |  |  |
| Lamination          |       |       |       |  |  |  |  |  |  |  |  |  |  |  |  |  |  |  |  |  |  |
| Others              | *1    |       |       |  |  |  |  |  |  |  |  |  |  |  |  |  |  |  |  |  |  |

\*1 Alignments of bioclasts parallel to bedding

|         |  |
|---------|--|
| Texture | M=Mudstone, W=Wackestone, P=Packstone<br>G=Grainstone, F=Floatstone, Bf= Bafflestone<br>Bi=Bjndstone, B=Boundstone, D=Dolomite |
| Matrix  | M=Micrite, Ms=Microspar, S=Spar, D=Dolomite  |

## A1.2.3 Bellignies-Bettrechies Quarry

○ = <1%    · = 1-20%    ● = 21-40%    ● = 41-60%    \* = >61%

| Sample number       | BB1  | BB2  | BB3  | BB5   | BB6   | BB7   | BB8   | BB9   | BB10  | BB11  | BB12  | BB13  | BB14  |
|---------------------|------|------|------|-------|-------|-------|-------|-------|-------|-------|-------|-------|-------|
| Height              | 1.8m | 4.5m | 6.4m | 16.9m | 19.5m | 21.5m | 22.8m | 26.8m | 28.8m | 28.98 | 36.1m | 40.3m | 42.6m |
| Thin Section/ Peel  | TS   | TS   | TS   | TS    | TS    | TS    | TS    | TS    | TS    | TS    | TS    | TS    | TS    |
| Microfacies         | R2   | R4a  | R4b  | R1    | R6    | R7    | R7    | R4b   | R4b   | R7    | R4a   | R4c   | R4b   |
| Texture             | WP   | G    | G    | W     | WP    | D     | D     | G     | G     | M     | G     | G     | G     |
| Grains:             |      |      |      |       |       |       |       |       |       |       |       |       |       |
| Peloids             |      | ●    | * ●  |       |       |       |       | * ●   | * ●   | ●     | ·     | ●     | ·     |
| Lithoclasts         |      |      |      |       |       |       |       | ○     |       |       | ·     |       | ●     |
| Oncoids             |      |      |      |       |       |       |       |       |       |       |       |       | ●     |
| Ooids               |      | ●    |      |       |       |       |       |       | ·     |       | * ●   |       |       |
| Aggregate grains    |      |      |      |       |       |       |       |       |       |       |       |       |       |
| Quartz/ silt grains |      |      |      |       |       |       |       |       |       |       |       |       |       |
| Bioclasts:          |      |      |      |       |       |       |       |       |       |       |       |       |       |
| Bulbous stroms.     |      |      |      |       |       |       |       |       |       |       |       |       |       |
| Laminar stroms.     |      |      |      |       |       |       |       |       |       |       |       |       |       |
| Dendroid stroms.    |      |      |      |       |       |       |       |       |       |       |       |       |       |
| Stachyodes          |      |      |      |       |       |       |       |       |       |       |       |       |       |
| Amphipora           |      |      |      |       |       |       |       |       |       |       |       |       |       |
| Colonial corals     |      |      |      |       |       |       |       |       |       |       |       |       |       |
| Solitary corals     |      |      |      |       |       |       |       |       |       |       |       |       |       |
| Thamnoporoids       |      |      |      |       |       |       |       |       |       |       |       |       |       |
| Bivalves            |      |      |      | ·     |       |       |       |       |       |       | ○     |       | ·     |
| Gastropods          |      |      |      | * ●   |       |       |       |       |       |       |       |       |       |
| Shell hash          |      |      |      |       |       |       |       |       |       |       |       | ●     |       |
| Brachiopods         | * ●  |      |      |       |       |       |       |       |       |       |       |       |       |
| Brachiopod spines   |      |      |      |       |       |       |       |       |       |       |       |       |       |
| Crinoids            | ○    |      | ·    |       |       |       |       |       | ·     |       |       |       |       |
| Tentaculites        |      |      |      |       |       |       |       |       |       |       |       |       |       |
| Trilobites          |      |      |      |       |       |       |       |       |       |       |       |       |       |
| Bryozoans           |      |      |      |       |       |       |       |       |       |       |       |       |       |
| Ostrocodes          | ·    |      |      | ·     |       |       |       |       |       |       | ○     | ·     | ·     |
| Leperditia          |      |      |      |       | * ●   |       |       |       | ·     |       |       |       |       |
| Calcispheres        |      |      |      | ·     | ·     |       |       |       |       | ●     |       |       |       |
| Forams              | ○    |      |      |       |       |       |       | ○     |       |       |       |       |       |
| Sponge spicules     |      |      |      |       |       |       |       |       |       |       |       |       |       |
| Umbellids           |      |      |      |       |       |       |       |       |       |       |       |       |       |
| Undetermined        |      | ·    |      |       | ·     |       |       |       |       |       |       |       |       |
| Codiaceans          |      |      |      |       |       |       |       |       |       |       |       |       |       |
| Dasycladaceans      |      |      |      |       |       |       |       |       |       |       |       |       |       |
| Girvanella Gp.      |      | ·    | ·    |       |       |       |       |       | ·     |       |       |       |       |
| Renalcis Gp.        |      |      | ·    |       |       |       |       |       |       |       |       |       |       |
| Hedstroemia Gp.     |      |      |      |       |       |       |       |       |       |       |       |       |       |
| Wetheredella Gp.    |      |      | ·    |       |       |       |       |       |       |       |       |       |       |
| Matrix              | M,D  | S    | S    | M     | M,S   | D     | D     | S     | M,S   | M     | S,M,D | S,M   | S     |
| Bioturbation        |      |      |      | ✓     |       |       | ✓     |       |       |       |       |       | ✓     |
| Micrite envelope    |      |      |      |       |       |       |       |       |       |       |       |       |       |
| Fenestrae: Tubular  |      |      |      |       |       |       |       |       |       |       |       |       |       |
| Laminoid/irregular  |      |      |      |       |       |       |       |       |       |       |       |       |       |
| Geopetals           |      |      |      |       |       |       |       |       |       |       |       |       |       |
| Gravity cements     |      |      |      |       |       |       |       |       |       |       |       |       |       |
| Lamination          |      |      |      |       |       | ✓     | ✓     |       |       | ✓     |       |       |       |
| Others              |      |      |      |       |       | *1    |       |       | *2    |       |       |       |       |

\*1 Pseudomorphs of gypsum?

\*2 Possible coprolite

|         |  |
|---------|--|
| Texture | M=Mudstone, W=Wackestone, P=Packstone<br>G=Grainstone, F=Floatstone, Bf= Bafflestone<br>Bi=Bjndstone, B=Boundstone, D=Dolomite |
| Matrix  | M=Micrite, Ms=Microspar, S=Spar, D=Dolomite  |

## Bellignies-Bettrechies Quarry

○ = <1%    · = 1-20%    ● = 21-40%    ● = 41-60%    \* = >61%

| Sample number       | BB15  | BB16  | BB17  | BB18  |
|---------------------|-------|-------|-------|-------|
| Height              | 47.3m | 50.5m | 52.2m | 61.8m |
| Thin Section/ Peel  | TS    | TS    | TS    | TS    |
| Microfacies         | R6a   | R6a   | R2    | R1    |
| Texture             | P     | WP    | P     | M     |
| Grains:             |       |       |       |       |
| Peloids             | ●     | ●     | ●     |       |
| Lithoclasts         |       |       | ·     |       |
| Oncoids             |       |       |       |       |
| Ooids               |       | ·     | ·     |       |
| Aggregate grains    |       |       |       |       |
| Quartz/ silt grains |       |       |       |       |
| Bioclasts:          |       |       |       |       |
| Bulbous stroms.     |       |       |       |       |
| Laminar stroms.     |       |       |       |       |
| Dendroid stroms.    |       |       |       |       |
| Stachyodes          |       |       |       |       |
| Amphipora           |       |       |       |       |
| Colonial corals     |       |       |       |       |
| Solitary corals     |       |       |       |       |
| Thamnoporoids       |       |       | ○     |       |
| Bivalves            |       |       |       |       |
| Gastropods          |       |       | ·     |       |
| Shell hash          |       |       | ●     |       |
| Brachiopods         |       |       | ·     |       |
| Brachiopod spines   |       |       |       |       |
| Crinoids            |       |       |       |       |
| Tentaculites        |       |       |       | ●     |
| Trilobites          |       |       |       |       |
| Bryozoans           |       |       |       |       |
| Ostrocodes          |       | ●     |       | ●     |
| Leperditia          | ●     | ·     |       |       |
| Calcispheres        |       |       |       |       |
| Forams              |       |       | ○     |       |
| Sponge spicules     |       |       |       |       |
| Umbellids           |       |       |       |       |
| Undetermined        |       |       |       |       |
| Codiaceans          |       |       |       |       |
| Dasycladaceans      |       |       |       |       |
| Girvanella Gp.      |       |       |       |       |
| Renalcis Gp.        |       |       |       |       |
| Hedstroemia Gp.     |       |       |       |       |
| Wetheredella Gp.    |       |       |       |       |
| Matrix              | M,S   | M     | M,S   | M     |
| Bioturbation        | ✓     | ✓     | ✓     | ✓     |
| Micrite envelope    |       |       | ✓     |       |
| Fenestrae: Tubular  |       |       |       | ✓     |
| Laminoid/irregular  |       |       |       |       |
| Geopetals           |       |       |       |       |
| Gravity cements     |       |       |       |       |
| Lamination          |       |       |       |       |
| Others              |       |       |       |       |

|         |   |
|---------|---|
| Texture | M=Mudstone, W=Wackestone, P=Packstone<br>G=Grainstone, F=Floatstone, Bf=Bafflestone<br>Bi=Bindstone, B=Boundstone, D=Dolomite |
| Matrix  | M=Micrite, Ms=Microspar, S=Spar, D=Dolomite   |

## A1.2.4 Bleiwäsche Quarry

○ = <1%    · = 1–20%    ● = 21–40%    ● = 41–60%    \* = >61%

| Sample number       | BL1  | BL2  | BL3  | BL4  | BL5  | BL6  | BL7  | BL8   | BL9   | BL10  | BL11  | BL12  | BL13  |
|---------------------|------|------|------|------|------|------|------|-------|-------|-------|-------|-------|-------|
| Height              | 0.1m | 1.3m | 2.1m | 3.2m | 5.2m | 6.4m | 8.0m | 10.0m | 12.1m | 13.2m | 16.6m | 16.9m | 19.4m |
| Thin Section/ Peel  | TS   | TS   | TS   | TS   | TS   | P    | TS   | TS    | TS    | TS    | TS    | TS    | TS    |
| Microfacies         | S7a  | S7a  | S2   | S3   | S10  | S4b  | S8a  | S2    | S4b   | S7a   | S7a   | S8c   | S4b   |
| Texture             | G    | G    | F    | G    | P    | F    | M    | F     | F     | G     | G     | F     | F     |
| Grains:             |      |      |      |      |      |      |      |       |       |       |       |       |       |
| Peloids             | *    | *    | *    | ●    | *    |      |      | ·     | ●     | *     | *     | *     | ●     |
| Lithoclasts         |      |      |      | ·    |      |      |      |       |       |       |       |       |       |
| Oncoids             |      |      |      |      |      |      |      |       |       |       |       |       |       |
| Ooids               |      |      |      |      |      |      |      |       |       |       |       |       |       |
| Aggregate grains    |      |      |      |      |      |      |      |       |       |       |       |       |       |
| Quartz/ silt grains |      |      |      |      |      |      |      |       |       |       |       |       |       |
| Bioclasts:          |      |      |      |      |      |      |      |       |       |       |       |       |       |
| Bulbous stroms.     |      |      |      |      |      |      |      | ●     |       |       |       |       |       |
| Laminar stroms.     |      |      |      |      |      |      |      |       |       |       |       |       |       |
| Dendroid stroms.    |      |      |      |      |      |      |      |       |       |       |       |       |       |
| Stachyodes          |      |      | ●    | ·    |      |      |      |       |       |       |       |       |       |
| Amphipora           |      | ·    |      | ●    | ·    | *    | ·    | ·     | ·     | ○     |       | ·     | ·     |
| Colonial corals     |      |      |      |      |      |      |      |       |       |       |       |       |       |
| Solitary corals     |      |      |      |      |      |      |      |       |       |       |       |       |       |
| Thamnoporoids       |      |      |      |      |      |      |      |       |       |       |       |       |       |
| Bivalves            |      |      |      |      |      |      |      |       |       |       |       | ·     |       |
| Gastropods          |      |      |      | ·    |      |      |      |       |       |       |       |       |       |
| Shell hash          |      |      |      |      |      |      |      |       |       |       |       |       |       |
| Brachiopods         |      |      |      |      |      |      |      |       |       |       |       |       |       |
| Brachiopod spines   |      |      |      |      |      |      |      |       |       |       |       |       |       |
| Crinoids            |      |      |      |      |      |      |      |       |       |       |       |       |       |
| Tentaculites        |      |      |      |      |      |      |      |       |       |       |       |       |       |
| Trilobites          |      |      |      |      |      |      |      |       |       |       |       |       |       |
| Bryozoans           |      |      |      |      |      |      |      |       |       |       |       |       |       |
| Ostrocodes          | ○    |      | ·    |      |      |      |      | ·     | ○     | ·     | ○     |       |       |
| Leperditia          |      |      |      |      |      |      |      |       |       |       |       |       |       |
| Calcispheres        | ●    | ·    | ·    | ·    |      |      | *    | ·     | ·     | ·     | ·     | ·     | ·     |
| Forams              | ·    |      |      | ○    |      | ·    | ·    | ·     | ·     | ·     | ·     | ·     | ·     |
| Sponge spicules     |      |      |      |      |      |      |      |       |       |       |       |       |       |
| Umbellids           |      |      |      |      |      |      |      |       |       |       |       |       |       |
| Undetermined        |      |      |      |      |      |      |      |       |       |       |       |       |       |
| Codiaceans          |      |      |      |      |      |      |      |       |       |       |       |       |       |
| Dasycladaceans      |      |      |      |      |      |      | ·    |       |       |       |       |       | ·     |
| Girvanella Gp.      |      |      |      |      |      |      |      |       |       |       |       |       |       |
| Renalcis Gp.        |      |      |      |      |      |      |      |       |       |       |       |       |       |
| Hedstroemia Gp.     |      |      |      | ·    |      |      |      |       |       |       |       |       |       |
| Wetheredella Gp.    |      |      |      |      |      |      |      |       |       |       |       |       |       |
| Matrix              | S    | S,M  | S    | S    | S,M  | M,S  | M    | S     | S     | S     | S     | M,S   | S     |
| Bioturbation        |      |      |      |      |      |      |      |       |       |       |       |       |       |
| Micrite envelope    | ✓    |      | ✓    | ✓    |      |      |      |       | ✓     |       |       | ✓     | ✓     |
| Fenestrae: Tubular  |      |      |      |      | ✓    |      | ✓    |       |       |       |       |       |       |
| Laminoid/irregular  |      |      |      |      | ✓    |      | ✓    |       |       |       |       | ✓     |       |
| Geopetals           |      |      |      |      | ✓    |      | ✓    |       |       |       |       | ✓     |       |
| Gravity cements     |      |      |      |      |      |      |      |       |       |       |       | ✓     |       |
| Lamination          |      |      |      |      | ✓    |      |      |       |       |       |       |       |       |
| Others              |      |      | *1   | *2   | *3   | *4   | *3   | *1    |       |       |       |       |       |

\*1 Sample of matrix to S2 facies

\*2 Cyanobacteria encrusting many grains

\*3 Fenestrae have internal fill of fine-grained sediment at base

\*4 Bioclasts aligned parallel to each other

|         |  |
|---------|--|
| Texture | M=Mudstone, W=Wackestone, P=Packstone<br>G=Grainstone, F=Floatstone, Bf= Bafflestone<br>Bi=Bindstone, B=Boundstone, D=Dolomite |
| Matrix  | M=Micrite, Ms=Microspar, S=Spar, D=Dolomite  |

## Bleiwäsche Quarry

○ = <1%    · = 1-20%    ● = 21-40%    ● = 41-60%    \* = >61%

| Sample number       | BL14  | BL15  | BL16  | BL17  | BL18  | BL19  | BL20  | BL21  | BL22  | BL23  | BL24  | BL25  |
|---------------------|-------|-------|-------|-------|-------|-------|-------|-------|-------|-------|-------|-------|
| Height              | 21.7m | 22.6m | 23.3m | 24.4m | 24.8m | 25.3m | 27.4m | 28.5m | 30.3m | 33.9m | 36.3m | 41.4m |
| Thin Section/ Peel  | TS    | TS    | TS    | TS    | TS    | TS    | TS    | TS    | TS    | TS    | TS    | TS    |
| Microfacies         | S2    | S6a   | S11   | S7a   | S11   | S4b   | S6a   | S7a   | S7a   | S4a   | S4a   | S4a   |
| Texture             | F     | W     | M     | G     | P     | M     | F     | W     | G     | G     | F     | F     |
| Grains:             |       |       |       |       |       |       |       |       |       |       |       |       |
| Peloids             | *     | ·     | ·     | *     | *     | ●     | ●     |       | *     | ●     |       |       |
| Lithoclasts         |       |       |       |       |       | ●     |       |       |       |       |       |       |
| Oncoids             |       |       |       |       |       |       |       |       |       |       |       |       |
| Ooids               |       |       |       |       |       |       |       |       |       |       |       |       |
| Aggregate grains    |       |       |       |       |       |       |       |       |       |       |       |       |
| Quartz/ silt grains |       |       |       |       |       |       |       |       |       |       |       |       |
| Bioclasts:          |       |       |       |       |       |       |       |       |       |       |       |       |
| Bulbous stroms.     |       |       |       |       |       |       |       |       |       |       |       |       |
| Laminar stroms.     |       |       |       |       |       |       |       |       |       |       |       |       |
| Dendroid stroms.    |       |       |       |       |       |       |       |       |       |       |       |       |
| Stachyodes          |       |       |       |       |       |       |       |       |       |       |       |       |
| Amphipora           | ●     | ·     |       |       |       |       | ·     |       | ·     | ·     | ·     | ●     |
| Colonial corals     |       |       |       |       |       |       |       |       |       |       |       |       |
| Solitary corals     |       |       |       |       |       |       |       |       |       |       |       |       |
| Thamnoporoids       |       |       |       |       |       |       |       |       |       |       |       |       |
| Bivalves            |       |       |       |       |       |       |       |       |       |       |       |       |
| Gastropods          |       |       |       |       |       |       |       |       |       |       |       |       |
| Shell hash          |       |       |       |       |       |       |       |       |       |       |       |       |
| Brachiopods         |       |       |       |       |       |       |       |       |       |       |       |       |
| Brachiopod spines   |       |       |       |       |       |       |       |       |       |       |       |       |
| Crinoids            |       |       |       |       |       |       |       |       |       |       |       |       |
| Tentaculites        |       |       |       |       |       |       |       |       |       |       |       |       |
| Trilobites          |       |       |       |       |       |       |       |       |       |       |       |       |
| Bryozoans           |       |       |       |       |       |       |       |       |       |       |       |       |
| Ostrocodes          |       | ·     |       |       |       |       | ·     | ·     | ○     | ·     | ·     |       |
| Leperditia          |       |       |       |       |       |       |       |       |       |       |       |       |
| Calcispheres        | ·     | ●     | ·     |       |       |       | ●     | ·     | ·     | ●     | ●     | ·     |
| Forams              | ○     | ·     |       | ○     |       |       | ·     | ·     | ·     | ·     | ●     | ○     |
| Sponge spicules     |       |       |       |       |       |       |       |       |       |       |       |       |
| Umbellids           |       |       |       |       |       |       |       |       |       |       |       |       |
| Undetermined        |       |       |       |       |       |       |       |       |       |       |       |       |
| Codiaceans          |       |       |       |       |       |       |       |       |       |       |       |       |
| Dasycladaceans      |       | ●     | *     | ·     |       |       |       | ●     |       |       |       | *     |
| Girvanella Gp.      | ·     |       |       |       | ·     |       | ·     |       |       |       | ·     | ·     |
| Renalcis Gp.        |       |       |       |       |       |       |       |       |       |       |       |       |
| Hedstroemia Gp.     |       |       |       |       |       |       |       |       |       |       |       |       |
| Wetheredella Gp.    |       |       |       |       |       |       |       |       |       |       |       |       |
| Matrix              | S     | M,S   | M     | S,M   | M,S   | M     | S     | M     | S     | S     | M,Ms  | M     |
| Bloturbation        |       | ✓     |       | ✓     |       |       |       | ✓     |       |       | ✓     | ✓     |
| Micrite envelope    | ✓     |       |       |       |       |       | ✓     |       |       | ✓     |       |       |
| Fenestrae: Tubular  |       |       | ✓     |       |       |       |       |       |       |       |       |       |
| Laminoid/irregular  |       |       | ✓     |       |       |       |       |       |       |       |       |       |
| Geopetals           |       |       |       |       |       |       |       |       |       |       |       |       |
| Gravity cements     |       |       |       |       |       |       |       |       |       |       |       |       |
| Lamination          |       |       |       |       | ✓     |       |       |       |       |       |       |       |
| Others              | *1    | *2    |       |       |       | *3    |       | *2    |       |       |       | *2    |

\*1 Sample of matrix

\*2 Matrix is very peloidal

\*3 Alignment of grains parallel to bedding

|         |   |
|---------|---|
| Texture | M=Mudstone, W=Wackestone, P=Packstone<br>G=Grainstone, F=Floatstone, Bf=Bafflestone<br>Bi=Bindstone, B=Boundstone, D=Dolomite |
| Matrix  | M=Micrite, Ms=Microspar, S=Spar, D=Dolomite   |

## A1.2.5 Bleiwäsche Road Cutting

○ = <1%    · = 1–20%    ● = 21–40%    ● = 41–60%    \* = >61%

| Sample number       | BRC1 | BRC2  | BRC3 | BRC4 | BRC5 | BRC6 | BRC7 | BRC8 |  |  |  |  |  |  |
|---------------------|------|-------|------|------|------|------|------|------|--|--|--|--|--|--|
| Height              | 0.4m | 1.2m  | 2.1m | 3.1m | 4.9m | 6.6m | 8.2m | 9.3m |  |  |  |  |  |  |
| Thin Section/ Peel  | TS   | TS    | TS   | TS   | TS   | TS   | TS   | TS   |  |  |  |  |  |  |
| Microfacies         | S6a  | S4a   | S4b  | S6a  | S6a  | S4b  | S4b  | S7a  |  |  |  |  |  |  |
| Texture             | W    | F     | G    | P    | WP   | G    | G    | G    |  |  |  |  |  |  |
| Grains:             |      |       |      |      |      |      |      |      |  |  |  |  |  |  |
| Peloids             |      |       | *    |      |      | ●    | *    | ●    |  |  |  |  |  |  |
| Lithoclasts         |      |       |      |      |      |      |      |      |  |  |  |  |  |  |
| Oncoids             |      |       |      |      |      |      |      |      |  |  |  |  |  |  |
| Ooids               |      |       |      |      |      |      |      |      |  |  |  |  |  |  |
| Aggregate grains    |      |       |      |      |      |      |      |      |  |  |  |  |  |  |
| Quartz/ silt grains |      |       |      |      |      |      |      |      |  |  |  |  |  |  |
| Bioclasts:          |      |       |      |      |      |      |      |      |  |  |  |  |  |  |
| Bulbous stroms.     |      |       |      |      |      |      |      |      |  |  |  |  |  |  |
| Laminar stroms.     |      |       |      |      |      |      |      |      |  |  |  |  |  |  |
| Dendroid stroms.    |      |       |      |      |      |      |      |      |  |  |  |  |  |  |
| Stachyodes          |      |       |      |      |      |      |      |      |  |  |  |  |  |  |
| Amphipora           | ●    | *     | ·    | ·    | ·    | ●    | ·    |      |  |  |  |  |  |  |
| Colonial corals     |      |       |      |      |      |      |      |      |  |  |  |  |  |  |
| Solitary corals     |      |       |      |      |      |      |      |      |  |  |  |  |  |  |
| Thamnoporoids       |      |       |      |      |      |      |      |      |  |  |  |  |  |  |
| Bivalves            |      |       |      |      |      |      |      |      |  |  |  |  |  |  |
| Gastropods          |      |       |      |      |      |      |      |      |  |  |  |  |  |  |
| Shell hash          |      |       |      |      |      |      |      |      |  |  |  |  |  |  |
| Brachiopods         |      |       |      |      |      |      |      |      |  |  |  |  |  |  |
| Brachiopod spines   |      |       |      |      |      |      |      |      |  |  |  |  |  |  |
| Crinoids            |      |       |      |      |      |      |      |      |  |  |  |  |  |  |
| Tentaculites        |      |       |      |      |      |      |      |      |  |  |  |  |  |  |
| Trilobites          |      |       |      |      |      |      |      |      |  |  |  |  |  |  |
| Bryozoans           |      |       |      |      |      |      |      |      |  |  |  |  |  |  |
| Ostrocodes          |      |       | ·    |      | ○    |      | ·    | ·    |  |  |  |  |  |  |
| Leperditia          |      |       |      |      |      |      |      |      |  |  |  |  |  |  |
| Calcispheres        | ●    | ·     | ·    | ·    | ·    |      | ·    | ·    |  |  |  |  |  |  |
| Forams              | ·    |       | ·    |      |      |      | ·    | ·    |  |  |  |  |  |  |
| Sponge spicules     |      |       |      |      |      |      |      |      |  |  |  |  |  |  |
| Umbellids           |      |       |      |      |      |      |      |      |  |  |  |  |  |  |
| Undetermined        |      |       |      |      |      |      |      |      |  |  |  |  |  |  |
| Codiaceans          | ·    |       |      |      |      |      |      |      |  |  |  |  |  |  |
| Dasycladaceans      |      |       | ·    | *    | *    |      |      | ●    |  |  |  |  |  |  |
| Girvanella Gp.      |      |       |      |      |      |      |      |      |  |  |  |  |  |  |
| Renalcis Gp.        |      |       |      |      |      |      |      |      |  |  |  |  |  |  |
| Hedstroemia Gp.     |      |       |      |      |      |      |      |      |  |  |  |  |  |  |
| Wetheredella Gp.    |      |       |      |      |      |      |      |      |  |  |  |  |  |  |
| Matrix              | M,D  | S,M,D | S    | M    | M,D  | S,M  | S,M  | S,M  |  |  |  |  |  |  |
| Bioturbation        | ✓    | ✓     |      | ✓    | ✓    | ✓    |      | ✓    |  |  |  |  |  |  |
| Micrite envelope    |      |       |      |      |      |      |      | ✓    |  |  |  |  |  |  |
| Fenestrae: Tubular  |      |       |      |      |      |      |      |      |  |  |  |  |  |  |
| Laminoid/irregular  |      |       |      |      |      |      |      |      |  |  |  |  |  |  |
| Geopetals           |      | ✓     |      |      |      |      |      |      |  |  |  |  |  |  |
| Gravity cements     |      |       |      |      |      |      |      |      |  |  |  |  |  |  |
| Lamination          |      |       |      |      |      |      |      |      |  |  |  |  |  |  |
| Others              |      |       |      |      |      |      |      |      |  |  |  |  |  |  |

|         |   |
|---------|---|
| Texture | M=Mudstone, W=Wackestone, P=Packstone<br>G=Grainstone, F=Floatstone, Bf=Bafflestone<br>Bi=Bindstone, B=Boundstone, D=Dolomite |
| Matrix  | M=Micrite, Ms=Microspar, S=Spar, D=Dolomite   |

## A1.2.6 Broadridge Wood Quarry

○ = <1%    · = 1–20%    ● = 21–40%    ● = 41–60%    \* = >61%

| Sample number       | BW1  | BW2  | BW3  | BW4  | BW5  | BW6  | BW7  | BW8  | BW9  | BW10 | BW11 | BW12  | BW13  |
|---------------------|------|------|------|------|------|------|------|------|------|------|------|-------|-------|
| Height              | 0.5m | 7.0m | 2.5m | 1.0m | 3.1m | 1.5m | 4.4m | 5.0m | 7.5m | 8.4m | 9.0m | 10.4m | 11.2m |
| Thin Section/ Peel  | TS   | TS   | TS   | TS   | TS   | TS   | TS   | TS   | TS   | TS   | TS   | TS    | TS    |
| Microfacies         | S14  | S6a  | S6b  | S4a  | S4a  | S2   | S4a  | S2   | S8a  | S6b  | S6a  | S6a   | S6a   |
| Texture             | W    | P    | M    | W    | W    | F    | F    | F    | MW   | M    | PG   | W     | W     |
| Grains:             |      |      |      |      |      |      |      |      |      |      |      |       |       |
| Peloids             | ●    |      |      | ●    |      |      |      |      |      |      | * ●  | ●     |       |
| Lithoclasts         |      |      |      |      |      |      |      |      |      | ·    |      |       | ·     |
| Oncoids             |      |      |      |      |      |      |      |      |      |      |      |       |       |
| Ooids               |      |      |      |      |      |      |      |      |      |      |      |       |       |
| Aggregate grains    |      |      |      |      |      |      |      |      |      |      |      |       |       |
| Quartz/ silt grains |      |      |      |      |      |      |      |      |      |      |      |       |       |
| Bioclasts:          |      |      |      |      |      |      |      |      |      |      |      |       |       |
| Bulbous stroms.     |      |      |      |      |      | *    |      | *    |      |      |      |       |       |
| Laminar stroms.     |      |      |      |      |      |      |      |      |      |      |      |       |       |
| Dendroid stroms.    | ●    |      |      |      |      |      |      |      |      |      |      |       |       |
| Stachyodes          |      |      |      |      |      |      |      |      |      |      |      |       |       |
| Amphipora           |      |      | ●    | ●    | ·    |      | ●    |      |      |      |      |       | ·     |
| Colonial corals     |      |      |      |      |      |      |      |      |      |      |      |       |       |
| Solitary corals     |      |      |      |      |      |      |      |      |      |      |      |       |       |
| Thamnoporoids       |      |      |      |      |      |      |      |      |      |      |      |       |       |
| Bivalves            |      | ·    |      |      |      |      |      |      |      |      |      |       |       |
| Gastropods          |      |      |      |      |      |      |      |      |      | ·    |      |       |       |
| Shell hash          |      |      |      |      |      |      |      |      |      |      |      |       |       |
| Brachiopods         |      | ●    |      |      |      |      |      |      |      |      |      |       |       |
| Brachiopod spines   |      |      |      |      |      |      |      |      |      |      |      |       |       |
| Crinoids            |      |      |      |      |      |      |      |      |      |      |      |       |       |
| Tentaculites        |      |      |      |      |      |      |      |      |      |      |      |       |       |
| Trilobites          |      |      |      |      |      |      |      |      |      |      |      |       |       |
| Bryozoans           |      |      |      |      |      |      |      |      |      |      |      |       |       |
| Ostrocodes          | ·    | ·    | ●    | ·    | ·    |      | ·    |      | ·    |      | ·    | ·     | ·     |
| Leperditia          |      |      |      |      |      |      |      |      |      |      |      |       |       |
| Calcspheres         |      | ·    | ·    | ·    | ·    |      | ·    |      | ●    | *    | ·    | ·     | ●     |
| Forams              | ·    | ●    |      | ·    | ●    |      | ●    |      | *    | ·    | ·    | ·     | ·     |
| Sponge spicules     |      |      |      |      |      |      |      |      |      |      |      |       |       |
| Umbellids           |      |      |      |      |      |      |      |      |      |      |      |       |       |
| Undetermined        |      |      |      |      |      |      |      |      |      |      |      |       |       |
| Codiaceans          |      |      |      |      |      |      |      |      |      |      |      |       |       |
| Dasycladaceans      |      | ·    |      |      | ·    |      | ·    |      | ○    |      | ·    | ·     | ·     |
| Girvanella Gp.      |      | ·    |      |      |      |      |      |      |      |      |      |       |       |
| Renalcis Gp.        |      |      |      |      |      |      |      |      |      |      |      |       |       |
| Hedstroemia Gp.     |      |      |      |      |      |      |      |      |      |      |      |       |       |
| Wetheredella Gp.    |      |      |      |      |      |      |      |      |      |      |      |       |       |
| Matrix              | M    | M    | M    | M    | M    |      | M    |      | M    | M,D  | M,S  | M,D   | M     |
| Bioturbation        |      | ✓    | ✓    | ✓    | ✓    |      | ✓    |      |      | ✓    | ✓    | ✓     | ✓     |
| Micrite envelope    |      |      |      |      |      |      |      |      |      |      |      |       |       |
| Fenestrae: Tubular  |      |      |      |      |      |      |      |      | ✓    |      |      |       |       |
| Laminoid/irregular  | ✓    |      |      |      |      |      |      |      | ✓    |      |      |       |       |
| Geopetals           |      |      |      |      |      |      |      |      | ✓    |      |      |       |       |
| Gravity cements     |      |      |      |      |      |      |      |      |      |      |      |       |       |
| Lamination          |      |      |      |      |      |      |      |      |      |      |      |       |       |
| Others              | *1   |      |      |      |      | *2   |      | *2   | *3   |      |      |       |       |

\*1 Calcrete. Circum-granular cracks, mottled floating texture, sediment-filled micro-cracks

\*2 Thin section cut through bulbous stromatoporoid

\*3 Vadose silt at base of fenestrae

|         |  |
|---------|--|
| Texture | M=Mudstone, W=Wackestone, P=Packstone<br>G=Grainstone, F=Floatstone, Bf= Bafflestone<br>Bi=Bindstone, B=Boundstone, D=Dolomite |
| Matrix  | M=Micrite, Ms=Microspar, S=Spar, D=Dolomite  |

## Broadridge Wood Quarry

○ = <1%    · = 1-20%    ● = 21-40%    ● = 41-60%    \* = >61%

| Sample number       | BW14  | BW15  | BW16  | BW17  | BW18  | BW19  | BW20  | BW21  | BW22  | BW23  | BW24  | BW25  | BW26  |
|---------------------|-------|-------|-------|-------|-------|-------|-------|-------|-------|-------|-------|-------|-------|
| Height              | 12.8m | 13.2m | 10.0m | 13.4m | 14.0m | 15.0m | 15.5m | 16.0m | 16.4m | 17.6m | 18.1m | 19.5m | 20.0m |
| Thin Section/ Peel  | TS    | P     | P     | TS    | P     | TS    | TS    | TS    | TS    | TS    | TS    | TS    | TS    |
| Microfacies         | S4a   | S10   | S7a   | S6b   | S2    | S6a   | S4a   | S6f   | S6a   | S6a   | S4a   | S4a   | S4a   |
| Texture             | F     | M     | G     | MW    | F     | MW    | F     | M     | W     | W     | Bf    | F     | Bf    |
| Grains:             |       |       |       |       |       |       |       |       |       |       |       |       |       |
| Peloids             |       | *     | *     |       |       |       |       |       |       |       |       |       |       |
| Lithoclasts         |       |       |       | ●     |       |       |       |       |       |       |       |       |       |
| Oncoids             |       |       |       |       |       |       |       |       |       |       |       |       |       |
| Ooids               |       |       |       |       |       |       |       |       |       |       |       |       |       |
| Aggregate grains    |       |       |       |       |       |       |       |       |       |       |       |       |       |
| Quartz/ silt grains |       |       |       |       |       |       |       |       |       |       |       |       |       |
| Bioclasts:          |       |       |       |       |       |       |       |       |       |       |       |       |       |
| Bulbous stroms.     |       |       |       |       |       |       |       |       |       |       |       |       |       |
| Laminar stroms.     |       |       |       |       |       |       |       |       |       |       |       |       |       |
| Dendroid stroms.    |       |       |       |       |       |       |       |       |       |       |       |       |       |
| Stachyodes          |       |       |       |       | ●     |       |       |       |       |       |       |       |       |
| Amphipora           | *     |       | ·     | ·     | ·     | ·     | ●     | ·     | ·     |       | *     | *     | *     |
| Colonial corals     |       |       |       |       |       |       |       |       |       |       |       |       |       |
| Solitary corals     |       |       |       |       | ·     |       |       |       |       |       |       |       |       |
| Thamnoporoids       |       |       |       |       |       |       |       |       |       |       |       |       |       |
| Bivalves            |       |       |       |       |       |       | ●     |       | ·     |       |       |       |       |
| Gastropods          |       |       |       |       |       |       | ·     |       |       |       |       |       |       |
| Shell hash          |       |       |       |       |       |       |       |       |       |       |       |       |       |
| Brachiopods         |       |       |       |       |       |       |       |       |       |       |       |       |       |
| Brachiopod spines   |       |       |       |       |       |       |       |       |       |       |       |       |       |
| Crinoids            |       |       |       |       |       |       |       |       |       |       |       |       |       |
| Tentaculites        |       |       |       |       |       |       |       |       |       |       |       |       |       |
| Trilobites          |       |       |       |       |       |       |       |       |       |       |       |       |       |
| Bryozoans           |       |       |       |       |       |       |       |       |       |       |       |       |       |
| Ostrocodes          |       | ·     | ·     | ·     | ·     | ·     | ·     | ●     | ·     | ·     | ·     | ·     |       |
| Leperditia          |       |       |       |       |       |       |       |       |       |       |       |       |       |
| Calcspheres         |       | ·     | ·     | ●     |       | ·     | ·     | ·     | ·     | ·     | ·     | ·     |       |
| Forams              |       | ○     | ○     | ·     |       | ●     | ·     | ●     | ●     | *     |       | ·     |       |
| Sponge spicules     |       |       |       |       |       |       |       |       |       |       |       |       |       |
| Umbellids           |       |       |       |       |       |       |       |       |       |       |       |       |       |
| Undetermined        |       |       |       |       |       |       |       |       |       |       |       |       |       |
| Codlaceans          |       |       |       |       |       |       |       | ·     |       |       |       |       |       |
| Dasycladaceans      |       | ○     |       | ·     |       | ·     | ·     | ●     |       | ·     |       |       |       |
| Girvanella Gp.      |       |       |       |       |       |       |       |       |       |       |       |       |       |
| Renalcis Gp.        |       |       |       |       |       |       |       |       |       |       |       |       |       |
| Hedstroemia Gp.     |       |       |       |       |       |       |       |       |       |       |       |       |       |
| Wetheredella Gp.    |       |       |       |       |       |       |       |       |       |       |       |       |       |
| Matrix              | D     | M     | S     | M     | M     | M     | M     | M     | M     | M     | D,M   | M,Ms  | D     |
| Bioturbation        |       | ✓     | ✓     |       | ✓     |       | ✓     | ✓     | ✓     | ✓     | ✓     | ✓     |       |
| Micrite envelope    |       |       | ✓     |       |       |       |       |       |       |       |       |       |       |
| Fenestrae: Tubular  |       | ✓     |       |       |       |       |       |       |       |       |       |       |       |
| Laminoid/irregular  |       |       |       |       |       |       |       |       |       |       |       |       |       |
| Geopetals           |       | ✓     | ✓     |       |       |       |       |       |       |       | ✓     |       |       |
| Gravity cements     |       |       |       |       |       |       |       |       |       |       |       |       |       |
| Lamination          |       |       |       |       |       |       |       |       |       |       |       |       |       |
| Others              | *1    |       |       |       |       |       |       |       |       |       |       |       |       |

\*1 Poor preservation, altered to dolomite

|         |  |
|---------|--|
| Texture | M=Mudstone, W=Wackestone, P=Packstone<br>G=Grainstone, F=Floatstone, Bf= Bafflestone<br>Bi=Bindstone, B=Boundstone, D=Dolomite |
| Matrix  | M=Micrite, Ms=Microspar, S=Spar, D=Dolomite  |

## Broadridge Wood Quarry

○ = <1%    · = 1-20%    ● = 21-40%    ● = 41-60%    \* = >61%

| Sample number       | BW27  | BW28  | BW19  | BW30  | BW31  | BW32  |  |  |  |  |  |  |  |  |  |
|---------------------|-------|-------|-------|-------|-------|-------|--|--|--|--|--|--|--|--|--|
| Height              | 20.4m | 20.9m | 24.5m | 25.1m | 27.5m | 29.2m |  |  |  |  |  |  |  |  |  |
| Thin Section/ Peel  | TS    | TS    | TS    | TS    | TS    | TS    |  |  |  |  |  |  |  |  |  |
| Microfacies         | S4a   | S8a   | S2    | S8a   | S8a   | S8a   |  |  |  |  |  |  |  |  |  |
| Texture             | F     | M     | F     | W     | W     | P     |  |  |  |  |  |  |  |  |  |
| Grains:             |       |       |       |       |       |       |  |  |  |  |  |  |  |  |  |
| Peloids             |       |       |       |       | ●     | *     |  |  |  |  |  |  |  |  |  |
| Lithoclasts         |       |       |       |       |       |       |  |  |  |  |  |  |  |  |  |
| Oncoids             |       |       |       |       |       |       |  |  |  |  |  |  |  |  |  |
| Ooids               |       |       |       |       |       |       |  |  |  |  |  |  |  |  |  |
| Aggregate grains    |       |       |       |       |       |       |  |  |  |  |  |  |  |  |  |
| Quartz/ silt grains |       |       |       |       |       |       |  |  |  |  |  |  |  |  |  |
| Bioclasts:          |       |       |       |       |       |       |  |  |  |  |  |  |  |  |  |
| Bulbous stroms.     |       |       |       |       |       |       |  |  |  |  |  |  |  |  |  |
| Laminar stroms.     |       |       |       |       |       |       |  |  |  |  |  |  |  |  |  |
| Dendroid stroms.    |       |       | ●     |       |       |       |  |  |  |  |  |  |  |  |  |
| Stachyodes          |       |       |       |       |       |       |  |  |  |  |  |  |  |  |  |
| Amphipora           | *     |       |       |       |       |       |  |  |  |  |  |  |  |  |  |
| Colonial corals     |       |       |       |       |       |       |  |  |  |  |  |  |  |  |  |
| Solitary corals     |       |       |       |       |       |       |  |  |  |  |  |  |  |  |  |
| Thamnoporoids       |       |       |       |       |       |       |  |  |  |  |  |  |  |  |  |
| Bivalves            |       |       |       |       |       |       |  |  |  |  |  |  |  |  |  |
| Gastropods          |       |       |       |       |       |       |  |  |  |  |  |  |  |  |  |
| Shell hash          |       |       |       |       |       |       |  |  |  |  |  |  |  |  |  |
| Brachiopods         |       |       |       |       |       |       |  |  |  |  |  |  |  |  |  |
| Brachiopod spines   |       |       |       |       |       |       |  |  |  |  |  |  |  |  |  |
| Crinoids            |       |       |       |       |       |       |  |  |  |  |  |  |  |  |  |
| Tentaculites        |       |       |       |       |       |       |  |  |  |  |  |  |  |  |  |
| Trilobites          |       |       |       |       |       |       |  |  |  |  |  |  |  |  |  |
| Bryozoans           |       |       |       |       |       |       |  |  |  |  |  |  |  |  |  |
| Ostrocodes          | ·     | ●     | ●     | ○     | ·     |       |  |  |  |  |  |  |  |  |  |
| Leperditia          |       |       |       |       |       |       |  |  |  |  |  |  |  |  |  |
| Calcspheres         | ·     | ●     | ·     | *     | ·     | ·     |  |  |  |  |  |  |  |  |  |
| Forams              | ·     | ●     |       | ●     | ·     | ·     |  |  |  |  |  |  |  |  |  |
| Sponge spicules     |       |       |       |       |       |       |  |  |  |  |  |  |  |  |  |
| Umbellids           |       |       |       |       |       |       |  |  |  |  |  |  |  |  |  |
| Undetermined        |       |       |       |       |       |       |  |  |  |  |  |  |  |  |  |
| Codiaceans          |       |       |       |       |       |       |  |  |  |  |  |  |  |  |  |
| Dasycladaceans      |       |       |       | ·     |       | ·     |  |  |  |  |  |  |  |  |  |
| Girvanella Gp.      |       |       |       | ○     |       |       |  |  |  |  |  |  |  |  |  |
| Renalcis Gp.        |       |       |       |       |       |       |  |  |  |  |  |  |  |  |  |
| Hedstroemia Gp.     |       |       |       |       |       |       |  |  |  |  |  |  |  |  |  |
| Wetheredella Gp.    |       |       |       |       |       |       |  |  |  |  |  |  |  |  |  |
| Matrix              | M,D   | M,D   | M     | M     | M     | M,S   |  |  |  |  |  |  |  |  |  |
| Bioturbation        |       | ✓     |       | ✓     | ✓     | ✓     |  |  |  |  |  |  |  |  |  |
| Micrite envelope    |       |       |       |       |       |       |  |  |  |  |  |  |  |  |  |
| Fenestrae: Tubular  |       |       |       |       | ✓     | ✓     |  |  |  |  |  |  |  |  |  |
| Laminoid/irregular  |       |       |       | ✓     | ✓     | ✓     |  |  |  |  |  |  |  |  |  |
| Geopetals           |       |       |       |       |       |       |  |  |  |  |  |  |  |  |  |
| Gravity cements     |       |       |       |       |       |       |  |  |  |  |  |  |  |  |  |
| Lamination          |       |       |       |       |       |       |  |  |  |  |  |  |  |  |  |
| Others              |       |       |       | *1    |       | *1    |  |  |  |  |  |  |  |  |  |

\*1 Vadose silt in the base of the fenestrae

|         |  |
|---------|--|
| Texture | M=Mudstone, W=Wackestone, P=Packstone<br>G=Grainstone, F=Floatstone, Bf= Bafflestone<br>Bi=Bindstone, B=Boundstone, D=Dolomite |
| Matrix  | M=Micrite, Ms=Microspar, S=Spar, D=Dolomite  |

## A1.2.7 Cul d'Houille Quarry

○ = <1%    · = 1–20%    ● = 21–40%    ● = 41–60%    \* = >61%

| Sample number       | CDH1  | CDH2 | CDH3 | CDH4  | CDH5 | CDH6 | CDH7  | CDH8  | CDH9  | CDH10 | CDH11 | CDH12 | CDH13 |
|---------------------|-------|------|------|-------|------|------|-------|-------|-------|-------|-------|-------|-------|
| Height              | 2.7m  | 2.8m | 3.2m | 5.55m | 8.4m | 8.6m | 9.75m | 11.0m | 12.3m | 14.2m | 15.7m | 16.3m | 22.6m |
| Thin Section/ Peel  | TS    | TS   | TS   | TS    | TS   | TS   | TS    | TS    | TS    | TS    | TS    | TS    | TS    |
| Microfacies         | S4a   | S12b | S2   | S6e   | S2   | S6d  | S7a   | S7a   | S6a   | S4a   | S4a   | S4a   | S7b   |
| Texture             | W     | G    | FB   | M     | F    | WP   | G     | G     | W     | F     | F     | D     | G     |
| Grains:             |       |      |      |       |      |      |       |       |       |       |       |       |       |
| Peloids             | ●     | ●    |      | ●     |      |      | ●     | *     | *     |       |       |       | ·     |
| Lithoclasts         |       | ·    |      |       |      | ●    | ·     |       |       |       |       |       | ●     |
| Oncoids             |       | ·    |      |       |      | ●    | ·     | ·     | ○     |       |       |       |       |
| Ooids               |       |      |      | ●     |      |      |       |       | ·     |       |       |       | ●     |
| Aggregate grains    |       |      |      |       |      |      |       |       |       |       |       |       |       |
| Quartz/ silt grains |       |      |      |       |      |      |       |       |       |       |       |       |       |
| Bioclasts:          |       |      |      |       |      |      |       |       |       |       |       |       |       |
| Bulbous stroms.     |       |      | *    |       | ●    |      |       |       |       |       |       |       |       |
| Laminar stroms.     |       |      |      |       |      |      |       |       |       |       |       |       |       |
| Dendroid stroms.    |       |      | ·    |       | ·    |      |       |       |       |       |       |       |       |
| Stachyodes          |       |      |      |       |      |      |       |       |       |       |       |       |       |
| Amphipora           |       |      |      |       |      |      |       |       |       | *     | *     |       |       |
| Colonial corals     |       |      |      |       |      |      |       |       |       |       |       |       |       |
| Solitary corals     |       |      |      |       |      |      |       |       |       |       |       |       |       |
| Thamnoporoids       | ●     |      | ·    |       | ●    |      |       |       |       |       |       |       |       |
| Bivalves            | ·     |      |      |       |      |      |       |       |       |       |       |       |       |
| Gastropods          | ·     |      |      |       |      |      |       |       |       |       |       |       |       |
| Shell hash          |       |      |      |       |      |      |       |       |       |       |       |       |       |
| Brachiopods         |       |      |      |       | ·    |      |       |       |       |       |       |       |       |
| Brachiopod spines   |       |      |      |       |      |      |       |       |       |       |       |       |       |
| Crinoids            |       |      |      |       |      |      |       |       |       |       |       |       |       |
| Tentaculites        |       |      |      |       |      |      |       |       |       |       |       |       |       |
| Trilobites          |       |      |      |       |      |      |       |       |       |       |       |       |       |
| Bryozoans           |       |      |      |       |      |      |       |       |       |       |       |       |       |
| Ostrocodes          | ·     | ·    |      | ●     | ○    | ·    | ○     |       |       |       |       |       |       |
| Leperditia          |       |      |      |       |      |      |       |       |       |       |       |       |       |
| Calcispheres        |       |      |      |       |      |      |       |       |       | ·     | ·     |       |       |
| Forams              | ·     |      |      |       |      | ○    |       | ○     |       |       |       |       |       |
| Sponge spicules     |       |      |      |       |      |      |       |       |       |       |       |       |       |
| Umbellids           |       |      |      |       |      |      |       |       |       |       |       |       |       |
| Undetermined        |       |      |      |       |      |      |       |       |       |       |       |       |       |
| Codiaceans          |       |      |      |       |      |      |       |       |       |       |       |       |       |
| Dasycladaceans      |       |      |      |       | ○    |      |       |       |       | ·     | ·     |       | ·     |
| Girvanella Gp.      |       | ·    |      | ·     |      | ·    | ●     |       |       |       |       |       |       |
| Renalcis Gp.        | ·     |      |      |       |      |      |       |       |       |       |       |       |       |
| Hedstroemia Gp.     |       |      |      |       |      |      |       |       |       |       |       |       |       |
| Wetheredella Gp.    |       |      |      |       |      |      |       |       |       |       |       |       |       |
| Matrix              | M,S,D | S,M  | D    | M,S   | M,D  | M    | S     | S,D   | M     | M,D   | M,D   | D     | S,M   |
| Bioturbation        | ✓     |      |      | ✓     |      | ✓    |       |       | ✓     | ✓     | ✓     |       |       |
| Micrite envelope    | ✓     |      |      |       |      |      |       | ✓     |       |       |       |       |       |
| Fenestrae: Tubular  |       |      |      |       |      |      |       |       |       |       |       |       |       |
| Laminoid/irregular  |       |      |      |       |      |      |       |       |       |       |       |       |       |
| Geopetals           |       |      |      |       |      |      |       |       |       |       |       |       |       |
| Gravity cements     |       |      |      |       |      |      |       |       |       |       |       |       |       |
| Lamination          |       |      |      |       |      |      |       |       |       |       |       |       |       |
| Others              | *1    | *1   |      |       | *1   |      |       |       |       | *1    |       |       | *1    |

\*1 Orientation of bioclasts parallel to bedding

|         |  |
|---------|--|
| Texture | M=Mudstone, W=Wackestone, P=Packstone<br>G=Grainstone, F=Floatstone, Bf= Bafflestone<br>Bi=Bindstone, B=Boundstone, D=Dolomite |
| Matrix  | M=Micrite, Ms=Microspar, S=Spar, D=Dolomite  |

## Cul d'Houille Quarry

○ = <1%    · = 1-20%    ● = 21-40%    ● = 41-60%    \* = >61%

| Sample number       | CDH14  | CDH15 | CDH16  | CDH17 | CDH18 | CDH19 | CDH20a | CDH20b | CDH21 | CDH22 | CDH23 | CDH25  | CDH26 |
|---------------------|--------|-------|--------|-------|-------|-------|--------|--------|-------|-------|-------|--------|-------|
| Height              | 26.85m | 30.2m | 33.05m | 33.7m | 37.4m | 39.2m | 39.4m  | 40.2m  | 41.6m | 44.2m | 45.4m | 52.45m | 58.3m |
| Thin Section/ Peel  | TS     | TS    | TS     | TS    | TS    | TS    | TS     | TS     | TS    | TS    | TS    | TS     | TS    |
| Microfacies         | S12a   | S7a   | S7a    | S6f   | S14   | S6b   | S7b    | S6a    | S6b   | S7b   | S6b   | S7a    | S12a  |
| Texture             | M      | G     | G      | W     | F     | M     | G      | P      | M     | W     | M     | G      | M     |
| Grains:             |        |       |        |       |       |       |        |        |       |       |       |        |       |
| Peloids             | *      | *     | ●      | ●     |       | *     | ·      | *      | *     | ·     |       | *      | ●     |
| Lithoclasts         |        |       | ●      |       |       |       |        |        |       | ·     |       |        |       |
| Oncoids             |        |       |        | ●     |       |       |        |        |       |       |       |        |       |
| Ooids               |        |       |        |       |       |       | ●      |        |       | *     |       |        |       |
| Aggregate grains    |        |       |        |       |       |       |        |        |       |       |       |        |       |
| Quartz/ silt grains |        |       |        |       |       |       |        |        |       |       |       |        |       |
| Bioclasts:          |        |       |        |       |       |       |        |        |       |       |       |        |       |
| Bulbous stroms.     |        |       |        |       | *     |       |        |        |       |       |       |        |       |
| Laminar stroms.     |        |       |        |       |       |       |        |        |       |       |       |        |       |
| Dendroid stroms.    |        |       |        |       |       |       |        |        |       |       |       | ·      |       |
| Stachyodes          |        |       |        |       |       |       |        |        |       |       |       |        |       |
| Amphipora           |        | ·     |        | ·     |       |       |        |        |       |       |       |        |       |
| Colonial corals     |        |       |        |       |       |       |        |        |       |       |       |        |       |
| Solitary corals     |        |       |        |       |       |       |        |        |       |       |       |        |       |
| Thamnoporoids       |        |       |        |       |       |       |        |        |       |       |       |        |       |
| Bivalves            |        |       |        |       |       |       |        |        |       |       |       |        |       |
| Gastropods          |        |       |        |       |       |       |        |        |       |       |       |        |       |
| Shell hash          |        |       |        |       |       |       |        |        |       |       |       |        |       |
| Brachiopods         |        |       |        |       |       |       |        |        |       |       |       |        |       |
| Brachiopod spines   |        |       |        |       |       |       |        |        |       |       |       |        |       |
| Crinoids            |        |       |        |       |       |       |        |        |       |       |       |        |       |
| Tentaculites        |        |       |        |       |       |       |        |        |       |       |       |        |       |
| Trilobites          |        |       |        |       |       |       |        |        |       |       |       |        |       |
| Bryozoans           |        |       |        |       |       |       |        |        |       |       |       |        |       |
| Ostrocodes          |        |       |        | ·     |       |       |        | ○      | ·     | ○     |       |        |       |
| Leperditia          |        |       |        |       |       |       |        |        |       |       |       |        |       |
| Calcispheres        | ○      |       |        |       |       | ○     |        | ·      | ·     |       |       | ○      | ·     |
| Forams              |        |       |        |       |       | ○     |        |        | ·     |       |       |        |       |
| Sponge spicules     |        |       |        |       |       |       |        |        |       |       |       |        |       |
| Umbellids           |        |       |        |       |       |       |        |        |       |       |       |        |       |
| Undetermined        |        |       |        |       |       |       |        |        |       |       |       |        |       |
| Codiaceans          |        |       |        |       |       |       |        |        |       |       |       |        |       |
| Dasycladaceans      |        |       |        |       |       |       |        |        |       |       |       |        | ·     |
| Girvanella Gp.      |        | ·     |        | ·     |       |       | ●      |        |       | ●     |       |        | ●     |
| Renalcis Gp.        |        |       |        |       |       |       |        |        |       |       |       |        |       |
| Hedstroemia Gp.     |        |       |        |       |       |       |        |        |       |       |       |        |       |
| Wetheredella Gp.    |        |       |        |       |       |       |        |        |       |       |       |        |       |
| Matrix              | M,S    | S     | S      | M     |       | M     | S      | M      | M     | S,M   | M     | S,D    | M,S   |
| Bioturbation        |        |       |        | ✓     |       | ✓     |        | ✓      | ✓     |       |       |        |       |
| Micrite envelope    |        |       |        |       |       |       |        | ✓      |       | ✓     |       | ✓      |       |
| Fenestrae: Tubular  |        |       |        |       |       |       |        |        |       |       |       |        |       |
| Laminoid/irregular  |        |       |        |       |       |       |        |        |       |       |       |        |       |
| Geopetals           |        |       |        |       |       |       |        |        |       |       |       |        |       |
| Gravity cements     |        |       |        |       |       |       |        |        |       |       |       |        |       |
| Lamination          | ✓      |       |        |       |       |       |        |        |       |       |       |        | ✓     |
| Others              |        |       |        |       | *1    |       |        |        |       |       | *2    |        |       |

\*1 Thin section cut through stromatopoid

\*2 No grains, dominated by lime mud

|         |  |
|---------|--|
| Texture | M=Mudstone, W=Wackestone, P=Packstone<br>G=Grainstone, F=Floatstone, Bf= Bafflestone<br>Bi=Bindstone, B=Boundstone, D=Dolomite |
| Matrix  | M=Micrite, Ms=Microspar, S=Spar, D=Dolomite  |

## Cul d'Houille Quarry

○ = <1%     · = 1-20%     ● = 21-40%     ● = 41-60%     ● = >61%

| Sample number       | CDH27 | CDH28 | CDH29  | CDH30 |  |  |  |  |  |  |  |  |  |  |  |  |  |  |  |  |  |
|---------------------|-------|-------|--------|-------|--|--|--|--|--|--|--|--|--|--|--|--|--|--|--|--|--|
| Height              | 60.5m | 40.0m | 39.85m | 39.8m |  |  |  |  |  |  |  |  |  |  |  |  |  |  |  |  |  |
| Thin Section/ Peel  | TS    | TS    | TS     | TS    |  |  |  |  |  |  |  |  |  |  |  |  |  |  |  |  |  |
| Microfacies         | S7a   | S14   | S14    | S14   |  |  |  |  |  |  |  |  |  |  |  |  |  |  |  |  |  |
| Texture             | G     | M     | M      | M     |  |  |  |  |  |  |  |  |  |  |  |  |  |  |  |  |  |
| Grains:             |       |       |        |       |  |  |  |  |  |  |  |  |  |  |  |  |  |  |  |  |  |
| Peloids             | ●     |       |        |       |  |  |  |  |  |  |  |  |  |  |  |  |  |  |  |  |  |
| Lithoclasts         | ●     |       |        |       |  |  |  |  |  |  |  |  |  |  |  |  |  |  |  |  |  |
| Oncoids             |       |       |        |       |  |  |  |  |  |  |  |  |  |  |  |  |  |  |  |  |  |
| Ooids               |       |       |        |       |  |  |  |  |  |  |  |  |  |  |  |  |  |  |  |  |  |
| Aggregate grains    |       |       |        |       |  |  |  |  |  |  |  |  |  |  |  |  |  |  |  |  |  |
| Quartz/ silt grains |       |       |        |       |  |  |  |  |  |  |  |  |  |  |  |  |  |  |  |  |  |
| Bioclasts:          |       |       |        |       |  |  |  |  |  |  |  |  |  |  |  |  |  |  |  |  |  |
| Bulbous stroms.     |       |       |        |       |  |  |  |  |  |  |  |  |  |  |  |  |  |  |  |  |  |
| Laminar stroms.     |       |       |        |       |  |  |  |  |  |  |  |  |  |  |  |  |  |  |  |  |  |
| Dendroid stroms.    |       |       |        |       |  |  |  |  |  |  |  |  |  |  |  |  |  |  |  |  |  |
| Stachyodes          |       |       |        |       |  |  |  |  |  |  |  |  |  |  |  |  |  |  |  |  |  |
| Amphipora           |       |       |        |       |  |  |  |  |  |  |  |  |  |  |  |  |  |  |  |  |  |
| Colonial corals     |       |       |        |       |  |  |  |  |  |  |  |  |  |  |  |  |  |  |  |  |  |
| Solitary corals     |       |       |        |       |  |  |  |  |  |  |  |  |  |  |  |  |  |  |  |  |  |
| Thamnoporoids       |       |       |        |       |  |  |  |  |  |  |  |  |  |  |  |  |  |  |  |  |  |
| Bivalves            |       |       |        |       |  |  |  |  |  |  |  |  |  |  |  |  |  |  |  |  |  |
| Gastropods          |       |       |        |       |  |  |  |  |  |  |  |  |  |  |  |  |  |  |  |  |  |
| Shell hash          |       |       |        |       |  |  |  |  |  |  |  |  |  |  |  |  |  |  |  |  |  |
| Brachiopods         |       |       |        |       |  |  |  |  |  |  |  |  |  |  |  |  |  |  |  |  |  |
| Brachiopod spines   |       |       |        |       |  |  |  |  |  |  |  |  |  |  |  |  |  |  |  |  |  |
| Crinoids            |       |       |        |       |  |  |  |  |  |  |  |  |  |  |  |  |  |  |  |  |  |
| Tentaculites        |       |       |        |       |  |  |  |  |  |  |  |  |  |  |  |  |  |  |  |  |  |
| Trilobites          |       |       |        |       |  |  |  |  |  |  |  |  |  |  |  |  |  |  |  |  |  |
| Bryozoans           |       |       |        |       |  |  |  |  |  |  |  |  |  |  |  |  |  |  |  |  |  |
| Ostrocodes          | ○     |       |        |       |  |  |  |  |  |  |  |  |  |  |  |  |  |  |  |  |  |
| Leperditia          |       | ●     |        |       |  |  |  |  |  |  |  |  |  |  |  |  |  |  |  |  |  |
| Calcispheres        |       | ·     |        |       |  |  |  |  |  |  |  |  |  |  |  |  |  |  |  |  |  |
| Forams              |       |       |        |       |  |  |  |  |  |  |  |  |  |  |  |  |  |  |  |  |  |
| Sponge spicules     |       |       |        |       |  |  |  |  |  |  |  |  |  |  |  |  |  |  |  |  |  |
| Umbellids           |       |       |        |       |  |  |  |  |  |  |  |  |  |  |  |  |  |  |  |  |  |
| Undetermined        |       |       |        |       |  |  |  |  |  |  |  |  |  |  |  |  |  |  |  |  |  |
| Codaceans           |       |       |        |       |  |  |  |  |  |  |  |  |  |  |  |  |  |  |  |  |  |
| Dasycladaceans      |       |       |        |       |  |  |  |  |  |  |  |  |  |  |  |  |  |  |  |  |  |
| Girvanella Gp.      |       |       |        |       |  |  |  |  |  |  |  |  |  |  |  |  |  |  |  |  |  |
| Renalcis Gp.        |       |       |        |       |  |  |  |  |  |  |  |  |  |  |  |  |  |  |  |  |  |
| Hedstroemia Gp.     |       |       |        |       |  |  |  |  |  |  |  |  |  |  |  |  |  |  |  |  |  |
| Wetheredella Gp.    |       |       |        |       |  |  |  |  |  |  |  |  |  |  |  |  |  |  |  |  |  |
| Matrix              | S,M   |       |        |       |  |  |  |  |  |  |  |  |  |  |  |  |  |  |  |  |  |
| Bioturbation        |       |       |        |       |  |  |  |  |  |  |  |  |  |  |  |  |  |  |  |  |  |
| Micrite envelope    |       |       |        |       |  |  |  |  |  |  |  |  |  |  |  |  |  |  |  |  |  |
| Fenestrae: Tubular  |       | ✓     |        |       |  |  |  |  |  |  |  |  |  |  |  |  |  |  |  |  |  |
| Laminoid/irregular  |       | ✓     |        |       |  |  |  |  |  |  |  |  |  |  |  |  |  |  |  |  |  |
| Geopetals           |       |       |        |       |  |  |  |  |  |  |  |  |  |  |  |  |  |  |  |  |  |
| Gravity cements     |       | ✓     |        |       |  |  |  |  |  |  |  |  |  |  |  |  |  |  |  |  |  |
| Lamination          |       |       |        |       |  |  |  |  |  |  |  |  |  |  |  |  |  |  |  |  |  |
| Others              | *1    | *2    | *2,*3  | *2,*3 |  |  |  |  |  |  |  |  |  |  |  |  |  |  |  |  |  |

\*1 Alignment of intraclasts parallel to bedding

\*2 Calcrete. Calcite-filled cracks, sepiolitic clays, iron-staining,

\*3 As CDH28

|         |   |
|---------|---|
| Texture | M=Mudstone, W=Wackestone, P=Packstone<br>G=Grainstone, F=Floatstone, Bf=Bafflestone<br>Bi=Bindstone, B=Boundstone, D=Dolomite |
| Matrix  | M=Micrite, Ms=Microspar, S=Spar, D=Dolomite   |

## A1.2.8 Dourbes Quarry

○ = <1%    · = 1-20%    ● = 21-40%    ● = 41-60%    ☀ = >61%

| Sample number      | D1   | D2   | D3   | D4    | D5     | D6    | D7    | D8    | D9    | D10   | D11   | D12   | D13   |
|--------------------|------|------|------|-------|--------|-------|-------|-------|-------|-------|-------|-------|-------|
| Height             | 1.8m | 4.8m | 7.5m | 8.3m  | 15.15m | 17.1m | 17.4m | 19.5m | 29.1m | 30.7m | 34.3m | 37.6m | 38.4m |
| Thin Section/ Peel | TS   | TS   | TS   | TS    | TS     | TS    | TS    | TS    | TS    | TS    | TS    | TS    | TS    |
| Microfacies        | S2   | -    | S12a | S6a   | S6a    | S6d   | S10   | S7a   | S7a   | S7a   | S12a  | S2    | S6b   |
| Texture            | F    | D    | M    | W     | WP     | W     | M     | G     | G     | G     | G     | B     | M     |
| Grains:            |      |      |      |       |        |       |       |       |       |       |       |       |       |
| Peloids            |      |      | ☀    | ●     | ☀      | ·     | ☀     | ☀     | ☀     | ☀     | ☀     | ●     |       |
| Lithoclasts        |      |      |      |       |        |       |       | ·     | ·     | ·     |       |       |       |
| Oncoids            |      |      |      |       | ●      | ●     |       |       |       |       |       |       |       |
| Ooids              |      |      |      |       |        |       |       | ●     |       |       |       |       |       |
| Aggregate grains   |      |      |      |       |        |       |       | ·     |       |       |       |       |       |
| Quartz/silt grains |      |      |      |       |        |       |       |       |       |       |       |       |       |
| Bioclasts:         |      |      |      |       |        |       |       |       |       |       |       |       |       |
| Bulbous stroms.    | ☀    |      |      |       |        |       |       |       |       |       |       |       |       |
| Laminar stroms.    |      |      |      |       |        |       |       |       |       |       |       |       |       |
| Dendroid stroms.   | ·    |      |      |       |        | ·     |       |       |       |       |       | ·     |       |
| Stachyodes         |      |      |      |       |        |       |       |       |       |       |       |       |       |
| Amphipora          |      |      |      |       |        |       |       |       |       |       |       | ·     |       |
| Colonial corals    |      |      |      |       |        |       |       |       |       |       |       |       |       |
| Solitary corals    |      |      |      |       |        |       |       |       |       |       |       |       |       |
| Thamnoporoids      |      |      |      |       |        |       |       |       |       |       |       |       |       |
| Bivalves           |      |      |      |       |        |       |       |       |       |       |       |       |       |
| Gastropods         |      |      |      |       |        |       |       |       |       |       |       |       |       |
| Shell hash         |      |      |      |       |        |       |       |       |       |       |       |       |       |
| Brachiopods        | ●    |      |      |       |        |       |       |       |       |       |       |       |       |
| Brachiopod spines  |      |      |      |       |        |       |       |       |       |       |       |       |       |
| Crinoids           |      |      |      |       |        |       |       |       |       |       |       |       |       |
| Tentaculites       |      |      |      |       |        |       |       |       |       |       |       |       |       |
| Trilobites         |      |      |      |       |        |       |       |       |       |       |       |       |       |
| Bryozoans          |      |      |      |       |        |       |       |       |       |       |       |       |       |
| Ostrocodes         |      |      | ·    | ●     |        | ·     |       |       | ○     | ·     |       | ·     | ·     |
| Leperditia         |      |      |      |       |        | ·     |       |       |       |       |       |       |       |
| Calcispheres       |      |      |      |       |        |       | ·     |       |       | ○     |       |       | ●     |
| Forams             |      |      | ○    |       | ·      | ·     |       |       |       |       |       |       |       |
| Sponge spicules    |      |      |      |       |        |       |       |       |       |       |       |       |       |
| Umbellids          |      |      |      |       |        |       |       |       |       |       |       |       |       |
| Undetermined       |      |      |      |       |        |       |       |       |       |       |       |       |       |
| Codiaceans         |      |      |      | ·     |        |       |       |       |       |       |       |       |       |
| Dasycladaceans     |      |      |      | ·     |        |       |       |       |       |       |       |       | ●     |
| Girvanella Gp.     |      |      |      |       | ·      | ●     |       |       |       |       | ·     | ·     |       |
| Renalcis Gp.       | ·    |      |      |       |        |       |       |       |       |       |       |       |       |
| Hedstroemia Gp.    |      |      |      |       |        |       |       |       |       |       |       |       |       |
| Wetheredella Gp.   |      |      |      |       |        |       |       |       |       |       |       |       |       |
| Matrix             | M    |      | M,S  | M,S,D | M,S    | M,S   | M     | S     | M,S   | S     | S     | S,M   | M     |
| Bioturbation       | ✓    |      |      | ✓     | ✓      | ✓     |       |       | ✓     |       |       |       | ✓     |
| Micrite envelope   |      |      |      |       |        |       |       |       |       |       |       |       |       |
| Fenestrae: Tubular |      |      |      |       |        |       |       |       |       |       |       |       |       |
| Laminoid/irregular |      |      |      |       |        |       | ✓     |       |       |       |       |       |       |
| Geopetals          |      |      |      |       |        | ✓     |       |       |       |       |       |       |       |
| Gravity cements    |      |      |      |       |        |       |       |       |       |       |       |       |       |
| Lamination         |      |      | ✓    |       |        |       | ✓     | ✓     |       |       |       | ✓     |       |
| Others             | *1   | *2   |      |       |        |       |       |       |       | *3    |       | *4    |       |

\*1 Matrix is clay-rich

\*2 Facies has been dolomitised

\*3 Lithoclasts aligned parallel to bedding

\*4 Microbial lamination encrusting bioclasts

|         |  |
|---------|--|
| Texture | M=Mudstone, W=Wackestone, P=Packstone<br>G=Grainstone, F=Floatstone, Bf= Bafflestone<br>Bi=Bindstone, B=Boundstone, D=Dolomite |
| Matrix  | M=Micrite, Ms=Microspar, S=Spar, D=Dolomite  |

## A1.2.9 Froid Lieu Quarry

○ = <1%    · = 1-20%    ● = 21-40%    ● = 41-60%    \* = >61%

| Sample number       | FL1   | FL2   | FL3   | FL4   | FL5   | FL6   | FL7   | FL8   | FL9   | FL10  | FL11 | FL12  | FL13 |
|---------------------|-------|-------|-------|-------|-------|-------|-------|-------|-------|-------|------|-------|------|
| Height              | 27.2m | 25.5m | 22.6m | 21.1m | 18.8m | 18.1m | 16.5m | 14.4m | 12.9m | 11.6m | 8.7m | 2.8m  | 2.2m |
| Thin Section/ Peel  | TS    | TS    | TS    | TS    | TS    | TS    | TS    | TS    | TS    | TS    | TS   | TS    | TS   |
| Microfacies         | S6b   | S6f   | S6b   | S8a   | S6a   | S6b   | S5    | S8a   | S5    | S8a   | S7a  | S5    | S6a  |
| Texture             | MW    | W     | M     | MW    | W     | MW    | WP    | W     | P     | M     | G    | G     | WP   |
| Grains:             |       |       |       |       |       |       |       |       |       |       |      |       |      |
| Peloids             |       | ●     |       | ·     |       |       | ●     |       | ●     |       | ●    | ·     | ·    |
| Lithoclasts         |       |       |       |       |       | ●     | ·     |       |       |       | ○    | ·     |      |
| Oncoids             |       |       |       |       |       |       |       |       |       |       |      |       |      |
| Ooids               |       |       |       |       |       |       |       |       |       |       |      |       |      |
| Aggregate grains    |       |       |       |       |       |       |       |       |       |       |      |       |      |
| Quartz/ silt grains |       |       |       |       |       |       |       |       |       |       |      |       |      |
| Bioclasts:          |       |       |       |       |       |       |       |       |       |       |      |       |      |
| Bulbous stroms.     |       |       |       |       |       |       |       |       |       |       |      |       |      |
| Laminar stroms.     |       |       |       |       |       |       |       |       |       |       |      |       |      |
| Dendroid stroms.    |       |       |       |       |       |       |       |       |       |       |      |       |      |
| Stachyodes          |       |       |       |       |       |       |       |       |       |       |      |       |      |
| Amphipora           |       |       |       | ·     |       |       |       |       |       |       |      |       |      |
| Colonial corals     |       |       |       |       |       |       |       |       |       |       | ·    |       |      |
| Solitary corals     |       |       |       |       |       |       |       |       |       |       |      |       |      |
| Thamnoporoids       |       |       |       |       |       |       | ·     |       |       |       |      |       |      |
| Bivalves            |       |       | ·     |       |       |       | ·     |       | ●     |       | ○    | ●     | ·    |
| Gastropods          |       |       |       |       |       |       |       | ·     | ·     |       |      | ·     |      |
| Shell hash          |       |       |       |       |       |       |       |       | ·     |       |      |       |      |
| Brachiopods         |       |       |       |       |       |       | ·     |       |       |       | ·    |       |      |
| Brachiopod spines   |       |       |       |       |       |       |       |       |       |       |      |       |      |
| Crinoids            |       |       |       |       |       |       |       |       |       |       |      |       |      |
| Tentaculites        |       |       |       |       |       |       |       |       |       |       |      |       |      |
| Trilobites          |       |       |       |       |       |       |       |       |       |       |      |       |      |
| Bryozoans           |       |       |       |       |       |       |       |       | ○     |       |      |       |      |
| Ostrocodes          | ·     | ·     | ·     | ●     | ·     | ·     | ·     | ·     | ·     | ·     | ·    | ·     | ●    |
| Leperditia          |       |       |       |       |       |       |       |       |       |       |      |       |      |
| Calcspheres         | *     | ●     | *     | ●     | *     | ●     | ·     | *     | ·     | ·     |      |       | ·    |
| Forams              |       | ·     |       |       |       | ·     | ·     |       | ·     |       |      | ·     | ●    |
| Sponge spicules     |       |       |       |       |       |       |       |       |       |       |      |       |      |
| Umbellids           |       |       |       |       |       |       |       |       |       |       |      |       |      |
| Undetermined        |       |       |       |       |       |       |       |       |       |       |      |       |      |
| Codlaceans          |       | ·     |       |       |       |       |       |       |       |       |      |       | ·    |
| Dasycladaceans      | ·     | ·     | ·     | ·     | ·     | ·     | ·     | ·     | ·     | ●     |      |       | ·    |
| Girvanella Gp.      |       |       |       |       |       |       |       |       |       |       |      | ·     |      |
| Renalcis Gp.        |       |       |       |       |       |       |       |       |       |       |      |       |      |
| Hedstroemia Gp.     |       |       |       |       |       |       |       |       |       |       |      |       |      |
| Wetheredella Gp.    |       |       |       |       |       |       |       |       |       |       |      |       |      |
| Matrix              | M,Ms  | M,D   | M     | M,D   | M     | M,D   | M,S   | M     | M,Ms  | M,Ms  | S    | M,S,D | M,Ms |
| Bloturbation        | ✓     | ✓     | ✓     |       | ✓     | ✓     | ✓     | ✓     | ✓     |       |      |       | ✓    |
| Micrite envelope    |       |       |       |       |       |       | ✓     |       | ✓     | ✓     | ✓    | ✓     |      |
| Fenestrae: Tubular  |       |       |       |       |       |       |       |       |       | ✓     |      |       |      |
| Laminoid/irregular  |       |       |       | ✓     |       |       |       | ✓     |       | ✓     |      |       |      |
| Geopetals           |       |       |       | ✓     |       |       |       | ✓     |       | ✓     |      |       |      |
| Gravity cements     |       |       |       |       |       |       |       |       |       |       |      |       |      |
| Lamination          |       |       |       |       |       |       |       |       |       |       |      |       |      |
| Others              |       |       |       | *1    |       |       |       | *1    |       | *1    |      |       |      |

\*1 Vadose silt in fenestrae

|         |  |
|---------|--|
| Texture | M=Mudstone, W=Wackestone, P=Packstone<br>G=Grainstone, F=Floatstone, Bf= Bafflestone<br>Bi=Bindstone, B=Boundstone, D=Dolomite |
| Matrix  | M=Micrite, Ms=Microspar, S=Spar, D=Dolomite  |

## Froid Lieu Quarry

○ = <1%   · = 1-20%   ● = 21-40%   ● = 41-60%   ★ = >61%

| Sample number       | FL14 | FL15 |   |  |  |  |  |  |  |  |  |  |  |  |  |  |  |  |  |  |  |
|---------------------|------|------|---|--|--|--|--|--|--|--|--|--|--|--|--|--|--|--|--|--|--|
| Height              | 0.9m | 0.4m |   |  |  |  |  |  |  |  |  |  |  |  |  |  |  |  |  |  |  |
| Thin Section/ Peel  | TS   | TS   |   |  |  |  |  |  |  |  |  |  |  |  |  |  |  |  |  |  |  |
| Microfacies         | S6f  | R4c  |   |  |  |  |  |  |  |  |  |  |  |  |  |  |  |  |  |  |  |
| Texture             | P    | G    |   |  |  |  |  |  |  |  |  |  |  |  |  |  |  |  |  |  |  |
| Grains:             |      |      |   |  |  |  |  |  |  |  |  |  |  |  |  |  |  |  |  |  |  |
| Peloids             | ★    | ●    |   |  |  |  |  |  |  |  |  |  |  |  |  |  |  |  |  |  |  |
| Lithoclasts         |      |      |   |  |  |  |  |  |  |  |  |  |  |  |  |  |  |  |  |  |  |
| Oncoids             |      |      |   |  |  |  |  |  |  |  |  |  |  |  |  |  |  |  |  |  |  |
| Ooids               |      |      |   |  |  |  |  |  |  |  |  |  |  |  |  |  |  |  |  |  |  |
| Aggregate grains    |      |      |   |  |  |  |  |  |  |  |  |  |  |  |  |  |  |  |  |  |  |
| Quartz/ silt grains |      |      |   |  |  |  |  |  |  |  |  |  |  |  |  |  |  |  |  |  |  |
| Bioclasts:          |      |      |   |  |  |  |  |  |  |  |  |  |  |  |  |  |  |  |  |  |  |
| Bulbous stroms.     |      |      |   |  |  |  |  |  |  |  |  |  |  |  |  |  |  |  |  |  |  |
| Laminar stroms.     |      |      |   |  |  |  |  |  |  |  |  |  |  |  |  |  |  |  |  |  |  |
| Dendroid stroms.    |      |      | · |  |  |  |  |  |  |  |  |  |  |  |  |  |  |  |  |  |  |
| Stachyodes          |      |      |   |  |  |  |  |  |  |  |  |  |  |  |  |  |  |  |  |  |  |
| Amphipora           |      |      |   |  |  |  |  |  |  |  |  |  |  |  |  |  |  |  |  |  |  |
| Colonial corals     |      |      |   |  |  |  |  |  |  |  |  |  |  |  |  |  |  |  |  |  |  |
| Solitary corals     |      |      |   |  |  |  |  |  |  |  |  |  |  |  |  |  |  |  |  |  |  |
| Thamnoporoids       |      |      | · |  |  |  |  |  |  |  |  |  |  |  |  |  |  |  |  |  |  |
| Bivalves            |      |      | · |  |  |  |  |  |  |  |  |  |  |  |  |  |  |  |  |  |  |
| Gastropods          |      |      | · |  |  |  |  |  |  |  |  |  |  |  |  |  |  |  |  |  |  |
| Shell hash          |      |      |   |  |  |  |  |  |  |  |  |  |  |  |  |  |  |  |  |  |  |
| Brachiopods         |      |      | ● |  |  |  |  |  |  |  |  |  |  |  |  |  |  |  |  |  |  |
| Brachiopod spines   |      |      |   |  |  |  |  |  |  |  |  |  |  |  |  |  |  |  |  |  |  |
| Crinoids            |      |      | · |  |  |  |  |  |  |  |  |  |  |  |  |  |  |  |  |  |  |
| Tentaculites        |      |      |   |  |  |  |  |  |  |  |  |  |  |  |  |  |  |  |  |  |  |
| Trilobites          |      |      |   |  |  |  |  |  |  |  |  |  |  |  |  |  |  |  |  |  |  |
| Bryozoans           |      |      |   |  |  |  |  |  |  |  |  |  |  |  |  |  |  |  |  |  |  |
| Ostrocodes          |      |      | · |  |  |  |  |  |  |  |  |  |  |  |  |  |  |  |  |  |  |
| Leperditia          |      |      |   |  |  |  |  |  |  |  |  |  |  |  |  |  |  |  |  |  |  |
| Calcspheres         |      |      | · |  |  |  |  |  |  |  |  |  |  |  |  |  |  |  |  |  |  |
| Forams              |      |      | ○ |  |  |  |  |  |  |  |  |  |  |  |  |  |  |  |  |  |  |
| Sponge spicules     |      |      |   |  |  |  |  |  |  |  |  |  |  |  |  |  |  |  |  |  |  |
| Umbellids           |      |      |   |  |  |  |  |  |  |  |  |  |  |  |  |  |  |  |  |  |  |
| Undetermined        |      |      |   |  |  |  |  |  |  |  |  |  |  |  |  |  |  |  |  |  |  |
| Codiaceans          |      |      |   |  |  |  |  |  |  |  |  |  |  |  |  |  |  |  |  |  |  |
| Dasycladaceans      |      |      | · |  |  |  |  |  |  |  |  |  |  |  |  |  |  |  |  |  |  |
| Girvanella Gp.      |      |      |   |  |  |  |  |  |  |  |  |  |  |  |  |  |  |  |  |  |  |
| Renalcis Gp.        |      |      |   |  |  |  |  |  |  |  |  |  |  |  |  |  |  |  |  |  |  |
| Hedstroemia Gp.     |      |      |   |  |  |  |  |  |  |  |  |  |  |  |  |  |  |  |  |  |  |
| Wetheredella Gp.    |      |      |   |  |  |  |  |  |  |  |  |  |  |  |  |  |  |  |  |  |  |
| Matrix              | M    | S    |   |  |  |  |  |  |  |  |  |  |  |  |  |  |  |  |  |  |  |
| Bioturbation        | ✓    |      |   |  |  |  |  |  |  |  |  |  |  |  |  |  |  |  |  |  |  |
| Micrite envelope    |      | ✓    |   |  |  |  |  |  |  |  |  |  |  |  |  |  |  |  |  |  |  |
| Fenestrae: Tubular  | ✓    |      |   |  |  |  |  |  |  |  |  |  |  |  |  |  |  |  |  |  |  |
| Laminoid/irregular  |      |      |   |  |  |  |  |  |  |  |  |  |  |  |  |  |  |  |  |  |  |
| Geopetals           |      |      |   |  |  |  |  |  |  |  |  |  |  |  |  |  |  |  |  |  |  |
| Gravity cements     |      |      |   |  |  |  |  |  |  |  |  |  |  |  |  |  |  |  |  |  |  |
| Lamination          |      |      |   |  |  |  |  |  |  |  |  |  |  |  |  |  |  |  |  |  |  |
| Others              |      | *1   |   |  |  |  |  |  |  |  |  |  |  |  |  |  |  |  |  |  |  |

\*1 Sediment-fill at base of fenestrae

|         |  |
|---------|--|
| Texture | M=Mudstone, W=Wackestone, P=Packstone<br>G=Grainstone, F=Floatstone, Bf= Bafflestone<br>Bi=Bindstone, B=Boundstone, D=Dolomite |
| Matrix  | M=Micrite, Ms=Microspar, S=Spar, D=Dolomite  |

## A1.2.10 Glageon Quarry

○ = <1%    · = 1-20%    ● = 21-40%    ● = 41-60%    \* = >61%

| Sample number       | GL1  | GL2  | GL3  | GL4  | GL5  | GL6  | GL7  | GL8   | GL9   | GL10  | GL11  | GL12  | GL13  |
|---------------------|------|------|------|------|------|------|------|-------|-------|-------|-------|-------|-------|
| Height              | 0.6m | 3.4m | 4.2m | 6.4m | 8.4m | 9.2m | 9.8m | 12.3m | 13.5m | 14.0m | 15.7m | 19.0m | 25.7m |
| Thin Section/ Peel  | P    | TS   | P    | P    | P    | P    | P    | P     | P     | P     | TS    | P     | P     |
| Microfacies         | R1   | R2   | R2   | R1   | R1   | R1   | R2   | R1    | R1    | R2    | R4b   | R3    | R4b   |
| Texture             | W    | G    | WP   | W    | WP   | W    | WP   | W     | W     | P     | G     | F     | G     |
| Grains:             |      |      |      |      |      |      |      |       |       |       |       |       |       |
| Peloids             |      | ●    |      |      |      |      |      |       |       |       |       |       | *●    |
| Lithoclasts         |      | ●    |      |      |      |      |      |       |       |       | *●    |       |       |
| Oncoids             |      |      |      |      |      |      |      |       |       |       |       |       |       |
| Ooids               |      |      |      |      |      |      |      |       |       |       |       |       |       |
| Aggregate grains    |      |      |      |      |      |      |      |       |       |       |       |       |       |
| Quartz/ silt grains |      |      |      |      |      |      |      |       |       |       |       |       |       |
| Bioclasts:          |      |      |      |      |      |      |      |       |       |       |       |       |       |
| Bulbous stroms.     |      |      |      |      |      |      |      |       |       |       |       |       |       |
| Laminar stroms.     |      |      |      |      |      |      |      |       |       |       |       |       |       |
| Dendroid stroms.    |      |      |      |      |      |      |      |       |       |       |       |       | ·     |
| Stachyodes          |      |      |      |      |      |      |      |       |       |       |       |       |       |
| Amphipora           |      |      |      |      |      |      |      |       |       |       |       |       |       |
| Colonial corals     |      |      |      |      |      |      |      |       |       |       |       | *●    |       |
| Solitary corals     |      |      |      |      |      |      |      |       |       |       |       |       |       |
| Thamnoporoids       |      |      |      |      |      |      |      |       |       |       |       |       |       |
| Bivalves            | ●    |      | ·    |      | ●    | ●    | ·    | ●     | ●     | ·     | ·     |       |       |
| Gastropods          | ·    |      | ●    | ·    | ●    | ·    |      | ·     | ·     | ·     | ·     |       |       |
| Shell hash          |      |      |      |      |      |      |      |       |       |       |       |       |       |
| Brachiopods         | ·    |      | ●    | *●   | ·    | ·    | *●   | ●     | ●     | ●     |       |       | ·     |
| Brachiopod spines   |      |      |      |      |      |      |      |       |       |       |       |       |       |
| Crinoids            | ·    |      | ●    |      |      |      | ○    |       |       | ·     | ○     |       |       |
| Tentaculites        |      |      |      |      |      |      |      | ·     |       |       |       |       |       |
| Trilobites          |      |      |      |      |      |      |      |       |       |       |       |       |       |
| Bryozoans           |      |      |      | ·    |      | ○    |      |       |       | ○     |       |       |       |
| Ostrocodes          | ·    | ·    |      |      |      | ·    |      | ·     |       | ●     |       |       |       |
| Leperditia          |      |      |      |      |      |      |      |       |       |       |       |       |       |
| Calcispheres        |      |      |      |      |      |      |      |       |       |       |       |       |       |
| Forams              |      |      |      |      |      |      |      |       |       |       |       | ○     |       |
| Sponge spicules     |      |      |      |      |      |      |      |       |       |       |       |       |       |
| Umbellids           |      |      |      |      |      |      |      |       |       |       |       |       |       |
| Undetermined        |      |      |      |      |      |      |      |       |       |       |       | ·     |       |
| Codiaceans          |      |      |      |      |      |      |      |       |       |       |       |       |       |
| Dasycladaceans      |      |      |      |      |      |      |      |       |       |       |       |       |       |
| Girvanella Gp.      |      |      |      |      |      |      |      |       |       |       |       |       |       |
| Renalcis Gp.        |      |      |      |      |      |      |      |       |       |       |       |       |       |
| Hedstroemia Gp.     |      |      |      |      |      |      |      |       |       |       |       |       |       |
| Wetheredella Gp.    |      |      |      |      |      |      |      |       |       |       |       |       |       |
| Matrix              | M,D  | S,D  | M,D  | M,D  | M,D  | M,D  | M    | M,D   | M,D   | M,D   | S,M,D |       | S,D   |
| Bioturbation        | ✓    |      | ✓    | ✓    | ✓    | ✓    | ✓    | ✓     | ✓     |       |       |       |       |
| Micrite envelope    |      | ✓    |      |      |      |      | ✓    |       |       |       | ✓     |       |       |
| Fenestrae: Tubular  |      |      |      |      |      |      |      |       |       |       |       |       |       |
| Laminoid/irregular  |      |      |      |      |      |      |      |       |       |       |       |       |       |
| Geopetals           |      |      |      |      |      |      |      |       |       |       |       |       |       |
| Gravity cements     |      |      |      |      |      |      |      |       |       |       |       |       |       |
| Lamination          |      |      |      |      |      |      |      |       |       |       |       |       |       |
| Others              |      |      |      |      |      |      | *1   |       | *1    |       |       | *2    |       |

\*1 Insoluble clays associated with matrix

\*2 Sample taken through coral

|         |  |
|---------|--|
| Texture | M=Mudstone, W=Wackestone, P=Packstone<br>G=Grainstone, F=Floatstone, Bf= Bafflestone<br>Bi=Bindstone, B=Boundstone, D=Dolomite |
| Matrix  | M=Micrite, Ms=Microspar, S=Spar, D=Dolomite  |

## Glageon Quarry

○ = <1%    · = 1-20%    ● = 21-40%    ● = 41-60%    \* = >61%

| Sample number       | GL15  | GL16  | GL17  | GL18  | GL19  | GL20  | GL21a | GL21b | GL22  | GL23  | GL24  | GL25  | GL26  |
|---------------------|-------|-------|-------|-------|-------|-------|-------|-------|-------|-------|-------|-------|-------|
| Height              | 28.1m | 31.4m | 34.2m | 35.9m | 40.4m | 43.2m | 46.3m | 49.8m | 54.2m | 60.9m | 62.0m | 63.6m | 64.8m |
| Thin Section/ Peel  | P     | P     | TS    | TS    | P     | P     | P     | P     | P     | P     | P     | P     | P     |
| Microfacies         | R2    | R1    | R4a   | R4a   | R1    | R1    | R2    | R1    | R1    | R2    | R1    | R2    | R1    |
| Texture             | P     | WD    | G     | G     | W     | MD    | P     | W     | W     | WP    | WD    | WP    | MW    |
| Grains:             |       |       |       |       |       |       |       |       |       |       |       |       |       |
| Peloids             |       |       | ·     | ·     |       |       |       |       |       |       |       |       |       |
| Lithoclasts         |       |       | ○     |       |       |       |       |       |       |       |       |       |       |
| Oncoids             |       |       |       |       |       |       |       |       |       |       |       |       |       |
| Ooids               |       |       | *     | *     |       |       |       |       |       |       |       |       |       |
| Aggregate grains    |       |       |       |       |       |       |       |       |       |       |       |       |       |
| Quartz/ silt grains |       |       |       |       |       |       |       |       |       |       |       |       |       |
| Bioclasts:          |       |       |       |       |       |       |       |       |       |       |       |       |       |
| Bulbous stroms.     |       |       |       |       |       |       |       |       |       |       |       |       |       |
| Laminar stroms.     |       |       |       |       |       |       |       |       |       |       |       |       |       |
| Dendroid stroms.    |       |       |       |       |       |       |       |       |       |       |       |       |       |
| Stachyodes          |       |       |       |       |       |       |       |       |       |       |       |       |       |
| Amphipora           |       |       |       |       |       |       |       |       |       |       |       |       |       |
| Colonial corals     |       |       |       |       |       |       |       |       |       |       |       |       |       |
| Solitary corals     |       |       |       |       |       |       |       |       | ·     | ·     |       |       |       |
| Thamnoporoids       |       |       |       |       |       |       |       |       |       |       |       |       |       |
| Bivalves            | ●     |       |       |       | ·     |       |       | ●     | ·     |       |       | ·     |       |
| Gastropods          | ·     |       |       |       | ·     |       |       | ·     | ·     |       | ·     | ·     |       |
| Shell hash          |       |       |       |       |       |       |       |       |       |       |       |       |       |
| Brachiopods         | ●     |       |       |       | ●     |       |       | ●     | ●     | ●     | ●     | ●     |       |
| Brachiopod spines   |       |       |       |       |       |       |       |       |       |       |       | ·     |       |
| Crinoids            |       |       |       |       | ·     |       | ○     | ·     | ·     | ·     | ·     |       |       |
| Tentaculites        |       |       |       |       |       |       |       |       |       |       |       |       |       |
| Trilobites          |       |       |       |       |       |       | ·     |       | ○     |       |       | ·     |       |
| Bryozoans           |       |       |       |       | ·     |       |       |       |       | ·     | ·     |       |       |
| Ostrocodes          | ·     |       |       |       | ·     |       | *     | ·     | ·     | ○     | ·     | ·     | *     |
| Leperditia          |       |       |       |       |       |       |       |       |       |       |       |       |       |
| Calcspheres         |       |       |       |       |       |       |       |       |       |       |       |       |       |
| Forams              |       |       |       |       |       |       | ·     |       |       |       |       |       |       |
| Sponge spicules     |       |       |       |       |       |       |       |       |       |       |       |       |       |
| Umbellids           |       |       |       |       |       |       |       |       |       |       |       |       |       |
| Undetermined        |       |       |       |       |       |       |       |       |       |       |       |       |       |
| Codiaceans          |       |       |       |       |       |       |       |       |       |       |       |       |       |
| Dasycladaceans      |       |       |       |       |       |       |       |       |       |       |       |       |       |
| Girvanella Gp.      |       |       |       |       |       |       |       |       |       |       |       |       |       |
| Renalcis Gp.        |       |       |       |       |       |       |       |       |       |       |       |       |       |
| Hedstroemia Gp.     |       |       |       |       |       |       |       |       |       |       |       |       |       |
| Wetheredella Gp.    |       |       |       |       |       |       |       |       |       |       |       |       |       |
| Matrix              | M,D   |       | S     | S     | M,D   | D,M   | S,D,M | M,D   | M     | D     | M,D   | M,D   | M,D   |
| Bioturbation        | ✓     |       |       |       | ✓     | ✓     | ✓     | ✓     | ✓     |       | ✓     | ✓     |       |
| Micrite envelope    | ✓     |       | ✓     | ✓     |       |       |       | ✓     | ✓     |       |       | ✓     | ✓     |
| Fenestrae: Tubular  |       |       |       |       |       |       |       |       |       |       |       |       |       |
| Laminoid/irregular  |       |       |       |       |       |       |       |       |       |       |       |       |       |
| Geopetals           |       |       |       |       |       |       |       |       |       |       |       |       |       |
| Gravity cements     |       |       |       |       |       |       |       |       |       |       |       |       |       |
| Lamination          |       |       |       |       |       | ✓     |       |       |       |       |       |       | ✓     |
| Others              | *1    | *2    | *3    |       |       |       | *4    |       |       |       | *1    | *4    |       |

\*1 Matrix is clay-rich

\*2 Sample very dolomitised

\*3 Apparent graded bedding

\*4 Alignment of bioclasts parallel to each other

|         |  |
|---------|--|
| Texture | M=Mudstone, W=Wackestone, P=Packstone<br>G=Grainstone, F=Floatstone, Bf= Bafflestone<br>Bi=Bindstone, B=Boundstone, D=Dolomite |
| Matrix  | M=Micrite, Ms=Microspar, S=Spar, D=Dolomite  |

## Glageon Quarry

○ = <1%    · = 1-20%    ● = 21-40%    ● = 41-60%    \* = >61%

| Sample number       | GL27  | GL28  | GL29  | GL30  | GL31  | GL32  | GL33  | GL34  | GL35  | GL36   | GL37   | GL38   | GL39   |
|---------------------|-------|-------|-------|-------|-------|-------|-------|-------|-------|--------|--------|--------|--------|
| Height              | 67.0m | 69.5m | 73.5m | 77.6m | 80.2m | 83.7m | 86.4m | 90.7m | 92.5m | 101.3m | 102.5m | 103.4m | 109.3m |
| Thin Section/ Peel  | P     | P     | P     | P     | P     | P     | P     | P     | TS    | P      | TS     | TS     | P      |
| Microfacies         | ?     | R1    | R3    | R2    | R1    | ?     | ?     | R1    | R4c   | R2     | R4b    | R7     | ?      |
| Texture             | D     | D     | F     | W     | WD    | D     | D     | DW    | G     | WP     | G      | Bi     | D      |
| Grains:             |       |       |       |       |       |       |       |       |       |        |        |        |        |
| Peloids             |       |       |       |       |       |       |       |       |       |        | ●      |        |        |
| Lithoclasts         |       |       |       |       |       |       |       |       |       |        | ·      |        |        |
| Oncoids             |       |       |       |       |       |       |       |       |       |        |        |        |        |
| Ooids               |       |       |       |       |       |       |       |       |       |        |        |        |        |
| Aggregate grains    |       |       |       |       |       |       |       |       |       |        |        |        |        |
| Quartz/ silt grains |       |       |       |       |       |       |       |       |       |        |        |        |        |
| Bioclasts:          |       |       |       |       |       |       |       |       |       |        |        |        |        |
| Bulbous stroms.     |       | *     |       |       |       |       |       |       |       |        |        |        |        |
| Laminar stroms.     |       |       |       |       |       |       |       |       |       |        |        |        |        |
| Dendroid stroms.    |       |       |       |       |       |       |       |       |       |        |        |        |        |
| Stachyodes          |       |       |       |       |       |       |       |       |       |        |        |        |        |
| Amphipora           |       |       |       |       |       |       |       |       |       |        |        |        |        |
| Colonial corals     |       |       |       |       |       |       |       |       |       |        |        |        |        |
| Solitary corals     |       |       |       | ·     | ●     |       |       |       | ○     |        |        |        |        |
| Thamnoporoids       |       |       |       |       |       |       |       |       |       |        |        |        |        |
| Bivalves            |       |       |       |       |       |       |       | ●     | ●     |        |        |        |        |
| Gastropods          |       |       |       |       |       |       |       | ·     | ·     | ·      | ·      |        |        |
| Shell hash          |       |       |       |       |       |       |       |       |       |        |        |        |        |
| Brachiopods         |       | ●     |       | ●     | ●     |       |       | ●     |       | ●      | ·      |        |        |
| Brachiopod spines   |       |       |       |       |       |       |       |       | ●     |        |        |        |        |
| Crinoids            |       |       |       | ●     | ●     |       |       | ·     | ●     | ●      |        |        |        |
| Tentaculites        |       |       |       |       |       |       |       |       |       |        |        |        |        |
| Trilobites          |       |       |       |       |       |       |       |       |       |        |        |        |        |
| Bryozoans           |       |       |       |       |       |       |       |       |       |        |        |        |        |
| Ostrocodes          |       |       |       |       |       |       |       |       |       | ·      |        |        |        |
| Leperditia          |       |       |       |       |       |       |       |       |       |        |        |        |        |
| Calcspheres         |       |       |       |       |       |       |       |       |       |        |        |        |        |
| Forams              |       |       |       |       |       |       |       |       |       |        |        | ·      |        |
| Sponge spicules     |       |       |       |       |       |       |       |       |       |        |        |        |        |
| Umbellids           |       |       |       |       |       |       |       |       |       |        |        |        |        |
| Undetermined        |       |       |       |       |       |       |       |       |       |        |        | *      |        |
| Codiaceans          |       |       |       |       |       |       |       |       |       |        |        |        |        |
| Dasycladaceans      |       |       |       |       |       |       |       |       |       |        |        |        |        |
| Girvanella Gp.      |       |       |       |       |       |       |       |       |       |        |        |        |        |
| Renalcis Gp.        |       |       |       |       |       |       |       |       |       |        |        |        |        |
| Hedstroemia Gp.     |       |       |       |       |       |       |       |       |       |        |        |        |        |
| Wetheredella Gp.    |       |       |       |       |       |       |       |       |       |        |        |        |        |
| Matrix              |       |       | D     | M,S   | D     |       |       | D     | S     | M,D    | S,M    |        |        |
| Bioturbation        |       |       |       |       |       |       |       |       |       | ✓      |        |        |        |
| Micrite envelope    |       |       |       |       |       |       |       |       | ✓     |        | ✓      |        |        |
| Fenestrae: Tubular  |       |       |       |       |       |       |       |       |       |        |        |        |        |
| Laminoid/irregular  |       |       |       |       |       |       |       |       |       |        |        |        |        |
| Geopetals           |       |       |       |       |       |       |       |       |       |        |        |        |        |
| Gravity cements     |       |       |       |       |       |       |       |       |       |        |        |        |        |
| Lamination          |       |       |       |       |       |       |       |       |       |        |        |        |        |
| Others              | *1    | *1    | *2    |       | *1    | *1    | *1    | *1,*2 |       | *2     |        | *3,*4  | *1     |

\*1 Sample thoroughly dolomitised

\*2 Matrix very clay-rich

\*3 Undetermined cyanobacteria

\*4 Pseudomorphs of gypsum

|         |  |
|---------|--|
| Texture | M=Mudstone, W=Wackestone, P=Packstone<br>G=Grainstone, F=Floatstone, Bf= Bafflestone<br>Bi=Bindstone, B=Boundstone, D=Dolomite |
| Matrix  | M=Micrite, Ms=Microspar, S=Spar, D=Dolomite  |

## Glageon Quarry

○ = <1%    · = 1-20%    ● = 21-40%    ● = 41-60%    ⚙ = >61%

| Sample number       | GL40   | GL41   | GL42   | GL44   | GL45   | GL46   |  |  |  |  |  |  |  |  |  |  |
|---------------------|--------|--------|--------|--------|--------|--------|--|--|--|--|--|--|--|--|--|--|
| Height              | 115.3m | 120.3m | 123.4m | 131.0m | 135.4m | 139.2m |  |  |  |  |  |  |  |  |  |  |
| Thin Section/ Peel  | P      | P      | P      | P      | P      | P      |  |  |  |  |  |  |  |  |  |  |
| Microfacies         | R1     | ?      | R3     | R3     | ?      | R2     |  |  |  |  |  |  |  |  |  |  |
| Texture             | M      | D      | F      | DF     | D      | W      |  |  |  |  |  |  |  |  |  |  |
| Grains:             |        |        |        |        |        |        |  |  |  |  |  |  |  |  |  |  |
| Peloids             |        |        |        |        |        |        |  |  |  |  |  |  |  |  |  |  |
| Lithoclasts         |        |        |        |        |        |        |  |  |  |  |  |  |  |  |  |  |
| Oncoids             |        |        |        |        |        |        |  |  |  |  |  |  |  |  |  |  |
| Ooids               |        |        |        |        |        |        |  |  |  |  |  |  |  |  |  |  |
| Aggregate grains    |        |        |        |        |        |        |  |  |  |  |  |  |  |  |  |  |
| Quartz/ silt grains |        |        |        |        |        |        |  |  |  |  |  |  |  |  |  |  |
| Bioclasts:          |        |        |        |        |        |        |  |  |  |  |  |  |  |  |  |  |
| Bulbous stroms.     |        |        |        | ●      |        |        |  |  |  |  |  |  |  |  |  |  |
| Laminar stroms.     |        |        |        | ●      |        |        |  |  |  |  |  |  |  |  |  |  |
| Dendroid stroms.    |        |        |        | ●      |        |        |  |  |  |  |  |  |  |  |  |  |
| Stachyodes          |        |        |        | ●      |        |        |  |  |  |  |  |  |  |  |  |  |
| Amphipora           |        |        |        | ·      |        |        |  |  |  |  |  |  |  |  |  |  |
| Colonial corals     |        |        |        |        |        |        |  |  |  |  |  |  |  |  |  |  |
| Solitary corals     |        |        |        |        |        |        |  |  |  |  |  |  |  |  |  |  |
| Thamnoporoids       |        |        |        |        |        |        |  |  |  |  |  |  |  |  |  |  |
| Bivalves            |        |        |        |        |        | ⚙      |  |  |  |  |  |  |  |  |  |  |
| Gastropods          |        |        |        |        |        | ·      |  |  |  |  |  |  |  |  |  |  |
| Shell hash          |        |        |        |        |        |        |  |  |  |  |  |  |  |  |  |  |
| Brachiopods         | ●      |        |        | ●      |        |        |  |  |  |  |  |  |  |  |  |  |
| Brachiopod spines   |        |        |        |        |        |        |  |  |  |  |  |  |  |  |  |  |
| Crinoids            |        |        |        |        |        | ·      |  |  |  |  |  |  |  |  |  |  |
| Tentaculites        |        |        |        |        |        |        |  |  |  |  |  |  |  |  |  |  |
| Trilobites          |        |        |        |        |        |        |  |  |  |  |  |  |  |  |  |  |
| Bryozoans           |        |        |        |        |        |        |  |  |  |  |  |  |  |  |  |  |
| Ostrocodes          | ⚙      |        |        |        |        |        |  |  |  |  |  |  |  |  |  |  |
| Leperditia          |        |        |        |        |        |        |  |  |  |  |  |  |  |  |  |  |
| Calcispheres        |        |        |        |        |        |        |  |  |  |  |  |  |  |  |  |  |
| Forams              |        |        |        |        |        |        |  |  |  |  |  |  |  |  |  |  |
| Sponge spicules     |        |        |        |        |        |        |  |  |  |  |  |  |  |  |  |  |
| Umbellids           |        |        |        |        |        |        |  |  |  |  |  |  |  |  |  |  |
| Undetermined        |        |        |        |        |        |        |  |  |  |  |  |  |  |  |  |  |
| Codiaceans          |        |        |        |        |        |        |  |  |  |  |  |  |  |  |  |  |
| Dasycladaceans      |        |        |        |        |        |        |  |  |  |  |  |  |  |  |  |  |
| Girvanella Gp.      |        |        |        |        |        |        |  |  |  |  |  |  |  |  |  |  |
| Renalcis Gp.        |        |        |        |        |        |        |  |  |  |  |  |  |  |  |  |  |
| Hedstroemia Gp.     |        |        |        |        |        |        |  |  |  |  |  |  |  |  |  |  |
| Wetheredella Gp.    |        |        |        |        |        |        |  |  |  |  |  |  |  |  |  |  |
| Matrix              | M      |        |        | D      |        | M,D    |  |  |  |  |  |  |  |  |  |  |
| Bioturbation        | ✓      |        |        |        |        | ✓      |  |  |  |  |  |  |  |  |  |  |
| Micrite envelope    |        |        |        |        |        |        |  |  |  |  |  |  |  |  |  |  |
| Fenestral: Tubular  |        |        |        |        |        |        |  |  |  |  |  |  |  |  |  |  |
| Laminoid/irregular  |        |        |        |        |        |        |  |  |  |  |  |  |  |  |  |  |
| Geopetals           |        |        |        |        |        |        |  |  |  |  |  |  |  |  |  |  |
| Gravity cements     |        |        |        |        |        |        |  |  |  |  |  |  |  |  |  |  |
| Lamination          |        |        |        |        |        |        |  |  |  |  |  |  |  |  |  |  |
| Others              |        | *1     | *1     | *1     | *1     |        |  |  |  |  |  |  |  |  |  |  |

\*1 Sample dolomitised

|         |  |
|---------|--|
| Texture | M=Mudstone, W=Wackestone, P=Packstone<br>G=Grainstone, F=Floatstone, Bf= Bafflestone<br>Bi=Bindstone, B=Boundstone, D=Dolomite |
| Matrix  | M=Micrite, Ms=Microspar, S=Spar, D=Dolomite  |

## A1.2.11 Goodrington Road Cutting

○ = <1%    · = 1-20%    ● = 21-40%    ● = 41-60%    \* = >61%

| Sample number       | G2   | G3   | G4   | G5   | G6   | G7   | G8   | G9   | G100 | G11  | G12  | G13   | G14   |
|---------------------|------|------|------|------|------|------|------|------|------|------|------|-------|-------|
| Height              | 2.6m | 2.7m | 3.4m | 4.0m | 5.6m | 6.3m | 9.3m | 7.0m | 7.5m | 8.0m | 9.9m | 11.0m | 12.3m |
| Thin Section/ Peel  | TS   | P    | P    | TS   | P    | P    | TS   | TS   | P    | TS   | TS   | TS    | P     |
| Microfacies         | ?    | ?    | S6a  | S6a  | ?    | ?    | S6a  | S4b  | ?    | S4a  | S6a  | S2    | S4a   |
| Texture             | D    | D    | W    | W    | D    | D    | W    | F    | D    | F    | M    | F     | W     |
| Grains:             |      |      |      |      |      |      |      |      |      |      |      |       |       |
| Peloids             |      |      |      |      |      |      |      |      |      |      |      |       |       |
| Lithoclasts         |      |      |      |      |      |      |      |      |      |      |      |       |       |
| Oncoids             |      |      |      |      |      |      |      |      |      |      |      |       |       |
| Ooids               |      |      |      |      |      |      |      |      |      |      |      |       |       |
| Aggregate grains    |      |      |      |      |      |      |      |      |      |      |      |       |       |
| Quartz/ silt grains |      |      |      |      |      |      |      |      |      |      |      |       |       |
| Bioclasts:          |      |      |      |      |      |      |      |      |      |      |      |       |       |
| Bulbous stroms.     |      |      |      |      |      |      |      | ·    |      |      |      |       |       |
| Laminar stroms.     |      |      |      |      |      |      |      |      |      |      |      |       |       |
| Dendroid stroms.    |      |      | ·    |      |      |      |      |      |      |      |      | ·     |       |
| Stachyodes          |      |      |      |      |      |      |      |      |      |      |      |       |       |
| Amphipora           |      |      | ·    |      |      |      | ·    | *    |      | *    | ·    |       | *     |
| Colonial corals     |      |      |      |      |      |      |      |      |      |      |      |       |       |
| Solitary corals     |      |      |      |      |      |      |      |      |      |      |      |       |       |
| Thamnoporoids       |      |      |      |      |      |      |      |      |      |      |      |       |       |
| Bivalves            |      |      |      |      |      |      |      |      |      |      |      |       |       |
| Gastropods          |      |      |      |      |      |      |      |      |      |      |      |       |       |
| Shell hash          |      |      |      |      |      |      |      |      |      |      |      |       |       |
| Brachiopods         |      |      |      |      |      |      |      |      |      |      |      |       |       |
| Brachiopod spines   |      |      |      |      |      |      |      |      |      |      |      |       |       |
| Crinoids            |      |      |      |      |      |      |      | ○    |      |      |      |       |       |
| Tentaculites        |      |      |      |      |      |      |      |      |      |      |      |       |       |
| Trilobites          |      |      |      |      |      |      |      |      |      |      |      |       |       |
| Bryozoans           |      |      |      |      |      |      |      |      |      |      |      |       |       |
| Ostrocodes          |      |      | ·    | ·    |      |      | ·    |      |      |      | ·    |       |       |
| Leperditia          |      |      |      |      |      |      |      |      |      |      |      |       |       |
| Calcspheres         |      |      |      | ○    |      |      | *    |      |      |      | *    | *     | ·     |
| Forams              |      |      | ●    |      |      |      | ·    |      |      | ·    | ·    | ·     |       |
| Sponge spicules     |      |      |      |      |      |      |      |      |      |      |      |       |       |
| Umbellids           |      |      |      |      |      |      |      |      |      |      |      |       |       |
| Undetermined        |      |      |      |      |      |      |      |      |      |      |      |       |       |
| Codiaceans          |      |      |      |      |      |      |      |      |      |      |      |       |       |
| Dasycladaceans      |      |      |      | *    |      |      |      |      |      |      |      |       |       |
| Girvanella Gp.      |      |      |      |      |      |      |      |      |      |      |      |       |       |
| Renalcis Gp.        |      |      |      |      |      |      |      |      |      |      |      |       |       |
| Hedstroemia Gp.     |      |      |      |      |      |      |      |      |      |      |      |       |       |
| Wetheredella Gp.    |      |      |      |      |      |      |      |      |      |      |      |       |       |
| Matrix              |      |      | M    | M,D  |      |      | M,Ms | D,M  |      | M,D  | M,D  | M,Ms  | M,Ms  |
| Bioturbation        |      |      | ✓    | ✓    |      |      |      |      |      |      |      |       |       |
| Micrite envelope    |      |      |      |      |      |      |      |      |      |      |      |       |       |
| Fenestrae: Tubular  |      |      |      |      |      |      |      |      |      |      |      |       |       |
| Laminoid/irregular  |      |      |      |      |      |      |      |      |      |      |      |       |       |
| Geopetals           |      |      | ✓    |      |      |      |      |      |      |      |      |       |       |
| Gravity cements     |      |      |      |      |      |      |      |      |      |      |      |       |       |
| Lamination          |      |      |      |      |      |      |      |      |      |      |      |       |       |
| Others              | *1   | *1   |      |      | *1   | *1   |      |      | *1   |      |      |       |       |

\*1 Sample has been dolomitised

|         |  |
|---------|--|
| Texture | M=Mudstone, W=Wackestone, P=Packstone<br>G=Grainstone, F=Floatstone, Bf= Bafflestone<br>Bi=Bindstone, B=Boundstone, D=Dolomite |
| Matrix  | M=Micrite, Ms=Microspar, S=Spar, D=Dolomite  |

## A1.2.12 Hanielsfeld Quarry

○ = <1%    · = 1-20%    ● = 21-40%    ● = 41-60%    \* = >61%

| Sample number       | HF1   | HF2  | HF3  | HF4  | HF5  |  |  |  |  |  |  |  |  |  |  |
|---------------------|-------|------|------|------|------|--|--|--|--|--|--|--|--|--|--|
| Height              | 0.1m  | 2.8m | 3.7m | 4.9m | 6.7m |  |  |  |  |  |  |  |  |  |  |
| Thin Section/ Peel  | TS    | TS   | TS   | TS   | TS   |  |  |  |  |  |  |  |  |  |  |
| Microfacies         | R1    | R3   | R3   | R3   | R3   |  |  |  |  |  |  |  |  |  |  |
| Texture             | M     | F    | F    | F    | F    |  |  |  |  |  |  |  |  |  |  |
| Grains:             |       |      |      |      |      |  |  |  |  |  |  |  |  |  |  |
| Peloids             |       |      |      |      |      |  |  |  |  |  |  |  |  |  |  |
| Lithoclasts         |       |      |      |      |      |  |  |  |  |  |  |  |  |  |  |
| Oncoids             |       |      |      |      |      |  |  |  |  |  |  |  |  |  |  |
| Ooids               |       |      |      |      |      |  |  |  |  |  |  |  |  |  |  |
| Aggregate grains    |       |      |      |      |      |  |  |  |  |  |  |  |  |  |  |
| Quartz/ silt grains |       |      |      |      |      |  |  |  |  |  |  |  |  |  |  |
| Bioclasts:          |       |      |      |      |      |  |  |  |  |  |  |  |  |  |  |
| Bulbous stroms.     |       |      |      |      |      |  |  |  |  |  |  |  |  |  |  |
| Laminar stroms.     |       | ·    | ●    |      |      |  |  |  |  |  |  |  |  |  |  |
| Dendroid stroms.    |       |      |      | *●   | ●    |  |  |  |  |  |  |  |  |  |  |
| Stachyodes          |       |      |      |      |      |  |  |  |  |  |  |  |  |  |  |
| Amphipora           |       |      |      |      |      |  |  |  |  |  |  |  |  |  |  |
| Colonial corals     |       | ●    | ●    |      |      |  |  |  |  |  |  |  |  |  |  |
| Solitary corals     |       |      |      |      |      |  |  |  |  |  |  |  |  |  |  |
| Thamnoporoids       |       |      |      |      |      |  |  |  |  |  |  |  |  |  |  |
| Bivalves            |       |      |      |      |      |  |  |  |  |  |  |  |  |  |  |
| Gastropods          |       |      |      |      |      |  |  |  |  |  |  |  |  |  |  |
| Shell hash          |       | ·    |      |      |      |  |  |  |  |  |  |  |  |  |  |
| Brachiopods         |       |      | ○    |      |      |  |  |  |  |  |  |  |  |  |  |
| Brachiopod spines   |       |      |      |      |      |  |  |  |  |  |  |  |  |  |  |
| Crinoids            | ·     | ·    | ·    |      | ●    |  |  |  |  |  |  |  |  |  |  |
| Tentaculites        |       |      |      |      |      |  |  |  |  |  |  |  |  |  |  |
| Trilobites          |       |      |      |      |      |  |  |  |  |  |  |  |  |  |  |
| Bryozoans           |       |      |      |      |      |  |  |  |  |  |  |  |  |  |  |
| Ostrocodes          | *●    |      | ·    |      | ○    |  |  |  |  |  |  |  |  |  |  |
| Leperditia          |       |      |      |      |      |  |  |  |  |  |  |  |  |  |  |
| Calcspheres         | ·     |      |      |      |      |  |  |  |  |  |  |  |  |  |  |
| Forams              |       |      |      |      |      |  |  |  |  |  |  |  |  |  |  |
| Sponge spicules     |       |      |      |      |      |  |  |  |  |  |  |  |  |  |  |
| Umbellids           |       |      |      |      |      |  |  |  |  |  |  |  |  |  |  |
| Undetermined        |       |      |      |      |      |  |  |  |  |  |  |  |  |  |  |
| Codiaceans          |       |      |      |      |      |  |  |  |  |  |  |  |  |  |  |
| Dasycladaceans      |       |      |      |      |      |  |  |  |  |  |  |  |  |  |  |
| Girvanella Gp.      |       |      |      |      |      |  |  |  |  |  |  |  |  |  |  |
| Renalcis Gp.        |       |      |      |      |      |  |  |  |  |  |  |  |  |  |  |
| Hedstroemia Gp.     |       |      |      |      |      |  |  |  |  |  |  |  |  |  |  |
| Wetheredella Gp.    |       |      |      |      |      |  |  |  |  |  |  |  |  |  |  |
| Matrix              | M     | M    | Ms   | D    | M    |  |  |  |  |  |  |  |  |  |  |
| Bioturbation        | ✓     | ✓    | ✓    |      | ✓    |  |  |  |  |  |  |  |  |  |  |
| Micrite envelope    |       |      |      |      |      |  |  |  |  |  |  |  |  |  |  |
| Fenestrae: Tubular  |       |      |      |      |      |  |  |  |  |  |  |  |  |  |  |
| Laminoid/irregular  |       |      |      |      |      |  |  |  |  |  |  |  |  |  |  |
| Geopetals           |       |      |      |      |      |  |  |  |  |  |  |  |  |  |  |
| Gravity cements     |       |      |      |      |      |  |  |  |  |  |  |  |  |  |  |
| Lamination          |       |      |      |      |      |  |  |  |  |  |  |  |  |  |  |
| Others              | *1,*2 | *3   | *3   |      | *3   |  |  |  |  |  |  |  |  |  |  |

\*1 Matrix is very peloidal

\*2 Bioclasts aligned parallel to each other

\*3 Stromatoporoid encrusts grains

|         |  |
|---------|--|
| Texture | M=Mudstone, W=Wackestone, P=Packstone<br>G=Grainstone, F=Floatstone, Bf= Bafflestone<br>Bi=Bindstone, B=Boundstone, D=Dolomite |
| Matrix  | M=Micrite, Ms=Microspar, S=Spar, D=Dolomite  |

## A1.2.13 Heggen Quarry

○ = <1%    · = 1-20%    ● = 21-40%    ● = 41-60%    \* = >61%

| Sample number       | HG1    | HG2    | HG3    | HG4    | HG5    | HG6    | HG7    | HG8    | HG9    | HG10   | HG11   | HG12   | HG13   |
|---------------------|--------|--------|--------|--------|--------|--------|--------|--------|--------|--------|--------|--------|--------|
| Height              | 163.1m | 162.5m | 157.5m | 155.9m | 149.0m | 144.0m | 143.0m | 141.5m | 135.7m | 133.3m | 130.5m | 130.1m | 124.0m |
| Thin Section/ Peel  | TS     | P      | P      | TS     | P      | P      | P      | P      | P      | P      | P      | P      | TS     |
| Microfacies         | S2     | S2     | S3a    | S3a    | S3a    | S3a    | S3a    | S2     | S3a    | S4b    | S3a    | S3a    | S3a    |
| Texture             | F      | F      | G      | G      | G      | G      | G      | B      | G      | G      | G      | G      | G      |
| Grains:             |        |        |        |        |        |        |        |        |        |        |        |        |        |
| Peloids             |        |        | ●      | ●      | ●      | ●      | ●      | ●      | ●      | ●      | ●      | ●      | ·      |
| Lithoclasts         |        |        |        |        |        |        |        |        |        |        |        |        |        |
| Oncoids             |        |        |        |        |        |        |        |        |        |        |        |        |        |
| Ooids               |        |        |        |        |        |        |        |        |        |        |        |        |        |
| Aggregate grains    |        |        |        |        |        |        |        |        |        |        |        |        |        |
| Quartz/ silt grains |        |        |        |        |        |        |        |        |        |        |        |        |        |
| Bioclasts:          |        |        |        |        |        |        |        |        |        |        |        |        |        |
| Bulbous stroms.     | ●      |        |        |        |        |        |        |        |        |        |        | ●      |        |
| Laminar stroms.     |        |        |        |        |        |        |        |        |        |        |        |        |        |
| Dendroid stroms.    |        |        |        |        | ·      |        | ·      |        |        | ·      |        | ·      | ●      |
| Stachyodes          |        |        | ·      |        |        | ·      |        |        | ·      |        |        |        |        |
| Amphipora           |        |        |        | ·      |        |        |        |        | ·      | ·      |        |        |        |
| Colonial corals     |        | ●      |        |        |        |        |        | ·      |        |        |        |        |        |
| Solitary corals     |        |        |        |        |        |        |        |        |        |        | ·      | ·      |        |
| Thamnoporoids       |        |        |        |        | ·      |        |        |        | ·      |        |        | ·      |        |
| Bivalves            |        |        |        |        |        |        |        |        |        |        |        |        |        |
| Gastropods          |        |        |        |        |        |        |        |        |        |        |        |        |        |
| Shell hash          |        |        |        |        |        |        |        |        |        |        |        |        |        |
| Brachiopods         |        |        | ○      |        |        | ·      | ·      |        | ○      |        | ·      |        |        |
| Brachiopod spines   |        |        |        |        |        |        |        |        |        |        |        |        |        |
| Crinoids            |        |        | ·      | ●      | ·      | ·      | ·      | ●      | ●      | ·      | ·      | ○      | ●      |
| Tentaculites        |        |        |        |        |        |        |        |        |        |        |        |        |        |
| Trilobites          |        |        |        |        |        |        |        |        |        |        |        |        |        |
| Bryozoans           |        |        |        |        |        |        |        |        |        |        |        |        |        |
| Ostrocodes          |        |        |        |        | ○      |        |        | ○      |        | ○      |        |        |        |
| Leperditia          |        |        |        |        |        |        |        |        |        |        |        |        |        |
| Calcispheres        |        |        |        |        |        |        |        |        |        |        |        |        |        |
| Forams              |        |        |        | ·      |        |        | ○      |        |        |        |        |        |        |
| Sponge spicules     |        |        |        |        |        |        |        |        |        |        |        |        |        |
| Umbellids           |        |        |        |        |        |        |        |        |        |        |        |        |        |
| Undetermined        |        |        |        |        |        |        |        |        |        |        |        |        |        |
| Codiaceans          |        |        |        |        |        |        |        |        |        |        |        |        |        |
| Dasycladaceans      |        |        |        |        |        |        |        |        |        |        |        |        |        |
| Girvanella Gp.      |        |        |        |        |        |        |        |        |        |        |        |        |        |
| Renalcis Gp.        |        |        |        |        |        |        |        |        |        |        |        |        |        |
| Hedstroemia Gp.     |        |        |        |        |        |        |        |        |        |        |        |        |        |
| Wetheredella Gp.    |        |        |        |        |        |        |        |        |        |        |        |        |        |
| Matrix              |        |        | S      | S      | S      | S      | S      | S      | S      | S      | S      | S      | S      |
| Bioturbation        |        |        |        |        |        |        |        |        |        |        |        |        |        |
| Micrite envelope    |        |        |        |        |        |        |        |        |        |        |        |        | ✓      |
| Fenestrae: Tubular  |        |        |        |        |        |        |        |        |        |        |        |        |        |
| Laminoid/irregular  |        |        |        |        |        |        |        |        |        |        |        |        |        |
| Geopetals           |        |        |        |        |        |        |        |        |        |        |        |        |        |
| Gravity cements     |        |        |        |        |        |        |        |        |        |        |        |        |        |
| Lamination          |        |        |        |        |        |        |        |        |        |        |        |        |        |
| Others              | *1     | *2     |        |        | *3     | *4     |        |        | *4     |        |        |        |        |

\*1 Slide is cut through bulbous stromatoporoid

\*2 Slide is cut through colonial coral

\*3 Cross-lamination

\*4 Bioclasts aligned parallel to bedding

|         |  |
|---------|--|
| Texture | M=Mudstone, W=Wackestone, P=Packstone<br>G=Grainstone, F=Floatstone, Bf= Bafflestone<br>Bi=Bindstone, B=Boundstone, D=Dolomite |
| Matrix  | M=Micrite, Ms=Microspar, S=Spar, D=Dolomite  |

## Heggen Quarry

○ = <1%    · = 1-20%    ● = 21-40%    ● = 41-60%    \* = >61%

| Sample number       | HG14  | HG16  | HG17  | HG18  | HG19  | HG20a | HG20b | HG21  | HG22  | HG23a | HG23b | HG24  | HG25 |
|---------------------|-------|-------|-------|-------|-------|-------|-------|-------|-------|-------|-------|-------|------|
| Height              | 94.6m | 87.3m | 82.3m | 70.2m | 58.0m | 56.8m | 36.9m | 36.5m | 35.2m | 30.4m | 28.0m | 26.1m | 9.7m |
| Thin Section/ Peel  | P     | P     | P     | P     | P     | TS    | TS    | P     | P     | TS    | P     | TS    | P    |
| Microfacies         | S3a   | S3a   | S3a   | S3a   | S3a   | S3a   | S2    | -     | -     | S3a   | S3a   | S3a   | S3a  |
| Texture             | G     | G     | G     | G     | G     | G     | F     | D     | D     | G     | G     | G     | G    |
| Grains:             |       |       |       |       |       |       |       |       |       |       |       |       |      |
| Peloids             | *     | *     | ●     | ●     | ●     | *     |       |       |       | ●     | ●     | *     | *    |
| Lithoclasts         |       |       |       |       |       |       |       |       |       |       |       |       |      |
| Oncoids             |       |       |       |       |       |       |       |       |       |       |       |       |      |
| Ooids               |       |       |       |       |       |       |       |       |       |       |       |       |      |
| Aggregate grains    |       |       |       |       |       |       |       |       |       |       |       |       |      |
| Quartz/ silt grains |       |       |       |       |       |       |       |       |       |       |       |       |      |
| Bioclasts:          |       |       |       |       |       |       |       |       |       |       |       |       |      |
| Bulbous stroms.     |       |       |       |       |       |       |       |       |       |       |       |       |      |
| Laminar stroms.     |       |       |       |       |       |       |       |       |       |       |       |       |      |
| Dendroid stroms.    | ·     | ·     |       | ·     |       |       | *     |       |       |       | ·     |       |      |
| Stachyodes          |       |       | ·     |       | ·     | ·     |       |       |       |       |       |       | ·    |
| Amphipora           |       |       | ·     |       |       | ·     |       |       |       |       |       |       | ·    |
| Colonial corals     |       |       |       | ·     |       |       |       |       |       |       |       |       |      |
| Solitary corals     |       | ·     |       |       | ●     |       |       |       |       |       |       |       | ·    |
| Thamnoporoids       | ·     |       | ·     |       | ·     |       |       |       |       |       |       |       |      |
| Bivalves            |       |       |       |       |       |       |       |       |       |       |       |       |      |
| Gastropods          |       |       |       |       |       |       |       |       |       |       |       |       | ○    |
| Shell hash          |       |       |       |       |       |       |       |       |       |       |       |       |      |
| Brachiopods         | ·     |       | ○     |       |       |       |       |       |       |       |       |       | ·    |
| Brachiopod spines   |       |       |       |       |       |       |       |       |       |       |       |       |      |
| Crinoids            | ●     | ·     | ·     | ·     | ·     | ·     |       |       |       | ●     | ·     | ·     | ·    |
| Tentaculites        |       |       |       |       |       |       |       |       |       |       |       |       |      |
| Trilobites          |       |       |       |       |       |       |       |       |       |       |       |       |      |
| Bryozoans           |       |       |       |       |       |       |       |       |       |       |       |       |      |
| Ostrocodes          |       | ○     |       |       |       |       |       |       |       | ·     |       | ·     |      |
| Leperditia          |       |       |       |       |       |       |       |       |       |       |       |       |      |
| Calcispheres        |       |       |       |       |       |       |       |       |       |       |       | ·     |      |
| Forams              |       |       |       |       |       | ○     | ·     |       |       |       | ·     | ·     | ·    |
| Sponge spicules     |       |       |       |       |       |       |       |       |       |       |       |       |      |
| Umbellids           |       |       |       |       |       |       |       |       |       |       |       |       |      |
| Undetermined        |       |       |       |       |       | ○     |       |       |       |       |       |       |      |
| Codiaceans          |       |       |       |       |       |       |       |       |       |       |       |       |      |
| Dasycladaceans      |       |       |       |       |       |       |       |       |       |       |       |       |      |
| Girvanella Gp.      |       |       |       |       |       |       | ○     |       |       |       |       |       |      |
| Renalcis Gp.        |       |       |       |       |       |       |       |       |       |       |       | ·     |      |
| Hedstroemia Gp.     |       |       |       |       |       |       |       |       |       |       |       |       |      |
| Wetheredella Gp.    |       |       |       |       |       |       |       |       |       |       |       |       |      |
| Matrix              | S     | S     | S     | S     | D,S   | S     | S,D   | D     | D     | D     | S     | S,D   | S    |
| Bioturbation        |       |       |       |       |       |       |       |       |       |       |       |       |      |
| Micrite envelope    | ✓     | ✓     |       | ✓     |       |       |       |       |       |       | ✓     | ✓     | ✓    |
| Fenestrae: Tubular  |       |       |       |       |       |       |       |       |       |       |       |       |      |
| Laminoid/irregular  |       |       |       |       |       |       |       |       |       |       |       |       |      |
| Geopetals           |       |       |       |       |       |       |       |       |       |       |       |       |      |
| Gravity cements     |       |       |       |       |       |       |       |       |       |       |       |       |      |
| Lamination          |       |       |       |       |       |       |       |       |       |       |       |       |      |
| Others              |       |       |       |       |       | *1    | *1,*2 | *3    | *3    | *3    | *1    |       |      |

\*1 Alignment of bioclasts parallel to each other

\*2 Bioclasts encrusted by *Girvanella*

\*3 Slide has been thoroughly dolomitised

|         |  |
|---------|--|
| Texture | M=Mudstone, W=Wackestone, P=Packstone<br>G=Grainstone, F=Floatstone, Bf= Bafflestone<br>Bi=Bindstone, B=Boundstone, D=Dolomite |
| Matrix  | M=Micrite, Ms=Microspar, S=Spar, D=Dolomite  |

## Heggen Quarry

○ = <1%    · = 1-20%    ● = 21-40%    ● = 41-60%    \* = >61%

| Sample number       | HG26 | HG27 | HG28 | HG29 |  |  |  |  |  |  |  |  |  |  |  |  |  |  |  |
|---------------------|------|------|------|------|--|--|--|--|--|--|--|--|--|--|--|--|--|--|--|
| Height              | 6.7m | 1.4m | 0.6m | 3.6m |  |  |  |  |  |  |  |  |  |  |  |  |  |  |  |
| Thin Section/ Peel  | P    | P    | P    | P    |  |  |  |  |  |  |  |  |  |  |  |  |  |  |  |
| Microfacies         | S3a  | S2   | S3a  | S3a  |  |  |  |  |  |  |  |  |  |  |  |  |  |  |  |
| Texture             | G    | F    | G    | G    |  |  |  |  |  |  |  |  |  |  |  |  |  |  |  |
| Grains:             |      |      |      |      |  |  |  |  |  |  |  |  |  |  |  |  |  |  |  |
| Peloids             | ●    |      | ●    | ●    |  |  |  |  |  |  |  |  |  |  |  |  |  |  |  |
| Lithoclasts         |      |      |      |      |  |  |  |  |  |  |  |  |  |  |  |  |  |  |  |
| Oncoids             |      |      |      |      |  |  |  |  |  |  |  |  |  |  |  |  |  |  |  |
| Ooids               |      |      |      |      |  |  |  |  |  |  |  |  |  |  |  |  |  |  |  |
| Aggregate grains    |      |      |      |      |  |  |  |  |  |  |  |  |  |  |  |  |  |  |  |
| Quartz/ silt grains |      |      |      |      |  |  |  |  |  |  |  |  |  |  |  |  |  |  |  |
| Bioclasts:          |      |      |      |      |  |  |  |  |  |  |  |  |  |  |  |  |  |  |  |
| Bulbous stroms.     |      | ●    |      | ·    |  |  |  |  |  |  |  |  |  |  |  |  |  |  |  |
| Laminar stroms.     |      |      |      |      |  |  |  |  |  |  |  |  |  |  |  |  |  |  |  |
| Dendroid stroms.    | ●    |      |      |      |  |  |  |  |  |  |  |  |  |  |  |  |  |  |  |
| Stachyodes          |      |      | ·    | ·    |  |  |  |  |  |  |  |  |  |  |  |  |  |  |  |
| Amphipora           |      |      |      |      |  |  |  |  |  |  |  |  |  |  |  |  |  |  |  |
| Colonial corals     |      |      |      |      |  |  |  |  |  |  |  |  |  |  |  |  |  |  |  |
| Solitary corals     |      |      |      |      |  |  |  |  |  |  |  |  |  |  |  |  |  |  |  |
| Thamnoporoids       |      |      |      |      |  |  |  |  |  |  |  |  |  |  |  |  |  |  |  |
| Bivalves            |      |      |      |      |  |  |  |  |  |  |  |  |  |  |  |  |  |  |  |
| Gastropods          |      |      |      |      |  |  |  |  |  |  |  |  |  |  |  |  |  |  |  |
| Shell hash          |      |      |      |      |  |  |  |  |  |  |  |  |  |  |  |  |  |  |  |
| Brachiopods         |      |      |      |      |  |  |  |  |  |  |  |  |  |  |  |  |  |  |  |
| Brachiopod spines   |      |      |      |      |  |  |  |  |  |  |  |  |  |  |  |  |  |  |  |
| Crinoids            |      |      | ·    | ·    |  |  |  |  |  |  |  |  |  |  |  |  |  |  |  |
| Tentaculites        |      |      |      |      |  |  |  |  |  |  |  |  |  |  |  |  |  |  |  |
| Trilobites          |      |      |      |      |  |  |  |  |  |  |  |  |  |  |  |  |  |  |  |
| Bryozoans           |      |      |      |      |  |  |  |  |  |  |  |  |  |  |  |  |  |  |  |
| Ostrocodes          |      |      | ○    |      |  |  |  |  |  |  |  |  |  |  |  |  |  |  |  |
| Leperditia          |      |      |      |      |  |  |  |  |  |  |  |  |  |  |  |  |  |  |  |
| Calcspheres         |      |      |      |      |  |  |  |  |  |  |  |  |  |  |  |  |  |  |  |
| Forams              |      |      | ○    |      |  |  |  |  |  |  |  |  |  |  |  |  |  |  |  |
| Sponge spicules     |      |      |      |      |  |  |  |  |  |  |  |  |  |  |  |  |  |  |  |
| Umbellids           |      |      |      |      |  |  |  |  |  |  |  |  |  |  |  |  |  |  |  |
| Undetermined        |      |      |      |      |  |  |  |  |  |  |  |  |  |  |  |  |  |  |  |
| Codiaceans          |      |      |      |      |  |  |  |  |  |  |  |  |  |  |  |  |  |  |  |
| Dasycladaceaens     |      |      |      |      |  |  |  |  |  |  |  |  |  |  |  |  |  |  |  |
| Girvanella Gp.      |      |      |      |      |  |  |  |  |  |  |  |  |  |  |  |  |  |  |  |
| Renalcis Gp.        |      |      |      |      |  |  |  |  |  |  |  |  |  |  |  |  |  |  |  |
| Hedstroemia Gp.     |      |      |      |      |  |  |  |  |  |  |  |  |  |  |  |  |  |  |  |
| Wetheredella Gp.    |      |      |      |      |  |  |  |  |  |  |  |  |  |  |  |  |  |  |  |
| Matrix              | D,S  |      | S    | S    |  |  |  |  |  |  |  |  |  |  |  |  |  |  |  |
| Bioturbation        |      |      |      |      |  |  |  |  |  |  |  |  |  |  |  |  |  |  |  |
| Micrite envelope    |      |      | ✓    | ✓    |  |  |  |  |  |  |  |  |  |  |  |  |  |  |  |
| Fenestrae: Tubular  |      |      |      |      |  |  |  |  |  |  |  |  |  |  |  |  |  |  |  |
| Laminoid/irregular  |      |      |      |      |  |  |  |  |  |  |  |  |  |  |  |  |  |  |  |
| Geopetals           |      |      |      |      |  |  |  |  |  |  |  |  |  |  |  |  |  |  |  |
| Gravity cements     |      |      |      |      |  |  |  |  |  |  |  |  |  |  |  |  |  |  |  |
| Lamination          |      |      |      |      |  |  |  |  |  |  |  |  |  |  |  |  |  |  |  |
| Others              |      | *1   |      |      |  |  |  |  |  |  |  |  |  |  |  |  |  |  |  |

\*1 Slide is cut through bulbous stromatoporoid

|         |  |
|---------|--|
| Texture | M=Mudstone, W=Wackestone, P=Packstone<br>G=Grainstone, F=Floatstone, Bf= Bafflestone<br>Bi=Bindstone, B=Boundstone, D=Dolomite |
| Matrix  | M=Micrite, Ms=Microspar, S=Spar, D=Dolomite  |

## A1.2.14 Keldenich Quarry

○ = <1%    · = 1–20%    ● = 21–40%    ● = 41–60%    \* = >61%

| Sample number       | KL1   | KL2   | KL3   | KL4   | KL5   | KL6   | KL7   | KL8   | KL9   | KL10 | KL11 | KL12  | KL13  |
|---------------------|-------|-------|-------|-------|-------|-------|-------|-------|-------|------|------|-------|-------|
| Height              | 27.1m | 27.3m | 28.7m | 30.0m | 32.1m | 32.4m | 35.5m | 36.5m | 38.2m | 2.9m | 5.6m | 12.0m | 13.0m |
| Thin Section/ Peel  | TS    | TS    | TS    | TS    | TS    | TS    | TS    | TS    | TS    | TS   | TS   | TS    | TS    |
| Microfacies         | S8a   | S5    | S6b   | S6c   | S6a   | S6f/c | S7a   | S6c   | S6a   | S4c  | S8a  | S5    | S13   |
| Texture             | W     | P     | M     | M     | W     | W     | G     | W     | W     | F    | W    | P     | M     |
| Grains:             |       |       |       |       |       |       |       |       |       |      |      |       |       |
| Peloids             |       |       |       |       |       |       | ●     |       |       |      | ·    |       |       |
| Lithoclasts         |       | ·     |       |       |       |       |       |       |       |      |      |       |       |
| Oncoids             |       |       |       |       |       |       |       |       |       |      |      |       |       |
| Ooids               |       |       |       |       |       |       |       |       |       |      |      |       |       |
| Aggregate grains    |       |       |       |       |       |       |       |       |       |      |      |       |       |
| Quartz/ silt grains |       |       |       |       |       |       |       |       |       |      |      |       |       |
| Bioclasts:          |       |       |       |       |       |       |       |       |       |      |      |       |       |
| Bulbous stroms.     |       |       |       |       |       |       |       |       |       |      |      |       |       |
| Laminar stroms.     |       |       |       |       |       |       |       |       |       |      |      |       |       |
| Dendroid stroms.    |       |       |       |       |       |       |       |       |       |      |      |       |       |
| Stachyodes          |       |       |       |       |       |       |       |       |       | ·    |      |       |       |
| Amphipora           |       |       |       |       |       |       |       |       |       |      |      |       |       |
| Colonial corals     |       |       |       |       |       |       |       |       |       |      |      |       |       |
| Solitary corals     |       |       |       |       |       |       |       |       |       |      |      |       |       |
| Thamnoporoids       |       | ·     |       |       |       |       |       |       |       |      |      |       |       |
| Bivalves            |       | *1    |       |       |       |       |       |       |       |      |      | ●     |       |
| Gastropods          |       | ·     |       |       |       |       |       |       |       | ·    |      |       |       |
| Shell hash          |       |       |       |       |       |       |       |       |       |      |      |       |       |
| Brachiopods         |       |       | ●     |       |       |       | ●     |       |       |      |      |       |       |
| Brachiopod spines   |       |       |       |       |       |       |       |       |       |      |      |       |       |
| Crinoids            |       |       |       |       |       |       |       |       |       |      |      |       |       |
| Tentaculites        |       |       |       |       |       |       |       |       |       |      |      |       |       |
| Trilobites          |       |       |       |       |       |       |       |       |       |      |      |       |       |
| Bryozoans           |       |       |       |       |       |       |       |       |       |      |      |       |       |
| Ostrocodes          | ●     | ·     | ·     | *1    | ·     | ·     | ·     |       | ·     | ·    | ●    | ·     | *1    |
| Leperditia          | ·     |       |       |       |       | ·     |       | ·     |       |      |      |       |       |
| Calcspheres         | ●     |       |       | ·     | ●     | ·     | ·     | ·     | ·     | ·    | ·    | ·     |       |
| Forams              | ·     |       | ●     | ·     | ●     | ·     | ·     |       |       |      |      | ·     |       |
| Sponge spicules     |       |       |       |       |       |       |       |       |       |      |      |       |       |
| Umbellids           |       |       |       |       |       |       |       |       |       |      |      |       |       |
| Undetermined        |       |       |       |       |       |       |       |       |       |      |      |       |       |
| Codiaceans          |       |       |       | ·     |       | ·     |       |       |       | ·    |      |       |       |
| Dasycladaceans      | ●     |       |       |       | ●     | ●     | ○     | ●     | ●     | ●    | ●    | ○     |       |
| Girvanella Gp.      |       |       |       |       |       |       |       |       |       |      |      |       |       |
| Renalcis Gp.        |       |       |       |       |       |       |       |       |       |      |      |       |       |
| Hedstroemia Gp.     |       |       |       |       |       |       |       |       |       |      |      |       |       |
| Wetheredella Gp.    |       |       |       |       |       |       |       |       |       |      |      |       |       |
| Matrix              | M     | M,Ms  | D     | M,Ms  | M,Ms  | M     | S     | M     | M,Ms  | M,D  | M    | M,S,D | M,D   |
| Bioturbation        | ✓     |       | ✓     | ✓     | ✓     | ✓     |       |       | ✓     |      |      |       |       |
| Micrite envelope    |       | ✓     | ✓     |       |       |       |       | ✓     |       |      |      | ✓     |       |
| Fenestrae: Tubular  | ✓     |       |       | ✓     |       | ✓     |       | ✓     |       |      | ✓    |       |       |
| Laminoid/irregular  | ✓     |       |       |       |       |       |       |       |       |      |      |       |       |
| Geopetals           |       |       |       |       |       |       |       |       |       |      | ✓    |       |       |
| Gravity cements     |       |       |       |       |       |       |       |       |       |      |      |       |       |
| Lamination          |       |       |       |       |       |       |       |       |       |      |      |       |       |
| Others              |       | *1    |       |       |       |       |       | *1    |       | *2   | *3   | *1    | *4    |

\*1 Bioclasts are aligned parallel to each other

\*2 Sample of matrix

\*3 Internal sediment-fill of vadose silt in base of fenestrae

\*4 Pseudomorphs of anhydrite

|         |  |
|---------|--|
| Texture | M=Mudstone, W=Wackestone, P=Packstone<br>G=Grainstone, F=Floatstone, Bf= Bafflestone<br>Bi=Bindstone, B=Boundstone, D=Dolomite |
| Matrix  | M=Micrite, Ms=Microspar, S=Spar, D=Dolomite  |



## A1.2.15 Linhay Hill Quarry

○ = <1%    · = 1-20%    ● = 21-40%    ● = 41-60%    \* = >61%

| Sample number       | LQ1  | LQ2  | LQ3  | LQ4  | LQ5  | LQ6  | LQ7  | LQ8  | LQ9  | LQ10  | LQ11  | LQ12  | LQ13  |
|---------------------|------|------|------|------|------|------|------|------|------|-------|-------|-------|-------|
| Height              | 0.1m | 1.5m | 2.9m | 3.4m | 3.8m | 4.7m | 7.3m | 8.8m | 9.8m | 10.6m | 11.8m | 12.1m | 14.5m |
| Thin Section/ Peel  | TS   | P    | TS   | P    | TS   | P    | P    | P    | TS   | P     | TS    | TS    | TS    |
| Microfacies         | S4a  | S5   | S3b  | S6a  | S3b  | S2   | S3b  | S4a  | S6b  | S4a   | S6b   | S6a   | S4a   |
| Texture             | F    | W    | W    | MW   | P    | F    | F    | W    | M    | F     | M     | W     | W     |
| Grains:             |      |      |      |      |      |      |      |      |      |       |       |       |       |
| Peloids             | ●    |      | ·    |      |      |      |      |      |      |       | ●     | ·     |       |
| Lithoclasts         |      |      |      |      |      |      |      |      |      |       |       |       |       |
| Oncoids             |      |      |      |      |      |      |      |      |      |       |       |       |       |
| Ooids               |      |      |      |      |      |      |      |      |      |       |       |       |       |
| Aggregate grains    |      |      |      |      |      |      |      |      |      |       |       |       |       |
| Quartz/ silt grains |      |      |      |      |      |      |      |      |      |       |       |       |       |
| Bioclasts:          |      |      |      |      |      |      |      |      |      |       |       |       |       |
| Bulbous stroms.     |      |      |      |      | ●    | ●    | ●    |      |      |       |       |       |       |
| Laminar stroms.     |      |      |      |      |      |      |      |      |      |       |       |       |       |
| Dendroid stroms.    |      | ·    |      |      |      |      |      |      |      |       |       |       |       |
| Stachyodes          |      |      | ●    |      |      |      | ·    |      |      |       |       |       |       |
| Amphipora           | ●    |      |      | ·    | ·    |      | ·    | ●    |      | ●     | ·     |       | ●     |
| Colonial corals     |      |      |      | ·    |      |      | ●    |      |      |       |       |       |       |
| Solitary corals     |      |      |      |      |      |      |      |      |      |       |       |       |       |
| Thamnoporoids       |      |      |      |      | ○    |      |      |      |      |       |       |       |       |
| Bivalves            |      |      |      |      |      |      |      |      |      |       |       |       | ·     |
| Gastropods          |      | ●    |      | ·    |      |      |      |      |      |       |       |       | ·     |
| Shell hash          |      |      |      |      |      |      |      |      |      |       |       |       |       |
| Brachiopods         |      |      |      |      | ·    |      | ·    |      |      |       |       |       | ●     |
| Brachiopod spines   |      |      |      |      |      |      |      |      |      |       |       |       |       |
| Crinoids            |      |      |      |      |      |      |      |      |      |       |       |       |       |
| Tentaculites        |      |      |      |      |      |      |      |      |      |       |       |       |       |
| Trilobites          |      |      |      |      |      |      |      |      |      |       |       |       |       |
| Bryozoans           |      |      |      |      |      |      |      |      |      |       |       |       |       |
| Ostrocodes          |      | ·    | ·    | ●    |      |      | ·    |      |      |       | ○     |       |       |
| Leperditia          | ·    |      |      |      |      |      |      |      |      |       |       |       |       |
| Calcspheres         |      |      | ·    |      |      |      |      | ·    |      |       | ●     | ●     | ·     |
| Forams              |      |      | ·    | ·    |      |      |      |      |      |       |       | ●     | ○     |
| Sponge spicules     |      |      |      |      |      |      |      |      |      |       |       |       |       |
| Umbellids           |      |      |      |      |      |      |      |      |      |       |       |       |       |
| Undetermined        |      |      |      |      |      |      |      |      |      |       |       |       |       |
| Codiaceans          |      |      |      |      |      |      |      |      |      |       |       |       |       |
| Dasycladaceans      |      |      |      |      |      |      |      |      |      |       |       |       |       |
| Girvanella Gp.      |      |      |      |      |      |      |      |      |      |       |       |       |       |
| Renalcis Gp.        |      |      |      |      |      |      |      |      |      |       |       |       |       |
| Hedstroemia Gp.     |      |      |      |      |      |      |      |      |      |       |       |       |       |
| Wetheredella Gp.    |      |      |      |      |      |      |      |      |      |       |       |       |       |
| Matrix              | M,S  | M    | M    | M    | M    |      | M    | M    | M    | D,M   | M     | M,D   | M     |
| Bioturbation        | ✓    |      |      | ✓    |      |      |      |      |      |       |       | ✓     |       |
| Micrite envelope    |      |      |      |      |      |      |      |      |      |       |       |       |       |
| Fenestrae: Tubular  |      |      |      |      |      |      |      |      |      |       |       |       |       |
| Laminoid/irregular  |      |      |      |      |      |      |      |      |      |       |       |       |       |
| Geopetals           |      |      |      |      |      |      |      |      |      |       |       |       |       |
| Gravity cements     |      |      |      |      |      |      |      |      |      |       |       |       |       |
| Lamination          |      |      |      |      |      |      |      |      | ✓    |       | ✓     |       |       |
| Others              |      |      |      |      | *1   | *2   | *1   |      |      |       |       |       |       |

\*1 Very organic-rich with abundant pyrite

\*2 Thin section through bulbous stromatoporeid

|         |  |
|---------|--|
| Texture | M=Mudstone, W=Wackestone, P=Packstone<br>G=Grainstone, F=Floatstone, Bf= Bafflestone<br>Bi=Bindstone, B=Boundstone, D=Dolomite |
| Matrix  | M=Micrite, Ms=Microspar, S=Spar, D=Dolomite  |

## Linhay Hill Quarry

○ = <1%    · = 1-20%    ● = 21-40%    ● = 41-60%    \* = >61%

| Sample number       | LQ14  | LQ15  | LQ16  | LQ17  | LQ18  | LQ19  | LQ20  | LQ21  | LQ22  | LQ23  | LQ24  | LQ25  | LQ26  |
|---------------------|-------|-------|-------|-------|-------|-------|-------|-------|-------|-------|-------|-------|-------|
| Height              | 15.0m | 16.5m | 18.3m | 19.5m | 24.6m | 25.0m | 26.6m | 27.9m | 28.4m | 30.0m | 31.0m | 32.7m | 33.2m |
| Thin Section/ Peel  | TS    | TS    | TS    | P     | P     | TS    | TS    | TS    | TS    | TS    | P     | P     | P     |
| Microfacies         | S6a   | S4a   | S4a   | S4a   | S6b   | S6b   | S6b   | S2    | S2    | S4a   | S6b   | S4a   | S4a   |
| Texture             | MW    | W     | F     | F     | M     | M     | M     | F     | F     | F     | M     | W     | Bf    |
| Grains:             |       |       |       |       |       |       |       |       |       |       |       |       |       |
| Peloids             |       |       |       |       |       |       |       |       |       |       |       |       |       |
| Lithoclasts         |       |       |       |       |       |       |       |       |       |       |       |       |       |
| Oncoids             |       |       |       |       |       |       |       |       |       |       |       |       |       |
| Ooids               |       |       |       |       |       |       |       |       |       |       |       |       |       |
| Aggregate grains    |       |       |       |       |       |       |       |       |       |       |       |       |       |
| Quartz/ silt grains |       |       |       |       |       |       |       |       |       |       |       |       |       |
| Bioclasts:          |       |       |       |       |       |       |       |       |       |       |       |       |       |
| Bulbous stroms.     |       |       |       | ●     |       |       |       | ●     | ●     |       |       |       |       |
| Laminar stroms.     |       |       |       |       |       |       |       |       |       |       |       |       |       |
| Dendroid stroms.    |       | ·     |       |       |       |       |       |       |       |       |       |       |       |
| Stachyodes          |       |       | ●     |       |       |       |       |       |       |       |       |       |       |
| Amphipora           |       | ●     |       |       |       |       |       |       |       | ●     |       | ●     | ●     |
| Colonial corals     |       |       |       |       |       |       |       |       |       |       |       |       |       |
| Solitary corals     |       |       |       |       |       |       |       |       |       |       |       |       |       |
| Thamnoporoids       |       |       |       |       |       |       |       |       |       |       |       |       |       |
| Bivalves            |       |       |       |       | ·     |       |       |       |       |       | ○     | ·     |       |
| Gastropods          |       |       |       |       |       |       |       |       |       |       |       |       |       |
| Shell hash          |       |       |       |       |       |       |       |       |       |       |       |       |       |
| Brachiopods         |       | ·     |       |       |       |       |       |       |       |       |       |       |       |
| Brachiopod spines   |       |       |       |       |       |       |       |       |       |       |       |       |       |
| Crinoids            |       | ·     |       |       |       |       |       |       |       |       |       |       |       |
| Tentaculites        |       |       |       |       |       |       |       |       |       |       |       |       |       |
| Trilobites          |       |       |       |       |       |       |       |       |       |       |       |       |       |
| Bryozoans           |       |       |       |       |       |       |       |       |       |       |       |       |       |
| Ostrocodes          | ●     |       | ○     |       | ·     | ○     | ·     |       |       |       |       | ·     |       |
| Leperditia          |       | ●     |       |       |       |       |       |       |       |       |       |       |       |
| Calcspheres         | ·     |       | ○     |       | ●     | ●     | ●     |       |       |       | ●     | ·     |       |
| Forams              | ●     |       |       |       | ·     | ·     | ·     |       |       |       |       | ·     |       |
| Sponge spicules     |       |       |       |       |       |       |       |       |       |       |       |       |       |
| Umbellids           |       |       |       |       |       |       |       |       |       |       |       |       |       |
| Undetermined        |       |       |       |       |       |       |       |       |       |       |       |       |       |
| Codiaceans          |       |       |       |       |       |       |       |       |       |       |       |       |       |
| Dasycladaceans      |       |       |       |       |       |       |       |       |       |       |       |       |       |
| Girvanella Gp.      |       |       |       |       |       |       |       |       |       |       |       |       |       |
| Renalcis Gp.        |       |       |       |       |       |       |       |       |       |       |       |       |       |
| Hedstroemia Gp.     |       |       |       |       |       |       |       |       |       |       |       |       |       |
| Wetheredella Gp.    |       |       |       |       |       |       |       |       |       |       |       |       |       |
| Matrix              | M,Ms  | Ms,M  | D,M   |       | M     | M     | M     |       |       | D     | M,Ms  | M,Ms  | M,Ms  |
| Bioturbation        | ✓     | ✓     |       |       |       |       |       |       |       |       | ✓     |       |       |
| Micrite envelope    |       |       |       |       |       |       |       |       |       |       |       | ✓     |       |
| Fenestrae: Tubular  |       |       |       |       |       |       |       |       |       |       |       |       |       |
| Laminoid/irregular  |       |       |       |       |       |       |       |       |       |       |       |       |       |
| Geopetals           |       |       |       |       |       |       |       |       |       |       |       |       |       |
| Gravity cements     |       |       |       |       |       |       |       |       |       |       |       |       |       |
| Lamination          |       |       |       |       |       |       |       |       |       |       |       |       |       |
| Others              |       | *1    |       | *2    | *1    |       | *1    | *2    | *2    |       |       |       | *1    |

\*1 Alignment of bioclasts parallel to bedding

\*2 Thin section dominated by bulbous stromatoporoids

|         |  |
|---------|--|
| Texture | M=Mudstone, W=Wackestone, P=Packstone<br>G=Grainstone, F=Floatstone, Bf= Bafflestone<br>Bi=Bindstone, B=Boundstone, D=Dolomite |
| Matrix  | M=Micrite, Ms=Microspar, S=Spar, D=Dolomite  |

## Linhay Hill Quarry

○ = <1%    · = 1-20%    ● = 21-40%    ● = 41-60%    \* = >61%

| Sample number       | LQ27  | LQ28  | LQ29  | LQ30  |  |  |  |  |  |  |  |  |  |  |  |  |  |  |  |  |
|---------------------|-------|-------|-------|-------|--|--|--|--|--|--|--|--|--|--|--|--|--|--|--|--|
| Height              | 41.0m | 42.3m | 47.2m | 50.5m |  |  |  |  |  |  |  |  |  |  |  |  |  |  |  |  |
| Thin Section/ Peel  | P     | TS    | P     | TS    |  |  |  |  |  |  |  |  |  |  |  |  |  |  |  |  |
| Microfacies         | S6b   | S4a   | S4a   | S4a   |  |  |  |  |  |  |  |  |  |  |  |  |  |  |  |  |
| Texture             | M     | W     | F     | Bf    |  |  |  |  |  |  |  |  |  |  |  |  |  |  |  |  |
| Grains:             |       |       |       |       |  |  |  |  |  |  |  |  |  |  |  |  |  |  |  |  |
| Peloids             |       |       |       |       |  |  |  |  |  |  |  |  |  |  |  |  |  |  |  |  |
| Lithoclasts         |       |       |       |       |  |  |  |  |  |  |  |  |  |  |  |  |  |  |  |  |
| Oncoids             |       |       |       |       |  |  |  |  |  |  |  |  |  |  |  |  |  |  |  |  |
| Ooids               |       |       |       |       |  |  |  |  |  |  |  |  |  |  |  |  |  |  |  |  |
| Aggregate grains    |       |       |       |       |  |  |  |  |  |  |  |  |  |  |  |  |  |  |  |  |
| Quartz/ silt grains |       |       |       |       |  |  |  |  |  |  |  |  |  |  |  |  |  |  |  |  |
| Bioclasts:          |       |       |       |       |  |  |  |  |  |  |  |  |  |  |  |  |  |  |  |  |
| Bulbous stroms.     |       |       |       |       |  |  |  |  |  |  |  |  |  |  |  |  |  |  |  |  |
| Laminar stroms.     |       |       |       |       |  |  |  |  |  |  |  |  |  |  |  |  |  |  |  |  |
| Dendroid stroms.    |       |       |       |       |  |  |  |  |  |  |  |  |  |  |  |  |  |  |  |  |
| Stachyodes          |       |       |       |       |  |  |  |  |  |  |  |  |  |  |  |  |  |  |  |  |
| Amphipora           |       | *     | *     | *     |  |  |  |  |  |  |  |  |  |  |  |  |  |  |  |  |
| Colonial corals     |       |       |       |       |  |  |  |  |  |  |  |  |  |  |  |  |  |  |  |  |
| Solitary corals     |       |       |       |       |  |  |  |  |  |  |  |  |  |  |  |  |  |  |  |  |
| Thamnoporoids       |       |       |       |       |  |  |  |  |  |  |  |  |  |  |  |  |  |  |  |  |
| Bivalves            | ●     |       |       |       |  |  |  |  |  |  |  |  |  |  |  |  |  |  |  |  |
| Gastropods          |       |       |       |       |  |  |  |  |  |  |  |  |  |  |  |  |  |  |  |  |
| Shell hash          |       |       |       |       |  |  |  |  |  |  |  |  |  |  |  |  |  |  |  |  |
| Brachiopods         |       |       |       |       |  |  |  |  |  |  |  |  |  |  |  |  |  |  |  |  |
| Brachiopod spines   |       |       |       |       |  |  |  |  |  |  |  |  |  |  |  |  |  |  |  |  |
| Crinoids            |       |       |       |       |  |  |  |  |  |  |  |  |  |  |  |  |  |  |  |  |
| Tentaculites        |       |       |       |       |  |  |  |  |  |  |  |  |  |  |  |  |  |  |  |  |
| Trilobites          |       |       |       |       |  |  |  |  |  |  |  |  |  |  |  |  |  |  |  |  |
| Bryozoans           |       |       |       |       |  |  |  |  |  |  |  |  |  |  |  |  |  |  |  |  |
| Ostrocodes          |       |       |       |       |  |  |  |  |  |  |  |  |  |  |  |  |  |  |  |  |
| Leperditia          |       |       |       |       |  |  |  |  |  |  |  |  |  |  |  |  |  |  |  |  |
| Calcspheres         | *     | ●     |       |       |  |  |  |  |  |  |  |  |  |  |  |  |  |  |  |  |
| Forams              |       | ·     |       | ·     |  |  |  |  |  |  |  |  |  |  |  |  |  |  |  |  |
| Sponge spicules     |       |       |       |       |  |  |  |  |  |  |  |  |  |  |  |  |  |  |  |  |
| Umbellids           |       |       |       |       |  |  |  |  |  |  |  |  |  |  |  |  |  |  |  |  |
| Undetermined        |       |       |       |       |  |  |  |  |  |  |  |  |  |  |  |  |  |  |  |  |
| Codiaceans          |       |       |       |       |  |  |  |  |  |  |  |  |  |  |  |  |  |  |  |  |
| Dasycladaceans      |       |       |       |       |  |  |  |  |  |  |  |  |  |  |  |  |  |  |  |  |
| Girvanella Gp.      |       |       |       |       |  |  |  |  |  |  |  |  |  |  |  |  |  |  |  |  |
| Renalcis Gp.        |       |       |       |       |  |  |  |  |  |  |  |  |  |  |  |  |  |  |  |  |
| Hedstroemia Gp.     |       |       |       |       |  |  |  |  |  |  |  |  |  |  |  |  |  |  |  |  |
| Wetheredella Gp.    |       |       |       |       |  |  |  |  |  |  |  |  |  |  |  |  |  |  |  |  |
| Matrix              | M     | M     | M     | M     |  |  |  |  |  |  |  |  |  |  |  |  |  |  |  |  |
| Bioturbation        | ✓     |       |       |       |  |  |  |  |  |  |  |  |  |  |  |  |  |  |  |  |
| Micrite envelope    |       |       |       |       |  |  |  |  |  |  |  |  |  |  |  |  |  |  |  |  |
| Fenestrae: Tubular  |       |       |       |       |  |  |  |  |  |  |  |  |  |  |  |  |  |  |  |  |
| Laminoid/irregular  |       |       |       |       |  |  |  |  |  |  |  |  |  |  |  |  |  |  |  |  |
| Geopetals           |       |       |       |       |  |  |  |  |  |  |  |  |  |  |  |  |  |  |  |  |
| Gravity cements     |       |       |       |       |  |  |  |  |  |  |  |  |  |  |  |  |  |  |  |  |
| Lamination          |       |       |       |       |  |  |  |  |  |  |  |  |  |  |  |  |  |  |  |  |
| Others              |       |       | *1    | *1    |  |  |  |  |  |  |  |  |  |  |  |  |  |  |  |  |

\*1 Alignment of bioclasts parallel to each other

|         |  |
|---------|--|
| Texture | M=Mudstone, W=Wackestone, P=Packstone<br>G=Grainstone, F=Floatstone, Bf= Bafflestone<br>Bi=Bindstone, B=Boundstone, D=Dolomite |
| Matrix  | M=Micrite, Ms=Microspar, S=Spar, D=Dolomite  |

## A1.2.16 Medenbach Quarry

○ = <1%    · = 1-20%    ● = 21-40%    ● = 41-60%    \* = >61%

| Sample number       | MB1  | MB2  | MB3  | MB4  | MB5  | MB6  | MB7   | MB8   | MB9   | MB10  | MB11  | MB12  | MB13  |
|---------------------|------|------|------|------|------|------|-------|-------|-------|-------|-------|-------|-------|
| Height              | 0.4m | 1.4m | 2.9m | 3.9m | 5.6m | 7.0m | 10.4m | 11.5m | 12.4m | 13.5m | 14.0m | 18.8m | 20.1m |
| Thin Section/ Peel  | TS   | TS   | P    | TS   | TS   | TS   | TS    | TS    | TS    | TS    | TS    | P     | TS    |
| Microfacies         | S4a  | S4a  | S4a  | S4a  | S4a  | S4a  | S4a   | S4a   | S4a   | S4a   | S6a   | S4a   | S4a   |
| Texture             | F    | F    | F    | W    | F    | F    | F     | W     | F     | F     | W     | W     | W     |
| Grains:             |      |      |      |      |      |      |       |       |       |       |       |       |       |
| Peloids             |      |      |      |      |      |      |       |       |       |       | *     |       | ·     |
| Lithoclasts         |      |      |      |      |      |      |       |       |       |       |       |       |       |
| Oncoids             |      |      |      |      |      |      |       |       |       |       |       |       |       |
| Ooids               |      |      |      |      |      |      |       |       |       |       |       |       |       |
| Aggregate grains    |      |      |      |      |      |      |       |       |       |       |       |       |       |
| Quartz/ silt grains |      |      |      |      |      |      |       |       |       |       |       |       |       |
| Bioclasts:          |      |      |      |      |      |      |       |       |       |       |       |       |       |
| Bulbous stroms.     |      |      |      |      |      |      |       |       |       |       |       |       |       |
| Laminar stroms.     |      |      |      |      |      |      |       |       |       |       |       |       |       |
| Dendroid stroms.    |      |      |      |      |      |      |       |       | ·     | ·     |       |       |       |
| Stachyodes          | ●    | ●    | ●    |      | ●    | ●    | *     | ·     | ●     |       | ·     |       |       |
| Amphipora           | *    | ●    | ●    | *    | *    | ●    | ·     | ●     | ·     | ·     |       | ●     |       |
| Colonial corals     |      |      |      |      |      |      |       |       |       |       |       |       |       |
| Solitary corals     |      |      | ·    |      |      |      |       |       | ·     |       |       |       |       |
| Thamnoporoids       |      | ·    |      |      |      |      | ·     |       |       | ○     |       | ●     |       |
| Bivalves            |      |      |      |      |      |      |       |       |       |       |       |       |       |
| Gastropods          |      | ○    |      |      |      |      |       |       |       |       |       |       |       |
| Shell hash          |      |      |      |      |      |      |       |       |       |       |       |       | *     |
| Brachiopods         |      |      |      |      |      |      |       |       |       | ●     |       |       |       |
| Brachiopod spines   |      |      |      |      |      |      |       |       |       |       |       |       |       |
| Crinoids            | ○    | ○    |      | ○    | ○    | ·    |       |       | ○     |       | ·     | ·     |       |
| Tentaculites        |      |      |      |      |      |      |       |       |       |       |       |       |       |
| Trilobites          |      |      |      |      |      |      |       |       |       |       |       |       |       |
| Bryozoans           |      |      |      |      |      |      |       |       |       |       |       |       |       |
| Ostrocodes          |      | ·    |      | ○    | ·    |      | ○     | ·     | ·     | ○     |       |       | ○     |
| Leperditia          |      |      |      |      |      |      |       |       |       |       |       |       |       |
| Calcispheres        |      | ·    |      | ·    | ·    | ·    | ·     | ○     | ·     | ·     | ●     |       | ·     |
| Forams              |      | ·    |      | ·    | ·    | ·    | ·     |       | ·     | ·     |       |       | ·     |
| Sponge spicules     |      |      |      |      |      |      |       |       |       |       |       |       |       |
| Umbellids           |      |      |      |      |      |      |       |       |       |       |       |       |       |
| Undetermined        |      |      |      |      |      |      |       |       |       |       |       |       |       |
| Codiaceans          |      |      |      |      |      |      |       |       |       |       |       |       |       |
| Dasycladaceans      |      |      |      |      |      |      |       |       |       |       |       |       |       |
| Girvanella Gp.      |      |      |      |      |      |      |       |       |       |       |       |       |       |
| Renalcis Gp.        |      | ○    |      | ·    |      |      |       |       |       |       |       |       |       |
| Hedstroemia Gp.     |      |      |      |      |      |      |       |       |       |       |       |       |       |
| Wetheredella Gp.    |      |      |      |      |      |      |       |       |       |       |       |       |       |
| Matrix              | D    | M,S  | M,S  | M    | M    | D    | M,D   | D     | M,S   | M     | M,S   | M     | M,Ms  |
| Bioturbation        |      | ✓    | ✓    | ✓    |      |      | ✓     |       | ✓     | ✓     | ✓     | ✓     | ✓     |
| Micrite envelope    | ✓    | ✓    |      |      |      |      |       |       |       |       |       |       |       |
| Fenestrae: Tubular  |      |      |      |      |      |      |       |       |       |       |       |       |       |
| Laminoid/irregular  |      |      |      |      |      |      |       |       |       |       |       |       |       |
| Geopetals           |      |      |      |      |      |      |       |       |       |       |       |       |       |
| Gravity cements     |      |      |      |      |      |      |       |       |       |       |       |       |       |
| Lamination          |      |      |      |      |      |      |       |       |       |       |       |       |       |
| Others              |      |      |      |      | *1   |      |       |       | *1    | *1    |       |       | *1    |

\*1 Matrix is very peloidal

|         |   |
|---------|---|
| Texture | M=Mudstone, W=Wackestone, P=Packstone<br>G=Grainstone, F=Floatstone, Bf=Bafflestone<br>Bi=Bindstone, B=Boundstone, D=Dolomite |
| Matrix  | M=Micrite, Ms=Microspar, S=Spar, D=Dolomite   |

## Mendenbach Quarry

○ = <1%    · = 1-20%    ● = 21-40%    ● = 41-60%    \* = >61%

| Sample number       | MB14  | MB15  | MB16  | MB17  | MB18  |  |  |  |  |  |  |  |  |  |  |
|---------------------|-------|-------|-------|-------|-------|--|--|--|--|--|--|--|--|--|--|
| Height              | 21.0m | 24.0m | 28.5m | 31.3m | 34.2m |  |  |  |  |  |  |  |  |  |  |
| Thin Section/ Peel  | P     | TS    | TS    | P     | TS    |  |  |  |  |  |  |  |  |  |  |
| Microfacies         | S4a   | S4a   | S7a   | S4a   | S4a   |  |  |  |  |  |  |  |  |  |  |
| Texture             | F     | F     | G     | F     | F     |  |  |  |  |  |  |  |  |  |  |
| Grains:             |       |       |       |       |       |  |  |  |  |  |  |  |  |  |  |
| Peloids             |       |       | *     |       |       |  |  |  |  |  |  |  |  |  |  |
| Lithoclasts         |       |       |       |       |       |  |  |  |  |  |  |  |  |  |  |
| Oncoids             |       |       |       |       |       |  |  |  |  |  |  |  |  |  |  |
| Ooids               |       |       |       |       |       |  |  |  |  |  |  |  |  |  |  |
| Aggregate grains    |       |       |       |       |       |  |  |  |  |  |  |  |  |  |  |
| Quartz/ silt grains |       |       |       |       |       |  |  |  |  |  |  |  |  |  |  |
| Bioclasts:          |       |       |       |       |       |  |  |  |  |  |  |  |  |  |  |
| Bulbous stroms.     |       |       |       |       |       |  |  |  |  |  |  |  |  |  |  |
| Laminar stroms.     |       |       |       |       |       |  |  |  |  |  |  |  |  |  |  |
| Dendroid stroms.    |       |       |       |       |       |  |  |  |  |  |  |  |  |  |  |
| Stachyodes          | ·     | ·     |       |       | ·     |  |  |  |  |  |  |  |  |  |  |
| Amphipora           | ●     | *     | ·     | ·     | *     |  |  |  |  |  |  |  |  |  |  |
| Colonial corals     |       |       |       |       |       |  |  |  |  |  |  |  |  |  |  |
| Solitary corals     | ·     |       |       | ·     |       |  |  |  |  |  |  |  |  |  |  |
| Thamnoporoids       | ●     | ●     |       | *     |       |  |  |  |  |  |  |  |  |  |  |
| Bivalves            |       |       |       |       |       |  |  |  |  |  |  |  |  |  |  |
| Gastropods          |       |       |       |       |       |  |  |  |  |  |  |  |  |  |  |
| Shell hash          |       |       |       |       |       |  |  |  |  |  |  |  |  |  |  |
| Brachiopods         |       |       |       |       |       |  |  |  |  |  |  |  |  |  |  |
| Brachiopod spines   |       |       |       |       |       |  |  |  |  |  |  |  |  |  |  |
| Crinoids            |       |       | ·     |       |       |  |  |  |  |  |  |  |  |  |  |
| Tentaculites        |       |       |       |       |       |  |  |  |  |  |  |  |  |  |  |
| Trilobites          |       |       |       |       |       |  |  |  |  |  |  |  |  |  |  |
| Bryozoans           |       |       |       |       |       |  |  |  |  |  |  |  |  |  |  |
| Ostrocodes          |       | ·     | ○     |       | ·     |  |  |  |  |  |  |  |  |  |  |
| Leperditia          |       |       |       |       |       |  |  |  |  |  |  |  |  |  |  |
| Calcispheres        |       |       | ·     |       | ·     |  |  |  |  |  |  |  |  |  |  |
| Forams              |       |       |       |       | ·     |  |  |  |  |  |  |  |  |  |  |
| Sponge spicules     |       |       |       |       |       |  |  |  |  |  |  |  |  |  |  |
| Umbellids           |       |       |       |       |       |  |  |  |  |  |  |  |  |  |  |
| Undetermined        |       |       |       |       |       |  |  |  |  |  |  |  |  |  |  |
| Codiaceans          |       |       |       |       |       |  |  |  |  |  |  |  |  |  |  |
| Dasycladaceans      |       |       |       |       |       |  |  |  |  |  |  |  |  |  |  |
| Girvanella Gp.      |       |       |       |       |       |  |  |  |  |  |  |  |  |  |  |
| Renalcis Gp.        |       |       |       |       | ·     |  |  |  |  |  |  |  |  |  |  |
| Hedstroemia Gp.     |       |       |       |       |       |  |  |  |  |  |  |  |  |  |  |
| Wetheredella Gp.    |       |       |       |       | ○     |  |  |  |  |  |  |  |  |  |  |
| Matrix              | D,M   | D     | S,M   | M     | M,S   |  |  |  |  |  |  |  |  |  |  |
| Bioturbation        |       |       | ✓     | ✓     | ✓     |  |  |  |  |  |  |  |  |  |  |
| Micrite envelope    |       |       |       |       |       |  |  |  |  |  |  |  |  |  |  |
| Fenestrae: Tubular  |       |       |       |       |       |  |  |  |  |  |  |  |  |  |  |
| Laminoid/irregular  |       |       |       |       |       |  |  |  |  |  |  |  |  |  |  |
| Geopetals           |       |       |       |       |       |  |  |  |  |  |  |  |  |  |  |
| Gravity cements     |       |       |       |       |       |  |  |  |  |  |  |  |  |  |  |
| Lamination          |       |       |       |       |       |  |  |  |  |  |  |  |  |  |  |
| Others              |       |       |       |       | *1    |  |  |  |  |  |  |  |  |  |  |

\*1 Bioclasts aligned parallel to each other

|         |  |
|---------|--|
| Texture | M=Mudstone, W=Wackestone, P=Packstone<br>G=Grainstone, F=Floatstone, Bf= Bafflestone<br>Bi=Bindstone, B=Boundstone, D=Dolomite |
| Matrix  | M=Micrite, Ms=Microspar, S=Spar, D=Dolomite  |

## A1.2.17 Nismes Quarry

○ = <1%    · = 1-20%    ● = 21-40%    ● = 41-60%    \* = >61%

| Sample number       | N1    | N2   | N3   | N4   | N5    | N6    | N7    | N8    | N9    | N10   | N11   |  |  |
|---------------------|-------|------|------|------|-------|-------|-------|-------|-------|-------|-------|--|--|
| Height              | 0.17m | 2.1m | 6.4m | 9.4m | 10.7m | 11.3m | 14.8m | 15.5m | 16.3m | 19.7m | 21.9m |  |  |
| Thin Section/ Peel  | TS    | TS   | TS   | TS   | TS    | TS    | TS    | TS    | TS    | TS    | TS    |  |  |
| Microfacies         | S6e   | S12a | S6e  | S7a  | S4c   | S12b  | S7b/a | S7a   | S5    | S6b   | S7a   |  |  |
| Texture             | M     | MP   | M    | G    | F     | G     | G     | G     | P     | M     | G     |  |  |
| Grains:             |       |      |      |      |       |       |       |       |       |       |       |  |  |
| Peloids             | ●     | *    | *    | *    |       | *     | ●     | *     | *     |       | *     |  |  |
| Lithoclasts         |       |      |      | .    |       |       |       |       | .     | .     |       |  |  |
| Oncoids             |       |      |      |      |       |       |       |       |       |       |       |  |  |
| Ooids               |       |      |      |      |       | ○     | ●     |       |       |       |       |  |  |
| Aggregate grains    |       |      |      |      |       |       |       |       |       |       |       |  |  |
| Quartz/ silt grains |       |      |      |      |       |       |       |       |       |       |       |  |  |
| Bioclasts:          |       |      |      |      |       |       |       |       |       |       |       |  |  |
| Bulbous stroms.     |       |      |      |      |       |       |       |       |       |       |       |  |  |
| Laminar stroms.     |       |      |      |      |       |       |       |       |       |       |       |  |  |
| Dendroid stroms.    |       |      |      |      |       |       |       |       | .     |       |       |  |  |
| Stachyodes          |       |      |      |      |       |       |       |       |       |       |       |  |  |
| Amphipora           |       |      |      |      | ●     |       |       |       |       |       |       |  |  |
| Colonial corals     |       |      |      |      |       |       |       |       |       |       |       |  |  |
| Solitary corals     |       |      |      |      |       |       |       |       |       |       |       |  |  |
| Thamnoporoids       |       |      |      |      | ●     |       |       |       |       |       |       |  |  |
| Bivalves            |       |      |      |      |       |       |       |       |       |       |       |  |  |
| Gastropods          |       |      |      |      |       |       |       |       |       |       |       |  |  |
| Shell hash          |       |      |      |      |       |       |       |       |       |       |       |  |  |
| Brachiopods         |       |      |      |      |       |       | .     | .     | .     |       |       |  |  |
| Brachiopod spines   |       |      |      |      |       |       |       |       |       |       |       |  |  |
| Crinoids            |       |      |      |      |       |       |       |       |       |       |       |  |  |
| Tentaculites        |       |      |      |      |       |       |       |       |       |       |       |  |  |
| Trilobites          |       |      |      |      |       |       |       |       |       |       |       |  |  |
| Bryozoans           |       |      |      |      |       |       |       |       |       |       |       |  |  |
| Ostrocodes          | ●     | ○    | ○    |      | ○     |       |       |       |       | ●     | ○     |  |  |
| Leperditia          |       |      |      |      |       |       |       |       |       |       |       |  |  |
| Calcispheres        |       |      |      |      |       | ○     |       | .     | .     | .     |       |  |  |
| Forams              |       |      |      |      | ○     |       |       |       | .     |       |       |  |  |
| Sponge spicules     |       |      |      |      |       |       |       |       |       |       |       |  |  |
| Umbellids           |       |      |      |      |       |       |       |       |       |       |       |  |  |
| Undetermined        |       |      |      |      |       |       |       |       |       |       |       |  |  |
| Codiaceans          |       |      |      |      |       |       |       |       |       | ●     |       |  |  |
| Dasycladaceans      |       |      |      |      | .     |       |       |       |       |       |       |  |  |
| Girvanella Gp.      |       |      |      |      |       | ○     | .     |       |       |       |       |  |  |
| Renalcis Gp.        |       |      |      |      |       |       |       |       |       |       |       |  |  |
| Hedstroemia Gp.     |       |      |      |      |       |       |       |       |       |       |       |  |  |
| Wetheredella Gp.    |       |      |      |      |       |       |       |       |       |       |       |  |  |
| Matrix              | M,S   | M,S  | M    | S    | M     | S,M   | S     | S,M   | M,S   | M     | S     |  |  |
| Bioturbation        |       |      | ✓    |      | ✓     |       |       | ✓     | ✓     | ✓     | ✓     |  |  |
| Micrite envelope    |       |      |      |      |       |       |       |       |       |       |       |  |  |
| Fenestrae: Tubular  |       |      |      |      |       |       |       |       |       |       |       |  |  |
| Laminoid/irregular  |       |      |      |      |       |       |       |       |       |       |       |  |  |
| Geopetals           |       |      |      |      |       |       |       |       |       |       |       |  |  |
| Gravity cements     |       |      |      |      |       |       |       |       |       |       |       |  |  |
| Lamination          | ✓     | ✓    | ✓    |      |       | ✓     |       |       |       |       |       |  |  |
| Others              |       |      |      |      |       | *1    |       |       |       |       |       |  |  |

\*1 Wavy laminae, sometimes thrombolitic

|         |  |
|---------|--|
| Texture | M=Mudstone, W=Wackestone, P=Packstone<br>G=Grainstone, F=Floatstone, Bf= Bafflestone<br>Bi=Bindstone, B=Boundstone, D=Dolomite |
| Matrix  | M=Micrite, Ms=Microspar, S=Spar, D=Dolomite  |

## A1.2.18 Oberrödinghausen Quarry

○ = <1%    · = 1-20%    ● = 21-40%    ● = 41-60%    \* = >61%

| Sample number       | ORH1 | ORH2 | ORH3 | ORH4 | ORH5 | ORH6 | ORH7 | ORH8  | ORH9  | ORH10 | ORH11 | ORH12 | ORH13 |
|---------------------|------|------|------|------|------|------|------|-------|-------|-------|-------|-------|-------|
| Height              | 1.0m | 2.0m | 3.4m | 3.9m | 6.4m | 7.2m | 9.2m | 11.5m | 15.6m | 17.9m | 18.5m | 20.1m | 21.2m |
| Thin Section/ Peel  | TS   | TS   | TS   | TS   | TS   | P    | P    | TS    | TS    | P     | P     | P     | P     |
| Microfacies         | S4a  | S8a  | S4a  | S4a  | S4a  | S4a  | S4a  | S2    | S4a   | S6a   | S4b   | S4a   | S6b   |
| Texture             | F    | W    | F    | P    | F    | F    | F    | B     | F     | WP    | G     | F     | M     |
| Grains:             |      |      |      |      |      |      |      |       |       |       |       |       |       |
| Peloids             | ·    | *    |      | ●    |      |      |      |       | ●     | *     | *     |       |       |
| Lithoclasts         |      |      |      |      |      |      |      |       |       |       |       |       |       |
| Oncoids             |      |      |      |      |      |      |      |       |       |       |       |       |       |
| Ooids               |      |      |      |      |      |      |      |       |       |       |       |       |       |
| Aggregate grains    |      |      |      |      |      |      |      |       |       |       |       |       |       |
| Quartz/ silt grains |      |      |      |      |      |      |      |       |       |       |       |       |       |
| Bioclasts:          |      |      |      |      |      |      |      |       |       |       |       |       |       |
| Bulbous stroms.     |      |      |      |      |      | *    |      | *     |       |       |       |       |       |
| Laminar stroms.     |      |      |      |      |      |      |      |       |       |       |       |       |       |
| Dendroid stroms.    |      |      |      |      |      |      |      |       |       |       |       |       |       |
| Stachyodes          | ●    | ·    | ●    | ·    | ●    |      | ·    |       | ·     |       |       | ·     |       |
| Amphipora           | ●    |      | ●    |      | ●    |      | *    |       | ●     | ·     | ·     |       | *     |
| Colonial corals     |      |      |      |      |      |      |      |       |       |       |       |       |       |
| Solitary corals     |      |      |      |      |      |      |      |       |       |       |       | ·     |       |
| Thamnoporoids       |      |      |      |      |      |      |      | ●     |       |       | ·     | *     |       |
| Bivalves            |      |      |      |      |      |      |      |       |       |       |       |       |       |
| Gastropods          |      |      |      |      |      |      |      |       |       |       |       |       |       |
| Shell hash          |      |      |      |      |      |      |      |       |       |       |       |       |       |
| Brachiopods         |      |      |      |      |      |      |      |       |       |       |       |       |       |
| Brachiopod spines   |      |      |      |      |      |      |      |       |       |       |       |       |       |
| Crinoids            |      |      |      |      |      |      |      |       |       |       |       |       |       |
| Tentaculites        |      |      |      |      |      |      |      |       |       |       |       |       |       |
| Trilobites          |      |      |      |      |      |      |      |       |       |       |       |       |       |
| Bryozoans           |      |      |      |      |      |      |      |       |       |       |       |       |       |
| Ostrocodes          | ○    | ○    |      | ·    | ○    |      |      |       | ○     |       | ·     | ○     |       |
| Leperditia          |      |      |      |      |      |      |      |       |       |       |       |       |       |
| Calcspheres         | ·    | ·    | ·    | ○    | ○    |      | ·    |       | ·     | ·     |       |       | ·     |
| Forams              | ·    | ·    | ·    | ·    |      |      |      |       | ·     | ·     | ·     |       | ·     |
| Sponge spicules     |      |      |      |      |      |      |      |       |       |       |       |       |       |
| Umbellids           |      |      |      |      |      |      |      |       |       |       |       |       |       |
| Undetermined        |      |      |      |      |      |      |      |       |       |       |       |       |       |
| Codiaceans          |      |      |      |      |      |      |      |       |       |       |       |       |       |
| Dasycladaceans      |      |      |      |      |      |      |      |       | ·     |       |       |       |       |
| Girvanella Gp.      |      |      | ○    | ○    |      |      |      |       |       |       |       |       |       |
| Renalcis Gp.        |      |      |      |      |      |      |      |       |       |       |       |       |       |
| Hedstroemia Gp.     |      |      |      |      |      |      |      |       |       |       |       |       |       |
| Wetheredella Gp.    |      |      |      |      |      |      |      |       |       |       |       |       |       |
| Matrix              | M,S  | M    | M,S  | M,S  | M    |      | M,S  |       | M,S   | M     | S,M   | M     | M     |
| Bioturbation        |      | ✓    | ✓    | ✓    | ✓    |      |      |       |       | ✓     | ✓     | ✓     | ✓     |
| Micrite envelope    |      |      |      |      |      |      |      |       |       |       |       |       |       |
| Fenestrae: Tubular  |      |      |      |      |      |      |      |       |       |       |       |       |       |
| Laminoid/irregular  |      | ✓    |      |      |      |      |      |       |       |       |       |       |       |
| Geopetals           | ✓    |      | ✓    |      |      |      |      |       | ✓     |       |       |       |       |
| Gravity cements     |      |      |      |      |      |      |      |       |       |       |       |       |       |
| Lamination          |      |      |      |      |      |      |      |       |       |       |       |       |       |
| Others              |      |      | *1   | *1   |      | *2   |      | *3    |       |       |       |       |       |

\*1 *Girvanella* encrusting bioclasts

\*2 Peel taken through bulbous stromatoporoid

\*3 Stromatoporoid is encrusting bioclasts

|         |  |
|---------|--|
| Texture | M=Mudstone, W=Wackestone, P=Packstone<br>G=Grainstone, F=Floatstone, Bf= Bafflestone<br>Bi=Bindstone, B=Boundstone, D=Dolomite |
| Matrix  | M=Micrite, Ms=Microspar, S=Spar, D=Dolomite  |

## Oberrödinghausen Quarry

○ = <1%    · = 1-20%    ● = 21-40%    ● = 41-60%    \* = >61%

| Sample number       | ORH14 | ORH16 | ORH17 | ORH18 | ORH19 | ORH20 | ORH21 | ORH22 | ORH23 | ORH24 | ORH25 | ORH26 | ORH27 |
|---------------------|-------|-------|-------|-------|-------|-------|-------|-------|-------|-------|-------|-------|-------|
| Height              | 22.3m | 26.4m | 26.9m | 29.7m | 30.5m | 31.4m | 35.0m | 40.5m | 41.8m | 44.0m | 48.8m | 50.0m | 50.0m |
| Thin Section/ Peel  | P     | P     | P     | P     | TS    | P     | P     | P     | TS    | TS    | P     | P     | P     |
| Microfacies         | S7a   | S4a   | S6b   | S2    | S2    | S6b   | S4a   | S2    | S3a   | S3a   | S3a   | S2    | S3a   |
| Texture             | G     | F     | M     | F     | F     | M     | F     | F     | G     | G     | G     | F     | G     |
| Grains:             |       |       |       |       |       |       |       |       |       |       |       |       |       |
| Peloids             | *     |       | *     |       | ●     |       |       |       |       | ●     | ·     |       | ·     |
| Lithoclasts         |       |       |       |       |       |       |       |       |       |       |       |       |       |
| Oncoids             |       |       |       |       |       |       |       |       |       |       |       |       |       |
| Ooids               |       |       |       |       |       |       |       |       |       |       |       |       |       |
| Aggregate grains    |       |       |       |       |       |       |       |       |       |       |       |       |       |
| Quartz/ silt grains |       |       |       |       |       |       |       |       |       |       |       |       |       |
| Bioclasts:          |       |       |       |       |       |       |       |       |       |       |       |       |       |
| Bulbous stroms.     |       |       |       | ●     |       |       |       | *     |       |       |       | *     |       |
| Laminar stroms.     |       |       |       |       |       |       |       |       |       |       |       |       |       |
| Dendroid stroms.    |       |       |       | ·     |       |       |       |       |       |       |       |       |       |
| Stachyodes          | ·     |       |       |       | ●     |       | *     |       | *     | ·     | ●     |       | ·     |
| Amphipora           | ·     | *     | ·     | ·     |       | ·     | ·     |       | ·     |       | ·     |       | ·     |
| Colonial corals     |       |       |       |       |       |       |       |       |       |       |       |       |       |
| Solitary corals     |       |       |       |       |       |       |       |       |       |       |       |       |       |
| Thamnoporoids       |       |       |       |       |       |       |       |       |       |       | ·     |       | ·     |
| Bivalves            |       |       |       |       |       |       |       |       |       |       |       |       |       |
| Gastropods          |       |       |       |       |       |       |       |       |       | ·     |       |       |       |
| Shell hash          |       |       |       |       |       |       |       |       |       |       |       |       |       |
| Brachiopods         |       |       |       |       |       |       |       |       |       |       |       |       |       |
| Brachiopod spines   |       |       |       |       |       |       |       |       |       |       |       |       | ○     |
| Crinoids            |       |       |       |       |       |       |       |       | ○     | ●     | ·     |       | ●     |
| Tentaculites        |       |       |       |       |       |       |       |       |       |       |       |       |       |
| Trilobites          |       |       |       |       |       |       |       |       |       |       |       |       |       |
| Bryozoans           |       |       |       |       |       |       |       |       |       |       |       |       |       |
| Ostrocodes          |       |       |       |       | ○     |       |       |       | ○     |       | ·     |       | ·     |
| Leperditia          |       |       |       |       |       |       |       |       |       |       |       |       |       |
| Calcspheres         | ·     |       | ·     |       | ○     | ●     |       |       |       |       |       |       |       |
| Forams              |       |       | ○     |       | ·     | ●     | ○     |       | ·     |       |       |       |       |
| Sponge spicules     |       |       |       |       |       |       |       |       |       |       |       |       |       |
| Umbellids           |       |       |       |       |       |       |       |       |       |       |       |       |       |
| Undetermined        |       |       |       |       |       |       |       |       |       |       |       |       |       |
| Codiaceans          |       |       |       |       |       |       |       |       |       |       |       |       |       |
| Dasycladaceans      |       |       |       |       |       |       |       |       |       |       |       |       |       |
| Girvanella Gp.      |       |       |       |       |       |       |       |       |       |       |       |       |       |
| Renalcis Gp.        |       |       |       |       |       |       |       |       |       |       |       |       |       |
| Hedstroemia Gp.     |       |       |       |       |       |       |       |       |       |       |       |       |       |
| Wetheredella Gp.    |       |       |       |       |       |       |       |       |       |       |       |       |       |
| Matrix              | S     | M     | M     | M     | M,S   | M     | M     |       | S     | S     | S     |       | S     |
| Bioturbation        |       |       | ✓     | ✓     | ✓     | ✓     | ✓     |       |       |       |       |       |       |
| Micrite envelope    |       |       |       |       |       |       |       |       | ✓     | ✓     |       |       |       |
| Fenestrae: Tubular  |       |       |       |       |       |       |       |       |       |       |       |       |       |
| Laminoid/irregular  |       |       |       |       |       |       |       |       |       |       |       |       |       |
| Geopetals           |       |       |       |       |       |       |       |       |       |       |       |       |       |
| Gravity cements     |       |       |       |       |       |       |       |       |       |       |       |       |       |
| Lamination          |       |       |       |       |       |       |       |       |       |       |       |       |       |
| Others              |       |       |       |       |       |       |       | *1    | *2    |       |       |       | *2    |

\*1 Matrix is very peloidal

\*2 Peel is cut through bulbous stromatoporoid

|         |  |
|---------|--|
| Texture | M=Mudstone, W=Wackestone, P=Packstone<br>G=Grainstone, F=Floatstone, Bf= Bafflestone<br>Bi=Bindstone, B=Boundstone, D=Dolomite |
| Matrix  | M=Micrite, Ms=Microspar, S=Spar, D=Dolomite  |

## Oberrödinghausen Quarry

○ = <1%    · = 1-20%    ● = 21-40%    ● = 41-60%    ☀ = >61%

| Sample number       | ORH28 | ORH29 | ORH30 |
|---------------------|-------|-------|-------|
| Height              | 59.2m | 60.4m | 93.0m |
| Thin Section/ Peel  | P     | P     | P     |
| Microfacies         | S3a   | S4a   | S2    |
| Texture             | G     | F     | F     |
| Grains:             |       |       |       |
| Peloids             |       |       | ●     |
| Lithoclasts         |       |       |       |
| Oncoids             |       |       |       |
| Ooids               |       |       |       |
| Aggregate grains    |       |       |       |
| Quartz/ silt grains |       |       |       |
| Bioclasts:          |       |       |       |
| Bulbous stroms.     | ☀     |       |       |
| Laminar stroms.     |       |       |       |
| Dendroid stroms.    |       |       | ●     |
| Stachyodes          |       | ●     |       |
| Amphipora           |       | ·     |       |
| Colonial corals     |       |       |       |
| Solitary corals     |       |       |       |
| Thamnoporoids       |       | ●     |       |
| Bivalves            |       |       |       |
| Gastropods          |       |       |       |
| Shell hash          |       |       |       |
| Brachiopods         |       |       |       |
| Brachiopod spines   |       |       |       |
| Crinoids            |       | ·     | ●     |
| Tentaculites        |       |       |       |
| Trilobites          |       |       |       |
| Bryozoans           |       |       |       |
| Ostrocodes          |       | ·     |       |
| Leperditia          |       |       |       |
| Calcispheres        |       |       |       |
| Forams              |       | ·     | ○     |
| Sponge spicules     |       |       |       |
| Umbellids           |       |       |       |
| Undetermined        |       |       |       |
| Codiaceans          |       |       |       |
| Dasycladaceans      |       |       |       |
| Girvanella Gp.      |       |       |       |
| Renalcis Gp.        |       |       |       |
| Hedstroemia Gp.     |       |       |       |
| Wetheredella Gp.    |       |       |       |
| Matrix              |       | M     | M,S   |
| Bioturbation        |       | ✓     | ✓     |
| Micrite envelope    |       |       |       |
| Fenestrae: Tubular  |       |       |       |
| Laminoid/irregular  |       |       |       |
| Geopetals           |       |       |       |
| Gravity cements     |       |       |       |
| Lamination          |       |       |       |
| Others              | *1    |       |       |

\*1 Peel is cut through a bulbous stromatopoid

|         |  |
|---------|--|
| Texture | M=Mudstone, W=Wackestone, P=Packstone<br>G=Grainstone, F=Floatstone, Bf= Bafflestone<br>Bi=Bindstone, B=Boundstone, D=Dolomite |
| Matrix  | M=Micrite, Ms=Microspar, S=Spar, D=Dolomite  |

## A1.2.19 Olloy-sur-Viroin Quarry

○ = <1%    · = 1-20%    ● = 21-40%    ● = 41-60%    \* = >61%

| Sample number       | OSV1 | OSV2 | OSV3 | OSV4 | OSV5  | OSV6 | OSV7 | OSV8   | OSV9  | OSV10 | OSV11 | OSV12 | OSV13 |
|---------------------|------|------|------|------|-------|------|------|--------|-------|-------|-------|-------|-------|
| Height              | 0.5m | 1.0m | 2.8m | 3.6m | 29.5m | 5.4m | 6.1m | 21.0m  | 22.1m | 23.6m | 24.4m | 24.9m | 26.2m |
| Thin Section/ Peel  | TS   | TS   | TS   | TS   | TS    | TS   | TS   | TS     | TS    | TS    | TS    | TS    | TS    |
| Microfacies         | R1   | R1   | R2   | R1   | S2    | R1   | S2   | S8a    | S8a   | S8a   | S3b   | S8a   | S4b   |
| Texture             | W    | W    | P    | W    | WP    | W    | F    | W      | W     | MW    | P     | W     | F     |
| Grains:             |      |      |      |      |       |      |      |        |       |       |       |       |       |
| Peloids             |      |      | *    |      | *     |      |      |        |       | ●     |       |       | ●     |
| Lithoclasts         |      |      |      |      | ·     |      |      |        |       |       |       |       |       |
| Oncoids             |      |      |      |      | ·     |      |      |        |       | ·     |       |       | ·     |
| Ooids               |      |      |      |      |       |      |      |        |       |       |       |       |       |
| Aggregate grains    |      |      |      |      |       |      |      |        |       |       |       |       |       |
| Quartz/ silt grains |      |      |      |      |       |      |      |        |       |       |       |       |       |
| Bioclasts:          |      |      |      |      |       |      |      |        |       |       |       |       |       |
| Bulbous stroms.     |      |      |      |      |       |      | ●    |        |       |       |       |       |       |
| Laminar stroms.     |      |      |      |      |       |      |      |        |       |       |       |       |       |
| Dendroid stroms.    |      | ●    | ·    | *    |       |      |      |        |       |       | *     |       |       |
| Stachyodes          |      |      |      |      |       |      |      |        |       |       |       |       |       |
| Amphipora           |      |      |      |      |       |      |      |        |       |       |       | ·     | ●     |
| Colonial corals     |      |      |      |      |       |      |      |        |       |       |       |       |       |
| Solitary corals     |      |      |      |      |       | ·    |      |        |       |       |       |       |       |
| Thamnoporoids       |      |      |      |      |       |      |      |        |       |       |       |       |       |
| Bivalves            |      |      |      |      | ·     |      |      |        |       | ·     |       |       |       |
| Gastropods          |      |      | ·    |      |       |      |      | ○      |       |       |       |       | ·     |
| Shell hash          |      |      |      |      |       |      |      |        |       |       |       |       |       |
| Brachiopods         | ·    | ·    |      | ·    |       | ●    |      |        |       |       |       |       |       |
| Brachiopod spines   |      |      | ○    | ·    |       |      |      |        |       |       |       |       |       |
| Crinoids            | *    | ●    | ·    | ·    |       | ●    | ●    |        |       |       |       |       |       |
| Tentaculites        |      |      |      |      |       |      |      |        |       |       |       |       |       |
| Trilobites          |      |      |      |      |       |      |      |        |       |       |       |       |       |
| Bryozoans           |      |      |      |      |       |      |      |        |       |       |       |       |       |
| Ostrocodes          | ○    |      |      | ·    | ·     |      |      | ●      | ·     | ·     |       | ·     |       |
| Leperditia          |      |      |      |      | ·     |      |      |        |       |       |       |       |       |
| Calcspheres         | ·    |      |      |      | ·     |      |      | ·      | ·     | *     |       | *     |       |
| Forams              | ·    | ·    | ·    | ·    | ·     |      |      | ●      | ·     |       |       |       |       |
| Sponge spicules     |      |      |      |      |       |      |      |        |       |       |       |       |       |
| Umbellids           |      |      |      |      |       |      |      |        |       |       |       |       |       |
| Undetermined        |      |      |      |      |       |      |      |        |       |       |       |       |       |
| Codiaceans          |      |      |      |      |       |      |      |        |       |       |       |       |       |
| Dasycladaceans      | ·    |      |      |      | ·     |      |      |        |       | ○     |       | ·     |       |
| Girvanella Gp.      |      |      |      |      |       |      |      |        |       |       |       |       |       |
| Renalcis Gp.        |      |      |      |      |       |      |      |        |       |       |       |       |       |
| Hedstroemia Gp.     |      |      |      |      |       |      |      | ·      |       |       |       |       |       |
| Wetheredella Gp.    |      |      |      |      |       |      |      |        |       |       |       |       |       |
| Matrix              | M,Ms | Ms   | M,Ms | M,Ms | M     | M    | S,M  | M      | M,Ms  | M     | M,Ms  | M     | S     |
| Bioturbation        | ✓    | ✓    |      | ✓    | ✓     | ✓    |      |        |       | ✓     |       | ✓     |       |
| Micrite envelope    |      |      |      |      |       |      | ✓    |        |       |       |       |       | ✓     |
| Fenestrae: Tubular  |      |      |      |      |       |      |      |        |       |       |       | ✓     | ✓     |
| Laminoid/irregular  |      |      |      |      |       |      |      | ✓      | ✓     | ✓     |       | ✓     |       |
| Geopetals           |      |      |      |      |       |      |      | ✓      |       |       |       | ✓     |       |
| Gravity cements     |      |      |      |      |       |      |      |        |       |       |       |       |       |
| Lamination          |      |      |      |      |       |      |      |        |       |       |       |       |       |
| Others              |      |      |      |      | *1    |      |      | *2, *3 |       |       |       | *3    |       |

\*1 Sample of matrix

\*2 Matrix intensely peloidal

\*3 Vadose silt in the base of fenestrae

|         |  |
|---------|--|
| Texture | M=Mudstone, W=Wackestone, P=Packstone<br>G=Grainstone, F=Floatstone, Bf= Bafflestone<br>Bi=Bindstone, B=Boundstone, D=Dolomite |
| Matrix  | M=Micrite, Ms=Microspar, S=Spar, D=Dolomite  |

## Olloy-sur-Viroin Quarry

○ = <1%    · = 1–20%    ● = 21–40%    ● = 41–60%    \* = >61%

| Sample number       | OSV14 | OSV15 | OSV16 | OSV17 | OSV18 | OSV20 | OSV21 | OSV22 | OSV23 | OSV24 | OSV25 |  |  |
|---------------------|-------|-------|-------|-------|-------|-------|-------|-------|-------|-------|-------|--|--|
| Height              | 36.2m | 36.9m | 37.3m | 38.2m | 39.9m | 41.5m | 43.0m | 31.0m | 31.4m | 33.1m | 34.0m |  |  |
| Thin Section/ Peel  | TS    | TS    | TS    | TS    | TS    | TS    | TS    | TS    | TS    | TS    | TS    |  |  |
| Microfacies         | S6a   | S5    | S6b/c | S5    | S8a   | S6f   | S8a   | S8a   | S6c   | S5    | S6a   |  |  |
| Texture             | W     | P     | M     | P     | M     | W     | WP    | W     | W     | W     | W     |  |  |
| Grains:             |       |       |       |       |       |       |       |       |       |       |       |  |  |
| Peloids             |       |       |       |       |       |       | ●     |       |       |       |       |  |  |
| Lithoclasts         |       |       | ·     | ·     |       |       | ·     |       |       |       |       |  |  |
| Oncoids             |       |       |       |       |       |       |       |       |       |       |       |  |  |
| Ooids               |       |       |       |       |       |       |       |       |       |       |       |  |  |
| Aggregate grains    |       |       |       |       |       |       |       |       |       |       |       |  |  |
| Quartz/ silt grains |       |       |       |       |       |       |       |       |       |       |       |  |  |
| Bioclasts:          |       |       |       |       |       |       |       |       |       |       |       |  |  |
| Bulbous stroms.     |       |       |       |       |       |       |       |       |       |       |       |  |  |
| Laminar stroms.     |       |       |       |       |       |       |       |       |       |       |       |  |  |
| Dendroid stroms.    |       |       |       |       |       |       |       |       |       |       |       |  |  |
| Stachyodes          |       |       |       |       |       |       |       |       |       | ·     |       |  |  |
| Amphipora           |       |       |       |       |       |       |       |       |       |       |       |  |  |
| Colonial corals     |       |       |       | ·     |       |       |       |       |       |       |       |  |  |
| Solitary corals     |       |       |       |       |       |       |       |       |       |       |       |  |  |
| Thamnoporoids       |       |       |       |       |       |       |       |       |       |       |       |  |  |
| Bivalves            |       | ●     | ·     | *     |       |       |       |       | ·     | ·     |       |  |  |
| Gastropods          |       | ·     |       | ·     |       |       |       |       | ·     | ·     |       |  |  |
| Shell hash          |       |       |       |       |       |       |       |       |       |       |       |  |  |
| Brachiopods         |       |       |       | ·     |       |       |       |       |       | ·     |       |  |  |
| Brachiopod spines   |       |       |       |       |       |       |       |       |       |       |       |  |  |
| Crinoids            |       |       |       |       |       |       |       |       |       |       |       |  |  |
| Tentaculites        |       |       |       |       |       |       |       |       |       |       |       |  |  |
| Trilobites          |       |       |       |       |       |       |       |       |       |       |       |  |  |
| Bryozoans           |       |       |       |       |       |       |       |       |       |       |       |  |  |
| Ostrocodes          | ·     | ·     | ·     | ·     | ·     |       | ·     | ●     | ·     | ·     |       |  |  |
| Leperditia          |       |       |       |       |       | ·     | ·     |       |       |       |       |  |  |
| Calcspheres         | *     | ·     | ●     | ·     | *     |       | ·     | ·     | ·     | ●     | ●     |  |  |
| Forams              |       | ·     | ·     | ·     |       | ·     | ·     |       |       | ·     |       |  |  |
| Sponge spicules     |       |       |       |       |       |       |       |       |       |       |       |  |  |
| Umbellids           |       |       |       |       |       |       |       |       |       |       |       |  |  |
| Undetermined        |       |       |       |       |       |       |       |       |       |       |       |  |  |
| Codiaceans          |       |       |       |       | ·     | ·     | ·     |       |       |       |       |  |  |
| Dasycladaceans      | ·     |       |       |       | ·     | *     | ●     | ●     | ●     |       | ·     |  |  |
| Girvanella Gp.      |       |       |       |       |       |       |       |       |       |       |       |  |  |
| Renalcis Gp.        |       |       |       |       |       |       |       |       |       |       |       |  |  |
| Hedstroemia Gp.     |       |       |       |       |       |       |       |       |       |       |       |  |  |
| Wetheredella Gp.    |       |       |       |       |       |       |       |       |       |       |       |  |  |
| Matrix              | M     | M     | M     | M,D   | M,D   | M,D   | M     | M     | M     | M     | M     |  |  |
| Bioturbation        |       |       | ✓     | ✓     | ✓     | ✓     | ✓     | ✓     | ✓     |       | ✓     |  |  |
| Micrite envelope    |       |       | ✓     | ✓     |       |       | ✓     | ✓     |       |       |       |  |  |
| Fenestrae: Tubular  |       |       |       |       |       |       | ✓     |       | ✓     |       |       |  |  |
| Laminoid/irregular  |       |       |       |       | ✓     |       | ✓     | ✓     |       |       |       |  |  |
| Geopetals           |       |       |       |       |       |       |       | ✓     | ✓     |       |       |  |  |
| Gravity cements     |       |       |       |       |       |       |       |       |       |       |       |  |  |
| Lamination          |       |       |       |       |       |       |       |       |       |       |       |  |  |
| Others              |       |       |       | *1    |       | *2    | *2    | *3    | *2    | *1    |       |  |  |

\*1 Bioclasts are aligned parallel to each other

\*2 Matrix is very peloidal

\*3 Vadose silt in the base of fenestrae

|         |  |
|---------|--|
| Texture | M=Mudstone, W=Wackestone, P=Packstone<br>G=Grainstone, F=Floatstone, Bf= Bafflestone<br>Bi=Bindstone, B=Boundstone, D=Dolomite |
| Matrix  | M=Micrite, Ms=Microspar, S=Spar, D=Dolomite  |

## A1.2.20 Resteigne Quarry

○ = <1%    · = 1-20%    ● = 21-40%    ● = 41-60%    \* = >61%

| Sample number       | R1   | R3   | R4    | R5    | R6    | R7    | R8    | R9   | R10   | R11   | R12   | R14   | R15   |
|---------------------|------|------|-------|-------|-------|-------|-------|------|-------|-------|-------|-------|-------|
| Height              | 3.3m | 9.4m | 12.7m | 13.0m | 19.6m | 24.5m | 25.7m | 5.2m | 34.4m | 41.0m | 42.3m | 47.1m | 52.6m |
| Thin Section/ Peel  | TS   | TS   | TS    | TS    | TS    | TS    | TS    | TS   | TS    | TS    | TS    | TS    | TS    |
| Microfacies         | S2   | S5   | S6a   | S6b   | S6a   | S5    | S3b   | S9   | S7    | S6a   | S12a  | S3b   | S12a  |
| Texture             | B    | P    | W     | MW    | P     | P     | W     | G    | G     | WP    | M     | P     | M     |
| Grains:             |      |      |       |       |       |       |       |      |       |       |       |       |       |
| Peloids             |      | ●    |       |       |       |       |       |      | *     | ●     | *     |       | *     |
| Lithoclasts         |      |      |       |       |       |       | ·     |      |       |       |       |       |       |
| Oncoids             |      |      |       |       |       |       |       |      |       |       |       |       |       |
| Ooids               |      |      |       |       |       |       |       |      |       |       |       |       |       |
| Aggregate grains    |      |      |       |       |       |       |       |      |       |       |       |       |       |
| Quartz/ silt grains |      |      |       | ○     |       |       |       |      |       |       |       |       | ·     |
| Bioclasts:          |      |      |       |       |       |       |       |      |       |       |       |       |       |
| Bulbous stroms.     |      |      |       |       |       |       |       |      |       |       |       |       |       |
| Laminar stroms.     |      |      |       |       |       |       |       |      |       |       |       |       |       |
| Dendroid stroms.    |      |      |       |       |       |       |       | ●    |       |       |       | ·     |       |
| Stachyodes          |      |      |       |       |       |       |       |      |       |       |       |       |       |
| Amphipora           |      |      | ·     |       |       |       |       |      |       |       |       |       |       |
| Colonial corals     | *    |      |       |       |       |       |       |      |       |       |       |       |       |
| Solitary corals     |      |      |       |       |       |       |       |      |       |       |       |       |       |
| Thamnoporoids       |      |      |       |       |       | ●     | ·     |      |       |       |       |       |       |
| Bivalves            |      | ●    |       | ·     |       | ●     |       |      | ·     | ●     |       | ○     |       |
| Gastropods          |      | ·    |       |       |       |       |       |      | ·     | ·     |       |       |       |
| Shell hash          |      |      |       |       |       |       |       |      |       |       |       |       |       |
| Brachiopods         |      |      |       |       |       | ·     | ●     | ●    |       |       |       | *     |       |
| Brachiopod spines   |      |      |       |       |       |       |       |      |       |       |       |       |       |
| Crinoids            |      |      |       |       |       |       |       |      |       |       |       | ·     |       |
| Tentaculites        |      |      |       |       |       |       |       |      |       |       |       |       |       |
| Trilobites          |      |      |       |       |       |       |       |      |       |       |       |       |       |
| Bryozoans           |      |      |       |       |       |       |       |      |       |       |       |       |       |
| Ostrocodes          |      | ·    | ●     | ●     | ●     |       | ·     |      | ·     | ·     |       |       |       |
| Leperditia          |      |      |       |       |       |       |       |      |       |       |       |       |       |
| Calcspheres         |      | ·    | ●     | ●     | ●     |       |       |      | ·     | ·     |       | ·     |       |
| Forams              |      |      |       |       |       |       |       |      |       |       |       |       |       |
| Sponge spicules     |      |      |       |       |       |       |       |      |       |       |       |       |       |
| Umbellids           |      |      |       |       |       |       |       |      |       |       |       |       |       |
| Undetermined        |      |      |       |       |       |       |       |      |       |       |       | ·     |       |
| Codiaceans          |      |      |       |       | ·     |       |       |      |       | ·     |       |       |       |
| Dasycladaceans      |      | ·    | ●     | ·     |       |       | ·     |      | ○     | ·     |       | ·     |       |
| Girvanella Gp.      |      |      |       |       |       |       | ·     |      |       |       |       |       |       |
| Renalcis Gp.        |      |      |       |       |       |       |       |      |       |       |       |       |       |
| Hedstroemia Gp.     |      |      |       |       |       |       |       |      |       |       |       |       |       |
| Wetheredella Gp.    |      |      |       |       |       |       |       |      |       |       |       |       |       |
| Matrix              | M    | M    | M,Ms  | M,Ms  | M,Ms  | M,Ms  | M,Ms  | S,M  | S,M   | M,Ms  | M,Ms  | M     | M,S   |
| Bioturbation        |      | ✓    | ✓     | ✓     | ✓     | ✓     |       |      | ✓     | ✓     |       | ✓     |       |
| Micrite envelope    |      | ✓    |       |       |       | ✓     |       | ✓    | ✓     | ✓     |       | ✓     |       |
| Fenestrae: Tubular  |      |      |       |       |       |       |       |      |       |       |       |       |       |
| Laminoid/irregular  |      |      |       |       |       |       |       |      |       |       |       |       |       |
| Geopetals           |      | ✓    |       |       |       |       |       | ✓    |       |       |       |       |       |
| Gravity cements     |      |      |       |       |       |       |       | ✓    |       |       |       |       |       |
| Lamination          |      |      |       |       |       |       |       |      |       |       | ✓     |       | ✓     |
| Others              |      |      |       |       |       |       |       |      |       |       |       | *1    |       |

\*1 Bioclasts are aligned parallel to each other

|         |  |
|---------|--|
| Texture | M=Mudstone, W=Wackestone, P=Packstone<br>G=Grainstone, F=Floatstone, Bf= Bafflestone<br>Bi=Bindstone, B=Boundstone, D=Dolomite |
| Matrix  | M=Micrite, Ms=Microspar, S=Spar, D=Dolomite  |

## Resteigne Quarry

○ = <1%    · = 1–20%    ● = 21–40%    ● = 41–60%    \* = >61%

| Sample number       | R17   | R18   | R19   | R20   |  |  |  |  |  |  |  |  |  |  |  |  |  |  |  |  |  |
|---------------------|-------|-------|-------|-------|--|--|--|--|--|--|--|--|--|--|--|--|--|--|--|--|--|
| Height              | 85.4m | 13.2m | 16.0m | 14.5m |  |  |  |  |  |  |  |  |  |  |  |  |  |  |  |  |  |
| Thin Section/ Peel  | TS    | TS    | TS    | TS    |  |  |  |  |  |  |  |  |  |  |  |  |  |  |  |  |  |
| Microfacies         | R1    | S5    | S6f   | S3b   |  |  |  |  |  |  |  |  |  |  |  |  |  |  |  |  |  |
| Texture             | W     | WP    | W     | WP    |  |  |  |  |  |  |  |  |  |  |  |  |  |  |  |  |  |
| Grains:             |       |       |       |       |  |  |  |  |  |  |  |  |  |  |  |  |  |  |  |  |  |
| Peloids             | ·     | ●     | ·     |       |  |  |  |  |  |  |  |  |  |  |  |  |  |  |  |  |  |
| Lithoclasts         | ·     | ·     |       |       |  |  |  |  |  |  |  |  |  |  |  |  |  |  |  |  |  |
| Oncoids             |       |       |       |       |  |  |  |  |  |  |  |  |  |  |  |  |  |  |  |  |  |
| Ooids               | ·     |       |       |       |  |  |  |  |  |  |  |  |  |  |  |  |  |  |  |  |  |
| Aggregate grains    |       |       |       |       |  |  |  |  |  |  |  |  |  |  |  |  |  |  |  |  |  |
| Quartz/ silt grains |       |       |       |       |  |  |  |  |  |  |  |  |  |  |  |  |  |  |  |  |  |
| Bioclasts:          |       |       |       |       |  |  |  |  |  |  |  |  |  |  |  |  |  |  |  |  |  |
| Bulbous stroms.     |       |       |       |       |  |  |  |  |  |  |  |  |  |  |  |  |  |  |  |  |  |
| Laminar stroms.     |       |       |       |       |  |  |  |  |  |  |  |  |  |  |  |  |  |  |  |  |  |
| Dendroid stroms.    |       |       |       |       |  |  |  |  |  |  |  |  |  |  |  |  |  |  |  |  |  |
| Stachyodes          |       |       |       |       |  |  |  |  |  |  |  |  |  |  |  |  |  |  |  |  |  |
| Amphipora           |       |       |       | ·     |  |  |  |  |  |  |  |  |  |  |  |  |  |  |  |  |  |
| Colonial corals     |       |       |       |       |  |  |  |  |  |  |  |  |  |  |  |  |  |  |  |  |  |
| Solitary corals     |       |       |       |       |  |  |  |  |  |  |  |  |  |  |  |  |  |  |  |  |  |
| Thamnoporoids       |       |       |       | ·     |  |  |  |  |  |  |  |  |  |  |  |  |  |  |  |  |  |
| Bivalves            |       | ·     |       |       |  |  |  |  |  |  |  |  |  |  |  |  |  |  |  |  |  |
| Gastropods          | ·     |       |       |       |  |  |  |  |  |  |  |  |  |  |  |  |  |  |  |  |  |
| Shell hash          | ·     |       |       |       |  |  |  |  |  |  |  |  |  |  |  |  |  |  |  |  |  |
| Brachiopods         | ·     |       |       | ·     |  |  |  |  |  |  |  |  |  |  |  |  |  |  |  |  |  |
| Brachiopod spines   |       |       |       |       |  |  |  |  |  |  |  |  |  |  |  |  |  |  |  |  |  |
| Crinoids            |       |       |       | ·     |  |  |  |  |  |  |  |  |  |  |  |  |  |  |  |  |  |
| Tentaculites        |       |       |       |       |  |  |  |  |  |  |  |  |  |  |  |  |  |  |  |  |  |
| Trilobites          |       |       |       |       |  |  |  |  |  |  |  |  |  |  |  |  |  |  |  |  |  |
| Bryozoans           |       |       |       |       |  |  |  |  |  |  |  |  |  |  |  |  |  |  |  |  |  |
| Ostrocodes          | ·     | ·     | ·     | ●     |  |  |  |  |  |  |  |  |  |  |  |  |  |  |  |  |  |
| Leperditia          |       |       | ●     | ·     |  |  |  |  |  |  |  |  |  |  |  |  |  |  |  |  |  |
| Calcispheres        | ·     | ·     | ●     | ·     |  |  |  |  |  |  |  |  |  |  |  |  |  |  |  |  |  |
| Forams              |       | ·     | ·     | ·     |  |  |  |  |  |  |  |  |  |  |  |  |  |  |  |  |  |
| Sponge spicules     |       |       |       |       |  |  |  |  |  |  |  |  |  |  |  |  |  |  |  |  |  |
| Umbellids           |       |       | ·     |       |  |  |  |  |  |  |  |  |  |  |  |  |  |  |  |  |  |
| Undetermined        | ·     |       |       |       |  |  |  |  |  |  |  |  |  |  |  |  |  |  |  |  |  |
| Codiceans           |       |       |       |       |  |  |  |  |  |  |  |  |  |  |  |  |  |  |  |  |  |
| Dasycladaceans      | ·     |       | ·     |       |  |  |  |  |  |  |  |  |  |  |  |  |  |  |  |  |  |
| Girvanella Gp.      |       |       |       |       |  |  |  |  |  |  |  |  |  |  |  |  |  |  |  |  |  |
| Renalcis Gp.        |       |       |       |       |  |  |  |  |  |  |  |  |  |  |  |  |  |  |  |  |  |
| Hedstroemia Gp.     |       |       |       |       |  |  |  |  |  |  |  |  |  |  |  |  |  |  |  |  |  |
| Wetheredella Gp.    |       |       |       |       |  |  |  |  |  |  |  |  |  |  |  |  |  |  |  |  |  |
| Matrix              | M,Ms  | M,S   | M,S   | M     |  |  |  |  |  |  |  |  |  |  |  |  |  |  |  |  |  |
| Bioturbation        | ✓     | ✓     | ✓     | ✓     |  |  |  |  |  |  |  |  |  |  |  |  |  |  |  |  |  |
| Micrite envelope    | ✓     |       |       | ✓     |  |  |  |  |  |  |  |  |  |  |  |  |  |  |  |  |  |
| Fenestrae: Tubular  |       |       |       |       |  |  |  |  |  |  |  |  |  |  |  |  |  |  |  |  |  |
| Laminoid/irregular  |       |       |       |       |  |  |  |  |  |  |  |  |  |  |  |  |  |  |  |  |  |
| Geopetals           |       |       |       |       |  |  |  |  |  |  |  |  |  |  |  |  |  |  |  |  |  |
| Gravity cements     |       |       |       |       |  |  |  |  |  |  |  |  |  |  |  |  |  |  |  |  |  |
| Lamination          |       |       |       |       |  |  |  |  |  |  |  |  |  |  |  |  |  |  |  |  |  |
| Others              |       |       |       |       |  |  |  |  |  |  |  |  |  |  |  |  |  |  |  |  |  |

Texture M=Mudstone, W=Wackestone, P=Packstone  
 G=Grainstone, F=Floatstone, Bf= Bafflestone  
 Bi=Bindstone, B=Boundstone, D=Dolomite  
 Matrix M=Micrite, Ms=Microspar, S=Spar, D=Dolomite

## A1.2.21 Rydon Quarry

○ = <1%    · = 1–20%    ● = 21–40%    ● = 41–60%    \* = >61%

| Sample number       | RQ1   | RQ2   | RQ3   | RQ4   | RQ5   | RQ6   | RQ7   | RQ8   | RQ9   | RQ10  | RQ11 | RQ12 | RQ13 |
|---------------------|-------|-------|-------|-------|-------|-------|-------|-------|-------|-------|------|------|------|
| Height              | 21.3m | 20.2m | 19.5m | 18.8m | 17.8m | 17.1m | 16.3m | 15.6m | 15.0m | 14.1m | 9.4m | 8.6m | 7.6m |
| Thin Section/ Peel  | TS    | TS    | TS    | TS    | TS    | TS    | TS    | TS    | P     | P     | TS   | TS   | TS   |
| Microfacies         | S6a   | S8c   | S4a   | S7a   | S4a   | S7a   | S3a   | S2    | S3a   | S4a   | S7a  | S6a  | S2   |
| Texture             | W     | G     | F     | G     | F     | G     | G     | F     | G     | W     | G    | W    | P    |
| Grains:             |       |       |       |       |       |       |       |       |       |       |      |      |      |
| Peloids             | *     | *     |       | *     |       | *     |       |       |       |       | *    |      | *    |
| Lithoclasts         |       |       |       |       |       | ·     |       |       |       |       |      |      |      |
| Oncoids             |       |       |       |       |       |       |       |       |       |       |      |      |      |
| Ooids               |       |       |       |       |       |       |       |       |       |       |      |      |      |
| Aggregate grains    |       |       |       |       |       |       |       |       |       |       |      |      |      |
| Quartz/ silt grains |       |       |       |       |       |       |       |       |       |       |      |      |      |
| Bioclasts:          |       |       |       |       |       |       |       |       |       |       |      |      |      |
| Bulbous stroms.     |       |       |       |       |       |       |       | *     |       |       |      |      |      |
| Laminar stroms.     |       |       |       |       |       |       |       |       |       |       |      |      |      |
| Dendroid stroms.    |       |       |       |       |       |       |       |       | ·     |       |      |      |      |
| Stachyodes          |       |       |       |       |       |       | ●     |       | ·     |       |      |      |      |
| Amphipora           | ·     |       | ●     | ·     | *     | ·     |       |       | *     | *     | ·    |      | ○    |
| Colonial corals     |       |       |       |       |       |       |       |       |       |       |      |      |      |
| Solitary corals     |       |       |       |       |       |       |       |       |       |       |      |      |      |
| Thamnoporoids       |       |       | ●     |       |       |       |       |       | ·     |       |      |      |      |
| Bivalves            |       |       |       |       |       |       |       |       |       |       |      |      |      |
| Gastropods          |       |       |       |       |       |       |       |       |       |       |      |      |      |
| Shell hash          |       |       |       |       |       |       |       |       |       |       |      |      |      |
| Brachiopods         |       |       |       |       |       |       |       |       |       |       |      |      |      |
| Brachiopod spines   |       |       |       |       |       |       |       |       |       |       |      |      |      |
| Crinoids            |       |       |       |       | ·     |       | ●     |       | ·     |       |      |      |      |
| Tentaculites        |       |       |       |       |       |       |       |       |       |       |      |      |      |
| Trilobites          |       |       |       |       |       |       |       |       |       |       |      |      |      |
| Bryozoans           |       |       |       |       |       |       |       |       |       |       |      |      |      |
| Ostrocodes          |       |       |       |       | ○     | ·     |       |       |       |       | ○    | ·    | ○    |
| Leperditia          |       |       |       |       |       |       |       |       |       |       |      |      |      |
| Calcispheres        | ·     | ·     | ·     | ·     | ○     |       |       |       |       | ·     | ·    | ●    | ·    |
| Forams              | ·     | ·     | ●     | ·     |       |       |       |       |       |       | ·    | ●    | ○    |
| Sponge spicules     |       |       |       |       |       |       |       |       |       |       |      |      |      |
| Umbellids           |       |       |       |       |       |       |       |       |       |       |      |      |      |
| Undetermined        |       |       |       |       |       |       |       |       |       |       |      |      |      |
| Codiaceans          |       |       |       |       |       |       |       |       |       |       |      |      |      |
| Dasycladaceans      |       |       |       |       |       |       |       |       |       |       |      |      |      |
| Girvanella Gp.      |       |       |       |       |       |       |       |       |       |       |      |      |      |
| Renalcis Gp.        |       |       |       |       |       |       |       |       |       |       |      |      |      |
| Hedstroemia Gp.     |       |       |       |       |       |       |       |       |       |       |      |      |      |
| Wetheredella Gp.    |       |       |       |       |       |       |       |       |       |       |      |      |      |
| Matrix              | M     | S     | M     | S     | M,D   | S,M   | S     | M     | S,M   | M     | S    | M,S  | M,S  |
| Bioturbation        |       |       | ✓     |       |       |       |       |       |       |       |      | ✓    | ✓    |
| Micrite envelope    |       |       |       |       |       |       |       |       |       |       | ✓    |      |      |
| Fenestrae: Tubular  |       |       |       |       |       |       |       |       |       |       |      |      |      |
| Laminoid/irregular  |       | ✓     |       |       |       |       |       |       |       |       |      |      |      |
| Geopetals           |       |       | ✓     |       |       |       |       |       | ✓     |       | ✓    | ✓    |      |
| Gravity cements     |       |       |       |       |       |       |       |       |       |       |      |      |      |
| Lamination          |       |       |       |       |       |       |       |       |       |       |      |      |      |
| Others              |       |       | *1    |       |       |       | *2    |       |       |       |      | *1   | *3   |

\*1 Micrite is very peloidal

\*2 Alignment of bioclasts parallel to each other

\*3 Sample of matrix

|         |  |
|---------|--|
| Texture | M=Mudstone, W=Wackestone, P=Packstone<br>G=Grainstone, F=Floatstone, Bf= Bafflestone<br>Bi=Bindstone, B=Boundstone, D=Dolomite |
| Matrix  | M=Micrite, Ms=Microspar, S=Spar, D=Dolomite  |

## Rydon Quarry

○ = <1%    · = 1-20%    ● = 21-40%    ● = 41-60%    \* = >61%

| Sample number       | RQ14 | RQ15 | RQ16 | RQ17 | RQ18 | RQ19 | RQ20 | RQ21 |  |  |  |  |  |  |
|---------------------|------|------|------|------|------|------|------|------|--|--|--|--|--|--|
| Height              | 6.4m | 6.4m | 6.2m | 5.4m | 4.5m | 4.0m | 3.0m | 0.5m |  |  |  |  |  |  |
| Thin Section/ Peel  | TS   | P    | TS   | P    | TS   | TS   | TS   | TS   |  |  |  |  |  |  |
| Microfacies         | S3a  | S3a  | S6a  | S3a  | S8a  | S4a  | S2   | S2   |  |  |  |  |  |  |
| Texture             | P    | G    | P    | G    | F    | F    | F    | F    |  |  |  |  |  |  |
| Grains:             |      |      |      |      |      |      |      |      |  |  |  |  |  |  |
| Peloids             |      |      | *    |      | ·    |      |      |      |  |  |  |  |  |  |
| Lithoclasts         |      |      | ·    |      | ·    |      |      |      |  |  |  |  |  |  |
| Oncoids             |      |      |      |      |      |      |      |      |  |  |  |  |  |  |
| Ooids               |      |      |      |      |      |      |      |      |  |  |  |  |  |  |
| Aggregate grains    |      |      |      |      |      |      |      |      |  |  |  |  |  |  |
| Quartz/ silt grains |      |      |      |      |      |      |      |      |  |  |  |  |  |  |
| Bioclasts:          |      |      |      |      |      |      |      |      |  |  |  |  |  |  |
| Bulbous stroms.     |      |      |      | ·    |      |      | *    | *    |  |  |  |  |  |  |
| Laminar stroms.     |      |      |      |      |      |      |      |      |  |  |  |  |  |  |
| Dendroid stroms.    | *    | *    |      | ●    |      |      |      |      |  |  |  |  |  |  |
| Stachyodes          |      |      |      | ●    |      |      |      |      |  |  |  |  |  |  |
| Amphipora           |      |      | ·    | ●    | ●    | ●    |      |      |  |  |  |  |  |  |
| Colonial corals     |      |      |      |      |      |      |      |      |  |  |  |  |  |  |
| Solitary corals     | ·    | ·    |      |      |      |      |      |      |  |  |  |  |  |  |
| Thamnoporoids       | ·    | ·    |      | ·    |      | ·    |      |      |  |  |  |  |  |  |
| Bivalves            |      |      |      |      |      |      |      |      |  |  |  |  |  |  |
| Gastropods          |      |      |      |      |      |      |      |      |  |  |  |  |  |  |
| Shell hash          |      |      |      |      |      |      |      |      |  |  |  |  |  |  |
| Brachiopods         |      |      |      |      |      |      |      |      |  |  |  |  |  |  |
| Brachiopod spines   |      |      |      |      |      |      |      |      |  |  |  |  |  |  |
| Crinoids            |      |      | ·    | ·    | ·    |      |      |      |  |  |  |  |  |  |
| Tentaculites        |      |      |      |      |      |      |      |      |  |  |  |  |  |  |
| Trilobites          |      |      |      |      |      |      |      |      |  |  |  |  |  |  |
| Bryozoans           |      |      |      |      |      |      |      |      |  |  |  |  |  |  |
| Ostrocodes          |      |      |      |      |      | ·    |      |      |  |  |  |  |  |  |
| Leperditia          |      |      |      |      |      |      |      |      |  |  |  |  |  |  |
| Calcispheres        |      |      | ·    |      |      | ·    |      |      |  |  |  |  |  |  |
| Forams              | ·    | ·    | ·    |      | ·    | ·    |      |      |  |  |  |  |  |  |
| Sponge spicules     |      |      |      |      |      |      |      |      |  |  |  |  |  |  |
| Umbellids           |      |      |      |      |      |      |      |      |  |  |  |  |  |  |
| Undetermined        |      |      |      |      |      |      |      |      |  |  |  |  |  |  |
| Codiaceans          |      |      |      |      |      |      |      |      |  |  |  |  |  |  |
| Dasycladaceans      |      |      |      |      |      |      |      |      |  |  |  |  |  |  |
| Girvanella Gp.      |      |      |      |      |      |      |      |      |  |  |  |  |  |  |
| Renalcis Gp.        |      |      |      |      |      |      |      |      |  |  |  |  |  |  |
| Hedstroemia Gp.     |      |      |      |      |      |      |      |      |  |  |  |  |  |  |
| Wetheredella Gp.    |      |      |      |      |      |      |      |      |  |  |  |  |  |  |
| Matrix              | M    | M    | M,S  | S    | M    | M    |      |      |  |  |  |  |  |  |
| Bioturbation        |      |      | ✓    |      | ✓    |      |      |      |  |  |  |  |  |  |
| Micrite envelope    |      |      | ✓    |      |      |      |      |      |  |  |  |  |  |  |
| Fenestrae: Tubular  |      |      |      |      |      |      |      |      |  |  |  |  |  |  |
| Laminoid/irregular  |      |      |      |      | ✓    |      |      |      |  |  |  |  |  |  |
| Geopetals           | ✓    | ✓    |      |      | ✓    | ✓    |      |      |  |  |  |  |  |  |
| Gravity cements     |      |      |      |      |      |      |      |      |  |  |  |  |  |  |
| Lamination          |      |      |      |      |      |      |      |      |  |  |  |  |  |  |
| Others              |      |      |      | *1   | *2   |      | *3   | *3   |  |  |  |  |  |  |

\*1 Cross lamination

\*2 Vadose silt in fenestrae

\*3 Sample through bulbous stromatoporoid

|         |  |
|---------|--|
| Texture | M=Mudstone, W=Wackestone, P=Packstone<br>G=Grainstone, F=Floatstone, Bf= Bafflestone<br>Bi=Bindstone, B=Boundstone, D=Dolomite |
| Matrix  | M=Micrite, Ms=Microspar, S=Spar, D=Dolomite  |

## A1.2.22 Sourd d'Ave Section

○ = <1%    · = 1–20%    ● = 21–40%    ● = 41–60%    \* = >61%

| Sample number       | SA1  | SA2  | SA3  | SA4  | SA5   | SA6   | SA7  | SA8  | SA9  | SA10 | SA11  | SA12 | SA13  |
|---------------------|------|------|------|------|-------|-------|------|------|------|------|-------|------|-------|
| Height              | 4.0m | 8.5m | 1.1m | 4.6m | 12.0m | 23.5m | 6.5m | 2.5m | 5.5m | 5.0m | 10.8m | 2.0m | 13.9m |
| Thin Section/ Peel  | TS   | TS   | TS   | TS   | TS    | TS    | TS   | TS   | TS   | TS   | TS    | TS   | TS    |
| Microfacies         | S2   | S6b  | S2   | S6a  | S4a   | S2    | S7b  | S7a  | S7a  | S6f  | S12b  | S2   | S6a   |
| Texture             | F    | M    | F    | P    | F     | F     | G    | G    | G    | G    | Bi    | F    | WP    |
| Grains:             |      |      |      |      |       |       |      |      |      |      |       |      |       |
| Peloids             | ●    | *    |      | ●    |       |       | ●    | *    | ●    | ●    |       |      | *     |
| Lithoclasts         | ○    |      |      |      |       |       | ·    | ●    | ●    | ·    |       | ·    |       |
| Oncoids             |      |      |      |      |       |       |      |      |      |      |       |      |       |
| Ooids               |      |      |      |      |       |       | ·    |      |      |      |       |      |       |
| Aggregate grains    |      |      |      |      |       |       |      | ·    | ·    | ·    |       |      |       |
| Quartz/ silt grains |      |      |      |      |       |       |      |      |      |      |       |      |       |
| Bioclasts:          |      |      |      |      |       |       |      |      |      |      |       |      |       |
| Bulbous stroms.     |      |      | *    |      |       | *     |      |      |      |      |       | ●    |       |
| Laminar stroms.     |      |      |      |      |       |       |      |      |      |      |       |      |       |
| Dendroid stroms.    | ●    |      |      |      |       |       |      | ·    |      |      |       |      |       |
| Stachyodes          |      |      |      |      |       |       |      |      |      |      |       |      |       |
| Amphipora           |      |      |      |      | ●     |       |      |      |      |      |       |      |       |
| Colonial corals     |      |      |      |      |       |       |      |      |      |      |       |      |       |
| Solitary corals     | ●    |      |      |      | ●     |       |      |      |      |      |       | ●    |       |
| Thamnoporoids       |      |      |      |      |       |       |      |      |      |      |       |      |       |
| Bivalves            | ·    |      |      |      |       |       |      |      |      |      |       |      |       |
| Gastropods          | ·    |      |      |      |       |       |      |      |      |      |       |      | ·     |
| Shell hash          |      |      |      |      | ●     |       |      |      |      |      |       |      |       |
| Brachiopods         | ·    |      |      |      |       |       |      |      |      |      |       |      |       |
| Brachiopod spines   |      |      |      |      |       |       |      |      |      |      |       |      |       |
| Crinoids            |      |      |      |      | ·     |       |      |      |      |      |       |      | ·     |
| Tentaculites        |      |      |      |      |       |       |      |      |      |      |       |      |       |
| Trilobites          |      |      |      |      |       |       |      |      |      |      |       |      |       |
| Bryozoans           |      |      |      |      |       |       |      |      |      |      |       |      |       |
| Ostrocodes          |      | ●    |      | *    | ·     |       | ●    |      |      |      |       | ·    | ·     |
| Leperditia          |      |      |      |      |       |       |      |      |      | ●    |       |      |       |
| Calcispheres        |      |      |      |      |       |       |      |      |      |      |       |      | ○     |
| Forams              |      |      |      |      | ·     |       |      |      |      | ·    |       | ·    | ·     |
| Sponge spicules     |      |      |      |      |       |       |      |      |      |      |       |      |       |
| Umbellids           |      |      |      |      |       |       |      |      |      |      |       |      |       |
| Undetermined        |      |      |      |      |       |       |      |      |      |      |       |      |       |
| Codiaceans          |      |      |      |      |       |       |      |      |      |      |       |      |       |
| Dasycladaceans      |      |      |      | ○    |       |       |      |      |      |      |       |      | ○     |
| Girvanella Gp.      | ·    |      |      |      |       |       |      |      |      |      | *     |      |       |
| Renalcis Gp.        |      |      |      |      |       |       |      |      |      |      |       |      |       |
| Hedstroemia Gp.     |      |      |      |      |       |       |      |      |      |      |       |      |       |
| Wetheredella Gp.    |      |      |      |      |       |       |      |      |      |      | ·     |      |       |
| Matrix              | M    | M    |      | M    | M,Ms  |       | S,M  | S    | S,M  |      | S     | M    | M,S   |
| Bioturbation        | ✓    | ✓    |      | ✓    | ✓     |       |      |      | ✓    |      |       |      | ✓     |
| Micrite envelope    |      |      |      |      |       |       |      | ✓    | ✓    |      |       |      | ✓     |
| Fenestrae: Tubular  |      |      |      |      |       |       |      |      |      |      |       |      |       |
| Laminoid/irregular  |      |      |      |      |       |       |      |      |      |      |       |      |       |
| Geopetals           |      |      |      |      |       |       |      |      |      |      |       |      |       |
| Gravity cements     |      |      |      |      |       |       |      |      |      |      |       |      |       |
| Lamination          |      |      |      |      |       |       |      |      |      |      |       |      |       |
| Others              |      |      | *1   |      |       | *1    | *2   |      |      |      | *3    |      |       |

\*1 Thin section taken through bulbous stromatopoid

\*2 Graded lenses

\*3 Unidentifiable cyanobacteria and meniscus cements

|         |  |
|---------|--|
| Texture | M=Mudstone, W=Wackestone, P=Packstone<br>G=Grainstone, F=Floatstone, Bf= Bafflestone<br>Bi=Bindstone, B=Boundstone, D=Dolomite |
| Matrix  | M=Micrite, Ms=Microspar, S=Spar, D=Dolomite  |

## Sourd d'Ave Section

○ = <1%    · = 1-20%    ● = 21-40%    ● = 41-60%    \* = >61%

| Sample number       | SA14  | SA15  | SA16  | SA17  | SA18  | SA19  | SA21  | SA22  |  |  |  |  |  |  |
|---------------------|-------|-------|-------|-------|-------|-------|-------|-------|--|--|--|--|--|--|
| Height              | 13.1m | 23.0m | 27.7m | 30.5m | 25.0m | 27.0m | 31.4m | 31.9m |  |  |  |  |  |  |
| Thin Section/ Peel  | TS    | TS    | TS    | TS    | TS    | TS    | TS    | TS    |  |  |  |  |  |  |
| Microfacies         | S5    | S8a   | S13   | S4a   | S8a   | S2    | S6a   | S6b   |  |  |  |  |  |  |
| Texture             | P     | W     | M     | F     | MW    | F     | MW    | M     |  |  |  |  |  |  |
| Grains:             |       |       |       |       |       |       |       |       |  |  |  |  |  |  |
| Peloids             | ·     |       | ●     | ·     |       |       |       | ●     |  |  |  |  |  |  |
| Lithoclasts         |       | ·     |       |       | ·     |       | ·     |       |  |  |  |  |  |  |
| Oncoids             |       |       |       |       |       |       |       |       |  |  |  |  |  |  |
| Ooids               |       |       |       |       |       |       |       |       |  |  |  |  |  |  |
| Aggregate grains    |       |       |       |       |       |       |       |       |  |  |  |  |  |  |
| Quartz/ silt grains |       |       |       |       |       |       |       |       |  |  |  |  |  |  |
| Bioclasts:          |       |       |       |       |       |       |       |       |  |  |  |  |  |  |
| Bulbous stroms.     |       |       |       |       |       |       | *     |       |  |  |  |  |  |  |
| Laminar stroms.     |       |       |       |       |       |       |       |       |  |  |  |  |  |  |
| Dendroid stroms.    |       |       |       |       |       |       |       |       |  |  |  |  |  |  |
| Stachyodes          |       |       |       |       |       |       |       |       |  |  |  |  |  |  |
| Amphipora           | ·     |       |       | *     |       |       |       |       |  |  |  |  |  |  |
| Colonial corals     |       |       |       |       |       |       |       |       |  |  |  |  |  |  |
| Solitary corals     |       |       |       |       |       |       |       |       |  |  |  |  |  |  |
| Thamnoporoids       |       |       |       |       |       |       |       |       |  |  |  |  |  |  |
| Bivalves            | *     |       |       |       |       |       |       |       |  |  |  |  |  |  |
| Gastropods          | ·     |       |       |       |       |       |       | ●     |  |  |  |  |  |  |
| Shell hash          |       |       |       |       |       |       |       |       |  |  |  |  |  |  |
| Brachiopods         |       |       |       |       |       |       |       |       |  |  |  |  |  |  |
| Brachiopod spines   |       |       |       |       |       |       |       |       |  |  |  |  |  |  |
| Crinoids            |       |       |       |       |       |       |       |       |  |  |  |  |  |  |
| Tentaculites        |       |       |       |       |       |       |       |       |  |  |  |  |  |  |
| Trilobites          |       |       |       |       |       |       |       |       |  |  |  |  |  |  |
| Bryozoans           |       |       |       |       |       |       |       |       |  |  |  |  |  |  |
| Ostrocodes          | ○     | ·     | ●     | ·     | ·     |       | ●     | ·     |  |  |  |  |  |  |
| Leperditia          |       |       |       |       |       |       |       |       |  |  |  |  |  |  |
| Calcspheres         |       | ●     |       | ·     | *     |       | ●     | ·     |  |  |  |  |  |  |
| Forams              |       | ●     |       |       | ●     |       |       | ·     |  |  |  |  |  |  |
| Sponge spicules     |       |       |       |       |       |       |       |       |  |  |  |  |  |  |
| Umbellids           |       |       |       |       |       |       |       |       |  |  |  |  |  |  |
| Undetermined        |       |       |       |       |       |       |       |       |  |  |  |  |  |  |
| Codlanceans         |       | ·     |       |       |       |       |       |       |  |  |  |  |  |  |
| Dasycladaceans      |       |       |       |       |       |       |       |       |  |  |  |  |  |  |
| Girvanella Gp.      |       |       |       |       |       |       |       |       |  |  |  |  |  |  |
| Renalcis Gp.        |       |       |       |       |       |       |       |       |  |  |  |  |  |  |
| Hedstroemia Gp.     |       |       |       |       |       |       |       |       |  |  |  |  |  |  |
| Wetheredella Gp.    |       |       |       |       |       |       |       |       |  |  |  |  |  |  |
| Matrix              | M,S   | M     | D     | M,Ms  | M     |       | M,D   | M,Ms  |  |  |  |  |  |  |
| Bioturbation        | ✓     | ✓     |       | ✓     | ✓     |       | ✓     |       |  |  |  |  |  |  |
| Micrite envelope    | ✓     |       |       |       |       |       |       |       |  |  |  |  |  |  |
| Fenestrae: Tubular  |       |       |       |       |       |       |       |       |  |  |  |  |  |  |
| Laminoid/irregular  |       | ✓     |       |       | ✓     |       |       |       |  |  |  |  |  |  |
| Geopetals           |       |       |       |       |       |       |       |       |  |  |  |  |  |  |
| Gravity cements     |       |       |       |       |       |       |       |       |  |  |  |  |  |  |
| Lamination          |       |       |       |       |       |       |       |       |  |  |  |  |  |  |
| Others              | *1    |       | *2    |       |       | *3    |       |       |  |  |  |  |  |  |

\*1 Bioclasts aligned parallel to each other

\*2 Pseudomorphs of evaporite minerals

\*3 Thin section taken through bulbous stromatoporoid

|         |  |
|---------|--|
| Texture | M=Mudstone, W=Wackestone, P=Packstone<br>G=Grainstone, F=Floatstone, Bf= Bafflestone<br>Bi=Bindstone, B=Boundstone, D=Dolomite |
| Matrix  | M=Micrite, Ms=Microspar, S=Spar, D=Dolomite  |

## A1.2.23 Teerstraßenbau Quarry

○ = <1%    · = 1–20%    ● = 21–40%    ● = 41–60%    \* = >61%

| Sample number       | TSB1 | TSB2 | TSB3 | TSB5  | TSB6  | TSB7  | TSB8  | TSB9  | TSB10 | TSB12 | TSB13 | TSB14 | TSB15 |
|---------------------|------|------|------|-------|-------|-------|-------|-------|-------|-------|-------|-------|-------|
| Height              | 2.3m | 6.0m | 8.9m | 13.0m | 15.0m | 17.8m | 20.4m | 21.0m | 23.9m | 24.9m | 27.7m | 30.9m | 32.8m |
| Thin Section/ Peel  | P    | P    | TS   | P     | P     | TS    | P     | P     | P     | P     | P     | P     | P     |
| Microfacies         | R2   | R2   | R1   | R1    | R1    | ?     | ?     | ?     | ?     | ?     | ?     | ?     | ?     |
| Texture             | WP   | WP   | WP   | W     | MD    | D     | D     | D     | D     | D     | D     | D     | D     |
| Grains:             |      |      |      |       |       |       |       |       |       |       |       |       |       |
| Peloids             |      |      |      |       |       |       |       |       |       |       |       |       |       |
| Lithoclasts         |      |      |      |       |       |       |       |       |       |       |       |       |       |
| Oncoids             |      |      |      |       |       |       |       |       |       |       |       |       |       |
| Ooids               |      |      |      |       |       |       |       |       |       |       |       |       |       |
| Aggregate grains    |      |      |      |       |       |       |       |       |       |       |       |       |       |
| Quartz/ silt grains |      |      |      |       |       |       |       |       |       |       |       |       |       |
| Bioclasts:          |      |      |      |       |       |       |       |       |       |       |       |       |       |
| Bulbous stroms.     |      |      |      |       |       |       |       |       |       |       |       |       |       |
| Laminar stroms.     |      |      |      |       |       |       |       |       |       |       |       |       |       |
| Dendroid stroms.    |      |      |      |       |       |       |       |       |       |       |       |       |       |
| Stachyodes          |      |      |      |       |       |       |       |       |       |       |       |       |       |
| Amphipora           |      |      |      |       |       |       |       |       |       |       |       |       |       |
| Colonial corals     |      |      |      |       |       |       |       |       |       |       |       |       |       |
| Solitary corals     |      | ·    |      |       |       |       |       |       |       |       |       |       |       |
| Thamnoporoids       |      |      |      |       |       |       |       |       |       |       |       |       |       |
| Bivalves            | ●    | ●    | ·    | *     |       |       |       |       |       |       |       |       |       |
| Gastropods          | ·    | ·    | ·    | ·     |       |       |       |       |       |       |       |       |       |
| Shell hash          |      |      |      |       |       |       |       |       |       |       |       |       |       |
| Brachiopods         | ·    | ·    | ●    | ·     | *     |       |       |       |       |       |       |       |       |
| Brachiopod spines   |      |      | ○    |       |       |       |       |       |       |       |       |       |       |
| Crinoids            | ●    | ●    | ·    |       |       |       |       |       |       |       |       |       |       |
| Tentaculites        |      |      | ○    |       |       |       |       |       |       |       |       |       |       |
| Trilobites          |      |      |      |       |       |       |       |       |       |       |       |       |       |
| Bryozoans           |      |      |      |       |       |       |       |       |       |       |       |       |       |
| Ostrocodes          | ·    |      | ·    |       | ●     |       |       |       |       |       |       |       |       |
| Leperditia          |      |      |      |       |       |       |       |       |       |       |       |       |       |
| Calcispheres        |      |      |      |       |       |       |       |       |       |       |       |       |       |
| Forams              |      |      | ○    |       |       |       |       |       |       |       |       |       |       |
| Sponge spicules     |      |      |      |       |       |       |       |       |       |       |       |       |       |
| Umbellids           |      |      |      |       |       |       |       |       |       |       |       |       |       |
| Undetermined        |      |      |      |       |       |       |       |       |       |       |       |       |       |
| Codiaceans          |      |      |      |       |       |       |       |       |       |       |       |       |       |
| Dasycladaceans      |      |      |      |       |       |       |       |       |       |       |       |       |       |
| Girvanella Gp.      |      |      |      |       |       |       |       |       |       |       |       |       |       |
| Renalcis Gp.        |      |      |      |       |       |       |       |       |       |       |       |       |       |
| Hedstroemia Gp.     |      |      |      |       |       |       |       |       |       |       |       |       |       |
| Wetheredella Gp.    |      |      |      |       |       |       |       |       |       |       |       |       |       |
| Matrix              | M    | M    | M    | D,M   | D     |       |       |       |       |       |       |       |       |
| Bioturbation        | ✓    | ✓    | ✓    | ✓     |       |       |       |       |       |       |       |       |       |
| Micrite envelope    |      |      |      |       |       |       |       |       |       |       |       |       |       |
| Fenestrae: Tubular  |      |      |      |       |       |       |       |       |       |       |       |       |       |
| Laminoid/irregular  |      |      |      |       |       |       |       |       |       |       |       |       |       |
| Geopetals           |      |      |      |       |       |       |       |       |       |       |       |       |       |
| Gravity cements     |      |      |      |       |       |       |       |       |       |       |       |       |       |
| Lamination          |      |      |      |       |       |       |       |       |       |       |       |       |       |
| Others              | *1   | *1   | *1   | *1    | *2    | *2    | *2    | *2    | *2    | *2    | *2    | *2    | *2    |

\*1 Matrix is clay-rich

\*2 Sample is completely dolomitised

|         |  |
|---------|--|
| Texture | M=Mudstone, W=Wackestone, P=Packstone<br>G=Grainstone, F=Floatstone, Bf= Bafflestone<br>Bi=Bindstone, B=Boundstone, D=Dolomite |
| Matrix  | M=Micrite, Ms=Microspar, S=Spar, D=Dolomite  |

## Teerstraßenbau Quarry

○ = <1%    · = 1–20%    ● = 21–40%    ● = 41–60%    ★ = >61%

| Sample number       | TSB16 | TSB17 | TSB18 | TSB20 | TSB21 | TSB22 | TSB23 | TSB24 | TSB25 | TSB26 | TSB27 | TSB28 | TSB29 |
|---------------------|-------|-------|-------|-------|-------|-------|-------|-------|-------|-------|-------|-------|-------|
| Height              | 37.6m | 42.0m | 43.1m | 50.0m | 70.7m | 72.0m | 73.5m | 75.1m | 76.9m | 79.1m | 80.0m | 82.6m | 83.1m |
| Thin Section/ Peel  | P     | P     | P     | P     | P     | P     | TS    | TS    | TS    | P     | TS    | P     | P     |
| Microfacies         | ?     | ?     | S5    | S3a   | S8c   | S7a   | S7a   | S10   | S7a   | S4a   | S7a   | S8c   | S6b   |
| Texture             | D     | D     | W     | G     | G     | G     | G     | G     | G     | F     | G     | G     | M     |
| Grains:             |       |       |       |       |       |       |       |       |       |       |       |       |       |
| Peloids             |       |       |       | ★     | ★     | ★     | ★     | ★     | ●     |       | ★     | ★     |       |
| Lithoclasts         |       |       |       |       |       |       | ·     | ·     | ·     |       |       |       |       |
| Oncoids             |       |       |       |       |       |       |       |       |       |       |       |       |       |
| Ooids               |       |       |       |       |       |       |       |       | ●     |       |       |       |       |
| Aggregate grains    |       |       |       |       |       |       |       |       |       |       |       |       |       |
| Quartz/ silt grains |       |       |       |       |       |       |       |       |       |       |       |       |       |
| Bioclasts:          |       |       |       |       |       |       |       |       |       |       |       |       |       |
| Bulbous stroms.     |       |       |       |       |       |       |       |       |       |       |       |       |       |
| Laminar stroms.     |       |       |       |       |       |       |       |       |       |       |       |       |       |
| Dendroid stroms.    |       |       |       |       |       |       |       |       |       |       |       |       |       |
| Stachyodes          |       |       |       |       |       |       |       |       |       | ●     |       |       |       |
| Amphipora           |       |       |       | ·     |       |       |       |       |       | ·     |       |       |       |
| Colonial corals     |       |       |       |       |       |       |       |       |       |       |       |       |       |
| Solitary corals     |       |       |       |       |       |       |       |       |       | ·     |       |       |       |
| Thamnoporoids       |       |       |       | ·     |       |       |       |       |       |       |       |       |       |
| Bivalves            |       |       | ●     |       |       |       |       |       | ○     |       |       |       |       |
| Gastropods          |       |       |       |       |       |       |       |       |       |       |       |       |       |
| Shell hash          |       |       |       |       |       |       |       |       |       |       | ○     |       |       |
| Brachiopods         |       |       | ●     |       |       |       |       |       |       | ·     |       |       |       |
| Brachiopod spines   |       |       |       |       |       |       |       |       |       |       |       |       |       |
| Crinoids            |       |       | ·     |       |       |       |       |       |       |       |       |       |       |
| Tentaculites        |       |       |       |       |       |       |       |       |       |       |       |       |       |
| Trilobites          |       |       |       |       |       |       |       |       |       |       |       |       |       |
| Bryozoans           |       |       |       |       |       |       |       |       |       |       |       |       |       |
| Ostrocodes          |       |       |       | ·     |       | ·     |       | ○     |       |       |       |       |       |
| Leperditia          |       |       |       |       |       |       |       |       |       |       |       |       |       |
| Calcspheres         |       |       |       |       |       |       | ·     |       |       |       |       |       |       |
| Forams              |       |       |       | ·     |       |       | ○     |       |       |       |       |       |       |
| Sponge spicules     |       |       |       |       |       |       |       |       |       |       |       |       |       |
| Umbellids           |       |       |       |       |       |       |       |       |       |       |       |       |       |
| Undetermined        |       |       |       |       |       |       |       |       |       |       |       |       |       |
| Codiaceans          |       |       |       |       |       |       |       |       |       |       |       |       |       |
| Dasycladaceans      |       |       |       |       |       |       |       |       |       |       |       |       |       |
| Girvanella Gp.      |       |       |       |       |       |       |       |       |       |       |       |       |       |
| Renalcis Gp.        |       |       |       |       |       |       |       |       |       |       |       |       |       |
| Hedstroemia Gp.     |       |       |       |       |       |       |       |       |       |       |       |       |       |
| Wetheredella Gp.    |       |       |       |       |       |       |       |       |       |       |       |       |       |
| Matrix              |       |       | M,D   | S     | S     | S,M,D | S     | S,M   | S     | M     | S,M   | S     | M,D   |
| Bioturbation        |       |       | ✓     |       |       |       |       |       |       | ✓     |       |       |       |
| Micrite envelope    |       |       |       |       |       |       | ✓     |       | ✓     |       |       |       |       |
| Fenestrae: Tubular  |       |       |       |       |       |       |       |       |       |       |       |       |       |
| Laminoid/irregular  |       |       |       |       | ✓     |       |       | ✓     |       |       |       |       |       |
| Geopetals           |       |       |       |       |       |       |       |       |       |       |       |       |       |
| Gravity cements     |       |       |       |       |       |       |       |       |       |       |       |       |       |
| Lamination          |       |       |       |       |       |       |       | ✓     |       |       |       |       |       |
| Others              | *1    | *1    | *2    |       |       |       |       |       |       | *1,*3 |       |       |       |

\*1 Sample is completely dolomitised

\*2 Residual clay associated with matrix

\*3 Bioclasts aligned parallel to each other

|         |  |
|---------|--|
| Texture | M=Mudstone, W=Wackestone, P=Packstone<br>G=Grainstone, F=Floatstone, Bf= Bafflestone<br>Bi=Bindstone, B=Boundstone, D=Dolomite |
| Matrix  | M=Micrite, Ms=Microspar, S=Spar, D=Dolomite  |

## A1.2.24 Vaucelles Quarry

○ = <1%    · = 1-20%    ● = 21-40%    ● = 41-60%    \* = >61%

| Sample number       | VC1  | VC2  | VC3  | VC4  | VC5  | VC6  | VC7   | VC8   | VC9   | VC10  | VC11  | VC12  |
|---------------------|------|------|------|------|------|------|-------|-------|-------|-------|-------|-------|
| Height              | 1.6m | 2.4m | 4.1m | 6.7m | 8.1m | 8.8m | 9.95m | 13.1m | 14.95 | 15.5m | 17.1m | 19.5m |
| Thin Section/ Peel  | TS   | TS   | TS   | TS   | TS   | TS   | TS    | TS    | TS    | TS    | TS    | TS    |
| Microfacies         | S6b  | S6b  | S6c  | S6b  | S6b  | S12a | S6b   | S6f   | S7a   | S6a   | S2    | S6b   |
| Texture             | M    | M    | M    | M    | M    | M    | M     | WP    | G     | W     | F     | M     |
| Grains:             |      |      |      |      |      |      |       |       |       |       |       |       |
| Peloids             |      |      |      |      |      | *    |       | ●     | *     |       | ●     |       |
| Lithoclasts         |      |      |      |      |      |      |       |       |       |       |       |       |
| Oncoids             |      |      |      |      |      |      |       |       |       |       |       |       |
| Ooids               |      |      |      |      |      |      |       |       |       |       |       |       |
| Aggregate grains    |      |      |      |      |      |      |       |       |       |       |       |       |
| Quartz/ silt grains |      |      |      |      |      |      |       |       |       |       |       |       |
| Bioclasts:          |      |      |      |      |      |      |       |       |       |       |       |       |
| Bulbous stroms.     |      |      |      |      |      |      |       |       |       |       |       |       |
| Laminar stroms.     |      |      |      |      |      |      |       |       |       |       |       |       |
| Dendroid stroms.    |      |      |      |      |      |      |       |       |       |       |       |       |
| Stachyodes          |      |      |      |      |      |      |       |       |       |       |       |       |
| Amphipora           |      |      |      |      |      |      |       |       |       |       |       |       |
| Colonial corals     |      |      |      |      |      |      |       |       |       |       |       |       |
| Solitary corals     |      |      |      |      |      |      |       |       |       |       |       |       |
| Thamnoporoids       | ·    |      |      |      |      |      |       |       |       |       |       |       |
| Bivalves            |      |      |      |      |      |      |       |       |       |       | ·     |       |
| Gastropods          |      |      |      |      |      |      |       |       |       | ·     |       |       |
| Shell hash          |      |      |      |      |      |      |       |       |       |       |       |       |
| Brachiopods         |      |      |      |      |      |      |       |       |       |       | ●     |       |
| Brachiopod spines   |      |      |      |      |      |      |       |       |       |       |       |       |
| Crinoids            |      |      |      |      |      |      |       |       |       |       | ·     |       |
| Tentaculites        |      |      |      |      |      |      |       |       |       |       |       |       |
| Trilobites          |      |      |      |      |      |      |       |       |       |       |       |       |
| Bryozoans           |      |      |      |      |      |      |       |       |       |       |       |       |
| Ostrocodes          | ·    | ●    | ●    | ·    | ●    |      |       |       |       |       | ○     | ·     |
| Leperditia          |      |      | ·    |      |      |      | ●     | ·     |       | ·     |       |       |
| Calcspheres         | ●    | *    | *    | ○    | ●    |      |       | ·     |       | ○     |       | ○     |
| Forams              |      |      |      |      |      |      |       |       |       |       |       |       |
| Sponge spicules     |      |      |      |      |      |      |       |       |       |       |       |       |
| Umbellids           |      |      |      |      |      |      |       |       |       |       |       |       |
| Undetermined        |      |      |      |      |      |      |       |       |       |       |       |       |
| Codiaceans          |      |      |      |      |      |      |       | ·     |       |       |       |       |
| Dasycladaceans      | ●    | ·    |      | *    | ●    |      | *     | ·     | ●     | ●     |       | *     |
| Girvanella Gp.      |      |      |      |      |      |      |       | ●     |       | ●     |       |       |
| Renalcis Gp.        |      |      |      |      |      |      |       |       |       |       |       |       |
| Hedstroemia Gp.     |      |      |      |      |      |      |       |       |       |       |       |       |
| Wetheredella Gp.    |      |      |      |      |      |      |       |       |       |       |       |       |
| Matrix              | M    | M,D  | M,D  | M,D  | M    | M,S  | M,D   | M,S,D | S     | M     | M,D   | M     |
| Bioturbation        | ✓    | ✓    | ✓    | ✓    | ✓    |      | ✓     | ✓     |       | ✓     | ✓     | ✓     |
| Micrite envelope    |      |      |      |      |      |      |       | ✓     | ✓     |       | ✓     |       |
| Fenestrae: Tubular  |      |      | ✓    |      |      |      |       |       |       |       |       |       |
| Laminoid/irregular  |      |      |      |      |      |      |       |       |       |       |       |       |
| Geopetals           |      |      |      |      |      |      |       |       |       |       |       |       |
| Gravity cements     |      |      |      |      |      |      |       |       |       |       |       |       |
| Lamination          |      |      |      |      |      |      | ✓     |       | ✓     |       |       |       |
| Others              |      |      |      |      |      |      |       |       | *2    |       | *1    |       |

\*1 Sample of matrix

\*2 Very well sorted

|         |  |
|---------|--|
| Texture | M=Mudstone, W=Wackestone, P=Packstone<br>G=Grainstone, F=Floatstone, Bf= Bafflestone<br>Bi=Bindstone, B=Boundstone, D=Dolomite |
| Matrix  | M=Micrite, Ms=Microspar, S=Spar, D=Dolomite  |

## A1.2.25 Voßbeck Quarry

○ = <1%    · = 1–20%    ● = 21–40%    ● = 41–60%    ★ = >61%

| Sample number       | V1    | V2   | V3   | V4    | V5   | V7    | V8    | V9    | V10   | V11   | V12   | V13   | V14   |
|---------------------|-------|------|------|-------|------|-------|-------|-------|-------|-------|-------|-------|-------|
| Height              | 0.05m | 2.1m | 4.1m | 7.6m  | 8.0m | 14.9m | 16.5m | 17.8m | 18.7m | 21.6m | 26.5m | 27.2m | 27.8m |
| Thin Section/ Peel  | TS    | TS   | TS   | TS    | TS   | TS    | TS    | TS    | TS    | TS    | TS    | TS    | TS    |
| Microfacies         | S4a   | S4a  | S4a  | S6b   | S7a  | S4a   | S4a   | S8a   | S2    | S4b   | S4a   | S6a   | S8a   |
| Texture             | F     | F    | F    | M     | G    | FBf   | F     | M     | FB    | F     | F     | W     | W     |
| Grains:             |       |      |      |       |      |       |       |       |       |       |       |       |       |
| Peloids             | ★     |      |      | ★     | ★    |       | ·     |       |       | ·     |       | ★     | ★     |
| Lithoclasts         |       |      |      |       |      |       |       |       |       |       |       |       |       |
| Oncoids             |       |      |      |       |      |       |       |       |       |       |       |       |       |
| Ooids               |       |      |      |       |      |       |       |       |       |       |       |       |       |
| Aggregate grains    |       |      |      |       |      |       |       |       |       |       |       |       |       |
| Quartz/ silt grains |       |      |      |       |      |       |       |       |       |       |       |       |       |
| Bioclasts:          |       |      |      |       |      |       |       |       |       |       |       |       |       |
| Bulbous stroms.     |       |      |      |       |      |       | ★     |       |       | ●     |       |       |       |
| Laminar stroms.     |       |      |      |       |      |       |       |       |       |       |       |       |       |
| Dendroid stroms.    | ·     |      | ●    |       |      |       |       |       |       |       |       |       |       |
| Stachyodes          |       |      |      |       |      |       |       |       |       |       |       |       |       |
| Amphipora           |       | ★    | ●    | ·     |      | ★     | ·     |       | ★     | ●     | ●     | ·     |       |
| Colonial corals     |       |      |      |       |      |       |       |       |       |       |       |       |       |
| Solitary corals     |       |      |      |       |      |       |       |       |       |       |       |       |       |
| Thamnoporoids       |       |      |      |       |      |       |       |       |       |       |       |       |       |
| Bivalves            |       |      |      |       |      |       |       |       |       |       |       |       |       |
| Gastropods          |       |      |      |       |      |       |       |       |       |       |       |       |       |
| Shell hash          |       |      |      |       |      |       |       |       |       |       |       |       |       |
| Brachiopods         |       |      |      |       |      |       |       |       |       |       |       |       |       |
| Brachiopod spines   |       |      |      |       |      |       |       |       |       |       |       |       |       |
| Crinoids            |       |      |      |       |      |       |       |       |       |       |       |       |       |
| Tentaculites        |       |      |      |       |      |       |       |       |       |       |       |       |       |
| Trilobites          |       |      |      |       |      |       |       |       |       |       |       |       |       |
| Bryozoans           |       |      |      |       |      |       |       |       |       |       |       |       |       |
| Ostrocodes          | ○     |      | ·    | ○     | ·    |       |       | ·     |       |       | ○     | ·     | ·     |
| Leperditia          |       |      |      |       |      |       |       |       |       |       |       |       |       |
| Calcspheres         |       | ·    | ·    | ·     | ·    |       |       | ●     |       | ·     | ·     | ●     | ·     |
| Forams              | ·     | ·    | ○    | ○     | ·    |       |       | ●     | ·     | ○     | ·     | ·     |       |
| Sponge spicules     |       |      |      |       |      |       |       |       |       |       |       |       |       |
| Umbellids           |       |      |      |       |      |       |       |       |       |       |       |       |       |
| Undetermined        |       |      |      |       |      |       |       |       |       |       |       |       |       |
| Codiaceans          |       |      |      |       |      |       |       |       |       |       |       |       |       |
| Dasycladaceans      |       | ·    | ·    |       |      |       | ○     |       |       |       |       |       |       |
| Girvanella Gp.      | ○     | ·    |      |       |      |       |       |       |       |       |       |       |       |
| Renalcis Gp.        |       |      | ·    |       |      |       |       |       | ·     |       |       |       |       |
| Hedstroemia Gp.     |       |      |      |       |      |       |       |       |       |       |       |       |       |
| Wetheredella Gp.    |       |      |      |       |      |       |       |       |       |       |       |       |       |
| Matrix              | M,S,D | M,D  | M,D  | M,S,D | S,M  | M     | M,S,D | M     | M,D   | M,S,D | M,D   | M,S   | M,S   |
| Bioturbation        | ✓     | ✓    | ✓    | ✓     |      |       | ✓     | ✓     |       |       | ✓     | ✓     |       |
| Micrite envelope    |       |      |      |       |      |       |       |       |       |       |       |       |       |
| Fenestrae: Tubular  |       |      |      |       |      |       |       |       |       |       |       |       |       |
| Laminoid/irregular  |       |      |      |       |      |       |       | ✓     |       |       |       |       | ✓     |
| Geopetals           |       | ✓    |      |       | ✓    |       |       | ✓     |       |       |       |       | ✓     |
| Gravity cements     |       |      |      |       |      |       |       |       |       |       |       |       |       |
| Lamination          |       |      |      |       |      |       |       |       |       |       |       |       |       |
| Others              | *1    | *1   | *1   |       |      |       |       | *2    |       |       | *3    |       | *2    |

\*1 Grains encrusted by cyanobacteria

\*2 Internal sediment-fill at base of fenestrae

\*3 Matrix very peloidal

|         |  |
|---------|--|
| Texture | M=Mudstone, W=Wackestone, P=Packstone<br>G=Grainstone, F=Floatstone, Bf= Bafflestone<br>Bi=Bindstone, B=Boundstone, D=Dolomite |
| Matrix  | M=Micrite, Ms=Microspar, S=Spar, D=Dolomite  |

## Voßbeck Quarry

○ = <1%   · = 1-20%   ● = 21-40%   ● = 41-60%   ★ = >61%

| Sample number       | V15   | V16   | V17    | V18   | V19   | V20   | V21   | V22   |
|---------------------|-------|-------|--------|-------|-------|-------|-------|-------|
| Height              | 30.7m | 32.7m | 35.4m  | 36.8m | 40.4m | 48.2m | 48.8m | 50.1m |
| Thin Section/ Peel  | TS    | TS    | TS     | TS    | TS    | TS    | TS    | TS    |
| Microfacies         | S7a   | S4a   | S2     | S2    | S2    | S4a   | S4a   | S4a   |
| Texture             | G     | F     | F      | F     | F     | W     | W     | P     |
| Grains:             |       |       |        |       |       |       |       |       |
| Peloids             | ★     | ★     |        |       |       |       |       |       |
| Lithoclasts         |       |       |        |       |       |       |       |       |
| Oncoids             |       |       |        |       |       |       |       |       |
| Ooids               |       |       |        |       |       |       |       |       |
| Aggregate grains    |       |       |        |       |       |       |       |       |
| Quartz/ silt grains |       |       |        |       |       |       |       |       |
| Bioclasts:          |       |       |        |       |       |       |       |       |
| Bulbous stroms.     |       |       | ★      | ★     | ★     |       |       |       |
| Laminar stroms.     |       |       |        |       |       |       |       |       |
| Dendroid stroms.    |       |       |        |       |       |       |       |       |
| Stachyodes          |       |       |        |       |       |       |       |       |
| Amphipora           | ·     | ·     |        |       |       | ·     | ●     |       |
| Colonial corals     |       |       |        |       |       |       |       |       |
| Solitary corals     |       |       |        |       |       |       |       |       |
| Thamnoporoids       |       |       |        |       |       |       |       |       |
| Bivalves            |       |       |        |       |       |       |       |       |
| Gastropods          |       |       |        |       |       |       |       |       |
| Shell hash          |       |       |        |       |       |       | ★     |       |
| Brachiopods         |       |       |        |       |       |       |       |       |
| Brachiopod spines   |       |       |        |       |       |       |       |       |
| Crinoids            |       |       |        |       |       |       |       |       |
| Tentaculites        |       |       |        |       |       |       |       |       |
| Trilobites          |       |       |        |       |       |       |       |       |
| Bryozoans           |       |       |        |       |       |       |       |       |
| Ostrocodes          |       |       |        |       |       | ○     | ·     |       |
| Leperditia          |       |       |        |       |       |       |       | ·     |
| Calcispheres        | ·     | ·     |        |       |       | ·     | ·     | ·     |
| Forams              | ·     | ·     |        |       |       | ·     | ·     | ·     |
| Sponge spicules     |       |       |        |       |       |       |       |       |
| Umbellids           |       |       |        |       |       |       |       |       |
| Undetermined        |       |       |        |       |       |       |       |       |
| Codiaceans          |       |       |        |       |       |       |       |       |
| Dasycladaceans      | ·     | ·     |        |       |       | ★     | ★     |       |
| Girvanella Gp.      |       |       | ·      |       |       |       |       |       |
| Renalcis Gp.        |       |       |        |       |       |       |       |       |
| Hedstroemia Gp.     |       |       |        |       |       |       |       |       |
| Wetheredella Gp.    |       |       |        |       |       |       |       |       |
| Matrix              | M,S   | M,S,D |        |       |       | M     | M,S   | M,S   |
| Bioturbation        | ✓     | ✓     |        |       |       | ✓     | ✓     | ✓     |
| Micrite envelope    |       |       |        |       |       |       |       |       |
| Fenestrae: Tubular  |       |       |        |       |       |       |       |       |
| Laminoid/irregular  |       |       |        |       |       |       |       |       |
| Geopetals           |       |       |        |       |       |       |       |       |
| Gravity cements     |       |       |        |       |       |       |       |       |
| Lamination          |       |       |        |       |       |       |       |       |
| Others              |       | *1    | *2, *3 | *2    | *2    | *1    | *1    |       |

\*1 Sample taken of matrix

\*2 Thin section taken through bulbous stromatoporoid

\*3 Stromatoporoid encrusted by *Girvanella*

|         |   |
|---------|---|
| Texture | M=Mudstone, W=Wackestone, P=Packstone<br>G=Grainstone, F=Floatstone, Bf=Bafflestone<br>Bi=Bindstone, B=Boundstone, D=Dolomite |
| Matrix  | M=Micrite, Ms=Microspar, S=Spar, D=Dolomite   |

## A1.2.26 Walheim Section 1

○ = <1%    • = 1-20%    ● = 21-40%    ● = 41-60%    \* = >61%

| Sample number       | WCP1  | WCP2  |  |  |  |  |  |  |  |  |  |  |  |  |  |
|---------------------|-------|-------|--|--|--|--|--|--|--|--|--|--|--|--|--|
| Height              | 7.15m | 6.0m  |  |  |  |  |  |  |  |  |  |  |  |  |  |
| Thin Section/ Peel  | TS    | TS    |  |  |  |  |  |  |  |  |  |  |  |  |  |
| Microfacies         | S12a  | S1    |  |  |  |  |  |  |  |  |  |  |  |  |  |
| Texture             | M     | M     |  |  |  |  |  |  |  |  |  |  |  |  |  |
| Grains:             |       |       |  |  |  |  |  |  |  |  |  |  |  |  |  |
| Peloids             | *1    |       |  |  |  |  |  |  |  |  |  |  |  |  |  |
| Lithoclasts         |       |       |  |  |  |  |  |  |  |  |  |  |  |  |  |
| Oncoids             |       |       |  |  |  |  |  |  |  |  |  |  |  |  |  |
| Ooids               |       |       |  |  |  |  |  |  |  |  |  |  |  |  |  |
| Aggregate grains    |       |       |  |  |  |  |  |  |  |  |  |  |  |  |  |
| Quartz/ silt grains |       |       |  |  |  |  |  |  |  |  |  |  |  |  |  |
| Bioclasts:          |       |       |  |  |  |  |  |  |  |  |  |  |  |  |  |
| Bulbous stroms.     |       |       |  |  |  |  |  |  |  |  |  |  |  |  |  |
| Laminar stroms.     |       |       |  |  |  |  |  |  |  |  |  |  |  |  |  |
| Dendroid stroms.    |       |       |  |  |  |  |  |  |  |  |  |  |  |  |  |
| Stachyodes          |       |       |  |  |  |  |  |  |  |  |  |  |  |  |  |
| Amphipora           |       |       |  |  |  |  |  |  |  |  |  |  |  |  |  |
| Colonial corals     |       |       |  |  |  |  |  |  |  |  |  |  |  |  |  |
| Solitary corals     |       |       |  |  |  |  |  |  |  |  |  |  |  |  |  |
| Thamnoporoids       |       |       |  |  |  |  |  |  |  |  |  |  |  |  |  |
| Bivalves            |       |       |  |  |  |  |  |  |  |  |  |  |  |  |  |
| Gastropods          |       |       |  |  |  |  |  |  |  |  |  |  |  |  |  |
| Shell hash          |       |       |  |  |  |  |  |  |  |  |  |  |  |  |  |
| Brachiopods         |       |       |  |  |  |  |  |  |  |  |  |  |  |  |  |
| Brachiopod spines   |       |       |  |  |  |  |  |  |  |  |  |  |  |  |  |
| Crinoids            |       |       |  |  |  |  |  |  |  |  |  |  |  |  |  |
| Tentaculites        |       |       |  |  |  |  |  |  |  |  |  |  |  |  |  |
| Trilobites          |       |       |  |  |  |  |  |  |  |  |  |  |  |  |  |
| Bryozoans           |       |       |  |  |  |  |  |  |  |  |  |  |  |  |  |
| Ostrocodes          | •     | •     |  |  |  |  |  |  |  |  |  |  |  |  |  |
| Leperditia          |       |       |  |  |  |  |  |  |  |  |  |  |  |  |  |
| Calcspheres         | •     | ●     |  |  |  |  |  |  |  |  |  |  |  |  |  |
| Forams              |       |       |  |  |  |  |  |  |  |  |  |  |  |  |  |
| Sponge spicules     |       |       |  |  |  |  |  |  |  |  |  |  |  |  |  |
| Umbellids           |       |       |  |  |  |  |  |  |  |  |  |  |  |  |  |
| Undetermined        |       |       |  |  |  |  |  |  |  |  |  |  |  |  |  |
| Codiaceans          |       |       |  |  |  |  |  |  |  |  |  |  |  |  |  |
| Dasycladaceans      | •     | •     |  |  |  |  |  |  |  |  |  |  |  |  |  |
| Girvanella Gp.      |       |       |  |  |  |  |  |  |  |  |  |  |  |  |  |
| Renalcis Gp.        |       |       |  |  |  |  |  |  |  |  |  |  |  |  |  |
| Hedstroemia Gp.     |       |       |  |  |  |  |  |  |  |  |  |  |  |  |  |
| Wetheredella Gp.    |       |       |  |  |  |  |  |  |  |  |  |  |  |  |  |
| Matrix              | M,S   | M,Ms  |  |  |  |  |  |  |  |  |  |  |  |  |  |
| Bioturbation        |       | ✓     |  |  |  |  |  |  |  |  |  |  |  |  |  |
| Micrite envelope    |       |       |  |  |  |  |  |  |  |  |  |  |  |  |  |
| Fenestrae: Tubular  |       |       |  |  |  |  |  |  |  |  |  |  |  |  |  |
| Laminoid/irregular  |       | ✓     |  |  |  |  |  |  |  |  |  |  |  |  |  |
| Geopetals           |       | ✓     |  |  |  |  |  |  |  |  |  |  |  |  |  |
| Gravity cements     |       |       |  |  |  |  |  |  |  |  |  |  |  |  |  |
| Lamination          | ✓     | ✓     |  |  |  |  |  |  |  |  |  |  |  |  |  |
| Others              | *1    | *2,*3 |  |  |  |  |  |  |  |  |  |  |  |  |  |

\*1 Grains aligned parallel to bedding

\*2 Vadose silt in base of fenestrae

\*3 Sample of clast in S1 breccia

|         |  |
|---------|--|
| Texture | M=Mudstone, W=Wackestone, P=Packstone<br>G=Grainstone, F=Floatstone, Bf= Bafflestone<br>Bi=Bindstone, B=Boundstone, D=Dolomite |
| Matrix  | M=Micrite, Ms=Microspar, S=Spar, D=Dolomite  |

## A1.2.27 Walheim Section 2

○ = <1%    · = 1–20%    ● = 21–40%    ● = 41–60%    \* = >61%

| Sample number       | WH1      | WH2      | WH3        | WH4     | WH5     | WH6      | WH7      | WH8     | WH9        | WH10     | WH11      | WH12        | WH13        |
|---------------------|----------|----------|------------|---------|---------|----------|----------|---------|------------|----------|-----------|-------------|-------------|
| Height              | 39.0m    | 37.8m    | 35.9m      | 32.7m   | 30.8m   | 28.7m    | 26.9m    | 23.6m   | 20.9m      | 19.0m    | 16.4m     | 15.7m       | 15.3m       |
| Thin Section/ Peel  | TS       | TS       | TS         | TS      | TS      | TS       | TS       | TS      | TS         | TS       | TS        | TS          | TS          |
| Microfacies         | S2       | S8a      | S2         | S6a     | S10     | S2       | S2       | S8a     | S13        | S4a      | S2        | S6a         | S8a         |
| Texture             | F        | W        | F          | W       | B       | F        | F        | W       | M          | W        | F         | W           | W           |
| Grains:             |          |          |            |         |         |          |          |         |            |          |           |             |             |
| Peloids             |          |          |            | ·       |         |          |          |         | * (WH9)    |          |           |             |             |
| Lithoclasts         |          |          |            |         |         |          |          |         |            |          |           |             |             |
| Oncoids             |          |          |            |         |         |          |          |         |            |          |           |             |             |
| Ooids               |          |          |            |         |         |          |          |         |            |          |           |             |             |
| Aggregate grains    |          |          |            |         |         |          |          |         |            |          |           |             |             |
| Quartz/ silt grains |          |          |            |         |         |          |          |         |            |          |           |             |             |
| Bioclasts:          |          |          |            |         |         |          |          |         |            |          |           |             |             |
| Bulbous stroms.     | * (WH1)  |          |            |         |         | * (WH6)  | * (WH7)  |         |            |          | * (WH11)  |             |             |
| Laminar stroms.     |          |          |            |         |         |          |          |         |            |          |           |             |             |
| Dendroid stroms.    |          | · (WH2)  | ● (WH3)    |         |         |          |          |         |            |          |           |             |             |
| Stachyodes          |          |          |            |         |         |          |          |         |            |          |           |             |             |
| Amphipora           |          |          |            |         |         |          |          | · (WH8) |            | · (WH10) |           | · (WH12)    | · (WH13)    |
| Colonial corals     |          |          |            |         |         |          |          |         |            |          |           |             |             |
| Solitary corals     |          |          |            |         |         |          |          |         |            |          |           |             |             |
| Thamnoporoids       |          |          |            |         |         |          |          |         |            |          |           |             |             |
| Bivalves            |          |          | · (WH3)    |         |         |          |          |         |            |          |           |             |             |
| Gastropods          |          |          |            |         |         |          |          |         |            |          |           |             |             |
| Shell hash          |          |          |            |         |         |          |          |         |            |          |           |             |             |
| Brachiopods         |          |          |            |         |         |          |          |         |            |          |           |             |             |
| Brachiopod spines   |          |          |            |         |         |          |          |         |            |          |           |             |             |
| Crinoids            |          |          |            |         |         |          |          |         |            |          |           |             |             |
| Tentaculites        |          |          |            |         |         |          |          |         |            |          |           |             |             |
| Trilobites          |          |          |            |         |         |          |          |         |            |          |           |             |             |
| Bryozoans           |          |          |            |         |         |          |          |         |            |          |           |             |             |
| Ostrocodes          |          | · (WH2)  | · (WH3)    | ○ (WH4) |         |          |          | ● (WH8) |            | · (WH10) |           | · (WH12)    | · (WH13)    |
| Leperditia          |          |          |            |         |         |          |          |         |            |          |           |             |             |
| Calcispheres        |          | · (WH2)  |            |         |         |          |          |         |            |          |           |             |             |
| Forams              |          | · (WH2)  | ● (WH3)    | ○ (WH4) |         |          |          | ○ (WH8) | · (WH9)    | · (WH10) |           |             | · (WH13)    |
| Sponge spicules     |          |          |            |         |         |          |          |         |            |          |           |             |             |
| Umbellids           |          |          | ● (WH3)    | · (WH4) |         |          |          |         |            |          |           | · (WH12)    |             |
| Undetermined        |          |          |            |         |         |          |          |         |            |          |           |             |             |
| Codiaceans          |          |          |            |         |         |          |          |         |            |          |           |             | ○ (WH13)    |
| Dasycladaceans      |          | ● (WH2)  |            | * (WH4) |         |          |          | * (WH8) |            | * (WH10) |           | * (WH12)    | ● (WH13)    |
| Girvanella Gp.      |          |          |            |         | * (WH5) |          |          |         |            |          |           |             |             |
| Renalcis Gp.        |          |          |            |         |         |          |          |         |            |          |           |             |             |
| Hedstroemia Gp.     |          |          |            |         |         |          |          |         |            |          |           |             |             |
| Wetheredella Gp.    |          |          | · (WH3)    |         |         |          |          |         |            |          |           |             |             |
| Matrix              |          | M (WH2)  | M,Ms (WH3) | M (WH4) |         |          |          | M (WH8) | M,Ms (WH9) | M (WH10) |           | M,Ms (WH12) | M,Ms (WH13) |
| Bioturbation        |          | ✓ (WH2)  | ✓ (WH3)    | ✓ (WH4) |         |          |          | ✓ (WH8) |            | ✓ (WH10) |           | ✓ (WH12)    | ✓ (WH13)    |
| Micrite envelope    |          |          | ✓ (WH3)    |         |         |          |          |         |            |          |           |             |             |
| Fenestrae: Tubular  |          |          |            |         |         |          |          | ✓ (WH8) |            |          |           |             |             |
| Laminoid/irregular  |          | ✓ (WH2)  |            |         | ✓ (WH5) |          |          | ✓ (WH8) |            |          |           |             |             |
| Geopetals           |          | ✓ (WH2)  |            |         |         |          |          |         |            |          |           |             |             |
| Gravity cements     |          |          |            |         |         |          |          |         |            |          |           |             |             |
| Lamination          |          |          |            |         |         |          |          |         |            |          |           |             |             |
| Others              | *1 (WH1) | *2 (WH2) | *3 (WH3)   |         |         | *1 (WH6) | *1 (WH7) |         | *4 (WH9)   |          | *1 (WH11) |             |             |

- \*1 Thin section cut through bulbous stromatoporoid  
 \*2 Fine-grained internal sediment at base of fenestrae  
 \*3 Sample of matrix  
 \*4 Pseudomorphs of anhydrite

|         |  |
|---------|--|
| Texture | M=Mudstone, W=Wackestone, P=Packstone<br>G=Grainstone, F=Floatstone, Bf= Bafflestone<br>Bi=Bindstone, B=Boundstone, D=Dolomite |
| Matrix  | M=Micrite, Ms=Microspar, S=Spar, D=Dolomite  |

## A1.2.28 Walheim Southern Limb

○ = <1%    • = 1–20%    ● = 21–40%    ● = 41–60%    \* = >61%

| Sample number       | WSL1 | WSL2 | WSL3 | WSL4 | WSL5 | WSL6  | WSL7 | WSL8 | WSL9  | WSL10 | WSL11  | WSL12 | WSL13 |
|---------------------|------|------|------|------|------|-------|------|------|-------|-------|--------|-------|-------|
| Height              | 0.5m | 1.6m | 4.6m | 5.3m | 7.8m | 8.05m | 8.4m | 9.3m | 11.5m | 11.8m | 12.35m | 14.2m | 15.1m |
| Thin Section/ Peel  | TS   | TS   | TS   | TS   | TS   | TS    | TS   | TS   | TS    | TS    | TS     | TS    | TS    |
| Microfacies         | S7a  | -    | -    | -    | S10  | S6b   | S7a  | S8c  | S6c   | S10   | S12-2  | S7a   | S6d   |
| Texture             | G    | D    | D    | D    | G    | M     | G    | G    | G     | G     | MG     | G     | W     |
| Grains:             |      |      |      |      |      |       |      |      |       |       |        |       |       |
| Peloids             | ●    |      |      |      | ●    |       | ●    | ●    | ●     | ●     | ●      | ●     |       |
| Lithoclasts         | •    |      |      |      |      |       | •    |      |       |       |        |       |       |
| Oncoids             |      |      |      |      |      |       | •    |      |       |       |        |       | ●     |
| Ooids               |      |      |      |      |      |       |      |      |       |       |        |       |       |
| Aggregate grains    |      |      |      |      |      |       |      |      |       |       |        |       |       |
| Quartz/ silt grains |      |      |      |      |      |       |      |      |       |       |        |       |       |
| Bioclasts:          |      |      |      |      |      |       |      |      |       |       |        |       |       |
| Bulbous stroms.     |      |      |      |      |      |       |      |      |       |       |        |       |       |
| Laminar stroms.     |      |      |      |      |      |       |      |      |       |       |        |       |       |
| Dendroid stroms.    |      |      |      |      |      |       |      |      |       |       |        |       |       |
| Stachyodes          |      |      |      |      |      |       |      |      |       |       | ●      |       |       |
| Amphipora           |      |      |      |      |      |       |      |      |       |       | •      |       | •     |
| Colonial corals     |      |      |      |      |      |       |      |      |       |       |        |       |       |
| Solitary corals     |      |      |      |      |      |       |      |      |       |       |        |       |       |
| Thamnoporoids       |      |      |      |      |      |       |      |      |       |       |        |       |       |
| Bivalves            |      |      |      |      |      |       | •    |      |       |       |        |       |       |
| Gastropods          |      |      |      |      |      |       |      |      |       |       |        |       |       |
| Shell hash          |      |      |      |      |      |       |      |      |       |       |        |       |       |
| Brachiopods         |      |      |      |      |      |       | ○    |      |       |       |        |       |       |
| Brachiopod spines   |      |      |      |      |      |       |      |      |       |       |        |       |       |
| Crinoids            |      |      |      |      |      |       | •    |      |       |       |        |       |       |
| Tentaculites        |      |      |      |      |      |       |      |      |       |       |        |       |       |
| Trilobites          |      |      |      |      |      |       |      |      |       |       |        |       |       |
| Bryozoans           |      |      |      |      |      |       |      |      |       |       |        |       |       |
| Ostrocodes          | •    |      |      |      | •    | ●     | •    | ○    | ○     | ○     | •      | ○     | ●     |
| Leperditia          |      |      |      |      |      |       |      |      |       |       |        |       |       |
| Calcispheres        | •    |      |      |      |      | •     |      |      | ○     | ○     |        |       | •     |
| Forams              | •    |      |      |      | •    | •     |      |      |       |       | ○      |       |       |
| Sponge spicules     |      |      |      |      |      |       |      |      | •     |       |        |       |       |
| Umbellids           |      |      |      |      |      |       |      |      |       |       |        |       |       |
| Undetermined        |      |      |      |      |      |       |      |      |       |       |        |       |       |
| Codiaceans          |      |      |      |      |      |       | •    |      |       |       |        |       |       |
| Dasycladaceans      |      |      |      |      |      |       |      |      |       |       |        |       |       |
| Girvanella Gp.      |      |      |      |      | •    |       |      |      |       |       |        |       |       |
| Renalcis Gp.        |      |      |      |      |      |       |      |      | •     |       |        |       |       |
| Hedstroemia Gp.     |      |      |      |      |      |       |      |      |       |       |        |       |       |
| Wetheredella Gp.    |      |      |      |      |      |       |      |      |       |       |        |       |       |
| Matrix              | S,M  |      |      |      | S,M  | M     | S    | S    | M,S   | S     | S      | M,S   | M     |
| Bioturbation        |      |      |      |      |      |       |      |      | ✓     |       |        | ✓     | ✓     |
| Micrite envelope    |      |      |      |      |      |       | ✓    |      |       |       | ✓      |       |       |
| Fenestrae: Tubular  |      |      |      |      | ✓    |       |      | ✓    | ✓     |       |        |       |       |
| Laminoid/irregular  |      |      |      |      | ✓    |       |      | ✓    |       | ✓     |        |       |       |
| Geopetals           |      |      |      |      |      |       |      |      |       |       |        |       |       |
| Gravity cements     |      |      |      |      |      |       |      |      |       |       |        |       |       |
| Lamination          |      |      |      |      | ✓    |       |      |      |       | ✓     | ✓      |       |       |
| Others              |      | *1   | *1   | *1   |      | *2    |      | *3   |       |       | *4     |       |       |

\*1 Dolomite is fabric-destructive

\*2 Alignment of bioclasts parallel to bedding

\*3 Fill of fine-grained peloids in base of fenestrae

\*4 Transition from S12 to S2 facies

|         |  |
|---------|--|
| Texture | M=Mudstone, W=Wackestone, P=Packstone<br>G=Grainstone, F=Floatstone, Bf= Bafflestone<br>Bi=Bindstone, B=Boundstone, D=Dolomite |
| Matrix  | M=Micrite, Ms=Microspar, S=Spar, D=Dolomite  |

## Walheim Southern Limb

○ = <1%    · = 1–20%    ● = 21–40%    ● = 41–60%    ★ = >61%

| Sample number       | WSL14 | WSL15 | WSL16  | WSL17 | WSL18  | WSL19 | WSL20 | WSL21 | WSL22 | WSL23  | WSL24  | WSL25 | WSL26 |
|---------------------|-------|-------|--------|-------|--------|-------|-------|-------|-------|--------|--------|-------|-------|
| Height              | 16.1m | 17.8m | 18.85m | 19.3m | 21.75m | 22.8m | 33.6m | 34.1m | 34.2m | 34.35m | 34.55m | 37.9m | 38.0m |
| Thin Section/ Peel  | TS    | TS    | TS     | TS    | TS     | TS    | TS    | TS    | TS    | TS     | TS     | TS    | TS    |
| Microfacies         | S6a   | S6b   | S6a    | S7a   | S6e    | S2    | S12a  | S8c   | S4a   | S2     | S8a    | S2    | R4c   |
| Texture             | W     | M     | WP     | G     | MG     | B     | PG    | G     | Bf    | P      | M      | G     | G     |
| Grains:             |       |       |        |       |        |       |       |       |       |        |        |       |       |
| Peloids             |       |       | ★      | ★     | ●      |       | ★     | ★     | ·     |        |        | ·     | ·     |
| Lithoclasts         |       |       | ○      | ●     |        |       |       |       |       |        |        |       |       |
| Oncoids             |       |       |        |       |        |       |       |       | ●     |        |        |       |       |
| Ooids               |       |       |        |       |        |       |       |       |       |        |        |       |       |
| Aggregate grains    |       |       |        |       |        |       |       |       |       |        |        |       |       |
| Quartz/ silt grains |       |       |        |       |        |       |       |       |       |        |        |       |       |
| Bioclasts:          |       |       |        |       |        |       |       |       |       |        |        |       |       |
| Bulbous stroms.     |       |       |        |       |        | ★     |       |       |       |        |        |       |       |
| Laminar stroms.     |       |       |        |       |        |       |       |       |       |        |        |       |       |
| Dendroid stroms.    |       |       |        |       |        |       |       |       |       |        |        |       |       |
| Stachyodes          |       |       |        |       |        |       |       |       |       |        |        |       |       |
| Amphipora           | ·     |       | ·      |       |        |       | ·     |       |       | ★      |        |       | ·     |
| Colonial corals     |       |       |        |       |        |       |       |       |       |        |        |       |       |
| Solitary corals     |       |       |        |       |        |       |       |       |       |        |        |       |       |
| Thamnoporoids       |       |       |        |       |        |       |       |       |       |        |        |       |       |
| Bivalves            |       |       |        |       |        |       |       |       |       |        |        |       |       |
| Gastropods          |       |       |        |       |        |       |       |       |       |        |        |       | ·     |
| Shell hash          |       |       |        |       |        |       |       |       |       |        |        |       |       |
| Brachiopods         |       |       |        |       |        |       |       |       |       | ○      |        | ★     | ★     |
| Brachiopod spines   |       |       |        |       |        |       |       |       |       |        |        |       |       |
| Crinoids            |       |       |        |       |        |       |       |       |       |        |        |       |       |
| Tentaculites        |       |       |        |       |        |       |       |       |       |        |        |       |       |
| Trilobites          |       |       |        |       |        |       |       |       |       |        |        |       |       |
| Bryozoans           |       |       |        |       |        |       |       |       |       |        |        |       |       |
| Ostrocodes          | ·     | ·     |        | ·     | ●      |       |       | ○     | ·     |        | ●      |       |       |
| Leperditia          |       |       |        |       |        |       |       |       |       |        |        |       |       |
| Calcspheres         | ●     | ★     | ○      |       | ○      |       | ·     | ○     |       | ○      | ·      |       |       |
| Forams              |       |       |        |       |        |       |       |       | ·     |        |        | ○     |       |
| Sponge spicules     |       |       |        |       |        |       |       |       |       |        |        |       |       |
| Umbellids           |       |       |        |       |        |       |       |       |       |        |        |       |       |
| Undetermined        |       |       |        |       |        |       |       |       |       |        |        |       |       |
| Codiaceans          |       |       |        |       |        |       |       |       | ●     |        |        |       |       |
| Dasycladaceans      | ●     |       |        |       |        |       | ·     | ○     |       | ·      | ●      |       |       |
| Girvanella Gp.      |       |       |        |       |        |       |       |       |       |        |        |       |       |
| Renalcis Gp.        |       |       |        |       |        |       |       |       |       |        |        |       |       |
| Hedstroemia Gp.     |       |       |        |       |        |       |       |       |       |        |        |       |       |
| Wetheredella Gp.    |       |       |        |       |        |       |       |       |       | ○      |        |       |       |
| Matrix              | M,D   | M     | M,S    | S     | M,S    |       | S,M   | S,M   | M,S   | M      | M      | S,D   | S,M   |
| Bioturbation        | ✓     | ✓     | ✓      |       |        |       |       |       | ✓     |        |        |       |       |
| Micrite envelope    |       |       |        |       |        |       |       |       |       |        |        | ✓     | ✓     |
| Fenestrae: Tubular  |       |       |        |       |        |       |       | ✓     |       |        | ✓      |       |       |
| Laminoid/irregular  |       |       |        |       |        |       |       | ✓     |       |        | ✓      |       |       |
| Geopetals           |       |       |        |       |        |       |       | ✓     |       |        |        |       |       |
| Gravity cements     |       |       |        |       |        |       |       |       |       |        |        |       |       |
| Lamination          |       |       |        |       | ✓      |       | ✓     |       |       |        |        |       |       |
| Others              |       |       |        |       |        | *1    |       | *2    |       | *3     |        |       |       |

\*1 Thin section cut through bulbous stromatoporoid

\*2 Fenestrae filled with fine-grained peloids at base

\*3 Alignment of bioclasts parallel to bedding

|         |  |
|---------|--|
| Texture | M=Mudstone, W=Wackestone, P=Packstone<br>G=Grainstone, F=Floatstone, Bf= Bafflestone<br>Bi=Bindstone, B=Boundstone, D=Dolomite |
| Matrix  | M=Micrite, Ms=Microspar, S=Spar, D=Dolomite  |

## Walheim Southern Limb

○ = <1%      · = 1-20%      ● = 21-40%      ● = 41-60%      \* = >61%

| Sample number       | WSL27 |  |  |  |  |  |  |  |  |  |  |  |  |  |
|---------------------|-------|--|--|--|--|--|--|--|--|--|--|--|--|--|
| Height              | 38.8m |  |  |  |  |  |  |  |  |  |  |  |  |  |
| Thin Section/ Peel  | TS    |  |  |  |  |  |  |  |  |  |  |  |  |  |
| Microfacies         | R2    |  |  |  |  |  |  |  |  |  |  |  |  |  |
| Texture             | P     |  |  |  |  |  |  |  |  |  |  |  |  |  |
| Grains:             |       |  |  |  |  |  |  |  |  |  |  |  |  |  |
| Peloids             |       |  |  |  |  |  |  |  |  |  |  |  |  |  |
| Lithoclasts         |       |  |  |  |  |  |  |  |  |  |  |  |  |  |
| Oncoids             |       |  |  |  |  |  |  |  |  |  |  |  |  |  |
| Ooids               |       |  |  |  |  |  |  |  |  |  |  |  |  |  |
| Aggregate grains    |       |  |  |  |  |  |  |  |  |  |  |  |  |  |
| Quartz/ silt grains |       |  |  |  |  |  |  |  |  |  |  |  |  |  |
| Bioclasts:          |       |  |  |  |  |  |  |  |  |  |  |  |  |  |
| Bulbous stroms.     |       |  |  |  |  |  |  |  |  |  |  |  |  |  |
| Laminar stroms.     |       |  |  |  |  |  |  |  |  |  |  |  |  |  |
| Dendroid stroms.    |       |  |  |  |  |  |  |  |  |  |  |  |  |  |
| Stachyodes          |       |  |  |  |  |  |  |  |  |  |  |  |  |  |
| Amphipora           |       |  |  |  |  |  |  |  |  |  |  |  |  |  |
| Colonial corals     |       |  |  |  |  |  |  |  |  |  |  |  |  |  |
| Solitary corals     |       |  |  |  |  |  |  |  |  |  |  |  |  |  |
| Thamnoporoids       |       |  |  |  |  |  |  |  |  |  |  |  |  |  |
| Bivalves            | ·     |  |  |  |  |  |  |  |  |  |  |  |  |  |
| Gastropods          |       |  |  |  |  |  |  |  |  |  |  |  |  |  |
| Shell hash          |       |  |  |  |  |  |  |  |  |  |  |  |  |  |
| Brachiopods         | *1    |  |  |  |  |  |  |  |  |  |  |  |  |  |
| Brachiopod spines   | ·     |  |  |  |  |  |  |  |  |  |  |  |  |  |
| Crinoids            |       |  |  |  |  |  |  |  |  |  |  |  |  |  |
| Tentaculites        |       |  |  |  |  |  |  |  |  |  |  |  |  |  |
| Trilobites          |       |  |  |  |  |  |  |  |  |  |  |  |  |  |
| Bryozoans           |       |  |  |  |  |  |  |  |  |  |  |  |  |  |
| Ostrocodes          |       |  |  |  |  |  |  |  |  |  |  |  |  |  |
| Leperditia          |       |  |  |  |  |  |  |  |  |  |  |  |  |  |
| Calcispheres        |       |  |  |  |  |  |  |  |  |  |  |  |  |  |
| Forams              |       |  |  |  |  |  |  |  |  |  |  |  |  |  |
| Sponge spicules     |       |  |  |  |  |  |  |  |  |  |  |  |  |  |
| Umbellids           |       |  |  |  |  |  |  |  |  |  |  |  |  |  |
| Undetermined        |       |  |  |  |  |  |  |  |  |  |  |  |  |  |
| Codiaceans          |       |  |  |  |  |  |  |  |  |  |  |  |  |  |
| Dasycladaceans      |       |  |  |  |  |  |  |  |  |  |  |  |  |  |
| Girvanella Gp.      |       |  |  |  |  |  |  |  |  |  |  |  |  |  |
| Renalcis Gp.        |       |  |  |  |  |  |  |  |  |  |  |  |  |  |
| Hedstroemia Gp.     |       |  |  |  |  |  |  |  |  |  |  |  |  |  |
| Wetheredella Gp.    |       |  |  |  |  |  |  |  |  |  |  |  |  |  |
| Matrix              | D,M   |  |  |  |  |  |  |  |  |  |  |  |  |  |
| Bioturbation        |       |  |  |  |  |  |  |  |  |  |  |  |  |  |
| Micrite envelope    |       |  |  |  |  |  |  |  |  |  |  |  |  |  |
| Fenestrae: Tubular  |       |  |  |  |  |  |  |  |  |  |  |  |  |  |
| Laminoid/irregular  |       |  |  |  |  |  |  |  |  |  |  |  |  |  |
| Geopetals           |       |  |  |  |  |  |  |  |  |  |  |  |  |  |
| Gravity cements     |       |  |  |  |  |  |  |  |  |  |  |  |  |  |
| Lamination          |       |  |  |  |  |  |  |  |  |  |  |  |  |  |
| Others              | *1    |  |  |  |  |  |  |  |  |  |  |  |  |  |

\*1 Bioclasts aligned parallel to bedding

|         |  |
|---------|--|
| Texture | M=Mudstone, W=Wackestone, P=Packstone<br>G=Grainstone, F=Floatstone, Bf= Bafflestone<br>Bi=Bindstone, B=Boundstone, D=Dolomite |
| Matrix  | M=Micrite, Ms=Microspar, S=Spar, D=Dolomite  |

## ***APPENDIX TWO***

|   |            |
|---|------------|
| <b>A2. DETAILED SEDIMENTARY LOGS.....</b> | <b>365</b> |
| A2.1 ALT BREINIG QUARRY.....              | 366        |
| A2.2 BEAURAING QUARRY.....                | 368        |
| A2.3 BELLIGNIES BETTRECHIES QUARRY.....   | 372        |
| A2.4 BLEIWÄSCHE QUARRY.....               | 377        |
| A2.5 BLEIWÄSCHE ROAD CUTTING.....         | 381        |
| A2.6 BROADRIDGE WOOD QUARRY.....          | 382        |
| A2.7 CUL D'HOUILLE QUARRY.....            | 385        |
| A2.8 DOORBES QUARRY.....                  | 390        |
| A2.9 FRIOD LIEU QUARRY.....               | 393        |
| A2.10 GLAGEON QUARRY.....                 | 396        |
| A2.11 GOODRINGTON ROAD CUTTING.....       | 407        |
| A2.12 HANIELSFELD QUARRY.....             | 408        |
| A2.13 HEGGEN QUARRY.....                  | 409        |
| A2.14 KELDENICH QUARRY.....               | 418        |
| A2.15 LINHAY HILL QUARRY.....             | 420        |
| A2.16 MEDENBACH QUARRY.....               | 424        |
| A2.17 NISMES QUARRY.....                  | 427        |
| A2.18 OBERRÖDINGHAUSEN QUARRY.....        | 429        |
| A2.19 OLLOY-SUR-VIROIN QUARRY.....        | 435        |
| A2.20 RESTEIGNE QUARRY.....               | 439        |
| A2.21 RYDON QUARRY.....                   | 446        |
| A2.22 SCHMIDHOF QUARRY.....               | 448        |
| A2.23 SOURD D'AVE.....                    | 450        |
| A2.24 TEERSTRABENBAU QUARRY.....          | 453        |
| A2.25 VAUCELLES QUARRY.....               | 459        |
| A2.26 VEWEGEN QUARRY.....                 | 461        |
| A2.27 VOBBECK QUARRY.....                 | 462        |
| A2.28 WALHEIM SECTION 1.....              | 466        |
| A2.29 WALHEIM SECTION 2.....              | 468        |
| A2.30 WALHEIM SOUTHERN LIMB.....          | 472        |

## A2. Detailed sedimentary logs

The following Appendix presents detailed logs for the studied successions. Logs were drawn up at a 1:10 scale in the field, and are presented in this Appendix at a 1:55 scale. All grains present in the rock are recorded on the log (including thin-section information, where samples were collected), as are the sample number, rock texture (using Dunham (1962) and Embry and Klovan (1971) schemes), sedimentary structures, salient features, cyclicity and microfacies. Figure A2-1 presents a key for the logs.













































|   |  |   |
|---|--|---|
| <u>Stromatoporoids</u>  |  bivalves             | <u>Sedimentary structures</u>   |
|  small bulbous         |  gastropods           |  mud polygons                  |
|  large bulbous & domal |  crinoids             |  cross-bedding                 |
|  laminar               |  shell hash           |  planar lamination             |
|  dendroid              |  ostracodes           |  convolute lamination          |
|  amphiporoids         |  algae/cyanobacteria |  argillaceous horizons        |
| <u>Corals</u>   |  calcispheres       |  graded bedding              |
|  colonial            |  forams             |  laminar/irregular fenestrae |
|  thamnoporoids       | <u>Carbonate grains</u>  |  tubular fenestrae           |
|  solitary            |  peloids            |  bioturbation                |
| <u>Bioclasts</u>  |  ooids              |  calcrete                    |
|  stringocephalids    |  lithoclasts        |  stylolite                   |
|  brachiopods         |  mudchips           |  breccia                     |
|  bryozoans           |  oncoids            |  dolomite                    |
|  tentaculitids       |  aggregate grains   |  cycle top                   |
|  trilobites          |  microbial lumps    |  cycle base                  |
|   |  nodules            |  sample number               |

Figure A2-1 Key to symbols used in logs.

A2.1 Alt Breinig quarry



Alt Breinig quarry

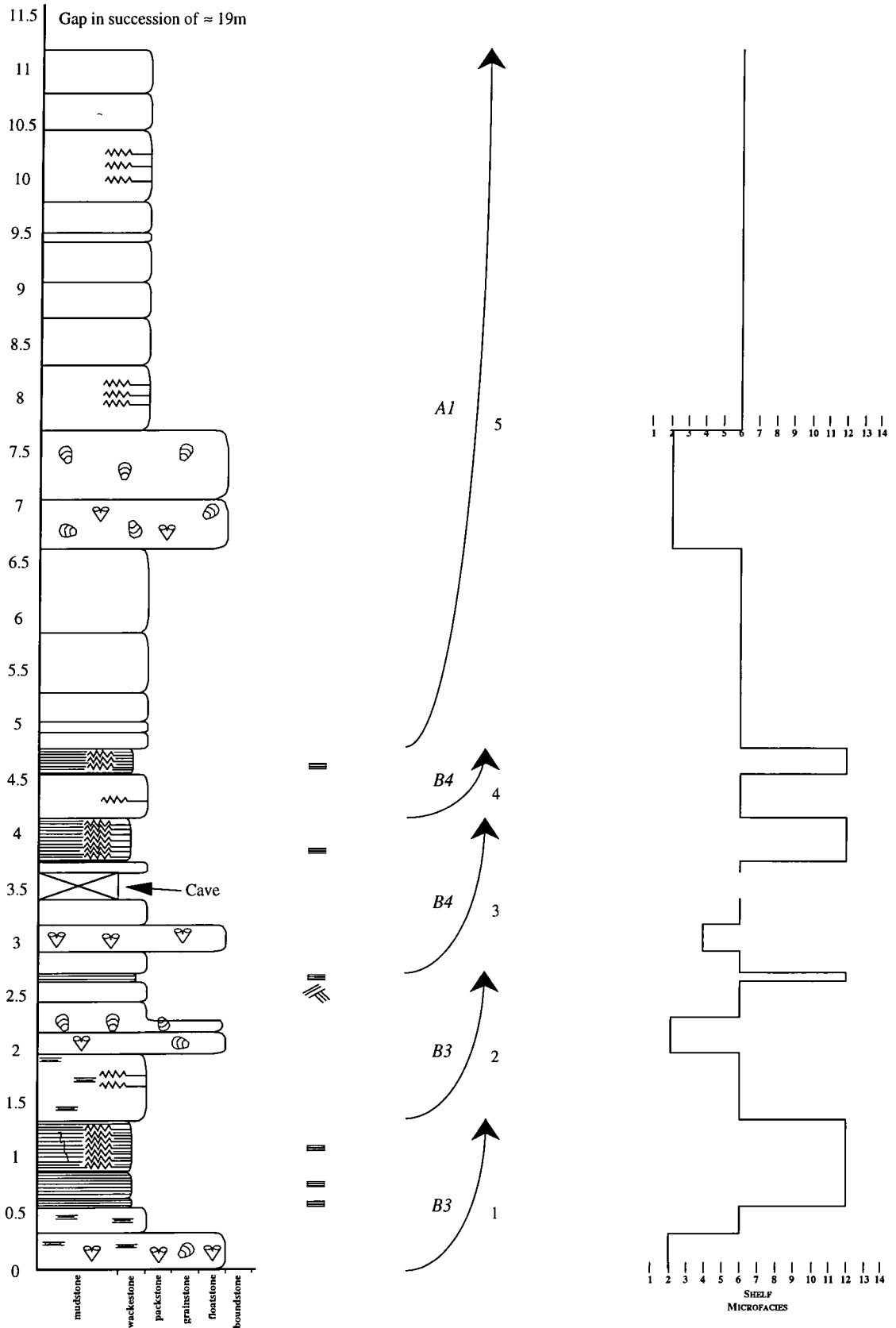
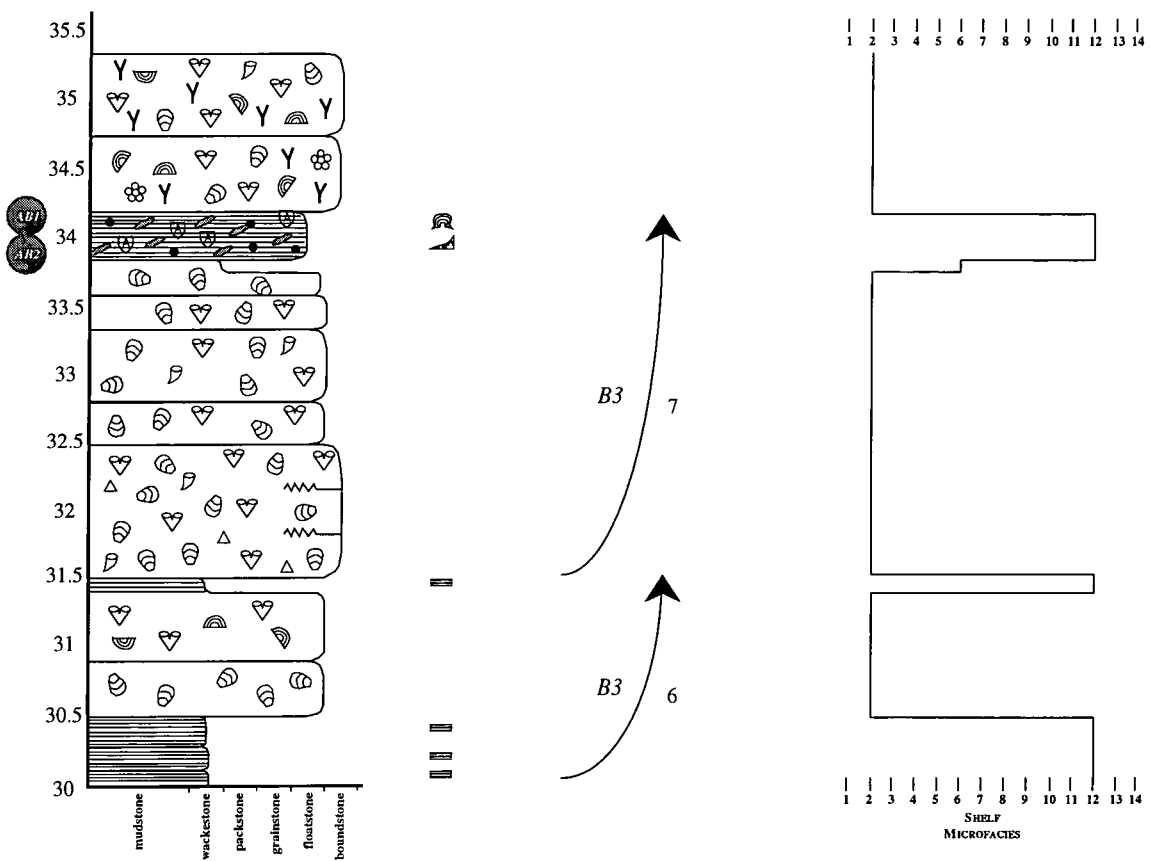

**A2.2 Beuraing quarry**

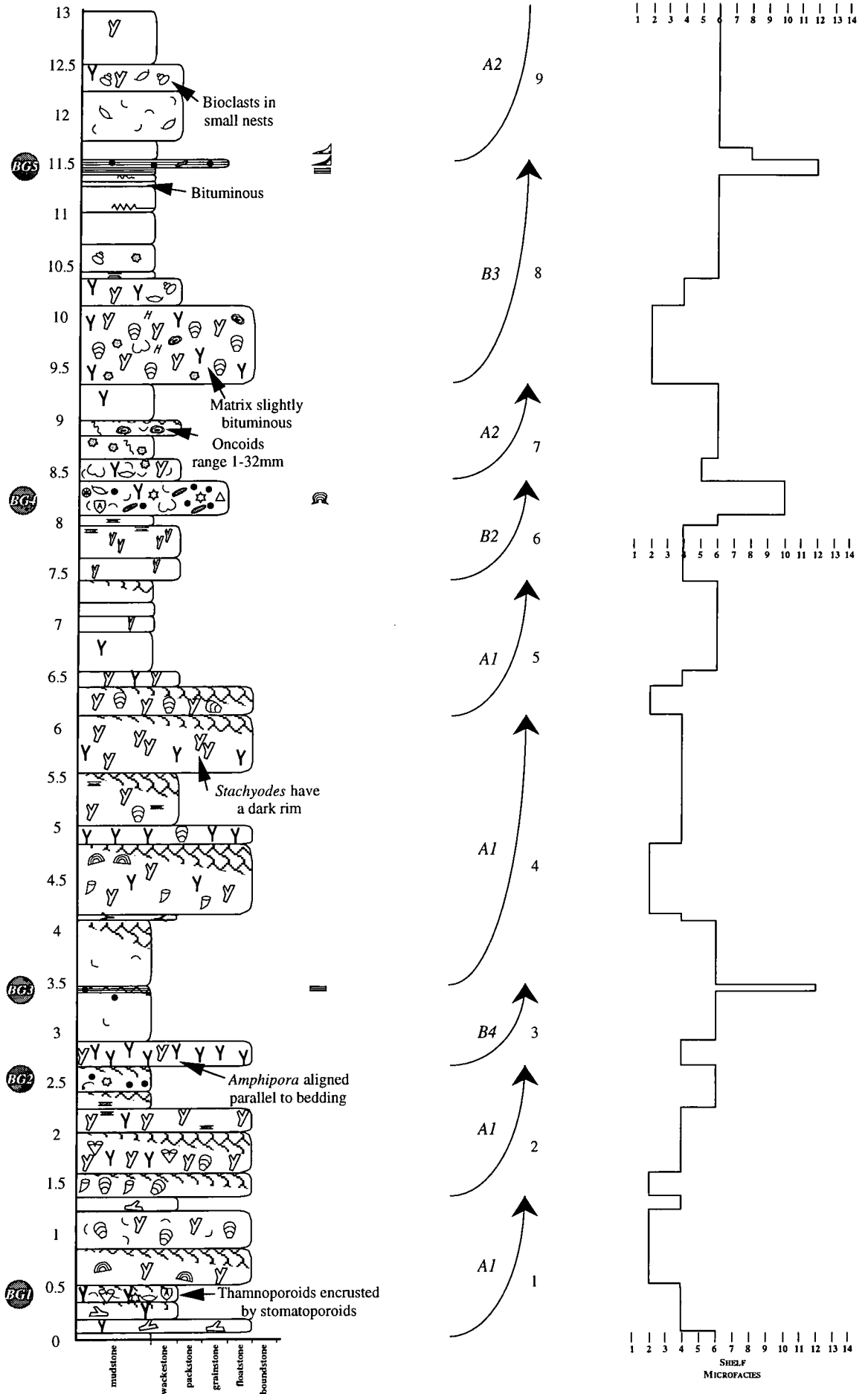

Beauraing quarry

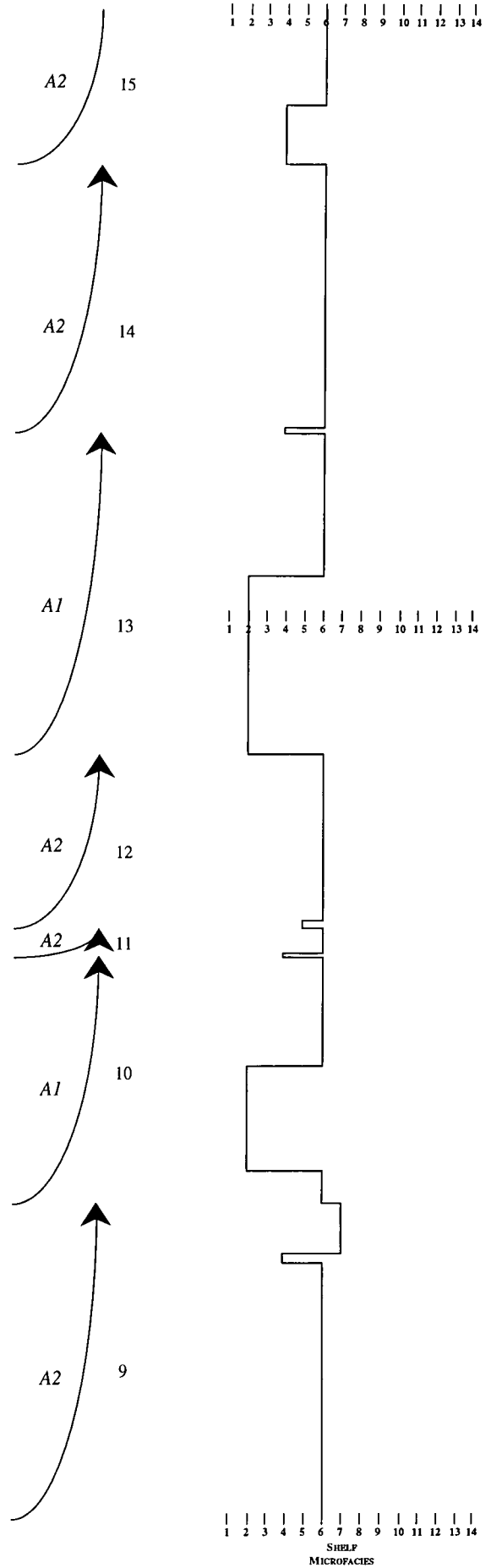
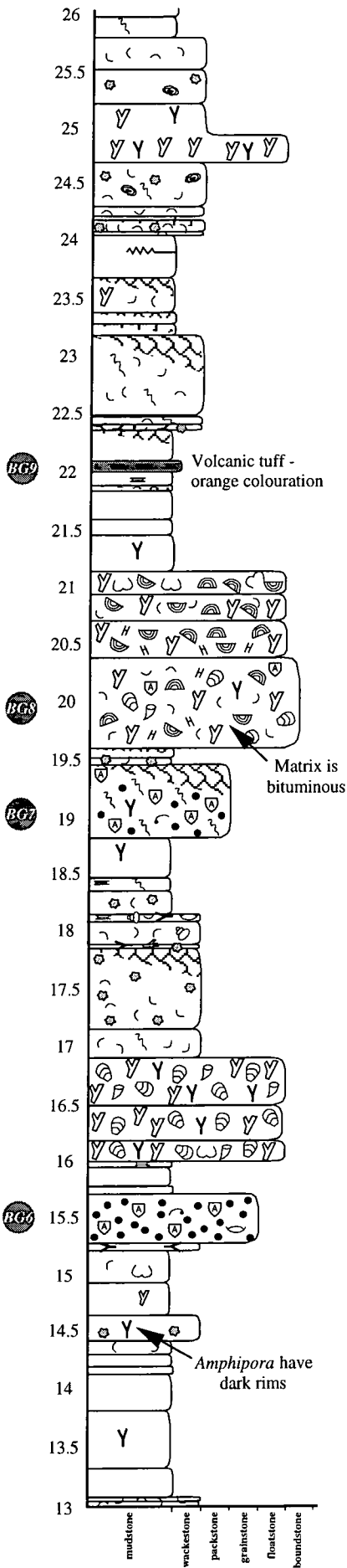

**Beauraing quarry**

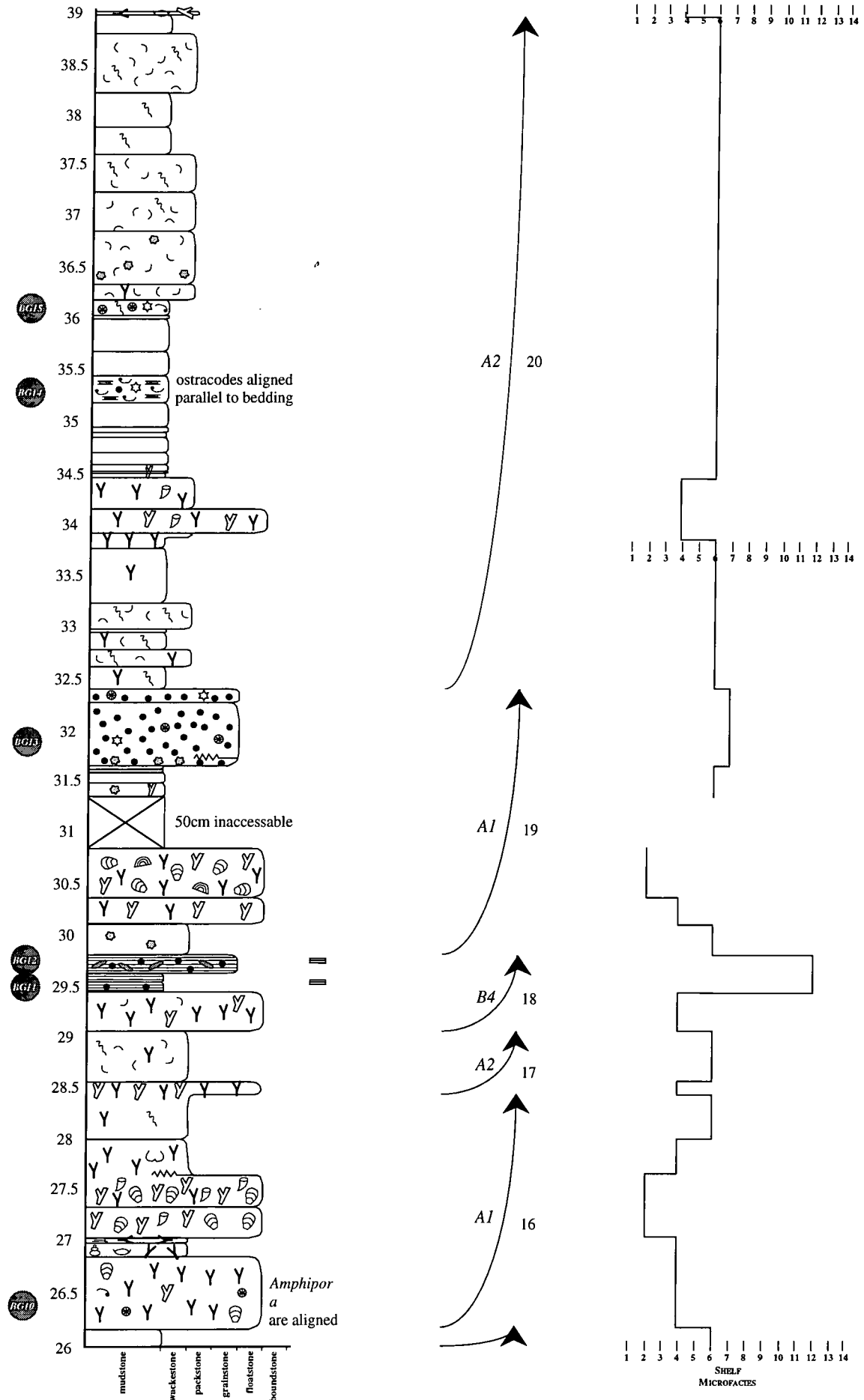

Beauraing quarry

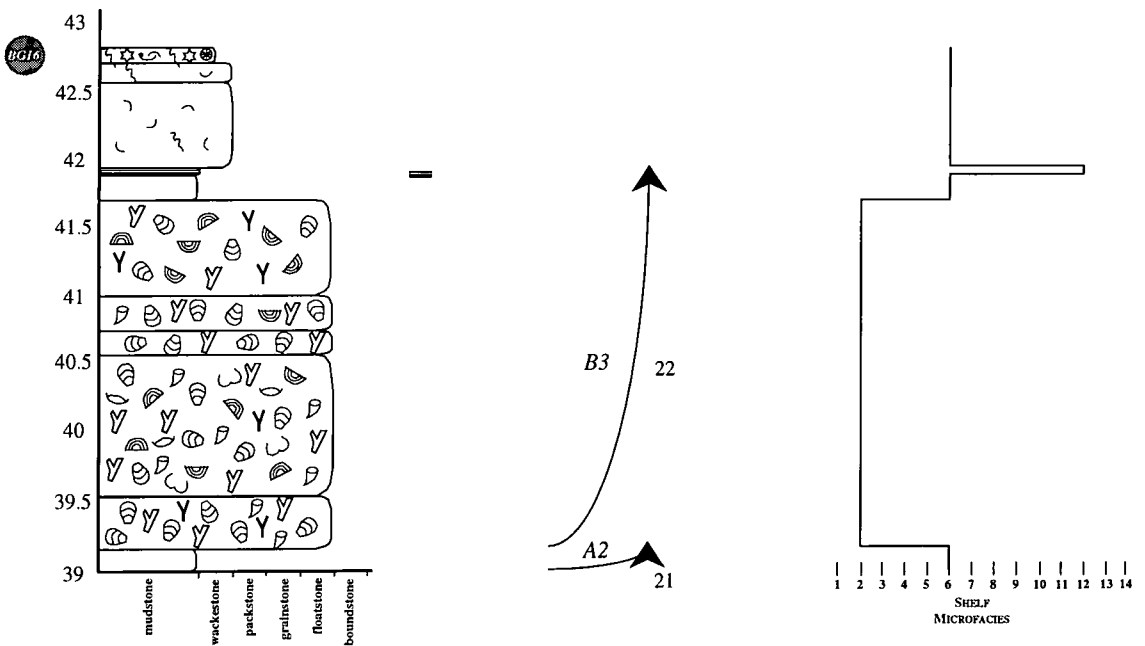

### A2.3 Bellignies-Bettrechies quarry

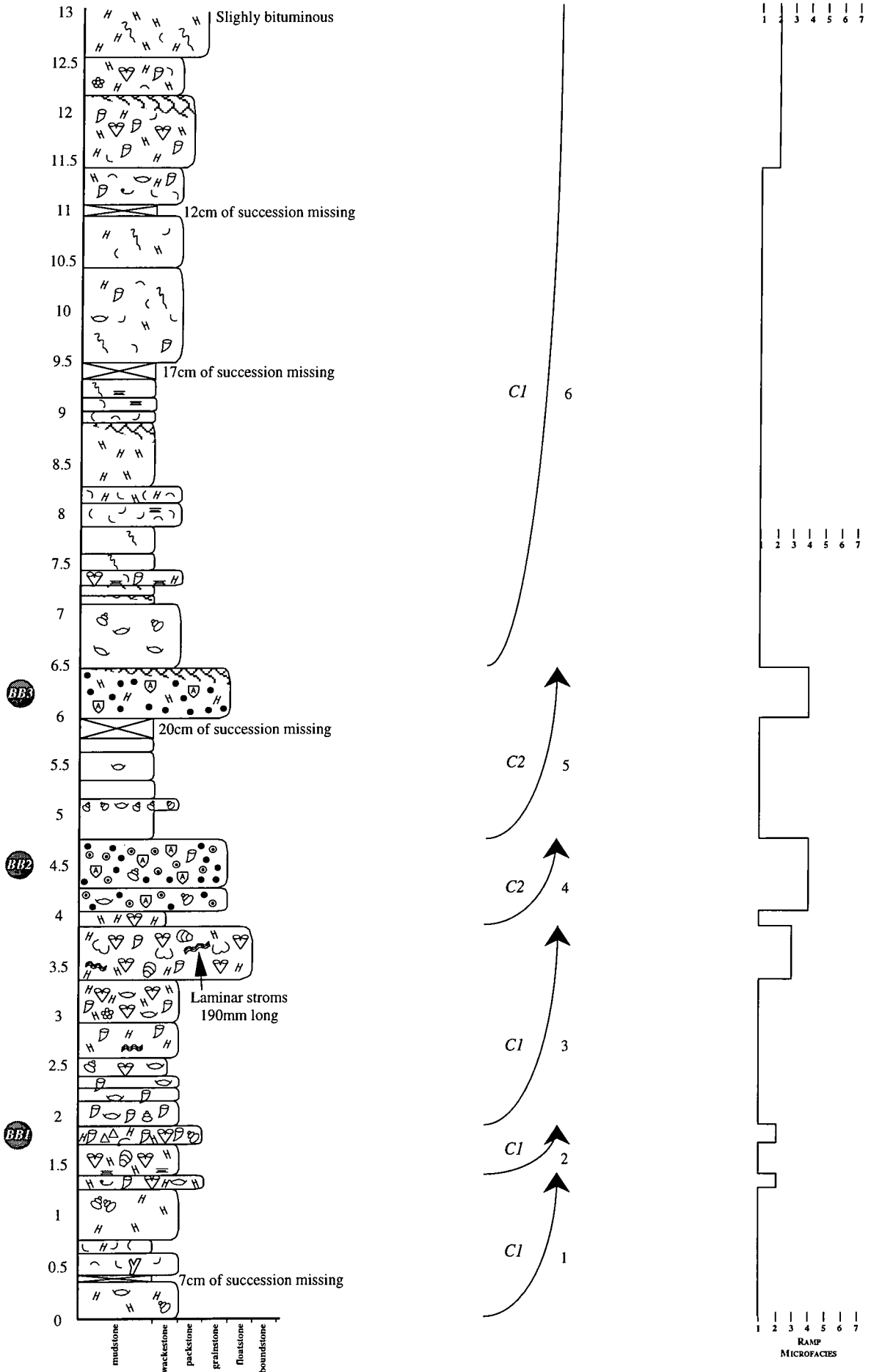

**Bellignies-Bettrechies quarry**

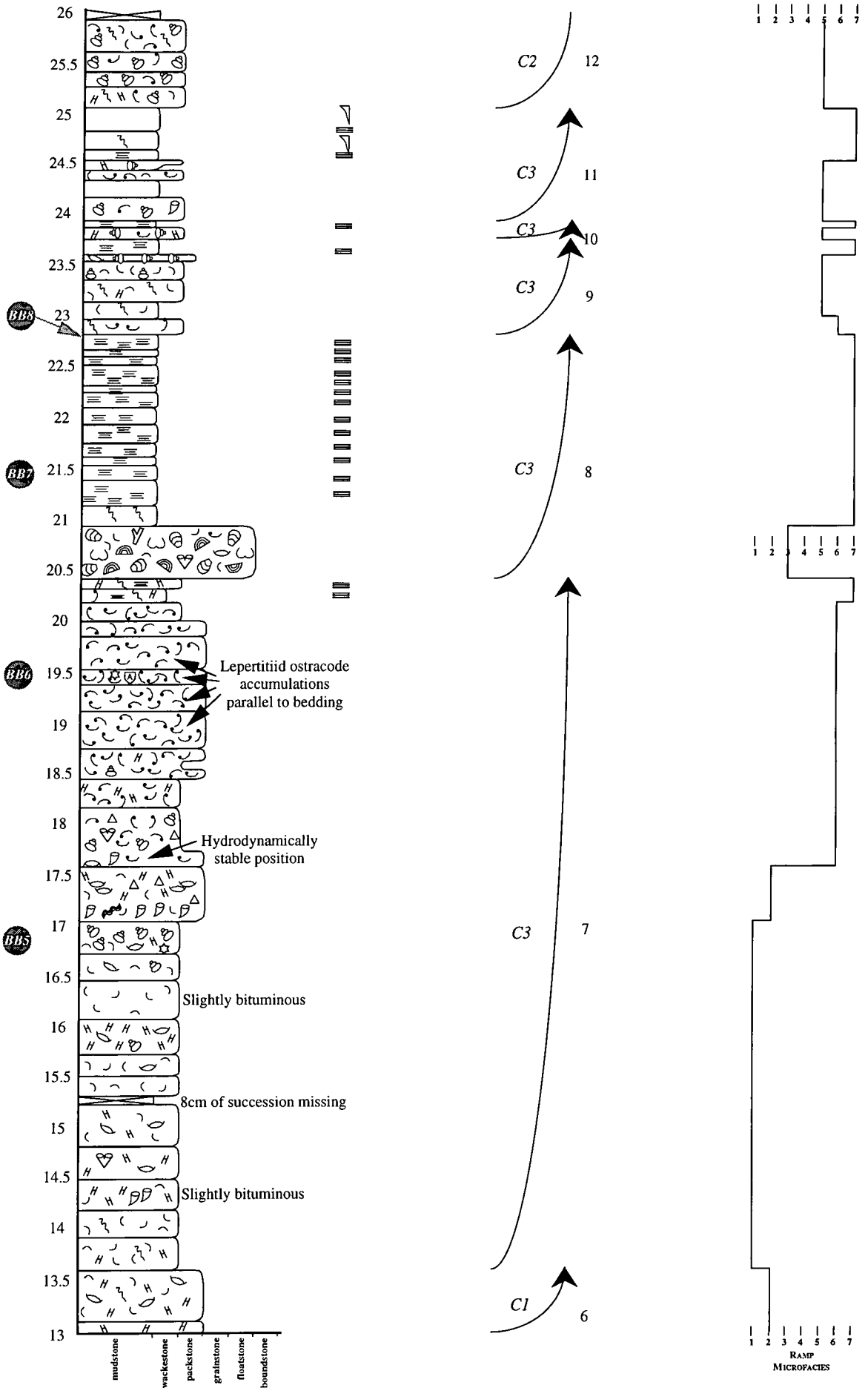

### Bellignies-Bettrechies quarry

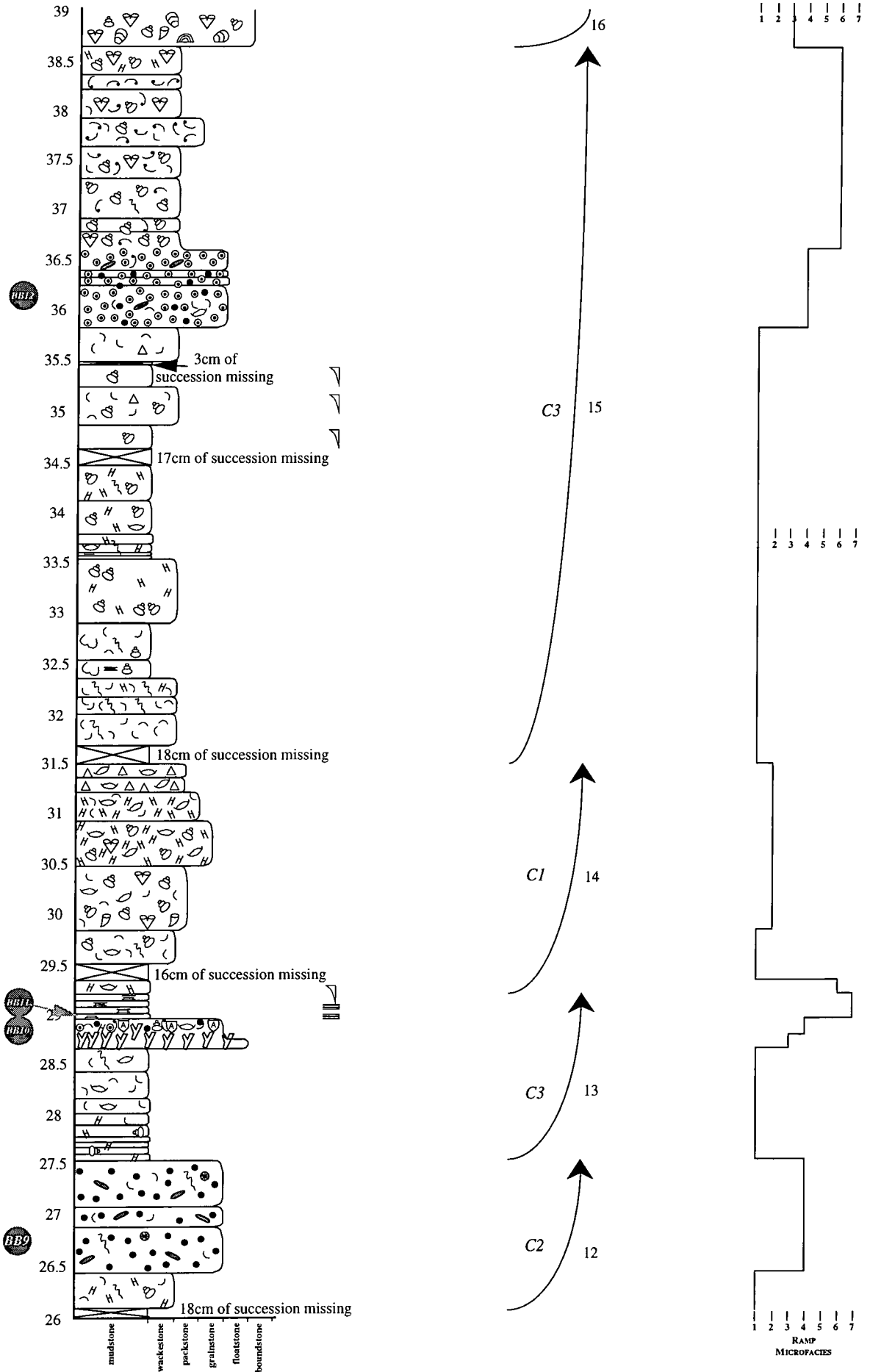

**Bellignies-Bettrechies quarry**

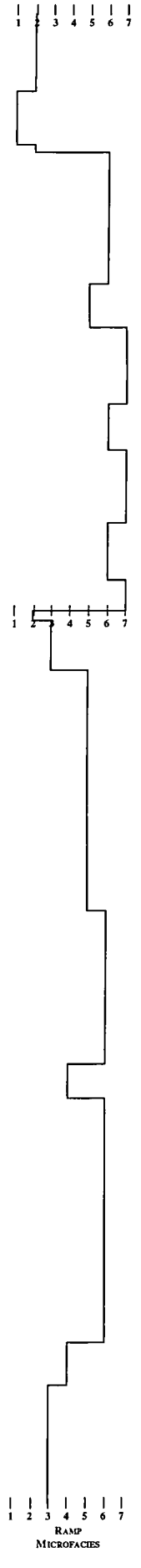
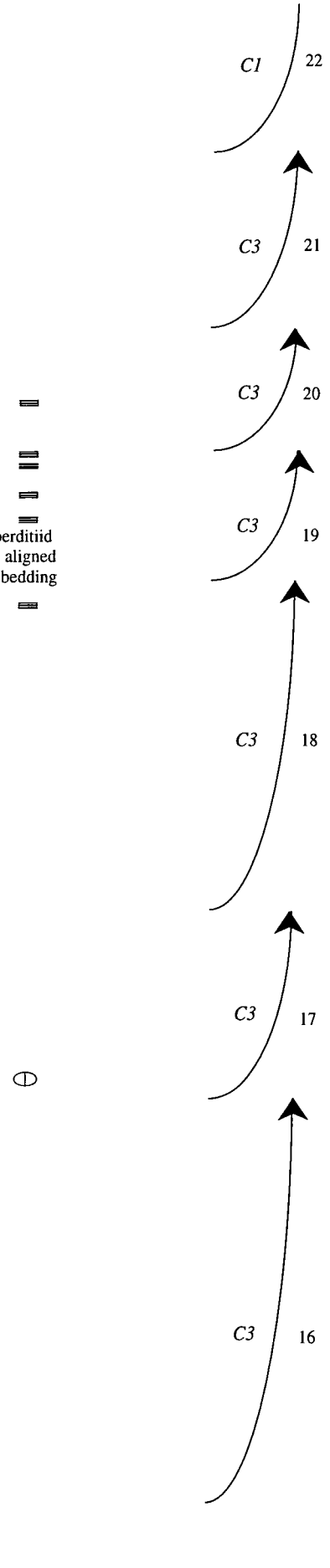
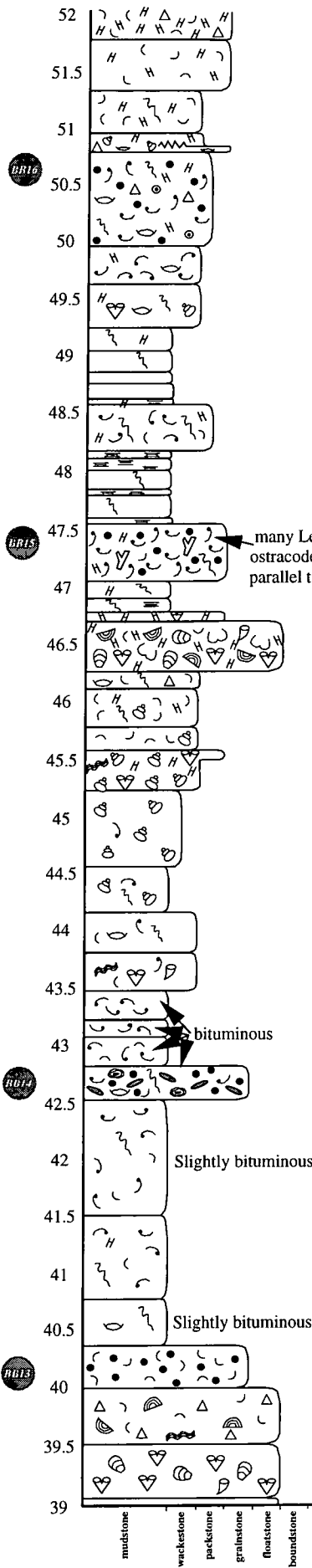

Bellignies-Bettrechies quarry

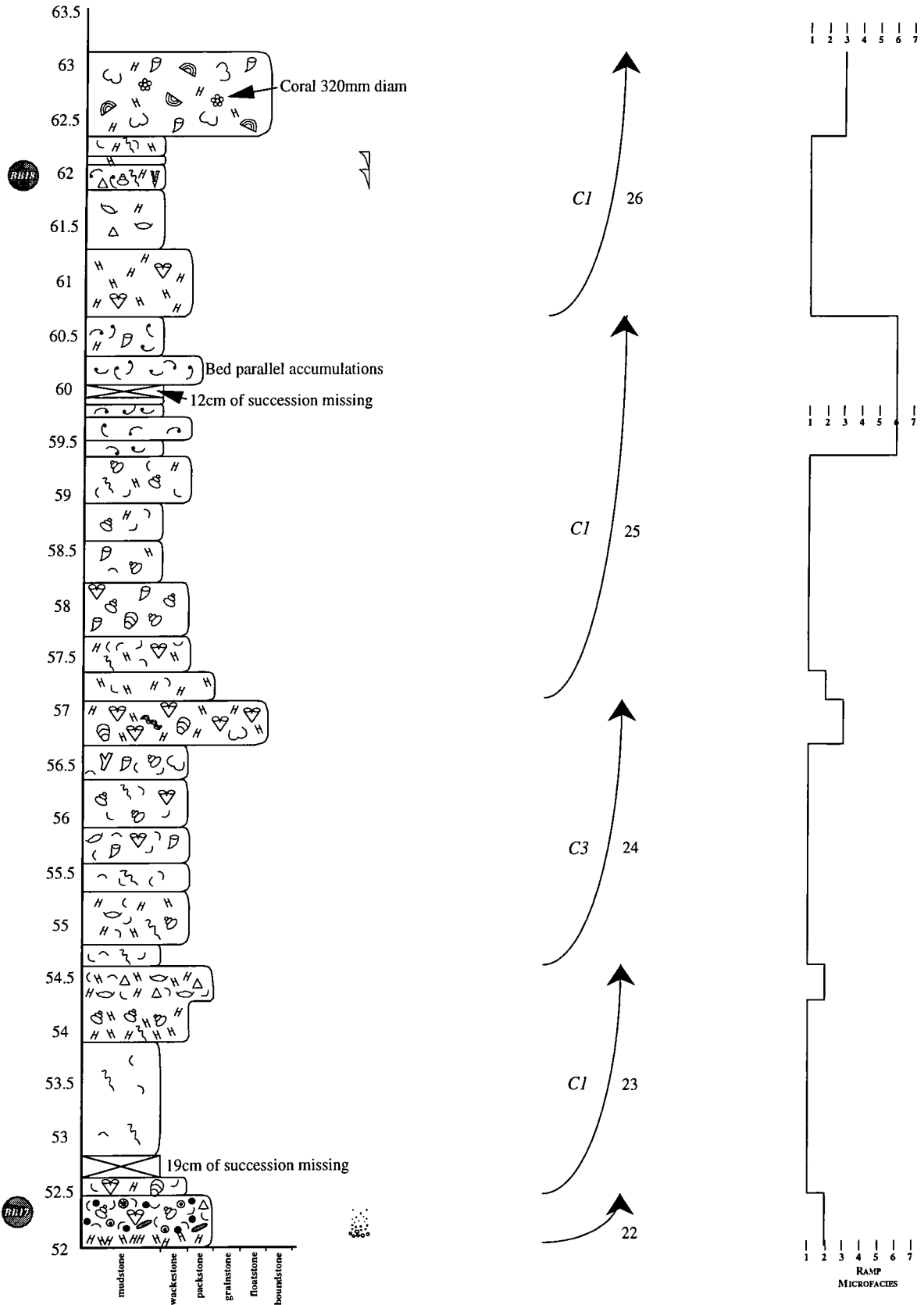

**A2.4 Bleiwäsche quarry**

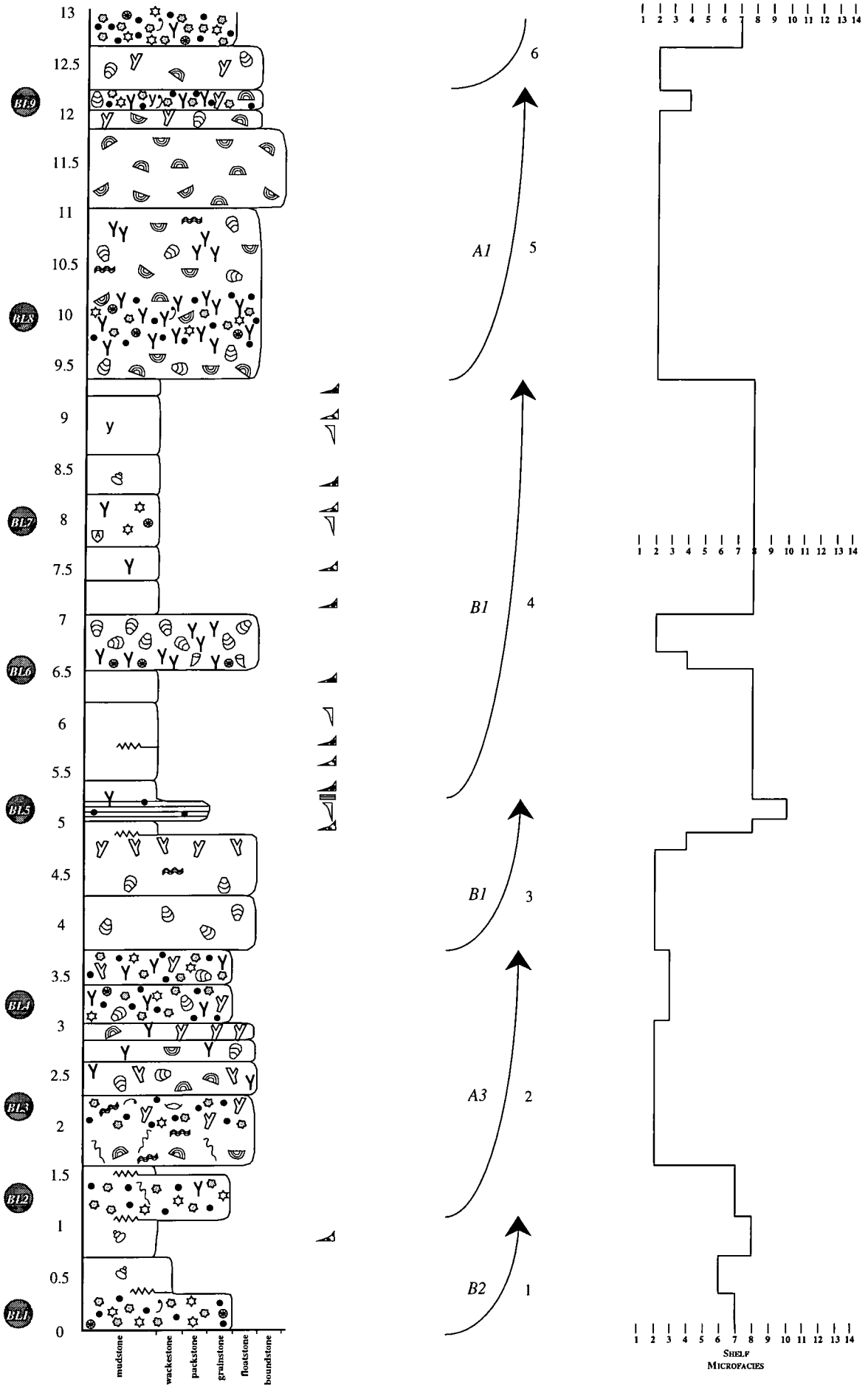

Bleiwäsche quarry

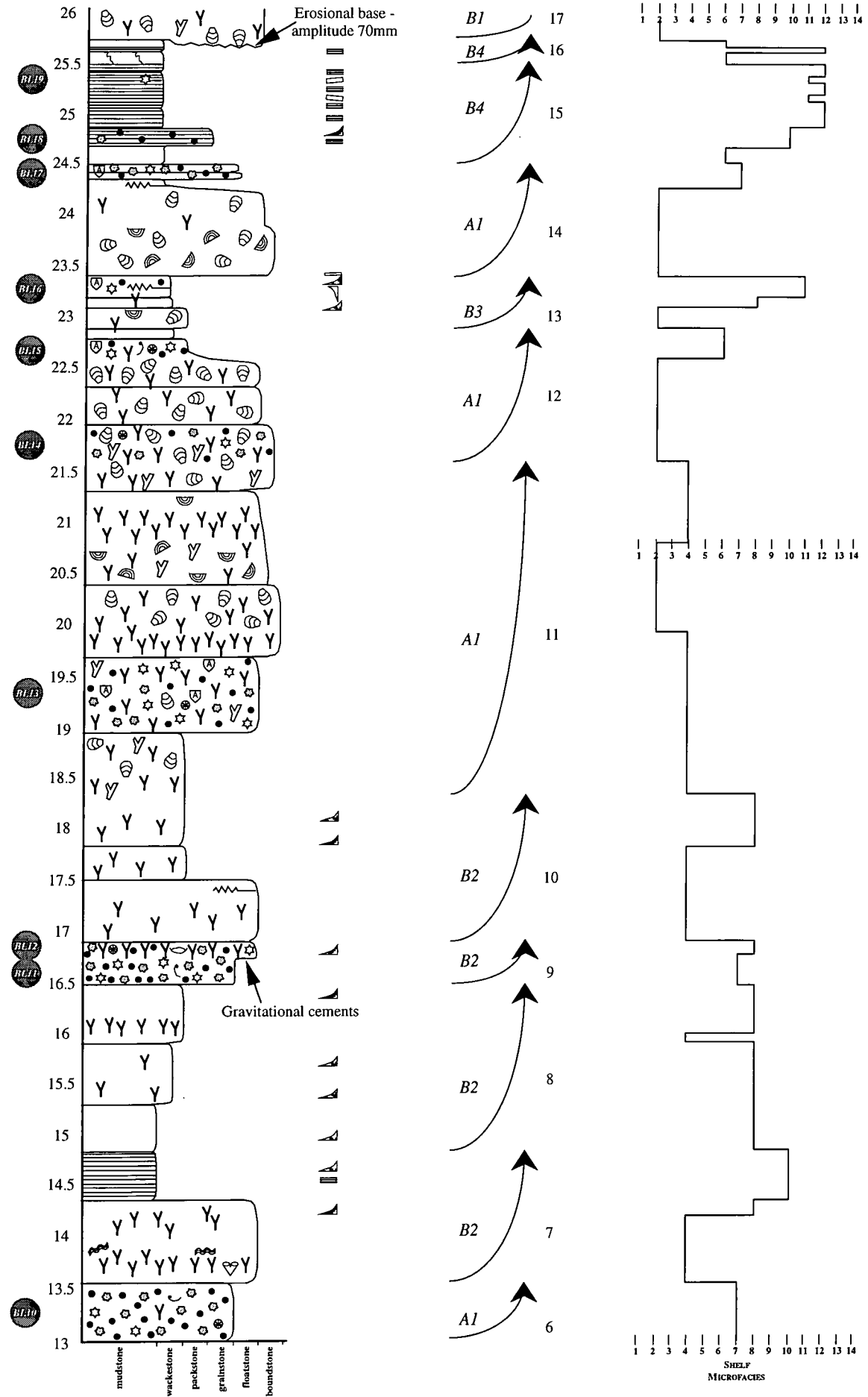

**Bleiwäsche quarry**

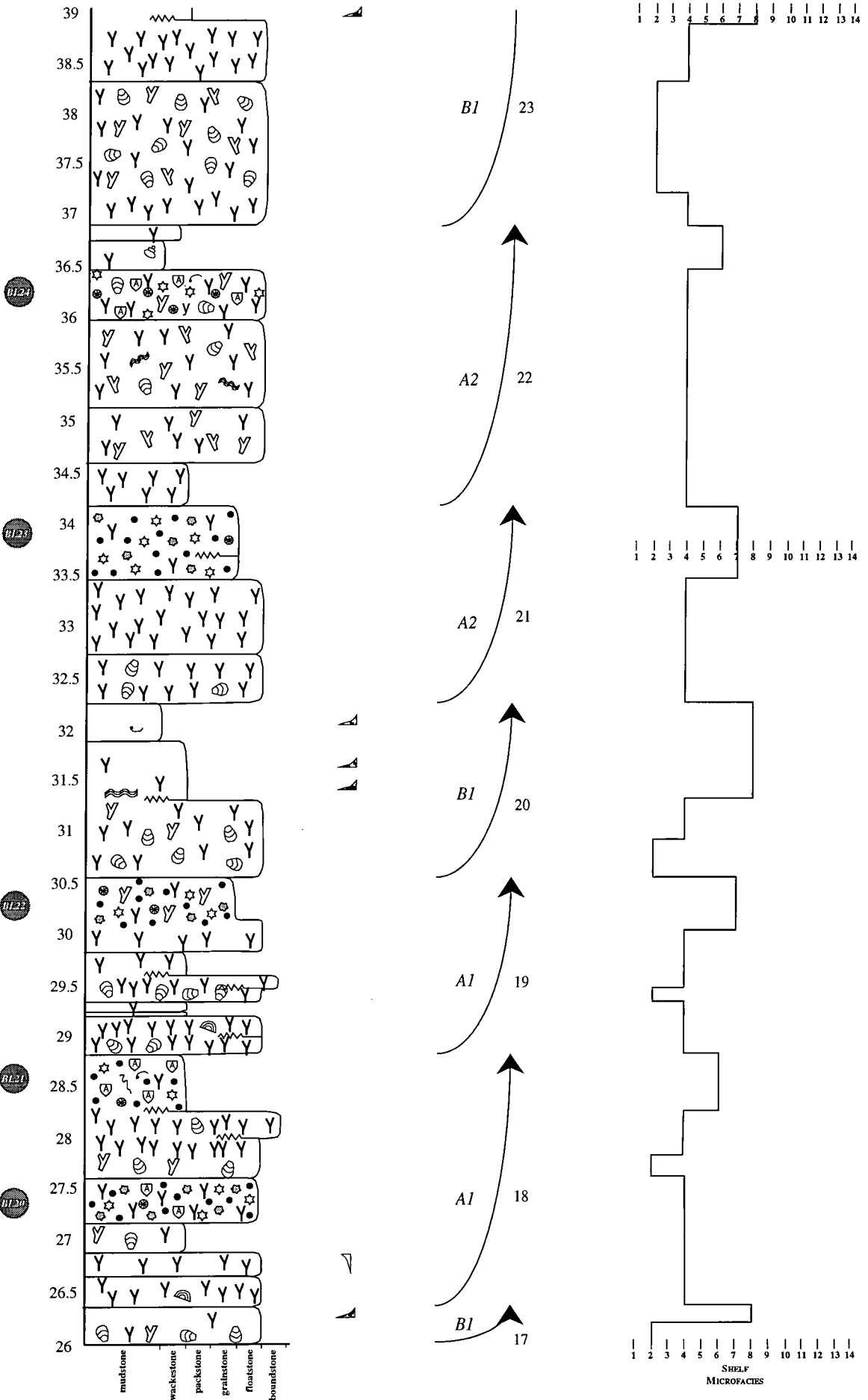

Bleiwäsche quarry

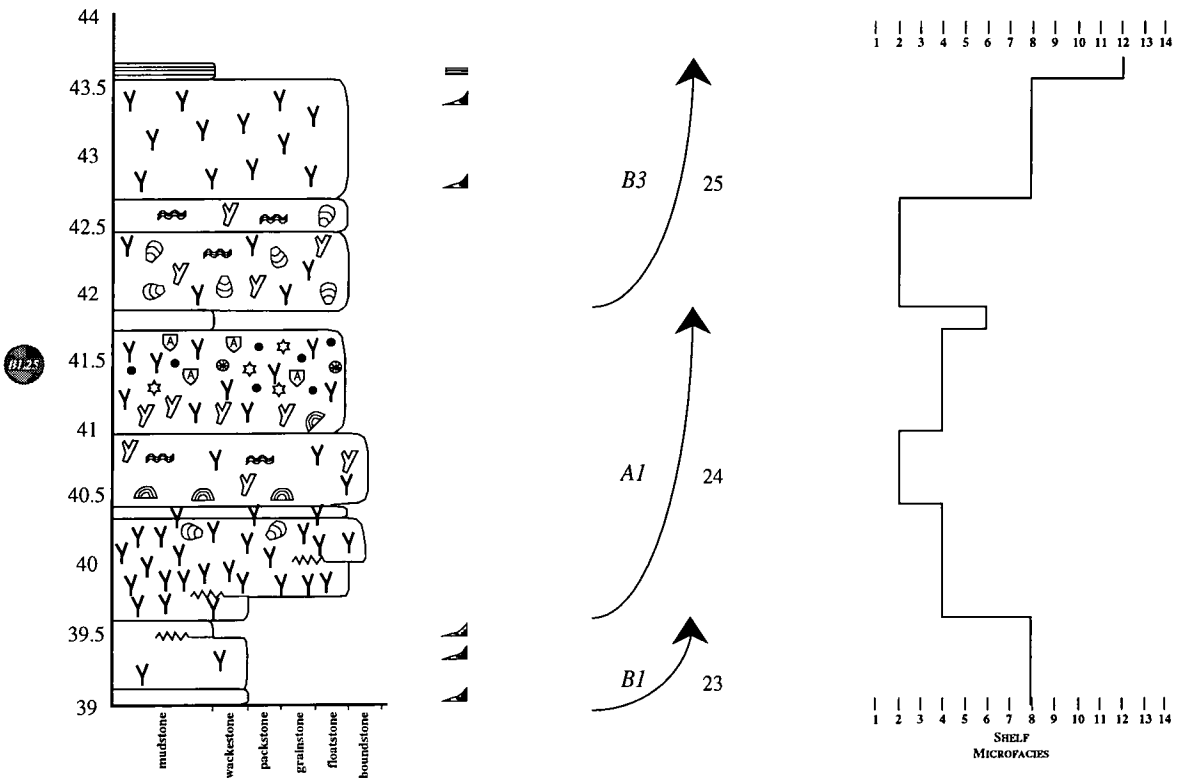

A2.5 Bleiwäsche Road Cutting

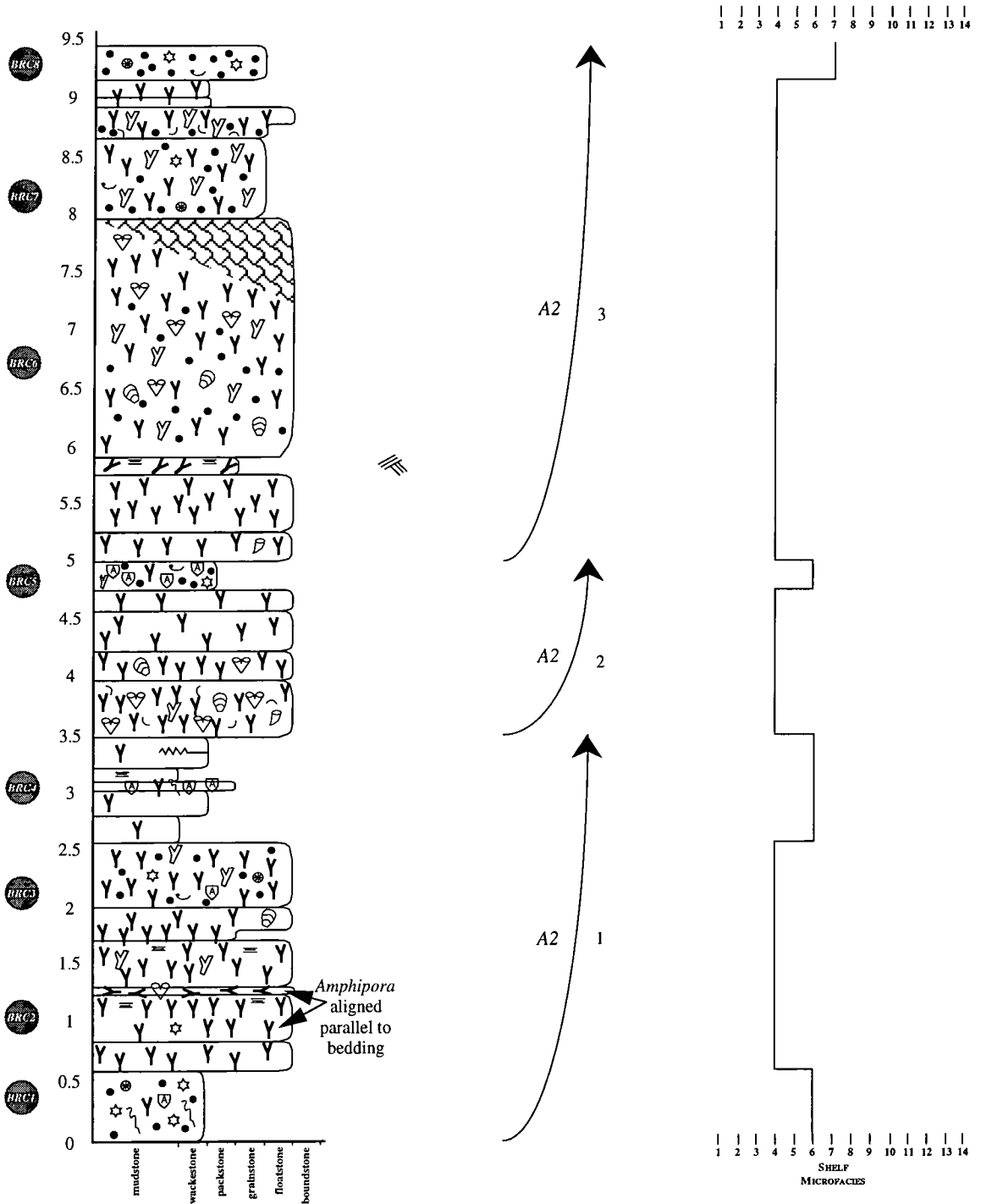

### A2.6 Broadridge Wood quarry

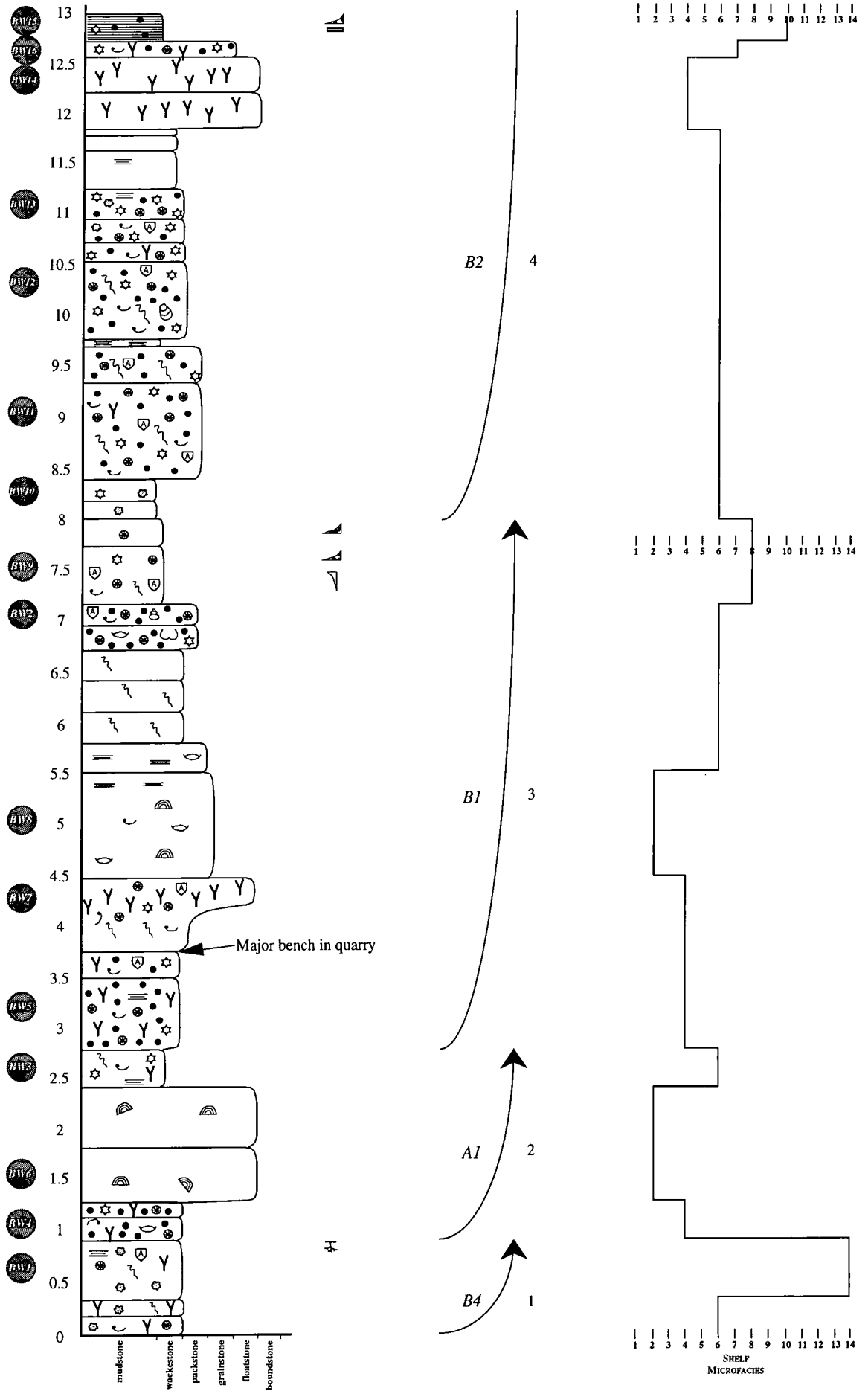

**Broadridge Wood quarry**

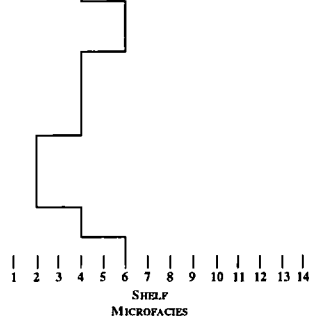
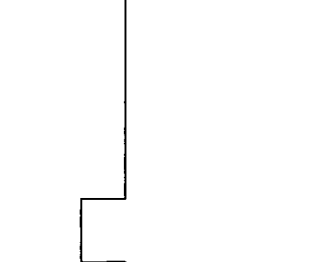
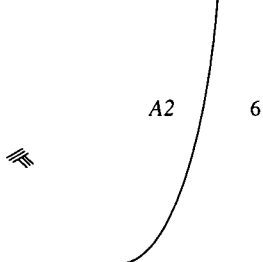
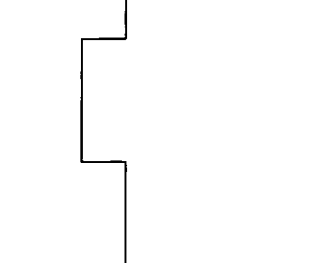
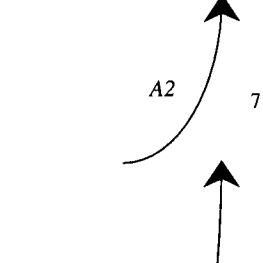
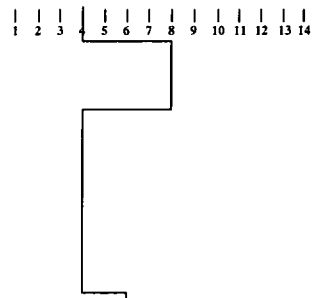
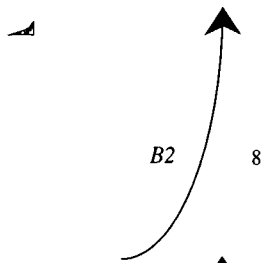
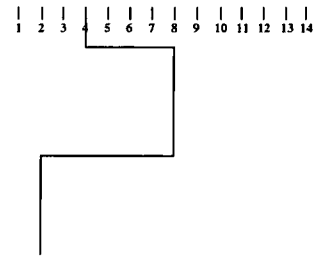
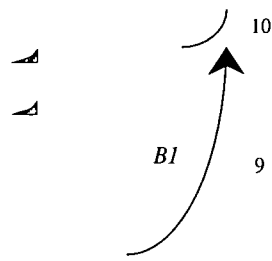
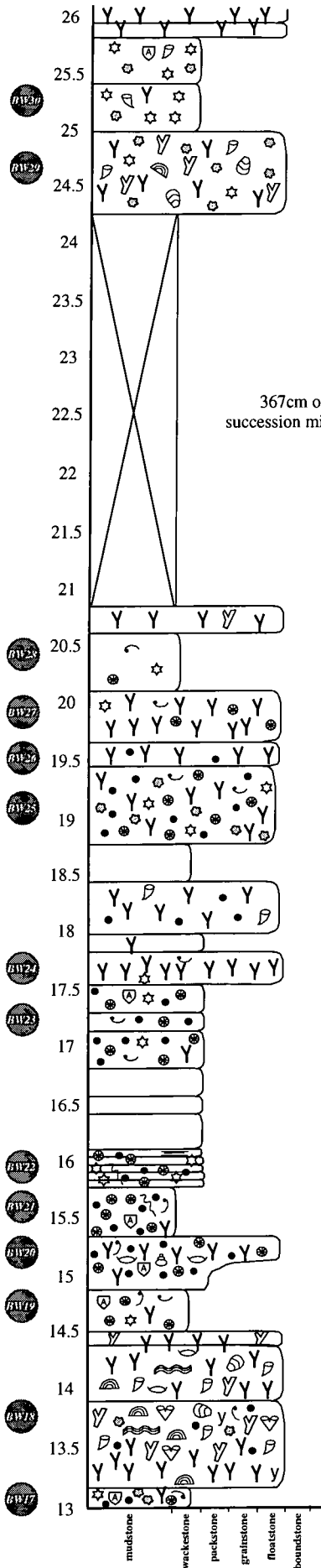

Broadridge Wood quarry

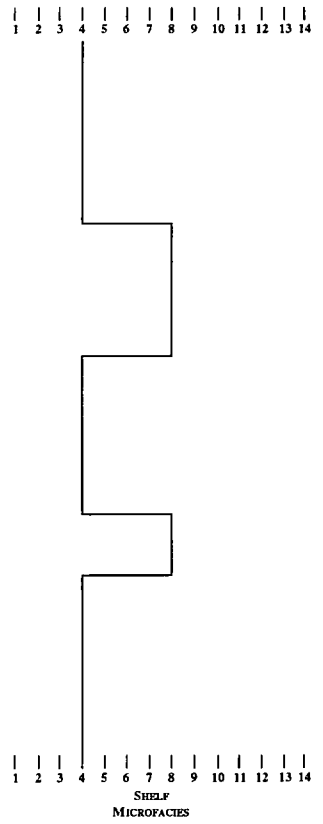
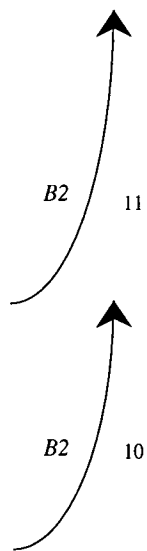
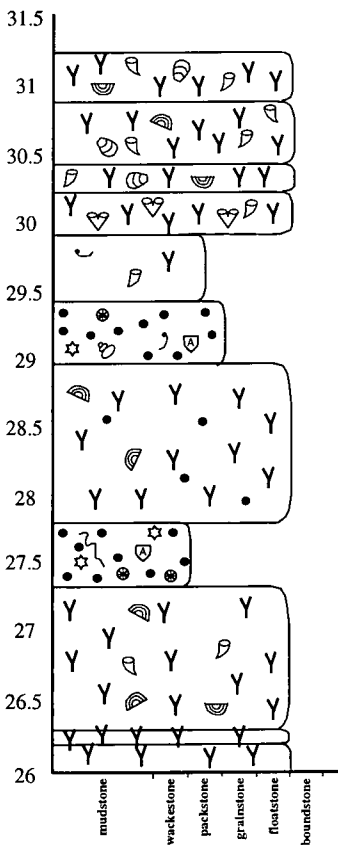

A2.7 Cul d'Houille quarry

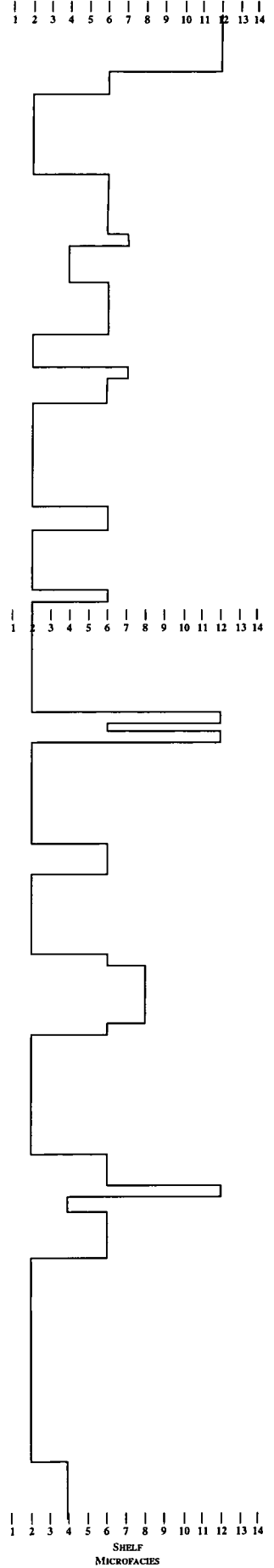
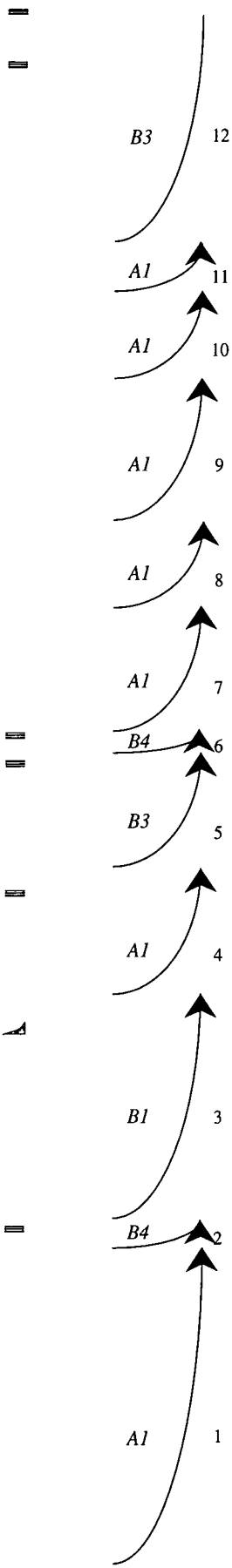
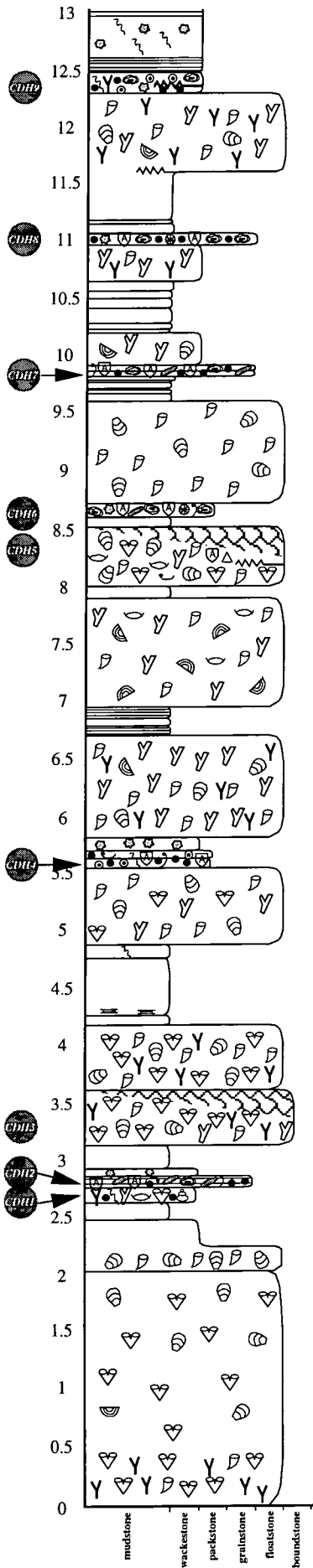

Cul d'Houille quarry

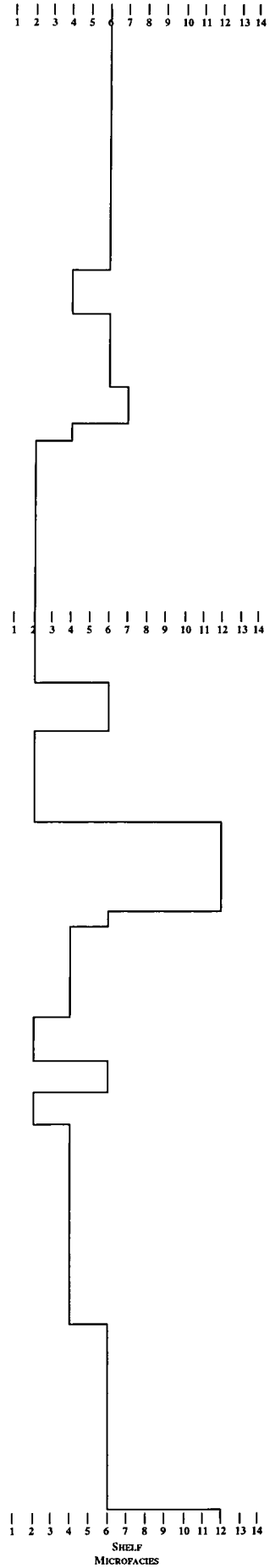
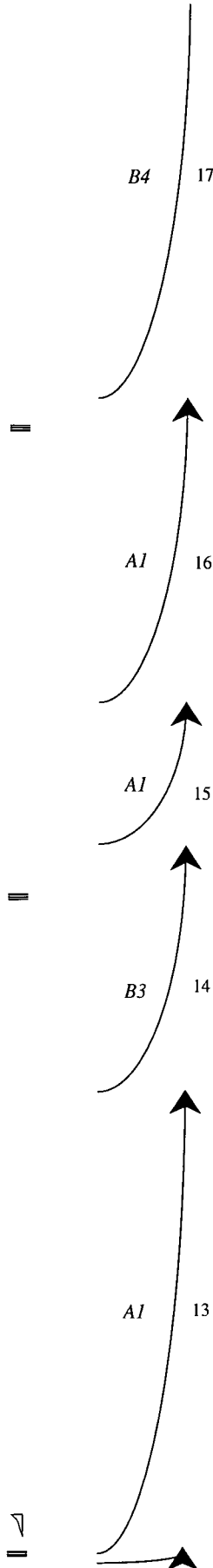
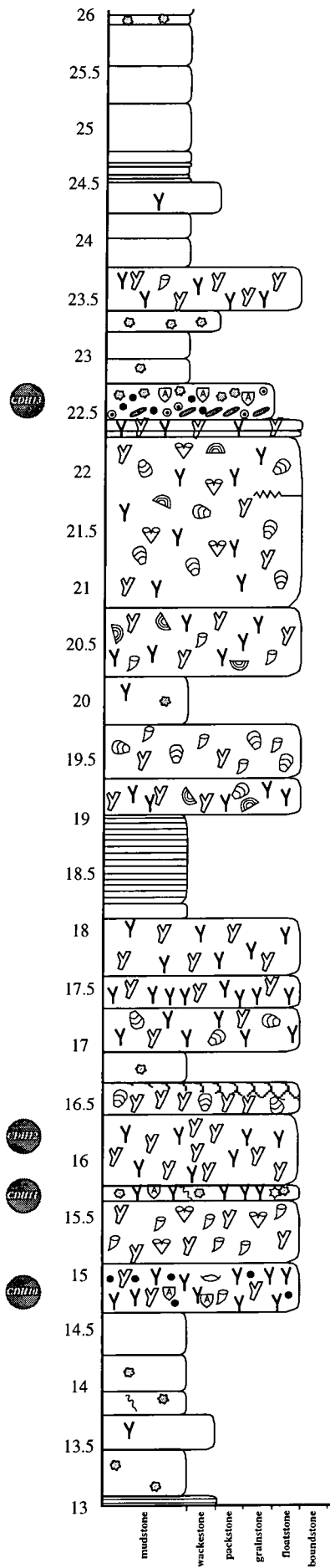

Cul d'Houille quarry

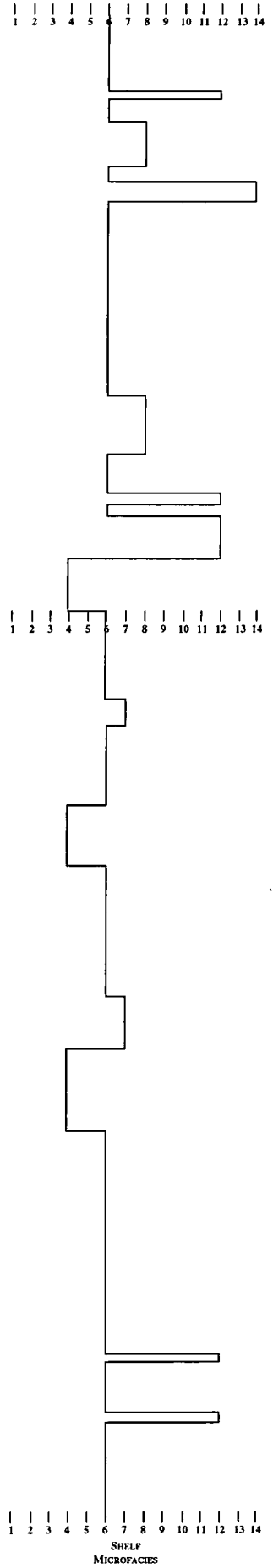
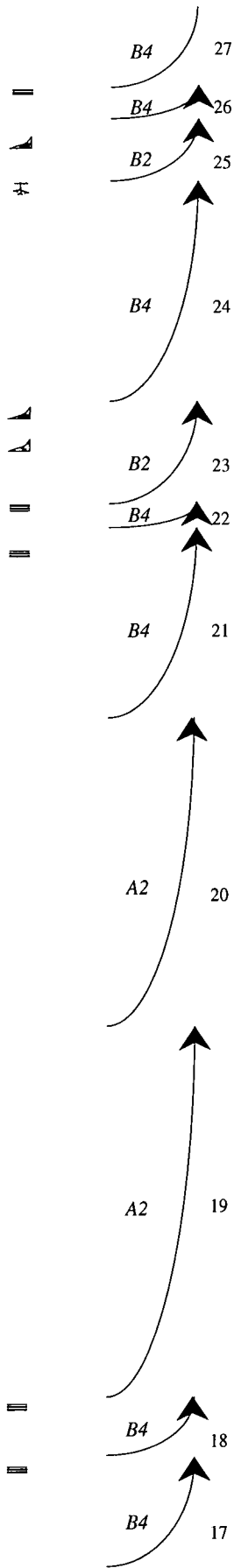
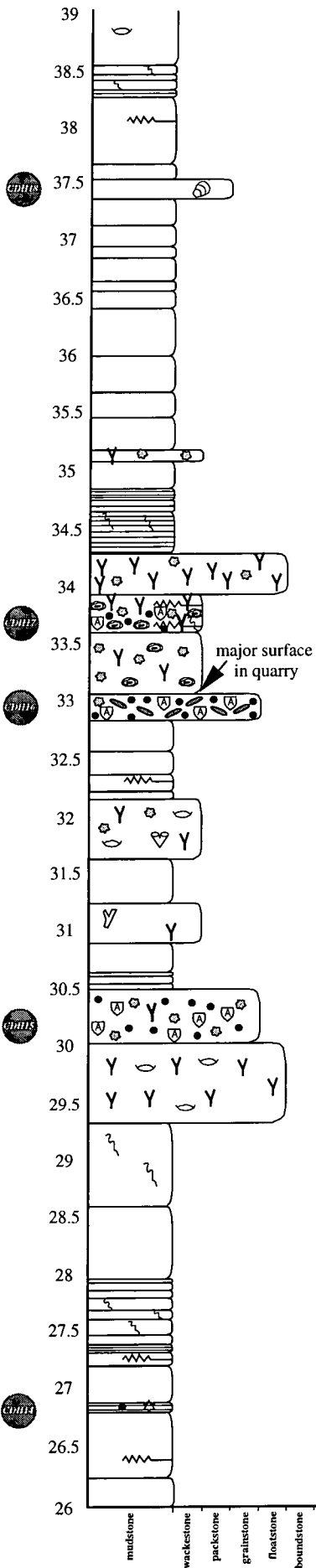

Cul d'Houille quarry

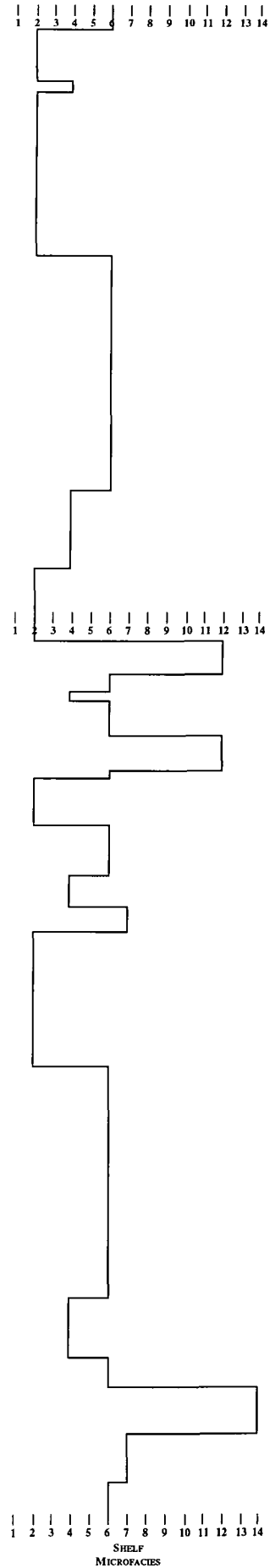
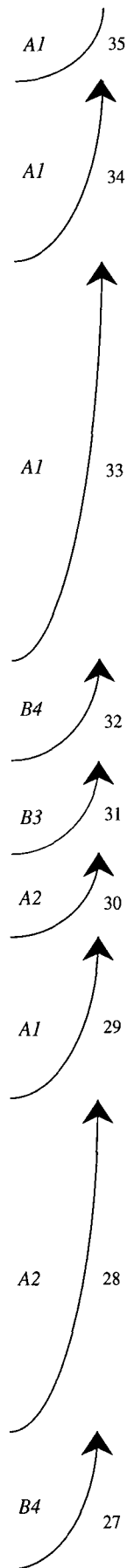
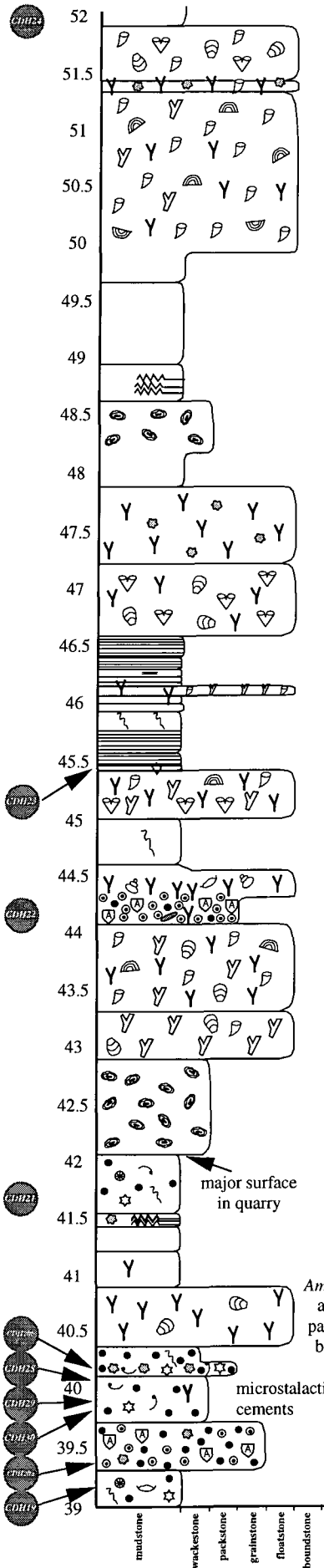

Cul d'Houille quarry

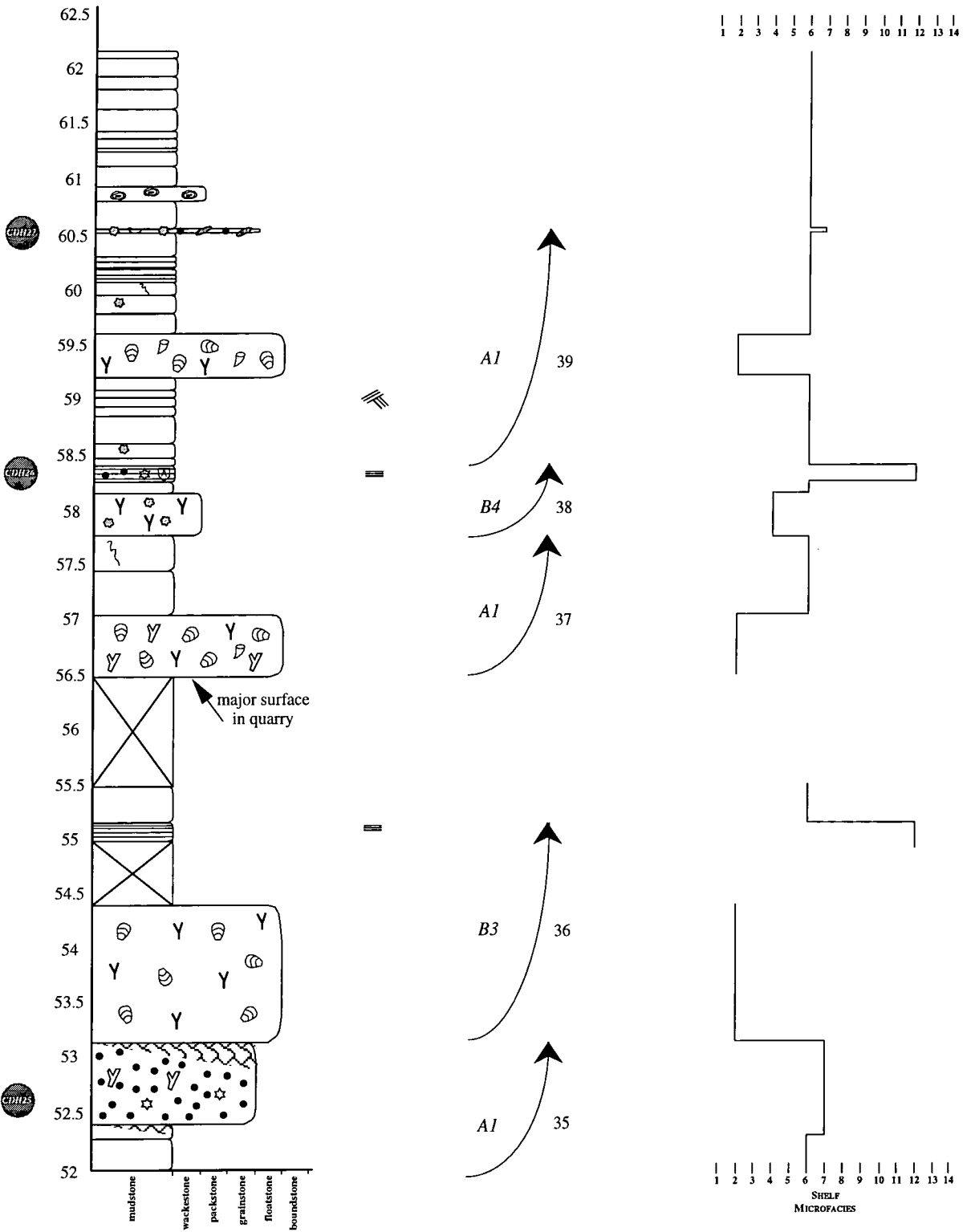

**A2.8 Dourbes quarry**

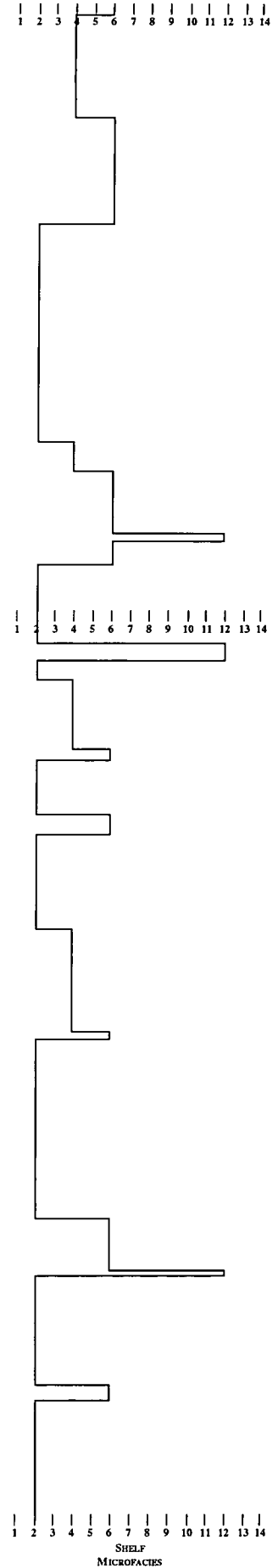
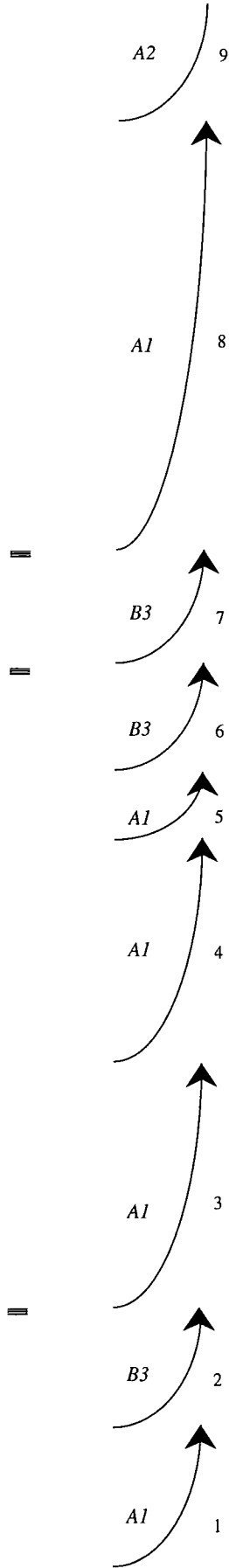
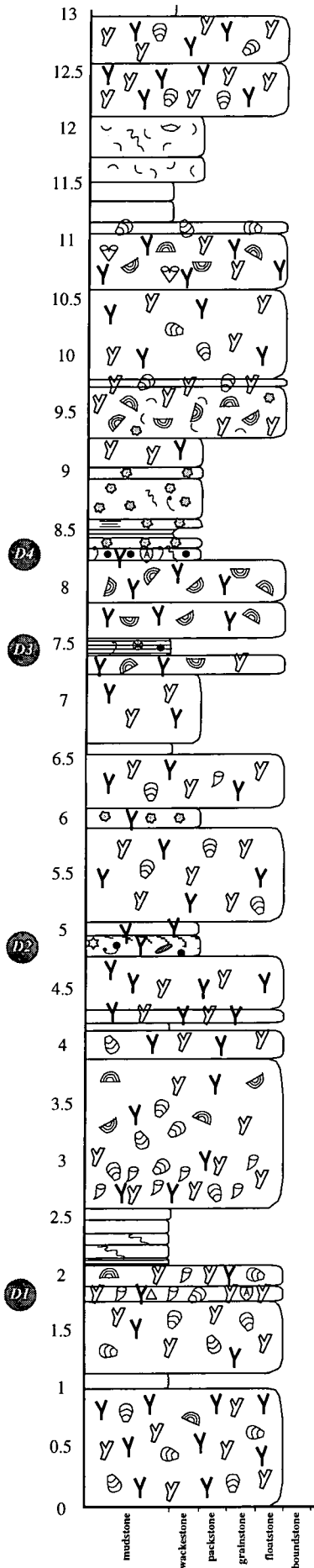

Dourbes quarry

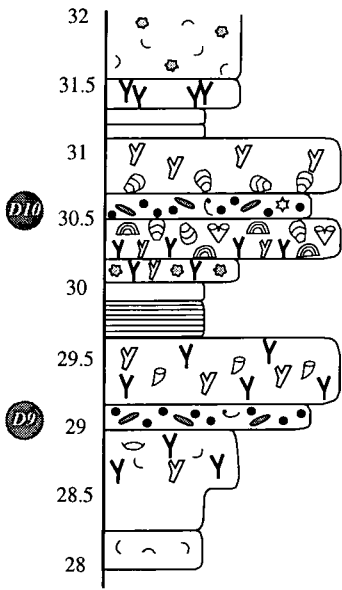

Gap in succession of ~7m

=  
∇

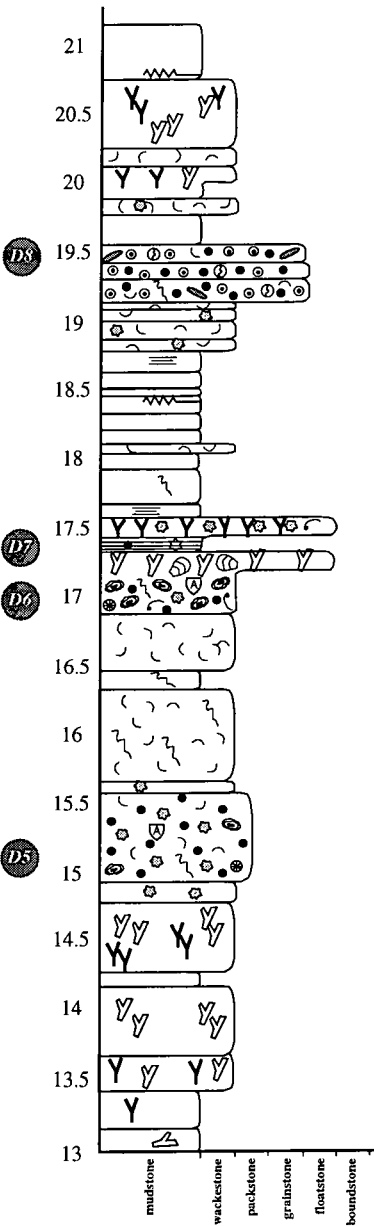
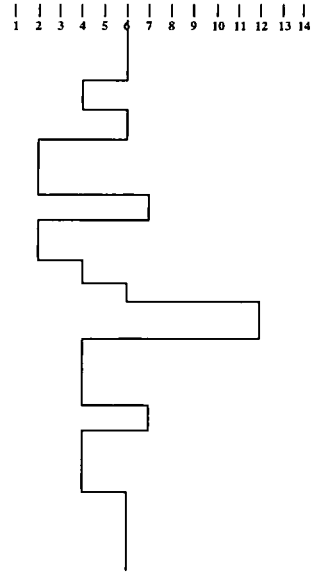
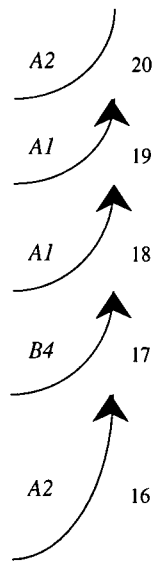

≡

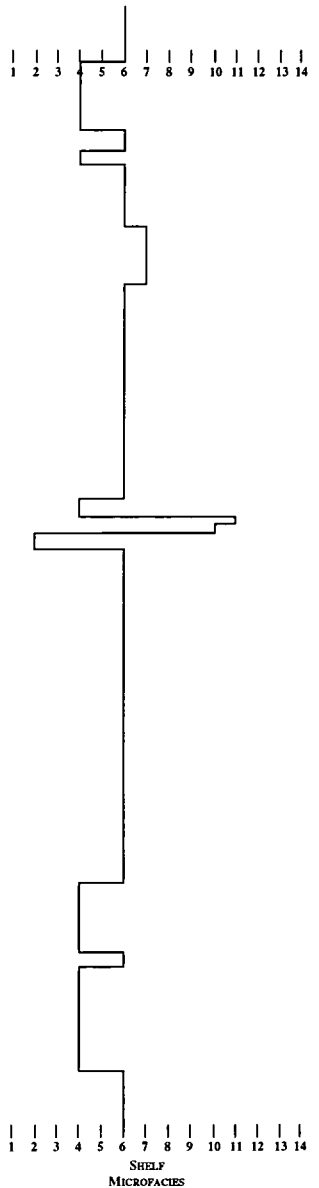
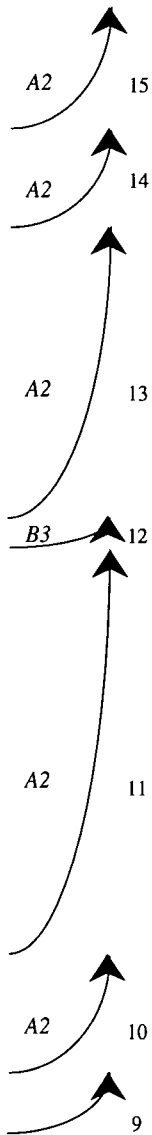

Dourbes quarry

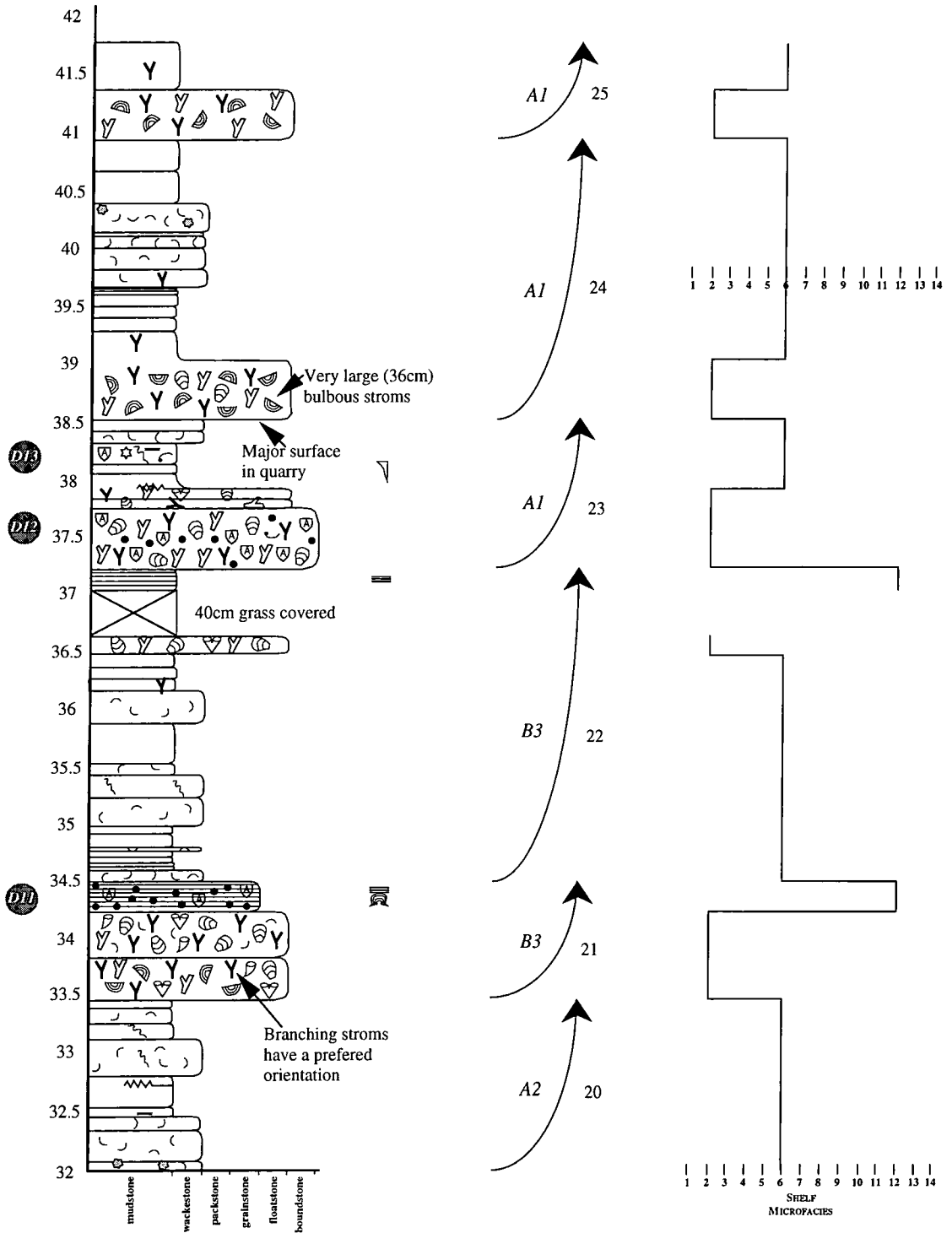

A2.9 Froid Lieu quarry

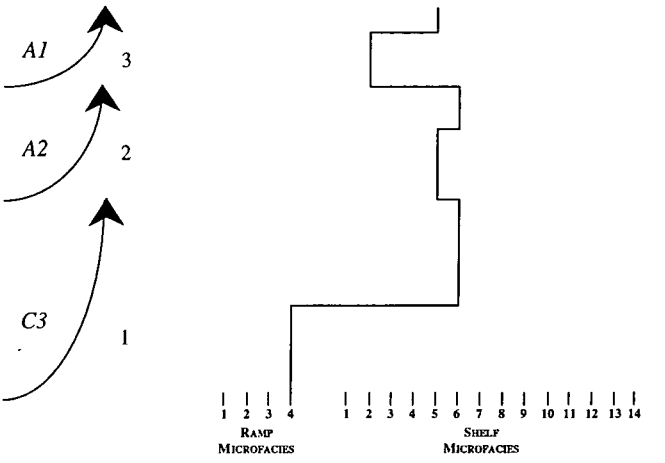
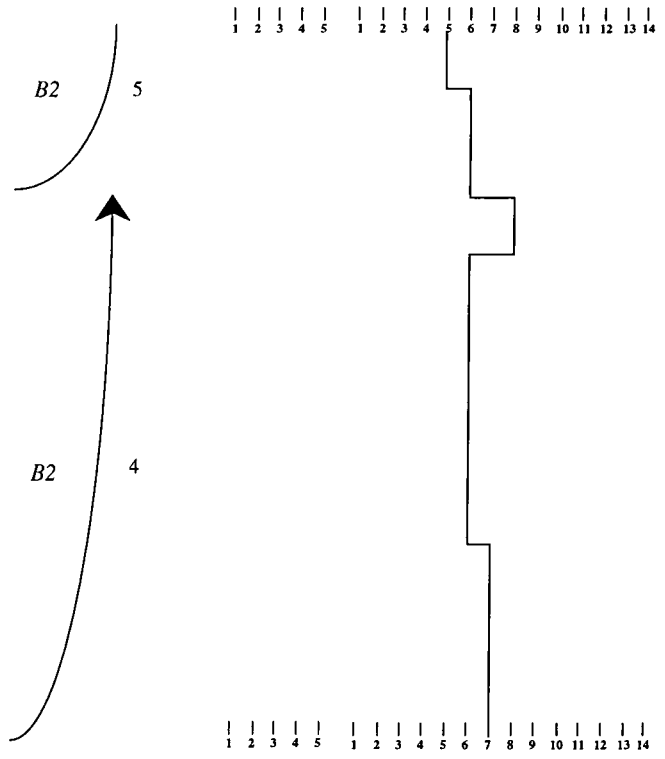
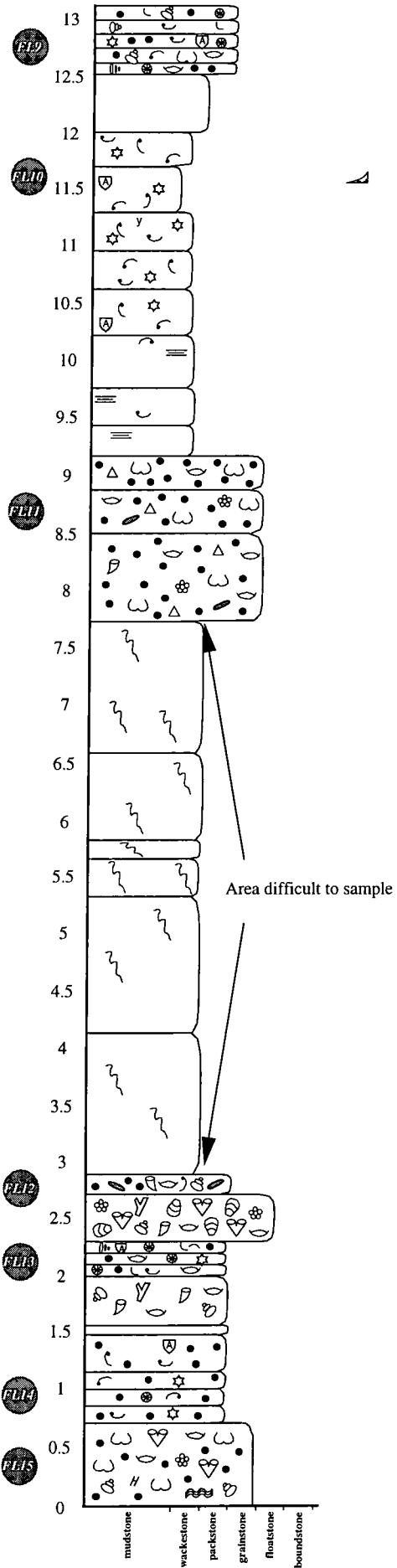

Froid Lieu quarry

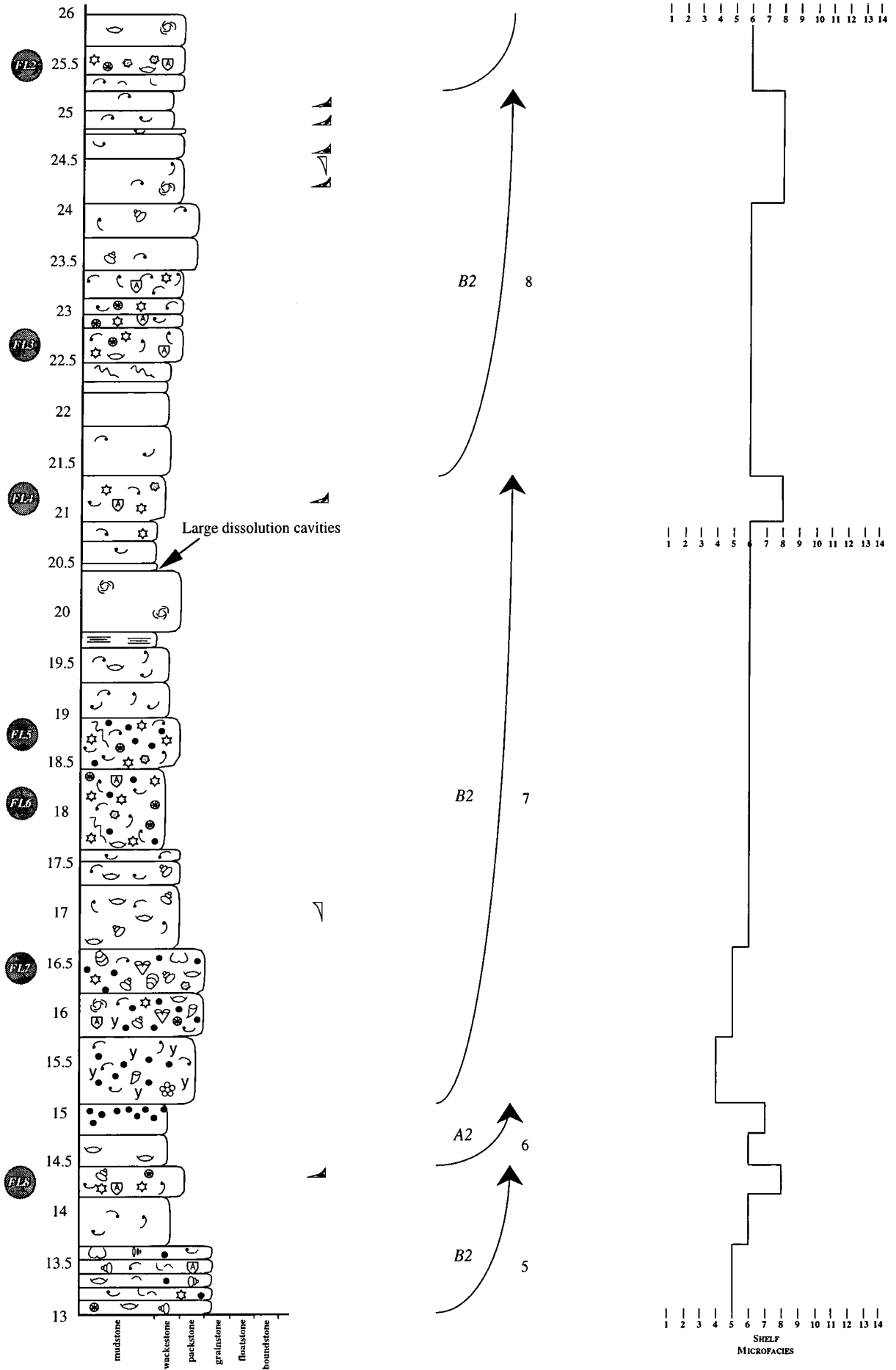

# Froid Lieu quarry

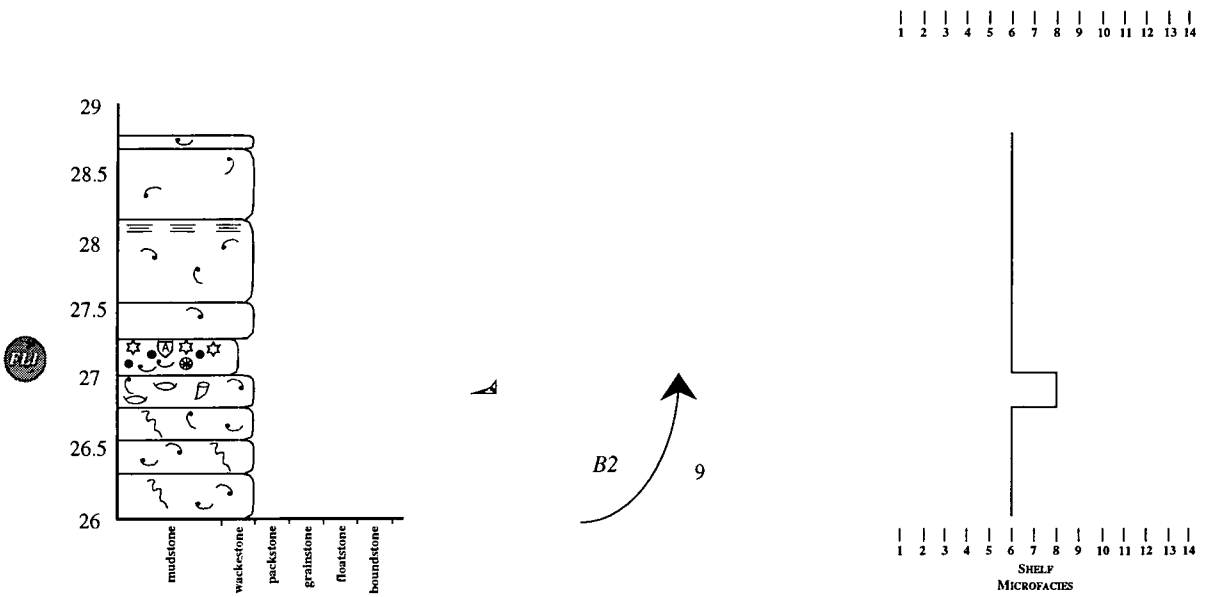

**A2.10 Glageon quarry**

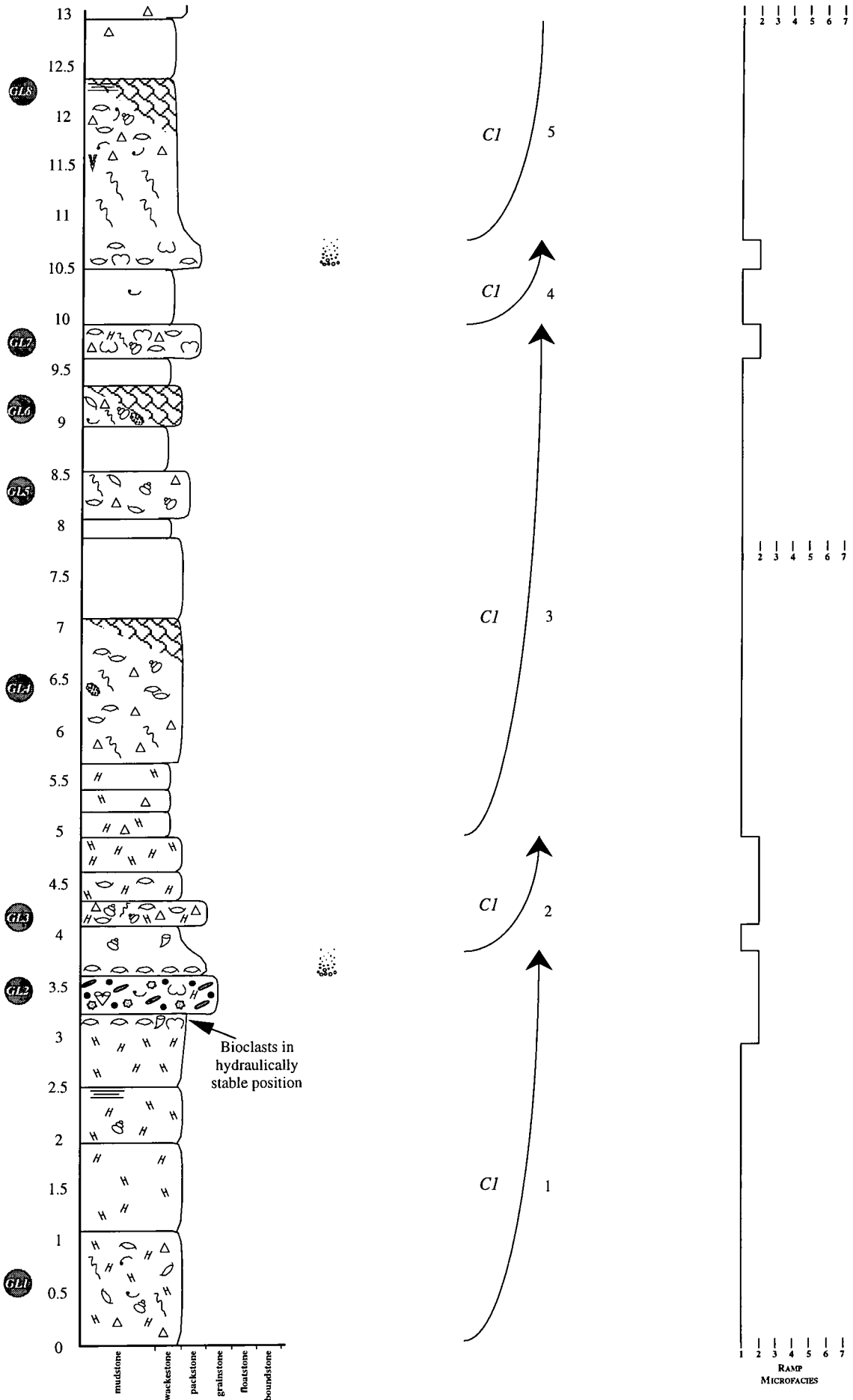

**Glageon quarry**

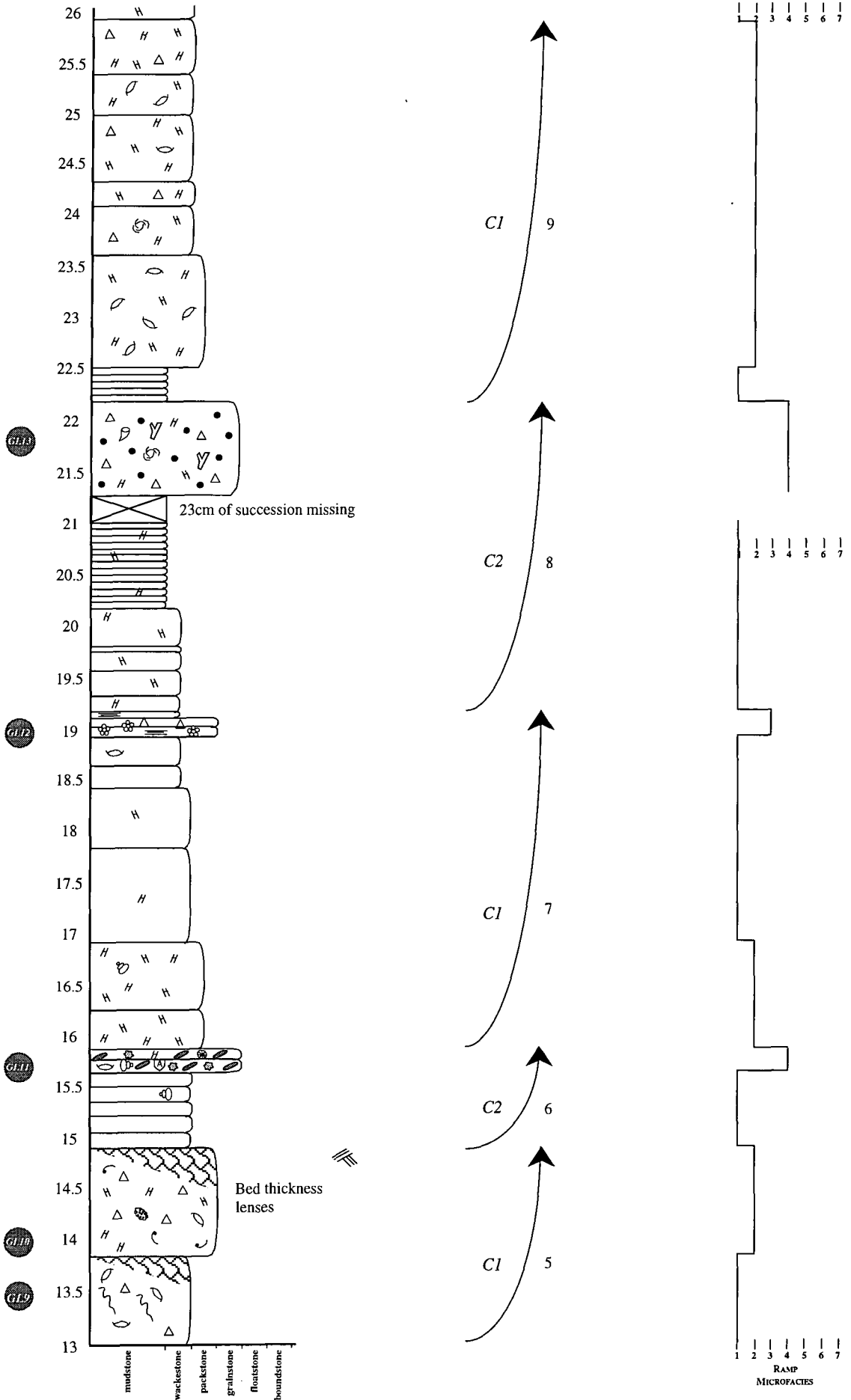

Glageon quarry

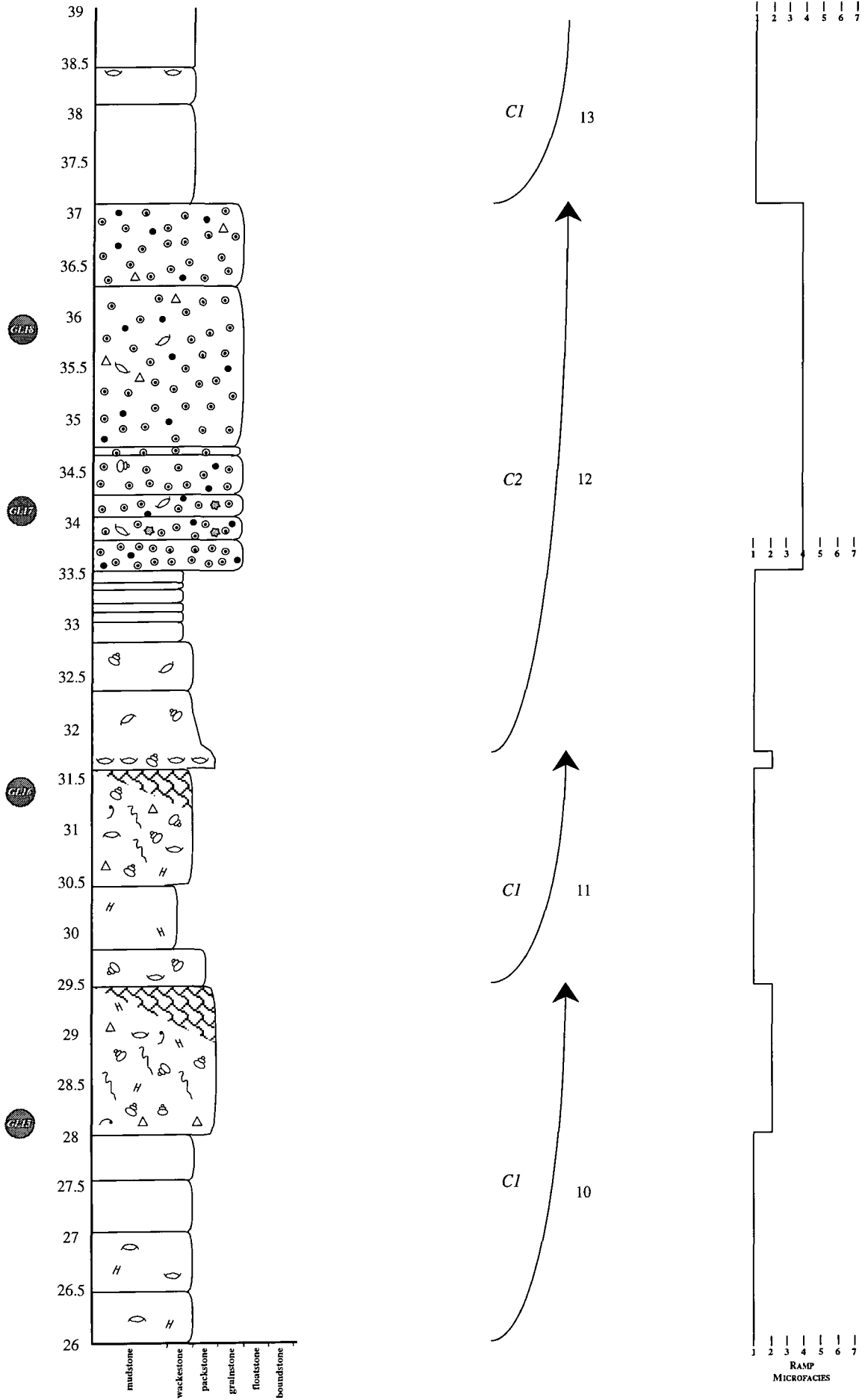

Glageon quarry

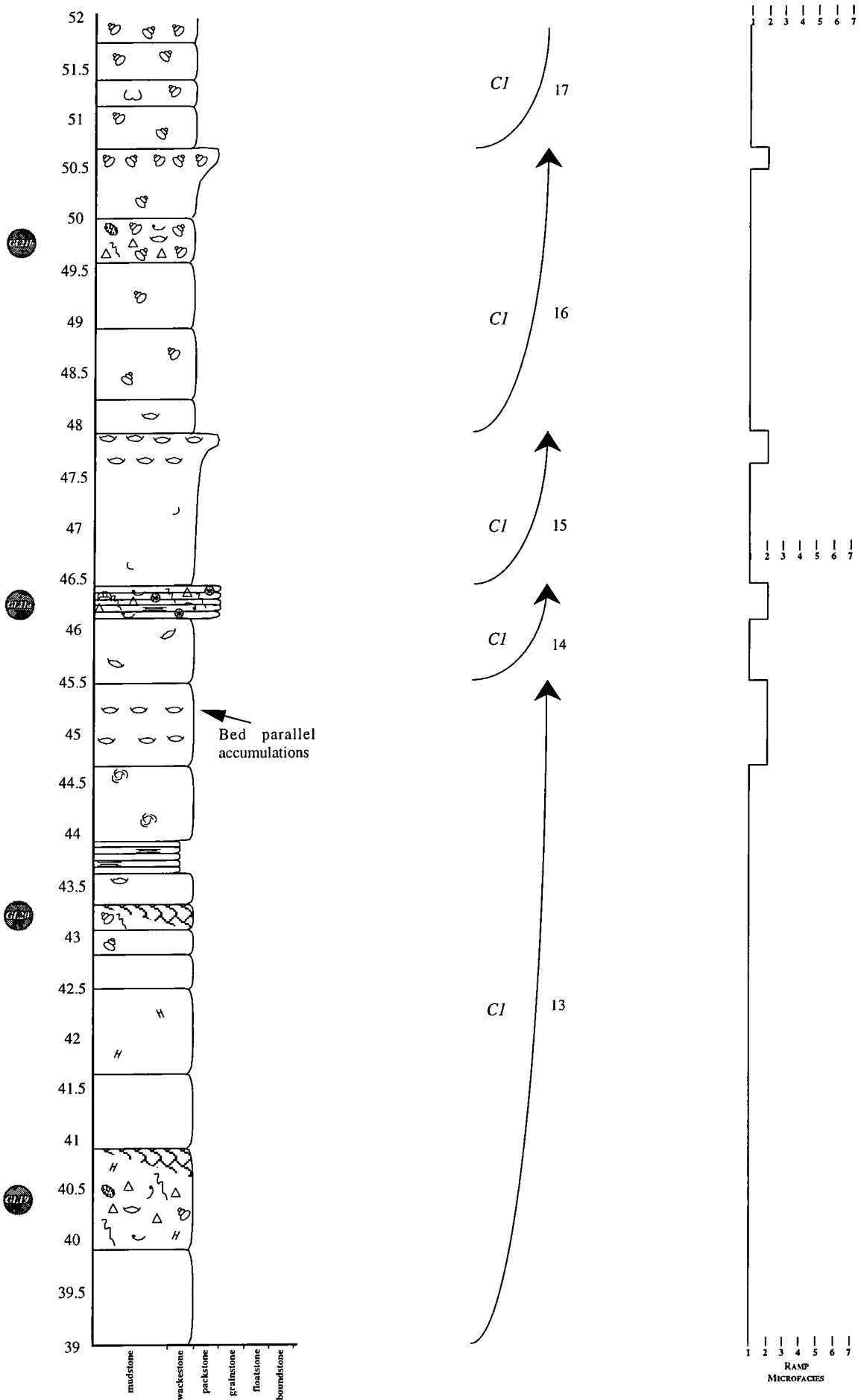

Glageon quarry

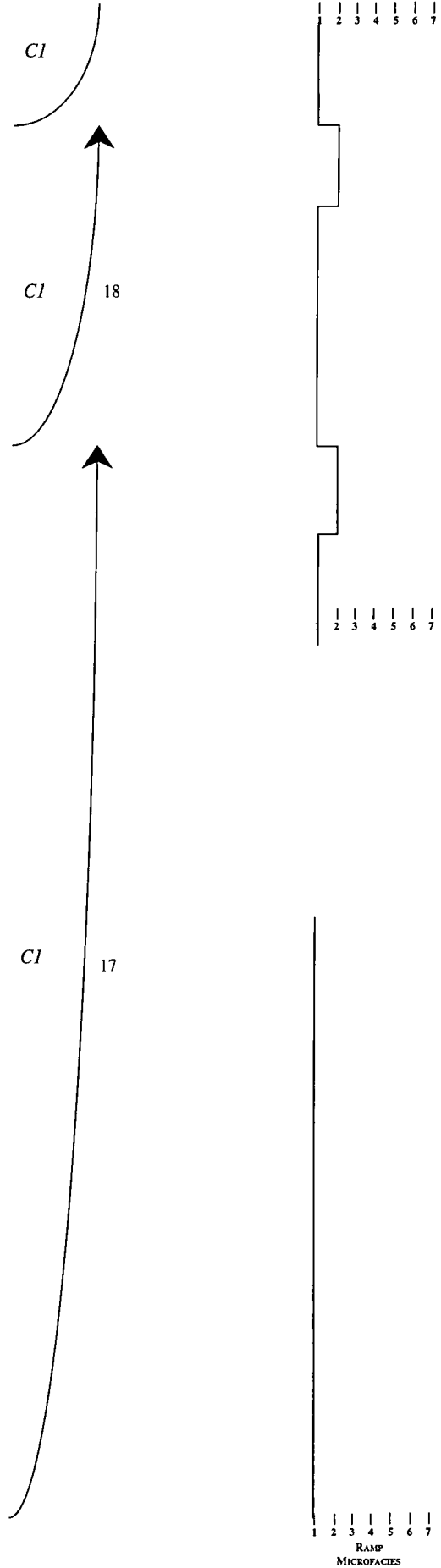
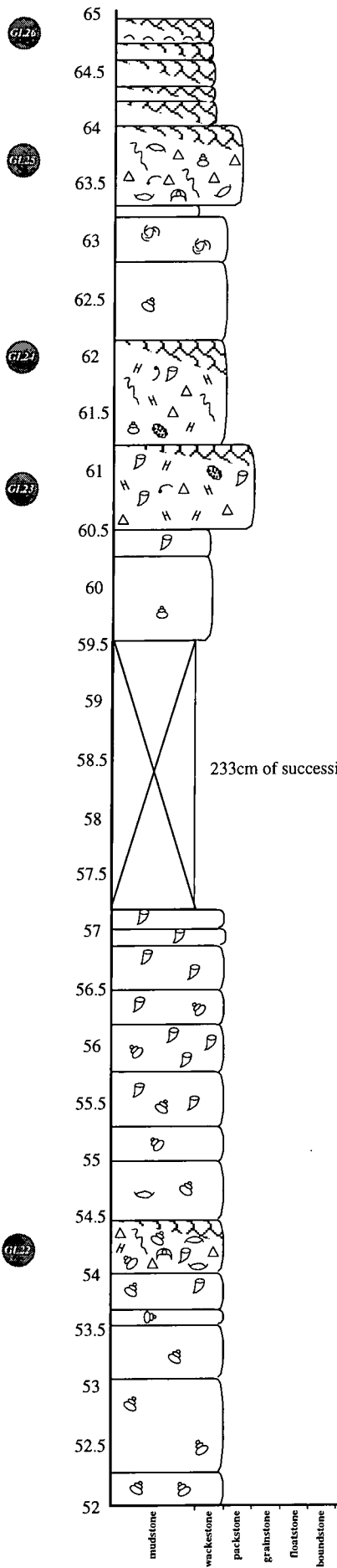

Glageon quarry

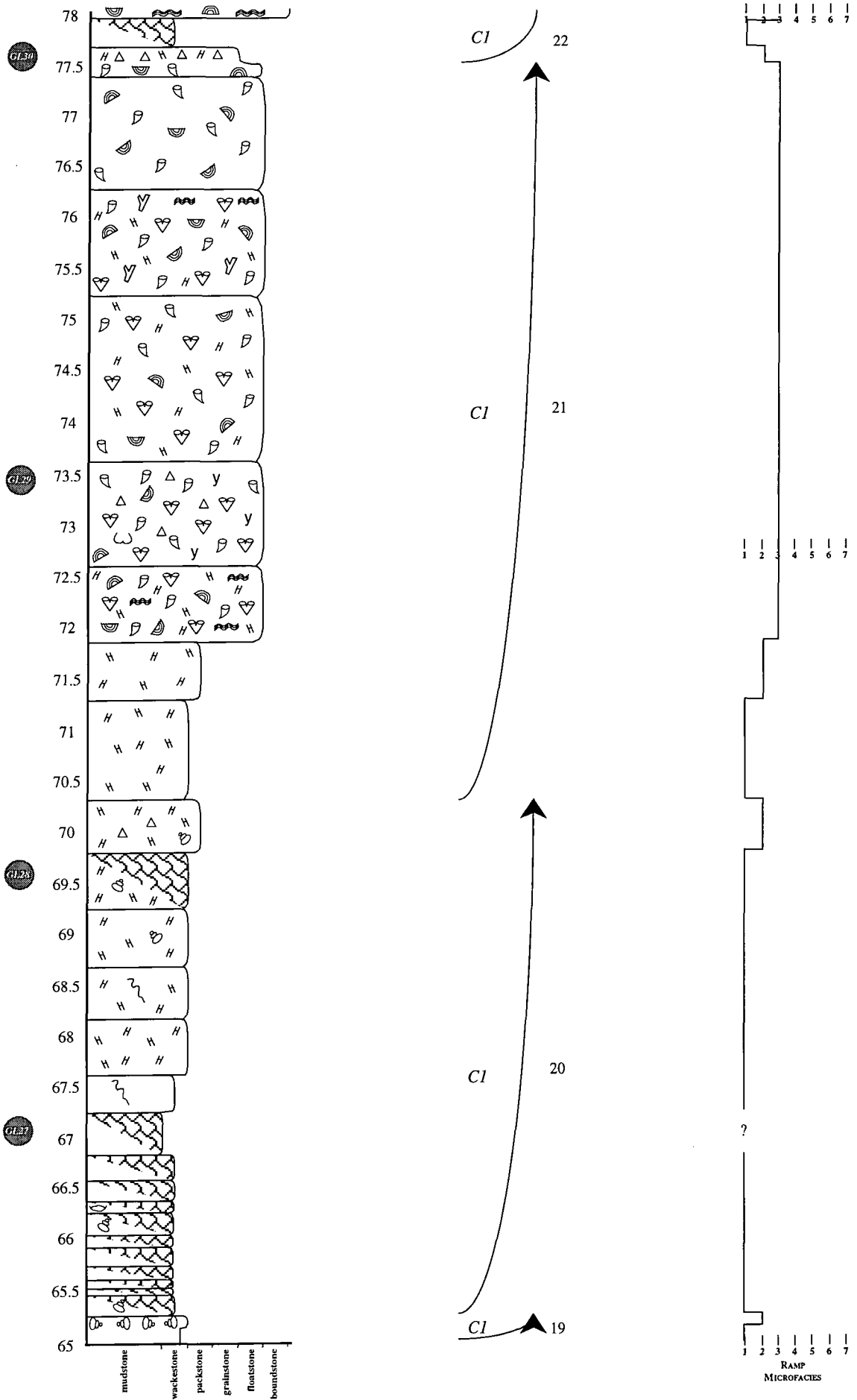

Glageon quarry

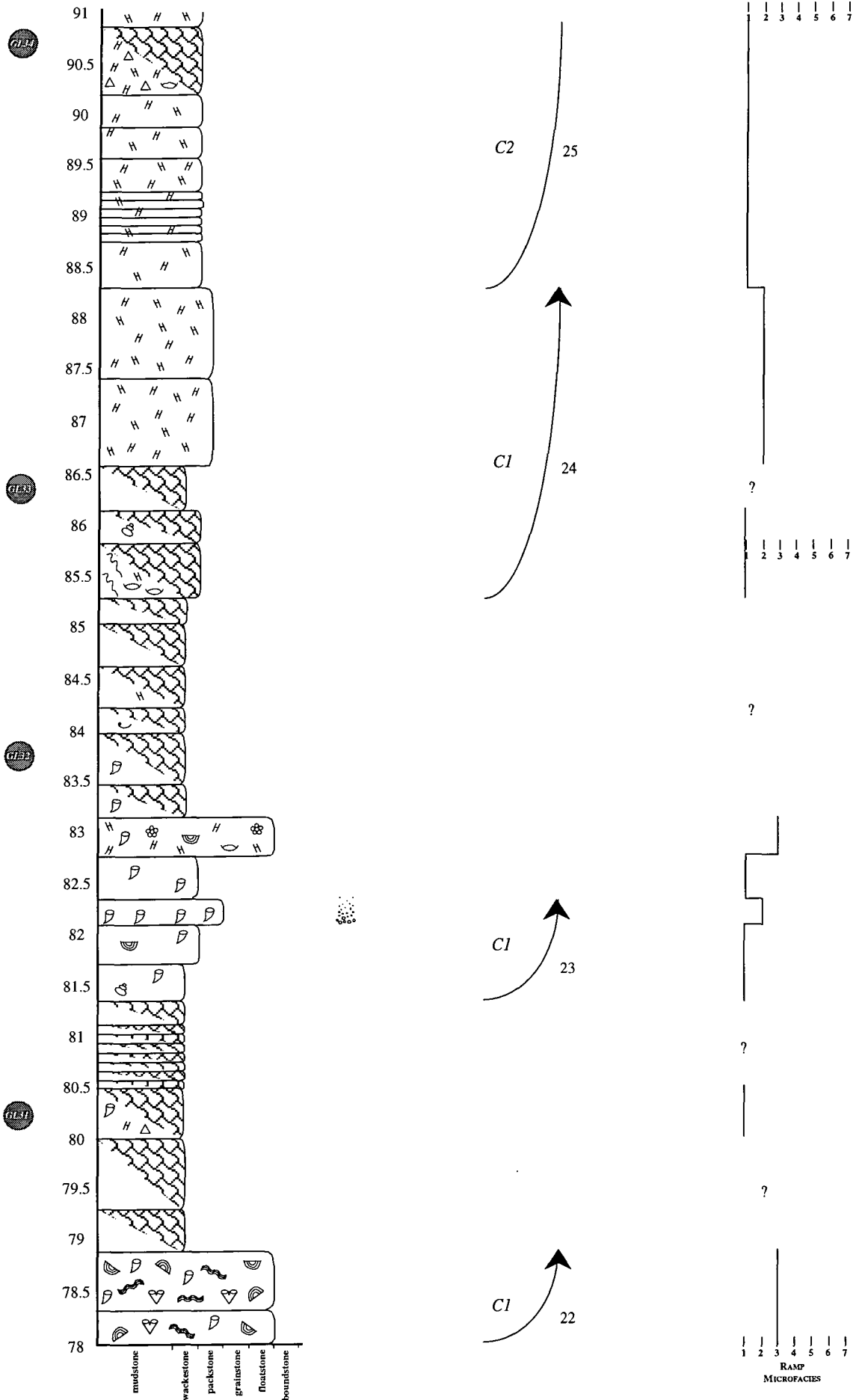

Glageon quarry

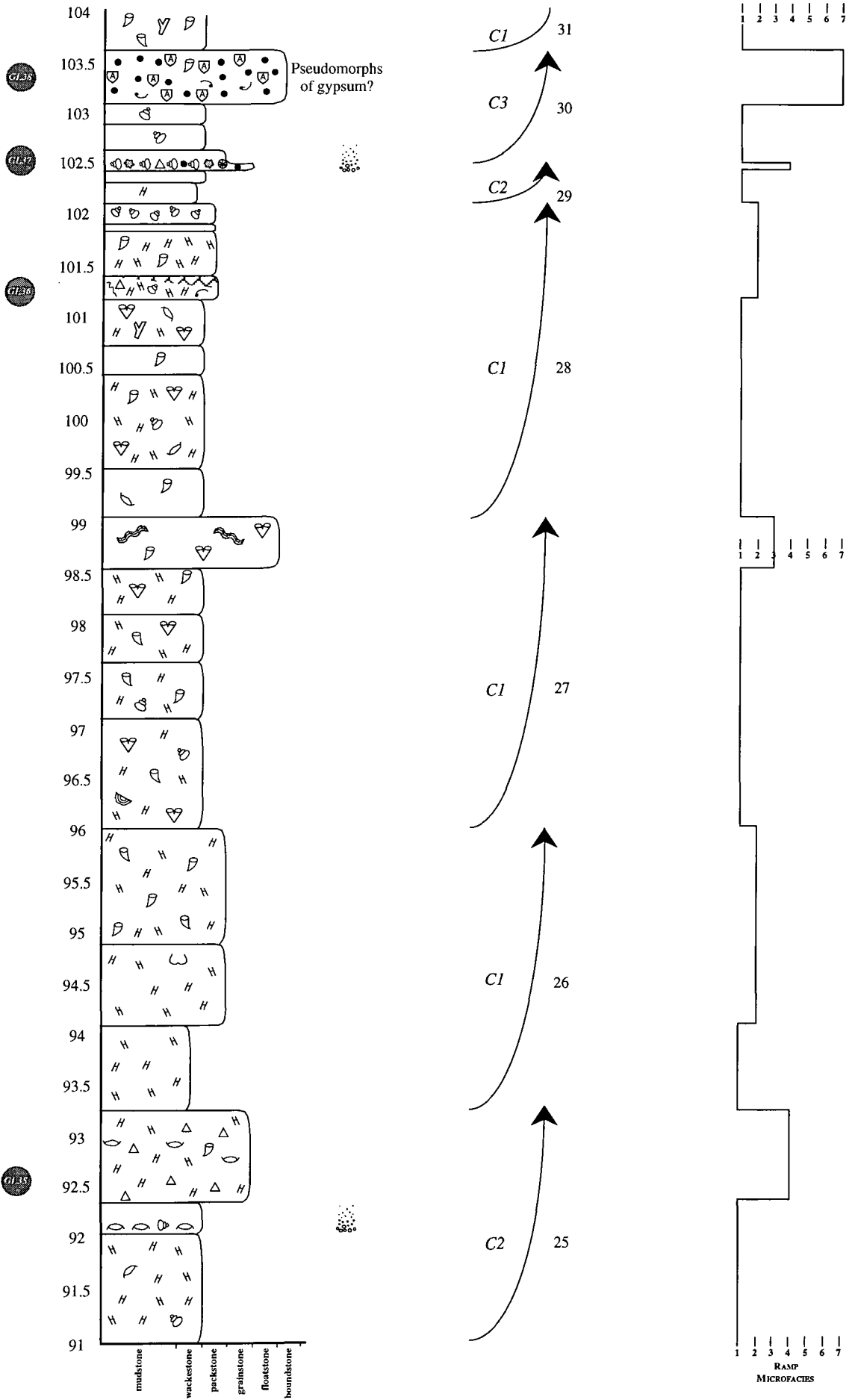

Glageon quarry

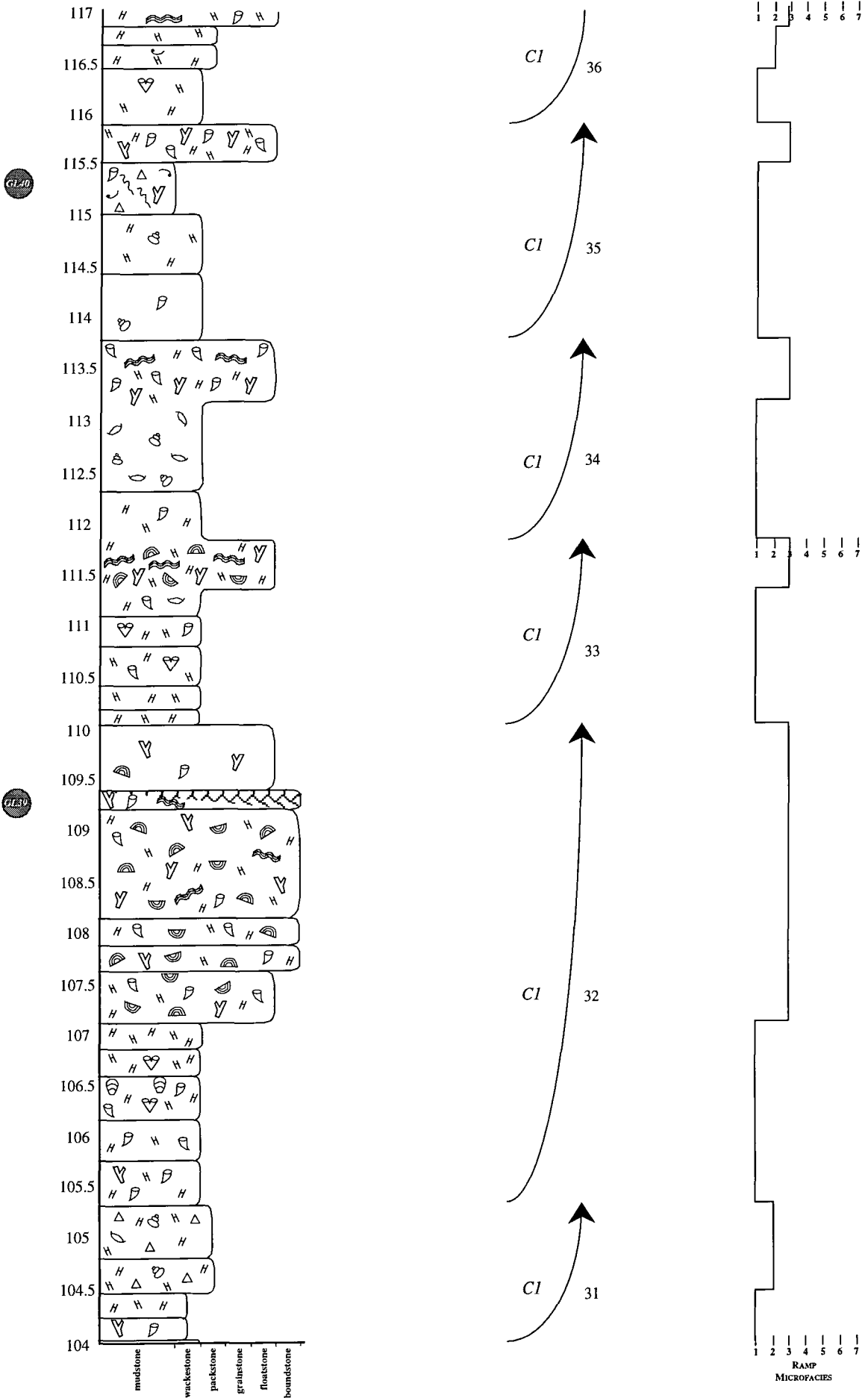

Glageon quarry

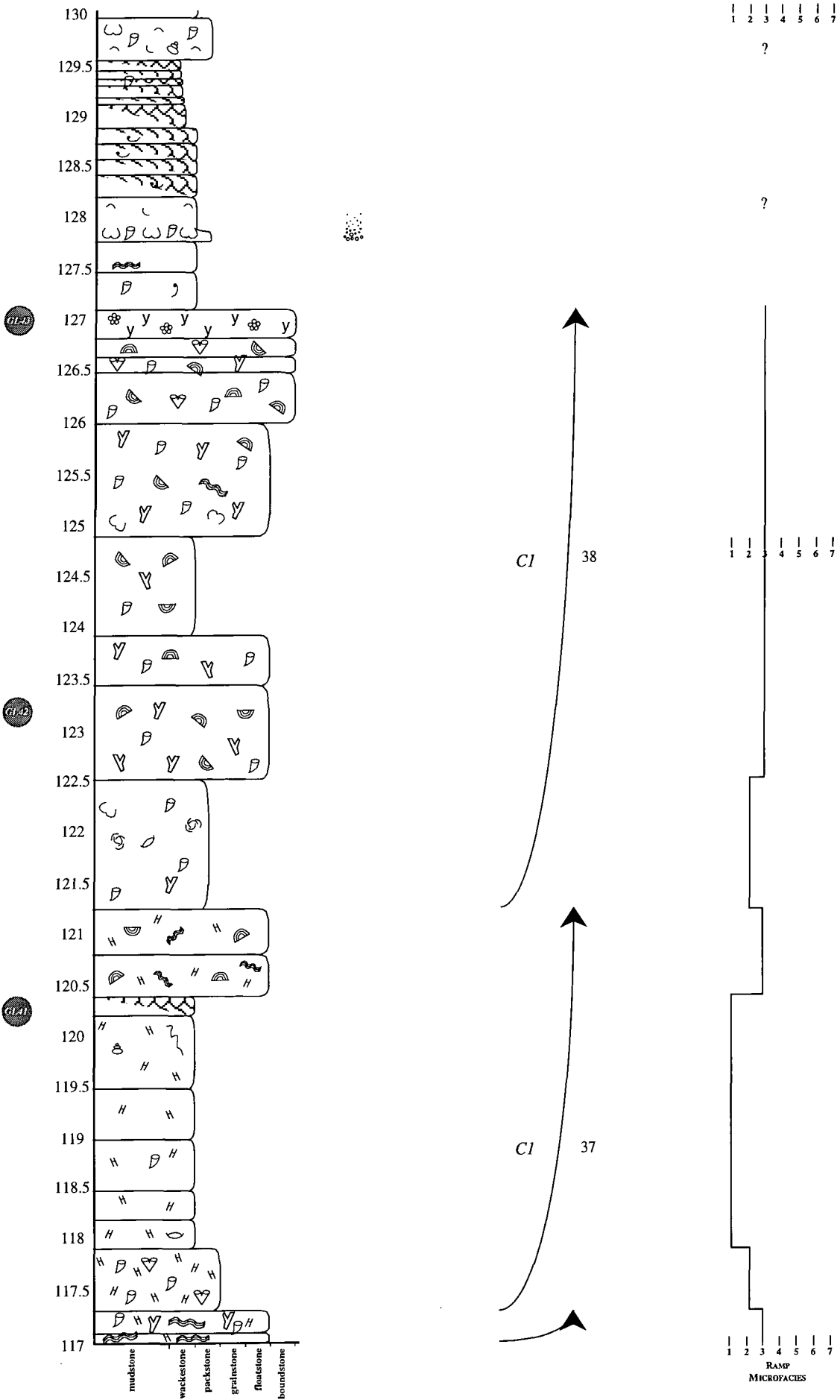

Glageon quarry

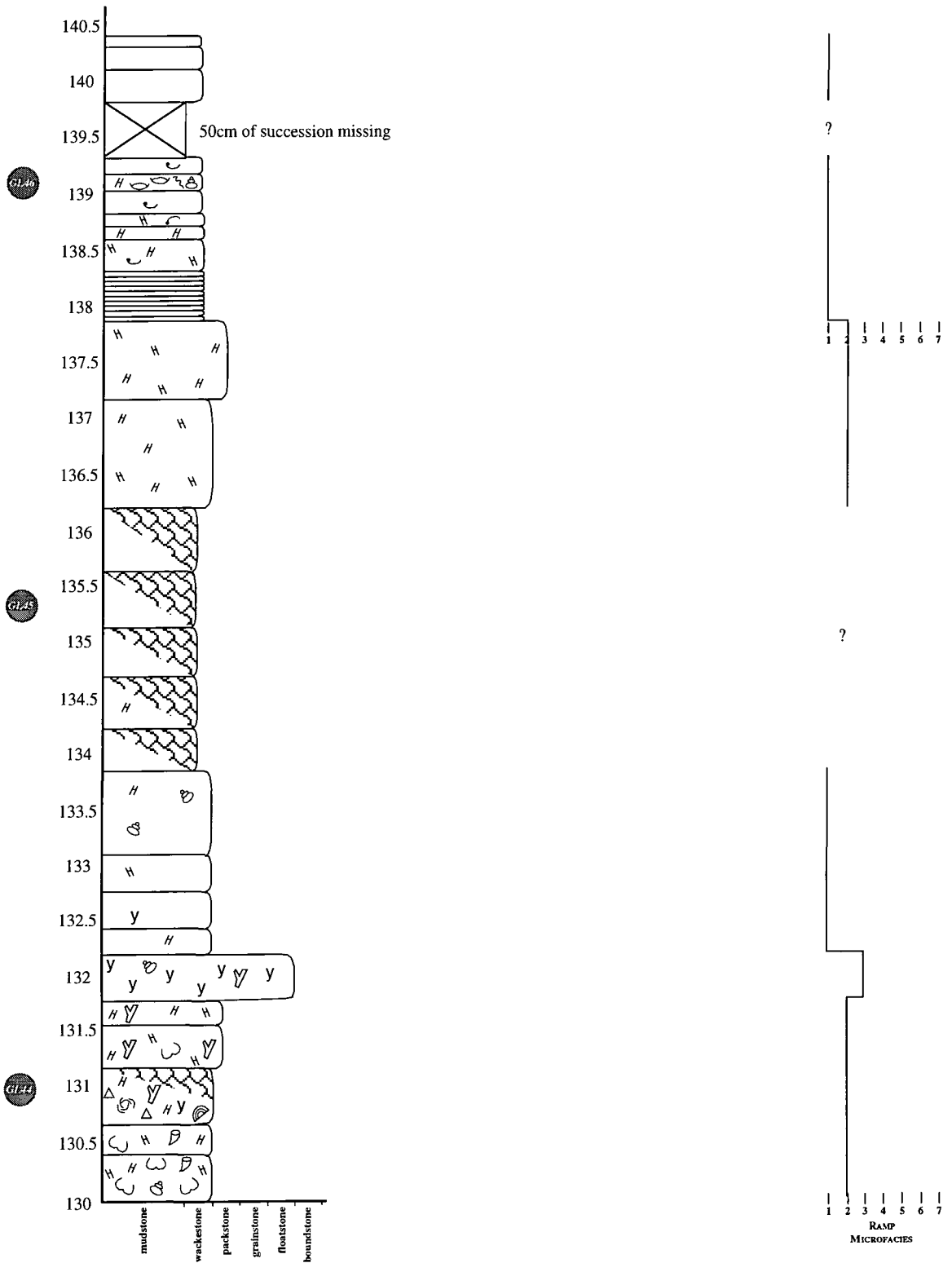

## A2.11 Goodrington Road Cutting

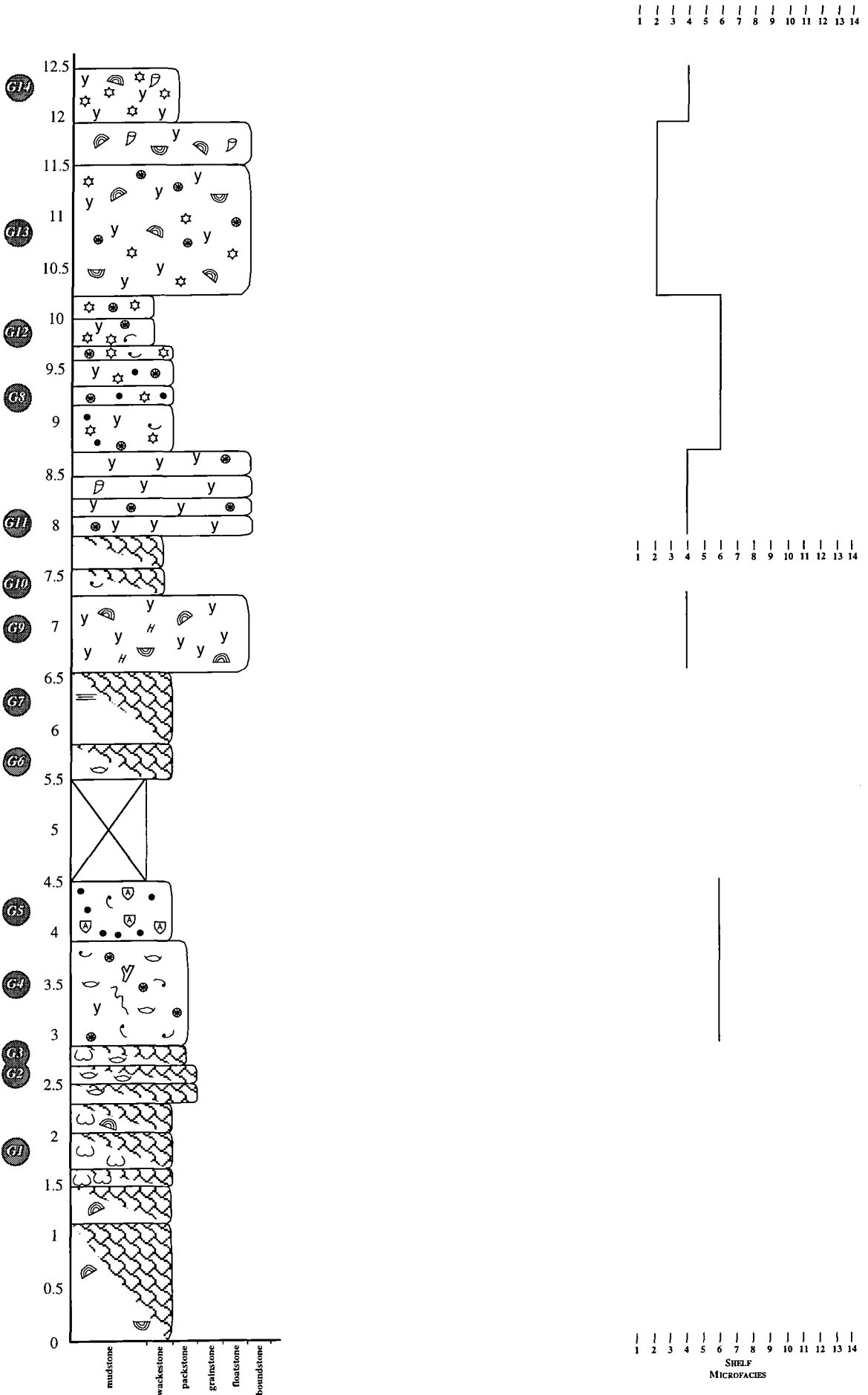

A2.12 Hanielsfeld quarry

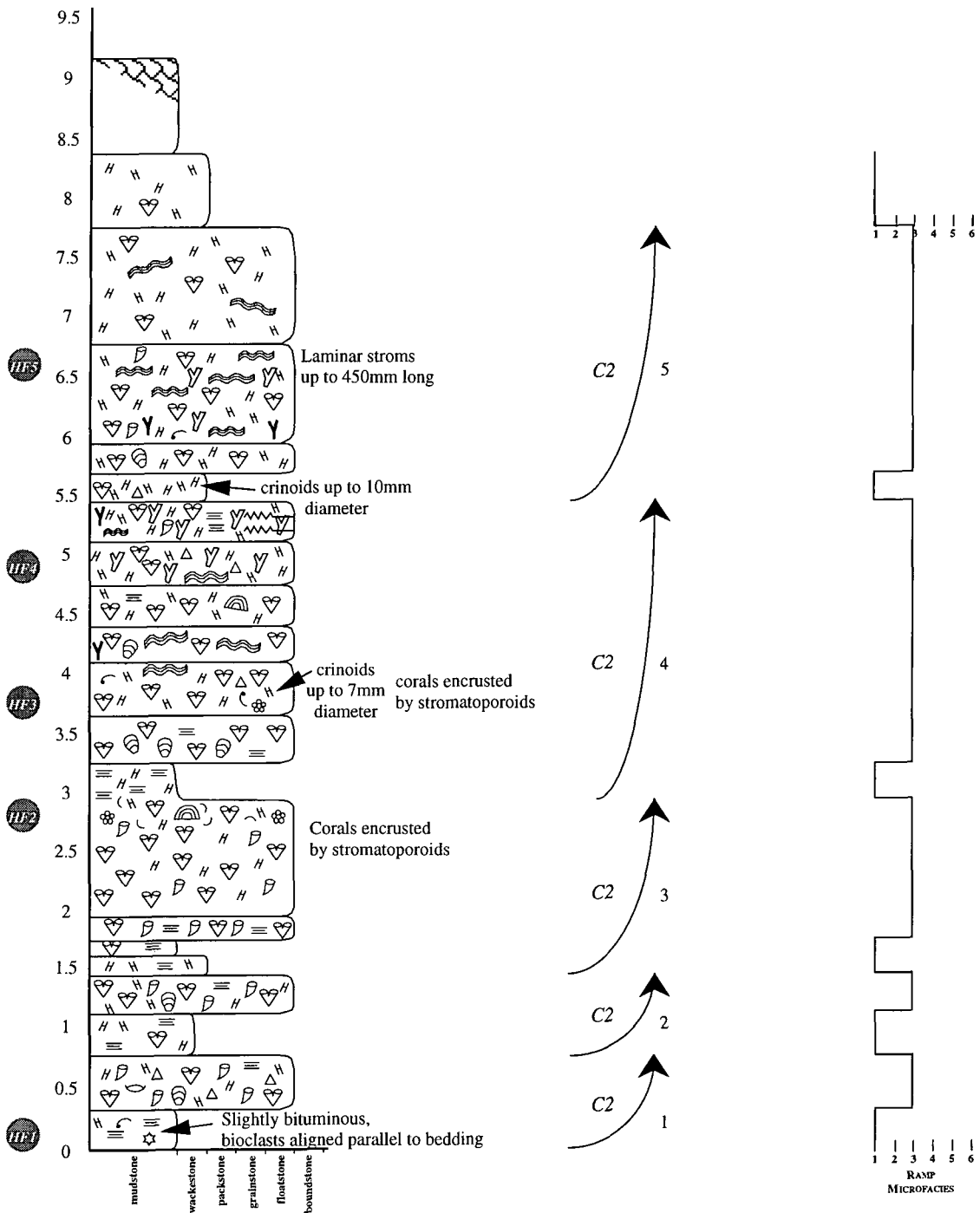

A2.13 Heggen quarry

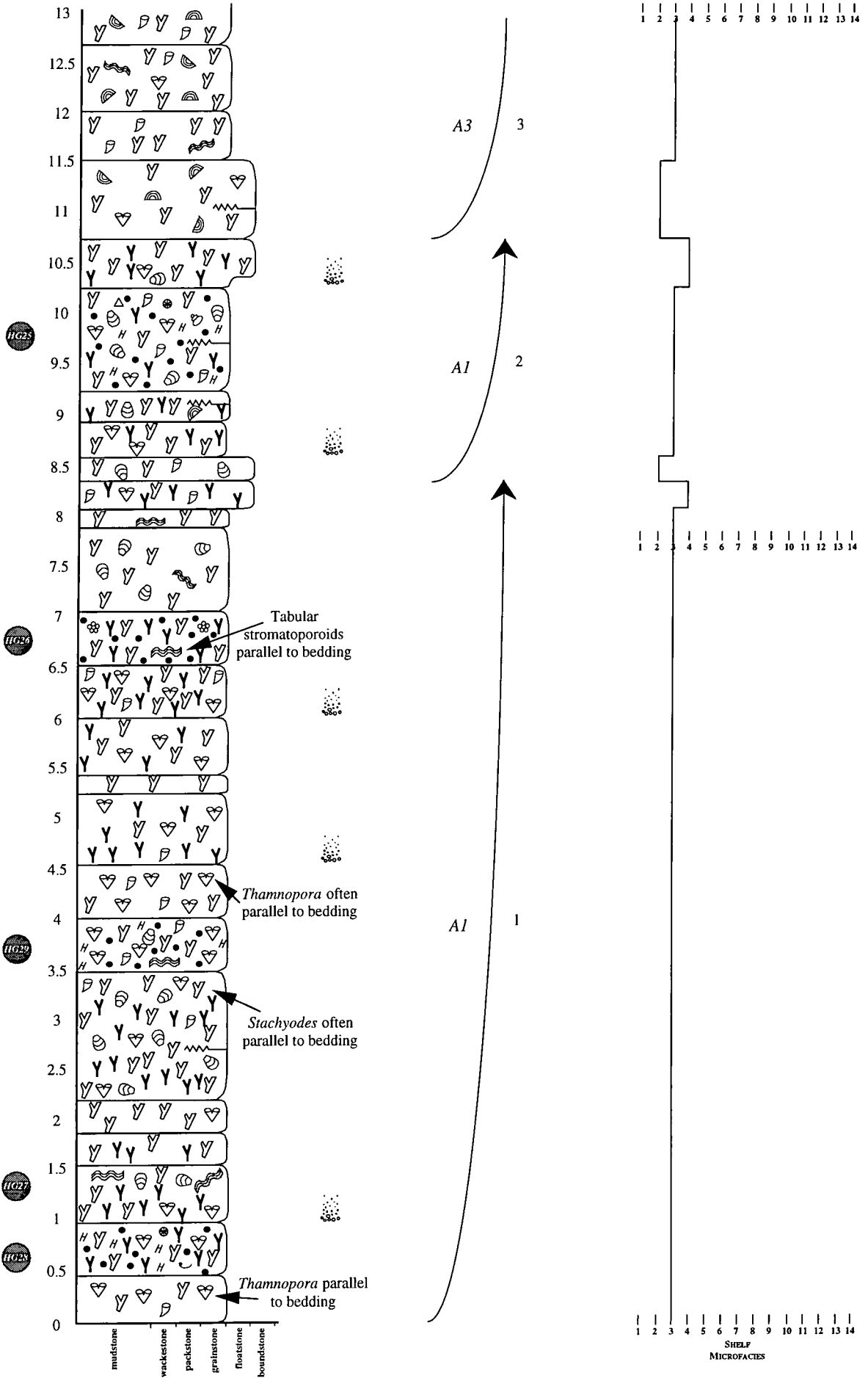

### Heggen quarry

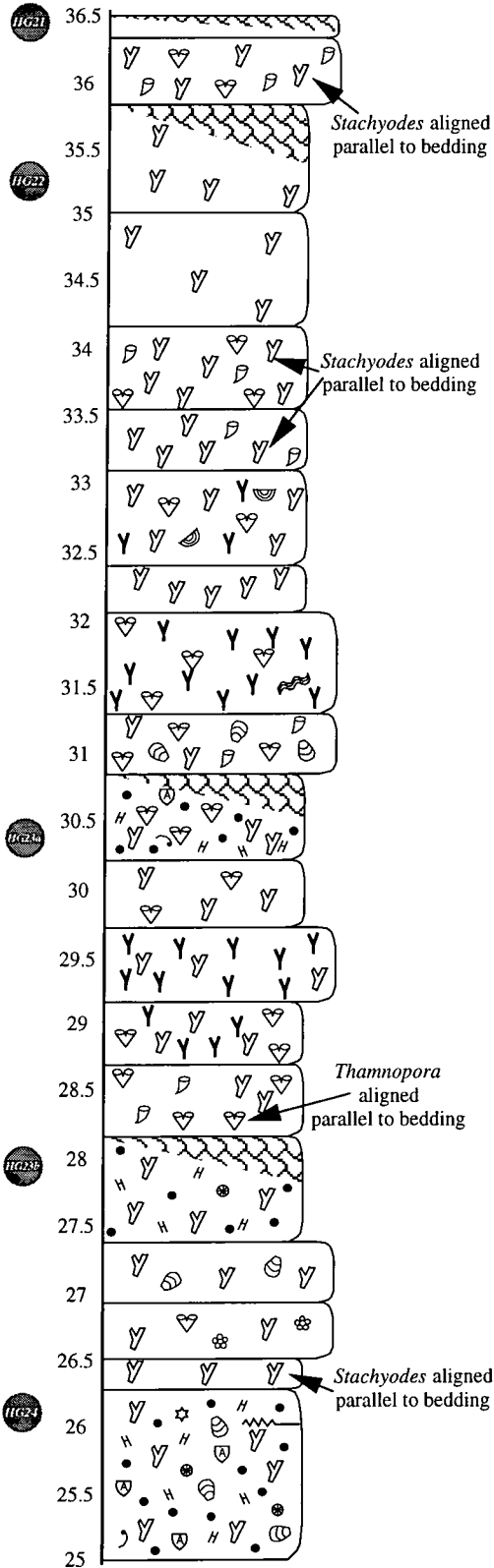

≈ 11 m gap in succession

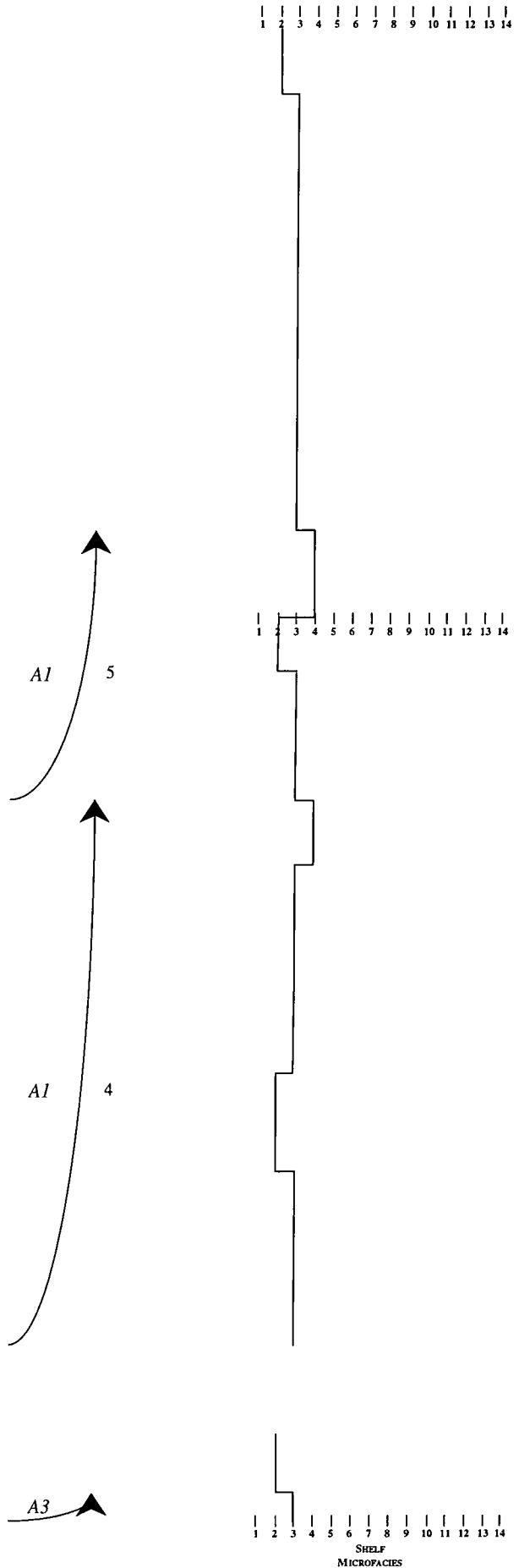
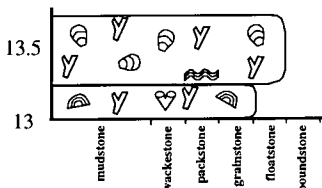

Heggen quarry

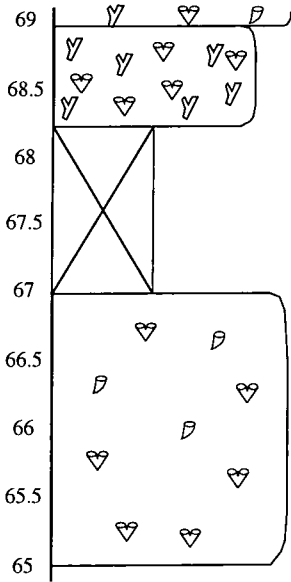

≈6m of succession missing

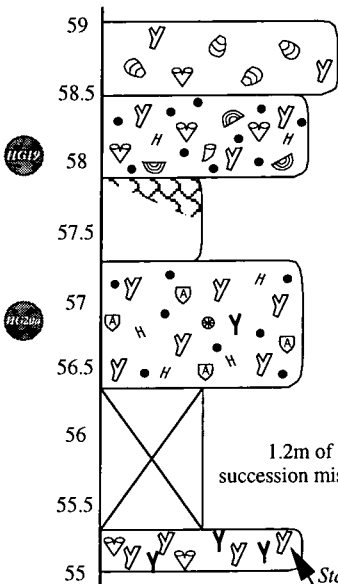
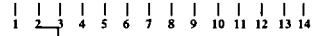
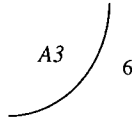

1.2m of succession missing

≈8m of succession missing

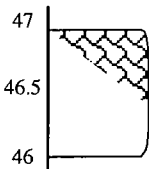
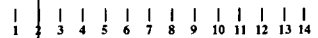

≈8m of succession missing

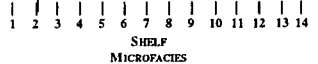
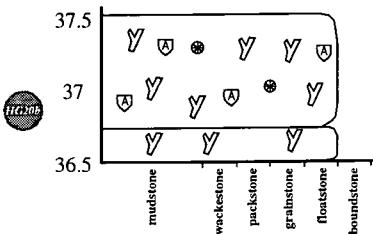

Heggen quarry

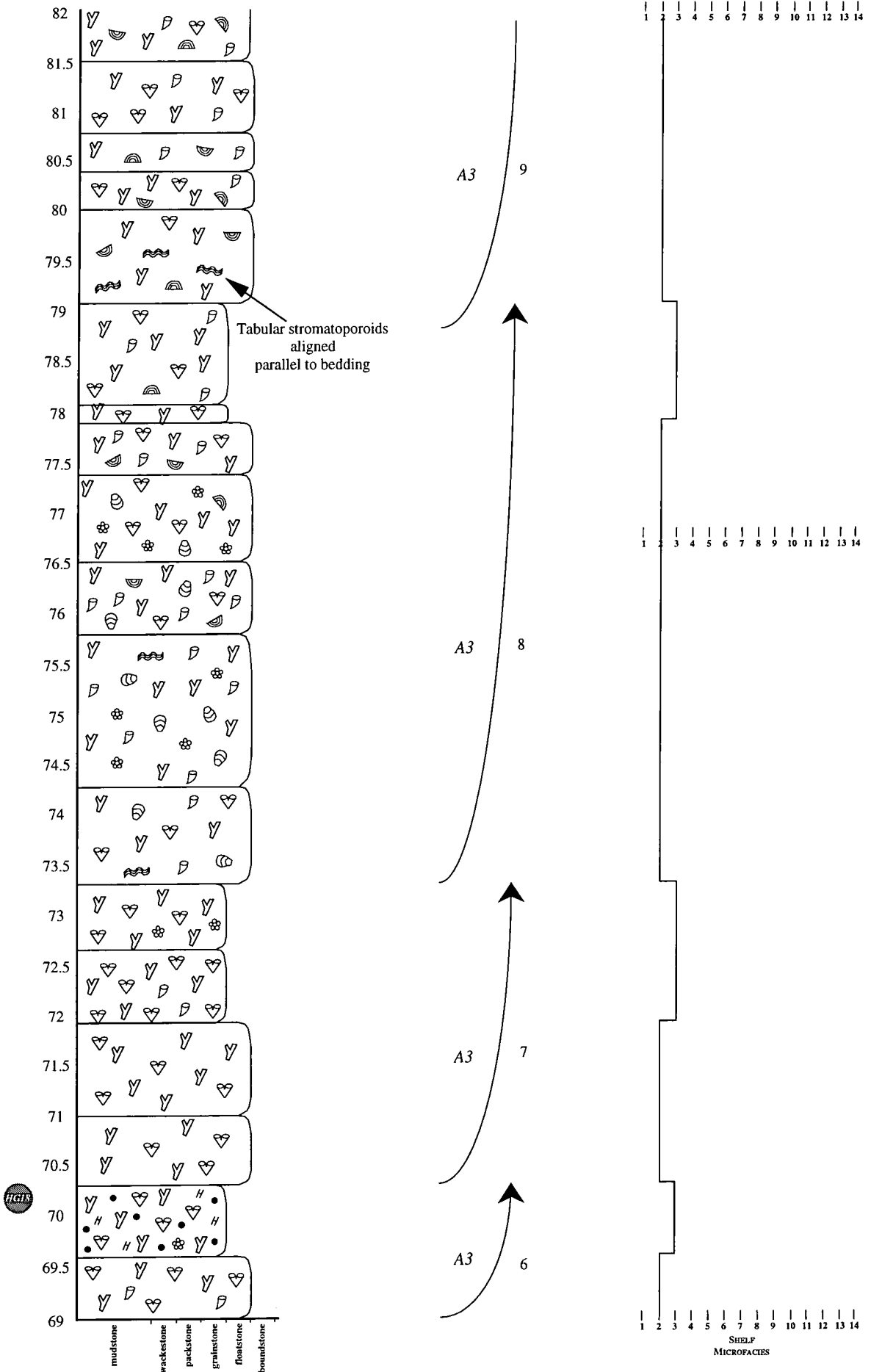

Heggen quarry

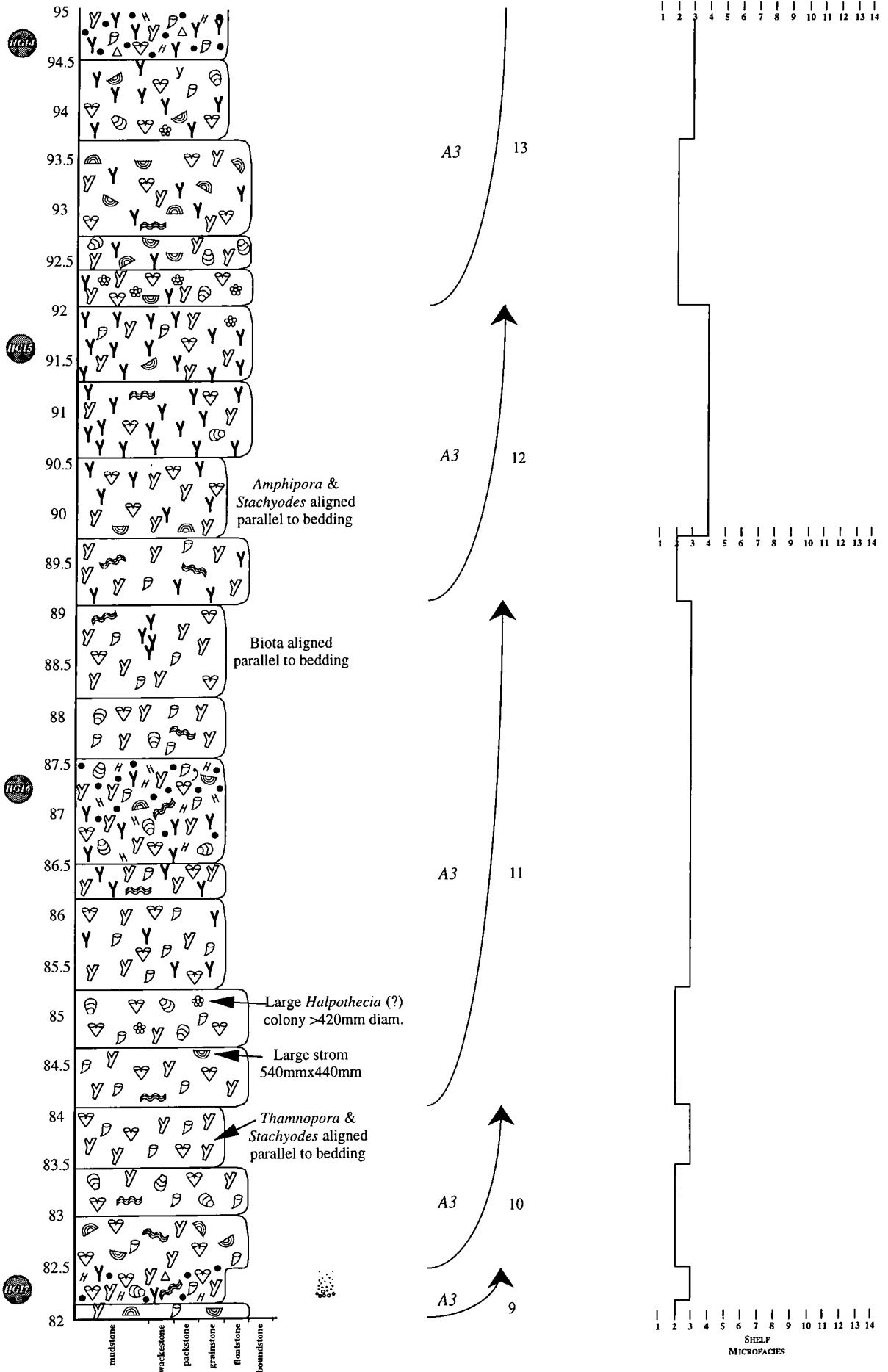

Heggen quarry

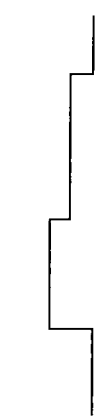
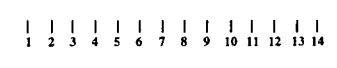
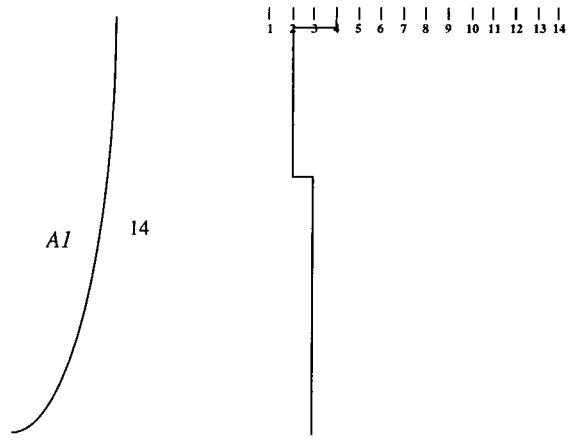
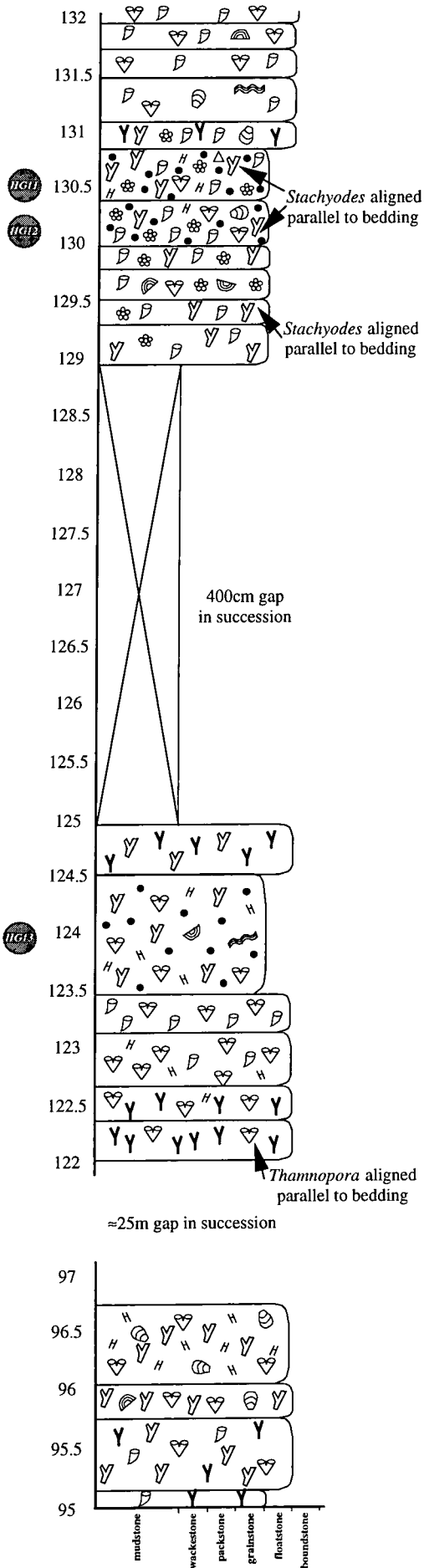

Heggen quarry

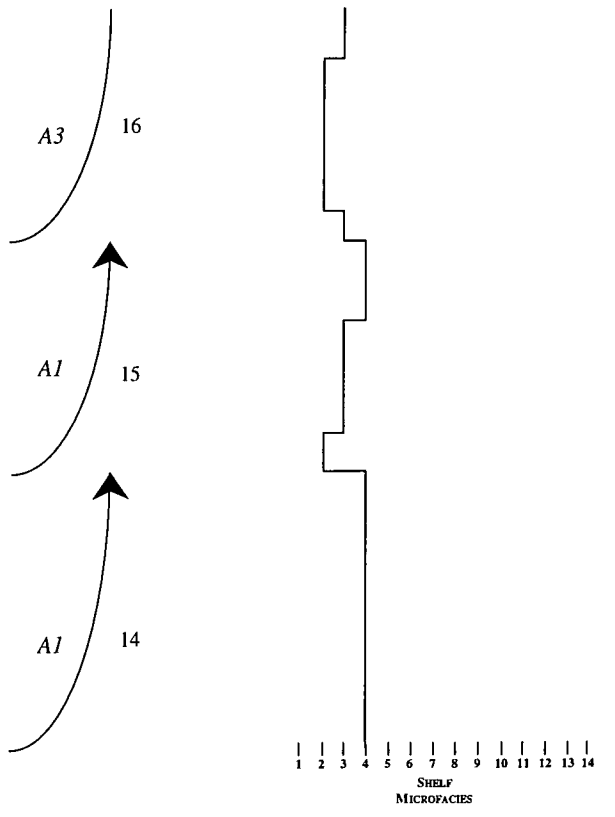
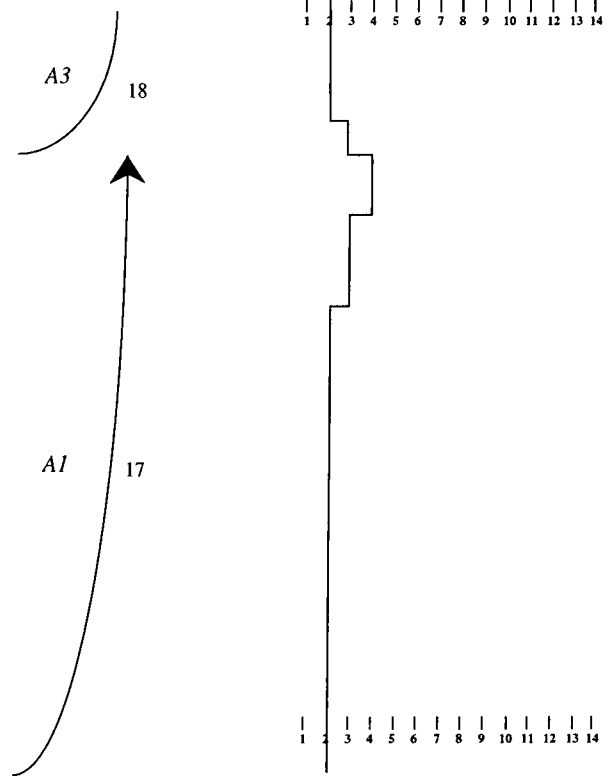
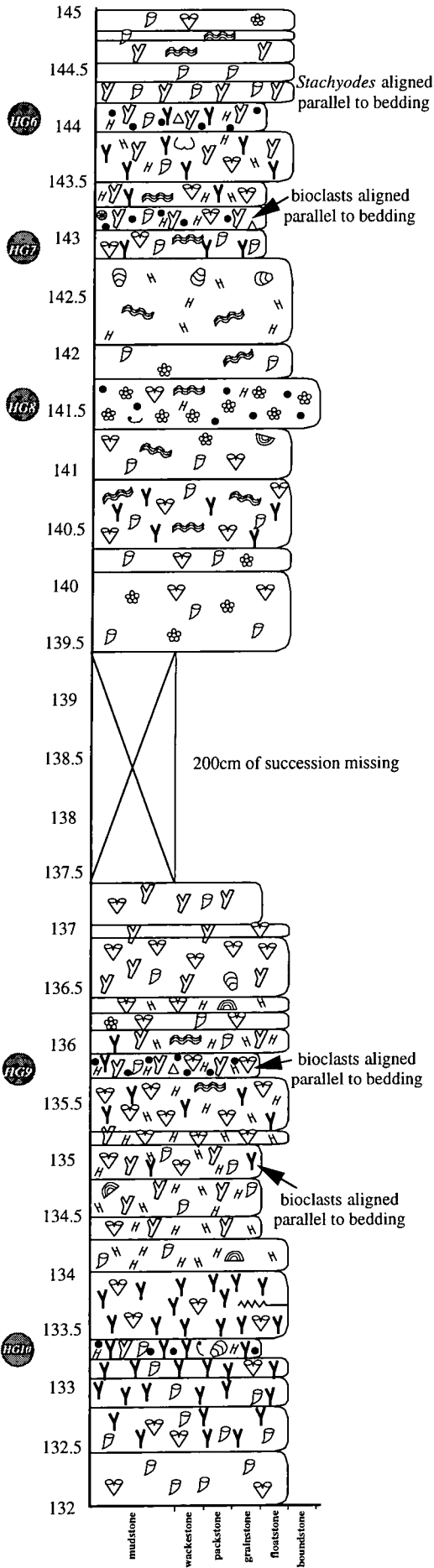

Heggen quarry

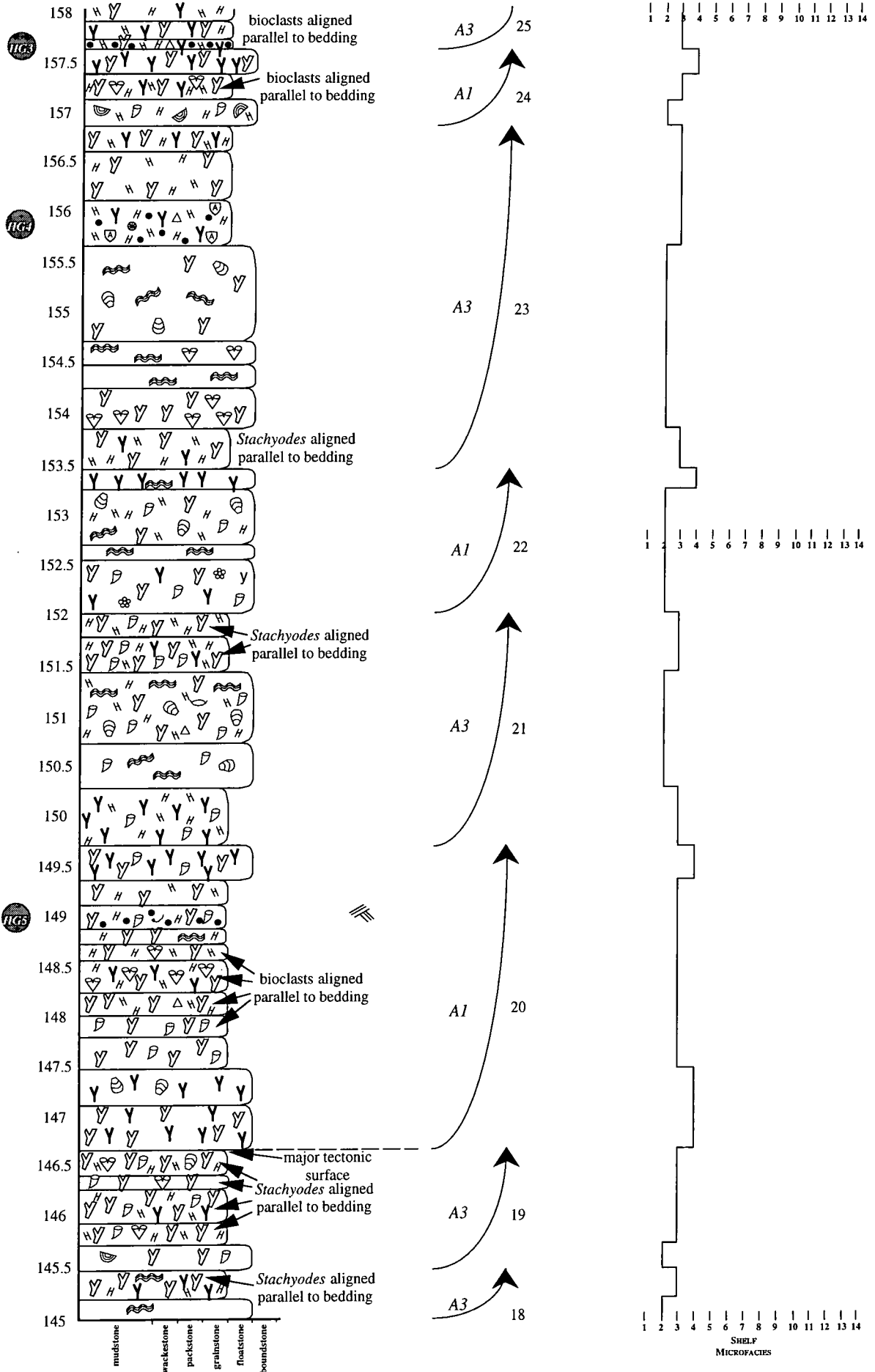

Heggen quarry

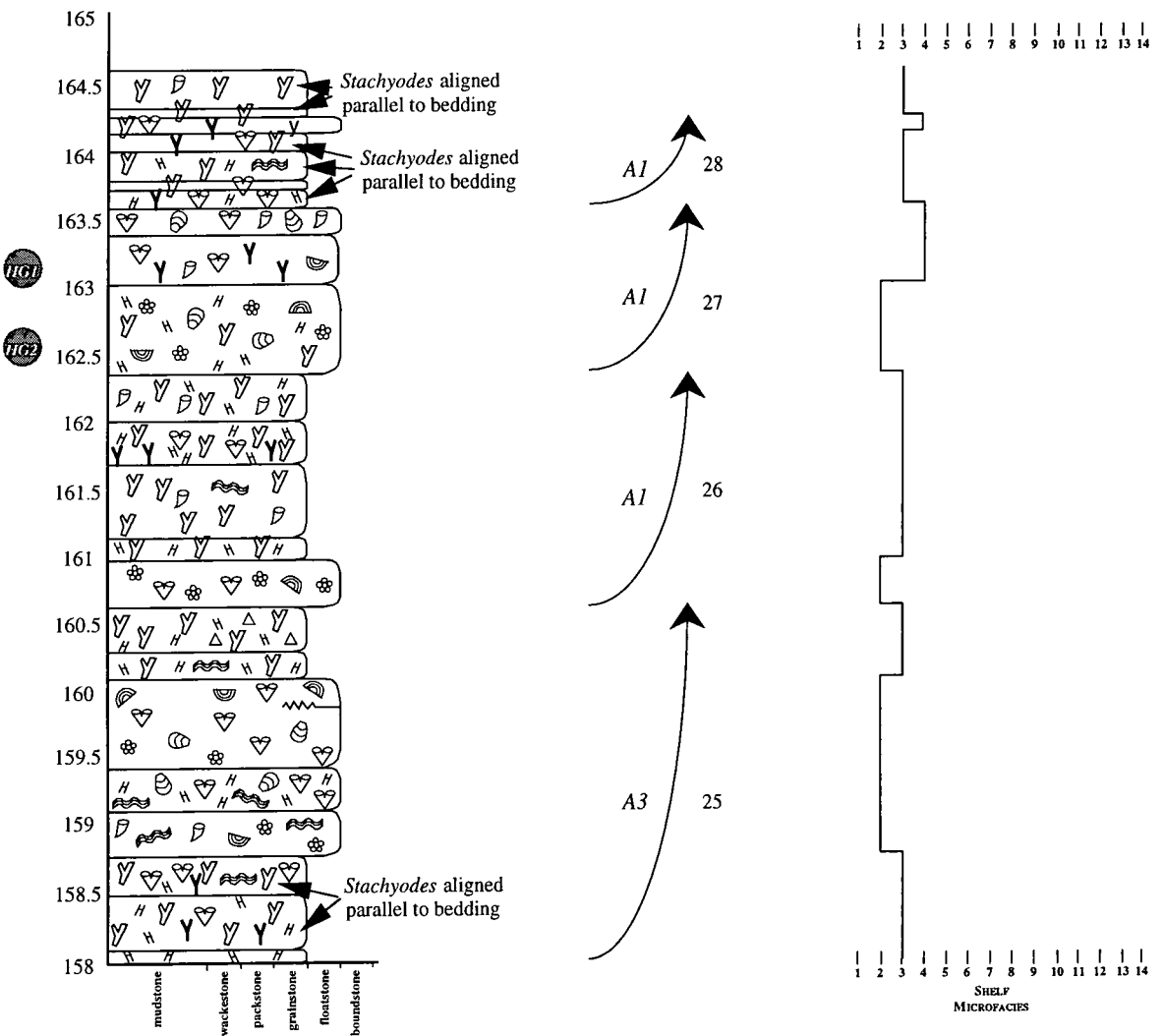

**A2.14 Keldenich quarry**

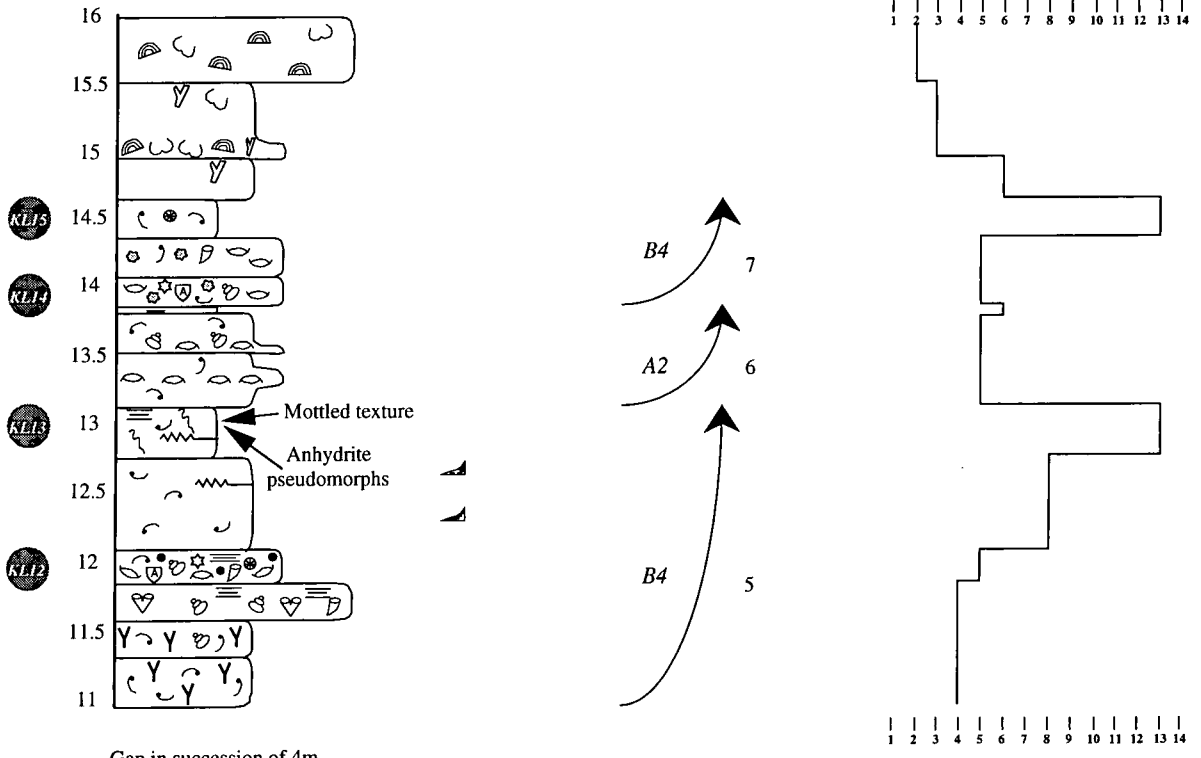

Gap in succession of 4m

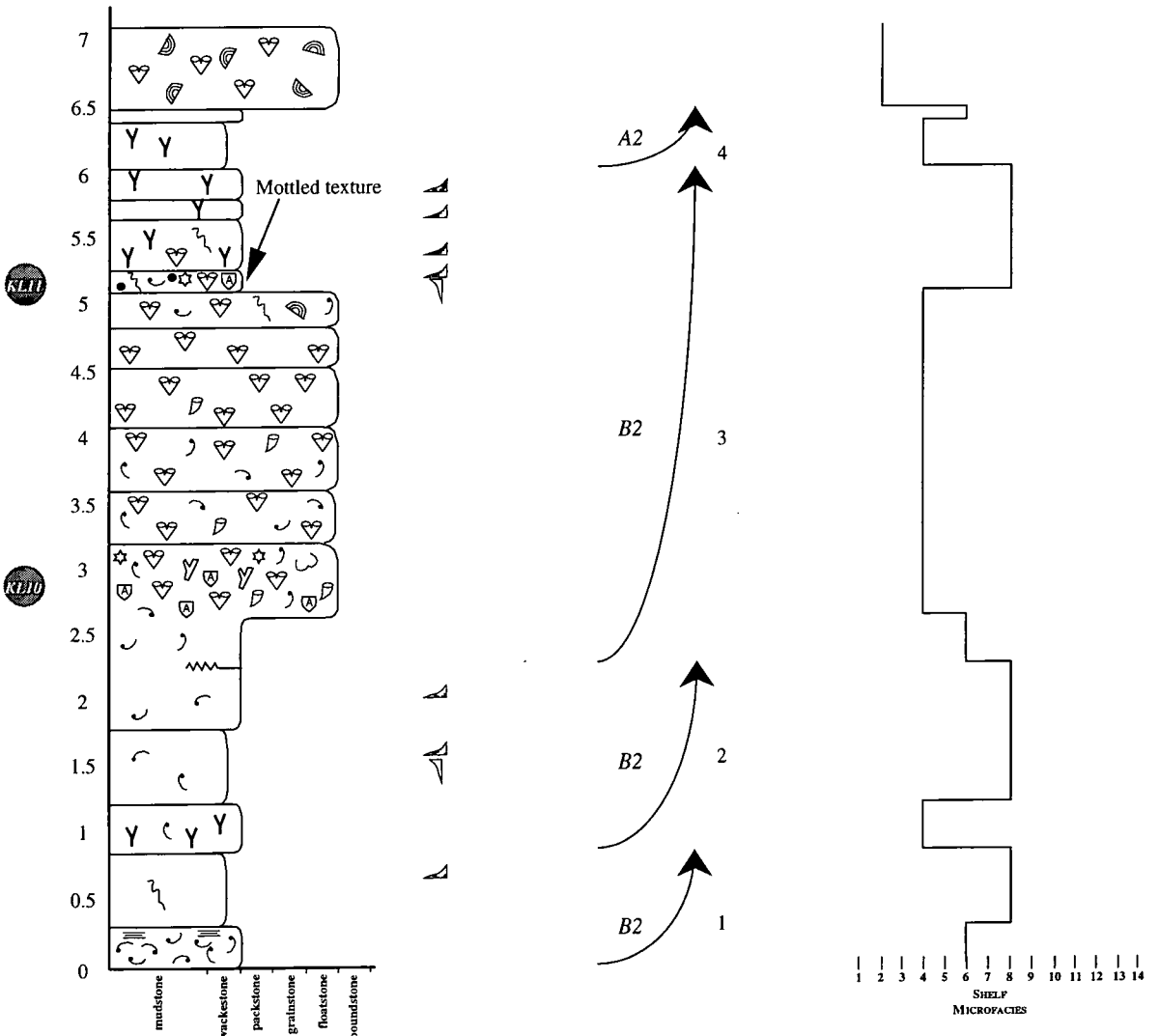

**Keldenich quarry**

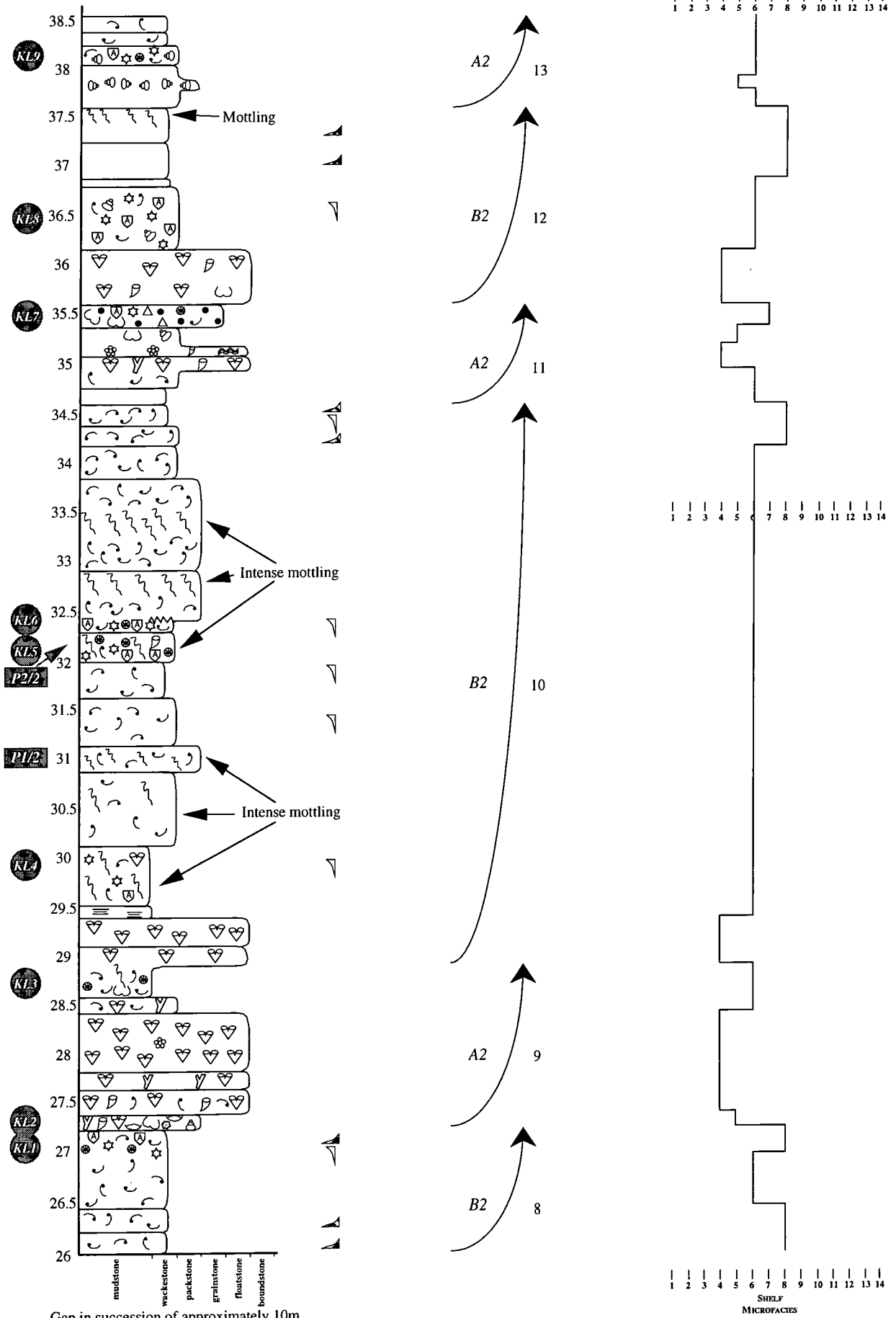

Gap in succession of approximately 10m

A2.15 Linhay Hill quarry

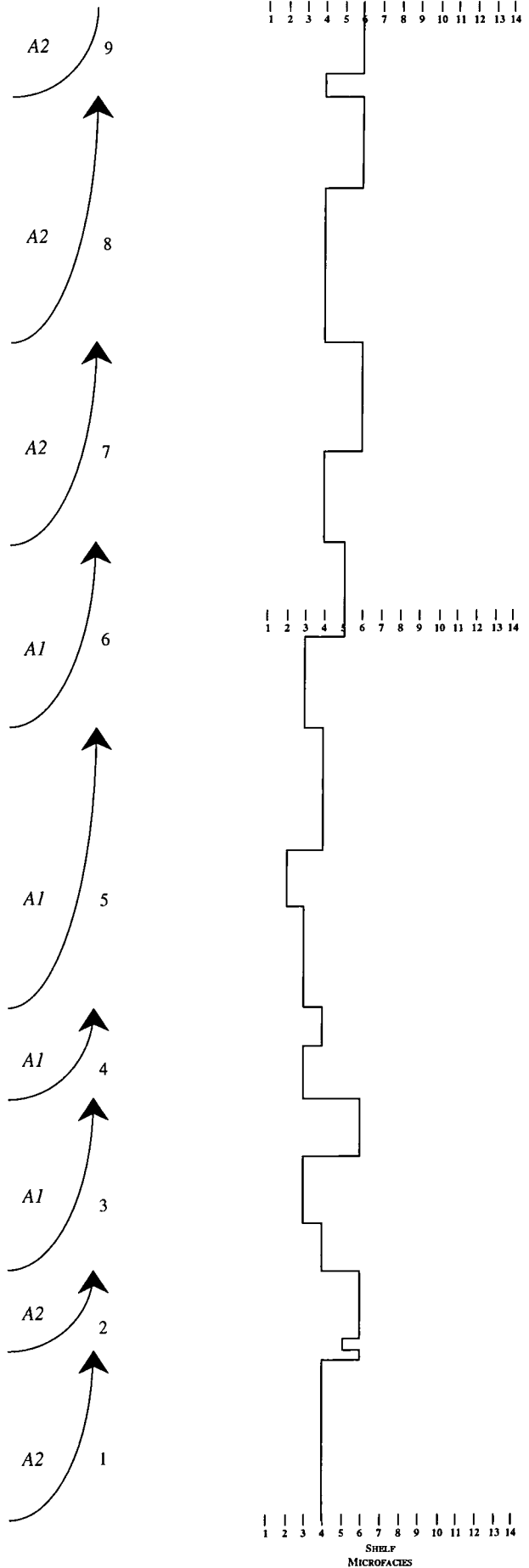
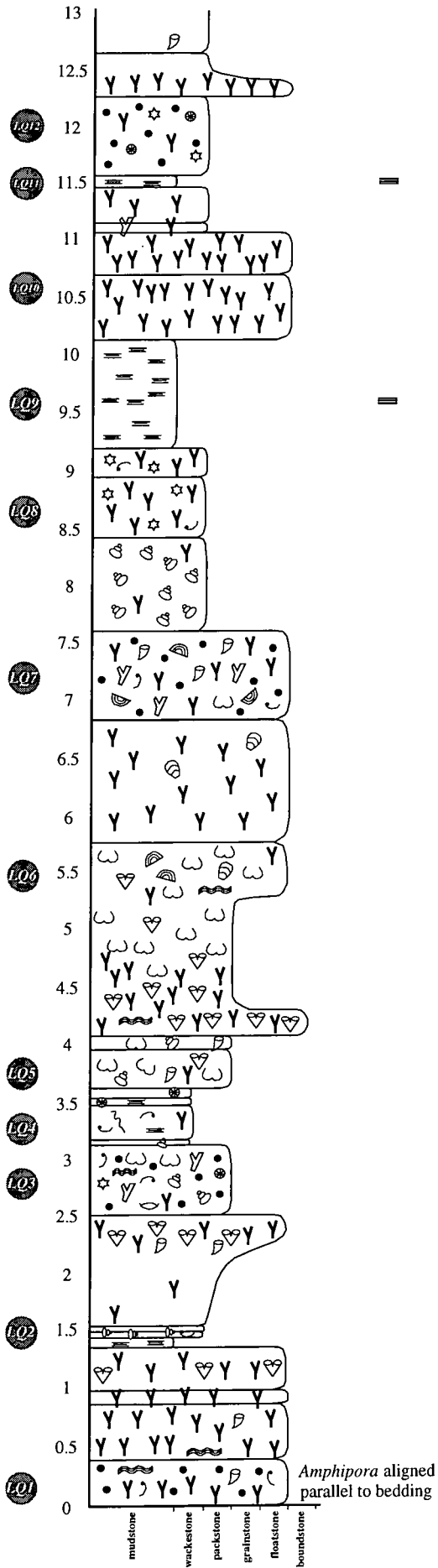

Linhay Hill quarry

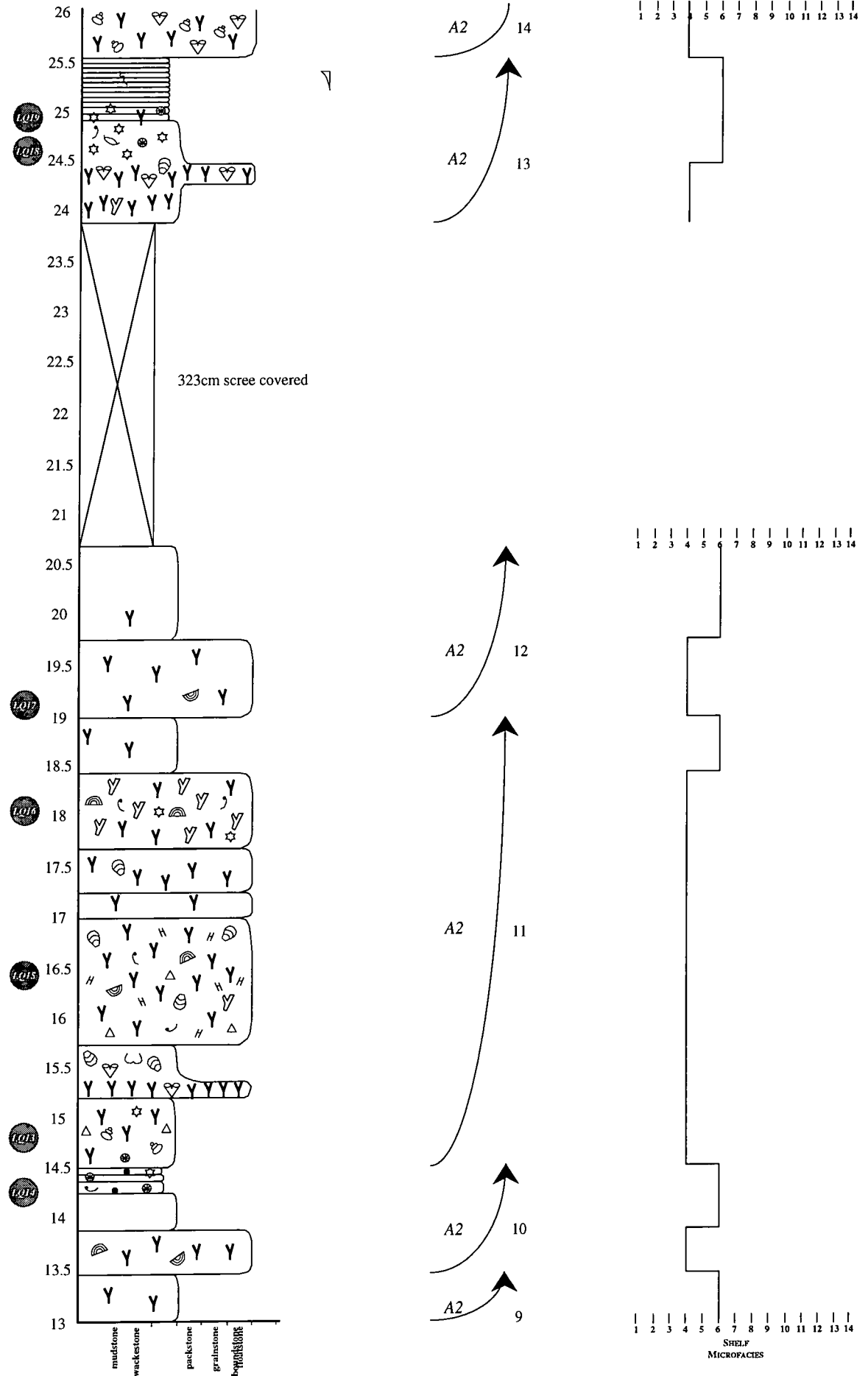

**Linhay Hill quarry**

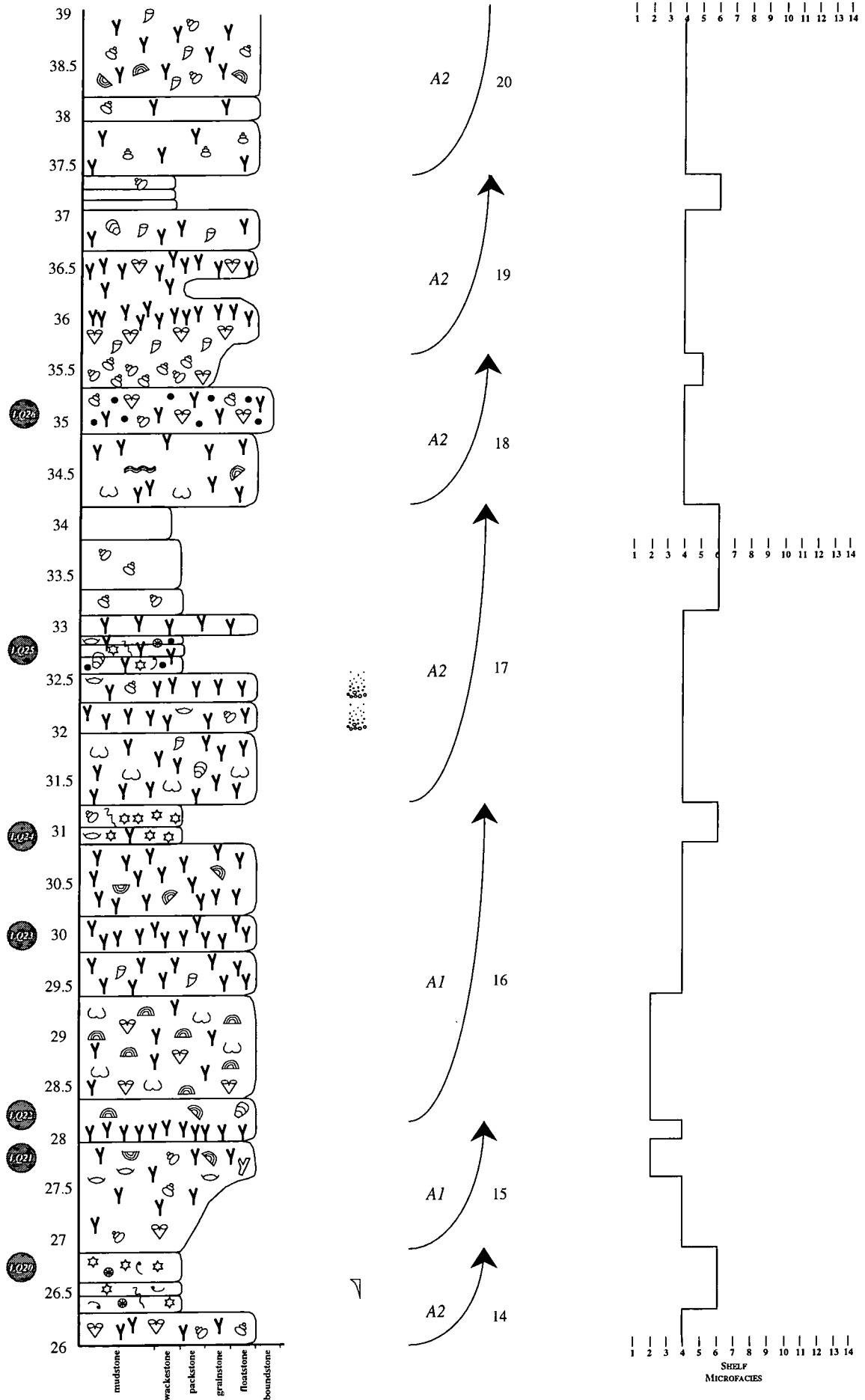

Linhay Hill quarry

1 2 3 4 5 6 7 8 9 10 11 12 13 14

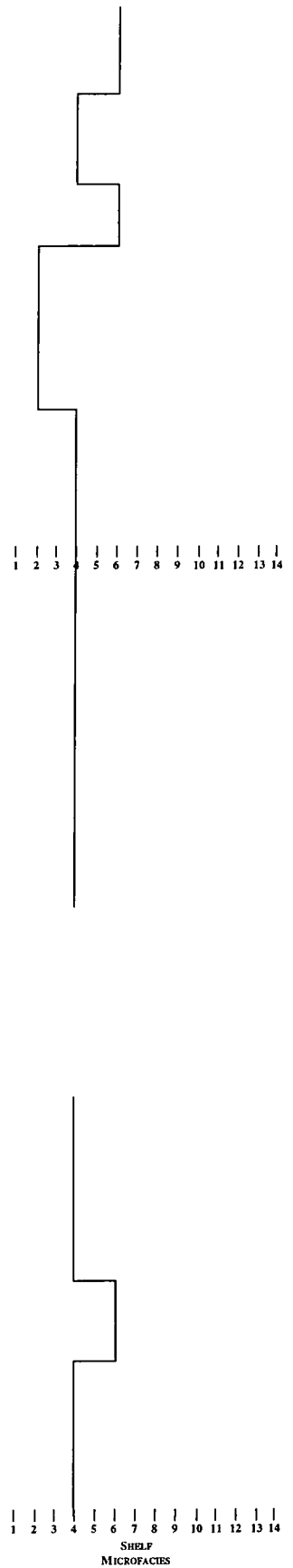
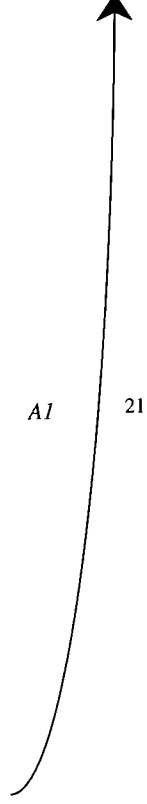
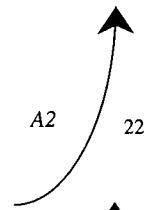
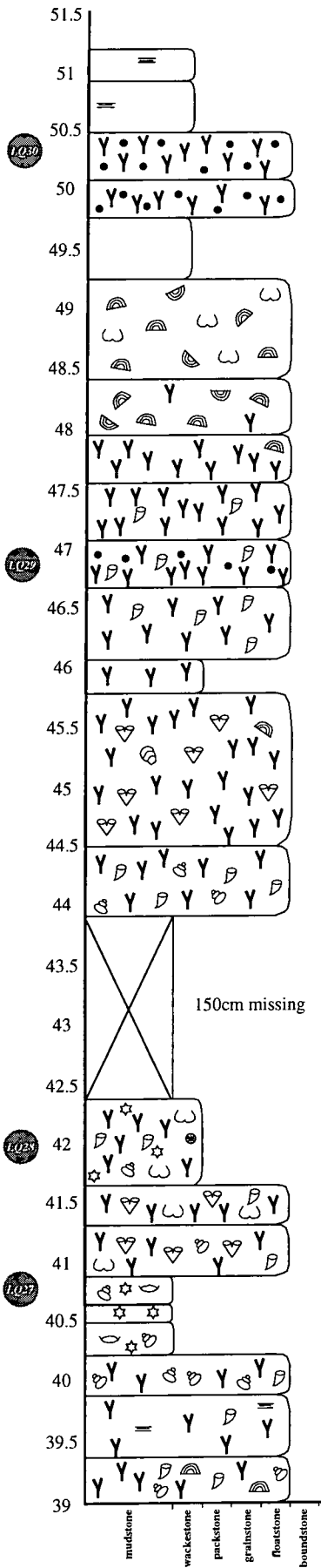

A2.16 Medenbach quarry

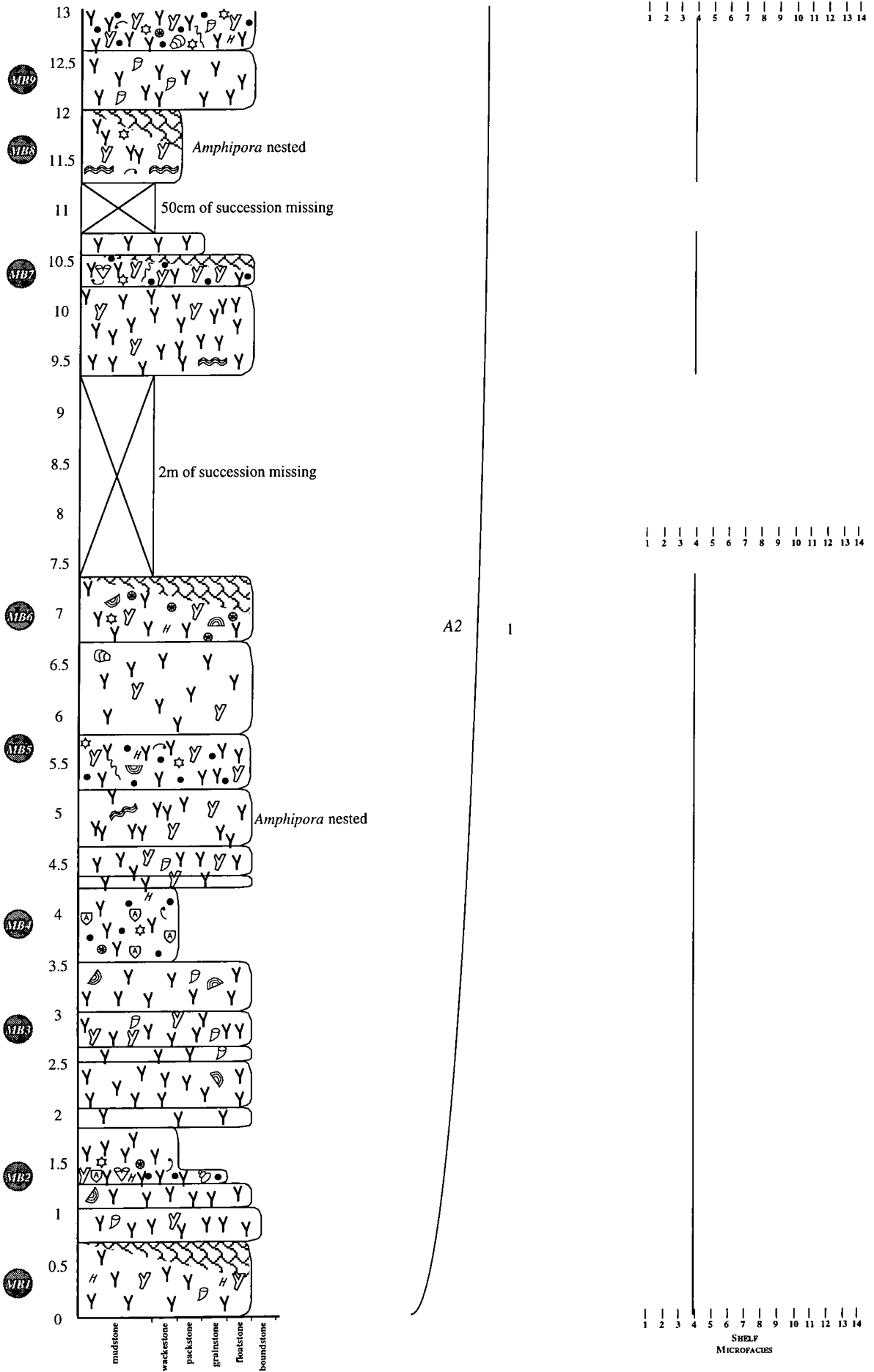

Medenbach quarry

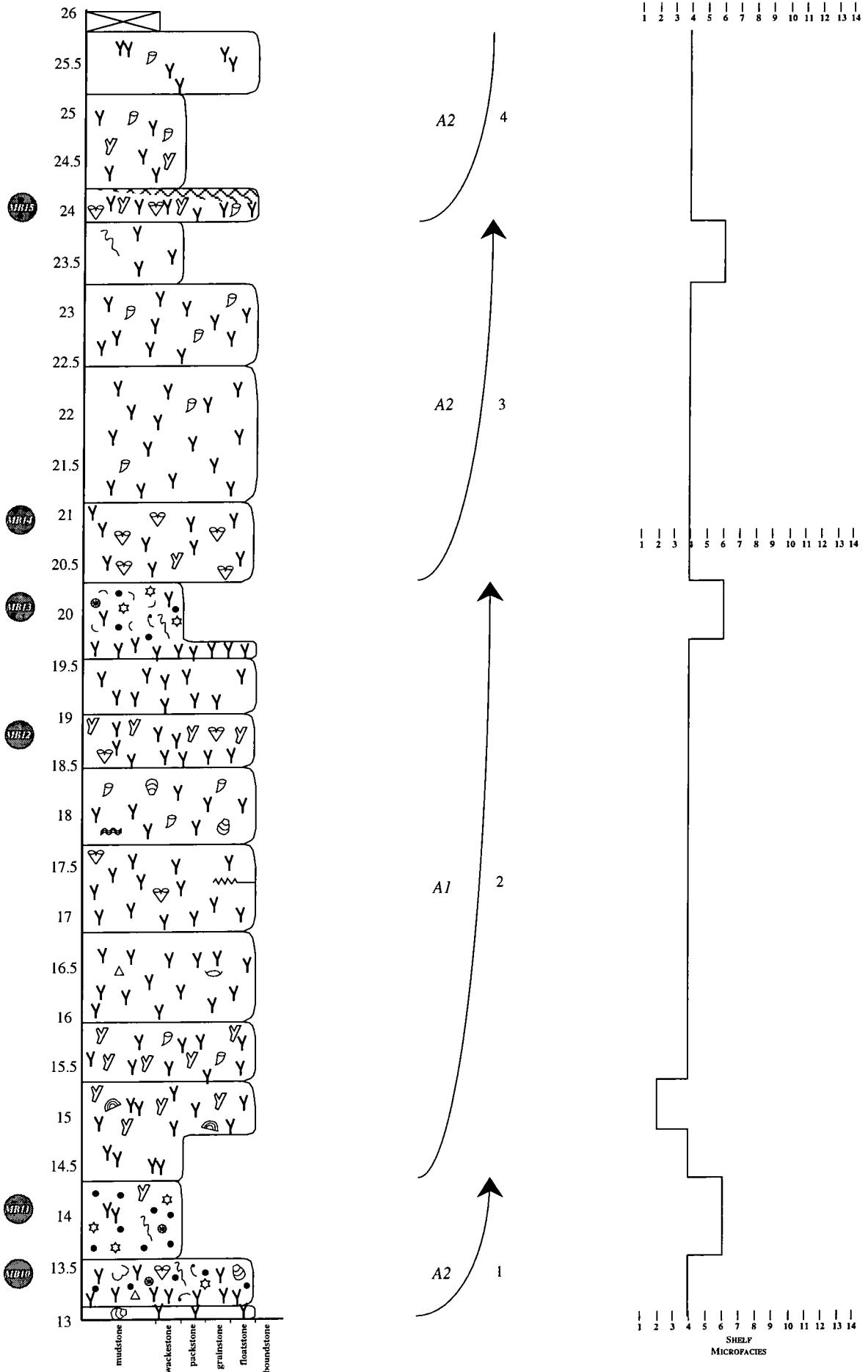

Medenbach quarry

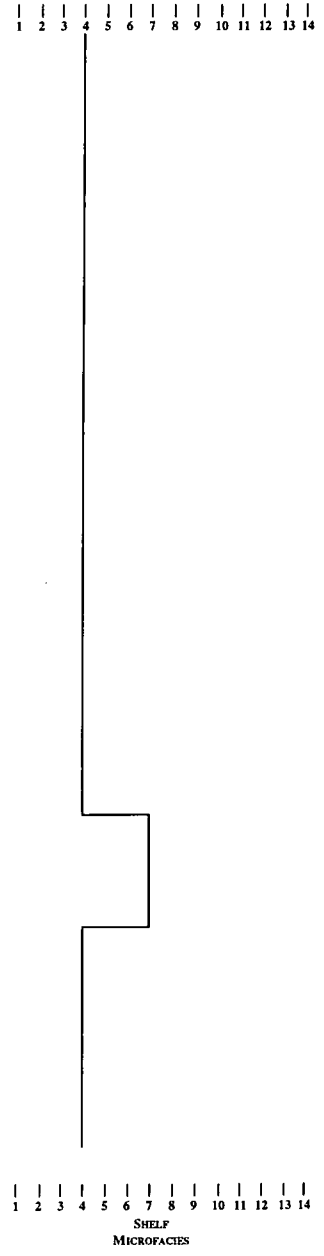
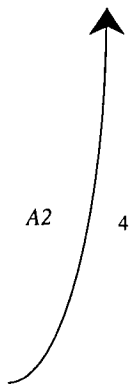
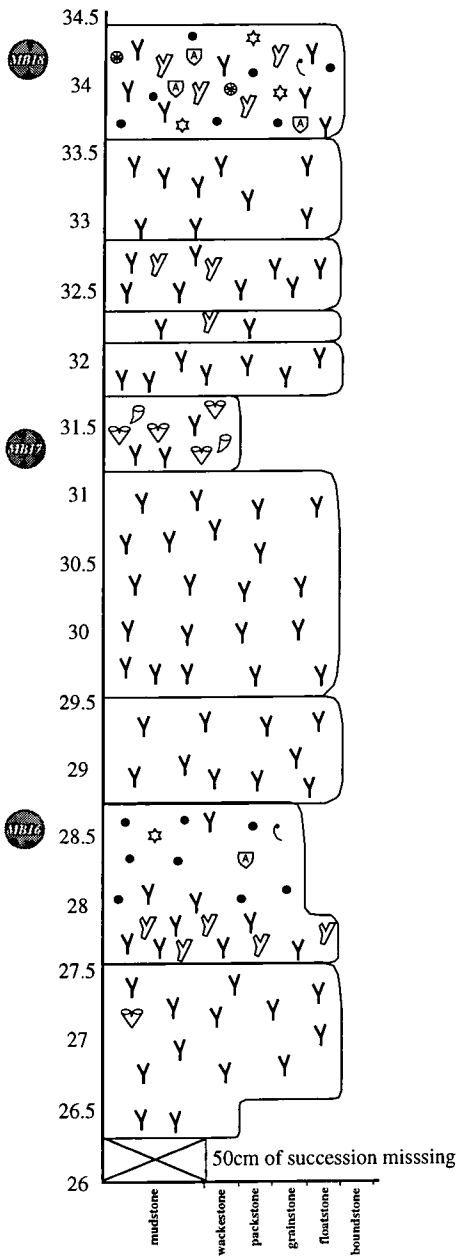

A2.17 Nismes quarry

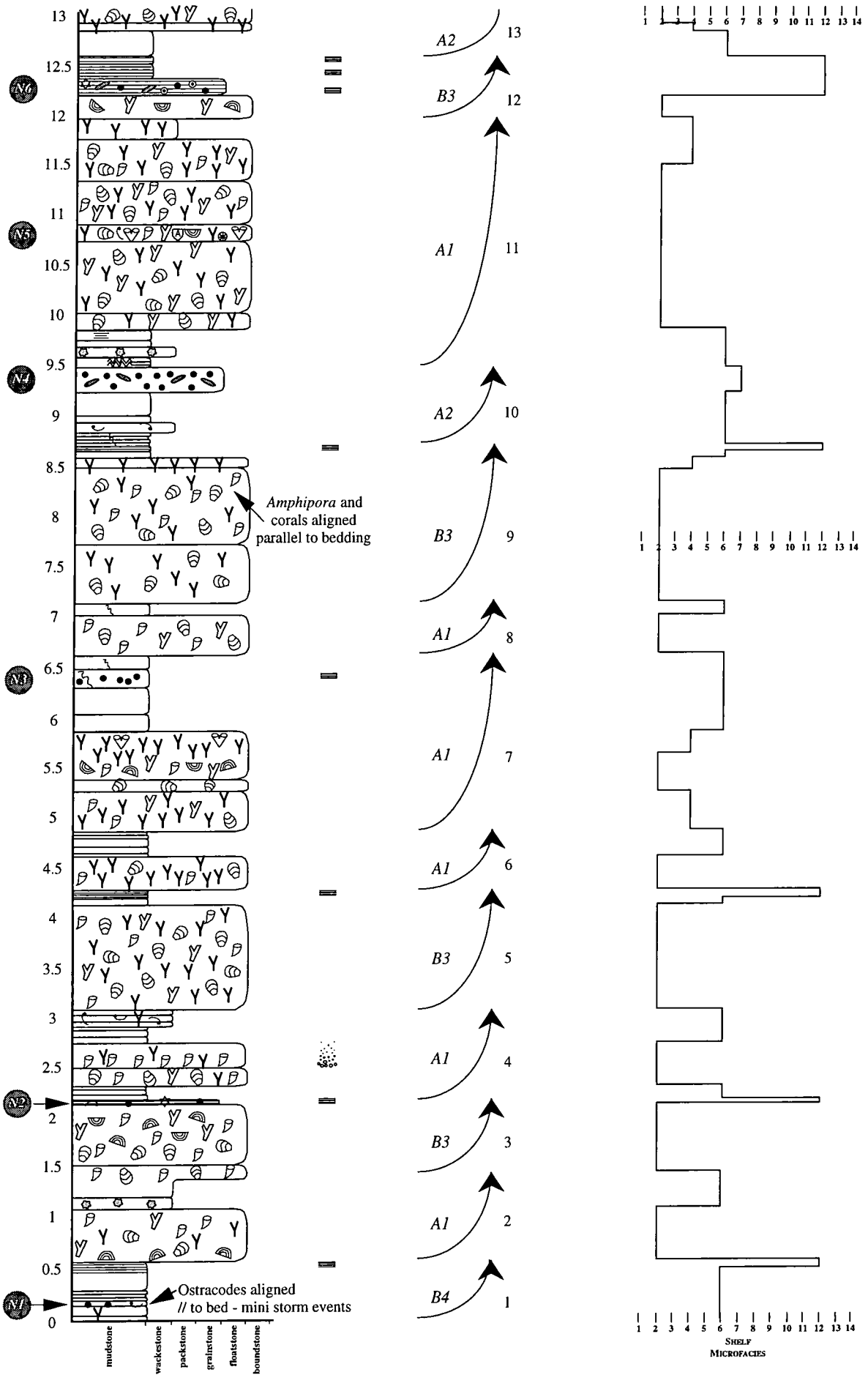

Nismes quarry

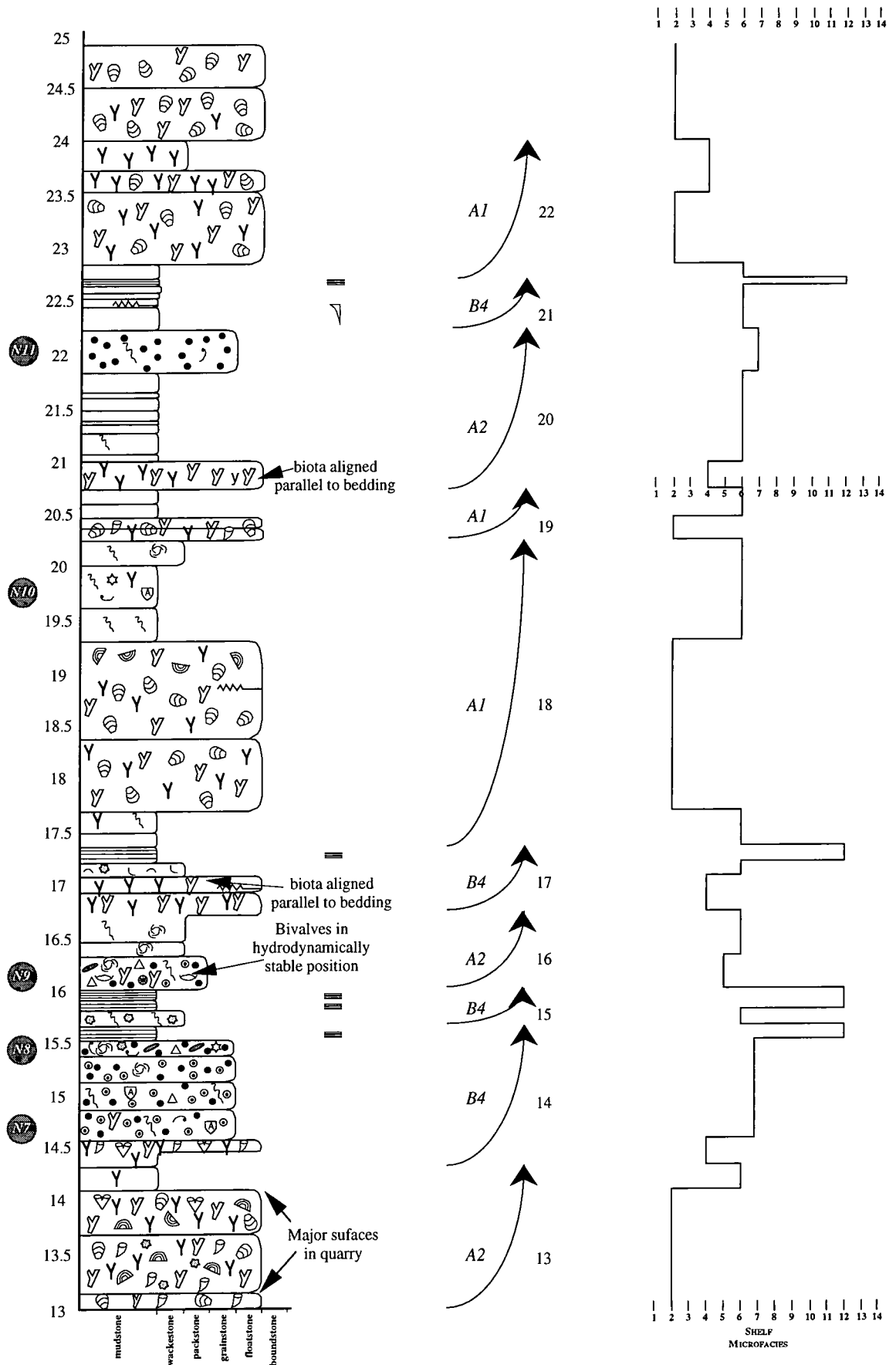

**A2.18 Oberrödinghausen quarry**

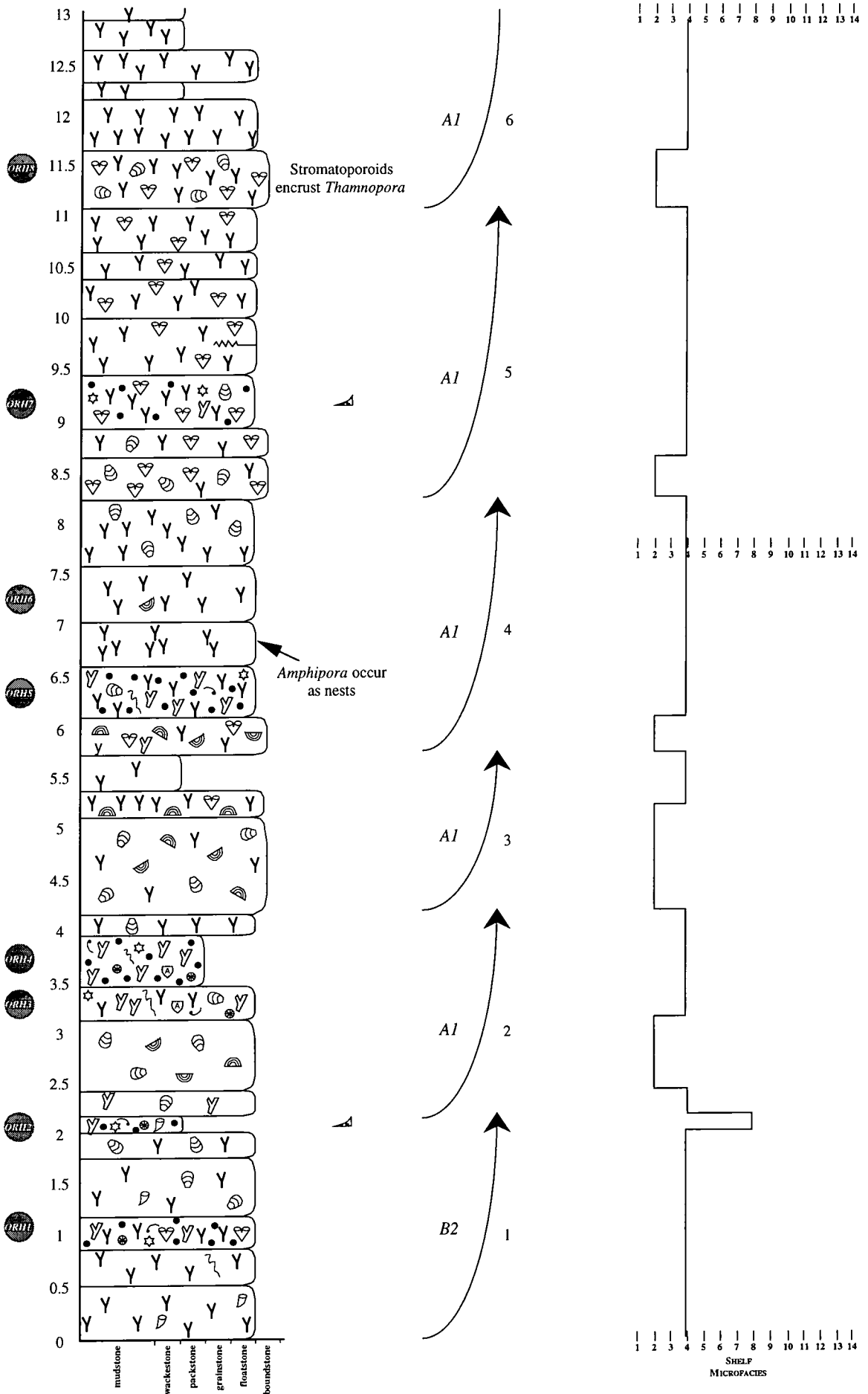

Oberrödinghausen quarry

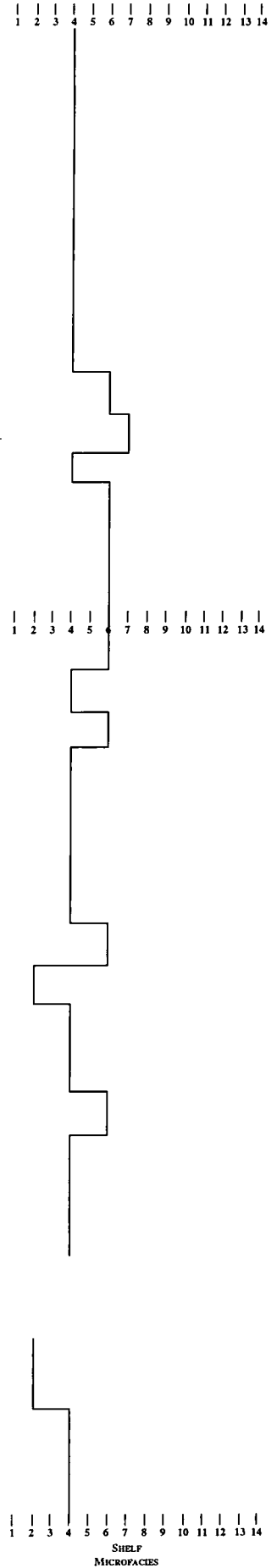
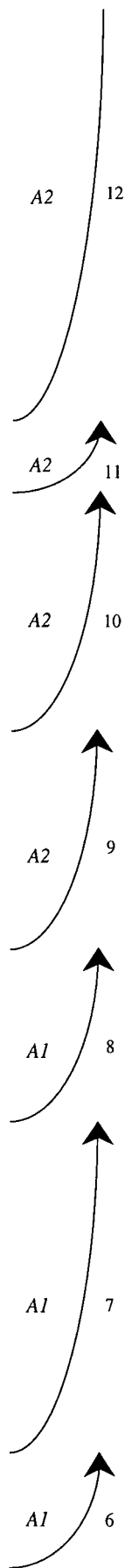
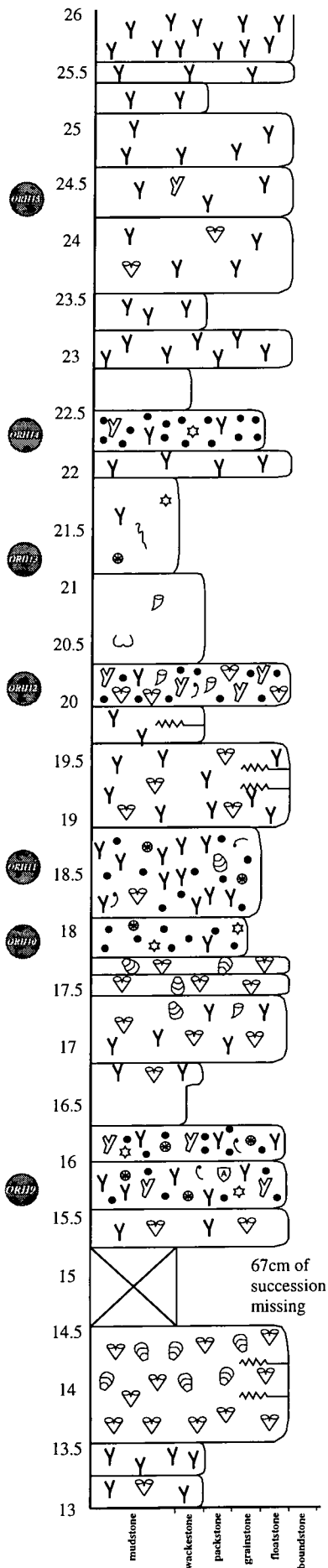

Oberrödinghausen quarry

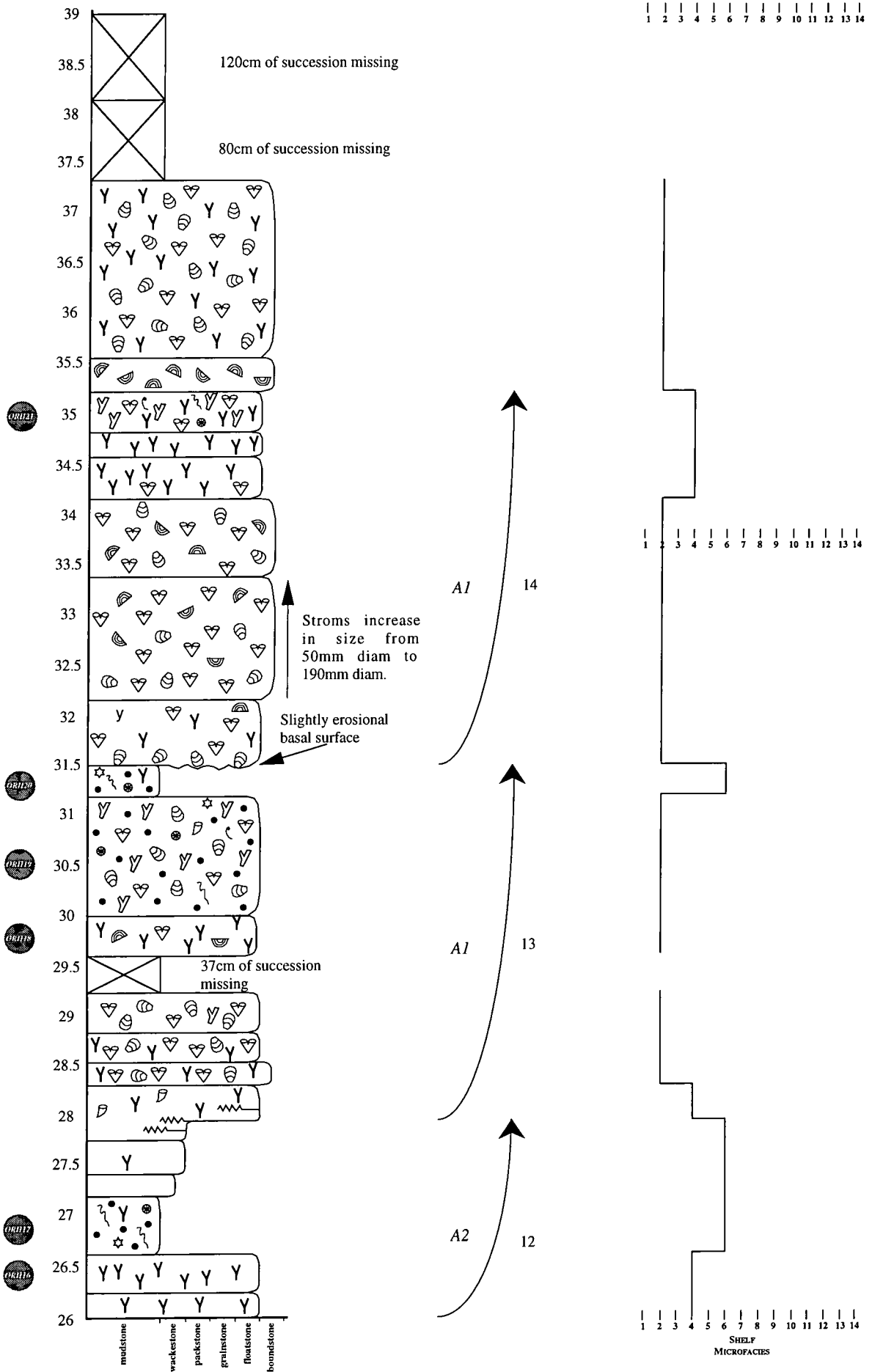

Oberrödinghausen quarry

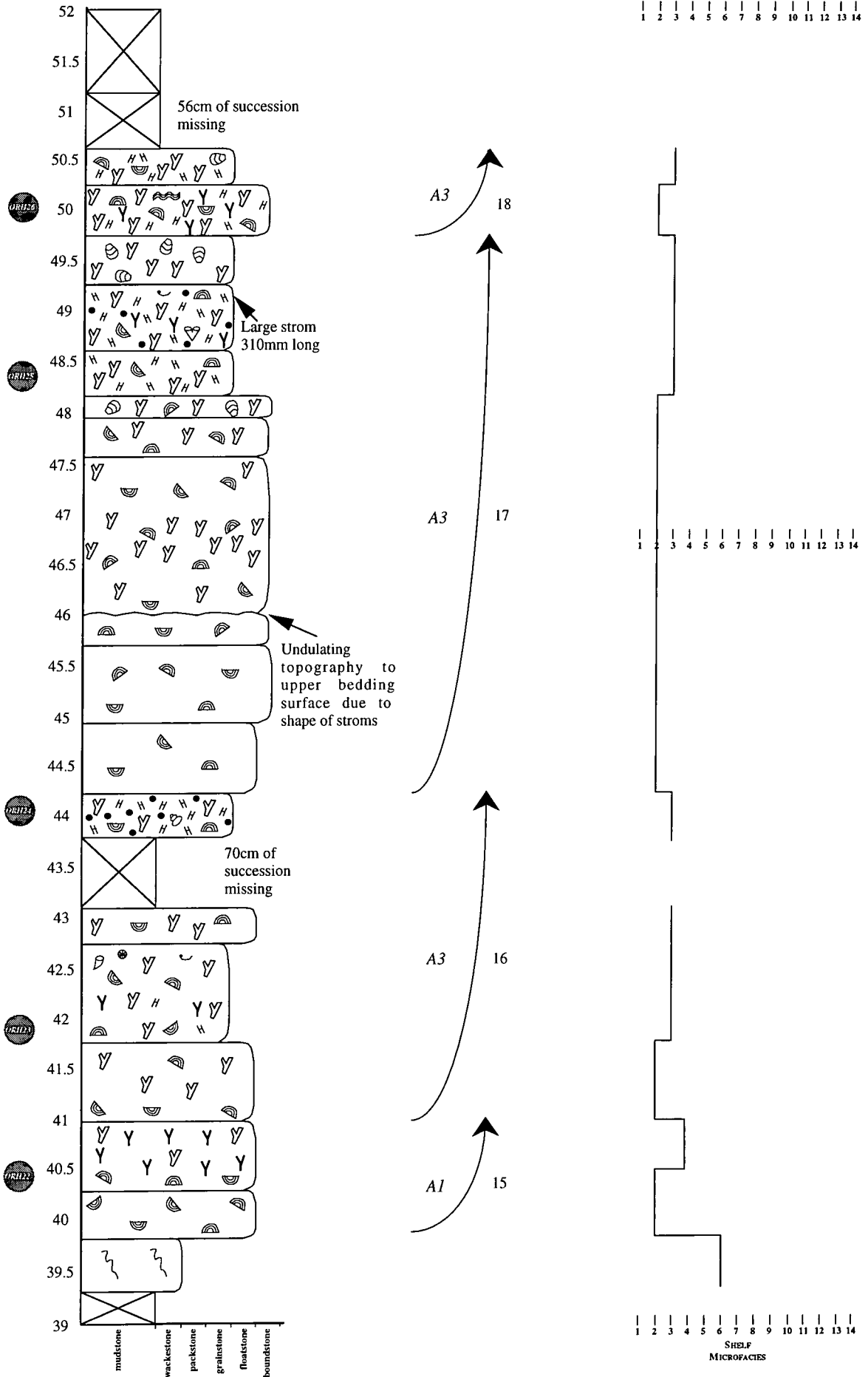

**Oberrödinghausen quarry**

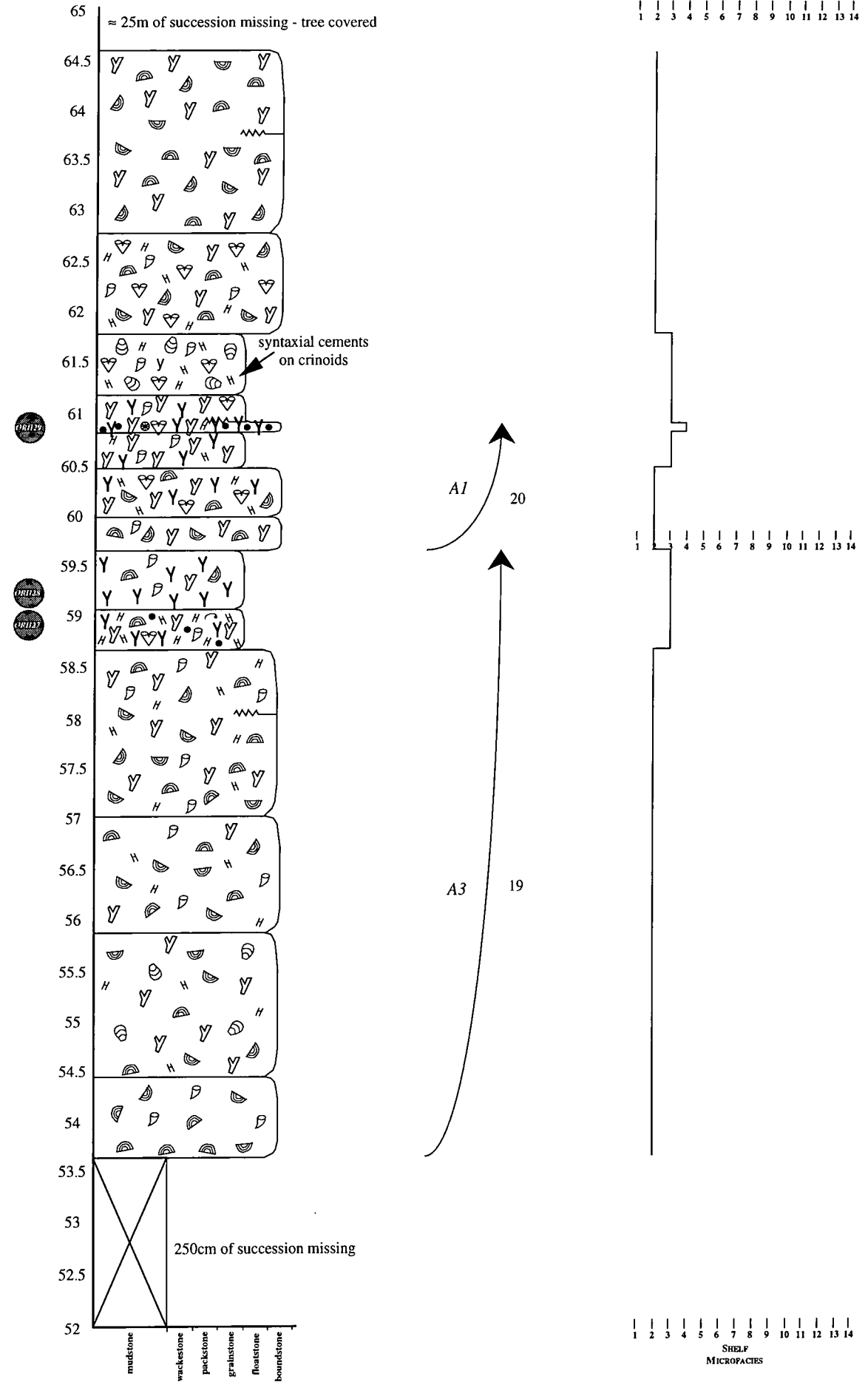

Oberrödinghausen quarry

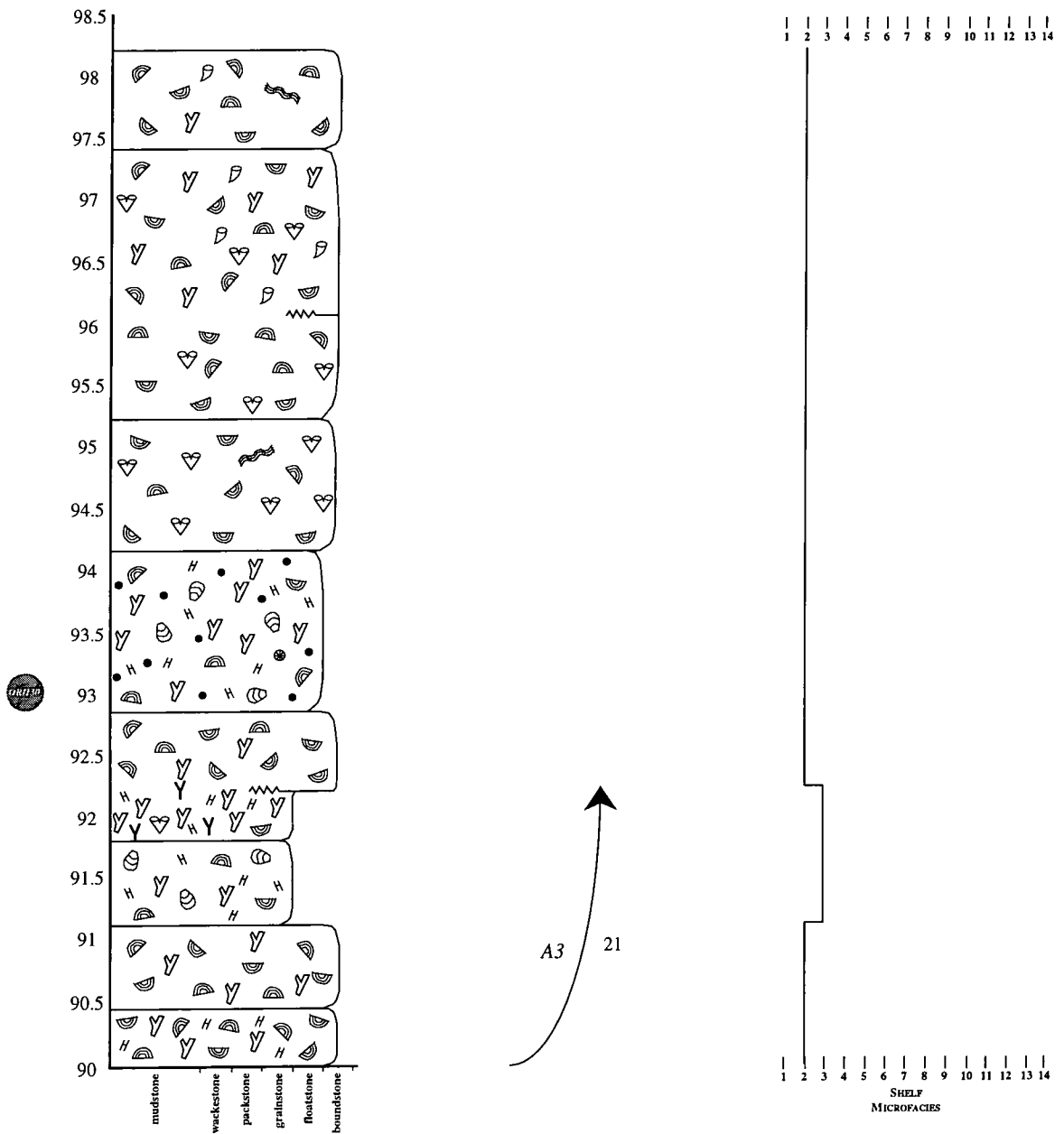

A2.19 Olloy-sur-Viroin quarry

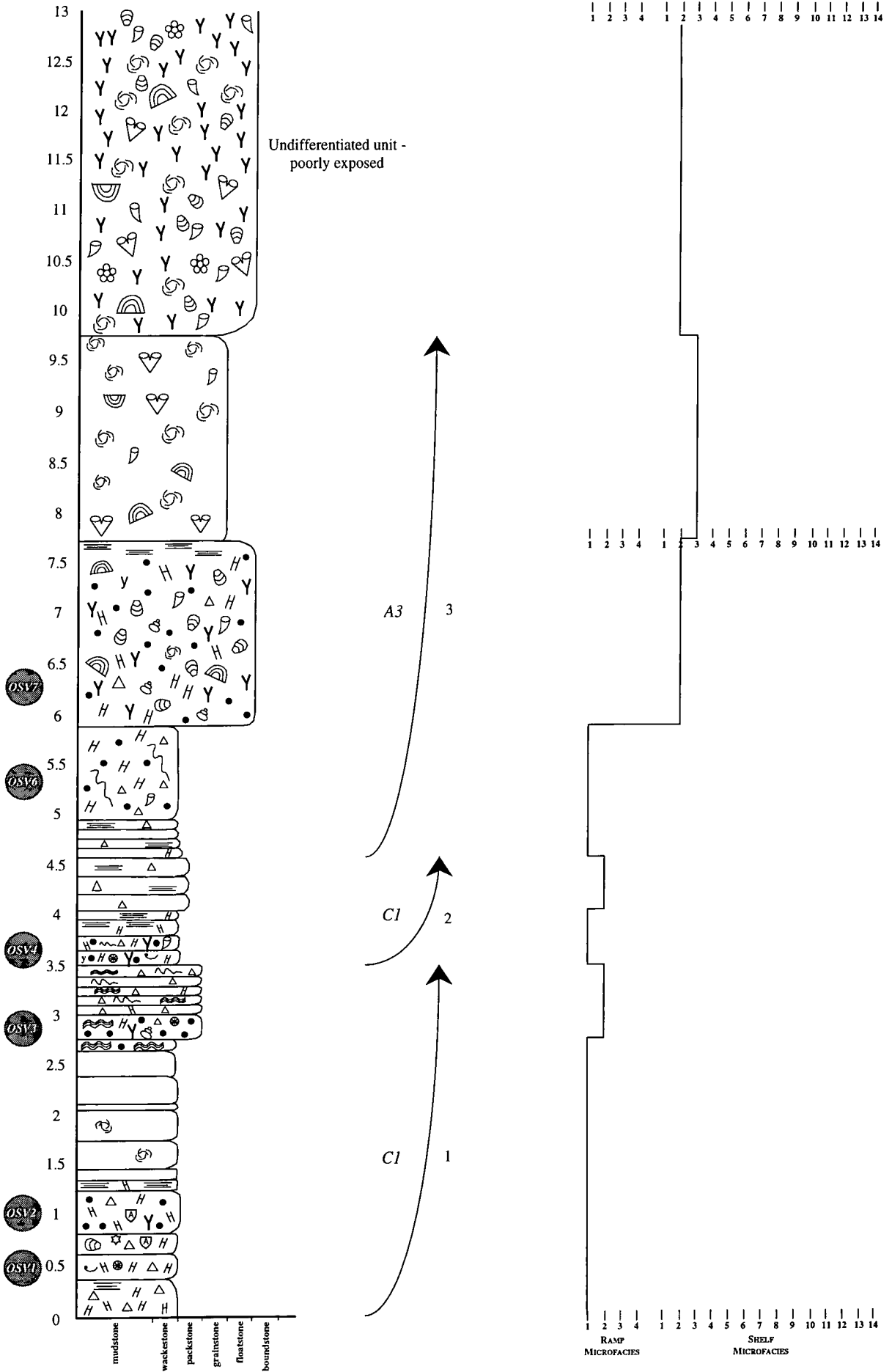

**Olloy-sur-Viroin quarry**

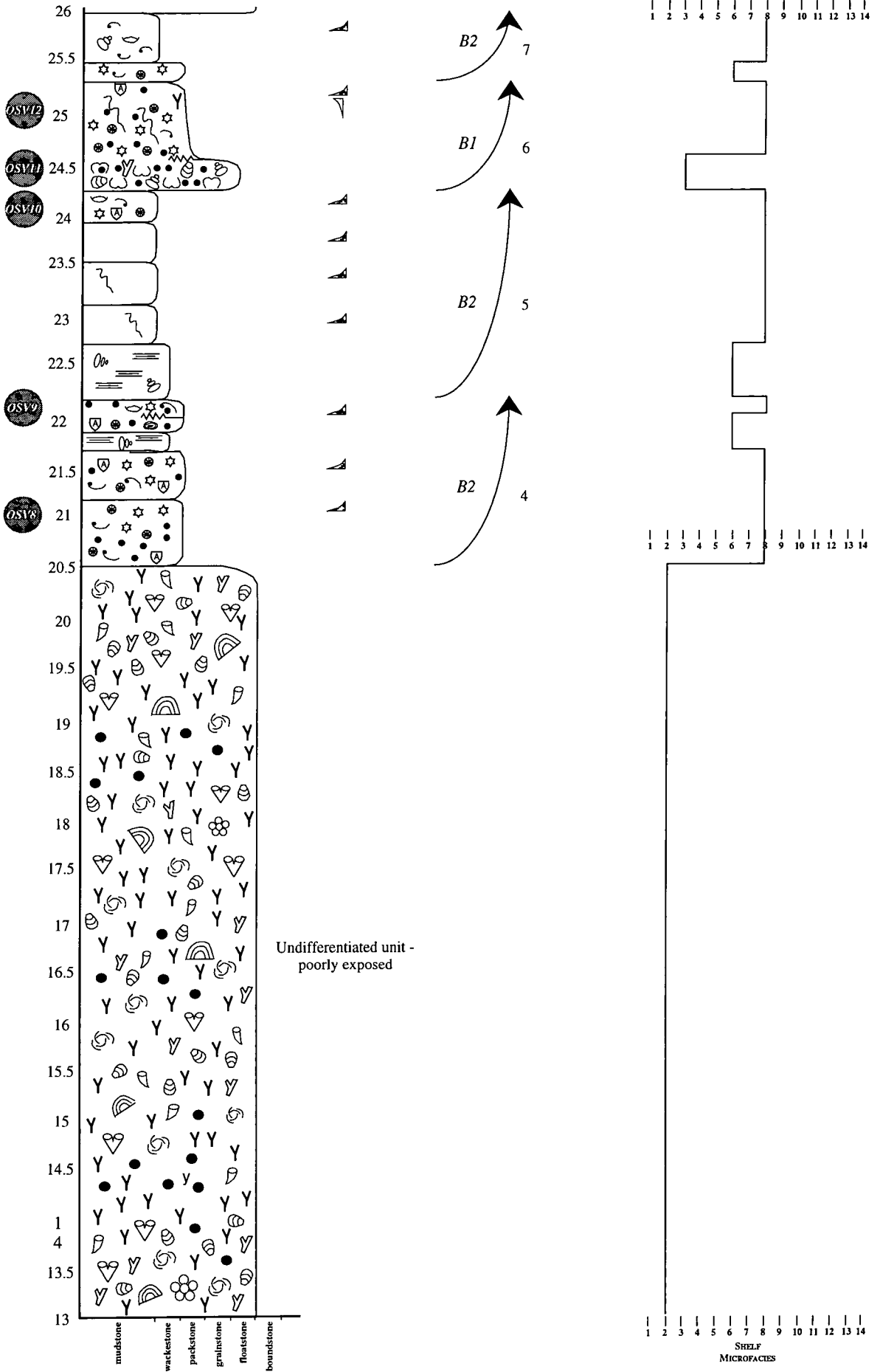

Olloy-sur-Viroin quarry

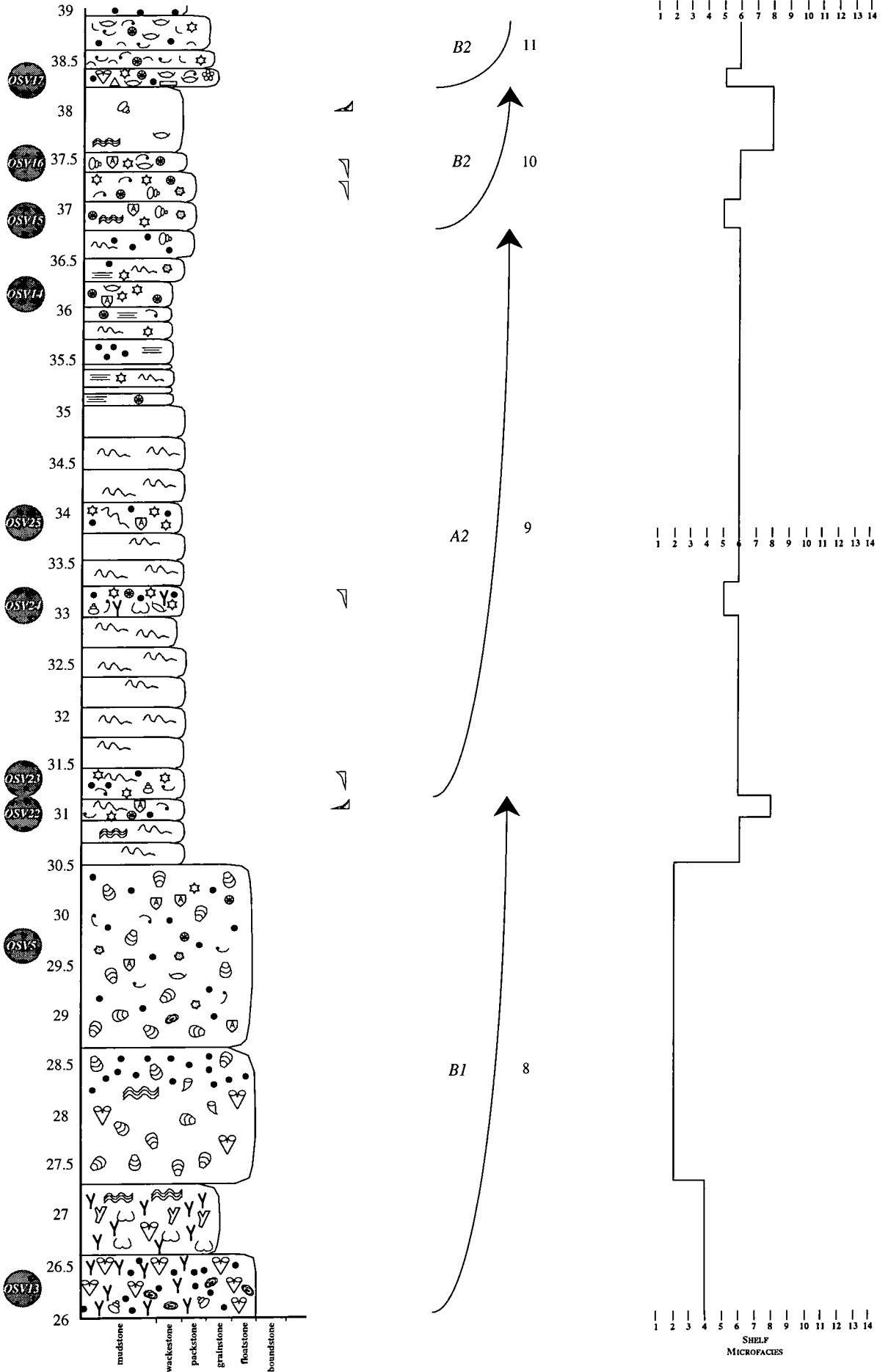

Olloy-sur-Viroin quarry

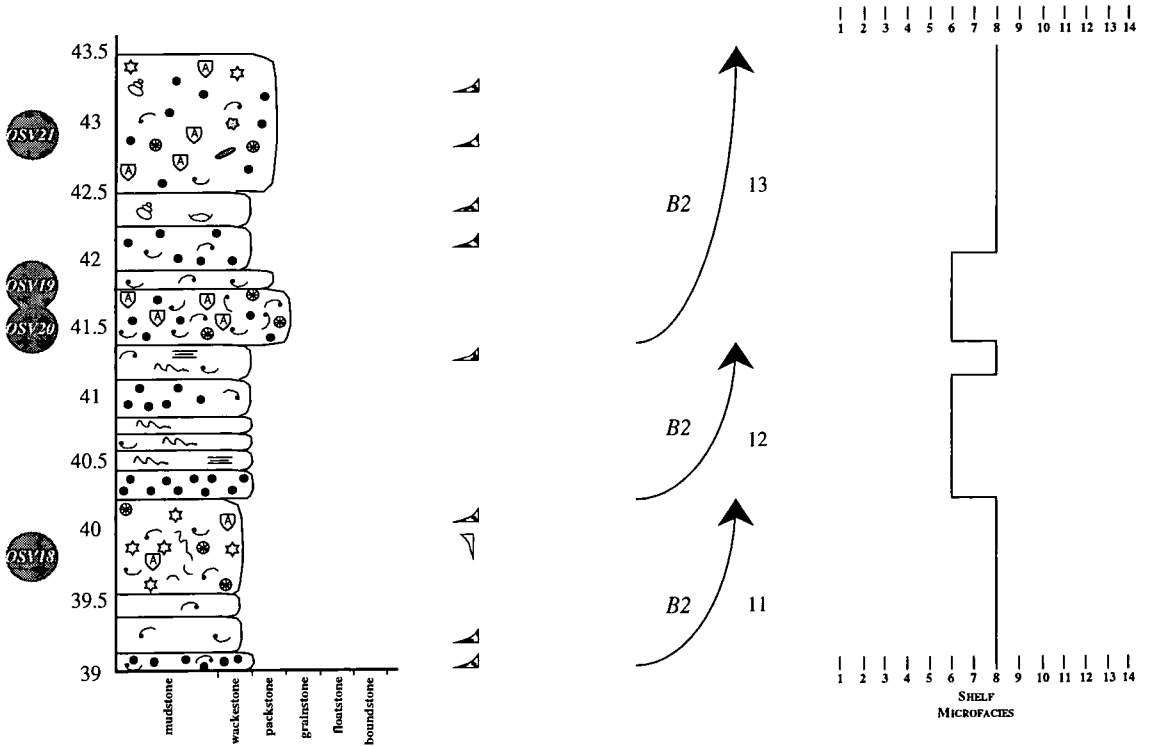

A2.20 Resteigne quarry

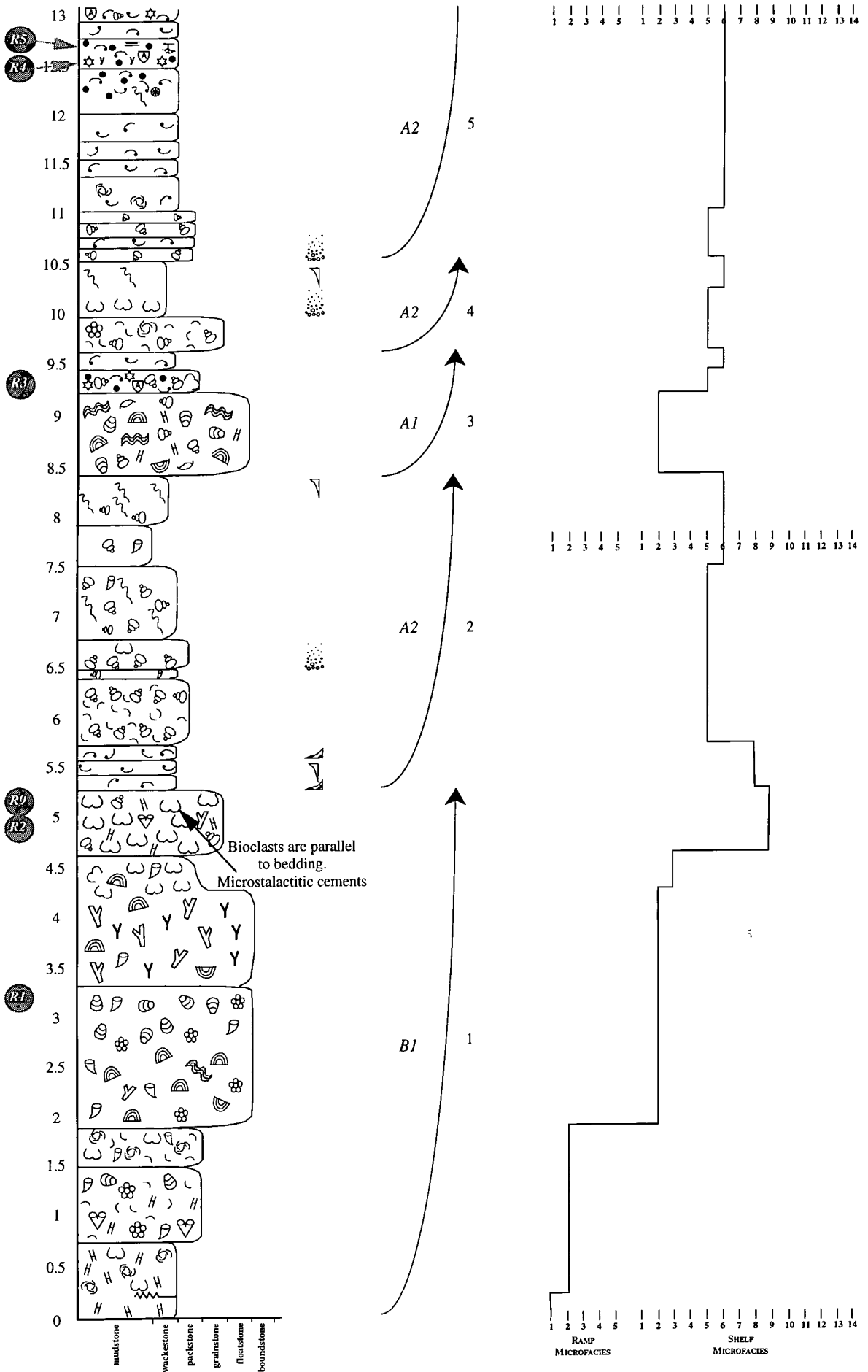

Resteigne quarry

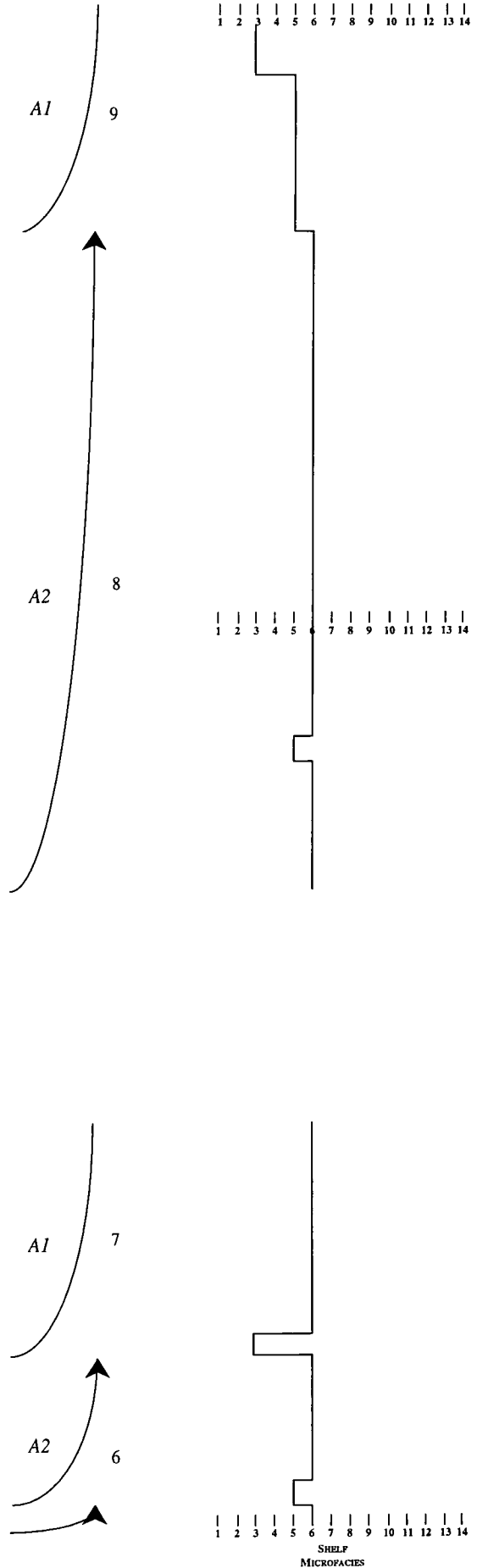
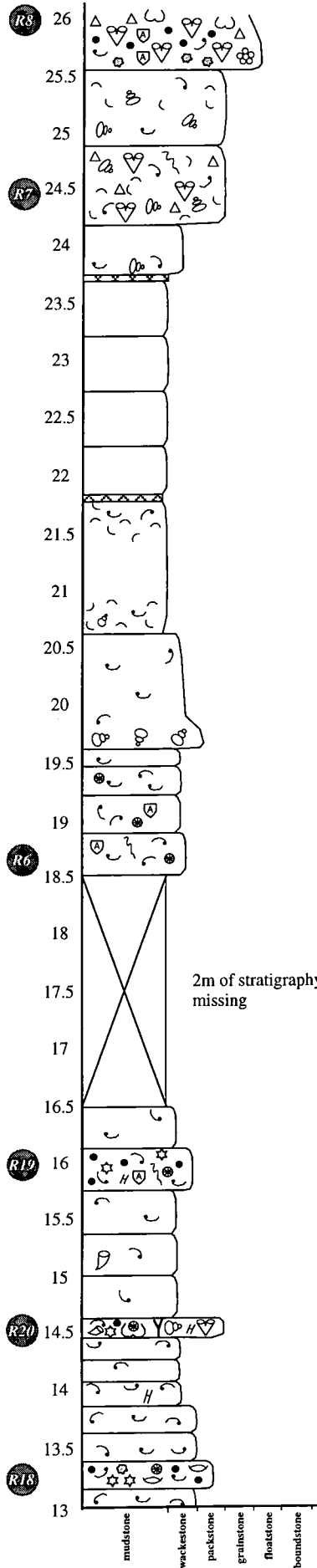

**Resteigne quarry**

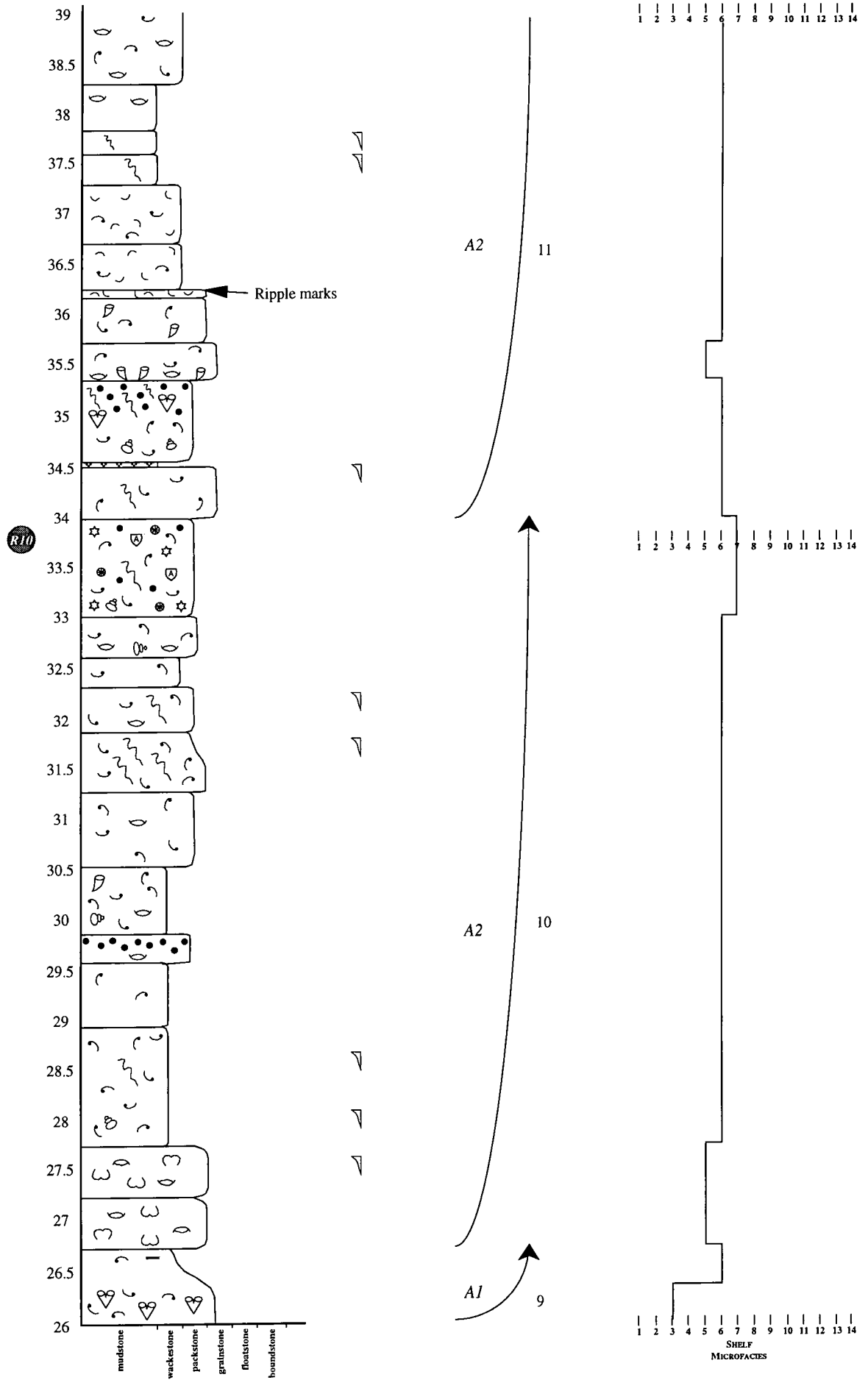

Resteigne quarry

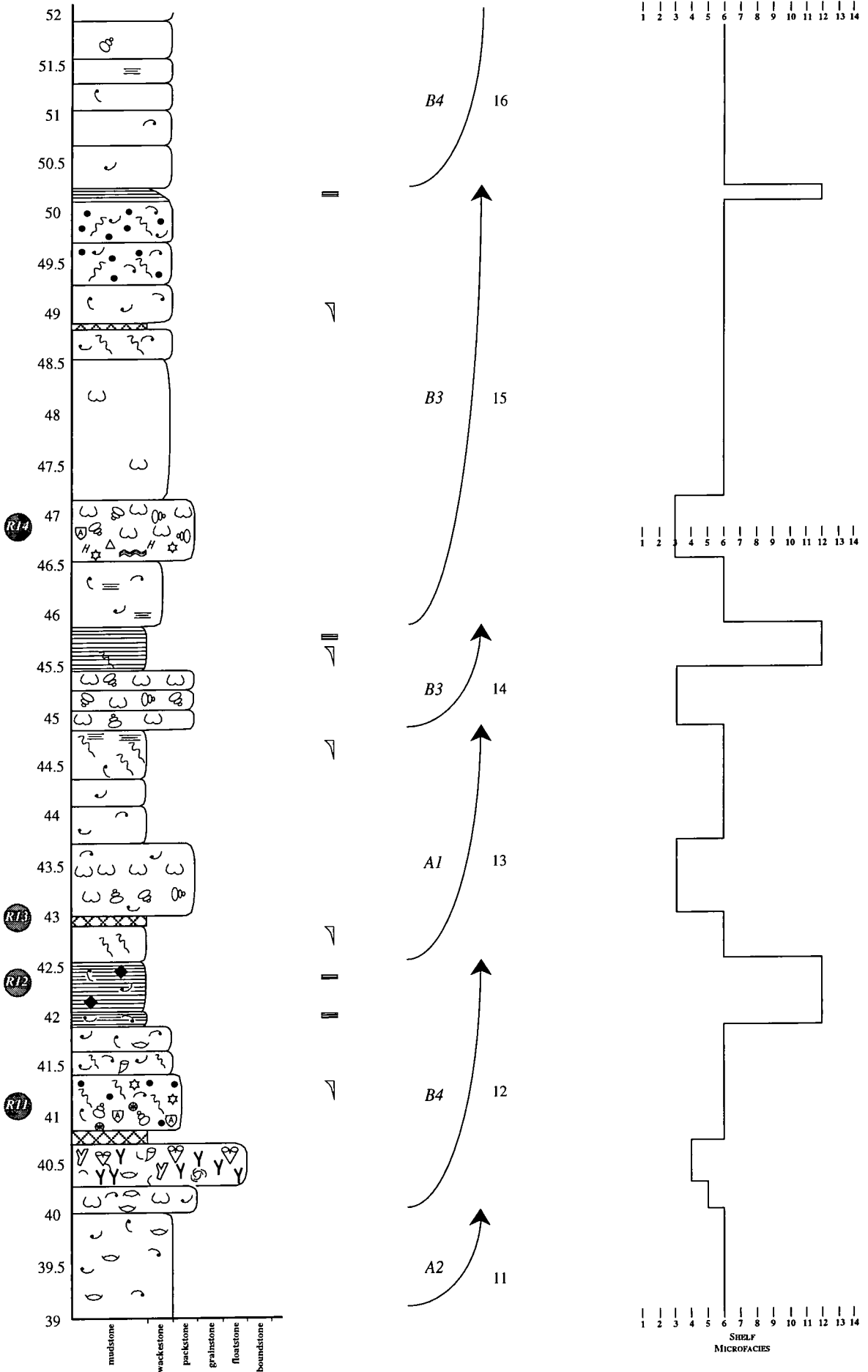

**Resteigne quarry**

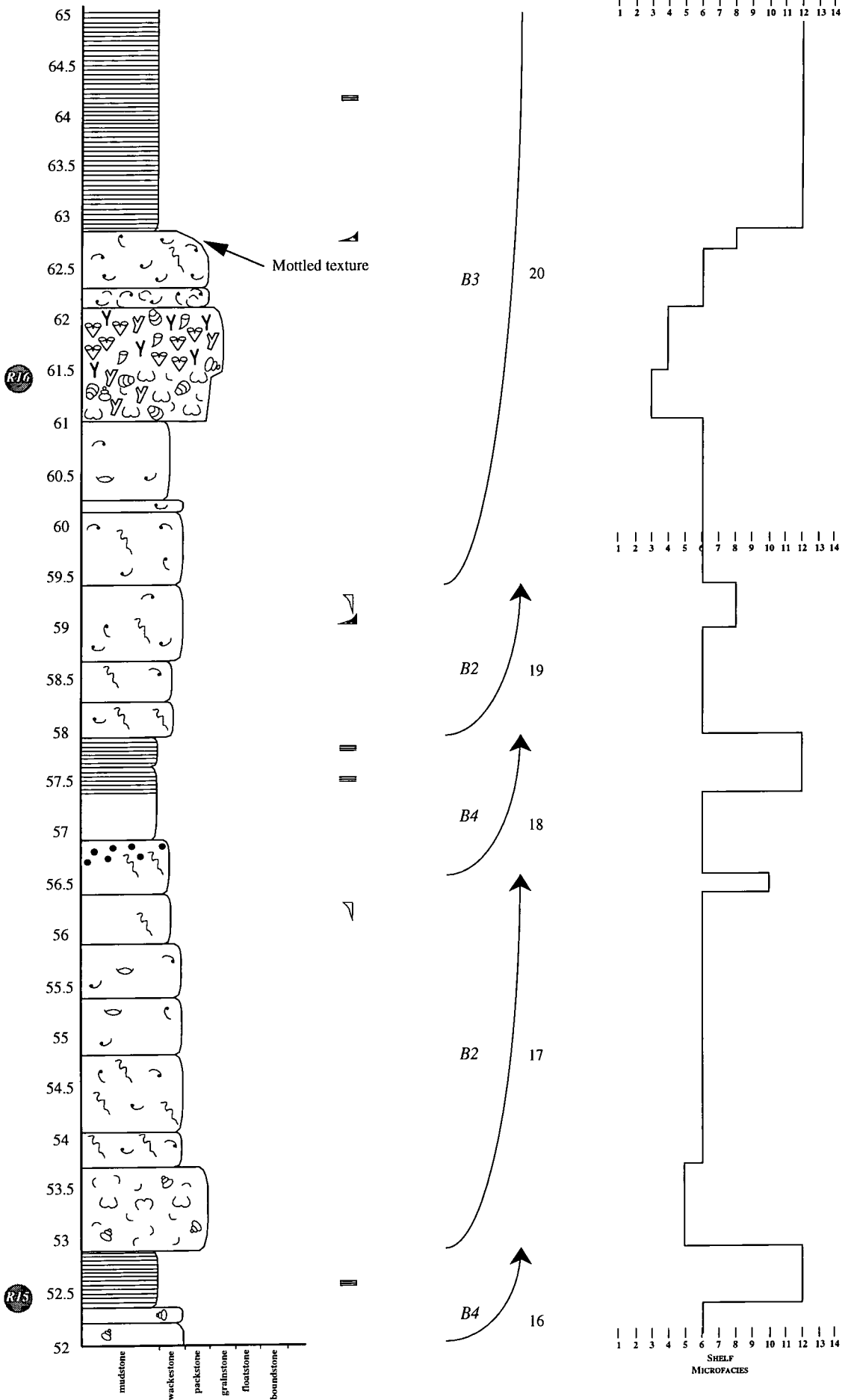

Resteigne quarry

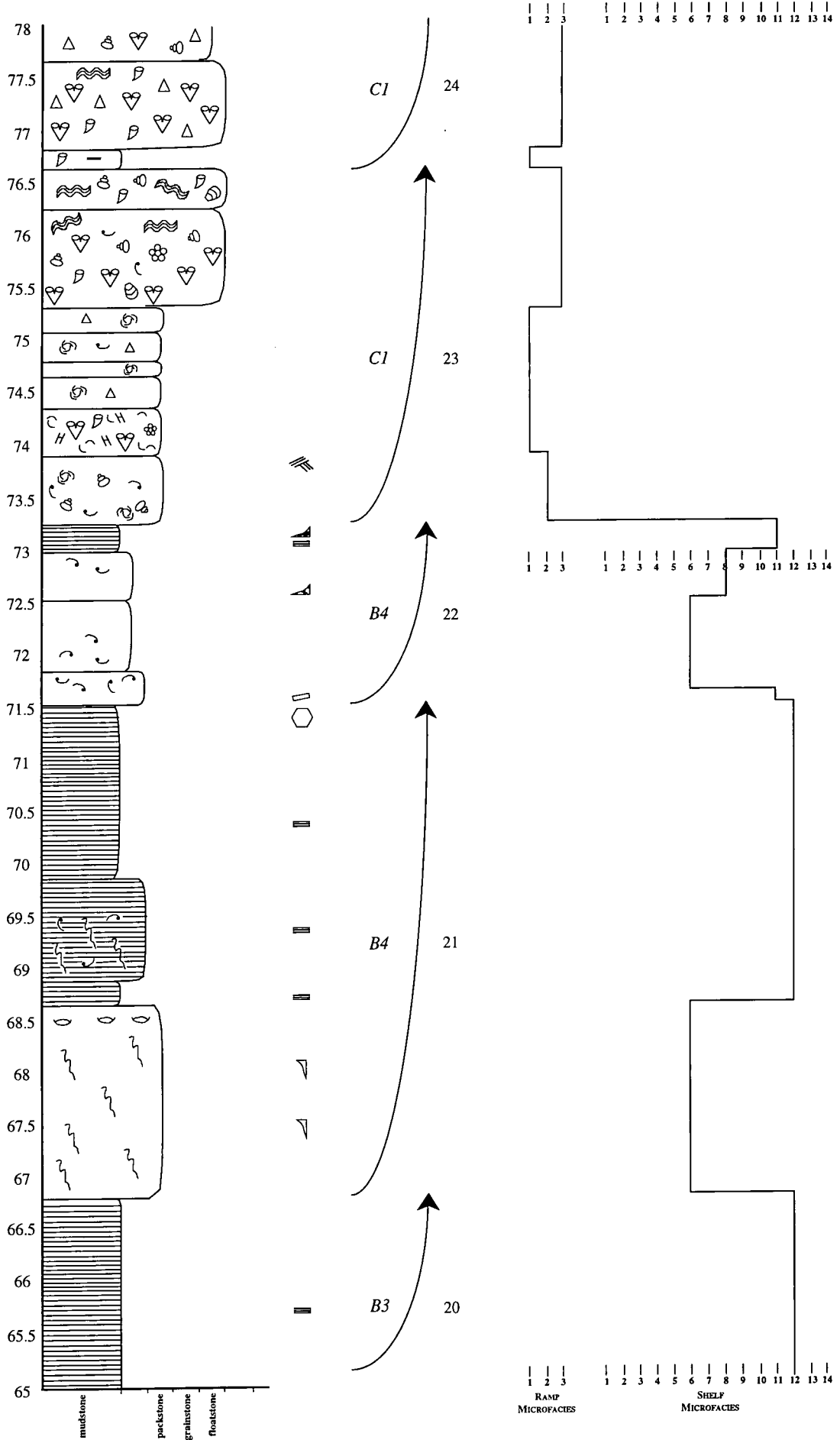

Resteigne quarry

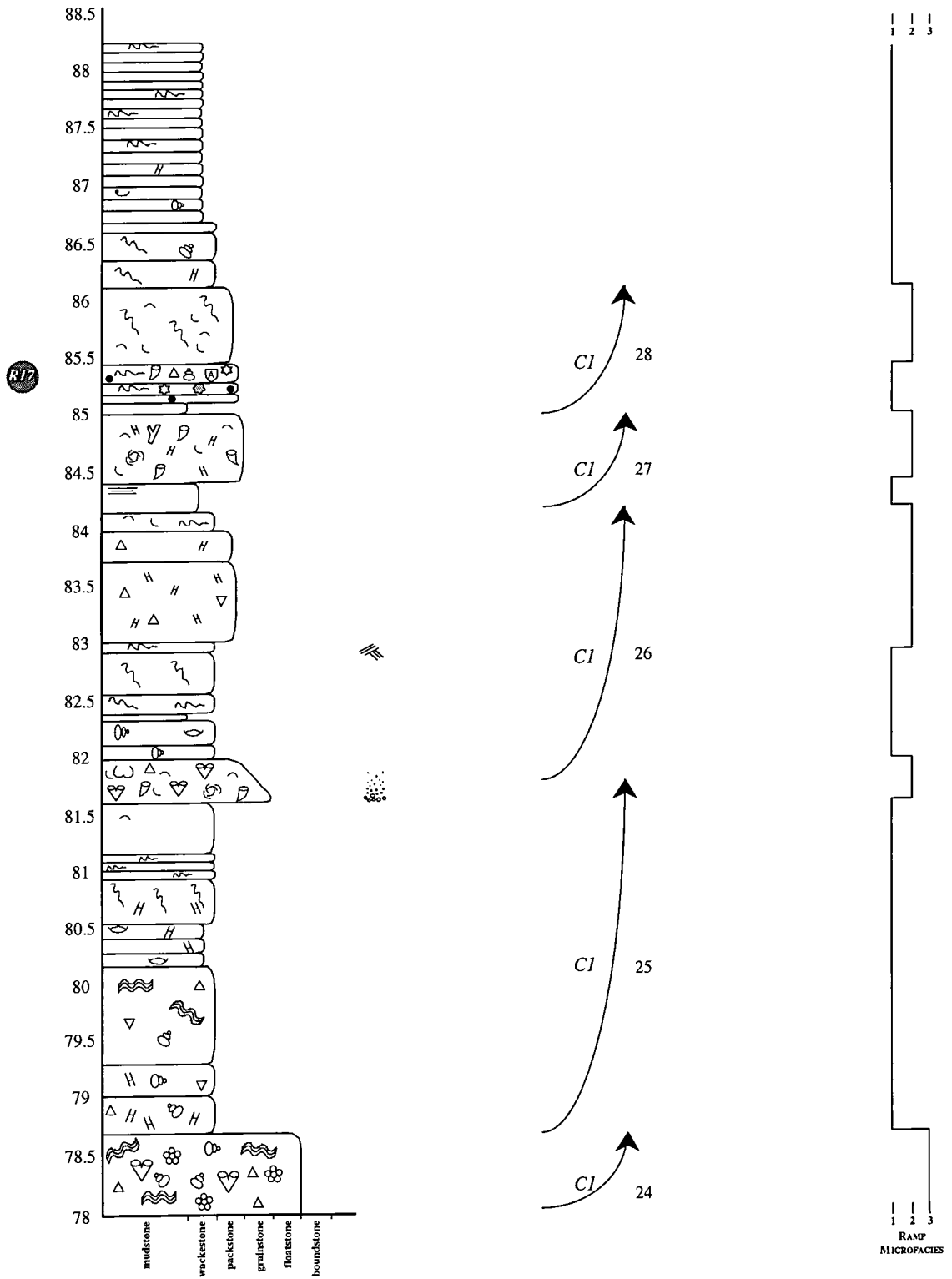

A2.21 Rydon quarry

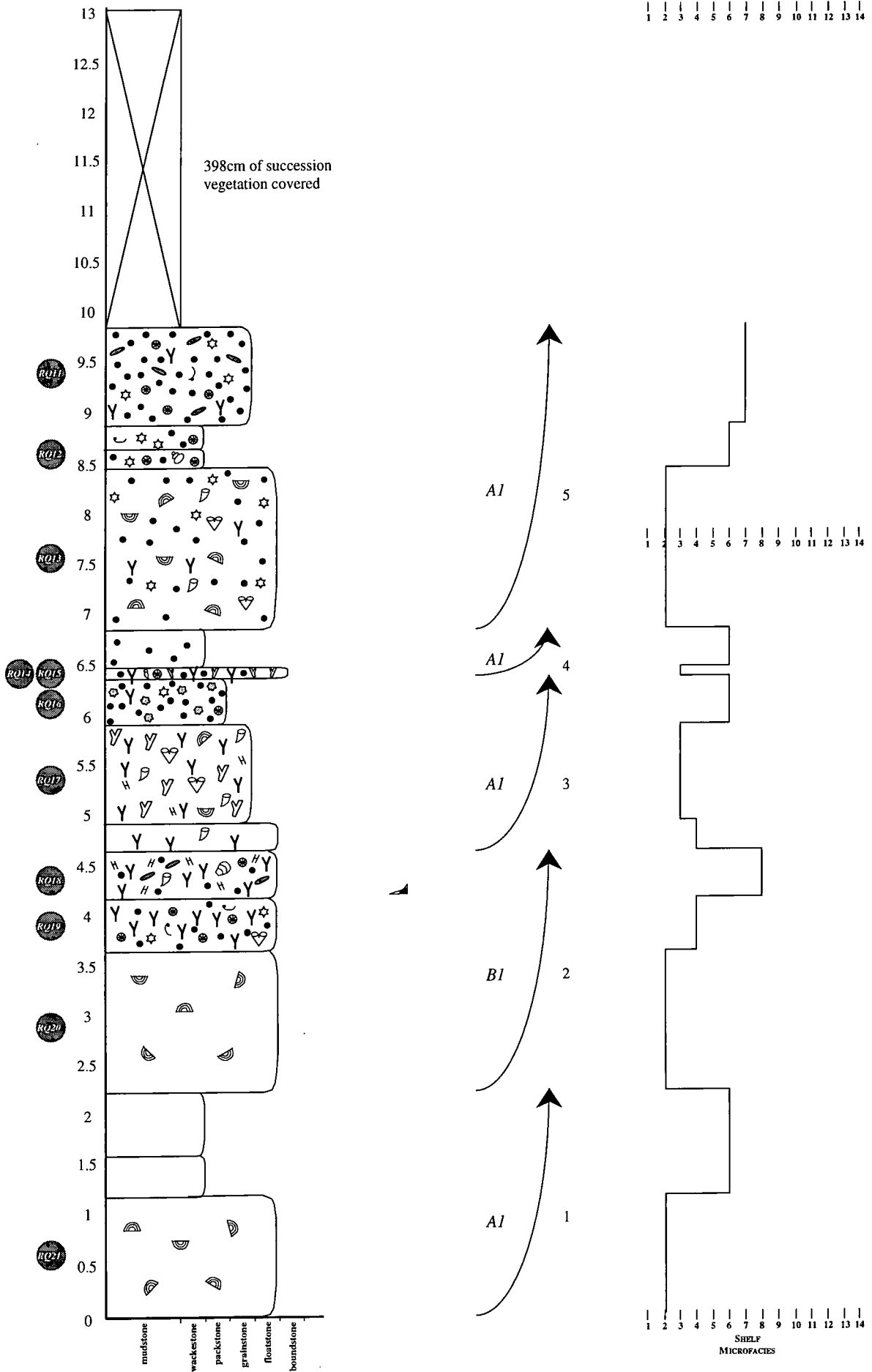

Rydon quarry

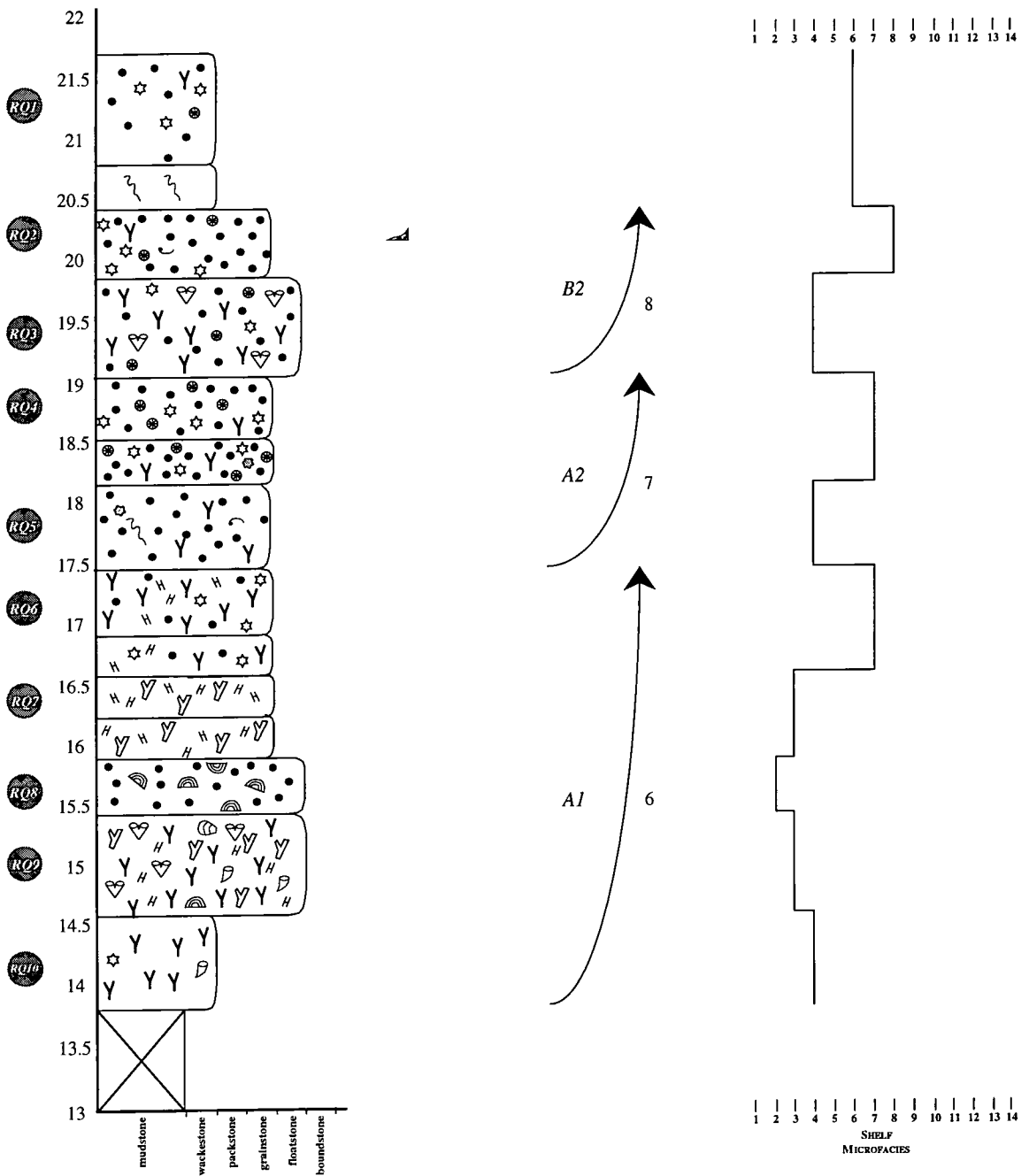

**A2.22 Schmithof quarry**

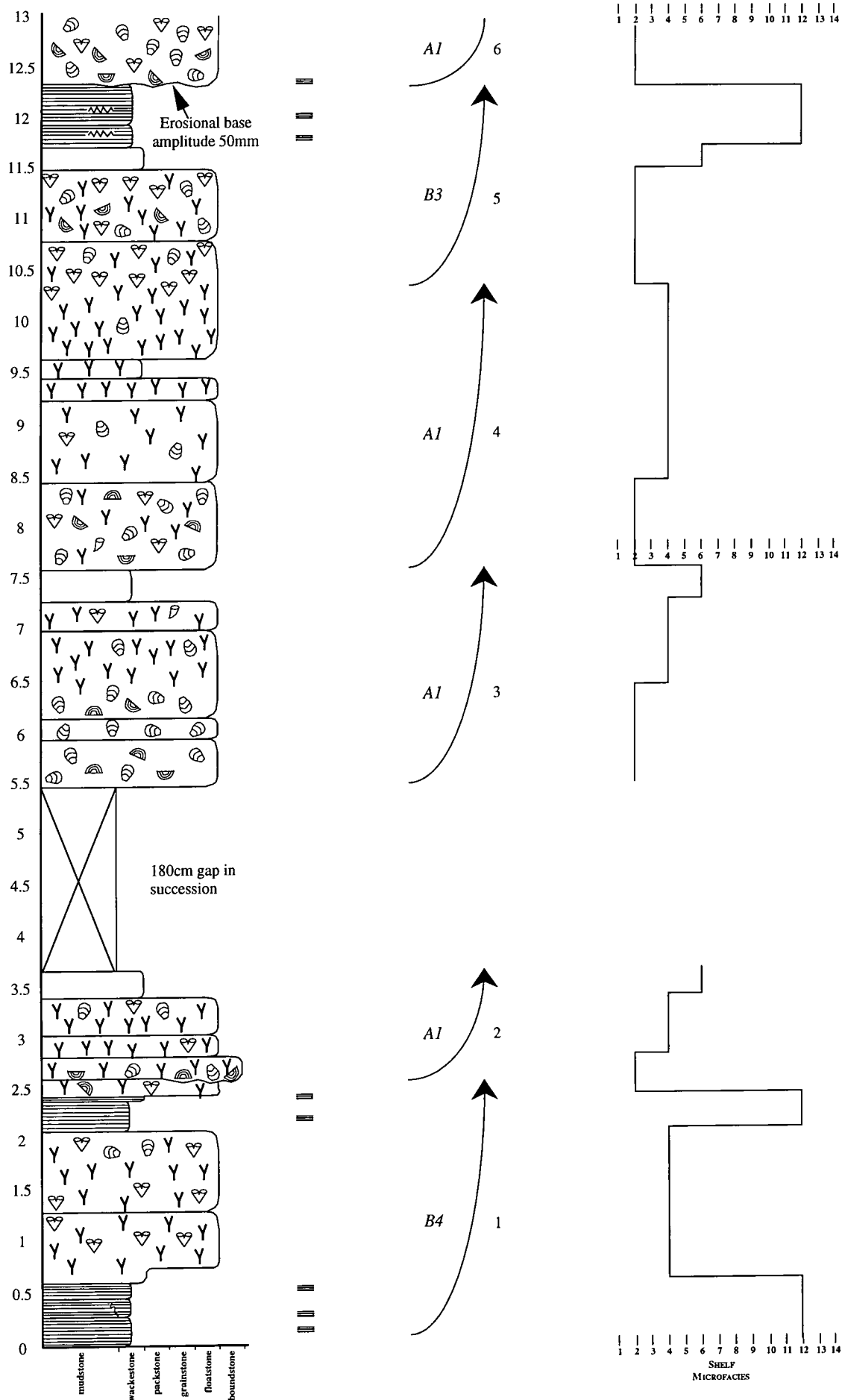

Schmithof quarry

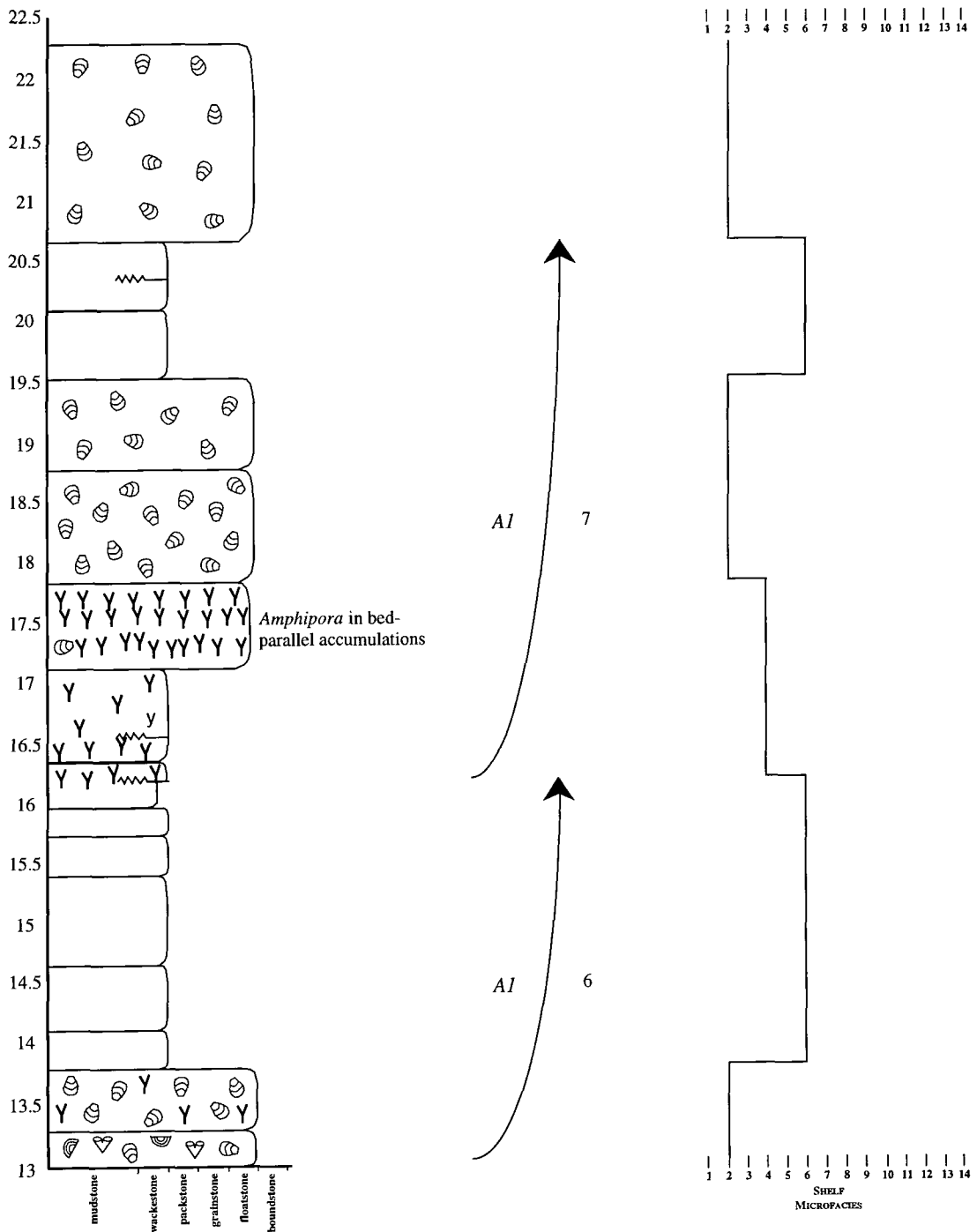

A2.23 Sourd d'Ave

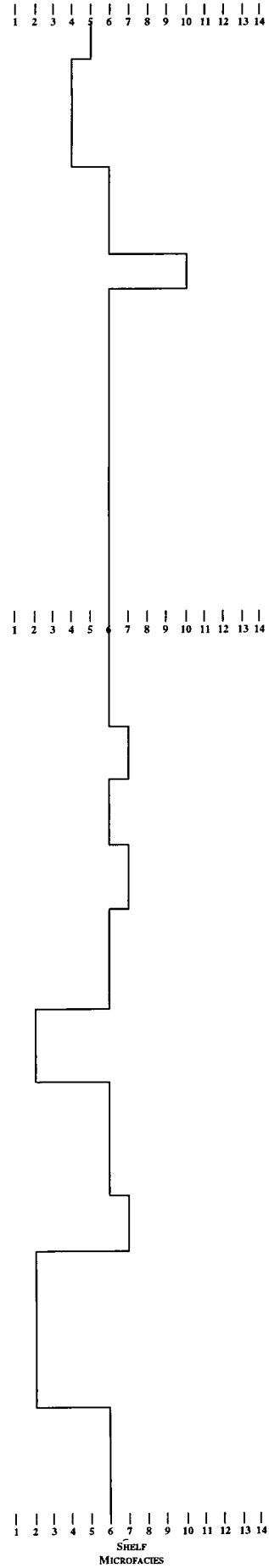
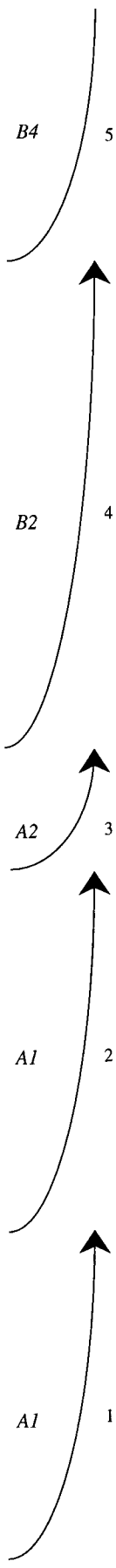
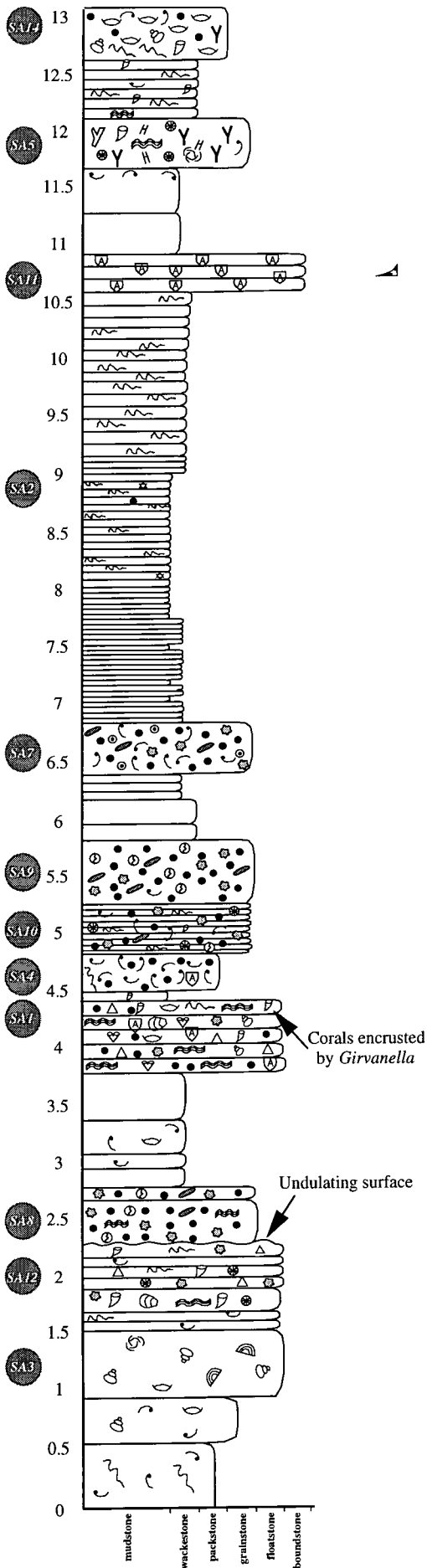

Sourd d'Ave

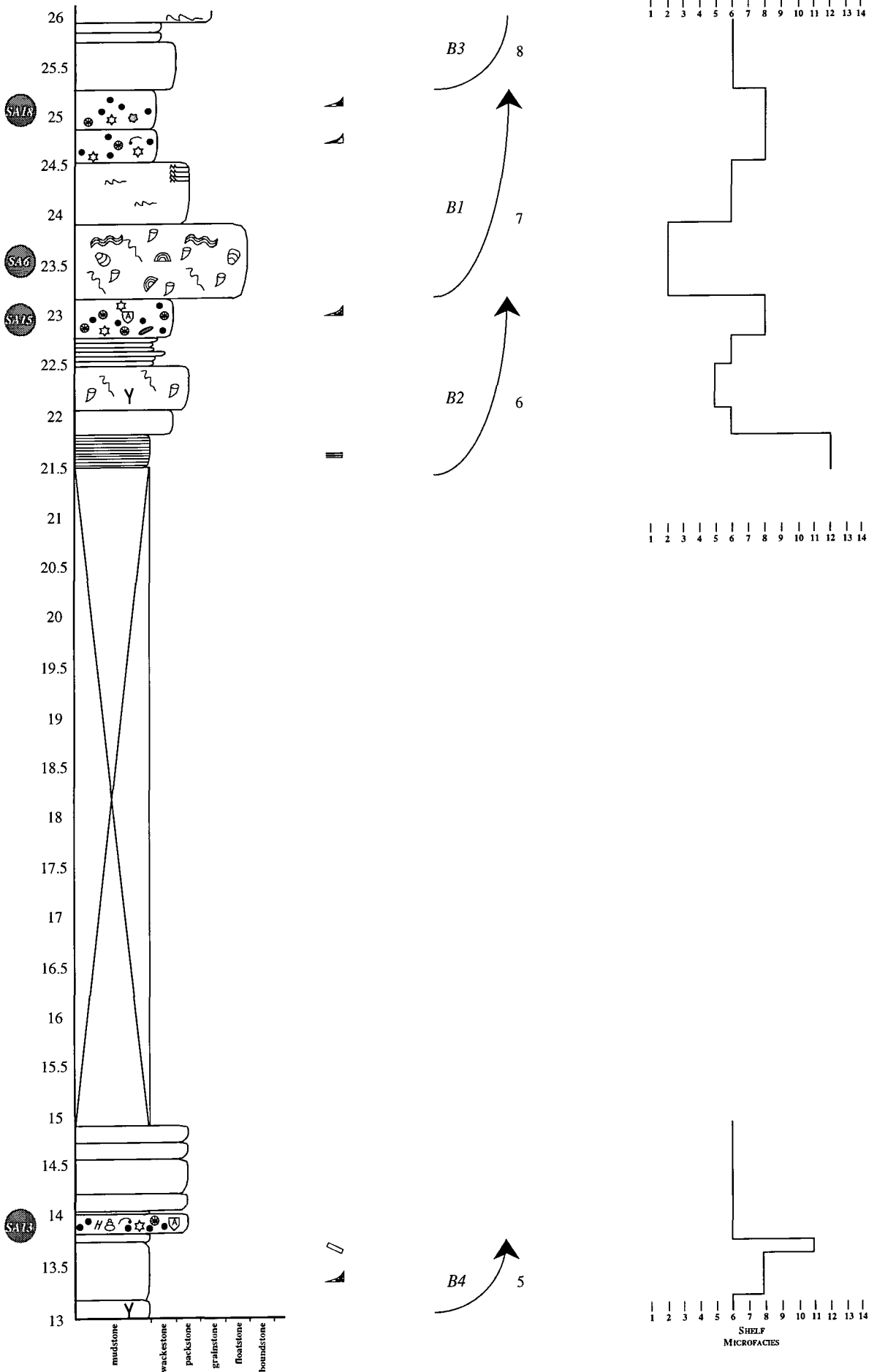

Sourd d'Ave

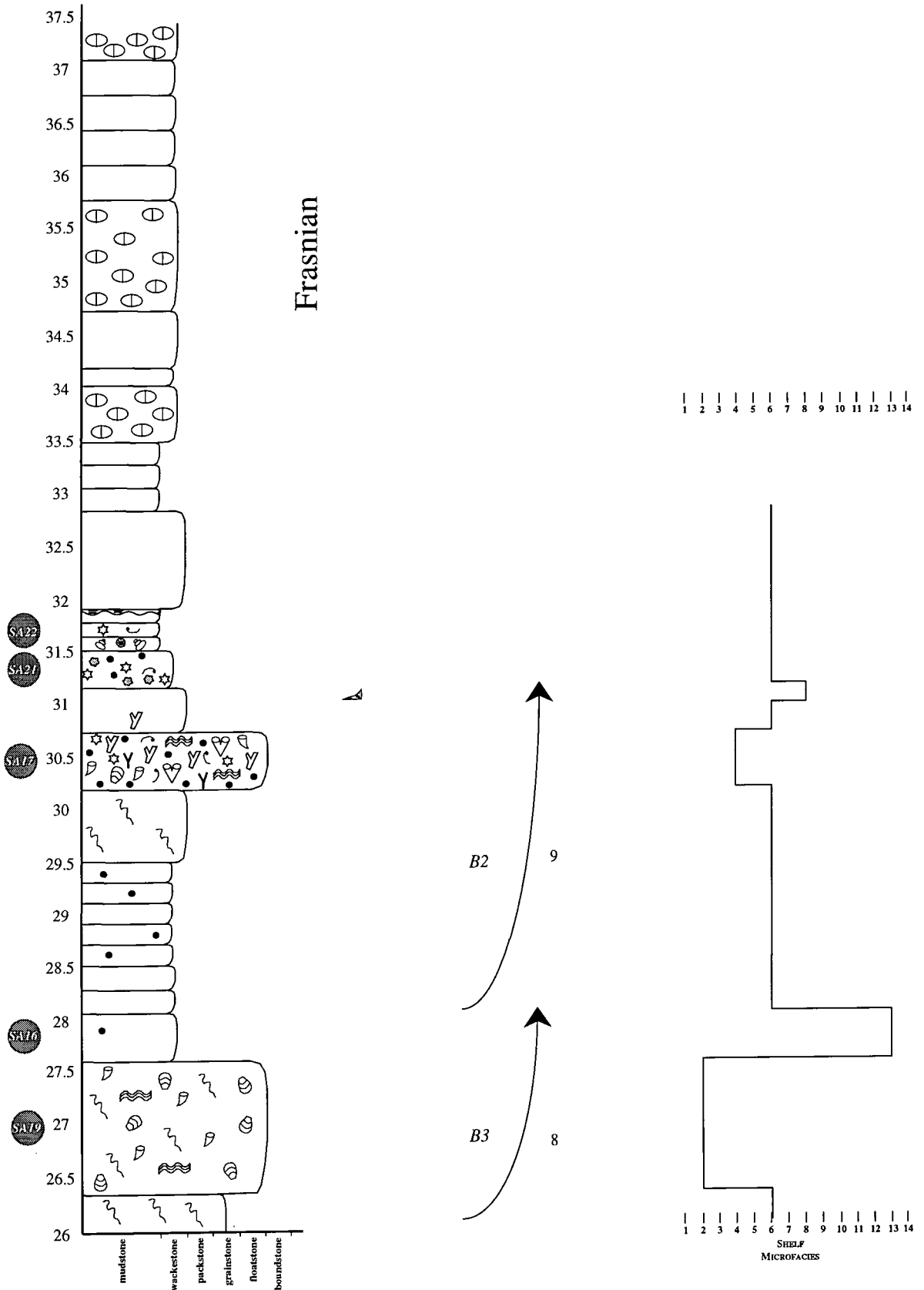

A2.24 Teerstraßenbau quarry

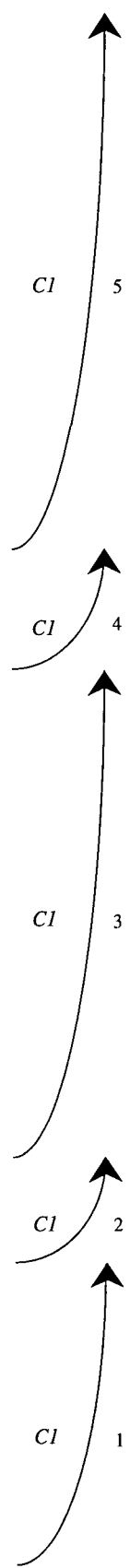
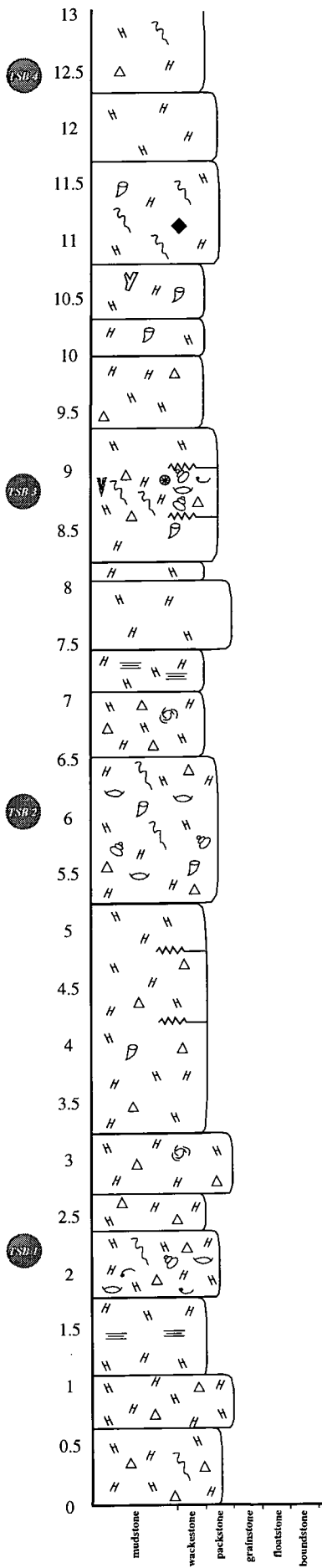

Teerstraßenbau quarry

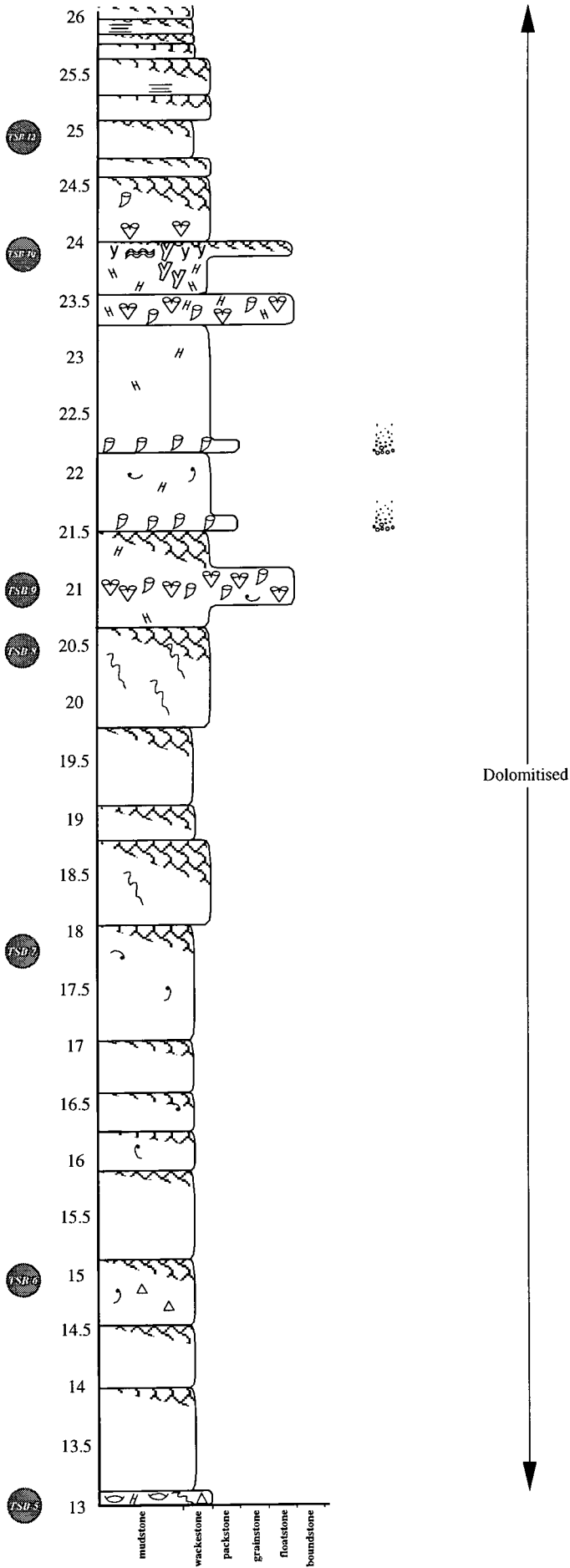

Teerstraßenbau quarry

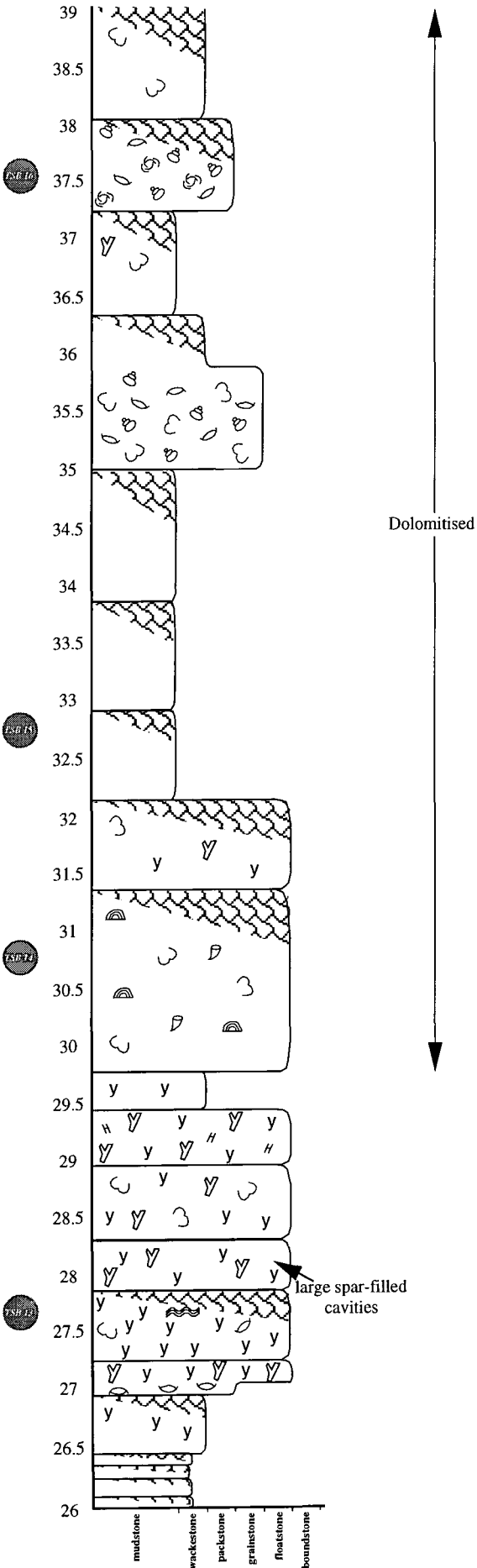

Teerstraßenbau quarry

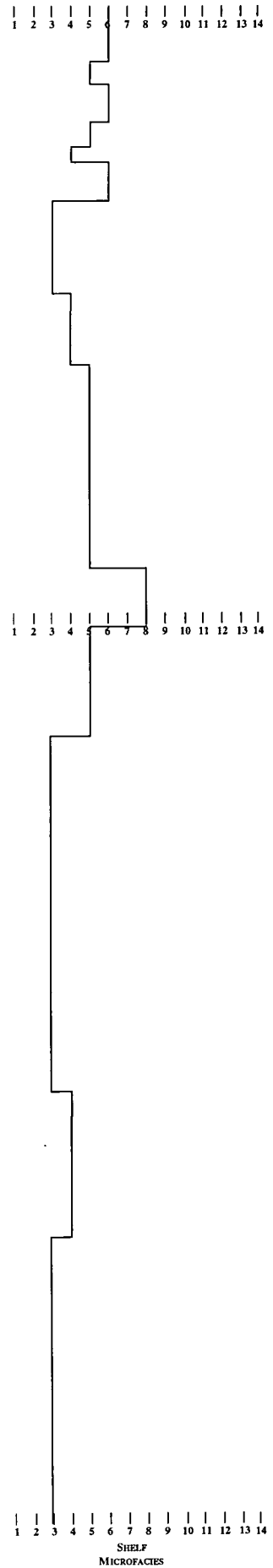
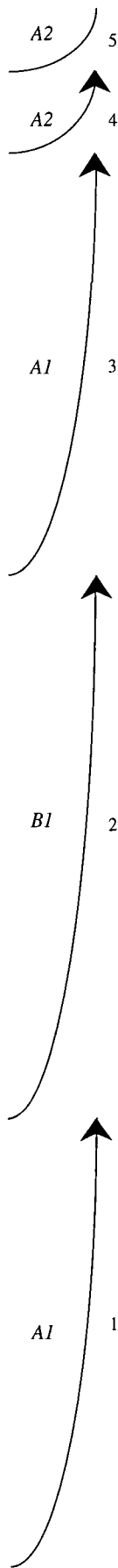
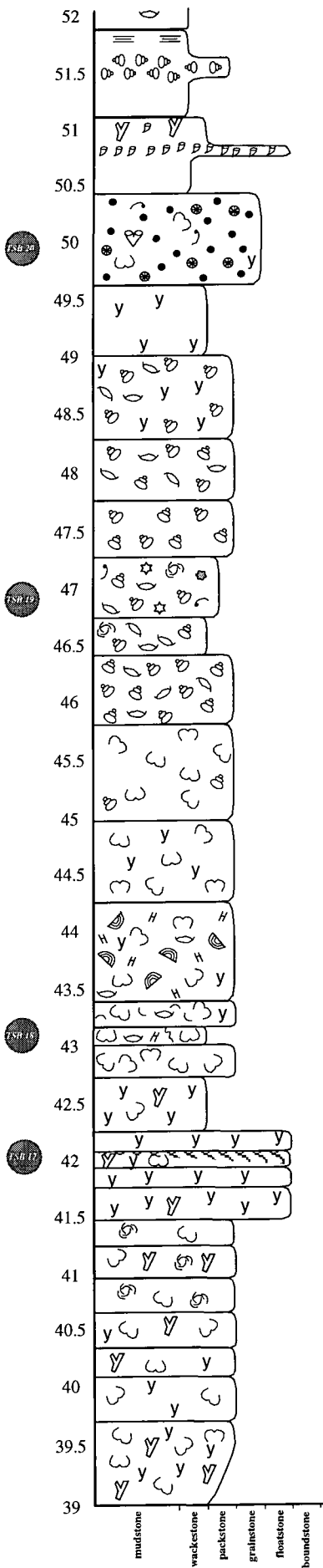

Teerstraßenbau quarry

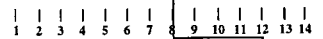
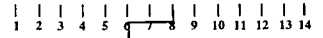
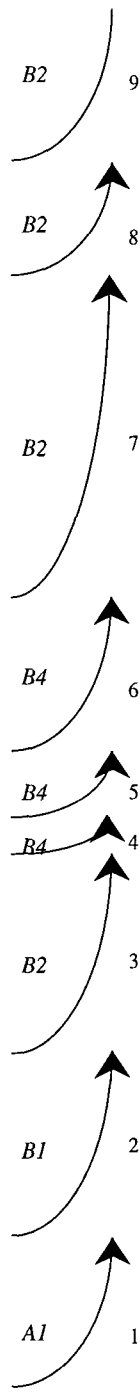
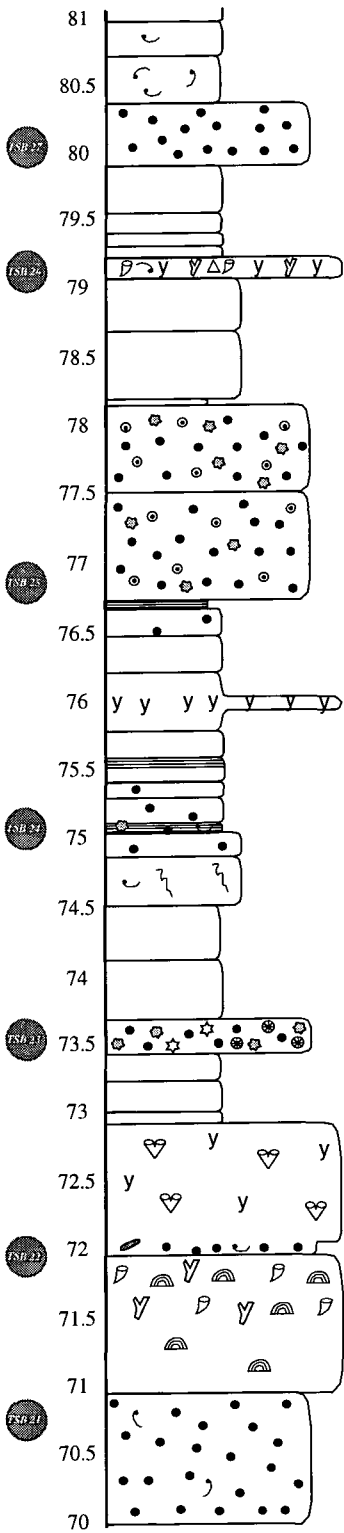

Gap in succession

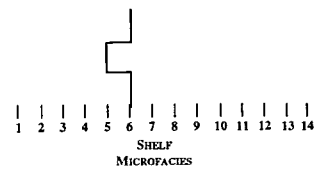
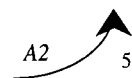
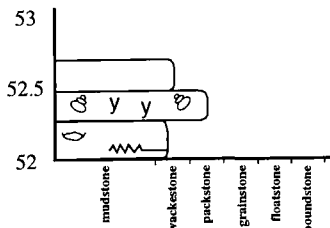

Teerstraßenbau quarry

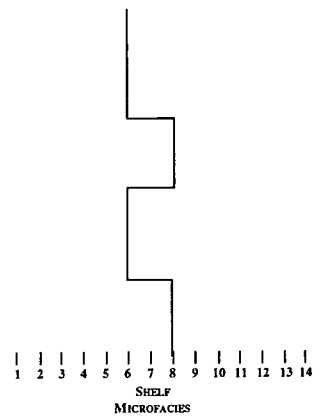
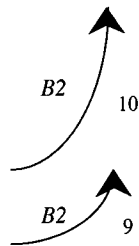
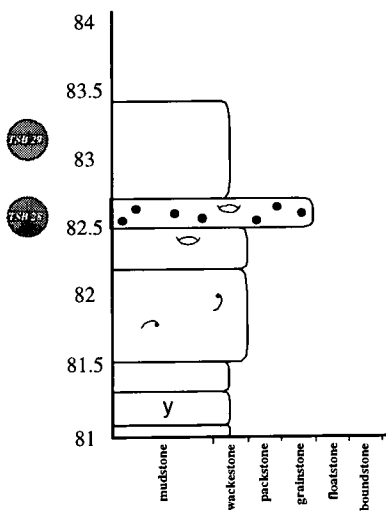

**A2.25 Vaucelles quarry**

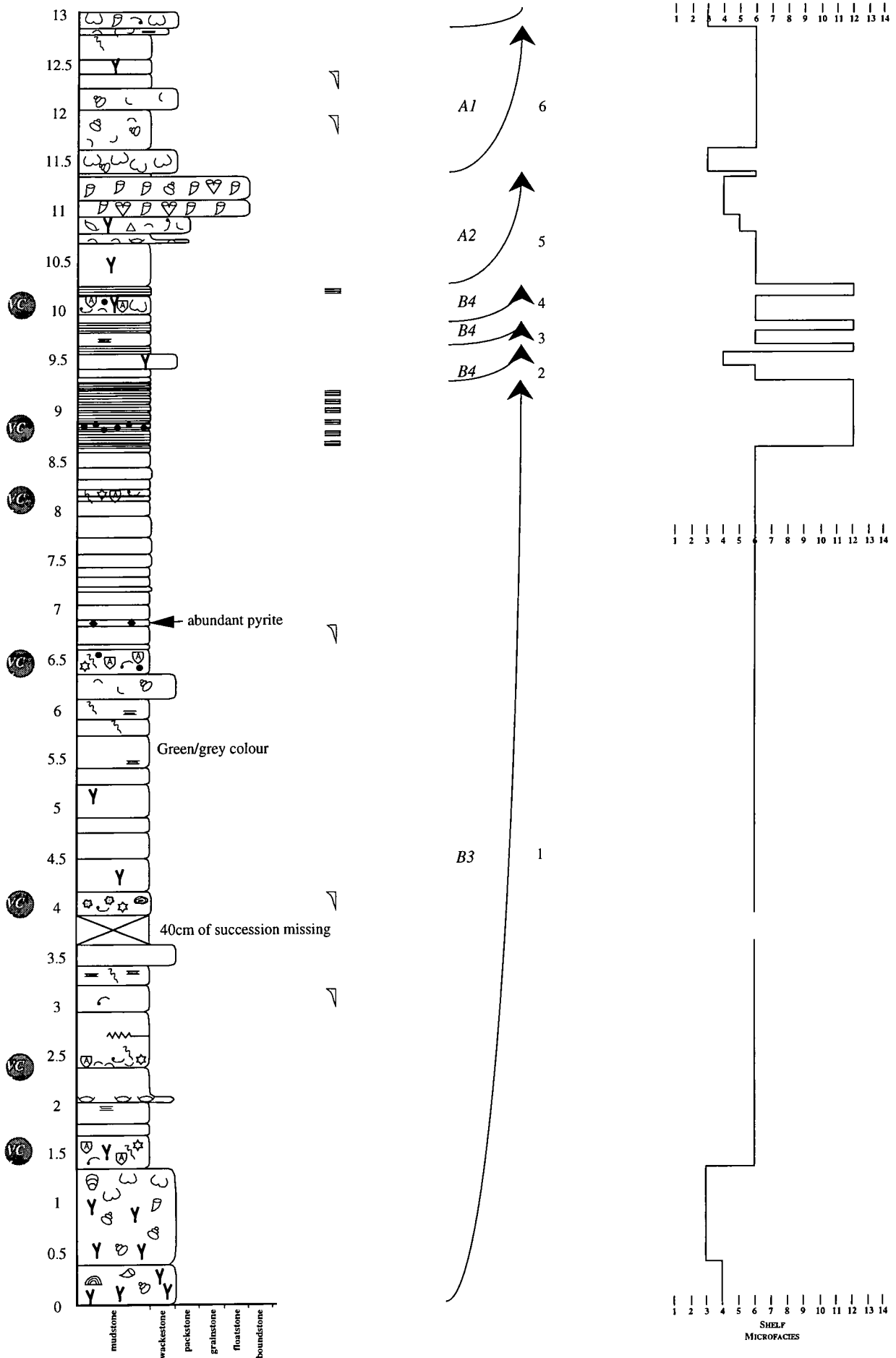

Vaucelles quarry

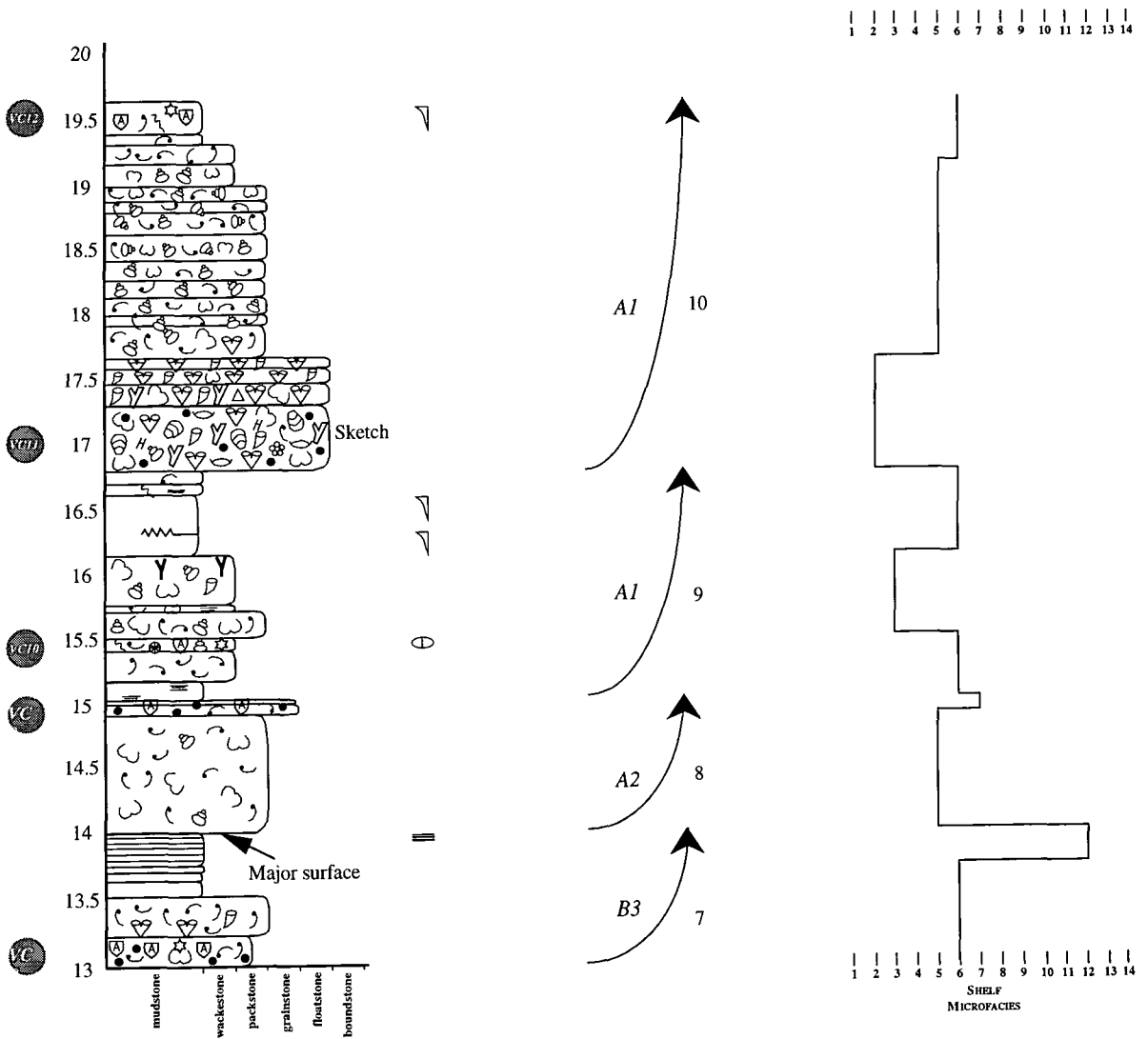

A2.26 Venwegen quarry

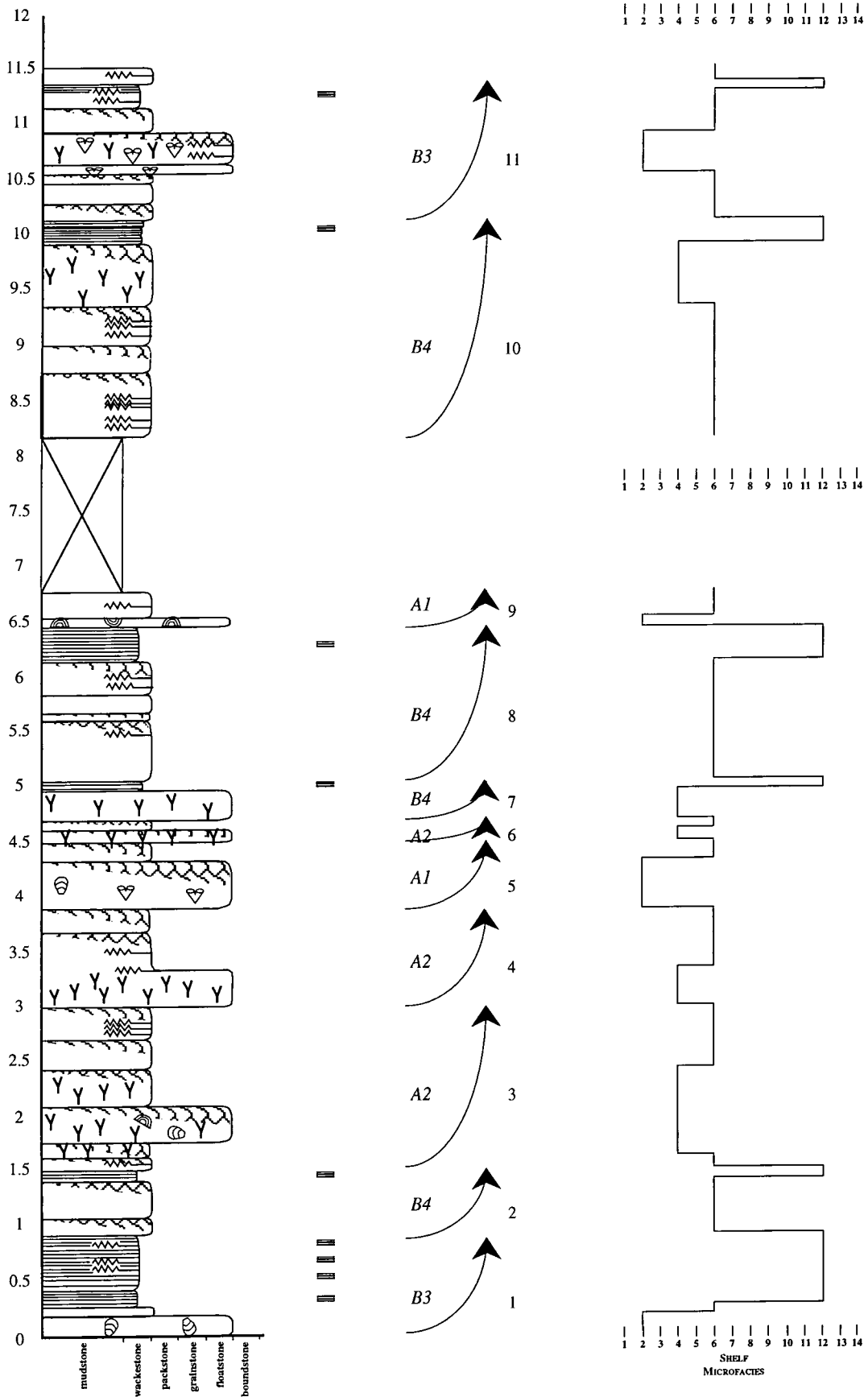

A2.27 Voßbeck quarry

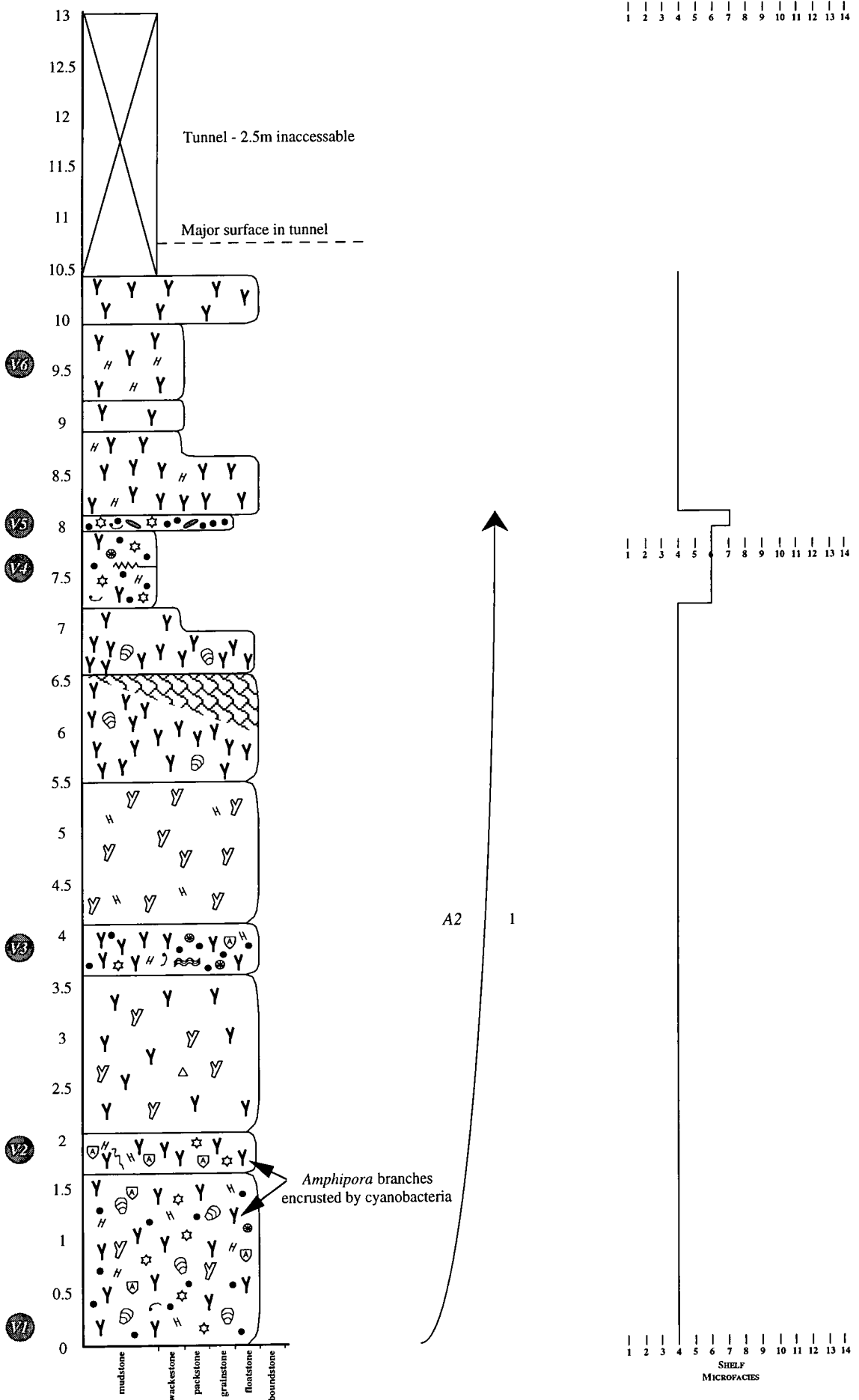

Voßbeck quarry

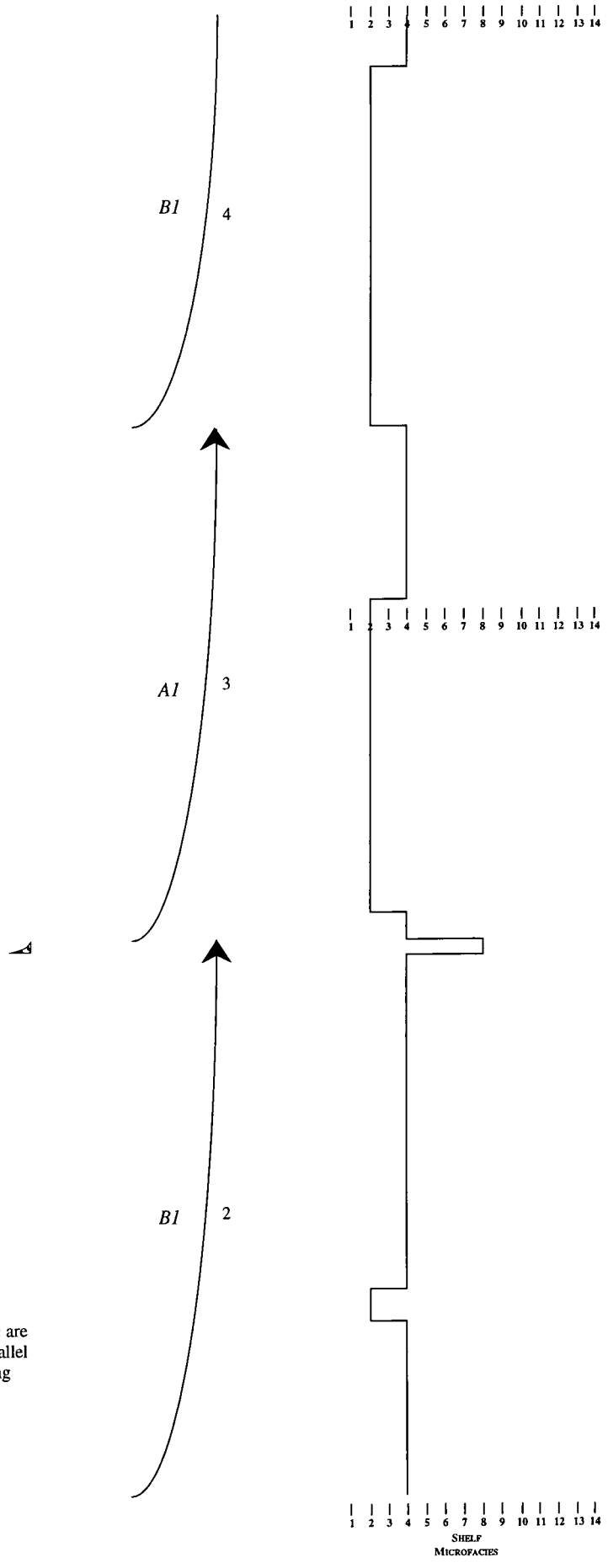
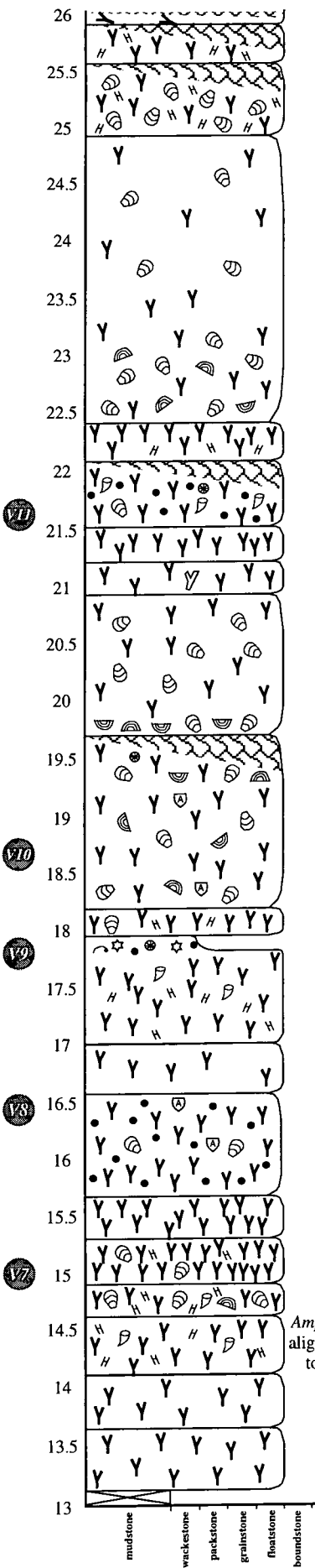

Voßbeck quarry

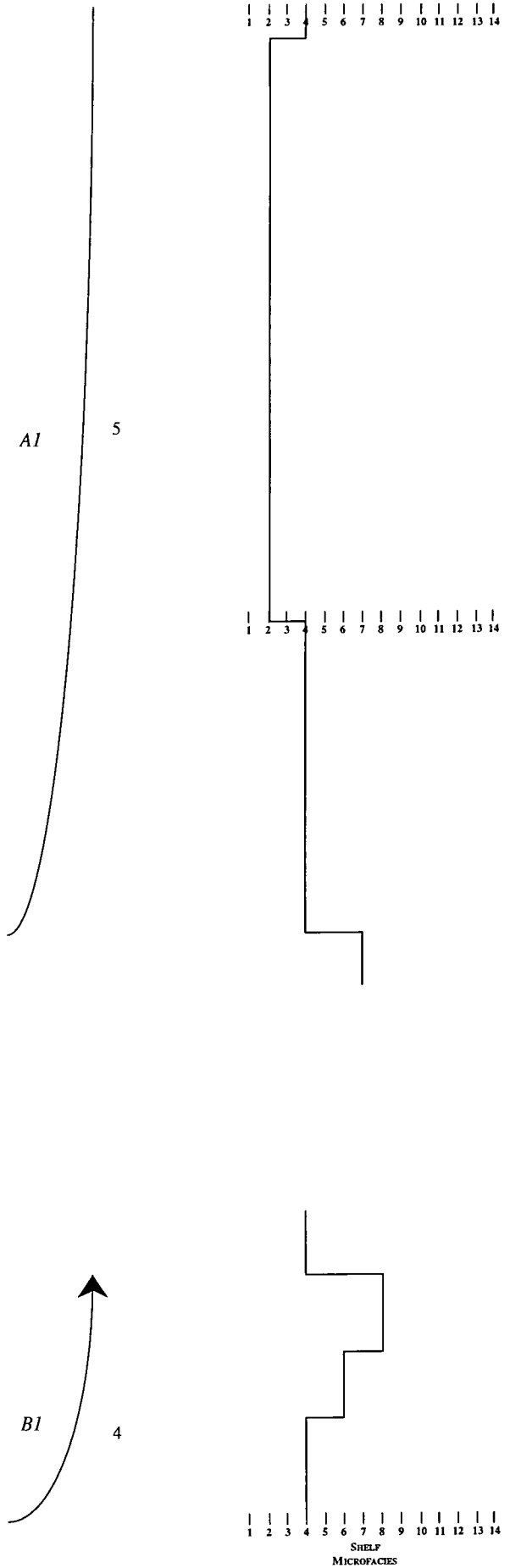
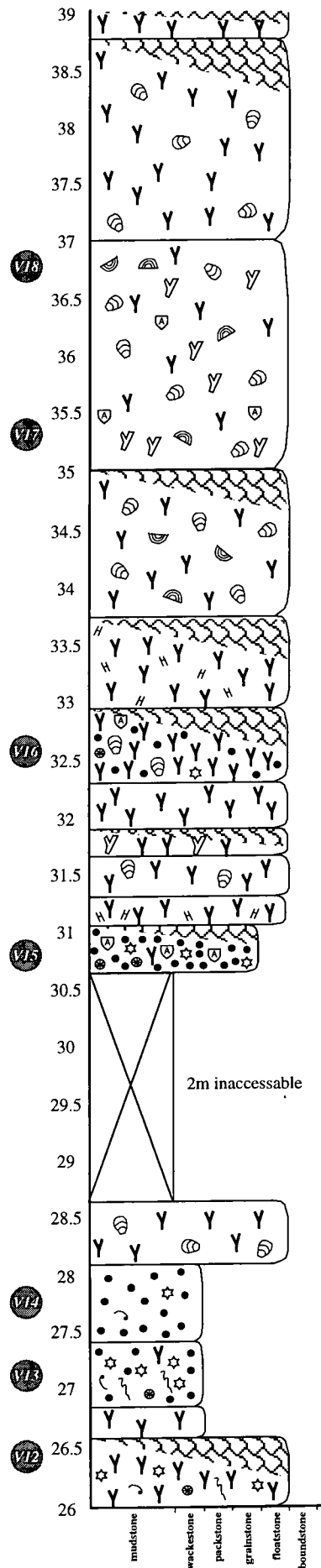

Voßbeck quarry

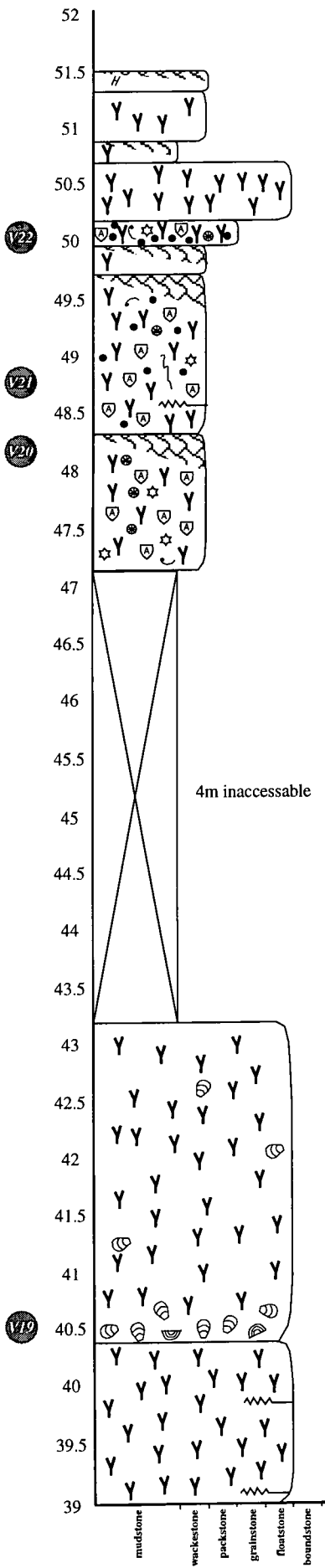

1 2 3 4 5 6 7 8 9 10 11 12 13 14

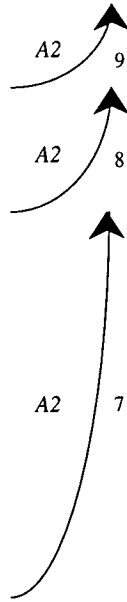

1 2 3 4 5 6 7 8 9 10 11 12 13 14



1 2 3 4 5 6 7 8 9 10 11 12 13 14  
SHELF MICROFACIES

**A2.28 Walheim Section 1**

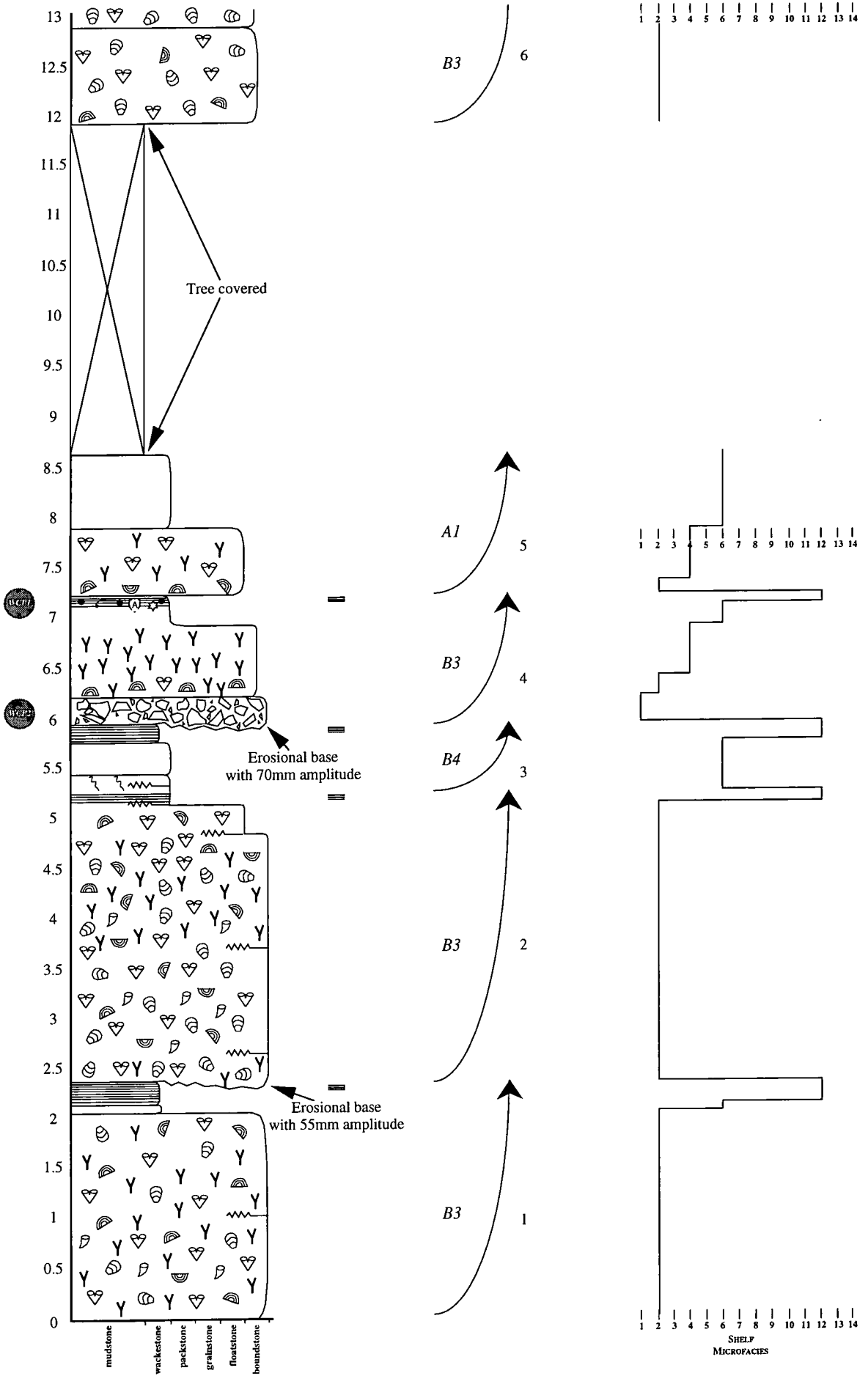

Walheim Section 1

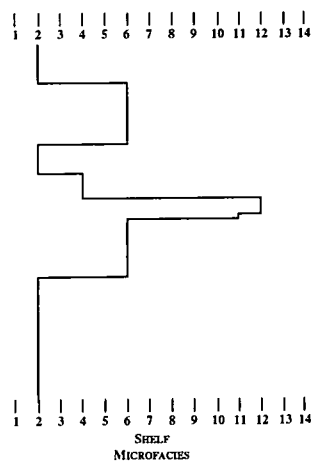
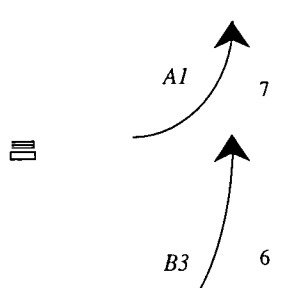
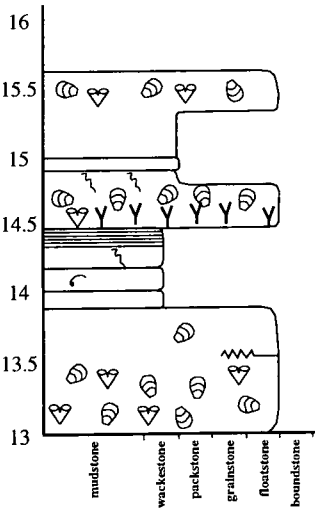

**A2.29 Walheim Section 2**

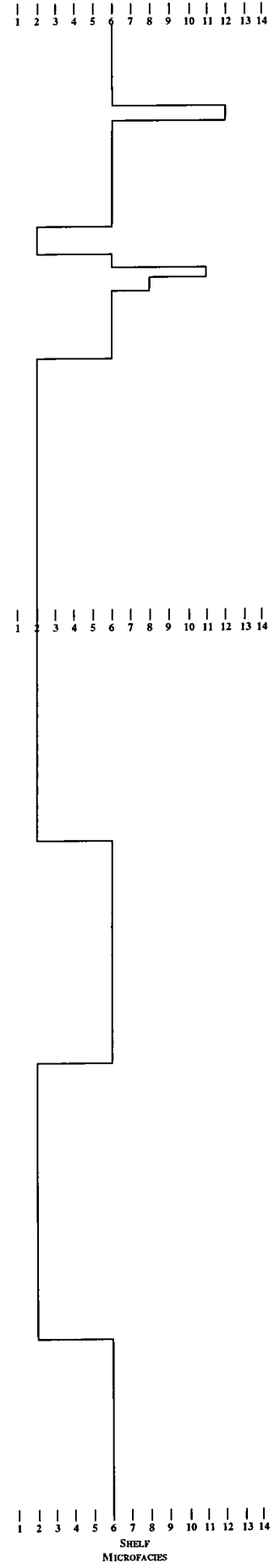
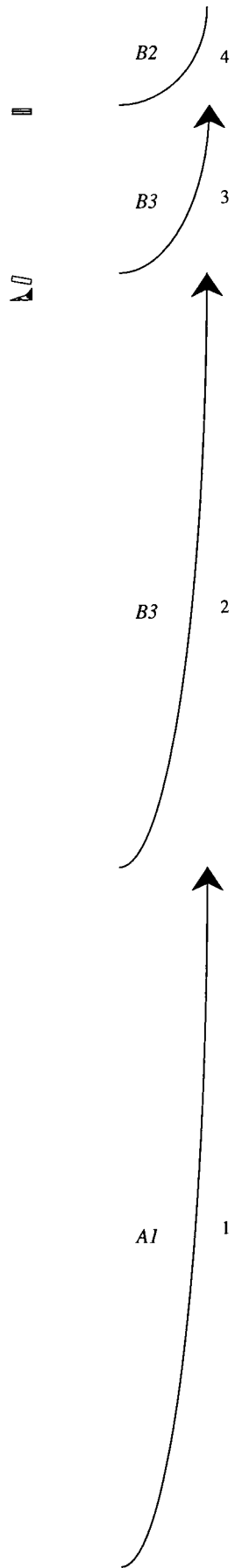
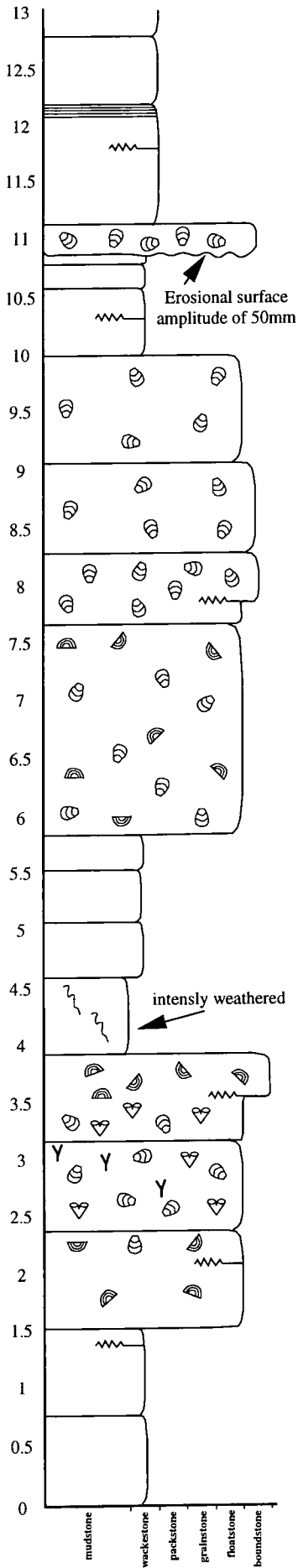

Walheim Section 2

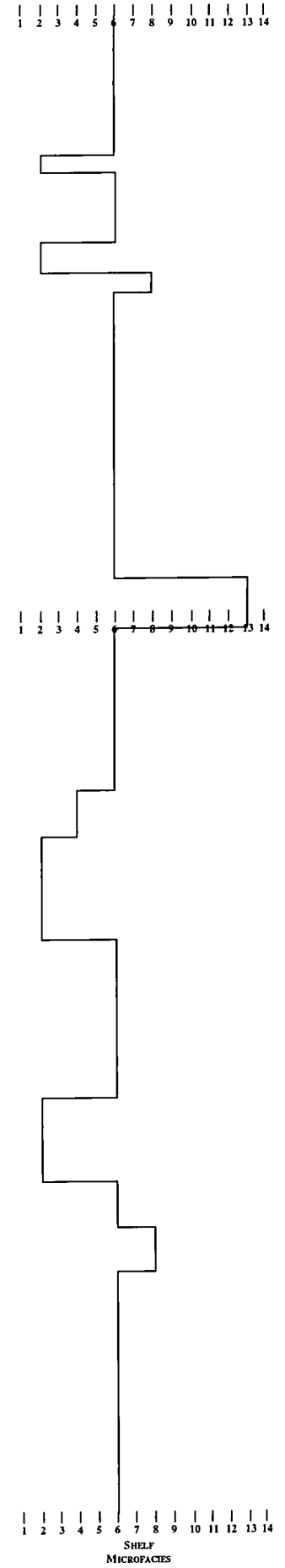
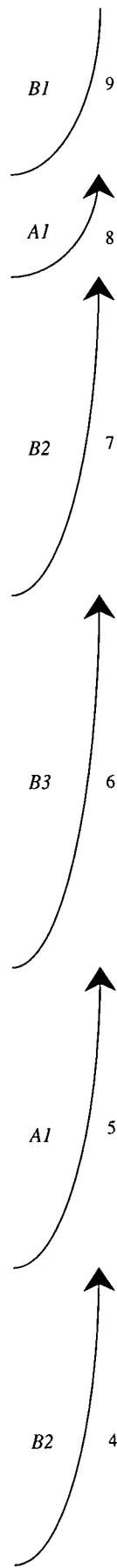
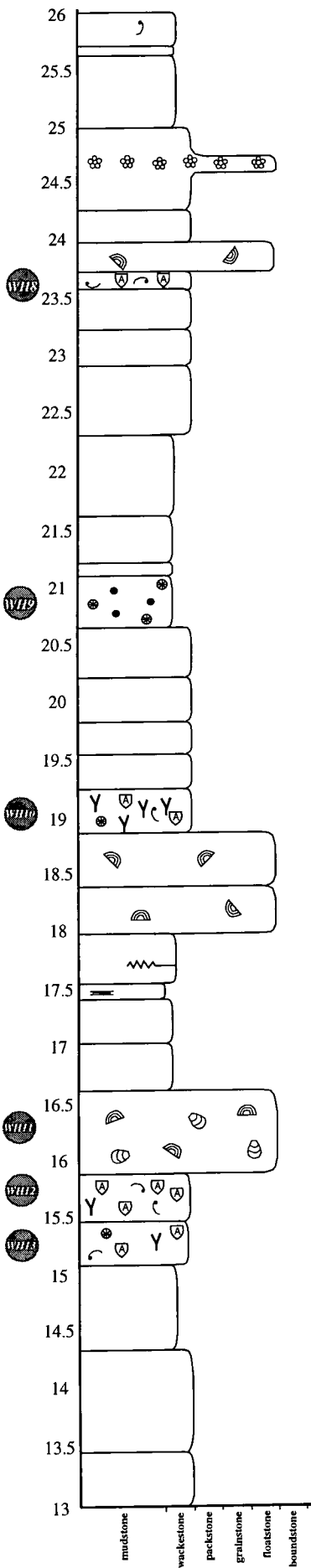

Walheim Section 2

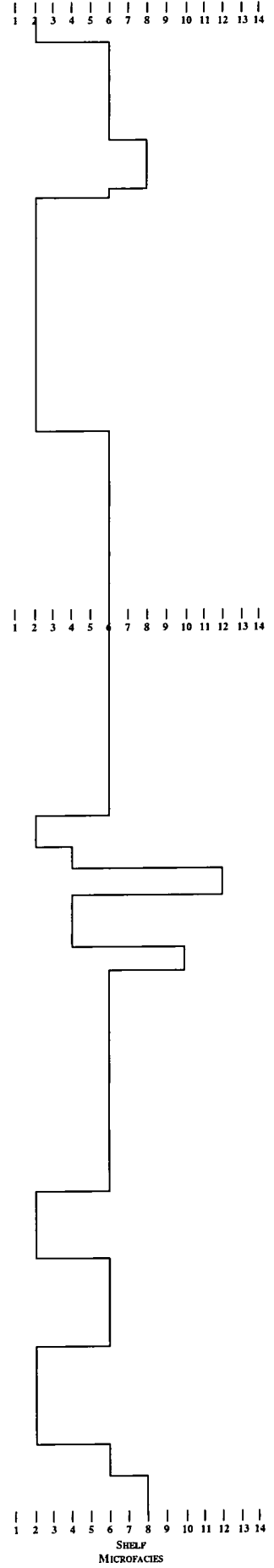
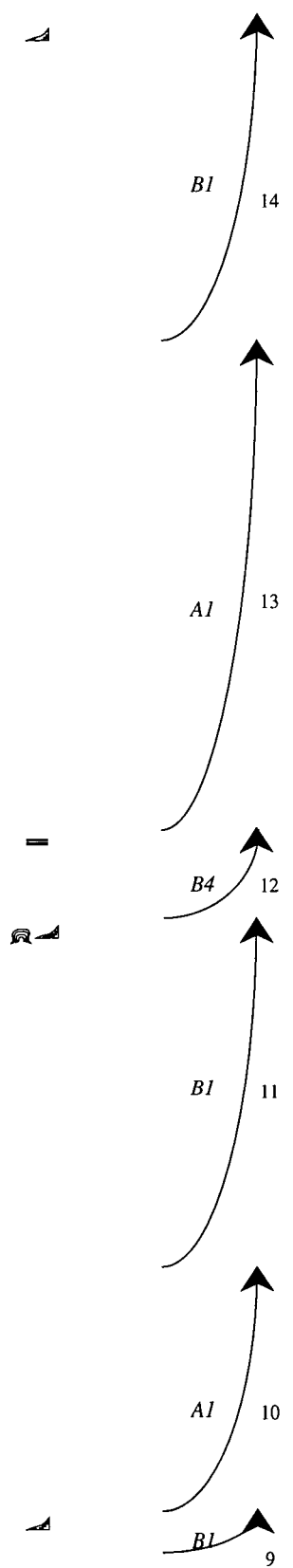
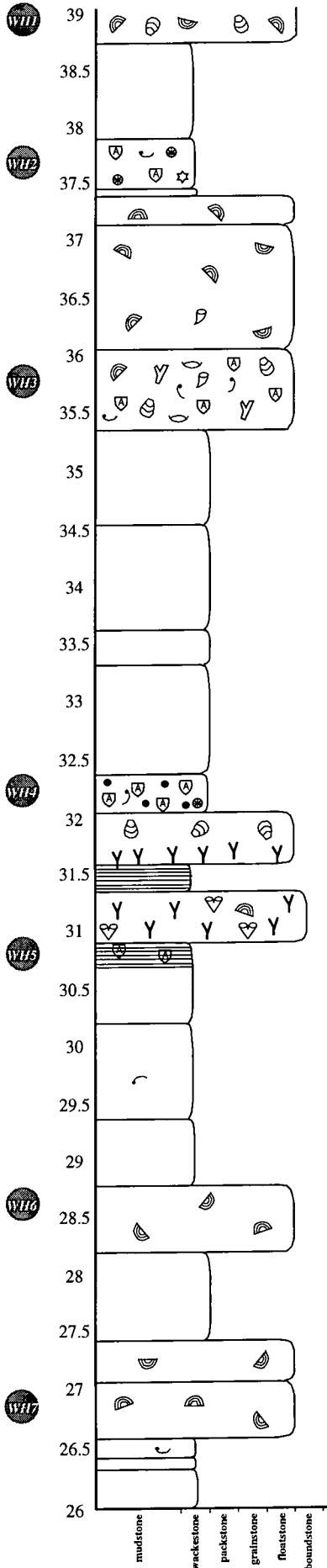

# Walheim Section 2

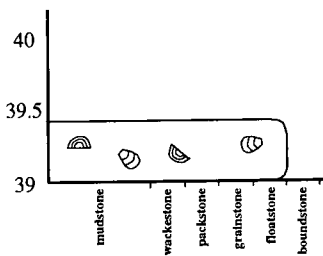

### A2.30 Walheim Southern Limb

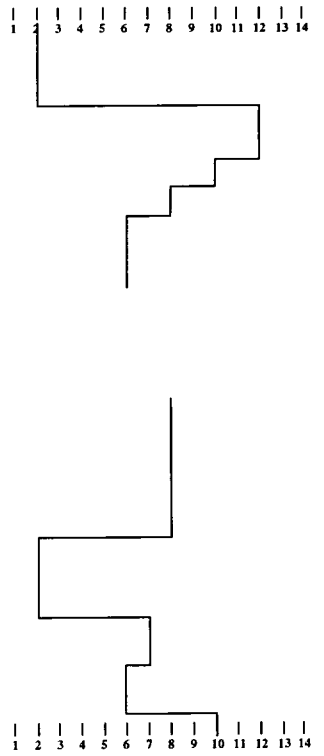
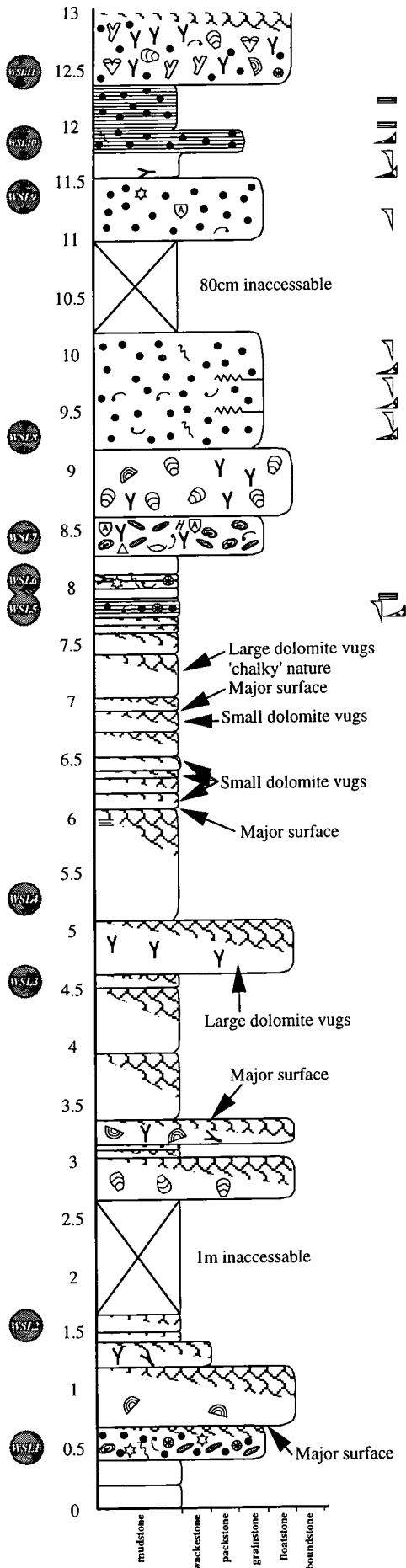

**Walheim Southern Limb**

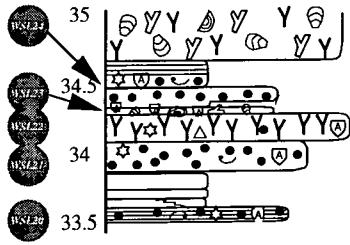

10m gap in succession

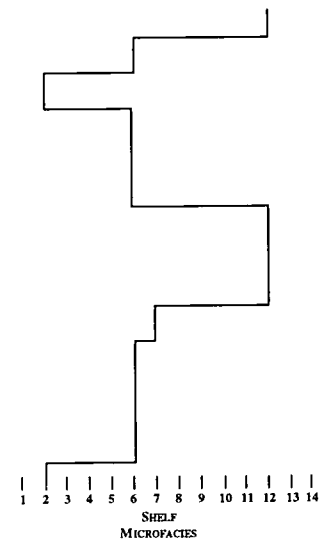
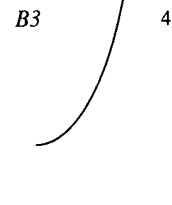
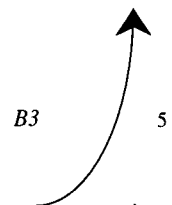
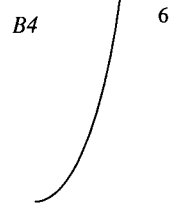
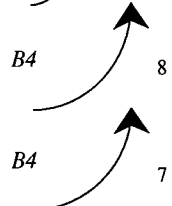
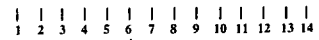
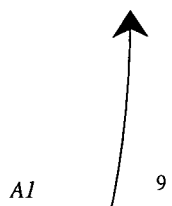
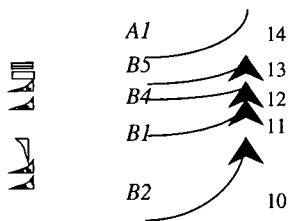
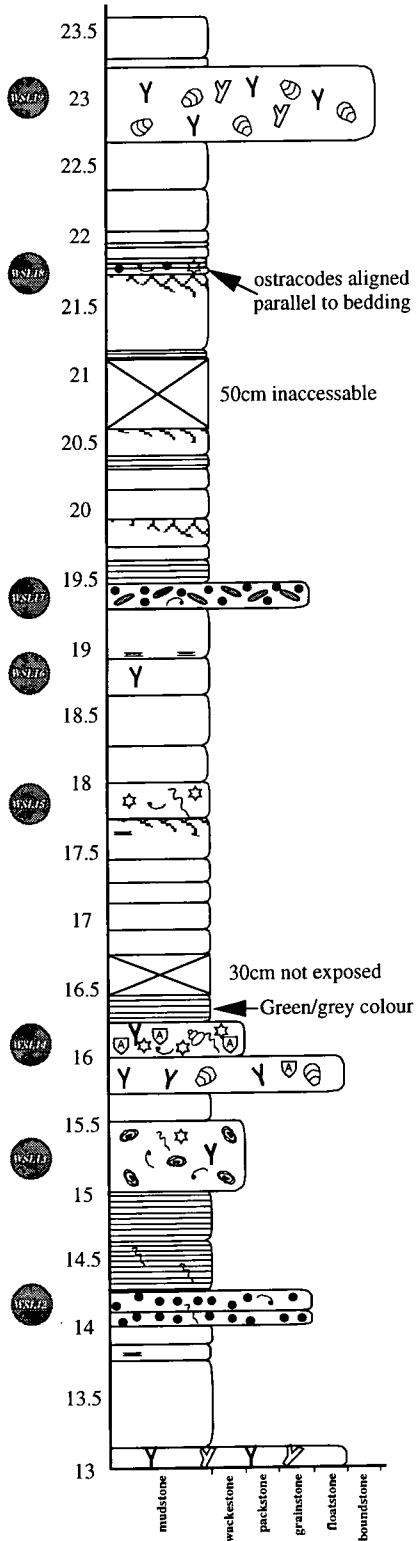

Walheim Southern Limb

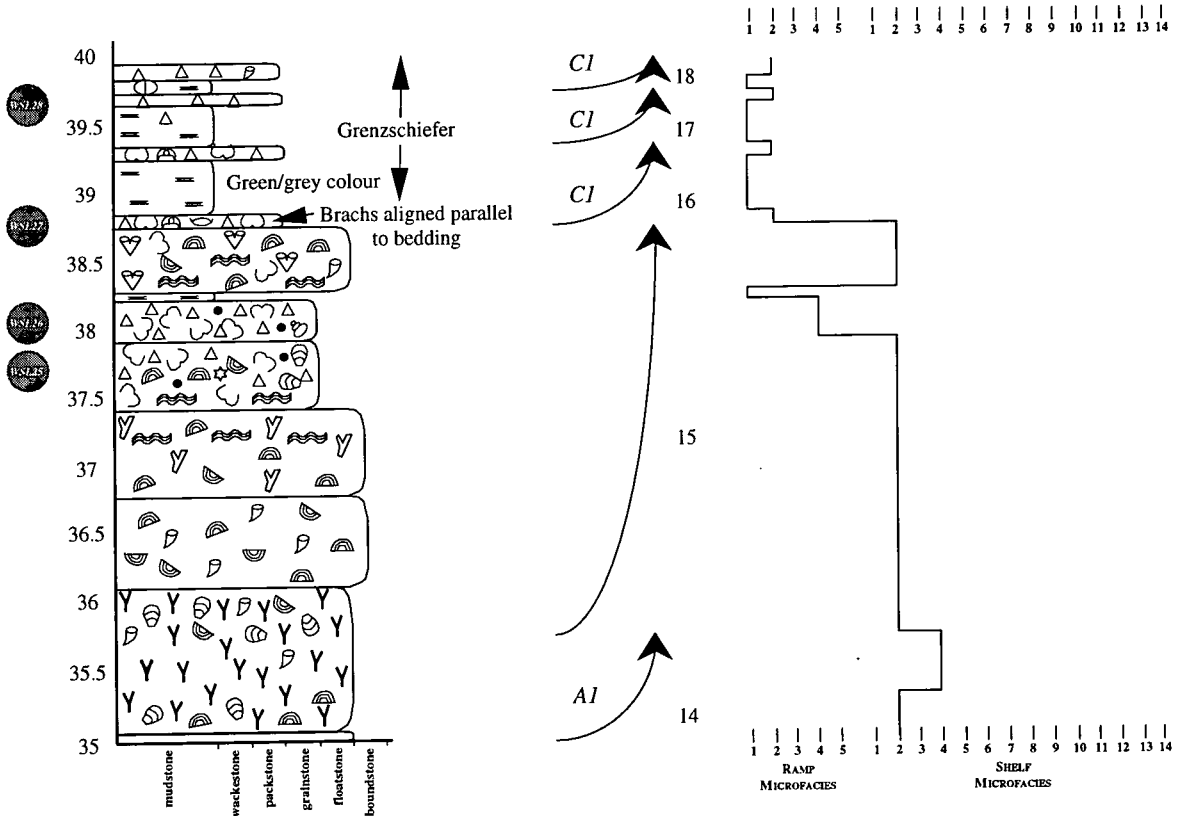

# *APPENDIX THREE*

A3. CYCLE THICKNESS DATA .....475

### A3. Cycle thickness data

The following tables provide all measured cycle thickness data which has been studied for this thesis. Tables are organised in alphabetical order.

#### Alt Breinig quarry

| Cycle number | Cycle type | Cycle thickness (cm) | Cumulative thickness (cm) | Semi-restricted facies (cm) | Restricted facies (cm) | Intertidal facies (cm) | Supratidal facies (cm) |
|--------------|------------|----------------------|---------------------------|-----------------------------|------------------------|------------------------|------------------------|
| 1            | B3         | 134cm                | 134cm                     | 33cm                        | 24cm                   | 0cm                    | 77cm                   |
| 2            | B3         | 136                  | 270                       | 32                          | 96                     | 0                      | 8                      |
| 3            | B4         | 142                  | 412                       | 0                           | 103                    | 0                      | 39                     |
| 4            | B4         | 63                   | 475                       | 0                           | 40                     | 0                      | 23                     |
| 5            | A1         | 642                  | 1117                      | 108                         | 534                    | 0                      | 0                      |
| 6            | B3         | 149                  | (Gap<br>1883cm)<br>3149   | 88                          | 0                      | 0                      | 61                     |
| 7            | B3         | 268                  | 3417                      | 234                         | 0                      | 0                      | 34                     |

#### Beuraing quarry

| Cycle number | Cycle type | Cycle thickness (cm) | Cumulative thickness (cm) | Semi-restricted facies (cm) | Restricted facies (cm) | Intertidal facies (cm) | Supratidal facies (cm) |
|--------------|------------|----------------------|---------------------------|-----------------------------|------------------------|------------------------|------------------------|
| 1            | A1         | 140cm                | 140cm                     | 72cm                        | 68cm                   | 0cm                    | 0cm                    |
| 2            | A1         | 127                  | 267                       | 22                          | 105                    | 0                      | 0                      |
| 3            | B4         | 80                   | 347                       | 0                           | 75                     | 0                      | 5                      |
| 4            | A1         | 264                  | 611                       | 68                          | 202                    | 0                      | 0                      |
| 5            | A1         | 133                  | 744                       | 29                          | 104                    | 0                      | 0                      |
| 6            | B2         | 97                   | 841                       | 0                           | 63                     | 34                     | 0                      |
| 7            | A2         | 95                   | 936                       | 0                           | 95                     | 0                      | 0                      |
| 8            | B3         | 220                  | 1156                      | 76                          | 129                    | 0                      | 15                     |
| 9            | A2         | 410                  | 1566                      | 0                           | 410                    | 0                      | 0                      |
| 10           | A1         | 215                  | 1781                      | 91                          | 124                    | 0                      | 0                      |
| 11           | A2         | 26                   | 1807                      | 0                           | 26                     | 0                      | 0                      |
| 12           | A2         | 151                  | 1958                      | 0                           | 151                    | 0                      | 0                      |
| 13           | A1         | 280                  | 2238                      | 156                         | 124                    | 0                      | 0                      |
| 14           | A2         | 230                  | 2468                      | 0                           | 230                    | 0                      | 0                      |
| 15           | A2         | 149                  | 2617                      | 0                           | 149                    | 0                      | 0                      |
| 16           | A1         | 230                  | 2847                      | 61                          | 169                    | 0                      | 0                      |
| 17           | A2         | 61                   | 2908                      | 0                           | 61                     | 0                      | 0                      |
| 18           | B4         | 75                   | 2983                      | 0                           | 38                     | 0                      | 37                     |
| 19           | A1         | 255                  | 3238                      | 49                          | 206                    | 0                      | 0                      |
| 20           | A2         | 655                  | 3893                      | 0                           | 655                    | 0                      | 0                      |
| 21           | A2         | 22                   | 3915                      | 0                           | 22                     | 0                      | 0                      |
| 22           | B3         | 282                  | 4197                      | 258                         | 18                     | 0                      | 6                      |

#### Bellignies-Bettrechies quarry

| Cycle number | Cycle type | Cycle thickness (cm) | Cumulative thickness (cm) | Outer ramp facies (cm) | Mid ramp facies (cm) | Inner ramp facies (cm) | Restricted facies (cm) |
|--------------|------------|----------------------|---------------------------|------------------------|----------------------|------------------------|------------------------|
| 1            | C1         | 142cm                | 142cm                     | 128cm                  | 14cm                 | 0cm                    | 0cm                    |
| 2            | C1         | 48                   | 190                       | 29                     | 19                   | 0                      | 0                      |
| 3            | C1         | 198                  | 388                       | 145                    | 53                   | 0                      | 0                      |
| 4            | C2         | 88                   | 476                       | 15                     | 0                    | 73                     | 0                      |
| 5            | C2         | 171                  | 647                       | 121                    | 0                    | 50                     | 0                      |
| 6            | C1         | 715                  | 1362                      | 496                    | 219                  | 0                      | 0                      |
| 7            | C3         | 677                  | 2039                      | 342                    | 70                   | 0                      | 265                    |
| 8            | C3         | 245                  | 2284                      | 0                      | 52                   | 0                      | 193                    |
| 9            | C3         | 92                   | 2376                      | 0                      | 0                    | 0                      | 92                     |
| 10           | C3         | 18                   | 2394                      | 0                      | 0                    | 0                      | 18                     |
| 11           | C3         | 111                  | 2505                      | 0                      | 0                    | 0                      | 111                    |
| 12           | C2         | 250                  | 2755                      | 35                     | 0                    | 110                    | 105                    |
| 13           | C3         | 166                  | 2921                      | 111                    | 8                    | 22                     | 25                     |
| 14           | C1         | 199                  | 3120                      | 29                     | 170                  | 0                      | 0                      |
| 15           | C3         | 743                  | 3863                      | 301                    | 0                    | 79                     | 222                    |
| 16           | C3         | 389                  | 4252                      | 137                    | 0                    | 36                     | 216                    |
| 17           | C3         | 163                  | 4415                      | 0                      | 0                    | 31                     | 132                    |
| 18           | C3         | 288                  | 4703                      | 0                      | 51                   | 0                      | 237                    |
| 19           | C3         | 114                  | 4817                      | 0                      | 0                    | 0                      | 114                    |

|    |    |     |      |     |     |   |     |
|----|----|-----|------|-----|-----|---|-----|
| 20 | C3 | 104 | 4921 | 0   | 0   | 0 | 104 |
| 21 | C3 | 153 | 5074 | 0   | 0   | 0 | 153 |
| 22 | C1 | 174 | 5248 | 27  | 147 | 0 | 0   |
| 23 | C1 | 220 | 5468 | 184 | 36  | 0 | 0   |
| 24 | C1 | 242 | 5710 | 201 | 41  | 0 | 0   |
| 25 | C3 | 353 | 6063 | 225 | 0   | 0 | 128 |
| 26 | C1 | 240 | 6309 | 167 | 79  | 0 | 0   |

## Bleiwäsche quarry

| Cycle number | Cycle type | Cycle thickness (cm) | Cumulative thickness (cm) | Semi-restricted facies (cm) | Restricted facies (cm) | Intertidal facies (cm) | Supratidal facies (cm) |
|--------------|------------|----------------------|---------------------------|-----------------------------|------------------------|------------------------|------------------------|
| 1            | B2         | 116cm                | 116cm                     | 0cm                         | 77cm                   | 39cm                   | 0cm                    |
| 2            | A3         | 264                  | 380                       | 264                         | 0                      | 0                      | 0                      |
| 3            | B1         | 146                  | 526                       | 94                          | 10                     | 42                     | 0                      |
| 4            | B1         | 408                  | 934                       | 43                          | 10                     | 355                    | 0                      |
| 5            | A1         | 286                  | 1220                      | 267                         | 19                     | 0                      | 0                      |
| 6            | A1         | 132                  | 1352                      | 45                          | 87                     | 0                      | 0                      |
| 7            | B2         | 123                  | 1475                      | 0                           | 65                     | 58                     | 0                      |
| 8            | B2         | 167                  | 1642                      | 0                           | 3                      | 164                    | 0                      |
| 9            | B2         | 42                   | 1684                      | 0                           | 33                     | 9                      | 0                      |
| 10           | B2         | 129                  | 1813                      | 0                           | 57                     | 72                     | 0                      |
| 11           | A1         | 319                  | 2132                      | 101                         | 218                    | 0                      | 0                      |
| 12           | A1         | 150                  | 2282                      | 123                         | 27                     | 0                      | 0                      |
| 13           | B3         | 51                   | 2333                      | 20                          | 0                      | 31                     | 0                      |
| 14           | A1         | 109                  | 2442                      | 84                          | 25                     | 0                      | 0                      |
| 15           | B4         | 94                   | 2536                      | 0                           | 15                     | 8                      | 71                     |
| 16           | B4         | 25                   | 2561                      | 0                           | 21                     | 0                      | 4                      |
| 17           | B1         | 76                   | 2637                      | 50                          | 0                      | 26                     | 0                      |
| 18           | A1         | 244                  | 2881                      | 30                          | 214                    | 0                      | 0                      |
| 19           | A1         | 173                  | 3054                      | 20                          | 95                     | 58                     | 0                      |
| 20           | B1         | 169                  | 3223                      | 40                          | 35                     | 94                     | 0                      |
| 21           | A2         | 191                  | 3414                      | 0                           | 191                    | 0                      | 0                      |
| 22           | A2         | 272                  | 3686                      | 0                           | 272                    | 0                      | 0                      |
| 23           | B1         | 268                  | 3954                      | 114                         | 87                     | 67                     | 0                      |
| 24           | A1         | 229                  | 4183                      | 52                          | 177                    | 0                      | 0                      |
| 25           | B3         | 179                  | 4362                      | 83                          | 85                     | 0                      | 11                     |

## Bleiwäsche Road Cutting

| Cycle number | Cycle type | Cycle thickness (cm) | Cumulative thickness (cm) | Semi-restricted facies (cm) | Restricted facies (cm) | Intertidal facies (cm) | Supratidal facies (cm) |
|--------------|------------|----------------------|---------------------------|-----------------------------|------------------------|------------------------|------------------------|
| 1            | A2         | 348cm                | 348cm                     | 0cm                         | 348cm                  | 0cm                    | 0cm                    |
| 2            | A2         | 140                  | 498                       | 0                           | 150                    | 0                      | 0                      |
| 3            | A2         | 445                  | 943                       | 0                           | 445                    | 0                      | 0                      |

## Broadridge Wood quarry

| Cycle number | Cycle type | Cycle thickness (cm) | Cumulative thickness (cm) | Semi-restricted facies (cm) | Restricted facies (cm) | Intertidal facies (cm) | Supratidal facies (cm) |
|--------------|------------|----------------------|---------------------------|-----------------------------|------------------------|------------------------|------------------------|
| 1            | B4         | 90cm                 | 90cm                      | 0cm                         | 33cm                   | 0cm                    | 57cm                   |
| 2            | A1         | 183                  | 273                       | 111                         | 72                     | 0                      | 0                      |
| 3            | B1         | 513                  | 786                       | 104                         | 327                    | 82                     | 0                      |
| 4            | B2         | 524                  | 1310                      | 0                           | 497                    | 27                     | 0                      |
| 5            | A1         | 180                  | 1490                      | 69                          | 111                    | 0                      | 0                      |
| 6            | A2         | 258                  | 1748                      | 0                           | 258                    | 0                      | 0                      |
| 7            | A2         | 133                  | 1881                      | 0                           | 133                    | 0                      | 0                      |
| 8            | B2         | 180                  | 2061                      | 0                           | 131                    | 49                     | 0                      |
| 9            | B1         | 152                  | (gap 367cm)<br>2580       | 71                          | 0                      | 81                     | 0                      |
| 10           | B2         | 202                  | 2782                      | 0                           | 156                    | 46                     | 0                      |
| 11           | B2         | 209                  | 2991                      | 116                         | 0                      | 93                     | 0                      |

## Cul d'Houille quarry

| Cycle number | Cycle type | Cycle thickness (cm) | Cumulative thickness (cm) | Semi-restricted facies (cm) | Restricted facies (cm) | Intertidal facies (cm) | Supratidal facies (cm) |
|--------------|------------|----------------------|---------------------------|-----------------------------|------------------------|------------------------|------------------------|
| 1            | A1         | 263cm                | 263cm                     | 174cm                       | 89cm                   | 0cm                    | 0cm                    |
| 2            | B4         | 22                   | 285                       | 0                           | 13                     | 0                      | 9                      |
| 3            | B1         | 188                  | 473                       | 104                         | 33                     | 51                     | 0                      |
| 4            | A1         | 105                  | 578                       | 67                          | 38                     | 0                      | 0                      |
| 5            | B3         | 96                   | 674                       | 88                          | 0                      | 0                      | 8                      |

|    |    |     |                     |     |     |    |    |
|----|----|-----|---------------------|-----|-----|----|----|
| 6  | B4 | 17  | 691                 | 0   | 7   | 0  | 10 |
| 7  | A1 | 105 | 796                 | 95  | 10  | 0  | 0  |
| 8  | A1 | 72  | 868                 | 52  | 20  | 0  | 0  |
| 9  | A1 | 118 | 986                 | 88  | 30  | 0  | 0  |
| 10 | A1 | 75  | 1061                | 29  | 46  | 0  | 0  |
| 11 | A1 | 42  | 1103                | 0   | 42  | 0  | 0  |
| 12 | B3 | 206 | 1309                | 71  | 70  | 0  | 65 |
| 13 | A1 | 386 | 1695                | 28  | 358 | 0  | 0  |
| 14 | B3 | 206 | 1901                | 37  | 92  | 0  | 77 |
| 15 | A1 | 120 | 2021                | 78  | 42  | 0  | 0  |
| 16 | A1 | 253 | 2274                | 207 | 46  | 0  | 0  |
| 17 | B4 | 415 | 2689                | 0   | 407 | 0  | 8  |
| 18 | B4 | 50  | 2739                | 0   | 44  | 0  | 6  |
| 19 | A2 | 311 | 3050                | 0   | 311 | 0  | 0  |
| 20 | A2 | 260 | 3310                | 0   | 260 | 0  | 0  |
| 21 | B4 | 159 | 3469                | 0   | 122 | 0  | 37 |
| 22 | B4 | 21  | 3490                | 0   | 12  | 0  | 9  |
| 23 | B2 | 80  | 3570                | 0   | 32  | 48 | 0  |
| 24 | B4 | 173 | 3743                | 0   | 167 | 0  | 6  |
| 25 | B2 | 51  | 3794                | 0   | 13  | 38 | 0  |
| 26 | B4 | 26  | 3820                | 0   | 20  | 0  | 6  |
| 27 | B4 | 194 | 4014                | 0   | 154 | 0  | 40 |
| 28 | A2 | 275 | 4289                | 0   | 275 | 0  | 0  |
| 29 | A1 | 143 | 4432                | 118 | 25  | 0  | 0  |
| 30 | A2 | 67  | 4499                | 0   | 67  | 0  | 0  |
| 31 | B3 | 72  | 4571                | 42  | 0   | 0  | 30 |
| 32 | B4 | 86  | 4657                | 0   | 58  | 0  | 28 |
| 33 | A1 | 332 | 4989                | 63  | 263 | 0  | 0  |
| 34 | A1 | 150 | 5139                | 140 | 10  | 0  | 0  |
| 35 | A1 | 176 | 5315                | 49  | 127 | 0  | 0  |
| 36 | B3 | 199 | 5514<br>(Gap 134cm) | 125 | 58  | 0  | 16 |
| 37 | A1 | 126 | 5774                | 56  | 70  | 0  | 0  |
| 38 | B4 | 62  | 5836                | 0   | 48  | 0  | 14 |
| 39 | A1 | 214 | 6050                | 40  | 274 | 0  | 0  |

## Dourbes quarry

| Cycle number | Cycle type | Cycle thickness (cm) | Cumulative thickness (cm) | Semi-restricted facies (cm) | Restricted facies (cm) | Intertidal facies (cm) | Supratidal facies (cm) |
|--------------|------------|----------------------|---------------------------|-----------------------------|------------------------|------------------------|------------------------|
| 1            | A1         | 113cm                | 113cm                     | 100cm                       | 13cm                   | 0cm                    | 0cm                    |
| 2            | B3         | 101                  | 214                       | 95                          | 0                      | 0                      | 6                      |
| 3            | A1         | 205                  | 419                       | 165                         | 40                     | 0                      | 0                      |
| 4            | A1         | 186                  | 605                       | 82                          | 104                    | 0                      | 0                      |
| 5            | A1         | 57                   | 662                       | 46                          | 11                     | 0                      | 0                      |
| 6            | B3         | 91                   | 753                       | 60                          | 17                     | 0                      | 14                     |
| 7            | B3         | 91                   | 844                       | 68                          | 20                     | 0                      | 3                      |
| 8            | A1         | 363                  | 1207                      | 188                         | 175                    | 0                      | 0                      |
| 9            | A2         | 137                  | 1344                      | 88                          | 49                     | 0                      | 0                      |
| 10           | A2         | 86                   | 1430                      | 0                           | 86                     | 0                      | 0                      |
| 11           | A2         | 293                  | 1723                      | 0                           | 293                    | 0                      | 0                      |
| 12           | B3         | 22                   | 1745                      | 10                          | 0                      | 0                      | 12                     |
| 13           | A2         | 209                  | 1954                      | 0                           | 209                    | 0                      | 0                      |
| 14           | A2         | 70                   | 2024                      | 0                           | 70                     | 0                      | 0                      |
| 15           | A2         | 90                   | 2114                      | 0                           | 90                     | 0                      | 0                      |
|              |            | (Gap 686cm)          |                           |                             |                        |                        |                        |
| 16           | A2         | 121                  | 2921                      | 0                           | 121                    | 0                      | 0                      |
| 17           | B4         | 75                   | 2996                      | 0                           | 49                     | 0                      | 26                     |
| 18           | A1         | 78                   | 3074                      | 0                           | 78                     | 0                      | 0                      |
| 19           | A1         | 62                   | 3136                      | 40                          | 22                     | 0                      | 0                      |
| 20           | A2         | 208                  | 3344                      | 0                           | 208                    | 0                      | 0                      |
| 21           | B3         | 101                  | 3445                      | 75                          | 0                      | 0                      | 26                     |
| 22           | B3         | 267                  | 3712                      | 15                          | 234                    | 0                      | 18                     |
| 23           | A1         | 131                  | 3843                      | 76                          | 55                     | 0                      | 0                      |
| 24           | A1         | 249                  | 4092                      | 40                          | 209                    | 0                      | 0                      |
| 25           | A1         | 83                   | 4175                      | 44                          | 39                     | 0                      | 0                      |

## Froid Lieu quarry

| Cycle number | Cycle type | Cycle thickness (cm) | Cumulative thickness (cm) | Ramp facies (cm) | Semi-restricted facies (cm) | Restricted facies (cm) | Intertidal facies (cm) |
|--------------|------------|----------------------|---------------------------|------------------|-----------------------------|------------------------|------------------------|
| 1            | C3         | 149cm                | 149cm                     | 72cm             | 0cm                         | 77cm                   | 0cm                    |
| 2            | A2         | 80                   | 229                       | 0                | 0                           | 80                     | 0                      |
| 3            | A1         | 59<br>(Gap 488cm)    | 288                       | 0                | 42                          | 17                     | 0                      |
| 4            | B2         | 400                  | 1176                      | 0                | 0                           | 364                    | 36                     |
| 5            | B2         | 271                  | 1447                      | 0                | 0                           | 241                    | 30                     |
| 6            | A2         | 62                   | 1509                      | 0                | 0                           | 62                     | 0                      |
| 7            | B2         | 622                  | 2131                      | 0                | 0                           | 577                    | 45                     |
| 8            | B2         | 386                  | 2517                      | 0                | 0                           | 274                    | 112                    |
| 9            | B2         | 179                  | 2696                      | 0                | 0                           | 155                    | 24                     |

## Glageon quarry

| Cycle number | Cycle type | Cycle thickness (cm)       | Cumulative thickness (cm) | Outer ramp facies (cm) | Mid ramp facies (cm) | Inner ramp facies (cm) | Restricted facies (cm) |
|--------------|------------|----------------------------|---------------------------|------------------------|----------------------|------------------------|------------------------|
| 1            | C1         | 377cm                      | 377cm                     | 302cm                  | 55cm                 | 0cm                    | 0cm                    |
| 2            | C1         | 117                        | 494                       | 33                     | 84                   | 0                      | 0                      |
| 3            | C1         | 499                        | 993                       | 467                    | 32                   | 0                      | 0                      |
| 4            | C1         | 69                         | 1062                      | 54                     | 15                   | 0                      | 0                      |
| 5            | C1         | 421                        | 1483                      | 317                    | 104                  | 0                      | 0                      |
| 6            | C2         | 93                         | 1576                      | 71                     | 0                    | 22                     | 0                      |
| 7            | C1         | 317                        | 1893                      | 198                    | 15                   | 104                    | 0                      |
| 8            | C2         | 302                        | 2195                      | 212                    | 0                    | 90                     | 0                      |
| 9            | C1         | 373                        | 2568                      | 33                     | 340                  | 0                      | 0                      |
| 10           | C1         | 360                        | 2928                      | 213                    | 147                  | 0                      | 0                      |
| 11           | C1         | 221                        | 3149                      | 211                    | 10                   | 0                      | 0                      |
| 12           | C2         | 539                        | 3688                      | 182                    | 0                    | 357                    | 0                      |
| 13           | C1         | 839                        | 4527                      | 758                    | 81                   | 0                      | 0                      |
| 14           | C1         | 94                         | 4621                      | 63                     | 31                   | 0                      | 0                      |
| 15           | C1         | 148                        | 4769                      | 128                    | 20                   | 0                      | 0                      |
| 16           | C1         | 276                        | 5045                      | 261                    | 15                   | 0                      | 0                      |
| 17           | C1         | 1042                       | 6087                      | 968                    | 74                   | 0                      | 0                      |
| 18           | C1         | 277                        | 6364                      | 209                    | 68                   | 0                      | 0                      |
| 19           | C1         | 134                        | 6498                      | 124                    | 10                   | 0                      | 0                      |
| 20           | C1         | 505                        | 7003                      | 453                    | 52                   | 0                      | 0                      |
| 21           | C1         | 703                        | 7706                      | 153                    | 550                  | 0                      | 0                      |
| 22           | C1         | 155<br>(244cm dolomitised) | 7861                      | 43                     | 112                  | 0                      | 0                      |
| 23           | C1         | 104<br>(288cm dolomitised) | 8209                      | 78                     | 26                   | 0                      | 0                      |
| 24           | C1         | 304                        | 8801                      | 128                    | 176                  | 0                      | 0                      |
| 25           | C2         | 497                        | 9298                      | 407                    | 0                    | 90                     | 0                      |
| 26           | C1         | 276                        | 9574                      | 83                     | 193                  | 0                      | 0                      |
| 27           | C1         | 303                        | 9877                      | 253                    | 50                   | 0                      | 0                      |
| 28           | C1         | 308                        | 10185                     | 213                    | 95                   | 0                      | 0                      |
| 29           | C2         | 40                         | 10225                     | 32                     | 0                    | 8                      | 0                      |
| 30           | C3         | 106                        | 10331                     | 56                     | 0                    | 0                      | 52                     |
| 31           | C1         | 172                        | 10503                     | 89                     | 83                   | 0                      | 0                      |
| 32           | C1         | 472                        | 10975                     | 179                    | 293                  | 0                      | 0                      |
| 33           | C1         | 167                        | 11142                     | 105                    | 62                   | 0                      | 0                      |
| 34           | C1         | 205                        | 11347                     | 147                    | 58                   | 0                      | 0                      |
| 35           | C1         | 210                        | 11557                     | 173                    | 37                   | 0                      | 0                      |
| 36           | C1         | 145                        | 11702                     | 56                     | 89                   | 0                      | 0                      |
| 37           | C1         | 391                        | 12093                     | 305                    | 86                   | 0                      | 0                      |
| 38           | C1         | 666                        | 12759                     | 126                    | 540                  | 0                      | 0                      |

## Hanielsfeld quarry

| Cycle number | Cycle type | Cycle thickness (cm) | Cumulative thickness (cm) | Outer ramp facies (cm) | Mid ramp facies (cm) |
|--------------|------------|----------------------|---------------------------|------------------------|----------------------|
| 1            | C2         | 78cm                 | 78cm                      | 33cm                   | 45cm                 |
| 2            | C2         | 67                   | 145                       | 35                     | 32                   |
| 3            | C2         | 153                  | 298                       | 29                     | 124                  |
| 4            | C2         | 244                  | 542                       | 25                     | 219                  |
| 5            | C2         | 233                  | 775                       | 23                     | 210                  |

## Heggen quarry

| Cycle number | Cycle type | Cycle thickness (cm) | Cumulative thickness (cm) | Semi-restricted facies (cm) | Restricted facies (cm) | Intertidal facies (cm) | Supratidal facies (cm) |
|--------------|------------|----------------------|---------------------------|-----------------------------|------------------------|------------------------|------------------------|
| 1            | A1         | 839cm                | 839cm                     | 811cm                       | 28cm                   | 0cm                    | 0cm                    |
| 2            | A1         | 231                  | 1070                      | 183                         | 48                     | 0                      | 0                      |
| 3            | A3         | 259<br>(Gap 1171cm)  | 1329                      | 259                         | 0                      | 0                      | 0                      |
| 4            | A1         | 471                  | 2971                      | 417                         | 54                     | 0                      | 0                      |
| 5            | A1         | 233                  | 3204                      | 158                         | 75                     | 0                      | 0                      |
| 6            | A3         | 553                  | 3757                      | 553                         | 0                      | 0                      | 0                      |
| 7            | A3         | (Gap 3060cm)<br>204  | 7021                      | 204                         | 0                      | 0                      | 0                      |
| 8            | A3         | 299                  | 7320                      | 299                         | 0                      | 0                      | 0                      |
| 9            | A3         | 577                  | 7897                      | 577                         | 0                      | 0                      | 0                      |
| 10           | A3         | 365                  | 8262                      | 365                         | 0                      | 0                      | 0                      |
| 11           | A3         | 147                  | 8409                      | 147                         | 0                      | 0                      | 0                      |
| 12           | A1         | 501                  | 8910                      | 501                         | 0                      | 0                      | 0                      |
| 13           | A3         | 295                  | 9205                      | 66                          | 229                    | 0                      | 0                      |
| 14           | A1         | 310<br>(Gap 3378cm)  | 9515                      | 310                         | 0                      | 0                      | 0                      |
| 15           | A1         | 510<br>(Gap 170cm)   | 13403                     | 298                         | 212                    | 0                      | 0                      |
| 16           | A3         | 170<br>(Gap 200cm)   | 13743                     | 170                         | 0                      |                        | 0                      |
| 17           | A1         | 450                  | 14393                     | 407                         | 43                     | 0                      | 0                      |
| 18           | A3         | 155                  | 14548                     | 155                         | 0                      | 0                      | 0                      |
| 19           | A3         | 117                  | 14665                     | 117                         | 0                      |                        | 0                      |
| 20           | A1         | 305                  | 14970                     | 178                         | 117                    |                        | 0                      |
| 21           | A3         | 229                  | 15199                     | 229                         | 0                      |                        | 0                      |
| 22           | A1         | 143                  | 15342                     | 123                         | 20                     |                        | 0                      |
| 23           | A3         | 342                  | 15684                     | 342                         | 0                      |                        | 0                      |
| 24           | A1         | 77                   | 15761                     | 51                          | 26                     |                        | 0                      |
| 25           | A3         | 300                  | 16061                     | 300                         | 0                      |                        | 0                      |
| 26           | A3         | 172                  | 16233                     | 172                         | 0                      |                        | 0                      |
| 27           | A1         | 123                  | 16356                     | 66                          | 57                     |                        | 0                      |
| 28           | A1         | 66                   | 16422                     | 53                          | 13                     |                        | 0                      |

## Keldenich quarry

| Cycle number | Cycle type | Cycle thickness (cm) | Cumulative thickness (cm) | Semi-restricted facies (cm) | Restricted facies (cm) | Intertidal facies (cm) | Supratidal facies (cm) |
|--------------|------------|----------------------|---------------------------|-----------------------------|------------------------|------------------------|------------------------|
| 1            | B2         | 84cm                 | 84cm                      | 0cm                         | 30cm                   | 54cm                   | 0cm                    |
| 2            | B2         | 144                  | 228                       | 0                           | 37                     | 107                    | 0                      |
| 3            | B2         | 371                  | 599                       | 0                           | 275                    | 96                     | 0                      |
| 4            | A2         | 43                   | 642                       | 0                           | 43                     | 0                      | 0                      |
| 5            | B4         | 213<br>(Gap 458cm)   | 1313                      | 0                           | 108                    | 66                     | 39                     |
| 6            | A2         | 64                   | 1377                      | 0                           | 64                     | 0                      | 0                      |
| 7            | B4         | 79                   | 1456                      | 0                           | 54                     | 0                      | 25                     |
| 8            | B2         | 121<br>(Gap 1144cm)  | 2721                      | 0                           | 101                    | 20                     | 0                      |
| 9            | A2         | 180                  | 2901                      | 0                           | 180                    | 0                      | 0                      |
| 10           | B2         | 551                  | 3452                      | 0                           | 508                    | 43                     | 0                      |
| 11           | A2         | 103                  | 3555                      | 0                           | 103                    | 0                      | 0                      |
| 12           | B2         | 201                  | 3756                      | 0                           | 123                    | 78                     | 0                      |
| 13           | A2         | 91                   | 3847                      | 0                           | 91                     | 0                      | 0                      |

## Linhay Hill quarry

| Cycle number | Cycle type | Cycle thickness (cm) | Cumulative thickness (cm) | Semi-restricted facies (cm) | Restricted facies (cm) | Intertidal facies (cm) | Supratidal facies (cm) |
|--------------|------------|----------------------|---------------------------|-----------------------------|------------------------|------------------------|------------------------|
| 1            | A2         | 141cm                | 141cm                     | 0cm                         | 141cm                  | 0cm                    | 0cm                    |
| 2            | A2         | 74                   | 215                       | 0                           | 74                     | 0                      | 0                      |
| 3            | A1         | 138                  | 353                       | 0                           | 138                    | 0                      | 0                      |
| 4            | A1         | 63                   | 416                       | 40                          | 23                     | 0                      | 0                      |
| 5            | A1         | 262                  | 678                       | 145                         | 117                    | 0                      | 0                      |
| 6            | A1         | 161                  | 839                       | 78                          | 83                     | 0                      | 0                      |
| 7            | A2         | 175                  | 1014                      | 0                           | 175                    | 0                      | 0                      |
| 8            | A2         | 213                  | 1227                      | 0                           | 213                    | 0                      | 0                      |

|    |    |     |                     |     |     |   |   |
|----|----|-----|---------------------|-----|-----|---|---|
| 9  | A2 | 120 | 1347                | 0   | 120 | 0 | 0 |
| 10 | A2 | 98  | 1445                | 0   | 98  | 0 | 0 |
| 11 | A2 | 445 | 1890                | 0   | 445 | 0 | 0 |
| 12 | A2 | 172 | 2062                | 0   | 172 | 0 | 0 |
| 13 | A2 | 167 | (Gap 323cm)<br>2552 | 0   | 167 | 0 | 0 |
| 14 | A2 | 134 | 2686                | 0   | 134 | 0 | 0 |
| 15 | A1 | 118 | 2804                | 50  | 68  | 0 | 0 |
| 16 | A1 | 327 | 3131                | 128 | 199 | 0 | 0 |
| 17 | A2 | 288 | 3419                | 0   | 288 | 0 | 0 |
| 18 | A2 | 123 | 3542                | 0   | 123 | 0 | 0 |
| 19 | A2 | 191 | 3733                | 0   | 191 | 0 | 0 |
| 20 | A2 | 354 | 4087                | 0   | 354 | 0 | 0 |
| 21 | A1 | 588 | (Gap 299cm)<br>4974 | 83  | 505 | 0 | 0 |
| 22 | A1 | 138 | 5112                | 0   | 138 | 0 | 0 |

## Medenbach quarry

| Cycle number | Cycle type | Cycle thickness (cm) | Cumulative thickness (cm) | Semi-restricted facies (cm) | Restricted facies (cm) | Intertidal facies (cm) | Supratidal facies (cm) |
|--------------|------------|----------------------|---------------------------|-----------------------------|------------------------|------------------------|------------------------|
| 1            | A2         | 1437cm               | 1437cm                    | 0cm                         | 1437cm                 | 0cm                    | 0cm                    |
| 2            | A1         | 595                  | 2032                      | 76                          | 519                    | 0                      | 0                      |
| 3            | A2         | 360                  | 2392                      | 0                           | 360                    | 0                      | 0                      |
| 4            | A2         | 482                  | 2874                      | 0                           | 482                    | 0                      | 0                      |

## Nismes quarry

| Cycle number | Cycle type | Cycle thickness (cm) | Cumulative thickness (cm) | Semi-restricted facies (cm) | Restricted facies (cm) | Intertidal facies (cm) | Supratidal facies (cm) |
|--------------|------------|----------------------|---------------------------|-----------------------------|------------------------|------------------------|------------------------|
| 1            | B4         | 55cm                 | 55cm                      | 0cm                         | 46cm                   | 0cm                    | 9cm                    |
| 2            | A1         | 80                   | 135                       | 52                          | 28                     | 0                      | 0                      |
| 3            | B3         | 80                   | 215                       | 75                          | 0                      | 0                      | 5                      |
| 4            | A1         | 88                   | 303                       | 19                          | 69                     | 0                      | 0                      |
| 5            | B3         | 120                  | 423                       | 106                         | 6                      | 0                      | 8                      |
| 6            | A1         | 61                   | 484                       | 34                          | 27                     | 0                      | 0                      |
| 7            | A1         | 177                  | 661                       | 36                          | 141                    | 0                      | 0                      |
| 8            | A1         | 51                   | 712                       | 40                          | 11                     | 0                      | 0                      |
| 9            | B3         | 157                  | 869                       | 136                         | 18                     | 0                      | 3                      |
| 10           | A2         | 80                   | 949                       | 0                           | 80                     | 0                      | 0                      |
| 11           | A1         | 245                  | 1194                      | 113                         | 132                    | 0                      | 0                      |
| 12           | B3         | 63                   | 1257                      | 24                          | 0                      | 0                      | 39                     |
| 13           | A2         | 177                  | 1434                      | 121                         | 56                     | 0                      | 0                      |
| 14           | B4         | 131                  | 1565                      | 0                           | 118                    | 0                      | 13                     |
| 15           | B4         | 35                   | 1600                      | 0                           | 15                     | 0                      | 20                     |
| 16           | A2         | 78                   | 1678                      | 0                           | 78                     | 0                      | 0                      |
| 17           | B4         | 56                   | 1734                      | 0                           | 41                     | 0                      | 15                     |
| 18           | A1         | 292                  | 2026                      | 161                         | 131                    | 0                      | 0                      |
| 19           | A1         | 50                   | 2076                      | 22                          | 28                     | 0                      | 0                      |
| 20           | A2         | 149                  | 2225                      | 0                           | 149                    | 0                      | 0                      |
| 21           | B4         | 48                   | 2273                      | 0                           | 42                     | 0                      | 6                      |
| 22           | A1         | 130                  | 2403                      | 70                          | 60                     | 0                      | 0                      |

## Oberrödinghausen quarry

| Cycle number | Cycle type | Cycle thickness (cm) | Cumulative thickness (cm) | Semi-restricted facies (cm) | Restricted facies (cm) | Intertidal facies (cm) | Supratidal facies (cm) |
|--------------|------------|----------------------|---------------------------|-----------------------------|------------------------|------------------------|------------------------|
| 1            | B2         | 219cm                | 219cm                     | 0cm                         | 202cm                  | 17cm                   | 0cm                    |
| 2            | A1         | 194                  | 413                       | 69                          | 125                    | 0                      | 0                      |
| 3            | A1         | 155                  | 568                       | 94                          | 61                     | 0                      | 0                      |
| 4            | A1         | 255                  | 823                       | 37                          | 218                    | 0                      | 0                      |
| 5            | A1         | 287                  | 1110                      | 41                          | 246                    | 0                      | 0                      |
| 6            | A1         | 286                  | 1396                      | 56                          | 230                    | 0                      | 0                      |
| 7            | A1         | 270                  | 1666                      | 63                          | 207                    | 0                      | 0                      |
| 8            | A1         | 145                  | 1811                      | 32                          | 113                    | 0                      | 0                      |
| 9            | A2         | 183                  | 1994                      | 0                           | 183                    | 0                      | 0                      |
| 10           | A2         | 202                  | 2196                      | 0                           | 202                    | 0                      | 0                      |
| 11           | A2         | 58                   | 2255                      | 0                           | 58                     | 0                      | 0                      |
| 12           | A2         | 545                  | 2800                      | 0                           | 545                    | 0                      | 0                      |
| 13           | A1         | 351                  | 3151                      | 287                         | 64                     | 0                      | 0                      |
| 14           | A1         | 372                  | 3523                      | 264                         | 108                    | 0                      | 0                      |
| 15           | A1         | (Gap 462cm)          | 4099                      | 66                          | 48                     | 0                      | 0                      |

|    |    |                     |      |     |    |   |   |
|----|----|---------------------|------|-----|----|---|---|
|    |    | 114                 |      |     |    |   |   |
| 16 | A3 | 324                 | 4423 | 324 | 0  | 0 | 0 |
| 17 | A3 | 552                 | 4975 | 552 | 0  | 0 | 0 |
| 18 | A3 | 86<br>(306cm gap)   | 5061 | 86  | 0  | 0 | 0 |
| 19 | A3 | 602                 | 5969 | 602 | 0  | 0 | 0 |
| 20 | A1 | 129                 | 6098 | 116 | 13 | 0 | 0 |
| 21 | A3 | (2902cm gap)<br>217 | 9217 | 217 | 0  | 0 | 0 |

## Olloy-sur-Viroin quarry

| Cycle number | Cycle type | Cycle thickness (cm) | Cumulative thickness (cm) | Ramp facies (cm) | Semi-restricted facies (cm) | Restricted facies (cm) | Intertidal facies (cm) |
|--------------|------------|----------------------|---------------------------|------------------|-----------------------------|------------------------|------------------------|
| 1            | C1         | 342cm                | 342cm                     | 342cm            | 0cm                         | 0cm                    | 0cm                    |
| 2            | C1         | 109                  | 451                       | 109              | 0                           | 0                      | 0                      |
| 3            | A3         | 544                  | 995                       | 129              | 415                         | 0                      | 0                      |
| 4            | B2         | (1080cm gap)<br>155  | 2230                      | 0                | 0                           | 33                     | 121                    |
| 5            | B2         | 206                  | 2436                      | 0                | 0                           | 59                     | 147                    |
| 6            | B1         | 103                  | 2539                      | 0                | 30                          | 0                      | 73                     |
| 7            | B2         | 71                   | 2610                      | 0                | 0                           | 15                     | 56                     |
| 8            | B1         | 518                  | 3128                      | 0                | 317                         | 179                    | 22                     |
| 9            | A2         | 587                  | 3715                      | 0                | 0                           | 587                    | 0                      |
| 10           | B2         | 127                  | 3842                      | 0                | 0                           | 64                     | 63                     |
| 11           | B2         | 189                  | 4031                      | 0                | 0                           | 63                     | 126                    |
| 12           | B2         | 111                  | 4142                      | 0                | 0                           | 86                     | 25                     |
| 13           | B2         | 215                  | 4357                      | 0                | 0                           | 55                     | 160                    |

## Resteigne quarry

| Cycle number | Cycle type | Cycle thickness (cm) | Cumulative thickness (cm) | Ramp facies (cm) | Semi-restricted facies (cm) | Restricted facies (cm) | Intertidal facies (cm) | Supratidal facies (cm) |
|--------------|------------|----------------------|---------------------------|------------------|-----------------------------|------------------------|------------------------|------------------------|
| 1            | B1         | 527cm                | 527cm                     | 197cm            | 273cm                       | 0cm                    | 67cm                   | 0cm                    |
| 2            | A2         | 317                  | 844                       | 0                | 0                           | 275                    | 42                     | 0                      |
| 3            | A1         | 123                  | 967                       | 0                | 83                          | 40                     | 0                      | 0                      |
| 4            | A2         | 79                   | 1046                      | 0                | 0                           | 79                     | 0                      | 0                      |
| 5            | A2         | 283                  | 1329                      | 0                | 0                           | 283                    | 0                      | 0                      |
| 6            | A2         | 122                  | 1451                      | 0                | 0                           | 122                    | 0                      | 0                      |
| 7            | A1         | 207                  | 1658                      | 0                | 22                          | 185                    | 0                      | 0                      |
| 8            | A2         | (200cm gap)<br>558   | 2416                      | 0                | 0                           | 558                    | 0                      | 0                      |
| 9            | A1         | 250                  | 2666                      | 0                | 55                          | 195                    | 0                      | 0                      |
| 10           | A2         | 724                  | 3390                      | 0                | 0                           | 724                    | 0                      | 0                      |
| 11           | A2         | 607                  | 3997                      | 0                | 0                           | 607                    | 0                      | 0                      |
| 12           | B4         | 248                  | 4245                      | 0                | 0                           | 183                    | 0                      | 65                     |
| 13           | A1         | 219                  | 4464                      | 0                | 72                          | 147                    | 0                      | 0                      |
| 14           | B3         | 102                  | 4566                      | 0                | 49                          | 0                      | 0                      | 53                     |
| 15           | B3         | 430                  | 4996                      | 0                | 61                          | 354                    | 0                      | 15                     |
| 16           | B4         | 270                  | 5266                      | 0                | 0                           | 216                    | 0                      | 54                     |
| 17           | B2         | 367                  | 5633                      | 0                | 0                           | 347                    | 20                     | 0                      |
| 18           | B4         | 130                  | 5763                      | 0                | 0                           | 72                     | 0                      | 58                     |
| 19           | B2         | 150                  | 5913                      | 0                | 0                           | 120                    | 30                     | 0                      |
| 20           | B3         | 754                  | 6667                      | 0                | 50                          | 100                    | 20                     | 584                    |
| 21           | B4         | 470                  | 7137                      | 0                | 0                           | 185                    | 0                      | 285                    |
| 22           | B4         | 172                  | 7309                      | 0                | 0                           | 90                     | 56                     | 26                     |
| 23           | C1         | 336                  | 7645                      | 95               | 132                         | 109                    | 0                      | 0                      |
| 24           | C1         | 206                  | 7851                      | 18               | 188                         | 0                      | 0                      | 0                      |
| 25           | C1         | 305                  | 8156                      | 286              | 19                          | 0                      | 0                      | 0                      |
| 26           | C1         | 233                  | 8389                      | 213              | 20                          | 0                      | 0                      | 0                      |
| 27           | C1         | 85                   | 8474                      | 85               | 0                           | 0                      | 0                      | 0                      |
| 28           | C1         | 114                  | 8588                      | 114              | 0                           | 0                      | 0                      | 0                      |

## Rydon quarry

| Cycle number | Cycle type | Cycle thickness (cm) | Cumulative thickness (cm) | Semi-restricted facies (cm) | Restricted facies (cm) | Intertidal facies (cm) | Supratidal facies (cm) |
|--------------|------------|----------------------|---------------------------|-----------------------------|------------------------|------------------------|------------------------|
| 1            | A1         | 222cm                | 222cm                     | 119cm                       | 103cm                  | 0cm                    | 0cm                    |
| 2            | B1         | 239                  | 461                       | 141                         | 52                     | 46                     | 0                      |
| 3            | A1         | 177                  | 638                       | 105                         | 72                     | 0                      | 0                      |
| 4            | A1         | 45                   | 683                       | 10                          | 35                     | 0                      | 0                      |

|   |    |     |                     |     |     |    |   |
|---|----|-----|---------------------|-----|-----|----|---|
| 5 | A1 | 300 | 983                 | 166 | 134 | 0  | 0 |
| 6 | A1 | 364 | (Gap 398cm)<br>1745 | 200 | 164 | 0  | 0 |
| 7 | A2 | 155 | 1900                | 0   | 155 | 0  | 0 |
| 8 | B2 | 137 | 2037                | 0   | 81  | 56 | 0 |

## Schmithof quarry

| Cycle number | Cycle type | Cycle thickness (cm) | Cumulative thickness (cm) | Semi-restricted facies (cm) | Restricted facies (cm) | Intertidal facies (cm) | Supratidal facies (cm) |
|--------------|------------|----------------------|---------------------------|-----------------------------|------------------------|------------------------|------------------------|
| 1            | B4         | 268cm                | 268cm                     | 24cm                        | 148cm                  | 0cm                    | 96cm                   |
| 2            | A1         | 106                  | 374                       | 22                          | 84                     | 0                      | 0                      |
| 3            | A1         | 212                  | (Gap 180cm)<br>766        | 102                         | 110                    | 0                      | 0                      |
| 4            | A1         | 266                  | 1032                      | 86                          | 180                    | 0                      | 0                      |
| 5            | B3         | 207                  | 1239                      | 123                         | 22                     | 0                      | 62                     |
| 6            | A1         | 381                  | 1620                      | 145                         | 236                    | 0                      | 0                      |
| 7            | A1         | 449                  | 2069                      | 0                           | 449                    | 0                      | 0                      |

## Sourd d'Ave section

| Cycle number | Cycle type | Cycle thickness (cm) | Cumulative thickness (cm) | Semi-restricted facies (cm) | Restricted facies (cm) | Intertidal facies (cm) | Supratidal facies (cm) |
|--------------|------------|----------------------|---------------------------|-----------------------------|------------------------|------------------------|------------------------|
| 1            | A1         | 275cm                | 275cm                     | 132cm                       | 143cm                  | 0cm                    | 0                      |
| 2            | A1         | 297                  | 572                       | 61                          | 236                    | 0                      | 0                      |
| 3            | A2         | 100                  | 672                       | 0                           | 100                    | 0                      | 0                      |
| 4            | B2         | 415                  | 1087                      | 0                           | 376                    | 39                     | 0                      |
| 5            | B4         | 295                  | 1382                      | 0                           | 238                    | 57                     | 0                      |
| 6            | B2         | 106                  | 1488                      | 0                           | 106                    | 0                      | 0                      |
| 7            | B1         | 203                  | (Gap 828cm)<br>2519       | 74                          | 56                     | 73                     | 0                      |
| 8            | B3         | 283                  | 2802                      | 124                         | 113                    | 0                      | 46                     |
| 9            | B2         | 307                  | 3109                      | 0                           | 287                    | 20                     | 0                      |

## Teerstrabenbau quarry

## Lower

| Cycle number | Cycle type | Cycle thickness (cm) | Cumulative thickness (cm) | Outer ramp facies (cm) | Mid ramp facies (cm) | Inner ramp facies (cm) | Restricted facies (cm) |
|--------------|------------|----------------------|---------------------------|------------------------|----------------------|------------------------|------------------------|
| 1            | C1         | 238cm                | 238cm                     | 68cm                   | 170cm                | 0cm                    | 0cm                    |
| 2            | C1         | 84                   | 322                       | 32                     | 52                   | 0                      | 0                      |
| 3            | C1         | 384                  | 706                       | 201                    | 183                  | 0                      | 0                      |
| 4            | C1         | 97                   | 803                       | 37                     | 60                   | 0                      | 0                      |
| 5            | C1         | 424                  | 1227                      | 274                    | 150                  | 0                      | 0                      |

## Middle

| Cycle number | Cycle type | Cycle thickness (cm) | Cumulative thickness (cm) | Semi-restricted facies (cm) | Restricted facies (cm) | Intertidal facies (cm) | Supratidal facies (cm) |
|--------------|------------|----------------------|---------------------------|-----------------------------|------------------------|------------------------|------------------------|
| 1            | A1         | 467cm                | 467cm                     | 343cm                       | 124cm                  | 0cm                    | 0cm                    |
| 2            | B1         | 390                  | 857                       | 221                         | 117                    | 52                     |                        |
| 3            | A1         | 352                  | 1209                      | 79                          | 273                    | 0                      | 0                      |
| 4            | A2         | 62                   | 1271                      | 0                           | 62                     | 0                      | 0                      |
| 5            | A2         | 92                   | 1363                      | 0                           | 92                     | 0                      | 0                      |

## Upper

| Cycle number | Cycle type | Cycle thickness (cm) | Cumulative thickness (cm) | Semi-restricted facies (cm) | Restricted facies (cm) | Intertidal facies (cm) | Supratidal facies (cm) |
|--------------|------------|----------------------|---------------------------|-----------------------------|------------------------|------------------------|------------------------|
| 1            | A1         | 109cm                | 109cm                     | 101cm                       | 8cm                    | 0cm                    | 0cm                    |
| 2            | B1         | 137                  | 246                       | 88                          | 0                      | 49                     | 0                      |
| 3            | B2         | 141                  | 387                       | 0                           | 106                    | 35                     | 0                      |
| 4            | B4         | 24                   | 411                       | 0                           | 17                     | 7                      | 0                      |
| 5            | B4         | 46                   | 457                       | 0                           | 10                     | 29                     | 7                      |
| 6            | B4         | 123                  | 580                       | 0                           | 73                     | 39                     | 11                     |
| 7            | B2         | 232                  | 812                       | 0                           | 141                    | 91                     | 0                      |
| 8            | B2         | 125                  | 937                       | 0                           | 80                     | 45                     | 0                      |
| 9            | B2         | 120                  | 1057                      | 0                           | 60                     | 60                     | 0                      |
| 10           | B2         | 118                  | 1175                      | 0                           | 67                     | 51                     | 0                      |

## Vaucelles quarry

| Cycle number | Cycle type | Cycle thickness (cm) | Cumulative thickness (cm) | Semi-restricted facies (cm) | Restricted facies (cm) | Intertidal facies (cm) | Supratidal facies (cm) |
|--------------|------------|----------------------|---------------------------|-----------------------------|------------------------|------------------------|------------------------|
|              |            |                      |                           |                             |                        |                        |                        |

|    |    |       |       |      |       |     |      |
|----|----|-------|-------|------|-------|-----|------|
| 1  | B3 | 919cm | 919cm | 96cm | 764cm | 0cm | 59cm |
| 2  | B4 | 37    | 956   | 0    | 29    | 0   | 8    |
| 3  | B4 | 25    | 981   | 0    | 14    | 0   | 11   |
| 4  | B4 | 38    | 1019  | 0    | 28    | 0   | 10   |
| 5  | A2 | 115   | 1134  | 0    | 115   | 0   | 0    |
| 6  | A1 | 149   | 1283  | 23   | 126   | 0   | 0    |
| 7  | B3 | 118   | 1401  | 17   | 76    | 0   | 25   |
| 8  | A2 | 103   | 1504  | 0    | 103   | 0   | 0    |
| 9  | A1 | 180   | 1684  | 65   | 115   | 0   | 0    |
| 10 | A1 | 280   | 1964  | 86   | 194   | 0   | 0    |

## Venwegen quarry

| Cycle number | Cycle type | Cycle thickness (cm) | Cumulative thickness (cm) | Semi-restricted facies (cm) | Restricted facies (cm) | Intertidal facies (cm) | Supratidal facies (cm) |
|--------------|------------|----------------------|---------------------------|-----------------------------|------------------------|------------------------|------------------------|
| 1            | B3         | 86cm                 | 86cm                      | 18cm                        | 8cm                    | 0cm                    | 60cm                   |
| 2            | B4         | 57                   | 143                       | 0                           | 48                     | 0                      | 9                      |
| 3            | A2         | 157                  | 300                       | 0                           | 157                    | 0                      | 0                      |
| 4            | A2         | 89                   | 389                       | 0                           | 89                     | 0                      | 0                      |
| 5            | A1         | 62                   | 451                       | 43                          | 19                     | 0                      | 0                      |
| 6            | A2         | 20                   | 471                       | 0                           | 20                     | 0                      | 0                      |
| 7            | B4         | 34                   | 505                       | 0                           | 26                     | 0                      | 8                      |
| 8            | B4         | 134                  | 639                       | 0                           | 102                    | 0                      | 32                     |
| 9            | A1         | 32                   | 671                       | 8                           | 24                     | 0                      | 0                      |
| 10           | B4         | 196                  | (Gap 140cm)<br>1007       | 0                           | 174                    | 0                      | 22                     |
| 11           | B3         | 121                  | 1128                      | 0                           | 117                    | 0                      | 4                      |

## Voßbeck Cycle Thickness Table

| Cycle number | Cycle type | Cycle thickness (cm) | Cumulative thickness (cm) | Semi-restricted facies (cm) | Restricted facies (cm) | Intertidal facies (cm) | Supratidal facies (cm) |
|--------------|------------|----------------------|---------------------------|-----------------------------|------------------------|------------------------|------------------------|
| 1            | A2         | 809cm                | 809cm                     | 0cm                         | 809cm                  | 0cm                    | 0cm                    |
| 2            | B1         | (Gap 504cm)<br>478   | 1791                      | 29                          | 433                    | 0                      | 0                      |
| 3            | A1         | 449                  | 2240                      | 273                         | 176                    | 16                     | 0                      |
| 4            | B1         | 570                  | 2810                      | 314                         | 190                    | 0                      | 0                      |
| 5            | A1         | (Gap 297cm)<br>923   | 4030                      | 502                         | 421                    | 66                     | 0                      |
| 6            | A1         | 280                  | 4310                      | 30                          | 250                    | 0                      | 0                      |
| 7            | A2         | (Gap 400cm)<br>280   | 4990                      | 0                           | 280                    | 0                      | 0                      |
| 8            | A2         | 89                   | 5079                      | 0                           | 89                     | 0                      | 0                      |
| 9            | A2         | 67                   | 5146                      | 0                           | 67                     | 0                      | 0                      |

## Walheim Section 1

| Cycle number | Cycle type | Cycle thickness (cm) | Cumulative thickness (cm) | Semi-restricted facies (cm) | Restricted facies (cm) | Intertidal facies (cm) | Supratidal facies (cm) |
|--------------|------------|----------------------|---------------------------|-----------------------------|------------------------|------------------------|------------------------|
| 1            | B3         | 235                  | 235                       | 203                         | 8                      | 0                      | 24                     |
| 2            | V3         | 273                  | 508                       | 249                         | 0                      | 0                      | 24                     |
| 3            | V4         | 77                   | 585                       | 0                           | 60                     | 0                      | 17                     |
| 4            | B3         | 127                  | 712                       | 48                          | 69                     | 0                      | 10                     |
| 5            | A1         | 140                  | 852                       | 19                          | 121                    | 0                      | 0                      |
| 6            | B3         | 257                  | (Gap 338cm)<br>1447       | 164                         | 79                     | 14                     | 0                      |
| 7            | A1         | 86                   | 1533                      | 13                          | 73                     | 0                      | 0                      |

## Walheim Section 2

| Cycle number | Cycle type | Cycle thickness (cm) | Cumulative thickness (cm) | Semi-restricted facies (cm) | Restricted facies (cm) | Intertidal facies (cm) | Supratidal facies (cm) |
|--------------|------------|----------------------|---------------------------|-----------------------------|------------------------|------------------------|------------------------|
| 1            | A1         | 580                  | 580                       | 240                         | 340                    | 0                      | 0                      |
| 2            | B3         | 499                  | 1079                      | 417                         | 112                    | 21                     | 0                      |
| 3            | B3         | 130                  | 1209                      | 25                          | 96                     | 0                      | 6                      |
| 4            | B2         | 330                  | 1539                      | 0                           | 292                    | 38                     | 0                      |
| 5            | A1         | 250                  | 1789                      | 73                          | 177                    | 0                      | 0                      |
| 6            | B3         | 312                  | 2101                      | 88                          | 179                    | 0                      | 45                     |
| 7            | B2         | 266                  | 2367                      | 0                           | 250                    | 16                     | 0                      |
| 8            | A1         | 86                   | 2453                      | 26                          | 60                     | 0                      | 0                      |
| 9            | B1         | 176                  | 2629                      | 15                          | 123                    | 38                     | 0                      |
| 10           | A1         | 186                  | 2815                      | 84                          | 102                    | 0                      | 0                      |

|    |    |     |      |     |     |    |    |
|----|----|-----|------|-----|-----|----|----|
| 11 | B1 | 271 | 3086 | 59  | 193 | 19 | 0  |
| 12 | B4 | 68  | 3154 | 45  | 0   | 0  | 23 |
| 13 | A1 | 381 | 3535 | 32  | 349 | 0  | 0  |
| 14 | B1 | 253 | 3788 | 203 | 7   | 43 | 0  |

## Walheim Southern Limb

| Cycle number | Cycle type | Cycle thickness (cm) | Cumulative thickness (cm) | Ramp facies (cm) | Semi-restricted facies (cm) | Restricted facies (cm) | Intertidal facies (cm) | Supratidal facies (cm) |
|--------------|------------|----------------------|---------------------------|------------------|-----------------------------|------------------------|------------------------|------------------------|
| 1            | A2         | (Gap 774cm)<br>84cm  | 858cm                     | 0cm              | 0cm                         | 73cm                   | 11cm                   | 0cm                    |
| 2            | B1         | 161                  | 1019                      | 0                | 59                          | 0                      | 102                    | 0                      |
| 3            | B4         | (Gap 80cm)<br>136    | 1235                      | 0                | 0                           | 54                     | 41                     | 41                     |
| 4            | B3         | 268                  | 1503                      | 0                | 80                          | 113                    | 0                      | 75                     |
| 5            | B3         | 142                  | 1645                      | 0                | 26                          | 96                     | 0                      | 20                     |
| 6            | B4         | (Gap 30cm)<br>287    | 1962                      | 0                | 0                           | 270                    | 0                      | 17                     |
| 7            | B4         | 77                   | 2039                      | 0                | 0                           | 67                     | 0                      | 10                     |
| 8            | B4         | 75                   | 2114                      | 0                | 0                           | 69                     | 0                      | 6                      |
| 9            | A1         | 244                  | 2358                      | 0                | 55                          | 189                    | 0                      | 0                      |
| 10           | B2         | (Gap 1000cm)<br>56   | 3414                      | 0                | 0                           | 12                     | 34                     | 10                     |
| 11           | B1         | 28                   | 3442                      | 0                | 5                           | 20                     | 4                      | 0                      |
| 12           | B4         | 11                   | 3453                      | 0                | 0                           | 7                      | 4                      | 0                      |
| 13           | B5         | 19                   | 3472                      | 0                | 0                           | 0                      | 5                      | 14                     |
| 14           | A1         | 97                   | 3569                      | 0                | 66                          | 31                     | 0                      | 0                      |
| 15           | C1         | 306                  | 3875                      | 82               | 224                         | 0                      | 0                      | 0                      |
| 16           | C1         | 60                   | 3935                      | 60               | 0                           | 0                      | 0                      | 0                      |
| 17           | C1         | 39                   | 3974                      | 39               | 0                           | 0                      | 0                      | 0                      |
| 18           | C1         | 20                   | 3994                      | 20               | 0                           | 0                      | 0                      | 0                      |

