

Durham E-Theses

*Application of electronic and physical techniques to
the study of short range atmospheric dispersion and
related topics*

Christopher D. Jones

How to cite:

Jones, Christopher D. (1995) Application of electronic and physical techniques to the study of short range atmospheric dispersion and related topics. Doctoral thesis, Durham University.

Use policy

The full-text may be used and/or reproduced, and given to third parties in any format or medium, without prior permission or charge, for personal research or study, educational, or not-for-profit purposes provided that:

- a full bibliographic reference is made to the original source
- a <https://etheses.durham.ac.uk/id/eprint/4878/> is made to the metadata record in Durham E-Theses
- the full-text is not changed in any way

The full-text must not be sold in any format or medium without the formal permission of the copyright holders.

Please consult the [full Durham E-Theses policy](#) for further details.

Application of Electronic and
Physical Techniques to the study
of Short Range Atmospheric
Dispersion and Related Topics.

Volume II.

A Thesis submitted for the Degree of Doctor
of Science

of the University of Durham

by

Christopher D Jones

PhD, FIMA, C. Math., FRMetSoc.

The copyright of this thesis rests with the author.

No quotation from it should be published without

his prior written consent and information derived

from it should be acknowledged.

1995.



Thesis
1995/
JON

RESTRICTED – COMMERCIAL

**DEVELOPMENT OF THE UVIC[®]
GAS/VAPOUR DETECTOR**

JULY 1994

by

C D Jones

RESTRICTED – COMMERCIAL

DEVELOPMENT OF THE UVIC®
GAS/VAPOUR DETECTOR

by

C D JONES

July 1994

The author wishes to acknowledge the contribution made to the work detailed herein, and in particular the development of the theoretical model of the UVIC® detector, by Prof Richard F Griffiths of UMIST. In this context occasional use has been made of material already published, revised as appropriate. The mathematical analysis and procedure for the calibration of the UVIC® detector, described in Annex F, was developed by Dr David Ride of CBDE.

As detailed in the report, the primary invention was developed solely by the author. Some of the derived inventions were conceived and developed jointly with Prof Griffiths and others, as shown in the list of Patent Applications located at Annex H.

AMD-2/WP/008/94/PJ



RESTRICTED-COMMERCIAL

EXECUTIVE SUMMARY

An account is given of the invention and subsequent development of the UVIC® (UltraViolet Ion Collector) gas/vapour detector system, from its origins as a research tool for field investigations on atmospheric dispersion, to its emergence as a commercially available device. The UVIC® detector is a portable gas/vapour detection and measurement device operating on the PID (Photo-Ionisation Detector) principle of ion collection following ionisation by UV irradiation of a contaminant species in a gas stream.

The original need for the UVIC® detector arose from research requirements concerning the nature of concentration fluctuation behaviour in atmospheric dispersion of pollutant or hazardous materials. It was recognised that the prediction by models, and the measurement by instruments, of concentrations of dispersing materials was usually limited to time-averaged values that gave no indication of the underlying higher frequency fluctuations that were actually present, but which were subsumed in the averaging. Numerous contexts in which such fluctuations would be important were identified, such as the assessment of malodour nuisance, the determination of flammability hazard ranges, and the toxic hazard for substances that displayed a weighting on concentration in their damage functions.

This research requirement imposed a need to measure rapid fluctuations in gas concentrations, preferably with high sensitivity so as to avoid the need to release large quantities of tracer gas during experiments (which is both expensive and inconvenient), and to be able to do this at multiple receptor points at distances from the source ranging from a few metres to about 1 km. Existing techniques were surveyed for their suitability to provide these requirements at reasonable cost, and in a manner sufficiently robust, flexible, and practicable for field use. This included the negatively ionised air tracer system developed by the author, which had become well established for use in atmospheric dispersion research. This survey revealed no suitable existing technique, although it was evident that PID devices offered some promise if certain problems could be overcome. These were mainly concerned with the following: speed of response; baseline drift; ease and stability of calibration; susceptibility to fouling of the UV source lamp due to debris and photo-ionisation products; and consistency of instrument performance in a variety of environmental conditions.

These requirements necessitated an approach that was not fettered by the conventional constraints of laboratory-based gas chromatography techniques, on which the existing commercially-available devices were based. The resultant instrument, which combined the advantages of the ionised air technique with greatly enhanced features of the PID principle, has now been developed and produced both in research and commercial versions. The UVIC® detector offers greatly superior performance as compared with other available PID based devices in terms of the characteristics listed above; as a result, it has made notable contributions to both the research and the commercial sectors.

RESTRICTED-COMMERCIAL

TABLE OF CONTENTS

<u>EXECUTIVE SUMMARY</u>	2
1. <u>BACKGROUND AND INTRODUCTION</u>	5
1.1 <u>Concentration Fluctuations</u>	5
1.2 <u>Instruments for Measuring Fluctuations</u>	7
1.3 <u>Assessment of Techniques</u>	8
1.4 <u>Assessment and Limitations of the Commercial PID Instruments</u>	10
2. <u>INVENTION AND INITIAL EVALUATION OF THE PROTOTYPE UVIC® DETECTOR</u>	13
2.1 <u>Origins</u>	13
2.2 <u>The Ionised Air Tracer Technique</u>	14
2.3 <u>Ion Collector Design and Performance</u>	16
2.4 <u>Integration of UV Photo-ionisation Technology with the Ion Collector</u>	17
3. <u>THEORETICAL MODELS OF UV PHOTO-IONISATION DETECTORS</u>	19
4. <u>FURTHER ADVANTAGES OF THE UVIC® DETECTOR SYSTEM</u>	23
4.1 <u>Primary vs Secondary Advantages</u>	23
4.2 <u>Secondary Advantages</u>	23
5. <u>DEVELOPMENT OF CALIBRATION SYSTEMS</u>	24
6. <u>DEVELOPMENT OF THE UVIC® DETECTOR AND RELATED SYSTEMS</u>	26
6.1 <u>Test Programme</u>	26
6.2 <u>Investigations on the Test Bed UVIC® Detector</u>	27
6.2.1 <u>Effect of Position of Tracer Gas in the Ionisation Region in Front of the UV Source</u>	28
6.2.2 <u>Effect of Collector Electrode Position</u>	29
6.2.3 <u>Effect of UVIC® detector fan speed</u>	29
6.2.4 <u>Effect of Lamp Spacing</u>	30
6.2.5 <u>Effect of Polarity</u>	30
6.2.6 <u>Tests at High Concentrations</u>	31
6.2.7 <u>Incorporation of DC Powered UV Lamp into the UVIC® Detector</u>	31
6.2.8 <u>Field Tests</u>	32
6.3 <u>Development of Further Instruments</u>	34
6.3.1 <u>Further Requirements</u>	34
6.3.2 <u>The Tube UVIC® Detector</u>	35
6.3.3 <u>The Polar Vector UVIC® Detector</u>	35
6.3.4 <u>The Differential Absorption Device (DAD)</u>	36
6.4 <u>The Pulsed UVIC® Detector</u>	36
6.5 <u>Hybrid UV Lamp Drive Arrangements</u>	38
7. <u>COMMERCIALISATION OF THE UVIC® DETECTOR</u>	39
7.1 <u>The Context for Commercial Exploitation</u>	39
7.2 <u>Arrangements for Commercial Exploitation</u>	40
7.3 <u>Marketing and Sales</u>	42
8. <u>APPLICATIONS OF THE UVIC® DETECTOR</u>	43
8.1 <u>Industrial Applications</u>	43
8.2 <u>Research applications of the UVIC® detector</u>	44
8.2.1 <u>Background</u>	44

RESTRICTED-COMMERCIAL

RESTRICTED-COMMERCIAL

8.2.2	<u>The 'Dual Source' Experiments</u>	45
8.2.3	<u>Sample Results Obtained</u>	46
8.2.4	<u>Summary</u>	47
9.	<u>CONCLUSIONS AND RECOMMENDATIONS</u>	48
9.1	<u>General</u>	48
9.2	<u>Research Sector</u>	48
9.3	<u>Commercial Sector</u>	48
9.4	<u>Provision of Services</u>	49
	<u>REFERENCES</u>	50
	<u>NOMENCLATURE</u>	52
	<u>ANNEX A</u>	55
	<u>ANNEX B</u>	67
	<u>ANNEX C</u>	79
	<u>ANNEX D</u>	81
	<u>ANNEX E</u>	83
	<u>ANNEX F</u>	91
	<u>ANNEX G</u>	97
	<u>ANNEX H</u>	103
	<u>ANNEX I</u>	127

1. BACKGROUND AND INTRODUCTION

1.1 Concentration Fluctuations

It is a matter of everyday experience that the process of dispersion of a contaminant in a turbulent fluid medium, such as the atmosphere, results in concentration distributions that are very non-uniform both in time, and in space. A few minutes observation of a chimney plume will serve to reveal that:

- a. on a near-instantaneous view, as in a photographic snapshot, the plume is highly structured with many patches of high concentration interspersed with regions of low or zero concentration, encompassed within the perceived boundaries of the plume; and
- b. over a period of time the main trajectory of the plume (as suggested by its centreline location observed over a succession of shorter time intervals) occupies a wide range of positions such that a given point of observation is only sometimes contained within the perceived plume boundaries.

As a result of this evident behaviour the time series of concentration experienced at a point consists of periods of fluctuating concentration interspersed with episodes of varying duration in which zero concentration is seen. The experience of zero concentration at a point is due in some instances to the fact that the plume is absent, i.e. the point lies outside of the plume boundaries, and at other times it is due to the fact that the point is enveloped by the boundaries of the plume, but, at a smaller scale than the plume itself, there are regions of clean entrained air that are intermittently presented to the observation point. In summary, if a sensor with sufficient spatial and temporal resolution sees zero concentration it is because either the sensor is in the clean air outside of the prevailing plume boundaries, or it is within the plume in a pocket of clean air. Any instrument will impose limits on the volume, path length or time period over which the sensed concentration is averaged. It follows that the concentration field will not be resolved to scales (in time or space) smaller than those imposed by the sensing instrument. Accordingly, this fine structure will be averaged out by instruments operating with long path averaging, or with large sampling volumes or long response times. Fig. 1.1 illustrates the points described above in the case of a gas release

RESTRICTED-COMMERCIAL

made upwind of a building, the concentration time series being measured in front of and behind the building.

In some cases the presence of these intermittent and fluctuating concentrations will be of no importance, and the averaged values will be quite adequate as a measure of exposure. However, there are numerous examples for which this is not so, in respect of which inappropriately averaged data can give seriously misleading indications. In descending order of concentration range, the following examples illustrate this point in a number of contexts.

- Flammability of gases and vapours typically involves concentrations in the range of a few to a few tens of percent by volume. Concentrations may fluctuate to values above, below and within the flammable range, and it is necessary to know this behaviour on a timescale corresponding to the timescale of ignition, which is a very small fraction of a second. It is of no use to know, say, the 10-minute average concentration in these circumstances.
- Acute toxic effects for many substances such as those of interest in the Major Hazards category are associated with concentrations covering a wide range, typically from a few hundred ppm (v/v) and upwards. For some of these substances the toxic response is simply related to the dosage, that is the product of concentration, C , and duration of exposure, τ . However, for a large group of substances the appropriate factor is of the form $C^n\tau$, where n is an index greater than 1, typically in the range 2 to 3. For such materials the concentration fluctuations are important because the high concentrations are heavily weighted by the index n , and there is no linear trade-off between concentrations above and below the mean.
- Malodour perception depends on concentration fluctuations in that the sense of smell becomes habituated (desensitised) to steady concentrations, and responds to changes in concentration. Knowledge of averaged concentration is not a good indicator of malodour nuisance potential. The range of concentrations involved is very large, extending down to very small values around the ppb (v/v) level for some materials.

RESTRICTED-COMMERCIAL

1.2 Instruments for Measuring Fluctuations

The presence of fine scale structure in turbulent dispersion has been recognised from the theoretical standpoint for a long time. However, it is only more recently that means have been developed to measure these characteristics. An early contribution to this field was made by Jones (1), who developed a system using a source of negatively-ionised air as a tracer, this being detected downwind by an aspirated tube ion collector. This system offered many advantages. Depending for its operation on gaseous electronics, it gave real time data series with a response time of a few milliseconds, and an absolute calibration capability once the collector flow rate had been fixed. Multiple collectors could be easily deployed, and the collector units were not costly. A substantial body of research was carried out using this technique, which was at its best in open terrain, for dispersion distances out to a few hundred metres. Limitations of the system were due to the nature of the tracer itself. First, electrostatic self-repulsion of the ions added an extra dilution to that attributable to the atmospheric turbulence alone, although this could be allowed for on theoretical considerations. Second, the tracer was not conservative, in that it was eventually lost in image charge recombination on surfaces. It was therefore not particularly suitable for use in enclosed flows or those with many obstructions such as a chemical plant or a group of buildings, although even in such circumstances it would still yield important results on concentration fluctuation statistics. Further discussion on this system is presented in § 2. In the course of the MOD sponsored research programme on atmospheric dispersion it was recognised (in 1984) that the negatively-ionised air tracer/detector system would soon be pushed to the limits of its capability. Accordingly, a search was commenced for a method that would meet the stringent technical requirements as regards speed of response, sensitivity, and ease and stability of calibration, whilst also being practicable and economic for field use.

A survey was conducted by the MOD sponsored research group at UMIST to identify and assess candidate techniques. This was carried out in early 1985, the methods used for the survey being 1) a search of the technical/scientific literature in journals, and manufacturers' product literature, 2) a mailed questionnaire to selected individuals identified as having an active research interest involving a requirement for such measuring techniques, and 3) a similar questionnaire to instrument manufacturers. Eight major categories of techniques were considered, as follows:

RESTRICTED-COMMERCIAL

- 1 - the negatively-ionised air method already in use in the MOD research programme;
- 2 - Oxygen deficiency, using pure nitrogen as the tracer gas;
- 3 - Flame photometry or flame ionisation detection, using gases or particulates as the tracer;
- 4 - Radioactive gases, such as Kr85, with Geiger-Muller detector tubes;
- 5 - Mass spectrometry, with a gas tracer;
- 6 - Optical extinction and/or scattering by particles, aerosols or gases (including LIDAR methods);
- 7 - Other spectral absorption methods using IR or UV, the latter including photo-absorption/photo-ionisation methods;
- 8 - Solid-state detection devices using gas-affected semiconductor (or other electrical) properties (including catalytic conversion devices).

1.3 Assessment of Techniques

The techniques were assessed against the suitability criteria described above. The main considerations were as below:

a. The negatively-ionised air method had already been pushed near to its limit, and was not suitable for use except in open terrain with few obstructions, as previously discussed; a related method, using a collector that measures flux of ions rather than concentration (Boreham et al 2), had been used successfully in wind tunnel applications, and looked promising for field use, but tests showed a complicated dependence of collection efficiency on windspeed which made interpretation of field data very difficult because of the wider range of turbulence conditions encountered in the field.

b. The oxygen deficiency method had been used in field trials on dense gases for release quantities of 1 tonne or more (McQuaid, 3), and had been pushed to give a response time of 0.05 seconds; however, the method would not be suitable for the small rates of release desired in the intended application since it depended on

RESTRICTED-COMMERCIAL

maintaining a measurable oxygen deficiency which could not be sustained with small releases;

c. Flame ionisation detectors required further development before a field version would become available, and would not be likely to achieve as good a performance on sensitivity as other techniques, and would always involve the limitations of needing bottled hydrogen to supply each detector; particulate-based photometry methods were rejected as being too cumbersome for field use, and not involving a passive tracer.

d. Radioactive tracers were demonstrated in earlier work (Ramsdell and Hinds 4), but had the disadvantages of needing rather long (10's of seconds) averaging times to accumulate sufficient counts; additionally, it was judged (in the regulatory climate of 1985) to be limited by regulatory restrictions to an extent that would be inhibiting to field research.

e. Mass spectrometry was able to offer very high sensitivity and speed of response, but was likely to suffer many breakdowns under the conditions of field use, particularly as regards airborne debris being aspirated by the inlet: the hardware was also very expensive per unit, as well as being heavy and bulky to deploy.

f. Optical extinction and/or scattering methods showed considerable performance, especially in LIDAR methods, but the spatial resolution was not fine enough for the envisaged application; nonetheless, LIDAR methods would probably constitute the most effective techniques at larger spatial scales, e.g. for plume structure and plume rise investigations; for the envisaged purposes optical extinction methods using aerosols such as oil fogs were not able to give sufficient spatial resolution, and the tracer was not passive.

g. UV and IR spectral methods were thought to offer considerable scope; on closer examination UV photoionisation methods looked very promising if instrument performance could be enhanced, but IR methods appeared unlikely to have sufficient sensitivity to be of use.

RESTRICTED-COMMERCIAL

RESTRICTED-COMMERCIAL

h. Solid state detectors were examined with particular interest in view of their compactness and low cost; however, catalytic devices were not sufficiently sensitive, and semiconductor devices were recognised as having problems due to poisoning of the detector, leading to problems in calibration stability and loss of sensitivity.

On balance it was concluded that PID methods were the most promising, given all the constraints, and detailed assessment of the available instruments was undertaken. Several commercially available portable PID instruments were on the market, all having much the same to offer as regards performance. In broad terms the relevant capabilities were:

response times in the range 1 to 3 seconds; lower limit of sensitivity about 0.1 ppm (v/v), with a useful calibratable range up to about 2000 ppm (v/v), with a progressive loss of linearity from about 500 ppm (v/v) and upwards.

Although not ideal, these performance figures were good enough to merit application of this technique in the field research programme, and the UMIST group purchased a dozen or so instruments for research applications. At the same time two other atmospheric dispersion research groups working in this field made the same decision, and an extensive programme of application and evaluation was undertaken, involving experiments conducted both jointly and individually.

1.4 Assessment and Limitations of the Commercial PID Instruments

Much useful research was accomplished over a period of about 4 years in which the commercial PID instruments were deployed (see for example Higson 5; Higson et al, 6; Mylne and Mason, 7). Most of these experiments were conducted using propylene gas as the tracer, although more recent work has made use of ethylene, and ammonia. With the exception of ethylene, for which the molecular weight is almost the same as that of air, there is a concern that the gas molecular weight may introduce non-passive dispersion behaviour making it unsuitable for this kind of experiment. However, provided the release rates are small then criteria for passivity are readily met. In this respect gas release rates up to a few hundred l min^{-1} still qualify as passive, and for most of the relevant experimental situations, involving release rates of tens of l min^{-1} , the conditions were well within the required limits.

RESTRICTED-COMMERCIAL

RESTRICTED-COMMERCIAL

A number of useful findings were established in the course of this research using the commercial PID devices, which constituted a considerable advance in obtaining simultaneous multi-point time series of concentration fluctuation behaviour. However, numerous difficulties and limitations were encountered, the following issues being particularly important.

Sensitivity was a major limiting factor with regard to the practicality of conducting field experiments. The sensitivity of the devices deployed was quite adequate for dispersion distances of a few hundred metres, or for very short range investigations with sources close to the measurement points, arranged, for example, around a building, with distances of a few tens of metres being of interest. For longer dispersion distances of a few hundred metres, gas release rates up to about 200 l min^{-1} were required, emptying a 25kg bottle of gas in about an hour.

At short range release rates of a few tens of l min^{-1} were sufficient. Release rates of this magnitude could readily be maintained without using an evaporator. At 200 l min^{-1} a water bath evaporator arrangement was sufficient. However, experiments at longer dispersion distances required much larger release rates, necessitating either the use of a substantial evaporator unit, or else as an expedient using many 25kg bottles of propylene released as liquid by inverting the bottle, a method adopted by Mylne and Mason (7). This has the disadvantage of introducing non-passive behaviour of the source. Clearly, there comes a limit to the release rates one can achieve in practice by such methods, and releasing larger and larger quantities in order to be able to work at longer distances is not an elegant or economic solution, nor is it technically satisfactory. Greatly enhanced instrument sensitivity was clearly required.

Baseline Stability was an important requirement, particularly as experiments were conducted continuously for periods up to several hours, or in sequences lasting a whole day. The PID devices displayed a great deal of drift over periods of a few hours, typical ranges being up to 20% of full scale reading. The need to allow for this in the analysis led to considerable data conditioning requirements, and to a poor efficiency of usable data acquisition.

RESTRICTED-COMMERCIAL

Calibration presented a considerable challenge in that the instruments would take some time to settle after first switching on, and the position of the baseline and the instrument sensitivity would change over a period of some hours. Additionally, the need to calibrate numerous instruments for a given experiment placed a considerable burden on the experimental procedure. Calibration of 12 devices to a satisfactory standard typically took 1 to 2 hours. Lack of stability of performance meant that this had to be done both before and after each experiment in some cases. It was also found that the procedure of calibrating on zero air and several levels of tracer gas in air supplied from bottled gas was very cumbersome and expensive. Furthermore, since neither the calibration zero air nor the calibration gas was from the same air and tracer as would actually be used in an experiment, there was doubt that the calibration was reliable since one could not be sure at what point on the operating curve of the instrument the background contaminants in the ambient air would place the nominal zero point. In practice this was hardly ever coincident with the zero obtained with zero air, and in view of the non-linearity of response at higher concentrations this was not satisfactory, and limited the data region that could be regarded as valid.

Lamp Fouling was quickly found to be a major problem. All of the devices used were prone to accumulate tracer gas ionisation products and other debris which necessitated frequent cleaning. This constituted a further deficiency in calibration stability, since it caused changes in both baseline level and sensitivity of response.

Speed of Response was not sufficient, at anything from 1 to 3 seconds, to resolve the fine structure that had been revealed by use of the negatively-ionised air technique. For some purposes this level of imposed averaging would lead to misleading results, as discussed above.

Consideration of the performance characteristics of the available PID devices, together with a detailed theoretical analysis of the physical mechanisms involved, led to the conclusion that all of the desired improvements could be achieved, but that a fresh approach was required. Existing portable devices were clearly all based on taking the PID components of a gas chromatograph and repackaging them in a portable format. However, experience from the MOD sponsored research programme showed that the characteristics that were suitable for a laboratory based instrument would not necessarily transfer optimally to a field device.

RESTRICTED-COMMERCIAL

Accordingly, the development undertaken to produce the new instrument took a new approach based on accumulated understanding and experience of making measurements in the field. The principal innovation was made early in 1991 by the author, who produced a working prototype instrument that was immediately subjected to field trials, with very promising results.

In essence, the new instrument combined the best features of the negatively-ionised air tracer technology (which had been developed over a period of about 15 years) with a source of UV radiation, but configured and operated in a manner quite distinct from conventional PID practice. The resulting instrument was referred to as the UVIC (Ultra-Violet Ion Collector) and subsequently as the UVIC® detector.

2. INVENTION AND INITIAL EVALUATION OF THE PROTOTYPE UVIC® DETECTOR

2.1 Origins

The invention and subsequent development of the UVIC® detector can be attributed to a number of factors and many of these have been discussed in some detail in § 1. In particular the needs of much current research into the spatial and temporal structure of clouds dispersing in the atmosphere have demanded both high sensitivity and exceptional speed of response, especially when the quantification of toxic hazard and/or response is involved. This was recognised as early as 1974 by Jones (8) and led directly to the application of the ionised air tracer technique to a number of atmospheric dispersion investigations (9, 10 and 11).

Whilst this technique is described fully in the references above, an awareness of its advantages and disadvantages is fundamental in appreciating the significance of the innovations associated with the UVIC® detector; accordingly, a description of the method is included here for completeness and readability.

2.2 The Ionised Air Tracer Technique

In principle it is possible to employ a considerable diversity of experimental techniques in order to obtain data on the structure of clouds dispersing in the atmosphere. Generally these can be divided into a number of categories based on the particular method of sampling and/or operation involved. In this context one may identify specifically the point and line sampling approaches employed respectively for example by Aspirated Probes and LIDARS. In practice, if good spatial resolution is required (eg for the purpose of estimating toxic hazard, flammability or malodour nuisance), that obtainable using current line or volume based sampling methods is far too coarse to provide the requisite information.

Consequently, acquisition of data at the necessary level of detail places quite stringent demands on the sampling instrumentation that must be deployed. Various approaches are still feasible in theory but the options reduce markedly when the constraining factors of financial cost, operability and environmental acceptability of the tracer are also taken into account. Additional restrictions on the choice of system arise from the need to comply with various scientific desiderata if the results obtained are to be of maximum utility. In this context the need to release tracer materials at rates which do not degrade the integrity of the data, through for example, density and/or momentum effects (unless this is intentional), has ramifications regarding the sensitivity of the detector required. In other words high sensitivity implies that low tracer release rates can be employed with clear technical, environmental and financial benefits.

The concept of using unipolarly-ionised air (ie releasing a predominance of either positive or negative charge carriers) is not new and owes its origins to observations of electric field made **downwind** of point discharges in thundery conditions. During such situations the ambient, ie **upwind**, electric field can often attain values of several kVm^{-1} and this leads to local electrical breakdown and corona discharge in the vicinity of elevated points and other exposed surfaces with small radii of curvature. An essential feature of such discharges is the asymmetric electric field distribution close to the 'point', which provides the conditions required for the release of unipolar charge of polarity opposite to that of the forcing electric field. The charge produced, ie the ionised air, then drifts downwind in the form of a plume and behaves in a way broadly similar to any other material released from a small source.

There must however be certain important differences in the behaviour of plumes carrying a net electric charge as compared with their uncharged counterparts. In physical terms two interfering influences may be discerned:

1. Mutual self-repulsion;
2. Electrical image effects.

It is possible to derive a number of useful criteria on which to base decisions regarding the feasibility of using electric charge as a dispersion tracer by application of simple concepts based on the conservation of electric charge, ionic mobility etc. However, these are essentially non-rigorous and cannot provide, on their own, a justification sufficiently cogent to warrant the adoption of the technique. The alternative is to proceed on a purely pragmatic basis ie develop the method, apply it and then evaluate the results obtained in an appropriately critical fashion.

In practice it is the latter course that has been followed but with the inherent limitations of the technique always being borne in mind. This applies particularly to its use in light winds (ie $< 2\text{ms}^{-1}$) where the linear charge density (for a given source strength) is increased according to the reciprocal of the wind speed, thus exacerbating the effects of self-repulsion. Additional restrictions arising from those of electrostatic induction (ie image charges) preclude the use of the technique close to either the Earth's surface or protruding structures eg buildings and trees. These restrictions, though rather extensive, were of little concern in many earlier research programmes because their main objectives were oriented toward obtaining data at quite short dispersion distances over flat terrain, at release heights of at least several metres, and in neutral conditions. In later work however attention needed to be focussed toward the dispersion of toxic substances in the vicinity of obstructions such as single and multiple buildings and, if possible, in stable conditions without associated light winds. Use of the ion tracer technique is not acceptable under such circumstances and this led to the quest for an alternative system based on the use of an uncharged tracer as described in § 1.3.

Although the ion tracer technique does possess definite limitations to its use as an atmospheric dispersion tracer, a detailed theoretical study by Chatwin (12,13) has shown that its range of applicability is rather wider than hitherto believed. This finding led to its successful deployment in both stable and unstable conditions in New Mexico as described in Mole and Jones (14).

The quantitative behaviour of ions in fluids is governed by a combination of the laws of electrostatics and fluid dynamics. In the case of laminar inviscid flows, ie those in which the vector field may be described explicitly and fully in terms of a velocity potential, the additional complication of the presence of distributed electric charge can frequently be allowed for by introducing appropriate terms into the equations of conservation of mass, momentum and charge. However, in most (if not all) cases of interest and relevance in atmospheric dispersion the flows are both inherently turbulent and spatially heterogeneous, and therefore the relatively simple mathematical treatment above is precluded. Even the case without the presence of electric charge is not solvable in any closed analytical form and has to be treated either numerically or by making appropriate closure assumptions. The difficulty arises from the fact that as soon as terms describing dissipative mechanisms (ie viscosity) are introduced into the equations non-linear derivatives of the vector fields appear, rendering analytical solution intractable.

2.3 Ion Collector Design and Performance

The original design of an atmospheric ion collector based on coaxial geometry can be traced to experimental work reported by Ebert (15). Fig 2.1 shows the design of the current instrument (excluding electronic circuitry) which offers extremely fast response (approx. 0.003s) to fluctuations in ambient ion tracer concentration. The current device has been optimised carefully in respect of electrode dimensions (ie diameter and length) together with bias voltage and air flow rate. It should be noted that these parameters are not independently variable but need to be adjusted and balanced according to a coupled pair of kinematic equations describing the motion of ions in the electric field taken in combination with the axial advective velocity arising from the aspirating fan. The fundamental design criterion of the device is clearly that all ions must be collected (ie discharged) by the time they reach the end of the collecting electrode, or else the response will be both reduced and non-linear. In

addition to this, various special features incorporated into both the mechanical and electronic design have resulted in exceptionally good performance as regards noise, drift and sensitivity. The UVIC® detector, which is based on the Ion Collector, therefore possesses analogous performance characteristics. This feature, above all, has enabled the new sensor to occupy the leading position in current UV photoionisation detector technology.

The ionised-air source used to produce the ions is only of secondary importance in the context of this report. Suffice it to state that early versions of this device employed a precision controlled EHT supply to a corona needle operating in a tube with a stabilised air flow through it. Unipolar ions could be generated at rates corresponding to plume currents of 1-300nA using this method. This was usually deployed so as to produce a negatively charged plume. Investigations in a wind tunnel did however reveal that despite many precautions such corona discharges are never very stable, because the rate of ion production is critically dependent on, inter alia, the condition of the electrode surfaces and the atmospheric humidity. This difficulty was later overcome by an elegant application of feedback control principles in a device referred to as the COIG (Controlled Output Ion Generator), for details of which see the patent by Jones, Elias and Taylor (16).

2.4 Integration of UV Photo-ionisation Technology with the Ion Collector

The limitations of the TIP and, by implication, the HNU detectors (TIP and HNU are particular commercial versions of PID's) have been discussed in § 1.4. It was quickly recognised that many of these performance defects were in fact associated with specific design flaws of the instruments themselves rather than weaknesses in the use of UV photo-ionisation techniques in principle. In particular, difficulties with zero drift and the lack of adequate high frequency response were undoubtedly caused by the need to measure small ionisation currents in combination with very low volumetric flow rates.

Consideration of the performance of the Ion Collectors (see § 2.3) together with a cursory review of the literature on UV photo-ionisation cross-sections and ionic recombination coefficients indicated that some exploratory investigations in this area could be worthwhile. In particular there was good reason to expect, even with quite low concentrations of UV ionisable gases ie a few ppm (v/v), that ion currents of several hundred pA (ie Amps x 10⁻¹²)

RESTRICTED-COMMERCIAL

would be observed. If this were the case then the potential performance advantages offered by the novel system both in terms of baseline drift and signal to noise ratio could be very substantial.

The first attempt at producing an Ultra-Violet Ion Collector was crude in the extreme and simply involved the fitting of a DC powered 9.6eV UV lamp to a cylindrical aluminium block. This block was then clamped to the inlet tube of a 0.06m diameter Ion Collector approximately 0.1 m upstream of the coaxial collecting electrodes - an aperture having been drilled in the tube to permit the entry of the UV radiation radially into the air flow being sampled (ie the radiative flux was normal to the air flow vector). In retrospect this configuration was far from optimal because the ion pairs, once created, had then to be advected some distance prior to separation and subsequent collection. Even though the time taken for this would have been of the order of 0.02s or less, significant recombination would have occurred and the charge available for collection reduced substantially. Additionally, the use of a 9.6eV source would restrict the range of substances that could be detected.

This prototype UVIC® detector was evaluated, in conjunction with an ongoing atmospheric dispersion research programme, at RAF Cardington (UK Meteorological Office Research Site) during March 1991. Despite the adverse configuration the device returned sensitivity, noise and drift figures which at least equalled those of the TIP detector deployed in close proximity. Also apparent and, of great significance, was that the embryonic UVIC® detector possessed a much faster response than the TIP and therefore was far more suited to research needs than the latter detector. At this stage it became clear after some analysis that additional performance gains could almost certainly be achieved if the UV source were mounted much closer to the collecting electrodes and installed in a smaller diameter tube. This is because the typical maximum range of UV radiation of ~10eV photon energy is about 0.02m, in air at atmospheric pressure, and therefore, if a tube larger than this be employed, the ions created are merely diluted by cross-wise mixing in the air stream with no additional capability for the generation of ion pairs being provided.

Accordingly, a second prototype device was fabricated but this time based on the 'miniature' Ion Collector (tube \varnothing 0.025m) and with the UV source (RF driven in this case) able to be located at any of three positions, all of which were much closer to the collecting electrodes

RESTRICTED-COMMERCIAL

than in the earlier version. A sketch of the new arrangement is given at Fig. 2.2. Initial tests of the new detector were conducted in conjunction with UMIST at their Altcar test site in July 1991. The results obtained were literally astounding, the limiting sensitivity of the device to propylene (C_3H_6) being estimated to be of the order of 20ppb (v/v) ie 20 parts in 10^9 (v/v).

3. THEORETICAL MODELS OF UV PHOTO-IONISATION DETECTORS

A detailed theoretical analysis of the mechanisms involved in the UV/PID class of instruments has been developed as part of the toolkit for optimising the UVIC[®] detector performance, and this has been incorporated into mathematical modelling procedures that have been converted to computer software. The details are presented in Annex A. Some of the main considerations are summarised here. The principles involved are drawn from an extensive literature on vacuum ultra-violet spectroscopy that saw major activity in the period from the second world war onwards. The mechanisms involved can be categorised in three regions of activity, namely 1) the ion production region in the vicinity of the UV source, 2) the advection region from the source to 3) the ion collection region. In the ion production region the UV flux is depleted by two main sinks, namely photo-absorption and photo-ionisation. The normal components of air are not ionisable at the photon energies used (around 10 to 11 eV in most instruments), although they are capable of absorbing strongly, particularly in oxygen and water vapour. Tracer gases that are detectable are ones that are ionisable at these photon energies, but photo-ionisation takes place alongside photo-absorption in the tracer, so that only about a third to a half of the UV flux absorbed in the tracer is used in ionisation. Following ionisation there is a region before ion collection takes place in which the ions are advected in the gas flow. In this region ions will recombine at a rate depending on the square of the ion concentration of one sign, and this depletes the number of ions available for separation by an electric field and collection as a current to an electrode and electrometer system.

Theoretical analysis predicts that the collectable ion current increases nearly linearly up to concentrations of a few tens of ppm (v/v), then progressively departs from linear behaviour to reach a maximum current value at a concentration that is typically a few thousand ppm (v/v). Having reached this maximum the ion current falls with further increases in concentration. As described in § 6.2.6 this behaviour was first encountered during tests on

RESTRICTED-COMMERCIAL

the instrument undertaken before the model was developed, and was initially assumed to be due to an instrument fault or a design problem. The development of the model provided the explanation, which is as follows. The reason for this behaviour is that for most tracer gases of interest the photo-absorption cross-section is considerably larger than it is for the components of the carrier gas, usually air. The photo-ionisation cross-section of the tracer gas is usually smaller than that for photo-absorption in non-ionising interactions with the tracer. This means that as tracer gas concentration increases, carrier gas is progressively replaced with a more absorbing species, ie the photo-absorbing fraction of the tracer gas. At the same time, for a given UV flux, more ions are produced in the photo-ionised fraction of the tracer gas, but the available flux is reduced because of enhanced absorption in the non-ionised but photo-absorbing fraction of the tracer. Thus, there is an increased utilisation of the UV flux in non-ionising interactions with the tracer gas which is not compensated by the corresponding reduction of absorption in the correspondingly reduced molecular number density of the carrier gas. The effect is to reduce the UV flux available, as though the UV source power was reduced. Additionally, as the ion concentration is increased, either by increasing the tracer concentration or by increasing the incident UV flux, there is a progressively increased opportunity for ions to recombine before they can be collected. At low concentrations recombination is insignificant, and the only way to increase the ion yield in a given instrument configuration is to increase the lamp power. At higher ion recombination causes a reduction in the population available for collection. These two factors together produce the progressive non-linearity and associated maximum signal behaviour described above. The trade-offs between these processes, and the factors that determine them, provide the opportunity for tuning the instrument performance for a desired application. Most of the commercial PIDs are configured to retain linearity over the lower part of the working range, but this is done at the expense of sensitivity. The location of the maximum in signal output can be shifted to higher concentrations by altering the conditions that affect recombination behaviour, but this feature cannot be eliminated. The options for achieving this shift are either to reduce the incident UV flux, at the expense of sensitivity at low concentrations, or to change the advection factors so that i) the initial ion concentration is reduced, but more air is carried through, so that the ion current is maintained, and ii) there is less time for recombination to occur. The configuration of the research version of the UVIC® detector is such that exceptional sensitivity is achieved, down to about 10 ppb (v/v).

RESTRICTED-COMMERCIAL

RESTRICTED-COMMERCIAL

For applications in which ultimate sensitivity was not the principal requirement, the options for matching performance to the particular requirements are now clearly identified.

The main inputs to this model specify the tracer and carrier gas characteristics (photo-absorption and photo-ionisation cross sections, and ion recombination coefficients), the flow geometry (advection speed and distance), and UV lamp characteristics (beam width and UV flux). Use of this model has enabled prediction of the main features of the UVIC[®] detector response to be achieved, with excellent agreement between predicted and observed behaviour. In particular, the model successfully predicts the turnover behaviour encountered at high concentrations, which had initially been very difficult to understand. An example of the agreement between observed and predicted UVIC[®] detector behaviour is shown in Figs 3.1 and 3.2 which are for propylene and ammonia in air respectively. The influence of the different parameters on the magnitude of the maximum signal and its location on the concentration axis are as follows. Increasing the lamp UV flux increases the peak signal, and shifts it to a lower concentration, (i.e. moves the peak upwards and to the left), whereas reducing the flux has the reverse effect, so that the linear portion of the response extends to higher concentrations at the expense of sensitivity at low concentrations. The complementary shift of the peak to a higher value of signal and at a higher concentration (i.e. upward and to the right) is effected by changing any parameter that decreases the opportunity for ion recombination to occur. Thus, increasing the advection speed achieves this both by reducing the initial ion concentration and by reducing the advection time; similarly, increasing the beam width at a given UV flux has the same effect, as does reducing the advection distance, and of course the same effect occurs if the tracer gas is replaced with one of lower recombination coefficient. At low concentrations, in the near-linear region up to a few tens of ppm (v/v) concentration, recombination is unimportant, and the signal is insensitive to all of these parameters, being influenced only by the UV flux, to which the signal is linearly proportional in this range.

These considerations lead directly to the expectation that for a given concentration expressed as ppm (v/v), decrease of pressure or increase of temperature will cause the peak signal to increase, and to shift to higher concentrations, since these pressure and temperature changes correspond to a reduction in the molecular number density. Thus, decreasing the pressure for a given low concentration should not affect the signal, but as the concentration is

RESTRICTED-COMMERCIAL

increased (in ppm (v/v) terms) the signal should be increased once the recombination influenced region is reached. Fig. 3.3 shows the model predictions for propylene in this respect for pressures of 1005 and 880 mbar, confirming the trends described above. Measurements have recently been made in which the UVIC® detector was operated in a chamber in which the pressure could be controlled for given tracer concentrations expressed as ppm (v/v). These measurements confirm:

- a. no influence of pressure reduction for concentrations up to about 200 ppm (v/v);
- b. a subsequent increase in signal developing over the concentration range up to 500 ppm (v/v), followed by;
- c. a near constant absolute difference in signal between the two pressure values at higher concentrations up to 2000 ppm (v/v), the larger signal being obtained at the lower pressure.

These results provide good confirmation of the validity of the modelling procedure. The model predicts that the signal becomes independent of concentration and pressure at very high concentrations; it is intended to pursue these investigations further, as it appears likely that improved estimates of recombination coefficients for gases of interest can be obtained using this method.

The ability of the model to predict UVIC® detector performance provides an important design tool for instrument development. Sensitivity analysis using the model shows that:

- a. at low concentrations, up to a few tens of ppm (v/v) (and sometimes a little higher depending on the gas involved) the signal is directly proportional to the output UV flux from the source lamp;
- b. at higher concentrations the position of the region of non-linearity, as well as the position of the maximum in signal output, can be predictably controlled by appropriate choices of lamp power, beam width, advection speed and distance (time of flight) to ion collection;

RESTRICTED-COMMERCIAL

c. linearity can be recovered at higher concentrations quite readily by reducing the UV flux, at the expense thereby of sensitivity at low concentrations. Sensitivity is more than adequate at high concentrations, so that the recovery of high concentration linearity is achievable without loss of useful performance. The method of doing this is simply to reduce the UV flux, which may be done either by reducing the lamp power, or by interposing an additional slice of somewhat absorbing window material in front of the face of a lamp operated at normal power. By such means the instrument can be configured to give optimum performance in the concentration range of interest in a particular application;

d. low concentration sensitivity can be enhanced by increasing the lamp UV flux. This could be done directly by boosting the lamp power, or possibly by installing a thinner UV window in the lamp. The existing DC lamp design would appear to permit the latter option to some extent.

4. FURTHER ADVANTAGES OF THE UVIC® DETECTOR SYSTEM

4.1 Primary vs Secondary Advantages

The superior performance characteristics of the UVIC® detector in terms of the primary considerations of sensitivity and speed of response are not the only advantages that it offers. It should be stressed that whilst it is often possible to envisage how superior performance might be obtained from an instrument, this will often entail the introduction of features that make the instrument more difficult and demanding to use and maintain. This is not the case for the UVIC® detector; the opposite is true, the instrument having several other advantages apart from its basic performance superiority.

4.2 Secondary Advantages

The first of these secondary advantages concerns the tendency for the UV source lamp to foul over a period of use, collecting debris on the lamp face thereby reducing the UV flux and degrading the calibration in the direction of reduced sensitivity. This tendency is greatly reduced in the UVIC® detector by virtue of the flow configuration, the gas stream being

RESTRICTED-COMMERCIAL

presented to the UV flux from the side rather than along the same axis. This means that only a small proportion of the tracer and other potential deposits is ever in the direct vicinity of the lamp face, whereas in the competitive instruments the gas flow is along the axis of the lamp so that the incoming gas is all deliberately impinged onto the lamp face. Additionally, the flow rate through the UVIC® detector is much greater than in the competitive devices, which also assists in preventing deposition of material.

The next advantage concerns the ease and frequency of calibration, which is in part related to the reduced lamp fouling tendency, and partly due to the improved performance of the DC powered lamp compared to the RF version. The DC lamp has a much steadier output due to the improved definition of the discharge region in the lamp, thereby providing a better degree of control of the UV emission.

A further advantage which is attributable to these improved discharge definition factors is the rapidity with which the instrument settles once it is switched on. Experience with the commercial devices as described above showed that a settling time of some minutes was quite normal, whereas the UVIC® detector settles in a very short time, of a few seconds at most from the moment when it is turned on. A further practical advantage is the ease of maintenance. The lamp and electrode system is easy to dismantle for cleaning if required, whereas the size and construction of the competitive devices makes this operation rather more difficult, the components being both smaller, and in a more involved structural configuration. Finally, both the research and the commercial versions of the UVIC® detector have been designed with flexibility of deployment in mind, so that the instrument can easily be used as an installed device on a mounting point or mast, as well as in a portable manner. The commercial competitor instruments have much less flexibility in this respect, being only intended for portable use, with no options being incorporated for use in an installed mode, other than by the user making ad hoc arrangements.

5. DEVELOPMENT OF CALIBRATION SYSTEMS

In order to overcome the difficulties outlined in § 1.4, and to support the development of the UVIC® detector, it was necessary to build a calibration rig to provide metered concentrations of test gas in air. A prototype apparatus was built for this purpose based on the principles

RESTRICTED-COMMERCIAL

set out in § 8 of the progress report on agreement 2044/159/CDE dated May 1989, which appears here as Annex E. The main features of this method are that the test gas to be used in the field experiment is used in admixture with background air to provide the calibration gas mixture. There is thus no dependence on pre-mixed calibration gases provided by gas suppliers, which do not use the local background air as the carrier, nor the identical batch of tracer gas as will be used in a field experiment. The scheme has been incorporated into a fully engineered calibration rig constructed by IDB, the details of which are shown in Fig. 5.1. The first implementation of this scheme involved two different means of supplying the metered tracer gas. For low concentrations tracer gas was delivered to the air carrier stream from a multi-syringe dose delivery unit, giving a direct measurement of the tracer gas flow rate by volume displacement. Higher concentrations were provided by delivering tracer gas via a thermal mass flow controller (MFC) device. This device operates by measuring the differential temperature reduction caused by the flow of the tracer gas through a bypass from the main gas flow when it passes a heated section of the bypass tube. A constant heater power is supplied, and when there is no gas flow the tube wall temperature profile along its length is symmetric about the point of heating. When gas flows the upstream section of the wall is cooled, and so is the downstream section, but to a lesser extent because of the increase in gas temperature due to its passage over the upstream section of the heated tube wall. These devices are available from several suppliers, and are widely used. Detailed examination of the performance of the MFC revealed a mismatch between concentrations indicated at the overlap between the syringe unit range and the MFC range. Investigation revealed errors in the simplifying assumptions used in the manufacturer's claims concerning the values and constancy of essential conversion factors to be applied over the full range of flow rates. These technical difficulties showed no prospect of being resolved in the immediate future, and it was decided forthwith to abandon the MFC method in favour of an extension of the multi-syringe system, encompassing the high concentration range. This has been implemented and retro-fitted to existing calibration rigs. Some problems with the temperature range in which the large syringe units can operate have been encountered, and an improved piston seal arrangement has been identified which will complete the conversion. This development has provided a very significant improvement in the ability to conduct calibrations in the field.

It is also necessary to calibrate with vapours from volatile liquids, apart from gases. For this purpose a second calibration rig has been devised which feeds a vapour-saturated air stream into the air flow feeding the instrument to be calibrated. Details of this device are shown in Fig. 5.2. A research prototype has been built and extensively tested in the field, both in the UK and in the USA, under very different environmental conditions, including pressure extremes associated with locations at sea level, and at 1500 metres altitude. Fig. 5.3 shows the results of eight different calibrations conducted over the indicated range of temperatures and pressures. The consistency of these results demonstrates the validity of the technique.

6. DEVELOPMENT OF THE UVIC® DETECTOR AND RELATED SYSTEMS

6.1 Test Programme

The performance of the UVIC® detector was examined over a period of 21 months from January 1992, during which time tests were carried out in the laboratory and in the field, utilising development versions of the instrument into which numerous improvements were incorporated as they emerged from the performance evaluations. Throughout this period close liaison was maintained with Mr. Emlyn Jones' group, IDB (UCNW), at Bangor, where the instrument developments were implemented. Tests were conducted in several phases, with numerous iterations as performance details were revealed. The main groups of tests and associated development efforts can be categorised as follows:

- Performance of the Test-Bed version of the UVIC® detector, including calibration procedures;
- Incorporation of a DC powered UV lamp in the research version of the UVIC® detector, to replace the RF powered source, and associated tests;
- Computational modelling of the UVIC® detector performance;
- Field tests of the research version of the UVIC® detector, and comparison with commercially available photo-ionisation devices.

In order to distinguish between various versions of the UVIC® detector, the following terms should be borne in mind:

RESTRICTED-COMMERCIAL

Test Bed UVIC® detector - this device was constructed by IDB, and was so designed as to permit a variety of settings, configurations, and geometry options of the UV source, gas flow and ion collection functions of the instrument to be investigated. The test bed UVIC® detector was used in the initial laboratory evaluations. This device incorporated only the RF powered UV lamp type;

Research UVIC® detector - this refers to the UVIC® detector configured for use in the field investigations forming part of CBDE's research programme; this version of the instrument is a fixed configuration device, except for the lateral position of the UV source lamp, which is adjustable. Its features have been optimised on the basis of the findings from both test bed and field investigations;

RF and DC powered lamps - the early versions of the research UVIC® detector, and the test bed UVIC® detector, featured a Radio-Frequency excited gas discharge lamp to provide the UV source. At an early stage in these evaluation tests the RF excited lamp was replaced in the research versions of the UVIC® detector by a DC electroded lamp made by Cathodeon, which gave preferable performance, but with some small loss of sensitivity.

In the course of these tests a very substantial quantity of data has been accumulated, which is still being used in continuing developments. The following sections summarise the principal findings of the investigation.

6.2 Investigations on the Test Bed UVIC® Detector

The early tests conducted in the laboratories at UMIST using the test bed UVIC® detector were carried out using propylene in air as the test gas. Subsequent tests were conducted using ethylene, and ammonia, instead of propylene. The test bed incorporated two RF excited UV lamps facing each other across the inlet tube, with means provided for varying the gap between their faces, the distance to the collector electrode, and the advection speed of the gas stream through the system of UV source and collector electrodes.

Additionally, the bias voltage and polarity could be altered, with allowance for the polarity change being provided in the current measuring electrometer.

The principal findings of the investigations using the test bed are described below:

6.2.1 Effect of Position of Tracer Gas in the Ionisation Region in Front of the UV Source

Gas was released from a fine hypodermic needle, the tip of which was tracked along a number of paths in the ionisation region, either across the lamp face at a fixed distance from the end face, or along a line parallel to the lamp axis. The purpose of these tests was to obtain information on the spatial variation of the UV flux in the ionisation region. The gas was supplied at 50 ppm (v/v) with a volume flow rate approximately 1% of the overall airflow rate through the instrument, all readings being on the 30 nA range of the detector. The results for different types of traverse are summarised below:

- a. Source traversed along a diameter of the lamp face, lateral to the air flow, on the face of the lamp. The signal ranged from 0 mV at the edge of the lamp, increasing steadily to 25 mV at the centre, with a symmetrical distribution about the centre.
- b. Source traversed along a tangent to the lamp face, lateral to the air flow, at the upstream edge of the lamp face. The signal ranged from 0 mV at the lateral edge of the traverse to 45 mV at the centre, with a symmetrical distribution about the centre.
- c. Source traversed along the axis of the lamp from the centre of its face to a distance 10 mm away. The signal fell steadily from 60 mV at the lamp face to 0 mV at 9 mm.
- d. Source traversed along a line parallel to the lamp axis from the centre of the upstream edge of the lamp, at its face, to a distance 10 mm away. The signal fell steadily from 75 mV at the lamp face to 0 mV at 9 mm. The signal in configuration (d) was larger than in configuration (c) only over the first 4 mm traverse from the lamp face, after which the signals were equal out to a distance of 9 mm.

These measurements revealed useful information on the spatial features of the ionisation region for the RF lamp which were important inputs for the modelling exercises conducted subsequently. These tests showed that the effective beam width of the ionisation region

could be taken as 8 mm, with a UV flux reduction (for the ionising wavelengths) to about one sixth of its initial value after a travel distance of 5 mm in air (i.e. with no tracer gas intervening). This information also proved valuable in the initial design of the Differential Absorption Device for the detection of gases, which is the subject of a separate development project, and is described briefly in § 6.3.4.

6.2.2 Effect of Collector Electrode Position

The test bed included provision to vary the proximity of the collector electrode to the UV lamp, such that the travel distance from the edge of the lamp was in the range 3 to 13 mm. It was found that the output signal decreased to one-fifth of its initial value for a concentration of 10 ppm (v/v), as the electrode distance was varied over this range. However, for a concentration of 70 ppm (v/v) the corresponding reduction was to one tenth of the initial value. The reason for the dependence of this reduction on gas concentration is that the effect of ion recombination during the time of flight to collection varies with the ion concentration. From the modelling exercise conducted subsequently, it was found that these tracer gas concentrations correspond to a range in which the associated ion concentration initially produced (which corresponds to an ionisation yield of the order of one ion per 100,000 tracer molecules) is such that recombination is just beginning to be a significant loss, so that travel time (and therefore distance) to collection is influential in determining the output signal. For smaller concentrations the effect is of diminishing significance.

6.2.3 Effect of UVIC® detector fan speed

The effect of increasing the fan speed was found to have a profound effect on the test bed UVIC® detector sensitivity. For a gas concentration of 40 ppm (v/v) the output signal was increased approximately 20 fold as the fan speed was increased from flow rates of about 5 to about 40 l min⁻¹. The reason for this effect is that i) the travel time to collection is obviously shorter for higher flow rates, and ii) the initially created ion concentration is smaller for higher advection speeds, because the ions created at a given number rate per unit time (which depends on, amongst other things, the UV flux from the lamp) are distributed in a larger volume for higher flow rates. This decreases the losses due to recombination, thus giving greater sensitivity.

6.2.4 Effect of Lamp Spacing

One of the purposes of incorporating two lamps facing each other in the test bed was to enable photoelectric emission by work function effects to be eliminated, by presenting a non-metallic target to the UV photons that survived their passage through the gas stream. A secondary purpose was to examine the effect of varying the inter-lamp gap. If the lamps are too close together then photons from one that might have produced ions are simply absorbed via the window of the facing lamp. If they are too far apart then the time of flight from the ionisation region in the immediate vicinity of the lamp face to the collection point is increased by the geometrical change in configuration, and sensitivity is lost. At some optimum position a maximum sensitivity should be found. This was found to be the case with a lamp spacing of about 4.5 mm, the signal falling by a factor of 2 if the spacing was decreased to 2 mm, or increased to 9 mm, the reduction becoming more severe at greater deviations from the optimum gap.

6.2.5 Effect of Polarity

The bias of the ion collector system can be chosen so that either positive or negative ion fragments are collected. With the bias voltage sufficient to ensure that all available ions were collected (ie none passed out in the air stream beyond the collector region) there was no discernible difference in sensitivity with choice of polarity. The research UVIC® detector permits either polarity of operation to be selected. It was considered to be preferable to operate the UVIC® detector so that the outer bias electrode was negative relative to the collector, so that photo-electric emission of electrons from stray UV photon impingement on the collector electrode was inhibited. However, no discernible difference in performance is detectable, and since the performance is satisfactory in either mode, no further investigation of this effect has been pursued. Nonetheless it is important to emphasise the necessity to ensure that future versions of the instrument and related devices are designed to avoid this potential problem.

6.2.6 Tests at High Concentrations

The foregoing tests were conducted with test gas concentrations up to 70 ppm (v/v). Up to these values the UVIC® detector response was nearly linear, with the beginnings of a departure from linearity just becoming evident at concentrations of around 20-40 ppm (v/v). Such values are usually adequate to cover the range of concentrations of interest in the atmospheric dispersion experiments for which the UVIC® detector was intended, but the question of how the instrument would respond at much higher concentrations, say 1000 ppm (v/v) and above, was naturally a matter of interest. Tests were conducted at concentrations from 500 ppm (v/v) to 10,000 ppm (v/v), which revealed a response regime which was so surprising that at first it was thought that there was some limitation in the electronic circuitry. The instrument response was found to increase for concentrations up to about 1000 to 2000 ppm (v/v), reach a maximum and then decline. At first it was thought that the bias supply was becoming drained at the high ion concentrations expected in these ranges, and a modification was made to the circuitry to allow for this possibility. However, the behaviour persisted, and other explanations were sought. This prompted the development of a physically based computational model of the UVIC® detector, as described in § 3 and Annex A.

6.2.7 Incorporation of DC Powered UV Lamp into the UVIC® Detector

Shortly after the main findings of the test bed investigations were established it became apparent that many of the performance characteristics could be improved by adopting a DC powered electroded lamp for the UV source. The main advantages were:

- Better stability of lamp UV output flux, due to tighter physical definition of the discharge region;
- Longer shelf life and operating life of the lamp due to improved robustness in construction;
- Better high frequency resolution due to finer definition of the ionisation region, the discharge originating in a capillary region of diameter 1.4 mm producing a beam with a 10 degree full angle divergence;

- Reduced cost, due to the fact that manufacture was in the UK rather than abroad. This fact also facilitated introducing special requirements in lamp construction, which would have been more difficult to achieve with an overseas supplier.

These advantages were judged to outweigh the one disadvantage of reduced sensitivity attributable to the reduced UV flux associated with the new lamp. The DC lamp was subsequently adopted for all UVIC® detectors constructed after the first three of the research version of the instrument. These later instruments have served the research programme extremely well, although in some applications, e.g. where the dispersion source release rate is very small, the more sensitive RF powered versions of the UVIC® detector are necessarily used, in spite of their limitations in other respects. In the DC version sensitivity can be restored by running the lamp with a larger current, and this option has been adopted in some of the research devices. However, this is expected to shorten the life of the lamp, and an alternative approach using a pulsed UV source has been developed; patent applications relating to this have been filed. The pulsed lamp option is described in § 6.4

6.2.8 Field Tests

Over the evaluation period covered by this investigation various versions of the UVIC® detector have been tested in the field both in dedicated tests and in the course of atmospheric dispersion field experiments. The performance has been highly satisfactory in terms of ease and stability of calibration, freedom from baseline drift and noise, and flexibility of use on both gaseous and volatile liquid substances. Experiments have been conducted using ammonia, propylene, ethylene, and diethylmalonate (DEM) as tracers. In addition, the research version of the UVIC® detector has been extensively tested with a co-located flame ionisation detector instrument, which has confirmed the region of linearity in the UVIC® detector response, as shown subsequently in Fig. 8.1

These tests confirm response times of about 0.02 seconds, ultimate sensitivity down to about 10 ppb (v/v), and a useful calibratable range up to about 1000 ppm (v/v), depending on the tracer, all achievable in one configuration of the instrument. In terms of useful near-linear

response, this is readily obtained up to about 20 → 100 ppm (v/v), which is sufficiently high for most field experiments.

Various tests were also carried out deploying the UVIC® detector in field experiments in which its performance was investigated alongside that of commercially available PID's. Typical results are shown in Figs. 6.1, 6.2 and 6.3. Fig. 6.1 shows results from a test in which the UVIC® detector (top trace) and a commercial PID were simultaneously exposed to a fluctuating concentration of propylene gas released at a rate of 50 l min⁻¹ from a source located 30 metres upwind. The commercial device is one displaying a speed of response rather better than 1 second. The UVIC® detector reveals finer structure, having a response time of about 1/50th of a second. The largest peaks are at about 20 ppm (v/v), and neither instrument is on its most sensitive range.

In Fig. 6.2 the conditions are as for Fig. 6.1 except that both instruments are on their most sensitive settings, and the gas release rate is reduced to 0.5 l min⁻¹. The UVIC® detector is still readily responding, but the commercial device is too insensitive and too slow to respond to these fluctuating gas concentrations, the largest peaks of which are at about 1 ppm (v/v).

Fig. 6.3 shows a comparison between the UVIC® detector and another commercially available PID instrument. In this case the speed of response of the commercial device is rather slower than the one used in the tests displayed in the previous Figs. The UVIC® detector reveals the fluctuating concentration pattern in detail, whilst the commercial device is slow to respond, with an evident delay in the position of the peak concentrations, and a significant upward drift in the zero position even over this short (5 second) interval.

In terms of the combination of speed of response, baseline stability and sensitivity the UVIC® detector has overwhelming superiority over these instruments. Further advantages such as relative freedom from lamp fouling are also enjoyed by the UVIC® detector because of its internal configuration. An important finding arising from the dynamic (as distinct from steady concentration) tests conducted in the field is the need to ensure that the internal geometry of the UVIC® detector contains no re-entrant contours or sharp edges where flow separation could occur, leading to the production of zones containing trapped material acting as secondary sources in recirculating flows within the instrument. This behaviour delays the

clearance of tracer gas from the instrument leading to the production of spurious concentration decay profiles that originate in the instrument rather than being actually present in the sampled gas stream. The UVIC[®] detector has been carefully designed to be free of this misleading feature, and it is important to ensure that this is also true of future versions of the UVIC[®] detector and related instruments.

6.3 Development of Further Instruments

6.3.1 Further Requirements

The basic UVIC[®] detector has the capability for measuring concentration in a gas carrier medium as described in previous sections. Whilst the performance is outstanding, it is nevertheless desirable to consider the limitations of the device and to develop extensions to instruments incorporating the UVIC[®] detector principle, or additional devices operating on other principles, so as to add to the overall capability. The UVIC[®] detector is limited in that i) the substances to be measured must be ionisable by the UV photons at or below the energy quantum of the UV flux that is able to penetrate the lamp window material, ii) the instrument will only give a measure of concentration, and iii) concentrations higher than the turnover point on the response curve cannot be distinguished from those giving the same signal on the portion of the curve at concentrations lower than the turnover point. Three additional instruments have been devised in respect of these considerations, and patent applications have been made. The mechanisms involved have been demonstrated for all three, whilst prototypes have been constructed and tested for two of them. No new technology is required in order to construct a prototype for the third. The first two devices utilise the UVIC[®] detector principle, at the same time providing a measurement of the carrier medium advection speed so that, given pressure and temperature information, the mass flux through the instrument can be deduced. In one case the advection speed is measured in one dimension only, in a tube; and in the other two orthogonal velocity components are measured between co-axial parallel discs. These instruments are accordingly referred to respectively as the Tube UVIC[®] detector and the Polar Vector UVIC[®] detector. The third device does not use the principle of the UVIC[®] detector, although it could be used in combination to achieve a useful composite performance. This instrument is referred to as the Differential Absorption Device.

6.3.2 The Tube UVIC® Detector

In this instrument, the bias and collector electrodes are segmented along the axial flow direction so that ions will arrive at different segments depending on the combination of ion mobility, bias voltage, and advection speed through the tube, the instrument being otherwise similar to the basic UVIC® detector except for the provision of extra electronics. The advection through the tube may be caused by the instrument's own fan, but a particularly useful application can be envisaged in which the fan is dispensed with, and the tube is aspirated by the flow in a duct or pipe in which it is installed. The instrument, having been calibrated in advance with regard to both advection speed and tracer concentration, could then provide a means of measuring the mass flux along the duct, a measurement of particular importance in emissions monitoring. Such combined measurements of flow velocity and concentration are specifically required in such applications, and are recommended in the HMIP Chief Inspector's Guidance Note series. The prospect of providing this information from a single instrument offers a very significant commercial opportunity.

6.3.3 The Polar Vector UVIC® Detector

This device is essentially a two-dimensional version of the Tube instrument, but the electrodes are configured as two parallel co-axial discs separated by a gap through which the flow passes. For example, the ambient windfield could constitute this flow. The electrodes are segmented into annular rings, and further into radial sectors, so that by monitoring which of these electrodes receive the ions one can determine the instantaneous concentration and the flow vector. Accordingly, a two-dimensional resolution of the flux of tracer may be obtained. This device does not seem likely to have significant commercial potential, but its applications for atmospheric dispersion research are very substantial, since it would normally require two separate instruments to make such measurements. The technical advantage of making the concentration and velocity measurements in precisely the same location is particularly significant.

6.3.4 The Differential Absorption Device (DAD)

This instrument is designed to be used to measure concentrations of materials that are not ionisable at the photon energy available from the UV lamps used in the UVIC® detector, but which will absorb at those energy levels without ionisation occurring. The device works by obtaining a measure of the UV flux that survives passage across the gap in front of the UV source, ie the quantity ϕ in terms of the nomenclature of Annex A. It does this by measuring the flux utilisation (the quantity ϕ) that occurs subsequently in a detector into which the surviving flux passes through a window which, like that on the source lamp, is transparent to the UV. This part of the detector may operate on one of a number of principles as set out in the patent application. The instrument has been demonstrated in prototype using krypton as the tracer gas, for concentrations in the range 10 to 2000 ppm (v/v). Extension to higher concentrations requires no additional technology, but is simply a matter of configuration. Because of its ability to measure the surviving UV flux it can be used directly to obtain the total photo-absorption cross section, Q , and in this respect provides a very useful means of obtaining this information under conditions that are fully representative of the normal conditions of application of this whole family of instruments. This has been found to be particularly useful where reliable literature sources have been lacking. It can be envisaged that the DAD could be combined with the UVIC® detector to permit discrimination between the two concentration regimes displayed by that device.

6.4 The Pulsed UVIC® Detector

A disadvantage of the UVIC® detector is the lack of specificity in its response; this is an inherent feature of the photo-ionisation process and, if specificity is required, then additional instrumentation eg a gas chromatograph is necessary. However, it is well known that the ionic mobility is quite sensitive to the species involved and therefore, if a means of determining that parameter (or a related quantity) could be incorporated simply into the UVIC® detector at least a generic identification of compounds may prove feasible. In practice a convenient method of achieving this can be based on the employment of a longitudinally segmented bias/collector electrode system so that the effective trajectory of the ion stream (assuming a single chemical species is involved) in the electric field may be deduced from the current distribution along the electrodes.

Whilst the scheme outlined above can provide discrimination between ionic species of differing mobilities in principle, the performance in this respect is generally rather unsatisfactory owing to the substantial mixing (cross-stream **and** longitudinal) caused by turbulence in the air flow. It was recognised early in the development of the UVIC® detector that, in certain applications, pulsing of the UV lamp source might provide numerous benefits in critical performance areas, notably ultimate sensitivity, power consumption and lamp life (see later). However, in the particular arrangement described here an additional advantage might be expected in that, if sufficiently short UV pulses could be applied, thus producing ‘plugs or puffs’ of ions, then the ‘blurring’ effects of at least the longitudinal mixing could be substantially reduced.

A schematic of the general mechanical arrangement of a prototype pulsed instrument is shown in Fig. 6.4 together with the details of the electrode arrangement at Fig. 6.5. Note that, unlike the conventional UVIC® detector, this version is based on coplanar rather than coaxial geometry. This construction is necessary in order to have a properly defined ion collection region in which the trajectories can be specified on the basis of the electric field distribution and axial advection speed. In addition this arrangement facilitated construction and kept costs at an acceptable level. The ion collecting system consists of 8 opposed electrode pairs of equal length in the streamwise direction (9mm + 1mm spacing) these being set in a rectangular duct 30mm wide. The separation between biasing and collecting electrodes was set at 10mm, and in this version all the biasing electrodes were connected in parallel to a variable voltage source (10-500V).

A schematic of the prototype instrument system is shown in Fig. 6.6. It should be understood that this is essentially a functional diagram and does not necessarily correspond to the **physical** arrangement of the new device. In essence a programmable control circuit supplies suitably shaped EHT pulses to a standard UV lamp via a time staggered relay driver. In this way it is possible to provide an accurately sequenced train of ‘clean’ 1ms 10mA current pulses to the lamp along with appropriately timed trigger voltages to initiate the data collection process. The timing arrangements for the latter are shown in Fig. 6.7.

An initial evaluation of the new device was recently carried out at IDB’s premises in which it was exposed to a variety of organic vapours and the responses compared with those

obtained from a colocated UVIC® detector. Although further detailed analysis is required (the data format, involving 8 electrode signals, is quite complex), it is already clear that:

1. The progression of the ion pulses through the electrode system can be distinguished clearly and, with suitable bias voltage applied, their distribution patterns are such that mobility based discrimination appears feasible;
2. The use of a high power pulse of low duty cycle conserves power whilst at the same time providing a several-fold sensitivity enhancement as compared with the standard UVIC® detector.

A software package, written in QuickBasic, has been developed to facilitate the analysis of the Pulsed UVIC® detector data and a listing is included at Annex G.

6.5 Hybrid UV Lamp Drive Arrangements

A major restriction in the use of current versions of the UVIC® detector arises in the context of its deployment in flammable/explosive atmospheres. This is a significant limitation in the capability of the instrument because there are many potential applications in such environments eg the petrochemical industry. The company manufacturing the commercial version of the UVIC® detector is currently developing a modified version of the instrument so that it can be accorded **Intrinsically Safe** certification. Various modifications are required most of which are associated with the need to limit the maximum stored electrical energy in circuit components having inductance and/or capacitance. The criterion applied is related to the propensity for an inadvertent short circuit of a critical element to create a spark sufficiently energetic to initiate combustion and/or detonation of the local atmosphere.

A feature of particular concern is the 1.5kV required to initiate the UV lamp discharge ie to cause the emission of radiation to commence. Once the lamp has 'started' it can be maintained by the application of a steady voltage in the region of 400V with a typical burning current of 0.8mA. Whereas the presence of this latter voltage is acceptable provided appropriate precautionary measures are taken in the design of the instrument, the application of 1.5kV even for a short time is on the limit of what is acceptable. An elegant solution to

this difficulty has been proposed based on the use of an RF (Radio Frequency) drive to initiate the discharge and then switching over to a DC voltage drive once it has been established. This is currently under evaluation. In this way all the advantages of the DC system can be retained (see §6.2.7) without the need to apply an unacceptably high voltage for lamp starting.

7. COMMERCIALISATION OF THE UVIC® DETECTOR

7.1 The Context for Commercial Exploitation

The enhanced performance of the research UVIC® detector in comparison with the available devices suggested that an opportunity for commercialisation existed, and the decision was made to pursue this objective. A number of patent applications were submitted, commencing with the basic innovations made by the author. Since the development had been undertaken in pursuit of Ministry of Defence funded research, the Intellectual Property Rights (IPR) holder is the Secretary of State for Defence, via the MOD patents branch. There followed a period of negotiation culminating in the licensing of the UVIC® detector production to EnviroSystems Ltd. (ESL), which has now launched the product. Many of the commercial applications of the UVIC® detector are driven by regulatory requirements in the Health, Safety and Environment fields, where a common theme is the need to demonstrate compliance with regard to the control of exposures and emissions, and the protection of persons and the environment. Examples are: the monitoring of exposures in the workplace under the Control of Substances Hazardous to Health Regs 1988; monitoring of normal operation emissions under the Environmental Protection Act 1990; and the detection of accidental releases under the Control of Industrial Major Accident Hazards Regs 1984, as amended in 1988 and 1990. Substances that are specifically identified under these various regulations include many for which the UVIC® detector is highly suitable. Additionally there are major monitoring requirements with regard to international undertakings such as the commitment to reduce emissions of Volatile Organic Compounds (VOC's) under the United Nations Economic Commission for Europe Protocol 1991, to which many European countries are signatories.

RESTRICTED-COMMERCIAL

Other applications arise from the need to avoid the economic loss of valuable materials by unintentional releases via leaks and fugitive emissions, which are individually small but very numerous, such as on an oil refinery. The monitoring and prevention of nuisance associated with episodes of malodour perception in the vicinity of plants also provides a need for the special capability of the UVIC® detector.

An important consideration in respect of the requirements under the Environmental Protection Act 1990 is the interpretation of the BATNEEC (Best Available Techniques Not Entailing Excessive Cost) principle. Operators are required to apply BATNEEC to prevent emissions, and where that is not practicable, to minimise them and render them harmless. The regulator's (Her Majesty's Inspectorate of Pollution) declared policy on emission monitoring (which the operator has to conduct) is that continuous monitoring of emissions is the prime objective. The UVIC® detector enables a high level of continuous monitoring to be achieved, and it will be important in this context for the UVIC® detector to gain recognition as being an example of BATNEEC.

Future developments such as the recently adopted EU Directive on Integrated Pollution Prevention and Control can be expected to enhance the opportunities for deployment of the UVIC® detector system on a European scale.

7.2 Arrangements for Commercial Exploitation

Although the performance of the first prototype UVIC® detector (tested in March 1991) was only slightly better than that of the TIP, except in the context of high frequency response as noted in §2, an entry was made in the AMD "Inventions Book" outlining the nature and potential significance of the new sensor. Such entries are screened at regular intervals by MOD (Patents Branch) and, although that did happen on this occasion, the possible commercial applications of the device were yet to be recognised. However, the second series of tests carried out in July 1991 removed all doubts regarding the need to secure patent protection as a preliminary step towards commercial development. In fact it was necessary to act as rapidly as practicable once the decision to apply for a patent had been made because the intention was to evaluate and/or operate the new instrument at a number of locations

RESTRICTED-COMMERCIAL

RESTRICTED-COMMERCIAL

where the IPR might be compromised if there were no protection. In view of this the initial application was made on 19 July 1991.

The next steps in the commercial exploitation of the UVIC® detector were taken in conjunction with the Environmental Technology Centre (ETC) at UMIST. The Centre has both broad and detailed experience of industrial processes involving pollutant release and the legislative and regulatory framework in which companies are required to operate. The view was taken that the UVIC® detector was a highly significant development in industrial pollution monitoring and standards enforcement because, for example, current environmental legislation now requires the application of the 'BATNEEC' philosophy. In their opinion the UVIC® detector represented the 'state-of-the-art' in PID technology and had, as a consequence, a considerable sales potential.

At about this time (Oct 1991) an EMR contract was placed with the ETC at UMIST for the main purpose of conducting a detailed investigation of the physics of the UVIC® detector. The primary objective of this work was that of providing a logical basis on which to design an instrument optimised specifically for CBDE's atmospheric dispersion research programme. The results obtained enabled considerable further improvements in general to the detector to be achieved, whilst at the same time, certain inherent limitations of PIDs emerged that were **not** made clear in any of the commercial product literature. These manifest themselves in the type of behaviour, described in § 3, whereby the ion current decreases with increasing concentration when the latter attains very high values. This behaviour is correctly predicted by the theoretical model described in Annex A. This model is incorporated in the software code SNAIL® (Annex B).

During their investigations the UMIST researchers took the opportunity, with CBDE approval, to demonstrate the new device to various potential entrepreneurs who might have an interest in capitalising its commercial development. It should be emphasised that all arrangements of this type were conducted under strict confidentiality agreements to prevent leakage of the IPR. Arising from this Sir David Trippier (former Minister of the Environment and Countryside) expressed an interest in taking the UVIC® detector into a commercial product and visited CBDE to discuss the possibilities during June 1992. Following this meeting and subsequent discussions with Patents Branch, Sir David, in collaboration with an

RESTRICTED-COMMERCIAL

RESTRICTED-COMMERCIAL

accomplished business colleague, Mr John Lawrence, secured the rights to manufacture and sell the UVIC® detector, an agreement being concluded in October 1992. For a variety of commercial and financial reasons, it was decided that a new company would be set up to develop and manufacture the UVIC® detector. The company was incorporated in September 1992 under the name of EnviroSystems Ltd and is based in Stockport, Cheshire.

Clearly the immediate priority for the new company was to develop the research UVIC® detector into a commercially viable instrument. In terms of technical factors, this was not a difficult task in principle, because the majority of these had already been examined in the development and application of the research instrument. However, the commercial product required a totally new packaging concept both to distinguish it in the market place, and to make it ergonomically efficient. Major resources of finance and expertise were committed by ESL to achieve these objectives. In this connection, the company sought regular consultancy advice/input from both the MOD (Dr C D Jones) and UMIST (Prof R F Griffiths). During this time a number of prototype devices were evaluated, often with the involvement of IDB (Mr E D Jones) at Bangor, N Wales.

In nearly all respects the commercial development of the UVIC® detector proceeded smoothly and rapidly with remarkably few problems being encountered. Indeed, to take a device from a prototype instrument to a fully-fledged industrial product in a little over two years is certainly a notable achievement.

7.3 Marketing and Sales

The marketing effort by the company has included stands at major environmental exhibitions, particularly the PITTCON meeting, in Chicago, and the Environmental Technology (ET) Show, held in Birmingham. Both of these took place in the first quarter of 1994, the PITTCON meeting being principally aimed at negotiating distributorship arrangements, and the ET Show being mainly for end users. Both were very successful in terms of response, and at the time of writing ESL are actively pursuing the negotiations to complete agreements on distributorship in 17 countries apart from the USA, where numerous options are being examined. In the first quarter of 1994 sales were made to eight countries, namely the UK, France, Germany, the Netherlands, Belgium, Sweden, Norway and Australia. The company

RESTRICTED-COMMERCIAL

has budgeted sales of 250 units for 1994 and current indications are that this figure will be met or even exceeded.

8. APPLICATIONS OF THE UVIC® DETECTOR

8.1 Industrial Applications

The UVIC® detector developed for research purposes provides a useful calibratable range from 0.01 to 1000 ppm (v/v) (ie 5 orders of magnitude in the dynamic range), with some variation depending on the tracer gas used. Response time of about 1/50th second has been achieved. Other requirements as regards baseline stability, resistance to fouling, and ease of calibration have also been met. However, it is worth considering whether the commercial device should have the same performance requirements, since applications are likely to be varied. Accordingly, speed of response in the commercial product is not pressed to the limit available in the research version, being specified at 0.2 seconds. Other features providing greater flexibility have been incorporated. Speed of response at this level is important in applications such as fugitive emission surveys, and leak detection; on a typical refinery survey one may need to monitor several thousand potential leakage points, and a delay in response of a second or more slows down the survey very considerably. In some applications sensitivity as well as speed of response is required, such as a malodour nuisance assessment. Cases can readily be envisaged where sensitivity is not at a premium, and for these the user's requirements can be specifically addressed so as to optimise instrument performance for the intended service conditions.

A wide range of applications is already served by PID based instruments, and this is likely to be considerably extended by the enhanced performance capabilities of the UVIC® detector. For example, there are applications in:

- Workplace Monitoring for Occupational Health and Safety requirements;
- Monitoring for Process Control purposes;
- Monitoring the performance of pollution abatement equipment;
- Discharge monitoring for releases made in normal operation;
- Detection of leaks and major accidental releases;

Environmental Monitoring for purposes such as contaminated land survey, and malodour nuisance assessment.

8.2 Research applications of the UVIC® detector

8.2.1 Background

As described in § 1, the original motivation for the development of the UVIC® detector arose from the requirements of CBDE's Research Programme on Concentration Fluctuations. Since that time the 'Research Version' of the instrument (as it is known) has been developed progressively into a very reliable and robust field detector which has been deployed in various major research projects. In particular, the unique ability of the UVIC® Detector to detect ammonia with fast temporal response led directly to an invitation from the Danish National Laboratory at Risø to participate in the CEC sponsored programme FLADIS (**F**lashing **L**iquid **A**mmonia **D**ISpersion). This activity led directly to much increased 'visibility' of the UVIC® detector and has considerably enhanced the possibility of its inclusion in other International Research Programmes. (This may well present commercial opportunities in the near to medium term future). In addition, the Research Version of the UVIC® detector has been deployed with great success in a number of Chemical Defence oriented programmes in the UK, USA and Sweden

A major component of the programme conducted in the USA, at the US Army Dugway Proving Ground (DPG), Utah, has been an investigation of the dispersion from a pair of physically separated sources releasing two different tracers. It has proved possible, by careful selection of source gases, to develop a system based on the use of a **colocated FID** (Flame Ionisation Detector) and **UVIC® detector** which is capable of quantifying the contributions arising from each source. This is the first time such experiments have been carried out and the data obtained have formed the basis for a significant advance in our understanding of the dispersion process in these situations. Information of this type is particularly relevant to the development of improved, ie more realistic, models of the concentration patterns produced by **multiple and extended** sources.

RESTRICTED-COMMERCIAL

The next section illustrates the capability of the Research Version of the UVIC® detector by reference to the 'Dual Source' experiments alluded to above. The omission of a description of the various other experimental campaigns in which the instrument has been involved is merely for reasons of brevity and not their lack of technical excellence.

8.2.2 The 'Dual Source' Experiments

The results obtained from these experiments are particularly illuminating not only in the context of their importance to extended and multiple source modelling but also because they provide unequivocal corroboration, via the colocated FID, of the performance of the UVIC® detector. Colocation of the detectors was effected by drilling a small hole (\varnothing 3mm) in the UVIC® detector inlet duct (\varnothing 25mm) approximately 5cm upstream of the UV lamp position. The FID inlet nozzle was inserted radially into the UVIC® detector tube such that it sampled the airstream at a point on the axis. The combined instrument, though rather cumbersome to set up, functioned very reliably in the field. It should be noted that the FID was neither as sensitive nor as stable as the UVIC® detector in operation.

Two series of experiments have been carried out at DPG, these being in November 1992 and May 1993. The earlier series employed propane (C_3H_8) and propylene (C_3H_6) as the two tracer gases. This was not ideal because, although the UVIC® detector was sensitive only to propylene, the FID responded to both gases. Consequently data analysis required the subtraction of the UVIC® detector signals from those of the FID in order to recover the propane concentration time series. Some difficulties arose with this procedure for two reasons:

- a. the FID sampled the incoming air stream slightly before the UVIC® detector (because of the upstream displacement of the former's inlet nozzle) and
- b. there was a slight mismatch in high frequency response of the two instruments - the FID being faster as a result of its very compact sampling head geometry.

Despite these difficulties it was clear from the data quality that the novel technique had much to commend it and, moreover, further benefits could be obtained if it were possible to

identify a tracer gas pair in which the respective contributions made to the total gas concentration could be determined directly. After further experimental work at the UMIST ETC's field site at Altcar (near Liverpool) it became clear that ammonia (NH₃), to which the UVIC® detector is very sensitive and the FID has no response, used in conjunction with propane, for which the converse applies, would be very suitable. This combination was employed with great success in the second experimental series at DPG and a brief account of this follows.

8.2.3 Sample Results Obtained

In view of the high degree of technical novelty in the new tracer/detector system an essential prerequisite before commencing the planned experiments was the need to confirm its 'integrity' ie what was the level of comparability between the sensor outputs when presented with nominally identical concentration fluctuation patterns. This objective could be readily accomplished by the simple expedient of juxtaposing the two gas sources at a point a few tens of metres upwind and examining the concentration time series produced by the two detectors. In the experiments the gases were released via long flexible hoses (Ø 20mm) attached to their respective flowmeters, regulators and cylinders. Although it would have been possible to provide true source colocation by premixing the gases and then releasing the mixture through a single pipe, this was not attempted and colocation was effected by merely taping the outlets together. (Note: the small crosswind separation resulting from this arrangement (20mm) will have been of little significance in terms of its effect on the data quality for the travel distances (20-50m) involved in the experiments).

Fig. 8.1 shows a 2s segment of data obtained with the experimental arrangements described above and it is evident that the level of correspondence between the sensors is exceptionally good. A summary of the quantitative results obtained is given below.

Sensor	Mean	SD.	Int.	CXCor.	JInt
UVIC	10.45	16.27	0.295	0.76	0.42
FID	12.48	22.74	0.370		

Note CXCor denotes conditional cross-correlation, JInt the Joint Intermittency. Units, where applicable are ppm (v/v).

The somewhat faster response of the FID is reflected both in the figure and the numerical results. In particular note the larger SD and Intermittency which is a direct result of the ability of the FID to resolve the fine structure more faithfully. This in turn leads to the emergence of higher peaks and deeper troughs, ie in this context, increased intermittency. Careful inspection of the figure also reveals that the FID signal leads that of the UVIC® detector by a small amount, typically in the region of 10ms. This arises from the fact that the FID inlet was placed upstream of the UVIC® detector photo-ionisation region, as described in the preceding section, and therefore receives the material to be sampled a little sooner. More precisely, this delay corresponds to the net difference in advection times to the sensing regions of the two instruments. (Note, however, that the digitisation rate of these data was 100Hz; hence temporal scales of this duration are inevitably poorly resolved).

The dramatic effect of separating the sources, even by as little as 0.3m, on a typical concentration fluctuation time series is shown in Fig. 8.2. It is evident that, whilst the large scale correspondence between the plume concentration fields is substantially maintained, significant differences have developed in their small scale structure. Although not entirely unexpected, this behaviour is an important finding in the research context because it shows, unequivocally, that our current modelling procedures for the description of concentration distributions, invariably based on the **Principle of Linear Superposition**, cannot possibly be correct at these scales. In addition, provided enough data of this type can be obtained, then these are good prospects for developing much more realistic models, based for example on turbulence spectrum/concentration covariance concepts.

8.2.4 Summary

The Research Version of the UVIC® detector offers an unparalleled capability for the examination of wide range of atmospheric dispersion phenomena. Its exceptionally good sensitivity, fast response and lack of baseline noise and drift provide opportunities to make rapid advances in many areas of applied research.

9. CONCLUSIONS AND RECOMMENDATIONS

9.1 General

The items addressed here concern only those aspects directly related to the instrument technology itself; future research objectives involving the use of such enhanced technologies are matters for CBDE policy and are accordingly outside the scope of this report. In view of the distinction to be drawn between research and commercial considerations as regards opportunities and priorities, separate comment is made in connection with each of these.

9.2 Research Sector

The principal opportunities as regards research are judged to centre on:

- a. The pulsed UVIC® detector in relation to sensitivity and a degree of specificity.
- b. The polar UVIC® detector with regard to two-dimensional resolution flux measurements in a single instrument.
- c. The combination of the UVIC® and DAD technology, particularly where high concentrations close to large sources are of interest.

Calibration arrangements are now satisfactory for field requirements and do not merit a high priority for further development.

9.3 Commercial Sector

Opportunities here overlap with those outlined above, but the emphasis differs particularly in the following respects:

- a. The pulsed UVIC® detector presents considerable opportunities in applications requiring speed of response and very high sensitivity, such as malodour nuisance assessment, and contamination detection for recyclable beverage containers.

b. Specificity is an important attribute which, if attainable, would greatly augment the sales potential of the instrument.

c. Of the tube and polar vector UVIC® detector options, it is the former that is likely to have commercial application, particularly where regulatory requirements call for estimates of mass emissions in addition to concentration monitoring.

d. The differential absorption device has particular application at higher concentrations and is therefore of interest in relation to the extension of the UVIC® detector capability to give unambiguous response beyond the concentration turnover region. This is of special importance for applications at concentrations where intrinsic safety is a paramount consideration, as well as in process control applications which also frequently involve the higher concentration range.

9.4 Provision of Services

There are numerous applications of the UVIC® detector and related devices where a combination of 'state-of-the-art' instrumental capability and specialist investigation and interpretation is in demand. This would, for example encompass problem solving for pollutant nuisance episodes, driven by regulations as well as by industry's desire to act as good neighbours to local residents. Ventures involving CBDE resources and expertise and external collaborators in promoting this activity are seen to offer an attractive business opportunity.

REFERENCES

1. JONES C D (1977). Ion concentration variations at short distances downwind of continuous and quasi-instantaneous point sources. *Pesticide Science*, 8, 84-95.
2. BOREHAM B W, JONES C D and GRIFFITHS R F (1985). Field evaluation of a new Langmuir-type probe for atmospheric dispersion studies using ions as a tracer. *J Phys E: Scientific Instruments*, 18, 218-223.
3. MCQUAID J (ed) (1985). Heavy gas dispersion trials at Thorney Island. *Chem Eng Monographs*, 22, Elsevier.
4. RAMSDELL J V and HINDS W T (1971). Concentration fluctuations and peak to mean concentration ratios in plumes from a ground level continuous point source. *Atmos Env*, 5, 483-495.
5. HIGSON H L (1993). Atmospheric dispersion around an isolated building. PhD Thesis, University of Manchester, Faculty of Technology.
6. HIGSON H L, GRIFFITHS R F, JONES C D, HALL D J (1994). Concentration measurements around an isolated building: A comparison between wind tunnel and field data. *Atmos Env*, 28, 1827-36.
7. MYLNE K R and MASON P J (1991). Concentration fluctuation measurements in a dispersing plume at a range of up to 1000m. *Q J Roy Met Soc*, 117, 177-206.
8. JONES C D (1974). A Study of Short Range Atmospheric Dispersion using artificially produced Electric Space Charge. PhD thesis, University of Durham, UK.
9. JONES C D (1979). Statistics of the concentration fluctuations in short range atmospheric diffusion. C J Harris (editor), *Mathematical modelling of turbulent diffusion in the environment*, Academic Press, New York, 277-298.

RESTRICTED-COMMERCIAL

10. JONES C D (1983). On the Structure of Instantaneous Plumes in the Atmosphere. *J Haz Mat*, 7, 87-112.
11. JONES C D (1977). Ionised Air as a Wind Tunnel Tracer. *J Phys E*, 10, 1287-91.
12. CHATWIN P C (1985). Interaction between turbulent and electrostatic effects in the atmospheric dispersion of electrically charged tracers. CBDE Report Ref: PTA/AZ/209.
13. CHATWIN P C, HAJIAN N T, MOLE N and JONES C D (1989). Investigations on the Atmospheric Dispersion of Clouds containing Charged Tracers. *IMA J Appl Math*, 42, 97-117.
14. MOLE N and JONES C D (1994). Concentration fluctuation data from dispersion experiments carried out in stable and unstable conditions. *Bound Layer Met*, 67, 41-74.
15. EBERT H (1901). Aspirations Apparat zur Bestimmung des Ionen Gehaltes der Atmosphäre. *Phys Zeit*, 2, 662-666.
16. JONES C D. Controlled Output Ion Generator UK Patent GB 2239740B. (Co-inventors J E Elias and D J Taylor).

RESTRICTED-COMMERCIAL

NOMENCLATURE

The nomenclature specified here is principally used in the technical appendices. The choice of units has been made on the basis of calculational convenience rather than on the principle of adopting a single system. Thus power is expressed in watts, whereas molecular properties that are found expressed in the CGS system in the literature are so expressed here. This avoids the need to abandon the conventional units for values such as Loschmidt's Number. The order of the list is arabic then greek symbols, and the units adopted are shown in brackets, with particular numerical values where appropriate.

Symbol	Meaning
b	an identifying label for a species present as a background concentration
C	concentration of a species (ppm v/v)
e	charge carried on the electron (1.6×10^{-19} Coulombs)
F	a dimensionless numerical factor defined as the ratio of two volumetric flow rates
f_i	a fraction defining the proportion of ions that survive at a specified time interval following their initial production
I	current (amps)
i	a subscript indicating an association with ions or ionisation
\bar{i}	as i, but the non-ionising case
j	an identifying label for the jth component of a gas mixture
k	a dimensionless correction factor to allow for pressures and temperatures other than STP
L	a distance over which ions travel between the production zone and the collection zone (cm)
m	an identifying label for a gas species acting as the medium in which tracer and background species are carried, e.g. air, or nitrogen [N_2 is used for the latter]
N	molecular number density of a gas species (cm^{-3})
N_0	total molecular number density at a reference value - Loschmidt's number is used here ($2.68719 \times 10^{19} \text{ cm}^{-3}$ at STP)
n	a counter denoting the nth member in a series; also an index raising a quantity to the nth power

RESTRICTED-COMMERCIAL

- o subscript zero, usually denoting a reference value of a quantity
- p pressure (units as defined in context)
- Q the total cross section for the absorption of radiation by a molecular (or atomic) gas species (cm^2). Absorption cross sections are dependent on the wavelength or photon energy of the radiation.
- q_i that part of the photo-absorption cross section attributable to events that result in ionisation (cm^2)
- $q_{\bar{i}}$ the complement of q_i , ie attributable to photo-absorption without ionisation (cm^2)
- R instrument response defined as the rate of change of output voltage with change of concentration (volts/ppm (v/v))
- T absolute temperature (K)
- Tot subscript denoting 'Total'
- t an identifying label for a species present as a tracer in a carrier medium
- V a signal output voltage (volts)
- V_i the ionisation potential (volts); the quantity eV_i defines the quantity of energy in electron-volts required to bring about an ionisation event
- v a gas volume (cm^3)
- \dot{v} a volumetric flow rate ($\text{cm}^3 \text{sec}^{-1}$)
- w the lateral width of a beam of radiation (cm)
- x, y, z the Cartesian spatial co-ordinate directions
- α, β, γ substitutions for dimensionless quantities of the form xqN
- α_i the ion recombination coefficient ($\text{cm}^3 \text{sec}^{-1}$)
- Δ prefix denoting a finite difference in the associated quantity
- Φ the total cross-sectional photon flux passing through the plane normal to the flux direction at a specified distance (watts)
- Φ' the photon flux utilised in photo-absorption processes in a specified travel distance (watts)
- τ time (sec)
- \varnothing denotes diameter (not to be confused with Greek phi)

RESTRICTED-COMMERCIAL

RESTRICTED-COMMERCIAL

MODEL OF THE UVIC® DETECTOR

Photo-Ionisation Detectors (PID's) operate by subjecting a gas stream to irradiation by photons of sufficient energy to ionise a proportion of the ionisable gas or vapour species present in the stream; a suitably biased electrode system then separates the positive and negative ion pairs and causes an electrometer to receive a flow of ions of one sign. This current of ions is expected to be interpretable as a measure of the concentration of the ionisable species presented to the system. Depending on the geometry of the instrument and the flow rate through it, the stream of ion pairs produced in the ionisation region may be depleted significantly by recombination prior to arrival at the collector electrode. Since the recombination rate is proportional to the product of the positive and negative ion concentrations (or to the square of the ion concentration of one sign if the positive and negative ion concentrations are equal) it follows that the potential for significant depletion by recombination becomes greater as the initial ion concentration is increased. For a given volumetric flow rate of the gas stream through the ionisation zone an increase in concentration of the ionisable species is synonymous with an increase in the ion concentration produced. However, this volumetric flow rate may be varied, either directly or indirectly through other instrument parameters such as the UV source geometry, thereby enabling the ion concentration produced for a given ionisable species concentration to be altered without changing the rate at which ions are produced. This relationship arises because the ionisation process is extremely inefficient, perhaps only about 1 in 10^5 of the ionisable species present being ionised. Accordingly, there is no appreciable reduction in the concentration of potentially ionisable molecules, so that for a given flux of UV photons, there is a constant rate of ion production, which can be incorporated in a volume of variable size depending on the parameters of the flow. The modelling approach adopted here is based only on the physics of the process as described above. Accordingly, no photochemical processes are explicitly described, although it is recognised that such reactions may occur in the instrument, for example the production of ozone by photo-dissociation of oxygen. However, such processes are implicitly allowed for if both the total and the photo-ionisation cross sections are available for the gases of interest.

RESTRICTED-COMMERCIAL

The model is constructed to address the following aspects:

- a. Processes of photo-ionisation and photo-absorption without ionisation that occur in the region of the gas stream on which the UV flux impinges, thereby progressively depleting the UV flux along its path through the gas stream;
- b. Advection of the ions from this region to the point of collection on the downstream electrode system, allowing for recombination to deplete the number of ions available for collection; and
- c. Summation of the contributions to the collected ion current from the differently ionised volume elements along the UV flux path.

The model makes no allowance for the flattening of the lateral-wise ion concentration profile that may occur due to cross-stream mixing during the advection period between formation and collection of the ions.

It should be emphasised that the UVIC[®] detector differs substantially from the previous generation of commercially available PID's in having a large volumetric flow rate, and a large advection distance, relative to these other instruments. This is deliberately so, and indeed is in part the reason for its better performance. However, it is consequently necessary to construct the model slightly differently in terms of the geometry of the computation mesh to cover both the UVIC[®] detector and its competitors, although the basic mechanisms are in all cases as stated above. Given these differences, the model is described first in terms of the generalities that apply to all configurations. The particular implementations for the two sub-categories of instrument are then described. The geometry is represented using the conventional cartesian axes x , y and z ; all UV fluxes are referenced to the point at which the radiation enters the gas stream normal to the face of the source lamp window, the radiation flux being along the x axis, and the face of the window falling in the y , z plane. The UV flux through the y , z plane at a distance x from its origin would conventionally be given the symbol Φ_x , and Φ_0 at $x = 0$. In order to avoid a cumbersome level of subscripting x is omitted here, so that Φ implies the flux at a distance x ; Φ_0 is retained for the incident flux at distance $x = 0$.

General Considerations

Ion production

The attenuation of an incident beam of radiation through a gas is determined by the total absorption cross section Q in the relation

$$\phi = \phi_0 \exp\{-xQN\} \quad (\text{A1.1})$$

where N is the molecular number density, and Q has units of cross-sectional area. The literature on this topic adopts the unit of Q as 10^{-18} cm^2 , the Megabarn, one barn being 10^{-24} cm^2 . Accordingly N is in units of number of molecules per cm^3 , with x in cm. The total absorption cross section Q includes all flux depleting processes such as dissociation and excitation as well as ionisation. These are expressed separately as q_i for the ionisation cross-section, and q_r for all other processes, thus

$$Q = q_r + q_i \quad (\text{A1.2})$$

(care should be taken not to misread the overbar above i as a minus sign).

Measured values of UV flux attenuation from the literature on vacuum UV spectroscopy normally provide q_i and either q_r or Q , so that this division is convenient in distinguishing the ionisation cross section explicitly, whilst the complement q_r includes all other losses without explicitly stating the partition of energy between, for example, dissociation and excitation.

If the gas in which this occurs consists of n distinct species then

$$\phi = \phi_0 \exp\left\{-x \sum_{j=1}^n (q_{rj} + q_{ij})N_j\right\} \quad (\text{A1.3})$$

RESTRICTED-COMMERCIAL

The right hand side of this expression, if expanded, would consist in full of Φ multiplied by a product series of proper fractions, with $2n$ such fractions in all. For all cases with non-zero values of the absorption cross sections these fractions would express the influence of that category of photo-absorption in the species identified in depleting the flux. This expanded form of the expression is conceptually useful, because it leads directly to the formulation of an expression for the flux utilised in any selected photo-absorption and species combination, namely that the flux utilisation in a specified combination (or family of such combinations) is equal to the total flux utilisation minus the utilisation in all other sinks excluding the specified combination(s). The expression in (A1.3) above is for the surviving flux at distance x ; accordingly the flux utilised (denoted as Φ') is given by

$$\Phi' = \Phi_0 - \Phi \quad (\text{A1.4})$$

Clearly, the total flux utilised Φ'_{Tot} (Tot denotes total) is found by evaluating this expression with all the active combinations included. In order to find the flux utilised in ionisation processes only (A1.4) should be evaluated for all non-ionising processes (ie with q_{ij} finite and $q_{ij} = 0$) and the difference obtained on subtraction is then the flux utilised in ionisation alone, ie

$$\Phi'_i = \Phi'_{Tot} - \Phi'_{\bar{i}} \quad (\text{A1.5})$$

The case of particular interest here (a single ionisable tracer in air) involves a tracer t that is both photo-absorbing and photo-ionising (ie q_{it} and q_{it} are finite), and a carrier medium m that is photo-absorbing but not photo-ionising (ie q_{im} is finite, and $q_{im} = 0$). The flux utilisation in ionising the tracer is thus Φ'_{it} , which is found according to the foregoing scheme as follows:

from (A1.4) and (A1.3)

$$\Phi'_{Tot} = \Phi_0 - \Phi_0 \exp\{-xq_{im}^- N_m\} \exp\{-xq_{it}^- N_t\} \exp\{-xq_{it} N_t\}$$

and

RESTRICTED-COMMERCIAL

$$\phi'_i = \phi_0 - \phi_0 \exp\{-xq_{im}^- N_m\} \exp\{-xq_{it}^- N_t\}$$

Substituting these in (A4) yields

$$\phi'_{it} = \phi_0 \exp\{-xq_{im}^- N_m\} \exp\{-xq_{it}^- N_t\} \{1 - \exp\{-xq_{it}^- N_t\}\} \quad (\text{A1.6})$$

It is convenient to adopt a reference value for the total molecular number density N_0 at a selected pressure P_0 and temperature T_0 and then to incorporate other pressure and temperature values P and T respectively. Additionally, if P and T are constant for a particular episode during which the tracer concentration is varying, then the total number density of tracer and carrier medium molecules must remain constant, ie tracer molecules displace an equivalent number of carrier medium molecules to maintain a constant total number density so that $N_m = N_0 - N_t$, where all N values are the equivalent at NTP. A convenient reference point for N_0 is provided by Loschmidt's number, which is the number of gas molecules per cubic centimetre at normal temperature (0°C) and pressure (760 mm Hg). N_0 takes a value of $2.68719 \times 10^{19} \text{ cm}^{-3}$.

Incorporating this set of considerations in (A1.6) with substitutions for the indices of the exponential terms (ie the quantities of the form xqN) gives

$$\phi'_{it} = \phi_0 \exp(\alpha) \exp(\beta) \{1 - \exp(\gamma)\} \quad (\text{A1.7})$$

where

$$\alpha = -xq_{im}^- (N_0 - N_t) k$$

$$\beta = -xq_{it}^- N_t k$$

$$\gamma = -xq_{it}^- N_t k$$

RESTRICTED-COMMERCIAL

and k is the pressure/temperature correction

$$k = \frac{PT_0}{P_0T}$$

or

$$k = \frac{P}{1013} \frac{273}{T}$$

when the pressure and temperatures are expressed in mbar and K respectively.

Equation A1.7 is the integral form of the flux utilisation in tracer ionisation over the pathlength x . Here it is required to establish the ion concentration profile over this path so that allowance can be made for recombination if significant. Accordingly, what is required is the change in this utilisation over a path element of length Δx so that the number of ions formed in a slab of this thickness can be specified. If the associated cross-sectional area through which the UV beam passes is also specified, the ion concentration in the element is then obtainable.

The element of flux utilisation $\Delta\Phi'_{it}$ attributable to tracer ionisation in the elemental slab of thickness Δx is accordingly

$$\Delta\Phi'_{it} = \left(\frac{d\Phi'_{it}}{dx} \right) \Delta x$$

If this is divided by the amount of energy required to create one singly ionised tracer molecule, then the rate of ion formation in the slab is specified. This quantity of energy is eV_i joules where e is the electronic charge and V_i is the first ionisation potential of the molecule. Some complexity arises here since the photon energy of the UV source will only be an exact match for those molecules whose ionisation potentials correspond to the spectral output of the UV lamp. In practice the krypton filled UV lamp used in many PID's (including the UVIC[®] detector) emits at two photon energies corresponding to resonance transitions in the filler gas at 10.03 and 10.64 electron-volts. For a molecule with an

RESTRICTED-COMMERCIAL

transitions in the filler gas at 10.03 and 10.64 electron-volts. For a molecule with an ionisation potential between these values, only the upper line may be effective in creating ions. If the molecule has an ionisation potential below 10.03 eV (as is the case for propylene, for example), then both lines are expected to be effective. For simplicity, the energy quantum is taken to be 10.6 eV per single ionisation, and any energy in excess of the actual ionisation potential is assumed to be used in giving the electron additional kinetic energy. Accordingly, the ion production rate is taken to be $\frac{\Delta\phi'_{it}}{eV_i}$. All PID's have arrangements for producing a gas flow through the instrument, and thus, although differently specified according to the particular geometry of the instrument, the volume element in which the ions are created is ventilated at a volumetric flow rate which is here specified as \dot{v} , which is to be detailed for particular geometries subsequently. It follows that the ions created at the rate specified above are incorporated into a specified volumetric flow rate, and thus the initial concentration of ions carried in this elemental ventilation tube emanating from the ionisation element is the initial number density of ions of the tracer, N_{it} , where

$$N_{it} = \left(\frac{d\phi'_{it}}{dx} \right) \frac{\Delta x}{(eV_i \dot{v})} \quad (\text{A1.8})$$

Referring back to eq. (A1.7) to obtain the required differential coefficient, the relationship is

$$\begin{aligned} \left(\frac{d\phi'_{it}}{dx} \right) &= \phi_0 \left\{ (\exp(\alpha)\exp(\beta)) \left\{ -\exp(\gamma) \frac{d\gamma}{dx} \right\} \right. \\ &\quad \left. + (1-\exp(\gamma))(\exp(\alpha)\exp(\beta)) \left(\frac{d\alpha}{dx} + \frac{d\beta}{dx} \right) \right\} \quad (\text{A1.9}) \\ &= \phi_0 \left\{ \exp(\alpha)\exp(\beta) \left[(1-\exp(\gamma)) \left(\frac{d\alpha}{dx} + \frac{d\beta}{dx} \right) - \exp(\gamma) \frac{d\gamma}{dx} \right] \right\} \end{aligned}$$

with

$$\frac{d\alpha}{dx} = -q_{im}^{-}(N_0 - N_i)k$$

$$\frac{d\beta}{dx} = -q_{ir}^{-}N_i k$$

$$\frac{d\gamma}{dx} = -q_{ir}^{-}N_i k$$

and k is as specified in the system of equations (A1.7).

Evaluating eq. (A1.8), making use of the system of equations (A1.9) in the process, yields the ion concentration emanating from the boundary of the ionisation volume element, advecting towards the collector electrode system. If no recombination takes place in the time interval between ion creation and impingement on the electrodes, then the ion current is simply obtained, because if all ions that are created survive to be collected, then the ion concentration profile along the x direction is not needed. In this special case the current collected is simply the flux utilisation (eq. A1.6) divided by the energy (eV_i) to create an ion, multiplied by the electronic charge e, or more simply the flux utilisation divided by the ionisation potential V_i (in volts). This estimate has some utility in defining the maximum current that it is obtainable for a given set of values of the variables and parameters involved, but for a full understanding of the instrument it is necessary to allow for recombination.

Recombination

Once an ion concentration is established in the ionisation element it is subject to depletion by recombination during the time of passage to the collector electrode system. The recombination rate is proportional to the product of the concentrations of positive and negative ions. For the case of interest ions are created in pairs of opposite sign, so the product of the positive and negative ion concentrations is the same as the square of the

RESTRICTED-COMMERCIAL

concentration of ions of one sign. The constant of proportionality is the recombination coefficient, α_i , thus the time rate of change of N_{it} is given by

$$\frac{dN_{it}}{d\tau} = -\alpha_i N_{it}^2 \quad (\text{A1.10})$$

where τ denotes time. Rearranging in integral form gives

$$\int \frac{dN_{it}}{N_{it}^2} = -\alpha_i \int d\tau$$

and specifying the conditions $N_{it}(0)$ at $\tau = 0$ and $N_{it}(\tau)$ at time τ gives

$$\left[\frac{-1}{N_{it}} \right]_{N_{it}(0)}^{N_{it}(\tau)} = -\alpha_i [\tau]_0^\tau$$

$$\left(\frac{1}{N_{it}(0)} - \frac{1}{N_{it}(\tau)} \right) = -\alpha_i \tau$$

Rearranging gives

$$N_{it}(\tau) = \frac{1}{\left(\frac{1}{N_{it}(0)} + \alpha_i \tau \right)} \quad (\text{A1.11})$$

This expression is used to modify the ion concentration during the advection period.

As indicated earlier, particularities of instrument geometry are dealt with individually, but it is possible to extract some useful information concerning the regimes in which recombination will be either insignificant, or of importance.

The fraction, f_p , of the originally produced ions that survive to be collected is clearly

$$f_i = \frac{N_{it}(\tau)}{N_{it}(0)}$$

which, utilising eq. (A1.11) can be expressed as

$$f_i = \frac{1}{(1 + N_{it}(0)\alpha_i\tau)} \quad (\text{A1.12})$$

Since in a given application the recombination coefficient is determined by the gas in question, it is of use to express this in the form

$$N_{it}(0)\tau = \frac{(1-f_i)}{\alpha_i f_i} \quad (\text{A1.13})$$

as this specifies the ion concentration at which, for a given advection time (which the instrument designer can determine), the recombination effect will be experienced to an extent that can be prescribed as a design target. For example, a typical advection time in the UVIC[®] detector is 10^{-3} sec, and α_i is typically 10^{-7} cm³/sec. If it is specified that the recombination loss should be tolerable if 0.9 of the ions survive, then the initial ion concentration should not exceed 10^9 ions/cm³. Given a typical efficiency of ionisation of about 10^{-5} , this corresponds to 10^{14} molecules/cm³ of tracer concentration. Since N_0 is of the order 10^{19} molecules/cm³ (at NTP) this implies that recombination will be experienced at the 90% ion survival level for tracer concentrations of about 10 ppm (v/v). This approximation corresponds well with the observed behaviour of the UVIC[®] detector, where non-linearity starts to be seen at a few 10's of ppm (v/v).

It should be appreciated that the appearance of non-linearity of response is not simply determined by this criterion, since the ion concentration profile produced in front of the UV source is not uniform, but falls with distance x . Additionally, non linearity is also affected by the progressive replacement of air molecules by the (usually) more photo-absorbing but non-ionising fraction of the tracer gas.

A1.4 Particular Considerations re: the UVIC® Detector

The application of the foregoing general considerations to the geometry of the UVIC® detector follows very straightforwardly, in that the ions produced in the ionisation region elements are advected along the y axis a distance L from the boundary of the ionisation element to the circular plane normal to the y direction defining the boundary of the collector electrode system. If the advection speed is $(dy/d\tau)$ then the advection time τ is simply $L/(dy/d\tau)$. The ion concentration established using eq (A1.8) is depleted in accordance with eq (A1.11), and this concentration of ions arrives at the collector electrode, making a contribution to the current ΔI given by

$$\Delta I = N_{ii}(\tau)ew\Delta x(dy/d\tau) \tag{A.14}$$

where w is the lateral width of the UV beam (in the z-direction).

The total current I is obtained by summing the contributions over all ionisation elements along the x-axis,

$$I = ew\Delta x(dy/d\tau) \sum_{all\ x} N_{ii}(\tau) \tag{A1.15}$$

In practice, calculation of the initial ion concentration is stopped at the point where the flux utilisation in ionisation first goes negative, ie all the available flux has been used. This corresponds to the condition that the collection of exponential terms in the square bracket in eq (A1.9) first becomes negative.

This modelling scheme is incorporated into the programme SNAIL®, which is listed in Annex B. Two versions are presented, the first (in BASIC) being the development version of the programme written to prove the procedure. This is relatively cumbersome for the unfamiliar user, having no data files or output formats other than tables of numbers. A second version has since been written (in OPL) incorporating numerous additional input and output features to make it convenient for the user. In particular, this has been written to run

RESTRICTED-COMMERCIAL

on a small palmtop computer for ease of use in the field. Fig. 3.3 in the main report was produced using this version of SNAIL®.

LISTINGS OF SNAIL[®] COMPUTER PROGRAMME

1. Development Version written in BASIC
2. Operational version, written in OPL, for field use on a 'Palm Top' Computer.

RESTRICTED-COMMERCIAL

```
1 INPUT "ntrstart ppm",Y
5 INPUT "ntrstep ppm",Z
6 INPUT "No. CONC STEPS",CC
7 INPUT "alpha recomb",B
8 INPUT "vel cm/sec",A
9 INPUT "beamwidth",D
10 INPUT "fi watts",F
11 INPUT "xstep cm",O
12 INPUT "qni",R
13 INPUT "qi",S
14 Q=5.2E-19
15 N=2.7E+19
16 R=R*IE-18
17 S=S*IE-18
25 FOR P=1 TO CC
26 T=Y+(P-1)*Z
27 PRINT T
28 T=T*2.7E+13
29 I=0
30 C=0
31 G=0
35 I=I+1
36 X=O*(I-.5)
37 U=-X*Q*(N-T)*.21
38 V=-X*R*T
39 W=-X*S*T
50 E=10.6*1.6E-19
51 K=(W/X)*EXP(W)
52 J=((U+V)/X)*(1-EXP(W))
53 IF (J-K)<0 THEN 180
54 L=EXP(U+V)
55 H=L*(J-K)
56 M=(F*H)/(E*A*D)
57 IF M=0 THEN:G=0:GOTO 200
58 C=C+D*A*O*(1/((B*1.3/A)+1/M))
60 G=G+F*L*(J-K)*O
62 IF I=1 THEN PRINT M;C
150 GOTO 35
180 C=C*1.6E-10
200 PRINT C;X;G
201 STOP
205 NEXT P
210 End
```

RESTRICTED-COMMERCIAL

RESTRICTED-COMMERCIAL

PROC Snail:

```
Local a%, Minconc,Concstep,Concnumb,Recomb,Airvel,Travdist
Local Uvbeam,Uvpower,Xstep,Xdim,Ani,Ai
Local Qtotair,Lochno,Ionenerg,II,JI,Ntconc,Nair
Local X,U,V,W,J,K,L,H,M
Local Gasconc,Ioncurr
Local Conc(460),Current(460)
Local
File$(12),b%,Float1,Float2,Ref$(255),Text1$(255),Text2$(255),Text3$(255)
Local c%,Number%,Opt%
Local d%,e%,Norm$(1),Maxcurr,Maxcurr$(8),Xincr,Xmax,Xpos,Ypos
Local f%,A$(128),B$(128),Ref1$(128),Ref2$(128),Ref3$(128)
Local LXpos,Filenumb,g%,Ref1a$(128),h%
Local i%,Delcurr(460),Mindel,Maxdel,Ydel,Maxconc$(8)
Local Airvel$(8),Travdst$(8),Uvbeam$(8),Uvpower$(8)
Local j%,Temp,Press,Temp$(8),Press$(8)
  Rem Set up initial dialogue.
  dInit "SNAIL"
  dText "", "Select Program Mode: "
  dText "" " "
  dText "",This Program operates in one of two modes:"
  dText"", " (1). Computations of ion current v. gas concentration."
  dText"", " (2). Plotting data from an OPD (data) file created earlier."
  dChoice Opt%,"Mode:", "1,2"
  Dialog
    If Opt%=2
      dInit " Information to set up plot"
      dEdit File$,"Filename to Plot:",12
      Dialog
        GoTo PLOT
    Endif
  Rem Now set up dialogue to select gas type.
  dInit "Tracer Gas Type Selection."
  dText "", "Program automatically inputs 'Ionisation Parameters'"
  dText, "" for propylene, ammonia and ethylene. It will request"
  dTextn", " them later for gases in the 'other' category."
  dChoice a%, "Gas Type:", "Propylene, Ammonia, Ethylene, Other"
  Dialog
  Rem Ascribe default values.
  Concstep = 100
  Concnumb = 10
  Airvel = 800
  Travdist = 1.10
  Uvbeam = 0.4
  Uvpower= 10.0
  Xstep =0.01
  dInit "Edit Parameter Values for Computations."
  dFloat Minconc,"Starting Concentration (ppm):",0,100000
  dFloat Concstep,"Concentration Step (ppm):",0,10000
  dFloat Concnumb,"Number of Concentration Steps:",0,459
  dFloat Airvel,"Advection speed of air flow cm/sec:",0,10000
  dFloat Travdist,"Travel dist lamp to ion collector cm:",0,1000
  dFloat Uvbeam,"UV lamp beamwidth cm:",0,100
  dFloat Uvpower,"UV lamp radiated power microwatts:",0,1000000
  dFloat Xstep,"Cross-stream step for integration (0.01 cm OK):",0,1
  Dialog
  Rem Increase Concnumb by unity to give range of concentrations
  Rem expected.
    Concnumb=Concnumb + 1
  Rem Convert Uvpower to Watts.
    Uvpower = Uvpower*1E-6
  Rem Set Cross stream dimension to 2.0 cm.
    Xdim=2.0
```

RESTRICTED-COMMERCIAL

RESTRICTED-COMMERCIAL

```
dInit "Treatment of Results."
dChoice b%,"Computed Data - Write to file:","yes,no"
Dialog
Rem Set defaults.
Rem Check to find whether any UVIC.*** files in the OPD directory.
    If not exist ("Uvic.000")
        File$ = "Uvic.000"
        GoTo SKIP
    Endif
Rem Check file list in OPD directory
    A$ = Dir$("M:\OPD\UVIC.*")
    While A$ <> ""
        Bf$=A$
        A$ = Dir$("")
    Endwh
Rem Latest file has name B$.

    Filenumb = Val(Right$(B$,3))
    Filenumb=Filenumb + 1001

File$ = "Uvic."+ Right$(Gen$(Filenumb,4),3) SKIP::
Rem Set Refl$
    If a% = 1
        Refl$ = "Propylene"
    Elseif a% = 2
        Refl$ = "Ammonia"
    Elseif a% = 3
        Refl$ = "Ethylene"
    Elseif a% = 4
        Refl$ = "User Defined"
    Endif
Rem Enter variables for optional incorporation on file.
Airvel$ = Gen$(Airvel/100.0,8)
Travdst$ = Gen$(Travdst/100,8)
Ref2$ = "Air vel:" + Airvel$+ "m/s., Electrode dist: "+Travdst$+" m."
Uvbeam$ = Gen$(Uvbeam * 10.0,8)
Uvpower$ = Gen$(Uvpower* 1 E6,8)
Ref3$ ="Uvbeam:" + Uvbeam$+" mm., Lamp power: + Uvpower$ + uW"
If b% = 1
    dInit "Data storage arrangements."
    dEdit File$,"Filename (Default shown):",12
    dEdit Refl$,"Text on file (line 1):",128
    dEdit Ref2$,"On file (line 2):",128
    dEdit Ref3$,"On file (line 3)",128
    Dialog
Endif

Rem Now select the cross sections appropriate for the particular gas
Rem of interest.
    If a% = 1
        Ani=29.8
        Ai = 14.8
        Recomb=2.81e-7
    Elseif a%=2
        Ani= 14.8
        Ai = 3.7
        Recomb = 4.61e-7
    Elseif a%=3
        Ani= 10.8
        Ai = 4.0
        Recomb = 3.42e-7
    Elseif a% = 4
        Rem Load default values for Dialogue.
        Ani = 30
```

RESTRICTED-COMMERCIAL

RESTRICTED-COMMERCIAL

```

                Ai = 10
                Recomb = 1e-7
                dInit "Tracer Gas Cross section and Recombination data."
Ani, "Non-ionising cross section Mbarns:",0,1000000
                dFloat Ai, "Ionising cross section Mbarns:",0,1000000
                dFloat Recomb, "Recombination coefficient cm^3/sec: ",0,1
                Dialog

Endif
Ani=Ani*1e-18
Ai = Ai*1e-18
Rem Define Total absorption value for air and Lochschmidt's Number (No of molecules per cm^3)
Qtotair = 3.4E- 19
Lochno=2.7E+ 19
Temp=0
Press= 1013.2
Rem Set up dialogue apply pressure and/or temperature correction.
dInit "Correction for Non-Standard Pressures/Temperatures."
dChoice j%, "Apply a 'Gas Law' based correction?","no,yes"
Dialog
    If j% = 2
        dlnit "Enter Pressure and Temperature."
        dFloat Temp, "Air Temperature ( C): ",-100,300
        dFloat Press, "Air Pressure (mb):",0.001,1E6
        Dialog
        Rem Now modify Refl$ to incorporate non-standard ambient conditions.
        Temp$ = Gen$(Temp,8)
        Press$ = Gen$(Press,8)
        Refl$=Refl$+"; "+Temp$+"°C; "+Press$+" mb."
        Rem Correct Lochno.
            Lochno=Lochno*(Press/1013.2)*(273.161(Temp+273.16))
        Endif
Rem Calculate energy to produce an ion, Ionenerg
Ionenerg - 10.6* 1.6E- 19
Rem Now commence calculation loop. Ntconc= number concentration of tracer.
Rem Outer loop counter is II.
Rem Next calculate the number concentration of the remaining air.(Nair).
Rem Evaluate parameters U,V and W.
II=0
    DO
        Ntconc = (Minconc + (II*Concstep)) * 1 E-6*Lochno
        Gasconc = Minconc + (II*Concstep)
        Nair = Lochno-Ntconc
        Ioncurr=0
        Rem Set up inner loop to cycle through X (the transverse distance)
        Rem Initialise loop counter (JJ).
        Rem Factor of 0.21 in the expression for U reflects that the UV absorption arises from
the oxygen only.
        JJ= 1
            DO
                X=Xstep*(JJ-0.5)
                U=-X*Qtotair*Nair*0.21
                V=-X*Ani*Ntconc
                W=-X*Ai*Ntconc
                J=(1-exp(W))*((U+V)/X)
                K=exp(W)*(W/X)
                L=exp(U+V)
                H=L*(J-K)
                M = (Uvpower*H)/(Ionenerg*Airvel*Uvbeam)
                IF M < 0
                    GoTo RESULT
                Elseif M=0
                    GoTo RESULT
                Endif
            Rem Now compute number contribution to the ion current

```

RESTRICTED-COMMERCIAL

RESTRICTED-COMMERCIAL

```
Ioncurr=Ioncurr+((Uvbeam*Airvel*Xstep)*(1/((Recomb*Travdist/Airvel)+ 1/M)))
Rem Program now checks if UV flux has been used up.J,K Condition and exits
loop if it has.
    IF (J-K) < 0
        GoTo RESULT
    Endif
    JJ=JJ+ 1
    Until JJ=Xdim/Xstep
RESULT::
Rem Convert current from ion number to nano amps.
Ioncurr = Ioncurr* 1.6E-10
gCls
gAt 160,20
gStyle 3
gPrint "'Snail' UVIC Prediction."
gAt 180,50
    If a% = 1
        gPrint"Gas: Propylene"
    Elseif a% =2
        gPrint "Gas: Ammonia"
    Elseif a% = 3
        gPrint "Gas: Ethylene"
    Elseif a% =4
        gPrint "Gas: Other"
    Endif
gStyle 0
gAt 80,80
gPrint "Gas concentration (ppm):"
gAt 320,80
gPrint Gasconc
gAt 80,105 gPrint "Ion Current (nA):"
gAt 320,105
Rem Modify Ioncurr to print 3dp.
Ioncurr=Int(1000*(Ioncurr + 0.0005))
Ioncurr = Flt(Ioncurr)/1000
gPrint Ioncurr
gAt 80,130
gPrint "Maximum X (cm):"
gAt 320,130
gPrint X
If b% =2
    gAt 115,155
    gPrint "Press any key for next result."
    Get
Endif
Rem Now Store Results in two Arrays.
II=II+ 1
Conc(II) = Gasconc
Current(II) = Ioncurr
Until II=Concnumb
    If b % = 1
        Rem Open/Create file for storing data.
        If not exist (File$)
            Create File$,A,Text1$,Text2$,Text3$,Float1,Float2
        Else
            Open File$,A,Text1$,Text2$,Text3$,Float1,Float2
        Endif
        Rem Input Header Information to file.
        A.Text1$=Ref1$
        A.Text2$=Ref2$
        A.Text3$=Ref3$
        A.Float1=0
        A.Float2=0
    Append
```

RESTRICTED-COMMERCIAL

RESTRICTED-COMMERCIAL

```
Rem Now assign a 'null string' to Ref$ to avoid taking up unnecessary space on file.
Ref$= ""
Rem Reset loop counter. (II)
II = 1
    DO
        A.Text1$=Ref$
        A.Text2$=Ref$
        A.Text3$=Ref$
        A.Float1 = Conc(II)
        A.Float2 = Current(II)
        Append
        II=II+ 1
    Until II- 1 = Concnumb
    Close
Endif
Beep 5,500
Pause 10
Beep 16,600

Rem Set up dialogue for data plotting etc.
Cls
dInit "Data Processing."
dEdit File$,"The current file is:",12
dChoice c%,"Plot out this file:","yes,no"
Dialog
    If c% = 1
        GoTo PLOT
        PLOT::
            dInit "Data Analysis."
            dEdit File$,"The current file is:",12
            dChoice d%,"Inspect file in detail?","no,yes"
            Dialog

            gCls
            gAt 80,20
            gStyle 3
            gFont 5
            gPrint "Opening File:"
            gStyle 0
            gAt 240,20
            gPrint File$
            Open File$,A,Text1$,Text2$,Text3$,Float1,Float2
            Number%=COUNT
            gAt 80,40
            gPrint "Number of records is:"
            gAt 240,40
            gPrint Number%
            Rem Initialise loop counter.(II) and locate pointer at start of file.
            II = 1
            First
                gAt 10,60
                gStyle 3
                gPrint "Text is:"
                gStyle 0
                gAt 75,60
                gPrint A.Text1$
                gAt 75,80
                gPrint A.Text2$
                gAt 75,100
                gPrint A.Text3$
                Get
            If d%=1
                GoTo ARRAYS
            Endif
    Endif
```

RESTRICTED-COMMERCIAL

RESTRICTED-COMMERCIAL

```
DO
    gCls
    gAt 80,30
    gPrint "Filename is:"
    gAt 250,30
    gPrint File$
    gAt 80,80
    gPrint "Concentration (ppm) is:"
    gAt 250,80
    gPrint A.Float1
    gAt 80,100
    gPrint "Ion Current (nA) is:"
    gAt 250,100
    gPrint A.Float2
    Next
If d%=2
    Get
    gCls
Endif
    Until EOF
ARRAYS::
Rem Next fill two arrays ready for plotting.
    II=1
    First
    Next
DO
    Conc(II) = A . Float 1
    Current(II) = A . Float2
    II=II+ 1
    Next
    Until EOF
Rem Concnumb is not entered from the keyboard if an imported
Rem file is being examined. Hence it is now set.
    Concnumb=II-1
Cls
Rem Find maximum Ioncurrent in order to scale plot.
    II = 1
    Maxcurr=0
    DO
        If Current(II) > Maxcurr
            Maxcurr = Current(II)
        Endif
        II=II+ 1
    Until II-1=Concnumb

Rem Set up dialog for y-axis scaling.
Maxcurr$ = Gen$(Maxcurr,8)
dInit "Y-axis Scaling."
dEdit Maxcurr$,"Maximum ion current (nA):",8
Choice e%,"Normalise using this value:","yes,no"
Dialog

If e%=2
    Rem Set Y-axis scaling.
    dInit "Manual Y-axis scaling."
    dFloat Maxcurr," Enter Y-axis maximum

(nA): ",0.001, 1000

    Dialog
    Rem Update Maxcurr$.
    Maxcurr$ = Gen$(Maxcurr,8)
Endif
Rem Clear screen for graphics.
gCls
Rem Graphics Housekeeping etc.
```

RESTRICTED-COMMERCIAL

RESTRICTED-COMMERCIAL

gStyle 2

```
gAt 40,145
gPrint "File:"
gAt 70,145
gPrint File$
```

Rem Check length of Refl\$ string before printing on the plot.
If Opt%=1

```
h % =Len(Refl $)
If h% < 30
Refla$= ("+Refl$+")
gAT 165,145
gPrint Refla$
```

Endif

Endif

Rem Print Text from file header (first line) on graph.

```
If Opt%=2
First
gAT 165,145
Refla$= ("+A.Textl$+")
gPrint Refla$
```

Rem Also find Concstep in case di/dC plot

```
Concstep = Conc(2)-Conc(1)
```

Endif

Rem Commence Plot.

```
gStyle 0
gAt 0,0
gBox 480,160
gAt 10,150
Rem Now set and initialise x increment.
Xincr = Int(460.0/(Concnumb- 1))
Xpos= 10
II= 1
```

DO

```
Ypos = 150-Int(Current(II)* 140/Maxcurr)
gLineto Xpos,Ypos
Xpos = Xpos + Xincr
II =II + 1
```

Until II =Concnumb + 1

Rem Note Final Xpos value (LXpos).

```
LXpos = Xpos-Xincr
```

Rem Now draw X and Y grids.

```
Xpos = 10
Ypos= 150
II = 1
```

DO

```
gAt Xpos,Ypos
gLineto Xpos,Ypos-140
Xmax=Xpos
Xpos= 10+Int(((LXpos-10)*II)/10.0)
II=II+ 1
```

Until II = 12

```
Xpos = 10
Ypos = 150
II = 1
```

DO

```
gAt Xpos,Ypos
glineto Xmax,Ypos
Ypos = Ypos-14
II=II+ 1
```

Until II= 12

Rem Label x-axis maximum.

is required.

RESTRICTED-COMMERCIAL

```
gAt LXpos-60,145
Maxconc$ =Gen$(Conc(Concnumb),8)
gPrint Maxconc$+"ppm"
```

```
Rem Label y-axis maximum.
gAt 15,35
gPrint Maxcurr$+"nA"
```

```
dInit "Examine i-C Linearity ?"
dChoice i%," Overlay plot of first derivative (di/dC)?","no,yes"
If i%=2
    Rem Set up array for derivative values.
    II = 1
    Rem Set up scaling for y-axis.
    Mindel=0
    Maxdel=0
    DO
        Delcurr(II)=(Current(II+1)- Current(II))/Concstep
        If Maxdel < Delcurr(II)
            Maxdel = Delcurr(II)
        Endif
        If Mindel > Delcurr(II)
            Mindel = Delcurr(II)
        Endif
        II=II+ 1
    Until II=Concnumb
    Rem Scale according to whichever (ie Mindel or Maxdel) has the larger modulus.
    If Mindel > 0
        Mindel = 0
    Elseif Mindel < 0
        Mindel = -Mindel
    Endif
    If Maxdei > Mindel
        Ydel = Maxdel gcls
    Elseif Maxdel < Mindel
        Ydel = Mindel
    Endif
    Rem Restore Mindel.
    Mindel= -Mindel
    Rem Scale Delcurr array in preparation for plotting.
    Rem Set up starting positions and plot.
    II= 1
    Xpos= 10+Int(Xincr/2.0)
    Ypos = 80-Int(Delcurr(II)$70/Ydel)
    gAt Xpos,Ypos
    II=2
    DO
        Delcurr(II) = Delcurr(II)/Ydel
        Ypos = 80-Int(Delcurr(II)*70)
        Xpos = Xpos + Xincr
        gLineto Xpos,Ypos
        II=II+ 1
    Until II=Concnumb
    Endif
    Get
    Close
Endif
gCls
Rem Set up Dialogue for further processing
dInit "Further Processing."
dChoice f%,"~Plot/examine another file:","no,yes"
Dialog
```

```
If f%=2
    Opt%=2
```

RESTRICTED-COMMERCIAL

RESTRICTED-COMMERCIAL

```
Rem Print list of files.
At 3,1
Print "OPD File List."
At 3,2
Print "*****"
      A$ = Dir$("M:\OPD\")
      While A$ <> " "
        Print A$
        A$ = Dir$("")
      Endwh
dInit "File Selection"
dEdit File$, " Filename:",13
dPosition 1,-1
Dialog
Cls
GoTo PLOT
Endif

Rem Short routine to enable data file to be printed now follows.
Rem Set up dialogue for file pnnting.
dInit "Data File Print-out Option."
dChoice g%,"Print out file:","no,yes"
dEdit File$,"Select file (Current shown):",12
Dialog
  If g% = 1
    GoTo FINISH
  Endif
Open File$,A,Text1$,Text2$,Text3$,Float1,Float2
  Lopen "PAR:A"
  Lprint "Filename is: "; File$
  Rem Blank line followed by Header.
  First
    Lprint Chr$(10)
    Lprint A.Text1$
    Lprint A.Text2$
    Lprint A.Text3$
  Next
  Lprint Chr$(10)
  DO
    Lprint
    A.Text1$,A.Text2$,A.Text3$,A.Float1,A.Float2
  Next
  Until EOF
  Lprint CHR$(12); :Lclose

FINISH::
ENDP
```

RESTRICTED-COMMERCIAL

RESTRICTED-COMMERCIAL

PARTICULAR CONSIDERATIONS re: THE TIP DETECTOR

Application of the modelling procedures to the TIP device involves consideration of the geometry of its ionisation cell, which consists of a flat cylindrical element, the bottom circular face being the UV lamp face, and the top circular disc being the entry point for the gas via a central hole. The gas impinges on the centre of the lamp face from the axial direction, and is then turned to flow radially across the face to an annular collector electrode surrounding the lamp window and coplanar with it. For modelling purposes the inflow is specified in terms of the gas volumetric flow rate \dot{v} . In a time step $\Delta\tau$ a volume element $\dot{v}\Delta\tau$ enters on the axis of the lamp and occupies a cylindrical volume of a specified height in the x direction. In the next time step, this volume element becomes a thin walled annular cylinder of the same volume, but surrounding the core volume, which is now occupied by the next incoming volume element. The internal radius of the annular cylinder is equal to the radius of the core cylinder, and since the volumes and heights of these elements are the same, the cross-sectional area presented to the UV flux remains constant as the annular cylinder spreads radially to occupy successively displaced and progressively thinner walled annular cylindrical volumes. Each time step of length $\Delta\tau$ results in a further radial displacement of the wall of the annular cylinder. The flux utilisation is calculated as for the general case described in Annex A, but allowance is made for the possibility that the ion concentration may not immediately achieve an equilibrium between production and recombination. Accordingly, the ion concentration at each position in the x direction grid is calculated by recalling the concentration from the previous time step of that element of carrier gas that now occupies the radial position specified. The ion concentration in each time step is thus

$$N_{ii}(n\Delta\tau) = N_{ii}((n-1)\Delta\tau) + \left(\frac{\Delta\phi'_{ii}}{eV_i} \right) \Delta\tau - \alpha_i N_{ii}^2((n-1)\Delta\tau)\Delta\tau \quad (\text{A3.1})$$

where n and $(n-1)$ denote the current and preceding time step respectively, and the volume element is followed through its sequence of radial positions. The contribution of each element in the x direction to the ion current is collected as soon as the element reaches the radius corresponding to the ionisation region circumference. In practice, an equilibrium ion concentration is established well before the element has completed its radial passage. This model, designated TIPC[®], has not been developed into a field-use version as has SNAIL[®] since the TIP is made obsolete by the UVIC[®] detector. The programme TIPC[®] is listed in Annex D.

LISTING OF TIPC®- WRITTEN IN BASIC

RESTRICTED-COMMERCIAL

```
10 INPUT "TIME STEP (s)=",DT
11 INPUT "XSTEP(cm)=",~S
12 INPUT "FIRST TRACER CONC(ppm~="",NTO
13 INPUT "CONC STEP(ppm)=",NST
14 INPUT "No CONC STEPS=",NOS
15 INPUT "RECOMB COEFF(cm^3/sec)=",AL
16 INPUT "NON ION ABS COEFF (MEGA BARNS)=",QNT
17 INPUT "ION ABS COEFF (MEGA BARNS)=",QIT
18 INPUT "TOTAL LAMP W FLUX(Watts)=",F
20 QC=5.2E-19
21 QNT=QNT*IE-- 18
22 QIT=QIT*IE-18
23 PI=22/7
30 EGAP=.2
31 VDOT=500/60
32 E=10.6*1.6E-19
34 RL=.4
35 LA=PI*(RL^2)
36 DA=VDOT*DT/EGAP
38 NO=2.7E+19
40 DIM X(1000)
41 DIM NEQ(1000)
42 DIM LASTN(1000)
43 DIM THISN(1000)
50 FOR CC=1 TO NOS
51 C=0
52 NT=(NTO+CC*NST)*2.7E+13
8 5 CT=0
90 CT=CT+1
91 IF CT=1 THEN THISRA=0:THISDR=SQR(DA/PI):GOTO 96
92 THISRA=LASTRA+LASTDR
93 THISDR=DA/(2*PI*THISRA)
96 I=0
100 I=I+1
105 X(I)=XS*(I-.5)
106 U=-X(I)*QC*(NO-NT)
107 V=-X(I)*QNT*NT
108 W=-X(I)*QIT*NT
110 J=((U+V)/X(I))*(1-EXP(W))
111 K=(W/X(I))*EXP(W)
112 IF J-K<0 THEN 140
115 H=(EXP(U+V))*(J-K)
116 NEQ(I)=SQR(F*H/(LA*E*AL))
120 IF CT=1 THEN LASTN(I)=0
122 THISN(I)=LASTN(I)+(DT*F*H/(E*LA))-(DT*AL*LASTN(I)^2)
125 IF THISN(I)/NEQ(I)>.99 THEN 130
126 GOTO 130
128 PRINT THISN(I);NEQ(I);X(I);THISRA
130 IF THISRA>RL THEN C=C+XS*VDOT*THISN(I)*1.6E-10/EGAP
131 LASTN(I)=THISN(I)
132 IF X<EGAP THEN 100
140 IF THISRA>RL THEN 2CC
148 LASTRA=THISRA
149 LASTDR=THISDR
150 GOTO 90
200 PRINT NT~2.7E
210 NEXT CC
220 END
```

RESTRICTED-COMMERCIAL

DEVELOPMENT OF CALIBRATION PROCEDURES AND EQUIPMENT

Experience gained in using the TIP Detector in the field led to the identification of difficulties in calibrating the device. This in turn motivated the devising and development of a fundamentally different approach that constituted the basis for the development of the gas and vapour calibration rigs that have now been committed to hardware and to thorough field testing. The basis of the calibration technique now in use arose from the realisation that there were some fundamental problems involved with both the TIP instrument performance, and the method of calibration using pre-blended gases supplied in cylinders. The following analysis identifies the problem areas. This section was originally an appendix to a progress report (2044/159 CDE May 1989). It is reproduced here with minor changes to the nomenclature to make it consistent with the rest of this report.

Analysis of TIP Response and Calibration Procedures

The TIP displays a voltage signal above its base level that is expected (on the basis of the manufacturer's literature) to be nearly linearly proportional to the concentration of ionisable species present over the useful working range of the instrument. The voltage displayed is assumed to differ only because of changes in the concentration of tracer gas once any baseline drift has been removed by the data analysis scheme. The analysis presented here considers the response of the device to a tracer, t , in a carrier gas medium, m , denoting the combination of tracers and medium as $(t_1, t_2; m)$ for example when there are two tracers in one medium.

It is assumed that the response to each tracer is independent of the presence of the others, so that if the response R of the TIP is defined as the change in output voltage V per unit change of concentration C of the given tracer then

$$\frac{dV}{dC_{(t_1; m)}} = R_{(t_1; m)} \quad (\text{A5.1})$$

and independence implies

RESTRICTED-COMMERCIAL

$$R_{(t1,t2,\dots,tn;m)} = R_{(t1;m)} + R_{(t2;m)} \dots + R_{(tn;m)} \quad (\text{A5.2})$$

It should be noted that the performance of the TIP in the absence of an ionisable tracer defines a reference level of output voltage, but this level may well differ from one medium gas to another; denoting the absence of a tracer by a zero, this means that

$$V_{(0;m1)} \neq V_{(0;m2)} \quad (\text{A5.3})$$

It follows that the response to a given tracer may depend on the medium, especially as non-linearity of response becomes greater, so that

$$R_{(t1;m1)} \neq R_{(t1;m2)} \quad (\text{A5.4})$$

This is evident in the case of air and nitrogen as the medium gases, where the odour of ozone is clearly detectable in the air expelled from the TIP, but not of course in the nitrogen. This being the case it is clear that some of the photon energy emitted by the internal UV lamp is expended in the photodissociation of oxygen, so that a different baseline may exist for pure nitrogen as the medium, and there will be less UV flux available in air than in nitrogen for ionisation of the tracer. It is therefore expected that there will be a lower sensitivity in air than in nitrogen for a given tracer, that is

$$R_{(t;\text{air})} < R_{(t;\text{N}_2)} \quad (\text{A5.5})$$

but it is not yet clear whether this difference is significant.

Fig. A5.1 depicts the voltage readings that one expects to see, based on the above assumptions, with air and N₂ as the media, and with a steady but unknown background of contaminant b (either a single species or a composite of several), using tracer t (e.g. propylene). Ambient air may contain tracer, and has the composite background contaminant, whereas N₂ from calibration gas bottles has tracer but should have no equivalent contaminant background (though experience from quality tests shows that this is not always so). Thus, the voltages seen are attributable to components as follows:

RESTRICTED-COMMERCIAL

1. $V_{(O,O;air)}$ - the reference baseline due to ambient air, excluding the ionisable components constituting the background. This may be obtained using a pure air calibration gas, but this reading is not accessible when the TIP is running in ambient air, since the reading seen then is $V_{(O,b;air)}$.
2. $V_{(O;b;air)}$ - the reference baseline due to the ambient air including its unknown composite background of ionisable contaminants.
3. $V_{(t;b;air)}$ - the signal seen when the tracer is present in ambient air.
4. $V_{(O;N2)}$ - the reference baseline due to nitrogen only, from a calibration gas bottle.
5. $V_{(t;N2)}$ - the signal seen when the tracer is present in a nitrogen medium, from a calibration gas bottle.

The slopes of lines 3) and 5) evidently correspond to the responses $R_{(t;b;air)}$ and $R_{(t;N2)}$ respectively. As depicted in the figure the background component is steady, so that these responses are for tracer only. In practice, baseline drift is attributable both to instrumental drift (due for example to temperature changes or lamp output changes) and to real variation in the background contaminant concentration. The scheme for baseline drift removal should yield a data record corresponding to $V_{(t;b;air)}$ with b made effectively constant and thus with variations due only to tracer, provided that the background varies only slowly compared to the tracer and the instrument itself does not change its response. The relationships between the various signals can be expressed as follows:

The signal seen when one calibrates with tracer in nitrogen is

$$V_{(t;N2)} = V_{(O;N2)} + R_{(t;N2)} C_{(t;N2)} \quad (A5.6)$$

thus, if one calibrates using the measured voltages $V2$, $V1$ obtained with calibration gases of known concentration $C2$ and $C1$ of tracer in nitrogen then one obtains $R_{(t;N2)}$ as

RESTRICTED-COMMERCIAL

$$R_{(t;N2)} = (V2 - V1)/(C2 - C1) \quad (A5.7)$$

The signal seen in a field experiment with tracer in ambient air is, for a steady background b ,

$$V_{(t,b;air)} = V_{(0;air)} + R_{(b;air)}C_{(b;air)} + R_{(t;air)}C_{(t;air)} \quad (A5.8)$$

If, as assumed, the first and second terms on the RHS are effectively steady, then the change in output voltage seen is attributable to change in tracer concentration,

$$\Delta V_{(t,b;air)} = R_{(t;air)}\Delta C_{(t;air)} \quad (A5.9)$$

and if we assume that $R_{(t;air)} = R_{(t;N2)}$ it follows that we can interpret the signal as

$$\Delta V_{(t,b;air)} = R_{(t;N2)}\Delta C_{(t;air)} \quad (A5.10)$$

However, the assumption that the responses in air and in nitrogen are the same is perhaps unsatisfactory, as discussed earlier, unless it is shown that the difference is small. Even so, it would be preferable to calibrate directly, using tracer in ambient air.

Suppose that ambient air and calibration gas (in its medium) is fed at volume flow rates $\dot{v}_{(b;air)}$ and $\dot{v}_{(t;N2)}$ respectively into a mixing plenum, and then this mixture is used to feed the TIP. The concentration of the tracer in N2 is known to be $C_{(t;N2)}$, and thus the concentration of tracer in the overall mixture is

$$\begin{aligned} C_{(t;air+N2)} &= \frac{C_{(t;N2)} \dot{v}_{(t;N2)}}{\dot{v}_{(t;N2)} + \dot{v}_{(b;air)}} \\ &= \frac{C_{(t;N2)}}{(1 + F)} \end{aligned} \quad (A5.11)$$

where

$$F = \frac{\dot{V}_{(b;air)}}{\dot{V}_{(t;N2)}}$$

Similarly, the concentration of the unknown background in the mixture is

$$\begin{aligned} C_{(b;air+N2)} &= \frac{C_{(b;air)} \dot{V}_{(b;air)}}{\dot{V}_{(b;air)} + \dot{V}_{(t;N2)}} \\ &= \frac{C_{(b;air)}}{\left(1 + \frac{1}{F}\right)} \end{aligned} \tag{A5.12}$$

The TIP signal derived from this mixture is

$$\begin{aligned} V_{(t;b;air+N2)} &= V_{(O;air+N2)} + R_{(b;air+N2)} C_{(b;air+N2)} \\ &+ R_{(t;air+N2)} C_{(t;air+N2)} \end{aligned} \tag{A5.13}$$

If ambient air only is now fed to the TIP the expected output is

$$V_{(b;air)} = V_{(O;air)} + R_{(b;air)} C_{(b;air)} \tag{A5.14}$$

Now, one of the reasons for questioning the assumptions that $R_{(t;air)} = R_{(t;N2)}$ and that $V_{(O;air)} = V_{(O;N2)}$ was the expected dissimilarity in behaviour between air and nitrogen on exposure to the UV source, so that in order to make any practical use of eqs. A5.13 and A5.14 it is necessary to make the approximation that (air + N2) as a medium acts effectively the same as air, so that the response terms are not altered by the presence of the calibration gas carrier medium; additionally, it would be convenient if the calibration gas carrier medium were supplied at a relatively low volume flow rate compared to that of the ambient air so that the concentration of the background in the overall mixture was not significantly different from its concentration in the ambient air. If $\dot{V}_{(t;N2)} \ll \dot{V}_{(b;air)}$ (ie F is large) then both these requirements should be met. Inspecting eq. A5.12 it is readily seen that if $F = 100$ then the concentration of the background in the mixture will be about 99% of the value in air.

RESTRICTED-COMMERCIAL

Further, the alteration in the oxygen content of the mixture would be 0.2% reduction from the normal 20% in air, so that the change in the response due to this change in composition should also be small. It is therefore argued that for a large value of F it can be assumed that the first two terms on the RHS of eq. A5.13 are equivalent to the RHS of eq. A5.14. Since it is also argued that under these conditions the equivalence of the response terms also holds, then subtraction of A5.14 from A5.13 yields, effectively

$$\Delta V_{(t,b;air)} = R_{(t;air)} \Delta C_{(t;air)} \quad (A5.15)$$

where

$$\Delta C_{(t;air)} = \frac{C_{(t;air)}}{(1 + F)} \quad (A5.16)$$

which provides the basis for a calibration procedure based on measurements using tracer in ambient air.

If two different concentrations of calibration gas are available then one could repeat the procedure with the mixture of calibration gas and ambient air to calibrate between two finite tracer concentrations in air rather than one finite and one zero. This would yield a further estimate of $R_{(t;air)}$, but is somewhat redundant in that even if the background included a contribution from tracer gas other than that from the calibration source, that contribution has been allowed for in the subtraction of eq. A5.14 from eq. A5.13.

Use of the above procedure requires knowledge of the volume mixing ratio F . Although the ratio can be reproduced readily enough using ordinary rotameters for regulating flow rates, such devices are not accurate enough to determine the value of F , and it would be desirable to find a way of eliminating the need for an accurate measurement of F . Unfortunately, this does not seem to be possible unless it proves to be that $R_{(t;air)} = R_{(t;N_2)}$. If this is the case then eqs. A5.7, A5.15 and A5.16 simply combine to give

$$1 + F = \frac{(V_2 - V_1)}{\Delta V_{(t,b;air)}} \quad (A5.17)$$

RESTRICTED-COMMERCIAL

where V_2 and V_1 are the voltage outputs from the direct calibration involving no dilution with ambient air, and the denominator is as defined above, using either one or two calibration gas concentrations. Clearly this argument requires that the question of whether $R_{(t,air)}$ does or does not approximately equal $R_{(t,N_2)}$ should be resolved, which is readily done by using calibration gases with equal concentrations of tracer in N_2 and in an artificial air composition. If they differ significantly, then F must be measured in order to calibrate in ambient air.

Postscript

Subsequent information confirmed the view that air and nitrogen would differ in their performance as carrier gases, principally because of their differing photo-absorption cross sections. In view of this fact it was considered desirable for reasons of operability, economy and technical validity to abandon the use of pre-blended gases supplied in cylinders for calibration purposes, and to adopt a direct metering system in which local background air and the tracer gas to be used were blended at the point of use thus overcoming the problems described above. The design of the calibration rigs described in § 5 was driven principally by these considerations.

RESTRICTED-COMMERCIAL

RESTRICTED-COMMERCIAL

Preface

Once concentration time series records have been obtained using the UVIC® detector they must be subjected to data analysis procedures so that results can be interpreted. It is necessary to have available an interpolation procedure so that the many data points in the signal record that do not coincide with the much smaller number of values selected for calibrating the instrument can be assigned an appropriate concentration. A procedure for achieving this has been developed by Dr David Ride, to whom the main author is obliged for devising the method, and for agreeing to its inclusion here under his authorship. It should be noted that this appendix has been written independently, and accordingly uses a self-contained nomenclature different from that of the main report. The procedure presented here makes use of an asymptotic limit, and though this behaviour is not displayed by the instrument, this is nonetheless an appropriate mathematical representation of the response up to the maximum signal level.

THE CALIBRATION CURVE OF THE UVIC® DETECTOR

by David Ride

1. The response curve of the UVIC® detector is not expected to be linear and is only approximately so over a limited concentration range; that is, the output current is not proportional to the concentration with which the instrument is challenged. The model described in Annex A relates the levels of signal and challenge concentration. Even so, the instrument must still be calibrated, making measurements of output signal resulting from the input of known concentrations. A calibration rig has been devised to perform this task simply and accurately; versions of this rig for use with gas and vapour have been built, as described in § 5.

2. Calibrations made to date confirm that the response curve is smooth and continuous showing a near linear portion up to concentrations of a few 10's of ppm (v/v), then progressively departs from linearity to reach a maximum, followed by a progressive decline

RESTRICTED-COMMERCIAL

with increasing concentration beyond that point. An offset current can be arranged with the UVIC® detector so that the output is some small positive value when the instrument is not challenged. Offset currents should be subtracted from the output before calibrating the values. In this way, a single calibration curve will serve for one instrument (for a given challenge chemical).

3. A system of calibration needs to include a chosen functional form for the calibration curve and a procedure for determining the constants in that function from measured spot values. It follows that, since the curve passes through the origin, as many calibration points are needed as there are independent constants needing determination. It is usual and desirable that even more spot values are measured so that the curve can be arranged to represent as accurately as possible the transformation from current to concentration over every part of the calibration range. In general, even if the calibration measurements are performed with absolute accuracy, the curve will not pass through all the points: there will be small discrepancies. Random errors of measurement add to these discrepancies. The functional form of the calibration curve must be chosen to minimise these discrepancies and procedures devised to spread them evenly along its length.

4. It is easy to fit a curve accurately through a few points. This gives the erroneous impression that the curve is a faithful one in that it truly represents the transfer function. By increasing the complexity of the curve's functional form, even more points can be fitted. Such an exercise degenerates into accommodating the errors instead of fitting them. For a curve appropriate to the UVIC® detector, no more than three independent constants should be used; more than this would mean that errors were certainly being fitted.

5. In a perfect situation, an instrument would never be used beyond the range over which it has been calibrated. In practice, some estimate of the concentration is often required beyond this limit. Whilst such estimates should be treated with caution, the calibration curve when extrapolated should not yield totally unrealistic estimates. For instance, it would be unacceptable to discard an otherwise excellent time series of measurements because one or two values went beyond the range of calibration. Good calibration methods must recognise this pragmatic departure from perfection.

RESTRICTED-COMMERCIAL

6. The function most commonly used to fit data is the straight line. Linear regression is often justified, but when curvature is known to exist, resort is often made to polynomial fits, or a transformation performed on the original data to force a strong measure of linearity. Polynomial regression is well documented and it can readily be implemented using standard computer packages. A technical problem can occur when using such software. The method of fitting invariably uses a minimum sum of squares criterion which tends to fit points with large values at the expense of lower valued ones. A better criterion is often to minimise the sum of the squares of the ratios of the departures to their computed values. This process equalises the proportional error over the length of the curve.

7. Care must be exercised when fitting polynomials. It is tempting to choose a high order polynomial to fit the points, but this is incorrect procedure, as described above. A cubic regression equation has been fitted to the UVIC® detector calibration data, but this still causes problems. First, the curve can make excursions into the negative axis region near the origin, thus indicating negative concentrations. Secondly, it can introduce inflexions into the curve. Thirdly, its behaviour beyond the last calibrated point (ie, the highest value) is unpredictable, leading to nonsensical estimates for any off-calibration values.

8. A technique is described below which overcomes these difficulties and has provided better fits than a cubic regression to some real calibrated sets. It employs five constants, but they are not independent and so can be derived from a minimum set of three calibration points - the same number as required for the cubic regression.

9. It is assumed that the curve passes through the origin and becomes asymptotic to a saturation current B. The simplest curve relating the concentration χ to the output current I is

$$\chi = A \cdot \frac{I}{(B-I)} \quad (1)$$

where A is a constant with the same dimensions as χ . If the substitution

RESTRICTED-COMMERCIAL

$$Z = \frac{I}{(B-I)} \quad (2)$$

is made, equation (1) becomes a linear regression on Z which is constrained to pass through the origin. Usually, the value of B will not be known; from a mathematical point of view it is simply another disposable constant whose value can be determined from the data in the process of obtaining a good fit. There may be occasions when the user wishes to specify a value of B , either from prior knowledge or for exploratory reasons.

10. The constants A and B can be determined from the n pairs of calibration values in the normal way by minimising the sum of squares:

$$S = \sum_{i=1}^{i=n} \left(\chi_i - A \cdot \frac{I_i}{B - I_i} \right)^2 \quad (3)$$

Differentiating S with respect to A and setting the result equal to zero, gives a formula for A :

$$A = \frac{\sum_{i=1}^{i=n} (\chi_i \cdot Z_i)}{\sum_{i=1}^{i=n} Z_i^2} \quad (4)$$

The value of B cannot be found explicitly. A guess is first made and then refined by iteration using a least sum of squares criterion.

11. The above procedure still biases the goodness of fit towards the higher values, and it is preferable to use a sum of squares of proportional values as criterion. Adopting this procedure leads to:

$$A = \frac{\sum_{i=1}^{i=n} (Z_i / \chi_i)}{\sum_{i=1}^{i=n} (Z_i / \chi_i)^2} \quad (5)$$

RESTRICTED-COMMERCIAL

12. Whilst equation (1) accounts for the bulk of the correlation, it is too simple a model (involving only the constant A - assuming that B has been specified) to be accurate enough for practice. It would be possible to employ a higher degree polynomial in Z, but a more satisfactory fit to observed data can be obtained using an alternative technique. The refinement consists of fitting a quadratic polynomial regression to values of X, the proportional departure of the actual values of concentration from those predicted by equation (1). The use of a quadratic is justified because it is expected (and found, so far) that the 'actual' calibration curve will cut equation (1) in no more than two places, leading to a U-shaped distribution of residual errors. The kurtosis of this latter curve can be matched more accurately to a quadratic polynomial by making a simple transformation of the I axis. Non-dimensionality is first obtained by dividing by the already established constant B, and non-dimensional constants α , β , γ and R are sought by systematic methods (analytical minimisation coupled with iteration) yielding the regression formula:

$$X = \alpha + \beta.(I/B)^R + \gamma.(I/B)^{2R} \quad (6)$$

where, for calculated spot values:

$$X_i = [\chi_i(\text{actual}) - \chi_i(\text{predicted})] / [\chi_i(\text{predicted})] \quad (7)$$

13. Gathering together the results of the various transformations and the modelling procedures yields the final calibration formula:

$$\chi = \frac{A.(I/B).[1 - \alpha - \beta.(I/B)^R - \gamma.(I/B)^{2R}]}{[1 - (I/B)]} \quad (8)$$

which brings out the fact that A is a scaling of χ and B is a scaling of I.

14. The only potential drawback to this method is that such statistical properties as the standard error attaching to the various constants cannot be derived analytically. This lack of determination is not important in the current context.

RESTRICTED-COMMERCIAL

15. An interactive computer program has been written in FORTRAN which will calculate α , β , γ and R for from three to 100 input spot calibrations. The value of B can either be specified or given a value chosen by the user.

PULSED UVIC® DETECTOR DATA

ANALYSIS PROGRAM

RESTRICTED-COMMERCIAL

```
REM*****PLUVIC DATA ANALYSIS*****
REM This a program to examine/process ASCII files produced by the IDB
REM Software Package for the PLUVIC.
DIM UVICOP(8193)
DIM PLUVICOP(8193)
DIM ELECTRODE(8, 1025)
DIM TIMEREF(1025)
DIM UVICY(1025)
DIM ELEC(1025)
DIM XTIME(1025)
CLS : PRINT : PRINT
PRINT "          PLUVIC DATA PROCESSING."
PRINT "          *****~
PRINT : PRINT
INPUT "Filename to examine/process:", File$
PRINT : PRINT
500 PRINT " The acquisition system for the PLUVIC/UVIC signals records data in"
PRINT " Blocks (termed 'FOLDERS') containing 4096 elements. The Channels,"
PRINT " two in this case, are interleaved. This program is limited to a"
PRINT " maximum capacity of 4 FOLDERS at any given time. This is because
PRINT " of restrictions on array size. The progmm contains an option"
PRINT " for examing additional FOLDERS as required. Starting FOLDER"
PRINT" Numbers should be 1,5,9 etc."
PRINT : PRINT
INPUT " 'FOLDER' Number at which to commence analysis: "; FOLDNUMB
PRINT : PRINT
REM Calculate Index in file corresponding to start of requested FOLDER Number.
INDEX = INT(FOLDNUMB / 2) * 4096
PRINT " File INDEX to be sought is: "; INDEX; " at start of FOLDER: "; FC
LDNUMB
PRINT : PRINT
PRINT " Now processing File: "; File$
OPEN File$ FOR INPUT AS #1

    IF INDEX = 0 THEN 90 ELSE 91
91 REM
    FOR J = 1 TO 2
        FOR I = 0 TO INDEX - 1
            IF EOF(1) THEN GOTO 100
            INPUT #1, NUMB
            INPUT #1, PARAM
        NEXT I
    NEXT J
90 REM Now Input file contents to Arrays.Initialise Array Counters etc.
    K = 0
    FOR J = 1 TO 2
        FOR I = 1 TO 4096
            IF EOF(1) THEN 100
            INPUT #1, NUMB
            INPUT #1, PLUVICOP(I + K)
        NEXT I
        FOR I = 1 TO 4096
            IF EOF(1) THEN 100
            INPUT #1, NUMB
            INPUT #1, UVICOP(I + K)
        NEXT I
        K = K + 4096
    NEXT J
    EFOLDER = I + 4095
    GOTO 101
100 PRINT " End of File encountered.": BEEP: SLEEP 10
101 CLOSE #1
    BEEP: BEEP
PRINT : PRINT
```

RESTRICTED-COMMERCIAL

RESTRICTED-COMMERCIAL

```
PRINT "      Data input Completed; Press any key to continue."
      WHILE INKEY$ = "": WEND
PRINT : PRINT
INPUT      View last 10 values in arrays for baseline examination (y/n)";
VW$
      IF VW$ = "y" THEN 370 ELSE 371
370 PRINT : PRINT

PRINT "          Last 10 values in arrays for baseline examination."
PRINT
      FOR I = EFOLDER - 10 TO EFOLDER
          PRINT USING "####.####"; TAB(10); I; PLUVICOP(I); UVICOP(I)
      NEXT I
      WHILE INKEY$ = "": WEND
371 PRINT : PRINT
INPUT "      Use these end of file values as defaults (y/n):", UVD$
      IF UVD$ = "n" THEN 150 ELSE 140
140 PRINT : PRINT "          Processing Data."
      BASE1 = PLUVICOP(EFOLDER - 1)
      BASE2 = UVICOP(EFOLDER - 1)
      GOTO 160
150 REM Default values not selected.
CLS
REM Now input baseline levels ready for subtraction.
PRINT : PRINT
PRINT "      INPUT MANUAL BASELINE CORRECTIONS."
PRINT "      *****"
PRINT : PRINT
INPUT "      Ch1 baseline value to be subtracted:"; BASE1
PRINT
INPUT "      Ch2 baseline value to be subtracted:"; BASE2
160 REM Now subtract baseline values.
      FOR I = 1 TO EFOLDER
          PLUVICOP(I) = PLUVICOP(I) - BASE1
          UVICOP(I) = UVICOP(I) - BASE2
      NEXT I
REM Apply block average to UVIC data ie average the 8 125us samples.
SHIFT = 0
PRINT : PRINT
      INPUT "          Apply block average to the 8x125usec UVIC data blocks (y/n
) :"; BLOCKAV$
          IF BLOCKAV$ = "n" THEN 410 ELSE 400
400 REM Block averaging the 8 element UVIC data blocks.
      REM Initialise various parameters.
      SHIFT = -7
          FOR J = 1 TO 8192 STEP 8
              SUM = 0
              FOR I = J TO J + 7
                  SUM = SUM + UVICOP(I)
              NEXT I
              SUM = SUM / 8!
              UVICOP(J) = SUM
          NEXT J
PRINT : PRINT
      INPUT "          Apply 'second layer' average of UVIC data into 8msec blocks (y/n): " SL8$
          IF SL8$ = "y" then 450 ELSE 460
450 REM
          FOR J = 1 TO 8192 STEP 64
              SUM = 0
              FOR I = J TO J + 56 STEP 8
                  SUM = SUM + UVICOP(I)
              NEXT I
              SUM = SUM / 8!
              FOR I = J TO J + 56 STEP 8
```

RESTRICTED-COMMERCIAL

RESTRICTED-COMMERCIAL

```
                UVICOP(I) = SUM
            NEXT I
        NEXT J
460 REM
PRINT : PRINT
PRINT "      Block Averaging UVIC Data done; now setting up PLUVIC Arrays."
410 REM Block averaging option not used.
REM Now set up 8 sub-arrays for the 8 PLUVIC Electrodes.
    J = 1
    FOR I = 1 TO EFOLDER STEP 8
        ELECTRODE(1, J) = PLUVICOP(I)
        ELECTRODE(2, J) = PLUVICOP(I + 1)
        ELECTRODE(3, J) = PLUVICOP(I + 2)
        ELECTRODE(4, J) = PLUVICOP(I + 3)
        ELECTRODE(5, J) = PLUVICOP(I + 4)
        ELECTRODE(6, J) = PLUVICOP(I + 5)
        ELECTRODE(7, J) = PLUVICOP(I + 6)
        ELECTRODE(8, J) = PLUVICOP(I + 7)
        J = J + 1
    NEXT I
REM Set up time reference array: TIMEREF. Refer to first electrode.
    L = 1
    II = 1
    FOR K = 1 TO 128
        FOR J = 1 TO 8
            TIMEREF(L) = II
            L = L + 1
            II = II + 1
        NEXT J
        II = II + 42
    NEXT K
REM Convert from msec to sec.
    FOR I = 1 TO 1024
        TIMEREF(I) = TIMEREF(I) / 1000
    NEXT I
120 REM
PRINT : PRINT : BEEP
INPUT "      Array starting index for sample data inspection: "; ARRAYSTART
CLS
PRINT : PRINT
PRINT " Index      1      2      3      4      5      6      7      8      UVIC
TIME"
        FOR I =      ARRAYSTART TO ARRAYSTART + 20
            PRINT USING "###.###"; I; ELECTRODE(1, I); ELECTRODE(2, I);
ELECTRODE(3, I); ELECTRODE(4, I); ELECTRODE(5, I); ELECTRODE(6, I); ELECTRODE(7, I);
ELECTRODE(8, I); UVICOP((8 * I) + SHIFT); TIMEREF(I)
        NEXT I
INPUT " Print another sequence of data (y/n): "; SDS
    IF SDS = "y" THEN 120 ELSE 130
130 REM Data Inspection Terminated.
CLS : PRINT : PRINT
PRINT "
PRINT "
PRINT "
PRINT : PRINT
INPUT "      Plot out the data (y/n): "; PLTS$
IF PLTS$ = "J" THEN 170 ELSE 180
170 PRINT : PRINT
INPUT "      Enter screen number for thls system (defaults to 12): "; SN
IF SN = 0 THEN 190 ELSE 200
190 SN = 12
200 REM Default not implemented.
360 CLS
PRINT : PRINT
```

DATA PLOTTING"

RESTRICTED-COMMERCIAL

RESTRICTED-COMMERCIAL

```
PRINT "                SETTING-UP PLOT."
PRINT                *****
PRINT : PRINT
INPUT "      Minimum index in data array (default is 1) to plot: "; ARRAYMIN
                IF ARRAYMIN = 0 THEN 350 ELSE 351
350 ARRAYMIN = 1
351 REM Continuing
PRINT : PRINT
INPUT "      Maximum index in data array (absolute max=1024) to plot: "; ARRAYMAX
                IF ARRAYMAX = 0 THEN 355 ELSE 356
355 ARRAYMAX = 1024
356 REM Continuing
REM First plot out UVIC data channel: TIMEREF for x-axis; UVICOP for y-axis.
SCREEN SN
REM Set Graphics parameters appropriate to Machine in use.
    SELECT CASE SN
        CASE 4
            YBOX1 = 70: YBOX2 = 390: YSPAN = 300: YINIT = 380
        CASE 12
            YBOX1 = 70: YBOX2 = 470: YSPAN = 380: YINIT = 460
    END SELECT
XINIT = 10
330 CLS
REM Draw box.
LINE (10, YBOX1)-(630, YBOX2), 2, B
INPUT " Plot UVIC Data (y/n): "; UVICPLT$
IF UVICPLT$ = "y" THEN 230 ELSE 240
230 LOCATE 2, 1
PRINT " Plotting."
REM Scale UVIC Data. Find Y-Max and Y-Min.
YMAX = 0
    FOR I = 1 TO 1024
        IF UVICOP((8 * I) + SHIFT) > YMAX THEN 210 ELSE 220
210 YMAX = UVICOP((8 * I) + SHIFT)
220 REM Continuing
    NEXT I
YMIN = YMAX
    FOR I = 1 TO 1024
        IF UVICOP((8 * I) + SHIFT) < YMIN THEN 211 ELSE 221
211 YMIN = UVICOP((8 * I) + SHIFT)
221 REM Continuing
    NEXT I
REM Now calculate Y-UVIC values.
    FOR I = 1 TO 1024
        UVICY(I) = YINIT - ((UVICOP((8 * I) + SHIFT) - YMIN) * YSPAN) / (YMAX - YMIN)
    NEXT I
240 REM X-coordinate values require calculation using the information in the REM TIMEREF Array.
    FOR I = ARRAYMIN TO ARRAYMAX
        XTIME(I) = INT((TIMEREF(I) - TIMEREF(ARRAYMIN)) * 620 / (TIMEREF(ARRAY MAX)
- TIMEREF(ARRAYMIN)))
    NEXT I
    IF UVICPLT$ = "n" THEN 340
    FOR I = ARRAYMIN TO ARRAYMAX - 1
        LINE (XINIT + XTIME(I), UVICY(I))-(XINIT + XTIME(I + 1), UVICY(I + 1)), 15
    NEXT I
340 REM Now offer option of plotting PLUVIC data.
    COL = 15
    LOCATE 2, 1
    PRINT "
    LOCATE 1, 1
    INPUT " Plot PLUVIC data (y/n): "; PLUVICPLT$
    IF PLUVICPLT$ = "y" THEN 250 ELSE 260
250 LOCATE 2, 1
    PRINT "
```

RESTRICTED-COMMERCIAL



RESTRICTED-COMMERCIAL

```
LOCATE 2, 1
INPUT " Electrode Number to plot (1-8): ", ELECNUMB
REM Now scale plot etc.
YMAX = 0
FOR I = 1 TO 1024
    IF ELECTRODE(ELECNUMB, I) > YMAX THEN 270 ELSE 280 270 YMAX =
ELECTRODE(ELECNUMB, I)
280 REM Continuing
NEXT I
REM Next find YMIN.
YMIN = YMAX
FOR I = 1 TO 1024
    IF ELECTRODE(ELECNUMB, I) < YMIN THEN 290 ELSE 300 290 YMIN =
ELECTRODE(ELECNUMB, I)
300 REM Continuing
NEXT I
FOR I = 1 TO 1024
    ELEC(I) = YINIT - (((ELECTRODE(ELECNUMB, I) - YMIN) * YSPA N) /
(YMAX - YMIN))
NEXT I
FOR I = ARRAYMIN TO ARRAYMAX - 1
    LINE (XINIT + XTIME(I), ELEC(I))-(XINIT + XTIME(I + 1), EL EC(I
+ 1)), COL - 1
NEXT I

LOCATE 3, 1
PRINT "
LOCATE 3, 1
INPUT " Overlay another plot (y/n): "; OVLPLT$
    IF OVLPLT$ = "y" THEN 251 ELSE 260
251 COL = COL - 1: GOTO 250
260 REM
LOCATE 4, 1
INPUT " Clear screen and start again (y/n): "; CLSSA$
    IF CLSSA$ = "y" THEN 310 ELSE 320

310 CLS
PRINT : PRINT
PRINT "
PRINT "
PRINT : PRINT
INPUT " Reset X-axis limits (y/n): "; XLIM$
    IF XLIM$ = "y" THEN 360 ELSE 330

320 WHILE INKEY$ = "": WEND
180 REM Graphics Option not selected.
CLS : PRINT : PRINT
PRINT "
PRINT "
PRINT : PRINT
INPUT " Examine additional folders (y/n): ", EAF$
PRINT : PRINT

    IF EAF$ = "y" THEN 500

END
```

RESTRICTED-COMMERCIAL

SUMMARY OF PATENT APPLICATIONS

The following list of patent applications specifies those made for the UVIC® detector and its derivatives as well as separate but related devices. For each application information is presented in the following format:

Short Title (may differ from that on the application).
 Patent Application Number (the first two digits indicate the year)
 Inventors (and Affiliation)
 IPR Holders
 Brief Explanatory Statement

Primary Patent Application

1. Basic UVIC® detector
 9201313 International Ref: WO 93/02354
 CDJ (MOD)
 MOD
Original concept based on fundamentally revised PID geometry

Derived and Other Patent Applications

2. Calibration Rig (Gas)
 9224304.7
 RFG (UMIST); JETL & AW (IDB)
 MOD
Means for blending tracer and carrier gas, under precise control, at point of use.
3. Differential Absorption Device (Basic)
 9224299.9
 RFG (UMIST)
 MOD
Device for measuring gas concentration for non-ionisable tracers
4. Bent UVIC® Detector
 9226663.4
 CDJ (MOD); RFG (UMIST)
 MOD
Modification to reduce the effect of recombination at high concentrations
5. Differential Absorption Device (Photoelectric)
 9304563
 CDJ (MOD)
 MOD
Photoelectric detection of UV flux

RESTRICTED-COMMERCIAL

6. Calibration Rig (Vapour)
9308614.8
RFG & IDR (UMIST); CDJ (MOD)
MOD
Variant on Gas calibration rig to facilitate use with volatile liquids
7. Material flux UVIC® Detector (Tube)
9304553.2
RFG (UMIST)
MOD
Variant to enable simultaneous concentration and flow speed (in one dimension) measurement
8. Material flux UVIC® Detector (Polar)
9304554.0
RFG (UMIST)
MOD
Variant to enable simultaneous concentration and velocity (in two dimensions) measurement
9. Pulsed UVIC® Detector I
9308615.5
CDJ (MOD); RFG (UMIST)
MOD
Application of UV lamp pulsing to velocity measurements
10. Pulsed UVIC® Detector II
9310785.2
CDJ (MOD); RFG (UMIST)
MOD
Application of UV lamp pulsing to enhance sensitivity and lamp function
11. Air Curtain
Information held by ESL
CDJ (MOD) + HAL (DA)
ESL
Protects UV lamp window from fouling by tracer
12. Hybrid UV lamp drive system
9405829.4
CDJ (MOD); RFG (UMIST)
MOD
Use of hybrid RF and DC driven UV lamp for Intrinsically Safe Applications

RESTRICTED-COMMERCIAL

Key to Abbreviations Used

1. Individuals

CDJ Dr C D Jones (CBDE)
RFG Prof R F Griffiths (UMIST)
IDR Mr I D Roberts (UMIST)
JETL Mr J E T Lawrence (IDB)
AW Mr A Williams (IDB)
HAL Dr H A Lightfoot (DA)

2. Affiliations/Organisations

CBDE Chemical and Biological Defence Establishment
UMIST University of Manchester Institute of Science and Technology
IDB Industrial Development, Bangor
DA Data Acquisition Ltd
ESL Enviro Systems Ltd

Note

A number of the patent applications cited above have recently been consolidated and unified into more logical submissions. This action has been taken, in particular, in the case of those relating to the Differential Absorption Device and the Pulsed UVIC[®] detector variants.

RESTRICTED-COMMERCIAL

RESTRICTED-COMMERCIAL

RESTRICTED-COMMERCIAL

Concentration
ppm

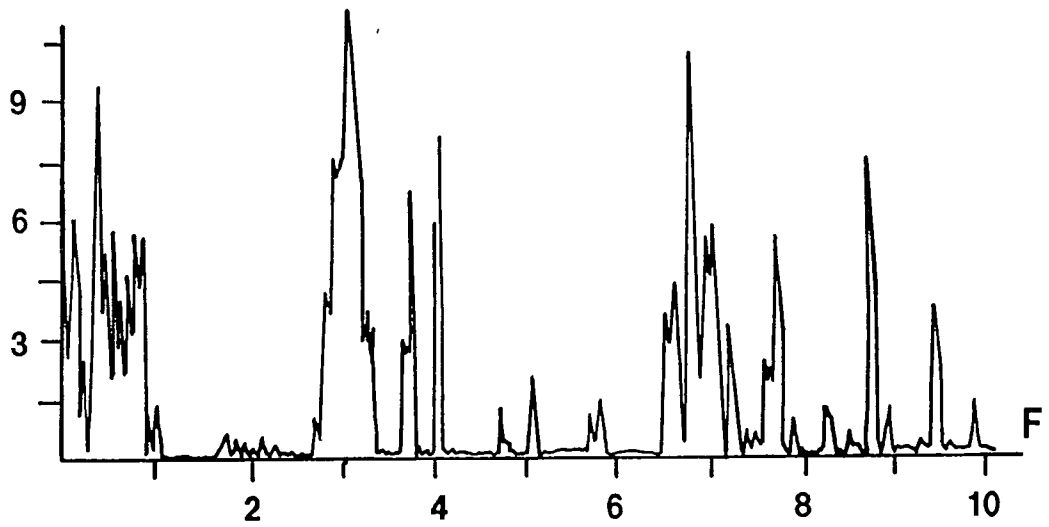

ppm

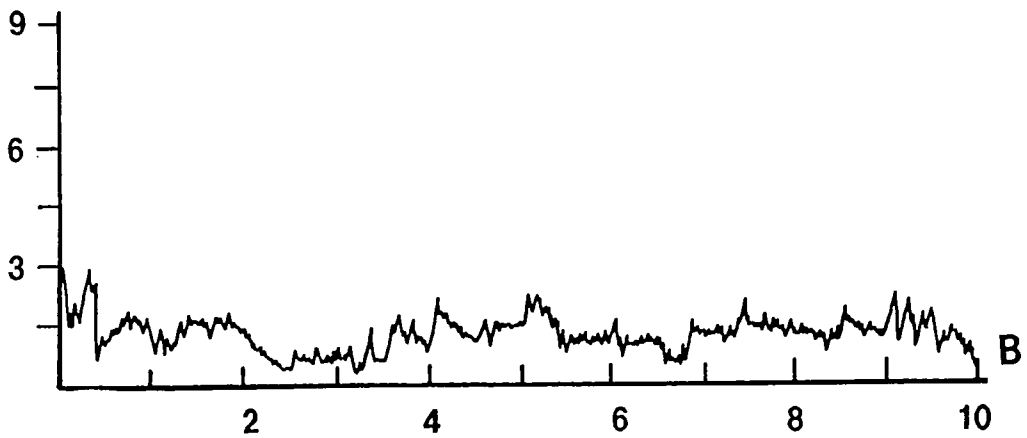

Time (minutes)

FIGURE 1.1

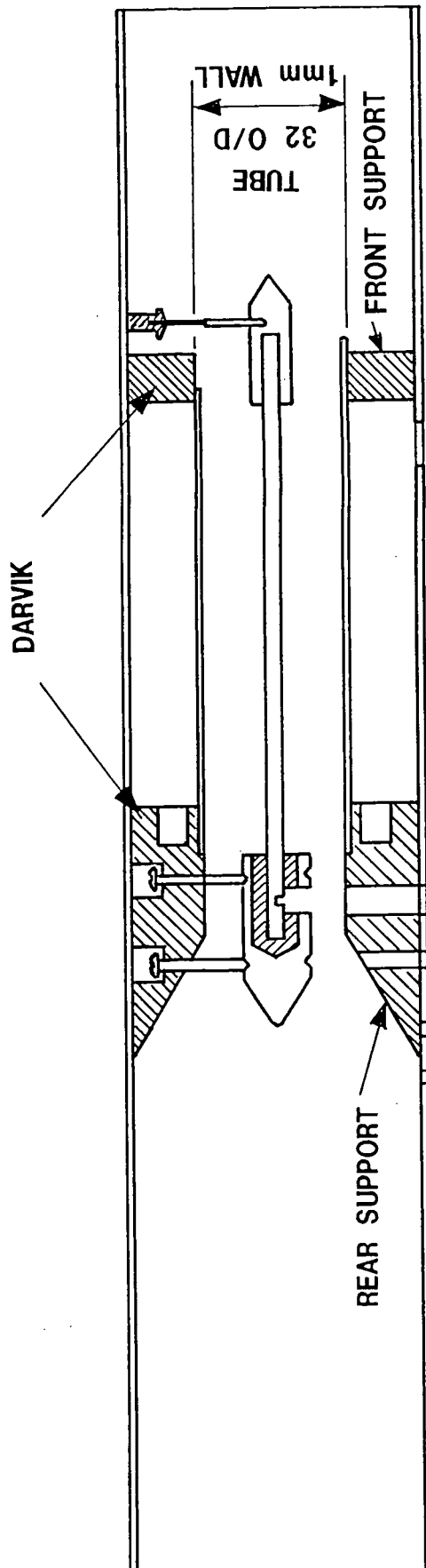

FIGURE 2.1 ION COLLECTOR 60 mm COLLECTOR TUBE

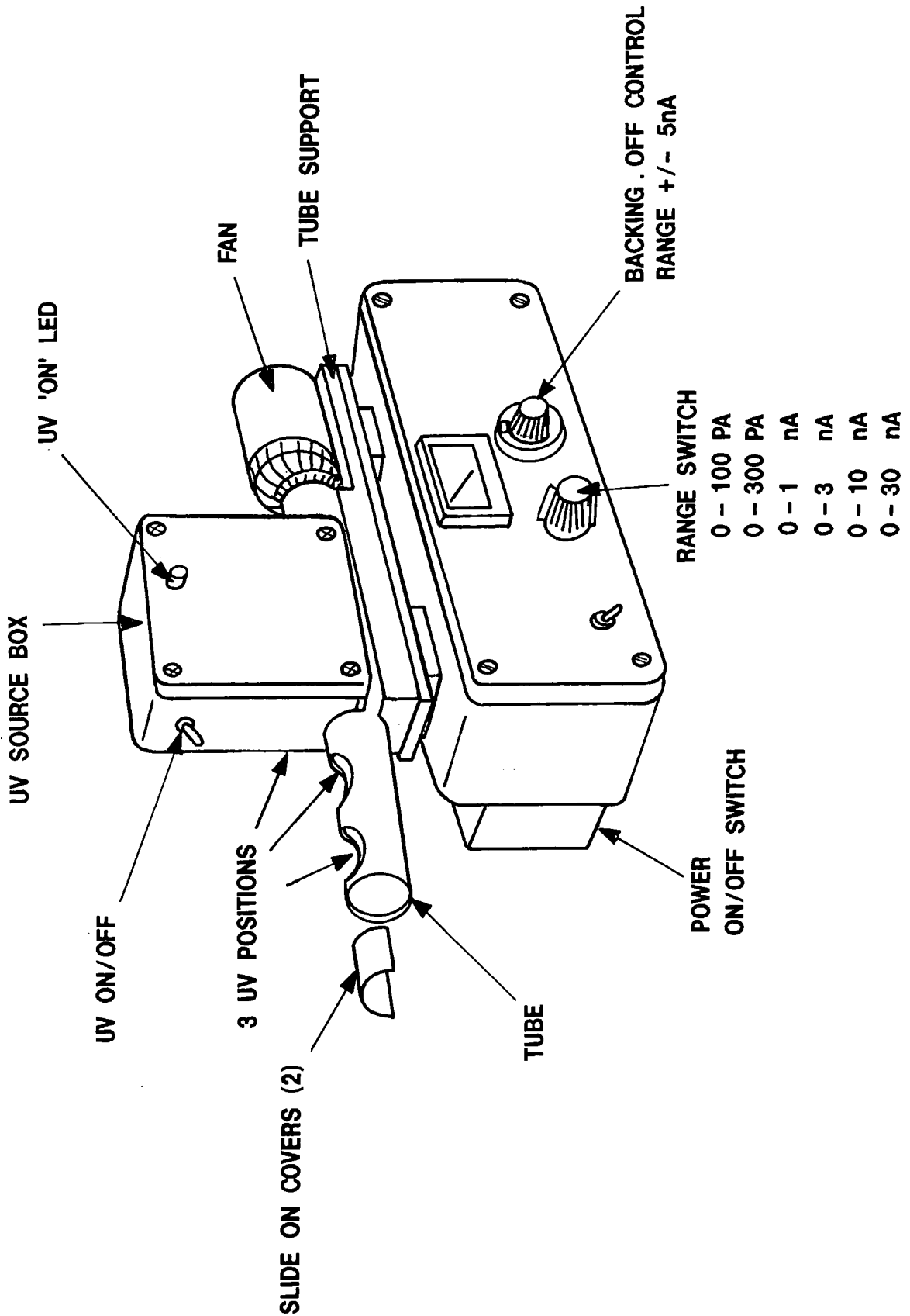

FIGURE 2.2. UV ACTIVATED ION COLLECTOR

Predicted and Observed Performances obtained with 'SNAIL' and UVIC 31.

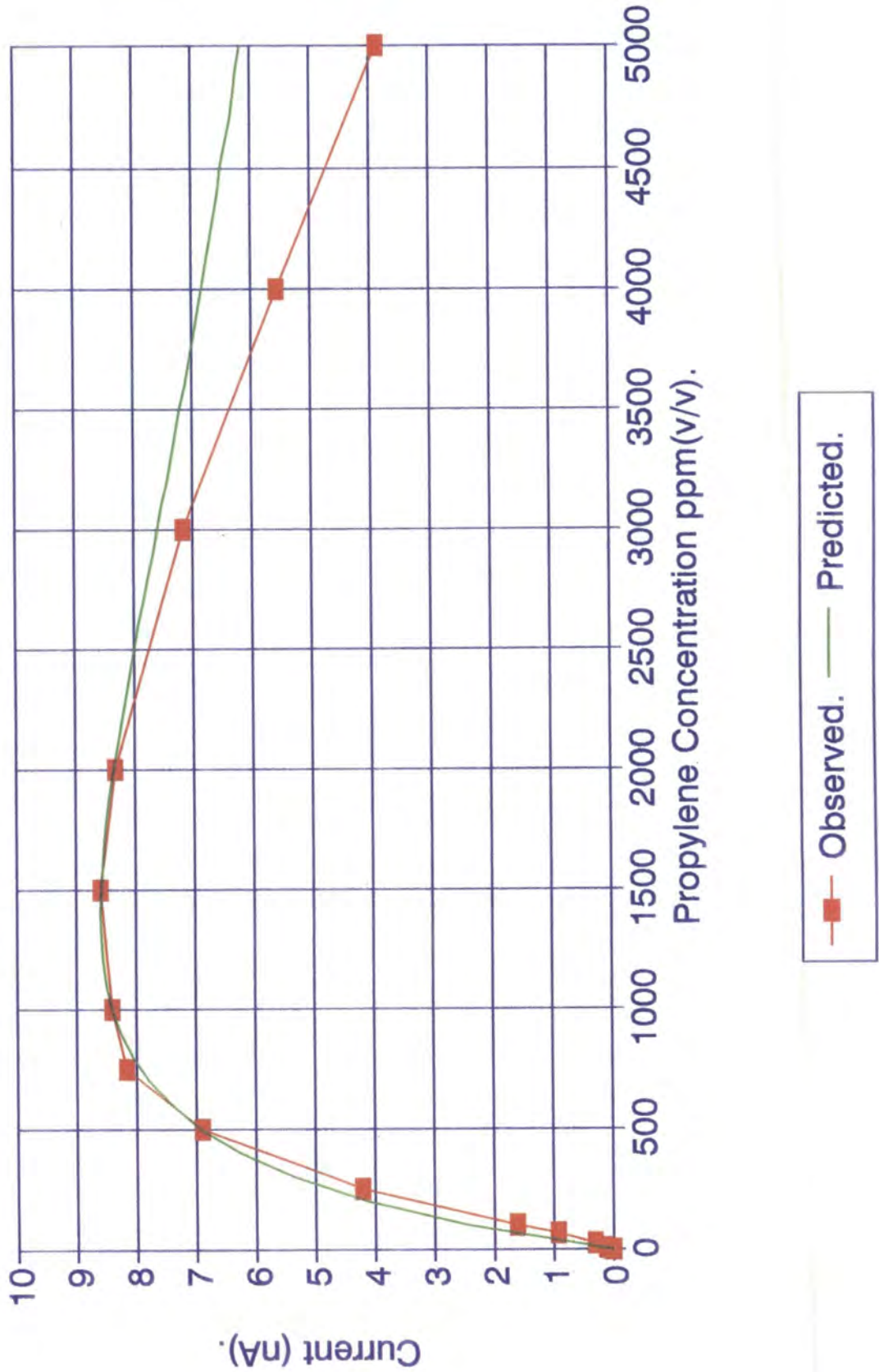

FIGURE 3.1. PREDICTED AND OBSERVED PERFORMANCES OBTAINED WITH 'SNAIL' AND UVIC 31

Predicted and Observed Performance Obtained with 'SNAIL' and UVIC 1.

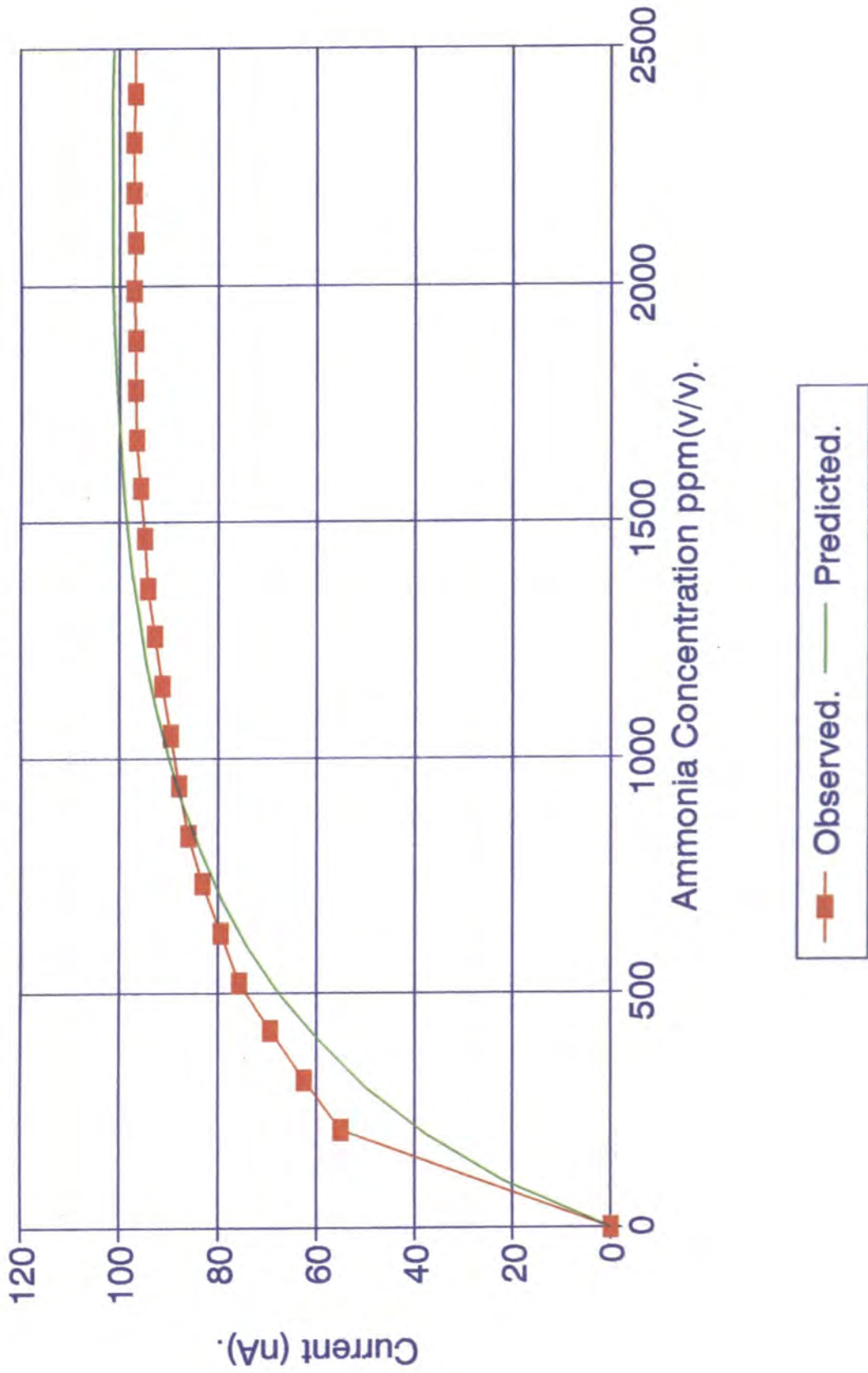

FIGURE 3.2. PREDICTED AND OBSERVED PERFORMANCES OBTAINED WITH 'SNAIL' AND UVIC 31

Predictions Obtained using 'SNAIL'
Current v. Concentration.

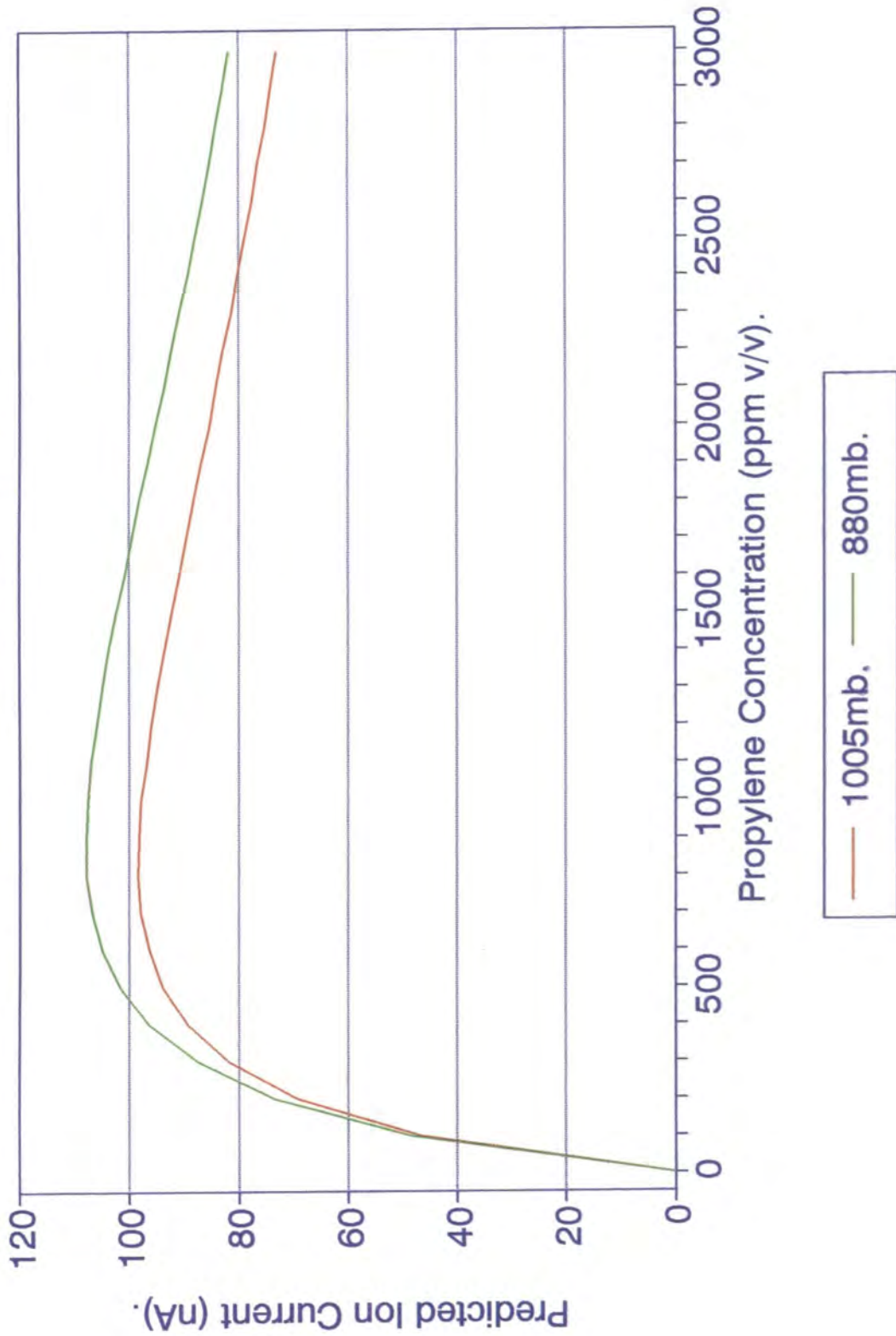

FIGURE 3.3. PREDICTIONS OBTAINED USING 'SNAIL'

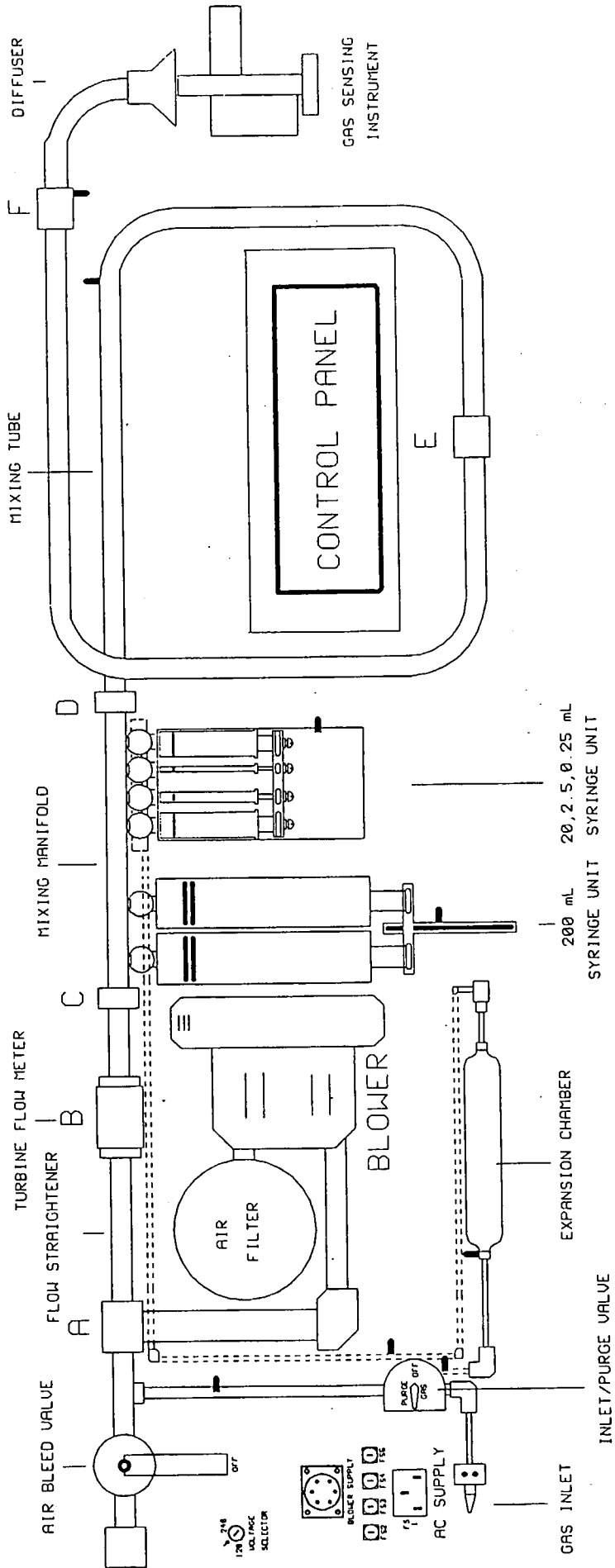
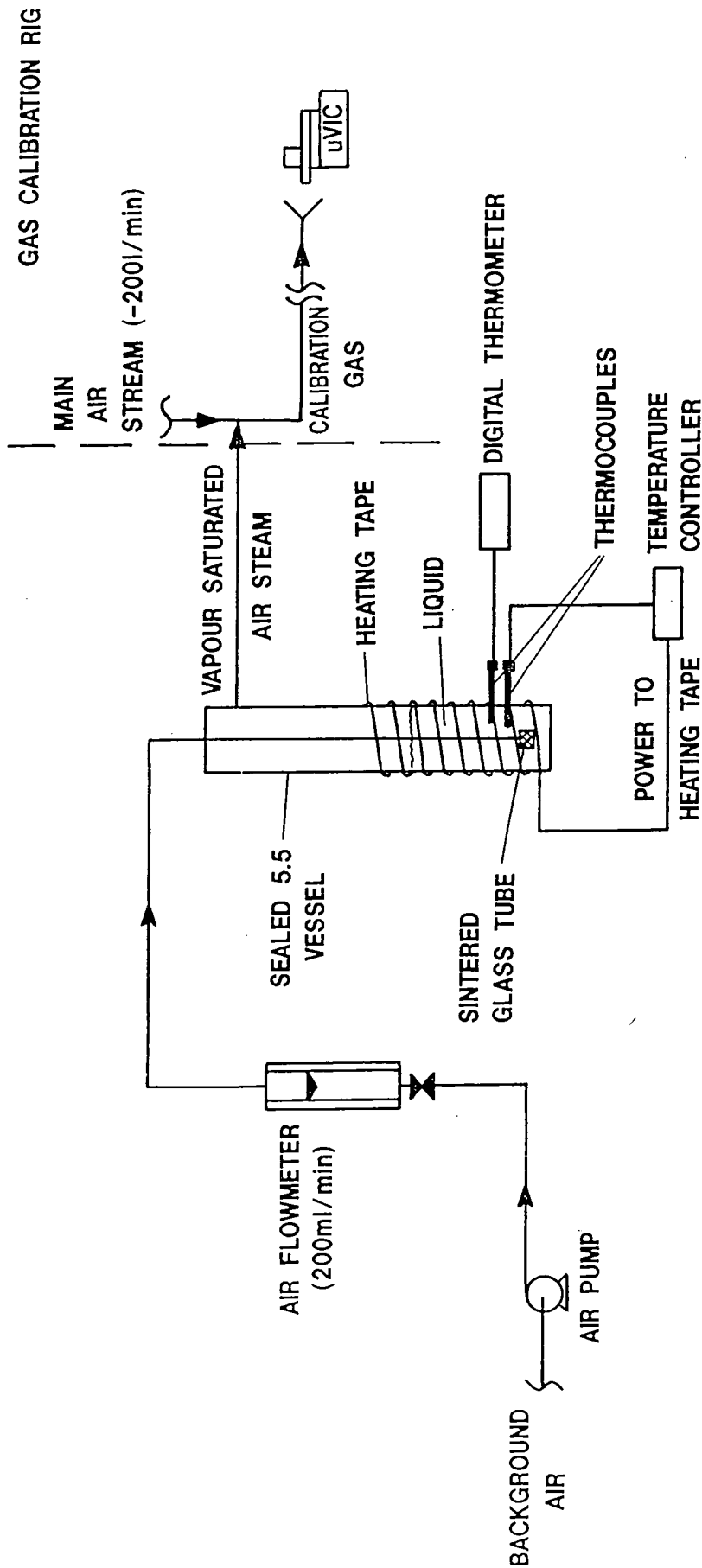

FIGURE 5.1a. GAS CALIBRATION SYSTEM - MECHANICAL LAYOUT



VESSEL DIMENSIONS: HEIGHT 40cm ; DIAMETER 5cm

SCHEMATIC OF uVIC CALIBRATION RIG FOR LIQUIDS

(NOT TO SCALE)

FIGURE 5.2. SCHEMATIC OF uVIC CALIBRATION RIG FOR LIQUIDS (NOT TO SCALE)

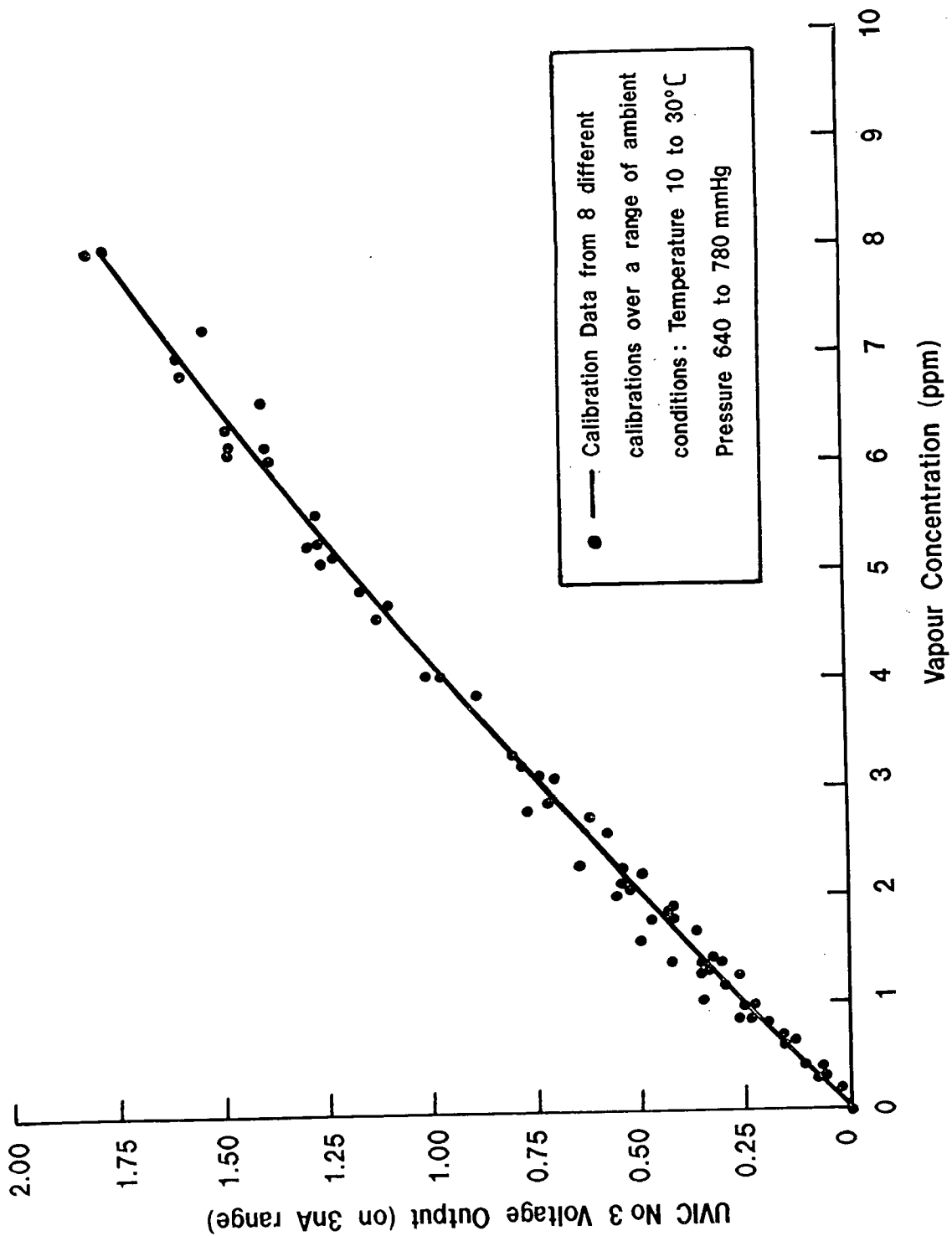
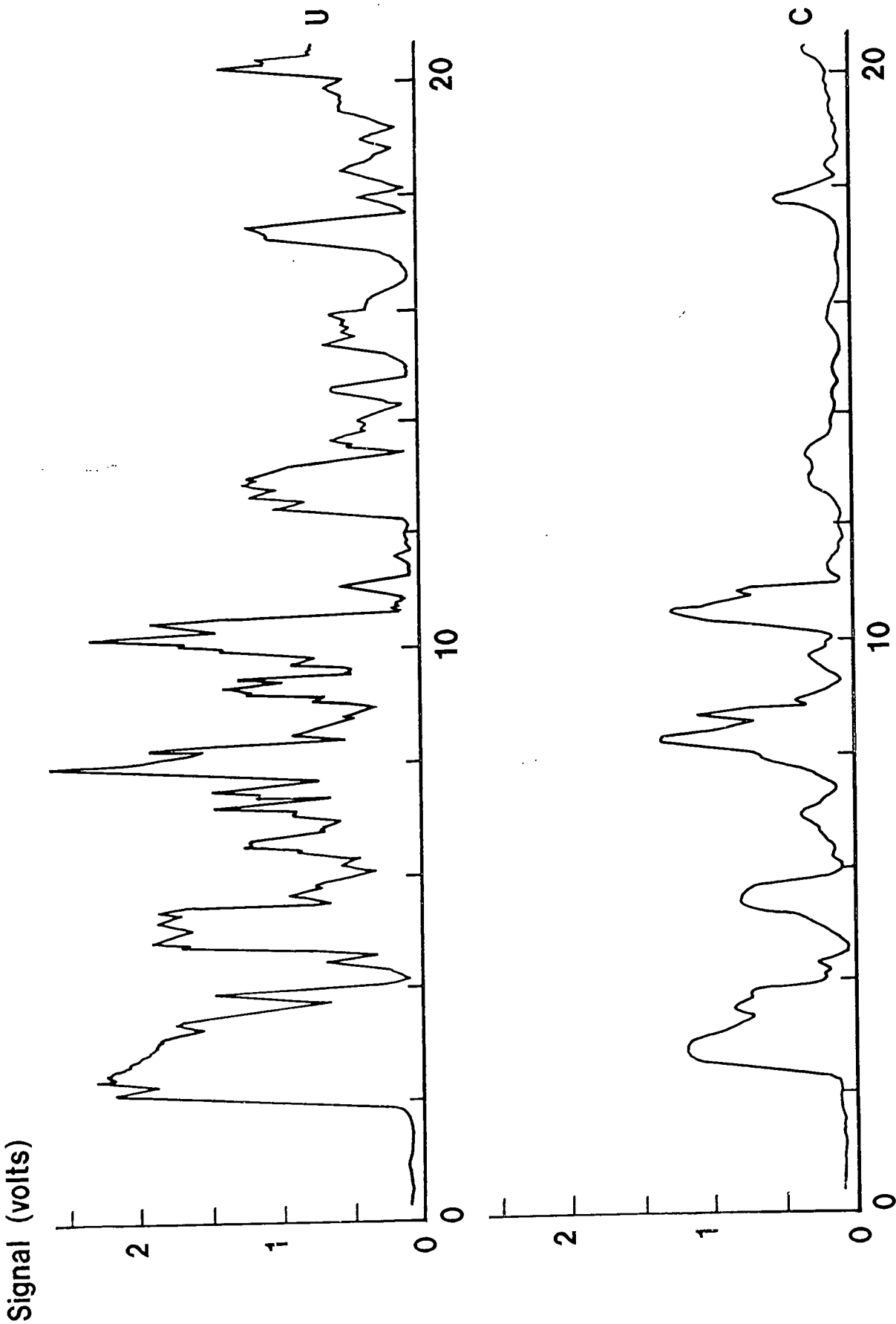

FIGURE 5.3. AN EXAMPLE OF CALIBRATIONS CONDUCTED WITH THE VAPOUR CALIBRATION RIG



Time (sec)

FIGURE 6.1

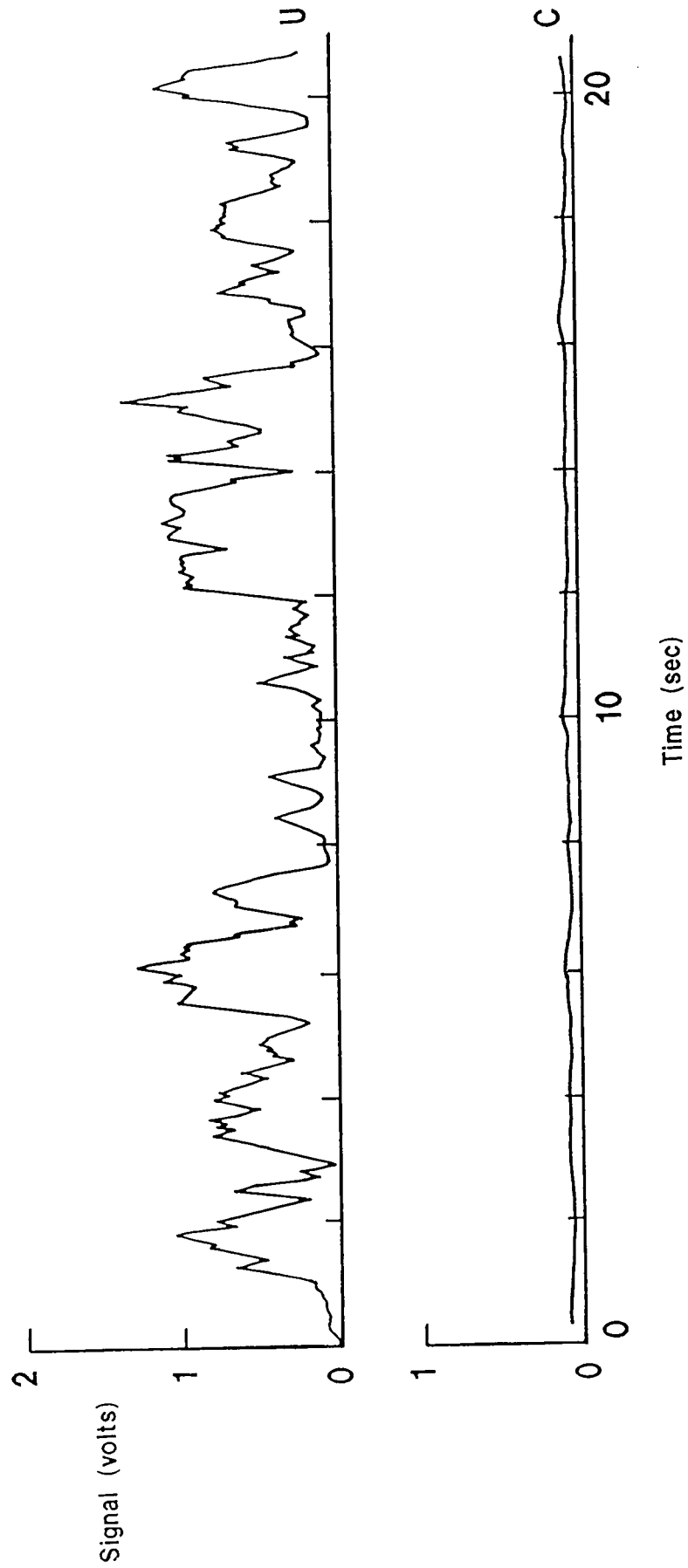

FIGURE 6.2

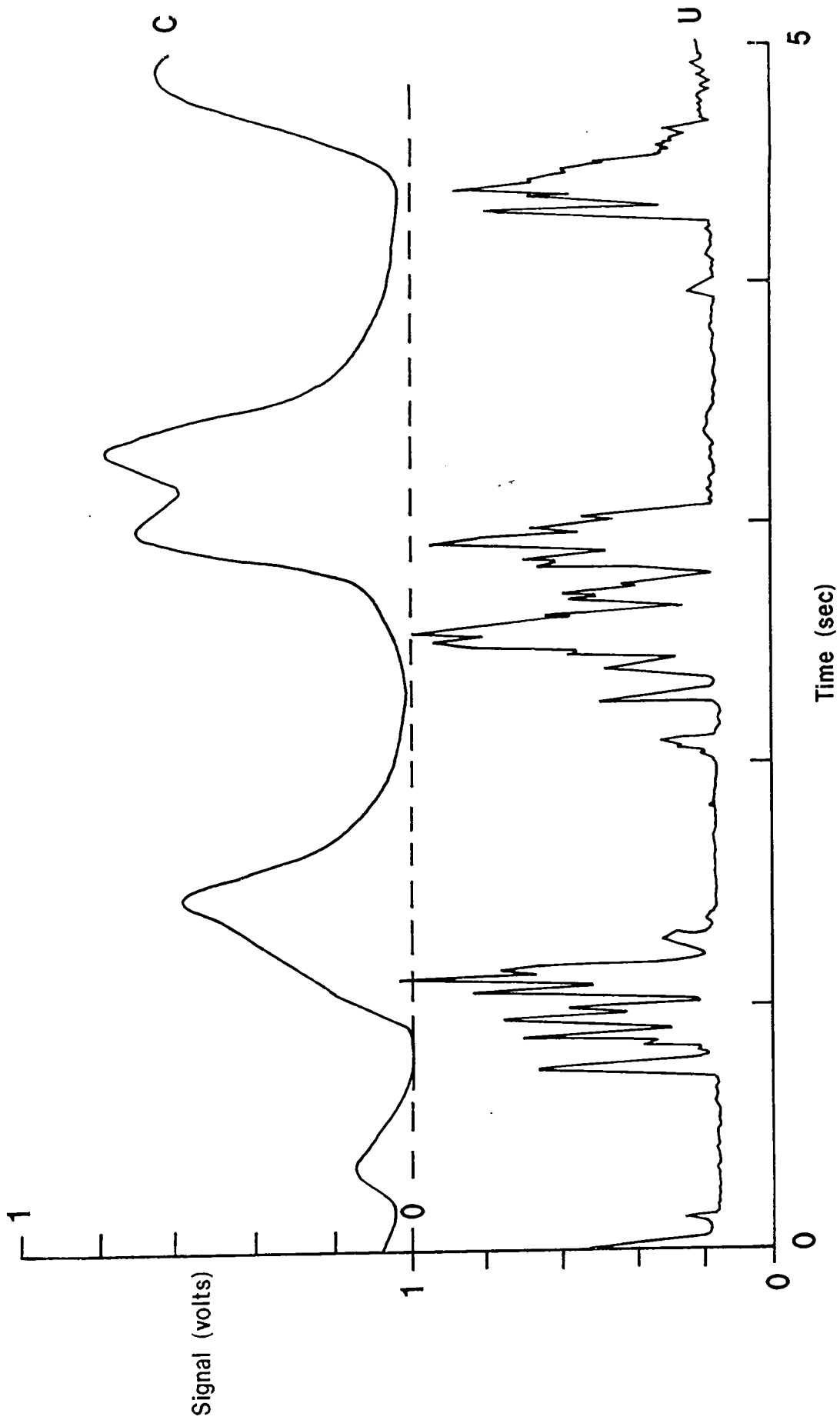

FIGURE 6.3

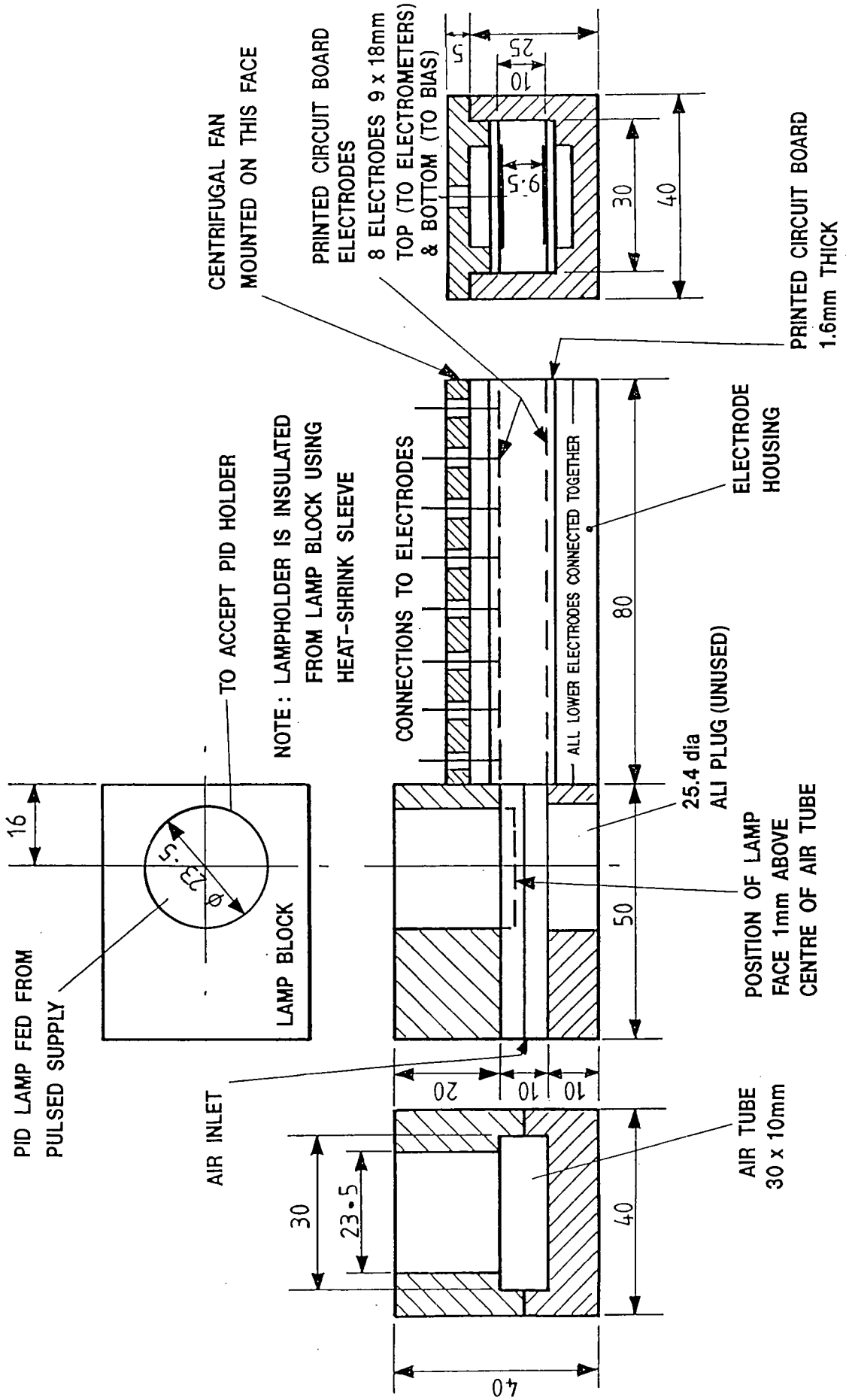
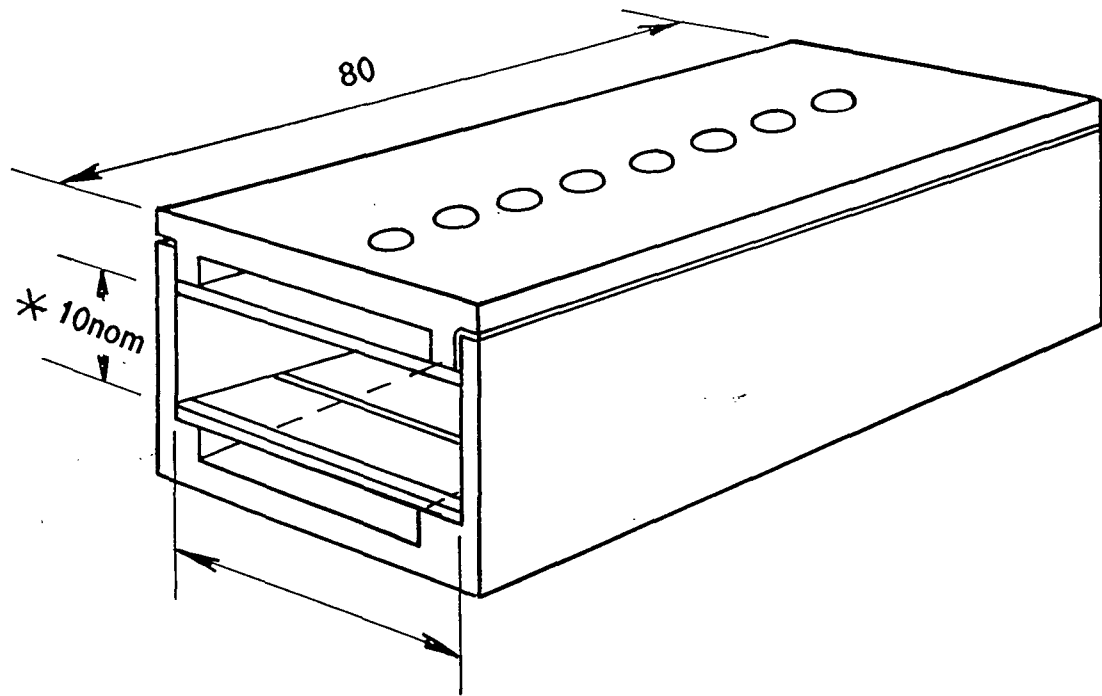
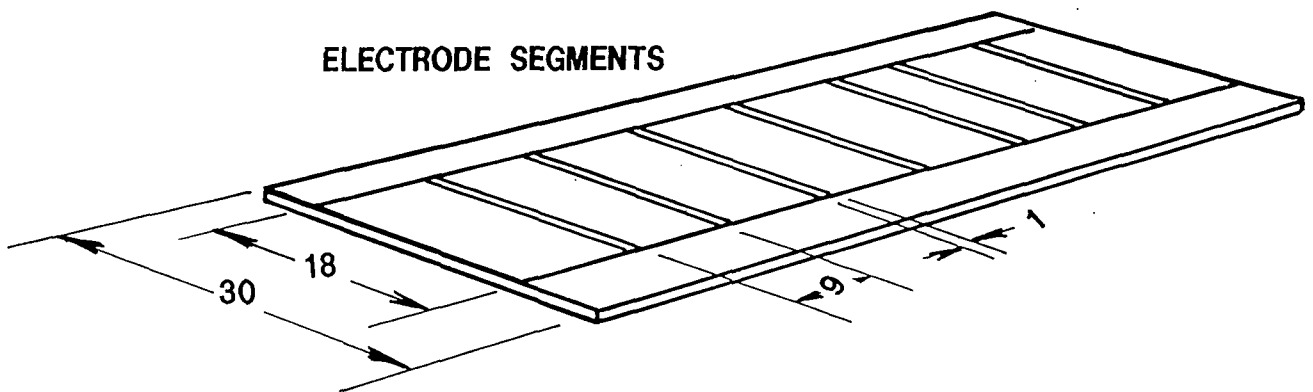

FIGURE 6.4. PULSED UVIC LINEAR ELECTRODE SYSTEM



* MEASURED ELECTRODE SPACING 9.5mm



PRINTED CIRCUIT BOARD (2 OFF)

FIGURE 6.5. PULSED UVIC LINEAR ELECTRODE SYSTEM

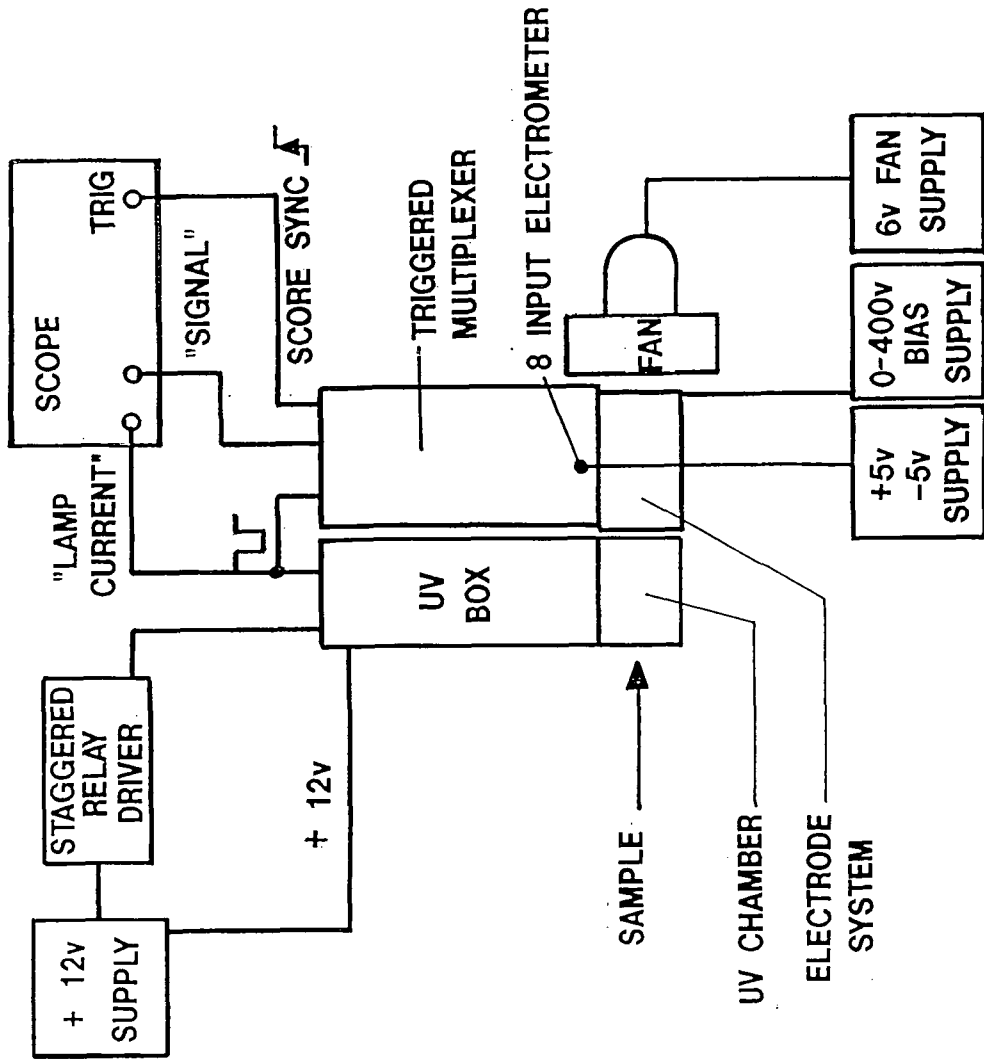

FIGURE 6.6. SEGMENTED UVIC BLOCK DIAGRAM

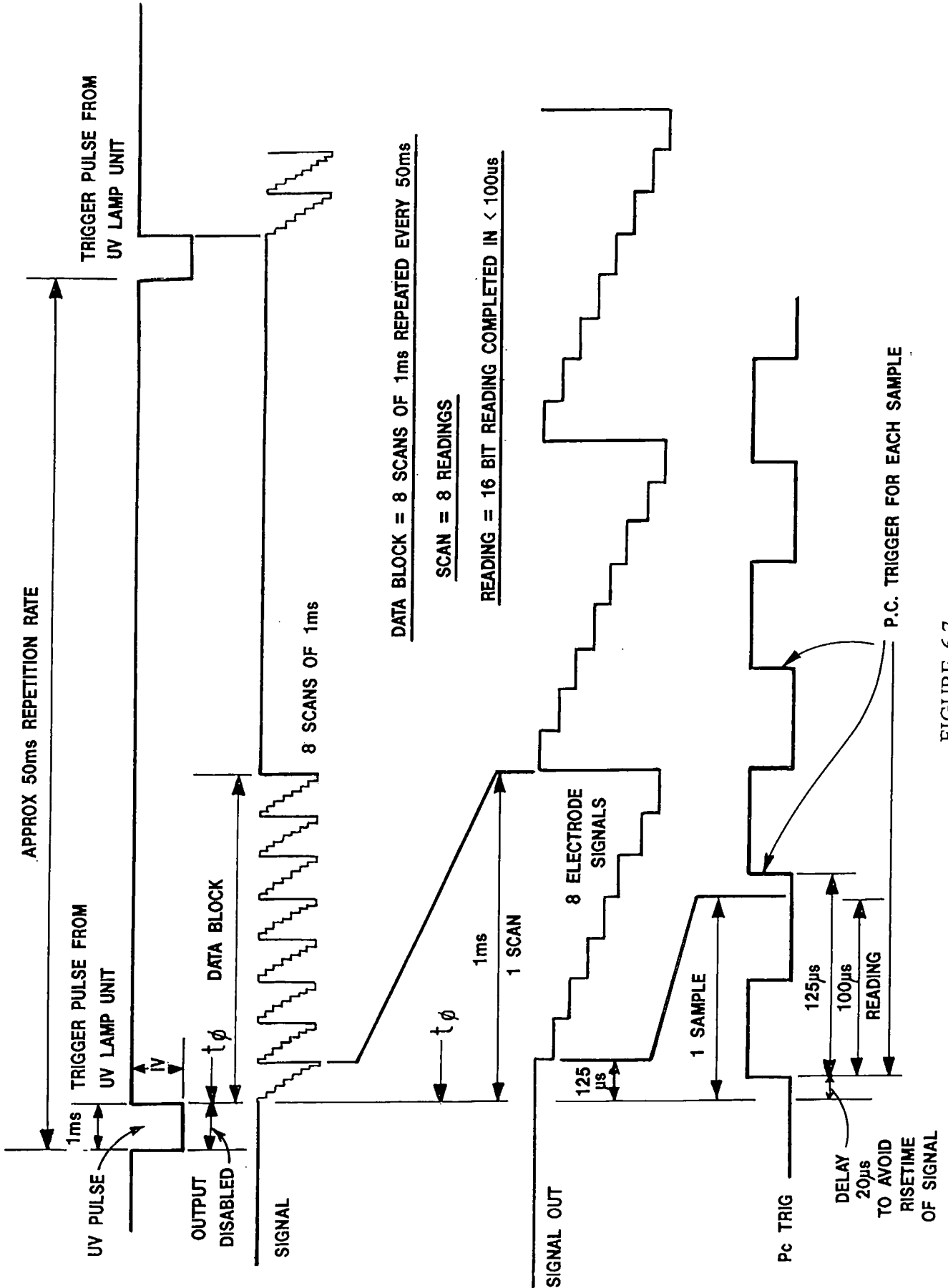

FIGURE 6.7

Comparison of Colocated FID and UVIC data from Coincident Sources.

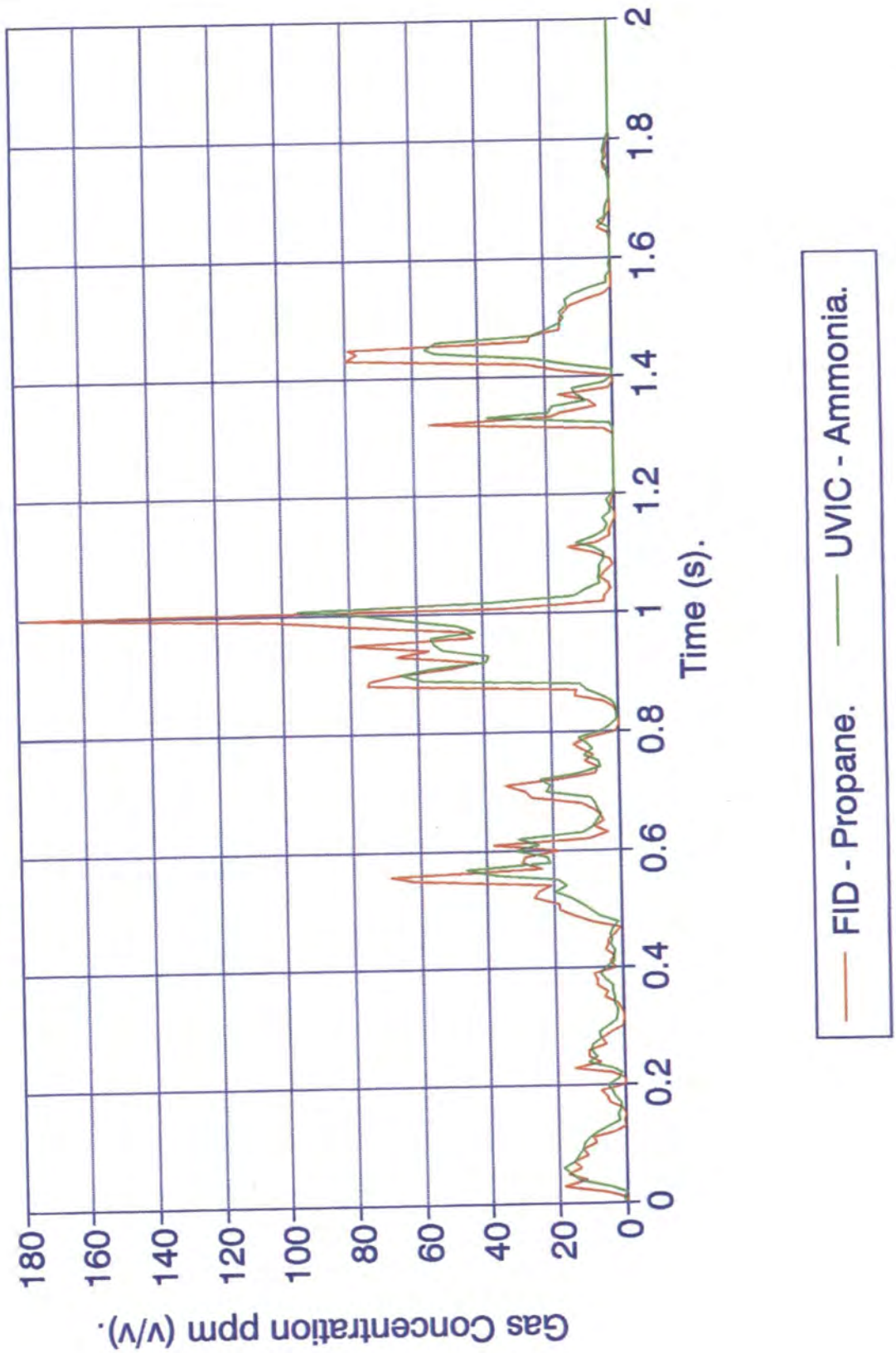

FIGURE 8.1. COMPARISON OF COLOCATED FID AND UVIC DATA FROM COINCIDENT SOURCES

Comparison of Colocated FID and UVIC data from Sources with 0.3m Separation.

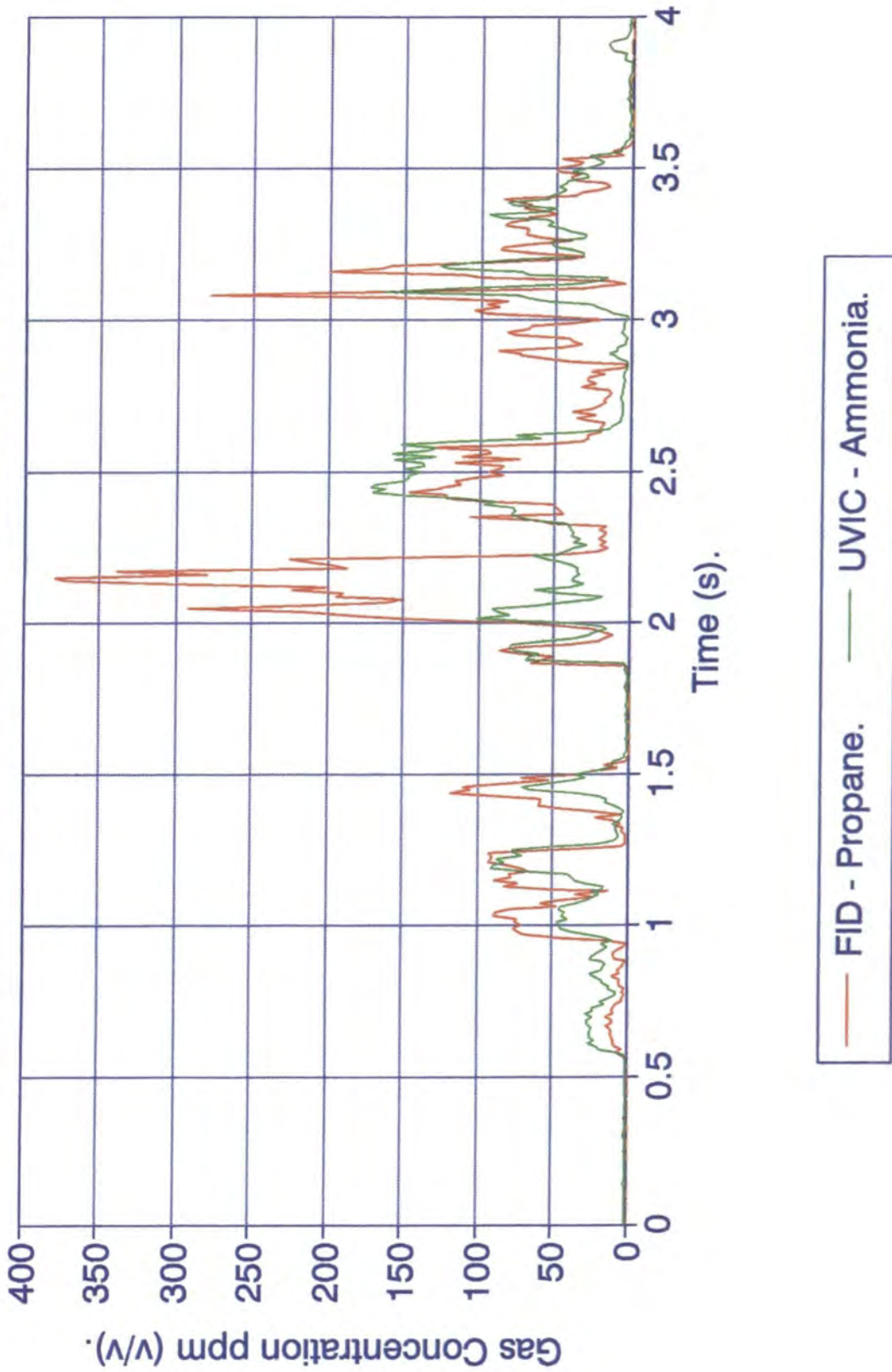
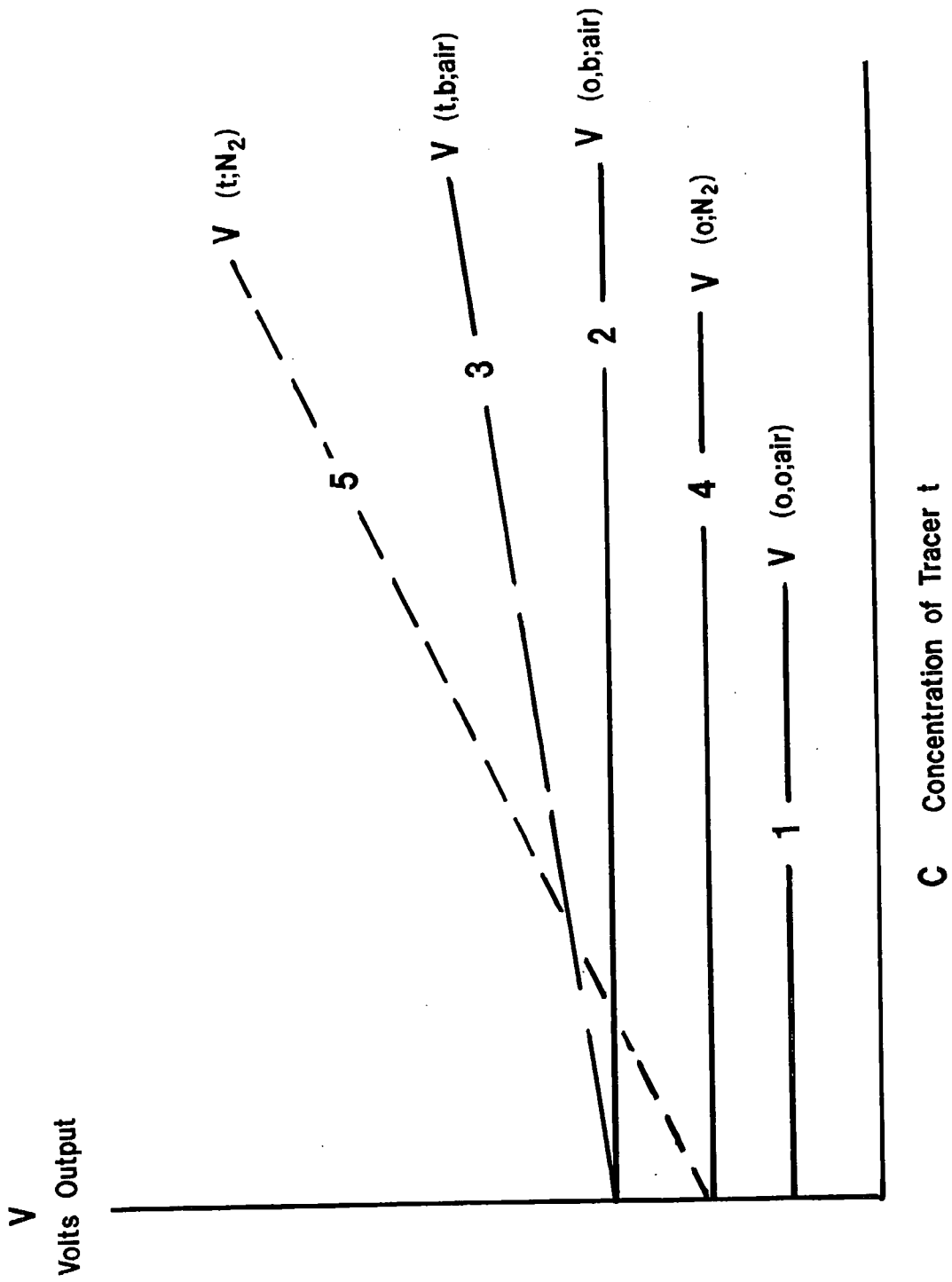
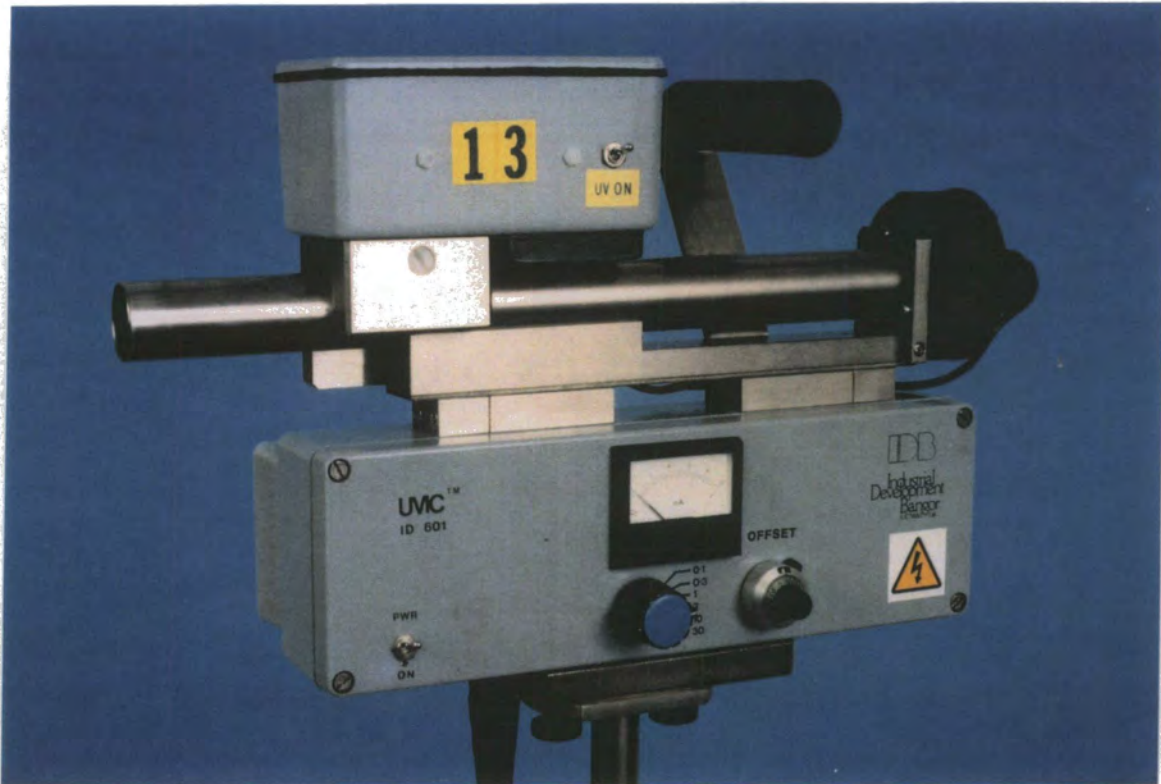

FIGURE 8.2. COMPARISON OF COLOCATED FID AND UVIC DATA FROM SOURCES WITH 0.3m SEPARATION



C Concentration of Tracer t



PHOTOGRAPH 1. THE RESEARCH VERSION OF THE UVIC® DETECTOR



PHOTOGRAPH 2. THE COMMERCIAL VERSION OF THE UVIC® DETECTOR (PHOTOGRAPH SHOWS THE INSTRUMENT IN ITS TRANSIT CASE WITH BATTERY CHARGER AND SAMPLING TUBE)

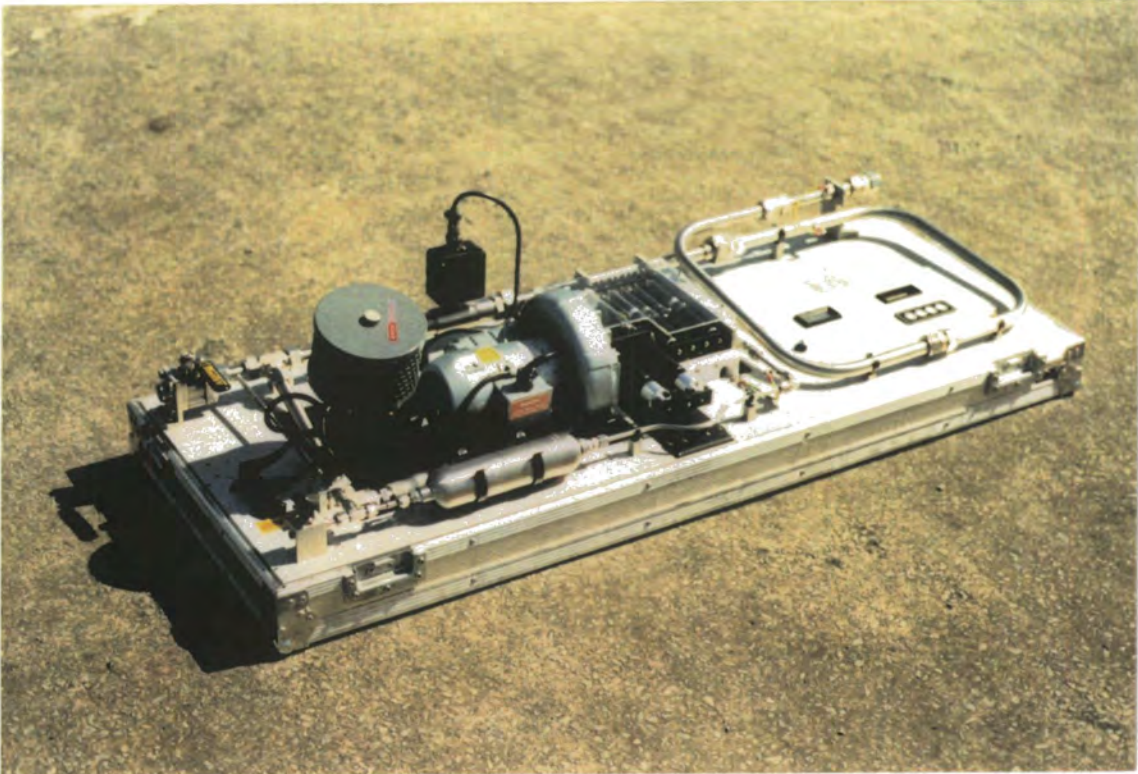

PHOTOGRAPH 3. THE CALIBRATION RIG

