

Durham E-Theses

Grip strength, forearm muscle fatigue and the response to handgrip exercise in rheumatoid arthritis

Catherine A. Speed

How to cite:

Speed, Catherine A. (1998) Grip strength, forearm muscle fatigue and the response to handgrip exercise in rheumatoid arthritis. Doctoral thesis, Durham University.

Use policy

The full-text may be used and/or reproduced, and given to third parties in any format or medium, without prior permission or charge, for personal research or study, educational, or not-for-profit purposes provided that:

- a full bibliographic reference is made to the original source
- a <https://etheses.durham.ac.uk/id/eprint/4871/> is made to the metadata record in Durham E-Theses
- the full-text is not changed in any way

The full-text must not be sold in any format or medium without the formal permission of the copyright holders.

Please consult the [full Durham E-Theses policy](#) for further details.



ARIA

mit verschiedenen Veränderungen für Cembalo mit 2 Manualen
 (Goldberg-Variationen)

ARIA

Schmeißel-Verz. 988



Grip strength, forearm muscle fatigue and the response to hand grip exercise in rheumatoid arthritis.

The copyright of this thesis rests with the author. No quotation from it should be published without the written consent of the author and information derived from it should be acknowledged.

Catherine A. Speed. B Med Sci, BMBS (University of Nottingham), MRCP (UK), DSMSA.

**A Thesis submitted for the Degree of Doctor of Philosophy
at the University of Durham.**



13 JAN 1999

To my parents, for teaching me the importance of “always getting my sums right” and for instilling in me the faith that over the brow of most hills good things usually lie in wait – “et le soleil brillait dans un ciel sans nuage.....”

Acknowledgements

The experiences of my three year fellowship has reinforced the knowledge that in research, as in life, the help and support of others is vital. I would like to express my gratitude to all those who assisted me in this work.

- My supervisors, Professor Tony Unsworth, Dr Patrick Jones and Professor Ian Haslock for their advice and assistance.
- Mr Robert Royall and the staff of the Regional Medical Physics Department at South Cleveland Hospital, for technical advice and support.
- Dr Peter Kelly for his good humour and statistical advice.
- Dr Robert Campbell, whose dedication made the MRI studies possible.
- The patients of the Rheumatology Department, South Cleveland Hospital, for their wonderful enthusiasm and commitment to the project.
- The staff in the Rheumatology Department, South Cleveland Hospital, particularly Jackie Bates and Olwynne Pitcher for their assistance with the bone densitometry work.
- Finally, my new friends and colleagues in Cambridge, who helped to keep me moving in the direction of the finishing line during the final 3 months of writing up.

ABSTRACT

Weakness and subjective fatigue are common features of rheumatoid arthritis (RA). However, whether there is a true increase in the fatigability of rheumatoid skeletal muscle, in which fibre atrophy has been frequently reported, is unclear. Such factors may influence the ability to respond to exercise programmes.

In this work, a reliable and sensitive technique for the objective measurement of forearm muscle fatigue during sustained grip was developed, using power spectral analysis of the surface myoelectric signal (SMES).

The inter-relationships between grip force (hand function) and the activity and severity of the rheumatoid disease process with muscle fatigue (defined as the decline in the median frequency of the SMES with work, (MDFG)) and the initial median frequency of the SMES (IMF) were examined. It has been previously suggested that the IMF of the SMES may reflect the fibre type of the underlying muscle. The response to a 12-week progressive right hand grip strengthening programme in healthy females and those with RA was also evaluated. Potential predictors of outcome and the mechanisms of strength gain were examined.

Forearm muscle fatigue in RA was not significantly greater than in healthy controls. However, higher levels of fatigue were associated with greater systemic disease activity and greater disease severity.

The IMF of the SMES was shown to be stable over a wide range of grip forces for a given individual. It was significantly elevated in rheumatoid subjects, and showed a direct association with greater disease severity.

Handgrip exercise was highly effective in improving hand function in females with RA. Strength gains were also demonstrated in healthy controls. Subjects with more severe disease and greater IMF of the SMES showed the greatest improvement in hand function. Greater systemic and local disease activity during the 12-week programme were limiting factors to improvement in grip. Local (right hand) disease activity remained stable or improved in the RA group overall, in spite of a trend towards deteriorating systemic and left handed disease activity.

The two main potential mechanisms of strength gain (neural adaptation and gains in muscle mass) were assessed in both rheumatoid and healthy groups. The former was assessed by evaluation of the neuromuscular efficiency, derived from the relationship of the root mean square of the SMES at a given grip force. Gains in muscle mass were also assessed using this technique and by volumetric analysis of forearm musculature using magnetic resonance imaging. Although significant gains in muscle mass were demonstrated in the control group, no such gains were seen in the rheumatoid subjects. This indicates that neural adaptation was an effective method of strength gain in the rheumatoid group.

Contents.

Page

Acknowledgements	ii
Abstract	iii
Contents	iv
Abbreviations	x
List of Figures	xi
List of Tables	xviii
Chapter One. Introduction.	1
Chapter Two: Literature Review	3
2.1 Rheumatoid muscle.	3
2.1.1. Introduction	3
2.1.2. Histological changes in muscle in rheumatoid arthritis.	3
2.2 Weakness in RA	7
2.2.1. Weakness in RA.	7
2.2.2. Arthrogenous weakness and muscle fibre atrophy in RA: a summary.	9
2.3 Fatigue.	9
2.3.1. Introduction.	9
2.3.2. Defining fatigue.	10
2.3.3. Fatigue in RA.	11
2.3.4. Mechanisms of fatigue in RA.	11
2.3.5. The description of the myoelectric signal.	12
2.3.6. Myoelectric manifestations of fatigue.	12
2.3.7. The RMS of the SMES as an indicator of fatigue.	13
2.3.8. Power spectral analysis of the surface myoelectric signal.	14
2.3.9. The description of the power spectrum: power spectral parameters.	14
2.3.10. The frequency spectrum in relation to EMG measures.	16
2.3.11. Power spectral compression during muscle fatigue.	19
2.3.12. The description of power spectral compression.	20
2.3.13. Mechanisms of power spectral compression during muscle fatigue.	21

2.4 Motor Unit control and the relationship between force and the SMES.	24
2.4.1 Introduction.	24
2.4.2 Motor unit control and the generation of force.	24
2.4.3 The relationship between the SMES and force.	27
2.4.4. Neuromuscular efficiency (NME).	28
2.4.5. The relationship between force and spectral parameters.	29
2.4.6. The relationship between power spectral compression and force.	30
2.4.7. The relationship between the signal amplitude and spectral parameters during fatigue.	31
2.4.8. Changes in the SMES and the frequency spectrum in disease.	31
2.4.9. The EMG in rheumatoid arthritis.	33
2.4.10. Recovery of myoelectric parameters after work.	34
2.5 Strength training in rheumatoid arthritis.	36
2.5.1. Introduction.	36
2.5.2. Mechanisms of strength gain in healthy individuals.	37
2.5.3. Important features of strength training programmes.	38
2.5.4. Assessing the mechanisms of strength gain.	39
2.5.5. Strength training and disuse weakness.	41
2.5.6. Strength training in RA.	42
2.6. Grip strength in rheumatoid arthritis.	43
2.6.1. Introduction.	43
2.6.2. The rheumatoid hand.	44
2.6.3. Factors affecting grip strength in RA.	45
2.6.4. The assessment of grip strength.	45
Chapter 3: Materials and methods.	47
3.1. The apparatus.	47
3.1.1. The grip bag.	47
3.1.2. Surface electromyography: signal acquisition and processing.	48

3.2. The SMES acquisition and analysis system: calibration and electrode placement	51
3.2.1. System description and calibration.	51
3.2.2. The placement of electrodes on the forearm for the recording of the SMES.	52
3.3. The assessment of grip strength.	54
3.3.1. Subject positioning and grip testing.	54
3.4 The assessment of forearm muscle cross-sectional area (CSA) and volume.	55
3.4.1. The assessment of the cross-sectional area of the forearm.	55
3.4.2. Volumetric analysis of the musculature of the forearm.	56
3.5. The assessment of rheumatoid disease.	58
3.6. The test protocol.	61
3.7. The grip strength exercise programme.	62
Chapter Four. Pilot Studies	64
4.1. Pilot studies I: The development of study techniques and protocols.	64
4.1.1. Introduction.	64
4.1.2. Skin preparation.	65
4.1.3. Grip tests.	65
4.1.4. Choice of bandwidth.	67
4.1.5. Interelectrode studies.	68
4.1.6. Hanning windows.	69
4.1.7 The effect of smoothing cycles on power spectral parameters.	71
4.2 Pilot studies II: The repeatability of the technique of SMES analysis of the forearm.	74
4.2.1. Introduction	74
4.2.2. The restitution study.	74
4.2.3. The long term repeatability of the technique of SMES analysis of the forearm.	80
4.2.4. The repeatability of forearm myoelectric parameters generated during sustained submaximal grip: discussions and conclusions.	90

4.3. Pilot studies III.	93
4.3.1. The relationship of grip force with SMES parameters.	93
4.3.2. Summary and discussion: the relationship of grip force with SMES parameters.	96
4.4. Pilot studies IV. The inter-relationship between forearm myoelectric parameters derived from the SMES during sustained submaximal grip.	99
4.4.1. Introduction.	99
4.4.2. Results.	99
4.4.3. Discussion.	101
Chapter Five. The assessment of the muscle mass in the right forearm. Pilot studies.	103
5.1. Introduction	103
5.2. Cross sectional area (CSA) of the right forearm using magnetic resonance imaging.	103
5.3. Volumetric analysis of the musculature of the right forearm.	104
5.3.1. The repeatability of volumetric analysis of the right forearm musculature.	104
5.3.2. Selection of the optimal MR scanning technique in volumetric analysis of forearm musculature.	106
5.4. A comparison of forearm muscle volume with proximal forearm cross-sectional area (CSA) as measured using magnetic resonance (MR) imaging.	106
5.5. The analysis of forearm muscle mass in the right forearm: a summary.	107
Chapter Six. Results.	108
6.1. Grip strength in RA.	108
6.1.1. Introduction.	108
6.1.2. Factors affecting grip strength in RA.	109
6.1.3. Summary.	115
6.2. Forearm myoelectric parameters during sustained grip in rheumatoid arthritis.	116
6.2.1. Introduction.	116

6.2.2. Grip strength and myoelectric parameters in RA: a comparison with healthy female controls.	116
6.3. The effect of the activity and severity of rheumatoid disease upon forearm myoelectric parameters during grip.	118
6.3.1. Introduction.	118
6.3.2. Factors influencing forearm myoelectric parameters during grip in healthy controls.	118
6.3.3. Factors influencing forearm myoelectric parameters during grip in females with rheumatoid arthritis.	118
6.4 Summary: Forearm myoelectric parameters during grip in rheumatoid arthritis.	121

Chapter Seven. Grip Strength Training in Rheumatoid Arthritis.

7.1. The response to grip strength training in rheumatoid arthritis.	122
7.1.1 Introduction.	122
7.1.2 The effects of handgrip exercise upon hand function in health and rheumatoid disease.	122
7.2. The effect of handgrip exercise on the IMF of the forearm SMES.	125
7.3. The effect of handgrip exercise on local disease activity in RA.	126
7.4. Predictors of the outcome of a handgrip exercise programme in RA.	128
7.5 Summary: Handgrip exercise in Rheumatoid Arthritis.	131

Chapter Eight. Mechanisms of grip strength gain in a hand exercise programme.

8.1. Introduction.	133
8.2. The assessment of the mechanisms of strength gain during a hand exercise programme using cross-sectional analysis of forearm musculature by magnetic resonance imaging.	133
8.3. The assessment of the mechanisms of strength gain during a hand exercise programme using volumetric analysis of the forearm musculature.	137
8.4. Summary.	146

Chapter Nine: Discussion.	147
9.1 Introduction.	147
9.2 The use of grip in the assessment of the myoelectric characteristics during work.	148
9.3 The initial median frequency of the forearm myoelectric signal as an indicator of muscle characteristics in RA.	149
9.4 Other factors associated with hand function in RA.	152
9.5 Fatigue in rheumatoid arthritis.	153
9.6 The response to a handgrip exercise programme in RA.	155
9.7 Mechanisms of strength gain in the hand exercise programme.	157
9.8 Implications for exercise programmes in rheumatoid disease.	159
9.9 Further work.	160
9.10 Summary.	161
Chapter Ten. Conclusions.	163
Chapter Eleven. References.	165
Chapter Twelve: Appendices.	197
12.1 Disease scores.	
12.1.1. Keital Hand Functional Index.	197
12.1.2 Fuchs Joint Score.	199
12.2. The hand exercise programme information sheet.	200

Contents.

	Page
Acknowledgements	ii
Abstract	iii
Contents	iv
Abbreviations	x
List of Figures	xi
List of Tables	xviii
Chapter One. Introduction.	1
Chapter Two: Literature Review	3
2.1 Rheumatoid muscle.	3
2.1.1. Introduction	3
2.1.2. Histological changes in muscle in rheumatoid arthritis.	3
2.2 Weakness in RA	7
2.2.1. Weakness in RA.	7
2.2.2. Arthrogenous weakness and muscle fibre atrophy in RA: a summary.	9
2.3 Fatigue.	9
2.3.1. Introduction.	9
2.3.2. Defining fatigue.	10
2.3.3. Fatigue in RA.	11
2.3.4. Mechanisms of fatigue in RA.	11
2.3.5. The description of the myoelectric signal.	12
2.3.6. Myoelectric manifestations of fatigue.	12
2.3.7. The RMS of the SMES as an indicator of fatigue.	13
2.3.8. Power spectral analysis of the surface myoelectric signal.	14
2.3.9. The description of the power spectrum: power spectral parameters.	14
2.3.10. The frequency spectrum in relation to EMG measures.	16
2.3.11. Power spectral compression during muscle fatigue.	19
2.3.12 The description of power spectral compression.	20
2.3.13. Mechanisms of power spectral compression during muscle fatigue.	21

2.4 Motor Unit control and the relationship between force and the SMES.	24
2.4.1 Introduction.	24
2.4.2 Motor unit control and the generation of force.	24
2.4.3 The relationship between the SMES and force.	27
2.4.4. Neuromuscular efficiency (NME).	28
2.4.5. The relationship between force and spectral parameters.	29
2.4.6. The relationship between power spectral compression and force.	30
2.4.7. The relationship between the signal amplitude and spectral parameters during fatigue.	31
2.4.8. Changes in the SMES and the frequency spectrum in disease.	31
2.4.9. The EMG in rheumatoid arthritis.	33
2.4.10. Recovery of myoelectric parameters after work.	34
2.5 Strength training in rheumatoid arthritis.	36
2.5.1. Introduction.	36
2.5.2. Mechanisms of strength gain in healthy individuals.	37
2.5.3. Important features of strength training programmes.	38
2.5.4. Assessing the mechanisms of strength gain.	39
2.5.5. Strength training and disuse weakness.	41
2.5.6. Strength training in RA.	42
2.6. Grip strength in rheumatoid arthritis.	43
2.6.1. Introduction.	43
2.6.2. The rheumatoid hand.	44
2.6.3. Factors affecting grip strength in RA.	45
2.6.4. The assessment of grip strength.	45
Chapter 3: Materials and methods.	47
3.1. The apparatus.	47
3.1.1. The grip bag.	47
3.1.2. Surface electromyography: signal acquisition and processing.	48

3.2. The SMES acquisition and analysis system: calibration and electrode placement	51
3.2.1. System description and calibration.	51
3.2.2. The placement of electrodes on the forearm for the recording of the SMES.	52
3.3. The assessment of grip strength.	54
3.3.1. Subject positioning and grip testing.	54
3.4 The assessment of forearm muscle cross-sectional area (CSA) and volume.	55
3.4.1. The assessment of the cross-sectional area of the forearm.	55
3.4.2. Volumetric analysis of the musculature of the forearm.	56
3.5. The assessment of rheumatoid disease.	58
3.6. The test protocol.	61
3.7. The grip strength exercise programme.	62
Chapter Four. Pilot Studies	64
4.1. Pilot studies I: The development of study techniques and protocols.	64
4.1.1. Introduction.	64
4.1.2. Skin preparation.	65
4.1.3. Grip tests.	65
4.1.4. Choice of bandwidth.	67
4.1.5. Interelectrode studies.	68
4.1.6. Hanning windows.	69
4.1.7 The effect of smoothing cycles on power spectral parameters.	71
4.2 Pilot studies II: The repeatability of the technique of SMES analysis of the forearm.	74
4.2.1. Introduction	74
4.2.2. The restitution study.	74
4.2.3. The long term repeatability of the technique of SMES analysis of the forearm.	80
4.2.4. The repeatability of forearm myoelectric parameters generated during sustained submaximal grip: discussions and conclusions.	90

4.3. Pilot studies III.	93
4.3.1. The relationship of grip force with SMES parameters.	93
4.3.2. Summary and discussion: the relationship of grip force with SMES parameters.	96
4.4. Pilot studies IV. The inter-relationship between forearm myoelectric parameters derived from the SMES during sustained submaximal grip.	99
4.4.1. Introduction.	99
4.4.2. Results.	99
4.4.3. Discussion.	101
Chapter Five. The assessment of the muscle mass in the right forearm.	
Pilot studies.	103
5.1. Introduction	103
5.2. Cross sectional area (CSA) of the right forearm using magnetic resonance imaging.	103
5.3. Volumetric analysis of the musculature of the right forearm.	104
5.3.1. The repeatability of volumetric analysis of the right forearm musculature.	104
5.3.2. Selection of the optimal MR scanning technique in volumetric analysis of forearm musculature.	106
5.4. A comparison of forearm muscle volume with proximal forearm cross-sectional area (CSA) as measured using magnetic resonance (MR) imaging.	106
5.5. The analysis of forearm muscle mass in the right forearm: a summary.	107
Chapter Six. Results.	108
6.1. Grip strength in RA.	108
6.1.1. Introduction.	108
6.1.2. Factors affecting grip strength in RA.	109
6.1.3. Summary.	115
6.2. Forearm myoelectric parameters during sustained grip in rheumatoid arthritis.	116
6.2.1. Introduction.	116

6.2.2. Grip strength and myoelectric parameters in RA: a comparison with healthy female controls.	116
6.3. The effect of the activity and severity of rheumatoid disease upon forearm myoelectric parameters during grip.	118
6.3.1. Introduction.	118
6.3.2. Factors influencing forearm myoelectric parameters during grip in healthy controls.	118
6.3.3. Factors influencing forearm myoelectric parameters during grip in females with rheumatoid arthritis.	118
6.4 Summary: Forearm myoelectric parameters during grip in rheumatoid arthritis.	121

Chapter Seven. Grip Strength Training in Rheumatoid Arthritis.

7.1. The response to grip strength training in rheumatoid arthritis.	122
7.1.1 Introduction.	122
7.1.2 The effects of handgrip exercise upon hand function in health and rheumatoid disease.	122
7.2. The effect of handgrip exercise on the IMF of the forearm SMES.	125
7.3. The effect of handgrip exercise on local disease activity in RA.	126
7.4. Predictors of the outcome of a handgrip exercise programme in RA.	128
7.5 Summary: Handgrip exercise in Rheumatoid Arthritis.	131

Chapter Eight. Mechanisms of grip strength gain in a hand exercise programme.

8.1. Introduction.	133
8.2. The assessment of the mechanisms of strength gain during a hand exercise programme using cross-sectional analysis of forearm musculature by magnetic resonance imaging.	133
8.3. The assessment of the mechanisms of strength gain during a hand exercise programme using volumetric analysis of the forearm musculature.	137
8.4. Summary.	146

Chapter Nine: Discussion.	147
9.1 Introduction.	147
9.2 The use of grip in the assessment of the myoelectric characteristics during work.	148
9.3 The initial median frequency of the forearm myoelectric signal as an indicator of muscle characteristics in RA.	149
9.4 Other factors associated with hand function in RA.	152
9.5 Fatigue in rheumatoid arthritis.	153
9.6 The response to a handgrip exercise programme in RA.	155
9.7 Mechanisms of strength gain in the hand exercise programme.	157
9.8 Implications for exercise programmes in rheumatoid disease.	159
9.9 Further work.	160
9.10 Summary.	161
Chapter Ten. Conclusions.	163
Chapter Eleven. References.	165
Chapter Twelve: Appendices.	197
12.1 Disease scores.	
12.1.1. Keital Hand Functional Index.	198
12.1.2 Fuchs Joint Score.	200
12.2. The hand exercise programme information sheet.	201

Abbreviations.

ESR:	Erythrocyte sedimentation rate.
CRP:	C-reactive protein.
MDF:	Median Frequency.
MDF_G:	Median Frequency Gradient
MNF:	Mean frequency.
IMF:	Initial Median Frequency.
SMES:	Surface Myoelectric Signal.
mg:	milligrams.
μV:	microvolts.
Hz:	Hertz.
BMI:	Body Mass Index.
BMD:	Bone Mineral Density.
MGS:	Maximum Grip Strength
MRI:	Magnetic Resonance Imaging.
CSA:	Cross Sectional Area.
RA:	Rheumatoid Arthritis.

Figures.

2.3.1	The frequency spectrum of the SMES.	15
2.3.2	The change in the median frequency of the SMES with time.	15
3.1.1	The Hand Assessment System.	47f
3.1.2	The pressure readings versus the ADC output (microvolts) from the grip bag compared with the sphygmomanometer (mmHg).	48f
3.1.3	The grip force: RMS gradient ($FRMS_G$).	49f
3.1.4	The SMES Analysis System	50
3.2.1	Calibration of the SMES acquisition and analysis system.	51
3.2.2.	Position of extensor electrodes and arm in rig for forearm SMES analysis during grip.	53
3.2.3	Position of flexor electrodes and arm in rig for forearm SMES analysis during grip.	53
3.3.1	Subject positioning for grip testing.	54
3.5.1	Patient positioning for bone densitometry of the right hand using a Lunar DPX-L Scanner	59
3.5.2	Close-up view of the position of the right hand on perspex board for hand bone densitometry.	59
3.5.3	An example of a right hand and wrist subluxation score in a female with RA.	60
3.6.1	The testing protocol.	61
4.1.1	Protocol: The repeatability of maximum grip strength (MGS) over 3 tests performed 20 seconds apart by 12 female subjects with RA and 12 controls.	66f
4.1.2	The repeatability of maximum grip strength (MGS) over 3 tests performed 20 seconds apart by 12 female subjects with RA and 12 controls.	66
4.1.3	Protocol: Maintenance of the target grip.	66f
4.1.4	Protocol: The repeatability of the chosen angle of wrist extension during standard 30-second grip tests performed at 2/3MGS, by 12 females with RA and 12 female controls.	67f
4.1.5	The repeatability of the chosen angle of wrist extension during standard 30-second grip tests performed at 2/3 MGS by 12 female subjects and 12 female controls.	67
4.1.6	Protocol: The effect of interelectrode separation (IES) distance upon SMES parameters in 10 female controls.	68f

4.1.7	The effect of the IES distance upon spectral parameters (expressed as mean (SD)) recorded from the extensor and flexor forearm musculature during standard grip tests at 2/3 MGS by 10 right handed female controls.	68
4.1.8	The effect of the IES distance upon the spectral peak and the RMS of the SMES (expressed as mean (SD)) recorded from the extensor and flexor forearm musculature during standard grip tests at 2/3 MGS by 10 right handed female controls.	69
4.1.9	The effect of smoothing cycles upon spectral parameters: data from the extensor channel from one standard grip test performed at 2/3 MGS by one subject with RA. Spectra before and after 10 smoothing cycles.	71
4.1.10	The effect of smoothing cycles upon spectral parameters: data from the extensor channel from one standard grip test performed at 2/3 MGS by one subject with RA.	72
4.2.1	Protocol: The short-term repeatability of SMES parameters from standard grip tests at 2/3MGS performed by 40 females with RA and 16 female controls.	74f
4.2.2	Repeatability of the RMS of the SMES (flexor channel) from standard grip tests at 2/3 MGS performed 5 minutes apart by 16 female controls.	75f
4.2.3	Repeatability of the RMS of the SMES (flexor channel) from standard grip tests at 2/3 MGS performed 5 minutes apart by 40 females with RA.	75f
4.2.4	Repeatability of the RMS of the SMES (extensor channel) from standard grip tests at 2/3 MGS performed 5 minutes apart by 16 female controls.	75
4.2.5	Repeatability of the RMS of the SMES (extensor channel) from standard grip tests at 2/3 MGS performed 5 minutes apart by 40 females with RA.	75
4.2.6	Repeatability of the MDF_G of the SMES (flexor channel) from standard grip tests at 2/3 MGS performed 5 minutes apart by 16 female controls.	76f
4.2.7	Repeatability of the MDF_G of the SMES (flexor channel) from standard grip tests at 2/3 MGS performed 5 minutes apart by 40 females with RA.	76f
4.2.8	Repeatability of the MDF_G of the SMES (extensor channel) from standard grip tests at 2/3 MGS performed 5 minutes apart by 16 female controls.	76
4.2.9	Repeatability of the MDF_G of the SMES (extensor channel) from standard grip tests at 2/3 MGS performed 5 minutes apart by 40 females with RA.	76
4.2.10	Repeatability of the IMF of the SMES (flexor channel) from standard grip tests at 2/3 MGS performed 5 minutes apart by 16 female controls.	77f
4.2.11	Repeatability of the IMF of the SMES (flexor channel) from standard grip tests at 2/3 MGS performed 5 minutes apart by 40 females with RA.	77f
4.2.12	Repeatability of the IMF of the SMES (extensor channel) from standard grip tests at 2/3 MGS performed 5 minutes apart by 16 female controls.	77

4.2.13	Repeatability of the IMF of the SMES (extensor channel) from standard grip tests at 2/3 MGS performed 5 minutes apart by 40 females with RA.	77
4.2.14	Protocol: The long-term repeatability of SMES parameters from standard grip tests at 1/3MGS performed 3 weeks apart by 19 females with RA and 18 female controls.	80f
4.2.15	Protocol: The long-term repeatability of SMES parameters from standard grip tests performed at 1/2 MGS weeks apart by 24 females with RA and 30 female controls.	80f
4.2.16	Protocol: The long-term repeatability of SMES parameters from standard grip tests at 2/3MGS performed 3 weeks apart by 18 females with RA and 21 female controls.	81f
4.2.17	Repeatability of the RMS of the SMES (extensor channel) from standard grip tests at 2/3 MGS performed 3 weeks apart by 18 females with RA.	81f
4.2.18	Repeatability of the RMS of the SMES (extensor channel) from standard grip tests at 2/3 MGS performed 3 weeks apart by 21 female controls.	81
4.2.19	Repeatability of the RMS of the SMES (flexor channel) from standard grip tests at 2/3 MGS performed 3 weeks apart by 21 female controls.	82
4.2.20	Repeatability of the RMS of the SMES (flexor channel) from standard grip tests at 2/3 MGS performed 3 weeks apart by 18 females with RA.	82
4.2.21	Repeatability of the MDF _G of the SMES (extensor channel) from standard grip tests at 2/3 MGS performed 3 weeks apart by 18 females with RA.	83f
4.2.22	Repeatability of the MDF _G of the SMES (extensor channel) from standard grip tests at 2/3 MGS performed 3 weeks apart by 21 female controls.	83
4.2.23	Repeatability of the MDF _G of the SMES (flexor channel) from standard grip tests at 2/3 MGS performed 3 weeks apart by 21 female controls.	84
4.2.24	Repeatability of the MDF _G of the SMES (flexor channel) from standard grip tests at 2/3 MGS performed 3 weeks apart by 18 females with RA.	84
4.2.25	Repeatability of the IMF of the SMES (flexor channel) from standard grip tests at 2/3 MGS performed 3 weeks apart by 21 female controls.	86f
4.2.26	Repeatability of the IMF of the SMES (flexor channel) from standard grip tests at 2/3 MGS performed 3 weeks apart by 18 females with RA.	86f
4.2.27	Repeatability of the IMF of the SMES (extensor channel) from standard grip tests at 2/3 MGS performed 3 weeks apart by 21 female controls.	86
4.2.28	Repeatability of the IMF of the SMES (extensor channel) from standard grip tests at 2/3 MGS performed 3 weeks apart by 18 females with RA.	86
4.3.1	The surface myoelectric parameters vs grip force levels protocol.	93

4.3.2	Mean RMS of the SMES (A) and linear regression lines (B) from extensor forearm musculature during standard grip tests versus percentage maximal grip pressure in 17 female controls.	94
4.3.3	Mean RMS of the SMES (A) and linear regression lines (B) from flexor forearm musculature during standard grip tests versus percentage maximal grip pressure in 17 female controls.	94
4.3.4	Mean MDF_G of the SMES (A) and linear regression lines (B) from extensor forearm musculature during standard grip tests versus percentage maximal grip pressure in 17 female controls.	94
4.3.5	Mean MDF_G of the SMES (A) and linear regression lines (B) from flexor forearm musculature during standard grip tests versus percentage maximal grip pressure in 17 female controls.	95
4.3.6	Mean IMF of the SMES (A) and linear regression lines (B) from extensor forearm musculature during standard grip tests versus percentage maximal grip pressure in 17 female controls.	95
4.3.7	Mean IMF of the SMES (A) and linear regression lines (B) from flexor forearm musculature during standard grip tests versus percentage maximal grip pressure in 17 female controls.	95
4.3.8	Mean spectral width (A) and linear regression lines (B) from extensor forearm musculature during standard grip tests versus percentage maximal grip pressure in 17 female controls.	96
4.3.9	Mean spectral width (A) and linear regression lines (B) from flexor forearm musculature during standard grip tests versus percentage maximal grip pressure in 17 female controls.	96
4.4.1	Test protocol: SMES acquisition and analysis from forearm surface electrodes during the following grip tests in 161 females with RA and 114 female controls.	99f
4.4.2	The MDF_G of the SMES recorded from the right forearm flexor channel versus that from the extensor channel during a standard right hand grip test performed at 2/3 MGS by 161 females with RA.	100f
4.4.3	The IMF of the SMES recorded from the right forearm flexor channel versus that from the extensor channel during a standard right hand grip test performed at 2/3 MGS by 161 females with RA.	100f
4.4.4	The relationship between the spectral width and the IMF of the extensor (A) and the Flexor (B) SMES in 161 females with RA and 114 healthy female controls.	100
5.3.1	The repeatability of the volumetric analysis of the right forearm using T1-W and proton scanning techniques over three testing sessions in ten subjects (mean(SD)).	105
5.3.2	Comparison of T1-W and Proton imaging techniques in volumetric analysis of right forearm musculature in 10 subjects.	106
5.4.1	Mean forearm muscle volume vs mean forearm CSA as measured using Proton and T1-W MR imaging in 10 subjects.	106

6.1.1	The relationship between MGS of the right hand and age in 161 right hand dominant females with RA and 114 female controls.	111f
6.1.2	MGS of the right hand vs the duration of disease in 161 right hand dominant females with RA.	111
6.1.3	The relationship between the MGS of the right hand and the flexor IMF of the SMES in 161 females with RA and 114 controls.	112
6.1.4	MGS of the right hand versus the right hand and wrist subluxation score in 161 right hand dominant females with RA.	112
6.1.5	The relationship between the right hand MGS and right hand BMD in 81 right hand dominant females with RA and 21 female controls.	113f
6.1.6	The relationship between the volume of the right forearm musculature and the MGS of the right hand in 27 right hand dominant females with RA and 14 female controls.	114f
6.2.1	The mean (SD) right hand MGS, IMF and spectral widths of the SMES derived from extensor and flexor forearm musculature during sustained grip at 2/3 MGS in 161 females with RA and 114 controls.	117
6.2.2	The relationship between right hand MGS and MDF _G of the extensor (A) and flexor (B) forearm musculature in 161 females with RA and 114 female controls.	117f
6.3.1	The relationship between right hand MGS and MDFG of the extensor (A) and flexor (B) forearm musculature in 161 females with RA and 114 female controls.	119f
6.3.2	The relationship between the extensor MDFG and the C-reactive protein (CRP) of 161 females with RA.	119
6.3.3	The relationship between the extensor MDFG and ulnar deviation of the right hand and wrist in 161 females with RA.	119
6.3.4	The relationship between the disease duration and the forearm flexor IMF in 161 females with RA.	120
7.1.1	The mean (SD) right hand MGS in the RA and control groups over the 12 week exercise programme.	124f
7.1.2	The mean percentage change (SD) from baseline in the right hand MGS in the RA and control groups over the 12 week exercise programme.	124
7.1.3	The mean percentage change (SD) in the right hand MGS compared to the previous test in the RA and control groups over the 12 week exercise programme.	124
7.2.1	The IMF of the SMES recorded from the extensor (A) and flexor (B) forearm channels in RA and control groups over the 12 week hand exercise programme (mean (SD)).	125f
7.3.1	Right and left hand disease parameters measured during a 12 week right hand exercise programme in 79 females with RA (mean (SD)).	127

7.4.1	The relationship between the change in the MGS of the right hand during a handgrip exercise programme and extensor IMF in 79 females with RA.	129
7.4.2	The relationship between the change in the MGS of the right hand during a handgrip exercise programme and the disease duration in 79 females with RA.	129
7.4.3	The relationship between the change in the MGS of the right hand during a handgrip exercise programme and the right hand and wrist subluxation score in 79 females with RA.	130
8.2.1	The relationship between the cross-sectional area of the right forearm and the maximum grip strength of the right hand in 27 females with RA prior to commencing a hand grip exercise programme.	134
8.2.2	The mean (SD) MGS of the right hand in 27 females with RA during a 12 week hand exercise programme.	134
8.2.3	The percentage changes in the CSA of the right forearm and in the MGS of the right hand in 27 females with RA after a 12 week handgrip exercise programme.	135f
8.2.4	The percentage change in the F:RMS gradients at the extensor and flexor channels vs that in right forearm CSA in 27 females with RA after a 12 week handgrip exercise programme.	135f
8.2.5	The relationship between changes noted in grip force : RMS of the SMES gradient (extensor channel) and MGS of the right hand after a 12 week handgrip exercise programme in 27 females with RA.	135
8.2.6	The relationship between changes noted in grip force : RMS of the SMES gradient (flexor channel) and MGS of the right hand after a 12 week handgrip exercise programme in 27 females with RA.	135
8.2.7	The percentage change in the F:RMS gradients at the flexor channel versus that of the extensor channel in 27 females with RA after a 12 week handgrip exercise programme.	136
8.3.1	The right forearm muscle volume and grip strength of the RA and control groups at baseline and after 12 weeks of a handgrip exercise programme (mean (SD)).	137f
8.3.2	The change in the volume of the right forearm musculature versus change in the MGS of the right hand in 14 female controls (A) and 14 females with RA (B) after a 12 week handgrip exercise programme.	138f
8.3.3	The change in the volume of the right forearm and the F:RMS gradients derived from the extensor (A) and flexor (B) channels after a 12 week hand exercise programme in females with RA.	138
8.3.4	The relationship between the change in forearm muscle volume and the F:RMS gradients derived from extensor and flexor channels after a 12 week exercise programme in 14 female controls.	139f
8.3.5	Grip strength vs RMS of the SMES for extensor and flexor channels in 14 female controls over a 12 week exercise programme. The associated changes in slope of the regression lines, MGS and forearm muscle volume are given in the associated tables.	140-2

8.3.6 Grip strength vs RMS of the SMES for extensor and flexor channels in 143-5
14 females with RA over a 12 week exercise programme. The %
changes in slope of the given regression lines, MGS and forearm muscle
volume are given in the associated tables.

Figures.

2.3.1	The frequency spectrum of the SMES.	15
2.3.2	The change in the median frequency of the SMES with time.	15
3.1.1	The Hand Assessment System.	47f
3.1.2	The pressure readings versus the ADC output (microvolts) from the grip bag compared with the sphygmomanometer (mmHg).	48f
3.1.3	The grip force: RMS gradient ($FRMS_G$).	49f
3.1.4	The SMES Analysis System	50
3.2.1	Calibration of the SMES acquisition and analysis system.	51
3.2.2.	Position of extensor electrodes and arm in rig for forearm SMES analysis during grip.	53
3.2.3	Position of flexor electrodes and arm in rig for forearm SMES analysis during grip.	53
3.3.1	Subject positioning for grip testing.	54
3.5.1	Patient positioning for bone densitometry of the right hand using a Lunar DPX-L Scanner	59
3.5.2	Close-up view of the position of the right hand on perspex board for hand bone densitometry.	59
3.5.3	An example of a right hand and wrist subluxation score in a female with RA.	60
3.6.1	The testing protocol.	61
4.1.1	Protocol: The repeatability of maximum grip strength (MGS) over 3 tests performed 20 seconds apart by 12 female subjects with RA and 12 controls.	66f
4.1.2	The repeatability of maximum grip strength (MGS) over 3 tests performed 20 seconds apart by 12 female subjects with RA and 12 controls.	66
4.1.3	Protocol: Maintenance of the target grip.	66f
4.1.4	Protocol: The repeatability of the chosen angle of wrist extension during standard 30-second grip tests performed at 2/3MGS, by 12 females with RA and 12 female controls.	67f
4.1.5	The repeatability of the chosen angle of wrist extension during standard 30-second grip tests performed at 2/3 MGS by 12 female subjects and 12 female controls.	67
4.1.6	Protocol: The effect of interelectrode separation (IES) distance upon SMES parameters in 10 female controls.	68f

4.1.7	The effect of the IES distance upon spectral parameters (expressed as mean (SD)) recorded from the extensor and flexor forearm musculature during standard grip tests at 2/3 MGS by 10 right handed female controls.	68
4.1.8	The effect of the IES distance upon the spectral peak and the RMS of the SMES (expressed as mean (SD)) recorded from the extensor and flexor forearm musculature during standard grip tests at 2/3 MGS by 10 right handed female controls.	69
4.1.9	The effect of smoothing cycles upon spectral parameters: data from the extensor channel from one standard grip test performed at 2/3 MGS by one subject with RA. Spectra before and after 10 smoothing cycles.	71
4.1.10	The effect of smoothing cycles upon spectral parameters: data from the extensor channel from one standard grip test performed at 2/3 MGS by one subject with RA.	72
4.2.1	Protocol: The short-term repeatability of SMES parameters from standard grip tests at 2/3MGS performed by 40 females with RA and 16 female controls.	74f
4.2.2	Repeatability of the RMS of the SMES (flexor channel) from standard grip tests at 2/3 MGS performed 5 minutes apart by 16 female controls.	75f
4.2.3	Repeatability of the RMS of the SMES (flexor channel) from standard grip tests at 2/3 MGS performed 5 minutes apart by 40 females with RA.	75f
4.2.4	Repeatability of the RMS of the SMES (extensor channel) from standard grip tests at 2/3 MGS performed 5 minutes apart by 16 female controls.	75
4.2.5	Repeatability of the RMS of the SMES (extensor channel) from standard grip tests at 2/3 MGS performed 5 minutes apart by 40 females with RA.	75
4.2.6	Repeatability of the MDF_G of the SMES (flexor channel) from standard grip tests at 2/3 MGS performed 5 minutes apart by 16 female controls.	76f
4.2.7	Repeatability of the MDF_G of the SMES (flexor channel) from standard grip tests at 2/3 MGS performed 5 minutes apart by 40 females with RA.	76f
4.2.8	Repeatability of the MDF_G of the SMES (extensor channel) from standard grip tests at 2/3 MGS performed 5 minutes apart by 16 female controls.	76
4.2.9	Repeatability of the MDF_G of the SMES (extensor channel) from standard grip tests at 2/3 MGS performed 5 minutes apart by 40 females with RA.	76
4.2.10	Repeatability of the IMF of the SMES (flexor channel) from standard grip tests at 2/3 MGS performed 5 minutes apart by 16 female controls.	77f
4.2.11	Repeatability of the IMF of the SMES (flexor channel) from standard grip tests at 2/3 MGS performed 5 minutes apart by 40 females with RA.	77f
4.2.12	Repeatability of the IMF of the SMES (extensor channel) from standard grip tests at 2/3 MGS performed 5 minutes apart by 16 female controls.	77

4.2.13	Repeatability of the IMF of the SMES (extensor channel) from standard grip tests at 2/3 MGS performed 5 minutes apart by 40 females with RA.	77
4.2.14	Protocol: The long-term repeatability of SMES parameters from standard grip tests at 1/3MGS performed 3 weeks apart by 19 females with RA and 18 female controls.	80f
4.2.15	Protocol: The long-term repeatability of SMES parameters from standard grip tests performed at 1/2 MGS weeks apart by 24 females with RA and 30 female controls.	80f
4.2.16	Protocol: The long-term repeatability of SMES parameters from standard grip tests at 2/3MGS performed 3 weeks apart by 18 females with RA and 21 female controls.	81f
4.2.17	Repeatability of the RMS of the SMES (extensor channel) from standard grip tests at 2/3 MGS performed 3 weeks apart by 18 females with RA.	81f
4.2.18	Repeatability of the RMS of the SMES (extensor channel) from standard grip tests at 2/3 MGS performed 3 weeks apart by 21 female controls.	81
4.2.19	Repeatability of the RMS of the SMES (flexor channel) from standard grip tests at 2/3 MGS performed 3 weeks apart by 21 female controls.	82
4.2.20	Repeatability of the RMS of the SMES (flexor channel) from standard grip tests at 2/3 MGS performed 3 weeks apart by 18 females with RA.	82
4.2.21	Repeatability of the MDF _G of the SMES (extensor channel) from standard grip tests at 2/3 MGS performed 3 weeks apart by 18 females with RA.	83f
4.2.22	Repeatability of the MDF _G of the SMES (extensor channel) from standard grip tests at 2/3 MGS performed 3 weeks apart by 21 female controls.	83
4.2.23	Repeatability of the MDF _G of the SMES (flexor channel) from standard grip tests at 2/3 MGS performed 3 weeks apart by 21 female controls.	84
4.2.24	Repeatability of the MDF _G of the SMES (flexor channel) from standard grip tests at 2/3 MGS performed 3 weeks apart by 18 females with RA.	84
4.2.25	Repeatability of the IMF of the SMES (flexor channel) from standard grip tests at 2/3 MGS performed 3 weeks apart by 21 female controls.	86f
4.2.26	Repeatability of the IMF of the SMES (flexor channel) from standard grip tests at 2/3 MGS performed 3 weeks apart by 18 females with RA.	86f
4.2.27	Repeatability of the IMF of the SMES (extensor channel) from standard grip tests at 2/3 MGS performed 3 weeks apart by 21 female controls.	86
4.2.28	Repeatability of the IMF of the SMES (extensor channel) from standard grip tests at 2/3 MGS performed 3 weeks apart by 18 females with RA.	86
4.3.1	The surface myoelectric parameters vs grip force levels protocol.	93

4.3.2	Mean RMS of the SMES (A) and linear regression lines (B) from extensor forearm musculature during standard grip tests versus percentage maximal grip pressure in 17 female controls.	94
4.3.3	Mean RMS of the SMES (A) and linear regression lines (B) from flexor forearm musculature during standard grip tests versus percentage maximal grip pressure in 17 female controls.	94
4.3.4	Mean MDF_G of the SMES (A) and linear regression lines (B) from extensor forearm musculature during standard grip tests versus percentage maximal grip pressure in 17 female controls.	94
4.3.5	Mean MDF_G of the SMES (A) and linear regression lines (B) from flexor forearm musculature during standard grip tests versus percentage maximal grip pressure in 17 female controls.	95
4.3.6	Mean IMF of the SMES (A) and linear regression lines (B) from extensor forearm musculature during standard grip tests versus percentage maximal grip pressure in 17 female controls.	95
4.3.7	Mean IMF of the SMES (A) and linear regression lines (B) from flexor forearm musculature during standard grip tests versus percentage maximal grip pressure in 17 female controls.	95
4.3.8	Mean spectral width (A) and linear regression lines (B) from extensor forearm musculature during standard grip tests versus percentage maximal grip pressure in 17 female controls.	96
4.3.9	Mean spectral width (A) and linear regression lines (B) from flexor forearm musculature during standard grip tests versus percentage maximal grip pressure in 17 female controls.	96
4.4.1	Test protocol: SMES acquisition and analysis from forearm surface electrodes during the following grip tests in 161 females with RA and 114 female controls.	99f
4.4.2	The MDF_G of the SMES recorded from the right forearm flexor channel versus that from the extensor channel during a standard right hand grip test performed at 2/3 MGS by 161 females with RA.	100f
4.4.3	The IMF of the SMES recorded from the right forearm flexor channel versus that from the extensor channel during a standard right hand grip test performed at 2/3 MGS by 161 females with RA.	100f
4.4.4	The relationship between the spectral width and the IMF of the extensor (A) and the Flexor (B) SMES in 161 females with RA and 114 healthy female controls.	100
5.3.1	The repeatability of the volumetric analysis of the right forearm using T1-W and proton scanning techniques over three testing sessions in ten subjects (mean(SD)).	105
5.3.2	Comparison of T1-W and Proton imaging techniques in volumetric analysis of right forearm musculature in 10 subjects.	106
5.4.1	Mean forearm muscle volume vs mean forearm CSA as measured using Proton and T1-W MR imaging in 10 subjects.	106

6.1.1	The relationship between MGS of the right hand and age in 161 right hand dominant females with RA and 114 female controls.	111f
6.1.2	MGS of the right hand vs the duration of disease in 161 right hand dominant females with RA.	111
6.1.3	The relationship between the MGS of the right hand and the flexor IMF of the SMES in 161 females with RA and 114 controls.	112
6.1.4	MGS of the right hand versus the right hand and wrist subluxation score in 161 right hand dominant females with RA.	112
6.1.5	The relationship between the right hand MGS and right hand BMD in 81 right hand dominant females with RA and 21 female controls.	113f
6.1.6	The relationship between the volume of the right forearm musculature and the MGS of the right hand in 27 right hand dominant females with RA and 14 female controls.	114f
6.2.1	The mean (SD) right hand MGS, IMF and spectral widths of the SMES derived from extensor and flexor forearm musculature during sustained grip at 2/3 MGS in 161 females with RA and 114 controls.	117
6.2.2	The relationship between right hand MGS and MDF _G of the extensor (A) and flexor (B) forearm musculature in 161 females with RA and 114 female controls.	117f
6.3.1	The relationship between right hand MGS and MDFG of the extensor (A) and flexor (B) forearm musculature in 161 females with RA and 114 female controls.	119f
6.3.2	The relationship between the extensor MDFG and the C-reactive protein (CRP) of 161 females with RA.	119
6.3.3	The relationship between the extensor MDFG and ulnar deviation of the right hand and wrist in 161 females with RA.	119
6.3.4	The relationship between the disease duration and the forearm flexor IMF in 161 females with RA.	120
7.1.1	The mean (SD) right hand MGS in the RA and control groups over the 12 week exercise programme.	124f
7.1.2	The mean percentage change (SD) from baseline in the right hand MGS in the RA and control groups over the 12 week exercise programme.	124
7.1.3	The mean percentage change (SD) in the right hand MGS compared to the previous test in the RA and control groups over the 12 week exercise programme.	124
7.2.1	The IMF of the SMES recorded from the extensor (A) and flexor (B) forearm channels in RA and control groups over the 12 week hand exercise programme (mean (SD)).	125f
7.3.1	Right and left hand disease parameters measured during a 12 week right hand exercise programme in 79 females with RA (mean (SD)).	127

7.4.1	The relationship between the change in the MGS of the right hand during a handgrip exercise programme and extensor IMF in 79 females with RA.	129
7.4.2	The relationship between the change in the MGS of the right hand during a handgrip exercise programme and the disease duration in 79 females with RA.	129
7.4.3	The relationship between the change in the MGS of the right hand during a handgrip exercise programme and the right hand and wrist subluxation score in 79 females with RA.	130
8.2.1	The relationship between the cross-sectional area of the right forearm and the maximum grip strength of the right hand in 27 females with RA prior to commencing a hand grip exercise programme.	134
8.2.2	The mean (SD) MGS of the right hand in 27 females with RA during a 12 week hand exercise programme.	134
8.2.3	The percentage changes in the CSA of the right forearm and in the MGS of the right hand in 27 females with RA after a 12 week handgrip exercise programme.	135f
8.2.4	The percentage change in the F:RMS gradients at the extensor and flexor channels vs that in right forearm CSA in 27 females with RA after a 12 week handgrip exercise programme.	135f
8.2.5	The relationship between changes noted in grip force : RMS of the SMES gradient (extensor channel) and MGS of the right hand after a 12 week handgrip exercise programme in 27 females with RA.	135
8.2.6	The relationship between changes noted in grip force : RMS of the SMES gradient (flexor channel) and MGS of the right hand after a 12 week handgrip exercise programme in 27 females with RA.	135
8.2.7	The percentage change in the F:RMS gradients at the flexor channel versus that of the extensor channel in 27 females with RA after a 12 week handgrip exercise programme.	136
8.3.1	The right forearm muscle volume and grip strength of the RA and control groups at baseline and after 12 weeks of a handgrip exercise programme (mean (SD)).	137f
8.3.2	The change in the volume of the right forearm musculature versus change in the MGS of the right hand in 14 female controls (A) and 14 females with RA (B) after a 12 week handgrip exercise programme.	138f
8.3.3	The change in the volume of the right forearm and the F:RMS gradients derived from the extensor (A) and flexor (B) channels after a 12 week hand exercise programme in females with RA.	138
8.3.4	The relationship between the change in forearm muscle volume and the F:RMS gradients derived from extensor and flexor channels after a 12 week exercise programme in 14 female controls.	139f
8.3.5	Grip strength vs RMS of the SMES for extensor and flexor channels in 14 female controls over a 12 week exercise programme. The associated changes in slope of the regression lines, MGS and forearm muscle volume are given in the associated tables.	140-2

- 8.3.6 Grip strength vs RMS of the SMES for extensor and flexor channels in 143-5
14 females with RA over a 12 week exercise programme. The %
changes in slope of the given regression lines, MGS and forearm muscle
volume are given in the associated tables.

Figures.

2.3.1	The frequency spectrum of the SMES.	15
2.3.2	The change in the median frequency of the SMES with time.	15
3.1.1	The Hand Assessment System.	47f
3.1.2	The pressure readings versus the ADC output (microvolts) from the grip bag compared with the sphygmomanometer (mmHg).	48f
3.1.3	The grip force: RMS gradient ($FRMS_G$).	49f
3.1.4	The SMES Analysis System	50
3.2.1	Calibration of the SMES acquisition and analysis system.	51
3.2.2.	Position of extensor electrodes and arm in rig for forearm SMES analysis during grip.	53
3.2.3	Position of flexor electrodes and arm in rig for forearm SMES analysis during grip.	53
3.3.1	Subject positioning for grip testing.	54
3.5.1	Patient positioning for bone densitometry of the right hand using a Lunar DPX-L Scanner	59
3.5.2	Close-up view of the position of the right hand on perspex board for hand bone densitometry.	59
3.5.3	An example of a right hand and wrist subluxation score in a female with RA.	60
3.6.1	The testing protocol.	61
4.1.1	Protocol: The repeatability of maximum grip strength (MGS) over 3 tests performed 20 seconds apart by 12 female subjects with RA and 12 controls.	66f
4.1.2	The repeatability of maximum grip strength (MGS) over 3 tests performed 20 seconds apart by 12 female subjects with RA and 12 controls.	66
4.1.3	Protocol: Maintenance of the target grip.	66f
4.1.4	Protocol: The repeatability of the chosen angle of wrist extension during standard 30-second grip tests performed at 2/3MGS, by 12 females with RA and 12 female controls.	67f
4.1.5	The repeatability of the chosen angle of wrist extension during standard 30-second grip tests performed at 2/3 MGS by 12 female subjects and 12 female controls.	67
4.1.6	Protocol: The effect of interelectrode separation (IES) distance upon SMES parameters in 10 female controls.	68f

4.1.7	The effect of the IES distance upon spectral parameters (expressed as mean (SD)) recorded from the extensor and flexor forearm musculature during standard grip tests at 2/3 MGS by 10 right handed female controls.	68
4.1.8	The effect of the IES distance upon the spectral peak and the RMS of the SMES (expressed as mean (SD)) recorded from the extensor and flexor forearm musculature during standard grip tests at 2/3 MGS by 10 right handed female controls.	69
4.1.9	The effect of smoothing cycles upon spectral parameters: data from the extensor channel from one standard grip test performed at 2/3 MGS by one subject with RA. Spectra before and after 10 smoothing cycles.	71
4.1.10	The effect of smoothing cycles upon spectral parameters: data from the extensor channel from one standard grip test performed at 2/3 MGS by one subject with RA.	72
4.2.1	Protocol: The short-term repeatability of SMES parameters from standard grip tests at 2/3MGS performed by 40 females with RA and 16 female controls.	74f
4.2.2	Repeatability of the RMS of the SMES (flexor channel) from standard grip tests at 2/3 MGS performed 5 minutes apart by 16 female controls.	75f
4.2.3	Repeatability of the RMS of the SMES (flexor channel) from standard grip tests at 2/3 MGS performed 5 minutes apart by 40 females with RA.	75f
4.2.4	Repeatability of the RMS of the SMES (extensor channel) from standard grip tests at 2/3 MGS performed 5 minutes apart by 16 female controls.	75
4.2.5	Repeatability of the RMS of the SMES (extensor channel) from standard grip tests at 2/3 MGS performed 5 minutes apart by 40 females with RA.	75
4.2.6	Repeatability of the MDF_G of the SMES (flexor channel) from standard grip tests at 2/3 MGS performed 5 minutes apart by 16 female controls.	76f
4.2.7	Repeatability of the MDF_G of the SMES (flexor channel) from standard grip tests at 2/3 MGS performed 5 minutes apart by 40 females with RA.	76f
4.2.8	Repeatability of the MDF_G of the SMES (extensor channel) from standard grip tests at 2/3 MGS performed 5 minutes apart by 16 female controls.	76
4.2.9	Repeatability of the MDF_G of the SMES (extensor channel) from standard grip tests at 2/3 MGS performed 5 minutes apart by 40 females with RA.	76
4.2.10	Repeatability of the IMF of the SMES (flexor channel) from standard grip tests at 2/3 MGS performed 5 minutes apart by 16 female controls.	77f
4.2.11	Repeatability of the IMF of the SMES (flexor channel) from standard grip tests at 2/3 MGS performed 5 minutes apart by 40 females with RA.	77f
4.2.12	Repeatability of the IMF of the SMES (extensor channel) from standard grip tests at 2/3 MGS performed 5 minutes apart by 16 female controls.	77

4.2.13	Repeatability of the IMF of the SMES (extensor channel) from standard grip tests at 2/3 MGS performed 5 minutes apart by 40 females with RA.	77
4.2.14	Protocol: The long-term repeatability of SMES parameters from standard grip tests at 1/3MGS performed 3 weeks apart by 19 females with RA and 18 female controls.	80f
4.2.15	Protocol: The long-term repeatability of SMES parameters from standard grip tests performed at 1/2 MGS weeks apart by 24 females with RA and 30 female controls.	80f
4.2.16	Protocol: The long-term repeatability of SMES parameters from standard grip tests at 2/3MGS performed 3 weeks apart by 18 females with RA and 21 female controls.	81f
4.2.17	Repeatability of the RMS of the SMES (extensor channel) from standard grip tests at 2/3 MGS performed 3 weeks apart by 18 females with RA.	81f
4.2.18	Repeatability of the RMS of the SMES (extensor channel) from standard grip tests at 2/3 MGS performed 3 weeks apart by 21 female controls.	81
4.2.19	Repeatability of the RMS of the SMES (flexor channel) from standard grip tests at 2/3 MGS performed 3 weeks apart by 21 female controls.	82
4.2.20	Repeatability of the RMS of the SMES (flexor channel) from standard grip tests at 2/3 MGS performed 3 weeks apart by 18 females with RA.	82
4.2.21	Repeatability of the MDF_G of the SMES (extensor channel) from standard grip tests at 2/3 MGS performed 3 weeks apart by 18 females with RA.	83f
4.2.22	Repeatability of the MDF_G of the SMES (extensor channel) from standard grip tests at 2/3 MGS performed 3 weeks apart by 21 female controls.	83
4.2.23	Repeatability of the MDF_G of the SMES (flexor channel) from standard grip tests at 2/3 MGS performed 3 weeks apart by 21 female controls.	84
4.2.24	Repeatability of the MDF_G of the SMES (flexor channel) from standard grip tests at 2/3 MGS performed 3 weeks apart by 18 females with RA.	84
4.2.25	Repeatability of the IMF of the SMES (flexor channel) from standard grip tests at 2/3 MGS performed 3 weeks apart by 21 female controls.	86f
4.2.26	Repeatability of the IMF of the SMES (flexor channel) from standard grip tests at 2/3 MGS performed 3 weeks apart by 18 females with RA.	86f
4.2.27	Repeatability of the IMF of the SMES (extensor channel) from standard grip tests at 2/3 MGS performed 3 weeks apart by 21 female controls.	86
4.2.28	Repeatability of the IMF of the SMES (extensor channel) from standard grip tests at 2/3 MGS performed 3 weeks apart by 18 females with RA.	86
4.3.1	The surface myoelectric parameters vs grip force levels protocol.	93

4.3.2	Mean RMS of the SMES (A) and linear regression lines (B) from extensor forearm musculature during standard grip tests versus percentage maximal grip pressure in 17 female controls.	94
4.3.3	Mean RMS of the SMES (A) and linear regression lines (B) from flexor forearm musculature during standard grip tests versus percentage maximal grip pressure in 17 female controls.	94
4.3.4	Mean MDF_G of the SMES (A) and linear regression lines (B) from extensor forearm musculature during standard grip tests versus percentage maximal grip pressure in 17 female controls.	94
4.3.5	Mean MDF_G of the SMES (A) and linear regression lines (B) from flexor forearm musculature during standard grip tests versus percentage maximal grip pressure in 17 female controls.	95
4.3.6	Mean IMF of the SMES (A) and linear regression lines (B) from extensor forearm musculature during standard grip tests versus percentage maximal grip pressure in 17 female controls.	95
4.3.7	Mean IMF of the SMES (A) and linear regression lines (B) from flexor forearm musculature during standard grip tests versus percentage maximal grip pressure in 17 female controls.	95
4.3.8	Mean spectral width (A) and linear regression lines (B) from extensor forearm musculature during standard grip tests versus percentage maximal grip pressure in 17 female controls.	96
4.3.9	Mean spectral width (A) and linear regression lines (B) from flexor forearm musculature during standard grip tests versus percentage maximal grip pressure in 17 female controls.	96
4.4.1	Test protocol: SMES acquisition and analysis from forearm surface electrodes during the following grip tests in 161 females with RA and 114 female controls.	99f
4.4.2	The MDF_G of the SMES recorded from the right forearm flexor channel versus that from the extensor channel during a standard right hand grip test performed at 2/3 MGS by 161 females with RA.	100f
4.4.3	The IMF of the SMES recorded from the right forearm flexor channel versus that from the extensor channel during a standard right hand grip test performed at 2/3 MGS by 161 females with RA.	100f
4.4.4	The relationship between the spectral width and the IMF of the extensor (A) and the Flexor (B) SMES in 161 females with RA and 114 healthy female controls.	100
5.3.1	The repeatability of the volumetric analysis of the right forearm using T1-W and proton scanning techniques over three testing sessions in ten subjects (mean(SD)).	105
5.3.2	Comparison of T1-W and Proton imaging techniques in volumetric analysis of right forearm musculature in 10 subjects.	106
5.4.1	Mean forearm muscle volume vs mean forearm CSA as measured using Proton and T1-W MR imaging in 10 subjects.	106

6.1.1	The relationship between MGS of the right hand and age in 161 right hand dominant females with RA and 114 female controls.	111f
6.1.2	MGS of the right hand vs the duration of disease in 161 right hand dominant females with RA.	111
6.1.3	The relationship between the MGS of the right hand and the flexor IMF of the SMES in 161 females with RA and 114 controls.	112
6.1.4	MGS of the right hand versus the right hand and wrist subluxation score in 161 right hand dominant females with RA.	112
6.1.5	The relationship between the right hand MGS and right hand BMD in 81 right hand dominant females with RA and 21 female controls.	113f
6.1.6	The relationship between the volume of the right forearm musculature and the MGS of the right hand in 27 right hand dominant females with RA and 14 female controls.	114f
6.2.1	The mean (SD) right hand MGS, IMF and spectral widths of the SMES derived from extensor and flexor forearm musculature during sustained grip at 2/3 MGS in 161 females with RA and 114 controls.	117
6.2.2	The relationship between right hand MGS and MDF _G of the extensor (A) and flexor (B) forearm musculature in 161 females with RA and 114 female controls.	117f
6.3.1	The relationship between right hand MGS and MDFG of the extensor (A) and flexor (B) forearm musculature in 161 females with RA and 114 female controls.	119f
6.3.2	The relationship between the extensor MDFG and the C-reactive protein (CRP) of 161 females with RA.	119
6.3.3	The relationship between the extensor MDFG and ulnar deviation of the right hand and wrist in 161 females with RA.	119
6.3.4	The relationship between the disease duration and the forearm flexor IMF in 161 females with RA.	120
7.1.1	The mean (SD) right hand MGS in the RA and control groups over the 12 week exercise programme.	124f
7.1.2	The mean percentage change (SD) from baseline in the right hand MGS in the RA and control groups over the 12 week exercise programme.	124
7.1.3	The mean percentage change (SD) in the right hand MGS compared to the previous test in the RA and control groups over the 12 week exercise programme.	124
7.2.1	The IMF of the SMES recorded from the extensor (A) and flexor (B) forearm channels in RA and control groups over the 12 week hand exercise programme (mean (SD)).	125f
7.3.1	Right and left hand disease parameters measured during a 12 week right hand exercise programme in 79 females with RA (mean (SD)).	127

7.4.1	The relationship between the change in the MGS of the right hand during a handgrip exercise programme and extensor IMF in 79 females with RA.	129
7.4.2	The relationship between the change in the MGS of the right hand during a handgrip exercise programme and the disease duration in 79 females with RA.	129
7.4.3	The relationship between the change in the MGS of the right hand during a handgrip exercise programme and the right hand and wrist subluxation score in 79 females with RA.	130
8.2.1	The relationship between the cross-sectional area of the right forearm and the maximum grip strength of the right hand in 27 females with RA prior to commencing a hand grip exercise programme.	134
8.2.2	The mean (SD) MGS of the right hand in 27 females with RA during a 12 week hand exercise programme.	134
8.2.3	The percentage changes in the CSA of the right forearm and in the MGS of the right hand in 27 females with RA after a 12 week handgrip exercise programme.	135f
8.2.4	The percentage change in the F:RMS gradients at the extensor and flexor channels vs that in right forearm CSA in 27 females with RA after a 12 week handgrip exercise programme.	135f
8.2.5	The relationship between changes noted in grip force : RMS of the SMES gradient (extensor channel) and MGS of the right hand after a 12 week handgrip exercise programme in 27 females with RA.	135
8.2.6	The relationship between changes noted in grip force : RMS of the SMES gradient (flexor channel) and MGS of the right hand after a 12 week handgrip exercise programme in 27 females with RA.	135
8.2.7	The percentage change in the F:RMS gradients at the flexor channel versus that of the extensor channel in 27 females with RA after a 12 week handgrip exercise programme.	136
8.3.1	The right forearm muscle volume and grip strength of the RA and control groups at baseline and after 12 weeks of a handgrip exercise programme (mean (SD)).	137f
8.3.2	The change in the volume of the right forearm musculature versus change in the MGS of the right hand in 14 female controls (A) and 14 females with RA (B) after a 12 week handgrip exercise programme.	138f
8.3.3	The change in the volume of the right forearm and the F:RMS gradients derived from the extensor (A) and flexor (B) channels after a 12 week hand exercise programme in females with RA.	138
8.3.4	The relationship between the change in forearm muscle volume and the F:RMS gradients derived from extensor and flexor channels after a 12 week exercise programme in 14 female controls.	139f
8.3.5	Grip strength vs RMS of the SMES for extensor and flexor channels in 14 female controls over a 12 week exercise programme. The associated changes in slope of the regression lines, MGS and forearm muscle volume are given in the associated tables.	140-2

8.3.6 Grip strength vs RMS of the SMES for extensor and flexor channels in 143-5
14 females with RA over a 12 week exercise programme. The %
changes in slope of the given regression lines, MGS and forearm muscle
volume are given in the associated tables.

List of Tables

3.2.1	SMES acquisition and analysis calibration.	52
4.1.1	Pilot studies I: Details of the study groups involved in initial pilot studies.	64
4.1.2	Comparison between the power spectral parameters of the SMES from the forearm extensor channel during a 30 second grip test performed at 2/3 MGS before and after the application of Hanning window (n=29). Mean (SD).	70
4.1.3	Comparison between the power spectral parameters of the SMES from the forearm flexor channel during a 30 second grip test performed at 2/3 MGS before and after the application of Hanning window (n=29). Mean (SD).	70
4.1.4	Comparison of 0, 3 and 10 smoothing cycles on forearm EMG spectral parameters in 16 female subjects with RA. Extensor channel (Mean (SD)).	72
4.1.5	Comparison of 0, 3 and 10 smoothing cycles on forearm EMG spectral parameters in 16 female subjects with RA. Flexor channel (Mean (SD)).	73
4.2.1	Details of the subject groups in the restitution study.	74
4.2.2	Repeatability of myoelectric parameters (extensor channel) from standard grip tests at 2/3 MGS performed 5 minutes apart by 16 female controls.	79f
4.2.3	Repeatability of myoelectric parameters (flexor channel) from standard grip tests at 2/3 MGS performed 5 minutes apart by 16 female controls.	79f
4.2.4	Repeatability of myoelectric parameters (extensor channel) from standard grip tests at 2/3 MGS performed 5 minutes apart by 40 females with RA.	79
4.2.5	Repeatability of myoelectric parameters (flexor channel) from standard grip tests at 2/3 MGS performed 5 minutes apart by 40 females with RA.	79
4.2.6	The study groups in the assessment of the repeatability of the technique of SMES analysis of the forearm.	80
4.2.7	Repeatability of myoelectric parameters (extensor channel) from standard grip tests at 2/3 MGS performed 3 weeks apart by 21 female controls.	87f
4.2.8	Repeatability of myoelectric parameters (flexor channel) from standard grip tests at 2/3 MGS performed 3 weeks apart by 21 female controls.	87f
4.2.9	Repeatability of myoelectric parameters (extensor channel) from standard grip tests at 2/3 MGS performed 3 weeks apart by 18 females with RA.	87

4.2.10	Repeatability of myoelectric parameters (flexor channel) from standard grip tests at 2/3 MGS performed 3 weeks apart by 18 females with RA.	87
4.2.11	Repeatability of myoelectric parameters (extensor channel) from standard grip tests at 1/2 MGS performed 3 weeks apart by 30 female controls.	88f
4.2.12	Repeatability of myoelectric parameters (flexor channel) from standard grip tests at 1/2 MGS performed 3 weeks apart by 30 female controls.	88f
4.2.13	Repeatability of myoelectric parameters (extensor channel) from standard grip tests at 1/2 MGS performed 3 weeks apart by 24 females with RA.	88
4.2.14	Repeatability of myoelectric parameters (flexor channel) from standard grip tests at 1/2 MGS performed 3 weeks apart by 24 females with RA.	88
4.2.15	Repeatability of myoelectric parameters (extensor channel) from standard grip tests at 1/3 MGS performed 3 weeks apart by 18 female controls.	89f
4.2.16	Repeatability of myoelectric parameters (flexor channel) from standard grip tests at 1/3 MGS performed 3 weeks apart by 18 female controls.	89f
4.2.17	Repeatability of myoelectric parameters (extensor channel) from standard grip tests at 1/3 MGS performed 3 weeks apart by 19 females with RA.	89
4.2.18	Repeatability of myoelectric parameters (flexor channel) from standard grip tests at 1/3 MGS performed 3 weeks apart by 19 females with RA.	89
4.4.1	Characteristics of the two study groups.	99f
5.2.1	The repeatability of the assessment of CSA of the right forearm using single slice magnetic resonance imaging in ten healthy subjects.	103
5.3.1	The repeatability of volumetric analysis of the forearm of ten subjects over three testing occasions using proton imaging.	104
5.3.2	The repeatability of the adjusted volume of the right forearm from T1-W imaging technique over three testing sessions (mean (SD); 95 % CI (voxels)).	105
6.1.1	Characteristics of the two study groups.	109f
6.1.2	Right hand and general disease parameters at baseline in the RA group consisting of 161 right hand dominant females with RA.	109f
6.1.3	Right hand disease parameters at baseline in the RA group consisting of 161 right hand dominant females with RA.	110f

6.1.4	Left hand disease parameters at baseline in the RA group consisting of 161 right hand dominant females with RA.	110f
6.1.5	The multiple regression analysis for the factors affecting grip strength in female healthy controls.	112f
6.1.6	The results of the multiple regression for grip strength (dependent variable) in females with rheumatoid arthritis.	112f
6.1.7	Subject characteristics of the main study group and subgroup in which right hand BMD was measured.	113
6.1.8	Characteristics of the RA subgroup assessed in the study of the CSA of the right forearm.	114
6.1.9	Characteristics of subgroups included in the study of the volumetric analysis of the right forearm musculature.	114
6.2.1	Myoelectric parameters measured from the right forearm in the two study groups during a standard right hand grip test performed at 2/3 MGS.	116f
6.3.1	The multiple regression analysis for the factors affecting the extensor MDF_G in female healthy controls.	118f
6.3.2	The multiple regression analysis for the factors affecting the flexor MDF_G in female healthy controls.	118f
6.3.3	The multiple regression analysis for the factors affecting the flexor IMF in female healthy controls.	118f
6.3.4	The multiple regression analysis for the factors affecting the extensor MDF_G in females with RA.	120f
6.3.5	The multiple regression analysis for the factors affecting the flexor MDF_G in females with RA.	120f
6.3.6	The multiple regression analysis for the factors affecting the extensor IMF in females with RA.	120f
7.1.1.	Basic characteristics of the two exercise groups.	123f
7.1.2	Maximum grip strength of the right hand in RA and control groups during the 12 week handgrip exercise programme.	123
7.2.1	The extensor and flexor forearm IMF in RA and control groups during the 12 week handgrip exercise programme.	125
7.3.1	Right and left hand disease parameters measured during a 12 week right hand exercise programme in 79 females with RA.	126
7.4.1	The results of the multiple regression for the percentage gain in grip strength (dependent variable) in females with rheumatoid arthritis.	128f

7.4.2	Details of the subgroup of females with RA taking part in the handgrip exercise programme in whom BMD of the right hand was measured.	130
8.2.1	Details of the study group consisting of 27 right hand dominant females with RA.	133f
8.3.1	Details of the RA and control groups in the analysis of mechanisms of strength gain in the handgrip exercise programme using volumetric analysis of the forearm.	139

Chapter One. Introduction.

Weakness, subjective fatigue and diminished function are significant problems in rheumatoid arthritis. These problems are multifactorial in origin, with potential contributing factors including pain, inflammation, deformity, reflex inhibition of muscle and deconditioning. Histological abnormalities, including muscle fibre atrophy, have been noted in several studies of rheumatoid skeletal muscle and have been suggested to be secondary to disuse atrophy, denervation, or both of these processes. The significance of such findings with respect to fatigue and functional capacity are unclear. In spite of the high prevalence of subjective fatigue in rheumatoid disease, the issue of whether there is increased fatiguability within the muscle has not been addressed.

Power spectral analysis of the surface myoelectric signal during sustained muscular work is an established technique in the assessment of muscle fatigue. The decrease in the median frequency with time has been shown to reflect metabolic and electrophysiological changes occurring within the muscle and is a useful indicator of muscle fatigue (Komi & Tesch, 1979; Sadoyama et al, 1988). Other myoelectric parameters which may be derived from the frequency spectrum have been shown to be altered in neuromuscular disorders, specifically primary myopathies and myopathies secondary to neuropathic lesions, including denervation. Such measures may therefore be useful in the assessment of the functional significance of neuromuscular abnormalities in subjects with rheumatoid disease and their relationship with disease measures.

The issue of therapeutic strengthening exercise in rheumatoid arthritis is an area of confusion. Much of the lack of a consensus of opinion is related to a lack of well designed, scientifically based research on the subject, a lack of functionally based programmes, difficulties with defining those subjects who will benefit, and concerns that such programmes will have adverse effects upon the disease.

This study addressed the inter-related issues of the significance of neuromuscular abnormalities and the response to a simple strengthening exercise programme in rheumatoid arthritis. Specific issues were addressed using the technique of power spectral analysis of the surface myoelectric signal during isometric contractions. Evidence of specific neuromuscular abnormalities in skeletal muscle of subjects with

RA was sought. The nature of these changes was examined, specifically whether they resembled changes typical of a primary myopathy or those of a myopathy secondary to denervation, in addition to whether there was abnormal fatigability of the muscle during isometric contractions. The relationship between these neuromuscular abnormalities and disease characteristics (that is the severity and activity of the disease) was also assessed.

It is not known whether the changes which have been noted within rheumatoid muscle affect the response to strengthening exercise in rheumatoid disease. Indeed, the mechanisms of strength gain in RA have also received little attention in spite of these being the basis for the development of exercise programmes in healthy individuals. These areas were also investigated in this study.

Grip strength was chosen as the functional task in this study for a number of reasons. Grip strength is the cornerstone of hand functional analysis and reflects disease severity and disease activity in rheumatoid disease. The forearm muscles, which are important in the performance of a gripping task, have the advantage of easy accessibility for surface electromyography. Hence, the assessment of myoelectric characteristics during a task that is known to reflect not only strength, but also many aspects of the rheumatoid disease process, was possible. The ability to grip is vital in daily function and is a task with which most individuals are familiar, which improves the reliability of measurements of strength and myoelectric characteristics. Performing a handgrip strengthening exercise programme has the potential advantage of improving function rather than simply the strength of a single muscle and allowed easy monitoring of disease status and myoelectric characteristics over the course of the programme.

Chapter Two. Grip strength, muscle fatigue and hand grip strength training in rheumatoid arthritis: a literature review.

2.1.1 Introduction

Diminished function in rheumatoid arthritis is multifactorial in origin, with potential contributing factors including pain, stiffness, deformity, psychological elements, muscle weakness and dysfunction and fatigue. Histological abnormalities exist within the skeletal muscle in RA, the potential significance of which – in particular in relation to weakness and fatigue - form the basis of the first three sections of the literature review. The effect of exercise upon hand function, measured as grip strength, in the presence of these factors in RA is unclear. This will be reviewed in the latter two sections of this chapter. Firstly, the literature to date on the subject of the characteristics of rheumatoid muscle will be addressed.

2.1.2 Histological changes in muscle in rheumatoid arthritis.

Muscle has a relatively limited range of histological changes in reaction to disease and most of these changes are non-specific (Cullen and Mastaglia, 1982; Neville, 1973). Myopathic changes have been noted in RA; however there are no histological changes in muscle which are specific to the disease (Magyar et al, 1977). A combination of features may suggest the diagnosis (Magyar et al, 1977; Halla et al, 1984).

Myopathies can be classified as primary, due to a defect in the muscle itself, or secondary to a defect within the nerves supplying the muscle, in which case the myopathy is neurogenic in origin (Jones and Round, 1990). Primary myopathies can be further subdivided into atrophic and destructive myopathies. Atrophic myopathies are associated with disuse and involve the reduction in fibre size with little, if any, reduction in total number. In destructive myopathies muscle fibres are lost. Although atrophic myopathies are often considered to preferentially affect type II fibres (Jones and Round, 1990), this is dependent upon the presence of factors such as arthrogenous inhibition and the nature of the disuse.

Disuse can be regarded as localised (when one joint is inflamed and held immobile) or generalised (secondary to systemic illness or changes in lifestyle). However, many workers fail to differentiate between the two (Russell and Hanna, 1988; Nordemar et al, 1976b).

In the situation of general disuse, but no joint immobilisation, Type II fibre atrophy predominates, probably because the patient does not make contractions strong enough to recruit high threshold motor units containing Type II muscle fibres (Grimby and Thomee, 1988). Preferential Type II fibre atrophy also occurs in relation to upper motor neurone lesions and spinal cord transection (Magyar et al, 1977). Brooke and Kaplan (1972) suggested that in mild RA, atrophy of Type II fibres occurs due to limitation of rapid, forceful movements. In severe RA, they proposed that Type II fibres actively 'splint' the joint, preventing atrophy of these fibres, but allowing Type I fibre atrophy, since the latter are inactive.

Between these two extremes, various mixtures of atrophy in the response to injury or disease may exist (Herbison et al, 1987; Young, 1993), possibly due to a coexistence of general disuse and local immobilisation, which may vary with time. Although most histological studies of muscle in RA have indicated preferential atrophy of type II fibres, as has been discussed (Haslock et al 1970; Magyar et al, 1977; Edstrom and Nordemar, 1974), this may be related to the characteristics of the subjects assessed, the muscle studied (Herbison et al, 1978) and the limitations of some of the techniques used in assessment in the earlier studies (Wroblewski and Nordemar, 1975). Nordemar et al (1976a; 1976b) demonstrated atrophy of both fibre types in the quadriceps of subjects with functional class I and II RA.

Histological studies have shown that muscle fibres do not atrophy uniformly (Magyar et al, 1977). The length of a muscle during a period of immobilisation influences the final length, the addition of new sarcomeres increasing the longitudinal length of a muscle if it is immobilised in a lengthened position (Haggmark et al, 1979). Conversely, if the muscle is held in a shortened position, shortening will occur due to the loss of sarcomeres (Gordon and Pattullo, 1993).

In an immobilised joint at a fixed angle, the pattern of atrophy is dependent upon the relative length of the muscle, which in turn influences the type and amount of impulses

from stretch receptors. In muscles immobilised in a relaxed state, type I fibre atrophy predominates (Grimby and Thomee, 1988). It has been suggested that the observed histological changes are due to fibre type transformation rather than a specific fibre atrophy possibly related to altered loading and changes in muscle length (Kilmer, 1996; Appell, 1990), although there is little evidence to support this. Muscle fibre atrophy and alterations in muscle length may have significant effects upon function, the frequency spectrum of the SMES and spectral parameters in fatiguing contractions, as will be described later.

Neurogenic myopathy can also give rise to atrophic fibres and usually affects both fibre types, which is a distinguishing feature from atrophic myopathy (Kilmer, 1996; Jones and Round, 1990). If the condition is chronic, then reinnervation often commences. Reinnervation occurs by the growth of nearby motoneurons, which form contact with the atrophic fibres and supply them. The muscle fibres then adopt the characteristics of the motoneurone supplying them; if the neurone is of the same type then the fibre characteristics remain the same (self-reinnervation) and if not, they change (Jones and Round, 1990; Milner-Brown et al, 1974; Thomas et al, 1987). Milner-Brown et al (1974) and Thomas et al (1987) studied MU recruitment in human muscles reinnervated by surgical reunion after complete section. Some motor units showed normal force threshold and twitch tension; others did not. Thomas et al (1987) concluded that the predictive factor in recovery of normal MU function was whether self-reinnervation occurred. Over a period of time, after a period of multiple innervation, the process of denervation–reinnervation continues, the end result of which may be fibres of a uniform type, or at least an increase in the relative amounts of one fibre type (Jones and Round, 1990; Engel, 1970)

Hence, in diseases of muscle of neurogenic origin, the successive denervation and reinnervation may give rise to fibres with their original characteristics or may result in fibres of a uniform type.

The most common histological findings in RA are muscle fibre atrophy and nodular myositis (Halla et al, 1984; Magyar et al, 1977). The latter involves nodular accumulations of mononuclear cells and although originally thought to be specific to RA (Curtis and Pollard, 1940; Steiner et al, 1946) it has since been noted in other connective tissue disorders (Sokoloff et al, 1950; Pearson, 1959). It is, however, a common finding

in RA; Sokoloff et al (1950) noted it to be present in approximately 56% of rheumatoid subjects.

Haslock et al (1970) described a wide variety of neuromuscular changes in RA, including fibre atrophy, peripheral neuropathy and myositis. Their proposal that **denervation** is an important association with fibre atrophy has been reported by many workers (Magyar et al, 1977; Curtis and Pollard 1940; Sokoloff et al, 1950; Halla et al 1984). Magyar et al (1977) in a study of muscle biopsies from 100 cases of RA, found atrophy of type II muscle fibres to be a common finding with the appearances of Type I fibres being “within normal limits”. They agreed with others (Morrison et al, 1947; Yates, 1963; Haslock et al, 1970) that the type II fibre atrophy was **neurogenic** in origin, based on the small diameter, angular arrangement and enzyme activity of the fibres. This is indicated further by the findings of abnormalities within intramuscular nerves.

In further biopsy and EMG studies in RA, Wroblewski and Nordemar (1975) confirmed the above findings, demonstrating muscle fibre atrophy and degenerative changes. Brooke and Kaplan (1972) found Types I and II fibre atrophy in severe and mild RA respectively. Russell and Hanna (1988) emphasised the importance of histochemical studies to the demonstration of isolated atrophy of Type II muscle fibres in RA. The mechanisms which may be involved in fibre atrophy will be discussed further in relation to weakness in RA.

Other non-specific changes have been noted in rheumatoid muscle; their significance is unclear and will be only briefly outlined here. Changes include degenerative changes in the sarcoplasm and interstitial changes such as perivascular nodular myositis, lymphocytic accumulations, abnormalities within the muscle spindles and different stages of vasculitis (Magyar et al, 1977; Wroblewski and Nordemar (1975), Engel 1966a, 1966b; Cape et al, 1970; Jerusalem et al, 1971). Focal muscle fibre necrosis and rheumatoid myositis (which is rare as a distinct entity) have also been demonstrated particularly when there is an inappropriately elevated ESR compared to the degree of synovitis (SERD) or a large increase in the level of creatine phosphokinase (Halla et al, 1984; Brooke et al, 1972; Reza and Verity, 1977).

The mode of selection of subjects for histological studies of rheumatoid muscle varied between those in which biopsies were taken during unrelated surgical procedures and those in which subjects had clinical symptoms such as weakness and muscle pain, necessitating

muscle biopsy. This adds to the difficulty in interpreting the relevance of the findings of such studies. The main disease parameter associated with histological abnormalities of rheumatoid muscle has been reported to be independent of both the activity and duration of the disease (Magyar et al, 1977).

2.2.1 Weakness in RA.

Weakness and dysfunction may be related to extrinsic factors such as altered joint mechanics and psychological elements (Stenstrom, 1994; Clough, 1991; Wolfe and Cathey, 1991) and to intrinsic factors associated with histological changes in muscle and arthrogenous muscle weakness. This latter term describes the inability to voluntarily generate the active tension in rested muscle that is necessary for the performance of everyday motor tasks, as result of joint disease (Stokes and Young, 1984). Functionally significant muscle weakness is a common problem in RA. Ekdahl and Broman (1992) demonstrated the existence of diminished functional capacity, isometric and isokinetic strength and isokinetic endurance in the lower limbs of subjects with class II RA. Isometric strength was found to be 75% of control values, isokinetic strength 65 - 75% and isokinetic endurance reduced to 45 % of the control level. These findings confirm earlier findings by others (Tiselius 1969; Ekblom et al, 1974; Nordesjo et al, 1983; Danneskiold-Samsøe and Grimby, 1986; Hsieh et al, 1987). Isometric and isokinetic weakness has also been reported in relation to the upper limbs (Ekblom et al 1974, Beals et al 1985; Danneskiold-Samsøe and Grimby, 1986; Hsieh et al, 1987) with upper limb endurance being reported as normal (Hsieh et al, 1987) or reduced (Nordesjo et al, 1983).

Arthrogenous muscle weakness, is multifactorial in origin (Lee et al, 1974; Helliwell et al, 1987; Young, 1993). Contributing factors include reflex inhibition and intrinsic changes within the muscle in the form of muscle fibre atrophy and other less specific changes.

As long ago as 1873, Sir James Paget recognised muscle wasting and weakness as a 'clinical sign of muscle atrophy associated with chronic inflammation of the joints' (Magyar et al, 1977). Such findings occur early and may be the initial manifestation of the disease (Ropes et al, 1959). Disuse, active rheumatoid disease with systemic manifestations, local joint disease, drugs, neurological, muscular, skeletal and soft tissue structural abnormalities, trauma and poor nutrition may all potentially play roles (Herbison et al, 1987; Stokes and Young, 1984; Haslock et al, 1970).

Primary muscle atrophy in injury or disease may be selective to the fibre type, the specific region of a muscle or muscle group or to agonists or antagonists. It will vary according to the **disease** and with **disuse, immobilisation and reflex inhibition** (Grimby and Thomee, 1988).

The effects of disuse upon muscle fibres have been described. Disuse (the term being used non-specifically) has been suggested to be the cause of muscle weakness in rheumatoid arthritis (Hollander and M^cCarty, 1972) and most workers agree that it does contribute (Haslock et al 1970; Magyar et al, 1977). However, as Hsieh et al (1987) demonstrated, weakness does occur in patients who are very active and functional.

True (painless) **arthrogenic reflex inhibition** is the voluntary inhibition of alpha motor neurones in the anterior horn cell of the spinal cord by afferent stimuli from the joint region (Young, 1993; de Andrade et al; 1965). This must be differentiated from **pain** inhibition, which is partly involuntary - involving long loop reflex pathways - and partly voluntary (Grimby and Thomee, 1988). Studies involving post-operative inhibition of muscle during painful and pain free periods have indicated that pain does not seem to be associated with reflex inhibition (Shakespeare et al, 1985).

Potential mechanisms of reflex inhibition are the presence of joint effusion, the joint position and muscle group involved. The aspiration of **joint effusions** reduces the inhibition of voluntary muscle contractions and reflex inhibition is more marked if the effusion is large (Stokes and Young, 1984). However, aspiration does not abolish the inhibition completely, implying that other factors are involved (Stokes and Young, 1984). Reflex inhibition alters with **joint angle**, as demonstrated in post meniscectomy patients in whom inhibition was less when the knee was exercised isometrically in flexion (Shakespeare et al 1983; Stokes and Young, 1984). There are obvious implications to this, since it will be more effective to increase strength and prevent atrophy by exercising the joint at an angle at which the reflex inhibition is at a minimum.

In joint disease, it is likely that reflex inhibition occurs in all muscles associated with a particular joint and may persist for years with possible dysfunction as a result (Young, 1993). However, different **groups** may be affected to different extents. Joint damage results in greater weakness of the extensor muscles than the flexors (Arvidsson and

Eriksson, 1986; Sargeant et al, 1977). The cause of this is not clear: reflex extensor inhibition and flexor facilitation have been proposed as potential mechanisms (Young, 1993).

There are other important factors associated with weakness in rheumatoid disease. These include disease duration, the use of specific drugs and disease activity. On the basis of the findings described above, the mechanism of weakness associated with the latter seems likely be due to reflex or pain inhibition.

Hsieh et al (1987) studied the isometric quadriceps and hamstrings strength in patients with early rheumatoid arthritis and minimal knee involvement. They found that the strengths of these muscles were approximately 80% of normal values, with the quadriceps being the weaker group. In a study of patients with RA awaiting knee surgery, with longer disease duration and more severe disease, the knee strength was found to be approximately 40% of normal (Nordesjo et al, 1983). These studies indicate the importance of disease duration to the extent of muscle weakness in RA, confirming the histological findings of more marked changes in such patients (Magyar 1977; Haslock et al, 1970).

2.2.2. Athrogenous weakness and muscle fibre atrophy in RA: a summary.

From the above description of rheumatoid muscle and related weakness, it is evident that there are two potential mechanisms of muscle atrophy in RA: denervation and disuse. Different fibre types may be affected according to the relative importance of the two mechanisms which may occur alone or in combination. In addition the effects upon fibre type will depend upon the nature of the immobilisation in the case of disuse and the pattern of reinnervation in the case of denervation. This, in addition to the wide variety of subjects studied, may help to explain the differences in the findings in different studies of muscle in RA.

2.3 Fatigue

2.3.1 Introduction

Like weakness, fatigue is a phenomenon with many definitions and is a common feature of rheumatoid disease (Belza, 1995; Pinals et al, 1981). However, although subjective fatigue

is a common complaint, the prevalence of objective fatigue in RA is unknown. This is partly a result of the many definitions of the phenomenon and the difficulties in its measurement, in addition to a lack of research in the area. The contribution of muscle abnormalities to fatigue in RA is also unknown. This section reviews the concept of fatigue, the phenomenon of fatigue in RA and its measurement.

2.3.2 Defining Fatigue.

Fatigue is an extremely complex phenomenon. It can be described and measured in terms of subjective, functional and physiological aspects (Edwards, 1981). These definitions do not necessarily reflect the same phenomena and different terminology is often used by different workers, adding to the confusion in the interpretation of the literature in relation to the concept of fatigue.

Subjective Fatigue is a conglomerate of symptoms related to physical and subjective exhaustion. It can be assessed by rating scales, including those of Borg (1982). Although it may reflect cardiovascular responses to work and is important in relation to function and performance, it may be poorly correlated with specific changes occurring at the level of the muscle (McArdle et al, 1991).

Functional fatigue may be defined as a failure to maintain the required or expected force (Edwards, 1981), or as a decrease in the force generating ability of a muscle resulting from recent activity (Bigland-Ritchie et al, 1984). It can be measured in terms of the loss (absolute or rate) of a given force, such as grip. Some workers call this physiological fatigue; however, **fatigue begins the moment a muscle begins to contract and must be regarded as a process rather than a single event** (Bigland Ritchie et al, 1986). Measuring and describing fatigue must involve assessing the changes which occur from the initiation of work. The above definitions of functional and subjective fatigue do not reflect this fact and a more sensitive definition is needed to better describe and measure muscle fatigue.

True **physiological fatigue** is a term that reflects the many metabolic changes and alterations at the level of the muscle fibre which occur during contraction. Ultimately, these are major factors which will predict the degree of fatigue an individual experiences (Windhorst and Mommaerts, 1996; Westerblad et al, 1991).

In the investigation of muscle fatigue, it is useful to focus upon the unit of muscle contraction, the motor unit, defined as an individual motor nerve cell and the muscle fibres it activates. Processes which occur during fatigue can affect the function of the motor unit, resulting in the changes which are commonly observed: a decline in performance, eventually subjective changes and if extreme, injury.

2.3.3 Fatigue in RA

Subjective fatigue in RA is extremely common, with a reported prevalence of 80 to 93% (Belza, 1995; Pinals et al, 1981). Belza (1995) reported that 61% of the variation in subjective fatigue in RA could be explained by pain, gender, poor sleep, reduced activity levels, comorbid conditions and functional status.

Unlike self-reported fatigue and in spite of the decline in functional capacity noted in RA (Ekdahl and Broman, 1992), physiological fatigue in this disease has not been investigated. Subjective scores cannot be assumed to represent functional or physiological fatigue, since subjective fatigue does not consistently correlate with objective measures of fatigue (Oberg, 1994). Subjects with RA are recognised as being deconditioned and at an increased risk of cardiovascular and peripheral vascular disease (Mylykangas-Luosujarvi et al, 1995), in addition to having the histological abnormalities within skeletal muscles which have been described. These factors may result in a reduced ability to cope with the metabolic by-products which accumulate with muscular work, which in turn will result in early muscle fatigue (Jones and Round, 1990; Edwards, 1981). Physiological fatigue in RA is further investigated in this study using analysis of the frequency spectrum of the surface myoelectric signal.

2.3.4 Mechanisms of Fatigue.

Numerous biological and motivational factors may potentially contribute to muscular fatigue, occurring anywhere along the 'chain of command' pathway involved in motor unit activity, from the higher centres in the CNS to cross bridge cycling within the muscle (Bigland Ritchie, 1981a, 1981b; Edwards, 1981). Metabolic influences upon muscle fatigue with exercise with time progressively include phosphocreatine depletion, lactate

and proton accumulation, glycogen depletion, reduction in blood glucose and an increase in the blood tryptophan:amino acid ratio. The former two features are particularly important limiting factors in exercise of higher intensities (Edwards et al, 1977).

Changes in the myoelectric signal have been noted to occur with fatigue and have been utilised in its assessment. These myoelectric manifestations of fatigue in relation to the surface myoelectric signal (SMES) during voluntary work will be described after a short description of the terminology used in electromyography.

2.3.5 The description of the myoelectric signal.

The myoelectric signal (MES) can be described and quantified in many ways. The interference pattern describes the pattern of the MES during a voluntary contraction, where many MU potentials are superimposed upon one another, making it impossible to define each MUAP individually. The MES may be quantified by the measurement of its power at different frequencies (by the process of frequency spectral analysis) or the voltage of the signal, expressed as the root mean square (RMS) voltage of the MES, or the integrated emg (IEMG). This can be further evaluated by the examination of the relationship between this measure and the force exerted. This relationship is termed the neuromuscular efficiency (NME) and will be described further in a later section. The use of such parameters in the assessment of muscle performance and fatigue in health and disease will now be detailed.

2.3.6 Myoelectric Manifestations of Fatigue.

During sustained muscular contractions, physiological and biochemical modifications occur. These include an elevated level of metabolites, resulting in an alteration of the pH of intra and extracellular fluid and modification of the electrical properties of muscle fibre membranes (Lindstrom and Petersen, 1981). As a result, changes occur in the amplitude, shape, spatial width and propagation velocity of the motor unit potential - and therefore in the myoelectric signal.

Since Edwards and Lippold described changes in the myoelectric signal during contraction in 1956, several changes in the myoelectric signal during work have been advocated as

indicators of muscle fatigue. These include a rise in signal voltage during a sustained submaximal contraction, a decrease in voltage during a sustained maximal voluntary contraction and a decrease in force if a given level of SMES amplitude is maintained (Lindstrom, 1970; Lindstrom et al, 1977; Edwards and Lippold, 1956). Changes in the frequency spectrum of the SMES also occur with fatigue (Lindstrom et al, 1977) and will be described further below.

2.3.7 The RMS of the SMES as an indicator of fatigue.

The increase in the SMES amplitude as a function of time during sustained submaximal contractions has been used as an indicator of muscular fatigue for over 4 decades. Stephens and Taylor (1972) studied the smoothed rectified integrated EMG (IEMG) from the first dorsal interosseous muscle in three subjects during contractions at 70-80% MVC sustained for 30 seconds. They noted that whilst force is maintained the IEMG increases, and declines once mechanical fatigue in the form of a reduction in contraction force occurs. A non linear rise in the amplitude of the SMES has been noted by West et al (1995) and others (Fugelvand et al 1993; Lind and Petrofsky, 1979). The increase in the IEMG and the root mean square (**RMS**) of the SMES with fatigue during sustained submaximal contractions (Kuroda et al, 1970) has been postulated as being related to a progressive increase in muscle fibre recruitment, impaired excitation-contraction coupling and/or an increase in firing frequency as contractile element failure of the initial muscle fibres involved commences (Edwards, 1981). However, although a rise in the RMS of the SMES and in the IEMG continue to be accepted as indicators of muscle fatigue (Stulen and DeLuca, 1978; Cooper et al 1993, Troup and Chapman, 1972), some workers have reported no change or a decline in this parameter with sustained work (Chapman et al 1970; Seidel et al 1987). Findings differ according to the muscle studied, and the intensity of the work involved. It is likely that this is related to the differences which exist between muscles in relation to their motor unit control schemes, as will be described in section 2.4. It is for these reasons that DeLuca (1985) and Edwards (1981) stated that the change in the signal amplitude is of little use as an indicator of fatigue. More recently, analysis of the SMES in the frequency domain (**power spectral analysis**) has been utilised in the monitoring of muscle fatigue.

2.3.8 Power spectral analysis (PSA) of the surface myoelectric signal.

The power spectrum describes the relationship between the signal amplitude and frequency (Lindstrom, 1970). Richardson (1951) was the first to use power spectral analysis, in dividing the EMG spectrum into two parts using a filter, to measure the spectral content. Walton (1952) and other workers (Fex and Krakau, 1957; Scott, 1967) further developed the technique for clinical use and the technique has been applied in a wide variety of settings (Lindstrom et al, 1970; Muro et al 1982; Lindstrom 1970; Kadefors et al, 1976). Various methods exist in the determination of the power spectrum of a signal (Duhamel and Vetterli 1990). However, subjecting the raw MES to a Fast Fourier Transform (FFT) algorithm is the most commonly accepted method in PSA (Petrofsky and Lind, 1980; Basano and Ottonello, 1986).

2.3.9 The description of the power spectrum and power spectral parameters.

The numerous parameters used to describe the power spectrum and changes which occur in response to activity include the mean, median and mode frequencies, the ratio parameter, peak frequency and spectral width.

The frequency spectrum of the MES is most commonly described in relation to the median (MDF), mean (MNF) or mode (M_0F) frequencies (Stulen and DeLuca, 1981; Merletti et al, 1992). The **MDF** is the frequency at which the power spectrum is divided into two regions of equal power. The **mode frequency**, is the frequency of the peak amplitude of the spectrum. The mode frequency is not suitable for use in power spectral analysis, as it has a high coefficient of variation (Schweitzer et al, 1979). The median frequency (**MDF**) is generally the preferred parameter, being superior to the others particularly in the estimation of changes in conduction velocity and it is less sensitive to noise (Stulen and DeLuca, 1981). The gradient of the median frequency of the SMES (**MDF_G**) describes the gradient of the regression line fitted to the median frequency versus time plot and has become a popular index of muscle fatigue during sustained submaximal isometric contractions. This is related to physiological changes that occur during the process of fatigue, as will be described further. The **initial median frequency (IMF)** describes the value obtained from the intercept of the of the regression line on the y axis (time = 0). The IMF represents the median frequency of the SMES prior to the onset of

fatigue. Spectral parameters are shown in relation to the power spectrum in figures 2.3.1 and 2.3.2.

Figure 2.3.1: The frequency spectrum of the SMES.

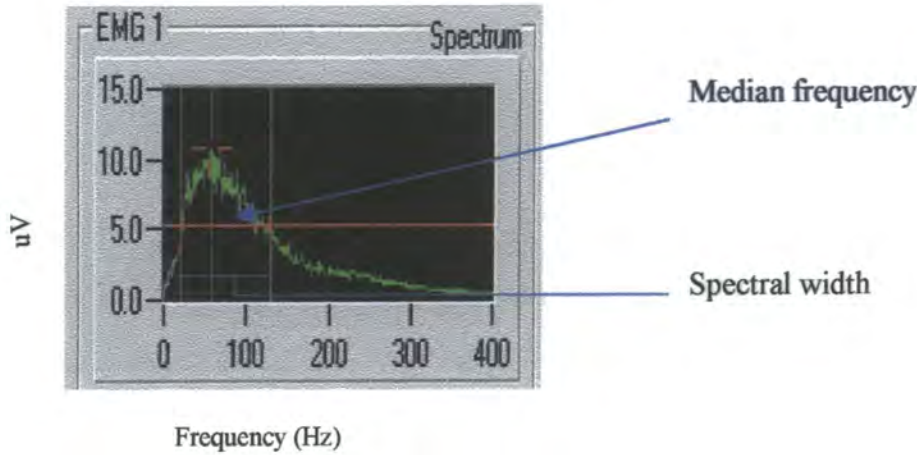

Figure 2.3.2: The change in the median frequency of the SMES with time.



The **spectral width (SW)** describes the width of the power spectrum at half the peak amplitude. This parameter has not been focused upon in the literature to date, possibly because its' physiological basis is unclear and it may add no additional information to that supplied by the MDF in relation to the behaviour of the underlying working muscle. Although the **ratio parameter**, which expresses the ratio of low frequency components to high frequency components (Schweitzer et al, 1979), is most sensitive to conduction velocity, the relation is non linear and it displays a high covariance (Stulen and DeLuca, 1981).

2.3.10 The frequency spectrum in relation to EMG measures.

The frequency spectrum of the myoelectric signal depends upon the action potentials of individual muscle fibres within the pick-up zone of the recording electrodes, the conduction velocity of the action potentials, the thickness and length of the muscle, the distance between the muscle fibres and the detection surface of the electrodes, the electrode configuration, the duration of the action potential, the number of phases, turns and zeros, fibre type and the level of force (Lindstrom et al, 1977). The relationship of the power spectrum with force will be described later.

In signal theory, the influence of the conduction velocity of a single fibre action potential will persist through all mathematical manipulations in the modelling of various processes. In all expressions describing the power spectrum, the velocity always appears together with the frequency as a quotient (frequency/velocity), thus any velocity change can be seen as a shift of the spectrum along the frequency axis (Lindstrom, 1970; Lindstrom and Magnusson, 1977). Fourier transformation of a potential of fixed geometrical shape also shows that the power spectrum density is inversely proportional to the squared value of the velocity (Lindstrom et al, 1970). When the conduction velocity decreases, a signal increase, in addition to a spectral shift, occurs. Such changes are important in the monitoring of muscle fatigue and will be outlined in the section 2.3.11.

The power spectrum obtained with **surface electrodes** will differ from that obtained using intramuscular electrodes, having a maximum in the frequency region between 10 and 100Hz, using surface electrodes compared with between approximately 100 Hz (or lower) and 200 Hz with intramuscular electrodes (Krivickas et al, 1996). The MES (and therefore the frequency spectrum) is strongly influenced by the **inter-electrode separation distance (IES)**, which affects the bandwidth and amplitude of the EMG signal. A smaller distance produces higher frequencies and lower amplitudes than a large IES.

The duration of a myoelectric signal is commonly used as a signal characteristic. It plays a large part in the determination of the distribution of power over the frequency interval; pulses of short duration contain more high frequency energy than pulses of longer duration. The power spectrum is strongly influenced by the number of phases of a motor unit, which in turn is strongly associated with the duration of the signal. When

the duration is constant, an increase in phase number causes a spectral shift towards higher frequencies. When the duration increases in proportion to the number of phases, a more pronounced peak is seen in the lower region of the power spectrum (Lindstrom and Petersen, 1981).

The **fibre type** composition of the muscle has been linked with the initial median frequency (IMF) and the change in the MDF with time during a fatiguing contraction (termed the MDF gradient, the MDF_G) (Linssen et al, 1991; Arendt-Nielsen et al, 1988; Portero et al, 1989; Merletti et al, 1990). Type II fibres have been shown to have higher MDFs than type I in contraction (Milner Brown et al, 1986) and display higher conduction velocities along the muscle fibre membrane (Linssen et al, 1991). The higher conduction velocity may be due to the generally larger diameters of Type II fibres (Broman et al, 1985; Kereshi et al, 1983), although Sadoyama et al (1988) found that the conduction velocity correlates with the cross-sectional area of the fibres, rather than the diameter. Many workers have proposed that the MFCV is related to fibre diameter: larger fibres with faster MFCVs will have greater mean power frequencies (MNFs) (Basmajian and DeLuca, 1985). However, the proposal that muscle fibre diameter is the important factor in determining the MDF must be brought into question when the muscle **fibre type** is considered. In studies of lower limb musculature, Gerdle et al (1988b) and Moritani et al (1985a) reported a strong relationship between the MNF of the EMG and the percentage of type II fibres. Westbury and Shaughnessy (1987) also documented this relationship in the masseter muscles of females. Many of the studies relating the MDF to fibre diameter have been performed upon men, in whom type II muscle fibres are larger than type I fibres in most muscles. Hence the increase in MDF with force may be due to either the fibre type *or* diameter. However, in women the size difference between fibre types is much less: many authors have reported type I fibres to be larger than type II fibres (Gerdle et al, 1991; Simoneau and Bouchard, 1989; Froese and Houston, 1985). Gerdle et al (1991) used this finding to examine the influence of the fibre type composition on the MNF, by studying a gradually increasing static knee extension in 10 women. The vastus lateralis and medialis and the rectus femoris muscles were studied; biopsies of the former showed larger type I fibres than type II in 8 subjects. Two important findings were reported: significant positive correlations between the MNF and torque were demonstrated for all 3 muscles and negative correlations between type I fibres and the MNF.

Although the Type II fibres in most muscles are larger than type I fibres, this is not true for a small number of muscles, including the erector spinae, temporalis and iliopsoas (Polgar et al, 1973). This may explain the atypical changes in the frequency spectrum of the SMES that has been observed in some of these muscles (Roy et al, 1989).

Hence, in order to interpret the frequency spectrum of the MES from forearm muscles, it is important to establish the relative size and proportions of fibre types in the forearms of healthy individuals. Johnson et al (1973) demonstrated the extensor digitorum communis (EDC) to consist of a slight predominance of Type II fibres (51.3 %), which are slightly larger than Type I fibres. Although no information on the flexor carpi radialis (FCR) is available in the literature, the flexor digitorum profundus also shows a predominance of Type II fibres (60.9 %), which were significantly larger than Type I fibres.

It is evident that fibre diameter is not the sole factor influencing the muscle fibre conduction velocity. As has been discussed, it has been demonstrated to be related to the metabolic state of the fibre. Conduction velocities have been demonstrated to be higher in type II fibres than type I (Mortimer et al, 1970); this may be related to physiological characteristics such as greater ATPase activity, Ca^{2+} flux and shorter action potentials and twitch times (Moritani et al, 1985b).

Muscle length has been found to have an effect on the power spectrum (Gerdle et al, 1988a; Inbar et al, 1987; Bazy et al, 1986). Most studies indicate that with the muscle in a lengthened state the low frequency part of the spectrum is more prominent than when at shorter lengths (Inbar et al, 1987; Bazy et al, 1986; Duchene and Goubel, 1993). In some studies which are presumed to be non-fatiguing, part of the observed spectral shift could be attributed to the change in muscle force with length. However, in studies at each muscle length where forces were expressed in terms of the percentage of the maximal voluntary contraction (MVC), similar results were obtained (Okada, 1987). Several possible mechanisms for these observations have been suggested (Kossev et al, 1992; Duchene and Goubel, 1993). A decline in conduction velocity with increasing muscle length can be explained in terms of modification of fibre diameter and/or reduction in the distance from the deeper, smaller diameter (low MFCV) fibres to the detection surface of the electrode (Bazy et al, 1986). Conversely, it is possible that the distance from the detection surface to the active MUs increases

when the muscle is lengthened, resulting in an increase in high-frequency filtering and the observed spectral shift (Lindstrom and Petersen, 1983a, 1983b).

Lindstrom (1974) found that reducing **muscle thickness** increases the power of high frequency components. However the opposite was found by Bazzzy et al (1986). This is one factor which causes variations in myoelectric characteristics between different muscles.

The SMES is affected by changes in **muscle temperature** (Petrofsky, 1979), possibly due to the effects on resistance of the sarcolemma (Fink and Luttgau, 1976). The temperature rise during an isometric contraction is linearly related to the force of contraction (Edwards et al, 1975). An increase in muscle temperature results in a reduction in signal amplitude, the RMS of the SMES and an increase in MNF (Petrofsky, 1979).

2.3.11 Power spectral compression during muscle fatigue.

Although Piper first described a reduction in the frequency of the MES with work in 1921 (the Piper rhythm) (Stulen and DeLuca, 1981), it was four decades before contraction-induced changes in the frequency content of the myoelectric signal were quantified by, amongst others, Kogi and Hakamada (1962) and Kaiser and Petersen (1962). These workers demonstrated a decline of power density in the high frequency region and an increase in the low frequency region during work, using octave band filtering. This was termed the "**power spectral shift**" and was subsequently confirmed by other workers (DeLuca, 1984; Lindstrom et al, 1977). Lindstrom (1970) pointed out that the conduction velocity of muscle fibres scales the power density of the myoelectric signal, implying that the power spectral "shift" to a lower frequency is actually a power spectral "**compression**".

Different time dependent phenomena take place within the muscle during an isometric contraction, including myoelectric and power spectral density changes as a result of alterations of amplitude, shape, width and propagation velocity of MUAPs, recruitment alterations of motor units, changes in the firing rates of individual motor units and changes in the force twitch of individual motor units (DeLuca, 1984). These have all been utilised as myoelectric manifestations of muscular fatigue and can be expressed in terms of the changes in mean and median frequencies, conduction velocity and amplitude (the

average rectified value and root mean square of the signal). Changes in the signal amplitude with fatigue have been discussed. Power spectral compression has been advocated as a sensitive measure of muscle fatigue and will be further described below.

2.3.12 The Description of Power Spectral Compression.

As outlined earlier, the MFCV has been shown to be closely associated with the frequency spectrum of the SMES. Lindstrom et al (1970) demonstrated that theoretically the power spectral shift towards lower frequencies and the increase in the myoelectric signal with fatigue could be accounted for by a single electrophysiological correlate, the conduction velocity. They further proposed that, since changes in the frequency can be used to determine changes in the conduction velocity, they could also be used to assess fatigue. However, in a review of potential myoelectric indicators of fatigue, Merletti et al (1990) concluded that certain spectral variables (mean and median frequencies - see below) are more sensitive to fatigue than the conduction velocity.

The mean and median frequencies are both appropriate indicators of power spectral compression and have been demonstrated in several studies to correlate with conduction velocity and muscle fibre type distribution as discussed in Section 2.3.10 (Linssen et al, 1991; Hakkinen and Komi, 1983; Viitasalo and Komi, 1978; Van Boxtel et al, 1983).

Changes in the MNF have been used to describe alterations in the power spectrum during fatiguing contractions (Hagberg, 1979; Broman and Kadefors, 1979; Ortengren et al, 1979; Lynne-Davies, 1979). Variability is small compared with its change with muscle fatigue, and it is stable and reliable (Daanen et al, 1990). However, the median frequency (MDF) is the preferred parameter (Stulen and De Luca, 1978, 1979; Sabbahi et al, 1979; Petrofsky and Lind, 1975). It is superior to the MNF for estimating changes in conduction velocity and is less sensitive to noise (Stulen and DeLuca, 1981).

Some workers have analysed the spectral changes which occur during muscle contraction by dividing the frequency spectra into a set of individual **frequency bands** (arbitrarily chosen) and also by examining the frequency contents (Dolan et al 1995; Moxham et al, 1982; Bigland-Ritchie et al, 1981a; Andersson et al, 1976; Hary et al, 1982; Schweitzer et al, 1979). Some studies have found that the high/low frequency ratio reflected fatigue-

induced changes in the muscle (Moxham et al, 1982; Bigland-Ritchie et al, 1981a; Andersson et al, 1976; Dolan et al, 1995). However others have found this method to be less reliable than the MDF as an index of fatigue (Hary et al, 1982; Schweitzer et al, 1979). This may be due to the arbitrary nature of the banding and the number of bands chosen. Dolan et al (1995) pointed out that 2 to 3 bands may not be adequate and used 10 bands with some success in reflecting fatigue.

2.3.13 Mechanisms of Power Spectral Compression during Muscle Fatigue.

Various overlapping theories for the main mechanism of spectral modification exist (Stulen and DeLuca, 1981; Fex and Krakau, 1957; Lindstrom et al, 1970, 1977; Duchene and Goubel, 1993; Mortimer et al, 1970; Mills, 1982). The phenomenon is likely to be associated with many inter-related factors, including altered muscle fibre conduction velocity, the synchronisation of motor unit firing, accumulation of metabolic by-products, ischaemia, and the muscle fibre type(s).

The **muscle fibre conduction velocity (MFCV)** is a basic physiological parameter that affects the myoelectric signal spectral density and contributes to its compression during fatigue (Merletti et al, 1990). The conduction velocity declines as voluntary muscular contractions progressively fatigue to exhaustion (Stalberg, 1966). Mortimer et al (1970) and others have suggested that that a reduction in conduction velocity is the most likely cause of power spectral compression (Lindstrom and Petersen, 1983a; Lindstrom, 1970; Kranz et al, 1983; Stulen and DeLuca, 1982). However, others pointed out that a decline in conduction velocity alone does not explain the power spectral changes seen (Bigland-Ritchie et al, 1981a; Merletti et al, 1990) and spectral modifications can occur independently of changes in MFCV (Brody et al, 1991). The mechanisms by which the decline in conduction velocity occurs remain unclear (Bigland-Ritchie et al, 1981a, 1981c).

The intramuscular accumulation of **metabolic by-products** during isometric contractions may be due to an increased production (Ahlborg, 1972) and/or reduced removal as a result of reduced blood flow during contractions (Couch et al, 1971; Mortimer et al, 1971). The accumulation of protons and lactic acid and the resulting reduction in pH (Dawson et al, 1977) is associated with functional fatigue (Sahlin et al, 1975; Karlsson, 1971) and has been suggested to cause power spectral shift in fatigue (Mortimer et al, 1970). This is

related to the decline in muscle fibre membrane excitability with decreasing pH (Tasaki et al, 1967), particularly intracellular pH (Terakawa et al, 1978). In addition, when pH drops, less calcium ions are available to produce a muscle contraction (Nakamura et al, 1972). A decline in membrane excitability leads to a reduction in conduction velocity, which in turn has been shown to be related to power spectral compression (Mortimer et al, 1970). Such findings have led many workers to conclude that the rate of decline in the MNF may be dependent upon the metabolic state of the fatiguing muscle (Nagata et al, 1981; Komi and Tesch, 1979; Moritani et al, 1985a).

Other studies have not been consistent with this hypothesis, suggesting that lactate accumulation is unlikely to be the sole cause of power spectral shift (Bouissou et al, 1989; Beliveau et al, 1991; Brody et al, 1991). Karlsson et al (1975) proposed that lactate influences the power spectral shift only for given intensities of isometric contraction. Bouissou et al (1989) demonstrated a correlation between MNF and lactate concentration, but found no relation with muscle pH - possibly due to difficulties in measuring cytosolic pH. Brody et al (1991) demonstrated an initial relationship between conduction velocity, pH and MDF, but MDF and conduction velocity altered differently in sustained stimulated contractions. Beliveau et al (1991) reported that MNF but not force generating capacity had completely recovered within a few minutes, despite persistence of acidosis indicating other processes are involved. In further work, Beliveau (1992) concluded that changes in power spectral frequency components in exercise are not uniquely determined by changes in muscle pH and conduction velocity and suggested that other metabolites such as inorganic phosphate and its diprotonated form may have a role. However, a study of simultaneous surface electromyography and ³¹P NMR spectroscopy by Bendahan et al (1996) found no overall correlation between the high/low frequency band ratio and changes in metabolism during fatiguing static contractions of forearm musculature.

Blood flow in contracting muscle is restricted or arrested (Naess and Storm-Mathiesen, 1955; Mottram, 1963). Stephens and Taylor (1972) and Fox and Kenmore (1967) suggested that impulse transmission in the neuromuscular system is most sensitive to **ischaemia**. In the evaluation of the recovery from fatigue by voluntary test contractions, Hara (1980) confirmed that ischaemia is involved in muscle fatigue; this is probably related to the accumulation of metabolites. Humphreys and Lind (1963) reported that the blood flow in the forearm is near to total occlusion during handgrip at 70% of the

maximum grip strength (70% MGS). During grips performed at levels between 30 and 60 % MGS, the blood flow is increased.

Studies have also been performed assessing the affect of **muscle length** on the power spectrum during fatiguing activity. Huijing et al (1986), assessing the triceps surae and gastrocnemius, found that changes in MNF with the muscle in the lengthened state were significantly greater than at shorter lengths. However, endurance at longer muscle lengths was greater. When this was allowed for in further assessments, no significant length-related effect was shown.

Much of the early work on the mechanism of power spectral shift concentrated on the **synchronisation of motor unit firing**. Lippold et al (1957) and others (Fex and Krakau 1957; Lago and Jones 1977; Bigland-Ritchie, 1983) suggested that the switch from the normal, desynchronised firing pattern to a synchronised form causes the spectral shift. Mortimer et al (1970) concluded that the phenomenon is not solely due to the synchronisation of MUAP's, but is largely due to the decline in conduction velocity, which has been detailed above.

There is evidence that **muscle fibres of different types** have different properties during fatiguing exercise. Larsson (1978) and Viitasalo and Komi (1978) were the first to propose that the MDF declines more rapidly during a sustained isometric contraction to exhaustion in subjects with a high proportion of Type II fibres than those with a high percentage of Type I fibres. Hakkinen and Komi (1983) found a relationship between the relative decrease in mean power frequency during a 50% MVC and the relative area of Type II fibres of the vastus lateralis muscle. Kourinka (1988) compared the fatigability in the human biceps (which contain a predominance of slow twitch fibres) and the triceps (which have a majority of fast twitch fibres) (Johnson et al, 1973, Fallentin et al, 1985) and demonstrated different power spectra and restitution patterns between the two muscle groups. Linssen et al (1991) identified the relative roles of types I and II muscle fibres in fatigue by assessing the muscle fibre and surface EMG studies in patients with congenital myopathies, comparing those who had 95-100 % type I fibre predominance with those patients with 80% type I fibres and with normal controls. They concluded that type II fibres have a greater force generating capacity and are more fatigable than type I fibres, as reflected by almost no decline in signal conduction velocity and only a slight increase in surface EMG amplitude during work in subjects

with myopathy. Overall, studies indicate that muscles with relatively high proportions of type II fibres have faster spectral shifts than do muscles with high proportions of type I fibres (Moritani et al, 1986; Van Boxtel et al, 1983; Arendt-Nielsen and Mills, 1988; Portero et al, 1989; Merletti et al, 1990; Huijing et al, 1986). On the basis of these studies, power spectral shift has been proposed to be related to the relative roles of different fibre types (Milner Brown et al, 1986; Braakhekke et al, 1989). This seems likely but other factors are also likely to be significant.

Duchene and Goubel (1993) emphasised the difficulties in interpreting the results relating to muscle fibre type and power spectral shift, in the light of other physiological changes that are occurring. These include altered MU recruitment and firing rates and alternations in activity between synergists (Duchene and Goubel, 1990). A description of the relation of the SMES to force and motor unit control patterns will now follow.

2.4. Motor unit control and the relationship between force and the SMES.

2.4.1 Introduction

Changes in neuromuscular control are involved in spectral modifications, as emphasised by Stulen and DeLuca (1981) and DeLuca and Creigh (1985). Changes in motor unit recruitment alter the frequency spectrum of the MES, whereas alterations in the MU firing rates have little effect (DeLuca et al, 1983; Solomonow et al, 1990). In order to interpret the alterations which occur in the SMES during muscular contractions and the inter-relationships between the myoelectric parameters and force, a review of the mechanisms of the modulation of MU activity is appropriate. Studies of the relationship between the SEMG and force will also be reviewed.

2.4.2 Motor unit control and the generation of force.

Motor unit (MU) control, through the **recruitment** of new motor units and **modulation of MU firing rates**, forms the basis of the maintenance of a given force during a sustained muscular contraction and in increasing levels of force output (Milner-Brown et al, 1972). Numerous workers have addressed the interaction between these two forms of MU

control with contradicting results. Much of the controversy relates to the examination of different muscles and the type and intensity of contractions performed. Since each muscle has unique anatomical and physiological characteristics, it is likely that they also differ in their motor control schemes (DeLuca et al, 1982a, 1982b; Lawrence and DeLuca, 1983).

Henneman and co-workers first described the orderly recruitment according to motor neurone size (**the size principle**) in a series of studies on MUs during reflex contractions of muscle in cats (Henneman et al, 1974; Bawa et al, 1984), smaller motor neurones being recruited earlier than larger ones. Milner-Brown et al (1973a) confirmed this pattern of orderly recruitment in voluntary contractions of the first dorsal interosseous muscle of the hand in humans. Other workers (Desmedt and Godaux, 1981; Nardone et al, 1989) have shown that MU recruitment according to the size principle does not occur universally in all muscles, raising the prospect of differences between muscles and during different types of work. This may in part be explained by the fact that the initial studies were performed using contractions of single muscles only, which does not of necessity reflect the situation in the functional setting.

The other mechanism of motor unit control in increasing levels of force is the modulation of motor unit firing rates, *rate coding*. The behaviour of MUs with respect to firing rates over a range of force remains an area of confusion. MU firing rates have been reported as varying monotonically with force (Milner-Brown et al, 1973b), as plateauing at submaximal force levels (Bigland and Lippold, 1954a,b; Monster and Chan, 1977) and as firing at constant rates, independent of force (Bracchi et al, 1966). Low threshold MUs have been reported to exhibit low firing rates by some workers (Burke, 1981; Kernell D, 1965) whereas others have reported them to fire at higher rates than higher threshold units (Person and Kudina, 1972; DeLuca and Erim, 1994; Erim et al, 1996).

Although the relative influence of the MU recruitment and firing frequency on the generation of force has been widely investigated (Milner Brown et al, 1973a, 1973b; Clamann, 1970; Bracchi et al, 1966; Erim et al, 1996; Bigland and Lippold, 1954a), there remains a lack of consensus of opinion, which is likely to be due to differences in the muscles studied and protocols used (Edstrom and Grimby, 1986). The mechanical properties of a muscle are dependent upon its composition with respect to the fibre type, which may in turn be expected to play a role in determining the specific modulation of motor units and recruitment strategies. Muscles with similar fibre compositions have been

shown to differ in their mechanisms of the maintenance and increase in force output. The relative roles of recruitment and rate coding may depend upon the size of the muscle and its functional requirements (Fugelvand et al, 1993). Recruitment of MUs has been shown to be the most important strategy in the generation of force in large muscles over a wide range of force (0-90% MVC), whereas rate coding is important in smaller muscles involved in finely controlled movements, with recruitment being important within the force range of 0-50%MVC (DeLuca et al, 1982a, 1982b). There is no available information relating to the number of motor units in the extensor digitorum communis (EDC) and flexor carpi radialis (FCR) muscles. However, in muscles such as those of the forearm which are medium sized and perform both powerful movements and finely controlled movements of the fingers and wrist, it seems likely that recruitment is the more important factor in the generation of increasing levels of force, since the rate of firing of motor units can vary on demand but only within a limited range of frequencies (Basmajian, 1963). Recruitment is especially important at low tensions, with frequency of firing contributing increasingly to stronger tensions (Milner-Brown et al, 1973b, 1973c). In relation to the forearm musculature, this has been confirmed in the EDC by Monster and Chan (1977). However, even at high tensions, recruitment has been found to be important in some muscles (Clamann, 1970; Hannerz, 1974).

Riek and Bawa (1992) assessed MU recruitment in two forearm muscles, extensor digitorum communis (EDC) and extensor carpi radialis (ECR), during sustained isometric wrist extension and radial deviation tasks at progressive unspecified force levels. They demonstrated size-ordered recruitment of MUs in both muscles during both tasks. Monster and Chan (1977) studied the behaviour of MUs in the EDC during voluntary isometric contractions, confirming that the size principle held true for this muscle under these circumstances. Jones et al (1993) showed that the size principle also applied to the recruitment of MUs in the flexor carpi ulnaris (FCU) during isometric wrist flexion and ulnar deviation. Although these tasks differ from the grip task used in this study, it is evident that the size principle does hold true for extensor and flexor forearm muscles during isometric contractions. Monster and Chan (1977) found motoneurone firing rates in the EDC during isometric contractions to increase with increasing force levels, plateauing at submaximal force levels.

Another important consideration in relation to MU activity in the clinical setting during a functional task, such as grip, is inter subject variation in MU activity, which in turn will

affect SMES parameters. Fleckenstein et al (1994) demonstrated large inter-individual variation in MU recruitment patterns in forearm flexor muscles during wrist flexion at a standard load. Although the use of a standard load rather than a percentage of maximum was a limitation of the study, it does indicate the need to consider inter-subject variation in MU recruitment in the performance of a functional task which may not be demonstrated in studies involving isolated muscle contraction.

Having described the mechanisms of MU modulation in the generation of force, the relationship between force and the SMES and between the RMS and spectral parameters will now be described.

2.4.3 The relationship between the SMES and force.

Since Lippold reported a linear relationship between the IEMG measured from the gastrocnemius and soleus muscles during plantar flexion of the foot in 1952, numerous reports have been published on IEMG-force relationships in human muscles. Reviews by Bouisset (1973), Bigland-Ritchie (1981b), Perry and Bekey (1981), Basmajian and De Luca (1985) and more recently Hof et al (1987) and Clancy and Hogan (1991) are amongst those to confirm that there is a close relationship between the two parameters for a range of muscles studied. The nature of the relationship varies between different studies, with disagreements as to whether the relationship is linear or non-linear (Perry and Bekey, 1981). Sources of variation include differences in the structural and physiological properties of the muscle(s) being assessed, as has been discussed in relation to MU control, the relative amounts of Types I and II fibres and their orientation, accompanying synergist/antagonist inter-relationships, work intensity and contraction type, viscoelastic properties and methodological aspects such as electrode type and configuration (Moritani and DeVries, 1978; Lawrence and DeLuca 1983; Perry and Bekey, 1981). Overall, it appears that the linear relationships obtained at low to moderate force levels are related to recruitment, whereas quadratic relationships observed at higher force levels are related to rate coding. The force levels at which the linear relationship becomes quadratic will vary according to the muscle involved (Perry and Bekey, 1981).

The presence of muscle synergism may help to explain the discrepancy between linear and parabolic relationships. Hof and van den Berg (1977) compared the IEMG-

isometric force relationship in the soleus whilst sitting and whilst standing, the latter also involving both heads of gastrocnemius. Although the relationship for the individual muscles were non-linear, once summed the relationship became linear. Hence when the muscle being studied is one of a group of synergists, the relationship is likely to be deceptively linear, particularly if bipolar electrodes are being used (Perry and Bekey, 1981).

Perry and Bekey (1981) also emphasised the importance of muscle length on the nature of the IEMG-force relationship. This has been confirmed by others who have demonstrated that the differences between the IEMG-force relationship obtained at different joint angles disappears when the force is expressed as the percentage of the maximum voluntary contraction (Vredenburg and Rau, 1973; Hof and van den Berg, 1977; Cnockaert et al, 1975). With regard to the forearm musculature, West et al (1995) reported the IEMG recorded from forearm flexor muscles to increase linearly with grip force over the range 30-75%.

Since there is a wide variation between muscles in their relationship between force and the MES, Lawrence and De Luca (1983) concluded that there is “no physiological model to describe accurately the relationship between the amplitude of the surface recorded MES and measured force output of different muscles in various contraction modes”.

2.4.4 Neuromuscular efficiency (NME)

Fischer and Merhautova (1961) first proposed the concept of the ‘efficiency of electrical activity’ (EEA) when they suggested plotting the IEMG as a function of the force of an isometric contraction. This later became known as **neuromuscular efficiency (NME)**. DeVries (1968) recommended that it was more logical to invert this ratio (force : IEMG) such that the ‘efficiency’ would vary directly with function and most workers have expressed NME in this way (Lindeman and Drukker, 1994; Milner-Brown et al, 1986; Woods and Bigland-Ritchie, 1983).

2.4.5 The relationship between force and spectral parameters.

Studies of the inter-relationship between force and the mean or median power frequencies of the power spectrum have involved the use of step contractions (Petrofsky and Lind, 1980; Hagberg and Hagberg, 1988, 1989; Duchene and Goubel, 1990) and ramp contractions (Gerdle et al 1991; Bilodeau et al 1990; Gerdle et al 1990; Hagberg and Hagberg, 1989).

Initial studies using step contractions (the maintenance of force for a few seconds of different percentages of the MVC, without apparent fatigue) suggested that mean power frequency was independent of contraction intensity (Petrofsky and Lind, 1980). More recent studies have suggested that the MNF increases with increasing work intensity at low levels of force (up to 25 to 30 %). An increase in the high frequency part of the spectrum when the level of contraction increased has been described for different muscles, such as elbow flexors (Hagberg and Ericson, 1982), plantar flexors (Hagberg and Hagberg, 1988) and masticatory muscles (Duchene and Goubel, 1990).

For higher levels of force, conflicting results have been reported. Some workers have found an absence of an increase in MNF with increasing force level (Hagberg and Hagberg, 1988; Hagberg and Ericson, 1982; Bazy et al, 1986; Van Boxtel and Schomaker, 1984; Merletti et al, 1984). Other workers have reported an increase MNF (Broman et al, 1985; Bilodeau et al, 1991), or a decrease (Westbury and Shaughnessy, 1987) with higher forces.

In studies using ramp contractions (for example, varying the force from 0 to 100 % of maximum for 5 seconds) results have also been conflicting. An increase in spectral parameters with increasing force has been noted (Gerdle et al 1991; Bilodeau et al 1990), but other studies have shown no significant increase (Gerdle et al 1990; Hagberg and Hagberg, 1989). When ramp and step contractions are compared, the increase in spectral parameters with the former is more pronounced (Bilodeau et al, 1991).

The inconsistency of findings in the study of MNF-force relationships may be related to differences between individual muscles, their fibre type composition and distribution

and their patterns of recruitment, in addition to the vast differences in study protocols. The other obvious limitation of both approaches to the assessment of the SMES: force relationship is the possibility that fatigue is taking place in the tests, particularly the ramp protocol.

2.4.6 The relationship between power spectral compression and force.

At very low levels of isometric contractions (approximately 10 % MVC), even in the presence of considerable subjective fatigue, there is generally no decrease in MDF or MNF with time. In fact, a rise has been noted for some muscles (Arendt-Nielsen et al, 1989; Hagberg and Hagberg, 1989), whilst no change has been noted for others (Fallentin et al, 1985; Christensen et al, 1988). In addition, since the muscle fibre conduction velocity (MFCV) is generally reported as increasing with force levels, the rise in the MDF or MNF which has been reported in studies of some muscles has been explained by the predominance of recruitment of new MUs - specifically type II fibres (Broman et al, 1985; Sadoyama, 1988) - over any other events (Duchene and Goubel, 1993).

For isometric contractions ranging from 15 to 30 % MVC, decreases in the median and mean frequencies have been reported for most muscles (Duchene and Goubel, 1990; Hagberg and Ericson, 1982). At this level of force, spectral parameters are probably affected by two mechanisms having opposite effects: the decline in muscle fibre conduction velocity in active motor units (due to local fatigue) and the recruitment of 'fresh' (large) motor units (Krogh-Lund and Jorgensson, 1991; Duchene and Goubel, 1993). For isometric contractions greater than 40 to 50%, declines in the MFCV and MDF are consistently noted (Linssen et al, 1990; Arendt-Nielsen and Mills, 1988; Duchene and Goubel, 1993).

It can be concluded from the available literature that spectral modification with fatigue is likely to be multifactorial in origin. At high levels of force, progressive recruitment of more MUs is less likely and the effect of factors such as accumulation of metabolites and reduction in conduction velocity predominates, causing spectral compression to lower frequencies.

Many studies assess fatigue up to the 'endurance point' - the point where the force begins to fall. Those studies that last beyond this point indicate a fall in SEMG amplitude and reinforcement in the decline in spectral variables and MFCV (Arendt-Nielsen and Mills, 1988). This may indicate that, after the endurance point, the slow fibres dominate in the recruitment pattern since they are less fatigable (Duchene and Goubel, 1993).

2.4.7 The relationship between the signal amplitude and spectral parameters during fatigue.

Although the alterations in the signal amplitude and frequency spectrum compression are both considered to be myoelectric manifestations of fatigue, their reported inter-relationship varies. Chan and Chuang (1996) reported an increase in the amplitude and decline in the MNF of the SMES recorded from the EDC during isometric contractions over a range of force from 25 to 100 % in 39 healthy subjects. In a combined intramuscular and surface EMG study of the mean power frequency (MNF) and RMS of the MES measured during sustained maximal and submaximal (50% MVC) contractions of the biceps brachii muscle, Moritani et al (1986) confirmed an increase in the RMS during submaximal contractions, with an accompanying decline in the MNF. During maximal work both the RMS and MNF progressively decreased with time, the decline in MNF being greater during the maximal than the submaximal test. This work emphasises the importance of considering the intensity of the muscular work involved when using the change in the RMS of the SMES with time as an indicator of fatigue. The authors concluded that the underlying mechanisms of spectral shift and those involved in the alteration of signal amplitude differ, with the spectral shift partly reflecting the underlying metabolic state of the muscle and the amplitude dependent upon characteristics of MU activity.

2.4.8 Changes in the SMES and the frequency spectrum in disease.

For decades, attempts have been made to define specific characteristics of the SMES which represent neuromuscular disorders (Walton, 1952). The interference pattern was first focused upon in this respect. In a neurogenic lesion, it is not possible to recruit the maximum number of motor units in a voluntary contraction and the interference pattern is reduced (Lenman and Ritchie, 1987). Action potentials are normal or slightly

increased in duration and are normal or slightly decreased in dimension (Buchthal and Pinelli, 1953). Polyphasic potentials are common and can result in an increase in the frequency of the signal and result in confusion in the differentiation from a myopathy (see below). In primary myopathic disorders, since there is no significant reduction in the number of MUs activated during a voluntary contraction, recruitment is normal and a full interference pattern is obtained (Lenman and Ritchie, 1987), although there may be a slight reduction in signal amplitude and abnormal spikes may be apparent (Kugelberg, 1949). Muro et al (1982) reported the IEMG per unit force recorded from the surface of the biceps during isometric contraction to be significantly higher in subjects with neuromuscular disorders, particularly those of neurogenic origin, in comparison with those with 'myogenic disorders' and healthy controls. That is, subjects with neuromuscular disorders show lower neuromuscular efficiencies than healthy subjects. This was confirmed by Lindeman and Drukker (1994). Examination of the interference pattern of the SMES may give an indication of the presence of a neuromuscular disorder (Larsson, 1975). However this measure lacks specificity and sensitivity, leading workers to examine the frequency content of the signal (Walton, 1952; Larsson, 1975).

Lower spectral frequencies in neurogenic disorders (Blanchi and Vila, 1985; Lindstrom et al, 1985, Muro et al, 1982; Herberts et al, 1973; Larsson, 1975) and higher spectral frequencies in subjects with myogenic disorders (Walton, 1952; Gersten et al, 1965; Lindstrom et al, 1985) have consistently been reported. In patients with primary myopathies, Lindstrom (1970) found the spectral peak to be displaced to frequencies as high as 400-600 Hz, whereas in patients with neuropathy, the high frequency content was lower than normal. Lindeman and Drukker (1994) noted the IMF of the SMES recorded from the quadriceps during isometric knee extension at 80% MVC to be raised in 33 patients with myotonic dystrophy (a myogenic disorder) and reduced in those with hereditary sensory and motor neuropathy (HSMN; a neurogenic disorder, n=29). Greater MDF gradients were noted in the myogenic group but not the neurogenic group compared to controls.

The higher spectral frequencies observed in primary myopathies have been suggested to be related to polyphasic, short potentials (Walton, 1952; Kugelberg, 1949). Workers who have reported the alterations seen in the frequency spectrum of the SMES in myopathies give little attention to the potential influence of fibre type to these changes.

For example, Lindeman and Drukker (1994) studied subjects with myotonic dystrophy, which is associated with the degeneration of type I fibres; there may be some increase in the size of type II fibres (Gilroy, 1990). This may help to explain the increased MDF and greater fatigability in the group with primary myopathy, since these are characteristics of type II fibres (Moritani et al, 1986; Merletti et al, 1990).

Two mechanisms have been proposed to explain the lower spectral frequencies noted in neurogenic disorders; reduced muscle fibre conduction velocities (Hermens et al, 1984; Lindstrom et al, 1985) and increased synchronisation of MU firing (Hermens et al 1984; Latash, 1988).

Larsson (1975) noted the shift towards higher frequencies in neurogenic lesions to correlate with the duration of symptoms of the disorder and described this as “functional evidence of the scar from the disease”. He also noted shifts to higher frequencies in those subjects in whom the disorder was of shorter duration and suggested this to be related to a relative increase of action potentials with thin components, characteristic of reinnervation. This would explain the high frequencies in subjects with neurogenic lesions reported by other workers (Engel, 1975; Cruz Martinez et al, 1984; Latash, 1988). Desynchronisation of muscle fibre contractions secondary to prolonged inactivity has also been suggested to play a role in the phenomenon of raised spectral frequencies in some subjects with neurogenic disorders (Latash, 1988). The possibility of a return to normal frequency spectral characteristics of the SMES if full reinnervation occurs has not been addressed. However, this may explain why some workers reported normal frequency spectra in subjects with previously documented neurogenic lesions (Walton, 1952).

2.4.9 The EMG in rheumatoid arthritis.

Few EMG studies of patients with rheumatoid arthritis have been published in the literature, particularly over the last 2 decades and those reports available utilised needle electrodes. Analysis of the frequency spectrum during muscle contraction has not been investigated in rheumatoid disease.

In a study of the deltoid, biceps brachii, abductor pollicis brevis and quadriceps muscles of 93 patients with RA, Steinberg and WynnParry (1961) noted changes

suggestive of a combination of denervation and a primary myopathy, with a full interference pattern (small amplitude, broken up short duration polyphasic action potentials), suggestive of myopathic lesions and abnormal intensity-duration curves with long duration polyphasic potentials – suggestive of denervation. The EMG findings did not correlate with the degree of weakness nor wasting, nor were they related to steroid therapy. There was some relation to disease activity. Seventy-nine patients were found to have EMG findings suggestive of polymyositis, mostly in proximal muscles - as found by Horowitz (1949). Lenman and Potter (1966) reported a reduction in neuromuscular efficiency in subjects with RA.

There seems little agreement about the presence of spontaneous EMG potentials, suggestive of denervation, in RA (Amick, 1960). Mueller and Mead (1952) demonstrated low amplitude action potentials and a disorganised pattern on the EMG, with no spontaneous activity in 25 patients with RA. Morrison et al (1947) showed spontaneous activity in 50% of 34 rheumatoid subjects, but normal EMGs on contraction. Wramner (1950) found spontaneous activity on the EMGs of 76% of 50 rheumatoids, whereas Newman et al (1953) found no such activity. The variation in findings is not surprising, since Lenman and Ritchie (1987) point out that the finding of abnormal activity in neurogenic lesions is highly variable and that fibrillation potentials can also occur in myogenic lesions.

Graudal and Hvid (1959) found inflammatory changes in the first dorsal interosseous muscles of 60% of 31 patients with RA; 18 other muscles were normal. In 17 other patients no changes were seen. Amick (1960) found no significant EMG changes in 25 patients with RA and muscle wasting. They concluded that wasting was due to disuse.

2.4.10 Recovery of the myoelectric parameters after work.

The **intrasession repeatability** of SMES analysis is concerned with the allowance of adequate rest intervals between the performance of each task, in order that the myoelectric parameters will be restored to their resting values. Such studies have been termed **restitution studies** (Kourinka, 1988). Larsson et al (1965) and Johansson et al (1970) showed rapid changes to occur in the power spectrum after fatiguing exercise. Mechanical and physiological recovery times seem to be longer than that of the frequency spectrum of the SMES (Funderburgh et al, 1974; Hara, 1980; Petrofsky, 1981). Mortimer

et al (1970) demonstrated that muscle fibre conduction velocity (which is closely related to the frequency spectrum) returns to normal within 2 minutes after ischaemic exercise, in parallel with the restitution of blood flow. Restitution of the power spectrum follows a logarithmic course with time (Kourinka, 1988; Kadefors et al, 1968; Petrofsky, 1981).

Most studies published to date using SMES analysis during work use rest intervals which seem to be chosen empirically, with no reference made to the assessment of adequate restitution of myoelectric parameters after these intervals.

There is little information available in the literature as to the repeatability of forearm myoelectric parameters specifically during grip. In a study of the SMES amplitude measured from 'medial and lateral forearm' musculature during sustained isometric grip at up to 70% MGS, Lind and Petrofsky (1979) noted the average half wave SMES amplitude to have returned to close to initial values within 3 minutes and completely by 7 minutes post exercise, in parallel with the MGS. Petrofsky and Lind (1980) reported the centre frequency of the SMES recorded from the FCR during grip over a range of 25-90% MGS to return to baseline levels within a rest interval of 1 minute.

Although most studies indicate that the repeatability of both same day and between-day testing of the RMS of the SMES is good for a variety of muscles (Lind and Petrofsky, 1979; Kadefors et al, 1968), some workers have shown poor recovery rates of this parameter after short rest periods. For example, Miller et al (1987) examined the recovery of the MVC, NME (force/rectified integrated EMG), and the metabolic state of the adductor pollicis muscle (phosphocreatine and pH) after thumb adduction at maximum force for 4 minutes. Whilst the MVC and metabolic parameters had recovered within 20 minutes of recovery, the NME had not recovered after 60 minutes, indicating the rectified IEMG was not fully restored.

Studies which aim to assess the restitution of the power spectral variables after exercise are more apparent in the literature than those of the signal amplitude. Most studies have indicated that the median and mean frequencies of the SMES recover significantly more quickly than muscle force and myoelectric parameters such as the RMS. Kadefors et al (1968) studied the frequency spectra of various muscles after isometric contractions and found that recovery of the MES varied according to the muscle assessed. They showed that 69% of extensor carpi radialis, 69 % of extensor carpi ulnaris and 42 % of extensor digitorum superficialis to have recovered within 90 seconds of terminating the

exercise. An early restoration of the MDF in advance of mechanical variables is confirmed by other workers (Funderburgh 1974; Petrofsky, 1981; Larsson et al, 1965; Johansson et al, 1970).

Since the *change* of the MDF with time during muscular work is most commonly used as the indicator of fatigue, the restitution of the **gradient of the MDF** of the SMES over time (the **MDF_G**) is an important feature to examine when assessing recovery intervals. Although there is little information available on the repeatability of this feature in forearm musculature, this issue has been addressed in studies of other muscles. Dolan et al (1995) examined the restitution of the MDF_G in back muscles in the study described above. They reported correlation coefficients of 0.92 (T10) and 0.50 (L3) on within day testing (after a rest interval approximately 1 hour). Krivickas et al (1996) reported an intraclass correlation coefficient of 0.43 ($p=0.006$) for the repeatability of the MDF_G of the SMES recorded from the biceps during isometric contractions sustained for 100 seconds repeated after a 5 minute rest interval.

It is evident from the literature that the frequency spectrum is highly repeatable on same day testing, after short rest periods. Many studies indicate that this is also true for the RMS of the SMES. The repeatability of the change in the RMS with time (expressed as the RMS gradient) is unclear.

2.5. Strength training in rheumatoid arthritis.

2.5.1 Introduction.

The use of therapeutic exercise in rheumatoid arthritis is an area of confusion and controversy. This is largely a result of the lack of well-structured research in the field, the large number of publications based upon anecdotal evidence and the concern that exercise will result in deterioration in disease (Mapp et al, 1995; Farrell et al, 1992). The following section will review the literature to date on strength training in relation to disuse weakness and rheumatoid arthritis. Handgrip strength training will be specifically focused upon, although where necessary studies in relation to isometric exercise of other muscles will be described. Firstly, the mechanisms of strength training will be detailed.

2.5.2 Mechanisms of strength gain in healthy individuals.

In healthy individuals, two main mechanisms of strength gain in a progressive strength training programme have been identified. Initially strength gains are related to neural factors; later, gains in muscle mass become important.

Neural factors

The nervous system is of paramount importance for the expression and development of strength. Indeed, it is probable that increases in strength can occur without morphological changes in muscle, but not without neural adaptations (Enoka, 1988).

The concept of **neuromuscular efficiency** (Muro et al, 1982) has been described earlier (2.4.4). Improved levels of neural activity and a motor learning effect have been observed with strength training (Moritani and DeVries, 1979). Ikai et al (1968) suggested that most people normally operate at a level of neural inhibition, as a protective mechanism, preventing them from demonstrating their true strength capacity. With training or in competition this inhibition may be removed. With training, subjects learn to recruit motor units - or to utilise the tensions the muscles can produce - more effectively (Moritani and DeVries, 1979; Komi, 1986; Enoka, 1988; Hakkinen, 1989).

Psychological factors, increased arousal and neural facilitation (disinhibition) may lead to full activation of muscle groups (Hakkinen et al, 1988). This **neural facilitation** (or **neural adaptation**) has been proposed to be the mechanism underlying the initial rapid strength gain in training programmes (Edstrom and Grimby, 1986; Sale, 1987). The phenomenon has been illustrated in various reports, including the demonstration of a training effect on the non-exercised contralateral limb of subjects who undergo unilateral arm or leg exercise (Enoka, 1988). In addition, specific training responses are more likely to be due to neural mechanisms than purely adaptations of muscle (Enoka, 1988).

The phenomenon of neural adaptation is most important in the first 2-3 weeks of strength training (Moritani and DeVries, 1979), but is maintained during subsequent training, when hypertrophy becomes the predominant factor in the further gain of strength.

Gains in muscle mass with strength training.

In 1935, Fenn and Marsh found muscle cross-sectional area (CSA) to be an important determinant of the maximum isometric force which could be produced by an isolated

skeletal muscle preparation. Since then it has been established that the strength of a muscle is in proportion to the physiological cross sectional area of the muscle (Arkin, 1938; Asmussen et al, 1965).

Muscular growth in response to overload training occurs primarily from hypertrophy of individual muscle fibres (Hakkinen and Komi, 1983; McDonagh and Davies, 1984). The process of hypertrophy is related to the synthesis of cellular material, particularly protein myofilaments. Myofibrils thicken and increase in number and additional sarcomeres are formed by an acceleration of protein synthesis and decreases in protein breakdown (Edstrom and Grimby, 1986; McDonagh and Davies, 1984).

Although muscle fibre **hyperplasia** has been reported with particular strength training regimes (Tesch, 1988; Larsson and Tesch, 1986), the literature supports **hypertrophy** as the greatest contribution to increased muscle size in response to strength training (McArdle et al, 1991; MacDougall et al, 1984).

In addition to changes in muscle fibre size, the evidence suggests that the contractile properties, metabolic capacity and associated enzymes can change with training (Gollnick et al, 1972), but the fibre type and twitch characteristics remain stable (Brooks and Fahey, 1985). However, there is some evidence that a fast twitch fibre **will** be transformed into a slow twitch fibre, but **only** if their nerve supplies are experimentally interchanged (Edgerton et al, 1980; Kilmer, 1996). The subject of fibre type transformation in healthy individuals in response to training remains highly controversial. However, as described earlier, it may be an important result of the process of reinnervation (Jones and Round, 1990).

2.5.3 Important features of strength training programmes.

In designing a strength training programme, it is important to establish the **specificity** of the exercise involved in relation to the required task, the **training threshold** above which improvements in strength will occur, and the **optimal intensity** needed to produce the greatest strength gains within the shortest period of time. This is extensively reviewed by numerous workers (McDonagh and Davies, 1984; Atha, 1981). It has been demonstrated that the optimal training intensity for both isometric and dynamic exercise involves

submaximal but high intensity, fatiguing contractions (Szeto et al, 1989). This is termed the **overload** principle (MacDougall et al, 1980).

Training threshold is a function of strength (Enoka, 1988). As strength increases in a training programme, the required muscle tensions for training must increase accordingly. Thus an effective training programme must utilise progressively higher resistance loads. McDonagh and Davies (1984) concluded that a threshold load of 25-30% MVC must be utilised in order to achieve increases in isometric strength.

The response of a muscle to training is specific to the type of exercise and the joint angle used and the speed of contraction (Manning et al, 1990). It will also be influenced by the cause(s) of the muscle weakness, where present. The best training for a task involves task specific muscle contraction, that is, the performance of the task itself (Carr and Shepherd, 1987; Rutherford, 1988). Contemporary approaches to strength training often involve the identification of which muscle groups to train from observation of task performance. However, it can be difficult to define accurately the muscle groups by this means, particularly when joint deformity and altered joint angles are present. By training task performance rather than concentrating on simple strength regimes for isolated muscle groups, it is likely that this can be avoided (Carr and Shepherd, 1987). However, it may contribute to abnormal muscle contraction or the utilisation of a compensatory strategy, particularly in patients with joint diseases, such as RA (Wynn Parry, 1983).

2.5.4 Assessing the mechanisms of strength gain.

De Vries (1968) and Moritani and DeVries (1979) utilised the measurement of the NME in the assessment of the mechanisms of strength gain in a strength training programme. They monitored the NME over the course of the programme and suggested that, if the strength gain were due to neural adaptation, the ratio of force to signal amplitude would be expected to remain the same. If this were due to gains in muscle mass, the ratio would increase.

Figure 2.5.1: Schema for the evaluation of mechanisms of strength gain, using the concept of neuromuscular efficiency, after Moritani and De Vries (1979).

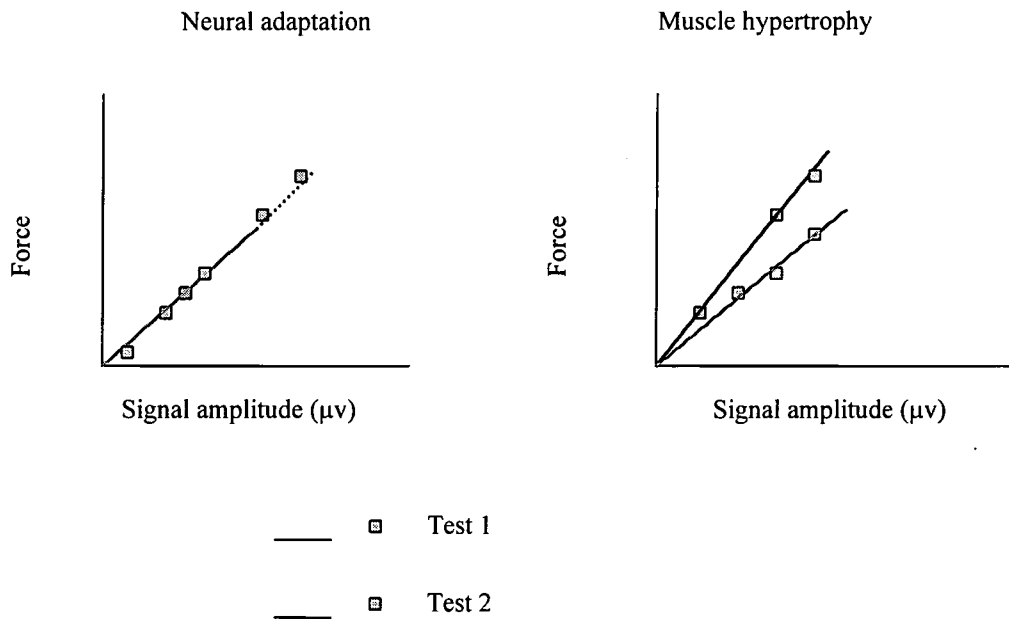

Since the strength of a muscle is in proportion to its cross-sectional area (CSA) (Arkin, 1938; Asmussen et al, 1965), changes in muscle size in limbs have been examined by the assessment of the limb CSA using **skin fold calipers** and, more recently, by imaging techniques such as **ultrasound and magnetic resonance imaging (MRI)**. The former technique involves the measurement of the skinfold thickness at two or more sites of the limb, and the CSA calculated. Helliwell and Jackson (1994) applied this technique to the assessment of forearm muscle mass, as shown in the following equation:

$$CSA (cm^2) = \pi \left[\frac{FOC - \frac{STd + STv}{40}}{2\pi} \right]^2 - R - U$$

where FOC = forearm circumference (cm)

STd = dorsal skin thickness (mm) (NB: double fold of skin thickness was measured)

STv = ventral skin thickness (mm)

R = area of radius (cm²)

U = area of ulna (cm²)

R and U taken from tables of bone diameter (Virtama and Helela, 1969), assuming circular cross-section (Horsman and Leach, 1974).

It has been shown that the estimation of muscle mass by this method is inaccurate (Young et al, 1980), although there may be some correlation between the two measures. Helliwell and Jackson (1994) reported this method of forearm CSA measurement to correlate closely with that obtained using computed tomography in six subjects with RA and one normal subject. These workers suggest that assessment of the CSA by skinfold callipers is a useful method for the monitoring of change in the muscle CSA. However, the repeatability of the technique was not reported.

Ultrasonography has been used to monitor changes in muscle CSA (Young et al, 1980). However, significant inter-observer variation has been reported (Howe and Oldham, 1996) and the sensitivity to change is unclear. In the study by Helliwell and Jackson (1994) described above, CT scanning was used in a single measurement of forearm cross-sectional area in 7 subjects, 6 of these with RA. The repeatability of scanning was not reported. The radiation associated with CT scanning limits its suitability for research.

Engstrom et al (1991) demonstrated that magnetic resonance imaging (MRI) accurately measures the CSA of skeletal muscle. MRI has also been shown to identify small changes in skeletal muscle induced by resistance training (Treuth et al, 1994). MRI has been used to assess lower limb muscle volume changes in healthy individuals over a 17-week period of bed rest, demonstrating declines in muscle mass over this period. The coefficient of variation over 1 week in a group of healthy controls was 1.1 %. Volumetric analysis of forearm musculature has not been described in the literature.

2.5.5 Strength training and disuse weakness.

Considerable discrepancy exists between animal studies and those of humans in relation to strength training and disuse weakness. Animal studies have shown a very rapid return to normal strength with training after a period of disuse (McDonagh and Davies, 1984), whereas human studies have varied. Humans with long standing disuse weakness can experience large strength gains with training (Hakkinen, 1994). However, studies involving strength training after a short period of immobilisation are less clear and have failed to show any difference between a wide variety of strength training regimes, including everyday motor tasks (Hakkinen, 1994).

The mechanisms of strength gain in such cases are also unclear. It is possible that neural adaptation and gains in muscle mass may be disrupted. Skeletal muscle fibres - like neurones - are permanent cells which do not divide after birth. Post-natal growth consists purely of the addition of cytoplasmic mass with no increase in muscle fibre number. The regeneration of muscle fibres after injury does occur to a limited degree, but is limited to a cytoplasmic response (i.e. a regrowth of sarcoplasm); lost muscle mass can only be replaced by hypertrophy of surviving fibres (Taussig, 1984).

2.5.6 Strength training in RA

Specific problems in relation to exercise to be considered in the patient with RA are related to the fluctuation in the activity of the disease (and therefore in pain and stiffness), the inter-subject variation in the condition of joints and ensuring that the joint condition is not worsened by the exercise. Other factors include the presence of joint deformity - which may make some strengthening regimes difficult - and the presence of complications associated with the systemic nature of rheumatoid disease, for example peripheral neuropathy and active clinical myositis (Herbison et al, 1987).

Isometric strengthening exercises are frequently recommended for patients with RA. Machover and Sapecky (1966) found a strength gain of 23% in the exercised limb and 18% in the contralateral (unexercised) limb, after a 7-week programme of daily isometric quadriceps exercises in 11 patients with RA. The latter indicates that the process of neural adaptation occurred.

Handgrip exercise has been demonstrated to improve grip strength in RA (Dellhag et al, 1992). For example, Hoenig et al (1993) demonstrated improved grip strength in RA with 12 weeks of balanced resistive hand exercise performed for 10-20 minutes, twice daily. Brighton et al (1993) also reported improvements in grip strength with daily active hand exercise in subjects with class I RA.

In all of the studies above, no adverse effects of the programmes were found. Lyngberg et al (1988) reported a reduction in the number of swollen joints by 35 - 45 %, including those joints which were stressed during a home exercise programme of bicycle ergometry, dynamic strength exercises and stretching in subjects with class I and II RA.

The issue of compliance in home exercise programmes was also examined by Ekdahl et al (1990), who found 4 initial training sessions to be as effective as 12, and Treusch and Krusen (1943) who found 2 supervisory sessions to improve compliance. Parker and Bender (1957) recommended a home therapy programme be reinforced every 2 months. Since RA is a fluctuating disease, the education of the patient with respect to exercise regimes and how to adapt them according to disease variations has been recommended (Mahowald et al, 1988, 1990). Lyngberg et al (1988), in the study described above, also emphasised the need for an initial period of supervision prior to the commencement of the home programme to ensure compliance.

In a rare study of the physiological changes associated with strength training in RA, Nordemar et al (1976a) performed a study of muscle fibre size (assessed on biopsy) and physical performance after physical training (involving aerobic and strength training –the type not clearly stated - predominantly of the lower limbs) in patients with RA of functional class I or II. Atrophic type I and II fibres were noted in most subjects. Strength gains were demonstrated in most subjects and an increase in muscle fibre size, of both Types I and II was noted, being more marked in the latter. No fibre type transformation with training was noted, nor was there extensive formation of new fibres.

2.6. Grip strength in rheumatoid arthritis.

2.6.1 Introduction.

Grip strength is a significant measurement in rheumatoid disease, reflecting hand function and disease activity and severity (Lansbury, 1958; Nordenskold and Grimby, 1997). Indeed, Nordenskold and Grimby (1997) found grip force to be a more accurate assessment of actual global disability than the widely used Health Assessment Questionnaire (HAQ) score. Pincus et al (1987) reported grip strength to be a predictor of increased mortality in rheumatoid disease. The assessment of forearm muscle fatigue and other myoelectric characteristics during grip and the investigation of the response to handgrip strength training has many advantages. Grip is a task that is familiar to most individuals, is a vital task in daily activity and reflects the functional impact of rheumatoid disease upon an individual (Pincus et al, 1987; Nordenskold and Grimby, 1997). Local disease activity, deformity and bone mineral density (a measure of disease

severity, particularly in early disease) can all be measured. The forearm musculature is actively involved in grip and is easily accessible for measurement of the SMES during work.

2.6.2 The rheumatoid hand.

In early rheumatoid disease, active inflammation of the joint and periarticular structures can result in diminished hand function through pain, swelling, stiffness, muscle weakness and triggering of tendons. As the disease progresses, the relative contributions of these features in addition to permanent deformity fluctuates (Myers et al, 1980; Hart and Huskisson, 1972; Wright and Johns, 1960).

Numerous deformities can occur either alone or in combination in the rheumatoid hand. The two which are most characteristic of the disease, ulnar deviation and anterior subluxation at the metacarpo-phalangeal (MCP) and wrist joints, can be explained by the change in forces seen in flexor tendons in this disease (Smith et al, 1964). The other mechanisms which have been proposed include contracture of the ulnar interossei, ulnar dislocation of the extensor tendons (Brewerton, 1957), hand use, unilateral capsular damage, gravity, joint shape and pull from the ulnar deviated little finger (Straub, 1962). None can be considered as a primary cause since they are not consistently present or do not work consistently in the direction of the deformity (Flatt, 1963), but each may play a part in accentuating or fixing the deformity (Bunnell, 1955).

The theories described lead to other conclusions in terms of the treatment and prevention of rheumatoid deformities of the hand. The exercise regime of squeezing a rubber ball has been proposed by some to be unsuitable (McGregor and Wright, 1967), since it is exercising the flexor tendons. The role of the forearm extensor muscles in grip is frequently not appreciated, although some workers have emphasised that the extensors are at least as important as the flexors to grip strength (Snijders et al, 1987; Hagg and Milerad, 1997). If the wrist is pulled into extension, then the extensors are exercised to a greater extent (Snijders et al, 1987; Hagg and Milerad, 1997). This should be beneficial, since grip is stronger with the wrist in some degree of extension (Simmons et al, 1981). Such a regime reflects a functional task and the acquisition of motor skills is an often neglected though highly important aspect of therapeutic exercise (Hakkinen, 1994). In injury or disease, the loss of strength in the flexor and extensor muscle groups can occur. This

emphasises the need to consider both groups in devising a suitable functionally orientated rehabilitation programme.

2.6.3 Factors Affecting Grip Strength in RA.

In RA, grip strength is reduced compared to the normal population (Mathiesen et al, 1991). This can be solely due to reflex inhibition, true muscle weakness, effusion, joint stiffness, pain (or related factors such as synovitis) or deformity (including bony deformity and soft tissue alterations with altered joint mechanics).

Spiegel et al (1987) found grip strength to correlate with walk time, wrist and hand tenderness, deformity, total joint tenderness, swelling, ESR and wrist and hand swelling. There was no correlation between subjective nor objective morning stiffness but other studies have disputed this (Myers et al, 1981).

Grip strength demonstrates circadian variation (Wright, 1959; Harkness et al, 1982) in both healthy and rheumatoid subjects. A decline occurs in early morning and evening. Nwuga (1975) found a positive correlation between grip strength and body weight in healthy females, as did Thorngren and Werner (1979), although the latter workers found no correlation with the rate of development of a MVC. No significant relationship was found between the body weight and endurance of grip (Nwuga, 1975). Schmidt and Toews (1970) found grip strength to decline after the age of 30 years in males and 40 years in females.

2.6.4 The assessment of grip strength.

The measurement of grip strength remains the foundation of hand assessment (Cantrell, 1976; Myers et al, 1980; Mathiesen et al, 1991). One of the most popular methods of grip strength measurement utilises the air filled bag. This is comfortable and easy to use and provides some tactile feedback to the subject during gripping. They allow a grip test of longer duration to be performed, which is often too uncomfortable with other devices (Pearson et al, 1982).

There are drawbacks to these devices, as highlighted by Unsworth et al (1990) and Lee et al (1974). Since pneumatic devices are filled with air, (which is compressible), the system

is non-linear in response and this is likely to lead to a very small error only. The pressure within the system is dependent upon the force divided by the area over which it is applied. The measured grip pressure is potentially influenced by hand size and alteration of hand position during and between measurements. It is therefore important to ensure all subjects maintain a standard hand position. Various bag sizes are available to suit different hand dimensions. It has been found that, for a given force, with larger bag and/or hand sizes, lower pressures are recorded. Also, for a given force applied at different starting pressures, different readings are obtained (Unsworth et al, 1990). It has also been demonstrated that different techniques of squeezing the cuff or bag will give rise to variations in pressure readings (Carus et al, 1985). For example, when the bag is gripped with the fingers "digging in", a greater pressure is recorded than when gripped with the fingers lying flat. On the basis of these potential sources of error, it is recommended that the volume, size and initial pressure of the bag is recorded with every measurement and subjects advised appropriately on their use (Unsworth et al, 1990).

The Durham gripper also provides measurement of grip strength which are sensitive and repeatable and can measure a wide range of forces (Jones, 1984). This is a 4-channel, stainless steel, strain gauge dynamometer, which can be used to measure grip and individual finger forces.

The most appropriate **index** of grip strength, for example the **maximal voluntary contraction (MVC)**, the time to attain the MVC, etc. remains controversial.

Various parameters have been used in the description of grip strength (Myers et al, 1980; Grindulis and Calverley, 1983). These include the maximum grip strength, the time taken to reach peak grip, the rate of loss of grip force from the maximum value (MVC) to the point of release ('fatigue rate'), the rate of loss of grip from the release point to the baseline value ('release rate') and the integral of the force-time curve, which reflects the total amount of work done.

There are few studies examining the inter-relationship between the functional parameters and their association with aspects of joint disease. Helliwell et al (1987) found that neither the area under the force-time curve, the fatigue rate nor the release rate provided additional information to the MVC. The time to reach peak grip was independent of the MVC and possibly being partly a reflection of joint stiffness.

Figure 3.1.1: THE HAND ASSESSMENT SYSTEM

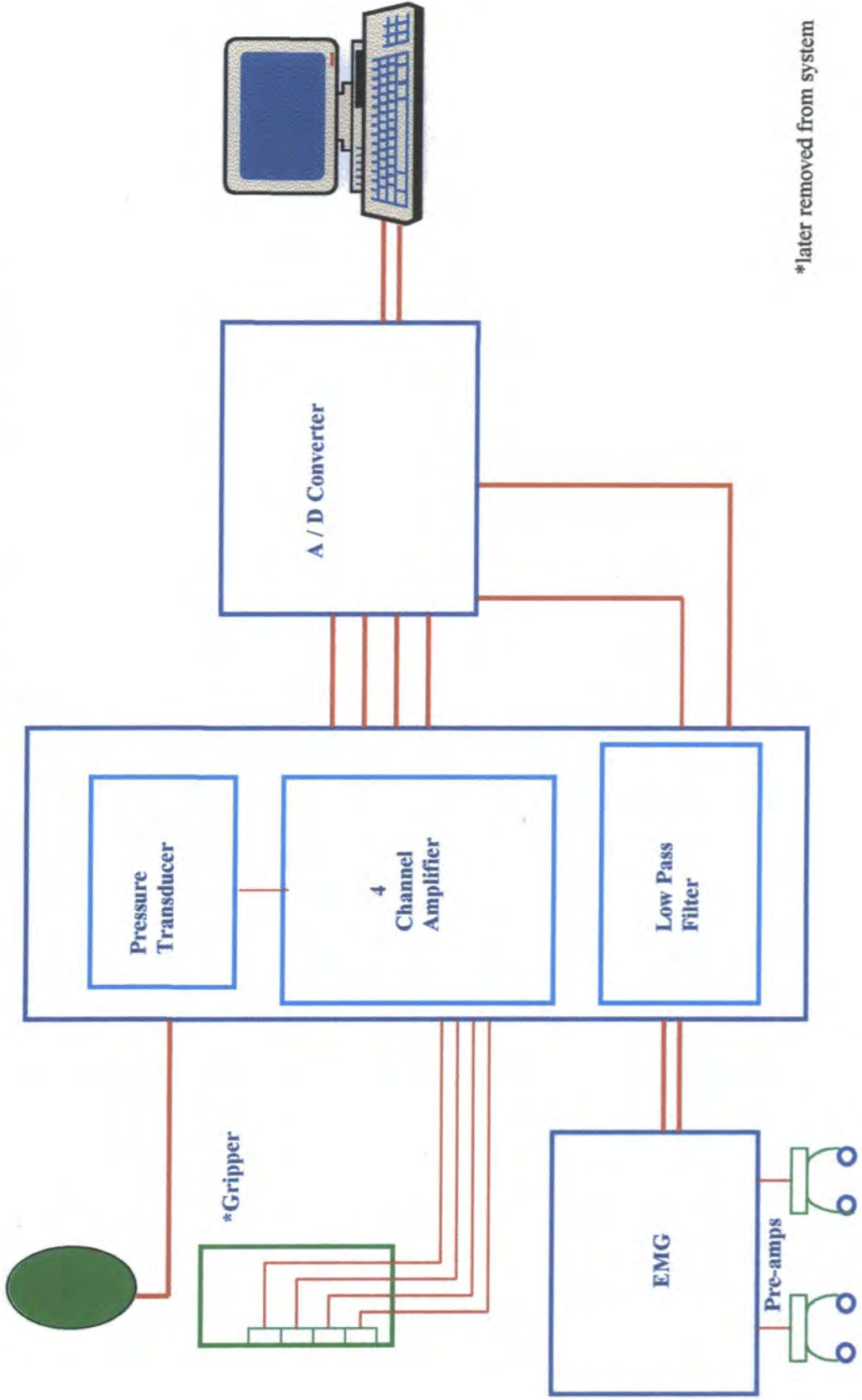

Chapter 3: Materials and Methods

3.1 The apparatus.

The apparatus consisted of a grip bag, pressure transducer, EMG amplifier, preamplifiers, filters and electrodes, a data acquisition (DAQ) card and laptop computer, as displayed in figure 3.1.1.

3.1.1 The Grip Bag

This was a 14.5 cm x 9.5 cm, cloth covered, air filled bag, which was connected to a pressure gauge, displaying the grip pressures on a dial. The bag was also connected to a pressure transducer, the signal from which was amplified, digitised and relayed to the computer. The pressure inside the bag was altered using a rubber bulb and valve. A feedback bar gauge on the computer display gave the subject a target pressure at which to aim; this target pressure was a given fraction of the individual's maximum grip strength: 1/3, 1/2 or 2/3 MGS, according to the specific test being performed. The starting pressure in the bag was 40 mmHg in all tests.

The grip bag and pressure transducer were **calibrated** against a mercury sphygmomanometer at the beginning of every week, using a specifically designed calibration programme. The bag was connected via a three-way tap to the pressure transducer and a mercury sphygmo - manometer, the latter giving the true pressure reading from the bag. The output from the pressure transducer was digitised by the DAQ card.

Using the baseline value of 40mmHg, the ADC output was recorded for steps of 10mmHg. Figure 3.1.2 shows the resultant graph of ADC output against bag pressure. The slope of this line gave the calibration factor which was multiplied by the ADC reading obtained from the tests.

Figure 3.1.2: The pressure readings versus the ADC output (microvolts) from the grip bag compared with the sphygmomanometer (mmHg).

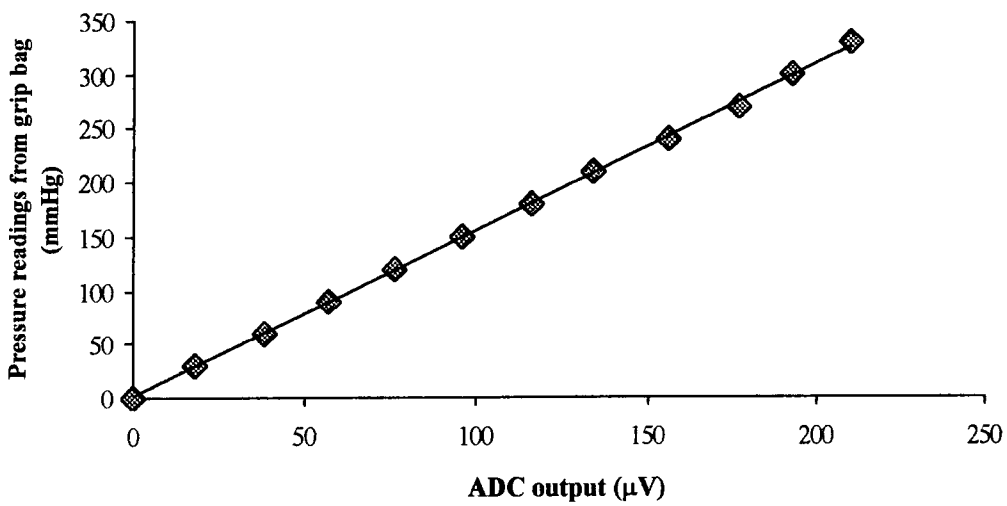

3.1.2 Surface Electromyography: Signal Acquisition and Processing.

The signal acquisition **hardware** included a Medelec MS92a EMG machine and pre-amplifiers for amplification of the myoelectric signals. These were then filtered by a set of filters, with a bandwidth of 3-512 Hz. The signals were then digitised by a **DAQCard-1200** (National Instruments), a multifunction analogue, digital and counter-timing IO PCMCIA card, with a fast 12-bit ADC with 8 analogue inputs. It converted the analogue pressure and surface myoelectric signals to digital signals for further processing by a **laptop computer** (a Viglen 486MHz Dossier). See Figure 3.1.1.

The system **software**, developed by Dr P Jones (Regional Medical Physics Dept., South Cleveland Hospital), consisted of **calibration, data acquisition and analysis programmes**. The **data acquisition program** initially cleared the input boxes for subject details and opened a file for the EMG and gripper/bag data. It then wrote the patient details into an individual file. Calibration constants from the grip bag were read in and a reading was taken from the grip bag (the starting pressure of 40mmHg) to act as a baseline.

Both the surface myoelectric signal (SMES) and grip pressure readings were sampled at 1024 samples per second (twice the Nyquist rate), in order to prevent high frequency aliasing of the SMES. Although such high sampling rates of the grip pressure were unnecessary, a uniform sampling rate for all signals simplified the acquisition programme. The pressure readings from the grip bag were displayed as a bar chart; the SMES was also displayed on the computer screen just prior to commencing the test, but processing limitations did not allow simultaneous display during the test. All data from each test (the SMES from both EMG channels and the grip pressure) were written to a file.

The software used to **analyse** the SMES from each EMG channel read the data in one-second epochs, each epoch consisting of 1024 samples. A fast Fourier transform algorithm was applied to each epoch to obtain a frequency amplitude spectrum for each epoch and the spectral **peak** and **median frequency** (MDF) were located. For each test, the mean MDF and spectral peak for the specific channel was calculated by averaging the values calculated from the 30, one-second epochs. The MDF for each 1-second epoch over the 30-second test

Figure 3.1.3: the grip force: RMS voltage gradient (F:RMS_G)

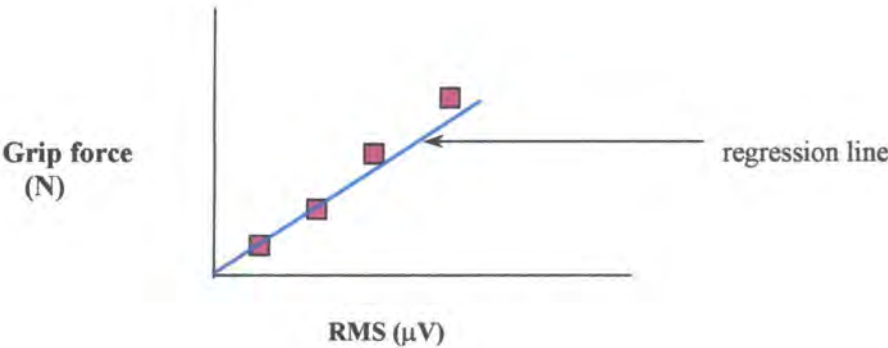

was plotted against time and a linear regression line fitted to the 30 sample points. The **initial median frequency (IMF)** was calculated from the intercept ($t=0$) of the regression line, in keeping with the findings of other workers that this is more reliable than using the MDF of the first one second epoch (Mannion & Dolan, 1994). The gradient of the regression line represented the **MDF gradient (MDF_G)**. The **spectral width** was determined by averaging the 30 amplitude spectra, applying a three point moving average with three passes to the composite spectrum and calculating the width of the spectrum at half the peak amplitude.

The option for data windowing was available, the effects of which were assessed in a pilot study (4.1.6). Data windowing was not used in the main study.

The root mean square voltage of the SMES (**RMS**) was calculated for each one second epoch by squaring each of the 1024 voltage samples scaled to EMG amplitude gain and taking the square root of the mean of these values. The **initial RMS (IRMS)** and the **RMS voltage gradient (RMS_G)** were determined from the intercept and slope respectively of a least squares regression fit to the RMS value for each epoch plotted against time.

The composite spectrum of each channel for each test was visually appraised, specifically to assess for the presence of significant interference spikes (e.g. 50 Hz mains pickup). The grip pressure readings over the test period were assessed to ensure that a constant force (within 5% of the target value) was maintained.

The grip force : RMS voltage gradient ($FRMS_G$).

The target grip force was plotted against the mean extensor and flexor RMS voltages from each grip test and linear regression lines fitted. The slopes of the regression lines were termed the **grip force : RMS gradients ($F:RMS_G$)** for each channel. This was used in assessing the mechanisms of strength gain during the handgrip exercise programme (Chapter 8). See Figure 3.1.3.

**Figure 3.1.4:
The SMES
Analysis
System**

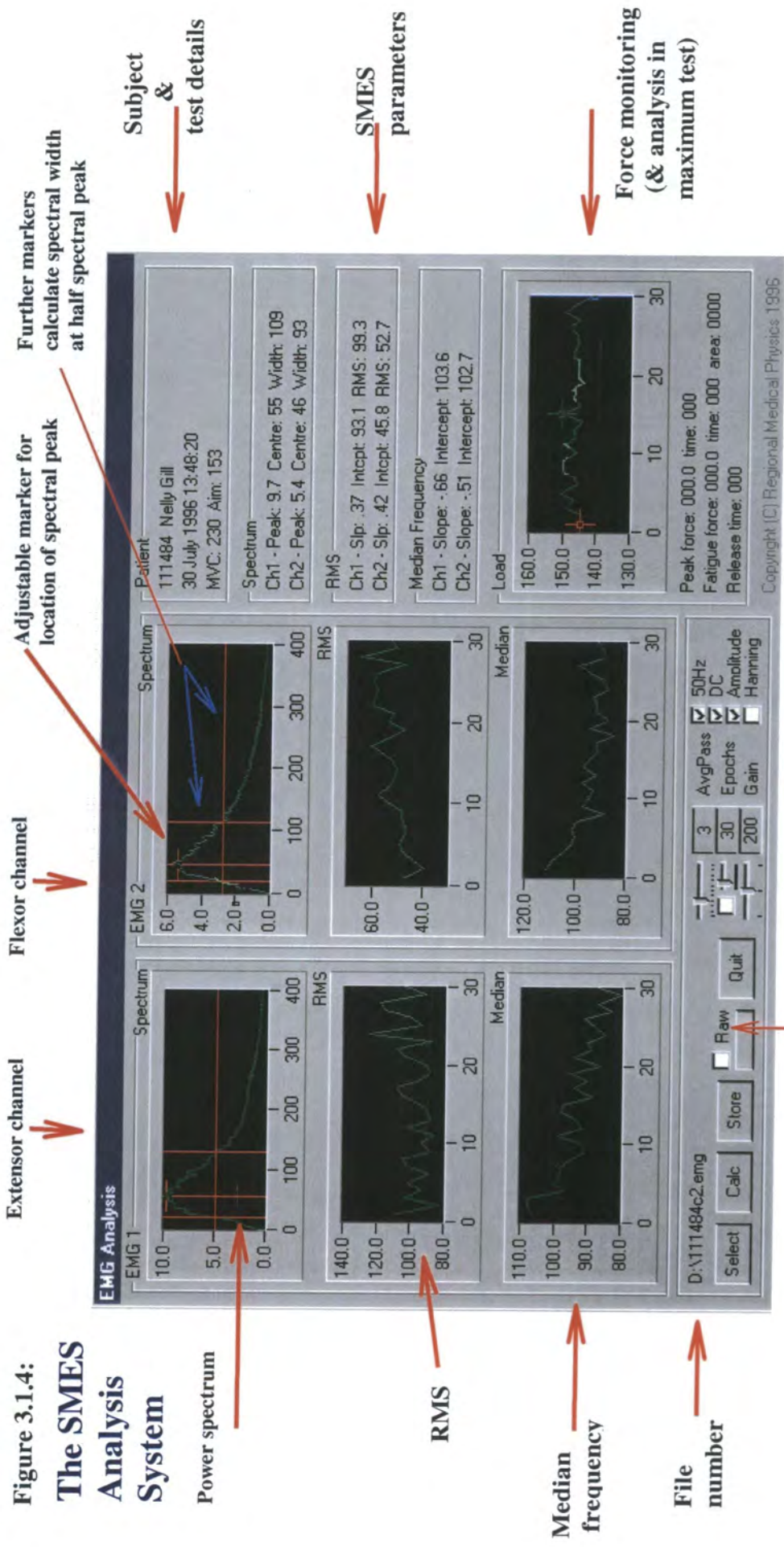

Extensor channel

Flexor channel

Adjustable marker for location of spectral peak

Further markers calculate spectral width at half spectral peak

Subject & test details

SMES parameters

Force monitoring (& analysis in maximum test)

Power spectrum

RMS

Median frequency

File number

Analysis options

Raw data analysis option allows examination of specific epochs

3.2. The SMES acquisition and analysis system: calibration and electrode placement.

3.2.1. System description and calibration.

The SMES acquisition and analysis system was calibrated using a signal generator. The frequency and amplitude of the generated signal were measured with an oscilloscope and a frequency counter. Signals of known frequencies were fed through the pre-amplifiers into the system and the centre frequency and RMS voltage of the SMES were then calculated using the analysis software. Signal acquisition was performed with the EMG amplifier set to a gain of $500 \mu\text{V}/\text{div}$ and $200 \mu\text{V}/\text{div}$, since these were the gains used in SMES recording. The results are shown in Table 3.2.1, showing **no difference** in the generated signal frequency and the system results. A maximum of less than 0.5% difference in the RMS of the SMES calculated by the system at a gain of $500 \mu\text{V}/\text{div}$ and 2.7% at a gain of $200 \mu\text{V}/\text{div}$ was found.

Figure 3.2.1: Calibration of the SMES acquisition and analysis system.

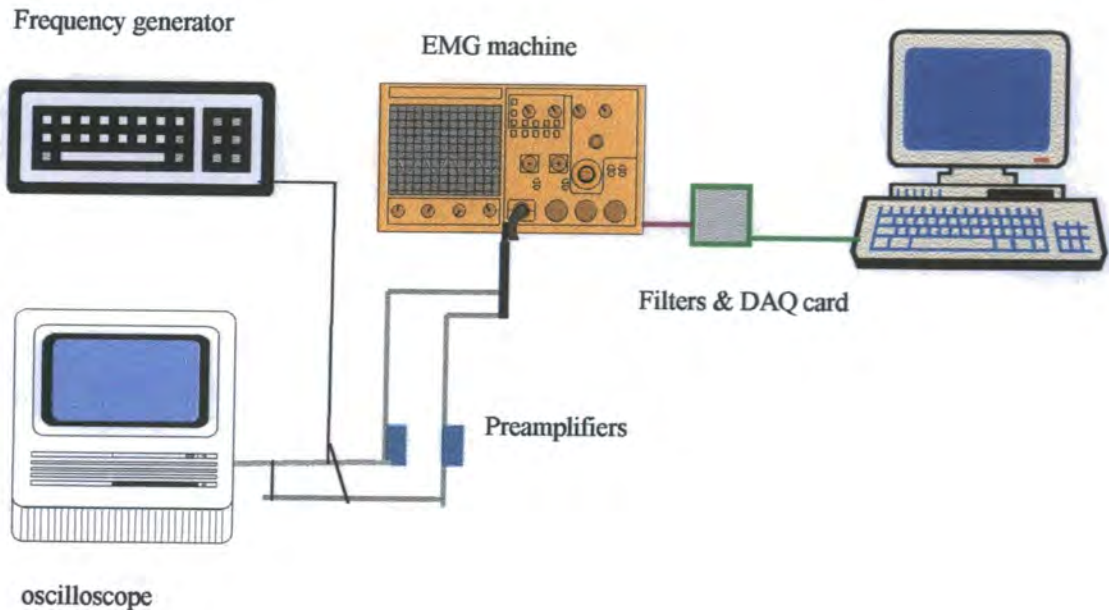

Table 3.2.1: SMES acquisition and analysis calibration.

Sensitivity	Parameter	Generated Signal	System Result: Extensor channel	System Result: Flexor channel
500μV	Frequency (Hz)	100 Hz	100 Hz	100 Hz
	RMS (μV)	1059 μ V	1064 μ V	1056 μ V
200 μV	Frequency (Hz)	100 Hz	100 Hz	100 Hz
	RMS (μV)	423.4 μ V	415 μ V	412 μ V

3.2.2. The placement of electrodes on the forearm for the recording of the SMES.

The specific sites for location of the extensor electrodes were on the belly of extensor digitorum communis (EDC), one third of the length of the forearm measured from the lateral epicondyle of the humerus. The flexor electrodes were located by firstly identifying the belly of the flexor carpi radialis (FCR) according to surface anatomy guidelines (Lumley, 1996), and identifying a point on the muscle, one third of the length of the forearm distal to the lateral epicondyle. The length of the forearm was taken as the distance between the lateral epicondyle and the radial styloid.

The skin of the right forearm was prepared at the landmark sites by rubbing with antiseptic 'Steret' wipes. The skin was allowed to dry, shaved with a disposable razor and finally rubbed with fine sandpaper ('Cardiopreps'). The skin impedance was then checked using an impedance meter to ensure a value less than 4 k Ω .

Nicolet Blue Sensor Disposable Pre-gelled Foam Backed Electrodes (Side Snap), with a detection surface area of 1 cm² were applied to the forearm on the extensor surface (extensor channel) and the flexor surface (flexor channel). A bipolar arrangement was used to allow differential amplification. Two electrodes per channel were applied, with an interelectrode distance of 1cm for each and the electrode positions were recorded using horizontal (a fixed scale on the arm rig) and vertical (inverted depth gauge) scales. The ground electrode was applied to the sternum.

Figure 3.2.2: Position of extensor electrodes and arm in rig for forearm SMES analysis during grip.

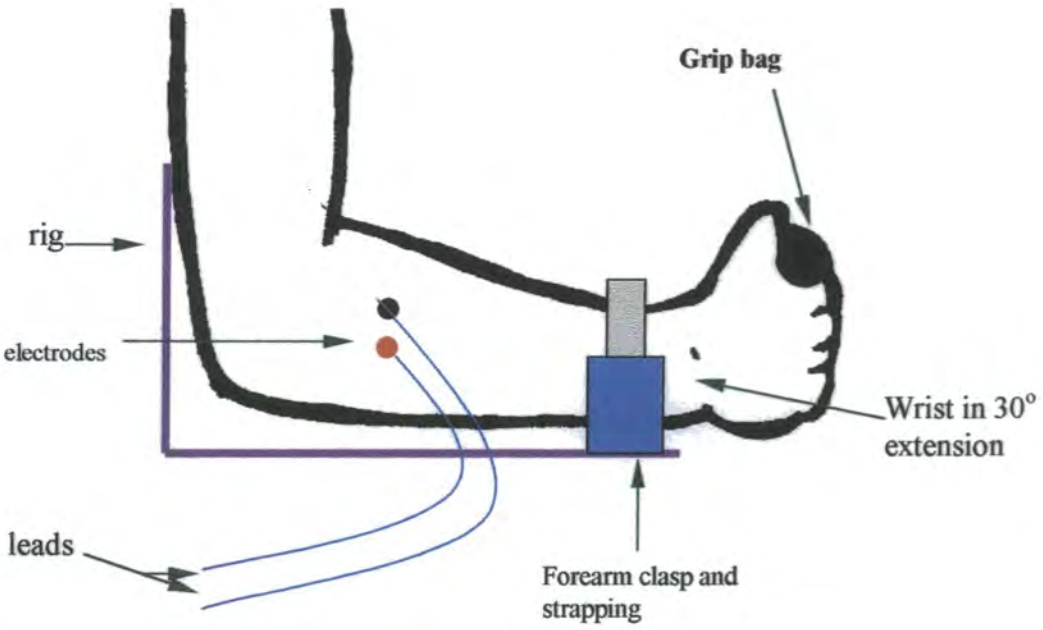
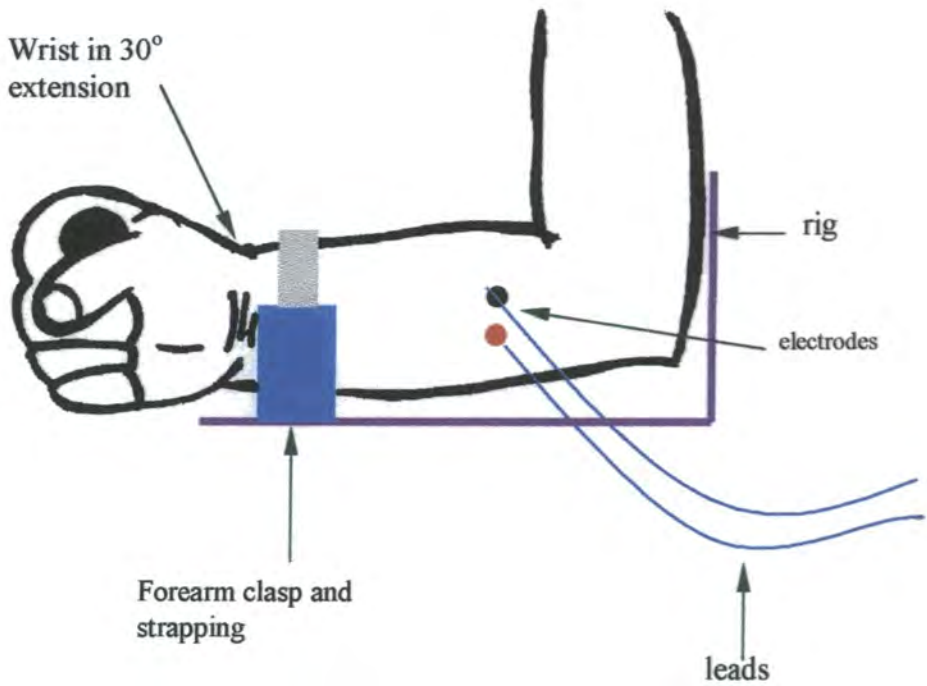

Figure 3.2.3: Position of flexor electrodes and arm in rig for forearm SMES analysis during grip.



3.3 The assessment of grip strength.

3.3.1 Subject positioning and grip testing.

The subject was positioned according to the American Society of Hand Therapists recommendations for the measurement of grip strength (Fess & Moran, 1981).

Figure 3.3.1: Subject positioning for grip testing.

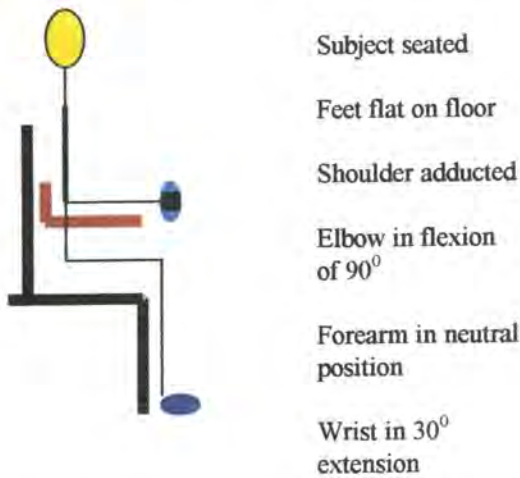

An arm rig with an adjustable elbow rest and wrist straps was mounted on a stand of adjustable height. The rig had a horizontal scale attached to allow recording of surface landmarks. The rig and stand allowed the subject to be positioned as shown in figure 3.3.1, which is the position recommended for grip strength testing (Fess & Moran, 1981). The peak grip strength was assessed using the grip bag. The subject was asked to perform her maximum grip on three sequential tests, at 20-second intervals, each lasting 3 seconds. The mean of the three tests was taken as the subject's maximum grip strength (**MGS**).

Software was developed* for testing and analysing grip, which allowed a target grip to be calculated according to the maximum grip. The subject had a visual feedback of their grip and the given target pressure was displayed on the computer screen.

3.4 The Assessment of Forearm Muscle Cross-sectional Area (CSA) and Volume.

Three methods of assessment of forearm muscle mass were applied during the study and compared to determine the optimal method. Two of these techniques involved the assessment of **CSA** and the other assessed muscle **volume**.

3.4.1 The Assessment of the Cross-sectional Area (CSA) of the Forearm.

Two methods of assessing the cross sectional area of the forearm were used. These were the skinfold caliper technique and single slice magnetic resonance imaging (MRI) of the forearm.

The skinfold caliper technique was used in the initial assessment of forearm CSA.

Skinfolds were measured at the site of maximum forearm circumference identified on the extensor aspect of the forearm and on the flexor aspect of the forearm level with the site on the extensor aspect, using calipers as described by Helliwell and Jackson, 1994.

$$CSA = \pi \left[\frac{FOC - (St_d + St_v)}{2\pi} \right]^2 - R - U \text{ cm}^2$$

where: FOC = forearm circumference (cm)

R = area of the radius (cm²)

U = area of the ulna (cm²)

St_d: forearm skinfold thickness measured on the extensor aspect of the forearm (mm)

St_v: forearm skinfold thickness measured on the flexor aspect of the forearm (mm)

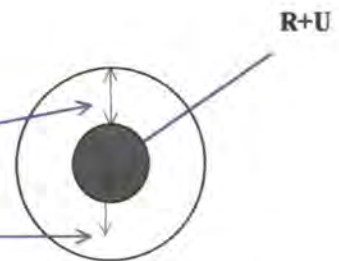

NB: a double fold of skin was measured by the calipers.

R and U taken from tables of bone diameter (Virtama and Helela, 1969), assuming circular cross-section (Horsman and Leach, 1974).

* Dr Patrick Jones, Regional Medical Physics Department, South Cleveland Hospital.

This technique was not found to be repeatable over same day testing of 8 controls and was therefore rejected as a method of evaluation of the CSA of the forearm.

As a result of this, **magnetic resonance imaging of the forearm**[#] was used for both cross-sectional area and volumetric measurements of the forearm muscle. The subjects were scanned in the prone position, with the study arm flexed and internally rotated at the shoulder, the elbow partially flexed and the forearm pronated. Cross sectional area of the right forearm musculature at the site of maximum extensor muscle area (located by initial imaging in the coronal plane) was measured from T_{W1} MRI sequences obtained on a 1.0T Siemens Impact Scanner. The outer edges of the forearm muscle compartments was identified visually on the computer screen and traced manually using a computer mouse and tracer tool. The area within the muscle compartments was then calculated using an analysis package.

3.4.2 Volumetric analysis of the musculature of the right forearm.

Volumetric analysis of the musculature of the right forearm was studied using a Siemens MRI Scanner[♣]. A 15 cm section of the right forearm was scanned, initially using three separate scanning techniques (T₁ weighted, Proton and 3D), in order to ascertain the optimal scanning protocol for use in further assessments in the main study. The details of this initial study are further described in Chapter Five. The proximal scanning slice was located just distal to the superior radioulnar joint. The subjects were scanned in the prone position, with the study arm flexed and internally rotated at the shoulder, the elbow partially flexed and the forearm pronated. Eight, 1 cm slices with 1 cm intervals were imaged using the T₁-W technique and fifteen, 1 cm slices imaged using the proton technique. The mean number of slices in the 3D studies was 22.

[#] Scanning was performed in the Department of Radiology, South Cleveland Hospital and analysis of the scans for forearm muscle CSA was performed by Dr Robert Campbell, Consultant Musculoskeletal Radiologist, South Cleveland Hospital .

[♣] Scanning was performed in the Department of Radiology, South Cleveland Hospital, under the supervision of Dr Robert Campbell, Consultant Musculoskeletal Radiologist. The development of the analysis technique and analysis of all scans were performed within the Regional Medical Physics Department, South Cleveland Hospital by Mr Darren Hogg & Mr Robert Royall.

Each slice was stored as an image file on the computer. The file format was a square matrix of 256*256 pixels, where each pixel had an intensity (grey level), representative of the tissue type at that point on the image. Since each slice was of known thickness (1cm for the T1-W and proton imaging and 0.6 cm for the 3D scanning technique), each pixel represented a calculable volume and is referred to as the voxel.

The segmentation process.

The digital processing in the form of segmentation was used to analyse the images, using the HERMES medical image processing software package (Nuclear Diagnostics Ltd). Segmentation used the technique of *region growing*, starting with the middle slice, where a pixel (the 'seed pixel') was chosen which reflected the muscle being assessed. A region of similar pixels was then identified (muscle region) and those pixels with intensities outside the seed pixel range were rejected (background). Similarity criteria (Homogeneity Range and Edge Weight) were set manually, which controlled the sensitivity of the identification of pixels as muscle or background.

The Homogeneity Range and Edge Weight settings were selected in order to allow the most consistent and sensitive identification of muscle tissue without misclassification of non muscle tissue, while being flexible enough to classify most muscle areas with a single seed pixel. These parameters then stayed fixed for all other images acquired using that specific scanning technique (e.g. T1-W imaging).

Segmentation of the other slices was then performed. Placement of the seed pixel in a similar position to that in the middle slice was found to be the most appropriate site for accurate seeding in the remaining slices. Some slices also contained isolated muscle regions; these needed to be segmented separately. Summation of the muscle voxels produced an estimate of the muscle volume in the section of the forearm studied.

In some cases, the distal (1st) image lacked adequate contrast to permit accurate definition of muscle tissue using the segmentation technique. In the assessment of the proximal (15th) image through the inferior RUJ, segmentation incorrectly classified the joint as muscle. Therefore the distal (1st) and proximal (15th) slices were discarded from each Proton series. Each series then contained 11 slices covering an 11cm region of the forearm.

3.5 The Assessment of Rheumatoid Disease.

The evaluation of rheumatoid disease status in subjects with RA involved the evaluation of the severity and activity of the disease. Assessment of the disease activity was subdivided into evaluation of the local disease activity in relation to the right hand and wrist and systemic disease activity.

The severity of disease was assessed by the grip strength of the right hand and a deformity score. In a subset of subjects, the hand bone density of the right hand was also used as an indicator of disease severity (Peel et al, 1994). Hand bone densitometry was performed according to the technique described by Devlin et al (1996) using a Lunar DPX-L Scanner. The subject was positioned as shown in figures 3.5.1 and 3.5.2, with the right hand placed flat, palm downwards upon a perspex board. The acquisition and analysis software used in this measurement was based on the small animal software package (Lunar Corporation, Madison, New York), in the method described by Devlin et al (1996). A six-point region of interest was used to measure the bone density of the right hand and wrist, excluding the distal radius and ulna.

Figure 3.5.1 Patient positioning for bone densitometry of the right hand using a Lunar DPX-L Scanner.



Figure 3.5.2. Close-up view of the position of the right hand on perspex board for hand bone densitometry.

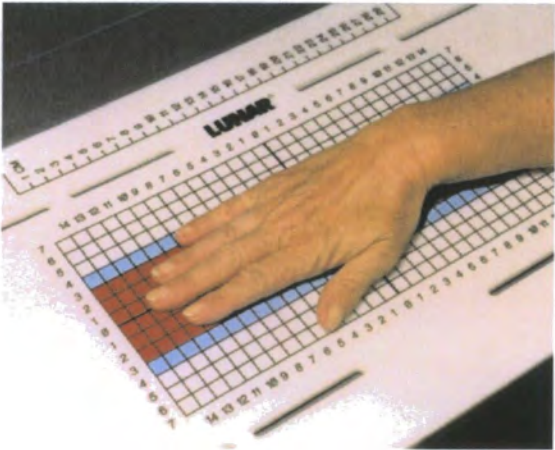

Hand function deteriorates with deformity in rheumatoid disease (Spiegel et al, 1987; Lansbury, 1958). The severity of the disease process affecting the right hand and wrist was assessed by a hand functional score, the **Keital Hand Functional Index** (Kalla et al, 1988, as detailed in **Appendix 12.1.1**) and a **wrist-weighted deformity score**, based on the score described by Helliwell and Jackson (1994), which evaluated the subluxation at each MCP and PIP joint (1 point for each if deformity present), and the wrist (a score of 5). This was further developed in this study in order to evaluate the severity and type of the deformity at the wrist and MCP. The severity was graded as mild, moderate or severe, with a score of 1, 2 or 3 at the MCP joint and 5, 10 or 15 at the wrist. The type(s) of deformity evaluated were subluxation and ulnar deviation, resulting in two deformity scores, one for subluxation and one for ulnar deviation, each with a maximum score of 30. An example of a deformity score for a subject with RA is shown in figure 3.5.3.

Figure 3.5.3: An example of a right hand and wrist subluxation score in a female with RA.

	Wrist	Thumb MCPJ	Index MCPJ	Middle MCPJ	Ring MCPJ	Little MCPJ
None	0	0√	0	0	0	0
Mild	5 √	1	1	1	1 √	1 √
Moderate	10	2	2 √	2 √	2	2
Severe	15	3	3	3	3	3

Total subluxation score in this case = 11/30.

The **systemic disease activity** in those subjects with rheumatoid arthritis was assessed by the serum C-reactive protein (CRP) level (Wollheim, 1993), the duration of general morning joint stiffness from the moment of waking and a 28-point upper limb weighted joint score (Boers et al, 1995; Tugwell and Boers, 1993; Fuchs et al, 1989). The Fuchs joint count is based upon the presence of tenderness and swelling when pressure is applied to the shoulder, elbow, wrist, metacarpophalangeal (MCP), proximal interphalangeal (PIP) joints

and knees. The scores for tenderness and swelling of the left and right were recorded. Local disease activity at the right hand and wrist was also evaluated by 11-point numerical rating scores for pain and stiffness in the right hand and wrist on the day of attendance (Boers et al, 1995; Tugwell and Boers, 1993). The Fuchs Score is shown in **Appendix 12.1.2.**

3.6 The Test Protocol

In all studies all subjects were advised to rest their upper limbs on the day of testing, prior to attendance for assessment. All subjects were tested between 11 a.m. and 4 p.m.

The maximum grip strength (MGS) was recorded using the grip bag, taken as the mean of 3 readings each performed 2 minutes apart. A fifty minute rest period followed, during which all subjects with RA were assessed using a **Fuchs joint score**, numerical scores for **pain and stiffness** in the right hand and wrist, and the **duration of general joint stiffness** that day. At the initial and final visits, the **Keitel Functional Index** and right and left **hand & wrist deformities** were also recorded. The **preferred wrist angle** (expressed in degrees of extension) for gripping the bag was recorded by asking the subject to grip the bag as they would normally whilst seated in the standard position, with the forearm in the test rig. Subjects performed all grip tests in 30° of wrist extension. The **C-reactive protein** was measured at each visit in all subjects with RA. and the **height** and **weight** of all subjects were also measured at the initial visit.

The circumference of the right arm and dorsal and ventral skinfolds were initially measured at the MRI landmark. These were repeated three times and the average of each reading taken. The **theoretical CSA** of the forearm at that site was calculated using the formula as described earlier. However, since this technique was not demonstrated to be repeatable over short and long term testing, this method was abandoned and the forearm muscle mass of subgroups of subjects was examined using MRI scanning which measured either the cross-sectional area of the forearm musculature or its volume.

The subject was seated in the standard position. On the initial visit, forearm landmarks for electrode positioning were identified. The right arm was secured in the arm rig, in mid supination/pronation. The extensor and flexor landmarks were recorded using horizontal and vertical scales.

The skin was prepared at each landmark. The electrodes were applied at the landmarks, two at each site, in transverse configuration, with 1 cm interelectrode separation at each site. A ground electrode was placed on the upper arm after similar skin preparation to the other sites. Skin impedance was checked to ensure a value less than 4 k Ω was achieved.

With the subject's arm in the study position, she was asked to maintain a grip of one third of her maximum strength (**1/3 MGS**), for 30 seconds. The test was started when she had achieved the target level. The computer screen had a feedback bar providing a target pressure at which to aim. A five minute rest period followed.

The procedure was then repeated, with a target set at **1/2 MGS**, followed by a further 5 minutes rest. The procedure was then repeated, with a target set at **2/3 MGS**.

The wrist was maintained in a position of 30° of extension in all tests.

3.7 The Grip Strength Exercise Programme.

The hand exercise programme involved balanced resistive, mid range gripping of a soft rubber ball, with the wrist in 30 degrees of extension. A small reference bar, with a 30° angle was provided to each patient. The regime was progressive, performed once daily for the first 6 weeks then twice daily for the following 6 weeks. Ten maximal repetitions (each lasting 10 seconds) were performed with one minute's rest between each repetition.

All subjects were supervised at the initial visit in performing the exercise programme and were contacted by telephone once weekly for the first two weeks of the programme to ensure that they were complying and coping with the regime.

All subjects received an information and instruction leaflet at the initial visit, as detailed in **Appendix 12.2**.

Chapter 4. Pilot Studies.

4.1 Pilot Studies I: The development of study techniques and protocols.

4.1.1 Introduction

Several factors may affect the frequency spectrum of the surface myoelectric signal (SMES). These can be categorised as factors associated with **muscle contractions**, **experimental technique** and aspects of **SMES analysis**. The work involved in this study was handgrip. This task was required to be such that all subjects could perform it. Repeatable, reliable measurements were essential.

Features of the measurement of the SMES which may influence the power spectrum include preparation of the detection surface, the skin and the interelectrode separation distance. The length of the muscle(s) from which the myoelectric signal is being generated is also important and is in turn influenced by the joint position. Lastly, aspects of the analysis of the SMES, including the use of windowing techniques and data smoothing may influence the spectral parameters. The following studies were performed in order to develop the technique of power spectral analysis of the forearm musculature during grip and standard protocols for the main study. Characteristics of the spectral width, a parameter which has not been evaluated, were also examined.

Two **study groups** were involved in the following pilot studies and are described in Table 4.1.1. All subjects were in the standard test position for all studies.

Table 4.1.1: Pilot studies I: Details of the study groups involved in initial pilot studies.

Group	Age (SD) (yrs)	Disease duration(SD) (yrs)
Controls (n=12)	47.8 (8.1)	————
RA (n=12)	55.4 (9.7)	12.5 (8.9)

4.1.2 Skin preparation

Basmajian and DeLuca (1985) recommended that the skin be prepared prior to electrode application by cleaning the skin with alcohol and rubbing with fine sandpaper. This did not result in consistently satisfactory levels of impedance ($<4k\Omega$), but shaving the skin between these two stages produced the required levels to achieve this.

4.1.3 Grip Tests

The Durham Gripper

Initial difficulties encountered with the dynamometer derived from the Durham hand assessment system (Jones, 1984) were its **size, weight, strain gauges and calibration and difficulties with maintaining a constant grip force**. The gripper was originally designed to be adjustable for different hand sizes. A study of 12 patients with RA and 12 normal subjects found that all preferred the gripper at its smallest size and found the adjustable bars to be cumbersome. It was therefore altered permanently to a small size, with a semi-cylindrical back for comfort of grip. Most subjects with RA found the gripper to be ‘too heavy’ and as a result it was placed in a moulded plastic holder on a flexible spring support which was mounted on a platform. The calibration of the gripper was not linear. There was no significant drift in the system demonstrable over a period of 36 hours, but the gripper was calibrated at least once daily. Subjects could not sustain a target grip with the gripper. This led to the introduction of the **grip bag** for the study protocol.

Initial studies using the grip bag

Initial studies using the grip bag were necessary in the development of the study protocol. These included the repeatabilities of maximum grip, choice of wrist position and the ability to maintain target grips and wrist position during submaximal tests.

The repeatability of maximum grip.

In order to ensure that the maximum grip strength (MGS) measured was repeatable, the ability of subjects to repeat a maximum grip on 3 occasions within 1 minute was assessed in a group of subjects with RA. All performed 3, three-second maximum grips in the standard test position at

Figure 4.1.1: Protocol: The repeatability of maximum grip strength (MGS) over 3 tests performed 20 seconds apart by 12 females with RA and 12 female controls.

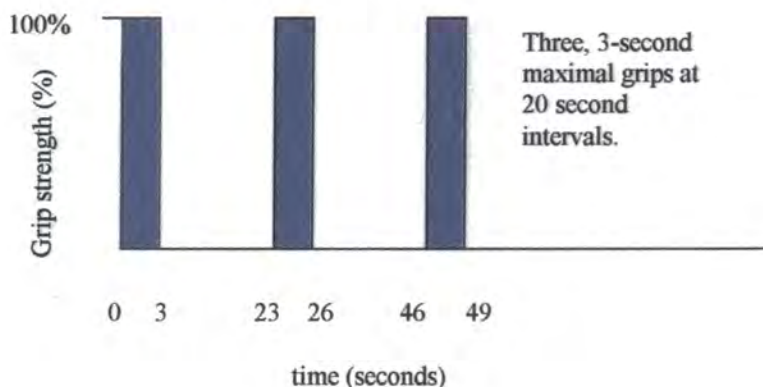

Statistical analysis:

Repeated measures ANOVA was used to test for significant variation between the three measurements.

Correlation between the measurements was assessed using the Spearman correlation test.

Figure 4.1.3: Protocol: maintenance of the target grip.

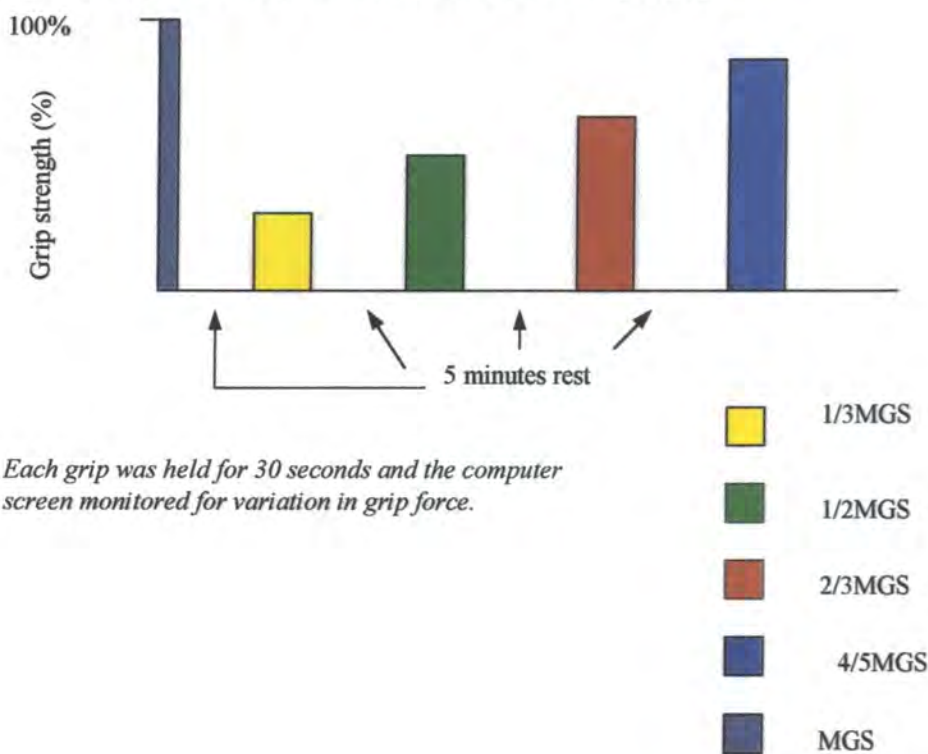

Each grip was held for 30 seconds and the computer screen monitored for variation in grip force.

20 second intervals. There was an extremely significant correlation ($p < 0.001$) between the test and retest MGS, as shown in figure 4.1.2 and Table 4.1.2.

Figure 4.1.2: The repeatability of maximum grip strength (MGS) over 3 tests performed 20 seconds apart by 12 subjects with RA and 12 controls.

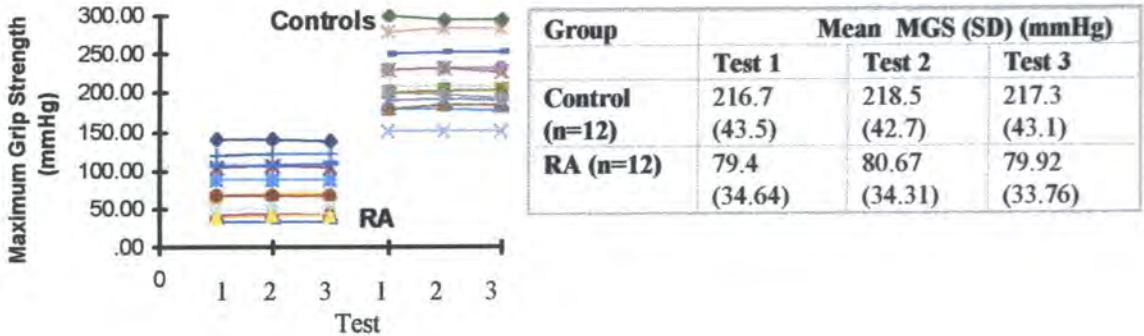

Maintenance of the target grip.

The ability of subjects to maintain a given grip pressure for 30 seconds, based on the target ‘bar’ on the computer screen was assessed. Most subjects (RA & controls) had no difficulty in maintaining grips at 1/3, 1/2 and 2/3 MGS. Although most subjects with RA could maintain grips at 80% of their MGS for 30 seconds, control subjects could not do so. Variations of force beyond 5% of the target were regarded as unsatisfactory.

Maintenance of a constant wrist position during testing.

Since joint angle has been noted to influence the power spectrum, the wrist position (angle of extension) was monitored during a 30-second grip test at 2/3 MGS performed by both subject groups. The joint angle was monitored manually every 5 seconds, using a small goniometer. All subjects maintained wrist joint angle with a maximum variation of 2°.

The repeatability of the choice of wrist position.

Twenty-four female subjects (12 with RA & 12 controls) were asked to perform a grip at 2/3 MGS for 30 seconds and their chosen angle of wrist extension noted using a goniometer. This was repeated on 2 further occasions at 5-minute intervals. The results, as displayed in figure

Figure 4.1.4. Protocol: The repeatability of the chosen angle of wrist extension during standard 30-second grip tests performed at 2/3MGS, by 12 females with RA and 12 female controls.

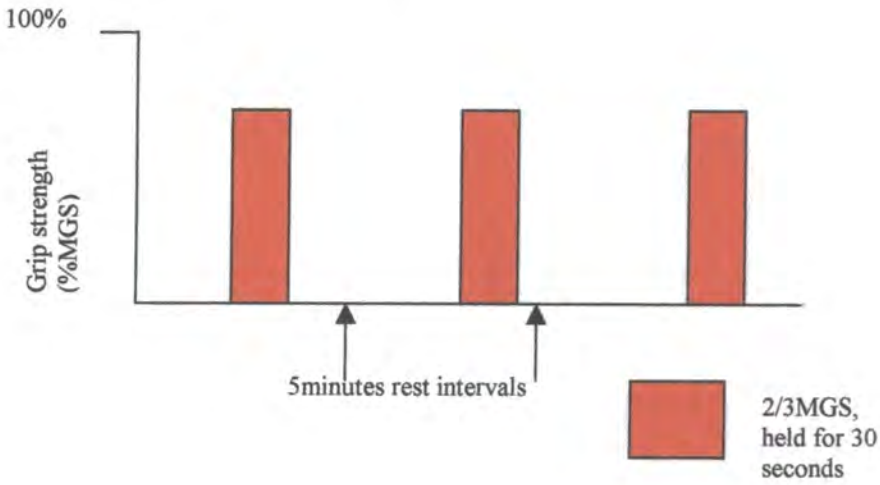

Statistical analysis:

The repeatability of the chosen angle of wrist extension in each group was assessed using repeated measures ANOVA.

The chosen angle of wrist extension by the RA and control groups was compared using an unpaired non-parametric t-test.

4.1.5, show that the chosen wrist angle is highly repeatable at the same testing session in both groups. The chosen angle of wrist extension was significantly greater in the controls than in the RA group ($p < 0.0001$).

Figure 4.1.5: The repeatability of the chosen angle of wrist extension* during standard 30-second grip tests performed at 2/3MGS by 12 female subjects with RA and 12 female controls.

Group	Mean angle of wrist extension (°) (SD °)		
	Test 1	Test 2	Test 3
RA (n=12)	22.1 (7.1)	22.3 (7.2)	22.5 (7.6)
Controls (n=12)	40.5 (7.29)	40.7 (7.2)	40.9 (7.4)

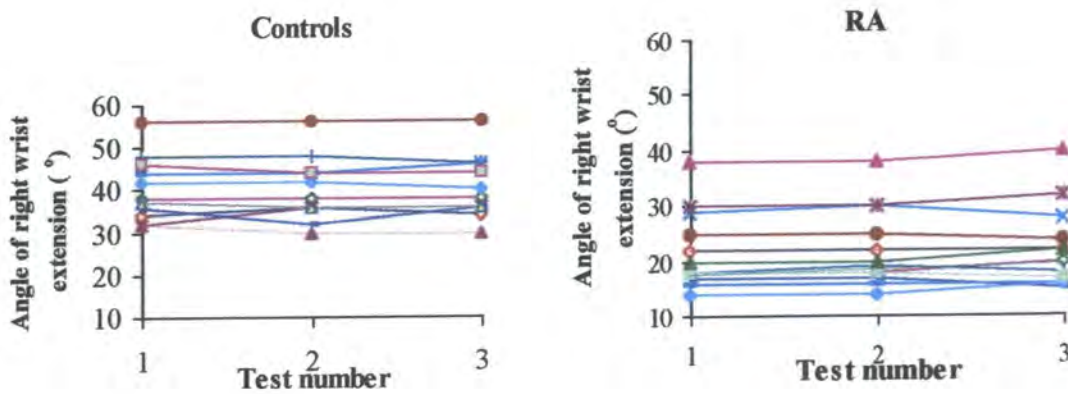

*The RA and control groups were compared using unpaired non-parametric t-tests. The repeatability of the angle of wrist extension within each group was assessed using repeated measures ANOVA.

4.1.4 Choice of bandwidth

The usable energy of the MES is limited to the 0 to 500 Hz frequency range, with the dominant energy generally being in the 50-150 Hz range for normal muscles (Latash, 1988). The appropriate bandwidth for SMES analysis from forearm musculature was assessed by studying the frequency spectra of the SMES measured from extensor and flexor channels during standard grip tests performed at 2/3 MGS by the subjects in both pilot study groups. Although a bandwidth of 300 Hz would have been appropriate for the majority of tests, a

Figure 4.1.6. Protocol: The effect of interelectrode separation (IES) distance upon SMES parameters in 10 female controls.

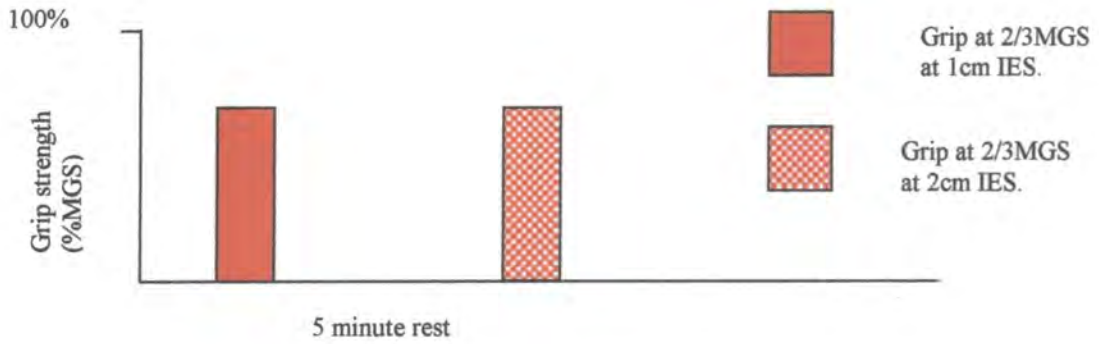

Statistical analysis for each SMES parameter:

A Wilcoxon signed rank test was used to assess for any significant variation between the SMES parameters obtained using the two IES distances.

Spearman correlation test was used to assess the correlation between the SMES parameters obtained using the two IES distances.

selected bandwidth of 500 Hz allowed for the occasional test in which the signal at frequencies above 300 Hz was noted.

4.1.5 Interelectrode Studies

The effects of the interelectrode separation (IES) distance on the SMES parameters were studied using Nicolet electrodes. Inter-electrode distances of 1 and 2 cm were compared during 30 second standard grip tests performed at 2/3 MGS at 5 minute intervals by 10 of the subjects from the control pilot study group. The results are shown in figures 4.1.7 and 4.1.8.

The spectral width was higher with the lower IES distance. The effect of the IES distance upon the IMF and decline in median frequency of the SMES with time (the MDF gradient, MDF_G) differed for the two channels; both spectral parameters being greater for the larger IES for the extensor channel, the opposite being the case for the flexor channel. The centre frequency was very similar at both IES distances. As expected, the spectral peak and RMS of the SMES were greater with the greater IES. None of the differences were statistically significant when assessed using a Wilcoxon signed rank test and all showed significant correlations between 1 and 2 cm IES distances (Spearman r ranging from 0.6383 to 0.8788 and p from 0.0235 to 0.0008) with the exception of extensor MDF gradient ($r = 0.1636$, $p=0.3257$).

Figure 4.1.7: The effect of IES distance upon spectral parameters (expressed as the mean (SD)) recorded from the extensor and flexor forearm musculature during standard grip tests at 2/3 MGS by 10 right handed female controls.

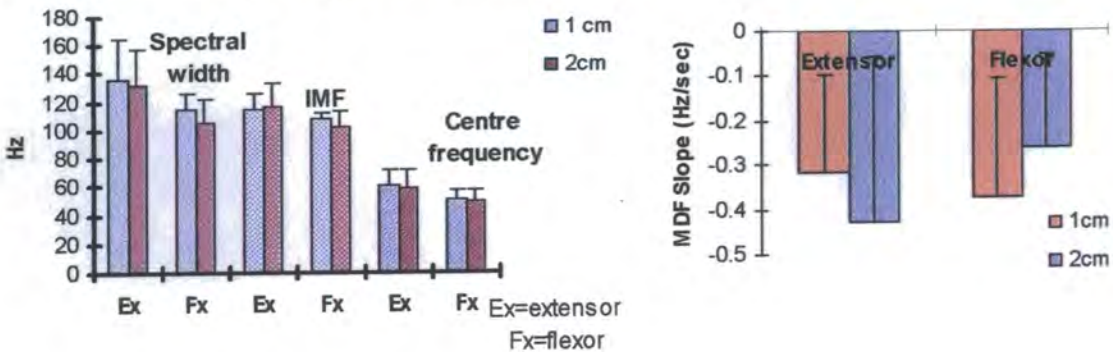
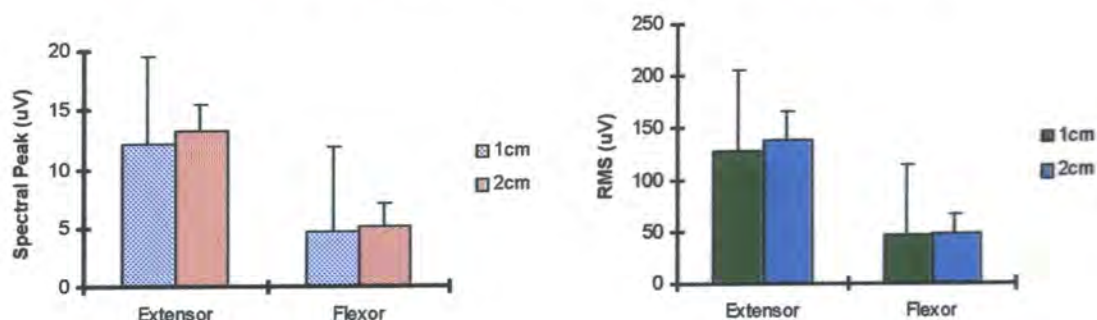

Figure 4.1.8: The effect of IES distance upon the spectral peak and the RMS of the SMES (expressed as the mean (SD)) recorded from the extensor and flexor forearm musculature during standard grip tests at 2/3 MGS by 10 right handed female controls.



It can be **concluded** that the interelectrode distance does have an effect upon the amplitude and frequency parameters measured from forearm musculature during sustained grip. Although these differences were not found to be statistically significant this may be related to the small size of the group assessed. A standard interelectrode separation of 1 cm for each channel was used for the study protocol, in keeping with that used by other workers at different sites (Bendahan et al, 1996).

4.1.6 Hanning windowing

Windowing techniques are used by some workers in order to reduce the effect of sampling a random signal over a short time interval. Other workers have not used data windowing. Windowing would not be expected to have an effect upon spectral parameters apart from the peak spectral amplitude. To assess the effect of a Hanning window on the surface myoelectric signal (SMES) a comparison between power spectral parameters of the SMES from both channels before and after application of a Hanning window was performed for data from a 30 second test at 2/3 MGS in 29 female subjects with RA (mean age (SD) 55.9 (7.2); disease duration 11.2 (6.8) years). As expected, the application of the Hanning window in the analysis of the SMES has a significant effect on the spectral peak. Small differences were also noted in the other spectral parameters, none were statistically significant.

Table 4.1.2: Comparison between the power spectral parameters of the SMES from the forearm extensor channel during a 30 second grip test performed at 2/3 MGS before and after the application of Hanning window (n=29). Mean (SD).

Window	Spectral peak (μV)	Centre Frequency (Hz)	Spectral width (Hz)	MDF Gradient (Hz/sec)	IMF (Hz)
Nil	9.8033 (9.777)	74.47(19.89)	153.60 (38.76)	-0.4550 (0.229)	118.60 (29.55)
Hanning	6.3233 (6.131)	71.61 (17.39)	153.8 (42.87)	-0.4577 (0.262)	118.20 (29.71)
*p	<0.0001	0.186	0.090	0.846	0.264

* Student's Paired T-Test.

Table 4.1.3: Comparison between the power spectral parameters of the SMES from the forearm flexor channel during a 30 second grip test performed at 2/3 MGS before and after the application of Hanning window (n=29). Mean (SD).

Window	Spectral peak	Centre Frequency (Hz)	Spectral width (Hz)	MDF Gradient (Hz/sec)	IMF (Hz)
Nil	5.48 (5.98)	55.97 (18.79)	123.67 (46.23)	-0.3957 (0.270)	115.06 (23.76)
Hanning	3.78 (3.86)	54.90 (16.43)	122.27 (46.53)	-0.3893 (0.272)	113.39 (23.95)
*p	0.0080	0.463	0.301	0.638	0.090

* Student's Paired T-Test.

It can be **concluded** that the application of a window in the analysis of the frequency spectrum of the SMES may have significant effects upon some spectral variables, specifically the spectral peak amplitude. In reviewing the findings of other workers, comparison between non-windowed and windowed data studies must be regarded with caution. Windowing techniques were not used in the analysis of the frequency spectra in further studies.

4.1.7 The Effect of Smoothing Cycles on Power Spectral Parameters.

Smoothing of the power spectrum was introduced in order to reduce noise in the spectra. Reducing noise without excessively smoothing the spectra is important because of automated analysis. The effect of smoothing on the power spectra of the SMES of forearm musculature generated during a 30 second grip test performed at 2/3 maximal grip can be demonstrated by examining a typical power spectrum before and after smoothing cycles from one standard grip test performed by a subject with RA.

Figure 4.1.9: The effect of smoothing cycles upon spectral parameters: data from the extensor channel from one standard grip test performed at 2/3 MGS by one subject with RA. Spectra before and after 10 smoothing cycles.

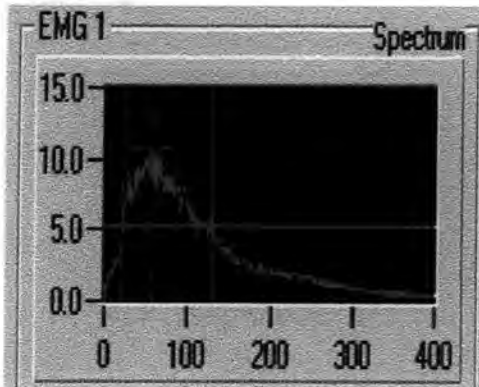

No spectral smoothing

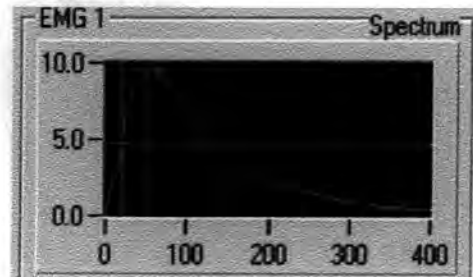

10 spectral smoothing cycles

Figure 4.1.10: The effect of smoothing cycles upon spectral parameters: data from the extensor channel from one standard grip test performed at 2/3 MGS by one subject with RA.

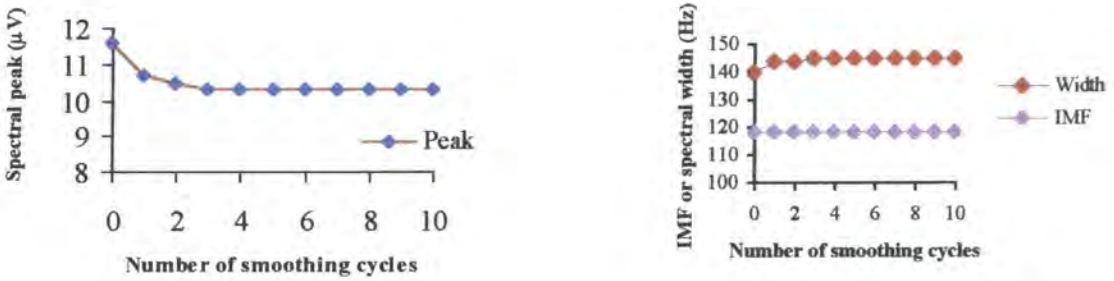

The effect of smoothing on the power spectra of the SMES of forearm musculature was further studied in 16 subjects with RA (mean age (SD) 56.8 (6.9) years; disease duration 10.9 (6.4) years). They performed a standard 30-second grip test performed at 2/3 maximal grip. The power spectra were subjected to 0, 3 and 10 smoothing cycles and the resulting spectral parameters compared using paired non-parametric tests. As can be seen in tables 4.1.4 and 4.1.5, smoothing cycles can have a significant effect upon the spectral peaks, centre frequencies and initial median frequencies of both flexor and extensor channels, but not on the median frequency slopes.

Table 4.1.4: Comparison of 0, 3 and 10 smoothing cycles on forearm EMG spectral parameters in 16 female subjects with RA. Extensor channel (Mean (SD)).

Parameter	No smoothing	3 cycles	10 cycles
Peak	6.269 (3.87)	5.562 (3.51))***	5.41 (3.43)***
Centre (Hz)	76.12 (20.74)	79.19 (22.86)	78.5 (22.00)
Width (Hz)	177.56 (34.79)	181.06 (33.61) *	183.38 (35.89)*
IMF (Hz)	137.99 (22.00)	138.15 (22.12) **	138.24 (22.15)**
MDF gradient (Hz/sec)	-0.3238 (0.2186)	-0.3275 (0.2167)	-0.3256 (0.2126)

Table 4.1.5: Comparison of 0, 3 and 10 smoothing cycles on forearm EMG spectral parameters in 16 female subjects with RA. Flexor channel (Mean (SD)).

Parameter	No smoothing	3 cycles	10 cycles
Peak	3.18 (2.95)	2.90 (2.70) ***	2.79 (2.60) **
Centre (Hz)	53.13 (14.12)	48.06 (8.71) **	47.44 (8.29) *
Width (Hz)	130.88 (53.48)	128.56 (51.30) **	133.00 (51.89) ***
IMF (Hz)	117.93 (23.47)	115.96 (24.38) ***	116.26 (24.48) ***
MDF gradient (Hz/sec)	-0.3631 (0.2281)	-0.3631 (0.2292)	-0.3656 (0.2257)

0 vs 3 cycles; *p derived from Wilcoxon signed rank test; * p<0.05; **p<0.01; ***p<0.001
 3 vs 10 cycles; *p derived from Wilcoxon signed rank test; *p<0.05; **p<0.01; ***p<0.001

Smoothing of the power spectrum may allow the spectral peak to be identified with greater precision. The process does affect some spectral parameters: the site at which the peak is located may in turn affect the width of the spectrum, and the centre and initial median frequencies. It was found that **3 smoothing cycles** provided an adequate degree of noise reduction to allow reliable identification of the spectral peak, without excessively smoothing the data.

Figure 4.2.1. Protocol: The short-term repeatability of SMES parameters from standard grip tests performed by 40 females with RA and 16 female controls.

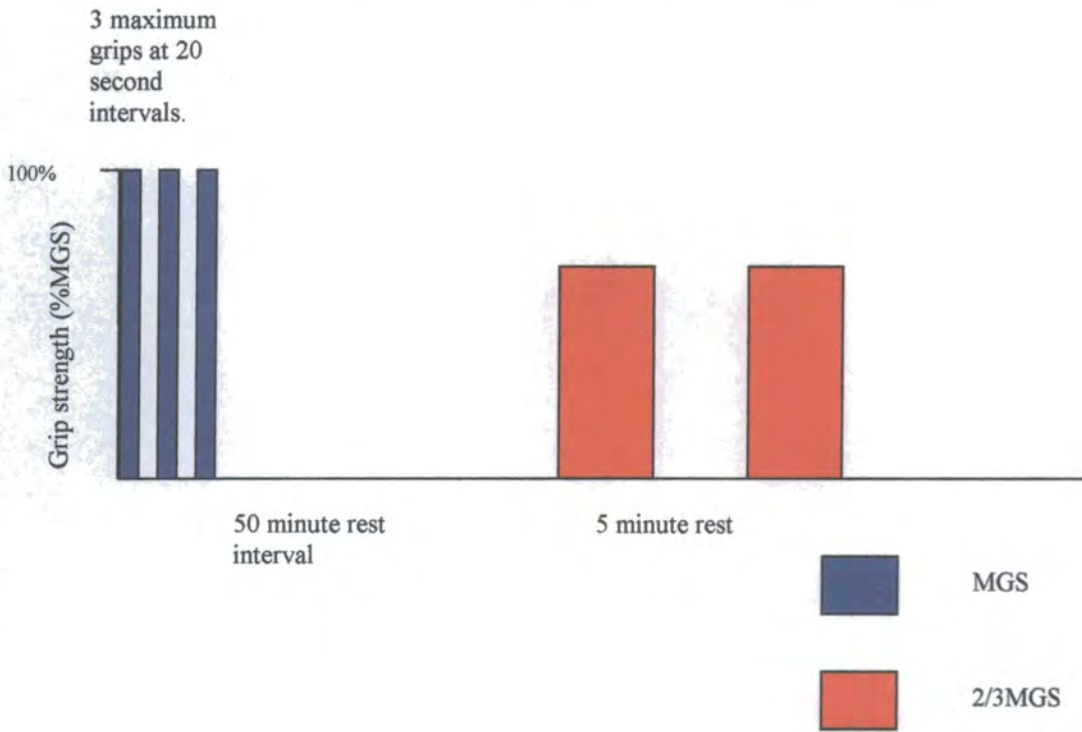

Statistical analysis:

For each SMES parameter, the mean percentage variation between the two tests was calculated. The correlation between the results from the two tests was assessed by a Spearman correlation test.

4.2 Pilot Studies II: The repeatability of the technique of SMES analysis of the forearm.

4.2.1 Introduction

In order to develop the study protocol two forms of repeatability studies were carried out. Firstly, a short-term repeatability study (the **restitution study**) was performed to assess the restitution of myoelectric parameters on repeated testing. This allowed an appropriate rest interval to be calculated, for repeated testing at a single session. Secondly, a **long-term repeatability** study was performed to assess the true repeatability of the technique over a 3 week period – which was the testing interval planned for the main study. These studies involved two subject groups, one consisting of subjects with RA, the other of healthy controls. All were right hand dominant females. The subjects studied for the restitution study differed from those in the long-term repeatability assessment. The short and long term repeatabilities were analysed using the method recommended by Mathews et al (1990), describing the mean absolute percentage variation between tests.

4.2.2 The restitution study

The repeatability of the technique over a period of 5 minutes, in rheumatoid and control subjects was assessed. The study groups are described in Table 4.2.1.

Table 4.2.1: Details of the subject groups in the restitution study.

Group	Age (SD) (years)	Disease duration (years)
Controls (n=16)	44.96 (8.12)	----
RA (n=40)	58.88(8.91)	11.17 (4.87)

On the day of testing, subjects rested their upper limbs prior to testing. All were tested between 11 am and 3 p.m. The MGS was assessed by taking the mean of three, 3 - second maximum grips, performed 20 seconds apart, followed by a 50-minute rest period. They then performed a standard right handgrip test at 2/3MGS for 30 seconds and after a 5-minute rest interval the 2/3MGS test was repeated. The electrodes were left in place between testing sessions. The myoelectric parameters from the two tests were then compared.

Figure 4.2.2: Repeatability of the RMS of the SMES (flexor channel) from standard grip tests at 2/3 MGS performed 5 minutes apart by 16 female controls.

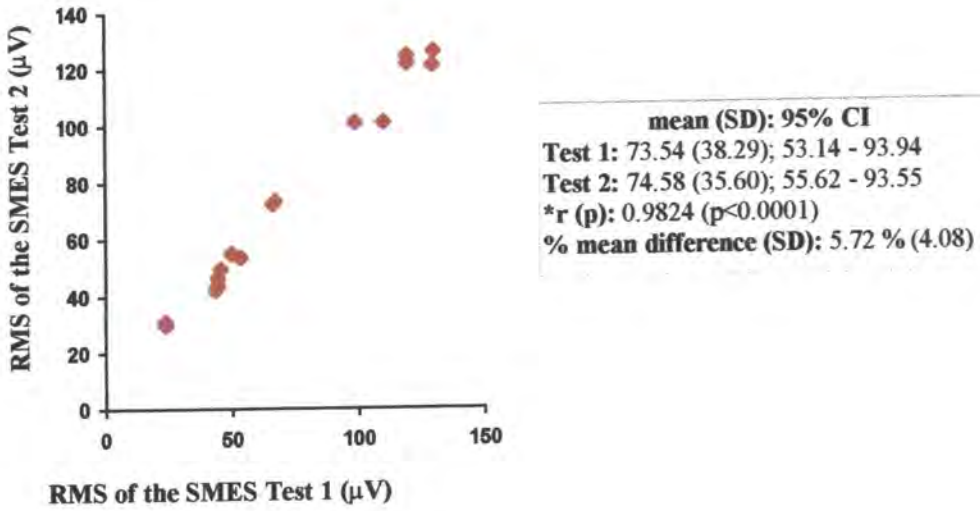
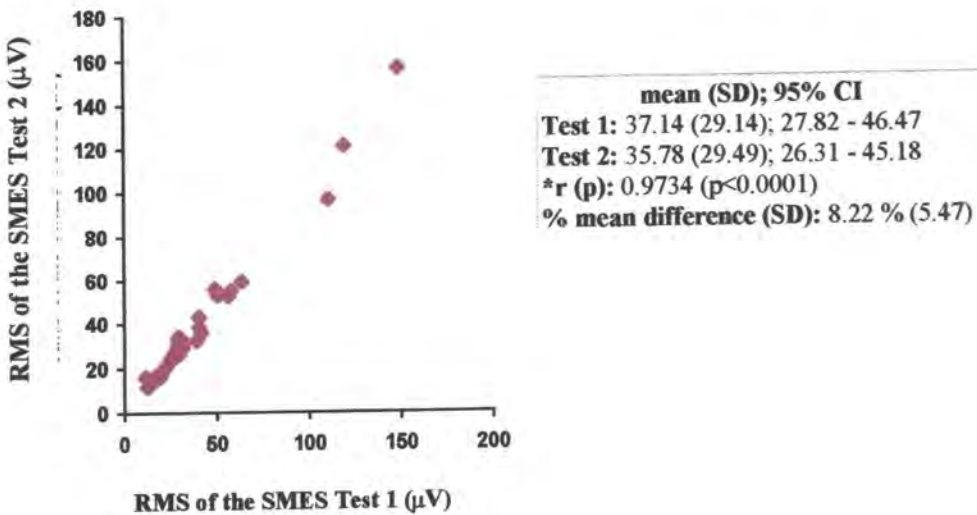

Figure 4.2.3: Repeatability of the RMS of the SMES (flexor channel) from standard grips at 2/3 MGS performed 5 minutes apart by 40 females with RA.



All subjects were able to repeat the required task of a sustained handgrip at 2/3MGS for 30 seconds after a 5-minute rest interval, with less than a 5% variation of grip force during each test. The repeatability of the surface myoelectric parameters was assessed in terms of the RMS of the SMES, the MDF_G , IMF and spectral width. The initial RMS of the SMES (IRMS) and the gradient of the RMS of the SMES (RMS_G) were also assessed.

The RMS of the SMES showed a mean variation of less than 10% on retesting after a 5 minute interval in all channels for both groups, ranging from 5.72 - 8.22%. This is shown for the RA and control groups in figures 4.2.2 and 4.2.3 (flexor channel) and 4.2.4 and 4.2.5 (extensor channel).

Figure 4.2.4: Repeatability of the RMS of the SMES (extensor channel) from standard grip tests at 2/3 MGS performed 5 minutes apart by 16 female controls.

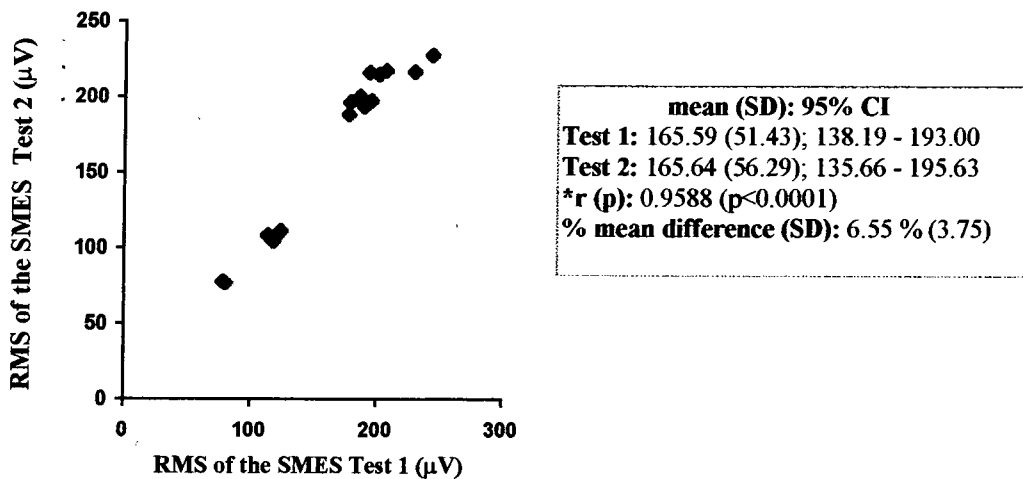

Figure 4.2.5: Repeatability of the RMS of the SMES (extensor channel) from standard grips at 2/3 MGS performed 5 minutes apart by 40 females with RA.

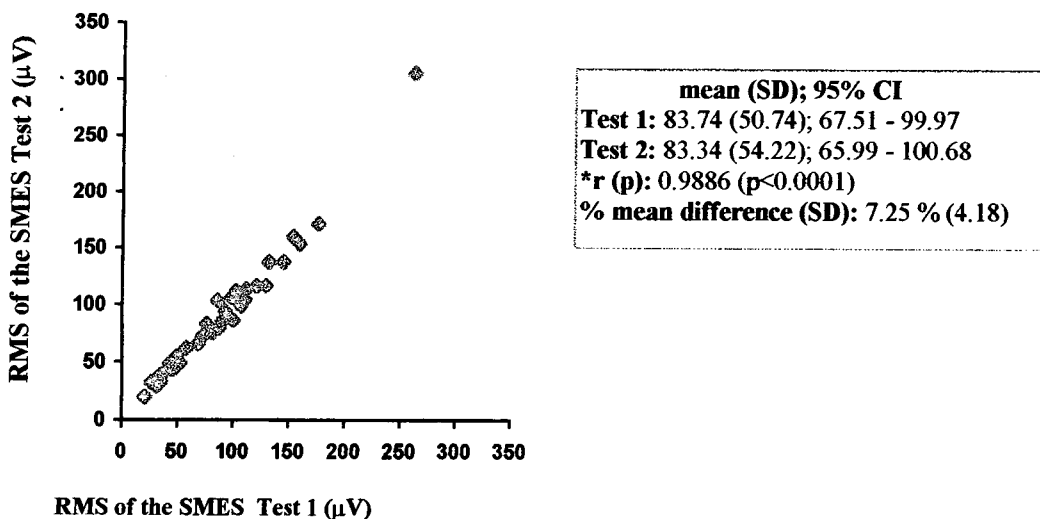

Figure 4.2.6: Repeatability of the $MDFG_G$ of the SMES (flexor channel) from standard grip tests at 2/3 MGS performed 5 minutes apart by 16 female controls.

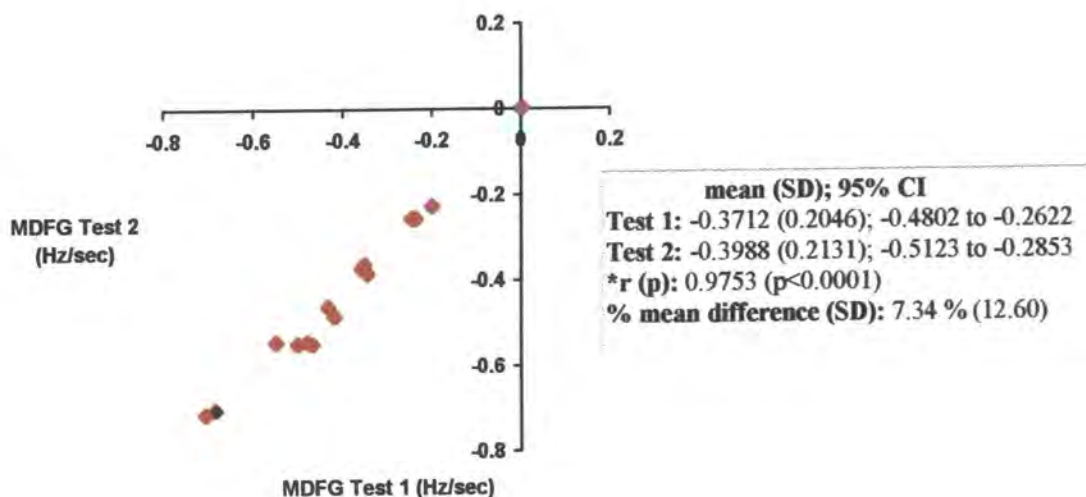
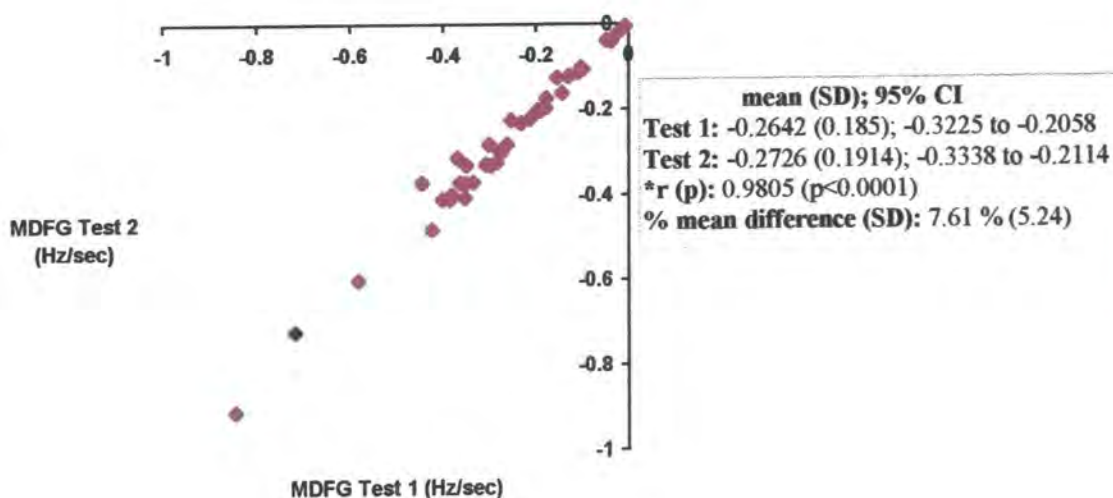

Figure 4.2.7: Repeatability of the $MDFG_G$ of the SMES (flexor channel) from standard grips at 2/3 MGS performed 5 minutes apart by 40 females with RA.



The **restitution of the power spectrum** was assessed by evaluating the repeatability of the MDF_G , IMF and spectral width. Significant recovery of the frequency spectrum was demonstrated in both groups within the 5 minute rest interval, as indicated by good short term repeatability of these three parameters. The mean percentage variation of the extensor and the flexor MDF_G ranged from 5.25 % to 7.61 % as shown in figures 4.2.6 to 4.2.9 and in tables 4.2.2 to 4.2.5.

Figure 4.2.8: Repeatability of MDF_G of the SMES (extensor channel) from standard grip tests at 2/3 MGS performed 5 minutes apart by 16 female controls.

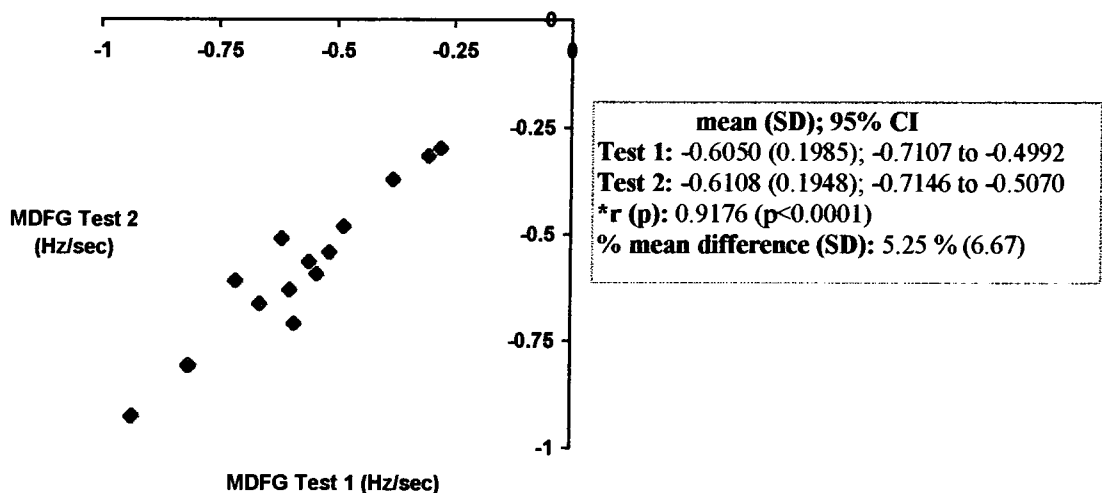

Figure 4.2.9: Repeatability of the MDF_G of the SMES (extensor channel) from standard grips at 2/3 MGS performed 5 minutes apart by 40 females with RA.

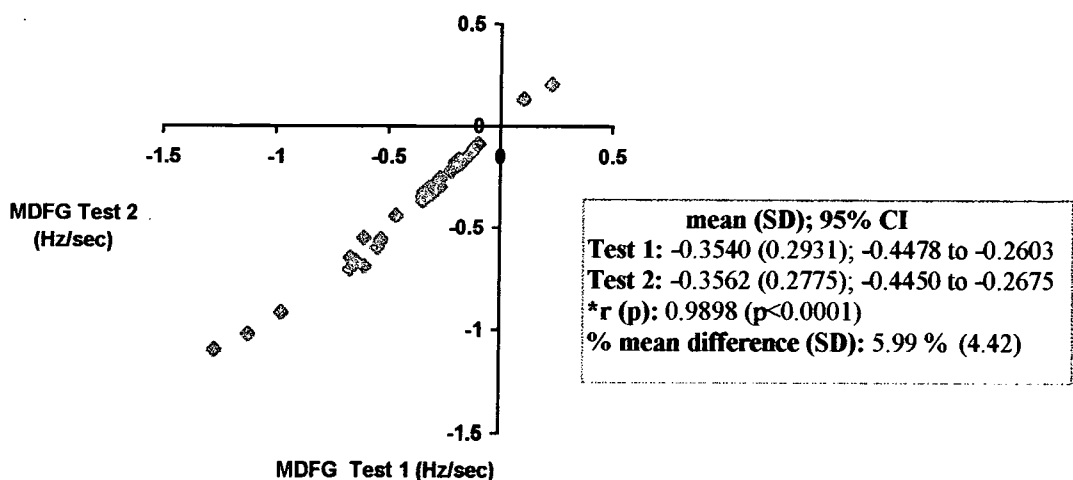

Figure 4.2.10: Repeatability of the IMF of the SMES (flexor channel) from standard grip tests at 2/3 MGS performed 5 minutes apart by 16 female controls.

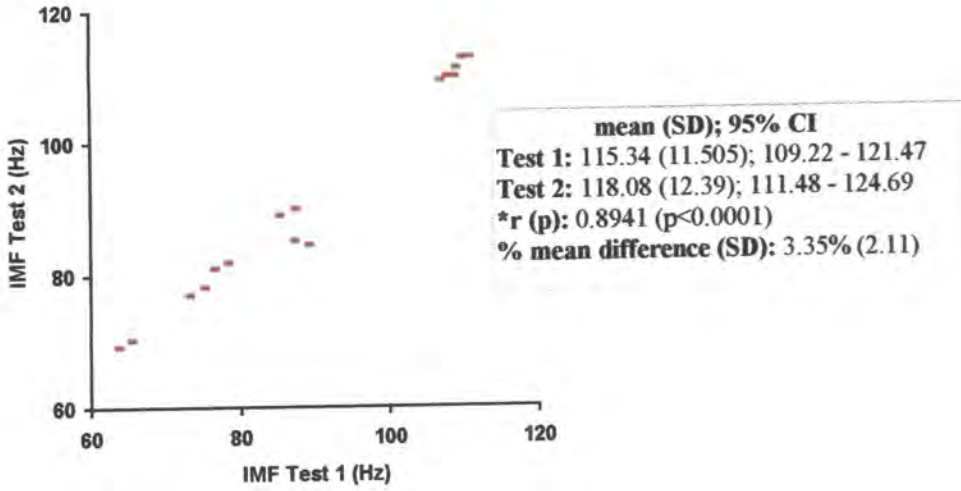
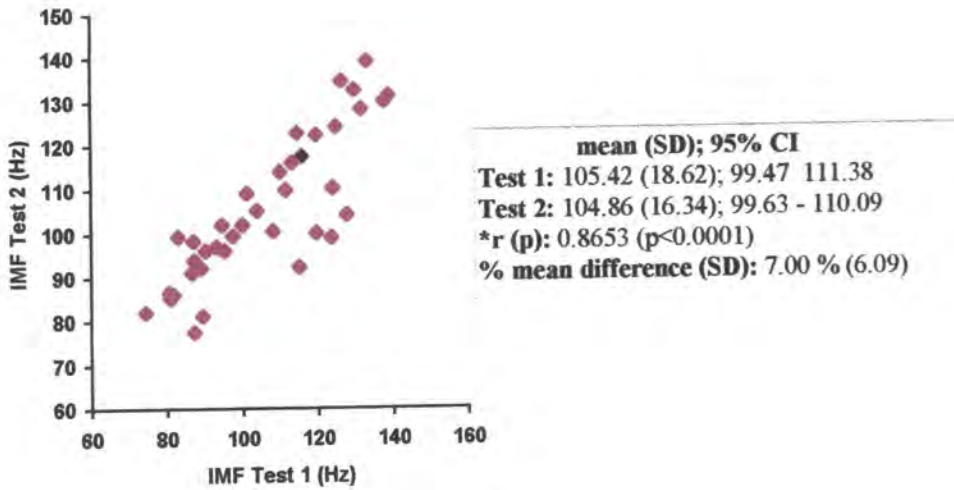

Figure 4.2.11: Repeatability of the IMF of the SMES (flexor channel) from standard grip tests at 2/3 MGS performed 5 minutes apart by 40 females with RA.



The IMF of the SMES was highly repeatable after the 5 minute rest interval in both groups, as shown in figures 4.2.10 – 4.2.13.

Figure 4.2.12: Repeatability of the IMF of the SMES (extensor channel) from standard grip tests at 2/3 MGS performed 5 minutes apart by 16 female controls.

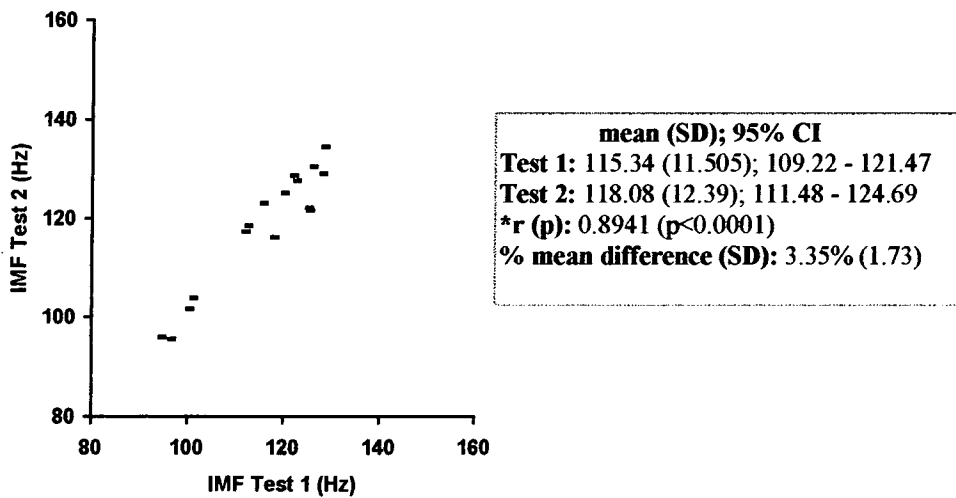
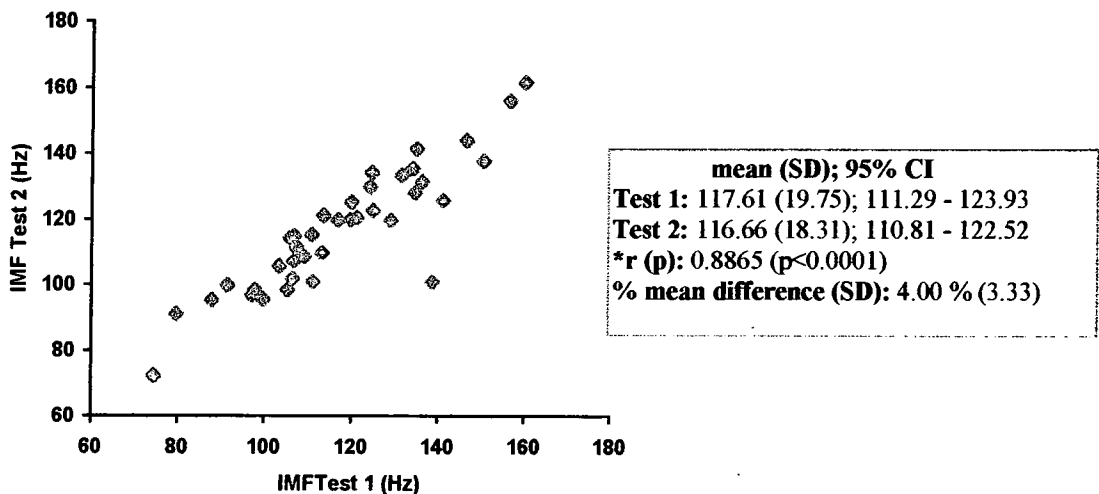

Figure 4.2.13: Repeatability of the IMF of the SMES (extensor channel) from standard grips at 2/3 MGS performed 5 minutes apart by 40 females with RA.



There is no information available in the literature on the restitution of **spectral width** after exercise. This parameter was found to be highly repeatable in extensor and forearm musculature for both study groups, with a mean percentage variation ranging from 5.91% to 9.96 %, as detailed in Tables 4.2.2 to 4.2.5.

The rate of change of the RMS of the SMES with time (the **RMS_C**) recorded from forearm musculature during grip at 2/3 MGS was not demonstrated to be a reliable

indicator of fatigue on repeated testing with 5minute intervals between tasks. The repeatability data for this parameter are given in Tables 4.2.2 to 4.2.5.

The initial RMS of the SMES (IRMS) repeated after the 5 minute interval correlated with the baseline value with r ranging from 0.7525 to 0.9375; however, the mean percentage difference ranged from 7.81 % to 32.12 %.

Table 4.2.2: Repeatability of myoelectric parameters (extensor channel) from standard grip tests at 2/3 MGS performed 5 minutes apart by 16 female controls.

	Mean (SD) Test 1	95 % C I Test 1	Mean (SD) Test 2	95 % C I Test 2	% mean difference (SD)
RMS (μV)	165.59 (51.43)	138.19 - 193.00	165.64 (56.29)	135.66 - 195.63	6.55 % (3.75)
MDFG (Hz/sec)	-0.6050 (0.1985)	-0.7107 to -0.4992	-0.6108 (0.1948)	-0.7146 to -0.5070	5.25 % (6.67)
IMF (Hz)	115.34 (11.51)	109.22 - 121.47	118.08 (12.39)	111.48 - 124.69	3.35 % (1.73)
Width (Hz)	120.00 (36.44)	100.59 - 139.41	117.06 (33.95)	98.98 - 135.15	7.54 % (3.55)
RMSG (μV/sec)	0.3921 (0.9120)	-0.1568 to 0.8149	1.391 (0.8034)	0.9629 - 1.819	109.27 % (89.54)
IRMS (μV)	158.76 (57.48)	128.14 - 189.38	150.49 (54.66)	121.37 - 179.61	7.81 % (8.37)

Table 4.2.3: Repeatability of myoelectric parameters (flexor channel) from standard grip tests at 2/3 MGS performed 5 minutes apart by 16 female controls.

	Mean (SD) Test 1	95 % C I Test 1	Mean (SD) Test 2	95 % C I Test 2	% mean difference (SD)
RMS (μV)	73.54 (38.29)	53.14 - 93.94	74.58 (35.60)	55.62 - 93.55	5.72 % (4.08)
MDFG (Hz/sec)	-0.3712 (0.2406)	-0.4802 to -0.2622	-0.3988 (0.2131)	-0.5123 (-0.2853)	7.34 % (12.60)
IMF (Hz)	89.46 (16.92)	80.45 - 98.48	92.01 (16.20)	83.34 - 100.64	3.68 % (2.11)
Width (Hz)	71.13 (320.05)	60.44 - 81.06	73.06 (19.16)	62.86 - 83.27	7.37 % (4.06)
RMSG (μV/sec)	0.4249 (0.6077)	0.1011 - 0.7486	2.028 - 2.468	0.7127 - 3.343	132.20 % (86.52)
IRMS (μV)	67.01 (35.47)	48.12 - 85.91	67.03 (26.27)	53.04 - 81.03	22.17 % (23.97)

Table 4.2.4: Repeatability of myoelectric parameters (extensor channel) from standard grip tests at 2/3 MGS performed 5 minutes apart by 40 females with RA.

	Mean (SD)		95 % CI		Mean (SD)		95 % CI		% mean difference (SD)
	Test 1	Test 2	Test 1	Test 2	Test 1	Test 2	Test 1	Test 2	
RMS (μ V)	83.74 (50.74)	83.34 (54.22)	67.51 - 99.97	83.34 (54.22)	65.99 - 100.68	7.25 % (4.18)			
MDFG (Hz/sec)	-0.3540 (0.2931)	-0.3562 (0.2775)	-0.4478 to -0.2603	-0.3562 (0.2775)	-0.4450 to -0.2675	5.99 % (4.42)			
IMF (Hz)	117.61 (19.75)	116.66 (18.31)	111.29 - 123.93	116.66 (18.31)	110.81 - 122.52	4.00 % (3.33)			
Width (Hz)	140.45 (31.06)	141.80 (29.76)	130.51 - 150.39	141.80 (29.76)	132.28 - 151.32	9.96 % (8.64)			
RMSG (μ V/sec)	-0.0693 (0.75510)	-0.0875 (0.8392)	-0.3095 to 0.1710	-0.0875 (0.8392)	-0.3559 to 0.01810	96.57 % (401.38)			
IRMS (μ V)	83.00 (53.19)	79.00 (53.14)	65.99 - 100.02	79.00 (53.14)	62.00 - 95.99	23.63 % (22.33)			

Table 4.2.5: Repeatability of myoelectric parameters (flexor channel) from standard grip tests at 2/3 MGS performed 5 minutes apart by 40 females with RA.

	Mean (SD)		95 % CI		Mean (SD)		95 % CI		% mean difference (SD)
	Test 1	Test 2	Test 1	Test 2	Test 1	Test 2	Test 1	Test 2	
RMS (μ V)	37.14 (29.14)	35.78 (29.49)	27.82 - 46.47	35.78 (29.49)	26.31 - 45.18	8.22 % (5.47)			
MDFG (Hz/sec)	-0.2642 (0.1850)	-0.2726 (0.1914)	-0.3225 to -0.2058	-0.2726 (0.1914)	-0.3338 to -0.2114	7.61 % (5.24)			
IMF (Hz)	105.42 (18.62)	104.86 (16.34)	99.47 - 111.38	104.86 (16.34)	99.63 - 110.09	7.00 % (6.09)			
Width (Hz)	163.71 (37.65)	163.74 (36.54)	155.20 - 172.21	163.74 (36.54)	155.49 - 171.99	5.91 % (5.19)			
RMSG (μ V/sec)	-0.1846 (0.5504)	-0.0009 (0.5622)	-0.3606 to -0.0085	-0.0009 (0.5622)	-0.1807 to 0.1790	105.34 % (126.24)			
IRMS (μ V)	27.07 (34.79)	31.79 (27.49)	15.94 - 38.20	31.79 (27.49)	23.00 - 40.59	32.12 % (26.48)			

Figure 4.2.14. Protocol: The long-term repeatability of SMES parameters from standard grip tests at 1/3MGS performed 3 weeks apart by 19 females with RA and 18 female controls.

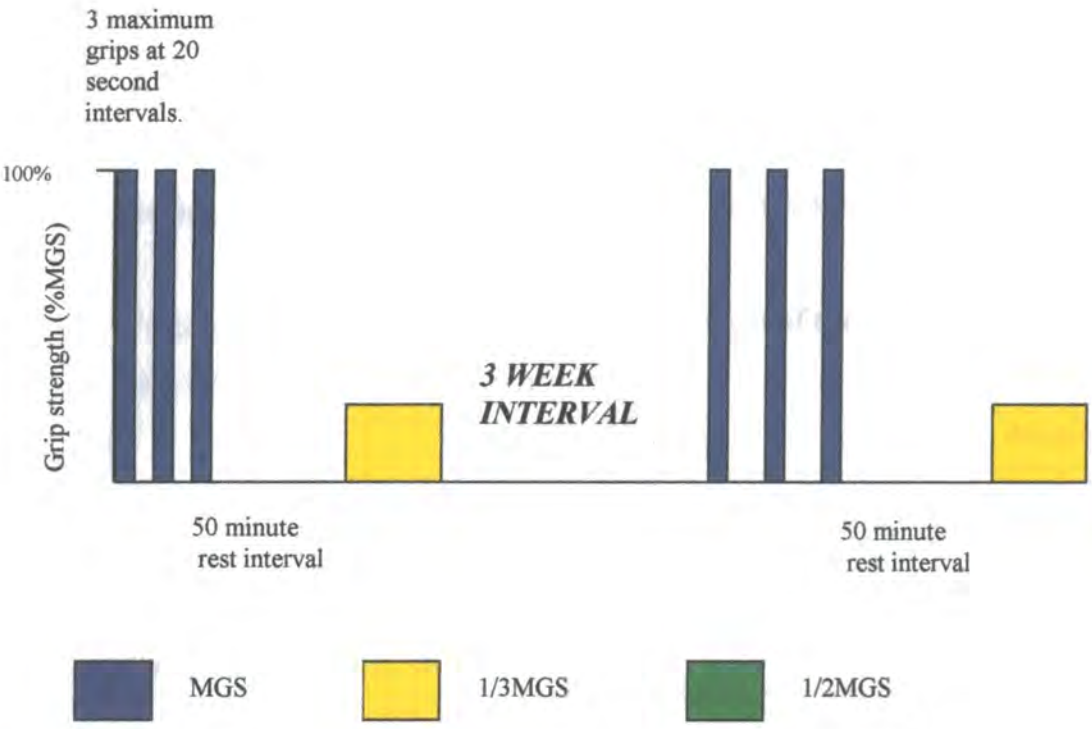

Figure 4.2.15. Protocol: The long-term repeatability of SMES parameters from standard grip tests at 1/2MGS performed 3 weeks apart by 24 females with RA and 30 female controls.

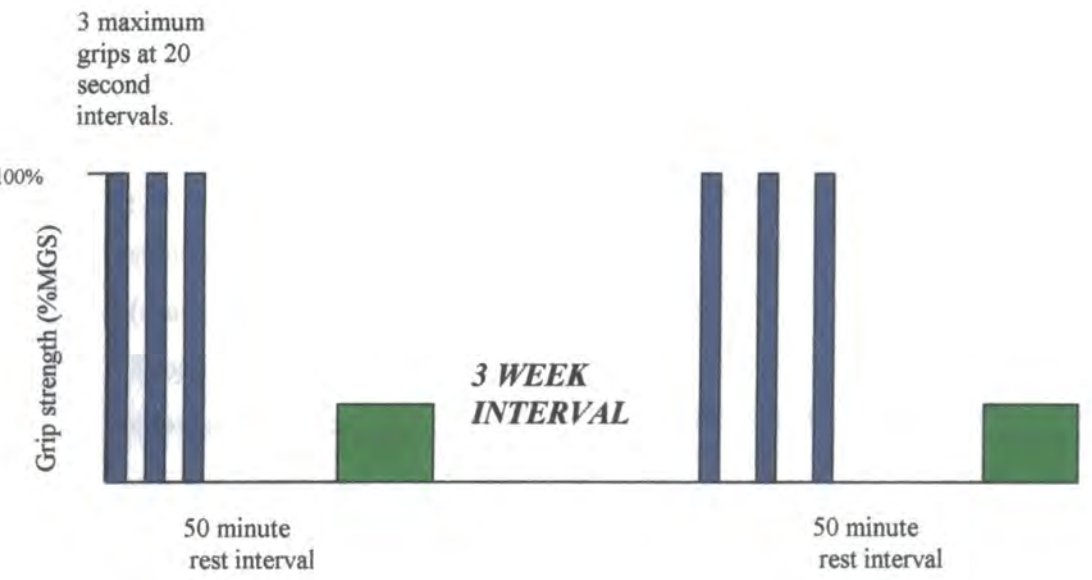

Figure 4.2.16. Protocol: The long-term repeatability of SMES parameters from standard grip tests at 2/3MGS performed 3 weeks apart by 18 females with RA and 21 female controls.

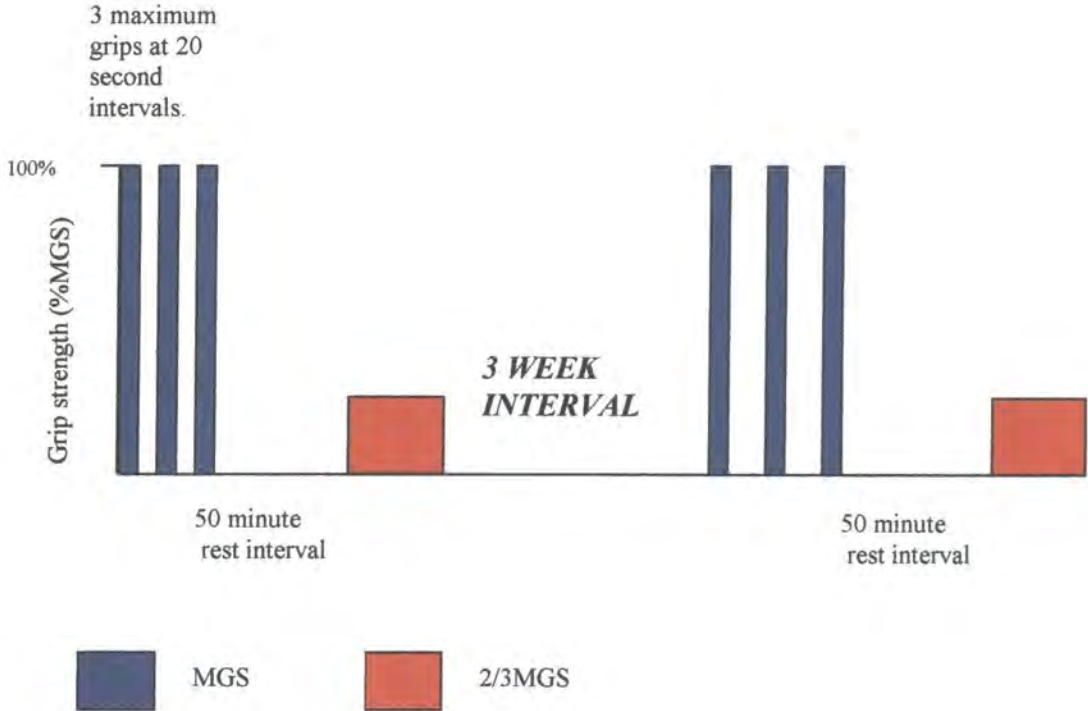
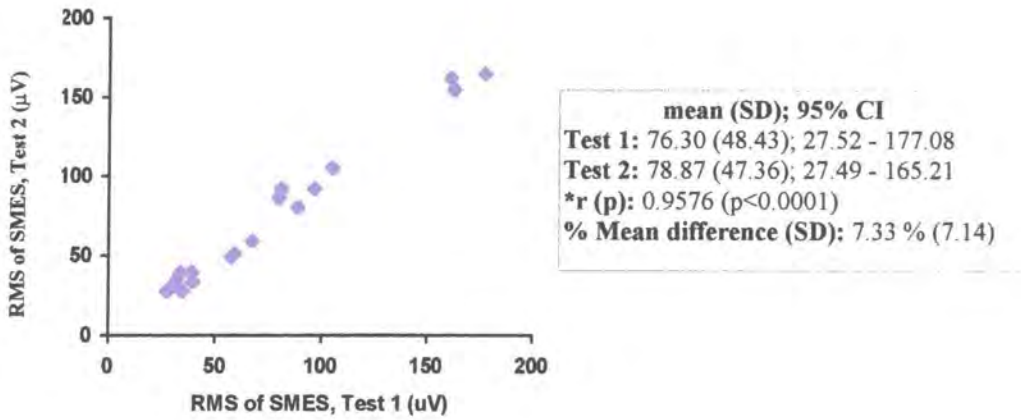
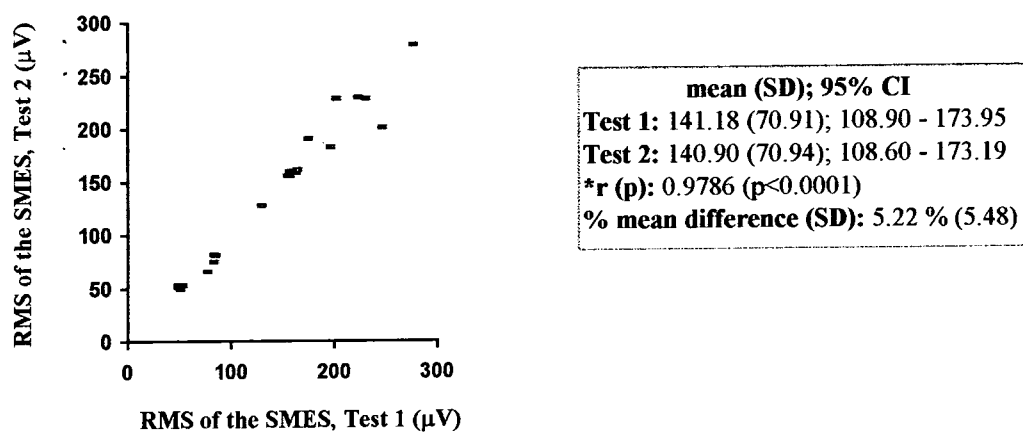

Figure 4.2.17: The repeatability of the RMS of the SMES (extensor channel) from standard grip tests at 2/3 MGS performed 3 weeks apart by 18 females with RA.



greater variation on retesting than the control groups at each grip level. The myoelectric parameters measured during the grip tests at 2/3 MGS showed the least variation on retesting. The mean percentage variation of the RMS of the SMES measured at the **extensor** channel during grip was 5.22 % for the control group and 7.33 % at the 2/3 MGS levels. The mean percentage variation at the lower grip force levels ranged from 8.41 % to 8.57 % in the two groups over the 3-week period. These findings are displayed in figures 4.2.17 and 4.2.18 (extensor channel) and 4.2.19 and 4.2.20 (flexor channel).

Figure 4.2.18: The repeatability of the RMS of the SMES (extensor channel) from standard grip tests at 2/3 MGS performed 3 weeks apart by 21 female controls.



The **RMS of the SMES** measured at the **flexor** channel during grip showed a greater mean percentage variation over the lower grip force levels than at the extensor channel, ranging from 8.09 to 11.58% at the lower two grip force levels. The mean percentage variation was less at the higher grip force level (2/3MGS), being 5.49% for the control group and 9.23% for the group with RA.

Figure 4.2.19: Repeatability of the RMS of the SMES (flexor channel) from standard grip tests at 2/3 MGS performed 3 weeks apart by 21 female controls.

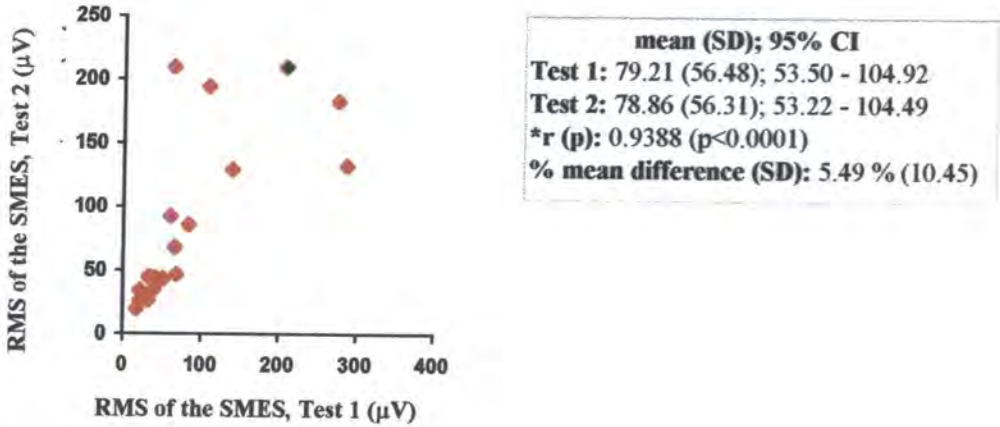
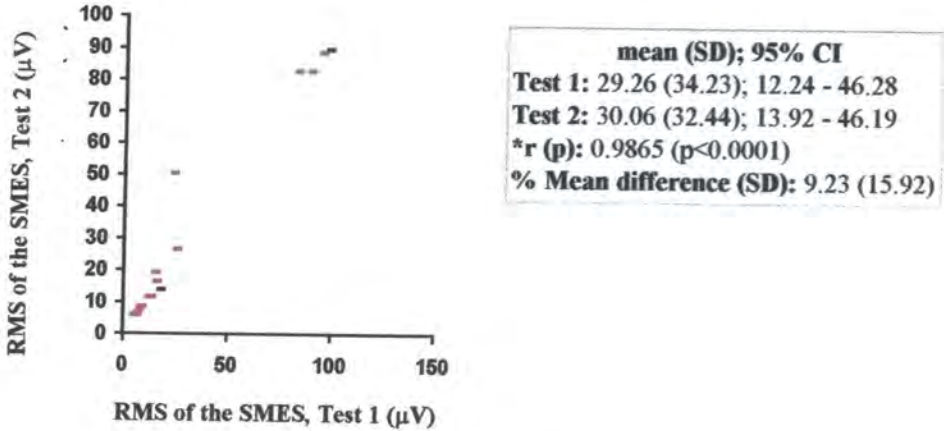
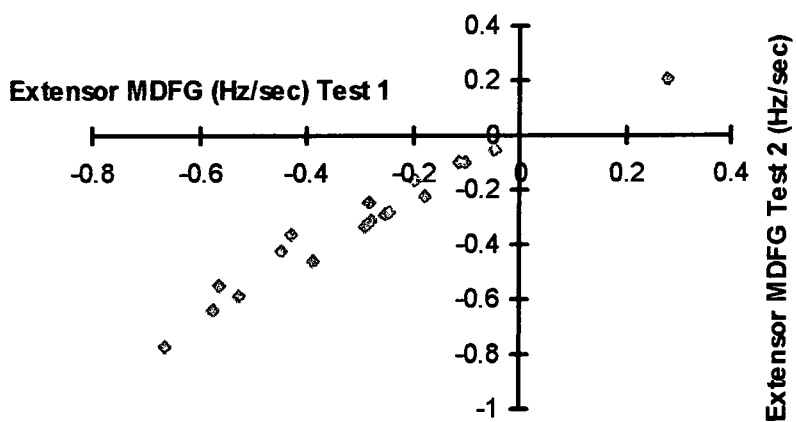

Figure 4.2.20: Repeatability of the RMS of the SMES (flexor channel) from standard grip tests at 2/3 MGS performed 3 weeks apart by 18 females with RA.



There was no significant difference between the extensor nor the flexor MDF_G of the SMES of Test 1 and Test 2 in either group, the mean percentage variation ranging from 14.25 to 17.66 %, as shown in figures 4.2.21 and 4.2.22 (extensor channel) and 4.2.23 and 4.2.24 (flexor channel). However, the repeatability of this parameter at the lower force levels was much poorer, the mean percentage variations being 23.15 % and 31.8 % in the control and RA groups respectively in the 1/2 MGS test and 61.3 % and over 270 % in the 1/3 MGS test.

Figure 4.2.21: The repeatability of the MDF_G of the SMES (extensor channel) from standard grip tests at 2/3 MGS performed 3 weeks apart by 18 females with RA.



mean (SD); 95% CI
Test 1: -0.2918 (0.2271); -0.4047 to -0.1788
Test 2: -0.3139 (0.2366); -0.4315 to -0.1962
***r (p):** 0.9768 (p<0.0001)
Wilcoxon Rank test: p = 0.0742
% mean difference (SD): 16.55 % (6.52)

The repeatability of the MDF_G measured at the **flexor** channel showed a similar pattern to the extensor channel, with the repeatability being satisfactory at the higher grip pressure level of 2/3 MGS (14.4 % & 15.9 % for the control and RA groups respectively), but not at the lower grip force levels. The flexor channel results showed a greater variation on retesting than the extensor channel. Overall, the variation on retesting was greater in the groups with RA.

Figure 4.2.22: The repeatability of the MDF_G of the SMES (extensor channel) from standard grip tests performed at 2/3 MGS 3 weeks apart by 21 female controls.

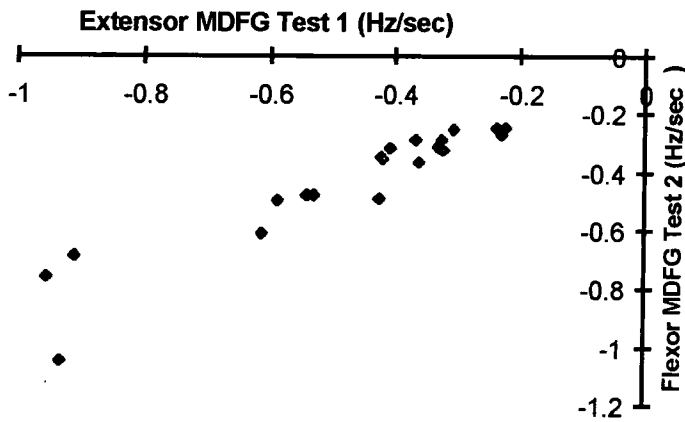

mean (SD); 95% CI
Test 1: -0.4637 (0.2277); -0.5650 to -0.3623
Test 2: -0.4279 (0.2055); -0.5214 to -0.3343
***r (p):** 0.9341 (p<0.0001)
Wilcoxon Rank Test: p = 0.051
% Mean difference (SD): 14.25% (8.20)

*Spearman correlation coefficient.

Figure 4.2.23: The repeatability of the MDF_G of the SMES (flexor channel) from standard grip tests at 2/3 MGS performed 3 weeks apart by 21 female controls.

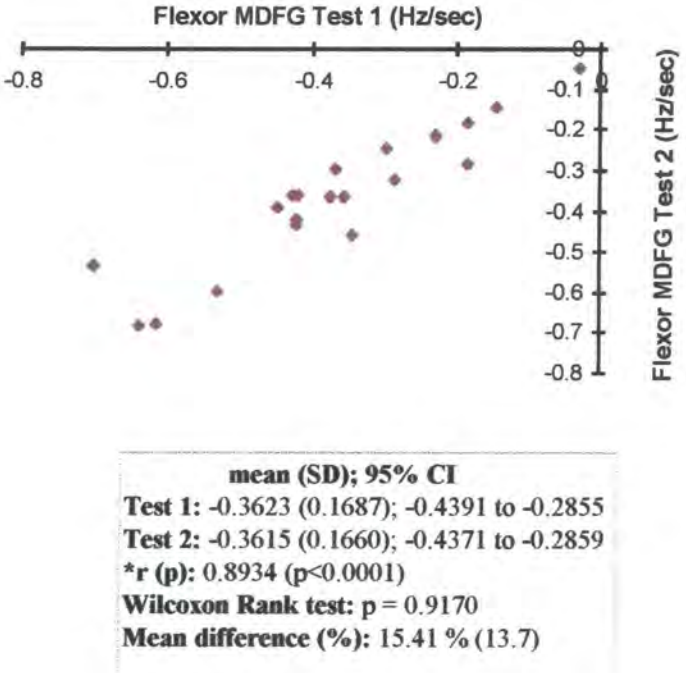
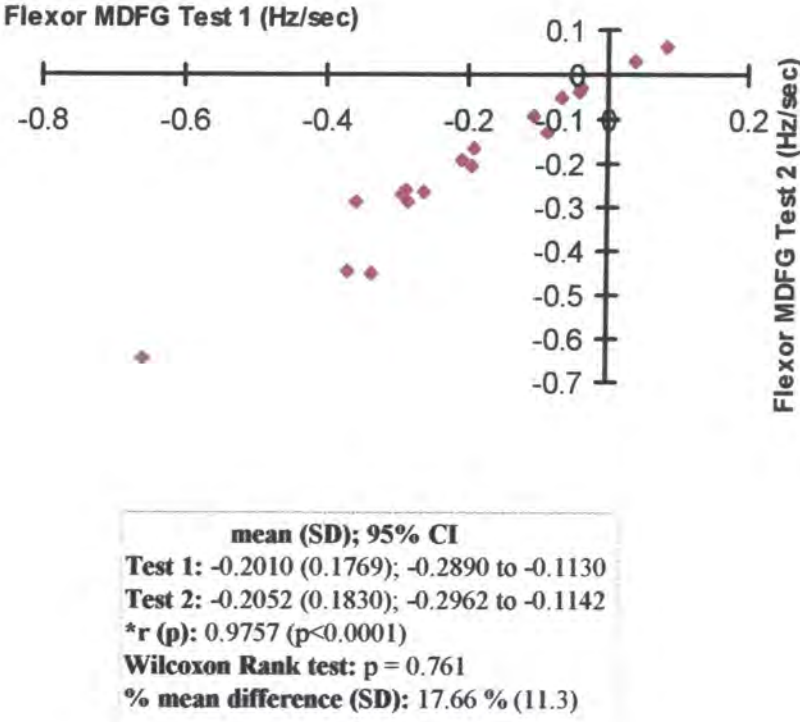

Figure 4.2.24: The repeatability of the MDFG of the SMES (flexor channel) from standard grip tests at 2/3 MGS performed 3 weeks apart by 18 females with RA.



The **IMF** showed a good repeatability over the range of grip forces at which subjects were tested, with a mean percentage variation of less than 9%, the results at the higher grip force level of 2/3MGS being the most repeatable.

The **IMF of the SMES** measured at the flexor channel showed a greater variation than the extensor channel. The variation at a grip force of 1/3MGS showed the greatest variation; 12.09 and 17.24 % for the control group and RA group respectively. At higher grip force levels, the mean percentage variation was less than 7.5%, with r ranging from 0.7232 to 0.9565 and all correlations reaching significance at $p < 0.0001$. The repeatability data of the IMF at 2/3MGS are displayed overleaf in figures 4.2.25 and 4.2.26 (flexor channel,) and 4.2.27 and 4.2.28 (extensor channel).

The **spectral width** measured at the extensor channel showed a mean variation ranging from 5.17% to 13.50 % over the three week period, as indicated in tables 4.2.7 to 4.2.22. The repeatability of the measurement of the spectral width of the flexor channel was less satisfactory than the extensor channel, with a mean percentage variation ranging from 8.92% to 25.30% (r : 0.5953 to 0.9119). The tests performed at a level of 2/3 MGS were the only to show a mean percentage variation of less than 10% for both groups. The least variation was shown at the higher grip force level for both subject groups, at both the extensor and flexor channels.

The **gradient of the RMS of the SMES (RMS_G)** - showed extremely poor repeatability over the 3 week period for both study groups at all levels of grip. The mean percentage variation of the RMS_G on retesting ranged from 55.29% to 270.29%, with no specific channel nor grip force level being superior.

The repeatability of the **initial RMS** of the SMES (**IRMS**) in both channels was variable, but most satisfactory for both groups at the higher grip force level. The IRMS measured at the extensor channel showed a mean percentage variation on retesting ranging from 7.51% to 47.98 % and 19.19% to 50.32% at the flexor channel. The repeatability of the IRMS was consistently poorer for the RA group at all grip force levels.

Figure 4.2.25: The repeatability of the IMF of the SMES (flexor channel) from standard grip tests at 2/3 MGS performed 3 weeks apart by 21 female controls.

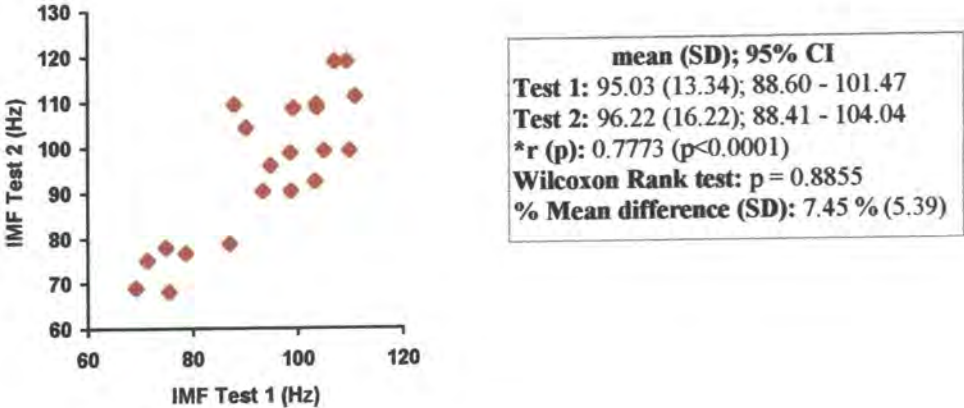

Figure 4.2.26: The repeatability of the IMF of the SMES (flexor channel) from standard grip tests at 2/3 MGS performed 3 weeks apart by 18 females with RA.

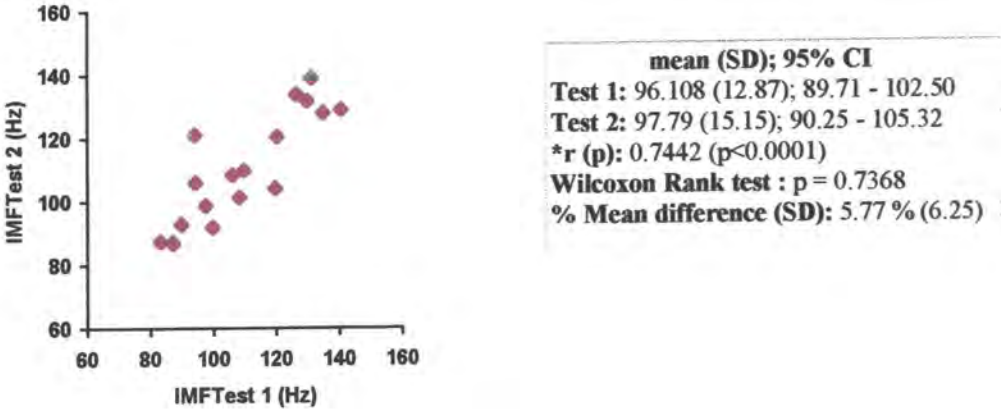

Figure 4.2.27: Repeatability of the Initial Median Frequency (IMF) of the SMES (extensor channel) from standard grip tests at 2/3 MGS performed 3 weeks apart by 21 female controls.

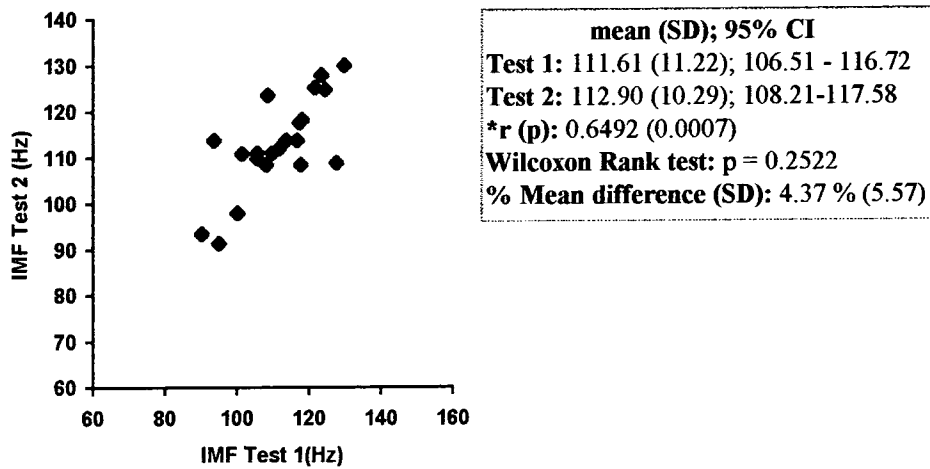

Figure 4.2.28: Repeatability of the IMF of the SMES (extensor channel) from standard grip tests at 2/3 MGS performed 3 weeks apart by 18 females with RA.

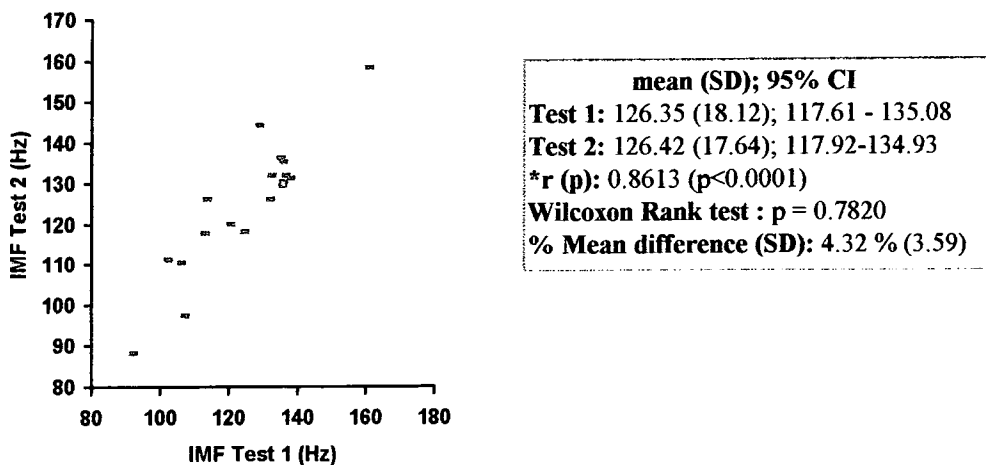

Table 4.2.7: Repeatability of myoelectric parameters (extensor channel) from standard grip tests at 2/3 MGS performed 3 weeks apart by 21 female controls.

	Mean (SD) Test 1	95 % CI Test 1	Mean (SD) Test 2	95 % CI Test 2	% mean difference (SD)
RMS (μV)	141.18 (70.91)	108.90 - 173.95	140.90 (70.94)	108.60 - 173.19	5.22 % (5.48)
MDF Slope (Hz/sec)	-0.4637(0.2277)	-0.5650 to -0.3623	-0.4279 (0.2055)	-0.5214 to -0.3343	14.25 % (8.2)
IMF (Hz)	111.61 (11.22)	106.51 - 116.72	112.90 (10.29)	108.21 - 117.58	4.37 % (5.57)
Width (Hz)	119.52 (25.12)	108.09 - 130.96	121.67 (26.49)	109.61 - 133.73	5.17 % (6.06)
RMS Slope ($\mu\text{V}/\text{sec}$)	0.1589 (0.9368)	-0.2675 to 0.5854	0.4274 (1.24)	-0.1384 to 0.9931	76.40 % (109.01)
RMS Intercept (μV)	133.13 (79.67)	96.85 - 169.41	133.60 (77.52)	98.32 - 168.89	7.51 % (9.51)

Table 4.2.8: Repeatability of myoelectric parameters (flexor channel) from standard grip tests at 2/3 MGS performed 3 weeks apart by 21 female controls.

	Mean (SD) Test 1	95 % CI Test 1	Mean (SD) Test 2	95 % CI Test 2	% mean difference (SD)
RMS (μV)	79.21 (56.48)	53.50 - 104.92	78.86 (56.31)	53.22 - 104.49	5.49 % (10.45)
MDF Slope (Hz/sec)	-0.3623 (0.1687)	-0.4391 -0.2855	-0.3615 (0.1660)	-0.4371 to -0.2859	15.41 % (13.70)
IMF (Hz)	95.03 (13.34)	88.60 - 101.47	96.22 (16.220)	88.41 - 104.04	7.45 % (5.39)
Width (Hz)	84.10 (23.75)	73.28 - 94.91	86.52 (24.65)	75.31 - 97.74	9.55 % (13.87)
RMS Slope ($\mu\text{V}/\text{sec}$)	0.4480 (0.4589)	0.2391 - 0.6569	0.4977 (0.4139)	0.3093 - 0.6861	60.40 % (75.31)
RMS Intercept (μV)	73.88 (67.22)	43.29 - 104.48	69.11 (52.37)	45.27 - 92.95	19.19 % (15.90)

Table 4.2.9: Repeatability of myoelectric parameters (extensor channel) from standard grip tests at 2/3 MGS performed 3 weeks apart by 18 females with RA.

	Mean (SD) Test 1	95 % C I Test 1	Mean (SD) Test 2	95 % C I Test 2	% mean difference (SD)
RMS (μ V)	76.30 (48.43)	27.52 - 177.08	78.87 (47.36)	27.49 - 165.21	7.33 % (7.14)
MDF Slope (Hz/sec)	-0.2918 (0.2271)	-0.4047 to -0.1788	-0.3139 (0.2366)	-0.4315 to -0.1962	16.55 % (6.52)
IMF (Hz)	126.35 (18.120)	117.61 - 135.08	126.42 (17.64)	117.92 - 134.93	4.32 % (3.59)
Width (Hz)	168.83 (41.67)	148.11 - 189.56	175.22 (42.33)	154.17 - 196.28	7.59 % (6.53)
RMS Slope (μ V/sec)	-0.1987 (0.1179)	-0.4475 to 0.0502	-0.1436 (0.2596)	-0.2727 to -0.0144	134 % (209.41)
RMS Intercept (μ V)	66.81 (41.85)	49.14 - 84.49	67.00 (49.58)	46.06 - 87.94	24.89 % (25.25)

Table 4.2.10: Repeatability of myoelectric parameters (flexor channel) from standard grip tests at 2/3 MGS performed 3 weeks apart by 18 females with RA.

	Mean (SD) Test 1	95 % C I Test 1	Mean (SD) Test 2	95 % C I Test 2	% mean difference (SD)
RMS (μ V)	29.26 (34.23)	12.24 - 46.28	30.06 (32.44)	13.92 - 46.19	9.23 % (15.92)
MDF Slope (Hz/sec)	-0.2010 (0.1769)	-0.2890 to -0.1130	-0.2052 (0.1830)	-0.2962 to -0.1142	17.66 % (11.34)
IMF (Hz)	96.11 (12.87)	89.71 - 102.50	97.79 (15.15)	90.25 - 105.32	5.77 % (6.25)
Width (Hz)	118.78 (36.76)	100.50 - 137.06	113.94 (36.79)	95.65 - 132.24	8.92 % (10.61)
RMS Slope (μ V/sec)	0.0305 (0.1333)	-0.058 to 0.0968	0.0889 (0.2079)	-0.0144 to 0.1923	149.01 % (274.43)
RMS Intercept (μ V)	26.89 (25.19)	15.10 - 36.68	30.81 (38.28)	12.90 - 48.73	24.17 % (19.44)

Table 4.2.11: Repeatability of myoelectric parameters (extensor channel) from standard grip tests at 1/2 MGS performed 3 weeks apart by 30 female controls.

	Mean (SD) Test 1	95 % C I Test 1	Mean (SD) Test 2	95 % C I Test 2	% mean difference (SD)
RMS (µV)	140.06 (93.92)	105.00 - 175.13	136.66 (81.80)	106.12 - 167.20	8.41 % (6.38)
MDFG (Hz/sec)	-0.3779 (0.2415)	-0.4680 to -0.2877	-0.3257 (0.2164)	-0.4335 to -0.2720	23.15 (18.06)
IMF (Hz)	111.20 (10.96)	107.11 - 115.29	109.03 (12.88)	104.23 - 113.84	6.44 % (7.20)
Width (Hz)	133.83 (20.09)	123.84 - 143.84	133.39 (18.21)	124.33 - 142.44	13.50 % (9.77)
RMSG (µV/sec)	0.3092 (0.8687)	-0.0212 to 0.6395	0.2299 (0.5777)	0.0102 to 0.4496	87.39 % (128.52)
IRMS (µV)	130.38 (74.65)	102.51 - 158.26	116.93 (56.65)	95.78 - 138.08	20.69 % (16.83)

Table 4.2.12: Repeatability of myoelectric parameters (flexor channel) from standard grip tests at 1/2 MGS performed 3 weeks apart by 30 female controls.

	Mean (SD) Test 1	95 % C I Test 1	Mean (SD) Test 2	95 % C I Test 2	% mean difference (SD)
RMS (µV)	60.47 (42.01)	44.78 - 76.15	62.36 (38.22)	48.09 - 76.63	9.65 % (8.63)
MDFG (Hz/sec)	-0.3114 (0.2682)	-0.4116 to -0.2113	-0.2944 (0.2299)	-0.3802 to -0.2085	35.16 % (35.38)
IMF (Hz)	94.88 (20.59);	87.19 - 102.57	95.12 (19.19)	88.04 - 102.36	8.00 % (3.9)
Width (Hz)	91.78 (36.57)	73.59 - 109.96	91.39 (31.63)	75.66 - 107.12	25.30 % (19.17)
RMSG (µV/sec)	0.4557 (0.5030)	0.2579 - 0.6335	0.3461 (0.4154)	0.1911 - 0.5012	55.29 % (22.56)
IRMS (µV)	53.01 (38.49)	38.64 - 67.38	59.98 (33.54)	47.46 - 72.51	24.47 % (22.47)

Table 4.2.13: Repeatability of myoelectric parameters (extensor channel) from standard grip tests at 1/2 MGS performed 3 weeks apart by 24 females with RA.

	Mean (SD) Test 1	95 % C I Test 1	Mean (SD) Test 2	95 % C I Test 2	% mean difference (SD)
RMS (μ V)	44.30 (23.01)	34.58 - 54.01	45.79 (22.38)	36.34 - 55.24	8.42 % (5.09)
MDFG (Hz/sec)	-0.1893 (0.194)	-0.2716 to -0.1070	-0.1819 (0.1622)	-0.2505 to -0.1134	31.77 (40.91)
IMF (Hz)	121.56 (12.24)	116.39 - 126.73	118.88 (13.55)	113.15 - 124.60	4.41 % (2.09)
Width (Hz)	150.50 (16.99)	143.32 - 157.68	142.08 (15.55)	135.52 - 148.65	7.06 % (5.03)
RMSG (μ V/sec)	-0.1372 (0.3282)	-0.2758 to 0.0014	-0.0061 (0.2676)	-0.1191 to -0.0107	74.54 % (245.45)
IRMS (μ V)	45.98 (25.72)	35.11 - 56.84	49.98 (25.00)	39.42 - 60.53	47.98 % (24.91)

Table 4.2.14: Repeatability of myoelectric parameters (flexor channel) from standard grip tests at 1/2 MGS performed 3 weeks apart by 24 females with RA.

	Mean (SD) Test 1	95 % C I Test 1	Mean (SD) Test 2	95 % C I Test 2	% mean difference (SD)
RMS (μ V)	13.21 (9.19)	9.24 - 17.18	13.35 (8.31)	9.75 - 16.94	10.21 % (8.72)
MDFG (Hz/sec)	-0.2065 (0.4570)	-0.3995 to -0.0135	-0.1976 (0.5565)	-0.4327 to 0.0374	46.86 (59.0)
IMF (Hz)	113.13 (21.99)	114.91 - 122.42	114.91 (25.69)	104.05 - 124.76	5.58 % (3.65)
Width (Hz)	117.29 (40.71)	100.10 - 134.48	116.79 (35.64)	101.74 - 131.84	10.96 % (5.47)
RMSG (μ V/sec)	0.0443 (0.0968)	0.0034 - 0.0851	0.0426 (0.1167)	-0.0067 to 0.9109	135.50 % (207.03)
IRMS (μ V)	12.24 (8.000)	8.78 - 15.70	15.05 (7.79)	11.68 - 18.42	34.34 % (20.11)

Table 4.2.15: Repeatability of myoelectric parameters (extensor channel) from standard grip tests at 1/3 MGS performed 3 weeks apart by 18 female controls.

	Mean (SD) Test 1	95 % C I Test 1	Mean (SD) Test 2	95 % C I Test 2	% mean difference (SD)
RMS (μ V)	101.14 (48.98)	76.78 - 125.50	97.98 (49.72)	73.25 - 122.71	6.84 % (11.49)
MDFG (Hz/sec)	-0.2573 (0.1350)	-0.4665 to -0.0024	-0.2209 (0.1782)	-0.3095 to -0.1902	61.29 (81.00)
IMF (Hz)	115.69 (12.64)	109.40 - 121.98	116.99 (9.33)	112.35 - 121.63	8.37 % (6.87)
Width (Hz)	133.83 (20.09)	123.84 - 134.83	133.39 (18.21)	124.33 - 142.44	13.50 % (9.77)
RMSG (μ V/sec)	0.1378 (0.3243)	-0.0235 to 0.2991	0.0902 (0.3728)	-0.0952 to 0.2756	175.00 % (152.33)
IRMS (μ V)	92.21 (55.94)	64.39 - 120.03	97.71 (46.02)	74.82 - 120.59	22.27 % (22.75)

Table 4.2.16: Repeatability of myoelectric parameters (flexor channel) from standard grip tests at 1/3 MGS performed 3 weeks apart by 18 female controls.

	Mean (SD) Test 1	95 % C I Test 1	Mean (SD) Test 2	95 % C I Test 2	% mean difference (SD)
RMS (μ V)	43.84 (18.92)	34.43 - 53.25	44.30 (18.91)	34.90 - 53.70	8.09 % (5.85)
MDFG (Hz/sec)	-0.2402 (0.1955)	-0.3374 to -0.1430	-0.2018 (0.1971)	-0.2998 to -0.1037	90.56 (62.46)
IMF (Hz)	91.65 (20.01)	81.69 - 101.60	90.32 (18.56)	81.09 - 99.55	12.09 % (11.91)
Width (Hz)	91.78 (36.57)	73.59 - 109.96	91.39 (31.63)	75.66 - 107.12	25.30 % (19.17)
RMSG (μ V/sec)	0.1840 (0.2454)	0.0620 to 0.3601	0.1738 (0.3660)	-0.0082 to 0.3559	175 % (152.33)
IRMS (μ V)	39.80 (28.53)	25.61 - 53.99	53.59 (35.75)	35.81 - 71.73	37.49 % (31.30)

Table 4.2.17: Repeatability of myoelectric parameters (extensor channel) from standard grip tests at 1/3 MGS performed 3 weeks apart by 19 females with RA.

	Mean (SD) Test 1	95 % C I Test 1	Mean (SD) Test 2	95 % C I Test 2	% mean difference (SD)
RMS (μ V)	60.29 (14.38)	53.36 - 67.23	60.29 (14.17)	53.46 - 67.12	8.57 % (3.71)
MDFG (Hz/sec)	-0.1520 (0.1583)	-0.2283 to -0.0757	-0.1397 (0.1568)	0.2153 to -0.0642	85.36 (58.29)
IMF (Hz)	127.76 (19.78)	118.22 - 137.29	129.34 (21.56)	118.95 - 139.73	6.45 % (6.64)
Width (Hz)	168.83 (41.67)	148.11 - 189.56	175.22 (42.33)	154.17 - 196.28	7.69 % (10.87)
RMSG (μ V/sec)	-0.1780 (0.1854)	-0.2674 to -0.0887	-0.2079 (0.3287)	-0.3664 to -0.0495	16.87 % (823.32)
IRMS (μ V)	56.16 (21.64)	45.73 - 66.59	60.29 (18.80)	51.23 - 69.36	27.78 % (24.76)

Table 4.2.18: Repeatability of myoelectric parameters (flexor channel) from standard grip tests at 1/3 MGS performed 3 weeks apart by 19 females with RA.

	Mean (SD) Test 1	95 % C I Test 1	Mean (SD) Test 2	95 % C I Test 2	% mean difference (SD)
RMS (μ V)	21.47 (19.36)	12.14 - 30.81	22.22 (20.230)	12.47 - 31.97	11.58 % (13.06)
MDFG (Hz/sec)	-0.1927 (0.4819)	-0.4250 to 0.0396	-0.2315 (0.4035)	-0.4260 to -0.0371	274.88 (472.34)
IMF (Hz)	114.79 (21.15)	104.00 - 124.38	119.32 (24.84)	107.35 - 131.30	17.24 % (16.46)
Width (Hz)	124.32 (39.46)	105.30 - 143.34	125.05 (43.27)	104.20 - 145.91	16.97 % (15.81)
RMSG (μ V/sec)	0.0369 (0.1181)	-0.0199 to 0.0939	-0.0078 (0.1041)	-0.0580 to 0.0424	270.29 % (215.99)
IRMS (μ V)	14.641 (10.66)	9.32 - 19.60	18.92 (22.77)	7.94 - 29.89	50.32 % (42.24)

4.2.4 The repeatability of forearm myoelectric parameters generated during sustained submaximal grip: discussion and conclusions.

The information available in the current literature relating to the intra-session and inter-session repeatabilities of myoelectric parameters have been outlined earlier in the review of the literature. In this study, specific myoelectric parameters during grip were demonstrated to be restored to near baseline values after a 5 minute rest interval. These were the RMS, MDF_G and the IMF of the SMES and the spectral widths. This early restoration of the RMS of the SMES from forearm musculature is in keeping with the findings of Petrofsky and Lind (1980) who reported the forearm SMES amplitude to be restored to normal range after a 3 minute interval after submaximal contraction. The long-term repeatability of the RMS of the SMES recorded from the forearm during submaximal contraction noted in this study is consistent with findings of others in relation to other muscles, including the elbow flexors. Moritani & DeVries (1978) reported a test-retest correlation of $r = 0.988$, $p < 0.001$ in isometric contractions of these muscles over a range of force levels. Chan and Chuang (1996), in one of the few studies examining the SMES of the EDC during isometric contraction, reported “excellent repeatability” of the RMS of the SMES but failed to provide any specific details.

The MDF_G of the forearm SMES returned to original baseline levels quickly in same day testing, as shown in the restitution studies. Although there is little available information in the literature relating to the *gradient* of the MDF derived from the SMES of forearm musculature over the test time, Kadefors et al (1968) reported the MDF of the SMES recorded from the extensor forearm musculature to be highly recovered within 90 seconds. Other workers have reported similar findings in the investigation of other muscles, as discussed earlier in Chapter Two.

The MDF_G of the SMES recorded from forearm musculature during grip was not a very stable parameter over time in comparison to the IMF and spectral widths, as demonstrated in the long term repeatability studies in section 4.2.3. The relative instability of the MDF_G of the forearm SMES over time has been noted by other workers, particularly in association with subjects with neuromuscular diseases. Lindeman and Drukker (1994) reported up to 80 % variation in the MDF_G obtained from the SMES of the rectus femoris during isometric contractions up to 80% of maximum in subjects with hereditary motor and sensory neuropathy or myotonic

dystrophy over 24 weeks. In this study, the mean (SD) percentage variation in the MDF_G of the forearm SMES from the most repeatable test, that at 2/3 MGS, ranged from 13 (8.2) % to 17 (11.3) %. This may have been related to variation in levels of upper limb activity over the interval between testing, both in the control and RA subjects. The very poor repeatability of the MDF_G at lower levels of grip is likely to reflect the variation in fatigue experienced at these levels and on different days. Given the variation and the large standard deviation within both the RA and control groups, very large subject numbers would have been required to investigate the MDF_G over a given time period such as the 3 month exercises programme.

There is no information in the literature as to the repeatability of the forearm IMF nor the spectral widths, which were found to be restored to baseline values after 5 minute intervals on same day testing and to be highly repeatable over a 3 week interval. High degrees of both inter- and intra-session repeatability of the IMF in other muscles such as the rectus femoris (Viitasalo & Komi, 1975) and the back (Dolan et al, 1995) has been demonstrated. The repeatability of the spectral width derived from the SMES from any musculature has not been reported.

The results of the restitution and long term repeatability studies in combination indicate that the MDF_G of the forearm SMES during grip at 2/3 MGS is a helpful and sensitive indicator of the fatigability of the forearm muscle at a given time and this fatigability alters over time. In addition to this, the high degrees of repeatability of the IMF of the SMES and spectral widths on same day and long term testing indicates that they are reflecting more stable characteristics of forearm muscle than does the MDF_G . The significant differences demonstrated between the extensor forearm musculature of the rheumatoid and control groups in relation to the former two parameters also suggest that they are reflecting intrinsic features of the forearm muscle during contraction that may be affected by the disease process in RA. This is further discussed in a later section.

It is possible that the MDF_G of the forearm SMES may be more repeatable over the long term if shorter exercise durations were used and / or higher levels of grip, since there was a trend towards higher repeatabilities at higher force levels. This can be explained by the increased likelihood of fatigue at higher force levels, as shown in the pilot studies of the relationship between grip force levels and the MDF_G (Section 4.3). The duration of the task used in this study, 30 seconds, was an arbitrary choice; other workers

(Merletti & Roy, 1996) have used similar durations, although others have used shorter or longer durations of exercise for tests.

The RMS intercept and the RMS gradient were not repeatable after the 5 minute interval, indicating they are unsuitable for use in repeated tests with rest intervals of 5 minutes. The RMS gradient of the RMS of the SMES (the RMS_G) and the initial RMS of the SMES were not repeatable over the three week period. The finding of poor restoration of the initial RMS and the gradient of the RMS of the SMES after a 5 minute rest interval demonstrates the sensitivity of such parameters to the effects of prolonged contraction.

The demonstration of poor repeatability of the RMS_G derived from forearm musculature during grip emphasises the hazards of using it as an indicator of fatigue and suggests that the results of studies which have not assessed the repeatability of this parameter prior to its use in such situations should be regarded with caution. The lack of correlation between the degrees of restoration of the MDF_G and the RMS_G after exercise also indicates that they are affected by differing – though not mutually exclusive – factors and that the RMS_G is possibly more sensitive to the effects of muscular contraction.

In view of the findings of the repeatability studies, the 2/3 MGS test was adopted for further use in the main study in the investigation of myoelectric characteristics of forearm musculature in health and rheumatoid disease. The highly reliable power spectral parameters, the IMF and spectral width, were examined further in terms of their relationship with disease parameters in RA and on the basis of these investigations (as will become evident) were assessed as potential use as predictors of outcome to an exercise programme. The RMS of the SMES was repeatable at all grip force levels, and values at different force levels at each testing were used to calculate the gradient of the regression line fitted to the plot of grip force versus the RMS of the SMES (the FRMS gradient, $FRMS_G$) and used in the investigation of the mechanisms of strength gain in the handgrip programme.

4.3. Pilot Studies III.

4.3.1 The relationship of grip force with SMES parameters.

The relationship of grip force levels with SMES parameters was studied in seventeen female controls (mean age (SD) 42.6 (6.1) years). Their MGS was determined according to the standard protocol. Fifty minutes later, they performed a series of grips as outlined in figure 4.3.1.

Figure 4.3.1: The surface myoelectric parameters vs grip force levels protocol.

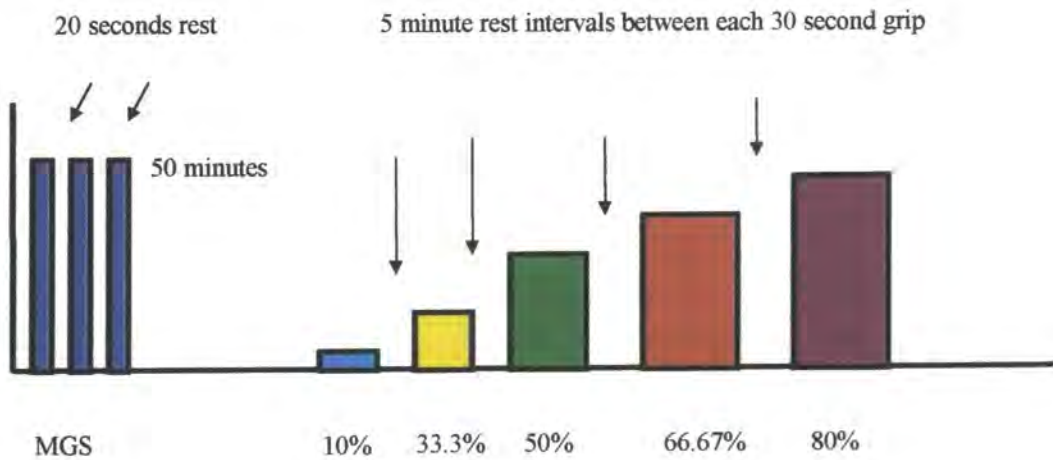

The results of this study are best described graphically and are outlined in figures 4.3.2 to 4.3.9. It can be seen that the RMS and the MDF_G of the SMES from both extensor and flexor forearm musculature correlate with increasing grip force levels. There was little effect of the level of grip force upon the IMF, nor upon the extensor spectral width. Whilst the flexor spectral width showed some linear trend with increasing force levels, there was no significant effect of grip force upon this parameter over the force range 30 to 66.7 % of the MGS, which were the levels of grip force used in the main study protocol.

Figure 4.3.2: Mean RMS of the SMES (A) and linear regression lines (B) from extensor forearm musculature during standard grip tests versus percentage maximal grip pressure in 17 female controls. ANOVA $F = 7.94$; $r^2 = 0.4951$, $p < 0.0001$.

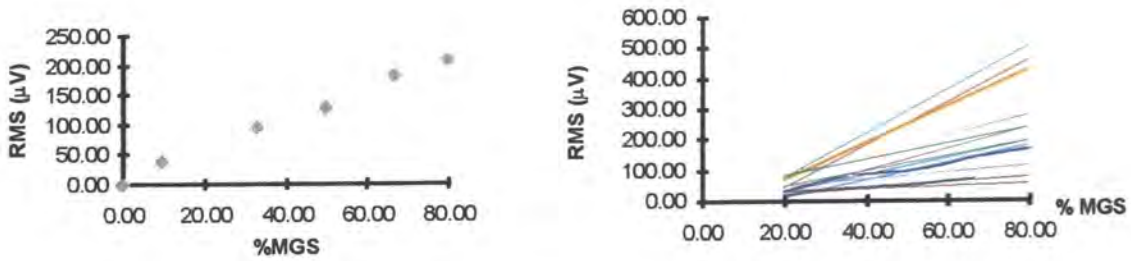

Figure 4.3.3: Mean RMS of the SMES (A) and linear regression lines (B) from flexor forearm musculature during standard grip tests versus percentage maximal grip pressure in 17 female controls. ANOVA $F = 16.43$; $r^2 = 0.2721$, $p < 0.0001$.

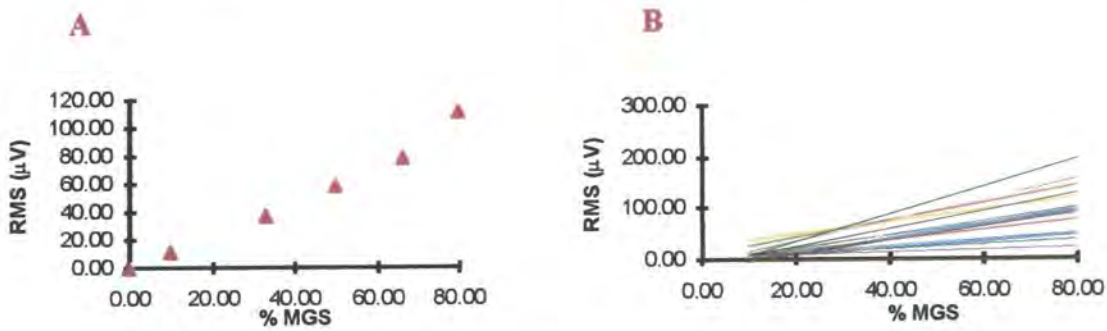

Figure 4.3.4: Mean MDF_C of the power spectrum of the SMES (A) and linear regression lines (B) from extensor forearm musculature during standard grip tests versus percentage maximal grip pressure in 17 female controls. ANOVA $F = 27.73$; $r^2 = 0.5766$, $p < 0.0001$

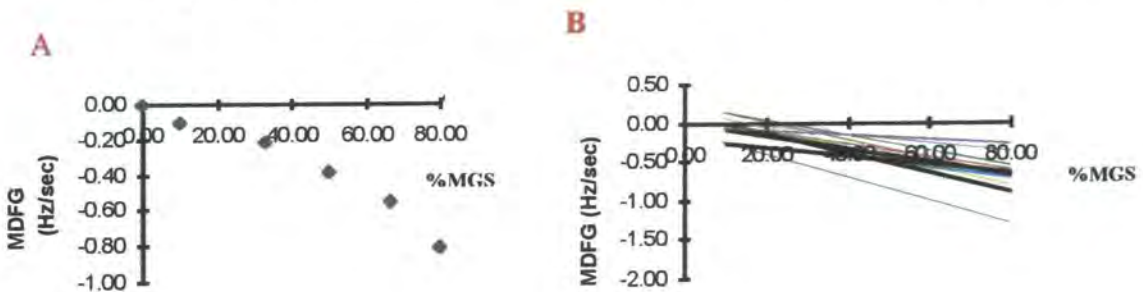

Figure 4.3.5: Mean MDF_G of the power spectrum of the SMES (A) and linear regression lines (B) from flexor forearm musculature during standard grip tests versus percentage maximal grip pressure in 17 female controls. ANOVA $F = 18.68$; $r^2 = 0.4825$, $p < 0.0001$.

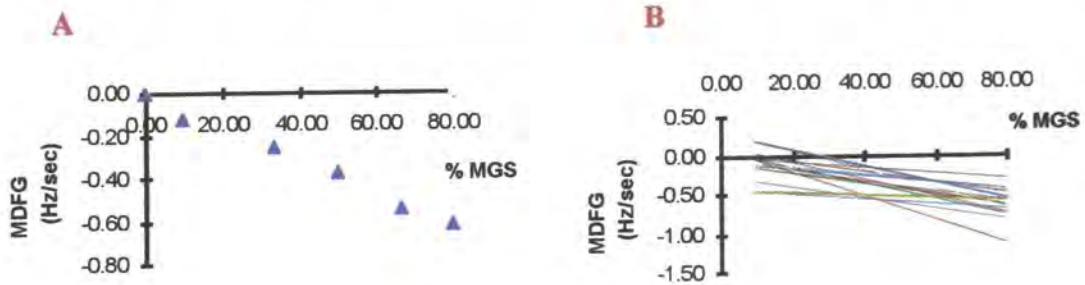

Figure 4.3.6: Mean IMF of the power spectrum of the SMES (A) and linear regression lines (B) from extensor forearm musculature during standard grip tests versus percentage maximal grip pressure in 17 female controls. ANOVA $F = 0.5579$, $p = 0.6939$.

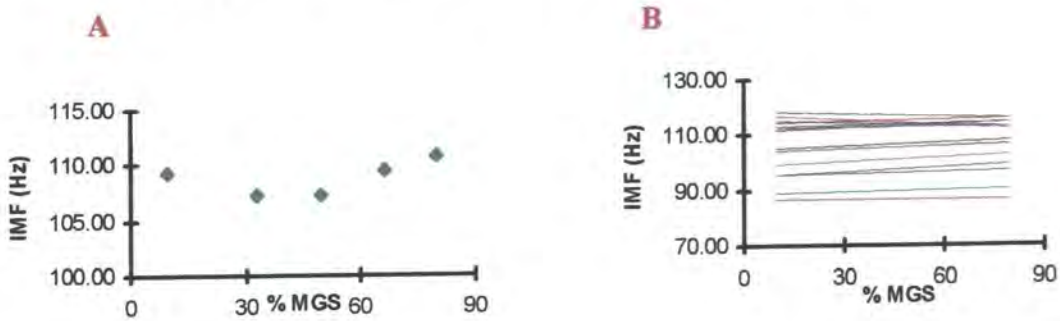

Figure 4.3.7: Mean IMF of the power spectrum of the SMES (A) and linear regression lines (B) from flexor forearm musculature during standard grip tests versus percentage maximal grip pressure in 17 female controls. ANOVA $F = 1.793$, $p = 0.1393$.

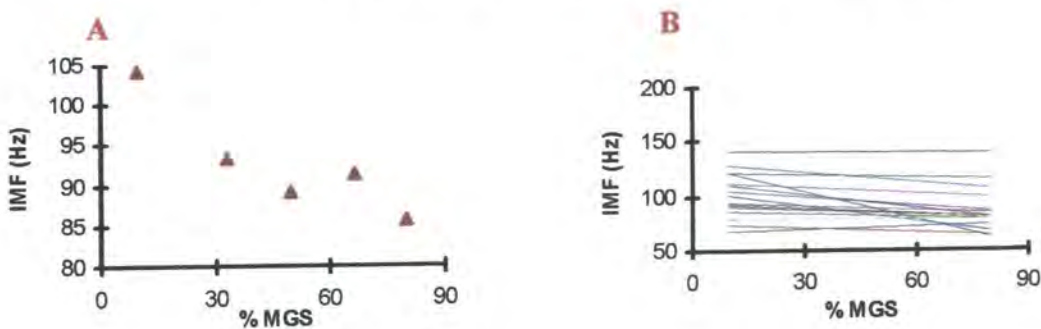

Figure 4.3.8: Mean spectral width (A) and linear regression lines (B) from extensor forearm musculature during standard grip tests versus percentage maximal grip pressure in 17 female controls. ANOVA $F = 1.732$; $p = 0.1522$.

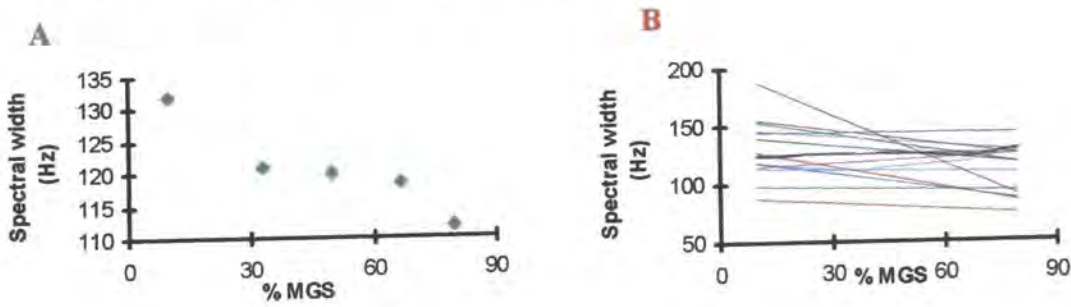
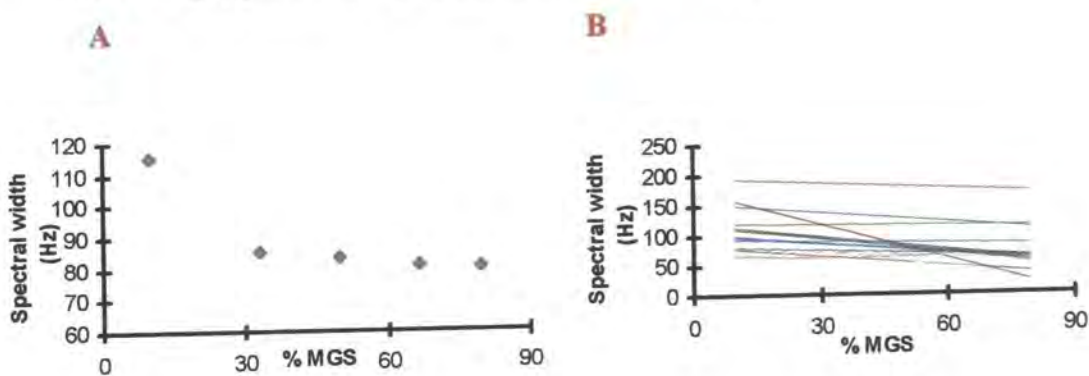

Figure 4.3.9: Mean spectral width (A) and linear regression lines (B) from flexor forearm musculature during standard grip tests versus percentage maximal grip pressure in 17 female controls. For grip force range 10 – 80% MGS: ANOVA $F = 2.65$; $r^2 = 0.073$, $p = 0.018$. For grip force range 33.3-66.7% MGS: $F = 0.0662$, $p = 0.9360$.



4.3.2. Summary and Discussion: The relationship of grip force with SMES parameters

In the attempts to use the EMG signal as an indicator of muscular force during an activity, the relationship between the EMG signal and the force exerted by a muscle or a muscle group has been the subject of intense research for many years. However, as Perry and Bekey (1981) point out and as has been detailed in the literature review, the quantification of EMG-force relationships is still clouded by confusion.

For the neuromuscular efficiency to be a valid measure, it was important to establish that a linear relationship exists between force and the RMS of the forearm SMES during

grip. This was demonstrated in this study to be the case in relation to the forearm musculature. The findings indicate that the RMS of both the flexor and extensor forearm SMES was linearly related to grip force over the levels used in this study, that is 30 – 66.7 % of maximum grip strength. Over this range of force, recruitment would be expected to be the major mechanism of modulation of force (Milner-Brown et al, 1973; Milner-Brown and Stein, 1975; Perry and Bekey, 1981), although this is very likely to be an over-generalisation (Duchene and Goubel, 1993) and muscles vary in their MU modulation mechanisms, as detailed in the literature review. Other mechanisms contributing to the increase in the RMS of the SMES with increasing force are the MU firing rates and the synchronisation of MU discharges (Duchene and Goubel, 1993)

In order to avoid the effects of muscle synergy, which can make the relationship between myoelectric parameters such as the RMS of the SMES and force deceptively linear (Hof and van den Berg, 1977; Perry and Bekey, 1981), the flexor and extensor muscle groups were assessed separately. However, this does not exclude synergistic activity within the muscle groups. Therefore it is important to emphasise that the relationships that were demonstrated between grip force and the myoelectric parameters apply to the flexor and extensor muscle *groups* rather than specific muscles within that group.

This study, which involved step contractions, demonstrated that grip force had relatively little effect upon the IMF 0 – 80 % MGS, particularly over the grip force range used in the main study (30 – 66.67 %). Petrofsky and Lind (1980) reported the mean power frequency of the SMES recorded from the flexor carpi radialis muscle during handgrip to be independent of contraction intensity over a wide range of grip force, from 25 to 100% MGS. Kaiser and Petersen (1965) reported similar results to the findings in this study and those of Petrofsky and Lind (1980), showing that, although some changes occurred in the low frequency range of the spectrum, most of the frequency components remained stable. In a mathematical model of myoelectric activity, Person and Libkind (1970) reported the frequency of the SMES is likely to depend upon the duration of the MUAPs, once a threshold number of MUs are firing.

In keeping with the findings of most workers relating to a variety of muscles, the MDF_G of the SMES recorded from forearm musculature increased (i.e. became more negative)

with increasing levels of force. This is likely to be related to a combination of the progressive recruitment of type II fibres at higher force levels (which, in forearm muscles, are larger (Polgar et al, 1973) and more fatiguable, with faster declines in the MDF_G than type I fibres), the synchronisation of motor unit discharges, ischaemia, the accumulation of metabolites and the decline in pH and muscle fibre conduction velocity with increasing sustained force levels.

Grip force had little effect upon the extensor spectral width over the grip force levels 30-80 % MGS. Similarly, grip force had little effect upon the flexor spectral width over the grip force range of 33.3 to 66.7 % of the MGS.

The RMS and MDF_G of the forearm SMES during submaximal grip were therefore demonstrated to be linearly related to force over the range used in the main study, that is, 33.3 – 66.67 % MGS. The IMF was demonstrated to be independent of grip strength levels over this range of grip strength.

Table 4.4.1: Characteristics of the two study groups.

	AGE (SD); range; (years)	Weight (SD); range (kg)	Body Mass Index (SD);range (kg/m ²)	MGS right hand (SD); range (mmHg)	Disease duration (SD); range (months)
RA (n=161)	51.93 (12.49); 22 - 75	63.198 (14.07); 50.95 - 82	24.25 (4.01); 18.03 - 31.73	94.62 (65.27); 9 - 350	117.08 (104.54); 2-672
Controls (n=114)	44.04 (13.29); 22-76	65.06 (10.71); 50 - 86	24.99 (3.93); 19.53 - 38.45	299.28 (81.49); 106 - 540	-----
# RA vs Control	p<0.0001	p=0.2141	p=0.1296	p<0.0001	-----

#unpaired t-test

Figure 4.4.1: Test protocol: SMES acquisition and analysis from forearm surface electrodes during the following grip tests in 161 females with RA and 114 female controls.

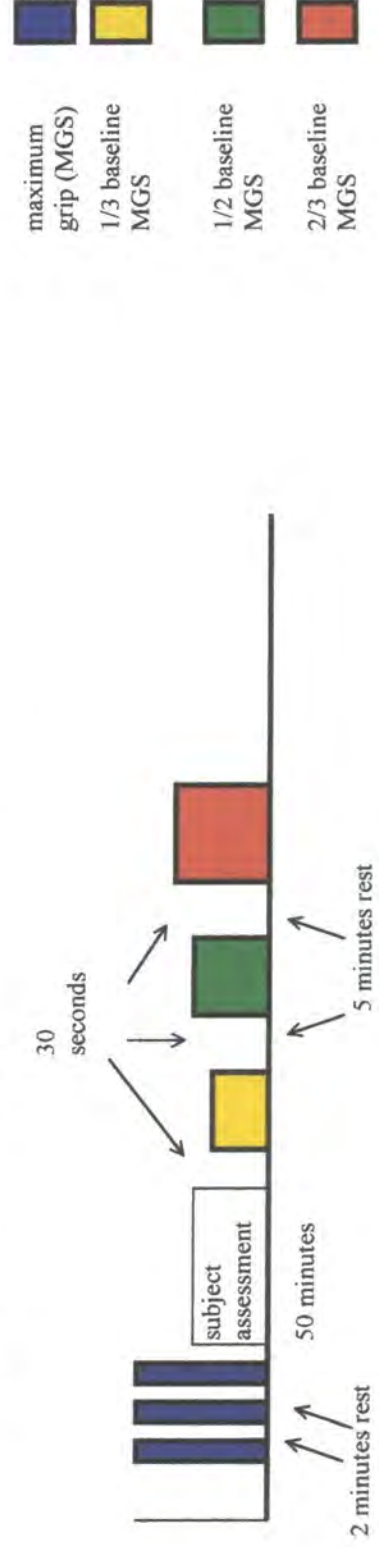

4.4 Pilot studies IV: The inter-relationship between forearm myoelectric parameters derived from the SMES during sustained submaximal grip.

4.4.1 Introduction

In this section the inter-relationship between the myoelectric parameters of the extensor and flexor myoelectric parameters will be described. In addition the relationship between the IMF (an established spectral parameter) and spectral width will be assessed. The spectral width is a feature of the frequency spectrum which has been demonstrated earlier to be a stable parameter on intra- and inter- session testing. It has not been utilised as a myoelectric parameter by other workers. The physiological significance of this parameter is unclear.

Two subject groups – one containing female subjects with RA, one with healthy female controls were evaluated. These groups were those involved in the main study and are detailed in Table 6.1.1 and repeated in Table 4.4.1, with the study protocol, on the facing page. Results from the 2/3MGS test are used in the examination of the inter-relationship between forearm myoelectric parameters derived from the SMES during sustained submaximal grip. This study is placed here, prior to the main study, as it adds insight into appropriate myoelectric parameters and helps in further interpretation of the studies which will follow.

4.4.2 Results: The inter-relationship between forearm myoelectric parameters derived from the SMES during sustained submaximal grip.

In the evaluation of the relationship between the myoelectric parameters of the extensor and flexor channels, the RMS voltage of the SMES was found to be significantly greater in the extensor channel, in both the healthy and the rheumatoid groups, with significant correlation between the two channels.

The MDF_G was also greater (that is, more negative) in the extensor muscle group than in the flexor group, although this difference did not reach statistical significance in either study group. A significant correlation between the two channels was again seen in

Figure 4.4.2: The MDF_G of the SMES recorded from the right forearm flexor channel versus that from the extensor channel during a standard right hand grip test performed at 2/3 MGS by 161 females with RA.

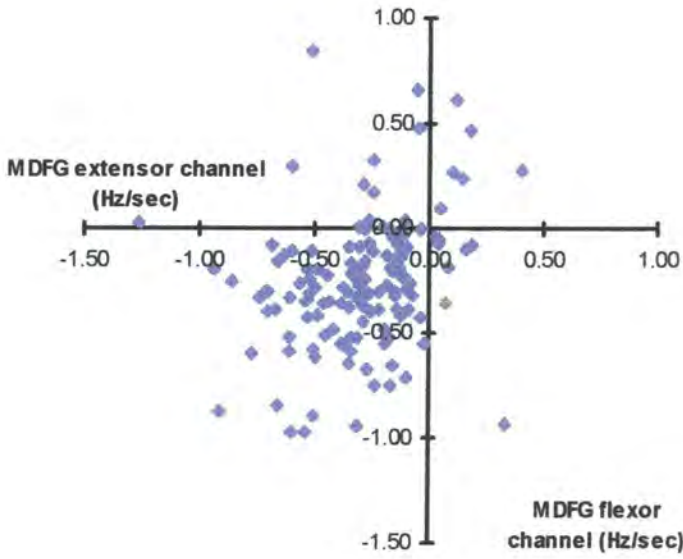
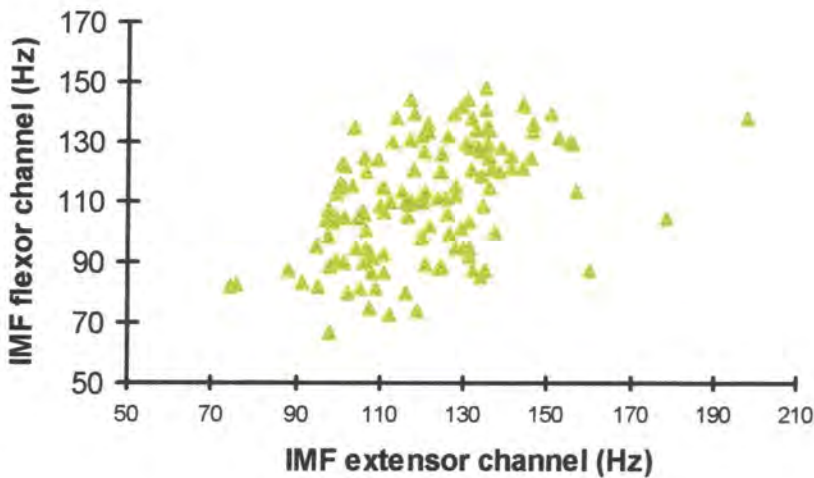

Figure 4.4.3: The IMF of the SMES recorded from the right forearm flexor channel versus that from the extensor channel during a standard right hand grip test performed at 2/3 MGS by 161 females with RA.



both groups ($r = 0.2346$, $p=0.0090$; $r = 0.2894$, $p = 0.0003$, for the control and RA groups, respectively). The IMF of the SMES was greater in the extensor channel in both the RA and control groups, this difference reaching statistical significance in the control group. A significant correlation between the two channels was demonstrated for the rheumatoid group only ($r=0.1428$, $p=0.1297$ and $r = 0.3120$, $p < 0.0001$, for the control and RA groups, respectively). There were significant correlations between the spectral widths from the two muscle groups in both the control group (0.3214 , $p < 0.0001$) and the RA group ($r = 0.3130$, $p < 0.0001$).

There was significant correlation between the IMF and spectral width in both channels in both the subjects with RA and in controls.

Figure 4.4.4: The relationship between the spectral width and the IMF of the extensor (A) and flexor (B) SMES in 161 females with RA and 114 healthy female controls.

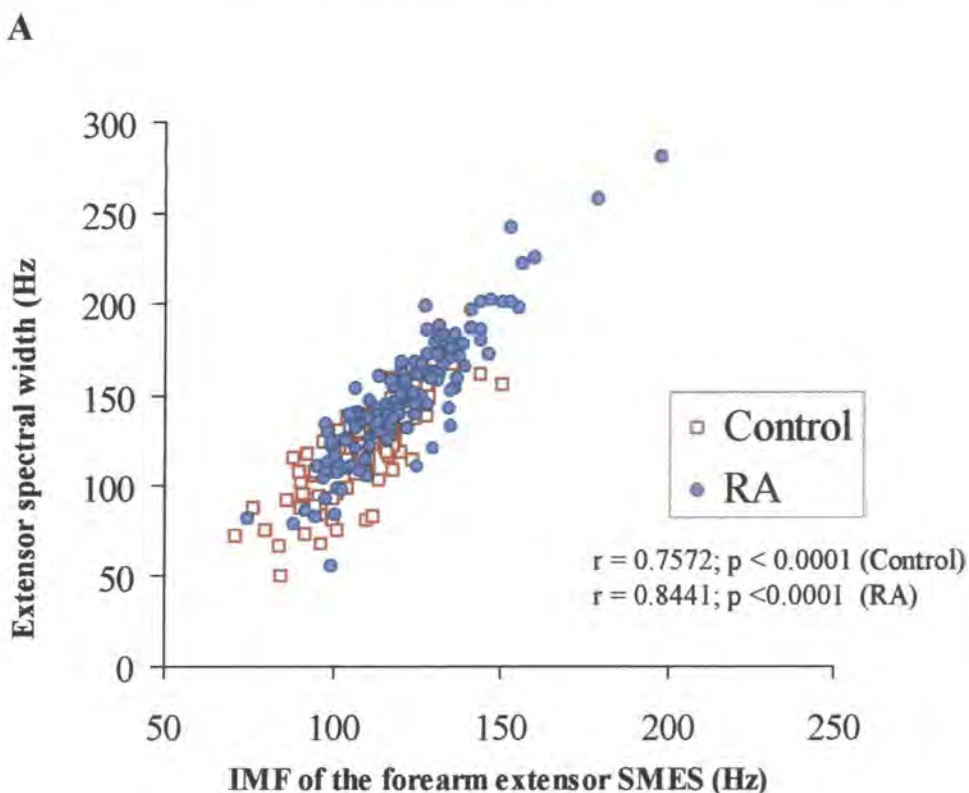

B

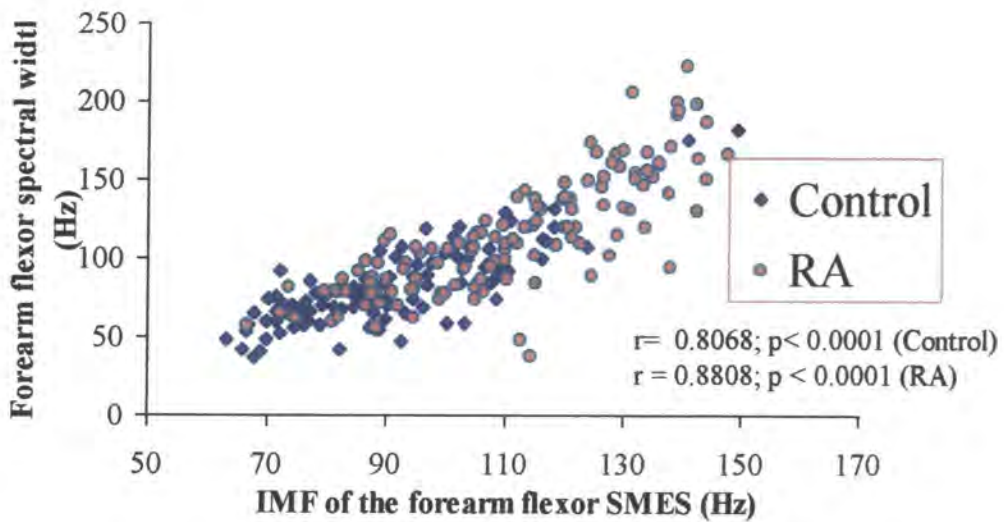

4.4.3 Discussion.

It is evident that, although correlation was demonstrated between some of the myoelectric parameters of the extensor and flexor forearm muscles of the healthy subjects, the relationship was not consistent. This indicates that the value of a myoelectric parameter cannot be assumed to represent that of another muscle in a given individual. However, the correlations between the two muscle groups were consistently significant for the RA group. This suggests that, if these myoelectric parameters are affected by rheumatoid disease - as will be investigated in later studies - then it appears that both muscle groups are affected.

The correlation between the spectral width and the IMF of the SMES in each muscle group and in both rheumatoid and healthy subjects indicates that the wider the spectrum, the higher the IMF. This is to be expected, since an increase in the spectral width occurs through increases in high frequency components of the spectrum. The physiological basis of the spectral width is unclear, although it may be a useful parameter in the assessment of muscle characteristics during contraction. The studies which have been described earlier indicate that this parameter is stable on both short term and long term testing, is independent of grip force over the range 30 – 66.7 % MGS and correlates with another spectral parameter, the IMF. Since the IMF has a sound physiological basis and has been shown to be helpful in the investigation of



neuromuscular disorders (Muro et al, 1982; Larsson, 1975), then the IMF was selected for further assessment of neuromuscular aspects of rheumatoid disease. The MDF_G was also utilised as an indicator of the fatiguability of muscle in RA. This parameter may be a useful measure of the frequency spectrum, particularly when evaluating the repeatability of techniques involving power spectral analysis. Further studies assessing characteristics of spectral width in relation to physiological changes occurring within the muscle are warranted.

Chapter 5. The Assessment of the muscle mass in the right forearm.

Pilot studies.

5.1. Introduction

The assessment of the cross-sectional area of the forearm using skinfold caliper techniques was not repeatable on between day testing in females with RA nor in healthy controls. Initial studies in relation to the assessment of muscle mass in the right forearm used magnetic resonance imaging. This involved measurement of the cross-sectional area of the forearm and, later in the study, the evaluation of forearm muscle volume. The repeatabilities of these techniques were assessed and the inter-relationship between the CSA of the right forearm and the forearm muscle volume was examined.

5.2 Cross Sectional Area (CSA) of the Right Forearm using Magnetic Resonance Imaging.

The repeatability of measurement of the cross-sectional area of the right forearm was assessed in ten healthy subjects (3 men and 7 women) by measurement on three occasions over one week; the results are given in Table 5.2.1. The technique was shown to be highly repeatable, with a mean (SD) percentage difference of 1.45 (1.00) %.

Table 5.2.1: The repeatability of the assessment of CSA of the right forearm using single slice magnetic resonance imaging in ten healthy subjects.

Mean CSA (SD) (cm²)			F ratio (p)	Mean difference (SD) (%)
Test 1	Test 2	Test 3		
23.95 (4.66)	24.67 (5.33)	23.8 (5.00)	0.0758 (0.9272)	1.45 (1.0) %

5.3: Volumetric analysis of the musculature of the right forearm.

In the development of the method of volumetric analysis of forearm musculature using magnetic resonance imaging, the repeatability of the technique was evaluated and different scanning modes examined in order to determine the optimal scanning technique.

5.3.1 The repeatability of volumetric analysis of the right forearm musculature.

Ten healthy volunteers were studied to assess the repeatability of the technique of volumetric analysis of the musculature of the right forearm, in addition to comparing different scanning techniques. A 15 cm section of the right forearm of all volunteers was scanned on three separate occasions over a 1 week period, using three separate scanning techniques (T1 weighted, Proton and 3D) on each occasion. The scanning techniques used are described earlier in section 3.4.

In the T1-W images, the distal (1st) image lacked adequate contrast to permit accurate definition of muscle tissue using the segmentation technique. In assessment of the proximal (8th) image through the inferior RUJ, segmentation incorrectly classified the joint as muscle. These slices were rejected and the remaining 6 slices used, covering a distance of 11 cm (including the spaces between slices). Due to similar problems when processing the Proton images and to ensure consistency, the distal (1st), second and proximal (15th) slices were discarded from each Proton series. Each series then contained 11 slices covering an 11cm region of the forearm.

The 3D scanning technique was rejected due to the poor sensitivity to segmentation techniques which will be described further below. The results of the other two scanning techniques are as shown in Tables 5.3.1 and 5.3.2.

Table 5.3.1: The repeatability of volumetric analysis of the forearm of ten subjects over three testing occasions using proton imaging.

Technique	mean volume (voxels) (SD); 95 % CI			*F ratio (p)	mean difference (SD) (%)
	Test 1	Test 2	Test 3		
Proton	78473 (17216); 66159 - 90788	79068 (17735); 66382 - 91754	78293 (17197); 65992 - 90594	1.228 (0.3163)	1.01 % (1.05%)

Table 5.3.2 : The repeatability of the adjusted volume of the right forearm from T1-W imaging technique over three testing sessions (mean (SD); 95 % CI (voxels)).

Technique	mean volume (voxels) (SD); 95 % CI			*F ratio (p)	mean difference (SD) (%)
	Test 1	Test 2	Test 3		
T1 W	74743 (16351); 63046 - 86439	75590.17 (17007); 63424 - 87754;	74974 (16811); 62949 - 7949	1.077 (0.3617)	1.315 % (1.55 %)

*ANOVA, Bonferonni repeated measures.

Figure 5.3.1: The repeatability of the volumetric analysis of the right forearm using T1-W and proton scanning techniques over three testing sessions in ten subjects (mean).

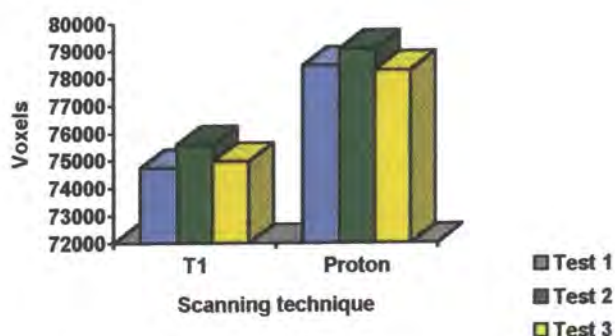

5.3.2 Selection of the optimal MR scanning technique in volumetric analysis of forearm musculature.

The 3D technique was rejected early in the study, due to poor sensitivity to segmentation techniques. In analysing the 3D images, it was not possible to select a seed pixel which would allow repeatable segmentation of scan slices. The 3D scanning process also took longer to perform and was therefore less preferable when considering the comfort of the subject or patient, particularly those with upper limb disorders such as RA.

Since the proton sequences contained 11 sections and the T1 slices only 6, then the former would be expected to be a more realistic representation of the forearm. The T1

and Proton Scanning techniques were compared in each of the ten subjects. The average percentage difference (SD) was 4.581 % (0.87), with the proton scans greater in all subjects as shown in figure 5.3.2.

Figure 5.3.2: Comparison of T1-W and Proton imaging techniques in volumetric analysis of right forearm musculature in 10 subjects.

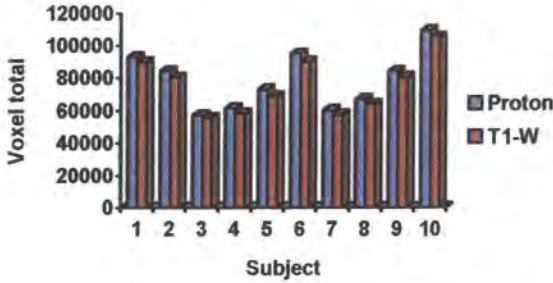

5.4. A comparison of forearm muscle volume with proximal forearm cross-sectional area (CSA) as measured using magnetic resonance (MR) imaging.

The CSA of the proximal image was compared with the total forearm muscle volume (within the 11 cm study section) assessed by both proton and T1W MR imaging in the ten study subjects. The mean of the three tests was taken for each parameter. Significant correlation was demonstrated between the forearm CSA and forearm muscle volume using both scanning techniques, with correlations of 0.9485 ($p < 0.0001$) and 0.9464 ($p < 0.0001$) for proton and T1W imaging modes, respectively. These findings are displayed in figure 5.4.1

Figure 5.4.1: Mean forearm muscle volume vs mean forearm CSA as measured using proton and T1-W MR imaging in 10 subjects.

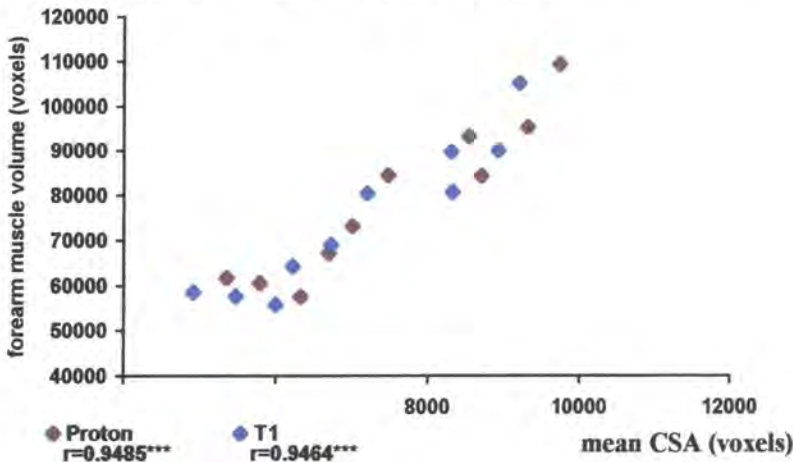

5.5. The analysis of forearm muscle mass in the right forearm: a summary.

The technique of evaluation of the forearm muscle cross-sectional area using skin-fold calipers (Helliwell and Jackson, 1994) was shown to be unreliable over short and long term testing. The evaluation of the CSA of the forearm using magnetic resonance imaging was demonstrated to be a highly repeatable technique. Later in the study, it became evident that volumetric analysis of the right forearm musculature may be a more sensitive method of monitoring the changes in muscle size. The technique for the assessment of forearm muscle volume using MRI scanning was then developed. The findings detailed above demonstrate this technique to be highly repeatable. Good correlation between the forearm muscle CSA and muscle volume was also demonstrated using magnetic resonance imaging. Imaging using the proton scanning technique was chosen for further imaging studies. Since more scanning slices were expected to reflect the true muscle volume more accurately and in addition it involved shorter scanning time compared to the 3D imaging technique.

Chapter 6. Results.

6.1. Grip Strength in RA.

6.1.1 Introduction

Reduced grip strength is frequently noted in rheumatoid disease and has been demonstrated to reflect global disability, hand function, disease activity and severity (Nordenskold and Grimby, 1997). It is therefore an important measurement in the subject with RA, yielding much information about the disease process in that subject. The reduction of grip strength is multifactorial in origin, with pain, stiffness, swelling, deformity, arthrogenic muscle weakness and altered muscle function all being potential contributing factors. The two main findings associated with rheumatoid muscle are significant loss of muscle mass and histological changes. There is very little known about the functional performance of rheumatoid muscle and the relevance of the frequently reported myopathic changes (suggestive of disuse and / or denervation) is unclear. It is possible that the disease process affecting the muscle will result in altered behaviour of muscle fibres in the muscle of subjects with rheumatoid disease and this in turn may be reflected in altered myoelectric characteristics, allowing subjects with significant myopathy to be identified. The specific myoelectric characteristics addressed in this study were the initial median frequency (IMF), the spectral width and the change in the median frequency over time during contraction expressed as the MDF gradient (MDF_G). One potential, though unproven, association with rheumatoid myopathy is increased muscle fatigue. Fatigue is a common complaint in rheumatoid subjects, but whether the muscle itself is abnormally fatiguable is unknown. This can be examined using the MDF_G of the SMES as an indicator of fatiguability. If rheumatoid myopathy is functionally significant, then the effects of this upon the response to exercise warrant investigation, since it is possible that rheumatoid muscle abnormalities prevents normal adaptations to exercise from occurring. Discerning the predictors of outcome to an exercise programme in such patients is important.

Table 6.1.1: Characteristics of the two study groups.

	AGE (SD); range; (years)	Weight (SD); range (kg)	Body Mass Index (BMI) (SD); range (kg/m ²)	MGS right hand (SD); range (mmHg)	Disease duration (SD); range (months)
RA (n=161)	51.93 (12.49); 22 - 75	63.198 (14.07); 50.95 - 82	24.25 (4.01); 18.03 - 31.73	94.62 (65.27); 9 - 350	117.08 (104.54); 2-672
Controls (n=114)	44.04 (13.29); 22-76	65.06 (10.71); 50 - 86	24.99 (3.93); 19.53 - 38.45	299.28 (81.49); 106 - 540	-----
# RA vs Control	p<0.0001	p=0.2141	p=0.1296	p<0.0001	-----

#unpaired t-test

Table 6.1.2: Right hand and general disease parameters at baseline in the RA group consisting of 161 right hand dominant females with RA.

	Right hand & wrist pain	Right hand & wrist stiffness	Duration of general joint stiffness (minutes)	CRP (IU/l)	Preferred wrist angle of extension during grip (°)
Mean	3.20	3.63	152.46	13.56	17.11
SD	2.57	2.42	334.15	23.84	13.75
Range	0-10	0 - 10	0 - 1440	0.860 - 236	-20.00 to 44.00

These issues were investigated in this study and the results will be detailed in the following chapters. Firstly the factors affecting hand function in RA, as reflected in grip strength – were evaluated. Secondly, the factors affecting forearm myoelectric characteristics during grip in both rheumatoid subjects and healthy controls were examined. The aims of such investigations were to detect whether a difference in muscle fatigue (as defined by the MDF_G), existed between the two groups; to assess whether there are specific myoelectric indicators of myopathy in RA and to determine the factors which are related to such indicators, should they exist.

Following these studies, the response to hand grip strength training in RA and controls were also assessed by grip strength, muscle fatigue and other myoelectric characteristics, in addition to the effects upon local disease activity in RA. In those subjects who did gain strength, the mechanisms of strength gain were investigated, specifically as to whether neural adaptation and / or gains in muscle mass occurred. Identifying those subjects in whom these changes occurred is also important and predictors of the outcome in relation to myoelectric and disease characteristics were also examined.

In summary, three main issues were addressed. Firstly, what are the effects of muscle and disease characteristics upon function in RA? Secondly, what are the effects of rheumatoid disease upon muscle? Finally, what are the effects of muscle and disease characteristics upon the response to exercise in RA?

6.1.2 Factors affecting grip strength in RA.

The evaluation of grip strength and myoelectric characteristics during grip involved the assessment of two study groups consisting of right hand dominant females. One hundred and sixty one subjects with established RA (American Rheumatism Association criteria, Arnett et al, 1988) formed the 'RA group' and there were one hundred and fourteen healthy controls. The characteristics of the study groups and baseline results are shown in Tables 6.1.1 – 6.1.4.

Table 6.1.3: Right hand disease parameters at baseline in the RA group consisting of 161 right hand dominant females with RA.

	MGS right hand (mmHg)	Tenderness score (right)	Swelling score (right)	Right hand & wrist subluxation	Right hand and wrist ulnar deviation	KFI Right hand
Mean	94.62	3.75	4.01	10.46	6.76	14.09
SD	65.27	3.67	3.37	6.64	5.45	5.45
Range	9 – 350	0 – 13	0 - 12	0 – 27	0 – 30	2 - 25

Table 6.1.4: Right hand disease parameters at baseline in the RA group consisting of 161 right hand dominant females with RA.

	MGS left hand (mmHg)	Tenderness score (left)	Swelling score (left)	Left hand & wrist subluxation	Left hand and wrist ulnar deviation	KFI Left hand
Mean	88.20	3.49	4.02	9.45	5.88	13.92
SD	58.48	3.64	4.07	6.35	5.48	5.44
Range	10 – 321	0 – 14	0 - 12	0 – 25	0 – 30	2 - 24

Step down multiple regression analyses followed by analysis of variance (ANOVA) were used in order to define the best predictors of the MGS, MDF_G and IMF of the SMES from forearm musculature in the two study groups. The subject characteristics studied in both groups were the age, BMI, the extensor and flexor MDF_G and IMF. Additional measurements in the RA group involved the assessment of the disease status in these subjects. This was evaluated by measurement of the duration of the disease, the disease severity (right hand and wrist subluxation and ulnar deviation scores and, in a subgroup, the bone mineral density of the right hand), systemic disease activity (CRP and the duration of morning stiffness), local disease activity (right hand swelling, tenderness, pain and stiffness scores), and the preferred wrist joint angle during grip.

In the **control** group, grip strength declined with age, confirming the findings of others (Hackel et al, 1992). Age, the extensor and flexor MDF_G and extensor IMF were significantly related to the MGS ($R^2 = 0.3029$; $F = 13.28$; $p < 0.0001$); all showing negative relationships with grip strength. The BMI had no significant influence upon the MGS, nor did the forearm muscle volume nor hand BMD have any significant relationship with the MGS in the control subjects in which these were measured, the details of which are shown later in figures 6.1.5 and 6.1.6. Further examination of the inter-relationship between grip and these latter two variables will be discussed later.

In the **rheumatoid** group the age, extensor MDF_G and the flexor IMF, the disease duration, CRP, right hand and wrist pain and subluxation score, the hand functional index, were the best independent predictors of maximum grip strength in RA, accounting for 57.55 % of the variation in MGS within the group ($F = 23.36$; $p < 0.0001$). All showed negative relationships with the MGS; with the exception of disease duration. Although the latter may seem to be a surprising finding, there was no relationship between the disease duration and other measures of disease severity in relation to the deformity scores. As will be discussed in the discussion of the study findings in Chapter Nine, there seems little relation between disease duration and hand function allowing for age. Hence, young individuals can have severe disease and, similarly, older individuals can have mild disease. Some of the relationships between grip strength and these parameters are shown in the figures which follow.

Figure 6.1.1: The relationship between MGS of the right hand and age in 161 right hand dominant females with RA and 114 female controls.

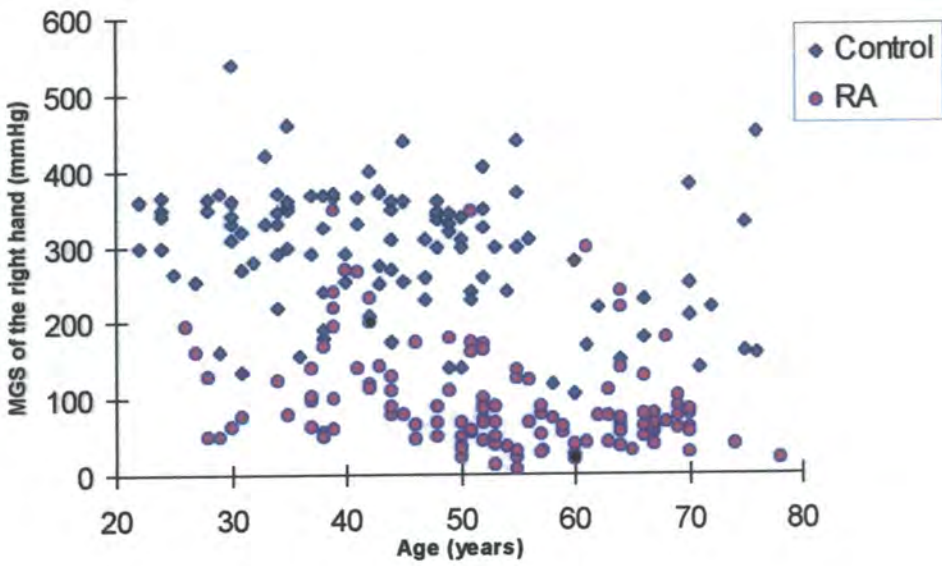

No significant relationship was demonstrated between the right and left hands in relation to maximum grip strength, hand joint scores (swelling and tenderness), hand functional index nor hand and wrist subluxation and ulnar deviation scores.

Hence at a given time, grip strength in healthy individuals is significantly related to age, intrinsic muscle characteristics (the extensor IMF) and the fatiguability of the muscle (extensor and flexor MDF_G). Those who are capable of gripping at higher levels show greater fatigue.

Grip strength in rheumatoid disease shows similar relationships to healthy controls with age, intrinsic muscle characteristics (the extensor IMF) and the fatiguability of the muscle (extensor MDF_G). In addition, it is significantly related to general disease activity (CRP), local disease activity (right hand and wrist pain), local disease severity (right hand and wrist subluxation), hand function (the Keitel index). A decline in grip strength occurs with increased local and general disease activity and local disease severity. Surprisingly, higher grip strengths were noted in those with longer disease duration.

Figure 6.1.2: MGS of the right hand versus the duration of disease in 161 right hand dominant females with RA.

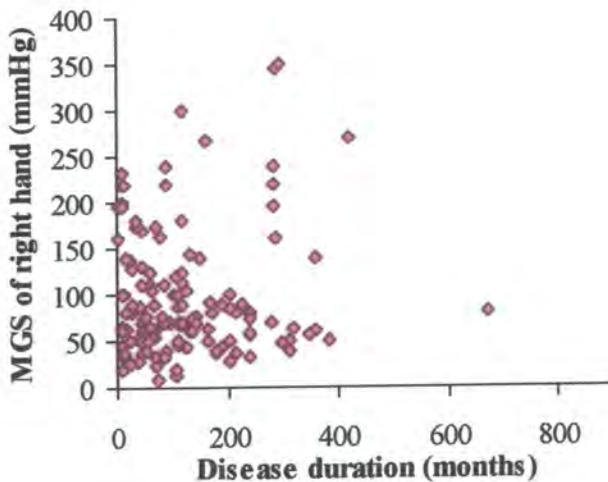

Table 6.1.5: The multiple regression analysis for the factors affecting grip strength in female healthy controls.

Variable	Coefficient	SD	T ratio	p
Age	-1.45	0.49	-2.93	0.0041
Extensor MDF _G	-77.67	20.53	-3.78	0.0003
Flexor MDF _G	-78.31	25.74	-3.04	0.0029
Flexor IMF	-0.91	0.41	-2.21	0.0289

$R^2 = 0.3029$; ANOVA: $F = 13.28$; $p < 0.0001$

Table 6.1.6: The multiple regression analysis for the factors affecting grip strength in females with rheumatoid arthritis.

Variable	Coefficient	SD	T ratio	p
Age	-0.88	-0.15	-2.51	0.013
Extensor MDF _G	-62.41	-0.25	-3.91	0.0002
Flexor IMF	-0.62	-0.18	-2.82	0.006
CRP	-0.48	-0.11	-1.88	0.0494
Pain in hand and wrist	-3.85	-0.15	-2.41	0.017
Subluxation score	-2.19	-0.22	-3.19	0.0018
Hand functional index	-3.37	-0.27	-3.74	0.0003
Disease duration	0.07	0.11	1.87	0.06

$R^2 = 0.5755$. ANOVA: $F = 23.36$; $p < 0.0001$.

Figure 6.1.3: The relationship between the MGS of the right hand and the flexor IMF of the SMES in 161 females with RA and 114 controls.

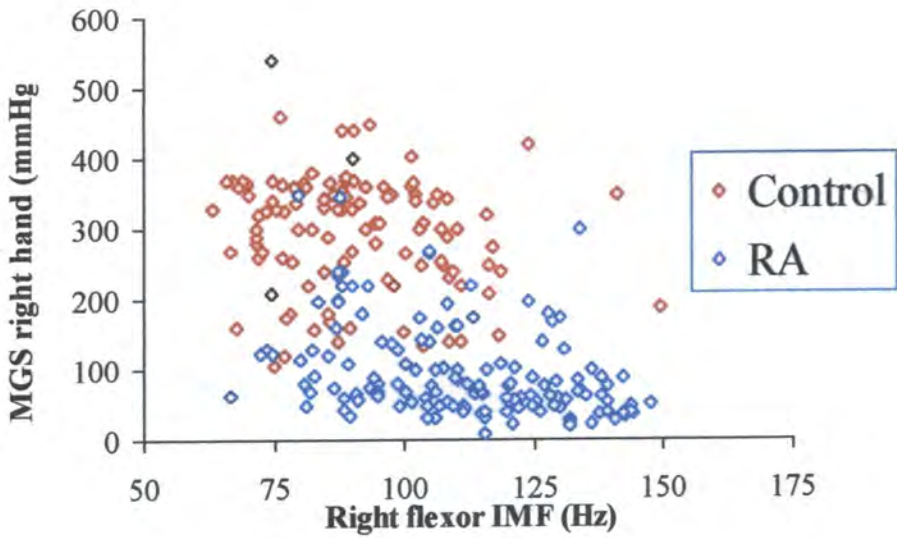

Figure 6.1.4: MGS of the right hand versus the right hand and wrist subluxation score in 161 right hand dominant females with RA.

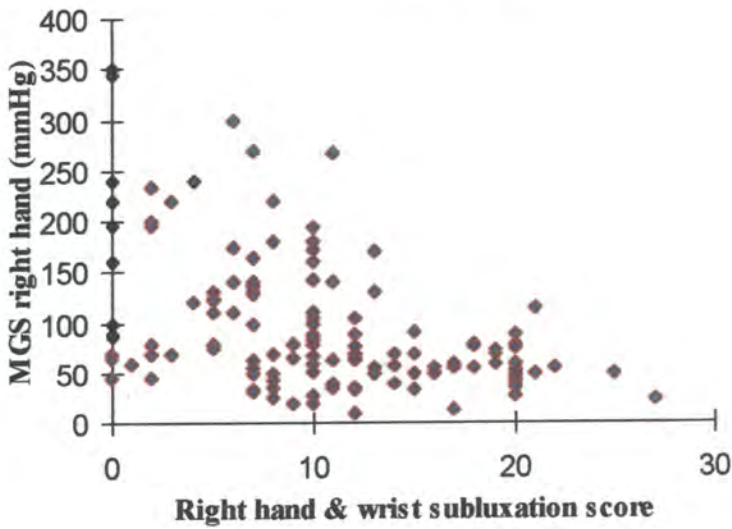
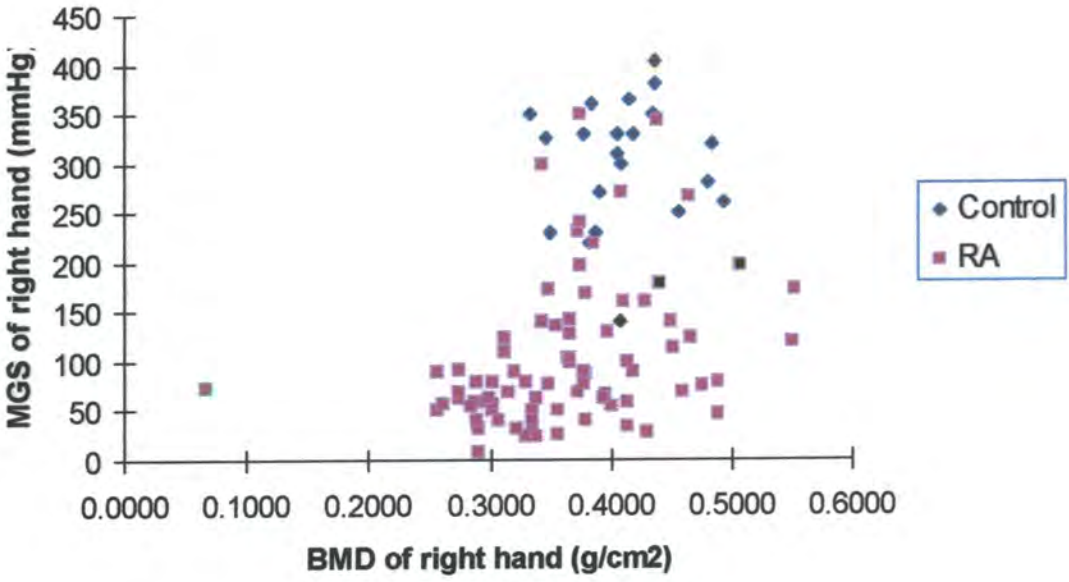

Figure 6.1.5: The relationship between the right hand MGS and right hand BMD in 81 right hand dominant females with RA and 21 female controls.



The **bone mineral density (BMD)** of the right hand is a recognised indicator of disease severity in RA (Peel et al, 1994). This was also found to be a significant predictor of the MGS in the subset of 81 females with RA in whom this was measured. Details of these subjects are given in table 6.1.7. No significant difference in age, disease duration nor body mass index existed between this subgroup and the main RA study group.

Table 6.1.7: Subject characteristics of the main study group and subgroup in which right hand BMD was measured (mean (SD)).

GROUP	Age (years)	Disease duration (months)	Body mass index (kg/m²)	MGS right hand (mmHg)	Hand BMD (g/cm²)
BMD RA subgroup (n=81)	51.621 (11.46)	120.025 (101.50)	24.386 (4.37)	102.03 (73.97)	0.3660 (0.067)
Main RA study group (n=161)	51.93 (12.49)	117.08 (104.54)	24.25 (4.01)	94.62 (65.27)	-----
BMD control subgroup (n=21)	46.45 (12.10)	-----	25.29 (3.70)	304.32 (63.29)	0.4100 (0.0431)
*p	> 0.05	-----	> 0.05	<0.01	p=0.0009
#p	> 0.05	> 0.05	> 0.05	> 0.05	-----

* unpaired non parametric test: RA BMD group versus control BMD group.

unpaired non parametric test RA BMD group versus main RA study group.

This finding is in keeping with the earlier finding, that grip strength declines with disease severity (right hand and wrist subluxation). The relationship between the hand BMD and grip strength in healthy females and those with RA is shown in figure 6.1.5 on the facing page.

Figure 6.1.6: The relationship between the volume of the right forearm musculature and the MGS of the right hand in 28 right hand dominant females with RA and 14 female controls.

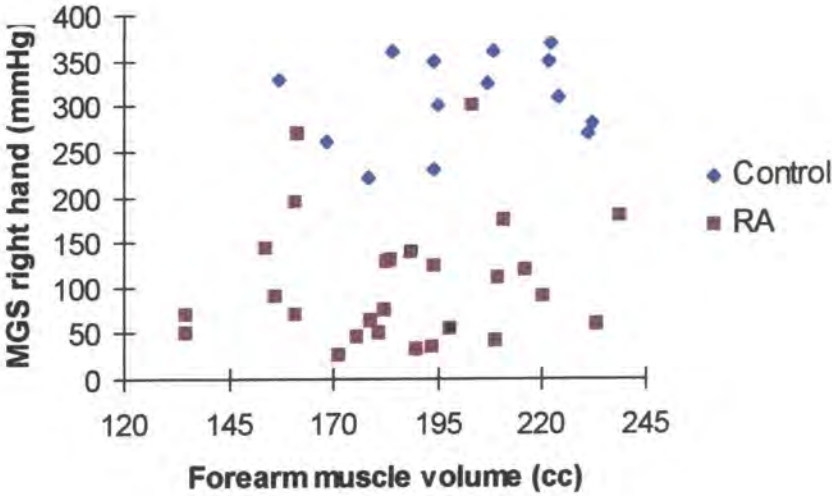

In the two further subgroups in which the **muscle mass** were studied (Tables 6.1.8 and 6.1.9), neither the cross-sectional area nor muscle volume of the forearm were demonstrated to be significantly related to the MGS in the subsets of rheumatoid subjects in which these were measured. The forearm muscle volume was lower in the RA group, although the difference was not significant.

The details of the groups in whom the CSA and the volume of the right forearm musculature were measured are shown in the following two tables. The grip strength and forearm muscle volume is also displayed in figure 6.1.6 on the facing page.

Table 6.1.8: Characteristics of the RA subgroup assessed in the study of the CSA of the right forearm (mean (SD); range).

Groups	Age (years)	BMI (kg/m ²)	MGS (mmHg)	Disease duration (months)	Right forearm CSA (cm ²)
RA (n=27)	51.15 (11.72); 36-75	23.48 (2.70); 19.00-30.10	102.27 (69.45); 24-267	125.42 (107.81); 9-384	26.40 (5.25); 20.50-44.9

All parameters showed no significant difference with the initial RA study group of 161 subjects.

Table 6.1.9: Characteristics of the subgroups included in study of the volumetric analysis of forearm musculature (mean (SD); range).

Groups	Age (years)	BMI (kg/m ²)	MGS (mmHg)	Disease duration (months)	Right forearm muscle volume (cc)
RA (n= 28)	49.66 (12.52); 28-74	23.88 (2.61); 20.20-32.16	106.69 (67.69); 26-300	104.14 (99.88); 5-420	186.84 (26.79); 134.71-238.59
Controls (n=14)	41.64 (12.36); 24-66	22.25 (2.25); 19.47-28.93	**330.71 (79.56); 220-540	-----	202.12 (23.41); 156.99-231.94

*p< 0.01; unpaired non parametric test: RA vs. controls.

6.1.3 Summary: Factors predicting maximum grip strength of the right hand in health and in rheumatoid disease.

The aims of this section were to examine the effects of muscle and disease characteristics upon hand function, as measured by grip strength in females with rheumatoid arthritis. Healthy females were also studied.

In both healthy females and those with rheumatoid disease, hand function is significantly related to age and emg characteristics of the muscle (the extensor IMF in the controls and the flexor IMF in the RA group). The greater the age and the higher the IMF, the lower the grip strength. Individuals who are capable of gripping at higher levels show higher levels of fatigue.

In rheumatoid disease, hand function is also significantly related to disease severity (hand subluxation and bone mineral density), general disease activity (CRP) and the local disease activity (pain in the right hand and wrist).

Although muscle mass is known to be an important factor in muscle strength, it is not an independent predictor of grip strength in health nor in RA.

The effects of muscle and disease characteristics upon function have now been examined. The effects of disease and function upon the muscle will now be assessed.

Table 6.2.1: Myoelectric parameters measured from the right forearm in the two study groups during a standard right hand grip test performed at 2/3 MGS.

	MGS right hand (SD); range (mmHg)	Extensor MDF_G(SD); range ((Hz/sec)	Flexor MDF_G (SD);range (Hz/sec)	Extensor IMF (SD); range (Hz)	Flexor IMF (SD); range (Hz)	RMS extensor/flexor ratio (SD); range
RA (n=161)	94.62 (65.27); 9 - 350	-0.3043 (0.2597); -1.260 to 0.4000	-0.2540 (0.3183); -0.9700 to 0.8400 ♣p>0.05	122.56 (18.77); 74.821 - 198.16	111.67 (18.96); 66.59 - 147.73 ♣p>0.05	3.937 (2.07); 0.690 - 10.570 ♣p<0.0001
Controls (n=114)	299.28 (81.49); 106-540	-0.4820 (0.3337); -2.012 to 0.1204	-0.3436 (0.2661); -1.002 to 0.4774 ♣p>0.05	109.13 (13.96); 71.49 - 150.62	90.55 (16.23); 63.47 - 149.45 ♣p<0.001	2.902 (2.04); 0.563 - 12.980 ♣p<0.0001
	#p<0.0001	♣p<0.0001	♣p=0.0078	♣p<0.0001	♣p<0.0001	#p=0.0001

#unpaired t-test

♣Mann-Whitney U-test

♣extensor vs flexor channel, non-parametric t test

	Extensor spectral width (mean (SD); range)(Hz)	Flexor Spectral width (mean (SD); range)(Hz)
RA (n=161)	150.78 (37.09); 54-281	116.23 (37.43); 49-223
Controls (n=114)	119.35 (25.40); 50-169	81.84 (25.34); 37-182

6.2 Forearm myoelectric parameters during sustained grip in rheumatoid arthritis.

6.2.1 Introduction

In the initial pilot studies described in Chapter Four, the MDF_G of the SMES, an established indicator of muscle fatiguability, was demonstrated to be a repeatable, force related measure on same day testing and is likely to be a sensitive indicator of *the state of fatiguability of the muscle at a given time*. The IMF was demonstrated to show little variation with force levels and to be stable over time and is a potential indicator of the *intrinsic characteristics* of the muscle, specifically in relation to muscle fibre composition and behaviour.

In the studies described in the following two sections, the results of the evaluation of the effects of rheumatoid disease upon these muscle characteristics will be discussed.

Firstly, the rheumatoid and control groups were compared in relation to hand function and myoelectric parameters, to assess the effects of the presence of rheumatoid disease upon the chosen characteristics of the muscle. Following this, the effects of rheumatoid disease on muscle were further investigated by examining the inter-relationships between measures of disease activity and severity and these myoelectric parameters.

6.2.2 Grip strength and myoelectric parameters in RA: a comparison with healthy female controls.

Characteristics of the two study groups have been given in Table 6.1.1. Further details describing the mean, standard deviation and range of the myoelectric parameters for these groups are outlined in Table 6.2.1. There was a significant difference between the RA and control groups in relation to age and grip strength, the RA group being older, with a lower MGS. As noted in the initial pilot studies, the standard deviations of maximum grip strength and MDF_G in both the control and the RA populations were large. The finding of a large SD of the MDF_G is often ignored by other workers, but was emphasised by Lindeman and Drukker (1994) in studies of lower limb musculature.

The two groups were compared in relation to the MGS and myoelectric parameters using unpaired, non-parametric t-tests. No significant differences existed between the extensor nor the flexor MDF_G in either. The IMF and the spectral widths of both flexor and extensor forearm musculature were significantly higher in the RA group, with $p < 0.0001$ in all cases. These findings are illustrated below in figure 6.2.1.

Figure 6.2.1: The mean (SD) right hand MGS, IMF and spectral widths of the SMES derived from extensor and flexor forearm musculature during sustained grip at 2/3 MGS in 161 females with RA and 114 controls.

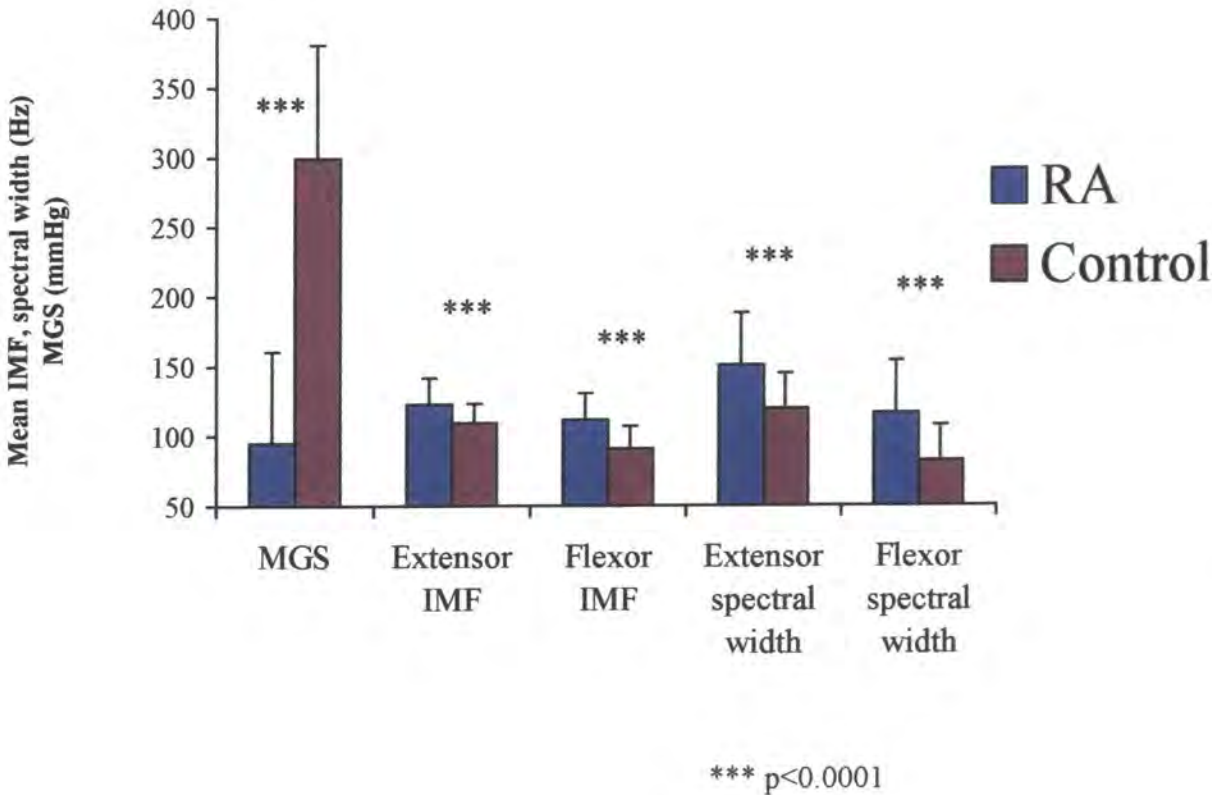

Table 6.3.1: The multiple regression analysis for the factors affecting the extensor MDF_G in female healthy controls.

Variable	Coefficient	SD	T ratio	p
MGS	-0.0018	0.0004	-5.348	< 0.0001

R² = 0.1963; ANOVA: F = 28.61; p < 0.0001

Table 6.3.2: The multiple regression analysis for the factors affecting the flexor MDF_G in female healthy controls.

Variable	Coefficient	SD	T ratio	p
MGS	-0.0010	0.0003	-3.223	0.0017

R² = 0.0767; ANOVA: F = 10.39; p < 0.0017

Table 6.3.3: The multiple regression analysis for the factors affecting the flexor IMF in female healthy controls.

Variable	Coefficient	SD	T ratio	p
MGS	-0.0360	0.0185	-1.946	0.0541

R² = 0.0241; ANOVA: F = 3.79; p = 0.0541

6.3 The effect of the activity and severity of rheumatoid disease upon forearm myoelectric parameters during grip.

6.3.1 Introduction

Having examined the effect of the presence of rheumatoid disease upon muscle characteristics, the effects of disease activity and severity upon these characteristics were then investigated.

The specific myoelectric parameters assessed were the extensor and flexor MDF_G and the IMF. These were derived from the SMES recorded from the forearm during a standard 30 second hand grip test performed at 2/3 MGS. Firstly, the factors affecting these myoelectric parameters in healthy controls were established, prior to the assessment of the rheumatoid group. There is a lack of information in the literature about power spectral analysis of the SMES during grip in healthy individuals, the evaluation of this group was important to establish normal patterns.

6.3.2 Factors influencing forearm myoelectric parameters during grip in healthy controls.

In the control group, a multiple regression model revealed the MGS to be the best predictor of both the extensor and flexor MDF_G ($R^2 = 0.1963$; $F = 28.61$, $p < 0.0001$), with age and BMI having no independent effect, allowing for grip strength. The extensor IMF was unaffected by the age, BMI nor the MGS. The MGS was the best predictor of the flexor IMF ($R^2 = 0.0241$; $F = 3.7880$, $p = 0.0541$).

6.3.3 Factors influencing forearm myoelectric parameters during grip in females with rheumatoid arthritis.

In the RA group, a multiple regression analysis revealed the MGS, CRP, joint stiffness and ulnar deviation score of the right hand were significantly related to the extensor MDF_G ($R^2 = 0.2376$; $F = 9.79$; $p < 0.0001$), all but joint stiffness having negative associations with the extensor MDF_G . The only significant predictor of the flexor MDF_G was the deformity of the hand, with right hand and wrist subluxation and ulnar deviation both showing significant relationships with this myoelectric parameter ($R^2 = 0.0182$,

Figure 6.3.1: The relationship between right hand MGS and MDFG of the extensor (A) and flexor (B) forearm musculature in 161 females with RA and 114 female controls.

A

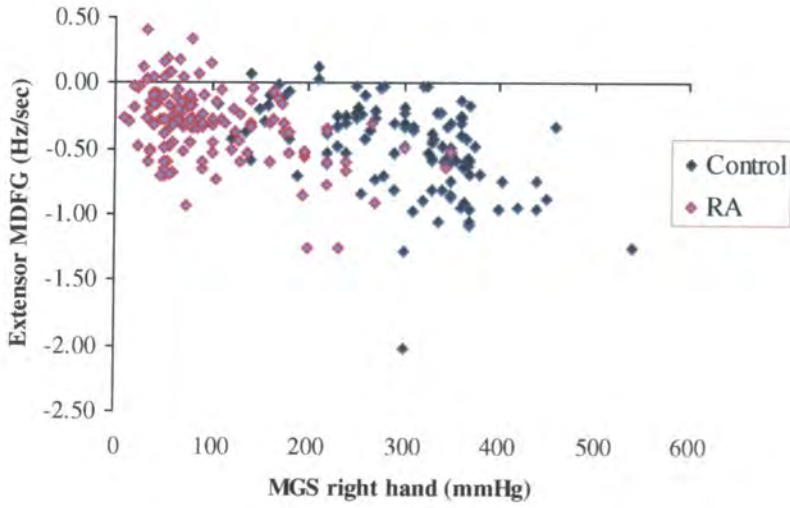

B

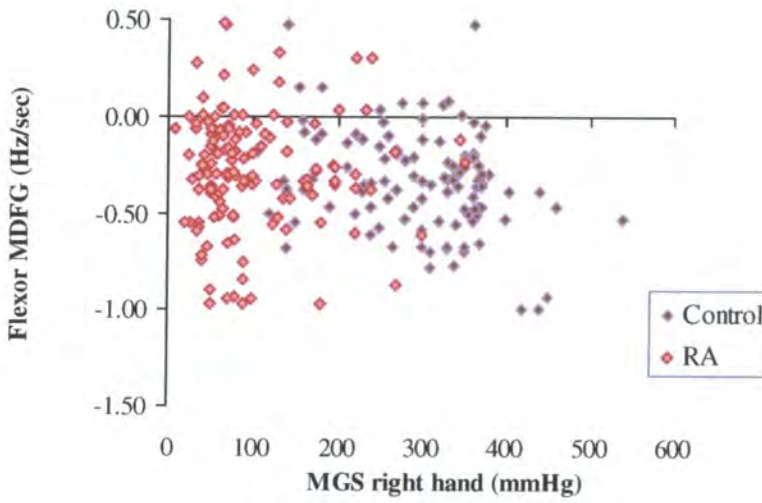

both showing significant relationships with this myoelectric parameter ($R^2 = 0.0182$, ANOVA: $F = 2.2478$; $p < 0.0001$), having positive and negative associations respectively with the MDF_G .

The relationship between the MDF_G and grip strength in RA and controls is shown in figures 6.3.1 on the facing page. The relationship between the MDF_G (fatigue) and the CRP (a measure of disease activity) and the ulnar deviation score (a measure of disease severity) are shown in figures 6.3.2 and 6.3.3.

Figure 6.3.2: The relationship between the extensor MDF_G and the C-reactive protein (CRP) of 161 females with RA.

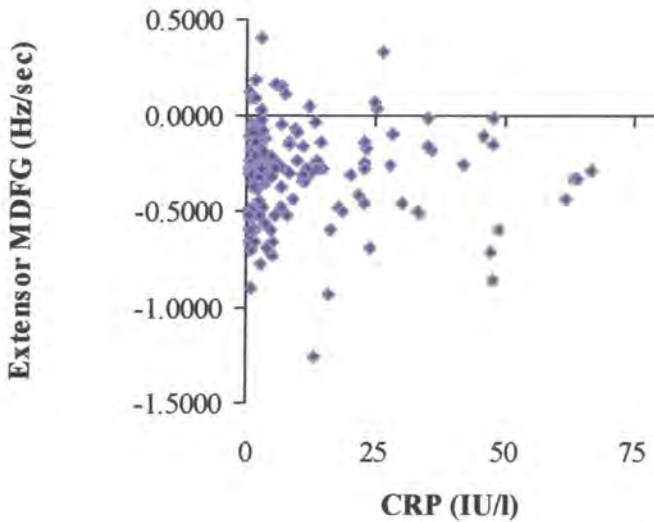

Figure 6.3.3: The relationship between the extensor MDF_G and the ulnar deviation of the right hand and wrist in 161 females with RA.

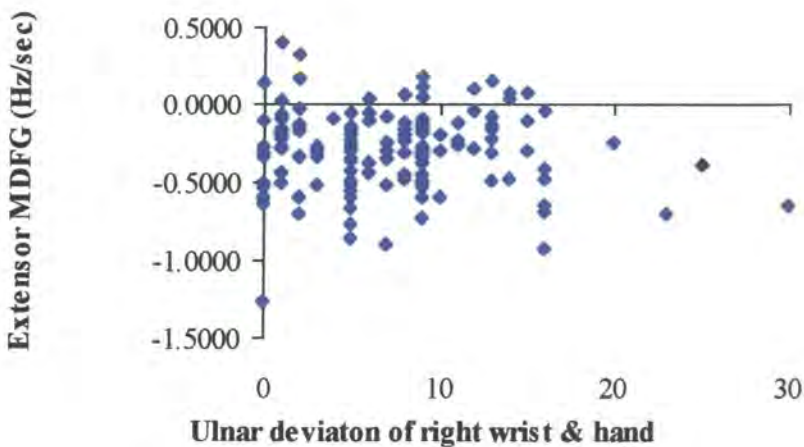

Table 6.3.4: The multiple regression analysis for the factors affecting the extensor MDF_G in females with RA.

Variable	Coefficient	SD	T ratio	p
Joint stiffness	0.0178	0.0088	2.028	0.0446
Ulnar deviation right hand and wrist	-0.0070	0.0036	-1.911	0.0582
MGS	-0.0019	0.0003	-5.853	<0.0001
CRP	-0.0017	0.0009	-2.006	0.0468
BMI	-0.0135	0.0055	-2.468	0.0148

$R^2 = 0.2376$; ANOVA: $F = 9.79$; $p < 0.0001$

Table 6.3.5: The multiple regression analysis for the factors affecting the flexor MDF_G in females with RA.

Variable	Coefficient	SD	T ratio	p
Ulnar deviation right hand and wrist	-0.0139	0.0068	-2.059	0.0415
Subluxation right hand and wrist	-0.0101	0.0056	1.811	0.0723

$R^2 = 0.0182$; ANOVA: $F = 2.25$; $p = 0.1096$

Table 6.3.6: The multiple regression analysis for the factors affecting the extensor IMF in females with RA.

Variable	Coefficient	SD	T ratio	p
Duration of morning stiffness	0.0095	0.0052	1.832	0.0692
Joint swelling	-1.7771	0.5270	-3.372	0.0010
Subluxation right hand and wrist	0.6308	0.2554	2.470	0.0147

$R^2 = 0.0720$; ANOVA: $F = 4.62$; $p = 0.0041$

The extensor IMF was significantly related to the duration of general morning stiffness (a measure of systemic disease activity), joint swelling (local disease activity) and the right hand and wrist subluxation score (disease severity) ($R^2 = 0.0720$; ANOVA: $F = 4.62$; $p = 0.0041$). Only the joint swelling showed a negative association with the IMF. The MGS, disease duration, right hand and wrist joint swelling and the subluxation score were the sole factors showing significant relationships with the flexor IMF ($R^2 = 0.1981$, ANOVA: $F = 9.46$; $p < 0.0001$), all but the latter having negative associations with the flexor IMF. The relationships between the MGS and extensor and flexor IMFs have been illustrated earlier in figures 6.1.3 and 4.3.7. The relationship between the flexor IMF and the disease duration is demonstrated in figure 6.3.4.

The IMF is therefore related to **disease severity** (measured by the subluxation score), systemic **disease activity** (morning stiffness) and local disease activity (joint swelling) and in the flexor muscles, the disease duration.

Figure 6.3.4: The relationship between the disease duration and the forearm flexor IMF in 161 females with RA.

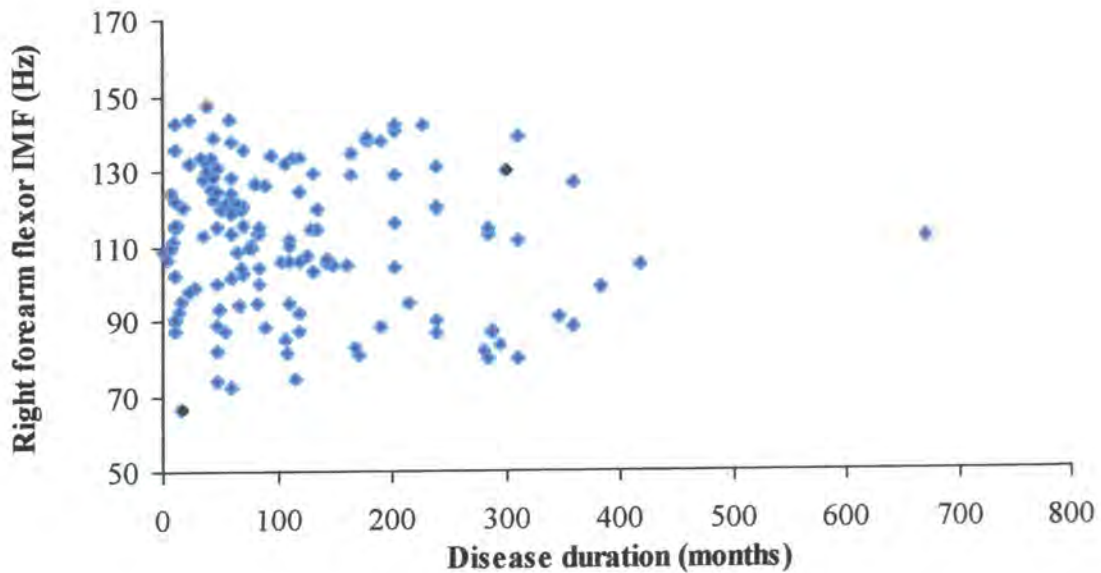

6.4 Summary: Forearm myoelectric parameters during grip in rheumatoid arthritis.

The results described in the previous two sections demonstrate the relationship between characteristics of muscle during grip and rheumatoid disease. Although the forearm muscles of rheumatoid subjects were no more fatiguable than in healthy controls, there were significant associations between forearm fatiguability and disease activity, severity and hand function.

The IMF and spectral widths were significantly higher in rheumatoid subjects than healthy controls and in further analyses of the IMF significant associations with disease severity and activity were demonstrated.

These results indicate that there is a significant association between the disease process in rheumatoid arthritis and both the **state** of a muscle at a given time – assessed by its fatiguability – and the condition or intrinsic characteristics of the muscle, assessed mainly by the IMF of the forearm SMES. These results will be further discussed in Chapter Nine.

Having established that the characteristics of muscle during grip in RA differ from healthy individuals and are associated with the disease process, the next two sections will investigate the significance of these features in relation to the response to exercise. Firstly, the question as to whether adaptations in function can occur in RA with an exercise programme will be addressed. Secondly, the ability to alter the IMF, which has been demonstrated in earlier sections to be an intrinsic muscle characteristic which is abnormal in RA, will be studied. Potential predictors of outcome to the exercise programme, specifically in relation to muscle characteristics, will also be investigated.

Chapter Seven. Grip Strength Training in Rheumatoid Arthritis.

7.1. The response to grip strength training in rheumatoid arthritis.

7.1.1 Introduction

The aims of the following investigation of the response to a handgrip exercise programme in females with rheumatoid disease were to assess the effect of exercise upon function (measured by grip strength) and upon the muscle itself – assessed by the IMF of the forearm SMES. Potential predictors of outcome to the exercise programme were also studied, with outcome being defined as the improvement in grip strength after 3 months of exercise. The effects of such a programme on local disease activity were examined, since one of the limiting factors in the use of therapeutic exercise programmes is the concern that exercise will cause deterioration in the disease. The final study examined the mechanisms of strength gain in such a programme.

7.1.2 The effects of handgrip exercise upon hand function in health and rheumatoid disease.

The response to the grip strength training programme described in Chapter Two was assessed in two study groups, consisting of 79 females with RA and 39 healthy female controls. All subjects in the exercise groups were drawn from the original baseline study groups described in Table 6.1.1. Their characteristics, initial grip strength and myoelectric parameters are described in Tables 7.1.1 and 7.1.2. The mechanisms of strength gain were also assessed in a subset of subjects from both groups, and will be described in Chapter Eight.

Subjects were assessed at baseline and 3, 6 and 12 weeks after commencing a progressive grip strength exercise programme, according to the study protocol, as described earlier in Chapter Three. No subjects withdrew from the study. There were six reported incidences of daily exercise sessions missed in relation to disease activity.

Table 7.1.1: Basic characteristics of the two exercise groups.

	AGE (SD); range; (years)	Weight (SD); range (kg)	Body Mass Index (BMI) (SD);range (kg/m²)	MGS right hand (SD); range (mmHg)	Extensor IMF (SD); range (Hz)	Flexor IMF (SD); range (Hz)	Disease duration (SD); range (months)
RA (n=79)	51.98 (12.21); 27 - 74	63.73 (13.40); 45 - 82	24.45 (5.04); 19.10 - 31.73	101.99 (68.814); 24 - 345	122.06 (20.48); 74.82 - 198.16	109.30 (20.28); 66.59 - 143.93	131.35 (117.77); 5 - 672
Controls (n=39)	50.23 (12.53); 22-76	65.06 (10.71); 50 - 86	24.07 (3.36); 19.53 - 33.07	303.68 (71.55); 140-460	110.72 (11.46); 90.41 - 129.96	91.45 (16.90); 65.99 - 149.45	-----
#	p=0.4708	p=0.5617	p=0.6279	p<0.0001	◆ p = 0.0002	◆ p<0.0001	

Unpaired t test

◆ *Mann-Whitney U-test*

At baseline, the MGS was significantly greater in the control group (mean (SD): 303.68 (71.55) mmHg versus 101.99 (68.81) mmHg; $p < 0.0001$; see Table 7.1.1). The two groups also differed in the IMF and spectral widths measured from both forearm channels at baseline, with values being significantly greater in the rheumatoid group.

An extremely significant ($p < 0.001$) increase in the MGS was noted in the RA group at 3 weeks compared to baseline; a further extremely significant increase was noted at 12 weeks compared to that at the 3 week assessment. This compares to a significant increase in the MGS noted at 12 weeks in the control group. These changes in hand function are illustrated in figures 7.1.1 to 7.1.3.

Table 7.1.2: Maximum grip strength (MGS) of the right hand in RA and control groups during the 12 week handgrip exercise programme (mean (SD); range).

Group	Mean MGS (SD); range (mmHg)			
	Week 0	Week 3	Week 6	Week 12
RA n=79	101.99 (68.81); 23-345	134.56*** (79.99); 26-450	146.95*** # (83.33); 33-460	157.53*** ### (80.82); 30-390
Control n=39	303.68 (71.55); 140-460	325.63 (57.96); 158-450	327.16(58.35); 165-460	345.68* (64.12); 165-540

Repeated measures ANOVA: * $p < 0.05$; *** $p < 0.001$ compared to baseline;

$p < 0.05$; ### $p < 0.001$ compared to result at 3 weeks.

Figure 7.1.1: The mean (SD) right hand MGS in the RA and control groups over the 12 week exercise programme.

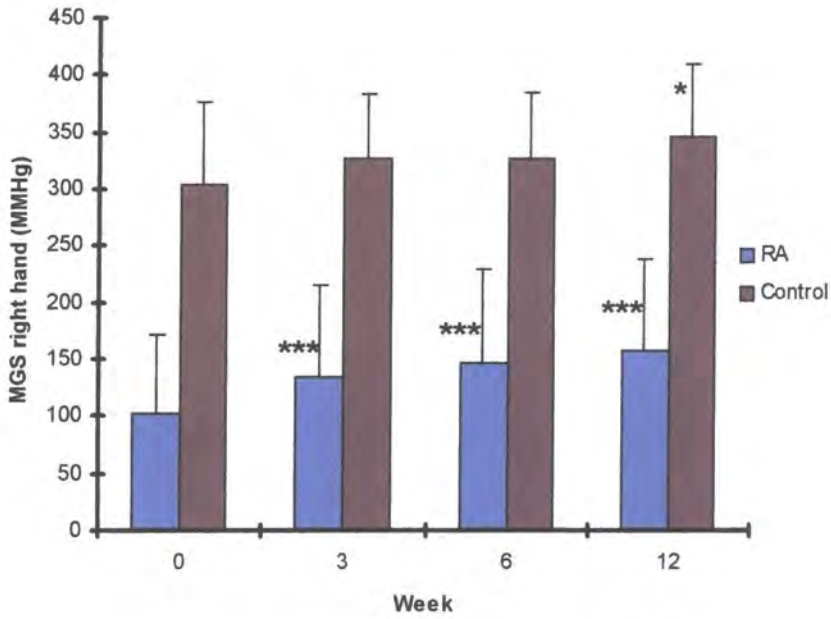

p < 0.05, *p < 0.001: paired non-parametric test*

Figure 7.1.2: The mean percentage change (SD) from baseline in the right hand MGS in the RA and control groups over the 12 week exercise programme.

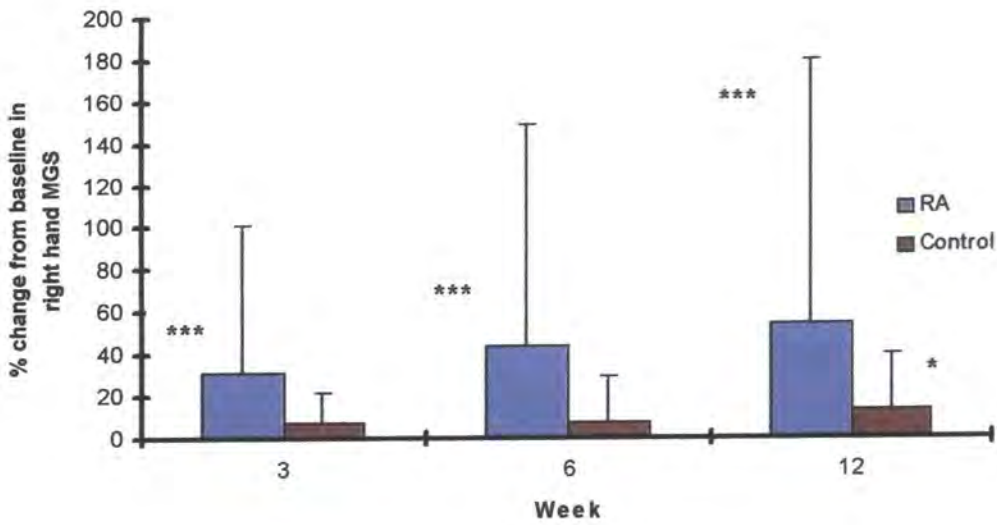

p < 0.05, *p < 0.001: paired non-parametric test*

Figure 7.1.3: The mean (SD) percentage change in the right hand MGS compared to the previous test in the RA and control groups over the 12 week exercise programme.

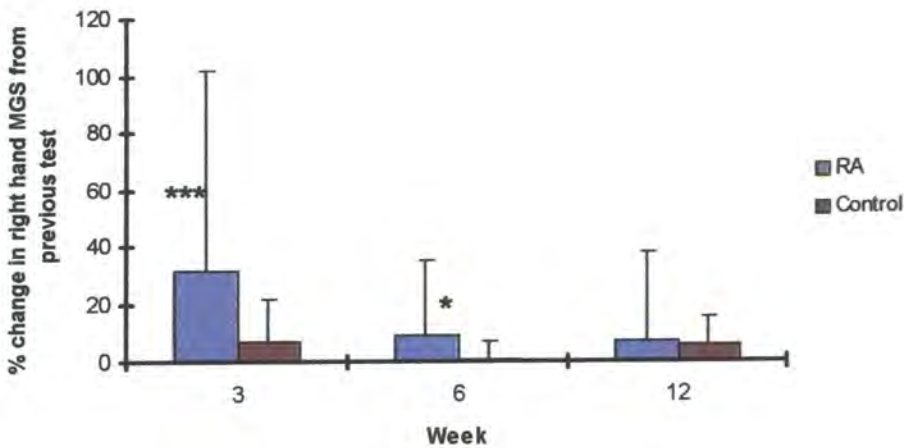

p < 0.05, *p < 0.001: paired non-parametric test*

Figure 7.2.1: The IMF of the SMES recorded from the extensor (A) and flexor (B) forearm channels in RA and control groups over the 12 week handgrip exercise programme (mean (SD)).

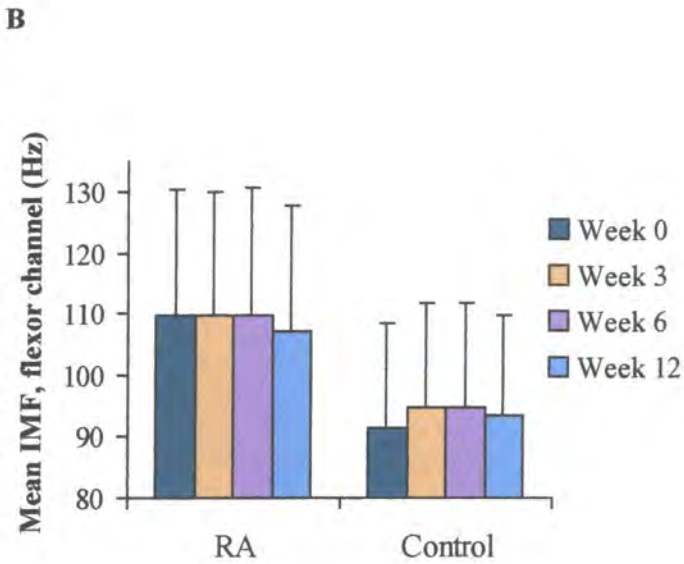
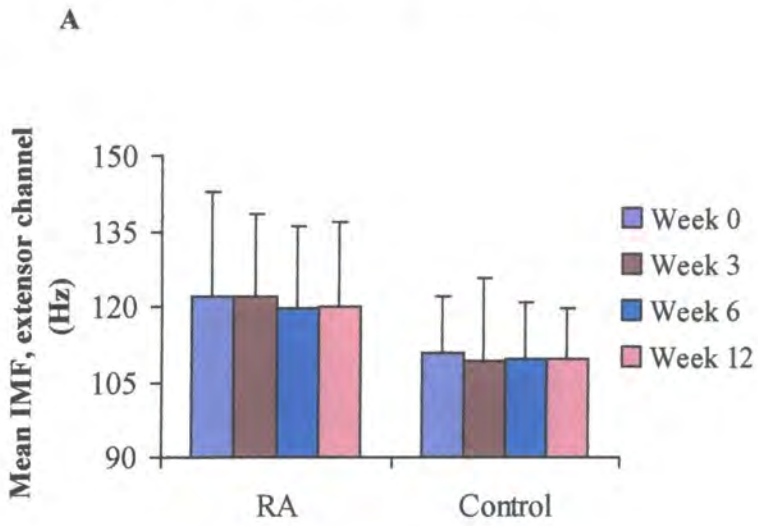

7.2.1 The effect of handgrip exercise on the IMF of the forearm SMES.

There were no significant changes in the chosen characteristic of the forearm muscle - the IMF of the SMES - noted in either the rheumatoid subjects nor in the controls over the 3 month handgrip exercise programme. These results are shown in Table and Figure 7.2.1.

Table 7.2.1: The extensor and flexor forearm IMF in RA and control groups during the 12 week handgrip exercise programme (mean (SD); range).

Group	Mean IMF, extensor channel (SD); range (mmHg)			
	Week 0	Week 3	Week 6	Week 12
RA n=79	122.06 (20.48); 74.82 - 198.16	122.16 (16.37); 88.36-165.07	119.78 (16.22); 80.50-159.52	119.83 (16.82); 79.84-170.77
Control n=39	110.72 (11.46); 90.41 - 129.96	109.03 (16.42); 32.11 - 125.85	109.49 (11.45); 90.05-132.02	109.47 (9.97); 90.29 - 127.99

Group	Mean IMF, flexor channel (SD); range (mmHg)			
	Week 0	Week 3	Week 6	Week 12
RA n=79	109.30 (20.28); 66.59 - 143.93	109.88 (20.17); 64.59-150.02	109.88(20.85); 68.38-159.66	107.24 (20.41); 68.32-153.84
Control n=39	91.45 (16.90); 65.99 - 149.45	94.84 (17.05); 69.79-140.05	94.64 (16.98); 69.95 - 146.47	93.53 (16.24); 69.89 - 136.33

7.3.1 The effect of handgrip exercise on local disease activity in RA.

In this section, the effects of right handgrip exercise upon local disease activity in the right hand and wrist will be described. The effects of the handgrip exercise upon local disease activity (right hand and wrist pain and stiffness, joint swelling and tenderness scores) were assessed and compared with local disease activity in the left hand (joint swelling and tenderness) and systemic disease activity measurements: the CRP and the duration of general morning stiffness. The mean, standard deviation and range of each of these parameters at baseline and three, six twelve weeks into the exercise programme are given in Table 7.3.1 and illustrated in Figure 7.3.1.

Table 7.3.1. Disease parameters in 79 females with RA during a 12 week hand exercise programme. (Mean (SD); range).

	Week 0	Week 3	Week 6	Week 12
CRP (IU/l)	9.78 (13.23); 0.86 – 61.90	11.41 (16.37); 0.89 - 80	16.69 (22.32); 0.89-99.40	14.352 (22.51); 0.89 – 120
Duration of morning stiffness (minutes)	95.82 (210.51); 0-1440	102.75 (281.87); 0-1440	122.14 (316.97); 0-1440	154.50 (353.79); 0-1440
#Right hand and wrist pain	2.77 (2.62); 0-10	2.72 (2.74); 0-10	2.87 (2.64); 0-10	3.04 (2.53); 0-10
#Right hand and wrist stiffness	3.253 (2.45); 0-10	2.947 (2.481); 0-9	2.99 (2.56); 0-10	3.09 (2.56); 0-10
Right joint swelling score	3.77 (3.29); 0-12	4.07 (3.34); 0-11	4.06 (3.19); 0-10	3.76 (3.04); 0-13
Left joint swelling score	3.57 (3.68); 0-13	*2.84 (3.02); 0-11	3.32 (2.700); 0-10	3.81 (3.46); 0-10
Right joint tenderness score	3.03 (3.30); 0-12	3.82 (3.91); 0-13	3.67 (3.81); 0-13	3.94 (3.50); 0-13
Left joint tenderness score	2.85 (3.10); 0-12	*3.84 (3.92); 0-15	3.66 (3.99); 0-15	**4.28 (4.17); 0-13

*Paired non-parametric test: *p < 0.05; ** p < 0.001 compared to baseline.*

0-10 numerical rating scale.

There was no evidence of an increase in local disease activity in the right hand during the course of the programme. Systemic disease activity, measured by the CRP and duration of morning stiffness, increased during the course of the programme, the trend not reaching statistical significance. There was an overall increase in disease activity in the left hand, with significant increase in joint tenderness noted at week 12 compared to baseline.

Figure 7.3.1: Right and left hand disease parameters measured during a 12 week right hand exercise programme in 79 females with RA (mean (SD)).

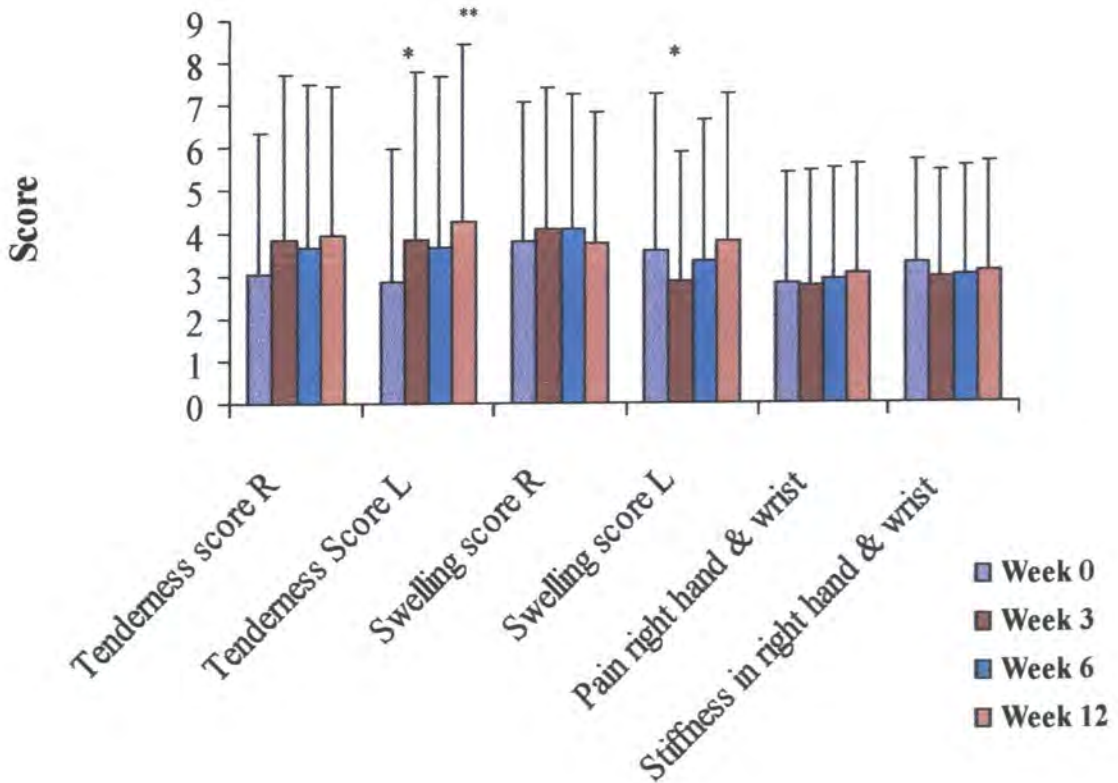

*Paired non-parametric test: *p < 0.05; ** p < 0.001 compared to baseline.*

Table 7.4.1: The results of the multiple regression for the percentage gain in grip strength (dependent variable) in females with rheumatoid arthritis.

Variable	Coefficient	SD	T ratio	p
Extensor IMF	1.64	0.26	2.59	0.012
Subluxation score	7.49	0.38	3.17	0.002
Tenderness score	22.30	0.52	3.78	0.0003
CRP	-0.159	-0.21	-0.208	0.042
Swelling score	-20.15	-0.41	-2.83	0.006
Disease duration	-0.27	-0.25	-2.44	0.018
Constant	-138.21	---	-1.67	0.100

$R^2 = 0.3078$; $F = 6.4113$; $p < 0.0001$

7.4.1 Predictors of the outcome of a handgrip exercise programme in RA

Handgrip exercise has been demonstrated earlier to be effective in improving grip strength in females with RA. In this section, the evaluation of potential, specific predictors of outcome to the handgrip exercise programme in females with RA will be examined.

The principal outcome measure in this study was the change in handgrip strength. Subject characteristics and the forearm IMF were assessed in both groups, in addition to the disease duration and severity and the disease activity over the course of the exercise programme. The mean disease activity was measured by the means of the four measurements of CRP, joint swelling and tenderness scores, patient-rated right hand pain and joint stiffness, and the duration of general morning stiffness taken over the 12 week programme. Disease severity was measured by the subluxation and ulnar deviation score of the right hand and wrist and, in a subset of 57 subjects, the right hand BMD at baseline.

In a step-down multiple regression model including these factors, the significant predictors of improvements in grip strength in the RA group were the disease duration, the mean CRP and right hand and wrist joint swelling over the course of the programme, which were negatively associated with the change in grip strength. The extensor IMF, the subluxation of the right hand and wrist and the mean tenderness over the programme were also significant predictors of outcome, having positive associations with the grip strength response. Thirty one percent of the variation in the final grip strength was accounted for by the above mentioned outcome predictors (ANOVA: $F = 6.41$; $p < 0.0001$; $R^2 = 0.31$). These relationships are further described in Table 7.4.1 and in figures 7.4.1 to 7.4.3. The mean MGS and myoelectric parameters of both groups over the 12 week programme are shown in Tables 7.1.2 - 7.2.1.

The final grip strength in the control group was best predicted by the MGS at baseline ($R^2 = 0.4869$; $F = 34.21$; $p < 0.0001$).

Figure 7.4.1. The relationship between the change in the MGS of the right hand during a handgrip exercise programme and the disease duration in 79 females with RA.

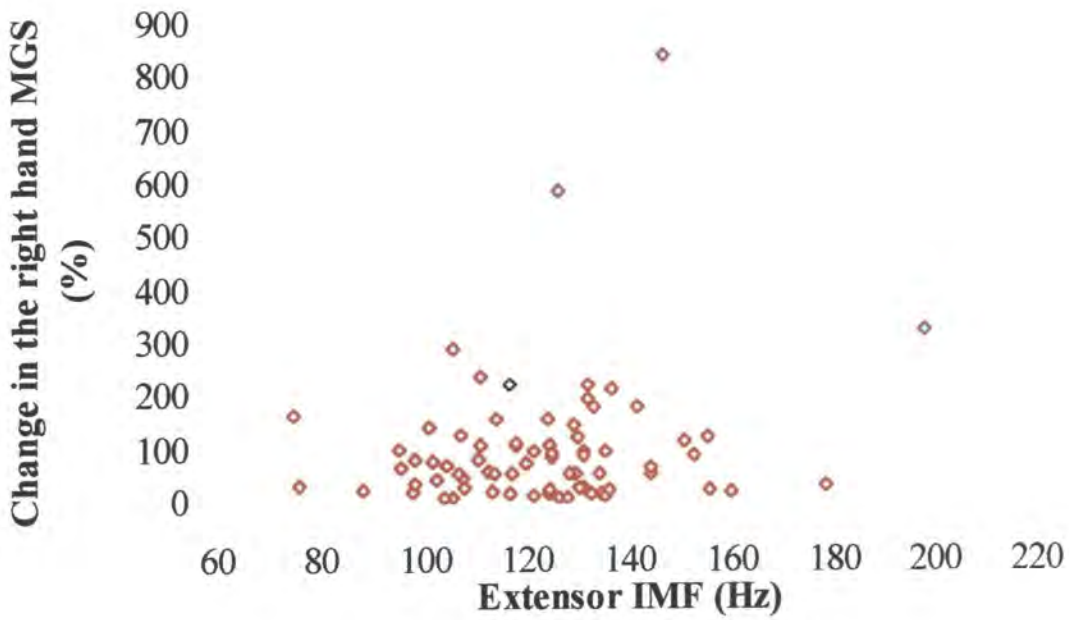

Figure 7.4.2 The relationship between the change in the MGS of the right hand during a handgrip exercise programme and the disease duration in 79 females with RA.

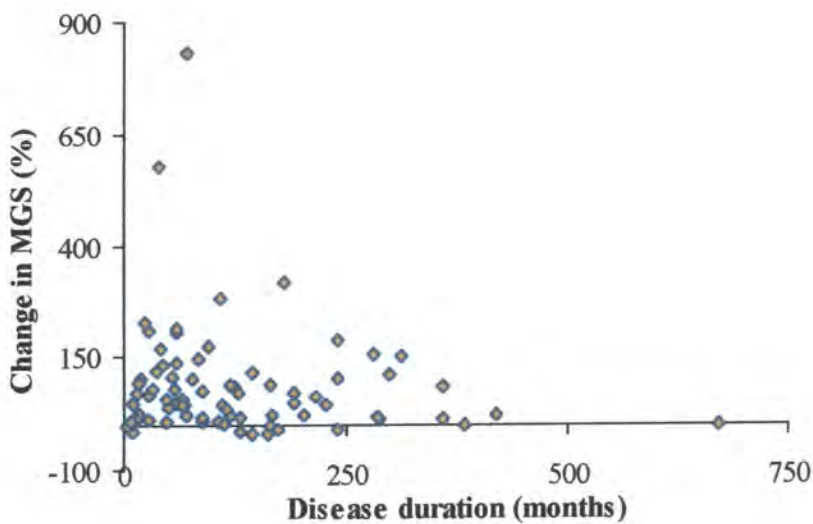
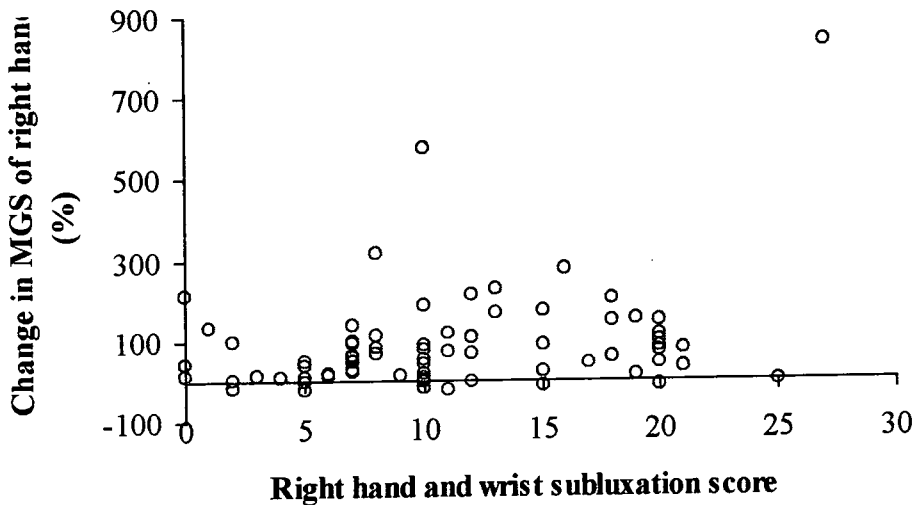

Figure 7.4.3: The relationship between the change in the MGS of the right hand during a handgrip exercise programme and the right hand and wrist subluxation score in 79 females with RA.



In a subset of 57 subjects with RA in whom the right hand BMD was measured, hand BMD was not demonstrated to be a significant predictor of gain in grip strength during the handgrip exercise programme. No significant differences existed between this group and the main exercise group in terms of the variables described in Table 7.4.2.

Table 7.4.2: Details of the subgroup of females with RA taking part in the handgrip exercise programme in whom BMD of the right hand was measured.

Parameter	Mean (SD); range
Age (years)	50.72 (12.14); 27 – 74
BMI (kg/m ²)	24.70 (5.67); 19.72 – 31.73
Disease duration (months)	119.16 (106.52); 5 – 420
Right MGS (mmHg), week 0	107.27 (74.11); 24 – 345
Right MGS (mmHg), week 12	161.82 (77.63); 30– 370
BMD of the right hand (g/cm ²)	0.3700 (0.07); 0.26 – 0.55
Extensor MDFG (Hz/sec), week 0	-0.3700 (0.2400); -1.259 to 0.1620
Flexor MDFG (Hz/sec), week 0	- 0.3100 (0.2300); -0.897- to 0.1750
Extensor IMF (Hz), week 0	122.07 (21.06); 74.82 – 178.76
Flexor IMF (Hz), week 0	108.83 (20.7); 66.69 – 143.93

7.5 Summary: Handgrip exercise in Rheumatoid Arthritis.

The studies which have been described of the effects of handgrip exercise in rheumatoid arthritis indicate that significant improvements in hand function occur with a simple home hand strength training programme.

The outcome measure of the exercise programme, the change in grip strength, was positively related to the **extensor IMF** from the initial visit. This myoelectric characteristic, which has been demonstrated earlier to be a highly repeatable parameter, significantly elevated in rheumatoid disease and related to disease severity (the right hand and wrist subluxation) showed no change over the twelve week exercise programme.

Subjects with severe disease, reflected in the lowest grip strength at baseline, higher IMFs and greater subluxation scores, were demonstrated to benefit the most from a handgrip exercise programme, relative to their hand function at baseline. Although grip strength was shown earlier to decline with increasing hand and wrist subluxation, subjects with significant deformity do benefit significantly with exercise, with, perhaps, "more to gain" than those who already exhibit good hand function. Tenderness also showed a surprising positive relation with improvements in hand function; however, this may have been related to an increased general use of the hand in those subjects who were improving the most. Significantly, it is evident that joint tenderness was not a limiting factor to the response to the hand exercise programme. Furthermore, there was no indication of exacerbation of local or systemic disease activity during the course of the programme.

Longer disease duration, high amounts of joint swelling over the course of the programme (a measure of local disease activity) and the CRP (systemic disease activity) were all significant negative predictors of the gain in grip strength during the programme.

It is evident, therefore, that subjects with rheumatoid disease benefit greatly from a simple hand strength training programme and suitable predictors of outcome have been identified, one of which is a stable characteristic of forearm muscle. The significance of these findings will be discussed further in the discussion section (Chapter Nine).

The last study addresses the question of the mechanisms of the observed strength gain in rheumatoid disease. It is evident that subjects with RA do have abnormal muscle characteristics, indicated by the presence of neuromuscular changes (muscle fibre atrophy related to denervation and / or disuse) on histology and the myoelectric characteristics, specifically the IMF. Whether these features interfere with the normal stages of strength gain – neural adaptation and muscle hypertrophy – during a handgrip strength training programme – will now be investigated.

Table 8.2.1: Details of the study group consisting of 27 right hand dominant females with RA (mean (SD); range).

Age (years)	Disease duration (months)	MGS (mmHg)		CSA (cm ²)		FRMSG (mmHg/uV)	
		baseline	12 weeks	baseline	12 weeks	baseline	12 weeks
51.50 (14.95); 36-75	122.32 (14.95); 9-384	102.81 (75.54); 24-267	154.96 (71.33); 50-320	26.40 (5.15); 20.5-44.9	26.68 (5.09); 20.3-44.9	Extensor 0.81 (0.70); 0.25-3.70	Extensor 1.12 (0.81); 0.23-3.88
						Flexor 2.73 (1.68); 1.07-7.64	Flexor 2.55 (1.22); 0.68-5.80

Chapter Eight. Mechanisms of grip strength gain in a hand exercise programme.

8.1. Introduction

The two main mechanisms of strength gain in a progressive strength training programme are neural adaptation and increased muscle mass, as has been discussed earlier in Chapter Two. The $FRMS_G$ (the regression line fitted to the plot of the grip force versus the RMS voltage) has been used by several workers to assess neural adaptation (no change in $FRMS_G$) and increases in muscle mass (indicated by an increase in $FRMS_G$). The mechanisms of strength gain in the hand exercise programme were investigated using magnetic resonance imaging techniques to measure changes in muscle mass and the $FRMS_G$ to assess both changes in muscle mass and neural adaptation.

8.2 The assessment of the mechanisms of strength gain during a hand exercise programme using cross-sectional analysis of forearm musculature by magnetic resonance imaging.

The initial study involved a comparison of the mechanisms of strength gain as indicated by the $FRMSG$ and the changes noted in the CSA of the right forearm using magnetic resonance imaging. The $FRMSG$ in a group of 27 females with RA performing the 12 week hand exercise programme was assessed at 0, 6 and 12 weeks during the programme; the forearm CSA was measured at baseline and at the end of the programme by MRI. Subject details and the pre and post exercise values are shown in Table 8.2.1.

At baseline, the CSA of the right forearm in these subjects with RA significantly correlated with grip strength ($r=0.4996$; $p=0.0110$; figure 8.2.1). However, as shown earlier using multiple regression analyses, there was no significant correlation between these two parameters allowing for factors such as body mass index and age.

Figure 8.2.1: The relationship between the cross-sectional area (CSA) of the right forearm and the maximum grip strength of the right hand in 27 females with RA prior to commencing a hand grip exercise programme.

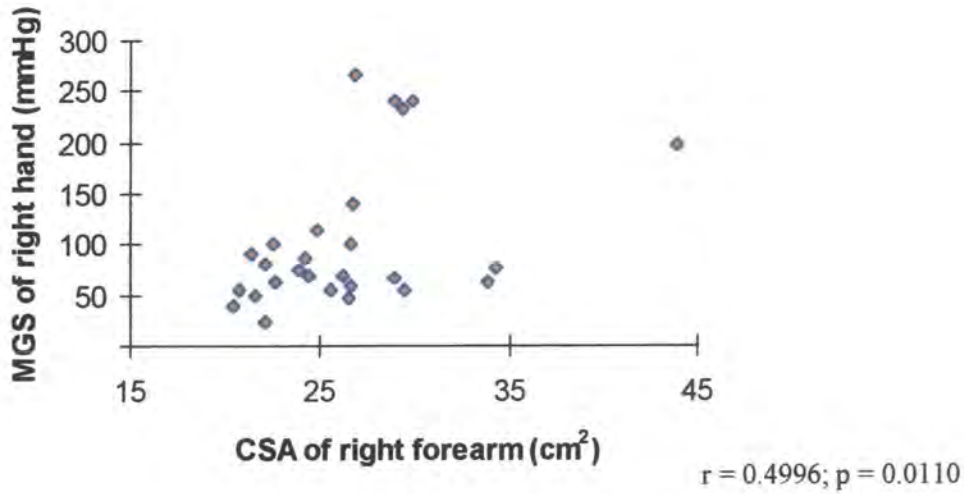

During the exercise programme, significant gains in grip strength were noted in the group, the change being significant at 6 weeks ($p < 0.05$) and extremely significant at 12 weeks ($p < 0.001$) compared to baseline.

Figure 8.2.2: The mean (SD) MGS of the right hand in 27 females with RA during a 12 week hand exercise programme.

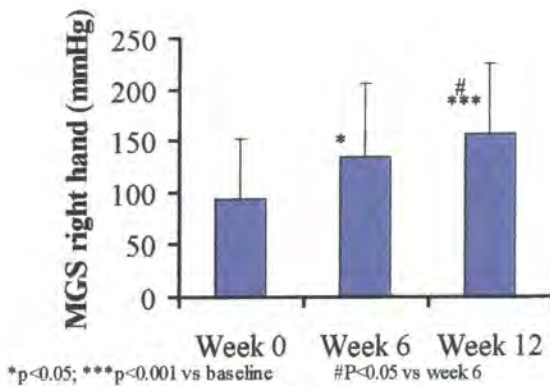

Figure 8.2.3: The percentage changes in the CSA of the right forearm and in the MGS of the right hand in 27 females with RA after a 12 week hand grip exercise programme.

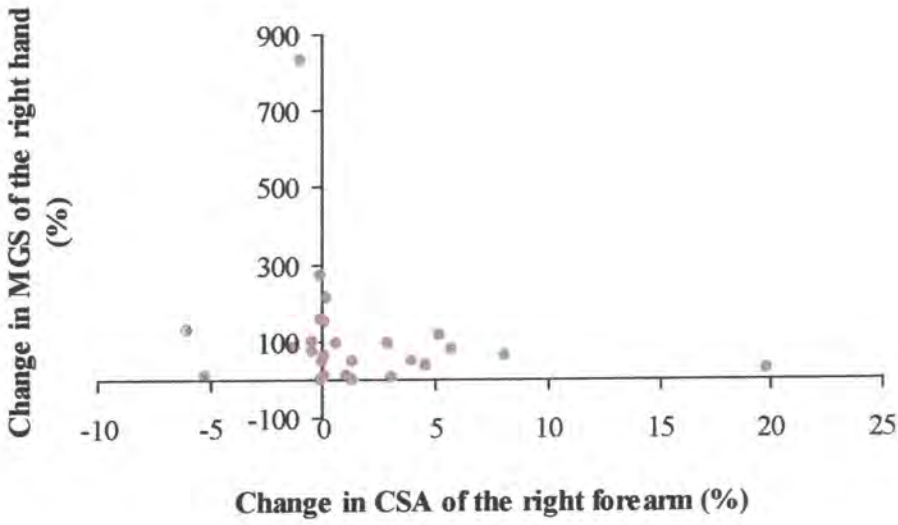
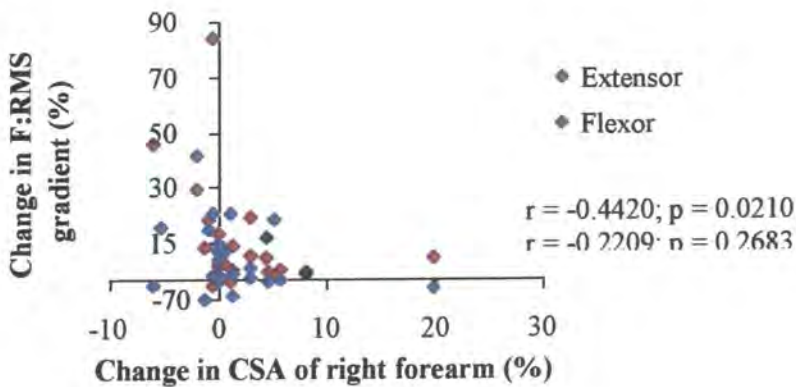

Figure 8.2.4: The percentage change in the F:RMS gradients at the extensor and flexor channels vs that in right forearm CSA in 27 females with RA after a 12 week handgrip exercise programme.



Changes in the $FRMS_G$ during the exercise programme were noted, with a significant increase in the mean $FRMS_G$ for the extensor channel. An overall increase in the slope for the flexor channel also occurred, the latter not reaching statistical significance. However, no relationship was demonstrated between the change in MGS and the change in the $FRMS_G$ of the extensor channel ($r = 0.2947$; $p = 0.2091$) nor the flexor channel ($r = 0.2448$; $p = 0.2184$).

Figure 8.2.5: The relationship between the changes noted in the grip force : RMS of the SMES gradient (FRMSG) (extensor channel) and MGS of the right hand after a 12 week hand grip exercise programme in 27 females with RA.

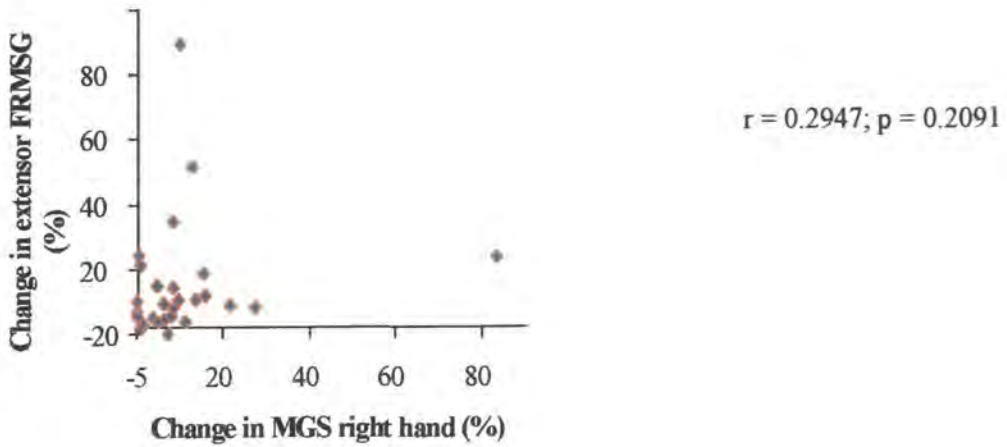
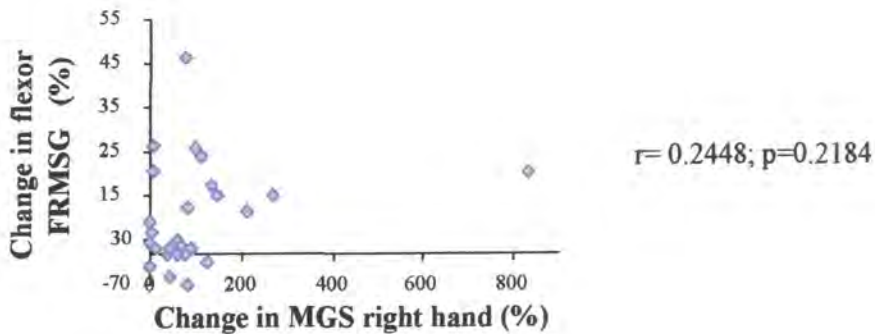
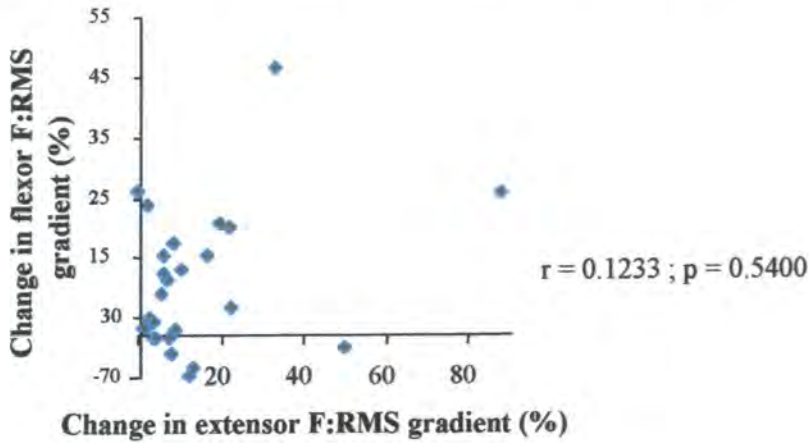

Figure 8.2.6: The relationship between the changes noted in the grip force : RMS of the SMES gradient (FRMSG) (flexor channel) and MGS of the right hand after a 12 week hand grip exercise programme in 27 females with RA.



No significant relationship was demonstrated between the changes noted in the FRMSG of the extensor and flexor channels, as demonstrated in figure 8.1.7.

Figure 8.2.7: The percentage changes in the FRMSG of the flexor channel versus that of the extensor channel in 27 females with RA after a 12 week handgrip exercise programme.



There was no significant relationship between the change in the forearm CSA and that in the FRMSG of the flexor channel (Spearman $r = -0.2209$; $p = 0.2683$). The change in the extensor FRMSG showed a significant *negative* correlation with the change in the CSA ($r = -0.4420$; $p = 0.0210$); see figure 8.2.4.

The CSA of the right forearm showed no significant change for the study group over the 12 week exercise period (26.40 cm^2 vs 26.70 cm^2 ; $p = 0.1442$) and no correlation was demonstrated between the change in MGS and change in CSA over the 12 week period. In view of these findings a different approach to the assessment of forearm muscle mass was developed, since the lack of change in the CSA may have been related to the insensitivity of the measurement.

Figure 8.3.1: The right forearm muscle volume and grip strength of the RA and control groups at baseline and after 12 weeks of a handgrip exercise programme (mean (SD)).

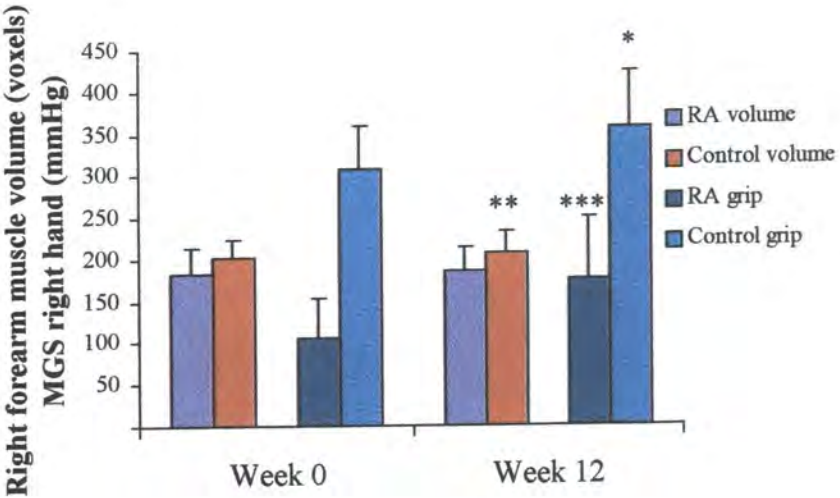

* p < 0.05; ** p < 0.01; *** p < 0.0001; paired non-parametric test

8.3. The assessment of the mechanisms of strength gain during a hand exercise programme using volumetric analysis of the forearm musculature.

The mechanisms of strength gain were further investigated using the FRMS_G and a different approach to the assessment of muscle mass: volumetric analysis of the musculature of the right forearm. This alternative approach to the assessment of muscle mass was pursued as there was a question as to the sensitivity of CSA assessment of small changes in muscle mass, particularly in individuals with RA, where the muscle fibre atrophy may be patchy.

Two study groups were assessed, consisting of fourteen subjects with RA and fourteen controls. All were right hand dominant females, the details of which are given in Table 8.3.1. Details of the FRMS_G at 0, 6 and 12 weeks of the programme, in addition to the changes in the forearm muscle volume and MGS of the right hand are shown in figures 8.3.1. - 8.3.3. No significant differences in age, weight nor BMI existed between the two groups. As shown earlier (section 6.1), in a multiple regression analysis there was no significant relationship demonstrated between the right forearm muscle volume and MGS of the right hand in neither the control nor the RA groups.

At **baseline**, the right hand MGS was significantly higher in the control group; no significant difference was detected between the forearm muscle volume. **After 12 weeks of exercise**, gains in right hand MGS were extremely significant and significant for the RA and control groups respectively. Significant increases in the right forearm muscle volume were detected for the control group, but not the RA group, as shown in figure 8.3.1. Changes in forearm muscle volume reflected the increases in grip strength noted in the control group, with significant correlation being demonstrated between the changes in the two parameters, as illustrated in figure 8.3.2. No such relationship was seen in the RA group.

Figure 8.3.2: The change in the volume of the right forearm musculature vs change in MGS of the right hand in 14 female controls (A) and 14 females with RA (B) after a 12 week handgrip exercise programme.

A

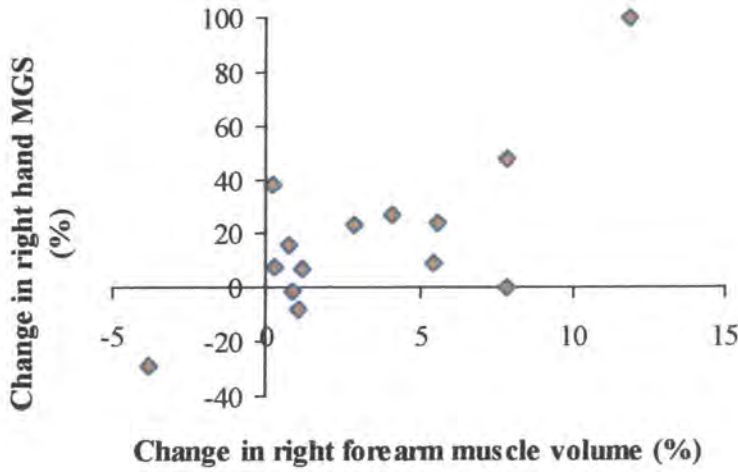

$r = 0.5824$; $p = 0.0289$

B

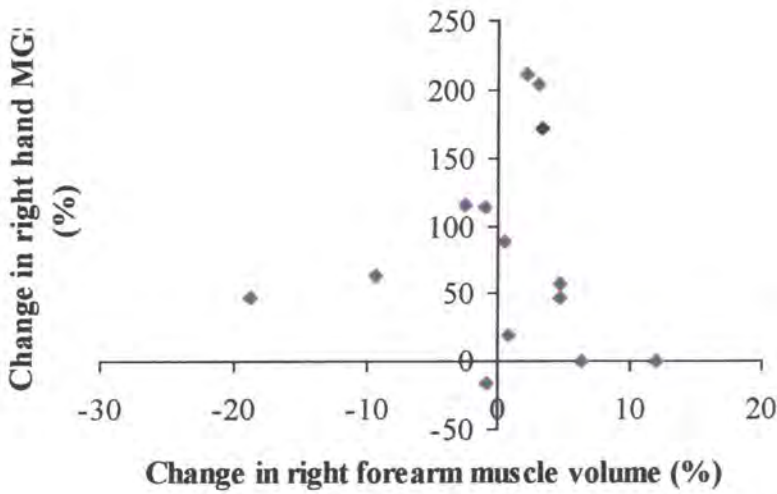

$r = -0.1253$; $p = 0.6696$

In the evaluation of the FRMS gradients at baseline and after 12 weeks of the exercise programme, a significant *decline* in the FRMS_G gradient was noted in the extensor channel of the control group after 12 weeks of hand exercise. Declines in the FRMS_G were noted in the flexor channels of both groups after 12 weeks and an increase in the gradient in the extensor channel of the RA group; none of these changes reached statistical significance (Table 8.3.1).

No significant correlation between the increase in forearm muscle volume noted on MRI and the changes in the FRMS_G were noted for any channel. These results are shown in figures 8.3.3 and 8.3.4. The high variation in the relationship between the changes in grip strength, muscle mass and the FRMSG is illustrated in figures 8.3.5 and 8.3.6, describing results for individual subjects.

Figure 8.3.3: The relationship between the change in forearm muscle volume and the F:RMS gradients derived from extensor (C) and flexor (D) channels after a 12 week hand exercise programme in 14 females with RA .

C

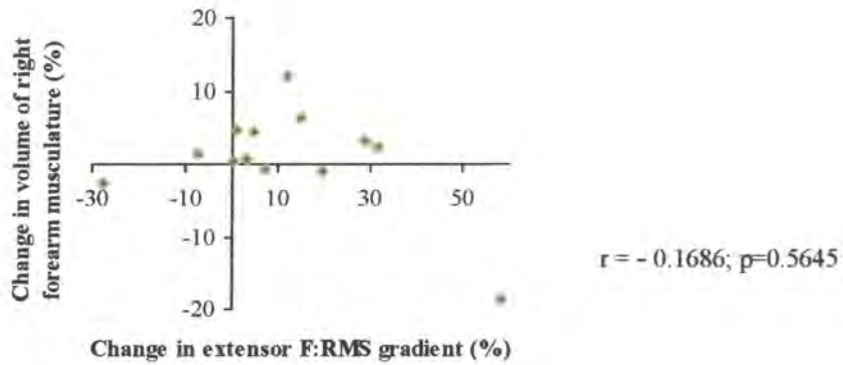

D

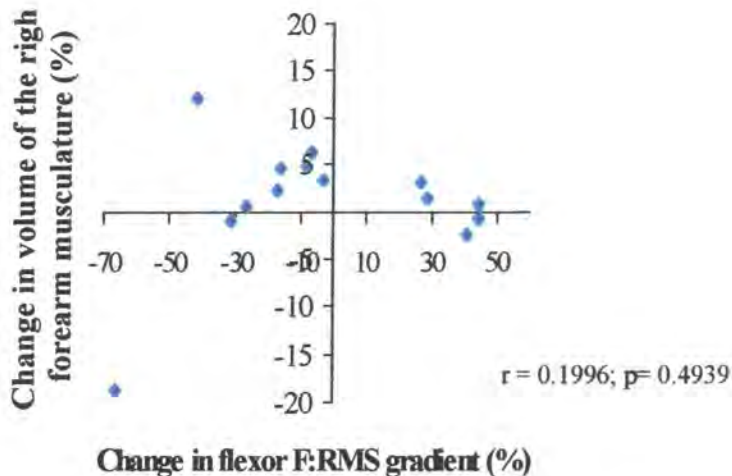
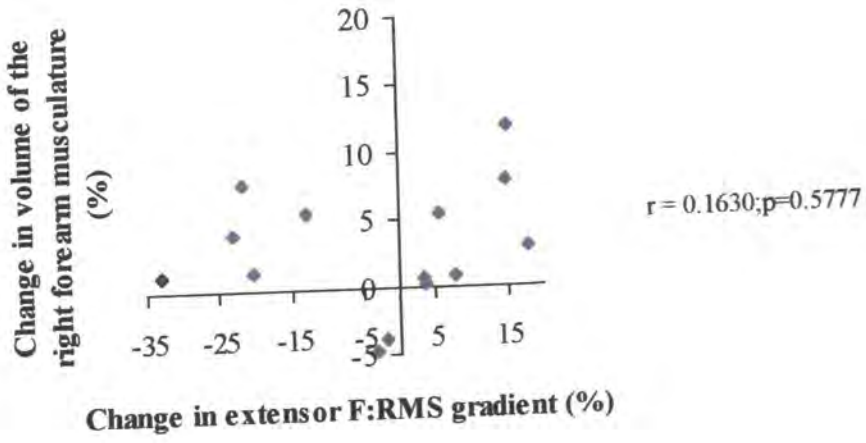

Figure 8.3.4: The relationship between the change in forearm muscle volume and the F:RMS gradients derived from extensor (A) and flexor (B) channels after a 12 week exercise programme in 14 female controls.

A



B

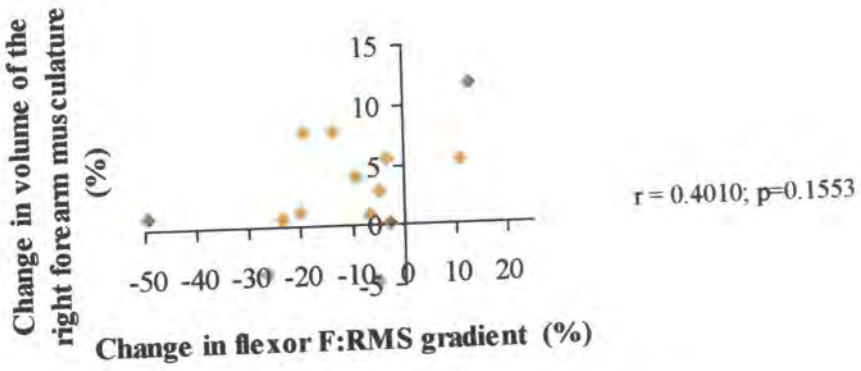
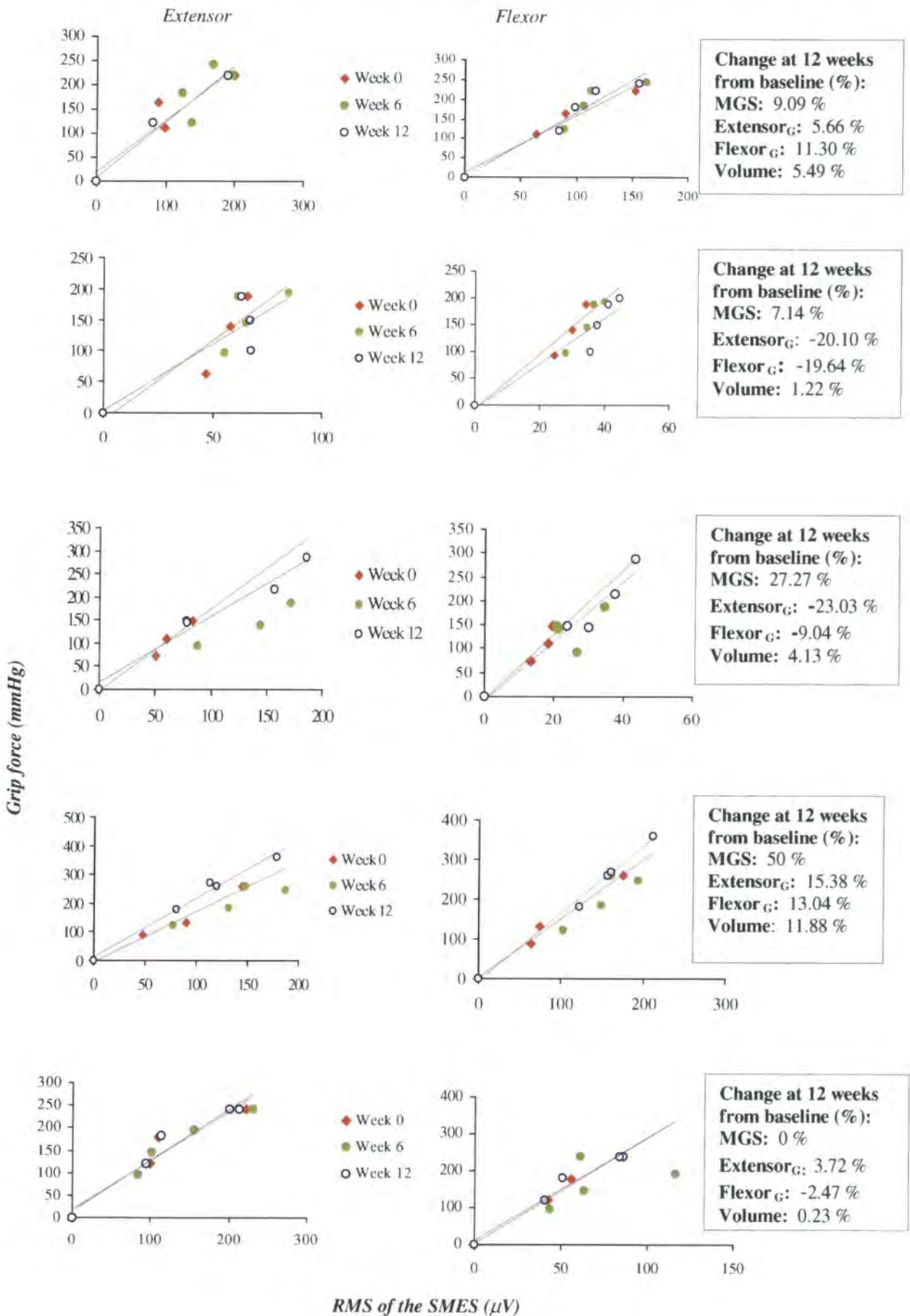

Table 8.3.1: Details of the RA and control groups in the analysis of mechanisms of strength gain in a handgrip exercise programme using volumetric analysis of the forearm.

	Age (years)	Weight (kg)	Disease duration (months)	BMI (kg/m ²)	MGS (mmHg)		Right forearm muscle volume (cc)		F:RMS _c (mmHg/uV)		F:RMS _c (mmHg/uV)	
					baseline	12 weeks	baseline	12 weeks	baseline	12 weeks	baseline	12 weeks
RA	49.64	62.27	87.5	23.87	105.14	***174.8	183.9	184.23	1.14	1.25	3.83	3.43
(n=14)	(12.530);	(6.50);	(66.3);	(3.0);	(48.08);	(76.4);	(29.3);	(30.1);	(0.493);	(0.513);	(1.64);	(1.34);
	28-74	51-74	5-240	21.0-32.2	34-180	50-340	134.7 -	133.3 -	0.38-1.25	64-2.36	1.68-6.65	1.76-5.88
							238.6	239.82				
Controls	46	60.77		23.43	311.67	*357	201.3	*207.87	1.71	*1.58	4.01	3.82
(n=14)	(14.14);	(7.03);	-----	(3.51);	(49.63);	(67.06);	(23.7)	(25.2)	(0.50);	(0.42);	(2.03);	(1.85);
	24-72	52-75.91		19.8-32.7	220-370	250-540	156.9-	165.6 -	0.99-2.59	0.88-2.17	1.46-6.93	1.65-6.74
							231.9	258.5				

* paired non-parametric test, change from baseline : * p<0.05; ***p<0.001; *p=0.0143

Figure 8.3.5 Grip strength vs RMS of the SMES for extensor and flexor channels in 14 female controls over a 12 week exercise programme. The associated changes in slope of the regression lines, MGS and forearm muscle volume are given in the associated tables.



extensor

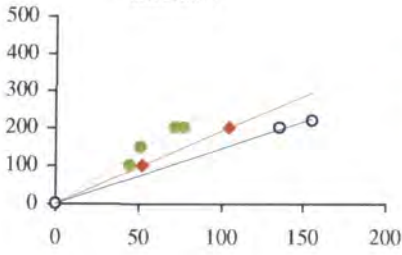

◆ Week 0
 ● Week 6
 ○ Week 12

flexor

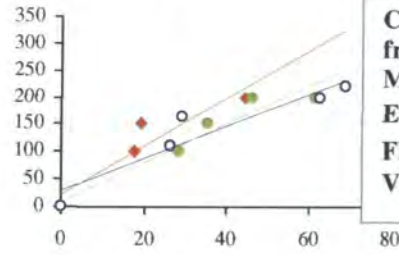

Change at 12 weeks from baseline (%):
MGS: 10 %
Extensor_G: -33.1 %
Flexor_G: -49.35 %
Volume: 0.23 %

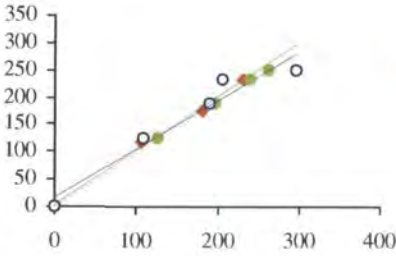

◆ Week 0
 ● Week 6
 ○ Week 12

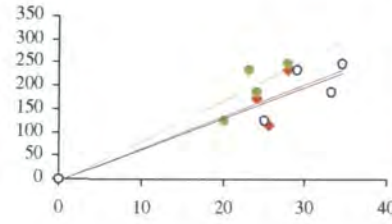

Change at 12 weeks from baseline (%):
MGS: 6.57 %
Extensor_G: -11.1 %
Flexor_G: -2.84 %
Volume: 1.11 %

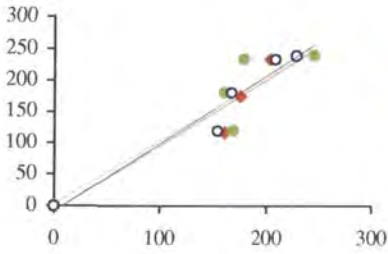

◆ Week 0
 ● Week 6
 ○ Week 12

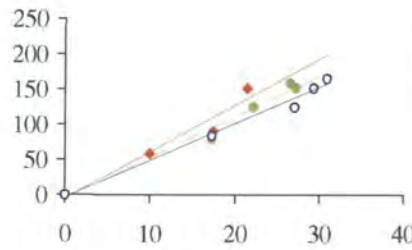

Change at 12 weeks from baseline (%):
MGS: 8.70 %
Extensor_G: -1.85 %
Flexor_G: -26.3 %
Volume: -3.77 %

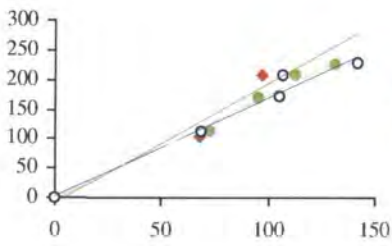

◆ Week 0
 ● Week 6
 ○ Week 12

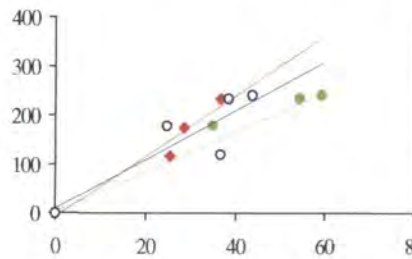

Change at 12 weeks from baseline (%):
MGS: 9.68 %
Extensor_G: -21.42 %
Flexor_G: -18.95 %
Volume: 7.91 %

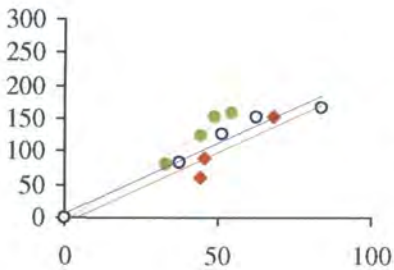

◆ Week 0
 ● Week 6
 ○ Week 12

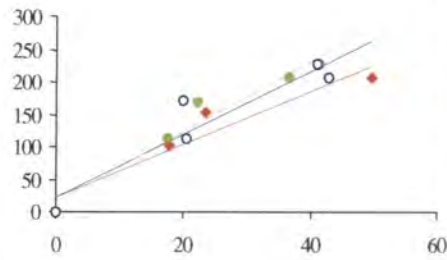

Change at 12 weeks from baseline (%):
MGS: 2.86 %
Extensor_G: 3.63 %
Flexor_G: -23.23 %
Volume: 0.75 %

RMS of the SMES (µV)

Grip force (mmHg)

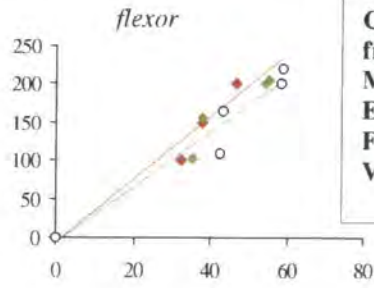
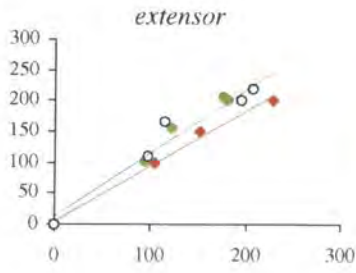

Change at 12 weeks from baseline (%):
MGS: 7.69 %
Extensor_G: 15.15 %
Flexor_G: -13.23 %
Volume: 7.91 %

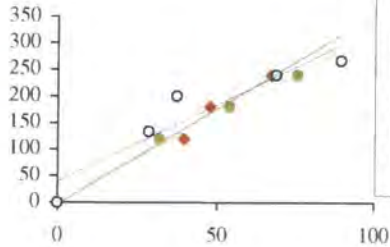
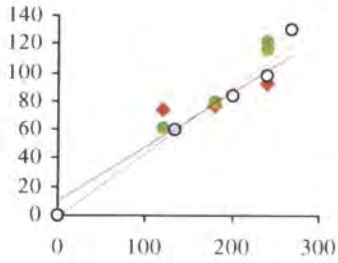

Change at 12 weeks from baseline (%):
MGS: 11.11 %
Extensor_G: 18.13 %
Flexor_G: -4.54 %
Volume: 2.92 %

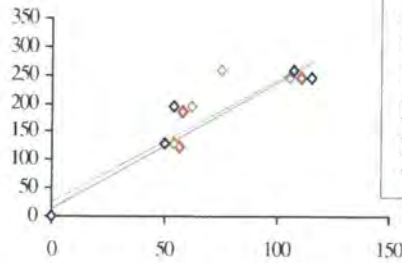
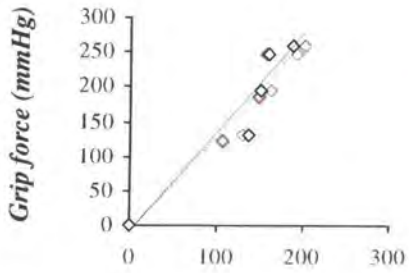

Change at 12 weeks from baseline (%):
MGS: 5.41 %
Extensor_G: -3.06 %
Flexor_G: -4.7 %
Volume: 0.28 %

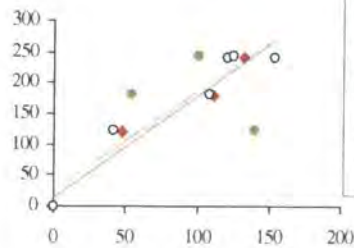
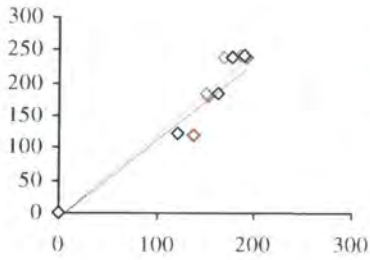

Change at 12 weeks from baseline (%):
MGS: 1.38 %
Extensor_G: 8.0 %
Flexor_G: -6.55 %
Volume: 0.91 %

RMS of the SMES (μV)

Figures 8.3.6: Grip strength vs RMS of the SMES for extensor & flexor channels in 14 females with RA over a 12-week exercise programme. The % changes in slope of the given regression lines, MGS and forearm muscle volume are given in the associated tables.

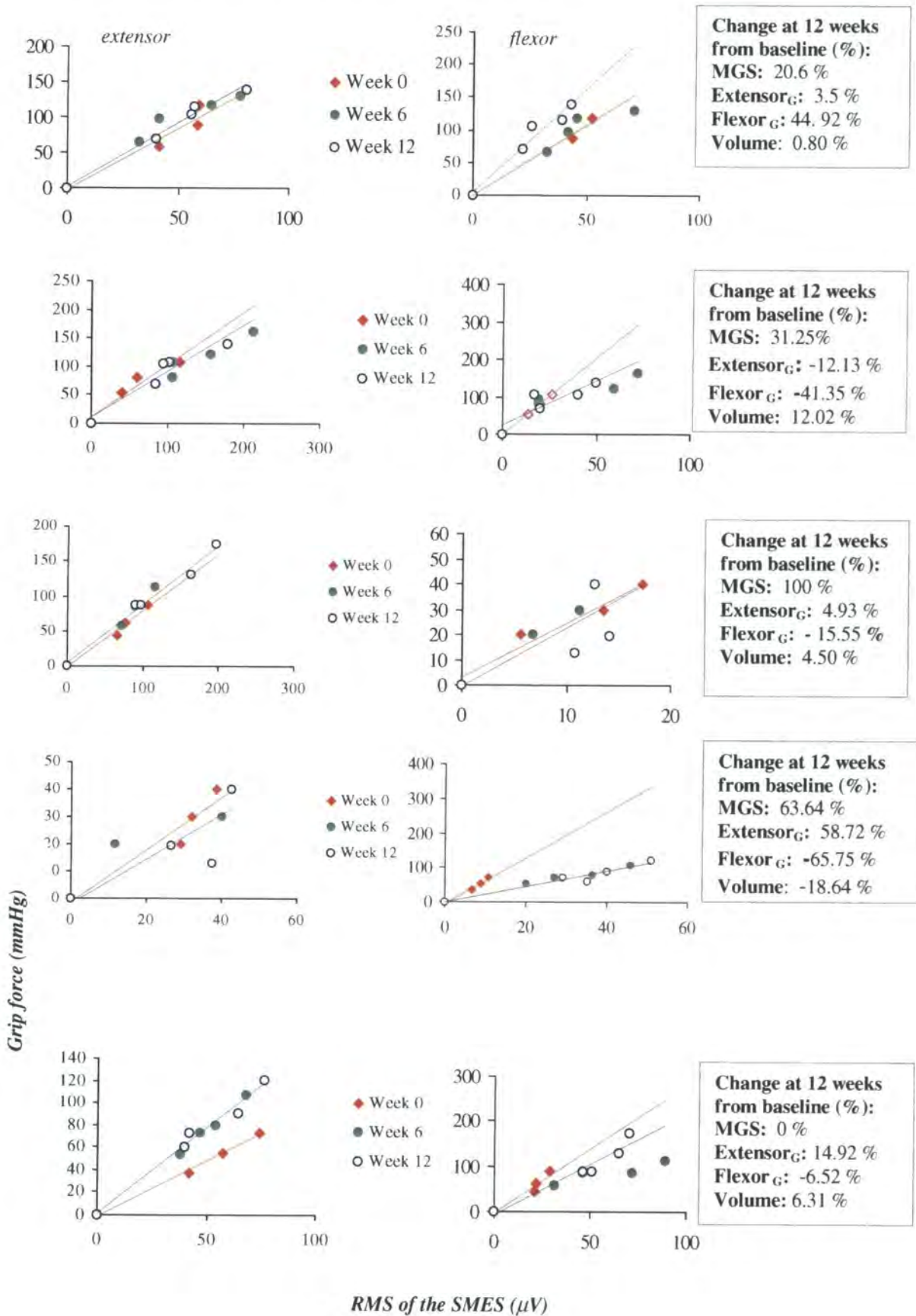

Grip force (mmHg)

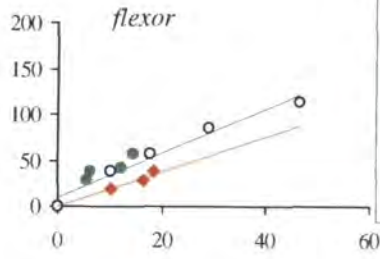
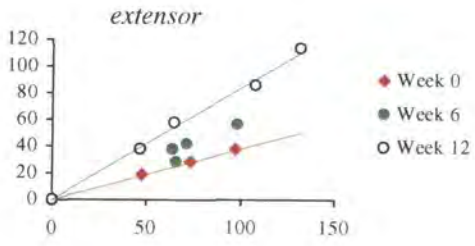

Change at 12 weeks from baseline (%):
MGS: 203.57 %
Extensor_G: 2840 %
Flexor_G: 27.20 %
Volume: 3.09 %

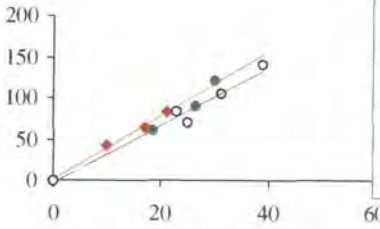
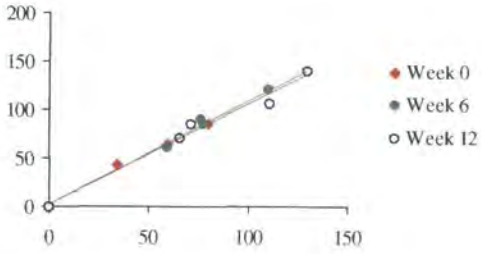

Change at 12 weeks from baseline (%):
MGS: 64.06 %
Extensor_G: -7.17 %
Flexor_G: 28.99 %
Volume: 1.34 %

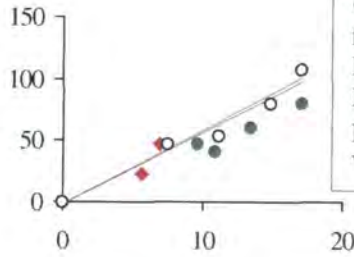
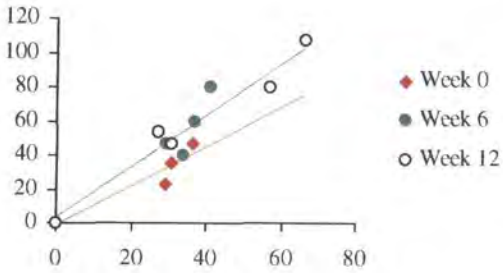

Change at 12 weeks from baseline (%):
MGS: 128.57 %
Extensor_G: 28.66 %
Flexor_G: -2.43 %
Volume: 3.22 %

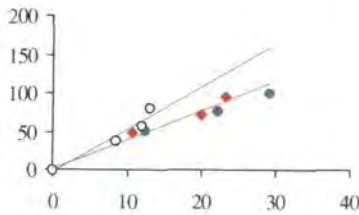
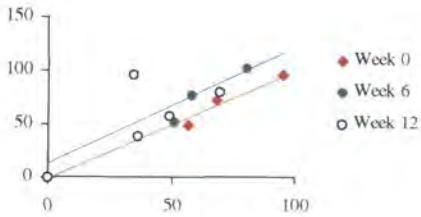

Change at 12 weeks from baseline (%):
MGS: -16.0 %
Extensor_G: 7.36 %
Flexor_G: 45.24 %
Volume: -0.82 %

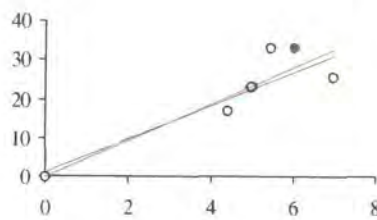
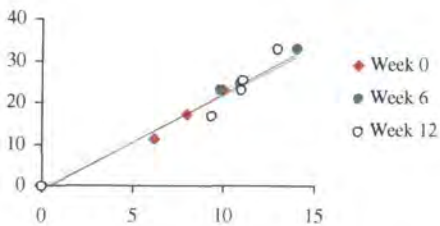

Change at 12 weeks from baseline (%):
MGS: 47.06 %
Extensor_G: 1.11 %
Flexor_G: -7.82 %
Volume: 4.77 %

RMS of the SMES (μ V)

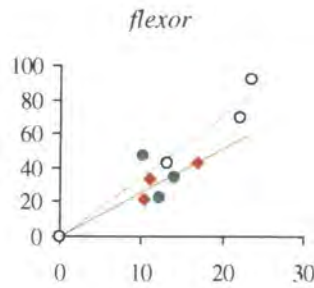
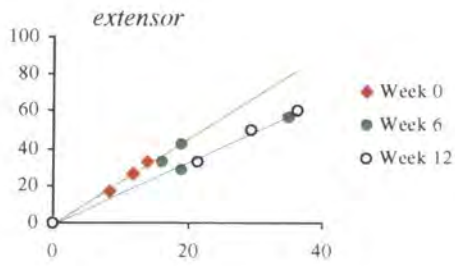

Change at 12 weeks from baseline (%):
MGS: 115.38 %
Extensor_G: - 27.26 %
Flexor_G: 40.97 %
Volume: - 2.49 %

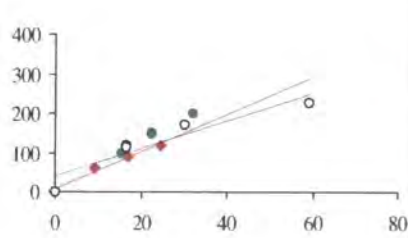
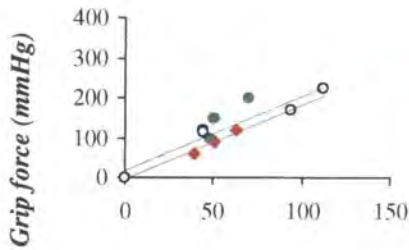

Change at 12 weeks from baseline (%):
MGS: 88.89 %
Extensor_G: 0.59 %
Flexor_G: - 25.69 %
Volume: 0.52 %

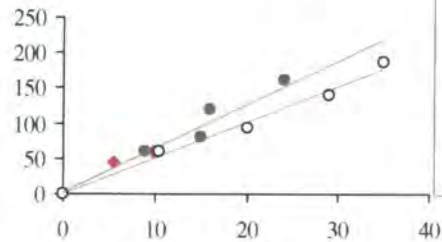
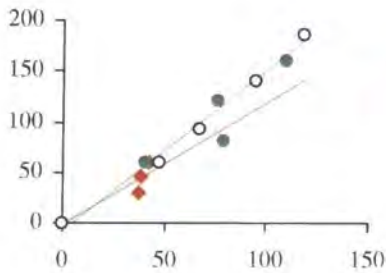

Change at 12 weeks from baseline (%):
MGS: 211.11 %
Extensor_G: 31.66 %
Flexor_G: -17.27 %
Volume: 2.24 %

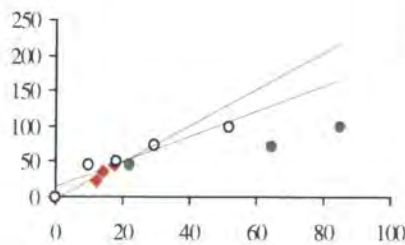
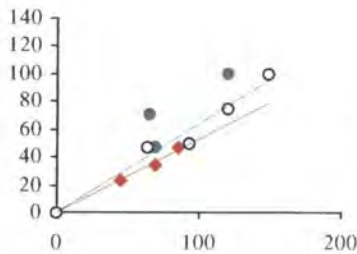

Change at 12 weeks from baseline (%):
MGS: 114.29 %
Extensor_G: 19.55 %
Flexor_G: - 31.29 %
Volume: -1.03 %

RMS of the SMES (μ V)

8.4 Summary

In the assessment of changes in forearm muscle mass during the hand exercise programme, significant gains were seen in some control subjects and the group as a whole, which correlated with the gains seen in grip strength. There were no significant changes in the mean muscle mass in rheumatoid subjects, as measured by the CSA in the first group nor total forearm muscle volume in the second group.

There was a wide variation in the $FRMS_G$ of both channels in both groups during the programme. Increases in the $FRMS_G$ showed no correlation with the changes in forearm muscle volume.

Chapter Nine. Discussion: Grip strength, forearm muscle fatigue and the response to hand grip exercise in rheumatoid arthritis.

9.1 Introduction

Muscle atrophy has been recognised as a clinical feature of rheumatoid arthritis for over a century. Over the last three decades histological abnormalities, in particular fibre atrophy, within skeletal muscle have been widely reported. However, the functional significance of fibre atrophy in RA and its relationship to the disease process and the response to rehabilitation programmes is unclear. Contributing factors to the lack of advance in the understanding of muscle disorders in RA are confusion surrounding the histological findings and a lack of specific measures which reflect the characteristics of underlying muscle. As has been clarified in Chapter Two, a review of the literature indicates that the histological findings suggest the presence of a combination of a primary myopathy secondary to disuse (local or generalised) and a neurogenic myopathy secondary to denervation related to the systemic disease process. Muro et al (1982) suggested that electrophysiological characteristics of muscle during contraction can be valuable measures in the assessment of neuromuscular disease. Studies have suggested that the assessment of the initial median frequency (the IMF, that is the median frequency (MDF) of the myoelectric signal prior to the onset of muscle fatigue) recorded from muscle during contraction can give valuable information on the intrinsic characteristics of the muscle, including the presence of myogenic or neurogenic fibre atrophy. Monitoring the change in the MDF (represented by the MDFG) during muscular contraction indicates the fatigability of the muscle at that time.

After developing the technique of power spectral analysis of forearm musculature during grip and initial pilot studies which examined the relationship between myoelectric parameters and grip force, this technique was used to examine neuromuscular disorders in rheumatoid arthritis. This is the first such study in this disease. Specific issues were addressed. Firstly, electrophysiological evidence for the

presence of neuromuscular abnormalities within rheumatoid muscle during a functional task (grip) were sought. Having demonstrated that there is such evidence of neuromuscular abnormalities, the relationship with the disease process in subjects with RA was examined and significant relationships with disease were demonstrated. The significance of such neuromuscular abnormalities to the response to a simple hand exercise programme in RA was then evaluated. Other important issues were examined in this study. These were the evaluation of factors affecting grip strength in RA and the assessment of forearm muscle mass and mechanisms of strength gain in hand exercise programmes in RA. The following discussion will address the findings relating to these issues that have been detailed in earlier sections.

9.2 The use of grip in the assessment of the myoelectric characteristics during contraction.

Many studies of myoelectric characteristics during contraction involve isolated contractions of an individual muscle, with which the subject may be unfamiliar and which may not reflect the characteristics of the muscle in the functional setting. In this study, the electrophysiological characteristics of the forearm were studied during grip. The use of this task confers many advantages. Grip is a functional task with which most subjects are familiar, even those with inflammatory arthritis. The assessment of grip strength remains the cornerstone of hand functional analysis and it is an extremely important measure in rheumatoid disease, since it reflects not only hand function but also the activity and severity of the disease (Lansbury, 1958; Nordenskold and Grimby, 1997). The involvement of the hand and wrist in rheumatoid disease usually occurs early in the disease process and, if abnormalities of muscle are associated with the disease, forearm muscles may be expected to be involved early. The study of myoelectric characteristics of the muscle during grip allows the evaluation of their relationship with disease measures, including local disease. Forearm muscles are easily accessible for the recording of the surface myoelectric signal (SMES) and this, in combination with the ease of the task involved, is likely to have contributed to the reliability of the technique of frequency analysis of the forearm SMES.

Some of the confusion surrounding the response to strength training programmes in RA relates to concerns over compliance with programmes, unfamiliarity with the required tasks and lack of association between the exercise and daily function. Handgrip was chosen as the basic task in a strength training programme for several reasons. It is essential to function and loss of grip strength in RA is a significant and common problem, as has been described. Familiarity with the task was likely to improve compliance. Monitoring changes in the myoelectric characteristics of the forearm at given intervals over the three-month programme was possible, allowing the monitoring of muscle fatigue (the MDF_G) and the possible identification of myoelectric predictors of outcome (such as the IMF). The assessment of changes in forearm muscle mass with exercise was also possible using magnetic resonance imaging.

9.3 The initial median frequency of the forearm myoelectric signal as an indicator of muscle characteristics in RA.

The investigation of neuromuscular abnormalities in rheumatoid disease using analysis of the surface myoelectric signal has many advantages over histological examination and intramuscular EMG studies. Histological examination of rheumatoid skeletal muscle gives a valuable 'picture' of the tissue, but does not convey any information as to whether such changes are evident during the performance of a functional task. Histological analysis and intramuscular EMG studies rely on examining an involved area of muscle; the patchy nature of the disease process within the muscle (Halla et al, 1984) may result in an uninvolved area being assessed.

Subjects with rheumatoid disease were shown to have lower neuromuscular efficiencies (NME) during grip, as described by the lower $FRMS_G$ values in this group. This is in keeping with the reports by other workers of a reduction in NME in neuromuscular diseases (Lenman and Potter, 1966; Muro et al, 1982; Lindeman and Drukker, 1994). However, it does not give any further specific information relating to the nature of the neuromuscular disorder.

In spite of the numerous reports of neuromuscular abnormalities in rheumatoid disease, their significance in relation to the disease process and functional outcome is unclear.

The initial median frequency of the myoelectric signal (the IMF) has been found to be a useful indicator of the presence of neuromuscular disease and in the differentiation between a primary myopathy and a myopathy that is neurogenic in origin. Those studies which have assessed frequency spectral changes in myopathic lesions have not addressed disuse atrophy specifically, and the reported spectral alterations are taken as representative of primary myopathic lesions as a whole (Walton, 1952; Lindstrom et al, 1985). However, if disuse atrophy did not result in the typical changes which result in the alterations in the frequency spectrum in other myopathic lesions then the observed elevation of the IMF can still be explained by the presence of disuse atrophy of predominantly type I fibres. In this study the IMF of the forearm myoelectric signal recorded during submaximal grip was shown to be a repeatable parameter on both short and long term testing. It was unrelated to the level of grip force for a given individual over the force range examined. This myoelectric parameter may represent **intrinsic characteristics of the forearm muscle** – specifically its fibre type composition and behaviour - in a given individual, which is stable over time and over the course of an exercise programme.

The IMF was higher in both the forearm flexor and extensor muscle groups in the rheumatoid subjects when compared to the controls and there was a significant correlation between the flexor and extensor IMF in the rheumatoid subjects. This latter finding indicates that those subjects with RA who had an abnormal extensor IMF also had abnormal flexor IMFs. Both the flexor and extensor IMFs were significantly associated with greater disease severity (right hand and wrist subluxation and in the case of the flexor IMF, grip strength), with higher IMFs being noted in more severe disease. Although a high IMF is associated with muscle lengthening, this cannot explain the high value in both muscle groups, since if one group lengthens in response to this deformity, the other group would be expected to shorten. It is therefore likely that the increase in IMF noted in rheumatoid forearm muscle is associated with changes in the fibre type composition of the muscle.

As detailed in the review of the literature, both a primary myopathy (related to disuse) and a neurogenic myopathy are thought to occur in RA, but it is unclear as to which is the more important of the two and their relevance to function and the response to rehabilitation programmes. It is possible that the relative contribution of each

mechanism varies between individuals according to the characteristics of the disease. In neuromuscular disorders, a high IMF usually reflects a primary myopathy. However, it may also be seen in subjects with neurogenic myopathies when there is reinnervation occurring, or possibly after reinnervation has occurred if the injured muscle fibres have become predominantly type II due to reinnervation by those motoneurons which usually supply type II fibres. This is termed neuromuscular plasticity (Gordon et al, 1988). Alteration of muscle fibres to a different fibre type has not been demonstrated in healthy fibres, even in response to training. However, it has been demonstrated experimentally (Edgerton et al, 1980) and is thought to occur in the response to injury (Kilmer, 1996). Regeneration and reinnervation after neural damage is a random process, unlike the specific nature of innervation during development (Gordon et al, 1988). If the findings in this study are taken to represent muscle reinnervation with a resulting type II fibre predominance, it would appear that the type I fibres had been more affected, with recovery through terminal sprouting of healthy type II motoneurons (Gordon et al, 1988). If the increased IMF observed in subjects with RA was related to muscle atrophy through disuse (i.e. a primary myopathy), then it still seems likely that the type I fibres were the greater affected, since the IMF is related to fibre type. However, there are other reasons which have been suggested for the raised median frequency of the MES observed in myopathies, including polyphasic, short potentials (Walton, 1952; Kugelberg, 1949).

Brooke and Kaplan (1972) reported type I fibre atrophy in severe RA. In this study, the subjects in the RA group were all drawn from a hospital population and it could be argued that they have more severe disease on that basis. This would be in keeping with the possible reasons that have been described for the raised IMF. Those studies which have reported type II fibre atrophy in RA (including Haslock et al, 1970; Magyar et al, 1977) have obtained biopsies mainly from the lower limb musculature. It is possible that the changes within the forearm musculature differ from those in the lower limbs. There are no histological studies of forearm muscle in rheumatoid disease available in the literature to confirm or disprove this.

The IMF of the SMES recorded from the forearm during submaximal grip is therefore an indicator of disease severity and indicates that the changes that occur within rheumatoid skeletal muscle are related to the severity of the disease process. The

extensor IMF showed positive correlation with systemic disease activity, reflected by the duration of general morning stiffness. Conversely, local disease activity in the hand - reflected by the hand joint swelling score - was negatively associated with the IMF. The flexor IMF showed a similar relationship with local joint swelling. This is difficult to explain. It is possible that general disease activity results in the preferential use of Type II fibres, (which may predominate in severe RA (Brooke and Kaplan, 1972)) and which may actively splint the joint, with inactivity of type I fibres and a resulting elevation in the IMF. Local disease activity may result in arthrogenous inhibition of the more powerful (type II) fibres, lowering the IMF. It is unclear whether arthrogenous inhibition affects one specific fibre type more than the other (Young, 1993).

It is evident that the IMF of the SMES, which reflects underlying changes within the muscle, is closely associated not only with the disease process, but also fluctuates with the systemic activity of the disease. The effects of arthrogenous inhibition upon the IMF are unclear but may be the reason for a decline in the IMF with increases in local disease activity.

The negative association between the flexor IMF and disease duration is another indication that, in this group, disease duration did not correlate with disease severity. It is also in keeping with the finding by Magyar et al (1977) that there was no relationship between disease duration and the extent of the neuromuscular changes noted on histological examination of skeletal muscle. In a thorough review of disease assessment indices in RA, Symmons (1995) gives no mention to the duration of the disease in relation to the severity nor the activity of the disease, indicating it is not considered to be an important feature of disease assessment nor its outcome.

9.4 Other factors associated with hand function in RA.

Grip strength is a well-established indicator of both hand function and global functional capacity in rheumatoid disease (Nordenskold and Grimby, 1997). The association between the IMF of the SMES, representing underlying neuromuscular changes, and grip strength has been discussed above. Other factors significantly related to grip strength in both groups were the age and the MDF_G (extensor and flexor in controls and

flexor only in the RA group). The decline of grip strength with age has been reported by others and reflects the decline in overall hand function with increasing age (Hackel et al, 1992).

The findings in this study that grip strength in rheumatoid disease significantly declined with increasing systemic disease activity (measured by the CRP), local disease activity (right hand and wrist pain), and the disease severity (hand subluxation) are in keeping with the findings by many other workers (Pincus et al, 1987; Spiegel et al, 1987; Ritchie et al, 1968; Lansbury, 1958;). The significant increase in grip strength with disease duration is initially surprising. However, in this study group, there was no correlation between disease severity and the duration of the disease and the lack of significance of disease duration in relation to the severity and outcome of the disease has been discussed. Also the decline in strength with immobilisation is most marked in the first week (Kilmer, 1996). Although there are several other factors associated with the decline in grip strength in RA, this does indicate that longer disease duration does not necessarily indicate greater muscle weakness in RA. As has been detailed, no relationship between the muscle changes noted on histological studies of rheumatoid muscle and the duration of the disease (Magyar et al, 1977). If such changes are related to functional weakness, as is suggested by the relationship found between the IMF and grip strength, then the findings in this study in relation to disease duration are not surprising.

9.5 Fatigue in rheumatoid arthritis.

The MDF_G of the SMES is a well-established indicator of muscle fatigue during submaximal work (Lindstrom et al, 1977). This parameter was demonstrated to be a sensitive and repeatable measurement on same day testing but showed a high variation on retesting after 3 weeks, as discussed earlier in the discussion of the pilot studies. This may indicate that the fatiguability of the muscle changes over short periods of time and measurements on a given day reflect the **state** of the muscle on that day. The variation over time makes it a less useful indicator of changes in fatigue in response to treatment, such as an exercise programme.

There is a theoretical basis for suspecting increased muscle fatigue in RA: reduced local blood flow in relation to vascular disease and vasculitis (Myllykangas-Luosujarvi et al, 1995), deconditioning (Ekdahl and Broman, 1992), the possibility of an increased ratio of type II: type I fibres (the former being more fatigable) and systemic disease may all play a part. Subjective fatigue has a reported incidence of up to 93 % (Belza, 1995). However, increased forearm muscle fatigue in rheumatoid disease was not demonstrated in this study. Indeed, subjects with RA worked at lower levels of muscular fatigue than did healthy individuals; this was associated with lower work intensities in the RA group. Working at lower levels of fatigue and at lower work intensities may be related to functional disability or to a protective mechanism against damaged and inflamed joints. No difference in the MDF_G between the two groups existed allowing for the difference in grip strength. It is possible that shortening of muscle fibres in relation to the disease and positions of immobilisation resulted in less marked power spectral shifts. This may have compensated for the other factors mentioned above which may have increased the spectral shifts.

Fatigue (measured by the MDF_G) was associated with the systemic activity of rheumatoid disease (measured by the CRP): the greater the disease activity, the greater was the extensor muscle fatigue experienced by subjects with RA. Greater disease severity, (measured by ulnar deviation of the hand and wrist) was also associated with greater fatigability of both the extensor and flexor forearm muscles. The association between reduced fatigability with greater hand and wrist subluxation scores in the flexor muscle group may be associated with flexor muscle shortening in such a deformity. The relationship demonstrated between joint stiffness - a measure of local disease activity - and reduced fatigability of the extensor forearm muscles again raises the issue of arthrogenous inhibition of muscle fibres playing a protective role in preventing excess fatigue from occurring.

Greater muscle fatigue was seen in the extensor muscles compared to the flexor muscles during grip in both the healthy subjects and in those with RA. The importance of the extensor forearm muscles to the vital task of gripping is often overlooked. As Hagg and Milerad (1997) point out, electromyographic studies of gripping have focused mainly on forearm flexors, in spite of the need for the extensors to stabilise the wrist against the action of the flexors (Snijders et al, 1987). Greater fatigue in the extensor muscles in

comparison to the flexors has been noted by other workers (Hagg and Milerad, 1997; Roy et al, 1991). These workers concluded that this is related to the work of the extensors in stabilising the wrist. This vital action of stabilising the wrist emphasises the fact that if the extensors are weakened then grip strength is likely to decline. Individuals with rheumatoid disease are often observed with their hands in a resting posture involving wrist forward flexion. This may be related to increasing the joint volume, making this position more comfortable in active disease. Unfortunately, it also is likely to contribute to over activity of the flexors and the resulting typical rheumatoid deformities (Smith et al, 1964). In addition, the extensors would be suspected of becoming more deconditioned, contributing to the deterioration in grip strength. This was an important factor in the handgrip exercise which individuals performed, which emphasised the action of pulling the wrist into 30 degrees of extension, thereby exercising the extensors even before the gripping task was commenced.

Subjective fatigue was not assessed in this study and therefore the relationship between subjective and objective fatigue cannot be reported. However, the high reported prevalence of fatigue in RA in spite of the lack of any demonstrable forearm muscle fatiguability in handgrip exercise indicates there is no relationship between the two parameters. This does not exclude the possibility of excessive fatiguability in rheumatoid muscle during other tasks, particularly dynamic exercise.

9.6 The response to a handgrip exercise programme in RA.

The handgrip exercise programme was found to be highly successful, particularly in subjects with rheumatoid disease. Significant gains in grip strength were noted, with no exacerbation of disease activity. In addition, no subjects withdrew from the programme. Such findings emphasise that simple home strength training programmes in rheumatoid arthritis can be highly effective in improving function without exacerbating disease activity.

The primary outcome measure of the handgrip exercise programme was the gain in grip strength expressed as a percentage of the strength at baseline. The greatest response was seen in those with the greatest disease severity, indicated by the subluxation score, the

flexor IMF and lowest grip strength at baseline. These subjects evidently had “more to gain” and demonstrate that exercise can be of significant benefit even in severe disease.

The finding that the flexor IMF was a predictor of outcome to the hand exercise programme is highly significant, since it indicates that neuromuscular abnormalities, which are associated with the severity of the rheumatoid disease, do not prevent the ability to respond to a strengthening programme.

Greater disease activity was a limiting factor to the response to the exercise programme. This may be related to arthrogenous muscle inhibition, pain inhibition and joint stiffness. All subjects were urged to continue the exercises unless severe disease activity prevented them from doing so: there were only six reported incidences of days missed in relation to disease activity. In addition, the general improvement in disease activity measures in spite of the deterioration of left hand and general activity scores indicates that such exercise programmes do not exacerbate the disease and may actually help it. This has been demonstrated by Harckom et al (1985) in an aerobic conditioning programme in subjects with RA.

Those subjects with longer disease duration also showed less improvement compared to those with earlier disease. As has been emphasised earlier, these were stronger than those with earlier disease and were not those with more severe disease - indicating they had “less to gain” relative to their initial strength. In addition, the less pronounced improvement seen in subjects with longer disease duration may be related to the inability to neurally adapt in longstanding disease, although there is no evidence in the literature to support this.

Greater tenderness of the right hand and wrist was noted in those subjects who showed the greatest improvement in grip strength. As has been discussed, there was no overall exacerbation of disease activity during the programme. The increased local tenderness may have been related to greater use of the hand as a result of gains in hand function. Perhaps most significantly, it is evident that the increased tenderness was not a limiting factor in response to the exercise programme.

Reported compliance with the exercise programme was excellent, possibly related to an initial supervisory session, regular follow-up in the form of phone calls (Stenstrom, 1994) and 3-weekly assessment sessions, the ease of the regime and familiarity with the task involved and the noted improvement by the subjects over the course of the programme, encouraging further compliance. Some workers have reported disease severity to be a limiting factor in the compliance with exercise programmes in RA (Gecht et al, 1996). This was not the case in this study, possibly due to the factors relating to compliance, which have been detailed here.

9.7 Mechanisms of strength gain in the hand exercise programme.

The examination of mechanisms of strength gain in RA involved the assessment of the processes of neural adaptation and gains in muscle mass. Initial approaches to the assessment of muscle mass involved the assessment of the forearm cross-sectional area by two techniques, one utilising skinfold calipers and the other magnetic resonance imaging. The former technique was not found to be repeatable on same-day nor on between-day testing. Helliwell and Jackson (1994) used this technique in the assessment of the forearm CSA in rheumatoid subjects and controls. They did not report the repeatability of the measurement but did demonstrate a correlation between CSA calculated according to the caliperiper method and that derived from CSA assessment of the forearm using computed tomography scanning. Other workers have reported the accuracy of skinfold caliperiper techniques to be unsatisfactory in the assessment of muscle cross-sectional area (Haggmark et al, 1978; Young et al, 1980).

The CSA of the forearm assessed using MRI was shown to be a repeatable measurement. No change in the forearm CSA was demonstrated with handgrip exercise in spite of significant gains in grip strength in the rheumatoid subjects. No control subjects were assessed in the CSA study. The lack of change in forearm CSA in the RA subjects may have been related to a true lack of change of muscle mass or to a lack of sensitivity of the measurement, since gains in muscle mass could have occurred out of the region scanned. In addition, since rheumatoid myopathy may be patchy in

distribution, the CSA may not accurately reflect the muscle mass. This was the basis for proceeding to the study involving volumetric analysis of forearm musculature before and after the hand exercise programme. Such a technique has been described in the assessment of lower limb musculature, but not for the measurement of muscle volume in the forearm. The technique used was shown to be sensitive and reliable. Cross-sectional area was demonstrated to correlate with muscle volume in both subjects with rheumatoid disease and healthy controls. No correlation was demonstrated between forearm muscle mass (neither the muscle cross-sectional area nor the muscle volume) and grip strength in subjects with RA nor controls. This illustrates that grip strength does not just rely upon muscle mass in health nor in joint disease.

The mechanisms of strength gain were studied in subgroups of rheumatoid and control subjects. Volumetric analysis of forearm musculature demonstrated that healthy subjects gained forearm muscle mass in response to the handgrip exercise programme. However, in spite of significant gains in grip strength by rheumatoid subjects, there was no gain in forearm muscle mass in this group. This is in agreement with the findings of Nordemar et al (1976b), who demonstrated atrophy of both type I and II muscle fibres in the quadriceps muscles of subjects with RA prior to a lower limb conditioning and strengthening exercise programme, but no change in the fibre size after 7 months. However, in a different study, the same workers showed a gain in muscle fibre size in a similar strength training regime after 6 weeks (Nordemar et al, 1976a). The findings in this study would indicate that gains in strength in this group occurred through the process of neural adaptation. This also seems likely from the time course noted in strength gain, with the improvements being noted predominantly in the first half of the programme. However, the occurrence of neural adaptation cannot be confirmed by the examination of the $FRMS_G$ (the neuromuscular efficiency), which showed a wide variation over the course of the study in both the RA and control groups, unrelated to strength gains. For example, some subjects showed significant gains in strength without gains in forearm muscle mass - indicating that neural adaptation was the main mechanism of strength gain. However, the $FRMSG$ showed a *decline* over the 3 month period, which is not consistent with either neural adaptation nor gains in muscle mass.

These findings indicate that the RMS of the SMES recorded from the forearm during grip is not a stable parameter over the course of a 3-month handgrip exercise

programme. As a result, the use of the relationship between grip force and the RMS (the $FRMS_G$) to define mechanisms of strength gain in such a programme is unreliable.

It seems likely therefore that subjects with rheumatoid disease gained strength predominantly through the process of neural adaptation. The ability to neurally adapt is vital to strength gain in a training programme (Enoka, 1988). Those subjects with more severe disease – and highest IMFs, possibly reflecting neuromuscular abnormalities - showed the greatest benefit relative to their initial function, indicating that the ability to neurally adapt is not limited in rheumatoid disease. The ability of reinnervated muscle to neurally adapt in response to strength training is not reported. Muscle weakness related to a disuse atrophy has been reported to improve with strengthening programmes (Hakkinen et al, 1994). However, this assumes that the injury or disease which led to the initial disuse atrophy has resolved, which is not the case in the ongoing process of rheumatoid disease.

9.8 Implications for exercise programmes in rheumatoid disease.

The demonstration that functional home based strength exercise programmes are safe and effective in subjects with RA with a wide range of age, disease duration and disease severity, indicates that such programmes should be used more regularly. Neither neuromuscular abnormalities nor muscle fatiguability were found to be limiting factors in the response to this programme. Indeed, those subjects who gained the most relative to their baseline hand function were those with severe disease, which included the most extreme neuromuscular abnormalities within the group, indicated by the elevated IMF.

Although it cannot be assumed that similar responses will be obtained with dynamic strength training regimes, there seems little reason to suspect that such regimes would be limited by the neuromuscular changes in rheumatoid subjects which were reflected in the increased IMF of the SMES. Dynamic strength training regimes have the advantage of reflecting functional activities more than do many isometric exercises and can result in greater gains in strength. Those studies of dynamic strength training programmes in RA indicate that such programmes are safe and effective (Stenstrom et al, 1997) and may be more effective than static training programmes (Ekdahl et al, 1990). Whether

excessive fatiguability during such dynamic strengthening exercise is present in RA would be more difficult to investigate with analysis of the frequency spectrum of the SMES, since the technique is based on the use of static muscular contractions (Stulen & DeLuca, 1979).

The use of aerobic conditioning programmes has potential advantages in RA, since these individuals are deconditioned and at increased risk of cardiovascular disease (Wollheim, 1993; Myllykangas-Luosujarvi et al, 1995). Strength training involves mostly the adaptations of type II fibres which, on the basis of the myoelectric findings described above, may have predominated in the forearms of the rheumatoid subjects. The response to more aerobically based, submaximal programmes involving type I fibres cannot be predicted from this study. However, the safety of the handgrip exercise programme in spite of high intensities of effort is reassuring when considering the potential safety of less intensive, aerobic programmes. Studies by Nordemar et al (1976b) confirm the safety of such forms of exercise in rheumatoid subjects.

9.9 Further work.

The list of the areas within the broad field of exercise and neuromuscular function in rheumatoid disease which merit research is endless. The work detailed in this study indicates that neuromuscular changes are evident in RA and related to the severity of the disease. These neuromuscular abnormalities are suggestive of type II muscle fibre predominance, either due to disuse atrophy of type I fibres or to the reinnervation predominantly by type II motor neurones of denervated muscle fibres. Such changes do not limit the response to a simple but effective handgrip strengthening programme. Whether they do have an impact upon the outcome to aerobic conditioning programmes in RA, which rely predominantly upon type I fibres programmes requires further investigation, since such programmes have numerous potential benefits in this disease. Similarly, the effect upon dynamic strengthening regimes is also a worthy focus for further research.

No abnormal fatiguability of muscle during forearm handgrip was demonstrated in subjects with rheumatoid arthritis in spite of the reported high prevalence of subjective

fatigue in this disease. This does not exclude excessive fatiguability during other forms of exercise, that is high intensity dynamic and lower intensity aerobic work. Since this may be a limiting factor in the response to rehabilitation programmes and will influence the design of such regimes, the fatiguability of muscle in rheumatoid disease during such tasks also merits investigation.

No gain in forearm muscle mass was demonstrated in females with RA in spite of the demonstration of increases in muscle mass in healthy controls. This was not a limiting factor in the response to the exercise programme, but the question remains as to whether muscle hypertrophy can occur in rheumatoid disease. Dynamic strengthening programmes have been shown to be safe in subjects with RA, the assessment of changes in muscle mass in such programmes is warranted.

9.10 Summary

The technique of power spectral analysis of the SMES recorded from forearm musculature during sustained handgrip was shown to be a reliable technique over same day testing in both healthy females and those with rheumatoid disease. Specific spectral parameters, the initial median frequency and spectral width, were highly repeatable over long term testing and were independent of the intensity of grip over the force range 33.2 to 66.7% MGS. The RMS of the SMES and the MDF_G were linearly related to grip force over this force range. The repeatability of the median frequency gradient was unsatisfactory for long term monitoring of forearm muscle fatigue. Although the RMS of the SMES was shown to be a repeatable measure over a 3 week period, it was demonstrated to be an unstable parameter over the course of the exercise programme by examination of the neuromuscular efficiency. The latter finding confirms the opinion of others (Lindeman & Drukker, 1994) that this measure is not a sensitive technique for the assessment of mechanisms of strength gain in handgrip exercise programmes.

The home based functional task related handgrip exercise programme was demonstrated to be a highly effective method of improving hand function in rheumatoid disease. Those subjects with the most severe disease and lowest levels of hand function

benefited the most from such a programme. There was no evidence of increased disease activity. In fact there was some improvement in the local disease activity in spite of deterioration in systemic disease activity and contralateral disease activity scores during the course of the programme.

The findings in this study indicate that neuromuscular abnormalities do exist in skeletal muscle of females with RA and are evident during the performance of a functional task. Such abnormalities are related to the severity of the disease and the systemic disease activity, but do not result in excessive fatiguability of the muscle. Subjects with RA work at lower levels of fatigue, in association with lower work intensities. Although muscle fatigue levels in RA are not excessive, greater fatiguability of rheumatoid muscle is associated with greater systemic disease activity and the severity of the disease. These neuromuscular abnormalities are suggestive of type II muscle fibre predominance, either due to disuse atrophy of type I fibres or to the reinnervation predominantly by type II motor neurones of denervated muscle fibres. Such changes do not limit the response to a simple but effective handgrip strengthening programme.

In the assessment of mechanisms of strength gain in response to the handgrip exercise programme, the use of the parameter neuromuscular efficiency, was not found to be a useful indicator of the mechanisms of response. Similarly, skinfold calliper techniques were not demonstrated to be repeatable nor accurate measures of forearm cross-sectional area. A sensitive and reliable technique for the assessment of forearm muscle mass involving volumetric analysis using magnetic resonance imaging was developed. No gains in muscle mass were demonstrated in females with rheumatoid disease, although changes in this parameter in healthy females were demonstrated.

Chapter Ten. Conclusions.

The use of power spectral analysis of the surface myoelectric signal recorded from forearm musculature is a reliable technique in the investigation of neuromuscular features of rheumatoid disease. The initial median frequency (IMF) of the SMES is repeatable over both short-term and long-term testing and may reflect the presence of neuromuscular abnormalities in the forearm musculature in females with functional classes I or II RA derived from a hospital population. Such abnormalities are detectable during the performance of a simple, functional task.

The median frequency gradient of the SMES is a repeatable and sensitive parameter on same-day testing although showed a poor repeatability on long-term testing. This indicates that it is a useful indicator of the state of fatiguability of forearm muscle at a given time, but is not a reliable measure for the monitoring of forearm muscle fatigue over long intervals. . This parameter is linearly related to grip force over the force range 33.3 to 66.7 % MGS.

The neuromuscular abnormalities demonstrated in the forearm musculature of females with RA during handgrip are suggestive of type II muscle fibre predominance, either due to disuse atrophy of type I fibres or to the reinnervation predominantly by type II motor neurones of denervated muscle fibres. These abnormalities are related to the severity of the disease and the systemic disease activity, but do not result in excessive fatiguability of the muscle. Subjects with RA work at lower levels of fatigue, in association with lower intensities of work. Although muscle fatigue levels in RA are not excessive, greater fatiguability of rheumatoid muscle is associated with greater systemic disease activity and the severity of the disease. Such changes do not limit the response to a simple but effective handgrip strengthening programme.

Home based handgrip strengthening exercise is a simple, safe and effective method of improving hand function in females with rheumatoid disease. Individuals with severe disease may benefit the most from such a programme. Gains in muscle mass were not

essential in the response to such a strengthening programme and indicate that neural adaptation is possible in subjects with rheumatoid disease.

Chapter Eleven. References.

Ahlborg B, Bergenstrom J, Ekelund LG, Guarnien G, Harris RC, Hultman E, Nordesjo L O. Muscle metabolism during isometric exercise performed at constant force. *J Appl Physiol* 1972; 33: 224-228.

Alfonsi E, Ricciardi L, Arrigo A, Lozza A, Sandrini, G, Zandrini C, Moglia A. Local venous lactate changes and spectral analysis of surface EMG during fatiguing isometric efforts in intrinsic hand muscles. *Functional neurology* 1991; 6: 121-127.

Amick LD. *Arthritis Rheum* 1960; 3: 54.

Andersson GBJ, Herberts P, Ortengren R. Myoelectric back muscle activity in standardised lifting postures. In: Komi PV, editor. *International Series on Biomechanics. Volume 1A. Biomechanics V-A*. University Park Press, 1976; 520-529.

Appell HJ. Muscular atrophy following immobilisation. *Sports medicine*. 1990; 10: 42-58.

Arendt-Nielsen L, Mills KR, Forster A. Changes in muscle fibre conduction velocity, mean power frequency and mean EMG voltage during prolonged submaximal contractions. *Muscle Nerve* 1989; 12: 493 -497.

Arendt-Nielsen L, Mills KR. Muscle fibre conduction velocity, mean power frequency, mean EMG voltage and force during submaximal fatiguing contractions of human quadriceps. *Eur J Appl Physiol* 1988; 58: 20-25.

Arkin M. Absolute muscle power. *The internal kinesiology of muscle*. Research Seminar Notes, Dept. of Orthopaedic Surgery, State University of Iowa. 1938; 12D:123.

Arnett FC, Edworthy SM, Bloch DA et al. The American Rheumatism Association 1987 Revised criteria for the classification of rheumatoid arthritis. *Arth Rheum*. 1988; 31(3): 315-324.

Arvidsson I, Eriksson E. Postoperative TENS pain relief after knee surgery.: objective evaluation. *Orthopaedics* 1986; 9: 1346-1351.

Asmusen E, Hansen O, Lammert O. The relation between isometric and dynamic muscle strength in man. *Comm Dan Nat Assoc Inf Paral*. 1965; 20: 11-

Atha J. Strengthening muscle. *Exerc. Sports Sci Review* 1981; 9: 1-73.

Basano L, Ottonello P. Real-time FFT to monitor muscle fatigue. *IEEE Trans Biomed Eng.* 1986; BME 33 (11): 1049-1051.

Basmajian JV, DeLuca CJ. *Muscles alive: Their functions revealed by electromyography.* 5th Edn. Baltimore: Williams & Wilkins. 1985.

Basmajian JV. Control and training of individual motor units. *Science* 1963; 141: 440-441.

Bawa P, Binder MD, Ruenzel P, Henneman E. Recruitment order of motoneurons in stretch reflexes is highly correlated with the axonal conduction velocity. *J Neurophysiol* 1984; 52: 410-420.

Bazzy AR, Korten JB, Haddad GG. Increase in electromyogram low-frequency power in nonfatigued contracting skeletal muscle. *J Appl Physiol* 1986; 61:1012-1017.

Beals CA, Lampman RM, Banwell BF et al. Measurement of exercise tolerance in patients with rheumatoid arthritis and osteoarthritis. *J Rheumatol* 1985; 12: 458-461.

Beliveau L, HHelal JN, Gaillard E, Van Hoeke J, Atlan G, Bioussou P. EMG spectral shift and ³¹P-NMR-determined intracellular pH in fatigued human biceps brachii muscle. *Neurology.* 1991; 41: 1998-2001.

Beliveau L, Van Hoeke J, Garapon-Bar C, Gaillard E, Herry JP, Atlan G, Bouissou P. Myoelectrical and metabolic changes in muscle fatigue. *Int J Sp Med.* 1992; 13: S153-155.

Belza BL. Comparison of self-reported fatigue in rheumatoid arthritis and controls. *J Rheumatol* 1995; 22: 639-643.

Bendahan D, Jammes Y, Salvan AM, Badier M, Confort-Gouny S, Guillot C, Cozzone PJ. Combined electromyography-³¹P magnetic resonance spectroscopy study of human muscle fatigue during static contraction. *Muscle Nerve.* 1996; 19: 715-721.

Bethlem J. *Muscle pathology.* Amsterdam-London: North Holland Publishing Company. 1970.

Bigland B & Lippold OCJ. Motor unit activity in the voluntary contraction of human muscle. *J Physiol (London).* 1954a; 125:322-335.

Bigland B, Lippold OCJ. The relation between force, velocity and integrated electrical activity in human muscles. *J Physiol* 1954b; 123: 214-224.

Bigland Ritchie B, Woods JJ. Changes in muscle contractile properties and neural control during human muscular fatigue. *Muscle Nerve* 1984; 7(9): 691-699.

Bigland Ritchie B, Cafarelli E, Vollestad NK. Fatigue of submaximal contractions. et al, *Acta Physiol Scand* 1986; 128: Suppl 556: 137-148.

Bigland-Ritchie B, Donovan EF, Roussos CS. Conduction velocity and EMG power spectrum changes in fatigue of sustained maximal efforts. *J Appl Physiol*. 1981; 51: 1300-1305.

Bigland-Ritchie B. EMG and fatigue in voluntary and stimulated contractions. In: *Proceedings of Ciba Foundation Symposium on Human Muscle fatigue : Physiological mechanisms*. 1981c; London: Pitman. Pp 130 - 156.

Bigland-Ritchie B. EMG/force relations and fatigue of human voluntary contractions. *Ex Sp Sci Rev*. 1981b;9 : 75 - 117.

Bilodeau M, Arsenault AB, Gravel D, Bourbonnais D. EMG power spectra of elbow extensors during ramp and step isometric contractions. *Eur J Appl Physiol* 1991; 63: 24 - 28.

Bilodeau M, Arsenault AB, Gravel D, Bourbonnais D. The influence of an increase in the level of force on the EMG power spectrum of elbow extensors. *Eur J Appl Physiol* 1990; 61: 461-466.

Blake DR, Merry P, Unsworth J et al. Hypoxic reperfusion injury in the inflamed human joint. *Lancet* 1989; 1: 289-293.

Blanchi JP, Vila A. Numerical analysis of electromyographic signals: definitions of three parameters for functional muscular value analysis. *Electromyogr Clin Neurophysiol*. 1985; 25: 245-252.

Boers M, van Riel PLCM, Felson DT, Tugwell P. Assessing the activity of rheumatoid arthritis. *Bailliere's Clinical Rheumatology* 1995; 9 (2): 305-317.

Borg G, Gunnar . Rate of perceived exertion. *Med Sci Sports Exercise* 1982; 14: 377-381.

Bouisset S. EMG and muscle force in normal motor activities. *Int Congr EMG 4th Brussels*, S Karger, Basel, 1973. 1.

Bouissou P, Estrade PY, Goubel F, Guezennec CY, Serrurier B. Surface EMG power spectrum and intramuscular pH in vastus lateralis muscle during dynamic exercise. *J Appl Physiol* 1989; 67: 1245-1249.

Braakhekke JP, Stegeman DF, Joosten EMG. Increase in median power frequency of the myoelectric signal in pathological fatigue. *Electroenceph Clin Neurol* 1989;73: 151-156.

Bracchi F, Decandia M, Gaultierotti T. Frequency stabilization in the motor centers of spinal cord and caudal brain stem. *Am J Physiol* 1966; 210: 1170-1177.

Brewerton DA. Hand deformities in rheumatoid disease. *Ann Rheumat Dis* 1957; 16:183-197.

Brighton SW, Lubbe JE, van der Merwe CA. The effect of a long term exercise programme on the rheumatoid hand. *Br J Rheum* 1993; 32(5): 392-395.

Brody L, Pollock M, Roy SH, Celli B, DeLuca CJ. Effects of bath pH on EMG median frequency and conduction velocity in the hamster diaphragm. In: *Electromyographical Kinesiology*. P Andersson, D Hobart, J Danoff (eds). Amsterdam: Elsevier 1990; 267-270.

Brody LR, Pollock MT, Roy SH, DeLuca CJ, Celli B. pH induced effects on median frequency and conduction velocity of the myoelectric signal. *J Appl Physiol* 1991; 71: 1878-1885.

Broman H, Bilotto G, DeLuca CJ. Myoelectric signal conduction velocity and spectral parameters : influence of force and time. *J Appl Physiol*. 1985; 58:1428-1437.

Broman H, Kadefors R. A spectral moment analyser for quantification of electromyograms. *Proc 4th Cong Int Soc Ephysiol & Kin*. 1979; 90-92.

Brooke MH, Kaplan H. Muscle pathology in rheumatoid arthritis, polymyalgia rheumatica and polymyositis: a histochemical study. *Arch pathol*. 1972;94:101-118.

Brooks GA, Fahey TD. In: *Exercise physiology: Human Bioenergetics and its Applications*. New York: Macmillan 1985.

Bunnell S. Surgery of the rheumatic hand. *JBJS* 1955; 37A; 759-808.

Burke RE. Motor units: anatomy, physiology, and functional organisation. in: Brooks VB (ed): *Handbook of Physiology. The Nervous System. Motor Control*. Bethesda, MD, American Physiological Society. 1981; 2: 345-422.

Cantrell T. Measurement of weakness and dysfunction in the rheumatoid hand. *Rheum Rehabil* 1976; 15: 182-183.

Cape CA, Johnson WW, Pitner SE. Nemaline structures in polymyositis. *Neurology (Minneapolis)* 1970; 20: 494-502.

Carr J, Shepherd RB. A motor learning model for rehabilitation . In: *Movement Science: Foundations for Physical Therapy in Rehabilitation* (Carr J, Shepherd RB, eds). London: Heinemann. 1987.

Carus DA, Hennedy J, Jain JS. A description of a versatile microcomputer-based system for the clinical measurement of hand strength. *Eng in med* 1985;14(3)137-140.

Chan RC, Chuang TY. Power spectrum analysis of EMG at different voluntary efforts in normal subjects. *Chin Med J*. 1996; 57: 54-58.

Chapman AE, Troup JDG. Prolonged activity of erector spinae : an electromyographic and dynamometric study of the effect of training. *AnnPhys Med*. 1970; 10:262-269.

Christensen H, Fuglsang-Frederiksen A. Quantitative surface EMG during sustained and intermittent contractions. *E2* 1988; 70: 239-247.

Clamann HP. Activity of single motor units during isometric tension. *Neurology* 1970; 20: 255-260.

Clancy EA, Hogan N. Estimation of joint torque from the surface EMG. *Proc 13th Annu Int Conf IEEE EMBS* 1991; 13; 877..

Clarke DH. Adaptations in strength and muscular endurance resulting from exercise. *Exerc Sports Sci Review*. 1973; 1: 73 -102.

Clough DH. The effects of cognitive distortion and depression on disability in rheumatoid arthritis. *Res Nurs Health* 1991; 14: 439-446.

Cnockaert JC, Linsel G, Pertuzon E. Relative contribution of individual muscles to the isometric contraction of a muscular group. *J Biomech* 1975; 8: 191-197.

Couch NP, Dmochowski JR, Van de Water, Harken DE, Moore FD. Muscle surface pH as an index of peripheral perfusion in man. *Ann Surg*. 1971; 173: 173-183.

Cooper RG, Stokes MJ, Sweet C, Taylor RJ, Jayson MIV. Increased central drive during fatiguing contractions of the paraspinal muscles in patients with chronic low back pain. *Spine* 1993; 18: 610-616.

Cruz Martinez A, Ferrer MT and Perez Conde MC. Automatic analysis of the electromyogram. 2. Studies in patients with primary muscle disease and neurogenic involvement . Comparison of diagnostic yields versus individual motor unit potential parameters. *Electromyogr Clin Neurophysiol* 1984; 24: 17-38.

Cullen MJ, Mastaglia FL. Pathological reactions of skeletal muscle. In: Mastaglia FL, Walton J eds: *Skeletal muscle pathology*. Edinburgh: Churchill Livingstone 1982; 88-139.

Curtis AC, Pollard HM. *Ann Intern Med*, 1940;13:2265.

Daanen HAM, Mazure M, Holewijn M, Van der Velde EA. Reproducibility of the mean power frequency of the surface electromyogram. *Eur J Appl Physiol* 1990; 61: 274-277.

Danneskiold-Samsoe B & Grimby G. Isokinetic and isometric muscle strength in patients with rheumatoid arthritis. The relationship to clinical parameters and the influence of corticosteroid. *Clin Rheum*,1986;5: 459-467.

Dawson MJ, Gadian DG, Wilkie DR. Contraction and recovery of living muscles studied by ³¹P nuclear magnetic resonance. *J Physiol* 1977; 267: 703-735.

de Andrade JR, Grant C, Dixon A St J. Joint distension and reflex muscle inhibition in the knee. *J Bone Joint Surg* 1965; 47: 313-322.

Dellhag B, Wollersjo I, Bjelle A. Effect of active hand exercise and wax bath treatment in rheumatoid arthritis patients. *Arthritis Care and Research* 1992; 5(2): 87-93.

DeLorme TL, Watkins AL. *Progressive resistance exercise*. New York, Appleton-Century. 1951.

DeLuca CJ, Creigh JL. Do the firing statistics of motor units modify the frequency content of the EMG signal during sustained contractions? Biomechanics IXA. In: Winter DA (ed) Human Kinetics Publishers Inc, Champaign, Ill., USA. 1985; 358-362.

DeLuca CJ. Myoelectric manifestation of localised muscular fatigue in humans. CRC Biomed Eng 1985; 11: 251-279.

DeLuca CJ, Erim Z. Common drive of motor units in regulation of muscle force. Trends Neurosci 1994; 17: 299-305.

DeLuca CJ, LeFever RS, McCue MP, Xenakis AP. Behaviour of human motor units in different muscles during linearly varying contractions. J Physiol (Lond) 1982a; 329: 113-128.

DeLuca CJ, LeFever RS, McCue MP, Xenakis AP. Control scheme governing concurrently active motor units during voluntary isometric contractions. J Physiol (Lond) 1982b; 329:129-142.

DeLuca CJ, Sabbahi MA, Stulen FB, Bilotto G. Some properties of the median frequency of the myoelectric signal during localised muscular fatigue. Proc 5th Int Symp Biochem Exerc. Chicago, Human Kinetics, 1983; 175-186.

Desmedt JE, Godaux E. Spinal motoneuron recruitment in man: deordering with direction, but not with speed of voluntary movement. Science Wash. DC 1981; 214:933-936.

Devlin J, Lilley, J, Gough A, Huissoon A, Holder R, Reece R, Perkins P, Emery P. Clinical associations of dual-energy x-ray absorptiometry measurement of hand bone mass in rheumatoid arthritis. Br J Rheum 1996; 35: 1256-1262.

DeVries HA. "Efficiency of electrical activity as physiological measure of functional state of muscle tissue. Am J Phys Med 1968; 47: 10-22.

Dolan P, Mannion AF, Adams MA. Fatigue of the erector spinae muscles. A quantitative assessment using "frequency banding" of the surface electromyography signal. Spine; 1995; 20: 149-159.

Downie WW, Leatham PA, Rhind VM, Pickup ME, Wright V. The visual analogue scale in the assessment of grip strength. Ann Rh Dis 1978;37:382-384.

Duchene J, Goubel F. EMG spectral shift as an indicator of fatiguability in an heterogeneous muscle group. Eur J Appl Physiol 1990; 61: 81 - 87.

Duchenne J, Goubel F. Surface electromyogram during voluntary contraction: processing tools and relation to physiological events. *Crit Rev Biomed Eng.* 1993; 21(4): 313-397.

Duhamel P & Vetterli M. Fast fourier transforms: a tutorial review and a state of the art. *Signal Processing.* 1990; 19: 259.

Edgerton VR, Goslo GE Jr, Rasmussen SA, Spector SA. Is resistance of a muscle to fatigue controlled by motor neurones? *Nature* 1980; 285: 589-590.

Edstrom L, Grimby L. Effect of exercise on the motor unit. *Muscle and Nerve* 1986; 9: 104-126.

Edstrom L, Nordemar R. Differential changes of type I and type II muscle fibres in rheumatoid arthritis. *Scand J Rheum,* 1974;3:155-160.

Edwards RG, Lippold OCJ. The relation between force and integrated electrical activity in fatigued muscle. *J Physiol.* 1956; 132: 677-681.

Edwards RHT, Hill DK, Jones DA. Heat production and chemical changes during isometric contractions of the human quadriceps muscle. *J Physiol* 1975a; 251: 303-315.

Edwards RHT, Hill DK, Jones DA, Merton PA. Fatigue of long duration in human skeletal muscle after exercise. *J Physiol* 1977; 272: 769-778.

Edwards RHT. Human muscle function and fatigue: physiological mechanisms. Pitman Medical, London (Ciba Foundation symposium 82) 1981; pp 1-18.

Ekblom B, Lovgren O, Alderin M, Fridstrom M, Satterstrom G. Physical performance in patients with rheumatoid arthritis. *Scand J Rheum* 1974; 3: 121 - 125.

Ekdahl B, Broman G. Muscle strength, endurance and aerobic capacity in rheumatoid arthritis: a comparative study with healthy subjects. *Annals Rheum Dis* 1992; 51: 35-40.

Ekdahl C, Andersson SI, Moritz U, Svensson B. Dynamic versus static training in patients with rheumatoid arthritis. *Scand J Rheumatol* 1990; 19: 17-26.

Ekdahl C. Muscle function in rheumatoid arthritis. Assessment and training. *Scand J Rheum* 1990; 86 (suppl): 9-61.

Engel AG. Late-onset rod myopathy (a new syndrome?): light and electron microscopic observations in two cases. *Proc Mayo Clin* 1966a; 41: 713-741.

Engel WK. A critique of congenital myopathies and other disorders. In: Milhorat AT (ed), *Exploratory concepts in muscular dystrophy and related disorders*, Amsterdam: Philadelphia: Lea and Febiger 1966b; 27-40.

Engel WK. Selective and nonselective susceptibility of muscle fibre types. *Arch Neurol* 1970; 22: 97-117.

Engel WK. Brief, small abundant motor unit action potentials. A further critique of electromyographic interpretation. *Neurology* 1975; 25: 173-176.

Engstrom CM, Loebe GE, Reid JG, Forrest WJ, Avruch L. Morphometry of the human thigh muscles. A comparison between anatomical sections and computed tomographic and magnetic resonance images. *J Anat* 1991; 176: 139-156.

Enoka RM. Muscle strength and its development. New perspectives. *Sports Medicine* 1988; 6: 146-168.

Erim Z, DeLuca CJ, Mineo K, Aoki T. Rank ordered regulation of motor units. *Muscle & Nerve* 1996; 19: 563-573.

Fallentin N, Sidenius B, Jorgensen K. Blood pressure, heart rate and EMG in low level static contractions. *Acta Physiol Scand.* 1985;125:265-275.

Farrell AJ, Williams RB, Stevens CR, Lawrie AS, Cix NL, Blake DR. Exercise induced release of von Willebrand factor: evidence for hypoxic reperfusion microvascular injury in rheumatoid arthritis. *Ann Rheum Dis* 1992; 51 (10): 1117-1122.

Fess EE, Moran C. Clinical assessment recommendations. Indianapolis: American Society of Hand Therapists Monograph. 1981.

Fex J, Krakau ET. Some experiences with Waltons frequency analysis of the electromyogram. *J Neurol, Neurosurg & Psychiatry.* 1957; 20: 178-184.

Fink R, Luttgau HC. An evaluation of the membrane constants and the potassium conductance in metabolically exhausted fibres. 1976; 263: 215-238.

Fischer A, Merhautova J. Electromyographic manifestations of individual stages of adapted sports technique. In *Health and Fitness in the Modern World*, Chapter 13. Chicago, The Athletic Institute, Library of Congress No. 16-12315, 1961.

Flatt AE. The care of the rheumatoid hand. St Louis: C V Mosby & Co. 1963. 141-148.

Fleckenstein JL, Watumull D, Bertocci LA, Nurenberg P, Peshock RM, Payne JP, Haller RG. Muscle recruitment variations during wrist flexion exercise: MR evaluation. *J Comput Ass Tomogr* 1994; 18(3): 449-453.

Fox JL, Kenmore PI. The effect of ischaemia on nerve conduction. *Exp Neurol* 1967; 17:403-419.

Froese EA, Houston ME. Torque-velocity characteristics and muscle fibre type in human vastus lateralis. *J Appl Physiol* 1985; 59(2): 309-314.

Fuchs HA, Brooks RH, Callahan LF, Pincus T. A simplified twenty-eight joint quantitative articular index in rheumatoid arthritis. *Arthritis Rheum* 1989; 32(5): 531-537.

Fugelvand AJ, Winter DA, Patla AE. Models of recruitment and rate coding organisation in motor-unit pools. *J Neurophysiol* 1993; 70(6): 2470-2488.

Funderburgh CF, Hipskind SG, Welton RC, Lind AR. Development of and recovery from fatigue induced by static effort at various tensions. *J Appl Physiol* 1974; 37: 392-396.

Gecht MR, Connell KJ, Sinacore JM, Prohaska TR. A survey of exercise beliefs and exercise habits among people with arthritis. *Arthritis Care Res* 1996; 9: 82-88.

Gerdle B, Eriksson NE, Brundin L, Edstrom M. Surface EMG recordings during maximum static shoulder forward flexion in different positions. *Eur J Appl Physiol*. 1988; 57:415 - 419.

Gerdle B, Eriksson NE, Brundin L. The behaviour of the mean power frequency of the surface electromyogram in biceps brachii with increasing force and during fatigue. With special regard to the electrode distance. *Electromyogr Clin Neurol* 1990; 30: 483 - 489.

Gerdle B, Henriksson-Larsen K, Lorentzon R, Wretling ML. Dependence of the mean power frequency of the electromyogram on muscle force and fibre type. *Acta Physiol Scand*. 1991; 142: 457.

Gerdle B, Wretling M-L, Henriksson-Larsen K. Do the fibre type proportion and the angular velocity influence the mean power frequency of the electromyogram ? *Acta Physiol Scand* 1988b; 134: 341-346.

Gersten JW, Cenkovich FS, Jones GD. Harmonic analysis of Duchene muscular dystrophy. *Arch Phys Med* 1965; 44: 235-240.

Gilroy J. *Basic Neurology*. Second edition, Pergammon Press, 1990; pp 388-389.

Gollnick PD, Armstrong RB, Saubert CW IV et al. Enzyme activity and fiber composition in skeletal muscle of untrained and trained men. *J Appl Physiol* 1972; 33: 312-319.

Gordon T, Bambrick L, Orozco R. Comparison of injury and development in the neuromuscular system. In: *Plasticity of the neuromuscular system*. Wiley, Chichester (Ciba Foundation Symposium 138). 1981; 210-226.

Gordon T, Thomas CK, Stein RB, Erdebil S. Comparison of physiological and histochemical properties of motor units after cross reinnervation of antagonistic muscles in the cat hindlimb. *J Neurophysiol* 1988; 60: 365-378.

Gordon T, Patullo MC. Plasticity of muscle fibre and motor unit types. In Holloszy JO (ed): *Exercise and Sports Science Reviews*. Vol 21. Baltimore, Williams and Wilkins, 1993; 331-362.

Graudal H, Hvid N. *Acta Rheumatol Scand* 1959; 5: 34.

Grimby G, Thomee R. Principles of rehabilitation after injuries. In: *Olympic Book of Sports Medicine*. Dirix A, Knuttgen, HG, Tittel K (eds). Blackwell Scientific Publications, London. 1988; 489-502.

Grindulis KA, Calverley M. Grip strength: peak or sustained pressure in rheumatoid arthritis? *J Chron Dis* 1983; 36 (12): 855-868.

Hackel ME, Wolfe GA, Bang SM, Canfield JS. Changes in hand function in the aging adult as determined by the Jebsen Test of hand function. *Phys Ther* 1992; 72(5): 373-377.

Hagberg C, Hagberg M. Surface EMG amplitude and frequency dependence on exerted force for the upper trapezius: a comparison between right and left sides. *Eur J Appl Physiol* 1989; 58: 641- 645.

Hagberg C, Hagberg M. Surface EMG frequency dependence on force in the masseter and the anterior temporal muscles. *Scand J Dent Res* 1988; 96: 451 - 456.

Hagberg M, Ericson BE. Myoelectric power spectrum dependence on muscular contraction level of elbow flexors. *Eur J Appl Physiol* 1982; 48: 147-156.

Hagberg M. The elevated arm: myoelectric amplitude and spectral changes in some shoulder muscles. *Proc 4th Cong Int Soc Ephysiol & Kin.* 1979; 70-71.

Hagg GM, Milerad E. Forearm extensor and flexor exertion during simulated gripping work - an electromyographic study. *Clinical Biomech* 1997; 12(1): 39-43.

Hagg GM. Interpretation of EMG spectral alterations and alteration indexes at sustained contraction. *J Appl Physiol* 1992; 73(4): 1211-1217.

Haggmark T, Jansson E, Eriksson E. Fiber type area and metabolic potential of the thigh muscle in man after knee surgery and immobilisation. *Int J Sp Med.* 1981;2:12.

Haggmark T, Jansson E, Svare B. Cross-sectional area of the thigh muscle in man measured by computed tomography. *Scand J Clin Lab Invest* 1978; 38: 355-360.

Hakkinen K, Komi PV. Electromyographic and mechanical characteristics of human skeletal muscle during fatigue under voluntary and reflex conditions. *Electroenceph Clin Neurophysiol.* 1983; 55: 436.

Hakkinen K. Neuromuscular and hormonal adaptations during strength and power training. A review. *J Sports Med Phys Fitness.* 1989; 29(1): 9-26.

Hakkinen K, Pakarinen A, Allen M, Kauhanen H, Komi PV. Neural and hormonal adaptations to strength training in 2 years. *J Appl Physiol* 1988; 65(6): 2406-2412.

Hakkinen K. Neuromuscular adaptation during strength training, aging, detraining and immobilisation. *Clin Rev Physical Rehabil Med* 1994; 6(3): 161-198.

Hakkinen A, Hakkinen K, Hannonen P. Effects of disease activity in patients with recent onset inflammatory arthritis. *Scand J Rheumatol* 1994; 23(5): 237-242.

Halla JT, Koopman WJ, Fallahi S, Oh SJ, Gay RE, Schrohenloher RE. Rheumatoid myositis. Clinical and histologic features and possible pathogenesis. *Arth Rheum* 1984;27:737-743.

Hannerz J. Discharge properties of motor units in relation to recruitment order in voluntary contraction. *Acta Physiol Scand* 1974a; 91: 374-384.

Hara T. Evaluation of recovery from local muscle fatigue by voluntary test contractions. *J Human Ergol*. 1980; 9:35-46.

Harckom TM, Lampman RM, Banwell BF, Castor CW. Therapeutic value of graded aerobic training in rheumatoid arthritis. *Arthritis Rheum* 1985; 28: 32-39.

Harkness JA, Richter MB, Panayi GS, van de Pelte K, Unger A, Pownall R, Geodawj M. Circadian variation in disease activity in rheumatoid arthritis. *Br Med J Clin Res Ed*. 1982; 284(6315); 551-554.

Hary D, Belman MJ, Propst J, Lewis S. A statistical analysis of the spectral moments used in EMG tests of endurance. *J Appl Physiol*. 1982; 53: 779-783.

Haslock DI, Wright V, Harriman DGF. Neuromuscular disorders in rheumatoid arthritis. A motor point biopsy study. *Q J Med*; 1970; XXXIX: 155:335-358.

Helliwell PS, Jackson S. Relationship between weakness and wasting in rheumatoid arthritis. *Annals Rheum Dis* 1994; 53: 726-728.

Helliwell P, Howe A, Wright V. Functional assessment of the hand: reproducibility, acceptability and utility of a new system for measuring strength. *Annals Rheum Dis* 1987; 46: 203-208.

Henneman E. Relations between size of neurones and their susceptibility to discharge. *Science* 1957; 126: 1345-1347.

Herberts P, Kaiser E, Mabnusson R, Petersen I. Power spectra of myoelectric signals in muscles of arm amputees and healthy human controls. *Acta Orthop Scand* 1973; 44: 161-193.

Herbison G, Ditunno JF, Jaweed MM. Muscle atrophy in rheumatoid arthritis. *J Rheumatol* 1987; (suppl 15) 14: 78-81.

Herbison GJ, Jaweed MM, Ditunno JF. Muscle atrophy after cast immobilisation in the rat. *APMR*, 1978; 59: 301-5.

Hermens HJ, Boon KL, Zilvold G. The clinical use of surface electromyography. *Electromyogr Clin Neurophysiol* 1984; 24: 243-265.

Hoenig H, Groff G, Pratt K, Goldberg E, Franck W. A randomised controlled trial of home exercise on the rheumatoid hand. *J Rheumatol* 1993; 20: 785-789.

Hof AL and van den Berg JW. EMG to force processing. II. Estimation of parameters of the Hill muscle model for the human triceps surae by means of a calf ergometer. *J Biomech* 1983; 14: 759-770.

Hof AL, van den Berg J. Linearity between the sum of the EMGs of the human triceps surae and the total torque. *J Biomech* 1977; 10 (9): 529-539.

Hof AL, Pronk CNA, Van Best JA. Comparison between EMG to force processing and kinetic analysis for the calf muscle moment in walking and stepping. *J Biomech* 1987; 20: 167.

Hollander JL, McCarty DJ Jr (eds): *Arthritis and Allied Conditions*, ed 8. Philadelphia, Lea & Febiger 1972.

Horowitz M. *Ann Rheum Dis* 1949; 8: 258.

Horsman A, Leach AE. The estimation of the cross sectional area of the ulna and radius. *Am J Phys Anthropol*. 1974; 40: 173-185.

Howe TE, Oldham JA. The reliability of measuring quadriceps cross-sectional area with compound B ultrasound scanning. *Physiother Res Int* 1996; 1(2): 112-126.

Hsieh LF, Didenko B, Schumacher R, Torg JS. Isokinetic and isometric testing of knee musculature in patients with rheumatoid arthritis with mild knee involvement. *Arch Phys Med Rehabil* 1987; 68: 294 - 297.

Huijing PA, Adelerhof ASP, Giesbergen R, Woittix RD, Rijnsburger WH. Triceps surae EMG power spectrum changes during sustained contractions at different muscle lengths. *Electromyogr Clin Neurol* 1986; 26: 181-192.

Humphreys PW, Lind AR. The blood flow through active and inactive muscles of the forearm during sustained handgrip contractions. *J Physiol*. 1963; 166:120-135.

Inbar GF, Allin J, Kranz H. Surface EMG spectral changes with muscle length. *Med Biol Eng Comput.* 1987; 25: 683-689.

Kugelberg E. Electromyography in Neuromuscular Disorders. *J Neurol Neurosurg Psychiatr.* 1949; 12:129-136.

Parker J, Bender L. Pain in rheumatoid arthritis: relationship to demographic, medical and psychological factors. *J Rheumatol* 1988; 15: 433-437.

Jerusalem F, Goetze H, Mumenthaler M. Zur diagnostischen Spezifität von nemalinen Strukturen. *Z Neurol.* 1971; 200: 148-157.

Johansson S, Larsson LE, Ortengren R. An Automated method for the frequency analysis of myoelectric signal, evaluated by an investigation of the spectral changes following strong sustained contractions. *MJ* 1970; 8: 257-264.

Johnson M, Friedl K, Frykman P, Moore R. Loss of muscle mass is poorly reflected in grip strength performance in young men. *Med Sci Sports Exerc* 1994; 26: 235.

Johnson MA, Polgar J, Weightman D, Appleton D. Data on the distribution of fibre types in thirty-six human muscles. *J Neurol Sci* 1973;18: 111-129.

Larsson LE, Tesch PA. Motor unit fibre density in extremely hypertrophied skeletal muscles in man. Electrophysiological signs of muscle fibre hyperplasia. *Eur J Appl Physiol* 1986; 55(2): 130-136.

Jones AR. The development of a microcomputer controlled hand assessment system for quantitative clinical measurement. PhD Thesis, Univ Of Durham., 1984.

Jones DA, Round JM. Skeletal muscle in health and disease. A textbook of muscle physiology. Manchester Univ Press. 1990; pp 189-204.

Jones KE, Bawa P, McMillan AS. Recruitment of motor units in human flexor carpi ulnaris. *Brain Research* 1993; 602: 354-356.

Kadefors R, Kaiser E, Petersen I. Dynamic spectrum analysis of myopotentials with special reference to muscle fatigue. *Electromyography*, 1968; 8:39-74.

Kadefors R, Kaiser E, Petersen I. Muscular reaction to welding work : an electromyographic investigation. *Ergonomics.* 1976; 19: 543-558.

Kaiser E, Petersen I. Frequency analysis of action potentials during tetanic contraction. *Electroenceph & Clin Neurophysiol.* 1962; 14:955.

Kaiser E, Petersen I. Muscle action potentials studied by frequency analysis and duration measurement. *Acta Neurol Scand (suppl)* 1965; 13.

Kalla AA, Kotze TJvW, Meyers OL, Parkyn ND. Clinical assessment of disease activity in rheumatoid arthritis: evaluation of a functional test. *Annals Rheum Dis* 1988; 47: 773-779.

Karlsson J. Muscle ATP, CP and lactate in submaximal and maximal exercise. In : *Advances in experimental medicine and biology, vol III: Muscle metabolism during exercise*, Bpernow & B Saltin (eds). Elmsford, NY, Pergammon. 1971.

Karlsson J, Funderburk CF, Essen B, Lind AR. Constituents of human muscle in isometric fatigue. *J1*; 1975; 38: 208-211.

Kereshi S, Manzano G, McComas AJ. Impulse conduction velocities in human biceps brachii muscles. *Exp Neurol.* 1983; 80: 652-682.

Kernell D. The limits of firing frequency in cat lumbosacral motoneurons possessing different time course of afterhyperpolarisation. *Acta Physiol Scand* 1965; 65: 87-100.

Kilmer DD. Functional anatomy of skeletal muscle. *Physical Med Rehabil* 1996; 10(30): 413-426.

Kogi K & Hakamada T. Slowing of surface electromyogram and muscle fatigue. *Resp Inst. Sci Labour.* 1962; 60: 27-41.

Komi PV, Tesch P. Emg frequency spectrum, muscle structure and fatigue during dynamic contractions in man. *Eur J Appl Physiol Occup Physiol* . 1979; 42: 41-50.

Komi P. Training of muscle strength and power: interaction of neuromotoric, hypertrophic and mechanical factors. *Int J Sports Med (suppl).* 1986; 7; 10.

Kossev A , Gantchev N, Gydikov A, Gerasimenko Y, Christova P. The effect of muscle fibre length changes on motor units potentials propagation velocity. *Electromyogr Clin Neurophysiol.* 1992; 32: 287 - 294.

Kourinka I. Restitution of EMG spectrum after muscular fatigue. *Eur J Appl Physiol.* 1988; 57: 311-315.

Kramer H, Lun A, Mucke R, Kuchler G. Changes in mechanical and bioelectric activity and in heart rate due to sustained voluntary isometric contractions and time required for recovery. *Electromyogr Clin Neurophysiol* 1979; 19: 381-386.

Kranz H, Williams AM, Cassell J, Caddy DJ, Silberstein RB. Factors determining the frequency content of the electromyogram. *J Appl Physiol: Respirat. Environ Exercise. Physiol.* 1983; 55 (2): 392-399.

Krivickas LS, Scott SF, Nadler DO et al. Spectral analysis during fatigue. Surface and fine wire comparison. *Am J Phys Med Rehabil* 1996; 75: 15-20.

Krogh-Lund C, Jorgensen K. Changes in conduction velocity, median frequency, and root mean square-amplitude of the electromyogram during 25% maximal voluntary contraction of the triceps brachii muscle, to limit of endurance. *Eur J Appl Physiol* 1991; 63; 60 - 69.

Kugelberg E. Electromyography in Neuromuscular Disorders. *J Neurol Neurosurg Psychiatr.* 1949; 12:129-136.

Kuroda E, Klissouras V, Milsum JH. Electrical and metabolic activities and fatigue in human muscle contraction. *J Appl Physiol* 1970; 219: 1324-1329.

Lago P, Jones NB. Effect of motor unit firing time statistics on EMG spectra. *Med Biol Eng Comput.* 1977; 15: 648-655.

Lamoreaux L, Hoffer MM. The effect of wrist deviation on grip and pinch strength. *Clinical Orthop & Rel Res* 1995; 314: 152-155.

Lansbury J. Report of a three year study on the systemic and articular indices in rheumatoid arthritis: theoretic and clinical considerations. *Arthritis and Rheum.* 1958; 1: 505-522.

Larsson L. Morphological and functional characteristics of the ageing skeletal muscle in man. *Acta Physiol Scand Suppl.* 1978; 457: 1 - 36.

Larsson LE, Linderholm H, Ringqvist T. The effect of sustained and rhythmic contractions on the electromyogram. *Acta Physiol Scand* 1965; 65: 310 - 318.

Larsson LE. On the relation between the EMG frequency spectrum and the duration of symptoms in lesions of the peripheral motor neurone. *Electroencephalog Clin Neurophysiol* 1975; 38: 69-78.

Larsson L, Tesch PA. Motor unit fibre density in extremely hypertrophied skeletal muscles in man. Electrophysiological signs of muscle fibre hyperplasia. *Eur J Appl Physiol* 1986; 55(2): 130-136.

Latash ML. Spectral analysis of the electromyogram (EMG) in spinal cord trauma patients: I: different types of the EMG and corresponding spectra. *Electromyogr Clin Neurophysiol* 1988; 28: 319-327.

Lawrence JH, De Luca CJ. Myoelectric signal versus force relationship in different muscles. *J appl physiol:Respirat Environ Exercise Physiol.* 1983; 54 (6):1653-1659.

Lee P, Baxter A, Carson Dick W, Webb J. An assessment of grip strength measurement in rheumatoid arthritis. *Scand J Rheumatol* 1974; 3: 17-23.

Lenman JAR and Ritchie AE. *Clinical Electromyography*. 4th Edition 1987; Churchill Livingstone. pp14-160.

Lenman JAR, Potter JL. Electromyographic measurement of fatigue in rheumatoid arthritis and neuromuscular disease. *Ann Rheum Dis* 1966; 25: 76-84.

Lind AR, Petrofsky JS. Amplitude of the surface electromyogram during fatiguing isometric contractions. *Muscle Nerve* 1979; 2: 257-264.

Lindeman E, Drukker J. Surface EMG in neuromuscular disorders. *J Rehabil Sci* 1994; 7(3): 20-23.

Lindstrom L, Magnusson R, Petersen I. Muscular fatigue and action potential velocity changes studied with frequency analysis of EMG signals. *Electromyography* 1970; 10: 341-356.

Lindstrom L and Magnusson RI. Interpretation of myoelectric power spectra: A model and its applications. *Proceedings of the Institute of Electrical and Electronic Engineers*. 1977; 65: 653-662.

Lindstrom L, Kadefors R, Petersen I. An electromyographic index for localized muscle fatigue. *J appl physiol: Respirat Environ Exercise Physiol.* 1977; 43 (4): 750-754.

Lindstrom L. On the frequency spectrum of EMG signals. Thesis, Research Laboratories for medical electronics, Goteborg. 1970.

Lindstrom L. Contributions to the Interpretation of Myoelectric Power Spectra (thesis). Goteborg, Sweden: Chalmers Univ of technology. 1974.

Lindstrom L, Petersen I. Power spectra of myoelectric signals: motor unit activity and muscle fatigue. In: Stalberg E, Young RR (eds) *Clinical Neurophysiology*, Butterworths. 1981; 66-87.

Lindstrom L, Petersen I. Electromyography in muscle fatigue studies: power spectrum and analysis and signal theory aspects. In: *International Symposium on Biochemistry and Exercise (5th, 1982 Boston)*, ed H Knuttgen, JA Vogel, J Poortmans. Champaign IL. Human Kinetics 1983, p 187-196.

Lindstrom L, Petersen I. Power spectrum analysis of EMG signals and its applications. In: *Computer aided electromyography*, Desmedt, JE (ed), Karger, Basel. 1983; 1-51.

Lindstrom L, Malmstrom JE, Petersen I. Clinical applications of spectral analysis of EMG. In: *Struppler A and Weindl A (eds). "Electromyography and Evoked Potentials. Theories and Applications"* pp. 108-113; Springer-Verlag, Berlin e.a. 1985.

Linssen WHJP, Stegeman DF, Joosten EMG, Binkhorst RA, Merks MJH, Laak HJT, Notermans SLH. Fatigue in type I fiber predominance: a muscle force and surface EMG study on the relative role of type I and type II muscle fibers. *Muscle & Nerve* 1991; 14: 829-837.

Lippold OCJ. The relation between integrated action potentials in a human muscle and its isometric tension. *J Physiol* 1952; 117: 492-499.

Lippold OCJ, Redfearn JWT, Vuco J. The rhythmical activity of groups of motor units in the voluntary contraction of muscle. *J Physiol* 1957; 137: 473-487.

Long C, Conrad MS, Hall EA, Furler SL. Intrinsic-extrinsic muscle control of the hand in power grip and precision handling. *J Bone Jt Surg (Amer)*. 1970; 52A: 853-867.

Lumley JSP. *Surface Anatomy. The anatomical basis of clinical examination*. 1996; Churchill Livingstone.

Lyngberg K, Danneskiold-Samsoe B, Halskov O. The effect of physical training on patients with rheumatoid arthritis: Changes in disease activity, muscle strength and aerobic capacity: A clinically controlled minimized cross-over study. *Clin Exp Rheumatol* 1988; 6:253 - 260.

Lynne-Davies P, Coker M, Simkins D, Widrow B. Adaptive filtering in respirator electromyogram processing. *Proc 4th Cong Int Soc Ephysiol & Kin.* 1979; 170-171.

MacDougall JD, Elder GCB, Sale DG et al. Effects of strength training and immobilisation on human muscle fibres. *Eur J Appl Physiol* 1980; 43: 25 - 34.

MacDougall JD, Sale DG, Always ST, Sutton HR. Muscle fibre number in biceps brachii in body builders. *J Appl Physiol* 1984; 57(5): 1399-1403.

Machover S, Sapecky AJ. Effect of isometric exercise on the quadriceps muscle in patients with rheumatoid arthritis. *Arch Phys Med Rehabil* 1966; 47: 737-741.

Mahowald ML, Steveken ME, Young M, Ytterberg SR. The Minnesota arthritis training programme: emphasis on self-management, not compliance. *Patient education and Counselling* 1988; 11: 235-241.

Mahowald ML, Krug H, Steveken ME, Ytterberg SR. Exercise and other physical therapies for rheumatoid arthritis. *J Musculoskel Med.* 1990; 7(6): 52-68.

Magyar E, Talerman A, Mohacsy J, Wouters HW, Bruijn WC de. Muscle changes in rheumatoid arthritis. A review of the literature with a study of 100 cases. *Virchows Arch A Path Anat Histol.* 1977; 373:267-278.

Manning RJ, Graves JE, Crpenter DM. Constant vs variable resistance knee extension training. *Med Sci Sports Exerc* 1990; 22: 397 - 401.

Mannion AF, Dolan P. Electromyographic median frequency changes during isometric contraction of the back extensors to fatigue. *Spine.* 1994; 19(11): 1223-1229.

Mapp PI, Grootveld MC, Blake DR. Hypoxia, oxidative stress and rheumatoid arthritis. *Br Med Bulletin* 1995; 51(2): 419-436.

Martin S, Neale G, Elia M. Factors affecting maximal momentary grip strength. *Hum Nutr Clin Nutr* 1984; 39C, 137 - 147.

Mathews JNS, Altman DG, Campbell MJ, Royston JP. Analysis of serial measurements in medical research. *Br Med J* 1990; 300: 230-235.

- Mathiesen FK, Rasmussen JO, Recht L, Lithman T. Impairment of grip function in rheumatoid arthritis - studies with a simple hand test. *Scand J Rheumatol* 1991; 20: 209-212.
- McArdle WD, Katch FI, Katch VL. *Exercise Physiology*. Lea & Febiger. Philadelphia 1991; 3rd edn.
- McDonagh MJ, Hayward CM, Davies CT. Isometric training in human elbow flexor muscles. The effects on voluntary and electrically evoked forces. *JBJS* 1983; 65: 355-358.
- McDonagh MJN and Davies CTM. Adaptive response of mammalian skeletal muscle to exercise with high loads. *Eur J Appl Physiol* 1984; 52: 139-155.
- McGregor M, Wright V. Occupational therapy for rheumatoid hands. A cautionary note. *Occ Ther* 1967; 34-36.
- Merletti R, Knaflitz M, DeLuca CJ. Myoelectric manifestations of fatigue in voluntary and electrically elicited contractions. *J Appl Physiol* 1990; 69(5): 1810-1820.
- Merletti R, Knaflitz M, DeLuca CJ. Electrically evoked myoelectric signals. *Crit Rev Biomed Eng* 1992; 19: 293-240.
- Merletti R, Sabbahi MA, De Luca CJ. Median frequency of the myoelectric signal. Effects of muscle ischaemia and cooling. *Eur J Appl Physiol* 1984; 52: 258 - 265.
- Mills KR. Power spectral analysis of electromyogram and compound muscle action potential during muscle fatigue and recovery. *J Physiol*. 1982; 326: 401-409.
- Miller RG, Giannini D, Milner-Brown S et al. Effects of fatiguing exercise on high energy phosphates, force and EMG: evidence for three phases of recovery. *Muscle & Nerve* 1987; 10: 810-821.
- Milner Brown HS, Stein RB, Yemm R. Mechanisms for increased force during voluntary contractions. *J Physiol* 1972; 226: 18-19.
- Milner-Brown HS, Stein RB, Yemm R. The orderly recruitment of human motor units during voluntary isometric contractions. *J Physiol*; 1973a; 230: 359-70.
- Milner-Brown HS, Stein RB, Yemm R. Changes in firing rate of human motor units during linearly changing voluntary contractions. *J Physiol* 1973b; 230: 371-390.

Milner-Brown HS, Stein RB, Yemm R. The contractile properties of human motor units during voluntary isometric contraction. *J Physiol* 1973c; 228: 285-306.

Milner-Brown HS, Stein RB, Lee RG. Pattern of recruiting human motor units in neuropathies and motor neurone disease. *J Neurol Neurosurg, Psychiat.* 1974; 37: 665-669.

Milner-Brown HS & Stein RB. The relation between the surface electromyogram and muscular force. *J Physiol* 1975; 246: 549-569.

Milner-Brown HS, Mellenthin M, Miller RG. Quantifying human muscle strength, endurance and fatigue. *Arch Phys Med Rehabil.* 1986; 7: 246-249.

Monster AW, Chan H. Isometric force production units of extensor digitorum communis muscle in man. *J Neurol* 1977; 40: 1432-1443.

Moritani T, DeVries HA. Reexamination of the relationship between the surface electromyogram and force of isometric contraction. *Am J Phys Med.* 1978; 57: 263-277.

Moritani T, deVries HK. Neural factors versus hypertrophy in the time course of muscle strength gain. *Am J Phys Med* 1979; 58: 115-130.

Moritani T, Gaffney FA, Carmichael T, Hargis J. Interrelationship among muscle fibre types, electromyogram, and blood pressure during fatiguing isometric contraction. In : *Biomechanics IX-A*, ed DA Winter et al, Illinois: Human Kinetics, 1985a, p 287-292.

Moritani T, Muro M, Kijima A. Electromechanical changes during electrically induced and maximal voluntary contractions: Electrophysiologic responses of different muscle fiber types during stimulated contractions. *Exp Neurol* 1985b; 88: 471-483.

Moritani T, Muro M, Nagata A. Intramuscular and surface electromyogram changes during muscle fatigue. *J Appl Physiol* 1986; 60 (4): 1179-1185.

Moritz U. Electromyographic studies in rheumatoid arthritis. *Acta Rheum Scand Suppl* 6: 1963.

Morrison LR, Short CL, Ludwig AO, Schwab RS. The neuromuscular system in rheumatoid arthritis. Electromyographic and histologic observations. *Amer J Med Sci* 1947; 214: 33.

Mortimer JT, Kerstein MD, Magnusson R, Petersen I. Muscle blood flow in the human biceps as a function of developed muscle force. *Arch Surg.* 1971; 103:376-377.

Mortimer JT, Magnusson P, Peterson I. Conduction velocity in ischaemic muscle: effect on EMG frequency spectrum. *Am J Physiol* 1970; 219: 1324-1329.

Mottram RF. The local blood flow changes due to isometric contractions of the human forearm muscles. *J Physiol (Lond.)*, 1963; 167: 57-58.

Moxham J, Edwards RHT, Aubier M, De Troyer A, Farkas G, Macklem PT, Roussos C. Changes in EMG power spectrum (high-to-low ratio) with force fatigue in humans. *J Appl Physiol*. 1982; 53 : 1094-1099.

Mueller EE, Mead S. *Amer J Med Sci* 1952; 31; 67.

Muller EA. Influence of training and of inactivity on muscle strength. *Arch Phys Med Rehabil* 1970; 51: 449-462.

Muro M, Nagata A, Murakami K, Moritani T. Surface EMG power spectral analysis of neuromuscular disorders during isometric and isotonic contractions. *Am J Phys Med*. 1982; 61:244-254.

Myers DB, Grennan DM, Palmer DG. Hand grip function in patients with rheumatoid arthritis. *Arch phys med rehabil* 1980; 61 (8): 369-373.

Myers DB, Wilson K, Palmer DG. An objective measurement of morning stiffness. *Rheumatoid Int* 1981; 1: 135-137.

Myllykangas-Luosujarvi RA, Aho K, Isomaki HA. Mortality in rheumatoid arthritis. *Semin Arthritis Rheum* 1995; 25(3): 193-202.

Naess K, Storm-Mathisen A. Fatigue of sustained tetanic contractions. *Acta Physiol Scand*. 1955; 34: 351-366.

Nagata A, Muro M, Moritani T, Yoshida T. Anaerobic threshold determination by blood lactate and myoelectric signals. *Jpn J Physiol*. 1981; 31: 585-597.

Nakamaru Y, Schwartz A. The influence of hydrogen ion concentration on calcium binding and release of skeletal muscle sarcoplasmic reticulum. *J Gen Physiol*. 1972; 59: 22 - 32.

- Nardone A, Romano C, Schieppati M. Selective recruitment of high-threshold motor units during voluntary isotonic contracting of active muscles. *J Physiol Lon* 1989; 409: 451-471.
- Neville HE. Ultrastructural changes in muscle disease. In: Dubowitz V, Brooke MH, eds. *Muscle biopsy: a modern approach*. Toronto, WB Saunders 1973; 383-439.
- Newman MK, Goldstein AS, Wall P. *J Mich Med Sci* 1953; 52: 956.
- Nordemar R, Edstrom L, Ekblom B. Changes in muscle fibre size and physical performance in patients with rheumatoid arthritis after short term physical training. *Scand J Rheum* 1976a; 5(2): 70-76.
- Nordemar R, Edstrom L, Ekblom B. Changes in muscle fibre size and physical performance in patients with rheumatoid arthritis after 7 months physical training. *Scand J Rheum* 1976b; 5: 233-238.
- Nordenskiold, U & Grimby G. Assessments of disability in women with rheumatoid arthritis in relation to grip force and pain. *Disability & Rehabil* 1997; 19 (1): 13-19.
- Nordesjo L, Nordgren B, Wigren A et al. Isometric strength and endurance in patients with rheumatoid arthritis or osteoarthritis in the knee joints. A comparative study in healthy men and women. *Scand J Rheumatol* 1983; 12: 152 - 156.
- Nwuga VC. Grip strength and grip endurance in physical therapy students. *Arch Phys Med Rehabil* 1975; 56(7): 297-300.
- Oberg T. Subjective and objective evaluation of shoulder muscle fatigue. *Ergonomics* 1994; 37(8): 1323-1333.
- Oh SJ. Electrodiagnostic studies in neuromuscular disease. *Ala J Med Sci* 1980; 17: 308-314.
- Okada M. Effect of muscle length on surface EMG waveforms in isometric contractions. *Eur J Appl Physiol*. 1987; 56: 482 - 486.
- Ortengren R, Lindstrom L, Petersen I. Electromyographic evaluation and modelling of localized muscle fatigue during periodic muscular work. *Proc 4th Cong Int Soc Ephysiol & Kin*. 1979; 96-97.
- Pearson CM. Rheumatic manifestations of polymyositis and dermatomyositis. *Arth Rheum* 1959; 2:127-143.

Pearson R, Mackinnon MJ, Meek AP, Myers DB, Palmer DG. Diurnal and sequential grip function in normal subjects and the effects of temperature change and exercise of the forearm on grip function in patients with rheumatoid arthritis and controls. *Scand J Rheum* 1982; 11: 113-118.

Peel NA, Spittlehouse AJ, Bax DE, Eastell R. Bone mineral density of the hand in rheumatoid arthritis. *Arthritis Rheum* 1994; 37: 983-991.

Perry J, Bekey GA. MG-Force relationships in skeletal muscles. *Crit Rev Biomed Eng.* 1981; 7: 1-22.

Person RS, Kudina LP. Discharge frequency and discharge pattern of human motor units during voluntary contraction of muscle. *Electroenceph Clin Neurophysiol* 1972; 32: 471-483.

Person RS, Libkind MS. Simulation of electromyograms showing interference patterns. *Electroencephalogr Clin Neurophysiol* 1970; 28: 625-632.

Petrofsky JS, Lind AR. Frequency analysis of the surface EMG during sustained isometric contractions. 1980; 43:173-182.

Petrofsky JS, Lind AR. Isometric strength, endurance and the blood pressure and heart rate responses during isometric exercise in healthy men and women with special reference to age and body fat content. *Pflugers Arch.* 1975; 360: 49-61.

Petrofsky JS. Frequency and amplitude analysis of the EMG during exercise on the bicycle ergometer. *Eur J Appl Physiol.* 1979; 41:1-15.

Petrofsky JS. Quantification through the surface EMG of muscle fatigue and recovery during sustained isometric contractions. *Aviat Space Environ Med.* 1981; 9: 545-550.

Pinals RS, Masi AT, Larsen RA. Preliminary criteria for clinical remission in rheumatoid arthritis. *Arth Rheum*, 1981; 24 (10):1308-1315.

Pincus T, Callahan LF, Vaughn WK. Questionnaire, walking time and button test measures of functional capacity as predictive markers for mortality in rheumatoid arthritis. *J Rheum.* 1987; 14: 240-251.

Polgar JM, Johnson MA, Weightman D, Appleton D. Data on fiber size in thirty-six muscles. An autopsy study. *J Neurol Sci.* 19: 307-318; 1973.

Portero P, Vanhoutte C, Goubel F. Effect of simulated weightlessness on muscle isometric contraction: an approach by EMG spectral analysis. Proc 31st Int Conf Physiological Sciences, Helsinki. 1989.

Reza M, Verity M. Neuromuscular manifestations of rheumatoid arthritis: a clinical and histomorphological analysis. Clin Rheum Dis 1977; 3: 565-588.

Richardson AT. St Thomas' Hospital Reports, Series 2 . Quoted by Walton, 1952.

Riek S, Bawa P. Recruitment of motor units in human forearm extensors. J Neurophysiol 1992; 68(1): 100-108.

Ritchie DM, Boyle JA, McInnes JM, Jasnai MK, Dalakos TG, Grieveson P, Buchanan WW. Clinical studies with an articular index for the assessment of joint tenderness in patients with rheumatoid arthritis. Quart J Med 1968; 37: 393-406.

Ropes MW, Bennett GA, Cobb S, Jacox R, Jessar RA. 1958 Revision of diagnostic criteria for rheumatoid arthritis. Bull Rheum Dis 1958; 9: 175-176.

Roy SH, DeLuca CJ, Casavant DA. Lumbar muscle fatigue and chronic lower back pain. Spine 1989; 14: 992-1001.

Roy SH, O'Hara JM, Briganti M. Use of EMG spectral parameters to evaluate fatigue associated with pressure glove work. IN: Electromyographical Kinesiology, ed. P Anderson, D Hobart, J Danoff. Elsevier Science, Excerpta Medica, International Congress Series 949, Amsterdam, 1991, 283-286.

Russell ML, Hanna WM. Ultrastructural pathology of skeletal muscle in various rheumatic diseases. J Rheumatol. 1988; 15:445-453.

Rutherford OM, Jones DA, Newham DJ. Clinical and experimental application of the percutaneous twitch superimposition technique for the study of human muscle activation. J Neurol, Neurosurg & Psychiatry 1986; 49: 1288-1291.

Rutherford OM. Muscular co-ordination and strength training. Implications for injury rehabilitation. Sports Med. 1988; 5: 196.

Sabbahi A, DeLuca CJ, Powers WR. Effect of ischaemia, cooling and local anaesthesia on the median frequency of the myoelectric signals. In : Fourth Congress of ISEK (Boston, USA); 1979; 94-95.

- Sadoyma T, Masuda T, Miyata H, Katsuda S. Fibre conduction velocity and fibre composition in human vastus lateralis. *Eur J Appl Physiol Occup Physiol*, 1988; 57: 767-771.
- Sahlin k, Harris RC, Hultman E. Creatine kinase equilibrium and lactate content compared with muscle pH in tissue samples obtained after isometric exercise. *Biochem J*. 1975; 152: 173-180.
- Sale DG. Influence of exercise and training on motor unit activation. *Exerc Sport Sci*. 1987; 15: 95-151.
- Sargeant AJ, Davies CTM, Edwards RHT, Maunder C, Young A. Functional and structural changes after disuse of human muscle. *Clin Sci Molec Med*.1977; 52: 337-342.
- Schmidt RT, Toews JV. Grip strength as measured by the Janar dynamometer. *Arch phys med rehab* 1970; 321-327.
- Schweitzer TW, Fitzgerald JW, Bowden JA, Lynne-Davies P. Spectral analysis of human inspiratory diaphragmatic electromyograms. *J Appl Physiol*. 1979; 46: 152-165.
- Scott RN. Myoelectric energy spectra. *Med and Biol Eng*. 1967; 5: 303-305.
- Seidel H, Beyer H, Brauer D. Electromyographic evaluation of back muscle fatigue with repeated sustained contractions of different strength. *Eur J Appl Physiol* 1987; 56: 592-602.
- Shakespeare DT, Stokes M, Sherman K, Young A. The effect of knee flexion on quadriceps inhibition after menisectomy. *Clinical Science* 1983; 65: 64-65P.
- Shakespeare DT, Stokes M, Sherman KP, Young A. Reflex inhibition of the quadriceps after menisectomy: lack of association with pain. *Clin Physiol*. 1985; 5:137 - 144.
- Simmons BBP. Physiology of flexion of the fingers. In: *Extract from The Hand (illus)*.pub. Saunders & Row 1981.
- Simoneau JA, Bouchard C. Human variation in skeletal muscle fibre type proportion and enzyme activities. *Am J Physiol* 1989; 257: E567-572.
- Simoneau JA, Lortie G, Boulay MR, Thibault MC, Theriault G, Bouchard C. Skeletal muscle histochemical and biochemical characteristics in sedentary male and female subjects. *Can J physiol Pharmacol*. 1985; 63: 30-35.

Smith EM et al. Role of the finger flexors in rheumatoid deformities of the metacarpophalangeal joints. *Arth Rheumat* 1964; 7: 467-480.

Snijders CJ, Volkers ACW, Michelse K, Vleeming A. Provocation of epicondylalgia lateralis (tennis elbow) by power grip or pinching. *Med Sci Sports Exerc* 1987; 19(5): 518-523.

Sokoloff L, Wilens SL, Bunim JJ, Mcewen C. Diagnostic value of histologic lesions of striated muscle in rheumatoid arthritis. *Amer J Med Sci.* 1950;219:174.

Solomonow M, Baten C, Smit J, Barata R, Hermens H, D'Ambrosia R, Shoji H. Electromyogram power spectra frequencies associated with motor unit recruitment strategies. *J Appl Physiol* 1990; 68:1177-1185.

Spiegel JS, Paulus HE, Ward NB, Spiegel TM, Leake B, Kane RL. What are we measuring? An examination of walk time and grip strength. *J Rheumatol* 1987; 14: 80-86.

Stalberg E. Propagation velocity in human muscle fibres in situ. *Acta Physiol Scand* 1966; 70: 1-112.

Steinberg VL, Wynn Parry CB. Electromyographic changes in rheumatoid arthritis. *Br Med J* 1961(March); 630-632.

Steiner G, Chason IL. Differential diagnosis of rheumatoid arthritis by biopsy of muscle. *Am J Clin Path* 1948; 18; 931.

Steiner G, Freund HA, Leichtentritt B, Maun ME. Lesions of skeletal muscle in rheumatoid arthritis. Nodular myositis. *Amer J Path.* 1946; 22:103.

Stenstrom CH. Home exercise in rheumatoid arthritis functional class II: Goal setting versus pain attention. *J Rheumatol* 1994; 21: 627-634.

Stenstrom CH. Therapeutic exercise in rheumatoid arthritis. *Arth Care & Res* 1994; 7: 190-197.

Stenstrom CH, Boested C, Carlsson M, Edstrom M, Reuterhall A. Why exercise? A preliminary investigation of an exercise motivation index among individuals with rheumatic conditions and healthy individuals. *Physiother Res Int* 1997; 2(1): 7-16.

Stephens JA, Taylor A. Fatigue of maintained voluntary contraction in man. *J Physiol (Lond.)*, 1972; 250:37-38.

- Stokes M, Young A. The contribution of reflex inhibition to arthrogenous muscle weakness. *Clin Sci*, 1984; 67: 7-14.
- Straub LR. Surgical rehabilitation of the hand and upper extremity in rheumatoid arthritis. *Bull Rheumat Dis* 1962; 12: 265-268.
- Stulen FB, De Luca CJ. The relation between the myoelectric signal and physiological properties of constant force isometric contractions. *Electroenceph Clin Neurophysiol*. 1978; 45: 681-698.
- Stulen FB, Deluca CJ. Muscle fatigue monitor: a noninvasive device for observing muscular fatigue. *IEEE Trans Biomed Eng*. 1982; bme 29: 760-768.
- Stulen FB, Deluca CJ. Frequency parameters of the myoelectric signal as a measure of muscle conduction velocity. 1981; *IEEE Trans Biomed Eng*. 28(7): 515-523.
- Stulen FB, DeLuca CJ. Median frequency of the myoelectric signal as a measure of localised muscular fatigue. In: *Proc 4th Cong Int Soc Electrophysiology Kinesiology*. 1979; 8:92-93.
- Symmons D. Disease assessment indices: activity, damage and severity. *Baillieres Clinical Rheumatol* 1995; 9(2): 267-285.
- Szeto G, Strauss GR, De Domenico G et al The effect of training intensity on voluntary isometric strength improvement. *Aust J Physiother* 1989; 35: 210.
- Tasaki I, Singer I, Takenaka T. Effects of internal and external ionic environment on excitability of squid giant axon. *J Gen Physiol*. 1967; 48: 1095-1123.
- Taussig MJ. *Processes in Pathology & Microbiology*. 2nd Ed. Blackwell Scientific Publications, London. 1984.

Terakawa S, Nagano M, Watanabe A. Intracellular pH and plateau duration of internally perfused squid giant axons. *Jap J Physiol.* 1978; 28: 847-862.

Tesch PA. Skeletal muscle adaptations consequent to long term heavy resistance exercise. *Med Sci Sports Exerc* 1988; 20(5 Suppl); S132-134.

Thorngren KG, Werner CO. Normal grip strength. *Acta Orthop Scand* 1979; 50(3): 255-259.

Thomas CK, Stein RB, Gordon T, Lee RG, Elleker MG. Patterns of reinnervation and motor unit recruitment in human hand muscles after complete ulnar and median nerve section and resuture. *J Neurol Neurosurg Psychiatr* 1987; 50: 259-268.

Tiselius P. Studies on joint temperature, joint stiffness, and muscle weakness in rheumatoid arthritis. *Acta Rheumatol Scand.* 1969;14(Suppl 14):871-87.

Treusch JV, Krusen FH. Physical therapy applied at home for arthritis. A follow-up study, with a supplementary summary of the sedimentation rate of erythrocytes in two hundred and twenty-nine cases of arthritis. *Arch Int Med* 1943; 72: 231-238.

Treuth MS, Ryan AS, Pratley RE, Rubin MA, Miller JP, Nicklas BJ, Sorkin J, Harman J, Harman SM, Goldberg AP, Hurley BF. Effects of strength training on total and regional body composition in older men. *J Appl Physiol* 1994; 77: 614-620.

Troup JDG, Chapman AE. Changes in the waveform of the electromyogram during fatiguing activity in the muscles of the spine & hips: the analysis of postural stress. *ECN.* 1972; 12: 347-365.

Tugwell P, Boers M for the OMERACT committee. Developing consensus on preliminary core efficacy endpoints for rheumatoid arthritis clinical trials.

Unsworth A, Haslock I, Vasandakumar V, Stamp J. A laboratory and clinical study of pneumatic grip strength devices. *Br J Rheum* 1990; 29: 440-444.

Van Boxtel A, Goudswaard P, Van Der Molen GM, Van den Bosch WEJ. Changes in electromyogram power spectra of facial and jaw elevator muscles during fatigue. *J Appl Physiol*, 1983; 54:51.

Viitasalo JT, Komi PV. Isometric endurance, EMG power spectrum and fibre composition in human quadriceps muscle. In: Biomechanics VI-A. Asmussen A, Jorgensen K, eds. University Park Press, Baltimore. 1978; p244.

Viitasalo JHT, Komi PV. Signal characteristics of EMG with special reference to reproducibility of measurements. *Acta Physiol Scand* 1975; 93: 531-539.

Virtaa P, Helela T. Radiographic measurements of cortical bone. *Acta Radiologica* 1969; (suppl) 293: 1-217.

Vredendregt J, Rau G. Surface electromyography in relation to force, muscle length and endurance. In: *New developments in EMG and Clinical Neurophysiology*, ed JE Desmedt. Basel Switzerland: Karger. 1973; vol 1:607-622.

Walton JN. The electromyogram in myopathy: Analysis with the audio-frequency spectrometer. *J Neurol Neurosurg Psychiatr.* 1952; 15: 219-226.

West W, Hicks A, Clements L, Dowling J. The relationship between voluntary electromyogram, endurance time and intensity of effort in isometric handgrip exercise. *Eur J Appl Physiol* 1995; 71: 301-305.

Westbury JR, Shaughnessy TG. Associations between spectral representations of the electromyogram and fiber type distribution and size in human masseter muscle. *Electromyogr Clin Neurophysiol* 1987; 27: 427-435.

Westerblad H, Lee JA, Lannergren J, Allen DG. Cellular mechanisms of fatigue in human skeletal muscle. *Am J Physiol* 1991; 261(Cell Physiol 30): C195-C209.

Williams R. Rheumatoid Arthritis as a systemic disease . Vol 4. Ed RC Williams. Philadelphia, WB Saunders Co., 1974; 85-105.

Windhorst U, Mommaerts WFHM, Physiology of skeletal muscle. In: *Comprehensive physiology. From cellular mechanisms to integration*. Greger R, Windhorst U (eds). Vol 1, Springer. London, 1996; pp 911-934.

Windsor J, Hill G. Grip strength: a measure of the proportion of protein loss in surgical patients. *Br J Surg* 1988; 75: 880.

Wolfe F, Cathey MA. The assessment and prediction of functional disability in rheumatoid arthritis. *J Rheumatol* 1991; 18: 1298 - 1306.

Wollheim FA. Rheumatoid arthritis - the clinical picture. In Maddison PJ, Isenberg DA, Woo P, Glass DN (eds) *Oxford Textbook of Rheumatology* 1993; Oxford University Press Oxford pp 651-661.

Woods JJ, Bigland-Ritchie B. Linear and non-linear surface EMG/force relationships in human muscle. *Am J Physic Med* 1983; 62: 287-299.

Wramner T. *Acta Med Scand.* 1950; 138; Suppl 242.

Wright V, Johns RJ. Physical factors concerned with the stiffness of normal and diseased joints. *Bull J Hop hosp* 1960; 106: 215-231.

Wroblewski R, Nordemar R. Ultrastructural and histochemical studies of muscle in rheumatoid arthritis. *Scand J Rheum.* 1975; 4: 197-204.

Wynn Parry CB. *Rehabilitation of the Hand.* 2nd Edn. pub Butterworths, 1983.

Yates DA. Muscular changes in rheumatoid arthritis. *Ann Rheum Dis.* 1963; 22: 342-347.

Young A, Hughes I, Parker MJ, Nichols PJR. Measurement of quadriceps muscle wasting by ultrasonography. *Rheum & Rehabil* 1980; XIX (3); 141 - 148.

Young A, Hughes I, Round JM, Edwards RHT. The effect of knee injury on the number of muscle fibres in the human quadriceps femoris. *Clin Sci* 1982; 62: 227-234. Parker MJ, Nichols PJR. Measurement of quadriceps muscle wasting by ultrasonography. *Rheum & Rehabil* 1980; XIX (3); 141 - 148.

Young A, Stokes M, Iles J F. Effects of joint pathology on muscle. In: Duthie RB, Young A, eds. *The pathophysiology of joint contractures and their correction.* *Clin Orthop* 1987; 219: 21-27.. The contribution of reflex inhibition to arthrogenous muscle weakness. *Clin Sci*, 1984; 67: 7-14.

Young A, Stokes M. Reflex inhibition of muscle activity and morphological consequences of inactivity. In: B Saltin (ed) *International Series of Sport Sciences, Vol 10. Biochemistry of exercise VI. Human Kinetics, Champaign.* 1966.

Young A. Rehabilitation for wasted muscles. In: Sarnar M, ed. Advanced medicine 18.
London : Pitman Medical, 1982.

Young A. Current issues in arthrogenous inhibition. *Annals Rheum Dis* 1993; 52: 829-834.

12.1.1 (APPENDIX A):The Keital Hand Functional Index

(Kalla et al, 1988).

(1) Tip of thumb to hypothenar 5th finger	Right	Left	0 = full & no delay 1 = full & effort/delay 2 = to prox phalanx 3 & 4 3 = less
(2) Bending of 2nd finger	Right	Left	0 = Clutched normally 1 = cannot bend normally, tip reaches palm 2 = fingertip does not reach palm
(3) 3rd finger	Right	Left	As above
(4) 4th finger	Right	Left	As above
(5) 5th finger	Right	Left	As above
(6) Forearm held horizontal, palms pressed together, point upward	Right	Left	1 = Full, no delay 2 = Full & effort/delay 3 = Volar & dorsal flexion of wrist 45

(7) Forearm held horizontal, volar surfaces pressed together, point downward

Right

Left

0 = Full , no delay

**1 = Full & effort / delay
2 = Palmar & ventral flexion of wrist 45**

Backs of hands on table, elbows rectangular, ulnar margin of hand lifted

Right

Left

0 = full

**1 = back of hands on table, margin cannot lift
2 = backs of hands not fully on table**

Radial margins of hands on table, thumbs pointing downward before table edge, planes of hands inclined inward, no lateral bending of trunk

Right

Left

0 = full

**1 = planes of hands perpendicular
2 = planes not vertical**

Appendix 12.1.1: The Fuchs 28 point disease activity score.

FUCHS INDEX

Name :

Date :

Visit :

	SWELLING	TENDERNESS
SHOULDER - R		
SHOULDER - L		
ELBOW - R		
ELBOW - L		
WRIST - R		
WRIST - L		
R : THUMB - MCP		
THUMB - PIP		
INDEX - MCP		
INDEX - PIP		
MIDDLE - MCP		
MIDDLE - PIP		
RING - MCP		
RING - PIP		
LITTLE - MCP		
LITTLE - PIP		
L: THUMB - MCP		
THUMB - PIP		
INDEX - MCP		
INDEX - PIP		
MIDDLE - MCP		
MIDDLE - PIP		
RING - MCP		
RING - PIP		
LITTLE - MCP		
LITTLE - PIP		
KNEE - RIGHT		
KNEE - LEFT		
TOTAL		

Normal: 0
Abnormal: 1

APPENDIX 12.2.1 The Hand Grip Strengthening Programme.

Choose a regular time every day to do your hand exercises, for example lunchtime (when your joints have loosened up).

Sit in a chair with your arms at your side, resting on the arm rests.

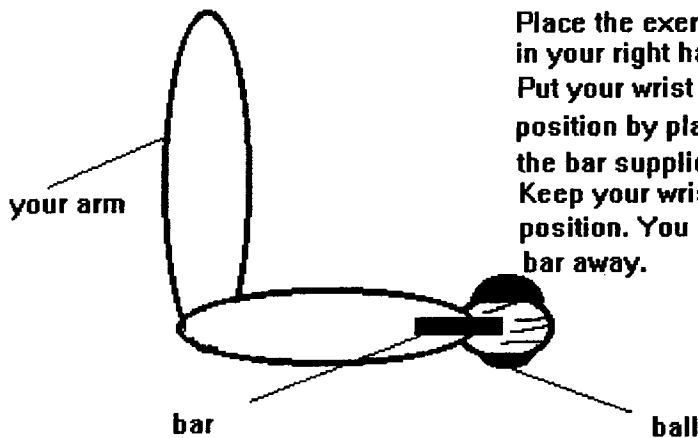
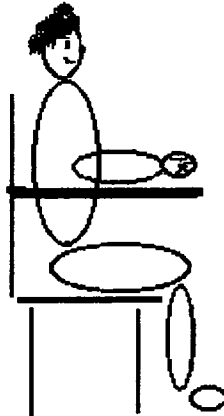

**Place the exercise ball in your right hand.
Put your wrist in the correct position by placing it against the bar supplied to you.
Keep your wrist in this position. You can take the bar away.**

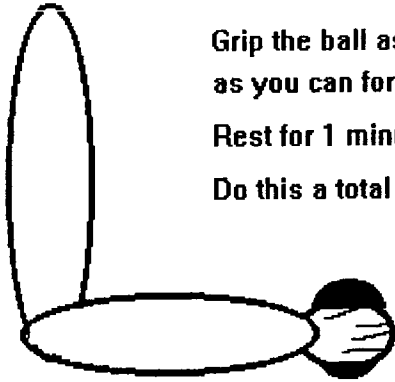

**Grip the ball as tightly
as you can for 10 seconds.
Rest for 1 minute.
Do this a total of 10 times.**

WELL DONE !!!

Do this **ONCE EVERY DAY FOR THE FIRST 6 WEEKS** of the programme, then increase the amount you do to **TWICE A DAY** for the remainder of the programme.

If there are problems with your exercise programme, please do not hesitate to let Dr Speed know.

