

Durham E-Theses

Computer simulation of a series and parallel hybrid electric vehicle

Wonhee Lee

How to cite:

Lee, Wonhee (1998) Computer simulation of a series and parallel hybrid electric vehicle. Masters thesis, Durham University.

Use policy

The full-text may be used and/or reproduced, and given to third parties in any format or medium, without prior permission or charge, for personal research or study, educational, or not-for-profit purposes provided that:

- a full bibliographic reference is made to the original source
- a <https://etheses.durham.ac.uk/id/eprint/4841/> is made to the metadata record in Durham E-Theses
- the full-text is not changed in any way

The full-text must not be sold in any format or medium without the formal permission of the copyright holders.

Please consult the [full Durham E-Theses policy](#) for further details.

Computer Simulation of a Series and Parallel Hybrid Electric Vehicle

Wonhee Lee

M.Sc. Thesis

The copyright of this thesis rests with the author. No quotation from it should be published without the written consent of the author and information derived from it should be acknowledged.

**School of Engineering
University of Durham**

September 1998



- 2 NOV 1999

Abstract

Although the internal combustion engine(ICE) vehicle is the most popular vehicle type in the world it has serious problems relating to its exhaust emissions and the limitation of petroleum resource. To try to solve these problems many kinds of vehicle have been developed which use alternative energies; electricity, compressed natural gas and solar energy etc. The hybrid vehicle, which combines the advantages of the ICE vehicle and the electric vehicle, is one of the most promising alternative vehicle structures.

This thesis describes the modelling and simulation of a Series and a Parallel Hybrid Vehicle using SIMULINK, the graphical user interface for MATLAB. The ICE vehicle and electric vehicle are also modelled and simulated to prove the accuracy of the simulation and to provide a base to compare the results of the hybrid vehicle simulation. This thesis also describes how to optimize the electric motor and IC engine size used in the series and parallel hybrid vehicle and how to minimize the fuel usage and the emissions of the IC engine.

Acknowledgements

I am very proud of having studied for my MSc in the School of Engineering at Durham University. This thesis could not have been produced without a great deal of help, advice and encouragement from others.

I owe a great debt of gratitude to my supervisor Dr. Jim Bumby, who was always on hand to listen to my ideas and always willing to contribute his own. Also, he took time to read the drafts of this thesis and provide invaluable feedback.

I thank deeply my parents and family who always pray for me. I also thank my wife who will live forever with me and I dedicate this thesis to all of them.

Above all I appreciate God who leads and prepares my life.

Copyright

The Copyright of this Thesis rests with the author. No quotation from it should be published without his prior written consent and information derived from it should be acknowledged.

Declaration

No part of the material offered has previously been submitted by the author for a degree in the university of Durham or in any other University. All of the work presented here is the sole work of the author and no-one else.

Contents

1. Introduction	1
2. Types of Vehicle	4
2.1 Internal Combustion Engine Vehicle	4
2.2 Electric Vehicle	6
2.3 Hybrid Vehicle	8
2.3.1 Series Hybrid Vehicle	9
2.3.2 Parallel Hybrid Vehicle	11
2.4 Conclusion	13
3. Simulation Software	14
3.1 Advantages of Computer Simulation	14
3.2 Structure and Components of SIMULINK	14
3.3 Structure and Components of JANUSLEE	16
3.4 Conclusion	18
4. Performance of the ICE Vehicle	19
4.1 Driving Cycles	19
4.2 Configuration of the ICE Vehicle	20
4.2.1 The Driver	22
4.2.2 The Throttle Controller	22
4.2.3 The Engine	22
4.2.4 The Clutch	24
4.2.5 The Gearbox	25
4.2.6 The Final Drive	26
4.2.7 The Wheels	26
4.2.8 The Vehicle	27
4.2.9 Data Files	28
4.3 Simulation of the ICE Vehicle	28
4.3.1 Analysis of the ICE Vehicle Simulation	29

4.3.2 Simulation Results	32
4.4 Conclusion	33
5. Performance of the Electric Vehicle	34
5.1 Configuration of the Electric Vehicle	34
5.1.1 Data Files	34
5.1.2 The Throttle Controller	35
5.1.3 The Motor	36
5.1.4 The Motor Controller	37
5.1.5 The Battery	38
5.2 Simulation of the Electric Vehicle	39
5.2.1 Analysis of the Electric Vehicle Simulation	39
5.2.2 Regenerative Braking Energy	41
5.2.3 Relationship between the Weight of Battery and Vehicle Range	43
5.3 Conclusion	44
6. Performance of the Series Hybrid Vehicle	45
6.1 Operating Modes of the Auxiliary Power Unit	45
6.2 Configuration of the Series Hybrid Vehicle	46
6.2.1 The APU Model	46
6.2.1.1 The Engine	46
6.2.1.2 The Generator	48
6.2.1.3 The APU Controller	48
6.2.2 The Motor	49
6.3 Consideration of Motor and Engine Size	49
6.4 Consideration of Engine Operating Point	52
6.5 Simulation of the Series Hybrid Vehicle	54
6.5.1 Analysis of the Series Hybrid Vehicle Simulation	54
6.5.2 Simulation Results	56
6.6 Conclusion	59

7. Performance of the Parallel Hybrid Vehicle	61
7.1 Operating Modes of the Parallel Hybrid Vehicle	61
7.2 Configuration of the Parallel Hybrid Vehicle	62
7.2.1 The Transfer	63
7.2.2 The Controller	63
7.3 Consideration of Engine and Motor Size	66
7.4 Simulation of the Parallel Hybrid Vehicle	67
7.4.1 Analysis of the Parallel Hybrid Vehicle Simulation	67
7.4.2 Effect of Maximum Throttle	68
7.4.3 Simulation Results	71
7.5 Conclusion	72
8. Comparison of the Series and Parallel Hybrid Vehicle	74
8.1 Structure	74
8.2 Control Logic	74
8.3 Fuel Economy	74
8.4 Emissions	77
8.5 Performance	77
9. Conclusion and Further Work	79
References	82
Appendices	85
Appendix 1 Driving Cycles	85
1.1 ECE-15	85
1.2 J227a_D	85
1.3 Extra_Urban	86
Appendix 2 Accent 1.3 Data Files	87
2.1 act3.m	87
2.2 act3_map.m	88

Appendix 3 ETV-1 Data Files	89
3.1 etv1.m	89
3.2 ev2_13.m	89
3.3 etv_mot1.m	90
Appendix 4 Series Hybrid Vehicle Data Files	91
4.1 shv.m	91
4.2 im8000.m	92
Appendix 5 Calculation File	93
Appendix 6 Parallel Hybrid Vehicle Data Files	94
6.1 phv.m	94

List of Symbols

- V = vehicle velocity, m/s
 ω = angular velocity, rad/s
 r = wheel radius, m
 F_t = traction force, N
 F_d = drag force, N
 F_r = rolling resistance force, N
 F_g = gravity force, N
 F_b = braking force, N
 ρ = density of air, kg/m³
 A = frontal area, m²
 C_r = coefficient of rolling resistance
 C_d = coefficient of drag
 M = mass of vehicle, kg
 g = acceleration due to gravity, 9.81m/s²
 θ = angle of gradient, degrees
 f_T = cold engine fuel flow factor
SOC = State of Charge
 P_{di} = battery power density, W/kg
 τ_p = battery discharge time, h

List of Figures

2.1 Main Layout of a IC Engine Vehicle	5
2.2 Main Layout of a Electric Vehicle	7
2.3 Main Layout of a Series Hybrid Vehicle	10
2.4 Main Layout of a Parallel Hybrid Vehicle	12
3.1 Initial Screen of the SIMULINK	15
3.2 Screen of the Nonlinear Library	16
3.3 Example Model of the SIMULINK	16
3.4 Initial Screen of the JANUSLEE	17
3.5 Screen of the Engine Library	17
3.6 Structure of the Series Hybrid Vehicle Engine	18
4.1 Extra_Urban Cycle	19
4.2 IC Engine Vehicle Model	21
4.3 Driver Model	22
4.4 Throttle Controller Model	22
4.5 Engine Model	24
4.6 Clutch Model	24
4.7 Gearbox Model	25
4.8 Final Drive Model	26
4.9 Wheels Model	27
4.10 Vehicle Model	28
4.11 Velocity Result	31
4.12 Engine Speed Result	31
4.13 Engine Torque Result	31
4.14 Fuel Rate Result	31
4.15 CO Emission Result	31
4.16 NO _x Emission Result	31
4.17 HC Emission Result	31

5.1 Electric Vehicle Model	34
5.2 Throttle Controller	36
5.3 Motor Model	37
5.4 Motor Controller Model	37
5.5 Battery Model	38
5.6 Extra_Urban Simulation Result	39
5.7 ECE-15 Velocity Result	39
5.8 Motor Speed Result	39
5.9 Motor Torque Result	39
5.10 Battery SOC Result	40
5.11 Energy Flow of ETV-1 over J227a_D Cycle	42
5.12 Range/Battery Weight	44
6.1 Series Hybrid Vehicle Model	47
6.2 Engine Model	47
6.3 Generator Model	48
6.4 APU Controller Model	48
6.5 Required Power Points on Three Cycles	50
6.6 Accent 1.3 BSFC and Emissions	53
6.7 Optimal Operating Region	54
6.8 Velocity Result	55
6.9 Motor Speed Result	55
6.10 Motor Torque Result	56
6.11 Battery SOC Result	56
6.12 Engine Speed Result	56
6.13 Engine Throttle Result	56
7.1 Parallel Hybrid Vehicle Model	62
7.2 Transfer Model	63
7.3 Controller Model	64
7.4 Total Maximum Torque Limit Curve	64
7.5 Engine Model of the Parallel Hybrid Vehicle	65

7.6 Velocity Result	68
7.7 Motor Torque Result	68
7.8 Percentage of Max. Engine Torque	68
7.9 Engine Speed Result	68
7.10 Accent 1.3 Engine (no Change)	69
7.11 Reduced Engine (without Throttle Limit)	69
7.12 Reduced Engine (with Throttle Limit)	70
8.1 Table 8.1 Condition1 of the Series Hybrid Vehicle	76
8.2 Table 8.1 Condition2 of the Series Hybrid Vehicle	76
8.3 Table 8.1 Condition of the Parallel Hybrid Vehicle	76

List of Tables

2.1 Comparison of the IC Engine Vehicle and Electric Vehicle	8
2.2 Electric Energy Flow of a Series Hybrid Vehicle.	10
4.1 Extra_Urban Cycle Profile	20
4.2 Accent 1.3 Vehicle Data	29
4.3 Accent 1.3 Simulation Results	32
4.4 Accent 1.3 Emissions Results	32
5.1 ETV-1 Vehicle Data	35
5.2 ETV-1 Simulation Results	41
5.3 Battery Weight and Vehicle Range	43
6.1 Design Specification of the Series Hybrid Vehicle	51
6.2 Series Hybrid Vehicle Data	55
6.3 Series Hybrid Vehicle Simulation Results	58
6.4 Series Hybrid Vehicle Simulation Results (Reduced Size for Urban Drive)	58
7.1 Possible Operating Modes for the Parallel Hybrid Vehicle	61
7.2 Parallel Hybrid Vehicle Data	67
7.3 Parallel Hybrid Vehicle Simulation Results	72
8.1 Comparison of the Series and Parallel Hybrid Vehicle Simulation Results	77

1.Introduction

Since the motor car was first invented the number of cars in every day use has increased at a surprisingly high rate. For example in South Korea, the author's home country, the number of cars has increased from 2 million in 1988 to 9 million in 1996.^[10] The car has now become a very important part of human life for business, leisure and even sports activity. It is now difficult to imagine life without a car.

Nevertheless the conventional internal combustion engine (ICE) vehicle has some problems which are difficult to solve. Firstly there is the problem of emissions. In large cities the emissions which are exhausted from cars are one of the biggest causes of air pollution. As a consequence many countries have introduced severe regulations about emissions. For example since 1998 every car company selling their cars in California has to sell 2% of Zero Emission Vehicles (ZEV).^[11] The main emissions of the conventional vehicle are Carbon Monoxide(CO), Nitrogen Oxide(NOx) and Hydrocarbon(HC).

The other serious problem with regards the conventional ICE vehicle is the limitation of petroleum resource. Everyday an unimaginable amount of petrol is used by cars throughout the world. For example in 1984 in the UK the daily usage of petrol and diesel for road transport was 6.8 million kg.^[12] Unfortunately for South Korea this high use of petroleum fuel is a very serious problem as the country has no natural oil resource. To try and solve these problems many car companies and research institutions throughout the world are actively researching new types of vehicles that use alternative energies such as electricity,



Compressed Natural Gas(CNG), solar energy etc.^{[13]-[17]}

The electric vehicle is one of the favoured solutions because it does not use petroleum fuel and does not have any exhaust emissions. However it has some technical problems that have yet to be overcome. For example the short vehicle range and the long battery charge time are big problems for the electric vehicle. One other solution is the hybrid vehicle which combines the advantages of the ICE vehicle and the electric vehicle

In the School of Engineering at Durham University hybrid vehicles have been researched actively since 1980's. In particular the structure and performance of hybrid vehicles have been studied through computer simulation and experimental test work.^{[11]-[9]}

This thesis is about the modelling and simulation of Series and Parallel Hybrid Vehicles. The aim of the thesis is to investigate some of the control options of the series and the parallel hybrid vehicle through the use of computer simulation written using MATLAB/SIMULINK. In particular the simulation studies will be used to investigate the fuel consumption and energy use of the different hybrid structures. The programs developed are named collectively as JANUSLEE. Firstly in Chapter 2 the simple layout and characteristics of each type of vehicle such as the IC engine vehicle, electric vehicle, series hybrid vehicle and parallel hybrid vehicle are discussed. Chapter 3 then describes the computer simulation program JANUSLEE which is used for this study. In chapter 4,5,6 and 7 the models for the computer simulation, the techniques for the modelling and simulation and the results of the simulation are discussed. In particular chapter 6 describes how to

decide on the size of motor and engine to use in a series hybrid vehicle and how to run the engine in such a vehicle. Chapter 7 describes how to select the engine and motor size for a parallel hybrid vehicle and how to optimise the engine operating condition. In Chapter 8 the simulation results of the series and parallel hybrid vehicle are compared and the best applications for each type of vehicle considered. Finally in Chapter 9 the conclusion from the work and the areas of further work is discussed.

2.Types of Vehicle

2.1 Internal Combustion Engine Vehicle

The majority of road vehicles used throughout the world are powered by internal combustion(IC) engines. There are two types of IC engine; the spark ignition and the compression ignition engine. The differences between the two engine types is the means of ignition and mixture preparation.

In spark ignition engines air and fuel are mixed before induction and this mixture leads to pre-mixed combustion in which a flame front propagates across the combustion chamber. In contrast in the compression ignition engine the fuel is injected into the combustion chamber immediately prior to combustion. Time is required for the fuel to ignite and then burn in a mode known as diffusion combustion.^[12]

The mechanical structure of the two types of engine is very similar with both having an operating characteristic where they produce power over a speed range of 1000 - 6000 rpm. Typically the compression ignition engine produces maximum torque at lower speed than the spark ignition engine and also has a lower maximum operating speed. The drive train of the IC engine vehicle is shown figure2.1. The Engine, provides the driving power, whilst the Clutch is used to engage or separate the power from the engine to the drive train and to facilitate starting from rest. The Gearbox is used to control the vehicle speed by selecting the gear ratio whilst the Final Drive is used to connect the gear box to the wheels by a constant gear ratio.

As the IC engine vehicle is universally used the mechanics of the vehicle are very well known making the maintenance and repair of these vehicles easy compared to other types of vehicle. Some of the disadvantages of the IC engine vehicle with regards fuel use and emissions were mentioned in the introduction but not mentioned was the inefficiency of the IC engine. According to the second law of thermodynamics "It is impossible for a machine to convert into work all the heat energy supplied to it." This means that there is no practical process that is 100% efficient. In fact the maximum efficiency of the diesel engine, which has a better efficiency than the spark ignition petrol engine, is not over 40% [18].

The modelling and simulation of the IC engine vehicle will be discussed in chapter 2 in detail.

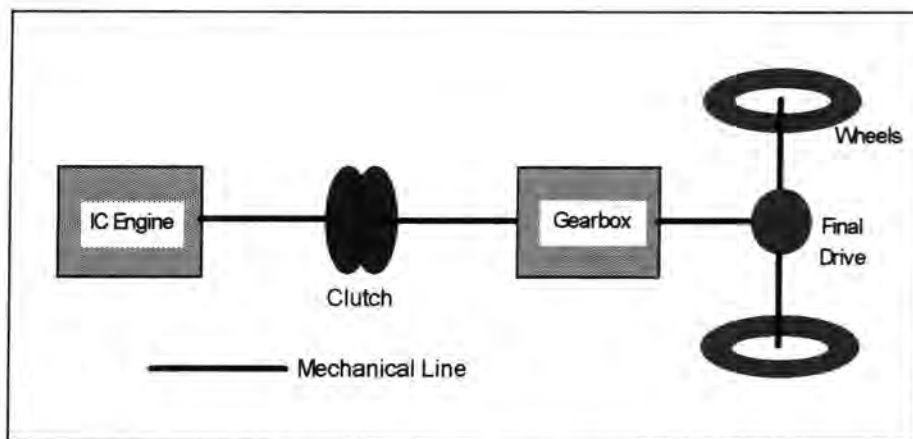

Figure 2. 1 Main Structure of a IC Engine Vehicle

The main advantages and disadvantages of the IC vehicle can be summarized as follows.

Advantages

1. very well known technology

2. simple mechanical layout
3. easy maintenance and repair

Disadvantages

1. poor efficiency
2. emissions
3. limited to the use of hydrocarbon fuels

2.2 Electric Vehicle

The electric vehicle is the ideal type of vehicle because it does not use petroleum fuel and does not have any exhaust emissions. Another excellent advantage of the electric vehicle is its simple structure. An Electric motor does not have an idle speed as does the IC engine, and can produce high torque in the low speed area 0 to 1000 rpm (revolution per minute). Consequently the electric motor can be connected directly to the final drive of the electric vehicle. This means there is no need for a clutch or gearbox which are used in the IC engine vehicle. Therefore the electric vehicle can be built using a very simple layout as shown in figure 2.2. There are two direction arrows in figure 2.2. These mean the electric power of the electric vehicle can flow in two directions. The arrow from left to right means that the electric vehicle is driven by constant speed or acceleration. The opposite direction arrow means that the electric vehicle is braking or decelerating. During braking the electric motor charges the battery because it acts like a generator. This is one of the advantages of the electric vehicle. However the electric vehicle has one big problem and that concerns the battery. Even the latest battery technologies, such as lead-acid or zinc-air battery^[19], do

not allow enough energy to be stored for general use so that the electric vehicle can not be used in the same way as a conventional ICE vehicle. The range of the electric vehicle is limited to under 100-200 kilometers. Consequently the electric vehicle can not be used on the highway for long journeys. In addition the long charging time necessary for large energy storage and the heavy weight of the battery are other problems that have yet to be solved. Table 2.1 shows the differences between a general ICE vehicle and electric vehicle as described above. For both vehicles the efficiency quoted in Table 2.1 refers to the conversion efficiency of the on-board stored energy to propulsion power at the road wheels.

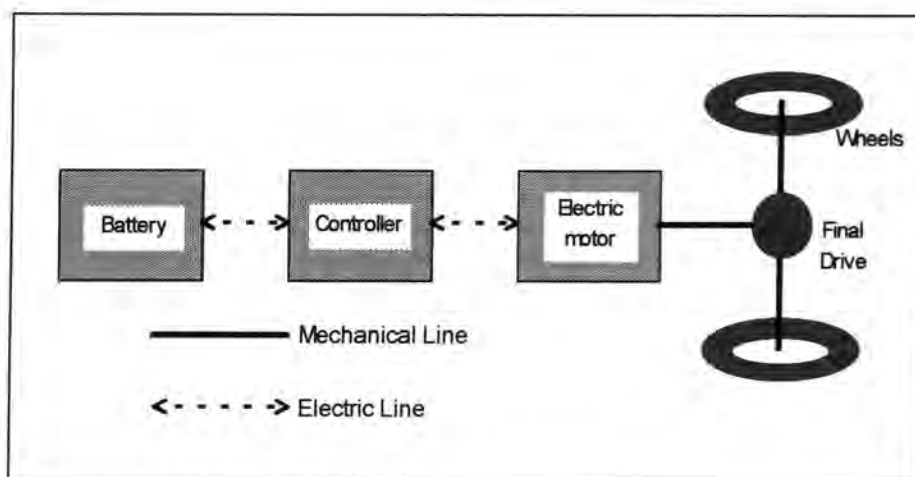

Figure 2. 2 Main Layout of a Electric Vehicle

The main advantages and disadvantages of the electric vehicle can be summarized as follows.

Advantages

1. very simple structure
2. regenerative braking energy

3. no need for petrol and therefore no exhaust emissions

Disadvantages

1. limitation of battery technology
 - heavy weight
 - low range
 - long charging time

	ICE Vehicle	Electric Vehicle
Vehicle Weight	1000 - 1400 kg	1500 - 1800 kg
Typical Efficiency	25 - 40%	85 - 90%
Range	600 - 900 km	100 - 150 km
Refueling	very fast	very slow
Cost	cheap (well known technology)	expensive (new technology)
Advantages	good performance easy maintenance	zero emissions, high efficiency
Disadvantages	emissions, petroleum resource limitation	inadequate battery technology, heavy vehicle weight

Table 2. 1 Comparison of the IC Engine and Electric Vehicle

2.3 Hybrid Vehicle

According to the Technical Committee (Electric Road Vehicles) of the International Electrotechnical Commission, the definition of a hybrid vehicle, is as follows; "A hybrid road vehicle is one in which propulsion energy, during specified operational missions, is available from two or more kinds or types of energy stores, sources, or converters. At least one store or converter must be on-board. A hybrid electric vehicle(HEV) is a hybrid vehicle in which at least one of the energy stores, sources, or converters can deliver electric energy. A

series hybrid is a HEV in which only one energy converter can provide propulsion power. A parallel hybrid is a HEV in which more than one energy converter can provide propulsion power.”^[20]

As defined above a hybrid vehicle can be classified as either a series or a parallel type. Of course both of these structures have specific advantages and disadvantages. The general structures and characteristics of the series and parallel hybrid vehicle will be explained in 2.3.1 and 2.3.2.

2.3.1 Series Hybrid vehicle

The series hybrid vehicle has the least complicated configuration of all the hybrid types. As shown in figure 2.3 the series hybrid vehicle has five main components which are the electric motor, the engine, the Generator, the battery and the power train. The engine and the generator is called the Auxiliary Power Unit (APU). The traction force is supplied by the electric motor with the electric motor getting its power from the battery and/or the APU. This means the series hybrid vehicle is driven by the electric motor only. Therefore the series hybrid vehicle needs a large size electric motor such as in the electric vehicle. The engine used in the APU is typically an IC engine although gas turbines have also been used.^[24] The electric power produced by the APU is supplied to the battery or used to drive the electric motor. When the electric power from the APU is bigger than the power required for traction this excess power is used for charging the battery. In contrast when the APU power is smaller than the power required for traction the additional power is supplied by the battery. Table 2.1

summarizes the different possible flows of electric power described above. The most important control decision to be made in the series hybrid vehicle is when and how to run the APU. A number of the control techniques for the APU will be discussed in Chapter 4.

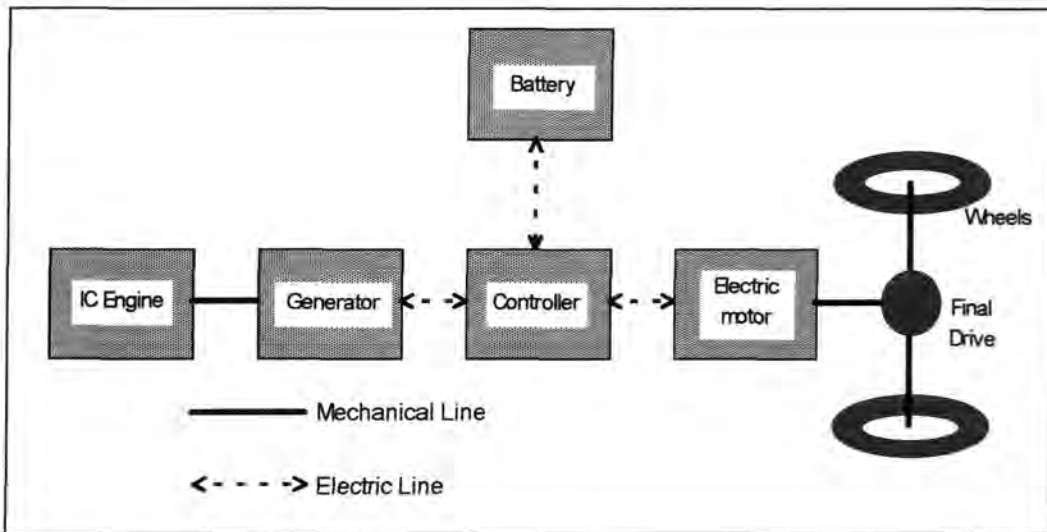

Figure 2. 3 Main Layout of a Series Hybrid Vehicle

State of APU	Condition	Power Source of Electric Motor	State of Battery
ON	Traction Power < APU Output	APU	Charging
ON	Traction Power > APU Output	APU and Battery	Discharging
OFF	-	Battery	Discharging

Table 2. 2 Electric Energy Flow of the Series Hybrid Vehicle

The main advantages and disadvantages of the series hybrid vehicle are as follows.

Advantages

1. simpler mechanism than the parallel hybrid (see section 2.3.2)
2. weight can be reduced (no clutch, no gearbox)

Disadvantages

1. needs a larger sized motor than the parallel hybrid
2. difficult to use for general purpose

2.3.2 Parallel Hybrid vehicle

As shown in figure 2.4 the parallel hybrid vehicle has an IC engine and an electric motor with the two power sources connected mechanically in parallel. This means the parallel hybrid vehicle can be driven by either one or both of the power sources at the same time. Therefore the parallel hybrid vehicle can have a smaller sized electric motor than the series hybrid vehicle. The parallel hybrid vehicle can be operated in many different modes which can be divided as follows

1. **Electric Mode:** The vehicle is driven by the electric motor only.

This mode is used mainly at low vehicle speed because the electric motor can produce high torque at low speed.

2. **IC Engine Mode:** The vehicle is driven by the IC engine only.

This mode is used mainly at high vehicle speed because the IC engine can produce high power at high speed. Of course regenerative braking energy is used for charging the battery as in the electric mode.

3. **Hybrid Mode:** The IC engine and the electric motor are used simultaneously when the vehicle needs large power.

The aim of the parallel hybrid vehicle is the minimization of both the

exhaust emissions and the amount of petrol used through the use of the operating modes mentioned above. The layout of the parallel hybrid vehicle is shown in fig2.4. The power from the IC engine and the electric motor are added in the transfer box. The controller controls everything; for example when the IC engine or electric motor is on or off, the torque and output from the engine etc. The rest of the components of the vehicle are the same as those used in the IC vehicle or the electric vehicle.

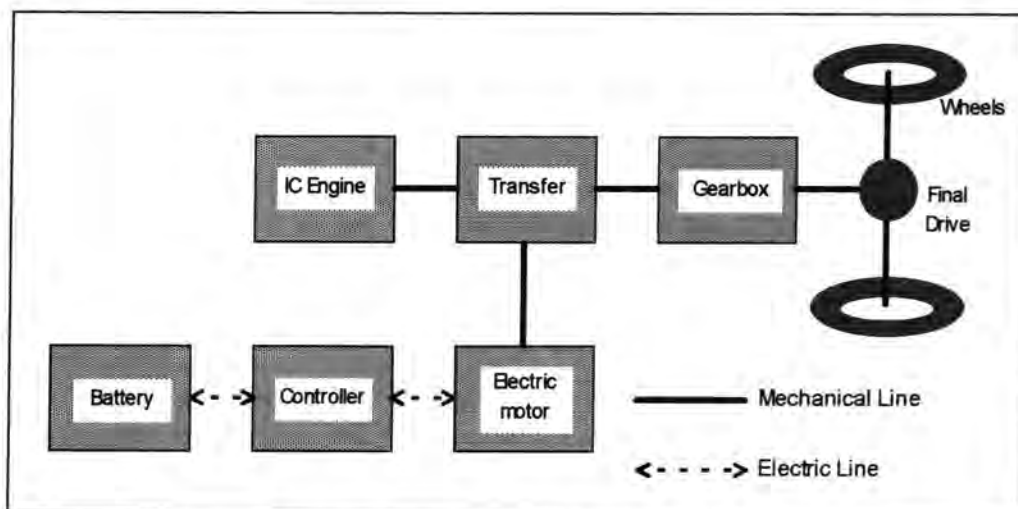

Figure2.4 Main Layout of a Parallel Hybrid Vehicle

The main advantages and disadvantages of the parallel hybrid vehicle are as follows.

Advantages

1. has versatile operating modes
2. more scope for optimizing the size of the motor and the engine than in the series hybrid

Disadvantages

1. increased weight
2. complicated control logic

2.4 Conclusion

The four kinds of vehicle described in this chapter have unique characteristics. Although the ICE vehicle is currently the most popular type of vehicle throughout the world it has big problems such as exhaust emissions and the limitation of petroleum resource.

The electric vehicle has many advantages; no emissions, no need for a petroleum resource, simple structure and regenerative braking energy. However the electric vehicle has fatal problems in the limitations of the battery which restrict the vehicle to short range use, require a long charging time and produce a heavy weight vehicle.

There are two basic types of hybrid vehicle; the series and the parallel hybrid. Both types of vehicle have similar components but the connection of those components is totally different. Consequently the two types of vehicle have contrasting characteristics. The control logic of the series hybrid vehicle is easier than that for the parallel hybrid vehicle. On the other hand the parallel hybrid vehicle can have a smaller sized electric motor than the series hybrid vehicle. In chapter 6 and 7 the series and the parallel hybrid vehicle are examined in order to try and maximise their advantages and minimise their disadvantages.

3.Simulation Software

3.1 Advantages of Computer Simulation

One of the most important aspects of this thesis is the study of the four kinds of vehicle through the use of computer simulation. To obtain good comparative results many tests or simulations are necessary and but for computer simulation this project would not be possible. Without the use of computer simulation at least four prototype cars would have to be made which would require a large amount of man-power and large research costs. By the use of computer simulation the project has been completed by one person in one year. This is the biggest advantage of computer simulation and the main reason why computer simulation is being used throughout the world by almost all car manufactures for studying the potential of new vehicle structures. Car companies use computer simulation in many areas for saving time, money and man-power for example design, crash test, air-bag test and driving test etc. On the other hand there will be some error in the computer simulation due to the models adopted and the values of the parameters used. However if necessary the magnitude of this error can be predicted and the tolerance on the results calculated by the computer program.

3.2 Structure and Components of SIMULINK

The simulation software used in this thesis is SIMULINK the graphical user interface (GUI) for MATLAB.^[21] SIMULINK is a graphical program so it is very easy to understand and operate. SIMULINK consists of

libraries which have many blocks each of which simulate different elements such as a relay, switch, workspace, function and clock etc. The initial SIMULINK screen is shown figure 3.1. From this screen the user can select a library which contains the simulation block required. For example to use the switch block this is contained in the Nonlinear or Extras library. Extras can be specially made from the blocks which are used most often. Any user can make not only the Extras library but also modify the rest of the libraries for their own use. Figure3.2 shows the screen of the Nonlinear library. The user can copy the Switch block to any model or file. Of course the user can change the values or conditions of the block. When very complicated functions or equations are required the Fcn, Matlab-Function or S-Function will be very helpful. In this way a model is made. Figure3.3 shows a example model for a battery which is made by combining many blocks from each libraries in the SIMULINK.

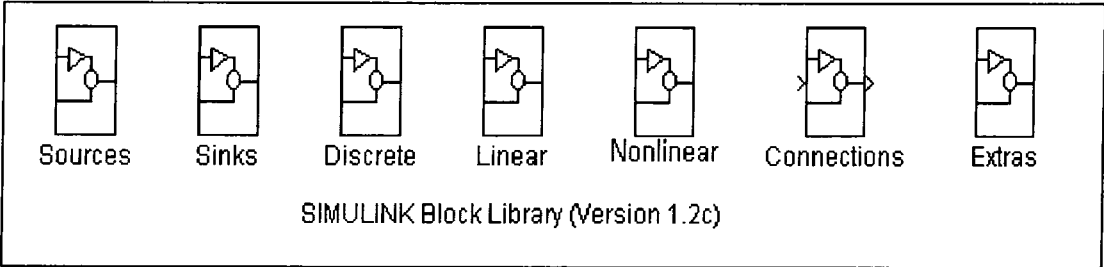

Figure3. 1 The Initial Screen of SIMULINK

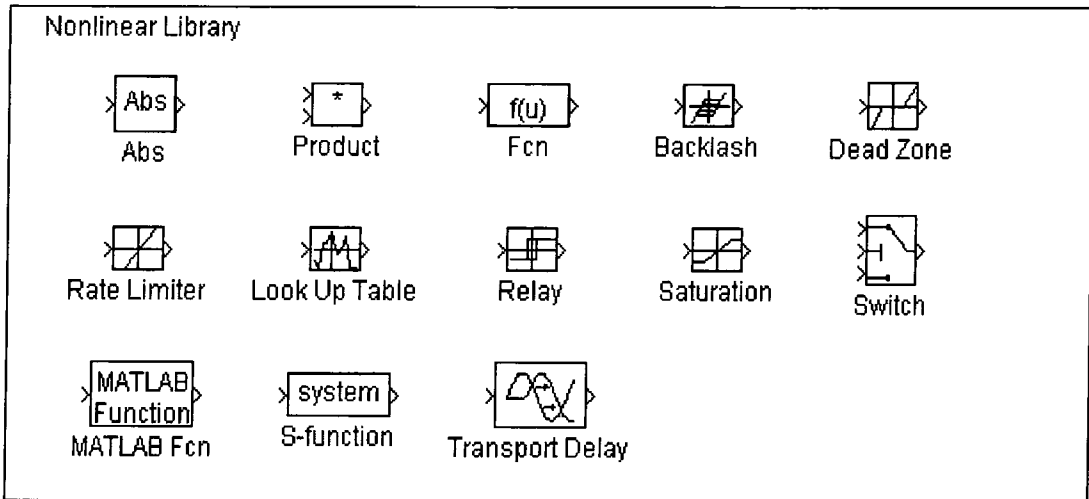

Figure3. 2 The Screen of the Nonlinear Library

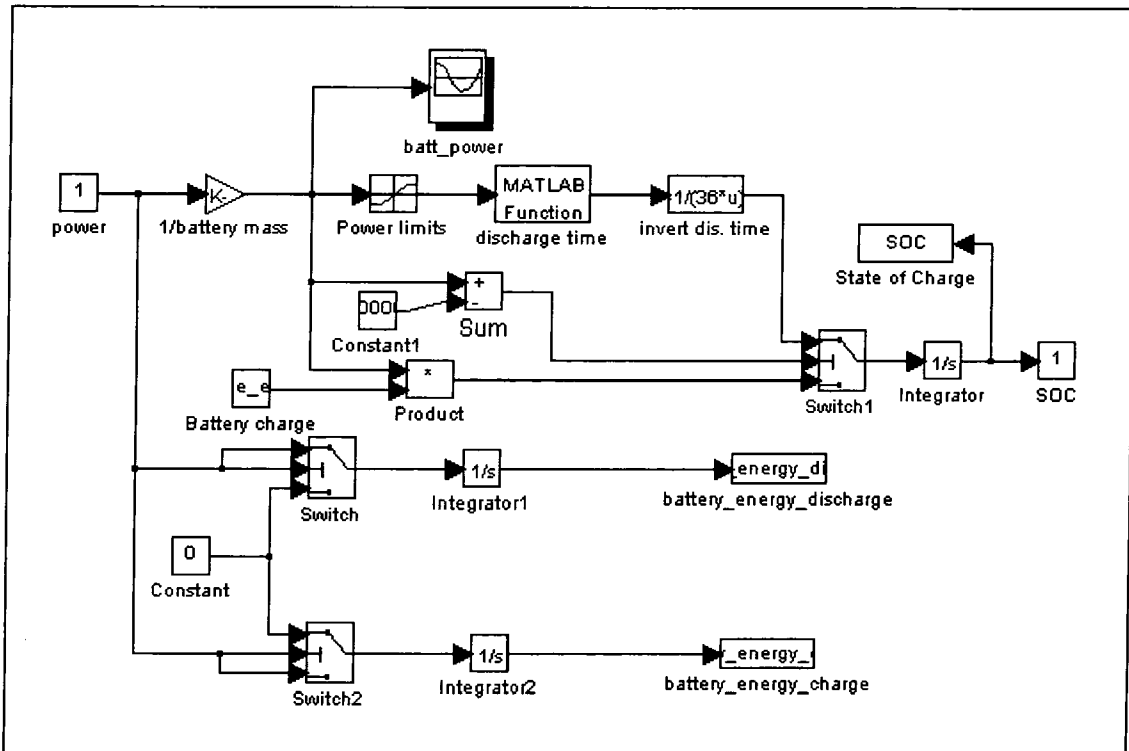

Figure3. 3 The Example Model of the SIMULINK

3.3 Structure and Components of JANUSLEE

JANUSLEE is one of the user library files made from SIMULINK for the simulations of the four kinds of vehicle mentioned in chapter 2.

Figure 3.4 shows the initial screen of JANUSLEE. Each model contains many components for the four kinds of vehicle. In this screen the user can select any model which is needed by a double click. For example if the user is looking for the engine used in a series hybrid vehicle the engine models in the engine library can be shown by double click. The engine library shown in figure 3.5 then appears. Of course each engine model shown in figure 3.5 is made up from the basic modelling components described in section 3.2. Figure 3.6 shows the structure of the engine for the series hybrid vehicle in the engine library.

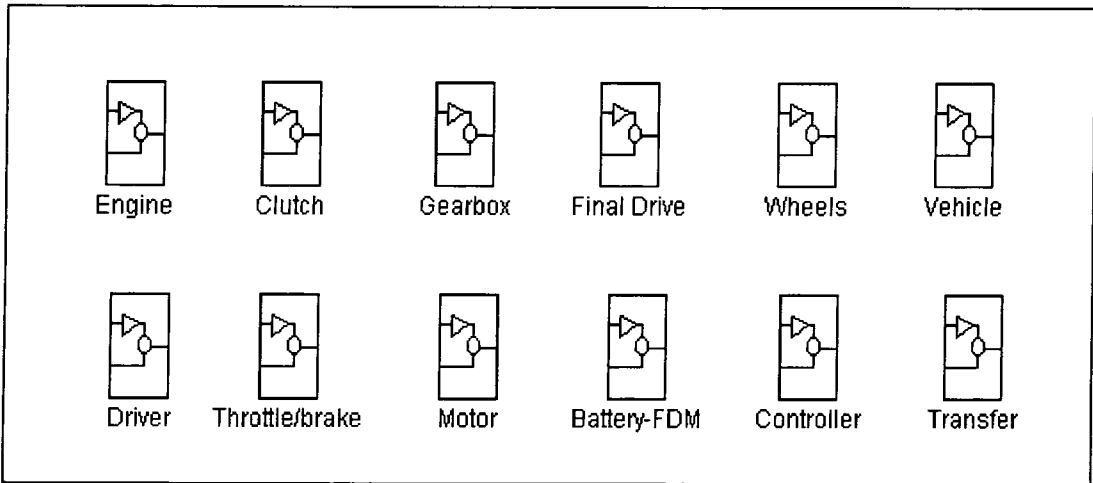

Figure3. 4 The Initial Screen of JANUSLEE

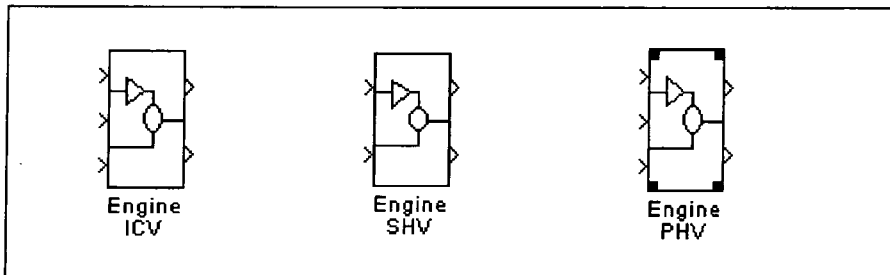

Figure3. 5 The Screen of the Engine Library

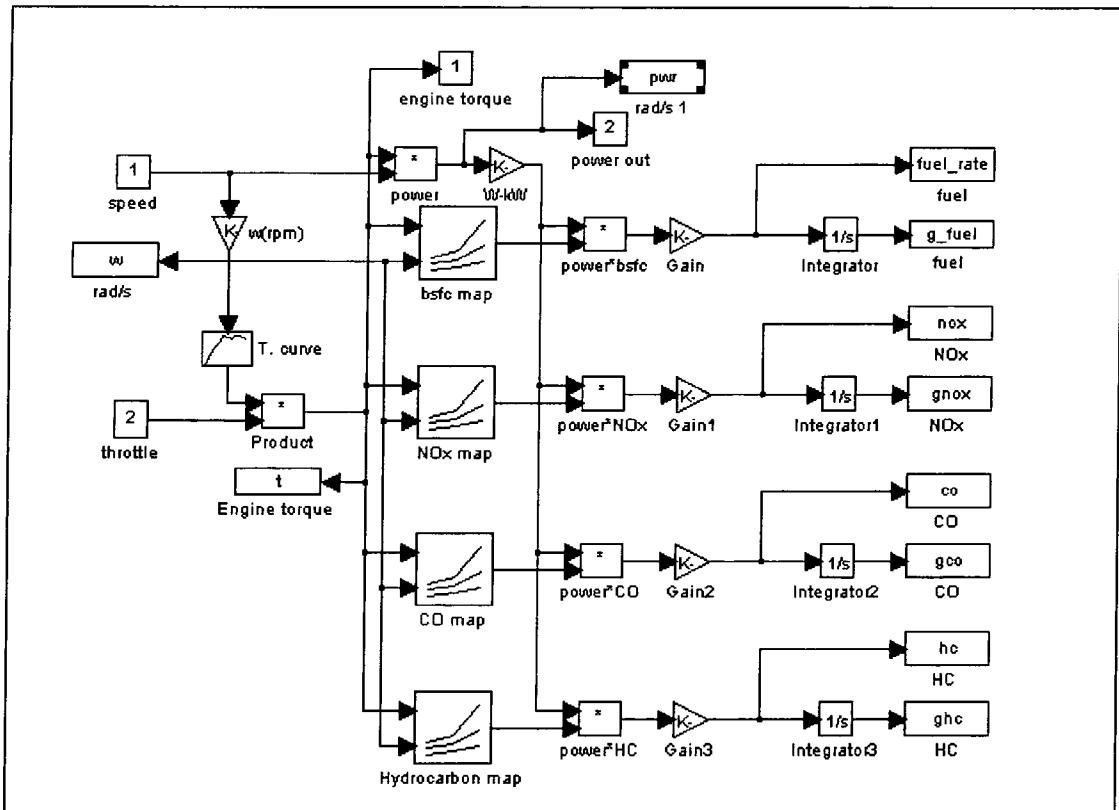

Figure3. 6 The Structure of the Series Hybrid Vehicle Engine

3.4 Conclusion

Computer Simulation has become very important not only for car manufactures but also for many other industrial areas because it has many advantages; saving time, saving research costs and needs minimum man-power etc. This thesis uses SIMULINK, the graphical user interface (GUI) for MATLAB, to develop the vehicle component library JANUSLEE. The component models in JANUSLEE can be combined to make a vehicle model. Therefore according to the specification the four types of vehicle described in Chapter 2 can be simulated very easily by JANUSLEE.

4 Performance of the ICE vehicle

4.1 Driving cycles

Computer simulation of vehicles uses standard driving cycles to produce the simulation results. The driving cycles are used by car manufactures or government for many purposes such as the driving test, fuel economy test and the comparison of vehicles. Driving cycles are composed of a velocity/time profile and the velocity of the test vehicle, or the simulation model, must follow this velocity profile. Depending on the road conditions of each country there are a number of different driving cycles. In this thesis the popular driving cycles such as ECE-15, J227a-D and the Extra_Urban driving cycle are used.^[1] The Extra_Urban cycle has a high average speed of 62.75km/h. On the other hand the ECE-15 cycle which is for an urban area test cycle has only an average speed of 19.21km/h. Figure 4.1 shows the shape of the Extra_Urban cycle. The characteristic of the Extra-Urban cycle is that the gear is set by the time-velocity profile as shown in table 4.1. The data files of the Extra_Urban, the ECE-15 and the J227a-D driving cycles are included in Appendix 1.

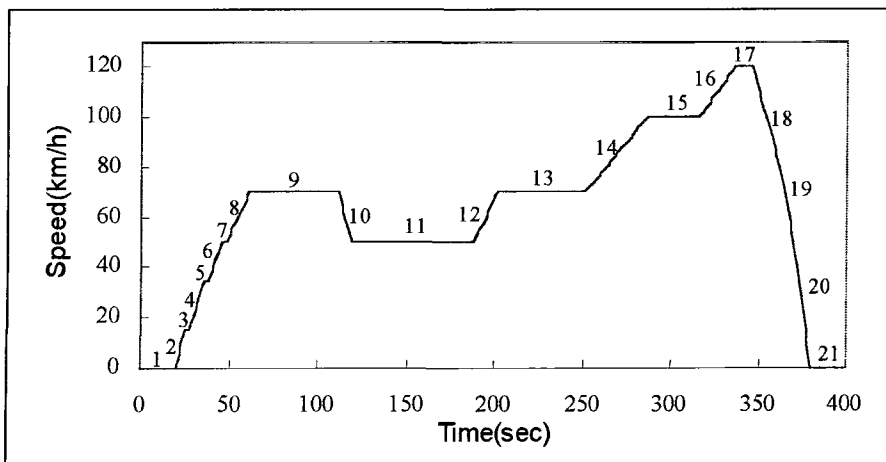

Figure 4. 1 Extra_Urban Cycle

No	Operation	Speed(Km/h)	Operation Time	Cumulative Time	Gear Ratio
1	Idling		20	20	*
2	Acceleration	0 - 15	5	25	1
3	Gear Change		2	27	-
4	Acceleration	15 - 35	9	36	2
5	Gear Change		2	38	-
6	Acceleration	35 - 50	8	46	3
7	Gear Change		2	48	-
8	Acceleration	50 - 70	13	61	4
9	Steady Speed	70	50	111	5
10	Deceleration	70 - 50	8	119	5(4s)+4(4s)
11	Steady Speed	50	69	188	4
12	Acceleration	50 - 70	13	201	4
13	Steady Speed	70	50	251	5
14	Acceleration	70 - 100	35	286	5
15	Steady Speed	100	30	316	5(**)
16	Acceleration	100 - 120	20	336	5(**)
17	Steady Speed	120	10	346	5(**)
18	Deceleration	120 - 80	16	362	5(**)
19	Deceleration	80 - 50	8	370	5(**)
20	Deceleration	50 - 0	10	380	*
21	Idling		20	400	PM(*)

*) PM = gearbox in neutral, clutch engaged first of fifth gear engaged, clutch disengaged

**) Additional gears can be used according to manufacturer recommendations if the vehicle is equipped with a transmission with more than five gears

Table 4.1 Extra_Urban Cycle Profile

4.2 Configuration of the ICE vehicle

The ICE vehicle simulated in this chapter is the Accent 1.3 built by the Hyundai Motor Company (HMC). Figure 4.2 shows the ICE vehicle model made by JANUSLEE. This model works by connecting each component in a similar way as in an actual vehicle. The final output of this model is the vehicle speed. The speed results are returned to the MATLAB workspace by the "spd" block and shown graphically by the "vehicle speed" graph block. The vehicle speed is compared with the

required speed(obtained from the driving cycle) in the “driver” block and then the input throttle position of the engine is decided in the throttle controller block. According to the input throttle position and engine speed the “engine” block calculates the engine torque. The engine torque is then passed through each block such as clutch, gearbox, final drive, wheels until in the vehicle block it is used to calculate vehicle speed as described in section 4.2.8. The components used in this vehicle model can be used for other kinds of vehicle with little or no change. For example, the final drive block can also be used in the electric vehicle without change, only the final drive ratio which is the inherent value of each vehicle should be changed. However to use the engine block in the series hybrid vehicle it needs some modification.

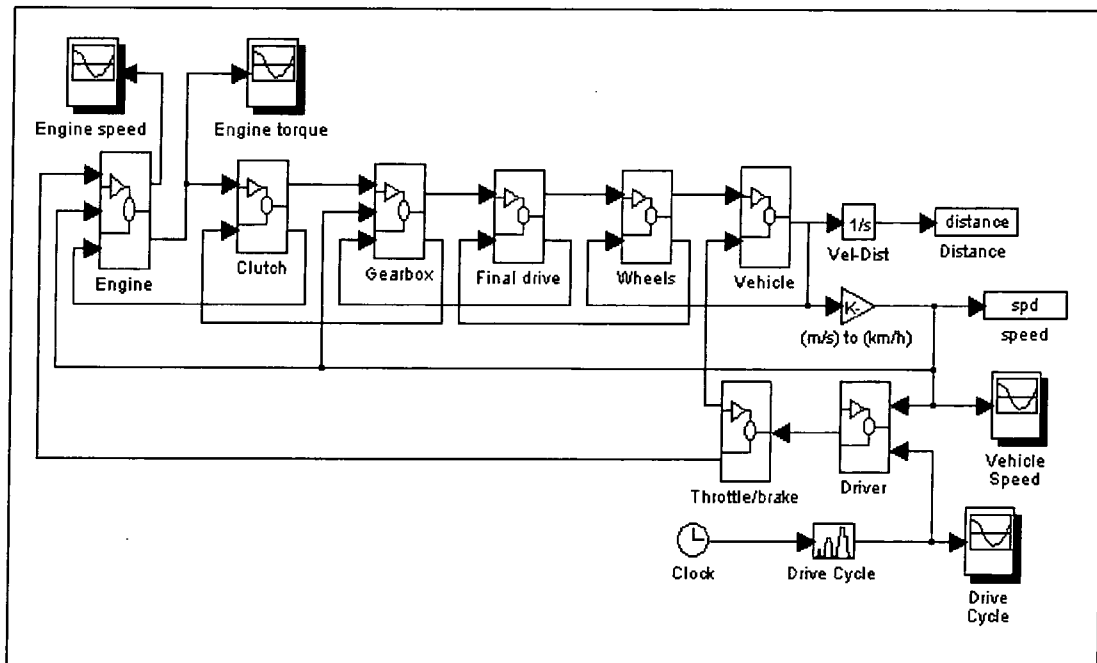

Figure 4. 2 IC Engine Vehicle Model

4.2.1 The Driver

Figure 4.3 shows the “driver” model. There are two inputs, the required speed and the actual speed. The “driver” compares the two input speeds and decides on the throttle position by a controller which has a constant gain. The throttle output is limited to between ± 1 by the saturation block before being supplied to the Throttle Controller model.

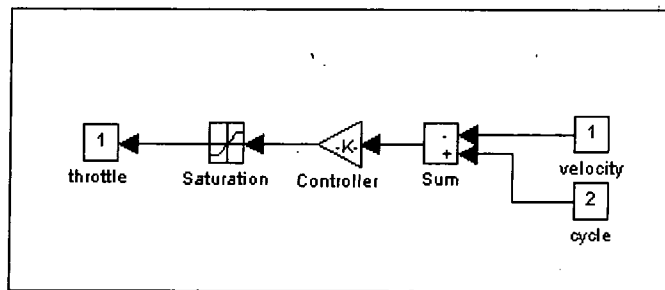

Figure 4. 3 Driver Model

4.2.2 The Throttle Controller

As shown in Figure 4.4 the input throttle is divided by two saturation blocks. The positive throttle position is sent to the engine model and the negative throttle position is sent to the vehicle model for friction braking.

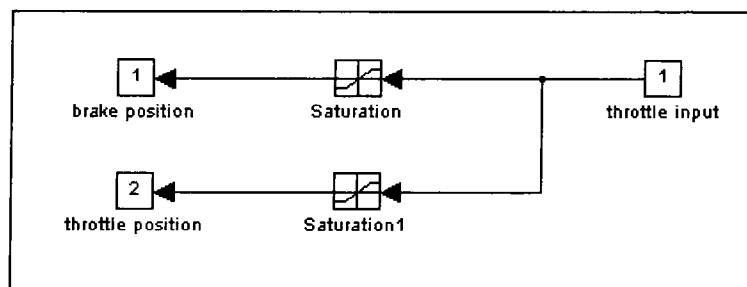

Figure 4. 4 Throttle Controller Model

4.2.3 The Engine

The Engine model is the most important component of the ICE vehicle.

It has a very complicated structure and is shown in Figure 4.5. The engine needs many data tables such as Brake Specific Fuel Consumption (BSFC), Carbon Monoxide (CO), Nitrogen Oxide (NO_x), Hydrocarbon (HC) table and torque curve. The full data files for these tables and the torque curve of the Accent 1.3 are included in Appendix 2. The input signals of the engine model are the actual speed of the vehicle, from the vehicle model, and the feedback speed from the clutch model. The actual speed is used to decide if the state of the engine is idle or not. If the state of the engine is idle the amount of idle fuel consumption and emissions are added to the sum5 to sum8 blocks. The engine torque is calculated depending on the throttle position and the engine speed. First of all the engine speed is converted from an angular velocity (rad/s) to revolutions per minute (rpm). Then the maximum torque value is calculated from the rpm and the maximum torque curve. The engine output torque is calculated from this maximum torque value and the throttle position. This engine output torque is sent to the Clutch model whilst the engine output torque and the engine speed are sent to the maps of BSFC, CO, NO_x and HC. Consequently the amount of the fuel consumption and emissions are calculated. The gain to gain3 blocks convert the unit of BSFC, CO, NO_x and HC from g/kWh to g/kWs. In addition the integrator – integrator3 blocks cumulate the amount of each output in order to calculate the amount of fuel used during the whole driving cycle.

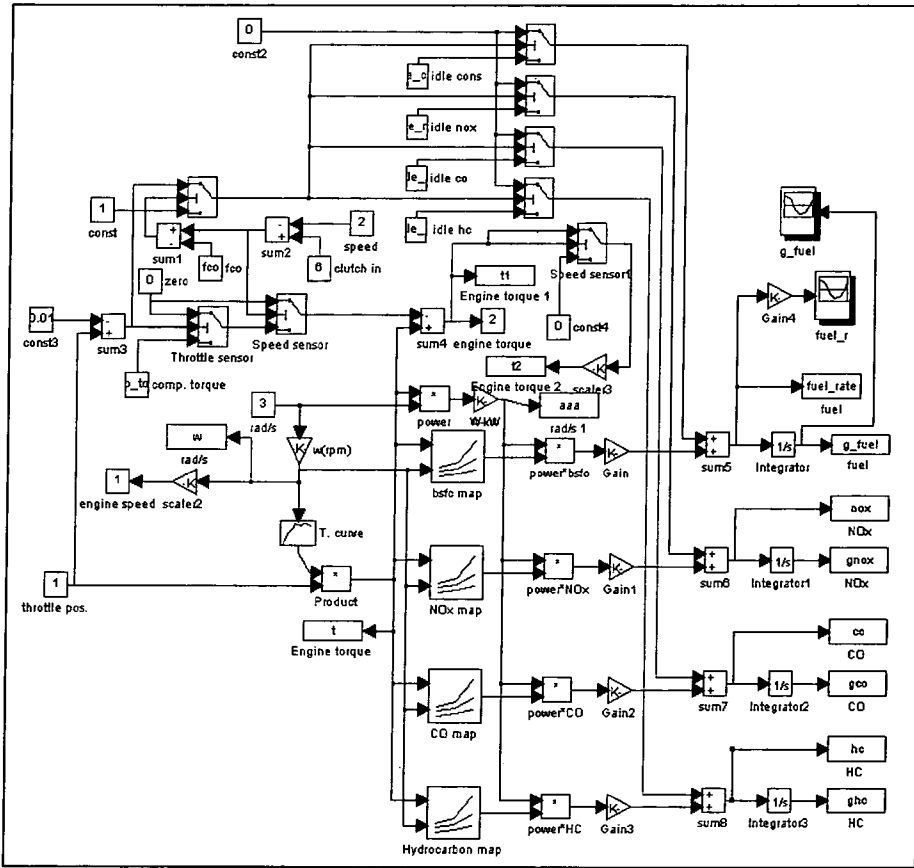

Figure 4. 5 Engine Model

4.2.4 The Clutch

The clutch is located between the engine and the gearbox. It transfers the torque from the engine to the gearbox without change. However the speed from the gearbox is limited to between the idle rpm and maximum rpm by the saturation block before sent to the engine block. The limitation values are the idle speed and the maximum speed of the engine. Figure 4.6 shows the clutch model.

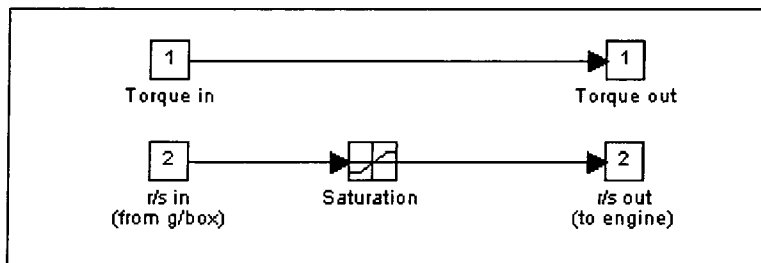

Figure 4. 6 Clutch Model

4.2.5 The Gearbox

The gearbox model is shown in Figure 4.7. There are three inputs, the torque from clutch model, the actual velocity of vehicle from the vehicle model and the speed from the final drive model. The two outputs are the torque, sent to the final drive model, and the speed, sent to the clutch model. The gear ratios to use are set by the car manufacture and which of these gears is to use decided by comparing the actual velocity of the vehicle with the velocity range of each gear. The output torque is obtained by multiplying the selected gear ratio by the engine input torque. The output torque is multiplied by the gearbox efficiency before being sent to the final drive. This gearbox efficiency is a constant value. As speed is calculated backwards from the road speed the speed output from the gearbox model is the engine speed. This is calculated by multiplying the input speed, from the final drive, by the selected gear ratio.

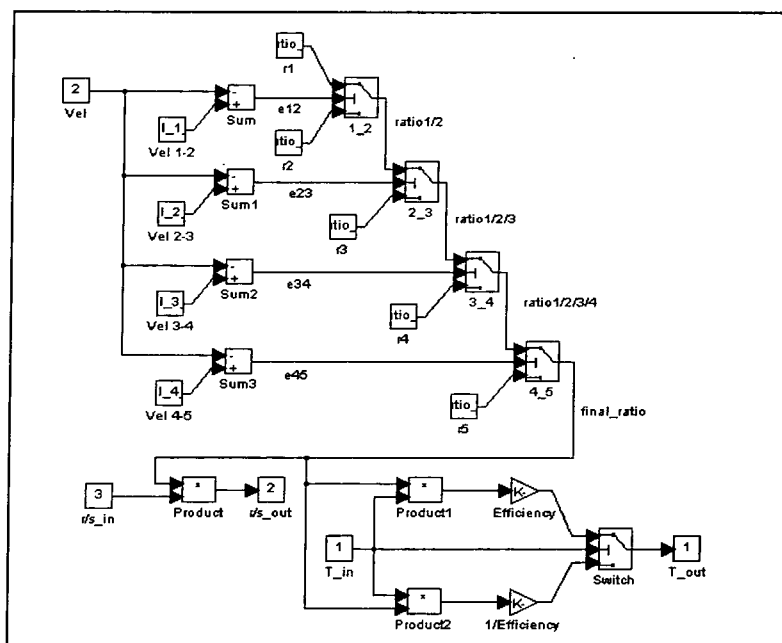

Figure 4.7 Gearbox Model

4.2.6 The Final Drive

The final drive changes the rotational speed by the fixed gear ratio between the wheels and the gearbox model. The input torque is multiplied by the fixed constant gear ratio and by the final drive efficiency. The final drive efficiency is inverted by the switch block when the input torque is negative. In the electric vehicle model this negative torque is used for regenerative braking. Figure 4.8 shows the final drive block.

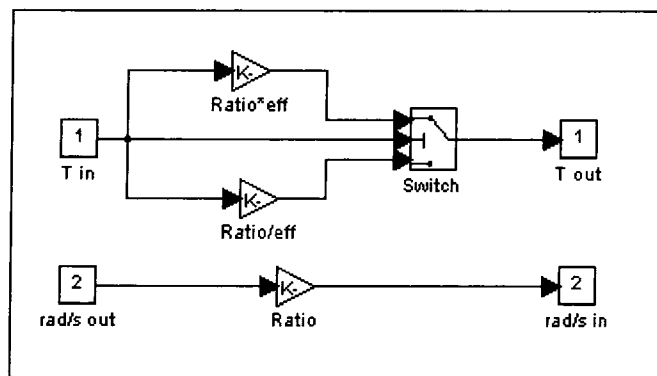

Figure 4. 8 Final Drive Model

4.2.7 The Wheels

The wheels block is shown in Figure 4.9 and serves two functions. Firstly it changes the linear velocity of the vehicle to the rotational speed of the wheels and secondly it connects the final drive torque to a traction force. The gain responsible for these two conversions is obtained by equation 4.1.

$$\text{Equation 4.1} \quad V = \omega \cdot r \quad \omega = V/r$$

$$\therefore \text{gain} = 1/r$$

Where V : vehicle velocity, m/s

ω : angular velocity, rad/s

r : wheel radius, m

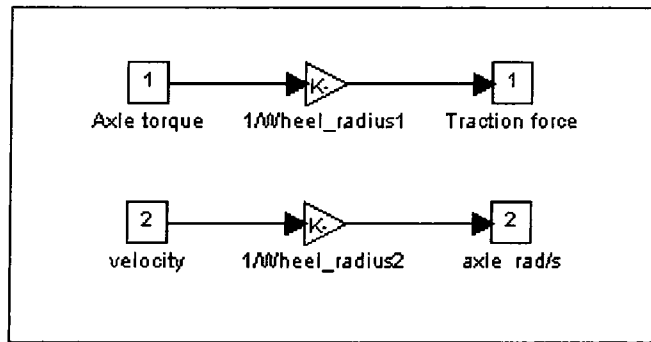

Figure 4. 9 Wheels Model

4.2.8 The Vehicle

The vehicle block is based on the standard equation of motion as described in equation 4.2. The required output of the vehicle model is the velocity of the vehicle therefore the vehicle model is realized as a visual block diagram as shown in Figure 4.10 This equation contains the constant parameter values relevant to the vehicle and the two input values traction force, from the wheels model, and the braking force from the throttle controller. The braking force is limited to between -1 and 0 by the driver and the throttle controller model as mentioned in section 4.2.1 and 4.2.2 and multiplied by the gain1 which is the maximum braking force. Typically the maximum braking force of 2000N is used.

Equation 4.2 $F = M \cdot a$

$$F_t - F_d - F_r - F_g + F_b = M \cdot dv/dt$$

Where F_t = Traction Force

$$F_d = 0.5 \cdot \rho \cdot C_d \cdot A \cdot V^2 \text{ (Drag Force)}$$

$$F_r = C_r \cdot M \cdot g \text{ (Rolling Resistance Force)}$$

$$F_g = M \cdot g \cdot \sin\theta \text{ (Gravity Force)}$$

F_b = Braking Force

ρ : density of air, kg/m^3 C_d : coefficient of drag

A: frontal area, m^2 V: vehicle velocity, m/s

C_r : coefficient of rolling resistance

M: mass of vehicle, kg

g: acceleration due to gravity, $9.81\text{m}/\text{s}^2$

θ : angle of gradient

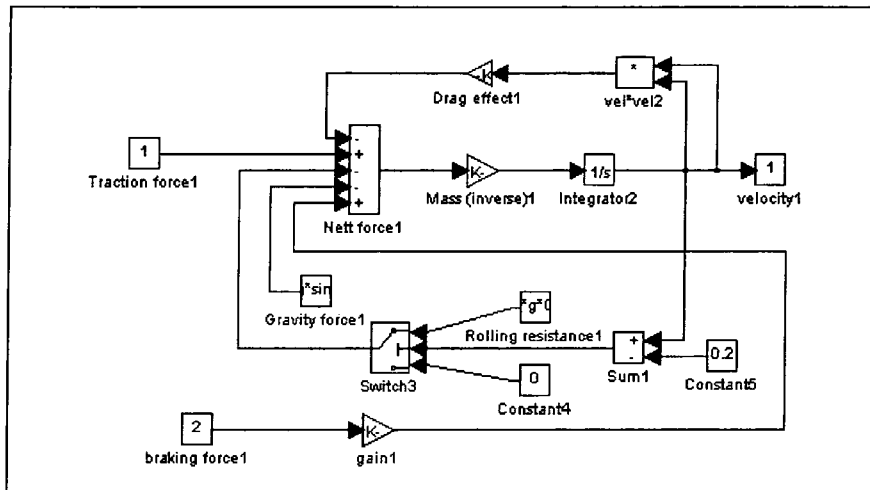

Figure 4. 10 Vehicle Model

4.2.9 Data Files

The ICE vehicle simulation requires a large quantity of data such as the driving cycle files, a specification file of the vehicle and BSFC and Emissions data files for the engine. All the data mentioned above are given in Appendix 1 and 2 for the Hyundai Accent 1.3. Of course if this data is available any car can be simulated by the ICE vehicle model described in this chapter.

4.3 Simulation of the ICE Vehicle

This section discusses the analysis and the results of the ICE vehicle

simulation. There are two purposes for the ICE vehicle simulation. Firstly is the demonstration of the accuracy and the efficiency of the computer simulation. In the case of the ICE vehicle the simulation results can be compared with real test data obtained by a manufacture or government test figures.

Secondly the simulation results for the electric or hybrid vehicle must be compared with those of the ICE vehicle. Unfortunately it is only possible to compare the fuel economy of the ECE-15 and the Extra_Urban cycle because other data such as the fuel economy of J227a_D cycle and the emissions data for all cycles were not available from the Hyundai Motor Company. In SIMULINK the user can get the simulation result by means of a numerical value or in the form of a graph. In this thesis the graphical results are mainly used in order to compare performance easily. Table 4.2 shows the Accent 1.3 test data, of course full profile data is listed in Appendix 2.

Vehicle Test Weight (kg)		1100
Drag Coefficient		0.317
Rolling Resistance Coefficient		0.018
Frontal Area (m ²)		1.91
Wheel Radius (m)		0.289
Engine Max. Speed (rev/min)		5500
Transmission Ratio	1st	3.462
	2nd	2.053
	3rd	1.370
	4th	1.031
	5th	0.838
Final Drive Ratio		3.842

Table 4. 2 Accent 1.3 Vehicle Data

4.3.1 Analysis of the ICE Vehicle Simulation

The Hyundai Accent 1.3 was the base vehicle simulated with full parameter details being given in Appendix 2. Figure 4.11 shows the difference between the required vehicle velocity, illustrated by the dotted line, and the actual velocity illustrated by the solid line. As shown in Figure 4.11 there is little difference between the two lines. Consequently the simulation has operated successfully. Figure 4.12 shows the change of the rpm of the engine during the cycle. The sudden drops in rpm is due to the change of the gear ratio. The drop points are exactly matched to the velocity ranges of the gearbox model which were mentioned in section 4.2.5. This demonstrates the correct functioning of the gearbox. The change of the engine torque is shown Figure 4.13. The dotted line which describes the cycle speed is used for comparison purpose. When there is a change in the gear ratio the engine torque changes in the shape of steps as the torque is effectively constant for constant acceleration. Figure 4.14 shows the fuel consumption of the cycle. It shows the difference in the fuel consumption when the vehicle is accelerating and when operating at constant speed very clearly. When the vehicle is idling or braking the idle fuel consumption is used as shown in Figure 4.14. Figure 4.15, 16, 17 show the emissions exhausted from the engine during the Extra_Urban driving cycle. The shapes of three emissions are very similar to the shape of the fuel consumption. However in the case of the NO_x emission there is nearly zero emission in the idling or low constant speed region.

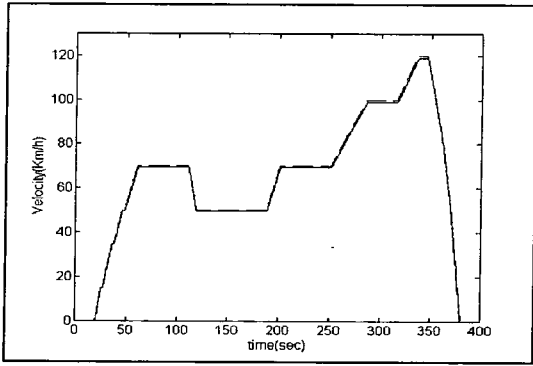

Figure 4.11 Velocity

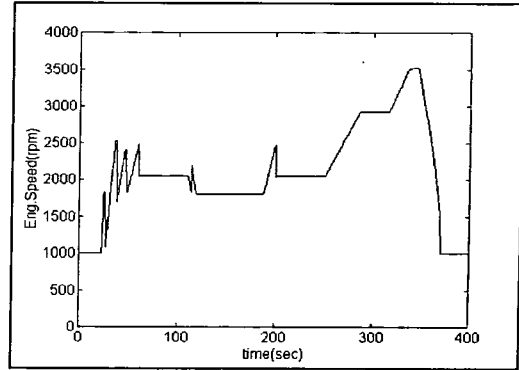

Figure 4.12 Engine Speed Result

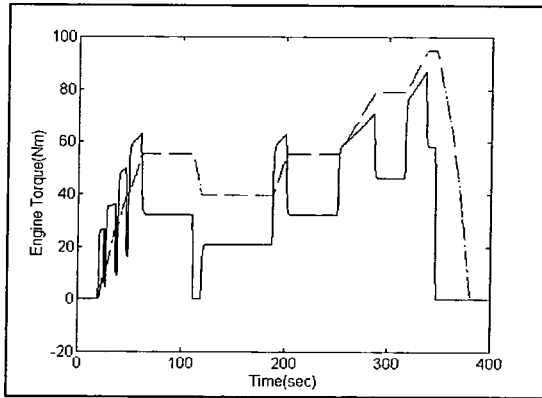

Figure 4.13 Engine Torque Result

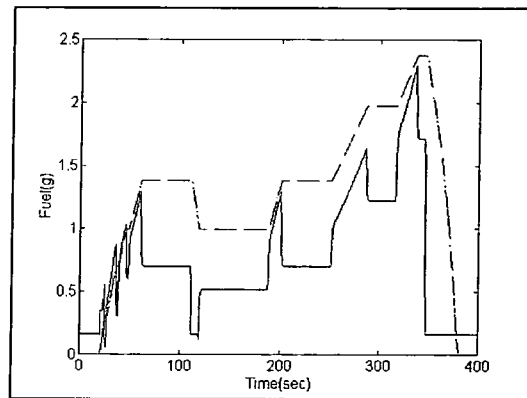

Figure 4.14 Fuel Rate Result

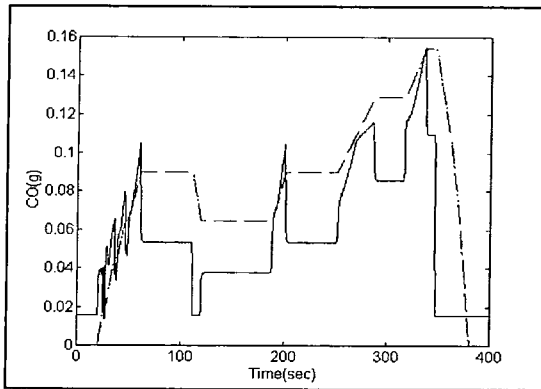

Figure 4.15 CO Emission Result

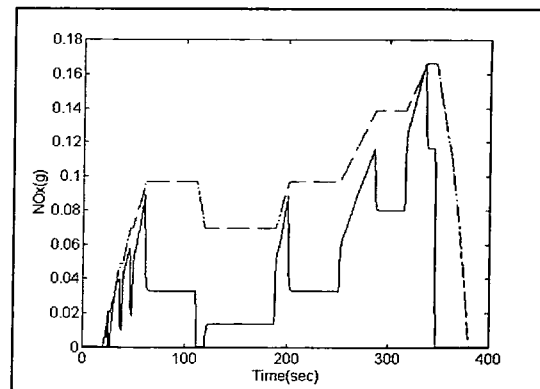

Figure 4.16 NOx Emission Result

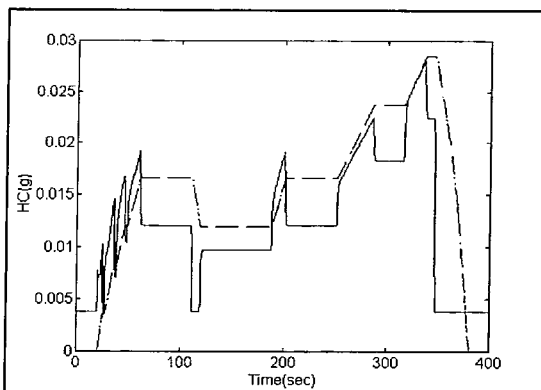

Figure 4.17 HC Emission Result

4.3.2 Simulation Results

Table 4.2 shows the simulation results for the Accent 1.3. The results for the Extra_Urban cycle show the simulation results to compare with Hyundai test data to within 5% and therefore give confidence to the accuracy of the simulation method for use in later chapters. The error over the ECE-15 cycle is bigger than the error for the Extra_Urban cycle because the real test data of the ECE-15 cycle from HMC is obtained from a cold start. The simulation results always assume a warm engine. If the starting temperatures are different the difference can be eliminated by Equation 4.3^[1]. It is not possible to compare the emissions data with official data because no emissions data for Accent 1.3 is available. However the emissions data are shown in Table 4.3 for comparison with the series or parallel hybrid vehicle in later Chapters.

	ECE-15	J227a_D	Extra_Urban
HMC Data(km/ ℓ)	10.88	-	15.80
Simulation Data(km/ ℓ)	12.26	15.86	16.49
Error(%)	+12.68	-	+4.37

Table 4. 3 Accent 1.3 Simulation Results

	ECE-15	J227a_D	Extra_Urban
CO(g/km)	5.36	3.68	3.39
Nox(g/km)	1.46	2.13	2.42
HC(g/km)	1.25	0.81	0.72

Table 4. 4 Accent 1.3 Emissions Results

Equation 4.3 $f_T = f_0 - T/20(f_{20} - f_0)$
 $f_0 = 0.88e^{1.42/(1.42+d)}$
 $f_{20} = 0.48e^{13.7/(13.7+d)}$

d is the cumulative distance traveled in kilometers and
T is the ambient temperature °C

4.4 Conclusion

In this chapter a model of ICE vehicle is assembled and simulated by JANUSLEE. Some component models, which are used for the ICE vehicle simulation, such as gearbox, final drive and wheels etc. are also used for other types of vehicle. According to the graphs illustrated in section 4.3.1 it is confirmed that the ICE vehicle model acts correctly. The fuel economy and the emissions data are also obtained by the simulation. The accuracy and reliability are proved by the comparison between the accent 1.3 simulation results and the real test data from Hyundai Motor Company. In addition these simulation results will be also used to compare with the series and the parallel hybrid vehicle simulation results.

the Chrysler Corporation.^[22]

In a similar way to the ICE vehicle model the electric vehicle model also requires a number of data files to be specified to allow the simulation to begin. The vehicle data file 'etv1.m' has many parameters and data such as vehicle weight, wheel radius and rolling resistance coefficient etc. The battery data file 'ev2_13.m' and the motor data file 'etv_mot1.m' which has the motor efficiency map also belong to 'etv1.m'. These three data files are listed in Appendix 3. Table 5.1 shows the ETV-1 test data used to simulate in this chapter.

Vehicle Test Weight (kg)	1795
Drag Coefficient	0.32
Rolling Resistance Coefficient	0.01
Frontal Area (m ²)	1.875
Wheel Radius (m)	0.28
Motor Max. Speed (rev/min)	5000
Motor Max. Power (kW)	30
Final Drive Ratio	5.68
Battery Weight (kg)	495
Battery Type	EV2-13 (lead-acid)

Table 5. 1 ETV-1 Vehicle Data

5.1.2 The Throttle Controller

The throttle controller model is slightly different from the one used in the ICE vehicle as shown in Figure 5.2. The throttle input is limited to between -1.5 and 1 by the driver model. The "saturation1" block limits the input throttle between -1 and 1 and provides to the "motor" model illustrated in Figure 5.1 for vehicle running and regenerative braking. The value between -1.5 and -1 is limited by the "saturation"

block and added to a constant value. This added value is provided to the “vehicle” model illustrated in Figure 5.1 for the friction braking.

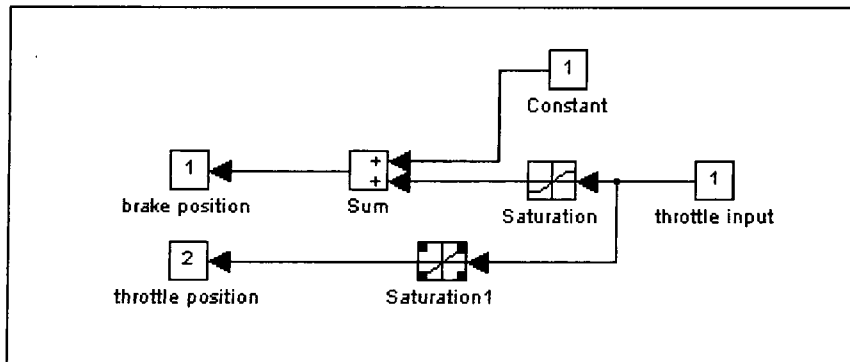

Figure 5.2 Throttle Controller

5.1.3 The Motor

The motor in the electric vehicle acts in the same way as the engine in the ICE vehicle. The motor block diagram is shown in Figure 5.3 and produces two important outputs; the motor torque output for driving the vehicle and the power input required from the battery model. The motor torque is calculated from the throttle position and the motor speed by a similar technique as that used in the ICE engine model. The throttle position is multiplied by the torque from the maximum torque curve to obtain the motor torque. The output motor torque is also used to calculate the power supplied to the motor. In this case output torque is multiplied by the rotational speed of the motor and then the result is multiplied by the motor efficiency. The switch block is used to distinguish the plus or minus sign of the motor torque. When the motor torque is positive power is supplied from the battery whilst when it is negative power is returned to the battery. This negative flow of power occurs during regenerative braking and is used to charge the battery.

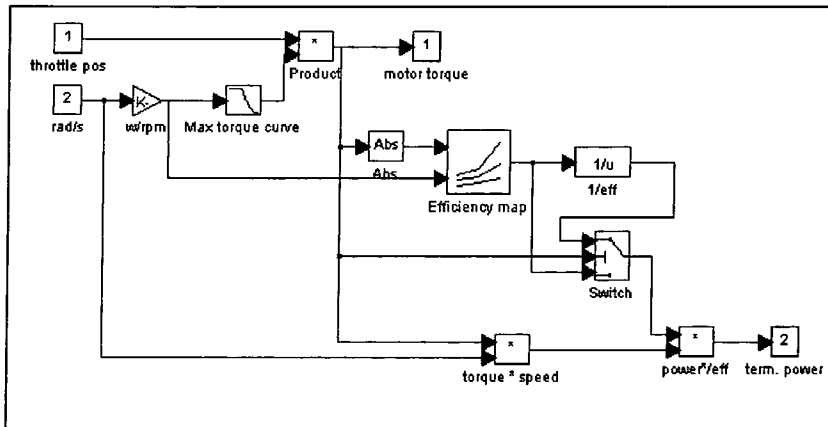

Figure 5.3 Motor Model

5.1.4 The Motor Controller

The motor controller has its own efficiency. Because in this part of the model power flow is “backwards” when the motor input power is positive power supplied by the battery to the motor the efficiency is inverted and then multiplied by the motor power. In contrast negative motor power is multiplied by the efficiency. Both of above results are supplied to the battery for updating the state of charge of the battery. Figure 5.4 shows a motor controller block. It should be noted that this controller efficiency could be combined, and included in, the motor efficiency. For some motors, such as the induction motor drive, this is the most convenient approach as the motor and controller form a complete unit. In the case of a d.c. motor such as that modelled here a separate efficiency is used.

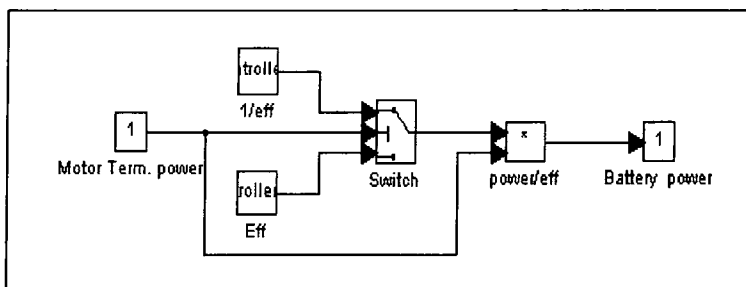

Figure 5.4 Motor Controller Model

5.1.5 The Battery

The ETV-1 electric vehicle uses EV2-13 lead-acid batteries which are modelled by the fractional discharged model (FDM). This battery model is based on energy and power density relationships and is shown in Figure 5.5. When the battery is discharging the equations 5.1 to 5.3 are used and when charging a constant charge efficiency is used.^[1]

Equation 5.1 $P_{di} = \exp[A(\ln \tau_p)^2 + B \ln(\tau_p) + C]$

Equation 5.2 $\tau_p = \exp\{1/2[-B/A + [(B/A)^2 - 4(C - \ln P_{di})/A]^{1/2}]\}$

Equation 5.3 $SOC(\text{State of Charge}) = \int (1/\tau_p 36) dt, \text{ SOC in \%}$

In the above equations A, B and C are constants depending on the battery type for example the values of the EV2-13 are as follow.

A: -0.03516 **B:** -0.69045 **C:** 3.31975

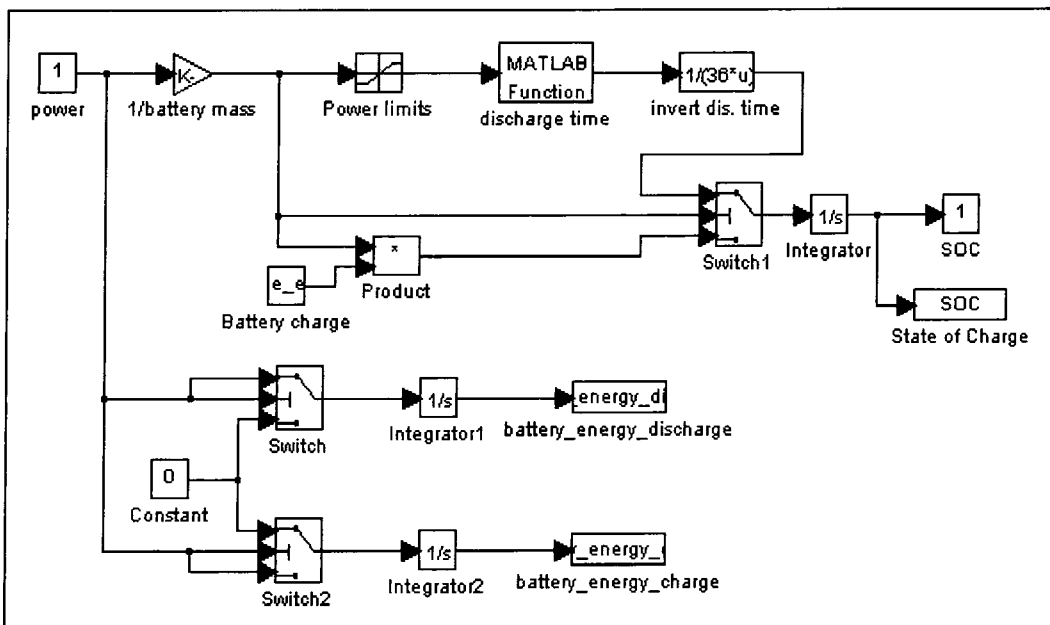

Figure 5.5 Battery Model

5.2 Simulation of the Electric Vehicle

5.2.1 Analysis of the Electric Vehicle Simulation

As shown in Figure 5.6 when simulated over the Extra_Urban cycle the ETV-1 can not meet the high speed acceleration requirement occurring at about 350s into the cycle because it has only a 30kW electric motor. At this point the power required by the vehicle can be calculated by the equation 4.2 as about 39kW. Consequently the ETV-1 can not be driven in the Extra_Urban cycle. Therefore in this chapter the performance of the vehicle over the ECE-15 and the J227a-d cycle is simulated with graphical results for the ECE-15 cycle simulation being discussed.

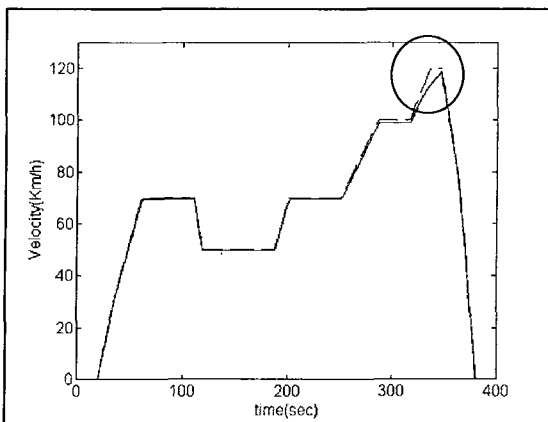

Figure 5. 6 Extra_Urban Simulation Result

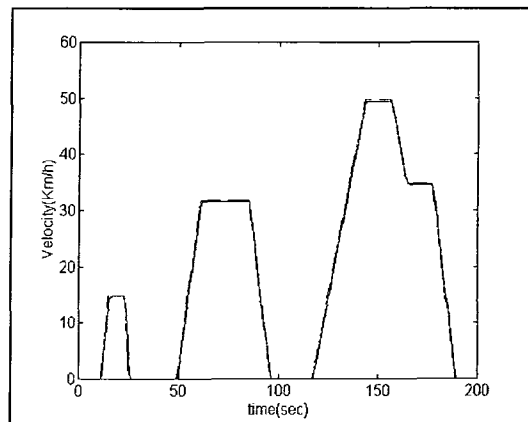

Figure 5. 7 ECE-15 Velocity Result

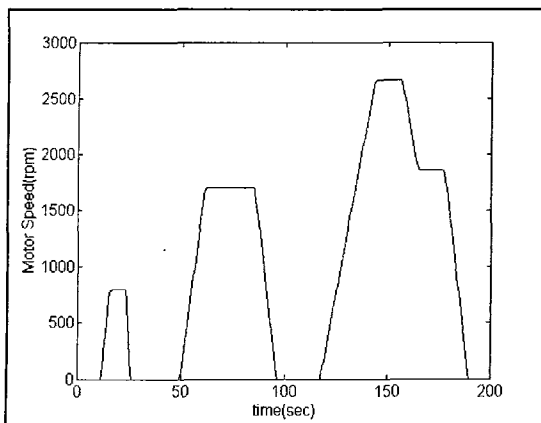

Figure 5. 8 Motor Speed Result

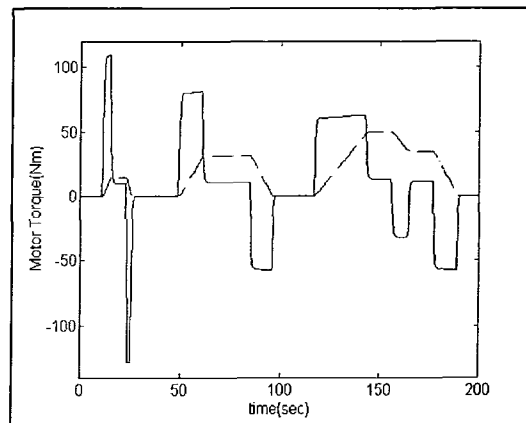

Figure 5. 9 Motor Torque Result

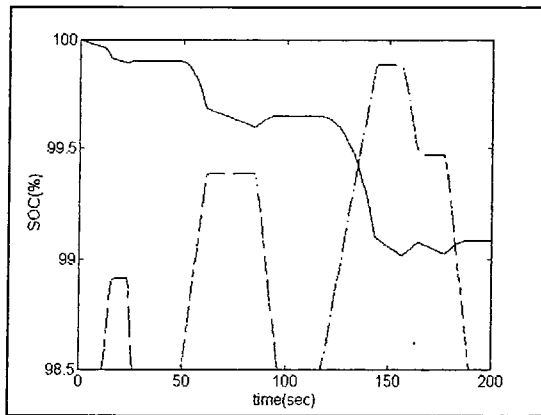

Figure 5. 10 Battery SOC Result

Figure 5.7 illustrates the difference between the required speed and simulation speed of the vehicle. The simulation speed is almost identical to the required speed therefore the simulation is successful. Figure 5.9 shows the motor torque during the ECE-15 cycle. There are no step changes in this graph because the electric vehicle does not have a variable ratio gearbox. The positive torque means that the vehicle is accelerating or being driven at constant speed. Negative torque means the vehicle is braking. Similarly the motor speed does not have the saw-toothed shapes shown in figure 5.8 because there is no variable ratio gearbox in the electric vehicle. Figure 5.10 shows the change of the state of charge(SOC) of the Battery. This graph shows the charging and the discharging situation very well. In particular when the vehicle is braking the SOC goes up showing that the regenerative braking energy acts properly. In contrast to the ICE vehicle when the electric vehicle is stationary no “fuel” is being used and the battery SOC remains constant. In the case of this simulation after one ECE-15 cycle the SOC changes from 100% to 99.0827%. This means 0.9173% of the SOC is used for one ECE-15 cycle. Therefore if

this vehicle is driven continuously over an ECE-15 cycle (urban conditions) it can be driven for only 107.73km as calculated using equation 5.4. Consequently the electric vehicle has a range limitation though it does not produce any exhaust emissions or need petroleum resource. The simulation results are shown in Table 5.2. As shown in this table the range limitation of the J227a_D cycle is much shorter than that of the ECE-15 cycle.

Equation 5.4 $100(\%)/(100 - 99.0827)(\%) = 109.02(\text{cycles})$

$109.2 * 0.9882(\text{km}) = 107.73(\text{km})$

where 0.9882km is a distance after one ECE-15 cycle

	SOC(%/cycle)	Distance(km/cycle)	Range(km)
ECE-15	0.9173	0.9882	107.7
J227a_D	2.0428	1.5506	75.9

Table 5. 2 ETV-1 Simulation Results

5.2.2 Regenerative Braking Energy

One of the big differences between the ICE vehicle and the electric vehicle is the recovery of energy through regenerative braking as demonstrated by Figure 5.10. In this section the amount of the regenerative braking energy and the energy flow in the electric vehicle will be described by reference to Figure 5.11. This diagram shows the flow of energy for the ETV-1 over the J227a_D cycle. It also shows how all the energy is used by the simulation. In addition this figure contains the real test results^[2]. In the figure bracketed data are the real test results and non-bracketed data are the simulation results. As

can be seen the differences are very small consequently the accuracy of the simulation can be proven. As shown in the graph 632.5kJ/km of energy flows through the motor and it is used to supply losses in the motor controller, motor and overcome drag and rolling resistance etc. 220.5kJ/km of energy is used for motoring and stored in the vehicle as kinetic energy. When the vehicle is braking some of this energy is used to supply losses in the vehicle drive system until finally 117.8kJ/km of energy is produced by the regenerative braking energy and passed back to the battery. This regenerative energy increases the vehicle range by approximately 10.5%.

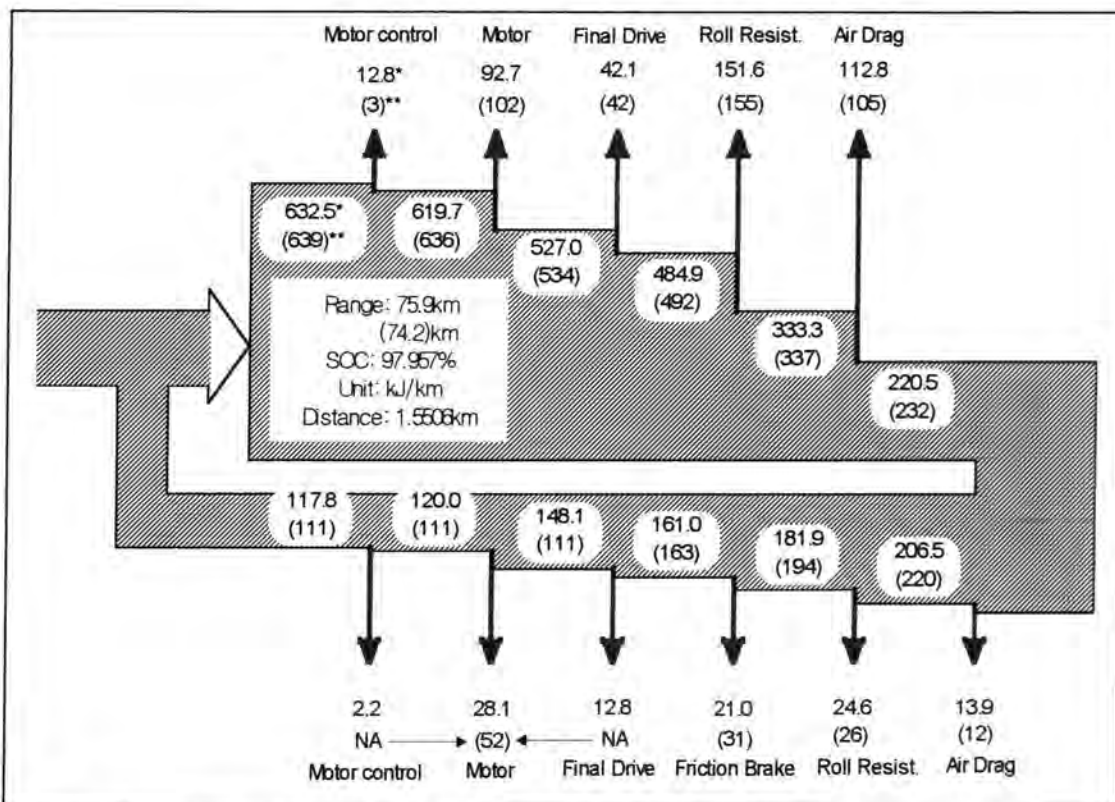

* JPL (Jet Propulsion Laboratories) dynamometer test data: bracketed

** JANUSLEE simulation data: non-bracketed

Figure 5. 11 Energy Flow of ETV-1 over J227a_D Cycle

5.2.3 Relationship between the Weight of Battery and Vehicle Range

The range of the ECE-15 cycle calculated in section 5.2.1 is 107.73km. This means ETV-1 can be driven 107.73km from 100% the SOC to 0% without charging. It is natural to assume that if an electric vehicle needs more range it must have a larger battery. However as the battery becomes heavier the weight of the vehicle also becomes heavier. In this case the way the battery energy is used has to be considered. Table 5.3 shows the data for the ETV-1 when the weight of the battery is changed from 200kg~800kg whilst Figure 5.12 plots specific range (defined as range per kilogram of battery) against specific weight (defined as the ratio of battery weight to total vehicle weight). As shown in the Figure 5.12 the “best” percentage of battery weight is 25~28%. At battery fraction above this most of extra energy is used in simply propelling the additional battery weight whereas at lower battery fractions the battery is not being used efficiently due to large specific battery powers (kW/kg). This curve is typical for a lead-acid battery.

Batt.Weight.(kg)	200	300	400	500	600	700	800
Batt.Wt/Veh.Wt(%)	13.3	18.8	23.5	27.8	31.6	35	38.1
SOC(%/cycle)	2.7738	1.6273	1.1481	0.9076	0.7604	0.6765	0.6179
Distance(m)	989.37	988.97	988.57	988.2	987.81	987.42	987.02
Range(km)	35.7	60.8	86.1	108.9	129.9	146	159.7
Range/Batt.Wt(km/kg)	0.1785	0.2025	0.2153	0.2178	0.2165	0.2085	0.1997

Table 5.3 Battery Weight and Vehicle Range

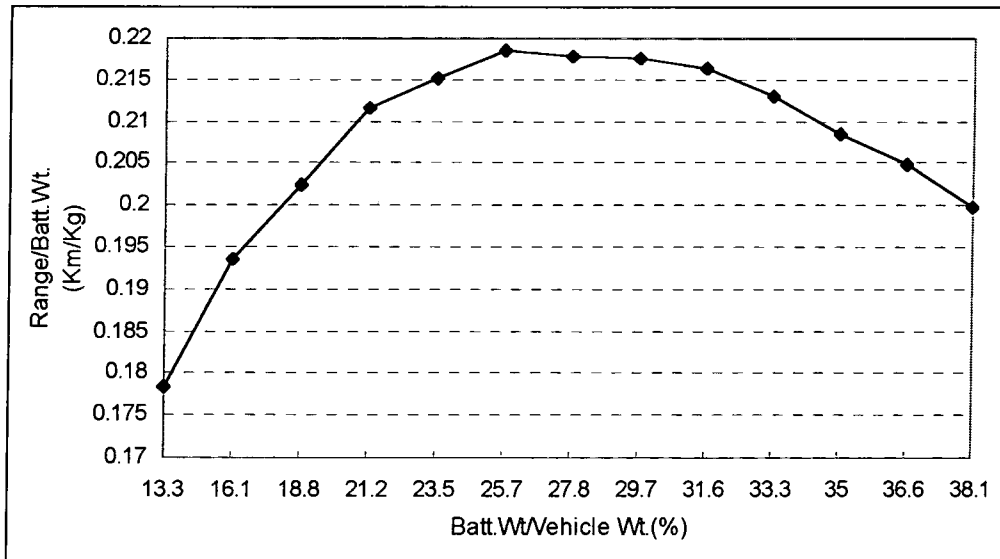

Figure 5.12 Range/Battery Weight

5.3 Conclusion

The electric vehicle has a very simple construction because it does not need a clutch or gearbox as described in section 5.1. Many of the modelling components which are used in the ICE vehicle such as the driver, the final drive and the vehicle blocks are used again for modelling the electric vehicle. The motor, motor controller and battery block are new components required for the electric vehicle model. The range of the electric vehicle is limited by the capacity of the battery, but it has no exhaust emissions and requires no petrol. Although the electric vehicle has no exhaust emissions, emissions will be produced by the power stations required to supply the electricity. The electric vehicle is very useful for commuting, shopping, and for delivery vehicles operating in an urban area. In particular it is most useful for the car which travels short distance each day, typically less than 50~70km, mainly through slow-moving traffic with a 20~30km/h average speed.

6. Performance of the Series Hybrid Vehicle

6.1 Operating Modes of the Auxiliary Power Unit

A significant advantage of the series hybrid electric vehicle is the ability to operate the engine completely independently of road conditions. The engine can be operated in a region of high efficiency and low emissions. Therefore the technique of how, and when, to run the IC engine is very important. There are basically two possible modes:

- **Constant operation** : The engine produces the average electrical power demand and operates all times.
- **Intermittent operation** : The engine is operated according to the battery SOC or the road power requirements which are monitored continuously. Hence, the engine is operated for part of the time. This means the vehicle can be driven as an electric vehicle when the engine is not needed.

In this chapter the intermittent operation operated by the battery SOC will be used. The engine is used only when the battery SOC lies between a specified minimum SOC and maximum SOC. For example in this chapter the minimum and maximum SOC are set at 40 and 60% respectively. Therefore the engine is switched on when the battery SOC becomes 40% and runs at a specified rpm and power output until the battery SOC becomes 60%. To achieve constant power output the engine can be operated by different control strategies; namely constant throttle operation or constant speed operation. The behavior and

characteristics of the electrical system must be analyzed in detail for the implementation of above two control methods and these two control methods were researched in detail in past work.[4][6][23]

6.2 Configuration of the Series Hybrid Vehicle

Figure 6.1 is a block diagram of the series hybrid vehicle model. As explained in section 1.3.1 only the electric motor drives the vehicle and consequently the series hybrid vehicle needs a large size motor for the Extra_Urban cycle which requires high speed and large power. This model of a series hybrid uses an induction motor which is more powerful than the d.c. motor used in the ETV-1. In addition the motor controller efficiency is included in the induction motor efficiency map therefore this model does not need the motor controller block as the electric vehicle. The auxiliary power unit(APU), which is composed of the IC engine, the generator and the APU controller, supplies electric energy to the battery or the motor. The structure of the series hybrid vehicle is very similar to the electric vehicle except for the APU and this will be discussed in following sections. The vehicle data file, shv.m, is listed in Appendix 4.

6.2.1 The APU Model

6.2.1.1 The Engine

The IC engine model for the series hybrid vehicle is simpler than that required for the ICE vehicle as it does not need to model idle conditions. The engine model shown in Figure 6.2 is similar to that described previously in section 4.2.3 but the blocks related to idle revolution have been removed.

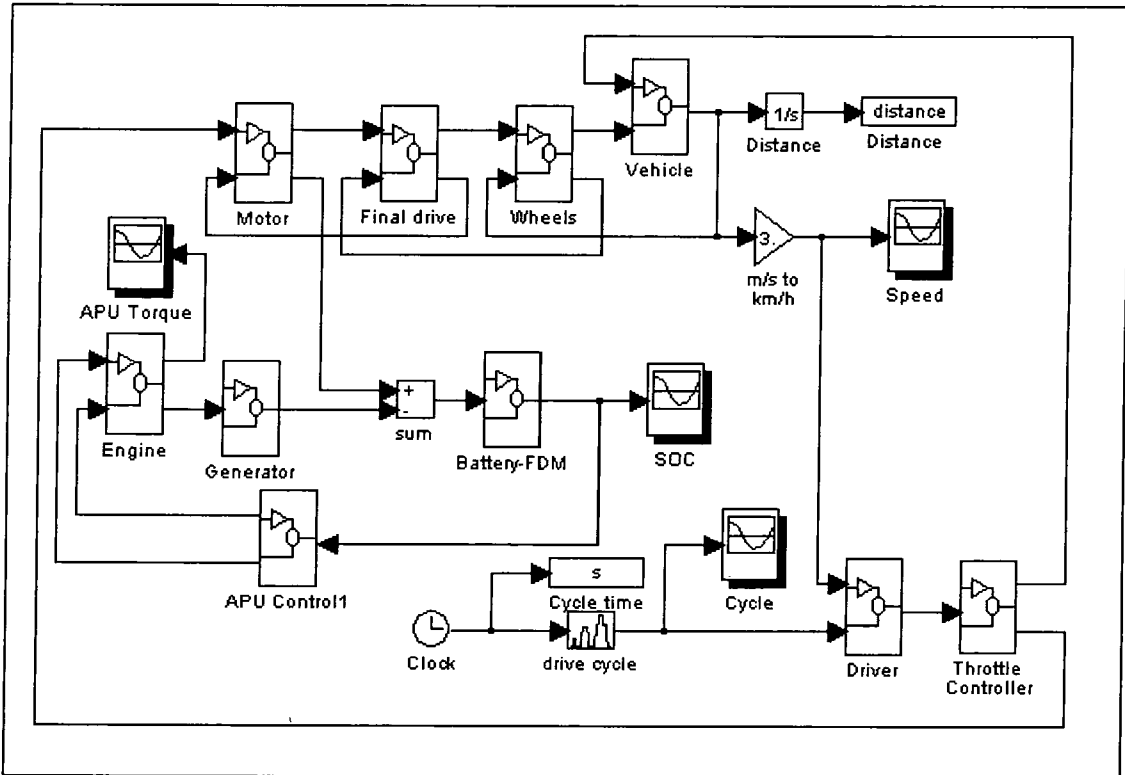

Figure 6.1 Series Hybrid Vehicle Model

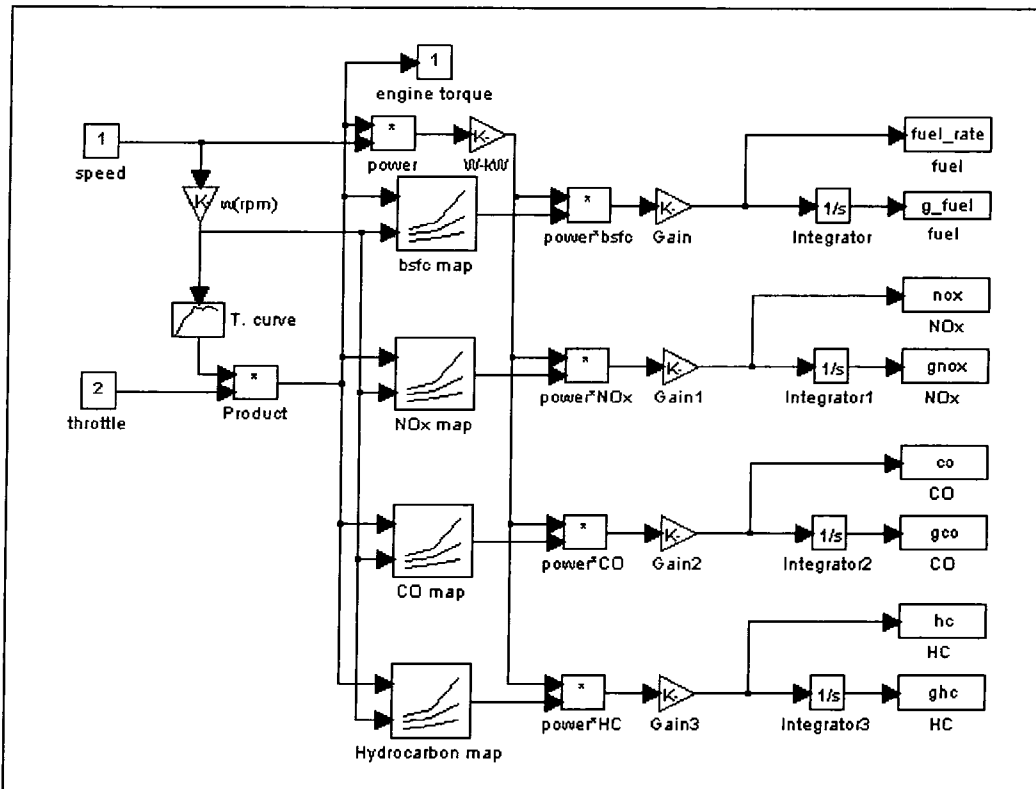

Figure 6.2 Engine Model

6.2.1.2 The Generator

The generator model converts the mechanical energy from the engine into the electrical energy to the battery and is modelled by a constant efficiency as illustrated in Figure 6.3.

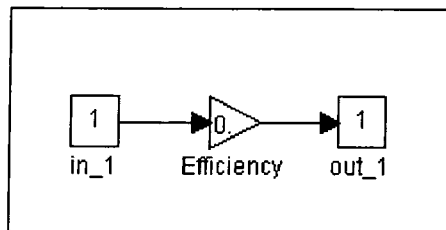

Figure 6.3 Generator Model

6.2.1.3 The APU Controller

The APU controller model is for intermittent operation of the APU. In particular this controller switches the IC engine on & off depending on the battery SOC. Figure 6.4 shows the block diagram of the APU controller. The two relay blocks monitor the battery SOC and supply the fixed engine speed and throttle opening when the battery SOC reaches the minimum allowed SOC. The APU stays in operation until the SOC reaches the maximum allowed value when it is switched off. When the APU is switched on the engine operates at constant power as determined by a fixed engine speed and throttle opening selected for good fuel consumption and low emissions. The decision about the engine size, the engine speed and the throttle opening will be discussed in sections 6.3 and 6.4.

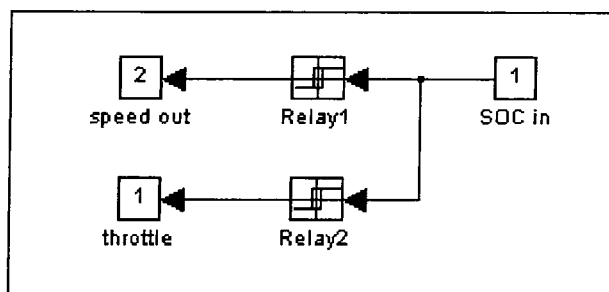

Figure 6.4 APU Controller Model

6.2.2 The Motor

The structure of the motor model is exactly same as the one for the ETV1 as shown in Figure 5.2. However the motor used in this series hybrid vehicle is an induction motor which has a maximum speed of 8000rpm and a maximum power of 37.3kW and not the DC motor used in the ETV1. With this induction motor the vehicle can drive the Extra_Urban cycle due to the motor increased power and speed range. The induction motor file 'im8000.m' is fully listed in Appendix 4 and contains details of the motor efficiency map. In addition the motor efficiency map includes the motor controller efficiency therefore the vehicle model shown in Figure 6.1 does not need the motor controller present in the electric vehicle model.

6.3 Consideration of Motor and Engine Size

It is very difficult to decide on the optimum size of the motor and the engine for use in a series hybrid vehicle because there are many factors which need to be considered in the design process.

Before the motor and the engine size can be determined the power required over the operating schedule must be known. Typically this operating schedule will be a set of defined driving cycles such as those described in section 4.1. These driving cycles are again shown in Figure 6.5 with particular points in these cycles numbered. At each of these points the velocity and acceleration can be tabulated as shown in Table 6.1. With this data, and knowing the vehicle weight, drag coefficient etc. then the required traction force can be calculated using equation 4.2. This force is readily converted into a motor torque and

power for a particular gear ratio. A constant efficiency of 96% is assumed for the drive train. These calculations are carried out by the MATLAB program included in Appendix 5. For example for a 1800kg vehicle with the data tabulated in Table 6.2 the power, torque and results in Table 6.1 are obtained. According to the table the maximum power required is 39.19kW at point 14 in the Extra_Urban cycle. This means if the motor size is bigger than 39.19kW this vehicle can be driven over all three cycles. As a vehicle also needs to be driven over cycles with some gradient steady speed conditions with a 2% and 5% gradient are also calculated. The 'Power Density' is the power per unit weight of battery and the maximum power density of the EV2-13 battery which is used in this series hybrid vehicle is only 80watt/kg. Therefore if this vehicle needs to satisfy all conditions of table 6.1 the size of the battery needs to be increased.

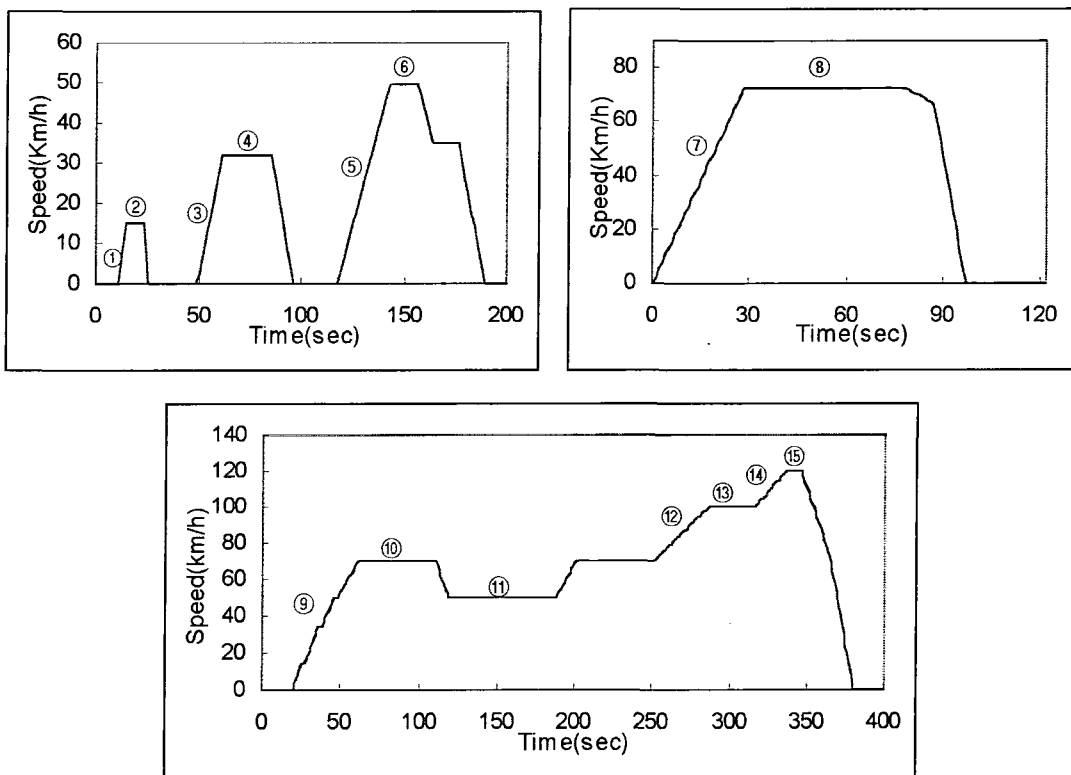

Figure 6. 5 Required Power points on Three Cycles

	Velocity (km/h)	Acc. (m/s ²)	Gradi- -ent(%)	Torque (Nm)	Speed (rpm)	Power (kW)	Cycle	P/Density (Watt/Batt.Kg)	Number on Graph
1	14.91	1.04	0	109.17	802	9.17	ECE-15	28.66	①
2	31.84	0.74	0	81.72	1,713	14.66	ECE-15	45.82	③
3	49.73	0.53	0	64.19	2,676	17.99	ECE-15	56.21	⑤
4	72.4	0.72	0	86.34	3,896	35.22	J227a_D	110.08	⑦
5	70	0.47	0	62.39	3,767	24.61	Extra_U	76.90	⑨
6	100	0.24	0	47.46	5,381	26.74	Extra_U	83.57	⑫
7	120	0.28	0	57.95	6,457	39.19	Extra_U	122.45	⑭
8	14.91	0.00	0	9.76	802	0.82	ECE-15	2.56	②
9	31.84	0.00	0	10.96	1,713	1.97	ECE-15	6.15	④
10	49.73	0.00	0	13.17	2,676	3.69	ECE-15	11.53	⑥
11	72.4	0.00	0	17.38	3,896	7.09	J227a_D	22.16	⑧
12	50	0.00	0	13.21	2,691	3.72	Extra_U	11.63	⑪
13	70	0.00	0	16.86	3,767	6.65	Extra_U	20.78	⑩
14	100	0.00	0	24.60	5,381	13.86	Extra_U	43.32	⑬
15	120	0.00	0	31.28	6,457	21.15	Extra_U	66.10	⑮
16	14.91	0.00	2	42.63	802	3.58	Gradient 2%	11.19	-
17	31.84	0.00	2	43.83	1,713	7.86		24.57	-
18	49.73	0.00	2	46.04	2,676	12.90		40.32	-
19	72.4	0.00	2	50.25	3,896	20.50		64.06	-
20	50	0.00	2	46.09	2,691	12.99		40.58	-
21	70	0.00	2	49.73	3,767	19.62		61.30	-
22	100	0.00	2	57.47	5,381	32.38		101.20	-
23	120	0.00	2	64.15	6,457	43.38		135.55	-
24	14.91	0.00	5	91.85	802	7.72	Gradient 5%	24.12	-
25	31.84	0.00	5	93.05	1,713	16.70		52.17	-
26	49.73	0.00	5	95.26	2,676	26.69		83.42	-
27	72.4	0.00	5	99.47	3,896	40.58		126.81	-
28	50	0.00	5	95.31	2,691	26.85		83.92	-
29	70	0.00	5	98.95	3,767	39.03		121.97	-
30	100	0.00	5	142.25	4,036	60.12		187.87	-

Table 6. 1 Design Specification of the Series Hybrid Vehicle

On the other hand if a vehicle is to be used for a particular purpose, such as short distance and low average speed urban operation the motor size can be reduced. For example if the series hybrid vehicle will be used for commuting, shopping or delivery etc. it is enough that the series hybrid vehicle can be driven over the ECE-15 and J227a_D cycle. Therefore this vehicle needs a motor which has a maximum power of 20kW as shown in Table 6.2 because the vehicle weight can be reduced. Of course this value is obtained by the program used in Table 6.1. The engine size depends on the motor size because if the battery SOC is below the minimum SOC set previously and, if the engine size is smaller than the motor size required for that particular operating condition, the vehicle would lose battery SOC. Consequently the engine size must be a similar size, 20kW, to the motor. In this case the 20kW is not the engine maximum power but a engine operating power set by the constant engine speed and throttle opening. Therefore, as can be seen in table 6.2, if an engine power of 20kW is needed the engine maximum power must be about 25kW.

6.4 Consideration of Engine Operating Point

Within the APU the engine operating point must be decided carefully in order to maximize fuel economy and minimize emissions. There are two stages in optimizing the power train for the series hybrid vehicle. The first stage is to decide what size engine must be used for the series hybrid to meet a particular purpose using the method discussed in section 6.3 and through simulation. The next stage is to decide on the optimal engine operating point. Figure 6.6 shows a 3-diminsional

graph of the BSFC and the emissions for Accent 1.3 engine listed in Appendix 2. As shown there is an optimal region of operation in each graph. For example in the BSFC graph the region with the least fuel consumption is located between 50%~90% of the peak torque and at 1500~5000 rpm. Similarly regions for low emission can be defined for each emission component..

After the optimal regions of each map are defined the four regions can be superimposed as shown in Figure 6.7. The darkest region is that region which satisfies all the conditions and is the preferred operating region. In this chapter an engine speed of 2500rpm and a throttle opening of 83% are used in the simulation. In other words when the engine is switched on the engine always runs at 2500rpm and 83% throttle opening.

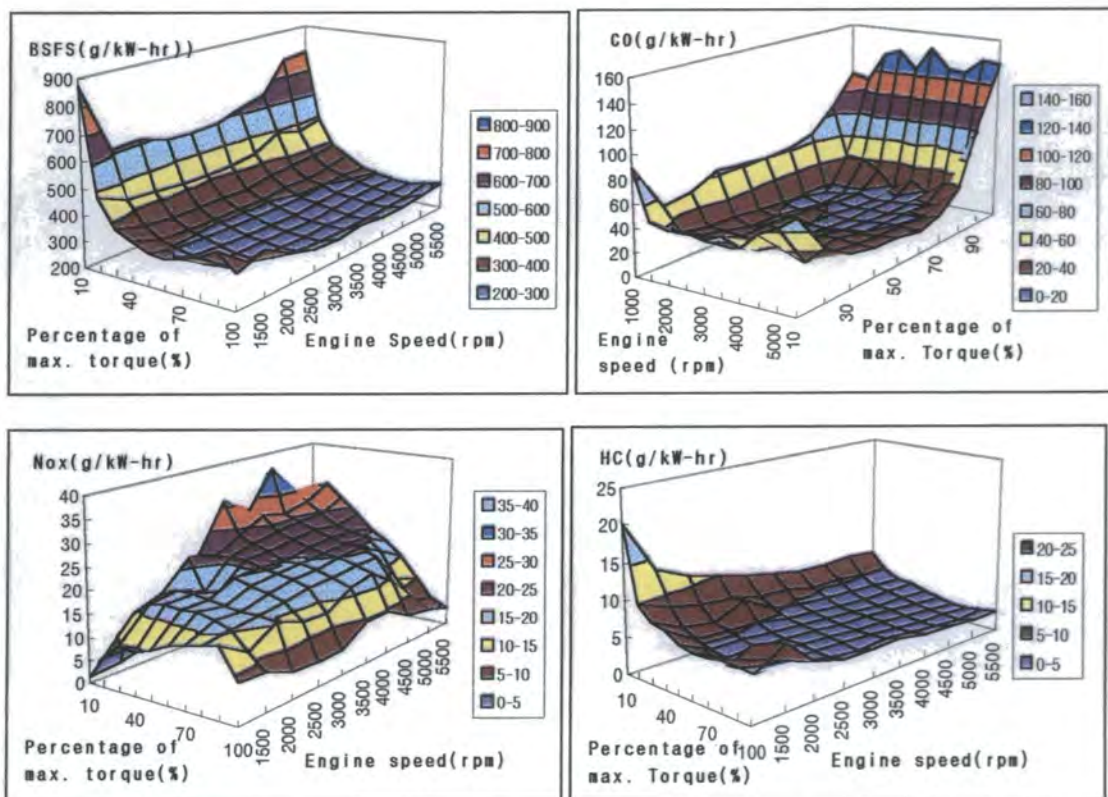

Figure 6. 6 Accent 1.3 BSFC and Emissions

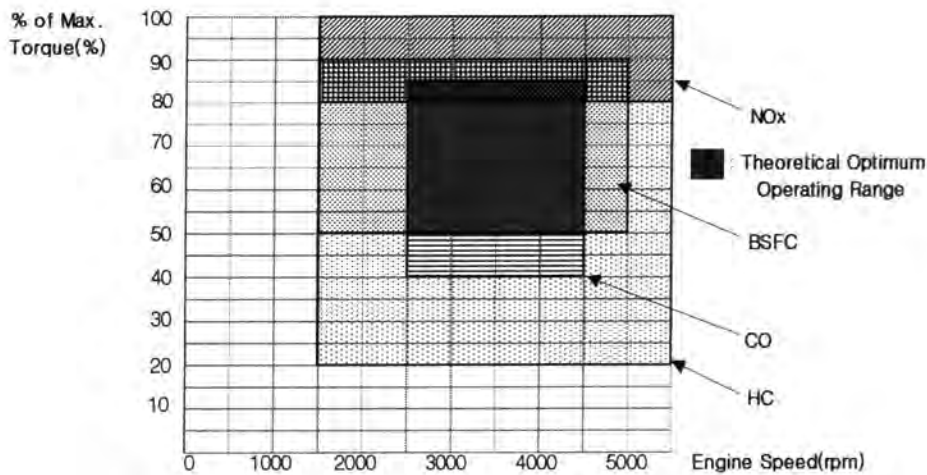

Figure 6.7 Optimal Operating Region

6.5 Simulation of the Series Hybrid Vehicle

6.5.1 Analysis of the Series Hybrid Vehicle Simulation

Figure 6.8 – 6.13 were obtained by the simulation using the vehicle data 1 tabulated in Table 6.2. This vehicle is a general purpose vehicle capable of both urban, extra-urban and long range, high speed cruise operation. In contrast the vehicle data 2 is the data of a reduced size vehicle for the particular purpose of urban operation mentioned in section 6.3. The simulation results for the two vehicles will be shown and compared in section 6.5.2. Figure 6.8 shows the actual speed of vehicle1 over the Extra_Urban cycle. The actual speed is well matched with the required speed and indicates that the size of the motor is sufficient to drive this cycle. As in the electric vehicle there is no gearbox and therefore no gear change points in the motor speed and the motor torque graph as shown in Figure 6.9 and 6.10. Figure 6.11 shows the change of the battery SOC. This simulation started with the battery at 58% SOC so that the APU was turned on. When the battery SOC becomes 60% the engine is switched off as shown in Figure 6.12

and 6.13. When the vehicle is braking the SOC goes up due to the transfer of regenerative braking energy. Figure 6.12 illustrates the engine running speed of 2500rpm and the engine stops when the SOC has increased to 60%; the SOC is described by the dotted line. In addition Figure 6.13 shows the constant engine throttle of 83%. The throttle position goes down to 0% when the SOC increases to 60%.

Specification	Vehicle Data 1	Vehicle Data 2
Vehicle Test Weight (kg)	1800	1350
Drag Coefficient	0.32	0.32
Rolling Resistance Coefficient	0.01	0.01
Frontal Area (m ²)	1.875	1.875
Wheel Radius (m)	0.28	0.28
Final Drive Ratio	5.68	5.68
Motor Max Speed (rev/min)	8000	8000
Motor Max Power (kW)	40	20
Engine Max Power (kW)	45	25
Engin-On SOC (%)	40	40
Engin-Off SOC (%)	60	60
Engine Running rpm (rev/min)	2500	2500
Constant Throttle Opening (%)	83	83
Engine Operating Power (kW)	37.4	20.8
Battery Weight (kg)	320	120
Battery Type	EV2-13 (lead-acid)	EV2-13 (lead-acid)

Table 6. 2 Series Hybrid Vehicle Data

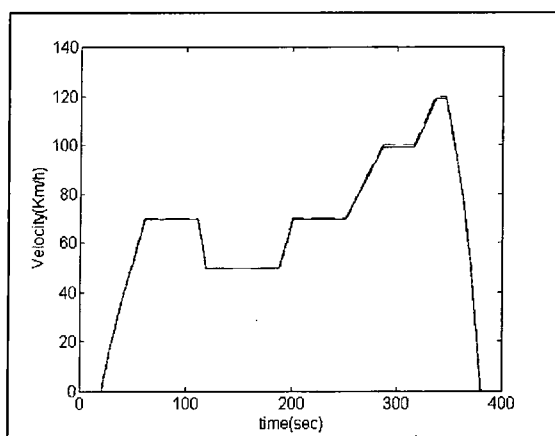

Figure 6. 8 Velocity Result

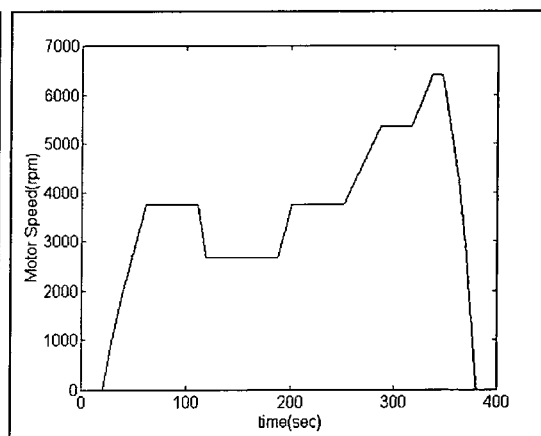

Figure 6.9 Motor Speed Result

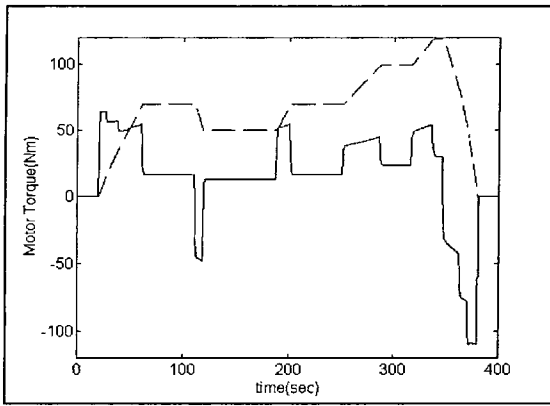

Figure 6.10 Motor Torque Result

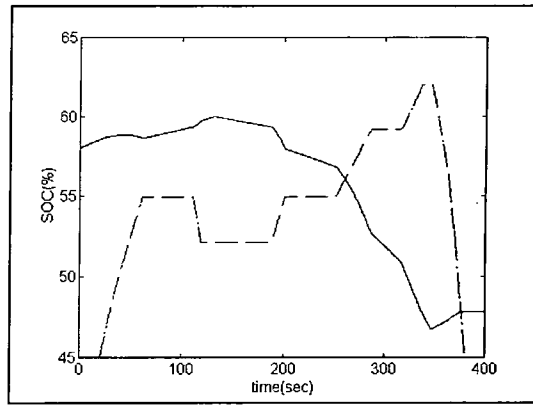

Figure 6.11 Battery SOC Result

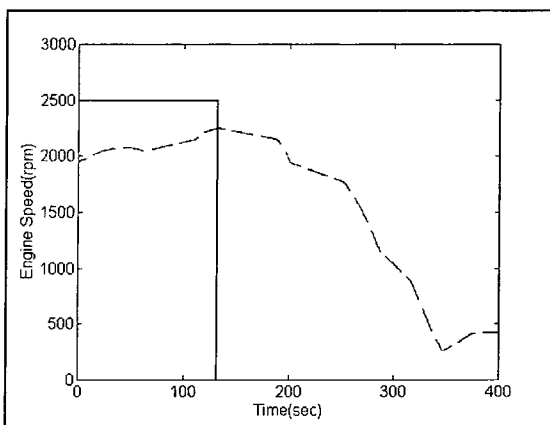

Figure 6.12 Engine Speed Result

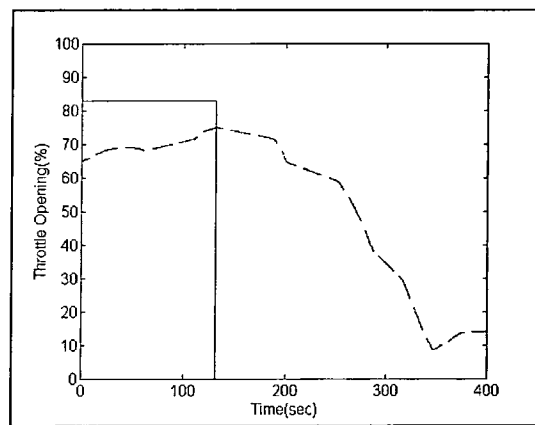

Figure 6.13 Engine Throttle Result

6.5.2 Simulation Results

It is quite difficult to evaluate the simulation results of the series hybrid vehicle because the results depend on the initial battery SOC. For example if the series hybrid vehicle was driven 30km over the ECE-15 cycle with an initial battery SOC of 100% the engine fuel consumption and emissions are zero because until the battery has reduced to 40% SOC the series hybrid vehicle can be driven as an electric vehicle. In contrast if the vehicle started from 40% battery SOC and travelled the same distance over the same cycle the APU would be switched on thereby using fuel and producing emissions. Consequently the fuel economy and the emissions are changeable and depend on the

starting conditions of battery SOC. Therefore in this section two conditions are used to compare the series hybrid vehicle with the ICE vehicle. In the first condition fuel economy is calculated assuming the vehicle starts with battery SOC of 40%. The APU is turned on and the battery is charged until the battery SOC is 60%. The vehicle then runs as an electric vehicle from 60% SOC to 40% SOC. This is the worst comparison condition for the series hybrid vehicle.

The second condition is very similar to the electric vehicle concept. If the battery is full charged, and if the purpose of the vehicle is for commuting, shopping, or delivery purposes the driving distance is usually less than 100km per day. Therefore the fuel economy and the emissions are quite different from those produced by the first condition.

Simulation results by the two conditions described above are compared in Table 6.3. The simulation results for a Hyundai Motor Company Lantra 1.6 is used for the ICE comparison as this vehicle has a similar specification to the series hybrid vehicle. Table 6.3 shows the general purpose series hybrid vehicle has advantages at low speed in cycles such as the ECE-15. However in the case of the J227a_D and Extra_Urban cycle the results are worse than those for the ICE vehicle. In particular the NO_x emission are always worse than the ICE vehicle regardless of driving cycle. This means that it is very difficult to satisfy the requirement for both reduced fuel economy and reduction of all emission components. Consequently this series hybrid vehicle does not appear to be suitable as a general purpose vehicle that can be used for both low average speed operation such as the ECE-15 cycle,

and high average speed operation such as Extra_Urban cycle. To satisfy the general purpose requirement a series hybrid vehicle needs quite a large size electric motor because the motor must supply the whole driving power to the vehicle alone. In this case the vehicle also needs a large size engine as mentioned in section 6.3. Consequently the weight of a vehicle is high and the fuel economy and emissions suffer.

		Condition 1*		Condition 2**		Lantr 1.6
ECE-15	Fuel (km/ ℓ)	10.22	-7.2%	15.11	+37.2%	11.01
	CO(g/km)	6.33	+5.3%	4.28	-28.8%	6.01
	NOx(g/km)	4.50	+174.4%	3.05	+86.0%	1.64
	HC(g/km)	0.99	-29.8%	0.67	-52.5%	1.41
J227a_D	Fuel (km/ ℓ)	10.89	-22.6%	14.98	+6.5%	14.07
	CO(g/km)	5.94	+45.9%	4.32	+6.1%	4.07
	NOx(g/km)	4.22	+88.4%	3.07	+37.1%	2.24
	HC(g/km)	0.93	0%	0.68	-26.9%	0.93
Extra_Urban	Fuel (km/ ℓ)	12.06	-18.2%	16.35	+10.9%	14.74
	CO(g/km)	5.36	+42.2%	3.96	+5.0%	3.77
	NOx(g/km)	3.82	+59.8%	2.81	+17.6%	2.39
	HC(g/km)	0.84	0%	0.62	-26.2%	0.84

*)Condition 1: start 40% of SOC when SOC is 60% engine stop and run until 40% of SOC

**)Condition 2: start 100% of SOC stop after 100Km of distance

Table 6. 3 Series Hybrid Vehicle Simulation Results

		Condition 1		Condition 2		Lantr 1.6
ECE-15	Fuel (km/ ℓ)	11.98	+8.8%	13.70	+24.4%	11.01
	CO(g/km)	5.40	-10.2%	4.72	-21.5%	6.01
	NOx(g/km)	3.84	+134.1%	3.36	+104.9%	1.64
	HC(g/km)	0.85	-39.7%	0.74	-47.5%	1.41
J227a_D	Fuel (km/ ℓ)	14.73	+4.7%	16.96	+20.5%	14.07
	CO(g/km)	4.39	+7.9%	3.81	-6.4%	4.07
	NOx(g/km)	3.12	+39.3%	2.71	+20.9%	2.24
	HC(g/km)	0.69	-25.8%	0.60	-35.5%	0.93

Table 6. 4 Series Hybrid Vehicle Simulation Results (Reduced Size for urban drive)

On the other hand as can be seen in Table 6.3 condition 2 the fuel economy and emissions can be much improved by the driving condition. In particular in the ECE-15 cycle the series hybrid vehicle can get the better fuel economy, CO and HC emissions than those of the Lantra 1.6. In the case of the CO emission it must be reduced because it is the greenhouse gas. In addition the NO_x emission can be also reduced by engine tuning at the engine design stage. Consequently if a series hybrid vehicle is to be used for a particular purpose, for example for commuting or delivery purposes in an urban area, where the average speed is only 30~40km/h then vehicle power train can be reduced in size. In the case of the series hybrid vehicle driven only over the ECE-15 and J227a-D cycle the simulation results with regards fuel use and emissions are better than the ICE vehicle without the range limitation of the electric vehicle. Table 6.4 shows the results of smaller sized series hybrid vehicle which has a 20kW motor and a 25kW engine shown in Table 6.2 vehicle data1.

6.6 Conclusion

In this chapter the series hybrid vehicle model was simulated assuming intermittent operation of the APU. A constant engine speed and a constant throttle opening were assumed by the control logic. Of course more complex control logic is possible such as variable engine speed and variable throttle opening. In order to simulate the series hybrid vehicle the motor and engine size should be optimized for the particular operating duty whilst the best operating point of the engine should also be set. Consequently the exact purpose of a vehicle should

be known and according to this purpose the required powers are calculated in order to size the electric motor and the engine used in the APU. The engine operating point can be set by examining the engine BSFC and emissions maps. From the simulation results obtained in this chapter the series hybrid vehicle has some advantages in urban areas where there is a low average speed and short travel distance. In other words the series hybrid vehicle is not appropriate for use as a general purpose vehicle where high average speeds may be encountered. Therefore if the series hybrid vehicle is developed for urban area driving with a small sized motor and engine it can produce quite good results.

7. Performance of the Parallel Hybrid Vehicle

7.1 Operating Modes of the Parallel Hybrid Vehicle

The parallel hybrid vehicle can have a number of operating modes because it has two power source such as an electric motor and an IC engine. For example the electric motor or the IC engine could be used alone or both of them could be used simultaneously. Table 7.1 describes the possible operating modes^[5].

Mode	Description
Electric mode	All propulsion power supplied by the electric-traction system
IC engine mode	All propulsion power supplied by the IC engine
Primary electric mode	The electric-traction system provides the principal torque but, when necessary, its maximum torque is augmented by the IC engine
Primary IC engine mode	The IC engine provides the principal torque but, when necessary, its maximum torque is augmented by electric-traction system
Hybrid mode	Both the IC engine and the electric-traction system together, in some way, provide the propulsion power
Battery-charge mode	The IC engine provides both the propulsion power and power to charge the batteries with the traction motor acting as a generator
Regenerative braking	During braking the vehicle kinetic energy is returned to the battery, with the traction motor acting as a generator
Accelerator kick-down'	Essentially a primary IC engine mode when increased torque is provided to give acceleration

Table 7.1 Possible Operating Modes for the Parallel Hybrid Vehicle

The parallel hybrid vehicle simulated in this chapter uses the electric mode and the primary IC engine mode. Vehicle speed is used to decide when to switch between modes. To change between the two modes the vehicle drives in the electric mode until the road speed is greater than the switching speed decided in the controller model. At the switching speed the motor is switched off and the engine is switched on. While in this primary IC engine mode if the input

throttle position is greater than the maximum throttle allowed by the controller, the additional throttle requirement is supplied by the electric traction motor. The switching speed, and the maximum allowed engine throttle opening can be optimized by a number of simulations. Of course the battery charge mode and the regenerative braking mode are also used.

7.2 Configuration of the Parallel Hybrid Vehicle

A parallel hybrid vehicle has a slightly more complicated structure than other types of vehicle described in this thesis because it has two power sources as shown in Figure 7.1. However most of the components have already been modelled for use in other types of vehicle. Therefore in this section only the transfer and the controller blocks which are dedicated to the parallel hybrid vehicle will be described. In addition the vehicle data file, phv.m, is fully listed in Appendix 6.

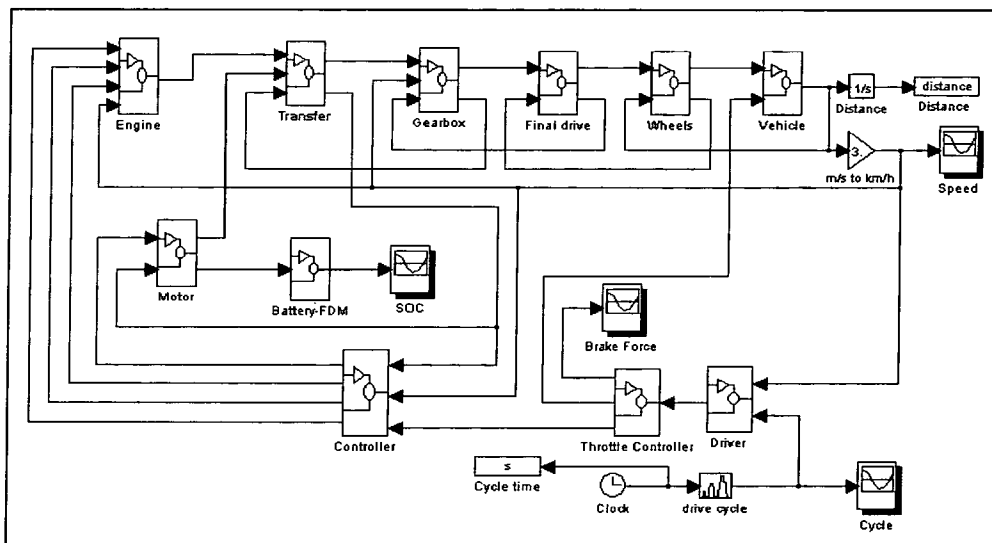

Figure 7. 1 Parallel Hybrid Vehicle Model

7.2.1 The Transfer Block

The role of the transfer block is to add the engine torque to the motor torque and to transfer the rotational speed from the gearbox to the controller as illustrated in Figure 7.2.

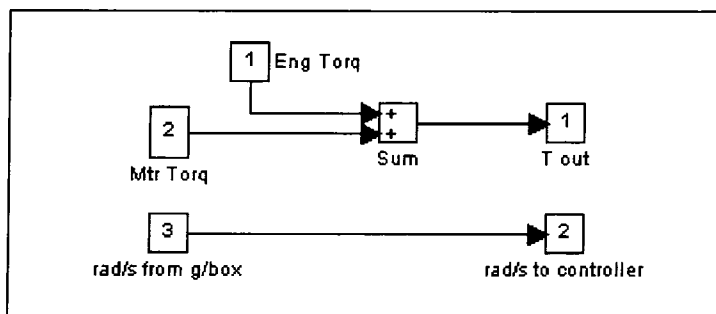

Figure 7.2 Transfer Model

7.2.2 The Controller

As shown in Figure 7.3 the parallel hybrid vehicle controller has a much more complicated structure than that used in the series hybrid vehicle. This controller is totally different from that of the series hybrid vehicle because this controller contains the total_torque_curve and calculates the engine and motor torque. This means that the engine block does not contain the engine and motor torque curve therefore the engine block only calculates the amount of fuel and emissions as shown in Figure 7.5. In order to schedule the torque and the throttle opening to the motor and engine the controller receives the throttle demand, the actual vehicle velocity and the rotational speed at the transfer point.

In this controller the most difficult part to understand is the total_max_torque curve block. When the vehicle is running in the electric mode the motor torque is determined by the switch5 block.

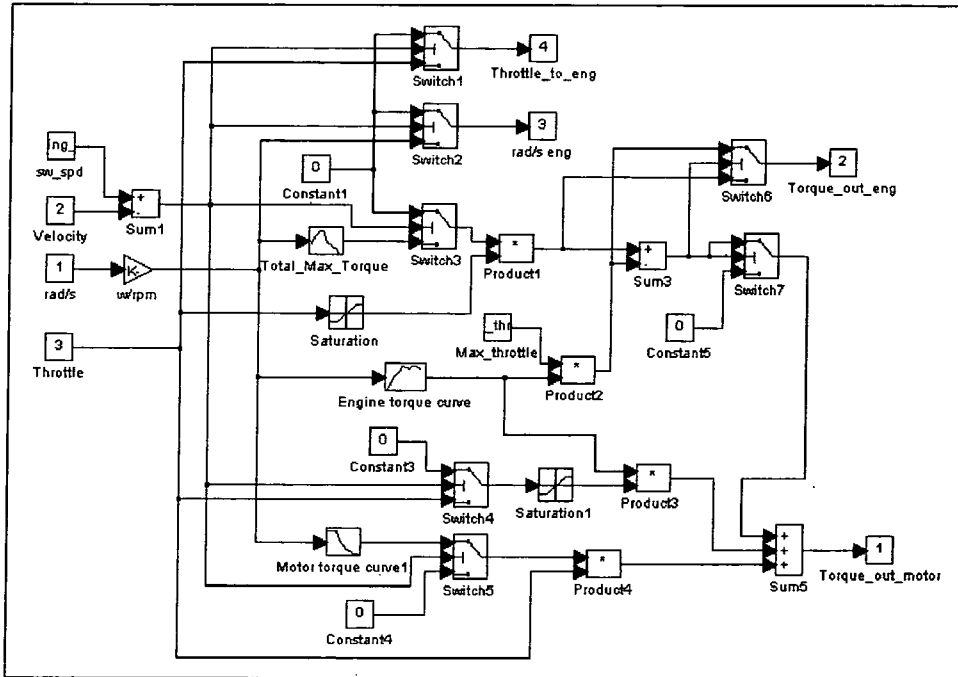

Figure 7.3 Controller Model

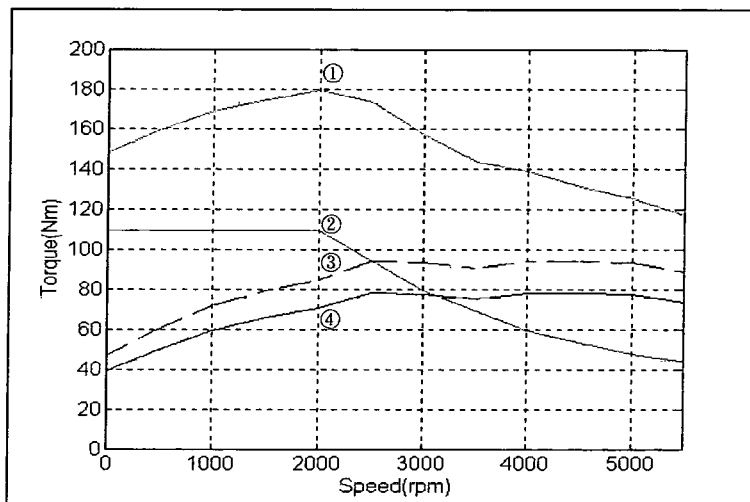

Figure 7.4 Total Maximum Torque Curve

This means the other two input signals value of the sum5 block are zero. However when the vehicle is running in the primary IC engine mode the engine and the motor torque are calculated by the total_max_torque curve block because now the vehicle can get power from both the engine and the motor. The total_max_torque curve block is made by the addition of the engine torque and motor torque curve

as shown in Figure 7.4. In this graph line① is the total_max_torque curve and line② is the maximum torque curve of the motor. Line④ is the maximum torque curve of the IC engine. In fact the maximum torque curve of the IC engine is the line③ but in order to optimize the fuel economy and the emissions it is limited by a fixed percentage as shown in the max_throttle block. This means that if the output torque from the total_max_torque curve is greater than the engine_torque_curve calculated by the product2 block it is limited by the switch6 block and the remainder of the torque is supplied to the sum5 block through the switch7 block. The actual speed and the switching speed are compared in the switch3 block through the sum1 block.

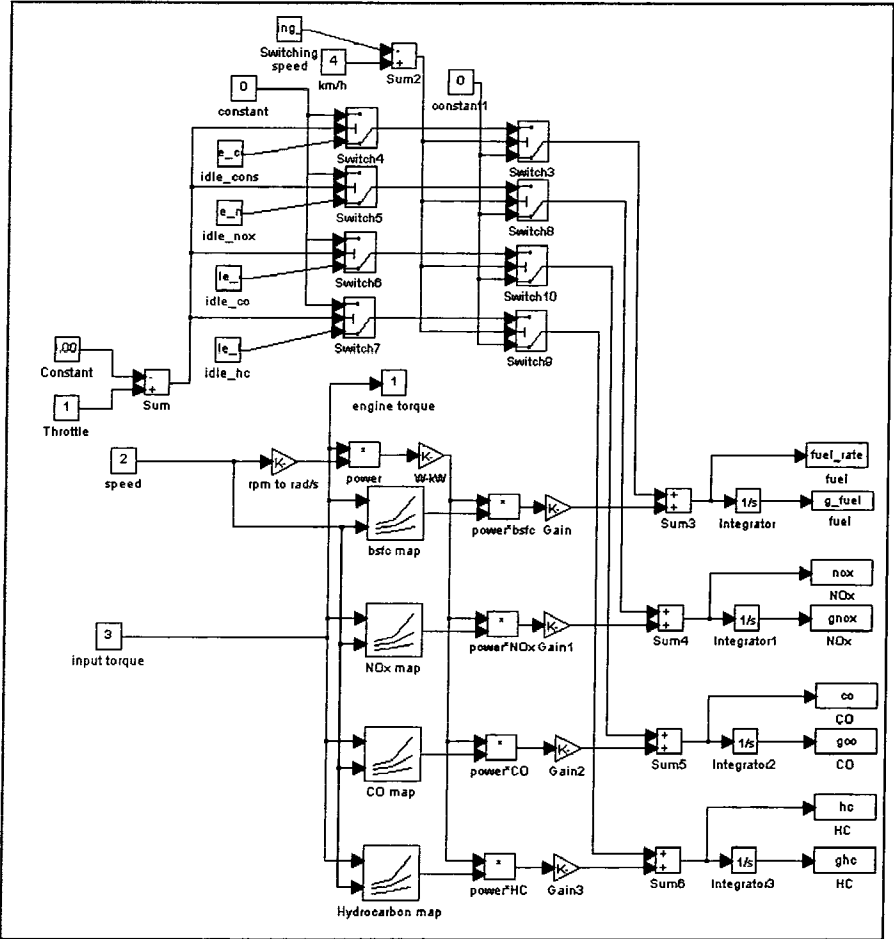

Figure 7. 5 Engine Model of the Parallel Hybrid Vehicle

7.3 Consideration of Engine and Motor Size

In order to decide on what motor and the engine size to use in the parallel hybrid vehicle a similar method is used as that for the series hybrid vehicle. (See section 6.3.) First of all an estimate of vehicle weight is made depending on the engine and motor rating and the power requirement at the different velocity and acceleration points calculated as in section 6.3. However the parallel hybrid vehicle does not need such a large size motor and engine as the series hybrid vehicle because if the motor size is smaller than the required power any additional power can be supplied by the other power source. In the case of the motor its size depends on the switching speed. If the switching speed is high then the motor must be made large because the electric mode will be used to a greater extent than if the switching speed is low. This means that only the motor drives the vehicle at low speeds. The engine size is determined by subtracting the motor size from the maximum required power because if the vehicle needs a power which is greater than the maximum engine power this additional power can be supplied by the motor. Of course also of importance is the maximum engine throttle opening to be allowed. For example if an engine has a maximum torque of 100N·m at 3000rpm the fuel consumption and the emissions would not be good. Generally fuel consumption and the emissions are improved if the maximum torque is limited to 80-85% of maximum torque by limiting the maximum allowed throttle opening.(see section 6.4) The effect of the maximum throttle limitation will be demonstrated in section 7.4.2. According to

above methods the parallel hybrid vehicle data is set as shown in Table 7.2.

Vehicle Test Weight (kg)		1735
Drag Coefficient		0.32
Rolling Resistance Coefficient		0.01
Frontal Area (m ²)		1.875
Wheel Radius (m)		0.28
Final Drive Ratio		5.68
Transmission Ratio	1st	3.462
	2nd	2.053
	3rd	1.370
	4th	1.031
	5th	0.838
Motor Max. Speed (rev/min)		8000
Motor Max. Power (kW)		25
Engine Max. Power (kW)		50
Max. Throttle Opening (%)		83
Switching Speed (km/h)		52 or 35
Battery Weight (kg)		320
Battery Type		EV2-13 (lead-acid)

Table 7. 2 Parallel Hybrid Vehicle Data

7.4 Simulation of the Parallel hybrid Vehicle

7.4.1 Analysis of the Parallel Hybrid Vehicle Simulation

The J227a_D cycle is used in the simulation to describe the general control behavior of the parallel hybrid vehicle because the acceleration requirements are quite severe and consequently this cycle will show the primary IC engine mode very well. Figure 7.6 shows that the simulation has been successful and that the engine and the motor size are appropriate to this cycle. According to Figures 7.7 and 7.8 the main power source has changed correctly from the motor to the engine

at the switching speed which is set 35km/h. In addition the motor supplies some power to the vehicle after the engine is switched on showing that the primary IC engine mode acts correctly. In addition the engine torque is limited to 83% by limiting the maximum throttle as shown in Figure 7.8. Figure 7.9 illustrates the engine speed. Figure 7.9 also demonstrates that the switching speed and primary IC engine mode act correctly and has a saw-toothed shape due to the gear changes.

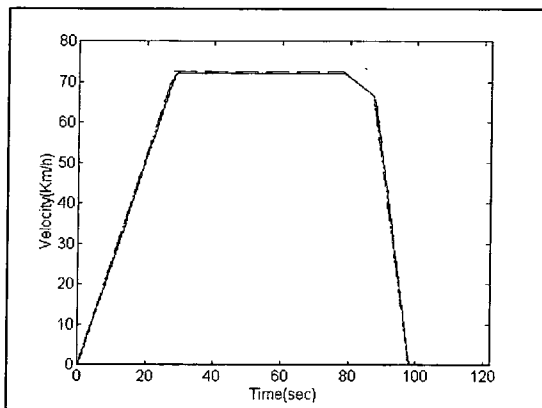

Figure 7.6 Velocity Result

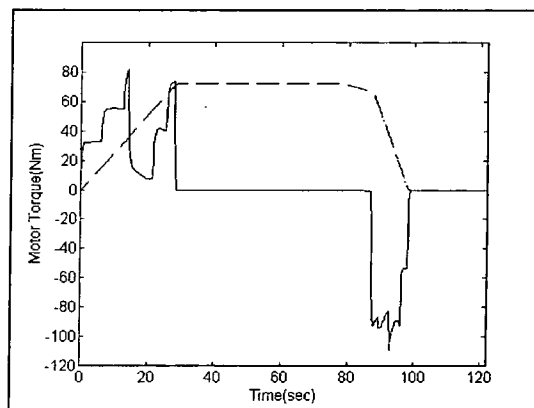

Figure 7.7 Motor Torque Result

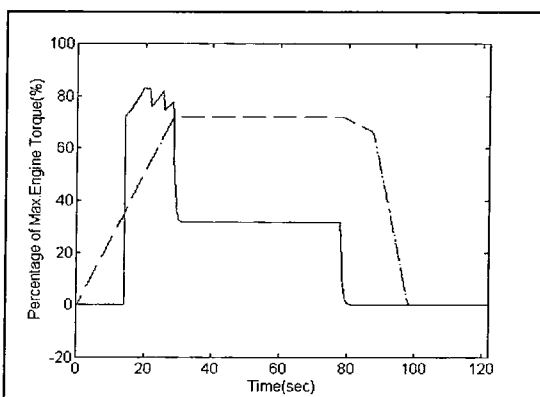

Figure 7.8 Percentage of Max. Engine Torque

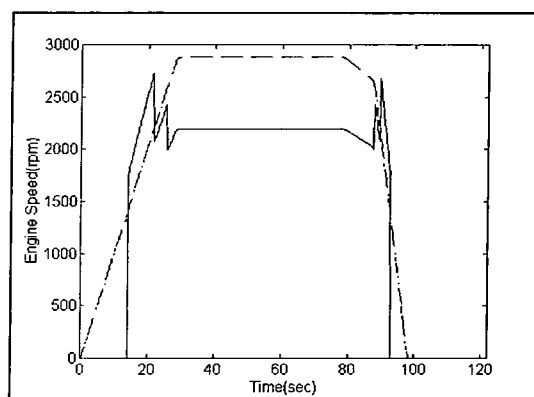

Figure 7.9 Engine Speed Result

7.4.2 Effect of Maximum Throttle

In order to improve the fuel economy and reduce emissions the throttle opening is limited by the controller as discussed in section 7.3.

In this section the effect of limiting the maximum throttle opening will be demonstrated through the simulation graphs. The J227a_d cycle is used for the simulations and two sizes of engine are also used. One of the two engines is the normal size engine used in the Accent 1.3 whilst the second engine is a reduced version of this engine and is the one used in Table 7.2. In this case the engine size has been reduced by 80% to a maximum torque of 94.36 N·m compared to the 117.95 N·m of the 1.3 Accent engine. In the following three figures the engine operating points are illustrated by 'X'.

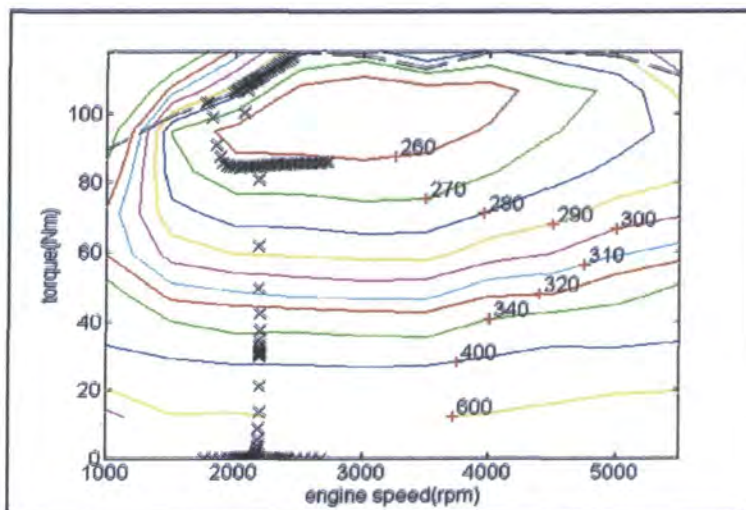

Figure7. 10 Accent 1.3 Engine (no change)

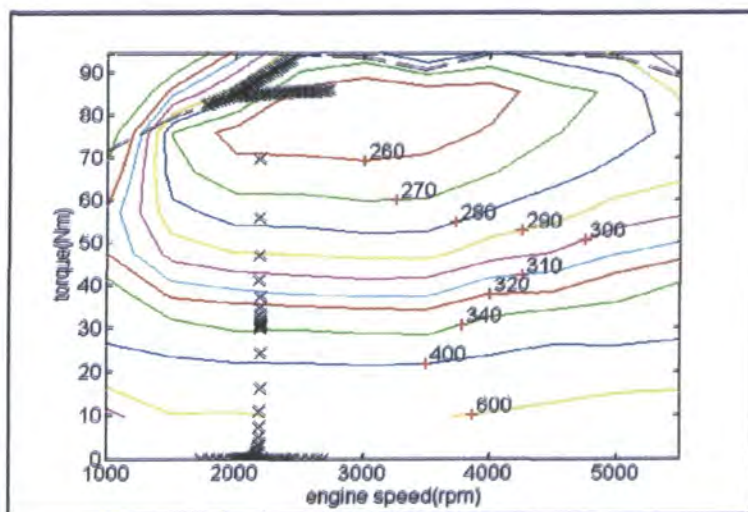

Figure 7.11 Reduced Engine (without Throttle Limit)

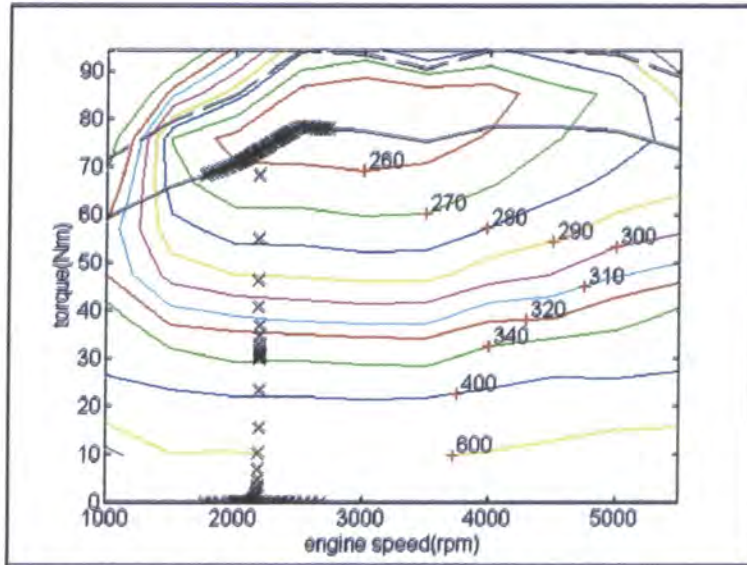

Figure 7.12 Reduced Engine(with Throttle Limit)

Figure 7.10 shows the operating points of the normal Accent 1.3 engine with the dashed line in the graph indicating the maximum torque line. Figure 7.9 shows that the engine mainly runs near the maximum torque line. This is an inefficient region. The dotted line of Figure 7.11 describes the reduced engine maximum torque line. However the maximum throttle opening of this engine is not limited and the engine operating points are located near the maximum torque line. The solid line in Figure 7.12 shows how maximum torque is reduced by limiting the maximum throttle opening. The original maximum torque line illustrated by the dashed line is same as the one in Figure 7.11. In Figure 7.12 the engine operating points can not cross the solid line because the maximum torque is limited by the maximum throttle opening. The engine operating points are restricted to a high efficiency region.

7.4.3 Simulation Results

The simulation results vary according to the switching speed. Therefore three switching speeds are simulated and the results are listed in Table 7.3. In this table 'Range as hybrid' means the range possible before the battery SOC reduces from 100% to 0%. For example, in the case of the Extra_Urban cycle and a switching speed of 52km/h the vehicle runs as an ICE vehicle after 410.34km because there is no battery SOC left. With 0% battery SOC this parallel hybrid vehicle can not drive over the three driving cycles because the electric motor can not supply the additional power required when the engine alone is unable to meet the cycle power demand. Therefore this case needs some special control logic. For example when the battery SOC falls below 40% battery SOC in the Extra_Urban cycle if the switching speed is reduced from 52km/h to 35km/h the battery SOC will not fall under 40% SOC because the amount of change of the battery SOC is only -0.0338% after one cycle as shown in Table 7.3. This means the amount of change of the battery SOC is very small negative value therefore the vehicle can be driven with the fuel economy and the emissions of condition2 without losing battery SOC and without the range limitation. In the case of the ECE 15 and the J227a-D cycle switching speeds 15km/h and 35km/h are more suitable than 52km/h due to the substantial low speed operation in these cycles. If the parallel hybrid vehicle uses the method described above to change the switching speed the ECE-15 and the Extra_Urban cycle are satisfied but the J227a_D cycle needs more consideration. In addition in order

to satisfy this control method the vehicle needs a device and software that can change the switching speed according to the battery SOC and the driving pattern. As can be seen in Table 7.3 the simulation results of a parallel hybrid vehicle are good at all parameters even NOx which is difficult to reduce in a series hybrid vehicle.

Switching Speed		Condition 1 15 km/h		Condition 2 35 km/h		Condition 3 52 km/h		Lantra 1.6
ECE-15	SOC(%/cycle)	+0.0288		-0.8843		-1.6397		
	Fuel (km/ l)	18.16	+64.9%	46.61	+323.3%	-	-	11.01
	CO(g/km)	3.28	-45.4%	1.12	-81.4%	0	-	6.01
	NOx(g/km)	1.68	+2.4%	0.75	-54.3%	0	-	1.64
	HC(g/km)	0.73	-48.2%	0.26	-81.6%	0	-	1.41
	Range as Hybrid(km)	unlimited		112.09		60.33		
J227a_D	SOC(%/cycle)	-0.2861		-0.7168		-1.5566		
	Fuel (km/ l)	19.56	+39.0%	22.22	+57.9%	26.56	+88.8%	14.07
	CO(g/km)	2.81	-31.0%	2.46	-39.6%	2.08	-48.9%	4.07
	NOx(g/km)	2.01	-10.3%	1.76	-21.4%	1.43	-36.2%	2.24
	HC(g/km)	0.61	-34.4%	0.54	-41.9%	0.46	-50.5%	0.93
	Range as Hybrid(km)	544.56		216.24		99.90		
Extra_Urban	SOC(%/cycle)	+0.3837		-0.0338		-1.6876		
	Fuel (km/ l)	17.91	+21.5%	18.45	+25.2%	22.35	+51.6%	14.74
	CO(g/km)	2.95	-21.8%	2.84	-24.7%	2.30	-39.0%	3.77
	NOx(g/km)	2.43	+1.7%	2.36	-1.3%	2.06	-13.8%	2.39
	HC(g/km)	0.62	-26.2%	0.60	-28.6%	0.49	-41.7%	0.84
	Range as Hybrid(km)	unlimited		20502		410.34		

Table 7. 3 Parallel Hybrid Vehicle Simulation Results

7.5 Conclusion

The performance and fuel economy of a parallel hybrid depends heavily on the control logic used. Depending on the vehicles purpose different control logic can be used to change between modes. In this chapter a simple speed based scheme has been used to switch between

the electric and the primary IC engine modes. As in the series hybrid vehicle the motor and the engine size must be carefully selected. However a smaller size of motor can be used compared to that than the series hybrid vehicle as both the engine and the motor can produce power for driving simultaneously. The simulation results shows good fuel economy and emissions when the switching speed is high . However there is a range limitation, as in an electric vehicle, when a high switching speed is used. In order to solve this problem the switching speed should be changed to lower value when the battery SOC becomes a low, for example less than 40%. In this way the battery does not lose SOC after one cycle. With this control logic the fuel economy and the emissions deteriorate slightly but the range limitation is removed. The parallel hybrid vehicle has some disadvantages compared to the series hybrid such as more complex control logic. However the parallel hybrid vehicle can be used as a general purpose vehicle which includes use at a high average speed. Depending on the purpose of the vehicle different fuel economy can be obtained from the simply by changing the control logic.

8. Comparison of the Series and Parallel Hybrid Vehicle

In this chapter the series and the parallel hybrid vehicle are compared based on the simulation results obtained in Chapter 6 and 7.

8.1 Structure

As illustrated in each layout diagram in Figure 6.1 and Figure 7.1 the series hybrid vehicle has a simpler structure than the parallel hybrid vehicle because there is no clutch, gearbox or transfer unit. It therefore has an advantage in designing over the parallel hybrid vehicle.

8.2 Control logic

The control logic used in the series hybrid is significantly simpler than that required by the parallel hybrid(See Figure 6.4 and 7.3). In the series hybrid vehicle the APU operating point, in terms of engine rpm and the engine throttle position, is of major importance as discussed in section 6.4.

On the other hand the parallel hybrid vehicle has many parameters and factors to consider for operation as discussed in 7.2.2.

8.3 Fuel Economy

The fuel economy results in Table 8.1 for the parallel hybrid vehicle are substantially better than those produced by the series hybrid. The series hybrid vehicle used in Table 8.1 is the general purpose vehicle discussed in section 6.5.2 and the parallel hybrid vehicle used in Table

8.1 is the vehicle described in Table 7.2. However these results depend on both the actual use of the vehicle and how they are calculated with regards battery SOC. This makes detailed comparison difficult. In particular it is more difficult to compare directly between a series and parallel hybrid vehicle.

In Table 8.1 condition1 of the series hybrid vehicle means that the vehicle starts with the battery SOC of 40%. The APU of the series hybrid vehicle is turned on and the battery is charged until the battery SOC is 60%. The vehicle then runs as an electric vehicle from 60% SOC to 40% SOC. Therefore the vehicle can be driven with condition1 without range limitation. However this is the worst comparison condition for the series hybrid vehicle. In the results of the condition2 the vehicle starts with 100% SOC and the results calculated when the vehicle has travelled 100km without regard to the battery SOC. If the vehicle is mainly used for urban area driving and the battery can be charged overnight condition2 is much more realistic. Figure 8.1 and 8.2 illustrate above two conditions.

In the case of the parallel hybrid vehicle the results depend on the switching speed. In Table 8.1 the parallel hybrid simulation results are calculated assuming switching speeds used in section 7.4.3. The vehicle starts with a battery SOC of 100% and a high switching speed is used until the battery SOC reaches 40% after which a lower switching speed is used. This ensures the battery does lose anymore SOC. Figure 8.3 shows this condition. Of course according to the driving cycle different switching speeds are used as explained in

section 7.4.3. Finally the fuel and emissions data of the parallel hybrid vehicle are normalized for a distance of 600km, the typical range of an ICE vehicle, to compare to the ICE vehicle.

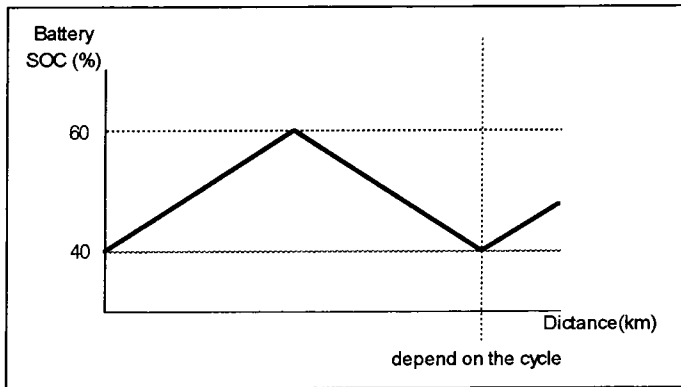

Figure 8. 1 Table 8.1 Condition1 of the Series Hybrid Vehicle

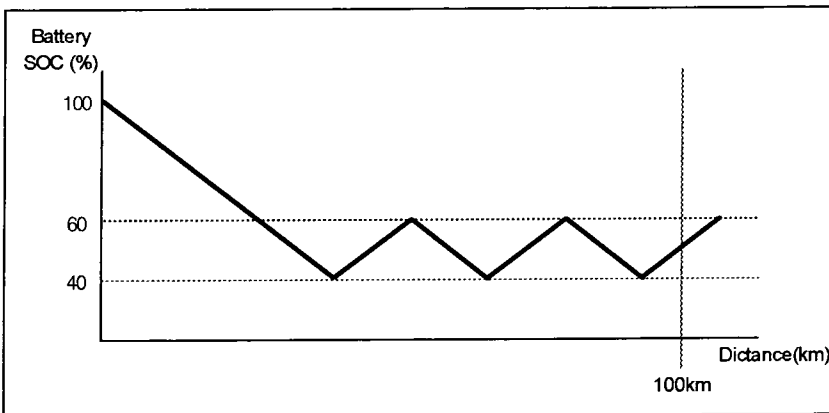

Figure 8. 2 Table 8.1 Condition2 of the Series Hybrid Vehicle

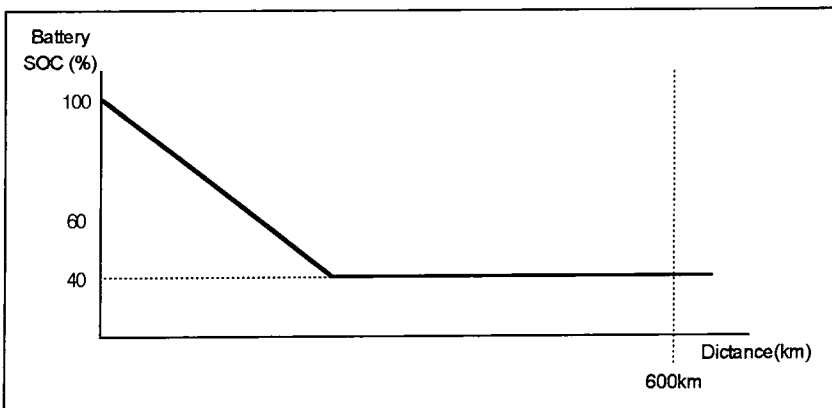

Figure 8. 3 Table 8.1 Condition of the Parallel Hybrid Vehicle

8.4 Emissions

It is very difficult to reduce CO, NOx and HC emissions all at the same time. In particular the way NOx emissions vary with engine load and speed is quite different to the other two types of emissions.(see Figure 6.6) Therefore a lower reduction(if any) in the NOx emissions must be accepted as shown in Table 8.1. However the results produced here use data for a standard engine whereas the worst emission such as the NOx would be reduced by engine tuning at the engine design stage. Such engine tuning could also be expected to improve the other emissions and fuel usage data for the hybrid vehicle.

		Series Hybrid				Parallel Hybrid		Lantra 1.6
		Condition 1*		Condition 2**				
ECE-15	Fuel (km/l)	10.22	-7.2%	15.11	+37.2%	21.35	+93.9%	11.01
	CO(g/km)	6.33	+5.3%	4.28	-28.8%	3.04	-49.4%	6.01
	NOx(g/km)	4.50	+174.4%	3.05	+86.0%	1.58	-3.7%	1.64
	HC(g/km)	0.99	-29.8%	0.67	-52.5%	0.68	-51.8%	1.41
J227a_D	Fuel (km/l)	10.89	-22.6%	14.98	+6.5%	20.55	+46.1%	14.07
	CO(g/km)	5.94	+45.9%	4.32	+6.1%	2.68	-34.2%	4.07
	NOx(g/km)	4.22	+88.4%	3.07	+37.1%	1.92	-14.3%	2.24
	HC(g/km)	0.93	0%	0.68	-26.9%	0.58	-37.6%	0.93
Extra_Urban	Fuel (km/l)	12.06	-18.2%	16.35	+10.9%	20.05	+36.0	14.74
	CO(g/km)	5.36	+42.2%	3.96	+5.0%	2.62	-30.5%	3.77
	NOx(g/km)	3.82	+59.8%	2.81	+17.6%	2.24	-6.3%	2.39
	HC(g/km)	0.84	0%	0.62	-26.2%	0.55	-34.5%	0.84

*)Condition 1: start 40% of SOC when SOC is 60% engine stop and run until 40% of SOC

**)Condition 2: start 100% of SOC stop after 100km of distance

Table 8. 1 Comparison of Series and Parallel Hybrid Vehicle Simulation Results

8.5 Performance

The parallel hybrid vehicle can be used as a general purpose vehicle with good results. However if the series hybrid vehicle is used as a

general purpose vehicle the results could be worse than those produced by similar sized ICE vehicle as shown in Table 8.1. Consequently to achieve acceptable results the engine size in the series hybrid vehicle should be reduced making this vehicle were suitable for urban operation as discussed in section 6.5.2 and Table 6.4.

9. Conclusion and Further Work

Conclusion

The aim of this project was to develop computer models for the ICE vehicle, electric vehicle and the series and parallel hybrid electric vehicles.

Component models have been developed using MATLAB/SIMULINK and form the vehicle library JANUSLEE. These component models have been used to assemble full vehicle models in order to simulate and compare the performance of different types of vehicle. In particular a comparative study of the series and parallel hybrid electric vehicle has been presented. The use of SIMULINK makes it possible to simulate without the need for real prototype cars. JANUSLEE has many component models which can be used to model many different kinds of vehicle.

The performance of the Accent 1.3 ICE vehicle was simulated and compared with test data from the Hyundai Motor Company. From this comparison the accuracy and the reliability of the SIMULINK model was proved.

Although the electric vehicle has many advantages the inadequate battery technology results in the vehicle having a heavy weight, low range and long charging time. This limits its use to short distance driving in urban areas.

The series hybrid vehicle is attractive for low speed cycles such as ECE-15, however in high speed cycles the results are worse than the

ICE vehicle. Therefore the series hybrid vehicle is best used for urban area driving when the motor and engine size can be reduced. In addition there are many control options possible for the APU.

Generally the parallel hybrid vehicle is better than the series hybrid vehicle. It has good results over all driving cycles. However the mechanical structure and the control logic is more complicated than that required by the series hybrid. The control logic needs further work to determine the best control strategy. This is discussed later in this chapter.

The series and parallel hybrid vehicle are being developed as possible replacements for the ICE vehicle. The best solution to reduce exhaust emissions and dependence on petroleum fuel is the electric vehicle. However there are still many problems with regards to battery technology. Consequently the hybrid vehicle can play an important part in replacing the ICE vehicle. The results of this project confirm the potential of the hybrid electric vehicle as a replacement for the ICE vehicle and suggest research and development of the hybrid vehicle should be continued.

Further Work

There are many possibilities for further work in the area of the hybrid vehicles. In particular topic related to this project are as follows.

◆ **Battery technology:** In the electric and hybrid vehicle the battery is a critical factor in their development. Many kinds of battery have been

developed and models of those batteries need to be available in the simulation software.

◆ **Further control of the series hybrid:** In this project only a simple control method was used in the simulation. However there are many other possible control options available and these need to be developed and simulated.

◆ **Further control of the parallel hybrid:** In order to further improve the performance of the parallel hybrid other kinds of control logic should be concerned; for example is it possible to mix the control logic of the series and parallel hybrid, how to change the switching speed while a vehicle is running etc.

◆ **Minimization of the simulation error:** When comparing real test data with the simulated performance of ICE vehicle there was some error between the two sets of results. This error should be minimized to obtain better simulation results. For example including engine temperature effects in start up, or the slip of the clutch, will help improve the simulation accuracy. However obtaining accurate test data and vehicle data is always a major problem.

References

1. J. R. Bumby, P. H. Clarke, I. Forster
'Computer modelling of the automotive energy requirements for internal combustion engine and battery electric-powered vehicles'
IEE Proceedings Vol. 132, Pt. A, No, 5, September, 1985
2. J. R. Bumby
'The integrated control of a hybrid i.c. engine / battery electric vehicle'
National Seminar on Hybrid Electric Vehicle Technology, Seoul, South Korea, September 5, 1995
3. J. R. Bumby, N. R. Everett
'Predicting the Performance of Hybrid Electric Vehicles'
UPEC, 1997
4. J. R. Bumby, Joe Peskett
'Control of the Auxiliary Power Unit in a Series Hybrid Electric Vehicle'
UPEC, 1997
5. N. R. Everett
'Simulation and Control of a Series Hybrid Electric Vehicle'
Final Year Project, University of Durham, April, 1997
6. Joe Peskett
'Control of the Auxiliary Power Unit in a Series Electric Hybrid Vehicle'
Final Year Project, University of Durham, April, 1997
7. J. R. Bumby, I. Forster
'Optimisation and control of a hybrid electric car'
IEE Proceedings Vol. 134, Pt. D, No, 6, November, 1987
8. J. R. Bumby, I. Forster
'A hybrid internal combustion engine/battery electric passenger car for petroleum displacement'
Proc. Inst. Mech. Engrs. Vol. 202 No. D1
9. J. R. Bumby
'A Test-Bed Facility for Hybrid IC-Engine/Battery-Electric Road Vehicle Drive Trains'
Trans. Inst. M C Vol. 10, No. 2, Apr-Jun, 1988
10. 10. The Ministry of Environment
'The viewpoint of government about the restriction of car emissions'
National Seminar on Hybrid Electric Vehicle Technology, Seoul, South Korea, September 5, 1995

11. John G. W. West
'DC, induction, reluctance and PM motors for electric vehicles'
Power Engineering Journal p77-p88 April, 1994
12. Richard Stone
'Motor Vehicle Fuel Economy'
Macmillan, 1989
13. A. Nagasaka, M. Nada, H. Hamada, S. Hiramatsu, Y. Kikuchi
'Development of the Hybrid/Battery ECU for the Toyota Hybrid System'
SAE 981122, 1998
14. Joerg O. Abthoff, Peter Antony, Michael Kramer, Jakob Seiler
'The Mercedes-Benz C-Class Series Hybrid'
SAE 981123, 1998
15. Michael R. Seal and Gavin Campbell
'The Ground-up Hybrid Vehicle Program at the Vehicle Research Institute'
SAE 951904, 1995
16. Wozniak J. J, Ecker J. A, Hildebrand R. J
'Advanced Natural-Gas Vehicle Development'
Johns Hopkins APL Technical Digest, Vol.16, No.1, p95-p100, 1995
17. Bhavnani S. H
'Design and Construction of a Solar-Electric Vehicle'
Journal of Solar Energy Engineering-Transactions of the ASME, Vol. 116, No.1,
p28-p34, 1994
18. Fritz A. F. Schmidt
'The Internal Combustion Engine'
Chapman and Hall, 1965
19. John F. Cooper, Dennis Fleming, Douglas Hargrove, Ronald Koopman, and Keith
Peterman
'A Refuelable Zinc/Air Battery for Fleet Electric Vehicle Propulsion'
SAE 951948, 1995
20. Mike Wahab
'Hybrid Vehicle Development May Offer Instant Solution'
World Automotive Environment & Safety Bulletin January, 1997
21. 'The Student Edition of MATLAB'
The MATH WORKS Inc. 1995
22. Donald W. Kurtz, Theodore W. Price, and James A. Bryant
'Performance Testing and System Evaluation of the DOE ETV-1 Electric Vehicle'
SAE 810418, 1981

23. Clark G. Hochgraf, Michael J. Ryan, Herman L. Wiegman
'Engine Control Strategy for a Series Hybrid Electric Vehicle Incorporating Load-Leveling and Computer Controlled Energy Management'
SAE 960230, 1996

24. P. Chudi, A. Malmquist
'A hybrid drive for the car of the future'
ABB Review 9/93 p3 - p12

Appendices

Appendix 1 Driving Cycles

1.1 ECE-15

% Time in seconds, velocity in km/h

% Specify cycle time and integrator initial value

time=200;

init=0;

```
cycle_data=[0.0    0.0;
            11.0   0.0;
            15.0  14.91;
            23.0  14.91;
            25.0   0.0;
            49.0   0.0;
            61.0  31.82;
            85.0  31.82;
            96.0   0.0;
            117.0 0.0;
            143.0 49.73;
            156.0 49.73;
            164.0 34.80;
            177.0 34.80;
            189.0 0.0;
            195.0 0.0];
```

cycle_time=0:1:195;

cycle_vel=interp1(cycle_data(:,1),cycle_data(:,2),cycle_time);

1.2 J227a_D

% Time in secs, velocity in km/h

time=122;

init=0;

```
cycle_data=[0.0    0.0;
            28    72.4;
            78    72.4;
            87    66.6;
            98     0;
            122    0];
```

cycle_time=0:1:122;

cycle_vel=interp1(cycle_data(:,1),cycle_data(:,2),cycle_time);

1.3 Extra_Urban

% Time in seconds, velocity in km/h

% Specify cycle time and integrator initial value

time=400;

init=0;

cycle_data=[0.0 0.0;

20.0 0.0;

27.0 15.0;

38.0 35.0;

48.0 50.0;

61.0 70.0;

111.0 70.0;

119.0 50.0;

188.0 50.0;

201.0 70.0;

251.0 70.0;

286.0 100.0;

316.0 100.0;

336.0 120.0;

346.0 120.0;

362.0 80.0

370.0 50.0;

380.0 0.0

400.0 0.0];

cycle_time=0:1:400;

cycle_vel=interp1(cycle_data(:,1),cycle_data(:,2),cycle_time);

Appendix 2 Accent1.3 Data Files

2.1 act3.m

```
% Vehicle test data for 1.3 litre Accent
% The engine map is available in act_map3.m

% Specify vehicle parameters:
mass=1100;
C_drag=0.317;
frontal_area=1.91;
C_roll=0.018;
wheel_radius=0.289;
theta=0;
g=9.81;

% Specify transmission details:
vel_1_2=15.0;
vel_2_3=32.0;
vel_3_4=55.0;
vel_4_5=65;
ratio_1=3.462;
ratio_2=2.053;
ratio_3=1.370;
ratio_4=1.031;
ratio_5=0.838;
final_drive_eff=0.96;
final_ratio=3.842;
gearbox_eff=0.96;

% Specify engine parameters and motor type:
max_motor_speed=5500;
max_torque=117.95;
max_speed=5500;
idle_speed=1000;
idle_cons=0.165;

idle_co=0.01534;
idle_hc=0.003769;
idle_nox=0.0003559;
comp_ratio=10;
crI=comp_ratio^0.1;
crII=comp_ratio^0.2;
crIII=comp_ratio^0.3;
cc=1341;
comp_torque=cc*(0.081*(crII-1)-(0.05*((crIII-1)/crI)));
act_map3;

%Specify whether fuel cut off valve is present: YES=0 NO=-1000
fco=-1000;

% Specify driver details; gain and reset time (when used):
K_driver=0.4;
T_i=30;
```

2.2 act3_map.m

```
% Hyundai 1.3 litre engine maximum torque and bsfc values
% The maximum torque values start at 0 and finish at 1 in 10% steps.
% The bsfc values start at (0,0) and finish at (1,1) in
% Max_speed (in rpm) and max_torque (in Nm) must be specified in "act3.m".
% Unit of bsfc, CO, HC and NOX : g/kW-hr

speed=0:max_speed/11:max_speed;
torque=0:max_torque/10:max_torque;
contorque=0:0.1:1;
% Specify the maximum torque curve
torque_limit=[0.50 0.64 0.76 0.84 0.90 1.00 0.99 0.96 1.00 1.00 0.99 0.94]
full_torque=torque_limit*max_torque;

bsfc=[0 0 0 0 0 0 0 0 0 0 0 0;
0 0 870.56 610.98 614.51 582.21 575.93 589.71 613.26 650.32 765.35 777.52;
0 0 481.30 435.19 425.51 423.80 417.73 422.14 439.97 494.03 473.89 494.38;
0 0 376.55 353.67 341.48 342.67 340.48 338.44 354.64 368.40 371.02 383.81;
0 0 352.47 315.85 311.69 308.79 307.24 307.70 318.96 320.77 331.11 349.04;
0 0 319.38 296.05 289.81 288.67 286.90 286.86 295.47 300.24 309.09 314.36;
0 0 316.45 283.50 275.52 275.22 273.14 273.54 280.67 286.48 294.27 298.46;
0 0 332.91 273.41 263.95 263.96 262.27 263.73 269.37 276.52 282.78 287.35;
0 0 352.57 269.57 255.31 254.89 254.57 255.86 261.15 269.36 275.53 283.26;
0 0 394.76 313.15 284.70 256.09 250.27 255.06 255.23 266.41 271.78 292.97;
0 0 334.57 374.69 315.04 282.14 276.82 289.58 279.06 284.83 291.23 309.11]

COtab=[0 0 119.42 67.32 58.35 61.70 56.71 67.42 49.91 77.97 91.24 105.97;
0 0 88.47 47.80 44.63 46.75 42.97 49.73 43.07 56.70 65.20 75.14;
0 0 49.57 30.52 30.91 32.48 27.60 32.46 35.89 35.40 29.13 44.05;
0 0 53.72 25.96 26.54 25.28 23.06 21.78 28.93 24.03 26.52 28.95;
0 0 63.84 25.77 21.13 25.21 21.02 21.44 24.29 25.62 24.47 23.62;
0 0 61.59 22.91 20.48 24.07 20.30 18.20 20.08 20.14 21.96 22.59;
0 0 59.33 21.26 17.35 21.56 18.84 17.51 17.63 18.94 20.72 19.59;
0 0 62.51 18.93 13.52 18.59 16.24 18.24 16.24 19.31 19.73 23.35;
0 0 68.38 14.45 15.24 17.41 14.85 16.83 16.33 18.84 23.70 37.85;
0 0 87.99 42.51 39.54 33.24 16.39 28.21 17.72 29.74 35.86 95.21;
0 0 114.56 109.72 133.82 140.23 125.55 145.59 128.18 125.77 139.49 137.95]

HCTab=[0 0 31.16 17.87 14.38 12.86 11.37 10.46 9.26 8.80 10.15 9.17;
0 0 20.12 13.06 11.04 10.04 8.88 8.24 7.30 7.09 7.56 6.96;
0 0 9.98 8.47 7.70 7.32 6.54 6.09 5.40 5.38 4.99 4.75;
0 0 8.13 6.35 5.77 5.69 5.28 4.73 4.28 4.20 3.97 3.73;
0 0 7.72 5.40 5.29 4.99 4.51 4.16 3.79 3.54 3.47 3.45;
0 0 6.57 4.53 4.61 4.32 3.98 3.75 3.49 3.21 3.06 2.78;
0 0 6.19 4.15 4.22 3.97 3.70 3.45 3.28 2.91 2.69 2.45;
0 0 6.39 3.76 3.97 3.83 3.56 3.21 3.08 2.63 2.41 2.21;
0 0 6.62 3.38 3.71 3.51 3.30 3.12 2.80 2.40 2.26 2.15;
0 0 7.28 6.08 4.32 3.41 2.99 3.17 2.70 2.31 2.16 2.31;
0 0 9.83 8.78 4.93 3.90 3.75 4.00 3.10 2.91 2.63 2.55]

NOxtab=[0 0 1.02 0.79 1.97 10.96 17.53 19.92 27.82 20.05 29.08 31.50;
0 0 1.24 1.95 3.83 16.36 20.79 30.93 26.80 36.18 28.72 19.82;
0 0 6.91 13.72 16.01 22.00 20.93 23.90 26.76 25.97 27.18 30.45;
0 0 9.90 16.79 17.59 15.15 21.15 22.50 23.73 24.37 24.72 27.45;
0 0 9.32 17.30 17.42 15.86 21.09 21.27 22.47 22.85 22.02 23.77;
0 0 10.99 17.16 16.99 19.94 20.34 19.44 21.26 21.90 21.48 20.46;
0 0 12.53 17.41 16.46 18.94 19.57 19.68 20.58 20.96 20.63 17.68;
0 0 13.46 16.70 16.05 17.87 18.73 19.34 19.90 20.63 17.97 14.97;
0 0 14.37 15.51 15.88 16.79 17.94 18.18 18.82 19.14 11.78 9.99;
0 0 15.15 11.42 15.42 13.37 12.94 16.64 17.84 14.09 7.51 5.87;
0 0 8.84 8.38 6.04 5.55 5.50 9.83 9.56 6.80 5.80 4.39]
```

Appendix 3 ETV1 Data Files

3.1 etv1.m

% Vehicle test data for the ETV1 electric car
% The motor map is available in etv_mot1.m

% Specify vehicle parameters - mass INCLUDES battery mass

mass=1795;
C_drag=0.32;
frontal_area=1.875;
C_roll=0.01;
wheel_radius=0.28;
theta=0; % Road gradient theta
g=9.81;

% Specify transmission details

final_drive_eff=0.92; % Final drive efficiency
final_ratio=5.68; % Final drive ratio

% Specify motor parameters and motor type

m_max_motor_speed=5000; % Maximum motor operating speed
m_max_torque=128; % Maximum motor torque
m_max_speed=5000;
etv_mot1; % Load motor data file etv_mot1

% Specify controller efficiency

controller_eff=0.98;

% Specify Battery details and initial soc (%)

battery_mass=495; % Battery mass
initial_soc=100; % Battery initial SOC
ev2_13;

% Specify driver details; gain and reset time (when used)

K_driver=0.5; % Driver proportional controller gain
T_j=30;

3.2 ev2_13.m

% Battery parameters for Globe Union EV2-13 lead acid batteries

% Specify coefficients of battery model

A=-0.03516;
B=-0.69045;
C=3.31975;

% Specify model accuracy limits, W/kg

Pd_max=80;
Pd_min=5;

% Calculate 5hr Energy Density in W/kg and specify battery charge efficiency

Edi_5=5*(exp(A*log(5)*log(5)+B*log(5)+C));
batt_charge_eff=0.87;

3.3 etv_mot1

% ETV1 maximum torque and motor efficiency values
 % The maximum torque values start at 0 and finish at 1 in 5% steps.
 % The efficiency values start at (0,0) and finish at (1,1) in
 % 5% steps for both torque and speed.
 % For this routine to work both max_speed (in rpm) and max_torque (in Nm) must be specified.
 In etv1.m

```
m_speed=0:m_max_speed/20:m_max_speed;
m_torque=0:m_max_torque/20:m_max_torque;
```

```
m_torque_limit=[1.000 1.000 1.000 1.000 1.000 1.000 1.000 1.000 1.000 1.000 0.900 0.815
                0.740 0.685 0.615 0.560 0.535 0.495 0.460 0.450 0.430];
m_full_torque=m_torque_limit*m_max_torque;
```

```
m_efficiency=[
0.050 0.050 0.050 0.050 0.050 0.050 0.050 0.050 0.050 0.050 0.050 0.050 0.050 0.050 0.050 0.050
0.050 0.050 0.050 0.050 0.050;
0.050 0.150 0.300 0.450 0.600 0.610 0.620 0.630 0.640 0.670 0.700 0.730 0.760 0.780 0.800 0.800
0.800 0.800 0.800 0.800 0.800;
0.050 0.270 0.550 0.600 0.650 0.680 0.710 0.715 0.720 0.760 0.800 0.827 0.855 0.858 0.861 0.861
0.862 0.861 0.860 0.860 0.860;
0.050 0.405 0.615 0.660 0.695 0.733 0.760 0.768 0.775 0.805 0.837 0.855 0.874 0.876 0.878 0.876
0.875 0.874 0.873 0.874 0.874;
0.050 0.540 0.680 0.720 0.760 0.785 0.810 0.820 0.830 0.851 0.873 0.883 0.892 0.893 0.894 0.892
0.891 0.887 0.886 0.887 0.888;
0.050 0.560 0.695 0.738 0.780 0.801 0.823 0.833 0.843 0.862 0.881 0.889 0.896 0.895 0.894 0.891
0.889 0.885 0.883 0.881 0.878;
0.050 0.580 0.710 0.755 0.800 0.817 0.835 0.845 0.856 0.873 0.890 0.895 0.900 0.897 0.894 0.890
0.886 0.883 0.880 0.874 0.868;
0.050 0.585 0.710 0.757 0.805 0.822 0.849 0.850 0.860 0.875 0.890 0.893 0.895 0.892 0.889 0.884
0.878 0.874 0.870 0.865 0.859;
0.050 0.590 0.710 0.760 0.810 0.827 0.844 0.854 0.864 0.877 0.890 0.890 0.890 0.887 0.884 0.877
0.871 0.865 0.860 0.855 0.850;
0.050 0.585 0.705 0.755 0.805 0.825 0.846 0.856 0.866 0.876 0.888 0.887 0.885 0.881 0.876 0.869
0.863 0.858 0.853 0.846 0.840;
0.050 0.580 0.700 0.750 0.800 0.824 0.843 0.858 0.868 0.876 0.885 0.883 0.880 0.874 0.868 0.871
0.855 0.850 0.845 0.837 0.830;
0.050 0.570 0.690 0.738 0.790 0.817 0.844 0.855 0.867 0.874 0.881 0.877 0.873 0.867 0.861 0.854
0.848 0.845 0.840 0.830 0.820;
0.050 0.560 0.670 0.725 0.780 0.810 0.840 0.852 0.865 0.871 0.876 0.871 0.866 0.860 0.854 0.847
0.840 0.835 0.830 0.820 0.810;
0.050 0.550 0.670 0.720 0.775 0.805 0.835 0.848 0.863 0.867 0.871 0.865 0.861 0.854 0.847 0.840
0.835 0.830 0.820 0.810 0.800;
0.050 0.540 0.660 0.715 0.770 0.800 0.830 0.845 0.860 0.863 0.866 0.860 0.855 0.847 0.840 0.835
0.830 0.820 0.810 0.800 0.790;
0.050 0.530 0.650 0.705 0.760 0.791 0.825 0.839 0.855 0.856 0.858 0.853 0.845 0.840 0.835 0.830
0.820 0.810 0.800 0.790 0.780;
0.050 0.520 0.640 0.695 0.750 0.783 0.821 0.836 0.850 0.850 0.850 0.843 0.835 0.830 0.825 0.820
0.810 0.800 0.790 0.780 0.770;
0.050 0.510 0.630 0.687 0.745 0.789 0.818 0.833 0.847 0.847 0.847 0.840 0.830 0.825 0.820 0.810
0.800 0.790 0.780 0.770 0.760;
0.050 0.500 0.620 0.680 0.740 0.795 0.815 0.830 0.845 0.845 0.845 0.836 0.825 0.820 0.810 0.800
0.790 0.780 0.770 0.760 0.750;
0.050 0.475 0.610 0.672 0.735 0.780 0.810 0.825 0.840 0.841 0.841 0.831 0.820 0.810 0.800 0.790
0.780 0.770 0.760 0.750 0.740;
0.050 0.450 0.600 0.665 0.730 0.765 0.800 0.818 0.836 0.837 0.838 0.829 0.810 0.800 0.790 0.780
0.770 0.760 0.750 0.740 0.730];
```

Appendix4 Series Hybrid Vehicle Data Files

4.1 shv.m

```
% Vehicle test data for the Sereis Hybrid Vehicle
% The motor map is available in im8000.m (Induction Motor)

% Specify vehicle parameters - mass INCLUDES battery mass
mass=1800;
C_drag=0.32;
frontal_area=1.875;
C_roll=0.01;
wheel_radius=0.28;
theta=0;
g=9.81;

% Specify transmission details
final_drive_eff=0.96;
final_ratio=5.68;

% Specify motor parameters and motor type
max_motor_speed=8000;
mt_max_torque=163;
limit=1.07;
m_max_torque=mt_max_torque*limit;
m_max_speed=8000;
im8000;

% Specify Battery details and initial SOC (%)
battery_mass=320;
initial_soc=60;
ev2_13;

% Specify driver details; gain and reset time (when used)
K_driver=0.5;
T_i=30;

% Specify Hyundai Accent 1.3L engine parameters
max_torque=84.5;
max_speed=5500;

% Specify engine controller parameters
engine_on=40;
engine_off=60;
run_speed=2500;
throttle_opening=0.83;

act_map3;
```

4.2 im8000.m

```
% Efficiency map for the GE induction motor and controller
% initial data torque inn ft-lb and speed in rpm
% Rating 50hp, break speed 2188 rpm, max torque 110 ft lb, max speed 8000 rpm
% In SI units max torque is 163 Nm, max power 37.3 kW
% m_max_torque and m_torque should be specified in Nm

speed=[0 500 1000 2000 3000 4000 5000 6000 7000 8000];
torque=[0 6.78 13.56 20.34 27.12 40.67 54.23 67.79 81.35 94.91 108.46 122.02
        135.58 149.14 163];

m_efficiency=[ 0.001 .394 .541 .660 .724 .793 .839 .857 .867 .862
               0.200 .394 .541 .660 .724 .793 .839 .857 .867 .862
               0.265 .532 .637 .731 .793 .850 .893 .903 .907 .898
               0.308 .617 .703 .770 .817 .865 .893 .903 .907 .898
               0.304 .608 .713 .789 .831 .874 .898 .912 .907 .898
               0.304 .608 .713 .812 .846 .869 .888 .903 .903 .888
               0.290 .580 .694 .817 .850 .865 .884 .893 .893 .888
               0.270 .542 .703 .808 .850 .865 .869 .879 .884 .874
               0.270 .542 .703 .808 .846 .855 .865 0 0 0
               0.260 .523 .684 .798 .836 .855 .855 0 0 0
               0.255 .513 .694 .789 .827 .846 .846 0 0 0
               0.250 .494 .675 .784 .808 .817 0 0 0 0
               0.228 .456 .656 .784 .798 0 0 0 0 0
               0.229 .223 .447 .646 .779 0 0 0 0 0
               0.220 .442 .641 .774 0 0 0 0 0 0];

m_speed=speed/8000*m_max_speed;
m_torque=torque/163*m_max_torque;
m_torque_limit=[1.000 1.000 1.000 1.000 0.7284 0.5463 0.4370 0.3642 0.3122 0.2732];

m_full_torque=m_torque_limit*m_max_torque;
```

Appendix 5 Calculation File

```
mass=1800
cd=0.32
cr=0.01
area=1.875
r=0.28
g=9.81
final_drive_eff=0.96
final_ratio=5.68
gearbox_eff=0.96

vel1=(v1*1000)/3600           % input value to calculate acceleration
vel2=(v2*1000)/3600

a=(vel2-vel1)/t              % acceleration (m/s2)

ft=(mass*a)+(vel2^2*0.5*1.226*cd*area)+(mass*g*sin(x*pi/180))+(mass*g*cr) % traction force

torq=((ft*r)/(final_drive_eff*final_ratio)) % required motor torque

spd=(vel2/r)*final_ratio     % motor speed (rad/s)

rpm=spd*30/pi                % motor speed (rpm)

power=(torq*spd)/1000        % required motor power (kW)
```

Appendix 6 Parallel Hybrid Vehicle File

6.1 phv.m

```
% Vehicle test data for the Parallel Hybrid Vehicle
% The motor map is available in im8000.m

% Specify vehicle parameters - mass INCLUDES battery mass
mass=1735;
C_drag=0.32;
frontal_area=1.875;
C_roll=0.01;
wheel_radius=0.28;
theta=0;
g=9.81;

% Specify transmission details
final_drive_eff=0.96;
final_ratio=5.68

% Specify motor parameters and motor type
mt_max_torque=163;
limit=0.67;
m_max_torque=mt_max_torque*limit;

m_max_speed=8000;
im8000;

% Specify Battery details and initial soc (%)
battery_mass=320;
initial_soc=100;
ev2_13;

% Specify driver details; gain and reset time (when used)
K_driver=0.5;
T_i=30;

% Specify Hyundai Accent 1.3 engine parameters
vel_1_2=15.0;
vel_2_3=32.0;
vel_3_4=55.0;
vel_4_5=65;

ratio_1=3.462;
ratio_2=2.053;
ratio_3=1.370;
ratio_4=1.031;
ratio_5=0.838;
gearbox_eff=0.96;

% Specify engine parameters and motor type:

max_motor_speed=5500;
e_max_torque=117.95;
e_limit=0.80;
```



```
max_torque=e_max_torque*e_limit;
max_speed=5500;
```

```
idle_speed=1000;
idle_cons=0.165;
idle_co=0.01534;
idle_hc=0.003769;
idle_nox=0.0003559;
```

```
comp_ratio=10;
crl=comp_ratio^0.1;
crlI=comp_ratio^0.2;
crlII=comp_ratio^0.3;
cc=1341;
comp_torque=cc*(0.081*(crlI-1)-(0.05*((crlII-1)/crl)));
act_map3;
```

```
%Hybrid mode parameters
```

```
t_max_torque=max_torque+m_max_torque;
t_max_speed=5500;
t_speed=0:t_max_speed/11:t_max_speed;
t_torque=0:t_max_torque/10:t_max_torque;
```

```
im_torque_limit=[1.0 1.0 1.0 1.0 1.0 0.8754 0.7284 0.6243 0.5463 0.4856 0.4370 0.3973]
```

```
t_torque_limit=[((im_torque_limit*m_max_torque)+(torque_limit*max_torque))/t_max_torque]
```

```
t_full_torque=t_torque_limit*t_max_torque;
```

```
%Specify whether fuel cut off valve is present: YES=0 NO=-1000
fco=-1000;
```

```
% Specify engine controller parameters
```

```
switching_speed=52; % switching speed from motor to engine
```

```
max_throttle=0.83; % throttle opening limitation
```

