

Durham E-Theses

New studies in halogenated tetrathiafulvalenes

Clare Louise Wood

How to cite:

Wood, Clare Louise (1998) New studies in halogenated tetrathiafulvalenes. Masters thesis, Durham University.

Use policy

The full-text may be used and/or reproduced, and given to third parties in any format or medium, without prior permission or charge, for personal research or study, educational, or not-for-profit purposes provided that:

- a full bibliographic reference is made to the original source
- a <https://etheses.durham.ac.uk/id/eprint/4760/> is made to the metadata record in Durham E-Theses
- the full-text is not changed in any way

The full-text must not be sold in any format or medium without the formal permission of the copyright holders.

Please consult the [full Durham E-Theses policy](#) for further details.

CLARE LOUISE WOOD, B.Sc.

NEW STUDIES IN HALOGENATED TETRATHIAFULVALENES

MASTER OF SCIENCE

1998

New Studies in Halogenated Tetrathiafulvalenes

by

Clare Louise Wood, B.Sc.

The copyright of this thesis rests with the author. No quotation from it should be published without the written consent of the author and information derived from it should be acknowledged.

Department of Chemistry
University of Durham

A Thesis submitted for the degree of
Master of Science at the University of Durham

June 1998



1 1 MAY 1999

Statement of Copyright

The copyright of this thesis rests with the author. No quotation from it should be published without their prior written consent and information derived from it should be acknowledged.

Acknowledgements

I would like to thank the following people who have helped and guided me through this M.Sc. at Durham: Professor Martin Bryce for offering me the opportunity to work within his group, and for his many helpful ideas, suggestions and discussions. Dr. Antony Chesney for offering his support throughout this course, and Dr. Adrian Moore for advice on all aspects of TTF chemistry. The rest of the Bryce group for their advice and helpfulness. The technical staff of the department for providing an excellent service and invaluable help.

Thanks to EPSRC for funding this work.

Declaration

The work described in this Thesis was carried out by the author in the Department of Chemistry, University of Durham. It has not been submitted previously for a degree at this or any other university.



Clare Louise Wood, B.Sc.

New Studies in Halogenated Tetrathiafulvalenes

Master of Science

June 1998

Abstract

Several halogenated derivatives of tetrathiafulvalene (TTF) have been synthesised, using a wide range of halogenating agents. Two distinct methods were used to obtain the desired iodo- and bromo-TTFs. Reaction conditions were optimised to increase the yields of products. Representative compounds include 4,5-Dibromo-4',5'-methylthio-tetrathiafulvalene, 4,5-Diiodo-4',5'-bis(2'-cyanoethylthio)-tetrathiafulvalene and 4-Bromo-4,5,5'-trimethyltetrathiafulvalene.

Examination of the electrochemistry of these TTFs, employing cyclic voltammetry, showed good donor ability for halogenated TTFs bearing one or two substituent groups.

X-ray crystallographic studies on 4,5-Dibromo-4',5'-bis(2'-cyanoethylthio)-tetrathiafulvalene, and the iodide salt of 4,5-Dibromo-4',5'-methylthio-tetrathiafulvalene, showed close *intra*- and *inter*-molecular contacts between halogen atoms and other atoms. This work points the way forward for using halogenated TTFs as donor components for radical ion salts, in which the halogen atom(s) contribute to the supramolecular ordering of the structure.

Contents

Chapter 1 - Introduction	p6
1.1 Organic Metals	p6
1.2 A Brief History	p6
1.3 Electrochemistry of TTF	p7
1.4 Discovery of TTF ⁺ TCNQ ⁻	p7
1.5 Solid State Properties of the Crystal Lattice	p9
1.5.1 One-dimensional Metals	p9
1.5.2 Band Theory	p10
1.5.3 The Peierls Distortion	p11
1.5.4 BEDT-TTF: A Model for Increased Dimensionality	p12
1.6 Crystal Engineering	p13
1.6.1 Definition	p13
1.6.2 Intermolecular Interactions	p13
1.6.2.1 π - π Interactions	p13
1.6.2.2 Hydrogen Bonding	p14
1.7 Halogenated TTFs: Rationale	p16
1.8 Halogenated TTFs: Recent Developments	p18
1.9 Aims of This Project	p20
Chapter 2 - Results and Discussion	p22
2.1 Introduction	p22
2.2 Novel TTF Systems	p23
2.3 Synthesis of Compounds 22 and 23	p23
2.3.1 Proposed Route to 22 and 23	p24
2.3.2 Intermolecular Coupling Method to Tetrachalcogenafulvalenes	p26

2.3.3 4,5-Diiodo-1,3-dithiol-2-thione	p27
2.3.4 4,5-Dibromo-1,3-dithiol-2-thione	p29
2.3.5 4,5-Bis(2'-cyanoethylthio)-1,3-dithiol-2-one	p30
2.3.6 Coupling Reactions	p31
2.3.7 Target Compounds 22 and 23	p34
2.4 4,5-Bis(2'-cyanoethylthio)-TTF and Its Derivatives	p38
2.5 Synthesis of Compounds 24 and 25 (Method B)	p41
2.6 Cyclic Voltammetry Data	p45
Chapter 3 - Experimental	p47
3.1 Table of Abbreviations	p47
3.2 General	p47
3.3 Method A	p48
3.4 Method B	p54
References	p56
Appendices	p59

Chapter 1

Introduction

Introduction

1.1 Organic Metals

Throughout the last 25 years, a great deal of research has been carried out into the synthesis and study of a relatively new type of organic system, termed organic metals. Unlike most organic solids, which are electrical insulators, organic metals exhibit very unusual physical properties, including high electrical conductivity, which in some cases approaches the conductivities of traditional metals. There are several types of organic metal, including polymeric systems¹ and charge-transfer complexes, the latter of which is relevant to this work. Organic superconductors are also known and will be mentioned below. This thesis focuses on the synthesis of novel donor molecules to make charge-transfer complexes, based on the organosulfur donor tetrathiafulvalene (TTF) (1).

1.2 A Brief History

The first conducting molecular material, an unstable bromine salt of perylene, was reported² in 1954 and had a conductivity of 1 Scm^{-1} . In the 1960s, the synthesis of tetracyano-*p*-quinodimethane (TCNQ) (2) was reported³, and this molecule was found to be a strong electron acceptor. Furthermore, many of its salts were shown to be organic semiconductors⁴.

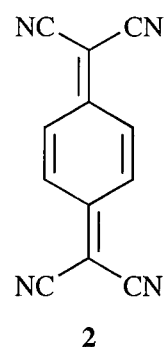
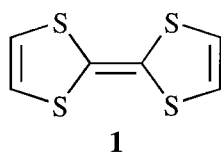

In 1972, Wudl et al.⁵ reported that the chloride salt of tetrathiafulvalene (TTF) (1) was a conducting material. These discoveries concerning TTF and TCNQ led to a whole new field of research into donor and acceptor species based on these two molecules⁶.

1.3 Electrochemistry of TTF

TTF undergoes two reversible, one-electron oxidations to form the stable radical cation and the less-stable dication species, respectively⁷ [neutral / radical cation: $E_{1/2}^1 = +0.34$ V; radical cation / dication: $E_{1/2}^2 = +0.71$ V (Ag/AgCl, MeCN)] (scheme 1.1).

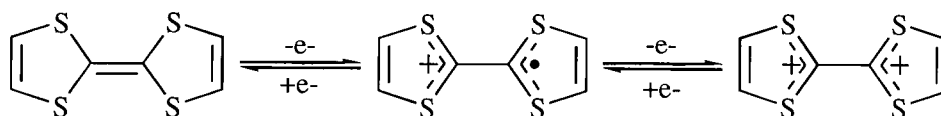

Scheme 1.1

The radical cation species is stabilised by the formation of the 6π electron 1,3-dithiolium system. Coulombic repulsion of two adjacent cations destabilises the dication.

1.4 Discovery of $\text{TTF}^+\text{-TCNQ}^-$

In 1972, a research group led by Cowan and Ferraris observed that crystals of the 1 : 1 salt $\text{TTF}^+\text{-TCNQ}^-$ exhibited metallic-like conductivities of about 500 Scm^{-1} at room temperature⁸. This compares with the conductivity of copper, known to be *ca.* 10^6 Scm^{-1} at room temperature. Furthermore, the conductivity of $\text{TTF}^+\text{-TCNQ}^-$ increases as temperature decreases⁸, which is characteristic of metallic behaviour⁹, a maximum conductivity of 10^4 Scm^{-1} being reached at 59K. At lower temperatures, the conductivity decreases as temperature decreases, a characteristic feature of semiconductors⁹. The conductivity / temperature profile of $\text{TTF}^+\text{-TCNQ}^-$ is shown in figure 1.1.

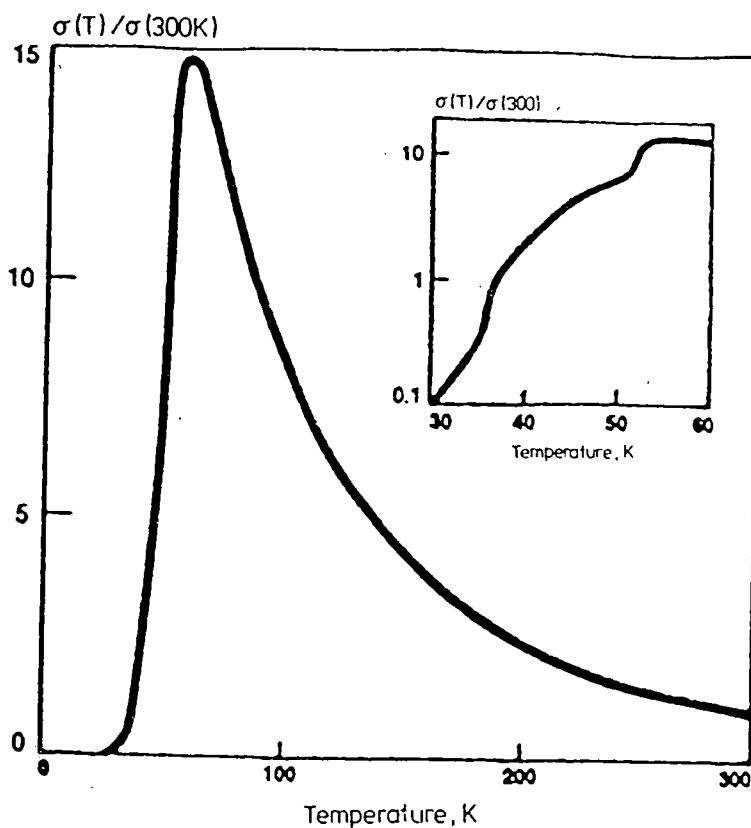
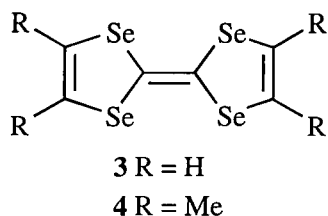

Figure 1.1 Conductivity of TTF^+-TCNQ^- - Variation with Temperature

Further breakthroughs in the search for new organic metals came in 1974, when tetraselenafulvalene (TSF)-TCNQ (**3**) was reported¹⁰ to have a conductivity of 700 Scm^{-1} , and in 1980, when the first organic superconductors based on tetramethyltetraselenafulvalene (TMTSF) (**4**) were reported¹¹.



One example of a superconducting organic material based on TMTSF is the salt $(TMTSF)_2PF_6$, for which superconductivity was observed at 0.9 K and 12 bar¹¹. Several other conducting molecules are shown below^{5c} (table 1.1).

Material	Conductivity Scm^{-1}	Classification
copper	1×10^6	Metal
tin	1×10^5	Metal
(TMTSF) ₂ -TCNQ	1×10^3	Metal
TTF ⁺ -TCNQ ⁻	5×10^2	metal
doped poly(3-alkylthiophene)	$1 - 1 \times 10^3$	Semiconductor
germanium	5×10^{-2}	semiconductor
silicon	1×10^{-3}	semiconductor
boron	6×10^{-6}	semiconductor / insulator
<i>cis</i> -polyacetylene	2×10^{-9}	insulator
polyvinyl chloride	1×10^{-10}	insulator
polyethylene	1×10^{-16}	insulator
sulfur	5×10^{-18}	insulator

Table 1.1 *Conductivities of Some Common Materials*

1.5 Solid State Properties of the Crystal Lattice

1.5.1 One-Dimensional Metals

Since these pioneering discoveries were made regarding TTF, and the analogous TSF, a great deal of research has been directed towards obtaining other charge-transfer complexes with similar electrical properties, using new donor and acceptor molecules^{6,12-14}.

Metallic and superconducting organic solids consist of an ordered array of donor and acceptor species, which must contain at least one thermodynamically stable radical

ion¹³. The salt $\text{TTF}^+-\text{TCNQ}^-$ is an example of a complex containing two radical ions, where both components are open-shell species⁸. TTF and TCNQ are essentially planar molecules, enabling them to stack closely with each other, in the direction perpendicular to their molecular planes¹⁵. X-ray analysis of the crystal structure of the salt $\text{TTF}^+-\text{TCNQ}^-$ shows how the molecules are arranged within the crystal lattice¹⁵ (figure 1.2).

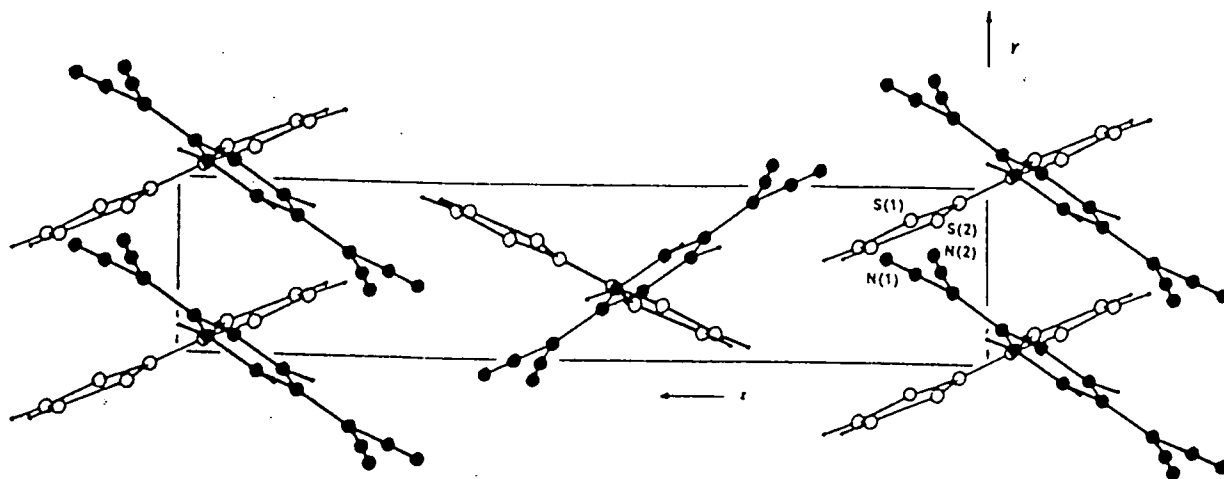

Figure 1.2 *Crystal Packing in TTF-TCNQ*

The crystal lattice consists of segregated stacks of TTF radical cations and TCNQ radical anions, arranged in parallel to optimise interstack interactions. The molecular planes of the molecules are tilted, giving rise to the “herringbone” conformation (figure 1.2). Conduction within the crystal lattice occurs along these stacks as π -molecular orbitals of neighbouring molecules overlap, creating a conduction band⁹. Crystals such as $\text{TTF}^+-\text{TCNQ}^-$ are termed one-dimensional (1D) metals due to their ability to conduct primarily along one crystallographic axis.

1.5.2 Band Theory

Conduction within a system arises from the movement of ions or electrons. When a large number of atoms or molecules congregate to form a crystalline solid or a polymeric chain, extensive overlap occurs between the outer electron orbitals, leading to the formation of energy bands. The formation of these bands, and their occupancy, may

lead to conducting, semiconducting or insulating properties within the system.

Metallic conduction is observed in systems possessing a partially-filled energy band. Electrons are promoted to higher energy states within the same band, hence conduction is attained under the influence of a small potential difference.

In insulating materials, the band gap between the fully occupied valence band and the empty conduction band is too large to be bridged by electrons, so conduction cannot take place. Semiconducting materials possess a somewhat smaller band gap, over which electrons can pass on thermal excitation (figure 1.3).

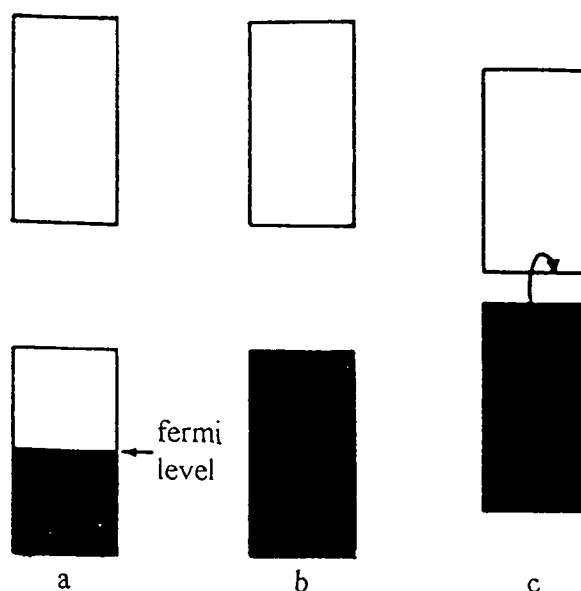

Figure 1.3 Band filling leads to; (a) metal; (b) insulator; (c) semiconductor.

1.5.3 The Peierls Distortion

1D systems are subject to distortions of electron density in the conduction band at lower temperatures, which gives rise to insulating properties¹⁶. This phenomenon, known as the Peierls instability, leads to a spontaneous transition at lower temperatures, from a metallic state to a semiconductor (Figure 1.4). The Peierls instability arises with the presence of a lattice distortion, where dimerisation of the molecular ions may occur

to produce an energetically more favourable state, allowing the formation of a filled band and an empty band at the Fermi level, separated by a band gap. At lower temperatures, electrons are unable to cross this energy gap, leading to a semiconducting state. At higher temperatures, thermal energy allows the electrons to be excited sufficiently to overcome this band gap. Low-dimensional packing of organic molecules therefore encourages the formation of insulating ground states at lower temperatures, adversely affecting the electronic properties of the system.

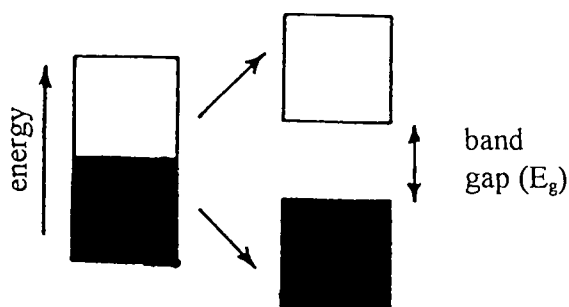
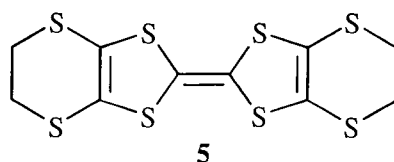

Figure 1.4 *Band Splitting - The Peierls Distortion*

Relatively strong intermolecular interactions between adjacent molecules, in two or three dimensions, are believed to reduce lattice distortions and hence to stabilise the metallic state at low temperatures.

1.5.4 BEDT-TTF: A Model for Increased Dimensionality

Several salts of bis-ethylenedithio-TTF (BEDT-TTF) (**5**) with inorganic anions are superconducting¹⁷ at temperatures below 12K. These salts were found to be two-dimensional materials (2D), *cf.* the 1D salt TTF⁺-TCNQ⁻. The conductivity observed in salts of BEDT-TTF is essentially isotropic in the plane of the molecular sheets, rather than in the direction of the stacks.



The extra sulfur atoms attached to the basic TTF framework in BEDT-TTF are able to participate in interstack interactions in addition to intra-stack interactions¹⁷. These inter- and intrastack interactions play a major role in minimising the Peierls distortion, thus optimising the electrical properties of the crystal lattice. Furthermore, the ethylene units are flexible, allowing each molecule to adopt a conformation which maximises intermolecular interactions within the crystal lattice, enabling closer packing of the molecules in the solid state.

1.6 Crystal Engineering

1.6.1 Definition¹⁸

‘The aim of crystal engineering is to establish reliable connections between molecular and supramolecular structure on the basis of intermolecular interactions.’

1.6.2 Intermolecular Interactions

Several factors influence the ways in which molecules pack within the crystal lattice of organic solids. These include Van der Waals forces, π - π stacking interactions, hydrogen bonding¹³, and other intermolecular interactions. All of these interactions are very weak compared to covalent bonds.

1.6.2.1 π - π Interactions

π - π Stacking interactions between adjacent molecules give rise to the formation of a energy band within the solid. These π - π intrastack interactions have been modified in several ways, by either changing the chalcogen atom in the parent molecule, or by extending the π conjugation of the TTF system¹⁹. This gives rise to a more polarisable system which should favour increased dimensionality.

1.6.2.2 Hydrogen Bonding

Hydrogen bonds play a pivotal role in the nature and dimensionality of crystal lattices^{20,21}. They are relatively strong in comparison to the weaker Van der Waals forces, and they are selective and directional, which are properties of great importance in the design of crystal systems. Numerous studies have been carried out into the syntheses and structural elucidation of salts containing functionalised TTF derivatives¹³. TTF has been derivatised with a multitude of substituent groups. In 1978, Green²² published the syntheses of several mono-substituted TTFs, which are summarised in scheme 1.2.

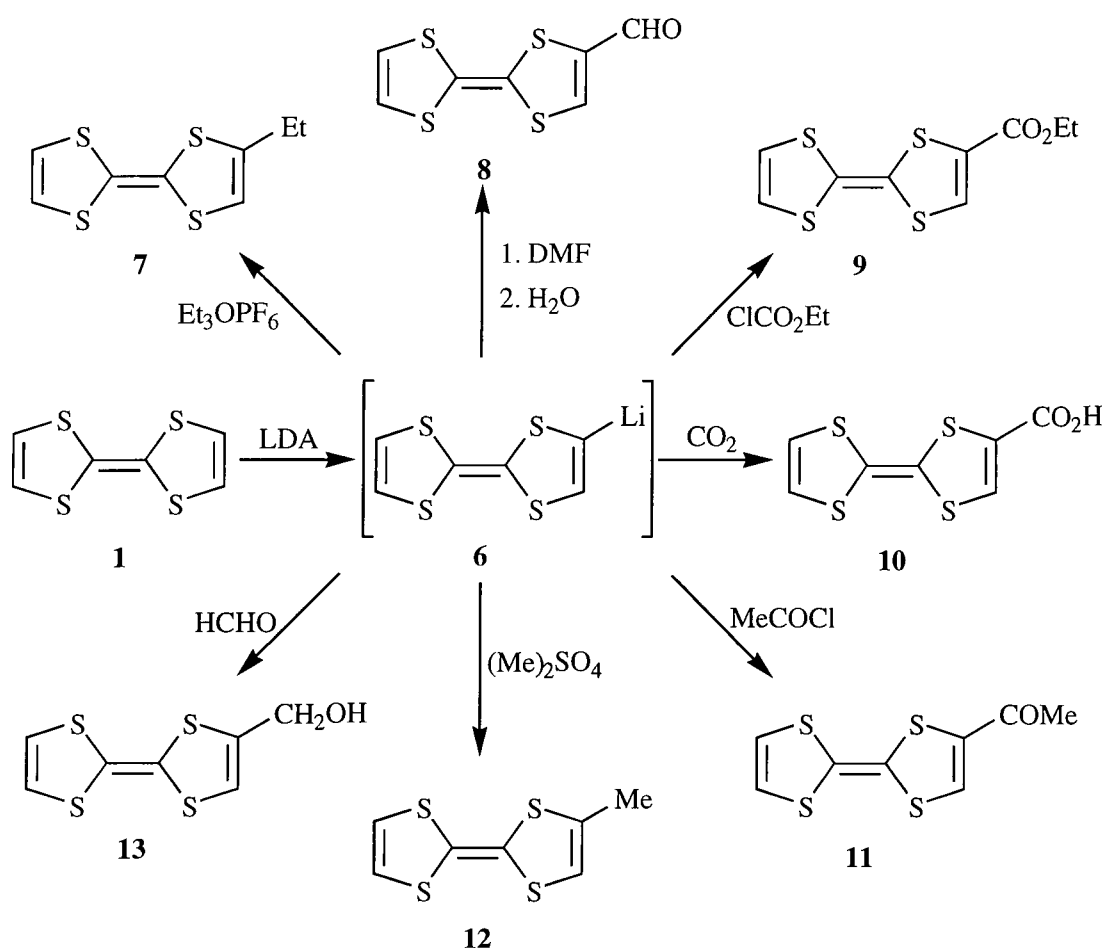

Scheme 1.2 Mono-substituted TTFs

Green also synthesised multi-substituted TTFs, and observed that both the reaction conditions, and the type of substituent group attached to the peripheral TTF framework, directly influenced the outcome of any further substitution reaction.

Bryce and co-workers²³ reported the first TTF derivatives containing thioamides, displaying interesting characteristics in terms of their crystal structures, obtained by X-ray analysis. The X-ray crystal structures of neutral compounds **14a** and **14b** showed the presence of weak intermolecular hydrogen bonding between N-H of a thioamido group, and the sulfur atom on an adjacent thioamido group (figure 1.5).

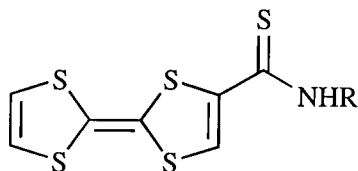

14a R = Ph

14b R = Me

In each case, weak S \cdots S contacts were also observed. However, different molecular stacking was observed for the two compounds. The N-(phenylthioamido) derivative **14a** (figure 1.5a) crystallised in segregated stacks, linked to molecules within the stack by thioamido hydrogen bonds, whilst links to adjacent stacks are formed by S \cdots S contacts. In contrast, the N-(methylthioamido) derivative **14b** (figure 1.5b) dimerised, each dimer packing in κ -fashion (the term used for orthogonal dimers), which are in turn linked to adjacent dimers *via* hydrogen bonding and S \cdots S contacts.

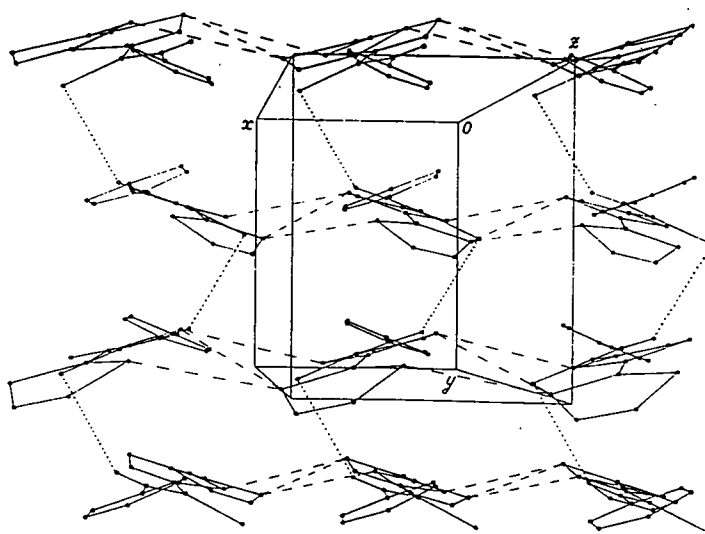

Figure 1.5a *N*-(phenylthioamido)TTF

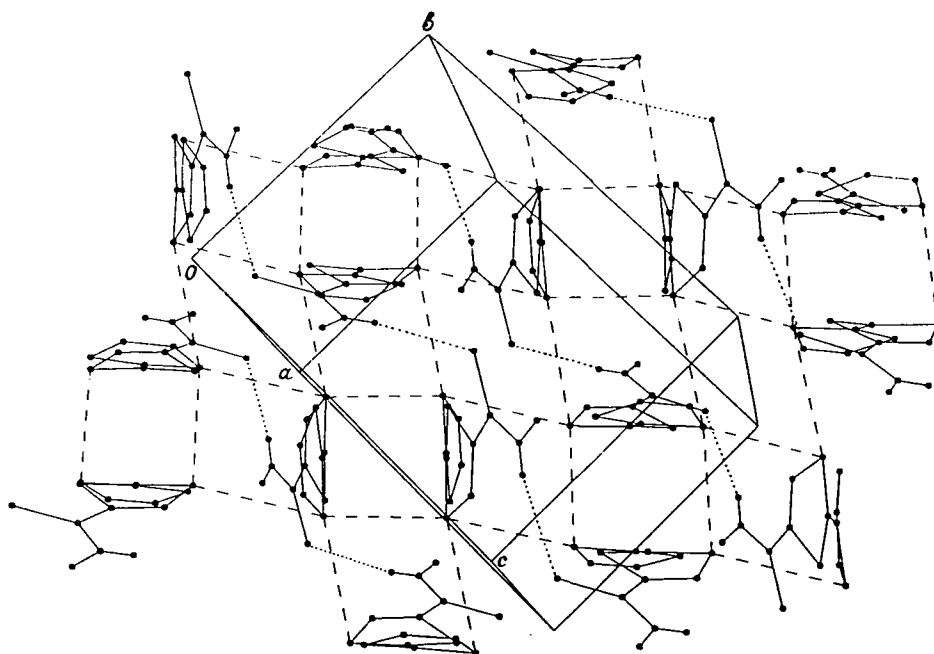

Figure 1.5b *N*-(methylthioamido)TTF

1.7 Halogenated TTFs: Rationale

Although many crystal structures of substituted TTFs have been elucidated, the way in which a particular TTF derivative will crystallise in the solid state remains unpredictable. Recent publications, some of which have appeared concurrently with our own work, have concerned the substitution of halogen atoms onto the TTF framework²⁴⁻²⁶.

At first sight it may seem counter-productive to attach an electronegative atom to a TTF molecule and thereby raise the oxidation potential as, in general, good donor molecules have low redox potentials. In the case of tetrachloro-TTF, the redox potential has been raised to a particularly high level²⁴, $E_{1/2}^1 = 0.94$ V, considerably reducing its donor capability (table 1.2).

Compounds ^a	$E_{1/2}^1/V$	$E_{1/2}^2/V$	$\Delta E=(E_{1/2}^2 - E_{1/2}^1)/V$
TTF	0.41	0.82	0.41
ITTF	0.48	0.90	0.42
4,5(4')-I ₂ TTF	0.58	0.96	0.38
Cl ₄ TTF	0.94	1.14	0.20
Br ₄ TTF	0.88	1.11	0.23
Cl ₂ Me ₂ TTF	0.62	0.98	0.36
Br ₂ Me ₂ TTF	0.58	0.94	0.36
I ₂ Me ₂ TTF	0.53	0.90	0.37
4,5-Me ₂ TTF	0.34	0.78	0.44

Table 1.2 Redox Potentials of Some Related TTF Derivatives²⁴.

Electrolyte solution: 0.1 mol L⁻¹ TBA·ClO₄ in PhCN; working electrode: glassy carbon; sweep rate: 100 mV s⁻¹; potentials are quoted vs. Ag/AgCl.

^a *Concentration: 2.5 x 10⁻⁴ mol L⁻¹.*

However, it is known²⁷ that the electronegativity of an iodine atom (2.21) is lower than that of a carbon atom (2.50), therefore iodine should not adversely affect the redox potential of the system. Furthermore, iodine and bromine atoms are soft, polarisable atoms, enabling them to form very close inter-molecular interactions between molecules within the crystal lattice[†].

[†]Conceptually this approach is comparable to the replacement of the sulfur atoms in TTF with other group VI atoms such as Se or Te, which has been widely explored³³. It is known that these larger, more polarisable chalcogens are able to stabilise radical cations more effectively than sulfur, and give greater orbital overlap, affording wider conduction bands. Tetraselenafulvalene (TSF) and tetratellurafulvalene (TTeF) have been used with promising results. Unfortunately, compounds containing Se and Te are difficult to synthesise and are frequently very insoluble, so research into them has its limitations. Most research, therefore, is based on sulfur-containing donors such as BEDT-TTF.

We reasoned that it should be possible to reach a compromise between optimisation of the dimensionality of the crystal structure, and retention of an acceptable oxidation potential in the substituted TTF, by limiting the number and type of halogen substituents attached to the parent TTF molecule.

1.8 Halogenated TTFs: Recent Developments

The synthesis of halogenated TTFs, particularly those containing bromine and iodine, has become a rapidly expanding area of interest in TTF chemistry. Several syntheses have been published, some of which are noted below.

Becker *et al.*^{24,28} synthesised several TTF derivatives bearing iodine and bromine substituents, the most notable of which are 4,5-dibromo-TTF (**15**) and 4,5-diiodo-4',5'-dimethyl-TTF (**16**). The X-ray crystal structure of **16** established the displacement of the two iodine atoms from the plane of the TTF, indicating the presence of close intermolecular contacts.

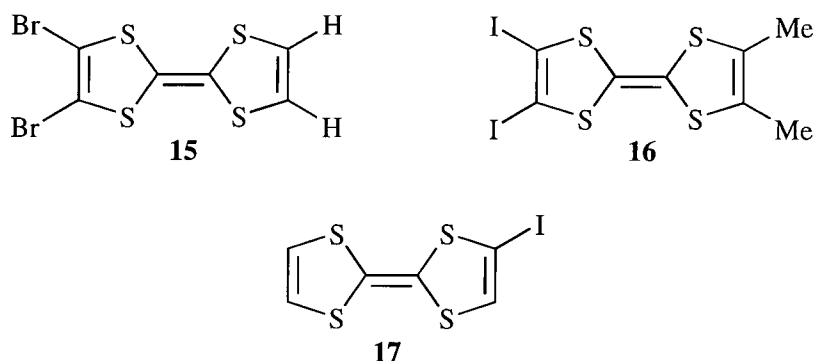

Bryce and co-workers²⁹ recently reported the synthesis and X-ray crystal structures of two radical cation salts of 4-iodotetrathiafulvalene (**17**), including that of the radical cation salt $[\text{ITTF}^+]_2\{\text{Pd}[\text{S}_2\text{C}_2(\text{CN})_2]_2\}^{2-}$ (figure 1.6).

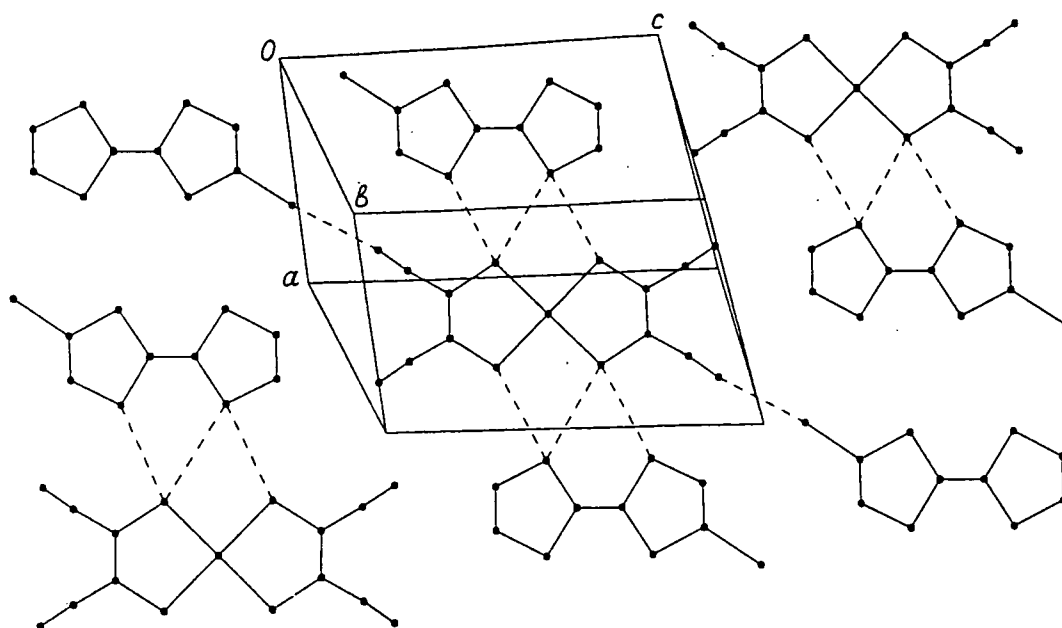

Figure 1.6

Calculation of the linear C-I...N-C interlayer contact showed that the distance observed was much shorter than the sum of the Van der Waal's radii. This evidence suggests that the iodine substituent contributes significantly to intermolecular interactions.

Imakubo *et al.*³⁰ reported the synthesis and characterisation of several novel halogen-based TTF systems, and elucidated the X-ray crystal structure of a radical cation salt of iodoethylenedithio-TTF, (IEDT - TTF)₂Br (figure 1.7). Strong I...Br...I interactions were observed, showing two TTF molecules bridged by a single bromide anion. Furthermore, both TTF molecules had parallel alignment, forming displaced stacks along one crystallographic axis. These strong and directional cation - anion interactions significantly reduced inter and intraplanar distances along the molecular axis.

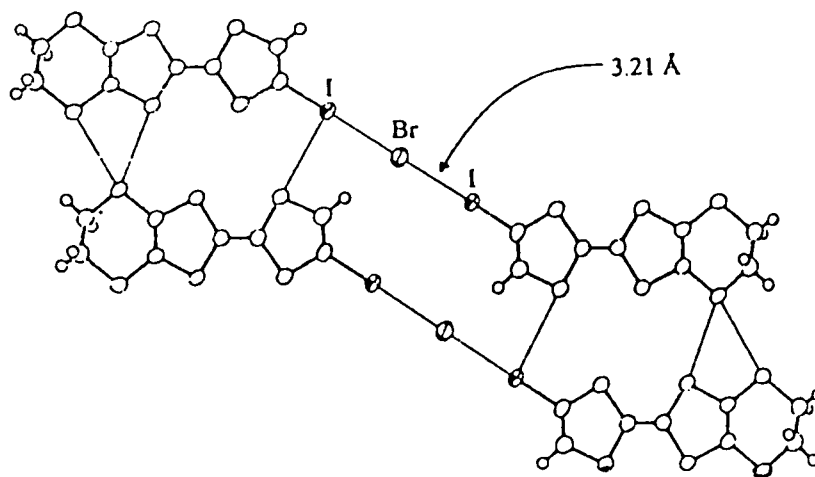

Figure 1.7

These studies into the effects of halogenated TTF derivatives on intermolecular interactions in the solid state have offered a novel route to the control of dimensionality within the crystal lattice.

1.9 Aims of This Project

The initial aim of this project is to synthesise and study the characteristics of novel TTF molecules bearing halogen substituents. This project is primarily concerned with mono- and bis-substitution on the basic TTF framework, using iodine and bromine atoms.

Chapter 2

Results and Discussion

Results and Discussion

2.1 Introduction

In chapter one, the possible advantages offered by halogenation of TTF in providing an opportunity to control the dimensionality, band filling and molecular assembly of charge-transfer complexes with suitable acceptor molecules were discussed. Previously reported TTFs were used to illustrate how this might be achieved.

There are two main routes to the synthesis of substituted TTFs.

A) The *inter*-molecular coupling between various 1,3-dichalcogenole-2-chalcogenones to form the desired TTF (scheme 2.1).

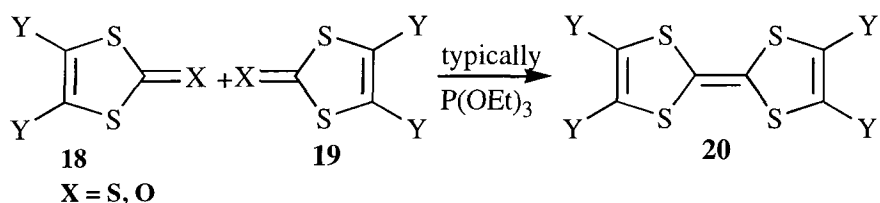

Scheme 2.1

This method is useful in the synthesis of symmetrical and unsymmetrical TTF molecules.

B) Lithiation of the TTF framework to abstract a proton, followed by electrophilic substitution²² (scheme 2.2). The TTF involved may be TTF itself, or a substituted derivative, such as trimethyl-TTF.

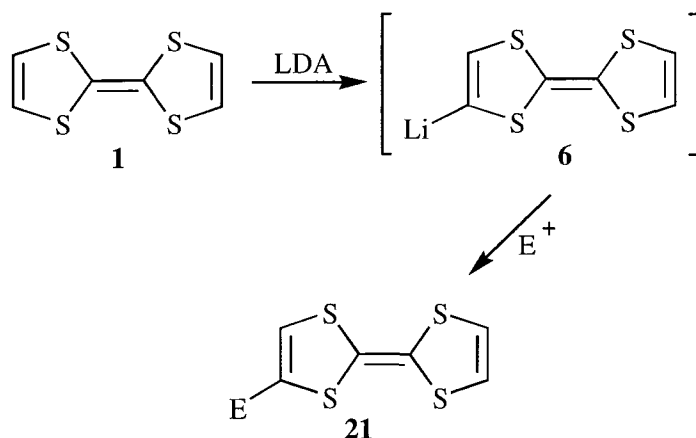

Scheme 2.2

This lithiation method is a widely used route to the synthesis of mono-substituted TTFs, and procedures are well-documented in the literature⁹.

2.2 Novel TTF Systems

With the rationale behind such efforts in mind, the synthesis of target compounds **22** - **25** was proposed.

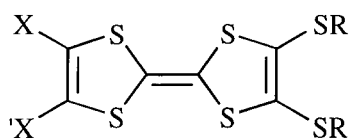

22a X = X' = I

22b X = I, X' = H

R = Me, Et

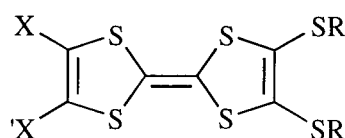

23a X = X' = Br

23b X = Br, X' = H

R = Me, Et

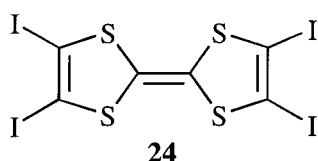

24

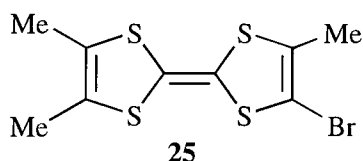

25

2.3 Synthesis of Compounds **22** and **23**

Method A was employed to synthesise **22** and **23**. Compounds **22** and **23** incorporate two halogen atoms on one dithiolenes ring of the TTF framework, whilst the other dithiolenes ring possesses two alkylthio groups. It was anticipated, as discussed in chapter one, that the presence of one or two halogen atoms would not cause large changes in the redox potential of the TTF system²⁴, allowing the molecule to form its radical cation and dication with reasonable ease, thereby enabling formation of charge-transfer complexes with suitable counter ions.

2.3.1 Proposed Route to **22** and **23**

The proposed synthetic route to compounds **22** and **23** is illustrated in scheme 2.3.

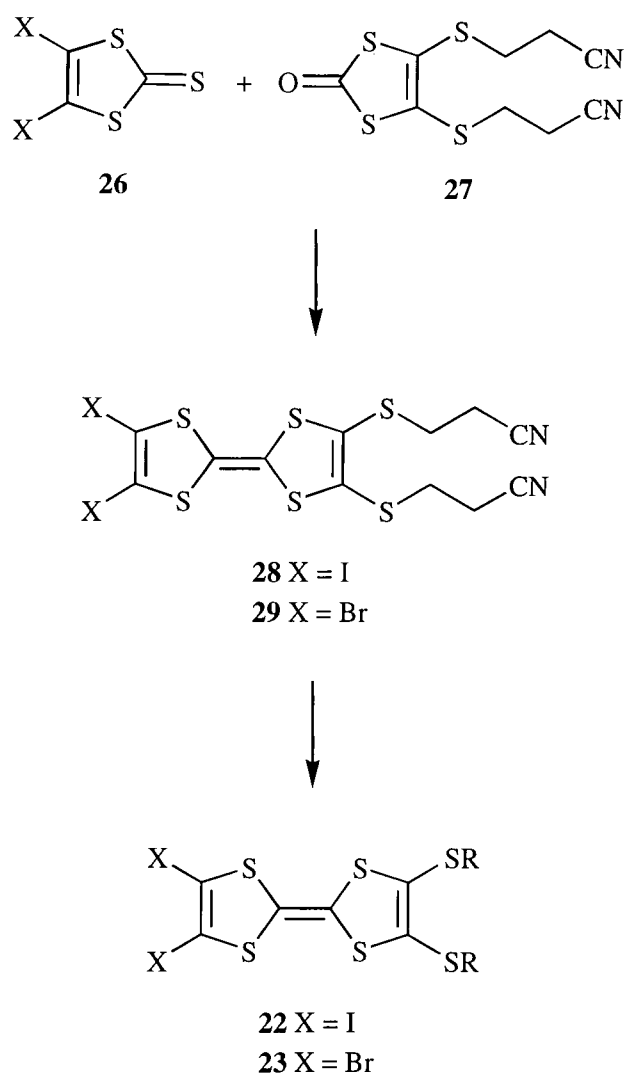

Scheme 2.3

Compounds **22** and **23** may be obtained directly from the new TTF systems **28** and **29**. The protection of the peripheral sulfur atoms in **28** and **29** with the cyanoethyl group should readily allow access to a wide variety of functionalised systems. The cyanoethyl group can be selectively removed by the addition of a base such as caesium hydroxide, liberating the free thiolate which can be trapped *in situ* by suitable electrophiles,^{31,32} eg. MeI. Use of the cyanoethyl protecting group has significant practical advantages over other protecting groups.

(1) On deprotection of the peripheral sulfur atoms, the liberated by-product, acrylonitrile, is easily removed *in vacuo* at low temperatures, thus simplifying work-up procedures.

(2) The presence of the cyanoethylthio side chain allows better separation, *via* column chromatography, of the cross-coupled products **28** and **29** from by-products (notably self-coupled compounds) formed in the reaction.

This synthesis involves an *inter*-molecular coupling between a 1,3-dithiol-2-thione (**26**) and the bis-protected 1,3-dithiol-2-one (**27**), to obtain the desired tetrathiafulvalenes **28** and **29**. The desired 1,3-dithiol-2-thione is synthesised from vinylene trithiocarbonate (**30**), which is prepared *via* the multistep reaction described below³³ (scheme 2.4).

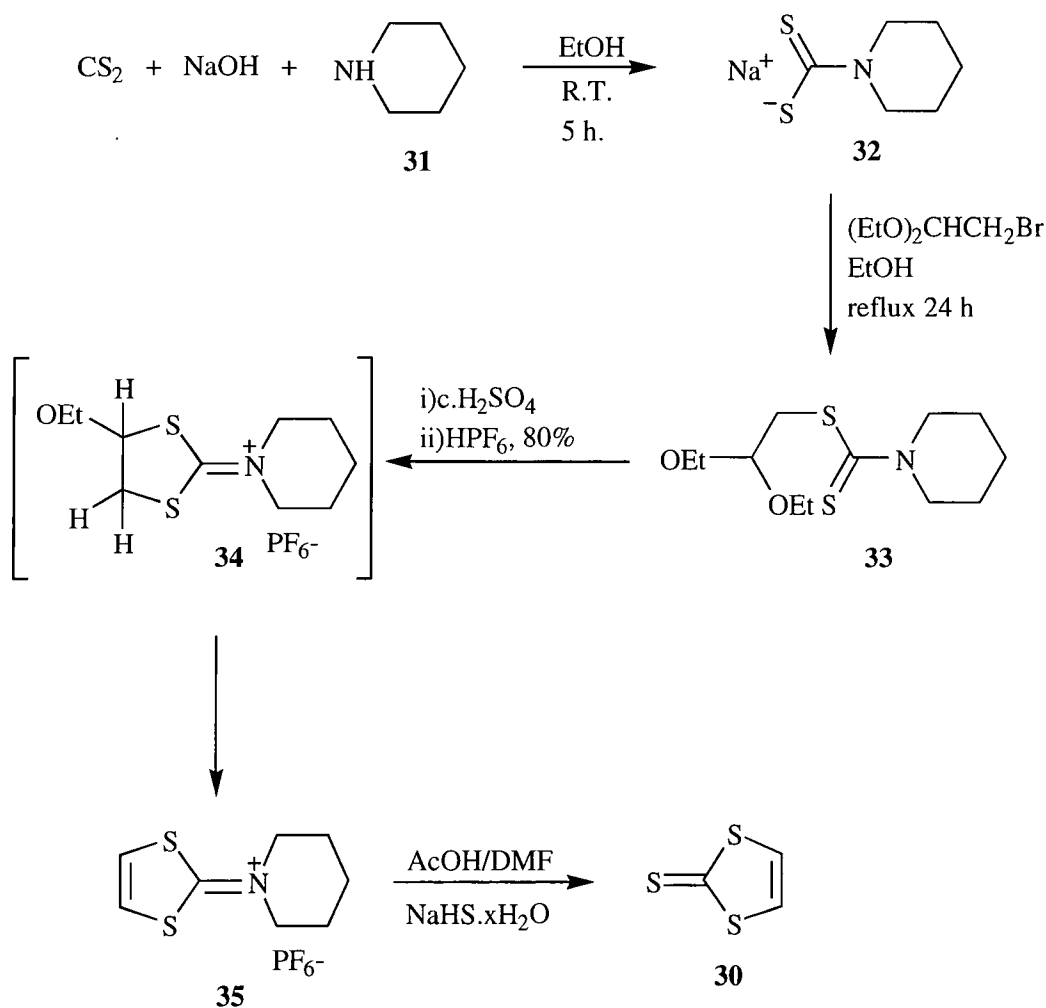

Scheme 2.4

2.3.2 Intermolecular Coupling Method to Tetrachalcogenafulvalenes

As outlined above, the formation of TTFs **28** and **29** was achieved *via* the *inter*-molecular coupling of two 1,3-dichalcogenole-2-chalcogenones **26** and **27**. Several reagents have been successfully utilised in *inter*-molecular coupling reactions to give both symmetrical and unsymmetrical TTF molecules^{31,32}. Coupling reactions involving carbonyl compounds such as dicobalt octacarbonyl^{34a-c} or triiron dodecacarbonyl³⁵ have been widely explored. Disadvantages of methods employing carbonyl reagents are that the yields of products obtained are somewhat unpredictable, and they are difficult to carry out.

In some reactions where both 1,3-dichalcogenole-2-chalcogenones are highly reactive e.g. when they have been converted to their corresponding cationic salts, it is sufficient to use a weak base such as triethylamine. However, the application of this method is limited.

The most effective methods employ the use of trivalent phosphorus reagents *i.e.* trialkylphosphines, triarylphosphines, trialkylphosphites and triarylphosphites^{36,37}. Numerous syntheses of TTFs employing *inter*-molecular phosphite-mediated couplings have been reported³⁸. These reactions are relatively simple to carry out, and yields are usually good. However, results are very sensitive to factors such as reaction conditions, the nature of the substituents on the 1,3-dichalcogenole-2-chalcogenone system, and the solubility of the final product. It is noteworthy that target compound **24** has been prepared from 4,5-diiodo-1,3-dithiol-2-thione (**36**) by such a method³⁹ (scheme 2.5).

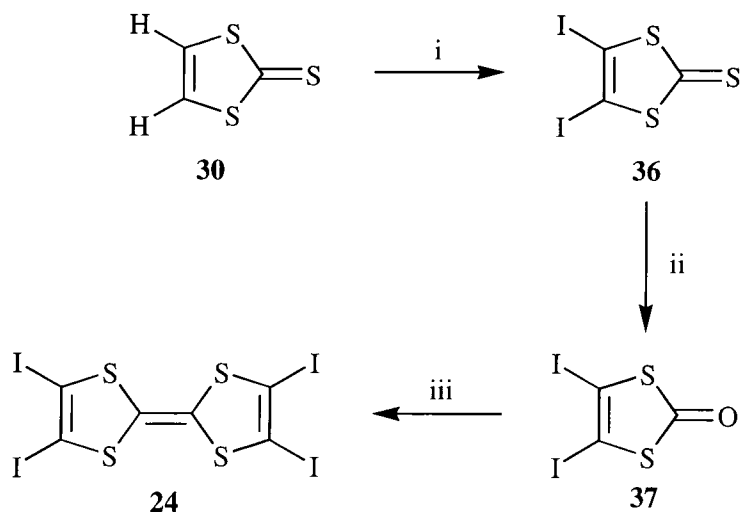

- i LDA, THF, TsI
 ii Hg(OAc)₂, CHCl₃ / AcOH
 iii (EtO)₃P, PhMe, 16 h, 110°C

Scheme 2.5

The coupling of two non-identical 1,3-dithiol-2-(thi)one units can result in a mixture of products being produced^{31,36}. Whilst it is impossible to prevent some self-coupling from taking place, steps can be taken to minimise this problem. For example, a high stoichiometric excess of one component often affords the desired product in high yield, with very little self-coupling of the limiting reagent taking place.

2.3.3 4,5-Diiodo-1,3-dithiol-2-thione

Initially, it was decided to synthesise 4,5-diiodo-1,3-dithiol-2-thione (36) according to the literature method³⁹ (scheme 2.5). These attempts, using *p*-toluenesulfonyl iodide⁴¹ as the source of electrophilic iodine, were however unsuccessful, possibly due to decomposition of *p*-toluenesulfonyl iodide in the presence of light, making it difficult to obtain a compound of high purity. This reaction was attempted using two solvents (THF and Et₂O), and with lithiation times ranging from 1 h to 6 h. Under all the conditions used, no product was identified or isolated despite the appearance of new materials by TLC. It was noted that, once work-up of the reaction

mixture had commenced, the products began to decompose rapidly. This approach was discontinued, and commercially-available iodine monochloride was used as the halogenating agent. Under the conditions outlined in scheme 2.6, two products were isolated in low yields, shown to be **36** and **39**, which decomposed rapidly in the presence of light. Since this work was carried out, a similar synthesis has been reported elsewhere⁴².

Attempted lithiation of **39** with lithium diisopropylamide, followed by halogenation (ICl) proved unsuccessful and, on one occasion, decomposition of **39** was observed.

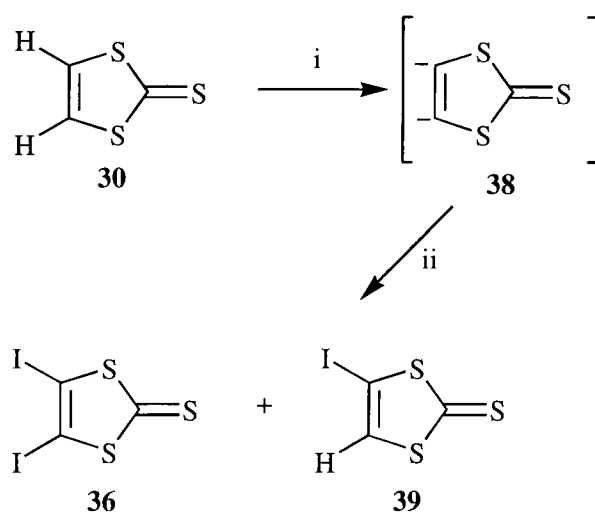

i LDA, -78°C , 3 h

ii TsI or ICl, -78°C - r. t.

Scheme 2.6

It is noteworthy that the observed melting point of **36** was found to be 161 - 162 $^{\circ}\text{C}$, which is very different from the value published by Gompper³⁹ *i.e.* 128 $^{\circ}\text{C}$. Furthermore, Garin⁴³ also observed a similar value to our observed melting point. In all cases, ^{13}C -NMR and elemental analyses suggested that **36** was isolated in high purity. It could be postulated that **36** decomposes to **39** on heating, hence the melting point, perhaps of a mixture of compounds, observed by Gompper is lower than the real value

for **36**.

2.3.4 4,5-Dibromo-1,3-dithiol-2-thione

An analogous route to the above was proposed for the synthesis of 4,5-dibromo-1,3-dithiol-2-thione (**40**) and 4-bromo-1,3-dithiol-2-thione (**41**), two previously unreported compounds (scheme 2.7). For the synthesis of **40** and **41**, the more stable *p*-toluenesulfonyl bromide was employed as the electrophilic source of bromine. This reagent was readily prepared from bromine water and sodium toluene-4-sulfinate by a literature procedure⁴¹, and two products, **40** and **41**, were isolated in low yields.

Later attempts, employing 1,2-dibromotetrafluoroethane as the brominating agent, gave slightly improved yields and products of high purity. It was noted that compounds **40** and **41** readily decomposed over 24 h when exposed to light.

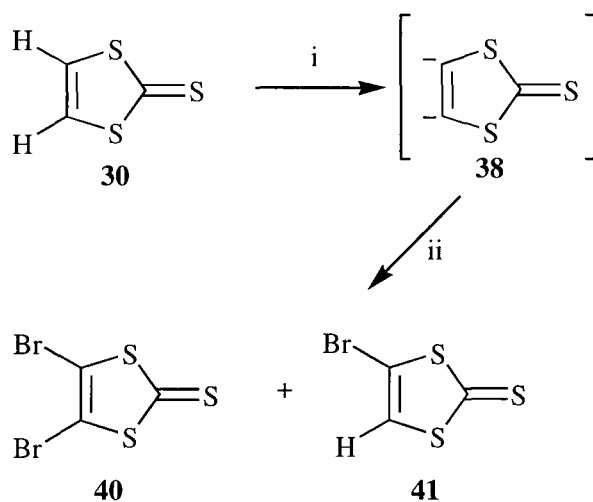

i LDA, -78°C, 3 h

ii TsBr or 1,2-Dibromotetrafluoroethane

Scheme 2.7

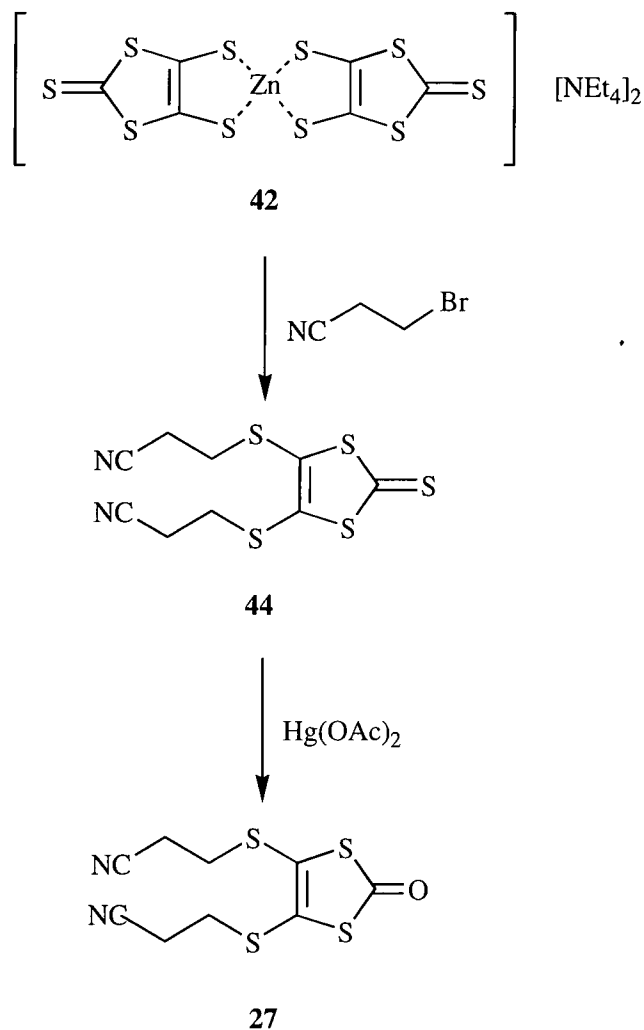

Scheme 2.9

2.3.6 Coupling Reactions

The synthesis of **28b** via *inter*-molecular coupling of **27** and **39** was attempted, employing triethyl phosphite as the coupling agent. Initially, a solution of **27** and **39** in neat triethyl phosphite was used. Investigation of the products obtained (after removal of the triethyl phosphite and purification through a plug of silica gel) showed that *ca.* 50 % loss of iodine had occurred (NMR evidence) (scheme 2.10i). Milder conditions (five equivalents of phosphite in a solution of toluene) did, however, afford the desired product **28b** in moderate yield (scheme 2.10ii).

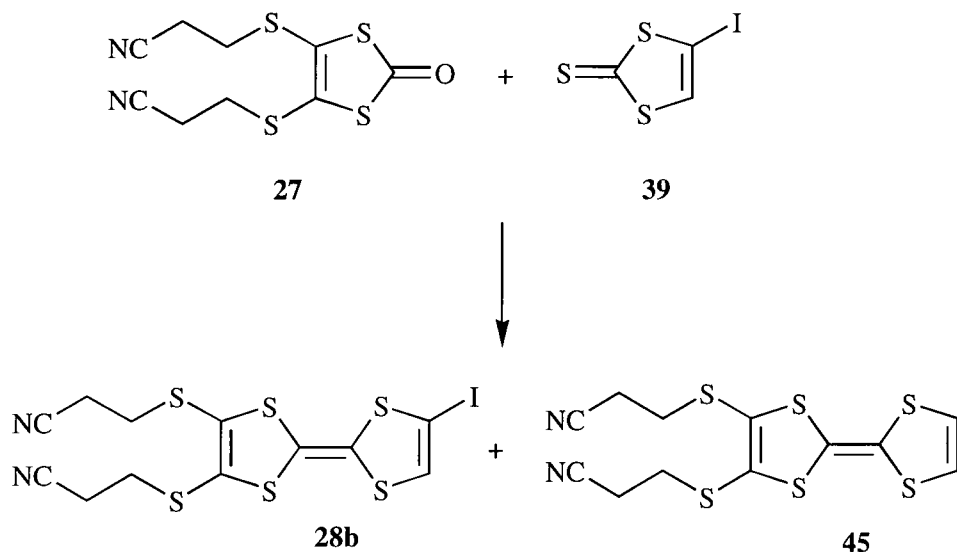

ratio 28b :45

i 1 : 1

ii 1 : 0

Scheme 2.10

Refluxing a solution of **39** in toluene under argon for 5 h lead to no decomposition (NMR evidence), indicating that decomposition was occurring as a result of the presence of triethyl phosphite in the mixture.

The *inter*-molecular coupling of **27** and **36** was also attempted, using the milder conditions described above. The desired product **28a** was obtained in low yields, along with trace amounts of **28b** and **45** (scheme 2.11).

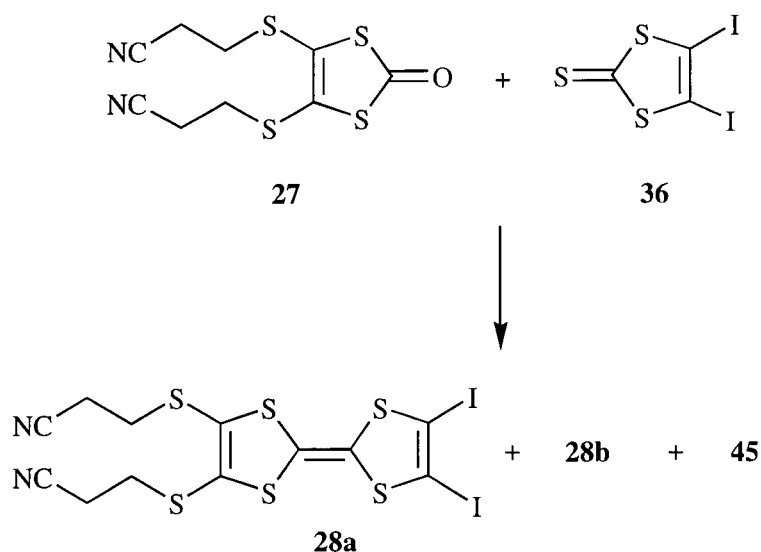

Scheme 2.11

A similar approach was used in the synthesis of **29a** and **29b**, by coupling of **27** and **40**: the major product obtained after purification by column chromatography was shown to be **29a**. In all reactions, trace amounts of **29b** were observed by TLC, indicating a relatively small loss of bromine had taken place.

The loss of iodine in the synthesis of **28a** and **28b**, and the less extensive loss of bromine observed in the synthesis of **29a**, may be attributed to the comparatively weaker carbon - iodine bonds present in the former.

X-ray crystallographic studies of crystals of **29a** showed a nearly planar TTF moiety, with only a small folding along the S(1)...S(2) and S(3)...S(4) vectors (2.6 and 6.7°, respectively) (Figure 2.1).

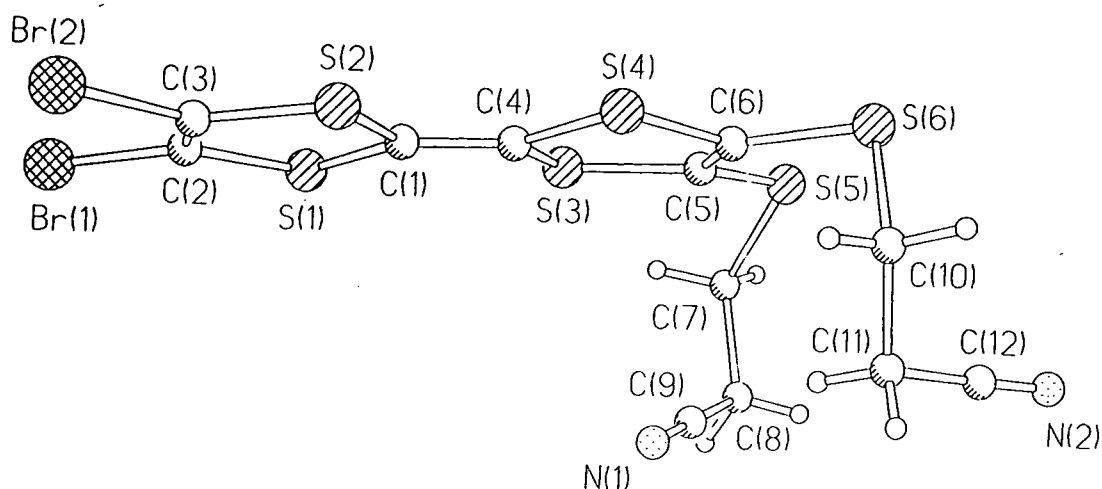

Figure 2.1

Furthermore, the molecules form no continuous stacks in the structure (Figure 2.2). Interestingly, there are no contacts whatsoever between bromine atoms and cyano groups. One of the shortest intermolecular contacts S...Br 3.68 Å is slightly longer than the average for a “normal” Van der Waals contact⁴⁷ (3.67 Å). The only shortened contact is the Br(1)...Br(2') one of 3.57 Å (*cf.* the standard of 3.70 Å).

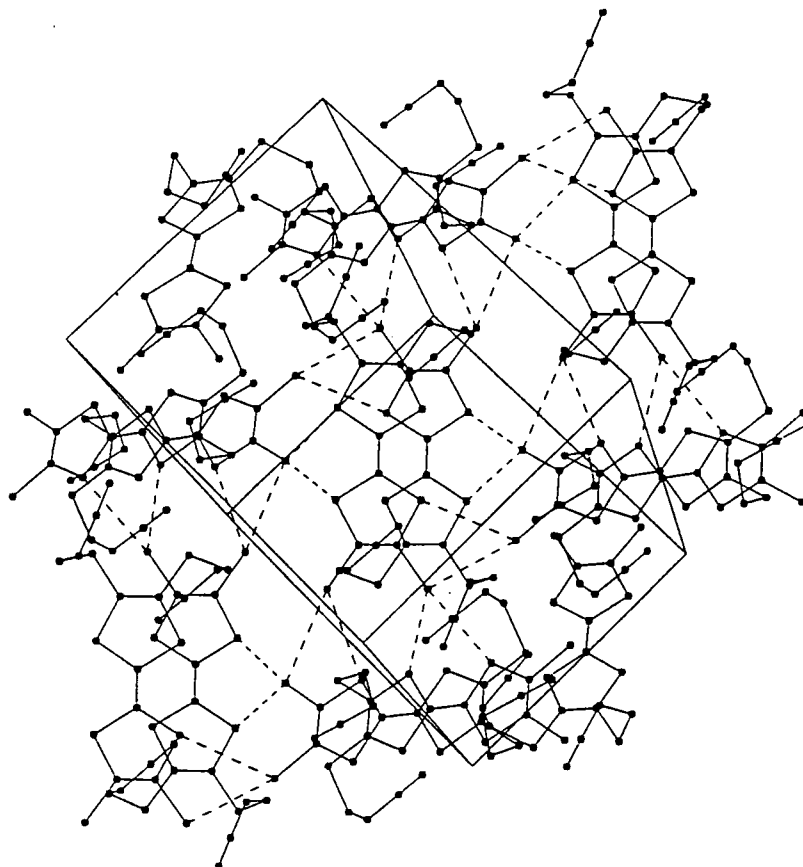
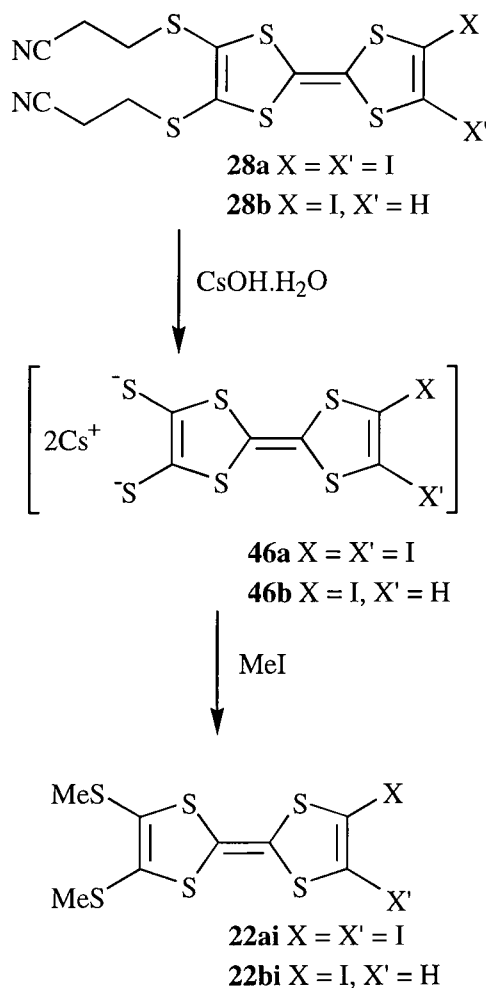

Figure 2.2

2.3.7 Target Compounds 22 and 23

Compounds **22** and **23** were readily obtained from **28** and **29**. Initial attempts at the deprotection and subsequent alkylation of **28a** and **28b** used a methanolic solution of cesium hydroxide monohydrate to selectively deprotect the cyanoalkyl group. The dithiolate formed was trapped with iodomethane to afford compound **22ai** and **22bi** (scheme 2.12).



Scheme 2.12

The resulting mixture of products obtained from these reactions primarily contained baseline materials, with minute quantities of the product present. Later work, carried out in our group by A. Chesney using this procedure, improved the yields of product **22ai**.

In concurrence with our own work, Imakubo *et al.*⁴² published details of the synthesis and properties of several TTF derivatives bearing iodine substituents, including compounds **36** and **39** which employed iodine monochloride as the iodinating agent. Imakubo observed that attempted cross-coupling of **36** and **39** with other 1,3-dichalcogenole-2-chalcogenones always resulted in some loss of iodine. Furthermore, the variations of yield and ratio of products observed was shown to be dependent upon the reactivities of the starting materials and the solubilities of the products. He also

observed that iodo-TTFs formed radical cation salts⁴⁸.

Conversion of **29ai** to **23ai** was carried out using the same method as for compound **22** (scheme 2.13). The dithiolate was trapped with iodomethane to afford **23ai**.

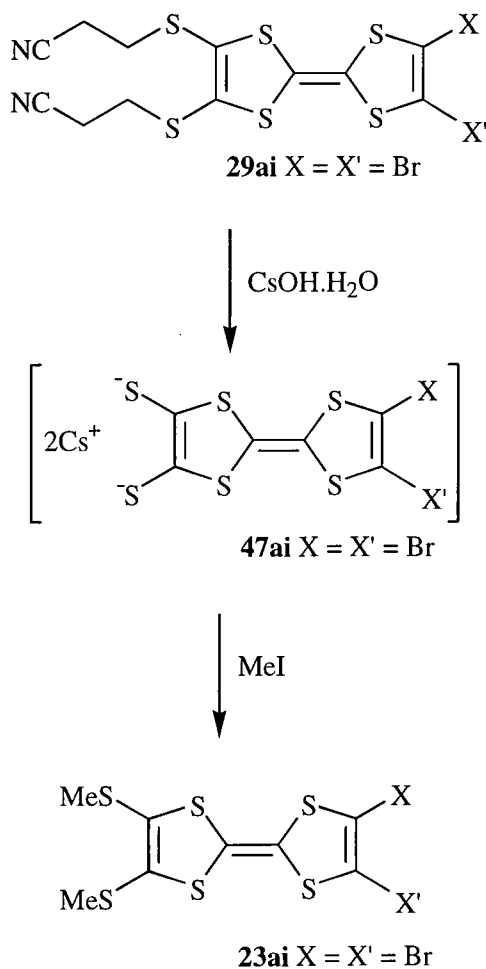

Scheme 2.13

While our work was in progress, Iyoda *et al.*⁴⁹ published details of the synthesis of **22ai**, **22bi** and **23ai**, using a different method to that shown above (scheme 2.14). Direct halogenation of bis(methylthio)tetrathiafulvalene (BMT-TTF) (**70**) gave higher yields of products (50%, 10% and 76% respectively).

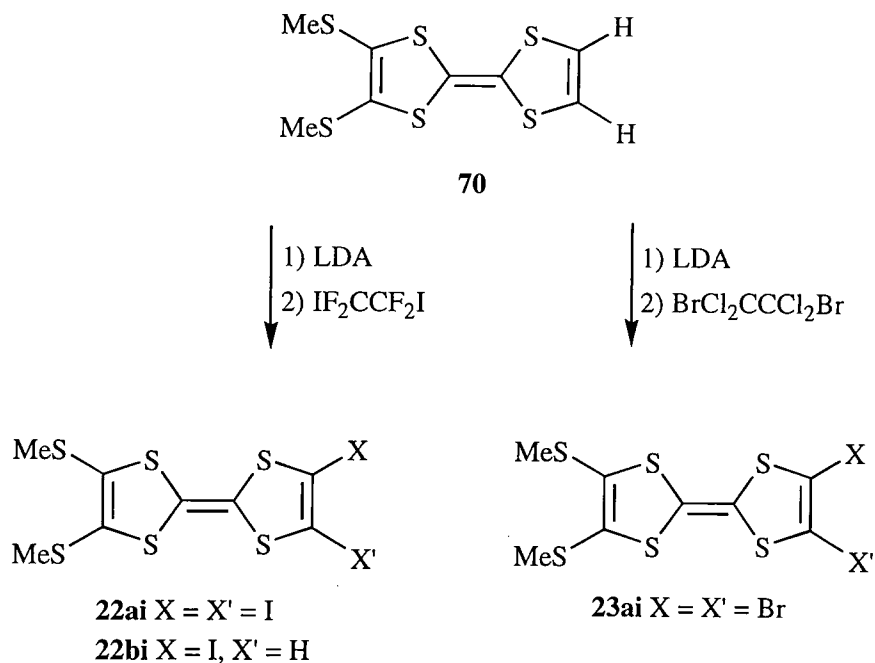

Scheme 2.14

Furthermore, a triiodide salt of donor **23ai** (1 : 1 stoichiometry) was prepared electrochemically, and its structure determined. In collaboration with Chesney and Batsanov in our group, we characterised the same salt **23ai**⁺ I₃⁻ which we obtained by simpler diffusion methods. The crystal structure (Figure 2.3) shows cations and anions in strictly planar layers with short Br ... I (3.604-3.872 Å) and S ... I (3.719-3.774 Å) contacts, while mixed stacks (interlayer separation of 3.55 Å) exist in the perpendicular direction.

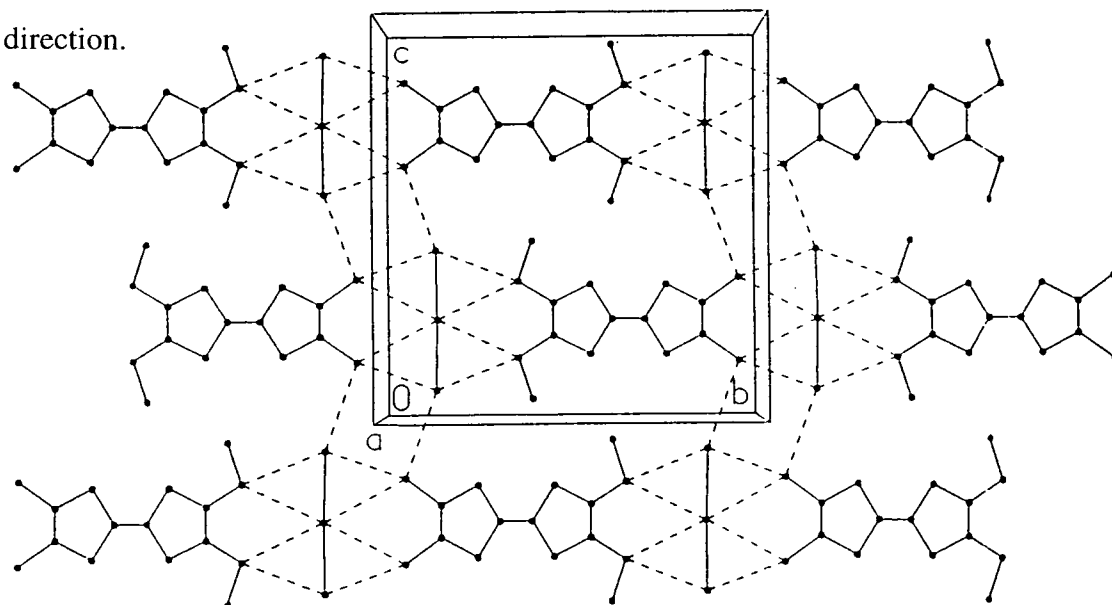
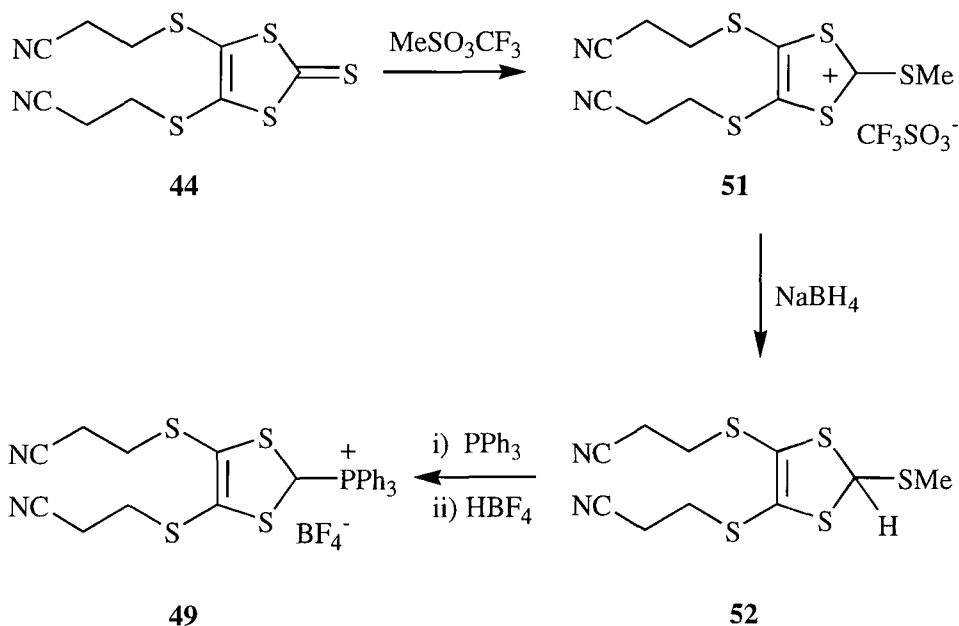
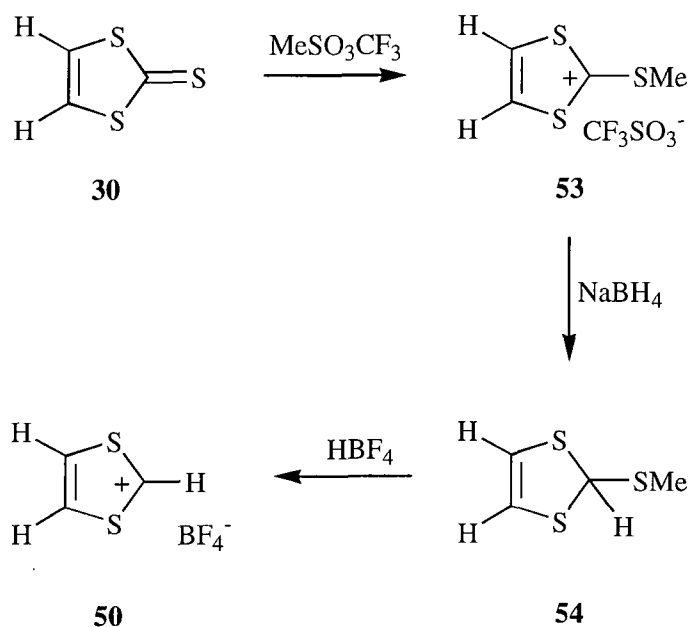

Figure 2.3



Scheme 2.16

Similarly, **30** was treated with methyl trifluorosulfonate. The cation was reduced using sodium borohydride to give compound **54**, followed by formation of the tetrafluoroborate salt from **54**⁵⁰ (scheme 2.17).



Scheme 2.17

Cations **49** and **50** were coupled together according to the literature route³⁶, using the weak base triethylamine as the coupling agent to give compound **45** in good yield (scheme 2.18).

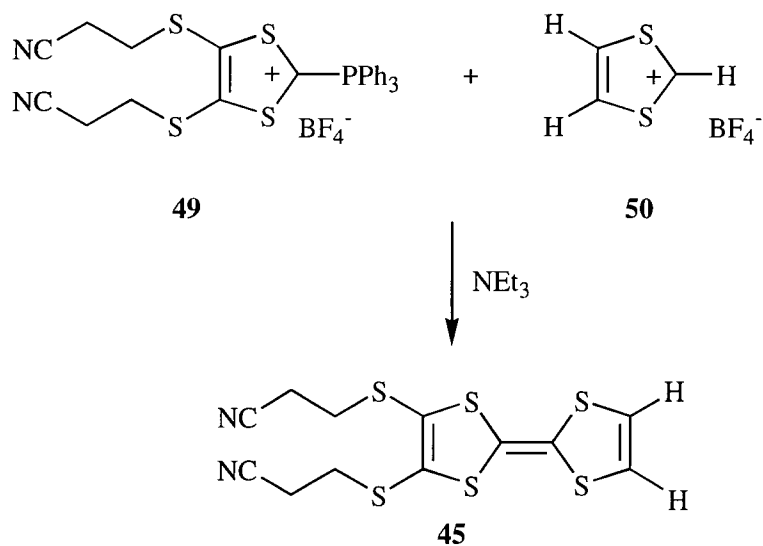

Scheme 2.18

Compound **45** was used to synthesise non-halogenated analogues of compounds **22** and **23**. Synthesis of the new compounds **55** and **56** was carried out, by analogy the synthesis of compounds **22** and **23** (schemes 2.13, 2.14).

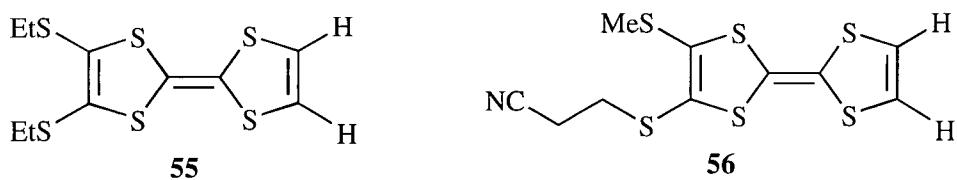

The synthesis of the analogous compound **71** is described in the literature⁵¹.

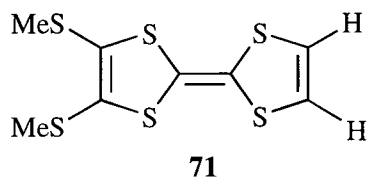

2.5 Synthesis of Compounds **24** and **25** (Method B)

The synthesis of halogenated TTFs can also be achieved by direct lithiation of TTF and its derivatives, followed by halogenation with an appropriate electrophile²². The proposed synthetic route to compounds **24** and **25** based on such methodology is illustrated in scheme 2.2.

The degree of electrophilic substitution on TTF is dependent upon the extent to which lithiation takes place²². At ambient temperatures, TTF-Li disproportionates to TTF-(Li)₂ and TTF, giving rise to multi-substituted products. It is essential, therefore, to maintain a low reaction temperature in order to synthesise one or two compounds only. The synthesis of compound **24** was attempted *via* the direct lithiation of TTF, using a large excess of LDA to favour complete substitution, followed by iodination (ICl) (scheme 2.19).

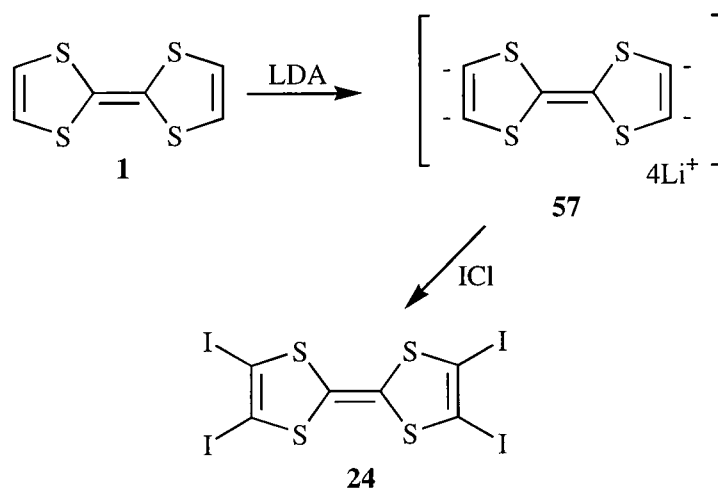

Scheme 2.19

Initial results were disappointing, giving a low yield of products after six attempts (average yield = 4 %). From communications with other workers in this field⁵², it was ascertained that the reaction is very time- and temperature-dependent. Initially, the reaction was carried out at -78 °C over 1 - 3 h. Modification of the reaction conditions, carrying out the lithiation at -50 °C over only 1 h, afforded an improved yield of red, micro-crystalline needles, thought to be tetraiodo-TTF (**24**) (scheme 2.19).

Evidence obtained points to the presence of some triiodo-TTF (**58**). Attempts to purify this mixture have so far proved unsuccessful.

Trimethyl-TTF (**59**) has been used as an alternative to TTF⁵³ as it has two important advantages over TTF.

- 1) It possesses only one replaceable proton, thus allowing only mono-lithiation to occur.
- 2) Trimethyl-TTF (**59**) has a lower redox potential than TTF [viz. TTF (**1**), $E_{1/2}^1$ 0.34 V; TriMe-TTF (**59**), $E_{1/2}^1$ 0.29 V]. The introduction of a halogen atom to the TTF framework raises the redox potential of the system, so halogenated trimethyl-TTF should have a redox potential similar to that of TTF itself.

Several derivatives of trimethyl-TTF are known⁵³, including aldehyde, ester and thioalkyl derivatives, and the synthesis of iodotrimethyl-TTF (**60**) was carried out in 21% yield⁵⁴ (scheme 2.20).

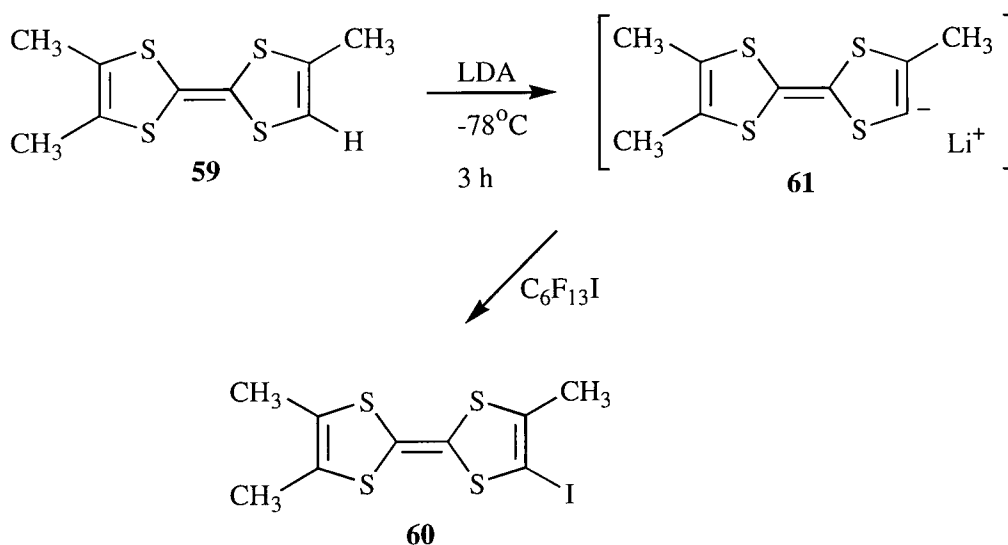

Scheme 2.20

Subsequent to this, **25** was synthesised in moderate yield, employing several different halogenating agents (scheme 2.21). It was noted that *p*-toluenesulfonyl bromide and 1,2-dibromotetrafluoroethane gave the best results.

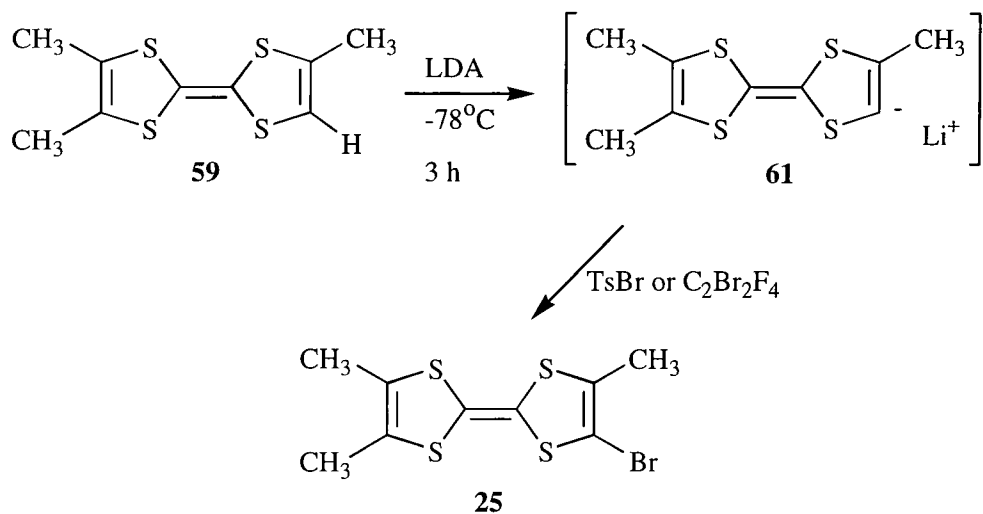

Scheme 2.21

Two salts based on **25** were made, **62** and **63**, using the acceptor species TCNQ (**2**) and dibromo-TCNQ (**64**) (schemes 2.22, 2.23). The salts obtained were both shown to have a 1 : 1 stoichiometry by elemental analysis. Based on the nitrile absorption frequency in the IR spectra⁵⁵ (2200 cm^{-1} and 2208 cm^{-1} for **62** and **63**, respectively) we believe there is a significant amount of charge-transfer from donor to acceptor in both complexes (neutral TCNQ, $\nu_{\text{max}} 2220$; anionic TCNQ, $\nu_{\text{max}} 2185 \text{ cm}^{-1}$). Attempts at growing crystals of these salts were unsuccessful.

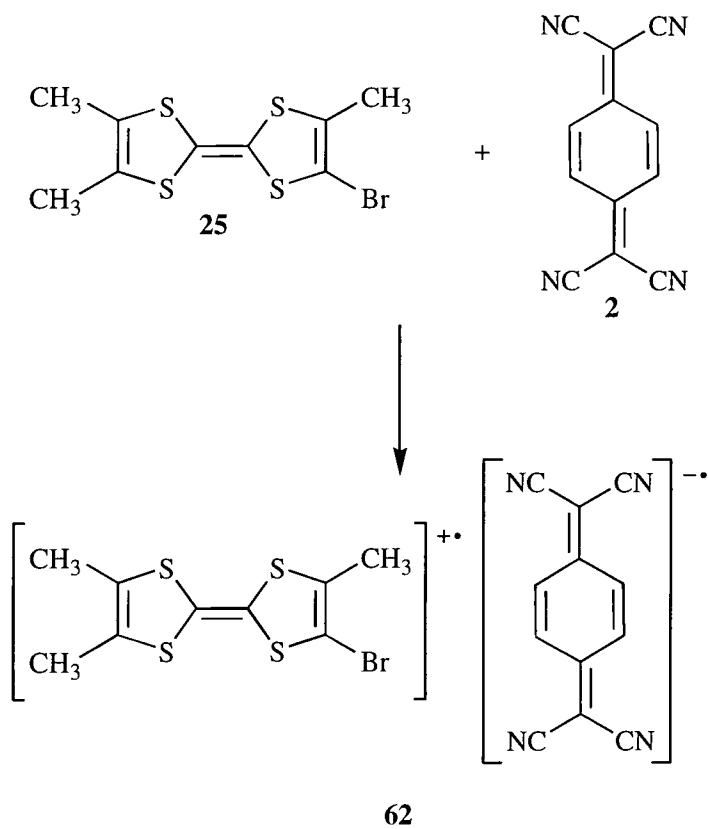

Scheme 2.22

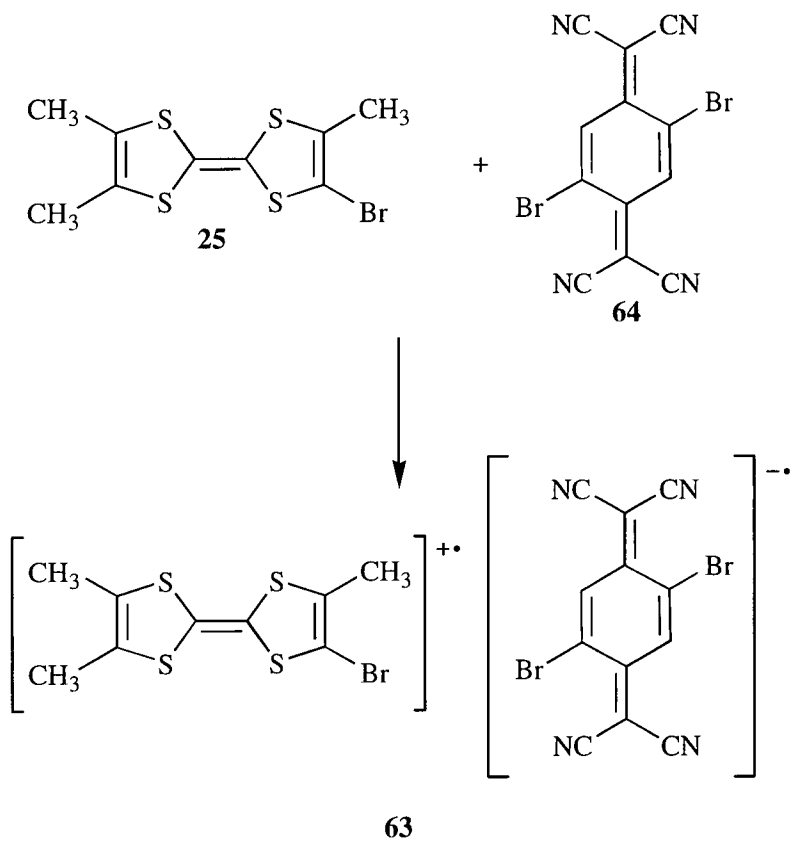

Scheme 2.23

2.6 CV Data

Insolubility or decomposition in solution prevented reliable CV data for **28a**, **28b** and **24** being recorded. Data obtained for **29a** and **55** are tabulated below alongside TTF and trimethyl-TTF for comparison.

Compounds	$E_{1/2}^1/V$	$E_{1/2}^2/V$
TTF 1 ^a	0.34	0.71
Me ₃ TTF 59 ^b	0.29	0.69
H ₂ (SCH ₂ CH ₂ CN) ₂ TTF 45 ^c	0.49	0.79
Br ₂ (SCH ₂ CH ₂ CN) ₂ TTF 29a ^d	0.65	0.89
(SEt) ₂ TTF 55 ^d	0.40	0.72

^aRef. 7; ^b Ref. 53; ^c Ref. 46.

^dElectrolyte solution for **29a** and **55**: 0.1 mol L⁻¹ TBA·ClO₄ in MeCN; potentials are quoted vs. Ag/AgCl.

The CV data obtained shows a moderate increase in the redox potential of TTF **29a** bearing two bromine atoms, relative to **45**. The data for **55** are consistent with a TTF derivative bearing two thioalkyl substituents (*cf.* **45**).

Chapter 3

Experimental

Experimental

3.1 Table of Abbreviations

DCM = methylene dichloride

THF = tetrahydrofuran

Et₂O = diethyl ether

MeCN = acetonitrile

LDA = lithium diisopropylamide

MgSO₄ = magnesium sulfate

CS₂ = carbon disulfide

ZnCl₂ = zinc chloride

MeOH = methanol

CsOH.H₂O = cesium hydroxide monohydrate

NMR = Nuclear Magnetic Resonance

3.2 General

Proton NMR spectra were recorded on Varian VXR 200 and Varian Gemini 200 instruments, operating at 200 MHz, and on a Varian VXR 300 instrument, operating at 300 MHz. Carbon-13 NMR spectra were recorded on Varian Gemini 200 and 400 instruments, operating at 200 and 400 MHz respectively. Chemical shifts are given in parts per million (ppm), and referenced to tetramethylsilane as the internal standard. *J* values are given in Hz. Infra-red spectra were recorded on a Perkin-Elmer 337 spectrophotometer. Mass spectra were obtained on a VG 7070E instrument with ionisation modes as indicated; the ionising gas used was ammonia. Melting points were recorded on a Kofler hot stage microscope apparatus and are uncorrected. The inert atmosphere used was argon, dried by passing through a column of phosphorus pentoxide. THF, Et₂O, toluene and MeCN were dried according to standard procedures.

3.3 Method A

Full data for compounds **36**, **40**, **28a** and **28b** could not be obtained owing to the instability of these materials in solution.

Vinylene trithiocarbonate (30) was prepared by the multistep route previously described³³ to afford the title compound **30** in 10% overall yield, mp 48-50 °C (lit.³³ 48-50 °C).

4,5-Diiodo-1,3-dithiol-2-thione (**36**) and 4-Iodo-1,3-dithiol-2-thione (**39**)

To a stirred solution of **30** (200 mg, 1.49 mmol) in dry THF (20 mL) at -78 °C under an inert atmosphere, was added LDA (3.0 mL, 4.47 mmol; 1.5M in cyclohexane) over 15 min. Stirring was continued for a further 3 h at -78 °C, whereupon iodine monochloride (0.23 mL, 4.47 mmol) was added and stirring continued for a further 1 h at -78 °C. The mixture was allowed to reach room temperature over 12 h. After evaporation of the solvent, the residue was extracted with DCM (3 x 100 mL). The organic extracts were combined, washed with water (2 x 100 mL), dried (MgSO₄) and the solvent removed *in vacuo* to afford a crude mixture of products. Separation of **36** and **39** was achieved by column chromatography (silica gel, eluent hexane - toluene 4 : 1 v / v) with compound **36** eluting first. The crude products were recrystallised from toluene / hexane to afford yellow needles of **36** (28 mg, 5%); mp 161-162 °C (dec.) [lit.³⁹ 128 °C (dec.), lit.⁴³ 162 °C], and **39** (90 mg, 25%); mp 95-96 °C.

36: found: C, 9.63%. C₃I₂S₃ requires C, 9.33%; MS (CI): *m/z* 387 (M⁺+1); ν_{\max} (KBr)/cm⁻¹ 1670 (C=S), 861 (C-I).

39: found: C, 13.82; H, 0.31%. C₃HIS₃ requires C, 13.85; H, 0.40%; δ_{H} (DMSO-d₆) 7.89 (1 H, s, vinyl H); δ_{C} (DMSO-d₆) 216.9 (C, s, C=S), 136.2 (C, s, C-H), 76.6 (C, s, C-I); MS (CI): *m/z* 261 (M⁺+1); ν_{\max} (KBr)/cm⁻¹ 1650 (C=S). The thermal stability of **39** was determined as follows: A solution of **39** (45 mg, 0.075 mmol) in dry toluene (10 mL) was refluxed under argon for 5 h. No colour change was observed. The solvent was removed *in vacuo* to afford a solid, which was found to be solely **39** by ¹H-NMR, mp 94-95 °C.

4,5-Dibromo-1,3-dithiol-2-thione (40) and 4-Bromo-1,3-dithiol-2-thione (41).

To a stirred solution of **30** (200 mg, 1.49 mmol) in dry Et₂O (20 mL) at -78 °C under an inert atmosphere was added LDA (3.0 mL, 4.47 mmol; 1.5M in cyclohexane) over 15 min. Stirring was continued for a further 3 h at -78 °C, whereupon a solution of *p*-toluenesulfonyl bromide **64** (1.06 g, 4.47 mmol) in dry Et₂O (10 mL) was added and stirring continued for a further 3 h at -78 °C. Work up and chromatography, as described for **36** and **39**, afforded products which were recrystallised from toluene / hexane, to afford golden crystals of **40** (40 mg, 10%); mp 90-92 °C (dec.), and **41** (27 mg, 9%); mp 92-95°C.

40: Found: C, 12.72%. C₃Br₂S₃ requires C, 12.33%; MS (EI): *m/z* 292 (M⁺); ν_{\max} (KBr)/cm⁻¹ 1672 (C=S) and 763 (C-Br).

41: Found: C, 17.49; H, 0.66%. C₃HBrS₃ requires C, 16.91; H, 0.47%; MS (EI): *m/z* 212, 214 (M⁺); δ_{H} (DMSO-d₆) 7.71 (1 H, s, vinyl H); δ_{C} (DMSO-d₆) 209.8 (C, s, C=S), 129.2 (C, s, C-H), 72.1 (C, s, C-Br).

Bis(tetraethylammonium)bis(1,3-dithiole-2-thione-4,5-dithiol) zincate (42) was prepared according to the literature procedure⁴⁴ from CS₂, sodium and ZnCl₂ in 58% yield, mp 202-203 °C (lit.⁴⁴ 206-208 °C).

4,5-Bis(2'-cyanoethylthio)-1,3-dithiol-2-thione (44) was prepared from **42** by the route previously described⁴⁶ to afford the title compound **44** in 70% yield, mp 77-78 °C (lit.⁴⁶ 80-81 °C).

4,5-Bis(2'-cyanoethylthio)-1,3-dithiol-2-one (27) was prepared from **44** by the route previously described⁴⁶ to afford the title compound **27** in 65% yield, mp 81-83 °C (lit.⁴⁶ 82-83 °C).

4-Iodo-4',5'-bis(2'-cyanoethylthio)-tetrathiafulvalene (28b).

Compounds **39** (50 mg, 0.1 mmol) and **27** (250 mg, 0.90 mmol) were dissolved in neat triethyl phosphite. The resultant solution was refluxed under argon for 3 h. Triethyl phosphite was removed by distillation to afford the products **28b** and **45**.

28b: δ_{H} (CDCl₃) 6.45 (1 H, s, vinyl H), 3.0-3.1 (4 H, t, *J* 7, CH₂CN), 2.70-2.80 (4 H, t, *J* 7, CH₂S); MS (CI): 501 (M⁺+1), 375.

45: δ_{H} (CDCl₃) 6.36 (2 H, s, vinyl H), 2.8 (4 H, t, *J* 7, CH₂CN), 2.6 (4 H, t, *J* 7, CH₂S); MS (CI): 375 (M⁺+1).

4,5-Diiodo-4',5'-bis(2'-cyanoethylthio)-tetrathiafulvalene (28a).

To a mixture of **36** (55 mg, 0.14 mmol) and **27** (164 mg, 0.60 mmol) in dry toluene (10 mL) was added triethyl phosphite (0.13 mL, 0.71 mmol). The resultant solution was refluxed under argon for 5 h. Removal of the solvent *in vacuo* afforded a solid, which was purified by column chromatography on silica gel, employing DCM as the eluent, to afford dark orange microcrystals of the product **28a** (41 mg, 45%); mp 102-103 °C. Found: C, 22.82; H, 1.18; N, 4.54%. C₁₂H₈I₂N₂S₆ requires C, 23.01; H, 1.29; N, 4.47%; MS (DCI): *m/z* 627 (M⁺+1), 501 (M-I⁺); δ_{H} (CDCl₃) 3.14 (4 H, t, *J* 7, CH₂CN), 2.79 (4 H, t, *J* 7, CH₂S).

4-Iodo-4',5'-bis(2'-cyanoethylthio)-tetrathiafulvalene (28b).

To a mixture of **39** (60 mg, 0.1 mmol) and **27** (265 mg, 0.92 mmol) in dry toluene (12 mL) was added triethyl phosphite (0.19 mL, 1.15 mmol). The resultant solution was refluxed under argon for 5 h. Work up and purification as for **28a** above gave pale orange microcrystals of the product **28b** (55 mg, 47%); mp 86-88 °C. Found: C, 29.47; H, 2.22; N, 5.14. C₁₂H₉IN₂S₆ requires C, 28.80; H, 1.81; N, 5.43%; MS (DCI): *m/z* 501 (M⁺+1); δ_{H} (CDCl₃) 6.45 (1 H, s, vinyl H), 3.08 (4 H, t, *J* 7, CH₂CN), 2.74 (4 H, t, *J* 7, CH₂S).

4,5-Dibromo-4',5'-bis(2'-cyanoethylthio)-tetrathiafulvalene (29a).

To a stirred solution of **40** (100 mg, 0.35 mmol) and **27** (400 mg, 1.4 mmol) in dry toluene (25 mL) under an inert atmosphere was added triethyl phosphite (0.35 mL, 2.0 mmol) and the mixture brought to reflux for 4.5 h. Removal of the solvent *in vacuo* afforded the crude product, which was purified by column chromatography on silica gel, initially using hexane as the eluent to remove excess triethyl phosphite, followed by DCM as the eluent to afford the product **29a** as dark yellow crystals (69 mg, 38%); mp 132-134 °C. Found: C, 27.15; H, 1.66; N, 5.18%. C₁₂H₈Br₂N₂S₆ requires C, 27.07; H, 1.51; N, 5.26%; MS (DCI): *m/z* 534, 536 (M⁺ + 1), 454, 456 (M-Br⁺); δ_{H} (CDCl₃) 3.13 (4 H, t, *J* 7, CH₂CN), 2.79 (4 H, t, *J* 7, CH₂S); δ_{C} (CDCl₃) 117.25 (C, s, CN), 31.60 (C, s, CH₂S), 18.9 (C, s, CH₂CH₂CN); CV (vs. Ag / AgCl) E₁^{1/2} = 0.65 V, E₂^{1/2} = 0.89 V. A solution of **29a** (10 mg) in dry MeCN (7 mL) was stoppered and left over several days at

22 °C to grow crystals of **29a** which were suitable for X-ray crystallographic studies. Crystal data for **29a** are shown in Appendix 1.

p-Toluenesulfonyl bromide was prepared from sodium toluene-4-sulfinate by the literature method⁴¹ to afford the title compound in 85% yield, mp 94-96 °C (lit.⁴¹ 96 °C).

4,5-Dibromo-4',5'-methylthio-tetrathiafulvalene (23ai)

To a stirred solution of **29a** (100 mg, 0.22 mmol) in dry THF (20 mL) was added a solution of CsOH.H₂O (35 mg, 0.21 mmol) in dry MeOH (5 mL) in one portion. Stirring was continued for a further 0.5 h, whereupon an excess of iodomethane (0.3 mL) was added and stirring continued for a further 2 h. After evaporation of the solvent and excess iodomethane, the residue was dissolved in DCM (30 mL), washed with water (3 x 30 mL), dried (MgSO₄) and the solvent removed *in vacuo* to afford the crude product which was purified by column chromatography (silica gel, eluent hexane - DCM 1 : 1 v / v) to afford pale orange-yellow crystals of the product **23ai** (9 mg, 9%); mp 121-122 °C.

Preparation of 23ai⁺ I₃⁻. The salt **23ai⁺ I₃⁻** was prepared by diffusion of iodine vapour into an acetonitrile solution of **23ai** in a sealed container at room temperature. Crystal data for **23ai⁺ I₃⁻** are shown in Appendix 2.

4,5-Dibromo-4'-cyanoethylthio-5'-ethylthio-tetrathiafulvalene (23aiii).

To a stirred solution of **29a** (100 mg, 0.19 mmol) in dry THF (20 mL) was added a solution of CsOH.H₂O (35 mg, 0.21 mmol) in dry MeOH (4 mL) in one portion. Stirring was continued for a further 0.5 h, whereupon an excess of iodoethane (0.2 mL) was added and stirring continued for a further 2 h. Work-up, as for **23ai** above, afforded pale orange crystals of the product **23aiii** (51 mg, 53%); mp 102-104 °C. Found: C, 25.92; H, 1.66; N, 2.84. C₁₁H₉Br₂NS₆ requires C, 26.04; H, 1.79; N, 2.76%; MS (DCI): *m/z* 509, 511 (M⁺ + 1); δ_H (CDCl₃) 2.96 (2 H, t, *J* 7, CH₂CH₂CN), 2.81 (2 H, q, *J* 7, CH₂CH₃), 2.62 (2 H, t, *J* 7, CH₂CN), 1.26 (3 H, t, *J* 7, CH₃); ν_{max} (KBr)/cm⁻¹ 2924 (aliphatic CH), 2249 (CN) and 735 (C-Br).

4,5-Bis(2'-cyanoethylthio)-2-methylthio-1,3-dithiolium

trifluoromethylsulfinate (51) was prepared by a variation of the literature method⁵⁰, using methyl trifluorosulfonate as the methylating agent, to afford the crude product **51** as a green-brown solid (4.90 g, 75%); mp 90-92 °C.

4,5-Bis(2'-cyanoethylthio)-2-methylthio-1,3-dithiole (52) was prepared from **51** by the literature method⁵⁰ described to afford the title compound **52** in 94% yield, mp 83-84 °C (ref.⁵⁰ 83-84 °C).

Triphenyl-[4,5-bis(2'-cyanoethylthio)-1,3-dithiol-2-yl]phosphonium

tetrafluoroborate (49) was prepared according to the literature procedure⁵⁰ previously described in 93% yield, mp 129-130 °C (lit.⁵⁰ 130-131 °C).

2-Methylthio-1,3-dithiolium trifluoromethylsulfinate (53) was synthesised according to the literature route⁵¹, again employing methyl trifluorosulfonate, to afford the crude product **53** as a pale brown oil (3.01 g, 96%).

2-Methylthio-1,3-dithiole (54) was prepared from **53** by the literature method⁵¹ to afford the title compound **54** in 87 % yield, mp 101-102 °C (lit⁵¹. 102-103 °C).

1,3-Dithiolium tetrafluoroborate (50) was prepared according to the literature procedure⁵¹ previously described in 91 % yield, mp 115-116°C (lit⁵¹ 116-117 °C).

4,5-Bis(2'-cyanoethylthio)-tetrathiafulvalene (45) was prepared from **49** and **50** by the literature method⁵⁰ to afford the title compound **45** as a dark red oil in 51% yield.

4,5-Bis(ethylthio)-tetrathiafulvalene (55).

To a stirred solution of **45** (220 mg, 0.59 mmol) in dry THF (40 mL) was added a solution of CsOH.H₂O (350 mg, 2.1 mmol) in dry MeOH (10 mL) in one portion. Stirring was continued for a further 0.5 h, whereupon an excess of iodoethane (0.2 mL) was added and stirring continued for a further 2 h. After evaporation of the solvent and excess iodoethane, the residue was dissolved in DCM (50 mL), washed with water (2 x 30 mL), dried (MgSO₄) and the solvent removed *in vacuo* to afford the crude product. The product was purified by column chromatography (silica gel, eluent hexane - DCM 3 : 1 v / v), to afford the product as an oil. Another column, employing the solvent system hexane - DCM 10 : 1 v / v afforded the product **55** as a dark, viscous oil (51 mg, 53%).

δ_{H} (d_6 -acetone) 6.66 (2 H, s, vinyl H), 2.89 (4 H, q, J 7, CH_2), 1.29 (6 H, t, J 7, CH_3); Found: C, 37.12; H, 3.87%. $\text{C}_{10}\text{H}_{12}\text{S}_6$ requires C, 37.01; H, 3.73%; CV (vs. Ag / AgCl) $E_1^{1/2} = 0.40$ V, $E_2^{1/2} = 0.72$ V.

4-(2'-cyanoethylthio)-5-(methylthio)tetrathiafulvalene (56).

To a stirred solution of **45** (220 mg, 0.59 mmol) in dry THF (30mL) was added a solution of CsOH.H₂O (114 mg, 0.65 mmol) in dry MeOH (7 mL) in one portion. Stirring was continued for a further 1 h, whereupon iodomethane (0.1 mL) was added and stirring continued for a further 2 h. After evaporation of the solvent and excess iodomethane, the residue was dissolved in DCM (50 mL), washed with water (3 x 40 mL), dried (MgSO_4) and the solvent removed *in vacuo* to afford the crude product. The product was purified by column chromatography (silica gel, eluent hexane - DCM 1 : 1 v / v), to afford a dark yellow powder of the product **56** (62 mg, 31 %); mp 68-69 °C. Found: C, 35.55; H, 2.48; N, 4.01%. $\text{C}_{10}\text{H}_9\text{NS}_6$ requires C, 35.80; H, 2.70; N, 4.17%; δ_{H} (CDCl_3) 6.35 (2 H, s, vinyl H), 3.02 (2 H, t, J 7, CH_2CN), 2.70 (2 H, t, J 7, CH_2S), 2.47 (3 H, s, CH_3).

3.4 Method B

4,5,4',5'-Tetraiodotetrathiafulvalene (**24**)[‡].

To a stirred solution of **1** (100 mg, 0.5 mmol) in dry THF (15 mL) at -50 °C under an inert atmosphere, was added a solution of LDA (2.67 mL, 4.0 mmol; 1.5M in cyclohexane) over 20 min. Stirring was continued for a further 1 h at -50 °C, whereupon perfluorohexyl iodide (0.86 mL, 4 mmol) was added and stirring continued at -50 °C for 1 h. The mixture was allowed to reach room temperature over 12 h. After evaporation of the solvent, the residue was extracted with CS₂ (2 x 70 mL), filtered, and the solvent evaporated *in vacuo* to afford the crude product. Two recrystallisations from chlorobenzene afforded red, needle-like crystals of the product **24** (52 mg, 15%); mp 201-203 °C (lit.³⁹ 175 °C (dec.); 203 °C⁵³). Found: C, 11.72%. C₆S₄I₄ requires C, 10.18; MS (DCI): *m/z* 708 (M⁺), 582 (M-I⁺), 457 (M-2I⁺), 331 (M-3I⁺).

[‡] This procedure was provided by Professor V. Khordorkovsky, Ben Gurion University of the Negev.

4-Iodo-4',5,5'-trimethyltetrathiafulvalene (60) was prepared from **59**⁵⁴ to afford the title compound **60** in 21% yield, mp 180 °C (ref.⁵⁴ 183 °C).

4-Bromo-4',5,5'-trimethyltetrathiafulvalene (**25**).

To a stirred solution of **59** (200 mg, 0.813 mmol) in dry Et₂O (25 mL) at -78 °C under an inert atmosphere was added a solution of LDA (0.6 mL, 0.894 mmol; 1.5M in cyclohexane) over 15 min. A yellow precipitate formed after 10 min, and stirring was continued for a further 3 h at -78 °C. 1,2-Dibromotetrafluoroethane (0.41 mL, 0.894 mmol) was added and stirring continued at -78 °C for 2 h. The mixture was allowed to warm to room temperature and stirred for 12 h. After evaporation of the solvent, the residue was extracted with Et₂O (3 x 100 mL). The organic extracts were combined, washed with water (3 x 100 mL), dried (MgSO₄) and the solvent evaporated *in vacuo* to afford the crude product. Recrystallisation from MeCN afforded **25** as red crystals (40 mg, 15%); mp 181-183 °C. Found: C, 33.47; H, 2.69%. C₉H₉S₄Br requires C, 33.23; H, 2.79%; MS (DCI): *m/z* 325, 327 (M⁺ + 1); δ_H (CDCl₃) 2.10 (3 H, s, CH₃), 2.03 (6 H, s, CH₃); δ_C (CDCl₃) 131.70, 122.81, 112.83, 61.23, 16.26, 13.46, 13.27; ν_{max} (KBr)/cm⁻¹ 2957 (aliphatic C-H), 1648 (C=C) and 911 (C-Br).

Preparation of [25⁺] [2⁻] (47). Solutions of **25** (10 mg, 0.031 mmol) and **2** (5 mg, 0.031 mmol), dissolved in the minimum volume of hot MeCN, were mixed together and left to stand for 1 h. The solid which formed was filtered and dried *in vacuo* to afford the salt **62** (8 mg, 50%). Found: C, 46.92; H, 2.37; N, 10.24. C₂₁H₁₃BrN₄S₄ (*i.e.* 1:1 stoichiometry) requires C, 47.62; H, 2.47; N, 10.58%; ν_{\max} (KBr)/cm⁻¹ 2200 (conj. CN).

Preparation of [25⁺] [Br₂TCNQ⁻] (63). Solutions of **25** (10 mg, 0.031 mmol) and **64** (10 mg, 0.031 mmol), dissolved in the minimum volume of hot MeCN, were mixed together and left to stand for 2 h. The solid formed was filtered and dried *in vacuo* to afford the salt **63** (10 mg, 47%). Found: C, 36.68; H, 1.32; N, 9.10%. C₂₁H₁₁Br₃N₄S₄ (*i.e.* 1 : 1 stoichiometry) requires C, 36.70; H, 1.61; N, 8.15%; ν_{\max} (KBr)/cm⁻¹ 2208 (conj. CN).

References

- 1 H. W. Gibson, F. C. Bailey, A. J. Epstein, H. Rommelmann, S. Kaplan, J. Harbour, X.-O. Yang, D. B. Tanner and J. M. Pochan, *J. Am. Chem. Soc.*, 1983, **105**, 4417.
- 2 H. Akamatu, H. Inokuchi and Y. Matsunaga, *Nature (London)*, 1954, **173**, 168.
- 3 D. S. Acker and W. R. Hertler, *J. Am. Chem. Soc.*, 1962, **84**, 3370.
- 4 L.R. Melby, R.J. Harder, W.R. Hertler, W. Mahler, R.E. Benson and W.E. Mochel, *J. Am. Chem. Soc.*, 1962, **84**, 3374.
- 5 F. Wudl, D. Wobschall and E. J. Hufnagel, *J. Am. Chem. Soc.*, 1972, **94**, 671.
- 6 For general reviews, see; a) M. R. Bryce and L. C. Murphy, *Nature (London)*, 1984, **309**, 119; b) Bechgaard and D. Jerome, *Sci. Amer.*, 1982, **247**, 50; c) D.O. Cowan and F.M. Wiygul, *Chem. and Eng. News*, 1986, **64 (29)**, 28.
- 7 F. Wudl, G. M. Smith and E. J. Hufnagel, *J. Chem. Soc. Chem. Commun.*, 1970, 1453.
- 8 J. Ferraris, D.O. Cowan, V.V. Walatka and J.H. Perlstein, *J. Am. Chem. Soc.*, 1973, **95**, 948.
- 9 J. M. Williams, J. R. Ferraro, R. J. Thorn, K. D. Carlson, U. Geiser, H. H. Wang, A. M. Kini and M.-H. Whangbo, *Organic Superconductors (Including fullerenes)*, Prentice Hall inc., New Jersey, 1992.
- 10 E.M. Engler and V.V. Patel, *J. Am. Chem. Soc.*, 1974, **96**, 7376.
- 11 a) D. Jerome, A. Mazand, M. Ribault and K. Bechgaard, *J. Physique Lett.*, 1980, **41**, L95; b) K. Bechgaard, C. S. Jacobsen, K. Mortensen, H. J. Pedersen and N. Thorup, *Solid State Commun.*, 1980, **33**, 1119.
- 12 A. E. Underhill, *J. Mater. Chem.*, 1992, **2**, 1-11.
- 13 M. R. Bryce, *J. Mater. Chem.*, 1995, **5**, 1481.
- 14 M. Adam and K. Mullen, *Adv. Mater.*, 1994, **6**, 439.
- 15 T. E. Phillips, T. J. Kistenmacher, J. P. Ferraris and D. O. Cowan, *J. Chem. Soc., Chem. Commun.*, 1973, 471.
- 16 R. E. Peierls, *Quantum Chemistry of Solids*, Clarendon Press: New York, 1964.
- 17 R.P. Shibaeva, E.B. Yagubskii, E.E. Lavkhina and V.N. Laukhin, *The Physics and Chemistry of Organic Superconductors*, ed. G. Saito and S. Kogoshima, Springer-Verlag, Berlin, 1990, *Springer Proceedings in Physics*, **51**, 342.
- 18 G. R. Desiraju, *Angew. Chem. Int. Ed. Engl.*, 1995, **34**, 2311.
- 19 K. Takahashi and T. Ise, *Heterocycles*, 1997, **45**, 1051.

- 20 P. Blanchard, K. Boubekeur, M. Salle, G. Duguay, M. Jubault, A. Gorgues, J. D. Martin, E. Canadell, P. Auban-Senzier, D. Jerome and P. Batail, *Adv. Mater.*, 1992, **4**, 579.
- 21 A. M. Kini, M. A. Beno, K. D. Carlson, J. R. Ferraro, U. Geiser, A. J. Schultz, H. H. Wang, J. M. Williams and M.-H. Whangbo, *The Physics and Chemistry of Organic Superconductors*, ed. G. Saito and S. Kogoshima, Springer-Verlag, Berlin, 1990, *Springer Proceedings in Physics*, **51**, 334.
- 22 D.C. Green, *J. Org. Chem.*, 1979, **44**, 1476.
- 23 A. S. Batsanov, M. R. Bryce, G. Cooke, A. S. Dhindsa, J. N. Heaton, J. A. K. Howard, A. J. Moore and M. C. Petty, *Chem. Mater.*, 1994, **6**, 1419.
- 24 C. Wang, J. Y. Becker, J. Bernstein, A. Ellern and V. Khodorkovsky, *J. Mater. Chem.*, 1995, **5**, 1559.
- 25 M. Jorgensen and K. Bechgaard, *Synthesis*, 1989, 207.
- 26 M. R. Bryce and G. Cooke, *Synthesis*, 1991, 263.
- 27 I. S. Butler and J. F. Harrod, *Inorganic Chemistry: Principles and Applications*, 1989, The Benjamin/Cummings Publishing Company. pp 59-61.
- 28 J. Y. Becker, J. Bernstein, S. Bittner, L. Shahal and S. S. Shaik, *J. Chem. Soc., Chem. Commun.*, 1991, 92.
- 29 A. S. Batsanov, A. J. Moore, N. Robertson, A. Green, M. R. Bryce, J. A. K. Howard and A. E. Underhill, *J. Mater. Chem.*, 1997, **7**, 387.
- 30 T. Imakubo, H. Sawa and R. Kato, *Synthetic Metals*, 1995, **73**, 117.
- 31 J. Becher, J. Lau, P. Leriche, P. Mork and N. Svenstrup, *J. Chem. Soc., Chem. Commun.*, 1994, 2715.
- 32 J. Becher, G. J. Kristensen, P. Mork, O. Simonsen, N. Svenstrup and K. B. Simonsen, *Synthesis*, 1996, 407.
- 33 A. J. Moore and M. R. Bryce, *Synthesis*, 1997, 407.
- 34 a) J. Le Costumer and Y. Mollier, *J. Chem. Soc., Chem. Commun.*, 1980, 38;
b) M. Salle, A. Gorgues, J.-M. Fabre, K. Bechgaard, M. Jubault and F. Texier, *J. Chem. Soc., Chem. Commun.*, 1989, 1520; c) A. Gorgues, P. Batail and A. Le Coq, *J. Chem. Soc., Chem. Commun.*, 1983, 405.
- 35 M. G. Miles, J. S. Wagner, J. D. Wilson and A. R. Seidle, *J. Org. Chem.*, 1975, **40**, 2577.
- 36 L. Binet, J.-M. Fabre, C. Montginoul, K. B. Simonsen and J. Becher, *J. Chem. Soc., Perkin Trans. 1*, 1996, 783.

- 37 M. R. Bryce, *Aldrichimica Acta.*, **18**, 73.
- 38 S. Yoneda, T. Kawase, M. Inaba and Z. Yoshida, *J. Org. Chem.*, 1978, **43**, 595.
- 39 R. Gompper, J. Hock, K. Polborn, E. Dormann and H. Winter, *Adv. Mater.*, 1995, **7**, 41.
- 40 K. Takimiya, Y. Aso and T. Otsubo, *Chem. Lett.*, 1995, 735.
- 41 R. F. Kovar, M. D. Rausch and H. Rosenberg, *Organometallics in Chemical Synthesis*, 1970, **1**, 173.
- 42 T. Imakubo, H. Sawa and R. Kato, *Synthetic Metals*, 1997, **86**, 1883.
- 43 J. Garin, personal communication.
- 44 C. Wang, A. S. Batsanov, M. R. Bryce and J. A. K. Howard, *Synthesis*, 1998 in press.
- 45 N. Svenstrup and J. Becher, *Synthesis*, 1995, 215.
- 46 N. Svenstrup, K. M. Rasmussen, T. K. Hansen and J. Becher, *Synthesis*, 1994, 809.
- 47 R. S. Rowland and R. Taylor, *J. Phys. Chem.*, 1996, **100**, 7384.
- 48 T. Imakubo, H. Sawa and R. Kato, *Synthetic Metals*, 1997, **86**, 1847.
- 49 M. Iyoda, Y. Kuwatani, K. Hara, E. Ogura, H. Suzuki, H. Ito and T. Mori, *Chem. Lett.*, 1997, 599.
- 50 T. K. Hansen, M. V. Lakshmikantham, M. P. Cava, R. M. Metzger and J. Becher, *J. Org. Chem.*, 1991, **56**, 2720.
- 51 M. Fourmigue, F. C. Krebs and J. Larsen, *Synthesis*, 1993, 509.
- 52 V. Khodorkovsky, personal communication.
- 53 A. J. Moore, M. R. Bryce, A. S. Batsanov, J. C. Cole and J. A. K. Howard, *Synthesis*, 1995, 675.
- 54 A. J. Moore, unpublished work.
- 55 J. S. Chappell, A. N. Bloch, W. A. Bryden, M. Maxfield, T. O. Poehler and D. O. Cowan, *J. Am. Chem. Soc.*, 1981, **103**, 2442.

Appendix 1
Crystal Data for 29a

Table 1. Crystal data and structure refinement for 1.

Identification code	98srv018
Empirical formula	C12 H8 Br2 N2 S6
Formula weight	532.38
Temperature	150(2) K
Wavelength	0.71073 Å
Crystal system	Orthorhombic
Space group	Pbca
Unit cell dimensions	a = 14.609(1) Å alpha = 90 deg. b = 11.607(1) Å beta = 90 deg. c = 21.020(1) Å gamma = 90 deg.
Volume	3564.3(4) Å ³
Z	8
Density (calculated)	1.984 g/cm ³
Absorption coefficient	5.246 mm ⁻¹
F(000)	2080
Crystal size	0.4 x 0.3 x 0.25 mm
Theta range for data collection	1.9 to 30.5 deg.
Index ranges	-20 ≤ h ≤ 20, -16 ≤ k ≤ 16, -27 ≤ l ≤ 28
Reflections collected	27012
Independent reflections	5108 [R(int) = 0.0566]
Observed reflections, I > 2σ(I)	4324
Absorption correction	Integration
Max. and min. transmission	0.3664 and 0.1762
Refinement method	Full-matrix least-squares on F ²
Data / restraints / parameters	5086 / 0 / 231
Goodness-of-fit on F ²	1.209
Final R indices [I > 2σ(I)]	R1 = 0.0291, wR2 = 0.0571
R indices (all data)	R1 = 0.0411, wR2 = 0.0655
Largest diff. peak and hole	.387 and -.552 e.Å ⁻³

Appendix 2
Crystal Data for $23\text{ai}^+ \text{I}_3^-$

Table 1. Crystal data and structure refinement for 1.

Identification code	98asb005
Empirical formula	C8 H6 Br2 I3 S6
Formula weight	835.01
Temperature	150(2) K
Wavelength	0.71073 Å
Crystal system	Orthorhombic
Space group	Cmcm
Unit cell dimensions	a = 7.098(1) Å alpha = 90 deg. b = 16.255(1) Å beta = 90 deg. c = 16.541(1) Å gamma = 90 deg.
Volume	1908.5(3) Å ³
Z	4
Density (calculated)	2.906 g/cm ³
Absorption coefficient	9.741 mm ⁻¹
F(000)	1516
Crystal size	0.3 x 0.3 x 0.04 mm
Theta range for data collection	2.4 to 30.5 deg.
Index ranges	-9 ≤ h ≤ 9, -22 ≤ k ≤ 21, -23 ≤ l ≤ 21
Reflections collected	9133
Independent reflections	1508 [R(int) = 0.0557]
Observed reflections, I > 2σ(I)	1345
Absorption correction	Integration
Max. and min. transmission	0.6776 and 0.0928
Refinement method	Full-matrix least-squares on F ²
Data / restraints / parameters	1504 / 0 / 69
Goodness-of-fit on F ²	1.188
Final R indices [I > 2σ(I)]	R1 = 0.0245, wR2 = 0.0561
R indices (all data)	R1 = 0.0305, wR2 = 0.0614
Extinction coefficient	0.00064(7)
Largest shift/e.s.d. ratio	0.001
Largest diff. peak and hole	1.042 and -0.880 e.Å ⁻³

